

## **4.5 Culvert Construction**

### **4.5.1 General**

There are two major classes of culvert installations, based upon the conditions that influence loads: 1) trenched, where culverts are placed in natural ground or compacted fill with a controlled trench width and 2) embankments, where culverts are usually placed in natural ground but are covered by a constructed embankment. A third method of installation for placing culverts is boring and jacking, used where deep installations are necessary or where conventional open excavation is not practical.

- Trenched

Trench installations are made in relatively narrow excavations on a carefully prepared bedding to distribute the load and the culvert is covered with earth backfill that extends to the ground surface. The trench load theory is based on the following assumptions:

- Earth loads on the pipe develop as the backfill settles.
- The resulting earth load on the pipe is equal to the weight of the material above the top of the pipe minus the shearing (frictional) forces on the side of the trench.
- Cohesion is negligible because, with cohesive soils, considerable time must elapse before effective cohesion between the backfill material and the sides of the trench can develop, and with cohesionless soils, would never develop. The assumption of no cohesion yields the maximum probable load on the pipe.
- For a rigid pipe, the side fills may be relatively compressible and the pipe will carry a large portion of the load over the entire width of the trench.
- For rigid pipe, active lateral pressure is neglected, which, in effect, increases the required pipe strength. (However, it should be taken into account if investigations and experience indicate such pressure is significant.)

For flexible culverts, a well-compacted soil envelope of adequate width is needed to develop the lateral pressures required to maintain the shape of the culvert. The width is a function of the strength of the surrounding in-situ soil and the size of the pipe.

The backfill load ultimately transmitted to the pipe is a function of the trench width. With rigid culvert placement, the determination of the backfill load is based on the trench width and a pipe strength is selected to withstand that load. **If the actual trench width exceeds the width assumed in design, the load on the culvert will be greater than estimated and structural distress may result.**

Figure 4-13 illustrates the load carried by a rigid culvert installed in a normal trench installation.

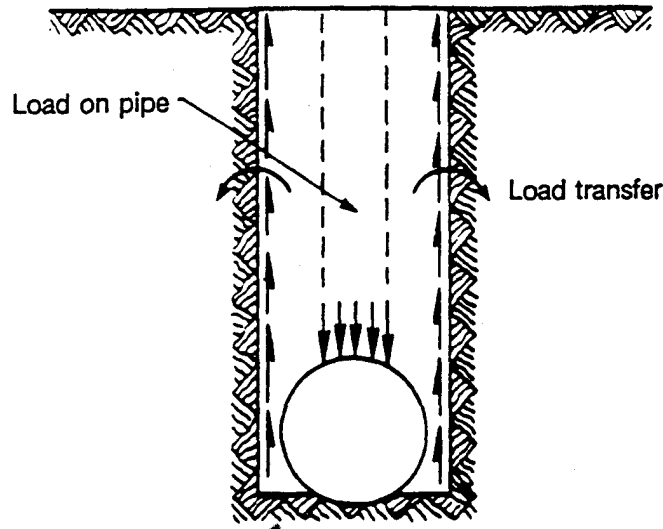

**Figure 4-13 Trench installation**

Figure 4-14 illustrates the increased load on the rigid culvert if the width of the trench is increased.

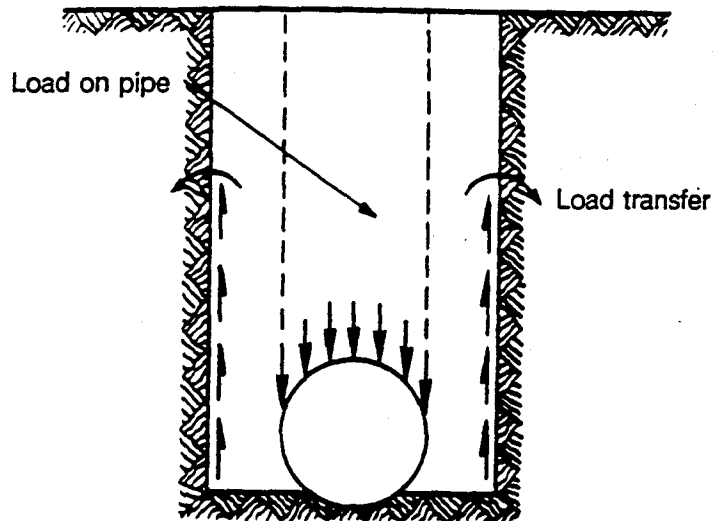

**Figure 4-14 Wide trench installation**

If an excessively wide trench is excavated or if the sides are sloped back, the culvert can be installed in a narrow subtrench excavated at the bottom of the wider trench, as shown in Figure 4-15, to avoid an increase in the backfill load.

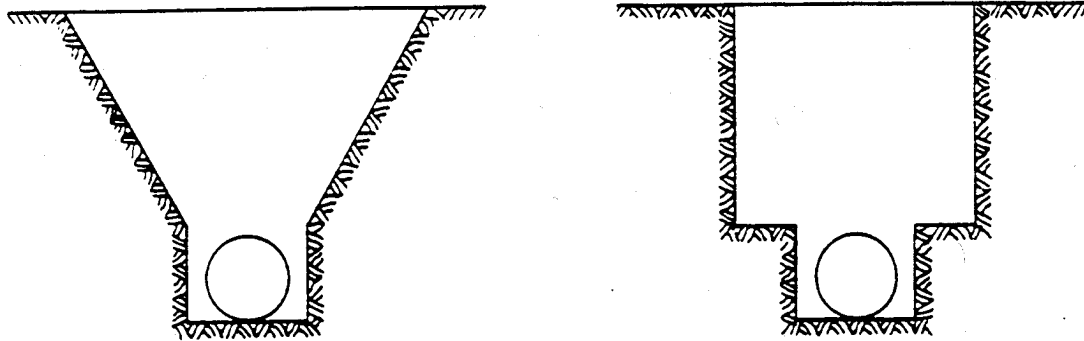

**Figure 4-15 Subtrench installation in a wide trench**

- **Bedding** - A stable and uniform foundation is necessary for the satisfactory performance of any culvert. Once a stable and uniform foundation is provided, the bedding should be prepared in accordance with the plans and specifications.

The bedding preparation is critical to both structural performance and service life. An important function of the bedding is to provide uniform support along the barrel of each pipe section. The bed should be placed to uniform grade and line to ensure good vertical alignment and to avoid excessive stresses at joints. The bed material should be free of rock formations, protruding stones, frozen lumps, roots, and other foreign matter that may cause unequal settlement. When a corrugated metal culvert is being placed, the corrugations should be firmly seated in the foundation material.

Transverse or circumferential cracks in rigid pipe may be caused by poor bedding. Cracks can occur across the bottom of the pipe (broken belly) when the pipe is only supported at the ends of each section. This is generally the result of poor installation practices such as not providing indentions (bell holes) in hard foundation material for the ends of bell and spigot-type pipe or not providing a sufficient depth of suitable bedding material. Cracks may occur across the top of pipe (broken back) when settlement occurs and rocks or other areas of hard foundation material near the midpoint of a pipe section are not adequately covered with suitable bedding material. Transverse cracking is illustrated in Figure 4-16.

The bedding distributes the load reaction around the lower periphery of the pipe. The required supporting strength of the pipe is directly related to this load distribution. Pipe set on a flat foundation without bedding results in high load, concentration at the bottom of the pipe and is likely to result in shear cracking of the pipe at the five o'clock and seven o'clock locations. Figure 4-17 illustrates how the distribution of the bedding over increasing percentages of the outside diameter can increase the supporting strength of the culvert. Any time a pipe is installed on a flat-bottom foundation, it is essential that the bedding material be uniformly compacted under the haunches of the culvert.

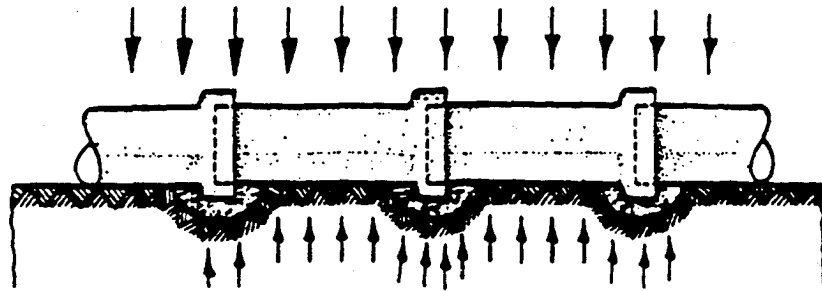

Properly prepared bedding evenly distributes loads.  
Improperly prepared bedding may result in stress concentrations.

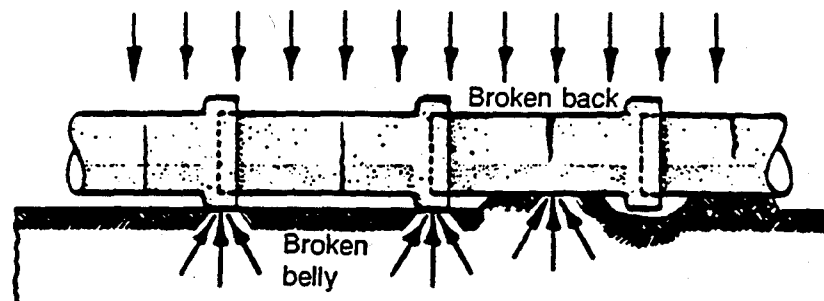

Improperly prepared bedding.

**Figure 4-16 Transverse or circumferential cracks**

- **Backfilling** - The backfill is made up of two areas that may require different material and separate compaction criteria. The first area extends from the bedding to approximately 300 mm (12 inches) above the culvert. The second area includes the remaining fill.

The load-carrying capacity of an installed culvert depends largely on the initial backfilling around the culvert. Since proper compaction of backfill material is so important, material and density criteria is often included in the bedding requirements.

For trench installations, where space is limited, tamping by pneumatic or mechanical impact tampers is usually the most effective means of compaction. Impact tampers are most effective for clay soils while granular soils are consolidated best by vibration. Backfill material should be placed in layers not exceeding 150 mm (6 inches) deep, deposited alternately on opposite sides of the culvert.

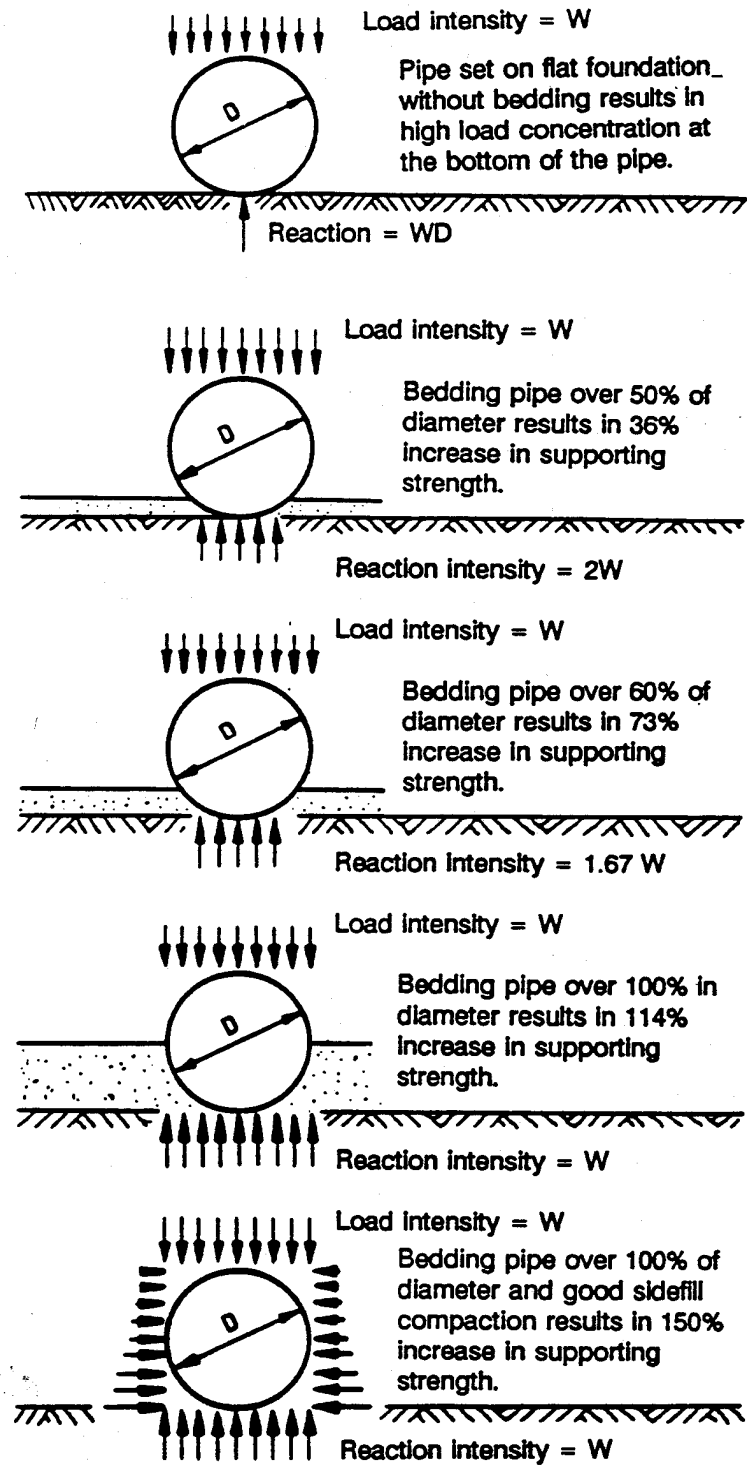
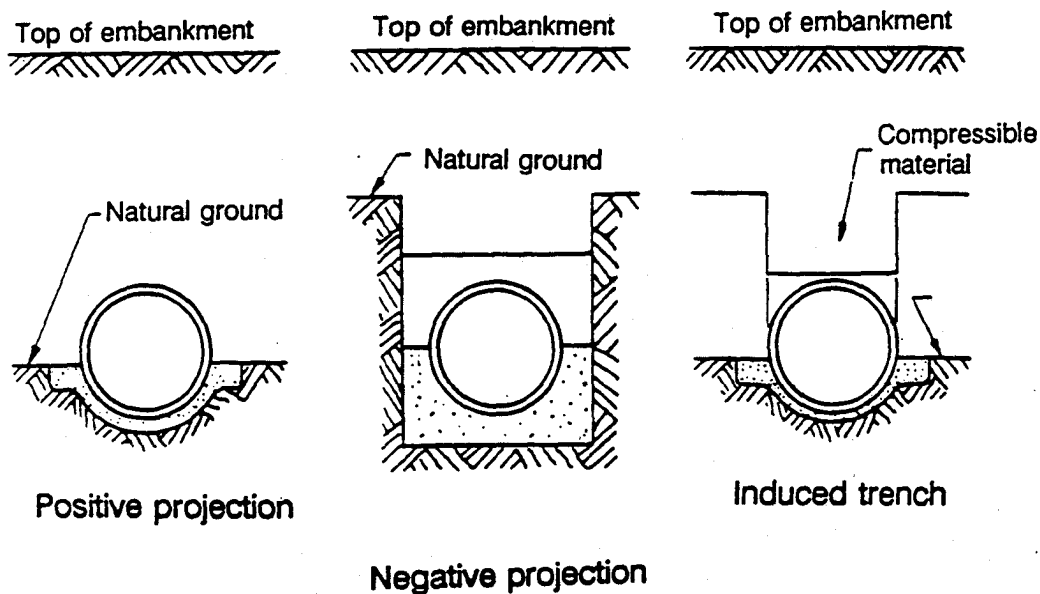

Figure 4-17 Correlation of bedding and supporting strength for rigid pipe

- **Embankments**

Culverts placed in an embankment are usually bedded in natural ground and are overlaid by a constructed embankment. The required supporting strength of a buried pipe is determined by the total load that is imposed upon the pipe. The magnitude of the load is influenced by the uniformity and stability of the support soil, as well as conditions around and over the pipe. However, the load-carrying capability of rigid culverts is essentially carried by the structural strength of the pipe itself since rigid pipe is stiffer than the surrounding soil. A well-compacted soil envelope is required to develop the lateral pressures necessary to maintain the shape of flexible culverts.

Embankment installations can be divided into three groups: positive projection, negative projection, and induced trench. The essential features of these types of installations are shown in Figure 4-18. Refer to ConnDOT Standard Sheets and Standard Specifications for trench and embankment pipe installation.



**Figure 4-18 Essential features of various types of installation**

Positive projection pipe is installed with the top of the pipe projecting above the surface of the natural ground, or compacted fill, and then covered with earth fill. Negative projection pipe is installed in relatively shallow trenches so that the top of the pipe is below the level of the natural ground or compacted fill. It is then covered with earth fill to the required depth. The induced trench pipe is usually installed as positive projection. However, when the fill has been placed to a depth of at least one pipe diameter over the proposed top of the pipe, a trench is excavated over the pipe and backfilled with a more compressible material.

- **Bored, Augured or Jacked**

The process of tunneling and jacking pipe culverts is used where deep installations are necessary or where conventional open excavation and backfill methods may not be practical.

The usual procedure in jacking pipe is to equip the leading edge with a cutter, or shoe, to protect the pipe. As succeeding lengths of pipe are added between the lead pipe and the jacks, and the pipe is jacked forward, soil is excavated and removed through the pipe. Material is trimmed so that the bore size slightly exceeds the outside diameter of the pipe and excavation does not precede the jacking operation more than is necessary. Such a procedure usually results in minimum disturbance to the natural soils adjacent to the pipe. A minimum 36" diameter is usually required for conventional jacking operations. A typical installation for jacking Pipe is shown in Figure 4-19.

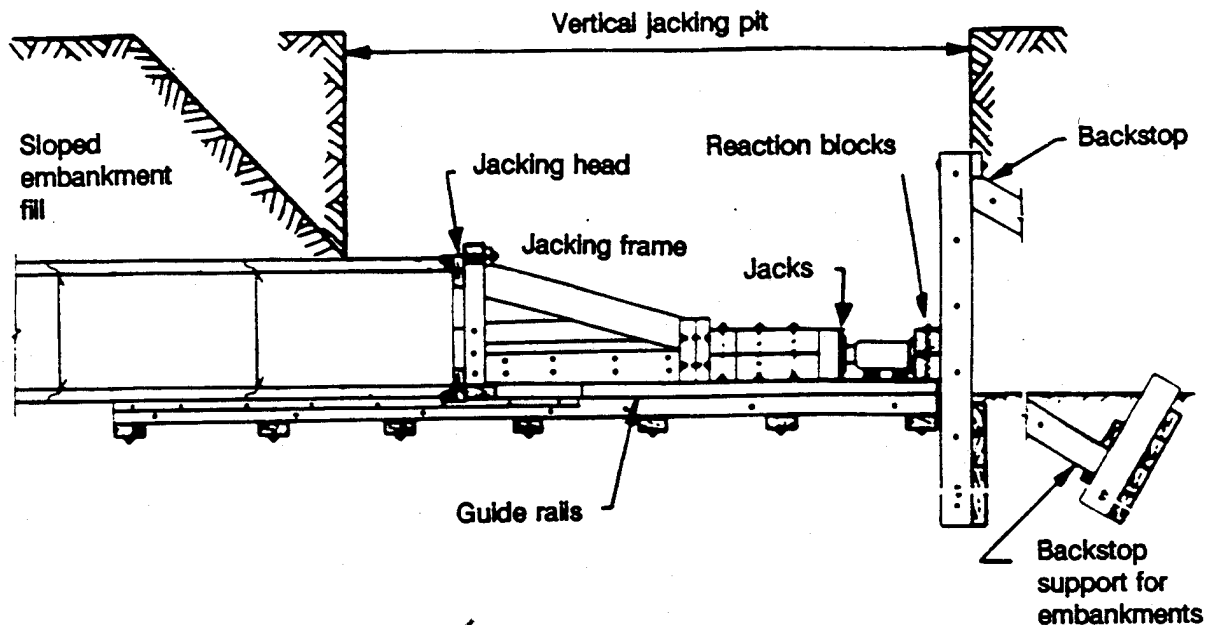

**Figure 4-19 Typical jacking installation**

A lubricant, such as a bentonite slurry, is sometimes pumped into the space between the tunnel bore and the outside of the pipe to reduce the frictional resistance. After the jacked pipe has reached its final position, grout is frequently pumped into the same space to, ensure continuous bearing with the surrounding soil.

Two types of loads are imposed upon concrete pipe installed by the jacking method: the axial load due to the jacking pressures applied during installation; and the earth loading due to the overburden, with some possible influence from live loadings, which generally become effective only after installation is completed.

There are several advantages to jacking pipe:

- Traffic is not interrupted on the overlying roadway.
- Depth of the installation is not a concern.
- Cutting and patching of the pavement can be avoided.
- Minimum disturbance to the natural soils is experienced.
- Loads on the pipe are less than loads in trenched installations.

The disadvantages are:

- Expensive equipment and skilled operators are required.
  - There must be adequate room within the right-of-way to construct the jacking pit.
- More detailed information can be found in the *Concrete Pipe Handbook* and *Design Data 13. Jacking Concrete Pipe*, both from the American Concrete Pipe Association.

- **Tunneling**

Tunneling techniques may be appropriate where a drainage structure must pass through an embankment or under a roadway or railway when open cutting is found to be too costly or too disruptive. Steel tunnel liner plates can be used to support an underground excavation. The design criteria set forth in AASHTO LRFD Bridge Design Specifications section 12.13 must be followed. Tunnel liner plates can also be used in the relining of existing structures when access is limited.

#### **4.5.2 Culvert Installation Methods**

The performance of culverts and their appurtenances is dependent on practices during installation. Items that require particular attention during design and construction of new culverts and repairs include:

- **Backfills and Fills**

Suitable backfill material and adequate compaction are of critical importance. A well-compacted soil envelope is needed to develop the lateral pressures required to maintain the shape of flexible culverts. Well-compacted backfill is also important to the performance of rigid culverts to prevent such things as settlement of the roadway and movement of water along the barrel. The design must specify material type and degree of compaction. Care should be taken that the backfill material does not contribute to corrosion of the culvert.

- **Trench Width**

Trench width can significantly affect the earth loads on rigid culverts. It is, therefore, important that trench widths be specified on the plans and that the specified width for rigid pipe not be exceeded without authorization from the design engineer. For flexible culverts a minimum trench width backfilled with premium backfill material is required to provide adequate side support. A narrower width of premium backfill for flexible pipe should not be provided without authorization from the design engineer.



- **Foundations and Bedding**

A foundation capable of providing uniform and stable support is important for both flexible and rigid culverts. Establishing a suitable foundation requires removal and replacement of any hard spots or soft spots. Bedding is needed to level out any irregularities in the foundation and to ensure uniform support. When using flexible culverts, bedding should be shaped to a sufficient width to permit compaction of the remainder of the backfill, and enough loose material should be placed on top of the bedding to fill the corrugations. When using rigid culverts, the bedding should conform to the bedding conditions specified in the plans and should be shaped to allow compaction and to provide clearance for the bell ends on bell and spigot-type rigid pipes. Adequate support is critical in rigid pipe installations, or shear stress may become a problem. The necessary details, when different from ConnDOT Standard Sheets, should be provided to the Soils and Foundations Section for approval.

- **Construction Loads**

Culverts are generally designed for the loads they must carry after construction is completed. Construction loads may exceed design loads. These heavy loads can cause damage if construction equipment crosses over the culvert installation before adequate fill has been placed or moves too close to the trench walls, creating unbalanced loadings. Additional protective fill or other measures may be needed for equipment crossing points.

- **Camber**

In high fills the center of the embankment may settle more than the areas under the embankment side slopes. In such cases it may be necessary to camber the foundation slightly, as shown in Figure 4-20. This should be accomplished by using a flat grade on the upstream half of the culvert and a steeper grade on the downstream half of the culvert. The initial grades should not cause water to pond or pocket. The method and dimensions for cambering should be coordinated with the Soils and Foundations Section.

- **Materials**

During construction, the materials delivered must be exactly as specified. Inadequate thickness, size, or quality of material can lead to maintenance problems or failure. During installation the materials must be handled properly to prevent defects and loss of intended shape, size, or quality.

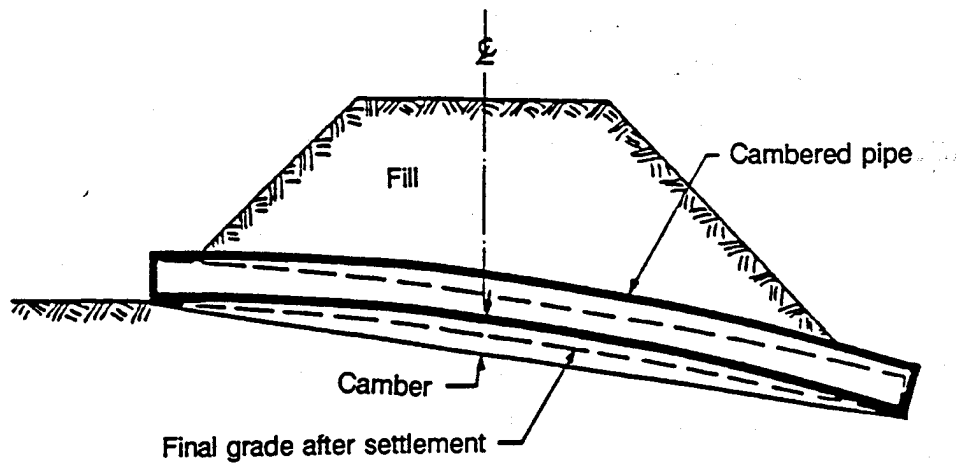

**Figure 4-20 Camber allows for settlement of a culvert under a high fill**