



# **BRIDGE DESIGN MANUAL**

**2003 Edition**  
(U.S. Customary Units)

**State of Connecticut**  
**Department of Transportation**

Revisions: 07/04, 11/04, 01/05, 03/05, 01/09, 03/09, 02/11, 04/19, 12/19, 12/22, 09/23

This Page is Intentionally Left  
Blank

## **INTRODUCTION**

The Division of Bridges publishes the Bridge Design Manual (**BDM**) to provide engineering and detailing standards, criteria, and guidelines to designers and detailers who design and analyze bridges and highway-related structures for the Connecticut Department of Transportation (**CTDOT**).

The use of the **BDM** is required of anyone performing design or analysis of bridges and highway-related structures for the **CTDOT**.

The **BDM**, supplemented by other **CTDOT** manuals, Engineering and Construction Directives Bulletins and Policy Statements, is the vehicle by which the design and rehabilitation of bridges and highway-related structures is implemented. Presented is a compilation of design, detail and plan presentation practices, specification interpretations and guidelines which constitute the Bridge Design Standard Practices of the **CTDOT**.

The design practices in the **BDM** have been established primarily for application to short and medium span bridges and other highway-related structures using conventional construction methods. These practices are subject to re-examination and may not, in some cases, be applicable to long spans, major river crossings or multi-level interchange complexes. For design requirements not described in the **BDM**, the designer should refer to Section 1.

While the **BDM** attempts to unify and clarify standard practices for design, it does not preclude justifiable deviations, subject to the concurrence of the **CTDOT**, provided the deviations are based on sound engineering principles. Good design practice will always require a combination of basic engineering principles, experience and judgment in order to furnish the best possible design within reasonable economic limitations.

To reflect changes to standard practices, revisions to the **BDM** will be issued periodically as Engineering and Construction Directives and Bulletins. The Engineering and Construction Directives and Bulletins are mandatory and supersede the current **BDM**. Recommendations for changes to the **BDM** are welcome, and should be submitted in writing to the **CTDOT** via the Division Chief of Bridges.

The **BDM** is provided in a searchable PDF format and is accessible via the **CTDOT** Internet Website.

<https://portal.ct.gov/DOT/State-Bridge-Design/State-Bride-Design-Manuals>

Please note that while it is possible for those with PDF editing software to download and modify the **BDM** PDF, the only recognized official version shall be the document that is provided on the **CTDOT** Internet Website.

For additional information regarding the **CTDOT**, visit the Department's Home Page located at:

<https://portal.ct.gov/DOT>

This Page is Intentionally Left  
Blank

## **PREFACE**

The Connecticut Department of Transportation Bridge Design Manual (**BDM**) has the following Divisions and Sections:

### **DIVISION 1 – STANDARD DESIGN PRACTICES AND PROCEDURES**

- Section 1 - General Design Requirements
- Section 2 - Design Submissions & Contract Documents
- Section 3 – Loads
- Section 4 - Seismic Design and Retrofit
- Section 5 - Abutments, Piers and Walls
- Section 6 - Concrete Structures
- Section 7 - Steel Structures
- Section 8 - Decks and Deck Protective Systems
- Section 9 – Bearings
- Section 10 - Deck Joints
- Section 11 - Surface Drainage
- Section 12 - Bridge Rails and Barriers
- Section 13 - Buried Structures
- Section 14 - Sign Supports
- Section 15 - Utility Installations
- Section 16 - Bridge Repair & Rehabilitation (VACANT)
- Section 17 - Post Design Responsibilities (VACANT)

### **DIVISION 2 – CONTRACT PLAN NOTES, TABLES & NOTICES**

- Appendix “A” - Plan Notes
- Appendix “B” - Structural Steel Notes

### **DIVISION 3 – DESIGN AIDS**

- Section 1 – General (VACANT)
- Section 2 - Bridge Geometry (VACANT)
- Section 3 - Substructure Details
- Section 4 - Structural Steel Details
- Section 5 - Prestressed Concrete Details
- Section 6 - Bridge Deck Details
- Section 7 - Expansion Joint Details
- Section 8 - Bridge Railing and Approach Rail Details
- Section 9 – Rehabilitation
- Section 10 - Buried Structures
- Section 11 - Sign Support (VACANT)

This Page is Intentionally Left  
Blank

**Revision 09/23**

---

**SECTION 5 ABUTMENTS, PIERS AND WALLS**

<b>Rev. 12/19 Article</b>	<b>Rev. 09/23 Article</b>	<b>Description of Change</b>
5.14.1	5.14.1	Article rewritten. Additional scour guidance has been added. Presented in two column format to mirror AASHTO LRFD BDS. Includes supplements to relevant articles.
5.14.1.1	-	Removed and replaced. See changes for Article 5.14.1.
5.14.1.1.1	-	Removed and replaced. See changes for Article 5.14.1.
5.14.1.1.2	-	Removed and replaced. See changes for Article 5.14.1.
5.14.1.2	-	Removed and replaced. See changes for Article 5.14.1.

**Revision 09/23**

---

**DIVISION 2 - APPENDIX A - PLAN NOTES**

<b>Rev. 12/19 Article</b>	<b>Rev. 09/23 Article</b>	<b>Description of Change</b>
A.3	-	Removed.
A.4	-	Removed.



**Revision 09/23**

---

**DIVISION 2 - APPENDIX B - PLAN NOTES**

<b>Rev. 12/19 Article</b>	<b>Rev. 09/23 Article</b>	<b>Description of Change</b>
B.3-2	B.3-2	Note revised.

This Page is Intentionally Left  
Blank

**DIVISION 1**

**STANDARD DESIGN PRACTICES  
AND  
PROCEDURES**

This Page is Intentionally Left  
Blank

**SECTION 1**  
**GENERAL DESIGN REQUIREMENTS**

**TABLE OF CONTENTS**

1.1 DESIGN SPECIFICATIONS (*Rev. 04/19*) ..... 1-1

    1.1.1 State of Connecticut, Department of Transportation: (CTDOT) ..... 1-1

    1.1.2 American Association of State Highway  
        and Transportation Officials (AASHTO) (*Rev. 12/19*) ..... 1-1

    1.1.3 American Railroad Engineering and Maintenance-of-Way Association (AREMA): .... 1-2

    1.1.4 American Welding Society (AWS): ..... 1-2

    1.1.5 American Society for Testing and Materials (ASTM): ..... 1-2

    1.1.6 Federal Highway Administration (FHWA): ..... 1-2

    1.1.7 Prestressed Concrete Institute (PCI): ..... 1-3

    1.1.8 Society for Protective Coatings (SSPC): ..... 1-3

1.2 ABBREVIATED REFERENCES (*Rev. 12/19*) ..... 1-3

1.3 LOAD RATINGS (*Rev. 04/19*) ..... 1-3

    1.3.1 General (*Rev. 12/19*) ..... 1-3

    1.3.2 Components for Evaluation (BLRM [1.5]) ..... 1-4

    1.3.3 Condition Factor (BLRM [4.1.2]) (*Rev. 12/19*) ..... 1-4

    1.3.4 System Factor (BLRM [4.1.3]) ..... 1-5

    1.3.5 Average Daily Truck Traffic (BLRM [4.1.4]) ..... 1-5

    1.3.6 Permit Load Rating (BLRM [4.4]) ..... 1-5

    1.3.7 Minimum Acceptable Rating Factors (*Rev. 12/19*) ..... 1-6

1.4 TRANSPORTATION OF STRUCTURAL MEMBERS  
    AND COMPONENTS (*Rev. 04/19*) ..... 1-7

    1.4.1 Background ..... 1-7

    1.4.2 Design Requirements ..... 1-8

1.5 BRIDGE INSPECTION AND EVALUATION REQUIREMENTS (*Rev. 04/19*) ..... 1-9

    1.5.1 Inspection Access ..... 1-9

    1.5.2 Notice to Bridge Inspectors ..... 1-9

    1.5.3 Inspection Manuals ..... 1-9

1.6 DESIGN FEATURES (*Rev. 04/19*) ..... 1-10

    1.6.1 General Features of Design ..... 1-10

        1.6.1.1 Width ..... 1-10

Connecticut Department of Transportation Bridge Design Manual

1.6.1.2 Sidewalks .....	1-10
1.6.1.3 Cross Section .....	1-10
1.6.1.4 Profile.....	1-11
1.6.1.4.1 Clearances .....	1-11
1.6.1.4.1.1 Structures Adjacent to or Crossing over Roadways ( <i>Rev. 11/04</i> ).....	1-11
1.6.1.4.1.2 Structures Crossing over Waterways .....	1-11
1.6.1.4.1.3 Structures Adjacent to or Crossing over Railroads.....	1-11
1.6.1.4.1.4 Through-Truss Highway Bridges .....	1-12
1.6.1.4.1.5 Railway Bridges .....	1-12

## **SECTION 1** **GENERAL DESIGN REQUIREMENTS**

### **1.1 DESIGN SPECIFICATIONS** *(REV. 04/19)*

The design and details of all structures and structure components shall conform to the requirements set forth in the latest editions, including the interim or updated specifications, of the following publications, as modified and amended by the **BDM** and other **CTDOT** manuals and publications:

#### **1.1.1 State of Connecticut, Department of Transportation: (CTDOT)**

- Standard Specifications for Roads, Bridges, Facilities and Incidental Construction, Form (latest)
- Bridge Load Rating Manual
- Highway Design Manual
- Drainage Manual
- Geotechnical Engineering Manual

#### **1.1.2 American Association of State Highway and Transportation Officials (AASHTO)** *(Rev. 12/19)*

- AASHTO LRFD Bridge Design Specifications
- The Manual for Bridge Evaluation
- AASHTO Guide Specifications for LRFD Seismic Bridge Design
- AASHTO LRFD Bridge Design Guide Specifications for GFRP-Reinforced Concrete
- AASHTO LRFD Guide Specifications for Design of Concrete-Filled FRP Tubes
- AASHTO LRFD Movable Highway Bridge Design Specifications
- AASHTO LRFD Road Tunnel Design and Construction Guide Specifications
- Bridge Security Guidelines
- Guide Specifications for Bridges Vulnerable to Coastal Storms
- Guide Specifications for Design and Construction of Segmental Bridges,
- Guide Specifications for Design of Bonded FRP Systems for Repair and Strengthening of Concrete Bridge Elements
- Guide Specifications for Design of FRP Pedestrian Bridges
- Guide Specifications for Internal Redundancy of Mechanically-Fastened Built-Up Steel Members
- Guide Specifications for Seismic Isolation Design
- Guide Specifications for the Design of Concrete Bridge Beams Prestressed with Carbon Fiber-Reinforced Polymer (CFRP) Systems
- LRFD Guide Specifications for Accelerated Bridge Construction
- LRFD Guide Specifications for the Design of Pedestrian Bridges,
- LRFD Specifications for Structural Supports for Highway Signs, Luminaires, and Traffic Signals
- Technical Manual for Design and Construction of Road Tunnels - Civil Elements

## Connecticut Department of Transportation Bridge Design Manual

- AASHTO LRFD Bridge Construction Specifications
- Guide Design Specifications for Bridge Temporary Works
- Construction Handbook for Bridge Temporary Works
- Guide Specifications for Wind Loads on Bridges During Construction
- A Policy on Design Standards - Interstate System
- A Guide to Standardized Highway Barrier Hardware
- Manual for Assessing Safety Hardware, Second Edition (2016)
- AASHTO Roadside Design Guide
- Standard Specifications for Transportation Materials and Methods of Sampling and Testing

### **1.1.3 American Railroad Engineering and Maintenance-of-Way Association (AREMA):**

- Manual for Railway Engineering

### **1.1.4 American Welding Society (AWS):**

- Bridge Welding Code ANSI/AASHTO/AWS D1.5
- Structural Steel Welding Code ANSI/AWS D1.1
- Structural Welding Code - Aluminum ANSI/AWS D1.2
- Structural Welding Code - Reinforcing Steel ANSI/AWS D1.4
- Guide for the Protection of Steel with Thermal Sprayed Coatings of Aluminum and Zinc and Their Alloys and Composites ANSI/AWS C2.18

### **1.1.5 American Society for Testing and Materials (ASTM):**

- Annual Book of ASTM Standards

### **1.1.6 Federal Highway Administration (FHWA):**

- FHWA Technical Advisory T5140.32, Uncoated Weathering Steel in Structures, dated October 3, 1989
- FHWA-IP-89-016, Design of Riprap Revetments, Hydraulic Engineering Circular No. 11 (HEC-11), March 1989
- FHWA-NHI-01-002, Stream Stability at Highway Structures, Hydraulic Engineering Circular No. 20 (HEC-20), 2001
- FHWA-NHI-01-001, Evaluating Scour at Bridges, Hydraulic Engineering Circular No. 18 (HEC-18), 2001
- FHWA-SA-92-010, Bridge Deck Drainage System, Hydraulic Engineering Circular No. 21 (HEC-21), May 1993
- FHWA-HRT-17-080, Design and Construction Guidelines for Geosynthetic Reinforced Soil Abutments and Integrated Bridge Systems, June 2018



**1.1.7 Prestressed Concrete Institute (PCI):**

- Manual for Quality Control for Plants and Production of Precast and Prestressed Concrete Products MNL-116

**1.1.8 Society for Protective Coatings (SSPC):**

- Steel Structures Painting Manual, Vol. 1, Good Painting Practice
- Steel Structures Painting Manual, Vol. 2, Systems and Specifications

**1.2 ABBREVIATED REFERENCES** (Rev. 12/19)

The following is a list of abbreviated references used in the **BDM** for the preceding design specifications:

<b>Design Specification</b>	<b>Abbreviated Reference</b>
CTDOT Bridge Design Manual	BDM
CTDOT Form (latest)	Standard Specifications
CTDOT Bridge Load Rating Manual	BLRM
CTDOT Highway Design Manual	HDM
AASHTO LRFD Bridge Design Specifications	LRFD
AASHTO Manual for Bridge Evaluation	MBE
AASHTO Manual for Assessing Safety Hardware	MASH
Manual for Railway Engineering	AREMA
Bridge Welding Code	AWS D1.5
Structural Steel Welding Code	AWS D1.1
Structural Welding Code – Aluminum	AWS D1.2
Structural Welding Code – Reinforcing Steel	AWS D1.4

References throughout the **BDM** use the following syntax:

- To reference a publication, only the abbreviated reference in a bold font is used. For example, **BLRM**.
- To reference a division, section or table in a publication, the abbreviated reference in a bold font followed by a description with a numerical reference in brackets is used. For example, **LRFD** [Table 3.5.1.1].
- To reference an article in a publication, the abbreviated reference in a bold font followed by a numerical reference in brackets is used. For example, **LRFD** [3.6.1.2].

**1.3 LOAD RATINGS** (Rev. 04/19)

**1.3.1 General** (Rev. 12/19)

Load rating requirements are based on the following general scope of work categories:

- New structure/superstructure replacement – includes new and replacement buried structures, superstructure replacements, new structures and full bridge replacements
- Major structure rehabilitation – includes deck replacement, structure widening, structural steel repair and modifications to buried structures
- Minor structure rehabilitation – includes deck patching, resurfacing and safety improvements

Design, legal, permit and emergency vehicle live load ratings shall be performed for all new/replacement bridges and buried structures, and existing bridges and buried structures where rehabilitation/repair of the structure will affect the live load rating in accordance with the **BLRM**, amended as follows:

- All existing bridges and buried structures undergoing minor structure rehabilitation need not be load rated provided a load rating, including the CT-TLC rating, is on file with **CTDOT** that reflects the final condition of the structure after completion of the minor rehabilitation and that meets the requirements of the **BLRM**.

Design, legal, permit and emergency vehicle live load ratings shall be performed for all temporary bridges in accordance with the **BLRM**. The design vehicle live load rating at the inventory level only is not required for temporary bridges that will be in service less than 3 years. The permit vehicle live load rating is not required if the permit vehicles are restricted from using the temporary bridge.

*Commentary: All existing bridges and buried structures undergoing minor structure rehabilitation with resurfacing shall be load-rated to determine if they are adequate for the construction equipment used to remove/place the HMA overlay. If resurfacing increases the overlay thickness on an existing bridge, or additional dead load is added to the bridge, a load rating is required.*

### **1.3.2 Components for Evaluation (BLRM [1.5])**

The bridge components requiring load rating shall be in accordance with the **BLRM**, amended as follows:

- For new bridges and bridges undergoing major structure rehabilitation, the pier caps and columns of all single column and multi-bent piers shall be evaluated.

### **1.3.3 Condition Factor (BLRM [4.1.2]) (Rev. 12/19)**

Condition factors shall be in accordance with the **BLRM**, amended as follows:

For new bridges, the value of the condition factor used in the rating analysis shall be 1.00.

For bridges undergoing a superstructure replacement or major structure rehabilitation, the existing members and component to be rated shall be rehabilitated to a good/satisfactory condition or better, allowing the use of a condition factor with a value of 1.00, unless otherwise indicated in **BLRM**.

For bridges undergoing minor structure rehabilitation and requiring a load rating, the value of the condition rating factor shall reflect the structural condition of the member. The **CTDOT** shall be notified if the value of the condition factor used in the rating is less than 0.95.

#### **1.3.4 System Factor (BLRM [4.1.3])**

System factors shall be in accordance with the **BLRM**, amended as follows:

The use of system factors that correspond to the **LRFD** load factor modifiers for load rating is not allowed.

#### **1.3.5 Average Daily Truck Traffic (BLRM [4.1.4])**

The average daily truck traffic shall be in accordance with **BLRM**, amended as follows:

For new bridges and bridges undergoing a superstructure replacement, load factors for legal and permit load ratings shall be based on average daily truck traffic (ADTT), in one direction, greater than 5000.

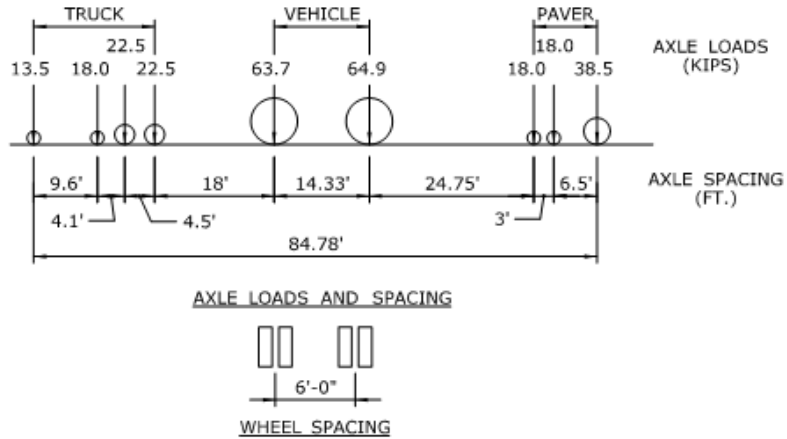
For bridges undergoing other major structure rehabilitation, the average daily truck traffic shall be in accordance with **BLRM** [4.1.1].

#### **1.3.6 Permit Load Rating (BLRM [4.4])**

Permit vehicle load ratings shall be performed for permit vehicles in accordance with the **BLRM**, amended as follows:

A load rating shall be performed, on all projects for which a load rating evaluation is required, for the following vehicle, load factor criteria and analysis parameters:

Permit load vehicle: CT-TLC (Paving Train)  
Permit Type: Special or Limited Crossing  
Frequency: Single Trip  
Loading Condition: Mix with traffic  
Distribution Factor: One lane  
Dynamic Load Allowance: 0.00



Note: TLC = tri-load combination of vehicles in paving train

**CT-TLC PERMIT LIVE LOAD VEHICLE**

279.6 kip on 9 axles

**1.3.7 Minimum Acceptable Rating Factors (Rev. 12/19)**

The minimum acceptable design, legal, permit and emergency vehicle rating factors for permanent bridges, are based on the general scope of work categories, and shall be no less than the values shown in Table 1.3.7-1.:

**Table 1.3.7-1**

<b>Rating Procedure</b>	<b>Minimum Acceptable Rating Factor (RF)</b>		
	<b>New Structure/ Superstructure Replacement</b>	<b>Major Structure Rehabilitation</b>	<b>Minor Structure Rehabilitation</b>
Design Load Rating, Evaluation Level – Inventory	1.20	1.20, unless permitted in writing by the CTDOT.	Report value
Design Load Rating, Evaluation Level – Operating	Report value	Report value	1.00, unless permitted in writing by the CTDOT.
Legal Load Rating	1.20	1.20, unless permitted in writing by the CTDOT.	1.00, unless permitted in writing by the CTDOT.
Permit Load Rating	1.20	1.20, unless permitted in writing by the CTDOT.	Report value, may be less than 1.00

Rating Procedure	Minimum Acceptable Rating Factor (RF)		
	New Structure/ Superstructure Replacement	Major Structure Rehabilitation	Minor Structure Rehabilitation
Permit Load Rating, CT-TLC	1.10	1.10, unless permitted in writing by the CTDOT.	Report value, may be less than 1.00
Emergency Vehicle Rating	1.20	1.20, unless permitted in writing by the CTDOT.	1.00, unless permitted in writing by the CTDOT.

The above table applies to all limit states. Fatigue and Service limit states shall be included under the “Design Load Rating Evaluation Level - Inventory” requirements in Table 1.3.7-1.

The minimum acceptable design, legal, permit and emergency vehicle rating factors for temporary bridges shall be 1.00.

When required, written permission shall be obtained from the Principal Engineer.

*Commentary: The target minimum acceptable rating factor of 1.20 was selected to account for future deterioration of members and components that would require the use of a condition factor of 0.85 and result in a rating factor greater than 1.00.*

## **1.4 TRANSPORTATION OF STRUCTURAL MEMBERS AND COMPONENTS** (REV. 04/19)

### **1.4.1 Background**

In general, the length, width, height and weight of a prefabricated structural member or component for use in a highway, pedestrian or railway structure is limited by the ability to ship the item over State highways and bridges.

These physical properties are indirectly limited by the vehicle regulations in the *Connecticut General Statutes*. The *General Statutes* include the following limitations on the dimensions of vehicles using State highways without the need for a permit:

- Vehicle Width (Section 14-262(a)(1)) - The width of a vehicle and combination vehicle and trailer, including its load, is limited to 8’-6”, without a permit.
- Vehicle Length (Section 14-262(c)) - The length of the semi-trailer portion of a tractor-trailer unit, including its load, is limited to 48 feet, without a permit.
- Vehicle Height (Section 14-264) - The height of a vehicle, with its load, is limited to 13’-6”, without a permit.

- Vehicle Weight (Section 14-267a(b)(8)) - The gross vehicle weight (weight of vehicle including its load) is limited to 80,000 pounds, on vehicles with a 51 feet wheelbase, without a permit.
- Axle Weights of Vehicles (Section 14-267a) - The axle weights of vehicles vary and are determined by vehicle type and axle spacing.

Section 14-270 of the *General Statutes* assigns authority to the Commissioner of Transportation to grant permits for vehicles exceeding the limits of the vehicular regulations.

To facilitate construction of the **CTDOT** projects, Policy Statement HO-10 was developed. It states that the **CTDOT** will grant a permit via an authorized permit route for the transportation of “any structural beam (member or component) that measures 120 feet or less and weighs no greater than 120,000 pounds provided the individual axle weights on the vehicle and trailer transporting the beam (member or component) do not exceed 20,000 pounds.” The phrase “structural beam” may be interpreted to mean any structural member or component.

### **1.4.2 Design Requirements**

The vehicle regulations of the *General Statutes* and **CTDOT** Policy Statement HO-10 establish design guidelines for the length, width, height and weight of prefabricated structural members and components.

To avoid problems associated with transporting materials during construction, prefabricated structural members or components that will require a permit to be transported should be identified early in the design phase.

The maximum member or component shipping length, width, height and weight shall be shown on the contract plans. For the preliminary submissions, the best available information should be shown on the plans. The actual, as designed, shipping lengths, widths, heights and weights should be shown on the plans for the final submission for review.

The shipping information will be reviewed by the **CTDOT** Oversize and Overweight Permits Section, which will determine if the members are transportable.

If a member exceeds the length and weight limits of **CTDOT** Policy Statement HO-10, the designer must submit adequate justification with a preliminary submission to **CTDOT**. If sufficient justification exists, the **CTDOT** Office of Engineering will request a waiver of HO-10 and confirmation that a permit will be granted to transport the member in accordance with Section 14-270 of the *General Statutes* from the **CTDOT** Oversize and Overweight Permits Section.

If a member, when transported, will exceed the height and width limits of the *General Statutes*, the designer must submit adequate justification with a preliminary submission to **CTDOT**. If sufficient justification exists, the **CTDOT** Office of Engineering will request confirmation that a permit will be granted to transport the member in accordance with Section 14-270 of the *General Statutes* from the **CTDOT** Oversize and Overweight Permits Section.

The special provision entitled “Section 1.06 - Control of Materials” should be included in all projects. This special provision addresses the shipping of materials in accordance with the *Connecticut General Statutes* and the **CTDOT** Policy Statement HO-10.

If a member exceeds the height and width limits of the *General Statutes* or the length and weight limits of HO-10, and the **CTDOT** Oversize and Overweight Permits Section confirms that a permit will be granted in accordance with Section 14-270 of the *General Statutes* to transport the member, the project’s contract documents should indicate that the **CTDOT** has confirmed with the Oversize/Overweight permit office that the proposed members are eligible to be “Permitted” in accordance with the **CTDOT** Permitting Regulations.

## **1.5 BRIDGE INSPECTION AND EVALUATION REQUIREMENTS (REV. 04/19)**

### **1.5.1 Inspection Access**

Per a recommendation in Administration Memorandum No. 80, all bridges shall include features, both off and on the structure, that will make them accessible to bridge inspectors and facilitate the future inspection of the structure. These features may include a shelf at the face of the abutment stem, ladder stops on slopes, catwalks, ladders, access doors (in bottom flanges and the ends of box girders), hand rails and cables, lighting and electrical outlets, and any other facility necessary for the inspection of the structure. The features may also include the design and placement of structural members and components (such as generous bridge seats for box girder structures, internal cross frames and bracing in box girders) that allow access for bridge inspectors.

For bridges that are excessively wide, where normal inspection equipment cannot access the interior members, the bridge may require permanent movable inspection platforms or permanent catwalks. The need for and type of permanent inspection platforms shall be determined by the **CTDOT**.

### **1.5.2 Notice to Bridge Inspectors**

As a result of a recommendation in Administration Memorandum No. 80, the Designer shall note on the General Plan any members and components needing special attention, such as fracture critical members, during the inspection of the structure. This information shall be contained in the “Notice to Bridge Inspectors” block.

The “Notice to Bridge Inspectors” block shall be shown on the Structure Layout for Design (SL/D) Plans and fully completed on the Final Plans for Review.

### **1.5.3 Inspection Manuals**

For movable bridges, segmental bridges and other bridges as directed by **CTDOT**, the Designer shall provide an inspection manual. The manual should contain the instructions, procedures, check lists, diagrams and details necessary to perform a complete in-depth

inspection of the various members and components of the bridge. Inspection manuals shall be submitted with the final submission for review.

## **1.6 DESIGN FEATURES (REV. 04/19)**

### **1.6.1 General Features of Design**

#### **1.6.1.1 Width**

Generally, the curb to curb width of highway bridges shall match the approach roadway (including shoulders). For highway bridges with off or on ramps, the curb to curb width shall match the geometry required for the roadway. Greater bridge widths may be necessary to meet sight distance requirements, to facilitate the maintenance of traffic and stage construction requirements or to accommodate standard width structural members.

Per Section 13a-86 of the *Connecticut General Statutes*, any bridge constructed or reconstructed on a State maintained highway with two or more lanes shall have a clear width of roadway of not less than 28.00 feet, exclusive of the width of any sidewalk, unless in the judgment of the Commissioner a lesser width is warranted.

#### **1.6.1.2 Sidewalks**

Sidewalks shall be provided on bridges in accordance with **CTDOT** Policy Statement E&C-19. The minimum sidewalk width shall be 5.0 feet. Sidewalk widths may be increased in areas of heavy pedestrian traffic, on designated bike routes, or at locations requiring additional sight distance.

Sidewalks should be carried across a bridge if the approach roadway has sidewalks or sidewalk areas. Elsewhere, one or two sidewalks may be provided as warranted by current developments, anticipated area growth, traffic or pedestrian studies, etc.

Sidewalk curb heights on structures shall match the exposed height of the approach curbing. Where curbs are not provided on the approaches, the exposed curb height on the structure shall be 6 inches.

Generally, the curb-to-curb width of pedestrian bridges shall match the approach pathway width.

#### **1.6.1.3 Cross Section**

Generally, deck cross slopes in both the travel lanes and the shoulders of highway bridges shall conform to the roadway cross slopes found in the **HDM**. Mechanical screeds, used when placing cast-in-place concrete decks, can accommodate multiple cross slope breaks. On bridges with precast components, such as precast adjacent box beams, the bituminous concrete overlay may be placed to match the approach roadway cross section.



#### **1.6.1.4 Profile**

The profile for highway bridges shall match the approach roadway. Preferably, the profile grade of all bridges shall provide for longitudinal surface drainage.

##### **1.6.1.4.1 Clearances**

###### **1.6.1.4.1.1 Structures Adjacent to or Crossing over Roadways (Rev. 11/04)**

The minimum horizontal and vertical clearance for any structure adjacent to or crossing over a roadway shall conform to the **HDM**. The provisions of **FHWA**'s "Recording and Coding Guide for the Structure Inventory and Appraisal of the Nation's Bridges" should be considered when the clearances specified in the **HDM** cannot be achieved, and a Design Exception is required to allow a lesser clearance.

The lowest portion of a structure mounted sign support shall be a minimum of 12 inches above the lowest component of the fascia member of the bridge to which it is attached.

###### **1.6.1.4.1.2 Structures Crossing over Waterways**

Navigational clearances, both horizontal and vertical, shall conform to the requirements of the U.S. Coast Guard. Permits for construction of a bridge over navigable waterways shall be obtained from the U.S. Coast Guard and/or other agencies having jurisdiction.

The waterway opening shall be consistent with the hydraulic characteristics of the waterway. For additional information, see **BDM** [1.4].

###### **1.6.1.4.1.3 Structures Adjacent to or Crossing over Railroads**

The minimum horizontal clearance for any structure adjacent to or crossing over a railroad shall conform to the **AREMA**. The horizontal clearance for any structure adjacent to or crossing over a railroad shall be in accordance with standards established and used by the affected railroad in its normal practice. The determination of the horizontal clearance shall also consider the economics and constructability of the structure, influence of railroad loads on the structure, site conditions, drainage and utility requirements, railroad access and future track expansion.

The minimum vertical clearance for any structure crossing over railroad tracks is limited by Section 13b-251 of the *Connecticut General Statutes*. The minimum vertical clearance for any structure crossing over railroad tracks shall be 20.50 feet (measured from the top of the rail to the bottom of the structure). The minimum

vertical clearance for any structure crossing over railroad tracks on which trains are operated by means of overhead electrical wires (electrified tracks) shall be 22.50 feet (measured from the top of the rail to the bottom of the structure). If the construction work includes only deck replacement (the removal and replacement of the bridge deck and supporting members) or minor widening of the structure, and the existing piers or abutments remain in place, the minimum vertical clearance shall be the structure's existing overhead clearance or 18.50 feet, whichever is greater.

#### **1.6.1.4.1.4 Through-Truss Highway Bridges**

The minimum vertical clearance from the roadway to the overhead cross bracing of a through-truss highway bridge should not be less than 17.50 feet.

#### **1.6.1.4.1.5 Railway Bridges**

Railway bridge clearances, both horizontal and vertical, shall conform to the **AREMA**.

**SECTION 2**  
**DESIGN SUBMISSIONS & CONTRACT DOCUMENTS**

**TABLE OF CONTENTS**

2.1 DESIGN REVIEW SUBMISSIONS.....	2-1
2.1.1 General.....	2-1
2.1.2 Hydrologic Study.....	2-1
2.1.3 Preliminary Hydraulic Study.....	2-1
2.1.4 Scour Analysis.....	2-2
2.1.5 Structure Type Studies.....	2-2
2.1.6 Bridge Rehabilitation Study ( <i>Rev. 12/22</i> ).....	2-3
2.1.6.1 Information Collection ( <i>Vacant</i> ).....	2-3
2.1.6.2 LRFD Analyses.....	2-3
2.1.6.2.1 Analysis Needs by Rehabilitation Sub-scope.....	2-3
2.1.6.2.2 Analysis Requirements by Rehabilitation Sub-scope.....	2-4
2.1.6.3 Rehabilitation Study Report (RSR) ( <i>Vacant</i> ).....	2-11
2.1.6.4 Presentation ( <i>Vacant</i> ).....	2-11
2.1.6.5 Determination and Report of Meeting ( <i>Vacant</i> ).....	2-11
2.1.7 Railroad Clearance Diagram.....	2-11
2.1.8 Structure Layout for Design Plans.....	2-12
2.1.9 Soil and Foundation Investigation.....	2-13
2.1.9.1 General.....	2-13
2.1.9.2 Soil and Foundation Reports.....	2-13
2.1.10 Final Hydraulic Study and Scour Reports.....	2-13
2.1.11 Final Plans for Review ( <i>Rev. 12/19</i> ).....	2-14
2.1.12 Incorporation of Review Comments.....	2-14
2.1.13 Final Submission ( <i>Rev. 04/19</i> ).....	2-14
2.2 REQUIREMENTS FOR FINAL CONTRACT DOCUMENTS.....	2-15
2.2.1 General.....	2-15
2.2.2 Final Plans ( <i>Rev. 12/19</i> ).....	2-15
2.2.2.1 Presentation of Drawings.....	2-16
2.2.2.2 Boring Logs.....	2-16
2.2.2.3 Quantities ( <i>Rev. 04/19</i> ).....	2-16

Connecticut Department of Transportation Bridge Design Manual

2.2.2.4 Transportation Dimensions and Weights .....	2-16
2.2.2.5 High, Low & Flood Water Elevations .....	2-17
2.2.2.6 Quantity Disclaimer Note .....	2-17
2.2.2.7 Notice to Bridge Inspector .....	2-17
2.2.2.8 Coordinate Tabulation .....	2-17
2.2.2.9 Beam or Girder Lengths.....	2-18
2.2.2.10 Utility Locations ( <i>Rev. 04/19</i> ).....	2-18
2.2.3 Specifications .....	2-18
2.2.3.1 Standard Specifications for Roads, Bridges, Facilities and Incidental Construction .....	2-18
2.2.3.2 Supplemental Specifications ( <i>Rev. 04/19</i> ) .....	2-18
2.2.3.3 Special Provisions .....	2-19
2.2.3.3.1 General ( <i>Rev. 12/22</i> ) .....	2-19
2.2.3.3.2 Contractor Designed Items ( <i>Rev. 12/22</i> ).....	2-19

## **SECTION 2**

### **DESIGN SUBMISSIONS & CONTRACT DOCUMENTS**

#### **2.1 DESIGN REVIEW SUBMISSIONS**

##### **2.1.1 General**

The following list outlines the design process and describes the submissions required for the design of bridges, box culverts and retaining walls. It should not be regarded as fully complete. The following items, where applicable, should be submitted in the order listed to the **CTDOT** for review and approval:

1. Environmental Review of the site,
2. Hydrologic Study,\*
3. Preliminary Hydraulic Study (including any temporary facility as required),\*
4. Scour Analysis (draft / final),\*
5. Structure Type Studies or Rehabilitation Study Report,
6. Railroad Clearance Diagram,
7. Structure Layout for Design (SL/D) plans and Soils & Foundation Report,
8. Final Hydraulic Study,\*
9. Final Plans for Review,
10. Incorporation of Review Comments, and
11. Final Submission.

\* for structures crossing a waterway

##### **2.1.2 Hydrologic Study**

Prior to the start of the structure design and prior to the start of a Hydraulic Study to determine the waterway opening, the design discharge shall be calculated and submitted for approval. All pertinent “backup” data shall be submitted to facilitate the review process. This work shall conform to the latest edition of the **Drainage Manual**.

##### **2.1.3 Preliminary Hydraulic Study**

A Hydraulic Study is required if the structure requires work within the floodplain of a watercourse or stream with a watershed area exceeding one square mile. All work within the floodplain must meet the requirements of Sections 13a-94, 22a-344 and 25-68b through 25-68h of the *Connecticut General Statutes* along with the **Drainage Manual**. If a floodway is established, every effort should be made to avoid encroachment into it. Note, certain activities, such as the construction of bridge piers within the floodway may be acceptable provided there is no increase in the “with floodway” water surface profile for the base flood or the ten year flood. Prior to the preparation of a Structure Type Study, a preliminary Hydraulic Study must be prepared and submitted for review and approval. If Stream Channel Encroachment Lines are established, they should be shown on the plans.

#### **2.1.4 Scour Analysis**

The potential for scour at bridges over waterways must be evaluated and submitted to the **CTDOT** for review and approval. For this purpose, the FHWA document entitled “Evaluating Scour at Bridges” (**HEC-18**) or successor documents shall be used. Substructures for bridges over waterways shall be designed to safely support the structure subjected to the design scour. Substructures, subjected to scour shall be designed with pile foundations, foundations on rock, foundations located below the maximum estimated scour depth, or any other means approved by the **CTDOT**, provided adequate scour protection is maintained. The preferred foundation types are pile foundations and foundations on rock.

#### **2.1.5 Structure Type Studies**

Structure Type Studies shall be prepared for each new highway, pedestrian and railway crossing. The studies should consider the safety, serviceability, maintainability, constructability, permit requirements, economics and aesthetics of the proposed structures. The studies shall be developed after careful appraisal of the site conditions, foundation conditions, hydraulic and drainage conditions, design discharge and scour potential, coordination with DEEP fisheries, rights of way, utilities, and highway limitations (including maintenance and protection of traffic and environmental impacts) both present and future. Additional studies may be requested if the **CTDOT** finds the original proposals unsuitable or inadequate.

Multiple studies done just for quantity are not desired but only those studies that show promise or feasibility within the parameters herein should be pursued. For a group of bridges in a contract, structure type should be similar so that similarity of construction details may result in economy of costs. Repetition of a structure type merely for ease of design is to be avoided. Attention to detail in the appearance of the structure is to be kept foremost in mind. New materials and developments may be incorporated into the design of the proposed structure with the prior approval of the **CTDOT**.

Where the structure is required to have more than one span, the resulting multi-span structure shall be designed as continuous to eliminate the need for deck joints.

The structure type studies shall incorporate or otherwise resolve all requirements and constraints from applicable studies, reports and analysis developed by groups both within and outside the **CTDOT** for the crossing location.

The structure studies are to be prepared in a pamphlet form on letter size sheets. US Customary units of measurement shall be used in all studies. The sheets are to be numbered and each structure study is to be indexed. Construction costs shall be prepared for each structure type. One complete quantity and cost estimate sheet per study or structure shall be prepared. Additional costs for contingencies, such as minor items not normally computed, shall not exceed five percent of the total cost.

The structure studies shall be submitted for review. A meeting will be held to review the structure studies and select the type of structure to be designed. Upon approval of the structure type, the designer shall be authorized to proceed with the preparation of the Structure Layout for Design (SL/D) Plans.

### **2.1.6 Bridge Rehabilitation Study (Rev. 12/22)**

A Bridge Rehabilitation Study is a documented process conducted during the Preliminary Design Phase for the purpose of determining the Final Design scope of work for bridge preservation or rehabilitation. Elements of a Rehabilitation Study include:

- **BDM 2.1.6.1** – Information Collection
- **BDM 2.1.6.2** – LRFD Analyses
- **BDM 2.1.6.3** – Rehabilitation Study Report (RSR)
- **BDM 2.1.6.4** – Presentation
- **BDM 2.1.6.5** – Determination and Report of Meeting

#### **2.1.6.1 Information Collection (Vacant)**

#### **2.1.6.2 LRFD Analyses**

Rehabilitation sub-scope is a means of classifying work on bridge components in a simple, meaningful way. One or more sub-scopes can be included in an overall scope of rehabilitation work.

##### **2.1.6.2.1 Analysis Needs by Rehabilitation Sub-scope**

Bridge components shall be evaluated by performing an analysis in accordance with **LRFD** for the common bridge rehabilitation sub-scopes listed in Table 2.1.6.2-1. If multiple sub-scopes are selected from the table below, designers should consider analyzing the components in all the selected sub-scopes. If a sub-scope is added to the overall scope, designers shall check the table to determine if additional component(s) are recommended to be analyzed.

**Table 2.1.6.2-1 – Bridge Components to be considered in LRFD Analysis**

Rehabilitation Sub-scope		Existing Bridge Components included in LRFD Analysis											
		Deck	Bridge Parapets	Girder System	Truss System	Bearings (*)	Abutments	Piers	Wingwalls/ Endwall	Foundations	Box Culverts	Pipes (Span > 6.0' )	Rigid Frame/Arches
<b>1</b>	Beam End Repair	-	-	✓	-	-	-	-	-	-	-	-	-
<b>2</b>	Deck Replacement	-	-	\$	\$	\$	\$	\$	-	\$	-	-	-
<b>3</b>	Parapet/Railing Modification	-	✓	\$	\$	-	-	-	-	-	-	-	-
<b>4</b>	Bridge Widening	✓	✓	✓	✓	✓	\$	\$	\$	\$	-	-	-
<b>5</b>	Deck Patching	-	-	-	-	-	-	-	-	-	-	-	-
<b>6</b>	Superstructure Replacement	-	-	-	-	-	✓	✓	-	✓	-	-	-
<b>7</b>	Superstructure Strengthening	-	-	✓	✓	✓	✓	✓	-	✓	-	-	-
<b>8</b>	Superstructure Preservation/Repair	-	-	\$	\$	-	-	-	-	-	-	-	-
<b>9</b>	Substructure Repair	-	-	-	-	-	✓	✓	-	-	-	-	-
<b>10</b>	Substructure Strengthening	-	-	-	-	-	✓	✓	✓	✓	-	-	-
<b>11</b>	Substructure Replacement	-	-	-	-	-	-	-	-	-	-	-	-
<b>12</b>	Bearing Replacement	-	-	-	-	-	-	-	-	-	-	-	-
<b>13</b>	Rehabilitation of Buried Structures	-	-	-	-	-	-	-	\$	-	✓	✓	✓

Key:

✓ This component should be analyzed in association with the rehabilitation scope.

(\*) Depending on existing bearing conditions and types.

\$ Only analyze these components when there is a change in loading associated with the scope.

**2.1.6.2.2 Analysis Requirements by Rehabilitation Sub-scope**

Analysis requirements will vary depending on the sub-scope proposed for rehabilitation. Each rehabilitation sub-scope shall include one or more of the following requirements:

- Bridge load rating analysis in accordance with **BDM 1.3**, including beam end analysis and construction loading. Construction loading includes:
  - CT-TLC (**BDM 1.3.6**)
  - Construction Loads (**BDM 3.4**)
  - **Form 818** – 1.07.05 – Load Restrictions

A new load rating analysis is required if any of the following is true:

- Additional critical section loss exists that is not considered in the load rating that is on file (the designer shall perform an As-Inspected load rating).



- The live load evaluated in the most current load rating on file does not meet the Load Rating Manual's requirements.
- Additional dead load exists that was not considered in the most current load rating.
- Earthquake analysis for horizontal restraint and for beam seat length in accordance with **BDM 3.8.1**. Rehabilitation sub-scopes may afford an opportunity to address earthquake force effects. Such opportunity may include installing earthquake horizontal restraint or increasing beam seat length.
- Analysis for Vehicle collision force (**LRFD** Section 13).
- Hydraulic analysis, which may include hydrologic analysis as well.
- Scour Analysis (**BDM 5.14.1.1**):
  - Scour evaluation
  - Structural evaluation of pile-supported substructures with piles exposed due to scour.
- Analysis for all other force effects required by **LRFD** for new designs as directed by the Bridge Principal Engineer. The opportunities to address these force effects are limited and will only be considered for critical bridges as identified by the Department.

### **1. Beam End Repair**

*Analysis considerations:* bridge load rating.

When analyzing a beam end for repair, a bridge load rating evaluation is required to determine beam end reactions. Evaluating an existing beam end is different than designing a new beam and requires analysis of different modes of failure to determine the capacity of the existing beam end. Beams that were under-designed and beams with section loss may exhibit modes of failures that are not accounted for in the **LRFD** Design Specifications. For new beam ends, the **LRFD** Design Specifications eliminate certain modes of failure from consideration by requiring the designer to meet a minimum web Depth-to-Thickness ratio. Prevention of failure of a new bearing stiffener by local buckling is ensured by following the minimum ratio for bearing stiffener Width-to-Thickness recommended in the Design Specifications. The designer is reminded that deterioration to the web that does not extend in front of the bearing does not cause beam shear failure. A beam end analysis program, CT-BeamEnd, is available at <https://portal.ct.gov/DOT/State-Bridge-Design/Load-Rating/Load-Rating>

### **2. Deck Replacement:**

*Analysis considerations:* bridge load rating, earthquake, construction loading, scour analysis.

A bridge load rating evaluation is required to determine the force effects of dead and live loads from the proposed deck on the existing superstructure. Unless waived by CTDOT, an analysis of the substructure is also required to determine if the proposed force effects may be accommodated by the substructure with or without modification. Depending on the capacity of the superstructure and substructure to accommodate these forces, the rehabilitation scope may need to change. The proposed deck is often thicker

than the existing deck and the overlay is often thicker and denser as well. The parapet also likely has a different cross-section and therefore different weight than the existing parapet. In some cases, new utilities are added to the bridge during the deck replacement because of the opportunity that it presents. The deadload force effect from the utilities shall also be considered. Corresponding force effects exerted on the substructure shall also be analyzed.

Analysis for earthquake loading shall be performed.

When a deck is to be replaced, there is an opportunity during this capital investment to evaluate the substructure for scour and propose potential scour countermeasures if required.

### **3. Parapet/Railing Modification:**

*Analysis considerations:* bridge load rating, vehicle collision force.

The term “railing” in AASHTO LRFD Specifications refers to traffic barrier when discussing both concrete parapet and open bridge rail. The term “modification” for the purpose of this sub-section refers to changes to bridge railing to bring it into compliance with current MASH requirements. There are two analyses of the deck-overhang and superstructure elements associated with this sub-scope:

- Vehicle impact force effect imposed.
- Increased dead load effect from modified railing loads.

The purpose of analyzing the deck-overhang and superstructure elements is to determine if these components must be strengthened or replaced in the RSR recommendations.

The analysis associated with vehicle impacts on the railing itself is discussed in conjunction with the design of the railing system and will not be discussed here.

### **4. Bridge Widening:**

*Analysis considerations:* bridge load rating, earthquake, scour analysis.

Bridge widening may include span bridges as well as buried structures.

#### *a. Span Bridges:*

Load Rating analysis of existing bridge components due to increased dead or live loads resulting from a bridge widening may be necessary as follows:

- When adding a traffic lane, the proposed widening may impose influence from a proposed traffic lane on the existing beams. Load rating of existing superstructure and substructure components shall be performed.
- The existing fascia beam may experience additional dead load from the widened superstructure and shall be analyzed.
- Bearings and substructure shall also be evaluated for additional dead and live loads.

Earthquake analysis is required for any bridge widening project due to the increased mass of the superstructure that must be restrained horizontally.

When a bridge is to be widened, there is an opportunity during this capital investment to evaluate the substructure for scour and propose potential scour countermeasures if required.

b. *Buried Structures:*

Widening of buried structures may involve additional length of structures to be constructed. No analysis of the proposed structure is required under this sub-scope.

Widening of buried structures may include the addition of fill above a portion of the existing structure. The structure shall be analyzed for the additional earth load and shall also consider any additional live load effects. Such widening may also require extension of wingwalls and headwalls to retain additional fill and possibly support live load surcharge. The analysis shall evaluate these components as well.

**5. Deck Patching:**

*Analysis considerations:* none.

**6. Superstructure Replacement:**

*Analysis considerations:* bridge load rating, earthquake, scour analysis, other force effects as directed.

When a superstructure can be replaced with an identical superstructure, no bridge load rating analysis is required. An earthquake analysis shall be performed to identify the need for horizontal restraint of the superstructure.

For most superstructure replacements, the dead load of the bridge is likely to increase, so a bridge load rating analysis is required to determine the dead load force effect on the substructure. This analysis shall also consider increased live load effect as well. For most superstructure replacement, a bridge load rating is the only analysis requirement, unless directed otherwise by the Department.

When a superstructure is to be replaced, there is an opportunity during this capital investment to evaluate the substructure for scour and propose potential scour countermeasures if required.

For select bridges, the substructure shall be analyzed for all the force effects required by **LRFD**.

**7. Superstructure Strengthening:**

*Analysis considerations:* bridge load rating.

For the purpose of this discussion, “superstructure” refers to the beam or girder system supporting the bridge deck. The term “strengthening” refers to an action that results in

increased capacity of an existing member beyond its as-built capacity. This does not include repairs intended to restore as-built capacity or a portion thereof.

Superstructure strengthening sub-scope requires that the entire bridge be analyzed for additional load effects. Superstructures that are strengthened to accommodate additional load effects may impose those load effects on the bearings and substructures, which should also be analyzed.

## **8. Superstructure Preservation/Repair:**

*Analysis considerations:* bridge load rating, earthquake.

For each of the following superstructure preservation/repair treatments, consider the following analyses:

- a. *Structural Repair:* When deterioration or other damage exists, a current structural analysis shall be used to determine if a structural repair is required. The analysis shall consider beam ends as well. See sub-scope 1 above for analysis requirements. The term “structural repair” should not be confused with “superstructure strengthening.” For this sub-scope, “structural repair” for superstructures refers to the addition of steel plates or other materials such as Ultra-High Performance Concrete (UHPC) to restore a specific capacity to a superstructure element, but not necessarily the as-built capacity.

The current analysis shall evaluate the entire load path from where the load is applied to the point of support. All possible failure modes along that load path shall be considered to determine if structural repair is necessary. It is possible that multiple failure modes exist and should be documented clearly in the project files and in the RSR.

Analysis for earthquake loading shall be performed.

- b. *Preservation and Cosmetic Treatment:* The goal of preservation is to protect the superstructure from deterioration and to increase the life of the structure. The goal of cosmetic treatment is to improve appearance of a bridge component. When structural repair is not needed by analysis, the designer shall determine if a preservation-type or cosmetic treatment is necessary or desired.

If a preservation or cosmetic treatment is specified, **no analysis is required.**

## **9. Substructure Repair:**

*Analysis considerations:* bridge load rating, earthquake, other force effects as directed, scour analysis (major repair only).

- a. *Concrete Substructures:*

There are different levels of repair associated with concrete substructures. There are reflected in the item names:

- Surface Repair Concrete – no analysis required.

- Structural Repair Concrete – for concrete bent structures that are heavily deteriorated, a stability evaluation may be required by the Department for horizontal forces generated by wind and earthquake. Should stability be a concern, the designer may recommend installation of temporary bracing to stabilize the structure temporarily.

b. *Steel Substructures:*

An analysis of deteriorated steel components is required to determine if there is adequate capacity. Some possible failure modes that can occur in deteriorated steel substructure include:

- Local and global buckling in columns
- Global stability
- Yielding in compression
- Flexure: tension, compression and local and global buckling of compression elements
- Shear

If steel substructure elements are not deteriorated, no analysis is required unless requested by the Department.

For steel substructures, an earthquake analysis is required to determine if horizontal restraint and beam seat length are adequate. If significant deterioration is present, failure mechanisms may form that make the substructures unstable when lateral earthquake force is applied. In such cases the substructures shall be checked for earthquake lateral force effects.

When a major repair to concrete or steel substructures is to be performed, there is an opportunity during this capital investment to evaluate the substructure for scour and propose potential scour countermeasures if required.

**10. Substructure Strengthening:**

*Analysis considerations:* bridge load rating, earthquake, other force effects as directed, scour analysis.

a. *Substructure types:*

- Solid-Wall: no analysis required
  - Abutment
  - Pier
- Caps and Columns:
  - Concrete:
    - Multiple columns with at least two pier columns and one pier cap. This may include one or more cantilevered caps. Bridge load rating analysis is required when increased loads and/or moments are identified on the substructure. The designer is reminded that this type of substructure contains both compression and beam-type elements, including

cantilever beams. The designer shall also take into consideration increased loadings on the columns due to continuity of the pier cap.

- Single column with balanced or unbalanced hammer-head pier cap: bridge load rating analysis is required when increased loads and/or moments are identified on the substructure. The analysis shall focus on not only concentric loading of the column but shall also focus on moments in the pier column due to unbalanced loads and horizontal force effects.
- Steel: an analysis of deteriorated steel components is required to determine if there is adequate capacity. Some possible failure modes that can occur in deteriorated steel substructure include local and global buckling in columns, global stability, yielding in compression, flexure: tension, compression and local and global buckling of compression elements, and shear.

If steel substructure elements are not deteriorated, no analysis is required unless requested by the Department.

- b. *Footings*: geotechnical analysis shall be performed to determine if the existing footings are adequate to support the desired loads. Footing types include:
  - Spread footing
  - Pile cap

An earthquake analysis is also required to determine if horizontal restraint and beam seat length are adequate for steel substructures.

For select bridges, the substructure shall be analyzed for all the force effects required by **LRFD** as directed.

When a bridge substructure is to be strengthened/replaced, there is an opportunity during this capital investment to evaluate the substructure for scour and propose potential scour countermeasures if required.

### **11. Substructure Replacement:**

*Analysis considerations:* the scope of analysis for substructure replacement shall be included in the scope for design of the proposed substructure.

### **12. Bearing Replacement:**

*Analysis considerations:* the scope of analysis for bearing replacement shall be included in the scope for design of the proposed bearings.

### **13. Rehabilitation of Buried Structures:**

*Analysis considerations:* bridge load rating, hydraulic analysis, scour analysis.

Buried structures include:

- Box Culverts

- Pipes with Span > 6.0 ft.
- Rigid Frame/Arches

When a buried structure is scoped for rehabilitation, a current bridge load rating analysis performed in accordance with the **BLRM** is required to compare against the minimum acceptable rating factor in **BDM** Table 1.3.7-1. All modifications of buried structures that include the addition of concrete inverts or liners are considered major structure rehabilitations. The analysis of a liner or a new invert is not included in this sub-scope of rehabilitation. Such design analysis should be included in the scope for design of the new elements.

Repairs to box culverts and pipes may include the addition of concrete inverts or liners. Both repair options may have negative consequences on hydraulic capacity. For rehabilitation of these buried structures, the rehabilitation is typically only performed after it is determined by hydraulic analysis that the repair will not adversely affect the hydraulic capacity. Repairs may cause an increased velocity of water in the structures. Therefore, a scour analysis shall also be performed to determine if roughness elements or scour countermeasures are required to be installed.

Concrete box culverts, rigid frames and arches may require surface or structural repairs to the concrete. These types of repairs typically do not require structural or hydraulic analysis. Analysis may be required if such concrete repairs must encroach into the hydraulic opening to:

- improve concrete cover
- increase thickness of concrete to improve capacity.

Scour analysis is not required for box culverts, but if the velocity of the flow is increased due to restriction of flow by repairs, erosion of the natural channel downstream of the outlet is possible and shall be investigated. Frames and arches founded on spread footings or deep foundations shall be evaluated for scour. If a valid and current scour evaluation is on file, this analysis can be waived by the Department.

#### **2.1.6.3 Rehabilitation Study Report (RSR) (Vacant)**

#### **2.1.6.4 Presentation (Vacant)**

#### **2.1.6.5 Determination and Report of Meeting (Vacant)**

### **2.1.7 Railroad Clearance Diagram**

The Designer shall develop a “Railroad Clearance Diagram” and an “Approval of Railroad Clearance” form for approval by the railroad and the **CTDOT**. See **BDM** [Division 2] for examples of the clearance diagram and approval form.

### **2.1.8 Structure Layout for Design Plans**

Upon approval of the structure type studies or the Rehabilitation Study Report, and following notification authorizing the start of the final design phase, the designer shall prepare Structure Layout for Design (SL/D) Plans for all bridges, box culverts and retaining walls.

The SL/D plans should be prepared on full size sheets. US Customary units of measurement shall be used in all plans. All details shall be drawn to scale. Extraneous information not relevant to the construction of the structure should not be shown on the plans. This includes miscellaneous topographic information such as trees, shrubs, signs, utility poles and other items that are detailed on the highway plans.

The SL/D plans shall contain the following:

- a. Site Plan - A plan showing the location of the structure and approaches, topographical data including original and final contours, adjacent ramp and intersecting roadways and channels, if any, etc.
- b. General Plan - A “Structure Plan” showing baseline stationing, controlling horizontal dimensions, span lengths, skew angle and clearances for the structure and approaches.

Projected below the “Structure Plan” should be an “Elevation” view showing the proposed structure with controlling dimensions and clearances, footing elevations, foundations, pertinent water and rock elevations, etc.

A typical cross section of the structure showing lane and shoulder arrangements, sidewalks if required, bridge railings, member spacing, slab thickness, and other pertinent details. For box culverts, this cross section shall show the number and size of the cells and type of construction, precast or cast-in-place.

The “General Plan” should also include a table of “Transportation Dimension and Weight” in accordance with **BDM** [1.3] and the “Notice to Bridge Inspectors” block.

- c. Boring Plan(s) - Borings shall be plotted in accordance with **BDM** [2.2.2.2].
- d. Stage Construction Plans, if applicable.
- e. Pier Plan(s) - A pier “Plan” and “Elevation,” if applicable, showing the proposed pier with controlling dimensions, footing elevations, foundation, etc.
- f. Additionally, architectural aspects of the structure shall be noted, on the SL/D plans, such as bridge railing, pier and abutment configuration, surface treatment, etc.

The inspection access features, if required, should be shown on the Structure Layout for Design (SL/D) Plans. The SL/D plans will be submitted to the Bridge Safety and Evaluation Unit for



review. The Bridge Safety and Evaluation Unit review should indicate one or more of the following:

- No special inspection access features required.
- The inspection access features shown are adequate.
- Certain inspection access features shown are not required.
- The following additional inspection access features are required.

The designer shall submit the SL/D plans, along with a copy of the Soils and Foundations Report for review and approval. Upon approval of the SL/D plans, the designer will be authorized to proceed with the development of the final contract documents.

## **2.1.9 Soil and Foundation Investigation**

### **2.1.9.1 General**

Subsurface exploration and testing programs shall be performed to provide pertinent and sufficient information for the design of substructures and retaining walls. The subsurface exploration and testing programs shall also provide pertinent and sufficient information for the design and construction of temporary support elements (sheet piling, cofferdams, soldier pile and lagging, etc.). The investigations shall conform to the **Geotechnical Engineering Manual**.

### **2.1.9.2 Soil and Foundation Reports**

A Soils and Foundation Report shall be prepared for each structure in accordance with the **Geotechnical Engineering Manual**. The Report shall include any information necessary for the proper design of all structural elements and components that may be influenced by subsurface conditions. The Report should include, but not be limited to, boring logs, excavation requirements, foundation recommendations, soil and rock properties and capacities, axial and lateral pile capacities, design criteria, backfill and drainage requirements, and related special provisions.

The Report shall be made entirely with US Customary units of measurement. The Report shall be submitted for review and approval. A copy of the Report shall be submitted with the Structure Layout for Design (SL/D) Plans.

## **2.1.10 Final Hydraulic Study and Scour Reports**

Final Hydraulic Study and Scour Reports based on the selected structural type must be prepared and submitted. The Final Hydraulic Study should address any concerns presented during the Preliminary Hydraulic Study and should contain a Hydrology Section as approved by the **CTDOT** in addition to the detailed hydraulic analysis. The hydraulic and scour data should be tabulated on the plans.

### **2.1.11 Final Plans for Review (Rev. 12/19)**

As part of the “Final Plans for Review Submission,” the designer shall submit the following structure related items. The actual number of copies required varies and must be coordinated with the individual Project Engineer for the particular job:

- Final Plans for Review,
- Specifications,
- proposal estimates,
- Soils Report – Structure,
- Final Hydraulic Report,
- design computations,
- load rating package,
- quantity computations,
- structure costs with estimated steel weights (if applicable), and
- Final Scour Report.

The “Final Plans for Review” shall be complete. All bridge plans not prepared by the **CTDOT** shall be signed by the responsible party from the Consultant Engineer or the Municipality.

Incomplete submissions of plans, specifications or other data required for the Final Plans for Review Submission will not be accepted. The structural material submitted and the design of the same should be well coordinated with the roadway and utility plans and shall satisfy the needs of maintenance and protection of traffic.

The “Final Plans for Review” for structures incorporating special features to facilitate inspection and items requiring special attention will be submitted to the Bridge Safety & Evaluation Unit for review. They will indicate whether these features are adequate for future inspection and return the plans with comments or signify that the plans are satisfactory.

### **2.1.12 Incorporation of Review Comments**

The various submissions will be reviewed, and the review comments will be forwarded to the designer. All comments received shall be incorporated into the design prior to the next submission or mutually resolved. Written responses to all comments are desired.

### **2.1.13 Final Submission (Rev. 04/19)**

Upon completion of the review of the “Final Plans for Review,” all plans, specifications and cost estimates that require modifications will be returned to the designer for incorporation of the review comments.

## **2.2 REQUIREMENTS FOR FINAL CONTRACT DOCUMENTS**

### **2.2.1 General**

The contract documents include the Final Plans and Specifications necessary to complete the contemplated construction work for a project.

US Customary units of measurement shall be used in all plans and specifications. All layout dimensions and elevations shall be given as decimal dimensions in feet. The following note shall be placed in the General Notes:

When dimensions are given to less than three decimal places, the omitted digits shall be assumed to be zeros
---

Detail dimensions (those not normally measured by the surveyors) should be given in feet and inches.

### **2.2.2 Final Plans** *(Rev. 12/19)*

The final plans should be prepared on full size sheets. All details shall be drawn to scale. Plans for individual bridges shall be self-contained sets. On large projects with multiple retaining walls or resurfacing projects with numerous bridges, these structures may be combined into one set of plans for efficiency of detailing.

The designer shall prepare final contract plans for all structures. The use of a “Limited Investigation Disclaimer” should be limited only to sheets pertaining to estimated quantities, borings, and substructure components.

Existing structures (houses, garages, storage tanks, etc.), which will be demolished before the project is constructed, shall not be indicated on the structure plans. The location of the existing foundation should be noted on the contract drawings. Any existing drainage facilities that are in conflict with footings, retaining walls, etc. should be shown on the plans.

The use of the phrase “by others” on contract plans is considered acceptable as long as the reference to whom the “others” are is specified within the contract plans.

For bridges on a horizontal curve, basic layout information shall be shown as described in **BDM** [Division 3].

All final plans shall be submitted to the **CTDOT** in “MicroStation” digital CADD format. Specific requirements and materials, such as level symbology and seed files, are available from the **CTDOT**.

### **2.2.2.1 Presentation of Drawings**

The following is the recommended order for the presentation of structure plans and generally follows the order of construction:

- General Plan (one or two sheets),
- Layout Plan (if required),
- Boring Logs,
- Stage Construction Plans,
- Foundation Plans,
- Abutment and Wingwall Plans,
- Pier Plans (if required),
- Framing Plans,
- Beam and Girder Details,
- Bearing Details,
- Slab Plans,
- Slab and Approach Slab Details,
- Joint Details,
- Metal Bridge Rail Detail Sheet (if required),
- Pedestrian Railing or Bicycle Railing Detail Sheet (if required),
- Protective Fence Detail Sheet (if required),
- Deck Drainage Details (Scuppers and Piping if required),
- Electrical Detail Sheet,
- Utility Sheets (if required), and
- Existing Structure Plans (if required).

### **2.2.2.2 Boring Logs**

The boring logs shall be in US Customary units of measurement and shall be shown on the plans. The format of the boring logs plotted on the plans shall be identical to the format of the **CTDOT**'s standard boring log forms. A list of boring log abbreviations used for describing the soil and rock, such as colors, textures, properties, and types, shall also be shown on the plans.

### **2.2.2.3 Quantities (Rev. 04/19)**

Quantities shall be tabulated and shown on the "Detailed Estimate Sheet" only.

### **2.2.2.4 Transportation Dimensions and Weights**

The maximum transportation lengths, widths and height of bridge members along with the maximum transportation weight must be shown on the "General Plan." The following is a sample of the information required:

Member	Shipping Length	Shipping Height	Shipping Width	Shipping Weight
G-1	115 ft	9 ft	10 ft	118,000 lbs.

**2.2.2.5 High, Low & Flood Water Elevations**

For structures over tidal waterways, the “General Plan” shall indicate the mean high water and mean low water elevations. For structures over non-tidal waterways, the plans shall indicate the watershed area, the magnitude, frequency and the water surface elevation for the design flood, as well as the normal water surface elevation.

**2.2.2.6 Quantity Disclaimer Note**

The following note must be placed on those Structure Sheets that contain estimated quantities, boring and substructure components:

The information, including estimated quantities of work, shown on these sheets is based on limited investigation by the State and is in no way warranted to indicate the true conditions of actual quantities or distribution of quantities of work which will be required.

**2.2.2.7 Notice to Bridge Inspector**

The designer shall note on the General Plan any item that would require special attention, such as fracture critical members, during inspection of the structure. This information shall be contained in the “Notice to Bridge Inspectors” block as shown in **BDM** [Division 2].

**2.2.2.8 Coordinate Tabulation**

The designer shall tabulate coordinates on each set of bridge plans for structures on a horizontal curve. These coordinates shall be tied into the Connecticut Coordinate Grid System. Coordinates shall be tabulated for the following:

- locations of working points,
- ends of wingwalls,
- ends of slabs,
- ends of approach slabs, and
- intersections of the centerlines of bearings at the abutments and piers with:
  - construction centerlines,
  - baselines,
  - points of application of grade,
  - gutterlines, and
  - centerlines of stringers.

### **2.2.2.9 Beam or Girder Lengths**

The horizontal lengths of beams or girders measured center to center of bearings along the centerline of the member shall be shown on the plans.

### **2.2.2.10 Utility Locations (Rev. 04/19)**

All existing underground utilities, including drainage facilities, in the vicinity of the construction must be shown on the General Plan and on all foundation drawings. It is imperative that utilities adjacent to but not actually within the excavation limits also be shown since heavy equipment, pile driving, or other deep foundation work may impact them. The size, type, owner and location of the utility must be given.

## **2.2.3 Specifications**

### **2.2.3.1 Standard Specifications for Roads, Bridges, Facilities and Incidental Construction**

This is the category of specifications that is commonly referred to as the “Standard Specs.” They are the basic construction specifications that describe and define the requirements of those items of construction most commonly used in highway construction. These specifications are in the charge of the “Standing Committee on Standard Specifications,” otherwise known as the “Specifications Committee.”

Amendments, additions to, or deletions from the standard specifications are accomplished through Committee action. The need for a particular action is usually brought to the attention of the Committee by those intimately concerned with the particular specification.

These specifications undergo constant change as new methods, materials and technology become available. The vehicle for accomplishing permanent change to a standard specification is the Supplemental Specification discussed in the following section.

### **2.2.3.2 Supplemental Specifications (Rev. 04/19)**

As previously stated, the Supplemental Specifications permanently add to, delete, or otherwise revise the Standard Specifications. Prior to publishing and disseminating these specifications, they must have been approved by the Specifications Committee and the Federal Highway Administration.

The Supplemental Specifications are issued twice a year by the Specifications Committee, containing all the current supplements and errata that have been issued since the acceptance of the last set of *Standard Specifications*.

The Supplemental Specifications date that is to be referenced in the contract will be associated with the Final Design Plans date.

The Supplemental Specifications may be considered part of the *Standard Specifications*. When a new set of standard specifications is accepted, these are automatically incorporated. Both the Supplemental Specifications and the *Standard Specifications* set with the supplements merged into it are posted on the Department's webpage.

### **2.2.3.3 Special Provisions**

#### **2.2.3.3.1 General (Rev. 12/22)**

In those cases where neither the standard specification nor subsequent supplemental specifications are found to be adequate, or where no specification exists, a special provision must be prepared.

The **CTDOT** has developed and maintains lists of standardized special provisions known as "Owned Special Provisions." The purpose of these special provisions is to establish uniformity in the specification of materials and construction methods, and to have a person (Subject Matter Expert) or Department Unit responsible for updates.

These "Owned Special Provisions," available on the [Department's web page](#), shall be inserted into the contract documents unchanged. The designer is responsible for the correct application of the recurring special provisions to each project. Written permission from the listed owner must be obtained should a change to an "Owned Special Provision" be required.

The Department's Contract Development Section web page has guidance for the format and content of special provisions. The designer should make sure to include any necessary materials and what quality (testing) is necessary to accomplish the specified work.

#### **2.2.3.3.2 Contractor Designed Items (Rev. 12/22)**

For all items requiring the Contractor to provide designs for permanent structural features, special provisions shall be included in the contract requiring the Contractor to provide PDF copies of all design plans. These PDFs shall conform to the **CTDOT's** standard format for structural design plans and shall be signed and sealed by a Connecticut Professional Engineer. The designer can include a reference to **Standard Specifications** [1.05.02] and any specific design requirements in the special provision.

This Page is Intentionally Left  
Blank



**SECTION 3**  
**LOADS AND LOAD FACTORS**

**TABLE OF CONTENTS**

3.1 LOAD MODIFIER (LRFD [1.3.2]).....	3-1
3.1.1 Ductility (LRFD [1.3.3]).....	3-1
3.1.2 Redundancy (LRFD [1.3.4]).....	3-1
3.1.3 Operational Importance (LRFD [1.3.5]).....	3-1
3.2 LOAD FACTORS AND LOAD COMBINATIONS (LRFD [3.4]) .....	3-1
3.2.1 Load Factors and Load Combinations (LRFD [3.4.1]).....	3-1
3.2.2 Load Factors for Construction Loads (LRFD [3.4.2.1]).....	3-2
3.3 PERMANENT LOADS (LRFD [3.5]) .....	3-2
3.3.1 Dead Loads .....	3-2
3.3.2 Overlay Allowance .....	3-2
3.4 Construction Loads .....	3-2
3.4.1 Construction Loads and Load Effects.....	3-2
3.5 LIVE LOADS (LRFD [3.6]).....	3-3
3.5.1 Live Load ( <i>Rev. 12/19</i> ) .....	3-3
3.6 Earth pressures (LRFD [3.11]) .....	3-3
3.6.1 Lateral Earth Pressure .....	3-3
3.6.2 Live Load Surcharge (LRFD [3.11.6.4]) .....	3-3
3.6.3 Unbalanced Loads.....	3-3
3.7 FORCE EFFECT DUE TO SUPERIMPOSED DEFORMATIONS (LRFD [3.12]).....	3-3
3.7.1 Temperature Range for Procedure A .....	3-3
3.8 EARTHQUAKE EFFECTS (LRFD [3.10]).....	3-4
3.8.1 General.....	3-4
3.8.2 Operational Classification (LRFD [3.10.5]) .....	3-4

This Page is Intentionally Left  
Blank

## **SECTION 3** **LOADS AND LOAD FACTORS**

### **3.1 LOAD MODIFIER (LRFD [1.3.2])**

#### **3.1.1 Ductility (LRFD [1.3.3])**

The ductility load modifier shall be no less than 1.0 for the strength limit state.

#### **3.1.2 Redundancy (LRFD [1.3.4])**

The design of non-redundant members or components is not permitted, unless approved in writing by the **CTDOT**.

Single-cell box superstructures and single column piers shall be considered non-redundant.

The redundancy load modifier shall be no less than 1.0 for the strength limit state.

#### **3.1.3 Operational Importance (LRFD [1.3.5])**

The operational importance load modifier shall be no less than 1.0 for the strength limit state.

*Commentary: The redundancy of members and components is addressed by the system factor described in the **MBE** and included in the load rating of the bridge. The determination of the operational importance load modifier requires the Operational Classification the bridge, see **BDM** [3.8.2].*

### **3.2 LOAD FACTORS AND LOAD COMBINATIONS (LRFD [3.4])**

#### **3.2.1 Load Factors and Load Combinations (LRFD [3.4.1])**

For permanent bridges, the load factor for design vehicle live load for the Extreme Event I limit state shall be 0.50.

For temporary works, such as jacking devices, falsework and shoring, the load factor for design vehicle live load for the Strength I limit state shall be 1.35.

For temporary bridges that will be in service less than 3 years, the load factor for design vehicle live load for the Strength I limit state shall be 1.35. For temporary bridges that will be in service less than 3 years, the load factor for design vehicle live load for the Extreme Event I limit state shall be 0.0.

*Commentary: Temporary bridges shall be designed at the “operating level” for the design vehicle live load.*

**3.2.2 Load Factors for Construction Loads (LRFD [3.4.2.1])**

When investigating load combinations for the Strength III limit state for load effects during construction, the load factor for wind shall not be less than 1.0.

**3.3 PERMANENT LOADS (LRFD [3.5])**

**3.3.1 Dead Loads**

The unit weights used in computing dead loads shall be in accordance with **AASHTO LRFD** [Table 3.5.1-1], amended as follows:

<b>Table 3.3.1</b>		
<b>Material</b>	<b>Unit</b>	<b>Load</b>
Compacted sand, gravel, silt and clay <sup>1</sup>	kcf	0.125
Reinforced concrete or prestressed concrete	kcf	<b>AASHTO LRFD</b> [Table 3.5.1-1] value plus 0.005
Bituminous concrete overlay, HMA overlay <sup>2</sup>	kcf	0.155

*Commentary: (1) Includes typical items Pervious Structure Backfill, Granular Fill, and Subbase, and in-situ soils. (2) Bituminous concrete (HMA) overlay unit weight accounts for increased weight of aggregate typically used in CT.*

**3.3.2 Overlay Allowance**

All vehicular bridges shall be designed to account for the load effects due to a bituminous concrete/HMA overlay, including bridges detailed to be constructed without an initial overlay.

*Commentary: For minimum overlay thickness, see **BDM** [8.2.1.2].*

**3.4 CONSTRUCTION LOADS**

**3.4.1 Construction Loads and Load Effects**

All bridges shall be designed to account for construction loads and their effects to ensure the adequacy of the structure during all phases of construction. Construction loads, including dynamic effects, assumed in the design shall be shown on the contract documents.

Construction live load shall be no less than 0.050 ksf.

### **3.5 LIVE LOADS (LRFD [3.6])**

#### **3.5.1 Live Load (Rev. 12/19)**

The design vehicle live load, during all phases of construction, shall be in accordance with **LRFD** [3.6.1.2.1] for both new and existing permanent bridges as well as temporary bridges. In addition to the design vehicle live load specified in the **LRFD**, the load rating requirements of **BDM** [1.2] shall be satisfied.

Live load effects shall be considered in the design of temporary works, such as jacking devices, falsework and shoring, required for construction.

*Commentary: The **LRFD** and the **LRFR** are design specifications and rating specifications, respectively. Since not all bridge components are subject to load rating, vehicular bridges should be designed by the **LRFD** and rated in accordance with **BDM** [1.2].*

### **3.6 EARTH PRESSURES (LRFD [3.11])**

#### **3.6.1 Lateral Earth Pressure**

For Pervious Structure Backfill, the effective angle of internal friction shall be taken as equal to 35 degrees.

#### **3.6.2 Live Load Surcharge (LRFD [3.11.6.4])**

Permanent earth retaining structures shall be designed for a minimum surcharge loading equivalent to 2 feet of soil. The load factor shall be in accordance with **LRFD** [3.4.1].

#### **3.6.3 Unbalanced Loads**

Structures with skewed end sections, such as concrete tunnels, integral or semi-integral abutments, rigid frames, box culverts, etc., will require special consideration in the design and sequence of backfilling in order to prevent cracking due to unbalanced loading. Backfilling requirements shall be shown on the plans to mitigate the load effects due to unbalanced backfilling.

*Commentary: For permanent structures designed and built during construction, backfill requirements should be included in the contract documents.*

### **3.7 FORCE EFFECT DUE TO SUPERIMPOSED DEFORMATIONS (LRFD [3.12])**

#### **3.7.1 Temperature Range for Procedure A**

The temperature ranges for cold climates shall be used for Procedure A in accordance with **LRFD** [3.12.2.1].

### **3.8 EARTHQUAKE EFFECTS (LRFD [3.10])**

#### **3.8.1 General**

All conventional bridges, new and existing bridges being rehabilitated, shall be designed for earthquake load effects in accordance with **LRFD** [3.10], except as noted below. Conventional bridges have slab, beam, girder, box-girder, deck unit, and truss superstructures; have single or multiple column piers, wall type piers or pile bents; and are founded on shallow or piled footings or shafts.

- All existing conventional bridges in Seismic Performance Zone 1 and undergoing major rehabilitation, such as bridge widening, superstructure replacement, deck replacement, bearing replacement, shall be analyzed and designed for earthquake load effects, unless specifically waived by **CTDOT**.
- All existing conventional bridges in other than Seismic Performance Zone 1 and undergoing major rehabilitation shall be analyzed for earthquake load effects. Bridge specific direction on how to address the results of the analysis will be provided by **CTDOT**.
- All existing bridges undergoing minor rehabilitation, such as deck patching, resurfacing and safety improvements need not be analyzed or designed for earthquake load effects.

All non-conventional bridges, new and existing bridges being rehabilitated, shall be designed for earthquake load effects as directed by the **CTDOT**. Non-conventional bridges include bridges with cable-stayed, cable-suspended superstructures, bridges with truss towers or hollow piers for substructures and arch bridges.

All buried structures described and listed in **LRFD** [C12.5.1], including associated end walls, wing walls and head walls, need not be analyzed or designed for earthquake load effects, except where they cross active faults.

The need to design retaining walls for the Extreme Event 1 limit state shall be determined in accordance with **LRFD** [11.5.4.2].

#### **3.8.2 Operational Classification (LRFD [3.10.5])**

Critical and Essential Bridges are defined as those bridges that are:

1. On or over the following National Highway System (NHS) routes:
  - a. Eisenhower Interstate System
  - b. Other NHS Routes
  - c. Strategic Highway Network (STRAHNET) Routes and Connectors

## Connecticut Department of Transportation Bridge Design Manual

2. On designated emergency evacuations routes.

**CTDOT** does not make any performance distinction between Critical and Essential bridges.

*Commentary: CTDOT bridge inspection reports include the following fields:*

*NBI 100 - indicates if the inventory route on the bridge is "on" or "not on" a STRAHNET route.*

*NBI 104 - indicates if the inventory route on the bridge is "on" or "not on" the NHS.*

*Information on the STRAHNET system can be found on the following website:*

<https://www.fhwa.dot.gov/policy/2004cpr/chap18.cfm>

*A map of the National Highway System in Connecticut may be found on the following website:*

[https://www.fhwa.dot.gov/planning/national\\_highway\\_system/nhs\\_maps/connecticut/ct\\_connecticut.pdf](https://www.fhwa.dot.gov/planning/national_highway_system/nhs_maps/connecticut/ct_connecticut.pdf)

*Additional information on the NHS can be found on the following website:*

[http://www.fhwa.dot.gov/planning/national\\_highway\\_system/nhs\\_maps/](http://www.fhwa.dot.gov/planning/national_highway_system/nhs_maps/)

This Page is Intentionally Left  
Blank



**SECTION 4**  
**STRUCTURAL ANALYSIS AND EVALUATION**

**TABLE OF CONTENTS**

4.1 Structural Analysis.....	4-1
4.1.1 Methods of Analysis [4.4].....	4-1
4.2 DISTRIBUTION OF LOADS TO SUPERSTRUCTURE COMPONENTS [4.6.2.2] .....	4-1
4.2.1 Distribution of Loads on Butted Prestressed Box Members with Varying I.....	4-1
4.3 Deflection Criteria and span-to depth ratios [2.5.6.2] .....	4-2
4.3.1 Criteria for Deflection.....	4-2
4.3.2 Criteria for Span to Depth Ratios.....	4-2
4.3.3 Railway Structures .....	4-2

This Page is Intentionally Left  
Blank

## **SECTION 4** **STRUCTURAL ANALYSIS AND EVALUATION**

### **4.1 STRUCTURAL ANALYSIS**

#### **4.1.1 Methods of Analysis [4.4]**

All new, existing and temporary bridges, and bridges during all phases of construction, shall be analyzed in accordance with **LRFD** [4.4]. Bridges with straight members and supports skewed greater than 30 degrees, and bridges with horizontally curved girders shall be analyzed by refined methods in accordance with **LRFD** [4.6.3]. For bridges with horizontally curved girders meeting the requirements of **LRFD** [4.6.1.2.4b or 4.6.1.2.4c], members may be analyzed as an individual straight girders.

*Commentary: The requirements for the methods of analysis are consistent with the **BLRM**.*

### **4.2 DISTRIBUTION OF LOADS TO SUPERSTRUCTURE COMPONENTS [4.6.2.2]**

#### **4.2.1 Distribution of Loads on Butted Prestressed Box Members with Varying I**

If prestressed box members with different moments of inertia are used in the same superstructure, the dead loads and pedestrian live load applied after the members are interconnected, shall be distributed in proportion to each member's moment of inertia according to the following:

$$DL_k = DL_{Total} * \frac{I_k}{(I_1 + I_2 + I_3 + \dots I_n)}$$

Where:

$DL_k$  = Dead load on member "k"

$DL_{Total}$  = Total dead loads, excluding member weight, applied to the superstructure, such as deck, sidewalks, railings, parapets, overlay, etc.

$I_k$  = moment of inertia of member "k"

$(I_1 + I_2 + I_3 + \dots I_n)$  = Total moment of inertia of all members

### **4.3 DEFLECTION CRITERIA AND SPAN-TO DEPTH RATIOS [2.5.6.2]**

#### **4.3.1 Criteria for Deflection**

For all highway and pedestrian bridges, the criteria for deflection in **LRFD** [2.5.2.6.2] and [3.6.1.3.2] is mandatory.

#### **4.3.2 Criteria for Span to Depth Ratios**

For all highway and pedestrian bridges, the criteria for span to depth ratios in **LRFD** [2.5.2.6.3] is mandatory.

#### **4.3.3 Railway Structures**

The analysis and design of members and components for railway structure shall be in accordance with the **AREMA**.

**SECTION 5**  
**ABUTMENTS, PIERS AND WALLS**

**TABLE OF CONTENTS**

5.1 GENERAL.....5-1

    5.1.1 Abutments.....5-1

    5.1.2 Piers .....5-1

    5.1.3 Walls.....5-1

    5.1.4 Foundations.....5-2

5.2 IDENTIFICATION NUMBERS .....5-2

5.3 EXCAVATION .....5-3

    5.3.1 General.....5-3

    5.3.2 Construction Requiring Cofferdam and Dewatering.....5-3

    5.3.3 Construction in the Dry .....5-4

5.4 EXPANSION, CONTRACTION AND CONSTRUCTION JOINTS .....5-4

5.5 DAMPPROOFING .....5-4

5.6 BACKFILL REQUIREMENTS .....5-5

    5.6.1 General.....5-5

    5.6.2 Backfill Limits .....5-5

5.7 SUBSURFACE DRAINAGE (*Rev. 04/19*) .....5-5

    5.7.1 General.....5-5

    5.7.2 Weepholes and Bagged Stone .....5-5

    5.7.3 Underdrains and Outlets (*Rev. 04/19*) .....5-5

    5.7.4 Subsurface Drainage Selection Criteria.....5-6

        5.7.4.1 Full Height Abutments .....5-6

        5.7.4.2 Perched Abutments.....5-6

5.8 APPROACH SLABS (*Rev. 04/19*) .....5-6

5.9 SLOPE PROTECTION .....5-7

    5.9.1 Selection Criteria .....5-7

    5.9.2 Limits of Slope Protection .....5-7

    5.9.3 Inspection Shelf.....5-7

5.10 SURFACE TREATMENTS .....5-8

    5.10.1 General.....5-8

Connecticut Department of Transportation Bridge Design Manual

5.10.2 Form Liners .....	5-8
5.10.3 Simulated Stone Masonry .....	5-8
5.10.4 Stone Veneer .....	5-9
5.11 REQUIREMENTS FOR ABUTMENTS .....	5-9
5.11.1 General .....	5-9
5.11.2 Gravity and Counterfort Abutments .....	5-9
5.11.2.1 Steel Girder and Concrete Bulb Tee and Box Girder Bridges .....	5-9
5.11.2.2 Butted Deck Unit and Box Beam .....	5-9
5.11.3 Integral Abutments .....	5-10
5.11.3.1 Fully Integral Abutments .....	5-10
5.11.3.2 Semi-Integral Abutments .....	5-10
5.12 REQUIREMENTS FOR PIERS .....	5-10
5.12.1 General .....	5-10
5.12.2 Wall Piers .....	5-11
5.12.3 Open Column Bents .....	5-11
5.12.4 Multiple Column Piers .....	5-12
5.12.5 Single Column Piers .....	5-12
5.12.6 Protection from Adjacent Traffic .....	5-12
5.13 REQUIREMENTS FOR WALLS .....	5-12
5.13.1 General .....	5-12
5.13.2 Wall Selection Criteria .....	5-13
5.13.2.1 Walls < 8 Feet (Measured from Front Grade to Back Grade) .....	5-13
5.13.2.1.1 Embankment Walls (Rev. 12/19) .....	5-13
5.13.2.1.2 Cast-in-Place Walls .....	5-13
5.13.2.2 Walls > 8 Feet (Measured from Front Slope to Back Slope) .....	5-14
5.13.2.2.1 Walls < Than 5,000 ft <sup>2</sup> of Vertical Face Area (Measured to Bottom of Footing)5-	
14	
5.13.2.2.2 Walls > 5,000 ft <sup>2</sup> of Vertical Face Area (Rev. 12/19) .....	5-14
5.13.2.2.3 Inverted Wall Systems (Rev. 12/19) .....	5-15
5.13.2.3 Architectural Treatments .....	5-15
5.13.2.4 Large Anticipated Settlements and Liquefaction .....	5-16
5.13.2.5 Walls Supporting Roadways .....	5-16
5.13.2.6 Multiple Walls in Same Project .....	5-16
5.13.2.7 Pre-Construction Procedures .....	5-16
5.13.3 Requirements for Cast-in-Place Non-Proprietary Walls .....	5-16

Connecticut Department of Transportation Bridge Design Manual

5.13.3.1 Flared Type Wingwalls and Retaining Walls.....	5-16
5.13.3.2 U-Type Wingwalls with Sidewalks.....	5-16
5.13.3.3 U-Type Wingwalls with Sloped Curb .....	5-17
5.14 REQUIREMENTS FOR FOUNDATIONS .....	5-17
5.14.1 Structures over Waterways (Rev. 09/23) .....	5-17
5.14.2 Spread Footings on Soil (Rev. 01/09).....	5-34
5.14.3 Foundations on Rock.....	5-34
5.14.4 Driven Piles (Rev. 01/09).....	5-34
5.14.5 Drilled Shafts .....	5-37
5.15 EARTH RETAINING SYSTEMS AND COFFERDAMS (Rev. 01/09) .....	5-37
5.15.1 Highway Applications (Rev. 01/09) .....	5-37
5.15.1.1 Permanent Steel Sheet Piling (Rev. 01/09).....	5-37
5.15.1.2 Temporary Earth Retaining Systems (Rev. 01/09).....	5-38
5.15.2 Railroad Applications (Rev. 01/09) .....	5-38
5.15.2.1 Permanent Steel Sheet Piling (Rev. 01/09).....	5-38
5.15.2.2 Temporary Earth Support Systems (Rev. 01/09).....	5-38
5.15.3 Water-Handling-Cofferdams and Temporary Water Redirection (Rev. 01/09) .....	5-39
5.15.3.1 Structure Excavation (Complete) (Rev. 07/04).....	5-39
5.15.3.2 Handling Water (Rev. 07/04).....	5-39
5.15.3.3 Cofferdam and Dewatering (Rev. 07/04).....	5-40

## **SECTION 5** **ABUTMENTS, PIERS AND WALLS**

### **5.1 GENERAL**

#### **5.1.1 Abutments**

An abutment supports the end of a bridge span, provides lateral support for approach roadway fill and supports the approach roadway and approach slab. Abutments may be described by their location relative to the approach embankments.

A stub (embankment) abutment is located at or near the top of the approach fill. A partial depth abutment is located approximately mid-depth of the front slope of the approach embankment. A full depth (shoulder) abutment is located at the approximate toe of the approach embankments.

Abutment types shall be selected considering structure aesthetics, foundation recommendations, structure location, and the loads it must transmit to the foundation. For structures over waterways, the abutment type and location should also be specified with consideration to hydraulic conditions at the site. Wherever possible, use stub (embankment) abutments for structures over waterways.

The acceptable abutments types include non-proprietary systems such as gravity walls, cantilever walls, counterfort walls and integral abutments. Preference shall be given to integral abutments. Abutments shall not be placed on fill supported by mechanically stabilized earth walls or prefabricated modular walls, except for Geosynthetic Reinforced Soil-Integrated Bridge Systems. Generally, for abutments and wingwalls founded on rock, where the footings are exposed, the abutment and wingwalls shall be designed without a toe.

#### **5.1.2 Piers**

A pier provides intermediate support between the superstructure and the foundation. Pier types shall be selected considering structure aesthetics, foundation recommendations, structure location, and the loads it must transmit to the foundation. If possible, on large projects with many piers, the type of pier shall be consistent throughout the entire project for reasons of economy. The acceptable concrete pier types include wall piers, open column bents, multiple column piers, and single column piers. The use of permanent steel pier bents is discouraged due to future maintenance.

#### **5.1.3 Walls**

Walls should be used where the construction of a roadway or facility cannot be accomplished with slopes. Walls can be classified as either retaining walls, or wingwalls. Wingwalls are used to provide lateral support for the bridge approach roadway embankment. For bridges



with long wingwalls that are parallel to the roadway, the wingwall shall be referred to as a retaining wall and may receive a wall number.

Wingwalls shall preferably be U-type (parallel to the roadway). Flared wingwalls are permitted where conditions warrant such as for hydraulic performance of waterway crossings. The acceptable wingwall types include non-proprietary systems such as gravity walls, cantilever walls and counterfort walls. Proprietary systems, such as mechanically stabilized earth and prefabricated modular walls, shall only be used for retaining walls.

Retaining walls may be non-proprietary systems such as gravity walls, cantilever walls, counterfort walls or tie-back walls, or may be proprietary systems such as mechanically stabilized earth walls or prefabricated modular walls.

The tops of retaining walls shall not be determined by the exact fill slope but shall follow a smooth unbroken line for a more pleasing appearance. This may require the use of vertical curves, in which case elevations shall be given at 5 foot intervals.

#### **5.1.4 Foundations**

A foundation serves to transmit the forces acting on the abutments, piers, or walls into the ground. Foundations are classified as either shallow or deep. A shallow foundation derives its support by transferring load directly to soil or rock at a shallow depth. Spread footings are shallow foundations. A deep foundation derives its support by transferring loads to soil or rock at some depth below the structure by end bearing, adhesion or friction or both. Driven piles, micropiles and drilled shafts are deep foundations.

Foundation type is generally based on the anticipated (structure) loads, underlying soil conditions, scour potential, and site constraints along with the ease and cost of construction.

### **5.2 IDENTIFICATION NUMBERS**

All abutments and piers shall be identified by numbers which start with the number “one” and progress consecutively but separately in the direction of stationing of the roadway, such as, Abutment 1, Pier 1, Abutment 2, etc.

All wingwalls shall be identified by a combination of a number and a letter (alphanumeric), such as 1A or 1B. The number used must correspond to the abutment to which the wingwall is attached. Looking up station, the letter “A” indicates the wingwall is on the left and the letter “B” indicates the wingwall is on the right.

Retaining walls shall be identified by three numbers that start at 101 and progress consecutively in the direction of stationing of the roadway, such as Retaining Wall 101, Retaining Wall 102. Parallel walls along both edges of roadway beginning at the same station are to follow wingwall rules. These numbers may designate a proprietary wall, a proprietary embankment wall, a cast-in-place wall or a soil nail wall. A table shall be provided in the contract identifying the relationship between the wall number, type and site number of the wall, and location as in the following:

RETAINING WALL NUMBER	DESCRIPTION	LOCATION
101	Embankment Wall – Site 1	Station 10+00 to 12+50
102	Retaining Wall – Site 2	Station 25+50 to 32+50
103	Cast-in-place – Site 3	Station 70+00 to 72+50
104	Retaining Wall – Site 4	Station 80+00 to 82+50

### 5.3 EXCAVATION

#### 5.3.1 General

Contract items for structure excavation, unless the work is included under other items, are required for the removal of all material of whatever nature necessary for the construction of foundations for bridges, box culverts, retaining walls and other structures. The items specified in the contract depends on the type of material removed, earth or rock, and whether or not separate payment will be made for the work related to cofferdams and dewatering.

On any project where only some of the structures and/or their components require cofferdams and some do not, a combination of structure excavation items shall be shown in the contract. The contract for the structures and components requiring “Cofferdam and Dewatering” shall clearly delineate the pay limits and the limits of the cofferdam.

#### 5.3.2 Construction Requiring Cofferdam and Dewatering

A cofferdam is a structure that retains water and soil that allows the enclosed area to be pumped out and excavated dry to permit construction.

At water crossings, where structures or their components are located partially or wholly in the water and the bottom of the footing is below water level, or where a considerable flow or concentration of water is present that cannot be diverted, partly or wholly, from the site, the contract shall include the following item:

ITEM NAME	PAY UNIT
Cofferdam and Dewatering	L.F.

The hydraulic design of the cofferdam should be done in accordance with the **Drainage Manual**.

The contract shall also include either one or both of the following items, as required for the type of material removed:

ITEM NAME	PAY UNIT
Structure Excavation – Earth (Excluding Cofferdam and Dewatering)	C.Y.
Structure Excavation – Rock (Excluding Cofferdam and Dewatering)	C.Y.

Where underwater (tremie) concrete may be used to seal the bottom of a cofferdam to allow dewatering, the weight of the tremie concrete, adjusted for buoyancy, shall be added to pile and foundation loads for design purposes.

### 5.3.3 Construction in the Dry

Where structures or their components are to be constructed in the dry or where water may be temporarily directed away from an excavation, eliminating the need for a cofferdam, the contract shall also include either one or both of the following items, as required for the type of material removed:

ITEM NAME	PAY UNIT
Structure Excavation – Earth (Complete)	C.Y.
Structure Excavation – Rock (Complete)	C.Y.

The temporary redirection of water or water courses, either partially or wholly, from an excavation or site, must be coordinated with hydraulic studies and DEEP, Federal and State permit submittals. At the sites where water is directed away from an excavation, the following item shall be included in the contract.

ITEM NAME	PAY UNIT
Handling Water (Site No.     )	L.S.

### 5.4 EXPANSION, CONTRACTION AND CONSTRUCTION JOINTS

Expansion and contraction joints in concrete abutment and wall stems shall be provided in accordance with **LRFD**. Construction joints shall be placed as conditions warrant. Construction joints other than those shown in the contract require prior approval from the Engineer. Expansion or contraction joints should not be provided in footings. Footings for abutments and walls should be continuous including any steps provided.

No reinforcement shall pass through expansion and contraction joints. Reinforcement shall pass through construction joints.

### 5.5 DAMPPROOFING

The rear face of cast-in-place and precast abutments and wall stems shall be damp- proofed.

## 5.6 BACKFILL REQUIREMENTS

### 5.6.1 General

Unless otherwise directed, all abutments, wingwalls and retaining walls shall be backfilled with Pervious Structure Backfill to the limits described below. Pervious Structure Backfill is a clean, granular soil. For design purposes, the effective angle of internal friction shall be taken as equal to 35 degrees.

### 5.6.2 Backfill Limits

Indicate a wedge of Pervious Structure Backfill above a slope line starting at the top of the heel and extending upward at slope of 1:1½ (rise to run) to the bottom of the subbase. In cut situations, the following note, with a leader pointing to the slope line, shall be placed in the contract:

Slope line except where undisturbed material obtrudes within this area.

## 5.7 SUBSURFACE DRAINAGE (Rev. 04/19)

### 5.7.1 General

Subsurface drainage shall be accomplished with the use of weepholes extending through the wall stems, or underdrains placed along the wall stems. Subsurface drainage for proprietary retaining walls shall conform to the owned special provisions governing their design and construction.

### 5.7.2 Weepholes and Bagged Stone

Except for structures placed on embankments, 4 inch diameter weepholes, sloped 1:8 (rise to run), shall be placed approximately 1 foot above the finished grade at the front face of the wall stem. For structures placed on embankments, the weepholes shall be extended through the slope with an outlet. Weepholes shall not drain onto adjacent sidewalks. Weepholes should be spaced at approximately 8 to 10 foot intervals unless conditions warrant a closer spacing. The spacing and invert elevations of the weepholes shall be shown in an elevation view.

The cost of furnishing and installing weepholes is included in the cost of the concrete. Bagged Stone is paid under "Pervious Structure Backfill".

### 5.7.3 Underdrains and Outlets (Rev. 04/19)

Underdrains shall have a 6 inch nominal diameter, perforated and placed at the base of the stem and sloped a minimum of 1%. Underdrains shall be either connected to the roadway drainage or to a free outlet. The location and limits of the underdrain shall be shown in plan view. The invert elevations shall be shown in an elevation view. Outlets for underdrains shall consist of

pipe laid in a trench and refilled with earth. The size and type of outlet pipe shall be the same as that of the underdrain to which it is connected, except that it shall not be pervious to water.

Underdrains shall be paid for under the item “6 inch Structure Underdrain”. Outlets shall be paid under “6 inch Outlets for Underdrain”. When an underdrain is connected to the roadway drainage, the pipe beyond the face of the wall stem or the end of the wall shall be shown in the contract to be included in the roadway items, and should be coordinated with the roadway designer.

#### **5.7.4 Subsurface Drainage Selection Criteria**

##### **5.7.4.1 Full Height Abutments**

At abutments in cut situations, either an underdrain or weepholes may be used with the latter being preferred. Weepholes should be used at abutments located on fills. When there is a sidewalk in front of any abutment, an underdrain should be used. Where this type of abutment is used at water crossings, drainage shall be provided by weepholes.

##### **5.7.4.2 Perched Abutments**

At abutments in wet cuts, an underdrain should be used. At abutments in dry cuts and fills, extended weepholes should be used. If the total length of the extended weepholes exceeds what’s required for underdrains, the latter is preferred.

For walls with a fully exposed face adjacent to a sidewalk, an underdrain should be used. For walls with a fully exposed face not adjacent to a sidewalk, weepholes should be used. For walls with a partially exposed face, an underdrain should be used.

#### **5.8 APPROACH SLABS (Rev. 04/19)**

Approach slabs shall be provided on all bridges carrying State highways. Approach slabs shall be strongly considered on all bridges undergoing superstructure replacement and local road bridges.

Approach slabs should extend the full width of the roadway (including shoulders), have a standard length of 16 feet and be 1.25 feet thick. Generally, approach slabs should follow the skew of the bridge for skew angles up to 35 degrees. For skew angles greater than 35 degrees, the ends of the approach slabs should be square to the roadway with a minimum length of 15 feet. Acute corners of approach slabs and approach pavement should be squared off for a distance of five feet from the gutter line. Approach slabs shall be anchored to the bridge abutment.

Approach slabs shall be constructed in accordance with **BDM** [6]. Approach slabs shall be covered with a waterproofing membrane and a bituminous concrete overlay. All the material items used in the construction of the approach slabs, including the overlay, shall be included in the structure items and quantities.

All elevations necessary for construction of the approach slabs shall be shown in the contract. These elevations shall include the elevations at the point of application of grade line, the gutter lines and at shoulder break lines at both ends of the approach slabs.

## **5.9 SLOPE PROTECTION**

Provisions shall be made for protection of earth slopes in front of abutments on bridges over State highways, local roads, railroads and waterways. The slope of the embankment in front of the abutment shall be no steeper than 1:2 (rise to run).

### **5.9.1 Selection Criteria**

The type of slope protection shall generally conform to the following criteria:

- Crushed Stone for Slope Protection shall be used under structures overpassing Interstate highways, railroads and waterways. Protection between the edge of the shoulder and the toe of the slope should be founded on a 6 inch granular fill base or geotextile. The limits of this base should be shown in the contract and shall be include in the estimated structure quantities.
- Concrete Block Slope Protection shall be used under structures overpassing State highways and local roads. The block shall be anchored or mortared into place to prevent vandalism. The use of granite block is not permitted due to its higher cost. Cast-in-place concrete is not permitted due to cracking and settlement of existing installations.
- Abutment slope protection for bridges over waterways should be designed in accordance with the procedures outlined in **HEC-18** or successor documents as well as documents referenced therein.

### **5.9.2 Limits of Slope Protection**

The limits of slope protection shall cover the complete area, exclusive of sidewalks, from the edge of the shoulder to the face of the abutment stem and transversely within lines parallel to and 2 feet outside of the bridge rails.

### **5.9.3 Inspection Shelf**

Provisions for inspection access (for bridge inspectors) shall be provided on all slopes. On stems with exposed heights less than or equal to 5 feet, access shall be provided by a shelf at the top of the slopes. On stems with exposed heights greater than 5 feet, access may be by a shelf at the top of the slopes or ladder stops on the slope itself. The contract shall include details of the intersection of the shelf and the slope along the wingwalls.

## **5.10 SURFACE TREATMENTS**

### **5.10.1 General**

In general, abutments, piers and walls shall be faced with standard formed concrete. Surface treatments other than standard formed concrete should only be considered in the following situations:

- When the structure has been determined by the **CTDOT** to be architecturally or historically significant.
- If there is a desire expressed for special surface treatments during the public involvement process of the project. The basis for surface treatments should involve the character of the area in which the wall is to be built. The use of special surface treatments should be coordinated with the town or city administration.
- Where the structure is to be built on a designated State scenic highway.
- The structure is part of the Merritt Parkway. For these structures, every attempt should be made to replicate the appearance and structure type that was originally built.
- The treatment of the structure is part of a right-of-way settlement with a property owner. For instance, if a property has an existing stone wall that is to be removed and relocated, the owner may request that the replacement wall also have a stone surface.

If special surface treatments are desired for a particular structure, every attempt should be made to achieve architectural aesthetics by means of shape and form, not through surface treatments alone. Surface treatments should generally be used in conjunction with the shape of the structure.

### **5.10.2 Form Liners**

When the use of surface treatments has been determined to be appropriate, the preferred method is the use of concrete form liners. Form liners offer a lower cost alternative to stone veneer. There is a wide variety of form liners available for different architectural treatments. Linear corrugated form liners should be avoided since it is difficult to hide joint lines and form tie holes. Form liners that replicate stone are preferred since the random nature of the surface makes it easy to hide form tie holes.

### **5.10.3 Simulated Stone Masonry**

In more sensitive areas, where the look of real stone is required, the use of simulated stone masonry may be considered. Simulated stone masonry utilizes a flexible form liner system and color stains or dry-colorant admixtures to provide the aesthetic appeal of natural stone with the durability of reinforced concrete.

#### **5.10.4 Stone Veneer**

The use of stone veneer on concrete should only be considered in very sensitive areas where the increased cost can be justified. Stone veneer shall only be used with approval from the **CTDOT**.

### **5.11 REQUIREMENTS FOR ABUTMENTS**

#### **5.11.1 General**

The abutments shall be designed, unless otherwise noted, in accordance with the **LRFD**.

Generally, abutments shall be constructed of reinforced concrete. Cast-in-place footings and stems shall be constructed in accordance with **BDM** [6].

#### **5.11.2 Gravity and Counterfort Abutments**

##### **5.11.2.1 Steel Girder and Concrete Bulb Tee and Box Girder Bridges**

Gravity, cantilever, and counterfort walls, with bridge seats, may be used for abutments.

Bridge seats shall be sloped with a minimum 2 inch draw from the front face of the backwall and closed at the ends. When determining bridge seat widths, consideration shall be given to superstructure jacking requirements as given in **BDM** [7.2.13] and the clear distance requirements between the end bearing diaphragms and the front face of the backwall as given in **BDM** [7.3.3.7]. On bridges constructed with box girders, the clear distance from the end of the box girder to the face of the backwall should be no less than two feet.

At the elevation of the bridge seat, the minimum dimension from the front face of the abutment stem to the centerline of the bearings shall be 1.25 feet. The minimum backwall thickness shall be 1.25 feet. Stem thicknesses may be less than the combined dimensions of the bridge seat and backwall.

##### **5.11.2.2 Butted Deck Unit and Box Beam**

Gravity, cantilever and counterfort walls, with bridge seats, may be used for abutments.

Bridge seats shall be sloped to match the grade of beams. Provisions should be provided on the contract plans to provide drainage at the low end of span.

At the elevation of the bridge seat, the minimum dimension from the front face of the abutment stem to the centerline of the bearings shall be 9 inches. The minimum backwall thickness shall be 1.25 feet. Stem thickness may be less than the combined dimensions of the bridge seat and backwall.



### 5.11.3 Integral Abutments

Integral abutments are defined as abutments that are cast integrally with the superstructure. Integral abutments should be considered on all bridges, and especially where pile supported foundations are required, since the use of integral abutments will greatly reduce the number of piles and simplify the abutment details.

All integral abutment bridges shall be designed with full width approach slabs in order to minimize surcharge loads and hydrostatic pressures. Integral abutments shall be designed with U-Type wingwalls.

#### 5.11.3.1 Fully Integral Abutments

Fully integral abutments are defined as abutments that are integral from the superstructure through to the piles. In order to control the effects of the soil mass on the abutment, the maximum height of the cast-in-place abutment shall be 8 feet.

The piles shall be placed in a single line and typically are oriented such that the weak axis of the pile is parallel to the abutment face. For design purposes, the connection of the superstructure to the substructure shall be modeled as a pinned connection. The piles shall be designed for vertical forces only and adhere to the guidelines in **HEC-18** and **HEC-22**. The effects of thermal expansion, end rotation of the superstructure, and soil forces should be neglected.

#### 5.11.3.2 Semi-Integral Abutments

Semi-integral abutments are defined as abutments that are integral from the superstructure through a portion of the abutment stem. Typically, a joint will be detailed in the abutment stem. In order to control the effects of the soil mass on the abutment, the maximum height of the integral portion of the cast-in-place abutment shall be 8 feet.

For design purposes, the connection of the superstructure to the substructure shall be modeled as a pinned connection. The lower portion of a semi-integral abutment shall be designed as a standard cantilever abutment with all vertical forces from the superstructure transmitted to lower portion of the abutment.

## 5.12 REQUIREMENTS FOR PIERS

### 5.12.1 General

The piers shall be designed, unless otherwise noted, in accordance with the **LRFD**. Generally, piers shall be constructed of reinforced concrete. While the design of steel pier caps is allowed, they are discouraged. For additional information, see **BDM** [7]. Piers may be made integral with the superstructure.

Footings, concrete pier stems, columns, and pier caps shall be constructed in accordance with **BDM** [6]. Post-tensioned concrete pier caps may require concrete with greater compressive strengths.

All reinforcement in piers shall conform to **BDM** [6]. The concrete cover over the reinforcement in pier footings, stems, columns, and pier caps shall be 3 inches.

Circular concrete columns are preferred over rectangular concrete columns. With circular columns, spiral reinforcement is preferred over ties.

Cantilever concrete pier caps shall be post tensioned in order to eliminate cracking. The design shall be based on zero tension in the top of the cap after all losses have occurred under all loads.

The top surfaces of concrete piers and concrete pier caps shall have a transverse slope of 1:10 (rise to run). The slope shall be in both directions from the centerline to the face of the pier with a minimum draw of 2 inches.

Drilling holes for anchor bolts will not be permitted in concrete pier caps for new structures. Anchor bolts installed before the concrete is placed shall be set and held accurately by a template. Anchor bolts to be set after the concrete is poured shall be set in forms that shall be placed before the concrete is poured. The designer shall indicate in the contract which method of setting anchor bolts is to be used.

For structures over waterways, the following criteria applies:

- Pier foundations on floodplains should be designed to the same elevation as pier foundations in the stream channel if there is likelihood that the stream channel will shift its location over the life of the bridge.
- Align piers with the direction of flood flows. Assess the hydraulic advantages of round piers, particularly where there are complex flow patterns during flood events.
- Streamline piers to decrease scour and minimize the potential for the buildup of ice and debris. Use ice and debris deflectors where appropriate.

### **5.12.2 Wall Piers**

A wall pier consists of a solid wall that extends up from its foundation. Generally, wall piers or wall piers combined with open bents should be considered at water crossings. Wall piers offer minimal resistance to water and ice flows.

### **5.12.3 Open Column Bents**

An open column bent consists of a pier cap beam and supporting columns in a frame-type structure. Open column bents should be considered for wide overpasses at low skew angles.

Open column bents founded on rock shall generally be designed with isolated footings while open column bents founded on soil shall generally be designed with combined footings. When these piers are founded on piles, they may be designed with either isolated or combined footings.

#### **5.12.4 Multiple Column Piers**

A multiple column pier consists of an individual column supporting each beam or girder. Multiple column piers should be considered for wide overpasses at low skew angles.

#### **5.12.5 Single Column Piers**

Single column piers are simple, easy to construct, require minimum space, and provide open appearance to traffic. Single column piers may have a hammer head pier cap. Hammer head piers should be considered for overpasses at high skew angles with tight alignment constraints. This type of pier provides open appearance when supporting structures with long spans.

#### **5.12.6 Protection from Adjacent Traffic**

To limit damage to piers by vehicular traffic, crash walls shall be provided. The minimum height of the wall shall be 42 inches, and shall be placed a minimum of 6 inches from the face of the pier.

To limit damage to piers by railroad equipment, crash walls shall be provided in accordance with **AREMA**. Extensions to crash walls may be required to satisfy site conditions. The top surface of the crash wall shall have a transverse slope of 12:1.

### **5.13 REQUIREMENTS FOR WALLS**

#### **5.13.1 General**

The following is a list of appropriate retaining wall types that may be considered:

1. Non-Proprietary: Precast and Cast-In-Place Reinforced Concrete
2. Proprietary:
  - Prefabricated Modular Wall Systems
  - Mechanically Stabilized Earth Walls (precast concrete)
  - Mechanically Stabilized Earth Embankment Walls (dry-cast block)

A design is required for the non-proprietary walls only. The Contractor shall be responsible for the structural/internal design of the proprietary walls. For projects where proprietary retaining walls are included, the walls will be bid as a lump sum for each site. The designer shall clearly define the horizontal, vertical, and transverse pay limits in the contract.

The **CTDOT** maintains a list of approved proprietary retaining walls for each category listed above. No other proprietary retaining walls will be allowed.

### **5.13.2 Wall Selection Criteria**

The designer shall select the appropriate retaining walls for each site. The designer may need to contact wall manufacturers to ensure that each wall will be suitable at each site, and fit within the available right-of-way. The following general criteria should be followed for the selection of appropriate retaining walls:

#### **5.13.2.1 Walls < 8 Feet (Measured from Front Grade to Back Grade)**

##### **5.13.2.1.1 Embankment Walls (Rev. 12/19)**

Embankment walls are defined as mechanically stabilized earth structures faced with dry cast concrete block that are less than 8 feet high and support an embankment. Embankment walls are typically used to support earth only, not roadways or where there is a potential for future underground utilities or drainage structures. The mechanical strength of the wall comes from soil reinforcements comprised of either geogrids or welded wire mesh.

Embankment walls are proprietary wall systems, and there are several approved manufacturers of these types of walls. It is not necessary to design a cast-in-place retaining wall as an alternate; however, the designer shall lay out the embankment wall in the contract with at least the following information:

- Retaining wall plan view with all required dimensions, contours, property lines, utilities, etc.
- Retaining wall elevation view showing top and bottom elevations, approximate step locations, existing and finished grade, etc. Where required, the designer shall also show the location of railings or fences required to be attached to the top of the wall.
- Typical sections (schematic) of the wall showing pay limits and minimum drainage requirements.
- Borings and soils information including the maximum factored bearing resistance.
- Temporary Sheeting required for excavation.

##### **5.13.2.1.2 Cast-in-Place Walls**

For locations where embankment walls are not appropriate (in accordance with the criteria listed above), a cast-in-place wall should be designed and detailed.

At the discretion of the **CTDOT**, proprietary walls may also be allowed if the wall is very long resulting in a large overall area. The designer shall provide the same information for proprietary walls as required in **BDM** [5.13.2.2.1].

If the appearance of stone is desired, architectural form liners should be used. These liners are significantly less costly than stone veneer. If there are multiple walls on a project, the surface treatment shall be similar for each wall.

### **5.13.2.2 Walls > 8 Feet (Measured from Front Slope to Back Slope)**

#### **5.13.2.2.1 Walls < Than 5,000 ft<sup>2</sup> of Vertical Face Area (Measured to Bottom of Footing)**

For this situation, a cast-in-place wall should be designed to be bid against the proprietary walls. The Contractor may be able to build the cast-in-place wall with his own forces at a lower cost. For these situations, the designer shall completely design and detail the cast-in-place wall. For the proprietary retaining wall, schematic typical cross sections combined with the cast-in-place details should be enough for the proprietary wall manufacturers to design their walls.

The designer shall provide a list of the specific wall types allowed for each site. For instance, the designer may limit the selection based on the available right of way at a site.

For mechanically stabilized earth walls with metallic soil reinforcements that are to be built in areas of potential stray currents within 200 feet of the structure (for example: an electrified railroad), a corrosion expert shall evaluate the potential need for corrosion control requirements.

If the wall is required to be designed for seismic loads, it shall be stated in the notes for the wall.

#### **5.13.2.2.2 Walls > 5,000 ft<sup>2</sup> of Vertical Face Area (Rev. 12/19)**

For this situation, proprietary retaining walls will most likely be more economical; therefore, a cast-in-place wall design should generally not be done except where site conditions or soil constraints may require a cast-in-place wall. The designer shall determine which proprietary retaining walls are appropriate for each site. The designer shall also lay out the proprietary retaining walls in the contract with at least the following information:

- A list of the specific walls allowed for each site. For instance, the designer may limit the selections based on the available right of way at a site.
- Retaining wall plan view with all required dimensions, offsets, contours, property lines, utilities, etc.

- Retaining wall elevation view showing top and bottom elevations, approximate footing step locations, existing and finished grade, etc. Where required, the designer shall also show the location of railings or fences, light standard and/or sign support anchorage locations, rigid metal conduit and junction boxes.
- Typical Sections (schematic) of the wall showing pay limits and minimum drainage requirements. Specific details are not required for each wall manufacturer, only for each wall type.
- All soils information normally used for the design of a cast-in-place wall shall be shown in the contract, including but not limited to borings and maximum factored bearing resistance.
- Temporary Sheet piling required for excavation.
- If the wall is required to be designed for seismic loads, it shall be stated in the notes for the wall.
- For mechanically stabilized earth walls with metallic soil reinforcements that are to be built in areas of potential stray currents within 200 feet of the structure (for example: an electrified railroad), a corrosion expert shall evaluate the potential need for corrosion control requirements.

#### **5.13.2.2.3 Inverted Wall Systems (Rev. 12/19)**

Inverted wall systems are modular block walls with a modified design methodology where smaller modular units are at the bottom of the wall and larger units at the top.

Due to the current sole source requirement, inverted wall systems can only be used where site conditions restrict the use of all other retaining wall systems. Inverted wall systems are well-suited for the specific scenario in which ground conditions restrict the use of temporary earth retaining systems (such as where ledge prohibits driven or drilled piles; adjacent structures may be damaged due to vibrations) and open excavation is restricted (e.g. – undermining of adjacent structures, utilities, etc.; Rights-of-Way constraints).

#### **5.13.2.3 Architectural Treatments**

If the appearance of stone is desired, architectural form liners should be used. These liners are significantly less costly than stone veneer. Several of the proprietary retaining walls can be built with form liners resembling stone. The designer should contact the approved wall manufacturers for specifics about available form liners. Every effort should be made to keep the surface treatment similar for all the wall types specified.

#### **5.13.2.4 Large Anticipated Settlements and Liquefaction**

If large settlements or liquefaction are anticipated that require a wall supported on piles, in general, proprietary retaining walls should not be used. Even though these walls can accommodate some settlement, the opening and closing of the joints would produce an undesirable appearance. For these situations, a cast-in-place wall should be designed supported on piles, or the proprietary retaining walls shall be detailed with pile supported full width footings.

#### **5.13.2.5 Walls Supporting Roadways**

If the wall supports a roadway where there is a possibility of future underground utilities and drainage structures, mechanically stabilized earth walls should not be used. This would not be the case for walls supporting limited access highways. If the utilities are extensive or deep, it may not be possible to use the modular wall options either.

#### **5.13.2.6 Multiple Walls in Same Project**

If there are several retaining walls within the same project, the designer may wish to require that all walls selected by the Contractor for the project be manufactured by the same wall supplier. This is especially true for walls that are close together.

#### **5.13.2.7 Pre-Construction Procedures**

The designer should contact the wall companies for tall walls or walls with unusual geometry to be sure that the proprietary walls will function at each site. This should be done during the preliminary design phase of the project.

Prior to construction advertising, the designer should inform in writing each proprietary wall company that they are listed as acceptable alternates in the contract. This will allow them to obtain the contract in order to accomplish preliminary design during advertising for the project. Part of this submission should include the anticipated advertising date.

### **5.13.3 Requirements for Cast-in-Place Non-Proprietary Walls**

#### **5.13.3.1 Flared Type Wingwalls and Retaining Walls**

The stems of flared type wingwalls shall be 1.33 feet wide at the top, with the rear face battered. The minimum batter shall be 10:1.

#### **5.13.3.2 U-Type Wingwalls with Sidewalks**

The top of the wingwall section shall conform to the parapet width for the full length. If a batter is required, the rear face shall be vertical to approximately 12 inches below the sidewalk.

### 5.13.3.3 U-Type Wingwalls with Sloped Curb

The top of the wingwall section shall conform to the parapet width for the full length. If a batter is required, the rear face shall be vertical to approximately 12 inches below the bottom of subbase.

## 5.14 REQUIREMENTS FOR FOUNDATIONS

### 5.14.1 Structures over Waterways (Rev. 09/23)

*Foundations for structures adjacent to or within waterways shall meet the requirements of Article 2.6 amended as follows:*

*This BDM section is presented in a format like that used in the LRFD. In the LRFD, the code is in the left column and the commentary is in the right column. Below the BDM practice is in the left column and the BDM commentary is in the right column.*

*The BDM practice and commentary amend the LRFD by supplementing, revising, or deleting the LRFD code and commentary.*

*Headings, table or figures, such as x.x.x.x-General, refer to the LRFD. Headings, table or figures, such as x.x.x.x.xCT or Table x.x.x.x.xCT are new requirements of the CTDOT.*

*References in the BDM practice to other articles in the BDM are shown as BDM [x.x] or BDM [Table x.x]. References to the LRFD are shown as Article x.x or Table x.x (which is consistent with the LRFD convention). Non-structural references in the practice are only made to other CTDOT engineering discipline manuals, such as the CTDOT Drainage Manual.*

*References in the BDM commentary to the BDM and LRFD match the format used in the BDM practice. The commentary may include references to documents from any source.*

## 2.6— HYDROLOGY AND HYDRAULICS

### 2.6.1— Hydraulic Analysis

#### 2.6.4—Bridge Foundations

##### 2.6.4.4.1 General

*This section shall be supplemented with the following:*

Foundations, for both new and existing structures, adjacent to or within waterways subjected to scour shall be designed for changes in foundation conditions resulting from the scour design flood and the scour check flood. Structure foundations shall include bridge foundations, supporting intermediate piers and abutments, foundations for 3-sided frames supporting pedestals and frame legs, and foundations for walls retaining transportation facilities. The design of foundations for scour encompasses both the placement of the foundations and the evaluation of the foundations for changes in conditions due to the scour. The scour design flood, scour check flood, and the changes in foundation conditions resulting from scour shall be determined in accordance with the CTDOT Drainage Manual.

##### C.2.6.4.4.1

*This section shall be supplemented with the following:*

The terms “scour design flood” and “scour check flood” used in this practice are consistent with *Evaluating Scour at Bridges*, 5<sup>th</sup> Edition, dated April 2012, FHWA-HIF-12-003, Hydraulic Engineering Circular No. 18 (HEC-18). The terms “scour design flood” and “scour check flood” are equivalent to the LRFD terms “design flood for bridge scour” and “check flood for bridge scour” respectively.

Since the terminology used by disciplines and documents varies, for clarification refer to *Technical Brief (TechBrief)* FHWA-HIF-19-060. The *TechBrief* defines terms, differentiates between hydraulic design and scour design and describes the interaction of limits states and scour depths in foundation design within the context of the LRFD.



This practice separates the design of foundations for scour into 2 parts, foundation support and placement, and foundation evaluation for limit states, to differentiate and clarify requirements.

Scour is determined in accordance with the CTDOT Drainage Manual. The manual refers to the use of HEC-18 for scour design.

Per CTDOT Drainage Manual, Section 9.5, scour information is presented in a scour evaluation report (see Section 9, Appendix C). The report may include, but not be limited to, the following: scour depths and limits, flow elevations and flood velocities for each flood event; recommended foundation placement elevations; limits and details for scour countermeasures; and hydraulic analysis assumptions for existing substructure components that remain in place.

Designers should understand that designing structures for scour requires coordination and collaboration between hydraulics, geotechnical and structural engineers. Multiple design iterations may be required before a final solution is developed that meets each discipline's requirements.

Regarding scour at bridges, the bridge abutment shall be defined to include the structure(s) fully or partially supported by the abutment foundation, such as the bridge end, abutment wall, curtain and wing walls, and approach slab, and walls critical to bridge stability. Retaining walls supporting the approach fill side slopes that are not critical to the bridge stability are not considered part of the bridge abutment for scour considerations.

*2.6.4.4.2—Bridge Scour*

*This section, including the title, shall be deleted and replaced with the following:*

*2.6.4.4.2—Foundation Scour*

The greatest scour depth may not occur at the least frequent flood (i.e., greatest discharge) event selected for the scour design flood frequency and scour check flood frequency. Flood events associated with low tail water, occurrence of ice or debris dams, overtopping conditions, waterway confluences, changes in the angle of approach flow due to movement of the channel or any other flood events that can adversely affect the scour depth shall be considered when determining the governing the flood event for the scour design flood and the scour check flood. The term scour design flood is used to designate a flood event, with a magnitude that is less than or equal to the discharge selected for the scour design flood frequency, that will cause the worst-case scour. Similarly, the term scour check flood is used to designate a flood event, with a magnitude that is less than or equal to the discharge selected for the scour check flood frequency, that will cause the worst-case scour.

*C2.6.4.4.2*

*This section shall be supplemented with the following:*

For additional information for determining scour depth, refer to the CTDOT Drainage Manual, HEC-18 and *TechBrief* FHWA-HIF-19-060.

Low tail water conditions, occurrence of ice or debris dams, overtopping flood conditions, or changes in the angle of approach flow due to movement of the channel tend to be the most problematic with regard to scour depth.

To eliminate the potential errors, the terms scour design flood and scour check flood should be used to designate the governing flood events that will cause the worst-case scour.

Designing foundations scour does not preclude potential damage to highway approaches from flood events. For additional information, refer to HEC-18, Section 2.1, Item 4.

The potential for stream migration and its effect on scour depth outside of the main channel shall be considered when determining the potential depth of scour at the bridge abutment and interior piers outside of the main channel.

The potential for scour to undermine the channel slope, resulting in a slope failure shall be considered when assessing the potential scour depth, including the potential of the scour-induced slope failure to cause lateral loading on the bridge foundations for the abutment as well as the nearby intermediate pier foundations.

For deep foundations, the effect of the foundation components, such as footing/pile caps, piles, etc., above the total scour depth shall be included in determining the total scour depth.

For new structures, changes in foundation conditions resulting from scour shall be determined without the benefits provided by scour countermeasures.

The provisions for tsunami-induced scour are contained in the AASHTO Guide Specifications for Bridges Subject to Tsunami Effects.

#### *2.6.4.4.3CT—Foundation Support and Placement*

Foundations adjacent to or within waterways subjected to scour shall be supported on piles or drilled shafts, scour resistant rock, or on spread footings founded below (outside) the scour limits. Supporting foundations subjected to scour on piles, drilled shafts or on scour resistant rock is preferred. The use of structural tremies (concrete placed under water) to directly support a foundation without piles is not permitted.

The use of scour countermeasures shall meet Article 2.6.4.4.5CT.

The placement of foundations subject to scour shall consider the type of foundation support, the location of the foundation within the channel, the migration of the thalweg, and the scour due to the scour design flood and scour check flood.

The potential for lateral channel migration shall also be considered in determining foundation placement. For abutment and pier foundations located outside the main channel, where there is potential for lateral channel migration and the foundation could end up in the migrated channel, the foundations shall be placed using the scour depth determined for the main channel.

Foundation placement shall meet the requirements of BDM [5.14.2], [5.14.3] and [5.14.4].

Foundation placement shall be adjusted to avoid effects of potential channel slope failure due to scour and to ensure proper embedment of scour countermeasures.

Recommendations for the placement of foundations subject to scour are provided in the scour evaluation report described in the CTDOT Drainage Manual.

For deep foundations, such as foundations on piles or drilled shafts with and without projecting footings/piles caps, subjected to scour, the bottom of abutment/pier stems (top of footing/pile cap, as applicable) shall be placed below (outside) the scour due

If scour induced slope failure of the channel bank and approach fill slope is possible, refer to the CTDOT Drainage Manual. The manual refers to the use of the document *Stream Stability at Highway Structures*, 4th edition, dated 2012, Hydraulic Engineering Circular (HEC-20), FHWA-HIF-12-004, for scour design.

For additional information on scour countermeasures, see Article 2.6.4.4.5CT.

HEC-18, Article 2.3.2, notes that the thalweg of channels can migrate within the bridge opening. Foundation placement shall consider this condition.

If the potential effects of lateral channel migration are not specifically addressed by the scour evaluation report, the designer should confirm with the hydraulics engineer that potential lateral channel migration will not affect the placement of the foundations.

The placement of foundations on piles or drilled shafts (deep foundations) with footings/piles caps is consistent with Section 2.2, Page 2.6, Item 6 entitled “For Deep Foundations (Drilled Shaft and Driven Piles) With Footings or Caps” of HEC-18.

## Connecticut Department of Transportation Bridge Design Manual

to the scour design flood. The scour, in this case, shall be no less than the summation of the long-term degradation and the contraction scour, and include the effect of lateral channel migration, as applicable.

For shallow foundations on spread footings, supported on soil or erodible rock, subjected to scour, the top of the footing shall be placed below the total scour due to the scour design flood and the scour check flood.

Shallow foundations supported on scour resistant rock shall be designed, detailed, and constructed to maintain the integrity of the supporting rock. The bottom of the foundation shall be at or below the top of scour resistant material.

For bridge abutments supported on a spread footings that are reliant for support on a retaining wall subject to scour, the bottom of retaining wall stem (top of footing/pile cap, as applicable) shall be placed below (outside) the total scour due to the scour design flood and the scour check flood regardless of whether the foundation is a deep foundation or a shallow foundation.

For recommendations on the placement of foundations for abutments and piers entirely outside the total scour limits, coordinate with hydraulic and geotechnical engineers.

The final foundation placement and details shall be determined in coordination with a multi-discipline group of structural, hydraulic, and geotechnical engineers. The foundation placement and details shall be clearly specified in the contract documents and shall meet the recommendations included the final scour evaluation report, the final hydraulics report and final geotechnical report.

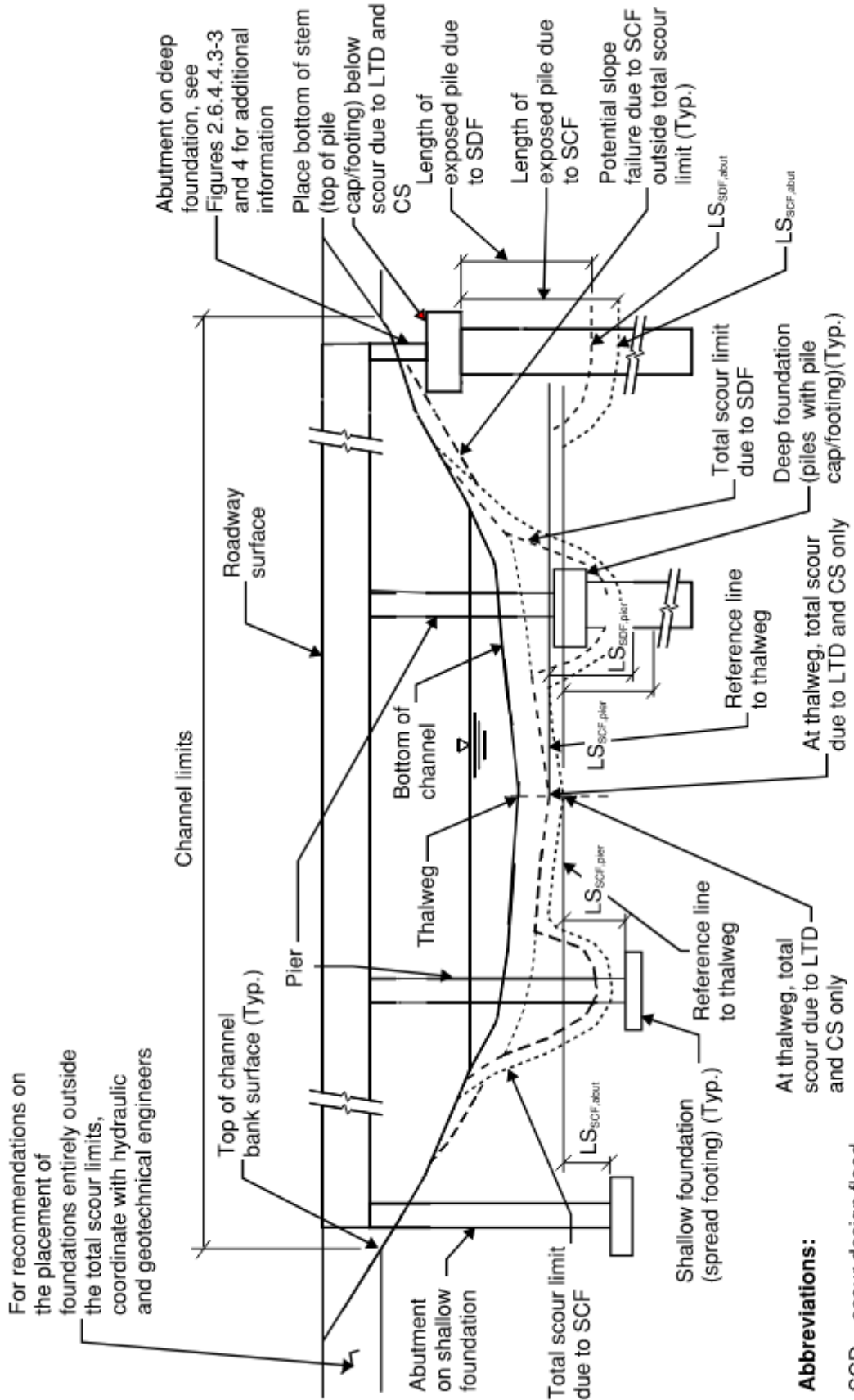
Figures 2.6.4.4.3-1CT, 2.6.4.4.3-2CT, 2.6.4.4.3-3CT, and 2.6.4.4.3-4CT, provide guidance on the bottom of abutment/pier stems (top of footing/pile cap, as applicable) placement.

The practice also addresses foundations on piles or drilled shafts (deep foundations) without projecting footings/piles caps, such as integral abutments. This foundation type is not specifically addressed by HEC-18. The placement of the bottom of the stem is consistent with foundations on piles or drilled shafts with footings/piles caps.

The placement of shallow foundations on spread footings is more conservative than the requirements in Section 2.2, Page 2.4, Item 1 entitled "Spread Footings on Soils – Piers" and Item 2 "Spread Footings on Soils – Abutments" in HEC-18.

For additional information for foundations supported on scour resistant rock, refer to HEC-18, Section 2.2, Page 2.5, Item 3 entitled "Spread Footings on Rock Highly Resistant to Scour".

Placing the bottom of retaining wall stem (top of footing/pile cap, as applicable) below (outside) the total scour ensures that the soil behind the stem will not be scoured and unavailable to support the abutment.

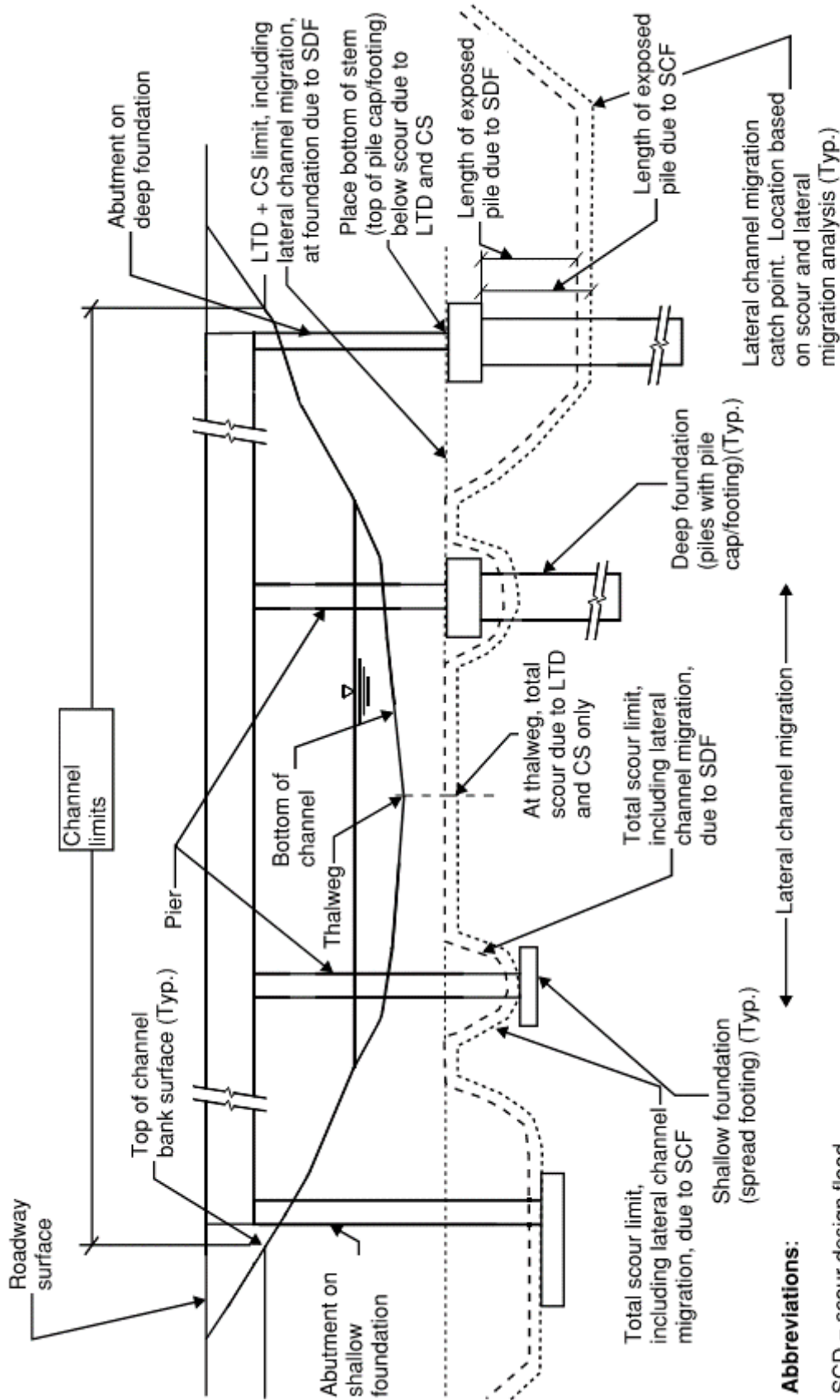


**Figure 2.6.4.4.3-1CT**  
**FOUNDATION SUPPORT AND PLACEMENT**  
**For scour without lateral migration**

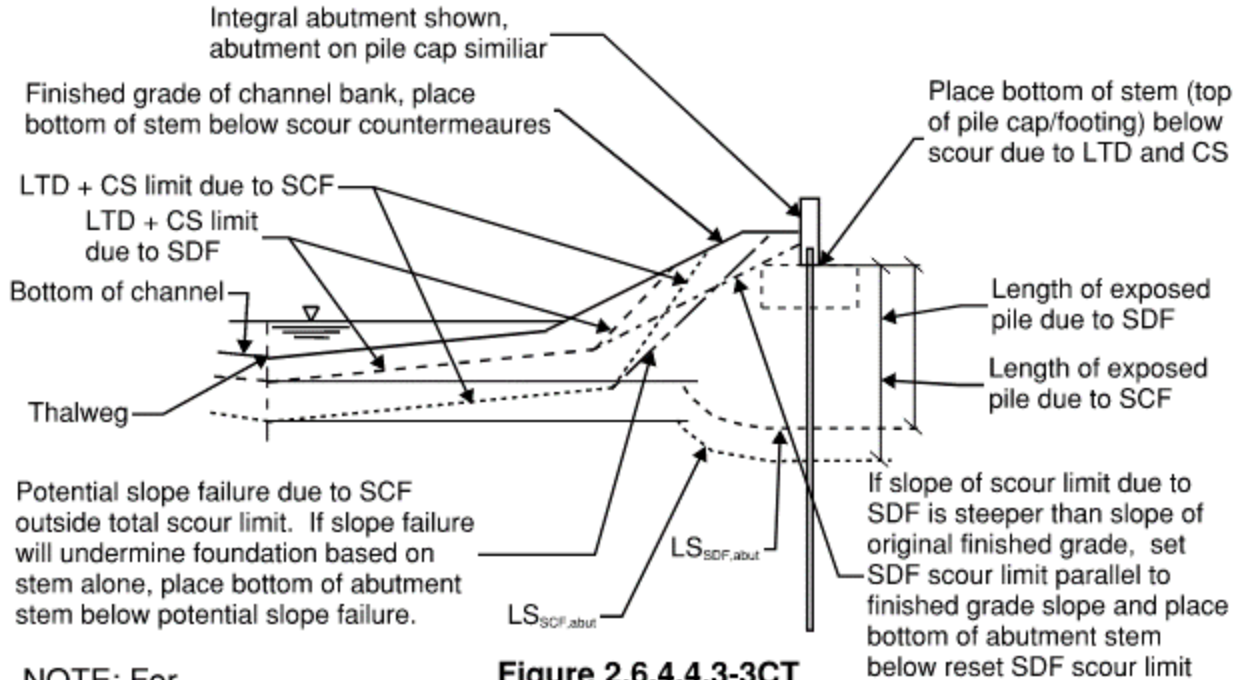
**Abbreviations:**

SCD = scour design flood  
 SCF = scour check flood

LTD = long-term degradation  
 CS = contraction scour  
 LS = local scour

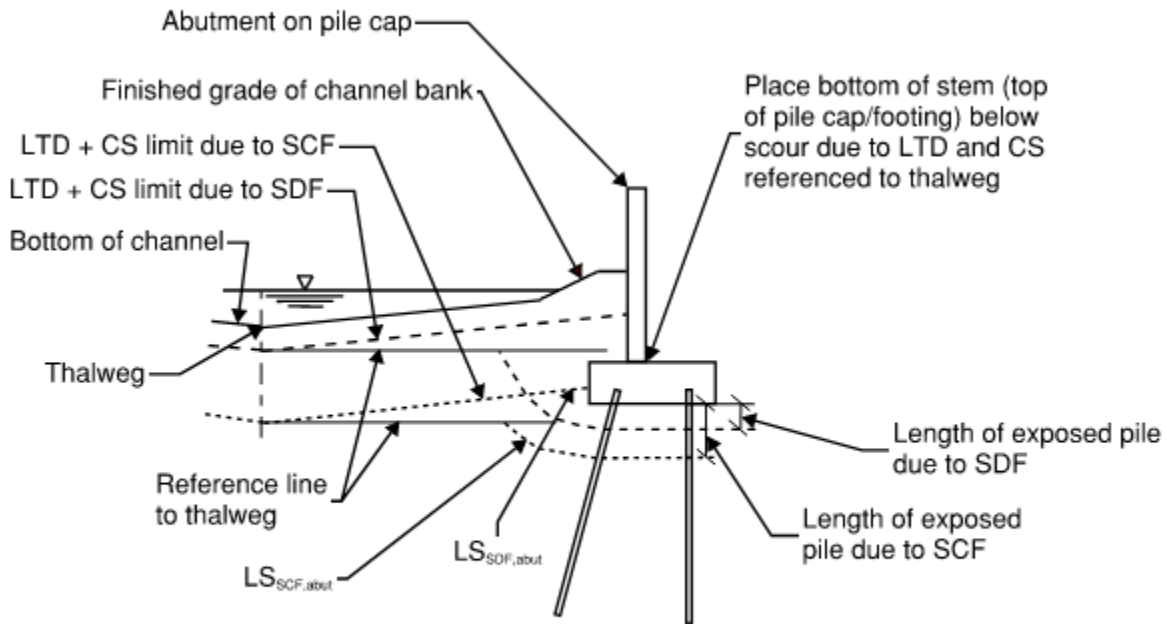


**Figure 2.6.4.3-2CT**  
**FOUNDATION SUPPORT AND PLACEMENT**  
**For scour with lateral migration**



NOTE: For abbreviations, see Figure 2.6.4.4.3-1CT.

**Figure 2.6.4.4.3-3CT**  
**FOUNDATION SUPPORT AND PLACEMENT**  
**For embankment abutment on deep foundation**  
**and scour without lateral migration**



NOTE: For abbreviations, see Figure 2.6.4.4.3-1CT.

**Figure 2.6.4.4.3-4CT**  
**FOUNDATION SUPPORT AND PLACEMENT**  
**For full height abutment on deep foundation and**  
**scour without lateral migration**

## Connecticut Department of Transportation Bridge Design Manual

### 2.6.4.4.4CT—Foundation Evaluation for Limit States

Foundations subject to scour shall meet and satisfy the applicable limit states for conditions with and without scour, and with aggradation.

Foundations shall be evaluated for the following conditions and satisfy the following limit states:

- For changes in foundation conditions resulting from a scour design flood, both during and after the flood event, bridges and walls shall be evaluated and satisfy the Strength, Service and Extreme Event limit states in Table 2.6.4.4.4-1CT assuming all the streambed material above the combined component scour has been removed and is unavailable for foundation support.
- For changes in foundation conditions resulting from a scour check flood, both during and after the flood event, bridges and walls shall be evaluated and satisfy the Extreme Event III limit state in Table 2.6.4.4.4-1CT assuming all the streambed material above the combined component scour has been removed and is unavailable for foundation support.
- For changes in foundation conditions resulting the yearly mean discharge flood event, bridges and walls shall be evaluated and satisfy the Extreme Event II limit state in Table 2.6.4.4.4-1CT assuming all the streambed material above the combined component scour has been removed and is unavailable for foundation support.

For Extreme Event I limit state, the 100%-100%-0% contribution from long-term degradation, contraction scour, and local scour, respectively addresses the following:

- A conservative assumption that a 975-year seismic event can occur near the end of an anticipated 75-year service life of a bridge when the full magnitude of long-term degradation is attained.
- The full magnitude of contraction scour would occur under the first 100-year flood event and retain the calculated value thereafter.
- 0% local scour assumes the holes refill shortly after the scour design flood event and is not considered probable in conjunction with 100% long-term degradation, 100% contraction scour, and a design seismic event.

The scour combination for Extreme Event II limit state for CV has been adapted from the *AASHTO Guide Specifications and Commentary for Vessel Collision Design of Highway Bridges* (2009).

**Table 2.6.4.4.4-1CT – Combination of Scour Components for Different Limit States (in %)**

Limit State	Long-term Degradation	Contraction Scour	Local Scour	Flood
Service	100	100	100	Scour Design Flood
Strength	100	100	100	Scour Design Flood
Extreme Event I	100	100	0	Scour Design Flood
Extreme Event II, Case A1 for CV	50	50	50	Scour Design Flood
Extreme Event II, Case A2 for IC	50	50	50	Scour Design Flood
Extreme Event II, Case B for CV	50	0	0	Yearly mean discharge
Extreme Event III	100	100	100	Scour Check Flood

For the design of bridges for scour conditions, the operational importance shall be independent of the bridge’s classification (critical/essential/typical) for the strength limit state. The factor related to operational importance,  $\eta_1$ , shall be taken as 1.05.

For the evaluation with scour conditions, at abutments, walls, and other structures subject to earth load effects, designers shall assume the earth may both remain and not remain in contact with and act upon the rear face of the stems, footings/pile caps

Since the revised factor related to operational importance affects the strength limit state, it only applies to changes in foundation conditions resulting from a scour design flood.

Scour conditions may result in the removal of only a portion of the streambed or adjacent embankment/backfill at a foundation. Load effects on foundations from all possible scour

## Connecticut Department of Transportation Bridge Design Manual

and drilled shafts/piles. Load cases shall include both balanced and unbalanced loading conditions.

The design vehicle live load shall include dynamic load allowance for load cases where the foundation components are no longer surrounded by soil because of scour.

The load effects of water shall be based on the elevations and velocities associated with the scour design flood and scour check flood.

Deep foundation design, for assessing overburden stress used for bearing resistance calculations, shall consider the effect of the lost soil due to scour as shown in Figure 2.6.4.4.4-1CT. Similarly, for shallow foundations (i.e., spread footings) located below Point C in the figure, the overburden stress used for assessing bearing resistance after scour should be calculated as shown in this figure.

Whenever total scour depth exposes deep foundation elements, the foundation evaluation shall also consider the potential for damage due to erosion, debris impacts, wood borers, corrosion from exposure to stream currents, or other environmental effects.

conditions shall be investigated. At the drilled shafts/piles soil arching should be considered.

The design vehicle live load is defined by Article 3.6.1.2.

The requirement for applying the dynamic load allowance to the design vehicle live load assumes that foundation components may no longer be surrounded by soil because of scour.

Shown in Figure 2.6.4.4.4-1CT is a simplification that can be used to calculate the overburden stress needed for foundation bearing resistance calculations for Service, Strength, and Extreme Event limit states. If a more accurate estimate of overburden stresses is needed, complex three-dimensional modeling would be required, and such modeling may be considered for use in foundation design subject to owner approval.

Additional design requirements for deep foundations with regard to scour are provided in Article 10.5.5.3.2 and 10.7.3.6, plus commentary.



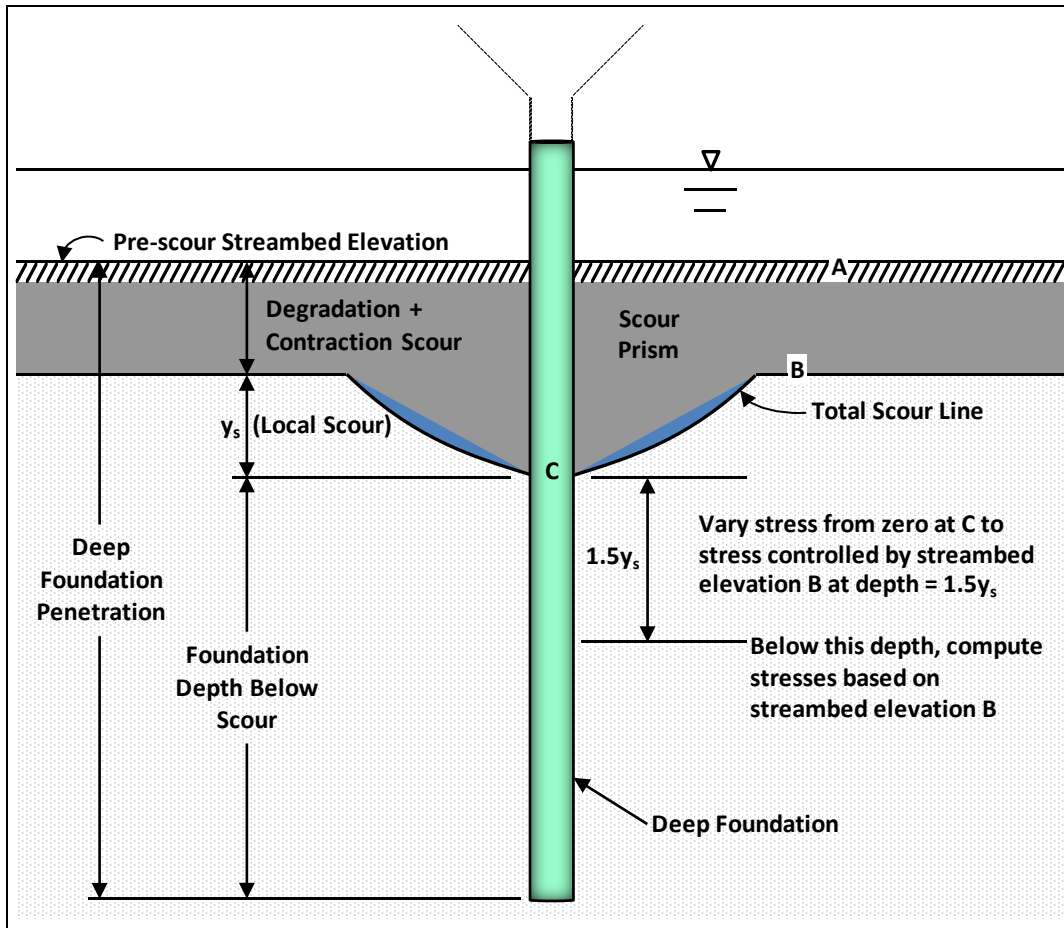


Figure 2.6.4.4.4-1CT Illustration of Scour Prism and its Effects on Deep Foundations (adapted FHWA-NHI-18-024 ,GEC10 - Drilled Shaft Manual)

2.6.4.4.5CT—Scour Countermeasures

Scour countermeasures shall meet the requirements of the CTDOT Drainage Manual.

For new bridges and new walls retaining highways, changes in foundation conditions resulting from a scour design flood and scour check flood shall be determined without the benefits provided by scour countermeasures.

For existing bridges and walls retaining highways undergoing rehabilitation where the existing substructure and walls will be retained, if the existing foundations do not meet the

C2.6.4.4.4CT

The limits, placement and details of scour countermeasures shall meet the requirements of the CTDOT Drainage Manual. The manual refers to the use of the document *Bridge Scour and Stream Instability Countermeasures: Experience, Selection, and Design Guidance*, 3rd Edition, dated September 2009, FHWA-NHI-09-112, Hydraulic Engineering Circular No. 23 (HEC-23) for additional guidance on countermeasure selection and design. For additional information is also included in the *Technical Brief (TechBrief)* FHWA-HIF-19-007.

For new bridges and new walls retaining highways, the use of revetments, armoring, permanent steel sheet piling, or permanent cofferdams, to reduce scour impact and foundation depths may only be permitted if the placement of the foundations to meet Article 2.6.4.4.3CT is proven not constructable due to the project constraints.

design criteria for new bridges and new walls retaining highways, scour countermeasures may be used to mitigate scour.

When fendering or other pier protection systems are used, their effect on pier scour and collection of debris shall be taken into consideration in the design. Since scour prediction equations are not available for this scenario, the structural, hydraulic, and geotechnical aspects of the design, based on advanced modeling, local experience and engineering judgment, shall be coordinated and differences resolved prior to implementation of fendering and other pier protection methodologies.

Advanced three-dimensional modeling may be needed to assess the effect of fendering or other pier protection systems on scour.

*2.6.4.4.6CT—Existing Substructure Components*

For bridge replacement projects with foundations adjacent to or within waterways, the extent of the removal of existing substructure components and elements, either wholly or partially, must be addressed during the design phase. The existing substructure components and elements may include abutment stems, wall stems, pier stems, footings, pile caps, and piles.

Considerations for leaving existing substructure components and elements, either wholly or partially, in place include efforts to minimize construction costs, facilitate water handling, simplify construction, reduce construction duration, limit hydraulic affects, or reduce environmental impacts. These efforts are constrained by the need to ensure that leaving existing substructure components and elements in place can be accurately reflected in both the hydraulic and scour analysis, will be environmentally permissible, and any future changes in the position of the components will not exacerbate conditions due to any event that result in an unacceptable hydraulic condition, scour conditions worse than the original design, or have a negative environmental impact.

The removal limits of existing substructure components and elements shall be coordinated, developed, and justified with a multi-discipline group of structural, hydraulic, geotechnical and environmental engineers along with representatives from the CTDOT Office of Environmental Planning. The removal limits shall be clearly specified in the contract documents and shall agree with the final scour evaluation report, the final hydraulics report, and the environmental permits.

New work shall be independent of the existing component parts that remain in place and shall not rely on existing component parts to provide any structural benefit.

**2.6.4.5—Roadway Approaches to Bridge**

*This section shall be supplemented with the following:*

Retaining walls shall be designed for scour as specified in Articles 11.6.3.4, 11.7.2.3, 11.10.1, and 11.10.2.2.

**C2.6.4.5**

*This section shall be deleted and replaced with the with the following:*

Highway embankments on floodplains serve to redirect overbank flow, causing it to flow generally parallel to the embankment and return to the main channel at the bridge. Roadway embankment and retaining wall designs should include countermeasures where necessary to limit damage caused by

overbank flow parallel to the embankment. Such countermeasures may include:

- relief bridges, culverts, or other structural openings,
- retarding the velocity of the overbank flow by promoting growth of trees and shrubs on the floodplain and highway embankment within the highway right-of-way or constructing small dikes along the highway embankment,
- protecting fill slopes subject to erosive velocities by use of riprap or other erosion protection materials on highway fills and spill-through abutments, and
- where overbank flow is large, utilize guide banks to protect abutments of main channel and relief bridges from turbulence and resulting scour.

Additional information and design guidelines on scour countermeasures are provided in HEC-23.

Although overtopping may result in failure of the embankment, this consequence is preferred to failure of the bridge. The low point of the overtopping section should not be located immediately adjacent to the bridge, because its failure at this location could cause damage to the bridge abutment. If the low point of the overtopping section must be located close to the abutment, due to geometric constraints, the scouring effect of the overtopping flow should be considered in the design of the abutment. Design studies for overtopping should also include evaluation of any flood hazards created by changes to existing flood flow patterns or by flow concentrations in the vicinity of developed properties.

Bridge approach embankment slopes exposed to scour should be protected with properly designed scour countermeasures designed in accordance with HEC-23 where possible, considering any regulatory requirements.

The risk of bridge approach fill failure due to scour may be an acceptable risk as the approach fill typically can be replaced quickly to restore access to the bridge crossing. The impact of such approach fill loss to bridge approach structures such as wing walls, bridge approach slabs, and small (i.e., short in height and length) retaining walls that support the approach embankment side slopes will need to be considered. This is especially important if significant stream channel migration risk is not low, as much more of the embankment could be affected, or, as illustrated in HEC-18, Figure 8.7(c), the bridge abutment could become like an intermediate bridge pier with regard to increased scour depth due to local and contraction scour.

The length of bridge approach embankment or wall relative to the bridge abutment location that can be affected by scour, and how deep the scour is likely to occur, will depend on several factors, including the length of the approach embankment within the floodplain and the potential for stream migration. For the portion of the approach retaining wall up on the flood plain (i.e., outside the main channel), scour due to long-term degradation is no longer applicable, and only contraction scour and local scour should be considered to locate the wall footing or wall base.

Connecticut Department of Transportation Bridge Design Manual

*Section 3 shall be supplemented as follows:*

*Revisions to Section 3 are needed due to the changes to Articles 2.6.4.4.1, 2.6.4.4.2, 2.6.4.4.3CT and 2.6.4.4.4CT.*

*Revise the 7th bullet and insert a new 8th bullet in Article 3.4.1 as follows:*

- Extreme Event II—Load combination relating to ice load, blast load, and collision by vessels and vehicles.
- Extreme Event III- Load combination for design considering the effects of check flood scour condition.

*Revise the 4th and 5th bullets in the bullet list in Article C3.4 as follows:*

- Although these limit states include water loads, *WA*, the effects due to *WA* are considerably less significant than the effects of changes to foundation condition due to scour. Article 2.6.4.4.4CT addresses the effects of scour combined with extreme event limit states.
- The joint probability of *BL*, *EQ*, *CT*, *CV*, and *IC* is extremely low, and, therefore, the events are specified to be applied separately. Under these extreme conditions, the structure may undergo considerable inelastic deformation by which locked-in force effects due to *TU*, *TG*, *CR*, *SH*, and *SE* are expected to be relieved.

*Add as the new 2nd paragraph of Article C3.4.1 as follows:*

Design for the scour check flood has been included in the Extreme Event III limit state to highlight the loads that will act on the bridge during such events. Furthermore, conditions of the foundations under scour check flood are evaluated to consider any reduction in geotechnical resistance and stiffness due to scour.

*The Extreme Event limit states in Table 3.4.1-1 shall be revised as follows:*

*Add the following to Article C3.4.1:*

Changes in foundation conditions resulting from a scour check flood shall be considered at the Extreme Event III limit state. The load factor LL, IM, CE, BR, PL, and LS is specified as 1.00 to ensure that the bridge can remain operational until the extent of any damage can be evaluated and repaired. PennDOT has a similar requirement. Consider a case where a flood event damages the highway approach to a multi-span bridge and scours material around abutment and pier foundations to a depth greater than the depth calculated for a scour design flood but less than a depth calculated for a scour check flood. By quickly rebuilding the highway approach the bridge can be opened for at least limited use by a design vehicle live load until the extent of any damage at the abutments and piers can be evaluated and repaired.

**Table 3.4.1-1 – Load Combination and Load Factors – Revised Extreme Event Limit States for Scour**

Load Combination Limit State	DC DD DW EH EV ES EL PS CR SH	LL IM CE BR PL LS	WA	WS	WL	FR	TU	TG	SE	Use One of These at a Time				
										EQ	BL	IC	CT	CV

Connecticut Department of Transportation Bridge Design Manual

Extreme Event I <sup>1</sup>	1.00	$\gamma_{EQ}$	1.00	—	—	1.00	—	—	—	1.00	—	—	—	—
Extreme Event II <sup>1</sup>	1.00	0.50/1.00	1.00	—	—	1.00	—	—	—	—	1.00	1.00	1.00	1.00
Extreme Event II, Case A1 <sup>1</sup>	1.00	1.00	1.00	—	—	1.00	—	—	—	—	—	—	—	1.00
Extreme Event II, Case A2 <sup>1</sup>	1.00	1.00	1.00	—	—	1.00	—	—	—	—	—	1.00	—	—
Extreme Event II, Case B <sup>2</sup>	1.00	1.00	1.00	—	—	1.00	—	—	—	—	—	—	—	1.00
Extreme Event III <sup>3</sup>	1.00	1.00	1.00	—	—	1.00	—	—	—	—	—	—	—	—
Notes: 1 - Flood event = Scour Design Flood 2 - Flood event = Yearly mean discharge 3 - Flood event = Scour Check Flood														

*Delete Articles 3.7.5 and C3.7.5*

*Add the following as a new paragraph and bulleted list following the last paragraph of Article 3.14.1:*

*Delete the 13th paragraph and bulleted list that follows in Article C3.14.1*

Evaluation of the following vessel collision events shall be combined with foundation conditions due to scour.

- Case A - A drifting empty barge breaking loose from its moorings and striking the bridge.
- Case B - A ship or barge tow striking the bridge while transiting the navigation channel under typical waterway conditions.

*Section 10 shall be supplemented as follows:*

*Revisions to Section 10 are needed due to the changes to Articles 2.6.4.4.1, 2.6.4.4.2, 2.6.4.4.3CT and 2.6.4.4.4CT.*

*Revise the 1st paragraph in Article 10.4.6.6 as follows:*

*Revise the 1st paragraph in Article C10.4.6.6 as follows:*

Consideration should be given to the physical characteristics of the rock and the condition of the rock mass when determining a rock's susceptibility to erosion in the vicinity of bridge foundations. Physical characteristics that should be considered in the assessment of erodibility include cementing agents, mineralogy, unconfined compressive strength, rock quality designation (RQD), joint spacing and orientation, joint roughness and alteration, and weathering.

There is no consensus on how to determine erodibility of rock masses near bridge foundations. Refer to HEC-18 (FHWA, 2012) and Arneson et al. (2012) when determining the potential for a rock mass to scour.

## Connecticut Department of Transportation Bridge Design Manual

*Add as the new 3rd paragraph in Article 10.5.1 as follows:*

Changes in foundation conditions resulting from scour, as specified in Article 2.6.4.4.4CT, shall be considered.

*Revise the 3rd bullet in the list of Article 10.5.2.1 as follows:*

- scour design flood

*Revise the 2nd bullet in the list of Article 10.5.3.1 as follows:*

- loss of lateral and vertical support due to scour, and

*Revise the 3rd paragraph in C10.5.2.1 as follows:*

The scour design flood is defined in Article 2.6.4.4 and its consideration under the service limit state specified in Article 2.6.4.4.4CT.

*Revise the 4th paragraph of Article C10.5.3.1 as follow:*

The scour design flood is defined in Article 2.6.4.4. and its consideration under the strength limit state is specified in Article 2.6.4.4.4CT.

*Revise Article C10.5.4.1 as follows:*

Extreme events include scour check flood, vessel and vehicle collision, seismic loading, and other site-specific situations that the Engineer determines should be included. Appendix A10 gives additional guidance regarding seismic analysis and design.

*Revise the 2nd paragraph of Article 10.5.5.1 as follows:*

A resistance factor of 1.0 shall be used to assess the ability of the foundation to meet the specified deflection criteria after soil removal due to the scour design flood.

*Revise the 3rd paragraph of Article 10.5.5.2.1 as follows:*

The foundation resistance after the scour design flood shall provide adequate foundation resistance using the resistance factors given in this Article. The resistance factors shall be those used in the Strength Limit State, without scour.

*Revise the 7th paragraph of Article C10.5.5.2.1 as follow:*

Design for the scour design flood must satisfy the requirement that the factored foundation resistance is greater than the factored load determined with the scoured soil removed.

*Revise the title of Article 10.5.5.3 as follows:*

### **10.5.5.3—Extreme Event Limit States**

*Revise the 1st paragraph of Article 10.5.5.3.2 as follows:*

The provisions of Article 2.6.4.4.4CT shall apply to the changed foundation conditions resulting from scour. Resistance factors at the extreme event shall be taken as 1.0 except that for uplift resistance of piles and shafts, the resistance factor shall be taken as 0.80 or less.

*Revise Article C10.5.5.3.2 as follows:*

The specified resistance factors should be used provided that the method used to compute the nominal resistance does not exhibit bias that is unconservative. See Article C10.7.3.6 for guidance regarding bias values for pile resistance prediction methods.

Design for scour is discussed in Hannigan et al. (2016).

*Revise the 1st paragraph of Article 10.6.1.2 as follows:*

*Revise the 2nd paragraph of Article C10.6.1.2 as follows:*

## Connecticut Department of Transportation Bridge Design Manual

Where the potential for scour, erosion or undermining exists, shallow foundations (i.e., spread footings) shall be located such that the top of the footing is located at or below the maximum anticipated depth of scour, erosion, or undermining as specified in Article 2.6.4.4.3CT.

*Revise the 1st and 2nd paragraphs of Article 10.7.3.6 as follows:*

The effect of scour shall be considered in determining the minimum pile embedment and the required nominal driving resistance,  $R_{ndr}$ . The pile foundation shall be designed so that the pile penetration after soil has been removed due to the scour design floods satisfies the required nominal axial and lateral resistance.

The resistance factors shall be those used in the design without scour. The side resistance of the material lost due to scour should be determined using a static analysis and it should not be factored, but consideration should be given to the bias of the static analysis method used to predict resistance.

*Revise the 3rd paragraph of Article 10.7.4 as follows:*

For spread footings founded on excavated or blasted rock, attention should be paid to the effect of excavation and/or blasting. Blasting of highly resistant competent rock formations may result in overbreak and fracturing of the rock to some depth below the bearing elevation. Blasting may reduce the resistance to scour within the zone of overbreak or fracturing. See Article 10.4.6.6 regarding factors affecting erodibility of rock.

*Revise Article C10.7.3.6 as follows:*

The piles will need to be driven to the required nominal bearing resistance plus the side resistance that will be lost due to scour. The nominal resistance of the remaining soil is determined through field verification. The pile is driven to the required nominal bearing resistance plus the magnitude of the side resistance lost as a result of scour, considering the prediction method bias. Bias is defined as the measured/predicted value of resistance, in this case pile side resistance. Typically, the average method bias, based on available databases should be used. This bias can be based on a national database, or based on a local database, if enough measurements are available to reliably establish an average value. Example bias values for various pile static resistance prediction methods based on a national database are provided in Paikowsky et al. (2004) and Allen (2005).

To use bias values to adjust pile resistance predictions, since a bias greater than 1.0 means the method predicts less resistance than is actually present and a bias less than 1.0 means that the method predicts more resistance than is actually present, the bias adjusted resistance is determined by multiplying the resistance lost due to scour by the bias value. Since in this case the goal is to estimate lost resistance due to scour, a conservative estimate is obtained when the method predicts more resistance than is actually present.

Another approach that may be used takes advantage of dynamic measurements. In this case, the static analysis method is used to determine an estimated length. During the driving of test piles, the side resistance component of the bearing resistance of pile in the scourable material may be determined by a signal matching analysis of the restrike dynamic measurements obtained when the pile tip is below the scour elevation. The material below the scour elevation must provide the required nominal resistance after scour occurs.

In some cases, the flooding stream will carry debris such as wood or ice that will induce horizontal loads on the piles.

Additional information regarding pile design for scour is provided in Hannigan et al. (2016).

## Connecticut Department of Transportation Bridge Design Manual

When designing for scour, the pile foundation design shall be conducted as described in Article 10.7.3.6, except that the scour resulting from the check flood and resistance factors consistent with Article 10.5.5.3.2 shall be used.

*Revise the last bullet in the list of Article 10.7.7 as follows:*

- extreme event limit state nominal bearing resistance considering scour as specified in Article 10.7.4.

*Revise Article 10.9.3.3 as follows:*

### **10.9.3.3—Scour**

The provisions of Article 10.7.3.6 shall apply.

*Revise C10.9.3.3 as follows:*

See Article C10.7.3.6.

---

*Section 11 shall be supplemented as follows:*

*Revisions to Section 11 are needed due to the changes to Articles 2.6.4.4.1, 2.6.4.4.2, 2.6.4.4.3CT and 2.6.4.4.4CT.*

---

*Revise the 1st paragraph in Article 11.6.3.4 as follows:*

For walls constructed along rivers and streams, scour of foundation materials shall be evaluated during design, as specified in Article 2.6. Where potential problem conditions are anticipated, adequate protective measures shall be incorporated in the design, including, but not limited to, locating the top of the wall footing below the scour depth determined in accordance with Articles 2.6.4.4.3CT and 2.6.4.5 or adding scour countermeasures to protect the wall footing.

*Revise the 1st paragraph in Article 11.7.2.3 as follows:*

The scour potential shall be determined, and the design shall be developed to prevent failure from this condition as specified in Articles 2.6.4.4.3CT and 2.6.4.5.

*Revise the 4th paragraph in Article C11.10.1 as follows:*

The potential for catastrophic failure due to scour is high for MSE walls if the reinforced fill is lost during a scour occurrence. Consideration should be given to lowering the base of the wall or to alternative methods of scour protection, such as sheet pile walls and/or riprap of sufficient size, placed to a sufficient depth to preclude scour.

*Revise the 3rd paragraph in Article 11.10.2.2 as follows:*

For walls constructed along rivers and streams, Article 11.6.3.4 applies, except that the embedment depths shall be established at a minimum of 2.0 ft below potential scour depth.

*Revise the 2nd paragraph in Article 11.11.4.1 as follows:*

Passive pressures shall be neglected in stability computations, unless the base of the wall extends below the scour depth as specified in Article 11.6.3.4, freeze-thaw, or other



disturbance. For these cases only, the embedment below the greater of these depths may be considered effective in providing passive resistance.

*Revise Article 11.11.4.5 as follows:*

Bin walls may be used in scour-sensitive areas only where their suitability has been established. The provisions of Article 11.6.3.4 shall apply.

**5.14.2 Spread Footings on Soil (Rev. 01/09)**

The top of all footings in soil should be a minimum of 12 inches below the finished grade. The bottom of all footings in soil shall not be less than 4 feet below, measured normal to the finished grade.

Generally, the use of footing keys to develop passive pressure against sliding is not allowed. The use of passive earth pressure along the sides of foundations to prevent sliding is also not allowed. Resistance from sliding shall be attained through friction between the foundation and the supporting material.

The contract shall show the following:

- The maximum design foundation pressure for the controlling Strength and Service Limit States.

Maximum Design Foundation Pressure = 3.2 TSF (Strength I)  
2.8 TSF (Service I)

- If applicable, also show the maximum design foundation pressure for the Extreme Event Limit State.

Maximum Design Foundation Pressure = 3.6 TSF (Extreme Event II)

**5.14.3 Foundations on Rock**

Generally, for cast-in-place construction, gravity-type or semi-gravity L-type sections shall be used for abutments, wingwalls and retaining walls founded on rock. There is no minimum embedment for footings placed on competent rock. Generally, structural underwater concrete is not permitted.

**5.14.4 Driven Piles (Rev. 01/09)**

Piles may be either end bearing or friction or a combination of the two. Piles end bearing on bedrock or dense hardpan typically are steel H-piles. Piles driven through a high compacted fill or into native soil containing numerous boulders and cobbles shall be steel H-piles. Generally, H-piles shall conform to the requirements of ASTM A709 Grade 50. Friction piles

shall be used for most other cases. Generally, friction piles are precast concrete, cast-in-place concrete or prestressed concrete. Timber piles are not permitted.

Piles may be installed vertical or battered. The path of battered piles should be checked to insure the piles remain within the right of way and do not interfere with piles from adjacent and existing substructure units, nor conflict with temporary sheeting or cofferdams.

Pile foundations supporting abutments shall have a minimum of two rows of piles, unless the piles are incorporated into a fully integral abutment. Piles shall be anchored to and embedded in the footings a minimum of 12 inches.

Maximum pile spacing and maximum nominal resistance per pile should be utilized to minimize the number of piles. The lateral resistance of a pile pattern is the combination of the lateral component of the force acting on the battered piles and the lateral resistance of each pile, vertical and battered, in the pattern.

Test piles are typically required to establish pile order lengths and pile capacity for friction piles. If pile driving records and pile load test data are available for a site (e.g. a bridge widening where the same pile type is proposed), specifying the pile order length in the contract may be considered. Test piles with dynamic monitoring will still be required to establish the ultimate pile capacity. Static pile load tests may also be considered.

Pile order lengths for end bearing piles on bedrock should be provided in the contract when there is confidence in the subsurface profile. If a test pile(s) is being considered to establish order lengths for end bearing piles on bedrock, the benefit of the refined pile order length shall be weighed against the time required to obtain the production piles. Test piles with dynamic monitoring and/or static load tests may still be required to establish the ultimate pile capacity. The need for test piles is evaluated by the geotechnical engineer and should be included in the Geotechnical Report.

Readily available pile types should be used whenever possible; especially if the order length cannot be established until after test piles are driven. The location of test piles and load tests should be in areas that are readily accessible, and allow enough room for the Contractor to perform the work. A preconstruction test pile program may be considered on large projects where a benefit can be realized by establishing pile type(s) and pile capacity during the design phase.

If no test piles are specified for a given substructure, the estimated pile length shall be used as the pile order length. For these cases, the estimated pile length should be increased slightly to insure there is sufficient length.

The top of all footings should be a minimum of 12 inches below the finished grade. The bottom of all pile caps shall not be less than 4 feet below, measured normal to the finished grade.

Connecticut Department of Transportation Bridge Design Manual

For H-piles, pile point reinforcement and splices shall be prefabricated. The contract shall specify that the Contractor is required to submit pile point reinforcement and splice details to the Engineer for review and approval.

This following note shall be included on the contract drawings:

Prior to driving the piles, the Contractor shall submit to the Engineer for review and approval his method and sequence of pile driving.
--

The pile plan(s) included in the contract drawings shall show or note the following:

- A legend denoting vertical, battered and test piles.
- The number, location and length of test piles, if applicable.
- The location of load test pile(s), if applicable.
- The location of dynamic monitoring (pda) pile(s), if applicable.
- The number, location and estimated length for vertical and battered production piles. If no test pile is specified or if the estimated pile length is intended to be used as the order length, the following note shall be included:

The estimated pile length(s) is to be used as the pile order length.
--

- Material designation of piles, including pile point reinforcement and splices.
- The maximum design pile load for the controlling Strength and Service Limit States for each foundation section.

Maximum Design Pile Load =	57 Tons (Strength I) 55 Tons (Service I)
----------------------------	---

If applicable, also show the maximum design pile load for the Extreme Event Limit State.

Maximum Design Pile Load =	67 Tons (Extreme Event II)
----------------------------	----------------------------

- The ultimate pile capacity for each foundation section, as defined as:  
Ultimate Pile Capacity = (Factored Design Load)/ $\phi$  + Scour + Downdrag

Scour= The estimated skin friction resistance of the soil above the predicted scour depths.

Downdrag= The estimated side friction resistance of a compressible soil above the neutral point (determined when computing the downdrag load (DD) due to settlement).

$\Phi$  = The resistance factor based on the design load limit state, resistance determination method, and required field testing.

Example:

ULTIMATE PILE CAPACITY	
Abutment 1	XX tons
Pier No. X	XX tons
Abutment 2	XX tons

The Scour and Downdrag resistance along with  $\Phi$  will be determined by the geotechnical engineer and included in the geotechnical report. The Contractor will use the Ultimate Pile Capacity to properly size pile driving equipment and load testing apparatus. The Engineer will use the Ultimate Pile Capacity to establish the required driving resistance and validate load test results.

#### **5.14.5 Drilled Shafts**

Vacant

### **5.15 EARTH RETAINING SYSTEMS AND COFFERDAMS (Rev. 01/09)**

#### **5.15.1 Highway Applications (Rev. 01/09)**

The location and limits, both horizontal and vertical, of all temporary and permanent earth retaining system contract items shall be shown at each location.

##### **5.15.1.1 Permanent Steel Sheet Piling (Rev. 01/09)**

Permanent Steel Sheet Piling is defined as a required and permanent structural element integral to the design of the structure. Permanent Steel Sheet Piling is designed and engineered by the Designer. To avoid unnecessary proprietary specificity, permanent steel sheet piling should be specified and designated by AASHTO or ASTM material classification and minimum required section modulus.

### **5.15.1.2 Temporary Earth Retaining Systems (Rev. 01/09)**

Temporary earth retaining system shall be any type of adequately braced temporary retaining wall which the Contractor elects to build to satisfy, and which does satisfy, the condition that existing facilities be properly retained during excavation or fill for the placement of substructure or other facilities. A Temporary Earth Retaining System shall be designated in the contract to be left in place only if its removal may be detrimental to the structure. The item “Earth Retaining System Left in Place” shall be used only for a Temporary Earth Retaining System designated by the Designer to be left in place. A Temporary Earth Retaining System requested by the Contractor to be left in place for his own convenience is not compensable for additional payment.

### **5.15.2 Railroad Applications (Rev. 01/09)**

The location and limits, both horizontal and vertical, of all temporary and permanent earth support systems necessary for the construction of railroad structures must be shown in the contract. All contract items for temporary and/or permanent earth support systems for railroad structures and facilities must be submitted to the affected railroad for review during the standard project design submission phases. Contract plan details for temporary earth support in railroad applications must be specific in name and include a railroad parenthetical in the contract item name. Typical items for such use are “Temporary Sheet Piling (Railroad)” and “Soldier Pile and Lagging (Railroad)”. The Designer should select the most appropriate temporary retaining system type in consideration of existing soil conditions and construction access limitations.

#### **5.15.2.1 Permanent Steel Sheet Piling (Rev. 01/09)**

Permanent Steel Sheet Piling adjacent to railroad tracks shall be designed for each specific location and shown in the contract. It should be specified and designated as noted in **BDM** [5.15.2] above.

#### **5.15.2.2 Temporary Earth Support Systems (Rev. 01/09)**

Through communication with the affected railroad company during a project’s scope development, a determination will be made whether or not a complete design for a temporary earth support system is required. When the temporary earth support system is fully designed by the Designer, the contract special provision for the subject item should allow for the Contractor to submit an alternate design.

The Designer shall evaluate the global stability of the railroad embankment for the temporary (and permanent) condition. In cases where the stability of the embankment may be compromised, the Designer shall either provide a complete design or include the necessary constraints for a Contractor to properly design the earth support system.

Working drawings and design calculations prepared by the Contractor shall be submitted to the **CTDOT** and affected railroad company for review.

Items, such as “Sheet Piling left in Place (Railroad)” and “Soldier Pile and Lagging Left in Place (Railroad)” shall be designated in the contract only if their removal may be detrimental to the structure, as determined by the Designer in concert with the affected railroad company. Any system requested to be left in place by the Contractor for his convenience is not compensable.

### **5.15.3 Water-Handling-Cofferdams and Temporary Water Redirection (Rev. 01/09)**

Water-Handling-Cofferdams and various methods to temporarily redirect water from the site are used so that construction can take place in the dry. Various methods and items may be used to achieve this end depending on the nature of the site, the nature of the construction, and the amount of water encountered. Because of the need to secure environmental permits, considerable detail of the dewatering plan intended may be required in the contract.

#### **5.15.3.1 Structure Excavation (Complete) (Rev. 07/04)**

The items “Structure Excavation-Earth (Complete)” or “Structure Excavation-Rock (Complete)” are generally used where water intrusion into the excavation results from groundwater seepage or very minor stream or drainage flow. There is no additional payment for dewatering or temporarily diverting water since the work required to construct in the dry is considered to be of such a minor nature that it can be considered to be incidental to the excavation items. Any cofferdams, temporary redirection, pumping, or any other dewatering methodology is included in the cost of the work. Generally, since the impact on water resources is so small, very little detailing is required in the contract.

#### **5.15.3.2 Handling Water (Rev. 07/04)**

If a structure cannot be constructed in the dry, a cofferdam is needed. The item “Handling Water” is generally used where a temporary redirection of a watercourse is required and is generally used for construction of culverts or retaining walls adjacent to the watercourse. This lump sum item includes any temporary water handling structures such as barriers, temporary pipes, or drainage channels, necessary to complete the work. Also included is any excavation required to accomplish the temporary redirection of surface water.

Any required excavation for the permanent construction will be paid for under the items “Structure Excavation-Earth (Complete).” “Structure Excavation-Rock (Complete)” or appropriate excavation items. A conceptual scheme showing all temporary water handling structures such as barriers, temporary pipes, and drainage channels, and a conceptual scheme for staging of construction for water handling must be shown in the contract and will usually be included in permit applications. The hydraulic design of the aforementioned temporary facilities is based on the watercourse hydrology and information contained in the **Drainage Manual** [6.15]. A temporary design water surface elevation associated with the proposed temporary hydraulic facility should be shown in the contract and the permit plates.

The contractor will be required to submit working drawings to detail the proposal shown in the contract. If the contractor's working drawings differ from the proposal shown on the contract to the extent that a revision to the permit is required, the contractor will be required to prepare and apply for any revisions required to the permit.

### **5.15.3.3 Cofferdam and Dewatering (Rev. 07/04)**

The item "Cofferdam and Dewatering" is generally used where substructure elements are located partly or wholly in the streambed and where the bottom of footing is below water level, or on foundation work where considerable flow or concentration of water is present that cannot be conveniently temporarily redirected from the site. The extent of work involved in placing and dewatering the cofferdam is such that it is more than a minor part of the excavation items and is not considered incidental to those items. This item should be used in conjunction with the items "Structure Excavation-Earth (Excluding Cofferdam and Dewatering)" and "Structure Excavation-Rock (Excluding Cofferdam and Dewatering)".

A cofferdam forms an enclosure that may be completely dewatered to allow work in the dry. It may consist of steel sheet piling or any other material the contractor elects to use to satisfy this requirement. Some sides of the cofferdam may be formed by the existing stream bank or by existing structures such as abutments or retaining walls. However, any existing structures intended to be used must extend below the anticipated bottom of excavation and must be resistant to intrusion of significant amounts of water from below the footing.

Cofferdams that encroach into water channels must be hydraulically analyzed based on the watercourse hydrology and information contained in the **Drainage Manual** [6.15]. A temporary design water surface elevation associated with the proposed temporary hydraulic facility should be shown in the contract and the permit plates.

The horizontal and vertical limits of the cofferdam must be shown in the contract. Cofferdams are designed and detailed by the Contractor and submitted to the Engineer for review.

**SECTION 6**  
**CONCRETE STRUCTURES**

**TABLE OF CONTENTS**

6.1 MATERIALS..... 6-1

6.1.1 Concrete ..... 6-1

6.1.1.1 Cast-In-Place Concrete (*Rev. 04/19*)..... 6-1

6.1.1.2 Precast, Non-Prestressed Concrete ..... 6-2

6.1.1.3 Precast, Prestressed Concrete..... 6-2

6.1.1.4 Rapid Setting Concrete (*Rev. 12/19*) ..... 6-2

6.1.1.5 Ultra High Performance Concrete (UHPC) (*Rev. 12/19*) ..... 6-2

6.1.1.6 Lightweight Concrete (*Rev. 12/19*)..... 6-2

6.1.2 Reinforcement..... 6-2

6.1.2.1 Non-Prestressed Steel (*Rev. 04/19*)..... 6-2

6.1.2.2 Prestressed Steel..... 6-3

6.1.3 Protective Coating on Concrete Surfaces (*Rev. 04/19*)..... 6-3

6.2 FABRICATION REQUIREMENTS ..... 6-3

6.2.1 General..... 6-3

6.2.2 Tolerances ..... 6-3

6.3 DESIGN AND DETAILING REQUIREMENTS..... 6-3

6.3.1 Cast-In-Place, Non-Reinforced Concrete Members ..... 6-3

6.3.2 Cast-In-Place, Reinforced Concrete Members ..... 6-4

6.3.2.1 General..... 6-4

6.3.2.2 Payment for Concrete Components (*Rev. 04/19*) ..... 6-4

6.3.2.2.1 Selecting Item Names and Components to be Included ..... 6-4

6.3.2.2.2 Plan Requirements ..... 6-5

6.3.2.3 Reinforcement..... 6-6

6.3.3 Precast, Non-Prestressed Concrete Members ..... 6-7

6.3.3.1 General..... 6-7

6.3.3.2 Concrete ..... 6-7

6.3.3.3 Reinforcement..... 6-7

6.3.4 Precast, Pretensioned Concrete Members..... 6-8

6.3.4.1 Structure/Member Types ..... 6-8



Connecticut Department of Transportation Bridge Design Manual

6.3.4.1.1 Standard Members ( <i>Rev. 04/19</i> ) .....	6-8
6.3.4.1.2 Modifications to Standard Members ( <i>Rev. 04/19</i> ).....	6-8
6.3.4.1.2.1 NEBT Girders .....	6-8
6.3.4.1.2.2 Prestressed Deck Units .....	6-9
6.3.4.2 Layout and Framing.....	6-9
6.3.4.2.1 Approximate Span Lengths ( <i>Rev. 04/19</i> ).....	6-9
6.3.4.2.2 Oversized Members .....	6-9
6.3.4.2.3 Skew Angle.....	6-9
6.3.4.2.4 Member Dimensions.....	6-10
6.3.4.2.5 Member Spacing .....	6-10
6.3.4.2.6 Framing Geometry .....	6-10
6.3.4.2.7 Cross Section .....	6-10
6.3.4.2.8 Deck Overhang .....	6-11
6.3.4.3 Composite Construction.....	6-11
6.3.4.3.1 General.....	6-11
6.3.4.3.2 Design Requirements .....	6-11
6.3.4.3.3 Detailing Requirements .....	6-11
6.3.4.4 Continuity on Multi-Span Structures .....	6-12
6.3.4.4.1 General.....	6-12
6.3.4.4.2 Continuous Decks Supported by Simple Spans.....	6-12
6.3.4.4.3 Continuous Decks Supported by Continuous Members .....	6-12
6.3.4.5 Concrete ( <i>Rev. 04/19</i> ) .....	6-12
6.3.4.6 Reinforcement.....	6-13
6.3.4.6.1 Non-Prestressed Steel ( <i>Rev. 04/19</i> ).....	6-13
6.3.4.6.2 Prestressed Steel.....	6-13
6.3.4.7 Camber.....	6-14
6.3.4.7.1 General.....	6-14
6.3.4.7.2 Simple Spans.....	6-14
6.3.4.7.3 Continuous Spans.....	6-15
6.3.4.8 Diaphragms .....	6-15
6.3.4.9 Post-Tensioned Transverse Strands .....	6-15
6.3.4.10 Drilling Holes.....	6-17
6.3.4.11 Seismic Restraint .....	6-18
6.3.4.11.1 General.....	6-18

Connecticut Department of Transportation Bridge Design Manual

6.3.4.11.2 Transverse Seismic Restraint..... 6-18

6.3.4.11.3 Longitudinal Seismic Restraint..... 6-18

6.3.4.12 Bearings ..... 6-18

6.3.4.13 Superstructure Jacking Requirements..... 6-19

6.3.4.13.1 General..... 6-19

6.3.4.13.2 Design Requirements ..... 6-19

6.3.4.14 Utilities..... 6-19

6.3.5 Cast-In-Place Concrete Beams ..... 6-19

6.3.6 Precast, Post-Tensioned Concrete Beams..... 6-20

This Page is Intentionally Left  
Blank

## **SECTION 6** **CONCRETE STRUCTURES**

### **6.1 MATERIALS**

#### **6.1.1 Concrete**

##### **6.1.1.1 Cast-In-Place Concrete** *(Rev. 04/19)*

Concrete shall conform to the **Standard Specification** requirements of “Section 6.01 – Concrete for Structures” and “Section M.03 – Portland Cement Concrete,” including modifications by Supplemental Specifications and Owned Special Provisions. The class of concrete specified for bridge components shall generally conform to the following guidelines:

- Substructure Components - Class PCC03340\*
- Bridge Superstructures – Class PCC04462

\*If “Z” is other than “0,” written permission shall be obtained from the Bridge Principal Engineer.

Occasionally, concrete classes that meet these guidelines are not appropriate for a specific use. In these instances and with permission from the **CTDOT**, Designers may modify the concrete class for the intended use as follows:

- For concrete components with extremely congested reinforcing, Designers shall consider specifying a concrete class with a smaller aggregate.
- Where higher 28-day strength or higher early strength is needed to resist applied loads, Designers may specify a class of concrete with a greater strength.

When the dimensions of a cast-in-place concrete component (not cast underwater) qualify it as “Mass Concrete,” in accordance with the Standard Specification, the PCC classification system will still be used to specify the compressive strength, aggregate size and Exposure Factor. Concrete suppliers may tailor the mix to address temperature and cracking in the concrete, but the Contractor shall prequalify the proposed mix with ample time to place the concrete. Designers shall verify that sufficient time is available in the contract for the Contractor to prequalify the mix before its intended use.

“Underwater Concrete” will also be specified using the PCC classification system. The Designer shall include a cofferdam in the contract to construct underwater concrete components and clearly designate the concrete as “Underwater Concrete.”

The density of cast-in-place concrete shall be assumed to be as follows, unless proof of another value is available:

- Normal Weight Concrete of all PCC Classes: 150 pounds per cubic foot
- Lightweight Concrete: 125 pounds per cubic foot

#### **6.1.1.2 Precast, Non-Prestressed Concrete**

Concrete for precast, non-prestressed members or components shall conform to the requirements in the **Standard Specifications** and **BDM** [6.3.3.1].

#### **6.1.1.3 Precast, Prestressed Concrete**

Concrete for prestressed concrete members or components shall conform to the requirements in the **Standard Specifications** and **BDM** [6.3.4.5].

#### **6.1.1.4 Rapid Setting Concrete** *(Rev. 12/19)*

Vacant

#### **6.1.1.5 Ultra High Performance Concrete (UHPC)** *(Rev. 12/19)*

Ultra High Performance Concrete (UHPC) shall conform to the requirements of the Owned Special Provision “Ultra High Performance Concrete”.

#### **6.1.1.6 Lightweight Concrete** *(Rev. 12/19)*

Vacant

### **6.1.2 Reinforcement**

#### **6.1.2.1 Non-Prestressed Steel** *(Rev. 04/19)*

Non-prestressed steel shall conform to the following:

- Uncoated bar reinforcement shall conform to the requirements of ASTM A615, Grade 60.
- Epoxy coated bar reinforcement shall conform to the requirements of ASTM A615, Grade 60 and be epoxy coated to the requirements of ASTM D3963.
- Stainless steel bar reinforcement shall conform to the requirements of ASTM A955.
- Galvanized bar reinforcement shall conform to the requirements of ASTM A615, Grade 60 and be galvanized, after fabrication, to the requirements of ASTM A767, Class 1, including supplemental requirements.
- Weldable bar reinforcement shall conform to the requirements of ASTM A706.
- Welded wire fabric shall conform to the requirements in the **Standard Specifications**.

### **6.1.2.2 Prestressed Steel**

Prestressing steel shall be 0.6 inch diameter, uncoated, low relaxation strands conforming to the requirements of AASHTO M203, Grade 270.

### **6.1.3 Protective Coating on Concrete Surfaces (Rev. 04/19)**

All concrete surfaces subjected to salt spray from marine environments, or spray from de-icing chemicals, shall be sealed with a clear, 100% silane or siloxane in accordance with the specification, "Penetrating Sealer Protective Compound." It is anticipated that silanes and siloxanes will protect concrete for approximately 7-12 years, after which time, they should be re-applied. Designers shall specify the application of a penetrating sealer in rehabilitation projects – including bridge preservation projects to ensure the continued protection of concrete surfaces.

The use of colored sealers is permitted only with the written approval of the **CTDOT**. Such sealers may experience blistering or peeling over time, creating an undesirable appearance. Colored stains for concrete shall not be considered to protect the concrete from de-icing chemicals. Stains may be incompatible with the penetrating sealer. Should colored concrete be desired, consideration shall be given to applying the pigment to the mix design so a penetrating sealer may be applied to the finished concrete.

For dampproofing requirements, see **BDM** [5].

## **6.2 FABRICATION REQUIREMENTS**

### **6.2.1 General**

The prestressed concrete fabricator's plant shall be certified by the Precast Prestressed Concrete Institute Plant Certification Program. The certification shall be as a minimum in the B3 Category, except for draped strand members, in which case a B4 Category certification is required. The certification requirements shall be shown on the plans.

### **6.2.2 Tolerances**

Tolerances for prestressed members shall conform to the limits specified in the *Manual for Quality Control for Plants and Production of Precast Prestressed Concrete Products* (MNL-116).

## **6.3 DESIGN AND DETAILING REQUIREMENTS**

### **6.3.1 Cast-In-Place, Non-Reinforced Concrete Members**

Cast-in-place, non-reinforced concrete members and components are not permitted, except for the use of underwater concrete for cofferdam seals. A cofferdam seal shall not be considered a structural member or component.

### 6.3.2 Cast-In-Place, Reinforced Concrete Members

#### 6.3.2.1 General

The use of cast-in-place reinforced concrete is acceptable for all types of members and components. Generally, cast-in-place concrete is used for substructure components, bridge decks and parapets. However, cast-in-place concrete may be used for superstructures when it is found to be economical and feasible.

#### 6.3.2.2 Payment for Concrete Components (Rev. 04/19)

##### 6.3.2.2.1 Selecting Item Names and Components to be Included

Pay item names reflect the character of the bridge components that will be measured for payment under the item. To reduce the number of item names, similar components may be included together under the same item. See Table 6.3.2.2.1-1 for a list of item names from which Designers may choose, and a list of components that may be considered similar enough to include with each item.

**TABLE 6.3.2.2.1-1**

<b>ITEM NAME</b>	<b>COMPONENTS INCLUDED</b>	<b>Concrete Mix Class (PCCXXXYZ<sup>1</sup>)</b>
Footing Concrete	Footings, leveling pads, pile caps, cut-off and return walls	PCC0334Z
Footing Concrete (Mass)	Footings, pile caps	
Abutment and Wall Concrete	Abutments, wingwalls, retaining walls, endwalls, headwalls, concrete bearing pedestals, cheekwalls, keeper blocks, curbs	
Abutment and Wall Concrete (Mass)	Abutments, wingwalls, retaining walls, endwalls	
Not Applicable	Steps, Copings	PCC0336Z
Surface Repair Concrete	Abutments, Walls, Columns, Caps, Parapets, Box Culverts	PCC04481, PCC05581
Structural Repair Concrete	Columns, Caps, Parapets, Box Culverts	
Column and Cap Concrete	Pier columns, pier caps, concrete bearing pedestals, keeper blocks	PCC0446Z
Column and Cap Concrete (Mass)	Pier columns, pier caps	
Approach Slab Concrete	Approach slabs, concrete aprons on grade	
Barrier Wall Concrete	Barrier Walls (includes footing, stem and parapet)	PCC04462
Bridge Deck Concrete	Bridge decks, haunches, backwalls cast integral with the deck, concrete curbs	

Connecticut Department of Transportation Bridge Design Manual

Bridge Deck Concrete (SIP-Forms)	Bridge decks, haunches, backwalls cast integral with the deck, concrete curbs	
Parapet Concrete	Parapets on bridge decks, parapets on wingwalls and parapets on retaining walls	
Bridge Sidewalk Concrete	Bridge sidewalks, curbs, raised medians	
<sup>1</sup> Exposure Factor, Z, shall be “0” unless another value is approved by the Bridge Principal Engineer		

When estimating the unit bid price of a cast-in-place concrete component, the largest contribution is not the cost of the concrete material. Additional factors that contribute to the cost of a concrete component are: complexity and congestion of reinforcing, forming and removal of forms, concrete placement and consolidation, sequence and timing of pours, finishing and access needs. When these factors are similar enough for different bridge components, those components may be included together in the same bid item.

Note that a component such as a concrete curb does not have its own pay item. This component may be measured for payment with the item in the contract whose character of work is most similar. The concrete curb may be included for measurement under the item, “Bridge Deck Concrete,” but if a “Bridge Sidewalk Concrete” item were included in the contract, it would be the preferable item with which to include the concrete curb because the character of work is more similar. If the structure were a box culvert with shallow fill, the contract may not include an item for “Bridge Deck Concrete” or “Bridge Sidewalk Concrete.” In such a case, if the item, “Abutment and Wall Concrete” is included for wingwalls, the curb could be measured for payment under that item. Note that in this situation, the character of work is not a close match, but the volume of concrete in the concrete curb may be small enough to have little effect on the unit bid price for “Abutment and Wall Concrete.” The total cost of the concrete curb will also be affected insignificantly by applying the unit bid price for “Abutment and Wall Concrete.” It would not be necessary to include an additional item exclusively to pay for the small volume of concrete curb.

New items may be created when, in the opinion of the **CTDOT**, no item exists in the Master Bid List that adequately describes the bridge component in question, or when the character of work of similar components is significantly different for a specific situation.

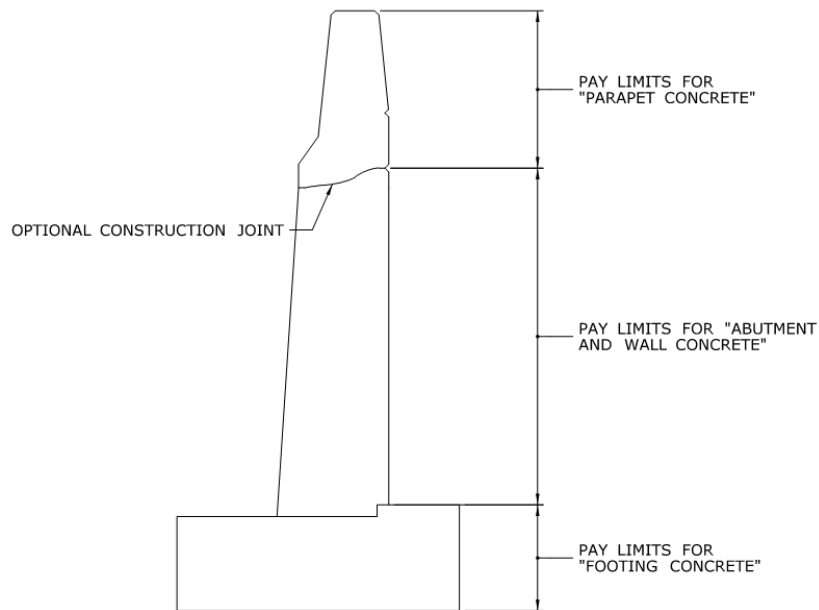
**6.3.2.2.2 Plan Requirements**

Concrete pay items shall be clearly listed in the General Notes within the plans. Adjacent to each pay item in the General Notes, list the cast-in-place concrete components to be measured for payment under that item. Following the list of components, specify the concrete mix class. Although components are grouped together under a pay item to reflect the character of work, the mix class may vary



among components within the pay item. In such a case, separate and group the components in the note by mix class.

Listing pay items and components in the General Notes may not provide sufficient clarity for measuring quantities and distinguishing pay limits between items. To provide clarity, drawings with pay limits may be needed. One such example is the item, "Parapet Concrete." Where a parapet is constructed at the top of a wall, delineation between the items, "Parapet Concrete" and "Abutment and Wall Concrete" is needed. A convenient limit for this is the optional construction joint between the two components (see Figure 6.3.2.2.3-1). Whether the Contractor elects to construct the wall with the joint or not, the drawing defines the pay limits for the items.



**CONCRETE WALL WITH PARAPET  
PAY LIMITS**

NOT TO SCALE

**FIGURE 6.3.2.2.3-1**

### 6.3.2.3 Reinforcement

Bar reinforcement shall meet the requirements of ASTM A615, Grade 60, and shall be galvanized after fabrication to the requirements of ASTM A767, Class 1, including supplemental requirements. Other reinforcement may only be specified with the approval of the Bridge Principal Engineer.

The minimum size bar shall be #4, unless otherwise authorized. The minimum cross sectional area of load-carrying reinforcement shall be that supplied by #5 bars spaced at 12 inches. Temperature and shrinkage reinforcement in walls will typically be #5 bars spaced at 18 inches.

Bar spacing shall meet the **LRFD** and, allow for proper placement and consolidation, based on the maximum aggregate size specified for the concrete mix class. It is desirable for the spacing of bar reinforcement to be in 6-inch increments for ease of placement and inspection. However, for bridge decks, columns, pier caps and other components, such a spacing may not be practical. Flexural reinforcement in walls and abutments may be adjusted to 9-inch increments to better align with temperature and shrinkage reinforcement.

Bar lengths shall be specified in 1-inch increments. The maximum length of bar reinforcement detailed shall be 40 feet. Where longer bars are required, splices shall be detailed. The use of mechanical connections to splice reinforcement is permitted, provided the connectors meet the **LRFD**. Mechanical connectors used to splice galvanized reinforcement shall be galvanized. Mechanical connectors shall be measured for payment by the number of connectors installed and accepted.

The designer is responsible for providing all of the details necessary to ensure that the reinforcement is embedded, developed and spliced in accordance with the **LRFD**.

The concrete cover over reinforcement shall conform to the requirements in the **LRFD**, unless otherwise noted. The concrete cover over the reinforcement shall be shown on the plans.

The reinforcement pay items shall be clearly noted on the plans.

### **6.3.3 Precast, Non-Prestressed Concrete Members**

#### **6.3.3.1 General**

Precast, non-prestressed superstructure members supporting vehicular traffic are not permitted.

For permanent and temporary precast concrete barrier requirements, see **BDM** [12]. For precast concrete box culvert requirements, see **BDM** [13].

#### **6.3.3.2 Concrete**

The design of precast, non-prestressed members shall be based on a minimum concrete compressive strength ( $f'_c$ ) of not less than 5000 pounds per square inch.

#### **6.3.3.3 Reinforcement**

Reinforcement shall conform to the requirements of **BDM** [6.3.2.3].

## **6.3.4 Precast, Pretensioned Concrete Members**

### **6.3.4.1 Structure/Member Types**

#### **6.3.4.1.1 Standard Members (Rev. 04/19)**

Precast, prestressed concrete members used in superstructures are generally limited to those available from area fabricators. Available member types include solid slabs, voided slabs, box beams, Northeast Bulbtee (NEBT) girders, Northeast Deck Bulb Tee (NEDBT) girders, Northeast Extreme Tee (NEXT) beams and Precast Concrete Economical Fabrication (PCEF) girders. For the latest listing of area fabricators and the bridge members produced, refer to the PCI Northeast website, [www.pcine.org](http://www.pcine.org).

Prestressed deck units are precast, pretensioned rectangular sections with or without voids. Sections with circular voids are referred to as voided slabs and sections with rectangular voids are referred to as box beams. Sections without voids are referred to as solid slabs.

Prestressed concrete bulb tee superstructure designs should consider the Northeast Bulbtee (NEBT) and the Precast Concrete Economical Fabrication (PCEF) beams with dimensions nominally equivalent to the NEBT dimensions. The prestressing shall be designed based on the NEBT dimensions and section properties, and shall be presented in the contract plan details with the following note to allow the use of the NEBT or PCEF section:

*“Prestressed concrete Northeast Bulbtee (NEBT) sections and Precast Concrete Economical Fabrication (PCEF) sections with dimensions nominally equivalent to one another are considered equivalent members for bidding purposes. The Contractor may select either section for fabrication. When selecting the PCEF section, the Contractor shall submit the actual section properties of the PCEF section for the Designer’s use in updating the bridge load rating.”*

#### **6.3.4.1.2 Modifications to Standard Members (Rev. 04/19)**

##### **6.3.4.1.2.1 NEBT Girders**

These girders shall not be altered or modified, except as follows:

- The top flange at the girder ends may be clipped to minimize the bridge seat widths at abutments
- Minor variations of NEBT girders are allowed for equivalent PCEF sections

#### **6.3.4.1.2.2 Prestressed Deck Units**

- Where the roadway vertical geometry will allow it, a 6 inch thick (minimum) concrete deck slab shall be cast on top of the prestressed deck units, designed to provide shear transfer between beams, and eliminate the need for transverse post-tensioning. In such cases, holes for post-tensioning shall not be formed in the beams. Shear keys of adequate width shall be shown between adjacent members. Transverse reinforcement from the deck unit shall protrude from the side of the deck unit and be developed within the shear key to assist in distributing loads between beams. An attempt shall be made to design and detail the deck unit width and protruding transverse reinforcement to fit within a form width of 4 feet.
- Prestressed deck units may be modified to facilitate the placement of reinforcement that extends from the tops of the members for components such as parapets and sidewalks or to accommodate drilled-in anchors for temporary precast barrier curb.
- The circular and rectangular voids in the deck units may be reduced in size or removed for placement of the reinforcement. Generally, the voids shall be placed symmetrically about the vertical axis of the member. The designer shall calculate the section properties for the modified sections.
- Spread deck units shall be detailed without shear keys and holes for post-tensioned transverse strands.
- The fascia members of structures composed of butted deck units shall be detailed without a shear key at the outside face, unless provision is being made for a future widening.

#### **6.3.4.2 Layout and Framing**

##### **6.3.4.2.1 Approximate Span Lengths (Rev. 04/19)**

Vacant

##### **6.3.4.2.2 Oversized Members**

Precast members over 120 feet in length or over 120,000 pounds will not be allowed due to shipping limitations. For members in excess of 120 feet, the use of field spliced post-tensioned bulb tees should be considered. For additional information, see **BDM** [1].

##### **6.3.4.2.3 Skew Angle**

On structures composed of butted deck units, the maximum allowable skew angle is 45 degrees.

#### **6.3.4.2.4 Member Dimensions**

Preferably, all members in a span shall have the same dimensions to facilitate fabrication and minimize costs. Generally, on multi-span structures, the individual span lengths may vary but the member depth should be constant.

Preferably, structures composed of butted deck units shall be designed with 3'-11½" wide members. Typically, the cost per square foot of deck surface is less for 3'-11½" wide members than it is for 2'-11½" wide members due to high fabrication costs.

If members with varying section properties are used in the same cross section, the distribution of loads must take into account the stiffness of each member. For more information, see **BDM** [3].

#### **6.3.4.2.5 Member Spacing**

In structures composed of bulb tee girders or spread deck units, the member spacing should be maximized in order to reduce the number of members required and to develop the full potential of each member, thereby reducing the costs for fabrication, shipping and erection. However, in order to provide redundancy, a minimum of 4 stringer lines should be used in a cross section.

In structures composed of butted deck units, the members shall be placed at a nominal spacing to provide a gap between the adjacent members that accommodates the sweep of the members. The 1'-11½" wide members should be nominally spaced at 3 feet. The 3'-11½" wide members should be nominally spaced at 4 feet. The nominal spacings were determined by increasing the actual member width to a convenient value. The spacings have not been set at the maximum allowable sweep, since it varies with the span length. If the actual sweep of the members will not allow the members to be placed at the nominal spacing shown, the members should be butted up to and placed parallel with the adjacent member.

#### **6.3.4.2.6 Framing Geometry**

Members should be placed parallel to traffic and each other, and shall be uniformly spaced as much as practical. If this is unavoidable, the live load distribution factors as outlined in the **LRFD** shall not be used. The designer should carefully investigate these situations to account for the variation in live load and member stiffness.

#### **6.3.4.2.7 Cross Section**

Structures composed of bulb tee girders or spread deck units require a composite concrete deck. The deck shall be detailed to match the roadway cross section. The members shall be placed plumb.

On structures composed of butted deck units, the members may be placed on either a straight (level or sloped) or broken cross section alignment. The alignment of the members need not match the roadway cross section. The bituminous concrete overlay shall be placed to match the roadway cross section.

#### **6.3.4.2.8 Deck Overhang**

The concrete deck overhang, measured from the centerline of the fascia member to the outside edge of the deck, should be limited to four feet or the depth of the member, whichever is less.

### **6.3.4.3 Composite Construction**

#### **6.3.4.3.1 General**

All structural members in contact with and supporting a concrete deck shall be designed for composite action. The members shall be designed assuming construction without shoring (unshored construction).

#### **6.3.4.3.2 Design Requirements**

The composite section used for computing live load stresses shall also be used for computing stresses induced by composite dead loads.

The elasticity ratio for composite design shall be computed based on the modulus of elasticity of the concrete deck and the modulus of elasticity of the prestressed concrete member.

The shear reinforcement used in the design of the members should be used to achieve composite action with the deck. Additional reinforcement may be added if the area of shear reinforcement is not sufficient to produce composite action. There is no need to extend all shear reinforcement into the deck if it is not required for composite action.

#### **6.3.4.3.3 Detailing Requirements**

Shear reinforcement used for composite action shall be extended into the concrete deck. In deck unit members, the reinforcement shall be fabricated from one bar and have two loops that extend into the deck. In bulb tee members, the reinforcement shall be terminated with a 90 degree hook.

The top surface of the members shall be roughened with a raked finish to assist in composite action. The following note, with a leader pointing to the top surface of the member, shall be shown on the plans:

Raked Finish

#### **6.3.4.4 Continuity on Multi-Span Structures**

##### **6.3.4.4.1 General**

Deck joints should be eliminated wherever possible. The number of deck joints over piers shall be minimized on multiple span structures by using continuous decks.

##### **6.3.4.4.2 Continuous Decks Supported by Simple Spans**

On multi-span structures composed of simple spans, the decks shall be made continuous over the piers with no positive moment connection, wherever practical. The supporting members shall be designed as simple spans.

National Cooperative Highway Research Program (NCHRP) Report Number 322 “Design of Precast Prestressed Bridge Girders Made Continuous” suggests that consideration should be given to the design of jointless bridges (that is, members with a continuous slab with no moment connection), since there is little or no structural advantage to designing for live load continuity.

On structures composed of bulb tee girders or spread deck units, the deck shall be placed continuous over a full height diaphragm. The diaphragm shall be placed at the piers between the ends of the members in adjacent spans and extend transversely between the parallel members.

On structures composed of butted deck units, the ends of the members shall be connected with a “T - shaped” closure pour.

##### **6.3.4.4.3 Continuous Decks Supported by Continuous Members**

Multi-span structures composed of continuous spans shall be designed with field spliced post-tensioned bulb tee girders. The bulb tee girders shall be pretensioned to control cracking during shipping and handling. The pretensioning of the girders shall be accounted for in the final design. Field splices in the members should be made near points of low dead load moment.

#### **6.3.4.5 Concrete (Rev. 04/19)**

The concrete design strength for prestressed members shall be as follows:

- The design of prestressed members shall be based on a minimum concrete compressive strength ( $f'_c$ ) of not less than 5000 pounds per square inch. The recommended concrete compressive strength is 6500 pounds per square inch. Concrete compressive strengths greater than 6500 pounds per square inch may be used subject to approval by the **CTDOT**.

- The compressive strength of the concrete at the time of transfer ( $f'_{ci}$ ) shall not be less than 4000 pounds per square inch.

The concrete stresses in the prestressed members shall conform to the **LRFD**.

The required compressive strength at the time of transfer  $f'_{ci}$  and the required 28-day compressive strength of concrete  $f'_c$  shall be clearly noted on the plans.

#### **6.3.4.6 Reinforcement**

##### **6.3.4.6.1 Non-Prestressed Steel** (*Rev. 04/19*)

In prestressed concrete members, the non-prestressed steel, including the reinforcement extending out of the units, shall be galvanized bar reinforcement.

The minimum size bar shall be #3. In general, the spacing of bar reinforcement shall be limited to four-inch increments.

Bar lengths, if specified, shall be in one-inch increments. The maximum length of bar reinforcement detailed shall be 40 feet. Where longer bars are required, splices must be detailed.

The designer is responsible for providing all of the details necessary to ensure the reinforcement is embedded, developed and spliced in accordance with the **LRFD**.

The concrete cover over reinforcement shall conform to the requirements in the **LRFD**, unless otherwise noted. The concrete cover over the reinforcement shall be shown on the plans.

The reinforcement pay items shall be clearly noted on the plans.

##### **6.3.4.6.2 Prestressed Steel**

The prestressing strands shall be tensioned to the allowable stresses listed in the **LRFD**.

Typical strand patterns and the maximum number of strands for the various prestressed members are shown in **BDM** [Division 3]. Generally, the strands are spaced two inches apart, both horizontally and vertically. The strand patterns are for design purposes only and shall not be shown on the plans.

Preferably, all members in a span shall have the same number of strands, prestressing force and distance to the center of gravity of the strands to facilitate fabrication and minimize costs.

Strands may be either draped or de-bonded to reduce the tensile stresses at the member ends. Mixing draped and de-bonded strands in a member is permitted.



If draped strands are used, the total hold down force of all the draped strands for each member should not exceed 75% of the total weight of the member.

If de-bonded strands are used, no more than 25% of the total number of strands may be de-bonded. All de-bonding shall be located within a distance of 15% of the span length from the end of the member. The de-bonded strands shall be well distributed across the member cross section. No two adjacent strands (either horizontally or vertically) shall be de-bonded, although diagonally adjacent strands may be de-bonded. The outermost strands of each layer shall not be de-bonded.

The following information shall be shown on the plans:

- the ultimate tensile strength of the strands,
- the jacking force per strand,
- the number of strands,
- the center of gravity of strands,
- the strand diameter,
- de-bonding locations (if required), and
- the approximate location of drape points (if required).

#### **6.3.4.7 Camber**

##### **6.3.4.7.1 General**

Camber induced by prestressing shall be computed in such a manner as to include the effects of creep and growth in the modulus of elasticity. Sufficient camber should be induced in each member such that a net positive camber will remain under all dead loads.

##### **6.3.4.7.2 Simple Spans**

Dead load deflection and camber diagrams are not required for simple span bridges. Dead load deflections and cambers shall be calculated at the mid-span of the structure for the following listed items for each member and tabulated on the plans:

- Prestressed Beam Deflections. Deflections due to the weight of the beams calculated using the moment of inertia of the prestressed beam.
- Additional Dead Load Deflections. Deflections due to the uncured concrete slab, haunches, diaphragms, utilities and any other loads supported by the prestressed beam section alone.
- Composite Dead Load Deflections. Deflections due to the parapets, curbs, sidewalks, railings, bituminous concrete overlay and any other loads that are placed after the slab has cured and are supported by the composite section. (Structures composed of prestressed beams with a composite deck only).
- Member Cambers (calculated at the following stages):

- At Transfer. Camber due to pretensioning force at transfer minus the deflection due to the dead load of the member.
- At Erection. Camber (due to pretensioning force minus the deflection due to the dead load of the member) that is present at approximately 30 days after transfer.
- Final. Camber after all dead loads are applied to the structure, and after long term creep and relaxation have taken place.

An acceptable method for estimating cambers and deflections in simple span members using multipliers can be found in the “PCI Design Handbook - Precast and Prestressed Concrete.”

#### **6.3.4.7.3 Continuous Spans**

Vacant

#### **6.3.4.8 Diaphragms**

Structures composed of prestressed concrete beams with a composite concrete deck shall have intermediate and end diaphragms.

On bridges with spans less than or equal to 80 feet, one intermediate diaphragm shall be placed between the members at mid-span. On bridges with spans greater than 80 feet, intermediate diaphragms shall be placed between the members at third points along the span.

On bridges skewed less than or equal to 30 degrees, the intermediate diaphragms shall be placed in line along the skew. On bridges skewed more than 30 degrees, intermediate diaphragms shall be placed normal to the main members and staggered, not placed in a line, across the width of the bridge.

End diaphragms shall be placed between members at all abutments and piers. End diaphragms shall be placed over and aligned with the centerline of each bearing line.

Intermediate and end diaphragms shall be comprised of cast-in-place concrete and be monolithic with the concrete deck. The use of steel diaphragms will not be permitted. The intermediate and end diaphragms shall be detailed to accommodate utilities as required. Diaphragms shall be completely cured prior to placement of the deck concrete in order to provide stability to the superstructure members.

#### **6.3.4.9 Post-Tensioned Transverse Strands**

Structures composed of deck units placed butted to each other without a composite deck shall be post-tensioned transversely with prestressing strands.

The number and location of these transverse ties is dependent upon the following: the length of the member, the depth of the member, the skew angle of the structure, and stage construction. Based on the skew angle of the structure, the ties may be placed parallel to the skew of the structure or normal to the sides of the member. See Division III for additional details.

The appropriate post-tensioning procedure along with the following note shall be shown on the plans:

No additional dead loads or live loads shall be applied to the butted deck units until the transverse ties have been fully tensioned and the grout in the longitudinal shear keys has reached a seven-day compressive strength of 4500 psi.

The transverse strands shall be post-tensioned in accordance with one of the following procedures:

For structures with skew angles less than or equal to 30 degrees:

**TRANSVERSE STRAND POST-TENSIONING PROCEDURE**

1. After erecting the prestressed deck units for the construction stage, install the transverse ties.
2. Tension each transverse tie to 5 kips.
3. Seal the bottom of the longitudinal shear keys with closed cell polyethylene foam backer rod and place non-shrink grout in the longitudinal shear keys and internal diaphragms. The grout shall be rodded or vibrated to ensure that all the voids in the shear keys are filled.

4. On shallow members with one row of ties, include the following note:

When the grout has attained a compressive strength of 1500 psi, tension each transverse tie to 30 kips.

On deep members with two rows of ties, include the following note:

When the grout has attained a compressive strength of 1500 psi, at each transverse tie location tension the bottom tie to 15 kips, then the top tie to 15 kips. Repeat this tensioning sequence once more so that each tie is tensioned to 30 kips.

**NOTE:** Where the total initial post-tensioning force of all the transverse ties is sufficient to displace the exterior members, the designer shall modify the

post-tensioning procedures to require placement of hardwood shims between the members. The designer shall specify the number and location of these shims. The shims shall be placed between as many members as is required such that the total initial post-tensioning force does not displace any members.

For structures with skew angles greater than 30 degrees:

**TRANSVERSE STRAND POST-TENSIONING PROCEDURE**

1. As each member is being erected, install the transverse ties and place hardwood shims between the adjacent deck units at each transverse tie hole location on the top and bottom.
2. On shallow members with one row of ties, include the following note:  
  
Secure each member to the preceding member by tensioning each transverse tie to 30 kips before erecting the next member.  
  
On deep members with two rows of ties, include the following note:  
  
Secure each member to the preceding member by first tensioning the bottom tie at each transverse tie location to 15 kips, then the top tie to 15 kips. Repeat this tensioning sequence once more so that each tie is tensioned to 30 kips.
3. After all the members have been erected, seal the bottom of the longitudinal shear keys with closed cell polyethylene foam backer rod and place non-shrink grout in the longitudinal shear keys and internal diaphragms. The grout shall be rodded or vibrated to ensure that all the voids in the shear keys are filled.
4. When the grout has attained a compressive strength of 1500 psi, remove the hardwood shims. The voids left in the grout from the top shims shall be filled with grout. The voids in the grout from the bottom shims may be left unfilled.

**6.3.4.10 Drilling Holes**

The drilling of holes in (or the use of power actuated tools on) prestressed members shall not be permitted. However, inserts for attachments may be placed in the members during fabrication.

The following note shall be shown on the plans:

The drilling of holes in (or the use of power actuated tools on) prestressed members will not be permitted.

### **6.3.4.11 Seismic Restraint**

#### **6.3.4.11.1 General**

All structures shall include restraint devices or connections, such as keeper blocks, bearings or dowels, designed to transfer seismic forces from the superstructure to the substructure.

The design and detailing of the restraint devices or connections shall account for thermal movement of the structure.

#### **6.3.4.11.2 Transverse Seismic Restraint**

On structures composed of prestressed concrete beams, supported by seat type abutments, the superstructure shall be restrained transversely by a keeper block placed between the center members at abutments. If necessary, multiple keeper blocks may be used at each abutment to resist the forces. At piers supporting members with a continuous deck, the superstructure shall be restrained with dowels projecting from the pier into the full height diaphragm. At piers supporting members with a discontinuous deck, the superstructure shall be restrained transversely by a keeper block placed between the center members at abutments.

On structures composed of butted deck units, the superstructure shall be restrained transversely by cheekwalls located at each end of the abutments and piers.

#### **6.3.4.11.3 Longitudinal Seismic Restraint**

On structures composed of bulb tee girders or spread deck units, the superstructure shall be restrained longitudinally by keeper blocks placed behind the end of each member at abutments after their erection.

On structures composed of butted deck units, the superstructure shall be restrained longitudinally by a backwall placed behind the ends of the members at the abutments after their erection.

### **6.3.4.12 Bearings**

In general, elastomeric bearings shall be used to support prestressed deck units and prestressed concrete girders. The bearings may be either plain or steel-laminated.

On structures composed of butted deck units, the use of a single sheet of elastomer, placed continuous between the fascia units, is not permitted. Each deck unit shall rest on two individual bearings.

For additional bearing requirements, see **BDM** [9].

### **6.3.4.13 Superstructure Jacking Requirements**

#### **6.3.4.13.1 General**

Since future maintenance of the elastomeric bearings is not anticipated, provisions for jacking the superstructure of prestressed concrete bridges supported by elastomeric bearings are not required. For other prestressed concrete bridges that incorporate sliding bearings, the following provisions shall apply.

#### **6.3.4.13.2 Design Requirements**

Provisions for jacking of the superstructure shall be provided at all locations that have bearings that will require future maintenance. These bearings include all types that have sliding or rolling surfaces such as pot, disc, spherical, etc. Supports designed with non-sliding type bearings such as elastomeric and fixed steel bearings do not need to have jacking provisions specifically designed.

Lift points shall be located adjacent to the bearings and may be on main or secondary members. Preferably, lift points shall be over the bridge seats of abutments and the tops of piers so that jacks may be founded on these components minimizing the need for extensive temporary structures.

The jacking lift points shall be designed for the total dead load and the live load plus impact. If there are more than five lines of girders, the jacking lift points shall be designed for 150% of these values in order to jack individual girders in the future.

Superstructure and substructure members and components shall be strengthened as required to support the jacking loads.

#### **6.3.4.14 Utilities**

On structures composed of prestressed concrete girders or spread deck units, the utilities may be placed between adjacent members. The intermediate and end diaphragms shall be detailed to accommodate utilities as required.

On structures composed of butted deck units, the utilities may be placed between two members in a utility bay located under a sidewalk. Under no circumstances will utilities be permitted to be located inside deck units.

For additional information, see **BDM** [15].

### **6.3.5 Cast-In-Place Concrete Beams**

Vacant

**6.3.6 Precast, Post-Tensioned Concrete Beams**

Vacant

**SECTION 7**  
**STEEL STRUCTURES**

**TABLE OF CONTENTS**

7.1 MATERIALS AND FABRICATION .....	7-1
7.1.1 Structural Steel Designations .....	7-1
7.1.2 Coated and Uncoated Structural Steel ( <i>Rev. 04/19</i> ).....	7-1
7.1.2.1 Uncoated Weathering Steel.....	7-2
7.1.2.2 Coated Structural Steel ( <i>Rev. 04/19</i> ).....	7-2
7.1.3 Fasteners ( <i>Rev. 04/19</i> ).....	7-3
7.1.4 Welding.....	7-3
7.1.5 Fabrication .....	7-4
7.1.5.1 General Requirements ( <i>Rev. 04/19</i> ).....	7-4
7.1.5.2 Special Fabrication Requirements for Box Girders .....	7-5
7.2 GENERAL DESIGN REQUIREMENTS .....	7-5
7.2.1 Structure Types .....	7-5
7.2.1.1 Cost Effective Span Lengths.....	7-5
7.2.1.2 Non-Redundant Systems.....	7-6
7.2.1.3 Box Girders.....	7-6
7.2.1.4 Short Spans .....	7-6
7.2.2 Span Layout .....	7-6
7.2.2.1 Member Spacing .....	7-6
7.2.2.2 Deck Overhang .....	7-7
7.2.2.3 Framing Geometry .....	7-7
7.2.3 Continuity .....	7-7
7.2.4 Fatigue.....	7-7
7.2.4.1 General Requirements.....	7-7
7.2.4.2 Rolled Beams .....	7-7
7.2.4.2.1 Simple Spans with Cover Plates .....	7-7
7.2.4.2.2 Continuous Spans with Cover Plates .....	7-7
7.2.4.3 Diaphragm Connection Plates.....	7-8
7.2.5 Fracture Critical Bridge Members .....	7-8



Connecticut Department of Transportation Bridge Design Manual

7.2.5.1 Definitions.....	7-8
7.2.5.2 General Provisions .....	7-8
7.2.6 Diaphragms and Cross-Sections .....	7-9
7.2.6.1 General Provisions .....	7-9
7.2.6.2 Skewed Bridges .....	7-9
7.2.6.3 I-Shaped Beams and Girders with Web Depth $\leq 4$ feet.....	7-9
7.2.6.3.1 Intermediate Diaphragms.....	7-9
7.2.6.3.2 End Bearing Diaphragms.....	7-10
7.2.6.4 I-Shaped Beams and Girders with Web Depths $> 4$ feet .....	7-10
7.2.6.4.1 Intermediate Diaphragms.....	7-10
7.2.6.4.2 End Bearing Diaphragms .....	7-10
7.2.6.5 Box-Girders.....	7-11
7.2.6.5.1 Intermediate Diaphragms.....	7-11
7.2.6.5.2 End Bearing Diaphragms.....	7-11
7.2.7 Lateral Bracing.....	7-11
7.2.7.1 Requirements for I-Shaped Members .....	7-11
7.2.7.1.1 Design Requirements .....	7-11
7.2.7.1.2 Detailing Requirements .....	7-12
7.2.7.2 Requirements for Box Girders .....	7-12
7.2.7.2.1 Design Requirements .....	7-12
7.2.8 Stiffeners .....	7-12
7.2.8.1 Bearing Stiffeners .....	7-12
7.2.8.1.1 Design Requirements .....	7-12
7.2.8.1.2 Detailing Requirements .....	7-13
7.2.8.2 Intermediate Transverse Stiffeners .....	7-13
7.2.8.2.1 Design Requirements .....	7-13
7.2.8.2.2 Detailing Requirements .....	7-13
7.2.8.3 Longitudinal Stiffeners .....	7-14
7.2.8.3.1 Design Requirements .....	7-14
7.2.8.3.2 Detailing Requirements .....	7-14
7.2.9 Connections and Splices .....	7-14
7.2.9.1 General.....	7-14
7.2.9.1.1 Design Requirements .....	7-14
7.2.9.1.2 Detailing Requirements .....	7-14

Connecticut Department of Transportation Bridge Design Manual

7.2.9.2 Bolted Splices .....	7-15
7.2.9.2.1 Detailing Requirements .....	7-15
7.2.9.3 Cross Member Connections .....	7-15
7.2.9.3.1 Design Requirements .....	7-15
7.2.9.3.2 Detailing Requirements .....	7-15
7.2.10 Composite Construction.....	7-16
7.2.10.1 Design Requirements .....	7-16
7.2.10.2 Detailing Requirements .....	7-16
7.2.11 Dead Load Deflection and Cambers .....	7-17
7.2.11.1 Simple Span Bridges.....	7-17
7.2.11.2 Continuous Span Bridges.....	7-18
7.2.12 Bearings .....	7-18
7.2.13 Superstructure Jacking Requirements.....	7-18
7.2.13.1 Design Requirements .....	7-18
7.2.13.1.1 New Construction .....	7-18
7.2.13.1.2 Rehabilitation Projects .....	7-19
7.2.13.2 Detailing Requirements .....	7-19
7.2.14 Inspection Hand Rails .....	7-19
7.3 STRUCTURE TYPE SPECIFIC REQUIREMENTS .....	7-20
7.3.1 Rolled Beams .....	7-20
7.3.2 I-Shaped Plate Girders .....	7-20
7.3.2.1 Hybrid Girders .....	7-20
7.3.2.2 Web Plates .....	7-20
7.3.2.3 Flange Plates .....	7-21
7.3.2.4 Shop Splices.....	7-21
7.3.3 Box Girders.....	7-21
7.3.3.1 Hybrid Girders .....	7-21
7.3.3.2 Web Plates .....	7-22
7.3.3.3 Flange Plates .....	7-22
7.3.3.4 Shop Splices.....	7-22
7.3.3.5 Bolted Field Splices .....	7-22
7.3.3.6 Fabrication Requirements .....	7-23
7.3.3.7 Access Manholes .....	7-23
7.3.3.8 Stay-In-Place Forms.....	7-23

Connecticut Department of Transportation Bridge Design Manual

7.3.3.9 Drainage .....	7-23
7.3.3.10 Utilities.....	7-23
7.3.4 Curved Girders (Includes rolled beams, plate girders and box girders) .....	7-24
7.3.5 Through-Girders .....	7-24
7.3.6 Trusses .....	7-25
7.3.7 Rigid Frames .....	7-25
7.3.8 Pin and Hanger Structures .....	7-25
7.3.9 Steel Piers and Pier Caps .....	7-25
7.3.10 Railway Bridges.....	7-25

## **SECTION 7** **STEEL STRUCTURES**

### **7.1 MATERIALS AND FABRICATION**

#### **7.1.1 Structural Steel Designations**

AASHTO M270, Grade 50 shall generally be used for all structural steel. If the structure is to remain uncoated and allowed to weather, AASHTO M270, Grade 50W should be used.

The structural steel designations shall be shown on the plans. The designations shall reference AASHTO material specifications and include the applicable suffix codes. The suffix “T” indicates a Non-Fracture Critical material whereas an “F” indicates a Fracture Critical material. The “T” or “F” is followed by the appropriate AASHTO temperature zone for Connecticut, which is “2.”

Examples:

Non-Fracture Critical Bridge Members	AASHTO M270 Grade 50 T2 AASHTO M270 Grade 50 WT2
Fracture Critical Bridge Members	AASHTO M270 Grade 50 F2 AASHTO M270 Grade 50 WF2

#### **7.1.2 Coated and Uncoated Structural Steel (Rev. 04/19)**

New structural steel bridges may be either coated or uncoated.

- Uncoated steel shall be weathering steel.
- Coated steel shall be either shop galvanized or metallized and top coated.

In order to reduce future maintenance, the use of coated steel should be minimized. Uncoated weathering steel should be the first choice for structural steel bridges with life-cycle cost as a consideration. The use of galvanizing or metallizing and top coating should also be considered where the look of weathering steel is objectionable.

Weathering steel should be the first consideration for most bridges, especially those in rural areas. The use of weathering steel in urban areas or where the bridge will be highly visible shall be discussed with the Municipal Officials prior to its use. Weathering steel shall be designated for all structural steel bridges over railroads.

Where the use of weathering steel is not appropriate, such as bridges subject to vehicular salt spray, near a salt water environment, or a heavy industrial area, the use of galvanized steel should be considered. Where the length of the structural steel members precludes use of

galvanized steel, shop metallizing should be used. Shop metallizing shall include a colored urethane top coat.

A paint only system shall only be used for existing structural steel bridges.

### **7.1.2.1 Uncoated Weathering Steel**

Where weathering steel has been found to be appropriate in accordance with **CTDOT** guidelines, its use should conform to the FHWA Technical Advisory T5140.22, “Uncoated Weathering Steel in Structures,” dated Oct. 3, 1989, and amended as follows:

- a. The design of weathering steel for bridges subject to vehicular salt spray, near a salt water environment, or a heavy industrial area should incorporate modest increases in flange plate thicknesses to allow for some minor section loss in the future.
- b. The interior surfaces of box girders, including all structural steel components within the box girders (such as diaphragms, cross-frames, connection plates, etc.) shall be painted in accordance with the special provision, entitled “Structural Steel (Site No. ).” The intermediate coat shall be white (Federal Standard 595 Color No. 27925) in order to facilitate bridge inspection.
- c. Whenever possible, unpainted weathering steel bridges must be designed to eliminate deck joints. If deck joints cannot be eliminated, the areas adjacent to the joints shall be protected from leakage. Generally, the ends of the beams directly under joints can be metallized or painted for protection. For bridge decks that extend past the backwall and integral abutments, beam ends need not be painted. The topcoat shall be Brown, Federal Standard 595 Color No. 20062. The steel should be metallized or painted for a distance approximately equal to one and one half times the depth of the girder on either side of the joint. All structural steel components within this distance (such as diaphragms, cross-frames, connection plates, stiffeners, etc.) shall also be painted.

The limits of the structural steel requiring painting shall be delineated on the plans.

- d. Proper precautions should also be taken to minimize substructure staining for construction conditions and the service life of the bridge. In general, this will include providing catchments and diversion bars at all bearings and ensuring that the Contractor adequately protects the substructure during construction.
- e. Provisions should also be included to control vegetation growth under the structure to reduce the moisture in the air that could have a detrimental effect on the structure.

### **7.1.2.2 Coated Structural Steel (Rev. 04/19)**

In general, coated structural steel bridges shall be galvanized or metallized and top coated. For existing bridges, when required, structural steel shall be prepared and coated in accordance with the special provision, entitled “Structural Steel (Site No. ).”

With the exception of major structures or architecturally or historically significant structures, the choice of color for shop and field painting the top coat of steel, shall be limited to the following:

- a. Green - Federal Standard 595, Color No. 24172
- b. Green - Federal Standard 595, Color No. 24277
- c. Blue - Federal Standard 595, Color No. 26329

Blue shall be used for bridges that span over waterways. Green shall be used for bridges that span over land or roadways.

The use of galvanized steel or metallizing should be considered in order to reduce future maintenance obligations.

### **7.1.3 Fasteners (Rev. 04/19)**

Fasteners shall be high-strength bolts conforming to the requirements of ASTM F3125 Grade A325 or F3125 Grade A490.

On coated structures, the high-strength bolts shall conform to ASTM F3125 Grade A325, Type 1 and be hot-dipped galvanized in accordance with ASTM F2329 or mechanically galvanized in accordance with ASTM B695, Class 55. On uncoated, weathering steel structures, the high-strength bolts shall conform to ASTM F3125 Grade A325, Type 3 or ASTM F3125 Grade A490, Type 3, although ASTM F3125 Grade A325 is preferred.

The high-strength bolt, nut and washer designations shall be shown on the plans. These designations shall reference ASTM *Specifications*, and include types and grades where applicable.

Generally, standard-sized holes shall be specified in the component parts of bolted connections. Where design considerations permit, however, connections should be designed to accommodate oversized holes to allow for potential enlargement of holes in the field where necessary to facilitate field erection.

### **7.1.4 Welding**

Welding of fracture critical and non-fracture critical structural steel members or components for highway bridges shall conform to the **AWS D1.5**.

Welding of structural steel members or components, such as sign supports and inspection platforms, shall conform to the **AWS D1.1**.

Welding symbols shall conform to the latest edition of AWS A2.4 - Standard Symbols for Welding, Brazing and Nondestructive Examination.

Fillet weld sizes shall be shown on the plans and shall conform to the sizes shown in **BDM** [Division 3]. Generally, the minimum size fillet weld shall be 5/16 inch. Smaller welds may be required for thin plates. Connections made with fillet welds placed on opposite sides of a common plane of contact shall not be detailed with the weld-all-around symbol. Per the **AWS D1.5**, “fillet welds deposited on opposite sides of a common plane of contact between two parts shall be interrupted at a corner common to both welds.”

Weld symbols for complete penetration groove welds shall be specified, without dimensions, by three capital letters, CJP. This allows the weld joint configuration and details to be determined by the fabricator.

Non-destructive testing (NDT) of welds shall be specified with symbols, combined with the welding symbols, for the welds requiring testing. The quantities of non-destructive testing methods required for field welds shall be shown in the “Inspection of Field Welds” block on the General Plan.

Multiple pass welds, inspected by the magnetic particle method, shall have each pass or layer inspected and accepted before proceeding to the next pass or layer.

The welding specifications shall be shown on the plans.

## **7.1.5 Fabrication**

### **7.1.5.1 General Requirements (Rev. 04/19)**

Fabrication of structural steel members or components for highway bridges shall conform to the **LRFD** [6].

The structural steel fabricator’s plant shall be certified by the AISC Quality Certification Program. The certification requirements depend on the category of structure being fabricated as follows:

For non-fracture critical members:

#### **1. Bridge Fabricator Simple (SBR) or Bridge Component (CPT).**

*Typical work includes:*

1. *Bridge cross frames for straight bridges with skew angles less than 30 degrees*
2. *Highway sign structures*
3. *Bridge inspection catwalks*
4. *Grid decks*
5. *Scuppers*
6. *Expansion joints*
7. *Bearings*

#### **2. Bridge Fabricator Simple (SBR).**

*Typical work includes:*

1. *Straight simple un-spliced rolled beams*

**3. Bridge Fabricator Intermediate (IBR).**

*Typical work includes:*

1. *Rolled beam with field or shop splices, straight or with radius over 500 feet*
2. *Built up I-shaped plate girder with constant depth except for dapped ends, with or without splices, either straight or with radius over 500 feet*
3. *Built up I-shaped plate girder with variable depth, either straight or with a radius over 1000 feet*
4. *Truss with a length 200 feet or less that is entirely pre-assembled at the verified facility and shipped in no more than three sub-assemblies*

**4. Bridge Fabricator Advanced (ABR).**

*Typical work includes:*

1. *Tub or trapezoidal box girders, closed box girder bridges*
2. *Curved girders with radius under 500 feet*
3. *Large or non-preassembled trusses, arches*
4. *Moveable bridges*
5. *Cable stayed bridges*

If the structure has fracture critical members or components, the fabricator’s plant shall also be certified to produce fracture critical members in accordance with a fracture control plan as defined by the **AWS D1.5**. A fabricator with this endorsement will have a suffix “F” added to the above categories (Category IBR,F or Category ABR,F).

The certification requirements for specific components shall be shown on the plans.

**7.1.5.2 Special Fabrication Requirements for Box Girders**

Vacant

**7.2 GENERAL DESIGN REQUIREMENTS**

**7.2.1 Structure Types**

**7.2.1.1 Cost Effective Span Lengths**

The following are appropriate ranges of cost effective span lengths for various steel bridges types:

TYPE OF BRIDGE	COST EFFECTIVE SPAN LENGTH (ft)
Rolled Beams	50 to 90
Plate Girders	80 to 250
Box Girders	150 to 250



The span lengths shown are for simple span bridges. For continuous bridges, these span lengths can be assumed to be measured from dead load inflection points.

For spans over 250 feet, special design studies must be done. Plate and box girders may still be the structure of choice since they provide redundancy. Other options are arches, trusses or cable stayed bridges, although these structure types should be limited to very long spans.

### **7.2.1.2 Non-Redundant Systems**

Non-redundant systems such as girder and floor beam bridges should be avoided even though they may have an initial lower cost. The reason for this is the lack of redundancy, fatigue problems, and difficulties involved with future widening associated with these types of structures.

The only situations where non-redundant bridges should be considered are in the case of through-girder or through-truss spans where the minimum depth of the superstructure is critical.

### **7.2.1.3 Box Girders**

Generally, box girders should be considered only for very long spans. They should also be investigated for use on curved roadways where torsional rigidity is required. Box girder cross sections shall be a trapezoidal shape with webs sloped equally out from the bottom flange. The webs shall be the same depth. The minimum web depth shall be 78 inches to allow for inspection and maintenance inside the box girders. In general, box girders shall be rotated so that the top and bottom flanges are parallel with the deck cross slope.

### **7.2.1.4 Short Spans**

Rolled beam and girder type bridges may also be used for shorter spans at locations where utilities must be supported between stringer lines.

## **7.2.2 Span Layout**

### **7.2.2.1 Member Spacing**

Member spacing should be maximized in order to reduce the number of members required thereby reducing the costs for fabrication, shipping, erection and future maintenance. However, in order to provide redundancy, a minimum of four stringer lines should be used in a bridge cross section.

Generally, the most economical spacing for rolled beams is between 8 feet and 9.5 feet. It is recommended that the minimum spacing for I-shaped plate girders and top flanges of box girders be kept to 9 feet.

### **7.2.2.2 Deck Overhang**

The concrete deck overhangs, measured from the centerline of the fascia member, should be limited to 4 feet or to the depth of the member, whichever is less. For deck overhangs greater than 4 feet, the designer shall include requirements in the contract documents for special forming requirements needed to prevent torsional rotation of the fascia member during concrete placement. This rotation is caused by the effect of the typical forming brackets used in construction.

### **7.2.2.3 Framing Geometry**

Members should be laid out parallel and uniformly spaced as much as practical. If this is unavoidable, the live load distribution factors, as outlined in the **LRFD**, shall not be used. The designer should carefully investigate these situations to account for the variation in live load and member stiffness.

## **7.2.3 Continuity**

Continuous spans shall be used for all multiple span bridges. Provisions for thermal movement of the bridge shall generally be made at or behind the abutments. For bridges on a grade, provisions for thermal movement of the bridge shall generally be made at the high end of the bridge.

## **7.2.4 Fatigue**

### **7.2.4.1 General Requirements**

The provisions in the **LRFD** shall be followed for the design of bridges. Fatigue requirements shall apply to elements of steel members where the summation of the calculated maximum live load tension stress and the dead load stresses results in net tension.

### **7.2.4.2 Rolled Beams**

#### **7.2.4.2.1 Simple Spans with Cover Plates**

For simple span rolled beams with cover plates, the cover plates shall be extended approximately full length. The cover plates shall be fillet welded across the ends.

#### **7.2.4.2.2 Continuous Spans with Cover Plates**

For continuous span rolled beams with cover plates, the cover plates shall be terminated with end welds in non-fatigue regions. For the bottom flange, the regions are near the interior supports and, for the top flange, the regions are near the middle of the spans.

### **7.2.4.3 Diaphragm Connection Plates**

For all types of steel bridges, the design of the flanges should be based on Category C in order to allow the welding of diaphragm connection plates to the flanges. If a preliminary design does not satisfy the requirements of Category C, then one of the following options should be followed:

- a. The flange can be increased in size to reduce the live load stress range.
- b. The location of flange splices can be changed to reduce the live load stress range.
- c. The connection can be bolted to reduce it to a Category B detail.

Note: For option c, the weld of the connection plate to the web adjacent to the flange is also a Category C detail, which is subject to virtually the same stress range, and may also need to be bolted. For this reason, this option should be avoided.

## **7.2.5 Fracture Critical Bridge Members**

### **7.2.5.1 Definitions**

Fracture Control Plan (FCP) - The Fracture Control Plan is the materials testing and fabrication provisions for Fracture Critical Members as outlined in the **AWS D1.5**.

Fracture Critical Member (FCM) - Fracture Critical members or member components are tension members or tension components of bending members (including those subject to reversal of stress), the failure of which would be expected to result in collapse of the bridge. The designation “FCM” shall mean fracture critical member or member component. Members and components that are not subject to tensile stress under any condition of live load are not fracture critical.

Attachments - Any attachments welded to a tensile zone of a FCM member shall be considered a FCM when any dimension of the attachment exceeds 4 inches in the direction parallel to the calculated tensile stress in the FCM. Attachments shall meet all requirements of the Fracture Control Plan.

Welds - All welds to FCM's shall be considered fracture critical and shall conform to the requirements of the Fracture Control Plan. Welds in compression members or compression areas of bending members are not fracture critical.

### **7.2.5.2 General Provisions**

All fracture critical members shall be identified on the plans. Each FCM shall be individually designated on the plans by three capital letters, FCM, enclosed in a diamond. Each portion of a bending member that is fracture critical including welds shall be clearly described giving the limits of the FCM.

Based on the definitions above, the following guidelines shall be followed for designation of FCM's on plans:

I-Shaped Girder Bridges - For longitudinal girder bridges, FCM components of the beams shall be considered fracture critical if there are three or less girders in the bridge cross section. This requirement does not apply to temporary stages in construction.

Box Girder Bridges - For longitudinal box girder bridges, FCM components of the beams shall be considered fracture critical if there are two or less box girders in the bridge cross section. For the case of a two-box girder cross section, the top flanges and the welds of the webs to the top flanges shall not be considered fracture critical. This requirement does not apply to temporary stages in construction.

## **7.2.6 Diaphragms and Cross-Sections**

### **7.2.6.1 General Provisions**

Intermediate and end bearing diaphragms and cross frames (cross members) shall be provided for rolled beams, plate girders and box girders. They shall be designed and located, unless otherwise noted, in accordance with the **LRFD**.

Intermediate cross members for rolled beams and plate girders shall preferably be placed at the 0.4 point of end spans of continuous bridges and at the center of interior spans. If practical, they should also be placed adjacent to a field splice. Cross members shall be spaced as far apart as possible to limit the overall number but still satisfying the AASHTO criteria. The need for cross members shall be investigated for all stages of construction.

### **7.2.6.2 Skewed Bridges**

On bridges skewed less than 20 degrees, the intermediate diaphragms shall be placed in line along the skew. On bridges skewed more than 20 degrees, intermediate cross members shall be placed normal to the main members and staggered, not placed in a line, across the width of the bridge.

### **7.2.6.3 I-Shaped Beams and Girders with Web Depth $\leq$ 4 feet**

#### **7.2.6.3.1 Intermediate Diaphragms**

Channel members shall be typically used for end and intermediate diaphragms. For intermediate diaphragms, the channel size shall be dependent upon the main member's depth. See the following table:

Member DEPTH (in)*	CHANNEL SIZE
21 - 24	C 12 x 20.7
27 - 30	C 15 x 33.9
33 - 36	MC 18 x 42.7

\* Member depth is normal beam depth for rolled beams, actual web depth for plate girders.

### **7.2.6.3.2 End Bearing Diaphragms**

End bearing diaphragms are required at all abutments and at intermediate locations where slab continuity is broken. These diaphragms shall preferably be channel sections and should be designed as simple span members with vertical dead loads, and live loads plus impact applied. The preferred channel size shall be C 15 x 33.9 and MC 18 x 42.7. For bridges with severe skew angles or wide girder spacings, wide flange sections or K-frames may be used in lieu of channels.

End diaphragms typically shall be placed along the centerline of bearings and be set on a sloped line. A minimum clear distance of 12 inches shall be provided between end diaphragms and front face of backwall.

The bridge skew angle shall be considered in determining the length of the end diaphragm. Consideration shall be given to composite action in the design of all end diaphragms. For both non-composite and composite end diaphragms, shear connectors, 7/8 inch diameter, with a maximum spacing of 12 inches, shall be welded to the top flange of the end diaphragms.

## **7.2.6.4 I-Shaped Beams and Girders with Web Depths > 4 feet**

### **7.2.6.4.1 Intermediate Diaphragms**

Cross frames shall be used for intermediate diaphragms. Intermediate cross frames shall be designed to satisfy the lateral wind load stresses and slenderness ratio,  $KL/r$ , requirements outlined in the **LRFD**. When computing the AASHTO allowable compressive stress, a value of 0.75 shall be used for the effective length factor,  $K$ .

The most economical intermediate cross frame considered for use shall be the X- type. When additional bracing is required, K-type frames should also be considered. All members shall be fabricated from equal leg angles or WT sections. Cross frames shall be as deep as practical. The cross frame depth shall be constant to facilitate fabrication.

### **7.2.6.4.2 End Bearing Diaphragms**

End bearing cross frames shall have a K-type configuration with a channel member typically used at the top. All other members shall be equal leg angles or WT sections.

The design of the top member shall follow that outlined for the end bearing diaphragms in **BDM** [7.6.3.2]. The size of the end diaphragm's bottom chord may be increased to provide for future jacking of the girder ends. For both non-composite and composite end bearing diaphragms, shear connectors, 7/8 inch diameter with a maximum spacing at 12 inches shall be welded to top flange of top chord member.

## **7.2.6.5 Box-Girders**

### **7.2.6.5.1 Intermediate Diaphragms**

Intermediate cross frames, not required for the completed bridge, may be required for construction purposes and shall be located and spaced as a matter of engineering judgment. They may be installed as temporary members or left-in-place as permanent members. Consideration shall be given to locate, at a minimum, intermediate cross frames at the lifting points of each shipping piece, on each side of a field splice, and at maximum positive moment sections. These cross frames shall be designed to satisfy the construction load stresses and slenderness ratio requirements. Typical cross frame configurations shall be the X and K types. All members shall be fabricated from the equal leg angles.

### **7.2.6.5.2 End Bearing Diaphragms**

For the design of simple and continuous bridges of moderate length supported by two or more single cell boxes, **LRFD** requires internal diaphragms at each support to resist transverse rotation, displacement and distortion. Intermediate cross members for these types of bridges are not required. If plate diaphragms are used, they shall be connected to the webs and flanges of the section. Access holes shall be provided.

## **7.2.7 Lateral Bracing**

### **7.2.7.1 Requirements for I-Shaped Members**

#### **7.2.7.1.1 Design Requirements**

For I-Shaped members, the need to laterally brace the bottom flanges shall be investigated as per **LRFD**. Lateral bracing should be avoided whenever possible. Reducing the cross frame spacing or modifying flange plate dimensions shall be considered when attempting to eliminate the bracing.

Bracing members, if required, shall be designed to satisfy lateral wind load stresses and slenderness ratio,  $KL/r$ , requirements. The allowable fatigue stress ranges shall not be exceeded at the connections. Warren type patterns with single members is recommended.

### **7.2.7.1.2 Detailing Requirements**

Bracing members shall typically consist of equal leg angles or WT sections attached to the flange or web via gusset plates, clip angles or WT sections. Gusset plates shall be bent to accommodate the difference in elevation between girders. If it is not practical to make connections to the flange, then connections shall be made to the web. Flange connections shall not interfere with the web to flange welds.

The minimum thickness of gusset plates shall be 9/16 inches. The minimum size angle used as a connecting or bracing member shall be L 4 x 4 x 5/16. Angles with unequal legs should not be used.

The need to temporarily brace the compression flange for stability during erection shall be investigated. This can be accomplished with intermediate diaphragms.

### **7.2.7.2 Requirements for Box Girders**

#### **7.2.7.2.1 Design Requirements**

For box girders, generally no external lateral bracing should be required between the box sections. To increase the torsional stiffness of an individual box section during fabrication, erection and placement of the slab, permanent, internal lateral bracing either full or partial length shall be placed at or near the plane of the top flanges.

Bracing members and their connections shall be similar to those for I-Shaped members. The bracing shall be designed to resist the shear flow across the top of the section, satisfying stress and slenderness ratio requirement. Warren type bracing without transverse members should be considered because of efficiency. X-bracing patterns should be avoided for economy.

Allowable fatigue stress ranges shall not be exceeded where the gusset plate attaches to the flange or web.

### **7.2.8 Stiffeners**

#### **7.2.8.1 Bearing Stiffeners**

##### **7.2.8.1.1 Design Requirements**

Rolled Beams - Bearing stiffeners are generally not required, but shall be provided when the web shear stress at the reaction exceeds that permitted by AASHTO. The full beam depth times the web thickness shall be used to compute the shear stress. When bearing stiffeners are required, their design shall follow the provisions for plate girders.

Plate Girders - Bearing stiffeners shall be placed at all bearing locations and other locations supporting concentrated loads.

When computing the AASHTO allowable compressive stress for the stiffener plates, a value of 0.75 shall be used for the effective length factor, K.

The stiffener plate to web fillet welds shall be designed to satisfy the total reaction and the **AWS D1.5**. The weld size shall not be less than 5/16 inches. For skewed plates, the **AWS D1.5** design requirements for skewed joints should be considered when sizing the welds.

#### **7.2.8.1.2 Detailing Requirements**

To simplify fabrication, the stiffener plates on any one structure should have the same width and thickness. The minimum thickness of a stiffener plate shall be 9/16 inches.

Stiffener plates which act as connection plates shall be fillet welded to the top flange and milled to bear and fillet welded to the bottom flange. To avoid possible warping of the bottom flange, complete penetration groove welds should not be used to attach the plate to the flange. When the plates are welded to the tension flange at interior supports of continuous bridges, the allowable fatigue stress range shall not be exceeded (see **BDM** [7.2.4]).

When the bearing stiffeners consist of two pairs of plates, they shall be offset sufficiently to permit proper welding.

The stiffener plates shall be placed symmetrically over the bearings and be vertical after the application of full dead loads.

### **7.2.8.2 Intermediate Transverse Stiffeners**

#### **7.2.8.2.1 Design Requirements**

The design of intermediate transverse stiffeners shall be according to the **LRFD**.

If intermediate stiffeners are used, they shall be designed for one side of the web only, for reasons of economy.

#### **7.2.8.2.2 Detailing Requirements**

To simplify fabrication, the stiffener plates on any one structure should have the same width and thickness. The minimum thickness of a stiffener plate shall be 9/16 inches.

Intermediate stiffeners not supporting concentrated loads shall be detailed with a tight fit against the compression flange and cut short at the tension flange. This will greatly reduce the amount of labor for the installation of the stiffener. For stiffeners that are also used as diaphragm connection plates, the requirements for diaphragm connection plates shall be followed.



The intermediate stiffeners shall be detailed on one side of the web. The use of intermediate stiffeners on the outside face of exterior girders is not acceptable.

For details, see **BDM** [Division 3].

### **7.2.8.3 Longitudinal Stiffeners**

#### **7.2.8.3.1 Design Requirements**

The design of longitudinal stiffeners shall be according to the **LRFD**. Generally, the use of longitudinal stiffeners is discouraged. Longitudinal stiffeners are generally not economical for spans less than 300 feet. If longitudinal stiffeners are used, for reasons of economy, they shall be designed for one side of the web only. Butt splices in longitudinal stiffeners shall be made before attachment to the web, and tested by the ultrasonic method.

#### **7.2.8.3.2 Detailing Requirements**

Longitudinal stiffeners shall be welded to the web plates and cut back 3/4 inches when interrupted by connection plates and bolted splices. The longitudinal stiffener need not be made continuous across bolted splices.

### **7.2.9 Connections and Splices**

#### **7.2.9.1 General**

Shop connections may be made by either bolting or welding. Generally, all field connections should be made with high strength bolts. The use of field welding is discouraged due to difficulties with achieving proper coatings in the field. Welded field splices are not allowed.

#### **7.2.9.1.1 Design Requirements**

All bolted connections shall be designed as slip critical connections in accordance with **AASHTO LRFD**. Connections on uncoated bridges and coated bridges shall be designed with Class B surface conditions. Connections on Metallized bridges shall be designed with Class B surface conditions and shall be unsealed only at the connection. Connections on galvanized bridges shall be designed with Class C surface conditions.

In general, connections shall be designed with 7/8 inch diameter ASTM F3125 Grade A325 high strength bolts.

#### **7.2.9.1.2 Detailing Requirements**

The bolt diameter, hole size, bolt spacing and edge distances shall be shown on the plans. The type of connection (slip critical) and the class of faying surfaces (Class B or C) shall be specified on the plans.

To facilitate steel erection, only one type and diameter of bolt should be specified on any one bridge. Splices should be designed as though oversized holes were to be used to allow reaming in the field to facilitate fit-up. However, standard sized holes shall be specified on the plans.

### **7.2.9.2 Bolted Splices**

#### **7.2.9.2.1 Detailing Requirements**

The bolt diameter, hole size, bolt spacing and edge distances shall be shown on the plans. The minimum thickness of web and flange splice plate shall be 9/16 inches. Splice plates shall be detailed with a minimum edge distance of 2 inches. The maximum distance between the ends of the members being spliced shall be 1 inch.

Location of shop and field splices is dependent upon such factors as design criteria, available length of plates and members, transportation of members, erection and site limitations, etc. Refer to **BDM** [1.3] on the transportation of members for additional information and guidance.

### **7.2.9.3 Cross Member Connections**

#### **7.2.9.3.1 Design Requirements**

The design of the connection of cross members shall be consistent with the design of the members being attached. The connections for the end bearing cross members shall be designed for the shear due to dead and live loads plus impact.

For intermediate diaphragm connections, the number of bolts should be kept to 4 on each side of the diaphragm. In all cases, the number of bolts should be kept to a minimum.

#### **7.2.9.3.2 Detailing Requirements**

In general, when detailing bolted connections, the size, number and general layout of the bolts should be shown. Bolt hole spacing and edge distances should be left to the fabricator.

Holes for end diaphragm connections shall be located parallel to the main member's web. Standard sized holes shall be used in the cross members while oversized holes, unless otherwise noted, shall be used in the stiffener or connection plates. At one side of a cross member, standard sized holes field drilled through the stiffener or connection plate may be used as an alternate method for erection.

Long slotted holes in the stiffener or connection plates shall be considered for erection of intermediate cross members for girders adjacent to a stage construction line.

For bridges with skews more than 20 degrees, when the differential dead load deflection of adjacent girders at any intermediate cross member connection is 3/4 inches or more, long slotted holes shall be detailed in the stiffener or connection plates attached to the girder with the larger deflection. The following note should appear on the plans when long slotted holes are used:

<p>Bolts in long slotted holes shall only be finger-tightened prior to pouring the deck slab and then fully-tightened immediately after completing the pour.</p>
--

Gusset plates shall be made rectangular to simplify fabrication.

Shop welds shall be made on one side, as much as practical, to avoid having to turn over the cross member assemblies in the fabricating shop.

## **7.2.10 Composite Construction**

### **7.2.10.1 Design Requirements**

All structural members in contact with and supporting a concrete deck shall be designed for composite action.

In general, 7/8 inch diameter stud type shear connectors shall be used for composite construction. Spirals, angles or channel shear connectors are not permitted.

### **7.2.10.2 Detailing Requirements**

The minimum height shear connector is 4 inches. The maximum height of unstacked shear connectors is 8 inches. Stacked shear connectors shall be used at the locations where the haunch depth exceeds 6 inches.

Shear connectors are typically welded to the members in the field. Field welding through a mist coat of up to 2 mils of zinc primer is permissible.

Only the diameter of the shear connectors shall be shown on the plans. Shear connector heights shall not be shown on the plans. The heights shall be determined after the erected members have been surveyed and the haunch depths calculated.

On flange splice plates, one row of shear connectors shall be placed along the centerline of the splice plates.

## 7.2.11 Dead Load Deflection and Cambers

### 7.2.11.1 Simple Span Bridges

Dead load deflection and camber diagrams are not required for simple span bridges. Dead load deflections and cambers shall be calculated at the mid-span of the structure for the following listed items for each member and tabulated on the plans:

1. Structural Steel Deflections. Deflections due to the weight of the beams or girders, including the diaphragms and bracing and calculated using the moment of inertia of the steel section.
2. Additional Dead Load Deflections. Deflections due to the uncured concrete slab and haunches, utilities, and any other loads supported by the steel section alone. These deflections shall be calculated using the moment of inertia of the steel section.
3. Composite Dead Load Deflections. Deflections due to the parapets, curbs, sidewalks, railings, bituminous concrete overlay and any other loads that are placed after the slab has cured. This deflection shall be calculated using the moment of inertia of the composite section with a modular ratio equal to 3 times that of the final section as outlined in the **LRFD**.
4. Total Dead Load Camber. Camber required to compensate for the summation of the structural steel, slab dead load and the composite dead load deflections listed above.
5. Vertical Curve Ordinate Camber. Camber required when the member falls within the limits of a summit vertical curve. When the member falls within the limits of a sag vertical curve, provisions for sag ordinates must be made within the concrete haunch and shall not be specified in the camber table.
6. Extra Camber. Extra camber shall be provided when the grade of the roadway is on a tangent grade or on a sag vertical curve and is computed as follows:
  - Extra Camber (inch) =  $L / 100$ , where:  $L$  = Span Length (feet)

When the roadway is on a crest vertical curve, the extra camber is to be specified only when it exceeds the vertical curve ordinate. In this case, the amount of extra camber to be tabulated shall be only that portion in excess of the vertical curve ordinate.

7. Total Camber. The Total Camber is equal to the summation of all calculated cambers and is that dimension to which the member is to be fabricated.

For a table for the dead load deflections and cambers, see **BDM** [Division 3].

### **7.2.11.2 Continuous Span Bridges**

Dead load deflections and cambers shall be tabulated for the following listed items for each member and shown on the plans. The locations tabulated shall be the member bearing points and points at equal spaces along the member at approximately 10 feet on center:

- Structural Steel Deflections: Same as for simple span bridges.
- Additional Dead Load Deflections: Same as for simple span bridges.
- Composite Dead Load Deflections: Same as for simple span bridges except that composite section properties should be used for both positive and negative moment regions.
- Total Dead Load Camber: Same as for simple span bridges but measured to a reference line, which is a theoretical straight line in each span connecting the points located at the top of the web at the centerlines of bearing.
- Vertical Curve Ordinate Camber: Same as for simple span bridges.
- Extra Camber: Extra camber shall not be provided for continuous bridges.
- Total Camber: The Total Camber is equal to the summation of all calculated cambers and is that dimension to which the member is to be fabricated.

For a table for the dead load deflections and cambers, see **BDM** [Division 3]. A diagram for dead load deflection shall not be shown. A total camber diagram shall be shown on the plans. For details of a total camber diagram, see **BDM** [Division 3].

### **7.2.12 Bearings**

For bearing requirements, see **BDM** [9].

### **7.2.13 Superstructure Jacking Requirements**

#### **7.2.13.1 Design Requirements**

Provisions for jacking of the superstructure shall be provided at all locations that have bearings that will require future maintenance. These bearings include all types other than fixed bearings.

##### **7.2.13.1.1 New Construction**

At abutments, preference shall be given to widening of the bridge seat and providing auxiliary jacking stiffeners so that jacks may be placed in front of the bearing to jack

under the beam. Provision for massive diaphragms, which restrict access to the ends of the beam and backwalls should be avoided.

At piers with continuous caps, preference shall be given to designing diaphragms for jacking forces and providing auxiliary pads on pier caps.

Other unusual situations (i.e., piers consisting of individual columns under each girder) will require special study and may require provisions for jacking from ground level.

#### **7.2.13.1.2 Rehabilitation Projects**

For superstructure replacements, jacking provisions shall be provided only if economically viable. Jacking requirements should not be allowed to justify major substructure modifications where the substructures are otherwise adequate.

Lift points shall be located adjacent to the bearings and may be on main or secondary members. Preferably, lift points shall be over the bridge seats of abutments and the tops of piers so that jacks may be founded on these components minimizing the need for extensive temporary structures.

The jacking lift points shall be designed for the total dead load and the live load plus impact. If there are more than 5 lines of girders, the jacking lift points shall be designed for 150% of these values in order to jack individual girders in the future.

Superstructure and substructure members and components shall be strengthened as required to support the jacking loads.

#### **7.2.13.2 Detailing Requirements**

Lift points shall be clearly identified on the plans. The dead and live loads required to jack the bearing shall also be shown on the plans. If there are more than five lines of girders, two sets of loads shall be shown. The loads shall be for simultaneous jacking of all girders, and for jacking of individual girders. Additional stiffeners or brackets, if required, shall be shown on the plans.

#### **7.2.14 Inspection Hand Rails**

When girders are 5 feet or more in depth, a safety hand bar shall be provided 42 inches above the bottom flange for inspection access on both sides of all girders except the outside face of fascia girders. The bar shall have a minimum diameter of 1 inch and shall be designed for a minimum point load of 270 pounds.

## **7.3 STRUCTURE TYPE SPECIFIC REQUIREMENTS**

### **7.3.1 Rolled Beams**

The use of rolled beams should be investigated for appropriate span lengths since the cost of fabrication is significantly lower than equivalent I-shaped plate girders.

If cover plates are used on rolled beams, the width of the cover plate shall be narrower than the flange. The minimum thickness of a cover plate shall be 9/16 inches. The ends of the cover plates shall be rectangular in shape with rounded corners. Tapered end cover plates are not permitted. The attachment of cover plates to rolled beams shall be made with fillet welds. Rolled beams with cover plates, if used, shall be designed for fatigue. See **BDM** [7.2.4].

All fillet welds connecting the cover plate to the beam shall be non-destructively tested by the magnetic particle method.

The plans shall clearly state that, if the cover plate is fabricated by butt welding two or more plates together, the butt welds shall be non-destructively tested by the ultrasonic tested prior to attaching the cover plate to the beam.

### **7.3.2 I-Shaped Plate Girders**

#### **7.3.2.1 Hybrid Girders**

The design of hybrid I-shaped plate girders should be avoided.

#### **7.3.2.2 Web Plates**

The minimum thickness of web plates shall be 3/8 inches. Web plate depths shall be specified in 2 inch increments.

In general, for plate girders with web depths less than 50 inches, unstiffened webs are more economical. For web depths greater than 50 inches, the following alternates shall be investigated for the web design to determine which is the most cost effective:

- a. Fully stiffened web with minimum web plate thickness.
- b. Unstiffened web.
- c. Partially stiffened web with only a few stiffeners near supports.

In order to determine which of these alternates is most cost effective, the 1 to 4 rule should be used. That is, if the web and flange material costs \$1 per pound, then the connection plate material costs \$4 per pound.

### **7.3.2.3 Flange Plates**

The minimum thickness of flange plates shall be 3/4 inches to eliminate warping of the plates when they are welded to the web. The flange plate widths shall be specified in 2 inch increments.

To minimize potential stability problems during various phases of construction, the minimum width of flange plates shall be determined based on the maximum of the following:

- a. the length of the unsupported field piece divided by 85, or
- b. 12 inches.

Flange width transitions shall generally be avoided. Flange plate thickness should be varied instead. At flange plate transitions, the thickness of the thinner plate shall not be less than 1/2 the thickness of the thicker flange.

The number and spacing of flange plate thickness transitions should be based on the total cost of the finished girder. While numerous flange transitions will produce the lightest girder, the fabrication costs for the splices may result in a higher total cost. The designer should investigate eliminating flange transitions, especially where they are closely spaced. As a rule, the approximate weight of flange material that should be saved in order to justify the introduction of a flange transition is as follows:

$$M = 255 + 21A$$

M = Weight of steel, pounds

A = Cross sectional area of thinner flange plate, square inches

In order to eliminate shop welded butt splices, field splices should be located at flange plate transitions.

### **7.3.2.4 Shop Splices**

Shop flange splices shall be located a minimum of 6 inches from web splices.

Both web and flange splices shall be located a minimum of 6 inches from stiffeners and connection plates.

This information on web and flange plate shop splices shall be shown on the plans.

## **7.3.3 Box Girders**

### **7.3.3.1 Hybrid Girders**

The design of hybrid box girders should be avoided.



### **7.3.3.2 Web Plates**

The minimum thickness of web plates shall be 3/8 inches. Web plate depths shall be specified 6 inch increments.

### **7.3.3.3 Flange Plates**

The minimum thickness of flange plates shall be 3/4 inches to eliminate warping of the plates when they are welded to the web. A maximum flange plate thickness of 3 inches shall be used for box girders.

The minimum is 2 inch increments.

Flange width transitions shall generally be avoided. Flange plate thickness may be varied instead. At flange plate transitions, the thickness of the thinner plate shall not be less than 1/2 the thickness of the thicker flange.

The number and spacing of flange plate thickness transitions should be based on the total cost of the finished girder. While numerous flange transitions will produce the lightest girder, the fabrication costs for the splices may result in a higher total cost. The designer should investigate eliminating flange transitions, especially where they are closely spaced. As a rule, the approximate weight of flange material that should be saved in order to justify the introduction of a flange transitions is as follows:

$$M = 255 + 21A$$

M = Weight of steel, pound

A = Cross sectional area of thinner flange plate, square inches

In order to eliminate a shop welded butt splice, field splices should be located at flange plate transitions.

### **7.3.3.4 Shop Splices**

Shop flange splices shall be located a minimum of 6 inches from web splices.

Both web and flange splices shall be located a minimum of 6 inches from stiffeners and connection plates.

This information on web and flange plate shop splices shall be shown on the plans.

### **7.3.3.5 Bolted Field Splices**

Where bolted field splices are called for, the splice shall be detailed to provide adequate clearance for bolting the connections at the acute corners between the top flange and the web for both bolts and splice plates.

### **7.3.3.6 Fabrication Requirements**

A minimum distance of 1 inch shall be provided between the outside face of the web and the edge of the bottom flange as a holding shelf for the flux deposited by the welding machine. At web stiffeners, provide a 1/2 inch clearance above a line 60 degrees from the bottom flange to accommodate a traveling welding machine.

### **7.3.3.7 Access Manholes**

Access manholes shall be provided in the end or bottom flange of box girders. These manholes shall be located and detailed such that bridge inspectors can gain access without the need for special equipment. The distance between the end diaphragm and the backwall should be increased to a minimum of 2 feet when access is provided in the end diaphragms of box girders. For access through the bottom flange, ladder supports shall be incorporated. The preferred location for access is through the ends of the boxes.

The manholes shall have rounded corners fitted with a hinged cover and provided with an appropriate locking system and all access doors shall open inward. When access is provided through the end diaphragms, the access door should be covered with a steel wire mesh to allow ventilation. If access manholes are provided through the bottom flange, the access doors should be designed to be lightweight. Access holes shall be provided through all solid diaphragms.

Stresses resulting from the introduction of access holes in steel members shall be investigated and kept within all allowable limits.

### **7.3.3.8 Stay-In-Place Forms**

Box girders shall be designed for the additional weight of remain-in-place forms placed within the boxes to form the deck slab.

### **7.3.3.9 Drainage**

In order to provide drainage of the inside of the box girder, 2 inch minimum diameter drains shall be provided at the low end of the girder. The corners of all plates should be clipped so as not to trap moisture inside the girder. Bridge deck drainage may extend vertically through the girder but shall not be carried longitudinally within it.

### **7.3.3.10 Utilities**

Gas, water and sewer lines are prohibited from being located within box girders. Electric, telephone and cable companies should be discouraged from locating their lines within the boxes. All utilities can generally be accommodated outside of and between the girders.

### **7.3.4 Curved Girders (Includes rolled beams, plate girders and box girders)**

When designing curved girder structures, designers must investigate all temporary and permanent loading conditions, including loading from wet concrete in the deck pour, for all stages of construction. Future re-decking must also be considered as a separate loading condition. Diaphragms must be designed as full load carrying members. A three-dimensional analysis representing the structure as a whole and as it will exist during all intermediate stages and under all construction loading conditions is essential to accurately predict stresses and deflections in all girders and diaphragms and must be performed by the designer.

The designer is responsible for assuring that the structure is constructable and that it will be stable during all stages and under all loading conditions. To achieve this end, the designer must supply basic erection data on the contract plans. This information must include, but is not limited to, the following:

- Pick points and reactions at pick points for all girder sections.
- Temporary support points to be used during all stages and loading conditions, and reactions for which support towers should be designed at all of these points.
- Deflections to be expected in all girders under all conditions of temporary support and under all anticipated loading conditions.
- Direction pertaining to the connection of diaphragms to assure stability during all temporary conditions.

Specifications prepared for this work must require the Contractor to submit full erection plans, prepared and stamped by a Professional Engineer registered in the State of Connecticut, for review by the **CTDOT**. These plans will be reviewed by the designer as a working drawing and comments forwarded from the Office of Engineering to the District Engineering Manager having jurisdiction over the project for transmittal to the Contractor. The designer's review must ensure that all information given on the Contract plans has been accurately accounted for in the Contractor's erection plans.

The designer shall provide any such additional information, up to and including full erection plans in the Contract documents as directed by the **CTDOT**.

Further design information for curved structures is contained in the *AASHTO Guide Specifications for Horizontally Curved Steel Girder Highway Bridges*.

### **7.3.5 Through-Girders**

Vacant

**7.3.6 Trusses**

Vacant

**7.3.7 Rigid Frames**

Vacant

**7.3.8 Pin and Hanger Structures**

The design of pin and hanger structures is not allowed.

**7.3.9 Steel Piers and Pier Caps**

Vacant

**7.3.10 Railway Bridges**

Vacant

This Page is Intentionally Left  
Blank

**SECTION 8**  
**DECKS AND DECK PROTECTIVE SYSTEMS**

**TABLE OF CONTENTS**

8.1 DECK TYPES .....	8-1
8.1.1 General.....	8-1
8.1.2 Cast-In-Place Concrete Decks .....	8-1
8.1.2.1 Materials ( <i>Rev. 04/19</i> ).....	8-1
8.1.2.2 Design ( <i>Rev. 12/19</i> ) .....	8-1
8.1.2.3 Minimum Slab Thickness ( <i>Rev. 03/05</i> ) .....	8-1
8.1.2.4 Haunches.....	8-1
8.1.2.5 Reinforcement Details .....	8-2
8.1.2.5.1 Main Reinforcement Placed Perpendicular to Traffic .....	8-2
8.1.2.5.2 Main Reinforcement Placed Parallel to Traffic .....	8-2
8.1.2.5.3 Cover Requirements ( <i>Rev. 03/05</i> ).....	8-2
8.1.2.5.4 Splices .....	8-2
8.1.2.5.5 Tie Down Bars .....	8-2
8.1.2.6 Construction Joints.....	8-3
8.1.2.7 Forming ( <i>Rev. 04/19</i> ).....	8-3
8.1.2.8 Deck Pouring Sequence .....	8-3
8.1.3 Adjacent, Transversely Post-Tensioned, Prestressed Box Members ( <i>Rev. 04/19</i> ).....	8-4
8.1.4 Precast Concrete Deck Panels.....	8-4
8.1.5 Bridge Grid Decking.....	8-4
8.1.6 Aluminum Bridge Decks .....	8-4
8.2 DECK PROTECTIVE SYSTEMS .....	8-4
8.2.1 Highway Bridges .....	8-4
8.2.1.1 General.....	8-4
8.2.1.2 Concrete Decks ( <i>Rev. 04/19</i> ) .....	8-4
8.2.1.3 Other Deck Types .....	8-6
8.3 FINISHED DECK AND GRADE ELEVATIONS .....	8-6
8.3.1 General.....	8-6
8.3.2 Finished Deck Elevations ( <i>Rev. 04/19</i> ).....	8-6
8.3.3 Finished Grade Elevations .....	8-6

This Page is Intentionally Left  
Blank

## **SECTION 8** **DECKS AND DECK PROTECTIVE SYSTEMS**

### **8.1 DECK TYPES**

#### **8.1.1 General**

A deck is defined as a component, with or without a wearing surface, which supports wheel loads directly and is supported by other components.

#### **8.1.2 Cast-In-Place Concrete Decks**

##### **8.1.2.1 Materials** *(Rev. 04/19)*

Refer to **BDM** [6].

##### **8.1.2.2 Design** *(Rev. 12/19)*

The design of cast-in-place reinforced concrete decks using the empirical design method described in the **LRFD** [9.7.2] is not permitted.

Cantilever deck overhangs shall be designed in accordance with **BDM** [12] for railing loads. For deck overhang limits, see **BDM** [6] and [7].

##### **8.1.2.3 Minimum Slab Thickness** *(Rev. 03/05)*

The minimum thickness of a cast-in-place concrete deck slab shall be 8.5 inches. The cover to the top mat of reinforcement shall be 2.5 inches. The top 0.5-inch shall be included in calculations as dead load only. It should be assumed to be sacrificial and not included as a permanent part of the deck for design purposes.

##### **8.1.2.4 Haunches**

The minimum haunch depth shall be 1 inch (2 inches for prestressed bulb tees) measured from the top of the top flange of the member to the bottom of the slab. For members with splices, the top of the member shall be the top of the splice plate. A deeper haunch may be required when the width of the top flange of a member exceeds 1.33 feet due to the cross slope of the slab. Changes in flange plate thicknesses and allowable camber tolerances shall be taken into consideration when determining the haunch depth to use in calculations.

Haunches with thicknesses less than 4 inches do not require reinforcement. Haunches with thicknesses from 4 inches to 6 inches shall be reinforced as shown in **BDM** [Division 3]. Reinforcement for haunches with thicknesses greater than 6 inches shall be detailed by the designer.



### **8.1.2.5 Reinforcement Details**

#### **8.1.2.5.1 Main Reinforcement Placed Perpendicular to Traffic**

For decks with a skew angle less than or equal to 20 degrees, the main reinforcement shall be placed on the skew. For decks with skew angles greater than 20 degrees, in general the main reinforcement shall be placed perpendicular to the centerline of the structure.

At acute corners of the deck, when the skew angle exceeds 20 degrees, additional reinforcement shall be placed parallel to the end of the slab with appropriate increase in slab thickness.

Additional distribution reinforcement shall be placed midway between the top and bottom longitudinal bars at the end of decks. The bar size and length shall be as follows:

- for spans up to 50 feet.....Use #5 x 5 feet
- for spans over 50 feet and up to 80 feet .....Use #5 x 8 feet
- for spans over 80 feet.....Use #5 x 10 feet

#### **8.1.2.5.2 Main Reinforcement Placed Parallel to Traffic**

Main reinforcement parallel to traffic shall be designed in accordance with **LRFD**.

#### **8.1.2.5.3 Cover Requirements (Rev. 03/05)**

The minimum concrete cover over top reinforcement shall be 2.5 inches. The minimum concrete cover over bottom reinforcement shall be 1 inch.

#### **8.1.2.5.4 Splices**

Splices for all deck reinforcement, both longitudinal and transverse, shall be shown on the plans. A minimum of 1 splice shall be detailed for the transverse reinforcement. The use of mechanical connectors to splice reinforcement is permitted when lap splices cannot be accommodated and more than 1 inch of cover is provided. For additional information, see **BDM** [6].

#### **8.1.2.5.5 Tie Down Bars**

Tie down bars aid in supporting and anchoring the mats of deck reinforcement. Tie down bars shall be shown on the plans.

### **8.1.2.6 Construction Joints**

Construction joints to facilitate deck construction are permitted. Transverse construction joints are typically required when a sequence of pours is necessary. Longitudinal construction joints may be required for stage construction. Decks adjacent to construction joints shall be properly designed and supported for all loading conditions. The members supporting the deck adjacent to the construction joints shall also be investigated to ensure that they are adequate for all loading conditions. Closure pours may be detailed for stage construction conditions where large differential deflection is anticipated.

### **8.1.2.7 Forming (Rev. 04/19)**

Typically, forms for the construction of cast-in-place concrete bridge decks may be removable or stay-in-place metal forms. Prestressed concrete stay-in-place forms may be used only with the written approval of the **CTDOT**.

The use of stay-in-place metal forms is permitted in all but the following locations:

- Under cantilever slabs such as the overhang outside of fascia girders.
- Under longitudinal deck joints between median girders
- A bridge less than 15 feet above mean high water level of a salt-laden body of water.

For all bridges where stay-in-place metal forms are permitted, the designer shall include the provision in his design calculations for the stay-in-place metal forms. All affected members shall be designed to carry the additional dead load of the stay-in-place forms. Lightweight foam filler shall be used to fill valleys of the stay-in-place forms. The cover for the bottom reinforcements shall be measured from the top of the stay-in-place metal forms. Welding of stay-in-place metal form supports to tension zones in girder top flanges is not allowed. The Designer shall clearly identify on the structural steel plans all top flange tension zones where welding of stay-in-place form supports is not permitted.

For all bridges for which stay-in-place metal forms are permitted, girder deck load deflection and camber calculations shall include the estimated weight of stay-in-place forms with foam valley fillers. Where stay-in-place metal forms are provided, the designer must note the assumed uniform weight of the stay-in-place metal forms on the bridge plans.

### **8.1.2.8 Deck Pouring Sequence**

For bridges with continuous members, cast-in-place concrete decks shall be placed in sequence. The sequence of pouring concrete shall be shown on the plans and include the following:

- sections in which the deck is to be poured,
- sequence in which the sections are to be poured,

- direction of pouring each section, and
- minimum compressive strength the concrete in each section must obtain prior to placing concrete in other sections.

Additionally, the following note shall be shown on the plans:

A deck pouring sequence different from that shown may not be used without the prior approval of the Engineer.
---

### **8.1.3 Adjacent, Transversely Post-Tensioned, Prestressed Box Members** (Rev. 04/19)

Vacant

### **8.1.4 Precast Concrete Deck Panels**

Vacant

### **8.1.5 Bridge Grid Decking**

Vacant

### **8.1.6 Aluminum Bridge Decks**

Vacant

## **8.2 DECK PROTECTIVE SYSTEMS**

### **8.2.1 Highway Bridges**

#### **8.2.1.1 General**

The decks of all bridges, both new and rehabilitated, shall be protected from damage, deterioration and corrosion due to deicing salts.

#### **8.2.1.2 Concrete Decks (Rev. 04/19)**

The preferred method to protect cast-in-place and precast concrete decks consists of using galvanized reinforcement and a membrane waterproofing protected with a bituminous concrete overlay.

The standard membrane waterproofing shall be "Membrane Waterproofing (Cold Liquid Elastomeric)." The membrane waterproofing for existing bridge decks with an anticipated remaining life of less than 20 years may be "Membrane Waterproofing (Woven Glass Fabric)."

If during construction, a temporary condition is required to restore traffic, the following shall apply:

- Temporary pavement is required
  - Not intended for winter shutdown
    - Apply bond breaker to deck and apply temporary pavement
    - For final pavement, remove temporary pavement and apply “Membrane Waterproofing (Cold Liquid Elastomeric)”
  - Intended for winter shutdown
    - Apply “Penetrating Sealer Protective Compound” to concrete, bond breaker and temporarily pave.
    - In spring, remove temporary overlay, apply “Membrane Waterproofing (Cold Liquid Elastomeric)”
- Temporary pavement is not required
  - Allow traffic to ride on bare deck and/or aggregated “Membrane Waterproofing (Cold Liquid Elastomeric).” Pave as soon as possible.

This membrane shall be protected by a bituminous concrete overlay. The minimum thickness of the bituminous overlay atop the membrane waterproofing shall be 3 inches on all new bridges as well as all existing bridges that have adequate load carrying capacity. The designer shall consult with the **CTDOT** for final verification of pavement type and determination of Traffic Level for the top course.

Existing bridges that do not have adequate load carrying capacity for a 3-inch overlay shall receive a 2.5-inch thick bituminous concrete overlay. The designer shall consult with the **CTDOT** for final verification of pavement type and determination of Traffic Level for the top course.

On new decks where it is necessary to increase the overlay thickness to obtain the proper profile and cross-slope, such as bridges composed of adjacent box members, the bituminous overlay shall have a top and bottom course, and an intermediate wedge course. The bottom course of bituminous concrete shall be a uniform 1-inch thick. The intermediate wedge course shall vary in thickness to achieve the desired profile and cross-slope. A detail and/or note shall be included on the plans providing pavement lift requirements for intermediate wedge courses. The top or finish course shall be a uniform 2-inch thick. The hot mix asphalt mix design to be used for the intermediate wedge course will be determined by the **CTDOT** based on the minimum and maximum thicknesses required.

Weepholes shall be provided in cast-in-place concrete decks to drain the membrane and overlay interface. Weepholes shall be placed along gutterlines adjacent to deck joints at the low end of spans on the low side of cross slopes. Weepholes shall outlet on the inside of fascia members. The outlet pipe of the weephole shall be extended as required so as not to drain onto the superstructure members and components. Weepholes shall not be located over travel lanes, shoulders, sidewalks, parking areas, or in spans over railroad tracks. Where easily achieved during rehabilitation projects, existing weepholes should be

plugged and paved over when not in accordance with these requirements.

Other methods to protect concrete decks such as using a cathodic protection system or latex modified concrete may only be used with the written approval of the **CTDOT**.

### **8.2.1.3 Other Deck Types**

Vacant

## **8.3 FINISHED DECK AND GRADE ELEVATIONS**

### **8.3.1 General**

All elevations necessary for construction of the deck and placement of the bituminous concrete overlay shall be shown on the plans.

Bridges located at merging and diverging roadways shall be carefully detailed with the dimensions and elevations necessary for construction.

### **8.3.2 Finished Deck Elevations (Rev. 04/19)**

For cast-in-place concrete decks, finished deck elevations and member deflections shall be tabulated at member bearing points and at points equally spaced along the members at approximately ten feet on center or at tenth points along the span, whichever is greater. The finished deck elevations are those elevations on the top of the concrete deck. The tabulated member deflections are those deflections due to all dead loads except the selfweight of the members and cross members. These elevations and deflections are to be used to calculate haunch depths.

For precast concrete deck panels, deck elevations shall be tabulated at edges of the panels at the panel joints. The deck elevations are those elevations on the top of the concrete panel.

### **8.3.3 Finished Grade Elevations**

Finished grade elevations are those elevations on top of the final riding surface (such as the bituminous concrete overlay). On all bridges, the finished grade elevations shall be shown at the following points:

- the intersection of the point of application of grade line with the deck joints and ends of slabs,
- the intersection of the gutter lines with the deck joints and ends of slabs, and
- the intersection of the cross slope breaks at the shoulders with the deck joints and ends of slabs.

**SECTION 9**  
**BEARINGS**

**TABLE OF CONTENTS**

9.1 GENERAL (*Rev. 12/19*) ..... 9-1

    9.1.1 Skew Effects ..... 9-1

    9.1.2 Curvature Effects ..... 9-1

    9.1.3 Temperature Range ..... 9-2

    9.1.4 Coefficient of Thermal Expansion ..... 9-2

    9.1.5 Seismic ..... 9-2

    9.1.6 Single Span Bridges ..... 9-2

    9.1.7 Multi-Span Bridges ..... 9-2

9.2 BEARING SPECIFIC DESIGN REQUIREMENTS ..... 9-2

    9.2.1 Steel Reinforced Elastomeric Bearings (*Rev. 12/19*) ..... 9-2

        9.2.1.1 Steel Bridge Beams ..... 9-3

        9.2.1.2 Prestressed Concrete Bridge Beams ..... 9-3

    9.2.2 Cotton Duck Reinforced Bearings with PTFE Slider ..... 9-3

    9.2.3 High Load Multi-Rotation Bearings ..... 9-4

    9.2.4 Steel Fixed Bearings ..... 9-4

This Page is Intentionally Left  
Blank

## **SECTION 9** **BEARINGS**

### **9.1 GENERAL (REV. 12/19)**

Bearings are structural devices that transmit loads from the superstructure to the substructure. Bearings may also be required to allow for horizontal movement due to temperature and time dependent causes, allow rotation due to loads on the superstructure, and transmit seismic forces from the superstructure to the substructure. The selection and layout of bearings shall be consistent with the proper functioning of the bridge.

Bearings may be fixed or movable as required for the bridge design. Movable bearings may include guides to control the direction of translation. Fixed and guided bearings shall be designed to resist all loads and restrain unwanted translation. Keeper blocks may also be used to restrain some of these loads. When anchor bolts are required at bearings, stainless steel bolts shall not be used.

Combinations of bearing types should not be used at the same line of bearing. Differing deflection and rotational characteristics may result in damage to the bearings or structure.

Several bearing types are recommended below for different situations. Other bearing devices may be used, provided that they have been approved by the **CTDOT**.

#### **9.1.1 Skew Effects**

Provisions shall be made in the bearing design for both lateral and longitudinal movement based on the geometry of the deck, the layout of the deck expansion joints and keeper assemblies. For bridges with complicated deck configurations, a thermal expansion analysis of the deck should be done in order to determine the thermal movements relative to the bridge bearings. The geometry of the deck, not the structural framing, should be the basis for the expansion analysis. For narrow bridges where the effects are minimal, transverse expansion may be neglected.

#### **9.1.2 Curvature Effects**

For curved superstructures, provisions shall be made in the alignment of bearing guides and keeper blocks for both lateral and longitudinal movement based on the geometry of the deck and the layout of the deck expansion joints. Generally, the direction of movement of the superstructure may be assumed to be parallel to the chord of the deck centerline taken from the joint to the neutral point of the superstructure. The neutral point is defined as the point where no thermal movement occurs.



### **9.1.3 Temperature Range**

The temperature range used for the calculation of thermal movement at bearings shall be 120°F. This temperature range is based on a mean low temperature of -10°F and a mean high temperature of +110°F. The median temperature for design of bearings shall be +50°F.

### **9.1.4 Coefficient of Thermal Expansion**

For the design of bearings, a coefficient of thermal expansion ( $\alpha$ ) shall be taken as  $6.4 \times 10^{-6}$  inches per °F. This equates to approximately 2.75-inch total movement for a 300 foot long bridge.

### **9.1.5 Seismic**

If the bridge is designed for seismic events, the bearings may be designed to transmit seismic forces from the superstructure to the substructure. The movement due to seismic forces shall be accommodated in the design of the bearings. It is important that the bearing remain stable under the maximum anticipated bridge displacement during the seismic event. For requirements for the design of seismic isolation bearings, see **BDM** [3].

Rocker type bearings should not be used due to the high susceptibility of overturning during seismic events.

### **9.1.6 Single Span Bridges**

The design of single span bridges may be based on providing elastomeric expansion bearings at both ends of the superstructure if the grade of the roadway is less than 5%. The designer should incorporate keeper assemblies in order to maintain alignment of the superstructure. Designs of this nature will reduce the amount of expansion at the bearings and deck joints. For simple span bridges, with a fixed and an expansion bearing, the fixed bearing should be located at the low end of the structure.

### **9.1.7 Multi-Span Bridges**

The design and layout of bearings in multi-span bridges should be based on the design of the deck expansion joints, the capacity of the bearings to accommodate the anticipated loads and movement, and the seismic design of the substructure where applicable.

## **9.2 BEARING SPECIFIC DESIGN REQUIREMENTS**

### **9.2.1 Steel Reinforced Elastomeric Bearings (Rev. 12/19)**

Steel reinforced elastomeric bearings shall be the first bearing of choice for any bridge bearing due to the low initial cost and the low future maintenance costs. These bearings should be considered for low to moderate load situations.

Steel reinforced elastomeric bearings may be designed as either rectangular or round. Round elastomeric bearings should be considered where significant movement occurs in both the longitudinal and transverse direction.

If the shearing force in the bearing is less than 20% of the minimum vertical load on the bearing, the interface of the bearing and the concrete bearing seat should not be attached or bonded. For cases where the shearing force is greater, the following possibilities should be investigated:

- a. The bearing should be redesigned to attempt to reduce the shearing force.
- b. The bearing should be shop vulcanized under heat and pressure to a bottom steel plate that is anchored to the substructure.
- c. A PTFE slider type bearing can be considered.

Steel reinforced elastomeric bridge bearings shall only be designed with virgin neoprene not natural rubber.

Elastomeric bearings shall be unanchored to the substructure. When anchor bolts are required, holes for anchor bolts shall not pass through the elastomeric bearing. If anchor bolts are required, then the bolts shall be located outside the limits of the bearing.

#### **9.2.1.1 Steel Bridge Beams**

For the design of steel bridge beams, the top of the bearing should be vulcanized under heat and pressure to a steel top plate to facilitate installation. The top plate should be bolted to a beveled sole plate. Field welding should be avoided due to the possibility of damage to the elastomer during welding.

#### **9.2.1.2 Prestressed Concrete Bridge Beams**

For prestressed concrete bridge beams without steel sole plates, if the grade of the roadway is less than 5% the bearings may be manufactured with a sloping top surface provided that the internal steel reinforcement plates are parallel and level.

#### **9.2.2 Cotton Duck Reinforced Bearings with PTFE Slider**

Cotton Duck fabric reinforced elastomeric bearings should be considered for locations with low to moderate loads combined with moderate to high movement.

The movement due to expansion is accommodated between the PTFE and the slider plate. The PTFE material should be bonded to the top surface of the bearing. The slider plate shall be welded to a top plate or the beveled sole plate.

### **9.2.3 High Load Multi-Rotation Bearings**

High Load Multi-Rotational bearings should be considered for locations with moderate to high loads combined to moderate to high movement. The designer should not completely design high load multi-rotational bearings for each location; however, a preliminary design should be done to determine the rough overall dimensions of the bearing. The specifications for high load multi-rotational bearings require that the Contractor or his Fabricator design the specific bearings based on the type of bearing that is supplied.

The sealing rings used to secure the elastomer disc within the pot shall be round in cross section. Flat rings will not be allowed due to problems with leakage of the elastomer.

### **9.2.4 Steel Fixed Bearings**

Steel bearings may be used where no movement is necessary and where the only rotation is in the transverse axis of the bridge. A 0.125-inch thick, 90 durometer random fabric pad should be used to seat the steel masonry plate on the concrete substructure bearing pad. For steel bridge beams, the anchor bolts for the bearing should not pass through the flange of the beam.

**SECTION 10**  
**DECK JOINTS**

**TABLE OF CONTENTS**

10.1 GENERAL.....	10-1
10.1.1 Location of Joints.....	10-1
10.1.2 Skew Effects .....	10-1
10.1.3 Curvature Effects .....	10-1
10.1.4 Temperature Range.....	10-2
10.1.5 Coefficient of Thermal Expansion.....	10-2
10.1.6 Movement Due to Seismic Events.....	10-2
10.2 TRANSVERSE JOINTS ( <i>Rev. 04/19</i> ).....	10-2
10.2.1 Fixed Joints .....	10-2
10.2.2 Expansion Joints .....	10-2
10.2.2.1 Box Culverts and Rigid, Buried Structures.....	10-2
10.2.2.2 Span Bridges .....	10-2
10.2.2.2.1 Joints with Thermal Movement Range (TMR) up to ½ inch ( <i>Rev. 12/19</i> ) .....	10-2
10.2.2.2.2 Joints with Thermal Movement Range (TMR) above ½ inch up to 1 ½ Inches .....	10-3
10.2.2.2.3 Joints with Thermal Movement Range (TMR) above 1 ½ Inches up to 3 Inches .....	10-3
10.2.2.2.4 Joints with Thermal Movement Range (TMR) between 3 Inches and 4 Inches ( <i>Rev. 04/19</i> ) .....	10-5
10.2.2.2.5 Joints with Thermal Movement Range (TMR) > 4 Inches .....	10-5
10.2.2.2.5.1 Joints at Abutments.....	10-5
10.2.2.2.5.1.1 Modular Joints .....	10-5
10.2.2.2.5.1.2 Finger Joints.....	10-5
10.2.2.2.5.2 Joints at Piers .....	10-6
10.2.2.2.5.2.1 Modular Joints .....	10-6
10.2.2.2.5.2.2 Finger Joints.....	10-6
10.2.2.2.6 Joints at Skewed Bridges .....	10-6
10.2.2.2.6.1 Asphaltic Plug Expansion Joints.....	10-6
10.2.2.2.6.2 Preformed Silicone Joint Seals .....	10-6

Connecticut Department of Transportation Bridge Design Manual

10.2.2.2.6.2.1 V-shaped Silicone Joint Seals .....	10-6
10.2.2.2.6.2.2 Foam-Supported Silicone Joint Seals .....	10-7
10.3 LONGITUDINAL JOINTS .....	10-8
10.3.1 Deck Joints .....	10-8
10.3.2 Concrete Median Barrier .....	10-8
10.4 JOINT SPECIFIC DESIGN REQUIREMENTS .....	10-8
10.4.1 Asphaltic Plug Expansion Joint System .....	10-8
10.4.2 Elastomeric Concrete Headers with Preformed Joint Seal ( <i>Rev. 04/19</i> ) .....	10-8
10.4.3 Reinforced Concrete Headers with a Neoprene Strip Seal ( <i>Rev. 04/19</i> ) .....	10-8
10.4.4 Modular Expansion Joints.....	10-9

## **SECTION 10** **DECK JOINTS**

### **10.1 GENERAL**

The selection and layout of deck joints shall allow for deformations due to temperature and time dependent causes, be consistent with the proper functioning of the bridge, be able to stand up to vehicular live load, and provide a water tight seal to prevent roadway runoff from falling on the structural members below.

The number of movable deck joints in a structure should be minimized. Continuous deck/superstructure systems should be used and, where appropriate, integral bridges.

Several joint types are recommended below for different situations. Other joints may be used, provided that **CTDOT** has approved them.

#### **10.1.1 Location of Joints**

Deck joints should be avoided at or near points of sag vertical curves.

Deck joints at abutments shall be located behind the abutment backwall so that any leakage of the joint would not damage the structural elements below. An exception to this may be for modular joints where future maintenance is required. In this case, the joint may have to be placed in front of the backwall.

Generally, open finger joints shall only be used behind the abutment backwall where the water and debris can be intercepted by a concrete drainage structure. (See **BDM** [Division 3])

#### **10.1.2 Skew Effects**

Provisions shall be made in the joint design for both lateral and longitudinal movement based on the geometry of the deck and the design of bearings and keeper assemblies. For bridges with complicated deck configurations, a thermal expansion analysis of the deck should be done in order to determine the thermal movements relative to the bridge joints.

#### **10.1.3 Curvature Effects**

For curved superstructures, provisions shall be made in the joint design for both lateral and longitudinal movement based on the geometry of the deck and the design of bearings. Generally, the direction of movement of the superstructure may be assumed to be parallel to the chord of the deck centerline taken from the joint to the neutral point of the superstructure as defined in **BDM** [9.1.2].

#### **10.1.4 Temperature Range**

The temperature range used for the calculation of thermal movement of deck joints shall be 120°F. This temperature range is based on a mean low temperature of -10°F and a mean high temperature of +110°F. The median temperature for design of joints shall be +50°F.

#### **10.1.5 Coefficient of Thermal Expansion**

For the design of deck joints, a coefficient of thermal expansion shall be taken as  $6.4 \times 10^{-6}/^{\circ}\text{F}$ . This equates to approximately 2¾” total movement for a 300-foot long bridge.

#### **10.1.6 Movement Due to Seismic Events**

If the bridge is designed for seismic events where significant movement is important to the proper function of bridge elements (such as seismic isolation bearings), the movement due to seismic forces shall be accommodated in the design of the joints. For other bridges, the joint need not be designed for seismic movement, and should not be designed to survive the seismic event undamaged.

### **10.2 TRANSVERSE JOINTS (Rev. 04/19)**

#### **10.2.1 Fixed Joints**

**For fixed joints at abutments and piers, an asphaltic plug joint is preferable to a sawed and sealed joint.**

Although the asphaltic plug joint is more expensive than a sawed and sealed joint to install and is prone to rutting under heavy wheel loads and shoving under heavy braking forces, it handles settlement at abutments better and the exact placement of the joint is not so critical to its functioning.

#### **10.2.2 Expansion Joints**

##### **10.2.2.1 Box Culverts and Rigid, Buried Structures**

It is not recommended to install transverse joints in the pavement for buried structures.

##### **10.2.2.2 Span Bridges**

###### **10.2.2.2.1 Joints with Thermal Movement Range (TMR) up to ½ inch (Rev. 12/19)**

For thermal movement ranges up to ½ inch, it is not recommended to install transverse joints in the pavement for bridges with slab over backwall.

For all other situations, it is recommended to install asphaltic plug expansion joints as specified in **BDM** [12.2.2.2].

#### **10.2.2.2.2 Joints with Thermal Movement Range (TMR) above ½ inch up to 1 ½ Inches**

**For deck joints at or beyond the back of the abutment backwall, first consideration shall be given to specifying an asphaltic plug expansion joint. Include a table on the plans specifying the thermal movement range at all asphaltic plug joint locations.**

**For joints located over the bridge seat or over pin and hanger expansion devices, specify a preformed joint seal secured between elastomeric concrete headers. Include a table on the plans specifying three products and corresponding installation information.**

See the [Guide Sheets](#) for typical details. The Designer is responsible for modifying these sheets as applicable for each project. For guidance on selecting and specifying a preformed joint seal, see 10.2.2.2.1.

Where one or more of the following conditions exist, the asphaltic plug expansion joint may not be appropriate:

- Heavy wheels from trucks may cause rutting
- Frequent braking forces from traffic are likely to shove the pavement
- The span contributing to expansion exceeds 100 feet
- The skew of the joint, in combination with the thermal movement range, exceeds the manufacturer's recommendation for the joint
- The combined grade and cross slope of the roadway is greater than 6%

#### **10.2.2.2.3 Joints with Thermal Movement Range (TMR) above 1 ½ Inches up to 3 Inches**

**Specify a preformed joint seal secured between elastomeric concrete headers or between two concrete surfaces. Include a table on the plans specifying three products and corresponding installation information.**

To install a preformed joint seal, there must be a joint gap in which to secure the sealing gland. This gap may be formed between the following components:

- Deck ends
- A backwall and a deck end
- A deck end with a double backwall
- A deck end and an approach slab
- A deck end with an approach structure



- Two parapet ends
- Two sidewalks

The deck joint gap (the gap between the tops of headers, measured perpendicular to the joint) shall conform to the joint manufacturer's recommendations for depth of shelf, minimum gap and minimum gap at installation. The deck joint gap will vary, depending on temperature. The gap will be maximum when the temperature is at its lowest (assumed to be -10°F). Although preformed joint seals (and other single gap systems, such as strip seals) are available for movement ranges larger than 3 inches, **LRFD** [14.5.3.2] limits the roadway surface gap, *W*, measured in the direction of travel, to 4 inches for single gaps. This is to ensure that the riding surface is not impaired, to prevent damage to vehicles and to ensure the safety of motorcyclists, bicycles and pedestrians.

The roadway surface gap is the result of combining the gap at installation with the thermal movement of the joint as the bridge contracts in addition to time-dependent movement. The Deck Joint Gap at Installation shall be set by the Designer with consideration for the maximum roadway surface gap. A joint with a thermal movement range of 3 inches will likely test the 4-inch maximum roadway surface gap limit set by the **LRFD**. **CTDOT** will allow up to a 4-inch roadway surface gap at 20°F. This will allow use of the single-gap joint in larger ranges of thermal movement. When the roadway surface gap at 20°F is greater than 4 inches, another type of joint shall be considered.

For each product, manufacturers typically identify the preformed joint seal by its nominal capacity (the manufacturer's recommended movement capacity of the seal in a joint installed perpendicular to the direction of movement). Designers shall select products from at least three manufacturers and list those products in a table on the contract plans using the manufacturers' designations. A template for this table is available for use under [Guide Sheets](#). One table shall be included with at least three products for each expansion joint location (for example, "Abutment No. 1," shall be included beside, "Description of Joint Location," at the top of the table for the Abutment No. 1 joint). Should there be products from less than three manufacturers that meet the design requirements, the Designer shall follow **CTDOT** ECD-2016-1 for proprietary product approval.

To assist Designers with selection of a preformed joint seal, an Excel spreadsheet is available under [Guide Sheets](#). Notes below the spreadsheet are provided to assist Designers with the use of the program. Designers shall be responsible for selecting a properly designed joint seal for the specific joint conditions. The spreadsheet is only a guide. Note that the spreadsheet is formatted similar to the Table template. This is to facilitate the transfer of design information into the Table template for inclusion in the plans.

When Designers propose preformed joint seals in bridge deck joints that pass through sidewalks, only foam-supported silicone joint seals shall be specified for that deck joint and the sidewalk joint. It is preferable to use the same joint seal in the parapet as well to allow the same joint gap in the parapet, sidewalk and deck. See the [Guide Sheets](#) for typical details at sidewalks.

The foam-supported silicone joint seals are preferred at sidewalk joints because they meet ADA requirements when installed as shown in the Typical Details. Since the sidewalk curb height is too low to allow a V-shaped seal from the deck joint to turn up the curb and rise sufficiently beneath a foam-supported seal in the sidewalk, both the deck joint and the sidewalk preformed joint seal shall be the foam-supported type.

#### **10.2.2.2.4 Joints with Thermal Movement Range (TMR) between 3 Inches and 4 Inches (Rev. 04/19)**

For joints where the total movement is between 3 inches and 4 inches, the first preference for joints should be Reinforced Concrete Headers with a Neoprene Strip Seal and anchored extrusions.

Designers shall compute the roadway surface gap,  $W$ , at 20°F. Should  $W$  exceed 4 inches, another type of joint shall be considered.

Strip seal joints in sidewalks shall be covered with sliding steel plates, detailed to meet ADA requirements. The steel plates shall be anchored into the sidewalk on both sides of the joint. See the [Guide Sheets](#) for typical details at sidewalks.

#### **10.2.2.2.5 Joints with Thermal Movement Range (TMR) > 4 Inches**

##### **10.2.2.2.5.1 Joints at Abutments**

###### **10.2.2.2.5.1.1 Modular Joints**

Modular expansion joints may be used at abutments, provided that the distance between the abutment backwall and the ends of the beams and diaphragms is kept to 2 feet minimum in order to facilitate inspection and future maintenance.

###### **10.2.2.2.5.1.2 Finger Joints**

Where a proper drainage structure can be constructed behind the abutment backwall, an open finger joint can be considered. The drainage structure should be provided with an access door or manhole for cleaning. The structure should also be connected to a storm drainage system or a standard outlet. Where the bottom of the drainage structure is not the top of the abutment footing, a 2-foot deep sump should be detailed to catch sediment.

## **10.2.2.2.5.2 Joints at Piers**

### **10.2.2.2.5.2.1 Modular Joints**

The first preference for joint type at piers should be Modular expansion joints. The distance between adjacent diaphragms shall be kept to 2 feet minimum in order to facilitate inspection and future maintenance. The beam-ends may be kept closer if proper maintenance can be accomplished. Joint manufacturers should be contacted for specific requirements for each joint.

### **10.2.2.2.5.2.2 Finger Joints**

Where the location of the joint is at the crest of a vertical curve, an open finger joint can be considered. A drainage trough shall be provided that is connected to a proper piping system (**BDM [11]**).

## **10.2.2.2.6 Joints at Skewed Bridges**

**Designers shall consider skew of the joint relative to the direction and magnitude of thermal expansion when selecting and sizing the joint.**

Each product manufacturer provides guidance as to how skew affects the way that product functions. Designers shall become familiar with how each type of joint functions to ensure that joints are properly designed.

### **10.2.2.2.6.1 Asphaltic Plug Expansion Joints**

Manufacturers limit the skew at which the joint may be installed. Typically, this skew is 45 degrees. Asphaltic plug expansion joints should generally not be specified for skews greater than 45 degrees.

### **10.2.2.2.6.2 Preformed Silicone Joint Seals**

Preformed Silicone Joint Seals are divided into two groups for this discussion:

- V-shaped silicone joint seals
- Foam-supported silicone joint seals

#### **10.2.2.2.6.2.1 V-shaped Silicone Joint Seals**

V-shaped silicone joint seals are designed to prevent tension from occurring in the seal or in the bonding point. The seal is adhered to both sides of the joint at the time of installation. Thermal movement causes the gap to open and close in the direction of travel for bridges on tangent alignments. When the seal is installed in a joint that is skewed to the direction of travel, the seal experiences

relative movements between both sides of the seal. The movement can be described as two components:

- normal to the joint
- movement parallel to the joint (also known as “racking”)

Seals in non-skewed joints experience movement predominantly normal to the joint. Seals in joints oriented normal to the roadway can reach their nominal capacity in thermal movement because this is how they are designed.

Seals in skewed joints experience additional movement parallel to the joint that introduces “racking” or shear forces into the seal. This reduces the nominal capacity of the seal. Manufacturers may provide written guidance regarding how skew affects the thermal movement capacity of their seal. In lieu of manufacturer guidance, **CTDOT** offers the following design guidance for selection of V-shaped silicone seals with adjustments to the manufacturer’s recommended nominal capacity:

Skews from 0 degrees to 30 degrees: No adjustment to nominal capacity is needed.

Skews above 30 degrees to 45 degrees: Multiply the calculated TMR by a factor of 1.5. Select a seal with that nominal capacity or larger.

Skews above 45 degrees: Multiply the calculated TMR by a factor of 1.75. Select a seal with that nominal capacity or larger.

#### **10.2.2.2.6.2.2 Foam-Supported Silicone Joint Seals**

Foam-supported silicone joint seals are pre-compressed foam seals with a waterproof silicone coating. They are not affected by skew to the degree that a V-shaped joint seal is because the foam is in compression at all times. The direction of movement is less important than the magnitude of movement. Due to vector components of movement on a skewed joint, however, **CTDOT** recommends that the size of the foam-supported silicone joint seals be selected as follows:

Skews from 0 degrees to 30 degrees: Select a seal with a movement capacity 1/4” larger than the calculated TMR.

Skews above 30 degrees to 45 degrees: Select a seal with a movement capacity 1/2” larger than the calculated TMR.

Skews above 45 degrees: Select a seal with a movement capacity 3/4” larger than the calculated TMR.

## **10.3 LONGITUDINAL JOINTS**

### **10.3.1 Deck Joints**

Longitudinal deck joints should be avoided wherever possible due to problems with motorcycle safety and difficulties associated with the intersection of the transverse deck joints. If longitudinal joints are unavoidable, they shall be located out of the traveled way. Since differential vertical movement is common in longitudinal joints, the only joints that should be considered are Elastomeric Concrete Headers with a Preformed Joint Seal or concrete headers with a Neoprene Strip Seal. A Preformed Joint Seal is preferred.

### **10.3.2 Concrete Median Barrier**

Vacant

## **10.4 JOINT SPECIFIC DESIGN REQUIREMENTS**

### **10.4.1 Asphaltic Plug Expansion Joint System**

The asphaltic plug expansion joint system shall always be placed after the final pavement has been placed on the bridge and the pavement in the area of the header has been saw cut and removed. This applies for rehabilitation and new construction.

The asphaltic plug joint should be detailed from curb to curb. The joint in the parapet should be sealed as detailed in typical details in the [Guide Sheets](#).

### **10.4.2 Elastomeric Concrete Headers with Preformed Joint Seal (Rev. 04/19)**

Elastomeric concrete headers with a Preformed Joint Seal shall always be placed after the final pavement has been placed on the bridge and approaches. This applies for rehabilitation and new construction.

The elastomeric header material should be recessed 1/8 inch below the bituminous overlay to account for long-term compaction of the bituminous overlay under traffic.

### **10.4.3 Reinforced Concrete Headers with a Neoprene Strip Seal (Rev. 04/19)**

The neoprene seal should be detailed from curb to curb and up to the top of the curb portion of the parapet (approximately 11 inches above the pavement). See the [Guide Sheets](#) for typical details.

The reinforced concrete header should be recessed 1/8 inch below the bituminous overlay to account for long-term compaction of the bituminous overlay under traffic.

#### **10.4.4 Modular Expansion Joints**

The design and detailing of modular expansion joints is the responsibility of the manufacturer of the joint; however, the designer should provide the proper room in the slab for the installation of the joint. The designer may have to contact each approved manufacturer to ensure that each joint can fit within the bridge slab.

The modular joints shall be detailed from curb to curb and up to the top of the curb portion of the parapet (approximately 11 inches above the pavement). For bridges with skews, the joint system should be run into the parapet on the skew and covered with curb plates. The curb plates shall be designed to accommodate all movements, and the free edge should overlap the parapet on the trailing edge of the parapet.

Only joints that have successfully tested for fatigue and approved by **CTDOT** may be used.

This Page is Intentionally Left  
Blank

**SECTION 11**  
**SURFACE DRAINAGE**

**TABLE OF CONTENTS**

11.1 GENERAL.....	11-1
11.2 Design Guidelines.....	11-1
11.2.1 Scuppers.....	11-1
11.2.2 Drainage Piping.....	11-1
11.2.3 Open Troughs.....	11-1
11.2.4 Underground Pipe.....	11-2



This Page is Intentionally Left  
Blank

## **SECTION 11** **SURFACE DRAINAGE**

### **11.1 GENERAL**

Generally, wherever possible surface drainage should be handled with roadway catch basins located before and after the bridge. When it is not possible to handle all the surface drainage off the bridge, the entire deck drainage system shall be designed to be as maintenance free as possible. Wherever possible, drainage routes shall be short and direct, and abrupt changes in direction shall be avoided. Pipes and troughs shall be sized to handle design flows, and slopes shall be maximized. Clean-outs shall be provided at strategic locations to simplify maintenance of the system.

Where pollution of streams, ponds and water supply areas may be a factor, further consideration is required.

### **11.2 DESIGN GUIDELINES**

Adequate facilities shall be provided to collect and dispose of the surface water on the structure by means of suitable scuppers, troughs and leaders where required by drainage requirements. Direct discharge from scuppers, etc., is preferable over waterways, and all other areas where the discharge will not be detrimental to the area below. This discharge shall not be allowed to fall on any components of the structure. The FHWA document entitled "Design of Bridge Deck Drainage" (**HEC-21**) or its successor shall be used.

#### **11.2.1 Scuppers**

Scuppers are to be located to avoid long runs of pipe/trough and shall be designed to satisfy the structural and drainage requirements. Scuppers shall be designed in accordance with the provisions of the latest edition of the **Drainage Manual**.

#### **11.2.2 Drainage Piping**

Drainage piping shall have a minimum diameter of 8 inches. For aesthetic reasons, leaders shall be located on the inside face of the fascia girders, on the rear face of piers, and recessed into the front face of abutments. Piping shall not be located within concrete pier columns. Piping should not be used where runs are required with an angle of less than 30 degrees to the horizontal.

#### **11.2.3 Open Troughs**

Where piping is not appropriate, open troughs shall be used. Troughs shall be of adequate depth and shall have a self-cleaning pitch of 3% or greater to carry the discharge and minimize the possibility of spilling or clogging. Provisions must be made to contain the splashing where scuppers spill into the troughs.

#### **11.2.4 Underground Pipe**

The underground drainage beyond the bridge piping must conform to the requirements of the **Drainage Manual** and shall be included in the roadway items.

**SECTION 12**  
**BRIDGE RAILS AND BARRIERS**

**TABLE OF CONTENTS**

12.1 TRAFFIC RAILS ( <i>Rev. 12/19</i> ).....	12-1
12.1.1 General.....	12-1
12.1.2 Interstate Highways, Freeways, and Expressways .....	12-1
12.1.3 Other Roadways.....	12-2
12.1.3.1 Scenic Overpass .....	12-2
12.1.4 Box Culverts and Short Bridges ( <i>Rev. 04/19</i> ).....	12-2
12.1.5 Retaining Walls.....	12-2
12.1.6 Deck Overhang Design ( <i>Rev. 12/19</i> ) .....	12-3
12.2 PEDESTRIAN RAILINGS, BICYCLE RAILINGS & FENCES ( <i>Rev. 12/19</i> ).....	12-4
12.2.1 General.....	12-4
12.2.1.1 Pedestrian Railing .....	12-4
12.2.1.2 Bicycle Railing.....	12-5
12.2.1.3 Fence .....	12-5
12.2.1.3.1 Railroad Overpasses.....	12-6
12.2.2 Drawings for Railings and Fences .....	12-6
12.2.3 Railings and Fences at Lighting and Signing Standards.....	12-6
12.3 CONCRETE BARRIERS.....	12-7
12.3.1 Permanent Median Barriers on Bridges ( <i>Rev. 04/19</i> ) .....	12-7
12.3.2 Temporary Precast .....	12-7
12.3.3 Concrete Barrier Wall .....	12-7

This Page is Intentionally Left  
Blank

## **SECTION 12** **BRIDGE RAILS AND BARRIERS**

### **12.1 TRAFFIC RAILS (REV. 12/19)**

#### **12.1.1 General**

Traffic or combination rails are required for all structures carrying vehicular traffic. Railings may be solid concrete parapets or an open rail system. All traffic or combination rails shall pass the crash testing requirements specified in **MASH** and shall be approved by the **CTDOT**. Exceptions may be allowed for structures on non-NHS highways and must be approved on a case-by-case basis by the Division Chief of Bridges. See the [Guide Sheets](#) for typical details of **MASH**-compliant railings. The Designer is responsible for modifying these sheets as applicable for each project, but no modifications to the details shall be permitted that adversely impact the crash worthiness of the selected rail system unless approved by the Division Chief of Bridges.

For continuous construction, the pouring sequence for all parapets shall be identical to that of the slab.

All new and retrofitted traffic and combination railings on bridges and retaining walls shall have an overall minimum height of 42 inches measured from a roadway or sidewalk surface. **MASH** Test Levels (TL) shall be shown on the plans.

The single slope barrier is preferred over the F-shape parapet. However, the F-shape parapet may be used where tie-in to adjacent barriers are F-shape. If sidewalks are required on the bridge, they shall be topped with an appropriate pedestrian railing, bicycle railing, or fence system.

Unfavorable geometric or other site conditions where vehicular rollover or barrier penetration could result in severe consequences may warrant a higher **MASH** TL as determined on a case-by-case basis.

The use of parapet end blocks above the top of the parapet shall be at the discretion of the designer. In areas involving sight distance problems, the parapet end blocks should not be used.

The end height of these blocks shall match the approach railing height. Where parapet end blocks are not provided, exposed rail ends and sharp changes in rail geometry shall be avoided.

#### **12.1.2 Interstate Highways, Freeways, and Expressways**

With the exception of the Merritt and Wilbur Cross parkways, a TL-4 shall be used (at a minimum) for all interstate highways, freeways and expressways.

### **12.1.3 Other Roadways**

A TL-3 shall be used (at a minimum) on all other state and local roadways.

The 42-inch high single slope and F-shape parapets may also be used on highways other than Interstate, expressway and freeways.

A concrete parapet with metal handrail adjacent to a sidewalk shall satisfy TL-3 crash test criteria.

#### **12.1.3.1 Scenic Overpass**

For bridges on non-limited access highways where there is a strong need to provide a scenic view, an open bridge rail system approved by the **CTDOT** should be used in place of a concrete parapet. The use of this system should be limited to very sensitive areas.

### **12.1.4 Box Culverts and Short Bridges (Rev. 04/19)**

On box culverts and very short span bridges, short runs of concrete parapet (less than 30 feet long) are visually disruptive and difficult to provide with an appropriate approach rail anchorage system.

Whenever possible, the first choice should be the use of one of the three nested W-beam rail systems developed to span over short bridges and culverts. These systems span over the structure by leaving out one, two or three of the rail posts. The structure should be extended far enough behind the rail to provide the required deflection distance. A drawing detailing these rail systems is available from the **CTDOT**.

If the structure is beyond the limits of these rail systems, a concrete parapet or open bridge rail system with end blocks shall be used with a continuous approach rail element attached to it.

On very short structures with low drop-off heights, the **CTDOT** on a case-by-case basis may waive the pedestrian and/or bicycle railing requirements. Where pedestrian or bicycle requirements are not waived, the **CTDOT**'s Pedestrian Railing may be used, refer to **BDM** [12.2.1.1].

### **12.1.5 Retaining Walls**

On retaining walls adjacent to traffic, traffic rails shall be solid concrete parapets, 42 inches high and topped with a fence system, as applicable. If the retaining wall is adjacent to a sidewalk, the parapet height above the top of the sidewalk shall be 36 inches and shall be topped with an appropriate pedestrian railing, bicycle railing, or fence system. An open bridge rail system should be used in place of a concrete parapet where the resulting concrete parapet would be less than 30 feet long.

**12.1.6 Deck Overhang Design (Rev. 12/19)**

On new bridge decks, all deck overhangs shall be designed for a minimum of TL-4 load effects.

The deck overhang shall be designed to resist the lesser of the resistance, Mc and T, of the parapet at its base calculated in accordance with **LRFD** [A13.4.2] or the vehicular impact moment, M<sub>CT</sub>, and the coincidental axial tension force, T<sub>CT</sub>, calculated as follows:

For impacts within a concrete railing segment:

$$M_{CT,int} = (\gamma_r * F_t * H_e) / (L_{c,int} * (2 * X))$$

$$T_{CT,int} = (\gamma_r * F_t) / ((L_{c,int} + (2 * x)) + (2 * H))$$

For impacts at end of a concrete railing segment or at joint where longitudinal rebar is discontinued:

$$M_{CT,end} = (\gamma_r * F_t * H_e) / (L_{c,end} * X)$$

$$T_{CT,end} = (\gamma_r * F_t) / ((L_{c,end} + X) + (2 * H))$$

Where:

$\gamma_r$  = 1.2 for new or modified rails, 1.0 for analysis of existing rails.

F<sub>t</sub> = Transverse vehicle impact force, in kips, from **BDM** [Table 12.1.6-1].

H<sub>e</sub> = Effective height of vehicle rollover force, in feet.

L<sub>c</sub> = Critical length yield line pattern, in feet.

H = Rail height, in feet.

X = distribution length increase at overhang deck section being designed, in feet. The value shall be based on a 30° angle from the traffic face of the barrier.

<b>Table 12.1.6-1 - TL-4 Railing Design Forces and Geometric Criteria</b>			
H, Rail height (in.)	36	42	Greater than 42
F <sub>t</sub> , Transverse vehicle impact force (kips)	67.2	79.1	93.3
F <sub>L</sub> , Longitudinal friction force (kips)	21.6	26.8	27.5
F <sub>v</sub> , Vertical force of vehicle (kips)	37.8	22	NA
L <sub>t</sub> and L <sub>L</sub> (ft.)	4	5	14
H <sub>e</sub> , Effective height of vehicle rollover force (in.)	25.1	30.2	45.5

*Commentary: LRFD [CA13.4.2] states, “the crash testing program is oriented toward survival and not necessarily the identification of the ultimate strength of the railing system. This could produce a railing system that is significantly over-designed, leading to the possibility that the deck overhang is also over-designed.”*

*Therefore, the design of a deck overhang for Design Case 1 is also based on F<sub>t</sub> corresponding to the test level as shown in **BDM** [Table 12.1.6-1], not on the capacity of the barrier rail. To account for uncertainties in the load and mechanisms of failure, and to provide an adequate safety margin, the value of F<sub>t</sub> has been increased by 20%.*



*The value of  $L_c$  at end of a concrete railing segment or at joint is typically less than the value within a concrete railing segment. The top reinforcement in the overhang should be designed to accommodate this increased demand in this region.*

*Caltrans and the ODOT are using a similar approach.*

**BDM** [Table 12.1.6-1] - Under TxDOT Research Project 9-1002 ‘Roadside Safety Device Crash Testing Program,’ Texas A&M Transportation Institute (TTI) researchers investigated the minimum height and lateral design load for **MASH TL-4** bridge rails. Researchers used impact simulations to calculate lateral impact loads imparted by the SUT (Single Unit Truck) based on **MASH TL-4** impact conditions for a rigid single slope barrier with various heights. Results indicated that the lateral loads for **MASH TL-4** were significantly greater than those specified for NCHRP Report 350 TL-4 impact conditions. Under **MASH**, the severity of TL-4 impacts increased 56% compared to NCHRP Report 350. Consequently, 32 inch tall barriers that met TL-4 requirements under NCHRP Report 350 do not satisfy **MASH**. The minimum rail height for **MASH TL-4** barriers was determined to be 36 inches. Further, the lateral impact force was found to vary with rail height. For a 36-inch tall barrier, the design impact load was determined to be approximately 68 kips. As the height of the barrier increases, more of the cargo box of the single unit truck is engaged and the lateral load on the barrier increases. For a barrier height of 42 inches, the lateral design impact load increases to approximately 80 kips. The 36-inch single slope bridge rail that was tested had a calculated capacity of approximately 70 kips. The continuous concrete rail performed well without any significant damage to the rail or deck. The values in **BDM** [Table 12.1.6-1] include the design impact loads in the lateral, longitudinal, and vertical direction, and the longitudinal distribution and height of the resultant lateral load were recommended for **MASH TL-4** impacts.

## **12.2 PEDESTRIAN RAILINGS, BICYCLE RAILINGS & FENCES (REV. 12/19)**

### **12.2.1 General**

When a traffic or combination rail is not required, a railing is required when the vertical drop off is greater than 30 inches, as measured from the top of the adjacent sidewalk, roadway, or ground elevation to the lower elevation. The railing shall be a pedestrian railing, bicycle railing, or fence.

#### **12.2.1.1 Pedestrian Railing**

A pedestrian rail is required on parapets less than 42 inches in height, and where a fence is not warranted. If a pedestrian rail is required, it is recommended to use the rail on both parapets, even if the one of the parapets is greater than 42 inches in height. A drawing is available for the **CTDOT**’s standard Metal Bridge Rail - Handrail. Alternative pedestrian railings shall be designed in accordance with **LRFD**. The top of rail members shall be at least 42 inches above the top of the sidewalk or roadway.

**12.2.1.2 Bicycle Railing**

For bridges on designated bicycle routes, a bicycle railing shall be designed in accordance with the **LRFD**. A map depicting designated bicycle routes in the State of Connecticut is available from the **CTDOT**.

**12.2.1.3 Fence**

For guidance on the placement of fencing at bridges, refer to **BDM** [Table 12.2.1.3-1].

**Table 12.2.1.3-1**

Feature Crossed (Beneath Bridge)		Feature Carried (Above Feature Crossed)				Non-motorized user facility
		Freeway		Non-freeway		
		With Sidewalk	Without Sidewalk	With Sidewalk	Without Sidewalk	
<b>Freeway</b>		Required (A)	Not generally required	Required (A)	Required (A)	Required (A) (B)
<b>Non-freeway</b>		Required (A)	Not generally required	Required (A)	Required (A)	Required (A) (B)
<b>Water</b>		Not generally required	Not generally required	Not generally required	Not generally required	Case by case
<b>Rail</b>	Non-electrified	Required (A) (C)	Required (A) (C)	Required (A) (C)	Required (A) (C)	Required (A) (B) (C)
	Electrified	Required (A) (D)	Required (E)	Required (D)	Required (E)	Required (B) (D)

**Legend of Requirements**

- A. Top of fence 8 feet (96 inches) above surface (i.e., road, sidewalk, trail) including any roadside barrier
- B. For rehabilitation of an existing structure with complete enclosure, consider retention of complete enclosure
- C. Maximum opening of 0.5 inch within 25 feet of tracks
- D. Top of solid barrier 9 feet (108 inches) above sidewalk
- E. Top of solid barrier 8 feet (96 inches) above road

For bridges that cross multiple features, the most restrictive requirements (height, material, and configuration) apply to the entire bridge length unless a Department-approved analysis indicates a transition to an adequate and less restrictive design for part of the length is cost effective.

The height of the fencing above the top of the sidewalk or roadway surface shall be a minimum of 8 feet. Curved top fencing is not required. The maximum size of the opening in the fence shall be 2 inches. All fences shall minimize the use of horizontal rails. Fence fabric shall be installed on the pedestrian side of posts. On sidewalk parapets, the face of the fence shall be flush with the parapet face adjacent to the sidewalk. Fence shall be set back as far as practical from the traffic face of the parapets as detailed in **BDM** [Division 3].

Under certain circumstances, fences are required by law as specified in Public Act No. 00-184. No waivers to these requirements that conflict with Public Act No. 00-184 will be granted under any circumstances.

Fencing should satisfy the aesthetic considerations of the structure and be designed in conformance with the **LRFD** for pedestrian railings. Where fencing is provided, it shall consist of black PVC coated fabric with galvanized steel posts and rails. Exceptions will only be allowed for showcase bridges or bridges with historical significance. A fence, if used, satisfies the requirements for either a pedestrian or bicycle railing.

#### **12.2.1.3.1 Railroad Overpasses**

Fencing is required on all structures over railroads. It shall be placed on both sides on the span over the railroad tracks. A solid barrier fence is required over electrified railroads.

On long structures over non-electrified railroads, the maximum size of the opening within 25 feet of the tracks shall be 0.5 inches. A larger opening may be used outside of these limits.

The designer shall coordinate with the Railroad on the requirement of curved top fencing.

#### **12.2.2 Drawings for Railings and Fences**

The following drawing are available from the **CTDOT**:

1. Pedestrian Railing (Bridge), (angular end for use without end blocks)

These drawings are available from the **CTDOT** in a MicroStation format and will be made available upon request.

#### **12.2.3 Railings and Fences at Lighting and Signing Standards**

When lighting or signing standards are located on structures, the railing or fence shall be continuous at these locations. The lighting or signing shall be located outside of the continuous railing or fence (between the railing or fence and the outside face of parapet). Fencing shall be designed with removable panels or other means to provide access to the handhole locations. The parapet details shall accommodate the lighting and signing standard anchorages outside of the railing or fence. The lighting or signing shall not generally be located on a span over a railroad-electrified zone. For details, see **BDM** [Division 3].

## **12.3 CONCRETE BARRIERS**

### **12.3.1 Permanent Median Barriers on Bridges** *(Rev. 04/19)*

Permanent median barriers on bridges shall be concrete and shall match the height and width on the roadway approaches. They may be either cast-in-place or precast concrete.

### **12.3.2 Temporary Precast**

Temporary barriers used to protect the traveling public during the construction of bridges shall be precast concrete and shall conform to the **CTDOT**'s standardized details. In all cases, if the distance from the backside of the barrier to the edge of the deck drop off is less than 6 feet, the barrier shall be rigidly attached to the deck. In cases where this distance is greater than 6 feet, factors such as the type of road; speed, volume and composition of traffic; and the need to protect work areas with limited escape routes shall be taken into account and the barrier rigidly attached if appropriate. Lines of barrier used strictly to separate opposing traffic need not be rigidly attached to the deck and shall be paid for as a roadway item. See the [Guide Sheets](#) for typical details of temporary precast barriers.

### **12.3.3 Concrete Barrier Wall**

When required by geometric or roadway design requirements, a concrete barrier wall should be detailed as shown in **BDM** [Division 3].

This Page is Intentionally Left  
Blank

**SECTION 13**  
**BURIED STRUCTURES**

**TABLE OF CONTENTS**

13.1 REINFORCED CONCRETE BOX CULVERTS AND FRAMES ( <i>Rev. 12/19</i> ).....	13-1
13.1.1 General.....	13-1
13.1.2 Excavation.....	13-1
13.1.3 Foundation .....	13-1
13.1.3.1 Culvert Bedding.....	13-1
13.1.3.2 Cutoff and Return Walls .....	13-2
13.1.3.3 Nosings between Adjacent Parallel Multicell Box Culverts.....	13-2
13.1.3.4 Sills .....	13-2
13.1.3.5 Headwalls ( <i>Rev. 12/19</i> ).....	13-2
13.1.3.6 Wingwalls ( <i>Rev. 12/19</i> ) .....	13-2
13.1.3.7 Dampproofing .....	13-3
13.1.3.8 Subsurface Drainage .....	13-3
13.1.3.9 Backfill Requirements .....	13-3
13.1.3.9.1 General.....	13-3
13.1.3.9.2 Backfill Limits .....	13-3
13.1.3.10 Membrane Waterproofing Requirements .....	13-4
13.1.3.11 Railing and Fences .....	13-4
13.1.4 Precast Concrete Box Culverts ( <i>Rev. 04/19</i> ).....	13-4
13.1.4.1 General ( <i>Rev. 12/19</i> ) .....	13-4
13.1.4.2 Concrete .....	13-4
13.1.4.3 Reinforcement Details ( <i>Rev. 12/19</i> ).....	13-4
13.1.4.4 Minimum Thickness of Floor, Sides and Roof.....	13-5
13.1.4.5 Headwalls.....	13-5
13.1.5 Cast-In-Place Concrete Box Culverts ( <i>Rev. 04/19</i> ) .....	13-5
13.1.5.1 General.....	13-5
13.1.5.2 Concrete .....	13-5
13.1.5.3 Minimum Thickness of Floor, Sides and Roof.....	13-5
13.1.5.4 Reinforcement Details .....	13-5
13.1.5.5 Expansion, Contraction and Construction Joints .....	13-6

Connecticut Department of Transportation Bridge Design Manual

13.1.6 Precast Concrete Frames ( <i>Rev. 12/19</i> ).....	13-6
13.1.6.1 General.....	13-6
13.1.6.2 Concrete.....	13-6
13.1.6.3 Reinforcement.....	13-6
13.2 REINFORCED CONCRETE JUNCTION BOXES.....	13-6

## **SECTION 13** **BURIED STRUCTURES**

### **13.1 REINFORCED CONCRETE BOX CULVERTS AND FRAMES (REV. 12/19)**

#### **13.1.1 General**

Reinforced concrete box culverts may be made of either precast or cast-in-place concrete. Generally, when conditions warrant a box culvert and frames, for reasons of economy, shall be made of precast concrete. Full-length cast-in-place concrete box culverts shall only be used with the approval of the **CTDOT**. Sections of box culverts may be cast in-place when required by site conditions such as transitions between different size culverts, transitions between new and existing box culverts, adjacent utilities that cannot be relocated, or highly skewed culvert ends.

The culvert dimensions shall be consistent with the hydraulic characteristics of the waterway. Preferably, the height of the box culvert or frame (the dimension from the top of the floor (invert) to the bottom of the roof) should be a minimum of 6 feet to facilitate its maintenance and inspection. For culverts that are designed to “silt in” with soil, the height should be measured from the invert of the channel.

For precast culverts and frames, the size selection should be coordinated with the manufacturers to be consistent with standard sizes that are readily available. On projects requiring more than one culvert or frame, of different size openings, an economic study should be conducted to determine if it is possible to use the same size opening for more than one structure.

Box culverts do not need to be analyzed for scour. However, erosion countermeasures may be required if recommended by the Hydraulics Report.

#### **13.1.2 Excavation**

For excavation requirements, refer to **BDM** [5].

#### **13.1.3 Foundation**

For excavation requirements, refer to **BDM** [5].

##### **13.1.3.1 Culvert Bedding**

Generally, box culverts shall be founded on 12 inches of “Granular Fill” to provide slightly yielding uniformly distributed support over the bottom width of the box section. The fill shall extend 2 feet beyond the sidewalls of the box culvert.

Box culverts founded on unyielding foundations, such as rock or piles, are not permitted.



### **13.1.3.2 Cutoff and Return Walls**

The inlet and outlet ends of box culverts shall rest on cutoff walls. The cutoff walls shall have return walls below the outside walls that extend a minimum of 4 feet from the rear face of the cutoff wall. These walls shall be embedded a minimum of 4 feet below the finished elevation of the bottom of the channel. The walls shall have a minimum thickness of 12 inches. Cutoff and return walls shall be constructed of Class PCC0334Z. The floor of the box culverts shall be connected to the cutoff walls with dowels.

### **13.1.3.3 Nosings between Adjacent Parallel Multicell Box Culverts**

The inlet and outlet ends of the walls between adjacent parallel multicell box culverts shall be protected with nosings. The nosings may be either cast-in-place or precast. Cast-in-place concrete nosing shall be constructed of Class PCC0334Z. The nosings shall be founded on the cutoff wall and connected to the walls.

The maximum allowable joint width between adjacent parallel units shall be one inch. In order to provide a positive means of lateral bearing between parallel units, after placing the nosing, the joint shall be filled with sand made flowable by mixing it with water.

### **13.1.3.4 Sills**

Sills shall be provided at the inlet and outlet ends of box culverts when warranted by hydraulic or environmental conditions. The dimensions shall be as recommended by the Hydraulic Report. The sills shall have a minimum thickness of 12 inches and shall be connected to the floor of the box culverts with dowels. Sills shall be constructed of Class PCC0334Z.

### **13.1.3.5 Headwalls (Rev. 12/19)**

Headwalls at the inlet and outlet shall be provided to satisfy the site grading conditions. Headwalls shall be constructed of Class PCC0334Z. The headwalls shall have a minimum thickness of 1.25 feet at the top. On precast concrete box culverts and frames, dowel bar mechanical connectors shall be used to connect headwall stems to the roof of the structure. The rear face of headwalls shall be dampproofed. Railings or fences shall be placed on all headwalls in accordance with the requirements of **BDM** [12].

*Commentary: The box culvert or frame roof thickness may be governed by the development of the reinforcement required to connect the headwall to the box culvert or frame.*

### **13.1.3.6 Wingwalls (Rev. 12/19)**

Generally, cast-in-place concrete wingwalls shall be provided at the inlet and outlet of all box culverts and frames. The designer should coordinate with the hydraulic engineer as to the appropriate angles for the flared wingwalls. The wingwalls should abut the ends of the outside walls of the box culvert or frame. Wingwall stems and footings shall be made

independent of the culvert or frames walls, cutoff and return walls. The elevation of the bottom of the wingwall footings shall match the cutoff, return walls, and frame foundation. Wingwalls shall be constructed of Class PCC0334Z concrete. The minimum thickness at the top of wingwall stems shall be 1.25 feet. The rear face of wingwalls shall be dampproofed. Railings or fences shall be placed on all wingwalls in accordance with the requirements of **BDM** [12].

### **13.1.3.7 Dampproofing**

Dampproofing is not required on precast concrete box culverts and frames.

### **13.1.3.8 Subsurface Drainage**

Provisions for subsurface drainage are not required for the culvert and frame backfill.

### **13.1.3.9 Backfill Requirements**

#### **13.1.3.9.1 General**

Unless otherwise directed, all box culverts, frames and their associated wingwalls shall be backfilled with “Pervious Structure Backfill” in accordance with the requirements of **BDM** [5].

#### **13.1.3.9.2 Backfill Limits**

Place a wedge of Pervious Structure Backfill above a slope line starting at the top of the heel and extending upward at slope of 1:1.5 (rise to run) to the bottom of the subbase. In cut situations, the following note, with a leader pointing to the slope line, shall be placed on the plans:

Slope line except where undisturbed material obtrudes within this area.

Rock fill or boulders shall not be placed within two feet of top of box culverts and frames. The following note, with leaders pointing to the limits, shall be placed on the plans:

No rock fill or boulders shall be placed within these limits.

In cut situations, if the material is soft silt or clay, the backfill limits shall be determined by the designer and submitted for review and approval with the Geotechnical Report.

#### **13.1.3.10 Membrane Waterproofing Requirements**

When the distance from the top of the box culvert and frame roof to top of the roadway surface is less than 2 feet, membrane waterproofing shall be placed on the box culvert and frame. The membrane waterproofing shall be “Membrane Waterproofing (Cold Liquid Elastomeric).” The membrane shall cover the entire exterior surface of the roof and extend 12 inches down the sidewalls.

#### **13.1.3.11 Railing and Fences**

For railing and fence requirements, refer to **BDM** [12].

### **13.1.4 Precast Concrete Box Culverts (Rev. 04/19)**

#### **13.1.4.1 General (Rev. 12/19)**

Precast concrete box culverts are items that are furnished and installed by the Contractor in accordance with the owned special provision “\_x\_ Precast Concrete Box Culvert.” The designer is responsible for reviewing the Contractor’s shop and working drawing submittals for the box culverts.

The designer is responsible for designing and detailing precast concrete box culverts including all other box culvert components, such as cutoff and return walls, nosings, sills, headwalls and wingwalls.

Precast concrete box sections shall be designed for all construction load effects that may be applied during all stages/phases of construction.

#### **13.1.4.2 Concrete**

The concrete for the precast box culvert sections shall have a minimum compressive strength ( $f'_c$ ) of 5,000 psi and a minimum electrical resistivity of 29  $k\Omega$ -cm in accordance with AASHTO T 358 at 28 days. The concrete mix design is submitted by the Contractor in accordance with the special provision “\_x\_ Precast Concrete Box Culvert” for review by the designer.

#### **13.1.4.3 Reinforcement Details (Rev. 12/19)**

The reinforcement shall conform to the requirements of **BDM** [6.3.2.3].

Generally, the minimum concrete cover over all reinforcement on any surface of the roof, floor and walls shall be 2 inches. In structures exposed to salt water, the minimum concrete cover over all reinforcement on any surface of the roof, floor and walls shall be 3 inches.

The designer shall determine the concrete cover requirements and note the requirements on the plans.

The reinforcement spacing to control cracking shall be based on Class 2 exposure conditions.

#### **13.1.4.4 Minimum Thickness of Floor, Sides and Roof**

The minimum thickness of the culvert floor, sides and roof shall be 8 inches. The designer shall note the minimum thickness requirements of the box culvert elements on the plans.

*Commentary: The thickness of the roof of the box culvert sections at the inlet and outlet may be governed by the development of the reinforcement required to connect the headwall to the box culvert.*

#### **13.1.4.5 Headwalls**

Headwalls are typically connected to box culvert roofs with dowel bar mechanical connections. The designer is responsible for designing and detailing the headwall connection to the box culvert. The designer shall check to ensure that the end sections of precast concrete box culverts adequately resist the load effects from the headwall.

### **13.1.5 Cast-In-Place Concrete Box Culverts (Rev. 04/19)**

#### **13.1.5.1 General**

The designer is responsible for designing and detailing cast-in-place concrete box culverts including all other box culvert components, such as cutoff and return walls, nosings, sills, headwalls and wingwalls.

#### **13.1.5.2 Concrete**

Cast-in-place concrete box culverts shall be constructed of Class PCC04462.

#### **13.1.5.3 Minimum Thickness of Floor, Sides and Roof**

The minimum thickness of the culvert floor, sides and roof shall be 12 inches.

#### **13.1.5.4 Reinforcement Details**

The reinforcement shall conform to the requirements of **BDM** [6.3.2.3].

The minimum cover over all reinforcement shall be 2 inches, except the cover over the outer reinforcement in the floor slab shall be 3 inches. The cover over all reinforcement in structures exposed to salt water shall be 4 inches.

### **13.1.5.5 Expansion, Contraction and Construction Joints**

Expansion and contraction joints in the culvert floor, sides and roof shall be provided in accordance with **AASHTO LRFD**. Construction joints shall be placed as conditions warrant.

No reinforcement shall pass through expansion and construction joints. Reinforcement shall pass through construction joints.

### **13.1.6 Precast Concrete Frames (Rev. 12/19)**

#### **13.1.6.1 General**

Precast concrete frames are 3-sided rigid frames that have uniform wall and top slab thicknesses. Precast concrete frames are furnished and installed by the Contractor in accordance with the special provision "Precast Concrete Frame." The designer is responsible for reviewing the Contractor's shop and working drawing submittals for the frames.

The designer is responsible for designing and detailing precast concrete frames including all other frame components, such as footings, nosings, headwalls and wingwalls.

Precast concrete frame sections shall be designed for all construction load effects that may be applied during all stages/phases of construction.

#### **13.1.6.2 Concrete**

The concrete for the precast concrete frame sections shall have a minimum compressive strength ( $f'_c$ ) of 5,000 psi and a minimum electrical resistivity of 29 k $\Omega$ -cm in accordance with AASHTO T 358 at 28 days. The concrete mix design is submitted by the Contractor in accordance with the special provision "Precast Concrete Frame" for review by the designer.

#### **13.1.6.3 Reinforcement**

The reinforcement shall conform to the requirements of **BDM** [6.3.2.3].

## **13.2 REINFORCED CONCRETE JUNCTION BOXES**

Vacant

**SECTION 14**  
**SIGN SUPPORTS**

**TABLE OF CONTENTS**

14.1 STRUCTURE MOUNTED SIGN SUPPORTS..... 14-1

    14.1.1 General ..... 14-1

    14.1.2 Design Responsibilities (*Rev. 04/19*) ..... 14-1

    14.1.3 Design Requirements (*Rev. 04/19*) ..... 14-1

    14.1.4 Material Requirements ..... 14-2

    14.1.5 Detail Requirements ..... 14-2

    14.1.6 Pay Items ..... 14-3

14.2 TUBULAR AND TRUSS SIGN SUPPORT STRUCTURES..... 14-3

    14.2.1 General ..... 14-3

    14.2.2 Design Responsibilities ..... 14-3

        14.2.2.1 Standard Sign Supports ..... 14-3

        14.2.2.2 Sign Supports Mounted on Structures (*Rev. 04/19*)..... 14-4

        14.2.2.3 Special Sign Supports ..... 14-4

    14.2.3 Shop Drawings (*Rev. 04/19*) ..... 14-4

This Page is Intentionally Left  
Blank

## **SECTION 14** **SIGN SUPPORTS**

### **14.1 STRUCTURE MOUNTED SIGN SUPPORTS**

#### **14.1.1 General**

A structure mounted sign support is a support that is connected to the fascia member and components of a bridge overpass and supports various types of traffic signs.

#### **14.1.2 Design Responsibilities (Rev. 04/19)**

The dimensions of the sign, the location of the sign over the roadway below, the angle between the sign and the centerline of the roadway below, and the tilt of the sign shall be determined by the Traffic Engineer. The structural designer is responsible for the design and details of the structure mounted sign support required supporting the traffic signs as required by the Traffic Engineer. Structure mounted sign supports require shop drawings that must be reviewed by the designer.

#### **14.1.3 Design Requirements (Rev. 04/19)**

Structure mounted sign supports shall be designed in accordance with the AASHTO *Standard Specifications for Structural Supports for Highway Signs, Luminaires and Traffic Signals*.

The design of all sign support structures shall be based on 120 miles per hour.

Structure mounted sign supports are, by their nature, complex and difficult to model structures. In all but the simplest cases (small signs with virtually no skew), a rigorous three-dimensional analysis is required.

The analysis of structure mounted sign supports shall, in general, be based on pin connected truss members. However, simplified connections, such as angles welded back to back, can sometimes result in substantial eccentricities from the assumed truss nodes. More detailed analysis taking these eccentricities into account may sometimes be necessary in order to reasonably model the structure.

Structures involving larger sign panels and/or significant skew angles may also require more highly detailed and precisely fabricated designs to eliminate eccentricities at the nodes.

Sufficient members shall be employed to brace the structure in all directions and maintain structural stability under all design assumptions. Horizontal rail elements between trusses should be designed as continuous members.



#### **14.1.4 Material Requirements**

The sign supports shall be constructed with structural steel conforming to AASHTO M270, Grade 36. Generally, sign supports are constructed with angles and WT sections except where otherwise required as noted in **BDM** [14.1.3]. The minimum size angle shall be L 4 x 4 x 3/8. The use of metal sign posts as members for structure mounted sign supports is not permitted. All structural steel shall be hot-dip galvanized in accordance with ASTM A123.

High strength bolts shall conform to the requirements of ASTM F3125 Grade A325, Type 1 and be mechanically galvanized in accordance with ASTM B695, Class 50. Carriage bolts shall conform to the requirements of ASTM A307 and be hot-dip galvanized in accordance with ASTM A123.

Welding shall conform to **BDM** [7.1.4].

#### **14.1.5 Detail Requirements**

Generally, structure mounted signs are supported by a framework of trusses connected together with lateral bracing and anchored to the bridge. The trusses, typically composed of angles, should be placed normal to the bridge fascia. The length of the trusses depends on the length of the sign and the angle the sign forms with the bridge fascia (skew angle).

In general, placement of signs on structure mounted supports is discouraged on bridges with skew angles of greater than 30 degrees. If the skew angle becomes excessive, particularly for larger signs, consideration should be given to placing the sign on a cantilever or overhead sign support structure adjacent to the bridge. The height of signs should be kept in reasonable proportion to the height of the sign support frame. Since the height of the frame is limited by the bridge superstructure depth, this limits the height of sign that can reasonably be supported in this manner. In general, the height of the sign should not exceed twice the height of the frame, particularly on bridges with significant skew.

The minimum distance from the sign to the bridge structure must allow for placement of the truss diagonal members. The lowest portion of a structure mounted sign support shall be a minimum of 12 inches above the lowest component of the fascia member of the bridge to which it is attached.

The truss members and lateral bracing are typically connected by shop and field welds. Generally, the truss sections of the supports are field welded to WT sections bolted to the bridge fascia components. Bolted connections to steel members should be made with high strength bolts. Bolted connections to concrete members should be made by bolting

through the component with carriage bolts and a plate washer.

For signs composed of interconnected extruded aluminum sign panels, the signs should be attached to WT members (sometimes referred to as hangers) with post clips. The post clips should be installed for the full height of the WT members on alternate sides. A sign stop should be placed at the bottom of the WT members. All members supporting sign and crown panels shall be positively connected to the sign support framework. The maximum spacing between the WT members is 6 feet. The maximum distance from a WT member to the edge of a sign shall be 3 feet. The minimum distance from a WT member to the edge of a sign shall be 12 inches.

#### **14.1.6 Pay Items**

Structure mounted sign supports shall be paid under the item “Structure Mounted Sign Support” which requires a special provision. The signs are traffic items, and shall be paid for under the appropriate traffic items.

### **14.2 TUBULAR AND TRUSS SIGN SUPPORT STRUCTURES**

#### **14.2.1 General**

Tubular and truss sign support structures refer to the following types of sign supports described in the **Standard Specifications**:

- Tubular Arch Sign Support Structure,
- Tubular Arch Cantilever Support Structure,
- Overhead Truss Sign Support (Type   ), and
- Overhead Cantilever Sign Support (Type   ).

These sign supports are designed to carry extruded aluminum sign panels. Details for these structures are shown on traffic standard sheets prepared by the **CTDOT**. These structures are designed to be supported by foundations embedded in the ground. The foundation details are shown on standard sheets prepared by the **CTDOT**.

#### **14.2.2 Design Responsibilities**

##### **14.2.2.1 Standard Sign Supports**

The locations and types of tubular and truss sign support structures, the dimensions of the signs, the location of the signs over the roadway below, the angle between the signs and the centerline of the roadway below, and the tilt of the signs shall be determined by the Traffic Engineer.

If the tubular or truss sign support structures will be supported as shown on the standard sheets, no additional design or details are required by the designer. If any of the details on the standard plans are varied or altered, the designer should check all the

details to ensure that they are applicable for the altered conditions.

If the tubular or truss sign support structures will support a sign structure other than an extruded aluminum sign, the designer shall analyze the entire support and foundation. The designer should also check all the details to ensure that they are applicable for the altered conditions.

#### **14.2.2.2 Sign Supports Mounted on Structures (Rev. 04/19)**

The locations and types of tubular and truss sign support structures on a bridge or wall, the dimensions of the signs, the location of the signs over the roadway below, the angle between the signs and the centerline of the roadway below, and the tilt of the signs shall be determined by the Traffic Engineer.

The tubular or truss sign support structures shown on the standard plans are not intended to be mounted on highway bridges, retaining walls or other structures. If an overhead or cantilever support is required to be mounted on a structure, it must be completely designed and detailed by the designer.

These structures shall be designed in accordance with the AASHTO *Standard Specifications for Structural Supports for Highway Signs, Luminaires and Traffic Signals*. The design shall be based on 120 mile per hour wind load, with the appropriate adjustment for height based on the elevation of the structure above surrounding ground or water.

If practical, the sign support materials and details should be similar to those shown on the tubular and truss sign support standard sheets to simplify fabrication and maintain a uniform appearance along the highway.

#### **14.2.2.3 Special Sign Supports**

For sign structures that are to support signs that are not extruded aluminum panels (such as variable message signs), the support must be completely designed and detailed by the designer.

The structure shall be designed in accordance with the AASHTO *Standard Specifications for Structural Supports for Highway Signs, Luminaires and Traffic Signals*. The design shall be based on 120 miles per hour wind load.

#### **14.2.3 Shop Drawings (Rev. 04/19)**

The tubular and truss sign support structures require working drawings and shop drawings to be submitted by the Contractor.

**SECTION 15**  
**UTILITY INSTALLATIONS**

**TABLE OF CONTENTS**

15.1 GENERAL DESIGN REQUIREMENTS ..... 15-1

15.2 UNDERGROUND FACILITIES ..... 15-1

15.3 AERIAL FACILITIES ..... 15-1

    15.3.1 Aerial Facilities Passing Over Structure (*Rev. 11/04*) ..... 15-1

    15.3.2 Aerial Facilities Passing Under Structure ..... 15-2

15.4 UTILITIES ADJACENT TO STRUCTURE ..... 15-2

15.5 EMERGENCY TEMPORARY INSTALLATIONS ..... 15-3

15.6 HIGHWAY ILLUMINATION POLES (*Rev. 11/04*) ..... 15-3

15.7 HIGH VOLTAGE TRANSMISSION FACILITIES (*Rev. 11/04*) ..... 15-4

This Page is Intentionally Left  
Blank

## **SECTION 15** **UTILITY INSTALLATIONS**

### **15.1 GENERAL DESIGN REQUIREMENTS**

To ensure that the structure remains functional and aesthetically pleasing wherever possible, the following Sections will apply to the installation of utilities on structures.

### **15.2 UNDERGROUND FACILITIES**

Permanent underground installations, which are to be carried on and are parallel to the longitudinal axis of the structure, shall be placed in an out of sight location between the beams. No part of the utility or its supporting structure shall project below the bottom of the bridge superstructure.

In those instances where the proposed superstructure type is not adaptable to carrying utilities in an out-of-sight location on the underside of the structure, an early determination must be made as to whether or not utilities are to be accommodated. If the utilities must be accommodated, the selection of superstructure type must be addressed accordingly.

In those instances where an existing structure type is not adaptable to carrying utilities in an out-of-sight location on the structure, the proposed utility installation shall be the subject of an individual study as to its disposition.

Underground facilities shall not be suspended from or attached to the outside face of the superstructure, unless otherwise approved by the **CTDOT**.

Where aesthetics are a prime consideration, the utility shall be placed underground to the extent necessary to preserve the aesthetics of the structure and the surrounding area.

### **15.3 AERIAL FACILITIES**

#### **15.3.1 Aerial Facilities Passing Over Structure** *(Rev. 11/04)*

Aerial facilities (telephone, electrical, cable television, etc.) located along a highway that continues onto a structure shall be made an underground installation at the ends of the structure and carried across the structure. These facilities shall be placed in an out of sight location either between the beams or inside of a sidewalk if available. Placing utilities inside of the sidewalk shall be used only for telephone or cable TV. Electric conduits shall in no case be cast inside of a sidewalk as excessive heat buildup may be detrimental to both the utility and the structure. No part of the utility or its supporting structure shall project below the bottom of the bridge superstructure. The facility should extend a minimum distance beyond the ends of the structure required to retain the aesthetics of the structure.

Where unnecessary expense would be incurred by going underground, facilities carried on support poles may be carried aerially alongside a structure if it is practical to span the entire crossing.

The determination to carry the utilities either aerially or underground shall be studied at an early stage of the design with regard to such factors as economy, aesthetics, safety, and maintaining the characteristics of the local environment

### **15.3.2 Aerial Facilities Passing Under Structure**

Aerial facilities (telephone, electrical, cable television, etc.) located along a highway that passes under a structure shall in no instance be permitted to pass over the structure but shall be attached to the underside of it. An underground installation within the structure limits should be considered. The underground portion of the installation shall extend a distance beyond the limits of the structure(s) required to retain the aesthetics of the structure.

Solutions to special or unusual conditions shall be determined at a field review with **CTDOT** and Utility Company representatives. The field review team shall include the Design Engineer and the Utilities Engineer. In the event that a mutually agreeable solution cannot be reached, the matter shall be forwarded through channels to the Transportation Chief Engineer for a ruling.

## **15.4 UTILITIES ADJACENT TO STRUCTURE**

When underground utilities (existing or proposed) are located in the vicinity of structures, a review of the utility installation relative to the substructure design is required to determine if protection of the substructure is necessary.

The factors to be considered are the type, size, and location of the utility, the pressure in the line, the soil conditions, the material composition of the utility and the structure foundation.

The initial installation and future maintenance of the utility shall be investigated for their effects on the structure.

If it is determined that protection of the utility is necessary, the following are variations that should be considered:

1. Relocation of the utility.
2. Relocation of the substructure unit.
3. Protection of the substructure unit with sheeting.
4. Sheeting the utility trench.

5. Placing the utility in adequate encasement (sleeves or deflectors).
6. Placing the substructure on piles.
7. Require material composition of the utility to be ductile iron, prestressed concrete or steel (desirable in all cases).
8. Use of shut-off valves on both sides of the bridge (desirable in all cases).

This does not preclude other possibilities, which the designer or the utility engineer may have to offer.

### **15.5 EMERGENCY TEMPORARY INSTALLATIONS**

Temporary installations of an emergency nature may be placed on the sidewalk of a structure, but such installation must be either removed or replaced by a permanent out-of-sight installation within one year of the date of the temporary installation. Where sidewalks are not available, special consideration and study will be required to insure a safe and acceptable placement of the temporary installation.

Upon completion of the temporary installation, immediate steps shall be initiated to ensure that the temporary installation is removed or replaced within the time limit above and in a manner acceptable to the **CTDOT**.

### **15.6 HIGHWAY ILLUMINATION POLES (Rev. 11/04)**

If poles for highway illumination are needed within the non-access lines in the proximity of the structure, the location and type of poles shall be approved by the **CTDOT**.

Illumination poles routinely provided by manufacturers are intended to be mounted on fixed, ground mounted foundations. Mounting on non-fixed structures subject to deflection and vibration, such as bridge spans, may result in unacceptable movement or vibration of the pole, possibly resulting in structural failure of the pole or damage to lighting fixture. Therefore, mounting of illumination poles on bridge spans should be avoided whenever possible. If standard illumination poles must be mounted on the span, they should be mounted as near as possible to abutment or piers for spans up to 200 feet. For spans over 200 feet, they should not be mounted over 50 feet from abutment or pier locations. If illumination poles are required in areas outside these limits, they must meet one of the following criteria:

- Be of a non-standard design that has been specifically designed for placement on a moving structure, and be appropriate for the amplitude and frequency of the motion anticipated.
- Be of reduced height (under 30 feet mounting height) and certified by the manufacturer as appropriate for this application.



**15.7 HIGH VOLTAGE TRANSMISSION FACILITIES** *(Rev. 11/04)*

Long distance high voltage transmission facilities shall be the subject of a special study. Where aesthetics are a consideration, the placement of the facility underground should be considered. The final determination shall be weighed considering both the economics and aesthetics of the location in question. If required, the alternate proposals shall be referred to the Transportation Chief Engineer for final determination.

**SECTION 16**  
**BRIDGE REPAIR AND REHABILITATION**

**TABLE OF CONTENTS**

VACANT

This Page is Intentionally Left  
Blank

**SECTION 17**  
**POST DESIGN RESPONSIBILITIES**

**TABLE OF CONTENTS**

VACANT

This Page is Intentionally Left  
Blank

## **DIVISION 2**

# CONTRACT PLAN NOTES, TABLES & NOTICES

This Page is Intentionally Left  
Blank

## **Appendix A** **PLAN NOTES**

### **A.1 GENERAL NOTES**

#### **A.1.1 Guidelines for Use**

Certain “General Notes” are required to be shown on the general plan sheets. The Designer shall develop the notes with the aid of the following guidelines:

<b><u>Note No.</u></b>	<b><u>Requirements for use</u></b>
G1	Must be shown on the General Plan Sheet.
G2	Must be shown on the General Plan Sheet.
G3	The classes of concrete and grades of reinforcing steel that are proposed for the structure shall be indicated. Indicate the applicable structural steel designations, $F_y$ (specified minimum yield point of steel) and the corresponding thicknesses, for the type of steel used in the structure only.
G4	Use this note for all new structures and for projects that include rehabilitation or preservation of an existing bridge.
G5	Use this note for projects addressing rehabilitation or preservation of existing bridges that cannot support or be strengthened sufficiently to support all design, legal and permit loads.
G6	For structure detailed without a Bituminous Concrete Overlay.
G7	For structure detailed with a Bituminous Concrete Overlay.
G8	For structures designed with steel members, use this note.
G9	Use is limited to the repair of, repainting of, or alterations to existing structures.
G10	For all new structures that require painting.
G11	For all new structures of weathering steel that therefore will not require painting.
G12	For all new structures of weathering steel that will require the ends of the girders to be painted at deck joints.
G13	Must be shown on the General Plan Sheet.



<u>Note No.</u>	<u>Requirements for use</u>
G14	The words “AND PILE LOADS” shall be deleted when there are no piles in the structure.
G15	Must be shown on the General Plan Sheet.
G16	To be used where existing structures are being modified or repaired.
G17	To be used where utilities are to be protected during construction. Designer to coordinate NTC as required.
G18	Must be shown on the General Plan Sheet for new or modified traffic & combination rails.

**A.1.2 LISTING OF GENERAL NOTES**

G1        SPECIFICATIONS: Connecticut Department of Transportation Form 817 (2016), Supplemental Specification dated (mm/yy) and Special Provisions.

G2        DESIGN SPECIFICATIONS: *AASHTO LRFD Bridge Design Specifications* (Edition - Year), with the Interim Specifications up to and including (year), as supplemented by the Connecticut Department of Transportation *Bridge Design Manual* (2003).

G3        MATERIAL STRENGTHS:

Concrete:

Class PCC 0334Z .....  $f'_c = 3,000$  psi

Class PCC 04462 .....  $f'_c = 4,000$  psi

Class PCC XXXYZ .....  $f'_c = XX,000$  psi

The concrete strength,  $f'_c$ , used in design of the concrete components is noted above. The compressive strength of the concrete in the constructed components shall conform to the requirements of 6.01 – Concrete for Structures, and M.03 – Portland Cement Concrete.

Reinforcement:

(ASTM A615 Grade 60) .....  $f_y = 60,000$  psi

Structural Steel:

(AASHTO M270, Grade 50) .....  $F_y = 50,000$  psi

(AASHTO M270, Grade 50W).....  $F_y = 50,000$  psi

(AASHTO M270, Grade HPS 70W) .....  $F_y = 70,000$  psi

- (AASHTO M270, Grade 100, up to 2 ½” thick) .....  $F_y = 100,000$  psi
- (AASHTO M270, Grade 100W, up to 2½” thick).....  $F_y = 100,000$  psi
- (AASHTO M270, Grade 100, over 2½” to 4”).....  $F_y = 90,000$  psi
- (AASHTO M270, Grade 100W, over 2½” to 4”).....  $F_y = 90,000$  psi

- G4 LIVE LOAD: HL-93, Legal and Permit Vehicles
- G5 LIVE LOAD: (Designer to specify all vehicles for which the bridge Rating Factors greater than 1)
- G6 FUTURE PAVING ALLOWANCE: 40 pounds per square foot
- G7 FUTURE PAVING ALLOWANCE: None
- G8 STRUCTURAL STEEL: See Structural Steel Notes for designations and requirements.
- G9 PAINT: Paint shall conform to the requirements of the special provision, “Field Painting of Structure (Site No. )” The color of the topcoat material on the structural steel shall conform to Federal Standard Color No. , (Color).

ADD THE FOLLOWING IF STEEL BOX GIRDERS ARE USED:

The interior portions of the boxes shall be painted white.

- G10 PAINT: Paint shall conform to the requirements of the special provision, “Structural Steel (Site No. \_\_).” The color of the topcoat material on the structural steel shall conform to Federal Standard Color No. , (Color).

ADD THE FOLLOWING IF STEEL BOX GIRDERS ARE USED:

The interior portions of the boxes shall be painted white.

- G11 PAINT: No painting of structural steel is required. Steel surfaces are to be prepared for weathering in accordance with the *Specifications*.
- G12 PAINT: Painting of the structural steel is only required at the ends of the girders. Steel surfaces are to be prepared for weathering in accordance with the *Specifications*.
- G13 BITUMINOUS CONCRETE OVERLAY: (The Designer shall request a pavement design from Pavement Management and include the thicknesses and mix classes in this note)

- G14      FOUNDATION PRESSURES AND PILE LOADS: The various Group Loadings noted on the substructure plan sheets refer to the Group Loads as given in the AASHTO *LRFD Bridge Design Specifications*.
- G15      DIMENSIONS: When decimal dimensions are given to less than three decimal places, the omitted digits shall be assumed to be zeros.
- G16      EXISTING DIMENSIONS: Dimensions of the existing structure shown on these plans are for general reference only. They have been taken from the original design drawings and are not guaranteed. The Contractor shall take all field measurements necessary to assure proper fit of the finished work and shall assume full responsibility for their accuracy. When shop drawings based on field measurements are submitted for review, the field measurements shall also be submitted for reference by the reviewer.
- G17      UTILITIES: The following utilities are located within the project limits and shall be protected during construction: (List all utility companies). The Contractor shall coordinate all work related to utility relocation with the respective utility companies.
- G18      MASH TEST LEVEL: The (rail type) meets the TL-(Level) criteria for MASH 2016.

## **A.2 CONCRETE NOTES**

### **A.2.1 Guidelines for Use**

Certain Concrete Notes are required to be shown on the plans. The actual notes required shall be determined with the aid of the following guidelines:

<u>Note No.</u>	<u>Requirements for use</u>
C1	Use this note on structures where Remain-In-Place forms are not to be allowed.
C2	Use this note if the extra load for Remain-In-Place forms has been included in the design of the structure or any portion of it (such as box girders). Indicate the load in pounds per square foot and the location where it applies.
C3	For structures designed with steel members, use this note. For temporary supports, indicate only the type of construction that applies.
C4	For structures designed with prestressed, precast concrete members, use this note.
C5	For all concrete structure components.

C6	Vacant
C7	Vacant
C8	Vacant
C9	Vacant
C10	Vacant
C11	Vacant
C12	Vacant
C13	Must be shown on the General Plan Sheet.
C14	Must be shown on the General Plan Sheet.
C15	For structures designed with Grade 60 reinforcement.
C16	Vacant
C17	Vacant
C18	Vacant
C19	Must be shown on the General Plan Sheet where applicable. Generally, used only when the slab rides over the backwall.
C20	Must be shown on the General Plan Sheet.
C21	Must be shown on the General Plan Sheet. Generally, used only when the slab rides over the backwall and bridge is on elastomeric bearings.
C22	Must be shown on the General Plan Sheet.

**A.2.2 LISTING OF CONCRETE NOTES**

C1	<u>REMAIN-IN-PLACE FORMS</u> : The use of remain-in-place forms on this structure is not allowed.
C2	<u>REMAIN-IN-PLACE FORMS</u> : The use of remain-in-place forms shall be allowed inside of box girders only. The box girders have been designed for the additional weight of 15 pounds per square foot for the remain-in-place forms inside to boxes.

C3     COMPOSITE CONSTRUCTION: No temporary intermediate supports shall be used during the placing and setting of the concrete deck slab. Temporary supports may be used for structural steel erection only. Construction loads and dead loads will be permitted when directed by the Engineer but only when the concrete has reached a strength of  $f'_c = 3500$  psi. Live loads (traffic) will be permitted on the structure after the concrete has reached a strength of  $f'_c = 4000$  psi.

C4     COMPOSITE CONSTRUCTION: No temporary intermediate supports shall be used prior to and during the placing and setting of the concrete deck slab. Construction loads and dead loads will be permitted when directed by the Engineer but only when the concrete has reached a strength of  $f'_c = 3500$  psi. Live loads (traffic) will be permitted on the structure after the concrete has reached a strength of  $f'_c = 4000$  psi.

C5     The following pay items and concrete classes are required for cast-in-place bridge components:

INCLUDE A TABLE SUCH AS THE FOLLOWING THAT INCLUDES APPLICABLE ITEMS, COMPONENTS AND MIX CLASSES:

<b>Item</b>	<b>Bridge Components</b>	<b>PCC Class</b>
Footing Concrete	Abutment and Wingwall Footings	PCC03340
Abutment and Wall Concrete	Abutment and Wingwall Stems, Concrete Bearing Pedestals, Keeper Blocks, Cheekwalls	PCC03340
Bridge Deck Concrete	Bridge Deck	PCC04462
Parapet Concrete	Wingwall Parapet	PCC03340
	Bridge Parapet	PCC04462

C6     Vacant

C7     Vacant

C8     Vacant

C9     Vacant

C10    Vacant

C11    Vacant

C12    JOINT SEAL: See Special Provisions.

- C13     EXPOSED EDGES: Exposed edges of concrete shall be beveled 1"x1" unless dimensioned otherwise.
- C14     CONCRETE COVER: All reinforcement shall have two inches cover unless dimensioned otherwise.
- C15     REINFORCEMENT: All reinforcement shall be galvanized after fabrication unless noted otherwise. All reinforcement shall conform to the requirements of ASTM A767, Class 1, including supplemental requirements. The cost of furnishing and placing this reinforcement shall be included in the item "Deformed Steel Bars – Galvanized."
- C16     Vacant
- C17     Vacant
- C18     Vacant
- C19     FELT: The cost of furnishing and placing 15-pound roofing felt is included in the item "Bridge Deck Concrete".
- C20     PREFORMED EXPANSION JOINT FILLER: The cost of furnishing and installing Preformed Expansion Joint Filler is paid for as "(Thickness and Type) Joint Filler for Bridges."
- C21     CLOSED CELL ELASTOMER: Furnishing and installing Closed Cell Elastomer shall be included in the item "(Thickness) Closed Cell Elastomer."
- C22     CONSTRUCTION JOINTS: Construction joints, other than those shown on the plans, will not be permitted without the prior approval of the Engineer.

**A.3    Vacant**

**A.4    Vacant**

**A.5 NOTICE TO BRIDGE INSPECTORS**

The following box shall be shown on the General Plan sheet for all bridges. The designer shall list any items that may require special inspection such as fracture critical members, hangers, joints, highly stressed members, etc.

<b>NOTICE TO BRIDGE INSPECTORS</b>	
The Department's Bridge Safety procedures require this bridge to be inspected for, but not limited to, all appropriate components indicated in the governing manuals for bridge inspection. Attention must be given to inspecting the following special components and details. (The listing for components for specific attention shall not be construed to reduce the importance of inspection of any other component of the structure.) The frequency of inspection of this structure shall be in accordance with the governing manuals for bridge inspection, unless otherwise directed by the Manager of Bridge Safety and Evaluation.	
Component or Detail	Structure Sheet Reference

## **APPENDIX B** **STRUCTURAL STEEL NOTES**

### **B.1 GENERAL**

Certain notes pertaining to the fabrication of structural steel are required to be shown on the plans. The actual notes required depend on the girder classification. Girder classifications shown below, and the notes required for each classification, are listed in TABLE B-1.

Note No. 13 should be used as required when the ratio of the unsupported top flange length (feet) to the top flange width (feet) at the section of maximum compressive stress is equal to or greater than one hundred (100).

Steel box girders require the same notes as for welded girders. In addition, Note No. 14 should be used for all box girder structures. Additional notes may be required for special conditions required by box girders.

### **B.2 GIRDER CLASSIFICATIONS**

#### **B.2.1 Simple Spans**

- Class “A” - Rolled Beams.
- Class “B” - Welded Girders.
- Class “C” - Welded Girders with Field Splices.
- Class “D” - Welded Curved Girders with Field Splices (Heat curving allowed).
- Class “E” - Welded Curved Girders with Field Splices (Heat curving not allowed).
- Class “F” - Welded Curved Girders w/o Field Splices (Heat curving allowed).
- Class “G” - Welded Curved Girders w/o Field Splices (Heat curving not allowed).

#### **B.2.2 Continuous Spans**

- Class “H” - Rolled Beams.
- Class “I” - Curved Rolled Beams.
- Class “J” - Welded Girders.
- Class “K” - Welded Curved Girders (Heat curving allowed).
- Class “L” - Welded Curved Girders (Heat curving not allowed)



**TABLE B-1: GIRDER CLASSIFICATIONS**

	A	B	C	D	E	F	G	H	I	J	K	L
1	x	x	x	x	x	x	x	x	x	x	x	x
2	x	x	x	x	x	x	x	x	x	x	x	x
3	x	x	x	x	x	x	x	x	x	x	x	x
4				x		x					x	
5					x		x					x
6		x	x		x		x			x		x
7				x		x					x	
8	x	x	x	x	x	x	x	x	x	x	x	x
9		x	x	x	x	x	x			x	x	x
10		x	x	x	x	x	x			x	x	x
11		x	x	x	x	x	x			x	x	x
12	x	x	x	x	x	x	x	x	x	x	x	x
13	x	x	x	x	x	x	x	x	x	x	x	x

x designates notes that must be included on the plans.

**B.3 LIST OF STRUCTURAL STEEL NOTES**

1. For Non-Fracture Critical bridge members use one of the following notes:

- “Structural Steel shall conform to AASHTO M270, Grade 50 T2”
- “Structural Steel shall conform to AASHTO M270, Grade 50 WT2”

For Fracture Critical bridge members use one of the following notes:

- “Structural Steel shall conform to AASHTO M270, Grade 50 F2”
- “Structural Steel shall conform to AASHTO M270, Grade 50 WF2”

Where uncoated steel is required:

- “ \* shall conform to AASHTO M270, Grade 50 WT2”
- (\* Insert component parts, such as bearings, expansion dams, troughs, etc.)

2. “Welding, welding procedures, welding inspection, and testing methods shall meet the ANSI/AASHTO/AWS D1.5-(year) - *Bridge Welding Code*, unless otherwise noted on the plans. The frequency, quantity, and type of non-destructive testing of shop and field welds shall be in accordance with D1.5 and any additional requirements specifically indicated in the Contract documents.”

3. “Field splices will not be allowed except with the written permission of the Engineer prior to the submission of shop drawings. If allowed, these splices shall be designed by the Contractor and approved by the Engineer. The cost of these splices, including the cost of design, shall be at no extra expense to the State.”

or

“Bolted field splices, other than those indicated on the plans, will not be allowed except with the written permission of the Engineer prior to the submission of shop drawings. If allowed, these splices shall be designed by the Contractor and approved by the Engineer. The cost of these splices, including the cost of design, shall be at no extra expense to the State. Welded field splices will not be allowed.”

4. “All welded girders shall be fabricated to the required horizontal curvature by heat curving or by cutting the flanges from larger size plates. Where curvature is provided by cutting the flanges, the Contractor shall indicate on the shop drawings the location of any additional splices required.”

5. “All welded girders shall be fabricated to the required horizontal curvature by cutting the flanges from larger size plates. Heat curving will not be allowed. The Contractor shall indicate on the shop drawings the location of any additional splices required.”

6. “All web to flange, web to bearing stiffener and bearing stiffener to flange fillet welds shall be inspected by the magnetic particle method.”

7. “All web to flange, web to bearing stiffener and bearing stiffener to flange fillet welds shall be inspected in their entirety by the magnetic particle method after heat curving.”

8. “Multiple pass welds, inspected by the magnetic particle method shall have each pass or layer inspected and accepted before proceeding to the next pass or layer, as determined by the Engineer.”

9. “Shop flange splices shall be located a minimum of 6 inches from web splices.”

10. “Flange or web splices shall be located a minimum of 6 inches from stiffeners and connection plates.”

11. “Ends of beams shall be vertical after the application of full dead loads.”

or

“Bearing stiffeners and the ends of girders shall be vertical after the application of full dead loads.”

or

“Bearing and intermediate stiffeners and the ends of girders shall be vertical after the application of full dead loads.”

12. For non-fracture critical members, include use one of the following notes:

**“Structural steel fabricators shall be certified under the AISC Certification Program Category for either Bridge Fabricator Simple (SBR)” or “Bridge Component QMS (CPT).”**

*Typical work includes:*

1. Bridge cross frames for straight bridges with skew angles less than 30 degrees
2. Highway sign structures
3. Bridge inspection catwalks
4. Grid decks
5. Scuppers
6. Expansion joints
7. Bearings

**“Structural steel fabricators shall be certified under the AISC Certification Program Category Bridge Fabricator Simple (SBR).”**

*Typical work includes:*

1. Straight simple un-spliced rolled beams

**“Structural steel fabricators shall be certified under the AISC Certification Program Category Bridge Fabricator Intermediate (IBR).”**

*Typical work includes:*

1. Rolled beam with field or shop splices, straight or with radius over 500 ft.
2. Built up I-shaped plate girder with constant depth except for dapped ends, with or without splices, either straight or with radius over 500 ft.
3. Built up I-shaped plate girder with variable depth, either straight or with a radius over 1000 ft
4. Truss with a length over 200 ft or less that is entirely pre-assembled at the certified facility and shipped in no more than three sub-assemblies

**“Structural steel fabricators shall be certified under the AISC Certification Program Category Bridge Fabricator Advanced (ABR).”**

*Typical work includes:*

1. Tub or trapezoidal box girders, closed box girder bridges
2. Curved girder with radius under 500 ft.
3. Large or no-preassembled trusses, arches
4. Moveable bridges
5. Cable stayed bridges

or

For fracture-critical members, include one of the following two notes:

**“Structural steel fabricators shall be certified under the AISC Certification Program Category Bridge Fabricator Intermediate with Fracture Critical endorsement (IBR, F).”**

*Examples:*

1. Rolled beam with field or shop splices, straight or with radius over 500 ft.

2. *Built up I-shaped plate girder with constant depth except for dapped ends, with or without splices, either straight or with radius over 500 ft.*
3. *Built up I-shaped plate girder with variable depth, either straight or with a radius over 1000 ft.*
4. *Truss with a length over 200 ft or less that is entirely pre-assembled at the certified facility and shipped in no more than three sub-assemblies*

**“Structural steel fabricators shall be certified under the AISC Certification Program Category certified Bridge Fabricator Advanced with Fracture Critical endorsement (ABR, F).”**

*Examples:*

1. *Tub or trapezoidal box girders, closed box girder bridges*
2. *Curved girder with radius under 500 ft.*
3. *Large or no-preassembled trusses, arches*
4. *Moveable bridges*
5. *Cable stayed bridges*

13. “The Contractor shall take the proper precautions to ensure the stability of all structural elements until the total structure is in being.”

14. “It shall be the Contractor’s responsibility to provide any additional temporary bracing required to maintain the geometry of the individual box girders, as well as the total steel structure, throughout all phases of construction including placement of the concrete deck.”

This Page is Intentionally Left  
Blank

# **DIVISION 3**

## **DESIGN AIDS**

This Page is Intentionally Left  
Blank

**DIVISION 3**  
**DESIGN AIDS**  
**TABLE OF CONENTS**

**SECTION 1 - GENERAL**

**1.1 – Design Operating Vehicles**

Design Operating Vehicles (*Rev. 04/19*)..... 1.1.1

**SECTION 2 – BRIDGE GEOMETRY (VACANT)**

**SECTION 3 – SUBSTRUCTURE DETAILS**

**3.1 – Abutment Sections & Details**

Seat Type Abutment..... 3.1.1

Pedestal Type Abutment – Typical Elevation View..... 3.1.2a

Pedestal Type Abutment – Section A ..... 3.1.2b

Pedestal Type Abutment – Section B .....3.1.2c

Pedestal Type Abutment – Pedestal Reinforcement ..... 3.1.2d

Pedestal Type Abutment – Corner Reinforcement ..... 3.1.2e

Pedestal Type Abutment – Access Details ..... 3.1.3a

Pedestal Type Abutment – Access Details ..... 3.1.3b

Pedestal Type Abutment – Access Details .....3.1.3c

Expansion Joint Detail at Abutment..... 3.1.4a

Expansion Joint Detail at Abutment..... 3.1.4b

Abutment Details for Precast Concrete Deck Units

    with Approach Slab (*Rev. 01/05*)..... 3.1.5

Abutment Details for Precast Concrete Deck Units

    without Approach Slab (*Rev. 01/05*)..... 3.1.6



**3.2 – Abutment Backfill & Drainage Requirements**

Shoulder Abutment Drainage & Backfill Requirements..... 3.2.1  
Embankment Abutment Drainage & Backfill Requirements (*Rev. 01/05*)..... 3.2.2  
Pedestal Type Abutment Drainage & Backfill Requirements ..... 3.2.3

**3.3 – Piers**

Anchor Bolt Forms at Piers..... 3.3.1

**3.4 – Wall Sections & Details**

Flared Type Wingwall or Retaining Wall ..... 3.4.1  
U-Type Wingwall or Retaining Wall with Sloped Curb ..... 3.4.2  
Standard Wingwall Parapet (32" High) ..... 3.4.3  
Standard Wingwall Parapet (42" High) ..... 3.4.4  
U-Type Wingwall or Retaining Wall with Sidewalk (*Rev. 01/05*)..... 3.4.5  
Wingwall Parapet with Sidewalk ..... 3.4.6  
Concrete Barrier Wall (32" High) ..... 3.4.7  
Concrete Barrier Wall (42" High) ..... 3.4.8  
Typical Section-Prefabricated Modular Wall  
(Sloping Backfill) (*Rev. 03/09*) ..... 3.4.9a  
Typical Section-Mechanically Stabilized Earth Wall  
(Sloping Backfill) (*Rev. 03/09*) ..... 3.4.9b  
Typical Section-Cast-In-Place Reinforced Concrete  
(Sloping Backfill) (*Rev. 03/09*) .....3.4.9c  
Typical Section-Prefabricated Modular Wall  
(Level Backfill) (*Rev. 03/09*)..... 3.4.10a  
Typical Section-Mechanically Stabilized Earth Wall  
(Level Backfill) (*Rev. 03/09*)..... 3.4.10b

Typical Section-Cast-In-Place Reinforced Concrete  
(Level Backfill) (Rev. 03/09).....3.4.10c  
Design Information for Alternate Walls (Rev. 03/09)..... 3.4.11  
Plan Notes for Alternate Walls (Rev. 12/19)..... 3.4.12  
Typical Section-Embankment Wall (Rev. 03/09) ..... 3.4.13  
Plan Notes for Embankment Walls (Rev. 03/09) ..... 3.4.14

**3.5 – Wall Backfill & Drainage Requirements**

Flared Type Wingwall or Retaining Wall – Drainage & Backfill Requirements.... 3.5.1  
U-Type Wingwall or Retaining Wall – Drainage & Backfill Requirements..... 3.5.2

**3.6 – Miscellaneous Details**

Vertical Stem Joint Details..... 3.6.1  
Abutment and Toe of Slope Locations (Height of Rock > 8'-0")..... 3.6.2  
Typical Embankment Abutment – Normal Section ( $H \leq 5'-0"$ ) ..... 3.6.3  
Typical Embankment Abutment – Normal Section ( $5'-0" < H \leq 8'-0"$ ) ..... 3.6.4  
Typical Embankment Abutment – Normal Section ( $H > 8'-0"$ ) ..... 3.6.5  
Footing Step Details ..... 3.6.6

**SECTION 4 – STRUCTURAL STEEL DETAILS**

**4.1 – Framing Plans**

Typical Framing Plan – Skew Angle  $\leq 20^\circ$  ..... 4.1.1a  
Typical Framing Plan – Skew Angle  $> 20^\circ$ ..... 4.1.1b

**4.2 – Girder Details**

Bearing Stiffeners ..... 4.2.1  
Clip & Weld Termination for Connection Plates and Bearing Stiffeners ..... 4.2.2  
Clip & Weld Termination for Intermediate Stiffeners..... 4.2.3

Connection Plates at Intermediate Diaphragms (*Rev. 01/05*)..... 4.2.4  
Connection Plates at End Bearing Diaphragms (*Rev. 01/05*)..... 4.2.5

**4.3 – Diaphragm Details**

End Bearing Diaphragm – Web Depth  $\leq 4'-0"$  ..... 4.3.1  
Intermediate Diaphragm – Web Depth  $\leq 4'-0"$  (*Rev. 01/05*)..... 4.3.2  
End Bearing Cross Frames – Web Depth  $> 4'-0"$  ..... 4.3.3  
Intermediate Cross Frames – Web Depth  $> 4'-0"$  ..... 4.3.4

**4.4 – Bearings**

Fixed Bearing ..... 4.4.1

**4.5 – Miscellaneous Steel Details**

Steel Box Girder – End Diaphragm Access Details ..... 4.5.1a  
Steel Box Girder – End Diaphragm Access Details ..... 4.5.1b  
Catenary Connection Detail for Bridges over Electrified Railroads ..... 4.5.2a  
Catenary Connection Detail for Bridges over Electrified Railroads ..... 4.5.2b

**SECTION 5 – PRESTRESSED CONCRETE DETAILS**

**5.1 – Adjacent Voided Slabs**

Section Properties – AASHTO Concrete Slabs –  $3'-0"$  Wide ..... 5.1.1a  
Section Properties – AASHTO Concrete Slabs –  $3'-0"$  Wide ..... 5.1.1b  
Section Properties – AASHTO Concrete Slabs –  $3'-0"$  Wide (*Rev. 01/05*) ..... 5.1.1c  
Section Properties – AASHTO Concrete Slabs –  $4'-0"$  Wide (*Rev. 01/05*) ..... 5.1.2a  
Section Properties – AASHTO Concrete Slabs –  $4'-0"$  Wide ..... 5.1.2b  
Section Properties – AASHTO Concrete Slabs –  $4'-0"$  Wide ..... 5.1.2c  
Strand Locations – AASHTO Concrete Slab (SI & SII –  $3'-0"$ ) ..... 5.1.3  
Strand Locations – AASHTO Concrete Slab (SIII & SIV –  $3'-0"$ ) ..... 5.1.4

Connecticut Department of Transportation Bridge Design Manual

Strand Locations – AASHTO Concrete Slab (SI & SII – 4'-0")..... 5.1.5

Strand Locations – AASHTO Concrete Slab (SIII & SIV – 4'-0") ..... 5.1.6

Strand Locations – AASHTO Concrete Slab (Design Information) ..... 5.1.7

Typical Midspan Section – AASHTO Concrete Slabs..... 5.1.8

End Block Reinforcement – AASHTO Concrete Slabs ..... 5.1.9a

End Block Reinforcement – AASHTO Concrete Slabs ..... 5.1.9b

**5.2 – Adjacent Box Beams**

Section Properties – AASHTO Concrete Box Beams..... 5.2.1a

Section Properties – AASHTO Concrete Box Beams..... 5.2.1b

Strand Locations – AASHTO Box Beams (Type BI, BI Modified & BII) ..... 5.2.2

Strand Locations – AASHTO Box Beams (Type BIII, BIV & BIV Modified)..... 5.2.3

Typical Midspan Section – AASHTO Box Beams..... 5.2.4

End Block Reinforcement – AASHTO Box Beams ..... 5.2.5a

End Block Reinforcement – AASHTO Box Beams ..... 5.2.5b

**5.3 – Transverse Tie Details**

Framing Plan – Precast Concrete Deck Units (Skew  $\leq 35^\circ$ ) ..... 5.3.1

Transverse Tie Strand Arrangement for Precast Concrete  
Deck Units (Skew  $\leq 35^\circ$ )..... 5.3.2

Framing Plan with Stage Construction – Precast Concrete  
Deck Units (Skew  $> 35^\circ$ )..... 5.3.3

Stage Construction Details for Precast Concrete Deck Units (Skew  $\leq 35^\circ$ )..... 5.3.4

Framing Plan – Precast Concrete Deck Units (Skew  $> 35^\circ$ ) ..... 5.3.5

Transverse Tie Strand Arrangement for Precast Concrete  
Deck Units (Skew  $> 35^\circ$ )..... 5.3.6

Transverse Tie Locations – Precast Concrete Deck Units..... 5.3.7

Connecticut Department of Transportation Bridge Design Manual

Internal Diaphragms for Precast Concrete Voided Slabs (Skew  $\leq 25^\circ$ ) ..... 5.3.8

Internal Diaphragms for Precast Concrete Voided Slabs (Skew  $> 25^\circ$ ) ..... 5.3.9

Internal Diaphragms – Precast Concrete Box Beams ..... 5.3.10

Typical Longitudinal Joint – Precast Concrete Deck Units..... 5.3.11

Vacant ..... 5.3.12

Transverse Tie Anchorage – Precast Concrete Deck Units..... 5.3.13

Transverse Tie Tensioning Notes for Precast Concrete

Box Beams (Skew  $\leq 35^\circ$ )..... 5.3.14

Transverse Tie Tensioning Notes for Precast Concrete

Box Beams (Skew  $> 35^\circ$ )..... 5.3.15

**5.4 – Bulb Tee Details**

Section Properties New England Bulb Tee Type (NEBT 40-72)..... 5.4.1

Typical Midspan Section New England Bulb Tee Beams ..... 5.4.2

Strand Locations and Hold Down Details (New England Bulb Tee Beams) ..... 5.4.3

**5.5 – Bearings**

Elastomeric Bearing Layout for Precast Concrete Deck Units..... 5.6.1

**5.6 – Parapets**

Standard parapet – 32” High (On Voided Slabs) ..... 5.6.1

Standard parapet – 32” High (On Butted Box Beams)..... 5.6.2

Standard parapet – 42” High (On Voided Slabs) ..... 5.6.3

Standard parapet – 42” High (On Butted Box Beams)..... 5.6.4

Parapet with Sidewalk (On Voided Slabs) ..... 5.6.5

Parapet with Sidewalk (On Butted Box Beams)..... 5.6.6

## SECTION 6 – Bridge Deck Details

### 6.1 – Slab Details

Typical Slab Section ( <i>Rev. 01/05</i> ) .....	6.1.1
Typical Section at Transverse Construction Joint in Slab .....	6.1.2
Tie-Down For Slab Reinforcement .....	6.1.3
Details at Ends of Slabs (Steel Stringers).....	6.1.4
Additional Reinforcement at Acute Corners (Skew > 20°) .....	6.1.5a
Additional Reinforcement at Acute Corners (Skew > 20°) .....	6.1.5b
Shear Connectors (Welded Stud).....	6.1.6
Deck Weephole Details (Welded Girders and Rolled Beams) .....	6.1.7
Deck Weephole Details (Steel Box Girders).....	6.1.8
Overlay Interface Drainage Details.....	6.1.9

### 6.2 – Parapet Details

Standard Parapet – 32” High ( <i>Rev. 12/19</i> ) .....	6.2.1
Standard Parapet – 42” High ( <i>Rev. 12/19</i> ) .....	6.2.2
Parapet with Sidewalk ( <i>Rev. 12/19</i> ).....	6.2.3
Design Information for Parapets ( <i>Rev. 12/19</i> ) .....	6.2.4
Anchorage for Regulatory, Warning and Guide Signs .....	6.2.5a
Anchorage for Regulatory, Warning and Guide Signs .....	6.2.5b
Anchorage for Box Truss Sign Support ( <i>Rev. 12/19</i> ).....	6.2.6a
Anchorage for Box Truss Sign Support ( <i>Rev. 12/19</i> ).....	6.2.6b
Parapet Reinforcement at Lighting Standard and Junction Box ( <i>Rev. 12/19</i> )...	6.2.7a
Parapet Reinforcement at Lighting Standard ( <i>Rev. 12/19</i> ).....	6.2.7b
Parapet Reinforcement at Lighting Standard ( <i>Rev. 12/19</i> ).....	6.2.7c
Parapet Reinforcement at Junction Box ( <i>Rev. 12/19</i> ).....	6.2.8a

Parapet Reinforcement at Junction Box (*Rev. 12/19*)..... 6.2.8b  
Parapet Reinforcement at Junction Box (Parapet and Sidewalk) (*Rev. 12/19*)..6.2.8c

**6.3 – Median Barrier Details**

Standard Split Median Barrier Curb (4’-9” High) (*Rev. 04/19*) ..... 6.3.1

**6.4 – Approach Slab Details**

Bridge Approach Slabs – Skew  $\leq 35^\circ$  ..... 6.4.1  
Bridge Approach Slabs – Skew  $> 35^\circ$  ..... 6.4.2  
Bridge Approach Slab Details..... 6.4.3a  
Bridge Approach Slab Details..... 6.4.3b

**SECTION 7 – Expansion Joint Details**

**7.1 – Asphaltic Plug Joints**

Asphaltic Expansion Joint System..... 7.1.1a  
Asphaltic Plug Expansion Joint System..... 7.1.1b

**7.2 – Strip Seals**

Elastomeric Concrete Expansion Joint System (*Rev. 04/19*)..... 7.2.1a-e

**7.3 – Finger Joints**

Finger Joint Details at Abutment..... 7.3.1  
Finger Joint Details at Abutment (End of Slab Section) ..... 7.3.2  
Finger Joint Details at Abutment (Backwall Section) ..... 7.3.3  
Finger Joint Details at Abutment (Finger Joint)..... 7.3.4

**7.4 – Modular Joints**

Modular Expansion Joint ..... 7.4.1

**7.5 – Expansion Joints**

Silicone Expansion Joint (*Rev. 04/19*) ..... 7.5.1a-e

**SECTION 8 – Bridge Railing and Approach Rail Details**

**8.1 – Metal Bridge Railing (VACANT)**

**8.2 – Protective Fence (VACANT)**

**8.3 – Approach Rail Attachments**

Parapet Anchorage – Three Cable Guide Railing (Type I) ..... 8.3.1

Parapet Anchorage – Three Cable Guide Railing (Type II) (*Rev. 12/19*)..... 8.3.2

Safety Shape Transition for Beam Rail Attachment

    Standard Parapet 42” High Leading End (*Rev. 12/19*) ..... 8.3.3a

Safety Shape Transition for Beam Rail Attachment

    Standard Parapet 42” High Leading End (*Rev. 12/19*) ..... 8.3.3b

Safety Shape Transition for Beam Rail Attachment

    Standard Parapet 42” High Leading End (*Rev. 12/19*) .....8.3.3c

Safety Shape Transition for Beam Rail Attachment

    Standard Parapet 42” High Leading End (*Rev. 12/19*) ..... 8.3.3d

Safety Shape Transition for Beam Rail Attachment

    Standard Parapet 42” High Trailing End (*Rev. 04/19*) ..... 8.3.4

Safety Shape Transition for Beam Rail Attachment

    Standard Parapet 32” High Leading End (*Rev. 12/19*) ..... 8.3.5a

Safety Shape Transition for Beam Rail Attachment

    Standard Parapet 32” High Leading End (*Rev. 12/19*) ..... 8.3.5b

Safety Shape Transition for Beam Rail Attachment

    Standard Parapet 32” High Leading End (*Rev. 12/19*) .....8.3.5c



Connecticut Department of Transportation Bridge Design Manual

Safety Shape Transition for Beam Rail Attachment

Standard Parapet 32" High Leading End (*Rev. 12/19*) ..... 8.3.5d

Safety Shape Transition for Beam Rail Attachment

Standard Parapet 32" High Trailing End (*Rev. 12/19*) ..... 8.3.6

Beam Rail Attachment for Vertical Face Parapet with Sidewalk

32" High Leading End (*Rev. 12/19*) ..... 8.3.7a

Beam Rail Attachment for Vertical Face Parapet with Sidewalk

32" High Leading End (*Rev. 12/19*) ..... 8.3.7b

Beam Rail Attachment for Vertical Face Parapet with Sidewalk

32" High Leading End (*Rev. 12/19*) .....8.3.7c

Beam Rail Attachment for Vertical Face Parapet with Sidewalk

32" High Leading End (*Rev. 12/19*) ..... 8.3.7d

Beam Rail Attachment for Vertical Face Parapet with Sidewalk

32" High Trailing End (*Rev. 12/19*) ..... 8.3.8

Beam Rail Attachments Beam Rail Notes ..... 8.3.9

Beam Rail Attachment for Reconstructed Vertical Face Parapet

With Sidewalk 42" High Leading End (*Rev. 12/19*)..... 8.3.9a

Beam Rail Attachment for Reconstructed Vertical Face Parapet

With Sidewalk 42" High Leading End (*Rev. 12/19*)..... 8.3.9b

Beam Rail Attachment for Reconstructed Vertical Face Parapet

With Sidewalk 42" High Leading End (*Rev. 12/19*).....8.3.9c

Beam Rail Attachment for Reconstructed Vertical Face Parapet

With Sidewalk 42" High Leading End (*Rev. 12/19*)..... 8.3.9d

Beam Rail Attachment for Vertical Face Parapet with Sidewalk

42" High Trailing End (*Rev. 04/19*) ..... 8.3.10

## **SECTION 9 – Rehabilitation**

### **9.1 – Deck Repairs**

Details for Removal of Portions of Existing Concrete Haunch .....	9.1.1
Details for Removal of Portions of Existing Concrete Haunch (Notes) .....	9.1.2

### **9.2 – Substructure Repairs (VACANT)**

### **9.3 – Parapet Modifications**

Parapet Modification Details .....	9.3.1a
Parapet Modification Details .....	9.3.1b
Parapet Modification Details (Notes) .....	9.3.1c

## **SECTION 10 – Buried Structures**

### **10.1 – Precast Concrete Box Culverts**

Vacant .....	10.1.1
Precast Box Culvert – Typical Section.....	10.1.2
Precast Box Culvert – Cast-in-Place Cutoff and Return Wall Detail ( <i>Rev. 01/05</i> ).....	10.1.3
Precast Box Culvert – Cast-in-Place Nosing and Footing Detail ( <i>Rev. 01/05</i> ).....	10.1.4a
Precast Box Culvert – Cast-in-Place Nosing Section .....	10.1.4b
Precast Box Culvert – Cast-in-Place Nosing Footing Section.....	10.1.4c
Precast Culvert Notes.....	10.1.5
Typical Box Culvert Wingwall Layout.....	10.1.6
Vacant .....	10.1.7

### **10.2 – Cast-in-Place Concrete Box Culverts**

Cast-in-Place Box Culvert – Reinforcement Details .....	10.2.1
---	--------

Connecticut Department of Transportation Bridge Design Manual

Joint and Backfill Details for Box Culverts ..... 10.2.2

**10.3 – Junction Boxes (VACANT)**

**SECTION 11 – Sign Supports (VACANT)**

**BRIDGE PLATES 1.1.1 AND 1.1.2 DELETED, 04/19**

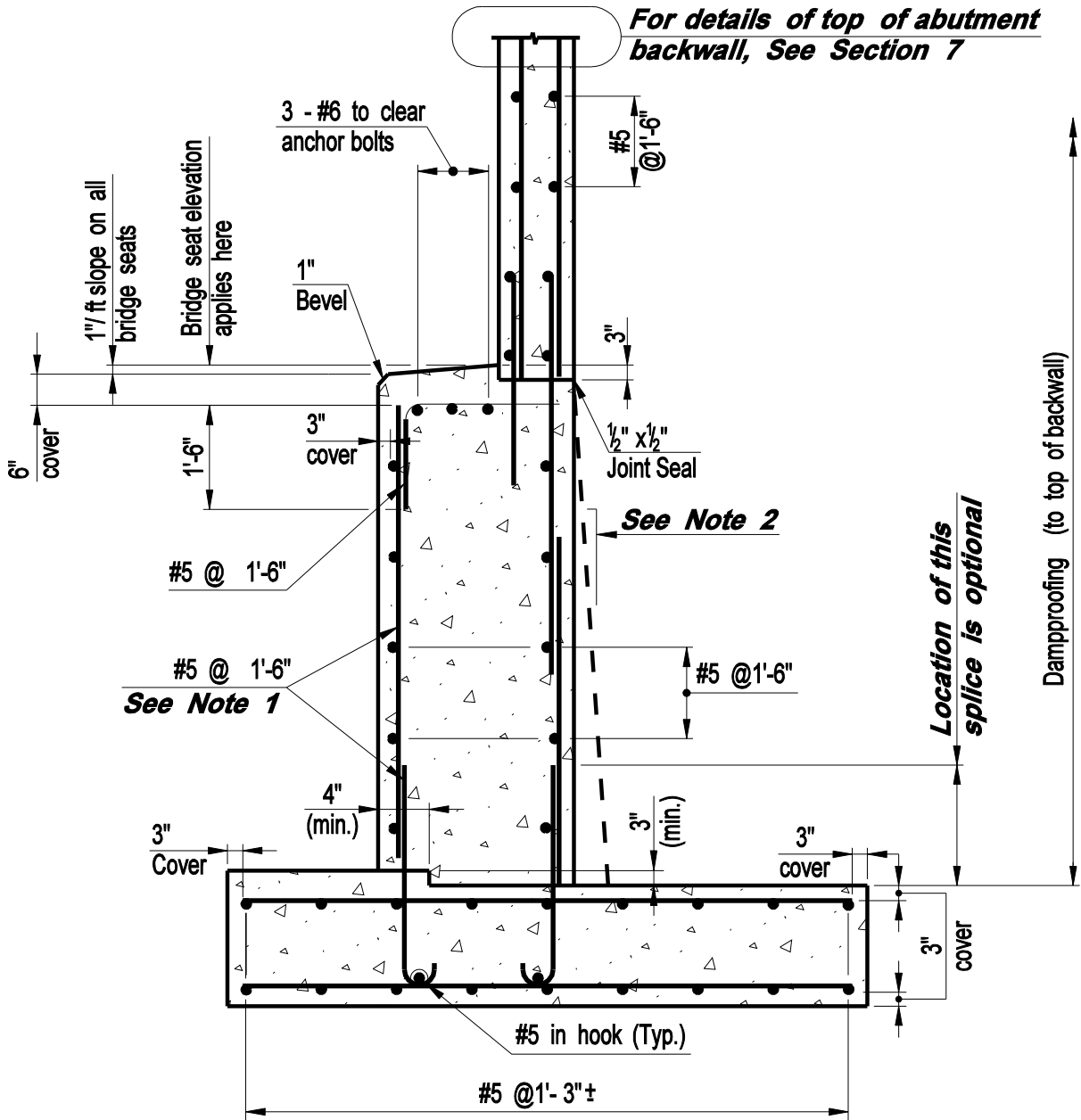
**CONNECTICUT  
BRIDGE DESIGN  
MANUAL**

DESIGN OPERATING  
VEHICLES

Issue Date: 10/03

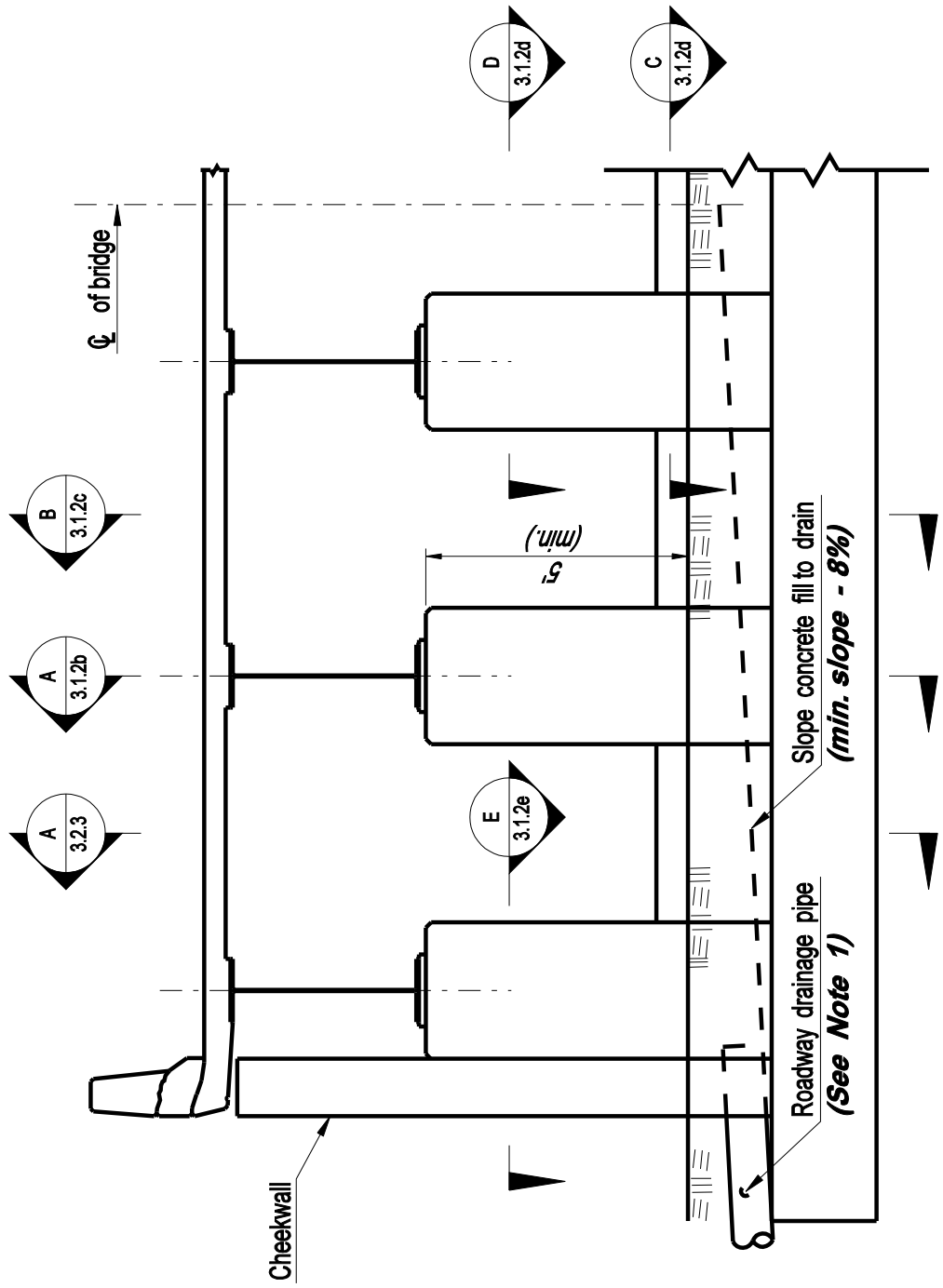
Revision Date: 04/19

Plate Number:  
1.1.1



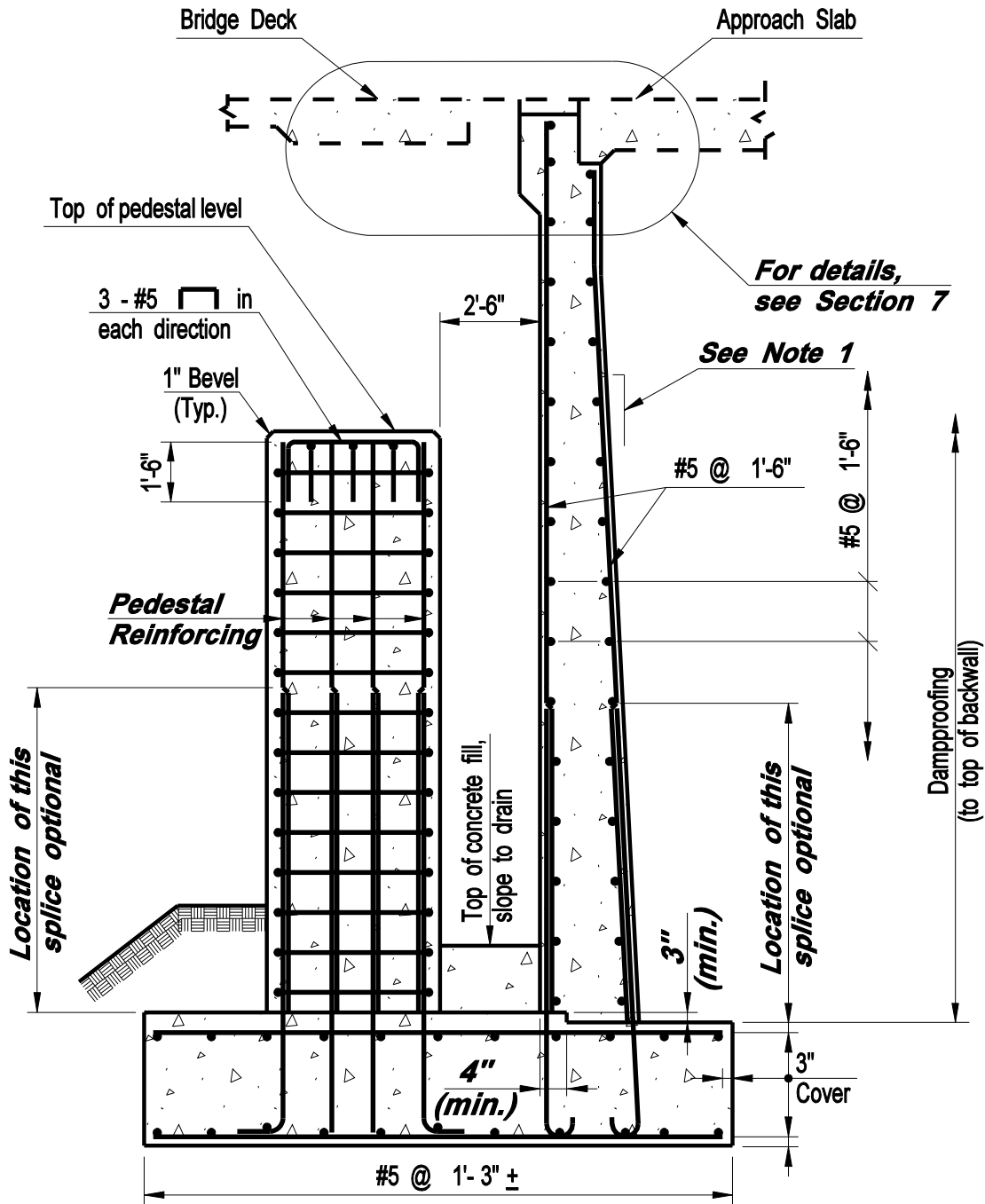
**NOTES:**

- 1. This reinforcement shall be designed for seismic forces.**
- 2. The rear face of the stem shall be battered if additional width at the base of the stem is required. The minimum batter shall be 1H:12V. Maintain a uniform top of batter elevation.**



**DESIGN INFORMATION**

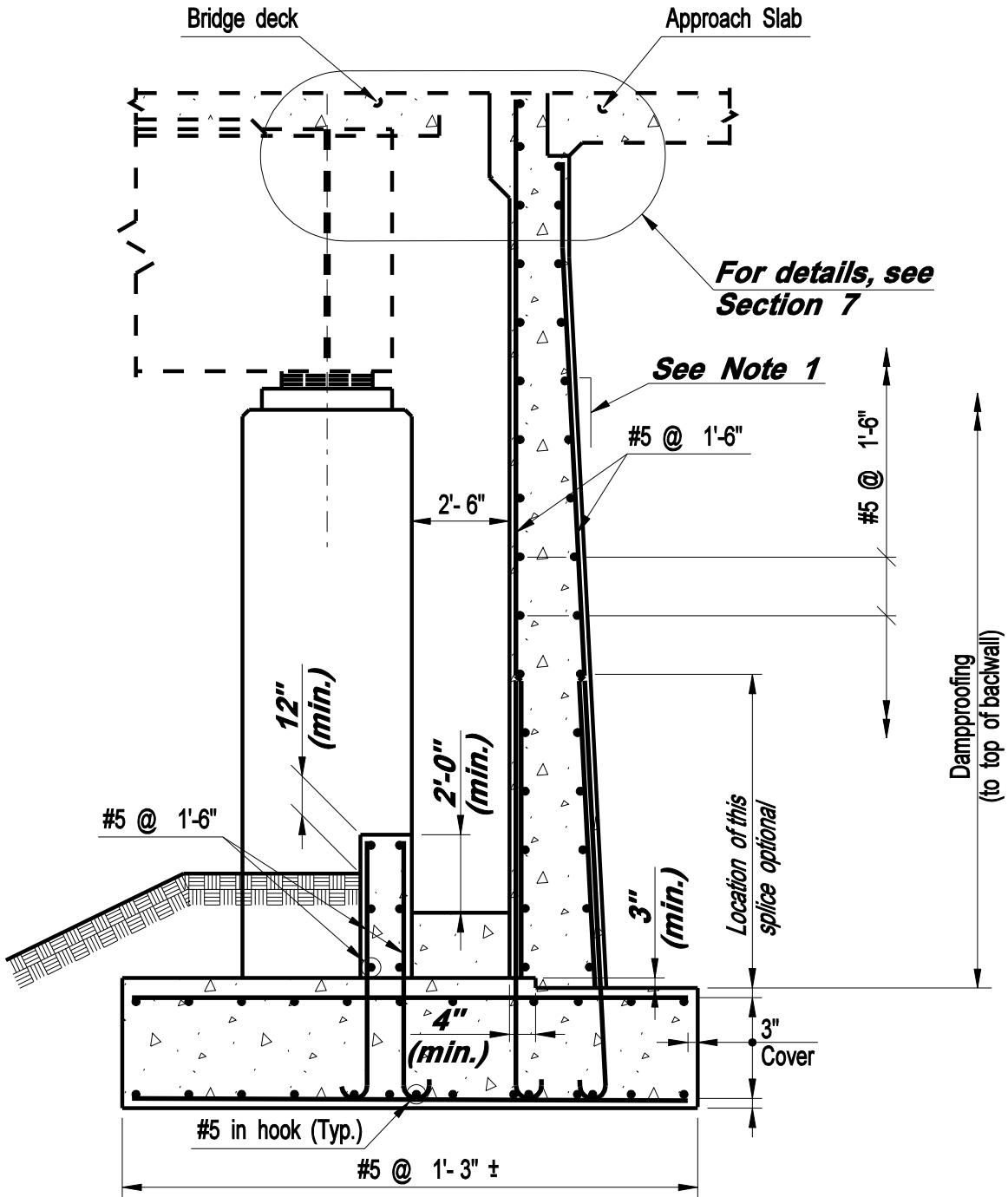
**1. Designer shall determine the size of the outlet pipe and shall connect it to the roadway drainage system. Minimum size shall be 12".**



SECTION A  
3.1.2a

**DESIGN INFORMATION**

1. The rear face of the stem shall be battered if additional width at the base of the stem is required. The minimum batter shall be 1H:12V. Maintain a uniform top of batter elevation.



SECTION B  
3.1.2a

**DESIGN INFORMATION**

1. The rear face of the stem shall be battered if additional width at the base of the stem is required. The minimum batter shall be 1H:12V. Maintain a uniform top of batter elevation.

**CONNECTICUT  
BRIDGE DESIGN  
MANUAL**

PEDESTAL TYPE ABUTMENT  
SECTION B

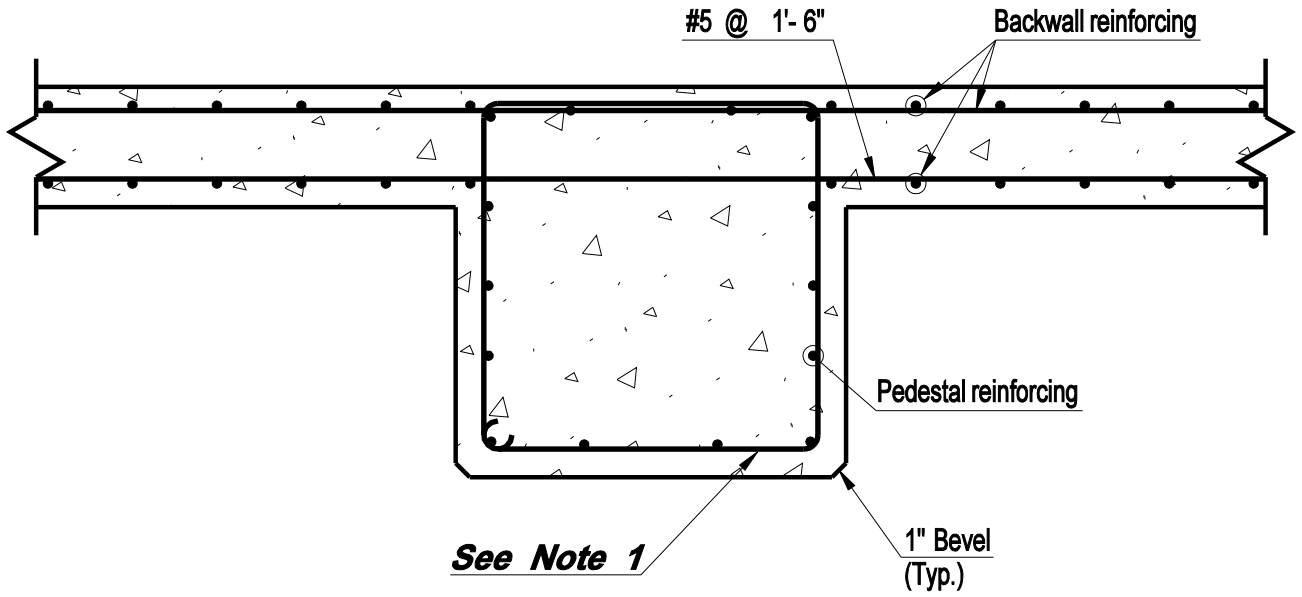
Issue Date: 10/03

Revision Date:

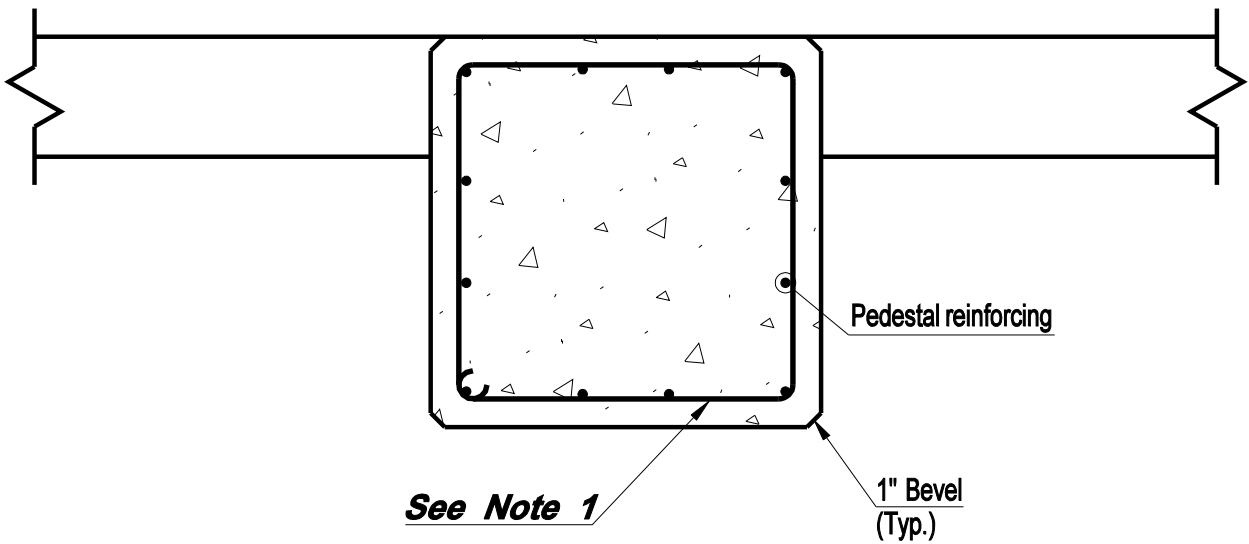
Plate Number:

3.1.2c





SECTION C  
3.1.2a



SECTION D  
3.1.2a

DESIGN INFORMATION

*1. Ties to be designed in accordance with AASHTO requirements.*

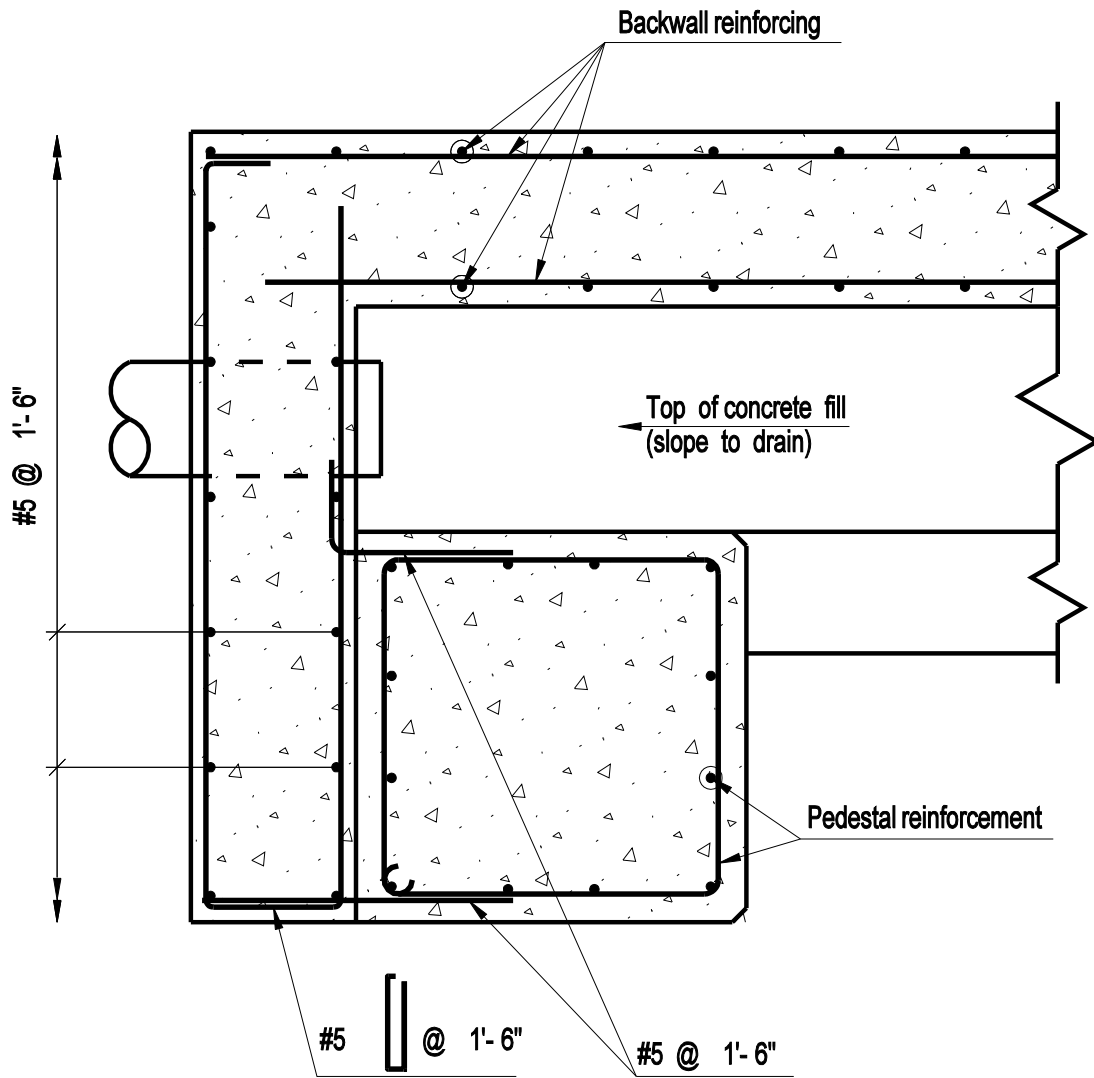
**CONNECTICUT  
BRIDGE DESIGN  
MANUAL**

PEDESTAL TYPE ABUTMENT  
PEDESTAL REINFORCEMENT

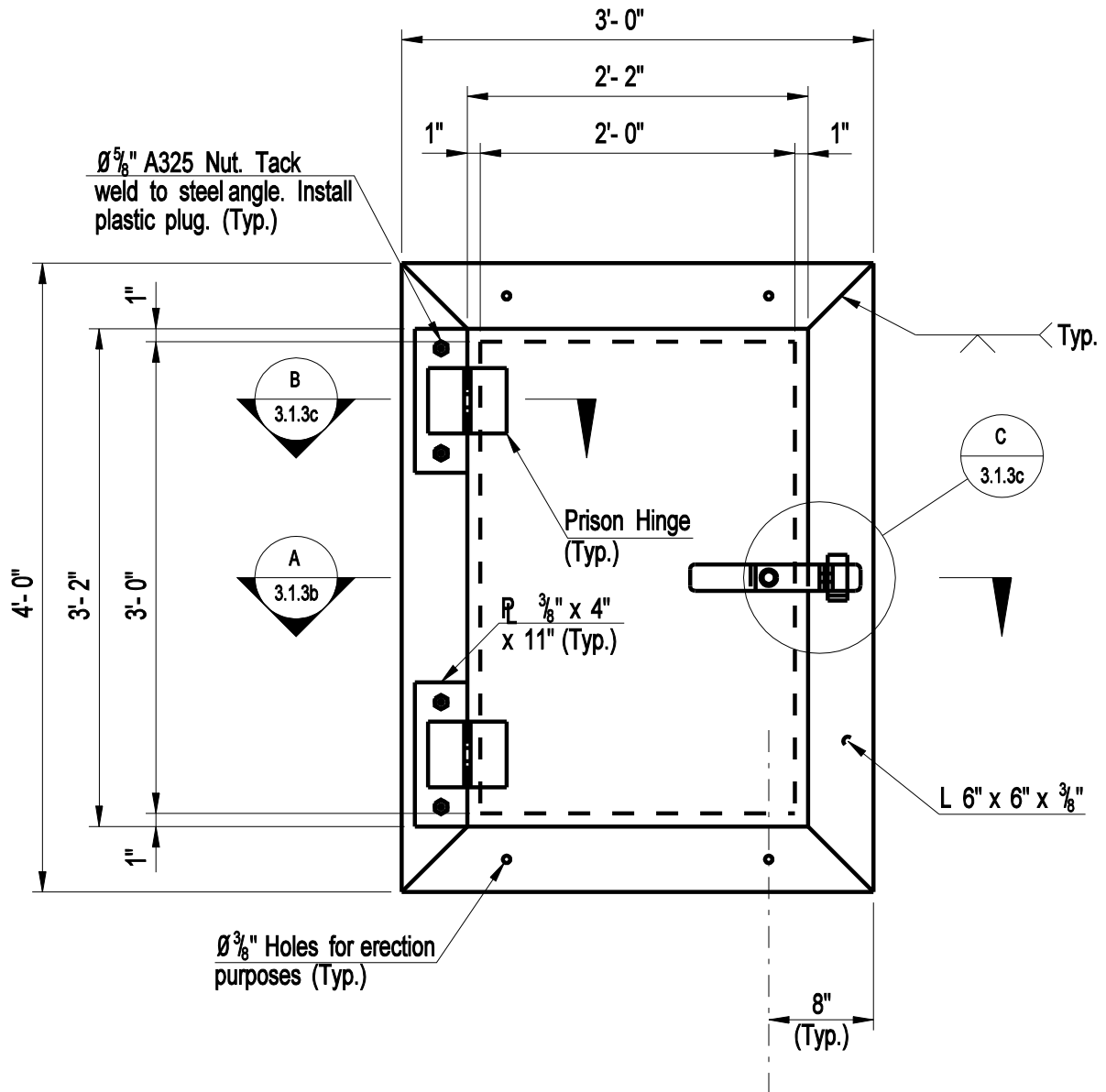
Issue Date: 10/03

Revision Date:

Plate Number:  
3.1.2d

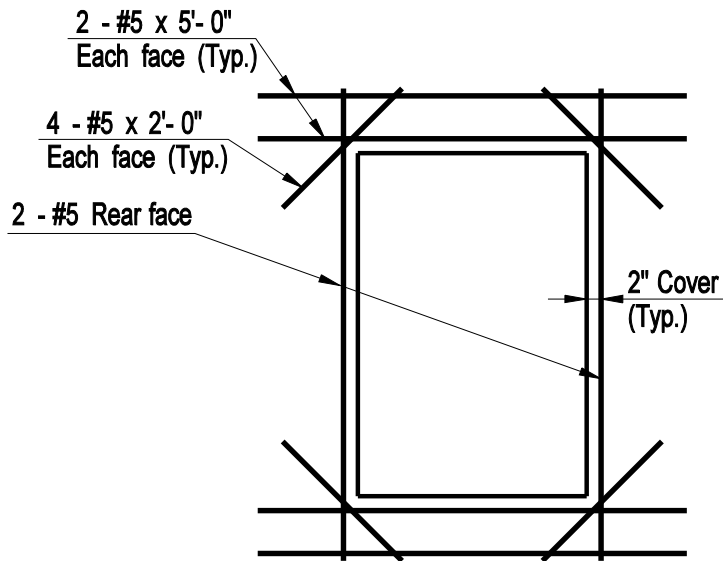


SECTION E  
3.1.2a

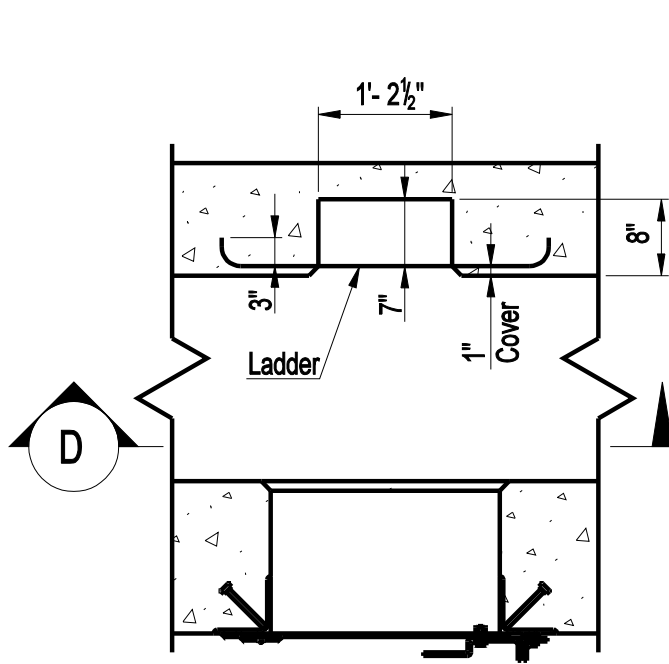


**NOTES:**

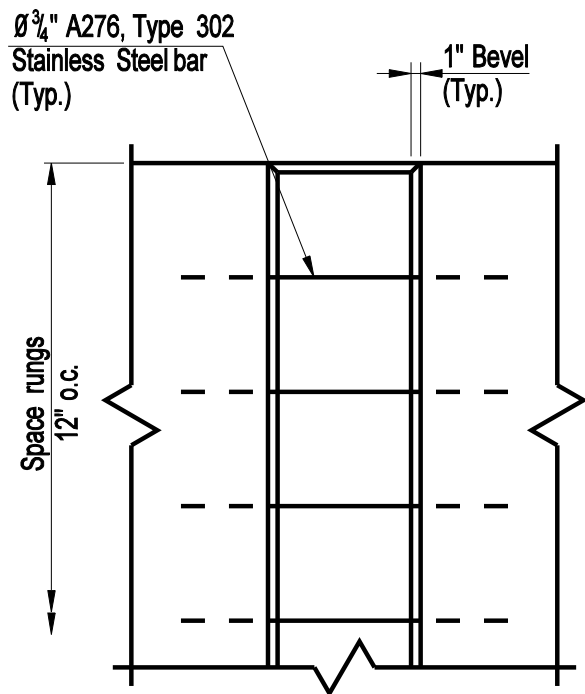
1. Material for access door and frame shall conform to the requirements of AASHTO M270 Grade 50.
2. Frame and door assembly shall be galvanized in accordance with ASTM A123 after fabrication.



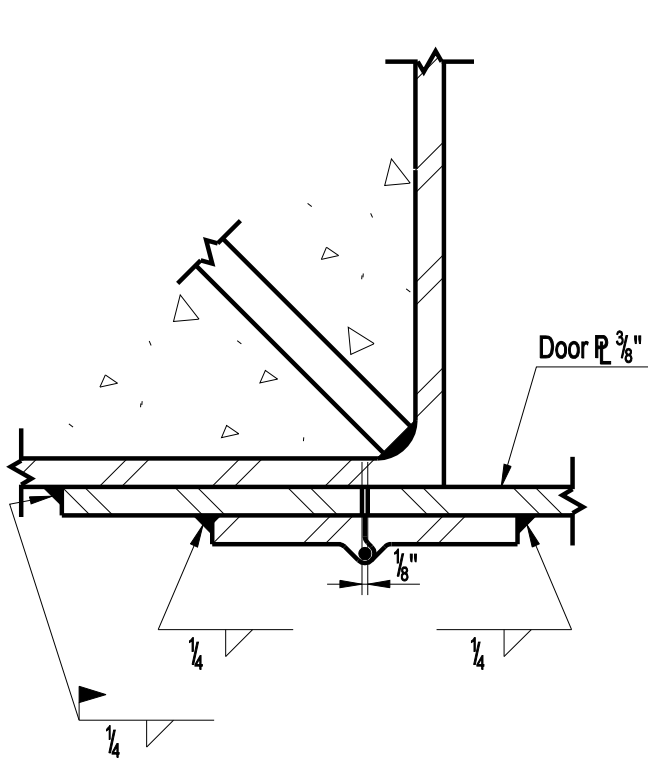
**ADDITIONAL REINFORCING  
AT ACCESS DOOR**



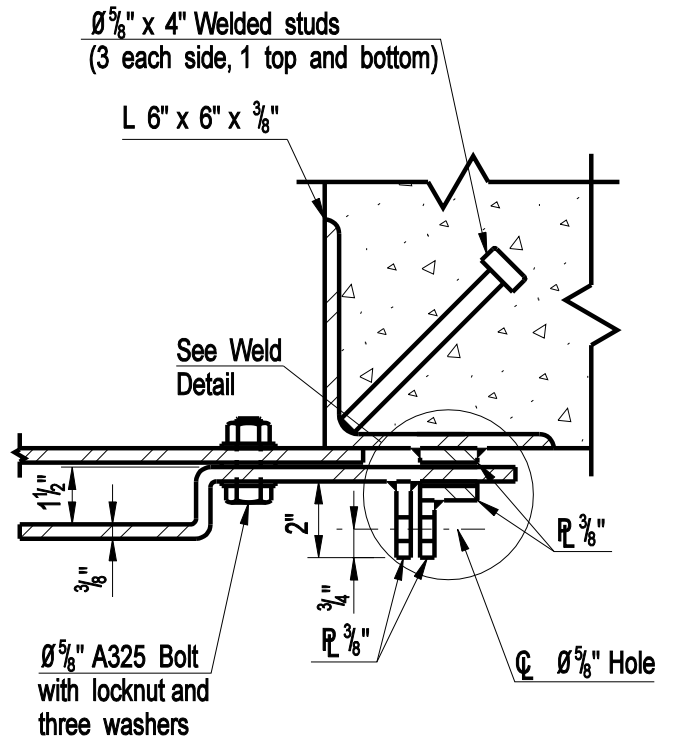
SECTION A  
3.1.3a



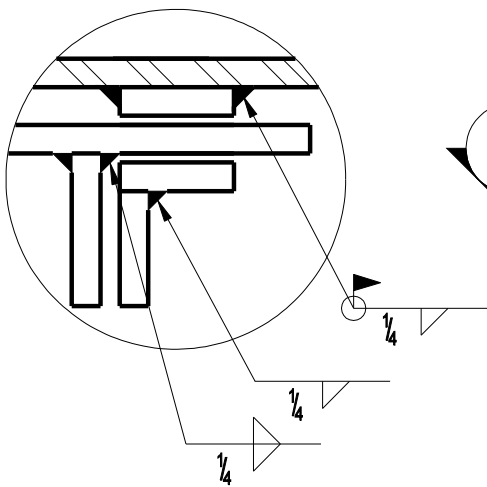
VIEW D



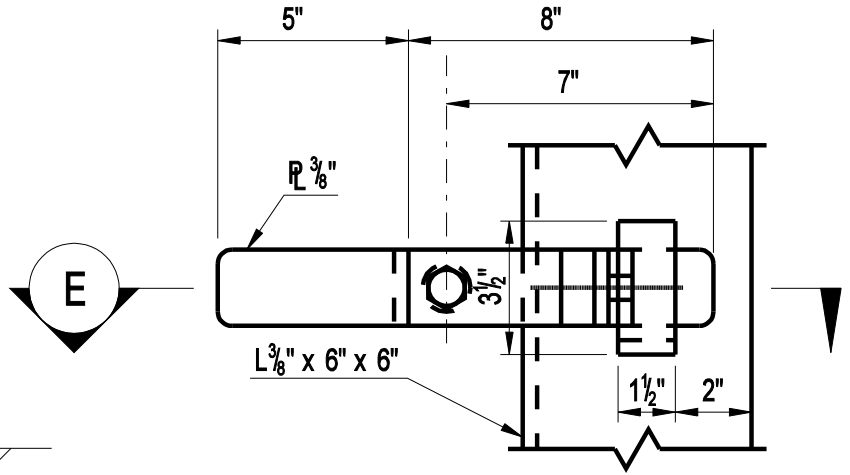
SECTION B



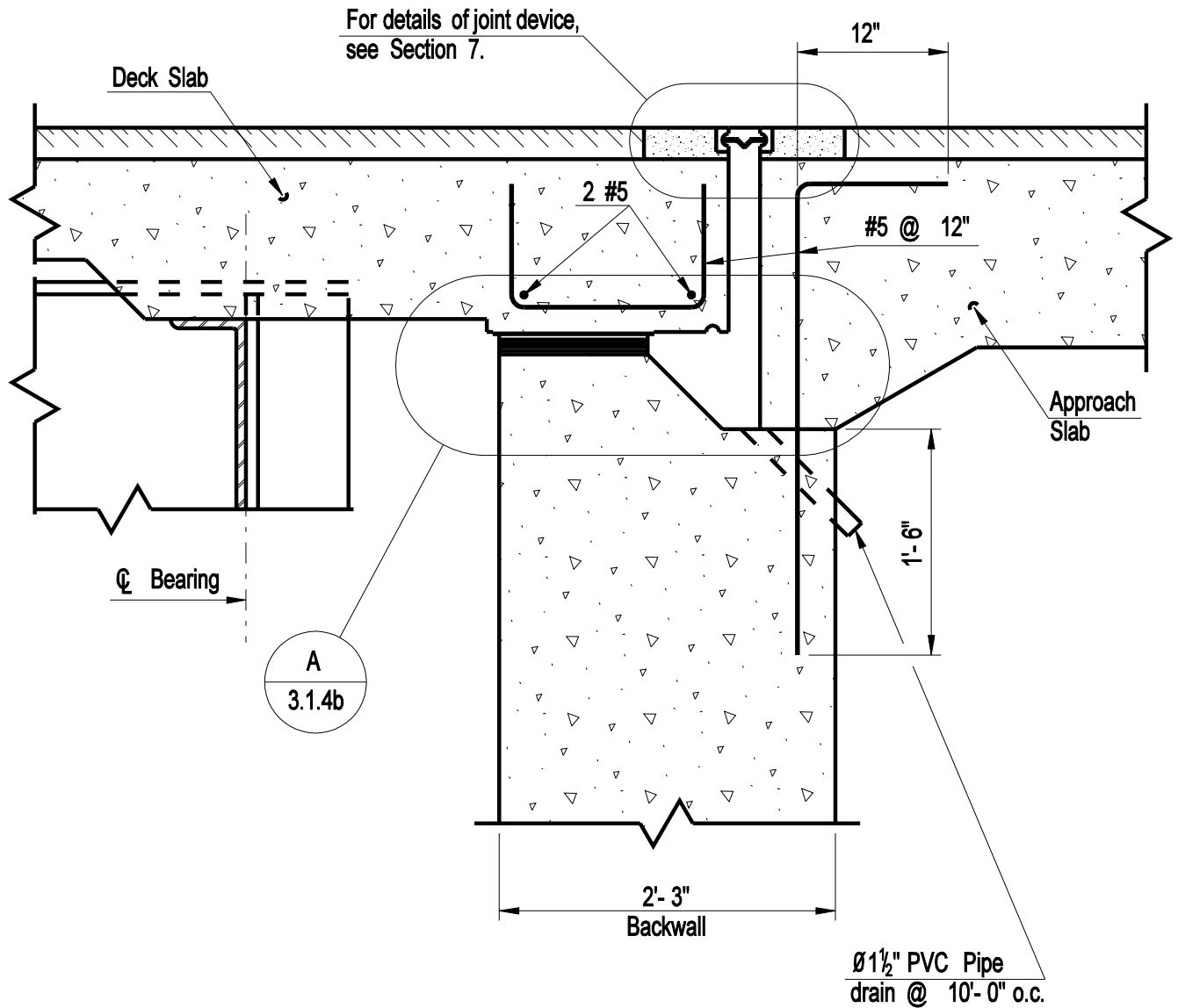
SECTION E



WELD DETAIL

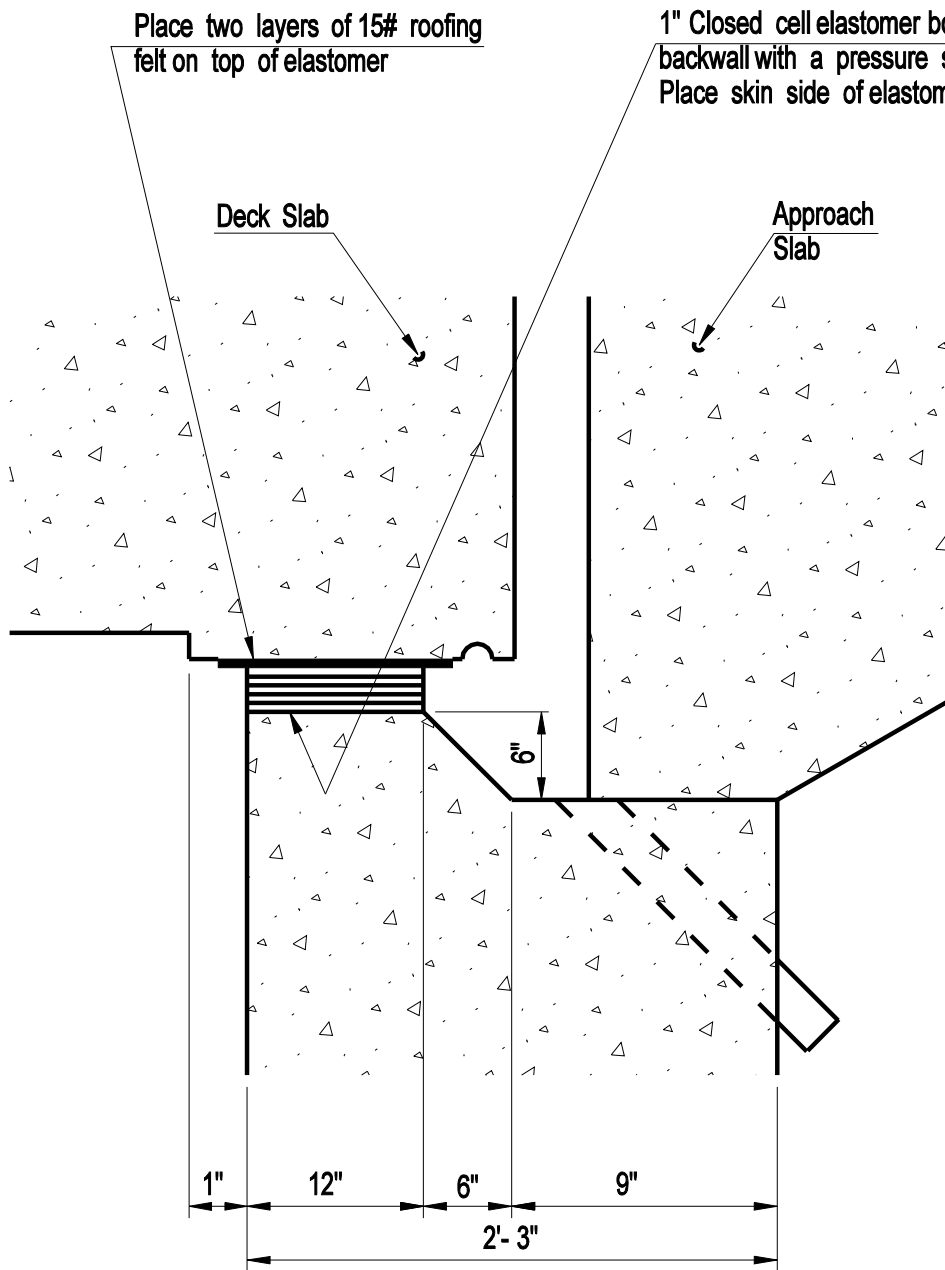


LATCH DETAIL C

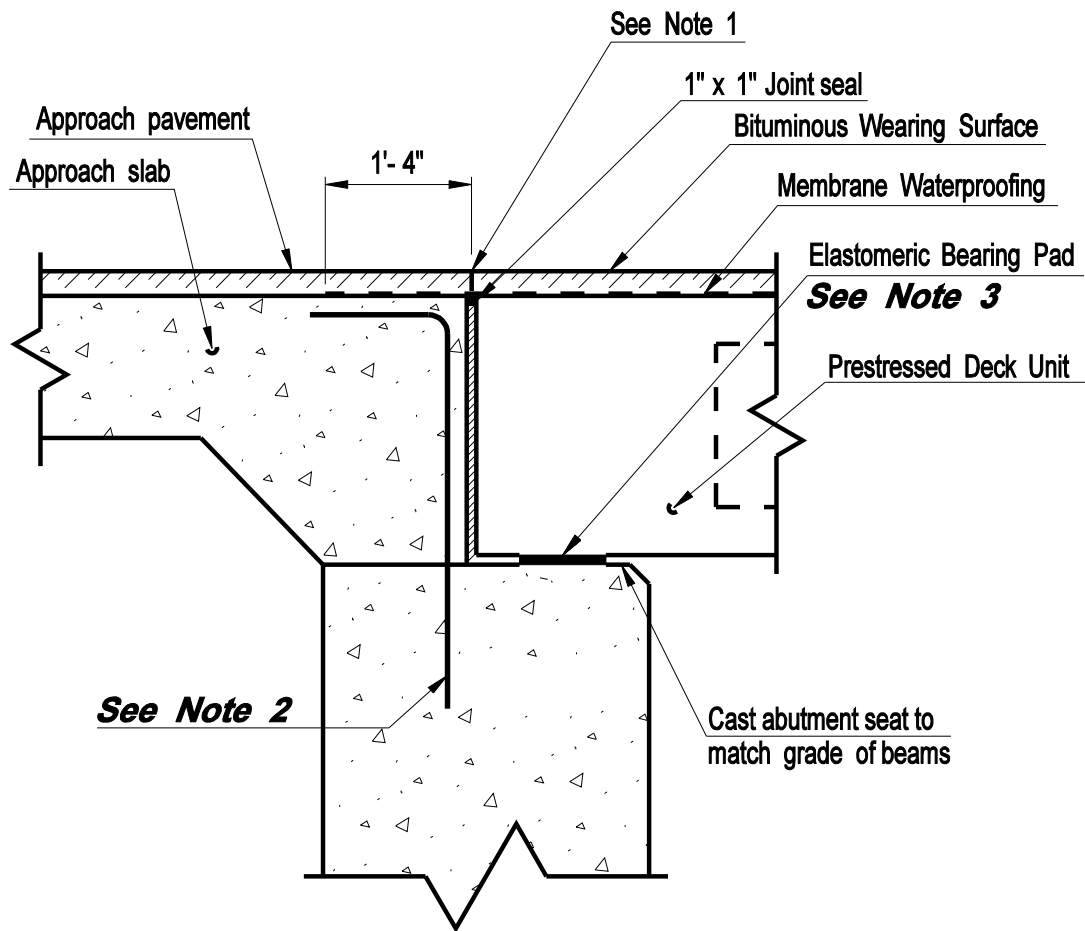


**NOTES:**

1. For slab information not shown, see Section 6.
2. For approach slab details, see Section 6.



DETAIL A



## TYPICAL SECTION THROUGH ABUTMENT AT BEARING

### NOTES:

1. Cut bituminous overlay with  $\frac{3}{8}$ " wide by  $1\frac{3}{4}$ " deep kerf and fill with pourable sealant.  
To be paid for under the item "Sawing and Sealing Joints in Bituminous Pavement".

### DESIGN INFORMATION:

2. *The approach slab and cheekwall reinforcement shall be designed to resist longitudinal and transverse seismic forces.*
3. *Elastomeric Bearing shall be designed according to Section 14 of the AASHTO specifications.*

**CONNECTICUT  
BRIDGE DESIGN  
MANUAL**

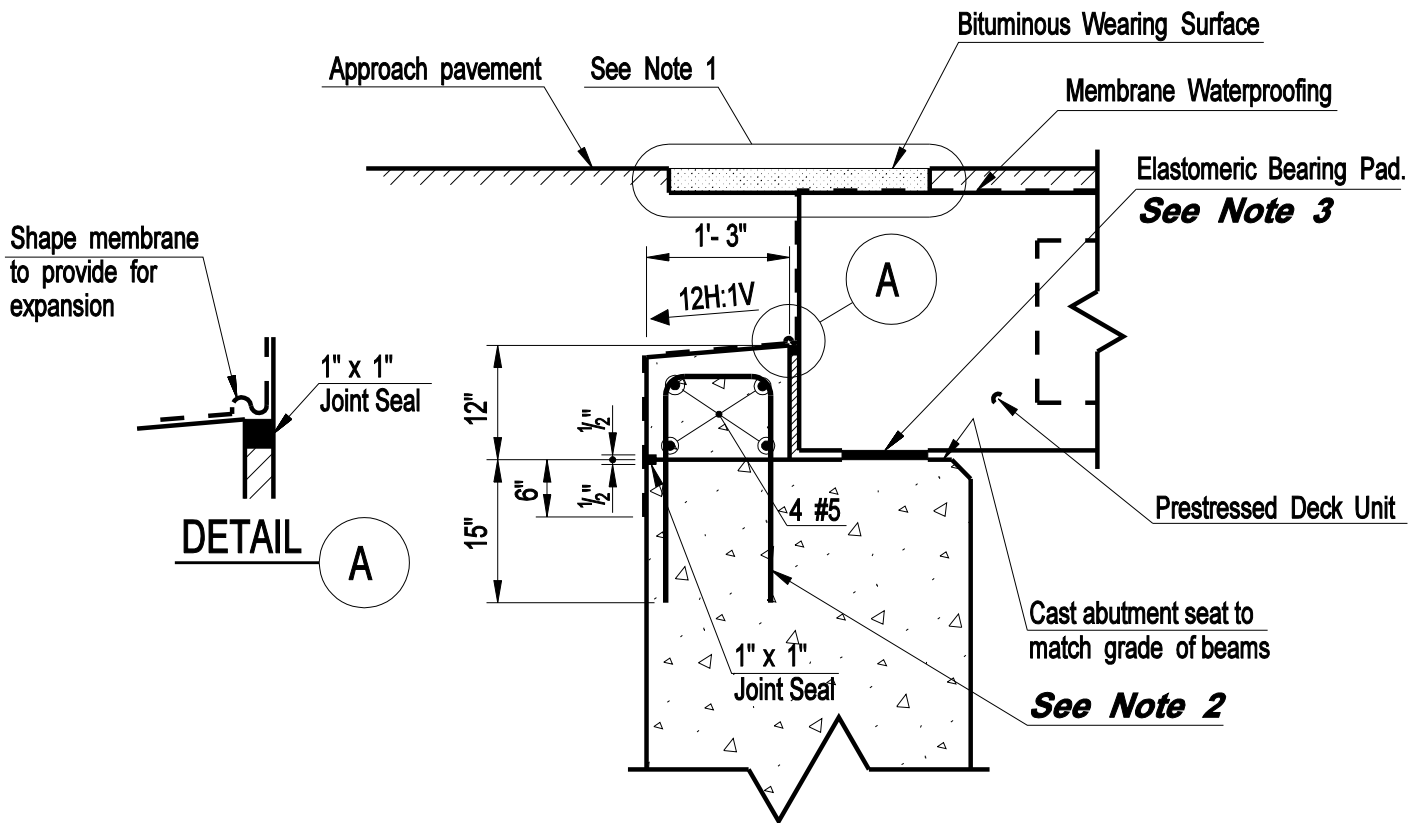
ABUTMENT DETAILS FOR  
PRECAST CONCRETE DECK  
UNITS WITH APPROACH SLAB

Issue Date: 01/05

Revision Date: 01/05

Plate Number:  
3.1.5





**TYPICAL SECTION THROUGH ABUTMENT AT BEARING**

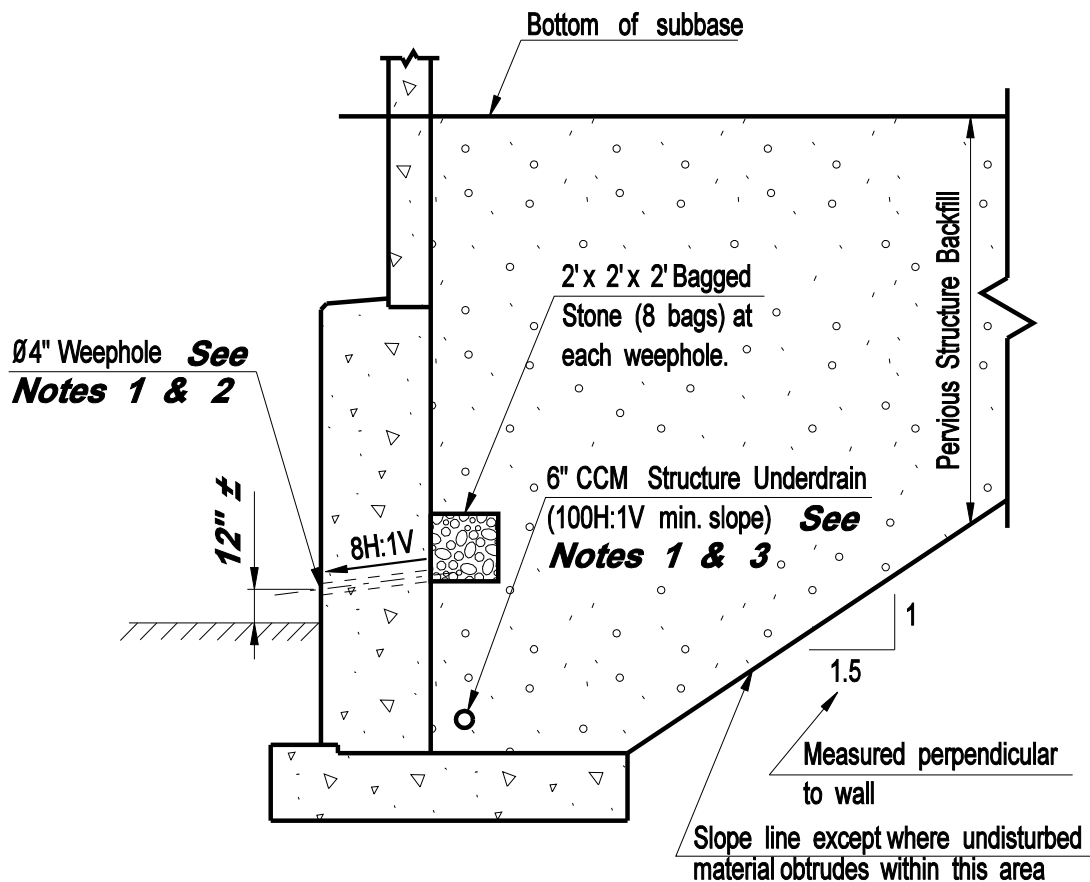
**NOTES:**

1. For details of joint device, see Section 7

**DESIGN INFORMATION:**

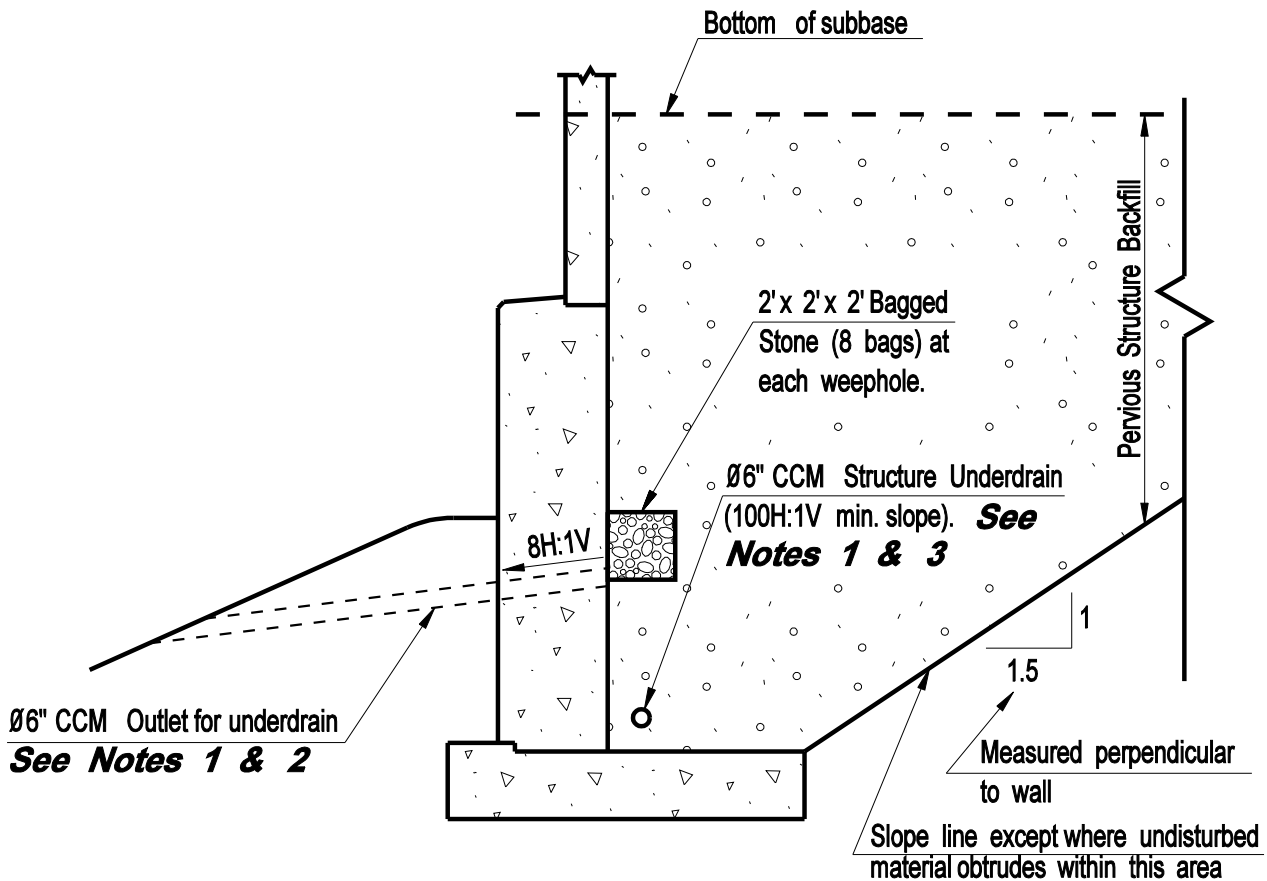
- 2. The backwall and cheekwall shall be designed to resist longitudinal and transverse seismic forces.**
- 3. Elastomeric Bearing shall be designed according to Section 14 of the AASHTO specifications.**
- 4. This detail should be used only with the express permission of the Department. In most cases, approach slabs shall be used as detailed on Plate 3.1.5. See Article 5.8, Section I for warrants for use.**

<b>CONNECTICUT BRIDGE DESIGN MANUAL</b>	<b>ABUTMENT DETAILS FOR PRECAST CONCRETE DECK UNITS WITHOUT APPROACH SLAB</b>	Issue Date: 10/03
		Revision Date: 01/05
		Plate Number: <b>3.1.6</b>



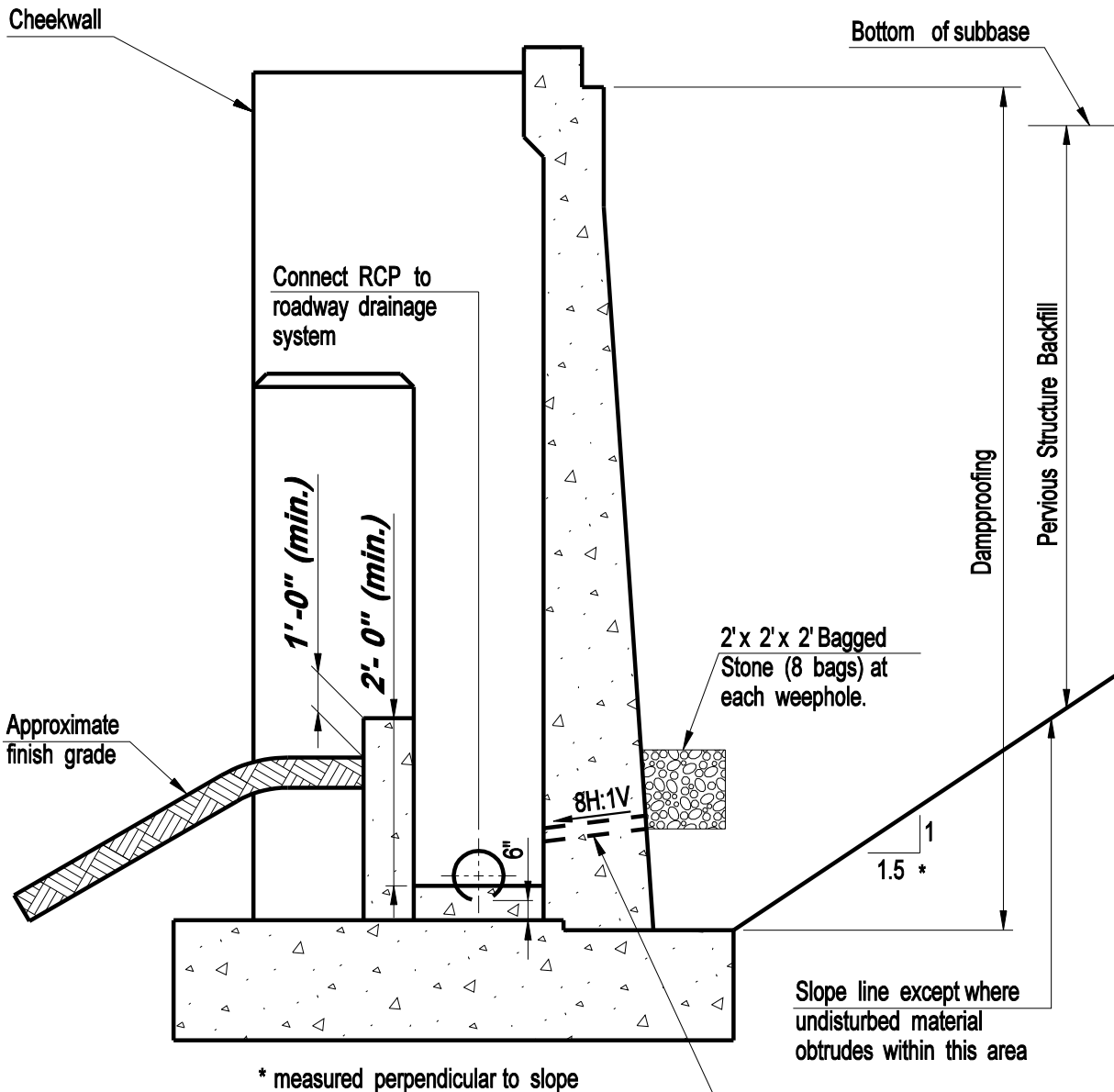
**DESIGN INFORMATION**

- 1. Plans should show either 4" weepholes or 6" structure underdrain. See Division I.**
- 2. Horizontal spacing and invert elevations of weepholes at the front face of abutment shall be shown on the abutment elevation views on the plans.**
- 3. 6" CCM Structure Underdrain and 6" CCM Outlet for Underdrain shall be included as Bridge Pay Items.**



**DESIGN INFORMATION**

- 1. Plans should show either 4" weepholes or 6" structure underdrain. See Division I.**
- 2. Horizontal spacing and invert elevations of extended weepholes at the front face of abutment shall be shown on the abutment elevation views on the plans.**
- 3. 6" CCM Structure Underdrain and 6" CCM Outlet for Underdrain shall be included as Bridge Pay Items.**



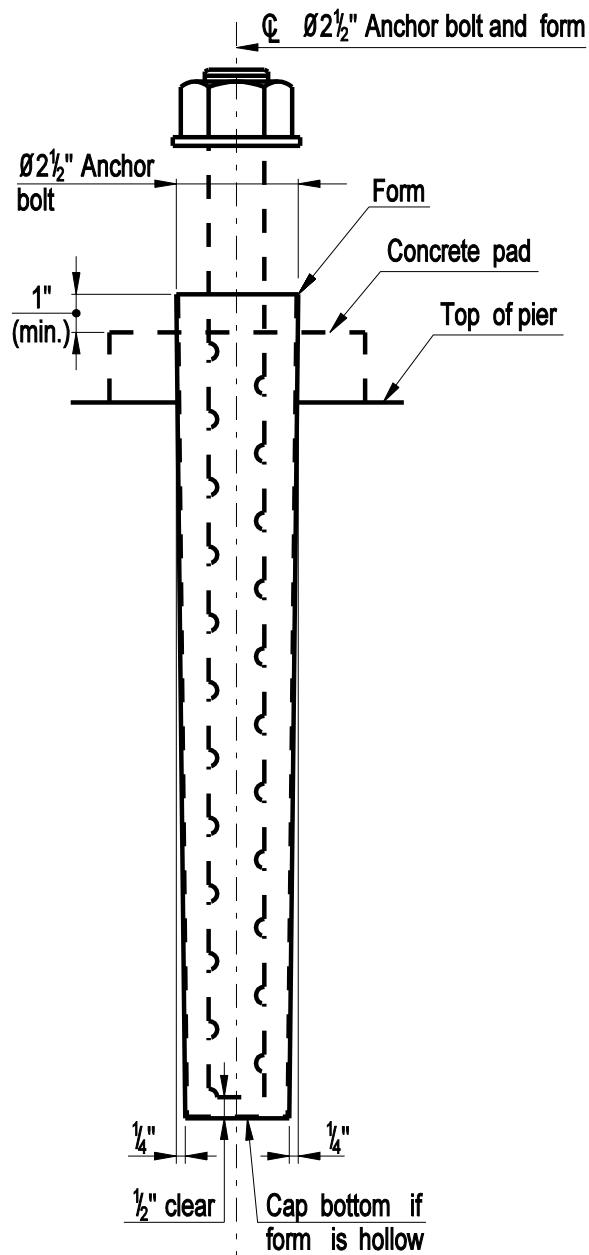
SECTION A  
3.1.2a

Ø4" Weepholes *See Notes 1 & 2*

**DESIGN INFORMATION**

- 1. Plan should show either 4" weep hole or 6" structure underdrain. See Section I.**
- 2. Horizontal spacing and invert locations of weepholes shall be shown on the abutment elevation views on the plans.**

<b>CONNECTICUT BRIDGE DESIGN MANUAL</b>	<b>PEDESTAL TYPE ABUTMENT DRAINAGE AND BACKFILL REQUIREMENTS</b>	Issue Date: 10/03
		Revision Date:
		Plate Number: <b>3.2.3</b>

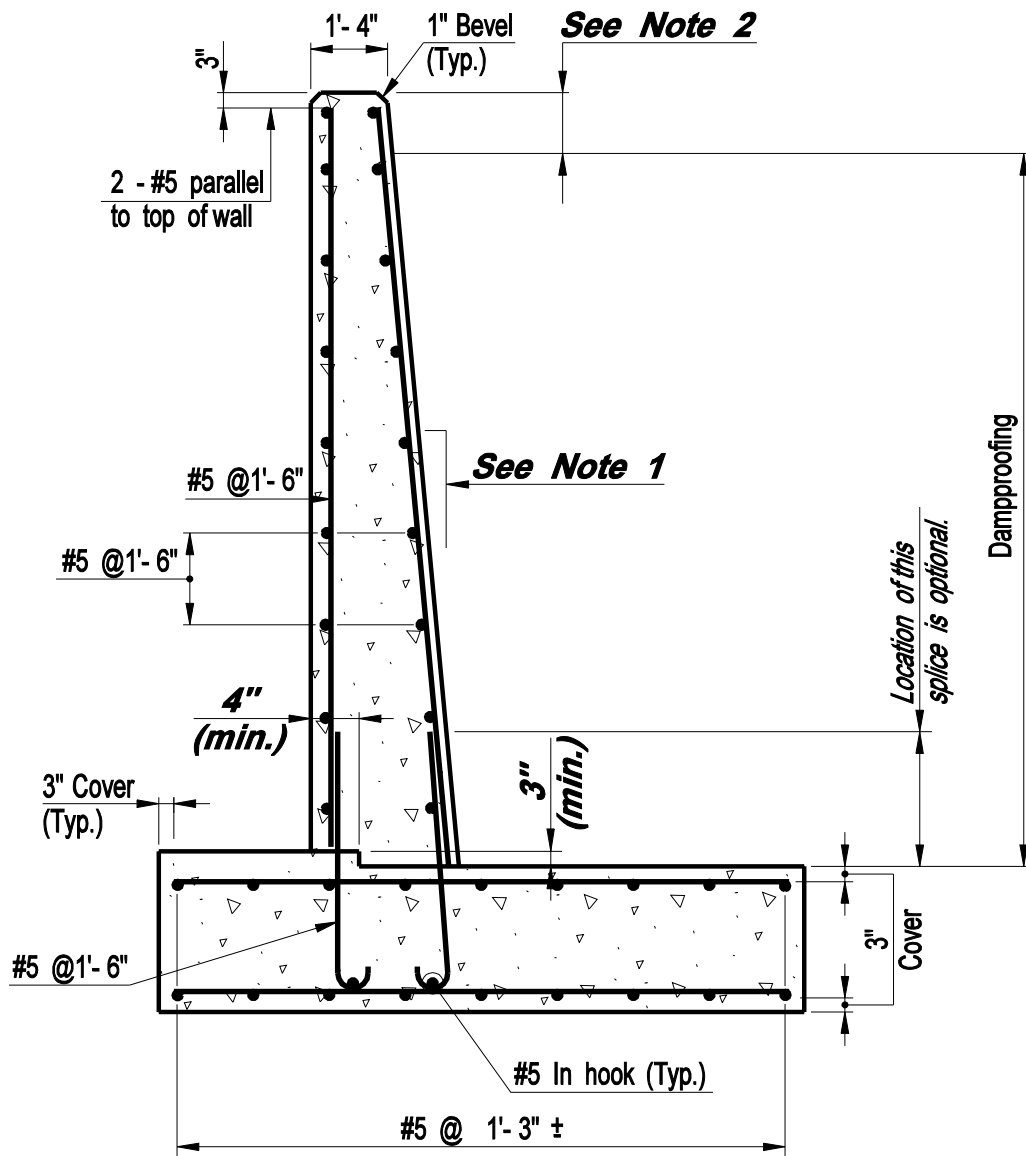


**NOTES:**

Forms shall be unoled, held in place accurately by template, and removed after concrete has hardened. Anchor bolts shall be set accurately and grouted with non-shrink grout. The cost of furnishing and installing forms to be included in the item "Class F Concrete".

**DESIGN INFORMATION**

*Designer to determine the exact location of forms in relation to reinforcement and, if necessary, respace or add extra rows of reinforcing. Forms are to be used primarily at piers but may also be used elsewhere at the discretion of the designer.*



**DESIGN INFORMATION**

1. *The rear face of the stem shall be battered if additional width at the base of the stem is required. The minimum batter shall be 1H:12V. Maintain a uniform top of batter elevation.*
2. *This dimension may be increased to follow finished grade.*

**CONNECTICUT  
BRIDGE DESIGN  
MANUAL**

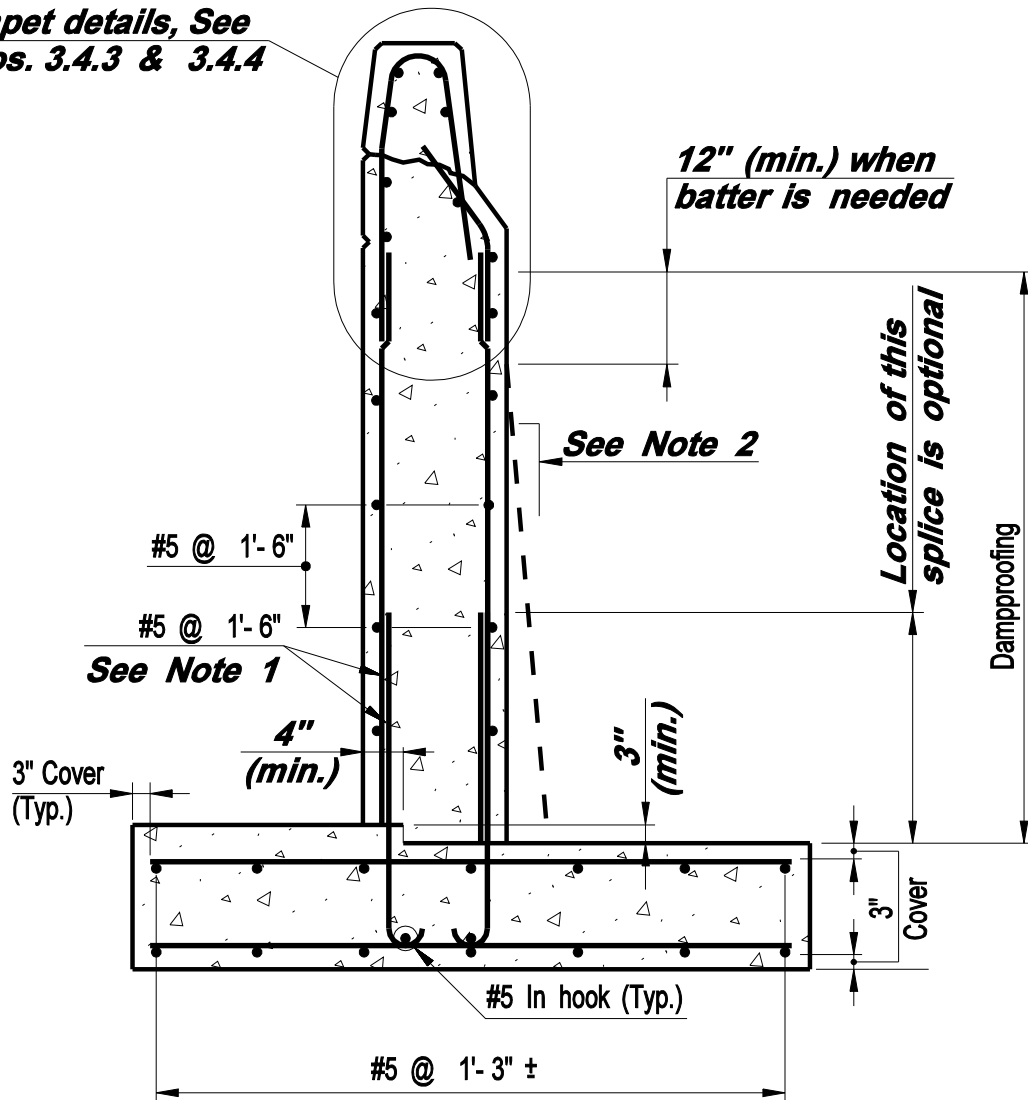
**FLARED TYPE WINGWALL  
OR RETAINING WALL**

Issue Date: 10/03

Revision Date:

Plate Number:  
3.4.1

*For parapet details, See Plate Nos. 3.4.3 & 3.4.4*



**DESIGN INFORMATION**

1. *This reinforcement shall be designed for seismic forces.*
2. *The rear face of the stem shall be battered if additional width at the base of the stem is required. The minimum batter shall be 1H:12V. Maintain a uniform top of batter elevation.*

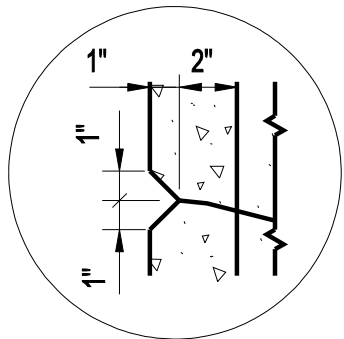
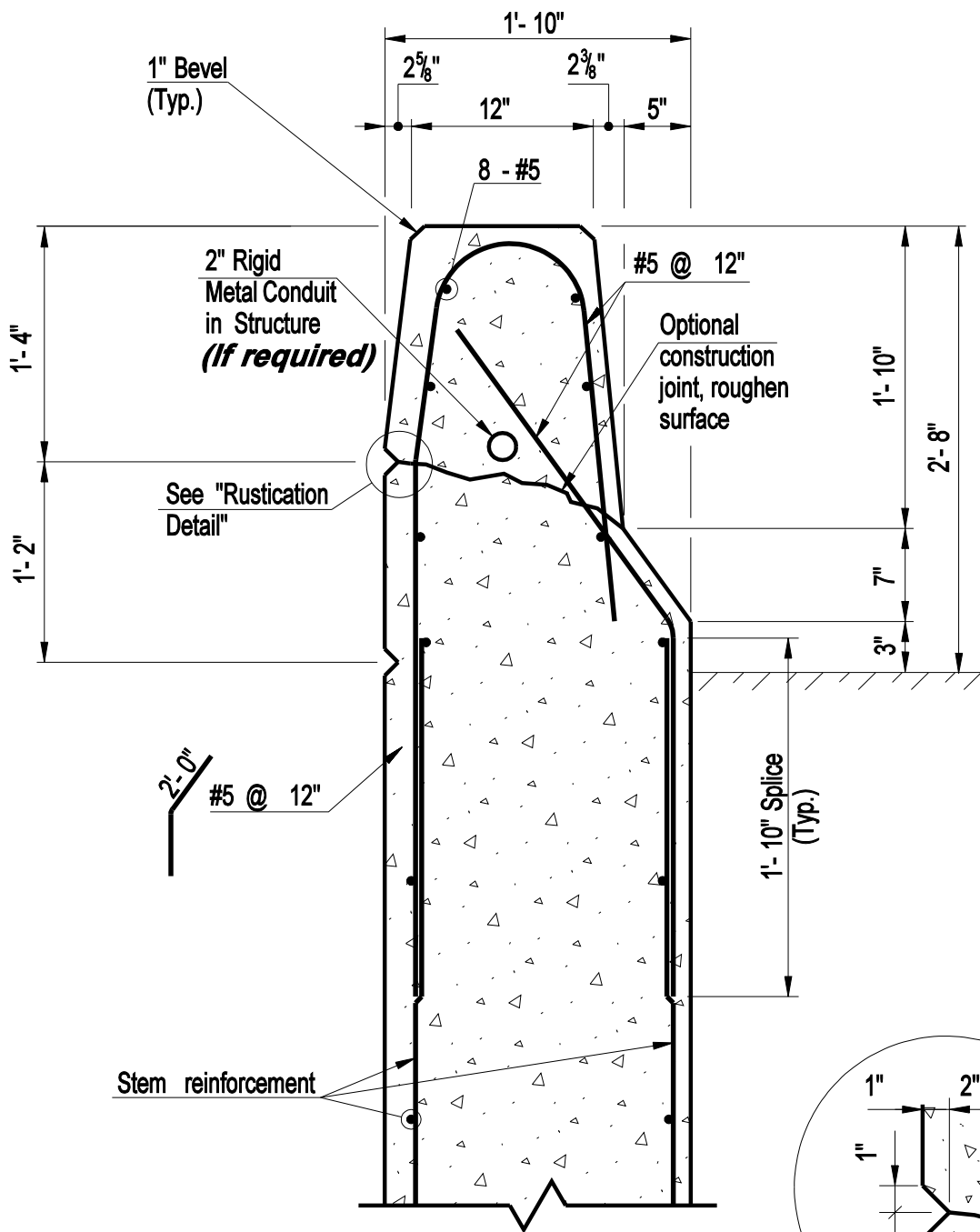
**CONNECTICUT  
BRIDGE DESIGN  
MANUAL**

**U - TYPE WINGWALL OR  
RETAINING  
WALL WITH SLOPED CURB**

Issue Date: 10/03

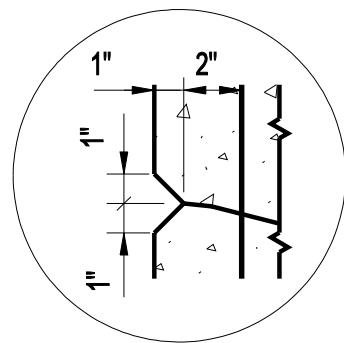
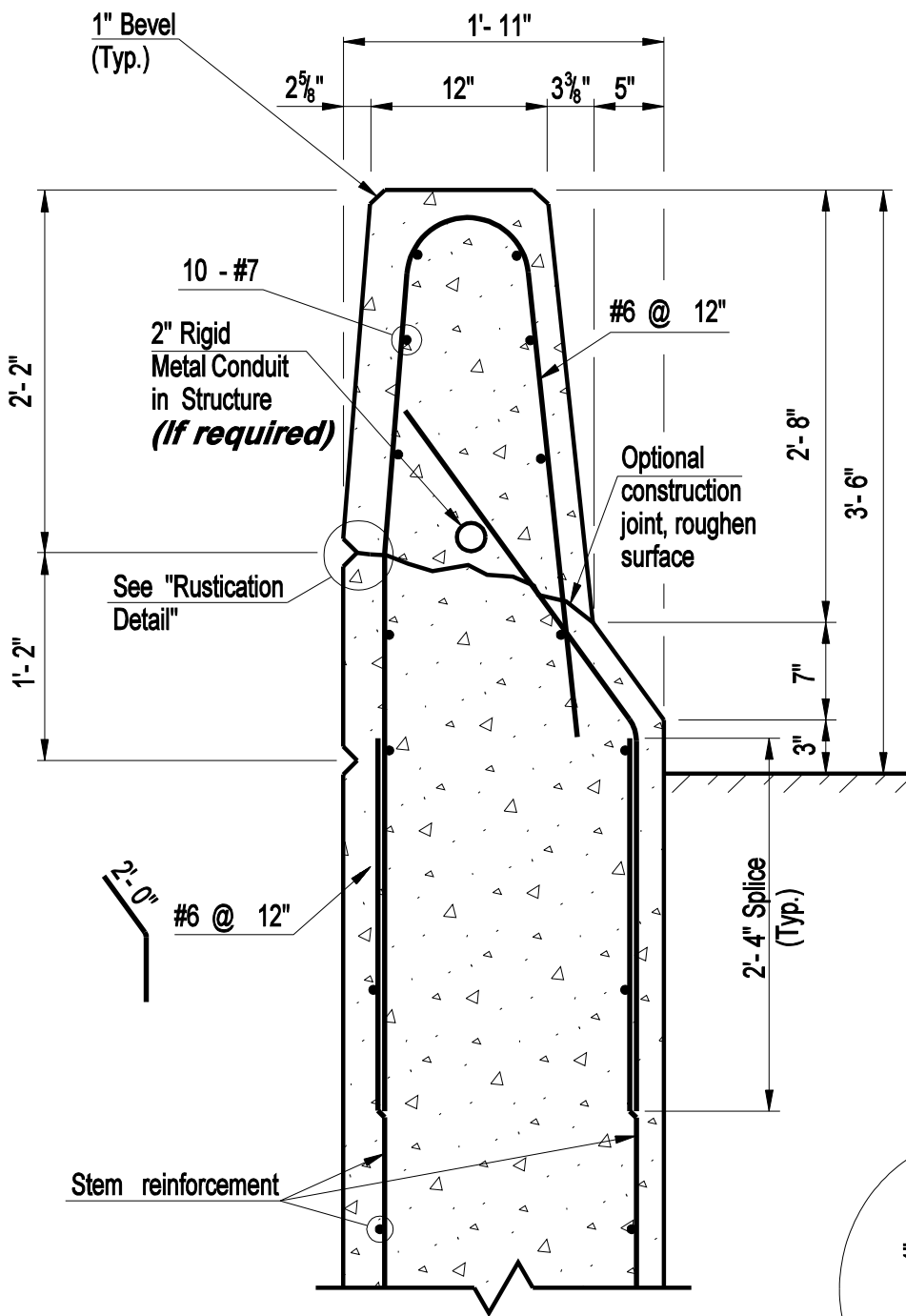
Revision Date:

Plate Number:  
**3.4.2**



Rustication Detail





Rustication Detail

**CONNECTICUT  
BRIDGE DESIGN  
MANUAL**

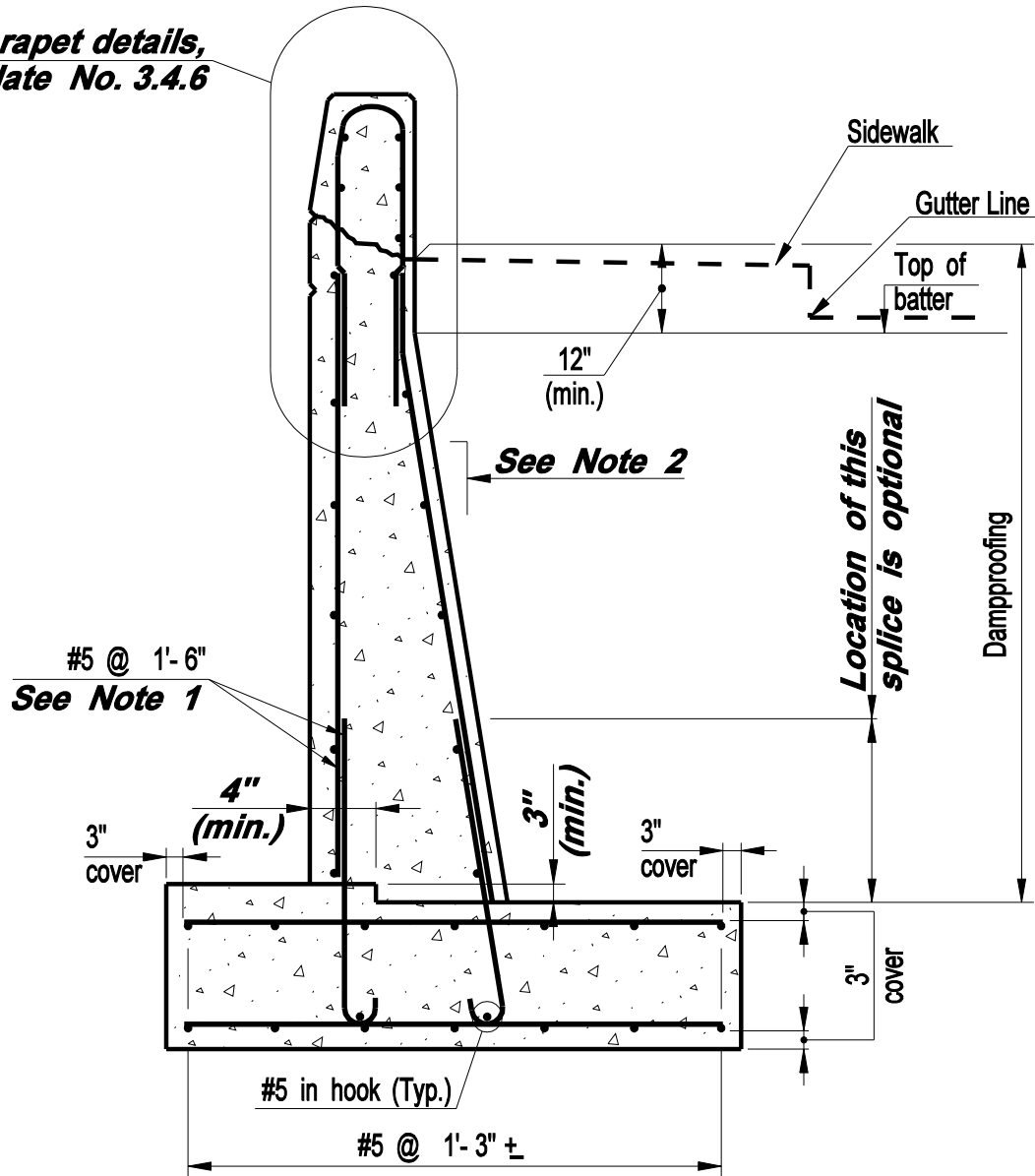
**STANDARD WINGWALL PARAPET  
(42" HIGH)**

Issue Date: 10/03

Revision Date:

Plate Number:  
**3.4.4**

***For parapet details,  
See Plate No. 3.4.6***



**DESIGN INFORMATION**

1. *This reinforcement shall be designed for seismic forces.*
2. *The rear face of the stem shall be battered if additional width at the base of the stem is required. The minimum batter shall be 1H:12V. Maintain a uniform top of batter elevation.*

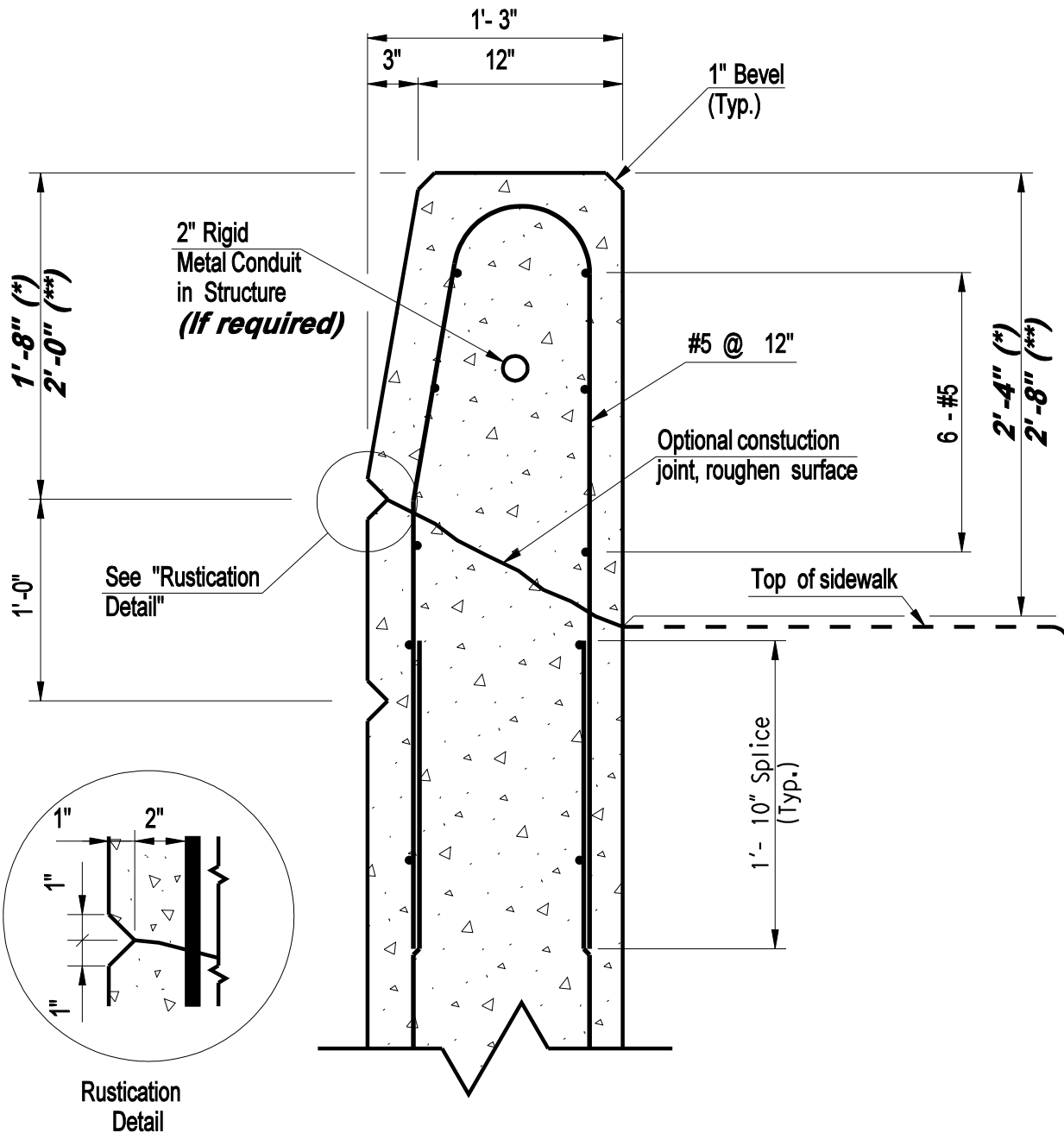
**CONNECTICUT  
BRIDGE DESIGN  
MANUAL**

**U-TYPE WINGWALL  
OR RETAINING  
WALL WITH SIDEWALK**

Issue Date: 10/03

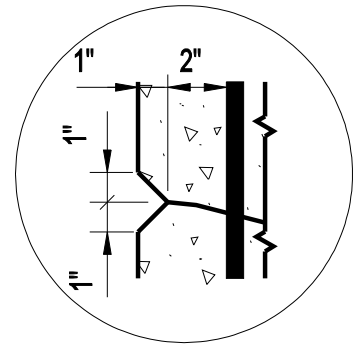
Revision Date: 01/05

Plate Number:  
**3.4.5**

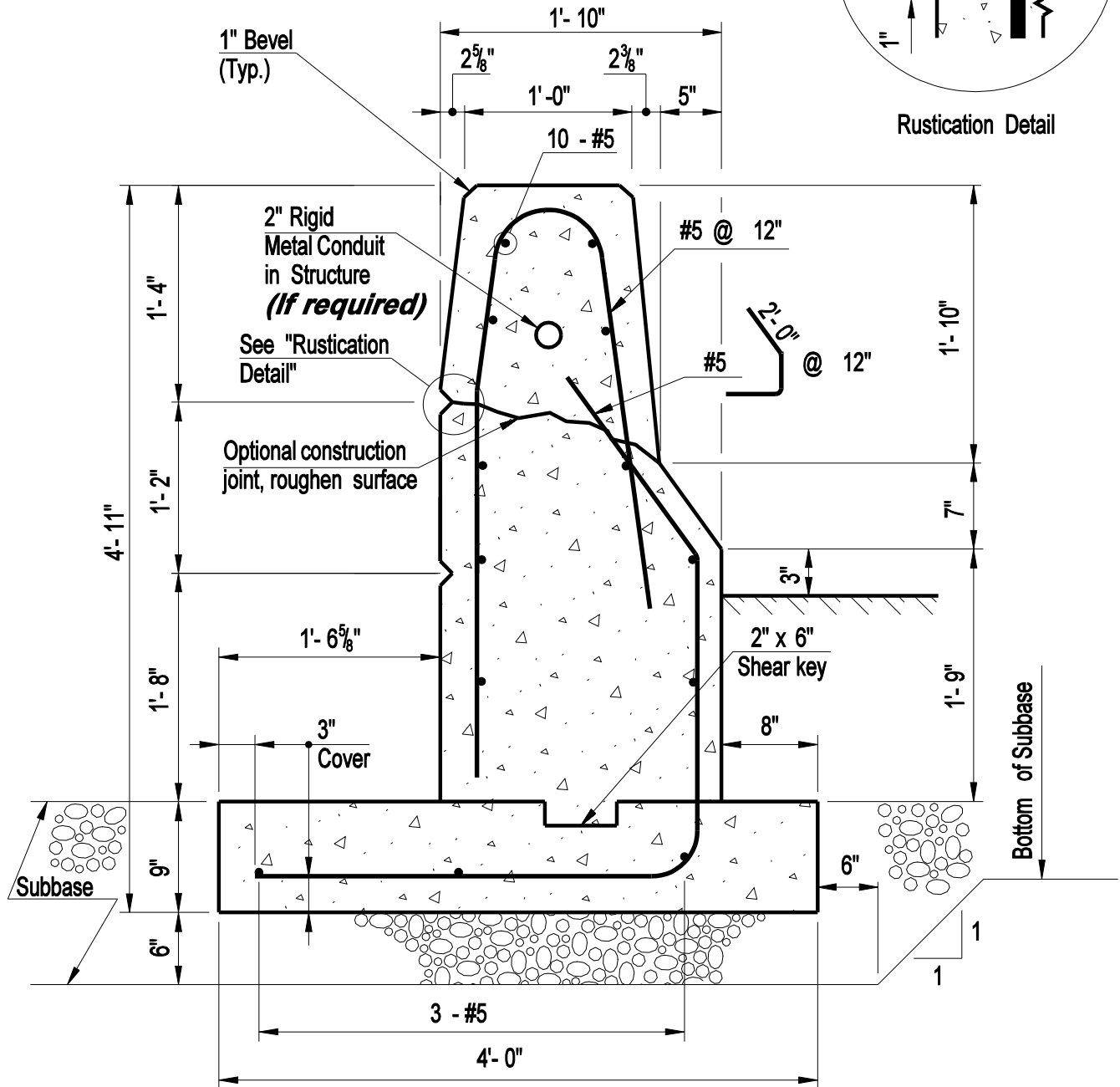


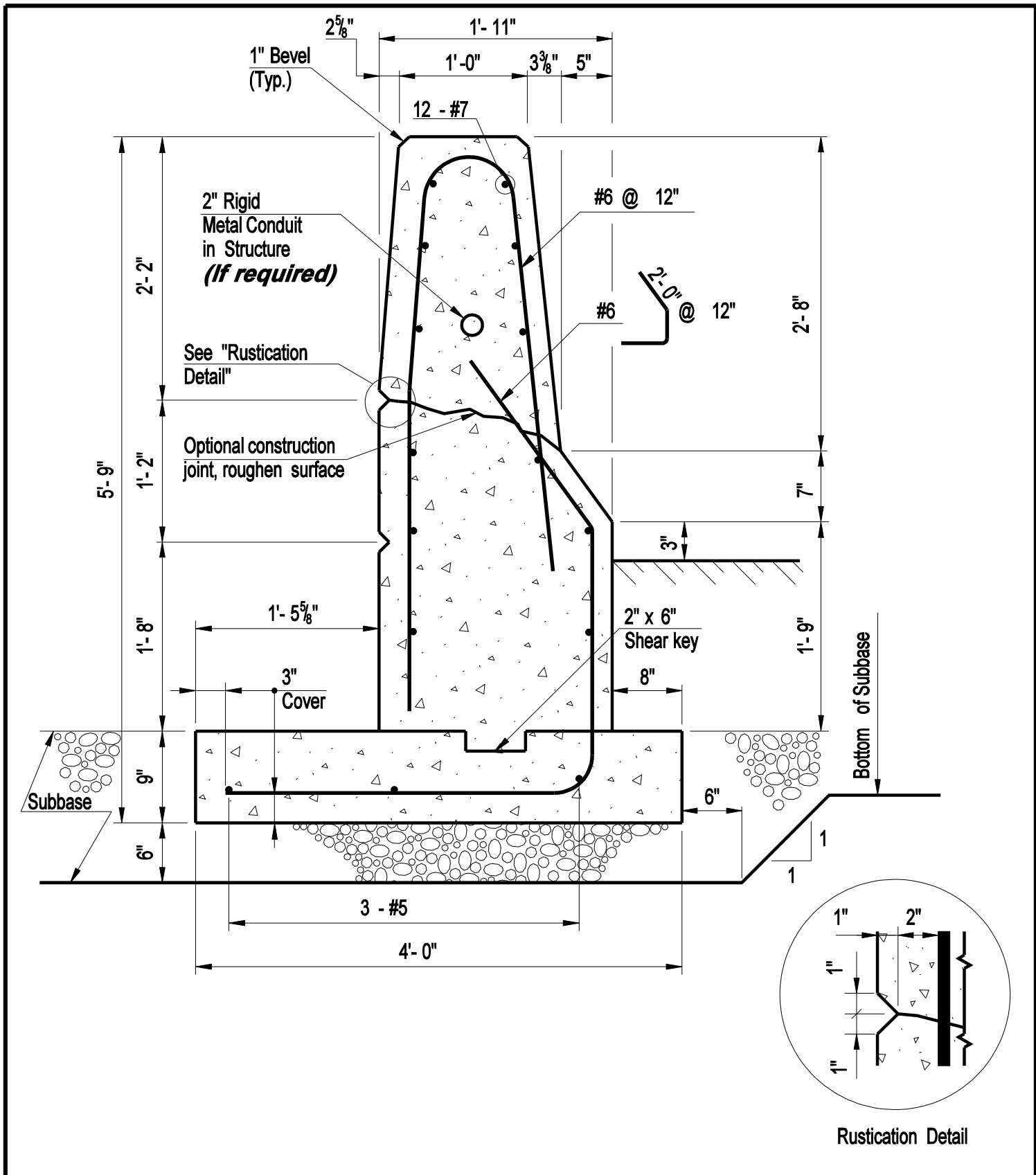
**DESIGN INFORMATION**

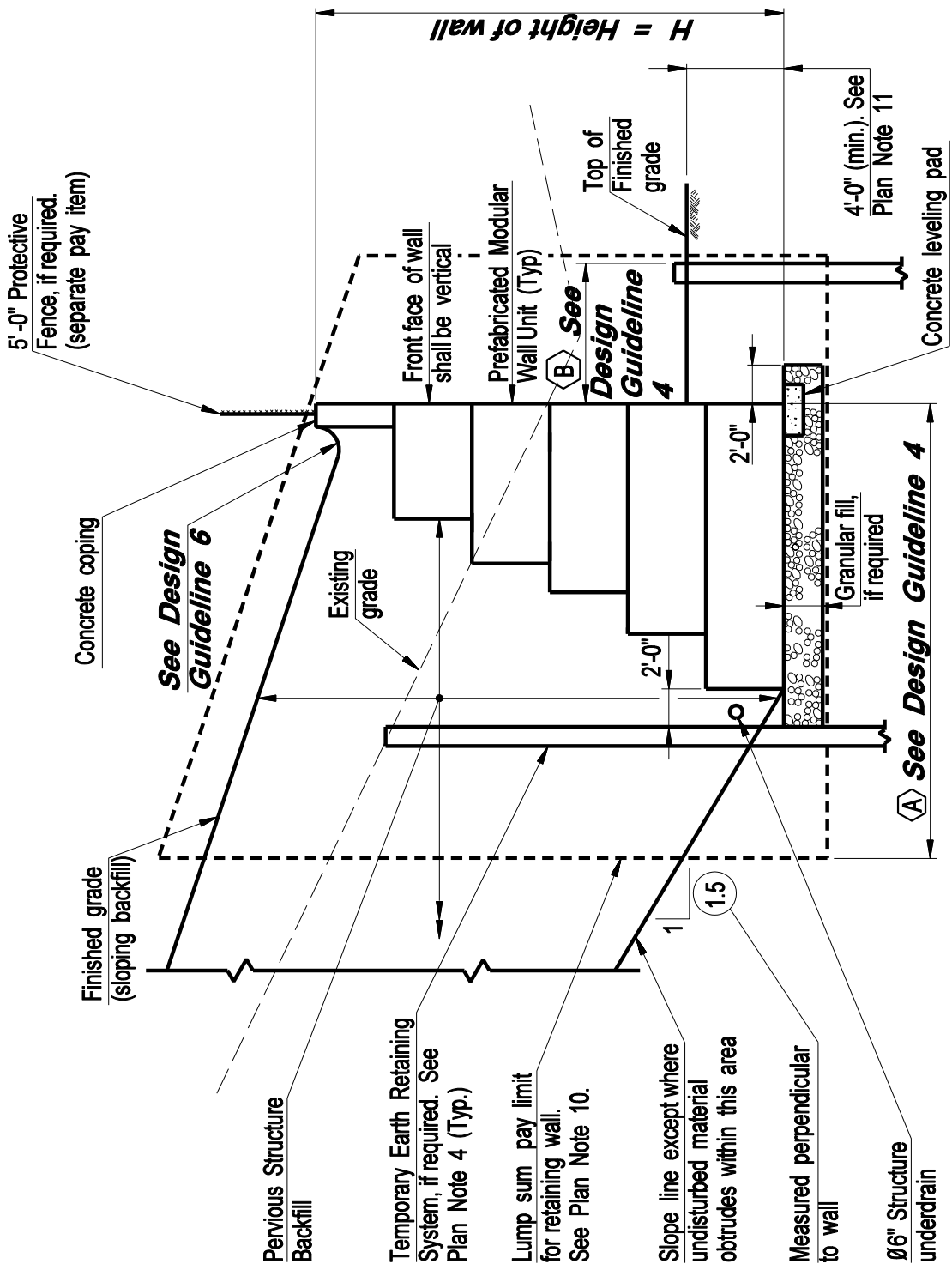
- \* with protective fence
- \*\* with pedestrian railing



Rustication Detail



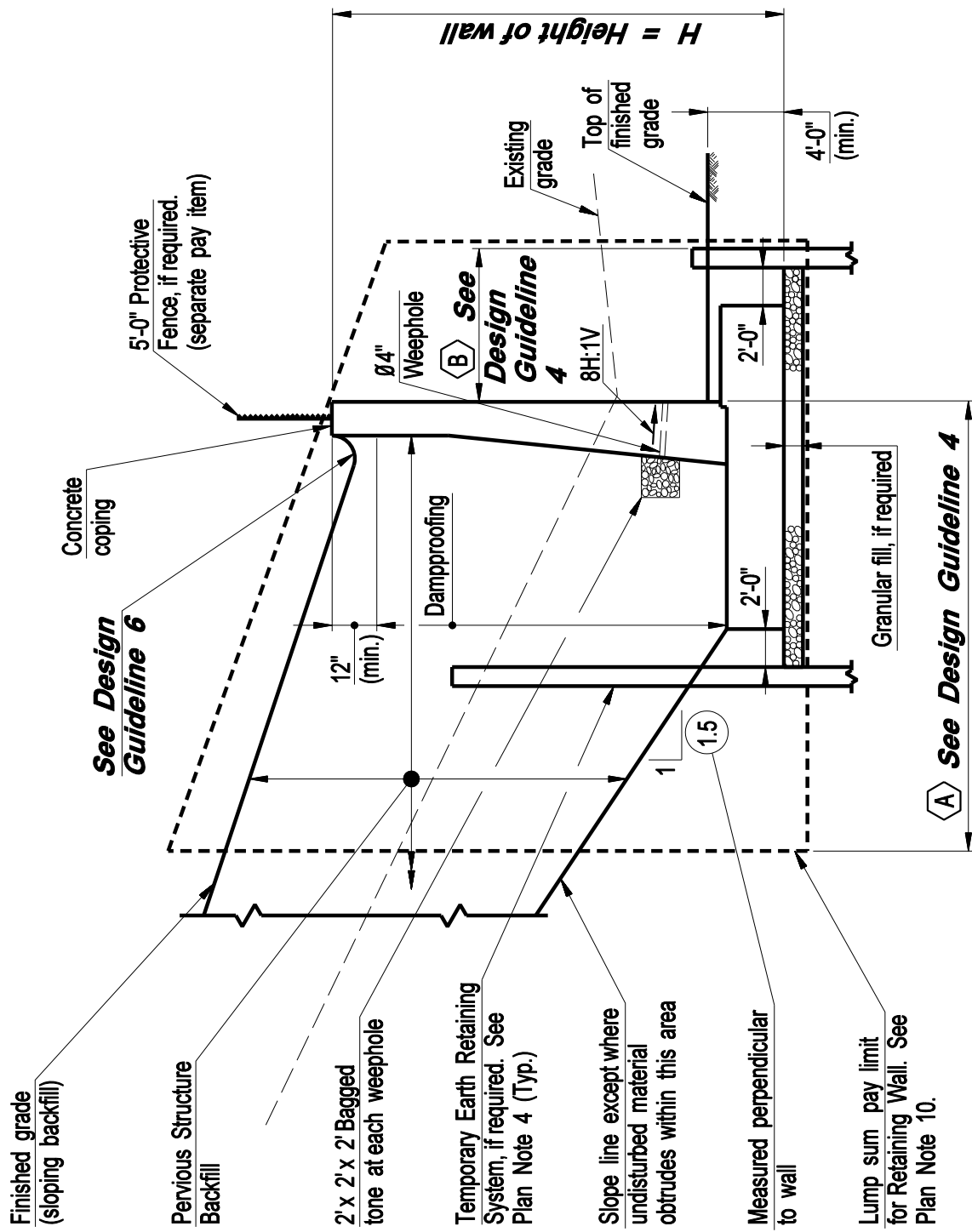




**Note: For Plan Notes, see plate 3.4.12.  
For Design Guidelines, see plate 3.4.11.**

<b>CONNECTICUT BRIDGE DESIGN MANUAL</b>	<b>TYPICAL SECTION PREFABRICATED MODULAR WALL (SLOPING BACKFILL)</b>	Issue Date: 10/03
		Revision Date: 3/09
		Plate Number: <b>3.4.9a</b>





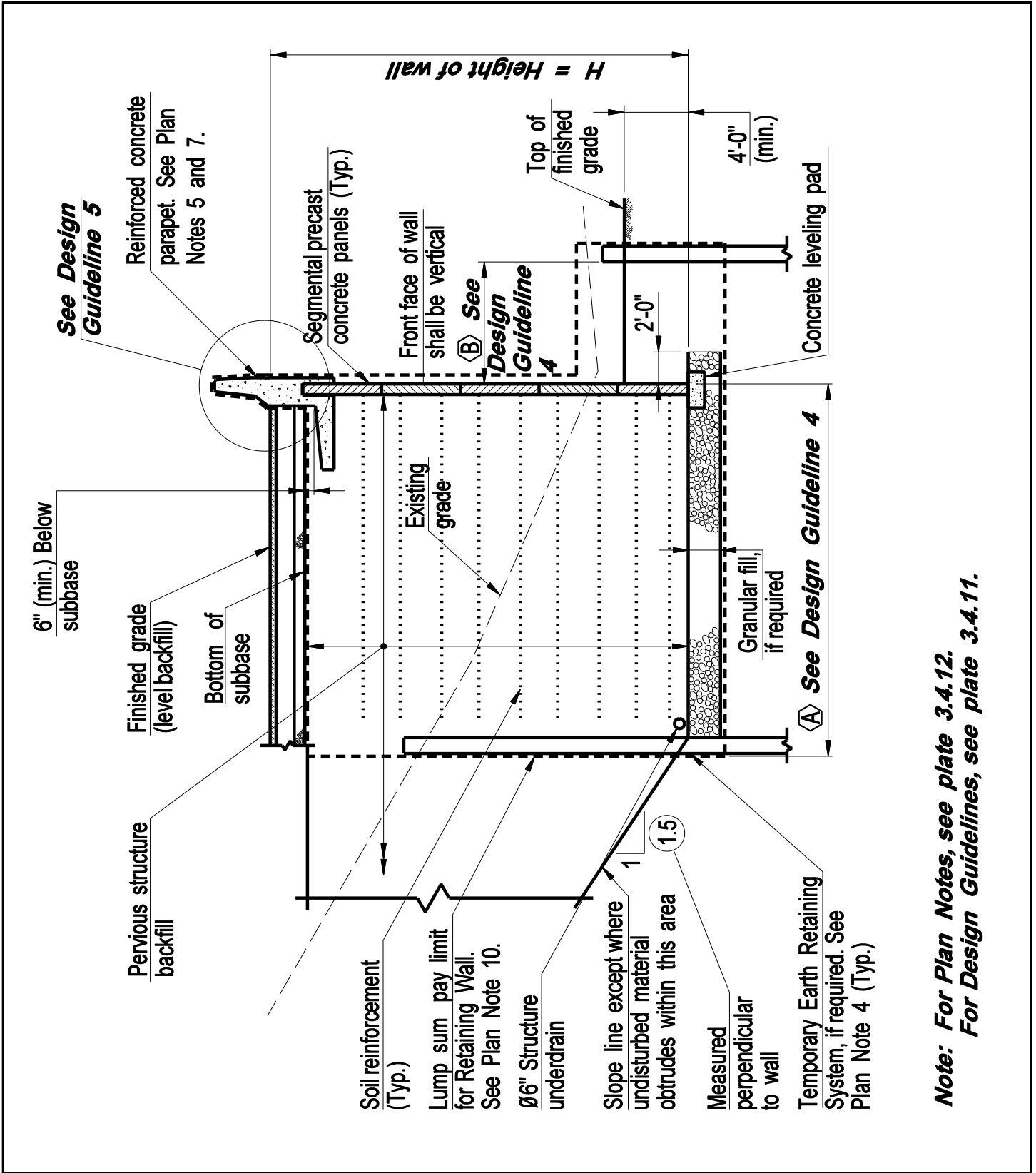
**CONNECTICUT  
BRIDGE DESIGN  
MANUAL**

**TYPICAL SECTION  
CAST-IN-PLACE  
REINFORCED CONCRETE  
(SLOPING BACKFILL)**

Issue Date:	10/03
Revision Date:	3/09
Plate Number:	3.4.9c

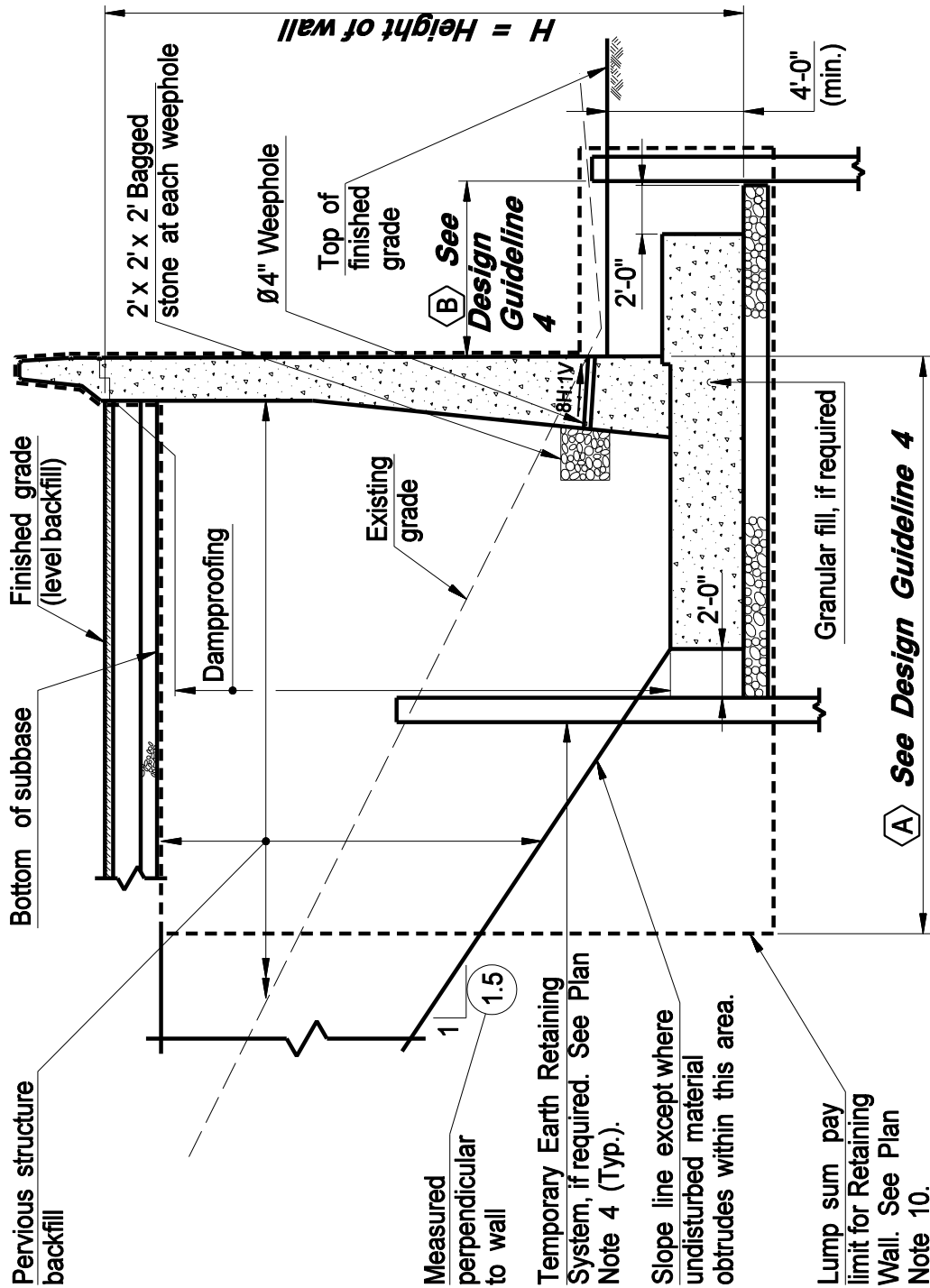






**Note: For Plan Notes, see plate 3.4.12.  
For Design Guidelines, see plate 3.4.11.**

<b>CONNECTICUT BRIDGE DESIGN MANUAL</b>	<b>TYPICAL SECTION MECHANICALLY STABILIZED EARTH WALL (LEVEL BACKFILL)</b>	Issue Date: 10/03
		Revision Date: 3/09
		Plate Number: <b>3.4.10b</b>



**Note: For Plan Notes see plate 3.4.12.  
For Design Guidelines, see plate 3.4.11.**

**CONNECTICUT  
BRIDGE DESIGN  
MANUAL**

**TYPICAL SECTION CAST-IN-PLACE  
REINFORCED CONCRETE  
(LEVEL BACKFILL)**

Issue Date: 10/03

Revision Date: 3/09

Plate Number:  
**3.4.10c**

DESIGN GUIDELINES:

- 1. The Proprietary Walls shall be designed, detailed, and constructed in accordance with the special provision "Retaining Wall (Site No.\_)".**
- 2. Proprietary walls shall not be designed for seismic forces.**
- 3. Wall height (H) for Mechanically Stabilized Earth Wall and Prefabricated Modular Wall sections shall be the same as for the Cast-in-Place Reinforced Concrete Wall type sections. Wall height (H) is equal to the distance measured from the bottom footing elevation to the finished grade.**
- 4. Pay limits for Mechanically Stabilized Earth Wall and Prefabricated Modular Wall sections shall be the same as for the Cast-in-Place Reinforced Concrete Wall Type section. The Designer shall determine all dimensions associated with the pay limits and show these dimensions on the plans. All horizontal pay limits are measured from the front face of the Cast-In-Place Concrete Wall.**
  - ⓑ Dimension shall be equal to 2'-0" plus the toe length.**
  - ⓐ Dimension ,as a minimum, shall be equal to (0.8)H plus 2'-0".**
- 5. If a Cast-in-place Reinforced Concrete wall alternate is not provided, the Engineer shall provide detailing and reinforcement of the parapet section above the gutter lines.**
- 6. Provide for surface drainage if necessary. Extent and details of ditch to be determined by the highway Engineer.**

**CONNECTICUT  
BRIDGE DESIGN  
MANUAL**

**DESIGN INFORMATION  
FOR ALTERNATE WALLS**

Issue Date: 10/03

Revision Date: 3/09

Plate Number:  
**3.4.11**

**PLAN NOTES:**

1. The Contractor shall select, design, (for proprietary walls only) and construct one of the following wall options in accordance with the special provision "Retaining Wall (Site No. \_)".  

(List of appropriate wall manufacturers)
2. The maximum factored bearing resistance = (       )
3. VACANT
4. Temporary Earth Retaining System below pay limits and any tiebacks and bracing associated with same shall be included in the lump sum cost of the wall.
5. Details shown on this sheet are not specific. The Contractor's Designer shall modify each section for each specific site.
6. Light standard anchorages, junction boxes, and rigid metal conduit shall be included in the lump sum pay item "Retaining Wall (Site No. \_\_\_\_ )".
7. The detailing and reinforcement of the parapet section above the gutter line shall be as shown for the Cast-In-Place Reinforced Concrete Wall section or as detailed elsewhere on the plans.
8. Reinforcing to have 2" cover except where shown otherwise.
9. All dimensions are specified with the applicable units of measurement.
10. Any additional pervious structure backfill required outside this limit shall also be included in the lump sum price.

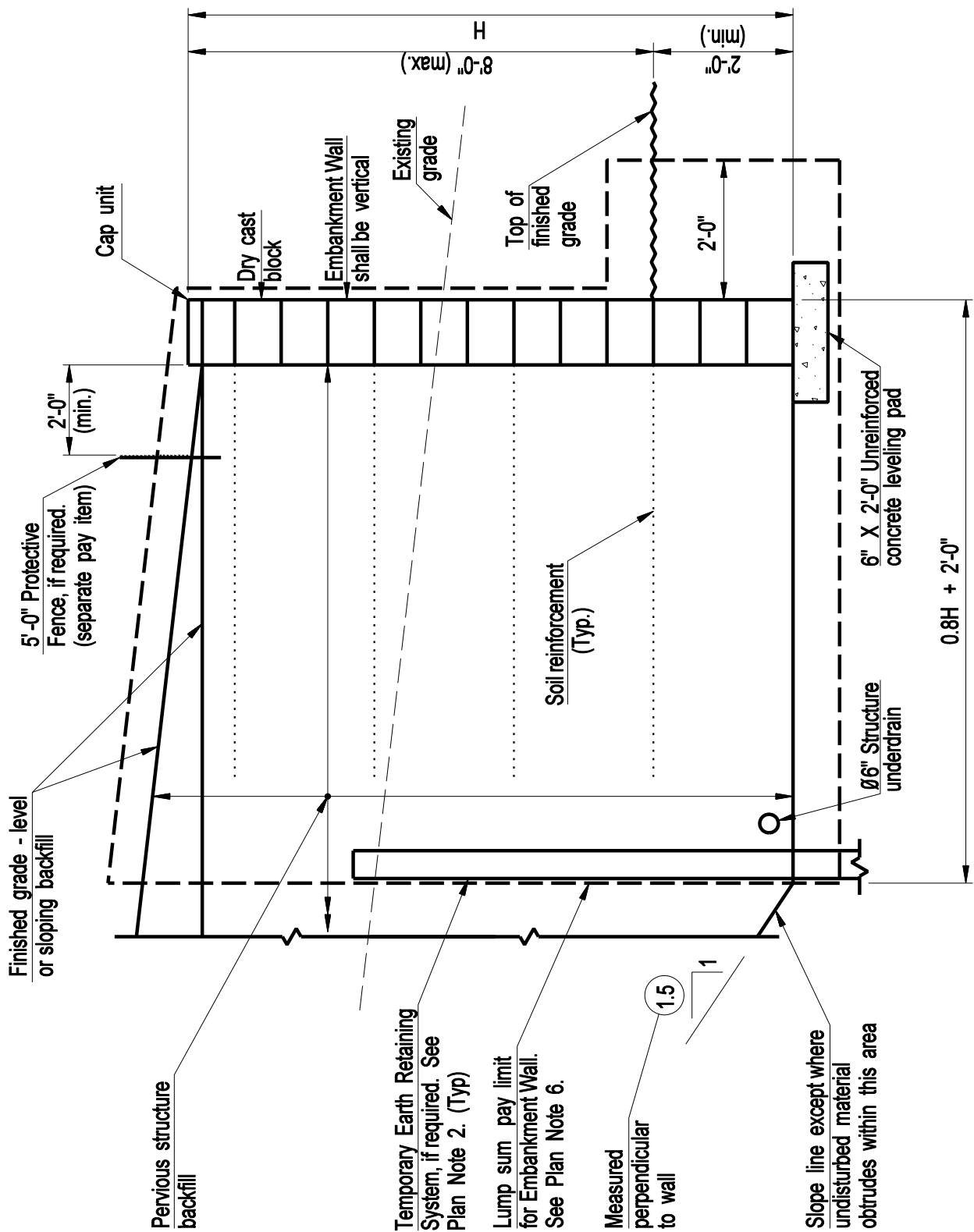
**CONNECTICUT  
BRIDGE DESIGN  
MANUAL**

**PLAN NOTES  
FOR ALTERNATE WALLS**

Issue Date: 10/03

Revision Date: 12/19

Plate Number:  
**3.4.12**



**CONNECTICUT  
BRIDGE DESIGN  
MANUAL**

**TYPICAL SECTION  
EMBANKMENT WALL**

Issue Date: 10/03

Revision Date: 3/09

Plate Number:  
**3.4.13**

PLAN NOTES:

1. The Embankment Wall shall be designed, detailed and constructed in accordance with the special provision "Embankment Wall (Site No. )".
2. Temporary Earth Retaining System below pay limits and any tiebacks and bracing associated with the sheet piling shall be included in the lump sum cost of the wall.
3. Details shown on this sheet are not specific. The Contractor's Designer should modify the section for each specific site.
4. The Contractor shall select, design (for proprietary walls only) and construct one of the wall options as listed in the special provision "Embankment Wall (Site No. )".
5. The color of the dry cast block shall be (        )
6. Any additional pervious structure backfill required outside this limit shall also be included in the lump sum price.

**CONNECTICUT  
BRIDGE DESIGN  
MANUAL**

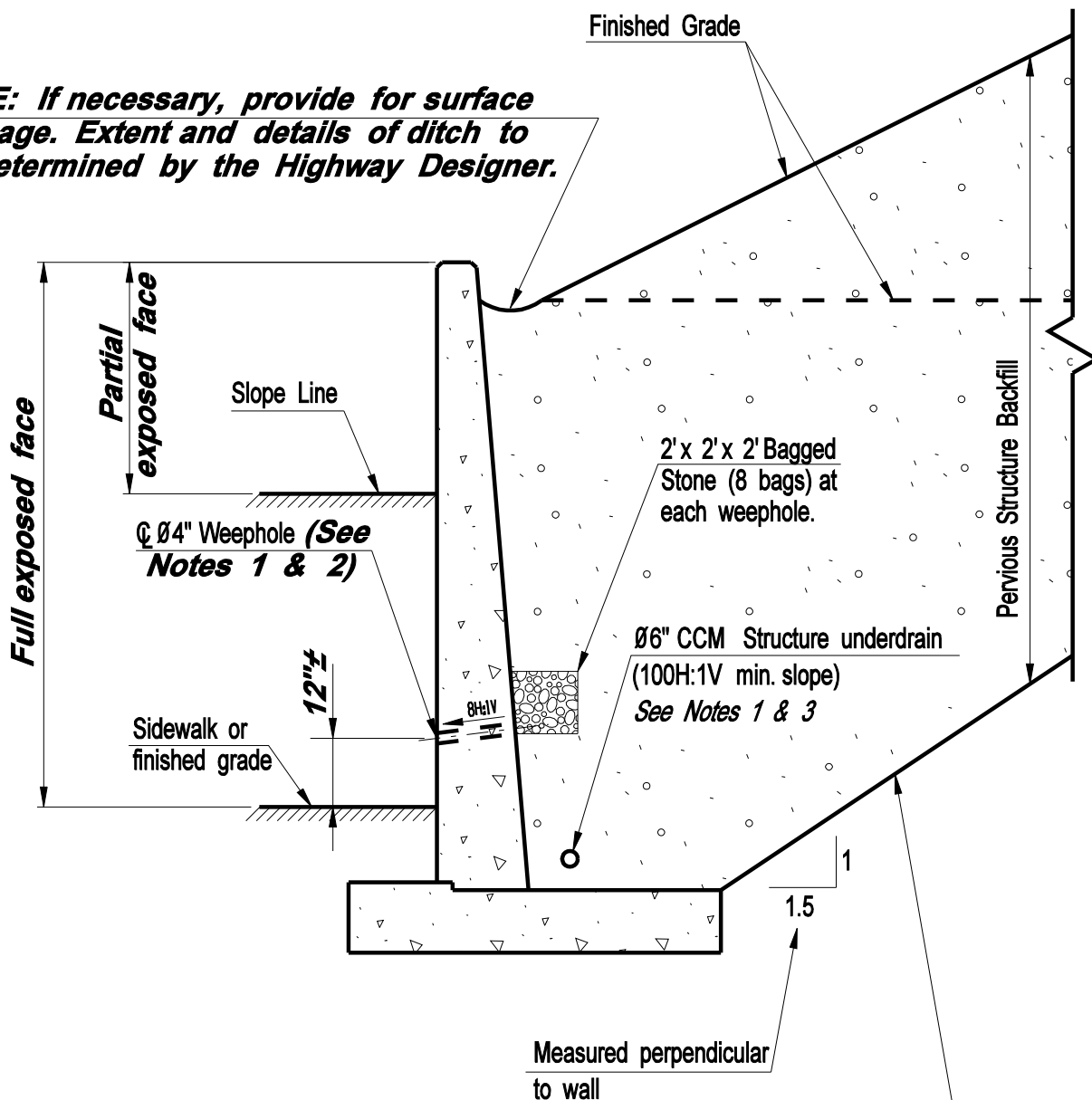
**PLAN NOTES  
FOR EMBANKMENT WALLS**

Issue Date: 10/03

Revision Date: 3/09

Plate Number:  
**3.4.14**

**NOTE: If necessary, provide for surface drainage. Extent and details of ditch to be determined by the Highway Designer.**



Slope line except where undisturbed material protrudes within this area.

**DESIGN INFORMATION**

1. Plan should show either 4" weep hole or Ø6" structure underdrain. See Division 1.
2. Horizontal spacing and invert locations of weep holes shall be shown on the wingwall elevation views on the plans.
3. Ø6" CCM Structure Underdrain and Ø 6" CCM Outlet for Underdrain shall be included as Bridge Pay Items.

**CONNECTICUT  
BRIDGE DESIGN  
MANUAL**

**FLARED WINGWALL OR RETAINING  
WALL - DRAINAGE  
AND BACKFILL REQUIREMENTS**

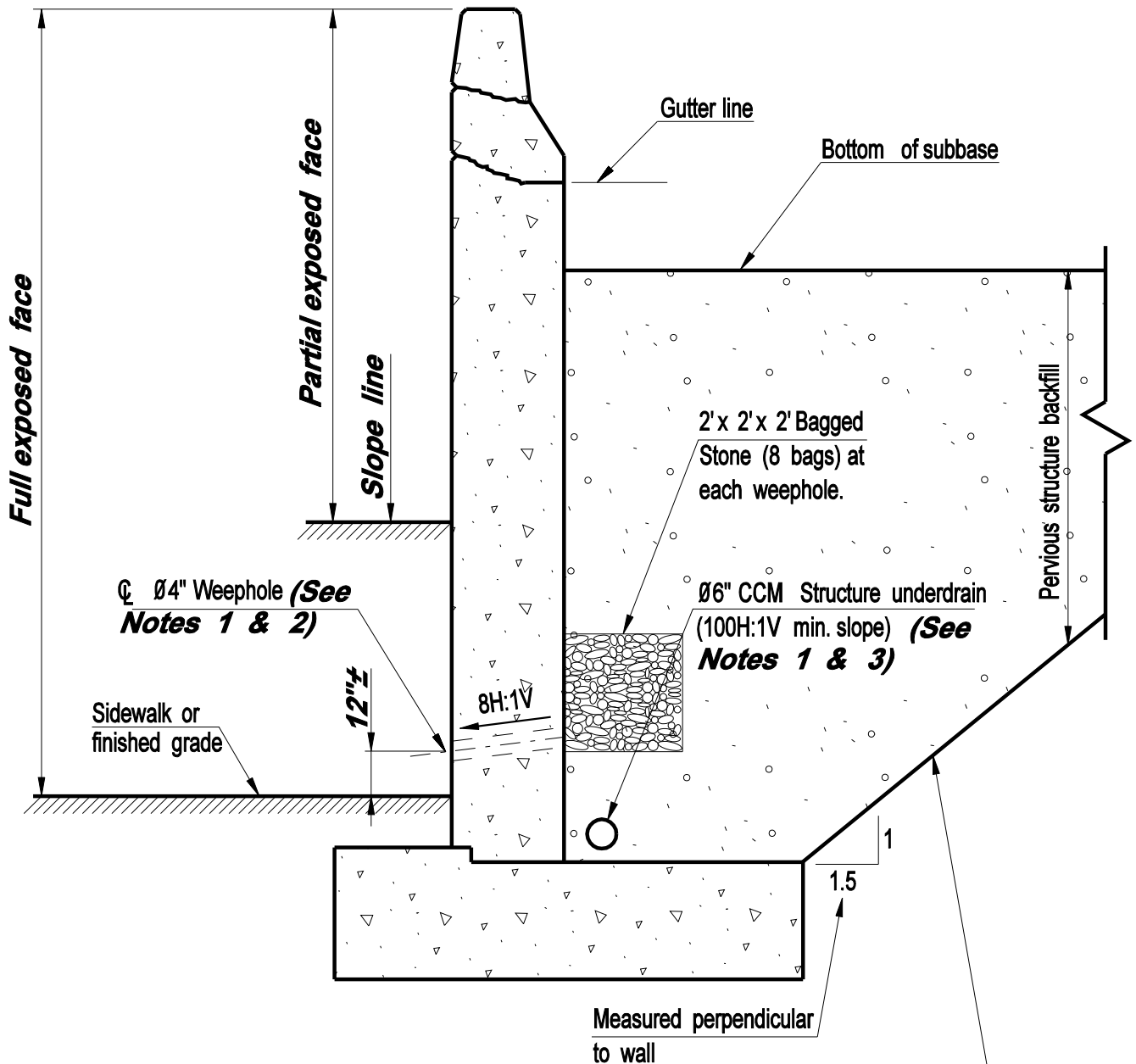
Issue Date: 10/03

Revision Date:

Plate Number:

3.5.1

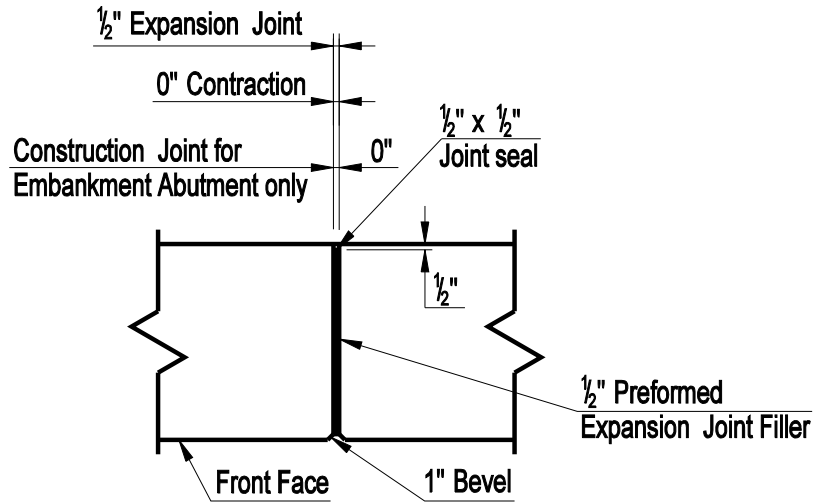




**DESIGN INFORMATION**

1. Plan should show either 4" weep hole or Ø6" structure underdrain. See Division I.
2. Horizontal spacing and invert locations of weep holes shall be shown on the wingwall elevation views on the plans.
3. Ø6" CCM Structure Underdrain and Ø 6" CCM Outlet for Underdrain shall be included as Bridge Pay Items.

Slope line except where undisturbed material obtrudes within this area



**DESIGN INFORMATION:**

- 1. Expansion joints shall be provided at intervals not exceeding 90'.**
- 2. Contraction joints shall be provided at intervals not exceeding 30'.**
- 3. All joints in abutments shall be located approximately midway between members.**
- 4. At embankment abutments, contraction joints shall be changed to construction joints.**

**NOTES:**

**JOINTS:** *The Designer shall include the following notes as appropriate:*

Joint seal to extend from top of footing to top of backwall and horizontally along top of backwall. **(Abutments)**

Joint seal to extend from top of footing to top of parapet and horizontally along this joint to outside face of parapet and horizontally along this joint to the outside face of wall. **(U - Type wings or Retaining walls with parapets)**

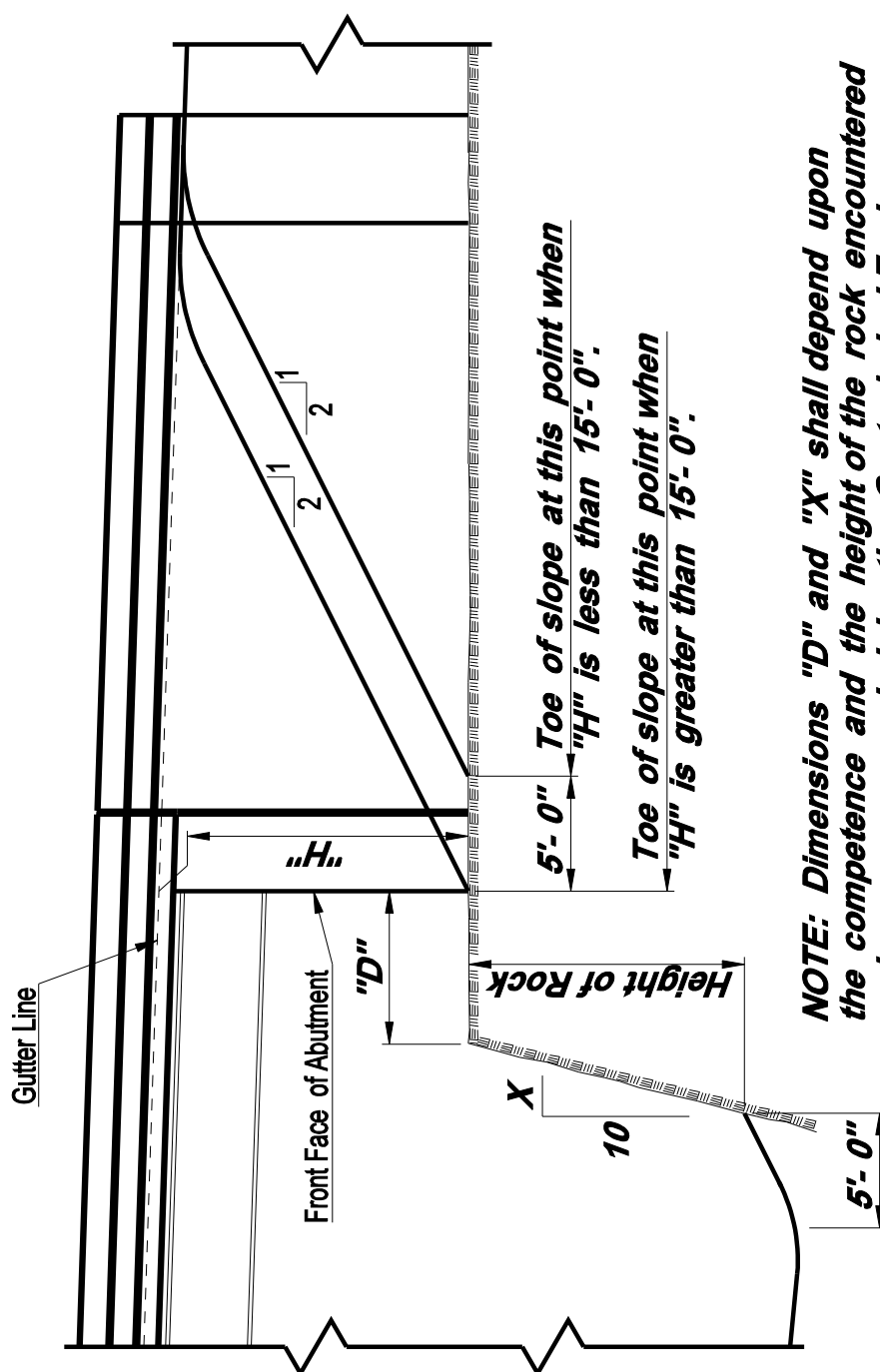
Joint seal to extend from top of footing to top of wall. **(Retaining Walls)**

Joint seal to extend from top of footing to top of wall. For the joints between the flared wings and superstructure, the joint seal shall extend from top of abutment backwall to top of wing. **(Flared wingwall)**

**REINFORCEMENT:**

No reinforcement shall pass through expansion or contraction joints.

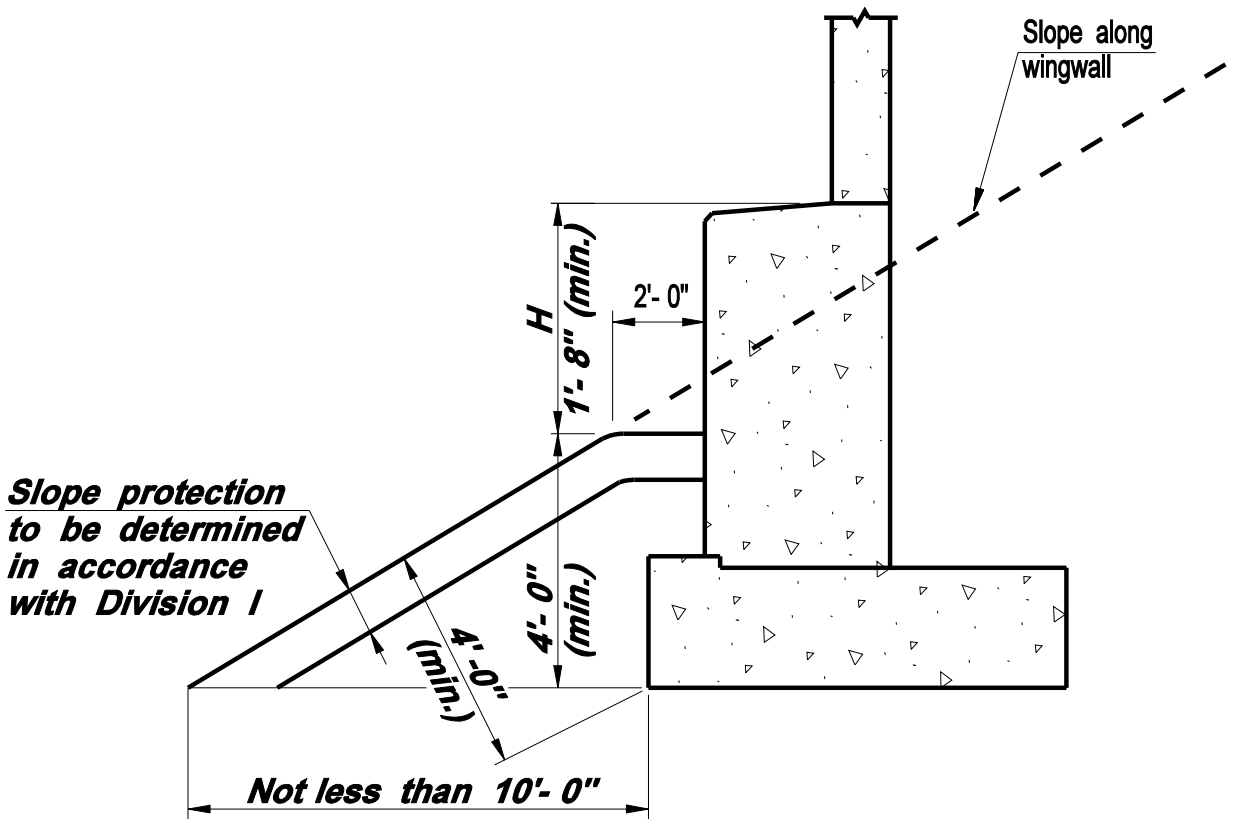
Reinforcement shall pass through construction joints.



5'-0" Toe of slope at this point when "H" is less than 15'-0".

Toe of slope at this point when "H" is greater than 15'-0".

**NOTE:** Dimensions "D" and "X" shall depend upon the competence and the height of the rock encountered and as recommended by the Geotechnical Engineer.



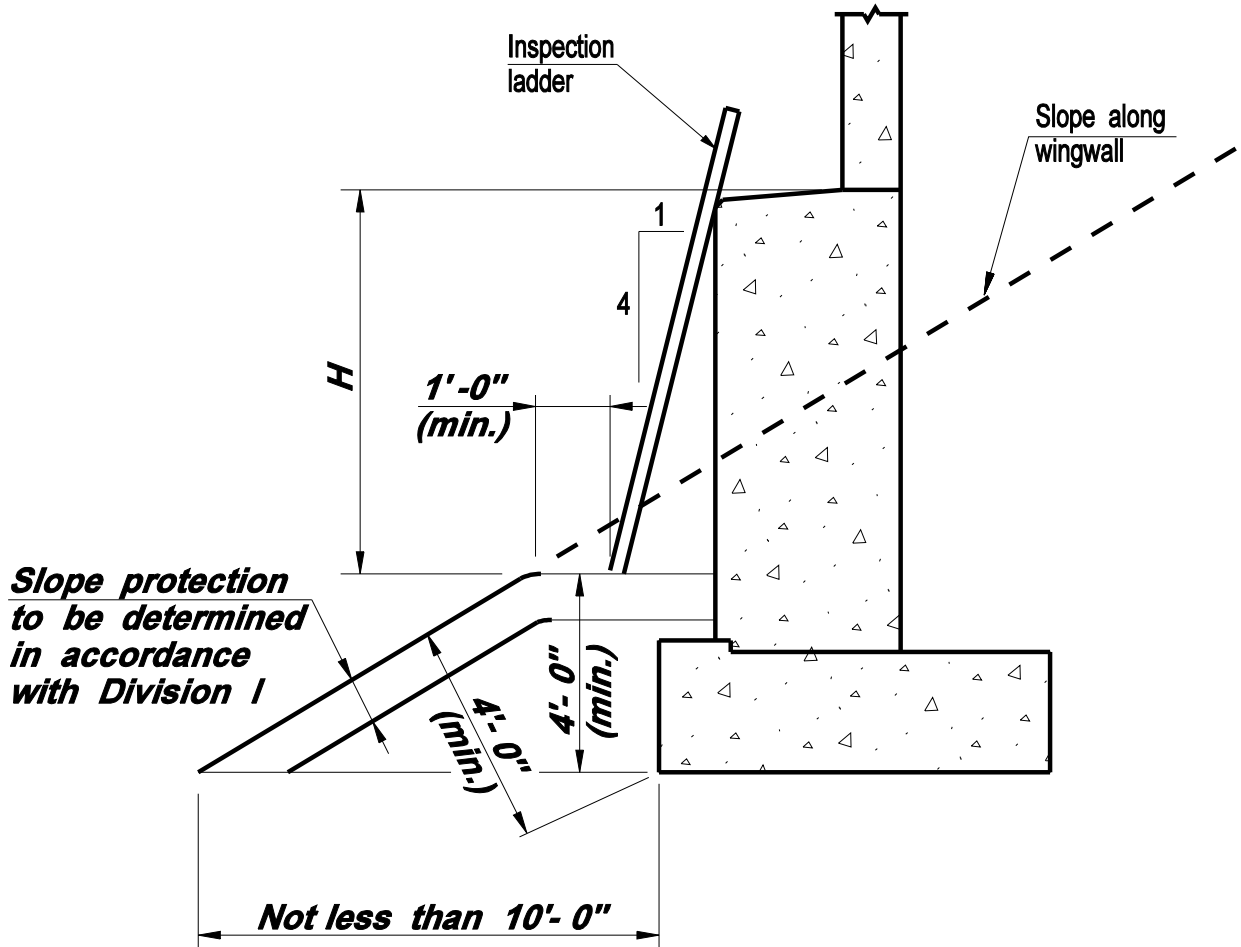
**CONNECTICUT  
BRIDGE DESIGN  
MANUAL**

**TYPICAL EMBANKMENT  
ABUTMENT NORMAL SECTION  
( $H \leq 5'-0''$ )**

Issue Date: 10/03

Revision Date:

Plate Number:  
**3.6.3**



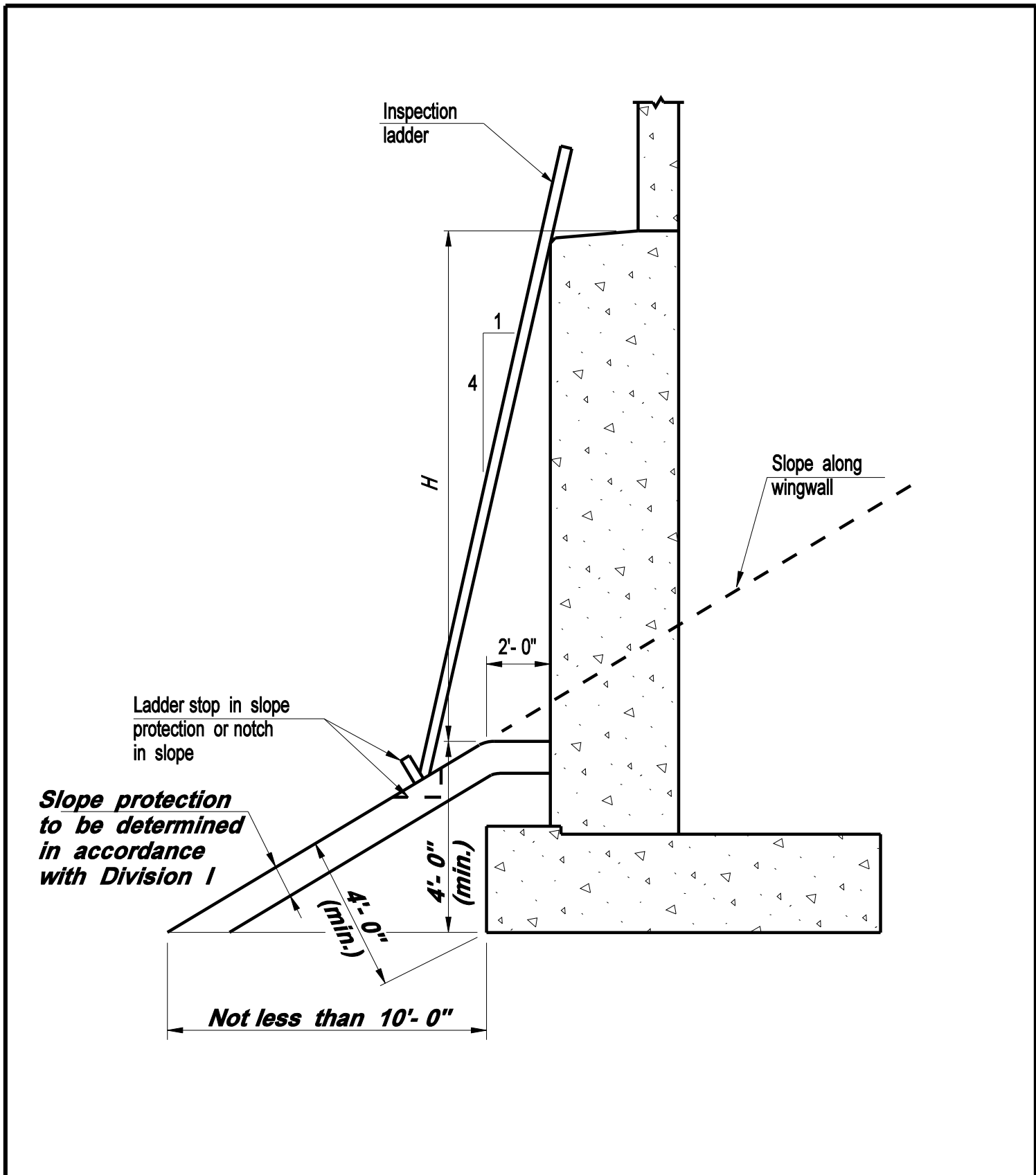
**CONNECTICUT  
BRIDGE DESIGN  
MANUAL**

TYPICAL EMBANKMENT  
ABUTMENT NORMAL SECTION  
( $5'-0'' < H \leq 8'-0''$ )

Issue Date: 10/03

Revision Date:

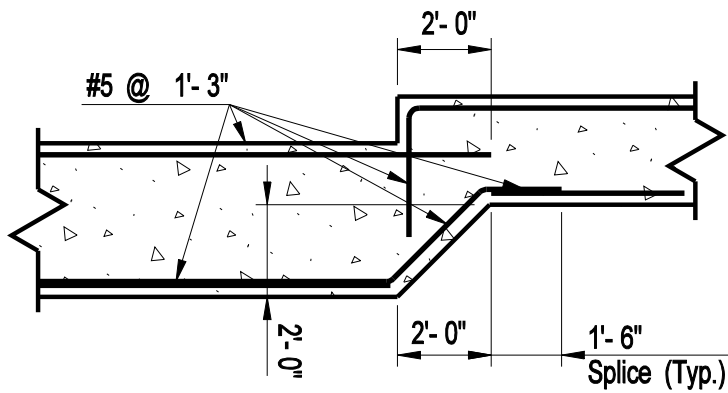
Plate Number:  
3.6.4



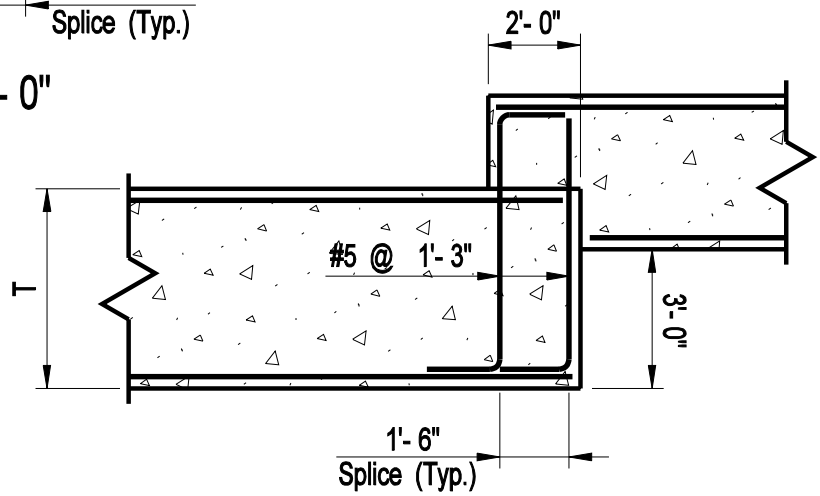
**CONNECTICUT  
BRIDGE DESIGN  
MANUAL**

TYPICAL EMBANKMENT  
ABUTMENT NORMAL SECTION  
(H > 8'-0")

Issue Date:	10/03
Revision Date:	
Plate Number:	3.6.5



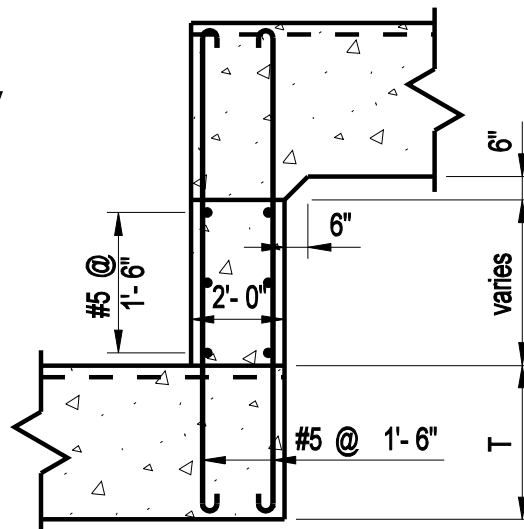
STEPPED FOOTING - 2'-0"



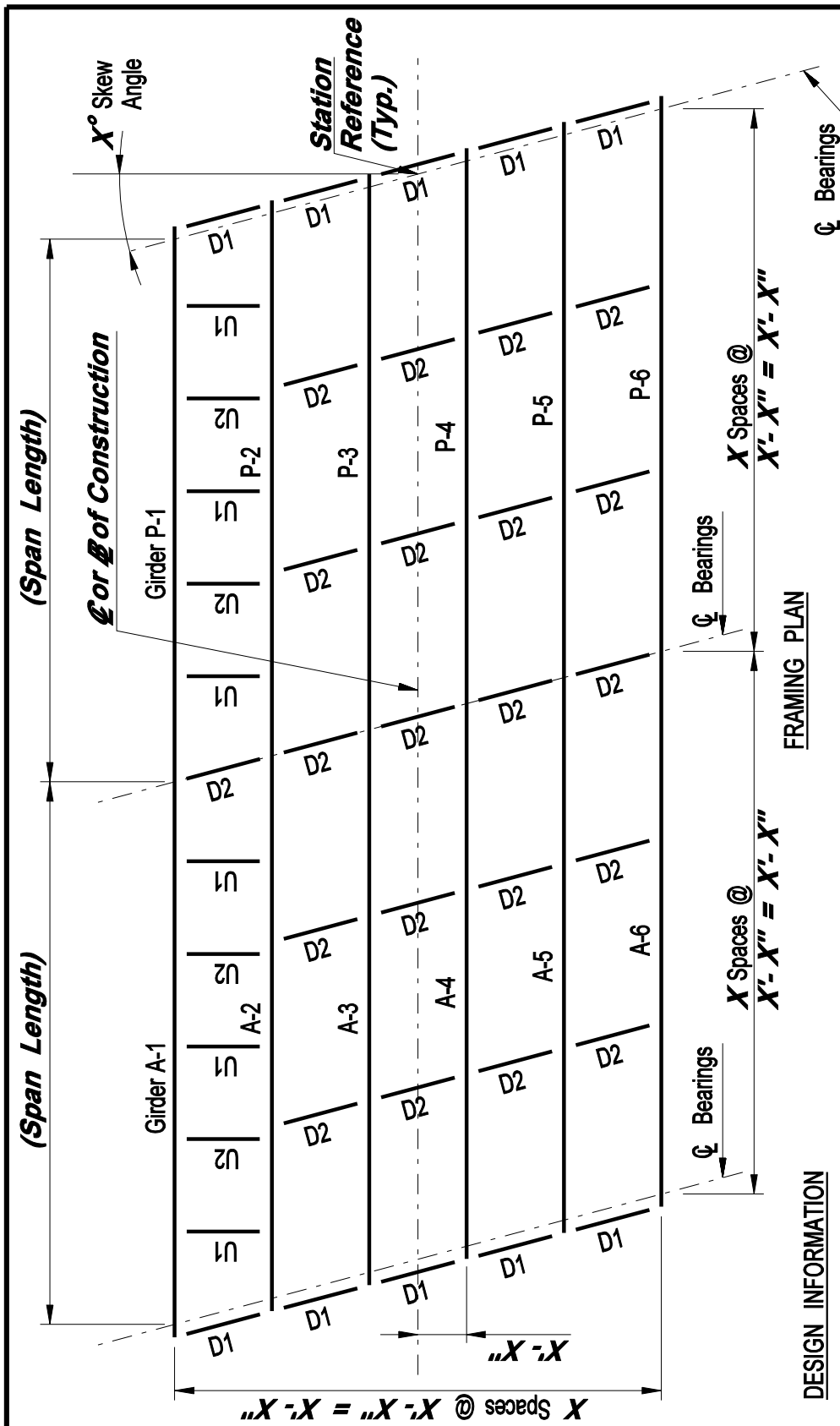
STEPPED FOOTING - 3'-0" to (T + 6")

DESIGN INFORMATION:

1. *The minimum step considered should be 2'-0".*
2. *Steps should be increased in 1'-0" increments.*



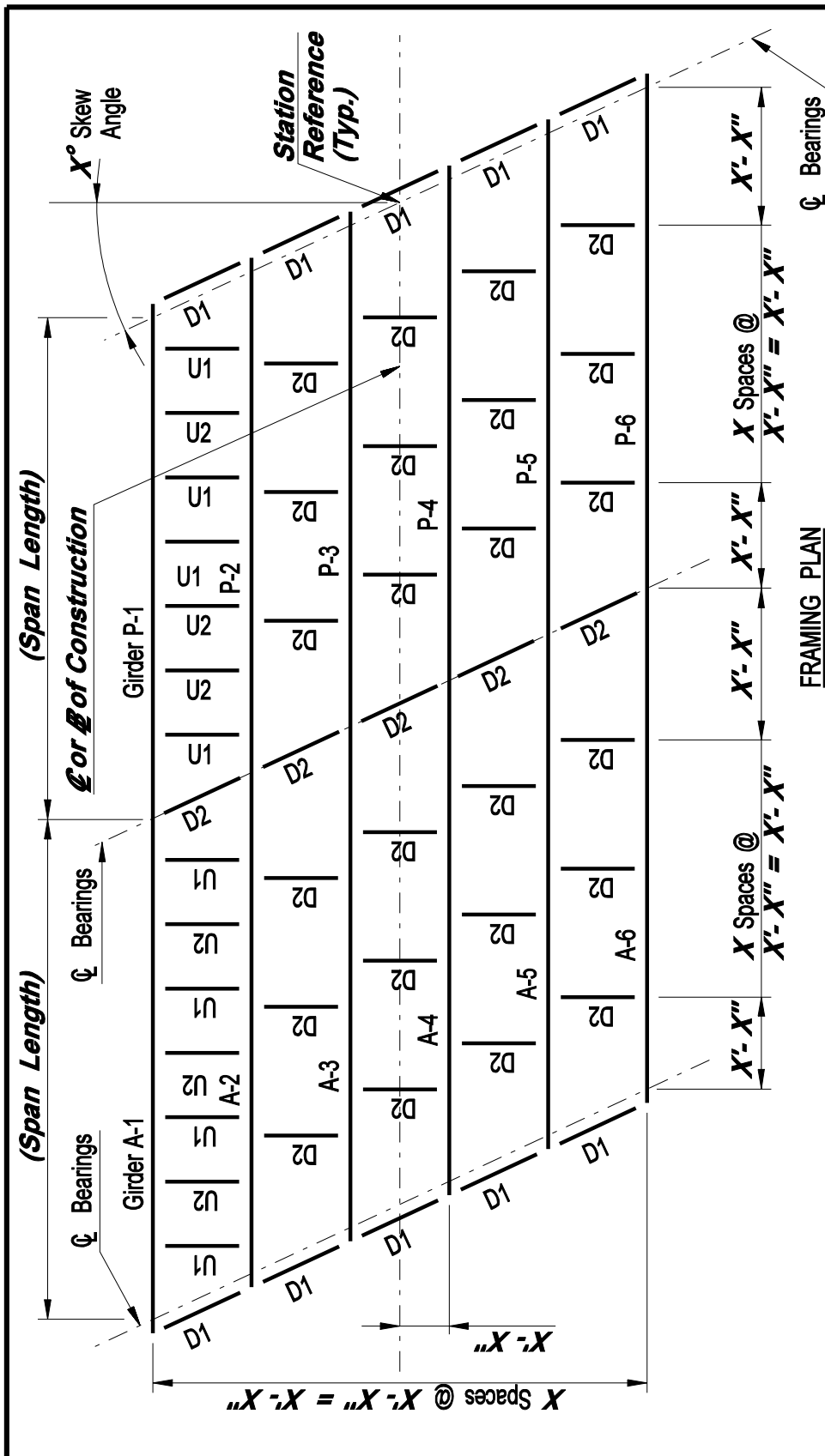
STEPPED FOOTING > (T + 6")



**D1 = End Bearing Diaphragm, see Plates 4.2.1 & 4.2.3**  
**D2 = Intermediate Diaphragm, see Plates 4.2.2 & 4.2.4**  
**U1 = Utility Support between diaphragms**  
**U2 = Utility Support Diaphragms**

1. The framing plan shall be drawn full length without breaks and to scale on the plans. Include all relevant survey data and North arrow.
2. Continuous two-span bridge shown, simple and multiple continuous span bridges are similar.
3. Where utilities interfere with the typical end diaphragm, provide an alternative end diaphragm detail.

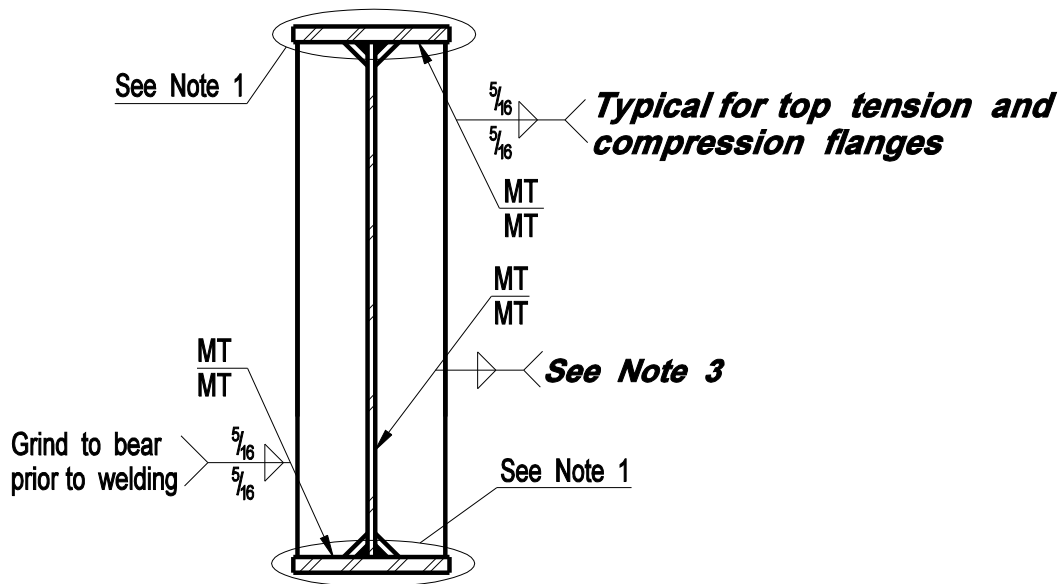




**DESIGN INFORMATION**

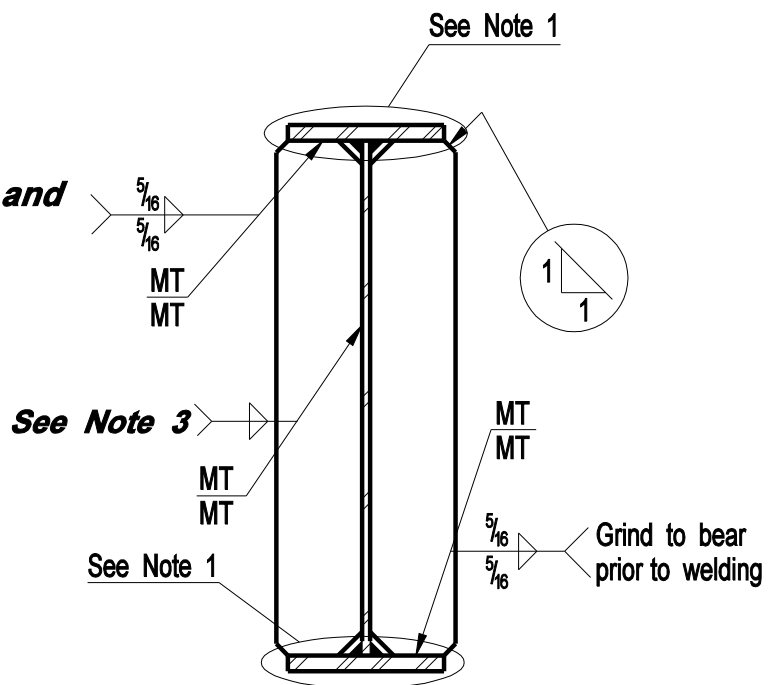
- D1 = End Bearing Diaphragm, see Plates 4.2.1 & 4.2.3
- D2 = Intermediate Diaphragm, see Plates 4.2.2 & 4.2.4
- U1 = Utility Support between diaphragms.
- U2 = Utility Support Diaphragm.

1. The framing plan shall be drawn full length without breaks and to scale on the plans. Include all relevant survey data and North arrow.
2. Continuous two-span bridge shown, simple and multiple continuous span bridges are similar.
3. Where utilities interfere with the typical end diaphragm, provide an alternative end diaphragm detail.



**STIFFENERS NARROWER THAN FLANGE**

*Typical for top tension and compression flanges*



**STIFFENERS WIDER THAN FLANGE**

**NOTES:**

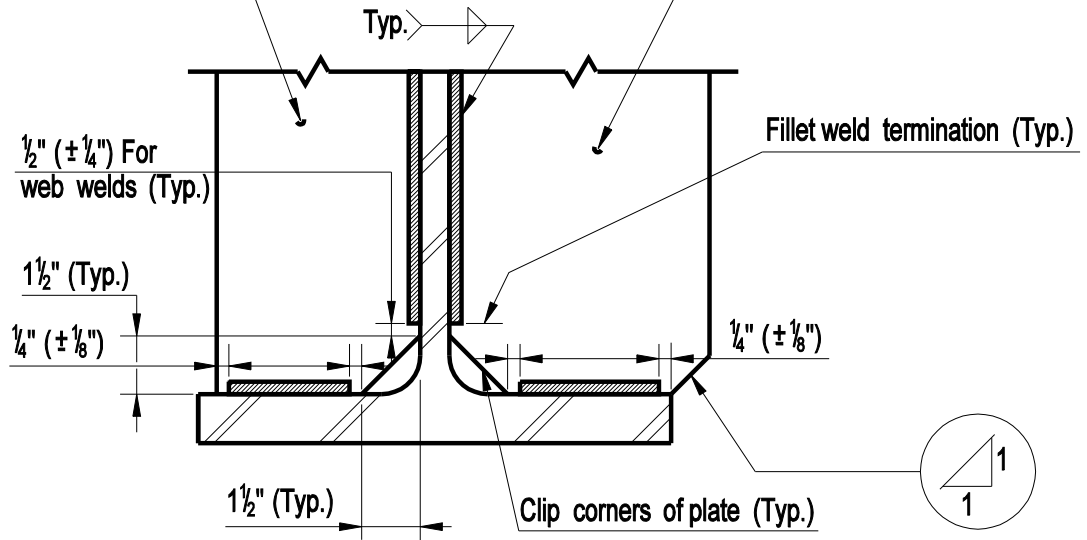
1. For clip and weld termination details, see Plate No. 4.2.2
2. For additional bearing stiffener details, see Plate No. 4.2.5

**DESIGN INFORMATION**

**3. Weld shall be designed, see Division I, Section 7**

*Plate narrower than flange*

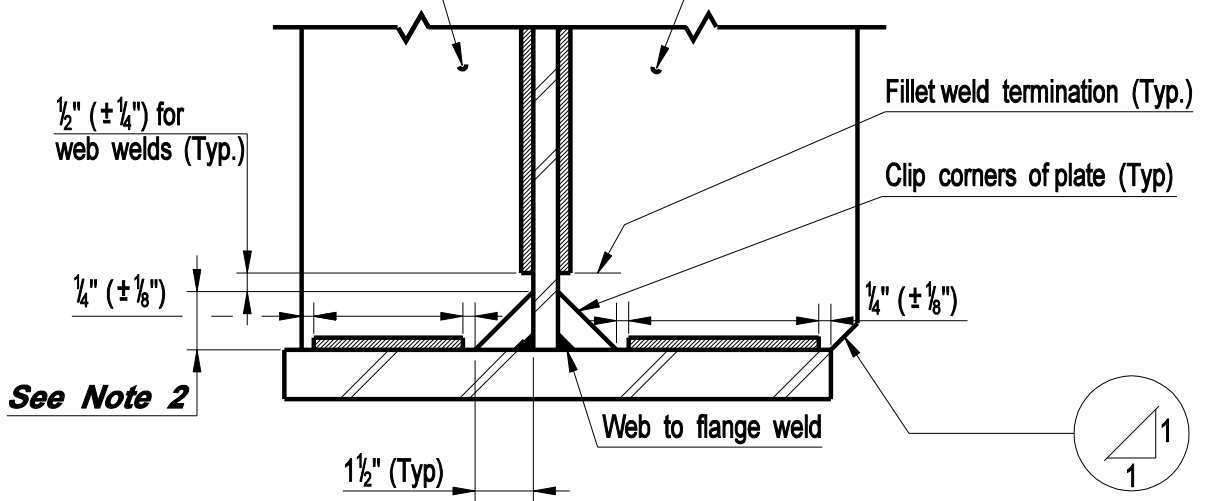
*Plate wider than flange*



**TYPICAL SECTION - ROLLED BEAMS**

*Plate narrower than flange*

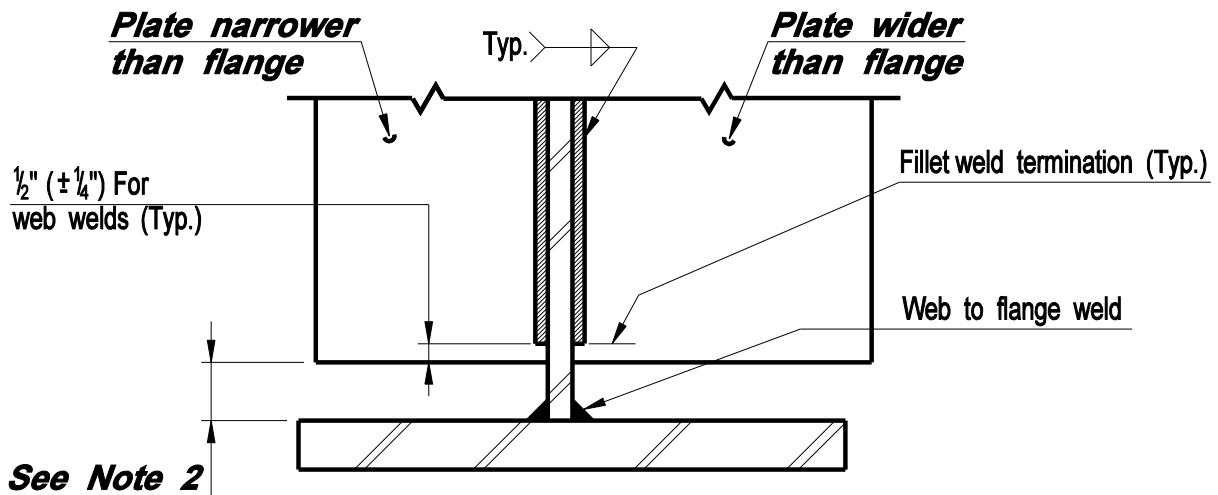
*Plate wider than flange*



**TYPICAL SECTION - PLATE GIRDERS**

**NOTES:**

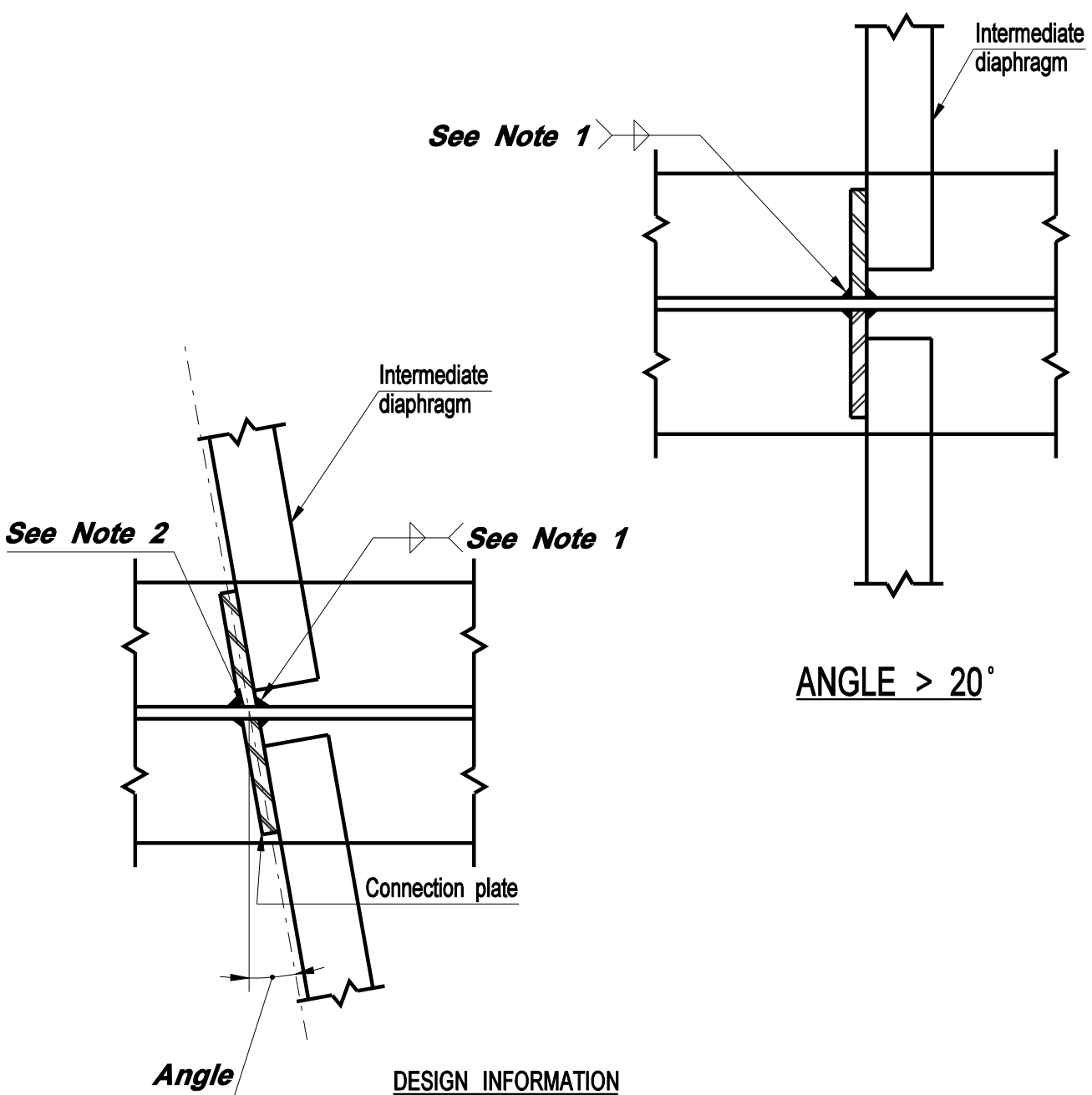
1. Details are shown for bottom flange, top flange is similar.
2. Designer shall determine this dimension.



### TYPICAL SECTION - PLATE GIRDERS

DESIGN INFORMATION:

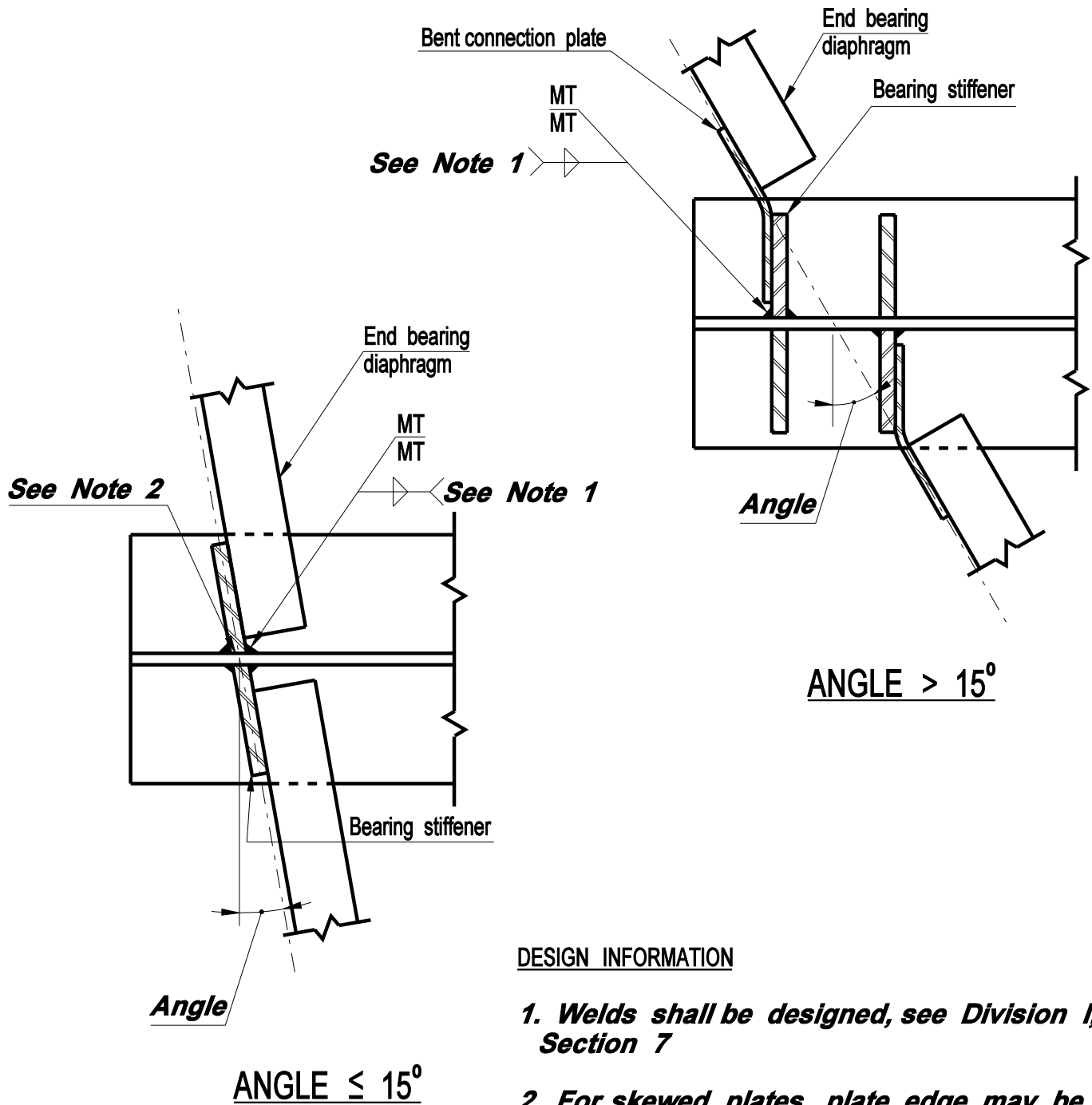
- 1. Details are shown for bottom flange, top flange is similar.**
- 2. Design shall determine this dimension.**



DESIGN INFORMATION

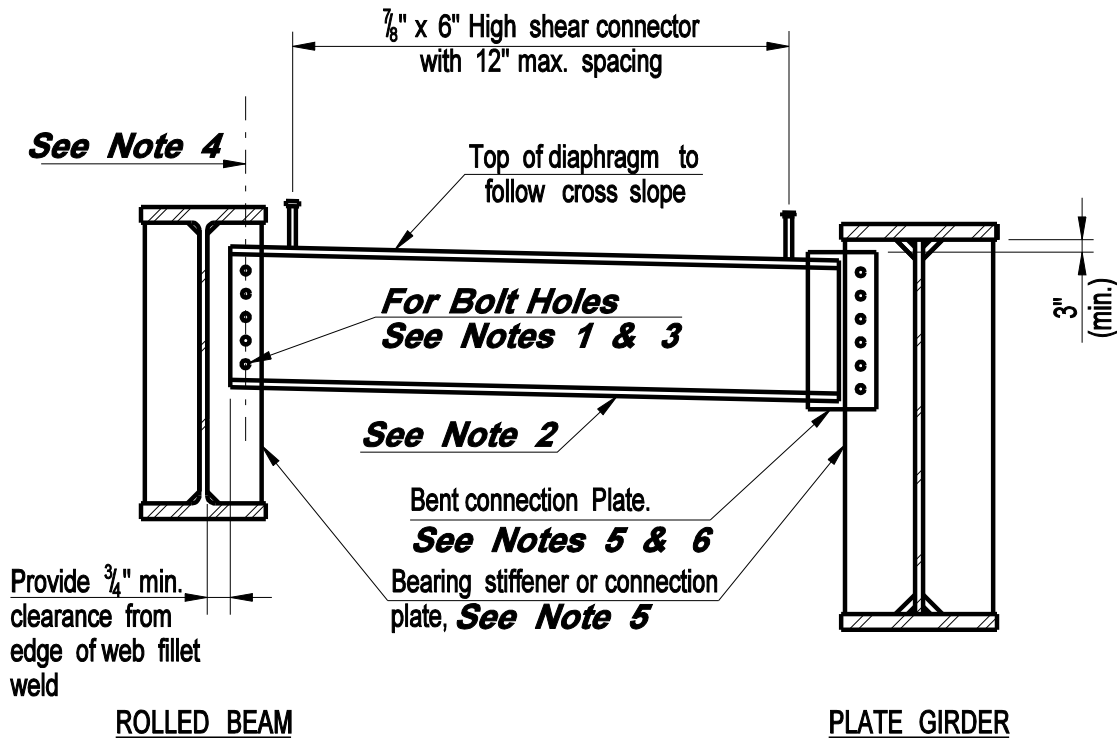
ANGLE ≤ 20°

1. Welds shall be designed, see Division I, Section 7
2. For skewed plates, plate edge may be beveled or square.



DESIGN INFORMATION

1. Welds shall be designed, see Division I, Section 7
2. For skewed plates, plate edge may be beveled or square.



**NOTES:**

1. Bolt holes in channels shall be  $\varnothing^{15/16}$ " (standard) for  $\varnothing^{7/8}$ " bolts. Bolt holes in connection or stiffener plates shall be  $\varnothing^{1 1/16}$ " (oversized).

**DESIGN INFORMATION**

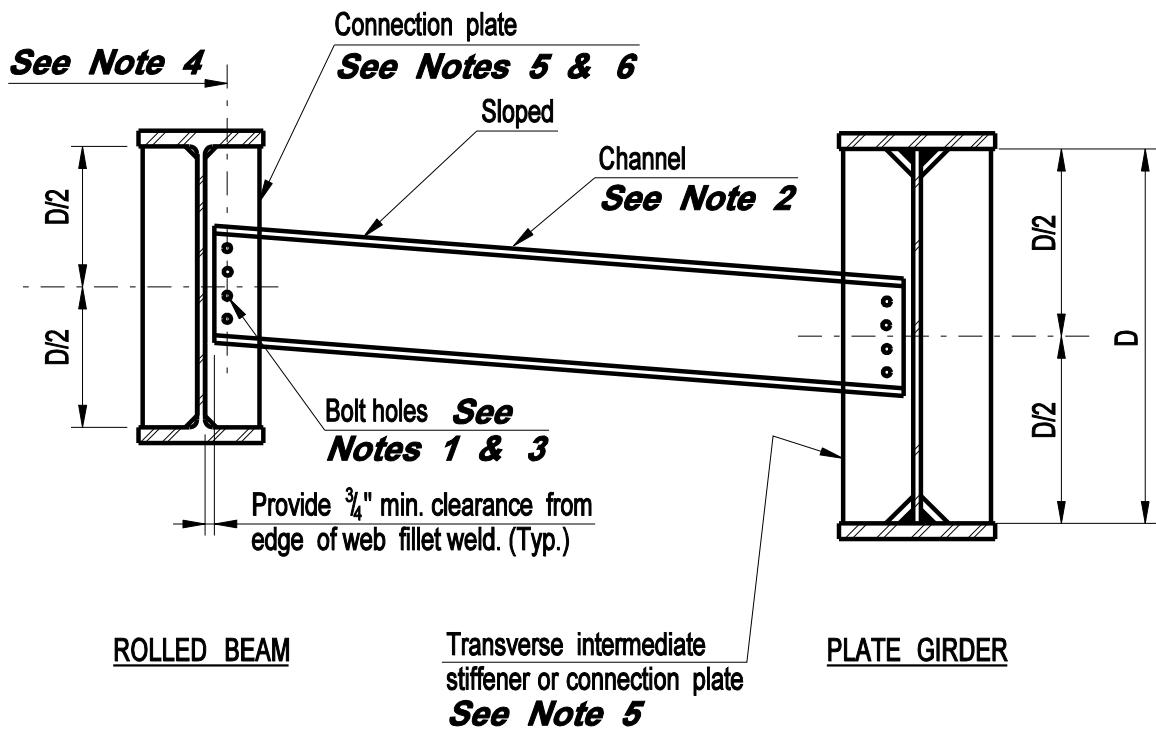
**2. Channel members shall be used for "I" shaped members. Size as determined by designer. C15 x 33.9 minimum.**

**3. Number of bolts shall be determined by the designer.**

**4. Centerline of bolt holes shall be vertical.**

**5. For connection and stiffener plate details, see Plate Nos. 4.2.1, 4.2.2 and 4.2.5.**

**6. Bent connection plate to be used for rolled beams or plate girders where skew angle > 15°. See Plate 4.2.5.**



<i>Member Depth *</i>	<i>Diaphragm</i>	<i>H.S. Bolts</i>
<b>33" - 48"</b>	<b>MC18 x 42.7</b>	<b>10</b>
<b>27" - 30"</b>	<b>C15 x 33.9</b>	<b>8</b>
<b>21" - 24"</b>	<b>C12 x 20.7</b>	<b>6</b>

*\* See Note 7*

**NOTES:**

1. Bolt holes in channels shall be  $\varnothing \frac{15}{16}$ " (standard) for  $\varnothing \frac{7}{8}$ " bolts. Bolt holes in connection or stiffener plates shall be  $\varnothing 1 \frac{1}{16}$ " (oversized).

**DESIGN INFORMATION**

- 2. Channel members shall be used for "I" shaped members.**
- 3. Number of bolts shall be determined by the designer.**
- 4. Centerline of bolt holes shall be vertical.**
- 5. For connection and stiffener plate details, see Plates 4.2.2 - 4.2.4.**
- 6. Connection plates shall be placed on skew for skew angle  $< 20^\circ$ .**
- 7. Member depth is nominal depth for rolled beams, actual web depth for plate girders.**

**CONNECTICUT  
BRIDGE DESIGN  
MANUAL**

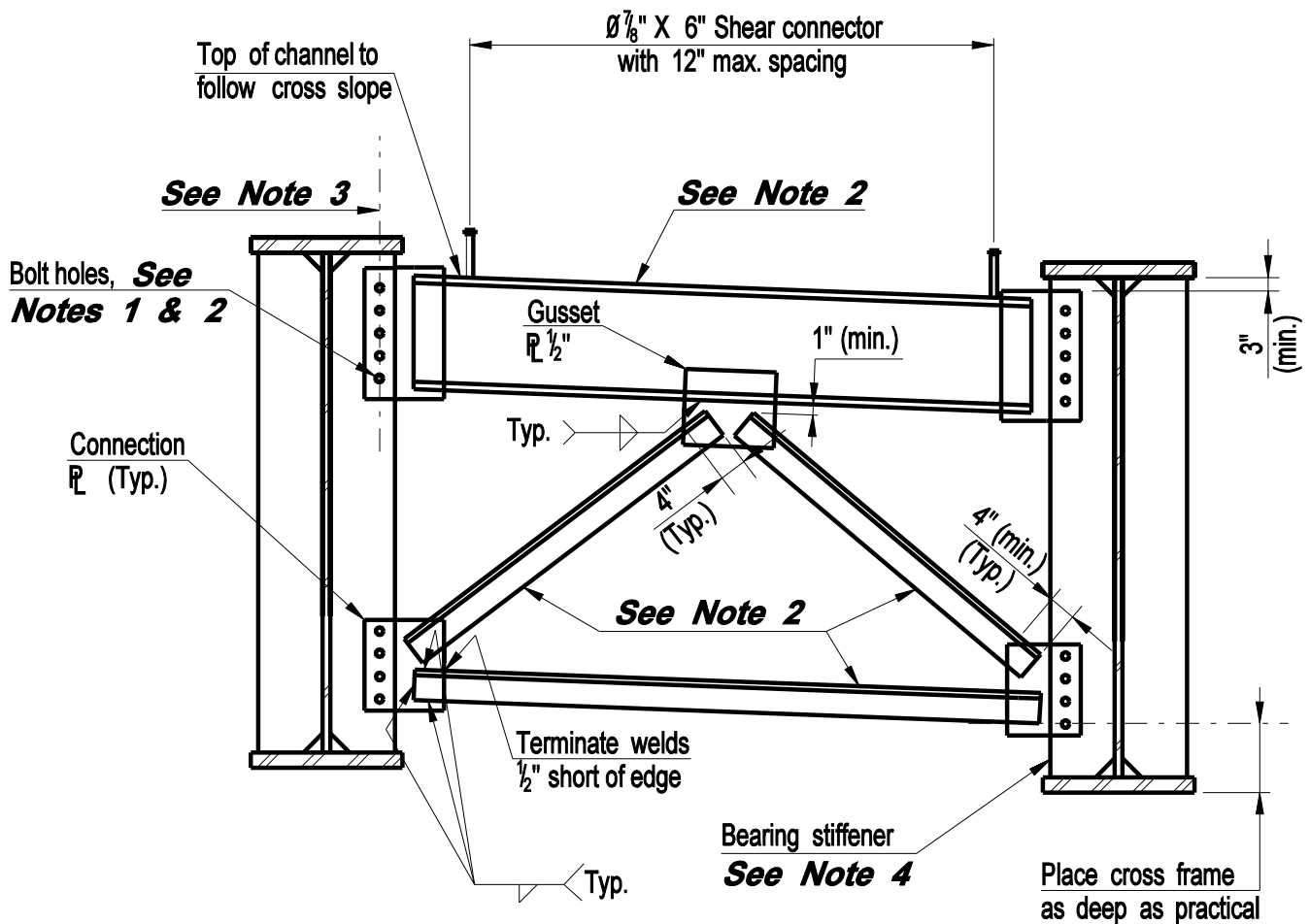
INTERMEDIATE DIAPHRAGM  
WEB DEPTH  $\leq 4'-0"$

Issue Date: 10/03

Revision Date: 01/05

Plate Number:  
**4.3.2**



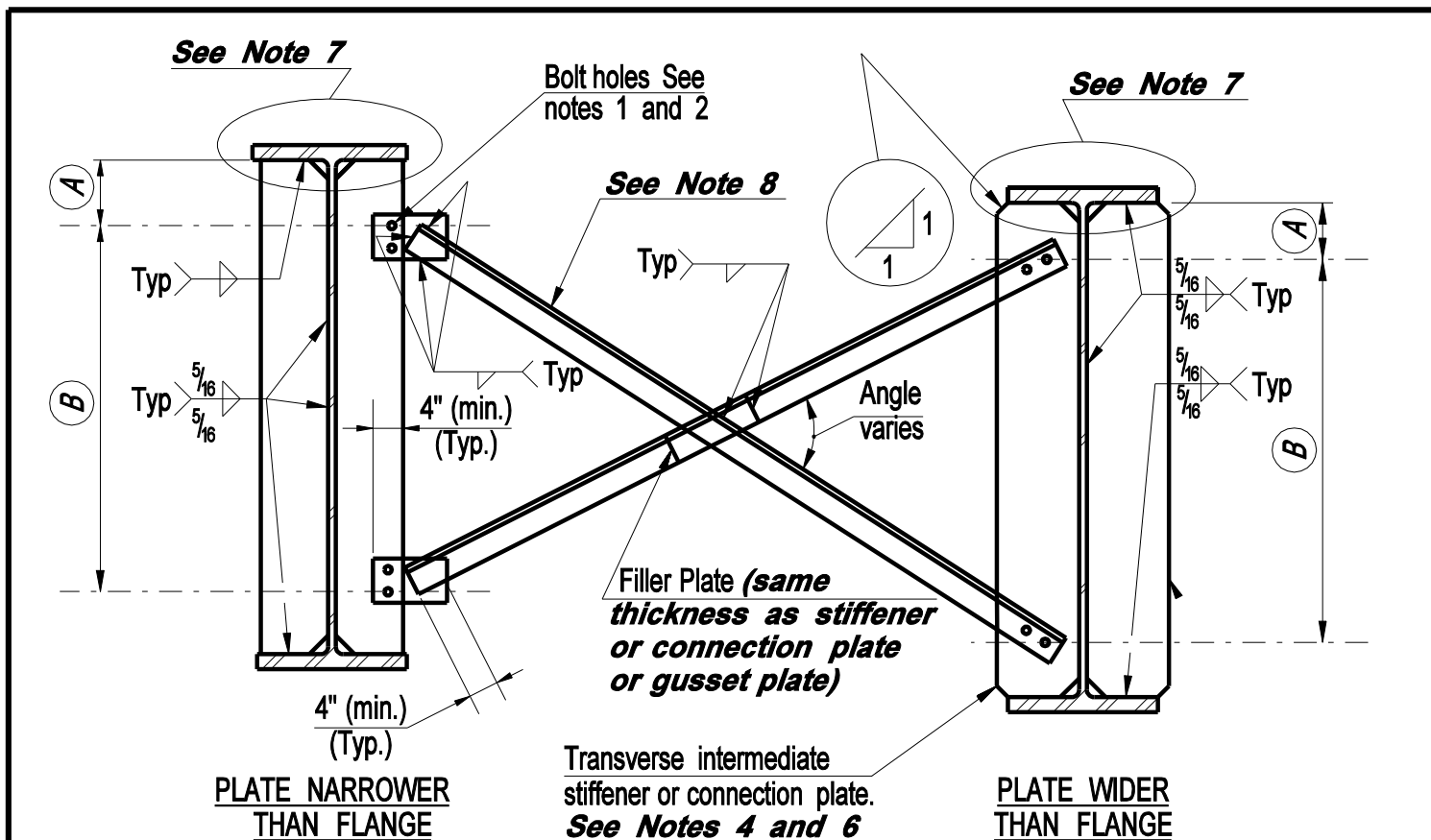


**NOTES:**

1. Bolt holes in channels shall be  $\varnothing 15/16$ " (standard) for  $\varnothing 7/8$ " bolts. Bolt holes in bearing stiffener shall be  $\varnothing 1 1/16$ " (oversized).

**DESIGN INFORMATION**

2. Channel and angle sizes along with the number of bolts shall be determined by the designer. Minimum angle size shall be L4" x 4" x 5/16".
3. Centerline of bolt holes shall be vertical.
4. For bearing stiffener details, see Plate Nos. 4.2.1, 4.2.2 and 4.2.5.



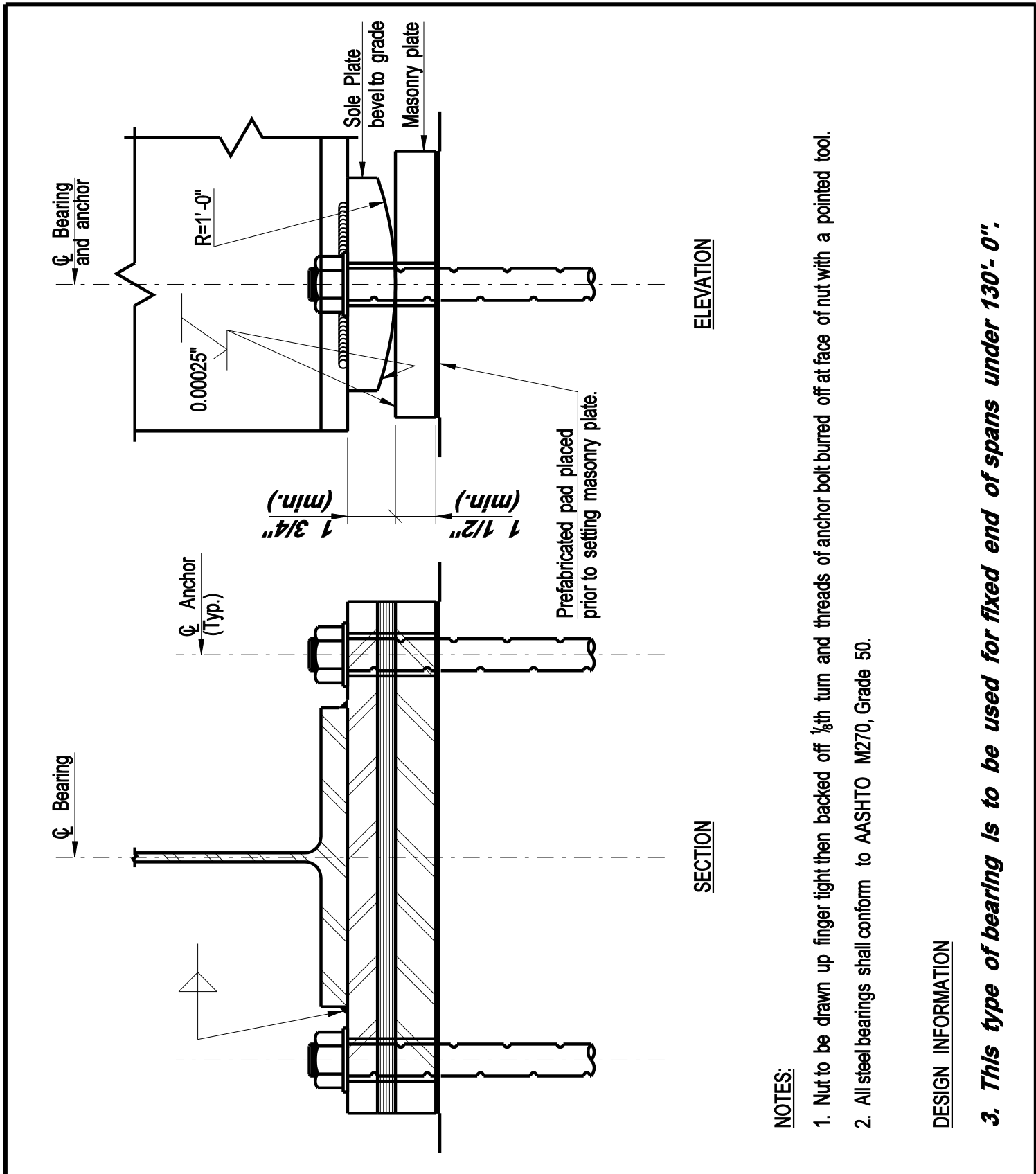
**NOTES:**

1. Bolt holes in angles and gusset plates shall be  $\varnothing 1\frac{5}{16}$ " (standard) for  $\varnothing 7/8$ " bolts. Bolt holes in transverse intermediate stiffener or connection plates shall be  $\varnothing 1\frac{1}{16}$ " (oversized).
2. Two bolts per connection shall be used.
3. Gusset plates shall be square or rectangular.

**DESIGN INFORMATION**

4. Designer may detail narrower stiffeners or connection plates with gusset plates, wider stiffeners or connection plates with angles connected directly thereto.
5. Dimensions A and B shall be the same for each girder. Cross frames shall be as deep as practical
6. For connection and stiffener plate details, see Plate Nos. 4.2.2, and 4.2.4.
7. For clip and weld termination details, see Plate No. 4.2.2.
8. Angles to be sized by designer.

<b>CONNECTICUT BRIDGE DESIGN MANUAL</b>	<b>INTERMEDIATE CROSS FRAME WEB DEPTH &gt; 4'- 0"</b>	Issue Date: 10/03
		Revision Date:
		Plate Number: <b>4.3.4</b>

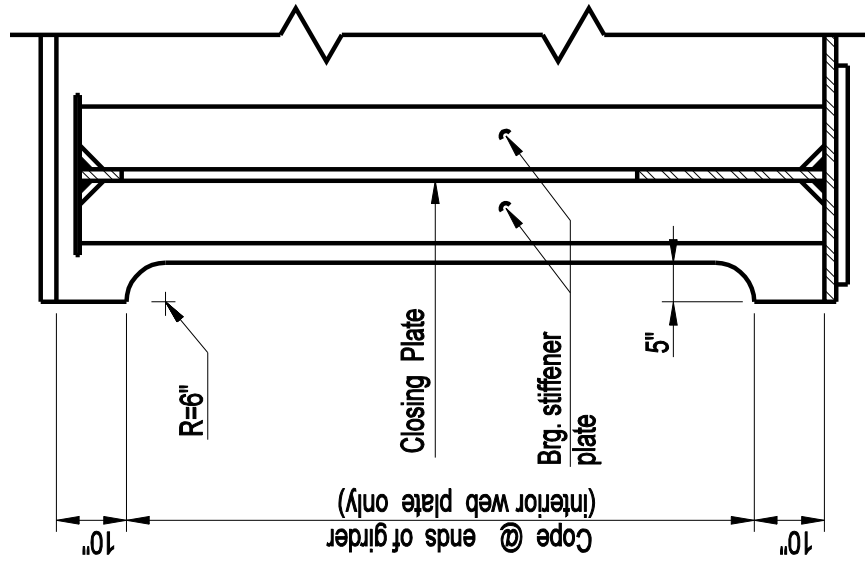


**NOTES:**

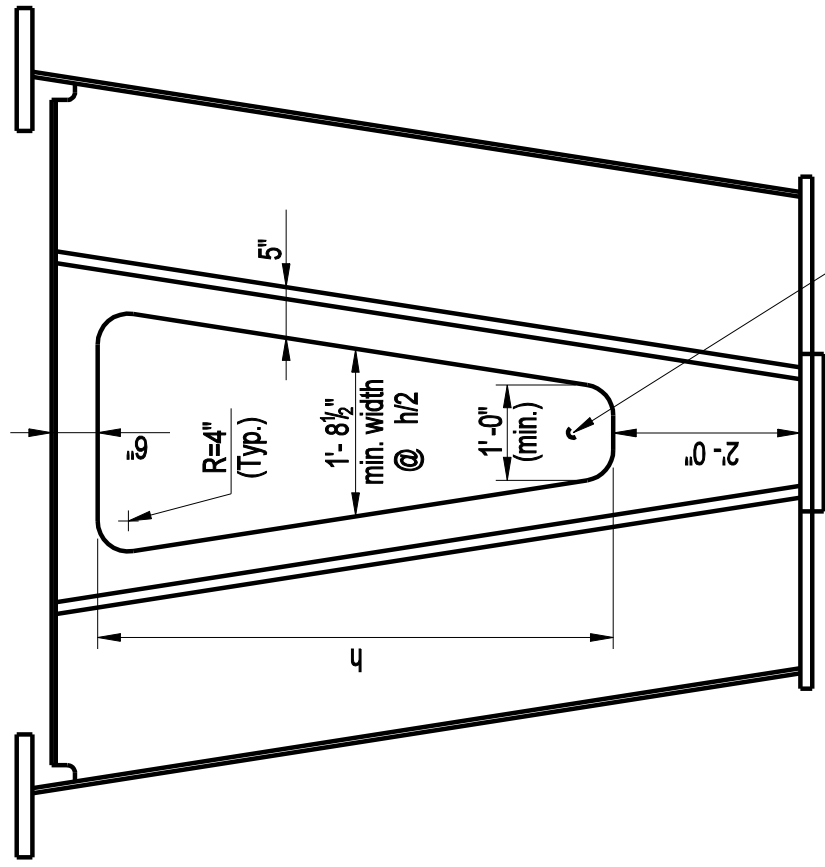
1. Nut to be drawn up finger tight then backed off 1/8th turn and threads of anchor bolt burred off at face of nut with a pointed tool.
2. All steel bearings shall conform to AASHTO M270, Grade 50.

**DESIGN INFORMATION**

***3. This type of bearing is to be used for fixed end of spans under 130'- 0" .***



SECTION A



END ELEVATION

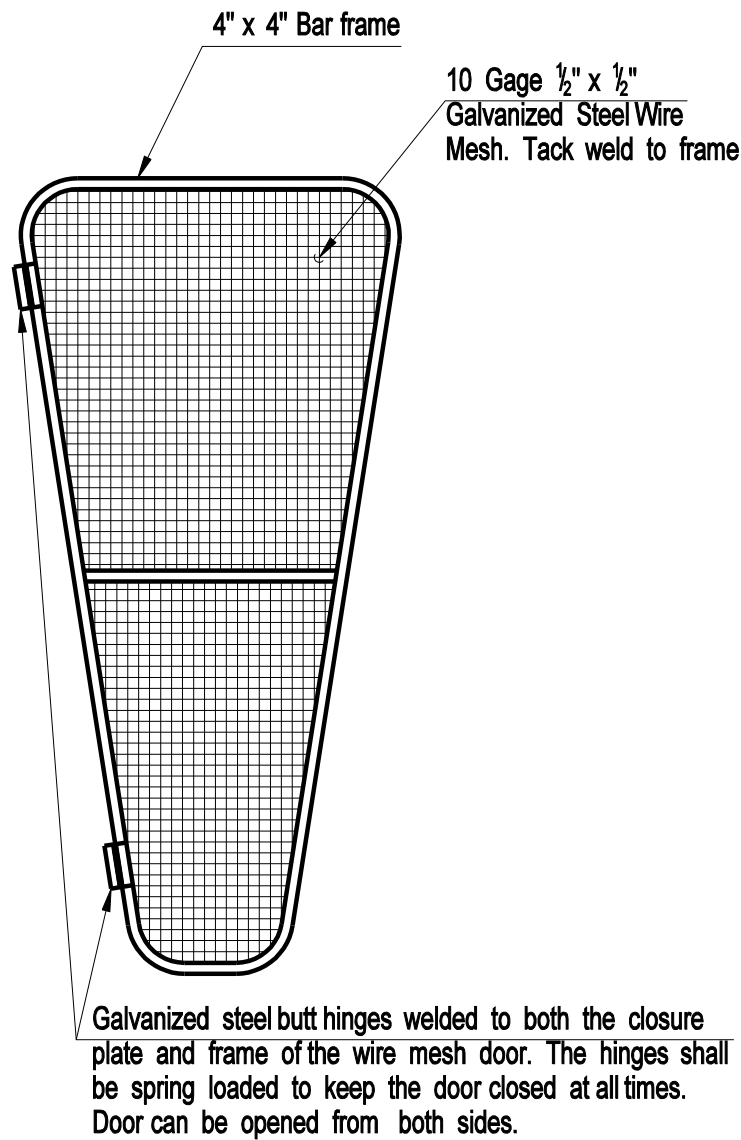
**CONNECTICUT  
BRIDGE DESIGN  
MANUAL**

STEEL BOX GIRDER END DIAPHRAGM  
ACCESS DETAILS

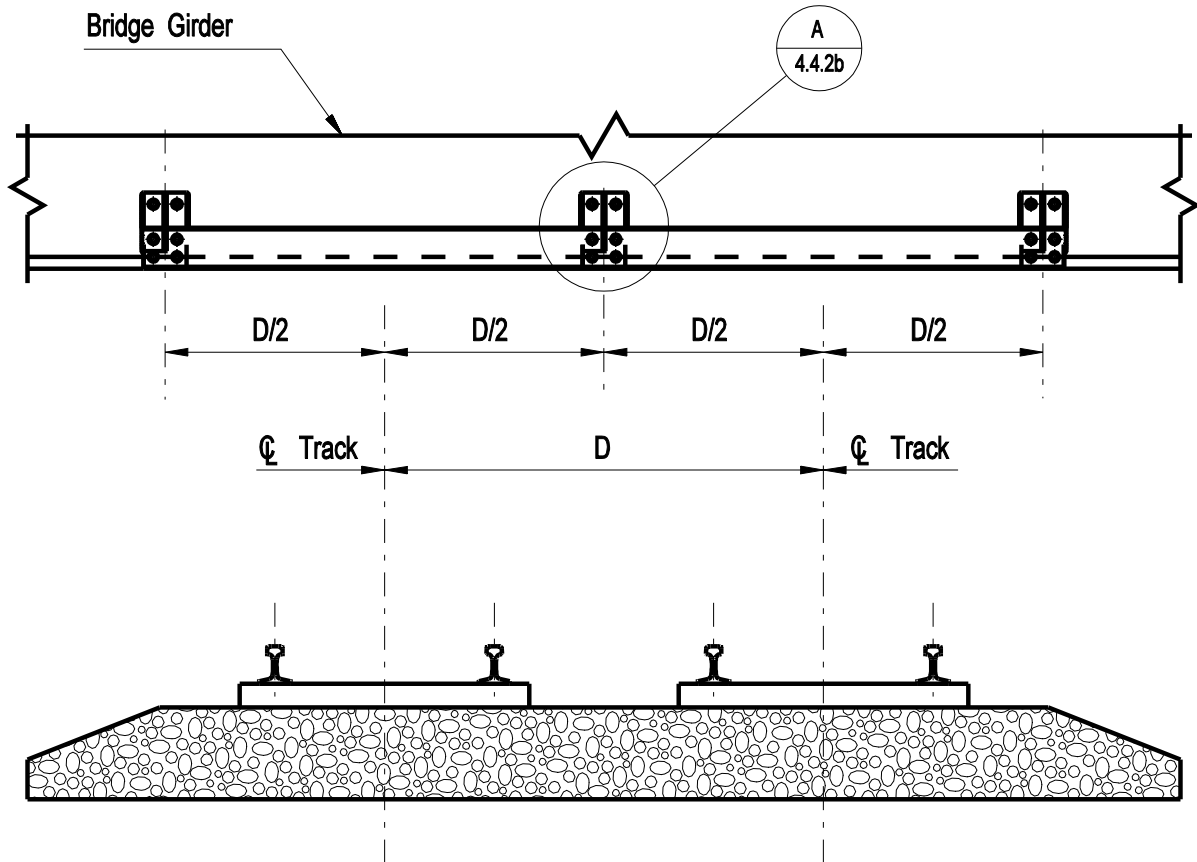
Issue Date: 10/03

Revision Date:

Plate Number:  
4.5.1a



### WIRE MESH CLOSURE



DESIGN INFORMATION

1. *The information shown should be used only as a guide and must be reviewed by the Railroad prior to its use.*
2. *The bottom elevation of the channel is to be at the same elevation as the bottom of the girder.*
3. *All steel shall be ASTM A709 Grade 50 unless the bridge is to be made of weathering steel. In this case all steel shall be ASTM A709 Grade 50W.*
4. *All bolts used with ASTM A709 Grade 50 steel shall be  $\emptyset 7/8$ " ASTM A325. Bolts used with ASTM A709 Grade 50W steel shall be  $\emptyset 7/8$ " ASTM A325 Type 3.*

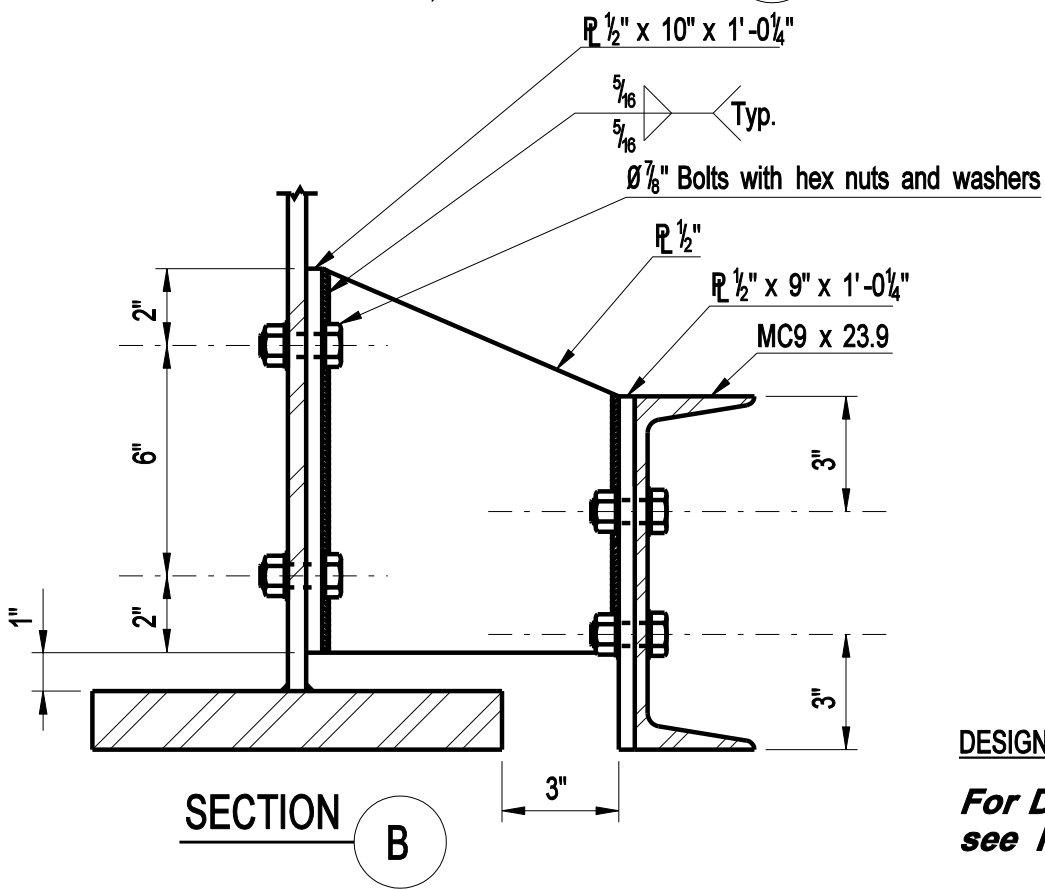
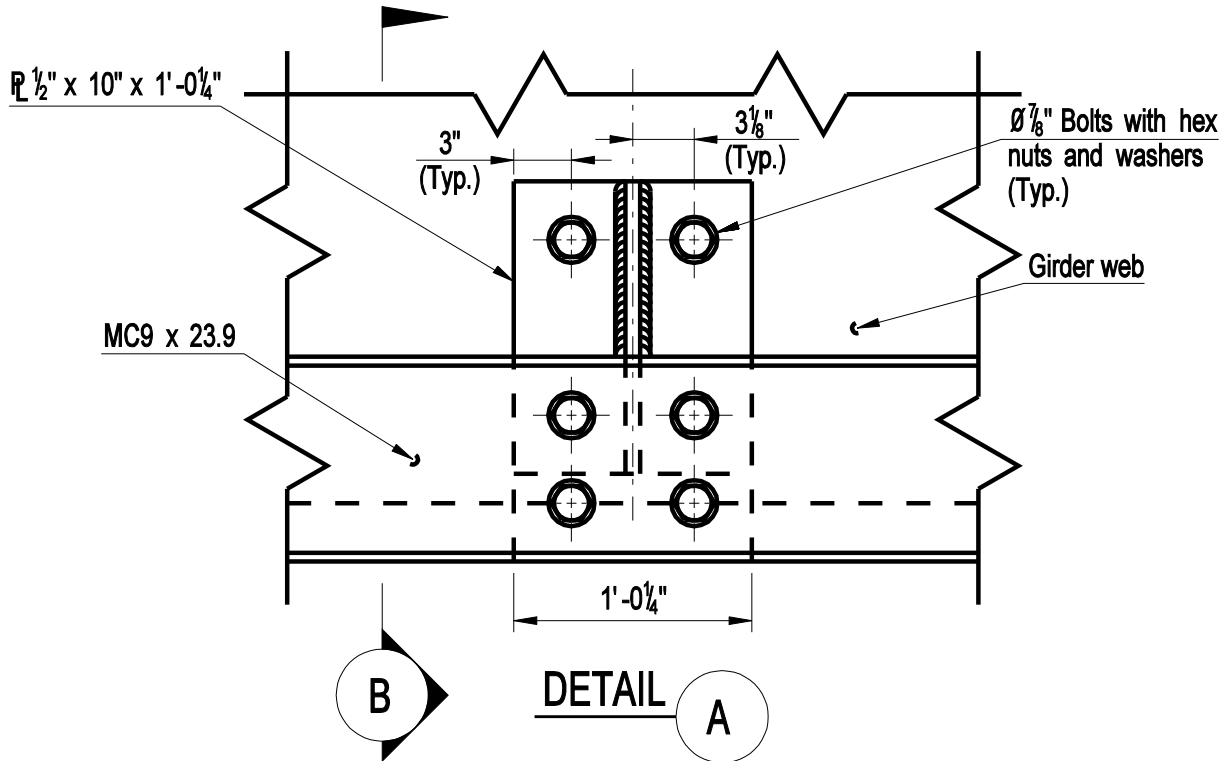
**CONNECTICUT  
BRIDGE DESIGN  
MANUAL**

CATENARY CONNECTION  
DETAIL FOR BRIDGES  
OVER ELECTRIFIED RAILROADS

Issue Date: 10/03

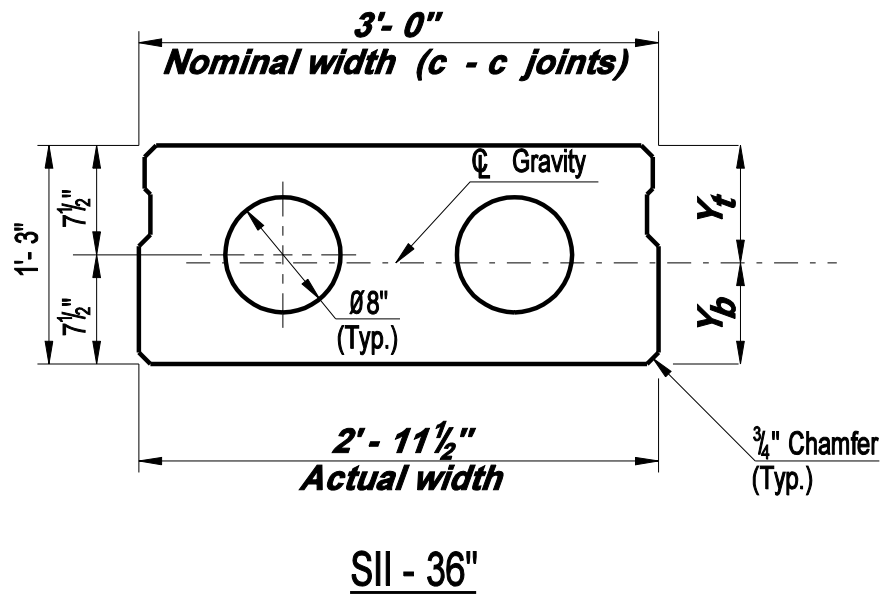
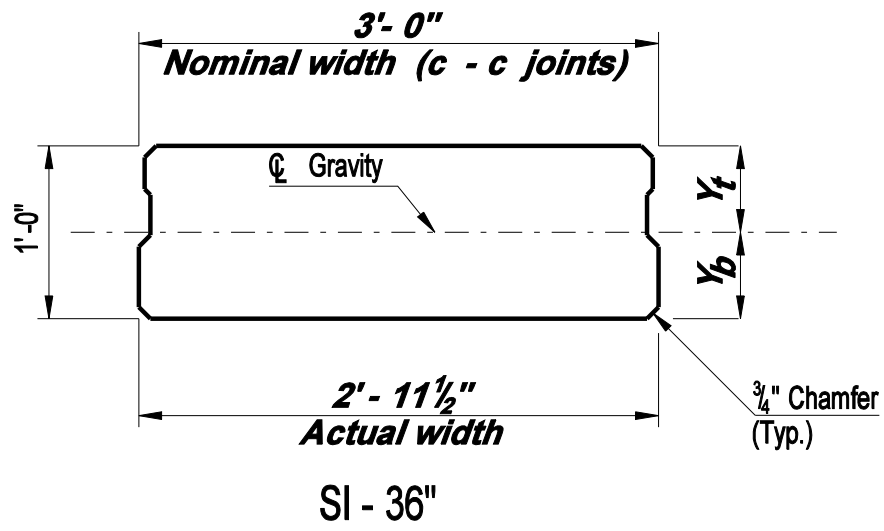
Revision Date:

Plate Number:  
4.5.2a



**DESIGN INFORMATION**

*For Design information, see Plate 4.5.2a*



DESIGN INFORMATION

*For Design information, see Plate 5.1.1c*

**CONNECTICUT  
BRIDGE DESIGN  
MANUAL**

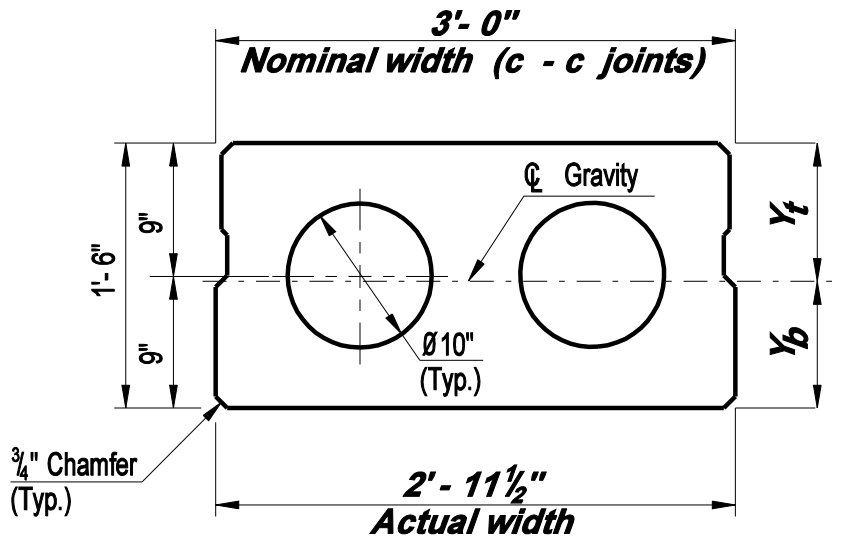
SECTION PROPERTIES  
AASHTO CONCRETE  
SLABS - 3'- 0" WIDE

Issue Date: 10/03

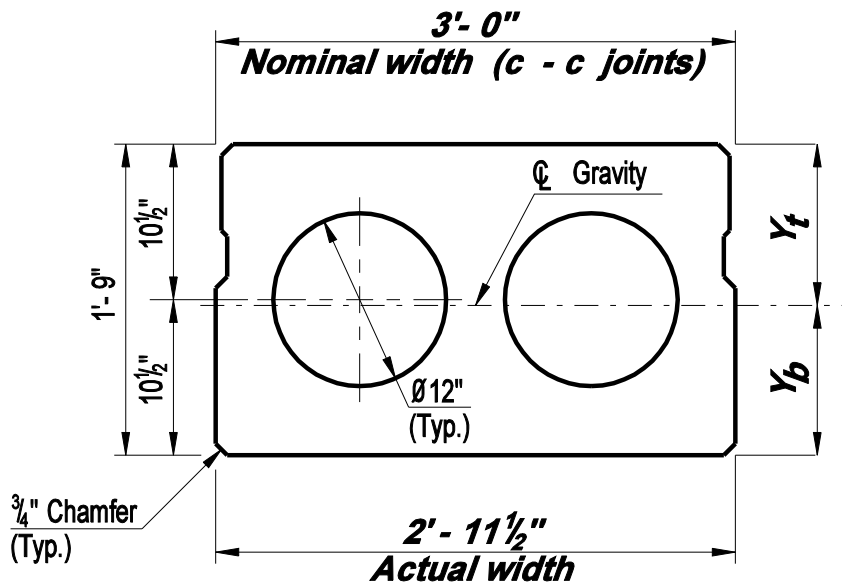
Revision Date:

Plate Number:  
5.1.1a





**SIII - 36"**



**SIV - 36"**

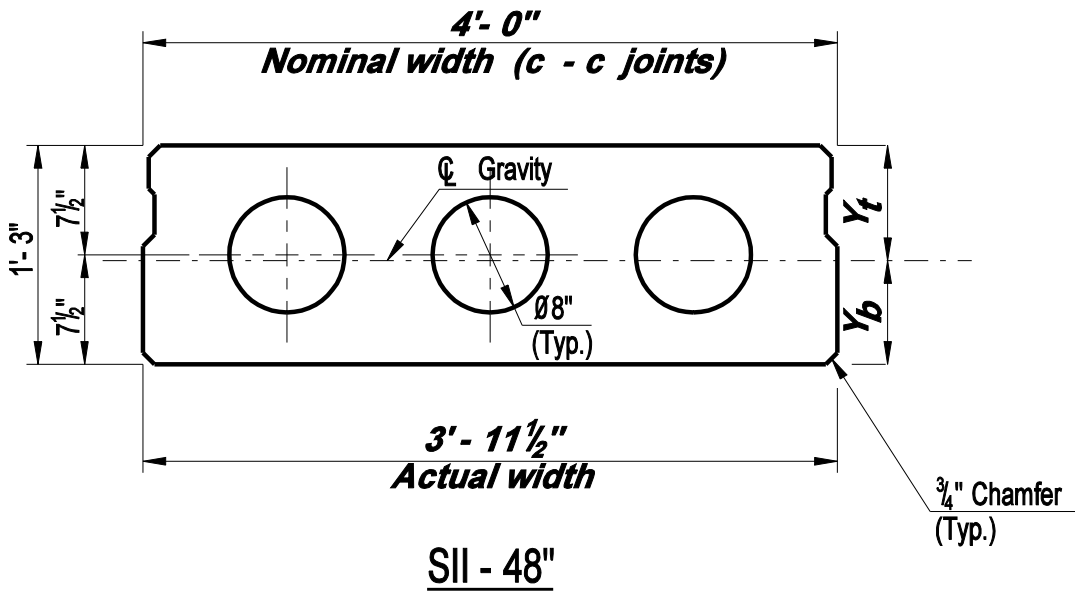
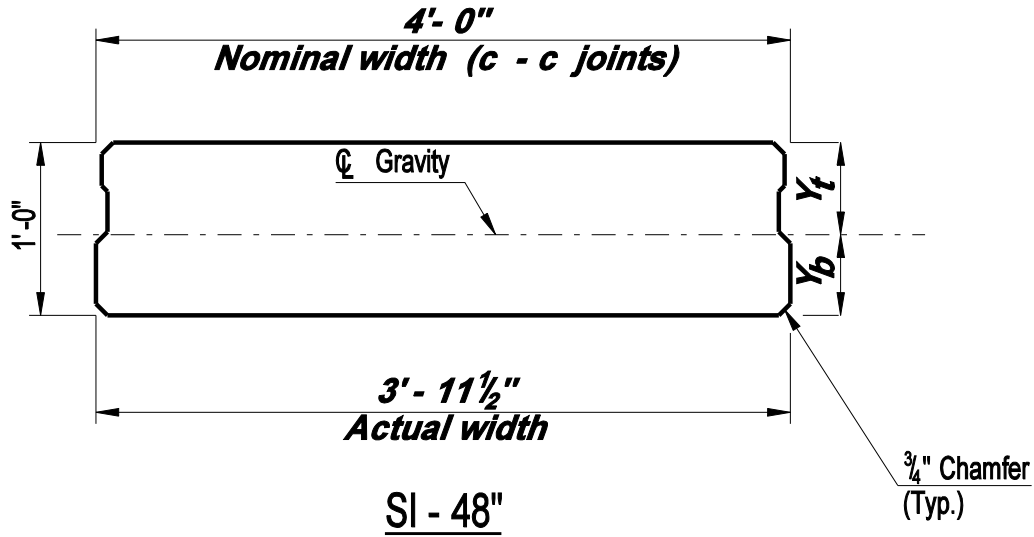
**DESIGN INFORMATION**

*For Design information, see Plate 5.1.1c*

BEAM TYPE	Width		Depth (inch)	A (inch <sup>2</sup> )	I (inch <sup>4</sup> )	Y <sub>b</sub> (in.)	Y <sub>t</sub> (in.)	S <sub>b</sub> (inch <sup>3</sup> )	S <sub>t</sub> (inch <sup>3</sup> )	Wt. (lb/ft)
	Nom. (inch)	Act. (inch)								
	SI-36	36.0								
SII-36	36.0	35.5	15.0	438	9728	7.44	7.56	1309	1287	457
SIII-36	36.0	35.5	18.0	473	16034	8.92	9.08	1798	1766	493
SIV-36	36.0	35.5	21.0	511	24987	10.40	10.60	2403	2358	532

DESIGN INFORMATION

1. *Weight of beam does not include weight of solid sections at transverse ties. Use the total weight (including solid sections) for design.*
2. *Voids may be eliminated to develop sidewalk/parapet reinforcement. See Section 5.6. The designer shall calculate and use the Modified Properties in this case.*
3. *For design details, see Plate 5.1.1a & 5.1.1b*
4. *If anchors must be drilled-in directly above a void for the purpose of anchoring Temporary Precast Concrete Barrier Curb, the size of the void should be adjusted to provide at least eight inches of thickness at the anchor locations.*



DESIGN INFORMATION

*For design information, see Plate 5.1.2c*

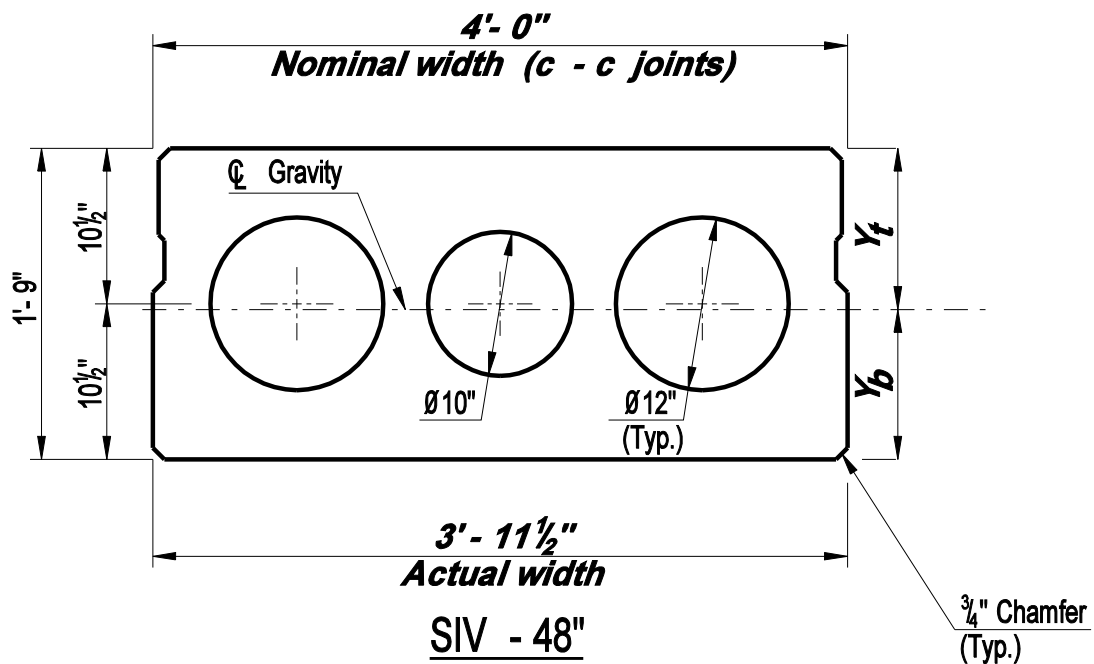
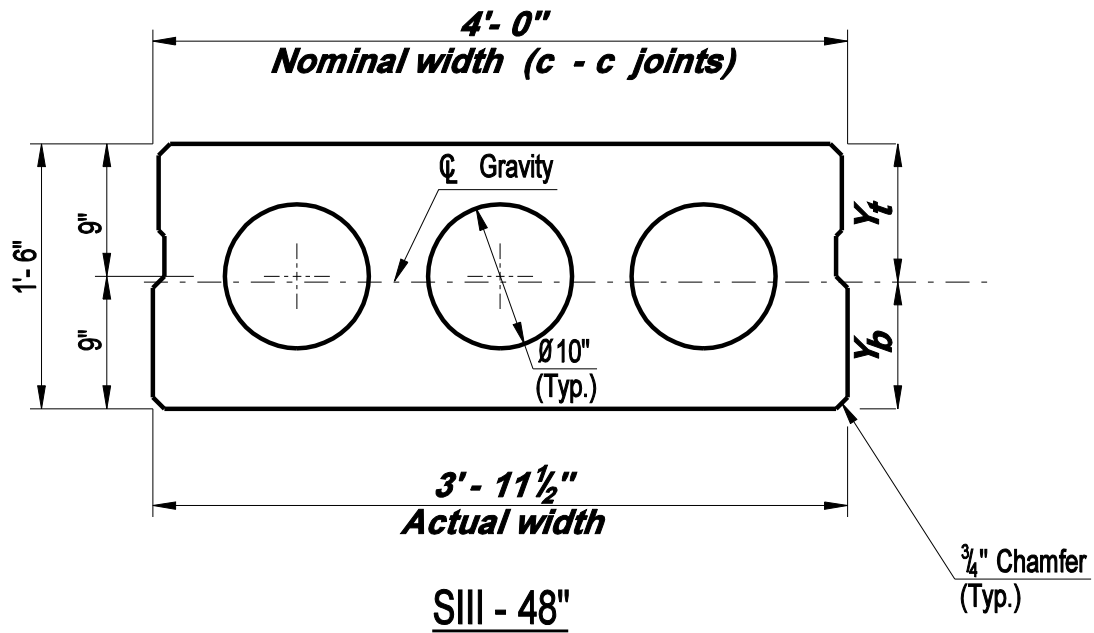
**CONNECTICUT  
BRIDGE DESIGN  
MANUAL**

**SECTION PROPERTIES  
AASHTO CONCRETE  
SLABS - 4'- 0" WIDE**

Issue Date: 10/03

Revision Date: 01/05

Plate Number:  
**5.1.2a**



**DESIGN INFORMATION**

*For design information, see Plate 5.1.2c*

**CONNECTICUT  
BRIDGE DESIGN  
MANUAL**

**SECTION PROPERTIES  
AASHTO CONCRETE  
SLABS - 4'- 0" WIDE**

Issue Date: 10/03

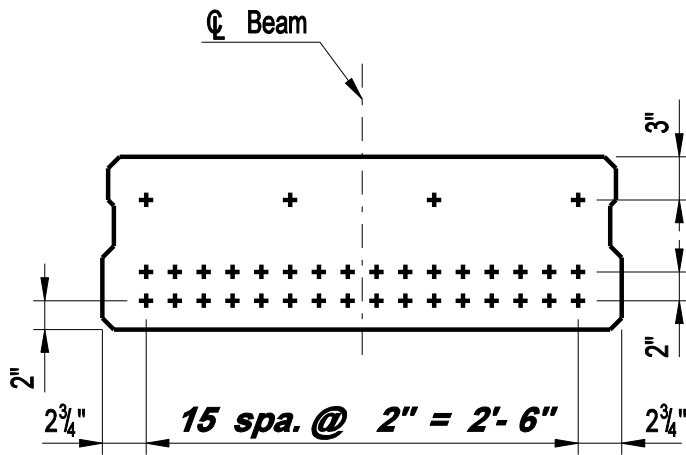
Revision Date:

Plate Number:  
**5.1.2b**

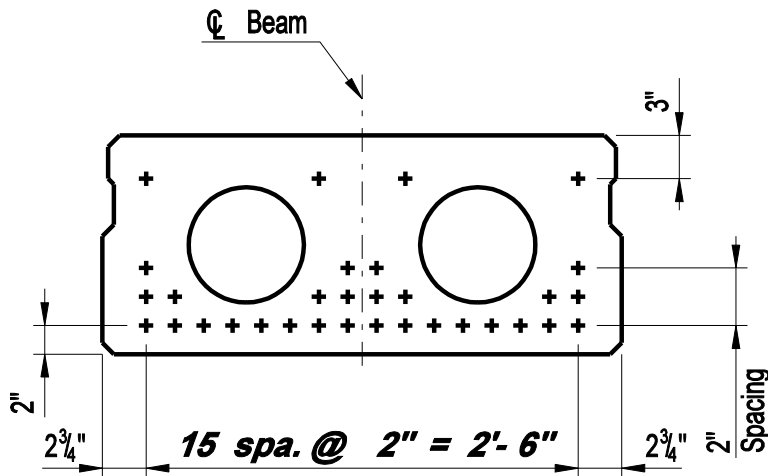
BEAM TYPE	Width		Depth	A	I	Y <sub>b</sub>	Y <sub>t</sub>	S <sub>b</sub>	S <sub>t</sub>	Wt.
	Nom. (inch)	Act. (inch)								
SI-48	48.0	47.5	12.0	561	6773	5.97	6.03	1135	1124	585
SII-48	48.0	47.5	15.0	553	12622	7.45	7.55	1695	1672	576
SIII-48	48.0	47.5	18.0	611	21376	8.94	9.06	2393	2359	636
SIV-48	48.0	47.5	21.0	684	33759	10.43	10.57	3238	3193	713

DESIGN INFORMATION

1. Weight of beam does not include weight of solid sections at transverse ties. Use the total weight (including solid sections) for design.
2. Voids may be eliminated to develop sidewalk/parapet reinforcement. See Section 5.6. The designer shall calculate and use the Modified Properties in this case.
3. For design details, see Plates 5.1.2a & 5.1.2b



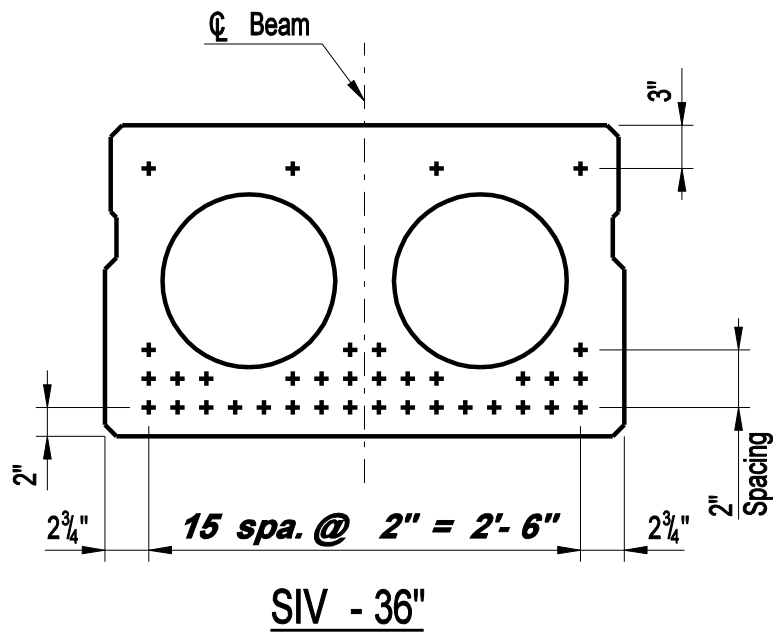
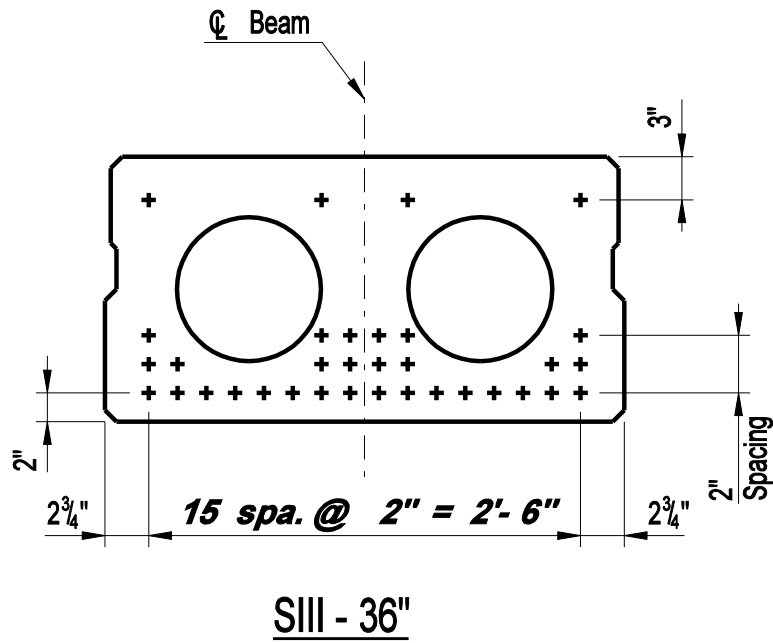
SI - 36"



SII - 36"

DESIGN INFORMATION

*For Design Information, see Plate 5.1.7*



DESIGN INFORMATION

*Design Information, see Plate 5.1.7*

**CONNECTICUT  
BRIDGE DESIGN  
MANUAL**

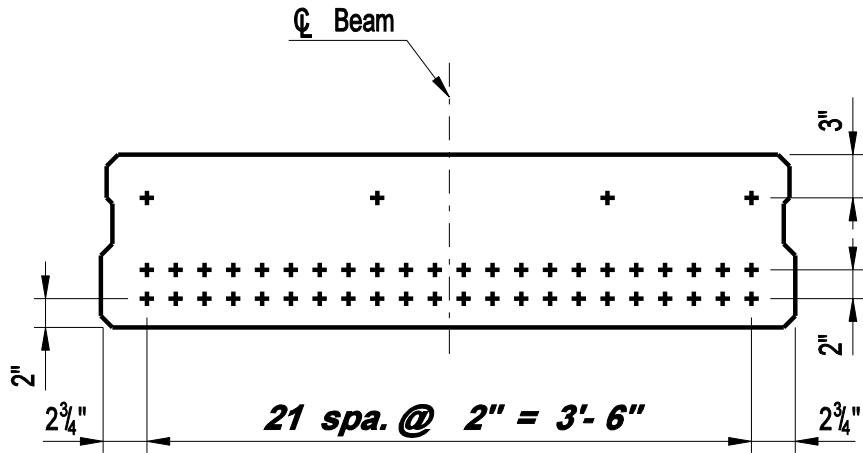
STRAND LOCATIONS  
AASHTO CONCRETE SLABS  
(S III & S IV - 3'-0" WIDE)

Issue Date: 10/03

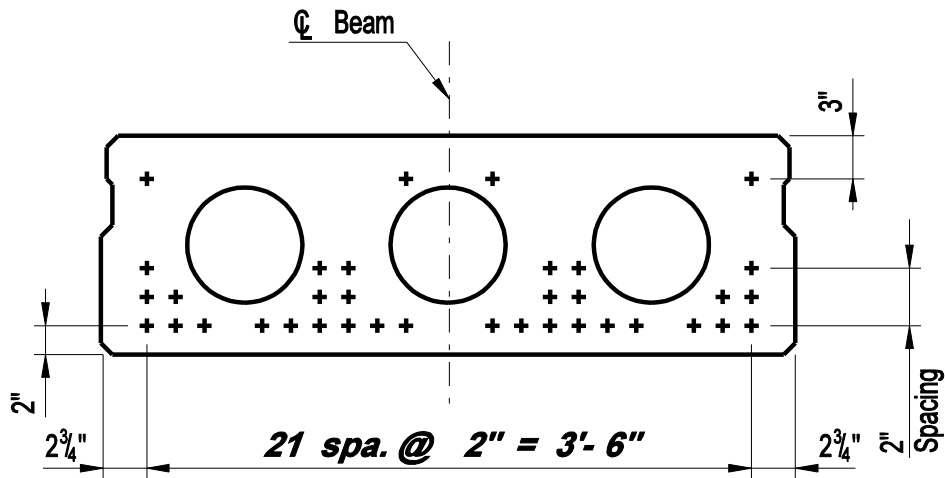
Revision Date:

Plate Number:

5.1.4



SI - 48"



SII - 48"

DESIGN INFORMATION

*Design Information, see Plate 5.1.7*

**CONNECTICUT  
BRIDGE DESIGN  
MANUAL**

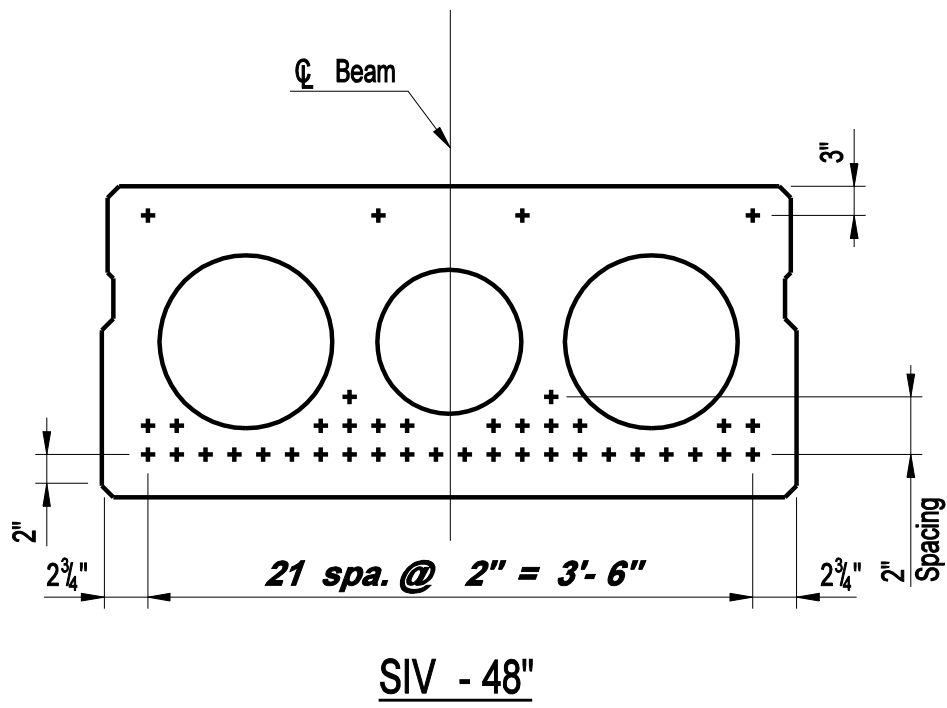
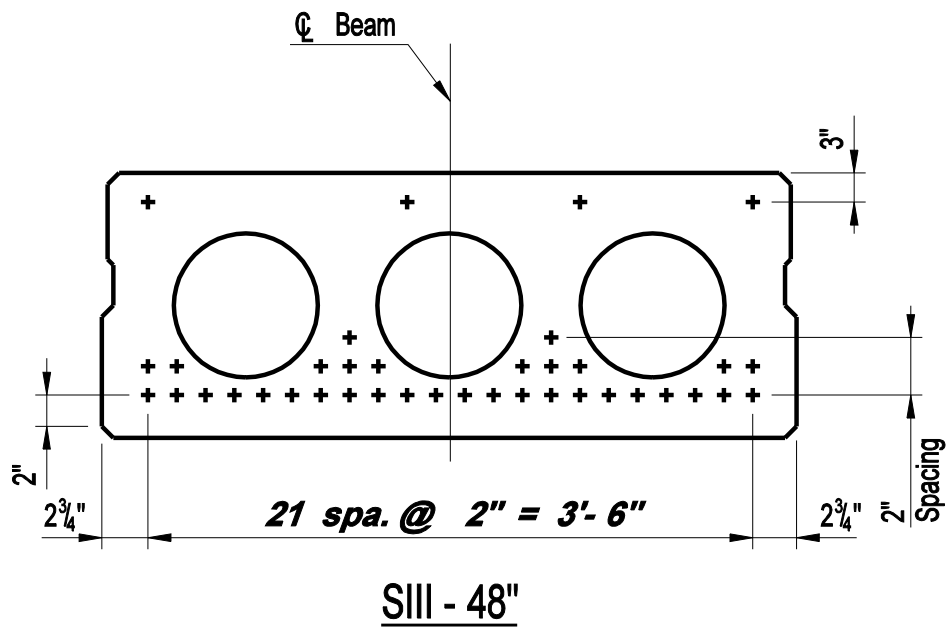
STRAND LOCATIONS  
AASHTO CONCRETE SLABS  
(S I & S II - 4'- 0" WIDE)

Issue Date: 10/03

Revision Date:

Plate Number:  
5.1.5





DESIGN INFORMATION

*For Design Information, see Plate 5.1.7*

<b>CONNECTICUT BRIDGE DESIGN MANUAL</b>	STRAND LOCATIONS AASHTO CONCRETE SLABS (S III & S IV - 4'-0" WIDE)	Issue Date: 10/03
		Revision Date:
		Plate Number: <b>5.1.6</b>

DESIGN INFORMATION

- 1. The standard strand pattern shown above depicts the maximum number of strands possible that can be located in a given beam while still meeting applicable fabrication clearances and tolerances. For most beam designs, strands shall be placed in as many locations within the pattern as required.**
- 2. + Denotes Prestressing strands**
- 3. Strand locations shown for design purposes only. Final plans shall only show number of strands and center of gravity.**
- 4. For design details, see Plates 5.1.3 - 5.1.6**

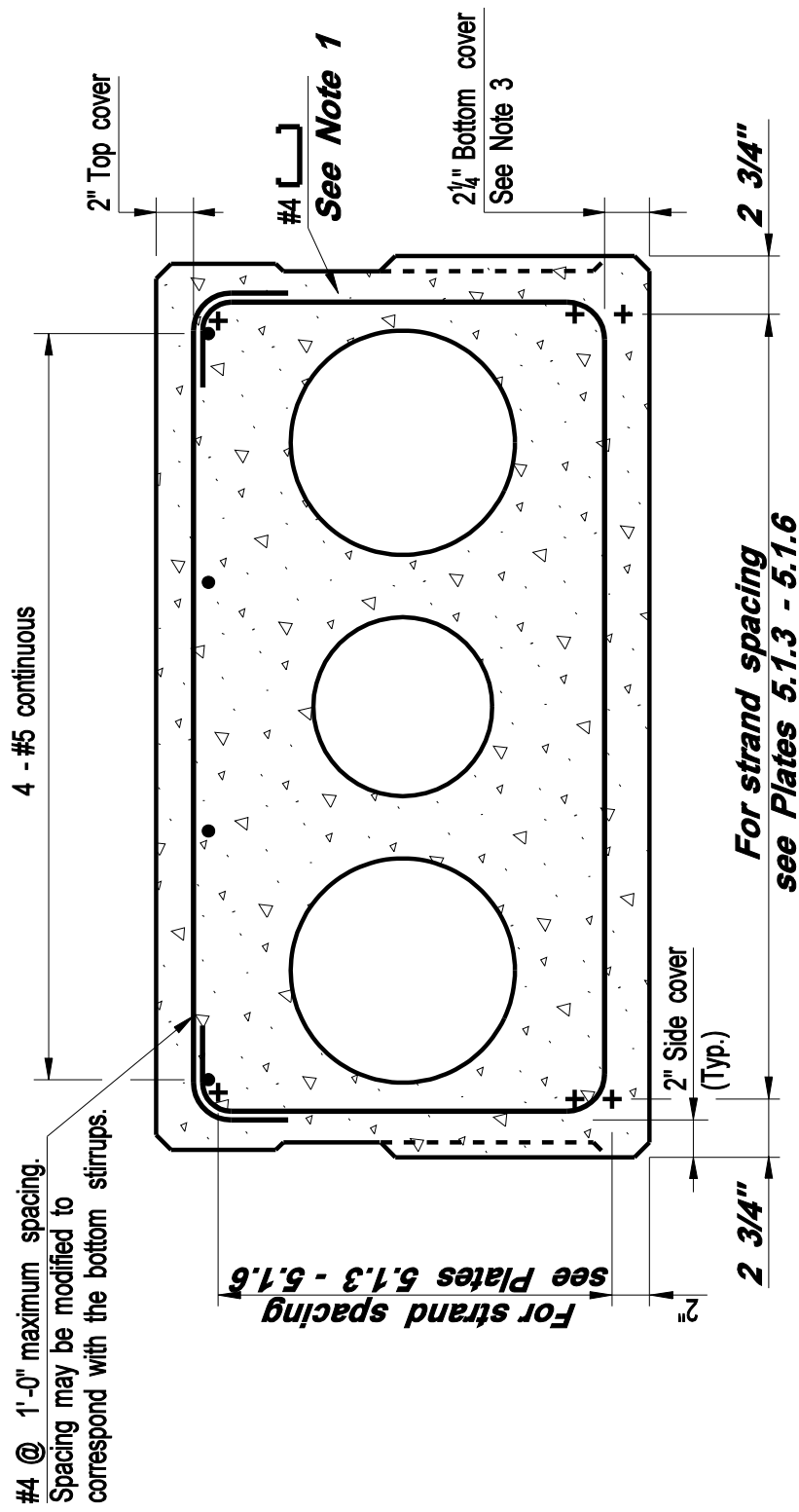
**CONNECTICUT  
BRIDGE DESIGN  
MANUAL**

**STRAND LOCATIONS  
AASHTO CONCRETE SLABS  
(DESIGN INFORMATION)**

Issue Date: 10/03

Revision Date:

Plate Number:  
5.1.7



**NOTES:**

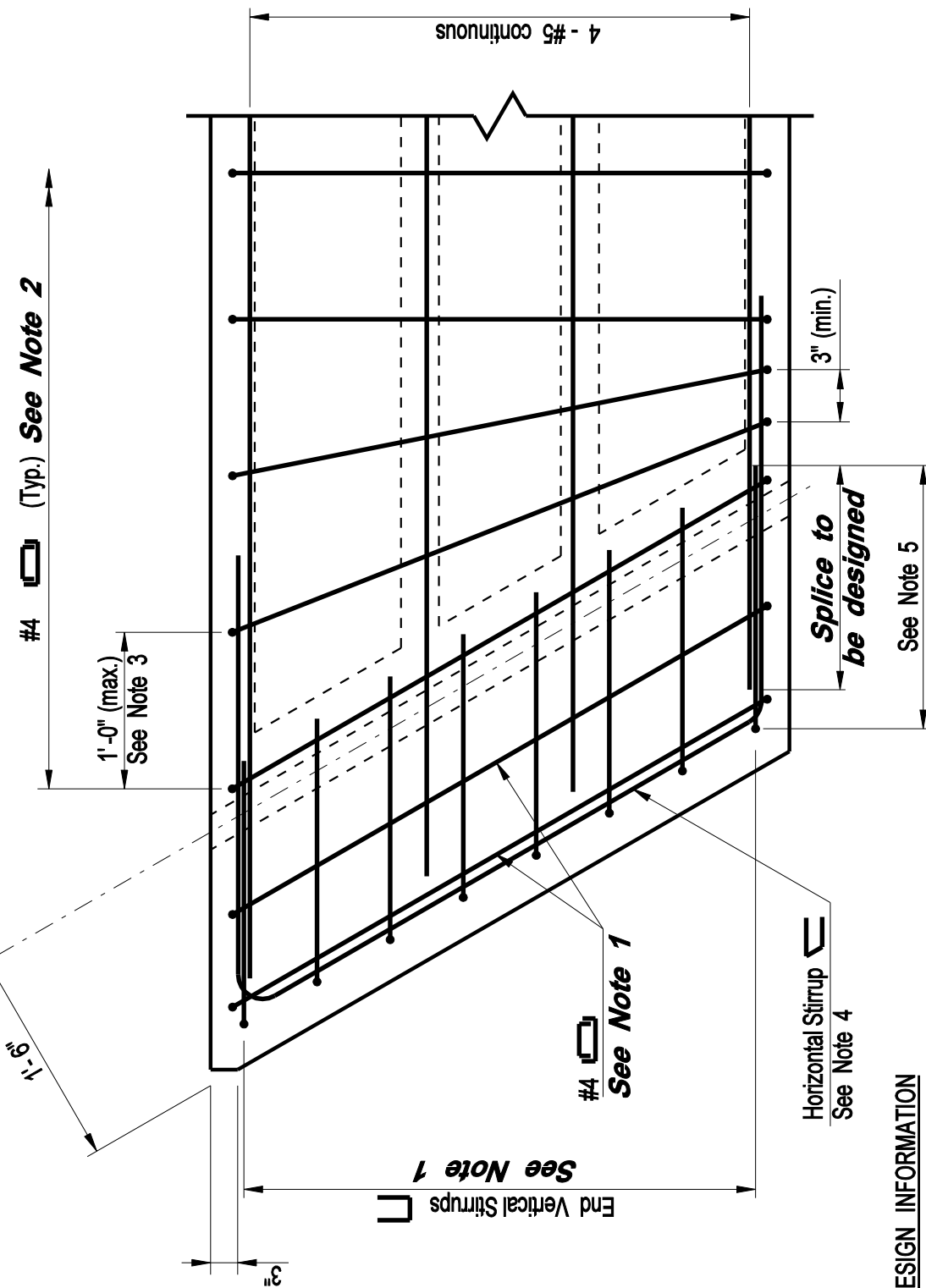
1. This cover is required to facilitate the placement of the bottom prestressing strands. The fabricator may modify cover (1 1/2" min.) if no conflicts exist with the prestressing strands.

**DESIGN INFORMATION**

1. *Stirrups shall be designed to conform to the requirements of AASHTO. The stirrups shall be #4 bars with a maximum spacing of 12".*

2. *+ Denotes prestressing strands*

∅ 02½" Transverse tie strand hole



DESIGN INFORMATION

For Notes 1 - 5, See Plate 5.1.9b

PLAN

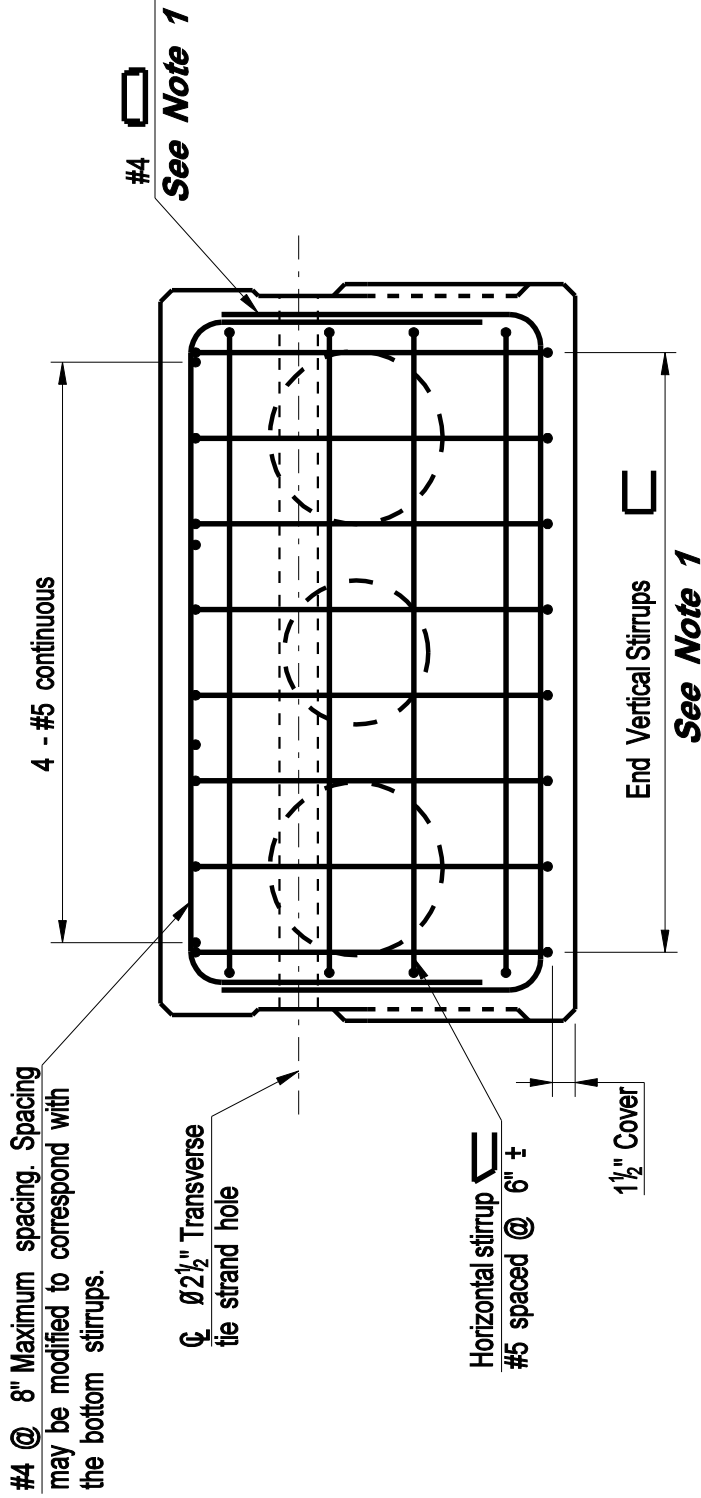
**CONNECTICUT  
BRIDGE DESIGN  
MANUAL**

END BLOCK REINFORCING  
AASHTO CONCRETE SLABS

Issue Date: 10/03

Revision Date:

Plate Number:  
5.1.9a

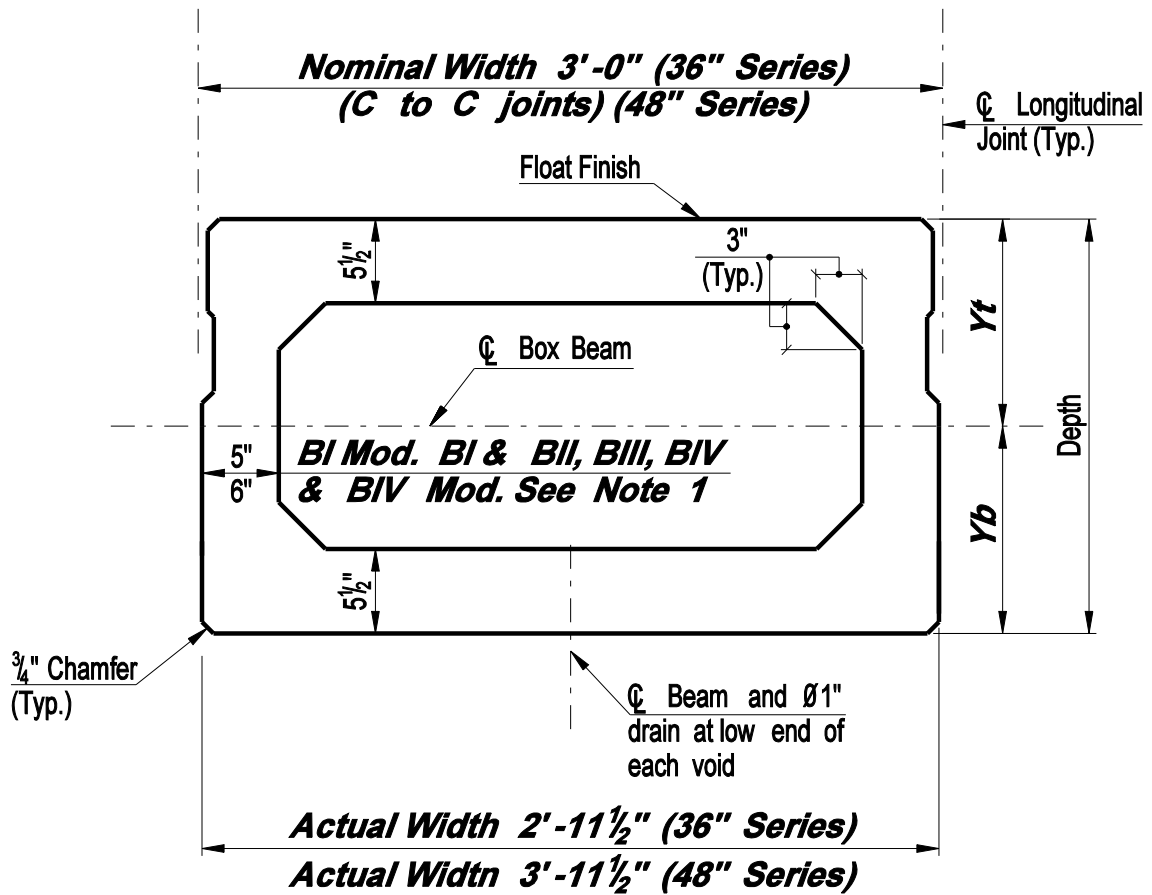


DESIGN INFORMATION

1. *The Engineer shall design the vertical legs of the last transverse stirrup and the end vertical stirrups to satisfy the requirements of AASHTO.*
2. *Stirrups shall be designed to conform to the requirements of AASHTO. The stirrups shall be #4 bars.*

NOTES:

3. Splay stirrups to avoid conflicts with transverse tie strand holes.
4. Extend longitudinal legs a minimum distance equal to the depth of the beam or 12" into the web of the voided section, whichever is larger.
5. Horizontal legs of the vertical stirrups are equal to the depth of the beam.



**DESIGN INFORMATION**

- 5" Web is to accommodate 1 column of draped strands.**
- 6" Web is to accommodate 2 columns of draped strands. For typical strand locations, see Plates 5.2.2 & 5.2.3.**
- 7. Top slab thickness shall be increased to eight inches where necessary to accommodate drilled-in anchors for Temporary Precast Concrete Barrier Curb.**

**CONNECTICUT  
BRIDGE DESIGN  
MANUAL**

**SECTION PROPERTIES  
AASHTO CONCRETE  
BOX BEAMS**

Issue Date: 10/03

Revision Date:

Plate Number:

**5.2.1a**

**CONNECTICUT  
BRIDGE DESIGN  
MANUAL**

**SECTION PROPERTIES  
AASHTO CONCRETE  
BOX BEAMS**

BEAM TYPE	Width		Depth	A ( <i>inch</i> <sup>2</sup> )	I ( <i>inch</i> <sup>4</sup> )	Y <sub>b</sub> ( <i>in.</i> )	Y <sub>t</sub> ( <i>in.</i> )	S <sub>b</sub> ( <i>inch</i> <sup>3</sup> )	S <sub>t</sub> ( <i>inch</i> <sup>3</sup> )	Wt. ( <i>lb/ft</i> )
	Nom. ( <i>inch</i> )	Act. ( <i>inch</i> )								
BI-36 Mod.	36.0	35.5	24.0	524.6	36136	11.87	12.13	3043	2980	546
BI-48 Mod.	48.0	47.5	24.0	656.6	47764	11.90	12.10	4014	3947	684
BI-36	36.0	35.5	27.0	554.6	49495	13.35	13.65	3709	3625	578
BI-48	48.0	47.5	27.0	686.6	65085	13.38	13.62	4886	4777	715
BIII-36	36.0	35.5	33.0	614.6	83834	16.30	16.70	5144	5019	640
BIII-48	48.0	47.5	33.0	746.6	109127	16.33	16.67	6681	6548	778
BIIV-36	36.0	35.5	39.0	730.6	132895	19.28	19.72	6894	6738	761
BIIV-48	48.0	47.5	39.0	862.6	170267	19.31	19.69	8817	8648	899
BIV-36	36.0	35.5	42.0	766.6	161387	20.76	21.24	7773	7599	799
BIV-48	48.0	47.5	42.0	898.6	205690	20.80	21.20	9890	9701	936
BIV-36 Mod.	36.0	35.5	45.0	802.6	193328	22.25	22.75	8689	8498	836
BIV-48 Mod.	48.0	47.5	45.0	834.6	245156	22.29	22.72	11001	10793	974

DESIGN INFORMATION

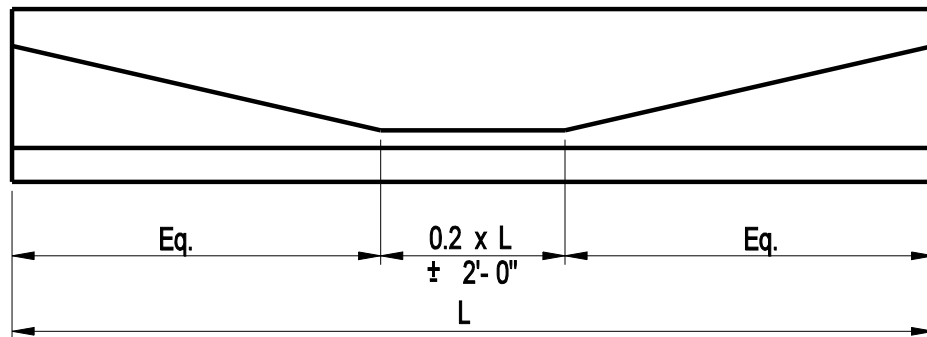
1. Weight of beam does not include weight of solid sections at transverse ties. Use the total weight (including solid sections) for design.
2. Thickness of top flange may have to be increased to develop sidewalk/parapet reinforcement. See Section 5.6. The designer shall calculate and use the Modified Properties in this case.

Issue Date: 10/03

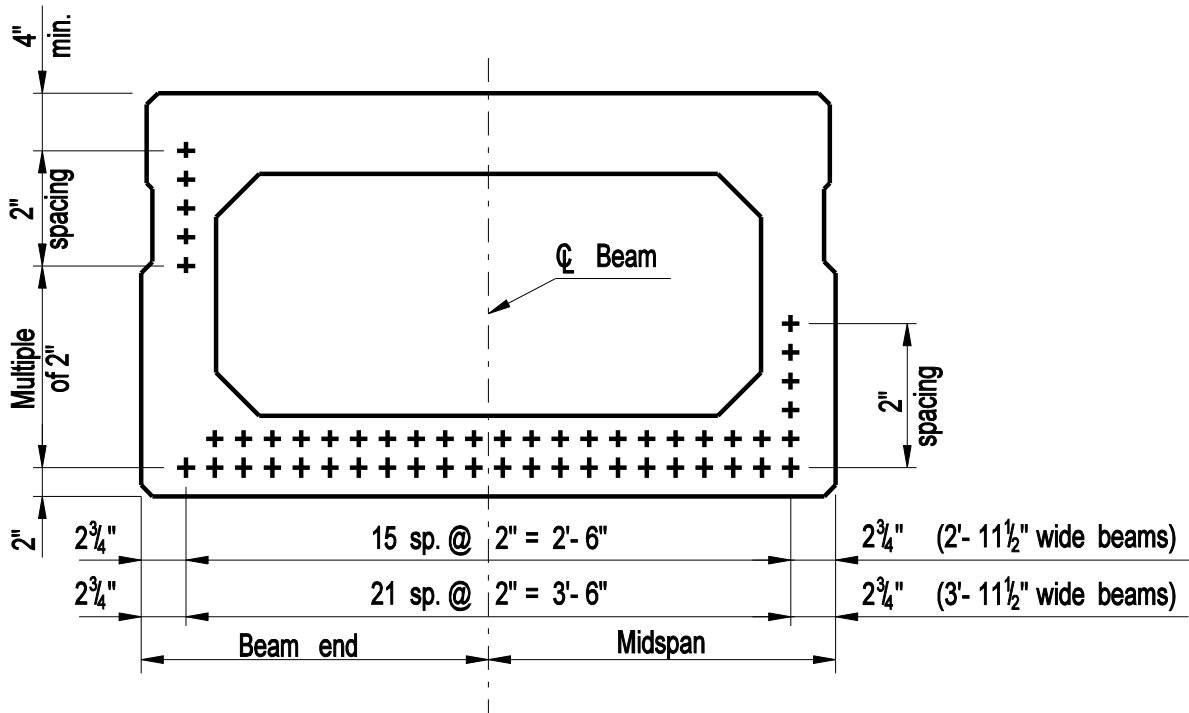
Revision Date:

Plate Number:

5.2.1b



HOLD DOWN POINTS FOR DRAPED STRANDS



STRAND LOCATIONS

DESIGN INFORMATION

1. *The standard strand pattern shown above depicts the maximum number of strands possible that can be located in a given beam while still meeting applicable fabrication clearances and tolerances. For most beam designs, strands shall be placed in as many locations within the pattern as required.*
2. *+ Denotes Prestressing strands*
3. *Strand locations shown for design purposes only. Final plans shall only show number of strands and center of gravity.*

**CONNECTICUT  
BRIDGE DESIGN  
MANUAL**

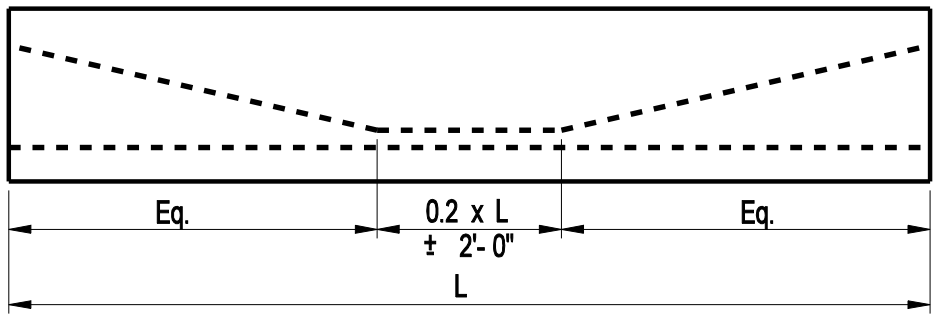
**STRAND LOCATIONS  
AASHTO BOX BEAMS  
(TYPE B I, B I MODIFIED & B II)**

Issue Date: 10/03

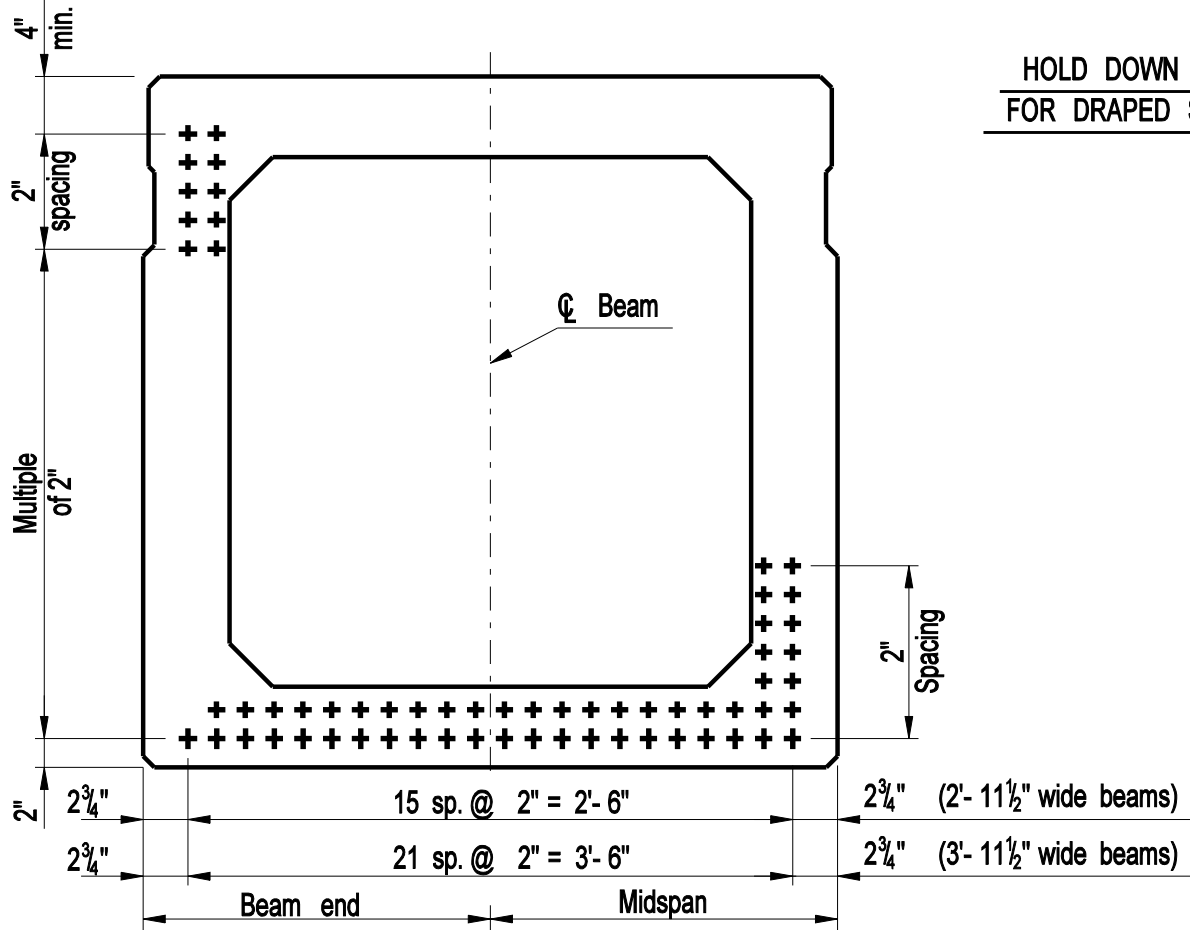
Revision Date:

Plate Number:  
5.2.2





HOLD DOWN POINTS  
FOR DRAPED STRANDS



STRAND LOCATION

DESIGN INFORMATION

1. *The standard strand pattern shown above depicts the maximum number of strands possible that can be located in a given beam while still meeting applicable fabrication clearances and tolerances. For most beam designs, strands shall be placed in as many locations within the pattern as required.*
2. *+ Denotes Prestressing strands*
3. *Strand locations shown for design purposes only. Final plans shall only show number of strands and center of gravity.*

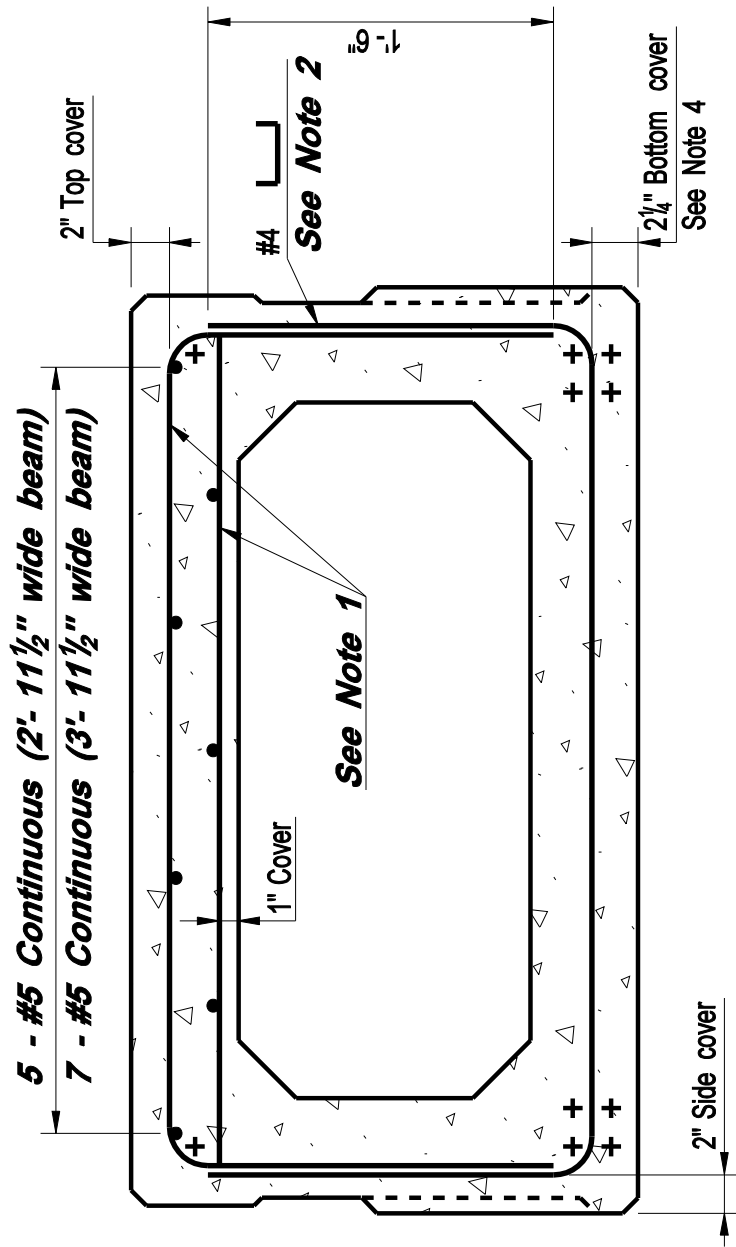
**CONNECTICUT  
BRIDGE DESIGN  
MANUAL**

**STRAND LOCATIONS  
AASHTO BOX BEAMS  
(TYPE B III, B IV & B IV MODIFIED)**

Issue Date: 10/03

Revision Date:

Plate Number:  
**5.23**

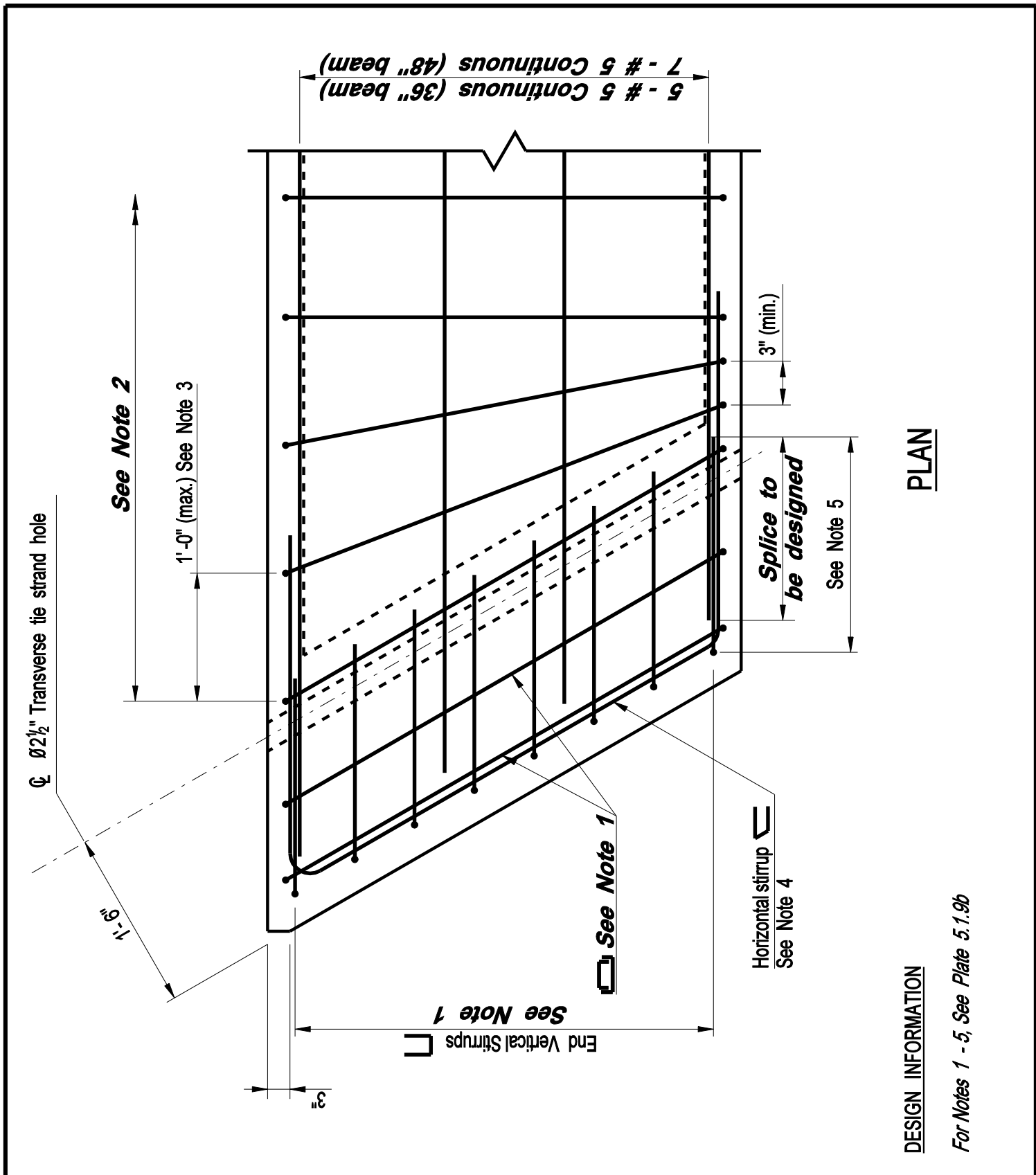


**DESIGN INFORMATION**

1. Use #4 or #5 bars only for the top transverse stirrups and slab reinforcement. Spacing shall not exceed 8".
2. Bottom transverse stirrups shall be placed at a multiple of the top bar spacing with a maximum spacing of 1'- 4".
3. + Denotes prestressed strand.

**NOTES:**

4. This cover is required to facilitate the placement of the bottom prestressing strands. The fabricator may modify cover (1 1/2" min.) if no conflicts exist with the prestressing strands.



**PLAN**

**DESIGN INFORMATION**

For Notes 1 - 5, See Plate 5.1.9b

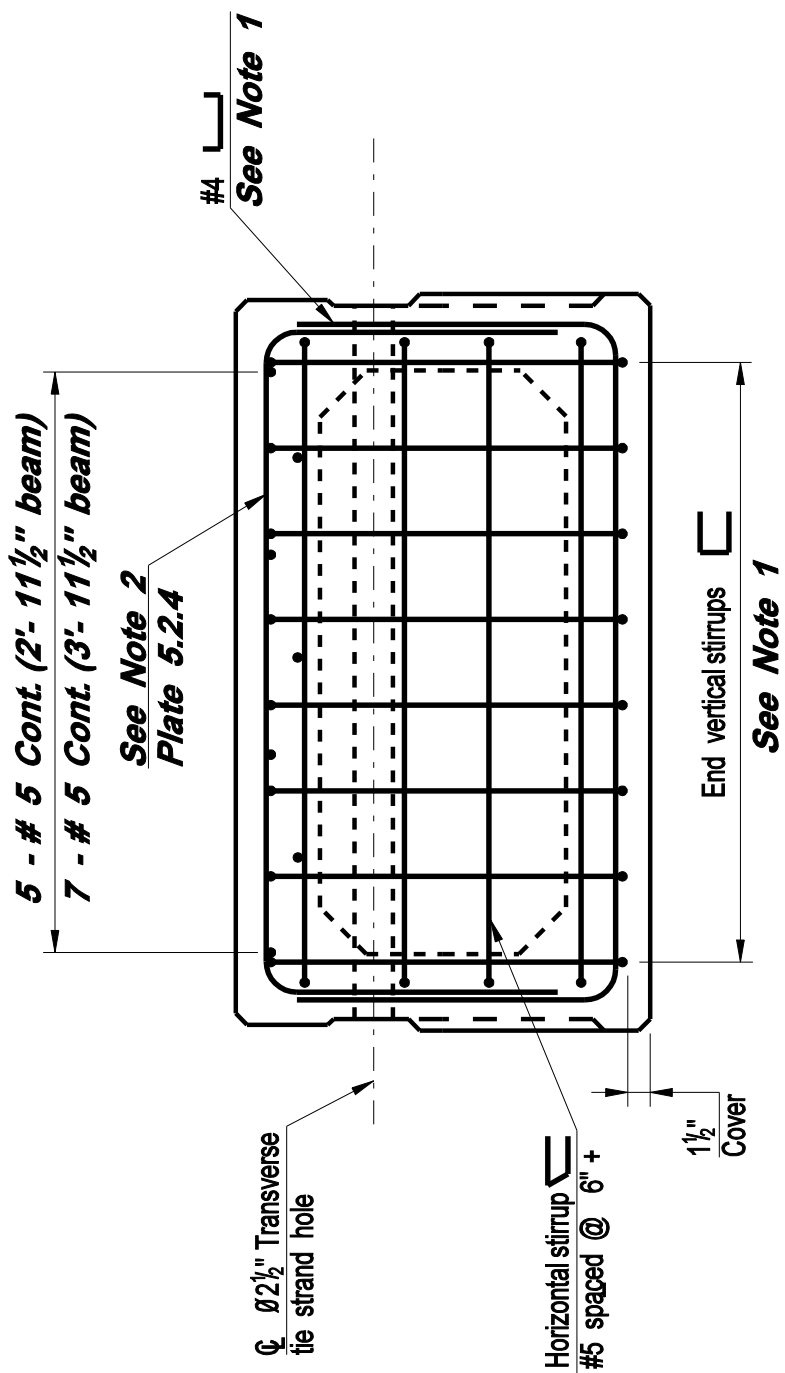
**CONNECTICUT  
BRIDGE DESIGN  
MANUAL**

**END BLOCK REINFORCING  
AASHTO BOX BEAMS**

Issue Date: 10/03

Revision Date:

Plate Number:  
**5.2.5a**



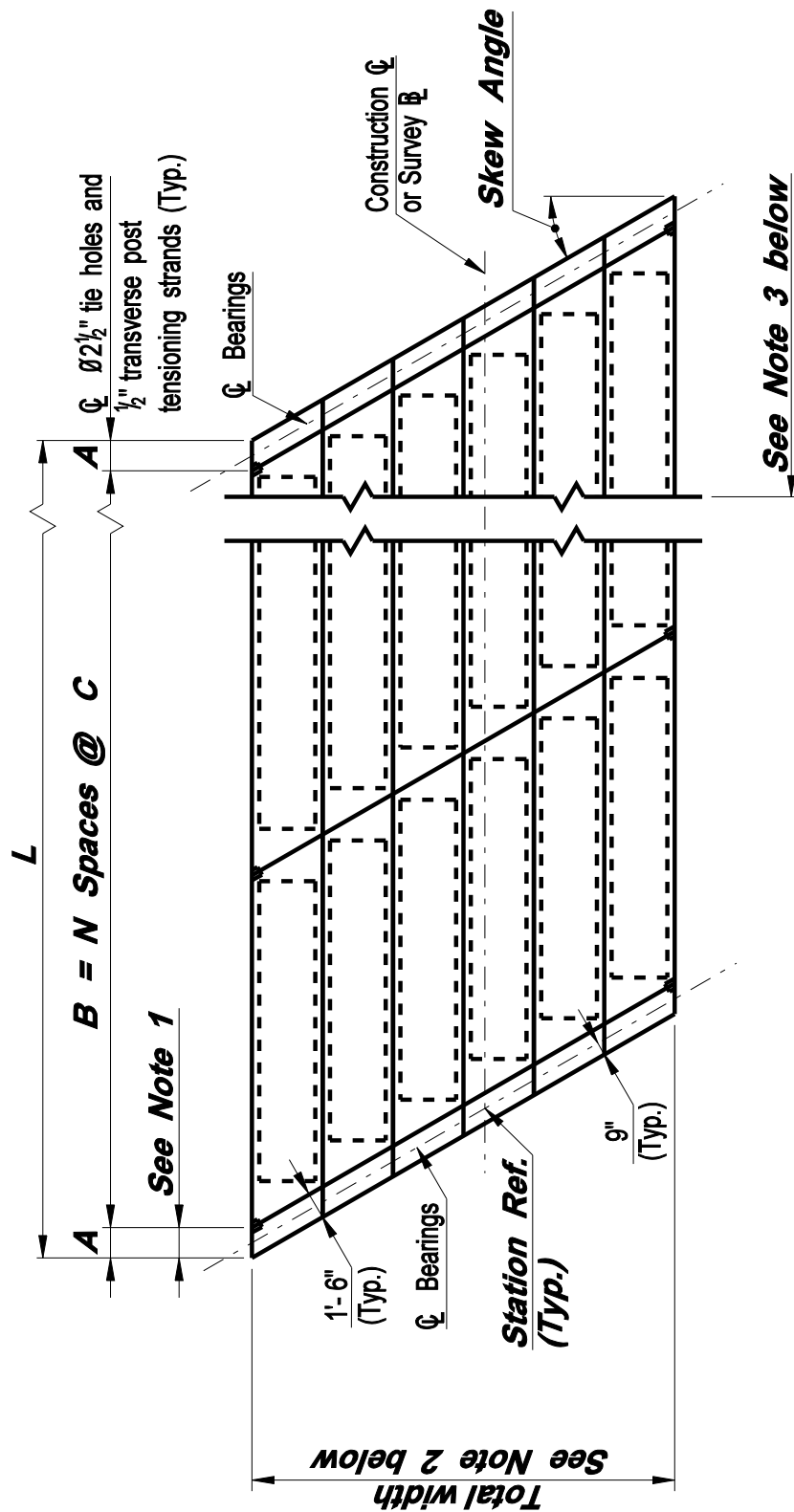
**END VIEW**

DESIGN INFORMATION

1. *The Engineer shall design the vertical legs of the last transverse stirrup and the end vertical stirrups to satisfy the requirements of AASHTO.*
2. *Stirrups shall be designed to conform to the requirements of AASHTO.*

NOTES:

3. Splay stirrups to avoid conflicts with transverse tie strand holes.
4. Extend longitudinal legs a minimum distance equal to the depth of the beam or 12" into the web of the voided section, whichever is larger.
5. Horizontal legs of the vertical stirrups are equal to the depth of the beam.



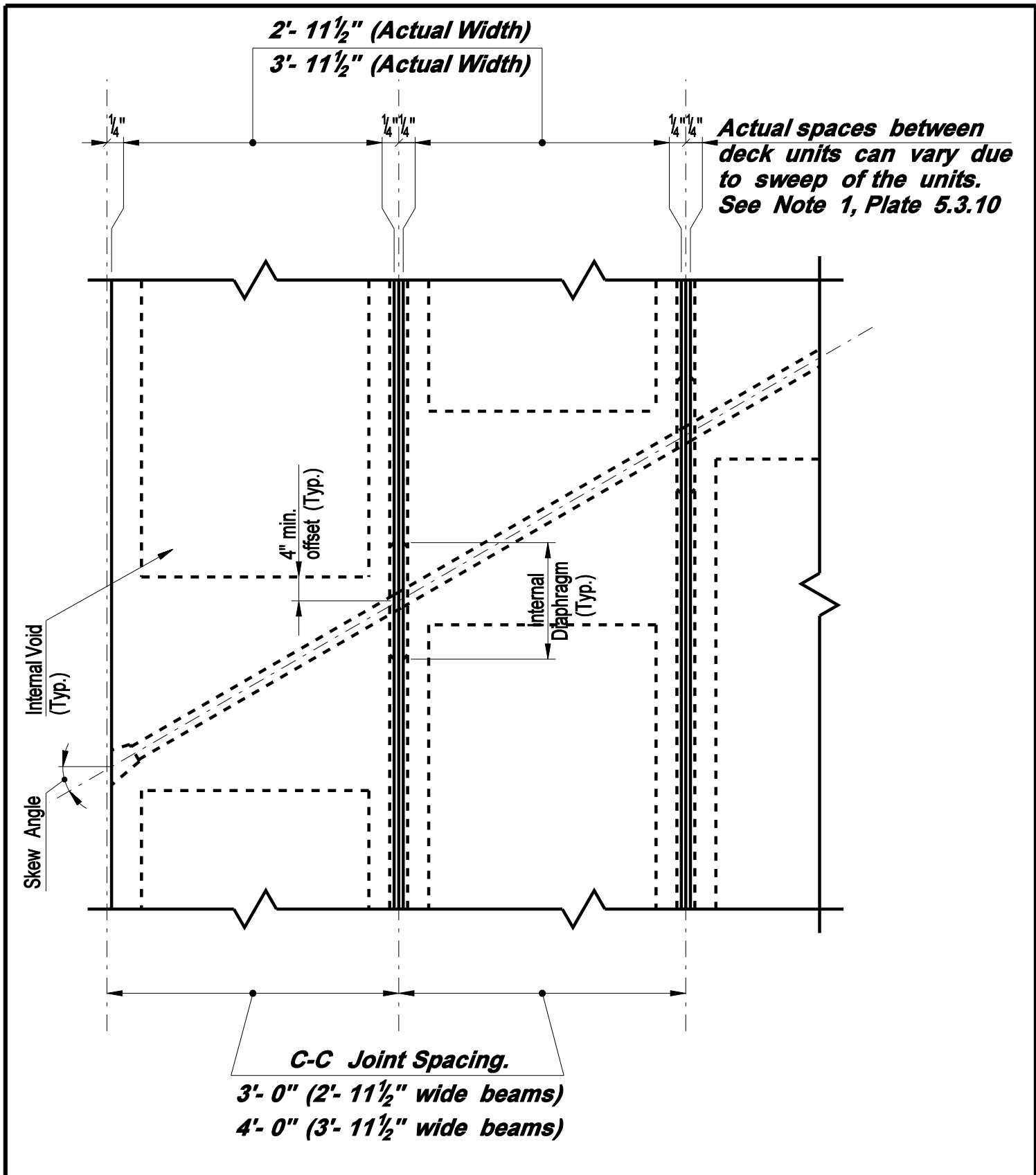
**DESIGN INFORMATION**

1.  $A = 18" / \cos(\text{Skew angle})$   
 $B = L - (2xA)$   
 $C = B/N$  where  $N = \text{Number of Internal voids. (See Plate No. 5.3.7 for the required number of transverse ties.)}$
2. Total width shall be calculated using 4'-0" for 48" series nominal units and 3'-0" for 36" series nominal units.
3. Framing plan shall be drawn full length without breaks and to scale on the construction plans. Show all internal voids, transverse ties and include North arrow.

See Note 3 below

See Note 2 below

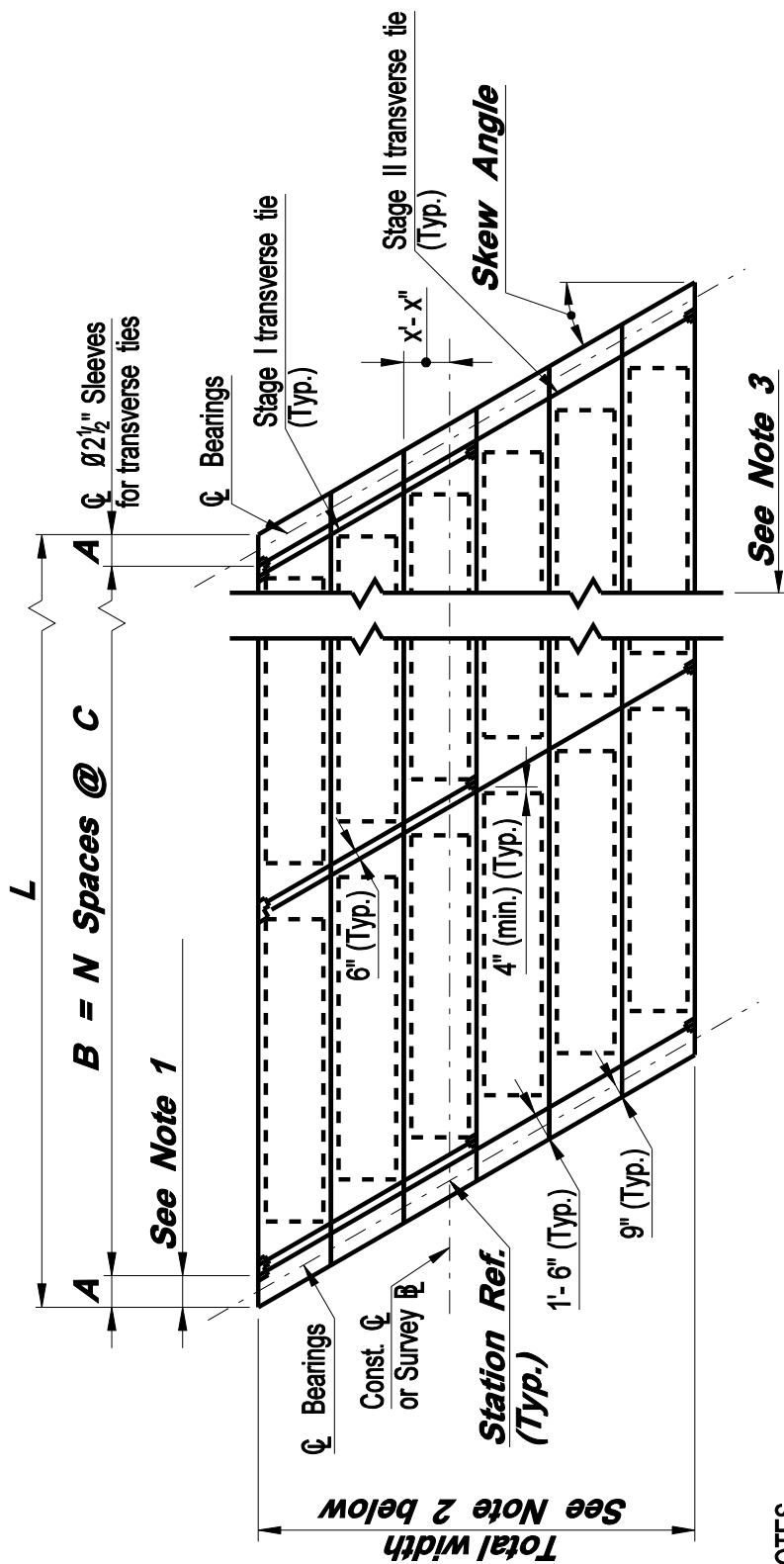
See Note 1



**CONNECTICUT  
BRIDGE DESIGN  
MANUAL**

TRANSVERSE TIE STRAND  
ARRANGEMENT FOR PRECAST  
CONCRETE DECK UNITS  
(SKEW ≤ 35°)

Issue Date:	10/03
Revision Date:	
Plate Number:	5.3.2



**NOTES**

Stage I: After erecting Stage I beams, install and tension transverse ties in Stage I sleeves.

Stage II: After erecting Stage II beams, install and tension transverse ties in Stage II sleeves full width of bridge.

**DESIGN INFORMATION**

1.  $A = 18" / \cos$  skew angle

$B = L - (2xA)$

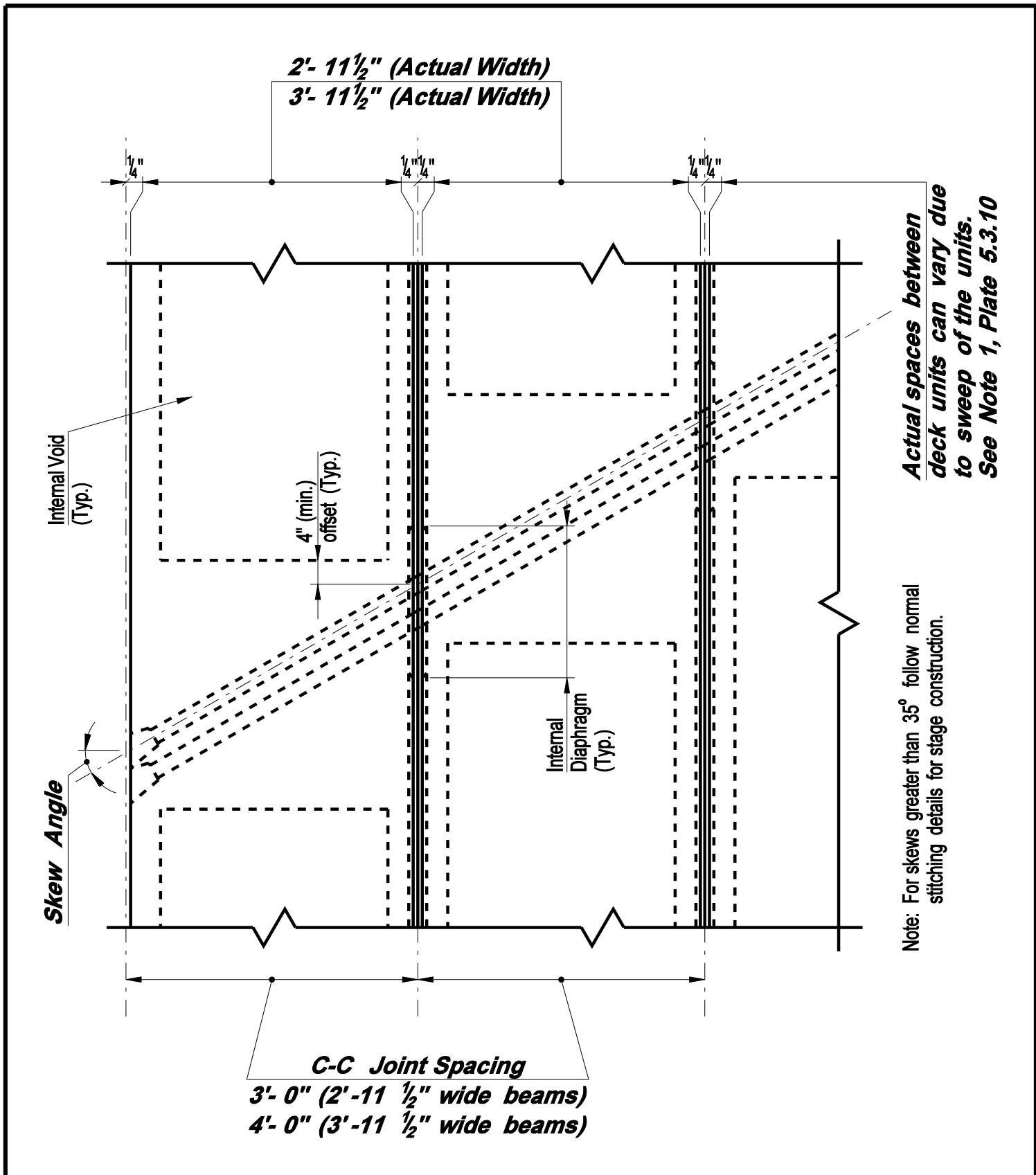
$C = B/N$  where  $N =$  Number of Internal voids. (See Plate No. 5.3.7 for the required number of transverse ties.)

$L =$  Span Length +  $A$

2. Total width shall be calculated using 4'-0" for 48" series nominal units and 3'-0" for 36" series nominal units.

3. Framing plan shall be drawn full length without breaks and to scale on the construction plans. Show all internal voids, transverse ties and include North arrow.

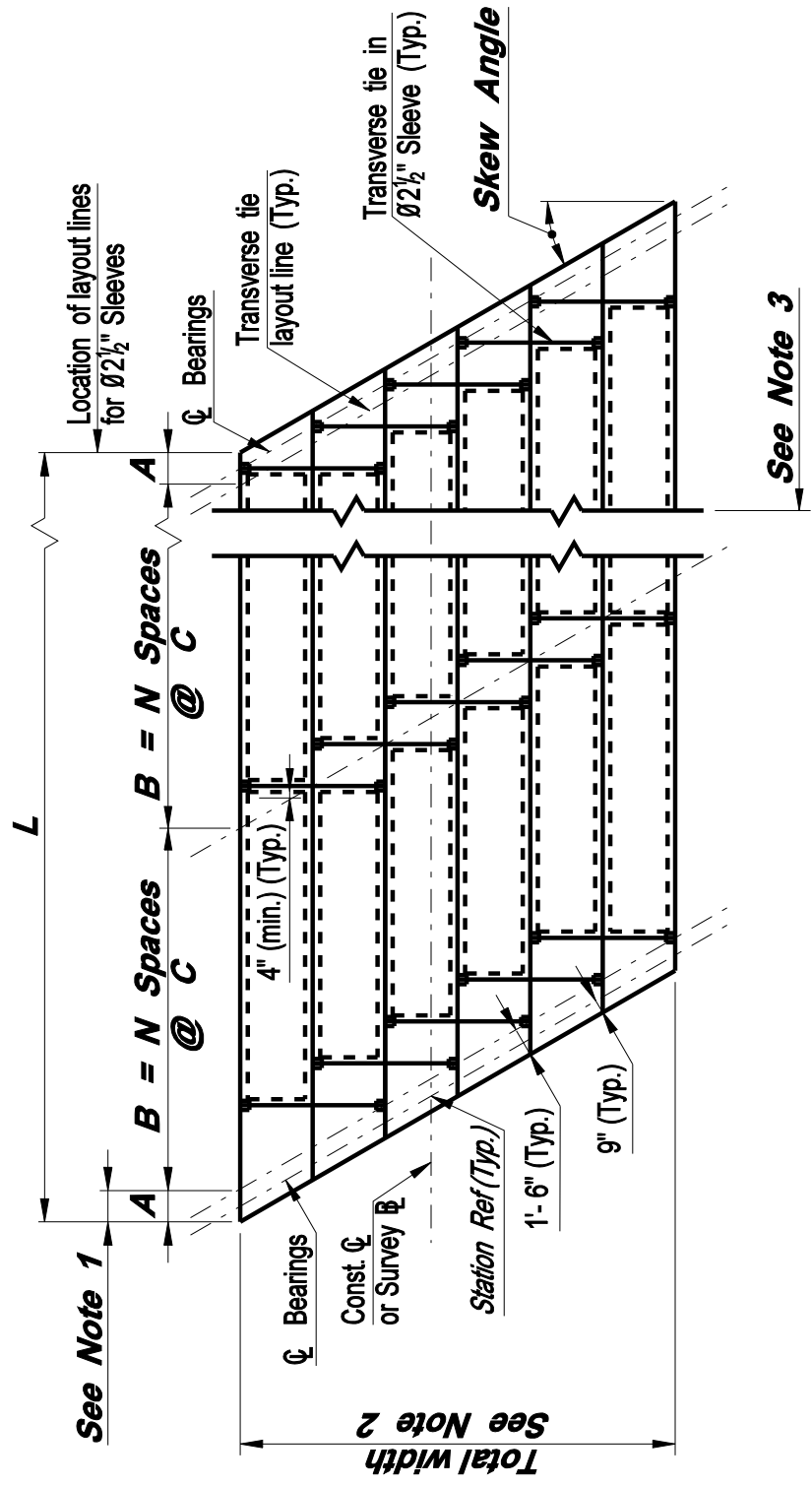
See Note 3





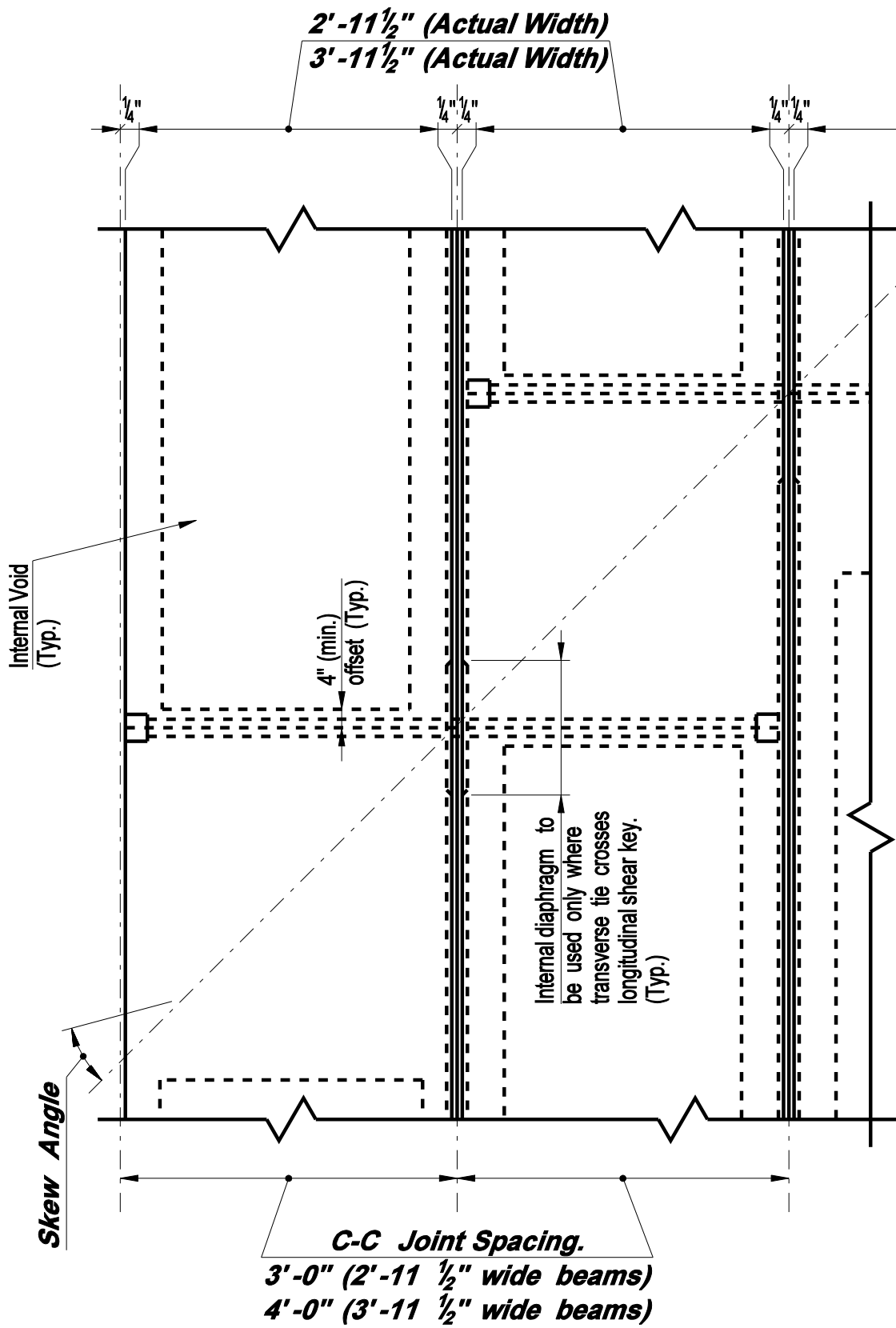
**FRAMING PLAN - PRECAST  
CONCRETE DECK UNITS  
(SKEW > 35°)**

Issue Date:	10/03
Revision Date:	
Plate Number:	5.3.5



**DESIGN INFORMATION**

1.  $A = 18'' / \cos \text{skew angle}$   
 $B = L - (2xA)$   
 $C = B/N$  where  $N = \text{Number of Internal Voids. (See Plate No. 5.3.7 for the required number of transverse ties.)}$   
 $L = \text{Span Length} + A$
2. Total width shall be calculated using 4'-0" for 48" series nominal units and 3'-0" for 36" series nominal units.
3. Framing plan shall be drawn full length without breaks and to scale on the construction plans. Show all internal voids, transverse ties and include North arrow.



**Actual spaces between deck units can vary due to sweep of the units. See Note 1, Plate 5.3.10**

**NOTES:**  
For skews greater than 35° follow normal stitching details for stage construction.

**CONNECTICUT  
BRIDGE DESIGN  
MANUAL**

**TRANSVERSE TIE STRAND  
ARRANGEMENT FOR PRECAST  
CONCRETE DECK UNITS  
(SKEW > 35°)**

Issue Date: 10/03

Revision Date:

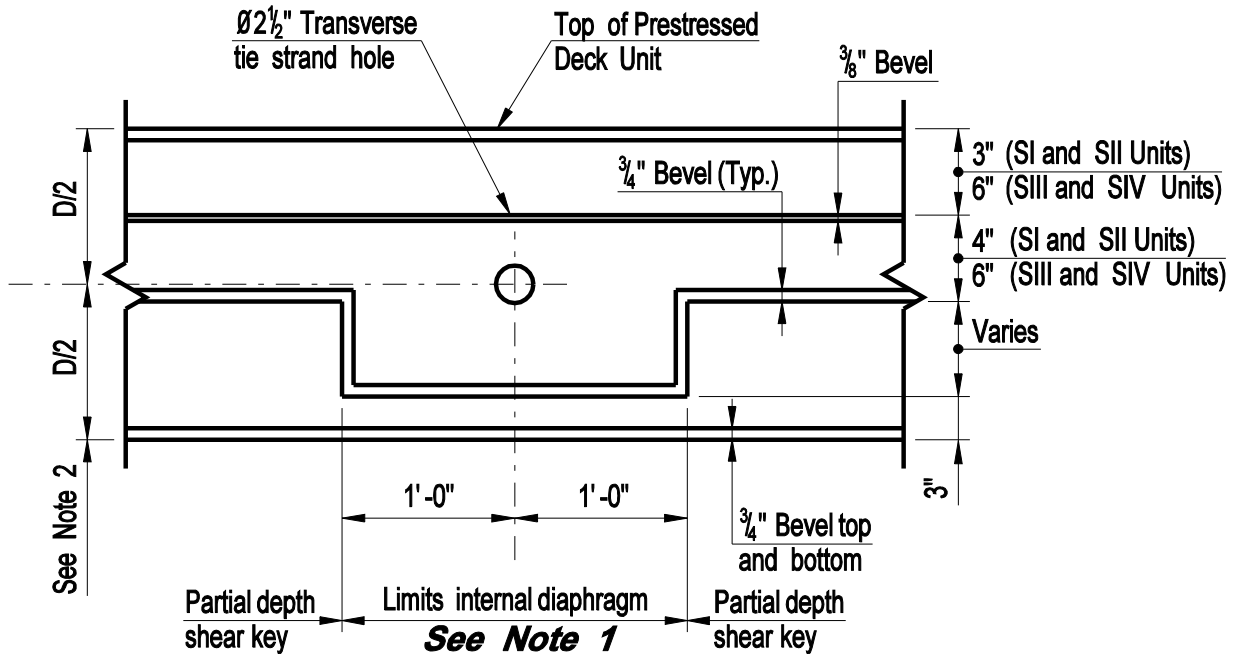
Plate Number:  
**5.3.6**

PRECAST CONCRETE VOIDED SLABS							
BEAM	SPANS	TIE LOCATIONS			TOP	BOTTOM	
		ENDS	1/3 POINTS	MIDSPAN		SKEW $\geq 25^\circ$ or STITCHED BEAMS	SKEW $\geq 25^\circ$
<i>SI Thru SIV</i>	$\leq 40'-0''$	X		X	X		X
	$> 40'-0''$	X	X		X		X

PRECAST CONCRETE BOX BEAMS								
BEAM	SPANS	TIE LOCATIONS				TOP	BOTTOM	
		ENDS	1/4 POINTS	1/3 POINTS	MIDSPAN		SKEW $\leq 25^\circ$ or STITCHED BEAMS	SKEW $\geq 25^\circ$
<i>BI &amp; BI Mod.</i>	$\leq 50'-0''$	X			X	X		X
	$> 50'-0''$	X		X		X		X
<i>BII</i>	$\leq 75'-0''$	X		X		X		X
	$> 75'-0''$	X	X			X		X
<i>BIII</i>	$\leq 75'-0''$	X				X	X	X
	$> 75'-0''$	X	X			X	X	X
<i>BIV &amp; BIV Mod.</i>	ALL	X	X		X	X	X	X

**NOTE:**

*The designer shall investigate the fascia beam for torsional load due to parapet overhang or utilities. Consideration shall be given to increasing the number of lateral tie strands, the amount of post-tensioning and/or providing additional internal diaphragms.*

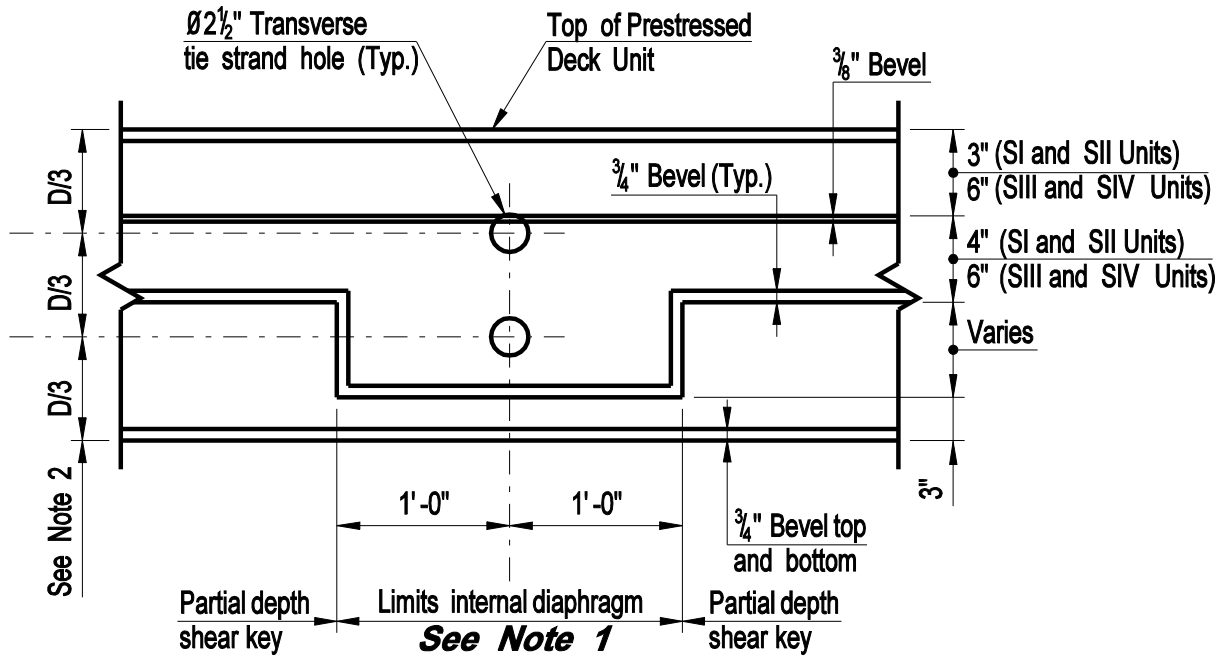


**DESIGN INFORMATION**

**1. If two sets of post-tensioning strands are used for stage construction, the width of the internal diaphragm shall be increased to 2'- 0" plus the longitudinal spacing of the two tie strand holes.**

**NOTES:**

2. The vertical location of the transverse tie strands must be coordinated with the location of the prestressed strands and adjusted as necessary by the fabricator.

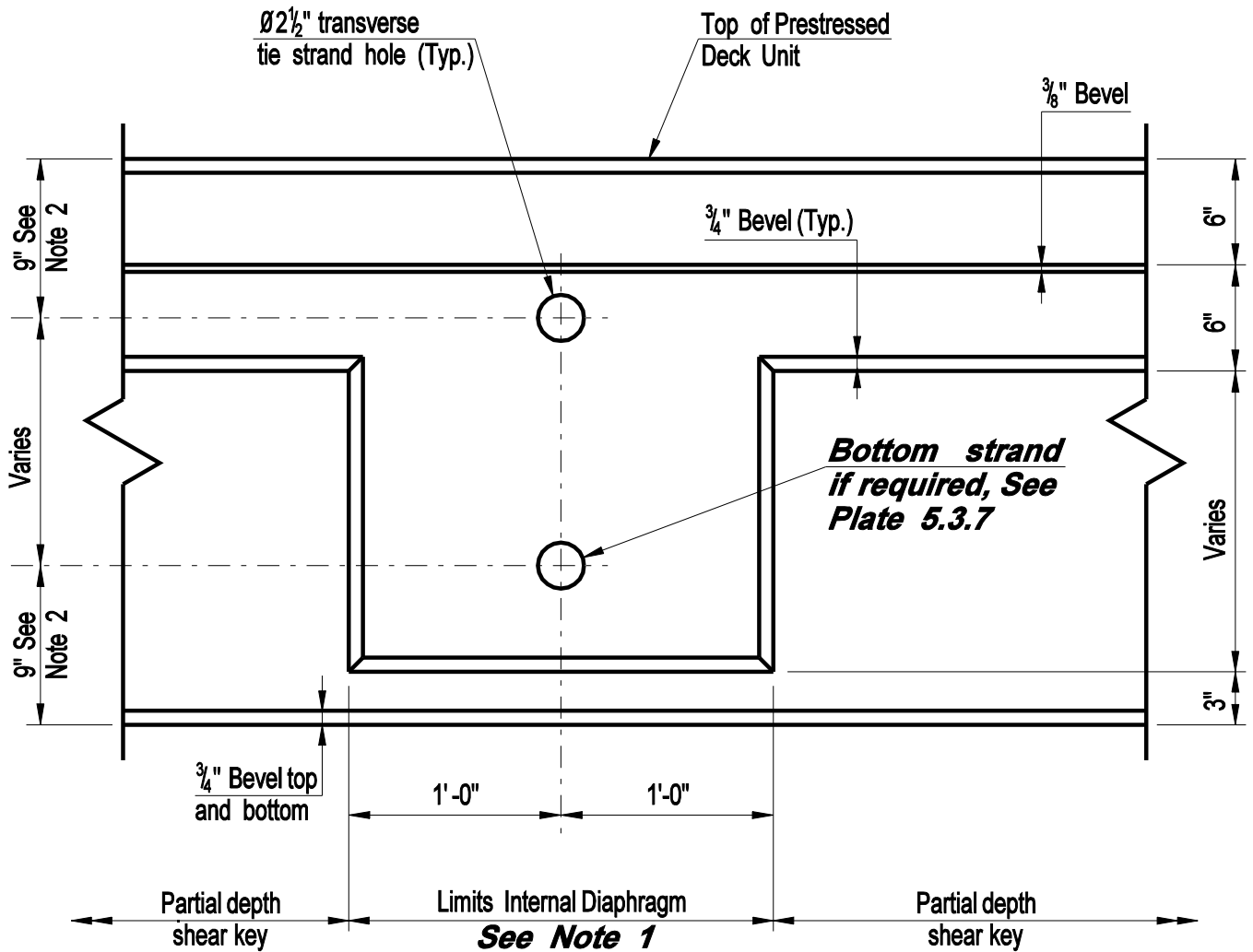


**DESIGN INFORMATION**

**1. If two sets of post-tensioning strands are used for stage construction, the width of the internal diaphragm shall be increased to 2'- 0" plus the longitudinal spacing of the two tie strand holes.**

**NOTES:**

2. The vertical location of the transverse tie strands must be coordinated with the location of the prestressed strands and adjusted as necessary by the fabricator.

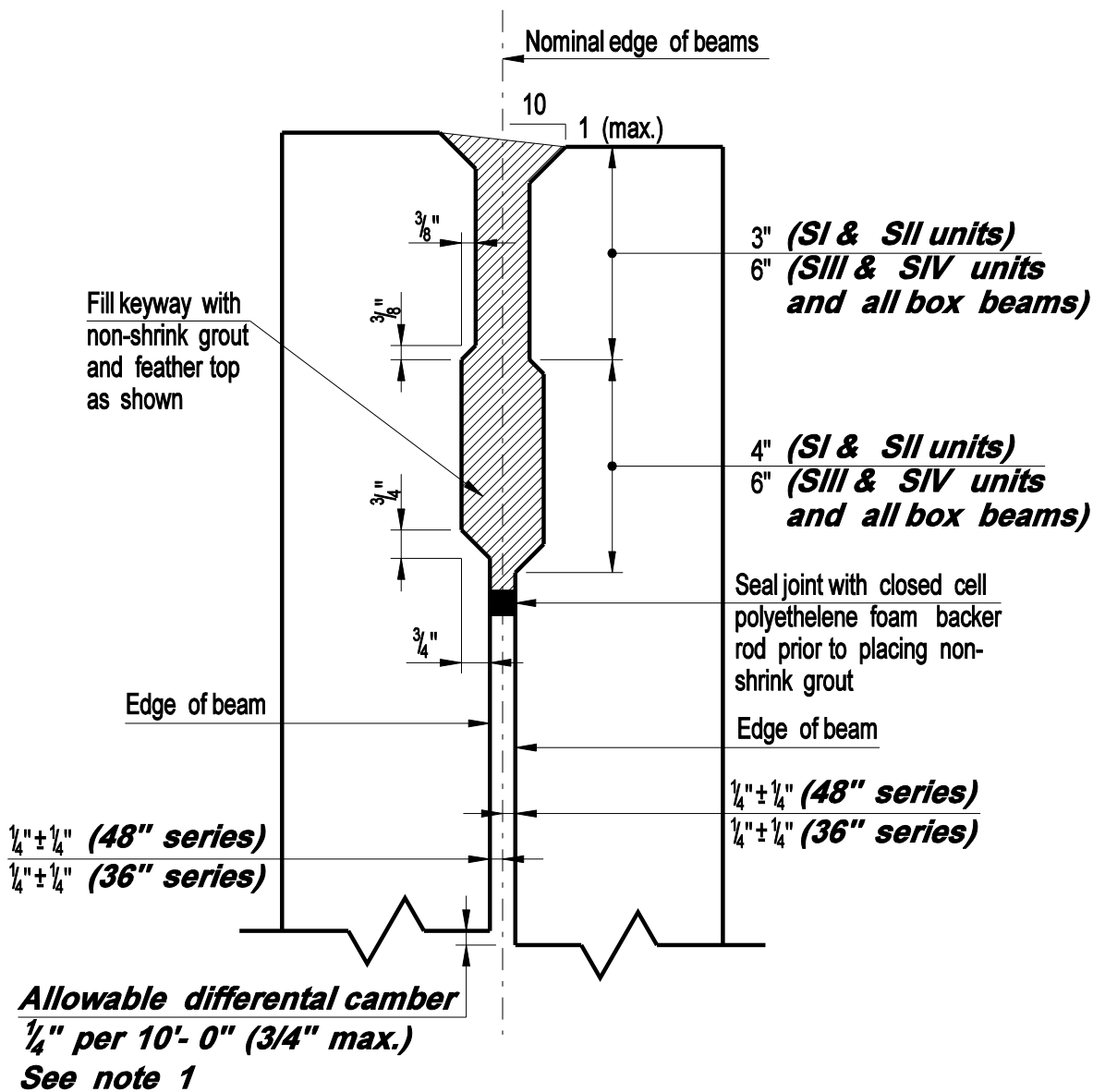


**DESIGN INFORMATION**

**1. If two sets of post-tensioning strands are used for stage construction, the width of the internal diaphragm shall be increased to 2'- 0" plus the longitudinal spacing of the two tie strand holes.**

**NOTES:**

2. The vertical location of the transverse tie strands must be co-ordinated with the location of the prestressed strands and adjusted as necessary by the fabricator.



**DESIGN INFORMATION**

**1. The variation indicated is due to fabrication tolerances for sweeps and camber of the deck units.**

**NOTES:**

- 2. The deck units shall be placed at the nominal spacing shown on the plan with a gap between the units. The width of the gaps will vary due to the sweep of the units.
- 3. Grout for shear keys shall be rodded or vibrated to ensure that all voids in the shear keys are filled.

**CONNECTICUT  
BRIDGE DESIGN  
MANUAL**

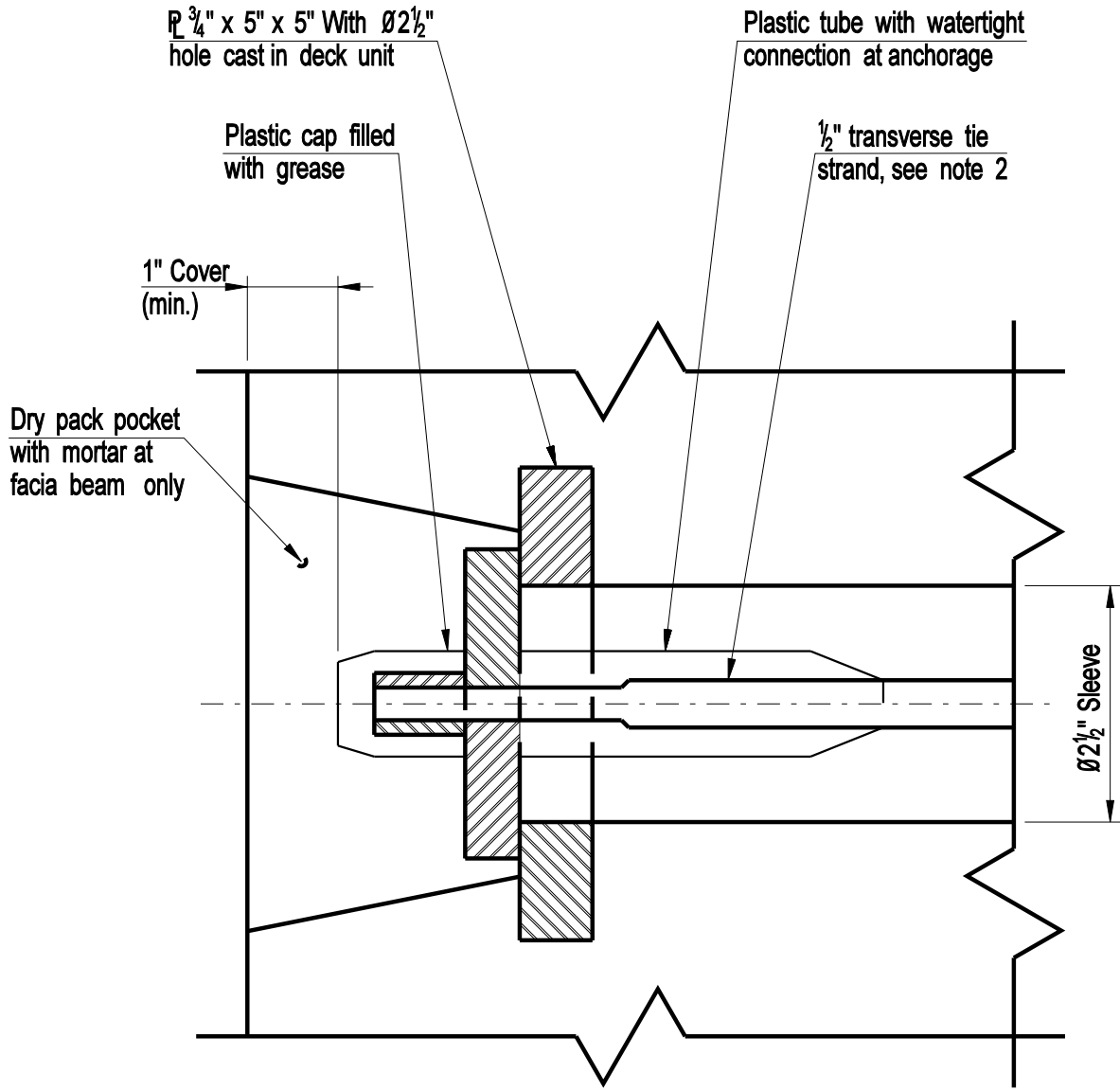
VACANT

Issue Date: 10/03

Revision Date:

Plate Number:  
5.3.12





**TRANSVERSE TIE POCKET DETAIL**

**NOTES:**

1. Other anchorage systems may be substituted with the approval of the Engineer. Alternate anchorage systems shall be watertight and corrosion proof.
2. Transverse ties shall be covered by a seamless polypropylene sheath, with corrosion inhibiting grease between the strand and sheath, for the full length of the strand except at the anchorage location.

<b>CONNECTICUT BRIDGE DESIGN MANUAL</b>	<b>TRANSVERSE TIE ANCHORAGE PRECAST CONCRETE DECK UNITS</b>	Issue Date: 10/03
		Revision Date:
		Plate Number: <b>5.3.13</b>

FOR SKEWS  $\leq 35^\circ$ :

TRANSVERSE TIE TENSIONING NOTES:

1. After all beams have been erected, tension each transverse tie to 5 kips.
2. Fill all keyways with non-shrink grout. The contractor shall cover and protect the keyways from the weather and debris until they are filled.
3. After the grout has attained a strength of 1500 psi (based on the manufacturers directions) tension each transverse tie to 30 kips. No traffic or heavy equipment will be permitted on the beams until all ties have been fully tensioned.

***(The above note applies to units with single transverse ties. See Plate 5.3.7)***

After the grout has attained a strength of 1500 psi (based on the manufacturers directions) at each transverse tie location, tension the bottom tie to 15 kips, then the top tie to 15 kips. Repeat the sequence once more so that each strand has 30 kips of tension. No traffic or heavy equipment will be permitted on the beams until all ties have been fully tensioned.

***(The above note applies to units with double transverse ties. See Plate 5.3.7)***

4. Concrete for sidewalk, curb and/or barrier sections shall not be placed until the transverse ties have been fully tensioned.

**CONNECTICUT  
BRIDGE DESIGN  
MANUAL**

TRANSVERSE TIE TENSIONING  
NOTES - PRECAST CONCRETE  
BOX BEAMS (SKEWS  $\leq 35^\circ$ )

Issue Date: 10/03

Revision Date:

Plate Number:  
5.3.14

FOR SKEWS > 35°:  
TRANSVERSE TIE TENSIONING NOTES:

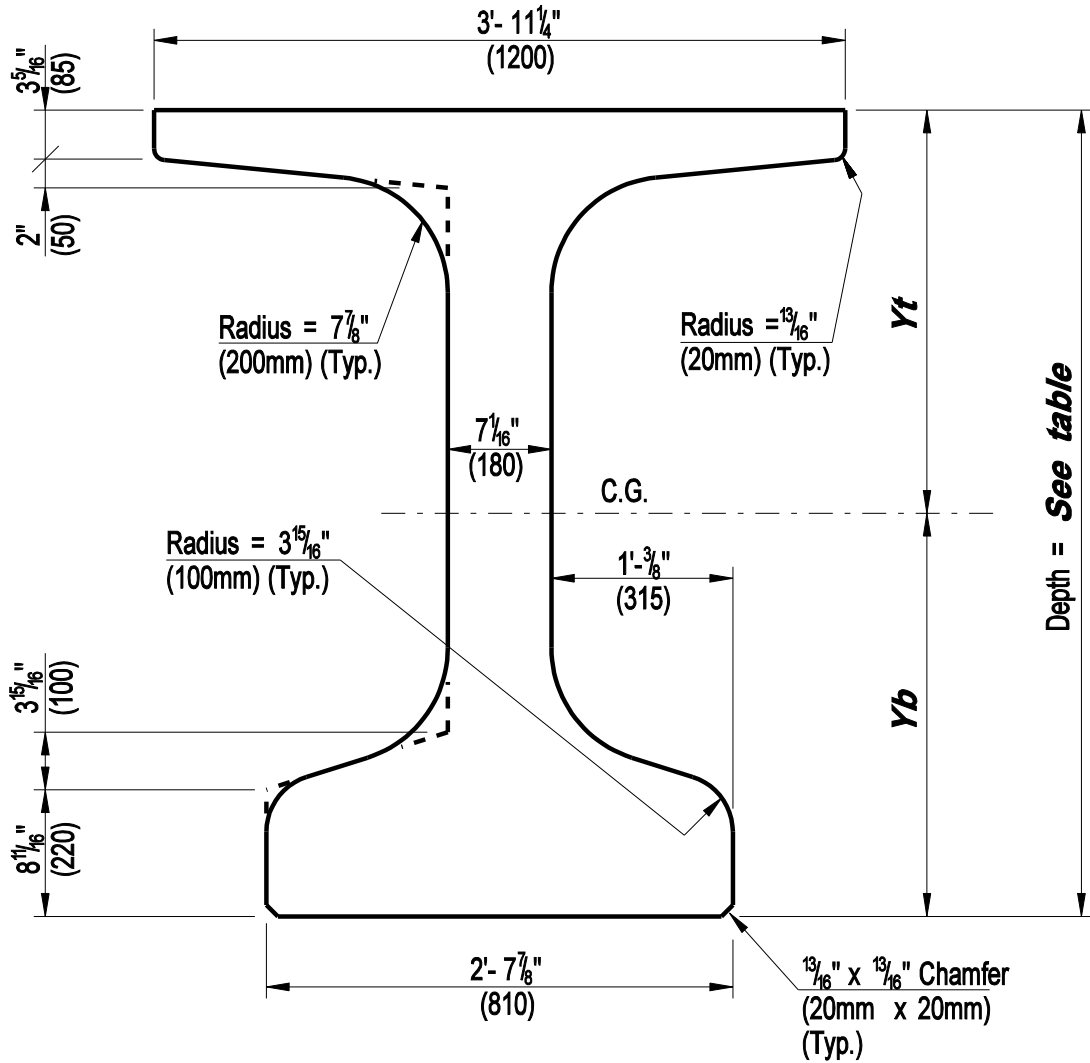
1. As each beam is being erected, install the transverse ties with hardwood wedges between the beams at each transverse tie location at the top and bottom of the beam.
2. Secure each beam to the preceding beam by tensioning each transverse tie to 30 kips before erecting the next beam.

***(The above note applies to units with single transverse ties.  
See Plate 5.3.7)***

Secure each beam to the preceding beam by first tensioning the bottom tie at each transverse tie location to 15 kips, then the top tie to 15 kips. Repeat the sequence once more so that each tie has 30 kips of tension before erecting the next beam.

***(The above note applies to units with double transverse ties.  
See Plate 5.3.7)***

3. Fill all keyways with non-shrinking grout after transverse ties have been tensioned. The contractor shall cover and protect the keyways from the weather and debris until they are filled. No traffic or heavy equipment will be permitted on the beams until all keyways have been filled and the grout has cured.
4. When the grout has attained a strength of 1500 psi (based on grout manufacturers directions) the wedges shall be removed and voids left by the top wedges shall be filled with grout.
5. Concrete for sidewalk, curb and/or barrier sections shall not be placed until grout has attained a strength of 1500 psi.



Beam Type	Depth (in)	Weight (lbs/ft)	Area (in <sup>2</sup> )	I <sub>x</sub> c.g. (in <sup>4</sup> )	I <sub>y</sub> c.g. (in <sup>4</sup> )	Y <sub>t</sub> (in)	Y <sub>b</sub> (in)	S <sub>t</sub> (in <sup>3</sup> )	S <sub>b</sub> (in <sup>3</sup> )
NEBT 1000	39.37	777.47	745.55	149,196	61,744	20.35	19.02	7323	7872
NEBT 1200	47.24	835.26	801.35	238,089	61,985	24.61	22.64	9703	10,496
NEBT 1400	55.12	893.72	857.15	353,169	62,225	28.86	26.26	12,205	13,425
NEBT 1600	62.99	951.51	912.95	492,514	62,465	33.03	29.96	14,890	16,415
NEBT 1800	70.87	1009.97	968.75	666,690	62,706	37.20	33.66	17,758	19,589

**DESIGN INFORMATION**

- $f'_c = 6500$  psi (precast)  
 $f'_c = 4500$  psi (deck)  
 Max. Beam spacing = 6'- 6"  
 Allowable Tension = 0.0

2. Metric dimensions are given ( ) for correlation to standard NEBT metric forms.

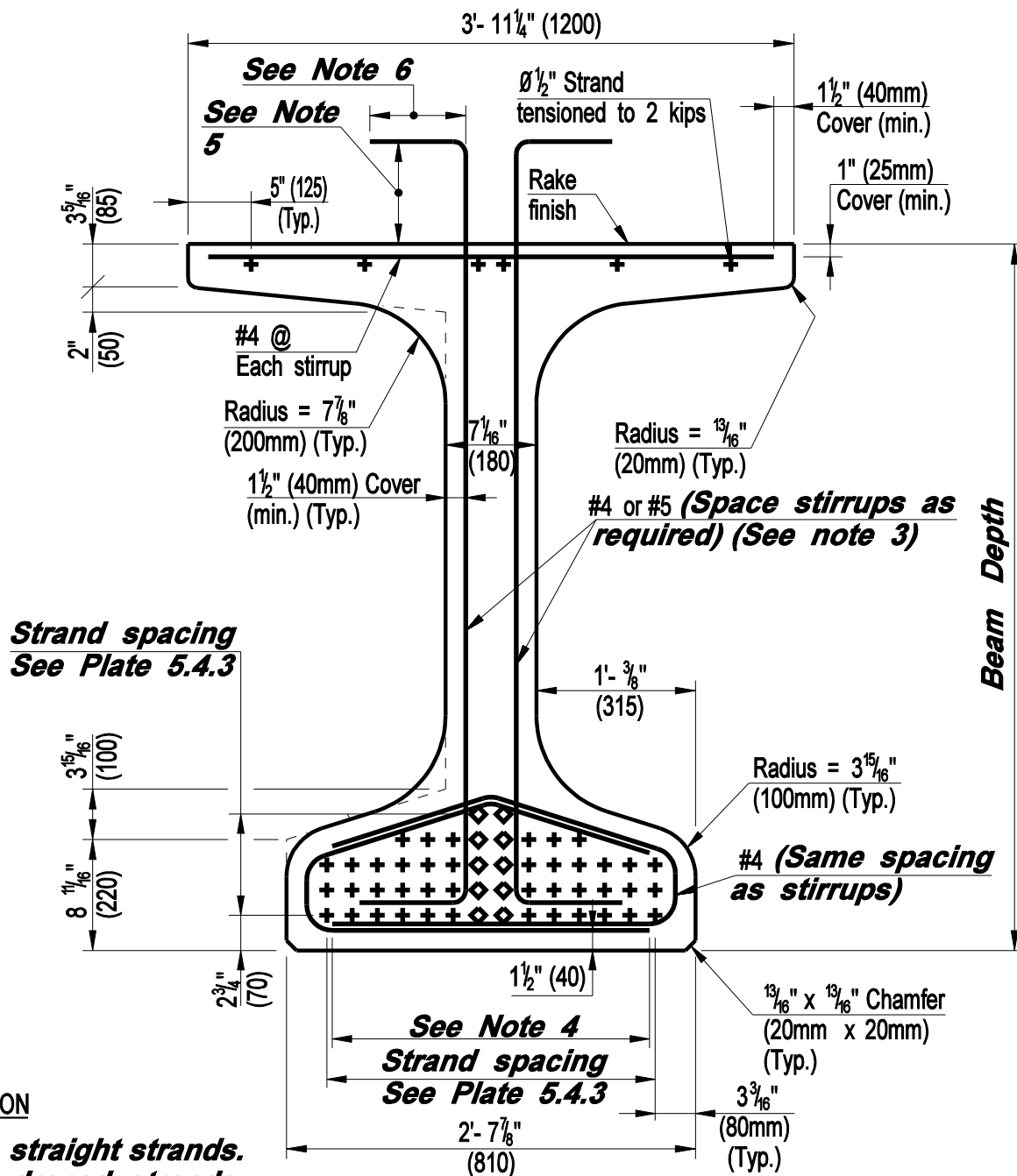
**CONNECTICUT  
BRIDGE DESIGN  
MANUAL**

SECTION PROPERTIES  
NEW ENGLAND BULB TEES  
(TYPE NEBT 40 - 72)

Issue Date: 10/03

Revision Date:

Plate Number:  
5.4.1



**DESIGN INFORMATION**

1. + Denotes straight strands.
2. ◇ Denotes draped strands.
3. Stirrups to be designed in accordance with AASHTO shear reinforcement requirements.
4. Lap splices in accordance with AASHTO requirements
5. Stirrups shall be checked for horizontal shear at the interface with the deck. Provide 6" (150mm) minimum embedment and 2" (50mm) minimum cover at top of deck.
6. Top of stirrups to constitute a standard hook in accordance with AASHTO.
7. Metric dimensions are given ( ) for correlation to standard NEBT metric forms.

**CONNECTICUT  
BRIDGE DESIGN  
MANUAL**

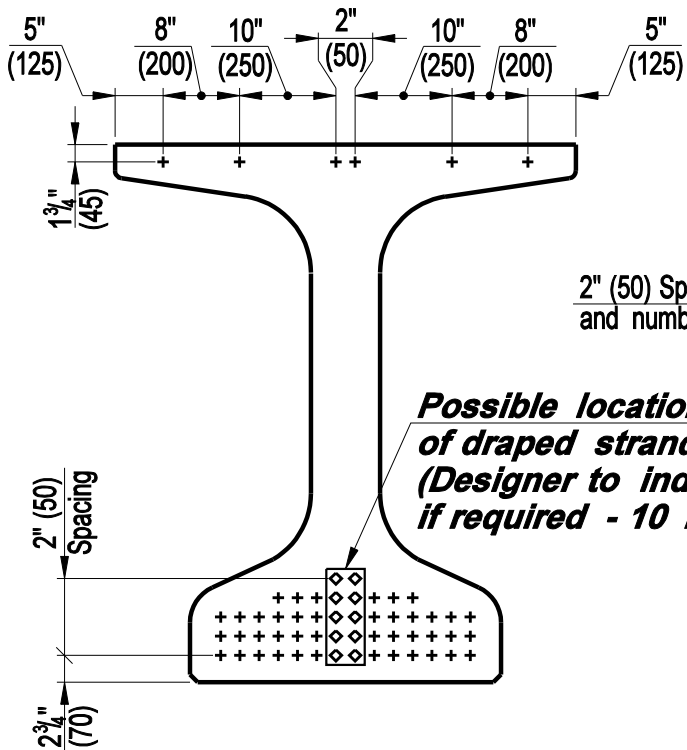
TYPICAL MIDSPAN SECTION  
NEW ENGLAND  
BULB TEE BEAMS

Issue Date: 10/03

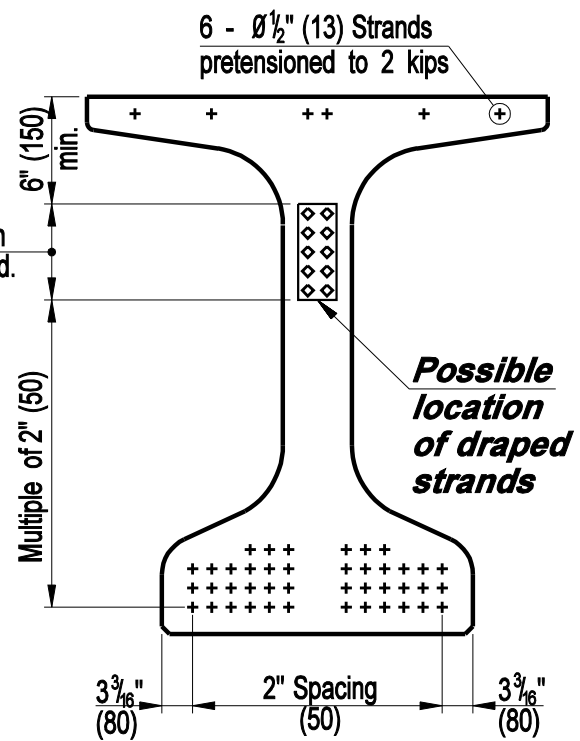
Revision Date:

Plate Number:

5.4.2



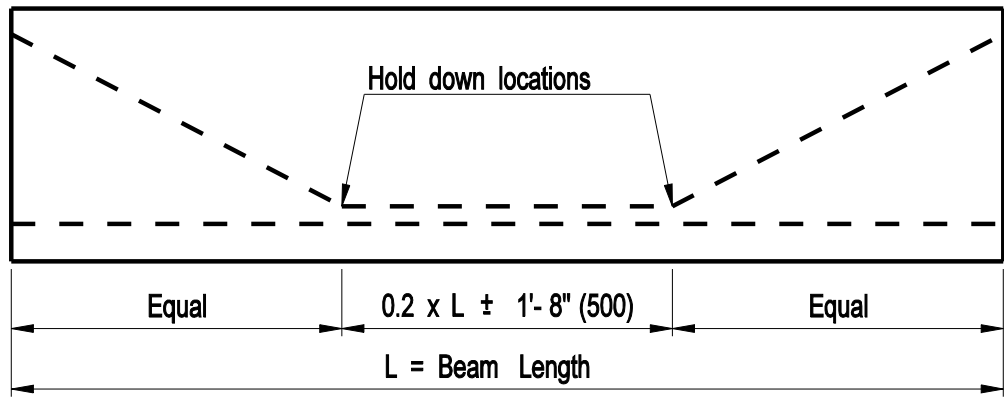
**STRAND LOCATION MIDSPAN**



**STRAND LOCATION BEAM END**

**DESIGN INFORMATION**

1. + Denotes straight strands.
2. ◇ Denotes draped strands.
3. Strands in top flange are for fabrication purposes only and are not considered in the design.
4. Strands shall be placed within a 2" x 2" (50mm x 50mm) grid. The number and location of the strands shall be as required by design.
5. Metric dimensions are given ( ) for correlation to standard NEBT metric forms.



**HOLD DOWN POINTS FOR DRAPED STRANDS**

**CONNECTICUT  
BRIDGE DESIGN  
MANUAL**

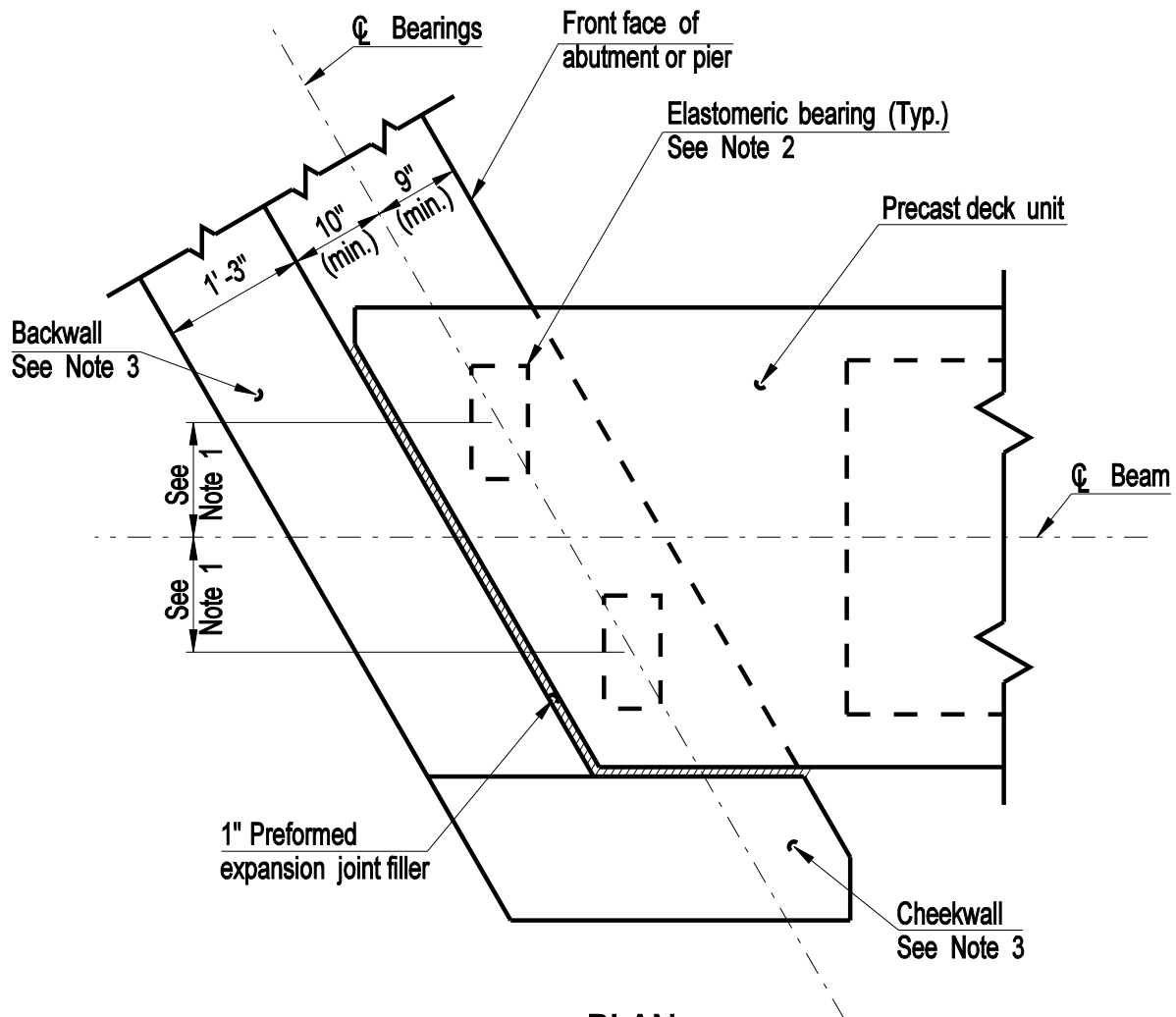
**STRAND LOCATIONS AND  
HOLD DOWN DETAIL NEW  
ENGLAND BULB TEE BEAMS**

Issue Date: 10/03

Revision Date:

Plate Number:

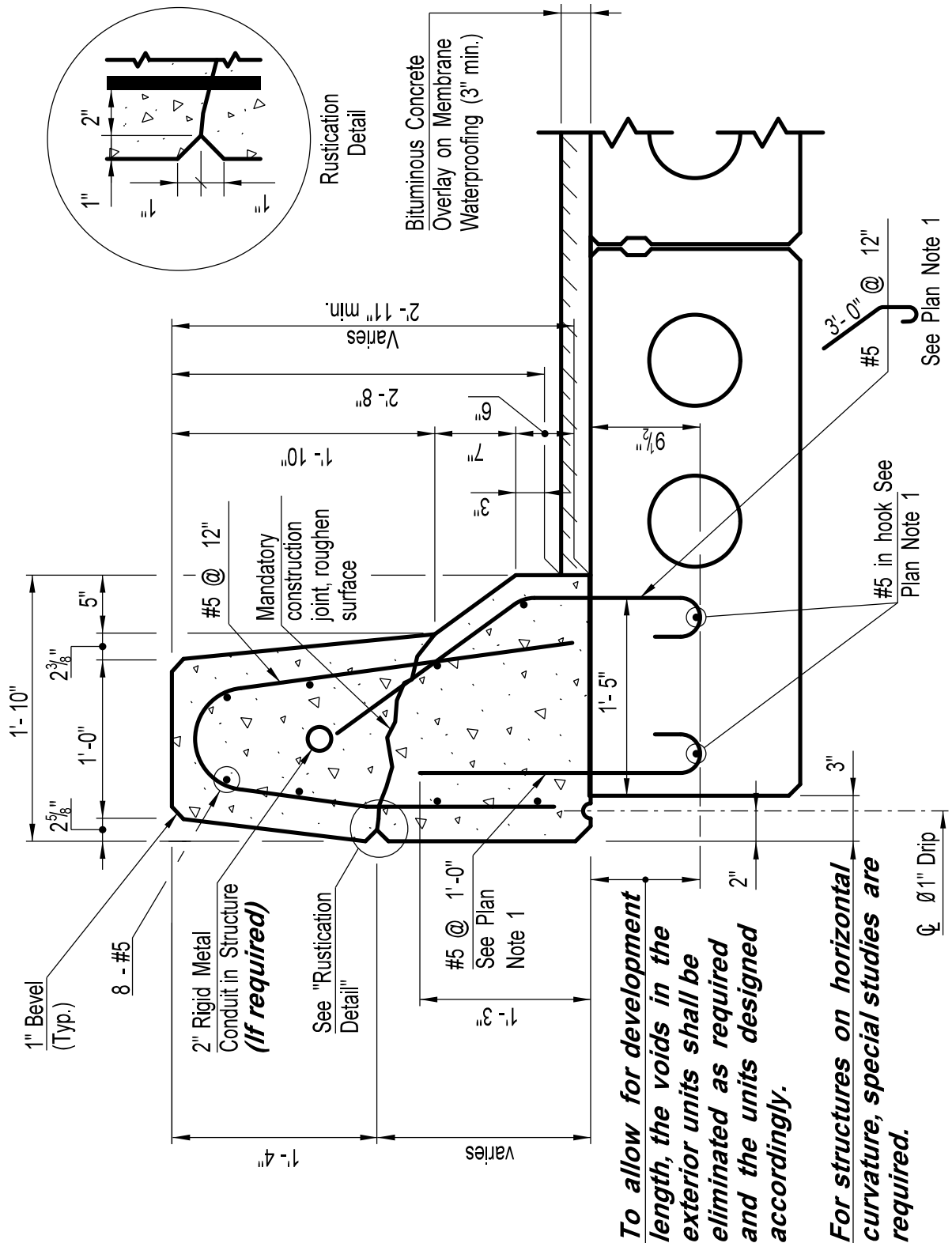
**5.4.3**



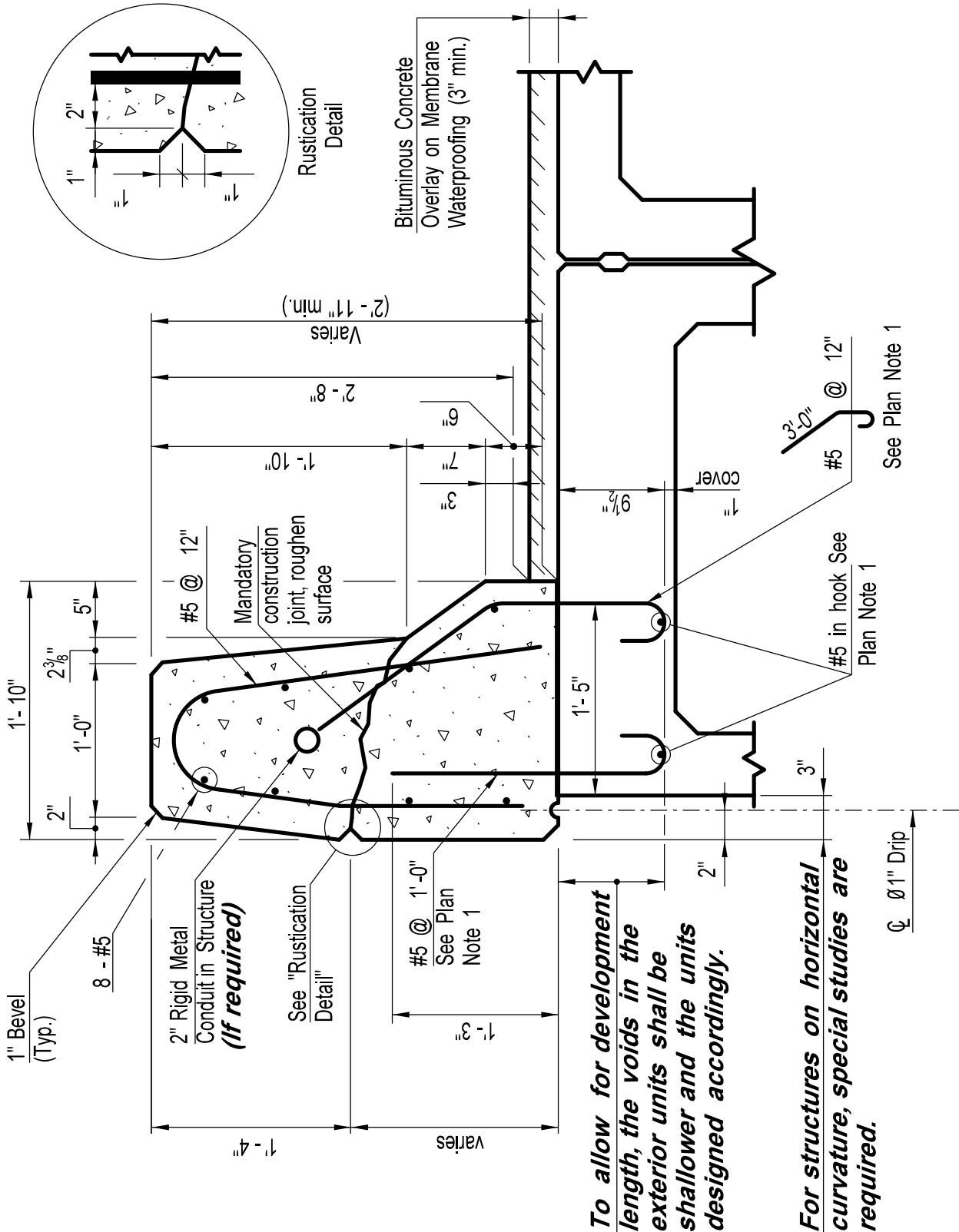
**PLAN**  
**ELASTOMERIC BEARING LAYOUT**

**NOTES:**

1. This dimension shall be the nominal beam spacing divided by four.
2. Elastomeric bearing shall be designed according to Section 14 of the AASHTO specifications. Neoprene shims may be used to provide uniform bearing on pads offset by beam skew.
3. The backwall and cheekwall shall be designed to resist longitudinal and transverse seismic forces.



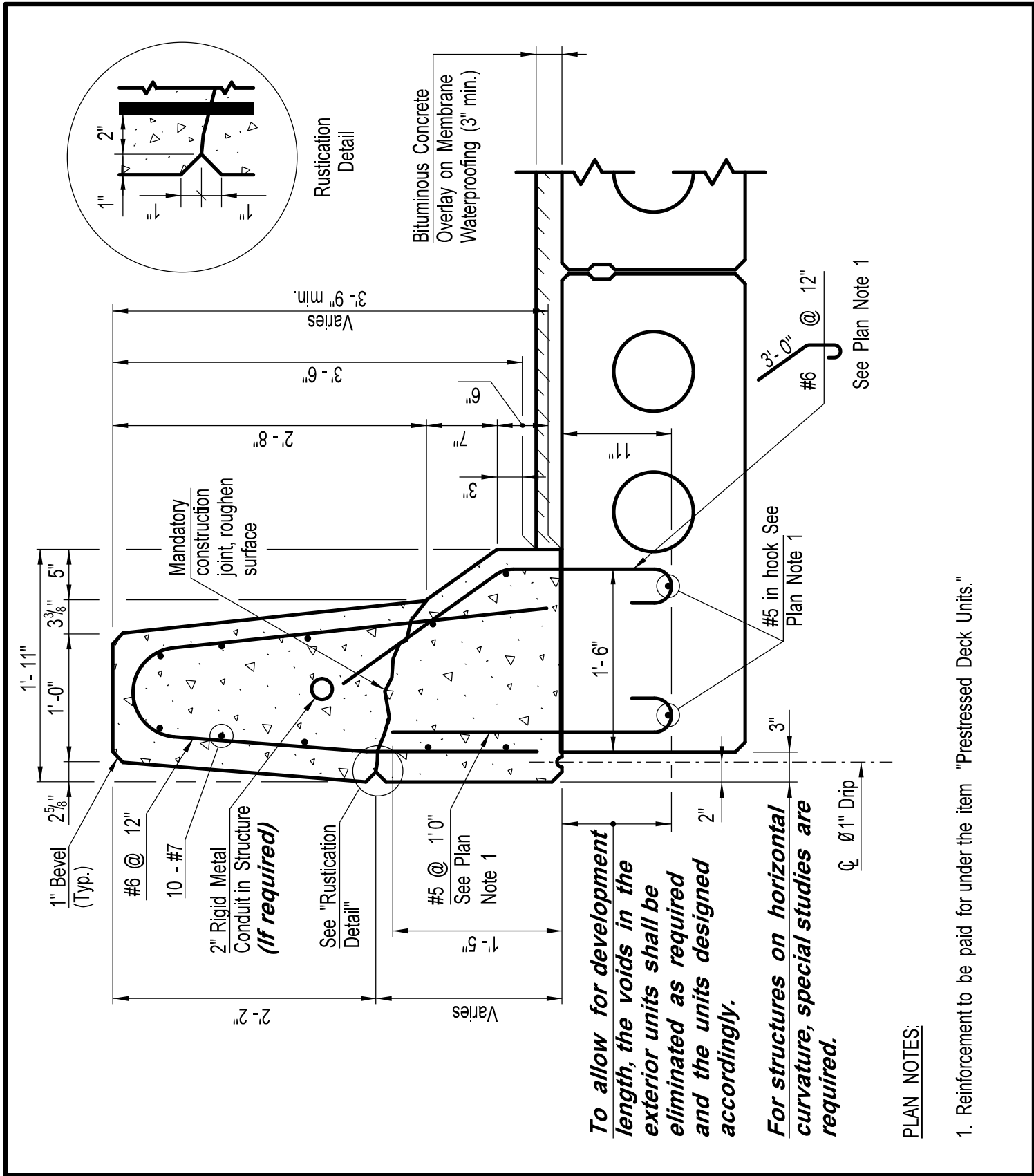




**CONNECTICUT  
BRIDGE DESIGN  
MANUAL**

**STANDARD PARAPET  
42" HIGH  
(ON VOIDED SLAB)**

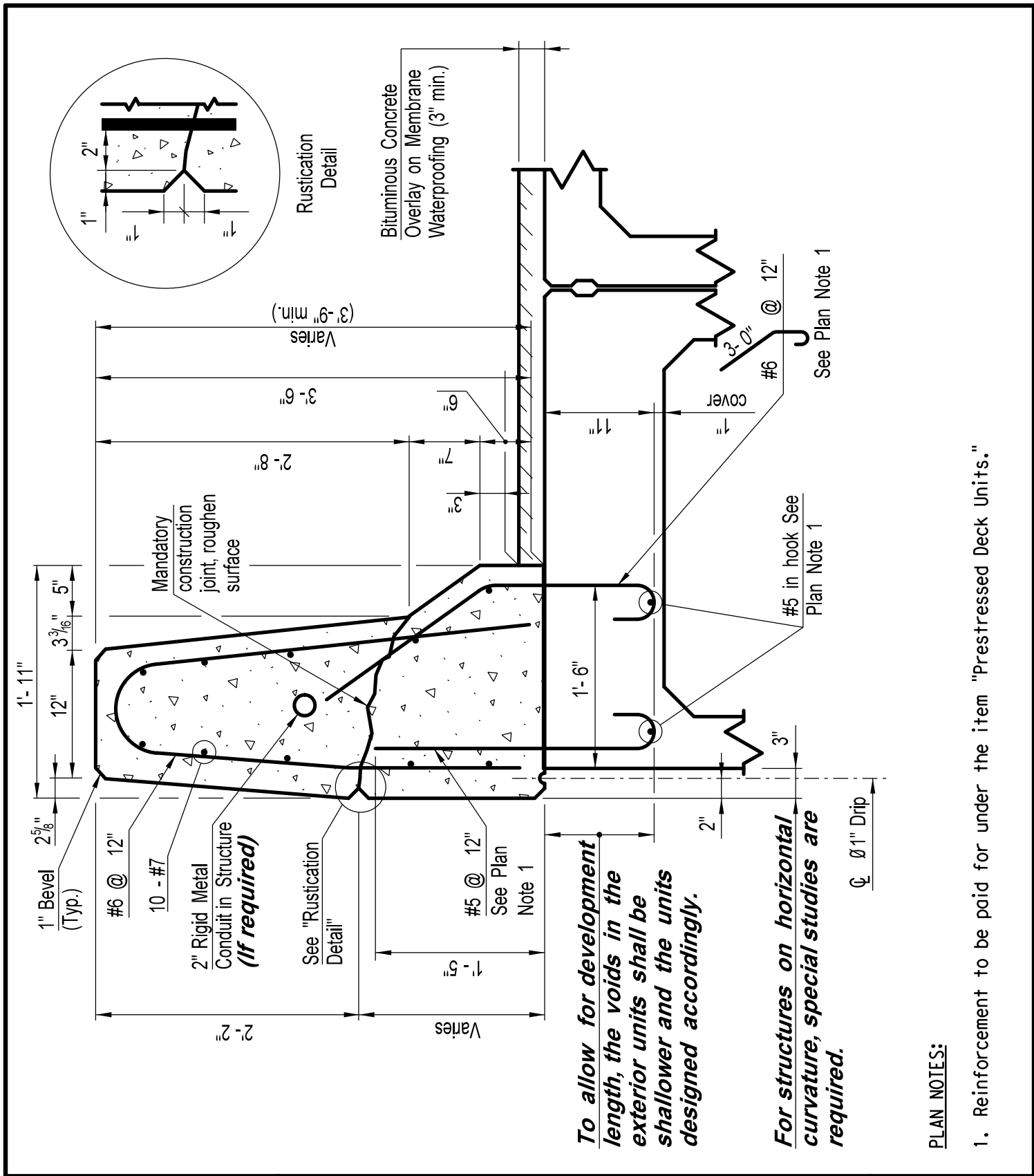
Issue Date:	10/03
Revision Date:	2/11
Plate Number:	5.6.3

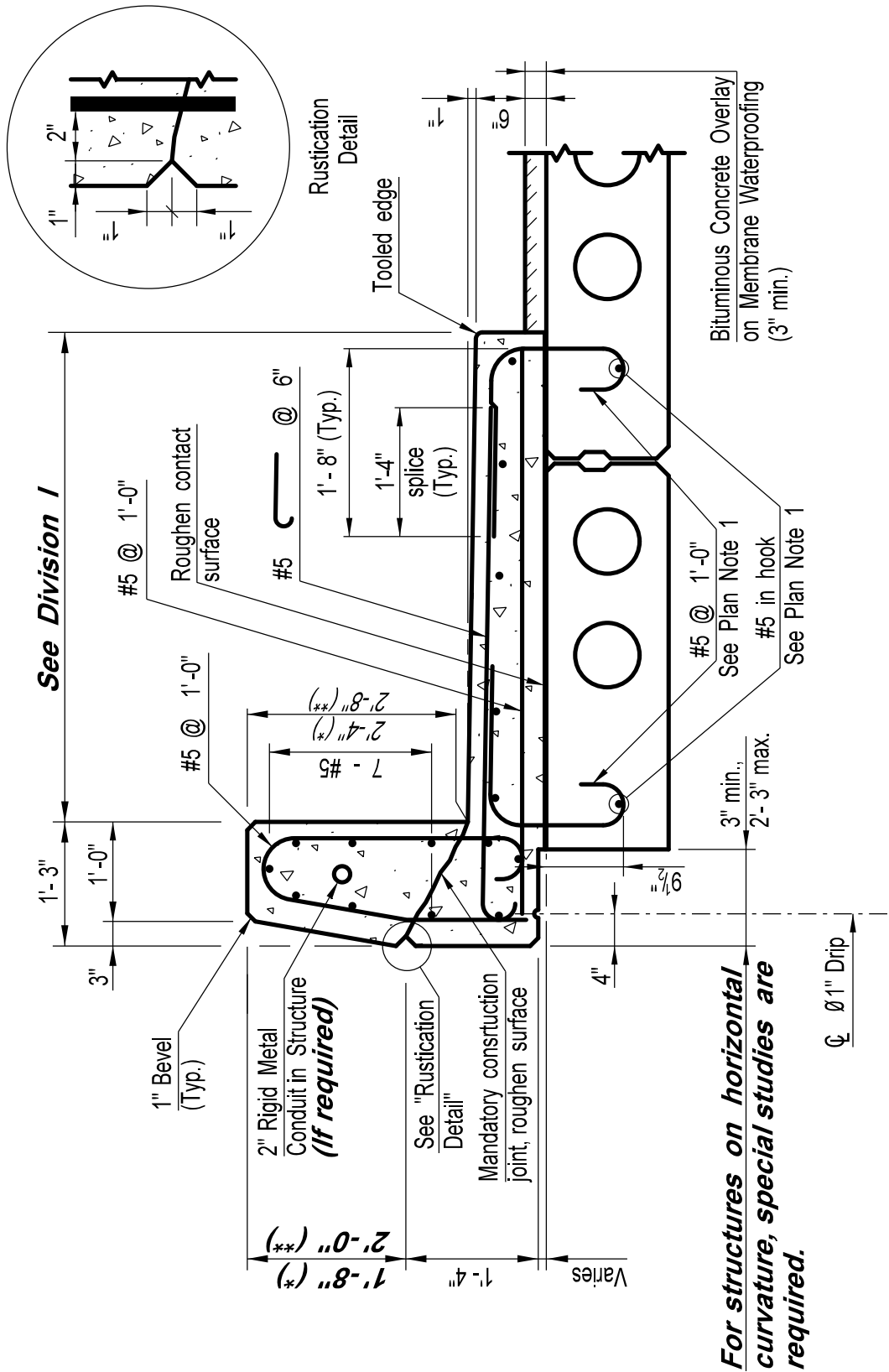


**CONNECTICUT  
BRIDGE DESIGN  
MANUAL**

**STANDARD PARAPET  
42" HIGH  
(ON BUTTED BOX BEAMS)**

Issue Date:	10/03
Revision Date:	2/11
Plate Number:	5.6.4



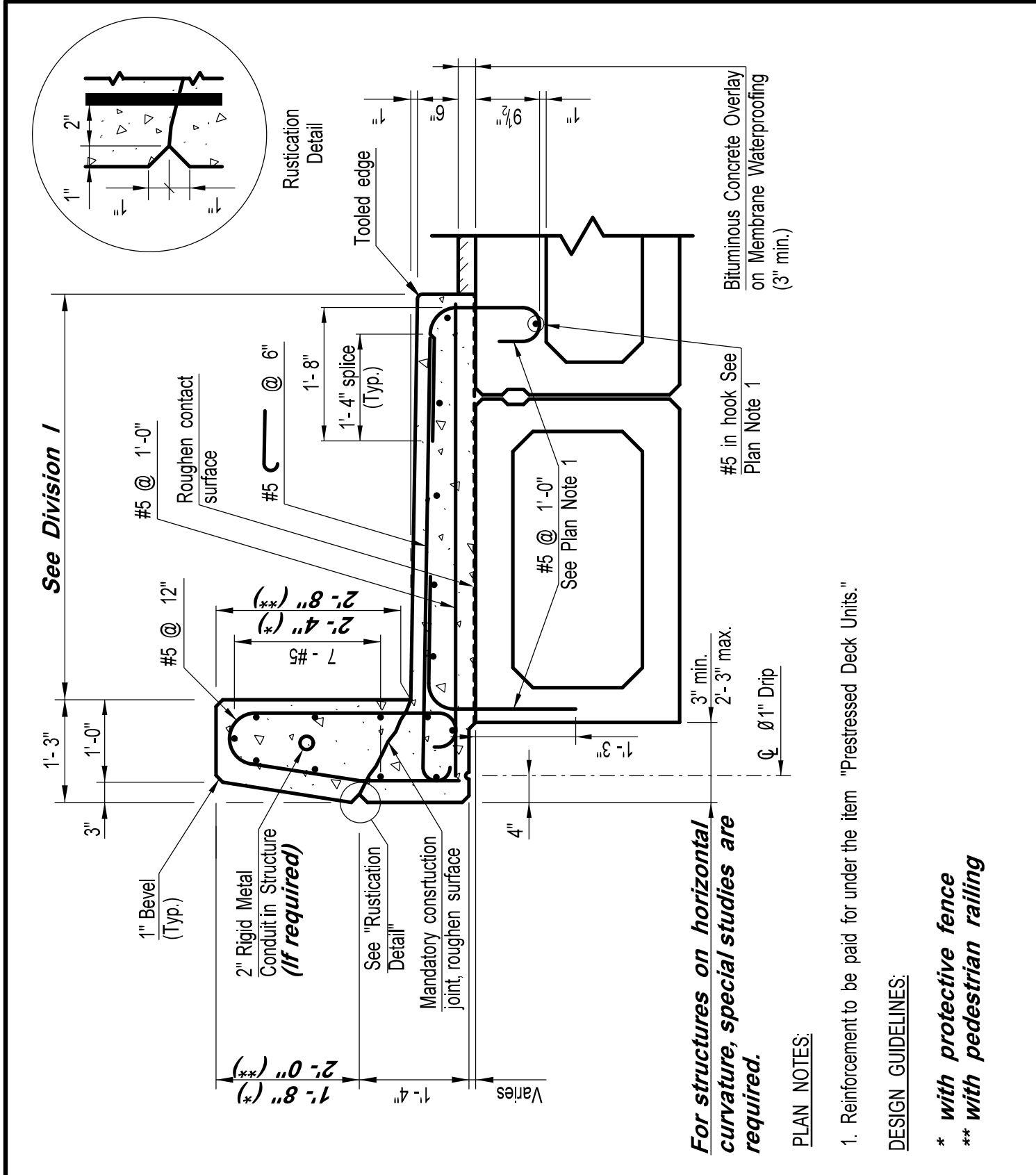


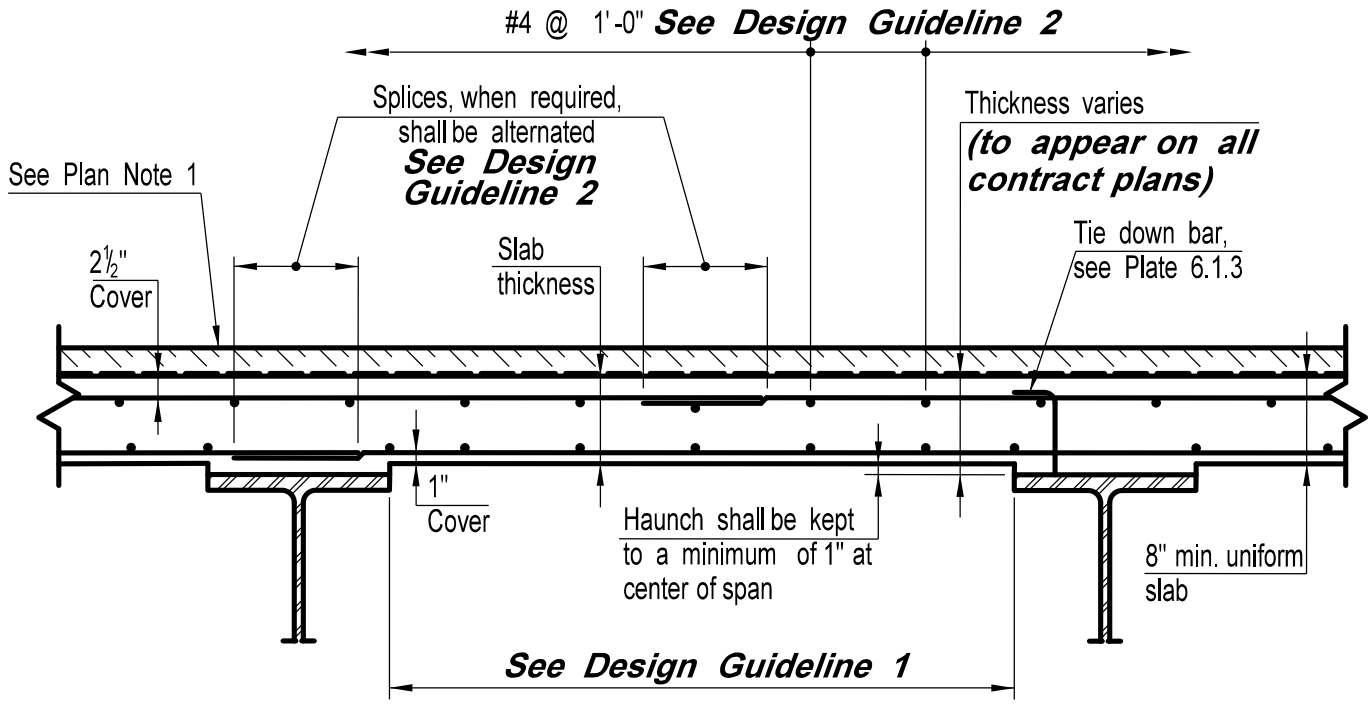
Plan Notes:

1. Reinforcement to be paid for under the item "Prestressed Deck Units."

DESIGN GUIDELINES:

- \* with protective fence
- \*\* with pedestrian railing





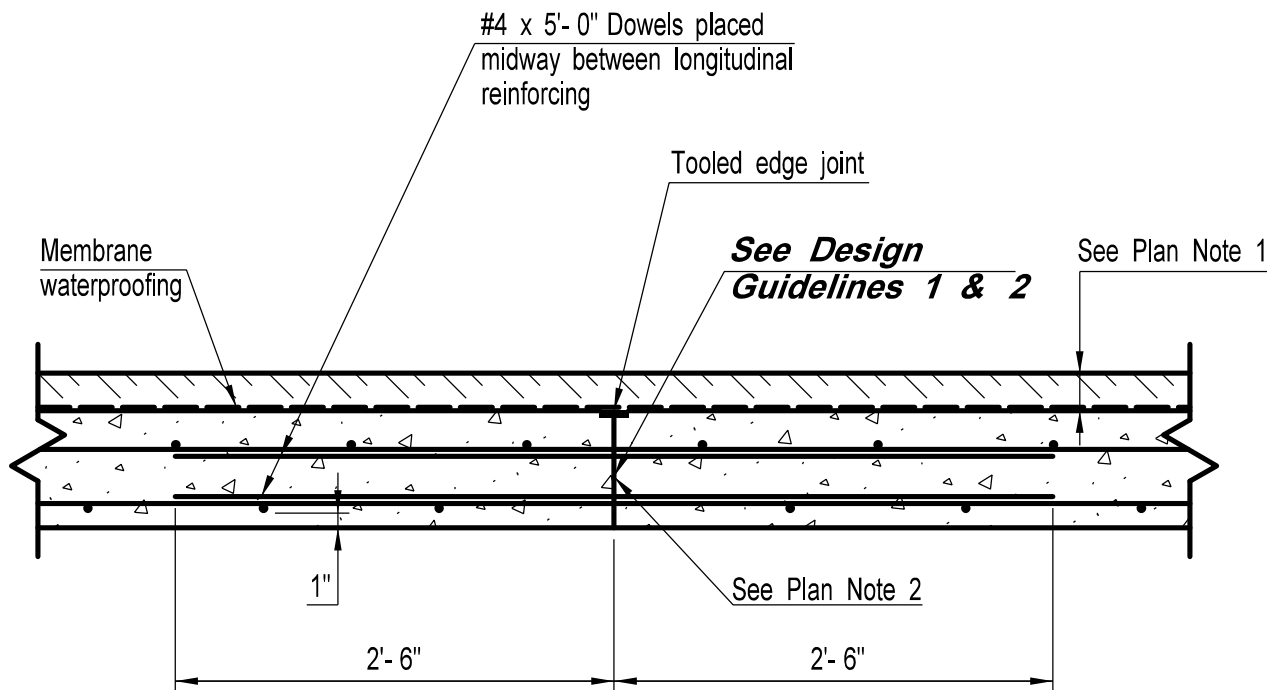
PLAN NOTES:

1. Bituminous concrete overlay on membrane waterproofing

DESIGN GUIDELINES:

1. Bars shall be designed in accordance with current AASHTO specifications. For additional longitudinal slab reinforcement at ends of slab, see Plate 6.1.4. For additional slab reinforcement at acute corners, (skew angle greater than 20°), see Plate 6.1.5a.
2. Splices and development lengths shall be determined by the designer in accordance with the latest AASHTO design criteria.

<b>CONNECTICUT BRIDGE DESIGN MANUAL</b>	TYPICAL SLAB SECTION	Issue Date: 10/03
		Revision Date: 2/11
		Plate Number: 6.1.1



PLAN NOTES:

1. Bituminous concrete overlay on membrane waterproofing.
2. Roughen surface, blast clean then apply a neat cement grout or other suitable bonding material immediately prior to placing adjacent pour. **See Note 3.**

DESIGN GUIDELINES:

1. ***Transverse reinforcement placed on a skew to this joint shall be continuous through this joint.***
2. ***This joint shall be allowed and shown on the plans only when sequence of pour is required.***

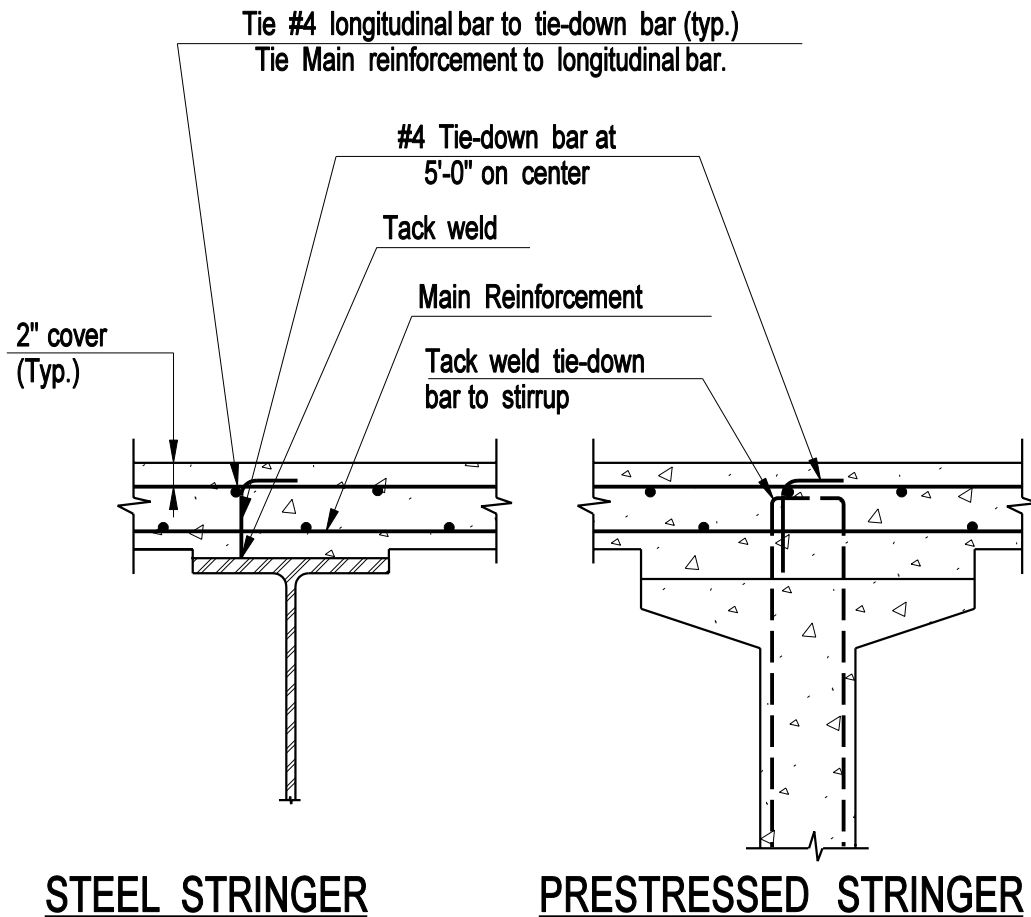
**CONNECTICUT  
BRIDGE DESIGN  
MANUAL**

TYPICAL SECTION AT  
TRANSVERSE CONSTRUCTION  
JOINT IN SLAB

Issue Date: 10/03

Revision Date: 2/11

Plate Number:  
6.1.2



**STEEL STRINGER**

**PRESTRESSED STRINGER**

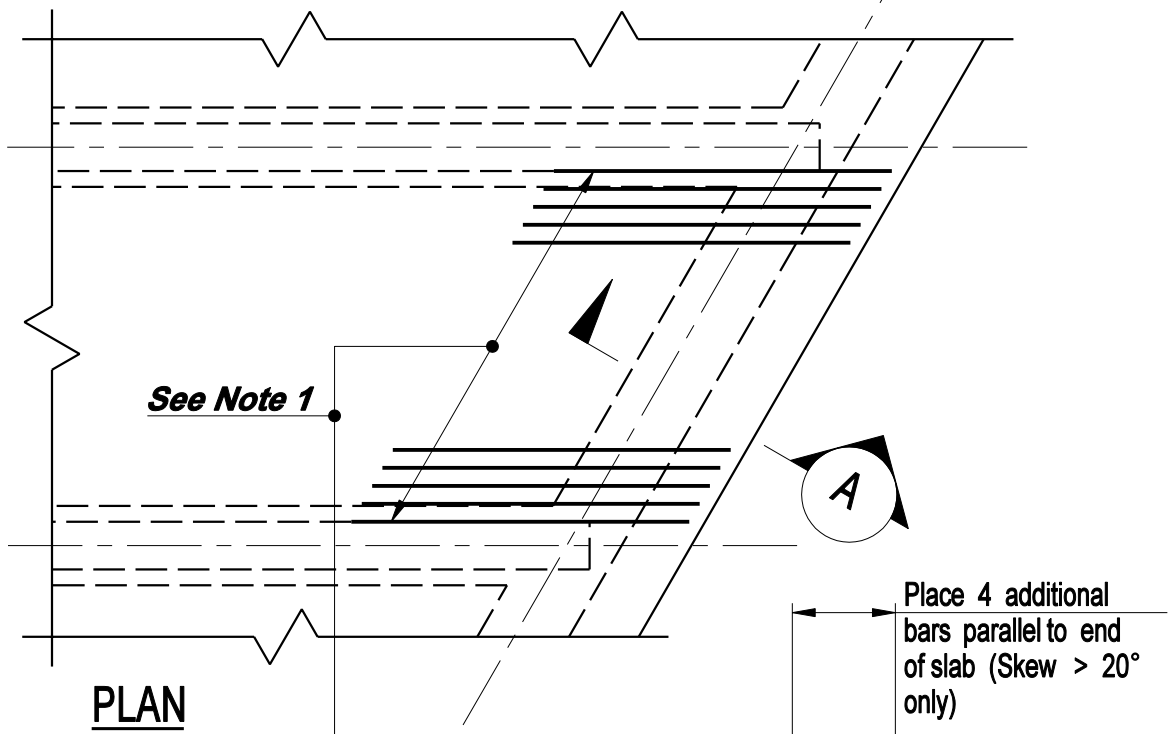
**PLAN NOTES**

1. Tie-down bars do not exclude the use of chairs for supporting the reinforcement mat.
2. The cost of furnishing and placing tie-down bars to be included in the contract item "Deformed Steel Bars".
3. Tie-down bars and longitudinal bars shall clear shear connectors.

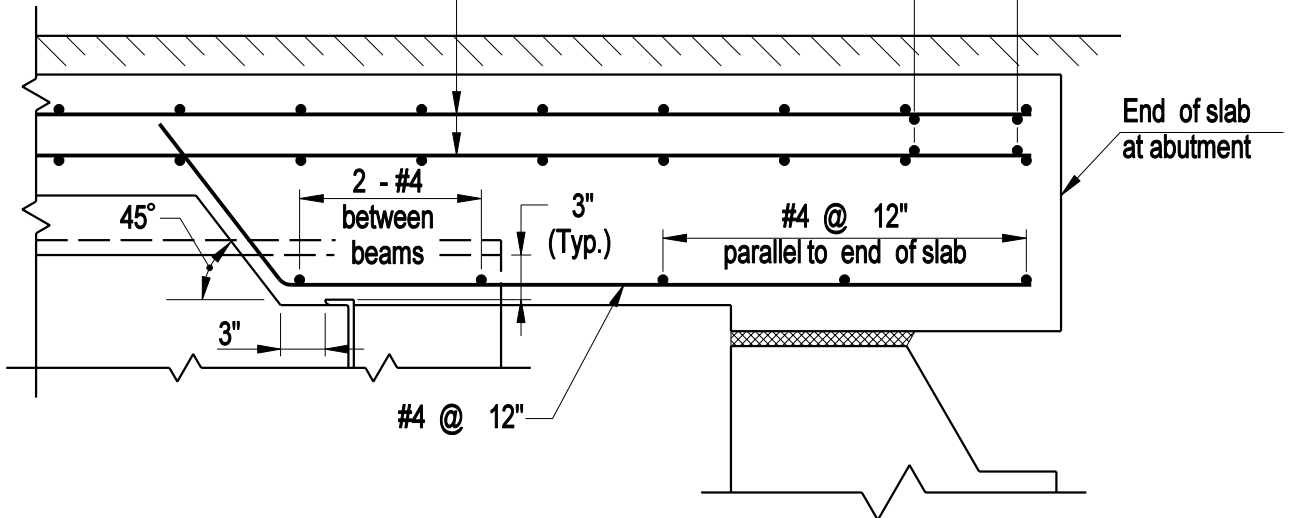
**DESIGN INFORMATION:**

*Tie-downs for reinforcement shall not be welded to steel members or parts subjected to tensile stress unless the range of stress at the point of attachment does not exceed the allowable range as stated in the current AASHTO specifications. Hence the plans shall indicate the locations where this attachment shall not be tack welded to the tension flanges with the following note: "No attachment shall be fillet welded, plug welded or tack welded to the tension flange within these limits."*





**PLAN**



**SECTION** A

**DESIGN INFORMATION**

**1. Place additional #5 bars midway between longitudinal bars on both fixed and expansion ends, at piers and abutments.**

*Spans < 50'- 0"*

*Spans > 50'- 0" to 80'- 0"*

*Spans > 80'- 0"*

*Use #4 x 5'- 0"*

*Use #4 x 8'- 0"*

*Use #4 x 10'- 0"*

**CONNECTICUT  
BRIDGE DESIGN  
MANUAL**

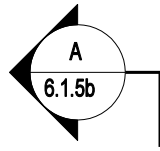
**DETAILS  
AT ENDS OF SLAB  
(STEEL STRINGERS)**

Issue Date: 10/03

Revision Date:

Plate Number:

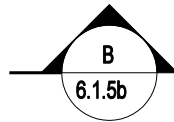
**6.1.4**



*Place additional reinforcement (top only) in this area. (#5 @ 9")*

*Reinforcement designed for slab continuous over 3 or more supports*

Limits of thickened slab

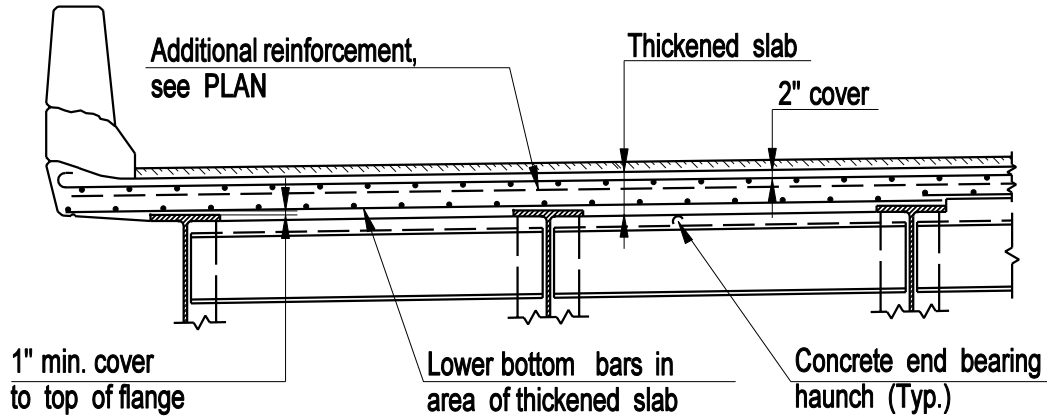


*Reinforcement designed for slab simply supported using increased depth*

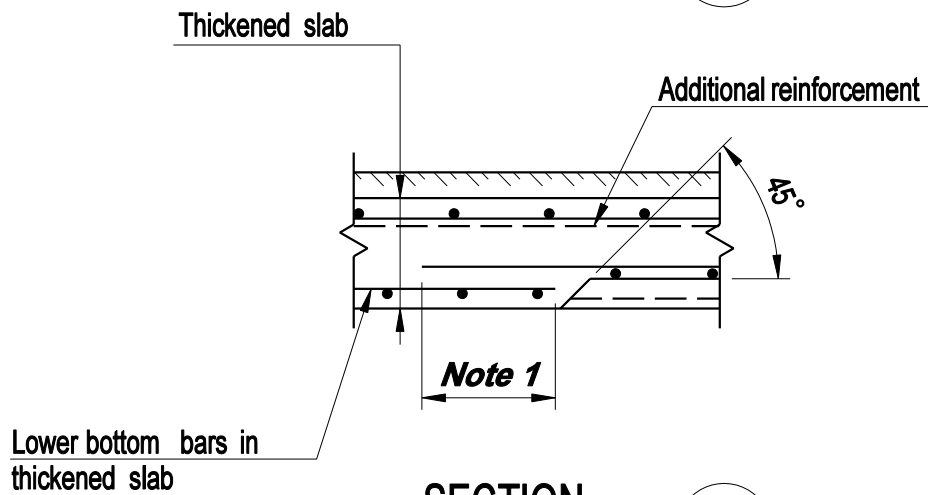
PLAN

DESIGN INFORMATION

*For design information, see Plate 6.1.5b*



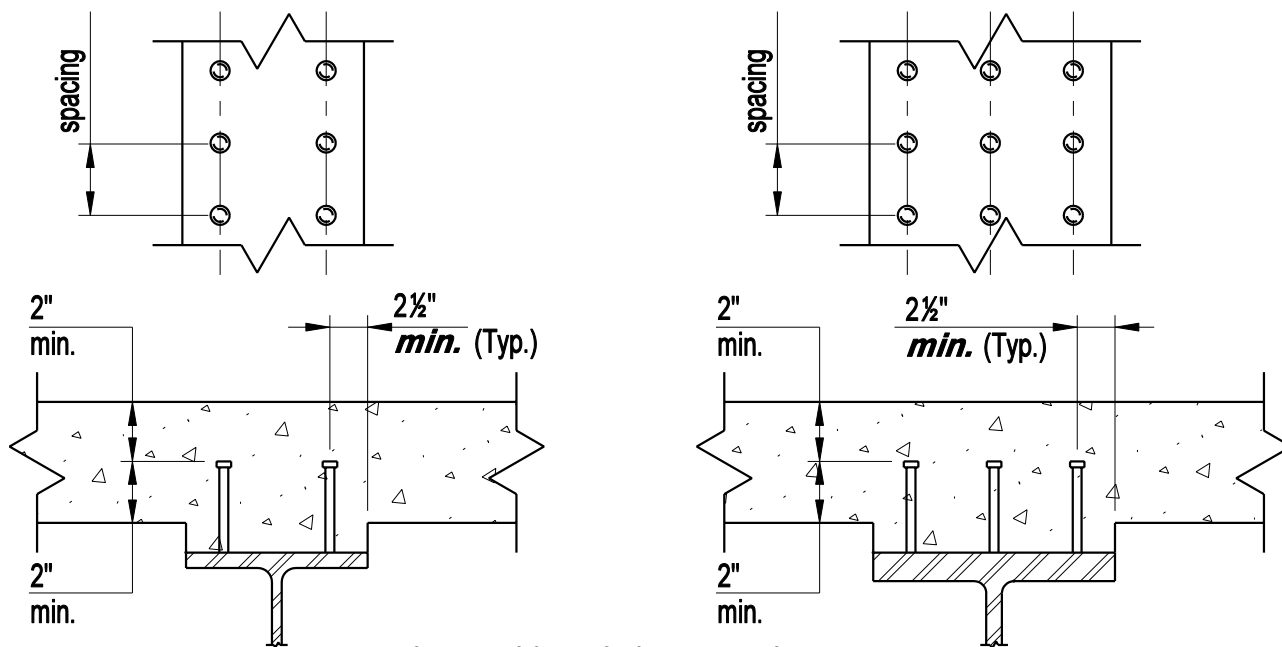
SECTION A



SECTION B

**DESIGN INFORMATION**

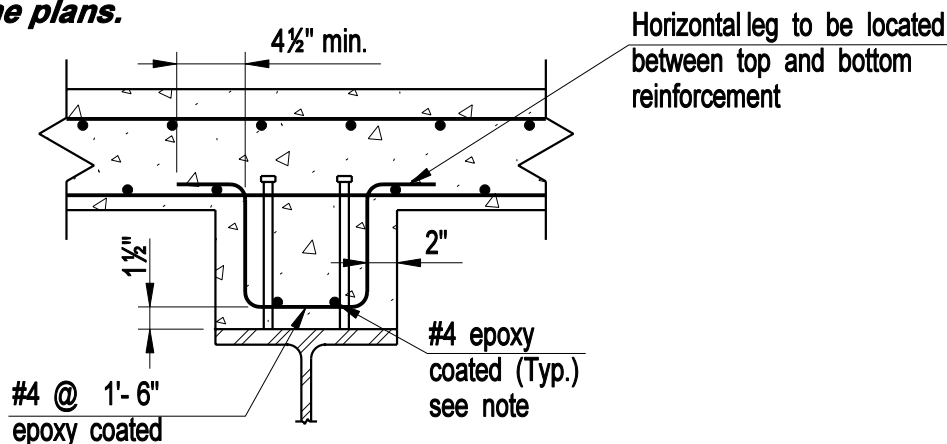
1. *Splice length shall be determined by the designer in accordance with the latest AASHTO design criteria.*
2. *Longitudinal reinforcement not indicated in "PLAN", detail shown at abutment, detail at pier similar.*



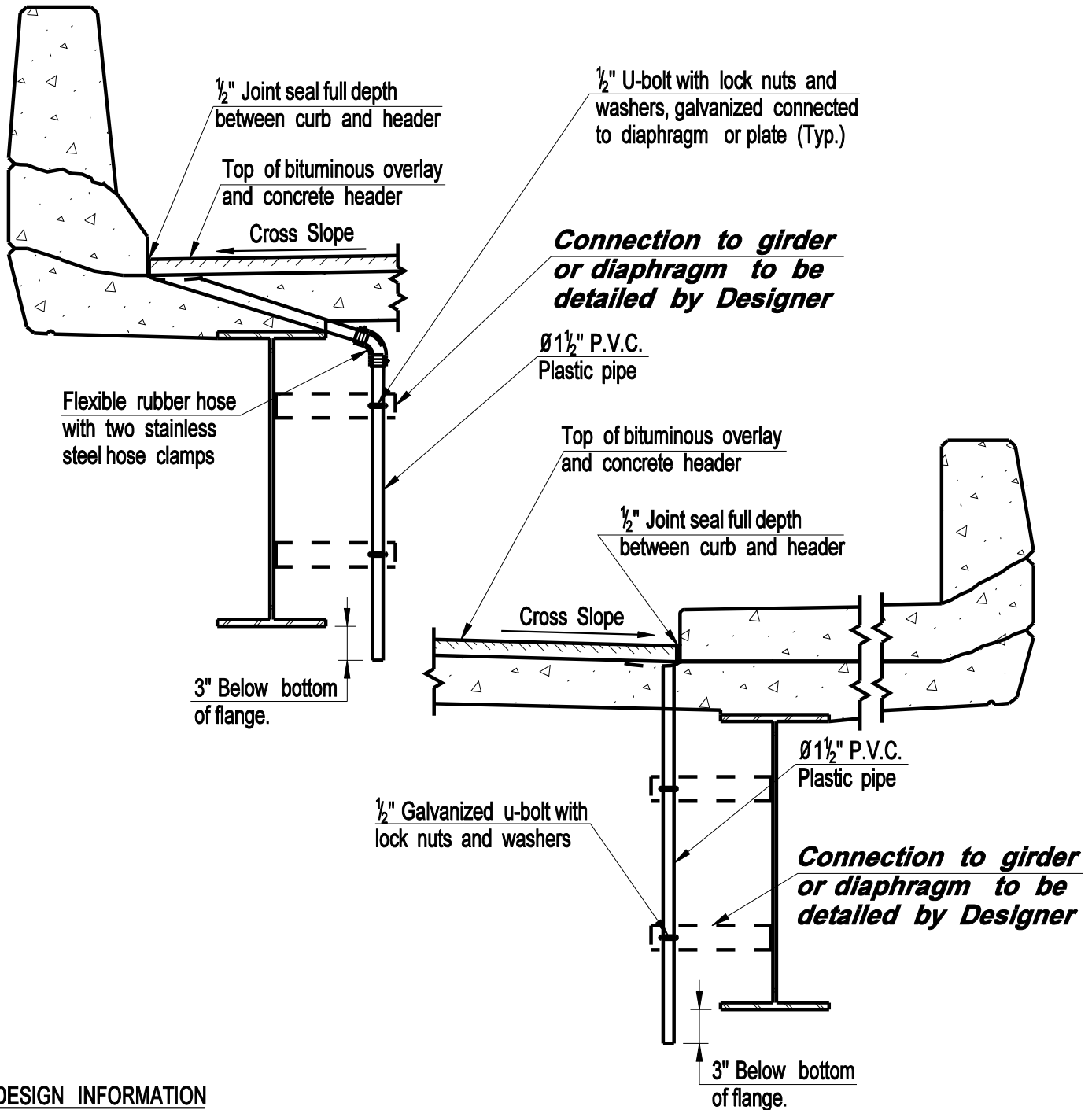
**SHEAR CONNECTOR DETAILS**

**DESIGN INFORMATION**

- 1. Preference shall be given to the use of 7/8" Ø studs. Lengths of studs shall be in increments of 1". Maximum permissible length of studs is 8". If the stud length required is in excess of 8", the required length may be obtained by stacking. Stacking of studs is provided for use in the specifications.**
- 2. Actual lengths or quantities of studs will not be given on the plans but shall be determined by the Contractor in accordance with the requirements shown in the details.**
- 3. Where the maximum depth of the haunch is excessive and studs are to be stacked, the haunch shall be reinforced as shown below.**
- 4. Haunch reinforcement shown is for haunch depth of 4" to 6". Reinforcement is not required for haunch depth less than 4". Reinforcement shall be designed for haunch depth greater than 6". If haunch depth in excess of 4" is anticipated, this detail shall be shown on the plans.**



**HAUNCH REINFORCEMENT DETAIL  
(SEE NOTE 4)**



**DESIGN INFORMATION**

- 1. In no case shall weepholes on bridges with welded steel girders or rolled beams outlet on the outside of fascia girder. Omit weepholes in cases where outletting on the inside is not feasible.**
- 2. For additional notes and design information, see Plate 6.1.9.**

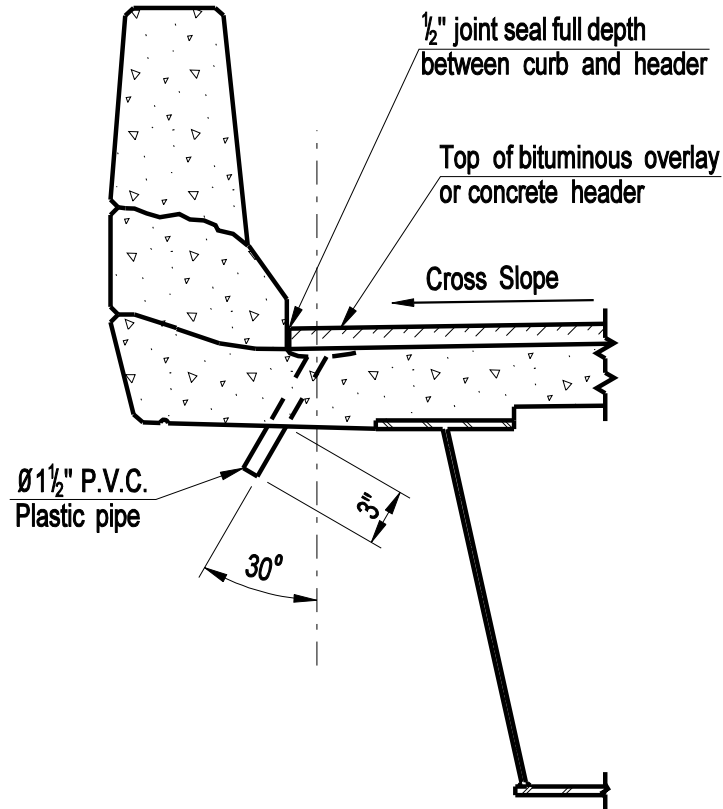
**CONNECTICUT  
BRIDGE DESIGN  
MANUAL**

**DECK WEEPHOLE DETAILS  
(WELDED GIRDERS AND  
ROLLED BEAMS)**

Issue Date: 01/05

Revision Date:

Plate Number:  
6.1.7



DESIGN INFORMATION

1. *Similar details may be used for bridges with concrete beams.*
2. *In no case shall weepholes which outlet on the outside of fascia girder extend more than 3" below the bottom of slab. Omit weepholes in cases where steel flanges or bearings are exposed to leakage.*
3. *For additional notes and design information, see Plate 6.1.9.*

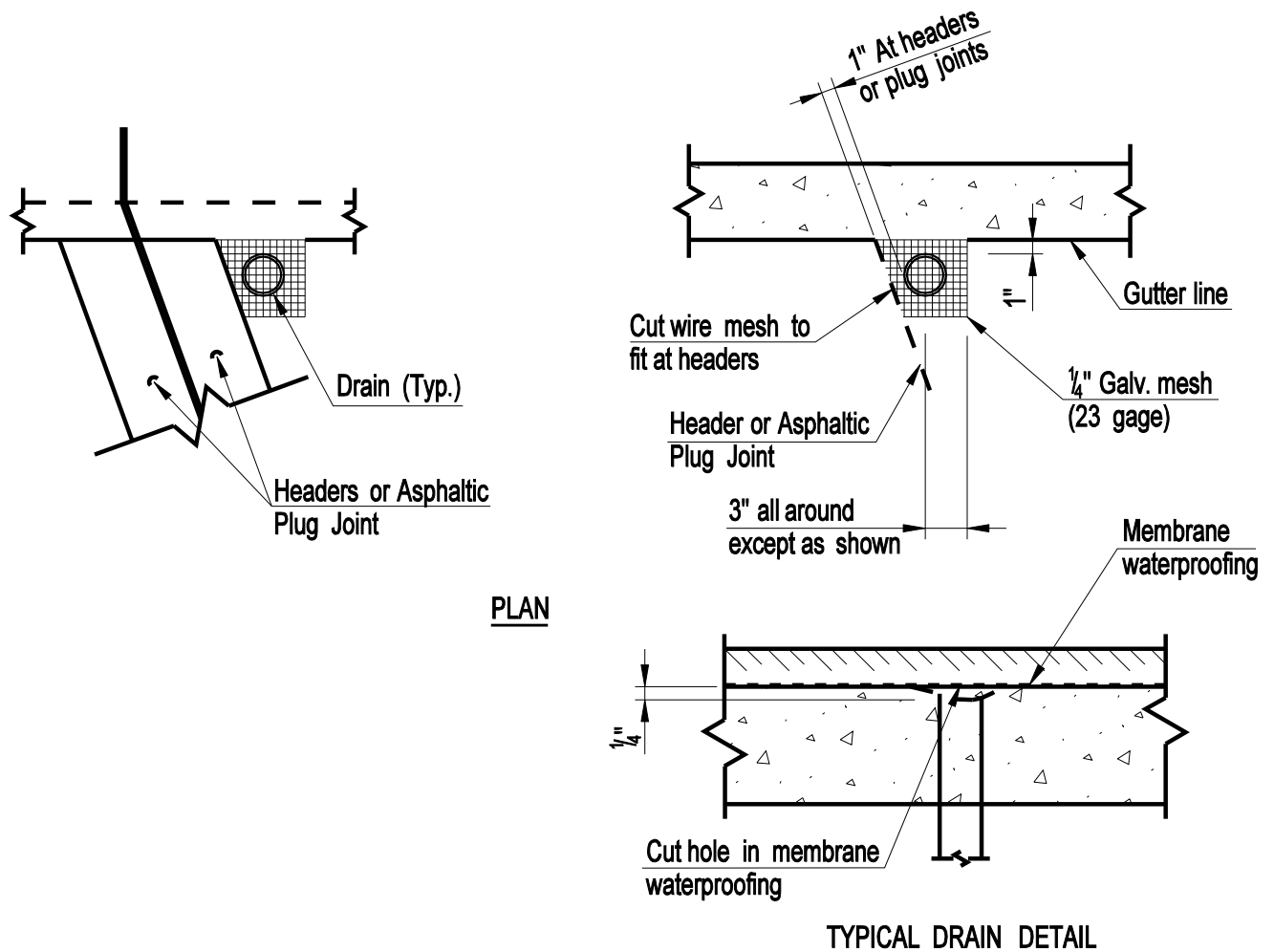
**CONNECTICUT  
BRIDGE DESIGN  
MANUAL**

**DECK WEEPHOLE DETAILS  
(STEEL BOX GIRDERS)**

Issue Date: 01/05

Revision Date:

Plate Number:  
6.1.8



PLAN

TYPICAL DRAIN DETAIL

NOTES:

The cost of furnishing and installing  $\frac{1}{4}$ " square galvanized wire mesh shall be included in the contract bid price for "Superpave 0.25".

DESIGN INFORMATION

**1. Weepholes to be located by the designer as follows:**

***Weepholes shall be placed along gutter line on the low end of cross slopes adjacent to headers and joints at the low end of span only. No weepholes shall be placed where they will drain onto travelways, shoulders, sidewalks or parking areas. Omit weepholes where these conditions cannot be met. On structures over railroads, the weepholes shall generally not be located in spans over tracks. However, for long span structures the pipes may be located in spans over tracks but shall not be located closer than 25 ft. from the center line of the outside tracks.***

**BRIDGE PLATES 6.2.1 THROUGH 6.2.4 DELETED, 12/19**

**CONNECTICUT  
BRIDGE DESIGN  
MANUAL**

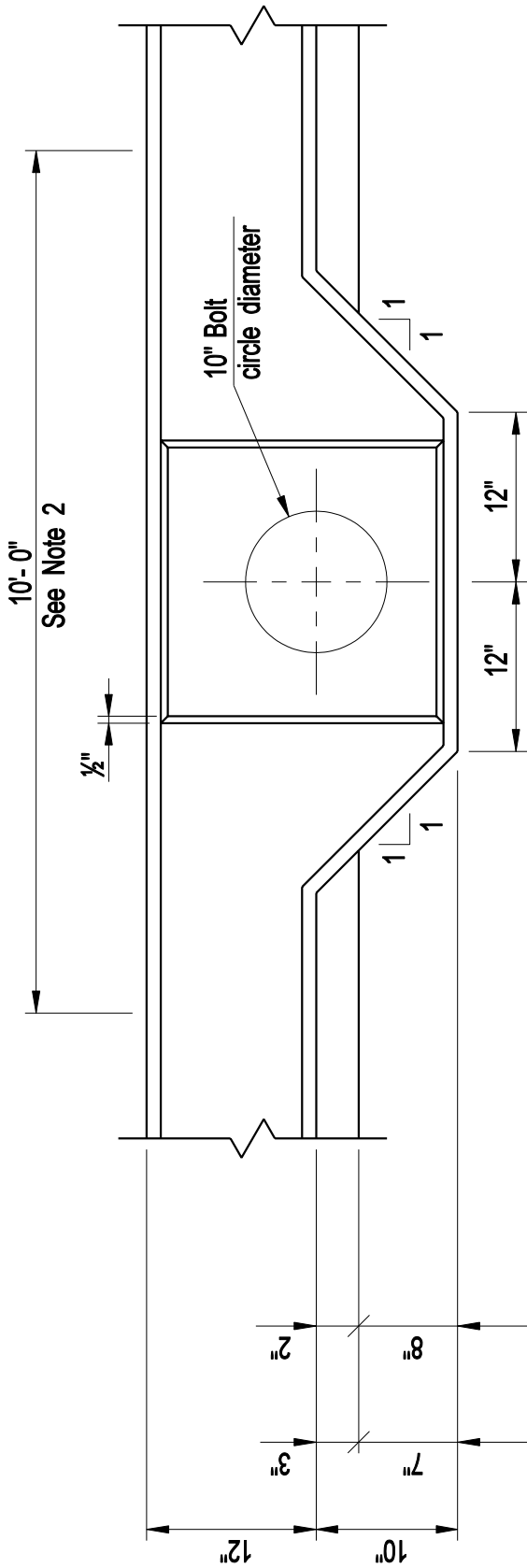
STANDARD PARAPET  
32" HIGH

Issue Date: 10/03

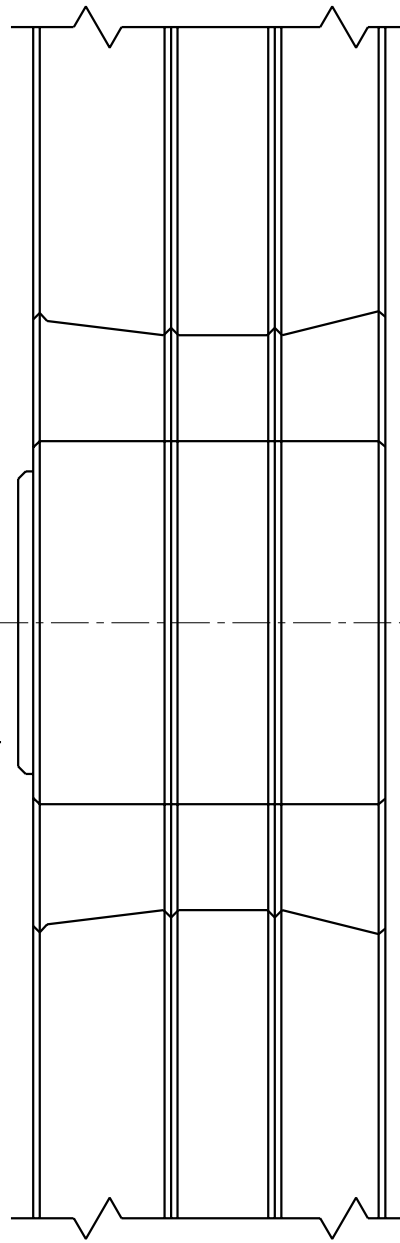
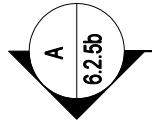
Revision Date: 12/19

Plate Number:  
6.2.1



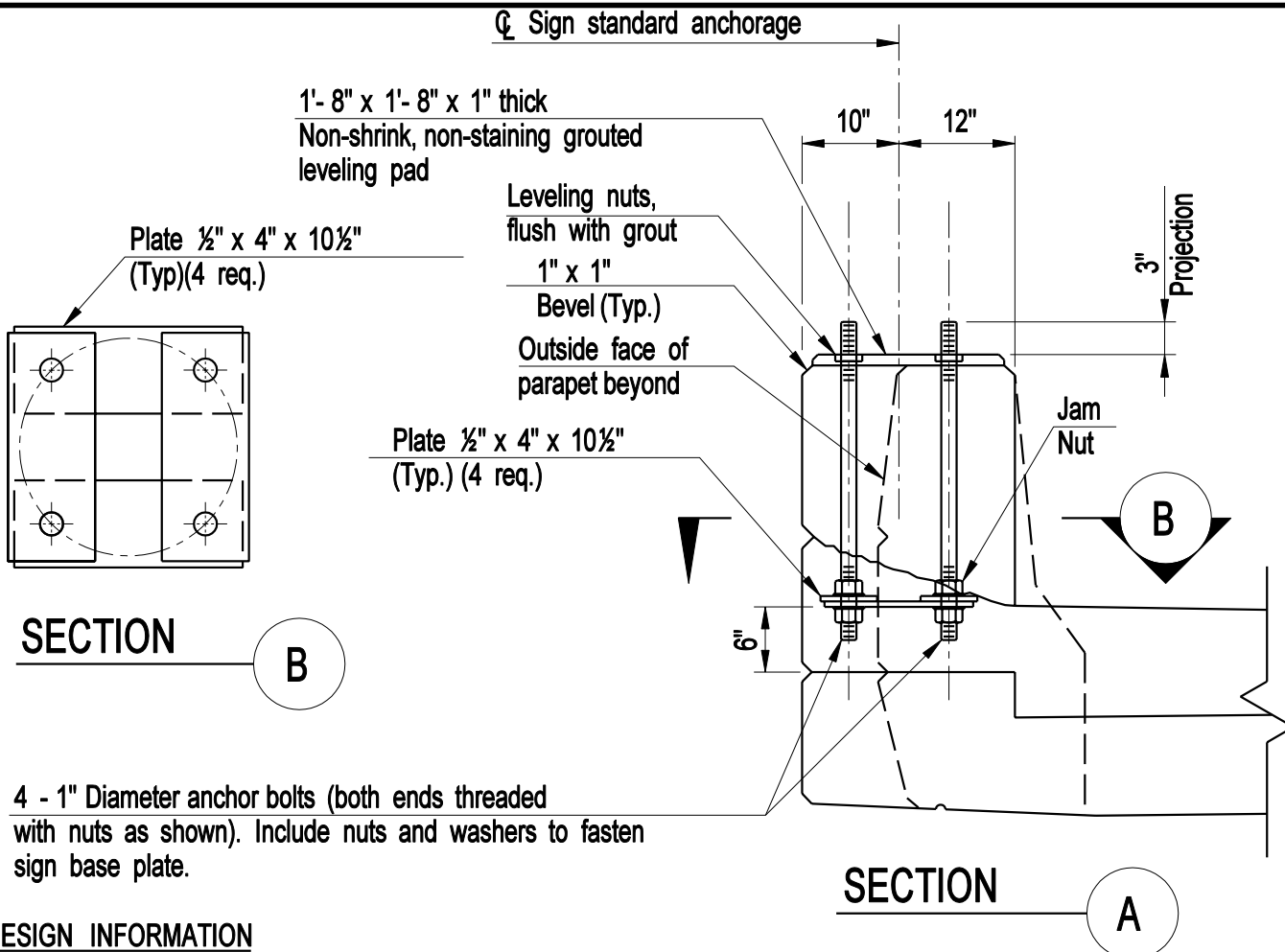


PLAN



DESIGN INFORMATION:

1. For design information, see Plate 6.2.5b
2. For parapet reinforcement within these limits, see Plate 6.2.7c



4 - 1" Diameter anchor bolts (both ends threaded with nuts as shown). Include nuts and washers to fasten sign base plate.

**DESIGN INFORMATION**

1. **Structural design for slab and details required, including reinforcement, shall be determined by the designer.**
2. **Maximum sign size is 4'- 0" x 8'- 6" at 8'- 2" above gutter line.**
3. **Dimensions shown will provide for continuity of "Metal Bridge Rail (Traffic)". These dimensions shall be reviewed for other railings as required to provide for continuity of rail.**

**Notes:**

4. Anchor bolts and nuts shall be manufactured of steel conforming to the following requirements:  
 Square leveling nuts may be low carbon steel.  
 Bolts - ASTM A-449  
 Hex Nuts - ASTM A-563 Grade DH  
 Anchor bolts and nuts shall be galvanized in accordance with ASTM A-153.  
 Structural steel plates shall conform to ASTM A-36.
5. Cost of furnishing and installing anchor bolts, nuts and steel plates to be paid for at the contract unit price per pound for "Deformed Steel Bars".

**BRIDGE PLATES 6.2.6a THROUGH 6.2.8c DELETED, 12/19**

<b>CONNECTICUT BRIDGE DESIGN MANUAL</b>	<b>ANCHORAGE FOR BOX TRUSS SIGN SUPPORT</b>	Issue Date: 10/03 Revision Date: 12/19 Plate Number: <b>6.2.6a</b>
---	---	---

**BRIDGE PLATE 6.3.1 DELETED, 04/19**

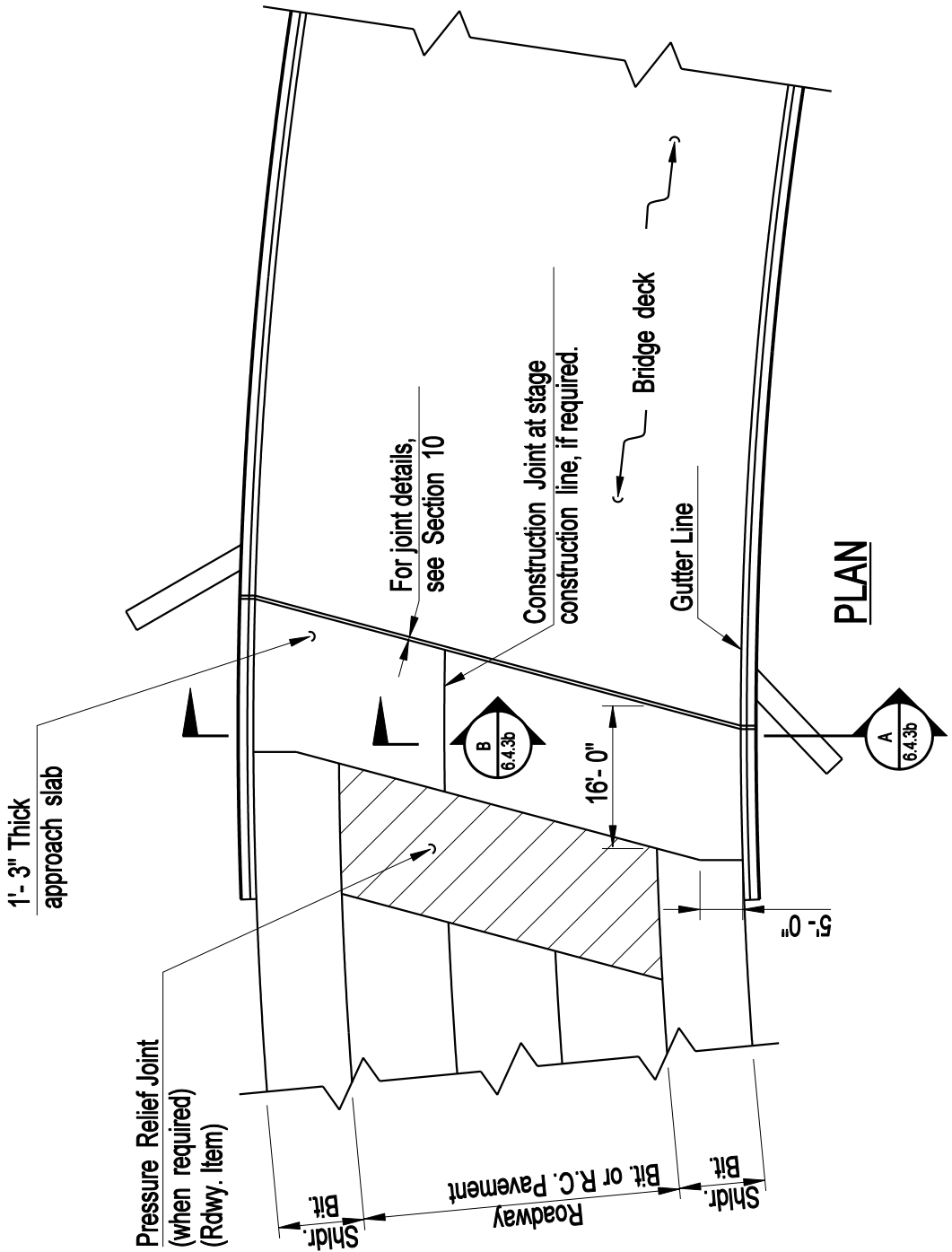
**CONNECTICUT  
BRIDGE DESIGN  
MANUAL**

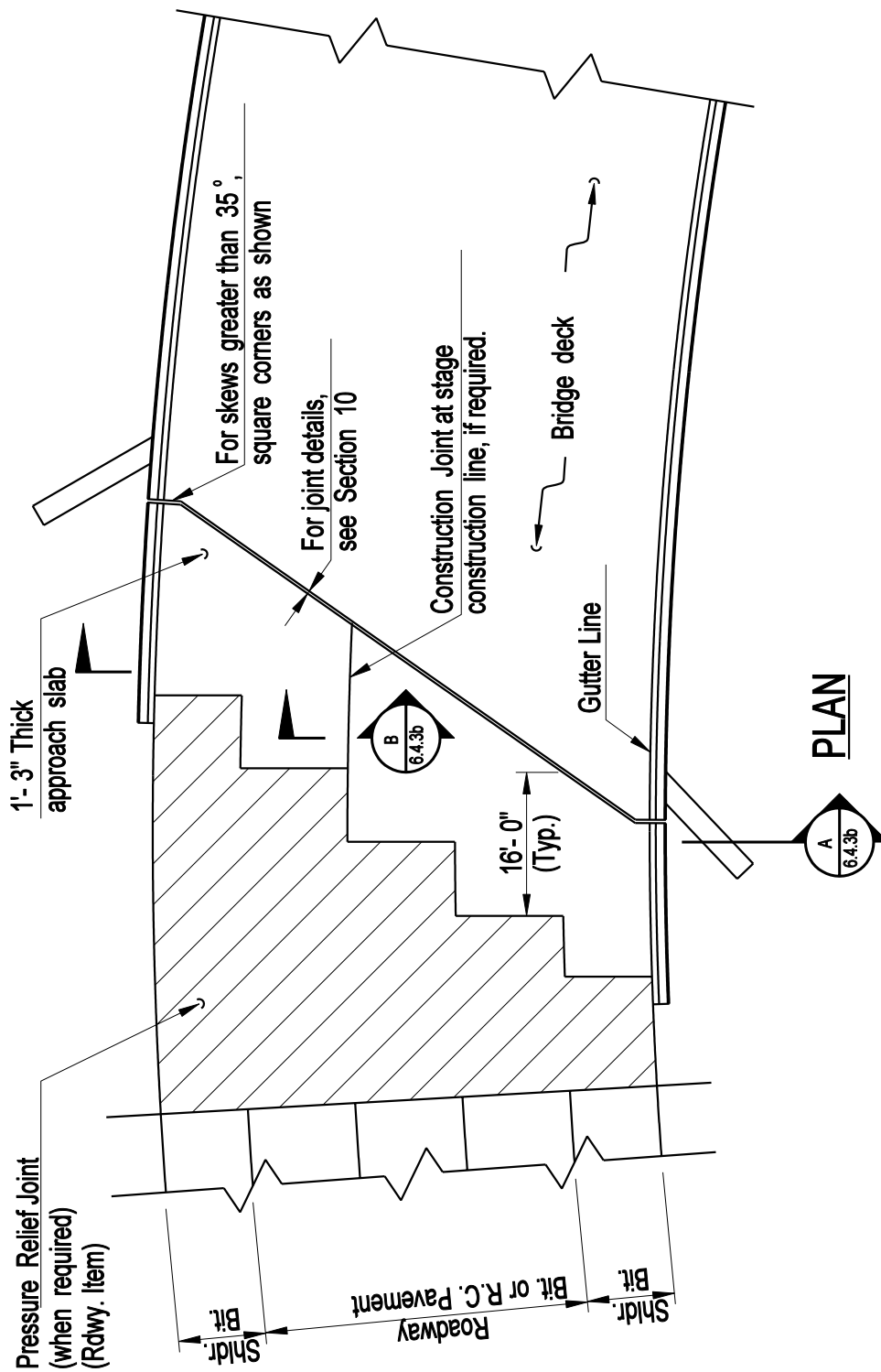
**STANDARD SPLIT MEDIAN  
BARRIER CURB (4'-9" HIGH)**

Issue Date: 10/03

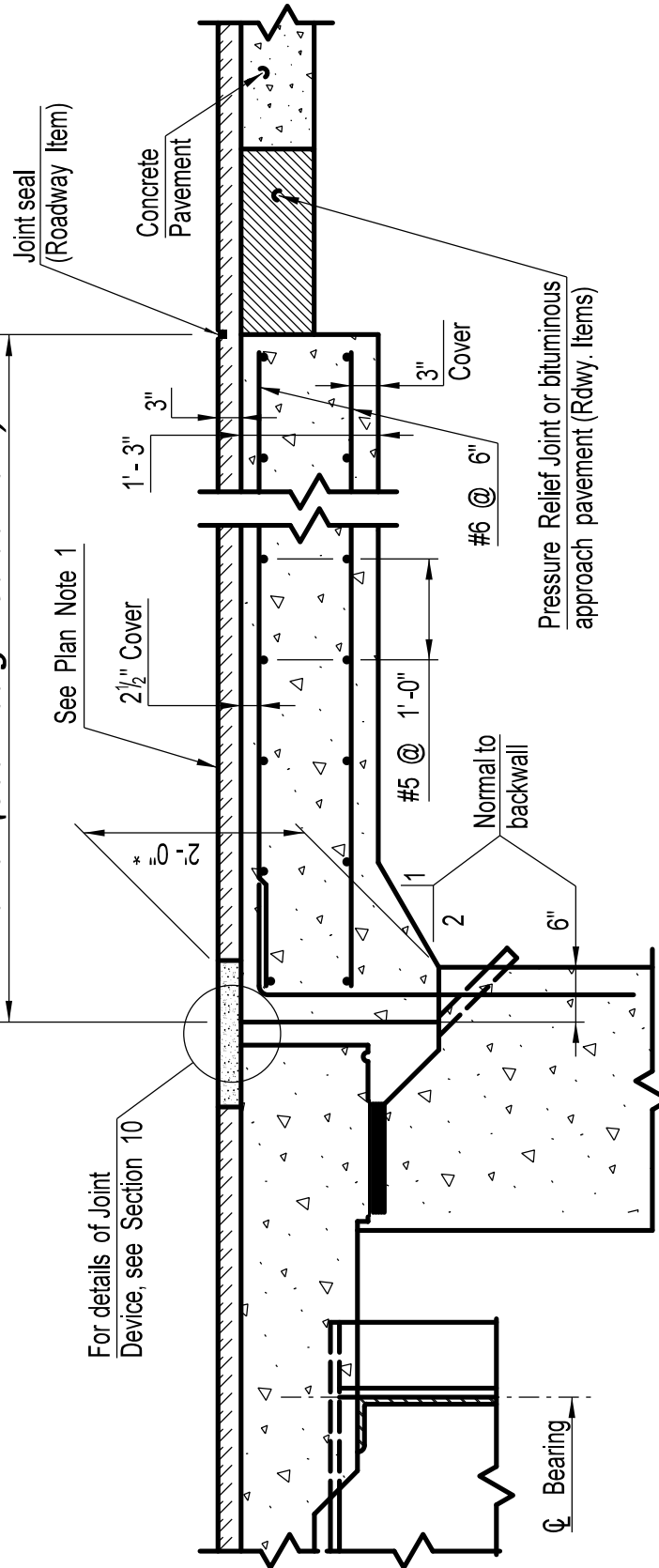
Revision Date: 04/19

Plate Number:  
**6.3.1**





16'-0" (See Design Guideline 1)



See Plan Note 1

For details of Joint Device, see Section 10

PLAN NOTES:

- 1. 3" bituminous concrete overlay on membrane waterproofing

DESIGN GUIDELINES:

- 1. On bridges with skew angle greater than 35°, ends of approach slabs are squared off and this dimension is the minimum length at the shortest point.

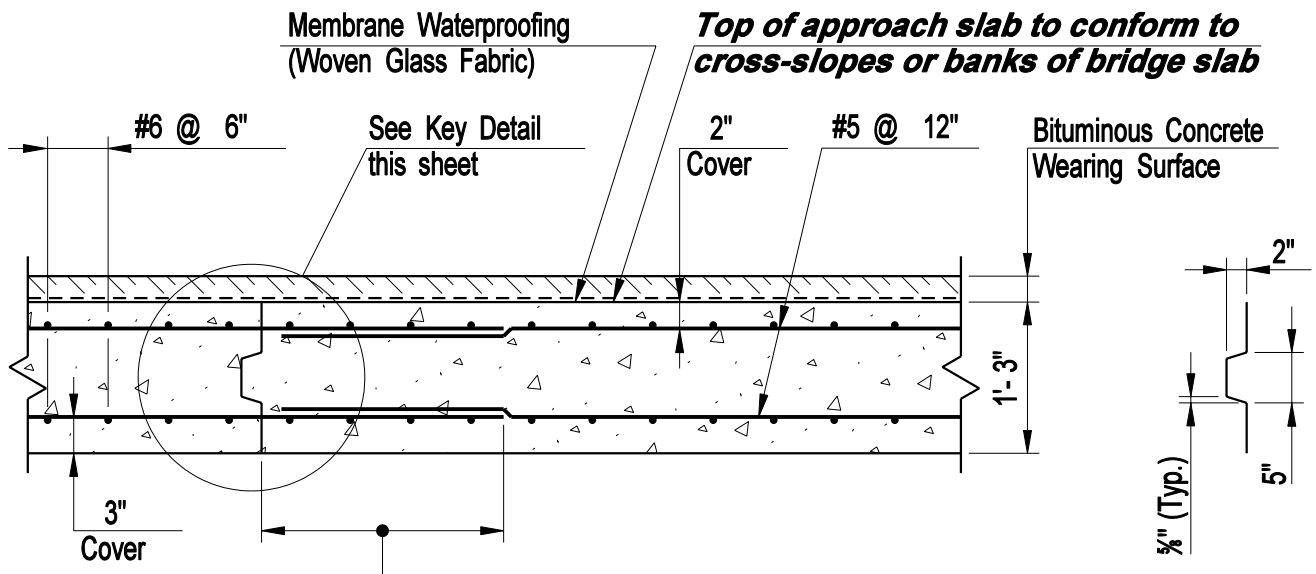
**CONNECTICUT  
BRIDGE DESIGN  
MANUAL**

**BRIDGE APPROACH  
SLAB DETAILS**

Issue Date: 10/03

Revision Date: 2/11

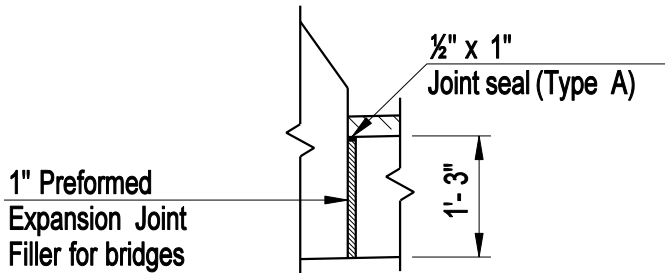
Plate Number:  
**6.4.3.a**



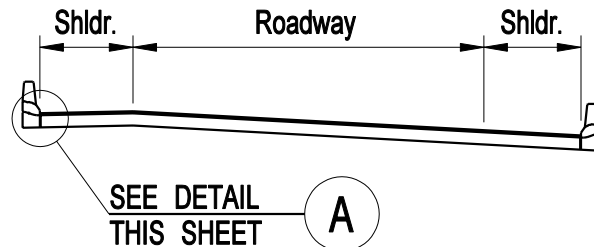
**2'- 0". At acute corners, eliminate splice and vary this length up to 12'- 0" to omit short bars in the adjacent slab.**

**KEY DETAIL**

**SECTION B**



**DETAIL A**

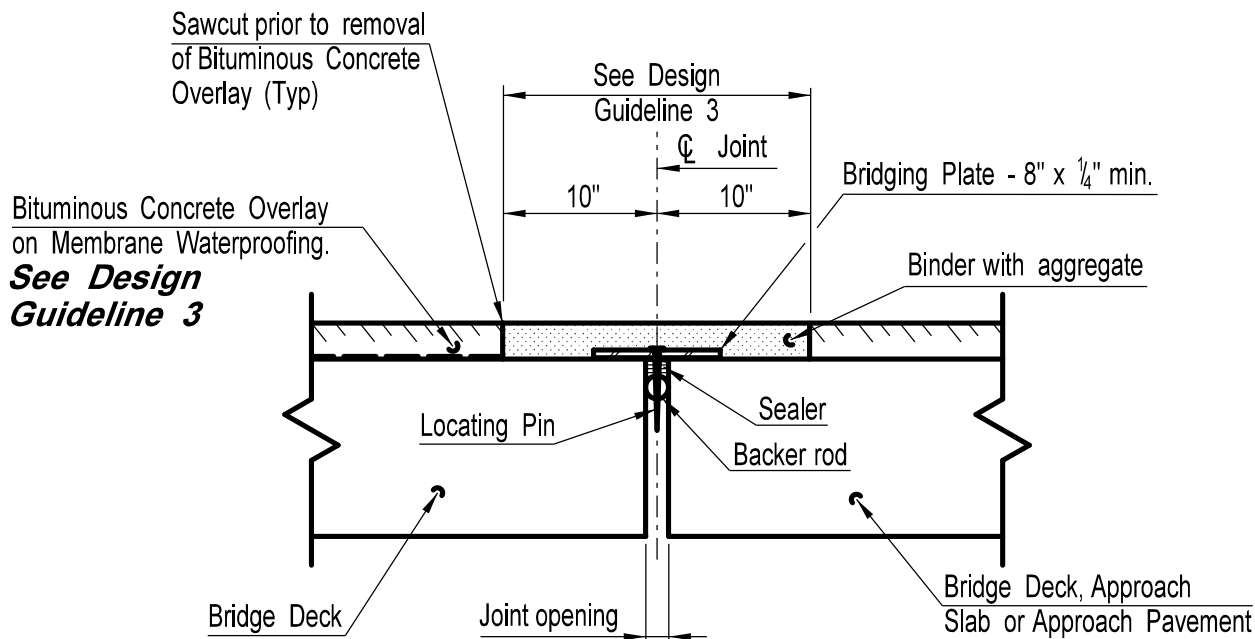


**SECTION A**

**DESIGN INFORMATION**

- 1. Reinforcing steel to be included in the item "Deformed Steel Bars (Epoxy Coated)."**
- 2. Concrete to be included in the item "Class "F" Concrete."**
- 3. This plate shall be used in conjunction with Plates 6.4.1 and 6.4.2.**





PLAN NOTES:

1. Remove new bituminous concrete overlay and membrane waterproofing. Replace with Asphaltic Plug Expansion Joint System. To be paid for under the item "Asphaltic Plug Expansion Joint System". (See Special Provision)

DESIGN GUIDELINES:

1. *Asphaltic Plug Expansion System shall be used at fixed and expansion joints with computed movements from 0" to 1½" based on a moderate climate in accordance with AASHTO.*
2. *Asphaltic Plug Expansion joints shall be installed when the ambient air temperature is between 40° F and 80° F.*
3. *Bituminous Concrete Overlay depth shall be indicated.*

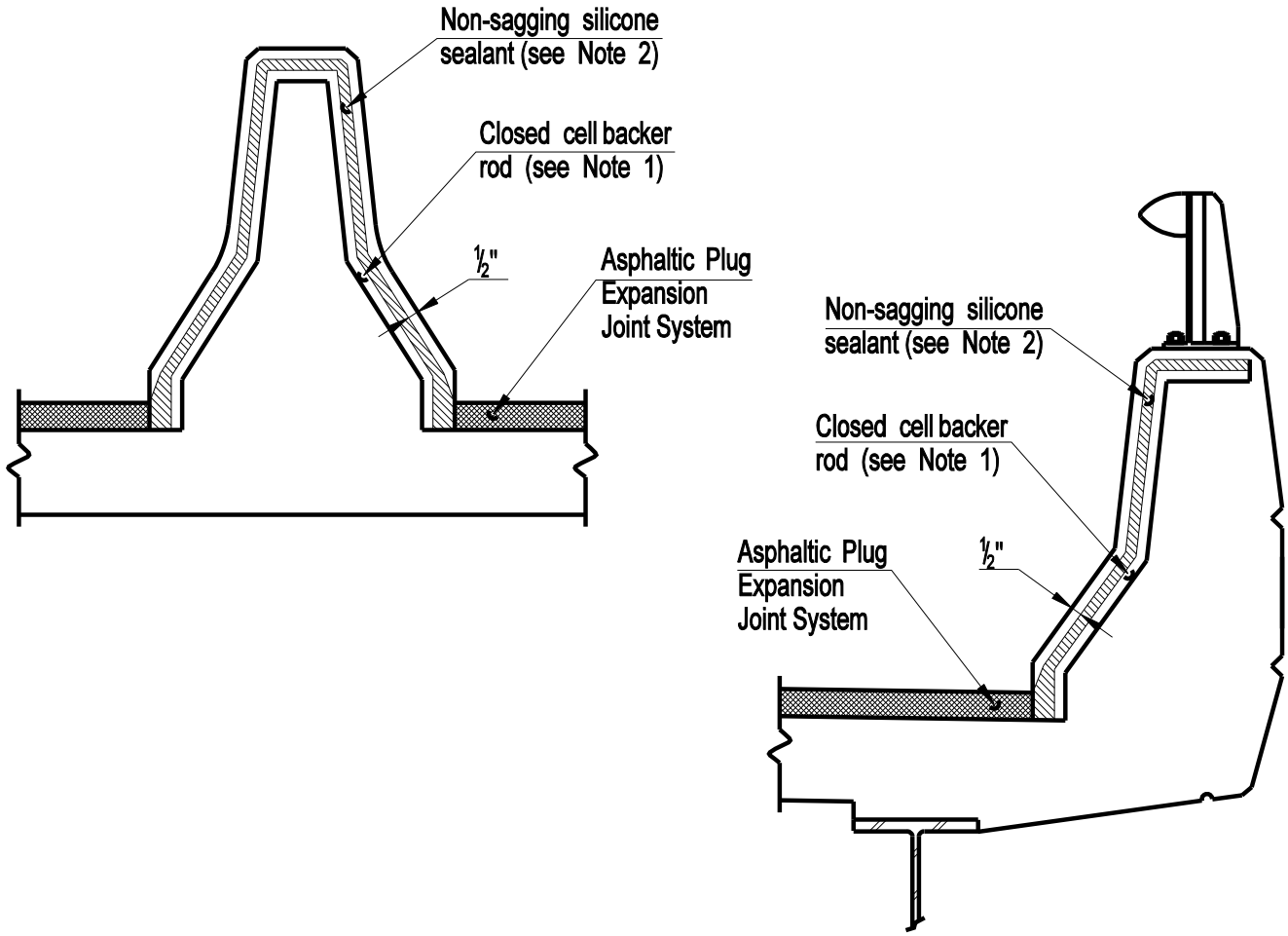
**CONNECTICUT  
BRIDGE DESIGN  
MANUAL**

ASPHALTIC PLUG  
EXPANSION JOINT SYSTEM

Issue Date: 10/05

Revision Date: 2/11

Plate Number:  
7.1.1a



**ASPHALTIC PLUG EXPANSION JOINT TREATMENT  
AT PARAPETS AND MEDIAN BARRIER**

**NOTES:**

- 1: The Closed Cell Backer Rod shall be placed a minimum of 2" from the outside face of parapets and median barriers.
- 2: The non-sagging silicone sealant shall be placed on the backer rod  $\frac{1}{2}$ " thick. At the gutter, the silicone sealant shall be placed flush with the outside face of concrete.
- 3: Prior to installing the silicone sealant, clean joint sides by sandblasting. Dust shall be removed by the method approved by the Engineer. This work shall be paid for under the item "Asphaltic Plug Expansion Joint System". (see special provisions)

**BRIDGE PLATES 7.2.1a THROUGH 7.2.1e DELETED, 04/19**

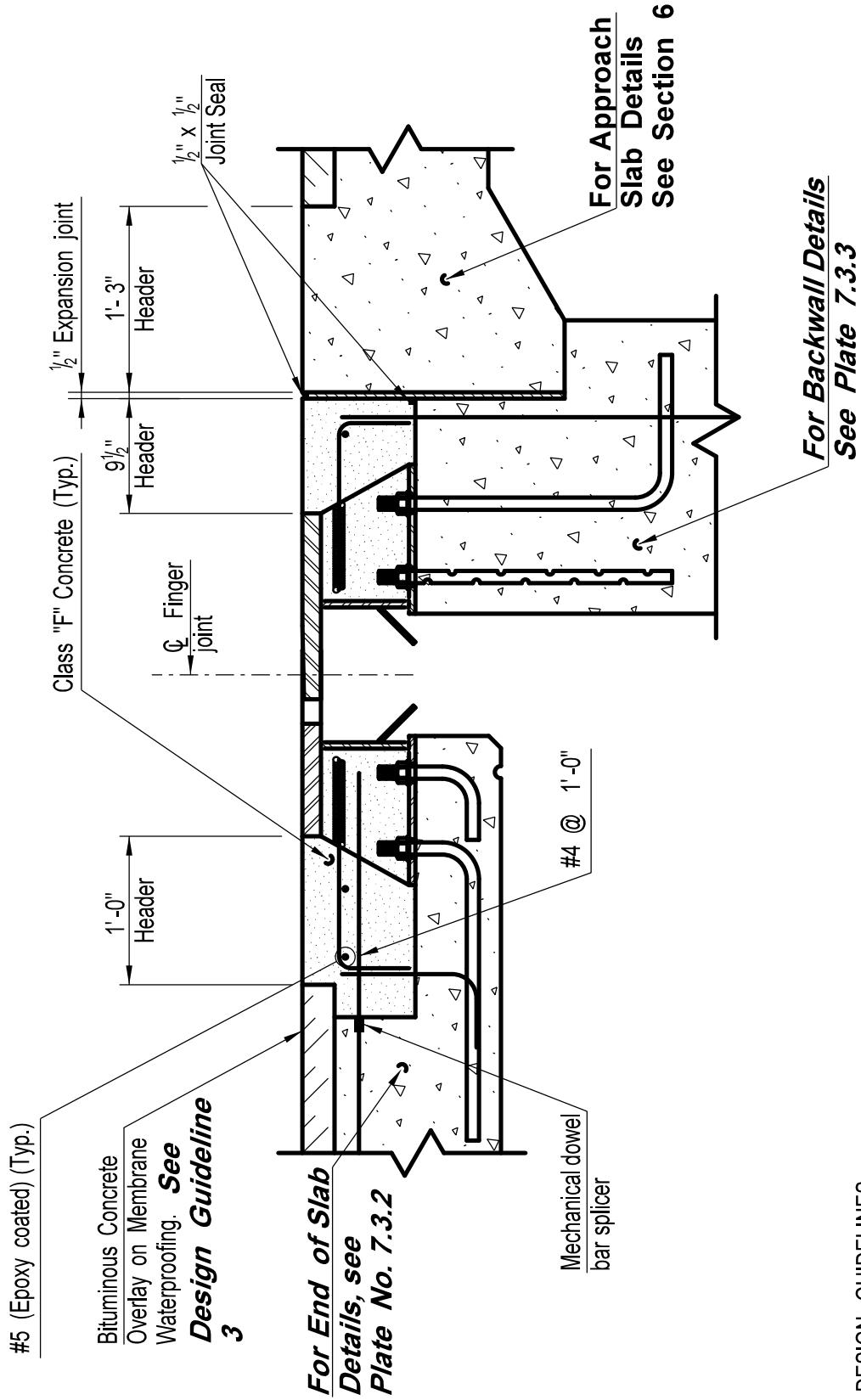
**CONNECTICUT  
BRIDGE DESIGN  
MANUAL**

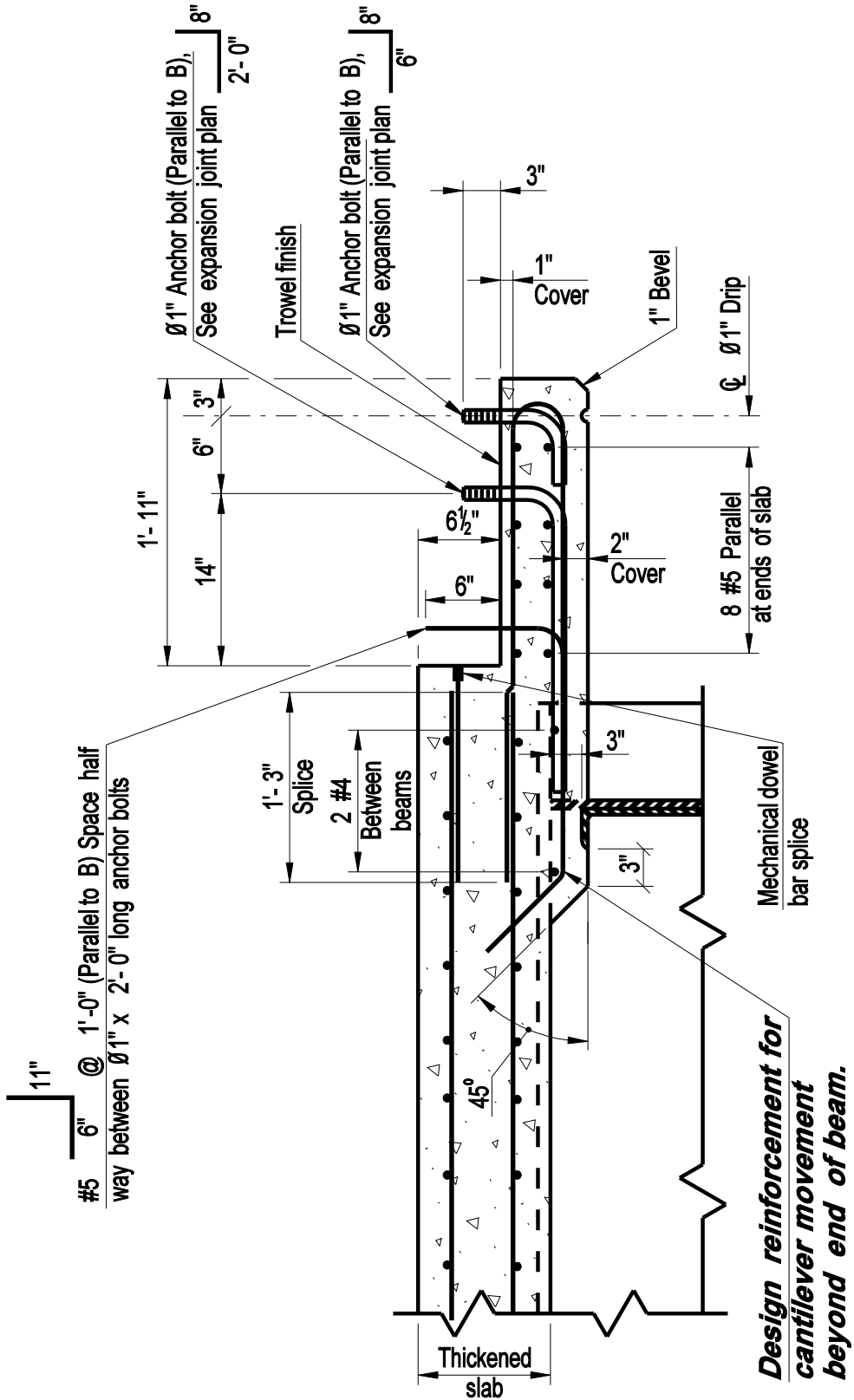
**ELASTOMERIC CONCRETE  
EXPANSION SYSTEM**

Issue Date: 10/03

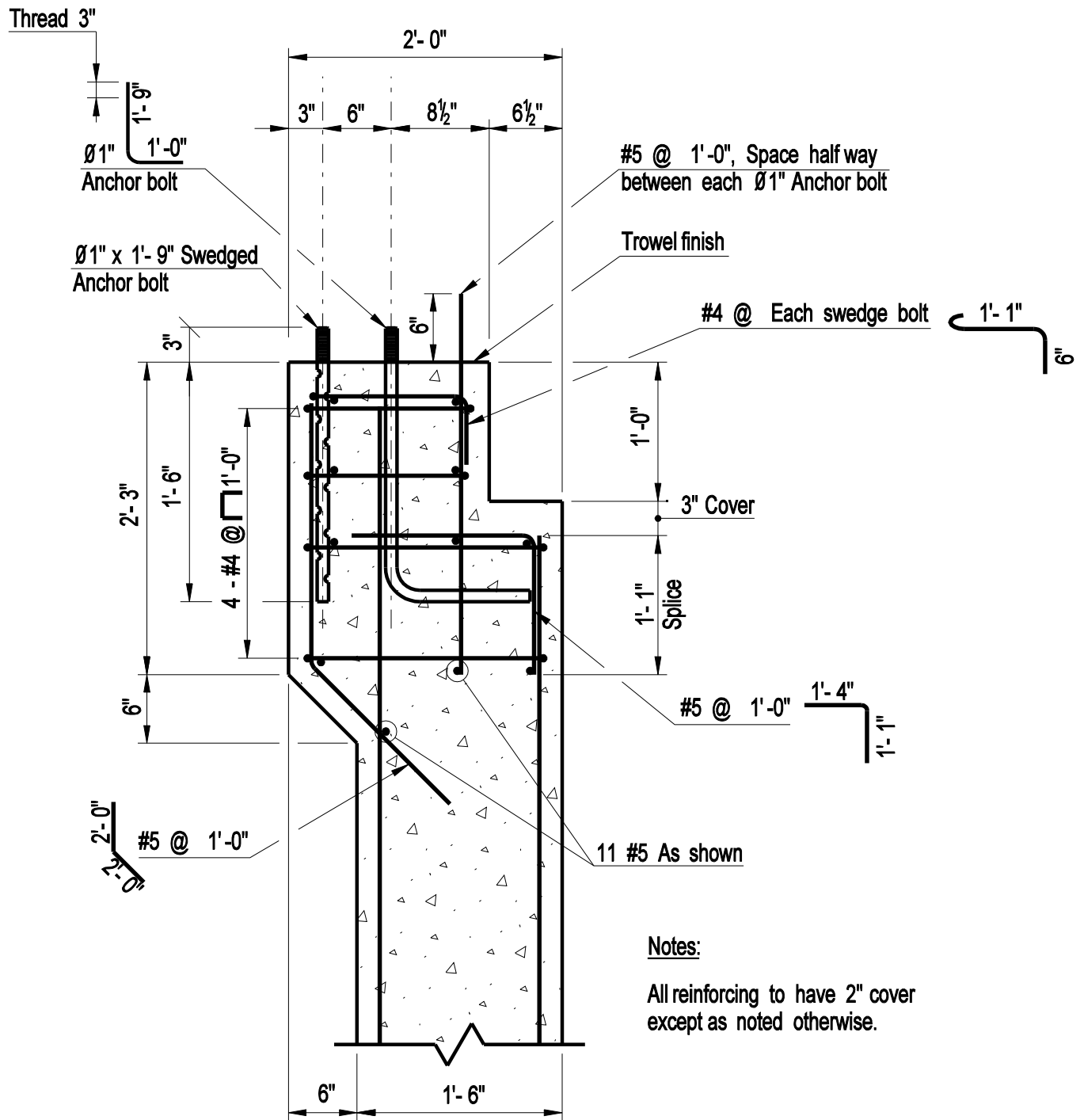
Revision Date: 04/19

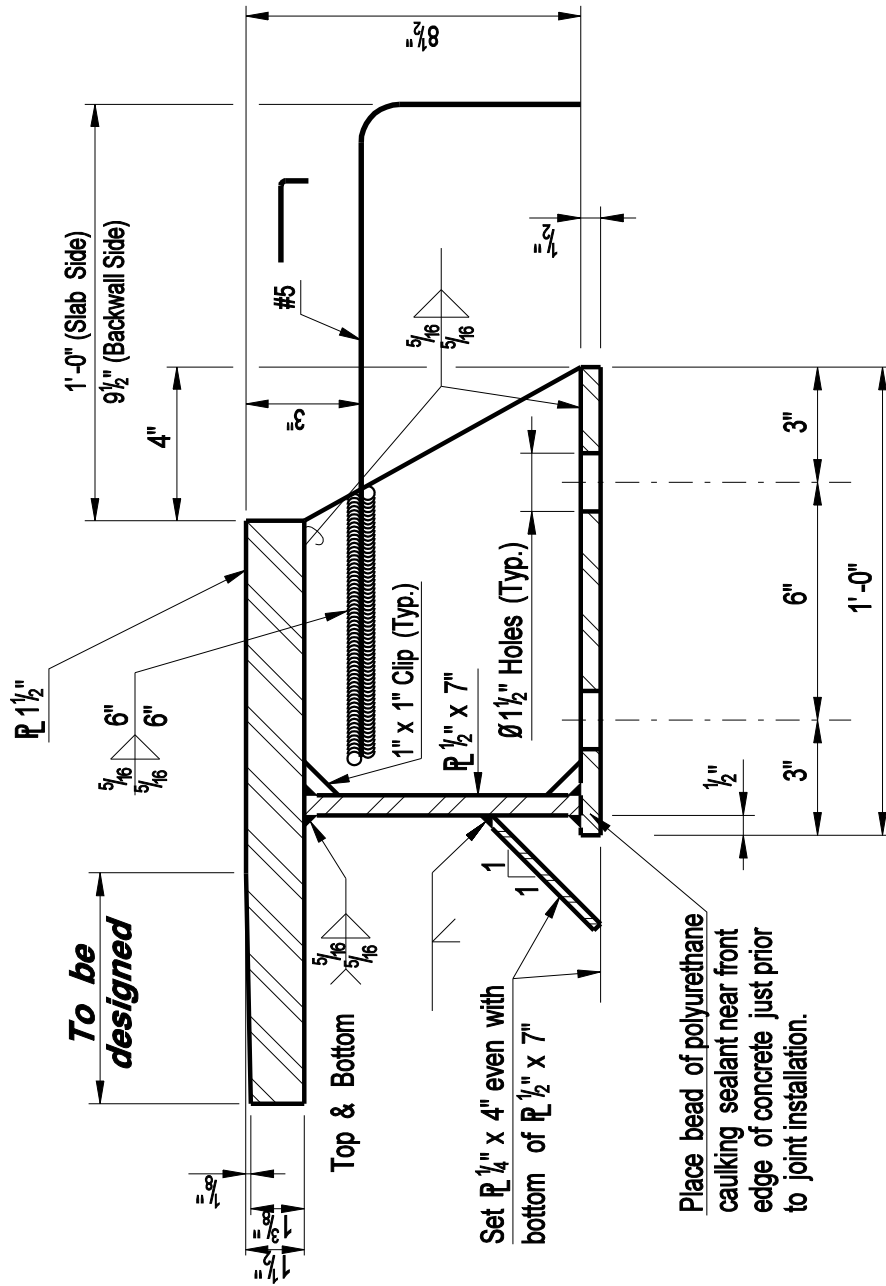
Plate Number:  
7.2.1a



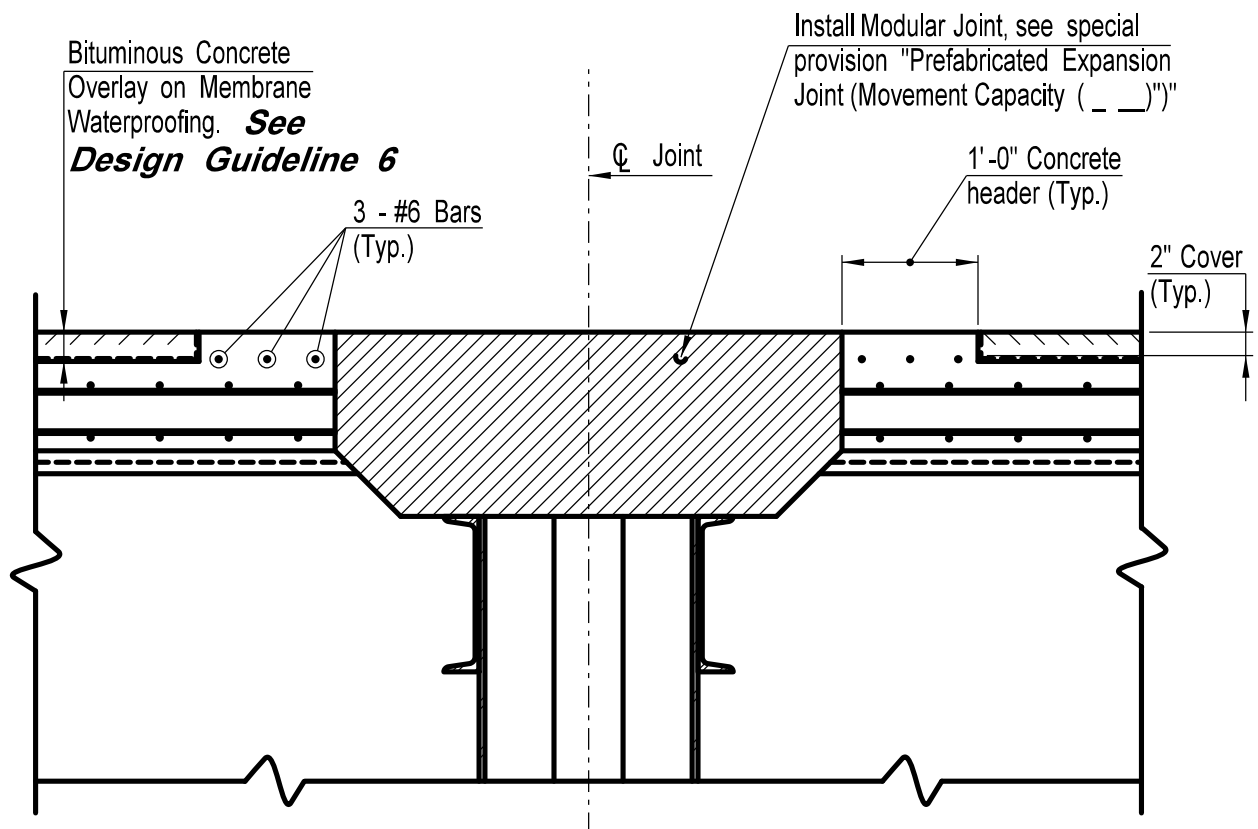


**SECTION AT END OF SLAB**





**SECTION AT FINGER JOINT**



TYPICAL SECTION

PLAN NOTES:

1. See special provision "Prefabricated Expansion Joint (Movement Capacity ( \_ \_ ))".

DESIGN GUIDELINES:

**1. The temperature range used for computation of movement shall be based on a moderate climate in accordance with AASHTO.**

**2. The required movement capacity of each joint shall be determined by the Designer and shown on the plans.**

**3. The contract plans shall show a blocked out area for the Modular Joint. The manufacturer will be responsible for the joint and anchorage details in accordance with the special provisions.**

**4. Modular joints should be used for joint movements greater than 4" at piers.**

**5. Depth of Bituminous Concrete overlay shall be indicated.**

**CONNECTICUT  
BRIDGE DESIGN  
MANUAL**

MODULAR EXPANSION  
JOINT SYSTEM

Issue Date: 10/03

Revision Date: 2/11

Plate Number:  
7.4.1



**BRIDGE PLATES 7.5.1a THROUGH 7.5.1e DELETED, 04/19**

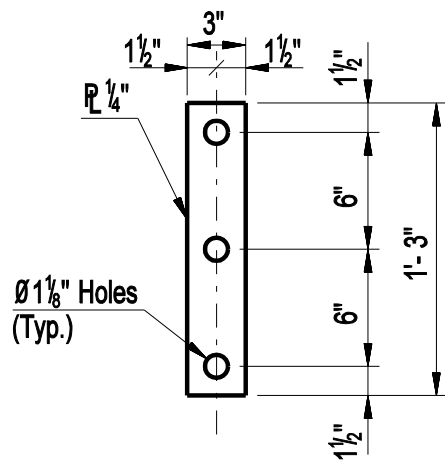
**CONNECTICUT  
BRIDGE DESIGN  
MANUAL**

**SILICONE  
EXPANSION  
JOINT SYSTEM**

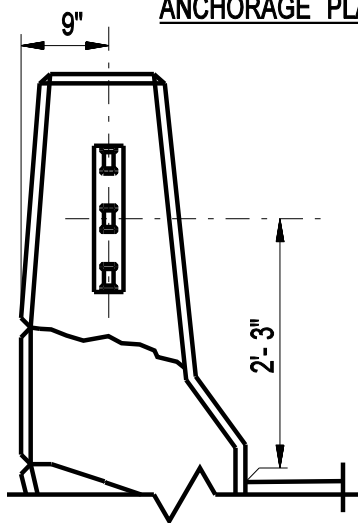
Issue Date: 10/03

Revision Date: 04/19

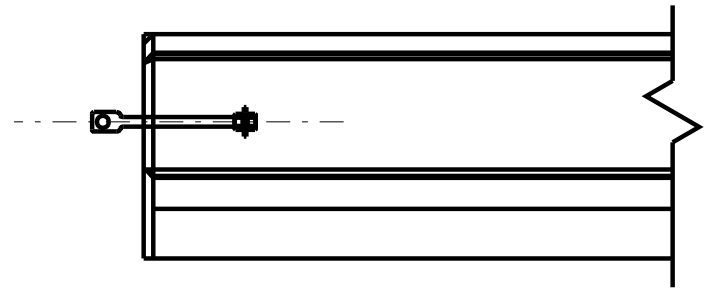
Plate Number:  
7.5.1a



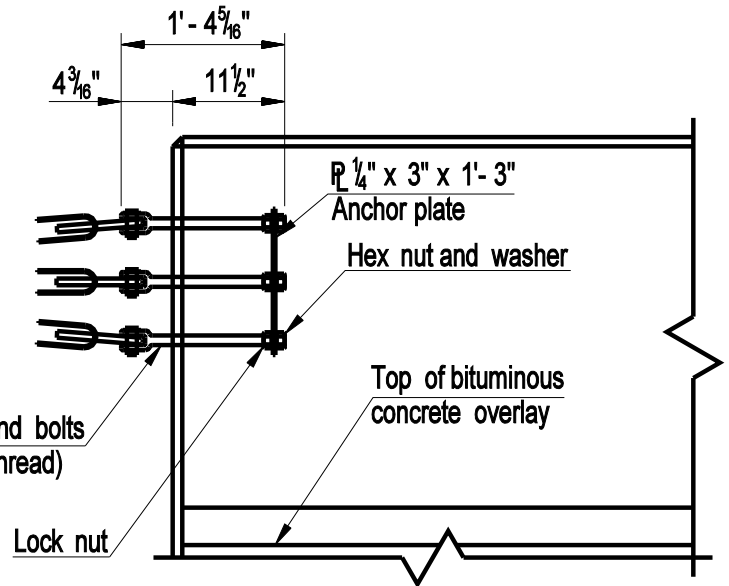
ANCHORAGE PLATE



END VIEW



PLAN



ELEVATION

Notes:

1. The shackle end bolts shall conform to the requirements of ASTM A688 Class E or AISI 1035 forged steel, galvanized in accordance with the requirements of ASTM A153.
2. The standard hex nuts, anchor plates and lock nuts shall conform to the requirements of ASTM A36.
3. Longitudinal reinforcement in parapet to clear anchor plate.
4. All anchorage material shall be paid for as part of the pay item "End Anchorage - Bridge Type" (Roadway Item).

DESIGN INFORMATION

*This detail to be used to anchor Three-Cable Guide Railing at trailing end of 3'-6" high parapets with sloped curb on one-way roads.*

**BRIDGE PLATES 8.3.2 THROUGH 8.3.3d DELETED, 12/19**

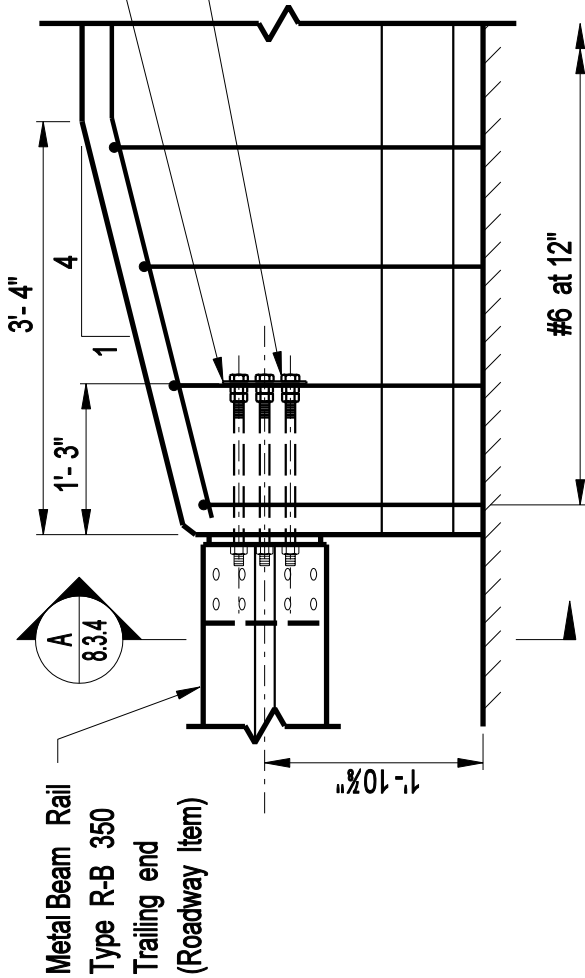
**CONNECTICUT  
BRIDGE DESIGN  
MANUAL**

PARAPET ANCHORAGE  
THREE CABLE GUIDE  
RAILING (Type II)

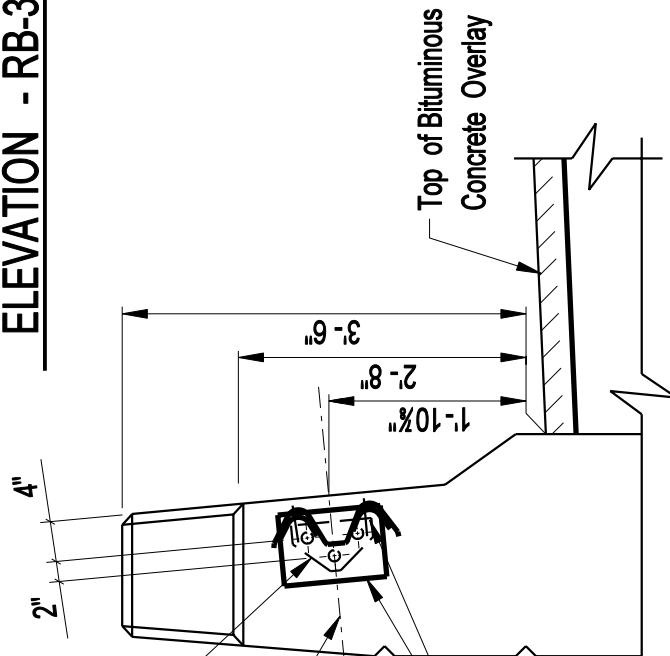
Issue Date: 10/03

Revision Date: 12/19

Plate Number:  
8.3.2



**ELEVATION - RB-350 RAIL**



**DETAIL  
ANCHORAGE PLATE**

1/2" anchorage plate. See Anchorage Plate Detail  
 Anchorage plate is to be set perpendicular to front parapet face.  
 Connection Plates See Roadway Dwgs.

**DESIGN INFORMATION:**  
*This detail to be used at trailing ends on uni-directional roadways only.*

**TRAILING END R-B 350 RAIL ATTACHMENT**

**BRIDGE PLATES 8.3.5a THROUGH 8.3.8 DELETED, 12/19**

**CONNECTICUT  
BRIDGE DESIGN  
MANUAL**

**SAFETY SHAPE TRANSITION FOR  
BEAM RAIL ATTACHMENT  
STANDARD PARAPET 32" HIGH  
LEADING END**

Issue Date: 10/03

Revision Date: 12/19

Plate Number:  
**8.3.5a**

PLAN NOTES:

1. Steel plates shall conform to the requirements of ASTM A36. The steel plates shall be hot-dip galvanized in accordance with the requirements of ASTM A123.
2. Anchor bolts shall conform to the requirements of ASTM A325, mechanically galvanized.
3. 1"  $\phi$  pipe shall conform to ASTM A53 Grade B or ASTM A501 and shall be galvanized in accordance with the requirements of ASTM A123.
4. Railway elements shall be paid for under the applicable Roadway items.
5. All rail anchorage material required for end attachments shall be paid for under the applicable Roadway items.

DESIGN INFORMATION

- 1. Beam rail notes to be included on construction plans with all beam rail attachment details.***

**BRIDGE PLATES 8.3.9a THROUGH 8.3.9d DELETED, 12/19**

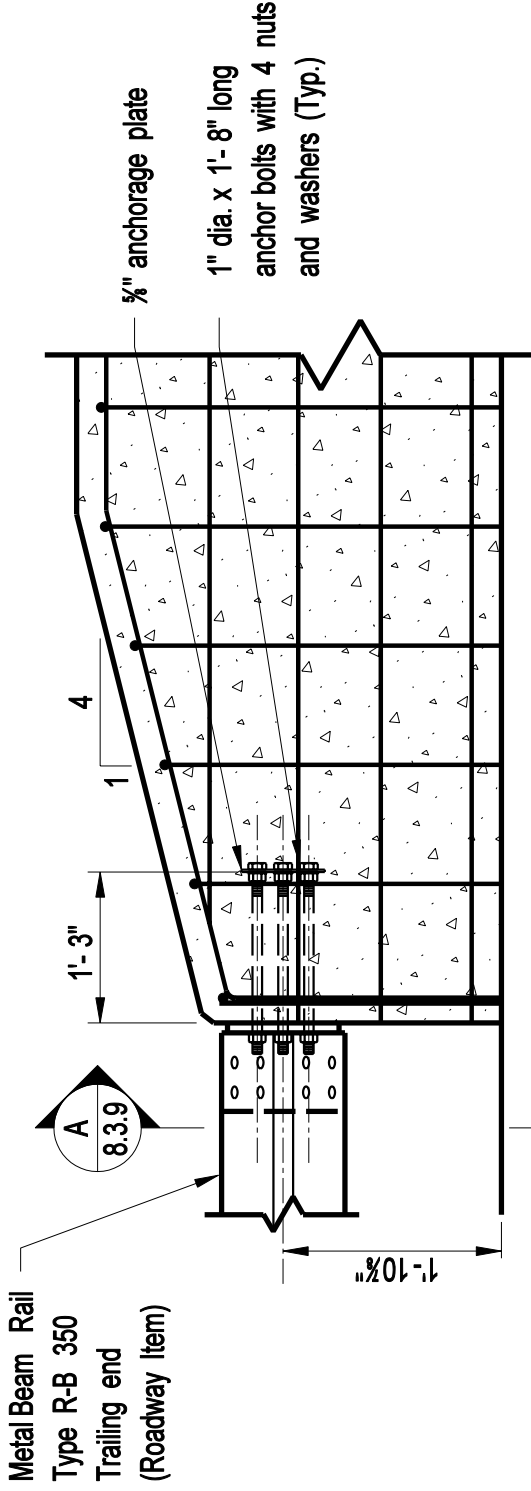
**CONNECTICUT  
BRIDGE DESIGN  
MANUAL**

BEAM RAIL ATTACHMENT FOR  
RECONSTRUCTED VERTICAL FACE  
PARAPET WITH SIDEWALK  
42" HIGH - LEADING END

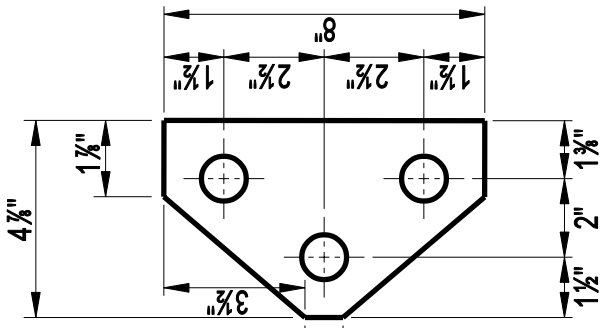
Issue Date: 10/03

Revision Date: 12/19

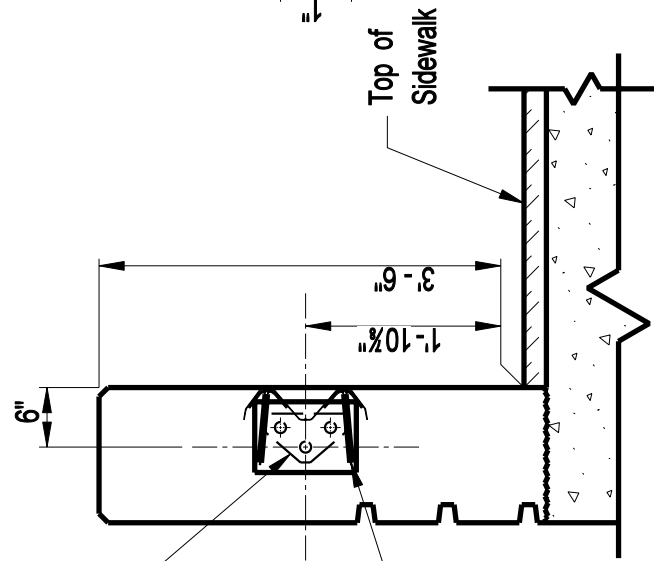
Plate Number:  
8.3.9a



**ELEVATION**



**ANCHORAGE PLATE  
DETAIL**



**SECTION B**

8.3.9a

Metal Beam Rail  
Type R-B 350  
Trailing end  
(Roadway Item)

3/8" anchorage plate  
1" dia. x 1'-8" long  
anchor bolts with 4 nuts  
and washers (Typ.)

3/8" anchorage plate.  
See Anchorage Plate  
Detail

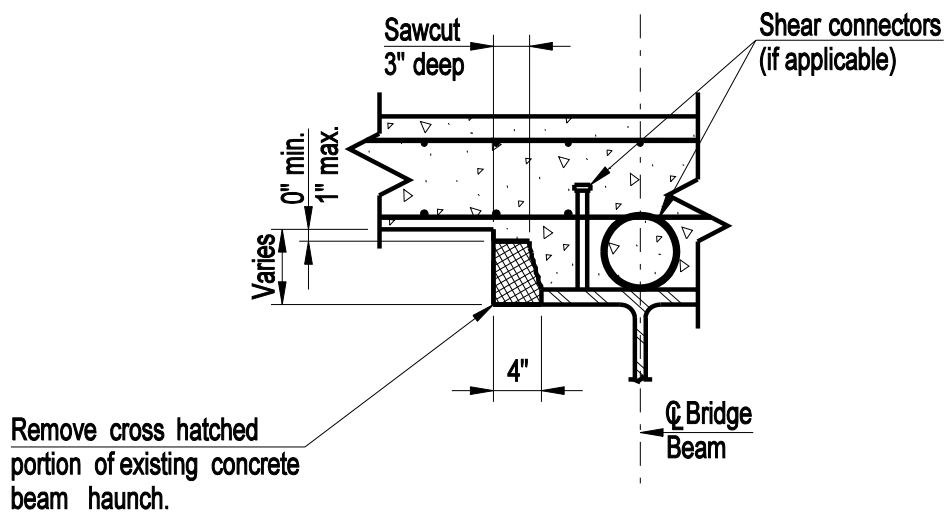
⊥ Anchorage plate is to  
be set perpendicular to  
front parapet face.

Connection Plates  
See Roadway Dwgs.

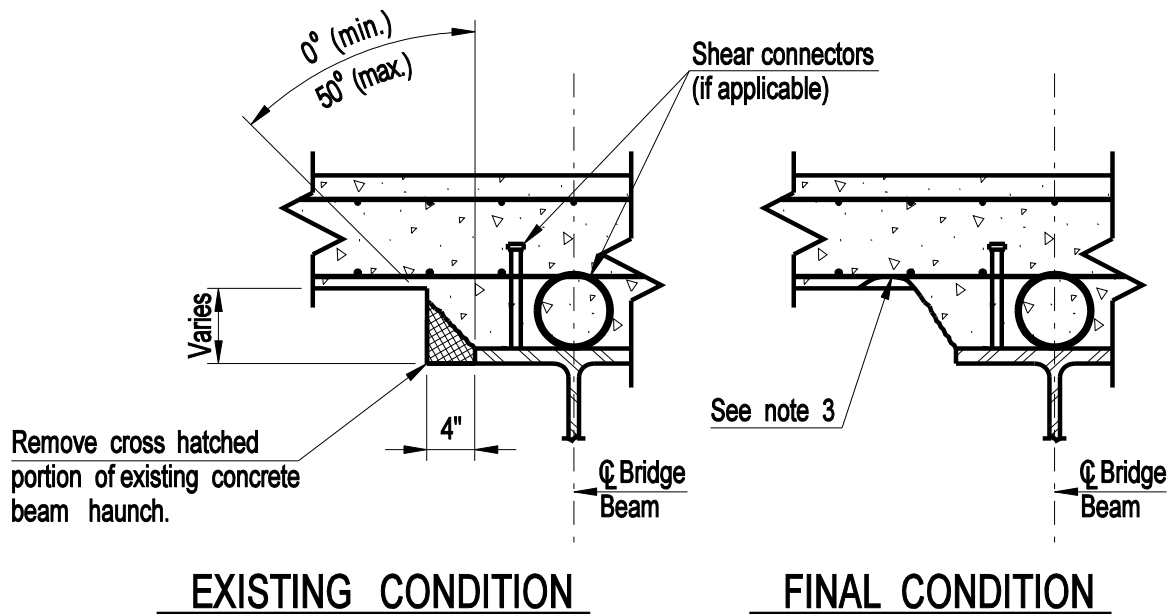
**DESIGN INFORMATION:**

*This detail to be used at  
trailing ends on uni-directional  
roadways only.*





### DETAILS FOR CONCRETE HAUNCH REMOVAL



### DETAILS FOR CONCRETE HAUNCH REMOVAL - INACCESSIBLE LOCATIONS\*

\* See Note 2

For notes and design information, see Plate 9.1.2.

**CONNECTICUT  
BRIDGE DESIGN  
MANUAL**

DETAILS FOR REMOVAL OF  
PORTION OF EXISTING  
CONCRETE HAUNCH

Issue Date: 01/05

Revision Date:

Plate Number:

9.1.1

NOTES:

1. The removal of the portion of the concrete haunch shown shall be paid for at the contract unit price per linear foot for "Concrete Haunch Removal"
2. This method to be used only in those areas having insufficient clearance for saw-cutting equipment such as above some diaphragms as ordered by the Engineer.
3. If over-removal results, apply two coats of epoxy resin to deck reinforcing steel exposed during haunch removal. All reasonable precautions shall be taken to avoid this condition.

DESIGN INFORMATION:

***This detail is to be included on contract plans for all existing bridges having this condition that pass over limited access highways within project limits. Other bridge applications such as limited access highway bridges over local roads and parking areas may be warranted but must be approved on a case-by-case basis.***

***The Designer shall indicate the limits of removal on the plans which will include all areas of haunches directly over travelways, shoulders and when approved, sidewalks and parking areas. Removal of haunches not over these areas will not be included regardless of their condition.***

***Quantities shall be computed separately for each beam edge.***

***Some fascia beams will require haunch removal on the inside face only, depending upon the design details of the existing conditions.***

**CONNECTICUT  
BRIDGE DESIGN  
MANUAL**

DETAILS FOR REMOVAL OF PORTION  
OF EXISTING CONCRETE HAUNCH  
NOTES

Issue Date: 01/05

Revision Date:

Plate Number:

9.1.2

**CONNECTICUT  
BRIDGE DESIGN  
MANUAL**

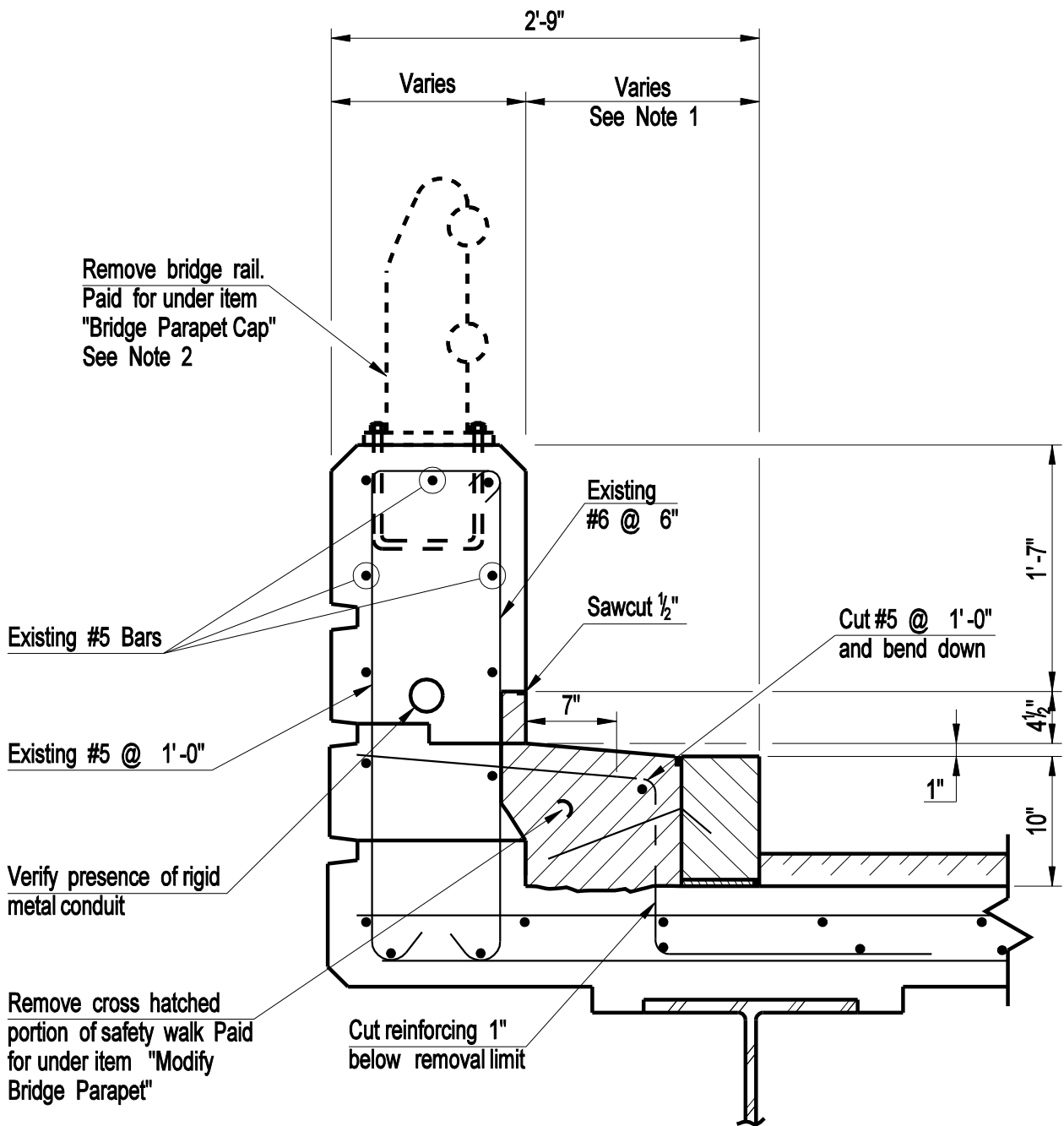
VACANT

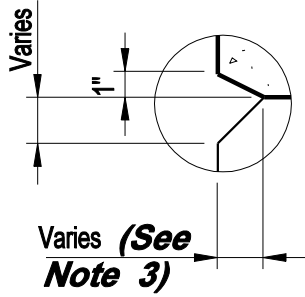
Issue Date:

Revision Date:

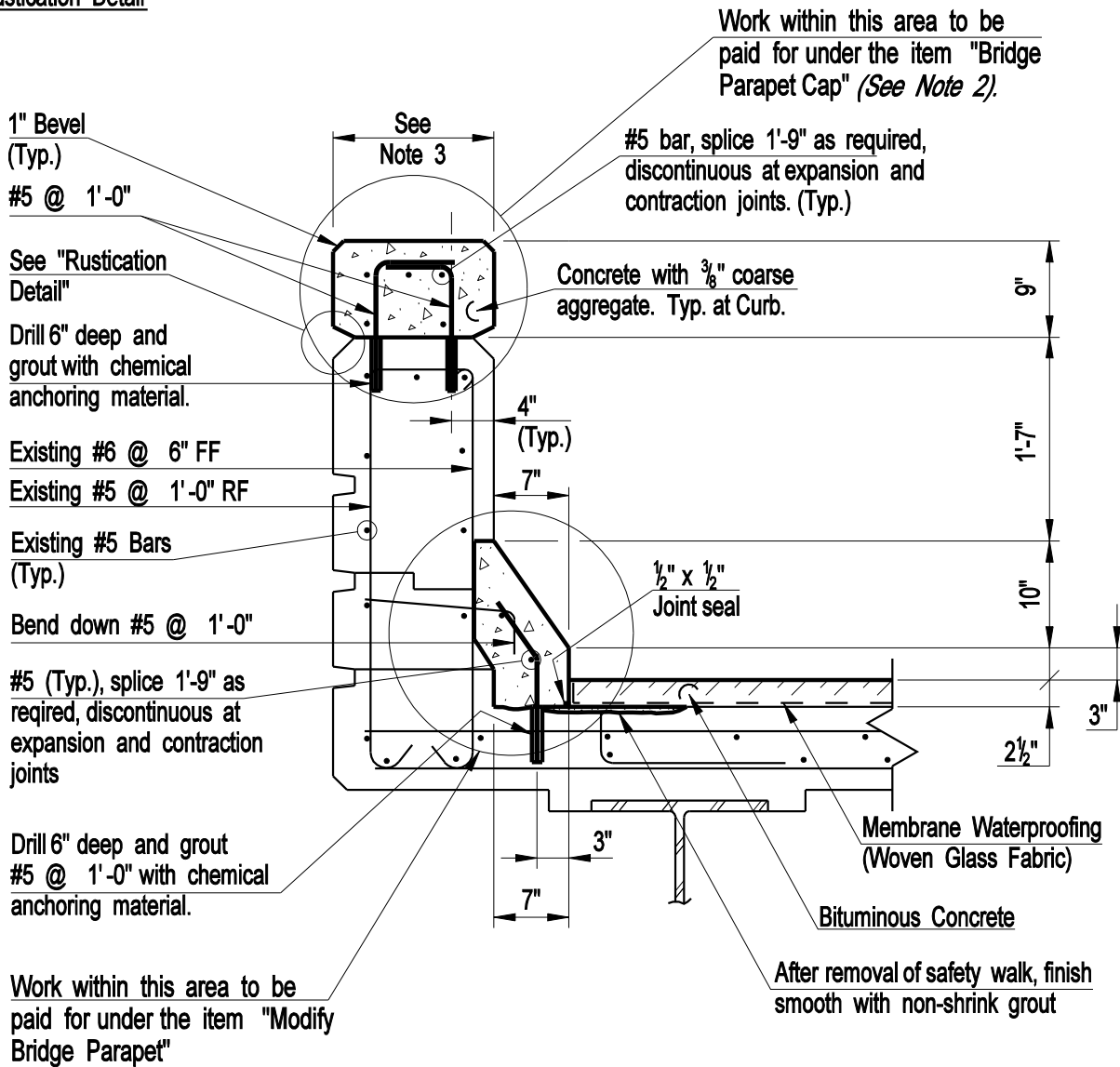
Plate Number:

9.2.1





Rustication Detail



PLAN NOTES:

1. The concrete for the parapet modifications shall be a portland cement concrete with a minimum  $f'_c = 4000$  psi, and shall be designed by the contractor
2. The reinforcement shall be uncoated and shall conform to ASTM A615, Grade 60.
3. Joints shall be formed in the sloped curb and the parapet cap at the joints between the bridge deck and wingwall parapets, at expansion joints in the bridge deck, at the expansion and contraction joints in the wingwalls. The joint width shall match that of the existing adjacent joint. No reinforcement shall pass through expansion or contraction joints.
4. The removal of the concrete safety curb, drilling and grouting dowels, furnishing and placing reinforcement and placing and finishing concrete for the reconstructed curbs shall be paid for under the item "Modify Bridge Parapet"
5. The removal and salvage of metal bridge rail (if specified for salvage), drilling and grouting dowels into the top of concrete parapets, furnishing and placing of reinforcement and placing concrete for the reconstructed parapet caps shall be paid for under the item "Bridge Parapet Cap".
6. Diameter of the drilled holes shall be per the chemical anchor manufacturer's instructions.
7. Removal of any existing curb plates in the safety walk shall be paid for under the item "Modify Bridge Parapet"

DESIGN INFORMATION:

- 1. Parapet curb modifications are to be done where safety walk or brush curb width exceeds 6". Brush curbs with width 6" or less shall not be modified.**
- 2. Metal bridge rails are to be replaced with concrete parapet caps on limited access highways only. On non-limited access roads, deteriorated metal bridge rails are to be replaced with appropriate new metal bridge rail.**
- 3. New "Bridge Parapet Cap" to match the width of existing parapet. Rustication depth is to match the dimension of existing chamfer at top of parapet.**

**CONNECTICUT  
BRIDGE DESIGN  
MANUAL**

VACANT

Issue Date:

Revision Date:

Plate Number:  
10.1.1

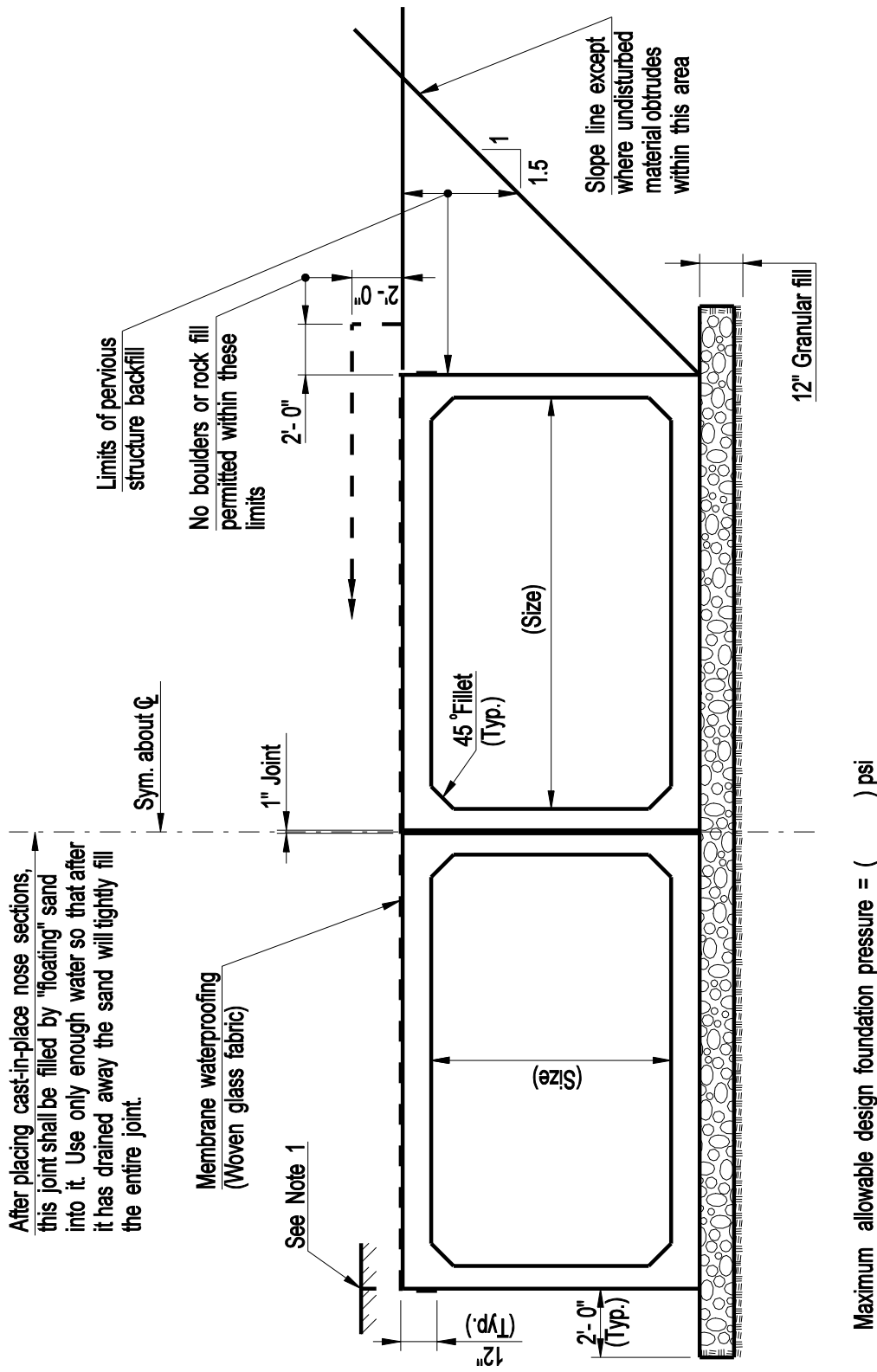
**PRECAST BOX CULVERT  
TYPICAL SECTION**

Issue Date: 10/03

Revision Date:

Plate Number:

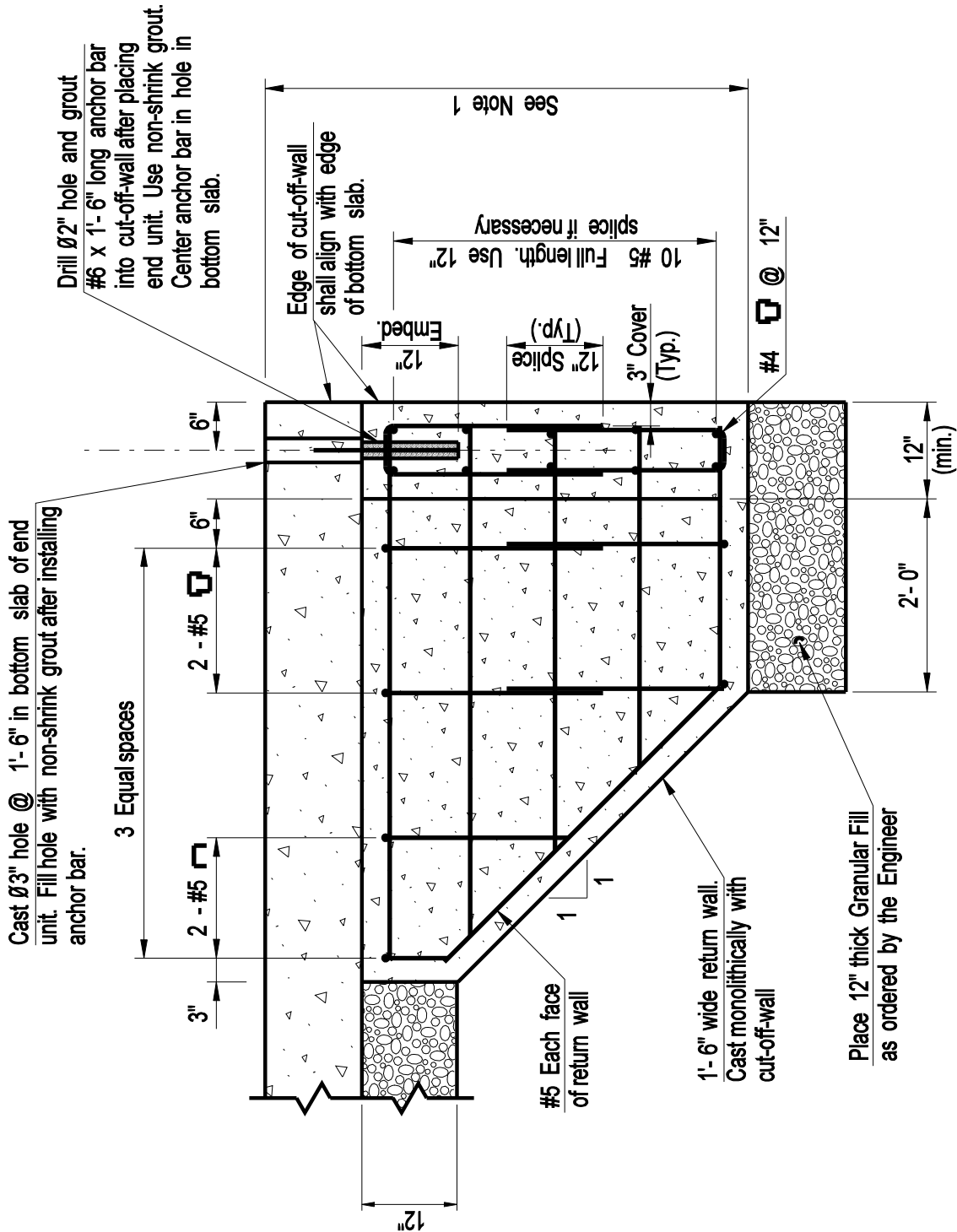
10.1.2



**NOTE:**

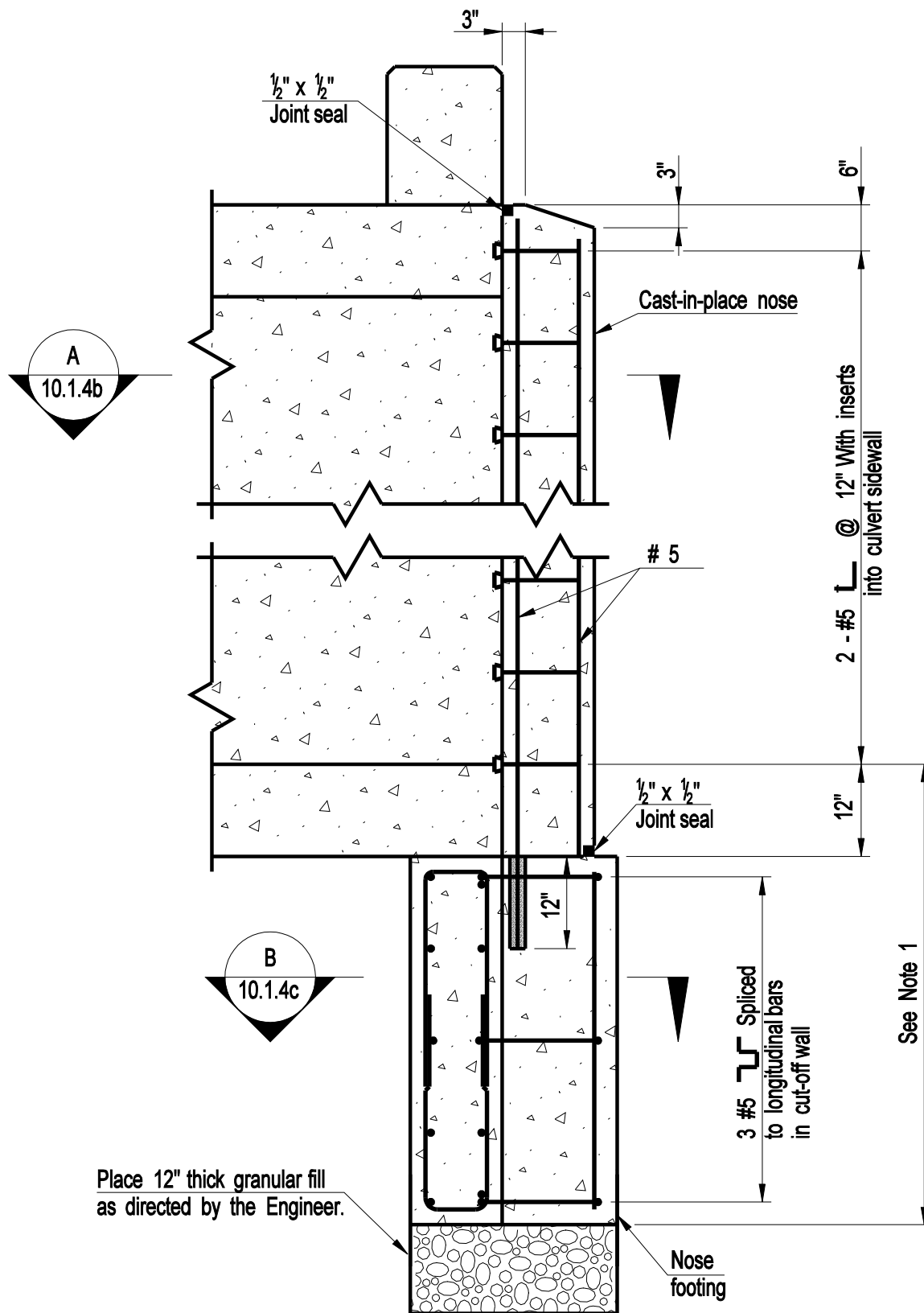
1. Cut overlay with a  $\frac{3}{8}$ " x  $1\frac{3}{4}$ " deep kerf and fill with a pourable sealant when cover is less than 2'-0" (from top of box to wearing surface). Cost of cutting and sealing to be paid for at the contact unit price for "Sawing and Sealing Joints".





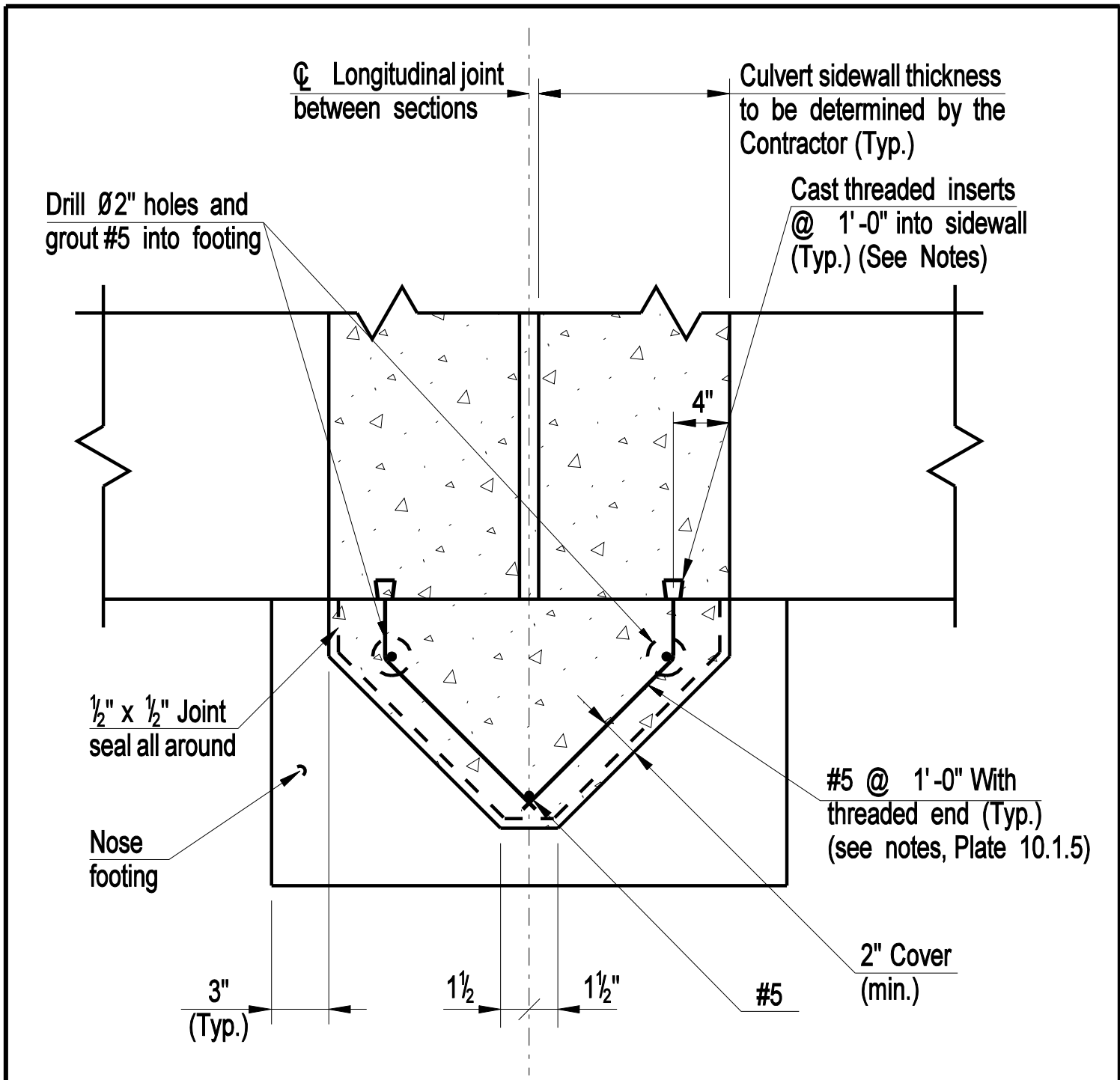
**NOTES:**

1. Bottom of cutoff wall and return walls shall be a minimum of 4'-0" below stream bed or 2'-0" below the bottom of culvert, whichever is greater.

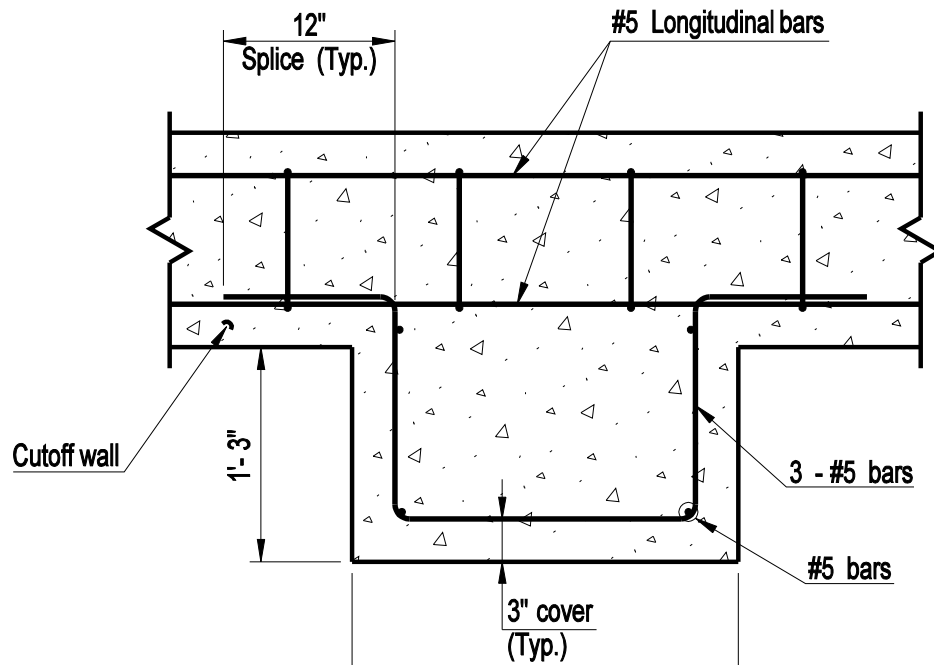


**NOTES:**

1. Bottom of cutoff wall and return walls shall be a minimum of 4'-0" below stream bed or 2'-0" below the bottom of culvert, whichever is greater.



SECTION A  
10.1.4a

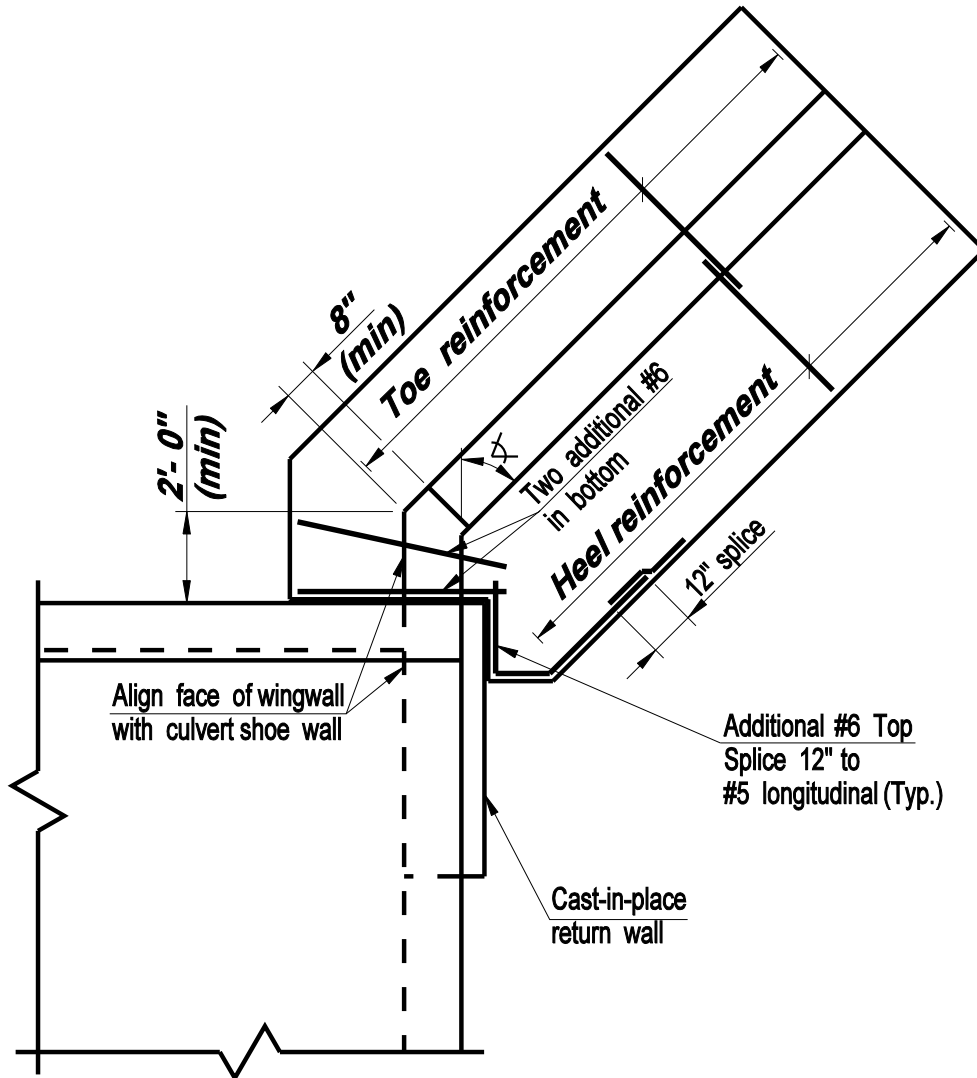


Build-out width to be determined by the Contractor. Provide dimensions for reinforcing on shop plans.

SECTION B  
10.1.4a

Notes:

1. The Contractor shall design, manufacture and construct Precast Box Culvert in accordance with the special provisions for "Precast Concrete Box Culvert" and the inside dimensions, length and details shown on these plans.
2. All inserts or holes cast into the culvert sections for the sole purpose of handling and setting the units shall be grouted over to a smooth finish upon completion of the work.
3. Non-shrink grout shall be used to grout the reinforcement.
4. The cost of furnishing and installing inserts shall be included in the item "11'- 0" x 9'- 0" Precast Concrete Box Culvert" and shall be one of the following:
  1. Star Expansion Industries Corp. Type P-35-T
  2. Richmond Screw Anchor Co. Type LF
  3. Dayton Superior Corp. Type F-57All inserts shall have a corrosive resistant coating.
5. The #5 bars with threaded end shall be compatible with the threaded inserts (see note 4). Threads shall be long enough to fully engage the inserts. The threaded bars shall conform to the requirements of ASTM A615, Grade 60.
6. All reinforcement to have 2" cover unless otherwise noted.



**CONNECTICUT  
BRIDGE DESIGN  
MANUAL**

VACANT

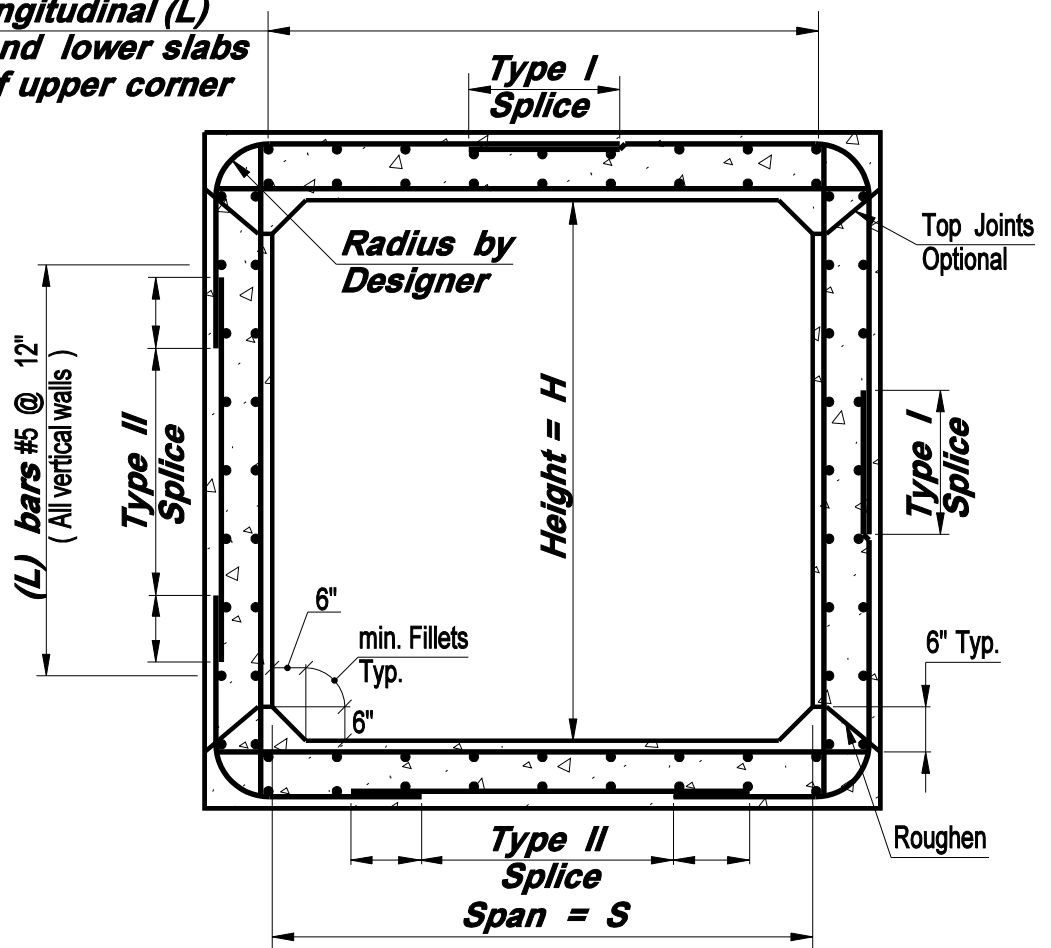
Issue Date:

Revision Date:

Plate Number:

10.1.7

**NOTE: Outer longitudinal (L) bars in upper and lower slabs shall be 35% of upper corner steel.**



**DESIGN INFORMATION:**

**Minimum thickness of top and bottom slab and sidewalls to be 12".**

**All bars shall have 2" cover except at bottom of lower slab where cover shall be 3". Where structure is exposed to the action of salt water, all cover shall be 4".**

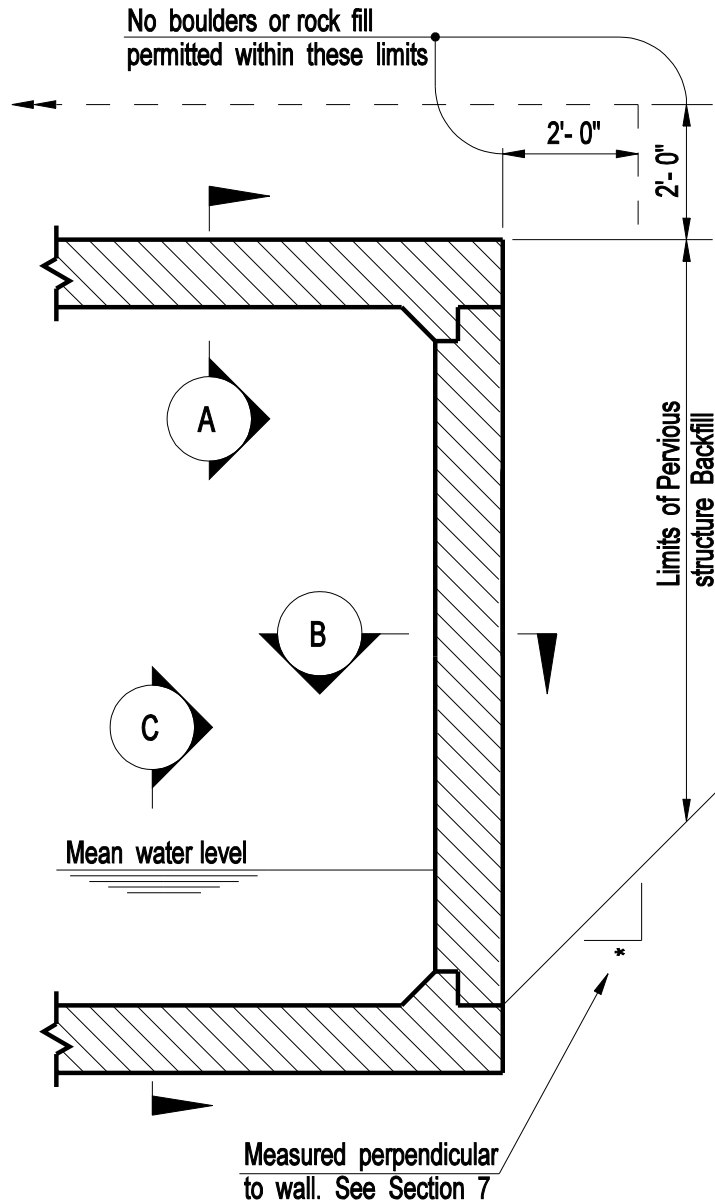
**Minimum bar requirements shall be #5 at 12".**

**Location of lap splices shall conform to either type (Type I or Type II) shown above. Lapped splices and development lengths shall be determined by the designer in accordance with latest AASHTO design criteria.**

**When the fill on the box is less than 2'- 0", the longitudinal (L) bars in the lower face of the top slab shall be a percentage of the main reinforcing steel required for positive moments as given in the latest AASHTO design criteria.**

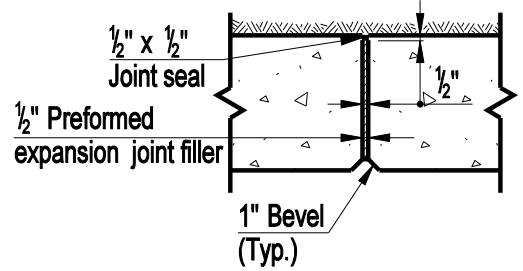
**Provisions for fishway may be required in bottom slab.**



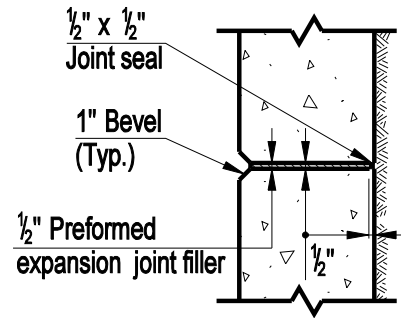


 = Indicates 1/2" preformed expansion joint filler

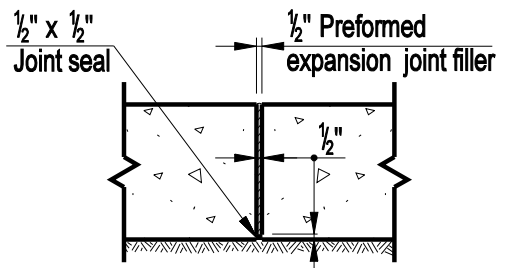
**PARTIAL SECTION THRU CULVERT AT EXPANSION JOINT**



**SECTION A**



**SECTION B**



**SECTION C**

**DESIGN INFORMATION:**

*The spacing of expansion joints in the culvert shall not exceed 30'- 0".*