

---

# ***CONNECTICUT DEPARTMENT OF TRANSPORTATION***



("The Charter Oak" Charles D. Brownell, 1857)

## ***HIGHWAY DESIGN MANUAL Revised October 2023***

***(U.S. Customary Units)***

---

## PREFACE

The *Connecticut Highway Design Manual* has been developed to provide uniform design practices for preparing roadway plans. The *Manual* presents most of the information normally required in the design of a typical highway project. The highway designer should attempt to meet all criteria presented in the *Manual*; however, the *Manual* should not be considered a standard that must be met regardless of impacts. The highway designer must consider the social, economic or environmental impacts that result from the design values selected. The highway designer should develop solutions that meet the Department's operational and safety requirements while preserving the aesthetic, historic or cultural resources of an area. The Department has designated certain highways or segments of highways that abut significant natural or cultural features as Scenic Highways. Designers must exercise good judgment on individual projects and, frequently, they must be imaginative, innovative and flexible in their approach to highway design. Designers are reminded that the projects they work on are not just Department projects, but everyone's project.

The Department has developed alternative design standards for bridge rehabilitation projects under the Local Bridge Program. These alternative design standards may be applied to municipally maintained bridges on facilities that are functionally classified as "Rural Local Roads," "Rural Minor Collectors" or "Urban Local Streets."

The Department of Transportation wishes to thank the following organizations for their assistance during the development of this *Manual*:

- Federal Highway Administration,
- Council of Small Towns,
- Rural Development Council,
- Connecticut Trust for Historic Preservation,
- Councils of Elected Officials,
- Regional Councils of Government,
- Regional Planning Agencies, and
- Connecticut Council on the Arts.

## FOREWORD

Connecticut is blessed with an exceptionally strong sense of time and place, its bustling towns and quiet villages linked by a web of roads, some of which began before the coming of Columbus as trails and paths linking Indian settlements. Whether local resident or visitor to the State, drivers know the experience of the journey can be a lot more than just getting from one point to the next.

The Connecticut landscape is one of great diversity. There are very few places in the country where you can see such varied and distinctive landscapes, all within a two-hour drive. Connecticut has mountainous and rolling uplands dropping down to broad agricultural plateaus, dissected by rocky, fast-moving streams. Connecticut has broad and fertile river valleys framed by distinctive landforms that have supported most of the urban population for its recent history. Connecticut has distinctive coastal plains separated by rocky outcrops and extensive salt marshes.

Beyond exceptional natural land forms, the State is blessed with a similar range of diversity in the ways people have inhabited the land. As was the case along much of the eastern seaboard, people settled Connecticut in a series of episodes that adapted to conditions of the land and changes in technology. For the first 120 or so years, the economy was agrarian, and the landscape was covered with small farms and homesteads. As technology evolved and industrialization began, these forms shifted and urban centers developed.

There are scenic places in both of these landscape types. Within the urban regions, the scenic qualities are a result of tenacious efforts by citizens to preserve what is left of the visible links between the land and people. Here, the scenic qualities are a result of relative scarcity. In the more rural regions, the scenic qualities are a result of tenacious efforts at making a living from the land. Scenic qualities are a result of continuous stewardship and care.

The rich heritage of Connecticut needs to continue. Highway and bridge engineers, amongst many others, are key players in achieving this goal. Engineers have the challenge to not only maintain and upgrade the transportation system to meet the operational and safety needs of the Department, but also to minimize the environmental, historic, cultural, aesthetic, social and economic impacts.

# ***CONNECTICUT HIGHWAY DESIGN MANUAL***

## **TABLE OF CONTENTS**

Preface

Foreword

Table of Contents

Date of Revisions

Chapter One .....	<i>MANUAL USAGE</i>
Chapter Two .....	GEOMETRIC DESIGN OF EXISTING HIGHWAYS (3R Non-Freeway Projects)
Chapter Three .....	GEOMETRIC DESIGN OF EXISTING HIGHWAYS (Freeway Projects)(Spot Improvements) (Preservation/Preventive Maintenance Projects)
Chapter Four .....	RURAL HIGHWAYS AND ROADS (New Construction/Reconstruction)
Chapter Five.....	URBAN HIGHWAYS AND STREETS (New Construction/Reconstruction)
Chapter Six .....	DESIGN CONTROLS
Chapter Seven .....	SIGHT DISTANCE
Chapter Eight .....	HORIZONTAL ALIGNMENT
Chapter Nine.....	VERTICAL ALIGNMENT
Chapter Ten .....	CROSS SECTIONS
Chapter Eleven.....	INTERSECTIONS AT-GRADE
Chapter Twelve.....	INTERCHANGES
Chapter Thirteen.....	ROADSIDE SAFETY
Chapter Fourteen.....	MAINTENANCE AND PROTECTION OF TRAFFIC THROUGH CONSTRUCTION ZONES



***CONNECTICUT HIGHWAY DESIGN MANUAL***

**TABLE OF CONTENTS**

(Continued)

Chapter Fifteen .....SPECIAL DESIGN ELEMENTS

Glossary

Index

## LIST OF SECTIONS SHOWING LATEST DATE OF REVISIONS

### ORIGINAL ISSUE DATE IS DECEMBER 2003

<u>Section Number</u>	<u>Date</u>	<u>Section Number</u>	<u>Date</u>
1-1.0	January 2023	2-4.0	
1-1.01	January 2023	2-4.01	
1-1.02	January 2023	2-4.02	
1-1.03	January 2023	2-4.03	
1-1.03.01	January 2023	2-5.0	
1-1.03.02	January 2023	2-5.01	
1-1.03.03	January 2023	2-5.02	October 2023
1-1.03.04	January 2023	2-6.0	
1-1.03.05	January 2023	2-6.01	
1-1.03.06	January 2023	2-6.02	
1-1.04	January 2023	2-6.03	
1-2.0		2-7.0	
1-2.01		2-7.01	January 2023
1-2.02		2-7.02	January 2023
1-2.03		2-7.02.01	January 2023
1-2.04		2-7.02.02	January 2023
1-2.05		2-7.03	
1-2.06		2-7.04	
1-2.07		2-8.0	
1-2.08	December 2006	2-8.01	
1-2.09		2-8.02	January 2023
1-2.10		2-9.0	
1-2.11		2-9.01	
1-2.12		2-9.01.01	January 2023
1-2.13		2-9.01.02	January 2023
1-2.14		2-9.02	January 2023
1-2.15		2-10.0	
2-1.0	January 2023	2-10.01	
2-2.0		2-10.02	January 2023
2-2.01		2-10.03	
2-2.02		2-10.04	
2-2.03	January 2023	2-11.0	January 2023
2-2.04		3-1.0	January 2023
2-2.05	January 2023	3-1.01	January 2023
2-3.0		3-1.02	
Figure 2-3A		3-1.03	January 2023
Figure 2-3B		3-1.04	
Figure 2-3C		3-1.04.01	
Figure 2-3D		3-1.04.02	January 2023
Figure 2-3E	January 2023	3-1.04.03	January 2023
Figure 2-3F	January 2023	3-1.04.04	January 2023
Figure 2-3G	January 2023	3-1.04.05	
Figure 2-3H	January 2023	3-1.04.06	
Figure 2-3I	January 2023	3-2.0	

## LIST OF SECTIONS SHOWING LATEST DATE OF REVISIONS

### ORIGINAL ISSUE DATE IS DECEMBER 2003

<u>Section Number</u>	<u>Date</u>	<u>Section Number</u>	<u>Date</u>
3-2.01	January 2023	6-2.01	October 2023
3-2.02	January 2023	6-2.02	
3-2.03	January 2023	6-2.03	
3-3.0	January 2023	6-3.0	
3-3.01	January 2023	6-3.01	
3-3.02	January 2023	6-3.02	
3-3.02.01	February 2013	6-3.03	
3-3.02.02	January 2023	6-4.0	
Figure 4A		6-5.0	January 2023
Figure 4B		6-5.01	January 2023
Figure 4C		6-5.02	January 2023
Figure 4D		6-5.03	January 2023
Figure 4E		6-5.03.01	January 2023
Figure 4F		6-5.03.02	January 2023
Figure 4G		6-5.04	January 2023
Figure 4H	December 2006	6-6.0	January 2023
Figure 4I	December 2006	7-1.0	
Figure 4J	December 2004	7-2.0	
Figure 5A		7-2.01	
Figure 5B	January 2023	7-2.02	
Figure 5C	January 2023	7-3.0	
Figure 5D	January 2023	7-4.0	
Figure 5E	January 2023	8-1.0	October 2023
Figure 5F	January 2023	8-2.0	October 2023
Figure 5G		8-2.01	
Figure 5H		8-2.02	
Figure 5I		8-2.02.01	
Figure 5J	December 2006	8-2.02.02	
Figure 5K	December 2006	8-2.02.03	
Figure 5L	December 2003	8-2.03	
Figure 5M	December 2006	8-2.03.01	
6-1.0		8-2.03.02	
6-1.01		8-2.03.03	
6-1.01.01		8-2.03.04	
6-1.01.02		8-2.03.05	
6-1.01.03		8-2.03.06	
6-1.02	January 2023	8-2.03.07	December 2004
6-1.02.01		8-2.04	
6-1.02.02	January 2023	8-2.04.01	
6-1.02.03		8-2.04.02	
6-1.03		8-2.04.03	
6-1.03.01		8-2.04.04	
6-1.03.02		8-2.04.05	
6-2.0		8-2.05	

## LIST OF SECTIONS SHOWING LATEST DATE OF REVISIONS

### ORIGINAL ISSUE DATE IS DECEMBER 2003

<u>Section Number</u>	<u>Date</u>	<u>Section Number</u>	<u>Date</u>
8-3.0	October 2023	10-3.0	
8-3.01		10-3.0	
8-3.02		10-3.01	
8-3.02.01		10-3.02	
8-3.02.02	January 2023	10-3.02.01	
8-3.02.03		10-3.02.02	
8-3.03		10-3.02.03	
8-3.04		10-4.0	
9-1.0		10-4.01	
9-1.01		10-4.01.01	
9-1.02		10-4.01.02	
9-2.0		10-4.02	
9-2.01		10-5.0	
9-2.02		10-6.0	
9-2.03		10-7.0	
9-2.04		11-1.0	
9-2.04.01		11-1.01	
9-2.04.02		11-1.01.01	
9-2.04.03		11-1.01.02	
9-3.0		11-1.02	January 2012
9-3.01		11-1.03	January 2012
9-3.02		11-1.04	
9-3.03		11-1.04.01	January 2012
9-4.0	January 2012	11-1.04.02	
9-5.0		11-1.05	
10-1.0		11-2.0	
10-1.01		11-2.01	
10-1.01.01		11-2.02	October 2023
10-1.01.02		11-2.03	February 2013
1-1.02		11-2.03.01	December 2006
10-1.02.01		11-2.03.02	December 2006
10-1.02.02		11-2.03.03	December 2006
10-1.03		11-2.04	December 2006
10-1.04		11-2.05	December 2006
10-1.05		11-2.06	December 2006
10-1.05.01		11-2.07	December 2006
10-1.05.02		11-2.08	December 2006
10-1.05.03	October 2023	11-2.09	December 2006
10-1.05.04		11-3.0	
10-2.0		11-3.01	
10-2.01		11-3.02	January 2012
10-2.01.01		11-3.03	January 2012
10-2.01.02		11-3.03.01	
10-2.02		11-3.03.02	
10-2.03		11-3.03.03	

## LIST OF SECTIONS SHOWING LATEST DATE OF REVISIONS

### ORIGINAL ISSUE DATE IS DECEMBER 2003

<u>Section Number</u>	<u>Date</u>	<u>Section Number</u>	<u>Date</u>
11-3.03.04		12-2.02	
11-3.03.05		12-2.03	
11-4.0		12-2.04	
11-4.01		12-2.05	
11-4.02		12-2.06	
11-4.02.01		12-3.0	
11-4.02.02		12-3.01	
11-4.02.03		12-3.01.01	October 2023
11-4.02.04		12-3.01.02	January 2009
11-4.02.05		12-3.01.03	
11-5.0		12-3.01.04	
11-5.01		12-3.01.05	
11-5.02	December 2004	12-3.02	
11-5.03		12-3.02.01	
11-5.04	December 2006	12-3.02.02	January 2009
11-5.05		12-3.02.03	
11-5.06	July 2004	12-3.03	
11-5.07	December 2006	12-4.0	
11-6.0		12-4.01	
11-6.01		12-4.02	January 2009
11-6.02		12-4.03	
11-6.03	January 2009	12-4.04	
11-7.0		12-5.0	
11-7.01		12-5.01	January 2009
11-7.02		12-5.02	
11-8.0		12-5.03	
11-8.01		12-6.0	
11-8.01.01		Appendix	July 2012
11-8.01.02		13-1.0	June 2020
11-8.02		13-2.0	June 2020
11-8.03		13-2.01	June 2020
11-8.03.01		13-2.02	June 2020
11-9.0	February 2013	13-2.03	June 2020
11-10		13-3.0	June 2020
12-1.0		13-3.01	June 2020
12-1.01		13-3.02	June 2020
12-1.01.01		13-3.03	June 2020
12-1.01.02	July 2012	13-3.04	June 2020
12-1.02.03	July 2012	13-3.05	June 2020
12-1.02		13-3.06	June 2020
12-1.02.01		13-3.07	June 2020
12-1.02.02		13-3.08	June 2020
12-2.0		13-4.0	June 2020
12-2.01		13-4.01	June 2020

## LIST OF SECTIONS SHOWING LATEST DATE OF REVISIONS

### ORIGINAL ISSUE DATE IS DECEMBER 2003

<u>Section Number</u>	<u>Date</u>	<u>Section Number</u>	<u>Date</u>
13-4.02	June 2020	13-9.10.02	June 2020
13-4.03	June 2020	13-9.11	June 2020
13-4.04	June 2020	13-9.11.01	June 2020
13-4.05	June 2020	13-9.11.02	June 2020
13-5.0	June 2020	13-9.11.03	June 2020
13-5.01	June 2020	13-9.12	June 2020
13-5.02	June 2020	13-10	June 2020
13-5.03	June 2020	13-10.01	June 2020
13-5.04	June 2020	13-10.02	June 2020
13-5.05	June 2020	13-10.03	June 2020
13-5.06	June 2020	13-10.03.01	October 2023
13-5.07	June 2020	13-10.03.02	June 2020
13-5.08	June 2020	13-10.03.03	June 2020
13-5.09	June 2020	13-10.03.04	June 2020
13-5.10	June 2020	13-10.03.05	June 2020
13-5.10.01	June 2020	13-10.03.06	June 2020
13-5.10.02	June 2020	13-11.0	June 2020
13-6.0	June 2020	14-1.0	January 2011
13-6.01	June 2020	14-1.01	January 2011
13-6.02	June 2020	14-1.02	January 2011
13-6.03	June 2020	14-2.0	
13-6.04	June 2020	14-2.01	
13-6.05	June 2020	14-2.02	
13-6.06	June 2020	14-3.0	
13-6.07	June 2020	14-3.01	
13-6.07.01	June 2020	14-3.02	
13-7.0	June 2020	14-3.03	
13-8.0	June 2020	14-3.04	
13-8.01	June 2020	14-3.05	
13-8.01.01	June 2020	14-3.06	
13-8.01.02	June 2020	14-3.07	
13-8.01.03	June 2020	14-4.0	January 2011
13-9.0	June 2020	14-4.01	
13-9.01	June 2020	14-4.02	
13-9.02	June 2020	14-4.03	
13-9.03	June 2020	14-4.04	January 2009
13-9.04	June 2020	14-4.05	
13-9.05	June 2020	14-5.0	
13-9.06	June 2020	15-1.0	
13-9.07	June 2020	15-1.01	
13-9.08	June 2020	15-1.02	
13-9.09	June 2020	15-1.03	
13-9.10	June 2020	15-1.03.01	
13-9.10.01	June 2020	15-1.03.02	

## LIT OF SECTIONS SHOWING LATEST DATE OF REVISIONS

### ORIGINAL ISSUE DATE IS DECEMBER 2003

<u>Section Number</u>	<u>Date</u>	<u>Section Number</u>	<u>Date</u>
15-1.04		15-6.04.01	
15-1.05		15-6.04.02	
15-1.05.01		15-6.04.03	
15-1.05.02	February 2013	15-6.04.04	
15-1.06		15-6.04.05	
15-1.07		15-6.04.06	
15-1.08		15-6.04.07	
15-1.08.01		15-6.04.08	
15-1.08.02	January 2009	15-6.05	
15-1.08.03		15-7.0	
15-1.08.04		15-7.01	
15-1.09		15-7.02	
15-1.10		15-7.03	
15-2.0		15-7.04	
15-2.01		15-7.05	
15-2.02		15-8.0	
15-2.02.01		15-9.0	
15-2.02.02		Glossary	October 2023
15-2.02.03		Index	January 2023
15-2.02.04			
15-2.03			
15-3.0			
15-3.01			
15-3.01.01			
15-3.01.02			
15-3.02			
15-3.02.01			
15-3.02.02			
15-3.02.03			
15-3.02.04			
15-4.0			
15-4.01			
15-4.02			
15-4.03			
15-5.0			
15-5.01			
15-5.02			
15-5.02.01			
15-5.02.02			
15-5.02.03			
15-6.0			
15-6.01			
15-6.02			
15-6.03			
15-6.04			

## Chapter One

### **MANUAL USAGE**

#### **Table of Contents**

<b><u>Section</u></b>	<b><u>Page</u></b>
1-1.0 OVERVIEW.....	1-1(1)
1-1.01 Objective .....	1-1(1)
1-1.02 Highway Elements .....	1-1(2)
1-1.03 Project Scope of Work .....	1-1(3)
1-1.03.01 New Construction .....	1-1(4)
1-1.03.02 Reconstruction (Freeway) .....	1-1(4)
1-1.03.03 Reconstruction (Non-Freeway) .....	1-1(6)
1-1.03.04 3R (Non-Freeways) .....	1-1(7)
1-1.03.05 Spot Improvements .....	1-1(9)
1-1.03.06 Preservation/Preventive Maintenance Projects .....	1-1(10)
1-1.04 Procedures for Scope Approval .....	1-1(10)
1-2.0 MANUAL SUMMARY.....	1-2(1)
1-2.01 Introduction .....	1-2(1)
1-2.02 Chapter Two “Geometric Design of Existing Highways (3R Non-Freeway Projects)” .....	1-2(1)
1-2.03 Chapter Three “Geometric Design of Existing Highways (Freeway Projects) (Spot Improvements) (Preservation/Preventive Maintenance Projects)” .....	1-2(1)
1-2.04 Chapter Four “Rural Highways and Roads (New Construction/Reconstruction)” .....	1-2(2)
1-2.05 Chapter Five “Urban Highways and Streets (New Construction/Reconstruction)” .....	1-2(2)
1-2.06 Chapter Six “Design Controls” .....	1-2(2)
1-2.07 Chapter Seven “Sight Distance” .....	1-2(3)
1-2.08 Chapter Eight “Horizontal Alignment” .....	1-2(3)
1-2.09 Chapter Nine “Vertical Alignment” .....	1-2(3)
1-2.10 Chapter Ten “Cross Sections” .....	1-2(3)
1-2.11 Chapter Eleven “Intersections At-Grade” .....	1-2(4)
1-2.12 Chapter Twelve “Interchanges” .....	1-2(4)
1-2.13 Chapter Thirteen “Roadside Safety” .....	1-2(5)
1-2.14 Chapter Fourteen “Temporary Traffic Control” .....	1-2(5)
1-2.15 Chapter Fifteen “Special Design Elements” .....	1-2(5)







# Chapter One

## MANUAL USAGE

### 1-1.0 OVERVIEW

#### 1-1.01 Objective

The *Connecticut Highway Design Manual* has been prepared to provide guidance on the geometric design of bridge and highway projects. This *Manual* shall be used in the design of highways and streets within the State Highway System, and may be used to design the local roadway network as applicable, to provide uniform design practices for preparing roadway plans. Although this *Manual* is primarily used by Highway engineers, lead Bridge and Traffic engineers should also use this *Manual* for guidance on design criteria when their projects involve highway related elements such as geometric alignments, roadside appurtenances, clear zones, etc...

Multimodal considerations are essential in the design of every bridge and highway projects and should reflect the roadway context and community needs. If used conscientiously and diligently, the *Manual* should be a significant benefit to designers in selecting cost-effective designs that will meet the objectives of the local community and those of the Department. Each project should be designed in compliance with the Department's Policy No. EX.O. – 31: *Complete Streets*, to include Context Sensitive and Complete Streets Design principles, specifically to fit into the context of the area where it will be constructed and consider all modes of transportation. The designer's goal should be a balanced design that ensures the safe and adequate accommodation of all users of the transportation system, including pedestrians, bicyclists, public transportation users, children, older individuals, individuals with disabilities, motorists, and freight vehicles, as appropriate. This does not necessarily mean that facilities for every mode are provided for every roadway. In fact, the appropriate balance among transportation modes may vary widely between specific roads and streets. The guiding design principle is that the balance among transportation modes, selected for each road and street, should be a conscious decision arrived at after thorough assessment of the needs of each mode, consideration of local and regional transportation plans, and understanding of community needs. The designs produced, especially those within rural areas, should reflect the natural, scenic and cultural landscape of the area. Where practical, designers should take advantage of the physical and topographical characteristics of an area to maximize aesthetics. For a highway project to ultimately be successful, public involvement must be established early in the design process so that a common goal may be achieved. The details of the Department's public involvement process are contained in the document entitled [Connecticut Department of Transportation: Public Involvement Procedures](#).

Throughout the design process, a designer is encouraged to use the flexibility provided by this *Manual* to produce a design solution that satisfies diverse and occasionally conflicting interests. To aid in building an understanding of sensitivity and flexibility in design, the Federal Highway

Administration has produced a guide, [Flexibility in Highway Design](#). Designers should refer to this guide for examples of how to successfully integrate aesthetic, historic and scenic values along with safety, accessibility, and added mobility into the design of projects. Designers shall coordinate with the Scenic Road Advisory Committee when designing projects involving roadways designated as “Scenic Roads” to ensure that there is no adverse effect on the roadways’ scenic characteristics. The List of Connecticut Scenic Roads and additional information can be found online at [Connecticut Scenic Roads](#). Also, the Department may have a number of corridor studies on file for State-designated “Scenic Roads,” which may include recommendations that will allow for roadway improvements while protecting the scenic character of these roadways. Designers should contact the Office of Strategic Planning and Projects in the Bureau of Policy and Planning for information on these studies and consider applying some of the design tools included in these studies to other projects within sensitive areas.

### **1-1.02      Highway Elements**

The *Connecticut Highway Design Manual* provides design criteria for the following highway elements:

1.      geometrics;
2.      roadside safety;
3.      temporary traffic control; and
4.      special design elements, such as:
  - a.      accessibility for disabled individuals,
  - b.      bikeways,
  - c.      landscaping,
  - d.      commuter lots, and
  - e.      fencing.

The designer should be aware of the projects’ surrounding environment and carefully integrate the design within its context. Through site visits, the designer may develop an appreciation of the physical characteristics of an area and an understanding of community values. The designer must be aware of the impacts that result from rigidly applying the criteria contained within this *Manual*. The designer should carefully evaluate each criterion so that the final design provides for safety and operational improvements while keeping harmony with the aesthetic, historic and cultural resources of the community. The *Manual* provides flexibility to a designer through the use of a range of design values where appropriate. Where the application of the minimum design criteria results in unreasonably high construction costs or extreme impacts to the surrounding environment, the design exception process can address the use of lower than minimum design values on a case-by-case basis. See Section 6-5.0.

The proper design of a highway project requires input from various disciplines. Early coordination is required so that their input may be effectively incorporated into the final design of

a project. Their input may impact the original scope or change the character of the project. The design of a highway project will likely include the evaluation and design of the following elements:

1. pavement design and rehabilitation;
2. hydraulic design of drainage appurtenances;
3. traffic engineering elements (e.g., traffic signals, lighting, signs, pavement markings);
4. consideration of all modes of transportation (including active transportation modes)
5. geotechnical elements (e.g., slope stability, soil bearing strength);
6. structural design elements (e.g., bridges, culverts, retaining walls);
7. environmental considerations including:
  - a. noise,
  - b. air and water quality,
  - c. Environmental Justice
  - d. natural resources, and
  - e. historical and archeological resources;
8. right-of-way impacts (e.g., property owners, utilities, railroads); and
9. highway capacity.

### **1-1.03 Project Scope of Work**

The *Connecticut Highway Design Manual* has been structured to select the applicable set of design criteria based on the following factors:

1. urban/rural location;
2. design classification, based primarily on the extent of roadside development (Section 6-1.03);
3. the functional class of the facility (Section 6-1.01):
  - a. freeway,
  - b. arterial,
  - c. collector, or
  - d. local.
4. the scope of work – This is a major control in the design of the proposed highway project. The project scope of work will reflect the basic intent of the highway project and will determine the overall level of highway improvement, taking into consideration all modes of travel to the extent practicable. New construction and reconstruction projects will often have significant impacts (e.g., considerable right-of-way involvement). In contrast, 3R non-freeway projects typically restrict improvements to the existing right-of-

way. The decision on the project scope of work will determine the use of the Department's *Highway Design Manual*.

The project scope of work are as follows:

- a. new construction,
- b. reconstruction (freeways),
- c. reconstruction (non-freeways),
- d. 3R (non-freeways),
- e. spot improvements, or
- f. preservation/preventive maintenance.

The following descriptions are intended to provide guidance for the determination of the project scope of work.

#### **1-1.03.01 New Construction**

New construction is defined as the following for the various highway elements:

1. Highway Mainline. New horizontal and vertical alignment at a new location is considered new construction of a highway mainline. Chapters Four and Five present the Department's criteria for new construction.
2. Intersections At-Grade. Any intersection that falls within the project limits of a new highway mainline is considered new construction. Likewise, any existing intersection that is relocated to a new point of intersection is considered new construction. Chapter Eleven presents the Department's criteria for the new construction of intersections; Chapters Four and Five present the Department's criteria for the width of cross-section elements within the intersection (e.g., auxiliary lane width).
3. Interchanges. Any construction of an interchange on a new highway mainline is considered new construction. In addition, the construction of a new interchange on an existing highway is considered new construction. Chapter Twelve presents the Department's criteria for the new construction of interchanges. Chapters Four and Five present the Department's criteria for the width of cross-section elements for the highway mainline within the interchange.
4. Bridges. Bridges on a new highway mainline are considered new construction for bridges. Chapters Four and Five present the Department's criteria for the width of bridges for new construction.

#### **1-1.03.02 Reconstruction (Freeway)**

Reconstruction on a freeway may or may not involve significant right-of-way acquisitions.

Reconstruction on a freeway (Freeway project) is defined as the following for the various highway elements:

1. Highway Mainline. Reconstruction work on an existing freeway mainline may include:
  - a. lane and/or shoulder full-depth pavement structure removal and replacement;
  - b. lane and/or shoulder widening;
  - c. addition of through and/or auxiliary lanes;
  - d. flattening a selected horizontal or vertical curve;
  - e. widening the roadside clear zone;
  - f. upgrading the safety appurtenances to meet current criteria;
  - g. flattening side slopes;
  - h. noise barrier installation;
  - i. structural, geometric and/or safety improvements to existing bridges or overhead sign structures within the project limits; and/or
  - j. upgrading the existing drainage system.

Section 3-1.0 presents the Department's criteria for the design of freeway projects on the existing highway mainline.

2. Interchanges. An existing interchange may be within the project limits of a Freeway project, or a Freeway project may be initiated solely to improve an existing interchange. The scope of work may range from total reconstruction of the existing interchange to selected design improvements. Most often, the level of improvement to an existing interchange within larger project limits will be commensurate with the level of improvement to the highway mainline. Therefore, Reconstruction work on an existing interchange might include:
  - a. upgrading the interchange type (e.g., converting a cloverleaf to a directional interchange);
  - b. adding new connections for movements;
  - c. adding collector-distributor roads;
  - d. lengthening an existing acceleration or deceleration lane;
  - e. improving roadside safety within the interchange limits;
  - f. noise barrier installation within the interchange limits;
  - g. realigning an existing ramp; and/or
  - h. widening an existing ramp.

Chapter Twelve discusses the Department's criteria for the design of the interchange elements.

3. Bridges. Freeway projects frequently include work on existing freeway bridges. The scope of work on freeway bridges varies based on minimum acceptable bridge load rating factors, impacts to each bridge and/or condition ratings for each bridge. The designer should coordinate with the Division of Bridges to develop the final scope of work on the bridges. Occasionally, a bridge may be within the limits of a Freeway project, but no improvement may be proposed. Therefore, the scope of work for a freeway bridge may be one of the following:
  - a. total replacement of an existing bridge, either as an independent project or within the limits of a mainline/interchange Freeway project;
  - b. bridge rehabilitation, either as an independent project or within the limits of a mainline/interchange Freeway project; or
  - c. preservation/preventive maintenance on bridges remaining in place within the limits of a mainline/interchange Freeway project.

Section 3-1.0 presents the Department's criteria for bridges on Freeway projects.

### **1-1.03.03 Reconstruction (Non-Freeway)**

Reconstruction on a non-freeway will usually require significant right-of-way purchases and will often have a major impact on the surrounding area. Reconstruction on non-freeways is defined as the following for the various highway elements:

1. Highway Through Lanes. Reconstruction of an existing highway through lane will typically include partial or full-depth pavement construction of the existing horizontal and vertical alignment but will be essentially within the existing highway corridor. The primary reason to perform reconstruction is because the existing facility cannot accommodate its current or future demands and requires an extensive improvement to provide an acceptable level of service. Any project that increases the basic number of through traffic lanes on an existing road is considered Reconstruction. Because of the significant level of work, the geometric design of the project should be determined by the criteria for new construction. Therefore, the values in Chapters Four and Five will be used to design reconstruction projects.
2. Intersections At-Grade. Any intersection that falls within the limits of a reconstruction project will also be evaluated for reconstruction. The scope of work for a project strictly to improve an existing intersection may also be considered reconstruction if the proposed work is extensive. This could include:
  - a. the addition of through and/or auxiliary lanes for all approaches;
  - b. the relocation and flattening of turning radii;
  - c. the addition of turning roadways;
  - d. flattening the approach and intersection gradients;
  - e. realigning the angle of intersection; and/or
  - f. re-channelizing the intersection.



Because of the extensive level of work for reconstruction, the criteria in Chapter Eleven will apply to the design of the intersection. The criteria in Chapters Four and Five apply for the width of the cross-section elements.

3. Interchanges. An existing interchange may be within the project limits of a non-freeway facility that is being redesigned as a reconstruction project. The interchange should also be evaluated for reconstruction. This may only apply to those interchange elements that directly impact the safety and operations of the non-freeway facility, not the entire interchange. In addition, the scope of work for a project strictly to improve an existing interchange may be considered reconstruction if the proposed work is extensive. This would apply to an interchange between two non-freeway facilities; if a freeway is one of the intersecting facilities, this will be a Freeway project. The reconstruction of an existing interchange may be characterized by:
  - a. upgrading the interchange type (e.g., converting a cloverleaf to a directional interchange);
  - b. adding new connections for movements that are currently not provided; and/or
  - c. adding collector-distributor roads.

When reconstruction is being performed on an existing interchange, the entire interchange should be evaluated according to the criteria in Chapters Four, Five and Twelve.

4. Bridges. Non-freeway reconstruction projects may include work on existing bridges. The scope of work on non-freeway bridges varies based on minimum acceptable bridge load rating factors, impacts to each bridge and/or condition ratings for each bridge. The designer should coordinate with the Division of Bridges to develop the final scope of work on the bridges. An independent project to perform work solely on a bridge and its approaches is a spot improvement (Section 1-1.03.05). Therefore, the scope of work as it applies to non-freeway bridges on reconstruction projects may be one of the following:
  - a. total replacement of an existing bridge, either as a spot improvement (Section 3-2.0) or as part of the reconstruction of a non-freeway (Section 10-4.0);
  - b. bridge rehabilitation, either as a spot improvement (Section 3-2.0) or as part of the reconstruction of a non-freeway (Section 10-4.0); or
  - c. preservation/preventive maintenance on bridges remaining in place within the limits of the reconstruction of a non-freeway (Section 10-4.0).

#### **1-1.03.04 3R (Non-Freeways)**

3R (resurfacing, restoration and/or rehabilitation) on non-freeways will typically involve either no or minor right-of-way acquisition (e.g., slivers, an occasional building). A 3R non-freeway project is defined as the following for the various highway elements:

1. Highway Through Lanes. 3R work on an existing highway through lane is work essentially on the existing highway alignment, which could include selected improvements to the highway geometrics. The basic number of through traffic lanes must be the same before and after the project. Typical improvements for 3R projects include:
  - a. lane and shoulder pavement resurfacing;
  - b. full-depth pavement structure removal and replacement of the travel lanes up to one third of the project length (full-depth pavement structure and removal for the total project length may be included with approval from the appropriate Division Chief);
  - c. shoulder full-depth pavement structure removal and replacement (for all or part of the project length);
  - d. lane and shoulder widening;
  - e. addition of auxiliary lanes;
  - f. flattening a selected horizontal or vertical curve;
  - g. widening the roadside clear zone;
  - h. converting an existing median to include left-turn lanes;
  - i. revising the location, spacing or design of existing driveways along the mainline;
  - j. adding or removing parking lanes;
  - k. adding curbs or sidewalks;
  - l. structural, geometric or safety improvements to existing bridges within the project limits;
  - m. relocating utility poles;
  - n. upgrading safety appurtenances to meet current criteria;
  - o. upgrading of the existing drainage system; and/or
  - p. upgrading of signing, pavement markings, traffic signals, etc.

Chapter Two presents the Department's criteria for the design of 3R non-freeway projects.

2. Intersections At-Grade. Any intersection within the limits of a 3R project will be evaluated for 3R-type improvements. In addition, an existing intersection may also be improved as an independent project. This may be considered as either a 3R project or a spot improvement (Section 1-1.03.05).

A 3R project at an existing intersection may include improvements such as:

- a. widening the approach roadway width,
- b. adding an auxiliary lane,

- c. lengthening an existing auxiliary lane,
- d. improving the intersection sight distance,
- e. flattening the existing turning radii,
- f. minor realignment of the intersection angle,
- g. adding a turning roadway,
- h. widening an existing turning roadway,
- i. minor re-channelization,
- j. upgrading the existing signal system, and/or
- k. upgrading the existing drainage system.

Chapter Two discusses the Department's design criteria for 3R work to an existing intersection. This is primarily a reference to the criteria in Chapter Eleven.

3. Interchanges. An interchange may be within the project limits of a 3R project on a non-freeway facility. The project should also include an evaluation of those interchange elements which directly impact the safety and operations of the non-freeway. 3R-type work to an existing interchange within a 3R project might include:
- a. lengthening an existing acceleration or deceleration lane,
  - b. improving roadside safety within the interchange limits,
  - c. realigning an existing ramp,
  - d. widening an existing ramp, and/or
  - e. improvements to the ramp/non-freeway intersection.

Chapter Twelve discusses the Department's design criteria for interchanges.

4. Bridges. 3R (non-freeway) projects may include work on existing bridges. The scope of work on these bridges varies based on minimum acceptable bridge load rating factors, impacts to each bridge and/or condition ratings for each bridge. The designer should coordinate with the Division of Bridges to develop the final scope of work on the bridges. An independent project to perform work solely on a bridge and its approaches is a spot improvement (Section 1-1.03.05). Therefore, the scope of work on existing bridges within a 3R project may be one of the following:
- a. bridge rehabilitation as part of a 3R project (Section 2-7.0); or
  - b. preservation/preventive maintenance on bridges remaining in place within the limits of a 3R project (Section 2-7.0).

### **1-1.03.05 Spot Improvements**

These projects are intended to correct a deficiency at an isolated location. This may be an intersection, a horizontal curve, a bridge or a limited roadside section. Section 3-2.0 discusses the Department's criteria for the design of spot improvement projects.

### **1-1.03.06      Preservation/Preventive Maintenance Projects**

The intent of these projects is to extend the life of a structurally sound facility by employing cost-effective preservation techniques. These projects generally do not require safety enhancements; however, they should address isolated or obvious deficiencies and in no way degrade safety.

1.    Highway Through Lanes. Preservation work on existing highway through lanes may include:
  - a.    lane and shoulder pavement resurfacing;
  - b.    replacement of deteriorated drainage basin tops.
  
2.    Bridges. The designer must coordinate with the Office of Maintenance and the various units within the Division of Bridges for the appropriate treatment on the bridges.

Section 3-3.0 discusses the scope and design criteria for preservation and preventive maintenance projects on state roads.

### **1-1.04      Procedures for Scope Approval**

The procedures for selecting and revising the project scope of work are integrated into the Department's Project Initiation and design process. These overall procedures are outlined in the *Project Development Guide*. The following provides additional details specifically for the project scope of work:

1.    Planning, Project Development, Traffic, Maintenance, Design or other groups may initiate projects. When the Recommended Project Memorandum (RPM) is prepared, the initiating unit will select the project scope of work.
  
2.    When the project is initiated, the designer will begin work on the project. At any time during design, the designer may recommend to revise the project scope of work based on an evaluation of actual field conditions. The Chief Engineer/Assistant Chief Engineer/Engineering Administrator must then approve the revised scope in accordance with Engineering and Construction Directive ECD-2022-3 *Delegation of Authority*. The designer must document the justification and approval of the scope change, and notify the Office of Capital Planning in the Bureau of Finance and Administration to ensure that the appropriate CORE/FMIS/STIP adjustments for the project are processed accordingly.

## **1-2.0    **MANUAL SUMMARY****

### **1-2.01    Introduction**

The following summarizes the content of the chapters within the *Connecticut Highway Design Manual*.

### **1-2.02    Chapter Two “Geometric Design of Existing Highways (3R Non-Freeway Projects)”**

ConnDOT often programs highway improvements on existing non-freeways for reasons other than geometric or safety deficiencies (e.g., pavement deterioration). These projects typically must be designed within restrictive right-of-way, financial limitations and environmental constraints. Therefore, the design criteria for new construction are often not attainable without major and, frequently, unacceptable adverse impacts. At the same time, however, the Department must take the opportunity to make cost-effective, practical improvements to the geometric design of existing highways and streets.

For these reasons, the Department has adopted revised limits for geometric design criteria for projects on existing non-freeways in Chapter Two which are, in many cases, lower than the values for new construction. Chapter Two presents the Department’s criteria for 3R non-freeway projects. These criteria are based on a sound, engineering assessment of the underlying principles behind geometric design and on how the criteria for new construction can be legitimately modified to apply to existing highways without sacrificing highway safety.

These criteria are intended to find the balance among many competing and conflicting objectives. These include the objective of improving Connecticut’s existing highways; the objective of minimizing the adverse impacts of highway construction; and the objective of improving the greatest number of miles within the available funds.

### **1-2.03    Chapter Three “Geometric Design of Existing Highways (Freeway Projects) (Spot Improvements) (Preservation/Preventive Maintenance Projects)”**

Based on the same approach to 3R non-freeway projects in Chapter Two, Chapter Three presents modified geometric design criteria for:

1.    freeway projects,
2.    spot improvement projects, and
3.    preservation/preventive maintenance projects.

The design criteria for these three project scopes of work reflect the practical constraints of designing highway improvements on existing facilities.

**1-2.04      Chapter Four “Rural Highways and Roads (New Construction/Reconstruction)”**

Chapter Four presents a set of summary tables of geometric design criteria for new construction/reconstruction projects in rural areas based on:

1. functional classification;
2. design classification on non-freeways (based on the average number of access points per mile per side); and
3. for arterials, two-lane versus multi-lane.

These tables provide the *Manual* user with a convenient summary of the geometric design criteria that apply to a specific facility. The tables also identify the controlling design criteria that require an approved design exception if not met.

**1-2.05      Chapter Five “Urban Highways and Streets (New Construction/Reconstruction)”**

Chapter Five presents a set of summary tables of geometric design criteria for new construction/reconstruction projects in urban areas based on:

1. functional classification;
2. design classification on non-freeways (based on the type of area); and
3. for arterials, two-lane versus multi-lane.

These tables provide the *Manual* user with a convenient summary of the geometric design criteria that apply to a specific facility. The tables also identify the controlling design criteria that require an approved design exception if not met.

**1-2.06      Chapter Six “Design Controls”**

Proper highway design must reflect the consideration of many basic design controls that provide the overall framework for highway design. Chapter Six discusses the Department’s application of these controls, including:

1. highway systems (e.g., functional classification, Federal-aid);
2. the various speed measurements (e.g., design speed);
3. highway capacity analyses;
4. access control; and

Chapter Six also discusses the Department’s process for requesting a design exception for those geometric design values that do not meet the Department’s criteria.

**1-2.07      Chapter Seven “Sight Distance”**

Sufficient sight distance is critical to safe highway operations. Chapter Seven presents the Department’s criteria for various sight distance elements, including stopping sight distance and decision sight distance. The Chapter also discusses the application of the two sight distance parameters. Intersection sight distance is addressed in Chapter Eleven “Intersections At-Grade.”

**1-2.08      Chapter Eight “Horizontal Alignment”**

Highway horizontal alignment has a significant impact on highway safety and construction costs. Chapter Eight presents the Department’s criteria that will establish the alignment of a highway facility. This includes:

1. types of horizontal curves;
2. minimum radii;
3. superelevation development (e.g., transition lengths, axis of rotation); and
4. sight distance around horizontal curves.

Because of their different operating conditions, Chapter Eight presents separate criteria for all rural highways/high-speed urban highways ( $V > 45$  mph) and for low-speed urban streets ( $V \leq 45$  mph).

**1-2.09      Chapter Nine “Vertical Alignment”**

Highway vertical alignment, perhaps more so than any other highway element, has a significant impact on construction costs and highway operations, especially where there is an appreciable volume of trucks. Chapter Nine presents the Department’s criteria on vertical alignment, including:

1. maximum and minimum grades,
2. critical lengths of grade,
3. warrants and design for climbing lanes,
4. the design of crest and sag vertical curves, and
5. vertical clearances.

**1-2.10      Chapter Ten “Cross Sections”**

The highway cross section has a significant impact on the driver’s perception of the serviceability and safety of the highway facility. Chapter Ten presents the Department’s criteria on cross section elements to supplement the design values in Chapters Two, Four and Five.

Chapter Ten discusses:

1. the roadway section (e.g., travel lanes, shoulders, cross slopes, parking lanes, curbs);
2. roadside elements (e.g., sidewalks, fill slopes, cut sections);
3. medians;
4. cross sections for bridges and underpasses; and
5. right-of-way.

### **1-2.11 Chapter Eleven “Intersections At-Grade”**

Intersections at-grade represent major points of conflict between crossing flows of traffic. Driver delay is inevitable because of the need to assign right-of-way, and crashes often cluster about intersections. Therefore, they merit considerable attention in highway design. Chapter Eleven presents the Department’s criteria for the design of intersections at-grade, including:

1. general design controls (e.g., capacity, selection of design vehicle, alignment, profile);
2. intersection sight distance;
3. design for right turns;
4. turning roadways;
5. auxiliary turning lanes (e.g., warrants, length, dual turn lanes);
6. median openings;
7. channelization; and
8. driveways.

### **1-2.12 Chapter Twelve “Interchanges”**

Interchanges offer the safest and most effective method to accommodate traffic operations between two intersecting highways. However, their high cost and significant impacts limit their application to freeways and other selected major facilities. Chapter Twelve presents the Department’s criteria for the selection and design of interchanges, including:

1. warrants;
2. types;
3. traffic operations (e.g., lane balance, lane reduction, capacity);
4. freeway/ramp junctions (e.g., exit and entrance ramps);
5. geometric design of ramps; and
6. design of the ramp/crossing road intersection.



**1-2.13      Chapter Thirteen “Roadside Safety”**

Regardless of the highway engineering design, a certain number of vehicles will run off the road. The roadside design should provide these drivers with a reasonable opportunity to recover and safely return to the highway. This is accomplished through the availability of a clear roadside and/or the installation, where warranted, of protective barriers. Chapter Thirteen presents the Department’s criteria for roadside safety, including:

1. clear zone criteria;
2. barrier warrants;
3. roadside barriers (types and selection);
4. median barriers (e.g., warrants, types, design);
5. barrier layout and design (e.g., length of need, flare rates, placement behind curbs); and
6. end treatments.

**1-2.14      Chapter Fourteen “Temporary Traffic Control”**

A significant portion of the Department’s future highway program will be to upgrade existing facilities. Because this will inevitably disrupt existing traffic operations, Chapter Fourteen presents the Department’s criteria on temporary traffic control to minimize operational and safety problems. The Chapter discusses:

1. the ConnDOT responsibilities for temporary traffic control,
2. temporary traffic control management,
3. geometric design through the construction zone, and
4. roadside safety through the construction zone.

**1-2.15      Chapter Fifteen “Special Design Elements”**

In addition to the traditional highway design elements, the Department is responsible for ensuring that the highway design properly incorporates a wide variety of special design elements. Chapter Fifteen presents the Department’s criteria for these elements, including:

1. accessibility for disabled individuals,
2. layout and design of commuter lots,
3. location and design of bus stops,
4. warrants and design of bikeways,
5. landscaping,
6. warrants and location for fencing, and
7. design implications for noise barriers.



## Chapter Two

### GEOMETRIC DESIGN OF EXISTING HIGHWAYS (3R Non-Freeway Projects)

#### Table of Contents

<u>Section</u>	<u>Page</u>
2-1.0 INTRODUCTION .....	2-1(1)
2-2.0 GENERAL .....	2-2(1)
2-2.01 Background .....	2-2(1)
2-2.02 Objectives.....	2-2(1)
2-2.03 Approach .....	2-2(2)
2-2.04 Application .....	2-2(3)
2-2.05 3R Project Evaluation .....	2-2(4)
2-3.0 3R GEOMETRIC DESIGN CRITERIA .....	2-3(1)
Figure 2-3A Multi-Lane Rural Arterials (3R Projects).....	2-3(2)
Figure 2-3B Two-Lane Rural Arterials (3R Projects).....	2-3(4)
Figure 2-3C Rural Collector Roads (3R Projects) .....	2-3(6)
Figure 2-3D Rural Local Roads (3R Projects).....	2-3(8)
Figure 2-3E Multi-Lane Principal Urban Arterials (3R Projects).....	2-3(10)
Figure 2-3F Two-Lane Principal Urban Arterials (3R Projects).....	2-3(12)
Figure 2-3G Minor Urban Arterials (3R Projects).....	2-3(14)
Figure 2-3H Urban Collector Streets (3R Projects) .....	2-3(16)
Figure 2-3I Local Urban Streets (3R Projects).....	2-3(18)
2-4.0 DESIGN CONTROLS .....	2-4(1)
2-4.01 Design Speed .....	2-4(1)
2-4.02 Highway Capacity.....	2-4(2)
2-4.03 Exceptions to Geometric Design Criteria.....	2-4(2)
2-5.0 HORIZONTAL ALIGNMENT .....	2-5(1)
2-5.01 Rural Highways and High-Speed Urban Highways .....	2-5(1)
2-5.02 Low-Speed Urban Streets .....	2-5(1)

**Table of Contents**

(Continued)

<b><u>Section</u></b>	<b><u>Page</u></b>
2-6.0 VERTICAL ALIGNMENT .....	2-6(1)
2-6.01 Grades.....	2-6(1)
2-6.02 Crest Vertical Curves.....	2-6(1)
2-6.03 Sag Vertical Curves.....	2-6(1)
2-7.0 CROSS SECTIONS.....	2-7(1)
2-7.01 Widths.....	2-7(1)
2-7.02 Bridges .....	2-7(2)
2-7.02.01 Bridge Rehabilitation.....	2-7(2)
2-7.02.02 Bridges to Remain in Place .....	2-7(2)
2-7.03 Climbing Lanes.....	2-7(4)
2-7.04 Other Cross Section Elements .....	2-7(4)
2-8.0 SPECIAL DESIGN ELEMENTS.....	2-8(1)
2-8.01 General.....	2-8(1)
2-8.02 Traffic Calming .....	2-8(1)
2-9.0 ROADSIDE SAFETY .....	2-9(1)
2-9.01 Clear Zones.....	2-9(1)
2-9.01.01 Basic 3R Criteria.....	2-9(1)
2-9.01.02 Rock Removal.....	2-9(2)
2-9.02 Safety Appurtenances .....	2-9(3)
2-10.0 INTERSECTIONS AT-GRADE .....	2-10(1)
2-10.01 Intersection Sight Distance.....	2-10(1)
2-10.02 Turning Radii .....	2-10(1)
2-10.03 Auxiliary Turning Lanes.....	2-10(2)
2-10.04 Driveway Design.....	2-10(2)
2-11.0 REFERENCES .....	2-11(1)

## Chapter Two

# GEOMETRIC DESIGN OF EXISTING HIGHWAYS (3R NON-FREEWAY PROJECTS)

### 2-1.0 INTRODUCTION

The geometric design of projects on existing highways must be viewed from a different perspective than that for a new construction project. This chapter presents the Department's criteria for the geometric design of existing highways for 3R (Non-Freeway) projects while Chapter Three addresses freeway projects, spot improvements and preservation/preventive maintenance projects. These 3R projects are often initiated for reasons other than geometric design deficiencies (e.g., pavement deterioration), and they often must be designed within restrictive right-of-way, financial limitations and environmental constraints. Therefore, the design criteria for new construction are often not attainable without major and, frequently, unacceptable adverse impacts. These 3R projects are initiated in communities where land use and cultural characteristics are well established. For these projects, it is essential to consider the community, land use, visual, historical and natural resources surrounding the proposed roadway improvement. Designers must be aware of the community context in which these projects are being proposed and select the design criteria accordingly. At the same time, however, the designer should take the opportunity to consider cost-effective, practical improvements to the geometric design of existing highways and streets when crash data suggest it is appropriate. The design produced should integrate these wide ranging and sometimes conflicting issues to produce a safe and attractive transportation facility.

Designers should be aware of projects that are located within State or town designated "Scenic Roads" or "Scenic Byways." The Department may have a number of corridor studies for State-designated scenic roads. These documents are typically prepared in cooperation with the Department, local Regional Planning Agencies and other local interested parties. To protect the scenic character of these roadways, these studies may include recommendations on land use, landscaping, view/scenic enhancements and geometric considerations. To ensure that proposed improvements on these scenic roadways will fit within the existing character of the roadway, along with protecting their scenic and visual quality, the recommendations of these studies should be considered. Although these studies were prepared for specific segments of roadway, designers should become familiar with the design tools presented in these documents and consider their inclusion on other projects. Designers should also be aware of locally designated scenic roadways. Local governing authorities may have specific criteria established for these roadways. The Department must be sensitive to these local issues and should incorporate their criteria where appropriate.

For these reasons, the Department has adopted revised limits for geometric design criteria for projects on existing highways that are, in many cases, lower than the values for new construction. These criteria are based on a sound, engineering assessment of the underlying principles behind geometric design and on how the criteria for new construction can be legitimately modified to apply to existing highways without sacrificing highway safety.

Chapter Two presents the Department's criteria for 3R non-freeway projects, and Chapter Three presents the criteria for freeway projects and spot improvements (non-freeways). These criteria are intended to find the balance among many competing and conflicting objectives. These include the objective of improving Connecticut's existing highways; the objective of minimizing the adverse impacts of highway construction on existing highways; and the objective of improving the greatest number of miles within the available funds.

## **2-2.0 GENERAL**

### **2-2.01 Background**

On June 10, 1982, the FHWA issued its Final Rule entitled *Design Standards for Highways; Resurfacing, Restoration and Rehabilitation of Streets and Highways Other Than Freeways*. This Final Rule modified 23 CFR Part 625 to adopt a flexible approach to the geometric design of 3R projects. Part 625 was modified again on March 31, 1983 to explicitly state that one objective of 3R projects is to enhance highway safety. In the Final Rule, FHWA determined that it was not practical to adopt 3R design criteria for nationwide application. Instead, each State can develop its own criteria and/or procedures for the design of 3R projects, subject to FHWA approval. The following material was developed within the intent of these regulations using various references available.

### **2-2.02 Objectives**

From an overall perspective, the 3R program is intended to improve the greatest number of highway miles within the available funds for highway projects. "Improve" is meant to apply to all aspects which determine a facility's serviceability, including:

1. the structural integrity of the pavement, bridges and culverts;
2. the drainage design of the facility to, among other objectives, minimize ponding on the highway, to protect the pavement structure from failure, and to prevent roadway flooding during the design-year storm;
3. from a highway capacity perspective, the level of service provided for the traffic flow;
4. the adequacy of access to abutting properties;
5. the geometric design of the highway to safely accommodate expected vehicular speeds and traffic volumes;
6. the roadside safety design to reduce, within some reasonable boundary, the adverse impacts of run-off-the-road vehicles; and
7. the traffic control devices to provide the driver with critical information and to meet driver expectancies.

These objectives are competing for the limited funds available for 3R projects on existing highways. The Department's responsibility is to realize the greatest overall benefit from the available funds. Therefore, on individual projects, some compromises may be necessary to achieve the goals of the overall highway program. Specifically, for geometric design and roadside safety, the compromise is between new construction criteria and what is practical for the specific conditions of each highway project.

Therefore, considering the above discussion, the Department has adopted, and FHWA has approved, its approach to the geometric design of 3R projects. The overall objective of the Department's criteria is to fulfill the requirements of the FHWA regulation and Technical Advisory that govern the 3R program (see Section 1-1.03.04). These objectives may be summarized as follows:

1. 3R projects are intended to extend the service life of the existing facility and to return its features to a condition of structural or functional adequacy.
2. 3R projects are intended to enhance highway safety.
3. 3R projects are intended to incorporate cost-effective, practical improvements to the geometric design of the existing facility.

### **2-2.03 Approach**

The Department's approach to the geometric design of 3R projects is to adopt, where justifiable, a revised set of numerical criteria. The design criteria throughout the other Manual chapters provide the frame of reference for the 3R criteria. The following summarizes the approach that has been used:

1. Design Speed. Figures 2-3A through 2-3I provide the values for design speed. Where the design speed is based on actual speeds measured in the field, see Section 2-4.01 for the procedure that should be used for determining the recommended design speed. The design speed selected should be consistent with respect to travel speed, topography, adjacent land use and the functional classification of the highway.
2. Speed-Related Criteria. Many geometric design values are calculated directly from the design speed (e.g., vertical curves, horizontal curve radii). The design speed is used to determine these speed-related criteria. For many of these elements, Chapter Two presents an acceptable threshold value for the element that is considerably below the selected design speed. For example, if the design speed of an existing crest vertical curve is within 15 mph of the 85th percentile speed and there is no adverse crash history, this is considered acceptable for the project without a design exception.
3. Cross Section Widths. The criteria in Chapters Four and Five have been evaluated relative to the typical constraints of 3R projects. Where justifiable, the lower values of the cross section width criteria have been reduced. The upper values from Chapters Four and Five have been incorporated into the 3R criteria to provide an upper range. This provides an expanded range of acceptable values for application on 3R projects. Where an existing roadway section exceeds the design minimum lane and shoulder widths, a proposed improvement should not result in a reduction to the existing cross section without approval from the appropriate Division Chief. See Section 2-7.0 for more discussion on cross section widths.



4. Other Design Criteria. The Department's *Highway Design Manual* contains many other details on proper geometric design techniques. These criteria are directly applicable to new construction and reconstruction. For 3R projects, these criteria have been evaluated and a judgment has been made on their proper application to 3R projects. Unless stated otherwise in this Chapter, the criteria in other chapters apply to 3R projects and should be incorporated, if practical. Additionally, 3R projects are expected to follow the requirements of Chapter 15 Section 15-1.0 with regard to the Americans with Disabilities Act of 1990.
5. Evaluation. The designer should evaluate available data (e.g., crash experience) when determining the geometric design of 3R projects. Section 2-2.05 discusses 3R project evaluation in more detail.

#### **2-2.04 Application**

The designer should realize the following factors when applying the design criteria in this Chapter:

1. Trigger Values. The designer will be evaluating the existing geometric design against the criteria in this Chapter. If an existing geometric design feature does not at least meet the lower criteria, the designer must evaluate the practicality of improving the feature. Note that to use the design criteria in Sections 2-5.0 and 2-6.02, the selected design speed is based on the 85th percentile speed.
2. Improvement Level. The Department has determined that, once the decision is made to improve a geometric design element, the level of improvement should be compatible with the project objective. Where a range of values is presented, the designer should strive to avoid selecting criteria from the lower range. The minimum acceptable level of improvement will be designated as one of the following:
  - a. In some cases, the 3R trigger value may be acceptable. For example, it will be acceptable to redesign sag vertical curves to meet the comfort criteria rather than the headlight sight distance criteria. See Section 2-6.03.
  - b. In some cases, the trigger value may only be applicable to evaluating the need for an improvement, but a different value becomes the minimum acceptable level of improvement. For example, Figure 2-5A is used to evaluate the need for improvements to a horizontal curve, but the criteria in Section 8-2.0 are used to make improvements.
3. Exception Process. Desirably, the geometric design of 3R projects will meet all of the criteria presented in this Chapter. However, only key geometric design elements (i.e., the controlling design criteria) require a formal exception when not met. The 3R design exception process is discussed in Section 2-4.03, which is the same as the exception process for new construction and reconstruction (Section 6-5.0).

### **2-2.05 3R Project Evaluation**

Sections 2-3.0 to 2-10.0 present the specific geometric design and roadside safety criteria that will be used to determine the design of 3R projects. The designer should also note that, in some cases, the Department's 3R geometric design criteria will allow the acceptance of geometric design values that may be considerably below those for new construction/reconstruction (e.g., for horizontal and vertical curves). In addition, several other factors must be considered in a 3R project, and the designer should conduct applicable technical evaluations in coordination with the appropriate Department units as necessary. The possible evaluations are discussed below:

1. Conduct Field Review. The designer will normally conduct a thorough field review of the proposed 3R project. Other personnel should accompany the designer as appropriate, including personnel from traffic, maintenance, construction, FHWA (NHS projects), etc. The objective of the field review should be to identify potential safety hazards and potential safety improvements to the facility.
2. Document Existing Geometrics. The designer will normally review the most recent highway plans and combine this with the field review to determine the existing geometrics within the project limits. The review includes lane and shoulder widths, horizontal and vertical alignment, intersection geometrics and roadside safety design.
3. Crash Experience. The crash data within the limits of the 3R project will be evaluated. Crash data can be obtained from [UCONN's CT Crash Data Repository](#). The following crash data analyses should be conducted:
  - a. Crash Rate versus Statewide Average (for that type of facility). This will provide an overall indication of safety problems within the 3R project limits.
  - b. Crash Analysis by Type. This will indicate if certain types of crashes are a particular problem. For example, a large number of head-on and/or sideswipe crashes may indicate inadequate roadway width. A large number of fixed object crashes may indicate an inadequate roadside clear zone.
  - c. Crash Analysis by Location. Crashes may cluster about certain locations, such as a horizontal curve or intersection. In particular, the analysis should check to see if any locations on the Department's [High Frequency Crash Location](#) list, as identified by the Department's crash data system, fall within the proposed project limits.
4. Speed Studies. As indicated in Section 2-4.01, the Division of Traffic Engineering will review existing speed studies in the vicinity of the project and, if necessary, conduct a field study to determine the design speed of the 3R project. In addition, it may be desirable to conduct spot speed studies at specific locations (e.g., in advance of a specific horizontal or vertical curve) to assist in the determination of geometric design improvements. The speed study should be conducted before the field review.
5. Traffic Volumes. As indicated in Section 2-4.02, the traffic volumes used for design will range between the current traffic volumes and those determined using a ten-year

projection. This will generate traffic volumes for any necessary highway capacity analyses.

6. Early Coordination for Right-of-Way Acquisition. Significant ROW acquisitions are typically outside the scope of 3R projects. However, the field review, crash and/or speed studies may indicate the need for selective safety improvements that would require ROW acquisitions. Therefore, the designer should determine improvements that will be incorporated into the project design as early as feasible and initiate the ROW process, if required.
7. Pavement Condition. 3R projects that are programmed due to significant deterioration of the pavement structure will generally be determined from the Department's Pavement Management Program. The extent of deterioration will influence the decision on whether a project can be designed using the 3R design criteria or whether it should be designed using reconstruction criteria. A 3R project may include full-depth pavement structure replacement for up to one-third of the project length. The one-third limit may be exceeded on a case-by-case basis with the approval from the appropriate Division Chief.

Whenever the proposed full-depth pavement structure replacement exceeds one-third of the project length, it may be practical to include significant geometric improvements (e.g., lane and shoulder widening) in the project design. However, the proper level of geometric improvement is often determined by many additional factors other than the extent of full-depth pavement structure replacement. These include available right-of-way, traffic volumes, crash experience and available funds for the project. Therefore, it may be appropriate for the 3R project to include, for example, full-depth pavement structure replacement with minimal geometric improvement, if deemed proper, to meet the safety and operational objectives of the 3R program.

8. Geometric Design of Adjacent Highway Sections. The designer should examine the geometric features and operating speeds of highway sections adjacent to the 3R project. This will include investigating whether or not any highway improvements are in the planning stages. The 3R project should provide design continuity with the adjacent sections. This involves a consideration of factors such as driver expectancy, geometric design consistency and proper transitions between sections of different geometric designs.
9. Physical Constraints. The physical constraints within the limits of the 3R project will often determine what geometric improvements are practical and cost-effective. These include topography, adjacent development, available right-of-way, utility and environmental constraints (e.g., wetlands).
10. Traffic Control Devices. All signing and pavement markings on 3R projects must meet the criteria of the *Manual on Uniform Traffic Control Devices* (MUTCD). The Division of Traffic Engineering is responsible for selecting and locating the traffic control devices on the project. The designer should work with the Division of Traffic Engineering to identify possible geometric and safety deficiencies that will remain in place (i.e., no improvement will be made). These include:

- a. narrow bridges,
- b. horizontal and vertical curves which do not meet the 3R criteria, and
- c. roadside hazards within the clear zone.

### 2-3.0 3R GEOMETRIC DESIGN CRITERIA

Figures 2-3A through 2-3I present the Department's criteria for the design of 3R projects for both rural and urban areas. The designer should consider the following in the use of the 3R design criteria:

1. Functional/Design Classification. The selection of design values for 3R projects depends on the functional and design classification of the highway facility. This is discussed in Section 6-1.0.

For rural highways, the design classification is based on the average number of access points per mile per side. The designer should realize that the values in the Figures are for guidance only; they should not be used as rigid criteria for determining the design classification on rural highways.

2. Cross Section Elements. The designer should realize that some of the cross section elements included in the Figures (e.g., median width) are not automatically warranted in the project design. The values in the Figures will only apply after the decision has been made to include the element in the highway cross section.
3. Manual Section References. These Figures are intended to provide a concise listing of design values for easy use. However, the designer should review the Manual section references for greater insight into the design elements.

**Figure 2-3A  
MULTI-LANE RURAL ARTERIALS  
(3R Projects)**

Design Element		*	Manual Section	Design Values (by Type of Roadside Development)			
				Open	Moderate Density	High Density	
Design Controls	Typical Number of Access Points/Mile/Side		6-1.03	0 – 15	15 – 30	>30	
	Design Forecast Year		2-4.02	Current – 10 years	Current – 10 years	Current – 10 years	
	Design Speed	x	2-4.01	See Section 2-4.01	See Section 2-4.01	See Section 2-4.01	
	Control of Access		6-4.0	Partial/Control by Regulation	Control by Regulation	Control by Regulation	
	Level of Service		6-3.0	B – C	B – C	B – C	
Cross Section Elements	Travel Lane Width	x	2-7.01	See Figure 2-7A			
	Shoulder Width	Right	x	2-7.01	4' – 8'	4' – 8'	4' – 8'
		Left	x	10-1.02	2' – 8'	2' – 8'	2' – 8'
	Typical Cross Slope	Travel Lane	x	10-1.01	1.5 – 2.0% for lanes adjacent to crown; 2.0% for lanes away from crown		
		Shoulder (W < 4 ft)			Same as Adjacent Travel Lane		
		Shoulder (W ≥ 4 ft)	x	10-1.02	4%	4%	Uncurbed: 4% Curbed: 6%
	Turn Lanes	Lane Width			1' Less than Travel Lane Width — Same as Travel Lane		
		Shoulder Width	x		2' – 4'		
	Median Width (Includes Left Shoulders)	Depressed		10-3.0	Project-by-Project Basis		
		Raised Island (V = 50 mph)			Project-by-Project Basis		
	Bicycle Lane	Width		15-4.0	5' or Shoulder Width, whichever is greater		
		Cross Slope			2%		
	Bridge Width/Cross Slope	x	2-7.02	See Figure 2-7B for Width; Meet Roadway Cross Slope	Sidewalk Width: 5'-6"		
	Underpass Width		10-4.02	Meet Approach Roadway Width Plus Clear Zones			
	Right-of-Way Width		10-5.0	Project-by-Project Basis			
Roadside Clear Zones	x	2-9.01	Figure 13-2A or R/W width, whichever is less				
Fill/Cut Slopes		10-2.02	Existing — See Figure 4G				

\* Controlling design criteria (see Section 6-5.0).

**Figure 2-3A (Continued)**  
**MULTI-LANE RURAL ARTERIALS**  
**(3R Projects)**

Design Element		*	Manual Section	Design Values (Based on Design Speed)			
				60 mph	55 mph	50 mph	
Alignment Elements	Stopping Sight Distance		x	7-1.0	570'	495'	425'
	Decision Sight Distance	Maneuver		7-2.0	990'	865'	750'
		Stop			610'	535'	465'
	Minimum Radius (e = 6.0%)		x	2-5.01	See Section 2-5.01		
	Superelevation	e <sub>max</sub>		2-5.01	6.0%		
		Rate	x		See Section 2-5.01		
	Horizontal Sight Distance			8-2.04	See Section 8-2.04		
	Maximum Grade		x	2-6.01	6%	7%	7%
	Minimum Grade			9-2.03	0.5%		
	Vertical Curvature (K-Value)	Crest		2-6.02	See Section 2-6.02		
		Sag		2-6.03	136	115	96
	Minimum Vertical Clearance: Arterial Under ...	New Highway Bridge	x	9-4.0	16'-3"		
		Existing Highway Bridge	x		14'-3"		
Pedestrian Bridge		x	17'-6"				
Overhead Sign		x	18'-0"				
Minimum Vertical Clearance (Arterial over Railroad)		x		Electrified: 22'-6" All Others: 20'-6"			

\* Controlling design criteria (see Section 6-5.0).

**Figure 2-3B  
TWO-LANE RURAL ARTERIALS  
(3R Projects)**

Design Element		*	Manual Section	Design Values (by Type of Roadside Development)			
				Open	Moderate Density	High Density	
Design Controls	Typical Number of Access Points/Miles/Side		6-1.03	0 – 15	15 – 30	>30	
	Design Forecast Year		2-4.02	Current – 10 years	Current – 10 years	Current – 10 years	
	Design Speed	x	2-4.01	See Section 2-4.01	See Section 2-4.01	See Section 2-4.01	
	Control of Access		6-4.0	Partial/Control by Regulation	Control by Regulation	Control by Regulation	
	Level of Service		6-3.0	B – C	B – C	B – C	
Cross Section Elements	Travel Lane Width	x	2-7.01	See Figure 2-7A			
	Shoulder Width	x	2-7.01 10-1.02	4' – 8'	4' – 8'	4' – 8'	
	Typical Cross Slope	Travel Lane	x	10-1.01	1.5 – 2.0%	1.5 – 2.0%	1.5 – 2.0%
		Shoulder	x	10-1.02	4%	4%	Uncurbed: 4% Curbed: 6%
	Turn Lanes	Lane Width	x	10-1.03	1' Less Than Travel Lane Width — Same as Travel Lane		
		Shoulder Width	x		2' – 4'		
	Bicycle Lane	Width		15-4.0	5' or Shoulder Width, whichever is greater		
		Cross Slope			2%		
	Bridge Width/Cross Slope	x	2-7.02	See Figure 2-7B for Width; Meet Roadway Cross Slope	Sidewalk Width: 5'-6"		
	Underpass Width		10-4.02	Meet Approach Roadway Width Plus Clear Zones			
	Right-of-Way Width		10-5.0	Project-by-Project Basis			
	Roadside Clear Zones	x	2-9.01	Figure 13-2A or R/W width, whichever is less			
	Fill/Cut Slopes		10-2.02	Existing — See Figure 4G			

\* Controlling design criteria (see Section 6-5.0).



**Figure 2-3B (Continued)**  
**TWO-LANE RURAL ARTERIALS**  
**(3R Projects)**

Design Element		*	Manual Section	Design Values (Based on Design Speed)				
				60 mph	55 mph	50 mph	45 mph	
Alignment Elements	Stopping Sight Distance			7-1.0	570'	495'	425'	360'
	Decision Sight Distance	Maneuver		7-2.0	990'	865'	750'	675'
		Stop			610'	535'	465'	395'
	Minimum Radius		x	2-5.01	See Section 2-5.01			
	Superelevation	e <sub>max</sub>		2-5.01	6.0%			
		Rate	x		See Section 2-5.01			
	Horizontal Sight Distance			8-2.04	See Section 8-2.04			
	Maximum Grade		x	2-6.01	6%	7%	7%	8%
	Minimum Grade			9-2.03	0.5%			
	Vertical Curvature (K-Value)	Crest		2-6.02	See Section 2-6.02			
		Sag		2-6.03	136	115	96	79
	Minimum Vertical Clearance: Arterial Under ...	New Highway Bridge	x	9-4.0	16'-3"			
		Existing Highway Bridge	x		14'-3"			
Pedestrian Bridge		x	17'-6"					
Overhead Sign		x	18'-0"					
Minimum Vertical Clearance (Arterial over Railroad)		x		Electrified: 22'-6" All Others: 20'-6"				

\* Controlling design criteria (see Section 6-5.0).

**Figure 2-3C  
RURAL COLLECTOR ROADS  
(3R Projects)**

Design Element		*	Manual Section	Design Values (by Type of Roadside Development)			
				Open	Moderate Density	High Density	
Design Controls	Typical Number of Access Points/Mile/Side		6-1.03	0 – 15	15 – 30	>30	
	Design Forecast Year		2-4.02	Current – 10 years	Current – 10 years	Current – 10 years	
	Design Speed	AAADT < 400	x	2-4.01	Posted Legal Speed Limit	Posted Legal Speed Limit	Posted Legal Speed Limit
		AAADT: 400 – 2000			40 – 50 mph	40 – 50 mph	40 – 50 mph
		AAADT > 2000			See Section 2-4.01	See Section 2-4.01	See Section 2-4.01
	Control of Access		6-4.0	Control by Regulation	Control by Regulation	Control by Regulation	
Level of Service		6-3.0	C – D	C – D	C – D		
Cross Section Elements	Travel Lane Width	AAADT < 400	x	2-7.01	See Figure 2-7A	See Figure 2-7A	See Figure 2-7A
		AAADT: 400 – 1500					
		AAADT: 1500 – 2000					
		AAADT > 2000					
	Shoulder Width		x	2-7.01 10-1.02	2' – 8'	2' – 8'	2' – 8'
	Typical Cross Slope	Travel Lane	x	10-1.01	1.5 – 2.0% for lanes adjacent to crown; 2.0% for lanes away from crown		
		Shoulder (W < 4')			Same as Adjacent Travel Lane		
		Shoulder (W ≥ 4')	x	10-1.02	4%	Uncurbed: 4% Curbed: 6%	Uncurbed: 4% Curbed: 6%
	Turn Lanes	Lane Width	x	10-1.03	1' Less than Travel Lane Width — Same as Travel Lane		
		Shoulder Width	x		2' – 4'		
	Bicycle Lane	Width		15-4.0	5' or Shoulder Width, whichever is greater		
		Cross Slope			2%		
	Bridge Width/Cross Slope		x	2-7.02	See Figure 2-7B for Width; Meet Roadway Cross Slope	Sidewalk Width: 5'-6"	
	Underpass Width			10-4.02	Meet Approach Roadway Width Plus Clear Zones		
Right-of-Way Width			10-5.0	Project-by-Project Basis			
Roadside Clear Zones		x	2-9.01	Figure 13-2A or R/W width, whichever is less			
Fill/Cut Slopes			10-2.02	Existing — See Figure 4G			

\* Controlling design criteria (see Section 6-5.0).

**Figure 2-3C (Continued)**  
**RURAL COLLECTOR ROADS**  
**(3R Projects)**

Design Element		*	Manual Section	Design Values (Based on Design Speed)					
				55 mph	50 mph	45 mph	40 mph	35 mph	
Alignment Elements	Stopping Sight Distance	x	7-1.0	495'	425'	360'	305'	250'	
	Decision Sight Distance		7-2.0	Maneuver	865'	750'	675'	600'	525'
				Stop	535'	465'	395'	330'	275'
	Minimum Radius	x	2-5.01	See Section 2-5.01					
	Superelevation		2-5.01	$e_{max}$	6.0%				
				Rate	x	See Section 2-5.01			
	Horizontal Sight Distance		8-2.04	See Section 8-2.04					
	Maximum Grade	x	2-6.01	9%	9%	10%	10%	11%	
	Minimum Grade		9-2.03	0.5%					
	Vertical Curvature (K-Value)			Crest	See Section 2-6.02				
				Sag	115	96	79	64	49
	Minimum Vertical Clearance: Collector Under ...	New Highway Bridge	x	9-4.0	14'-6"				
Existing Highway Bridge		x	14'-3"						
Minimum Vertical Clearance (Collector over Railroad)		x	Electrified: 22'-6" All Others: 20'-6"						

\* Controlling design criteria (see Section 6-5.0).

**Figure 2-3D  
RURAL LOCAL ROADS  
(3R Projects)**

Design Element		*	Manual Section	Design Values (by Type of Roadside Development)			
				Open	Moderate Density	High Density	
Design Controls	Typical Number of Access Points/Mile/Side		6-1.03	0 – 15	15 – 30	>30	
	Design Forecast Year		2-4.02	Current – 10 years	Current – 10 years	Current – 10 years	
	Design Speed	x	2-4.01	Posted Legal Speed Limit	Posted Legal Speed Limit	Posted Legal Speed Limit	
	Control of Access		6-4.0	Control by Regulation	Control by Regulation	Control by Regulation	
	Level of Service		6-3.0	C – D	C – D	C – D	
Cross Section Elements	Travel Lane Width	x	2-7.01	9' – 12'	9' – 12'	9' – 12'	
	Shoulder Width	x	2-7.01 10-1.02	0' – 4'	0' – 4'	0' – 4'	
	Typical Cross Slope	Travel Lane	x	10-1.01	1.5 – 2.0%	1.5 – 2.0%	1.5 – 2.0%
		Shoulder (W < 4')			Same as Adjacent Travel Lane		
		Shoulder (W ≥ 4')	x	10-1.02	4%	Uncurbed: 4% Curbed: 6%	Uncurbed: 4% Curbed: 6%
	Turn Lanes	Lane Width	x	10-1.03	9' – 12'		
		Shoulder Width	x		0' – 2'		
	Bicycle Lane	Width		15-4.0	5' or Shoulder Width, whichever is greater		
		Cross Slope			2%		
	Bridge Width/Cross Slope	x	2-7.02	See Figure 2-7B for Width; Meet Roadway Cross Slope	Sidewalk Width: 5'-6"		
	Underpass Width		10-4.02	Meet Approach Roadway Width Plus Clear Zones			
	Right-of-Way Width		10-5.0	Project-by-Project Basis			
	Roadside Clear Zones	x	2-9.01	Figure 13-2A or R/W width, whichever is less			
Fill/Cut Slopes		10-2.02	Existing — See Figure 4G				

\* Controlling design criteria (see Section 6-5.0).

**Figure 2-3D (Continued)**  
**RURAL LOCAL ROADS**  
**(3R Projects)**

Design Element		*	Manual Section	Design Values (Based on Design Speed)							
				50 mph	45 mph	40 mph	35 mph	30 mph	25 mph	20 mph	
Alignment Elements	Stopping Sight Distance	x	7-1.0	425'	360'	305'	250'	200'	155'	115'	
	Decision Sight Distance	Maneuver		750'	675'	600'	525'	450'	N/A	N/A	
		Stop		465'	395'	330'	275'	220'			
	Minimum Radius	x	2-5.01	See Section 2-5.01							
	Superelevation	e <sub>max</sub>		2-5.01	6.0%						
		Rate	x		See Section 2-5.01						
	Horizontal Sight Distance			8-2.04	See Section 8-2.04						
	Maximum Grade		x	2-6.01	10%	11%	12%	12%	12%	13%	13%
	Minimum Grade			9-2.03	0.5%						
	Vertical Curvature (K-Value)	Crest		2-6.02	See Section 2-6.02						
		Sag		2-6.03	96	79	64	49	37	26	17
	Minimum Vertical Clearance: Local Road Under ...	New Highway Bridge	x	9-4.0	14'-6"						
Existing Highway Bridge		x	14'-3"								
Minimum Vertical Clearance (Local Road over Railroad)		x		Electrified: 22'-6" All Others: 20'-6"							

\* Controlling design criteria (see Section 6-5.0).

**Figure 2-3E**  
**MULTI-LANE PRINCIPAL URBAN ARTERIALS**  
**(3R Projects)**

Design Element		*	Manual Section	Design Values (by Type of Area)			
				Suburban	Intermediate	Built-up	
Design Controls	Design Forecast Year		2-4.02	Current – 10 years	Current – 10 years	Current – 10 years	
	Design Speed	x	2-4.01	See Section 2-4.01	See Section 2-4.01	See Section 2-4.01	
	Access Control		6-4.0	Partial/Control by Regulation	Control by Regulation	Control by Regulation	
	Level of Service		6-3.0	B – D	B – D	B – D	
	On-Street Parking		10-1.04	None	None	Sometimes	
Cross Section Elements	Travel Lane Width	x	2-7.01	11' – 12'	11' – 12'	10' – 12'	
	Shoulder Width	Right (Non-NHS)	x	2-7.01	2' – 8'	2' – 8'	2' – 8'
		Right (NHS)	x	10-1.02	4' – 8'	4' – 8'	4' – 8'
		Left (All)	x		2' – 4'	2' – 4'	2' – 4'
	Cross Slope	Travel Lane	x	10-1.01	1.5 – 2.0% for lanes adjacent to crown; 2.0% for lanes away from crown		
		Shoulder (W < 4')	x	10-1.02	Same as Adjacent Travel Lane		
		Shoulder (W ≥ 4')	x		4% – 6%	4% – 6%	4% – 6%
	Turn Lanes	Lane Width	x	10-1.03	1' Less than Travel Lane Width — Same as Travel Lane		
		Shoulder Width	x		1' – 4'	1' – 4'	1' – 4'
	Parking Lane Width		10-1.04		N/A	N/A	10' – 11'
	Median Width (Includes Left Shoulders)	Depressed		10-3.0	Project-by-Project Basis		
		Raised Island (V ≤ 50 mph)			Project-by-Project Basis		
	Sidewalk Width		10-2.01		5' Minimum	5' Minimum	5' Minimum
	Bicycle Lane	Width		15-4.0	5'	5'	5'
		Cross Slope			2%	2%	2%
	Bridge Width/Cross Slope	x	2-7.02		See Figure 2-7B for Width; Meet Roadway Cross Slope	Sidewalk Width: 5'-6"	
	Underpass Width		10-4.02		Meet Approach Roadway Width Plus Clear Zones		
	Right-of-Way Width		10-5.0		Project-by-Project Basis		
	Roadside Clear Zones	x	2-9.01		See Section 2-9.01		
	Fill/Cut Slopes		10-2.02		Existing — See Figure 5H		

\* Controlling design criteria (see Section 6-5.0).

**Figure 2-3E (Continued)**  
**MULTI-LANE PRINCIPAL URBAN ARTERIALS**  
**(3R Projects)**

Design Element		*	Manual Section	Design Values (Based on Design Speed)							
				60 mph	55 mph	50 mph	45 mph	40 mph	35 mph	30 mph	
Alignment Elements	Stopping Sight Distance		x	7-1.0	570'	495'	425'	360'	305'	250'	200'
	Decision Sight Distance	Maneuver		7-2.0	U: 1280' SU: 1125'	U: 1135' SU: 980'	U: 1030' SU: 890'	U: 930' SU: 800'	U: 825' SU: 715'	U: 720' SU: 625'	U: 620' SU: 535'
		Stop			1150'	1030'	910'	800'	690'	590'	490'
	Minimum Radius		x	2-5.01 2-5.02	See Section 2-5.01			715' (e = 4%)	535' (e = 4%)	375' (e = 4%)	250' (e = 4%)
	Superelevation	e <sub>max</sub>		2-5.01	6.0%	6.0%	6.0%	4.0%	4.0%	4.0%	4.0%
		Rate	x	2-5.02	See Section 2-5.01			See Figure 8-3C			
	Horizontal Sight Distance			8-2.04	See Section 8-2.04						
	Maximum Grade		x	2-6.01	8%	8%	9%	9%	9%	10%	11%
	Minimum Grade			9-2.03	0.5%						
	Vertical Curvature (K-Value)	Crest		2-6.02	See Section 2-6.02						
		Sag		2-6.03	136	115	96	79	64	49	37
	Minimum Vertical Clearance: Arterial Under ...	New Highway Bridge	x	9-4.0	16'-3"						
		Existing Highway Bridge	x		14'-3"						
		Pedestrian Bridge	x		17'-6"						
Overhead Sign		x	18'-0"								
Minimum Vertical Clearance (Arterial over Railroad)		x		Electrified: 22'-6" All Others: 20'-6"							

\* Controlling design criteria (see Section 6-5.0).

U: Urban

SU: Suburban

**Figure 2-3F  
TWO-LANE PRINCIPAL URBAN ARTERIALS  
(3R Projects)**

Design Element		*	Manual Section	Design Values (by Type of Area)			
				Suburban	Intermediate	Built-up	
Design Controls	Design Forecast Year		2-4.02	Current – 10 years	Current – 10 years	Current – 10 years	
	Design Speed	x	2-4.01	See Section 2-4.01	See Section 2-4.01	See Section 2-4.01	
	Access Control		6-4.0	Partial/Control by Regulation	Control by Regulation	Control by Regulation	
	Level of Service		6-3.0	B – D	B – D	B – D	
	On-Street Parking		10-1.04	None	None	Sometimes	
Cross Section Elements	Travel Lane Width	x	2-7.01	11' – 12'	11' – 12'	10' – 12'	
	Shoulder Width	Non-NHS	x	2-7.01	2' – 8'	2' – 8'	2' – 8'
		NHS	x	10-1.02	4' – 8'	4' – 8'	4' – 8'
	Cross Slope	Travel Lane	x		1.5 – 2.0%	1.5 – 2.0%	1.5 – 2.0%
		Shoulder (W < 4')	x	10-1.01	Same as Adjacent Travel Lane		
		Shoulder (W ≥ 4')	x		4% – 6%	4% – 6%	4% – 6%
	Turn Lanes	Lane Width	x		1' Less than Travel Lane Width — Same as Travel Lane		
		Shoulder Width	x	10-1.03	1' – 4'	1' – 4'	1' – 4'
	Parking Lane Width		10-1.04	N/A	N/A	10' – 11'	
	Sidewalk Width		10-2.01	5' Minimum	5' Minimum	5' Minimum	
	Bicycle Lane	Width		15-4.0	5'	5'	5'
		Cross Slope			2%	2%	2%
	Bridge Width/Cross Slope	x	2-7.02	See Figure 2-7B for Width; Meet Roadway Cross Slope Sidewalk Width: 5'-6"			
	Underpass Width		10-4.02	Meet Approach Roadway Width Plus Clear Zones			
	Right-of-Way Width		10-5.0	Project-by-Project Basis			
Roadside Clear Zones	x	2-9.01	See Section 2-9.01				
Fill/Cut Slopes		10-2.02	Existing — See Figure 5I				

\* Controlling design criteria (see Section 6-5.0).



**Figure 2-3F (Continued)**  
**TWO-LANE PRINCIPAL URBAN ARTERIALS**  
**(3R Projects)**

Design Element		*	Manual Section	Design Values (Based on Design Speed)					
				55 mph	50 mph	45 mph	40 mph	35 mph	
Alignment Elements	Stopping Sight Distance		x	7-1.0	495'	425'	360'	305'	250'
	Decision Sight Distance	Maneuver		7-2.0	U: 1135' SU: 980'	U: 1030' SU: 890'	U: 930' SU: 800'	U: 825' SU: 715'	U: 720' SU: 625'
		Stop			1030'	910'	800'	690'	590'
	Minimum Radius		x	2-5.01/ 2-5.02	See Section 2-5.01		715' (e = 4%)	535' (e = 4%)	375' (e = 4%)
	Superelevation	e <sub>max</sub>		2-5.01/ 2-5.02	6.0%	6.0%	4.0%	4.0%	4.0%
		Rate	x		See Section 2-5.01		See Figure 8-3C		
	Horizontal Sight Distance			8-2.04	See Section 8-2.04				
	Maximum Grade		x	2-6.01	8%	9%	9%	10%	11%
	Minimum Grade			9-2.03	0.5%				
	Vertical Curvature (K-Value)	Crest		2-6.02	See Section 2-6.02				
		Sag		2-6.03	115	96	79	64	49
	Minimum Vertical Clearance: Arterial Under ...	New Highway Bridge	x	9-4.0	16'-3"				
		Existing Highway Bridge	x		14'-3"				
Pedestrian Bridge		x	17'-6"						
Overhead Sign		x	18'-0"						
Minimum Vertical Clearance (Arterial over Railroad)		x		Electrified: 22'-6" All Others: 20'-6"					

\* Controlling design criteria (see Section 6-5.0).

U: Urban

SU: Suburban

**Figure 2-3G**  
**MINOR URBAN ARTERIALS**  
**(3R Projects)**

Design Element		*	Manual Section	Design Values (by Type of Area)			
				Suburban	Intermediate	Built-up	
Design Controls	Design Forecast Year		2-4.02	Current – 10 years	Current – 10 years	Current – 10 years	
	Design Speed	x	2-4.01	See Section 2-4.01	See Section 2-4.01	See Section 2-4.01	
	Access Control		6-4.0	Control by Regulation	Control by Regulation	Control by Regulation	
	Level of Service		6-3.0	B – D	B – D	B – D	
	On-Street Parking		10-1.04	None	Sometimes	Sometimes	
Cross Section Elements	Travel Lane Width	x	2-7.01	11' – 12'	10' – 12'	10' – 12'	
	Shoulder Width	Right (Non-NHS)	x	2-7.01 10-1.02	2' – 8'	2' – 8'	2' – 8'
		Right (NHS)	x		4' – 8'	4' – 8'	4' – 8'
		Left (All)	x		2' – 4'	2' – 4'	2' – 4'
	Cross Slope	Travel Lane	x	10-1.01	1.5 – 2.0% for lanes adjacent to crown; 2% for lanes away from crown		
		Shoulder (W < 4')	x	10-1.02	Same as Adjacent Travel Lane		
		Shoulder (W ≥ 4')	x		4% – 6%	4% – 6%	4% – 6%
	Turn Lanes	Lane Width	x	10-1.03	1' Less than Travel Lane Width — Same as Travel Lane		
		Shoulder Width	x		1' – 4'	1' – 4'	1' – 4'
	Parking Lane Width			10-1.04	N/A	9' – 11'	8' – 11'
	Sidewalk Width			10-2.01	5' Minimum	5' Minimum	5' Minimum
	Bicycle Lane	Width		15-4.0	5'	5'	5'
		Cross Slope			2%	2%	2%
	Bridge Width/Cross Slope	x	2-7.02		See Figure 2-7B for Width; Meet Roadway Cross Slope	Sidewalk Width: 5'-6"	
	Underpass Width			10-4.02	Meet Approach Roadway Width Plus Clear Zones		
	Right-of-Way Width			10-5.0	Project-by-Project Basis		
Roadside Clear Zones	x	2-9.01		See Section 2-9.01			
Fill/Cut Slopes			10-2.02	Existing — See Figure 5I			

\* Controlling design criteria (see Section 6-5.0).

**Figure 2-3G (Continued)**  
**MINOR URBAN ARTERIALS**  
**(3R Projects)**

Design Element		*	Manual Section	Design Values (Based on Design Speed)					
				50 mph	45 mph	40 mph	35 mph	30 mph	
Alignment Elements	Stopping Sight Distance		x	7-1.0	425'	360'	305'	250'	200'
	Decision Sight Distance	Maneuver		7-2.0	U: 1030' SU: 890'	U: 930' SU: 800'	U: 825' SU: 715'	U: 720' SU: 625'	U: 620' SU: 535'
		Stop			910'	800'	690'	590'	490'
	Minimum Radius		x	2-5.01/ 2-5.02	See Section 2-5.01	715' (e = 4%)	535' (e = 4%)	375' (e = 4%)	250' (e = 4%)
	Superelevation	e <sub>max</sub>		2-5.01/ 2-5.02	6.0%	4.0%	4.0%	4.0%	4.0%
		Rate	x		See Section 2-5.01			See Figure 8-3C	
	Horizontal Sight Distance			8-2.04	See Section 8-2.04				
	Maximum Grade		x	2-6.01	9%	9%	10%	11%	11%
	Minimum Grade			9-2.03	0.5%				
	Vertical Curvature (K-Value)	Crest		2-6.02	See Section 2-6.02				
		Sag		2-6.03	96	79	64	49	37
	Minimum Vertical Clearance: Arterial Under ...	New Highway Bridge	x	9-4.0	16'-3"				
Existing Highway Bridge		x	14'-3"						
Minimum Vertical Clearance (Arterial over Railroad)		x	9-4.0	Electrified: 22'-6" All Others: 20'-6"					

\* Controlling design criteria (see Section 6-5.0).

U: Urban

SU: Suburban

**Figure 2-3H  
URBAN COLLECTOR STREETS  
(3R Projects)**

Design Element		*	Manual Section	Design Values (By Type of Area)			
				Suburban	Intermediate	Built-up	
Design Controls	Design Forecast Year		2-4.02	Current – 10 years	Current – 10 years	Current – 10 years	
	Design Speed	x	2-4.01	See Section 2-4.01	See Section 2-4.01	See Section 2-4.01	
	Access Control		6-4.0	Control by Regulation	Control by Regulation	Control by Regulation	
	Level of Service		6-3.0	C – D	C – D	C – D	
	On-Street Parking		10-1.04	Sometimes	Sometimes	Sometimes	
Cross Section Elements	Travel Lane Width	x	2-7.01	10' – 12'	10' – 12'	10' – 12'	
	Shoulder Width	x	2-7.01 10-1.02	2' – 8'	2' – 8'	2' – 8'	
	Cross Slope	Travel Lane (with curb)			1.5 – 3.0%	1.5 – 3.0%	1.5 – 3.0%
		Travel Lane (without curb)	x		1.5 – 2.0% for lands adjacent to crown; 2% for lanes away from crown		
		Shoulder (W < 4')	x	10-1.01	Same as Adjacent Travel Lane		
		Shoulder (W ≥ 4')	x		4% – 6%	4% – 6%	4% – 6%
	Turn Lanes	Lane Width	x		1' Less than Travel Lane Width — Same as Travel Lane		
		Shoulder Width	x	10-1.03	1' – 4'	1' – 4'	1' – 4'
	Parking Lane Width		10-1.04	7' – 10'	7' – 10'	7' – 10'	
	Sidewalk Width		10-2.01	5' Minimum	5' Minimum	5' Minimum	
	Bicycle Lane	Width		15-4.0	5'	5'	5'
		Cross Slope			2%	2%	2%
	Bridge Width/Cross Slope	x	2-7.02	See Figure 2-7B for Width; Meet Roadway Cross Slope Sidewalk Width: 5'-6"			
	Underpass Width		10-4.02	Meet Approach Roadway Width Plus Clear Zones			
	Right-of-Way Width		10-5.0	Project-by-Project Basis			
Roadside Clear Zones	x	2-9.01	See Section 2-9.01				
Fill/Cut Slopes		10-2.02	Existing — See Figure 5I				

\* Controlling design criteria (see Section 6-5.0).

**Figure 2-3H (Continued)**  
**URBAN COLLECTOR STREETS**  
**(3R Projects)**

Design Element		*	Manual Section	Design Values (Based on Design Speed)				
				45 mph	40 mph	35 mph	30 mph	
Alignment Elements	Stopping Sight Distance		x	7-1.0	360'	305'	250'	200'
	Decision Sight Distance	Maneuver		7-2.0	U: 930' SU: 800'	U: 825' SU: 715'	U: 720' SU: 625'	U: 620' SU: 535'
		Stop			800'	690'	590'	490'
	Minimum Radius (e = 4%)		x	2-5.02	715'	535'	375'	250'
	Superelevation	e <sub>max</sub>		2-5.02	4.0%	4.0%	4.0%	4.0%
		Rate	x		See Figure 8-3C			
	Horizontal Sight Distance			8-2.04	See Section 8-2.04			
	Maximum Grade		x	2-6.01	11%	12%	13%	13%
	Minimum Grade			9-2.03	0.5%			
	Vertical Curvature (K-Value)	Crest		2-6.02	See Section 2-6.02			
		Sag		2-6.03	79	64	49	37
	Minimum Vertical Clearance: Collector Under ...	New Highway Bridge	x	9-4.0	14'-6"			
		Existing Highway Bridge	x		14'-3"			
Minimum Vertical Clearance (Collector over Railroad)		x	9-4.0	Electrified: 22'-6" All Others: 20'-6"				

\* Controlling design criteria (see Section 6-5.0).

U: Urban

SU: Suburban

**Figure 2-3I  
LOCAL URBAN STREETS  
(3R Projects)**

Design Element		*	Manual Section	Design Values (By Type of Area)			
				Suburban	Intermediate	Built-up	
Design Controls	Design Forecast Year		2-4.02	Current – 10 years	Current – 10 years	Current – 10 years	
	Design Speed	x	2-4.01	See Section 2-4.01	See Section 2-4.01	See Section 2-4.01	
	Access Control		6-4.0	Control by Regulation	Control by Regulation	Control by Regulation	
	Level of Service		6-3.0	C – D	C – D	C – D	
	On-Street Parking		10-1.04	Sometimes	Sometimes	Sometimes	
Cross Section Elements	Travel Lane Width	x	2-7.01	10' – 11'	10' – 11'	9' – 11'	
	Shoulder Width	x	2-7.01	2' – 4'	2' – 4'	2' – 4'	
	Cross Slope	Travel Lane	x	10-1.01	1.5 – 2.0% (1.5-3.0% with curbing)	1.5 – 2.0% (1.5-3.0% with curbing)	1.5 – 2.0% (1.5-3.0% with curbing)
		Shoulder (W < 4')	x	10-1.02	Same as Adjacent Travel Lane		
		Shoulder (W ≥ 4')	x		4% – 6%	4% – 6%	4% – 6%
	Turn Lanes	Lane Width	x	10-1.03	1' Less than Travel Lane Width (9' Min.) — Same as Travel Lane		
		Shoulder Width	x		1' – 4'	1' – 4'	1' – 4'
	Parking Lane Width		10-1.04	7' – 10'	7' – 11'	7' – 11'	
	Sidewalk Width		10-2.01	5' Minimum	5' Minimum	5' Minimum	
	Bicycle Lane	Width		15-4.0	5'	5'	5'
		Cross Slope			2%	2%	2%
	Bridge Width/Cross Slope	x	2-7.02	See Figure 2-7B for Width; Meet Roadway Cross Slope	Sidewalk Width: 5'-6"		
	Underpass Width		10-4.02	Meet Approach Roadway Width Plus Clear Zones			
	Right-of-Way Width		10-5.0	Project-by-Project Basis			
	Roadside Clear Zones	x	2-9.01	See Section 2-9.01			
Fill/Cut Slopes		10-2.02	Existing — See Figure 5I				

\* Controlling design criteria (see Section 6-5.0).

**Figure 2-3I (Continued)**  
**LOCAL URBAN STREETS**  
**(3R Projects)**

Design Element		*	Manual Section	Design Values (Based on Design Speed)			
				30 mph	25 mph	20 mph	
Alignment Elements	Stopping Sight Distance		x	7-1.0	200'	155'	115'
	Decision Sight Distance	Maneuver		7-2.0	U: 620' SU: 535'	N/A	N/A
		Stop			490'	N/A	N/A
	Minimum Radius (e = 4%)		x	2-5.02	250'	155'	90'
	Superelevation	e <sub>max</sub>		2-5.02	4.0%	4.0%	4.0%
		Rate	x		See Figure 8-3C		
	Horizontal Sight Distance			8-2.04	See Section 8-2.04		
	Maximum Grade		x	2-6.01	12%	13%	13%
	Minimum Grade			9-2.03	0.5%		
	Vertical Curvature (K-Value)	Crest		2-6.02	See Section 2-6.02		
		Sag		2-6.03	37	26	17
	Minimum Vertical Clearance: Local Street Under ...	New Highway Bridge	x	9-4.0	14'-6"		
Existing Highway Bridge		x	14'-3"				
Minimum Vertical Clearance (Local Street over Railroad)		x	9-4.0	Electrified: 22'-6" All Others: 20'-6"			

\* Controlling design criteria (see Section 6-5.0).

U: Urban

SU: Suburban





## 2-4.0 DESIGN CONTROLS

Reference: Section 1-1.03.04

### 2-4.01 Design Speed

Reference: Section 6-2.02

Unless the design speed is specified in Figures 2-3A through 2-3I, use the following procedure on 3R projects to determine the design speed, which is based on the actual speed measured in the field:

1. The Division of Traffic Engineering will be requested to provide existing speed studies in the vicinity of the proposed project. If there are no recent studies available, then field measurements may be required. The designer should carefully evaluate the speed data to determine an 85th percentile speed which represents the operating characteristics of a lengthy segment of the road, not just a short segment near the proposed project.
2. Based on the Department's adopted traffic engineering practices, the Division of Traffic Engineering will determine the 85th percentile of the existing traffic speeds.
3. The designer will select the 3R design speed according to Figure 2-4A. This design speed will be used to evaluate the geometric design features of the existing highway for those elements based on design speed.

85 <sup>th</sup> Percentile "V" (mph)	Design Speed (mph)
$0 \leq V \leq 20$	20
$20 \leq V \leq 25$	20/25
$25 \leq V \leq 30$	25/30
$30 \leq V \leq 35$	30/35
$35 \leq V \leq 40$	35/40
$40 \leq V \leq 45$	40/45
$45 \leq V \leq 50$	45/50
$50 \leq V \leq 55$	50/55
$55 \leq V \leq 60$	55/60
$V > 60$	60/70

**DESIGN SPEEDS FOR 3R PROJECTS  
(Based on 85th Percentile Speeds)**

**Figure 2-4A**

**2-4.02 Highway Capacity**

Reference: Section 6-3.0

Three major factors determine the results of a capacity analysis. Their specific application to 3R projects is discussed below:

1. Level of Service (LOS). Figures 2-3A through 2-3I provide the range of LOS criteria for 3R projects.
2. Design Volume. The highway facility should be designed to accommodate the LOS for the selected DHV and/or AADT. The design volume may range from the current traffic volumes to ten years beyond the expected construction completion date.
3. Capacity Analysis. The analytical techniques in the *Highway Capacity Manual* will be used to conduct the capacity analysis.

**2-4.03 Exceptions to Geometric Design Criteria**

Reference: Section 6-5.0

The discussion in Section 6-5.0 on exceptions applies equally to the geometric design of 3R projects. The designer will be evaluating the proposed design against the criteria presented in Chapter Two.

## **2-5.0 HORIZONTAL ALIGNMENT**

Chapter Eight discusses horizontal alignment criteria for all highways. These criteria will apply to 3R projects, except where discussed in the following Sections.

### **2-5.01 Rural Highways and High-Speed Urban Highways**

Reference: Section 8-2.0

Figure 2-5A will be used to determine the design speed of an existing horizontal curve. This should be compared to the 85th percentile speed. In the absence of an adverse crash history, all existing horizontal curves with a design speed within 15 mph of the 85th percentile speed are acceptable. No formal design exception is required for horizontal curves within this range; however, it should be documented in the project files.

Figure 2-5A can be used only to decide if corrective action should be considered. Once the decision has been made to improve the curve, the designer should use the criteria in Figure 8-2A to determine the proper combination of curve radius and superelevation to meet the 3R design speed.

If the existing curve satisfies the above criteria for design speed, the designer will not normally need to check other details of the horizontal curve (e.g., superelevation transition length, distribution of superelevation between tangent and curve).

### **2-5.02 Low-Speed Urban Streets**

Reference: Section 8-3.0

Section 8-3.0 discusses horizontal alignment criteria for low-speed urban streets (i.e., design speed less than or equal to 45 mph), and Figure 8-3C can be used to determine the design speed of an existing horizontal curve. Once this is determined, the 3R evaluation of the horizontal curve on a low-speed urban street will be similar to that for rural highways/high-speed urban highways in Section 2-5.01.

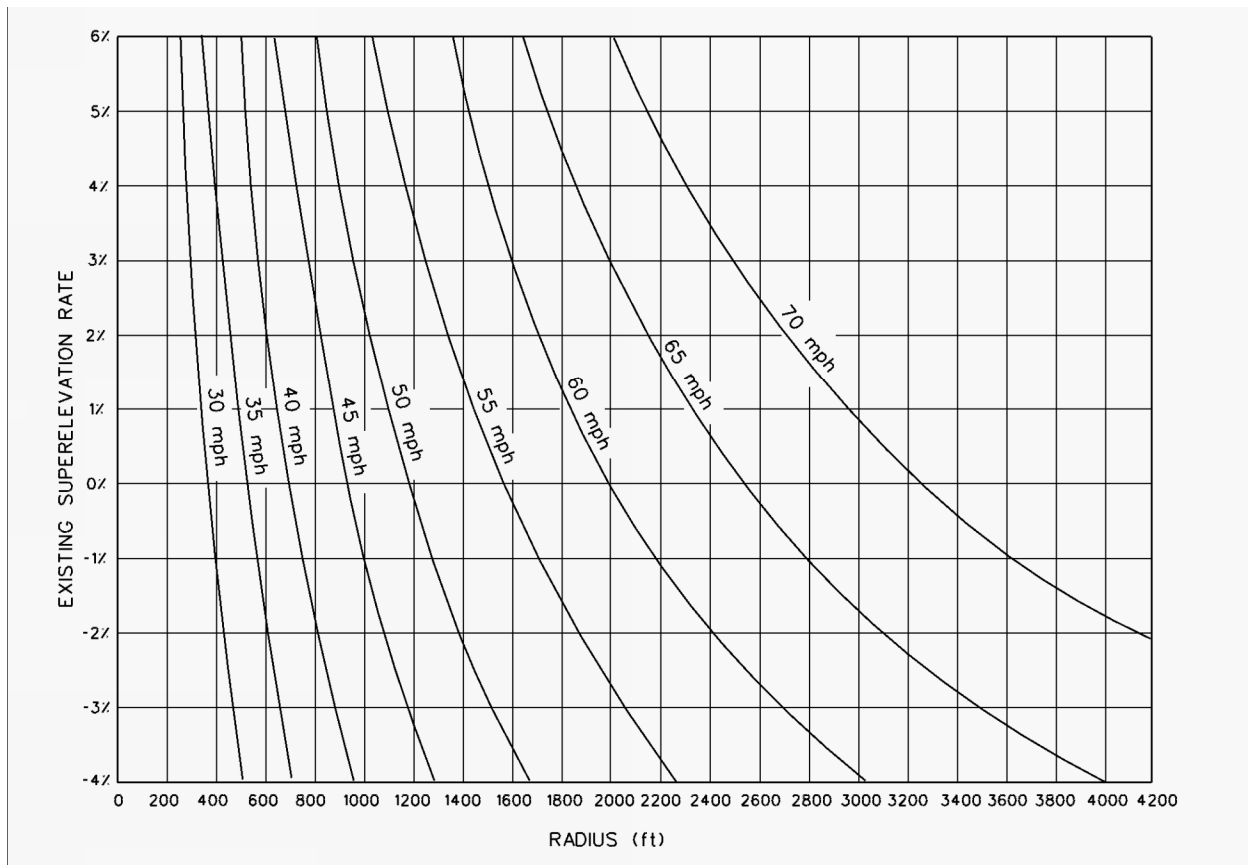

### Example

**Given:** The 85th percentile speed for the 3R project will be 55 mph. An existing curve within the project limits has the following data:

$$R = 1600 \text{ ft}$$

$$e = 3.0\%$$

**Problem:** Determine if improvements should be considered.

**Solution:** Using the Figure, the existing curve is adequate for a design speed of 55 mph. Therefore, no improvement is necessary. Note that if Figure 8-2A was used, the necessary superelevation rate would be 5.4%.

This figure will be used to determine if an existing horizontal curve is acceptable. Use Figure 8-2A if any improvements are made to the curve. Use Figure 8-3C for low-speed urban streets.

### RADII FOR RETAINING EXISTING HORIZONTAL CURVES (3R Projects)

Figure 2-5A

## **2-6.0 VERTICAL ALIGNMENT**

### **2-6.01 Grades**

Reference: Section 9-2.0

Figures 2-3A through 2-3I present the Department's criteria for maximum and minimum grades on 3R projects. The maximum grades are 2% steeper than those for new construction/reconstruction.

### **2-6.02 Crest Vertical Curves**

Reference: Section 9-3.02

Section 9-3.02 presents the Department's criteria for the design of crest vertical curves. This information will be used to determine the design speed of an existing crest vertical curve, which will then be compared to the 85th percentile speed. The following summarizes the 3R design criteria for crest vertical curves:

1. Crest Vertical Curves. In the absence of an adverse crash history, all existing crest vertical curves with a design speed within 15 mph of the 85th percentile speed are acceptable. No formal design exception is required for crest vertical curves within this range; however, it should be documented in the project files.
2. Angle Points. It is acceptable to retain an existing "angle" point (i.e., no vertical curve) of 1% or less.

If the decision is made to flatten the crest vertical curve, the designer should reconstruct the curve to meet the criteria for new construction/reconstruction in Section 9-3.02.

### **2-6.03 Sag Vertical Curves**

Reference: Section 9-3.03

Section 9-3.03 presents the Department's criteria for the design of sag vertical curves for new construction and reconstruction. These criteria are based on designing the sag to allow the vehicle's headlights to illuminate the pavement for a distance equal to the stopping sight distance for the design speed. For 3R projects, the following will apply:

1. Evaluation. The comfort criteria represent the minimum criteria for the retention of an existing sag vertical curve. Figure 2-6A presents the comfort criteria. If an existing sag does not meet these criteria, then the designer should consider flattening the sag vertical curve.
2. Corrective Action. If the decision is made to flatten the sag, the design should meet the criteria for headlight sight distance in Section 9-3.03. As an alternative, the re-designed

sag may meet the comfort criteria in Figure 2-6A, if there is proper illumination of the sag vertical curve.

3. Angle Points. It is acceptable to retain an existing "angle" point (i.e., no vertical curve) of 1% or less.

Design Speed (mph)	K-Values $K = V^2/46.5$
20	9
25	14
30	20
35	27
40	35
45	44
50	54
55	65
60	78

**K-VALUES FOR SAG VERTICAL CURVES  
(3R Projects)**

**Figure 2-6A**

## 2-7.0 CROSS SECTIONS

### 2-7.01 Widths

Reference: Chapters Four and Five

Chapters Four and Five present the Department's criteria for cross section elements for new construction and reconstruction. Figure 2-7A presents the travel lane widths for rural 3R collectors and arterials. The Figures in Section 2-3.0 present the shoulder widths for rural 3R projects and present the travel lane and shoulder widths for urban 3R projects. In general, the 3R widths have been established considering the minimum acceptable width for the element from an operational and safety perspective; considering what will be available for a practical improvement on a "typical" 3R project; and considering that, in general, it is better to improve more miles to a lower level than to improve fewer miles to a higher level. All of these considerations are consistent with the overall objectives of the Department's 3R program.

Design Year AADT	Functional Class	Design Speed (mph)	Lane Width	
			T ≥ 10%	T < 10%
1 – 750	Collector/Arterial	≤ 45	10'	9'
		> 45	10'	10'
750 – 1500	Collector	≤ 45	11'	10'
		> 45	11'	11'
	Arterial	≤ 45	11'	10'
		> 45	12'	11'
1500 – 2000	Collector/Arterial	≤ 45	11'	10'
		> 45	12'	11'
> 2000	Collector/Arterial	All	12'	12'

Note: T = Trucks

### TRAVEL LANE WIDTHS (Rural 3R Projects)

Figure 2-7A

## 2-7.02 Bridges

Reference: Section 10-4.01

### 2-7.02.01 **Bridge Rehabilitation**

A bridge or several bridges may be within the limits of the 3R project. The bridge structure may be partially or entirely rehabilitated as part of the 3R project and shall be designed in accordance with the Bridge Design Manual. It is desirable to carry the full approach width, including shoulders, across the structure. *Note: CGS 13a-86 requires a minimum bridge width of 28 ft on any two-lane highway maintained by the Commissioner, exclusive of any sidewalk width. No exceptions to this criterion will be allowed on State-maintained highways unless, in the judgment of the Commissioner, a lesser width is warranted. The criterion in CGS 13a-86 does not apply to bridges on highways maintained by a municipality.*

Items #2 and #3 in Section 2-7.02.02 also apply.

### 2-7.02.02 **Bridges to Remain in Place**

If an existing bridge is structurally sound and if it meets the Department's design loading structural capacity, it is unlikely to be cost effective to propose geometric improvements to the bridge. However, the geometric deficiencies may be severe, and/or there may be an adverse crash experience at the bridge. Therefore, the following will apply to all bridges to remain in place:

1. Width. The width of the existing bridge should be evaluated against the criteria in Figure 2-7B. If the existing bridge does not meet these criteria, it should be evaluated for widening, including a review of the crash experience at the bridge.
2. Narrow Bridges. All bridges that are narrower than the approach roadway width (including shoulders) should be evaluated for special narrow bridge treatments. At a minimum, the signing and pavement markings must meet the criteria of the MUTCD. In addition, NCHRP 203 *Safety at Narrow Bridge Sites* provides criteria specifically for narrow bridges (e.g., special pavement markings). The designer, in coordination with the Division of Traffic Engineering, should evaluate the value of these additional treatments at the bridge site.
3. Bridge Rails and Parapets, Approach Guiderail Transitions and Bridge Attachments. All existing bridge rails and/or parapets, approach guiderail transitions, and bridge attachments on the project should be evaluated to determine if they are structurally adequate and/or meet the Department's current criteria. See guidance established in Chapter Thirteen.



Design Year AADT	Functional Class	Clear Bridge Width (Note 1)
0 – 750	All	Approach Traveled Way Width
750 – 1500	Local/Collector	Approach Traveled Way Width Plus 2' or 22' whichever is less.
	Arterial	Approach Traveled Way Width Plus 2'
1500 – 2000	Local/Collector	Approach Traveled Way Width Plus 2' or 24' whichever is less.
	Arterial	Approach Traveled Way Width Plus 2'
2000 – 4000	All	Approach Traveled Way Width Plus 4'
> 4000	Local/Collector	Approach Traveled Way Width Plus 4' or 28' whichever is less.
	Arterial	Approach Traveled Way Width Plus 4'

*Notes:*

1. Clear Bridge Width. *The width between curbs or rails, whichever is less.*
2. Long Bridges (Locals/Collectors). *For bridges on these facilities with a total length greater than 100 ft, the widths in the table do not apply. These structures should be analyzed individually considering the existing width, safety, traffic volumes, remaining structural life, design speed, costs to widen, etc.*

**WIDTHS FOR EXISTING BRIDGES TO REMAIN IN PLACE  
(3R Projects)**

**Figure 2-7B**

**2-7.03 Climbing Lanes**

Reference: Section 9-2.0

The design criteria in Section 9-2.0 will apply to existing or proposed climbing lanes within the limits of 3R projects; however, the following criteria are acceptable for 3R projects:

1. Lane Width. The minimum width of the climbing lane will be 11 ft.
2. Shoulder Width. The minimum width of the shoulder adjacent to the climbing lane will be 4 ft.

**2-7.04 Other Cross Section Elements**

Reference: Chapters Four, Five and Ten

These Chapters provide the Department's criteria and details for many other cross section elements, including:

1. location and type of parking lanes,
2. warrants for and types of curbs,
3. warrants for and design of sidewalks,
4. slope rounding,
5. roadside ditches,
6. median type, and
7. fill and cut slopes.

The designer should evaluate the cross section of the existing highway or street and, as part of the 3R project, should make any improvements that are considered cost effective. Some of the design information in Chapter Ten applies directly to 3R projects (e.g., warrants for curbs and sidewalks); some of the design information will only apply if practical (e.g., slope rounding).

## **2-8.0 SPECIAL DESIGN ELEMENTS**

### **2-8.01 General**

Reference: Chapter Fifteen

Chapter Fifteen provides the Department's criteria and design details for many special design elements. The designer should review this Chapter to determine if these criteria apply to the 3R project. For example, Section 15-5.0 presents information on landscaping. Aesthetics can play a significant role in the community's acceptance of a roadway improvement. Designers should aim to preserve or restore as much of the existing landscape as practical. Chapter Fifteen provides the necessary tools and references that should be considered to maintain or improve the visual quality of the roadway.

### **2-8.02 Traffic Calming**

Traffic calming measures (TCM) consist of a variety of techniques and treatments designed to mitigate the impacts of vehicular travel. Traffic calming is typically limited to municipal streets but may be considered on State-maintained facilities off the NHS. TCMs typically refer to an assortment of physical features placed within the limits of the roadway environment including; but not limited to the following:

1. intersection diverters,
2. roundabouts,
3. channelization,
4. speed humps,
5. speed tables,
6. street narrowing,
7. angle point/chicanes,
8. driveway links,
9. gateway/perimeter treatments, and
10. street closure.

Municipalities that have developed TCM guidelines may explore traffic calming strategies on a project-by-project basis. An effective traffic calming strategy may integrate more than one TCM into a comprehensive traffic-calming program for the study area. Additional information on traffic calming strategies and measures can be found in several online sources such as ITE, FHWA and TRB websites.



## 2-9.0 ROADSIDE SAFETY

### 2-9.01 Clear Zones

Reference: Section 13-2.0

#### 2-9.01.01 Basic 3R Criteria

Section 13-2.0 presents the Department's criteria for roadside clear zones on new construction and reconstruction projects. The designer should make every reasonable effort to provide a clear zone equal to the criteria in Section 13-2.0 for 3R projects. However, attempting to achieve a roadside clear zone on a 3R project can cause significant problems. The roadside environment is typically cluttered with any number of natural and man-made obstacles. To remove or relocate these obstacles can present formidable problems and public opposition, and it can be very costly. On the other hand, the designer cannot ignore the consequences to a run-off-the-road vehicle. Therefore, the designer must exercise considerable judgement when determining the appropriate clear zone on the 3R project. The designer should consider the following:

1. Application. The designer may consider a selective application of the roadside clear zone criteria. Along some sections of highway, it may be practical to provide the clear-zone criteria from Section 13-2.0; along other sections, it may be impractical. In addition, some obstacles will be more hazardous than others. Judgement will be necessary for the application of the clear zone criteria. For 3R projects, the criteria in Section 13-2.0 may be modified as follows:
  - a. On urban and rural collectors and local roads where the 3R design speed is 45 mph and below, the minimum clear zone should be 10 ft. If practical, the clear zone should be increased where the side slope is 1:6 or steeper. The criteria in Section 13-2.0 can be used to determine the applicable adjustments.
  - b. It will often be impractical on 3R projects to obtain additional right-of-way specifically to meet the criteria in Section 13-2.0 or, sometimes, even the minimum clear zone criteria noted above. The designer should use his/her engineering judgement on whether or not to purchase right-of-way to meet the criteria in Section 13-2.0 as modified above or use the existing right-of-way line for the minimum clear zone criteria. See further discussion on design exceptions below.
2. Crash Data. The designer should review the crash data to estimate the extent of the roadside safety problem. In particular, there may be sites where clusters of run-off-the-road crashes have occurred.
3. Utilities. Utility poles are a common roadside obstacle on 3R projects. Relocation is required when the utility poles physically conflict with the proposed construction. The designer should evaluate, consider, and apply engineering judgement when there is a safety benefit for relocating utility poles that are not impacted by the proposed construction on a project-by-project basis. Poles should be located as near as practical to the right-of-

way line. In restricted right-of-way areas, every effort should be made to provide the clear zone used in design. The use of armless single-pole construction with vertical configuration of wires and cables and/or other special construction, as may be appropriate, should be considered. In urban areas, the designer should also consider burying the utilities underground when relocation is impractical.

4. Public. Public acceptance of widened clear zones can be a significant issue, especially when the removal of trees is being considered. The designer must evaluate the community impact and subjectively factor this into the decision-making process.
5. Safety Appurtenances. Installing guiderail or impact attenuators is an alternative to providing a wider clear zone. Section 13-3.0 presents warrants for guiderail, and Section 13-10.0 presents warrants for impact attenuators. However, this can lead to lengthy runs of guiderail along the roadside. The designer should understand that guiderail warrants are based on the relative severity between a hazard and guiderail; they are not intended to justify the cost-effectiveness of guiderail installation. Therefore, on 3R projects, engineering judgement should be used to determine if guiderail should be installed to shield a hazard within the clear zone. See Section 2-9.02 for more discussion.
6. Design Exceptions: For the purpose of deciding when a design exception is necessary, the proposed clear zone will be measured against Section 13-2.0, as modified by #1(a) above, or against the existing right-of-way, whichever is less. If the clear zone used in design is the existing right-of-way line and if existing utility poles are as near as practical to the right-of-way line, then the utility poles can intrude into the clear zone without the need for a design exception.

### **2-9.01.02 Rock Removal**

Because of the often-considerable expense to remove rock to meet the Department's roadside clear zone criteria, the Department has adopted a policy specifically for this design element. If the costs and associated impacts with removing rock to meet the 3R clear zone criteria are insignificant, the designer should implement the improvement. If, however, there are negative impacts and/or the costs are significant, the designer should evaluate the following factors:

1. Project Scope. Based on the overall project objectives, the designer should judge if the potential benefits and costs of the rock removal are consistent with the project scope of work.
2. Crash Data. The designer should review the crash data along the 3R project route to identify the specific roadside hazards related to the presence of rock.
3. Other Benefits. The rock removal may generate benefits other than those for roadside safety. These include:
  - a. improving intersection sight distance;
  - b. improving sight distance around horizontal curves; or

- c. improving any rock stability, ground water and/or icing problems.

Any additional benefits should be considered when determining the extent of rock removal.

4. Alternative Improvements. Where the designer determines that the existing rock presents a significant roadside hazard, the designer should consider alternative improvements in lieu of rock removal. These include:
  - a. installing concrete barrier or guiderail, and
  - b. providing a positive slope with rounding at its toe up to the face of the rock (i.e., 1:4 or steeper) to provide limited vehicular redirection.
5. Application. If rock is within the clear zone and more than 18 ft from the edge of traveled way, the CTDOT Design Exception Committee will review the case and will either:
  - a. determine that rock removal is appropriate because of its crash potential, or
  - b. grant a design exception of the clear zone criteria.

Designers should also document and evaluate the existing rock face for potential flaking and/or falling debris due to rock instability or icing conditions. The designer should consider the need for roadside barrier protection, not only to provide a catchment area between the roadway and the rock face but also to re-direct run-off-the-road vehicles away from any potential debris. This should be documented in the project file and verification sought from the Design Exceptions Committee.

## **2-9.02 Safety Appurtenances**

Reference: Chapter Thirteen

During the design of a 3R project, all existing safety appurtenances should be examined to determine if they meet the Department's current safety performance and design criteria. This includes guiderail, median barriers, end treatments, sign supports, luminaire supports, etc. Normally, all existing safety appurtenances will be upgraded to meet the most recent criteria in accordance with the guidance established in Chapter Thirteen. Chapter Thirteen also presents the Department's criteria for the layout of guiderail, median barriers and end treatments.

Guiderail warrants on 3R projects can be especially difficult to resolve. Basically, the evaluation process is as follows:

1. Determine if guiderail is warranted in accordance with Section 13-3.0. However, also see Item #5 in Section 2-9.01.01. As part of this process, the designer must decide if the guiderail will create a greater hazard than the obstacle that it is shielding.
2. If an existing run of guiderail is located where none is warranted, remove the guiderail.

3. If guiderail is warranted, consider removing or relocating the hazard; reducing the hazard (e.g., flattening a slope); or making it breakaway.
4. If the hazard cannot be eliminated and guiderail is considered cost effective, then install guiderail. For existing runs of guiderail, ensure that they meet the applicable performance and design criteria, including:
  - a. operational acceptability (hardware, height, etc.) in accordance with Section 13-4.0,
  - b. dynamic deflection criteria,
  - c. length of need,
  - d. flare rate,
  - e. lateral placement, and
  - f. placement on slopes and behind curbs.



## **2-10.0 INTERSECTIONS AT-GRADE**

Reference: Chapter Eleven

Chapter Eleven provides criteria for the detailed design of intersections at-grade. Where practical, these criteria apply to 3R projects and should be implemented. The following Sections indicate areas where modifications to the intersection criteria may be made for 3R projects.

### **2-10.01 Intersection Sight Distance**

Reference: Section 11-2.0

The criteria in Section 11-2.0 on intersection sight distance will apply to 3R projects.

### **2-10.02 Turning Radii**

Reference: Section 11-3.0

Section 11-3.0 presents criteria for the selection of a design vehicle, for acceptable encroachment, and for turning radii criteria at intersections. Where practical, these criteria should be met on 3R projects and, typically, this is practical in rural areas. However, in urban areas, space limitations and existing curb radii have a significant impact on selecting a practical design for right-turning vehicles. The designer should consider the following when determining the appropriate right-turn treatment for urban intersections on 3R projects:

1. Simple radii of 15 to 25 ft are adequate for passenger vehicles. These radii may be retained on 3R projects on existing streets and arterials at:
  - a. intersections with minor roads where very few trucks will be turning;
  - b. intersections where the encroachment of SU and semitrailer vehicles onto adjacent lanes is acceptable (Section 11-3.03); and
  - c. intersections where a parking lane is present on one or more approach legs, and the parking lane is set back at a sufficient distance away from the intersection, and the parking lane is available for use throughout the day.
2. Where practical, simple radii of 30 ft or simple radii with tapers (for an SU design vehicle) should be used at all major intersections and at all minor intersections with some truck turning volumes.
3. At intersections where semitrailer combinations and buses turn frequently, a simple radius of 40 ft or more should be provided. Preferably, the designer will use a radius with taper offsets for the selected design vehicle.

**2-10.03      Auxiliary Turning Lanes**

Reference: Section 11-5.0

Section 11-5.0 presents warrants for right-turn and left-turn lanes. These criteria apply to 3R projects. Section 11-5.0 also presents design details for auxiliary turning lanes, and these should be met for 3R projects. However, in urban areas these criteria may be impractical because of restricted conditions. In these cases, the designer will provide the best design practical for the existing field conditions.

**2-10.04      Driveway Design**

Reference: Section 11-8.0

The criteria in Section 11-8.0 on driveway design will apply to 3R projects.

**2-11.0 REFERENCES**

1. *A Policy on Geometric Design of Highways and Streets*, AASHTO, 2018.
2. Special Report 214 *Designing Safer Roads; Practices for Resurfacing, Restoration and Rehabilitation*, TRB, 1987.
3. [Technical Advisory T5040.28 "Developing Geometric Design Criteria and Processes for Non-Freeway RRR Projects," FHWA, 1988.](#)

### Chapter Three

## GEOMETRIC DESIGN OF EXISTING HIGHWAYS (Freeway Projects) (Spot Improvements) (Preservation/Preventive Maintenance Projects)

### Table of Contents

<u>Section</u>	<u>Page</u>
3-1.0	FREEWAY PROJECTS .....3-1(1)
3-1.01	Background .....3-1(1)
3-1.02	Objectives.....3-1(2)
3-1.03	Approach .....3-1(2)
3-1.04	Geometric Design of Freeway Projects .....3-1(3)
3-1.04.01	Design Speed .....3-1(3)
3-1.04.02	Traffic Volumes.....3-1(3)
3-1.04.03	Vertical Clearances.....3-1(4)
3-1.04.04	Bridges.....3-1(4)
3-1.04.05	Safety Appurtenances .....3-1(5)
3-1.04.06	Interchanges .....3-1(5)
3-2.0	SPOT IMPROVEMENTS (NON-FREEWAYS) .....3-2(1)
3-2.01	Objectives.....3-2(1)
3-2.02	Approach .....3-2(1)
3-2.03	Geometric Design of Highway Bridge Replacement/Rehabilitation projects using Federal-Aid.....3-2(2)
3-3.0	PRESERVATION/PREVENTIVE MAINTENANCE PROJECTS .....3-3(1)
3-3.01	Pavement Preservation Projects on State-Owned Roadways .....3-3(1)
3-3.02	Pavement Preservation and Rehabilitation Projects on Municipally Owned and Maintained Roadways .....3-3(1)
3-3.02.01	Objective .....3-3(2)
3-3.02.02	Approach .....3-3(2)



# Chapter Three

## GEOMETRIC DESIGN OF EXISTING HIGHWAYS

### (Freeway Projects) (Spot Improvements) (Preservation/Preventive Maintenance Projects)

Chapter Three presents the Department's criteria for the geometric design of existing highways for the following project types:

1. freeway projects,
2. spot improvements on non-freeways, and
3. preservation/preventive maintenance projects.

For projects on the Merritt Parkway, the geometric design criteria will be determined on a case-by-case basis.

Note: 3R criteria do not apply to freeways.

#### **3-1.0 FREEWAY PROJECTS**

##### **3-1.01 Background**

The Department began construction of its freeway system in the 1950's and today, the Connecticut system is nearing completion. The freeway system has introduced a level of mobility and safety for the traveling public that was unattainable without its special features, such as full control of access, wide roadway widths and high design speeds.

The freeway system requires periodic repair and upgrading which exceeds the limits of normal maintenance. In general, these capital improvements are referred to as freeway projects. As with non-freeway 3R projects, it is often impractical to fully apply new construction criteria to freeway projects without some qualifications. Therefore, the geometric design of freeway projects requires special design considerations that are discussed in the following Sections.

### **3-1.02      Objectives**

The objective of a freeway project is, within practical limits, to return the freeway to its original level of serviceability or to improve its serviceability to meet current and future demands. This objective applies to all aspects of the freeway's serviceability, including:

1. structural adequacy,
2. drainage,
3. level of service for the traffic flow,
4. geometric design,
5. roadside safety, and
6. traffic control.

### **3-1.03      Approach**

Freeway projects are most often initiated to make a specific improvement to the freeway. Therefore, the Department's approach to the geometric design of freeway projects is to selectively evaluate and improve the existing geometrics. This approach is summarized as follows:

1. Nature of Improvement. Identify the specific improvement intended for the freeway project. For example, geometric improvements might include:
  - a. adding through lanes to improve the level of service,
  - b. upgrading roadside safety,
  - c. increasing the length of one or more acceleration lanes at an interchange,
  - d. widening an existing bridge as part of a bridge rehabilitation project, and/or
  - e. eliminating a weaving area at an interchange.
2. Numerical Criteria. Apply the Department's new construction criteria specifically to the geometric design element that is improved, unless it is otherwise addressed in this chapter for freeway projects. The new construction criteria are presented in Chapters Four and Five. Chapter Ten discusses cross sections; Chapter Thirteen discusses roadside safety; and Chapter Twelve presents geometric design criteria for interchanges.
3. Secondary Impacts. Identify and evaluate any secondary impacts that may be precipitated by the freeway improvement. For example:
  - a. The installation of a concrete median barrier may restrict horizontal sight distance.
  - b. The addition of through lanes on the outside may reduce the available roadside clear zone to fall below the Department's allowable criteria.

- c. Pavement rehabilitation may require the adjustment of guiderail height or reduce the vertical clearance.
4. Other Improvements. Identify other geometric design deficiencies within the project limits. The designer will exercise his/her engineering judgment when determining any other improvements that can be practically corrected without exceeding the intended project scope of work. For example, when pavement widening is required to improve acceleration lanes, it may be reasonable to construct additional pavement widening to improve deficient shoulders at the same time. Where appropriate, the designer should consider designing temporary widening for M&PT so that it can be used as permanent shoulder or lane width upgrades. Where a design feature can be improved for a portion of the project, these improvements should be incorporated.
5. Exceptions. The discussion in Section 6-5.0 on design exceptions applies equally to the geometric design of Freeway projects. However, it will only apply to the geometric design of the specific freeway improvement that resulted in project initiation and to any secondary impacts that may result from the improvement.

#### **3-1.04      Geometric Design of Freeway Projects**

As stated in Section 3-1.03, the Department's design criteria for new construction also apply to freeway projects. However, the designer must still make certain decisions, and there is some flexibility that can be applied. These are discussed in the following Sections.

##### **3-1.04.01      Design Speed**

Chapters Four and Five present the Department's criteria for selecting the design speed for new freeway construction. At a minimum, these apply to freeway projects. However, the designer may consider that these design speeds are less than the 85th percentile speeds for the project under design. Therefore, the designer has the option of requesting a speed study from the Division of Traffic Engineering to determine the 85th percentile speed on the existing freeway. The designer should follow the procedure in Section 2-4.0 for this determination.

##### **3-1.04.02      Traffic Volumes**

Some design elements on freeway projects will require the selection of the DHV (e.g., level of service) or AADT (e.g., roadside clear zones). The freeway will be designed to meet the geometric design criteria for traffic volumes determined for 10 to 20 years beyond the expected construction completion date. It should be noted that for New or Revised Interstate Access requiring approval from FHWA, the operational analysis for the proposed change in access will need to be designed to a Design Year which is 20 years after the date when the construction of the project is scheduled to be complete and open to the traveling public.



### 3-1.04.03 Vertical Clearances

For freeway projects, it is desirable to provide the minimum vertical clearance criteria per Section 9-4.0 over the entire roadway width, including auxiliary lanes and shoulders. However, it may be cost and/or environmentally prohibitive to meet these criteria. Therefore, when there is work proposed on the freeway underneath an existing bridge to remain in place or on a freeway bridge over a non-freeway, the designer should consider the following:

1. Maintain the existing minimum vertical clearances when they are greater than 14'-6".
2. On structures with vertical clearances less than or equal to 14'-6", investigate the feasibility of increasing the minimum vertical clearance to remove the "low clearance" sign posting.

### 3-1.04.04 Bridges

The following discusses the Department's design criteria for bridges on freeway projects:

1. Bridges to Remain in Place. A freeway project may be primarily intended, for example, to improve the pavement condition over several miles. A bridge or several bridges may be within the limits of the freeway project. Desirably, the bridge widths will equal the full approach roadway width, including shoulders. However, this may not be the case. If the existing bridge is structurally sound and if it meets the Department's design loading structural capacity, it is unlikely to be cost effective to improve the geometrics of the bridge. However, the geometric deficiencies may be severe, and/or there may be an adverse crash experience at the bridge. In this case, it may be warranted to widen the bridge as part of the freeway project.

If a bridge remains in place, its minimum width must be equal to the approach traveled way + 10 ft (right shoulder) + 4 ft (left shoulder); otherwise, a design exception will be necessary. In addition, existing bridge rails on the project should be evaluated to determine if they meet the Department's current safety performance criteria.

2. Bridge Replacement/Rehabilitation. Freeway projects will often include bridge replacements or bridge rehabilitation and, in some cases, this will be the entire project scope of work. The following will apply to the geometric design of these projects:
  - a. Horizontal and Vertical Alignment. For bridge replacement projects, the designer should evaluate the practicality of realigning the bridge to meet the applicable alignment criteria for new construction. For bridge rehabilitation projects, it is unlikely to be cost effective to realign the bridge to correct any alignment deficiencies.
  - b. Width. The bridge width should equal the full approach roadway width, including shoulders, as determined by the criteria in Chapters Four and Five for the most likely level of future highway improvement on the approaches. If practical, this

decision should be based on a capacity analysis for the selected DHV at the selected level of service. This analysis could determine the need for additional travel lanes and/or the need for wider shoulders. For example, if the predicted volume of trucks exceeds 250 DDHV, the future shoulder width on the approach should be 12 ft. Because freeway bridges represent major economic investments with a longer design life, it may be warranted to provide the wider widths as part of a bridge replacement or rehabilitation project.

As another example, a capacity analysis may indicate the need for an additional through lane to meet the level-of-service criteria for the design year. The decision may be made to widen the bridge as part of the replacement/rehabilitation project. Until the roadway approach is widened, it may be necessary to indicate with pavement markings that the additional width on the bridge cannot be used by through traffic.

3. Length. The length of the freeway bridge determines the width of the underpass for the facility passing beneath the freeway. Therefore, if practical, the freeway bridge should be long enough to accommodate any likely future widening of the roadway underneath. This may involve an assessment of the potential for further development in the general vicinity of the underpass. The Bureau of Policy and Planning should be consulted for traffic projections at this area.
4. Bridge Rails and Parapets, Approach Guiderail Transitions and Bridge Attachments. All existing bridge rails and/or parapets, approach guiderail transitions, and bridge attachments on the project should be evaluated to determine if they are structurally adequate and/or meet the Department's current criteria. See guidance established in Chapter Thirteen.

#### **3-1.04.05 Safety Appurtenances**

One of the objectives of a freeway project may be to upgrade roadside safety along the freeway. Guiderail warrants and design can present difficult problems (e.g., guiderail height). The discussion in Section 2-9.0 on 3R non-freeway projects also applies to safety appurtenances on freeway projects.

#### **3-1.04.06 Interchanges**

A freeway project may include proposed work on a freeway interchange. The work may be to rehabilitate the entire interchange or to make only selective improvements to the interchange geometrics. Chapter Twelve will be used to design the interchange element.



### **3-2.0 SPOT IMPROVEMENTS (NON-FREEWAYS)**

#### **3-2.01 Objectives**

Spot improvements are intended to correct an identified deficiency at an isolated location on non-freeways. Occasionally, more than one location is included in a project for design or construction purposes. This project scope of work is consistent with the Department's responsibility to provide a safe driving environment for the motoring public that is free of unexpected demands on the driver. Experience has demonstrated the benefits of improving relatively short roadway sections or spot locations with recognized geometric deficiencies to at least a level consistent with the adjacent highway sections. This will provide drivers with a facility that is consistent with the principles of driver expectancy.

The deficiency that the spot improvement project will correct may be related to structural, geometric, safety, drainage or traffic control problems. These projects are not intended to provide a general upgrading of the highway, unlike projects categorized as new construction, reconstruction or 3R. For these reasons, a flexible approach is necessary to determine the appropriate geometric design criteria that will apply to spot improvements.

Spot improvement projects may also be affected by special criteria that may apply to a particular funding category. Below is an example:

Safety Projects. These projects are intended to provide cost-effective improvements to sites identified as having an unusually high number of crashes or crash rate. Typical projects are intersection improvements, flattening a horizontal curve, installing guiderail, or installing traffic control devices. Most often, projects will only be funded when the B/C ratio is estimated to be above 1.0. The Division of Traffic Engineering is responsible for conducting a preliminary evaluation of the site and recommending improvements. When roadway work is involved, the Office of Engineering is responsible for preparing the detailed project design.

#### **3-2.02 Approach**

The Department has adopted a flexible approach to the geometric design of spot improvement projects. The following summarizes the approach:

1. Numerical Criteria. The designer should consider the level of improvement that will most likely be used to upgrade the highway in the future. If this is deemed to be reconstruction, then the criteria in Chapters Four and Five for new construction/reconstruction will provide the frame of reference for the spot improvement. Chapter Eleven will apply to an intersection project. If a 3R project is considered the most likely level of improvement, then the criteria in Chapter Two will apply.
2. Design Speed. The design speed of the adjacent sections should be used for the spot improvement; however, a speed less than the posted speed should not be used. The

selection of the applicable design speed will be left to the judgment of the designer. Some factors that may be considered include:

- a. the results from a speed study by the Division of Traffic Engineering, if requested;
  - b. the design speeds for new construction in Chapters Four and Five; and
  - c. the posted/legal speed limit (this will be a minimum).
3. Application. The designer should apply the selected criteria specifically to the geometric improvement related to the objective of the spot improvement project (e.g., install guiderail, flatten a horizontal curve, add a left-turn lane). In addition, the designer should evaluate other geometric design deficiencies within the project limits. The designer should consider improving any severe deficiencies, even if not related to the specific objective of the spot improvement. The designer will exercise his/her engineering judgment when determining any other improvements that may be justified.
4. Exceptions. The design exception process in Section 6-5.0 applies to bridge widths, underpass widths and vertical clearances on spot improvement projects. For other geometric design elements, it will only apply to the geometric design of the specific geometric design improvement that resulted in project initiation, and it will also apply to any secondary impacts that may result from the improvement. For example, if a spot improvement is initiated to install an exclusive left-turn lane on the major road, it will not be necessary to seek a design exception for the intersection sight distance (ISD) if the ISD does not meet the Department's criteria, unless the deficiency is caused or made worse by the installation of the new lane. It should be noted that the addition of the left-turn lane will result in a need to increase the minimum ISD required on the minor road because of the additional width that the vehicle will need to cross compared to existing conditions.

### **3-2.03 Geometric Design of Highway Bridge Replacement/Rehabilitation projects using Federal-Aid**

The spot improvement approach discussed in Section 3-2.02 also applies to Highway Bridge Replacement/Rehabilitation projects that use Federal-Aid funds. The following offers additional factors to consider:

1. Horizontal and Vertical Alignment. Many existing bridges have alignments that do not meet the Department's current criteria. For bridge replacement projects, the designer should evaluate the practicality of realigning the bridge to meet the applicable alignment criteria (reconstruction or 3R). For bridge rehabilitation projects, it is unlikely to be cost-effective to realign the bridge to correct any alignment deficiencies unless the bridge is within a future highway project area that has already been scheduled. The bridge designer should verify that no projects are scheduled before using the existing alignment.

2. Width. The bridge width should equal or exceed the full approach roadway width, including shoulders, as determined from the Department's criteria for the most likely level of future highway improvement on the approaches (reconstruction or 3R). The tables in Chapters Two, Four or Five will determine this width. If the decision is made not to provide the applicable width, the designer must comply with the design exception process (Section 6-5.0). *Note: Section 13a-86 of the Connecticut Statutes requires a minimum bridge width of 28 ft, exclusive of any sidewalk width. No exceptions to this criterion will be allowed on State-maintained highways and bridges.*
3. Narrow Bridges. All bridges which are narrower than the approach roadway width (including shoulders) should be evaluated for widening and/or special narrow bridge treatments. At a minimum, the signing and pavement markings must meet the criteria of the MUTCD. In addition, NCHRP 203 Safety at Narrow Bridge Sites provides criteria specifically for narrow bridges (e.g., special pavement markings). The designer, in coordination with the Division of Traffic Engineering, should evaluate the value of these additional treatments at the bridge site.
4. Bridge Rails and Parapets, Approach Guiderail Transitions and Bridge Attachments. All existing bridge rails and/or parapets, approach guiderail transitions, and bridge attachments on the project should be evaluated to determine if they are structurally adequate and/or meet the Department's current criteria. See guidance established in Chapter Thirteen.



### **3-3.0 PRESERVATION/PREVENTIVE MAINTENANCE PROJECTS**

#### **3-3.01 Pavement Preservation Projects on State Owned Roadways**

Pavement preservation is a network level program which may employ preventive maintenance, minor rehabilitation (non-structural), or routine maintenance activities to extend the life of an existing, structurally sound pavement. The general scope and limits of these projects are based on recommendations from the Department's Pavement Management Unit. The strategies and treatments employed in these projects are only those which have been approved for use. The Department's draft [Pavement Preservation Manual](#) provides information on the evaluation of existing pavement conditions for preservation eligibility including treatment techniques and selection.

The appropriate treatment on the bridges within the limits of these projects must be coordinated with the Office of Maintenance and the various units within the Division of Bridges.

The design exception process is not applicable to these projects provided that the selected pavement preservation treatment does not negatively impact any existing design criteria (e.g., vertical clearance).

Certain pavement preservation projects are considered "alterations" to the existing facility and must follow the requirements in Chapter 15 Section 15-1.0 with regards to the Americans with Disabilities Act of 1990.

Each pavement preservation project shall also include a safety review. Any safety related item which has been negatively impacted by the preservation activity shall be restored as part of the project. These projects shall in no way degrade safety. Safety enhancements are generally not within the scope of these projects; however, isolated or obvious deficiencies need to be addressed. The crash history should be a consideration in determining what safety work shall be addressed. Guiderail upgrades that are identified in the safety review but are not included in the project shall be forwarded to the Design Development Unit for their use in prioritizing future safety improvement projects. The safety review's recommendations and their disposition shall be included as part of the Request for Design Approval.

Lane and shoulder widths are to be evaluated, as described in the "construction surveying" specification, to determine if any adjustments to the pavement markings can be made to better accommodate the needs of non-motorized users.

#### **3-3.02 Pavement Preservation and Rehabilitation Projects on Municipally Owned and Maintained Roadways**

This section provides guidance for Pavement Preservation and Pavement Rehabilitation projects on municipally owned and maintained facilities.



**3-3.02.01 Objective**

The objective of these projects is to improve the pavement condition and extend the serviceability of municipally owned and maintained facilities by resurfacing, reclamation or other rehabilitation techniques. Therefore, significant geometric or other major improvements are not likely within the established project scope and budget. Even so, designers should always attempt to provide safety enhancements that are warranted. The design criteria should be selected from the appropriate category; however, the design exception process is not generally applicable to these projects.

Typical pavement rehabilitation treatments include: designed overlays with pre-treatment (milling and/or patching) of the existing pavement structure; removal and replacement of the bituminous concrete (“peel and pave”); and reclamation.

Full-depth reconstruction projects are excluded from this section.

**3-3.02.02 Approach**

All Pavement Preservation and Pavement Rehabilitation projects should consider appropriate ways to maintain or enhance the current level of safety and accessibility. Each pavement preservation/rehabilitation project shall include a safety review, including accident experience, for the purpose of deciding upon safety work to be implemented before, at the time of, or deferred to a later date after the project is completed. Recommendations should address isolated or obvious deficiencies and in no way shall the project degrade highway safety. Pavement preservation or rehabilitation activities may not require safety enhancements if the initial safety review, including an analysis of crash data, does not indicate any deficiencies.

Existing safety related items negatively impacted by the pavement preservation or rehabilitation activity shall be restored by the contractor as part of the project, or by municipal forces immediately following project completion. For example, pavement markings removed during the construction process shall be restored as part of the pavement preservation project. Some other examples of safety items that must be addressed immediately include but are not limited to: mitigation of pavement edge drop offs; resetting guide rail left at an improper height as a result of the pavement preservation or rehabilitation treatment; and installing guide rail if missing or not extending to the point of need if a serious roadside hazard exists. Safety enhancements which may be deferred and performed by municipal forces at a later time include: installing additional or updated signing or delineation; installation or repair/reset/upgrading of guiderail; removal of fixed objects; and/or brush removal.

Certain Pavement Preservation and Pavement Rehabilitation projects are expected to follow the requirements of Chapter 15 Section 15-1.0 with regard to the Americans with Disabilities Act of 1990 and Section 504 of the Rehabilitation Act of 1973.

The safety review recommendations and the disposition of those recommendations shall be included in the Request for Design Approval for each Pavement Preservation and Pavement Rehabilitation project.

**Chapter Four****RURAL HIGHWAYS AND ROADS  
(New Construction/Reconstruction)****Table of Contents**

<b><u>Section</u></b>		<b><u>Page</u></b>
Figure 4A	Rural Freeways.....	4(2)
Figure 4B	Multi-Lane Rural Arterials .....	4(4)
Figure 4C	Two-Lane Rural Arterials .....	4(6)
Figure 4D	Rural Collector Roads.....	4(8)
Figure 4E	Local Rural Roads .....	4(10)
Figure 4F	Typical depressed Median Section (Rural Freeways) .....	4(12)
Figure 4G	Typical Two-Lane Section (Rural Arterial/Collector/Local Road).....	4(14)
Figure 4H	Miscellaneous Details, Various Classes .....	4(16)
Figure 4I	Typical Median Section for Freeways (66 ft or Less).....	4(17)
Figure 4J	Details of Cut Sections.....	4(18)



## Chapter Four

# RURAL HIGHWAYS AND ROADS

## (New Construction/Reconstruction)

This chapter presents the Department's criteria for the design of rural highways and roads. They apply to new construction and reconstruction projects. The designer should consider the following in the use of the figures:

1. Functional/Design Classification. The selection of design values for new construction and reconstruction depends on the functional and design classification of the highway facility. This is discussed in Section 6-1.0. For non-freeways, the design classification is based on the average number of access points per mile per side. The designer should realize that the values in the figures are for guidance only; they should not be used as rigid criteria for determining the design classification on rural highways. Each project should be designed as part of the total environment, specifically designed to fit into the context of the area where it is to be constructed. Before selecting design values, the designer should take into consideration the community, land use, visual, historical and natural resources of the area. Designers should attempt to maintain the character of an area, but at the same time meet the transportation needs of the project.
2. Capacity Analyses. Section 6-3.0 discusses highway capacity. Several highway design elements (e.g., the number of travel lanes) will be determined in part by the capacity analysis. As discussed in Section 6-3.0, the capacity analysis will be based on:
  - a. the design hourly volume (DHV), usually 20 years from the construction completion date;
  - b. the level of service, as determined from the figures in this chapter; and
  - c. the capacity analysis, using the techniques in the HCM.
3. Cross Section Elements. The designer should realize that some of the cross section elements included in a figure (e.g., median width) are not automatically warranted in the project design. The values in the figures will only apply after the decision has been made to include the element in the highway cross section.
4. Manual Section References. These figures are intended to provide a concise listing of design values for easy use. However, the designer should review the *Manual* section references for greater insight into the design elements.

**Figure 4A**  
**RURAL FREEWAYS**  
**New Construction/Reconstruction**

Design Element		*	Manual Section	Design Values	
Design Controls	Design Forecast Year		6-3.02	20 Years	
	Design Speed	x	6-2.02	70 mph	
	Control of Access		6-4.0	Full Control	
	Level of Service		6-3.0	B – C	
Cross Section Elements	Lane Width	x	10-1.01	12'	
	Shoulder Width (1)	Right	x		10'
		Left — 4 Lanes	x	10-1.02	8' (4' Paved + 4' Graded)
		Left — 6+ Lanes	x		10'
	Typical Cross Slope	Travel Lane	x	10-1.01	1.5 – 2.0% for lanes adjacent to crown; 2.0% for lanes away from crown
		Shoulder	x	10-1.02	4%; with CMB, 4% – 6% for left shoulder
	Median Width (includes left shoulders)		10-3.0	See Figure 4I – 100'	
	Bridge Width/Cross Slope	x	10-4.01	Meet Approach Roadway Width and Cross Slope	
	Underpass Width		10-4.02	Meet Approach Roadway Width Plus Clear Zones	
	Right-of-Way Width		10-5.0	Desirable: 100' Beyond Edge of Traveled Way	
	Roadside Clear Zones	x	13-2.0	See Section 13-2.0	
Fill/Cut Slopes		10-2.02	See Figure 4F		

\* Controlling design criteria (see Section 6-5.0).

**Footnote:**

(1) Shoulder Width. Where the truck volumes exceed 250 DDHV, both the right and left shoulders should be 12 ft.

**Figure 4A (Continued)**  
**FIGURE FREEWAYS**  
**New Construction/Reconstruction**

Design Element		*	Manual Section	Design Values (Based on Design Speed)	
				70 mph	
Alignment Elements	Stopping Sight Distance		x	7-1.0	730'
	Decision Sight Distance	Maneuver		7-2.0	1105'
		Stop			780'
	Minimum Radius (e = 6.0%)		x	8-2.02	2050'
	Superelevation	e <sub>max</sub>		8-2.02	6.0%
		Rate	x		See Figure 8-2A
	Horizontal Sight Distance			8-2.04	See Section 8-2.04
	Maximum Grade		x	9-2.03	4%
	Minimum Grade			9-2.03	0.5%
	Vertical Curvature (K-Value)	Crest		9-3.02	247
		Sag		9-3.03	181
	Minimum Vertical Clearance: Freeway Under ...	New Highway Bridge	x	9-4.0	16'-3"
Existing Highway Bridge		x	16'-0"		
Pedestrian Bridge/ Overhead Sign		x	18'-0"		
Minimum Vertical Clearance (Freeway over Railroad)		x	9-4.0	23'-0"	

\* Controlling design criteria (see Section 6-5.0).

**Figure 4B**  
**MULTI-LANE RURAL ARTERIALS**  
**New Construction/Reconstruction**

Design Element		*	Manual Section	Design Values (by Type of Roadside Development)			
				Open	Moderate Density	High Density	
Design Controls	Typical Number of Access Points/Mile/Side			6-1.03	0 – 15	15 – 30	>30
	Design Forecast Year			6-3.02	20 Years	20 Years	20 Years
	Design Speed		x	6-2.02	50 – 60 mph	50 – 55 mph	50 – 55 mph
	Control of Access			6-4.0	Partial/Control by Regulation	Control by Regulation	Control by Regulation
	Level of Service			6-3.0	B – C	B – C	B – C
Cross Section Elements	Travel Lane Width		x	10-1.01	12'	12'	12'
	Shoulder Width	Right	x	10-1.02	4' – 8'	4' – 8'	4' – 8'
		Left	x		4' – 8'	4' – 8'	4' – 8'
	Typical Cross Slope	Travel Lane	x	10-1.01	1.5 – 2.0% for lanes adjacent to crown; 2.0% for lanes away from crown		
		Shoulder	x	10-1.02	4%	4%	Uncurbed: 4% Curbed: 6%
	Turn Lanes	Lane Width	x	10-1.03	12'	12'	11' – 12'
		Shoulder Width	x		2' – 4'		
	Median Width (Includes Left Shoulders)	Depressed		10-3.0	50' – 90'	50' – 90'	N/A
		Raised Island (V = 50 mph)			N/A	N/A	8' – 20'
	Bicycle Lane	Width		15-4.0	5' or Shoulder Width, whichever is greater		
		Cross Slope			2%		
	Bridge Width/Cross Slope		x	10-4.01	Meet Approach Roadway Width and Cross Slope		Sidewalk Width: 5'-6"
	Underpass Width			10-4.02	Meet Approach Roadway Width Plus Clear Zones		
	Right-of-Way Width			10-5.0	Project-by-Project Basis		
Roadside Clear Zones		x	13-2.0	See Section 13-2.0			
Fill/Cut Slopes			10-2.02	See Figure 4G			

\* Controlling design criteria (see Section 6-5.0).

**Figure 4B (Continued)**  
**MULTI-LANE RURAL ARTERIALS**  
**New Construction/Reconstruction**

Design Element		*	Manual Section	Design Values (Based on Design Speed)			
				60 mph	55 mph	50 mph	
Alignment Elements	Stopping Sight Distance	x	7-1.0	570'	495'	425'	
	Decision Sight Distance	Maneuver		990'	865'	750'	
		Stop		7-2.0	695'	535'	465'
	Minimum Radius (e = 6.0%)	x	8-2.02	1340'	1065'	840'	
	Superelevation	e <sub>max</sub>		8-2.02	6.0%	6.0%	6.0%
		Rate	x		See Figure 8-2A		
	Horizontal Sight Distance		8-2.04	See Section 8-2.04			
	Maximum Grade	x	9-2.03	4%	5%	5%	
	Minimum Grade		9-2.03	0.5%			
	Vertical Curvature (K-Value)	Crest		9-3.02	151	114	84
		Sag		9-3.03	136	115	96
	Minimum Vertical Clearance: Arterial Under ...	New Highway Bridge	x	9-4.0	16'-3"		
Existing Highway Bridge		x	14'-3"				
Pedestrian Bridge Overhead Sign		x	18'-0"				
Minimum Vertical Clearance (Arterial over Railroad)	x	9-4.0	Electrified: 22'-6" All Others: 20'-6"				

\* Controlling design criteria (see Section 6-5.0).



**Figure 4C**  
**TWO-LANE RURAL ARTERIALS**  
**New Construction/Reconstruction**

Design Element		*	Manual Section	Design Values (by Type of Roadside Development)			
				Open	Moderate Density	High Density	
Design Controls	Typical Number of Access Points/Mile/Side		6-1.03	0 – 15	15 – 30	>30	
	Design Forecast Year		6-3.02	20 Years	20 Years	20 Years	
	Design Speed	x	6-2.02	50 – 60 mph	50 – 55 mph	45 – 50 mph	
	Control of Access		6-4.0	Partial/Control by Regulation	Control by Regulation	Control by Regulation	
	Level of Service		6-3.0	B – C	B – C	B – C	
Cross Section Elements	Travel Lane Width	x	10-1.01	12'	12'	12'	
	Shoulder Width	x	10-1.02	4' – 8'	4' – 8'	4' – 8'	
	Typical Cross Slope	Travel Lane	x	10-1.01	1.5 – 2.0%	1.5 – 2.0%	1.5 – 2.0%
		Shoulder	x	10-1.02	4%	4%	Uncurbed: 4% Curbed: 6%
	Turn Lanes	Lane Width	x	10-1.03	12'	12'	11' – 12'
		Shoulder Width	x		2' – 4'		
	Bicycle Lane	Width		15-4.0	5' or Shoulder Width, whichever is greater		
		Cross Slope			2%		
	Bridge Width/Cross Slope	x	10-4.01	Meet Approach Roadway Width and Cross Slope		Sidewalk Width: 5'-6"	
	Underpass Width		10-4.02	Meet Approach Roadway Width Plus Clear Zones			
	Right-of-Way Width		10-5.0	Project-by-Project Basis			
Roadside Clear Zones	x	13-2.0	See Section 13-2.0				
Fill/Cut Slopes		10-2.02	See Figure 4G				

\* Controlling design criteria (see Section 6-5.0).

**Figure 4C (Continued)**  
**TWO-LANE RURAL ARTERIALS**  
**New Construction/Reconstruction**

Design Element		*	Manual Section	Design Values (Based on Design Speed)				
				60 mph	55 mph	50 mph	45 mph	
Alignment Elements	Stopping Sight Distance		x	7-1.0	570'	495'	425'	360'
	Decision Sight Distance	Maneuver		7-2.0	990'	865'	750'	675'
		Stop			610'	535'	465'	395'
	Minimum Radius (e = 6.0%)		x	8-2.02	1340'	1065'	840'	665'
	Superelevation	e <sub>max</sub>		8-2.02	6.0%	6.0%	6.0%	6.0%
		Rate	x		See Figure 8-2A			
	Horizontal Sight Distance			8-2.04	See Section 8-2.04			
	Maximum Grade		x	9-2.03	4%	5%	5%	6%
	Minimum Grade			9-2.03	0.5%			
	Vertical Curvature (K-Value)	Crest		9-3.02	151	114	84	61
		Sag		9-3.03	136	115	96	79
	Minimum Vertical Clearance: Arterial Under ...	New Highway Bridge	x	9-4.0	16'-3"			
		Existing Highway Bridge	x		14'-3"			
Pedestrian Bridge Overhead Sign		x	18'-0"					
Minimum Vertical Clearance (Arterial over Railroad)		x	9-4.0	Electrified: 22'-6" All Others: 20'-6"				

\* Controlling design criteria (see Section 6-5.0).

Figure 4D

**RURAL COLLECTOR ROADS  
New Construction/Reconstruction**

Design Element		*	Manual Section	Design Values (by Type of Roadside Development)			
				Open	Moderate Density	High Density	
Design Controls	Typical Number of Access Points/Mile/Side		6-1.03	0 – 15	15 – 30	>30	
	Design Forecast Year		6-3.02	20 Years	20 Years	20 Years	
	Design Speed	AADT < 400	x	6-2.02	30 – 35 mph	N/A	N/A
		AADT: 400 – 2000			35 – 50 mph	35 – 45 mph	N/A
		AADT > 2000			50 mph	45 – 50 mph	35 – 45 mph
	Control of Access		6-4.0	Control by Regulation	Control by Regulation	Control by Regulation	
Level of Service		6-3.0	C – D	C – D	C – D		
Cross Section Elements	Travel Lane Width	AADT < 400	x	10-1.01	10'	N/A	N/A
		AADT: 400 – 1500			11' (V≥35); 10' (V≤30)	11' (V≥35); 10' (V≤30)	N/A
		AADT: 1500 – 2000			11'	11'	N/A
		AADT > 2000			12'	12'	12'
	Shoulder Width	AADT ≤ 1500	x	10-1.02	2' – 8'	2' – 8'	N/A
		AADT > 1500			4' – 8'	4' – 8'	4' – 8'
	Typical Cross Slope	Travel Lane	x	10-1.01	1.5 – 2.0%	1.5 – 2.0%	1.5 – 2.0%
		Shoulder	x	10-1.02	4%	Uncurbed: 4% Curbed: 6%	Uncurbed: 4% Curbed: 6%
	Turn Lanes	Lane Width	x	10-1.03	1' Less than Travel Lane Width — Same as Travel Lane		
		Shoulder Width	x		2' – 4'		
	Bicycle Lane	Width		15-4.0	5' or Shoulder Width, whichever is greater		
		Cross Slope			2%		
	Bridge Width/Cross Slope (1)		x	10-4.01	Meet Approach Roadway Width and Cross Slope	Sidewalk Width: 5'-6"	
	Underpass Width			10-4.02	Meet Approach Roadway Width Plus Clear Zones		
	Right-of-Way Width			10-5.0	Project-by-Project Basis		
Roadside Clear Zones		x	13-2.0	See Section 13-2.0			
Fill/Cut Slopes			10-2.02	See Figure 4G			

\* Controlling design criteria (see Section 6-5.0).

Footnote:

(1) Bridge Width. See Section 10-4.01 for additional information on minimum bridge widths.

**Figure 4D (Continued)**  
**RURAL COLLECTOR ROADS**  
**New Construction/Reconstruction**

Design Element		*	Manual Section	Design Values (Based on Design Speed)				
				50 mph	45 mph	35 mph	30 mph	
Alignment Elements	Stopping Sight Distance	x	7-1.0	425'	360'	250'	200'	
	Decision Sight Distance	Maneuver		7-2.0	750'	675'	525'	450'
		Stop			465'	395'	275'	220'
	Minimum Radius (e = 6.0%)		x	8-2.02	840'	665'	385'	275'
	Superelevation	e <sub>max</sub>		8-2.02	6.0%	6.0%	6.0%	6.0%
		Rate	x		See Figure 8-2A			
	Horizontal Sight Distance			8-2.04	See Section 8-2.04			
	Maximum Grade		x	9-2.03	7%	8%	8%	9%
	Minimum Grade			9-2.03	0.5%			
	Vertical Curvature (K-Value)	Crest		9-3.02	84	61	29	19
		Sag		9-3.03	96	79	49	37
	Minimum Vertical Clearance: Collector Under ...	New Highway Bridge	x	9-4.0	14'-6"			
Existing Highway Bridge		x	14'-3"					
Minimum Vertical Clearance (Collector over Railroad)		x	9-4.0	Electrified: 22'-6" All Others: 20'-6"				

\* Controlling design criteria (see Section 6-5.0).

**Figure 4E**  
**RURAL LOCAL ROADS**  
**New Construction/Major Construction**

Design Element		*	Manual Section	Design Values (by Type of Roadside Development)			
				Open	Moderate Density	High Density	
Design Controls	Typical Number of Access Points/Mile/Side			6-1.03	0 – 15	15 – 30	>30
	Design Forecast Year			6-3.02	20 Years	20 Years	20 Years
	Design Speed	AA DT < 50	x	6-2.02	20 – 30 mph	N/A	N/A
		AA DT: ≥ 50			30 – 35 mph	30 – 35 mph	30 – 35 mph
	Control of Access			6-4.0	Control by Regulation	Control by Regulation	Control by Regulation
Level of Service			6-3.0	C – D	C – D	C – D	
Cross Section Elements	Travel Lane Width	AA DT < 400	x	10-1.01	9' (V≤40); 10' (V≥45)	N/A	N/A
		AA DT: 400 – 1500			10' (V≤40); 11' (V≥45)	10' (V≤40); 11' (V≥45)	N/A
		AA DT: 1500 – 2000			11'	11'	11'
		AA DT > 2000			12'	12'	12'
	Shoulder Width		x	10-1.02	2' – 4'	2' – 4'	2' – 4'
	Typical Cross Slope	Travel Lane	x	10-1.01	1.5 – 2.0%	1.5 – 2.0%	1.5 – 2.0%
		Shoulder (W < 4')			Same as Adjacent Travel Lane		
		Shoulder (W ≥ 4')	x	10-1.02	4%	Uncurbed: 4% Curbed: 6%	Uncurbed: 4% Curbed: 6%
	Turn Lanes	Lane Width		10-1.03	1' Less Than Travel Lane Width — Same as Travel Lane		
		Shoulder Width	x		2' – 4'		
	Bicycle Lane	Width		15-4.0	5' or Shoulder Width, whichever is greater		
		Cross Slope			2%		
	Bridge Width/Cross Slope (1)		x	10-4.01	Meet Approach Roadway Width and Cross Slope	Sidewalk Width: 5'-6"	
	Underpass Width			10-4.02	Meet Approach Roadway Width Plus Clear Zones		
Right-of-Way Width			10-5.0	Project-by-Project Basis			
Roadside Clear Zones		x	13-2.0	See Section 13-2.0			
Fill/Cut Slopes			10-2.02	See Figure 4G			

\* Controlling design criteria (see Section 6-5.0).

Footnote:

(1) Bridge Width. See Section 10-4.01 for additional information on minimum bridge widths.

**Figure 4E (Continued)**  
**RURAL LOCAL ROADS**  
**New Construction/Reconstruction**

Design Element		*	Manual Section	Design Values (Based on Design Speed)						
				45 mph	40 mph	35 mph	30 mph	25 mph	20 mph	
Alignment Elements	Stopping Sight Distance	x	7-1.0	360'	305'	250'	200'	155'	115'	
	Decision Sight Distance	Maneuver		7-2.0	675'	600'	525'	450'	N/A	N/A
		Stop			395'	330'	275'	220'		
	Minimum Radius (e = 6.0%)		x	8-2.02	665'	510'	385'	275'	190'	120'
	Superelevation	e <sub>max</sub>		8-2.02	6.0%	6.0%	6.0%	6.0%	6.0%	6.0%
		Rate	x		See Figure 8-2A					
	Horizontal Sight Distance			8-2.04	See Section 8-2.04					
	Maximum Grade		x	9-2.03	9%	10%	10%	10%	11%	11%
	Minimum Grade			9-2.03	0.5%					
	Vertical Curvature (K-Value)	Crest		9-3.02	61	44	29	19	12	7
		Sag		9-3.03	79	64	49	37	26	17
	Minimum Vertical Clearance: Local Road Under ...	New Highway Bridge	x	9-4.0	14'-6"					
Existing Highway Bridge		x	14'-3"							
Minimum Vertical Clearance (Local Road over Railroad)		x	9-4.0	Electrified: 22'-6" All Others: 20'-6"						

\* Controlling design criteria (see Section 6-5.0).



## TYPICAL DEPRESSED MEDIAN SECTION

### (Rural Freeways)

#### Notes to Figure 4F

1. Median: This section will apply to all medians greater than 66 ft. See Figure 4I for median widths of 66 ft or less, which will warrant a median barrier.
2. Slope Rounding: This is the recommended treatment and, when used, the slope rounding should be 8 ft. This will apply to all conditions, except where the design speed is 70 mph and where an unprotected 1:4 slope is provided. In this case, the recommended rounding is 11 ft. Rounding is not necessary on fill slopes protected by guiderail. See Figure 4H for detail if guide rail is used.
3. Clear Zone: The outside limit of rounding for the backslope should be outside of the clear zone as determined by Section 13-2.0. If this is within the clear zone, the backslope should be safely traversable (See Figure 13-3D).
4. Point of Grade Application: The following criteria will apply:

<u>Pavement Width</u>	<u>Point of Grade Application</u>
Two 12-ft lanes	12 ft from inside edge of traveled way
Three 12-ft lanes	12 ft from inside edge of traveled way
Four 12-ft lanes	24 ft from inside edge of traveled way

5. Left Shoulder: As indicated on the figure, the left shoulder is 8 ft graded with 4 ft paved. For three or more lanes in one direction, use a 10-ft paved left shoulder.
6. Fill Slope: These should be as flat as practical. Consider the following criteria:

<u>Fill Height</u>	<u>Fill Slope</u>	<u>Guiderail</u>
0 ft – 10 ft	1:6	No
10 ft – 25 ft	1:4	No
>25 ft	1:2	Yes

Also, see Figure 4H for treatment at bottom of fill slope and for guide rail placement on fill slopes.

7. Cut Slope: These should be as flat as practical, but should not exceed 1:2. Also see the clear zone discussion in Note #3. A uniform rate of slope should be maintained throughout a cut section. Where site conditions dictate a change from one rate of slope to another within a cut section, the length of transition will be as long as practical to effect a natural appearing contour. Figure 4J contains detailed information on earth and rock cuts.
8. Shoulder Superelevation (Low-Side): The slope of the shoulder should be 4% or "e", whichever is greater.
9. Shoulder Superelevation (High-Side): See Figure 4H for treatment of high-side shoulder. For the 8-ft shoulder (two lanes in one direction), use 8 ft when reading into the table in Figure 4H.
10. Median Slope: When the axis of rotation is at the centerline of the two roadways, a compensating median slope must be used on a superelevated section, or independent profiles must be used.
11. Stage Construction: When Stage Construction requires excavation for future lanes, the extent and details of grading and drainage will be determined during design of initial construction. Where rock is encountered, it will be removed in the initial construction as necessary to preclude subsequent operational interference.





## TYPICAL TWO-LANE SECTION (Rural Arterial/Collector/Local Roads)

### Notes to Figure 4G

1. Slope Rounding: This is the recommended treatment and, when used, the slope rounding should be 8 ft. Rounding is not necessary on fill slopes protected by guiderail. See Figure 4H for detail if guiderail is used.
2. Clear Zone: The outside limit of rounding for the backslope should be outside of the clear zone as determined by Section 13-2.0. If this is within the clear zone, the backslope should be safely traversable (see Figure 13-3D).
3. Lane and Shoulder Width: See Figures 4C, 4D and 4E for criteria on lane and shoulder width.
4. Curb Sections: If curbing is required for drainage, see Figure 5I for typical section.
5. Sidewalks: See Figure 4H for typical treatment of sidewalks, if warranted.
6. Fill Slope: These should be as flat as practical. Consider the following criteria:

<u>Fill Height</u>	<u>Fill Slope</u>	<u>Guiderail</u>
0.0 ft – 10 ft	1:6	No
10 ft – 25 ft	1:4	No
> 25 ft	1:2	Yes

Also, see Figure 4H for treatment at bottom of fill slope. If a curb is used, see Figure 4H for treatment of guiderail and curb used in combination.

7. Cut Slope: These should be as flat as practical, but should not exceed 1:2. Also, see the clear zone discussion in Note #2. A uniform rate of slope should be maintained throughout a cut section. Where site conditions dictate a change from one rate of slope to another within a cut section, the length of transition will be as long as practical to effect a natural appearing contour. Figure 4J contains detailed information on earth and rock cuts.
8. Shoulder Superelevation (Low-Side): The slope of the shoulder should be 4% or "e", whichever is greater.
9. Shoulder Superelevation (High-Side): See Figure 4H for treatment of high-side shoulder.

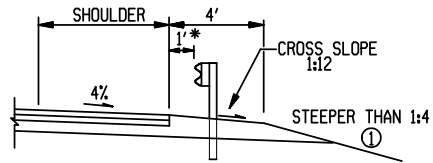

\*TYPICAL OR FLUSH WITH EDGE OF PAVEMENT  
RAILING PLACEMENT WITHOUT CURB

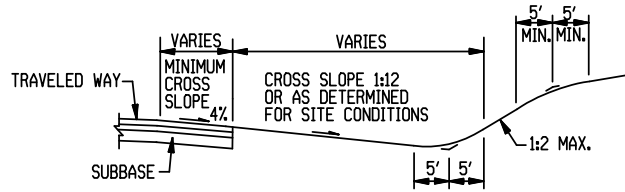

SIGHT LINE CUT OR WIDENED EARTH CUT

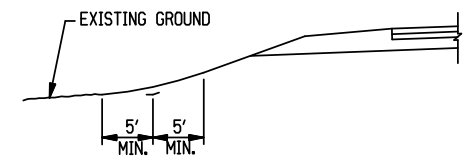

TREATMENT AT BOTTOM OF FILL SLOPES

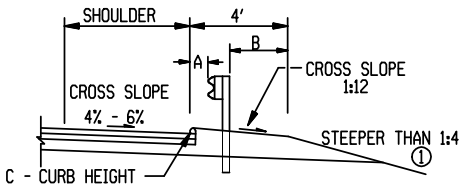

TYPE OF GUIDERAIL	A	B (MINIMUM)	C (MAXIMUM)
METAL BEAM RAIL (TYPE R-B 350) (V < 45mph)	9"	24"	6"
METAL BEAM RAIL (TYPE R-B 350) (V ≥ 45mph)	0"	24"	4"
THREE-CABLE GUIDERAILING (I-BEAM POST)	12" MAX.	24"	*

① USE METAL BEAM RAIL (TYPE R-B 350) OR THREE-CABLE GUIDERAILING (I-BEAM POST) ON FILL SLOPES STEEPER THAN 1:4 WITH CURBING. GUIDERAIL MAY ALSO BE REQUIRED WHERE ROADSIDE HAZARDS ARE LOCATED WITHIN THE ROADSIDE CLEAR ZONE. REFER TO CHAPTER THIRTEEN.

\* CURBING, WHERE USED IN CONJUNCTION WITH THREE-CABLE GUIDERAILING ON HIGH-SPEED ROADWAYS (V ≥ 45mph) SHALL BE 4" MAX. IN HEIGHT.

RAILING PLACEMENT WITH CURB

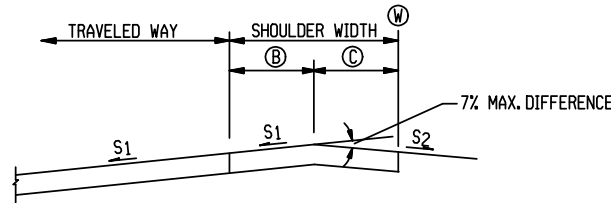

W	B	C
< 4'	0' TO 4'	0'
4' TO < 8'	0' TO 4'	4'
≥ 8'	0'	≥ 8'

GENERAL NOTES:

- MAY REQUIRE ATTACHABLE EXTENSIONS OR CUT-OFF PLATES ON PAVING EQUIPMENT.
- WHERE S<sub>2</sub> IS FLATTER THAN 2%, THE CONTRACTOR SHALL VERIFY THE CROSS SLOPE AT EACH 25' INTERVAL (PAYMENT SHALL BE INCLUDED IN THE COST OF THE BITUMINOUS CONCRETE PAY ITEM - THERE WILL BE NO DIRECT PAYMENT.)
- S<sub>2</sub> SHALL BE 1% MINIMUM.
- DO NOT PROVIDE CURBING ON 4' SHOULDERS WITH SUPERELEVATION > 4%.
- ALL OTHER TREATMENTS SHALL BE USED ONLY WITH PRIOR APPROVAL FROM THE HYDRAULICS AND DRAINAGE, PROJECT DEVELOPMENT, AND PAVEMENT MANGEMENT UNITS.
- INCLUDE NOTE 1 ON ALL CONTRACT DRAWINGS. INCLUDE NOTE 2 ON ALL CONTRACT DRAWINGS WHERE THE SUPERELEVATION RATES ARE STEEPER THAN 4%.

SHOULDER TREATMENT HIGH SIDE OF BANK

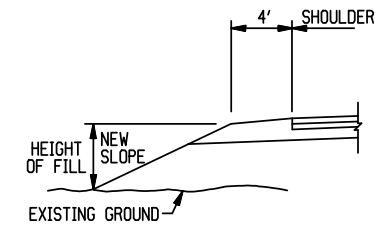

METHOD OF DETERMINING HEIGHT OF FILL AS RELATED TO SIDE SLOPE DESIGN

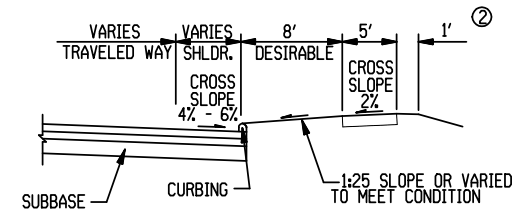

CURB AND WALK AREA

② IF GUIDERAIL IS REQUIRED, IT WILL BE PLACED BEYOND THE SIDEWALK. THEREFORE, THIS DIMENSION WILL BE INCREASED AS NECESSARY TO ALLOW FOR PROPER GUIDERAIL PLACEMENT.

MISCELLANEOUS DETAILS VARIOUS CLASSES

Figure 4H

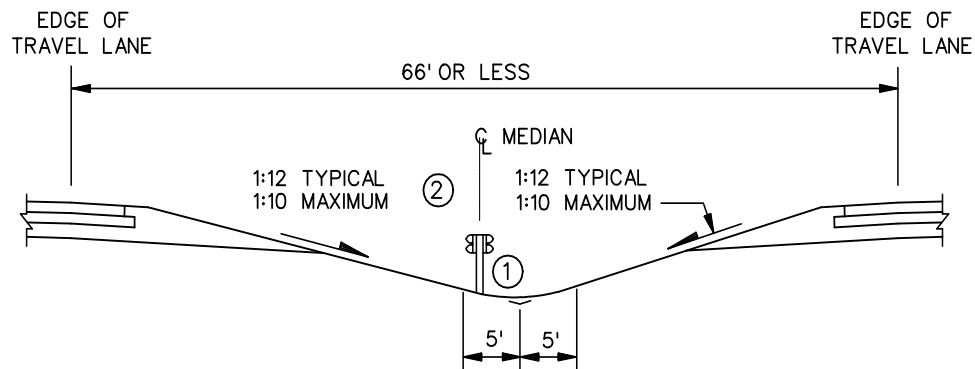

TYPICAL DEPRESSED MEDIAN  
(With Metal-Beam Barrier)

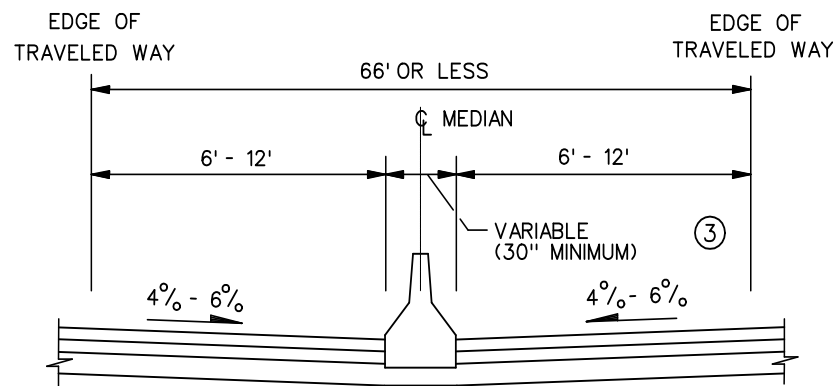

TYPICAL MEDIAN  
(With Concrete Median Barrier)

1. **Placement of Median Barrier:** The preferred location of the median barrier is in the center of the median. This will require that the drainage system be offset from the center as indicated in the figure.
2. **Median Slope on Superelevated Sections:** The designer must ensure that the slope leading up to the median barrier does not exceed 1:10. This may require the use of independent profiles for the two roadways. Another option is to place the barrier near the edge of the shoulder; however, this is undesirable and should be avoided.
3. **CMB Width:** Consider providing a 4' width from the curb line to the pier face to accommodate clearance to bridge piers of overpassing structures or other appurtenances in the median.

### TYPICAL MEDIAN SECTION FOR FREEWAYS (66 ft or Less)

Figure 4I

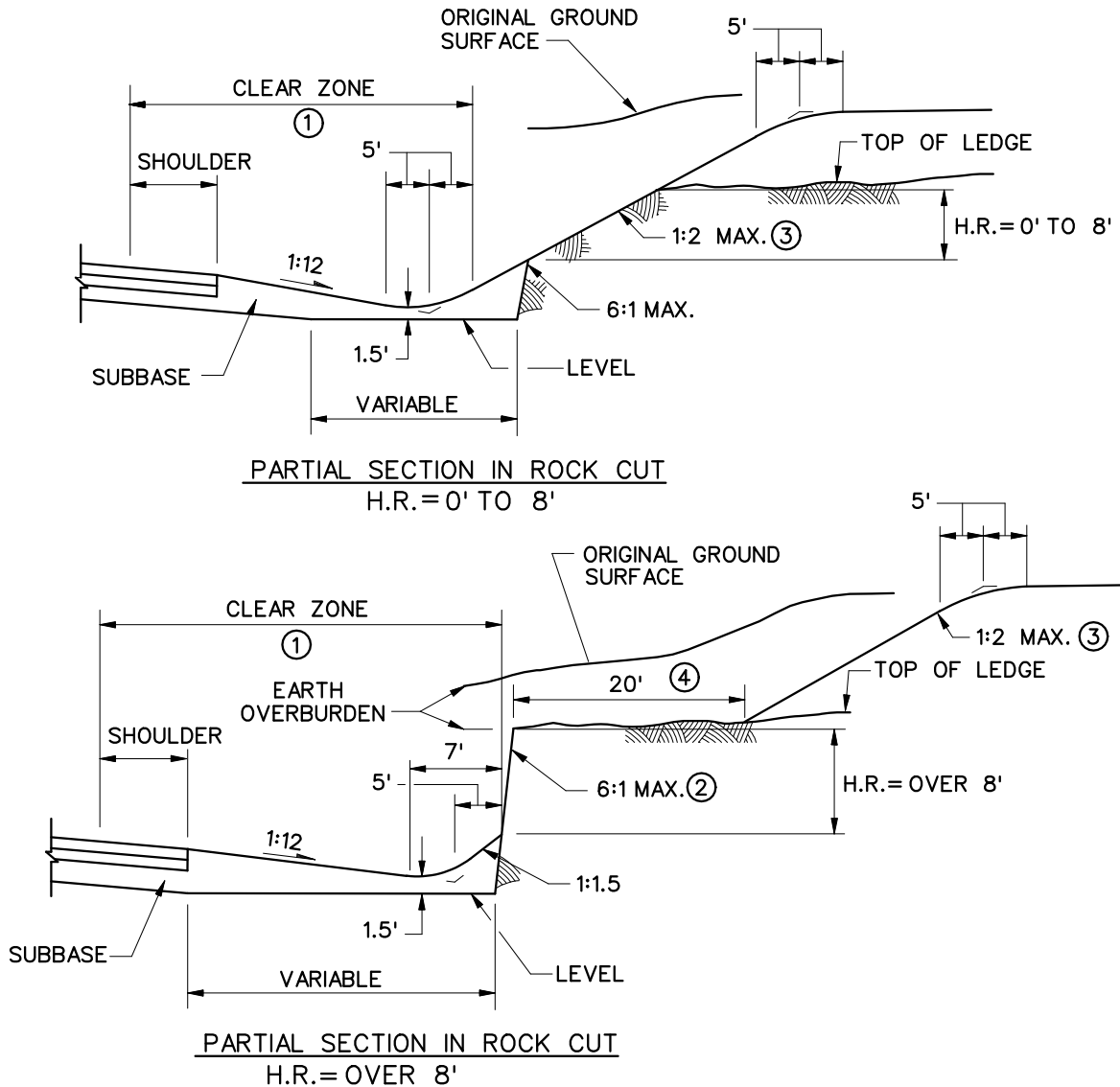

- ① To be increased as rock competence decreases or as height of rock cut increases.
- ② Rock slopes should be determined by geological investigations and analysis.
- ③ Slopes flatter than the 1:2 maximum are preferred and should be used where site conditions allow. Generally, a uniform rate of slope should be held throughout a section. Where site conditions dictate a change from one rate of slope to another within a cut section, the length of transition should be as long as possible to affect a natural appearing contour.
- ④ The 20-ft rock shelf may be reduced to a minimum of 5 ft when (a) during construction, the rock elevation is found to be lower than anticipated during design, (b) it is desirable to reduce surplus excavation, and (c) it is desirable to minimize right-of-way needs.

**DETAILS OF CUT SECTIONS**

**Figure 4J**

**Chapter Five****URBAN HIGHWAYS AND STREETS  
(New Construction/Reconstruction)****Table of Contents**

<b><u>Section</u></b>		<b><u>Page</u></b>
Figure 5A	Urban Freeways .....	5(2)
Figure 5B	Multi-Lane Principal Urban Arterials .....	5(4)
Figure 5C	Two-Lane Principal Urban Arterials .....	5(6)
Figure 5D	Median Urban Arterials .....	5(8)
Figure 5E	Urban Collector Streets .....	5(10)
Figure 5F	Local Urban Street.....	5(12)
Figure 5G	Typical Depressed Median Section (Urban Freeways) .....	5(14)
Figure 5H	Typical Raised Median Section (Urban Arterials).....	5(16)
Figure 5I	Typical Two-Lane Section (Urban Arterial/Collector/Local Streets) .....	5(18)
Figure 5J	Miscellaneous Details, Various Classes .....	5(20)
Figure 5K	Typical Median Section for Freeways (66 ft or Less) .....	5(21)
Figure 5L	Details of Cut Sections .....	5(22)
Figure 5M	Typical Section for Urban Freeways (High-Volume/Incident Management)....	5(23)



## Chapter Five

# URBAN HIGHWAYS AND STREETS

### (New Construction/Reconstruction)

This chapter presents the Department's criteria for the design of urban highways and streets. They apply to new construction and reconstruction projects. The designer should consider the following in the use of the Figures:

1. Functional/Design Classification. The selection of design values for new construction and reconstruction depends on the functional and, for non-freeways, the design classification of the highway facility. This is discussed in Section 6-1.0.
2. Capacity Analyses. Section 6-3.0 discusses highway capacity. Several highway design elements (e.g., the number of travel lanes) will be determined in part by the capacity analysis. As discussed in Section 6-3.0, the capacity analysis will be based on:
  - a. the design hourly volume (DHV), usually 20 years from the construction completion date;
  - b. the level of service, as determined from the tables in this chapter; and
  - c. the capacity analysis, using the techniques in the HCM.
3. Cross Section Elements. The designer should realize that some of the cross section elements included in a table (e.g., median width) are not automatically warranted in the project design. The values in the tables will only apply after the decision has been made to include the element in the highway cross section.
4. Manual Section References. These tables are intended to provide a concise listing of design values for easy use. However, the designer should review the *Manual* section references for greater insight into the design elements.



**Figure 5A**  
**URBAN FREEWAYS**  
**New Construction/Reconstruction**

Design Element		*	Manual Section	Design Values (By Type of Area)		
				Suburban/Intermediate	Built-up	
Design Controls	Design Forecast Year		6-3.02	20 Years	20 Years	
	Design Speed	x	6-2.02	65 – 70 mph	50 – 55 mph	
	Control of Access		6-4.0	Full Control	Full Control	
	Level of Service		6-3.0	B – C	B – C	
Cross Section Elements	Lane Width	x	10-1.01	12'	12'	
	Shoulder Width (1)	Right	x		10'	10'
		Left — 4 Lanes	x	10-1.02	8' (4' Paved + 4' Graded)	8' (4' Paved + 4' Graded)
		Left — 6+ Lanes	x		10'	10'
	Typical Cross Slope	Travel Lane	x	10-1.01	1.5 – 2.0% for lanes adjacent to crown; 2.0% for lanes away from crown	
		Shoulder	x	10-1.02	4%; with CMB, 4% – 6% for left shoulder	4%; with CMB, 4% – 6% for left shoulder
	Median Width (includes left shoulders)		10-3.0	See Figure 5K - 90'	See Figure 5K - 90'	
	Bridge Width/Cross Slope	x	10-4.01	Meet Approach Roadway Width and Cross Slope		
	Underpass Width		10-4.02	Meet Approach Roadway Width Plus Clear Zones		
	Right-of-Way Width		10-5.0	Desirable: 100' Beyond Edge of Traveled Way		
Roadside Clear Zones	x	13-2.0	See Section 13-2.0			
Fill/Cut Slopes		10-2.02	See Figure 5G			

\* Controlling design criteria (see Section 6-5.0).

**Footnote:**

- (1) Shoulder Width. Where the truck volumes exceed 250 DDHV, both the right and left shoulders should be 12 ft. Where warranted for high-volume/incident management sites, use a 16-ft left shoulder.

Figure 5A (Continued)

**URBAN FREEWAYS  
New Construction/Reconstruction**

Design Element		*	Manual Section	Design Values (Based on Design Speed)					
				70 mph	65 mph	60 mph	55 mph	50 mph	
Alignment Elements	Stopping Sight Distance		x	7-1.0	730'	645'	570'	495'	425'
	Decision Sight Distance	Maneuver		7-2.0	U: 1445' SU: 1275'	U: 1365' SU: 1220'	U: 1280' SU: 1125'	U: 1135' SU: 980'	U: 1030' SU: 890'
		Stop			1410'	1275'	1150'	1030'	910'
	Minimum Radius (e = 6.0%)		x	8-2.02	2050'	1665'	1340'	1065'	840'
	Superelevation	e <sub>max</sub>		8-2.02	6.0%	6.0%	6.0%	6.0%	6.0%
		Rate	x		See Figure 8-2A				
	Horizontal Sight Distance			8-2.04	See Section 8-2.04				
	Maximum Grade		x	9-2.03	4%	4%	4%	5%	5%
	Minimum Grade			9-2.03	0.5%				
	Vertical Curvature (K-Value)	Crest		9-3.02	247	193	151	114	84
		Sag		9-3.03	181	157	136	115	96
	Minimum Vertical Clearance: Freeway Under ...	New Highway Bridge	x	9-4.0	16'-3"				
Existing Highway Bridge		x	16'-0"						
Pedestrian Bridge		x	17'-6"						
Overhead Signs		x	18'-0"						
Minimum Vertical Clearance (Freeway over Railroad)		x	9-4.0	23'-0"					

\* Controlling design criteria (see Section 6-5.0).

U: Urban

SU: Suburban

Figure 5B

**MULTI-LANE PRINCIPAL URBAN ARTERIALS  
(New Construction/Reconstruction)**

Design Element		*	Manual Section	Design Values (by Type of Area)			
				Suburban	Intermediate	Built-up	
Design Controls	Design Forecast Year		6-3.02	20 Years	20 Years	20 Years	
	Design Speed	x	6-2.02	45 mph – 60 mph	35 mph – 50 mph	30 mph – 45 mph	
	Access Control		6-4.0	Partial/Control by Regulation	Control by Regulation	Control by Regulation	
	Level of Service		6-3.0	B – D	B – D	B – D	
	On-Street Parking		10-1.04	None	None	Sometimes	
Cross Section Elements	Travel Lane Width	x	10-1.01	12'	12'	11' – 12'	
	Shoulder Width	Right	x	10-1.02	4' – 8'	4' – 8'	4' – 8'
		Left	x		2' – 4'	2' – 4'	2' – 4'
	Cross Slope	Travel Lane	x	10-1.01	1.5 – 2.0% for lanes adjacent to crown; 2.0% for lanes away from crown		
		Shoulder (W < 4')		10-1.02	Same as Adjacent Travel Lane		
			Shoulder (W ≥ 4')			4% – 6%	4% – 6%
	Turn Lanes	Lane Width	x	10-1.03	11' – 12'	11' – 12'	11' – 12'
		Shoulder Width	x		2' – 4'	2' – 4'	2' – 4'
	Parking Lane Width			10-1.04	N/A	N/A	10' – 11'
	Median Width (Includes Left Shoulders)	Depressed		10-3.0	50' – 0'	N/A	N/A
		Raised Island (V = 50 mph)			8' – 20'	8' – 20'	8' – 20'
	Sidewalk Width			10-2.01	5' Minimum	5' Minimum	5' Minimum
	Bicycle Lane	Width		15-4.0	5'	5'	5'
		Cross Slope			2%	2%	2%
	Bridge Width/Cross Slope	x		10-4.01	Curb-to-Curb: Meet Approach Roadway Width & Cross Slope		Sidewalk Width: 5'-6"
Underpass Width			10-4.02	Meet Approach Roadway Width Plus Clear Zones			
Right-of-Way Width			10-5.0	Project-by-Project Basis			
Roadside Clear Zones	x		13-2.0	See Section 13-2.0			
Fill/Cut Slopes			10-2.02	See Figure 5H			

\* Controlling design criteria (see Section 6-5.0).

Figure 5B (Continued)

**MULTI-LANE PRINCIPAL URBAN ARTERIALS  
(New Construction/Reconstruction)**

Design Element		*	Manual Section	Design Values (Based on Design Speed)							
				60 mph	55 mph	50 mph	45 mph	40 mph	35 mph	30 mph	
Alignment Elements	Stopping Sight Distance		x	7-1.0	570'	495'	425'	360'	305'	250'	200'
	Decision Sight Distance	Maneuver		7-2.0	U: 1280' SU: 1125'	U: 1135' SU: 980'	U: 1030' SU: 890'	U: 930' SU: 800'	U: 825' SU: 715'	U: 720' SU: 625'	U: 620' SU: 535'
		Stop			1150'	1030'	910'	800'	690'	590'	490'
	Minimum Radius		x	8-2.02 8-3.02	1340' (e = 6%)	1065' (e = 6%)	840' (e = 6%)	715' (e = 4%)	535' (e = 4%)	375' (e = 4%)	250' (e = 4%)
	Superelevation	e <sub>max</sub>		8-2.02	6.0%	6.0%	6.0%	4.0%	4.0%	4.0%	4.0%
		Rate	x	8-3.02	See Section 8-2A			See Figure 8-3C			
	Horizontal Sight Distance			8-2.04	See Section 8-2.04						
	Maximum Grade		x	9-2.03	6%	6%	7%	7%	8%	8%	9%
	Minimum Grade			9-2.03	0.5%						
	Vertical Curvature (K-Value)	Crest		9-3.02	151	114	84	61	44	29	19
		Sag		9-3.03	136	115	96	79	64	49	37
	Minimum Vertical Clearance: Arterial Under ...	New Highway Bridge	x	9-4.0	16'-3"						
		Existing Highway Bridge	x		14'-3"						
		Pedestrian Bridge	x		17'-6"						
		Overhead Sign	x		18'-0"						
Minimum Vertical Clearance (Arterial over Railroad)		x	9-4.0	Electrified: 22'-6" All Others: 20'-6"							

\* Controlling design criteria (see Section 6-5.0).

U: Urban

SU: Suburban

Figure 5C

**TWO-LANE PRINCIPAL URBAN ARTERIALS  
(New Construction/Reconstruction)**

Design Element		*	Manual Section	Design Values (by Type of Area)			
				Suburban	Intermediate	Built-up	
Design Controls	Design Forecast Year		6-3.02	20 Years	20 Years	20 Years	
	Design Speed	x	6-2.02	45 mph – 55 mph	35 mph – 50 mph	30 mph – 45 mph	
	Access Control		6-4.02	Partial/Control by Regulation	Control by Regulation	Control by Regulation	
	Level of Service		6-3.0	B – D	B – D	B – D	
	On-Street Parking		10-1.04	None	None	Sometimes	
Cross Section Elements	Travel Lane Width	x	10-1.01	12'	11' – 12'	11' – 12'	
	Shoulder Width	x	10-1.02	4' – 8'	4' – 8'	4' – 8'	
	Cross Slope	Travel Lane	x	10-1.01	1.5% – 2.0%	1.5% – 2.0%	1.5% – 2.0%
		Shoulder	x		4% – 6%	4% – 6%	4% – 6%
	Turn Lanes	Lane Width	x	10-1.03	11' – 12'	11' – 12'	11' – 12'
		Shoulder Width	x		2' – 4'	2' – 4'	2' – 4'
	Parking Lane Width		10-1.04	N/A	N/A	10' – 11'	
	Sidewalk Width		10-2.01	5' Minimum	5' Minimum	5' Minimum	
	Bicycle Lane	Width		15-4.0	5'	5'	5'
		Cross Slope			2%	2%	2%
	Bridge Width/Cross Slope	x	10-4.01	Curb-to-Curb: Meet Approach Roadway Width and Cross Slope    Sidewalk Width: 5'-6"			
	Underpass Width		10-4.02	Meet Approach Roadway Width Plus Clear Zones			
	Right-of-Way Width		10-5.0	Project-by-Project Basis			
Roadside Clear Zones	x	13-2.0	See Section 13-2.0				
Fill/Cut Slopes		10-2.02	See Figure 5I				

\* Controlling design criteria (see Section 6-5.0).

Figure 5C (Continued)

**TWO-LANE PRINCIPAL URBAN ARTERIALS  
(New Construction/Reconstruction)**

Design Element		*	Manual Section	Design Values (Based on Design Speed)						
				55 mph	50 mph	45 mph	40 mph	35 mph	30 mph	
Alignment Elements	Stopping Sight Distance		x	7-1.0	495'	425'	360'	305'	250'	200'
	Decision Sight Distance	Maneuver		7-2.0	U: 1135' SU: 980'	U: 1030' SU: 890'	U: 930' SU: 800'	U: 825' SU: 715'	U: 720' SU: 625'	U: 620' SU: 535'
		Stop			1030'	910'	800'	690'	590'	490'
	Minimum Radius		x	8-2.02/ 8-3.02	1065' (e = 6%)	840' (e = 6%)	715' (e = 4%)	535' (e = 4%)	375' (e = 4%)	250' (e = 4%)
	Superelevation	e <sub>max</sub>		8-2.02/ 8-3.02	6.0%	6.0%	4.0%	4.0%	4.0%	4.0%
		Rate	x		See Figure 8-2A			See Figure 8-3C		
	Horizontal Sight Distance			8-2.04	See Section 8-2.04					
	Maximum Grade		x	9-2.03	6%	7%	7%	8%	8%	9%
	Minimum Grade			9-2.03	0.5%					
	Vertical Curvature (K-Value)	Crest		9-3.02	114	84	61	44	29	19
		Sag		9-3.03	115	96	79	64	49	37
	Minimum Vertical Clearance: Arterial Under ...	New Highway Bridge	x	9-4.0	16'-3"					
		Existing Highway Bridge	x		14'-3"					
		Pedestrian Bridge	x		17'-6"					
Overhead Sign		x	18'-0"							
Minimum Vertical Clearance (Arterial over Railroad)		x	9-4.0	Electrified: 22'-6" All Others: 20'-6"						

\* Controlling design criteria (see Section 6-5.0).

U: Urban

SU: Suburban

Figure 5D

**MINOR URBAN ARTERIALS**  
**(New Construction/Reconstruction)**

Design Element		*	Manual Section	Design Values (by Type of Area)			
				Suburban	Intermediate	Built-up	
Design Controls	Design Forecast Year		6-3.02	20 Years	20 Years	20 Years	
	Design Speed	x	6-2.02	45 mph – 50 mph	30 mph – 45 mph	30 mph – 40 mph	
	Access Control		6-4.0	Control by Regulation	Control by Regulation	Control by Regulation	
	Level of Service		6-3.0	B – D	B – D	B – D	
	On-Street Parking		10-1.04	None	Sometimes	Sometimes	
Cross Section Elements	Travel Lane Width	x	10-1.01	11' – 12'	11' – 12'	10' – 12'	
	Shoulder Width	Right	x	10-1.02	4' – 8'	4' – 8'	4' – 8'
		Left	x		2' – 4'	2' – 4'	2' – 4'
	Cross Slope	Travel Lane	x	10-1.01	1.5 – 2.0% for lanes adjacent to crown; 2% for lanes away from crown		
		Shoulder (W < 4')	x	10-1.02	Same as Adjacent Travel Lane		
		Shoulder (W ≥ 4')	x		4% – 6%	4% – 6%	4% – 6%
	Turn Lanes	Lane Width	x	10-1.03	11'	11'	11'
		Shoulder Width	x		2' – 4'	2' – 4'	2' – 4'
	Parking Lane Width			10-1.04	N/A	10' – 11'	10' – 11'
	Sidewalk Width			10-2.01	5' Minimum	5' Minimum	5' Minimum
	Bicycle Lane	Width		15-4.0	5'	5'	5'
		Cross Slope			2%	2%	2%
	Bridge Width/Cross Slope	x		10-4.01	Curb-to-Curb: Meet Approach Roadway Width and Cross Slope		Sidewalk Width: 5'-6"
	Underpass Width			10-4.02	Meet Approach Roadway Width Plus Clear Zones		
	Right-of-Way Width			10-5.0	Project-by-Project Basis		
Roadside Clear Zones	x		13-2.0	See Section 13-2.0			
Fill/Cut Slopes			10-2.02	See Figure 5I			

\* Controlling design criteria (see Section 6-5.0).

**Figure 5D (Continued)**  
**MINOR URBAN ARTERIALS**  
**(New Construction/Reconstruction)**

Design Element		*	Manual Section	Design Values (Based on Design Speed)					
				50 mph	45 mph	40 mph	35 mph	30 mph	
Alignment Elements	Stopping Sight Distance		x	7-1.0	425'	360'	305'	250'	200'
	Decision Sight Distance	Maneuver		7-2.0	U: 1030' SU: 890'	U: 930' SU: 800'	U: 825' SU: 715'	U: 720' SU: 625'	U: 620' SU: 535'
		Stop			910'	800'	690'	590'	490'
	Minimum Radius		x	8-2.02/ 8-3.02	840' (e = 6%)	715' (e = 4%)	535' (e = 4%)	375' (e = 4%)	250' (e = 4%)
	Superelevation	e <sub>max</sub>		8-2.02/ 8-3.02	6.0%	4.0%	4.0%	4.0%	4.0%
		Rate	x		See Figure 8-2A		See Figure 8-3C		
	Horizontal Sight Distance			8-2.04	See Section 8-2.04				
	Maximum Grade		x	9-2.03	7%	7%	8%	8%	9%
	Minimum Grade			9-2.03	0.5%				
	Vertical Curvature (K-Value)	Crest		9-3.02	84	61	44	29	19
		Sag		9-3.03	96	79	64	49	37
	Minimum Vertical Clearance: Arterial Under ...	New Highway Bridge	x	9-4.0	16'-3"				
		Existing Highway Bridge	x		14'-3"				
Minimum Vertical Clearance (Arterial over Railroad)		x	9-4.0	Electrified: 22'-6" All Others: 20'-6"					

\* Controlling design criteria (see Section 6-5.0).

U: Urban

SU: Suburban



Figure 5E

**URBAN COLLECTOR STREETS  
(New Construction/Reconstruction)**

Design Element		*	Manual Section	Design Values (by Type of Area)			
				Suburban	Intermediate	Built-up	
Design Controls	Design Forecast Year		6-3.02	20 Years	20 Years	20 Years	
	Design Speed	x	6-2.02	35 mph – 45 mph	30 mph – 45 mph	30 mph – 40 mph	
	Access Control		6-4.0	Control by Regulation	Control by Regulation	Control by Regulation	
	Level of Service		6-3.0	C – D	C – D	C – D	
	On-Street Parking		10-1.04	Sometimes	Sometimes	Sometimes	
Cross Section Elements	Travel Lane Width	x	10-1.01	11' – 12'	11' – 12'	10' – 12'	
	Shoulder Width	x	10-1.02	4' – 8'	4' – 8'	2' – 8'	
	Cross Slope	Travel Lane	x	10-1.01	1.5-2.0% (1.5-3.0% w/curbing)	1.5-2.0% (1.5-3.0% w/curbing)	1.5-2.0% (1.5-3.0% w/curbing)
		Shoulder (W <4' )			Same as Adjacent Travel Lane		
		Shoulder (W ≥ 4')	x		4% – 6%	4% – 6%	4% – 6%
	Turn Lanes	Lane Width	x	10-1.03	11'	11'	11'
		Shoulder Width	x		2' – 4'	2' – 4'	2' – 4'
	Parking Lane Width		10-1.04	8' – 10'	8 – 10'	8' – 10'	
	Sidewalk Width		10-2.01	5' Minimum	5' Minimum	5' Minimum	
	Bicycle Lane	Width		15-4.0	5'	5'	5'
		Cross Slope			2%	2%	2%
	Bridge Width/Cross Slope	x	10-4.01	Curb-to-Curb: Meet Approach Roadway Width and Cross Slope      Sidewalk Width: 5'-6"			
	Underpass Width		10-4.02	Meet Approach Roadway Width Plus Clear Zones			
	Right-of-Way Width		10-5.0	Project-by-Project Basis			
	Roadside Clear Zones	x	13-2.0	See Section 13-2.0			
Fill/Cut Slopes		10-2.02	See Figure 5I				

\* Controlling design criteria (see Section 6-5.0).

Figure 5E (Continued)

**URBAN COLLECTOR STREETS  
(New Construction/Reconstruction)**

Design Element		*	Manual Section	Design Values (Based on Design Speed)				
				45 mph	40 mph	35 mph	30 mph	
Alignment Elements	Stopping Sight Distance		x	7-1.0	360'	305'	250'	200'
	Decision Sight Distance	Maneuver		7-2.0	U: 930' SU: 800'	U: 825' SU: 715'	U: 720' SU: 625'	U: 620' SU: 535'
		Stop			800'	690'	590'	490'
	Minimum Radius (e = 4%)		x	8-3.02	715'	535'	375'	250'
	Superelevation	e <sub>max</sub>		8-3.02	4.0%	4.0%	4.0%	4.0%
		Rate	x		See Figure 8-3C			
	Horizontal Sight Distance			8-2.04	See Section 8-2.04			
	Maximum Grade		x	9-2.03	9%	10%	10%	11%
	Minimum Grade			9-2.03	0.5%			
	Vertical Curvature (K-Value)	Crest		9-3.02	61	44	29	19
		Sag		9-3.03	79	64	49	37
	Minimum Vertical Clearance: Collector Under ...	New Highway Bridge	x	9-4.0	14'-6"			
Existing Highway Bridge		x	14'-3"					
Minimum Vertical Clearance (Collector over Railroad)		x	9-4.0	Electrified: 22'-6" All Others: 20'-6"				

\* Controlling design criteria (see Section 6-5.0).

U: Urban

SU: Suburban

**Figure 5F**  
**LOCAL URBAN STREETS**  
**(New Construction/Reconstruction)**

Design Element		*	Manual Section	Design Values (by Type of Area)			
				Suburban	Intermediate	Built-up	
Design Controls	Design Forecast Year		6-3.02	20 Years	20 Years	20 Years	
	Design Speed	x	6-2.02	25 mph – 30 mph	25 mph – 30 mph	20 mph – 25 mph	
	Access Control		6-4.0	Control by Regulation	Control by Regulation	Control by Regulation	
	Level of Service		6-3.0	C – D	C – D	C – D	
	On-Street Parking		10-1.04	Sometimes	Sometimes	Sometimes	
Cross Section Elements	Travel Lane Width	x	10-1.01	10' – 11'	10' – 11'	10' – 11'	
	Shoulder Width	x	10-1.02	2' – 4'	2' – 4'	2' – 4'	
	Cross Slope	Travel Lane	x	10-1.01	1.5% – 2.0% (1.5%-3.0% with curbing)	1.5% – 2.0% (1.5%-3.0% with curbing)	1.5% – 2.0% (1.5%-3.0% with curbing)
		Shoulder (W < 4')	x	10-1.02	Same as Adjacent Travel Lane		
		Shoulder (W ≥ 4')	x		4% – 6%	4% – 6%	4% – 6%
	Turn Lanes	Lane Width	x	10-1.03	10' – 11'	10' – 11'	10' – 11'
		Shoulder Width	x		2' – 4'	2' – 4'	2' – 4'
	Parking Lane Width		10-1.04	7' – 10'	7' – 11'	7' – 11'	
	Sidewalk Width		10-2.01	5' Minimum	5' Minimum	5' Minimum	
	Bicycle Lane	Width		15-4.0	5'	5'	5'
		Cross Slope			2%	2%	2%
	Bridge Width/Cross Slope	x	10-4.01	Curb-to-Curb: Meet Approach Roadway Width and Cross Slope      Sidewalk Width: 5'-6"			
	Underpass Width		10-4.02	Meet Approach Roadway Width Plus Clear Zones			
	Right-of-Way Width		10-5.0	Project-by-Project Basis			
	Roadside Clear Zones	x	13-2.0	See Section 13-2.0			
Fill/Cut Slopes		10-2.02	See Figure 5I				

\* Controlling design criteria (see Section 6-5.0).

**Figure 5F (Continued)**  
**LOCAL URBAN STREETS**  
**(New Construction/Reconstruction)**

Design Element		*	Manual Section	Design Values (Based on Design Speed)			
				30 mph	25 mph	20 mph	
Alignment Elements	Stopping Sight Distance		x	7-1.0	200'	155'	115'
	Decision Sight Distance	Maneuver		7-2.0	U: 620' SU: 535'	N/A	N/A
		Stop			490'	N/A	N/A
	Minimum Radius (e = 4%)		x	8-3.02	250'	155'	90'
	Superelevation	e <sub>max</sub>		8-3.02	4.0%	4.0%	4.0%
		Rate	x		See Figure 8-3C		
	Horizontal Sight Distance			8-2.04	See Section 8-2.04		
	Maximum Grade		x	9-2.03	10%	11%	11%
	Minimum Grade			9-2.03	0.5%		
	Vertical Curvature (K-Value)	Crest		9-2.02	19	12	7
		Sag		9-3.03	37	26	17
	Minimum Vertical Clearance: Local Street Under ...	New Highway Bridge	x	9-4.0	14'-6"		
Existing Highway Bridge		x	14'-3"				
Minimum Vertical Clearance (Local Street over Railroad)		x	9-4.0	Electrified: 22'-6" All Others: 20'-6"			

\* Controlling design criteria (see Section 6-5.0).

U: Urban

SU: Suburban

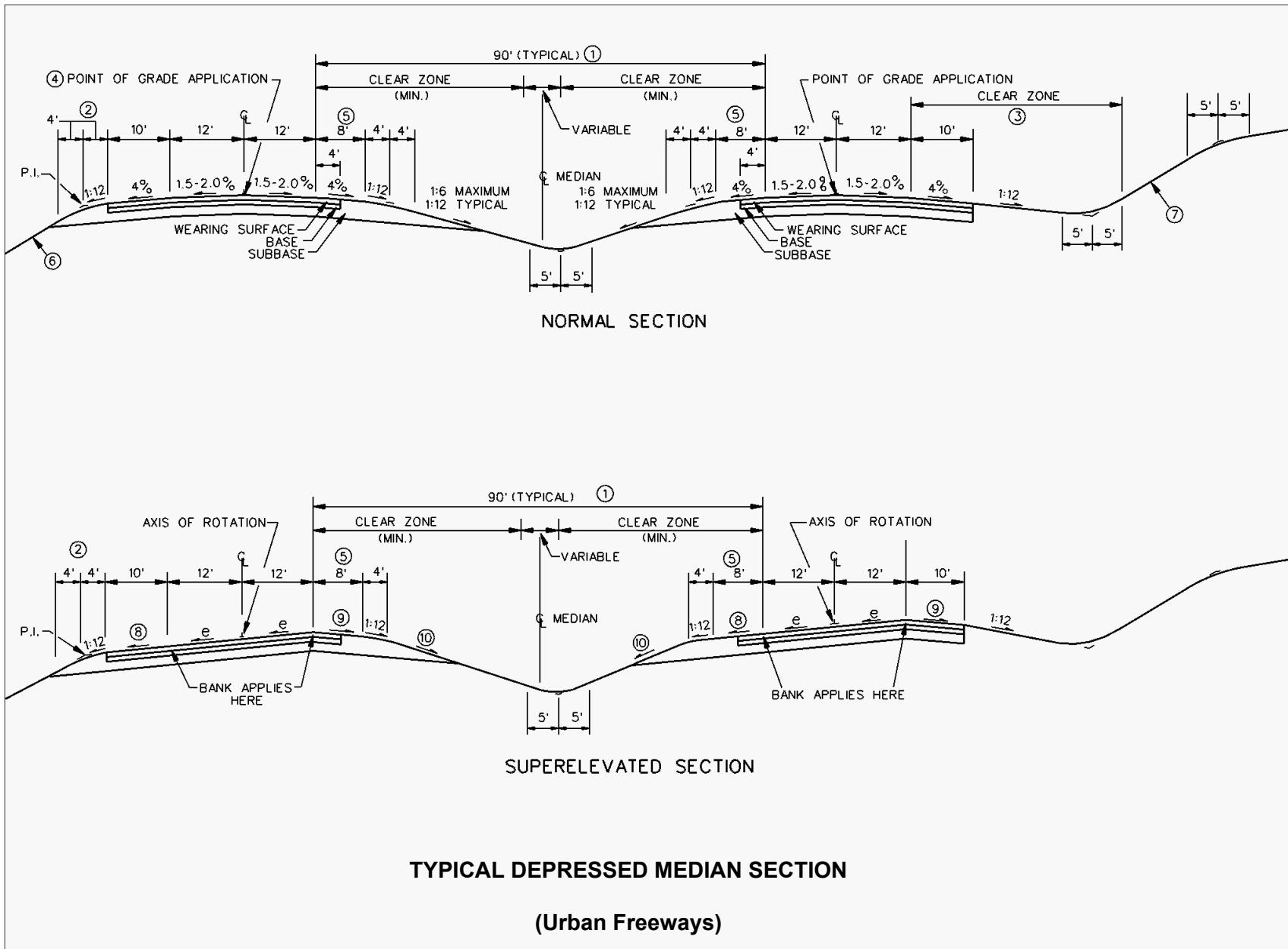

Figure 5G

## TYPICAL DEPRESSED MEDIAN SECTION (Urban Freeways)

### Notes to Figure 5G

1. Median. This section will apply to all medians greater than 66 ft. See Figure 5K for median widths of 66 ft or less, which will warrant a median barrier.
2. Slope Rounding: This is the recommended treatment and, when used, the slope rounding should be 8 ft. This will apply to all conditions, except where the design speed is 70 mph and where an unprotected 1:4 slope is provided. In this case, the recommended rounding is 11 ft. Rounding is not necessary on fill slopes protected by guiderail. See Figure 5J for details if guiderail is used.
3. Clear Zone: The outside limit of rounding for the backslope should be outside of the clear zone as determined by Section 13-2.0. If this is within the clear zone, the backslope should be safely traversable (See Figure 13-3D).
4. Point of Grade Application: The following criteria will apply:

<u>Pavement Width</u>	<u>Point of Grade Application</u>
Two 12-ft lanes	12 ft from inside edge of traveled way
Three 12-ft lanes	12 ft from inside edge of traveled way
Four 12-ft lanes	24 ft from inside edge of traveled way

5. Left Shoulder. As indicated on the Figure, the left shoulder is 8 ft graded with 4 ft paved. For three or more lanes in one direction, use a 10-ft paved left shoulder.
6. Fill Slope. These should be as flat as practical. Consider the following criteria:

<u>Fill Height</u>	<u>Fill Slope</u>	<u>Guiderail</u>
0 ft – 10 ft	1:6	No
10 ft – 25 ft	1:4	No
> 25 ft	1:2	Yes

Also, see Figure 5J for treatment at bottom of fill slope and for guiderail placement on fill slopes.

7. Cut Slope. These should be as flat as practical, but should not exceed 1:2. Also, see the clear zone discussion in Note #3. A uniform rate of slope should be maintained throughout a cut section. Where site conditions dictate a change from one rate of slope to another within a cut section, the length of transition will be as long as practical to affect a natural appearing contour. Figure 5L contains detailed information on earth and rock cuts.
8. Shoulder Superelevation (Low Side). The slope of the shoulder should be 4% or "e", whichever is greater.
9. Shoulder Superelevation (High Side). See Figure 5J for treatment of high-side shoulder. For the 8-ft shoulder (two lanes in one direction), use 8 ft when reading into the table in Figure 5J.
10. Median Slope. When the axis of rotation is at the centerline of the two roadways, a compensating median slope must be used on a superelevated section, or independent profiles must be used.
11. Stage Construction. When Stage Construction requires excavation for future lanes, the extent and details of grading and drainage will be determined during design of initial construction. Where rock is encountered, it will be removed in the initial construction as necessary to preclude subsequent operational interference.

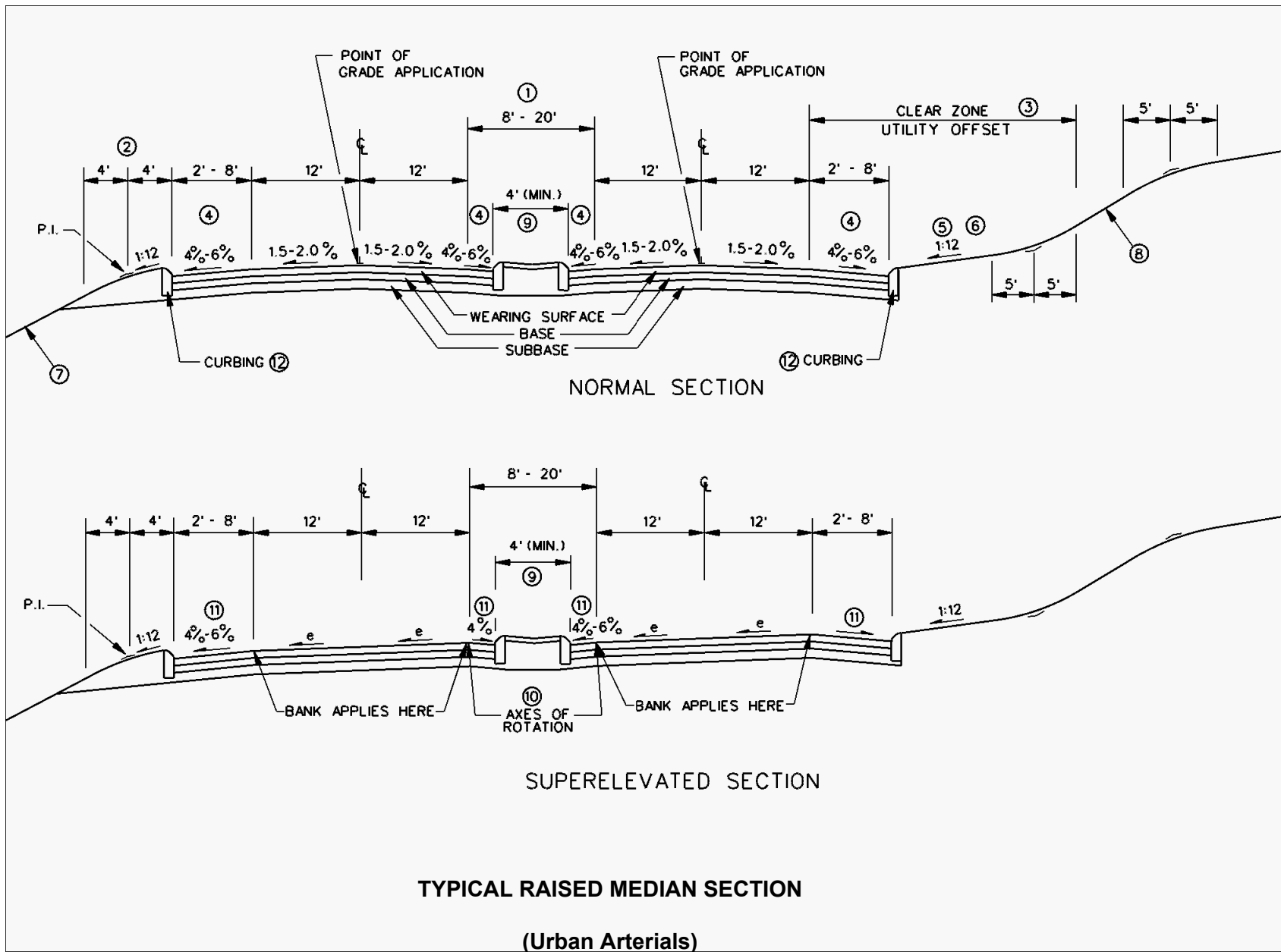

Figure 5H

## TYPICAL RAISED MEDIAN SECTION (Urban Arterials)

### Notes to Figure 5H

1. Median: In addition to a raised median, a flush median may also be used (see Section 10-3.0).
2. Slope Rounding: This is the recommended treatment and, when used, the slope rounding should be 8 ft. Rounding is not necessary on fill slopes protected by guiderail. See Figure 5J for detail if guiderail is used.
3. Clear Zone. A minimum horizontal, obstruction-free clearance of 18 in should be provided as measured from the gutter line of the curb. This applies to both vertical and sloping curbs. If practical, the designer should provide obstruction-free clearances beyond the curb greater than 18 in. See Section 13-2.04 for Department policy on utility offsets.
4. Shoulders. See Figure 5B for criteria on right and left shoulder widths. If on-street parking is provided, see criteria in Figure 5B for parking lane width. Also, note that the 4%–6% shoulder cross slope will only apply if the shoulder width is 4 ft or greater. If less than 4 ft, the shoulder cross slope will be the same as the travel lane cross slope.
5. Sidewalks: See Figure 5J for typical treatment of sidewalks.
6. Cross Slope: Positive cross slope upward from curb is preferred; however, negative cross slope may be used if site conditions warrant.
7. Fill Slope: These should be as flat as practical. Consider the following criteria:

<u>Fill Height</u>	<u>Fill Slope</u>	<u>Guiderail</u>
0 ft – 10 ft	1:6	No
10 ft – 25 ft	1:4	No
> 25 ft	1:2	Yes

Also, see Figure 5J for treatment at bottom of fill slope and for guiderail placement on fill slopes.

8. Cut Slope: These should be as flat as practical, but should not exceed 1:2. A uniform rate of slope should be maintained throughout a cut section. Where site conditions dictate a change from one rate of slope to another within a cut section, the length of transition will be as long as practical to affect a natural appearing contour. Figure 5L contains detailed information on earth and rock cuts.
9. Median Width: The raised portion of the median should be wide enough to accommodate the width of any anticipated signs plus 1 ft on each side of the sign.
10. Superelevated Section: Superelevation in built-up urban areas should be avoided if practical, provided that the maximum side friction factors are not exceeded. See Section 8-3.0. For the example shown on Figure 5H, axes of rotation are at the two median edges. This allows the raised median to remain in a horizontal plane. The axes of rotation may also be at the two roadway centerlines with a compensating slope in the raised median.
11. Shoulder Superelevation: See Figure 5J for treatment of high-side superelevated shoulder. Note that, if the shoulder width is less than 4 ft, the shoulder will be superelevated at the same rate and in the same direction as the travel lane. This applies to both the high side and the low side.
12. Curbing. On high-speed roadways, the designer should avoid the use of curbing.



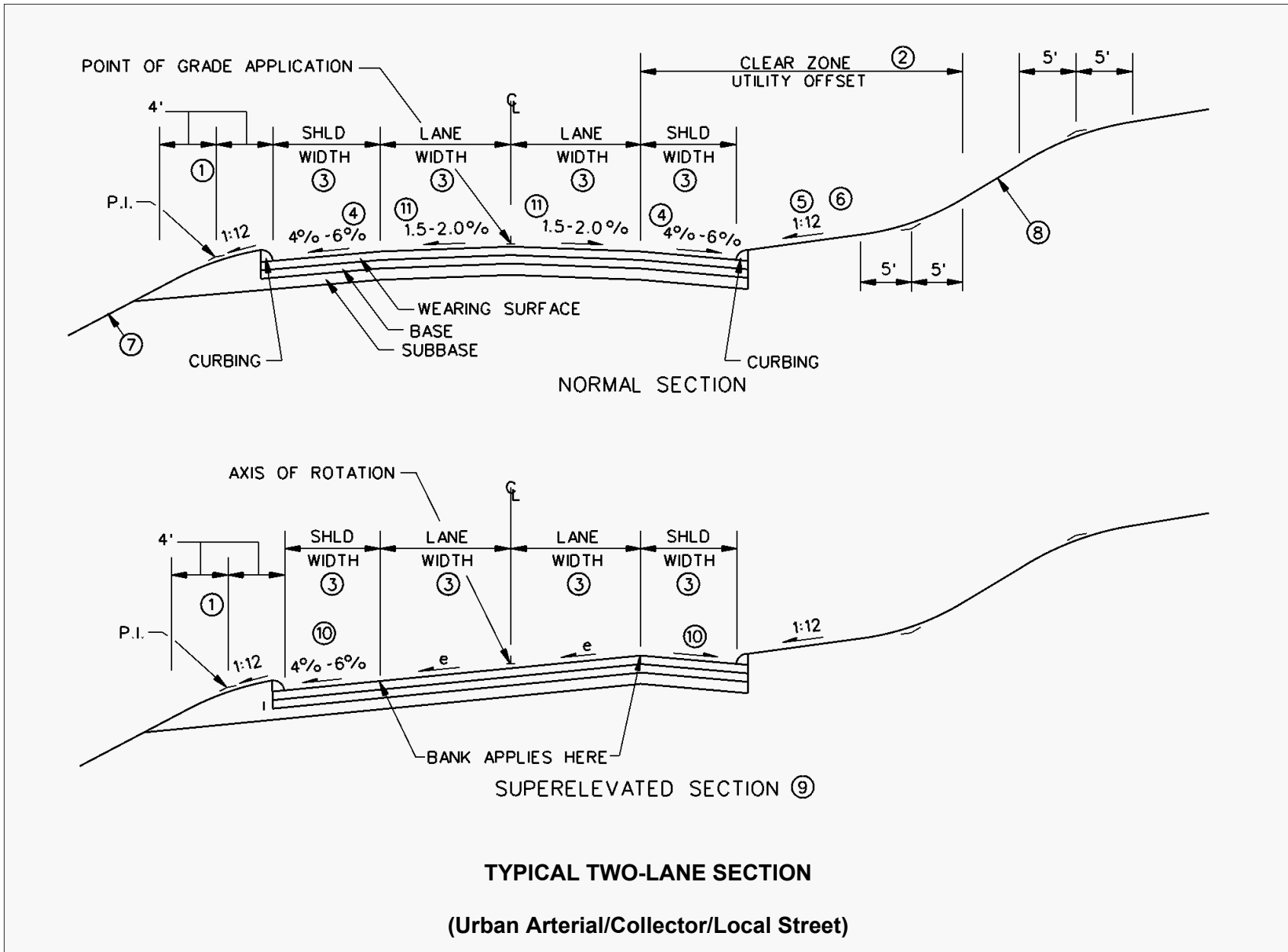

Figure 5I

## TYPICAL TWO-LANE SECTION (Urban Arterial/Collector/Local Street)

### Notes to Figure 5I

1. Slope Rounding: This is the recommended treatment and, when used, the slope rounding should be 8 ft. Rounding is not necessary on fill slopes protected by guiderail. See Figure 5J for detail if guiderail is used.
2. Clear Zone: A minimum horizontal, obstruction-free clearance of 18 in should be provided as measured from the gutter line of the curb. This applies to both vertical and sloping curbs. If practical, the designer should provide obstruction-free clearances beyond the curb greater than 18 in. See Section 13-2.04 for Department policy on utility offsets.
3. Lane and Shoulder Width: See Figures 5C through 5F for criteria on lane and shoulder widths. If on-street parking is provided, see criteria in Figures 5C through 5F for parking lane widths.
4. Shoulder Cross Slopes: Note that the 4%–6% shoulder cross slope will only apply if the shoulder is 4 ft or greater. If less than 4 ft, the shoulder cross slope will be the same as the travel lane cross slope.
5. Sidewalks: See Figure 5J for typical treatment of sidewalks.
6. Cut Section Cross Slope: Positive cross slope upward from curb is preferred; however, a negative cross slope may be used if site conditions warrant.
7. Fill Slope: These should be as flat as practical. Consider the following criteria:

<u>Fill Height</u>	<u>Fill Slope</u>	<u>Guiderail</u>
0 ft – 10 ft	1:6	No
10 ft – 25 ft	1:4	No
>25 ft	1:2	Yes

Also, see Figure 5J for treatment at bottom of fill slope. If a curb is used, see Figure 5J for treatment of guiderail and curb used in combination.

8. Cut Slope: These should be as flat as practical, but should not exceed 1:2. A uniform rate of slope should be maintained throughout a cut section. Where site conditions dictate a change from one rate of slope to another within a cut section, the length of transition will be as long as practical to affect a natural appearing contour. Figure 5L contains detailed information on earth and rock cuts.
9. Superelevated Section: Superelevation in built-up urban areas should be avoided if practical, provided that the maximum side friction factors are not exceeded. See Section 8-3.0.
10. Shoulder Superelevation: See Figure 5J for treatment of high-side superelevated shoulder. Note that, if the shoulder width is less than 4 ft, the shoulder will be superelevated at the same rate and in the same direction as the travel lane. This applies to both the high side and the low side.
11. Cross Slope: On Urban Collector Streets and Urban Local Streets that have curbing, a 1.5% – 3.0% cross slope may be used on the travel lane.

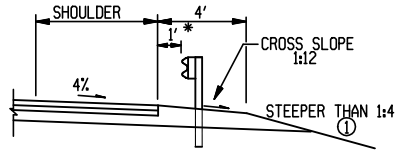

\*TYPICAL OR FLUSH WITH EDGE OF PAVEMENT  
RAILING PLACEMENT WITHOUT CURB

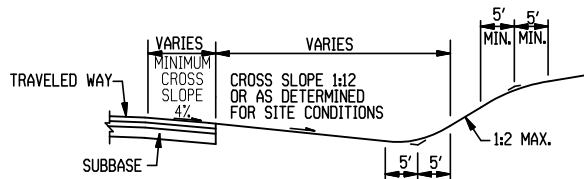

SIGHT LINE CUT OR WIDENED EARTH CUT

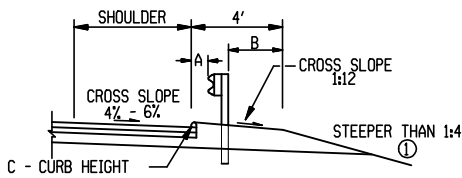
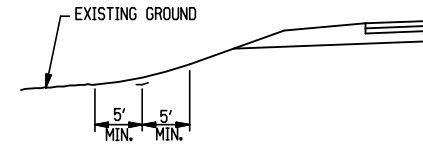

TYPE OF GUIDERAIL:	A	B (MINIMUM)	C (MAXIMUM)
METAL BEAM RAIL (TYPE R-B 350) (V < 45mph)	9"	24"	6"
METAL BEAM RAIL (TYPE R-B 350) (V ≥ 45mph)	0"	24"	4"
THREE-CABLE GUIDERAILING (I-BEAM POST)	12" MAX.	24"	*

① USE METAL BEAM RAIL (TYPE R-B 350) OR THREE-CABLE GUIDERAILING (I-BEAM POST) ON FILL SLOPES STEEPER THAN 1:4 WITH CURBING. GUIDERAIL MAY ALSO BE REQUIRED WHERE ROADSIDE OBSTRUCTIONS ARE LOCATED WITHIN THE ROADSIDE CLEAR ZONE.

\* CURBING, WHERE USED IN CONJUNCTION WITH THREE-CABLE GUIDERAILING ON HIGH-SPEED ROADWAYS (V ≥ 45mph), SHALL BE 4" MAX. IN HEIGHT.

RAILING PLACEMENT WITH CURB

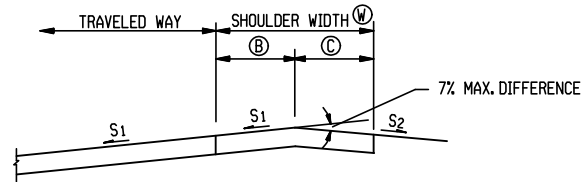

W	B	C
< 4'	0' TO 4'	0'
4' TO < 8'	0' TO 4'	4'
≥ 8'	0'	> 8'

**GENERAL NOTES:**

- MAY REQUIRE ATTACHABLE EXTENSIONS OR CUT-OFF PLATES ON PAVING EQUIPMENT.
- WHERE  $S_2$  IS FLATTER THAN 2%, THE CONTRACTOR SHALL VERIFY THE CROSS SLOPE AT EACH 25' INTERVAL (PAYMENT SHALL BE INCLUDED IN THE COST OF THE BITUMINOUS CONCRETE PAY ITEM - THERE WILL BE NO DIRECT PAYMENT.)
- $S_2$  SHALL BE 1% MINIMUM.
- DO NOT PROVIDE CURBING ON 4' SHOULDERS WITH SUPERELEVATION > 4%.
- ALL OTHER TREATMENTS SHALL BE USED ONLY WITH PRIOR APPROVAL FROM THE HYDRAULICS AND DRAINAGE, PROJECT DEVELOPMENT, AND PAVEMENT MANAGEMENT UNITS.
- INCLUDE NOTE 1 ON ALL CONTRACT DRAWINGS. INCLUDE NOTE 2 ON ALL CONTRACT DRAWINGS WHERE THE SUPERELEVATION RATES ARE STEEPER THAN 4%.

SHOULDER TREATMENT HIGH SIDE OF BANK

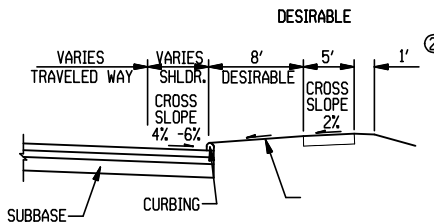
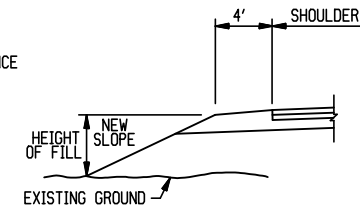

②

CURB AND WALK AREA

**MISCELLANEOUS DETAILS**

(Various Classes)

Figure 5J

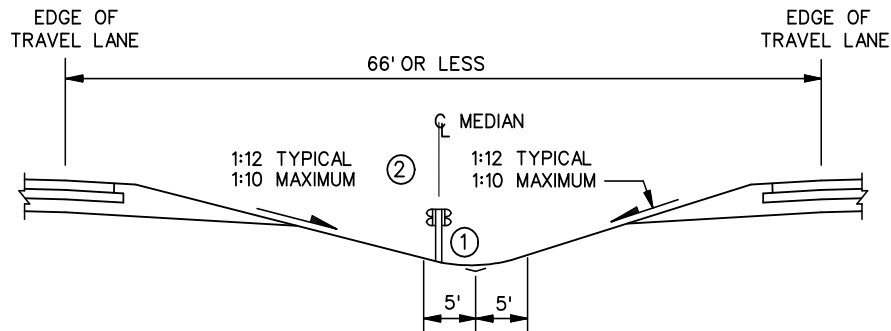

TYPICAL DEPRESSED MEDIAN  
(With Metal-Beam Barrier)

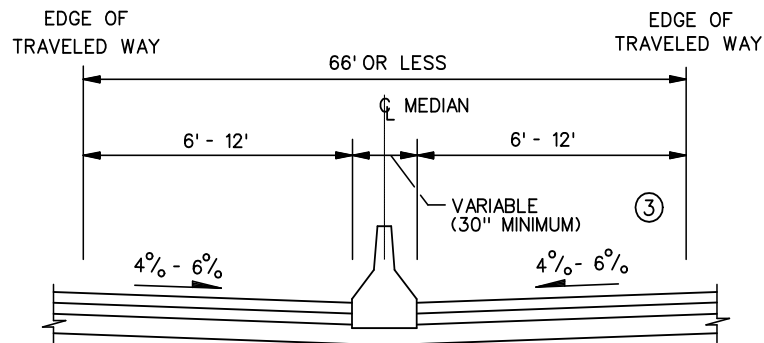

TYPICAL MEDIAN  
(With Concrete Median Barrier)

1. Placement of Median Barrier. The preferred location of the median barrier is in the center of the median. This will require that the drainage system be offset from the center as indicated in the Figure.
2. Median Slope on Superelevated Sections. The designer must ensure that the slope leading up to the median barrier does not exceed 1:10. This may require the use of independent profiles for the two roadways. Another option is to place the barrier near the edge of the shoulder; however, this is undesirable and should be avoided.
3. CMB Width. Consider providing a 4' width from the curb line to the pier face to accommodate clearance to bridge piers of overpassing structures or other appurtenances in the median.

### TYPICAL MEDIAN SECTION FOR FREEWAYS

(66 ft or Less)

Figure 5K

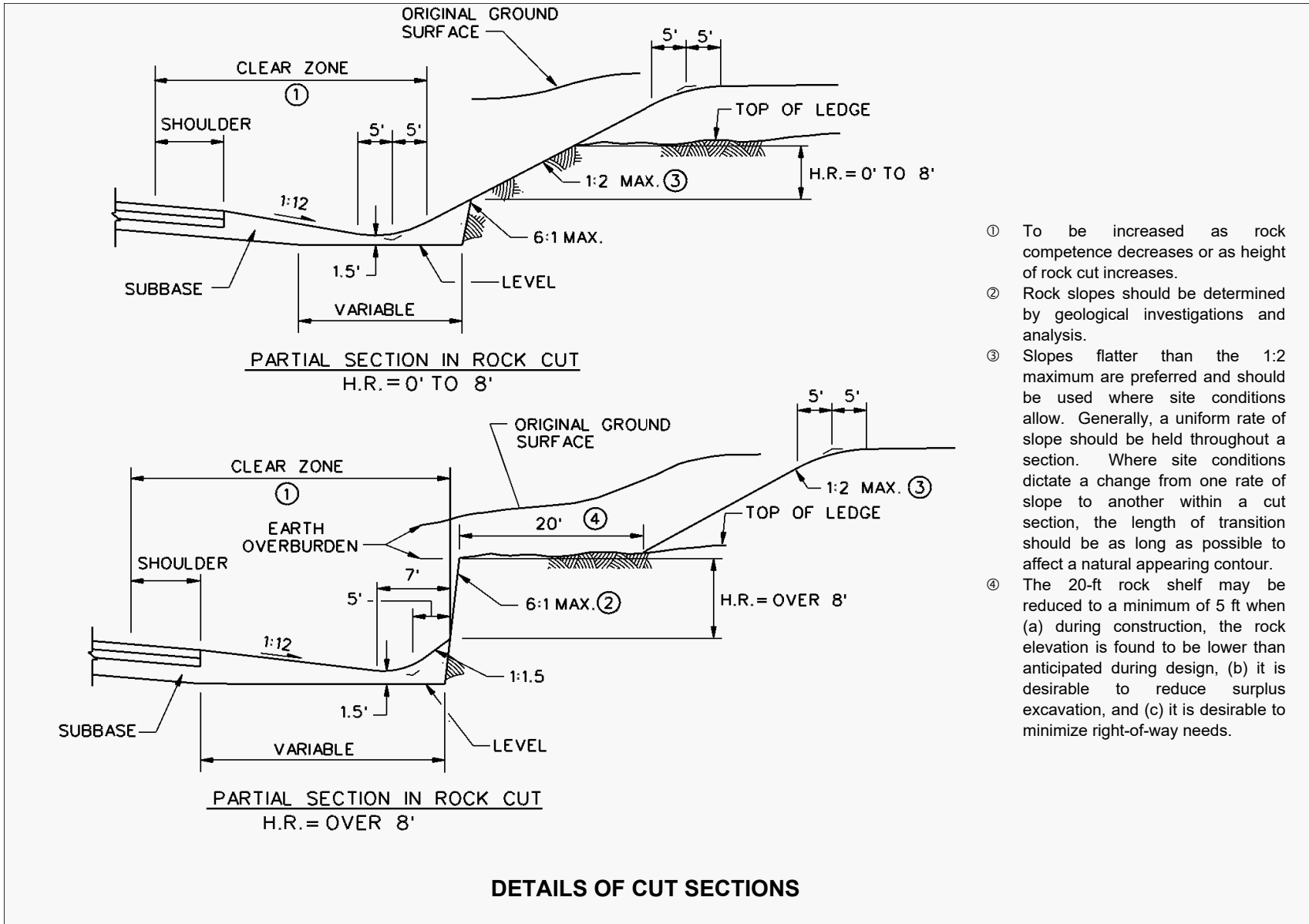

- ① To be increased as rock competence decreases or as height of rock cut increases.
- ② Rock slopes should be determined by geological investigations and analysis.
- ③ Slopes flatter than the 1:2 maximum are preferred and should be used where site conditions allow. Generally, a uniform rate of slope should be held throughout a section. Where site conditions dictate a change from one rate of slope to another within a cut section, the length of transition should be as long as possible to affect a natural appearing contour.
- ④ The 20-ft rock shelf may be reduced to a minimum of 5 ft when (a) during construction, the rock elevation is found to be lower than anticipated during design, (b) it is desirable to reduce surplus excavation, and (c) it is desirable to minimize right-of-way needs.

Figure 5L

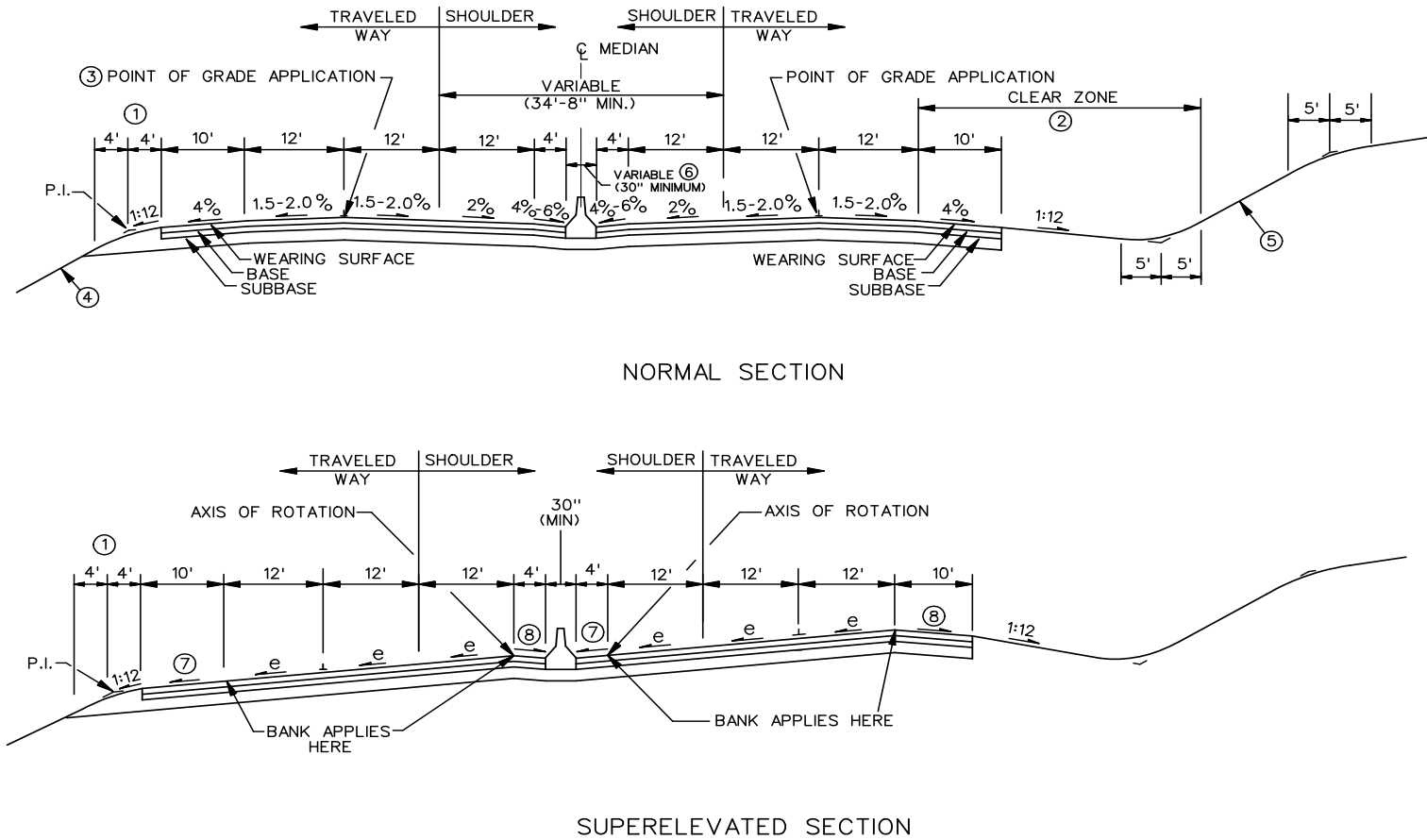

Note: See Section 10-6.0 for a discussion on this typical section. See Figure 5K.

**TYPICAL SECTION FOR URBAN FREEWAYS  
(High-Volume/Incident Management Freeways)**

**Figure 5M**

## TYPICAL SECTION FOR URBAN FREEWAYS

### (High-Volume/Incident Management Freeways)

#### Notes to Figure 5M

1. Slope Rounding: This is the recommended treatment and, when used, the slope rounding should be 8 ft. This will apply to all conditions, except where the design speed is 70 mph and where an unprotected 1:4 slope is provided. In this case, the recommended rounding is 11 ft. Rounding is not necessary on fill slopes protected by guiderail. See Figure 5J for detail if guiderail is used.
2. Clear Zone: The outside limit of rounding for the backslope should be outside of the clear zone as determined by Section 13-2.0. If this is within the clear zone, the backslope should be safely traversable (See Figure 13-3D).
3. Point of Grade Application: The following criteria will apply:

<u>Pavement Width</u>	<u>Point of Grade Application</u>
Two 12-ft lanes	12 ft from inside edge of traveled way
Three 12-ft lanes	12 ft from inside edge of traveled way
Four 12-ft lanes	24 ft from inside edge of traveled way

4. Fill Slope: These should be as flat as practical. Consider the following criteria:

<u>Fill Height</u>	<u>Fill Slope</u>	<u>Guiderail</u>
0 ft - 10 ft	1:6	No
10 ft – 25 ft	1:4	No
> 25 ft	1:2	Yes

Also, see Figure 5J for treatment at bottom of fill slope and for guiderail placement on fill slopes.

5. Cut Slope: These should be as flat as practical, but should not exceed 1:2. Also see the clear zone discussion in Note #3. A uniform rate of slope should be maintained throughout a cut section. Where site conditions dictate a change from one rate of slope to another within a cut section, the length of transition will be as long as practical to affect a natural appearing contour. Figure 5L contains detailed information on earth and rock cuts.
6. CMB Width: Consider providing 4' width from the curb line to the pier face to accommodate clearance to bridge piers of over passing structures or other appurtenances in the median.
7. Shoulder Superelevation (Low-Side): The slope of the shoulder should be the typical shoulder cross slope or "e", whichever is greater.
8. Shoulder Superelevation (High-Side): See Figure 5J for treatment of high-side shoulder.
9. Stage Construction: When Stage Construction requires excavation for future lanes, the extent and details of grading and drainage will be determined during design of initial construction. Where rock is encountered, it will be removed in the initial construction as necessary to preclude subsequent operational interference.

## Chapter Six

### DESIGN CONTROLS

#### Table of Contents

<u>Section</u>	<u>Page</u>
6-1.0 HIGHWAY SYSTEMS .....	6-1(1)
6-1.01 Functional Classification System .....	6-1(1)
6-1.01.01 Arterials .....	6-1(1)
6-1.01.02 Collectors .....	6-1(2)
6-1.01.03 Local Roads and Streets .....	6-1(2)
6-1.02 Federal-Aid System .....	6-1(2)
6-1.02.01 National Highway System .....	6-1(2)
6-1.02.02 Non-NHS/State Highway System .....	6-1(3)
6-1.03 Classification by Type of Area .....	6-1(3)
6-1.03.01 Rural Highways and Roads .....	6-1(3)
6-1.03.02 Urban Highways and Streets .....	6-1(4)
6-2.0 SPEED .....	6-2(1)
6-2.01 Definitions .....	6-2(1)
6-2.02 Design Speed .....	6-2(1)
6-2.03 Posted Speed Limit .....	6-2(3)
6-3.0 HIGHWAY CAPACITY .....	6-3(1)
6-3.01 Definitions .....	6-3(1)
6-3.02 Selection of Design Hourly Volume .....	6-3(2)
6-3.03 Capacity Analyses .....	6-3(3)
6-4.0 ACCESS CONTROL .....	6-4(1)



**Table of Contents**  
(Continued)

<b><u>Section</u></b>	<b><u>Page</u></b>
6-5.0 EXCEPTIONS TO GEOMETRIC DESIGN CRITERIA.....	6-5(1)
6-5.01 Department Intent .....	6-5(1)
6-5.02 Controlling Design Criteria.....	6-5(1)
6-5.03 Application .....	6-5(3)
6-5.03.01 Project Scope of Work .....	6-5(3)
6-5.03.02 Highway System/Funding Source.....	6-5(3)
6-5.04 Procedures for Exceptions.....	6-5(3)
6-6.0 REFERENCES.....	6-6(1)

# Chapter Six

## DESIGN CONTROLS

### 6-1.0 HIGHWAY SYSTEMS

#### 6-1.01 Functional Classification System

The Department's *Highway Design Manual* is based on the functional classification concept. Chapters Two through Five summarize the Department's design criteria for each functional class for rural and urban highways and streets and for the Project Scope of Work.

The Department has functionally classified all public highways and streets within Connecticut. The functional classification for each State highway can be found online in the Department's Highway Log or at [Functional Classification Interactive App | CTDOT Open Data \(arcgis.com\)](#) or by contacting the Office of Roadway Information Systems.

#### 6-1.01.01 Arterials

Arterial highways are characterized by a capacity to quickly move relatively large volumes of traffic. They are sometimes deliberately restricted in their service to abutting properties. The arterial functional class is subdivided into principal and minor categories for rural and urban areas:

1. Principal Arterials. In both rural and urban areas, the principal arterials provide the highest traffic volumes and the greatest trip lengths. The designer should review the project scope of work and the environmental documents to determine which of the following principal arterials should be used in design and identify its corresponding criteria:
  - a. Freeways. The freeway is the highest level of principal arterials. Full control of access, high design speeds and a high level of driver comfort and safety characterize these facilities. For these reasons, freeways are considered a special type of highway within the functional classification system, and separate design criteria have been developed for these facilities.
  - b. Expressways. These are divided-highway facilities that are characterized by full or partial control of access. Expressways with full control of access are actually freeways. Partial control of access is characterized by a few at-grade intersections with other public roads, and there may be an occasional private access.
  - c. Urban/Rural Arterials. These facilities usually consist of 2 or 4 lanes with or without a median. Partial control of access is desirable along these facilities. A high level of geometric design is desirable to move the high traffic volumes quickly and efficiently through an area.

2. Minor Arterials. In rural areas, minor arterials will provide a mix of interstate and interregional travel service. In urban areas, minor arterials may carry local bus routes and provide intracommunity connections, but they will not, for example, penetrate neighborhoods. When compared to the principal arterial system, the minor arterials provide lower travel speeds, accommodate shorter trips and distances and lower traffic volumes but provide more access to property.

#### **6-1.01.02 Collectors**

Collector routes are characterized by a relatively even distribution of access and mobility functions. Traffic volumes and speeds will typically be somewhat lower than those of arterials. In rural areas, collectors serve intraregional travel needs and provide connections to the arterial system. All cities and towns within a region will be connected. In urban areas, collectors act as intermediate links between the arterial system and points of origin and destination. Urban collectors typically penetrate residential neighborhoods and commercial and industrial areas. Local bus routes will often include collector streets.

#### **6-1.01.03 Local Roads and Streets**

All public roads and streets not classified as arterials or collectors will have a local classification. Local roads and streets are characterized by their many points of direct access to adjacent properties and their relatively minor value in accommodating mobility. Speeds and volumes are usually low and trip distances short. Through traffic is often deliberately discouraged.

#### **6-1.02 Federal-Aid System**

There are various FHWA program funds available for roadways and bridges within the Federal-aid system. The following sections briefly describe the current Federal-aid system.

##### **6-1.02.01 National Highway System**

The National Highway System (NHS) is a system of those highways determined to have the greatest national importance to transportation, commerce and defense in the United States. It consists of the Interstate highway system, logical additions to the Interstate system, selected other principal arterials, and other facilities that meet the requirements of one of the subsystems within the NHS. The NHS represents approximately 4%-5% of the total public road miles in the United States. Specifically, the NHS includes the following subsystems (note that a specific highway route may be on more than one subsystem):

1. Interstate. The Interstate system of highways has a separate identity within the NHS. There are also provisions to add miles to the existing Interstate subsystem.

2. Other Principal Arterials. These are highways in rural and urban areas that provide access between an arterial and a major port, airport, public transportation facility or other intermodal transportation facility.
3. Strategic Highway Network (STRAHNET). This is a network of highways that are important to the United States' strategic defense policy and that provide defense access, continuity and emergency capabilities for defense purposes.
4. Major Strategic Highway Network Connectors. These are highways that provide access between major military installations and highways that are part of the STRAHNET.

#### **6-1.02.02 Non-NHS/State Highway System**

The State Highway System includes both NHS and Non-NHS facilities. The following describes the State Highway System:

1. State Primary Highways. These are highways serving the predominant flow of traffic between principal towns of the state and between such towns and similar towns of the surrounding states.
2. State Secondary Highways. These are highways which are connecting, and feeder highways which supplement, the state primary system by serving the predominant flow of traffic between the smaller towns of the state and between such towns and other towns in the state and in surrounding states.
3. State Special Service Highways. These highways provide access from the primary and secondary systems of state highways to federal and state facilities.

#### **6-1.03 Classification by Type of Area**

The functional classification system is based on urban or rural designation. For a highly developed State like Connecticut, this is not sufficient to determine the appropriate project design. Therefore, the design criteria in Chapters Two, Four and Five are further divided by the type of area where the project is located. This refinement to the highway design process will allow the designer to better tailor the project to the constraints of the surrounding environment.

The following sections briefly discuss the classifications by type of area for urban and rural locations. The designer is responsible for determining which type of area is most appropriate for the project under design.

##### **6-1.03.01 Rural Highways and Roads**

Chapter Four presents the Department's design criteria for new construction or reconstruction of rural highways and roads; Chapter Two presents the criteria for 3R non-freeway projects. Many

highways in Connecticut are classified as rural but frequently pass through relatively built-up areas. Therefore, Chapters Two and Four present design criteria based on the extent of roadside development. The tables in the chapters provide criteria for the average number of access points per mile per side. These criteria provide some guidance for the designer, but they should not be considered rigid. In addition, the designer should consider the following narrative descriptions:

1. Open. This fits the traditional concept of a rural area. The driver has almost total freedom of movement and is generally not affected by occasional access points along the highway or road. For the purpose of determining the classification, access points will average less than 15 per mile per side. Right-of-way is usually not a problem.
2. Low/Moderate Density. The roadside development has increased to a level where the prudent driver will instinctively reduce his/her speed as compared to an open highway. The driver must be more alert to the possibility of entering and exiting vehicles, but he/she is still able to maintain a relatively high travel speed. The estimated number of access points will average between 15 and 30 per mile per side. Right-of-way may be difficult to attain.
3. Moderate/High Density. The roadside development has increased to a level that is comparable to a suburban area within an urbanized boundary. The extent of the development will have a significant impact on the selected travel speed of a prudent driver. Exiting and entering vehicles are frequent, and traffic signals are typical at major intersections. The estimated number of access points will average greater than 30 per mile per side. Right-of-way is usually quite difficult to attain.

### **6-1.03.02 Urban Highways and Streets**

Chapter Five presents the Department's design criteria for new construction or reconstruction of urban highways and streets; Chapter Two presents the criteria for 3R non-freeway projects. The type of area where the project is located subdivides each functional classification table. The designer should consider the following descriptions when selecting the applicable type of area:

1. Suburban. These areas are usually located at the fringes of urbanized and small urban areas. The predominant character of the surrounding environment is usually residential, but it will also include a considerable number of commercial establishments. There may also be a few industrial parks in suburban areas. On suburban roads and streets, drivers usually have a significant degree of freedom but, nonetheless, they must also devote some of their attention to entering and exiting vehicles. Roadside development is characterized by low to moderate density. Pedestrian activity may or may not be a significant design factor. Right-of-way is often available for roadway improvements.

Local and collector streets in suburban areas are typically located in residential areas, but may also serve a commercial area. Posted speed limits typically range between 25 and 40 mph. The majority of intersections will have stop or yield control, but there will be an

occasional traffic signal. A typical suburban arterial will have strip commercial development and perhaps a few residential properties. Posted speed limits usually range between 35 mph and 50 mph, and there will usually be a few signalized intersections along the arterial.

2. Intermediate. As its name implies, intermediate areas fall between suburban and built-up areas. The surrounding environment may be either residential, commercial or industrial or some combination of these. On roads and streets in intermediate areas, the extent of roadside development will have a significant impact on the selected speeds of drivers. The increasing frequency of intersections is also a major control on average travel speeds. Pedestrian activity has now become a significant design consideration, and sidewalks and crosswalks at intersections are common. The available right-of-way will often restrict the practical extent of roadway improvements.

Local and collector streets in intermediate areas typically have posted speed limits between 25 and 35 mph. The frequency of signalized intersections has increased substantially when compared to suburban areas. An arterial in an intermediate area will often have intensive commercial development along its roadside. Posted speed limits range between 30 and 40 mph. These arterials typically have several signalized intersections per mile.

3. Built-up. These areas normally refer to the central business district within an urbanized or small urban area. The roadside development has a high density and is often commercial. However, a substantial number of roads and streets in built-up areas pass through a high-density, residential environment (e.g., apartment complexes, row houses). Access to property is the primary function of the road network in built-up areas; the average driver rarely passes through a built-up area for mobility purposes. Pedestrian considerations may be as important as vehicular considerations, especially at intersections. Right-of-way for roadway improvements is usually not available.

Because of the high density of development in built-up areas, the distinction between the functional classes (local, collector or arterial) becomes less important when considering signalization and speeds. The primary distinction among the three functional classes is often the relative traffic volumes and, therefore, the number of lanes. As many as half the intersections may be signalized; posted speed limits typically range between 25 and 35 mph.



## 6-2.0 SPEED

### 6-2.01 Definitions

1. Design Speed. Design speed is a selected speed used to determine the various geometric design features of the roadway. A design speed is selected for each roadway being improved on a project, which will establish the criteria for several design elements for that specific roadway.
2. Low Speed. For geometric design applications, low speed is defined as less than or equal to 45 mph.
3. High Speed. For geometric design applications, high speed is defined as greater than 45 mph.
4. Average Running Speed. Running speed is the average speed of a vehicle over a specified section of highway. It is equal to the length of the highway section divided by the running time required for the vehicle to travel through the section. The average running speed is the distance summation for all vehicles divided by the running time summation for all vehicles.
5. Average Travel Speed. Average travel speed is the distance summation for all vehicles divided by the total time summation for all vehicles. (Note: Average running speed only includes the time the vehicle is in motion. Therefore, on uninterrupted flow facilities that are not congested, average running speed and average travel speed is equal).
6. Operating Speed. Operating speed, as defined by AASHTO, is the speed at which drivers are observed operating their vehicles during free-flow conditions. The 85th percentile of the distribution of observed speeds is the most frequently used measure of the operating speed associated with a particular location or geometric feature.
7. 85th-Percentile Speed. The 85th-percentile speed is the speed below which 85 percent of vehicles travel on a given highway. The most common application of the value is its use as one of the factors, and usually the most important factor, for determining the posted, regulatory speed limit of a highway section. In most cases, field measurements for the 85th-percentile speed will be conducted during off-peak hours when drivers are free to select their desired speed.

### 6-2.02 Design Speed

Design speed, perhaps more so than any other design control, will have a major impact on all facets of geometric design. Many design elements, such as horizontal and vertical curvature, superelevation and sight distances, are directly dependent on the design speed; i.e., the selected design speed is used directly in the equations for these geometric design elements. Other features, such as lane and shoulder width and clear zones, logically vary with design speed but are not a direct function of the design speed.



Chapters Four and Five present the minimum design speeds for new construction and reconstruction. The design speed will vary according to functional classification, urban/rural location and type of area. Chapter Two presents the Department's policy for determining the design speed on 3R non-freeway projects. Design speeds are selected at 5-mph increments.

The following should be evaluated when determining the project design speed:

1. Balance. The selected design speed should be a reasonable balance between topography, urban or rural character, and the functional use of the highway. The designer must weigh the benefits of a desired degree of safety, mobility and efficiency against the environmental, right-of-way and cost impacts.
2. Driver Expectancy. The element of driver expectancy should be considered when selecting the design speed. The driver expects to be able to drive at certain maximum speeds based on the functional and rural or urban character of the highway. Therefore, the design speed should fit the travel desires and habits of the great majority of drivers. Driver expectancy should also be considered where design speed transitions are introduced. If a restrictive field condition is obvious, drivers are more likely to accept a lower speed than if there is no apparent reason for it.
3. Traffic Volumes. This may also impact the selection of design speed. With all other factors equal, a higher volume highway may justify a higher design speed because of the increased capacity and savings in vehicular operating costs. However, the designer should consider that at low volumes, drivers are likely to travel at higher speeds. Therefore, the values in Chapters Four and Five are applicable to a wide range of traffic volumes.
4. Consistency. When a substantial length of highway is under design, the designer should assume a constant design speed. Where restrictive conditions dictate a lower design speed, it should be introduced gradually over a sufficient distance to transition drivers down to the lower speed.
5. Design Speed as Minimum Control. Although the selected design speed establishes the minimum criteria for highway alignment, the designer should consider providing flatter horizontal curves and longer sight distances if compatible with community objectives. Even in difficult terrain, an occasional tangent or flat curve may be appropriate. The designer should also be especially careful when providing a long tangent on any highway and then a minimum curve radius at the end of the tangent. A lengthy tangent section may encourage a driver to exceed the design speed of the horizontal curve.
6. Posted Speed Limit. For all new construction/reconstruction projects, the selected design speed should equal or exceed the anticipated posted or regulatory speed limit of the completed facility. This requirement recognizes the important relationship between likely travel speeds and the highway's design. It also recognizes that a posted speed limit creates a definite driver expectation of safe operating speed. The design speeds in Chapters Four and Five and the procedure in Chapter Two for 3R non-freeway projects

are intended to achieve this objective. Section 6-2.03 discusses the Department's policy on determining the posted speed limit.

### **6-2.03     Posted Speed Limit**

The Traffic Engineering Division is responsible for recommending the posted speed limit on all State highways to the Department's Office of the State Traffic Administration. It also typically assists or advises municipalities in determining the posted speed on other public roads and streets. The Traffic Engineering Division conducts an engineering evaluation of each site. The following factors are evaluated:

1.     the 85th percentile speed,
2.     roadway geometrics,
3.     functional classification and type of area,
4.     type and density of roadside development,
5.     crash experience, and
6.     pedestrian activity.



## 6-3.0 HIGHWAY CAPACITY

### 6-3.01 Definitions

1. AM/PM Peak Volumes. The one-hour volumes for each movement at an intersection or interchange in the morning and evening. Both AM/PM Peak Volumes should be used for intersection and interchange analyses in suburban and urban areas where traffic volumes are high.
2. Average Annual Daily Traffic (AADT). The total yearly volume in both directions of travel divided by the number of days in the year.
3. Average Daily Traffic (ADT). The calculation of average traffic volumes in both directions of travel in a time period greater than one day and less than one year and divided by the number of days in that time period. Although not precisely correct, ADT is often used interchangeably with AADT. The use of ADT could be biased because of seasonal peaks.
4. Capacity. The maximum sustainable flow rate at which vehicles can reasonably be expected to traverse a point or uniform section of a road during a given time period under prevailing roadway, traffic and control conditions. The time period most often used for analysis is 15 minutes.
5. Delay. A critical performance measure on interrupted flow facilities, especially at signalized intersections. For this element, average stopped-time delay is measured, which is expressed in seconds per vehicle.
6. Density. The number of vehicles occupying a given length of lane, averaged over space. It is usually expressed as vehicles per mile (vpm) per lane.
7. Design Hourly Volume (DHV). The 1-hr volume in both directions of travel in the design year selected for determining the highway's design. Section 6-3.02 discusses the Department's policy for selecting the DHV for highway design. The 30th highest hourly volume is normally used for design.
8. Directional Design Hourly Volume (DDHV). The 1-hr volume in one direction of travel in the selected design year.
9. Directional Distribution (D). The division, by percent, of the traffic in each direction of travel during the design hour.
10. K. The ratio of DHV to AADT. K will vary based on the hour selected for design and the characteristics of the specific highway facility.
11. Level of Service (LOS). A qualitative concept that has been developed to characterize acceptable degrees of congestion. LOS is used to describe operational conditions within a traffic stream based on service measures such as speed, travel time and delay. In the *Highway Capacity Manual*, the qualitative descriptions of each level of service (A to F) have been converted into quantitative measures for the capacity analysis for each highway element (e.g., freeway, signalized intersection). Chapters Four and Five present

- guidelines for selecting the level of service for highway design. These apply to all highway elements (mainline, intersections, weaving areas, etc.)
12. Peak-Hour Factor (PHF). A ratio of the total hourly volume to the maximum 15-min rate of flow within the peak hour.
  13. Rate of Flow. The equivalent hourly rate at which vehicles pass over a given point or section of a lane or roadway during a given time interval less than one hour, usually 15 minutes.
  14. Service Flow Rate. The maximum hourly vehicular volume that can reasonably pass through a highway element under prevailing roadway traffic and control conditions while maintaining a designated level of service.
  15. Truck Factor (T). A factor that reflects the percentage of heavy vehicles (trucks, buses and recreational vehicles) in the traffic stream during the DHV, ADT and/or AADT. The poorer operating capabilities and larger size of heavy vehicles must be reflected in the capacity analysis.

### **6-3.02      Selection of Design Hourly Volume**

For most geometric design elements that are impacted by traffic volumes, the peaking characteristics are most significant. The highway facility should be able to accommodate the predicted traffic volumes for the great majority of time at the selected level of service. An analysis of peaking trends has led to the conclusion that the 30th highest hourly volume (30 HV) in the selected design year is a reasonable design control. This design hourly volume (DHV) will affect many design elements including the number of travel lanes, lane and shoulder width, and intersection geometrics.

A highway should be designed to accommodate the traffic that might occur within the life of the facility under reasonable maintenance. This involves projecting the traffic conditions for a selected future year. For new construction and reconstruction, traffic volume projections are usually based on 20 years from the expected construction completion date. This is a reasonable compromise between a facility's useful life, the uncertainties of long-range projections and the consequences of inaccurate projections.

For 3R non-freeway projects, the designer should provide a highway facility that desirably, will accommodate the DHV for ten years in the future at the selected level of service. At a minimum, the highway facility should accommodate current traffic volumes at the selected level of service. Chapter Two discusses the geometric design of 3R non-freeway projects in detail.

Bridge design life is considered to be approximately 50 years. This should be considered in the geometric design of bridges and in the design of roadways that pass beneath a bridge.

The designer should analyze the proposed design using the a.m. and p.m. DHVs separately. This could have an impact on the geometric design of the highway.

The Office of Roadway Information Systems in the Bureau of Policy and Planning prepares traffic forecasts for DHV, AADT, directional distribution and percentage of heavy vehicles. A simple traffic analysis would be predicting the 30th highest hourly volume in 20 years by applying the traffic growth factors to present volumes. The forecaster must also incorporate the impact of any anticipated land development or traffic diversions onto or away from the facility. In addition, the forecaster must determine the traffic characteristics of directional distribution and composition specifically during the DHV. For intersections and interchanges, DHV forecasts must be made for every possible through and turning movements.

### **6-3.03      Capacity Analyses**

The highway mainline, intersection or interchange should be designed to accommodate the selected design hourly volume (DHV) at the selected level of service. This may involve adjusting the various highway factors that affect capacity until a design is developed that will accommodate the DHV. The detailed calculation factors and methodologies are in the *Highway Capacity Manual* (HCM). In reality, the design service volume of the facility should be calculated. When a highway is at capacity, it is assumed to have a level of service E; design service volume is defined as the maximum volume of traffic that a projected highway of designed dimensions is able to serve without the degree of congestion falling below a preselected level.



#### 6-4.0 ACCESS CONTROL

Access control is defined as the condition where the public authority fully or partially controls the right of abutting owners to have access to and from the public highway. The functional classification of a highway (Section 6-1.0) is partially determined by the degree of access it allows. Access control may be exercised by statute, zoning, right-of-way purchases, driveway controls, turning and parking regulations, or geometric design (e.g., grade separations and frontage roads).

Chapters Two to Five provide the typical degree of access control for the various functional classes and for the type of area. The following provides definitions for the three basic types:

1. Full Control. Full control of access is achieved by giving priority to through traffic by providing access only at grade separation interchanges with selected public roads. No at-grade crossings or private driveway connections are allowed. The freeway is the common term used for this type of highway. Full control of access maximizes the capacity, safety and vehicular speeds on the freeway.
2. Partial Control. Partial control of access is an intermediate level between full control and regulatory restriction. Priority is given to through traffic, but a few at-grade intersections and private driveway connections may be allowed. The proper selection and spacing of at-grade intersections and service connections will provide a balance between the mobility and access service of the highway.
3. Control by Regulation. All highways warrant some degree of access control. If access points are properly spaced and designed, the adverse effects on highway capacity and safety will be minimized. These points should be located where they can best suit the traffic and land-use characteristics of the highway under design. Their design should enable vehicles to enter and exit safely with a minimum of interference to through traffic.

The Department and all Connecticut municipalities exercise control by regulation to determine where private interests may have access to and from the public road system. Occasionally, statutory control is used on arterials to restrict access to only public roads and major traffic generators. Zoning may be used to effectively control the adjacent property development so that major generators of traffic will not develop. However, zoning restrictions are at the discretion of the local government. Driveway regulations and permits are used to control the geometric design of an entrance, driveway spacing and driveway proximity to public road intersections. Section 11-8.0 discusses the applicable criteria for driveway design. The Department's [Highway Encroachment Permit Regulations](#) discusses the procedures and design criteria for obtaining driveway permits onto State highways.





## **6-5.0 EXCEPTIONS TO GEOMETRIC DESIGN CRITERIA**

This Section discusses the Department's procedures for identifying, justifying and processing exceptions to the geometric design criteria in the *Highway Design Manual*.

### **6-5.01 Department Intent**

The general intent of the Connecticut Department of Transportation is that all design criteria in this *Manual* should be met. Where a range of values is presented, the designer should use the upper values within the range where the cost, social, economic, community and environmental impacts are not critical. This is intended to ensure that the Department will provide a highway system that meets the transportation needs of the State and provides a reasonable level of safety, comfort and convenience for the traveling public. However, recognizing that this will not always be practical, the Department has established a process to evaluate and approve exceptions to geometric design criteria.

### **6-5.02 Controlling Design Criteria**

Controlling design criteria are those highway design elements that are judged to be the most critical indicators of a highway's safety and its overall serviceability. Obviously, not all design criteria in the Department's *Highway Design Manual* are equally important. Therefore, the Department and FHWA have identified those design elements that qualify as controlling criteria and, therefore, must complete the formal documentation and approval process when not met.

The designer is also responsible for meeting the other design criteria in the *Manual*, if practical. These criteria represent good engineering practice, and the designer should make every reasonable effort to meet these criteria on all projects.

The following establishes the controlling criteria for the design exception process:

1. design speed;
2. travel lane and shoulder widths;
3. auxiliary lane and shoulder widths;
4. bridge widths;
5. structural capacity;
6. horizontal alignment:
  - a. minimum radii, and
  - b. compound curves which do not meet the 1.5:1 ratio;

7. vertical curvature based on:
  - a. level SSD at crests, and
  - b. level SSD at sags;
8. maximum grades;
9. stopping sight distance (based on level grades);
10. cross slopes;
11. superelevation:
  - a. rate based on  $e_{\max} = 6.0\%$ , and
  - b. transition lengths;
12. vertical clearances;<sup>1</sup>
13. accessibility requirements for disabled individuals;<sup>2</sup>
14. roadside clear zones; and<sup>3</sup>
15. intersection sight distance, see Section 11-2.02.<sup>3</sup>

The designer is encouraged to use the Department's recommended design speed and then seek design exceptions for individual elements that do not meet the applicable criteria for that design speed (e.g., minimum radius, SSD at crest vertical curve).

---

<sup>1</sup> For any design exception for vertical clearance on Interstate Routes I-84, I-91, I-95 and I-395, the Department must receive concurrence from the Military Surface Deployment and Distribution Command Transportation Engineering Agency (SDDCTEA) prior to requesting FHWA approval. The coordination form can be found by clicking on the following link, <https://www.fhwa.dot.gov/design/090415.cfm>, and should be submitted to the SDDCTEA with a copy to the FHWA.

<sup>2</sup> No design exceptions are permitted which do not meet CGS Sections 7-118a and 14-253a or which do not meet the Americans with Disabilities Act (Public Law 101-336).

<sup>3</sup> Not FHWA controlling design criteria. Not controlling design criteria for projects designed by municipalities (or their consultants) on facilities owned and maintained by the municipality except where they intersect with State highways.

### **6-5.03     Application**

#### **6-5.03.01     Project Scope of Work**

This design exception process will apply to:

1. all new construction projects,
2. all reconstruction projects,
3. all 3R projects, and
4. bridge widths, underpass widths and vertical clearances on spot improvement projects which involve work on a bridge. For other design elements, the design exception process will apply to spot improvements as discussed in Section 3-2.02.

#### **6-5.03.02     Highway System/Funding Source**

The design exception process will apply as follows:

1. NHS. The process will apply to all projects on the National Highway System regardless of the source of funding.
2. Non-NHS/State Highway System. The process will apply to all projects on State highways not on the NHS regardless of the source of funding.
3. Off-State Highway System. The process will apply to all projects off the State highway system that include Federal and/or State funds. It will not apply to projects off the State highway system with 100% local funds.

### **6-5.04     Procedures for Exceptions**

The designer will not request an exception to controlling design criteria until he/she has evaluated the impacts of providing the minimum or better design values. If these impacts are judged to be unacceptable, then the designer can initiate the exception process. The designer's goal should be to identify and seek approval of design exceptions prior to obtaining Design Approval.

The following establishes the procedures that the designer should follow for all proposed exceptions to design criteria:

1. The designer should present information to demonstrate the impacts of meeting the minimum or lower design criteria. This can include but is not limited to:
  - a. construction costs,
  - b. environmental consequences,
  - c. right-of-way impacts, and
  - d. community involvement/concerns.

2. The designer should provide sufficient information to demonstrate the consequences of using a design value that does not meet the minimum criteria. Where appropriate, this may include but is not limited to:
  - a. impacts on traffic serviceability (i.e., level of service);
  - b. impacts on safety (i.e., crash history);
  - c. impacts on traffic operations; and
  - d. impacts on future maintenance.
3. The designer should prepare a written summary of the information and submit it to the appropriate Division Chief for review.
4. The designer will then arrange a meeting through the office of the Engineering Administrator to discuss all proposed design exceptions. The Engineering Administrator, Division Chief and the Project Manager and/or Engineer will usually attend the meeting. The FHWA will also be represented on all projects that have been designated as Projects of Division Interest (PODI), and all projects that involve interstate routes.

**6-6.0 REFERENCES**

1. *A Policy on Geometric Design of Highway and Streets*, AASHTO, 2018.
2. *Highway Capacity Manual*, TRB, 2000.
3. *Code of Federal Regulations 23*, Office of the Federal Register, published April 1 of every year.

**Chapter Seven**

**SIGHT DISTANCE**

**Table of Contents**

<b><u>Section</u></b>	<b><u>Page</u></b>
7-1.0 STOPPING SIGHT DISTANCE .....	7-1(1)
7-2.0 DECISION SIGHT DISTANCE.....	7-2(1)
7-2.01 Application .....	7-2(1)
7-2.02 Examples.....	7-2(2)
7-3.0 INTERSECTION SIGHT DISTANCE .....	7-3(1)
7-4.0 REFERENCES.....	7-4(1)





## Chapter Seven

# SIGHT DISTANCE

### 7-1.0 STOPPING SIGHT DISTANCE

Stopping sight distance (SSD) is the sum of the distance traveled during a driver's perception/reaction (or brake reaction) time and the distance traveled while decelerating to a stop. Figure 7-1A presents the SSD values used in design. The designer is referred to AASHTO *A Policy on Geometric Design of Highways and Streets* for the criteria and assumptions used to develop the SSD. The designer should also consider the following:

1. Height of Eye. When applying the SSD values, the height of eye is assumed to be 3.5 ft.
2. Height of Object. The height of object is assumed to be 2 ft.
3. Rounding. The SSD values, as determined from the AASHTO equations, have been rounded up to the next highest 5-ft increment. A design exception is not required if the SSD meets the computed value, and, if due to rounding, does not achieve the value in Figure 7-1A.
4. Grade Adjustments. Because of gravitational forces, downgrades require greater distances for braking and upgrades require lesser distances. Figure 7-1A provides adjusted SSD values for grades. Selection of the appropriate gradient and SSD will be based on the longitudinal gradient at the site of the brake application. Note that, for design exception purposes, only those values that do not meet or exceed the "Level" SSD criteria will require a design exception as discussed in Section 6-5.0.

Design Speed (mph)	Downgrades			Level	Upgrades		
	-9% (ft)	-6% (ft)	-3% (ft)	0% (ft)	+3% (ft)	+6% (ft)	+9% (ft)
20	130	120	120	115	110	110	105
25	175	165	160	155	150	145	140
30	230	215	205	200	200	185	180
35	290	275	260	250	240	230	225
40	355	335	315	305	290	280	270
45	430	400	380	360	345	335	320
50	510	475	450	425	405	390	375
55	595	555	520	495	470	450	435
60	690	640	600	570	540	515	495
65	790	730	685	645	615	585	565
70	895	825	775	730	690	660	635

**Notes:**

1. For grades intermediate between columns, use a straight-line interpolation to calculate SSD. For example:

$$V = 55 \text{ mph}$$

$$G = -4.3\%$$

$$\text{SSD} = 520 + \left( \frac{4.3 - 3}{6 - 3} \right) (555 - 520)$$

$$= 520 + 15.2$$

$$= 535.2 \text{ ft}$$

2. See Section 9-3.0 for application of SSD to crest and sag vertical curves.

**STOPPING SIGHT DISTANCE****Figure 7-1A**

## 7-2.0 DECISION SIGHT DISTANCE

### 7-2.01 Application

At some sites, drivers may be required to make decisions where the highway environment is difficult to perceive or where unexpected maneuvers are required. These are areas of concentrated demand where the roadway elements, traffic volumes and traffic control devices may all compete for the driver's attention. This relatively complex environment may increase the required driver perception/reaction time beyond that provided by the SSD values (2.5 seconds) and, in some locations, the desired vehicular maneuver may be a speed/path/direction change rather than a stop. At these locations, the designer should consider providing decision sight distance to provide an additional margin of safety. Decision sight distance reaction times range from 3 to 10 seconds depending on the location and expected maneuver. The various avoidance maneuvers assumed in the development of Figure 7-2A are:

1. Avoidance Maneuver A: Stop on rural road.
2. Avoidance Maneuver B: Stop on urban road.
3. Avoidance Maneuver C: Speed/path/direction change on rural road.
4. Avoidance Maneuver D: Speed/path/direction change on suburban road.
5. Avoidance Maneuver E: Speed/path/direction change on urban road.

Design Speed (mph)	Decision Sight Distance for Avoidance Maneuver (ft)				
	A	B	C	D	E
30	220	490	450	535	620
35	275	590	525	625	720
40	330	690	600	715	825
45	395	800	675	800	930
50	465	910	750	890	1030
55	535	1030	865	980	1135
60	610	1150	990	1125	1280
65	695	1275	1050	1220	1365
70	780	1410	1105	1275	1445

## DECISION SIGHT DISTANCE

Figure 7-2A

In general, the designer should consider using decision sight distance at any relatively complex location where the driver perception/reaction time may exceed 2.5 seconds. Example locations where decision sight distance may be appropriate include:

1. freeway exit/entrance gores;
2. freeway lane drops;
3. left-side entrances or exits;
4. at-grade intersections near a horizontal curve;
5. railroad/highway grade crossings;
6. approaches to detours and lane closures;
7. along high-speed, high-volume urban arterials with considerable roadside friction; or
8. traffic signals on high-speed rural highways.

As with SSD, the driver height of eye is 3.5 ft and the height of object is typically 2 ft. However, candidate sites for decision sight distance may also be candidate sites for assuming that the "object" is the pavement surface (e.g., freeway exit gores). Therefore, the designer may assume a 0.0-in height of object for application at some sites.

## 7-2.02 Examples

\* \* \* \* \*

### Example 7-2.1

#### Given:

An exit on a suburban freeway under design (design speed = 60 mph) is located just beyond a bridge. The freeway passes over. The grade on each side of the overpass is 3%. The freeway will carry high traffic volumes.

#### Problem:

Determine the needed sight distance to the exit gore.

#### Solution:

A freeway exit is a major decision point for the driver, and the highway design should provide decision sight distance to the exit gore. The avoidance maneuver is a speed/path/direction change (i.e., Avoidance Maneuver D).

1. From Figure 7-2A, the decision sight distance = 1125 ft.
2. Calculate the length of the crest vertical curve for the freeway overpass. The algebraic difference in grade change is 6%. A height of object of 0.0 in to the exit gore will be used. Section 9-3.0 provides the following equations for vertical curve lengths:

$$L = \frac{AS^2}{200 (\sqrt{h_1} + \sqrt{h_2})^2}$$

$$L = \frac{(6)(1125)^2}{200 (\sqrt{3.5} + \sqrt{0.0})^2}$$

$$L = 10,848 \text{ ft}$$

3. The calculated length of vertical curve is obviously unrealistic for normal design. Therefore, to meet the decision sight distance value, the designer should attempt to flatten the upgrade and downgrade of the crest vertical curve.

### **Example 7-2.2**

#### Given:

An at-grade intersection is located just beyond a horizontal curve on an urban 2-lane highway. Both the highway and the intersection carry heavy traffic volumes. Frequent driveway entrances exist on the highway. The design speed is 45 mph. The intersection has experienced a disproportionate number of rear-end crashes on the mainline. The existing conditions are:

$$R = 1500 \text{ ft}$$

$$\text{Middle ordinate} = 33 \text{ ft}$$

$$\text{Available Sight Distance} = 500 \text{ ft}$$

#### Problem:

Determine the need for any sight distance improvements.

#### Solution:

The combination of a horizontal curve, an intersection, high traffic volumes and frequent driveways presents a relatively complex situation for the driver. The high crash rate at the intersection indicates that the existing sight distance around the horizontal curve may be inadequate. This is true even though the existing sight distance exceeds the criteria for stopping sight distance at 45 mph. Therefore, improvements should be considered to provide decision sight distance for a stop condition (i.e., Avoidance Maneuver B):

1. From Figure 7-2A, the decision sight distance = 800 ft.
2. Calculate the middle ordinate needed for the horizontal curve (see Chapter Eight):

$$M = R \left( 1 - \cos \frac{28.65S}{R} \right)$$

$$M = 1500 \left( 1 - \cos \frac{(28.65)(800)}{1500} \right)$$

$$M = 53 \text{ ft}$$

3. Therefore, the roadside obstructions along the horizontal curve should be cleared approximately an additional 20 ft to provide the extra sight distance. If this is impractical, warning signs should be provided to give the driver advance warning of the situation consistent with the values for decision sight distance.

\* \* \* \* \*

**7-3.0 INTERSECTION SIGHT DISTANCE**

Section 11-2.0 discusses the design requirements of sight distance for intersections at-grade.





**7-4.0 REFERENCES**

1. *A Policy on Geometric Design of Highways and Streets*, AASHTO, 2018.



## Chapter Eight

### HORIZONTAL ALIGNMENT

#### Table of Contents

<u>Section</u>	<u>Page</u>
8-1.0 DEFINITIONS .....	8-1(1)
8-2.0 RURAL HIGHWAYS/HIGH-SPEED URBAN HIGHWAYS.....	8-2(1)
8-2.01 General Controls.....	8-2(1)
8-2.02 Horizontal Curvature .....	8-2(2)
8-2.02.01 Theoretical Discussion.....	8-2(2)
8-2.02.02 Application .....	8-2(2)
8-2.02.03 Types of Curvature .....	8-2(5)
8-2.03 Superelevation Development.....	8-2(7)
8-2.03.01 Axis of Rotation.....	8-2(8)
8-2.03.02 Transition Length (Two-Lane Roadways).....	8-2(8)
8-2.03.03 Transition Length (Multilane Highways).....	8-2(9)
8-2.03.04 Application of Transition Length .....	8-2(10)
8-2.03.05 Effects of Curvature Type .....	8-2(10)
8-2.03.06 Shoulder Superelevation .....	8-2(11)
8-2.03.07 Typical Figures .....	8-2(12)
8-2.04 Sight Distance Through Curves.....	8-2(12)
8-2.04.01 Sight Obstruction (Definition).....	8-2(12)
8-2.04.02 Length of Curve > Sight Distance .....	8-2(17)
8-2.04.03 Length of Curve < Sight Distance .....	8-2(19)
8-2.04.04 Application .....	8-2(22)
8-2.04.05 Longitudinal Barriers.....	8-2(22)
8-2.05 Crossover Line.....	8-2(22)
8-3.0 LOW-SPEED URBAN STREETS .....	8-3(1)
8-3.01 General Controls.....	8-3(1)
8-3.02 Horizontal Curvature.....	8-3(1)

**Table of Contents**

(Continued)

<b><u>Section</u></b>		<b><u>Page</u></b>
	8-3.02.01 Theoretical Discussion.....	8-3(1)
	8-3.02.02 Application .....	8-3(1)
	8-3.02.03 Types of Curvature .....	8-3(5)
8-3.03	Superelevation Development.....	8-3(5)
8-3.04	Sight Distance Restrictions on the Inside of Curves.....	8-3(5)

## Chapter Eight

# HORIZONTAL ALIGNMENT

### 8-1.0 DEFINITIONS

1. Simple Curves. These are continuous arcs of constant radius that achieve the necessary highway deflection without an entering or exiting transition.
2. Compound Curves. These are a series of two or more simple curves with deflections in the same direction immediately adjacent to each other.
3. Reverse Curves. These are two simple curves with deflections in opposite directions that are joined by a relatively short tangent distance.
4. Broken-Back Curves. These are closely spaced horizontal curves with deflection angles in the same direction with an intervening, short tangent section.
5. Spiral Curves. A curve of continuously varying radius.
6. Superelevation (e). Superelevation is the amount of cross slope or “bank” provided on a horizontal curve to counterbalance, in combination with side friction, the centrifugal force of a vehicle traversing the curve.
7. Maximum Superelevation ( $e_{max}$ ). The maximum rate of superelevation ( $e_{max}$ ) is an overall superelevation control used on a specific facility. Its selection depends on several factors including climatic conditions, terrain conditions, type of area (rural or urban), and highway functional classification.
8. Side Friction (f). The interaction between the tire and the pavement surface to counterbalance, in combination with the superelevation, the centrifugal force of a vehicle traversing a horizontal curve.
9. Maximum Side Friction ( $f_{max}$ ). Limiting values selected by AASHTO for use in the design of horizontal curves. The designated  $f_{max}$  values represent a threshold of driver discomfort and not the point of impending skid.
10. Superelevation Transition Length. The superelevation transition length is the distance required to transition the roadway from a normal crown section to full superelevation. The superelevation transition length is the sum of the tangent runout (TR) and superelevation runoff (L) distances:
  - a. Tangent Runout (TR). Tangent runout is the distance needed to change from a normal crown section to a point where the adverse cross slope of the outside lane or lanes is removed (i.e., the outside lane(s) is level).

- b. Superelevation Runoff (L). Superelevation runoff is the distance needed to change the cross slope from the end of the tangent runout (adverse cross slope removed) to a section that is sloped at the design superelevation rate.
11. Axis of Rotation. The superelevation axis of rotation is the line about which the pavement is revolved to superelevate the roadway. This line will maintain the normal highway profile throughout the curve. The axis of rotation is generally located at the point of application of grade.
12. Crossover Line. The lane line between any two adjacent lanes of traffic.
13. Superelevation Rollover. Superelevation rollover is the algebraic difference (A) between the superelevated travel lane slope and the shoulder slope on the outside of a horizontal curve.
14. Normal Crown (NC). The typical cross section on a tangent section of roadway (i.e., no superelevation).
15. Remove Adverse Crown (RC). A superelevated roadway section that is sloped across the entire traveled way in the same direction and at a rate equal to the cross slope on the tangent section.
16. Relative Longitudinal Slope. In superelevation transition sections on two-lane facilities, the relative gradient between the profile grade and edge of traveled way.
17. Open Roadways. All urban facilities with a design speed greater than 45 mph and all rural facilities for all design speeds.
18. Low-Speed Urban Streets. All streets within an urbanized or small urban area with a design speed less than or equal to 45 mph.
19. Point of Application of Grade. The point on the cross section where the elevation of the calculated profile grade list is located.

## **8-2.0 RURAL HIGHWAYS/HIGH-SPEED URBAN HIGHWAYS**

This Section presents horizontal alignment criteria for all rural highways and for high-speed urban highways ( $V > 45$  mph). See Section 8-3.0 for horizontal alignment criteria for low-speed urban streets ( $V \leq 45$  mph).

### **8-2.01 General Controls**

Much of the criteria for horizontal alignment seek to establish minimum design values that are based on specific limiting factors. These include side-friction factors, superelevation, longitudinal gradients for superelevation transition, and middle ordinate values for sight distance. In addition, the designer should adhere to several general controls for horizontal alignment. These are based on aesthetic and safety considerations. They include:

1. Horizontal alignment should be as directional as possible. Where feasible, minimum radii should be avoided. Flatter curvature with shorter tangents is generally preferable to sharp curves connected by long tangents.
2. Curves with small deflection angles should be long enough to avoid the appearance of a kink. For a central angle of  $5^\circ$  or less, the curve should be at least 500 ft long. On freeways, the designer should try to provide a curve length, in feet, of at least 30 times the design speed in mph. On other major highways, try to provide a curve length 15 times the design speed.
3. Very small deflection angles may not require a horizontal curve; i.e., the roadway may be designed with an angular break. As a general guide, the designer may consider using an angle point when the deflection angle is less than  $1^\circ$ . The evaluation on the use of an angle point will be based on urban/rural location, aesthetics, construction costs and the visibility of the kink.
4. Broken back curvature should be avoided.
5. Sharp horizontal curves should not be introduced near crest or sag vertical curves. The combination of horizontal and vertical curves can greatly reduce sight distance, and the likelihood of crashes is increased.
6. Horizontal curves and superelevation transitions should be avoided on bridges. These cause design, construction and operational problems when snow and ice are present. The designer should not, however, avoid placing a curve on a bridge if this results in sharp horizontal curves on the approaching roadway. Where a curve is necessary on a bridge, a simple curve should be used on the bridge, and any superelevation development should be placed on the approaching roadway.
7. Normally, simple circular curves will be used in design. However, spiral curves may be considered throughout the length of a curve to fit the roadway into a restricted roadside. Spiral transition curves should be considered in areas where high speeds are anticipated.

in combination with tight curvature. For additional information, refer to any available Survey Manual.

8. The crossover line will often be a control for setting the rates of superelevation and radius and profile where two roadways converge. Freeway gores are an example.
9. The radius of a ramp curve ending parallel to a freeway should be within 1000 ft of the radius of the freeway.

## 8-2.02 Horizontal Curvature

### 8-2.02.01 Theoretical Discussion

From the laws of mechanics, the point mass formula for vehicular operation on a curve is used to define the curvature radius. The basic equation is:

$$R = \frac{V^2}{15(e + f)}$$

where:      R = radius of curve, ft  
              e = superelevation rate (expressed as a decimal)  
              f = side-friction factor  
              V = vehicle speed, mph

A number of assumptions are reflected in the values used in highway design for rural highways and high-speed urban highways. These apply both to the limiting values for curvature and to the method of determining superelevation for radii greater than the minimum. The designer should reference *A Policy on Geometric Design of Highways and Streets* for more information.

### 8-2.02.02 Application

Figure 8-2A provides design superelevation rates for combinations of radii and design speeds. The figure also provides the design lengths for superelevation runoff (from the end of the tangent runout to full superelevation). This is discussed in detail in Section 8-2.03. Note that Figure 8-2A is based on  $e_{\max} = 6.0\%$ . In built-up areas where attaining the superelevation rates in Figure 8-2A is impractical, it is acceptable to use  $e_{\max} = 4.0\%$ . Refer to *A Policy on Geometric Design of Highways and Streets* for superelevation rates based on  $e_{\max} = 4.0\%$ .

Figure 8-2B presents the minimum radii for which the normal crown (NC) section can be maintained around the curve. Figure 8-2B also presents the radii for which remove (adverse) crown (RC) applies. In this range, it is considered sufficient to remove the crown and superelevate the pavement at a rate of 1.5%. These combinations of radii and design speed are also noted as "RC" in Figure 8-2A.



R* (ft)	V = 25 mph			V = 30 mph			V = 35 mph			V = 40 mph			V = 45 mph		
	e (%)	L (ft)		e (%)	L (ft)		e (%)	L (ft)		e (%)	L (ft)		e (%)	L (ft)	
		A	B		A	B		A	B		A	B		A	B
23000	NC	0	0	NC	0	0	NC	0	0	NC	0	0	NC	0	0
20000	NC	0	0	NC	0	0	NC	0	0	NC	0	0	NC	0	0
17000	NC	0	0	NC	0	0	NC	0	0	NC	0	0	NC	0	0
14000	NC	0	0	NC	0	0	NC	0	0	NC	0	0	NC	0	0
12000	NC	0	0	NC	0	0	NC	0	0	NC	0	0	NC	0	0
10000	NC	0	0	NC	0	0	NC	0	0	NC	0	0	NC	0	0
8000	NC	0	0	NC	0	0	NC	0	0	NC	0	0	NC	0	0
6000	NC	0	0	NC	0	0	NC	0	0	NC	0	0	RC	44	67
5000	NC	0	0	NC	0	0	NC	0	0	RC	41	62	RC	44	67
4000	NC	0	0	NC	0	0	RC	39	58	RC	41	62	2.3	51	77
3500	NC	0	0	NC	0	0	RC	39	58	2.1	43	65	2.6	58	87
3000	NC	0	0	RC	36	55	RC	39	58	2.4	50	74	2.9	64	97
2500	NC	0	0	RC	36	55	2.3	45	67	2.8	58	87	3.3	73	110
2000	RC	34	51	2.2	40	60	2.8	54	81	3.3	68	102	3.8	84	127
1800	RC	34	51	2.4	44	65	3.0	58	87	3.6	74	112	4.1	91	137
1600	2.1	36	54	2.7	49	74	3.3	64	96	3.8	79	118	4.4	98	147
1400	2.3	39	59	2.9	53	79	3.6	70	105	4.1	85	127	4.7	104	157
1200	2.6	45	67	3.3	60	90	3.9	75	113	4.5	93	140	5.0	111	167
1000	3.0	51	77	3.7	67	101	4.3	83	125	4.9	101	152	5.5	122	183
900	3.2	55	82	3.9	71	106	4.5	87	131	5.1	106	158	5.7	127	190
800	3.4	58	87	4.1	75	112	4.8	93	139	5.4	112	168	5.9	131	197
700	3.7	63	95	4.4	80	120	5.1	99	148	5.7	118	177	6.0	133	200
600	4.0	69	103	4.7	85	128	5.4	105	157	5.9	122	183	R <sub>min</sub> = 665		
500	4.3	74	111	5.1	93	139	5.7	110	165	R <sub>min</sub> = 510					
450	4.5	77	116	5.3	96	145	5.9	114	171						
400	4.8	82	123	5.6	102	153	6.0	116	174						
350	5.1	87	131	5.8	105	158	R <sub>min</sub> = 385								
300	5.4	93	139	6.0	109	164									
250	5.7	98	147	R <sub>min</sub> = 275											
200	6.0	103	154												
e <sub>max</sub> = 6.0%		R <sub>min</sub> = 190													

- Key:
- R = Radius of curve (ft)
  - V = Design speed (mph)
  - e = Superelevation rate (%)
  - L = Minimum length of superelevation runoff (from adverse cross slope removed to full super) (ft)
  - A = "L" for 2-lane, 2-way roadway rotated about the centerline
  - B = "L" for 4-lane divided highway rotated about the two median edges
  - NC = Normal crown
  - RC = Remove (adverse) crown

\* For curve radii intermediate between table values, use a straight-line interpolation to determine the superelevation rate.

Note: See Section 8-2.03.03 and Figure 8-2E for superelevation runoff lengths for conditions other than "A" and "B."

**RATE OF SUPERELEVATION AND MINIMUM LENGTH OF RUNOFF**

**Figure 8-2A**

R* (ft)	V = 50 mph			V = 55 mph			V = 60 mph			V = 65 mph			V = 70 mph		
	e (%)	L (ft)		e (%)	L (ft)		e (%)	L (ft)		e (%)	L (ft)		e (%)	L (ft)	
		A	B		A	B		A	B		A	B		A	B
23000	NC	0	0	NC	0	0	NC	0	0	NC	0	0	NC	0	0
20000	NC	0	0	NC	0	0	NC	0	0	NC	0	0	NC	0	0
17000	NC	0	0	NC	0	0	NC	0	0	NC	0	0	NC	0	0
14000	NC	0	0	NC	0	0	NC	0	0	NC	0	0	RC	0	0
12000	NC	0	0	NC	0	0	NC	0	0	RC	56	84	RC	60	90
10000	NC	0	0	NC	0	0	RC	53	80	RC	56	84	2.1	63	95
8000	NC	0	0	RC	51	77	RC	53	80	2.3	64	96	2.5	75	113
6000	RC	48	72	2.2	56	84	2.6	69	104	2.9	81	121	3.2	96	144
5000	2.2	53	79	2.6	66	100	3.0	80	120	3.4	95	142	3.7	111	167
4000	2.7	65	97	3.1	79	119	3.6	96	144	4.0	112	167	4.4	132	198
3500	3.0	72	108	3.5	89	134	3.9	104	156	4.4	123	184	4.9	147	221
3000	3.4	82	122	3.9	100	149	4.3	115	172	4.8	134	201	5.3	159	238
2500	3.8	91	137	4.3	110	165	4.8	128	192	5.3	148	222	5.8	174	261
2000	4.3	103	155	4.9	125	188	5.4	144	216	5.8	162	243	R <sub>min</sub> = 2050		
1800	4.6	110	165	5.1	130	195	5.6	149	224	6.0	167	251			
1600	4.9	118	176	5.4	138	207	5.9	157	236	R <sub>min</sub> = 1665					
1400	5.2	125	187	5.7	146	218	6.0	160	240						
1200	5.6	134	202	5.9	151	226	R <sub>min</sub> = 1340								
1000	5.9	142	212	R <sub>min</sub> = 1065											
900	6.0	144	216												
R <sub>min</sub> = 840															

Key:

- R = Radius of curve (ft)
- V = Design speed (mph)
- e = Superelevation rate (%)
- L = Minimum length of superelevation runoff (from adverse cross slope removed to full super) (ft)
- A = "L" for 2-lane, 2-way roadway rotated about the centerline
- B = "L" for 4-lane divided highway rotated about the two median edges
- NC = Normal crown
- RC = Remove (adverse) crown

\* For curve radii intermediate between table values, use a straight-line interpolation to determine the superelevation rate.

Note: See Section 8-2.03.03 and Figure 8-2E for superelevation runoff lengths for conditions other than "A" and "B."

## RATE OF SUPERLEVATION AND MINIMUM LENGTH OF RUNOFF

Figure 8-2A  
(Continued)

Design Speed (mph)	Radius (ft)		
	Normal Crown	Remove (Adverse) Crown	See Figure 8-2A
25	$R \geq 2308$	$2308 > R \geq 1656$	$R < 1656$
30	$R \geq 3154$	$3154 > R \geq 2269$	$R < 2269$
35	$R \geq 4134$	$4134 > R \geq 2979$	$R < 2979$
40	$R \geq 5249$	$5249 > R \geq 3789$	$R < 3789$
45	$R \geq 6499$	$6499 > R \geq 4698$	$R < 4698$
50	$R \geq 7886$	$7886 > R \geq 5708$	$R < 5708$
55	$R \geq 9426$	$9426 > R \geq 6839$	$R < 6839$
60	$R \geq 11,114$	$11,114 > R \geq 8081$	$R < 8081$
65	$R \geq 12,530$	$12,530 > R \geq 9143$	$R < 9143$
70	$R \geq 14,049$	$14,049 > R \geq 10,289$	$R < 10,289$

Note: Flatter radius is based on a theoretical superelevation rate of +.015.

Sharper radius is based on a theoretical superelevation rate of +.020.

## RANGE OF RADII FOR NORMAL CROWN SLOPE AND REMOVE CROWN SLOPE

Figure 8-2B

### 8-2.02.03 Types of Curvature

Horizontal curves are necessary to achieve deflectional changes in alignment on the roadway. This may be accomplished by one of two methods — a simple curve or a compound curve. The following discusses each of the horizontal curvature types:

1. Simple Curves. A simple curve is a constant, circular radius that achieves the desired deflection without using an entering or exiting transition. Considering their simplicity and ease of design, survey and construction, the Department uses this type of curve most often. Figure 8-2C illustrates a typical simple curve layout.
2. Compound Curves. Compound curves are often used to avoid some control or obstacle that cannot be relocated. Compound curves can be developed with any number of individual simple curves (2-centered, 3-centered, etc.), and they can be symmetrical or asymmetrical. The geometry of each curve within the compound curvature arrangement is identical to that of a simple curve (Figure 8-2C). Figure 8-2D provides the layout of a symmetrical, 3-centered curve. This is only one example of how a compound curve can be designed.

When compound curves are used on mainline, the radius of the flatter circular arc ( $R_1$ ) should not be more than 50% greater than that of the sharper arc ( $R_2$ ); i.e.,  $R_1 \leq 1.5R_2$ .

CURVE SYMBOLS

- $\Delta$  = Deflection Angle, degrees  
 T = Tangent Distance = distance from PC to PI = distance from PI to PT  
 L = Length of curve in feet = distance from PC to PT along curve  
 R = Radius of curve  
 E = External Distance (PI to mid-point of curve)  
 LC = Length of long chord — PC to PT  
 M = Middle Ordinate (mid-point of arc to mid-point of long chord)

CIRCULAR CURVE ABBREVIATIONS

- P.C. = PC = Point of Curvature (Beginning of Curve)  
 P.T. = PT = Point of Tangency (End of Curve)  
 P.I. = PI = Point of Intersection of Tangents  
 P.C.C. = PCC = Point of Compound Curvature

CURVE FORMULA

$$T = R \left( \tan \frac{\Delta}{2} \right) = \frac{R \sin \left( \frac{\Delta}{2} \right)}{\cos \left( \frac{\Delta}{2} \right)}$$

$$L = \frac{\Delta}{360} 2\pi R$$

$$E = \frac{R}{\cos \left( \frac{\Delta}{2} \right)} - R$$

$$E = T \tan \left( \frac{\Delta}{4} \right)$$

$$LC = 2R \left( \sin \frac{\Delta}{2} \right) = 2T \left( \cos \frac{\Delta}{2} \right)$$

$$M = R \left( 1 - \cos \left( \frac{\Delta}{2} \right) \right)$$

$$M = E \left( \cos \left( \frac{\Delta}{2} \right) \right)$$

$$O = R - \sqrt{R^2 - t^2} = R - R (\cos \phi)$$

$$\tan \alpha = \frac{1 - \cos \phi}{\tan \left( \frac{\Delta}{2} \right) - \sin \phi}$$

$$\pi = 3.141592653$$

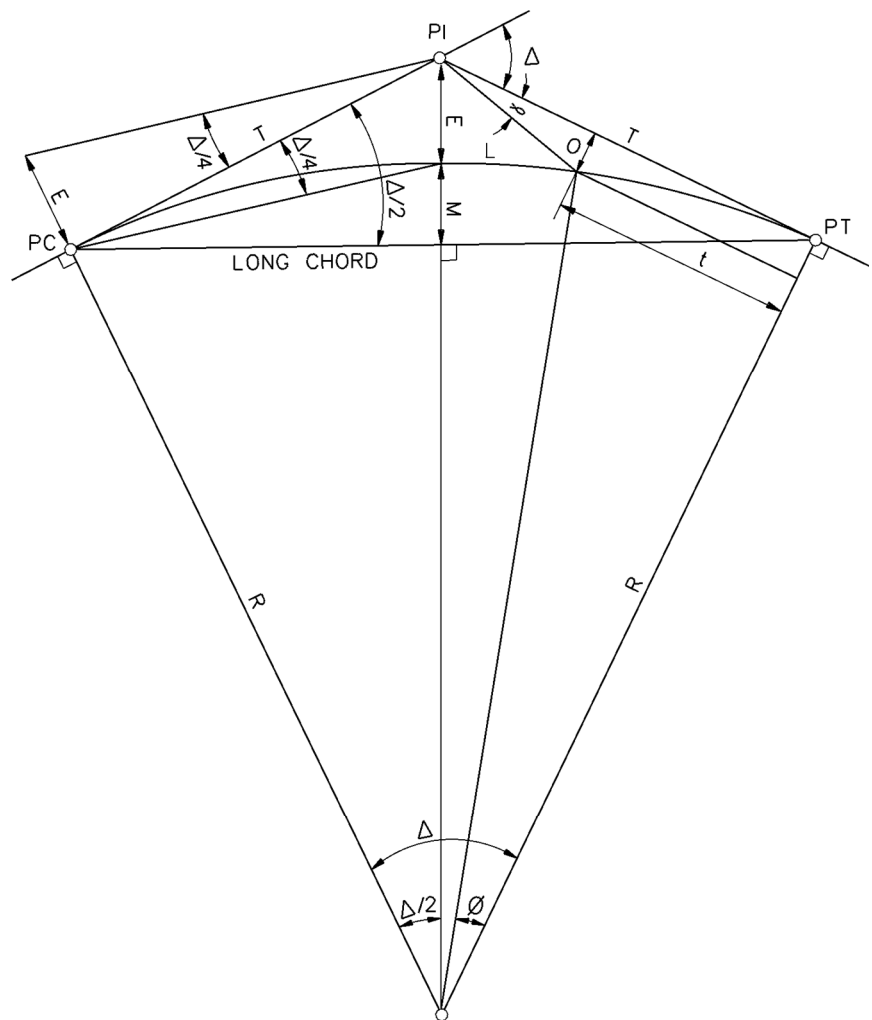

LAYOUT OF SIMPLE CURVE

Figure 8-2C

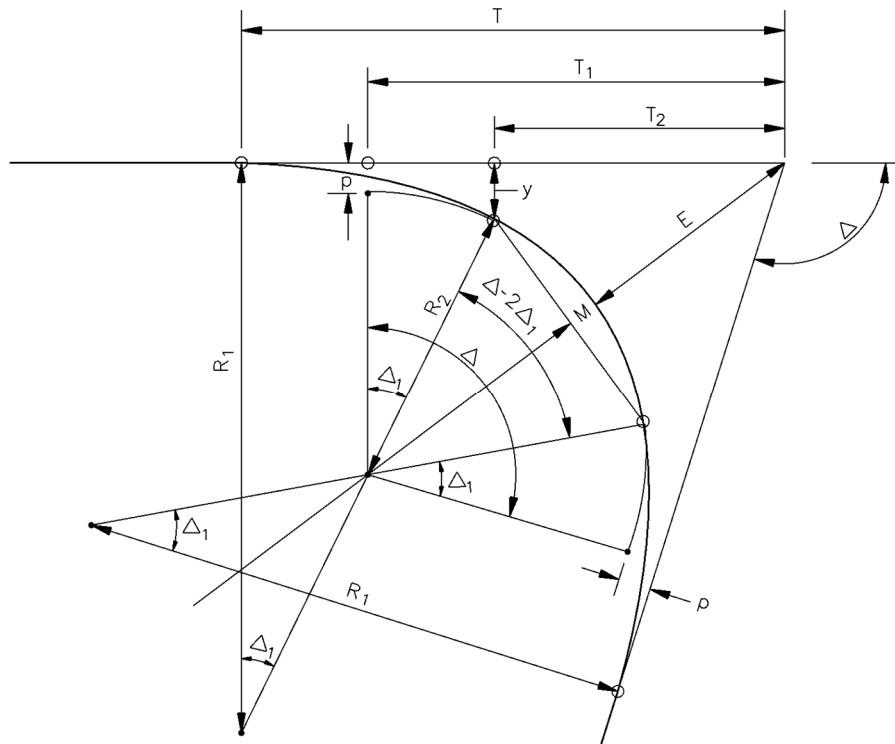

Given:  $R_1$ ,  $R_2$ ,  $\Delta_1$  and  $p$

$$1. \quad T_1 = (R_2 + p) \tan \frac{\Delta}{2}$$

$$2. \quad \Delta_1 = \cos^{-1} \left[ \frac{R_1 - R_2 - p}{R_1 - R_2} \right]$$

$$3. \quad T = T_1 + (R_1 - R_2) \sin \Delta_1$$

$$4. \quad T_2 = T_1 - R_2 \sin \Delta_1$$

$$5. \quad E = \frac{R_2 + p}{\cos(\Delta/2)} - R_2$$

$$6. \quad M = R_2 - [R_2 \cos(\Delta/2 - \Delta_1)]$$

$$7. \quad y = (R_2 + p) - R_2 \cos \Delta_1$$

Note: "p" is the offset location between the interior curve (extended) to a point where it becomes parallel with the tangent line.

### THREE-CENTERED SYMMETRICAL COMPOUND CURVE

Figure 8-2D

### **8-2.03 Superelevation Development**

#### **8-2.03.01 Axis of Rotation**

The axis of rotation is the line about which the pavement is revolved to superelevate the roadway. This line will maintain the normal highway profile throughout the horizontal curve.

On 2-lane and undivided multilane highways, the axis of rotation will almost always be the centerline of the roadway (see Figure 8-2G). This method results in the least amount of elevation differential between the edges of the travel lanes and their normal profile. For 2-lane roadways, the designer will use the lengths from Column A in Figure 8-2A. Occasionally, it may be warranted to rotate the pavement about the inside edge of the travel lane. This may be preferable when the lower edge profile is a major control, as for drainage. For 2-lane roadways in this case, the designer will use the lengths from Column B in Figure 8-2A.

Divided highways with medians require special consideration. The basic choices for selecting the axis of rotation are:

1. Rotate about the centerline of the median, which will also be the centerline of the entire roadway section.
2. Rotate about the two median edges and hold the median in a horizontal plane.
3. Rotate each roadway separately and provide a compensating slope in the median.
4. On roadways with independent alignment, rotate each one separately.

Several highway features may significantly influence the superelevation development for divided highways. These include guiderail, median barriers and drainage. The designer should carefully consider the intended function of these features and ensure that the superelevated section does not compromise their operation. Chapters Four and Five provide typical cross section figures for superelevated urban and rural highways for both divided and undivided highways.

#### **8-2.03.02 Transition Length (Two-Lane Roadways)**

The superelevation transition length is the distance required to transition the roadway from a normal crown section to the full superelevation needed. The length combines both the tangent runoff distance (TR) and the superelevation runoff length (L).

Figure 8-2A presents the lengths of superelevation runoff. The tangent runoff length, which is the distance from the normal crown to where the adverse cross slope is removed, is in addition to the superelevation runoff length. Typically, the relative longitudinal gradient for the tangent runoff will be set equal to that for the superelevation runoff. The designer may also use graphical methods to determine the tangent runoff.

**8-2.03.03 Transition Length (Multilane Highways)**

The superelevation runoff distance for multilane highways is calculated by:

$$L = C \times L_2$$

where:

- L = Superelevation runoff length for multilane highway, ft
- L<sub>2</sub> = Superelevation runoff length for a 2-lane roadway, ft
- C = Ratio of runoff length for a multilane highway to runoff length for a 2-lane roadway (see Figure 8-2E)

Number of Lanes Being Rotated*	C
One	1.0
Two	1.5**
Three	2.0
Four	2.5

\* This column refers to the number of lanes being rotated on either side of the axis rotation. Select the higher value. For example, if the axis of rotation for a 3-lane roadway is about the edge of the interior lane, two lanes will be rotated on one side of the axis and one lane will be rotated on the other side. The higher number is two, and C is 1.5.

Note also that a C = 1.5 should be used to determine the superelevation runoff length for a 2-lane, 2-way roadway where the axis of rotation is about either edge of the traveled way.

As another example, consider a 5-lane roadway (i.e., four through lanes and a two-way, left-turn lane (TWLTL)) with the axis of rotation in the center of the TWLTL. In this case, the number of lanes being rotated is 2.5; therefore, C = 1.75.

\*\* Column B in Figure 8-2A presents values based on C = 1.5.

**C VALUES**  
**(Superelevation Runoff Lengths, Multilane Highways)**

**Figure 8-2E**

### 8-2.03.04 Application of Transition Length

The location of the transition length may be shifted within the indicated limits to obtain practical beginning and ending points. In most cases, the designer will likely locate the transition termini at the nearest 50-ft or 100-ft station. In addition, the designer should examine the relationship between the horizontal and vertical alignment to provide a desirable visual impact.

### 8-2.03.05 Effects of Curvature Type

Horizontal curvature may be a simple curve or a compound curve. Superelevation development will vary for each type. In addition, superelevation development must be carefully addressed at closely spaced reverse curves. Each is discussed:

1. Simple Curves. The typical figures in Section 8-2.03.07 illustrate superelevation development for simple curves. The designer must distribute the placement of the transition length between the tangent section (where no superelevation is needed) and the curve section (where full superelevation is needed). No distribution method can be completely justified. As an approximation, 60% - 80% of the full superelevation should be reached at the PC. If practical, try to provide 0.67e at the PC. This superelevation rate will be reached at 0.67 of the superelevation runoff length.
2. Compound Curvature. The typical figure in Section 8-2.03.07 illustrates the superelevation development for compound curvature. These criteria should be met:
  - a. Figure 8-2A provides the runoff lengths required for various design speeds and radii. Regardless of the radius, the gradient for all runoff lengths in this chart is essentially the same for any design speed. This relative gradient is what is important when establishing a superelevation diagram for a compound curve. In some cases, the distance between the PC and the PCC in a compound curve will allow a single uniform longitudinal gradient to be used, providing that it does not vary significantly from the gradient based on the runoff length from the chart. As an approximation, 60% to 80% of the full superelevation should be reached at the PC. If practical, try to provide 0.67e at the PC. Between 60% and 100% of the full superelevation should be reached at the PCC.
  - b. If the distance between the PC and the PCC or between two PCC points is such that a single uniform longitudinal gradient cannot be used without varying significantly from the gradient based on the runoff length from the chart, then the superelevation for each curve should be transitioned separately using the same design speed gradient. Where superelevation for the entering curve equals or exceeds 0.67e for the next curve, begin transitioning at approximately the PCC using essentially the same gradient as for the entering curve. Remember that the gradients are essentially the same for any design speed. Where superelevation for the entering curve is less than 0.67e for the next curve, use approximately the same gradient as for the entering curve, transitioning through the PCC as for simple curves trying to provide 0.67e at the PCC.



3. Reverse Curves. For closely spaced reverse curves, it is not necessary to achieve an intermediate crowned section between the curves; i.e., a continuously rotating plane may be provided. The designer should adhere to the applicable superelevation development criteria for each curve. For example, assume that each curve is a simple curve and assume that 0.67 of the full superelevation is provided at the PT and PC. This means that the minimum length of the tangent section between the PT and PC is:

$$L_{\text{tan}} = 0.67 L_1 + TR_1 + TR_2 + 0.67 L_2$$

where:

$L_{\text{tan}}$	=	Tangent distance between PT and PC, ft
$L_1$	=	Superelevation runoff length for first curve, ft
$TR_1$	=	Tangent runout length for first curve, ft
$TR_2$	=	Tangent runout length for second curve, ft
$L_2$	=	Superelevation runoff length for second curve, ft

It is undesirable to have a zero tangent distance between the two curves (i.e., where the PT of the first curve is coincident with the PC of the second curve). This type of alignment requires the driver to shift his steering from a curve in one direction to a curve in the other at exactly the point of reverse curvature if he is to remain within his lane. It is not possible to have a minimum amount of superelevation at the beginning of the curve, and transitions are more difficult. This lowers the effective design speed of the curve within the transition zone. It is preferable to use tighter radii to provide the tangent length required to effect the introduction of superelevation and allow the driver time to react. Tangent length is required even when superelevation is not used in order to accomplish steering maneuvers. Provide a minimum of 2.5 seconds of travel time on a tangent section between two reverse curves at the design speed.

### 8-2.03.06 Shoulder Superelevation

Figures 4H and 5J provide the detail for shoulder superelevation on the high side of the roadway. This detail will apply when the shoulder width is 4 ft or more and will apply to the entire range of superelevation rates (1.5% to 6.0%). When the shoulder width is less than 4 ft, it will be superelevated at the same rate and in the same direction as the travel lane. In this case, the designer should ensure that the drainage for the area beyond the roadway will not flow into the roadway.

On the low side, the shoulder cross slope will remain equal to its rate on the tangent section until the superelevated rate exceeds that value. Then, the shoulder will be sloped at the same rate as the superelevated travel lanes.

Section 10-1.02.02 contains criteria on shoulders across superelevated bridges.

**8-2.03.07 Typical Figures**

Based on the discussion in the previous Sections, the following figures illustrate the Department's methods for superelevation development:

1. Figure 8-2F is applicable to 2-lane roadways rotated about the centerline where a simple curve is used.
2. Figure 8-2G is applicable to 2-lane roadways rotated about the centerline where compound curvature is provided.
3. Figure 8-2H is applicable to roadways with three or four lanes where a simple curve is used. The axis of rotation is about the centerline (4-lane roadways) or about one inside edge of travel lane (3-lane roadways). If a compound curve is used, the designer will modify the superelevation development as illustrated in Figure 8-2G.
4. Figure 8-2I is applicable to roadways with five or six lanes where a simple curve is used. The axis of rotation is about the centerline (6-lane roadway) or about either edge of the center lane (5-lane roadways). If a compound curve is used, the designer will modify the superelevation development as illustrated in Figure 8-2G.

**8-2.04 Sight Distance Through Curves**

The designer must evaluate the impact of sight obstructions that are located laterally on the inside of horizontal curves. These may interfere with the required sight distance and should be removed if practical.

**8-2.04.01 Sight Obstruction (Definition)**

Sight obstructions on the inside of a horizontal curve are defined as significant obstacles that interfere with the line of sight. These include walls, cut slopes, wooded areas, buildings and high farm crops. In general, point obstacles such as traffic signs and utility poles are not considered sight obstructions on the inside of horizontal curves. The designer must examine each curve individually to determine whether it is necessary to remove an obstruction or adjust the horizontal alignment to obtain the required sight distance.

MAXIMUM RELATIVE LONGITUDINAL SLOPE (G) BETWEEN PROFILES OF OUTSIDE EDGES OF TRAVELED WAY AND AXIS OF ROTATION (CL ROADWAY)

DESIGN SPEED (mph)	SLOPE (G)
25	0.70%
30	0.66%
35	0.62%
40	0.58%
45	0.54%
50	0.50%
55	0.47%
60	0.45%
65	0.43%
70	0.40%

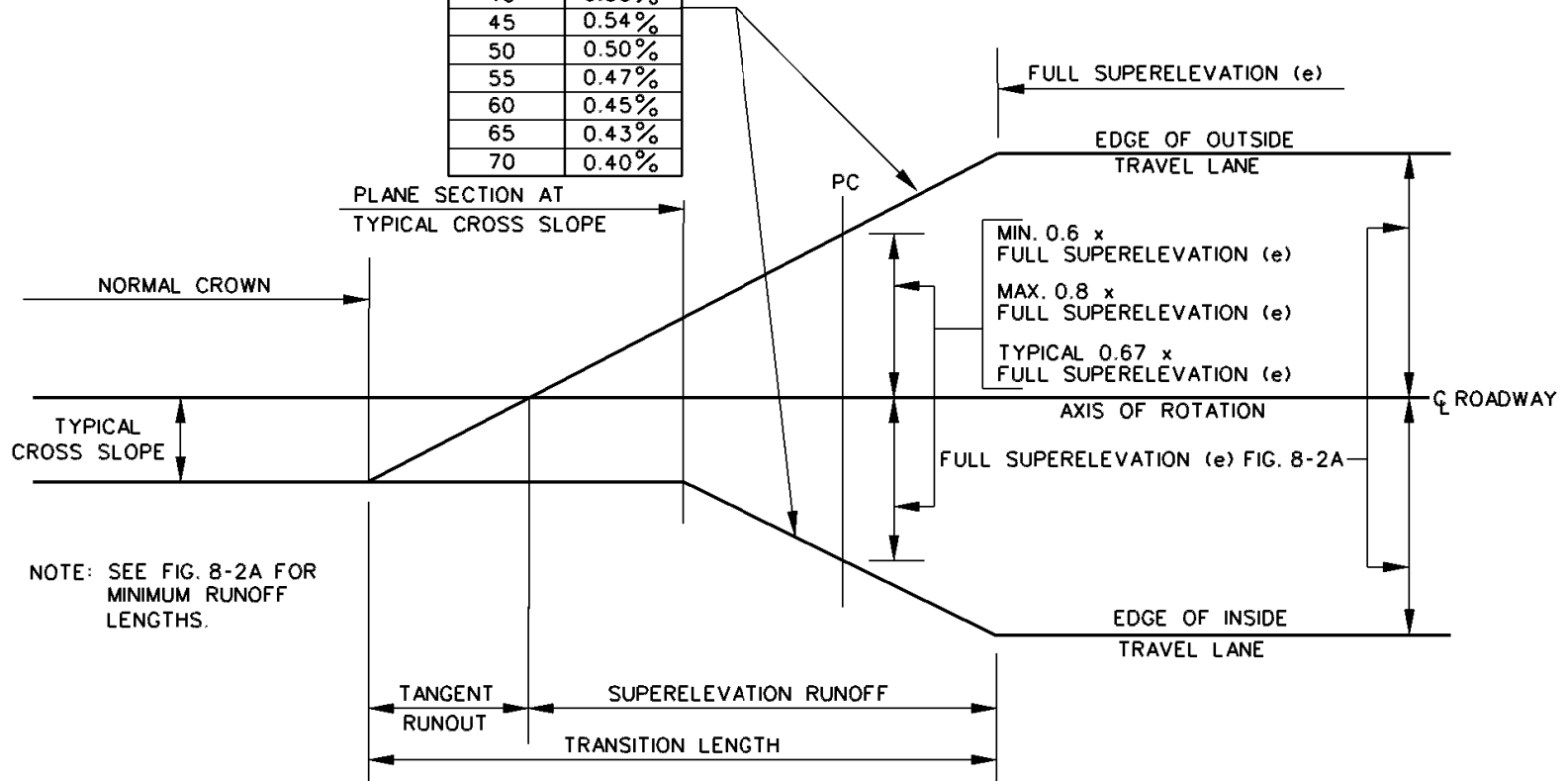

NOTE: SEE FIG. 8-2A FOR MINIMUM RUNOFF LENGTHS.

**SUPERELEVATION DEVELOPMENT ON TWO-LANE ROADWAYS  
(Simple Curve)**

**Figure 8-2F**

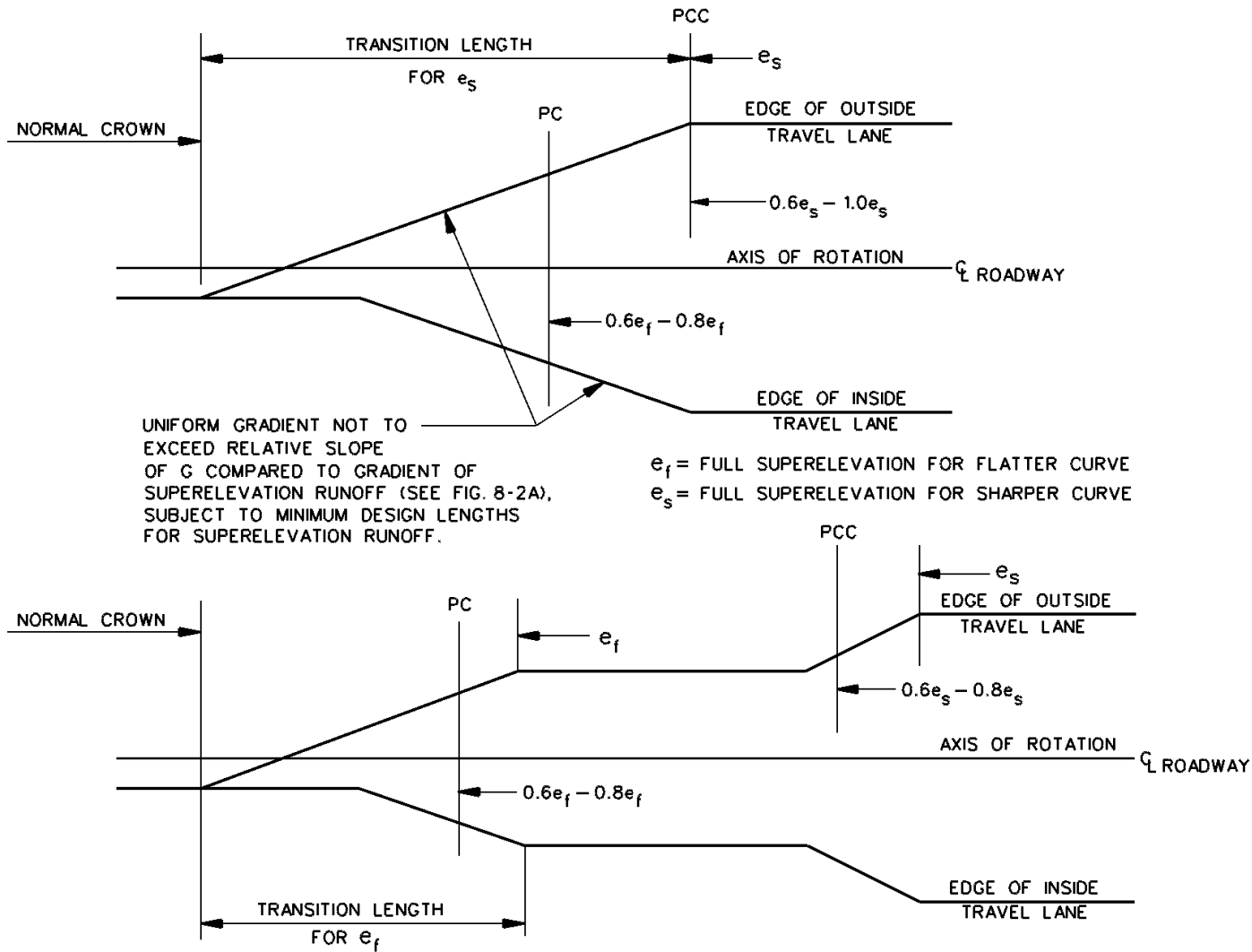

**SUPERELEVATION DEVELOPMENT ON TWO-LANE ROADWAYS  
(Compound Curves)**

**Figure 8-2G**

MAXIMUM RELATIVE LONGITUDINAL SLOPE (G) BETWEEN PROFILES OF OUTSIDE EDGES OF TRAVELED WAY AND AXIS OF ROTATION (CL ROADWAY)

DESIGN SPEED (mph)	SLOPE (G)
25	0.94%
30	0.88%
35	0.83%
40	0.77%
45	0.72%
50	0.67%
55	0.63%
60	0.60%
65	0.57%
70	0.53%

NOTES:

1. MODIFY SUPERELEVATION DEVELOPMENT FOR COMPOUND CURVES ACCORDING TO METHODS ILLUSTRATED IN FIG. 8-2G.
2. SEE FIG. 8-2A FOR MINIMUM RUNOFF LENGTHS.

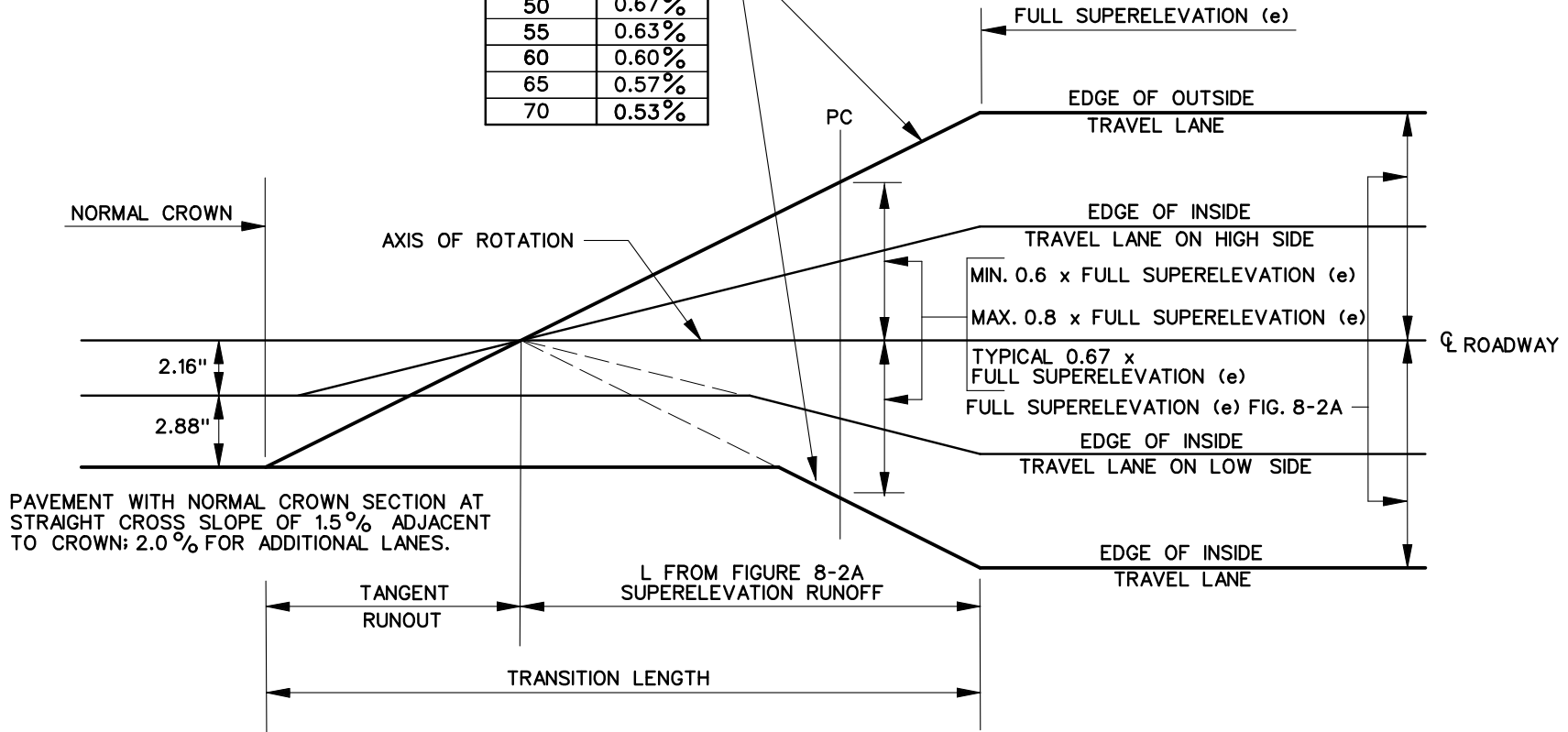

**SUPERELEVATION DEVELOPMENT ON THREE-LANE AND FOUR-LANE ROADWAYS (Simple Curve)**

**Figure 8-2H**

MAXIMUM RELATIVE LONGITUDINAL SLOPE (G) BETWEEN PROFILES OF OUTSIDE EDGES OF TRAVELED WAY AND AXIS OF ROTATION (Q ROADWAY)

DESIGN SPEED (mph)	SLOPE (G)
25	1.05 %
30	0.99 %
35	0.93 %
40	0.87 %
45	0.81 %
50	0.75 %
55	0.70 %
60	0.68 %
65	0.65 %
70	0.60 %

NOTES:

1. MODIFY SUPERELEVATION DEVELOPMENT FOR COMPOUND CURVES ACCORDING TO METHODS ILLUSTRATED IN FIG. 8-2G.
2. SEE FIG. 8-2A FOR MINIMUM RUNOFF LENGTHS.

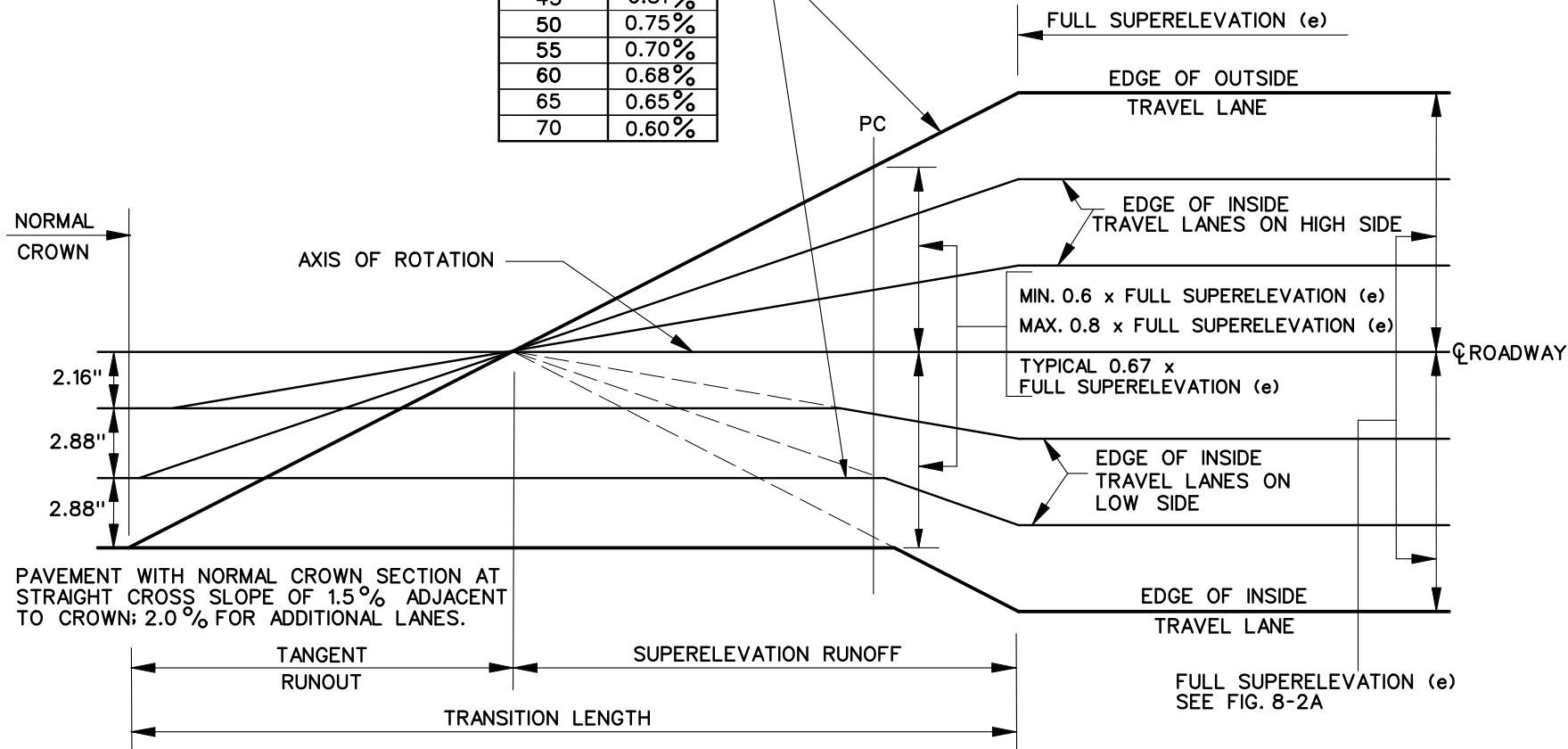

**SUPERELEVATION DEVELOPMENT ON FIVE-LANE AND SIX-LANE ROADWAYS**

(Simple Curve)

Figure 8-21

**8-2.04.02 Length of Curve > Sight Distance**

Where the length of curve (L) is greater than the sight distance (S) used for design, the needed clearance on the inside of the horizontal curve is calculated as follows:

$$M = R \left( 1 - \cos \left( \frac{28.65 S}{R} \right) \right) \quad (\text{Equation 8-2.1})$$

Where:

M = Middle ordinate, or distance from the center of the inside of the travel lane into the obstruction, ft

R = Radius of centerline of inside travel lane, ft

S = Sight distance, ft

Note: The expression  $\left( \frac{28.65 S}{R} \right)$  is in degrees, not radians.

**Stopping Sight Distance (SSD)**

At a minimum, SSD will be available throughout the horizontal curve. Figure 8-2J provides the horizontal clearance criteria (i.e., middle ordinate) for various combinations of stopping sight distance and curve radii. For those selections of S which fall outside of the figures (e.g., M > 40 ft and/or R < 100 ft), the designer should use Equation 8-2.1 to calculate the needed clearance.

The Example on Figure 8-2K illustrates the determination of clearance requirements at a horizontal curve based on SSD.

**Decision Sight Distance (DSD)**

At some locations, it may be warranted to provide decision sight distance at the horizontal curve. Chapter Seven discusses candidate sites and provides design values for these sight distance criteria. These "S" values should be used in the basic equation to calculate "M" (Equation 8-2.1).

**Entering/Exiting Portions**

The M values from Figure 8-2L apply between the PC and PT. In addition, some transition is needed on the entering and exiting portions of the curve. The designer should use the following steps:

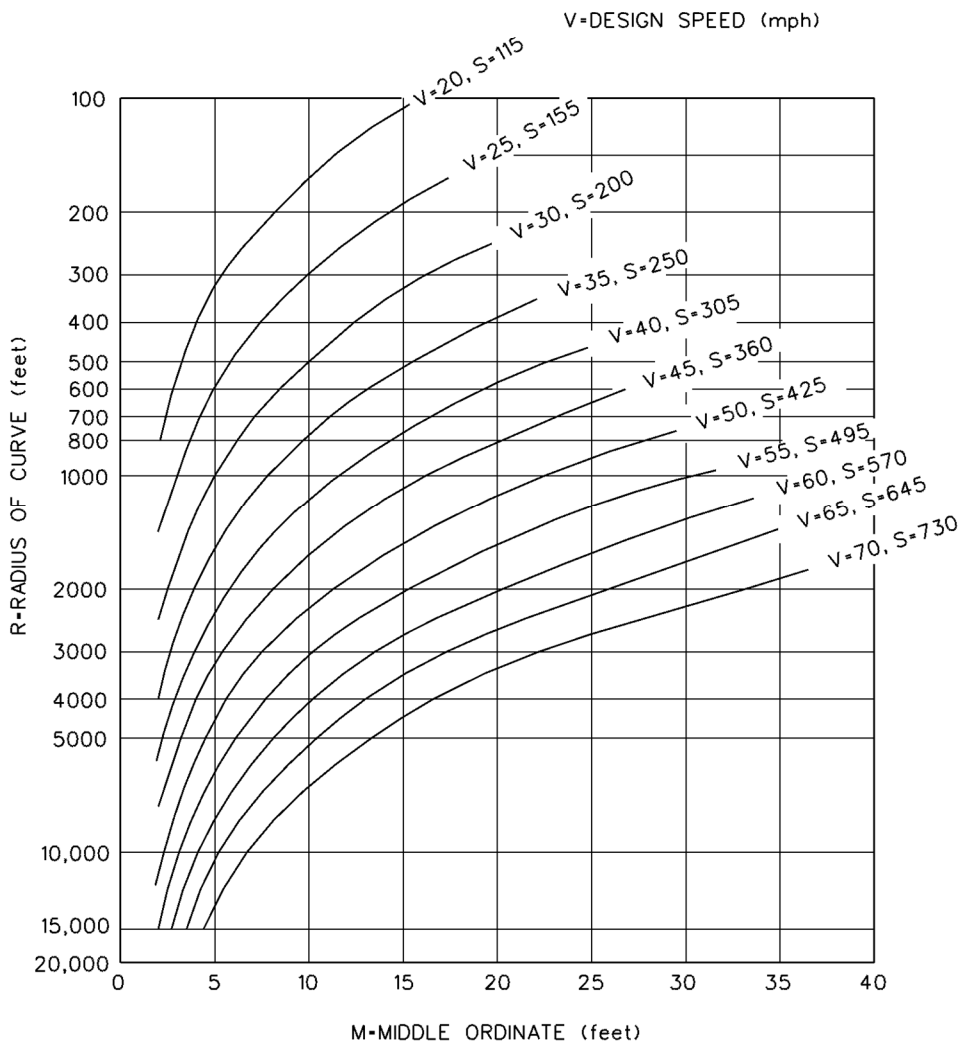
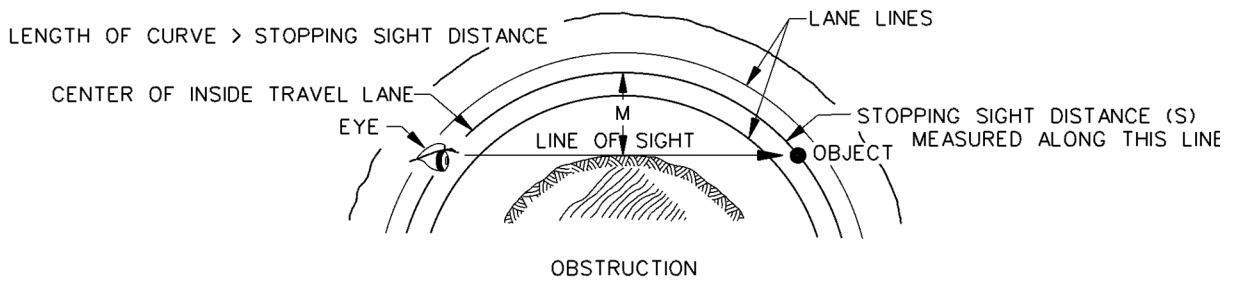

**SIGHT DISTANCE AT HORIZONTAL CURVES  
(SSD on Level Grade)**

**Figure 8-2J**



- Step 1: Locate the point that is on the outside edge of shoulder and a distance of  $S/2$  before the PC.
- Step 2: Locate the point which is a distance  $M$  measured laterally from the center of the inside travel lane at the PC.
- Step 3: Connect the two points located in Step #s 1 and 2. The area between this line and the roadway should be clear of all continuous obstructions.
- Step 4: A symmetrical application of Step #s 1 through 3 should be used beyond the PT.

The Example on Figure 8-2K illustrates the determination of clearance requirements entering and exiting from a curve.

### 8-2.04.03 Length of Curve < Sight Distance

Where the length of curve is less than the sight distance used in design, the  $M$  value from the basic equation will never be reached. As an approximation, the horizontal clearance for these curves should be determined as follows:

- Step 1: For the given  $R$  and  $S$ , calculate  $M$  assuming  $L > S$ .
- Step 2: The maximum  $M'$  value will be needed at a point of  $L/2$  beyond the PC.  $M'$  is calculated from the following proportion:

$$\frac{M'}{M} = \frac{1.2 L}{S}$$

$$M' = \frac{1.2 (L) (M)}{S} \quad \text{(Equation 8-2.2)}$$

$$\text{Where: } M' \leq M$$

- Step 3: Locate the point that is on the outside edge of shoulder and a distance of  $S/2$  before the PC.
- Step 4: Connect the two points located in Step #s 2 and 3. The area between this line and the roadway should be clear of all continuous obstructions.
- Step 5: A symmetrical application of Step #s 2 through 4 should be used on the exiting portion of curve.

The Example on Figure 8-2L illustrates the determination of the clearance requirements where  $L < S$ .

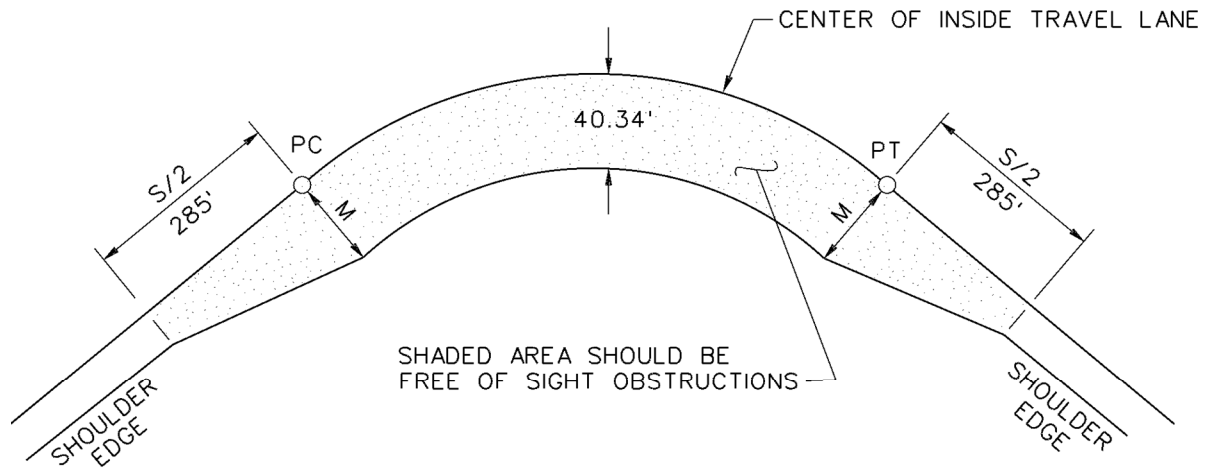

### Example 8-2.1

Given: Design Speed = 60 mph  
R = 1000 ft

Problem: Determine the horizontal clearance requirements for the horizontal curve to meet the SSD on level grade.

Solution: Figure 7-1A yields a SSD = 570 ft. Using the equation for horizontal clearance ( $L > S$ ):

$$M = R \left( 1 - \cos \left[ \frac{28.65 S}{R} \right] \right)$$

$$M = 1000 \left( 1 - \cos \left[ \frac{(28.65)(570)}{1000} \right] \right) = 40.34 \text{ ft}$$

The above figure also illustrates the horizontal clearance requirements for the entering and exiting portion of the horizontal curve.

### SIGHT CLEARANCE REQUIREMENTS FOR HORIZONTAL CURVES ( $L > SSD$ )

Figure 8-2K

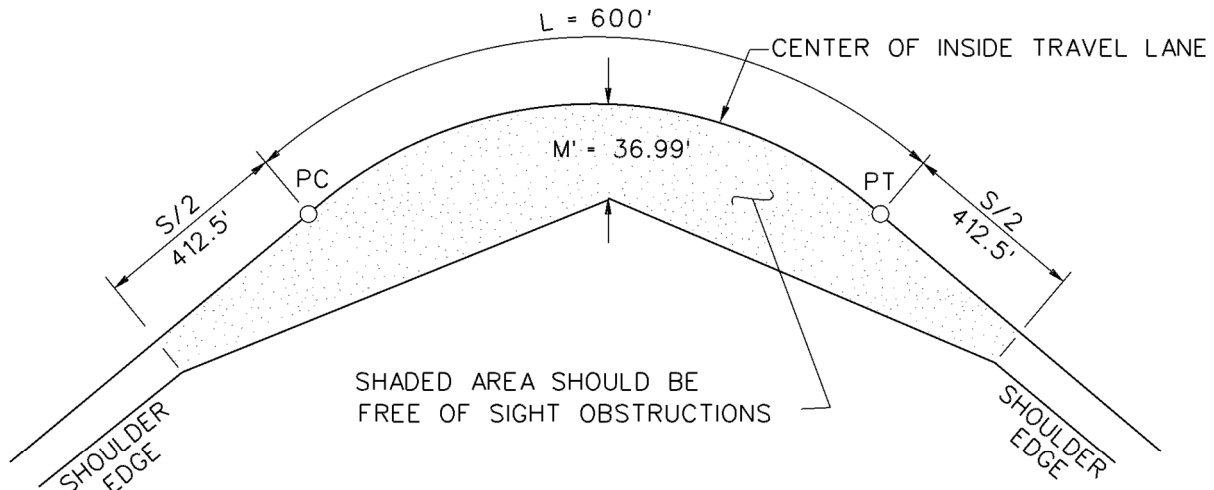
**Example 8-2.2**

Given: Design Speed = 70 mph  
 $R = 2000$  ft  
 $L = 600$  ft  
 Grade = 6.0% downgrade

Problem: Determine the horizontal clearance requirements for the horizontal curve.

Solution: Because the downgrade is greater than 3.0%, the curve should be designed adjusted for grade. Figure 7-1A yields a SSD value of 825 ft for 70 mph and a 6.0% downgrade. Therefore,  $L < S$  (600 ft < 825 ft), and the horizontal clearance is calculated first using Equation 8-2.1:

$$M(L > S) = 2000 \left[ 1 - \cos \frac{(28.65)(825)}{2000} \right] = 42.39 \text{ ft}$$

Then, using Equation 8-2.2:

$$M'(L < S) = \frac{1.2(600)(42.39)}{825}$$

$$M' = 36.99 \text{ ft}$$

Therefore, a maximum clearance of 36.99 ft should be provided at a distance of  $L/2 = 300$  ft beyond the PC.

**SIGHT CLEARANCE REQUIREMENTS FOR HORIZONTAL CURVES  
 (L < SSD)**

**Figure 8-2L**

**8-2.04.04 Application**

For application, the height of eye is 3.5 ft and the height of object is 2 ft. Both the eye and object are assumed to be in the center of the inside travel lane. The line-of-sight intercept should be unobstructed at least 2.75 ft above ground level where it is outside of the paved roadway.

**8-2.04.05 Longitudinal Barriers**

Longitudinal barriers (e.g., bridge rails, guiderail, CMB) may cause sight distance problems at horizontal curves because barriers are placed relatively close to the travel lane (often, 10 ft or less) and because their height is sometimes greater than 2.75 ft.

The designer should check the line of sight over a barrier along a horizontal curve and attempt, if practical, to locate the barrier such that it does not block the line of sight. The following should be considered:

1. Superelevation. A superelevated roadway will elevate the driver eye and, therefore, improve the line of sight over the barrier.
2. Grades. The line of sight over a barrier may be improved for a driver on an upgrade and lessened on a downgrade.
3. Barrier Height. The higher the barrier, the more obstructive it will be to the line of sight.

Each barrier location on a horizontal curve will require an individual analysis to determine its impacts on the line of sight. The designer must determine the elevation of the driver eye (3.5 ft above the pavement surface), the elevation of the object (2 ft above the pavement surface) and the elevation of the barrier where the line of sight intercepts the barrier run. If the barrier does block the line of sight to a 2-ft object, the designer should consider relocating the barrier or revising the horizontal alignment. If the barrier blocks the sight distance needed for minimum SSD on the mainline, it will be necessary to obtain a design exception.

**8-2.05 Crossover Line**

When adjacent lanes have different cross slopes and the driver moves from one lane to the other, there is a pull on the vehicular steering. This pull can cause erratic behavior when it becomes excessive. To control this, the difference in cross slope on adjacent lanes must be within the limit shown in Figure 8-2M. This will limit the radius and superelevation rates which may be used under certain conditions (e.g., when a ramp enters a freeway).

Design Speed (mph)	Maximum Algebraic Difference in Cross Slope at Crossover Line (%)
20 and under	5.0 to 8.0
25 and 30	5.0 to 6.0
35 and over	4.0 to 5.0

**MAXIMUM ALGEBRAIC DIFFERENCE IN CROSS SLOPE AT CROSSOVER LINES****Figure 8-2M**



### **8-3.0 LOW-SPEED URBAN STREETS**

This section presents horizontal alignment criteria for low-speed urban streets (design speed less than or equal to 45 mph). The operating conditions on these facilities are significantly different from those on rural highways and high-speed urban highways. Also, urban areas present physical constraints that should be recognized. Therefore, some of the assumptions for horizontal alignment can be legitimately revised for low-speed urban streets. However, much of the criteria in Section 8-2.0 on open highways also apply to low-speed urban streets. Therefore, this Section will reference Section 8-2.0 where applicable.

#### **8-3.01 General Controls**

The criteria in Section 8-2.01 also apply to low-speed urban streets.

#### **8-3.02 Horizontal Curvature**

##### **8-3.02.01 Theoretical Discussion**

The point mass formula for curvature is also used for low-speed urban streets. However, the assumptions for the values within the formula differ from those for open highways. See the AASHTO *A Policy on Geometric Design of Highways and Streets* for the theoretical discussion.

For low-speed urban streets,  $e_{\max} = 4.0\%$  once the decision is made that a curve requires superelevation. This lower value reflects the problems often encountered when attempting to superelevate in urban areas where roadside development is extensive.

##### **8-3.02.02 Application**

Figure 8-3A presents the minimum radii for various design speeds for low-speed urban streets. The designer should wherever practical provide horizontal curvature flatter than the minimum radius.

Figure 8-3B presents the minimum radii for which the normal crown (NC) section can be maintained around a curve. The values assume that the pavement cross slope is 1.5%, which yields a superelevation rate of -1.5% for one direction of travel when the normal crown section is maintained. The figure also presents the range of radii for which remove crown (RC) applies. In this range, the curve must be superelevated at a rate of +1.5% across the entire highway section.

Design Speed (mph)	e <sub>max</sub>	f <sub>max</sub>	e + f	Minimum Radius (ft)
20	4.0%	0.27	0.31	90
25	4.0%	0.23	0.27	155
30	4.0%	0.20	0.24	250
35	4.0%	0.18	0.22	375
40	4.0%	0.16	0.20	535
45	4.0%	0.15	0.19	715

### MINIMUM RADII ON LOW-SPEED URBAN STREETS

Figure 8-3A

Design Speed (mph)	Radius (ft)		
	Normal Crown	Remove Crown	See Figure 8-3C
20	R > 105	105 ≥ R ≥ 95	R < 95
25	R > 195	195 ≥ R ≥ 170	R < 170
30	R > 325	325 ≥ R ≥ 280	R < 280
35	R > 495	495 ≥ R ≥ 420	R < 420
40	R > 740	740 ≥ R ≥ 610	R < 610
45	R > 1000	1000 ≥ R ≥ 820	R < 820

Note: Flatter radius is based on a theoretical superelevation rate of -1.5%.

Sharper radius is based on a theoretical superelevation rate of +1.5%.

### RANGE OF RADII FOR NORMAL CROWN SLOPE AND REMOVE CROWN SLOPE (Cross Slope = 1.5%)

Figure 8-3B

Figure 8-3C provides the superelevation rates for combinations of curve radius and design speed for those curves when NC or RC is inadequate. The following examples illustrate how to use Figures 8-3B and 8-3C.



e (%)	V <sub>d</sub> = 15 mph	V <sub>d</sub> = 20 mph	V <sub>d</sub> = 25 mph	V <sub>d</sub> = 30 mph	V <sub>d</sub> = 35 mph	V <sub>d</sub> = 40 mph	V <sub>d</sub> = 45 mph
	R (ft)	R (ft)	R (ft)	R (ft)	R (ft)	R (ft)	R (ft)
-6.0	58	127	245	429	681	1067	1500
-5.0	56	121	231	400	628	970	1350
-4.0	54	116	219	375	583	889	1227
-3.0	52	111	208	353	544	821	1125
-2.8	51	110	206	349	537	808	1107
-2.6	51	109	204	345	530	796	1089
-2.4	51	108	202	341	524	784	1071
-2.2	50	108	200	337	517	773	1055
-2.0	50	107	198	333	510	762	1039
-1.5	49	105	194	324	495	736	1000
0	47	99	181	300	454	667	900
1.5	45	94	170	279	419	610	818
2.0	44	92	167	273	408	593	794
2.2	44	91	165	270	404	586	785
2.4	44	91	164	268	400	580	776
2.6	43	90	163	265	396	573	767
2.8	43	89	161	263	393	567	758
3.0	43	89	160	261	389	561	750
3.2	43	88	159	259	385	556	742
3.4	42	88	158	256	382	550	734
3.6	42	87	157	254	378	544	726
3.8	42	87	155	252	375	539	718
4.0	42	86	154	250	371	533	711
4.2	41	85	153	248	368	528	703
4.4	41	85	152	246	365	523	696
4.6	41	84	151	244	361	518	689
4.8	41	84	150	242	358	513	682
5.0	41	83	149	240	355	508	675
5.2	40	83	148	238	352	503	668
5.4	40	82	147	236	349	498	662
5.6	40	82	146	234	346	494	655
5.8	40	81	145	233	343	489	649
6.0	39	81	144	231	340	485	643

**SUPERELEVATION RATES  
(Low-Speed Urban Streets)**

**Figure 8-3C**

**Notes:**

1.  $e_{max} = 4.0\%$  (typical). Although 4% is listed as the maximum low speed superelevation rate for urban areas in the design charts, it is permissible to use up to a 6% maximum superelevation rate in an urban area when this does not cause problems with driveways or other roadside features.
2. The Figure provides a range of curves and superelevation rates which apply to a selected design speed.
3. Negative superelevation values beyond -2.0 percent should be used for unpaved surfaces such as gravel, crushed stone and earth. However, a normal cross slope of -2.5 percent may be used on paved surfaces in areas with intense rainfall.

\* \* \* \* \*

**Example 8-3.1**

Given: Design speed = 40 mph  
Radius = 750 ft  
Cross slope = 1.5%

Problem: Determine the superelevation rate.

Solution: Per Figure 8-3B, normal crown should be maintained.

**Example 8-3.2**

Given: Design speed = 40 mph  
Radius = 650 ft  
Cross slope = 1.5%

Problem: Determine the superelevation rate.

Solution: Figure 8-3C yields a required superelevation rate of +0.45%. The normal crown would provide a rate of -1.5%, which is unacceptable. Therefore, the pavement should be superelevated at a rate of +1.5% across the entire pavement for ease of design and construction. This is consistent with the RC criteria in Figure 8-3B.

**Example 8-3.3**

Given:        Design speed = 40 mph  
              Radius = 550 ft  
              Cross slope = 1.5%

Problem:     Determine the superelevation rate.

Solution:    Figure 8-3C yields a required rate of +3.4%. Therefore, the entire pavement should be transitioned and superelevated at this rate.

\* \* \* \* \*

**8-3.02.03    Types of Curvature**

The discussion and figures in Section 8-2.02.03 also apply to low-speed urban streets.

**8-3.03    Superelevation Development**

Once the decision is made to provide superelevation on a low-speed urban street, the methods presented in Section 8-2.03 will apply. Section 8-2.03 discusses the length of transition, the effects of the type of curvature (e.g., simple) and the axis of rotation.

For the length of transition, Figure 8-2A presents superelevation runoff lengths for high-speed urban facilities and all rural highways. Although this figure is based on  $e_{\max} = 6.0\%$ , the designer may also use the lengths for low-speed urban streets but up to 4%, the  $e_{\max}$  for these facilities. As discussed in Section 8-2.03.03, the adjustments to superelevation runoff lengths in Figure 8-2E based on the number of lanes rotated also apply to low-speed urban streets.

**8-3.04    Sight Distance Restrictions on the Inside of Curves**

The criteria presented in Section 8-2.04 also apply to horizontal sight distance on low-speed urban streets.



**Chapter Nine****VERTICAL ALIGNMENT****Table of Contents**

<b><u>Section</u></b>	<b><u>Page</u></b>
9-1.0 DESIGN PRINCIPLES AND PROCEDURES .....	9-1(1)
9-1.01 General Controls for Vertical Alignment .....	9-1(1)
9-1.02 Coordination of Horizontal and Vertical Alignment .....	9-1(2)
9-2.0 GRADES.....	9-2(1)
9-2.01 Terrain (Definitions) .....	9-2(1)
9-2.02 Critical Length of Grade .....	9-2(1)
9-2.03 Maximum and Minimum.....	9-2(4)
9-2.04 Truck-Climbing Lanes.....	9-2(4)
9-2.04.01 Warrants .....	9-2(4)
9-2.04.02 Capacity Analysis .....	9-2(5)
9-2.04.03 Design.....	9-2(7)
9-3.0 VERTICAL CURVES.....	9-3(1)
9-3.01 General.....	9-3(1)
9-3.02 Crest Vertical Curves.....	9-3(1)
9-3.03 Sag Vertical Curves .....	9-3(6)
9-4.0 VERTICAL CLEARANCES .....	9-4(1)
9-5.0 REFERENCES.....	9-5(1)



# Chapter Nine

## VERTICAL ALIGNMENT

### 9-1.0 DESIGN PRINCIPLES AND PROCEDURES

#### 9-1.01 General Controls for Vertical Alignment

As discussed elsewhere in Chapter Nine, the design of vertical alignment involves, to a large extent, complying with specific limiting criteria. These include maximum and minimum grades, sight distance at vertical curves and vertical clearances. In addition, the designer should adhere to certain general design principles and controls that will determine the overall safety of the facility and will enhance the aesthetic appearance of the highway. These design principles for vertical alignment include:

1. Consistency. Use a smooth grade line with gradual changes, consistent with the type of highway and character of terrain, rather than a line with numerous breaks and short lengths of tangent grades.
2. Environmental Impacts. Vertical alignment should be properly coordinated with environmental impacts (e.g., encroachment onto wetlands).
3. Long Grades. On a long ascending grade, it is preferable to place the steepest grade at the bottom and flatten the grade near the top. It is also preferable to break the sustained grade with short intervals of flatter grades.
4. Intersections. Maintain moderate grades through intersections to facilitate turning movements. See Chapter Eleven for specific information on vertical alignment through intersections.
5. Roller Coaster. Avoid using “roller-coaster” type profiles. Roller-coaster profiles are where the horizontal alignment is generally straight and roadway profile closely follows a rolling natural ground line. This type of profile may be proposed in the interest of economy, but it is aesthetically undesirable and may be more difficult to drive.
6. Broken-Back Curvature. Avoid “broken-back” grade lines (two crest or sag vertical curves separated by a short tangent). One long vertical curve is more desirable.
7. Sags. Avoid using sag vertical curves in cut sections unless adequate drainage can be provided.
8. Coordination with Natural/Man-Made Features. The vertical alignment should be properly coordinated with the natural topography, available right-of-way, utilities, roadside development and natural/man-made drainage patterns.

**9-1.02      Coordination of Horizontal and Vertical Alignment**

Horizontal and vertical alignment should not be designed separately, especially for projects on new alignment. Their importance demands that the designer carefully evaluate the interdependence of the two highway design features. This will enhance highway safety and improve the facility's operation. The following should be considered in the coordination of horizontal and vertical alignment:

1.     Balance. Curvature and grades should be in proper balance. Maximum curvature with flat grades or flat curvature with maximum grades does not achieve this desired balance. A compromise between the two extremes produces the best design relative to safety, capacity, ease and uniformity of operations and aesthetics.
2.     Coordination. Vertical curvature superimposed upon horizontal curvature (i.e., vertical and horizontal P.I.'s at approximately the same stations) generally results in a more pleasing appearance and reduces the number of sight distance restrictions. Successive changes in profile not in combination with the horizontal curvature may result in a series of humps visible to the driver for some distance, which may produce an unattractive design. However, under some circumstances, superimposing the horizontal and vertical alignment must be tempered somewhat by Comment #'s 3 and 4 as follows.
3.     Crest Vertical Curves. Do not introduce sharp horizontal curvature at or near the top of pronounced crest vertical curves. This is undesirable because the driver cannot perceive the horizontal change in alignment, especially at night when headlight beams project straight ahead into space. This problem can be avoided if the horizontal curvature leads the vertical curvature or by using design values which well exceed the minimums.
4.     Sag Vertical Curves. Do not introduce sharp horizontal curves at or near the low point of pronounced sag vertical curves or at the bottom of steep vertical grades. Because visibility to the road ahead is foreshortened, only flat horizontal curvature will avoid an undesirable, distorted appearance. At the bottom of long grades, vehicular speeds often are higher, particularly for trucks and erratic operations may occur, especially at night.
5.     Intersections. At intersections, horizontal and vertical alignment should be as flat as practical to provide designs that produce sufficient sight distance and gradients for vehicles to slow or stop. See Chapter Eleven.
6.     Divided Highways. On divided facilities with wide medians, it is frequently advantageous to provide independent alignments for the two one-way roadways. Where traffic justifies a divided facility, a superior design with minimal additional cost generally can result from the use of independent alignments.
7.     Residential Areas. Design the alignment to minimize nuisance factors to neighborhoods. Generally, a depressed facility makes the highway less visible and reduces the noise to adjacent residents. Minor adjustment to the horizontal alignment may increase the buffer zone between the highway and residential areas.



8. Aesthetics. Layout the alignment in such a way to enhance attractive scenic views of rivers, rock formations, parks, golf courses, etc. The highway should head into rather than away from those views that are considered to be aesthetically pleasing. The highway should fall towards those features of interest at a low elevation and rise toward those features that are best seen from below or in silhouette against the sky.

The designer should coordinate the layout of the horizontal and vertical alignment as early as practical in the design process. Alignment layouts are typically completed after the topography and ground line have been drafted. The designer should use the computer visualization programs within CADD to visualize how the layout will appear in the field. The designer should review several alternatives to ensure that the most pleasing and practical design is selected.



## 9-2.0 GRADES

### 9-2.01 Terrain (Definitions)

1. Level. Highway sight distances are either long or could be made long without major construction expense. The terrain is generally considered to be flat, which has minimal impact on vehicular performance.
2. Rolling. The natural slopes consistently rise above and fall below the roadway grade and, occasionally, steep slopes present some restriction to the desirable highway alignment. In general, rolling terrain generates steeper grades, causing trucks to reduce speeds below those of passenger cars.
3. Mountainous. Longitudinal and transverse changes in elevation are abrupt and benching and side hill excavations are frequently required to provide the desirable highway alignment. Mountainous terrain aggravates the performance of trucks relative to passenger cars, resulting in some trucks operating at crawl speeds.

In Connecticut, only the rolling level terrain criteria will be applicable. Even though a roadway may pass through a level or hilly site, the State as a whole is still considered to be rolling terrain.

### 9-2.02 Critical Length of Grade

In addition to the maximum grade, the designer must consider the length of the grade. The critical length of grade is the maximum length of a specific upgrade on which a loaded truck can operate without an unreasonable reduction in speed. The highway gradient in combination with the length of grade will determine the truck speed reduction on upgrades. The following will apply to the critical length of grade:

1. Design Vehicle. For critical-length-of-grade determinations, the Department has adopted the 200-lb/hp truck as the most representative design vehicle for Connecticut.
2. Criteria. Figure 9-2A provides the critical lengths of grade for a given percent grade and acceptable truck speed reduction. Although Figure 9-2A is based on an initial truck speed of 70 mph, it applies to any design speed. For design purposes, use the 10 mph speed reduction curve to determine if the critical length of grade is exceeded.
3. Measurement. Vertical curves are part of the length of grade. Figure 9-2B illustrates how to measure the length of grade to determine the critical length of grade from Figure 9-2A.
4. Highway Types. The critical-length-of-grade criteria apply equally to two-lane or multi-lane highways and apply equally to urban and rural facilities.
5. Application. If the critical length of grade is exceeded, the designer should either flatten the grade, if practical, or should evaluate the need for a truck-climbing lane (see Section 9-2.04).

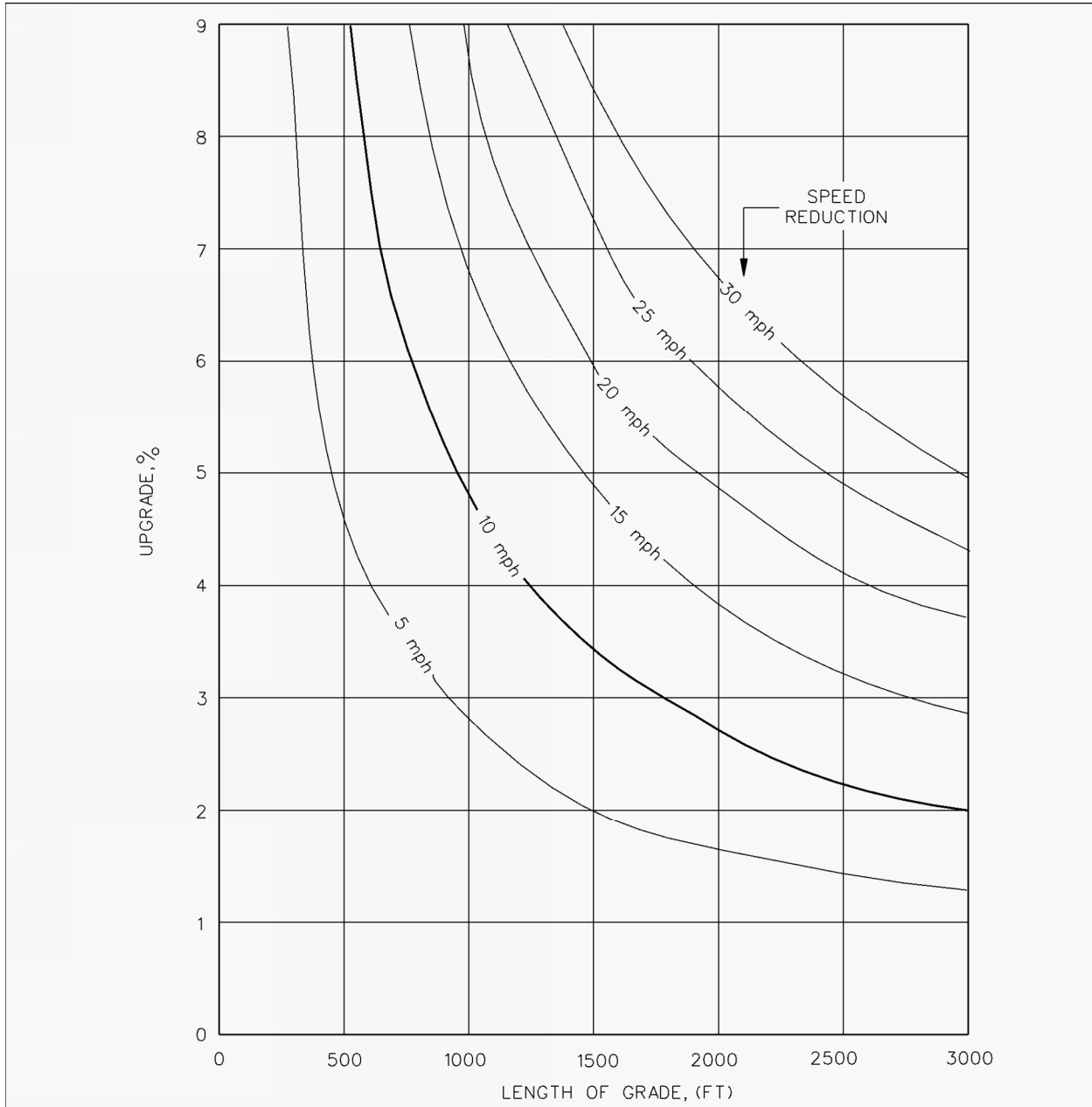

**Notes:**

1. Typically, the 10 mph curve will be used.
2. Figure based on a truck with initial speed of 70 mph. However, it may be used for any design speed.

**CRITICAL LENGTH OF GRADE  
(200-lb/hp Truck)**

**Figure 9-2A**

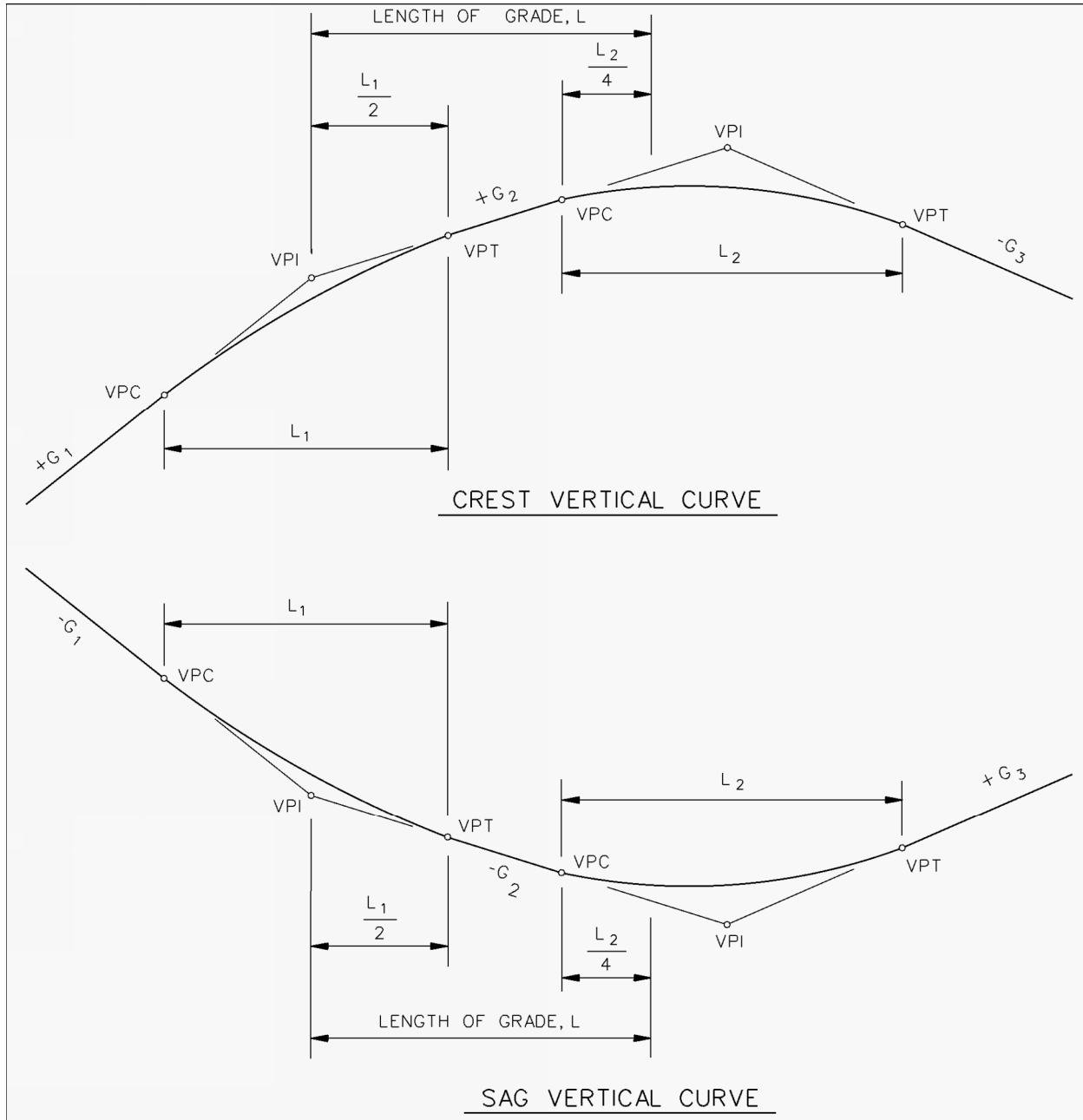
**Notes:**

1. For vertical curves where the two tangent grades are in the same direction (both upgrades or both downgrades), 50% of the curve length will be part of the length of grade.
2. For vertical curves where the two tangent grades are in opposite directions (one grade up and one grade down), 25% of the curve length will be part of the length of grade.
3. The above diagram is included for illustrative purposes only. Broken-back curves are to be avoided wherever practical.

**MEASUREMENT FOR LENGTH OF GRADE****Figure 9-2B**

\* \* \* \* \*

**Example 9-2.1**

Given: Level Approach  
G = + 4%  
L = 1500 ft (length of grade)  
Rural Arterial

Problem: Determine if the critical length of grade is exceeded.

Solution: Figure 9-2A yields a critical length of grade of 1250 ft for a 10-mph speed reduction. The length of grade (L) exceeds this value. Therefore, the designer should flatten the grade, if practical, or evaluate the need for a climbing lane.

**9-2.03 Maximum and Minimum**

The highway gradient will significantly impact vehicular operations and safety. The Department has adopted criteria for maximum gradient based on functional classification, urban/rural location, design speed and project scope of work. These values are presented in Chapters Two, Four and Five. Flatter grades should be used wherever practical.

The minimum longitudinal gradient is 0.5%. This applies to all highways with or without curbs.

**9-2.04 Truck-Climbing Lanes****9-2.04.01 Warrants**

A truck-climbing lane may be warranted to allow a specific upgrade to operate at an acceptable level of service. A truck-climbing lane will generally be warranted if the following conditions are satisfied:

1. the critical length of grade is exceeded for the 10 mph speed reduction curve (see Figure 9-2A; and
2. one of the following conditions exists:
  - a. the level of service (LOS) on the upgrade is E or F, or
  - b. there is a reduction of two or more LOS when moving from the approach segment to the upgrade; and
3. the construction costs and the construction impacts (e.g., environmental, right-of-way) are considered reasonable.

Truck-climbing lanes may also be warranted where the above criteria are not met if, for example, there is adverse crash experience on the upgrade related to slow-moving trucks. In addition, on four-lane freeways if the speed profile reveals an operating speed of less than 30 mph at any point, a climbing lane will be warranted regardless of the results of the capacity analysis.

#### **9-2.04.02 Capacity Analysis**

The objective of the capacity analysis procedure is to determine if the warranting criteria in Section 9-2.04.01 are met. Accomplish this by calculating the service flow rate for each LOS level (A through D) and comparing that to the actual flow rate on the upgrade. Because a LOS worse than D warrants a truck-climbing lane, it is not necessary to calculate the service flow rate for LOS E.

The designer should analyze the operations on the grade using the procedures set forth in the *Highway Capacity Manual*. Note that the default values for determining the appropriate passenger car equivalent (E) values in the *Highway Capacity Software* (HCS) are acceptable for determining the LOS on climbing lanes (i.e., the default truck in the HCS is acceptable).

To determine if a climbing lane is warranted, these basic steps should be followed:

1. Review the project to determine if a climbing lane should be considered. Steep and/or long grades should be considered for climbing lanes.
2. For highways with a single grade, the critical length of grade can be directly determined from Figure 9-2A. However, most highways have a continuous series of grades. Often, it is necessary to find the impact of a series of significant grades in succession. If several different grades are present, then a speed profile must be developed using Figure 9-2C and the procedures set forth in the *Highway Capacity Manual*. If there is a 10 mph reduction, then the first warrant is met. The speed profile should note the truck speed at the beginning of the full-width climbing lane, the PVC, the PVT and the end of the full-width lane.
3. Determine the total traffic volumes, the truck volumes on the grade and those on the approach prior to the upgrade.
4. Using the procedures set forth in the *Highway Capacity Manual*, determine the appropriate level of service for both the approach and the grade. If the level of service on the upgrade is E/F or if there is a reduction of 2 or more levels of service on the upgrade from the approaches, then the second warrant is met.

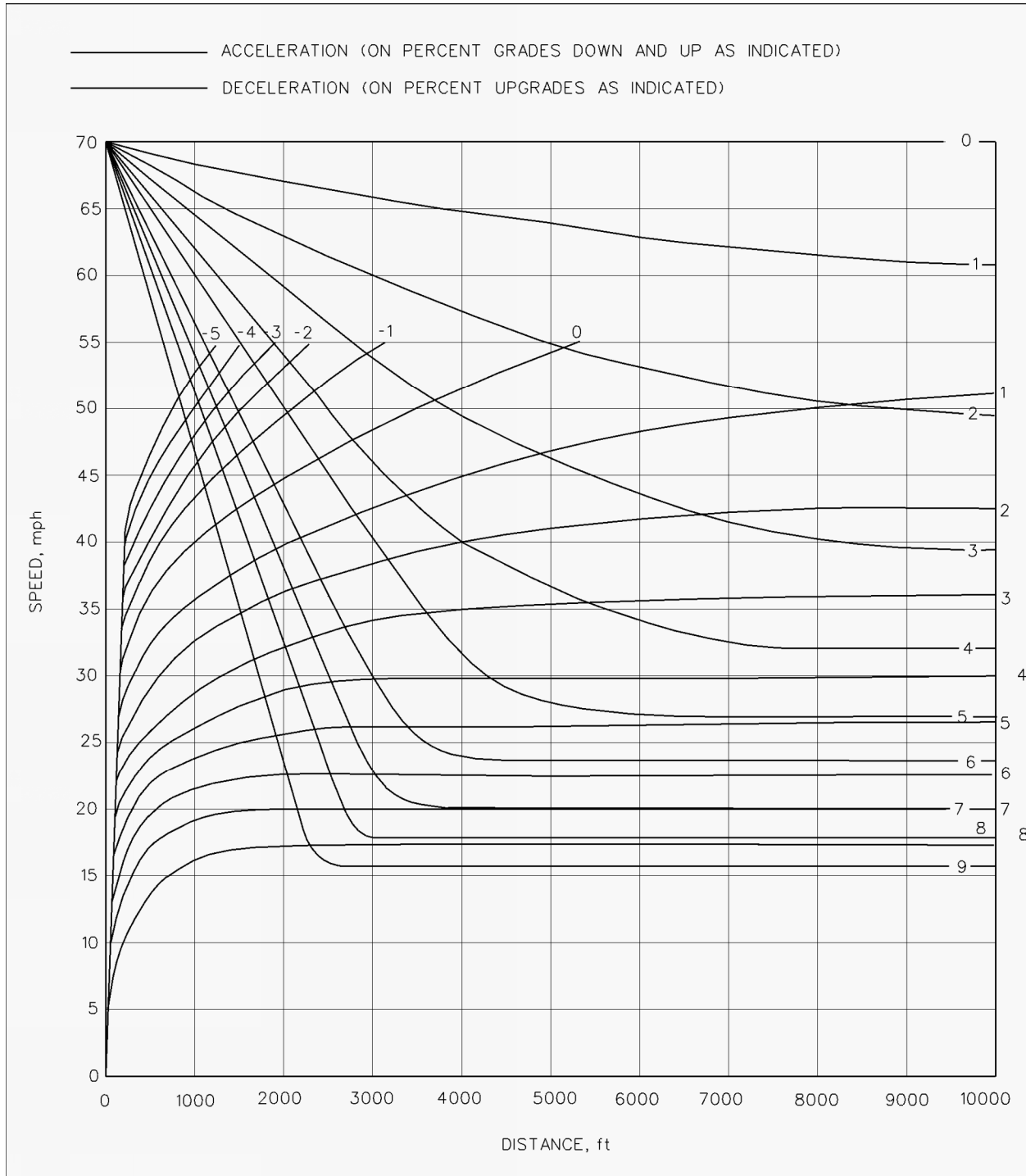

*Note: For design speeds above 70 mph use an initial speed of 70 mph. For design speeds 70 mph and below, use the design speed as the initial speed.*

**PERFORMANCE CURVES FOR LARGE TRUCKS  
(200 lb/hp)**

**Figure 9-2C**



**9-2.04.03 Design**

Figure 9-2D summarizes the design criteria for climbing lanes. It should be noted, that actual placement of the tapers for the beginning and end of climbing lanes should consider sight distance to the tapers. The placement of the terminal taper should maximize the available sight distance. The shoulder width along the climbing lane will be the normal shoulder width for the appropriate highway classification. The tables in Chapters Four and Five provide the shoulder widths.

The Traffic Standard Details provide the typical signing and pavement marking patterns for the climbing lanes.

Highway Type	Design				
	Begin Climbing Lane	End Climbing Lane	Taper Length (Begin/End)	Lane Width	Shoulder Width
Freeways	45 mph	50 mph	300 ft/600 ft	12 ft	Same as preceding roadway section.
Other Facilities	10 mph below design speed or 45 mph, whichever is less.	10 mph below design speed or 45 mph, whichever is less	25:1/(1)	See Chapters Four and Five	Same as preceding roadway section.

(1) The taper length on other facilities for ending the climbing lane will be determined by the following taper rates:

Design Speed (mph)	End Taper Rates
20	7:1
25	10:1
30	15:1
40	25:1
45	45:1
50	50:1
55	60:1
65	65:1
70	70:1
75	75:1

### DESIGN CRITERIA FOR CLIMBING LANES

Figure 9-2D

### 9-3.0 VERTICAL CURVES

#### 9-3.01 General

The principal concern in the design of crest vertical curves is to ensure that at least stopping sight distance is provided. Headlight sight distance will usually control the design of sag vertical curves. Two factors affect the availability of sight distance — the algebraic difference between gradients of the intersecting tangents and the length of the vertical curve. With a small algebraic difference in grades, the length of the vertical curve may be relatively short. To obtain the same sight distance with a large algebraic difference in grades, a much longer vertical curve will be necessary. If the grade break is 0.5 percent or less, then the designer may use an “angle” point (i.e., no vertical curve).

All vertical curves are in the shape of a parabola. Figure 9-3A illustrates the geometric details of a symmetrical vertical curve. Figure 9-3B provides an example of how to determine the elevations along a vertical curve.

#### 9-3.02 Crest Vertical Curves

The basic equations for crest vertical curves are:

$$L = KA \text{ or } L = 3V, \text{ whichever is larger} \quad (\text{Equations 9-3.1 and 9-3.2})$$

$$K = \frac{S^2}{200(\sqrt{h_1} + \sqrt{h_2})^2} \quad (\text{Equation 9-3.3})$$

$$L = \frac{AS^2}{200(\sqrt{h_1} + \sqrt{h_2})^2} \quad (\text{Equation 9-3.4})$$

where: L = length of vertical curve (ft)  
 A = absolute value of the algebraic difference between the two tangent grades (%)  
 S = sight distance (ft)  
 h<sub>1</sub> = height of eye above road surface (ft)  
 h<sub>2</sub> = height of object above road surface (ft)  
 K = horizontal distance needed to produce a 1% change in gradient

For the design of crest vertical curves, the following will apply:

1. Stopping Sight Distance. Stopping sight distance is the minimum design for crest vertical curves. A height of eye of 3.5 ft and a height of object of 2 ft are used. Using Equation 9-3.4, this yields the following equation:

$$L = \frac{AS^2}{2158} \quad (\text{Equation 9-3.5})$$

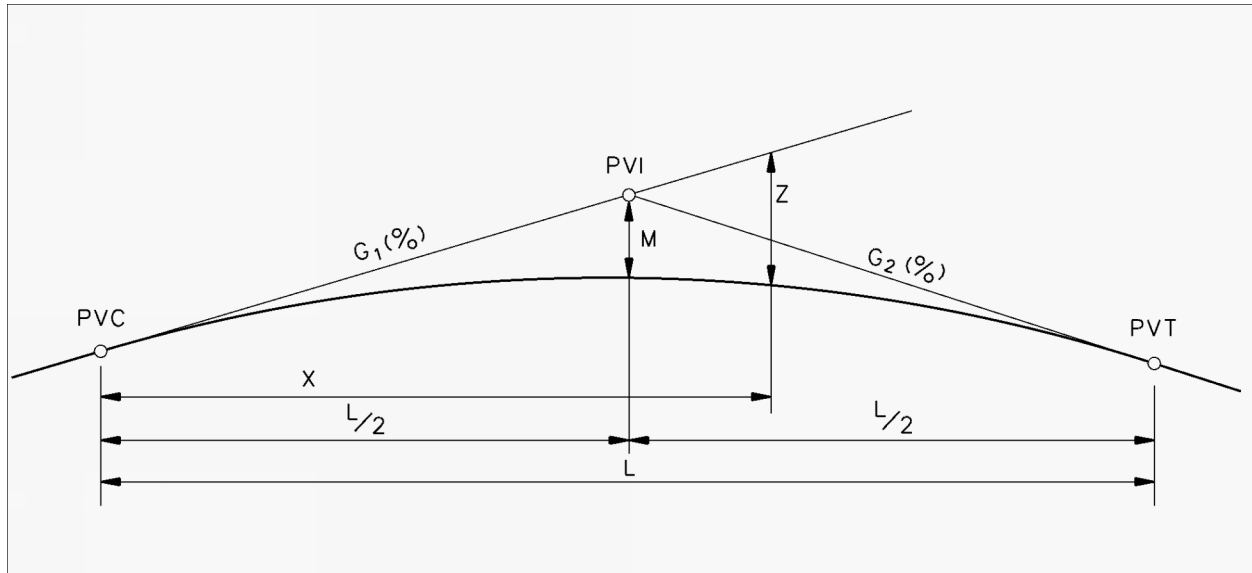

- M = Mid-ordinate (ft)  
 Z = Any tangent offset (ft)  
 L = Horizontal length of vertical curve (ft)  
 X = Horizontal distance from PVC or PVT to any ordinate "Z" (ft)  
 \$G\_1\$ & \$G\_2\$ = Rates of grade, expressed algebraically (%)

Note: All expressions should be calculated algebraically.

Elevations of PVI and PVT:

$$PVI_{\text{elev}} = PVC_{\text{elev}} + G_1 \frac{L}{200}$$

$$PVT_{\text{elev}} = PVC_{\text{elev}} + (G_1 + G_2) \frac{L}{200}$$

2. For offset "Z" at distance "X" from PVC or PVT:

$$Z = M \left( \frac{X}{L/2} \right)^2 \text{ or } Z = \frac{X^2 (G_2 - G_1)}{200L}$$

### SYMMETRICAL VERTICAL CURVE EQUATIONS

Figure 9-3A

3. For slope "S" of a line tangent to any point on the vertical curve at an "X" distance measured from the PVC:

$$S (\%) = G_1 - \left[ X \left( \frac{G_1 - G_2}{L} \right) \right]$$

4. Calculating high or low point on curve:

$$X_T = \frac{LG_1}{G_1 - G_2}$$

Where:

$X_T$  equals the horizontal distance from the PVC to the high or low point on the curve in feet.

5. Elevation of high or low point on curve:

$$\text{ELEV}_{\text{High or Low Point}} = \text{PVC}_{\text{elev}} - \frac{LG_1^2}{(G_2 - G_1)200}$$

### SYMMETRICAL VERTICAL CURVE EQUATIONS

(Continued)

Figure 9-3A

**Example 9-3.1**

Given:  $G_1 = -1.75\%$   
 $G_2 = +2.25\%$   
 Elev. of PVI = 585.00 ft  
 Station of PVI = 29+00.00  
 $L = 500$  ft

Problem: Compute the grade for each 50-ft station. Compute the low point elevation and stationing.

Solution:

6. Draw a diagram of the vertical curve and determine the station of the beginning (PVC) and the end (PVT) of the curve.

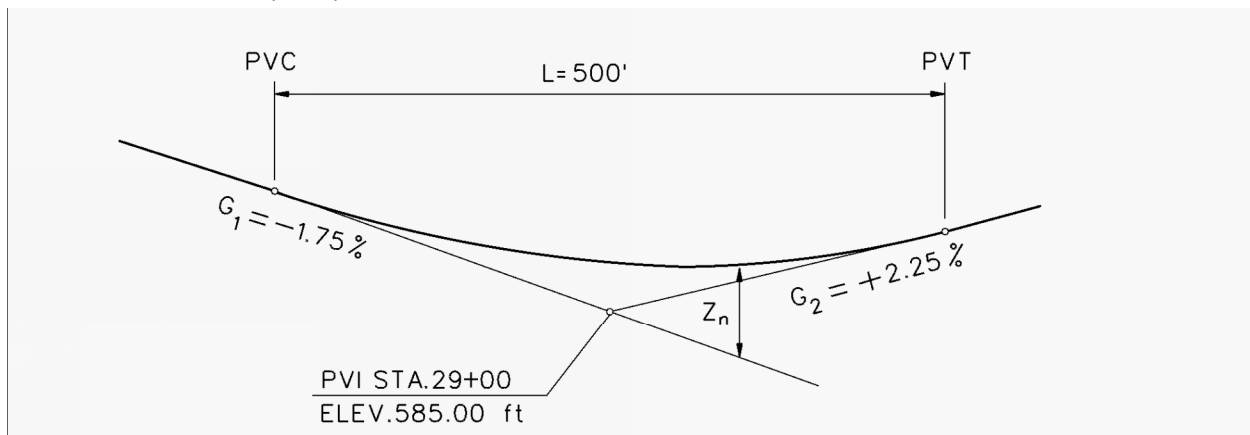

Beginning Station (PVC) = PVI Sta -  $\frac{1}{2}L = (29 + 00) - (0 + 250) = 26 + 50$

End Station (PVT) = PVI Sta +  $\frac{1}{2}L = (29 + 00) + (0 + 250) = 31 + 50$

7. From the vertical curve equations in Figure 9-3A:

$$M = \frac{(G_2 - G_1)L}{800} = \frac{[2.25 - (-1.75)] 500}{800} = 2.5 \text{ ft}$$

$$Z = M \left( \frac{X}{L/2} \right)^2 = \frac{4M}{L^2} X^2 = \frac{(4)(2.5)}{250,000} X^2 = \frac{X^2}{25,000}$$

**VERTICAL CURVE COMPUTATIONS**

(Example 9-3.1)

Figure 9-3B

**Example 9-3.1** (continued)

8. Set up a table to show the vertical curve elevations at the 50-ft stations:

Station (n)	Inf.	Tangent Elevation (Along $G_1$ )	X	$X^2$	$Z_n$	Grade Elevation
26 + 50	PVC	589.38	0	0	0	589.38
27 + 00		588.50	50	2500	.100	588.60
27 + 50		587.63	100	10,000	.400	588.03
28 + 00		586.75	150	22,500	.900	587.65
28 + 50		585.88	200	40,000	1.600	587.48
29 + 00	PVI	585.00	250	62,500	2.500	587.50
29 + 50		584.13	300	90,000	3.600	587.73
30 + 00		583.25	350	122,500	4.900	588.15
30 + 50		582.38	400	160,000	6.400	588.78
31 + 00		581.50	450	202,500	8.100	589.60
31 + 50	PVT	580.63	500	250,000	10.000	590.63

4. Calculating low point:

$$X_T = \frac{LG_1}{G_1 - G_2} = \frac{500(-1.75)}{-1.75 - 2.25} = \frac{-875}{-4.00} = 218.75 \text{ ft from PVC}$$

therefore, the Station at low point equals:

$$(26 + 50) + (02 + 18.75) = (28 + 68.75)$$

and the elevation of low point on the curve equals:

$$\begin{aligned} \text{ELEV}_{\text{LOW}} &= \text{PVC}_{\text{elev}} - \frac{LG_1^2}{(G_2 - G_1) 200} = 589.38 - \frac{500(-1.75)^2}{(2.25 - (-1.75)) 200} \\ &= 589.38 - 1.91 = 587.47 \text{ ft} \end{aligned}$$

**VERTICAL CURVE COMPUTATIONS****(Example 9-3.1)**

(Continued)

**Figure 9-3B**

Figure 9-3C presents the K-values for crest vertical curves. These values have been calculated by using the SSD values from Figure 7-1A and Equation 9-3.6.

2. Grade Adjustments. When determining S for crest vertical curves, the designer should consider the effects of grade on stopping sight distance (SSD). The following thresholds may be used for determining the thresholds for “Level” K-values:

$$V \geq 50 \text{ mph: } -1\% < G < +1\%$$

$$V < 50 \text{ mph: } -2\% < G < +2\%$$

The selection of “G” at a crest vertical curve will depend on which grade is steeper and whether the roadway is one-way or two-way. On a one-way roadway, “G” should always be the grade on the far side of the crest when considering the direction of travel. On a two-way roadway, “G” should always be the steeper of the two grades on either side of the crest.

For design exception purposes, only the “Level” SSD value will require an exception. For designs where, because of rounding in the charts, the “Level” SSD is met but not the K-value, an exception will not be required.

3. Decision Sight Distance. Section 7-2.0 discusses the general warrants for decision sight distance. The procedure will determine the appropriate “S” and height of object for the specific site conditions. These values should then be used in Equation 9-3.3 to determine the necessary curve length at the site.
4. Drainage. Drainage should be considered in the design of crest vertical curves where curbed sections are used. Drainage problems should not be experienced if the vertical curvature is sharp enough so that a minimum longitudinal grade of at least 0.3% is reached at a point about 50 ft from either side of the apex. To ensure that this objective is achieved, the length of the vertical curve should be based upon a K-value of 167 or less. For crest vertical curves on curbed sections where this K-value is exceeded, the drainage design should be more carefully evaluated near the apex.

For uncurbed sections of highway, drainage should not be a problem at crest vertical curves.

### 9-3.03 Sag Vertical Curves

Headlight sight distance is the primary design control for sag vertical curves. The height of the headlights is assumed to be 2.0 ft. The upward divergence of the beam is  $1^\circ$  from the longitudinal axis of the vehicle. The curvature of the sag should allow sufficient pavement illumination to provide adequate sight distance. These criteria yield the following equations:

$$L = KA \text{ or } L = 3V, \text{ whichever is larger} \quad (\text{Equations 9-3.6 and 9-3.7})$$



Design Speed (mph)	Downgrades			Level 0%	Upgrades		
	-9%	-6%	-3%		+3%	+6%	+9%
20	8	7	7	7	6	6	6
25	15	13	12	12	11	10	10
30	25	22	20	19	19	16	15
35	39	35	32	29	27	25	24
40	59	52	46	44	39	37	34
45	86	75	67	61	56	52	48
50	121	105	94	84	76	71	66
55	164	143	126	114	103	94	88
60	221	190	169	151	136	123	114
65	290	247	218	193	176	159	148
70	372	316	279	247	221	202	187

- Notes:
1. For grades intermediate between columns, use a straight-line interpolation to calculate the K-value.
  2. Only the "Level" SSD are applicable for design exception purposes.
  3. Stopping sight distances (SSD) are from Figure 7-1A.
  4. Maximum K-value for drainage on curbed roadways is 167; see Section 9-3.02.
  5.  $K = \frac{S^2}{2158}$ , where  $h_1 = 3.5$  ft,  $h_2 = 2.0$  ft.

### K-VALUES FOR CREST VERTICAL CURVES

Figure 9-3C

$$K = \frac{S^2}{200h_3 + 3.5S}$$

$$L = \frac{AS^2}{200h_3 + 3.5S} \quad \text{(Equation 9-3.9)}$$

where:

L	=	length of vertical curve (ft)
A	=	absolute value of algebraic difference between the two tangent grades (%)
S	=	sight distance (ft)
$h_3$	=	height of headlights (ft)
K	=	horizontal distance needed to produce a 1% change in gradient

For the design of sag vertical curves, the following will apply:

1. Stopping Sight Distance (SSD). Figure 9-3D presents the K-values for sag vertical curves. These values have been calculated by using the SSD values from Figure 7-1A and Equation 9-3.8.
2. Grade Adjustments. Section 9-3.02 discusses the application of SSD to crest vertical curves pertaining to the grade correction. The grade correction and the thresholds also apply to sag vertical curves.

For design exception purposes, only the "Level" SSD value will require an exception. For designs where, because of rounding in the charts, the "Level" SSD is met but not the K-value, an exception will not be required.

3. Decision Sight Distance. Section 7-2.0 discusses the general warrants for decision sight distance. The procedure will determine the appropriate "S" and height of object for the specific site conditions. These values should then be used in Equation 9-3.9 to determine the necessary curve length at the site.
4. Drainage. Drainage considerations also impact the design of sag curves. The criteria is the same as for crest vertical curves, which yields a  $K = 167$  for the maximum length of curve. Where this K value is exceeded, the designer should consider special drainage treatments, especially on curbed pavements. In addition, the designer should avoid the placement of bridges or other structures at the low point of sag vertical curves because of the potential drainage problems.

Design Speed (mph)	Downgrades			Level 0%	Upgrades		
	-9%	-6%	-3%		+3%	+6%	+9%
20	20	18	18	17	16	16	15
25	31	28	27	26	25	24	22
30	44	41	38	37	37	33	32
35	60	56	52	49	47	44	43
40	77	72	66	64	60	57	55
45	97	89	84	79	74	72	68
50	119	110	103	96	91	87	83
55	143	132	122	115	108	103	99
60	170	156	144	136	128	121	115
65	198	181	168	157	149	140	135
70	227	207	193	181	170	161	154

- Notes:
1. For grades intermediate between columns, use a straight-line interpolation to calculate the K-value.
  2. Only the "Level" SSD's are applicable for design exception purposes.
  3. Stopping sight distances (SSD) are from Figure 7-1A.
  4. Maximum K-value for drainage on curbed roadways and bridges is 167; see Section 9-3.03.
  5.  $K = \frac{S^2}{400 + 3.5S}$ , where  $h_3 = 2.0$  feet.

### K VALUES FOR SAG VERTICAL CURVES

Figure 9-3D



### 9-4.0 VERTICAL CLEARANCES

Figure 9-4A summarizes the minimum vertical clearances for new bridges for various highway classifications and conditions.

Type	Clearance
Freeway or Expressway Under	16'-3" over the entire roadway width (1) (2)
Arterial Under	16'-3" over the entire roadway width (1)
Collector Under	14'-6" over the entire roadway width (1)
Local Under	14'-6" over the entire roadway width (1)
Railroad Under Highway	22'-6" from the top of the rail to the bottom of the structure (electrified only); 20'-6" other railroads (5)
Railroad Under Freeway	23'-0" from the top of the rail to the bottom of the structure
Highway Under Sign Truss or Pedestrian Bridge	17'-3" over the entire roadway width
Parkway Under	14'-6" over the entire roadway width

- Notes:
1. Table values allow 3 in for resurfacing.
  2. The minimum vertical clearance beyond the edge of shoulder must be sufficient to accommodate a 14'-3" vehicle in height by 8.5 ft in width. On the Interstate system, the minimum vertical clearance is 16'-3" beyond the edge of shoulder.
  3. For vertical clearances in the vicinity of airports, see 23 CFR 620 which discusses airspace management on Federal-aid highways.
  4. Department practice is to post a "low-clearance" sign on structures with vertical clearances less than or equal to 14'-3".
  5. Exceptions to the vertical clearances over railroads require approval from the Connecticut Legislature and ConnDOT.
  6. Exceptions to the vertical clearance over interstate freeways may require additional coordination with the SDDCTEA as defined in Section 6-5.02.

### MINIMUM VERTICAL CLEARANCES (New Bridges)

Figure 9-4A



**9-5.0 REFERENCES**

1. *A Policy on Geometric Design of Highways and Streets*, AASHTO, 2018.
2. *Highway Capacity Manual 2000*, TRB, 2000.





## Chapter Ten

### CROSS SECTIONS

#### Table of Contents

<u>Section</u>	<u>Page</u>
10-1.0	ROADWAY SECTION.....10-1(1)
10-1.01	Travel Lanes.....10-1(1)
10-1.01.01	Width.....10-1(1)
10-1.01.02	Cross Slope .....10-1(1)
10-1.02	Shoulders .....10-1(2)
10-1.02.01	Shoulder Widths/Types.....10-1(2)
10-1.02.02	Shoulder Cross Slope.....10-1(2)
10-1.03	Turn Lanes .....10-1(3)
10-1.04	Parking Lanes.....10-1(3)
10-1.05	Curbs .....10-1(4)
10-1.05.01	Types .....10-1(4)
10-1.05.02	Safety.....10-1(4)
10-1.05.03	Application on Low-Speed Roads/Streets .....10-1(5)
10-1.05.04	Application on High-Speed Highways.....10-1(6)
10-2.0	ROADSIDE ELEMENTS.....10-2(1)
10-2.01	Sidewalks .....10-2(1)
10-2.01.01	Guidelines for Sidewalk Construction .....10-2(1)
10-2.01.02	Sidewalk Design Criteria.....10-2(1)
10-2.02	Fill and Cut Slopes .....10-2(2)
10-2.03	Utilities .....10-2(3)
10-3.0	MEDIANS .....10-3(1)
10-3.01	Median Widths.....10-3(1)
10-3.02	Median Types.....10-3(2)

**Table of Contents**

(Continued)

<b><u>Section</u></b>		<b><u>Page</u></b>
	10-3.02.01 Flush Medians.....	10-3(2)
	10-3.02.02 Raised Medians .....	10-3(2)
	10-3.02.03 Depressed Medians .....	10-3(4)
10-4.0	BRIDGE AND UNDERPASS CROSS SECTION.....	10-4(1)
	10-4.01 Bridges .....	10-4(1)
	10-4.01.01 New Construction.....	10-4(1)
	10-4.01.02 Reconstruction (Non-Freeways) .....	10-4(1)
	10-4.02 Underpasses .....	10-4(2)
10-5.0	RIGHT-OF-WAY .....	10-5(1)
10-6.0	TYPICAL SECTIONS.....	10-6(1)
10-7.0	REFERENCES.....	10-7(1)

# Chapter Ten

## CROSS SECTIONS

Chapters Four and Five “Geometric Design Tables” present the design values for the widths of the various cross section elements on new construction and reconstruction projects. These are based on the functional classification (freeway, arterial, collector or local road or street). Chapters Four and Five also provide typical tangent and superelevated cross section figures. Chapter Two provides design values for cross section widths on 3R projects. Chapter Ten discusses cross section elements and provides additional information and guidance that should be considered in the highway design.

### 10-1.0 ROADWAY SECTION

#### 10-1.01 Travel Lanes

##### 10-1.01.01 Width

Travel lane widths will vary between 9 ft and 12 ft, depending upon the functional classification, traffic volumes and rural/urban location. Chapters Two, Four and Five provide specific criteria for travel lane widths for these various conditions.

##### 10-1.01.02 Cross Slope

Surface cross slopes are required for proper drainage of through travel lanes on tangent sections. To determine the appropriate slope, the following will apply:

1. Two-Lane Highways. Crown the traveled way at the centerline with a cross slope of 1.5% – 2% sloping away from the centerline.
2. Multi-Lane Highways. For multi-lane highways, the following will apply:
  - a. Undivided Facilities. For undivided facilities, crown the pavement at the centerline. The cross slope of the travel lanes adjacent to the crown should be 1.5% – 2%. The lanes beyond this should be sloped at 2%.
  - b. Divided Facilities. For divided facilities, the pavement is crowned at the centerline of each roadway. For three-lane sections, the pavement is typically crowned along the lane edge between the middle lane and the lane adjacent to the median. The right two lanes are sloped to the outside and the median lane to the inside.

The cross slope of the lanes adjacent to the crown should be 1.5% – 2%.  
The lanes beyond this should be sloped at 2%.

- c. Uneven Sections. Where an uneven cross section is used (e.g., three lanes in one direction and one lane in the other), or to match a short section of a new road to an existing section, it may be appropriate to place the crown line in a different location.
3. Breaks. In general, all cross slope breaks should occur at lane edges. One exception to this may be where a two-way, left-turn lane is provided.
4. Bridges. Carry the approach roadway cross section across the bridge.

## **10-1.02     Shoulders**

### **10-1.02.01     Shoulder Widths/Types**

Shoulder widths will vary according to project scope of work, functional classification, urban or rural location, traffic volumes and the presence of curbs. Chapters Two, Four and Five present the recommended shoulder widths for these various conditions. All shoulders on State routes should be paved. For roads under local jurisdictions, if requested by the municipality, a well-graded, stabilized aggregate or surface-treated shoulder will be acceptable. There should be no drop off between the traveled way and the graded shoulder. Where curbing is provided, the shoulder must be paved. The designer should also note that, in no case would the area outside of the curb be considered as part of the shoulder width.

### **10-1.02.02     Shoulder Cross Slope**

The shoulder cross slope will vary depending on the shoulder width and whether or not there is curbing. Chapters Two, Four and Five provide the shoulder cross slope criteria. In addition, the designer should consider the following:

1. Narrow Shoulders. If the shoulder width is less than 4 ft, the shoulder cross slope will be the same as the travel lane cross slope. This applies to both tangent and superelevated sections.
2. Shoulder Adjacent to Traveled Way (Tangent Section). For highways without curbs, the typical shoulder cross slope is 4%. Where curbs are present, the typical shoulder cross slope is 6%. Where wide shoulders are used with 4-in curbing, use a 4% cross slope. The designer should verify that the depth of storm water does not exceed the height of the 4-in curb.
3. Shoulder Adjacent to Traveled Way (Superelevated Section). On the low side, the shoulder cross slope will remain equal to its rate on the tangent section until the

superelevated rate exceeds that value. Then, the shoulder will be sloped at the same rate as the superelevated travel lanes.

On the high side, the break between the travel lane and shoulder cross slope will be designed according to the miscellaneous detail in Figures 4H and 5J. The location of the break is dependent on the width of the shoulder. Shoulders less than 4 ft are not broken. This detail applies to the entire range of superelevation rates (1.5% to 6.0%).

4. Shoulders on Bridges. On bridges, the shoulder cross slopes will match the approach roadway shoulder slopes.
5. Ramps. For ramps, the following will apply:
  - a. Tangent Section. The lower side shoulder will slope at the same rate as the travel lane. On the high side, the last 4 ft will slope away in the same manner as the high-side shoulder adjacent to a superelevated mainline (see Figure 12-4B).
  - b. Superelevated Section. The division between the ramp traveled way and shoulder may vary, and it is often determined by the pavement markings. Regardless of this division, 4 ft of the ramp width should slope away from the remaining ramp width on the high side of the superelevated section. The details of the break between the two sections will be determined by the detail in Figures 4H and 5J.

### **10-1.03**     Turn Lanes

Turn lanes include left- and right-turn lanes. Chapters Two, Three and Four provide the specific travel lane and shoulder width criteria for turn lanes. See Section 10-1.01.02 for turn lane cross slopes.

### **10-1.04**     Parking Lanes

Chapters Two and Five provide the recommended widths for parking lanes. Where a parking lane is currently being used as a travel lane during peak hours, or where it may potentially be converted to a travel lane in the future, and if curbing is present, increase the parking lane width to 13 ft.

Many urban streets provide on-street parking. In addition to parking lane width, the designer must consider the following:

1. Capacity. In general, on-street parking reduces capacity, impedes traffic flow, produces undesirable traffic operations and increases the crash potential. Therefore, the designer should carefully consider these impacts before introducing on-street parking to an urban street. If these problems have become unacceptable on an urban street with existing on-street parking, the designer should eliminate parking. However, if sufficient replacement

off-street parking is unavailable, it may be impractical to completely eliminate the on-street parking. As an alternative, parking may be prohibited during peak traffic hours to improve the level of service during periods of maximum flow.

2. Parallel Versus Angle Parking. Parallel on-street parking is greatly preferred over angle parking. Angle parking has been associated with higher crash rates, because parked vehicles are required to back into the flow of traffic where adjacent parked vehicles may block the line of sight. Therefore, where on-street parking is being introduced to an urban street, the designer should provide parallel parking. Where angle parking currently exists, the designer should, if practical, convert these to parallel parking.
3. Intersection Sight Distance. Parking should be prohibited within the corner sight triangles for intersection sight distance at intersections and driveways. See Section 11-2.0 for the detailed criteria for intersection sight distance.
4. Railroads. Parking should be prohibited within 50 ft of the nearest rail of a railroad/highway crossing.

Coordinate all design decisions related to on-street parking with the Division of Traffic Engineering.

#### **10-1.05    Curbs**

Curbs are used extensively at the outside of the shoulder on urban streets and occasionally on rural highways. Curbs contain the pavement drainage within the road and away from adjacent properties, provide pavement delineation, assist in channelization and driveway control for orderly roadside development, provide a physical separation between vehicles and pedestrians, and are considered aesthetically pleasing. However, do not use curbs on highways with design speeds of 50 mph or greater, except under special conditions.

##### **10-1.05.01    Types**

There are generally two types of curbs — sloping and vertical. By definition, sloping curbs have a height of 6 in or less with a batter no steeper than 3 vertical to 1 horizontal. Vertical curbs range in height, but are typically 6 in, with a batter steeper than 3 vertical to 1 horizontal. Typically, ConnDOT vertical curbs are vertical. The *Connecticut Standard Drawings* provide the design details for the various types of curbs used by the Department.

##### **10-1.05.02    Safety**

When impacted by a vehicle, curbs may result in the loss of vehicular control. In addition, a curb close to the travel lane may cause a driver to shy away, which reduces highway capacity. For these reasons, the disadvantages of a curb must be weighed against its benefits before a curb

is introduced on any highway facility. Where a curb and barrier are used together, see Section 13-6.0 for design details.

### 10-1.05.03 Application on Low-Speed Roads/Streets

A low-speed road or street is defined as one that has a design speed less than or equal to 45 mph. In urban areas, curbs have a major benefit in containing the drainage within the pavement area and in channelizing traffic into and out of adjacent properties. On rural, low-speed roads curbs should only be used where drainage is necessary or where roadside development is a problem.

The designer must also select the type of curb for the project. The following guidance should be used:

1. Non-State Facilities. On non-State highways, the curb should be the type that currently exists or should be as agreed upon with the local government.
2. 3R Projects. For 3R projects on State highways, the designer should match the existing curb type.
3. Curb Type. For reconstruction or new construction projects on State highways, the designer should select the most practical type of curb. The *Connecticut Standard Drawings* provide the various curb types used by the Department (e.g., BCLC, concrete, stone curbing). The designer should consider initial cost, life expectancy, availability of materials, construction operations, maintenance requirements and appearance. For example, stone curbing may be justified on heavily traveled urban streets with parking lanes, street-cleaning operations and heavy use of de-icing materials. The superior durability of the stone curbing may make it a more cost-effective selection.
4. Stone Curbing. Whenever stone curbing is used, Department practice is that granite will always be used, except where existing curbs are bluestone.
5. Sidewalks. Where sidewalks are adjacent to the roadway or where they may be constructed in the future, curbs should be included in the project design.
6. Intersections. At intersections, curbs may be used to channelize vehicular paths and provide a target area for islands. In these cases, use sloping curbs.
7. Disabled. Curbs should be designed with curb ramps at all pedestrian crosswalks to provide adequate access for the safe and convenient movement of physically disabled individuals. See Section 15-1.0 for details on the design and location of curb ramps.

**10-1.05.04 Application on High-Speed Highways**

In general, curbs should not be used on highways with a design speed of 50 mph or greater because of their adverse effect on vehicular behavior when impacted. Their use is limited to these conditions:

1. Drainage. Where containing the drainage within the pavement area is absolutely essential, sloping curbs may be used. For more information, the designer should refer to the Department's *Drainage Manual* for more specific uses of a curb for drainage purposes.
2. Bridges. For approaches to a bridge superstructure, use concrete curbing or granite stone curbing. This curbing will transition to the protruding blunt end of the bridge curbing and, therefore, helps guide the motorist away from the bridge curb and prevents plow damage to the structure. On a one-way structure, the transition curbing serves no purpose on the trailing end and should not be provided, unless required for drainage.
3. Raised Medians. Sloping curbs are acceptable for design speeds up to 50 mph.

Where curbing is determined to be necessary, use a 4-in sloping curb as shown in the *Connecticut Standard Drawings*.



## 10-2.0 ROADSIDE ELEMENTS

### 10-2.01 Sidewalks

#### 10-2.01.01 Guidelines for Sidewalk Construction

ConnDOT Policy “HWYS-19 — SIDEWALKS” provides the Department’s guidelines for when a new sidewalk should be considered or where an existing sidewalk should be replaced. This Policy also discusses the State’s municipalities’ funding and maintenance responsibilities.

#### 10-2.01.02 Sidewalk Design Criteria

In determining the sidewalk design, the designer should consider the following:

1. Widths. Sidewalk widths may vary from 4 ft to 8 ft with 5 ft considered typical. On bridges, the typical width is 5.5 ft. High pedestrian volumes may warrant widths greater than 5 ft. In special cases (e.g., schools), the designer may need to conduct a detailed capacity analysis to determine the sidewalk width. Use the *Highway Capacity Manual* for this analysis.
2. Central Business District (CBD) Areas. The entire area between the curb and building is often fully used as a paved sidewalk.
3. Appurtenances. The designer should also consider the impacts of roadside appurtenances within the sidewalk (e.g., fire hydrants, parking meters, utility poles). These elements will reduce the effective width because they interfere with pedestrian activity. Preferably, place these appurtenances behind the sidewalk. If they are placed within the sidewalk, the sidewalk should have a minimum clear width of 3 ft to 4 ft. The clear width will be measured from the edge of the appurtenance to the edge of the sidewalk. The 3-ft minimum is necessary to meet the ADA requirements (see Section 15-1.0).
4. Cross Slope. The typical cross slope on the sidewalk is 2% towards the roadway. If the sidewalk is on an accessible route for disabled individuals, then the maximum cross slope will be 2% (see Section 15-1.0).
5. Buffer Areas. If the available right-of-way is sufficient, consider providing a buffer area between the curb and sidewalk. These areas provide space for snow storage and allow a greater separation between vehicle and pedestrian. The buffer area should be at least 2 ft wide to be effective. Provide a 2.5 ft wide separation where the strip accommodates utility poles with a minimum 1.5 ft clearance from the curb face. The designer should consider providing buffer areas between 8 ft and 10 ft wide. Buffer areas may also be used for the placement of roadside appurtenances, if necessary. However, this is undesirable because the proximity to the traveled way increases the likelihood of vehicle/fixed-object crashes. Also, their presence in buffer areas detracts from the appearance of the highway environment.

Section 13b-17-27 of the Department's "Highway Encroachment Permit Regulations" contains additional information related to the design of sidewalks. Section 15-1.0 of the *Highway Design Manual* contains information related to accessibility requirements for disabled individuals that applies to sidewalk design.

### **10-2.02 Fill and Cut Slopes**

Fill and cut slopes should be designed to ensure the stability of the roadway and be as flat as practical to enhance roadside safety. Much of the necessary information for design will be provided in the Soils Report, if one is necessary for the project. The designer should consider the following when selecting a fill or cut slope design:

1. Fill Slopes. Fill slopes should be 1:6 or flatter. All soils will be stable at this rate. Maintenance efforts are greatly reduced, the erosion potential is reduced, and the slopes are traversable at 1:6. For fill heights between 10 ft and 25 ft, 1:4 slopes are acceptable. For fill heights greater than 25 ft, 1:2 slopes protected by guiderail are typical. If site conditions require a slope steeper than 1:2, slope-retaining structures are normally used. The geotechnical engineer must approve any proposed slope steeper than 1:2. The typical section figures in Chapters Four and Five provide additional information on slope rates for various classes of highway.
2. Clear Zones. The steeper the fill slope, the greater the clear zone will be where guiderail is not provided (see Figure 13-2A).
3. Slope Rounding. Round slope transitions adjacent to shoulders at the top of fills. As indicated in the typical cross section figures in Chapters Four and Five, the recommended rounding is 8 ft. Measure this from the edge of the shoulder to where the rounded section intercepts the fill slope. For safety purposes, this will be sufficient with one exception. Where the design speed is 70 mph and where an unprotected 1:4 slope is provided, the recommended rounding distance is 11 ft. (Note: Rounding is not necessary on fill slopes protected by guiderail).

The typical rounding at the toe of a fill slope and at the top of a cut slope is 10.0 ft.

4. Erosion Control. Erosion possibilities should be minimized. To the extent practical, preserve the natural and existing drainage patterns. Severely rutted side slopes can cause vehicular rollover even on relatively flat slopes. In good soil, turf can be established on slopes as steep as 1:2. However, flatter slopes obviously reduce the erosion potential and should be used where feasible. The Department's *Drainage Manual* discusses erosion prevention in more detail.
5. Rock Cuts. Slopes up to vertical are possible in rock cuts using presplitting methods. Where practical, place the bottom of the rock-cut slope outside of the calculated clear zone. All jagged rock outcroppings exposed to possible vehicular impacts should be removed. Figures 4J and 5L provide details for rock cuts. The geotechnical engineer will determine the appropriate slope in rock cuts.

6. Earth Cuts. In earth cuts, a rounded swale will normally be provided. Deep earth cuts may warrant terracing. These reduce erosion and enhance soil stability. The recommendation of the geotechnical engineer will govern.
7. Slope Protection. Generally, earth cut or fill slopes should be 1:2 or flatter to ensure a stable slope upon which turf may be established. Under favorable soil conditions, earth slopes as steep as 1:1.5 may be used, provided a proper slope protection system is used.

The slope protection system selected should be consistent with the context of the design and the surrounding environs. Because the treatment of slopes can greatly influence the public's acceptance and overall success of a project, the designer should consult with the geotechnical engineer, structural engineer, and landscape architect to identify appropriate slope protection alternatives. Where a vegetated slope is not a feasible alternative, crushed stone slope protection may be considered. However, due to its undesirable impact on aesthetics, minimize the use of this treatment.

### **10-2.03     Utilities**

Consider the following:

1. Placement. Space for the placement of utilities is an integral part of the highway design process. To ensure adequate space for the placement of utilities, the designer should consider utility placement early in the design phase of a project's development.
2. Utility Test Pit Data (Cross Sections). For actual utility test pit data, show the existing location(s) of the underground utilities on the cross sections. Do not show theoretical (interpolated data between two actual test pits) location(s) of existing underground utilities on the cross sections.



## 10-3.0 MEDIANS

### 10-3.01 Median Widths

The median width is measured from the edge of the two inside travel lanes and includes the left shoulders if present. The design width will depend on the functional class, type of median, availability of right-of-way, construction costs, maintenance considerations, traffic operations at crossing intersections, safety and field conditions. Chapters Two, Four and Five provide the design range for median widths based on the functional classification and area type. In general, the median should be as wide as can be used advantageously. In addition, the designer should consider the following when determining the appropriate median width:

1. Left Turns. Consider the need for left-turn bays when selecting a median width.
2. Crossing Vehicles. A median should be approximately 25 ft wide to safely allow a crossing passenger vehicle to stop between the two roadways. In areas where trucks are commonly present (e.g., truck stops), increase the median width to allow trucks to stop between roadways. Median widths from 30 ft to 50 ft should be carefully considered. These widths may encourage drivers to attempt the crossing independently; however, they may not be wide enough to fully protect longer vehicles from the through traffic.
3. Signalization. At signalized intersections, wide medians can lead to inefficient traffic operations and may increase crossing times.
4. Median Barrier. A median barrier is warranted for medians 66 ft or less on freeways and other divided arterials. If feasible, the median should be wide enough to eliminate the need for a barrier.
5. Operations. Several vehicular maneuvers at intersections are partially dependent on the median width. These include U-turns and turning maneuvers at median openings, which are discussed in Chapter Eleven. The designer should evaluate the likely maneuvers at intersections and provide a median width that will accommodate the selected design vehicle.
6. Uniformity. In general, try to provide a uniform median width. However, variable-width medians may be advantageous where right-of-way is restricted, at-grade intersections are widely spaced ( $\frac{1}{2}$  mile or more), or an independent alignment is practical.
7. Roadway Elements. Do not reduce the widths of the other roadway cross section elements to provide additional median width.
8. Wide Medians. Median widths in the range of 50 ft to 80 ft may cause confusion for drivers on the intended operations for the multiple intersections encountered (e.g., going the wrong way on a one-way roadway).

9. Preferences. Drivers prefer medians that are obviously narrow or are wide enough to provide adequate refuge to allow independent crossings.

The typical cross section figures in Chapters Four and Five illustrate typical median types and other design details for median cross sections.

### **10-3.02 Median Types**

The type of median selected will depend upon many factors, including:

1. drainage,
2. availability for median width,
3. snow and ice impacts,
4. impacts of superelevation development,
5. urban or rural location, and
6. traffic volumes.

#### **10-3.02.01 Flush Medians**

Flush medians may be used on urban highways and streets. A flush median should be crowned to avoid ponding water on the median area. A slightly depressed median in conjunction with median drains can be used to avoid carrying all of the drainage across the travel lanes.

#### **10-3.02.02 Raised Medians**

Raised medians are often used on urban highways and streets, both to control access and left turns and to improve the capacity of the facility. Figure 5H illustrates a typical raised median.

#### Advantages

When compared to flush medians, raised medians offer several advantages:

1. Mid-block left turns are controlled.
2. Left-turn channelization can be more effectively delineated if the median is wide enough.
3. A distinct location is available for traffic signs, signals, pedestrian refuge and snow storage.
4. The median edges are much more discernible during and after a snowfall.
5. Drainage collection may be improved.
6. Limited physical separation is available.

### Disadvantages

The disadvantages of raised medians when compared to flush medians are:

1. They are more expensive to construct and more difficult to maintain.
2. They may need greater widths to serve the same function (e.g., left-turn lanes at intersections) because of the raised island and offset between curb and travel lane.
3. Curbs may result in adverse vehicular behavior upon impact.
4. Prohibiting mid-block left turns may overload street intersections and may increase the number of U-turns.
5. They may complicate the drainage design.
6. Access for emergency vehicles (e.g., fire, ambulance) may be more difficult.

### Design

If a raised median will be used, the designer should consider the following in the design of the median:

1. Design Speed. Raised medians should only be used where the design speed is 50 mph or less.
2. Curb Type. Either vertical or sloping curbs may be used.
3. Appurtenances. If practical, the placement of appurtenances within the median is strongly discouraged (e.g., traffic signal poles, light standards).
4. Width. The width of a raised median is measured from the two inside edges of the traveled ways and, therefore, includes the left shoulders. The width of a raised median should be sufficient to allow for the development of a channelized left-turn lane. Therefore, the typical width is 22 ft, which provides for:
  - a. a 12-ft left-turn lane,
  - b. a 2-ft shoulder between the turn lane and raised island,
  - c. a 2-ft shoulder between the opposing traveled way and the raised island, and
  - d. a minimum 6-ft raised island.

If practical at an unsignalized intersection, a raised median should be 25 ft in width to permit storage of a vehicle crossing or turning left onto the mainline.

5. Minimum Width. Under restricted conditions, the recommended minimum width of a raised median should be 8 ft. This assumes a minimum 4-ft raised island with 2-ft shoulders on each side adjacent to the through travel lanes.

### 10-3.02.03 Depressed Medians

A depressed median is typically used on rural freeways. Depressed medians have better drainage and snow storage characteristics than flush or raised medians and, therefore, are preferred on major highways.

Figures 4F and 5G illustrate the use of depressed medians on rural and urban freeways and expressways. A depressed median should typically be 100 ft wide in rural areas and 90 ft wide in urban areas. This allows for the addition of future travel lanes on the inside while still maintaining a sufficient width of a depressed median. The designer should consider providing wider median widths, within the constraints of additional right-of-way and construction costs. When selecting a width for a depressed median, consider the following:

1. Median Barriers. All medians 66 ft or less on freeways will require a median barrier. Therefore, to eliminate the need for a median barrier, consider providing a depressed median width greater than 66 ft.
2. Slopes. Figures 4F and 5G illustrate a median slope range of 1:6 to 1:12; slopes greater than 1:10 should only be used if there is no median barrier placed on the slope. The designer should make every reasonable effort to provide a median width that will allow the flatter slopes but still provide the necessary depth for the depressed median.
3. Longitudinal Gradient. The center longitudinal gradient of a depressed median should be a minimum of 0.5%.



## **10-4.0 BRIDGE AND UNDERPASS CROSS SECTION**

The bridge or underpass cross section will depend upon the cross section of the approaching roadway, its functional classification, and whether the project entails new construction, reconstruction (freeways and non-freeways), 3R work (non-freeways) or a spot improvement.

### **10-4.01 Bridges**

This Section presents the Department's criteria for bridges that are within the limits of a new construction project (all functional classes) or within the limits of a reconstruction project (non-freeways). The designer should reference the following sections for the Department's criteria on bridge widths for other conditions:

1. freeway projects — Section 3-1.04.
2. 3R non-freeway projects — Section 2-7.02.
3. Bridge rehabilitation/replacement (freeways) — Section 3-1.04.
4. Bridge rehabilitation/replacement (spot improvements, non-freeways) — Section 3-2.03.

#### **10-4.01.01 New Construction**

This refers to bridges within the limits of a new construction project. In all cases, the full approach roadway width, including shoulders, will be carried across the structure. The approach width will be determined by the criteria in Chapters Four and Five. Where sidewalks are provided, they will be 5.5 ft wide as measured from the gutter line.

#### **10-4.01.02 Reconstruction (Non-Freeways)**

This refers to bridges within the limits of a reconstruction project on a non-freeway facility. The Department's criteria are as follows:

1. Bridge Rehabilitation. The bridge substructure and/or superstructure may be partially or entirely rehabilitated as part of the reconstruction project. For example, this would be necessary if the project included the addition of travel lanes. If this work includes rehabilitation of the bridge deck, carry the full approach width, including shoulders, across the structure. Connecticut General Statutes (CGS) 13a-86 requires a minimum bridge width of 28 ft on any 2-lane highway maintained by the Commissioner, exclusive of any sidewalk width. No exceptions to this criterion will be allowed, unless in the judgment of the Commissioner a lesser width is warranted. Note that the criterion in CGS 13a-86 does not apply to bridges on highways maintained by a municipality.
2. Bridges to Remain in Place. If an existing bridge within the project limits is structurally sound and if it meets the Department's design loading structural capacity, it is unlikely to be cost effective to improve the geometrics of the bridge. These are considered existing bridges to remain in place. However, the geometric deficiencies may be severe, and/or

there may be an adverse crash experience at the bridge. Therefore, the designer should consider widening the bridge to meet the approach roadway width as part of the reconstruction project. Figure 10-4A provides the minimum widths for existing bridges to remain in place within the limits of a reconstruction project. In addition, all existing bridge rails and the approach transitions will be evaluated to determine if they meet the Department's current criteria.

Functional Class	Design Year AADT	Clear Bridge Width (Note 1)
Arterial	All	Approach Traveled Way + 4 ft
Collector	0-1500	22 ft
	1500-2000	24 ft
	>2000	28 ft
Local	0-250	20 ft
	250-1500	22 ft
	1500-2000	24 ft
	> 2000	28 ft

*Notes:*

1. Clear Bridge Width. This is the width between curbs or rails, whichever is less.
2. Long Bridges (Locals/Collectors). For bridges on these facilities with a total length greater than 100 ft, the widths in the table do not apply. These structures should be analyzed individually considering the existing width, safety, traffic volumes, remaining structural life, design speed, costs to widen, etc.

**WIDTHS FOR EXISTING BRIDGES TO REMAIN IN PLACE  
(Reconstruction Projects)**

**Figure 10-4A**

**10-4.02 Underpasses**

The discussion in this Section will apply to all functional classes and to all project scopes of work.

The approaching roadway cross section, including clear zones, should be carried through the underpass. If an auxiliary lane passes through the underpass adjacent to the mainline, measure the clear zone distance from the edge of the auxiliary lane. The lateral clearances for any

collector-distributor roads should be treated separately from the mainline, with its clear zone based on its own design speed, side slope and traffic characteristics.

When determining the cross section width of a highway underpass, the designer should also consider the likelihood of future roadway widening. Widening an existing underpass in the future can be extremely expensive and it may be warranted, if some flexibility is available, to allow for possible future developments. Therefore, the designer should evaluate the potential for further development in the vicinity of the underpass that would significantly increase traffic volumes. The Bureau of Policy and Planning should be consulted for its projections. As an example, a reasonable allowance for future widening may be to provide sufficient lateral clearance for one additional lane in each direction.



## 10-5.0 RIGHT-OF-WAY

For information on the types of rights-of-way (e.g., permanent, temporary, easements), the designer should review the Department's *Policies and Procedures for Property Maps*. The right-of-way width should be sufficiently wide to provide the selected cross section elements and dimensions, to provide proper drainage, to allow maintenance of the facility and to provide for future expansion of the cross section. However, restrictions along the highway corridor may require some compromises in determining the ROW width. In these cases, the selected highway cross section may be limited by the available ROW.

The following summarizes the Department's criteria for determining the ROW width:

1. Freeways (All Projects). The upper range of the ROW width should be the sum of the travel lane and median width plus 100 ft beyond the edge of the outside travel lane on each side or side slope requirements, whichever governs. In urban areas, the minimum ROW width will be the sum of the travel lane and median widths plus the roadside clear zone on each side or side slope requirements, whichever governs.
2. Other Arterials and Collectors (New Construction/Reconstruction). The ROW width will be determined on a project-by-project basis. In determining the ROW width, the designer should consider travel lane widths, median widths, roadside clear zones, utility strips, side slope requirements, etc.
3. Other Arterials and Collectors (3R Projects). The acquisition of significant amounts of ROW is often outside the scope of a 3R project. Therefore, the existing ROW will often be unchanged by the 3R project. However, the designer should, wherever practical, secure additional ROW to allow cost-effective geometric and roadside safety improvements.
4. Local Roads and Streets (All Projects). The ROW width will be as required for the purpose of the project and will be determined by the local government.

ROW width should be uniform, but this is not a necessity. In urban areas, variable widths may be necessary due to the existing development; varying side slopes and embankment heights may make it desirable to vary ROW width; and ROW limits will likely have to be adjusted at intersections and freeway interchanges. The following special ROW controls should also be considered:

1. Sight Distances. At horizontal curves and intersections, additional ROW may be warranted to ensure that the necessary sight distance is always available in the future.
2. Restricted Areas. In areas where the necessary ROW widths cannot be reasonably obtained, the designer should consider using steeper slopes, revising grades or using slope-retaining structures.
3. Railroads. On sections of highway adjacent to railroads, avoid any encroachment onto railroad ROW whenever feasible.

4. Interchanges. Special ROW considerations at interchanges are discussed in Chapter Twelve.

### 10-6.0 TYPICAL SECTIONS

Chapters Four and Five present several typical section figures for both normal and superelevated sections. The figures are based on:

1. rural or urban location;
2. multilane or 2-lane;
3. type of median (e.g., depressed, raised, with a median barrier); and
4. curbed or uncurbed.

In addition, Figure 5M presents a typical section for a high-volume/incident-management freeway. "Incident management" refers to events (e.g., crashes) that have the potential to produce major disruptions to the flow of traffic on a freeway. The critical feature of this typical section is the provision of a left shoulder with sufficient width to assist in accommodating traffic in the event of a highway incident in the interim.

The use of this typical section will be determined on a case-by-case basis.





**10-7.0 REFERENCES**

1. *A Policy on Geometric Design of Highways and Streets*, AASHTO, 2018.
2. *Highway Capacity Manual*, TRB, 2000.
3. *Roadside Design Guide*, AASHTO, 2002.
4. TS-80-204, *Design of Urban Streets*, FHWA, September, 1980.
5. *Parking Principles*, Special Report No. 125, Highway Research Board, 1971.
6. FHWA-RD-79-75/76, *Safety Aspects of Curb Parking*, FHWA, 1979.



## Chapter Eleven

### INTERSECTIONS AT-GRADE

#### Table of Contents

<u>Section</u>	<u>Page</u>
11-1.0	GENERAL DESIGN CONSIDERATIONS.....11-1(1)
11-1.01	Capacity .....11-1(1)
11-1.01.01	Design Year and Level of Service.....11-1(1)
11-1.01.02	Capacity Methodology for Signalized Intersections ..11-1(1)
11-1.02	Design Vehicle.....11-1(1)
11-1.03	Intersection Alignment.....11-1(2)
11-1.04	Intersection Profile.....11-1(4)
11-1.04.01	Approach Gradient.....11-1(4)
11-1.04.02	Cross Section Transitions .....11-1(4)
11-1.05	Intersection Spacing .....11-1(6)
11-2.0	INTERSECTION SIGHT DISTANCE (ISD).....11-1(1)
11-2.01	General .....11-2(1)
11-2.02	Design Procedures .....11-2(1)
11-2.03	Case B – Intersections with Stop Control on the Minor Road .....11-2(4)
11-2.03.01	Case B1– Left-Turn from the Minor Road.....11-2(5)
11-2.03.02	Case B2 – Right-Turn From the Minor Road .....11-2(8)
11-2.03.03	Case B3 – Crossing Maneuver From the Minor Road .....11-2(8)
11-2.04	Case D – Intersections with Traffic Signal Control .....11-2(9)
11-2.05	Case E – Intersections With All-Way Stop Control.....11-2(9)
11-2.06	Case F – Left Turns From the Major Road.....11-2(11)
11-2.07	Effect of Skew.....11-2(11)
11-2.08	ISD Worksheet .....11-2(11)
11-2.09	ISD Application .....11-2(16)
11-3.0	TURNING RADII (Right Turns) .....11-3(1)
11-3.01	Types of Treatment .....11-3(1)
11-3.02	Design Vehicle Selection.....11-3(1)

11-3.03	Designs for Pavement Edge/Curb Line .....	11-3(3)
11-3.03.01	Tolerable Encroachment.....	11-3(3)
11-3.03.02	Inside Clearance .....	11-3(6)
11-3.03.03	Parking Lanes/Shoulders.....	11-3(6)
11-3.03.04	Pedestrians .....	11-3(6)
11-3.03.05	Summary.....	11-3(6)
11-4.0	TURNING ROADWAYS.....	11-4(1)
11-4.01	Guidelines .....	11-4(1)
11-4.02	Design Criteria.....	11-4(1)
11-4.02.01	Design Speed .....	11-4(1)
11-4.02.02	Horizontal Alignment.....	11-4(1)
11-4.02.03	Width.....	11-4(5)
11-4.02.04	Angle of Turn .....	11-4(5)
11-4.02.05	Acceleration/Deceleration Lanes .....	11-4(9)
11-5.0	AUXILIARY TURNING LANES .....	11-5(1)
11-5.01	Guidelines for Right-Turn Lanes.....	11-5(1)
11-5.02	Guidelines for Left-Turn Lanes.....	11-5(1)
11-5.03	Design Details for Auxiliary Turning Lanes.....	11-5(8)
11-5.04	Typical Treatments for Auxiliary Turning Lanes .....	11-5(8)
11-5.05	Dual Turn Lanes .....	11-5(13)
11-5.06	Extension of Additional Through Lanes.....	11-5(15)
11-5.07	Two Way Left Turn Lanes (TWLTL).....	11-5(18)
11-6.0	MEDIAN OPENINGS .....	11-6(1)
11-6.01	Guidelines .....	11-6(1)
11-6.02	Design .....	11-6(1)
11-6.03	Median Openings on Freeways.....	11-6(3)
11-7.0	CHANNELIZATION.....	11-7(1)
11-7.01	Design Principles.....	11-7(1)
11-7.02	Design Details (Islands).....	11-7(1)
11-8.0	DRIVEWAYS.....	11-8(1)
11-8.01	Design .....	11-8(1)
11-8.01.01	Detailed Criteria .....	11-8(1)
11-8.01.02	Criteria (Existing Driveways).....	11-8(6)

---

11-8.02	Driveway Spacing and Corner Clearances.....	11-8(6)
11-8.03	Major Traffic Generators.....	11-8(8)
11-8.03.01	Section 13b-17-15 "Driveways" from the Highway Encroachment Permit Regulations .....	11-8(8)
11-9.0	ROUNDBABOUTS .....	11-9(1)
11-10.0	REFERENCES.....	11-10(5)



# Chapter Eleven

## INTERSECTIONS AT-GRADE

### 11-1.0 GENERAL DESIGN CONSIDERATIONS

#### 11-1.01 Capacity

##### 11-1.01.01 Design Year and Level of Service

To perform the capacity analysis, the designer must select a future design year. For new construction and reconstruction, this is typically 20 years from the construction completion date. For 3R and spot improvement projects, the intersection should be designed to accommodate current traffic volumes to 10-year future traffic volumes. If the intersection is within the limits of a longer project, the design year for the intersection will be the same as that for the project.

The geometric design tables in Chapters Two, Four and Five present the recommended levels of service for highways based on functional classification and urban or rural location. The intersection level of service for the selected design year should meet these criteria so that the highway facility will operate at a consistent serviceability. At a minimum, the intersection should operate at no worse than LOS D.

When a project has experienced a significant delay during design, the designer may be required to perform an updated capacity analysis. The need for this updated analysis will be determined on a case-by-case basis.

##### 11-1.01.02 Capacity Methodology for Signalized Intersections

The Division of Traffic Engineering is responsible for most capacity calculations at intersections. The Department has adopted the unsignalized and signalized intersection methods presented in the *Highway Capacity Manual* (HCM). For use of other computerized capacity analysis programs, the designer should contact the Division of Traffic Engineering to determine which programs and versions are acceptable to the Department.

#### 11-1.02 Design Vehicle

Designs for right and left turns should accommodate the turning paths of the applicable design vehicle. The detailed design criteria for right turns at intersections are presented in Section 11-3.0. The Department has adopted the following design vehicles for intersection design:

1. P — passenger car

2. SU — single unit vehicle (e.g., delivery truck)
3. BUS — intercity or city transit bus. Note that is often necessary to design for specific buses rather than the generic BUS template.
4. WB-62 — semitrailer truck or tractor-trailer combination with a 48-ft trailer, 62-ft wheelbase, and 68.5-ft overall length.
5. WB-67 (“Large” Truck) — tractor with a 53-ft trailer, 67-ft wheelbase, and 73.5-ft overall.

The turning characteristics of the applicable design vehicle are used to test the adequacy of an existing or proposed design at an intersection. The designer should determine the amount of vehicular encroachment upon adjacent lanes when making right and left turns. This, combined with several other factors discussed in Section 11-3.0, will allow the designer to select the appropriate turning treatment.

### **11-1.03 Intersection Alignment**

All legs of an intersection should be on tangent rather than curved sections. Where a minor road intersects a major road on a horizontal curve, this complicates the geometric design of the intersection — particularly sight distance, turning movements, channelization and superelevation. If relocation of the intersection is not practical, the designer may be able to realign the minor road to intersect the major road perpendicular to a tangent at a point on the horizontal curve. Although this is an improvement, this arrangement may still result in difficult turning movements if the superelevation is high.

At-grade intersections should intersect at angles between 60° and 90°; see Figure 11-1A. Excessively skewed intersections increase the travel distance across the major highway, adversely affect sight distance, and complicate the designs for turning movements. Minimizing the skew is especially important where large trucks are expected to turn since the swept area of the trailer increases quickly with acute turn angles and acute angles are very difficult for the driver to negotiate optimally. If the angle of intersection is less than 60°, the intersections should be realigned if practical. Where there is a high density of older drivers, 65 years of age and older, the skew angle should ideally be between 75° and 90°.

The alignment should direct the through vehicle into the appropriate receiving lane across the intersection.



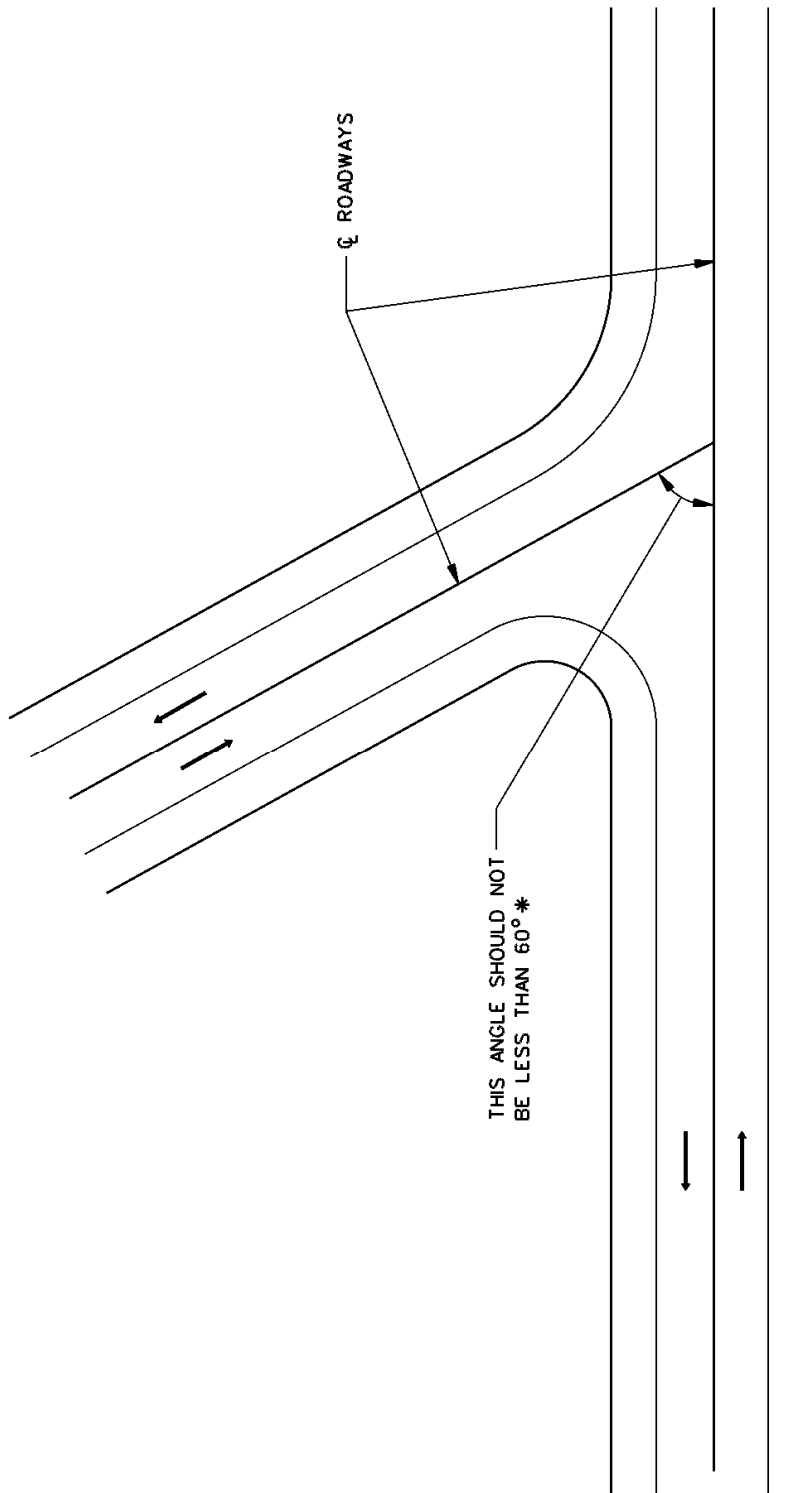

\* USE 75° WHERE THERE IS A HIGH DENSITY OF OLDER DRIVERS.

**SKEWED INTERSECTIONS  
11-1A**

## 11-1.04 Intersection Profile

### 11-1.04.01 Approach Gradient

The vertical profile of an at-grade intersection should be as level as practical, subject to drainage requirements. This also applies to the distance along any intersection leg, called the landing area, where vehicles stop waiting to pass through the intersection. Grades approaching or leaving the intersection will affect vehicular deceleration distances (and therefore stopping sight distance) and vehicular acceleration distances. Therefore, the gradient on the landing area should be 3% or less. Because the horizontal alignment, curb returns, and profile interact, the designer must ensure that the profiles along the vehicle path and along the curb line are acceptable. When designing the profile of a minor road crossing a major highway, the designer should maintain stopping sight distance to the brake lights of the preceding vehicle, approximately 2 ft.

### 11-1.04.02 Cross Section Transitions

One or more of the approaching legs of the intersection may need to be transitioned (or warped) to meet the cross section of the two crossing roads. The designer should consider the following:

1. Stop Controlled. When the minor road is stop controlled, the profile and cross section of the major road will normally be maintained through an intersection, and the cross slope of the stop-controlled leg will be transitioned to match the major road cross slope and profile.
2. Signalized Intersection. At signalized intersections, or potential signalized intersections, the cross section of the minor road will typically be transitioned to meet the profile and cross slope of the major road. If both intersecting roads have approximately equal importance, the designer may want to consider transitioning both roadways to form a plane section through the intersection. Where compromises are necessary between the two major roadways, the smoother riding characteristics should be provided for the roadway with the higher traffic volumes and operating speeds. Cross slopes should also be appropriate for the design speed of each leg.
3. Transition Rates. Where one or both intersecting roadways are transitioned, the designer must determine the length and rate of transition from the normal section to the modified section; see Figure 11-1B. Consider providing a transition design that meets the general principles of superelevation transition that apply to that roadway (i.e., open-road or low-speed urban street conditions). See Chapter Eight for a complete discussion on superelevation development. Where these criteria are applied to transition rates, the applied design speed is typically:
  - a. 30 mph for a stop-controlled leg,
  - b. the highway design speed for a free-flowing leg, or
  - c. the highway design speed for all legs of a signalized intersection.

PROFILE AND CROSS-SECTION OF MAJOR HIGHWAY IS TYPICALLY MAINTAINED THROUGH AN INTERSECTION. IF BOTH INTERSECTING ROADS HAVE APPROXIMATELY EQUAL IMPORTANCE OR TO MEET DIFFICULT FIELD CONDITIONS, BOTH ROADWAYS MAY BE TRANSITIONED.

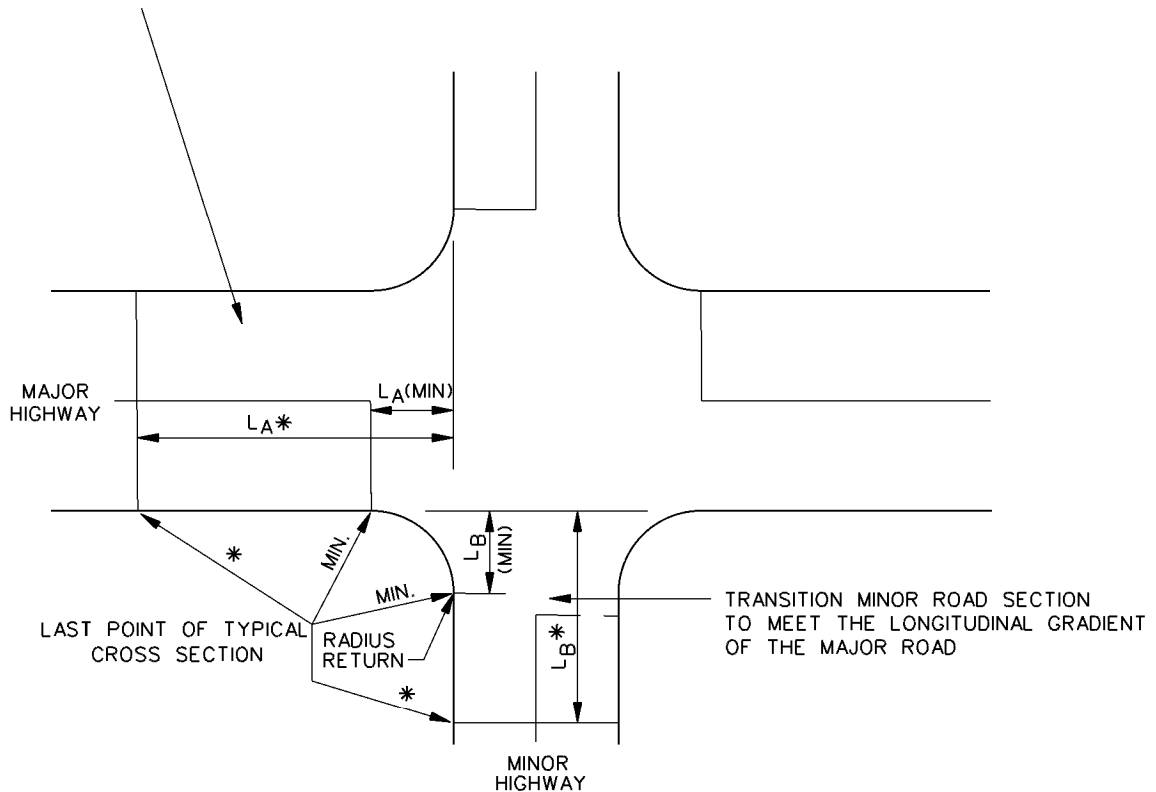

$L_A$  = TRANSITION LENGTH FOR MAJOR HIGHWAY

$L_B$  = TRANSITION LENGTH FOR MINOR HIGHWAY

\* = TRANSITION LENGTH BASED ON SUPERELEVATION TRANSITION CRITERIA FOR THE ROADWAY

**Notes:**

1. See discussion in Section 11-1.04.02.
2. Spot elevations of the pavement area should be provided to determine drainage requirements, roadway profiles and their effect on the turning path of the design vehicle.

**PAVEMENT TRANSITIONS THROUGH INTERSECTIONS**

**Figure 11-1B**

At a minimum, the approaching legs of an intersection should be transitioned within the curb or curve radius length of the intersection consistent with practical field conditions; see Figure 11-1B.

#### **11-1.05     Intersection Spacing**

Short distances between intersections should be avoided if practical because they tend to impede traffic operations. For example, if two intersections are close together and require signalization, they may need to be considered as one intersection for signalization purposes. To operate safely, each leg of the intersection may require a separate green cycle, thereby greatly reducing the capacity for both intersections. To operate efficiently, signalized intersections should be  $\frac{1}{4}$  mile apart.

In addition, short gaps between opposing "T" intersections should also be avoided. Drivers tend to encroach into the opposing lanes (corner cutting) so that they can make their turning maneuvers in one movement. In general, all new intersections should preferably be at least 400 ft apart.

## 11-2.0 INTERSECTION SIGHT DISTANCE (ISD)

### 11-2.01 General

All intersections within the project limits and any intersection outside the project limits that is influenced by the transportation improvement must be analyzed to determine if sufficient ISD exists. The designer needs to review the ISD values for left turns, right turns, crossing movements and turning left across oncoming traffic for each intersection. At each intersection, ensure that sufficient sight distance is provided for a driver to perceive potential conflicts and to perform the actions needed to negotiate the intersection safely. The additional costs and impacts to achieve this sight distance are often justified based on the safety and operational considerations.

In general, intersection sight distance (ISD) refers to the available distance that allows a driver corner sight distance available in intersection quadrants that allows a driver approaching an intersection to observe the actions of vehicles on the crossing leg(s). ISD evaluations involve establishing the needed sight triangle in each quadrant by determining the legs of the triangle on the two intersecting roadways. The necessary clear sight triangle is based on the type of traffic control at the intersection and on the design speeds of the two roadways. The types of traffic control and maneuvers are as follows:

- Case A – Intersections with no control,
- Case B – Intersections with stop control on the minor road:
  - + Case B1 – Left-turn from the minor road,
  - + Case B2 – Right-turn from the minor road,
  - + Case B3 – Crossing maneuver from the minor road,
- Case C – Intersections with yield control on the minor road:
  - + Case C1 – Crossing maneuver from the minor road,
  - + Case C2 – Left or right-turn from the minor road,
- Case D – Intersections with traffic signal control,
- Case E – Intersections with all-way stop control, and
- Case F – Left turns from the major road.

Because all intersections on State highways are either stop controlled or signalized, no guidelines are provided for no control intersections. The use of yield-controlled intersections is limited to right turns that are channelized at major intersections and separated from the signal. For these types of intersections, the designer should review NCHRP Report 383, *Intersection Sight Distance* and/or the 2001 AASHTO *Policy on the Geometric Design of Highways and Streets* for additional guidance.

### 11-2.02 Design Procedures

The Department uses gap acceptance as the conceptual basis for its intersection sight distance (ISD) criteria at stop-controlled and traffic-signal controlled intersections. The intersection sight distance is obtained by providing clear sight triangles both to the right and left as shown in

Figure 11-2A. All legs of the intersections must be addressed similarly. The following discussion assumes a stop-controlled side street entering a major through street:

1. Minor Road. The length of leg along the minor road is based on two parts. The first is the location of the driver's eye on the minor road. This is typically assumed to be 15 feet from the edge of the major road and in the center of the lane on the minor road; see Figure 11-2A. In restricted locations, this may be a minimum of 15 ft from the traveled way of the major road. The second part is based on the distance to the center of the vehicle on the major road. For right-turning vehicles, this is assumed to be the center of the closest travel lane from the left. For left-turning vehicles, this is assumed to be the center of the closest travel lane for vehicles approaching from the right; see Figure 11-2A.
2. Major Road. The length of the sight triangle leg or ISD along the major road is determined using the following equation:

$$\text{ISD} = 1.47 V_{\text{major}} t_g \quad (\text{Equation 11-2.1})$$

Where:

ISD	=	length of sight triangle leg along major road (ft)
$V_{\text{major}}$	=	design speed of major road (mph)
$t_g$	=	time gap for entering the major road (sec)

The time gap ( $t_g$ ) varies according to the design vehicle, the maneuver type, the grade on the minor road approach, the number of lanes on the major roadway, the type of operation and the intersection skew.

3. Height of Eye/Object. The height of eye for passenger cars is assumed to be 3.5 feet above the surface of the minor road. The height of object (approaching vehicle on the major road) is also assumed to be 3.5 feet. An object height of 3.5 feet assumes that a sufficient portion of the oncoming vehicle must be visible to identify it as an object of concern by the minor road driver. If there are a sufficient number of trucks to warrant their consideration, assume an eye height of 7.6 feet for a tractor/semitrailer and 6 feet for single-unit trucks and buses. If a truck is the assumed entering vehicle, the object height will still be 3.5 feet for the passenger car on the major road. The designer must also ensure that adequate ISD for passenger cars is provided, because there are situations where trucks have ISD and smaller vehicles do not.

Within this clear sight triangle, if practical, the objective is to remove, lower any object, trim lower tree branches, etc., that obstruct the driver's view. These objects may include buildings, parked or turning vehicles, trees, hedges, tall crops, unmowed grass, fences, retaining walls and the actual ground line. In addition, where a crossroad intersects the major road near a bridge on a crest vertical curve, items such as bridge parapets, piers, abutments, guardrail or the crest vertical curve itself may restrict the clear sight triangle.

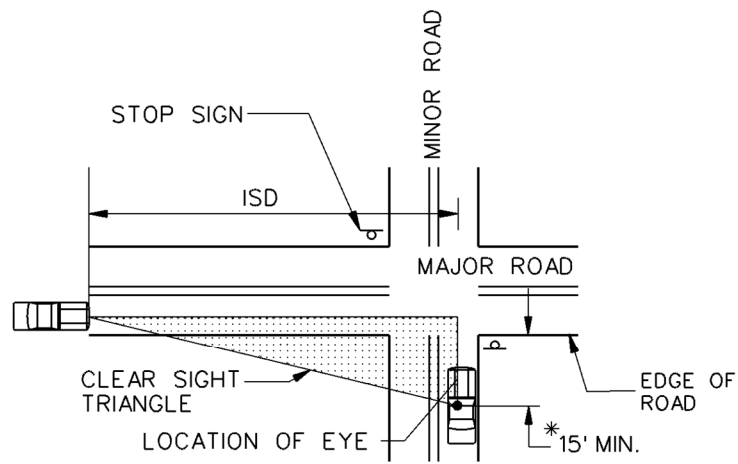

CLEAR SIGHT TRIANGLE FOR VIEWING TRAFFIC APPROACHING FROM THE LEFT

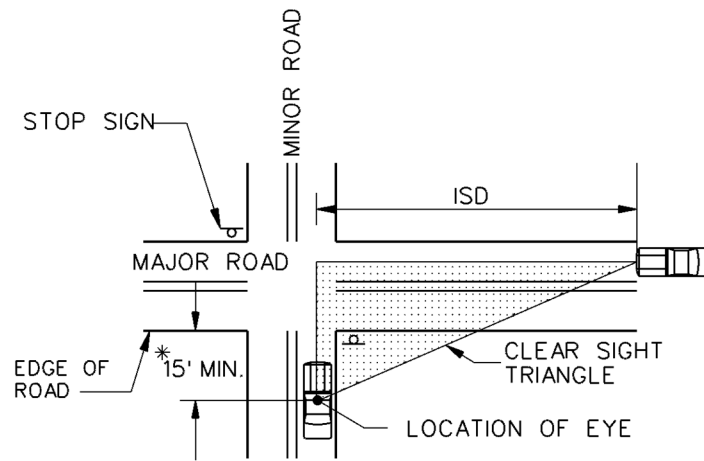

CLEAR SIGHT TRIANGLE FOR VIEWING TRAFFIC APPROACHING FROM THE RIGHT

\* Desirably measured from the edge of road. However, can be measured from edge of traveled way where restrictions limit offset.

**CLEAR SIGHT TRIANGLES (STOP-CONTROLLED) INTERSECTIONS**

**Figure 11-2A**

4. Design Exceptions. The following will apply:
- a. ISD is a ConnDOT controlling criteria at all signalized and un-signalized intersections which connect to State highways.
  - b. Commercial drives and multi-residential drives shall meet the same ISD standards as street intersections. An exception to standards is required when ISD requirements are not met.
  - c. ISD from all drives to a single family residential dwelling unit should meet full ISD standards. If the existing ISD meets standards, the drive must be designed to meet standards. If the drive has limited existing ISD, it shall not be reduced. If the project adds lanes or otherwise increases the need for ISD at a drive with limited existing ISD, the designer shall provide ISD of equivalent design speed to the preexisting condition. Exceptions are required if these conditions are not met.
  - d. The clear sight triangle as shown on Figure 11-2A for any private driveway shall fall within the respective property and/or within the public ROW. Property shall not be acquired to provide the required ISD for private driveways.
  - e. The presence of permanent fixed objects (e.g., buildings, cut slopes, parking lots, etc.) within the sight triangle will require a design exception. The designer shall not create new sightline restrictions within the sight triangle as part of the project design.
  - f. A design exception is not required where the minimum ISD is not met due to the parked vehicles within the roadway.
  - g. ISD is not a controlling criterion for projects designed by municipalities for roadways owned and maintained by the municipality (i.e., local road projects). In the event a local road project intersects a State highway, the designer shall evaluate the ISD at the State highway intersection, make improvements as feasible, and request a design exception if the minimum ISD cannot be obtained. Note that the designer is still responsible for providing ISD according to Town standards on the Town road system even though it is exempt from the State exception process.
  - h. See Section 6-5.0 for design exception procedures.

#### **11-2.03 Case B – Intersections with Stop Control on the Minor Road**

Where traffic on the minor road of an intersection is controlled by stop signs, the driver of the vehicle on the minor road must have sufficient sight distance for a safe departure from the stopped position assuming that the approaching vehicle comes into view as the stopped vehicle begins its departure. At a four-leg intersection, the designer should also check the sight distance across the intersection.



**11-2.03.01 Case B1– Left-Turn from the Minor Road**

To determine the intersection sight distance for vehicles turning left onto the major road, the designer should use Equation 11-2.1 and the gap times ( $t_g$ ) presented in Figure 11-2B. Figure 11-2B also presents adjustments to the gap times for multilane facilities and steep grades on the minor road approach. Figures 11-2C and 11-2D, which solve Equation 11-2.1, provide the ISD values for left-turning design vehicles onto a 2-lane level facility and a 4-lane level facility, respectively. The designer should also consider the following:

1. Multilane Facilities. For multilane facilities, the gap acceptance times presented in Figure 11-2B should be adjusted (i.e., add 0.5 second for passenger cars or 0.7 second for trucks for each additional lane to be crossed by the turning vehicle) to account for the additional distance required by the turning vehicle to cross the additional lanes or median.
2. Medians. The following will apply:
  - a. For a multilane facility that does not have a median wide enough to store a design vehicle, divide the median width by 12 feet to determine the corresponding number of lanes, then use the criteria presented in Figure 11-2B to determine the appropriate time factor.

Design Vehicle	Gap Acceptance Time ( $t_g$ ) (sec)
Passenger Car	7.5
Single-Unit Truck	9.5
Tractor/Semi trailer	11.5

*Adjustments:*

1. Multilane Highways. For left turns onto 2-way multilane highways, add 0.5 second for passenger cars or 0.7 second for trucks for each additional lane from the left, in excess of one, to be crossed by the turning vehicle. Assume that the left-turning driver will enter the left-travel lane on the far side of the major road. For right turns, no adjustment is necessary.
2. Minor Road Approach Grades. If the approach grade on the minor road exceeds +3%, the following will apply:
  - a. For right turns, multiply 0.1 seconds times the actual percent grade on the minor road approach and add this number to the base time gap.
  - b. For left turns, multiply 0.2 seconds times the actual percent grade on the minor approach and add this number to the base time gap.
3. Major Road Approach Grade. Major road grade does not affect calculations.

**GAP ACCEPTANCE TIMES  
(Left Turns From Minor Road)**

**Figure 11-2B**



Design Speed ( $V_{\text{major}}$ ) (mph)	ISD (ft)		
	Passenger Cars	Single-Unit Trucks	Tractor/Semitrailers
20	225	280	340
25	280	350	425
30	335	420	510
35	390	490	595
40	445	560	680
45	500	630	765
50	555	700	850
55	610	770	930
60	665	840	1015
65	720	910	1100
70	775	980	1185

*Notes:*

1. *These ISD values assume a left or right turn onto a 2-lane facility without a median.*
2. *These ISD values assume a minor road approach grade less than or equal to +3%.*

**INTERSECTION SIGHT DISTANCES**  
**(Two-Lane Highway or Street)**  
**Figure 11-2C**

Design Speed ( $V_{\text{major}}$ ) (mph)	ISD (ft)		
	Passenger Cars	Single-Unit Trucks	Tractor/Semitrailers
20	240	300	360
25	295	375	450
30	355	450	540
35	415	525	630
40	475	600	720
45	530	675	810
50	590	750	900
55	650	825	990
60	710	900	1080
65	765	975	1170
70	825	1050	1260

*Notes:*

1. *These ISD values assume a left turn onto a 4-lane facility without a median.*
2. *These ISD values assume a minor road approach grade less than or equal to +3%.*
3. *These ISD values assume the left-turning vehicle will enter the inside travel lane on the far side of the major road.*
4. *For a right turn from a minor road (i.e., ISD to the left), use the ISD values presented in Figure 11-2C.*

**INTERSECTION SIGHT DISTANCES  
(FOUR-LANE HIGHWAY WITHOUT MEDIAN)**

**Figure 11-2D**

- b. On facilities with a median wide enough to store the design vehicle (e.g., 3 feet clearance at both ends of vehicle), the designer should evaluate the sight distance needed in two separate steps:
  - First, with the vehicle stopped on the side road (the bottom portion in Figure 11-2E), use the gap acceptance times and distances for a vehicle turning right (Figure 11-2B) to determine the applicable ISD. Under some circumstances, it may be necessary to check the crossing maneuver to determine if it is the critical movement. Crossing criteria are discussed in Section 11-2.03.03.
  - Second, with the vehicle stopped in the median (top portion in Figure 11-2E), assume a 2-lane roadway design and use the adjusted gap acceptance times and distances for vehicles turning left (Figure 11-2B) to determine the applicable ISD.
3. Approach Grades. If the approach grade on the minor road exceeds 3%, see the criteria in Figure 11-2B.
4. Design Vehicle. A passenger vehicle is used in most design ISD situations. However, at some intersections (e.g., near truck stops, interchange ramps, schools), the designer should consider using trucks for the design vehicle in determining the ISD. The gap acceptance times ( $t_g$ ) for single-unit and tractor/semitrailer trucks and buses are provided in Figure 11-2B. ISD values for level, 2-lane roadways are presented in Figure 11-2C. The height of eye for these vehicles is discussed in Section 11-2.02

#### **11-2.03.02 Case B2 – Right-Turn From the Minor Road**

Intersection sight distance for right turns is determined in the same manner as discussed in Section 11-2.03.01. Note that there are no adjustments required for facilities with medians.

#### **11-2.03.03 Case B3 – Crossing Maneuver From the Minor Road**

In the majority of cases, the intersection sight distance for turning vehicles typically will provide adequate sight distance to allow a vehicle to cross the major road. However, in the following situations, the crossing sight distance may be the more critical movement:

1. where left and/or right turns are not permitted from a specific approach and the crossing maneuver is the only legal or expected movement (e.g., indirect left turns);
2. where the design vehicle must cross more than six travel lanes or, with medians, the equivalent distance; or
3. where a substantial volume of heavy vehicles cross the highway and there are steep grades on the minor road approach.

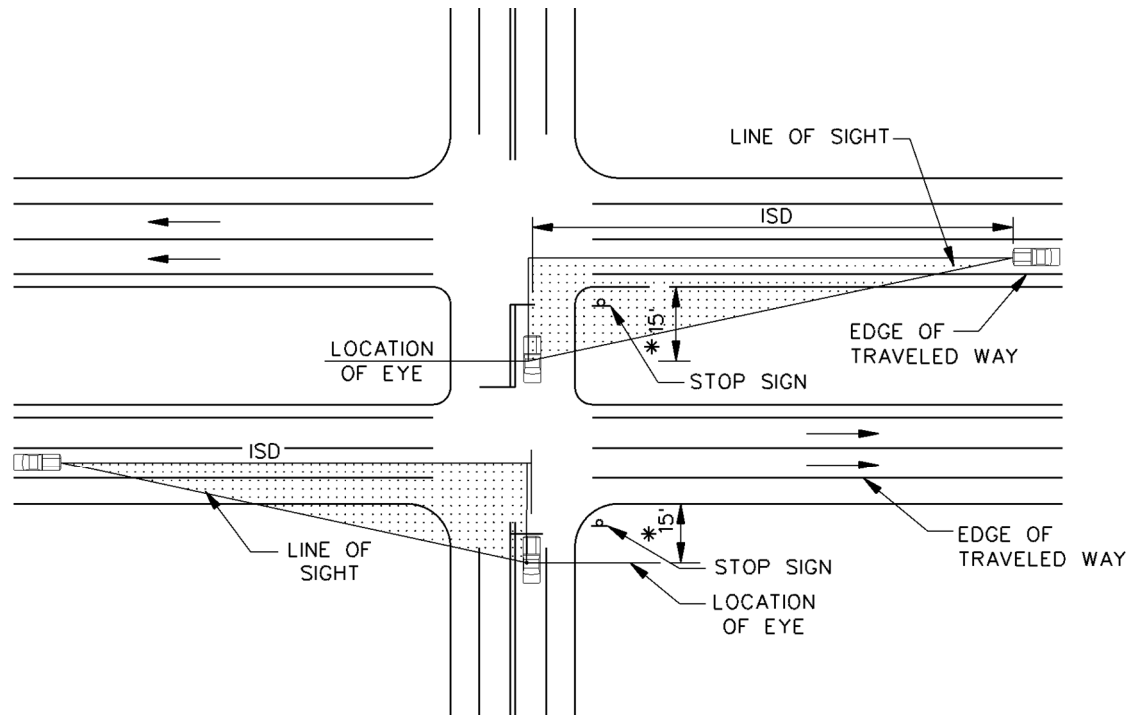

\* Desirably measured from the edge of road. However, can be measured from edge of traveled way where restrictions limit offset.

### INTERSECTION SIGHT DISTANCE (Divided Facilities)

Figure 11-2E

Use Equation 11-2.1 and the adjusted gap acceptance times ( $t_g$ ) in Figure 11-2F to determine the ISD for crossing maneuvers. Figure 11-2G presents the applicable ISD values for crossing maneuvers for a level, 2-lane highway with no median. Where medians are present, include the median width in the overall length to determine the applicable gap time. Divide this width by 12 feet to determine the corresponding number of lanes for the crossing maneuver.

#### 11-2.04 Case D – Intersections with Traffic Signal Control

Traffic signals should not be an alternative to providing adequate sight distance. For signalized intersections, provide sufficient intersection sight distance as described in Section 11-2.03.

#### 11-2.05 Case E – Intersections With All-Way Stop Control

For intersections with all-way stop control, provide sufficient sight distance so that the first stopped vehicle on each approach is visible to all other approaches. The ISD criteria for left- or right-turning vehicles as discussed in Section 11-2.03 are not applicable in this situation. Often, intersections are converted to all-way stop control to address limited sight distance at the intersection.

Design Vehicle	Gap Acceptance Time ( $t_g$ ) (sec)
Passenger Car	6.5
Single-Unit Truck	8.5
Tractor/Semitrailer	10.5

*Adjustments:*

1. Multilane Highway. Where the design vehicle is crossing a major road with more than two lanes, add 0.5 second for passenger cars or 0.7 second for trucks for each additional lane in excess of two. See the discussion in Section 11-2.03.01 for additional guidance.
2. Approach Grade. If the approach grade on the minor road exceeds 3%, multiply 0.1 seconds times the actual percent grade of the minor road approach, and add this number to the base time gap.

**GAP ACCEPTANCE TIMES  
(Crossing Maneuvers)**

**Figure 11-2F**

Design Speed ( $V_{major}$ ) (mph)	ISD (ft)		
	Passenger Cars	Single-Unit Trucks	Tractor/Semitrailers
20	195	250	310
25	240	315	390
30	290	375	465
35	335	440	545
40	385	500	620
45	430	565	695
50	480	625	775
55	530	690	850
60	575	750	930
65	625	815	1005
70	670	875	1080

*Notes:*

1. These ISD values assume crossing a 2-lane facility without a median.
2. These ISD values assume a minor road approach grade of 3% or less.

**TWO-LANE INTERSECTION SIGHT DISTANCES  
(Crossing Maneuvers)**

**Figure 11-2G**

**11-2.06 Case F – Left Turns From the Major Road**

For all intersections, regardless of the type of traffic control, the designer should consider the sight distance for a stopped vehicle turning left from the major road. This situation is illustrated in Figure 11-2H. The driver will need to see straight ahead for a sufficient distance to turn left and clear the opposing travel lanes before an approaching vehicle reaches the intersection. Sight distance for opposing left turns may be increased by offsetting the left-turn lanes.

Use Equation 11-2.1 and the gap acceptance times ( $t_g$ ) from Figure 11-2I to determine the applicable intersection sight distances for the left-turning vehicle. Where the left-turning vehicle must cross more than one opposing lane, add 0.5 second for passenger cars or 0.7 second for trucks for each additional lane in excess of one. Where medians are present and the left-turns are not offset, the designer will need to consider the median width in the same manner as discussed in Section 11-2.03.01. Figure 11-2J provides the ISD values for typical design vehicles and two common left-turning situations.

**11-2.07 Effect of Skew**

Where it is impractical to realign an intersection that is greater than 30° from the perpendicular, adjust the gap acceptance times ( $t_g$ ) presented in the above sections to account for the additional travel time required for a vehicle to make a turn or cross a facility. For oblique-angled intersections, determine the actual path length for a turning or crossing vehicle by dividing the total distance of the lanes and/or median to be crossed by the sine of the intersection angle. If the actual path length exceeds the total width of the lanes to be crossed by 12 ft or more, apply the applicable adjustment factors; see Figure 11-2K.

**11-2.08 ISD Worksheet**

The ISD that is required may vary for each approach. Use Figure 11-2L to document the required and actual ISD available at an intersection.



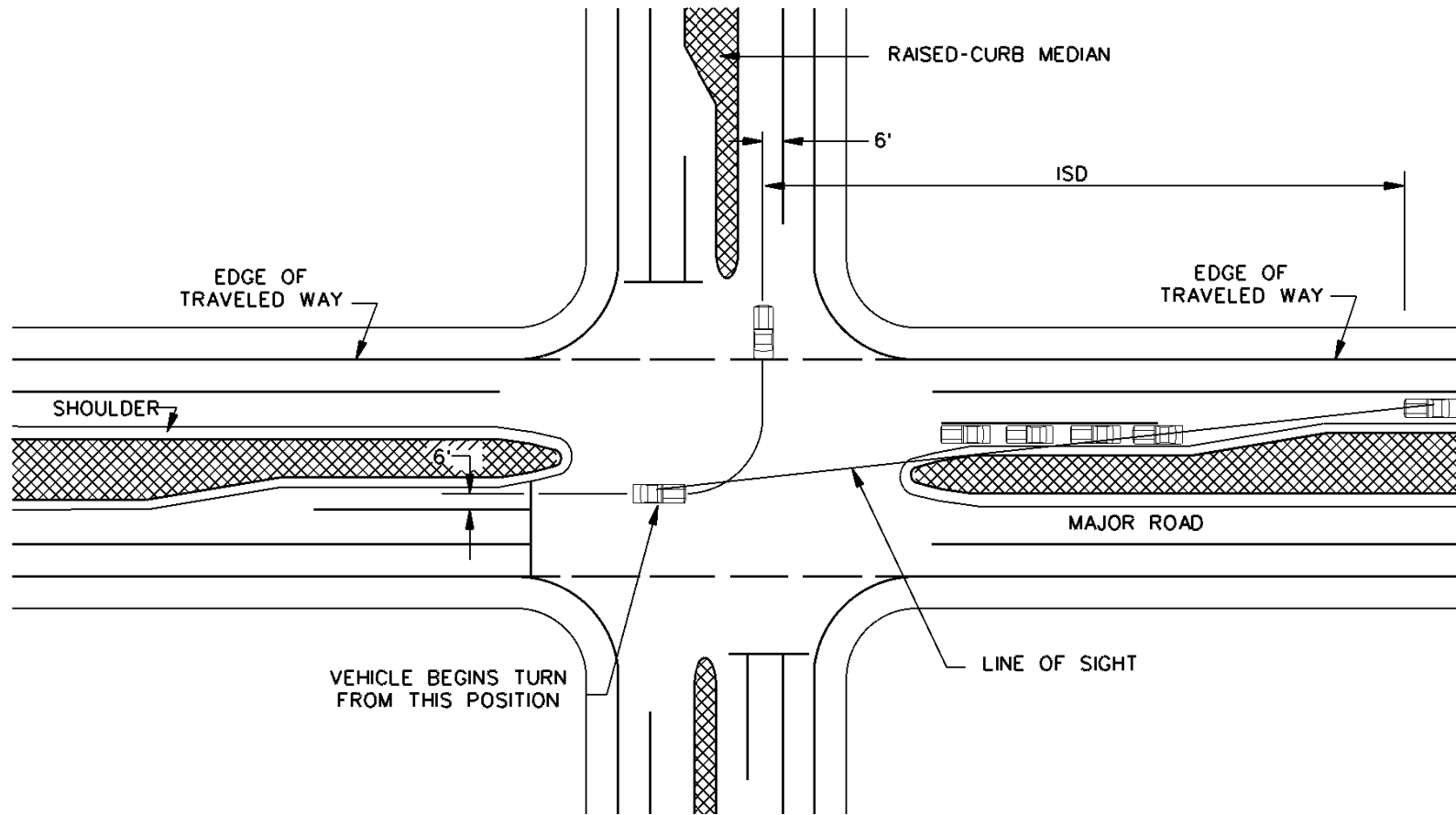

Notes:

1. See Figure 11-2J for ISD values.
2. See Section 11-2.06 for discussion and application.

**INTERSECTION SIGHT DISTANCE FOR A STOPPED VEHICLE TURNING LEFT  
(On Major Road)**

**Figure 11-2H**

Design Vehicle	Gap Acceptance Time ( $t_g$ ) (sec)
Passenger Car	5.5
Single-Unit Truck	6.5
Tractor/Semitrailer	7.5

*Adjustments:* Where left-turning vehicles cross more than one opposing lane, add 0.5 seconds for passenger cars or 0.7 seconds for trucks for each additional lane in excess of one. See Section 11-2.06 for additional guidance on median widths.

**GAP ACCEPTANCE TIMES  
(Left Turns From Major Road)**

**Figure 11-2I**

Design Speed ( $V_{major}$ ) (mph)	ISD (ft)					
	Passenger Cars		Single-Unit Trucks		Tractor/Semitrailers	
	Crossing 1 lane	Crossing 2 lanes	Crossing 1 lane	Crossing 2 lanes	Crossing 1 lane	Crossing 2 lanes
20	165	180	195	210	225	245
25	205	225	240	265	280	305
30	245	265	290	320	335	365
35	285	310	335	375	390	425
40	325	355	385	425	445	485
45	365	400	430	480	500	545
50	405	445	480	530	555	605
55	445	490	530	585	610	665
60	485	530	575	635	665	725
65	530	575	625	690	720	785
70	570	620	670	745	775	845

*Note:* Assumes no median on major road.

**INTERSECTION SIGHT DISTANCES  
(Left Turns From Major Road)**

**Figure 11-2J**

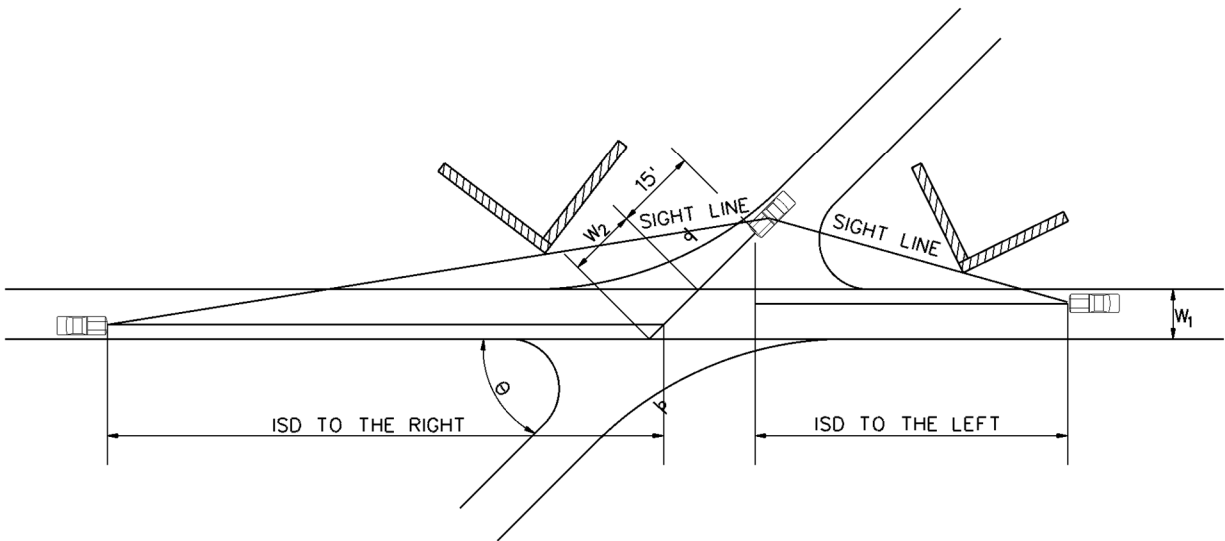

$$W_2 = \frac{W_1}{\sin \theta}$$

Where:  $W_1$  = Major road traveled way width (ft)  
 $W_2$  = Adjusted width for skew (ft)  
 $\theta$  = Intersection angle

### SIGHT DISTANCE AT SKEWED INTERSECTIONS

Figure 11-2K

INTERSECTION SIGHT DISTANCE

Project Number: \_\_\_\_\_

INTERSECTION: \_\_\_\_\_

NAME OF N/S ROADWAY	DISTANCE FROM EYE LOCATION TO NEAREST THROUGH LANE	APPROACH SPEED OF CROSSING TRAFFIC	REQUIRED ISD	ACTUAL ISD AVAILABLE*
NORTHBOUND LEFT LANE LOOKING LEFT				
NORTHBOUND RIGHT LANE LOOKING RIGHT				
SOUTHBOUND LEFT LANE LOOKING LEFT				
SOUTHBOUND RIGHT LANE LOOKING RIGHT				
EASTBOUND LEFT LANE LOOKING LEFT				
EASTBOUND RIGHT LANE LOOKING RIGHT				
WESTBOUND LEFT LANE LOOKING LEFT				
WESTBOUND RIGHT LANE LOOKING RIGHT				

\*A design exception will be required for each location where this is less than the required.

ISD WORKSHEET

Figure 11-2L

**11-2.09 ISD Application**

The following three examples illustrate the application of the ISD criteria:

**Example 11-2.09(1)**

Given: Minor road intersects a 4-lane highway with opposing left-turn lanes.  
 Minor road is stop controlled and intersects major road at 90°.  
 Design speed of the major highway is 45 mph.  
 All travel lane widths are 12 ft  
 The left-turn lane widths are 12 ft  
 Grade on minor road is 1%.  
 Trucks are not a concern.

Problem: Determine the intersection sight distance to the left and right from the minor road.

Solution: The following steps will apply:

1. For the passenger car turning right, the ISD to the left can be determined directly from Figure 11-2C. For the 45 mph design speed, the ISD to the left is 500 ft.
2. For the passenger car turning left, the ISD to the right must reflect the additional time required to cross the additional lanes and the left-turn lane; see Section 11-2.03.01. The following will apply:
  - a. First, determine the extra width required by the one additional travel lane and the left-turn lane and divide this number by 12 ft:

$$\frac{(12 + 12)}{12} = 2.0 \text{ lanes}$$

- b. Next, multiply the number of lanes by 0.5 second to determine the additional time required:

$$(2.0 \text{ lanes})(0.5 \text{ sec/lane}) = 1.0 \text{ seconds}$$

- c. Add the additional time to the basic gap time of 7.5 seconds and insert this value into Equation 11-2.1:

$$\text{ISD} = (1.47)(45)(7.5 + 1.0) = 562 \text{ ft}$$

Provide an ISD of 565 ft to the right for the left-turning vehicle.

3. Check the crossing vehicle, as discussed in Section 11-2.03.03. The following will apply:
  - a. First determine the extra width required by the two additional travel lanes and the turn lane and divide this number by 12 ft:

$$\frac{(12 + 12 + 12)}{12} = 3.0 \text{ lanes}$$

- b. Next, multiply the number of lanes by 0.5 second to determine the additional time required:

$$(3.0 \text{ lanes})(0.5 \text{ sec/lane}) = 1.5 \text{ seconds}$$

- c. Add the additional time to the basic gap time of 6.5 seconds and insert this value into Equation 11-2.1:

$$\text{ISD} = (1.47)(45)(6.5 + 1.5) = 529 \text{ ft}$$

The 529 ft for the crossing maneuver is less than the 565 ft required for the left-turning vehicle and, therefore, is not the critical maneuver.

### **Example 11-2.09(2)**

Given: Minor road intersects a 4-lane divided highway.  
 Minor road is stop controlled and intersects major road at 90°.  
 Design speed of the major highway is 60 mph.  
 All travel lane widths are 12 ft.  
 The median width is 50 ft.  
 Grade on minor road is 4%.  
 Grade in median is 1%.  
 The design vehicle is a 64-passenger school bus that is 35.8 ft long.

Problem: Determine the intersection sight distance to the left and right from the minor road.

Solution: The following steps apply:

1. For a school bus, assume an SU design vehicle.
2. For the school bus turning right, the ISD to the left can be determined directly from Figure 11-2C. For the 60 mph design speed, the ISD to the left is 840 ft. However, the approach grade is greater than 3%; therefore, increase the 840 ft as discussed in Figure 11-2B. Use Equation 11-2.1 and Figure 11-2B:

$$\text{ISD} = (1.47)(60)(9.5 + (4 \times 0.1)) = 875 \text{ ft}$$

3. Determine if the crossing maneuver is critical; see Section 11-2.03.03. Also, because the approach is greater than 3%, the value must be increased as discussed in Figure 11-2F. Using Equation 11-2.1 and Figure 11-2F:

$$\text{ISD} = (1.47)(60)(8.5 + (4 \times 0.1)) = 785 \text{ ft}$$

The crossing maneuver ISD is less than the right-turning maneuver and, therefore, is not critical.

4. For the school bus turning left, it can be assumed the school bus can safely stop in the median (i.e., 50 ft minus 35.8 ft). The ISD to the right can be determined directly from Figure 11.2C. For the 60 mph design speed, the ISD to the right for the left turn is 840 ft. The crossing maneuver will not be critical.

### **Example 11-2.09(3)**

Given: Minor road intersects a 4-lane divided highway.  
 Minor road is stop controlled and intersects major road at 90°.  
 Design speed of the major highway is 50 mph.  
 All travel lane widths are 12 ft.  
 Existing median width is 24 ft.  
 Trucks are not a concern.  
 The design vehicle is a passenger car that is 19 ft long.

Problem: Determine the intersection design and sight distance for a vehicle turning left from the major road.

Solution:

The median is too narrow to store the turning vehicle. Therefore, the turning movement must be made in one motion. For the passenger car turning left, the ISD must reflect the additional time required to cross the median and additional lanes; see Section 11-2.06. The following will apply:

1. First, determine the extra width required by the one additional travel lane and the median and divide this number by 12 ft:

$$\frac{(12 + 24)}{12} = 3 \text{ lanes}$$

2. Next, multiply the number of lanes by 0.5 second to determine the additional time required:

$$(3 \text{ lanes})(0.5 \text{ sec/lane}) = 1.5 \text{ seconds}$$

3. Add the additional time to the basic gap time of 5.5 seconds and insert this value into Equation 11-2.1:

$$\text{ISD} = (1.47)(50)(5.5 + 1.5) = 515 \text{ ft}$$

Provide an ISD of 515 ft for the left-turning vehicle.





### **11-3.0 TURNING RADII (RIGHT TURNS)**

#### **11-3.01 Types of Treatment**

At intersections, the designer must decide how best to accommodate right-turning vehicles. A design must be selected for the edge of pavement or curb lines, which may be one of the following types:

1. simple radius,
2. simple radius with entering and exiting tapers,
3. 3-centered symmetric compound curve, or
4. 3-centered asymmetric compound curve.

Each basic design type has its advantages and disadvantages. The simple radius is the easiest to design and construct and, therefore, it is the most common. However, the designer should also consider the benefits of the simple radius with an entering and exiting taper. Its advantages as compared to other designs include:

1. The simple radius with tapers provides approximately the same transitional benefits as the compound curvature arrangements, but it is easier to design, survey and construct.
2. To accommodate a specific vehicle with no encroachment, a simple radius requires greater intersection pavement area than a radius with tapers. For large vehicles, a simple radius is often an unreasonable design, unless a channelized island is used.
3. A simple radius results in greater distances for pedestrians to cross than a radius with tapers.
4. For angles of turn greater than 90°, a radius with tapers is a better design than a simple radius, primarily because less intersection area is required.

#### **11-3.02 Design Vehicle Selection**

In general, the selected design vehicle should be the largest vehicle likely to make the turn with some frequency; however, there are also advantages at some locations to minimizing the size of the intersection. Therefore, the appropriate design vehicle may vary from intersection to intersection, and the selection will involve an assessment of the number and types of vehicles that will make the turn, accident history, pedestrian volume, etc. Figure 11-3A presents suggested criteria that the designer should use as a starting point.

The WB-67 design vehicle (large truck) is allowed on the National Truck Network (the Interstate highway system and other freeways in Connecticut except the Merritt Parkway). Large trucks must have reasonable access to truck facilities for a distance of 1 mi from the Network route. Therefore, large trucks may be allowed to make right turns at some at-grade intersections, and the designer should consider this possibility. The designer should exercise judgment when deciding which intersections should be designed according to the turning characteristics of the

large truck. Some intersections (e.g., those near truck stops) are obvious candidates. The designer should also consider whether or not an intersection might in the future need to accommodate the large truck. Individuals or entities may apply for access permits for greater distances through the Commissioner of CONNDOT by applying to the Motor Transport Services Division in the Bureau of Public Transportation. Finally, the designer should consider that even longer trucks than the WB-67 vehicle may today or in the future be negotiating the intersection. Where a significant number of these are expected, the designer should take this into consideration.

In many locations, there is a conflict between the need to accommodate trucks and a public desire to reduce the size of intersections. It may occasionally be appropriate to use a lesser design vehicle; however, the designer is responsible for ensuring that vehicles have appropriate access.

For Turn Made From	For Turn Made Onto	Minimum Suggested Design Vehicle	Turning Radii (ft)
Freeway Ramp	All	WB-62 WB-67 <sup>4</sup>	60
Arterial	Arterial Collector Local	WB-62	60
Collector	Arterial Collector Local	SU	60
Local	Arterial Collector Local	SU	45

*Notes:*

1. *The criteria apply to both urban and rural intersections.*
2. *See Section 11-3.02 for a discussion of the selection of a WB-67 truck for intersection design.*
3. *Radii are minimum for the outer wheel of the turning vehicle or tractor cab.*
4. *WB-67 must be physically able to make the turn.*

**DESIGN VEHICLE SELECTION**  
**Figure 11-3A**

### **11-3.03     Designs for Pavement Edge/Curb Line**

Once the designer has selected the design vehicle (Figure 11-3A) and the type of right-turn treatment (e.g., simple radius), he/she must now determine the appropriate design for the pavement edge or curb line. Figure 11-3B presents recommended criteria. The designer should consider that there are certain assumptions built into these numbers. The following presents the major assumptions:

1.     Encroachment. The criteria in Figure 11-3B will allow the indicated vehicle to make the turn entirely within its lane of travel; i.e., no encroachment into adjacent lanes will occur.
2.     Speed. The criteria in Figure 11-3B have been developed assuming a turning speed of less than 10 mph.
3.     Inside Clearance. The criterion in the table assumes that a 2-ft clearance is maintained throughout most of the turn and that the clearance is never less than 1 ft.
4.     Parking Lanes/Shoulders. The criteria in the table assume that no parking lanes or shoulders are available which would, of course, allow the vehicle additional space on the inside to make the turn.

Because of these assumptions, the criteria in Figure 11-3B should serve as a starting point to determine the design for the pavement edge or curb line. To determine the final design, the designer must use a turning template for the selected design vehicle. The turning template should be used to check both right and left turns to ensure that the design vehicle has adequate receiving width in both directions. The designer should also consider the discussion in the following sections.

#### **11-3.03.01     Tolerable Encroachment**

To determine the tolerable encroachment, the designer should evaluate several factors, including traffic volumes, one-way or two-way operation and the functional classes of the intersecting roads or streets. Figure 11-3C presents recommended criteria for tolerable encroachment for right-turning vehicles. The designer must evaluate these criteria against the construction and right-of-way impacts for meeting the encroachment recommendations. For example, if these impacts are significant and if through and/or turning volumes are relatively low, the designer may decide to accept encroachment for the design vehicle which exceeds the criteria in Figure 11-3C. Considering local conditions, the width of local side road at the back of the curb return should be 30 ft.

Angle of Turn	Design Vehicle	Simple Curve Radius (ft)	Simple Curve Radius With Taper			3-Centered Compound Curve Symmetric		3-Centered Compound Curve Asymmetric	
			Radius (ft)	Offset (ft)	Taper	Radii (ft)	Offset (ft)	Radii (ft)	Offset
30	P	60							
	SU	100							
	WB-40	150							
	WB-50	200							
	WB-62	360	220	3.0	15:1				
45	P	50							
	SU	75							
	WB-40	120							
	WB-50	175	120	2.0	15:1	200-100-200	3.0		
	WB-62	230	145	4.0	15:1	460-240-460	2.0	120-140-500	3.0-8.5
60	P	40							
	SU	60							
	WB-40	90							
	WB-50	150	120	3.0	15:1	200-75-200	5.5	200-75-275	2.0-7.0
	WB-62	170	140	4.0	15:1	400-100-400	15.0	110-100-200	10.0-12.5
75	P	35	25	2.0	10:1	100-75-100	2.0		
	SU	55	45	2.0	10:1	120-45-120	2.0		
	WB-40		60	2.0	15:1	120-45-120	5.0	120-45-195	2.0-6.5
	WB-50		65	3.0	15:1	150-50-150	6.5	150-50-225	2.0-10.0
	WB-62		145	4.0	20:1	440-75-440	15.0	140-100-540	5.0-12.0
90	P	30	20	2.5	10:1	100-20-100	2.5		
	SU	50	40	2.0	10:1	120-40-120	2.0		
	WB-40		45	4.0	10:1	120-40-120	5.0	120-40-200	2.0-6.5
	WB-50		60	4.0	15:1	180-60-180	6.5	120-40-200	2.0-10.0
	WB-62		120	4.5	30:1	400-70-400	10.0	160-70-360	6.0-10.0
105	P		20	2.5		100-20-100	2.5		
	SU		35	3.0		100-35-100	3.0		
	WB-40		40	4.0		100-35-100	5.0	100-55-200	2.0-8.0
	WB-50		55	4.0	15:1	180-45-180	8.0	150-40-210	2.0-10.0
	WB-62		115	3.0	15:1	520-50-520	15.0	360-75-600	4.0-10.5
120	P		20	2.0		100-20-100	2.0		
	SU		30	3.0		100-30-100	3.0		
	WB-40		35	5.0		120-30-120	6.0	100-30-180	2.0-9.0
	WB-50		45	4.0	15:1	180-40-180	8.5	150-35-220	2.0-12.0
	WB-62		100	5.0	15:1	520-70-520	10.0	80-55-520	24.0-17.0
135	P		20	1.5	10:1	100-20-100	1.5		
	SU		30	4.0	10:1	100-30-100	4.0		
	WB-40		30	8.0	15:1	120-30-120	6.5	100-25-180	3.0-13.0
	WB-50		40	6.0	15:1	160-35-160	9.0	130-30-185	3.0-14.0
	WB-62		80	5.0	20:1	600-60-600	12.0	100-60-640	14.0-7.0
150	P		18	2.0	10:1	75-20-75	2.0		
	SU		30	4.0	8:1	100-30-100	4.0		
	WB-40		30	6.0	8:1	100-30-100	6.0	90-25-160	1.0-12.0
	WB-50		35	7.0	6:1	160-35-160	7.0	120-30-180	3.0-14.0
	WB-62		60	10.0	10:1	480-55-480	15.0	140-60-560	8.0-10.0
180	P		15	0.5	20:1	50-15-50	0.5		
	SU		30	1.5	10:1	100-30-100	1.5		
	WB-40		20	9.5	5:1	100-20-100	9.5	85-20-150	6.0-13.0
	WB-50		25	9.5	5:1	130-25-130	9.5	100-25-180	6.0-13.0
	WB-62		55	10.0	15:1	800-45-800	20.0	100-55-900	15.0-15.0

Note: Many assumptions have been made in the development of these criteria. See Section 11-3.03 for a discussion.

**EDGE OF PAVEMENT DESIGNS FOR TURNS AT INTERSECTIONS**  
**Figure 11-3B**

Type of Traffic Control	For Turn Made From	For Turn Made Onto	Tolerable Encroachment for Selected Design Vehicle	
			For Road/Street From Which Turn Made	For Road/Street Onto Which Turn Made
Stop-Controlled	Stop-Controlled Road/Street	Through Road/Street	No encroachment into adjacent lanes	No encroachment beyond outermost or right travel lane
	Through Road/Street	Stop-Controlled Road/Street	No encroachment into adjacent lanes	No encroachment into opposing lanes of travel
Signalized	Either Road/Street	Either Road/Street	No encroachment into adjacent lanes	No encroachment into opposing lanes of travel

- Notes:
1. See Figure 11-3A for design vehicle selection.
  2. For all conditions, the design vehicle is assumed to be in the outermost through travel lane or exclusive right-turn lane, whichever applies, before the turn made.
  3. The table indicates those conditions where the turning vehicle cannot encroach into the opposing lanes of travel. In addition, for roads/streets with two or more through travel lanes, consider providing a design so that the turning vehicle does not encroach beyond the outermost or right travel lane.
  4. For the indicated tolerable encroachment (e.g., none into adjacent lanes), the design vehicle should not come closer than 9 in to the lane at any point in the turn.
  5. Regardless of the selected design vehicle or the criteria for encroachment, a WB-50 should physically be able to make all turns at all intersections without backing up and without impacting curbs, parked cars, utility poles, mailboxes or any other obstruction.

### RECOMMENDED TOLERABLE ENCROACHMENTS FOR RIGHT-TURNING VEHICLES

Figure 11-3C

### **11-3.03.02 Inside Clearance**

The following will apply to the assumed inside clearance of the turning vehicle:

1. Maximum. The selected design vehicle will make the right turn while maintaining approximately a 2-ft clearance from the pavement edge or curb line and will not come closer than 9 in.
2. Minimum. At restricted sites, it may be necessary to assume a less generous clearance. At a minimum, the selected design vehicle may be allowed to make the right turn so that its wheels will almost touch the pavement edge or curb line. This means that the vehicle will overhang beyond the edge. Therefore, the designer must ensure that the turning vehicle will not impact any obstructions (e.g., signal poles, mailboxes, signs).

### **11-3.03.03 Parking Lanes/Shoulders**

At many intersections, parking lanes and/or shoulders will be available on one or more approach legs, and this additional roadway width may be carried through the intersection. This will greatly decrease the turning problems for large vehicles at intersections with small curb radii. Figure 11-3D illustrates the turning paths of several design vehicles with curb radii of 15 ft or 25 ft and where 8-ft to 10-ft parking lanes are provided. The presence of a shoulder 8 ft to 10 ft in width will have the same impact as a parking lane. The figure also illustrates the necessary distance to restrict parking before the P.C. (15 ft) and after the P.T. (20 to 40 ft) on the cross street. The designer will, of course, need to check the proposed design with the applicable turning template and encroachment criteria. The designer should not consider the beneficial effects of a parking lane if the lane will be used for through traffic part of the day or if parking will likely be prohibited in the future.

### **11-3.03.04 Pedestrians**

The greater the turning radius or the number of lanes, the farther pedestrians must walk in the roadway. This is especially important to disabled individuals. Therefore, the designer should consider this when determining the edge of pavement or curb line design. This may lead to, for example, the decision to use a turning roadway (see Section 11-4.0) to provide a pedestrian refuge. In addition, where the pedestrian must cross more than four lanes, the designer should evaluate the accommodation of pedestrian traffic.

### **11-3.03.05 Summary**

In summary, the designer should determine the proper design for the edge of pavement or curb line to accommodate right-turning vehicles as follows:

1. Select the type of turning treatment:

- a. simple radius,
- b. simple radius with entering and exiting tapers,
- c. 3-centered symmetric compound curve, or
- d. 3-centered asymmetric compound curve.

Use Figure 11-3B as a starting point.

2. Select the design vehicle (Figure 11-3A).
3. Determine the tolerable encroachment (Figure 11-3C).
4. Determine the appropriate inside clearance (Section 11-3.03.02).
5. Consider the benefits of any parking lanes or shoulders (Section 11-3.03.03).
6. Consider impacts on pedestrians (Section 11-3.03.04).
7. Check all proposed designs with the applicable vehicular turning template.
8. Revise design as necessary to accommodate the right-turning vehicle or determine that this is not practical because of adverse impacts.

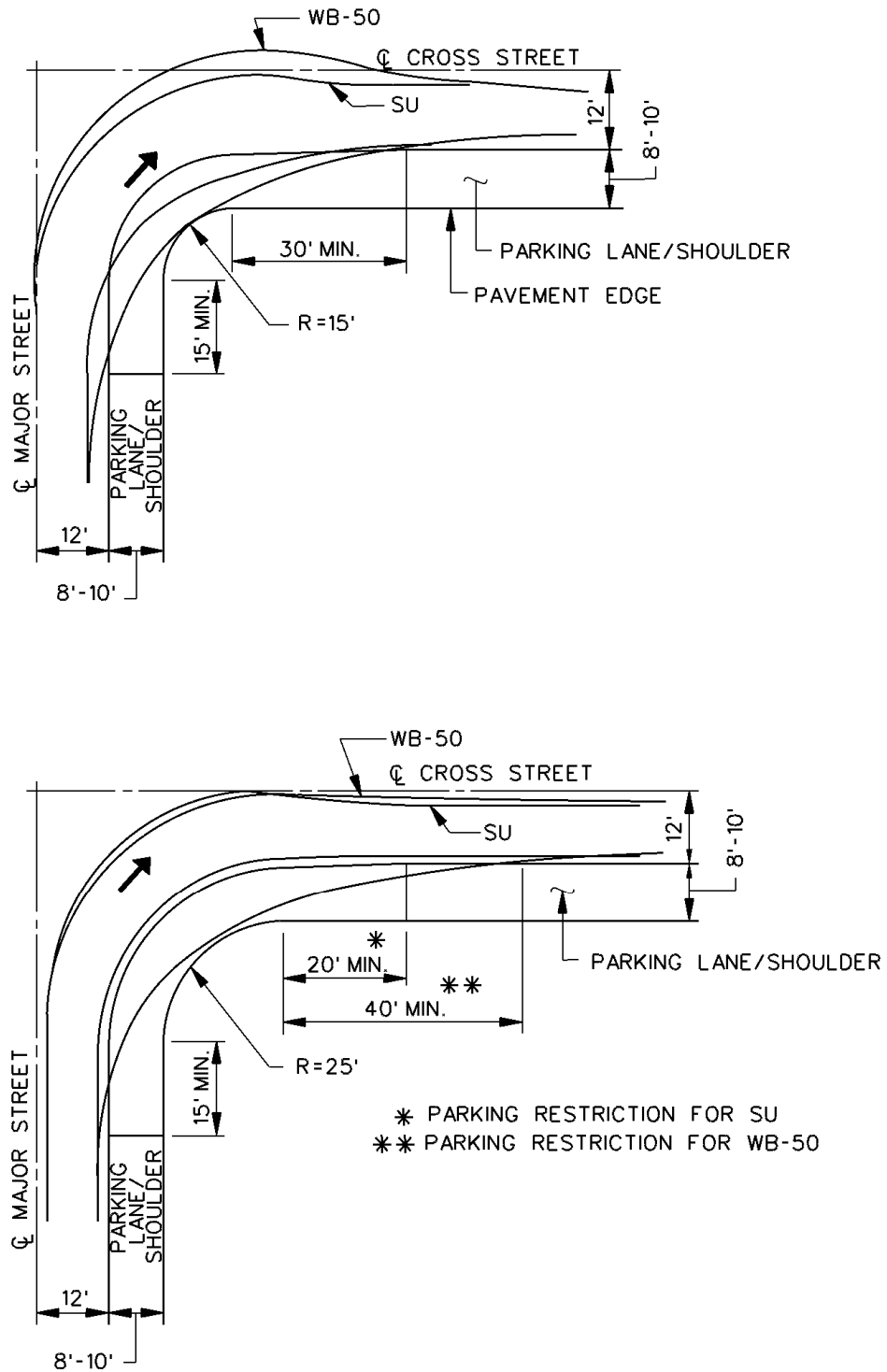

**EFFECT OF CURB RADII AND PARKING ON TURNING PATHS**  
**Figure 11-3D**



## 11-4.0 TURNING ROADWAYS

Turning roadways are channelized areas (painted or raised) at intersections at-grade.

### 11-4.01 Guidelines

The need for a turning roadway will be determined on a case-by-case basis. The designer should consider using turning roadways when:

1. there is a need to allow right turns at 15 mph or more on, for example, rural or urban arterials;
2. The angle of turn will be greater than 90°;
3. the volume of right turns is especially high;
4. there is significant amount of unused pavement; and/or
5. the selected design vehicle is a semi-trailer combination.

### 11-4.02 Design Criteria

Figure 11-4A illustrates a typical design for a turning roadway at an urban intersection. The following sections provide additional guidance on the design of a turning roadway.

#### 11-4.02.01 Design Speed

Where practical, the design speed on a turning roadway should be within 20 mph of the mainline design speed. However, a turning roadway even at a low design speed (e.g., 15 mph) will still provide a significant benefit to the turning vehicle regardless of the speed on the approaching highway. Typically, the design speed for a turning roadway will be in the range of 15-20 mph. For 3-centered compound curves, this criterion applies to the design speed of the sharpest curve.

#### 11-4.02.02 Horizontal Alignment

The horizontal alignment of turning roadway design differs from that of open-roadway conditions, which are discussed in Chapter Eight. The following discusses several of the assumptions used to design horizontal alignment for turning roadways:

1. Curvature Arrangement. For many turning roadway designs, a 3-centered compound curve is the preferred curvature arrangement.

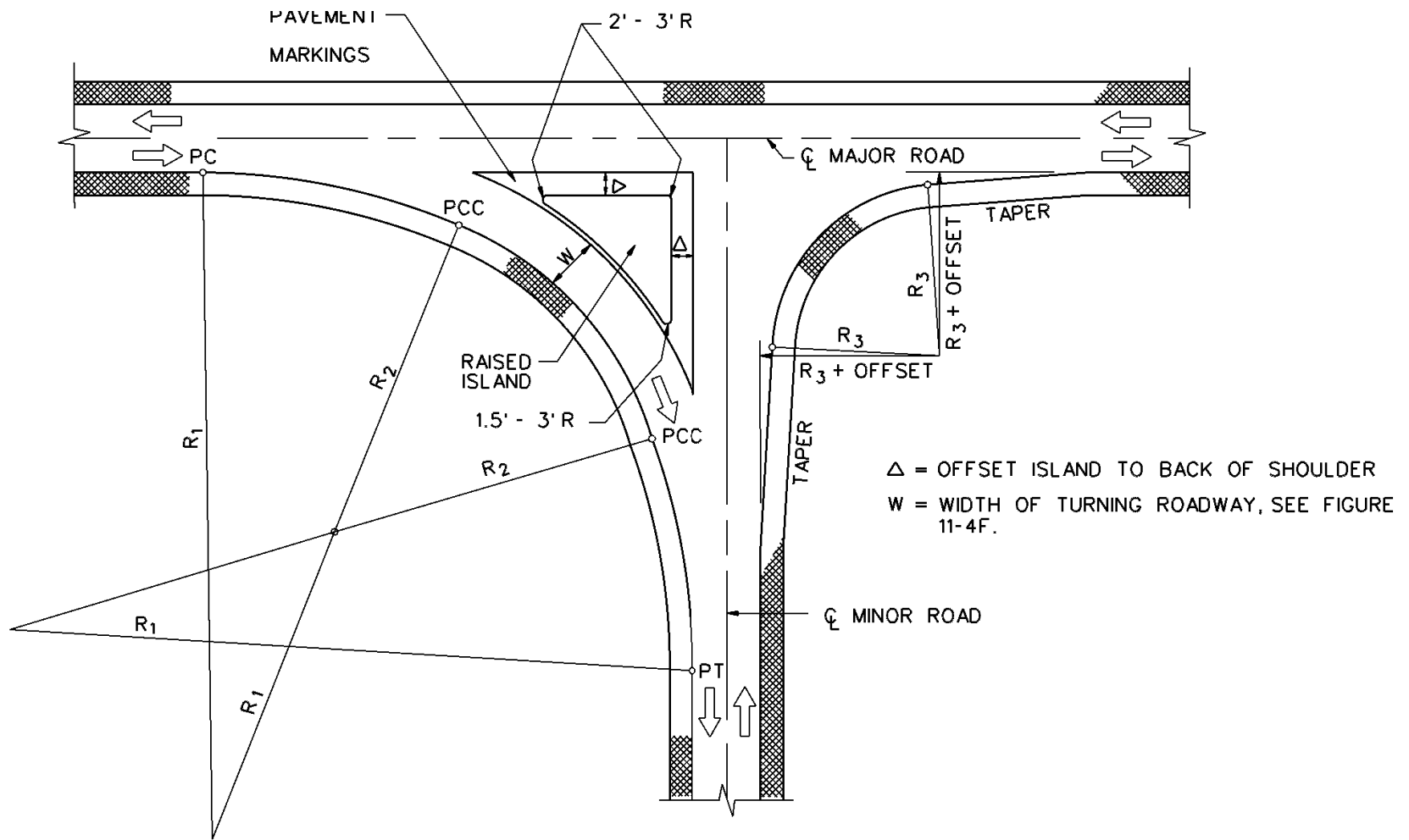

EXAMPLE DESIGN FOR TURNING ROADWAY

Figure 11-4A

2. **Superelevation.** Turning roadways are often relatively short in length. This greatly increases the difficulty of superelevating the roadway. Therefore, a flexible approach is used for superelevating turning roadways. Figure 11-4B provides a range of superelevation rates that the designer may select for various combinations of curve radii and design speeds. For many turning roadways with low design speeds (e.g., 15 - 20 mph), the superelevation rate will typically be 2%. The maximum superelevation rate for turning roadways should not exceed 6%. Selection of the appropriate superelevation rate will be based on field conditions and will be determined on a site-by-site basis.

Radius (ft)	Range in Superelevation Rate for Turning Roadways with Design Speed (mph) of					
	15	20	25	30	40	45
50	2%-6%	—	—	—	—	—
90	2%-6%	2%-6%	—	—	—	—
150	2%-5%	2%-6%	4%-6%	—	—	—
230	2%-4%	2%-6%	3%-6%	6%	—	—
310	2%-3%	2%-4%	3%-6%	5%-6%	—	—
430	2%-3%	2%-3%	3%-5%	4%-6%	6%	—
600	2%	2%-3%	2%-4%	3%-5%	5%-6%	—
1000	2%	2%-3%	2%-3%	3%-4%	4%-5%	5%-6%
1500	2%	2%	2%	2%-3%	3%-4%	4%-5%

**SUPERELEVATION RATES  
(Turning Roadways)**

**Figure 11-4B**

3. **Superelevation Transitions.** When a turning roadway is superelevated, the transition length should meet the criteria presented in Chapter Eight for the relative longitudinal slope. However, due to the restrictive nature of turning roadways and their typically short lengths, actual transition lengths will be determined on a case-by-case basis. The designer should review the field conditions, deceleration and acceleration taper lengths, right-of-way restrictions and construction costs to produce a practical design for superelevation transition lengths at turning roadways.
4. **Superelevation Development.** Figure 11-4C illustrates a schematic of superelevation development at a turning roadway. The actual development will depend upon the practical field conditions combined with a reasonable consideration of the theory behind horizontal curvature. The following presents criteria that should be met:

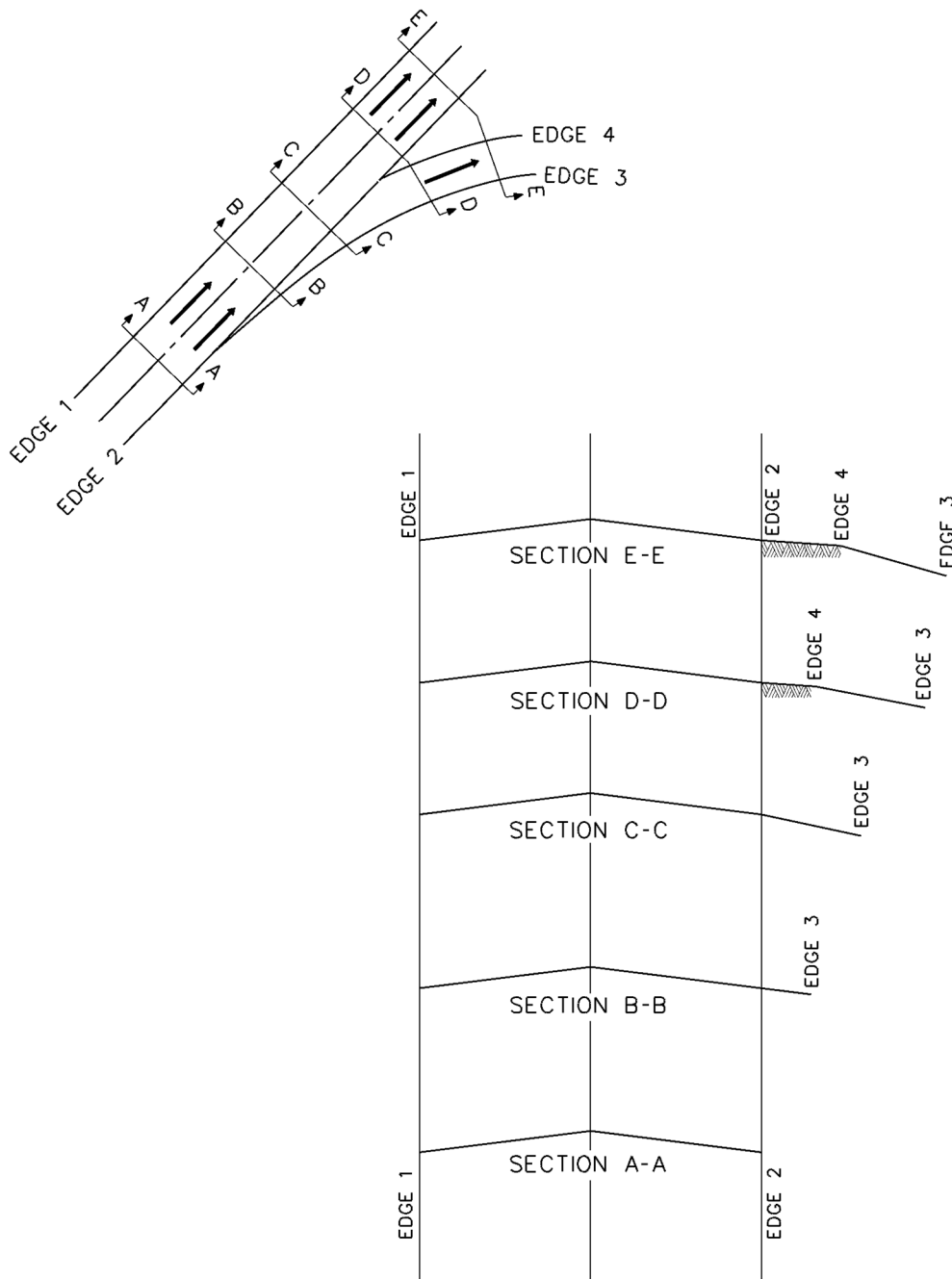

Note: The axis of rotation is first about Edge 2 and then about Edge 4.

**DEVELOPMENT OF SUPERELEVATION AT  
TURNING ROADWAY TERMINALS**

**Figure 11-4C**

- a. No change in the normal cross slope is necessary up to Section B-B. Here, the width of turning roadway is nominally less than 3 ft.
  - b. The full width of the turning roadway should be attained at Section D-D. The amount of superelevation at D-D will depend upon the practical field conditions.
  - c. Beyond Section D-D, the turning roadway pavement should be rotated as needed to provide the required superelevation for the design speed of the turning roadway.
  - d. The minimum superelevation transition length should meet the criteria set forth in Item #3.
  - e. The superelevation treatment for the existing portion of the turning roadway should be similar to that described for the entering portion. However, for stop-control merges the superelevation on the turning roadway should match the cross slope on the merging highway or street.
5. Minimum Radius. The minimum turning roadway radii are based on design speed, side-friction factors and superelevation; see Chapter Eight. Figure 11-4D presents minimum radii for various turning roadway conditions. As discussed in Item #2, a range of superelevation rates may be used. Therefore, Figure 11-4D presents minimum radii for several assumed superelevation rates. In addition, the lengths of the entering and exiting curves should meet the criteria in Note 3 of Figure 11-4D.
6. Cross Slope Rollover. Figure 11-4E presents the maximum allowable algebraic difference in the cross slopes between the mainline and turning roadway where they are adjacent to each other. In Figure 11-4C, these criteria apply between Section A-A and Section D-D. This will likely be a factor only when a superelevated mainline is curving to the left.

#### **11-4.02.03 Width**

Turning roadway widths are dependent upon the turning radii and design vehicle selected. Figure 11-3A provides the criteria for selection of the appropriate design vehicle. Figure 11-4F presents the turning roadway pavement widths for various design vehicles based on 1-lane, one-way operation with no provision for passing a stalled vehicle. This design is generally appropriate for most at-grade intersections. The pavement widths in Figure 11-4F provide an extra 6-ft clearance beyond the design vehicle's swept path. This additional width provides extra room for maneuverability, driver variances and the occasional larger vehicle.

#### **11-4.02.04 Angle of Turn**

Figure 11-4F is applicable to highways that intersect at 90°. Figure 11-4G presents turning roadway criteria for oblique angles of intersection.

Turning Roadway Design Speed (mph)	Maximum Side Friction (f)	Assumed Super-Elevation (e)	Calculated Radius (ft)	Design Radius (ft)
15	0.32	2%	44	45
		4%	42	45
		6%	39	40
20	0.27	2%	92	95
		4%	86	90
		6%	81	85
25	0.23	2%	167	170
		4%	154	155
		6%	144	145
30	0.20	2%	273	275
		4%	250	250
		6%	231	235
35	0.18	2%	408	410
		4%	371	375
		6%	340	340
40	0.16	2%	593	595
		4%	533	535
		6%	485	485

*Notes:*

1. For design speeds greater than 40 mph, use rural conditions. See Chapter Eight.
2. See Figure 11-4B for the recommended range of superelevation rates for a given radius and design speed. The lower values are more appropriate for urban and high-volume areas.
3. A flatter curve, no more than twice the design radius of the sharper curve, should be used to transition into and out of the sharper radius. The length of the flatter transition curve will be:

Radius of Sharper Curve (ft)		100	150	200	250	300	400	500 or more
Length of Flatter Transition Curve	Minimum (ft)	40	50	60	80	100	120	140
	Upper Range (ft)	60	70	90	120	140	180	200

**MINIMUM RADII FOR TURNING ROADWAYS****Figure 11-4D**

Design Speed of Curve at Section D-D* (mph)	Maximum Algebraic Difference in Cross Slope at Crossover Line (%)
15-20	5-8
25-30	5-6
>30	4-5

\* See Figure 11-4C.

**PAVEMENT CROSS SLOPE AT TURNING ROADWAY TERMINALS**  
**Figure 11-4E**

Radius on Inner Edge of Pavement R (ft)	Width of Turning Roadways (ft)			
	P	SU	WB-50	WB-62
50	13	18	32	43
75	13	17	25	29
100	13	16	22	25
150	12	15	19	21
200	12	15	18	20
300	12	15	17	18
400	12	15	17	18
500	12	15	17	18
Tangent	12	14	15	15

*Notes:*

1. *If a vertical curb is used on one side, then a curb offset of 1 ft should be added to the table value.*
2. *If a vertical curb is used on both sides, then a curb offset of 2 ft (1 ft on each side) should be added to the table value.*

**PAVEMENT WIDTHS FOR TURNING ROADWAYS**

**Figure 11-4F**

Angle of Turn (degrees)	Design Classification	Three-Centered Compound Curves		Width of Lane (ft)	Approx. Island Size (ft <sup>2</sup> )
		Radii (ft)	Offset (ft)		
75	A	150-75-150	3.5	14	60
	B	150-75-150	5.0	18	50
	C	180-90-180	3.5	20	50
90	A	150-50-150	3.0	14	50
	B	150-50-150	5.0	18	80
	C	180-65-180	6.0	20	125
105	A	120-40-120	2.0	15	70
	B	100-35-100	5.0	22	50
	C	180-45-180	8.0	30	60
120	A	100-30-100	2.5	16	120
	B	100-30-100	5.0	24	90
	C	180-40-180	8.5	34	220
135	A	100-30-100	2.5	16	460
	B	100-30-100	5.0	26	370
	C	160-35-160	9.0	35	640
150	A	100-30-100	2.5	16	1400
	B	100-30-100	6.0	30	1170
	C	160-35-160	7.1	38	1720

**Notes:**

1. *Asymmetric three-centered compound curves and straight tapers with a simple curve can also be used without significantly altering the width of roadway or corner island size.*
2. *Painted island delineation is recommended for islands less than 75 ft<sup>2</sup> in size.*
3. *Design classification:*
  - A — *Primarily passenger vehicles; permits occasional single-unit truck to turn with restricted clearances.*
  - B — *Provides adequately for SU; permits occasional WB-50 to turn with slight encroachment on adjacent traffic lanes.*
  - C — *Provides fully for WB-50.*

**TURNING ROADWAY DESIGN****Figure 11-4G**



**11-4.02.05 Acceleration/Deceleration Lanes**

As discussed in Section 11-4.02.01, the design speed on the turning roadway should be within 20 mph of the mainline design speed. Where this is not practical, the designer should consider using a deceleration lane. They are especially beneficial where mainline and turning volumes are high; at these intersections, the deceleration lane may also be needed for storage. An acceleration lane for the exiting portion of the turning roadway may also be justified. However, it may not be used to good advantage if the turning roadway will be stop controlled. Acceleration and deceleration lanes should be considered at intersections that include turning roadways for arterials with a design speed of 50 mph or more. See Section 11-5.0 for the design details of the auxiliary lanes.



## **11-5.0 AUXILIARY TURNING LANES**

This section presents criteria for the design and guidelines for auxiliary lanes at intersections. In particular the designer should consider that deceleration lanes are advantageous, especially on high-speed highways. A driver leaving the highway has no choice but to slow down in the through travel lane if a deceleration lane is not provided.

### **11-5.01 Guidelines for Right-Turn Lanes**

In general, exclusive right-turn lanes should be provided for at-grade intersections as follows:

1. at any unsignalized intersection on a 2-lane urban or rural highway which satisfies the criteria in Figure 11-5A;
2. at any intersection where a capacity analysis determines a right-turn lane is necessary to meet the level-of-service criteria; or
3. at any intersection where the crash experience, existing traffic operations, sight distance restriction or engineering judgment indicates a significant problem related to right-turning vehicles.

### **11-5.02 Guidelines for Left-Turn Lanes**

In general, exclusive left-turn lanes should be provided for at-grade intersections as follows:

1. on all divided urban and rural highways with a median wide enough to allow a left-turn lane (this applies to intersections with public roads and to major traffic generators);
2. for all approaches at arterial/arterial intersection;
3. at any unsignalized intersection on a 2-lane urban or rural highway which satisfies the criteria in Figures 11-5B, 11-5C, 11-5D, 11-5E or 11-5F;
4. at any intersection where a capacity analysis determines a left-turn lane is necessary to meet the level-of-service criteria;
5. at any intersection included or expected to be within an interconnected signal system where the presence of standing left-turning vehicles would disrupt the progression of platooned traffic; or
6. at any intersection where the crash experience, traffic operations, sight distance restrictions or engineering judgment indicates a significant problem related to left-turning vehicles.

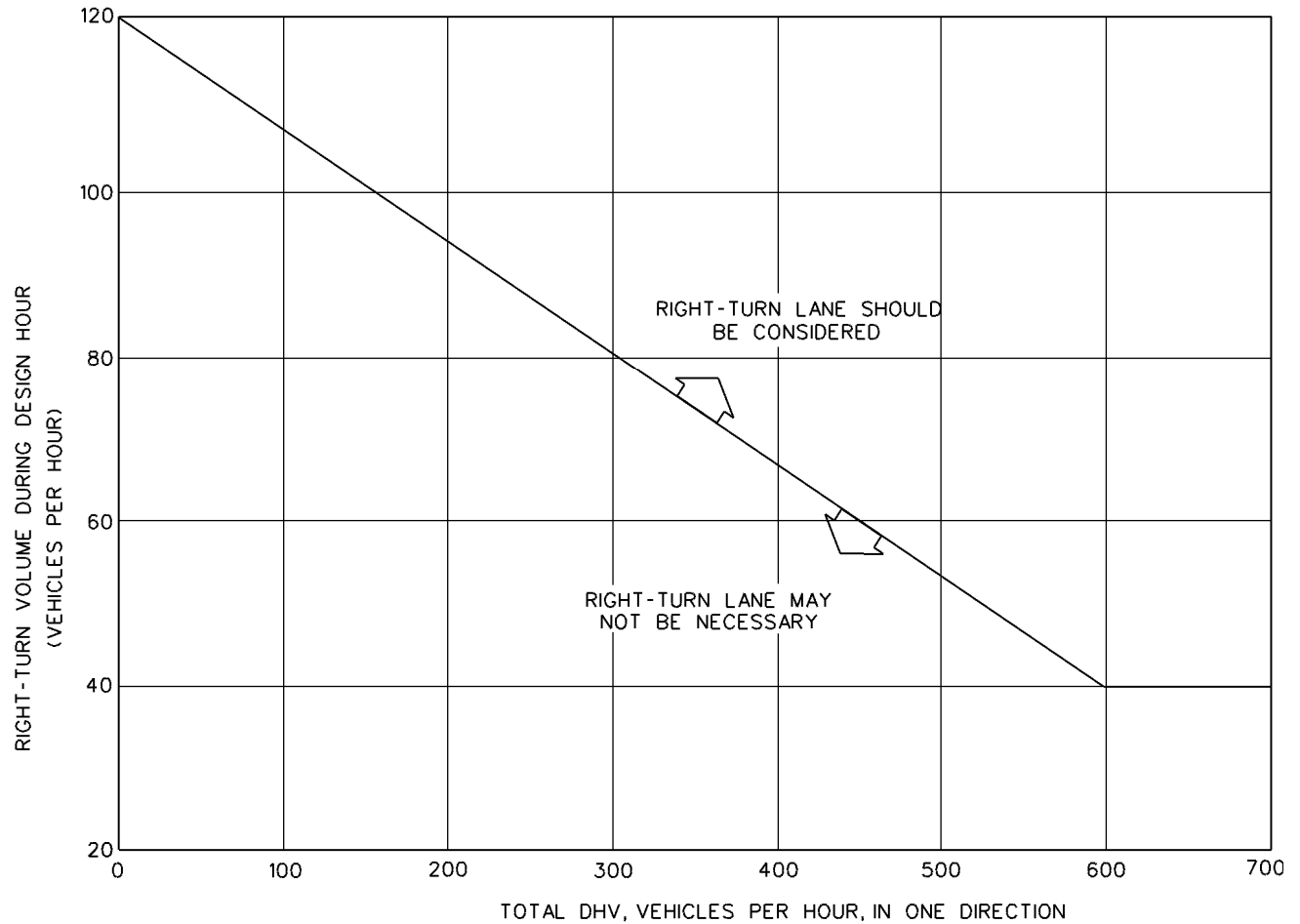

Note: For highways with a design speed below 50 mph *and* DHV < 300 *and* Right Turns > 40, an adjustment should be used. To read the vertical axis of the chart, subtract 20 from the actual number of right turns.

Example:

Given: Design Speed = 40 mph  
 DHV = 250 VPH  
 Right Turns = 100 VPH

Problem: Determine if a right-turn lane is warranted.

Solution: To read the vertical axis, use  $100 - 20 = 80$  VPH. The figure indicates that a right-turn lane is not warranted, unless other factors (e.g., high-rash rate) indicate a lane is needed.

**GUIDELINES FOR RIGHT-TURN LANES  
 AT UNSIGNALIZED INTERSECTIONS ON 2-LANE HIGHWAYS  
 Figure 11-5A**

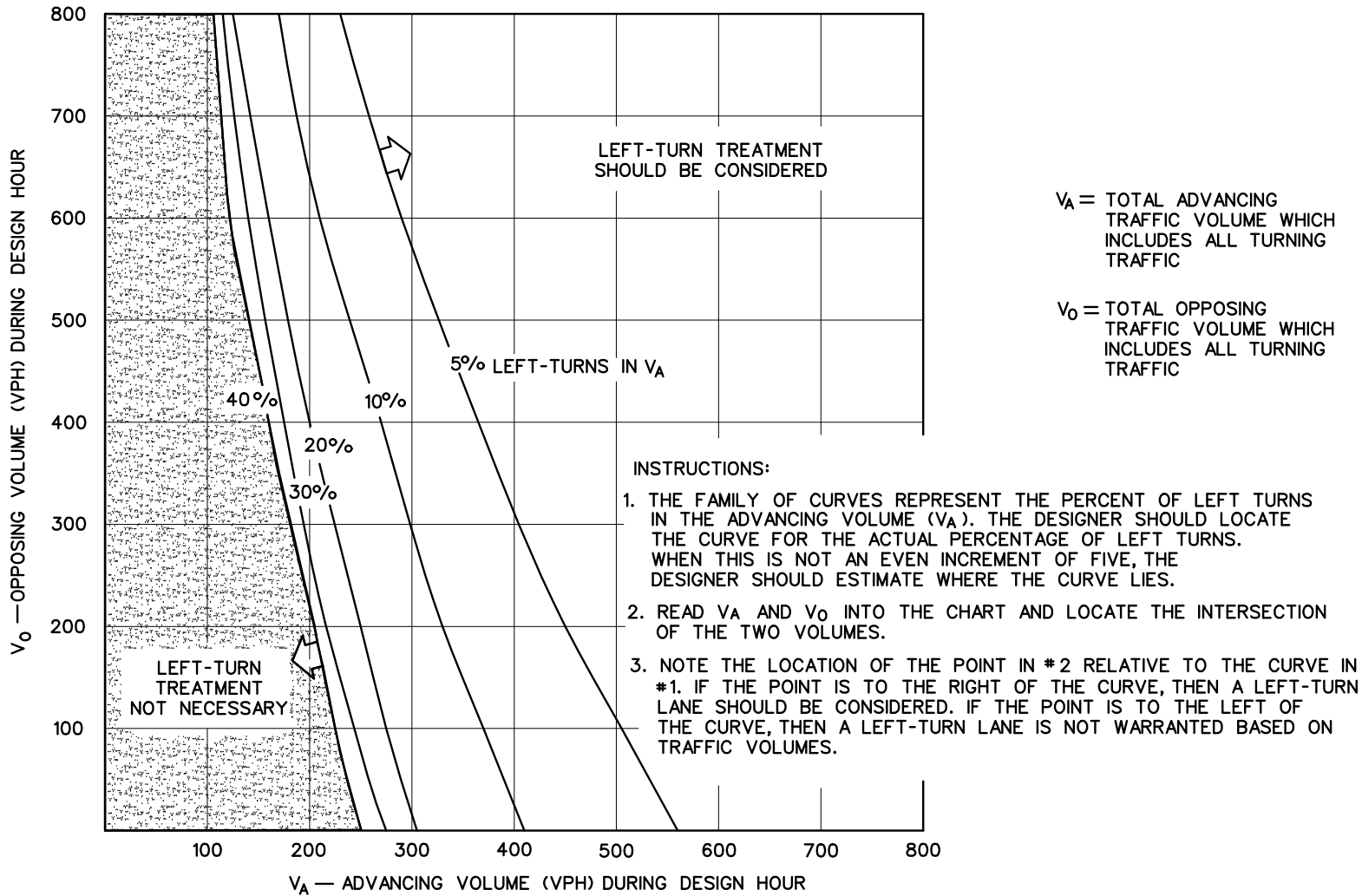

**VOLUME GUIDELINES FOR LEFT-TURN LANES AT UNSIGNALIZED INTERSECTIONS ON 2-LANE HIGHWAYS (60 mph)**

**Figure 11-5B**

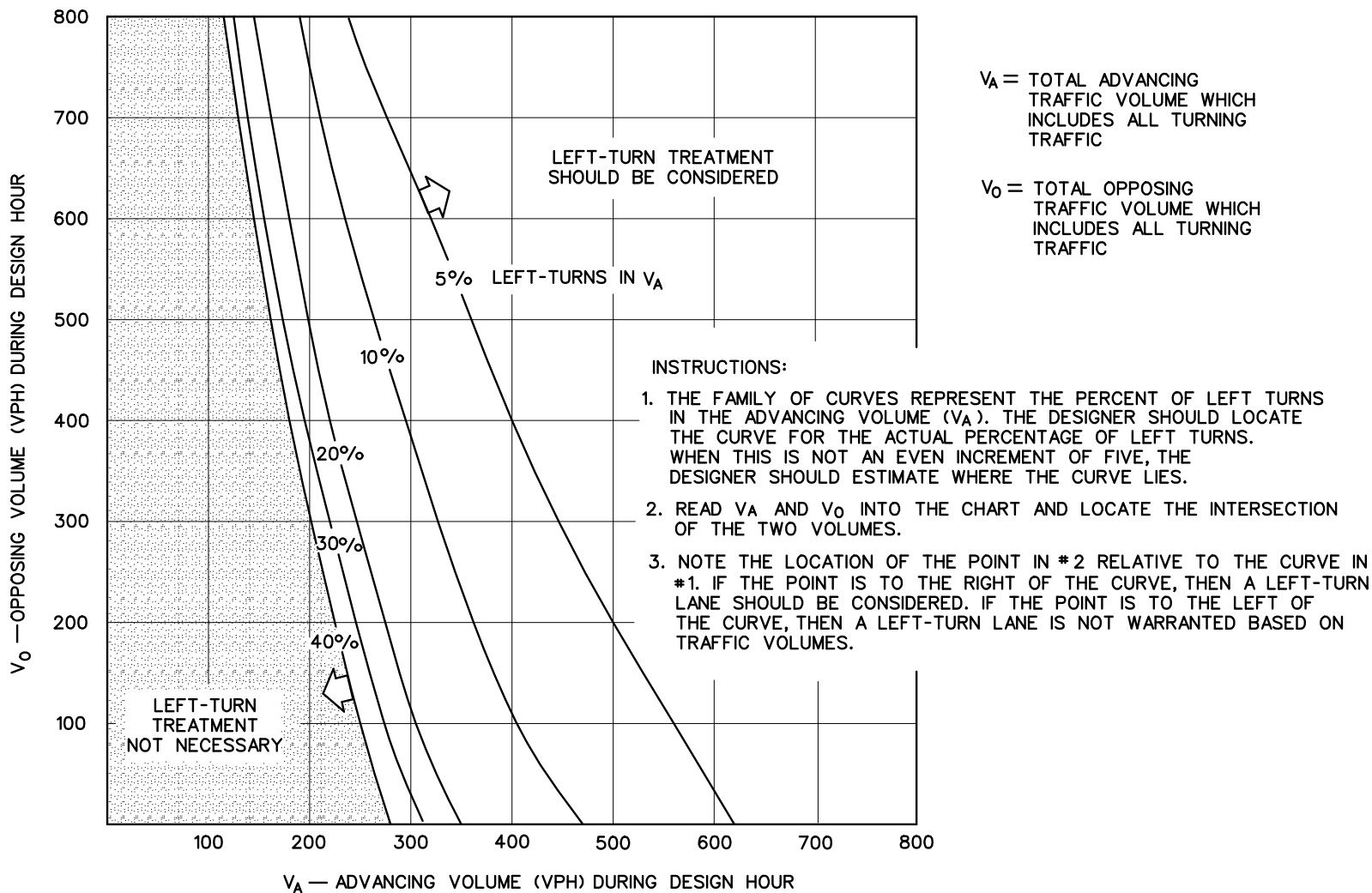

**VOLUME GUIDELINES FOR LEFT-TURN LANES AT UNSIGNALIZED INTERSECTIONS ON 2-LANE HIGHWAYS (55 mph)**

**Figure 11-5C**

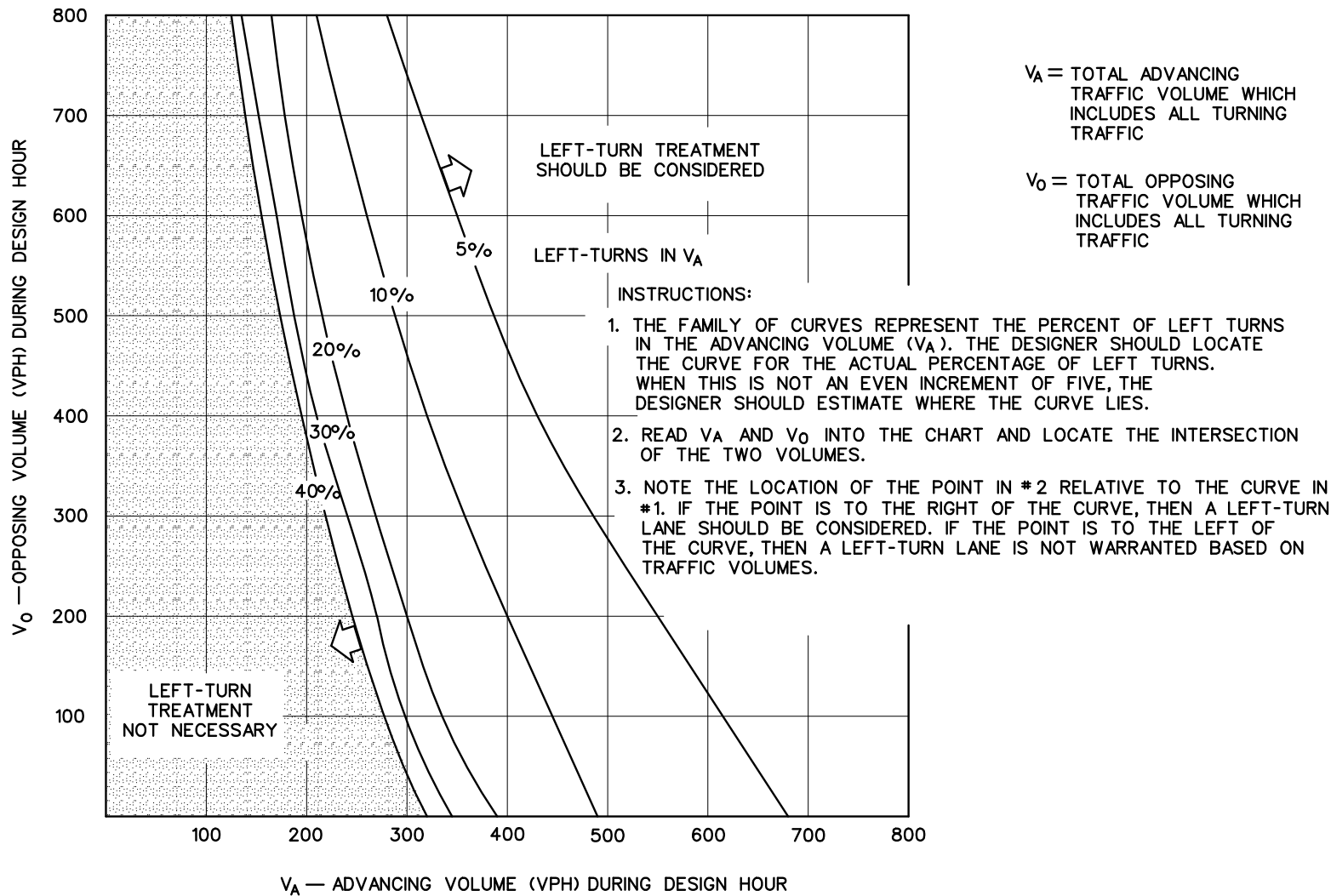

VOLUME GUIDELINES FOR LEFT-TURN LANES AT UNSIGNALIZED INTERSECTIONS ON 2-LANE HIGHWAYS (50 mph)

Figure 11-5D

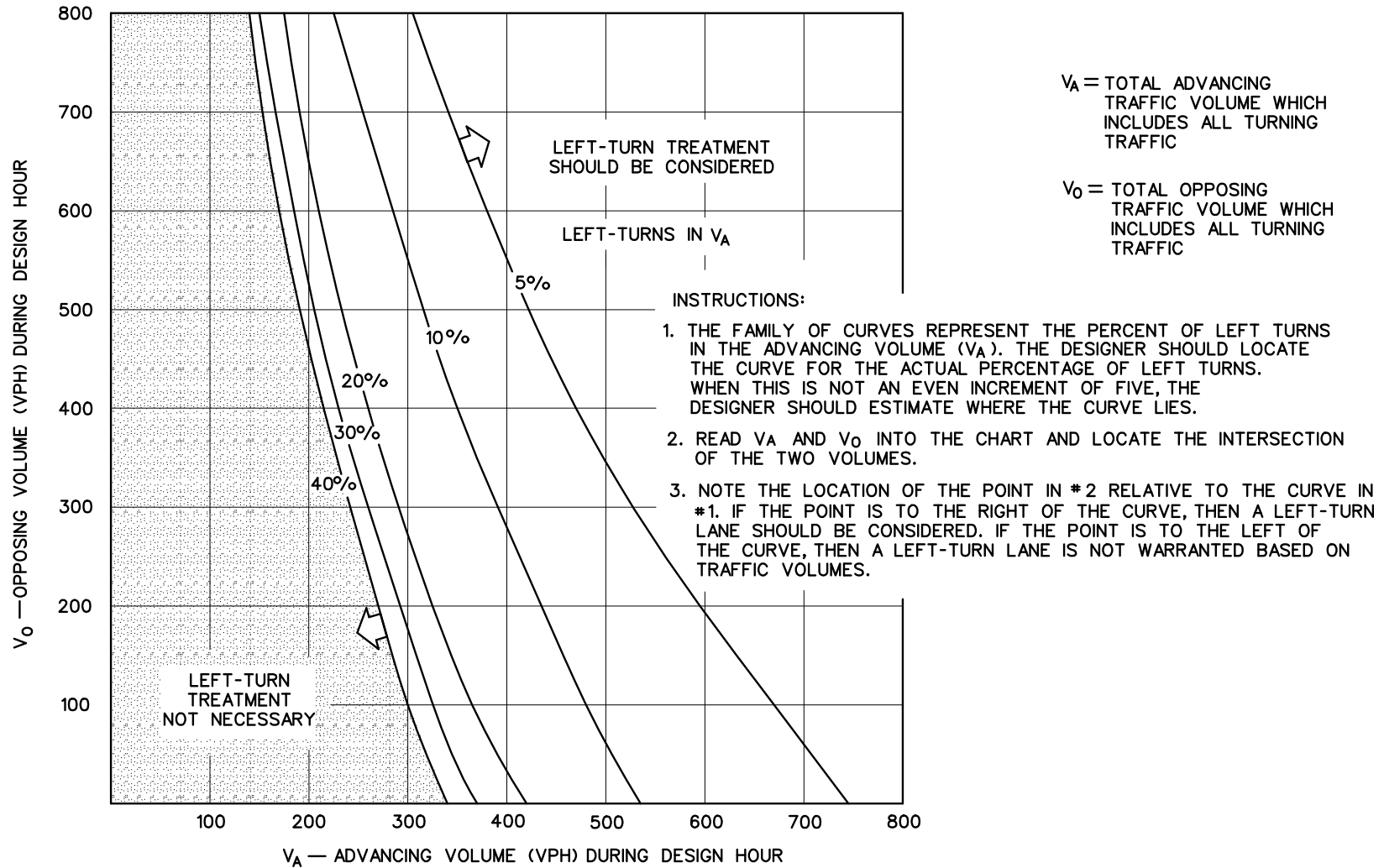

**VOLUME GUIDELINES FOR LEFT-TURN LANES AT UNSIGNALIZED INTERSECTIONS ON 2-LANE HIGHWAYS (45 mph)**

Figure 11-5E



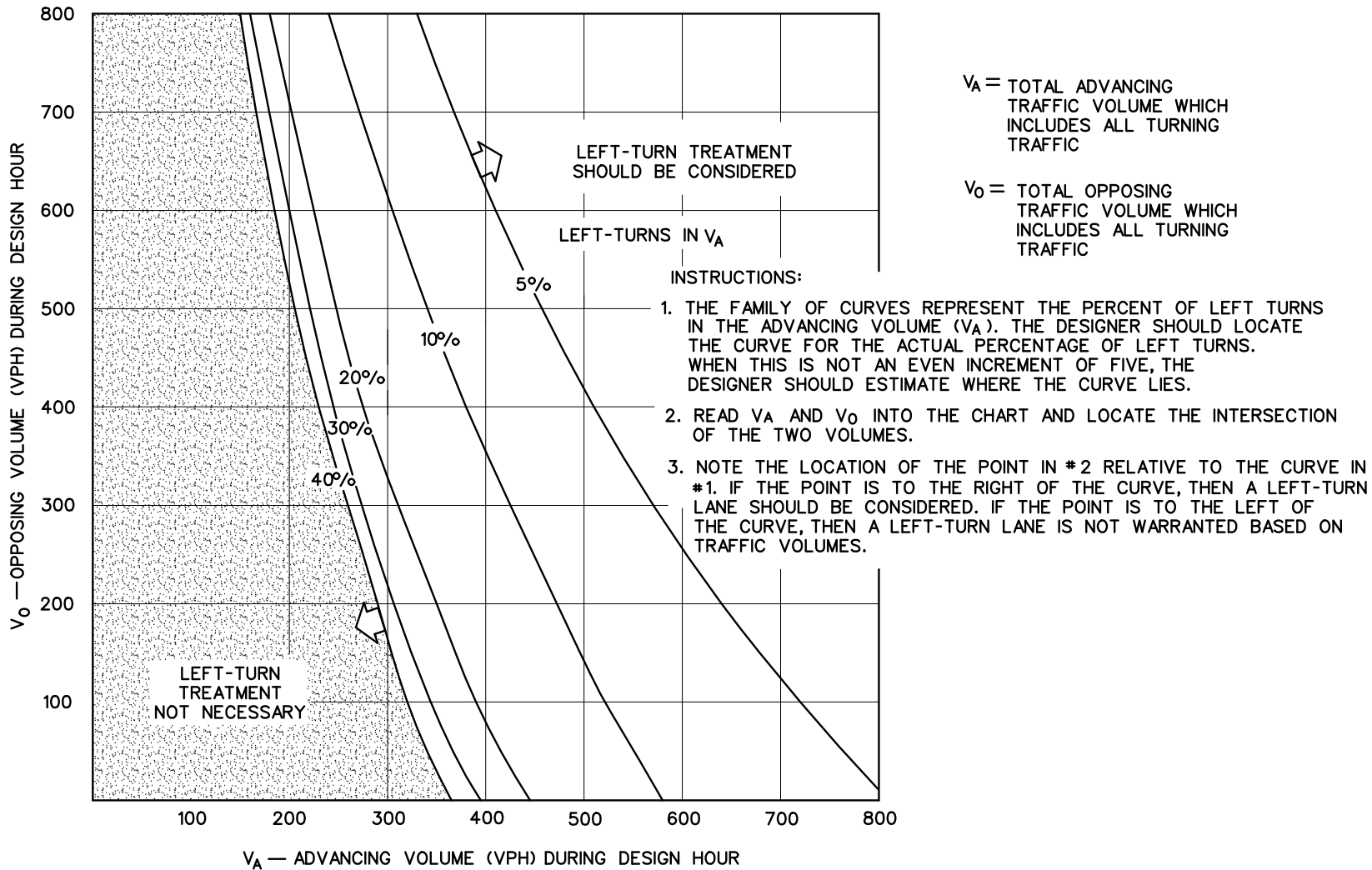

**VOLUME GUIDELINES FOR LEFT-TURN LANES AT UNSIGNALIZED INTERSECTIONS ON 2-LANE HIGHWAYS (40 mph)**

**Figure 11-5F**

### 11-5.03 Design Details for Auxiliary Turning Lanes

The following criteria will apply to the design of auxiliary turning lanes:

1. Length. The length of a turning lane will be the sum of its taper and storage lengths. Figure 11-5G provides the design criteria that should be used to determine these lengths. The designer will coordinate with the Division of Traffic Engineering to determine if additional length to accommodate deceleration within the auxiliary lane is warranted.
2. Width. The width of the turn lane should be according to the functional class, urban/rural location and project scope of work. Chapters Two, Four and Five present the applicable widths for auxiliary lanes. When curbing is provided, at a minimum, a 2-ft shoulder should be provided along the turning lane.
3. Parking Lanes. A right-turn lane in an urban area will often require parking restrictions beyond the typical restricted distances from the intersection. Also, it may require relocating near-side bus stops to the far side of the intersection.
4. Median Openings. These should be designed according to the criteria in Section 11-6.0.

### 11-5.04 Typical Treatments for Auxiliary Turning Lanes

The following presents typical treatments for right- and left-turn lanes:

1. Right-Turn Lanes. Figure 11-5H illustrates the typical development of an exclusive right-turn lane. Note the insertion of short horizontal curves ( $R = 50$  ft) at the beginning and end of the taper. Consider providing these where curbs define the edge of the turn lane.
2. Channelized Left-Turn Lanes. On divided highways, the design presented in Figure 11-I will apply to the development of an exclusive left-turn lane in the median. Figure 11-5J illustrates the typical development of a channelized left-turn lane on a 2-lane highway. The objective is to transition the pavement widening to meet the *MUTCD* criteria.
3. By-Pass Area. Figure 11-5K illustrates the typical design for a by-pass area. This is a relatively inexpensive design to provide for through and left-turn movements at intersections. The by-pass area is appropriate for T-intersections (signalized or unsignalized) where left-turning volumes are light to moderate. It may be used at signalized 4-way intersections, but only if turning volumes are low.

The decision to use either the channelized left-turn lane (Figure 11-5J) or the by-pass area (Figure 11-5K) will be based on comparative costs, crash history, right-of-way availability, through and turning traffic volumes, design speed and available sight distance.

Design Element	Design Speed (mph)	Traffic Control	Upper	Lower
Taper Rate	30 - 45 50 - 60	All	1:8 1:15	1:8 1:8
Storage Length (Full Width)	All	Unsignalized	Based on number and type of vehicles likely to arrive in an average 2-minute period during the design hour. (See Notes 1, 5, 6)	Based on number and type of vehicles likely to arrive in an average 1-minute period during the design hour. (See Notes 1, 2, 5, 6)
		Signalized	Based on 2.0 times the average number of cars that will store in the turning lane during the design hour. (See Notes 3, 4, 5, 6)	Based on 1.5 times the average number of cars that will store in the turning lane during the design hour. (See Notes 2, 3, 4, 5, 6)

- Vehicular Lengths. Use the following design lengths per vehicle for calculating storage length: :  

P:	25 ft	BUS:	40 ft
SU:	30 ft	Semi-Trailer:	55 ft
- Minimum Storage Length. For all intersections where traffic volumes are too low to govern, the minimum storage length will be 50 ft ( $T \leq 10\%$ ) or 80 ft ( $T > 10\%$ ), where  $T$  is the % of trucks turning. These minimum lengths may also apply to right-turn lanes at unsignalized intersections if there is little likelihood of the turning vehicle having to wait.
- Queue Length of Through Traffic. In addition to the table criteria, the length of the turning lane should exceed the calculated queue length in the through travel lane adjacent to the turning lane for the design hour.
- Highway Capacity Manual. The designer should use the criteria in the HCM to calculate storage length.
- Overall Length. The length of the auxiliary lane should include consideration of the number of vehicles expected to be stored and the extent to which deceleration should take place in the auxiliary lane.
- Division of Traffic Engineering. The designer should coordinate with the Division of Traffic Engineering to determine the design length of the turning lane.

## LENGTH OF AUXILIARY TURNING LANES

Figure 11-5G

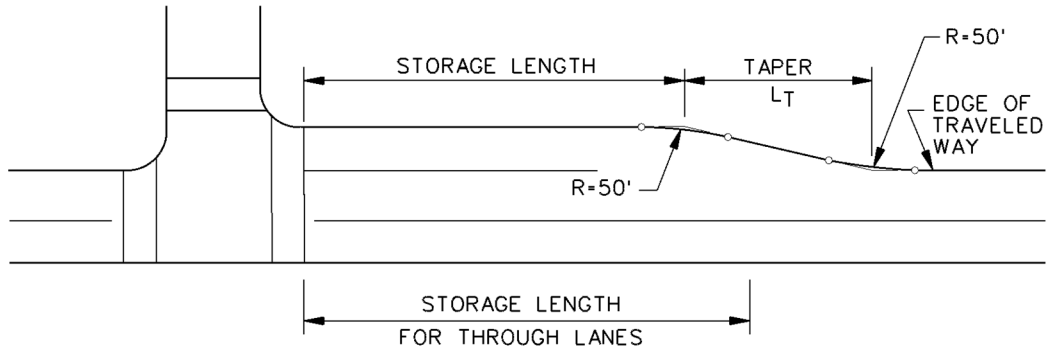

Note: See Figure 11-5G for criteria on taper rate and storage length.

**TYPICAL RIGHT-TURN LANE**

**Figure 11-5H**

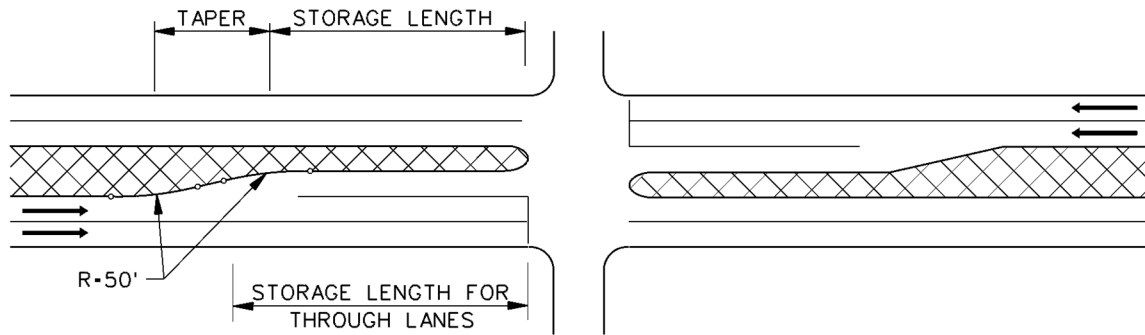

Note: See Figure 11-5G for criteria on taper rate and storage length.

**TYPICAL LEFT-TURN LANE ON DIVIDED HIGHWAY**

**Figure 11-5I**

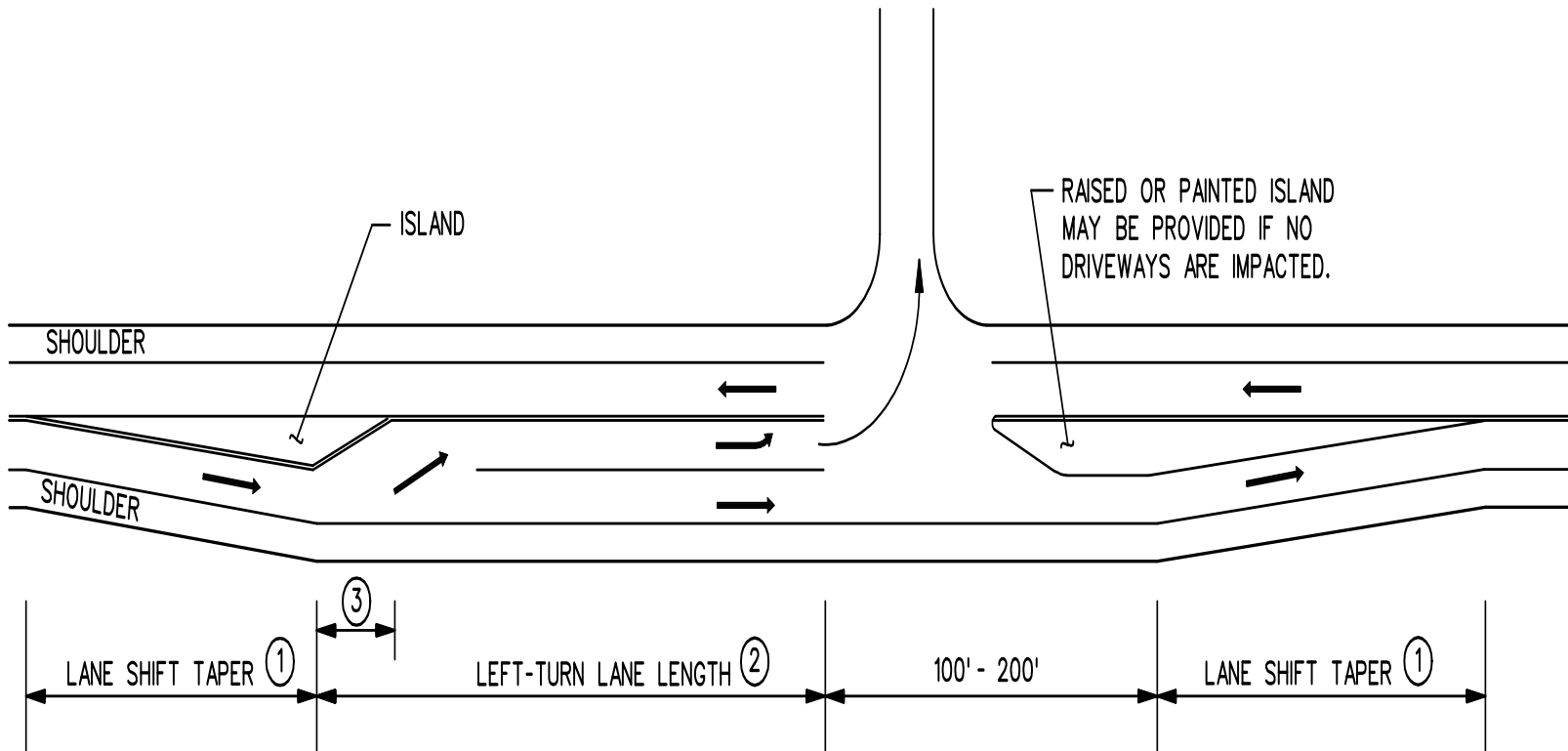

Notes: 1. The taper distance is calculated from:

- $L = WS$  ( $S \geq 45$  mph) or  $L = WS^2/60$  ( $S < 45$  mph)
- $L$  = taper length, ft
- $W$  = transition width, ft
- $S$  = design speed, mph

Choose formula based on the posted speed limit. Then use 85th percentile speed or design speed in formula.

- 2. Increase length if storage requirements exceed 100 ft. See Figure 11-5G.
- 3. Lane add taper . see Figure 11-5G.

**CHANNELIZED LEFT-TURN LANE ON 2-LANE HIGHWAY**

**Figure 11-5J**

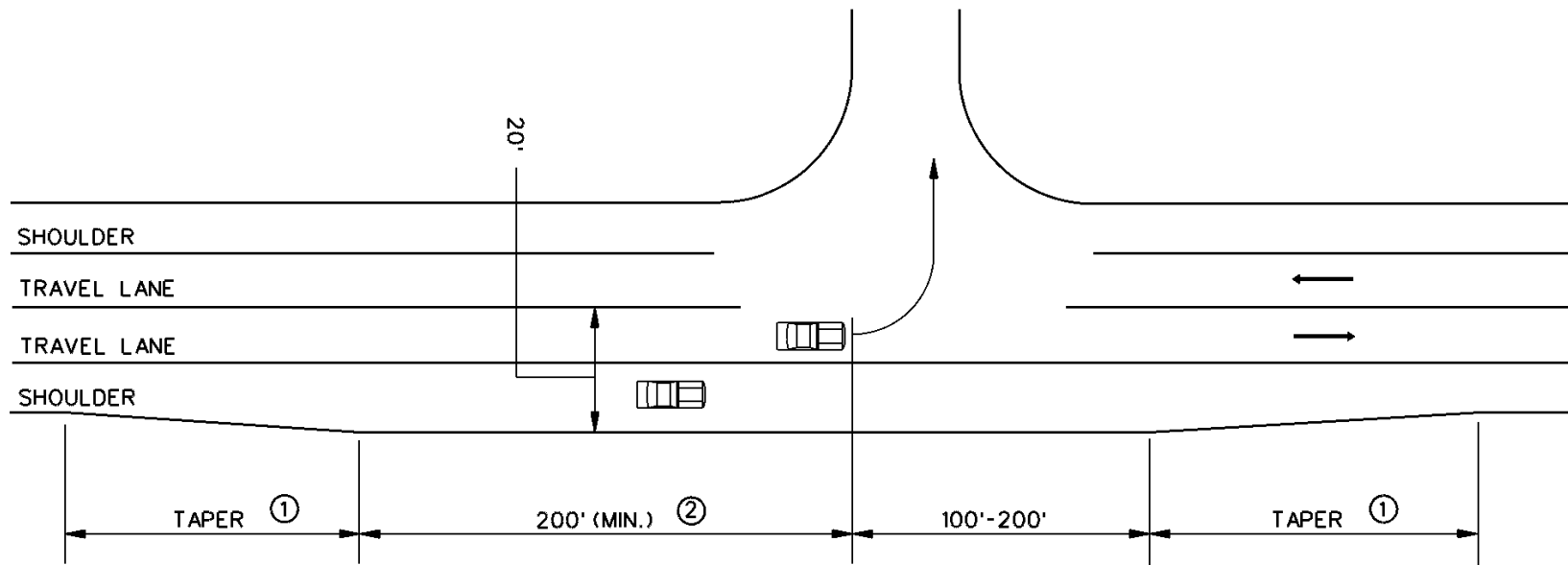

Notes: 1. The taper distance is calculated from:

$$L = WS \text{ (} S \geq 45 \text{ mph) or } L = WS^2/60 \text{ (} S < 45 \text{ mph)}$$

$L$  = taper length, ft

$W$  = transition width, ft

$S$  = design speed, mph

Choose formula based on the posted speed limit. Then use 85th percentile speed or design speed in formula.

2. See Figure 11-5G.

### TYPICAL BY-PASS AREA ON A 2-LANE HIGHWAY

Figure 11-5K

4. Offset Left-Turn Lanes. On medians wider than 18 feet, it is desirable to align the left-turn lane so that it will reduce the width of the median nose to 6 to 8 feet. This alignment will place the vehicle waiting to make the turn as far to the left as practical, maximize the offset between the opposing left-turn lanes, and provide improved visibility to the opposing through traffic. The advantages of offsetting the left-turn lanes are:
  - a. better visibility of opposing through traffic;
  - b. decreased probability of a conflict between opposing left-turn movements within the intersection; and
  - c. more left-turn vehicles can be served in a given period of time, especially at signalized intersections.

Offset designs may be either the parallel or taper design; see Figure 11-5L. The parallel design may be used at signalized and unsignalized intersections. However, the taper design is primarily only used at signalized intersections. Offset turn left-lanes should be separated from the adjacent through traveled way by painted or raised channelization.

#### **11-5.05 Dual Turn Lanes**

Dual right- and left-turn lanes should be considered when:

1. there is not sufficient space to provide the calculated length of a single turn lane;
2. the calculated length of a single turn lane becomes prohibitive; or
3. the necessary time for a protected left-turn phase becomes unattainable to meet the level-of-service criteria (average delay per vehicle).

Dual right-turn lanes do not work as well as dual left-turn lanes because of the more restrictive space available for two abreast right turns. If practical, the designer should find an alternative means to accommodate the high number of right-turning vehicles. For example, a turning roadway may accomplish this purpose.

A dual-turn lane (both lanes exclusive) can potentially discharge approximately 1.9 times the number of cars that will discharge from a single exclusive turn lane. However, to work properly, several design elements must be carefully considered. Figure 11-5M presents both dual right- and left-turn lanes to illustrate the more important design elements. The designer should consider the following:

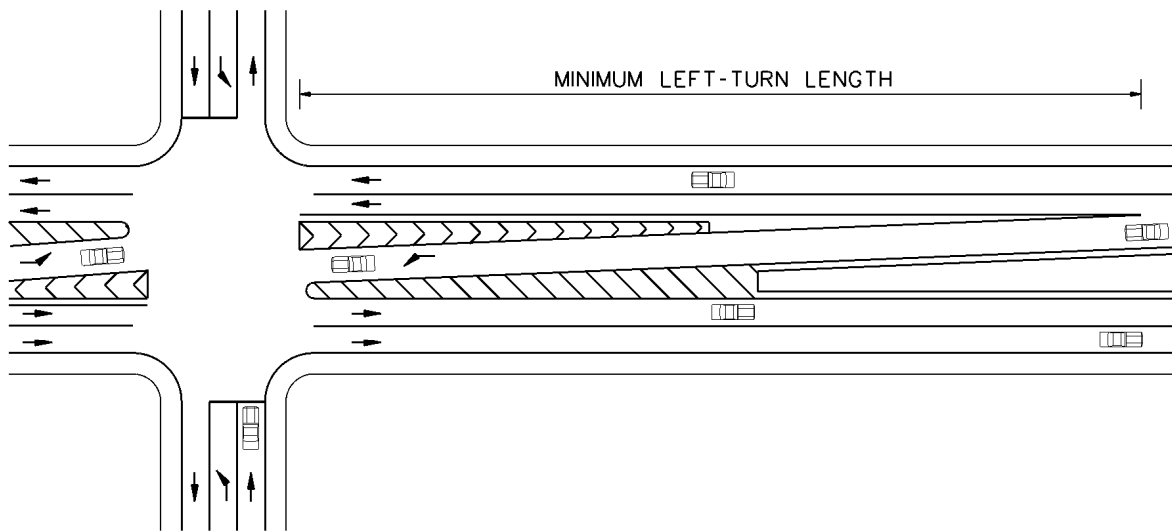

(a) TAPERED-OFFSET TURN LANE

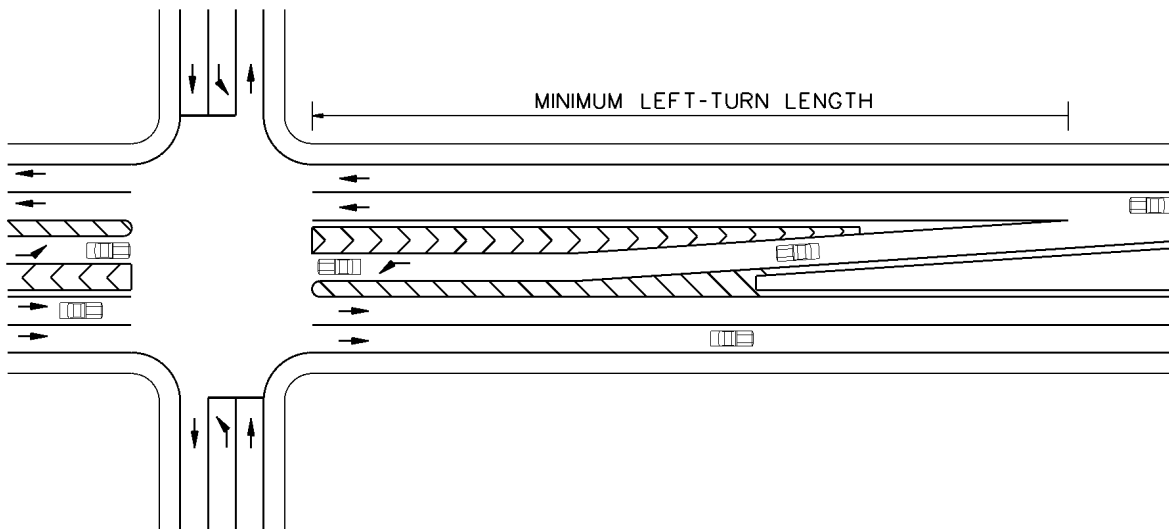

(b) PARALLEL-OFFSET TURN LANE

See Figure 11-5G for minimum turn lane lengths.

**OFFSET LEFT-TURN LANES**

**Figure 11-5L**



1. Throat Width. Because of the off-tracking characteristics of turning vehicles, the normal width of two travel lanes may be inadequate to properly receive two vehicles turning abreast. Therefore, the receiving throat width may need to be widened. For 90° intersections, the designer can expect that the throat width for dual turn lanes will be approximately 30 to 36 ft. If the angle of turn is less than 90°, it may be acceptable to provide a narrower width. When determining the available throat width, the designer can assume that the paved shoulder, if present, will be used to accommodate two-abreast turns.
2. Widening Approaching Through Lanes. If a 30-ft or 36-ft throat width is provided to receive dual-turn lanes, the designer should also consider how this would affect the traffic approaching from the other side. The designer should also ensure that the through lanes line up relatively well to ensure a smooth flow of traffic through the intersection.
3. Special Pavement Markings. As illustrated in Figure 11-5M, these can effectively guide two lines of vehicles turning abreast. The Division of Traffic Engineering will help determine the selection and placement of any special pavement markings.
4. Opposing Left-Turn Traffic. If simultaneous, opposing left turns will be allowed; the designer should ensure that there is sufficient space for all turning movements. This is always a factor, but dual left-turn lanes can cause special problems. If space is unavailable, it may be necessary to alter the signal phasing to allow the two directions of traffic to move through the intersection on separate phases.
5. Turning Templates. Use the applicable turning template to check all intersection design elements for dual turn lanes. The design vehicle will be assumed to be in each lane turning side by side.

#### **11-5.06     Extension of Additional Through Lanes**

To meet the level-of-service criteria, it may be necessary to add through lanes approaching the intersection. However, these additional lanes must be extended beyond the intersection to realize the capacity benefits. Figure 11-5N provides criteria for determining how far these lanes should be extended beyond the intersection.

The designer should recognize that the full-width lengths of the through lane extensions ( $D_E$ ) are those distances needed for the stopped vehicle to accelerate to 5 mph below the design speed of the highway. These distances may or may not be sufficient for the vehicle to merge into the “primary” through lane. The merging characteristics will be based on vehicular acceleration, rate of departure through the intersection and headways in the “primary” lane. Therefore, the criteria in Figure 11-5N should be used for preliminary design purposes. For final design, the designer will coordinate with the Division of Traffic Engineering, who will perform a more detailed analysis.

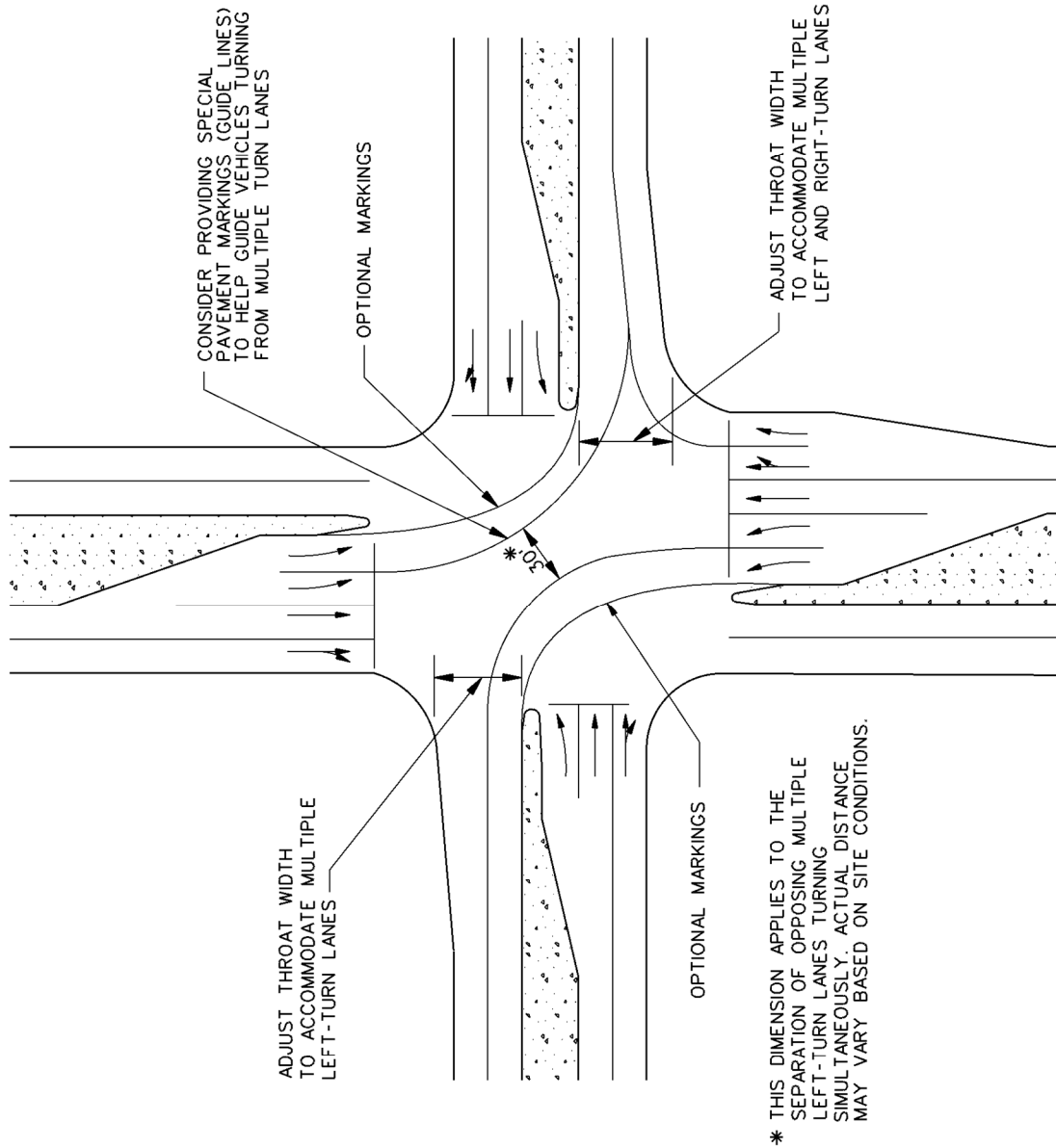

DESIGN OF DUAL TURN LANES

Figure 11-5M

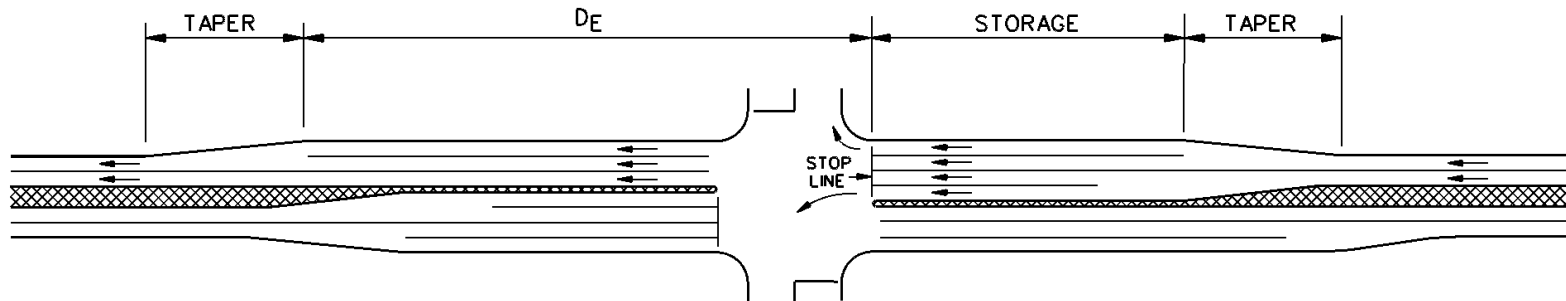

Notes:

1.  $D_E$  is that distance required by the vehicle to accelerate from a stop to 5 mph below the design speed (300 ft minimum). At a signalized intersection, when it is not practical to obtain a specified  $D_E$ , contact the Division of Traffic Engineering for a determination of  $D_E$  based upon capacity and green time.
2. The taper distance is calculated from:  
 $L = WS$  ( $S \geq 45$  mph) or  $L = WS^2/60$  ( $S \leq 40$  mph)  
 Where:  $L$  = taper length, ft  
 $W$  = 12 ft  
 $S$  = design speed, mph
3. These criteria are for preliminary design purposes. See discussion in Section 11-5.06.
4. Lane addition and removal on 2-lane highways is similar.
5. Figure is not intended to show striping. Striping is based upon the MUTCD.

Design Speed (mph)	$D_E^*$ (ft)	Taper* (ft)
30	300	180
35	300	245
40	300	320
45	360	540
50	560	600
55	720	660
60	960	720
65	1200	780
70	1410	840

\*Rounded for design assuming a 12-ft lane.

TYPICAL EXTENSION OF ADDITIONAL THROUGH LANES

Figure 11-5N

**11-5.07    Two Way Left Turn Lanes (TWLTL)**

In locations where there are many access points at irregular intervals along both sides of the highway, it may be appropriate to provide a center two way left turn lane to allow turning vehicles to stop outside the through travel lanes. This configuration has inherent potential conflicts between vehicles moving in opposite directions. Therefore, appropriate highway alignment and sightlines are essential.

TWLTLs should be wider than normal left turn lanes. Recommended TWLTL widths are 14' (12' minimum) in all locations. Since there are many locations in which a TWLTL may not be appropriate for various reasons, all TWLTLs must be developed in conjunction with the Division of Traffic and the Project Development Unit.

In general, the crown line should be located in the center of the TWLTL on a normal typical section. However, there are locations where an alternative crown line location may be preferable. The final crown line location should be determined in conjunction with the Project Development Unit.

## 11-6.0 MEDIAN OPENINGS

### 11-6.01 Guidelines

The designer should consider providing median openings on divided non-freeways at all intersections with public roads and major traffic generators (e.g., shopping centers). The following recommended minimum spacings should be evaluated when determining the need for a median opening:

1. Rural Intersections. Openings are generally provided at all public road intersections.
2. Urban Intersections. In general, median openings are typically provided at all intersections. However, to improve capacity and traffic efficiency, the designer may elect not to provide an opening for a traffic generator if there are other points of access within a reasonable distance of the generator.

Median openings should normally be located between 0.25 mi and 0.5 mi apart.

### 11-6.02 Design

Median openings must be designed to properly accommodate left-turning vehicles, which trace essentially the same path as right-turning vehicles. Figure 11-6A illustrates a typical median opening design. The following criteria will apply to the design of a median opening:

1. Nose Design. The bullet nose design should be used for the median nose. The radius at the nose should be approximately 1.5 ft to 3.0 ft. The semicircular design is acceptable, but it requires a greater median width or length of opening to accommodate a given design vehicle.
2. Design Vehicle. The design vehicle for median openings should be the largest vehicle that will be making the turn with some frequency. The process for the selection of the design vehicle is the same as for a right-turning vehicle; see Section 11-3.02.
3. Encroachment. In all cases, the designer should consider providing a design that will allow the selected design vehicle to make the left turn entirely within the inside lane (i.e., there will be no encroachment into the lane adjacent to the inside lane). This will be the minimum design at unsignalized intersections. At signalized intersections, the minimum design will be to allow the selected design vehicle to encroach to the outside edge of the traveled way. For dual left-turn lanes, the designer may assume that the design vehicle will turn from the outer left-turn lane.
4. Length of Opening. The length of a median opening should properly accommodate the turning path of the design vehicle. The minimum median opening length is 40 ft. However, each median opening should be evaluated individually to determine the proper length of opening. The designer should consider the following factors in the evaluation:

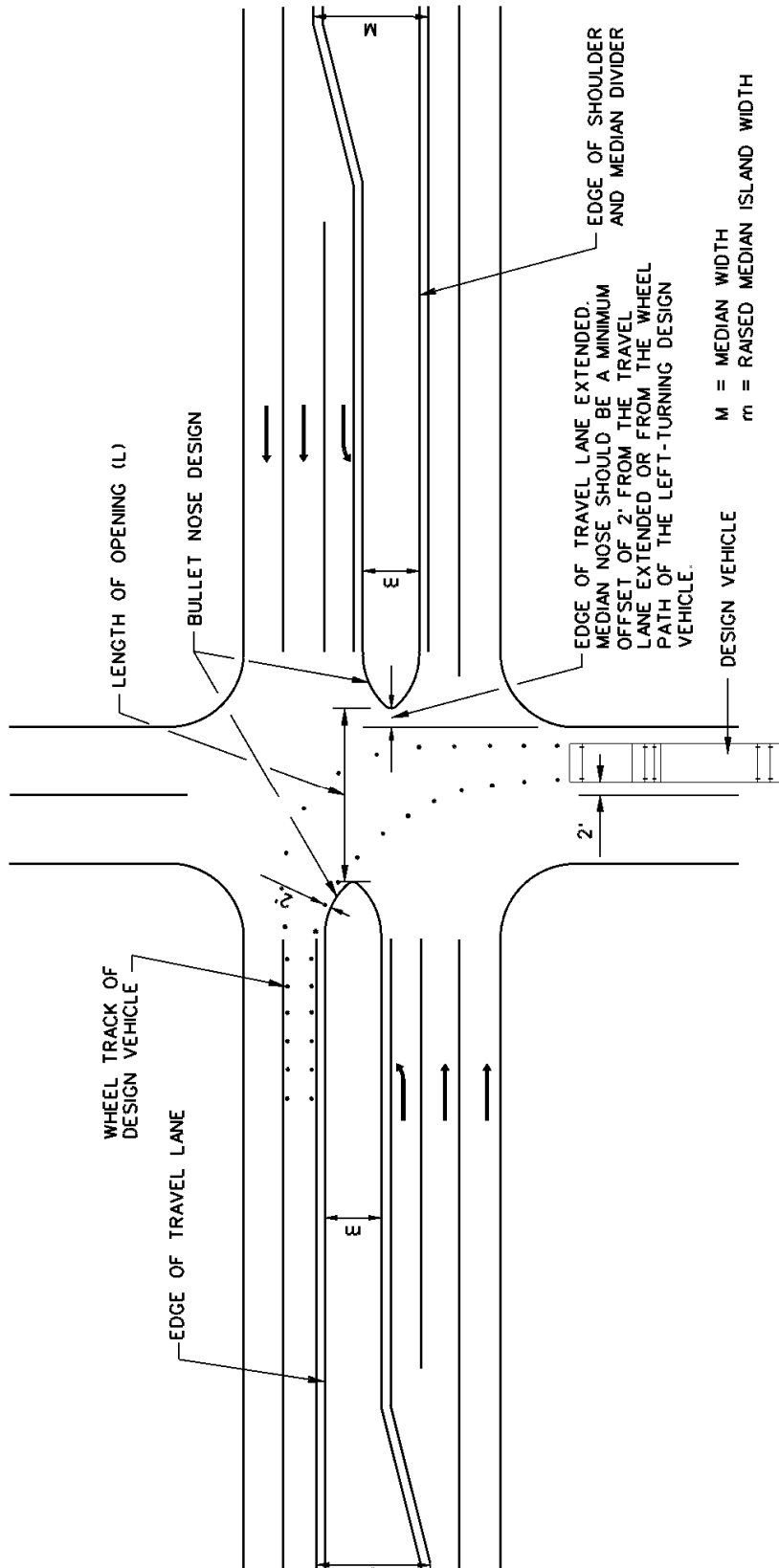

**MEDIAN OPENING DESIGN**  
Figure 11-6A

- a. Turning Templates. The designer should check the proposed design with the turning template for the design vehicle most likely to use the intersection. Consideration should be given to the frequency of the turn and to the encroachment onto adjacent travel lanes or shoulders by the turning vehicle.
  - b. Nose Offset. At 4-leg intersections, traffic passing through the median opening (going straight) will pass the nose and the median end (semicircular or bullet nose). To provide a sense of comfort for these drivers, the offset between the nose and the through travel lane (extended) should be at least 2 ft.
  - c. Lane Alignment. The designer should ensure that lanes line up properly for crossing traffic.
  - d. Location of Crosswalks. Where practical, pedestrian crosswalks should intersect the median nose to provide some refuge for pedestrians. Therefore, the median opening design should be coordinated with the location of crosswalks.
5. U-turns. Median openings are sometimes used only to accommodate U-turns on divided non-freeways. Figure 11-6B provides information on minimum U-turn median opening design.

### **11-6.03     Median Openings on Freeways**

On access-controlled freeways, median crossings are denied to the public. However, occasional median openings or emergency crossovers are needed to accommodate maintenance and emergency vehicles. The following should be considered:

1. Warrants and Location. Emergency crossovers are normally placed away from any mainline conflicts. As a general guide, median openings may be considered when the distance between interchanges exceeds 3 mi. Two crossovers may be considered where the distance between interchanges exceed 6 mi. In addition, crossovers may be placed at State lines, maintenance section ends and at interchanges for winter maintenance. The Median Opening Committee reviews locations for median openings. The Director of Maintenance chairs this Committee.
2. Sight Distance. Because of the unexpected U-turn maneuver, sight distances should be large when vehicles make U-turns on freeways. The designer should attempt to select a location that can achieve a sight distance of 2000 ft to the right of the crossover in both directions. If this cannot be achieved, then intersection sight distance as discussed in Section 11-2.0 may be used.
3. Median Width. The median should be wide enough to accommodate the design vehicle.

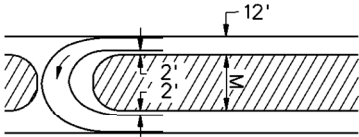
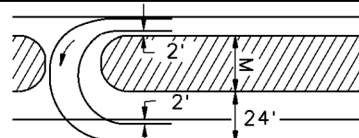
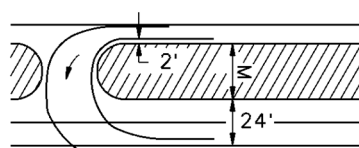
Type of Maneuver		M - Min. width of median (ft) for design vehicle				
		P	SU	BUS	WB-40	WB-50
		Length of design vehicle (ft)				
		19	30	40	50	55
Inner Lane to Inner Lane		30	63	63	61	71
Inner Lane to Outer Lane		18	51	51	49	59
Inner Lane to Shoulder		8	41	41	39	49

Note: For freeway median openings, use the SU design vehicle.

### MINIMUM DESIGNS FOR U-TURNS

Figure 11-6B

4. **Median Barriers.** Emergency crossovers should be avoided where a median barrier is present. If a crossover must be provided, the barrier should be terminated as described in Section 13-5.03.03. The width of the opening should be about 25 ft to 30 ft. This is wide enough to safely allow a vehicle to turn through, but it is narrow enough to minimize the possibility of a run-off-the-road vehicle passing through.
5. **Design.** Figure 11-6B provides the minimum width of median for several design vehicles and types of U-turn maneuvers. If practical, the design should allow the inner lane to inner lane design. This design also allows the vehicle to be fully protected within the median, if the driver must stop here. Figure 11-6C provides additional design details for a median opening. Depress the crossover below the shoulder level to be inconspicuous to traffic. Provide 1V:10H or flatter sideslopes to minimize its effect as an obstacle to errant vehicles.



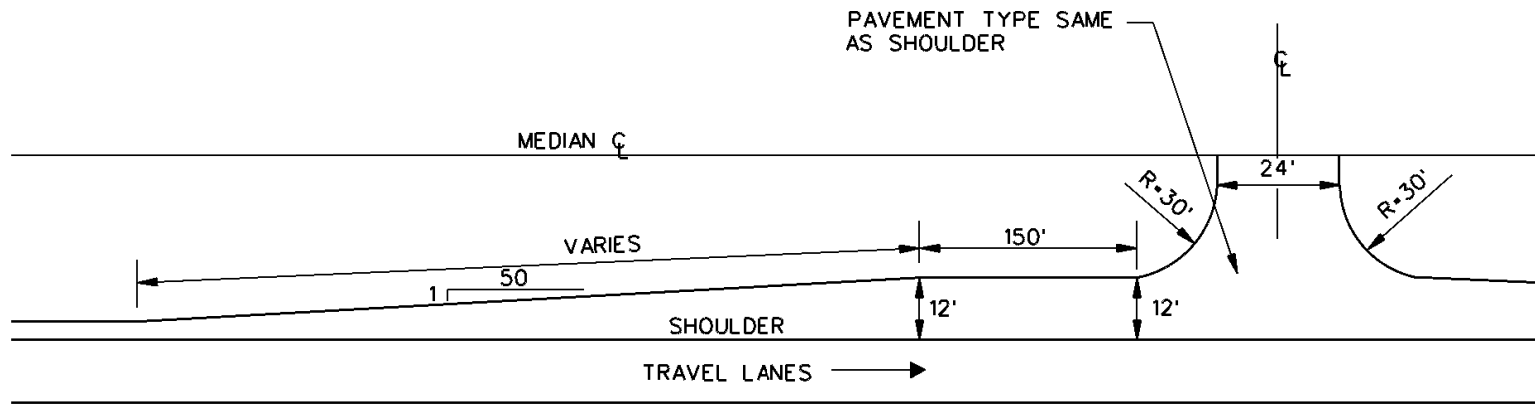

*Notes:*

1. *The median opening is symmetrical about the centerline.*
2. *The gradient through the opening should be as flat as practical.*
3. *Curbs should not be used.*

**TREATMENT OF MEDIAN OPENING ON FREEWAY**  
**Figure 11-6C**



## 11-7.0 CHANNELIZATION

### 11-7.01 Design Principles

Intersection channelization directs traffic into definite paths of travel. When properly applied, channelization can increase capacity, improve safety and maximize the sense of driver comfort. Improper channelization can greatly confuse drivers and may be worse than no channelization at all. The designer should incorporate the following principles into the channelization design:

1. Motorists should not be confronted with more than one decision at a time.
2. Unnatural paths that require turns greater than 90° or sudden and sharp reverse curves should be avoided.
3. Areas of vehicular conflict should be reduced as much as practical. However, merging and weaving areas should be as long as conditions permit.
4. Traffic streams that cross without merging and weaving should intersect at or near right angles.
5. The angle of intersection between merging streams of traffic should be small.
6. Refuge areas for turning vehicles should be provided clear of through traffic.
7. Prohibited turns should be discouraged wherever practical by the use of, for example, sharp radii curbs.
8. Safe location of essential traffic control devices should be an integral part of the design of a channelized intersection.

### 11-7.02 Design Details (Islands)

Flush or raised islands are used to create the intersection channelization. The designer should adhere to the following criteria when designing islands:

1. Types. Islands may be flush or raised, paved or turf, and triangular or elongated. Raised islands (with curbs) should be used where pedestrian traffic is significant and where traffic control devices are needed within the island. The designer should consider lighting the intersection where raised islands are used. Flush (painted) islands are appropriate in lightly developed areas, where approach speeds are above 40 mph and where the intersection is not lighted. Elongated islands are used to divide two flows of traffic.
2. Size. In general, an island must be large enough to command attention. For triangular islands, the minimum size is 50 ft<sup>2</sup> at urban intersections and 75 ft<sup>2</sup> at rural intersections. Where right-of-way is available, provide a triangular island of at least 100 ft<sup>2</sup>. The minimum width of an elongated island should be not less than 4 ft wide and preferably 6 ft.

3. Approach Treatment. Islands with curbs are acceptable where the design speed is 50 mph or less. Flush islands should be used at higher speeds; however, raised islands with the BCLC are acceptable where the “target” value of a raised island is considered desirable. The corners of curbed islands should be constructed with nose radii of 1 ft to 3 ft. For good delineation, pavement markings should be placed in advance of the island approach to warn the driver.
4. Island Offset to Through Lanes. Where there are no curbs on the roadway approach, the curbed island should be offset 2 ft to 3 ft from the travel lane. This applies to approach roadways without shoulders. Where shoulders are present, the curbed island should be offset a distance equal to the shoulder width. Although the value of the offset is not as critical for flush islands, they should desirably be treated in the same manner as raised islands.

Figure 11-7A provides an illustration of a channelized intersection.





## 11-8.0 DRIVEWAYS

### 11-8.01 Design

#### 11-8.01.01 Detailed Criteria

Figure 11-8A summarizes the Department's recommended criteria for the design of driveways. The designer should also consider the following:

1. Driveway Type. As indicated in Figure 11-8A, the Department has designated three driveway types for the purpose of design. These are residential, minor commercial and major commercial.
2. Vertical Profile. Figures 11-8B, 11-8C and 11-8D present the Department's driveway entrance designs for the vertical profile. The designer should meet these criteria, if practical. However, actual field conditions may make this unattainable.
3. Auxiliary Lanes. Deceleration and acceleration lanes should be considered at high-volume driveway entrances, especially on high-speed, high-volume arterials. Section 11-5.0 further discusses the design and warrants for auxiliary turn lanes. In addition, it may be warranted to provide a right-turn lane if the change in grade is abrupt at the driveway entrance.
4. Turning Template. The designer should check the driveway entrance with the applicable turning template to ensure that the design vehicle can make the turn within the driveway width.
5. Sight Distance. Intersection sight distance should be evaluated at all driveways (see Section 11-2.0). However, only intersection sight distance for major commercial driveways will be considered as a controlling design criteria and will require an exception if the minimum values are not met. Residential and minor commercial driveways will not require an exception if the minimum values are not met. However, the designer should verify that adequate sight distance at an existing drive is not reduced below minimum values, and drives that are already substandard are not made worse.
6. Transverse Slopes. Where the highway mainline intersects a driveway, a slope transverse to the mainline will be present. See Section 13-3.07. If impacted by a run-off-the-road vehicle, the angle of impact will likely be close to 90°. Even for relatively flat side slopes, this will result in vehicular vaulting; for steeper slopes the vehicle bumper may "catch" in the slope resulting in an abrupt stop and high occupant decelerations. For these reasons, transverse slopes should be as flat as practical. For design speeds greater than 45 mph, the slope should be 1:10 or flatter. For 45 mph or below, the slope should be 1:6 or flatter.
7. Curb Returns. Where curbs are used, the curb return should be constructed into the driveway. The radius of the curb return should not be less than 2 ft nor more than 50 ft.

Driveway Design Element		Driveway Type		
		Residential	Minor Commercial	Major Commercial
Design Vehicle		P	SU* (WB-50 can physically make turn)	WB-50*
Tolerance Encroachment by Design Vehicle Turning Into/Out of Driveway	Adjacent Lane on Through Road	None into opposing lanes of travel. Acceptable into lanes moving in same direction; however, consider providing a design so that there will be no encroachment.		
	In Driveway	Use all of driveway width if 1-way; no encroachment into driveway entrance or exit lane if 2-way, unless low-volume driveway.		
Width		Based on 1-way or 2-way operation; on selected design vehicle template; on encroachment criteria; and on assumed speed. (Note: Minimum residential driveway width = 10 ft. Maximum width is 30 ft.)		
Grades on Driveway Proper		≤ 10% - 12%	≤ 5% - 8%	≤ 5% - 8%
Maximum Change in Grade Without Vertical Curve ( $\Delta G$ )	Driveway Entrance	See Figures 11-8B, 11-8C and 11-8D		Designed like street intersection
	Driveway Proper	15%	6%	3%

*\*Where multiple drives are present, only the route to and from the loading area needs to accommodate trucks.*

## RECOMMENDED DRIVEWAY DESIGN CRITERIA

Figure 11-8A



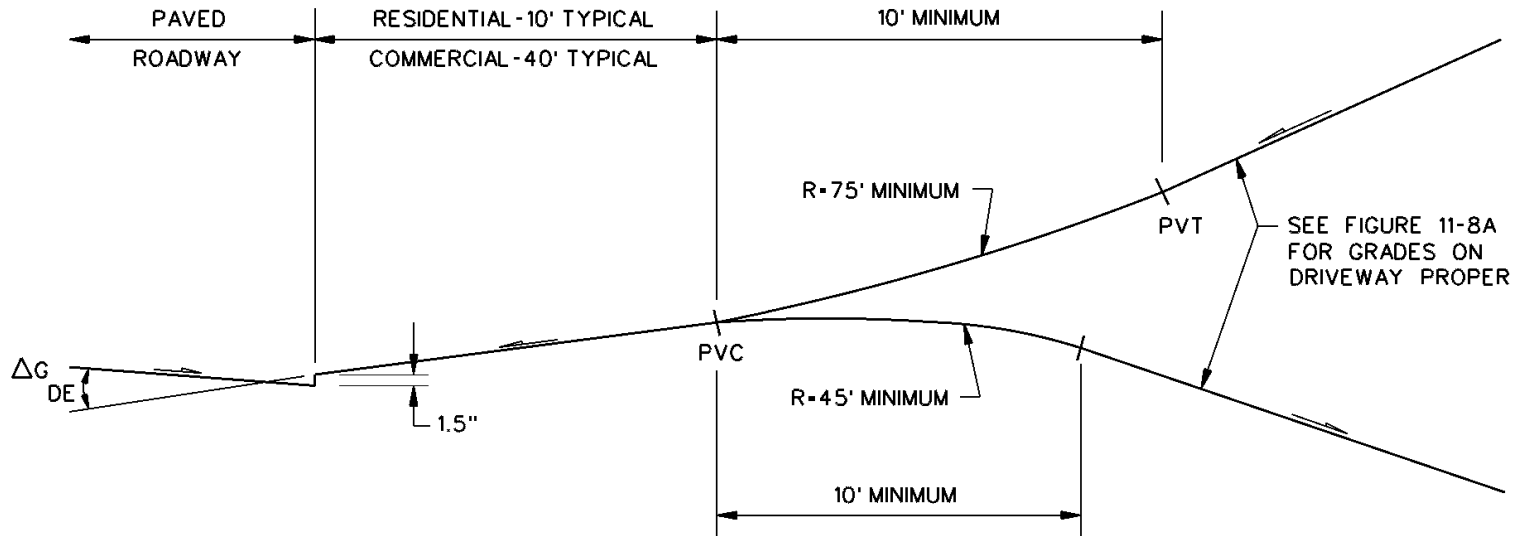

1. This design applies with or without curbs.
2. As an alternative to providing a vertical curve, the designer may use an angular break that does not exceed the  $\Delta G_{DE}$  criteria in Figure 11-8A for the driveway proper.
3. The maximum  $\Delta G_{DE}$  will be as follows:

<u>Turn From</u> <u>Travel Lane</u> 8%	<u>Turn From Shoulder</u> <u>or Turn Lane</u> 12%
--	---

Note that a shoulder must be at least 7 ft wide to use the higher  $\Delta G_{DE}$  values.

4. When determining the appropriate vertical design for the driveway entrance, the designer should also consider the highway design speed, through traffic volumes, driveway volumes, turning speeds allowed by the available curb radius and crash history.
5. See the Department's Standard Drawings for additional details.

**TYPICAL DRIVEWAY ENTRANCE  
(No Provision for Sidewalks)  
Figure 11-8B**

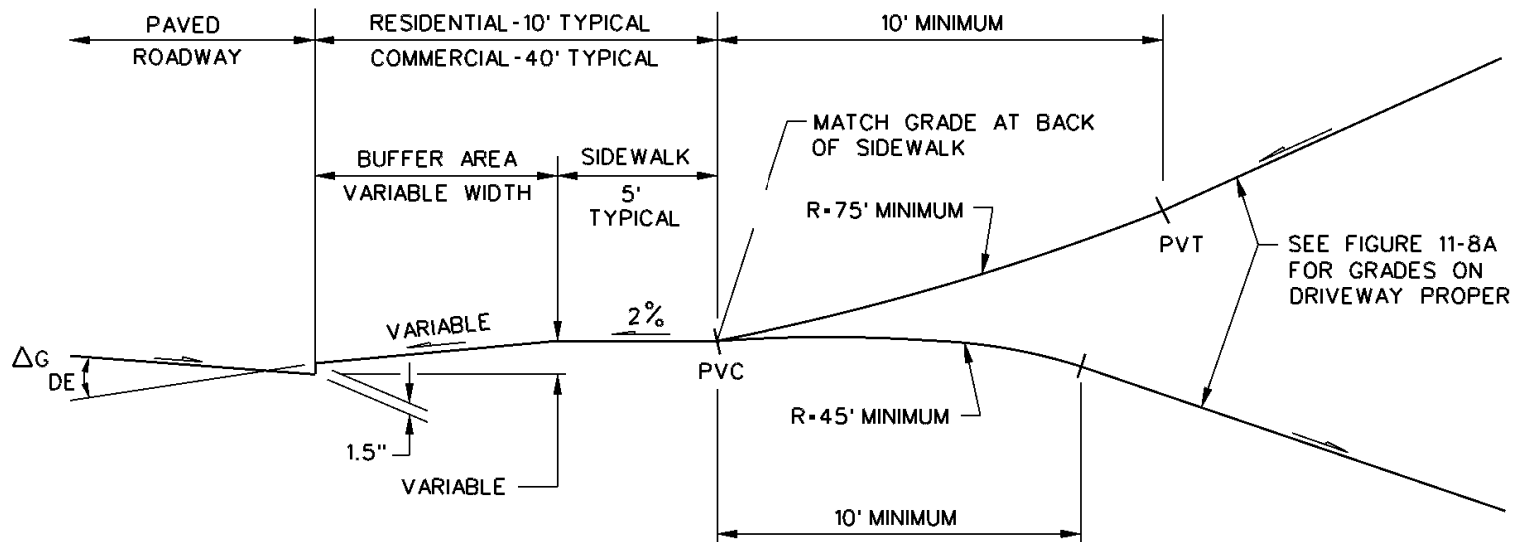

1. This design applies with or without curbs.
2. As an alternative to providing a vertical curve, the designer may use an angular break which does not exceed the  $\Delta G_{DE}$  criteria in Figure 11-8A for the driveway proper.
3. The maximum  $\Delta G_{DE}$  will be as follows:

<u>Turn From</u> <u>Travel Lane</u>	<u>Turn From</u> <u>Shoulder or Turn Lane</u>
8%	12%

Note that a shoulder must be at least 7 ft wide to use the higher  $\Delta G_{DE}$  values.

4. The grade for the driveway portion through the border area should not exceed the grades on the driveway proper in Figure 11-8A.
5. When compromises are necessary, the criteria for the max  $\Delta G_{DE}$  should receive more weight than the 2% sidewalk cross slope (i.e., the sidewalk should be warped as necessary to allow the smallest practical  $\Delta G_{DE}$ ). This, in effect, gives preference to the safety of the vehicular traffic. If the turn will be made from a travel lane, it will usually be necessary to alter the sidewalk cross slope if curbs are present. However, if the sidewalk is on an accessible route, the designer must also consider ADA criteria for disabled individuals, see Section 15-1.0.
6. When determining the appropriate vertical design for the driveway entrance, the designer should also consider the highway design speed, through traffic volumes, driveway volumes, turning speeds allowed by the available curb radius and crash history.
7. See the Department's Standard Drawings for additional details.

**TYPICAL DRIVEWAY ENTRANCE**  
**(Sidewalk With Buffer Area)**  
**Figure 11-8C**

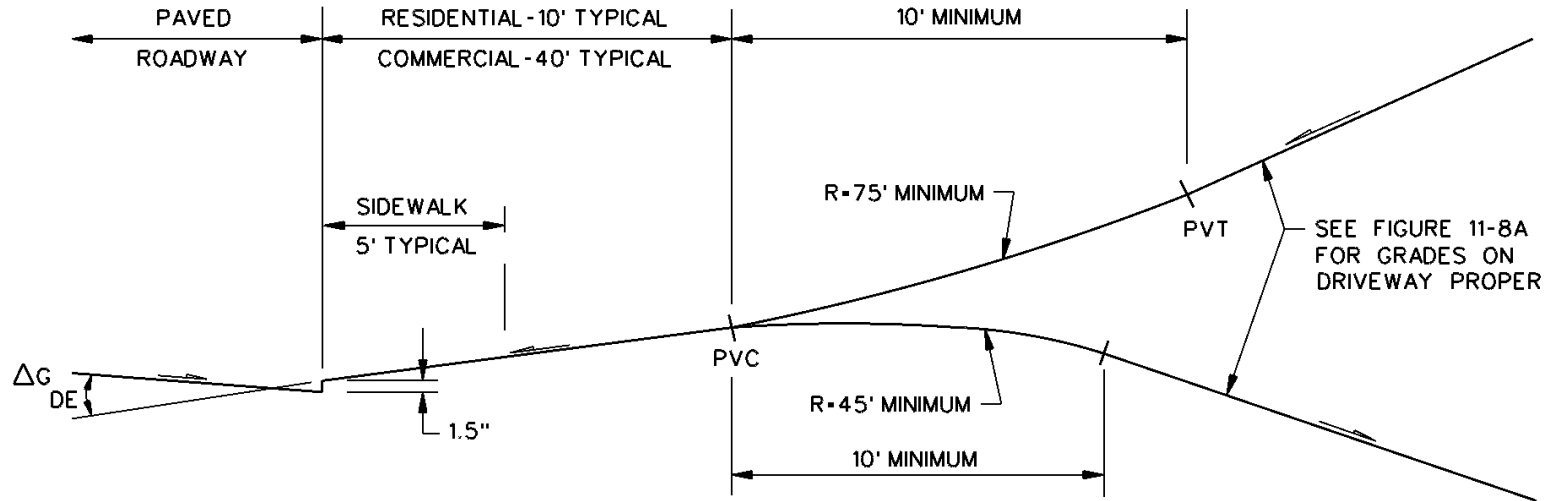

1. This design applies with or without curbs.
2. As an alternative to providing a vertical curve, the designer may use an angular break that does not exceed the  $\Delta G$  criteria in Figure 11-8A for the driveway proper.
3. The maximum  $\Delta G_{DE}$  will be as follows:

Turn From  
Travel Lane  
8%

Turn From Shoulder  
or Turn Lane  
12%

Note that a shoulder must be at least 7 ft wide to use the higher  $\Delta G_{DE}$  values.

4. The typical design assumes that the sidewalk will be warped so that the  $\Delta G_{DE}$  criteria can be satisfied. However, if the sidewalk is on an accessible route, the designer must also consider ADA criteria for disabled individuals; see Section 15-1.0.
5. When determining the appropriate vertical design for the driveway entrance, the designer should also consider the highway design speed, through traffic volumes, driveway volumes, turning speeds allowed by the available curb radius and crash history.
6. See the Department's Standard Drawings for additional details.

**TYPICAL DRIVEWAY ENTRANCE  
(Sidewalk Adjacent to Curb)  
Figure 11-8D**

**11-8.01.02 Criteria (Existing Driveways)**

The following will apply to projects that impact existing driveways:

1. Grades. When an existing driveway is impacted by the project construction, the designer should, whenever practical, ensure that the reconstructed driveway grade will not exceed the grade of the existing driveway. When the grade must be adjusted, the new grade should not exceed the criteria in Figure 11-8A.

If an existing driveway grade exceeds the criteria in Figure 11-8A, the designer should attempt to flatten the grade as part of the project.

2. Procedures. If it is determined during the Preliminary Design review that there will be a substantial increase in the grade of the driveway or if the length of the driveway will be significantly revised, then the words, "Right to construct, reconstruct and/or relocate driveway required," should be noted on the construction plans. This will signify that the property owner must be contacted and permission obtained. It will be the responsibility of the Right-of-Way representative to contact the property owner to explain the proposed construction. This will be done during the acquisition stage of property in the vicinity.

If the proposed reconstruction of a driveway will exceed the Department's driveway design criteria, alternative solutions will be discussed at the Preliminary Design meeting. These solutions will be presented to the property owner during the regular acquisition of property in the vicinity. If neither alternative is acceptable to the owner, the designer may meet with the Right-of-Way project coordinator for the area concerned to review the driveway design.

3. Project Plans. To ensure a clear understanding of the intended driveway construction and, especially, to depict the treatment of the grade to prevent roadway drainage from flowing into the property, the normal indication of proposed driveways on 1:40 scale plans and profiles will be supplemented by a standard sheet, a driveway section or a special detail. The section or detail will contain a scale and will be sufficiently detailed so that there will be no misunderstanding by construction personnel or claim of misrepresentation by the Contractor.

**11-8.02 Driveway Spacing and Corner Clearances**

Closely spaced driveways can cause operational problems, especially with high-volume roadways and/or high-volume driveways. These problems can also result if driveways are too close to at-grade intersections. The following criteria will apply to driveway spacing and corner clearance:

1. Upper Design Values. Figure 11-8E presents criteria that, where practical, should be met. On new construction and reconstruction projects, the designer should be able to achieve these criteria. This will help provide good traffic operations for the main facility and for driveways.



2. Minimum. Section 13b-17-15 of the Department's Highway Encroachment Permit Regulations discusses criteria for driveway spacing and location. For convenience, Section 13b-17-15 is presented at the end of Section 11-8.0. At a minimum, the designer will ensure that these criteria are met. This will often be applicable on 3R projects. In addition, it will not be permissible to place any part of a driveway (including its entrance radius) within the radius of a public road at an intersection. If these criteria cannot be met for properties in intersection corners, one possible solution is to relocate the driveway entrance from the major road to the minor road, if applicable.

### **11-8.03     Major Traffic Generators**

The State Traffic Commission (STC) is responsible for processing and approving access requests for major traffic generators (e.g., shopping malls). The Department may be requested to review and comment on the engineering aspects of the access requests. Section 14-311 of the General Statutes provides the regulatory basis for the authority of the STC to regulate the access of major traffic generators onto public roads.

#### **11-8.03.01     Section 13b-17-15 "Driveways" from the Highway Encroachment Permit Regulations**

Approval of an application for a permit for a driveway shall be subject to Sec. 13a-143a Driveway Permits, which reads "No person shall construct a new driveway or relocate an existing driveway leading onto a state highway without first obtaining a permit from the Commissioner of Transportation. In determining the advisability of issuing such permit, the Commissioner shall include, in his consideration, the location of the driveway with respect to its effect on highway drainage, highway safety, the width and character of the highways affected, the density of traffic thereon, and the character of such traffic. The person to whom the permit is issued shall comply with the provisions and restrictions contained therein at his own expense."

Such approval shall also be subject to the following conditions:

- (1) The applicant is the owner of the property, or owner jointly with the contractor, and any driveway approach constructed is for the bona fide purpose of securing access to the property and not for the purpose of parking or servicing vehicles on the highway right-of-way.
- (2) Any driveway, approach or improvement constructed under permit within the right-of-way shall be subject to inspection at any time by the State. The District Maintenance Manager reserves the right to require such changes, additions and relocations thereto as, in the manager's opinion, may be necessary for the relocation, reconstruction, widening or maintenance of the highway or to provide protection to life and property on or adjacent to the highway.
- (3) No driveway, approach or other improvement constructed on the right-of-way, under permit, shall be relocated, or its dimensions altered, without written permission of the District Maintenance Manager.

(4) The applicant agrees to comply with all insurance requirements set forth in section 13b-17-9 of these regulations.

(5) The proposed location, design and construction of any driveways under permit shall be evaluated by the State in accordance with the following criteria:

(a) For permit purposes, the priority of use by the abutting land-owner of that portion of the roadside fronting on his/her land shall be confined between lines drawn from the frontage corners of the property to the centerline of the roadway either at right angles to the centerline on tangents or on a radial line on curves.

(b) No more than one combination entrance and exit shall be allowed for any property with frontage of less than 50 feet. Parcels having a frontage from 50 to 100 feet may be permitted two entrances if a minimum of one-third of the total frontage is used to separate driveways. Lots with frontage in excess of 100 feet shall conform to such driveway and channelization layout as the District Maintenance Manager shall prescribe.

(c) The width of any entrance or exit shall not exceed 30 feet, measured parallel to the direction of the State highway at the property line, except as may otherwise be designated by the District Maintenance Manager because of municipal ordinance or other valid reason. The area within State property between the entrance and exit shall not be improved to facilitate vehicular traffic or parking. This area shall be considered restricted and may be developed on as hereinafter provided in paragraph (1).

(d) The grade of entrances and exits shall conform to current Highway Design Standards for typical treatment of drives.

(e) In rural or suburban regions, no entrance or exit shall be so constructed that any part of such entrance or exit is less than ten feet from the extended common boundary separating adjacent private properties, except for returns, the radius of which shall not exceed 50 feet. In urban areas, or where there is a curb and gutter, the distance from the boundary may be five feet. See paragraph 5(a) above for limitations on radius termini.

(f) The construction of parking areas on the highway right-of-way is prohibited, except as provided for under the regulations governing parking areas under lease within the highway right-of-way. Places of business requiring parking space for their customers shall provide such facilities on their own premises.

(g) Drainage discharged from a State highway or flowing within the right-of-way shall not be altered or impeded and the permittee must provide suitable drainage structures as directed by the District Maintenance Manager.

(h) When a curb and gutter are removed, the entrance and exit shall be constructed so that the curbing along the highway shall be returned into the entrance and exit on a radius of not less than 2 feet or more than 50 feet unless otherwise directed by the District Maintenance Manager.

(i) All entrances and exits shall be so located that vehicle operators approaching or using them shall have adequate sight distances in both directions along the State highway in accordance with current Department of Transportation geometric design standards. The permit applicant shall stabilize all slopes by loaming and seeding or other method directed by the Permit Inspector.

(j) All entrances and exits constructed under permit shall be paved on the entire section within the State highway right-of-way with bituminous concrete, portland cement concrete, or as directed by the District Maintenance Manager. The remainder of the area graded to drain to the State highway shall be stabilized to prevent erosion and washing of material onto the State highway. All costs of such paving shall be borne by the permittee. The pavement shall be joined in a straight line at its intersection with the State highway shoulder and shaped, as the Inspector shall require accommodating highway drainage.

(k) No entrance or exit shall be constructed at the intersection of two State highways, town road, or city street within the area lines drawn perpendicular to the centerline of the highway from points on the right-of-way lines, for a distance of 25 feet from the intersection of said right-of-way lines at non-signalized intersections. Driveways at signalized intersections shall be constructed as directed by the District Maintenance Manager.

(l) The area between entrances and exits and those portions of rights-of-way which have been defined herein above in (c) as restricted area may be filled in only when surface drainage is provided, so that all surface water on the improved area is carried away from the highway roadbed and shoulder in a suitable manner, and when the drainage facility installed under any filled area is adequate to carry the water along the State highway. No headwall or other structure so designed as to be a hazard to an errant vehicle shall be constructed in the highway right-of-way within the clear zone as specified in the Guidelines for Highway Design. The District Maintenance Manager will determine whether or not berms or curbs are to be constructed around this separating island area and also along the edges of any end island area. Driveway side slopes within the highway clear zone should not exceed 1:6 maximum.

(m) At locations of new, single homes being constructed adjacent to and lower than the State highway pavement, the property owner is required to grade the frontage within highway limits so as to confine highway surface water to the gutter or construct a bituminous concrete berm. These berms, either grassed earth or bituminous concrete, are maintained by the State upon satisfactory completion by the permittee. Particular care must be exercised to see that the permittee constructs driveway entrances so as to confine surface drainage to the highway gutter.

(n) At new housing developments, shopping centers, industrial parks, and similar developments, the owner shall be required to construct a bituminous concrete lip curb adjacent to the gutter along the entire frontage of the property being developed unless otherwise directed by the District Maintenance Manager.

(o) In instances where the property abutting a State highway is already developed and it becomes necessary to construct a bituminous concrete berm to confine the highway surface drainage, the total cost of constructing the berm is the obligation of the Department.



## 11-9.0 ROUNDABOUTS

Roundabouts are circular intersections with specific design and traffic control features. These features include yield control of all entering traffic, channelized approaches, and geometric curvature to limit travel speeds on the circulatory roadway.

NCHRP Report 672, "Roundabouts: An Informational Guide," presents the various roundabout types and parameters. Based on this documentation, an EXCEL spreadsheet that can be used in investigating the adequacy of a roundabout has been developed and is attached. There are software programs that assist with the design and analysis of roundabouts; the Department will accept both Rodel and Vissim at this time.

Any request for the construction of a roundabout should be submitted to the Roundabout Review Team (RRT) and address all the information listed herein. The RRT will review the submission and make a determination on the appropriateness of a roundabout for the particular location.

When determining the use of a roundabout, the following checklist needs to be considered prior to a submittal to the RRT:

1. Single lane roundabouts are the preferred types of roundabouts. The Department recommends that multi-lane roundabouts only be considered if there is a compelling need. Extra scrutiny will be required in the review of multi-lane roundabouts.
2. Typically a single lane roundabout can handle peak hour volumes of 1800-2000 vph (total entering volume). Generally the entering plus the circulating volumes on any leg should be no more than 1100-1400 vph.
3. Capacity analysis using design year volumes should be done for each leg. If the V/C ratio is greater than 0.85 on any approach then it will essentially operate as a stop controlled intersection.
4. Capacity, Level of Service and Queuing analyses should be performed comparing what is expected for a roundabout versus a signalized intersection using design year volumes.
5. The signal warrants should be provided. Those locations, which just meet or nearly meet the warrants, may be given consideration for roundabout installation. Intersections that are, or proposed to be, all-way stop controlled may also be good candidate locations for a roundabout.
6. Right-of-way impacts need to be assessed. While roundabouts usually require less R.O.W. on the approaches to the intersection, additional R.O.W. impacts may be required at the corners of the intersection.
7. A cost comparison of the use of a roundabout and more traditional engineering options needs to be provided.

8. The grade of both the roundabout approaches and the circulating roadway must be considered. High grades may limit visibility and make it difficult for large vehicles to maneuver.
9. Adequate sight lines must be provided before considering the use of a roundabout. These sight lines shall include the visibility of the motorist in the roundabout, the motorist entering the roundabout, and the visibility to and from pedestrians and cyclists.
10. The accident history of the location must be reviewed. Head-on, left-turning, and angle accidents may be reduced by the introduction of a roundabout.
11. The functional classification of all intersecting roadways needs to be considered. The roundabout gives each approach equal weight for assigning the right of way. Therefore, consideration must be given to any delay added to the higher class of roadway.
12. A high percentage of left-turning vehicles onto the minor roadway generally make a roundabout safer and more efficient than a conventional intersection.
13. Roundabouts should not be installed when located in a coordinated signal system. The roundabout will break up the platoons of traffic.
14. A bottleneck downstream, such as a drawbridge, an at-grade railroad crossing or an oversaturated intersection may cause operational concerns, since traffic can back up into the roundabout.
15. Pedestrian activity needs to be considered. Visually impaired pedestrians have difficulty negotiating the crossings, especially at multi-lane roundabouts. High pedestrian activity may also cause the roundabout to breakdown as traffic yielding to pedestrians can back up into the roundabout.
16. Truck volume needs to be considered. Trucks may encounter difficulty maneuvering through roundabouts. Truck aprons are installed to help mitigate this situation. Additionally the ability of the oversized vehicles and "low boy" vehicles to negotiate a roundabout must be considered. In some cases, such vehicles may have to fully circulate a roundabout to make a right turn. Heavy vehicles should be converted to passenger car equivalents when performing a traffic analysis. Please contact the Office of Motor Transport for their input on oversized vehicles in the area.
17. Bicycles need to be considered. Bicycle accidents are a concern with roundabouts. If high volumes of bicycles are present, the roundabout may not be the best option.
18. Illumination is essential to light up the inner circle and the pedestrian crossings. If illumination is not acceptable to the stakeholders, the use of a roundabout is not recommended.
19. An intersection with an unusual number of legs or where the major move makes a 90-degree turn may be better served with a roundabout.

Roundabouts should not be used solely for traffic calming. They can be used in conjunction with other traffic calming strategies. Roundabouts, when combined with a raised median, can be an effective and efficient means of addressing access management.



**11-10.0 REFERENCES**

1. *A Policy on Geometric Design of Highways and Streets*, AASHTO, 2018.
2. *Highway Capacity Manual 2000*, TRB, 2000.
3. NCHRP Report 383, *Intersection Sight Distance*, Transportation Research Board, 1996.
4. NCHRP Synthesis 225, *Left-Turn Treatments at Intersections*, TRB, 1996.
5. *Manual on Uniform Traffic Control Devices, Millennium Edition*, FHWA, ATSSA, AASHTO, and ITE, 2001.
6. NCHRP 279, *Intersection Channelization Design Guide*, TRB, 1985.
7. *Guidelines for Driveway Location and Design*, ITE, 1987.
8. "Volume Warrants for Left-Turn Storage Lanes at Unsignalized Grade Intersections," M.D. Harmelink, Highway Research Record 211, 1967.
9. "Parameters Affecting Intersection Sight Distance", Special Studies Unit, Connecticut Department of Transportation, October 1985.
10. NCHRP 375, *Median Intersection Design*, TRB, 1995.
11. *Highway Encroachment Permit Regulations*, Connecticut Department of Transportation, 1992.
12. "Major Traffic Generators Procedure for Engineering and Preparation of State Traffic Commission Report", Connecticut State Traffic Commission, January 1977.





**Table of Contents**

(Continued)

<b><u>Section</u></b>		<b><u>Page</u></b>
12-3.02	Entrance Ramps.....	12-3(6)
	12-3.02.01    Acceleration Lanes .....	12-3(6)
	12-3.02.02    Sight Distance.....	12-3(6)
	12-3.02.03    Superelevation.....	12-3(10)
12-3.03	Critical Design Elements .....	12-3(10)
12-4.0	RAMP DESIGN.....	12-4(1)
	12-4.01    Design Speed .....	12-4(1)
	12-4.02    Cross Section .....	12-4(2)
	12-4.03    Horizontal Alignment .....	12-4(2)
	12-4.04    Vertical Alignment.....	12-4(6)
12-5.0	RAMP/CROSSING ROAD INTERSECTION .....	12-5(1)
	12-5.01    Design of At-Grade Intersections .....	12-5(1)
	12-5.02    Frontage Road Intersection.....	12-5(4)
	12-5.03    Access Control .....	12-5(4)
12-6.0	REFERENCES.....	12-6(1)
Appendix	.....	12-A(1)



## Chapter Twelve

# INTERCHANGES

### 12-1.0 GENERAL

#### 12-1.01 Warrants

##### 12-1.01.01 Guidelines

Although an interchange is a high-level compromise for intersection problems, its high cost and environmental impact require that interchanges only be used after careful consideration of its costs and benefits. Because of the great variance in specific site conditions, ConnDOT has not adopted specific interchange warrants. When determining the need for an interchange or grade separation, the following guidelines should be considered:

1. Design Designation. Once it has been decided to provide a fully access-controlled facility, each intersecting highway must be terminated, rerouted, provided a grade separation or provided an interchange. The importance of the continuity of the crossing road and the feasibility of an alternative route will determine the need for a grade separation or interchange. An interchange should be provided on the basis of the anticipated demand for access to the minor road.

On facilities with partial control of access, intersections with public roads will be terminated or accommodated by an interchange or with an at-grade intersection; grade separations alone are not normally provided. Typically, an interchange will be selected for the higher-volume intersecting roads. Therefore, on a facility with partial control of access, the decision to provide an interchange will be, in general, based on the criteria in the following comments.

2. Functional Classification. Interchanges will be provided at all freeway-to-freeway crossings. On fully access-controlled facilities, interchanges should be provided with all major highways, unless this is determined inappropriate for other reasons. Interchanges to other highways may be provided if practical.
3. Congestion. An interchange may be considered where the level of service (LOS) at an at-grade intersection is unacceptable, and the intersection cannot be redesigned at-grade to operate at an acceptable LOS. Although LOS criteria is the most tangible of any interchange guideline, ConnDOT has not adopted any specific levels which, when exceeded, would demand an interchange.
4. Safety. The crash reduction benefits of an interchange should be considered at an existing at-grade intersection that has a high-crash rate. Section 12-2.04 provides additional information on various safety considerations relative to interchange selection.

5. Site Topography. At some sites, the topography may be more adaptable to an interchange than an at-grade intersection.
6. Road-User Benefits. Interchanges significantly reduce the travel time when compared to at-grade intersections but may increase the travel distances. If an analysis reveals that road-user benefits over the service life of the interchange will exceed costs, then an interchange may be considered.
7. Traffic Volumes. A traffic volume warrant is the most tangible of any interchange warrant. Although the Department has not adopted specific numbers that, when exceeded, would demand an interchange, it is still an important factor. For example, the point at which volumes for an at-grade intersection exceed capacity may warrant an interchange, if the at-grade intersection cannot be practically upgraded. In addition, other factors (e.g., costs, right-of-way, environmental concerns) need to be considered.
8. Interchange Spacing. When interchanges are spaced farther apart, freeway operations are improved. Spacing of urban interchanges between interchange crossroads should not be less than 1 mi. This should allow for adequate distance for an entering driver to adjust to the freeway environment, to allow for proper weaving maneuvers between entrance and exit ramps, and to allow for adequate advance and exit signing. In urban areas, a spacing of less than 1 mi may be developed by grade-separated ramps or by collector-distributor roads. In rural areas, interchanges should not be spaced less than 3 mi apart on the Interstate system or 2 mi on other systems.

#### **12-1.01.02 New/Revised Access Points on the Interstate System**

The Department's goal is to maintain the highest practical level of service, safety and mobility on its Interstate System. Among other design features, this is accomplished by controlling access onto the system. In general, new access points on existing fully access-controlled facilities are discouraged. Proposals for new or revised access points on an existing Interstate must fully address the following considerations:

1. Traffic Volumes. The proposal must demonstrate that existing interchanges and/or local roads and streets within the corridor cannot satisfactorily accommodate, nor can the existing network be feasibly improved to accommodate, the expected design-year traffic volumes.
2. Alternatives. The proposal must demonstrate that all reasonable alternatives for design options, locations and transportation system management type improvements (e.g., ramp metering, mass transit, HOV facilities) have been evaluated, provided for, and/or provision made for future incorporation.
3. Impacts. The proposed new access point should not have a significant adverse impact on the safety and operation of the Interstate facility based on an analysis of current and future traffic (e.g., 20 years in the future). The operational analysis for existing conditions should include:

- a. an analysis of Interstate sections to, and including, at least the first adjacent existing or proposed interchange on either side; and
  - b. an analysis of crossroads and other roads/streets to ensure their ability to collect and distribute traffic to and from the proposed interchange.
4. Connections. The proposed new interchange will only be connected to a public road, and it will provide for all traffic movements. Less than “full interchanges” for special purpose access for transit vehicles, for HOV entrances or to park-and-ride lots may be considered on a case-by-case basis.
  5. Land Use. The proposal must address the consistency of the interchange with local and regional development plans and transportation system improvements. For possible multiple interchange additions, the proposal must be supported by a comprehensive Interstate network study that should address all proposed and desired access within the context of a long-term plan.
  6. New/Expanded Development. Where new or revised access is requested, due to a proposed or expanded development, document that the appropriate coordination has taken place with the developer in conjunction with other transportation system improvements.
  7. Design. The Department’s design criteria for interchanges as presented in this Chapter must be met or adequately addressed.

All proposed new or revised access points on the Interstate System will require formal approval from the FHWA. See Federal Register, Vol. 74, No. 165, Thursday, 8/27/2009 provides further guidance on access points.

Each entrance and exit point on the mainline, including “locked gate” access (e.g., utility opening), is defined as an access point (e.g., diamond interchanges have four access points). A revised access is considered to be a change in the interchange configuration even though the number of access points may not change (e.g., replacing a diamond interchange ramp with a loop).

### **12-1.01.03 FHWA Access Approval**

The “[Procedure Manual for New or Revised Interstate Access Approval in Connecticut](#),” dated April 2018, an excerpt of which is contained in Appendix A, is applicable to new or revised access points on the existing Interstate System. FHWA approval for access revisions is required, irrespective of the funding source or whether the work is performed by public and/or private contract, including such changes that may be required by the State Traffic Commission. The FHWA approval constitutes a Federal action and, as such, requires that *National Environmental Policy Act (NEPA)* procedures are followed. The policy applies only to the Interstate System. FHWA approval is not required for access revisions for Non-Interstate National Highway System freeways.

FHWA access approval is required for new interchanges, new partial interchanges or new ramps to and from frontage roads, locked gate access, major modifications to existing interchanges, completion of basic movements at partial interchanges, shifting existing mainline gore areas, abandoning ramps or interchanges and adding continuous travel lanes to an on-ramp.

FHWA access approval may be required for decreasing or increasing the length of acceleration or deceleration lanes. The designer should consult the policy for specifics.

FHWA access approval is not required for the addition of left-turn, right-turn or through lanes on the ramp at its terminus, relocating or shifting the ramp terminus, the addition of a single auxiliary lane between two adjacent interchange ramps and signalization improvements at the ramp terminus. New signing, pavement markings, resurfacing and safety type improvements do not require FHWA approval, provided the geometric features of a ramp do not change.

Additional guidance can be obtained by contacting the Bureau of Policy and Planning, Office of Intermodal Planning.

## **12-1.02     Interchange Type Selection**

### **12-1.02.01     General Evaluation**

The AASHTO *A Policy on Geometric Design of Highways and Streets* presents the various interchange types that may be used at a given site. The Office of Intermodal Project Planning normally determines the type of interchange for the site. Typically, the Office will evaluate several types for potential application considering:

1. compatibility with the surrounding highway system;
2. route continuity;
3. level of service for each interchange element (e.g., freeway/ramp junction, ramp proper);
4. operational characteristics (e.g., single versus double exits, weaving, signing);
5. road user impacts (e.g., travel distance and time, safety, convenience, comfort);
6. driver expectancy;
7. geometric design;
8. construction and maintenance costs;
9. potential for stage construction;
10. right-of-way impacts and availability;
11. environmental impacts; and
12. potential growth of surrounding area.

All interchanges should provide for all movements, even when the anticipated turning volume is low. An omitted movement may cause confusion to those drivers searching for the exit or entrance. In addition, unanticipated future developments may increase the demand for that movement.

### 12-1.02.02 Types

This Section presents the basic types of interchanges in Connecticut. The AASHTO *A Policy on Geometric Design of Highways and Streets* discusses the advantages and disadvantages for each interchange type. Each interchange must be custom-designed to fit the individual site considerations. The final design may be a minor or major modification of one of the basic types or may be a combination of two or more basic types. The following are the basic types of interchanges used in Connecticut:

1. Three-Leg. Three-leg interchanges, also known as T- or Y-interchanges, are provided at intersections with three legs.
2. Diamond. The diamond is the simplest and perhaps the most common type of interchange. One-way diagonal ramps are provided in each quadrant with two at-grade intersections provided at the minor road. If these two intersections can be properly designed, the diamond is usually the best choice of interchange where the intersecting road is not access controlled.
3. Single Point Urban Interchange. The single point urban interchange is a special type of diamond interchange. With this interchange, all legs of the interchange meet at a single point. It can significantly increase the interchange capacity, alleviate the operational problems of having two closely spaced at-grade intersections on the minor road, and overcome the left-turn lane storage problem for drivers wishing to enter the freeway.
4. Full Cloverleafs. Cloverleaf interchanges are used at 4-leg intersections and employ loop ramps to accommodate left-turn movements. Loops may be provided in any number of quadrants. Full cloverleaf interchanges are those with loops in all four quadrants; all others are partial cloverleafs.
5. Partial Cloverleafs. Partial cloverleaf interchanges are those with loops in one, two or three quadrants. They are appropriate where right-of-way restrictions preclude ramps in one or more quadrants. They are also advantageous where a left-turn movement can be provided onto the major road by a loop without the immediate presence of an entrance loop from the minor road.
6. Directional and Semi-Directional. Directional or semi-directional interchanges are used for heavy left-turn movements to reduce travel distance, to increase speed and capacity and to eliminate weaving. These types of connections allow an interchange to operate at a better level of service than is possible with cloverleaf interchanges.



## 12-2.0 TRAFFIC OPERATIONAL FACTORS

Several traffic operational factors are important in the design of an interchange. Adhering to these factors will minimize confusion, operational problems and the number of crashes. The designer must work closely with the Design Development Team to ensure that all operational factors are properly considered.

### 12-2.01 Basic Number of Lanes and Lane Balance

The basic number of lanes is the minimum number of lanes over a significant length of highway based on the overall capacity needs of that section. The number of lanes should remain constant over short distances. For example, a lane should not be dropped at the exit of a diamond interchange and then added at the downstream entrance simply because the traffic volume between the exit and entrance drops significantly. A basic lane should also not be dropped between closely spaced interchanges simply because the estimated traffic volume in that short section of highway does not warrant the higher number of lanes.

The number of lanes on the freeway mainline should not be reduced by more than one lane at an exit or increased by more than one lane at an entrance. This principle is lane balance. It would prohibit, for example, dropping two lanes at a 2-lane exit ramp. One lane must provide the option of remaining on the freeway.

Figure 12-2A illustrates how to coordinate lane balance and the basic number of lanes at an interchange. Figure 12-2B illustrates how to achieve lane balance at the merging and diverging points of branch connections.

### 12-2.02 Lane Reductions

Freeway lane drops, where the basic number of lanes is decreased, must be carefully designed. They should occur on the freeway mainline away from any other turbulence (e.g., interchange exits and entrances). Figure 12-2C illustrates the recommended design of a lane drop beyond an interchange. The following criteria are important when designing a freeway lane drop:

1. Location. The lane drop should occur 2000 ft to 3000 ft beyond the previous interchange. This distance allows adequate signing and driver adjustments from the interchange, but yet is not so far downstream that drivers become accustomed to the number of lanes and are surprised by the lane drop. In addition, a lane should not be dropped on a horizontal curve or where other signing is required, such as for an upcoming exit.
2. Transition. The length of transition is 840 ft, which is based on a 70:1 taper rate.

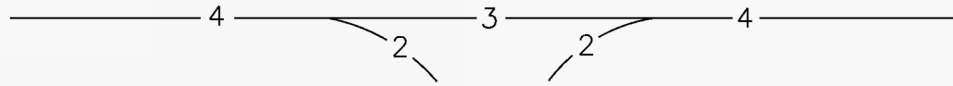

LANE BALANCE BUT NO COMPLIANCE WITH BASIC NUMBER OF LANES

-A-

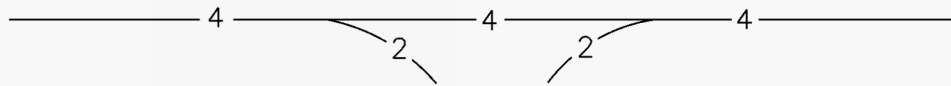

NO LANE BALANCE BUT COMPLIANCE WITH BASIC NUMBER OF LANES

-B-

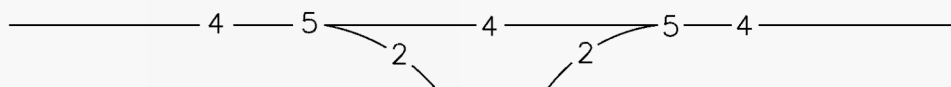

COMPLIANCE WITH BOTH LANE BALANCE AND BASIC NUMBER OF LANES

-C-

### COORDINATION OF LANE BALANCE AND BASIC NUMBER OF LANES

Figure 12-2A



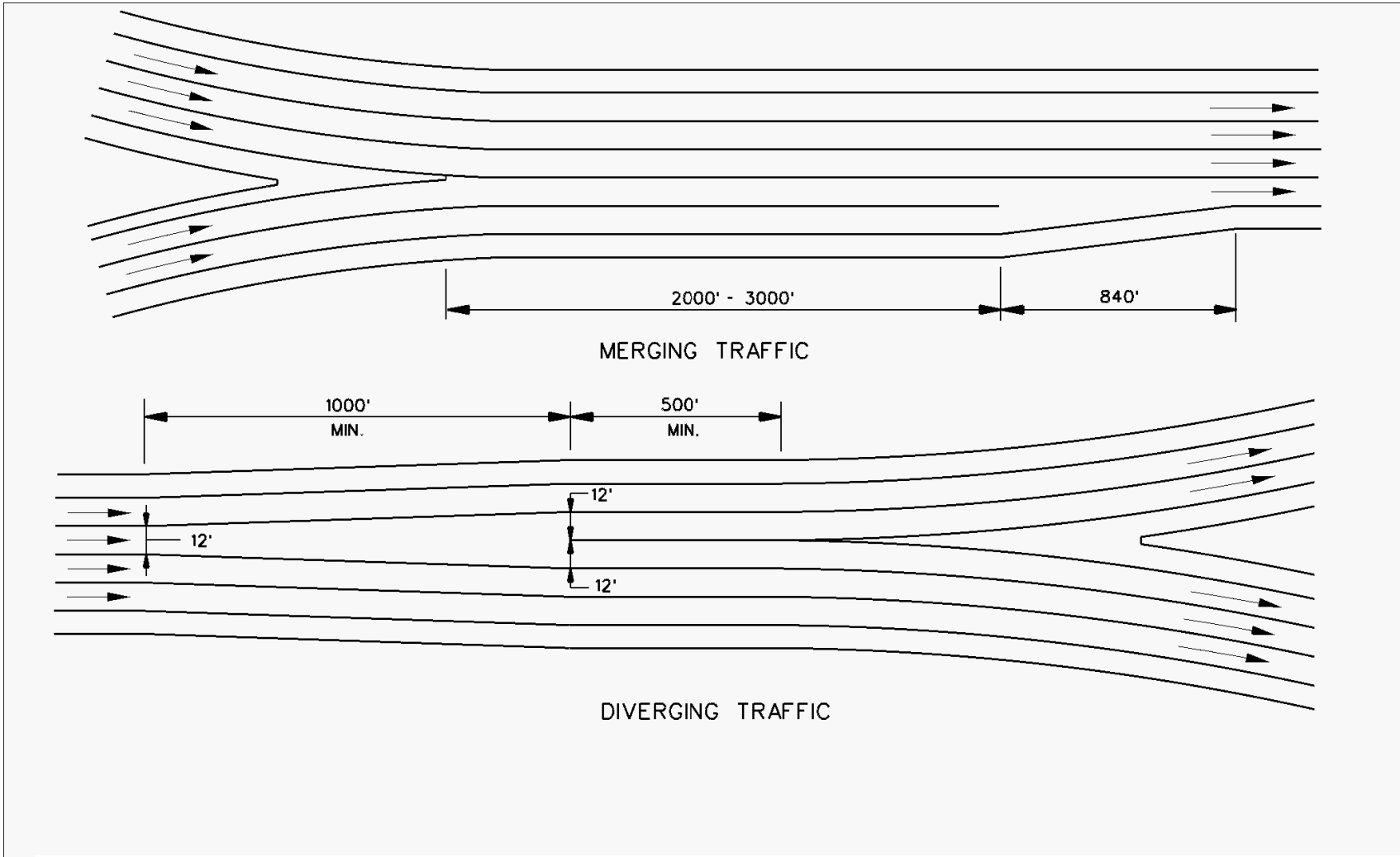

**LANE BALANCE AT BRANCH CONNECTIONS**

**Figure 12-2B**

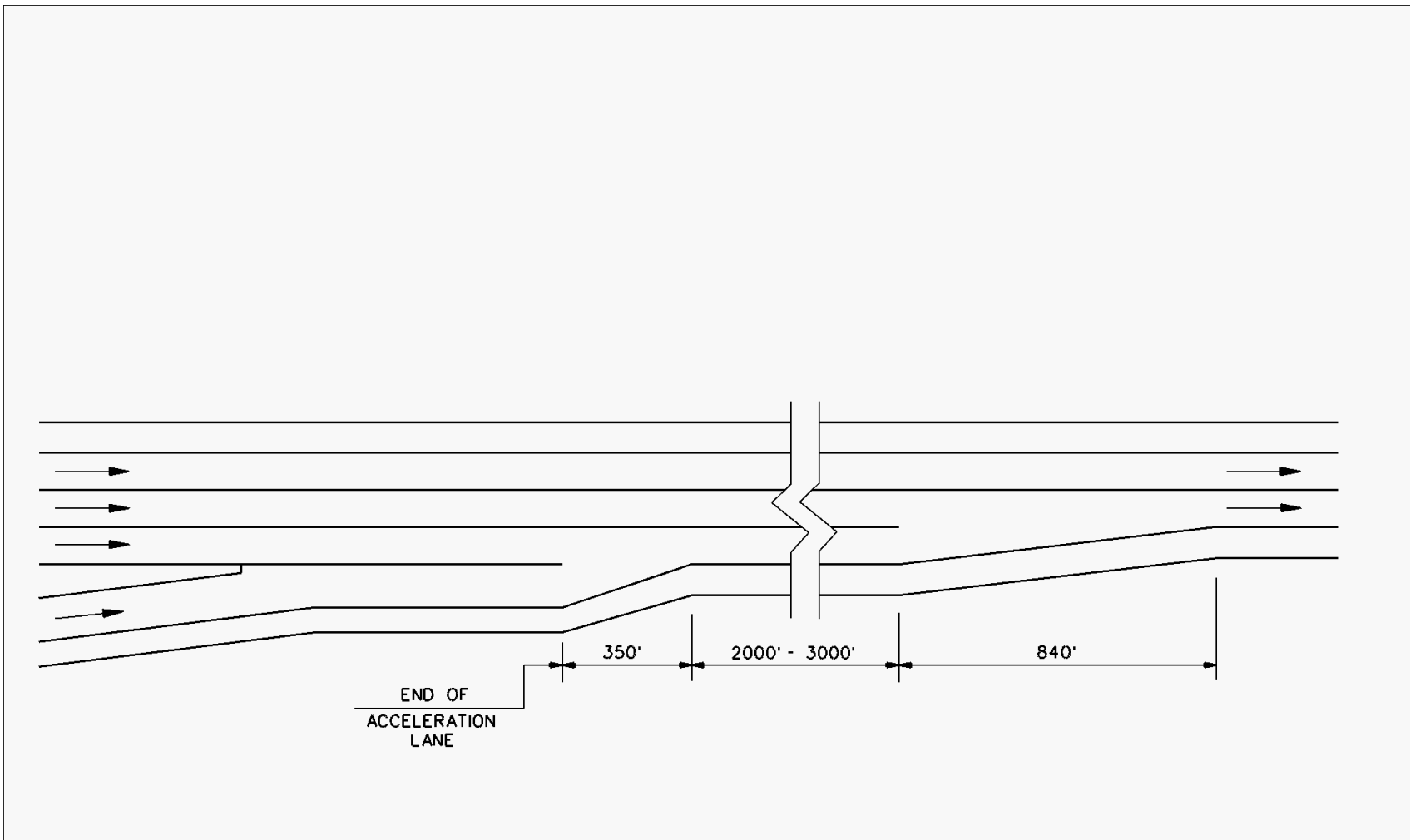

**FREEWAY LANE DROP BEYOND INTERCHANGE**

**Figure 12-2C**

3. Sight Distance. Where practical, decision sight distance (DSD) should be available to any point within the entire lane transition (840 ft). See Figure 7-2A for applicable DSD values. When determining the availability of DSD, the height of object should be 0.0 in (the roadway surface); however, it is acceptable to use 2 ft. These criteria would favor, for example, placing a freeway lane drop within a sag vertical curve rather than just beyond a crest.
4. Right-Side versus Left-Side Drop. All freeway lane drops should be on the right side, unless specific site conditions greatly favor a left-side lane reduction.

In urban areas, interchanges may be closely spaced for considerable lengths of highway. In these cases, it may be necessary to drop a freeway lane at an exit. Figure 12-2D illustrates the recommended design. One key design feature is the “escape lane” provided just beyond the exit gore. Some drivers may miss the signs that notify them that the mainline lane is being dropped at the exit. The escape lane provides these drivers with an opportunity to merge left into the remaining through lanes. As discussed in Section 12-2.01 on basic number of lanes, this design should not be used unless there is a large decrease in traffic demand for a significant length of freeway.

### **12-2.03     Distance Between Successive Freeway/Ramp Junctions**

Frequently, successive freeway/ramp junctions must be placed relatively close to each other, especially in urban areas. The distance between the junctions must be sufficient for vehicular maneuvering, signing and capacity. Figures 12-2E and 12-2F provide recommended minimum distances for spacing for freeway/ramp junctions.

In addition, the *Highway Capacity Manual* provides a detailed methodology for calculating the level of service for many combinations of freeway/ramp junctions. This will be a major factor in determining appropriate distances between these junctions. The Design Development Team will review the analysis to determine the applicable spacing for a specified level of service. The greater of the distances from Figures 12-2E and 12-2F or from the capacity analysis will govern.

### **12-2.04     Safety Considerations**

The following summarizes significant safety considerations that should be evaluated in the design of an interchange:

1. Exit Points. Where practical, provide decision sight distance at freeway exits, and use the pavement surface for the height of object (0.0 in). A 2-ft height of object is acceptable. See Section 12-3.01 for the application of decision sight distance to freeway exits. Proper advance signing of exits is also essential.

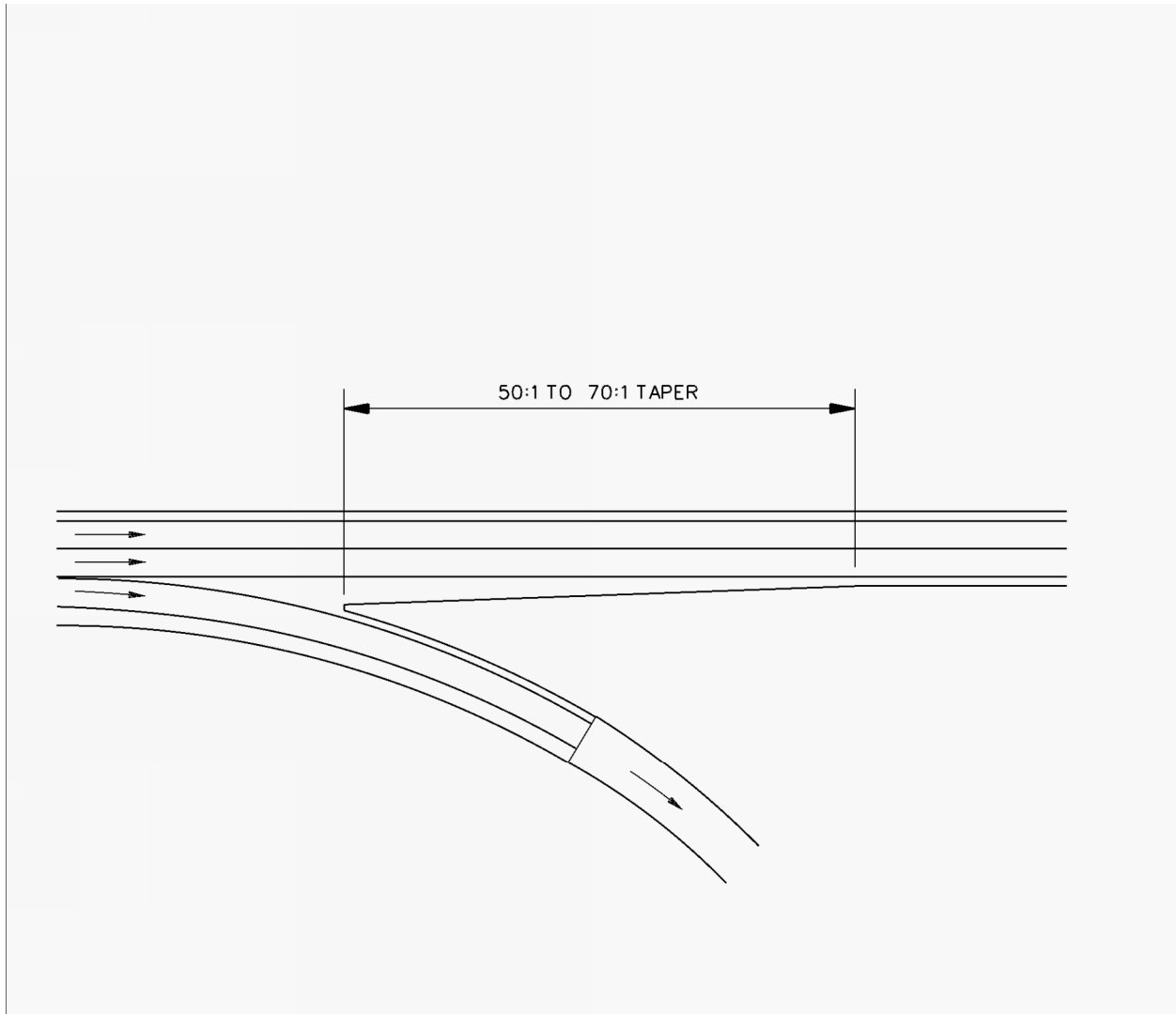

*Note:*

*A reduction in the number of lanes at an interchange is an appropriate layout only where the traffic warrants for a considerable section of the freeway beyond the interchange do not require the greater number of lanes. Because of the difficulty of predicting the daily and hourly fluctuations of traffic on low-volume ramp movements, the number of lanes should not be reduced within the interchange area, such as between successive "off" and "on" ramps.*

**REDUCTION IN NUMBER OF TRAFFIC LANES AT INTERCHANGE**

**Figure 12-2D**

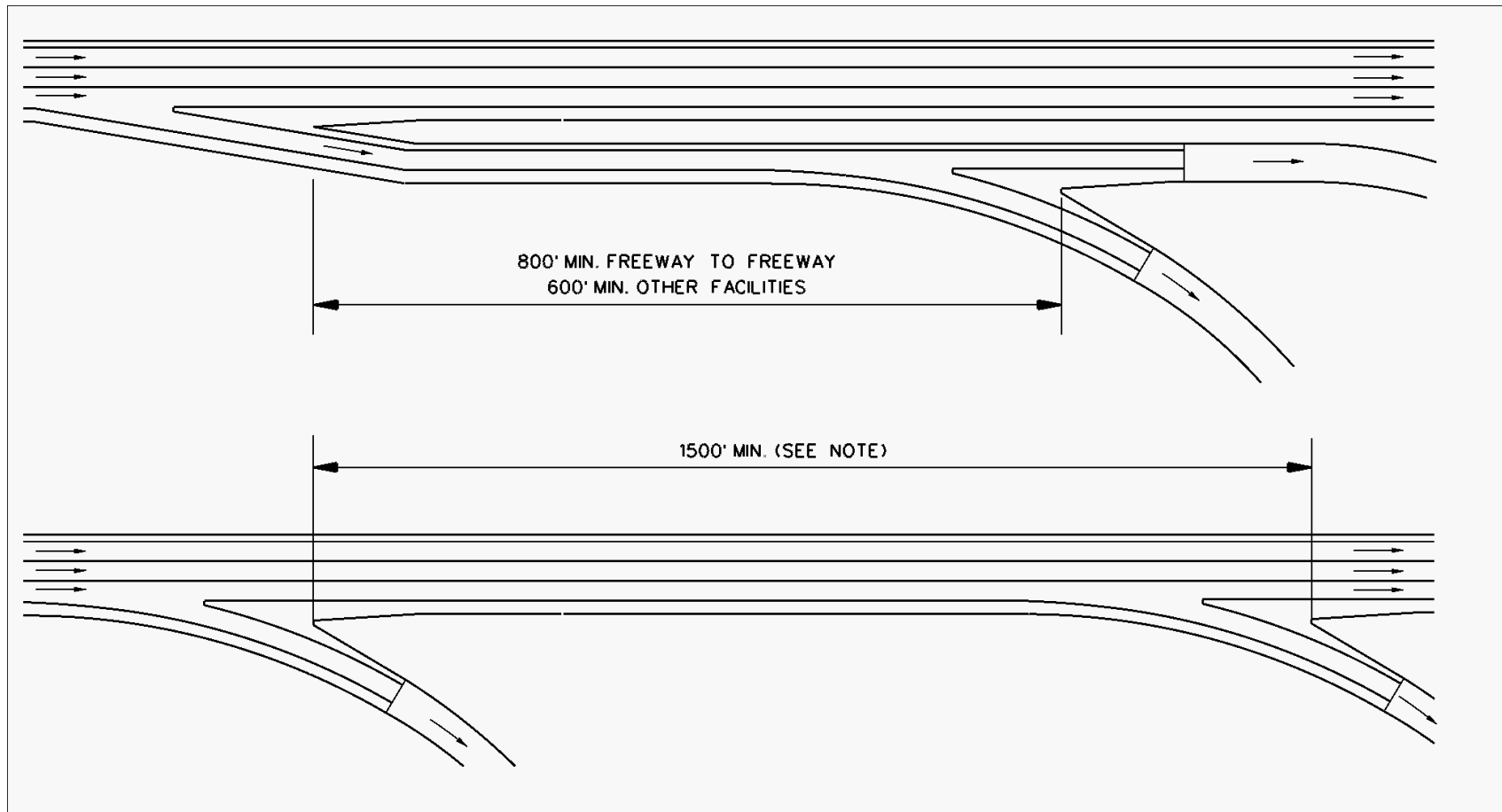

**Note:**

*The spacing of exit terminals should be based upon considerations of signing to permit the driver adequate time to make decisions. Exit terminals should not be spaced closer than 1 mi except where conditions, such as ramp or local terminal capacity, may make it necessary to reduce this distance. Between exit terminals, 1500 ft is considered the minimum distance that will provide safe and efficient operation. Closer spacings should be used under the lower speed situation provided by the distributor road arrangement shown in the upper sketch. In addition, the Highway Capacity Manual should be used to determine the actual distance based on a specified level of service.*

**SUCCESSIVE EXIT TERMINAL SPACINGS**

**Figure 12-2E**

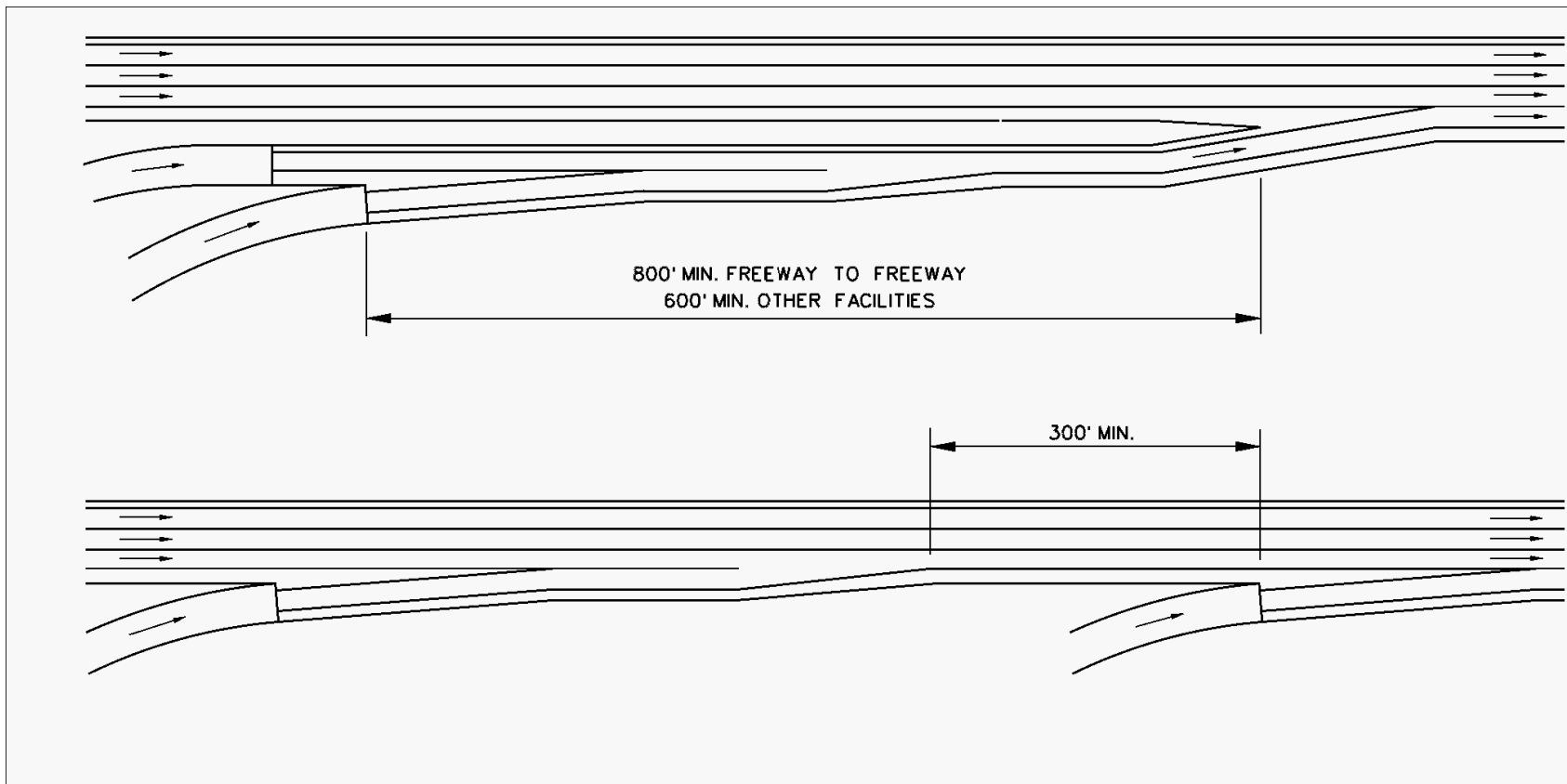

**Note:**

The spacing of entrance terminals should be based upon considerations of maintaining smooth operations on the through traffic lanes. Entrance terminals often cause turbulence that should not extend through successive entrance areas. 300 ft is considered the minimum distance of normal cross section necessary for the turbulence associated with lane changing to subside. Where closer spacing of entrance terminals is required, the collector road detail shown in the upper sketch may be employed. In addition, the Highway Capacity Manual should be used to determine the actual distance based on a specified level of service.

**SUCCESSIVE ENTRANCE TERMINAL SPACINGS**

**Figure 12-2F**

2. Exit Speed Changes. The design should provide enough distance to allow safe deceleration from the freeway design speed to the design speed of the first governing geometric feature on the ramp, typically the horizontal exit curve. See Section 12-3.01 for applicable values for deceleration length.
3. Merges. Rear-end collisions on entrance merges onto a freeway may result from a driver attempting the complicated maneuver of simultaneously searching for a gap in the mainline traffic stream and watching for vehicles in front. An acceleration distance of sufficient length should be provided to allow a merging vehicle to attain speed and find a sufficient gap to merge into.
4. Fixed-Object Crashes. A number of fixed objects may be located within interchanges, such as signs at exit gores or bridge piers. These should be removed where practical, made breakaway, or shielded with barriers or impact attenuators. See Chapter Thirteen for a detailed discussion on roadside safety.
5. Wrong-Way Entrances. In almost all cases, wrong-way maneuvers originate at interchanges. Some cannot be avoided, but many result from driver confusion due to poor visibility, deceiving ramp arrangement or inadequate signing. The interchange design must attempt to minimize wrong-way possibilities. The designer should coordinate with the Division of Traffic Engineering to achieve this objective.
6. Incomplete Interchanges. If practical, the designer should ensure that all movements are provided at an interchange, even if projected turning volumes are low. A missing movement may cause confusion for those drivers seeking that movement. In addition, if future demand for the movement increases, it may be relatively expensive and disruptive to provide the connection.
7. Driver Expectancy. Interchanges can be significant sources of driver confusion; therefore, they should be designed to conform to the principles of driver expectancy. Several of these principles are discussed below:
  - a. Avoid using left-hand exits and entrances. It is difficult for a driver entering from a ramp to safely merge with the high-speed left lane on the mainline. Therefore, left exits and entrances should not be used, because they are not consistent with the concept of driver expectancy when they are mixed with right-hand entrances and exits.
  - b. Do not place exits in line with the freeway tangent section at the point of mainline curvature to the left.
  - c. Avoid placing exits immediately beyond structures.

**12-2.05     Capacity and Level of Service**

The capacity of an interchange will depend upon the operation of its individual elements:

1.     basic freeway section where interchanges are not present,
2.     freeway/ramp junctions,
3.     weaving areas,
4.     ramp proper, and
5.     ramp/crossing road intersection.

The basic capacity reference is the *Highway Capacity Manual (HCM)*. The *HCM* provides the analytical tools to analyze the level of service for each element listed above.

The interchange should operate at an acceptable level of service. The level of service values presented in Figures 4A and 5A for freeways will also apply to interchanges. The level of service of each interchange element should be as good as the level of service provided on the basic freeway section. At a minimum, interchange elements should not operate at more than one level of service below that of the basic freeway section. In addition, the operation of the ramp/crossing road intersection in urban areas should not impair the operation of the mainline. This will likely involve a consideration of the operational characteristics on the minor road for some distance in either direction from the interchange. The Design Development Team is responsible for conducting the capacity analyses for all interchange elements. However, coordinate the capacity analyses at ramp/crossing road intersections with the Division of Traffic Engineering.

**12-2.06     Collector-Distributor Roads**

Collector-distributor (C-D) roads are sometimes provided within an interchange to improve its operational characteristics. C-D roads will:

1.     remove weaving maneuvers from the mainline,
2.     provide single exits and entrances from the mainline, and
3.     provide all mainline exits in advance of the structure.

C-D roads are most often warranted when traffic volumes are so high that the interchange without them cannot operate at an acceptable level of service, especially in weaving sections. C-D roads may be one or two lanes, depending upon the traffic volumes and weaving conditions. Lane balance should be maintained at the exit and entrance points of the C-D road. The design speed should be the same as the mainline, but not more than 15 mph below the mainline. The separation between the C-D road and mainline should be as wide as practical, but not less than that required to provide the applicable shoulder widths and a longitudinal barrier between the two.



## **12-3.0 FREEWAY/RAMP JUNCTIONS**

### **12-3.01 Exit Ramps**

#### **12-3.01.01 Deceleration Lanes**

Sufficient deceleration distance is needed to safely and comfortably allow an exiting vehicle to leave the freeway mainline. All deceleration should occur within the full width of the deceleration lane. The length of the deceleration lane will depend upon the design speed of the mainline and the design speed of the first governing geometric control on the exit ramp. This will most often be a horizontal curve but could be, for example, stopping sight distance on a vertical curve or the back of a traffic queue. Figure 12-3A provides the deceleration distances for various combinations of highway design speeds and ramp design speeds. Greater distances should be provided if practical. If the deceleration lane is on a grade of 3% or more, the length of the lane should be adjusted according to the criteria in Figure 12-3B.

The specific use of the deceleration criteria to horizontal curves warrants some elaboration. The following will apply:

1. Based on the highway design speed and the design speed of the first curve on the exit ramp, Figure 12-3A will yield the required length of the deceleration lane. This will apply from the point where the deceleration lane becomes 12 ft wide to the PC of the horizontal curve.
2. For compound curves on the ramp, the minimum length of the entering flatter curve should allow for safe deceleration to the design speed of the sharper curve. Figure 12-3A provides the criteria to determine the minimum distance between the PC and PCC or between the PCC and PCC.

Department policy is that taper ramps will be used for all freeway exits. Figure 12-3C illustrates the typical design for a freeway taper exit. However, at restrictive sites where a taper design cannot be provided, a parallel lane may be considered. If used, it should be introduced with a taper of 25:1. The AASHTO *A Policy on Geometric Design of Highways and Streets* provides the design criteria for parallel lane designs.

#### **12-3.01.02 Sight Distance**

Where practical, decision sight distance should be provided for drivers approaching an exit. This sight distance is particularly important for exit loops beyond the structure. Vertical curvature or bridge piers can obstruct the exit points if not carefully designed. When measuring for adequate sight distance, the height of object should be 0.0 in (the roadway surface); however, it is acceptable to use 2 ft. Figure 12-3C illustrates the application of the decision sight distance to freeway exits.

Highway Design Speed (mph) (V)	Speed Reached (mph) (V <sub>a</sub> )	L = Deceleration Length (ft)								
		For Design Speed of First Governing Geometric Control (mph) (V')								
		Stop	15	20	25	30	35	40	45	50
		For Average Running Speed on Exit Curve (mph) (V' <sub>a</sub> )								
		0	14	18	22	26	30	36	40	44
30	28	235	200	170	140	—	—	—	—	—
35	32	280	250	210	185	150	—	—	—	—
40	36	320	295	265	235	185	155	—	—	—
45	40	385	350	325	295	250	220	—	—	—
50	44	435	405	385	355	315	285	225	175	—
55	48	480	455	440	410	380	350	285	235	—
60	52	530	500	480	460	430	405	350	300	240
65	55	570	540	520	500	470	440	390	340	280
70	58	615	590	570	550	520	490	440	390	340

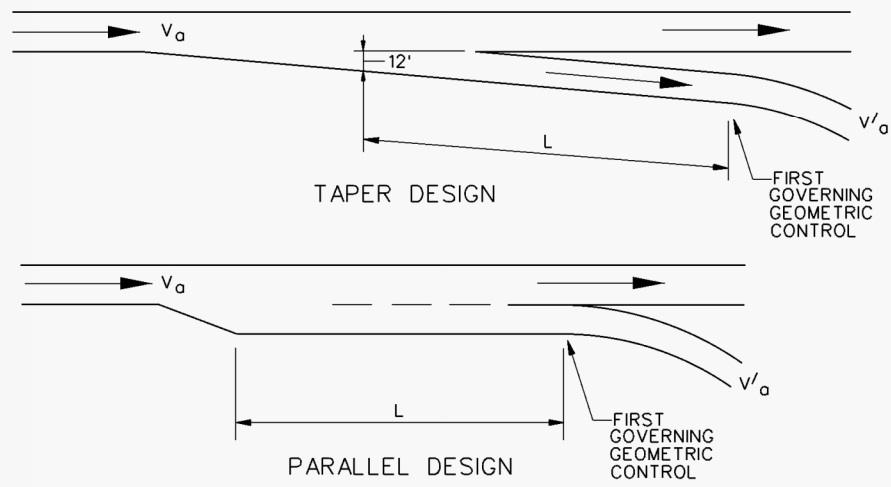

Notes:

1. The deceleration lengths are calculated from the distance needed for a passenger car to decelerate from the average running speed of the highway mainline to the average running speed of the first governing geometric control.
2. These values are for grades less than 3%. See Figure 12-3B for steeper upgrades or downgrades.

**MINIMUM LENGTH OF DECELERATION LANES**  
**Figure 12-3A**

Direction of Grade	Deceleration Lane: Ratio of Length on Grade to Length on Level				
	$G < 3\%$	$3\% \leq G \leq 4\%$	$4\% < G < 5\%$	$5\% \leq G \leq 6\%$	$G > 6\%$
Upgrade	1.0	0.9	0.85	0.8	0.7
Downgrade	1.0	1.2	1.28	1.35	1.5

**Notes:**

1. Table applies to all highway design speeds.
2. The "grade" in the table is the average grade over the distance used for measuring the length of the deceleration lane. See Figure 12-3C.

**Example 12-3.01(1)**

Given: Highway Design Speed - 70 mph  
 First Exit Curve Design Speed - 40 mph  
 Average Grade - 5% downgrade

Problem: Determine length of deceleration lane.

Solution: Figure 12-3A yields a minimum deceleration lane of 440 ft on the level. According to Figure 12-3B, this should be increased by 1.35.

Therefore:  $L = 440 \times 1.35$   
 $L = 594 \text{ ft}$

A 594-ft deceleration lane would be provided from the full width of the lane to the PC of the first exit curve.

**GRADE ADJUSTMENTS ON DECELERATION LANES****Figure 12-3B**

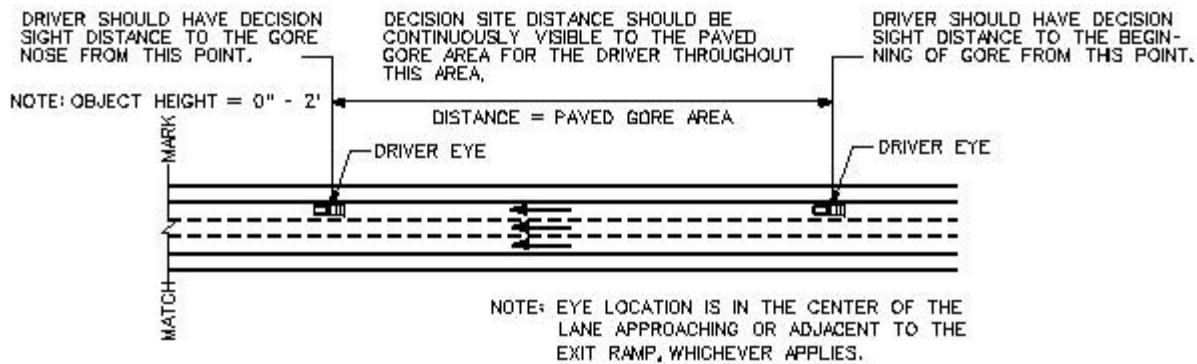
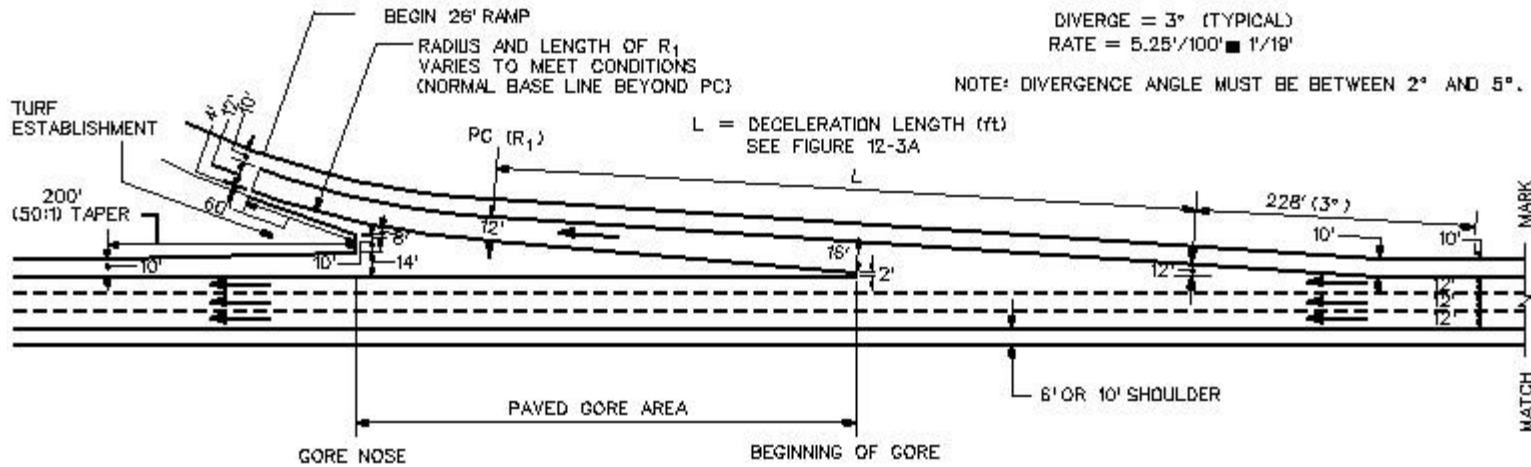

TYPICAL EXIT RAMP DESIGN  
(3° Divergence)

Figure 12-3C

### 12-3.01.03 Superelevation

The superelevation at an exit ramp must be developed to properly transition the driver from the mainline to the curvature at the exit. The principles of superelevation for rural highways and high-speed urban facilities, as discussed in Section 8-2.0, should be applied to the exit ramp design.

The maximum superelevation rate is 6%. Figure 8-2A presents the design superelevation rate for various combinations of radii and design speed. Typically, the exit lane should be transitioned so that 0.67 of the design superelevation is reached at the PC of the first exit curve. At a minimum, the length of runoff should be based on the distances provided in Figure 8-2A.

### 12-3.01.04 Gore Area

The gore area is normally considered to be both the paved triangular area between the through lane and the exit lane, plus the graded area which may extend 300 ft or more downstream beyond the gore nose. The following should be considered when designing the gore:

1. Traffic Control Devices. If practical, the area beyond the gore nose should be free of signs and luminaire supports for approximately 300 ft beyond the gore nose. If they must be present, they must be yielding or breakaway or shielded by guiderail or a impact attenuator; see Chapter Thirteen.
2. Grading. The graded area beyond the gore nose should be as flat as practical. If the elevation between the exit ramp or loop and the mainline increases rapidly, this may not be practical. These areas will likely be non-traversable and the gore design must shield the motorist from these areas. At some sites, the vertical divergence of the ramp and mainline will warrant protection for both roadways beyond the gore.
3. Paved Gore. The paved triangular gore area between the through lane and exit lane should be safely traversable. The effects of snow storage and melt in the gore area design must be carefully considered. The typical gore grading design will collect the highway runoff in a swale section and direct it off the highway into the earth gore or collect it in a subsurface drainage system. This will minimize icing problems during winter maintenance activities. The maximum break in pavement cross slopes through the swale area should not exceed 8% at any point. Where this treatment is not practical, a straight cross slope may be used provided drainage and snow melt issues are adequately addressed. In no case should the cross slope of gore be steeper than the adjacent travel lane cross slope. To ensure adequate consideration is given to the combination of drainage and geometric factors, careful evaluation will be necessary early in the design process.
4. Signing. Signing in advance of the exit and at the divergence should be according to current ConnDOT practices. This also applies to the pavement markings in the triangular area upstream from the gore nose. Signing and pavement markings should be coordinated with the Division of Traffic Engineering.

**12-3.01.05 Cross Slope Rollover**

The cross slope rollover is the algebraic difference between the slope of the through lane and the slope of the exit lane, when these two are adjacent to each other (i.e., before the gore begins). The maximum algebraic difference is 5%.

**12-3.02 Entrance Ramps****12-3.02.01 Acceleration Lanes**

A properly designed acceleration lane will facilitate driver comfort, traffic operations and safety. The length of the acceleration lane will primarily depend upon the design speed of the last (or controlling) curve on the entrance ramp and the design speed of the mainline. Figure 12-3D provides the criteria for minimum lengths of acceleration lanes. These lengths are for the full width of the acceleration lane; taper lengths, typically 350 ft, are in addition to the table lengths. However, in restrictive locations, up to 50 ft of the taper length may be used to meet the criteria for the acceleration distance. Where grades of 3% or more occur on the acceleration lane, adjustments should be made in its length according to Figure 12-3E. Figure 12-3F illustrates the typical design for entrance ramps. The designer should coordinate with the Design Development Team to determine the actual length of the acceleration lane.

The values in Figure 12-3D provide sufficient distance for vehicular acceleration; they may not safely allow a vehicle to merge into the mainline if traffic volumes are high. Where the mainline and ramp will carry traffic volumes approaching the design capacity of the merging area, the parallel portion of the acceleration lane should be increased to a maximum of 1200 ft in length.

**12-3.02.02 Sight Distance**

Where practical, decision sight distance should be provided for drivers on the mainline approaching an entrance terminal. They need sufficient distance to see the merging traffic so they can adjust their speed or change lanes to allow the merging traffic to enter the freeway. Likewise, drivers on the entrance ramp need to see a sufficient distance upstream from the entrance to locate gaps in the traffic stream for merging.

Highway Design Speed (mph) (V)	Speed Reached (mph) (V <sub>a</sub> )	L = Acceleration Length (ft)								
		For Entrance Curve Design Speed (mph)								
		Stop	15	20	25	30	35	40	45	50
		And Initial Speed (mph) (V' <sub>a</sub> )								
		0	14	18	22	26	30	36	40	44
30	23	180	140	–	–	–	–	–	–	–
35	27	280	220	160	–	–	–	–	–	–
40	31	360	300	270	210	120	–	–	–	–
45	35	560	490	440	380	280	160	–	–	–
50	39	720	660	610	550	450	350	130	–	–
55	43	960	900	810	780	670	550	320	150	–
60	47	1200	1140	1100	1020	910	800	550	420	180
65	50	1410	1350	1310	1220	1120	1000	770	600	370
70	53	1620	1560	1520	1420	1350	1230	1000	820	580

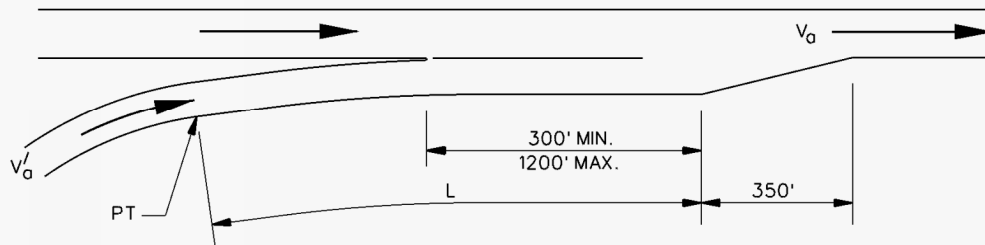

Notes:

1. The acceleration lengths are calculated from the distance needed for a passenger car to accelerate from the average running speed of the entrance curve to a speed of 5 mph below the average running speed on the mainline.
2. These values are for grades less than 3%. See Figure 12-3E for steeper upgrades or downgrades.
3. Use the value of L or 300 ft beyond the 2-ft nose, whichever is greater.

**MINIMUM LENGTH OF ACCELERATION LANES**

**Figure 12-3D**

Design Speed Of Highway (mph)	Acceleration Lanes				
	Ratio of Length on Grade to Length for Design Speed of Entrance Ramp Curve (mph)				
	20	30	40	50	All Speeds
	3% to 4% upgrade				3% to 4% downgrade
40	1.3	1.3	–	–	0.7
45	1.3	1.35	–	–	0.675
50	1.3	1.4	1.4	–	0.65
55	1.35	1.45	1.45	–	0.625
60	1.4	1.5	1.5	1.6	0.6
65	1.45	1.55	1.6	1.7	0.6
70	1.5	1.6	1.7	1.8	0.6
	5% to 6% upgrade				5% to 6% downgrade
40	1.5	1.5	–	–	0.6
45	1.5	1.6	–	–	0.575
50	1.5	1.7	1.9	–	0.55
55	1.6	1.8	2.05	–	0.525
60	1.7	1.9	2.2	2.5	0.5
65	1.85	2.05	2.4	2.75	0.5
70	2.0	2.2	2.6	3.0	0.5

- Notes: 1. *No adjustment is needed on grades less than 3%.*
2. *The “grade” in the table is the average grade measured over the distance for which the acceleration length applies. See Figure 12-3F.*

### **Example 12-3.01(2)**

Given: Highway Design Speed - 70 mph  
Entrance Ramp Curve Design Speed - 40 mph  
Average Grade - 5% upgrade

Problem: Determine length of acceleration lane.

Solution: Figure 12-3D yields an acceleration lane of 1000 ft on the level. According to the above, this should be increased by a factor of 2.6.

Therefore:  $L = 1000 \times 2.6$   
 $L = 2600 \text{ ft}$

A 2600-ft acceleration lane should be provided from the PT of the entrance ramp curve to the beginning of the taper.

## **GRADE ADJUSTMENTS ON ACCELERATION LANES**

**Figure 12-3E**



RAMP TYPE	R Min.
DIAMOND	900'
CLOVERLEAF - OUTER CONNECTION	510'
CLOVERLEAF - INNER LOOP	150'
(NORMAL BASE LINE)	

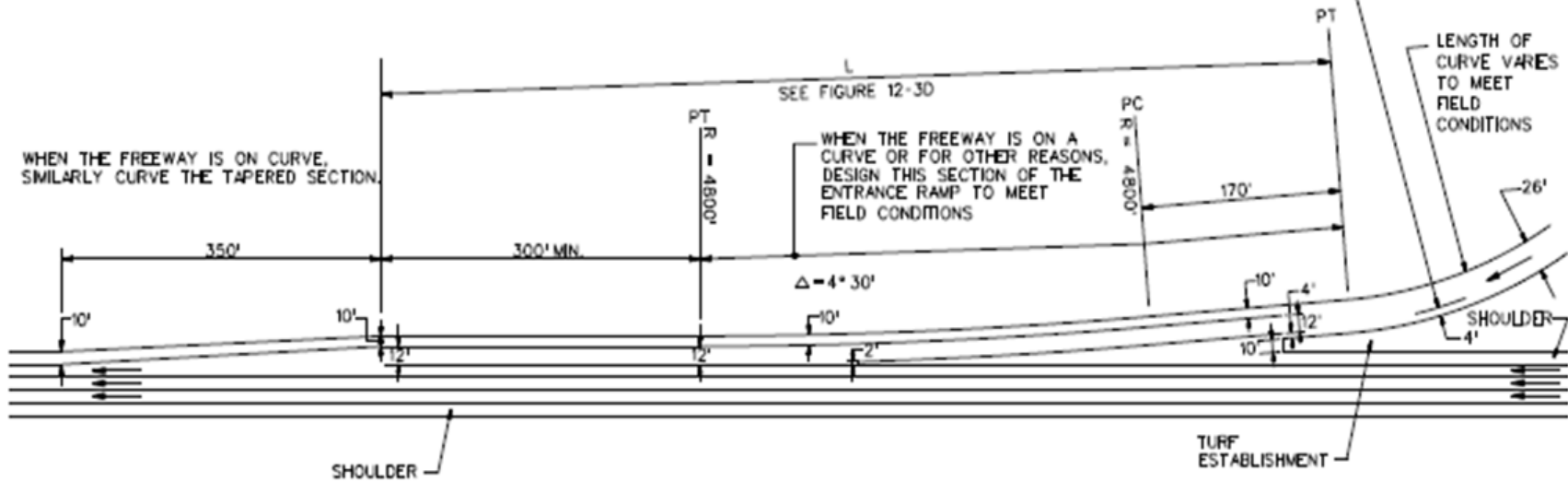

TYPICAL ENTRANCE RAMP DESIGN

Figure 12-3F

**12-3.02.03 Superelevation**

The ramp superelevation should be gradually transitioned to meet the normal cross slope of the mainline. The principles of superelevation for rural highways, as discussed in Section 8-2.0, should be applied to the entrance design. The following criterion should be used:

1. The maximum superelevation rate is 6%.
2. The maximum algebraic difference between the slopes of the acceleration lane and through lane is 5%, when these two lanes are adjacent to each other.
3. At a minimum, the superelevation runoff length should be based on the distance provided in Figure 8-2A.

**12-3.03 Critical Design Elements**

The designer should provide a freeway/ramp junction design that meets all criteria presented in Section 12-3.0. However, the following elements are especially important to the safety and proper operation of the junction:

1. the minimum length of deceleration for an exit ramp (Figure 12-3A),
2. the deflection (taper) angle for a taper exit ramp (Figure 12-3C),
3. the minimum length of acceleration for an entrance ramp (Figure 12-3D), and
4. the parallel portion of the acceleration lane for an entrance ramp (300 ft minimum).

## 12-4.0 RAMP DESIGN

### 12-4.01 Design Speed

Figure 12-4A provides the acceptable ranges of ramp design speed based on the design speed of the mainline. In addition, the designer should consider the following:

1. Freeway/Ramp Junctions. The design speeds in Figure 12-4A apply to the ramp proper and not to the freeway/ramp junction. Freeway/ramp junctions are designed using the freeway mainline design speed.
2. At-Grade Terminals. If a ramp will be terminated at an at-grade intersection with a stop or signal control, the design speeds in the figure may not be applicable to the ramp portion near the intersection.
3. Variable Speeds. The ramp design speed may vary based on the two design speeds of the intersecting roadways. Higher design speeds should be used on the portion of the ramp near the higher-speed facility while lower design speeds may be selected near the lower-speed facility. The designer needs to ensure that sufficient deceleration distance is available between design elements with varying design speeds (e.g., two horizontal curves).
4. Ramps for Right Turns. Design speeds for right-turn ramps are typically in the mid to high range. This includes, for example, a diagonal ramp of a diamond interchange.
5. Loop Ramps. Design speeds in the high range are generally not attainable for loop ramps. For mainline design speeds greater than 50 mph, the loop design speed should not be less than 25 mph. However, design speeds greater than 30 mph will require significantly more right-of-way and may not be practical in urban areas.
6. Semidirect Connections. Design speeds between the mid and high ranges should be used for semidirect connections. Design speeds less than 30 mph should not be used. Design speeds greater than 50 mph are generally not practical for short, single-lane ramps. For two-lane ramps, values in the mid to high ranges should be used.
7. Direct Connections. For direct connections, the design speed should be in the mid to high range. The design speed should not be less than 40 mph.

Mainline Design Speed (mph)	45	50	55	60	65	70
<u>Ramp Design Speed (mph)</u>						
High Range (85%)	40	45	50	50	55	60
Mid Range (70%)	35	35	40	45	45	50
Low Range (50%)	25	25	30	30	30	35

### RAMP DESIGN SPEEDS

Figure 12-4A

### 12-4.02 Cross Section

Figure 12-4B presents the typical cross section for ramps. The following will also apply to the ramp cross section:

1. Width. The minimum paved width of a one-way, one-lane ramp will be 26 ft. For pavement marking purposes, this will normally be distributed as 4 ft – 12 ft – 10 ft (i.e., 4-ft left shoulder, 12-ft traveled way, 10-ft right shoulder when viewed in the direction of travel). This arrangement is illustrated on Figures 12-3C and 12-3F for exit and entrance ramp designs.

The minimum width of a one-way, two-lane ramp will be 38 ft. This width yields two 12-ft ramp lanes, a 4-ft left shoulder and an 10-ft right shoulder.

2. Bridges and Underpasses. The full width of the ramp or loop should be carried over a bridge or beneath an underpass.
3. Side Slopes. Fill and cut slopes should be as flat as practical. Consider providing slopes flat enough so that they do not warrant guiderail (see Section 13-3.0).
4. Lateral Clearances to Obstructions. The lateral clearance from the outside edge of shoulder will be equal to its clear zone as calculated from Section 13-2.0.
5. Right-of-Way. The right-of-way/non-access line adjacent to the ramp will be the same as that determined for the freeway mainline in the vicinity of the interchange.

### 12-4.03 Horizontal Alignment

Flexibility must be applied when determining the horizontal alignment on ramps. This recognizes their unique character. In general, horizontal alignment will be determined by the design speed and type of ramp. The following should be considered:

1. Minimum Radius. The criteria in Figure 8-2A for rural highways also apply to the minimum radius on all ramps, except for loop ramps. Because of the normally restrictive condition for loop ramps, it is typically impractical to use rural criteria. Therefore, the criteria in Figure 11-4D for turning roadways may be used on loop ramps. The design speed or the anticipated operating speed at the curve should be selected to determine the minimum radius.
2. Outer Connection. The outer connection at cloverleaf interchanges should be as directional as practical. However, if site conditions are restrictive, it may be warranted to follow a reverse-path alignment around the inner loop.

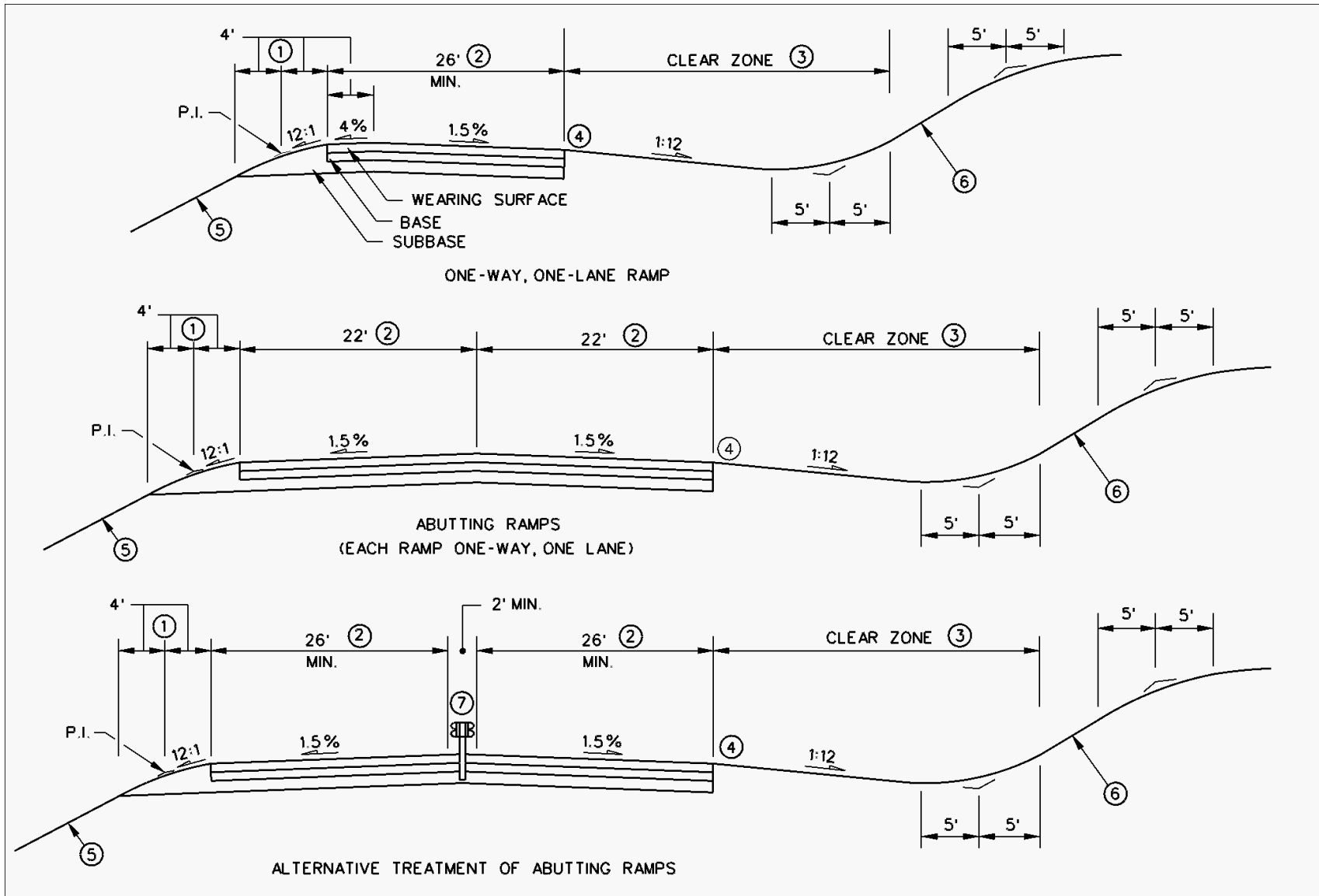

TYPICAL RAMP CROSS SECTIONS

Figure 12-4B

## TYPICAL RAMP CROSS SECTIONS

### Notes to Figure 12-4B

- Slope Rounding: This is the recommended treatment and, when used, the slope rounding should be 8 ft. Rounding is not necessary on fill slopes protected by guiderail. See Figure 4H for detail if guiderail is used.
- Ramp Width: For 2-lane, 1-way ramps, minimum width is 40 ft.
- Clear Zone: The outside limit of rounding for the backslope should be outside of the clear zone as determined in Section 13-2.0. If this is within the clear zone, the backslope should be safely traversable (see Section 13-3.0).
- Curb Sections: If curbing is required for drainage, see Figure 4H for typical section.
- Fill Slope: These should be as flat as practical. The following criteria are typical:

<u>Fill Height</u>	<u>Fill Slope</u>	<u>Guiderail</u>
0 ft – 10 ft	1:6	No
10 ft – 25 ft	1:4	No (without curb) Yes (with curb)
> 25 ft	1:2	Yes

Also, see Figure 4H for treatment at bottom of fill slope. If a curb is used, see Figure 4H for treatment of guiderail and curb used in combination.

- Cut Slope: These should be as flat as practical, but should not exceed 1:2. Also, see the clear zone discussion in Note □. A uniform rate of slope should be maintained throughout a cut section. Where site conditions dictate a change from one rate of slope to another within a cut section, the length of transition should be as long as practical to effect a natural appearing contour. Figure 4J contains detailed information on earth and rock cuts.
- Barrier: The metal-beam rail is preferred, but the CMB is acceptable.
- Superelevated Section: The axis of rotation will be about a line 4 ft from the left edge of pavement in the direction of travel. This means that, on a 26-ft ramp, 22 ft will be superelevated at the design "e" and 4 ft will slope away from the 22 ft. The break in the slope will be rounded according to the detail on Figure 4H. This criterion applies to curves in both the left and right directions; applies to both 1-lane and 2-lane ramps; and applies regardless of the pavement markings on the ramp.
- Abutting Ramps: See Figure 12-5B for pavement striping details for abutting ramps at an at-grade intersection.

3. Loops. Loop ramps should be on a continuously curved alignment in a compound curve arrangement. The radius of the flatter curve should be no more than twice the radius of the sharper curve. Figure 11-4D presents minimum curve lengths for turning roadways at intersections. These also apply to ramp loops.
4. Compound Curves. Where compound curves are used in the vicinity of an exit ramp, the designer should ensure that the length of the flatter curve provides a sufficient distance to decelerate to the design speed of the sharper curve. The deceleration criteria in Figure 12-3A should be used to determine the minimum lengths of curves in a compound curvature arrangement. In addition, the designer should provide a ratio of 1.5:1 between the radius of the flatter curve and that of the succeeding sharper curve. However, in restricted locations, it may be 2:1.
5. Superelevation. The following applies:

- a. The maximum superelevation rate is 6%.
- b. The criteria for rural highways and high-speed urban highways discussed in Section 8-2.0 also apply to ramps for transitioning to and from the needed superelevation. This includes the superelevation runoff lengths presented in Figure 8-2A. However, because of the restrictive nature of some ramps, this may not be practical. The minimum longitudinal slope should not exceed 1%, which corresponds to a "P" of 100. This value should be used in the following equation to calculate the superelevation transition length:

$$L = (e) (W) (P)$$

where:	L	=	superelevation transition length (ft)
	P	=	100
	e	=	superelevation rate (expressed as a decimal)
	W	=	width of pavement rotation (ft)

- c. The axis of rotation will be about a line 4 ft from the inside edge of pavement. This means that, on a 26-ft ramp, 22 ft will be superelevated at the design "e" and 4 ft will slope away from the 22-ft section. The break in the slope will be rounded according to the detail on Figures 4H and 5J. This criterion applies to curves in both the left and right directions and applies regardless of the pavement markings on the ramp.
- d. The designer should not superelevate curves on ramps such that the design "e" is maintained on the curve for a very short distance. No specific minimum length is provided; these will be evaluated on a case-by-case basis.
- e. If the ramp will be terminated at an at-grade intersection with stop or signal control, it is not appropriate to fully superelevate curves near the terminal.

6. Sight Distance. Section 8-2.04 describes how to determine the middle ordinate to provide stopping sight distance at horizontal curves.

#### 12-4.04 Vertical Alignment

Maximum grades for vertical alignment cannot be as definitively expressed as those for the highway mainline. General values of limiting gradient are shown in Figure 12-4C, but for any one ramp the selected gradient is dependent upon a number of factors. These factors include the following:

1. The flatter the gradient on the ramp relative to the freeway grade, the longer it will be. At restricted sites, it may be necessary to provide a steeper grade for the purpose of shortening the length of ramp.
2. The steepest gradients should be designed for the center part of the ramp. Landing areas or storage platforms at at-grade intersections should be as flat as practical.
3. Downgrades on ramps should follow the same guidelines as upgrades. They may, however, safely exceed these values by 2%, with 8% considered a recommended maximum.
4. Practical ramp gradients and lengths can be significantly impacted by the angle of intersection between the two highways. The direction and grade on the two mainlines may also have a significant impact.
5. Stopping sight distance will be the minimum design for vertical curves; see Section 9-3.0.

Ramp Design Speed (mph)	25	30	40	45	50
Maximum Grade Range (%)	6-8	5-7	4-6	3-5	3-5

*Note: Downgrades may exceed the table values by 2%, but should not exceed 8%.*

### RAMP GRADIENT GUIDELINES

Figure 12-4C



## 12-5.0 RAMP/CROSSING ROAD INTERSECTION

### 12-5.01 Design of At-Grade Intersections

Where the ramp will intersect the minor road at-grade, this intersection should be treated as described in Chapter Eleven. This will involve a consideration of capacity and the physical geometric design elements (e.g., design vehicle, sight distance, angle of intersection, acceleration lanes, grade, channelization, turning lanes). However, several points warrant special attention in the design of the ramp/crossing road intersection:

1. Capacity. In urban areas where traffic volumes are often high, inadequate capacity of the ramp/crossing road intersection can adversely affect the operation of the ramp/freeway junction. In a worst-case situation, a backup onto the freeway itself may impair the safety and operation of the mainline. Therefore, special attention should be given to providing sufficient capacity and storage for an at-grade intersection or merge with the crossing road. This could lead to the addition of lanes at the intersection or on the ramp proper (see Figure 12-5A), or it could involve traffic signalization where the ramp traffic will be given priority. The analysis must also consider the operational impacts of the traffic characteristics in either direction on the intersecting road. Coordinate this analysis with the Division of Traffic Engineering. See Chapter Eleven for additional information.
2. Sight Distance. Section 11-2.0 discusses the criteria for intersection sight distance. These criteria also apply to a ramp/crossing road intersection. Special attention must be given to the location of the bridge pier or abutment because these will present major sight distance obstacles. The bridge obstruction and the required intersection sight distance may result in the need to relocate the ramp/crossing road intersection.
3. Wrong-Way Movements. Most wrong-way movements originate at the ramp/crossing road intersection. This intersection must be properly signed and designed to minimize the potential for a wrong-way movement.
4. Abutting Ramps. Figure 12-4B illustrates the use of a metal-beam rail to divide abutting ramps. This provides a physical separation and discourages wrong-way entry. Where the ramp intersects the crossing road, the median barrier should be terminated with an approved end terminal. Where a median barrier is not used, the abutting ramps should intersect the minor road as shown in Figure 12-5B.

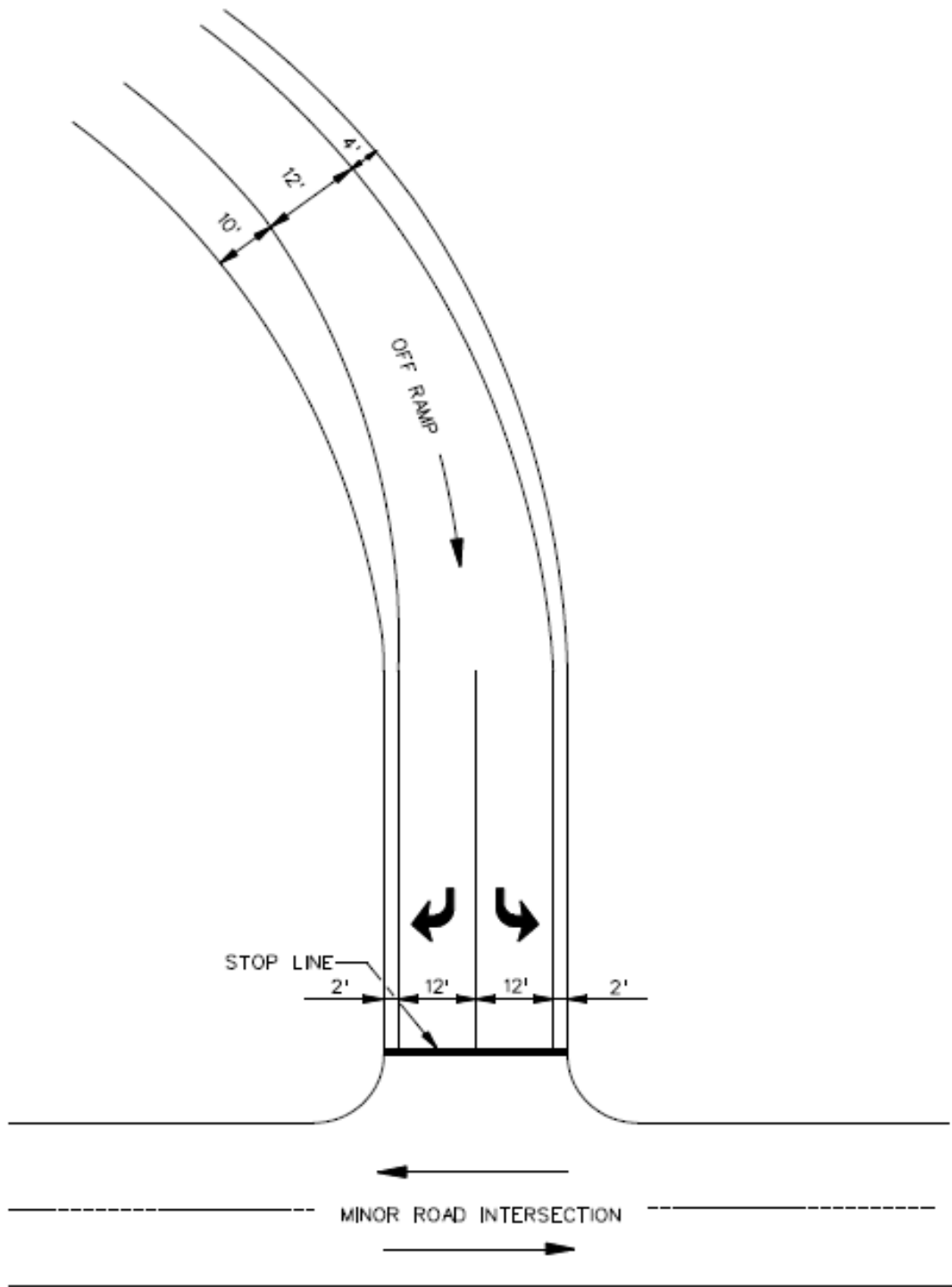

**MULTIPLE-LANE RAMP AT MINOR ROAD INTERSECTION**

**Figure 12-5A**

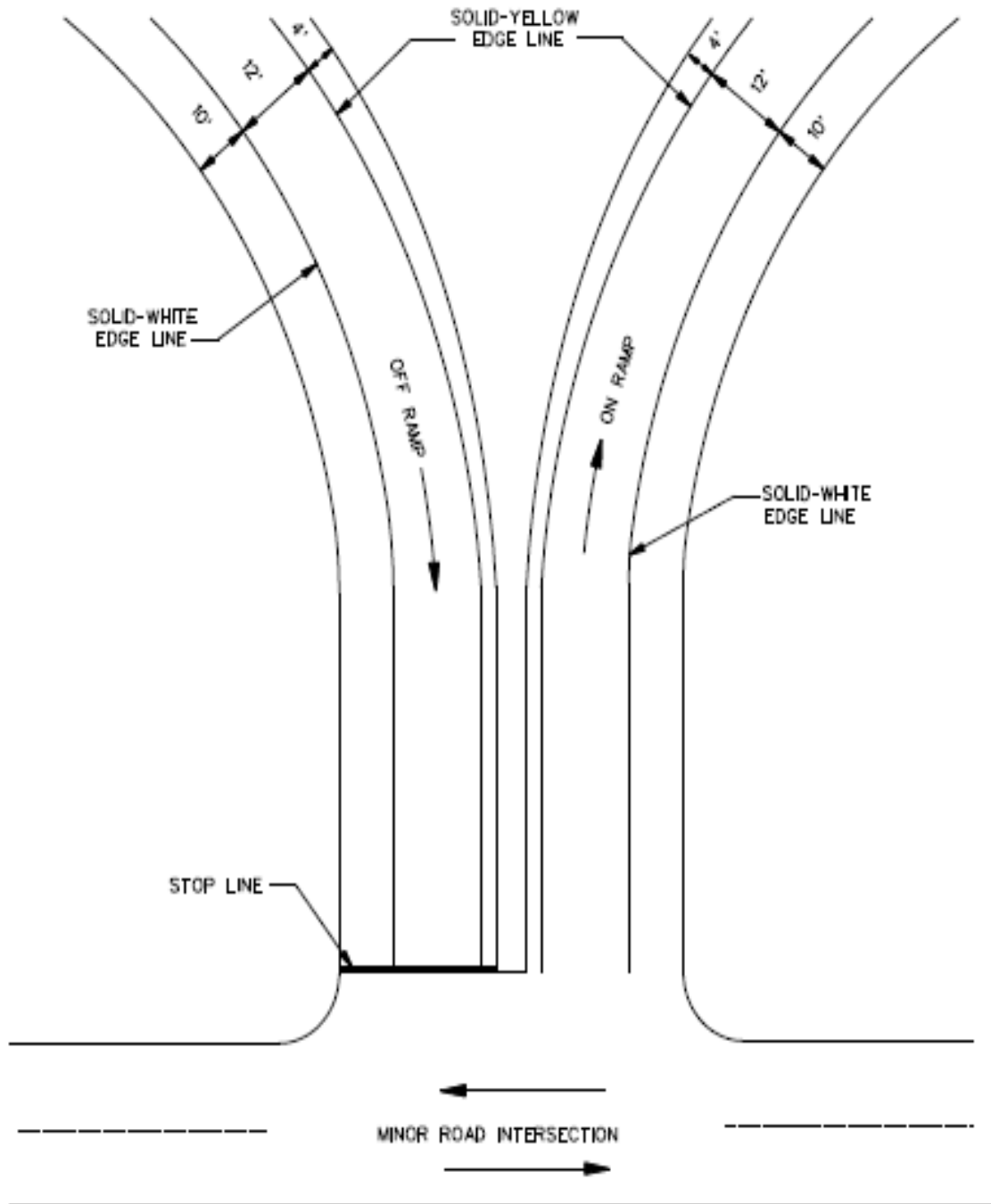

**ABUTTING RAMPS AT MINOR ROAD INTERSECTION**

**Figure 12-5B**

**12-5.02 Frontage Road Intersection**

Where frontage roads are adjacent to freeways, the ramp/crossing road intersection is greatly complicated. If practical, the frontage road should be curved away from the interchange and allowed to intersect the minor road a sufficient distance from the ramp intersection. If the ramp intersects the crossing road at approximately 90 degrees, this distance should be at least 300 ft. If the ramp traffic merges with the crossing road, the distance should be 300 ft beyond where the taper of the acceleration lane ends. This treatment allows the two intersections to operate independently, and it eliminates the operational and signing problems of providing the same point of exit and entrance for the frontage road and freeway ramp.

At some interchanges, it may be impractical to separate the intersections of the ramp and frontage road with the crossing road. In these cases, the only alternative is to combine the ramp and frontage road before the intersection with the crossing road. This can apply to either the exit or entrance ramp. A detailed analysis will be necessary to establish the needed distance to properly accommodate traffic volumes and speeds, weaving, stopping and intersection storage. Coordinate this analysis with the Division of Traffic Engineering.

**12-5.03 Access Control**

Proper access control must be provided along the crossing road in the vicinity of the ramp/crossing road intersection. This will ensure that the intersection has approximately the same degree of freedom and absence of conflict as the freeway itself. Figure 12-5C illustrates the Department's policy for the location of the non-access line at ramp/crossing road intersections. Any proposals that do not meet these criteria will require an exception to the controlling design criteria. See Section 6-5.0. This applies to all of the access control criteria in Figure 12-5C. This also applies both to new interchanges and to existing non-access lines at existing interchanges.

One situation warrants a special discussion. Many interchanges were initially constructed in Connecticut when the surrounding area was rural in character. Since that time, the area may have become suburban or urban. As indicated in Figure 12-5C, the Department has adopted different criteria for the access control at urban and rural interchanges. However, the change in area character alone is not a sufficient justification to alter the location of the non-access line.

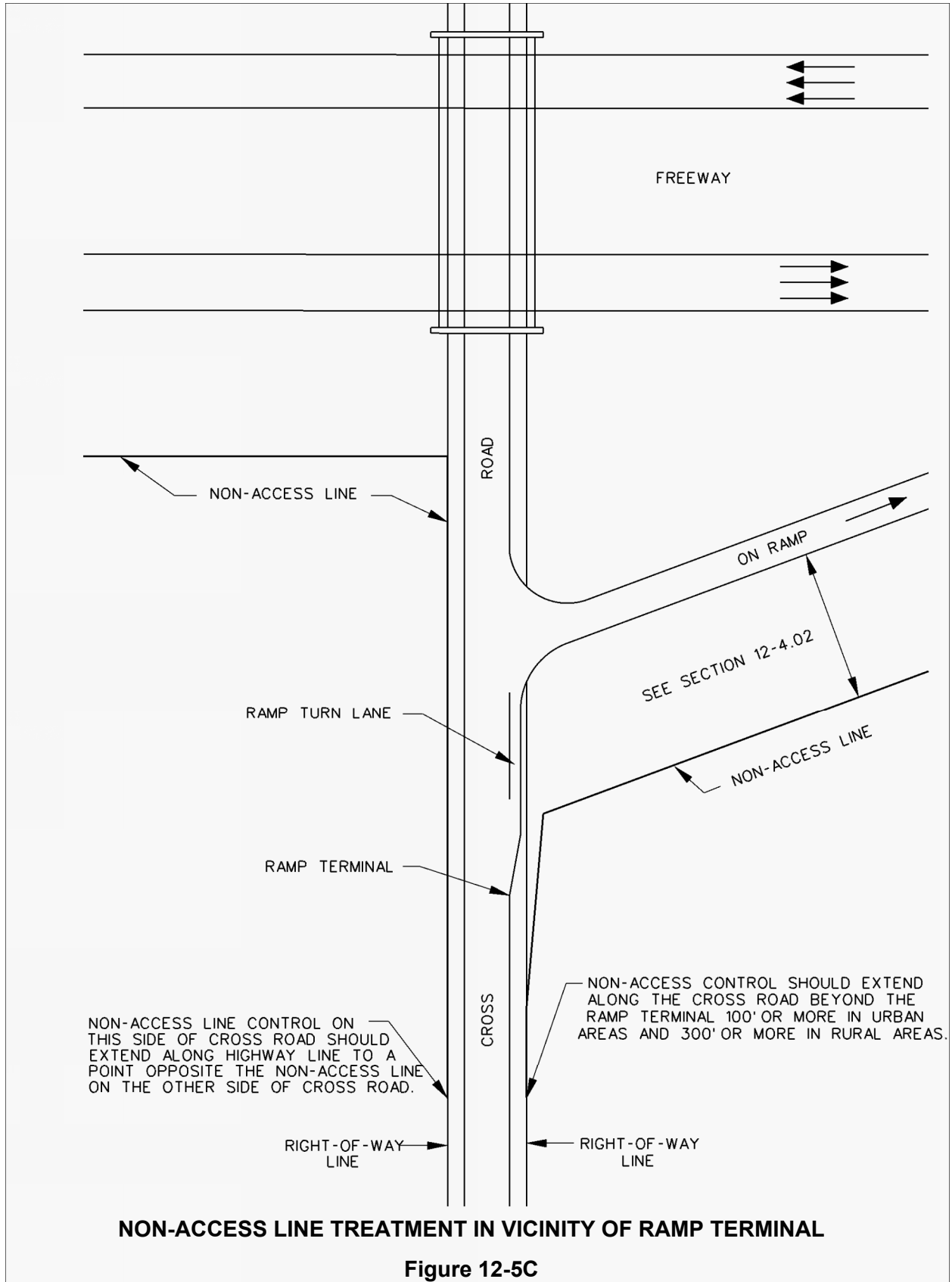



**12-6.0 REFERENCES**

1. *A Policy on Geometric Design of Highways and Streets*, AASHTO, 2001.
2. *Highway Capacity Manual 2000*, TRB, 2000.
3. "Additional Interchanges to the Interstate System," *Federal Register*, Vol. 74, No. 165, August 27, 2009.
4. NCHRP 345, *Single Point Urban Interchange Design and Operations Analysis*, TRB, 1991.
5. NCHRP 175, *Freeway Lane Drops*, TRB, 1976.





**Appendix**

This Appendix to Chapter Twelve presents the following:

An excerpt from "[Procedure Manual for New or Revised Interstate Access Approval in Connecticut](#)." Dated April 2018. Entire policy document is located in [Engineering and Construction Information Resources \(ct.gov\)](#):

**Chapter Thirteen**  
**ROADSIDE SAFETY**

**Table of Contents**

<b><u>Section</u></b>		<b><u>Page</u></b>
13-1.0	DEFINITIONS .....	13-1(2)
13-2.0	CLEAR ZONES .....	13-2(1)
13-2.01	Background .....	13-2(1)
13-2.02	Application .....	13-2(1)
13-2.03	Utility Setback Procedures .....	13-2(5)
13-3.0	BARRIER WARRANTS.....	13-3(1)
13-3.01	Embankments .....	13-3(1)
13-3.02	Roadside Hazards .....	13-3(1)
13-3.03	Bridge Rails and Approaches .....	13-3(4)
13-3.04	Bridge Piers, Abutments and Overhead Sign Structures.....	13-3(4)
13-3.05	Vertical Drop-Offs .....	13-3(6)
13-3.06	Roadside Ditches, Channels and Swales.....	13-3(6)
13-3.07	Transverse Slopes .....	13-3(9)
13-3.08	Median Barrier Warrants.....	13-3(9)
13-4.0	DISPOSITION OF EXISTING BARRIER .....	13-4(1)
13-4.01	Application .....	13-4(1)
13-4.02	Longitudinal Barrier .....	13-4(1)
13-4.03	End Treatments .....	13-4(2)
13-4.04	Bridge Attachments .....	13-4(2)
13-4.05	Curbs and Curb/Barrier Combinations .....	13-4(2)
13-5.0	ROADSIDE BARRIERS .....	13-5(1)
13-5.01	Three-Cable Guiderail (I-Beam Post).....	13-5(1)
13-5.02	Metal Beam Rail (Type R-B 350).....	13-5(1)
13-5.03	Metal Beam Rail (R-B MASH) .....	13-5(2)
13-5.04	Curved Guiderail Treatment .....	13-5(2)
13-5.05	Span Sections Type II and Type III .....	13-5(3)
13-5.06	Metal Beam Rail (Box Beam) .....	13-5(3)
13-5.07	Precast Concrete Barrier Curb (PCBC).....	13-5(3)
13-5.08	Merritt Parkway Guiderail .....	13-5(3)

13-5.09	Merritt Parkway Concrete Barrier .....	13-5(4)
13-5.10	Bridge Attachments .....	13-5(4)
13-5.10.01	Thrie-Beam Attachment .....	13-5(4)
13-5.10.02	R-B 350 Bridge Attachment .....	13-5(4)
13-6.0	MEDIAN BARRIERS .....	13-6(1)
13-6.01	Metal Beam Rail (Type MD-B 350).....	13-6(1)
13-6.02	Metal Beam Rail (MD-B MASH) .....	13-6(1)
13-6.03	Precast Concrete Barrier Curb (PCBC).....	13-6(1)
13-6.04	Merritt Parkway Median Guiderail .....	13-6(1)
13-6.05	Merritt Parkway Concrete Median Barrier .....	13-6(1)
13-6.06	Metal Beam Rail (8"x6" Box Beam).....	13-6(2)
13-6.07	Median Bridge Attachments .....	13-6(2)
13-6.07.01	MD-B 350 Median Barrier – Safety Shape Attachment .....	13-6(2)
13-7.0	BARRIER DEFLECTIONS .....	13-7(1)
13-8.0	ZONE OF INTRUSION (ZOI) Background.....	13-8(1)
13-8.01	Application.....	13-8(2)
13-8.01.01	Scope of Projects for ZOI Evaluation.....	13-8(2)
13-8.01.02	Evaluation .....	13-8(2)
13-8.01.03	ZOI Design Guidance .....	13-8(3)
13-9.0	BARRIER LAYOUT .....	13-9(1)
13-9.01	Length-of-Need.....	13-9(1)
13-9.02	Flare Rate.....	13-9(1)
13-9.03	Lateral Placement.....	13-9(1)
13-9.04	Curbs and Curb/Barrier Combinations .....	13-9(2)
13-9.05	Required Grading .....	13-9(3)
13-9.06	Processed Aggregate for Railing.....	13-9(3)
13-9.07	Guiderail Gaps.....	13-9(4)
13-9.08	Treatment at Intersecting Roads and Driveways.....	13-9(4)
13-9.09	Guiderail Curvature Criteria.....	13-9(6)
13-9.10	Transitions .....	13-9(6)
13-9.10.01	Transitions Within Same Barrier Type .....	13-9(6)

	13-9.10.02	Transitions Between Different Barrier Types .....	13-9(7)
13-9.11		Median Barrier Placement.....	13-9(7)
	13-9.11.01	General .....	13-9(7)
	13-9.11.02	Basic Application.....	13-9(7)
	13-9.11.03	Divided Median Barriers.....	13-9(7)
13-9.12		Glare Screens.....	13-9(10)
13-10.0		END TREATMENTS .....	13-10(1)
	13-10.01	Definitions.....	13-10(1)
	13-10.02	General.....	13-10(1)
	13-10.03	End Treatment Selection .....	13-10(3)
	13-10.03.01	W-Beam Metal Beam Rail (Type R-B 350 & R-B MASH).....	13-10(3)
	13-10.03.02	Three-Cable Guiderail.....	13-10(3)
	13-10.03.03	Merritt Parkway Guiderail.....	13-10(4)
	13-10.03.04	Median Metal Beam Rail (Type MD-B 350 & MD-B MASH)	13-10(4)
	13-10.03.05	Metal Beam Rail (6X6 or 6X8 Box Beam).....	13-10(4)
	13-10.03.06	Concrete Median or Roadside Barrier .....	13-10(4)
13-11.0		REFERENCES.....	13-11(1)



## Chapter Thirteen

# ROADSIDE SAFETY

This Chapter provides the Designer with guidance on measures to reduce the number and/or severity of crashes when vehicles leave the traveled way.

The “forgiving roadside” concept, developed in the 1960s, has been a long-standing philosophy in Connecticut. As a result, many of Connecticut’s State highways have been constructed to meet this design philosophy. In addition, guidance for installing roadside safety hardware has gradually evolved to reflect the results of crash test programs.

The American Association of State Highway and Transportation Officials (AASHTO) has incorporated many of the crash test results and roadside safety design concepts into the *Roadside Design Guide*.

Chapter Thirteen is a supplement to the *Roadside Design Guide*. Where there is a discrepancy between the two, Chapter Thirteen will take precedence.

On October 1, 1998, FHWA mandated that all new roadside safety hardware installed on the National Highway System (NHS) meet crash testing criteria found in the National Cooperative Highway Research Program (NCHRP) Report 350, Recommended Procedures for the Safety Performance Evaluation of Highway Features. FHWA further recommended that all roadside safety appurtenances installed on all public roads meet the testing criteria found in NCHRP Report 350. On November 20, 2009, AASHTO published a successor to that manual entitled Manual for Assessing Safety Hardware (MASH), with an update in 2016.

FHWA requires all roadside safety hardware to be MASH 2016 compliant on NHS roadways in order to receive federal reimbursement as a means to phase out some of the NCHRP Report 350 compliant products. The Department is applying this requirement with TL-3 as a minimum standard on all roadways unless otherwise specified. For example, TL-2 is allowed in certain applications on low speed roadways as described in the following sections.

**13-1.0 DEFINITIONS**

1. Recoverable Parallel Slope: Slopes that can be safely traversed, and upon which the driver of an errant vehicle has a reasonable opportunity to stop and return to the roadway. The Department considers slopes *flatter* than 1:4 as recoverable.
2. Non-Recoverable Parallel Slope: Slopes that are traversable, but are too steep to recover and return to the roadway. The Department considers 1:4 slopes as non-recoverable.
3. Critical Parallel Slope: Slopes upon which a vehicle is likely to overturn. Under the Department's roadside criteria, slopes *steeper* than 1:4 and slopes of 1:4 with curbing at the top are critical.
4. R-B: Roadside Barrier
5. MD-B: Median Barrier
6. MASH: Manual for Assessing Safety Hardware

These definitions vary slightly from those in the *Roadside Design Guide*

## 13-2.0 CLEAR ZONES

### 13-2.01 Background

The clear zone concept was first established in the 1967 AASHTO report entitled Highway Design and Operational Practices Related to Highway Safety, known as the Yellow Book and was revised in 1974. It provided the Designer with a numerical value of 30 ft as the lateral extent needed for 80%-85% of run-off-the-road vehicles to recover. The 30 ft clear zone was predicated on the following set of conditions:

1. 60-mph vehicular speed,
2. tangent section, and
3. flat side slope.

If these conditions vary, the 30 ft clear zone should be adjusted accordingly. For example, at higher speeds, vehicles will travel farther before recovering; at lower speeds, vehicles will travel less before recovering.

Section 13-2.02 presents clear zone distances for various roadway conditions. The overall objective of these clear zone values is to achieve the 80%-85% target recovery area for run-off-the-road vehicles on any given roadway.

### 13-2.02 Application

The calculated clear zone widths presented in Figure 13-2A are recommended values and need not be achieved at all costs. The methodology used to determine the values in this chart is valid and provides the Designer with a good frame of reference for making decisions to design safer roadside recovery areas. However, the Designer must exercise judgment when applying the distances because they do not apply to every conceivable set of highway conditions. Each application of the clear zone distance must be evaluated individually.

When applying the clear zone distance, the Designer must consider right-of-way availability, environmental concerns, economic factors, identification of potential hazards, safety needs and crash history. The following items further describe the proper usage of the clear zone distances presented in Figure 13-2A:

1. Boundaries: The Designer should not use the clear zone distances as boundaries for introducing roadside hazards such as bridge piers, non-breakaway sign supports or utility poles. These should be placed as far from the roadway as practical. At locations where roadside hazards must be placed along the highway, at a minimum they should be placed at the clear zone boundary and possibly shielded.
2. Fill Slopes: Figure 13-2B illustrates the clear zone application on fill slopes with a negative shelf. Barn-roof fill slopes may be designed with two slope rates where the second slope is steeper than the slope adjacent to the shoulder. See Figure 13-2B(b). This design requires less right-of-way and embankment material than a continuous, flatter slope. Although a "weighted" average of the slopes may be used, a simple average of the clear zone distances for each slope is sufficiently accurate if the variable slopes are approximately the same width. If one slope is significantly wider, the clear zone computation based on that slope alone may be used.

Because non-recoverable slopes are still traversable, it can be expected to have vehicles reach the toe of the slopes. Therefore, the clear zone cannot logically end along the slope.



The slope, as well as a 10 ft runout area at the toe of the slope, should be clear of any hazards. It is preferred to grade the runout area with a recoverable slope.

3. Cut Slopes:

The outside limit of rounding for the backslope should be outside of the clear zone. This is illustrated in the typical section figures in Chapters Four and Five. When this is not achievable, the following approach should be used to calculate the clear zone for a ditch section:

- a. Calculate the percentage of the clear zone from Figure 13-2A (negative shelf) available to the toe of the backslope.
- b. Subtract this percentage from 100 percent and multiply the results by the clear zone for the backslope from Figure 13-2A (positive shelf).
- c. Add the available clear zone to the toe of the backslope to the value determined in b. This yields the required clear zone from the edge of traveled way to a point on the backslope.

The Designer must reference Section 13-3.06 for guidance on the proper treatment of drainage features encountered within the clear zone.

4. Urban Facilities: A minimum horizontal obstruction-free clearance of 1.5 ft should be provided as measured from the gutter line to any utility pole, sign or traffic signal pole. This distance is not considered a clear zone, but an operational offset. Clear zones to other fixed objects such as buildings should conform to Figure 13-2A. Refer to Section 13-2.03 - Utility Setback Procedures.
5. Auxiliary Lanes: For auxiliary lanes, such as climbing lanes, passing lanes, etc., the clear zone will be the same as for the mainline and will be measured from the outside edge of the auxiliary lane. The clear zone will not normally apply to left- and right-turning lanes at intersections. When evaluating crossover crash potential for undivided roadways, the clear zone will be measured from the left edge of the through traveled way.
6. Horizontal Curves: Additional clear zone may be provided on the outside of horizontal curves by the use of curve correction factors that are included in the *Roadside Design Guide*. These increases should be considered only where crash histories indicate a need or where specific investigations indicate a high potential for crashes and where the increase to the clear zone is cost effective.

Design Speed	Design Year ADT	Cuts or Fills (Negative Shelf)		Cuts or Fills (Positive Shelf)	
		1:6 or flatter	1:4	1:4	1:6 or flatter
40 mph or less	Under 750	7	7	7	7
	750-1500	10	12	10	10
	1500-6000	12	14	12	12
	Over 6000	14	16	14	14
45 – 50 mph	Under 750	10	12	8	10
	750-1500	14	16	12	14
	1500-6000	16	20	14	16
	Over 6000	20	24	18	20
55 mph	Under 750	12	14	10	10
	750-1500	16	20	14	16
	1500-6000	20	24	16	20
	Over 6000	22	26	20	22
60 mph	Under 750	16	20	12	14
	750-1500	20	26	16	20
	1500-6000	26	30	18	24
	Over 6000	30	30	24	26
65 – 70 mph	Under 750	18	20	14	14
	750-1500	24	28	18	20
	1500-6000	28	30	22	26
	Over 6000	30	30	26	28

## Notes:

1. All distances are measured from the edge of traveled way. See Section 13-2.02, Comment #5.
2. See Section 13-2.02, Comment #2, for application of clear zone criteria on fill slopes.
3. See Figure 5H for illustration of a cut section with a positive shelf. See Section 13-2.02, Comment #3, on cut slopes and ditch sections.
4. The values in the table apply to all facilities both urban and rural. See Section 13-2.02, Comment #4, for utility poles in urban areas.

**RECOMMENDED CLEAR ZONE DISTANCES (ft)****Figure 13-2A**

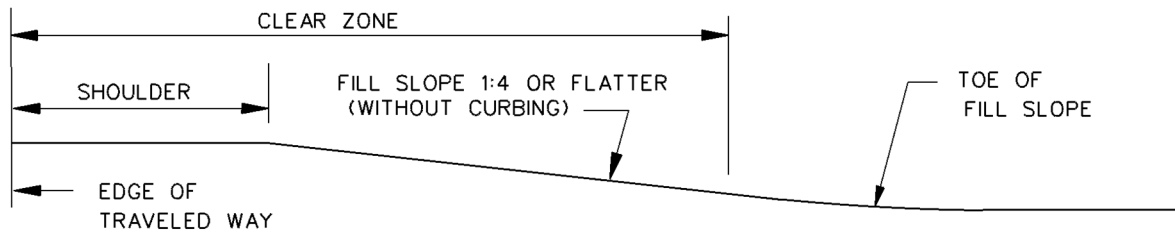

RECOVERABLE PARALLEL SLOPE (a)

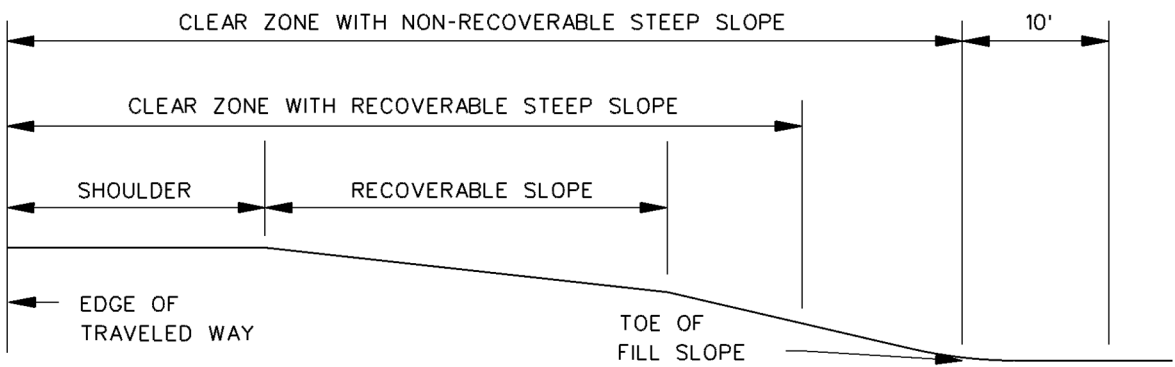

BARN-ROOF PARALLEL SLOPE (b)

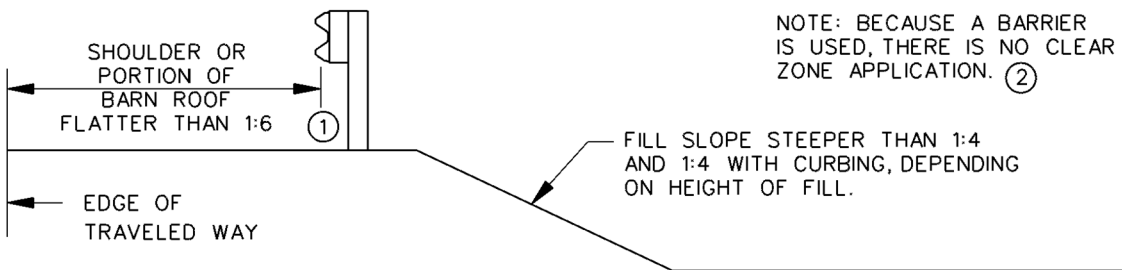

CRITICAL PARALLEL SLOPE (c)

- ① WHEN GUIDERAIL IS NOT USED AND THE CLEAR ZONE EXTENDS BEYOND THE TOP OF THE SLOPE, A MINIMUM DISTANCE OF 10 FT WILL BE CLEARED AT THE TOE OF SLOPE.
- ② SEE FIGURE 13-3A TO DETERMINE BARRIER NEED.

**CLEAR ZONE APPLICATION FOR FILL SLOPES  
(Negative Shelf)  
Figure 13-2B**

**13-2.03 Utility Setback Procedures**

There will be many sites where it will be impractical to locate utility poles outside the clear zone. This is especially prevalent in urban areas but could apply to any project, depending upon the circumstances.

The following are options, in order of priority, that are to be followed for the placement of permanent utility poles:

1. Utility poles should be positioned outside the clear zone whenever practical. The Department may require a setback up to a maximum of 30 ft if conditions such as, but not limited to, a high frequency of crashes related to the presence of utility poles exists.
2. A maximum utility pole setback of 10 ft from the edge of the road, irrespective of the clear zone, is permissible. This setback dimension is consistent with the capabilities of the utility company's installation and maintenance equipment. The maximum 10 ft setback is also consistent with the utility company's corporate strategy of providing a quick response to power outages, etc.
3. Along urban highways, the Department will require poles to be placed as close to the right-of-way line as practical. If sufficient space is not available, the Department may allow poles to be placed between the curb and sidewalk at a minimum of 1.5 ft behind the face of curb. In general, when sidewalks are present, it is the Department's preference to place poles behind the sidewalk.

A design exception for utility poles within the clear zone is not required when the preceding guidance is followed.



### 13-3.0 BARRIER WARRANTS

Existing conditions may limit the Designer's options when determining the need for guiderail. Factors such as project cost, environmental impacts and right-of-way involvement should be considered in the decision-making process.

Section 1.2 of the *Roadside Design Guide* provides the Designer with six design options, in order of priority, for redesigning the roadside to eliminate roadside hazards or determining the need for guiderail. These steps (provided below) should become an integral part of all Department projects.

1. Remove the hazard to eliminate the need for guiderail.
2. Redesign the hazard so it can be safely traversed.
3. Relocate the hazard to a point where it is less likely to be struck.
4. Reduce impact severity by using an appropriate breakaway device.
5. Shield the hazard with a longitudinal barrier designed for redirection or use a crash cushion.
6. Delineate the hazard if the previous alternatives are not appropriate.

The following Sections illustrate where guiderail may be warranted.

#### 13-3.01 Embankments

The severity of the roadside condition depends upon the rate and height of the fill slope. Refer to Figure 13-3A – Warrants for Embankments. This figure is a modified version of Figure 5.1 of the *Roadside Design Guide*. Depending on the height of fill slope, guiderail may be needed to shield a fill slope steeper than 1:4 and slopes of 1:4 with curbing. See Section 13-9.04 for curb and curb/barrier combinations. Guiderail is not required on fill slopes flatter than 1:4 if there are no roadside hazards within the clear zone as calculated from Section 13-2.0. Barrier with deflections of 8 ft or greater should not be placed atop embankments of 1:2 or steeper.

#### 13-3.02 Roadside Hazards

The recommended clear zone distances for various roadway conditions presented in Section 13-2.0 should be free of any fixed objects and non-traversable hazards. Roadside hazards that may warrant guiderail include, but are not limited to, the following:

1. Non-breakaway sign and luminaire supports,
2. concrete bases extending more than 4 in. above the ground,
3. bridge piers and abutments at underpasses,
4. retaining walls,
5. culvert end-walls,
6. trees with diameter greater than 4 in. (at maturity),
7. rough rock cuts,
8. large boulders,

9. streams or permanent bodies of water,
10. stone fences,
11. blunt ends,
12. vertical drop-offs, and
13. embankments as explained in 13-3.01

Isolated hazards at the edge of the clear zone may not always warrant guiderail. For example, to install guiderail to protect an errant vehicle from an isolated tree at the edge of a 30 ft clear zone may not be practical.

The Designer should recognize that even barriers installed to deflect errant vehicles away from fixed objects may be hazards themselves. Preference should therefore be given to eliminating or relocating the potential hazard rather than placing guiderail in front of it whenever possible. Guiderail should only be placed if it is considered to be less of a hazard than the potential hazard the guiderail is shielding.

It is not the Department's policy to design guiderail to protect the traveling public from utility poles. However, if guiderail is provided for other reasons and utility poles exist within the deflection distance of the guiderail, then strengthening of the guiderail for the utility poles is required.

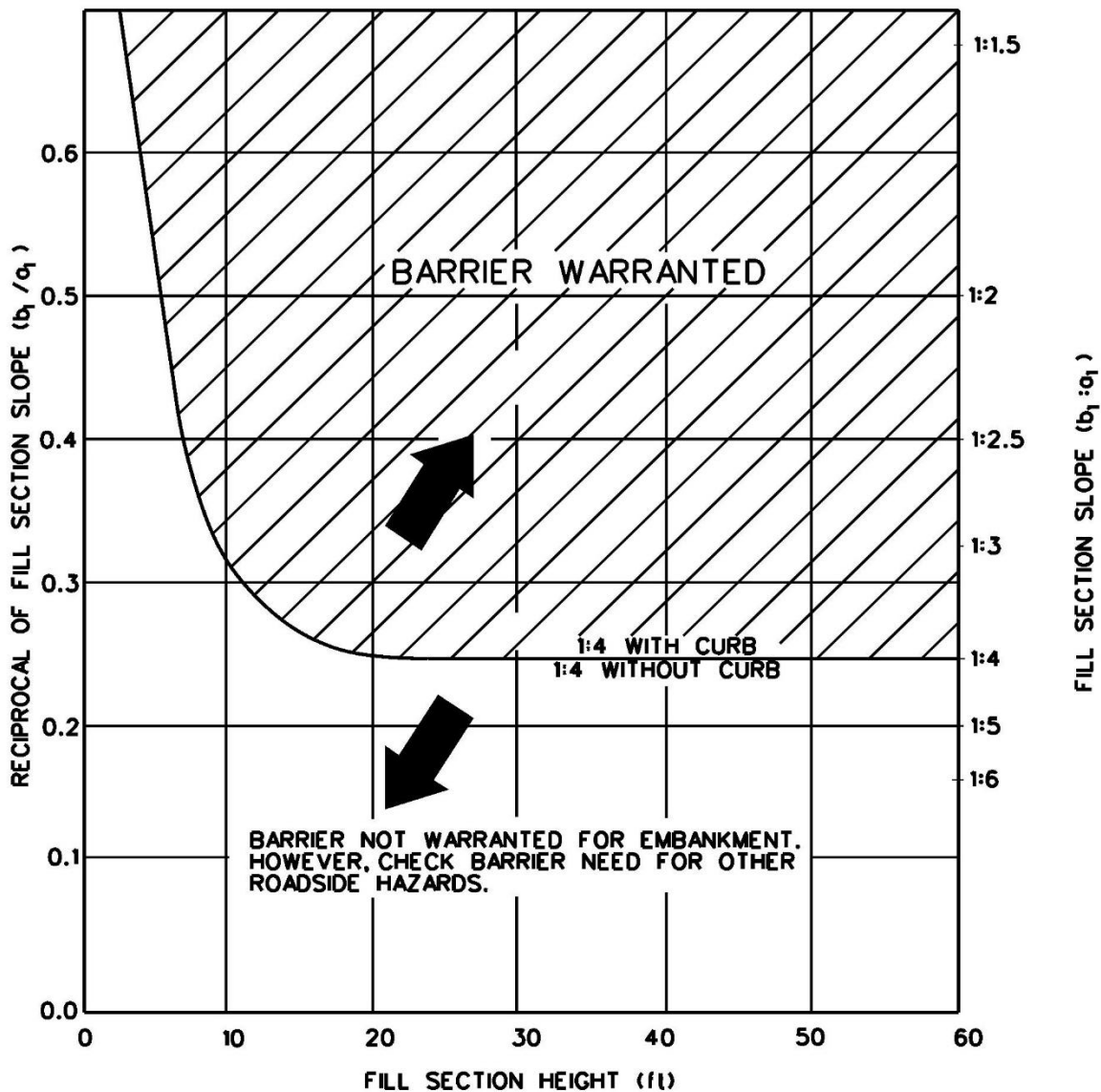
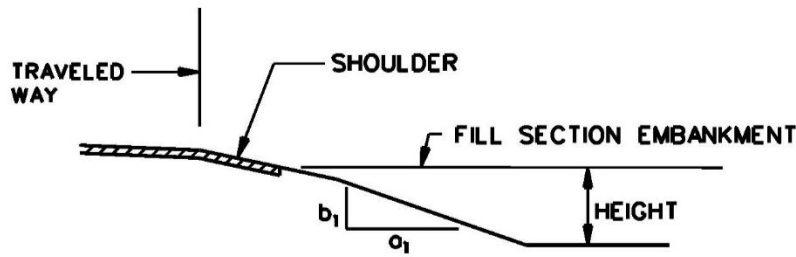

NOTE: POINTS WHICH FALL ON THE SOLID LINE DO NOT WARRANT A BARRIER.

**WARRANTS FOR EMBANKMENTS**

Figure 13-3A



**13-3.03 Bridge Rails and Approaches**

The leading and trailing ends of bridge rails normally warrant protection. The blunt ends on all four corners of a bridge on a bi-directional roadway shall be considered a hazard and therefore treated with a leading end transition, regardless of clear zone requirements. Figure 13-3B illustrates warrants for providing guiderail approaching a bridge rail.

**13-3.04 Bridge Piers, Abutments and Overhead Sign Structures**

Structures should normally be placed outside the design clear zone. However, many bridge piers, abutments and overhead sign support structures are within the design clear zone and cannot be relocated. Where this occurs, guiderail or concrete barrier protection is warranted. Where full-height abutments are immediately outside the clear zone, guiderail treatment may be warranted.

The Designer shall determine whether zone of intrusion clearance considerations (Section 13-8.0) are applicable. Designers should then coordinate their roadside designs in the vicinity of structures with the Bridge Design Unit.

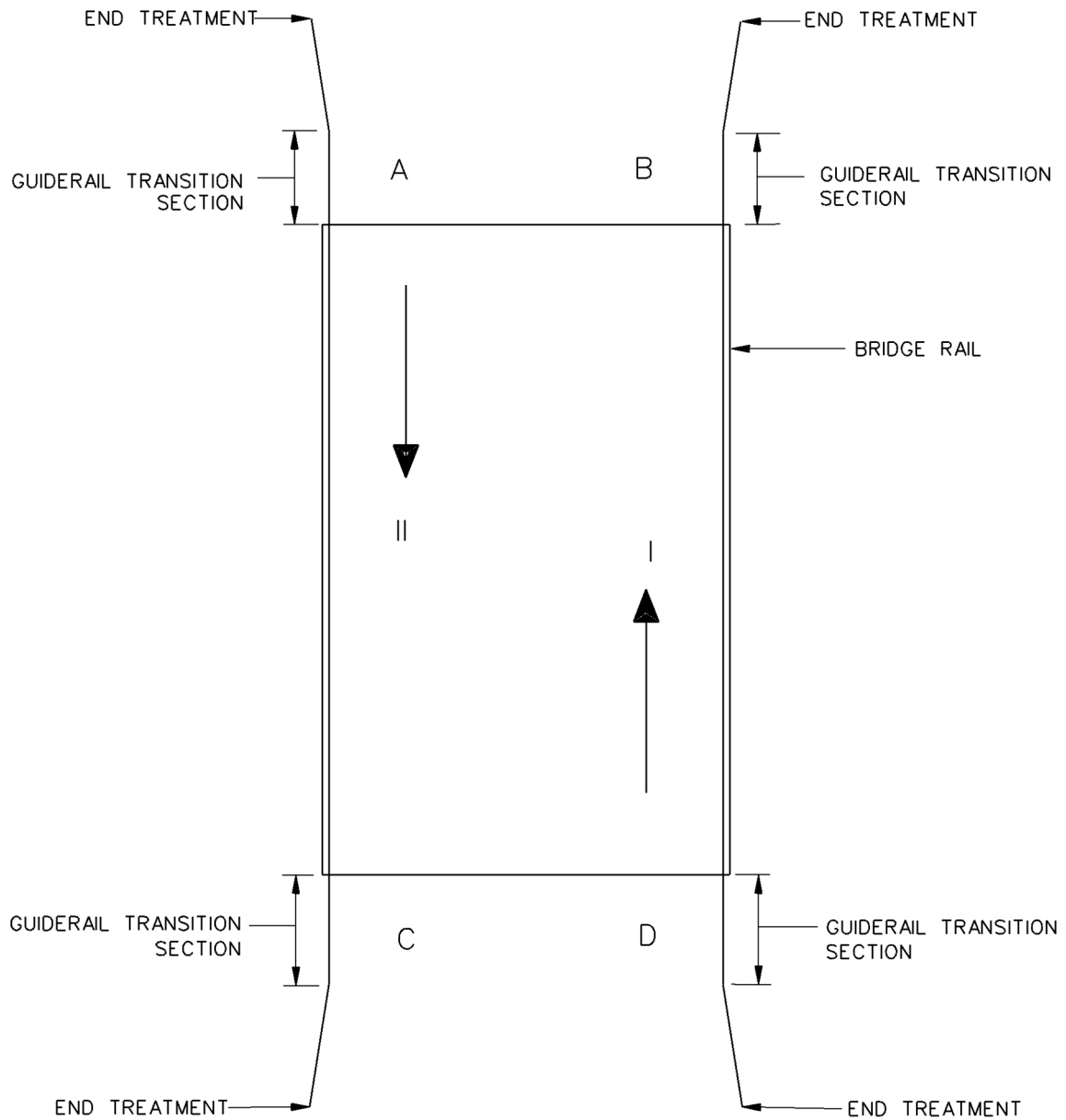

TRAFFIC DIRECTION  
 I and II  
 II Only  
 I Only

LEADING END TRANSITION REQUIRED AT  
 A B C D  
 A B \*  
 C D \*

\* FOR THESE CASES, TRAILING END TRANSITIONS MAY BE WARRANTED FOR THE TRAILING END OF THE BRIDGE.

**WARRANTS FOR GUIDERAIL APPROACH TO BRIDGE RAIL**

**Figure 13-3B**

**13-3.05 Vertical Drop-Offs**

Barrier should be considered for a vertical drop-off within the clear zone that exceeds 2.5 ft. Figure 13-3C provides details on where barrier may be required.

**13-3.06 Roadside Ditches, Channels and Swales**

If a vehicle departs the roadway and encounters ditches, channels or swales, the roadside configuration may introduce abrupt changes in vehicular direction that can result in destabilization of the vehicle. Figure 13-3D illustrates the relative traversability of various combinations of front slopes, ditch widths and backslopes for roadside channels, ditches and swales.

The typical section figures in Chapters Four and Five illustrate the standard roadside swales in a cut section. For highways without curbs, the front slope is 1:12, the rounded ditch width is 10 ft and the backslope is variable but not to exceed 1:2. The typical sections also show that the outside limit of rounding for the backslope should be outside the clear zone distance determined from Section 13-2.0. Where this limit is within the clear zone, the Designer should attempt to relocate the outside limit of rounding to beyond the clear zone.

Ditch sections that fall within Zone 1 in Figure 13-3D may warrant guiderail. However, the Designer should consider the cost effectiveness of installing lengthy sections of guiderail to shield a ditch. This is not always desirable and may warrant revising the ditch cross section to eliminate the need for guiderail.

If the dimensions of an existing or proposed ditch section fall within Zone 2 in Figure 13-3D, the backslope should be flattened if practical. If this is not feasible, guiderail is not warranted because of the ditch cross section alone. In this Zone, guiderail is considered more of a hazard than the ditch itself and, therefore, may not be warranted.

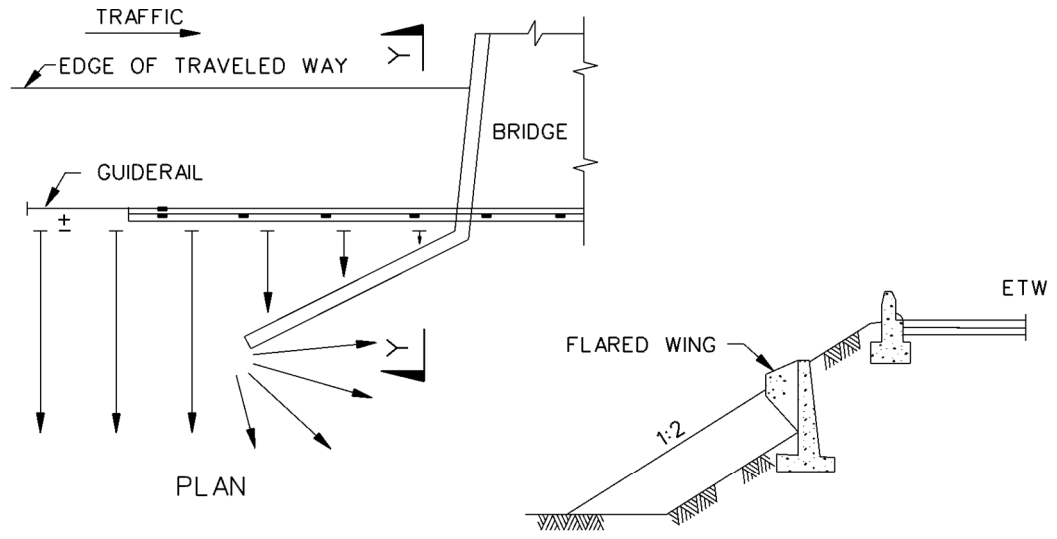

SECTION "Y-Y"  
ROADSIDE BARRIER TREATMENT AT FLARED WINGS

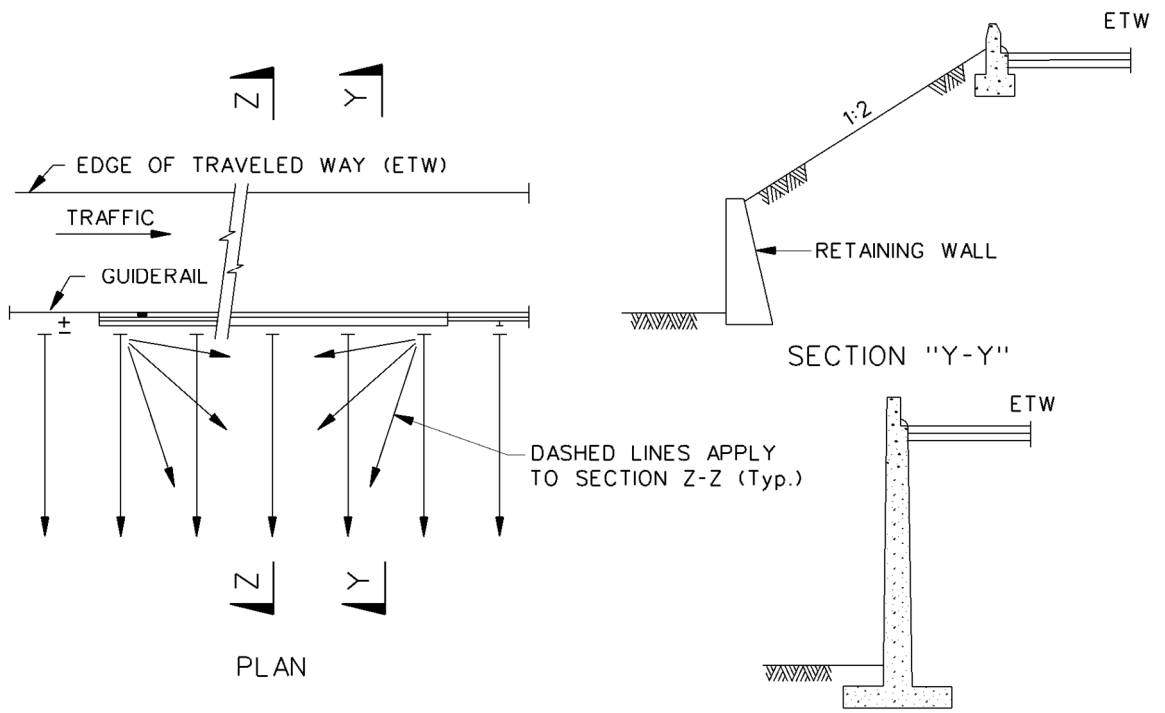

SECTION "Y-Y"  
SECTION "Z-Z"  
ROADSIDE BARRIER TREATMENT AT EMBANKMENT RETAINING WALLS

**BARRIER WARRANTS FOR VERTICAL DROP-OFFS**

**Figure 13-3C**

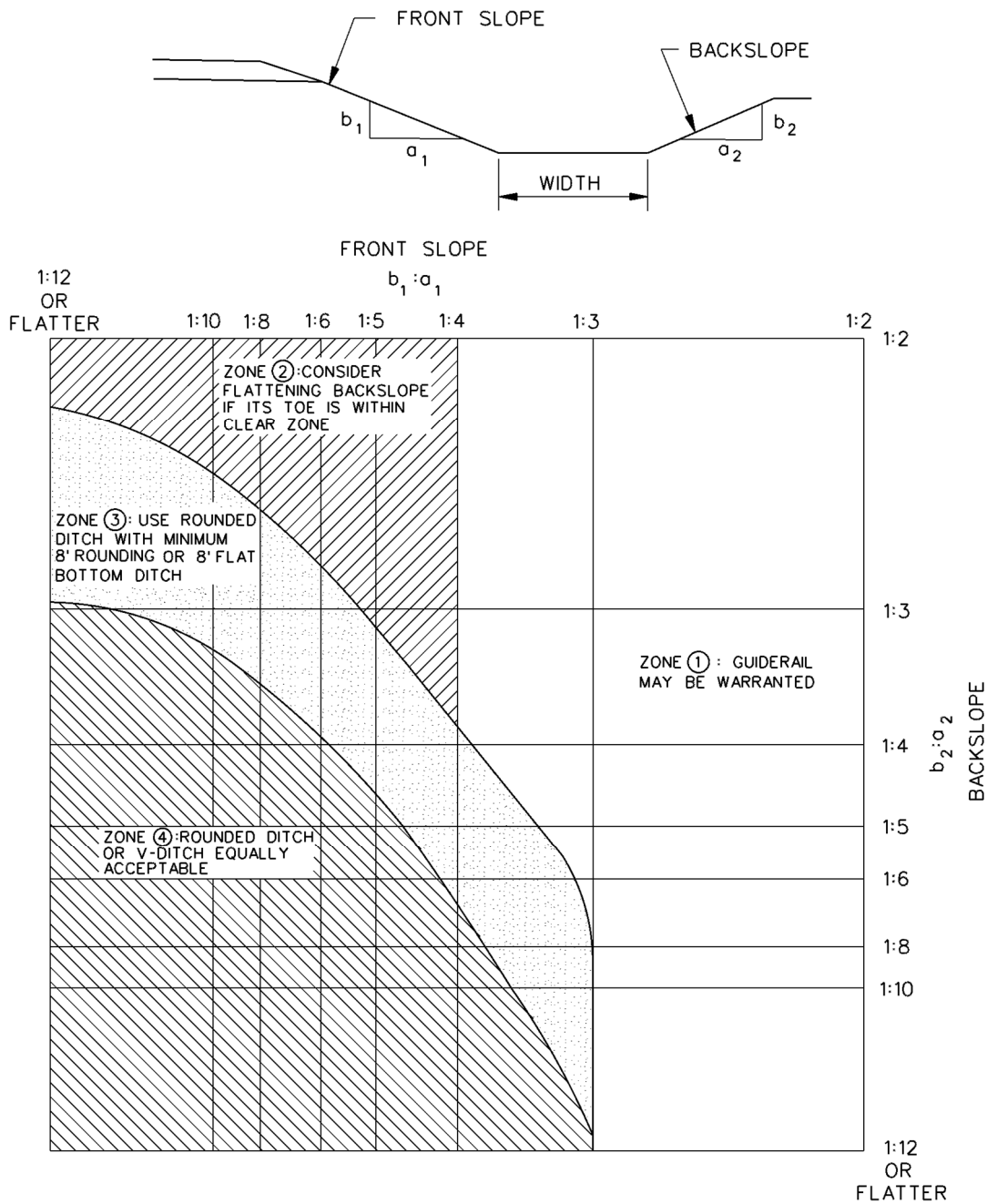

Notes:

1. Figure is based on impacts at 60 mph and 25 degrees.
2. Zones in figure are numbered indicating their relative hazard with Zone 1 being the most hazardous.

**TRAVERSABILITY OF ROADSIDE DITCHES, CHANNELS AND SWALES**

**Figure 13-3D**

### **13-3.07 Transverse Slopes**

Where the highway mainline intersects a driveway, side road, or median crossing, a slope transverse to the mainline will be present. See Figure 13-3E. The exposure of transverse slopes is less than that of foreslopes or backslopes, yet they are generally more critical to errant motorists because run-off-the-road vehicles typically strike them head-on. Transverse slopes can typically result in vehicular vaulting, or in the case of steep transverse slopes, “catching” of the bumper in the slope, resulting in an abrupt stop and high occupant deceleration forces.

For these reasons, transverse slopes should be as flat as practical. For design speeds greater than 45 mph, the slope should be 1:12 typical or 1:10 maximum or flatter. For 45 mph or below, the slope should be 1:6 or flatter. If these criteria cannot be met practically, guiderail may be considered. The decision to use guiderail should be made on a case-by-case basis considering costs, traffic volumes, severity of the proposed transverse slope and other relevant factors. If guiderail is needed around the corners of intersecting roads or driveways, see Figure 13-9D for placement criteria on radii. The Designer should also investigate the use of the “Curved Guiderail Treatment” on roadways with design speeds less than or equal to 50 mph. See Section 13-5.04 – Curves Guiderail Treatment.

### **13-3.08 Median Barrier Warrants**

1. Freeways: Median barrier is warranted on all medians with a width of 66 ft or less, as measured from edge of travelway to edge of travelway, to avoid a head-on collision of two departing vehicles. A median barrier may also be warranted on wider medians if a significant number of crashes have occurred. Medians may vary in width. If a section warrants a median barrier and the adjacent wider section does not, the barrier should be extended into the wider median section by approximately 100 ft.
2. Non-Freeways: The Designer should evaluate the crash history, traffic volumes, travel speeds, median width, alignment, and sight distance to determine if median barrier is warranted. It is recommended to include documentation in the project files when it is determined that median barrier is not warranted.
3. Hazards: The roadside clear zone discussed in Section 13-2.0 applies to each direction of travel for median applications.

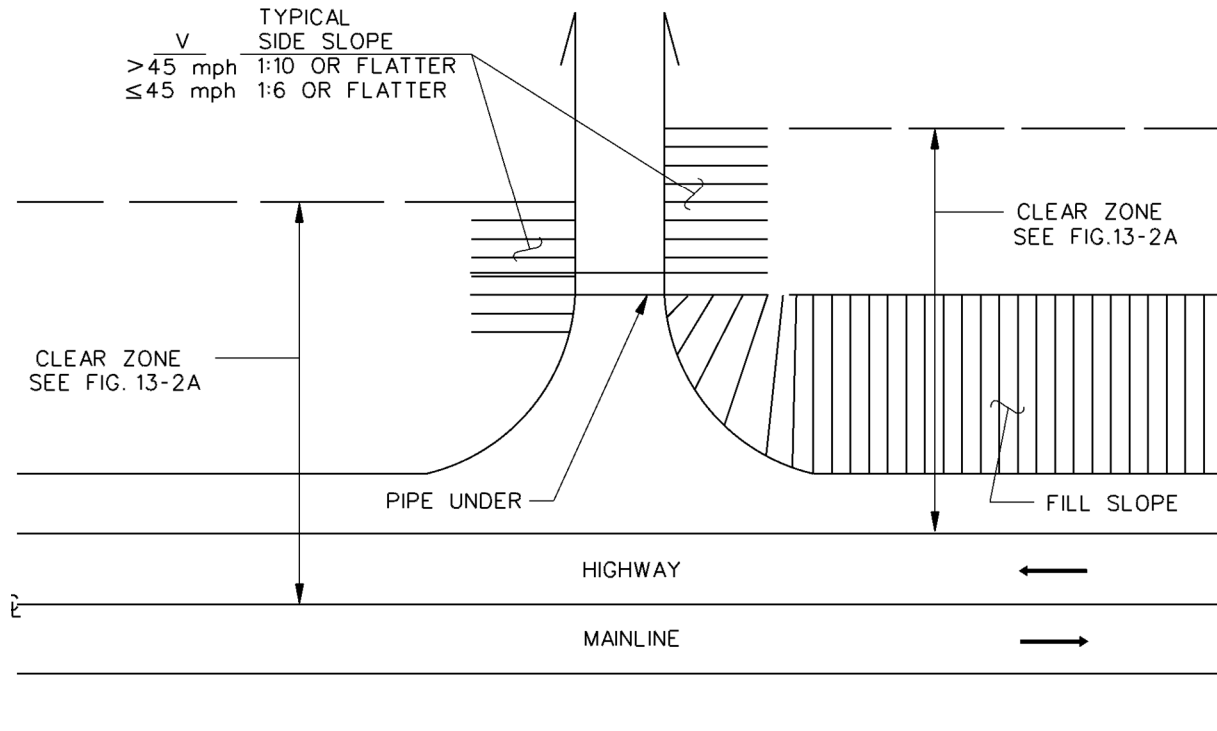

**TRANSVERSE SLOPES**

**Figure 13-3E**

## **13-4.0 DISPOSITION OF EXISTING BARRIER**

### **13-4.01 Application**

All projects must consider appropriate ways to maintain or enhance safety. There are many factors that should be considered when evaluating whether safety appurtenances should be installed, removed or upgraded. The project scope, roadway classification, design speed, right-of-way availability, crash history, etc., all contribute to this decision making process to determine if a safety enhancement is warranted. When a proposed improvement relies on the functionality of existing barrier, any obsolete barrier must be upgraded to current standards. It is recognized that enhancing roadside safety may be beyond the scope of certain project types; however, the project improvements must not degrade highway safety.

Preventive maintenance type projects, such as pavement striping and pavement preservation, do not require the replacement of obsolete longitudinal barrier as long as they are not negatively impacted. Isolated or obvious deficiencies should be addressed.

Designers must apply the guidelines in Section 13-3.0 when evaluating existing barrier to provide the most forgiving roadside environment possible, consistent with the scope of the project.

### **13-4.02 Longitudinal Barrier**

The following longitudinal barriers are classified as obsolete and their replacement is required in accordance with Chapter 2, Chapter 3 and Section 13-4.01:

- Two-cable on wood posts.
- Three-cable with steel brackets on steel strong-posts or wood posts.
- R-I W-beam guiderail on weak steel posts with rail splice at each post.
- R-B and MD-B W-beam guiderail with steel blockouts and rail splice at posts.
- Concrete Barrier less than 32 in. height.
- R-B 350 and MD-B 350 with a rail height less than or equal to 27 in. with plastic blockouts and rail splices at posts.

The following longitudinal barriers are acceptable to remain provided that they meet length-of-need, deflection requirements and condition, but require replacement when impacted by construction activities:

- Modified R-I W-beam guiderail at 32 in.  $\pm$ 1 in. rail height, 12 ft - 6 in. post spacing, mid-span rail splice, on weak steel posts without blockouts.
- MD-I W-beam guiderail at 32 in.  $\pm$ 1 in. rail height, on weak steel posts with rail splice at each post.
- R-B 350 and MD-B 350 with a rail height greater than 27 in., rail splice at posts with plastic blockouts.
- Three-cable guiderail with 29 in. height to the top wire.
- Concrete Barrier greater than or equal to 32 in. height.



- Thrie-Beam 350 guiderail at 34 in.  $\pm$ 1 in. rail height

The Designer should review Section 13-7.0 for general guidance to determine if there are any hazards within the deflection distance of any existing guiderail that is to remain.

#### **13-4.03 End Treatments**

The following end treatments, within the project limits, shall be replaced or upgraded to an approved end treatment in accordance with Section 13-10.0:

1. Leading end turned-down end anchors within the clear zone, except three-cable guiderail on weak steel posts.
2. Leading end blunt ends.
3. Trailing end turned-down end anchors for W-beam guiderail on bi-directional roadways shall be replaced/upgraded if it is within the clear zone for the opposite direction of travel.

Designers should also consider replacing an existing impact attenuator with an end anchor if it only requires extending the rail up to 200 ft. Grading adjacent to existing end treatments should be reviewed and corrected in accordance with Section 13-10.0.

#### **13-4.04 Bridge Attachments**

All existing bridge attachments not meeting NCHRP Report 350 within the limits of a project shall be converted to one of the bridge attachments meeting the MASH 2016 criteria. NCHRP Report 350 attachments may be considered when MASH attachments are not available or cannot be installed within the existing site constraints. Designers shall consult with the Bridge Design Unit to determine the extent of bridge modifications that would be required.

#### **13-4.05 Curbs and Curb/Barrier Combinations**

See Section 13-9.04 for evaluating existing curbing within the project limits.

Granite stone transition curbing shall be replaced with the Department's current standard curbing when installing a new bridge attachment.

## 13-5.0 ROADSIDE BARRIERS

### 13-5.01 Three-Cable Guiderail (I-Beam Post)

Three-cable guiderail is a weak-post flexible system with a large dynamic deflection. The tensile forces developed in the cable strands supply most of the resistance to impact. Upon impact, the cables break away from the posts, and the vehicle is able to knock down the posts as it is redirected by the cables. The detached posts do not contribute to controlling the lateral deflection. However, the posts that remain in place do provide a substantial part of the lateral resistance to the impacting vehicle and are therefore critical to proper performance.

Three-cable guiderail is the most forgiving of the available systems because of its large dynamic deflection. Its use should be tempered by the following considerations:

1. Transitions: Do not use three-cable guiderail for leading end transitions into bridge rails.
2. Slopes: Do not use three-cable guiderail on fill slopes steeper than 1:2, unless the distance between the back of the posts and the break in the fill slope is at least 8 ft.
3. Minimum Radius: Three-cable guiderail shall not be used on radii less than or equal to 440 ft. See Figure 13-9E for guiderail curvature criteria.
4. Cable Tension: For three-cable guiderail to provide full impact performance, the cables must be tensioned properly. Therefore, maintenance forces should ensure that the cable strands are tensioned properly at all times.
5. Minimum Length: Post spacing shall not vary within a run of three-cable guiderail. The following minimum lengths shall apply:

Post Spacing (ft)	Minimum Length (ft)
16	248
12	248
8	156

**Three-Cable Minimum Lengths**

**Figure 13-5A**

Three-cable guiderail is ineffective after one impact and is therefore not the appropriate guiderail to use where crash history shows a significant number of run-off-the-road crashes have occurred.

### 13-5.02 Metal Beam Rail (Type R-B 350)

Metal beam rail (Type R-B 350) is a strong-post semi-rigid system with steel posts and routed recycled plastic block outs. This system is oriented such that the rail element splices are at the posts and the rail height is installed at 29 in. The deflection distance of R-B 350 guiderail is much less than that of three-cable guiderail. The deceleration forces on vehicular occupants when impacting R-B 350 are significantly higher than impacts with three-cable guiderail. R-B 350 guiderail has significant maintenance advantages by safely sustaining a second impact even after a first major impact.

R-B 350 may only be installed when a transition length is not available for the installation of R-B MASH, such as at short lengths of rail followed by a bridge attachment, curved guiderail treatment, earth cut slope anchor, or rock cut slope anchor. See section 13-4.0 for disposition of existing barrier.

The Designer should provide a minimum of 2 ft between the back of post and the hinge point. This distance is especially important atop embankments because it provides the soil support to help resist or limit deflection of the barrier during impact. The post length can be increased to provide the necessary soil support when installing the back of post at the hinge point of an embankment of 1:2 or steeper. Crash tests have been successfully performed with installing longer posts spaced at 3 ft-1.5 in. placed at the hinge point resulted in deflections similar to that of the standard post spacing. The 7 ft-6 in. post detailed on the Connecticut Highway Standard Drawings should be used when Designers specify this application.

### **13-5.03 Metal Beam Rail (R-B MASH)**

Metal beam rail (R-B MASH) is a strong-post semi-rigid system with steel posts and routed recycled plastic block outs. This system is oriented such that the rail element splices are between the posts and the rail height is installed at 31 in. The R-B MASH guiderail passed the TL-3 testing criteria according to the MASH. The deflection distance is similar to that of metal beam rail (R-B 350). The deceleration forces on vehicular occupants when impacting R-B MASH are significantly higher than impacts with three-cable guiderail. R-B MASH guiderail has significant maintenance advantages by safely sustaining a second impact even after the first major impact. For this reason, R-B MASH guiderail should be strongly considered where a site has a history of frequent run-off-the-road incidents, or where the greater deflection distance required for three-cable guiderail is either not available or is only available intermittently.

The Designer should provide a minimum of 2 ft between the back of post and the hinge point. This distance is especially important atop embankments because it provides the soil support to help resist or limit deflection of the barrier during impact. Crash tests have been successfully performed with installing standard sized posts at standard post spacing placed at the hinge point of a 1:2 embankment resulted in deflections of approximately 5 ft-1 in. from the back of the post. When that deflection is not feasible, it is recommended to propose the half-post spacing system which results in a 4 ft-3 in. deflection distance.

There are two reduced post spacing options available to reduce the deflection of R-B MASH at isolated locations within the length of guiderail. The quarter post spacing requires 25 ft of half post spacing on either end for strength transitioning purposes. See Figure 13-7C for deflection distances for each respective reduced post spacing options. Also see the Connecticut Highway Standard Drawings for details.

Where isolated underground conflicts exist, crash tests have shown that one post can be omitted every 25 ft without affecting system performance.

### **13-5.04 Curved Guiderail Treatment**

The curved guiderail treatment is a TL-2 NCHRP Report 230 device meant to be used when specific radii less than or equal to 35 ft is required. It should only be used on roadways with design speeds less than 50 mph with the designated clear area as noted on the Connecticut Standard Drawings. The system uses controlled releasing terminal (CRT) post along its radius. A minimum 12.5 ft of R-B 350 is required at either end of the system with appropriate transitions when used

within the length of R-B MASH, followed by a reduced post spacing system, or following a bridge attachment. Figure 13-9D in Section 13-9.08 provides guidance on laying out this treatment. Also see the Connecticut Highway Standard Drawings for the available radii and associated designated clear areas.

### **13-5.05 Span Sections Type II and Type III**

R-B MASH has been successfully crash tested with omitting two or three posts for TL-3 testing criteria according to the MASH. This system may be used to avoid any underground conflicts. Each system uses controlled releasing terminal (CRT) posts on either side of the omitted posts. Each system also has a specific length of R-B MASH required, which extends beyond the length of the CRT post limits. A minimum of 12.5 ft of R-B MASH on either end of the system is required before introducing any other guiderail types. These systems are not intended to be used in conjunction with curbing and they should not be installed with a radius. Note that these systems use a 12 in. blockout and still requires 2 ft between the back of post and the hinge point; therefore, impacting the embankment grading. Any headwall within the deflection distance of 6 ft behind the post should have a 2 in. reveal or less.

### **13-5.06 Metal Beam Rail (Box Beam)**

The box beam guiderail passed the TL-3 crash test criteria in NCHRP Report 350. It is a weak-post semi-rigid guiderail with a TS 6 in x 6 in x 0.25 in steel box tube. In the absence of a standard drawing for 6 in. x 6 in. Box Beam, 8 in. x 6 in. Box Beam may be installed on roadside applications. The deflection distance for either box beam guiderail can be reduced by reducing the post spacing. These additional posts are only driven behind the box beam guiderail and are not fastened to it. Either type may be used at selected sites on a case-by-case basis with approval of the Designer's Division Chief and coordination with the Bureau of Highway Operations.

### **13-5.07 Precast Concrete Barrier Curb (PCBC)**

PCBC may be used on the roadside in front of rigid objects or vertical drop-offs where a higher performing barrier with minimal deflection distance is required. A 42 in. high single slope PCBC is the Department's preferred rigid barrier type on new construction projects due to its advantage over the F-shape in its ability to accommodate pavement elevation changes without affecting performance. It has been successfully crashed tested for TL-4 testing criteria according to the MASH 2016. Short runs of new 45 in. F-Shape PCBC can be considered if 45 in. F-Shape PCBC currently exists at the limits of construction. The half-section PCBC may be used on the roadside when installed with backfill. The full-section PCBC shall be used on the roadside if the barrier cannot be backfilled, see Section 13-6.03. See Connecticut Standard Drawings for details of each barrier type and appropriate transitions.

### **13-5.08 Merritt Parkway Guiderail**

The Merritt Parkway Guiderail is a steel-backed timber guiderail that combines aesthetic appeal with acceptable safety performance. It passed the TL-3 crash testing criteria in NCHRP Report 350. The Department has approved this rail for use solely on the Merritt Parkway. However aesthetically appealing, this rail has a high maintenance and installation cost which precludes its widespread application on other State-owned roadways. There are also no end treatments available for this guiderail which limits its use on other roadways.

The Merritt Parkway guiderail with standard post spacing may be installed on either side of the median greater than 13 ft wide on the Merritt Parkway. The Merritt Parkway Guiderail System 2

with a 5 ft post spacing may be used on either side of a median that is between 9ft - 6 in. and 13 ft wide. The Merritt Parkway Guiderail System 3 with a 2 ft - 6 in. post spacing may be used on either side of a median that is between 6 ft - 6 in. and 9 ft - 6 in. wide. Refer to the Connecticut Highway Standard Drawings for details. Ideally, Designers should install the appropriate steel-backed timber guiderail system with the proper deflection needed for the site.

#### **13-5.09 Merritt Parkway Concrete Barrier**

The Merritt Parkway Concrete Barrier combines aesthetic appeal with acceptable safety performance. It is a vertical wall barrier that meets the TL-3 crash testing criteria in the NCHRP Report 350. The Department has approved this barrier for use solely on the Merritt Parkway.

#### **13-5.10 Bridge Attachments**

##### **13-5.10.01 Thrie-Beam Attachment**

The Thrie-Beam attachment is a strong-post transition system with steel posts and routed recycled plastic block outs. This attachment has passed the TL-3 testing criteria according to the MASH 2016. It is installed at a 34 in. height and includes a thrie-beam to w-beam transition element where the w-beam portion of the system is installed at a 31 in. height to continue with R-B MASH. The Designer should provide a minimum 2 ft shelf between the back of post and the hinge point. Only 4 in. curbing is allowed with this attachment. See the Connecticut Highway Standard Drawings.

##### **13-5.10.02 R-B 350 Bridge Attachment**

The R-B 350 Bridge Attachment is a strong-post transition system that uses a w-beam element with steel posts and routed recycled plastic block outs. This attachment also includes a rubrail to prevent wheels from snagging the blunt end of whatever structure it is attached to. This attachment meets the TL-3 crash testing criteria according to the NCHRP-Report 350 and therefore can only be used where applications prevent the installation of the Thrie-Beam Attachment. See the Connecticut Highway Standard Drawings.

## **13-6.0 MEDIAN BARRIERS**

### **13-6.01 Metal Beam Rail (Type MD-B 350)**

Metal beam rail (Type MD-B 350) is a strong-post semi-rigid median barrier with steel posts and routed recycled plastic block outs. Its performance is similar to Metal Beam Rail (Type R-B 350). MD-B 350 median guiderail is most applicable in medians with narrow or intermediate widths. One special application for MD-B 350 is to separate adjacent on/off ramps at interchanges. MD-B 350 should only be installed when the transition length between MD-B MASH and NCHRP Report 350 systems is not available.

### **13-6.02 Metal Beam Rail (MD-B MASH)**

Similar to MD-B 350, MD-B MASH is a strong-post semi-rigid median barrier with steel posts and routed recycled plastic block outs. This system is oriented such that the rail element splices are between the posts and the rail height is installed at 31 in. MD-B MASH guiderail passed the TL-3 testing criteria according to the MASH and performs similar to MD-B 350. MD-B MASH is most applicable in medians with narrow or intermediate widths. Another application for MD-B MASH is to separate adjacent on/off ramps at interchanges.

### **13-6.03 Precast Concrete Barrier Curb (PCBC)**

PCBC may be used in the median in front of rigid objects, vertical drop-offs or on freeways with narrow medians where a higher performing barrier with minimal deflection distance is required. Median PCBC shall be located 12 ft or less from the traveled way as illustrated in Chapter 4 Figure 4I and Chapter 5 Figure 5K, except for the Incident Management section for urban freeways as illustrated in Chapter 5 Figure 5M. A full-section 42 in. high single slope PCBC is the Department's preferred rigid barrier type on new construction projects due to its advantage over the F-Shape because of its ability to accommodate pavement elevation changes without affecting performance. It has been successfully crashed tested for TL-4 testing criteria according to the MASH 2016. Short runs of new 45 in. F-Shape PCBC can be considered if 45 in. F-Shape PCBC currently exists at the limits of construction. Half-sections of PCBC may be used in the median when installed with backfill. See Connecticut Highway Standard Drawings for details of each barrier type and appropriate transitions.

### **13-6.04 Merritt Parkway Median Guiderail**

As with the Merritt Parkway roadside guiderail, the Merritt Parkway median guiderail combines aesthetic appeal with acceptable safety performance. It meets the TL-3 crash testing criteria in NCHRP Report 350. This guiderail may be used in medians where the overall width is greater than or equal to 10 ft, excluding shoulders. The use of individual sections of roadside Merritt Parkway Guiderail may be considered so long as the deflection, flare rate and maximum cross slope criteria are met. See Section 13-5.08 for additional guidance. As with the roadside Merritt Parkway Guiderail, the Department has approved the use of this rail solely on the Merritt Parkway.

### **13-6.05 Merritt Parkway Concrete Median Barrier**

Where the median width is too narrow to accommodate the deflection of the Merritt Parkway Median Guiderail, the Merritt Parkway Concrete Median Barrier may be used. This is a vertical shape barrier that meets TL-3 crash testing criteria in NCHRP Report 350 that also provides an aesthetic appeal. The Department has approved the use of this barrier solely on the Merritt Parkway.

**13-6.06 Metal Beam Rail (8"x6" Box Beam)**

The 8 in. x 6 in. Box Beam guiderail is a semi-rigid median guiderail with a S3 x 5.7 weak steel post and a TS 8 in. x 6 in. x 0.25 in. steel tube. This box beam guiderail passed the TL-3 crash test criteria in NCHRP Report 350. See 13-5.06 for discussion on reduced post spacing when 8 in. x 6 in. box beam rail is installed in a roadside application. Reduced post spacing cannot be installed in a median application. The 8 in. x 6 in. box beam rail may be used at selected sites on a case-by-case basis with approval of the Designer's Division Chief and coordination with the Bureau of Highway Operations.

**13-6.07 Median Bridge Attachments****13-6.07.01 MD-B 350 Median Barrier – Safety Shape Attachment**

The MD-B 350 Median Barrier – Safety Shape Attachment is a strong-post transition system that uses a steel post, and is double sided with a w-beam element and routed recycled plastic block outs. This attachment is used on roadways with narrow medians and can be attached to a Jersey Shape or F-Shaped structure. It is available in two different types: Type I and Type II. The Type I is used for bi-directional roadways where a rubrail is used to prevent wheels from snagging the blunt end of whatever structure it is attached to on the leading end. Whereas Type II provides a rubrail on both sides of the system for use on roadways where traffic is traveling in the same direction. This attachment meets the TL-3 crashing testing in NCHRP-350 Report and therefore can only be used when a MASH 2016 attachment is not available. See the Connecticut Highway Standard Drawings.

### 13-7.0 BARRIER DEFLECTIONS

The “deflection distance” is defined as the lateral distance that the outside face (side away from traffic) of a barrier will deflect when struck by an errant vehicle before that barrier system stops the movement of the vehicle away from the road. The available deflection distance for strong-post systems is measured from the back side of the posts. This distinction is made because weak-post rail systems usually separate from the posts when struck, while the rail on strong-post systems will usually remain attached. The clear distance to an obstruction must therefore include an allowance for the width of the strong-post system.

The deflection distance is an important parameter for two reasons. First, it determines the magnitude of the lateral deceleration. Rigid systems, such as concrete barriers, produce essentially instantaneous lateral decelerations that are more likely to result in occupant injuries. Therefore, the use of a less rigid system is favorable. The second reason is that it determines the space that must be maintained between the hazard and the barrier. All hazards should be kept outside of the deflection distance. The potential for vegetation to grow within the deflection distance should be considered.

Figure 13-7C presents the deflection distances expected when various barrier systems are impacted with a standard vehicle. These dimensions are based on crash test research and have been selected as a representative and conservative singular deflection value. However, vehicles traveling at lower speeds on narrow roadways with reduced lateral offsets tend to impact guiderail at flatter angles thereby creating a smaller deflection in the guiderail. For this reason, Figure 13-7A is used when needed to determine the maximum lateral offset for narrow roads. Figure 13-7B should be used to establish applicable reduction factors that may be used to decrease the deflection distance of guiderail when proposed for installation on lower speed, narrow roadways. Refer to the example problem in Figure 13-7B.

The Department’s policy for selecting guiderail with respect to deflection needs is summarized below:

1. The barrier system with the largest acceptable deflection should be selected when a barrier is required.
2. The deflection of the selected guiderail system must be less than the distance from the back of the guiderail post to the nearest hazard that cannot be removed or relocated.

All removable hazards must be removed from the area within the deflection distance of the selected guiderail. Maintenance work may be needed to prevent trees within the deflection distance from growing to more than 4 in. in diameter. Because the Department cannot control development beyond the right-of-way (ROW) line, the selection of a barrier system should ensure that its deflection will not extend beyond the ROW.

The Designer should note that when a vehicle impacts a barrier, the vehicle may lean over the top of the barrier and strike bridge piers, sign supports, light poles, etc., that have been placed behind the barrier.

If practical, fixed objects should be placed beyond the clear zone, instead of behind and above the barrier. Designers should refer to Section 13-8.0 and the Connecticut Highway Standard Drawings for placement of PCBC adjacent to bridge piers, abutments and sign supports.



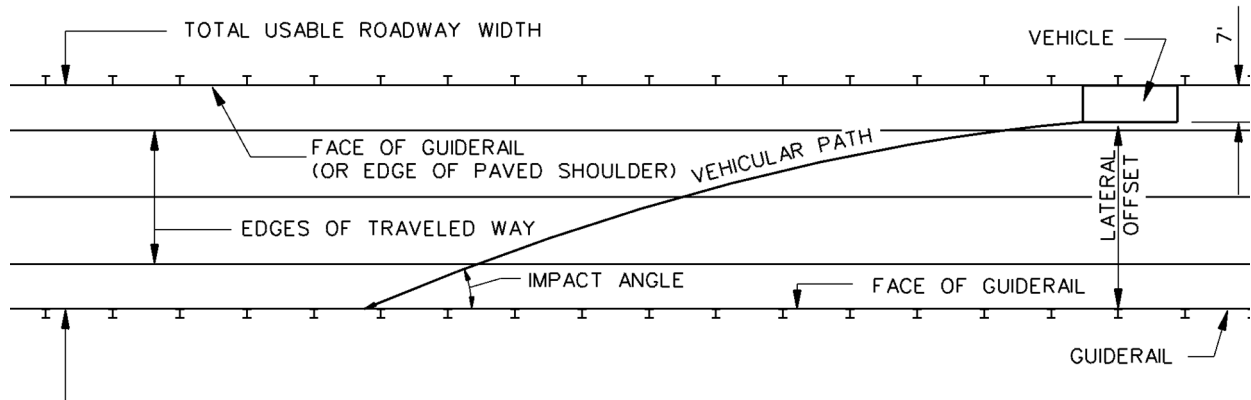

### MAXIMUM LATERAL OFFSET

(For use with Figure 13-7B)

Figure 13-7A

#### Notes:

1. Factors will not be less than 0.5.
2. As illustrated in Figure 13-7A.
3. Reduction factors are used at specific locations when a smaller deflection is needed on a lower speed roadway to protect motorists from immovable objects.

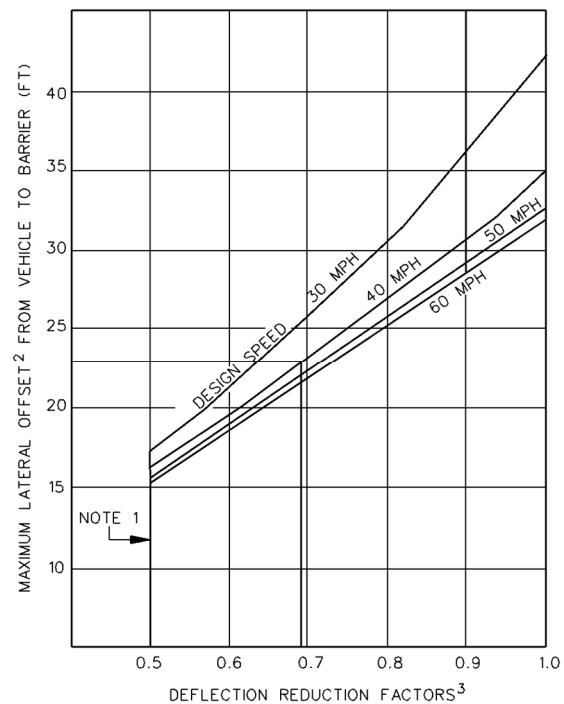

#### Example:

1. Determine that the maximum lateral offset (as defined in Figure 13-7A) equals 23 ft.
2. Determine that the guideway's standard deflection (obtained from Figure 13-7C) is 8 ft.
3. Determine the design speed to be 40 mph.
4. From the graph in this figure, the reduction factor is 0.69.
5. Multiply 8 ft by 0.69 = 5.52 ft.
6. Use a reduced deflection of 5.5 ft, due to the narrow offset

### DEFLECTION REDUCTION FACTORS

Figure 13-7B

System Name (Post)	Barrier Type and Category	Post Spacing	Deflection Distances
Three-cable Guiderail (S3x5.7) weak-post	3-3/4" Dia. steel cables Flexible System	16'-0" 8'-0"	12'-6" 8'-0"
Type R-I Type Modified R-I (S3x5.7) weak-post	Steel W-Beam Element Flexible System	12'-6" 6'-3" 3'-1½"	8'-0" 6'-0" 4'-6"
Type R-B 350 Type R-B MASH (W6 x 8.5) strong-post	Steel W-Beam Element Semi-rigid Systems	6'-3" 3'-1½" 1'-6¾"	4'-3" 2'-8" 1'-10"
Span Section Type II & III	Steel W-Beam Element Semi-rigid Systems	N/A	6'-0"
Type MD-I (S3x5.7) weak-post	Steel W-Beam Element Flexible Systems	12'-6" 6'-3"	6'-0" 4'-0"
Type MD-B 350 Type MD-B MASH (W6 x 8.5) strong-post	Steel W-Beam Element Semi-rigid Systems	6'-3"	2'-0"
6" x 6" Box Beam (S3x5.7) weak-post	Steel 6" x 6" Tube Semi-rigid System	6'-0" 3'-0"	4'-10" 4'-0"
8" x 6" Box Beam (S3x5.7) weak-post	Steel 8" x 6" Tube Semi-rigid System	6'-0" 3'-0"	6'-6" 4'-0"
Thrie-beam 350 (W6 x 8.5) strong-post	Steel Thrie-beam Element Semi-rigid System	6'-3"	4'-4"
Merritt Parkway Guiderail (W6 x 15) strong-post	Rough Sawn Timber Element Semi-rigid System	10'-0" 5'-0" 2'-6"	4'-0" 2'-6" 1'-0"
Merritt Parkway Median Guiderail (W6 x 15) strong post	Rough Sawn Timber Element Semi-rigid System	10'-0"	3'-0"
Safety, F-Shape, Single Slope and Vertical Shapes	Concrete Barriers, Rigid	N/A	0

## Notes:

1. Deflection distance measured from the back of post for w-beam guiderail systems.
2. Minimum Lengths:
  - a. Three-Cable guiderail = See Section 13-5.01
  - b. W-Beam guiderail systems (Roadside and Median) = 62.5 feet (Excluding anchors)
  - c. Box Beam guiderail systems = 130 feet

**BARRIER DEFLECTION DISTANCES****Figure 13-7C**



**13-8.0 ZONE OF INTRUSION (ZOI) BACKGROUND**

Crash testing and field experience has shown that during an angled impact, a large truck or similar high-center-of-gravity vehicle will typically lean over and extend for some distance behind a rigid or semi-rigid barrier and may strike an object placed on or just behind the barrier (Figure 13-8A). The expected distance of this intrusion behind a barrier is called "Zone of Intrusion" (ZOI). Depending on the barrier type and height, the roll or lean of an impacting large truck cargo box can reach obstacles up to as much as 10 ft behind a rigid barrier.

Infrastructure or objects which exist or are placed within this Zone of Intrusion distance may be impacted by the vehicle causing injury to vehicle occupants, or possible secondary crashes after the initial impact (Figure 13-8B).



**Box Truck Crash Test**

**Figure 13-8A**

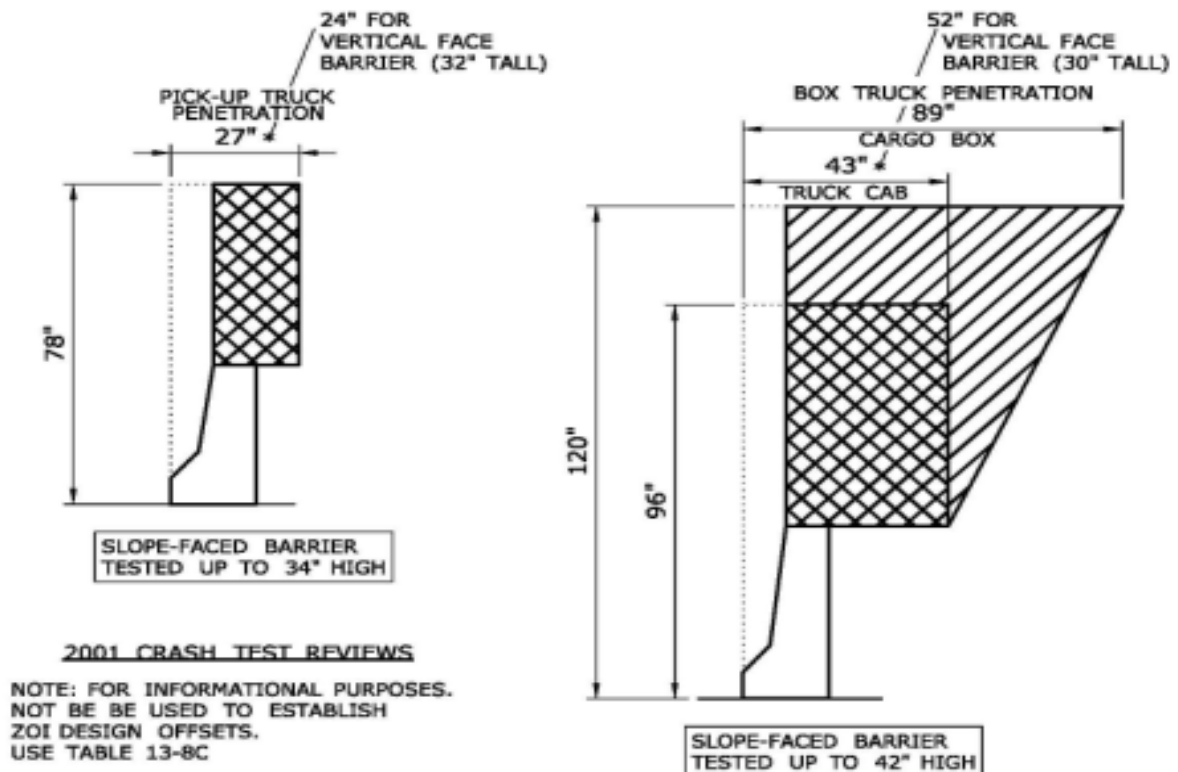

**Typical Intrusion Zones from Crash Test Reviews**

**Figure 13-8B**

### **13-8.01 Application**

Due to the higher volumes, speeds, percentage of trucks, and the greater number of bridge piers, abutments, cantilever and full-span overhead sign support structures typically encountered on freeways, ZOI distances, as discussed below, should be considered on all freeways (excluding the Merritt Parkway).

#### **13-8.01.01 Scope of Projects for ZOI Evaluation**

The application of ZOI criteria should be evaluated on freeways (excluding the Merritt Parkway) for all major projects and projects that will provide a general upgrading of the facility, including the following project types:

- new construction or reconstruction
- addition of lanes
- lane or shoulder reconstruction or widening
- complete bridge replacement
- safety improvements, including the installation of concrete median barriers and/or roadside barrier replacement
- pavement rehabilitation (placing more than 3 in. of new bituminous concrete)

However, it is recognized that ZOI considerations may be beyond the scope of certain project types, such as spot improvements or projects intended to address a single type of deficiency on the freeway. Accordingly, the application of ZOI criteria need not be considered for the following project types:

- spot improvements
- sign support replacements
- pavement striping
- pavement preservation (placing up to 3 in. of new bituminous concrete)
- other limited scope improvements

#### **13-8.01.02 Evaluation**

Although objective warrants for applying ZOI criteria do not presently exist, the following subjective factors should be considered at each specific location:

- roadway geometry,
- crash history and existing barrier performance,
- design, construction and maintenance costs (i.e. barrier systems, longer bridges, and larger overhead sign support structures).

**13-8.01.03 ZOI Design Guidance**

Engineering judgment is required when choosing, placing, and designing barrier systems to provide a balance between risk and cost. If the determination is made that ZOI distances will be applied at a specific location, Designers should first consider:

1. modifying the design to place the object out of the ZOI distance for the selected barrier system; or,
2. using a higher performing barrier (barrier height or shape) to reduce vehicular lean during an impact.

Based on crash test reviews and research reports, the observed intrusion by pickup truck and box truck cabs was used to develop ZOI distances. The ZOI distances shown in Table 13-8C have been established for use by Designers as practical design parameters.

<b>Object Distance (d) (measured from toe of barrier face)</b>	<b>Barrier Type</b>
$d \geq 8'$	W-Beam Guiderail <sup>1</sup> 32" Jersey Shape <sup>2</sup>
$4' \leq d < 8'$	42" Jersey Shape
$2' \leq d < 4'$	42" – 45" F-shape 45" Vertical Shape
$d < 2'$	54" Vertical Shape <sup>3</sup>

Notes:

1. Although crash test reviews for ZOI distances on semi-rigid systems are not available, it is considered reasonable for a Designer to combine the dynamic deflection of the system with a ZOI distance of 4 ft until more information becomes available. This combined distance is measured from the front face of the rail system. It should be noted that R-B MASH and R-B 350 Guiderail is not specifically designed to meet test level 4 and higher criteria.
2. Existing 32 in. Jersey barrier at this distance may remain in place as directed in 13-4.0. New installations of concrete barrier shall be in accordance with Sections 13-5.07 and 13-6.03.
3. A minimum of 10 ft of 54 in. barrier is required in advance of the object.

**ZOI Distances****Table 13-8C**

ZOI distances shall not be directly applied to flexible railing systems. At locations where ZOI is a concern and the object distance is beyond 12 ft from the face of the guiderail system, ZOI is considered to be met.



## **13-9.0 BARRIER LAYOUT**

### **13-9.01 Length-of-Need**

The Department's criteria for determining the length-of-need is found in the AASHTO Roadside Design Guide, Section 5.6.4.

### **13-9.02 Flare Rate**

It may be necessary to laterally relocate a run of guiderail to terminate the end anchorage outside the clear zone or to meet a bridge parapet. This lateral relocation may increase the angle of impact on the guiderail. Therefore, guiderail flare rates should be based on Figure 13-9A.

### **13-9.03 Lateral Placement**

Guiderail should be placed as far as practical from the edge of the traveled way. This will minimize the chance that it will be struck, and provides the driver with a chance to regain control of the vehicle before impacting the guiderail. The following factors should be considered when determining guiderail lateral placement:

1. The deflection distance of the guiderail, as shown in Figure 13-7C, should be met. The Zone of Intrusion of a vehicle getting over and behind the rail should also be considered when it is applicable.
2. Designers should refer to Sections 13-5.0 and 13-6.0 for guidance when designing the lateral placement of a selected barrier type.
3. Drivers tend to reduce speed and change the vehicle's position when roadside objects appear as an obstacle. The distance between the edge of travel way and the object is known as the shy-line offset. Figure 13-9B illustrates this suggested distance in relation to design speed. It is recommended to laterally place short lengths of guiderail beyond the shy-line offset. The distance is not as critical for long runs of guiderail, especially when the guiderail is introduced beyond the shy-line. Note that the shy-line offset is not a controlling criteria when designing the guiderail.
4. Guiderail should typically be placed with the rail element flush with the back of the sidewalk.



Design Speed (mph)	Flare Rate for Barrier Inside Shy-Line	Flare Rate for Barrier Beyond Shy-Line	
		Rigid	Flexible/Semi-Rigid
30	13:1	8:1	7:1
40	16:1	10:1	8:1
45	18:1	12:1	10:1
50	21:1	14:1	11:1
55	24:1	16:1	12:1
60	26:1	18:1	14:1
70	30:1	20:1	15:1

### BARRIER FLARE RATES

Figure 13-9A

Design Speed (mph)	Shy-Line Offset (ft)
30	4.0
40	5.0
45	6.0
50	6.5
55	7.0
60	8.0
70	9.0

### SUGGESTED SHY-LINE OFFSETS

(from Edge of Traveled Way)

Figure 13-9B

#### 13-9.04 Curbs and Curb/Barrier Combinations

When the tires of an errant vehicle strike a curb, the impact tends to bounce the vehicle upwards which may contribute to vaulting or penetration of the rail. This problem is increased when curbs are located between 1 ft and 10 ft in front of guiderail. As a result, curbing should not be installed when guiderail is in this range, including when guiderail is flared. Where curbing is required, the Designer should consider using a curb no higher than 4 in.

The following criteria will apply for curbing and curb/barrier combinations:

1. Curbing of any height is not permitted for use in conjunction with either concrete barriers, end treatments, or Span Sections.
2. Curbing shall not be used in gore areas.

3. Curbing with a maximum height of 4 in. may be used in combination with barrier when it is necessary for drainage purposes in accordance with the following:
  - a. Any w-beam guiderail shall be installed flush with the face of curbing. See Connecticut Highway Standard Drawings.
  - b. Three-cable guiderail shall be installed a maximum of 1 ft from the face of curbing. See Connecticut Highway Standard Drawings.

### 13-9.05 Required Grading

If guiderail is improperly located on slopes, an errant vehicle could impact the rail too high or too low, causing destabilization of the vehicle. Therefore, the following criteria will apply:

1. It is preferred to place w-beam guiderail on slopes 1:12 or flatter. This also applies to the areas in front of the flared section of guiderail. See Figure 13-9C. A 1:10 slope may be considered where grading is restricted.
2. Three-cable guiderail may be placed on slopes between 1:10 and 1:6 when needed (i.e., barn-roof sections). It has been demonstrated through crash test evaluation that the cable engages vehicles better than other rail systems for this range of slopes.

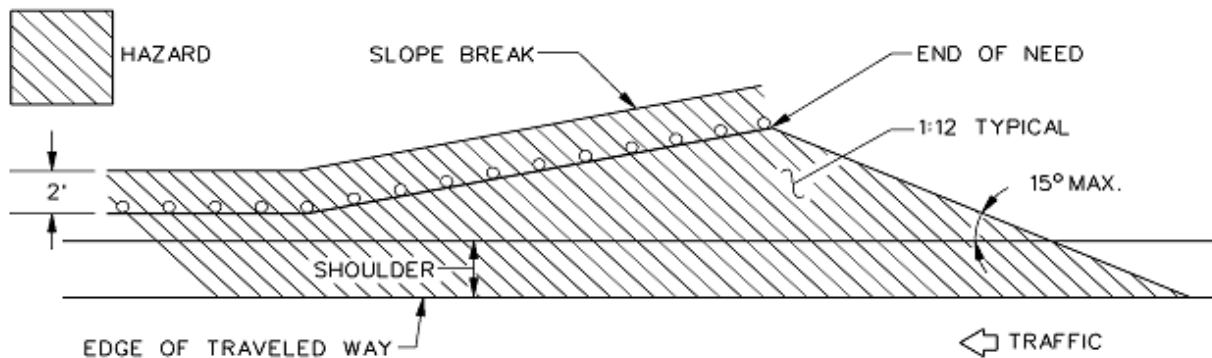

**GRADING IN FRONT OF GUIDERAIL**

**Figure 13-9C**

### 13-9.06 Processed Aggregate for Railing

Processed Aggregate should be included in construction contracts underneath any guiderail. The Designer should include a detail in the plans to show a depth of approximately 6 in. of Processed Aggregate to be installed under all new guiderail. Processed Aggregate should be placed as needed to correct any rutting/wash-outs and to back-up any curbing/edge of road when an obsolete longitudinal barrier is being replaced or converted.

**13-9.07 Guiderail Gaps**

Short gaps between runs of guiderail are undesirable. In general, gaps less than 200 ft between guiderail termini should be connected into a single run. However, this may not be possible on roadways with numerous driveway openings. Removing the need for guiderail should always be investigated to prevent short runs of guiderail or multiple short gaps of guiderail.

**13-9.08 Treatment at Intersecting Roads and Driveways**

Guiderail runs on non-freeway facilities are most often interrupted by intersecting roads and driveways. Figure 13-9D presents the typical treatment that should be used for terminating guiderail at intersecting roads and driveways. When using this figure, the Designer should consider the following:

1. Studies have shown that there is an increased chance for vehicles to impact this type of guiderail installation at 90 degrees. Three-cable guiderail should not be used because of the potential for high-angle impacts.
2. The guiderail should be flared away from the main road whenever possible to allow sufficient sight distance for vehicles on the intersecting road or driveway. Do not install curbing where guiderail is flared for sight line.
3. On roadways and driveways with design speeds of less than or equal to 50 mph, Designers should investigate the possibility of using the Curved Guiderail Treatment as discussed in Section 13-5.04 or an R-B Terminal section as detailed in the Connecticut Highway Standard Drawings. Each of these systems require appropriate transitions when attached to R-B MASH guiderail.

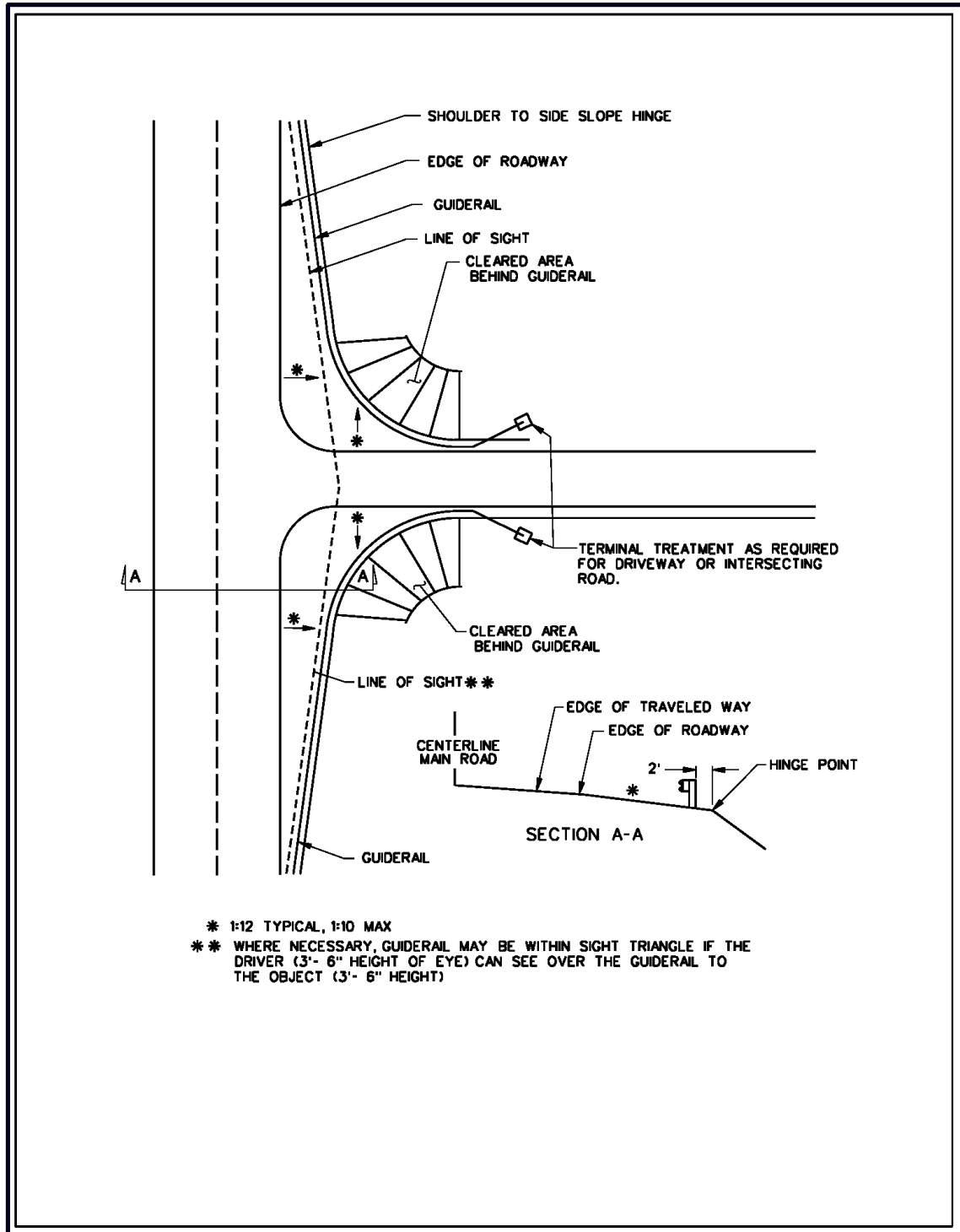

**GUIDERAIL TREATMENT AT INTERSECTING ROADS AND DRIVEWAYS**

**Figure 13-9D**

### 13-9.09 Guiderail Curvature Criteria

Guiderail must sometimes be placed on the inside of radii at, for example, interchange ramps. This condition presents a problem when standard post spacing is used because a vehicle may impact the guiderail at close to 90 degrees. Figure 13-9E illustrates the appropriate curved guiderail treatment for a corresponding radius. It is important to note that w-beam guiderail must be shop fabricated for radii less than or equal to 150 ft; therefore, the Designer should callout the radius on the plans.

Radius of Curve	Curved Guiderail Treatment For $\leq 50$ mph
$R > 720$ ft	Three cable @ 16-ft post spacing Type R-B 350/MASH
$720 \text{ ft} \geq R \geq 440$ ft	Three cable @ 12-ft post spacing <sup>2,3</sup> Type R-B 350/MASH
$440 \text{ ft} > R > 35$ ft	Type R-B 350/MASH <sup>1</sup>
$R = 35$ ft, 25.5 ft, 17 ft or 8.5 ft	Refer to <i>Connecticut Highway Standard Drawing</i> for Curved Guiderail Treatment Details <sup>4</sup>

Notes:

1. W-Beam guiderail must be shop fabricated for radii less than or equal to 150 ft. The radius should be called out on the plans.
2. Three-cable guiderail should not be used for radii less than 440 ft. For radii less than 440 ft, use the appropriate w-beam guiderail.
3. Three-cable guiderail installed on a radius with 12 ft post spacing has a design deflection of standard post spacing.
4. Curved Guiderail treatment is a TL-2 system and requires a transition when connecting to any w-beam guiderail system. Refer to the appropriate Connecticut Highway Standard Drawing.

## CRITERIA FOR GUIDERAIL CURVATURE

Figure 13-9E

### 13-9.10 Transitions

#### 13-9.10.01 Transitions Within Same Barrier Type

Where conditions allow, Designers should always choose the guiderail with the largest deflection distance possible. The available distance between the guiderail and the hazard will govern this selection. However, there may be sites where this distance is interrupted by short sections where the available deflection distance is less. The desirable treatment, if practical, is to stiffen the existing guiderail by reducing the post spacing through the section of reduced deflection distance. This treatment does not apply with Three-Cable Guiderail as described in Section 13-5.01. Transitions for metal beam rail are illustrated in the Connecticut Highway Standard Drawings, and the deflection distance associated to reduce post spacing for different rail types are listed in Figure 13-7C.

### **13-9.10.02 Transitions Between Different Barrier Types**

Overlapping of three cable and metal beam rail shall be avoided. See the Connecticut Highway Standard Drawings for details of all approved transitions for longitudinal barrier. Designers shall review Section 13-3.03 when attaching guiderail to any concrete structure or barrier.

### **13-9.11 Median Barrier Placement**

#### **13-9.11.01 General**

The ideal location for the median barrier is in the center of the median, which will provide a maximum clear recovery area for each direction of travel. The presence of excessive slopes or existing drainage in the center may make it impossible to locate a barrier there. Therefore, a median barrier should not be placed where the roadside slope leading up to the barrier exceeds 1:10. For Precast Concrete Barrier Curb, the slope leading up to the barrier will be the shoulder slope. Existing median slopes greater than 1:10 should be flattened to a desirable 1:12 rate or maximum 1:10 rate.

#### **13-9.11.02 Basic Application**

Figure 13-9F varies slightly from Figure 6-18 of the *Roadside Design Guide* which illustrates three basic types of sloped medians. The following discusses each type and also varies slightly from *Roadside Design Guide* where it assumes a median barrier is warranted:

1. For Cross Section I, the Designer should determine if the individual slopes warrant protection based on the criteria in Section 13-3.0. If both slopes warrant protection (Illustration 1), guiderail should be placed at “b” and “d”. If one slope warrants protection, a median barrier should be placed to shield that slope. If neither slope warrants protection and both slopes are steeper than 1:10 (Illustration 2), a median barrier should be placed at “b” or “d”, whichever is shielding the steeper slope. If the slopes are 1:10 or flatter (Illustration 3), the median barrier should be placed slightly to one side of the center of the median so that it does not interfere with highway drainage.
2. For Cross Section II, the slope in the median will determine the proper treatment. If the slope is between 1:10 and 1:4 (Illustration 4), the median barrier should be placed at “b.” If the median slope is 1:4 or steeper, guiderail at “b” is the only necessary treatment. If the median slope is a roadside hazard (e.g., rough rock cut) (Illustration 5), guiderail should be placed at both “b” and “d.” If the median slope is 1:10 or flatter (Illustration 6), the median barrier should be placed in the center of the median.
3. For Cross Section III (Illustration 7), the redirective capacity of the median slope will determine the proper treatment. If the median slope is 1:4 or steeper and greater than 3 ft in vertical height, no roadside nor median barrier is necessary. If the median slopes are flatter than 1:4 and/or less than 3 ft in vertical height, the median barrier should be placed at the apex of the cross section.

#### **13-9.11.03 Divided Median Barriers**

It may be necessary to intermittently divide a median barrier. The slope criteria in Section 13-9.11.02 or a fixed object in the median may require this. The median barrier may be divided by one of these methods:

1. An F-shaped PCBC may encase a fixed object.

2. A single-faced F-shaped PCBC may be used on both sides to shield a fixed object. Backfilling may be necessary.

Median metal beam rail may be split into two separate runs of guiderail passing on either side of the median hazard (fixed object or slope). Designers should consider access for maintenance purposes. When maintenance access is not a concern, reference the applicable Connecticut Highway Standard Drawings and adhere to the acceptable flare rates (Figure 13-9A). Where practical, the flare rate should be 50:1.

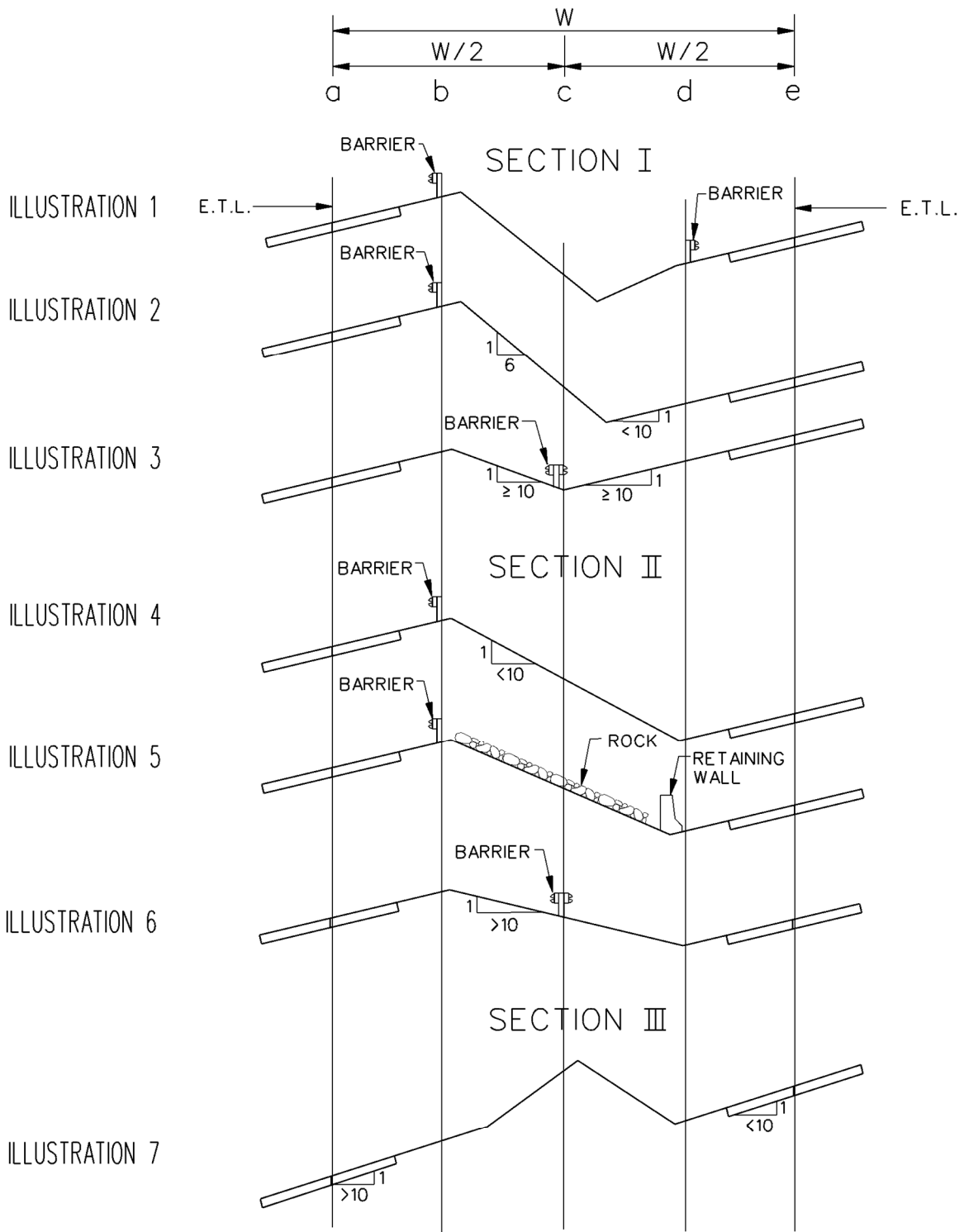

**SLOPED MEDIANS**

**Figure 13-9F**



### 13-9.12 Glare Screens

Headlight glare from opposing traffic can be bothersome and distracting. Glare screens can be used in combination with median barriers to eliminate this problem.

The typical application, however, is on urban freeways with narrow medians and high traffic volumes or between on/off ramps at interchanges where the two ramps adjoin each other. Here, the sharp radii of curvature and the narrow separation may make headlight glare especially bothersome. Designers should consider the use of glare screens at these sites especially if the Department has received a significant number of public complaints.

Blocking headlight glare can be achieved in several ways:

1. Vegetation can be used; however, the Designer should not introduce hazardous fixed objects in a narrow median.
2. Several commercial glare screens are available. Considering both effectiveness and ease of maintenance, the paddle glare barrier may be the best choice. These are a series of plastic paddles that are usually mounted to a PCBC.

Glare screens should be designed for a cutoff angle of 20 degrees. This is the angle between the median centerline and the line of sight between two vehicles traveling in opposite directions. The glare screen should be designed to block the headlights of oncoming vehicles up to the 20 degrees cutoff angle. On horizontal curves, the design cutoff angle should be increased to allow for the effect of the curvature on headlight direction. See Figure 13-9G. The criteria is:

$$\text{Cutoff Angle} = 20^\circ + 5729.6/R$$

where R = Curve radius, ft.

The Designer should also evaluate the impact of a glare screen on horizontal sight distance on curves to the left. The screen could significantly reduce the available middle ordinate for stopping sight distance. See Section 8-2.0 for a discussion of sight distance at horizontal curves.

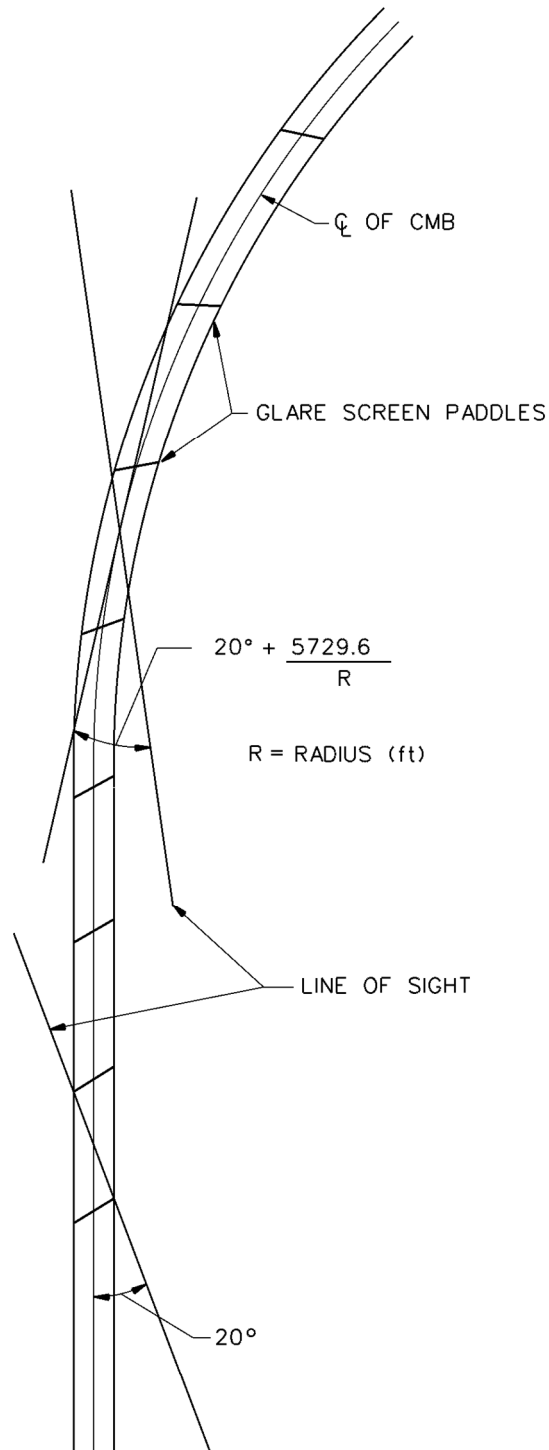

**CUTOFF ANGLE FOR GLARE SCREENS**

**Figure 13-9G**



## **13-10.0 END TREATMENTS**

### **13-10.01 Definitions**

Designers are encouraged to fully understand the following definitions before specifying impact attenuators:

1. Length of Need (LON). That part of a longitudinal barrier or terminal designed to contain and redirect an errant vehicle.
2. Anchorages. These devices anchor a flexible or semi-rigid barrier to the ground to develop its tensile strength during an impact. Anchorages are not considered crashworthy and should be located outside the clear zone on the leading end of a flexible or semi-rigid barrier.
3. Terminals. These devices are essentially crashworthy anchorages which are used to anchor a flexible or semi-rigid barrier where the end of a barrier is located within the clear zone. Most terminals are designed for vehicular impacts from only one side of the barrier; however, a few terminal designs have been developed for median applications and may be installed where there is a potential for impact from either side.
4. Crash cushions. These devices typically are attached to or placed in front of rigid concrete barriers (i.e., median barriers, roadside barriers, or bridge railings) or other rigid fixed objects, such as bridge piers.
5. Redirective End Treatment. A device designed to contain and redirect a vehicle impacting downstream from the nose of the system.
6. Non-Redirective End Treatment. A device designed to contain and capture a vehicle impacting downstream from the nose of the system.
7. Gating End Treatment. A device designed to allow controlled penetration of the vehicle when impacted between the nose and the beginning of the LON of the device.
8. Non-Gating End Treatment. A device designed to contain and redirect a vehicle when impacted along its entire length.
9. Energy-Absorbing Device. A device designed to dissipate significant amounts of kinetic energy in a head-on crash and to stop impacting vehicles in a relatively short distance (usually 50 feet or less). Where typical guiderail run-out lengths are not available or limited, an energy absorbing system should be chosen.

### **13-10.02 General**

End treatments for longitudinal barrier are needed to provide tensile strength to the system and or to safely redirect or decelerate a vehicle upon impact. End treatments present a potential roadside hazard if not designed appropriately. End treatments used by the Department are categorized as either anchorages or impact attenuators.

Anchorages are used to anchor the ends of flexible or semi-rigid barrier to the ground so that it develops tensile strength during impact. Standard anchorages used by the Department are generally not crashworthy and are typically used in the following applications:

- The trailing end of a roadside barrier on one-way roadways,

- The approach or trailing end of a barrier located outside the clear zone,
- Buried in an earth cut slope,
- Attached to a rock cut,
- Shielded by another barrier system.

If a crashworthy end treatment is not required, an anchorage is generally a lower-cost alternate to an impact attenuator.

When an end treatment is required to be crashworthy, an impact attenuator will be used. Terminals and crash cushions are types of impact attenuators used by the Department.

Terminals are essentially crashworthy anchorages and are typically used at the end of flexible or semi-rigid roadside and median barrier. Tangential, Flared and Median-Gore Impact Attenuation Systems are the approved types of terminals listed on the Department's Qualified Product List (QPL). See the Connecticut Highway Standard Drawings for specific grading requirements in advance of and adjacent to each terminal type. Some terminals are designed to dissipate significant amounts of the kinetic energy in a head-on crash and are considered to be energy-absorbing. In high-speed, head-on impacts on the terminal nose, energy-absorbing terminals have demonstrated their ability to stop impacting vehicles in relatively short distances; typically, 50 ft. or less. Other terminals, including most flared designs, are classified as non-energy-absorbing designs and allow vehicles to travel a long distance beyond the terminal head when struck at high speeds. The decision to use either an energy-absorbing terminal or a non-energy-absorbing terminal should be based on the likelihood of a near head-on impact and the nature of the recovery area immediately behind and beyond the terminal.

Crash cushions significantly reduce the severity of impacts with fixed objects by gradually decelerating a vehicle to a safe stop for head-on impacts and by redirecting a vehicle away from the fixed object for side impacts. Crash cushions are typically used at the end of rigid concrete barrier and may also be used at the end of semi-rigid barrier in cases where a terminal does not provide adequate protection from a fixed object. Crash cushions are designed to absorb the energy of the vehicle by the progressive deformation or crushing of the elements of the system. Non-Gating and Non-Gating-High-Incident impact attenuation systems are approved types of crash cushions on the QPL. Sand barrel arrays are also a type of a crash cushion; however, these systems are typically not used by the Department for new permanent installations. See Chapter 14 for the temporary application of sand barrel arrays.

### **13-10.03 End Treatment Selection**

#### **13-10.03.01 W-Beam Metal Beam Rail (Type R-B 350 & R-B MASH)**

For the leading ends of w-beam metal beam rail, the following shall apply:

1. Anchorage Outside Clear Zone: The preferred end treatment is to flare the guiderail to outside the clear zone and use an End Anchorage Type I for design speeds greater than 45 mph or an End Anchorage Type II for design speeds less than or equal to 45 mph. See the Connecticut Highway Standard Drawings for details of the end anchorages.
2. Anchorage within the Clear Zone: When the approach slope is sufficiently steep (1V:2H or steeper), and the required grading can be provided, a buried anchor in earth cut or rock cut slope may be used. Refer to the Connecticut Highway Standard Drawings for the details associated with these anchorages with the R-B 350. When using R-B MASH, a R-B 350 transition is required prior to the installation of an Earth Cut or Rock Cut Slope anchorage.
3. Terminal Within Clear Zone (High speed > 45 mph): If a crashworthy end treatment is required to terminate a W-beam guiderail within the clear zone, choose the appropriate type of terminal based on the advanced and adjacent grading that can be provided as well as runout length available. Tangential or flared systems are typically used for roadside barrier; however, a median-gore system may be considered if there is a potential for the terminal to be struck from the back side. Refer to the Connecticut Highway Standard Drawings for required grading.
4. Terminal Within Clear Zone (Low speed  $\leq$  45 mph): If a crashworthy end treatment is required to terminate a W-beam guiderail within the clear zone, Designers should choose an appropriate impact attenuator type as noted in the previous section or consider installing a R-B Terminal Section as detailed in the Connecticut Highway Standard Drawings.

See Figure 13-9D for guiderail treatment at intersecting roads and driveways.

For the trailing ends of metal beam rail guiderail, the following will apply:

1. Undivided Facilities: The above criteria for the approach ends also apply to its trailing end on a two-way facility and on an undivided multi-lane facility.
2. One-Way Roadways: The trailing end may be the End Anchorage Type I for design speeds greater than 45 mph or the End Anchorage Type II for design speeds less than or equal to 45 mph and may be placed within the clear zone.

#### **13-10.03.02 Three-Cable Guiderail**

Three-cable guiderail End Anchor Type I is considered NCHRP Report 350 TL-3 crashworthy and may be placed within the clear zone. Refer to the Connecticut Highway Standard Drawings for additional details of this anchorage.

### 13-10.03.03 Merritt Parkway Guiderail

The anchorage used with Merritt Parkway Guiderail is not considered crashworthy. One of the following methods shall be used to terminate the leading-end:

1. Anchor the rail to a rock face.
2. Bury the anchorage in an earth cut slope or built-up berm that is 1V:2H or steeper.
3. Place the anchorage outside the clear zone and bury the end.

Trailing end of Merritt Parkway Guiderail may use an anchorage buried within the clear zone. See the Connecticut Highway Standard Drawings for additional details.

### 13-10.03.04 Median Metal Beam Rail (Type MD-B 350 & MD-B MASH)

For the leading ends of median beam rail, the following apply:

1. Anchorage Outside Clear Zone: An MD-B End Anchorage Type I is used when the median metal beam rail can be flared to a point outside the clear zone. Refer to the Connecticut Highway Standard Drawings for details of this end treatment type.
2. Terminal Within Clear Zone: A Median-Gore Impact Attenuation System is typically used when the terminal must be placed within the clear zone. Refer to the Connecticut Highway Standard Drawings for grading requirements associated with this terminal. At locations where historical crash data indicates a high probability of high speed head-on impact, a crash cushion may be considered. Refer to Section 13-5.0 – Roadside Barriers or 13-6.03 – Precast Concrete Barrier Curb (PCBC) for additional details.

When the median rail extends onto an on/off ramp to a “T” type intersection, the end treatment shall be placed so that the sight line is not compromised and that the clear zone requirements for the intersecting road are met.

### 13-10.03.05 Metal Beam Rail (6X6 or 6X8 Box Beam)

When terminating box beam guiderail, the following will apply:

1. Anchorage Outside Clear Zone: A box beam end assembly is used if the anchorage can be placed outside the clear zone. Refer to the Connecticut Highway Standard Drawings for details.
2. Terminal Within the Clear Zone: A Median-Gore or Tangential Impact Attenuation System is typically used when the terminal must be placed within the clear zone. Refer to the Connecticut Highway Standard Drawings for grading details.

### 13-10.03.06 Concrete Median or Roadside Barrier

When a concrete median or roadside barrier does not transition to another type of longitudinal barrier, a crash cushion is typically required. A Non-Gating Impact Attenuation System is typically used; however, sites with a crash history, or with limited work area available for repairs, a Non-Gating-High-Incident Impact Attenuation System may be considered.

When determining the appropriate type of crash cushion, the following shall be considered:

1. Width of the hazard to be shielded,

2. Grading requirements in advance of, adjacent to, or runout beyond the system,
3. Required transitions,
4. Anticipated frequency of impact,
5. Available work area for repairs,
6. Need for low maintenance and/or self-restoring system, i.e. High-Incident Systems.

The Designer should, as early as practical in the project design process, determine the need for and approximate dimensions of an impact attenuator. This will avoid late changes that could significantly affect the project design. Figure 13-10A provides recommended criteria for the impact attenuator reserve area. Installation of crash cushions on bridge superstructures should be avoided due to potential performance problems. To minimize future maintenance problems, crash cushions should be installed on a concrete pad.

The Designer should refer to the Department's Qualified Product List for available approved systems. Depending on site constraints, not all approved systems may be compatible and a proprietary item may be required. On low-speed roadways where there is limited space for the crash cushion, a TL-2 system may be considered.



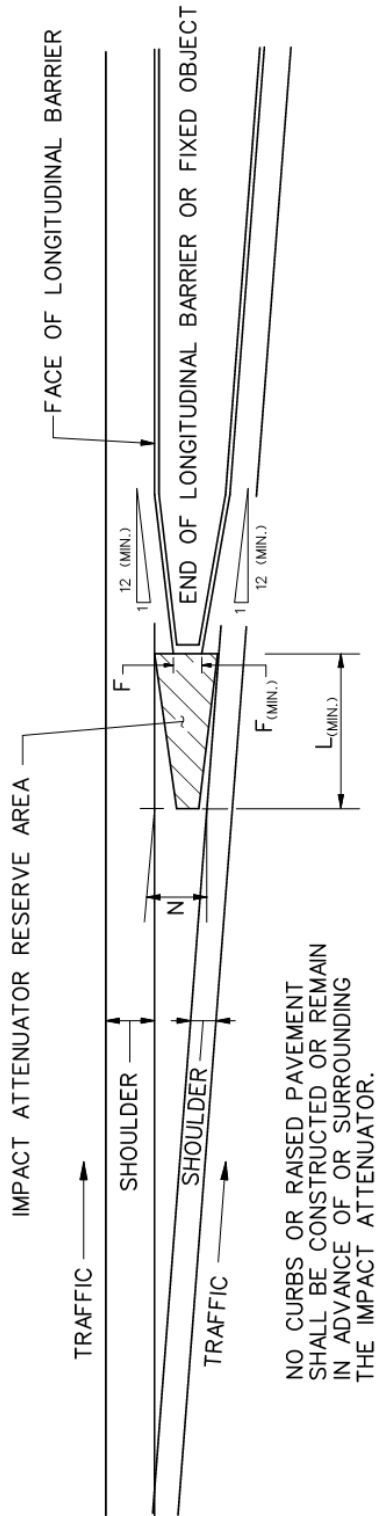

NO CURBS OR RAISED PAVEMENT SHALL BE CONSTRUCTED OR REMAIN IN ADVANCE OF OR SURROUNDING THE IMPACT ATTENUATOR.

NOTE(S) THE MINIMUM RESERVE AREA DIMENSION(S) FOR PRELIMINARY DESIGN PURPOSES:  
 N=6 FOOT WIDTH OF SPACE FOR PLACEMENT OF CRASH CUSHION.  
 F=2 FOOT CRASH CUSHION WIDTH FOR THE SYSTEM TO SHIELD A FIXED OBJECT.  
 L= LENGTH OF SPACE REQUIRED FOR PLACEMENT OF CRASH CUSHION.

REFER TO THE DEPARTMENT'S QUALIFIED PRODUCT LIST (QPL) FOR THE APPROVED NON-GATING AND NON-GATING-HIGH INCIDENT IMPACT ATTENUATION SYSTEM'S DIMENSIONS.

Design Speed (V) (mph)	Impact Attenuator Speed (mph)	
	Freeways	Non-Freeways
≥ 45	60	60
< 45	--	45

**RESERVE AREA FOR IMPACT ATTENUATOR IN GORES**

**Figure 13-10A**

**13-11.0 REFERENCES**

1. Roadside Design Guide, AASHTO, 2011.
2. Guide for Selecting, Locating, and Designing Traffic Barriers, AASHTO, 1977.
3. A Supplement to A Guide for Selecting, Locating, and Designing Traffic Barriers, Texas Transportation Institute, March, 1980.
4. Safety Design and Operational Practices for Streets and Highways, FHWA, May, 1980.
5. FHWA-IP-83-4 A Procedure for Determining Frequencies to Inspect and Repair Highway Safety Hardware, December, 1983.
6. Research Report 67-1 New Highway Barriers, The Practical Application of Theoretical Design, New York Department of Public Works, May, 1967.
7. NYSDOT-ERD-76-RR38 Testing of Highway Barriers and Other Safety Appurtenances, New York State Department of Transportation, December, 1976.
8. Transportation Research Record 970, "Development of Proposed Height Standards and Tolerances for Light-Post Traffic Barriers," James E. Bryden, 1984.
9. "A Roadside Design Procedure," James Hatton, Federal Highway Administration, January, 1974.
10. FHWA/NY/RR-80/83 Crash Tests of Sharply Curved Light-Post Guide Rail, New York State Department of Transportation, July, 1980.
11. NCHRP Report 150 Effect of Curb Geometry and Location on Vehicle Behavior, Transportation Research Board, 1974.
12. NCHRP Report 158 Selection of Safe Roadside Cross Sections, Transportation Research Board, 1975.
13. NCHRP Synthesis 66 Glare Screen Guidelines, Transportation Research Board, December 1979.
14. NCHRP Report 350 Recommended Procedures for the Safety Performance of Highway Features, Transportation Research Board, 1993.
15. Impact Attenuators – Selection and Design Criteria, FHWA, 1975.
16. "Impact Attenuators, Safety Systems," Technical Notebook, Energy Absorption Systems, Inc.
17. American Association of State Highway and Transportation Officials Manual for Assessing Safety Hardware (MASH), 2016
18. Midwest Roadside Safety Facility Research Report No. 03-320-16 & 03-185-10



**Chapter Fourteen****TEMPORARY TRAFFIC CONTROL****Table of Contents**

	<b><u>Page</u></b>
14-1.0 GENERAL .....	14-1(1)
14-1.01 Responsibilities .....	14-1(1)
14-1.02 Maintenance and Protection of Traffic (MPT) Plans .....	14-1(1)
14-2.0 TEMPORARY TRAFFIC CONTROL MANAGEMENT .....	14-2(1)
14-2.01 Work Zone Type.....	14-2(1)
14-2.02 Work Zone Traffic Control Strategy.....	14-2(2)
14-3.0 GEOMETRIC DESIGN.....	14-3(1)
14-3.01 Design Speed.....	14-3(1)
14-3.02 Sight Distance .....	14-3(1)
14-3.03 Lane/Shoulder Widths .....	14-3(1)
14-3.04 Transition Taper Rates.....	14-3(2)
14-3.05 Alignment .....	14-3(2)
14-3.06 Interchanges .....	14-3(4)
14-3.07 Exceptions.....	14-3(4)
14-4.0 ROADSIDE SAFETY .....	14-4(1)
14-4.01 Warrants for Positive Protection.....	14-4(1)
14-4.02 Clear Zones.....	14-4(2)
14-4.03 Roadside Barriers .....	14-4(2)
14-4.04 End Treatments.....	14-4(2)
14-4.05 Design/Layout .....	14-4(6)
14-5.0 REFERENCES.....	14-5(1)
Appendix .....	14-A(1)



## Chapter Fourteen

# TEMPORARY TRAFFIC CONTROL

### 14-1.0 GENERAL

Because much of the Department's highway program will include work on existing highways, highway construction will often disrupt existing traffic operations. Therefore, the designer must devote special attention to temporary traffic control in construction zones to minimize possible operational and safety problems through the work zone. The Department has developed policy statements regarding the safety, accessibility and impacts of work zones. See the Appendix.

#### 14-1.01 Responsibilities

The following summarizes the division of responsibilities for the Maintenance and Protection of Traffic (MPT):

1. Designer. The prime designer is responsible for initiating action on the MPT, and he/she will request input from the Division of Traffic Engineering. If a temporary road will be constructed for traffic during construction (i.e., a detour), the designer is responsible for its geometric and roadside safety design. The designer will work with Traffic to determine the traffic control strategy for the MPT on existing roads; see Section 14-2.0. The designer is responsible for providing an alternate pedestrian route, which maintains a similar level of accessibility, when the existing pedestrian route can not be maintained. Also, the designer is responsible for ensuring that the highway can be constructed using the developed MPT plans.
2. Division of Traffic Engineering. Traffic will prepare or review the temporary traffic control plans, including all traffic control devices, on all projects on all temporary, proposed and existing roads. Traffic also maintains special standard drawings for traffic control devices, which are included with all projects. For a temporary road that will be used by traffic during construction, Traffic will provide the layout or review the layout of all traffic control devices on that road. Traffic and the designer will work together to determine the temporary traffic control strategy for the MPT.

#### 14-1.02 Maintenance and Protection of Traffic (MPT) Plans

The purpose of the MPT plans is to ensure a safe, efficient, and accessible highway environment for all users of the roadway traveling through a work zone and to establish a safe and secure area to protect those who must construct and maintain the highway system from vehicles traveling through the work zone. Users of the roadway include vehicular traffic as well as motorcyclists, bicyclists, and pedestrians, including those with disabilities. All mobility modes should be considered in the development of project-specific plans. In particular, the level of accessibility for disabled individuals that was experienced prior to the project should be provided during construction and maintenance operations. The MPT plans may range in scope from a

set of plans that describes every detail of traffic accommodation to the standard temporary traffic control plan sheets provided by the Division of Traffic Engineering. The scope of the MPT plans will depend on the complexity and duration of the construction project.

The MPT plans are included in the plans, specifications and estimates (PS&E) submission for every project. These plans should address the following, as applicable:

1. signing;
2. application and removal of pavement markings;
3. temporary signalization;
4. delineation and channelization;
5. lane closures;
6. detours and crossovers;
7. bicyclist and pedestrian access (existing level of accessibility to be maintained)
8. selection and placement of all traffic control devices;
9. locations and types of safety appurtenances;
10. means of maintaining access to and from existing interchange ramps and/or roadside properties;
11. flagging;
12. use of uniformed law enforcement officers;
13. work scheduling restrictions, if applicable;
14. storage of equipment and materials;
15. traffic regulations, if applicable;
16. duration of use of any traffic control feature (throughout construction period, only during closure of left lane, etc.);
17. surveillance and inspection requirements;
18. contractor access to the work site;
19. coordination with any other construction projects;
20. truck-mounted attenuators;

21. capacity analyses;
22. liquidated damages; and/or
23. use of special materials.

For construction work that may involve a significant disruption to existing traffic operations, the designer should consider during the MPT plan development the likely impact on all affected local interests. These include, where applicable, the operations of the local:

1. public works or highway/street department,
2. police,
3. fire department,
4. ambulance services,
5. public transportation services,
6. school boards,
7. businesses, and
8. homeowners/local access.





## 14-2.0 TEMPORARY TRAFFIC CONTROL MANAGEMENT

### 14-2.01 Work Zone Type

There are several basic work zone types that may be considered in a temporary traffic control management plan. Note that work sites which are completely off the roadway and do not disrupt traffic are not addressed because they will generally not have a major effect on traffic. The following presents a description for each of the work zone applications:

1. Lane Constriction. This work zone type is configured by reducing the width of one or more lanes to retain the number of lanes normally available to traffic. This application is the least disruptive of all work zone types, but it is generally appropriate only if the work area is mostly outside the normal traffic lanes. It should be noted that narrow lane widths may reduce the facility's capacity, especially where there is significant truck traffic. The use of shoulders as part of the lane width will help reduce the amount of lane width reduction that may be required. Where this application is applied for long-term work zones, the current lane markings must be obliterated to avoid motorist confusion. Section 14-3.0 discusses the minimum lane widths that must be provided.
2. Lane Closure. This work zone type closes off one or more normal traffic lanes. Capacity and delay analyses may be required to determine whether serious congestion will result from lane closures. In some cases, use of the shoulder or median area as a temporary lane will mitigate the problems arising from the loss in capacity. Upgrading or replacement of existing pavement may be necessary.
3. Alternating One-Way Traffic Operation. This work zone type involves utilizing one lane for both directions of traffic. Flaggers or signals are normally used to coordinate the alternating directions of traffic. Signing alone may be sufficient for short-term work zones on very low-volume, two-lane roads. This work zone type is generally only applicable for low- and intermediate-volume roads or short-term work zones.
4. Temporary Roadway. This work zone involves the total closure of the roadway (one or both directions) where work is being performed and the traffic is rerouted to a temporary roadway. This application may require the purchase of temporary right-of-way and usually requires extensive preparation of the temporary roadway.
5. Intermittent Closure. This work zone type involves stopping all traffic in one or both directions for a relatively short period of time to allow the work to proceed. After a specific time, depending on traffic volumes, the roadway is re-opened and all vehicles can travel through the area. This application is normally only appropriate on low-volume roadways or during time periods where there are very low volumes (e.g., Sunday mornings).
6. Use of Shoulder or Median. This work zone type involves using the shoulder or the median as a temporary traffic lane. To use this technique, it may be necessary to upgrade the shoulder to adequately support the anticipated traffic loads. This technique may be used in combination with other work zone types or as a separate technique.

7. Crossover. This work zone type involves routing a portion or all of one direction of the traffic stream across the median to the opposite traffic lanes. This application might also incorporate the use of shoulders and/or lane constrictions to maintain the same number of lanes. Section 14-3.0 discusses the geometric design criteria that should be used to develop crossovers.
8. Detour. This work zone type involves total closure of the roadway (one or both directions) where work is being performed and rerouting the traffic to existing alternate facilities. This application may be used where there is unused capacity on roads running parallel to the closed roadway.

The designer must also carefully consider the impact that the detoured traffic will have on other State or local roads. A detour agreement with the town is required when the State highway traffic is detoured onto a local road. The Division of Traffic Engineering is responsible for coordinating between the State and town(s).

#### **14-2.02 Work Zone Traffic Control Strategy**

Selection of the appropriate work zone type represents one of the most significant elements of a traffic control strategy. Other elements of a traffic control strategy that should be considered include length of the work zone, time of work, number of lanes, width of lanes, traffic speeds and right-of-way. Considering these and other factors, reasonable alternatives can be narrowed to a selected few for further review. Typically, only a small number of feasible work zone alternatives will emerge for a particular project and, in many cases, only one may be practical. Identification of these alternatives at an early stage in the planning process can reduce significantly the analysis effort necessary.

Figure 14-2A provides guidelines for identifying feasible work zone alternatives based on roadway type, lane closure requirements, shoulder width, traffic volume, and the availability of right-of-way and detour routes. However, it should be recognized that every work zone location will have a wide variation of conditions and that an all-inclusive selection matrix is not practical.

In using Figure 14-2A, local policy and regulations should be recognized. Many jurisdictions have adopted safety regulations and public convenience policies as safeguards against the unacceptable impacts of work zones. These regulations and policies may impose additional constraints regarding the types of control strategies that can be implemented. Knowing these constraints can help eliminate infeasible alternatives from consideration. The public convenience policies or local regulations may specify peak hour restrictions, access requirements, noise level limitations, material storage and handling, excavation procedures, work zone lengths and number of traffic lanes that must remain open.

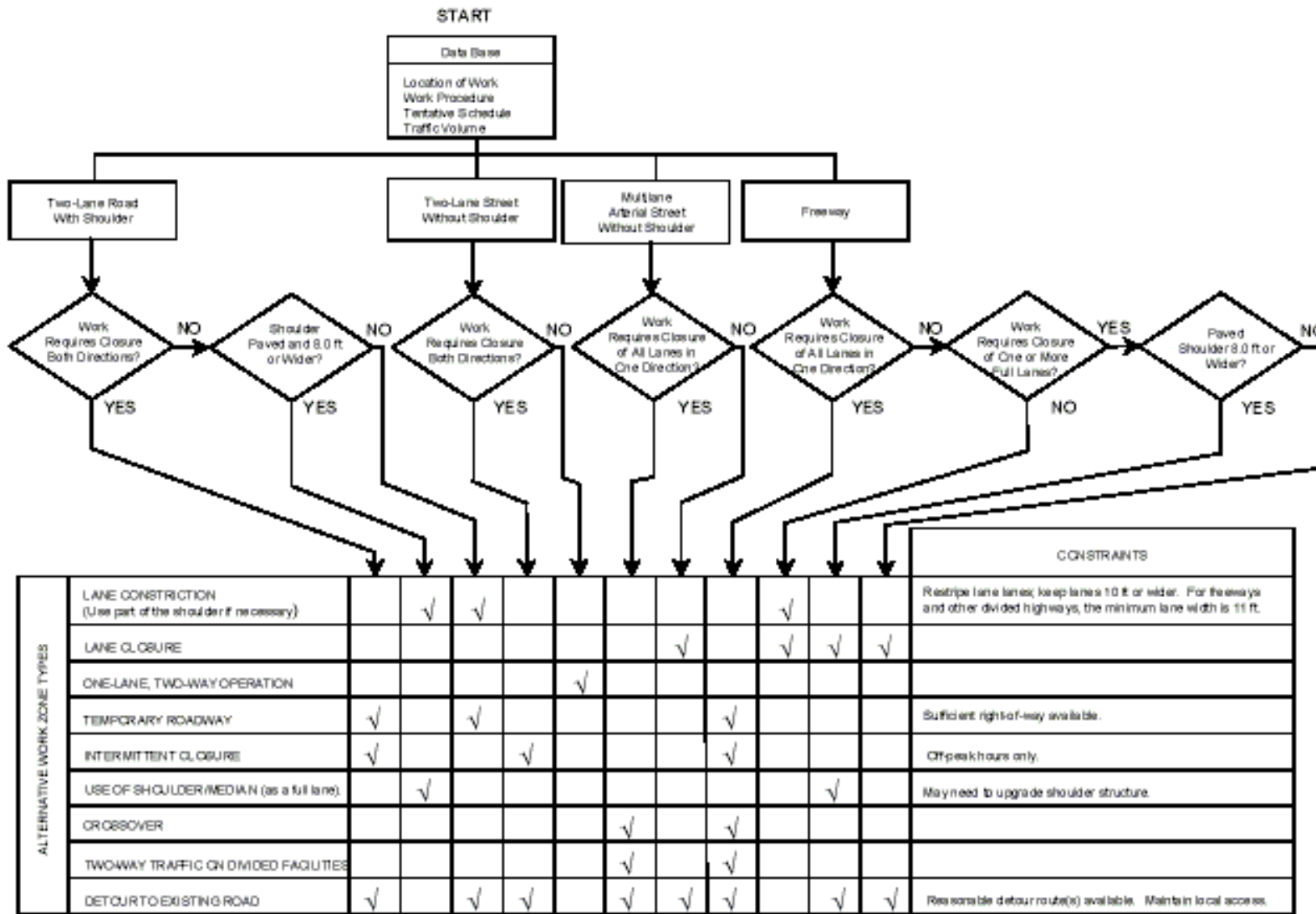

✓ Practical Alternatives

**CHART FOR IDENTIFICATION OF FEASIBLE WORK ZONE TYPES**

Figure 14-2A



### **14-3.0 GEOMETRIC DESIGN**

The following sections present design criteria that apply to temporary crossovers on divided highways, existing roadways through construction zones and detours specifically designed for construction projects (e.g., crossovers, temporary roadways). These criteria do not apply to detours over existing routes.

#### **14-3.01 Design Speed**

Do not select a construction-zone design speed that is significantly lower than a facility's existing design speed and then attempt to mitigate the driver's speed by regulatory or advanced warning means. This may lead to poor operating conditions. With the exception of, perhaps, warning signs at horizontal curves, regulatory and warning speed signs are generally ineffective for controlling excessive vehicular speeds through construction zones. Consider providing a construction-zone design speed that will be the same as that for the existing facility.

#### **14-3.02 Sight Distance**

For the approach to the first physical indication of the construction zone, where practical, the sight distance available to the motorist should be based on the decision sight distance criteria provided in Section 7-2.0 and, at a minimum, based on the stopping sight distance criteria provided in Section 7-1.0. Through the construction zone itself, the designer should ensure that at least the stopping sight distance is available to the driver. Unfortunately, the location of many design features is often dictated by construction operations. However, some elements may have an optional location. For example, lane closures and transitions should be located where the approaching driver has decision sight distance available to the lane closure or transition. Through horizontal curves in the construction area, the designer should check the horizontal clearance (i.e., the middle ordinate) of the horizontal curve using its radius and the stopping sight distance for the construction-zone design speed (see Chapter Eight).

#### **14-3.03 Lane/Shoulder Widths**

In general, there should not be a reduction in the roadway cross section width through the construction zone. However, this is often not practical. Section 14-3.04 presents the minimum taper rates that should be used on approaches to lane width reductions. The following minimum lane and shoulder widths should be used in construction zones:

1. Divided Highways. For freeways and other divided highways, at a minimum, an 11-ft lane width should be maintained with, preferably, 2-ft or wider right and left shoulders.
2. Undivided Highways. For other highway facilities, the designer should maintain a minimum 11-ft lane width and 1-ft wide shoulder. Under restricted conditions, the shoulder width may be 0 ft.

### 14-3.04 Transition Taper Rates

Lane closures, lane width reductions and lane shifts require the use of transition tapers to safely maneuver traffic around the encroaching restriction. Figures 14-3A and 14-3B present the minimum taper lengths for various taper applications in construction zones (e.g., lane closures, lane shifts).

### 14-3.05 Alignment

Once the design speed is selected for the construction zone, the designer will use the criteria in Chapter Two (geometric design of 3R projects) for alignment considerations. Note that, although Chapter Two applies to the permanent design of non-freeways, the 3R criteria in Chapter Two are applicable to the design of the construction zones for all facilities. One application of the 3R criteria, for example, will be the minimum radius for maintaining the normal crown section through a horizontal curve for a given design speed and given (negative) superelevation (see Figure 2-5A). This will then be the minimum radius for a horizontal curve which transitions traffic from the mainline to a temporary roadway without superelevation. For low-speed urban streets, the designer will use Figure 8-3B for the minimum radius for a normal crown section.

Type of Taper	Taper Length
<u>Upstream Tapers</u>	
Merging Taper	L Minimum
Shifting Taper	L/2 Minimum
Shoulder Taper	L/3 Minimum
Alternating One-Way Traffic Taper	100 ft Maximum/50 ft Minimum
<u>Downstream Tapers</u> (Optional)	
	100 ft per lane

Length "L" is determined using the following:

$$L = WS \quad (S \geq 45 \text{ mph})$$

$$L = \frac{WS^2}{60} \quad (S \leq 40 \text{ mph})$$

Where:

- L = minimum length of transition (ft)
- S = 85th percentile speed (mph), or, at a minimum, posted speed limit before construction (mph)
- W = width of offset (ft)

**TAPER LENGTH CRITERIA FOR CONSTRUCTION ZONES**  
**Figure 14-3A**

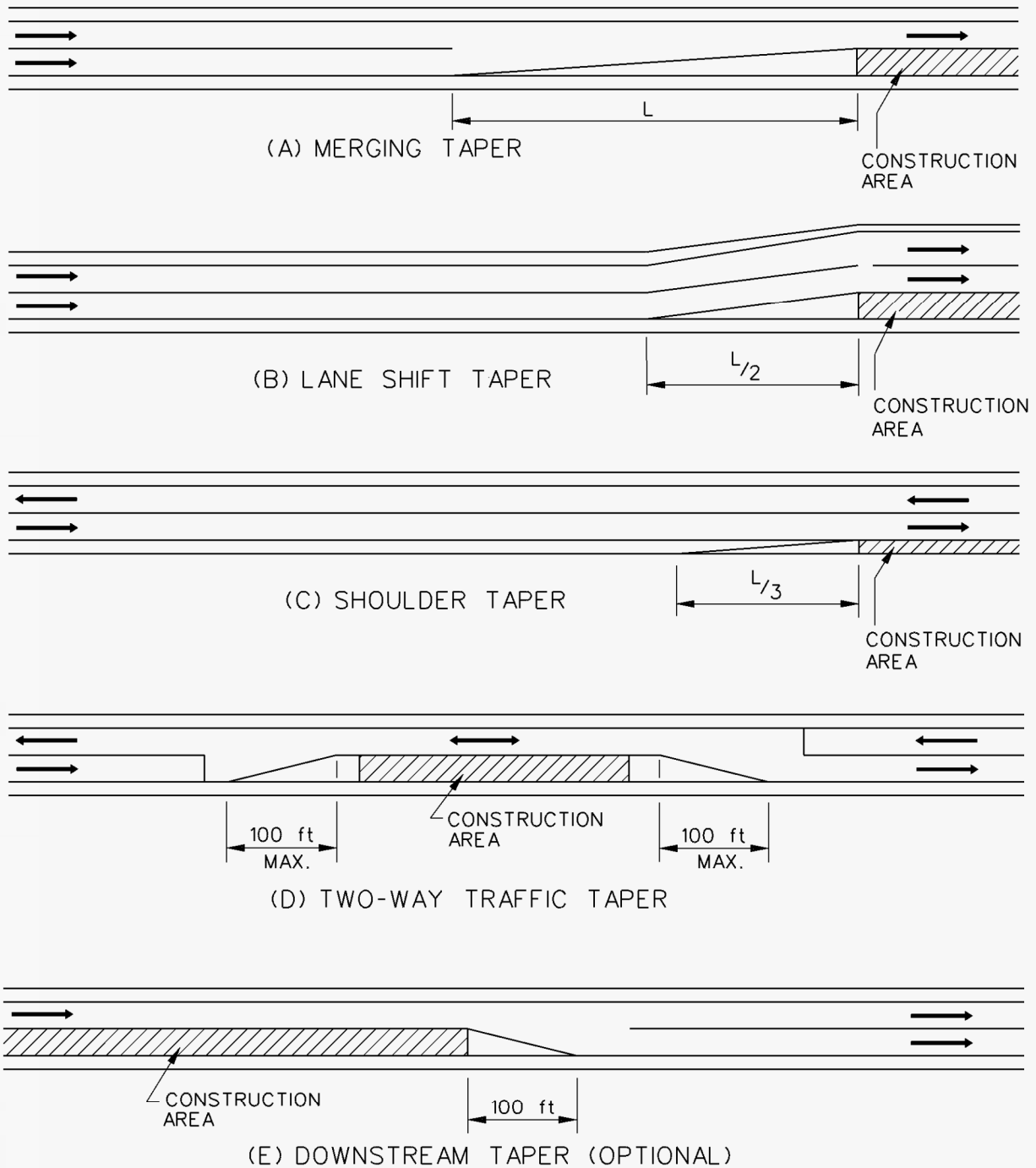

Note: Length "L" is determined from Figure 14-3A.

**TAPER LENGTH CRITERIA FOR CONSTRUCTION ZONES  
(Application)**

**Figure 14-3B**



**14-3.06 Interchanges**

For construction zones through interchanges, the designer should review the criteria presented in Chapter 12. In particular, the designer should review the available acceleration and taper areas for on ramps; see Section 12-3.02.

**14-3.07 Exceptions**

It is not Department policy to obtain formal design exceptions for temporary conditions in construction zones.

#### **14-4.0 ROADSIDE SAFETY**

Through a construction zone, drivers are often exposed to numerous hazards (e.g., restrictive geometrics, construction equipment, opposing traffic). Of equal importance is the safety of workers performing tasks within the construction zone. The designer must devote special attention to reducing hazards for motorists posed by the work zone and workers from vehicles passing through the work zone. The following sections offer roadside safety criteria that apply only to the roadside elements within the construction zone. These criteria do not apply to detours over existing routes.

##### **14-4.01 Warrants for Positive Protection**

Positive protection for run-off-the-road vehicles and to protect workers from vehicles passing through the work zone may be warranted in construction zones. This decision will be made on a project-by-project and site-by-site basis. The following factors should be considered:

1. duration of construction activity;
2. traffic volumes (including seasonal fluctuations);
3. nature of hazard (e.g., edge of travel lane drop-offs);
4. design speed;
5. highway functional class;
6. proximity between traffic and construction workers and construction equipment;
7. adverse geometrics which may increase the likelihood of run-off-the-road vehicles;
8. length and depth of dropoffs;
9. length of hazard; and/or
10. lane closures or lane transitions; and/or
11. work zones where workers have no means of escape from traffic, such as on bridges.

During the planning and design of a project, careful consideration should be given to temporary traffic control plan alternatives that do not require the use of temporary barriers. The alternatives include construction of detour roadways, minimizing the exposure time and depth of drop-offs, and providing maximum separation between traffic and workers.

However, even with proper project planning and design, there will be many instances where barriers are clearly needed. In a barrier system, the greatest hazard occurs at the approach end. To achieve the safest condition, three goals are important:

1. flare the approach end to a location outside the clear zone or as far away from the through traffic lanes as practical;
2. if the approach end cannot be placed outside the clear zone, provide the most crashworthy end treatment as technically and economically feasible; and
3. provide adequate delineation in advance of and along the temporary barrier.

Where traffic is directed onto the opposing roadway, the designer should consider the effect this will have on the operational characteristics of roadside appurtenances. For example, existing trailing ends of unprotected bridge rails may require approach guardrail transitions or impact attenuators, or blunt guardrail terminals may need to be protected with an acceptable end treatment.

#### **14-4.02 Clear Zones**

Section 13-2.0 provides the appropriate clear zone values for new construction/reconstruction projects. For construction zones, the clear zone should be the distances in Section 13-2.0. It is important to select the appropriate clear zone based on the construction zone design speed and not the posted speed. If the recommended clear zone cannot be achieved, the safest end treatment should be provided consistent with cost-effectiveness and geometric considerations.

#### **14-4.03 Roadside Barriers**

In general, there are two types of roadside barriers — guiderailing and temporary precast concrete barrier curb (TPCBC). Design and installation details for temporary guiderailing should be the same for permanent installations; see Chapter Thirteen for additional information. Metal beam rail must first be stiffened before it is attached to TPCBC.

When it has been determined that TPCBC should be used in a work zone, special care must be given to its layout. Although it provides the greatest protection to the work zone, it is also the least forgiving to the driver. Impact with the blunt end of concrete barrier (including contractor's access openings) will result in an intolerable impact, even at low speeds. All barriers will require an appropriate end treatment; see Section 14-4.04.

TPCBC should be extended at an appropriate flare rate to a point beyond the clear zone. The flare rate for TPCBC on freeways is 1:10, and for non-freeways the flare rates should be based on the design speed through the work zone. The TPCBC flare rates for non-freeways are shown in Figure 14-4A. The designer should meet these flare rates unless extenuating circumstances render these rates impractical (e.g., stop conditions, driveways, intersections).

#### **14-4.04 End Treatments**

The end treatments for guiderailing should be designed the same as for permanent installations. See Chapter Thirteen. Figure 14-4B lists acceptable crashworthy end treatments for TPCBC, in descending order of preference, together with recommended specific limitations and/or criteria. Figures 14-4C and 14-4D illustrate typical end treatments for TPCBC.

Design Speed	Flare Rates
30 mph or less	4 to 1
31 mph - 45 mph	6 to 1
greater than 45 mph	8 to 1

### TPCBC FLARE RATES FOR NON-FREEWAYS

Figure 14-4A

Type of End Treatment	Maximum Design Speed	Remarks
Physically connected to existing barrier.	N/A	Ensure connections provide adequate strength and potential for snag is minimized.
Buried in Backslope	N/A	Ditches may pose difficulty.
Terminate end behind existing guiderailing	N/A	Ensure proper deflection of guiderailing is available. See Figure 14-4C.
Protected by a impact attenuator (e.g., sand-filled plastic barrels).	Limited by impact attenuator design and available space.	See Figure 14-4D.

### END TREATMENTS FOR TEMPORARY CONCRETE MEDIAN BARRIERS

Figure 14-4B

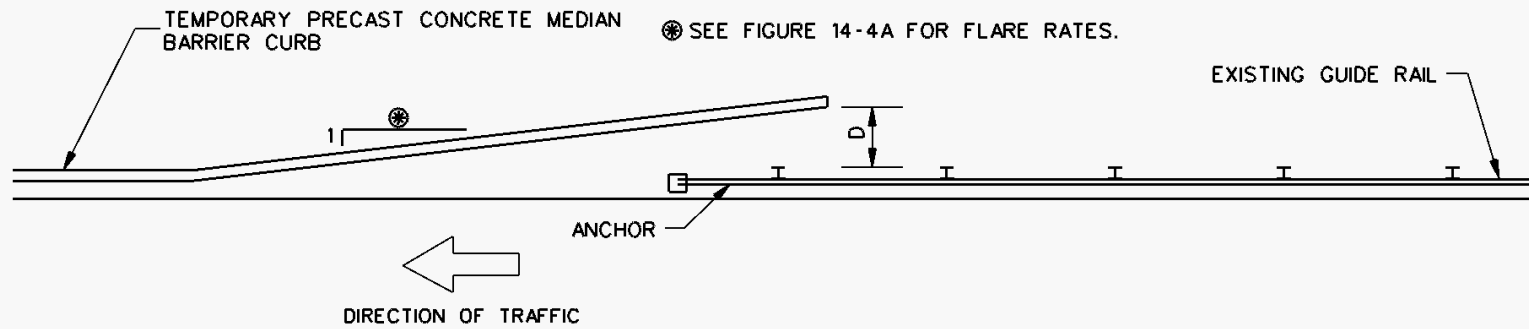

Existing Guiderail Type	Overlap Offset D (ft)
3 Cable Rail I-Beam Posts	12
Cable Rail Wood or Steel Posts	12
Metal Beam Rail Type R-I	8
Metal Beam Rail Type R-B	4
R-I System 2	6
R-I System 3	4.5
R-I System 4	3
R-I System 6	2

**TRANSITION OF EXISTING GUIDERAIL TO TEMPORARY PRECAST CONCRETE  
MEDIAN BARRIER CURB FOR TEMPORARY TRAFFIC CONTROL  
(One-Way Traffic)**

**Figure 14-4C**

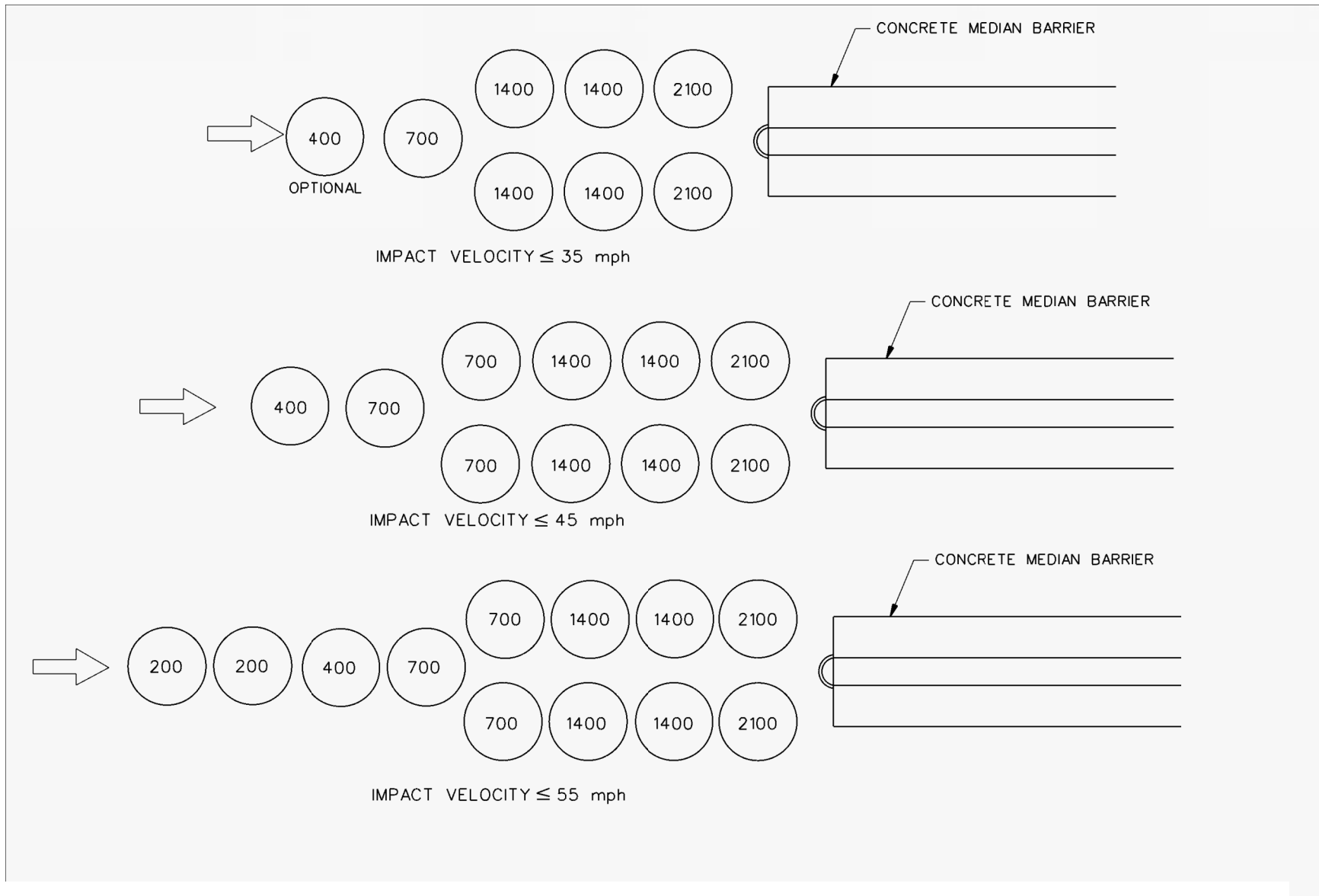

Note: Numbers indicates mass of sand in pounds in each barrel. These array designs should only be used for temporary installations.

**INERTIAL SYSTEM (SAND BARRELS)**

**Figure 14-4D**

#### 14-4.05 Design/Layout

Where practical, temporary roadside safety appurtenances should be designed and located as determined in Chapter Thirteen. However, it is usually not cost effective to meet the permanent installation criteria due to the limited time a motorist is exposed to construction hazards. The following offers several alternatives the designer may use in designing and locating temporary roadside safety appurtenances within construction zones:

1. Length of Need. For temporary locations in construction areas, the length of barrier needed can be determined by the intersection of a line along the barrier with a line at an angle of 10° to 15° from the back of the hazard or from the clear zone distance off the travelway, whichever is less. The approach end of the barrier may be flared to a point outside of clear zone or shielded with a crashworthy end terminal or impact attenuator. For barrier lengths less than 100 ft, the designer should consider removing the barrier because the barrier may be more of a hazard than the obstacle itself.
2. Restricted Widths. Where barriers are located near the traveled way on both sides of the roadway, the beginning of the barriers should be staggered to minimize the tendency drivers have to shy away from the barrier ends.
3. Flare Rates. Where practical, the TPCBC terminal should be flared beyond the travelway to a point outside of the construction clear zone. Figure 14-4A presents the flare rates that should be used for the TPCBC based on the selected construction-zone design speed. The designer should provide these flare rates unless extenuating circumstances render this impractical (e.g., stop conditions, driveways, intersections).
4. Openings. Openings in the barriers should be avoided, if practical. Where necessary, barrier ends should have an acceptable end treatment as discussed in Section 14-4.04. This also applies to breaks in the barrier for the contractor's access to the work site.
5. Delineation. Appropriate delineation should be provided in advance of and along the temporary concrete barrier installation. Reflectorized drums or barricades placed according to the MUTCD in advance of the concrete barrier should help to reduce the probability of vehicular encroachment and impact. Reflective devices, as shown on the details of the barrier, should be installed to provide the recommended delineation along the barrier. These should supplement but not replace the need for reflectorized edge line markings.

**14-5.0 REFERENCES**

1. *Manual on Uniform Traffic Control Devices, Millennium Edition*, ATSSA, AASHTO, ITE and FHWA, 2001.
2. *Planning and Scheduling Work Zone Traffic Control*, FHWA-IP-81-6, FHWA, 1981.
3. *A Policy on Geometric Design of Highways and Streets*, AASHTO, 2001.
4. *Roadside Design Guide*, AASHTO, 2002.





## **Appendix**

The Appendix presents the following policy statements:

[E&C-40: Work Zone Safety and Accessibility](#)

[E&C-46: Systematic Consideration and Management of Work Zone Impacts](#)



# CONNECTICUT DEPARTMENT OF TRANSPORTATION

# POLICY STATEMENT

POLICY NO. E&C - 40  
April 8, 2011

SUBJECT: Work Zone Safety and Accessibility

The Department is committed to ensure a safe and accessible highway environment for all users of the roadway (motorist, pedestrian, and bicyclist) traveling through a work zone and to establish a safe and secure area for those who must construct and maintain the highway system.

In order to achieve a safe and accessible highway environment during construction and maintenance periods, a uniform set of vehicular traffic control plans have been developed to establish a consistent application of traffic control patterns. These plans were developed using the principles set forth in the Manual of Uniform Traffic Control Devices (MUTCD), published by the Federal Highway Administration in cooperation with the American Association of State Highway and Transportation Officials. When applicable, these plans shall be utilized by all Department units, contractors, and permittees working within the highway right-of-way.

It is recognized that the development of detailed standards that would be adequate to cover all construction and maintenance applications is not practical. There will be occasions when the typical set of signs or other traffic control devices will not adequately address the field conditions impacting vehicles, pedestrians, or bicyclists for a given project. Such conditions should be anticipated and special traffic control plans, specifications, and/or transportation management plans reflecting the principles set forth in the MUTCD should be developed for the particular project or activity to address the identified concerns. All mobility modes should be considered in the development of project-specific plans. In particular, the level of accessibility for disabled individuals that was experienced prior to the project should be provided during construction and maintenance operations.

(This Policy Statement abolishes Policy Statement No. E&H.O -46 dated February 19, 2009)

A handwritten signature in black ink, which appears to read "James P. Redeker".

---

James P. Redeker  
Acting Commissioner



# CONNECTICUT DEPARTMENT OF TRANSPORTATION

# POLICY STATEMENT

POLICY NO. E&C - 46  
April 8, 2011

SUBJECT: Systematic Consideration and Management of Work Zone Impacts

It is the policy of the Department to systematically consider and manage work zone impacts of significant projects.

In establishing this Work Zone policy, the Department's objectives are to:

1. Provide a high level of safety for both workers and the public.
2. Minimize congestion and community impacts.
3. Provide both maintenance forces and contractors adequate access to the highway to efficiently conduct their work.

In order to meet these objectives, appropriate planning, design, construction, maintenance, and public awareness strategies shall be employed on all significant projects. For the purposes of this policy, a significant project is defined as:

A stationary highway construction or maintenance activity which causes sustained mobility impacts on I-84, I-91, I-95, I-291, I-384, or I-691 for more than three (3) days with either intermittent or continuous lane closures. In addition, any highway construction or maintenance activity that alone or in combination with other concurrent activities nearby, which is expected based on engineering judgment, to cause sustained mobility impacts that are considered greater than what is considered tolerable relative to typical traffic operations experienced in the area of the work zone, may be declared a significant project.

It is recognized that the Department's emergency operations may not always allow a systematic consideration of work zone impacts. In such situations, the objectives of this policy will be honored as much as practicable.

(This Policy Statement abolishes Policy Statement No. E&H.O -57 dated August 10, 2007)

A handwritten signature in cursive script, reading "James P. Redeker".

---

James P. Redeker  
Acting Commissioner

## Chapter Fifteen

### SPECIAL DESIGN ELEMENTS

#### Table of Contents

<u>Section</u>	<u>Page</u>
15-1.0 ACCESSIBILITY FOR DISABLED INDIVIDUALS .....	15-1(1)
15-1.01 Buildings.....	15-1(1)
15-1.02 Bus Stops.....	15-1(1)
15-1.03 Parking.....	15-1(2)
15-1.03.01 Off-Street Parking .....	15-1(2)
15-1.03.02 On-Street Parking .....	15-1(5)
15-1.04 Accessible Route.....	15-1(7)
15-1.05 Sidewalks .....	15-1(7)
15-1.05.01 Criteria for Accessible Routes.....	15-1(7)
15-1.05.02 Criteria for Public Rights-of-Way.....	15-1(9)
15-1.06 Stairs .....	15-1(10)
15-1.07 Ramps .....	15-1(10)
15-1.08 Curb Ramps .....	15-1(11)
15-1.08.01 General .....	15-1(11)
15-1.08.02 Location .....	15-1(11)
15-1.08.03 Crossing Controls .....	15-1(14)
15-1.08.04 Types .....	15-1(14)
15-1.09 Pedestrian Overpasses and Underpasses.....	15-1(18)
15-1.10 Detectable Warning Surfaces.....	15-1(18)
15-2.0 COMMUTER LOTS .....	15-2(1)
15-2.01 General.....	15-2(1)
15-2.02 Layout.....	15-2(1)
15-2.02.01 Entrances and Exits .....	15-2(1)
15-2.02.02 Traffic Circulation .....	15-2(1)
15-2.02.03 Pedestrian and Bicyclist Considerations.....	15-2(2)
15-2.02.04 Accessibility for Disabled Individuals .....	15-2(2)

**Table of Contents**

(Continued)

<b><u>Section</u></b>	<b><u>Page</u></b>
15-2.03 Design Elements .....	15-2(2)
15-3.0 BUS STOPS AND TURNOUTS .....	15-3(1)
15-3.01 Location .....	15-3(1)
15-3.01.01 Bus Stops .....	15-3(1)
15-3.01.02 Bus Turnouts .....	15-3(1)
15-3.02 Design .....	15-3(2)
15-3.02.01 Bus Stops .....	15-3(2)
15-3.02.02 Bus Turnouts .....	15-3(2)
15-3.02.03 Bus Stop Pads .....	15-3(2)
15-3.02.04 Bus Shelters .....	15-3(2)
15-4.0 BIKEWAYS .....	15-4(1)
15-4.01 Bikeway Classifications .....	15-4(1)
15-4.02 Warrants .....	15-4(1)
15-4.03 Bikeway Design Elements .....	15-4(2)
15-5.0 LANDSCAPING .....	15-5(1)
15-5.01 General Benefits .....	15-5(1)
15-5.02 Landscaping Policies .....	15-5(2)
15-5.02.01 Planting Policy .....	15-5(2)
15-5.02.02 Protection of Existing Vegetation .....	15-5(2)
15-5.02.03 Turf Establishment, Topsoil and Sodding .....	15-5(2)
15-6.0 FENCING .....	15-6(1)
15-6.01 General Warrants and Location .....	15-6(1)
15-6.02 Freeways .....	15-6(1)
15-6.03 Unlimited Access Highways .....	15-6(2)
15-6.04 Fencing and Railings on Highway Structures .....	15-6(3)
15-6.04.01 General .....	15-6(3)
15-6.04.02 Highway Overpasses with Sidewalks .....	15-6(3)
15-6.04.03 Highway Overpasses without Sidewalks .....	15-6(3)

**Table of Contents**

(Continued)

<b><u>Section</u></b>		<b><u>Page</u></b>
	15-6.04.04 Stream and Wetland Overpasses .....	15-6(4)
	15-6.04.05 Railroad Overpasses .....	15-6(4)
	15-6.04.06 Pedestrian Overpasses.....	15-6(5)
	15-6.04.07 Walls .....	15-6(5)
	15-6.04.08 Railing and Fencing at Lighting and Signing Standards .	15-6(5)
	15-6.05 Fencing Delineation on Contract Plans .....	15-6(5)
15-7.0	NOISE BARRIER IMPACTS .....	15-7(1)
	15-7.01 Roadside Safety .....	15-7(1)
	15-7.02 Sight Distance .....	15-7(1)
	15-7.03 Right-of-Way .....	15-7(1)
	15-7.04 Interference with Roadside Appurtenances .....	15-7(1)
	15-7.05 Additional Design Criteria.....	15-7(2)
15-8.0	ILLUMINATION (Cutoff Lighting) .....	15-8(1)
15-9.0	REFERENCES .....	15-9(1)
Appendix		





# Chapter Fifteen

## SPECIAL DESIGN ELEMENTS

### 15-1.0 ACCESSIBILITY FOR DISABLED INDIVIDUALS

Many highway elements can affect the accessibility and mobility of disabled individuals. These include sidewalks, parking lots, buildings at transportation facilities, overpasses and underpasses. The Department's accessibility criteria comply with the 1990 *Americans with Disabilities Act* (ADA) and the *General Statutes of Connecticut* (CGS). The following Sections present accessibility criteria that are based on information presented in the *ADA Accessibility Guidelines* for Buildings and Facilities (*ADA Guidelines*). Designers are required to meet the criteria presented in the following Sections. Where other agencies or local codes require standards that exceed the *ADA Guidelines*, the stricter criteria may be required. This will be determined on a case-by-case basis.

#### 15-1.01 Buildings

*ADA Reference:* Section 4.1

For interior accessibility criteria in all buildings, airport terminals, rest areas, weigh stations and transit stations (e.g., stations for intercity bus, intercity rail, high-speed rail and other fixed guideway systems), the accessibility criteria set forth in the *ADA Guidelines* shall apply. The designer should review the *ADA Guidelines* to determine the appropriate accessibility requirements for building interiors, including rest rooms, drinking fountains, elevators, telephones, etc.

#### 15-1.02 Bus Stops

*ADA Reference:* Section 10.2

The following accessibility criteria apply to the construction of bus stops:

2. Bus Stop Pads. New bus stop pads constructed to be used in conjunction with a lift or ramp shall meet the following criteria:
  - a. A firm stable surface must be provided.
  - b. It must have a minimum clear length of 96 in (measured from the curb or roadway edge) and minimum clear width of 60 in (measured parallel to the roadway) depending on the legal or site constraints.
  - c. It must be connected to streets, sidewalks or pedestrian paths by at least one accessible route.

- d. The slope of pad parallel to the roadway must be the same as the roadway to the maximum extent practical.
- e. For drainage purposes, a maximum cross slope of 2% perpendicular to the roadway is allowable.
3. **Bus Shelters.** Where new or replaced bus shelters are provided, they must be installed or positioned to permit a wheelchair user to enter from the public way and reach a location within the shelter having a minimum clear floor area of 30 in by 48 in. An accessible route shall be provided from the shelter to the boarding area.
4. **Signing.** All new bus route identification signs should be sized based on the maximum dimensions permitted by local, State or Federal regulations or ordinances. The signs shall have an eggshell, matte or other non-glare finish. The characters or symbols shall contrast with their background (i.e., light characters on a dark background or dark characters on a light background).

### **15-1.03      Parking**

*ADA Reference:*            *Section 4.1.2*

*Connecticut General Statutes: CGS 14-253a Parking privileges for blind or handicapped persons. Identification card. License plates. Parking spaces. Penalty.*

#### **15-1.03.01    Off-Street Parking**

*ADA Reference:*            *Section 4.1.2 and 4.6*

The following criteria apply to off-street disabled parking spaces:

1. **Minimum Number.** Figure 15-1A provides the criteria for the minimum number of accessible spaces. A typical disabled parking stall layout is shown in Figure 15-1B.
2. **Location.** Parking spaces for disabled individuals and accessible passenger loading zones that serve a particular building shall be the spaces or zones closest to the nearest accessible entrance on an accessible route. In separate parking structures or lots that do not serve a particular building, parking spaces for disabled individuals shall be located on the shortest possible circulation route to an accessible pedestrian entrance of the parking facility. In buildings with multiple access entrances with adjacent parking, accessible parking spaces shall be dispersed and located closest to the accessible entrances.

Total Number of Parking Spaces	Minimum Number of Accessible Spaces
1 to 25	1
26 to 50	2
51 to 75	3
76 to 100	4
101 to 150	5
151 to 200	6
201 to 300	7
301 to 400	8
401 to 500	9
501 to 1000	2% of total
1001 and over	20 plus one for each 100 over 1000

*Notes:*

- a. *If one or more passenger loading zones are provided, then at least one passenger-loading zone shall comply with Item #5 in Section 15-1.03.01.*
- b. *Use the universal parking space design for all parking lots; see Figure 15-1B. Consequently, all disabled parking spaces are considered van accessible and signing for vans is not required.*
- c. *The total number of accessible parking spaces may be distributed among closely spaced parking lots, if greater accessibility is achieved.*

**MINIMUM NUMBER OF ACCESSIBLE SPACES FOR DISABLED USERS**

**Figure 15-1A**



ramp complying with Section 15-1.08 shall be provided. Vehicular standing spaces and access aisles shall be essentially level. Surface slopes shall not exceed 2% in all directions.

The criteria above shall meet any requirements of *CGS 14-253a* for parking spaces.

### **15-1.03.02 On-Street Parking**

Where new on-street paid or time-limited parking is provided and designated in districts zoned for business uses, the designer should consider the following accessibility criteria for the on-street parking:

1. Minimum Number. Figure 15-1A provides the criteria for the minimum number of on-street accessibility spaces.
2. Location. On-street accessibility parking spaces will be dispersed throughout the project area. To the maximum extent feasible, accessible on-street parking should be located in level areas.
3. Dimensions. At a minimum, a 60-in wide perpendicular access aisle must be provided at the head or foot of the parking space. This is illustrated in Figure 15-1C. The travel lane shall not encroach into the access aisle.
4. Signing. Aboveground signs with white lettering against a blue background shall designate parking spaces for the disabled, and the signs shall bear the international symbol of access (see MUTCD) and the words "Disabled Parking State Permit Required" and "Violators Will Be Fined." These signs will be located so as to be visible from a driver's seat.
5. Curb Ramps. If there are curbs next to an on-street accessible parking space, then a curb ramp complying with Section 15-1.08 shall be provided. Access parking spaces adjacent to intersections may be served by the sidewalk curb ramp at the intersection, provided that the path of travel from the access aisle to the curb ramp is within the pedestrian crossing area.
6. Parking Meters. Where provided, parking meter controls shall be a maximum of 48 in above the sidewalk or pedestrian circulation path. Controls and operating mechanisms shall be operable with one hand and shall not require tight grasping, pinching or twisting of the wrist. The force required to activate controls shall be no greater than 5 lbs. A firm, stable and slip-resistant area (30 in by 48 in), with the least possible slope, shall be provided at the controls and shall be connected to the sidewalk by a continuous passage that is a minimum of 36 in wide.

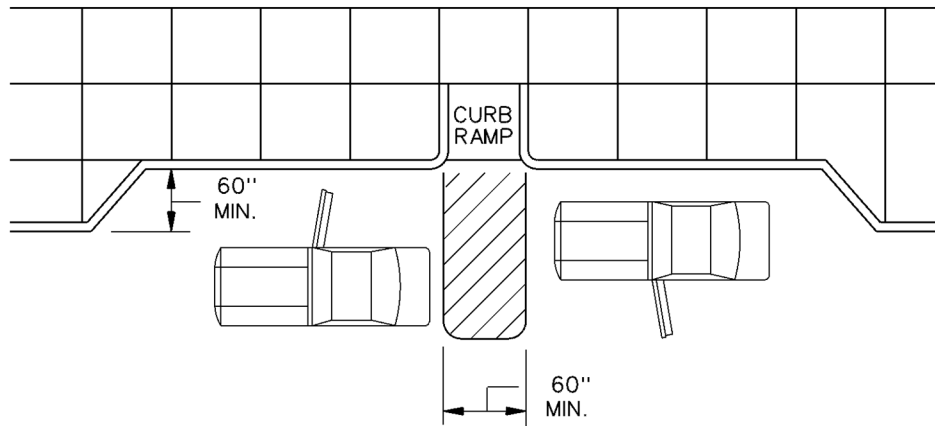

(a) TWO ACCESSIBLE PARALLEL PARKING SPACES IN SERIES, SEPARATED BY AN ACCESSIBLE AISLE, WITH BOTH DRIVER-SIDE AND PASSENGER-SIDE ACCESS DEMONSTRATED.

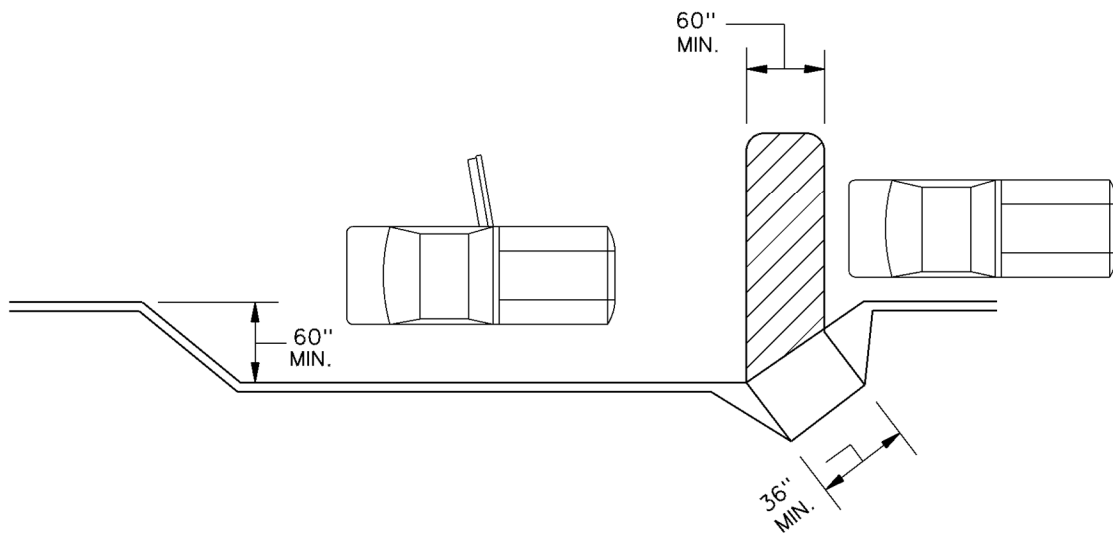

(b) SINGLE ACCESSIBLE PARALLEL PARKING SPACE WITH DRIVER-SIDE ACCESS DEMONSTRATED; PASSENGER SIDE ACCESS CAN BE PROVIDED BY PARKING IN LINE WITH STANDARD ON-STREET SPACES.

**DISABLED PARKING  
(On-Street Parking)**

**Figure 15-1C**

**15-1.04 Accessible Route**

ADA Reference: Section 4.3

An accessible route is a continuous, unobstructed path connecting all accessible elements and spaces in a building, facility or site. A “site” is defined as a parcel of land bounded by a property line or a designated portion of a public right-of-way. A “facility” is defined as all or any portion of buildings, structures, site improvements, complexes, equipment, roads, walks, passageways, parking lots, or other real or personal property on a site. Interior accessible routes may include corridors, floors, ramps, elevators, lifts and clear floor space at fixtures. Exterior accessible routes may include parking access aisles, curb ramps, crosswalks at vehicular ways, walks, ramps and lifts.

Accessible routes must be provided as follows:

1. At least one accessible route within the boundary of the site shall be provided from public transportation stops, accessible parking, accessible passenger-loading zones, and public streets or sidewalks to the accessible building entrance they serve. The accessible route shall, to the maximum extent feasible, coincide with the route for the general public.
2. At least one accessible route shall connect accessible buildings, facilities, elements and spaces that are on the same site.
3. At least one accessible route shall connect accessible buildings or facility entrances with all accessible spaces and elements and with all accessible dwelling units within the building or facility.

For highway projects, the application of the accessible route criteria applies to definitive sites that are related to highway purposes. These include rest areas, recreational areas, park-and-ride lots, etc. Section 15-1.05 provides the accessibility requirements for sidewalks. Most sidewalks along public right-of-way are considered non-accessible.

### **15-1.05      Sidewalks**

Section 10-2.01 presents the Department’s warrants and design criteria for sidewalks. In addition, all sidewalks must comply with the *ADA Guidelines* presented in the following Sections.

#### **15-1.05.01    Criteria for Accessible Routes**

*ADA Reference:*      *Various.*

For sidewalks on accessible routes, the following accessibility criteria shall be met:

1. Width. The minimum clear width shall be 36 in, except at doors that may have a minimum width of 32 in.
2. Passing Space. If the sidewalk has less than 60 in clear width, then passing spaces at least 60 in by 60 in shall be located at reasonable intervals not to exceed 200 ft. A T-intersection between two walks is an acceptable passing space. Paved driveways also provide acceptable passing space in residential areas.
3. Surface. All sidewalk surfaces shall be stable, firm and slip resistant. The longitudinal gradient should be flush and free of abrupt changes. However, changes in level up to 0.25 in may be vertical and without edge treatment. Changes in level between 0.25 in and 0.5 in shall be beveled with a slope no greater than 50%. Changes greater than 0.5 in shall be accommodated with a ramp; see Section 15-1.07.  
  
Gratings should not be placed within the walking surface. If, however, gratings are located in walking surfaces, they shall have spaces no greater than 0.5 in wide in one direction. If gratings have elongated openings, then they shall be placed so that the long dimension is perpendicular to the dominant direction of travel.
4. Slope. The sidewalk cross slope shall not exceed 2%. If the longitudinal gradient exceeds 5%, the sidewalk must meet the accessibility criteria for ramps (see Section 15-1.07).
5. Protruding Objects. Objects projecting from walls (e.g., signs, telephones, canopies) with their leading edges between 27 in and 80 in above the finished sidewalk shall not protrude more than 4 in into any portion of the sidewalk. Freestanding objects mounted on posts or pylons may overhang their mountings up to a maximum of 12 in when located between 27 in and 80 in above the sidewalk or ground surface. Protruding objects less than 27 in or greater than 80 in may protrude any amount provided that the effective width of the sidewalk is maintained. Where the vertical clearance is less than 80 in, a barrier shall be provided to warn the blind or visually impaired person.
6. Separation. Sidewalks will be separated from roadways by curbs, snow shelf or other barriers, which will be continuous except where interrupted by driveways, alleys or connections to accessible elements.
7. Bus Stops. Where bus passenger-loading areas or bus shelters are provided on or adjacent to sidewalks, they must comply with the criteria in Section 15-1.02.
8. Curb Ramps. All curb ramps on an accessible route must comply with the criteria in Section 15-1.08.



**15-1.05.02 Criteria for Public Rights-of-Way**

All sidewalks along the public rights-of-way should be made accessible to people with disabilities. In general, a sidewalk supported by a new or an altered structure shall be made fully accessible using the accessible route criteria for sidewalks and ramps. A sidewalk at street or highway grade shall be designed to meet accessible route criteria for sidewalks to the maximum extent feasible.

The scope of a project shall determine the level of accessibility improvements that must be provided on a project. For all projects that include new construction, reconstruction, and/or 'alterations' to existing facilities, the proposed improvements within the project limits (transverse limits as well as longitudinal limits) shall be made accessible to the maximum extent feasible.

In addition, certain pavement preservation and resurfacing projects are considered an 'alteration' to the existing facility and therefore these 'alteration' projects must provide accessible curb ramps at all legal crosswalks (marked or unmarked) which abut the project paving limits. An existing non-accessible sidewalk along a roadway being altered does not need to be specifically addressed as the sidewalk is beyond the limits of the project.

For the purposes of this section, a pavement preservation or resurfacing project shall be considered an 'alteration' unless the proposed work is limited to 'maintenance activities' and the proposed work does not include milling of the entire roadway prior to the application of a pavement overlay/treatment. 'Maintenance activities' include, but is not limited to: pavement treatments an inch or less in thickness (ultra-thin bonded hma, chip seals, microsurfacing, etc.), joint repair, pavement patching (filling potholes), signing, striping, minor signal upgrades, and repairs to drainage systems.

In all cases, any proposed improvement must ensure that accessibility is not degraded in any way

Existing public right-of-way need not be expanded solely for the purpose of accessibility; however, if additional right-of-way is being acquired for other project needs, the designer should explore if additional right-of-way may be acquired to provide full accessibility. Designers should consult the Department's ADA Transition Plan for Public Rights-of-Way to determine if related work has been identified as needed to achieve accessibility in existing facilities at the same location. Accessibility issues which are identified, but are not being addressed within a project, should be forwarded to the Design Development Unit for inclusion in the Department's Transition Plan.

For sidewalks along the public right-of-way, there may be locations where a sidewalk is being constructed or altered and it is technically infeasible to make it fully accessible. Steep physical terrain or site constraints (existing buildings and bridges, historic properties, etc) are instances where providing full accessibility may be technically not feasible. A sidewalk at street or highway grade shall not exceed the general grade established for the adjacent street or highway. When it is determined that it is technically not feasible to provide full accessibility, the designer shall document in the project file the issue(s) and what solutions were explored.

Accessibility issues should be identified and addressed at the earliest stage possible to reduce or prevent conflicts with other design considerations. Use of special plan details to remove

accessibility barriers may be necessary; refer to the Appendix of this chapter for additional resources concerning accessible design.

### 15-1.06 Stairs

*ADA Reference:* Section 4.9

Stairs shall not be part of an exterior accessible route because individuals in wheelchairs cannot safely negotiate them. Where stairs are used, they should be designed to be accessible by other disabled individuals. Therefore, the design of stairs must comply with Section 4.9 of the *ADA Guidelines* and the *Connecticut Standard Drawings*. This includes the provision of handrails.

### 15-1.07 Ramps

*ADA Reference:* Sections 4.1.6, 4.8 and 4.26

Any part of an accessible route with a slope greater than 5% shall be considered a ramp and shall conform to the *ADA Guidelines*. This includes the provision of handrails. The following criteria must be met for ramps on accessible routes:

1. Slope and Rise. The least possible slope should be used for any ramp. Figure 15-1D provides the maximum allowable ramp slopes for new construction. Curb ramps and ramps to be constructed on existing sites or in existing buildings or facilities may have slopes and rises as shown in Figure 15-1E, if space limitations prohibit the use of a 1:12 slope or less.
2. Width. The minimum clear width of a ramp shall be 36 in.

Slope	Maximum Rise	Maximum Run
Steeper than 1:16 but no steeper than 1:12	30 in	30 ft
Steeper than 1:20 but no steeper than 1:16	30 in	40 ft

*Note:* A slope steeper than 1:12 is not allowed.

### ALLOWABLE RAMP DIMENSIONS (New Construction)

Figure 15-1D



Slope	Maximum Rise	Maximum Run
Steeper than 1:10 but no steeper than 1:8	3 in	2 ft
Steeper than 1:12 but no steeper than 1:10	6 in	5 ft

*Note: A slope steeper than 1:8 is not allowed.*

**ALLOWABLE RAMP DIMENSIONS  
(Existing Sites, Buildings and Facilities)**

**Figure 15-1E**

3. Landings. Ramps shall have level landings at the bottom and top of each run. Landings shall have the following features:
  - a. The landing shall be at least as wide as the ramp run leading to it.
  - b. The landing length shall be a minimum of 60 in clear.
  - c. If ramps change direction at landings, the minimum landing size shall be 60 in by 60 in.
4. Handrails. If a ramp run has a rise greater than 6 in or a horizontal projection greater than 72 in, then it shall have handrails on both sides. Handrails are not required on curb ramps. Handrails shall have the following features:
  - a. Handrails shall be provided along both sides of ramp segments. The inside handrail on switchback or dogleg ramps shall be continuous.
  - b. If handrails are not continuous, they shall extend at least 12 in beyond the top and bottom of the ramp segment and shall be parallel with the floor or ground surface.
  - c. The clear space between the handrail and the wall shall be 1.5 in.
  - d. Gripping surfaces shall be continuous.
  - e. Top of handrail gripping surfaces shall be mounted between 34 in and 38 in above ramp surfaces.
  - f. Ends of handrails shall be either rounded or returned smoothly to floor, wall or post.
  - g. Handrails shall not rotate within their fittings.

5. Cross Slope and Surfaces. The cross slope of ramp surfaces shall be no greater than 2%. Ramp surfaces shall comply with the criteria for "Surface" for sidewalks (Section 15-1.05).
6. Edge Protection. Ramps and landings with drop-offs shall have curbs, walls, railings or projecting surfaces that prevent people from slipping off the ramp. Curbs shall be a minimum of 2 in high.
7. Outdoor Conditions. Outdoor ramps and their approaches shall be designed so that water will not accumulate on walking surfaces.

#### **15-1.08      Curb Ramps**

*ADA Reference:*      *Section 4.7*

*Connecticut General Statutes:*      *CGS 7-118a*

##### **15-1.08.01      General**

"Curb cuts" and "curb ramps" are terms that describe the treatment at intersections for gradually lowering the elevation of sidewalks with curbs to the elevation of the street surface. The term "curb ramps" will be used in this *Manual*.

All curbs and sidewalks shall be designed with curb ramps at all pedestrian crosswalks to provide adequate and reasonable access for the safe and convenient movement of physically disabled persons. This applies to new construction, reconstruction, 3R and spot improvement projects. For the purpose of this Section, a pedestrian crosswalk is defined as that portion of a highway or street ordinarily included within the prolongation or connections of lateral lines of sidewalks at intersections. It also includes any portion of a highway or street distinctly indicated as a crossing for pedestrians by lines or other markings on the surface, except such prolonged or connecting lines from an alley across a street.

##### **15-1.08.02      Location**

When determining the need for a curb ramp, the designer should consider the following:

1. If at least one curb will be disturbed by construction at an existing intersection, then curb ramps shall be constructed at all crosswalks which extend from a paved sidewalk in that intersection.
2. For all projects, curb ramps will be constructed at all crosswalks that provide pedestrian access in that intersection and will be provided on all corners. At T-intersections, the designer must ensure that curb ramps are located on the side opposite the minor intersecting road if warranted for pedestrian access.

3. Opposing ramps must always be provided on adjacent legs of an intersection even if outside project limits.
4. Curb ramps shall be positioned so as not to cause a safety hazard for blind pedestrians.
5. Curb ramps shall be located or protected to prevent their obstruction by parked vehicles.
6. Curb ramps at marked crossings shall be wholly contained within the markings, excluding any flared sides.
7. A diagonal curb ramp shall be wholly contained within the painted markings, including any flared sides. There shall be at least 24 in of full-height curb within the crosswalk. In addition, there shall be at least 48 in between the gutter line and the corner of the two intersecting crosswalks. See Figure 15-1F for an illustration of these criteria.
8. The function of the curb ramp must not be compromised by other highway features (e.g., guiderail, catch basins, utility poles, signs).
9. Curb ramps are required at all curbed intersections with sidewalks or along all accessible routes.
10. The location of the curb ramp must be consistent with the operation of pedestrian-actuated traffic signals, if present. In addition, a pedestrian push-button must be located so wheelchair-bound individuals can reach it.
11. The designer will provide the Division of Traffic Engineering with a set of plans at the preliminary design stage and before the preliminary design review. The Division of Traffic Engineering, in its review, will determine the need and location of mid-block curb ramps. These recommendations will be incorporated into the design before the

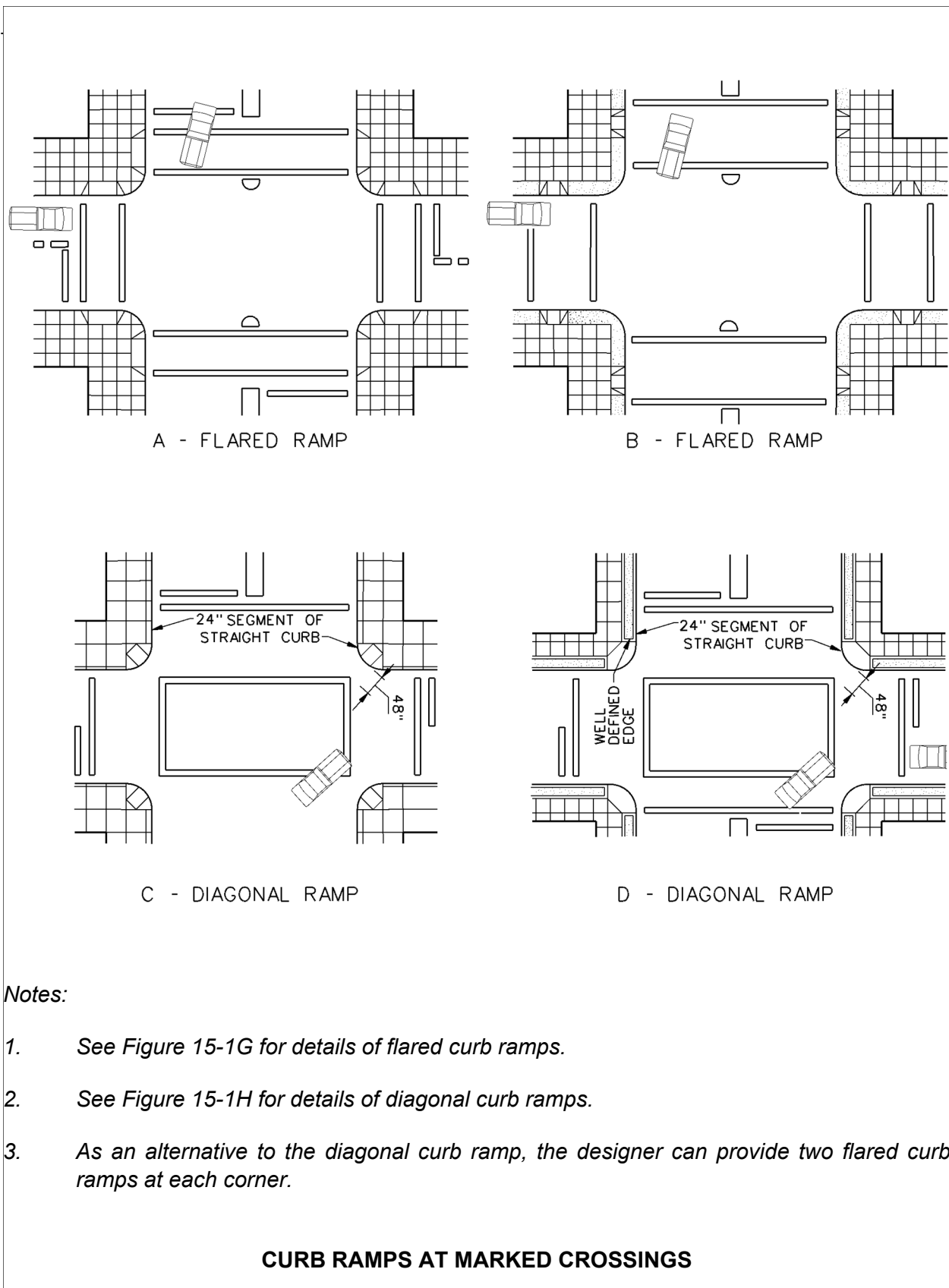

preliminary design review. In addition, the Division of Traffic Engineering will be notified of any geometric changes that will impact the location of any curb ramp included in the preliminary design review.

### 15-1.08.03 Crossing Controls

If a pedestrian crosswalk and curb ramp are present at an intersection with a traffic signal that has pedestrian detectors (push buttons), the following will apply:

1. Location. Controls shall be located as close as practical to the curb ramp and, to the maximum extent feasible, shall permit operation from a level area immediately adjacent to the controls.
2. Surface. A firm, stable and slip-resistant area, a minimum of 36 in by 48 in, shall be provided to allow a forward or parallel approach to the controls.

### 15-1.08.04 Types

Figure 15-1F illustrates the two basic types of curb ramps — flared and diagonal. Details for the construction of flared curb ramps are provided in Figure 15-1G and for diagonal curb ramps in Figure 15-1H.

The following provides several suggestions for selecting the appropriate curb ramp:

1. Crosswalk Markings and Stop Bars. The placement of curb ramps affects the placement of crosswalk markings and stop bars. Conversely, the location of existing crosswalk markings and stop bars affect the placement of curb ramps. Some of the crosswalk-marking constraints are shown in Figure 15-1F and in the *Connecticut Standard Drawings*. The *MUTCD* contains additional constraints on crosswalk markings and stop bar placement.
2. Obstructions. It is desirable to move any obstructions from curb ramps whenever practical. When this is not practical, the direction of traffic relative to the placement of the curb ramp must be considered. It is important that drivers can see the disabled person using the curb ramp.
3. Diagonal Curb Ramps. The usage of a diagonal curb ramp should be avoided whenever practical due to its effect on the crosswalk width. It is preferable to use the straight curb ramp or several straight ramps rather than to use a diagonal curb ramp.
4. Islands. Any raised islands in a pedestrian crosswalk shall be cut through level with the street or have curb ramps at both sides and a level area at least 48 in long in the part of the island intersected by the crossing; see Figure 15-1I.



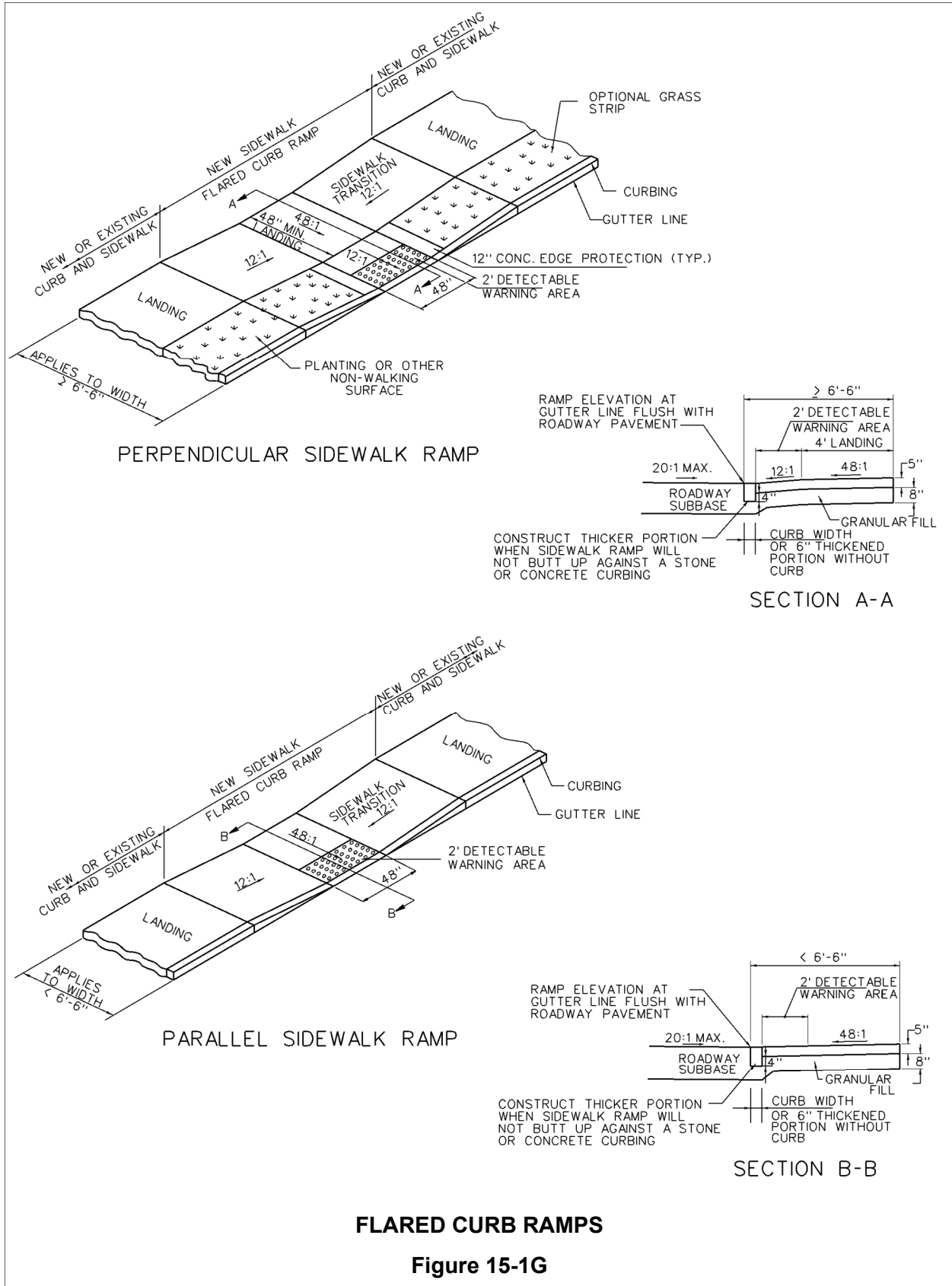

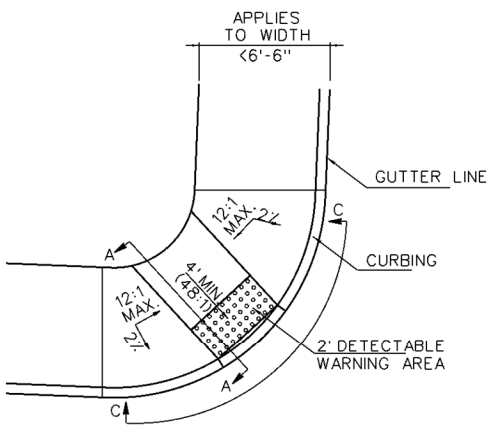

DIAGONAL/PARALLEL SIDEWALK RAMP

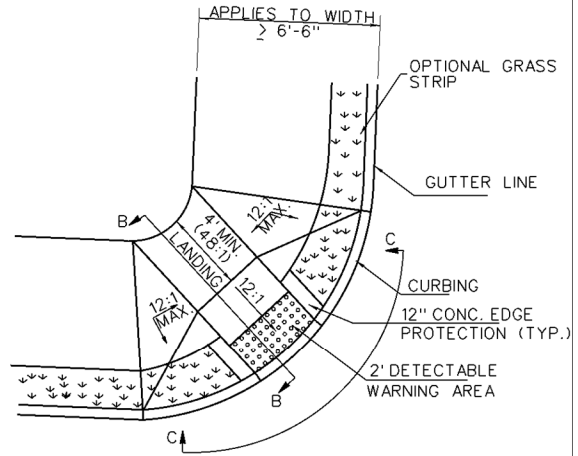

DIAGONAL SIDEWALK RAMP

RAMP ELEVATION AT GUTTER LINE FLUSH WITH ROADWAY PAVEMENT

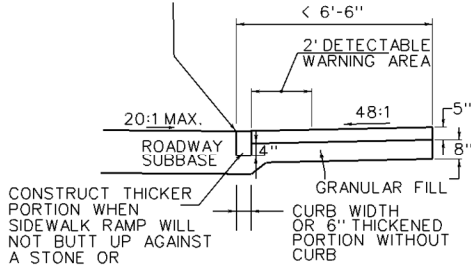

SECTION A-A

RAMP ELEVATION AT GUTTER LINE FLUSH WITH ROADWAY PAVEMENT

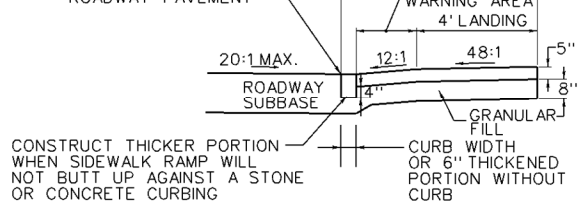

SECTION B-B

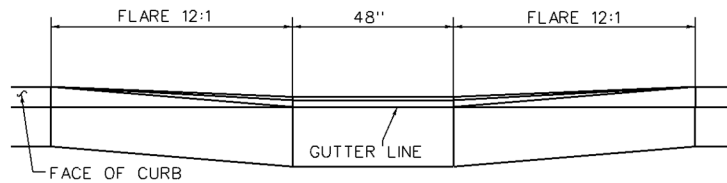

SECTION C-C

**DIAGONAL CURB RAMPS**

**Figure 15-1H**

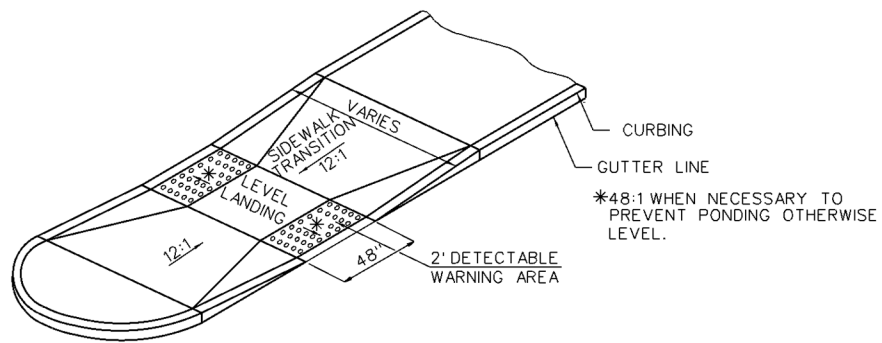

RAISED ISLAND SIDEWALK RAMP

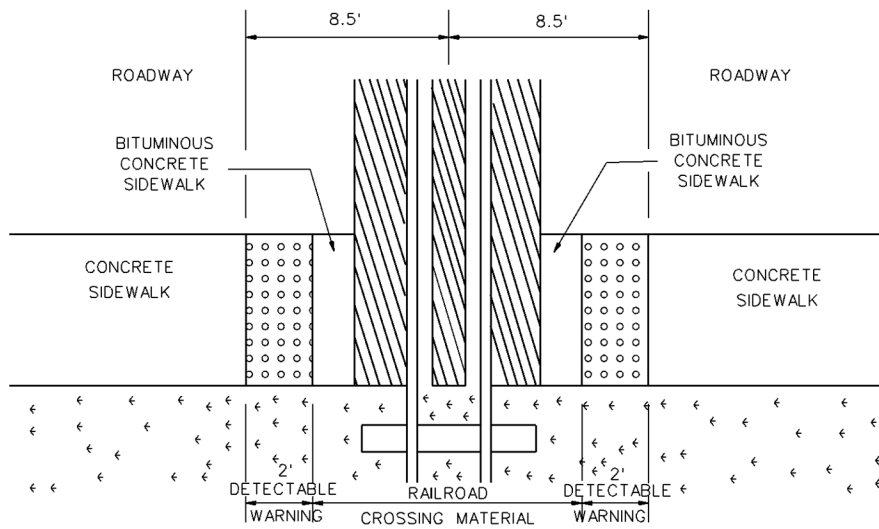

DETECTABLE WARNINGS AT RAILROAD CROSSING

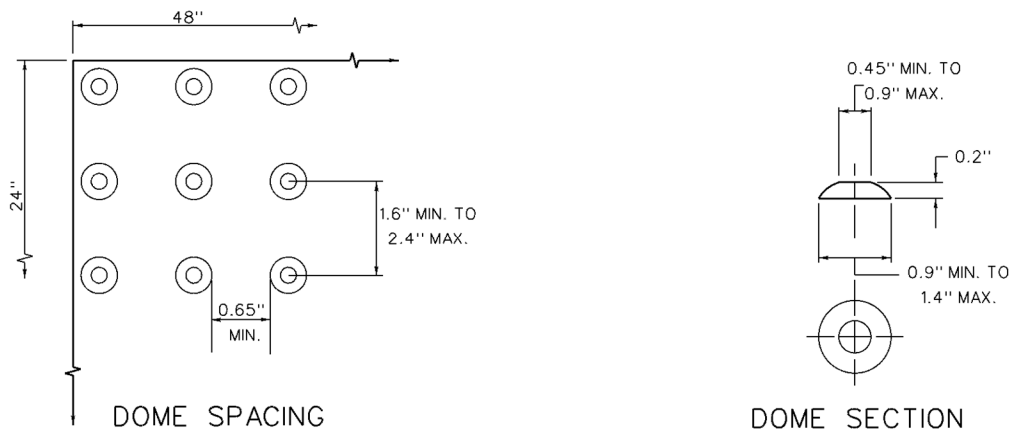

DOME DETAILS FOR DETECTABLE WARNINGS

Figure 15-11

5. Material. Regardless of the type of pavement of the adjacent sidewalk, all curb ramps shall be constructed of Portland cement concrete. Also, all curb ramps shall be

constructed in accordance with the details of the *Connecticut Standard Drawings* for concrete sidewalk, except for the ramp, which will have a textured and non-slip surface.

6. Specifications. Curb ramps shall be constructed, measured and paid for as concrete sidewalks, as referred to in the Department's *Standard Specifications for Roads, Bridges and Incidental Construction*, latest issue.

### **15-1.09 Pedestrian Overpasses and Underpasses**

*ADA Reference:*        *Various*

When deciding where to locate a pedestrian crossing, the highway and structure designers must coordinate their efforts to properly address the accessibility considerations. The following are applicable:

1. All current and future accessible routes must be identified. If existing routes are inaccessible, the designer must evaluate the likelihood the routes will be made accessible in the future. This could be done as part of the project under design.
2. The evaluation in Item #1 may lead to the decision to relocate the pedestrian overpass or underpass to another site where accessibility can be more easily provided.
3. The proposed design must meet the *ADA Guidelines* criteria for stairs, ramps, curb ramps and accessible routes.
4. The designer should reference FHWA-IP-84-6 *Guidelines for Making Pedestrian Crossing Structures Accessible* for additional design information.

### **15-1.10 Detectable Warning Surfaces**

*ADA Reference:*        *4.29*

Detectable warnings are required on all curb ramps and at sidewalk railroad crossings. Details for the construction of detectable warnings are provided in Figures 15-1G, 15-1H and 15-1I.

The following provides guidance for the installation of detectable warnings:

1. Any island that is to be used for pedestrian refuge shall have detectable warnings on the curb ramps located at both sides of the island.
2. Where a railroad crosses pedestrian facilities at grade, detectable warnings shall be installed in the sidewalk on both sides of the railroad crossing.



## **15-2.0 COMMUTER LOTS**

### **15-2.01 General**

Commuter lots may be located in rural or urban areas to accommodate car-pooling or to provide access to transit terminals. By locating these lots outside of the downtown area, congestion is reduced, parking lot property costs are lowered, and accessibility is improved. The general location and size of commuter lots is normally determined during planning studies for transportation facilities by the Bureau of Planning. Guidance for site selections can be found in the *AASHTO Guide for the Design of Park-and-Ride Facilities*. The designer is responsible for the internal design and layout of the commuter lot.

### **15-2.02 Layout**

#### **15-2.02.01 Entrances and Exits**

The designer should locate entrances and exits so that they will have the least disruption to existing traffic on the street, allow easy access to and from the lot, and provide the maximum storage space within the lot. In addition, consider the following:

1. Location. Separate entrances and exits whenever practical, preferably on different streets. The entrance should be on the “upstream” side of the traffic flow nearest the lot and the exit on the “downstream” side. If separation is not possible, the combined entry-exit point should be as close to mid-block as practical.
2. Spacing. Entrances and exits should be at least 150 ft apart and 150 ft from a public intersection. Where practical, these distances should be 300 ft. For lots with less than 150 spaces, these dimensions may be reduced to 100 ft.
3. Storage. The designer needs to ensure that there is sufficient storage on the mainline for entering the lot. This may require providing a separate left-turn lane. Also, check the exiting traffic to ensure the exiting queue will not adversely affect the traffic circulation in the lot itself.
4. Design. Design all entrance and exits for capacity, sight distance, turning radii, acceleration and deceleration lanes, turn lanes, etc., according to the criteria in Chapter Eleven. The typical design vehicle will be a BUS.

#### **15-2.02.02 Traffic Circulation**

Arrange the traffic circulation to provide maximum visibility and minimum conflict between small vehicles (e.g., autos, taxis) and large vehicles (e.g., large vans, buses). Locate major circulation routes at the periphery of the lot to minimize vehicular-pedestrian conflicts. A counter-clockwise circulation of one-way traffic is preferred. This allows vehicles to unload from the right side.

### **15-2.02.03 Pedestrian and Bicyclist Considerations**

The designer should consider pedestrian and bicycle routes when laying out the commuter lot. Avoid entrance and exit points in areas with high pedestrian volumes, if practical. Provide sidewalks between the parking areas and the modal transfer points. Locate passenger waiting areas in a central location or near the end of the facility. Maximum walking distances to loading area should not exceed 1000 ft. Longer walking distances may require more than one loading area.

Crosswalks should be provided where necessary and clearly marked and signed. Include signing and pavement markings for all pedestrian and bicycle paths to eliminate indiscriminate movements. In high-volume lots, fencing, barriers or landscaping may be warranted to channel pedestrians and bicyclists to appropriate crossing points. Crossings at major two-way traffic circulation lanes should have a refuge island separating the travel directions.

Include a bicycle parking area relatively close to the loading area. Provide bicycle stalls that allow the use of locking devices. If a large volume of bicycle traffic is expected, provide a designated bicycle lane to and from the bicycle parking area.

### **15-2.02.04 Accessibility for Disabled Individuals**

Section 15-1.0 discusses the accessibility criteria for disabled individuals, which also apply to commuter lots.

### **15-2.03 Design Elements**

Consider the following elements in the design of a commuter lot:

1. Parking Stall Dimensions. Figure 15-2A provides the design dimensions for 9 ft x 18.5 ft parking stalls based on one-way circulation and angle of parking. Where feasible, the lot should provide two-way flow with 90° parking spaces.
2. Bus Loading Areas. Design the bus loading and unloading areas to provide for continuous counter-clockwise circulation and for curb parking without backing maneuvers. The traffic lanes and the curb loading area should each be 12 ft wide. Figure 15-2B provides criteria for the recommended lengths of bus-loading areas. Section 15-3.0 discusses bus stops along streets and other access facilities.
3. Sidewalk Dimensions. All sidewalks should be paved and be at least 5 ft wide. In loading areas, the width should be at least 12 ft. Provide a 6-in raised platform in the loading area to assist in the loading. Curb-cut ramps are required for access to sidewalks and loading areas, see Section 15-1.0.



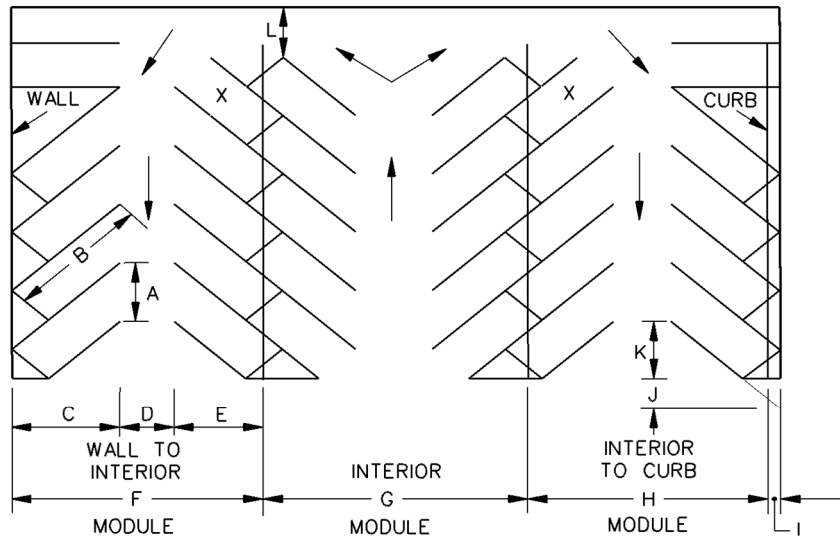

X = STALL NOT ACCESSIBLE IN CERTAIN LAYOUTS

**Parking Layout Dimension (in ft) for 9 ft x 18.5 ft Stalls at Various Angles**

Dimension	On Diagram	Angle			
		45°	60°	75°	90°
Stall width, parallel to aisle	A	12.7	10.4	9.3	9.0
Stall length of line	B	25.0	22.0	20.0	18.5
Stall depth to wall	C	17.5	19.0	19.5	18.5
Aisle width between stall lines	D	12.0	16.0	23.0	26.0
Stall depth, interlock	E	15.3	17.5	18.8	18.5
Module, wall to interlock	F	44.8	52.5	61.3	63.0
Module, interlocking	G	42.6	51.0	61.0	63.0
Module, interlock to curb face	H	42.8	50.9	58.8	60.5
Bumper overhang (typical)	I	2.0	2.3	2.5	2.5
Offset	J	6.3	2.7	0.5	0.0
Setback	K	11.0	8.3	5.0	0.0
Cross aisle, one-way	L	14.0	14.0	14.0	14.0
Cross aisle, two-way	—	24.0	24.0	24.0	24.0

**Notes:**

1. See Section 15-1.0 for criteria on the number and dimensions of parking spaces for disabled individuals.
2. If a special section is designated for subcompact vehicles, these stalls can be 8 ft x 15 ft for a 90° angle.
3. The designer should consider bumper overhang when placing lighting, railing, etc. Place these appurtenances beyond dimension "I" in the figure.
4. Two-way traffic may only be used with a 90° parking angle.

**PARKING STALL DIMENSIONS**

**Figure 15-2A**



**RECOMMENDED LENGTHS FOR BUS-LOADING AREAS**

**Figure 15-2B**

5. Cross Slope. To provide proper drainage, the minimum gradient on the commuter lot should be 1%. At a maximum, the gradient should not exceed 5%. If available, design the lot to direct the drainage runoff into existing drainage systems. If water impoundment cannot be avoided along pedestrian routes, bicycle routes and standing areas, provide drop inlets and underground drainage. In parking areas, design the drainage to avoid standing water. The detailed drainage design for the lot should be prepared using the Department's *Drainage Manual* to determine design frequency, pavement discharge and capacity of drainage inlets.
6. Pavement Design. A typical pavement design for a commuter lot is 2 to 3 in of bituminous concrete on 10 in of subbase. Where curbs are used within the lot, they will normally be the bituminous concrete lip curbing (BCLC) type.
7. Shelters. Where a loading area for buses or trains will be provided, include a shelter in the design. The shelter should provide approximately 5.0 ft<sup>2</sup> of covered area per person. At a minimum, the shelter should provide lighting, benches and trash receptacles. Other amenities may include routing information signs and a telephone. For disabled accessibility requirements, see Section 15-1.0.
8. Lighting. Light the commuter lot for pedestrian safety and lot security. Ensure provisions are considered for location of lighting supports and power lines. Coordinate the lighting design with the Division of Traffic Engineering. All interior light standards should be protected from bumper damage.
9. Traffic Control Devices. Provide signs and pavement markings to direct drivers and pedestrians to appropriate loading zones, parking areas, bicycle facilities, disabled parking and entrances and exits. Coordinate the use of traffic control devices with the Division of Traffic Engineering.
10. Fencing. Provide fencing around the entire lot according to field conditions.
11. Landscaping. In some locations, consider landscaping to minimize the visual impact of the commuter lot. This may include providing a buffer zone around the perimeter of the lot or improving the aesthetics of the lot itself. Desirably, include a 10 to 20 ft buffer zone around the lot to accommodate vegetation screens. Also, traffic islands and parking lot separators provide suitable locations for shrubs and trees. Section 15-5.0 discusses Department policies on landscaping. Specifically for commuter lots, landscaping should include low maintenance vegetation and vegetation which does not cause visibility problems.
12. Maintenance Considerations. To minimize maintenance, the design should include a 10-ft to 20-ft snow shelf around the perimeter of the lot, at least on two sides, to provide storage space for snow removal. This area can coincide with the buffer zone around the lot, provided that the entire area is not filled with shrubs or trees. Place any fencing outside the snow shelf. Also, keep raised traffic islands to a minimum; painted islands are preferred.



## **15-3.0 BUS STOPS AND TURNOUTS**

### **15-3.01 Location**

#### **15-3.01.01 Bus Stops**

If local bus routes are located on an urban or suburban highway, the designer should consider their impact on normal traffic operations. The stop-and-go pattern of local buses will disrupt traffic flow, but certain measures can minimize the disruption. The location of bus stops is particularly important. These are determined not only by convenience to patrons, but also by the design and operational characteristics of the highway and the roadside environment. If the bus must make a left-turn, for example, do not locate a bus stop in the block preceding the left turn.

Some considerations in selecting an appropriate bus-stop location are listed below:

1. Far-Side Stops. The far side of at-grade intersections is generally superior to near-side or mid-block bus stops. Far-side stops produce fewer impediments to through traffic and right-turning traffic; they do not interfere as much with corner sight distance; and they lend themselves better to bus turnouts.
2. Near-Side Stops. Near-side stops allow easier vehicle re-entry into the traffic stream where curb parking is allowed, and they can increase street capacity. At intersections where there is a high volume of right-turning vehicles, near-side stops can result in traffic conflicts and should be avoided. However, near-side stops must be used where the bus will make a right turn at the intersection.
3. Mid-Block Stops. Mid-block bus stops may be advantageous where the distance between intersections is large or where there is a fairly heavy and continuous transit demand throughout the block. They may be appropriate if a large traffic generator is located in mid-block. Mid-block bus stops may also be considered where right turns at an intersection are high (250 in peak hour) and far-side stops are not practical.

#### **15-3.01.02 Bus Turnouts**

Providing bus turnouts can reduce interference between buses and other traffic significantly. Turnouts remove stopped buses from the through lanes and provide a well-defined user area for bus stops. Consider turnouts under the following conditions:

1. The street provides arterial service with high-traffic speeds and volumes and high-volume bus patronage.
2. Right-of-way width is sufficient to prevent adverse impact on sidewalk pedestrian movements.
3. Curb parking is prohibited, at least during peak hours.
4. During peak-hour traffic, there are at least 500 vehicles per hour in the curb lane.

5. There are at least 100 buses per day and at least 10 to 15 buses during the peak hour.
6. The average bus dwell time generally exceeds 10 seconds per stop.
7. At locations where specially equipped buses are used to load and unload disabled individuals.

## 15-3.02 Design

### 15-3.02.01 Bus Stops

Figure 15-3A provides the recommended distances for the prohibition of on-street parking near bus stops. Where articulated buses are expected to use these stops, add an additional 20 ft to these distances. Provide an additional 50 ft of length for each additional bus expected to stop simultaneously at any given bus stop area. This allows for the length of the extra bus (i.e., 40 ft) plus 6 ft between buses.

### 15-3.02.02 Bus Turnouts

The following design criteria will apply:

1. The bus turnout should be 10 ft to 12 ft wide.
2. The full-width area of the turnout should be at least 50 ft long. Where articulated buses are expected, the turnout should be 70 ft. For a two-bus turnout, add 50 ft.
3. Figure 15-3B illustrates the design details for bus turnouts.

### 15-3.02.03 Bus Stop Pads

All new bus stops that are constructed for use with lifts or ramps must meet the disabled accessibility criteria set forth in Section 15-1.0.

### 15-3.02.04 Bus Shelters

Provide shelters at all major bus stops (more than 100 boarding or transferring passengers per day). Also, provide shelters at stops that primarily serve the elderly and disabled individuals (e.g., retirement homes, hospitals). Benches are also desirable at these locations. The designer should consider the following in the design of bus shelters:

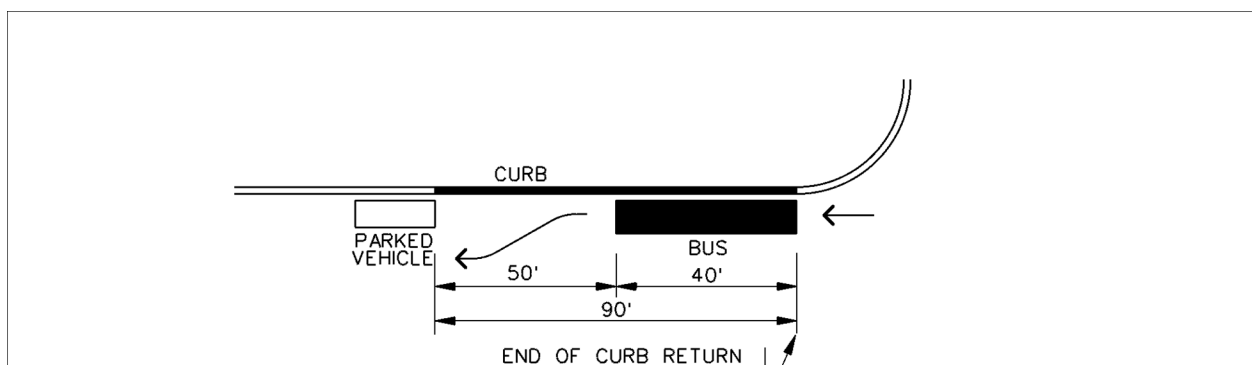

\* Provide an additional 50 ft of length for each additional bus expected to stop simultaneously.

**ON-STREET BUS STOPS**

**Figure 15-3A**

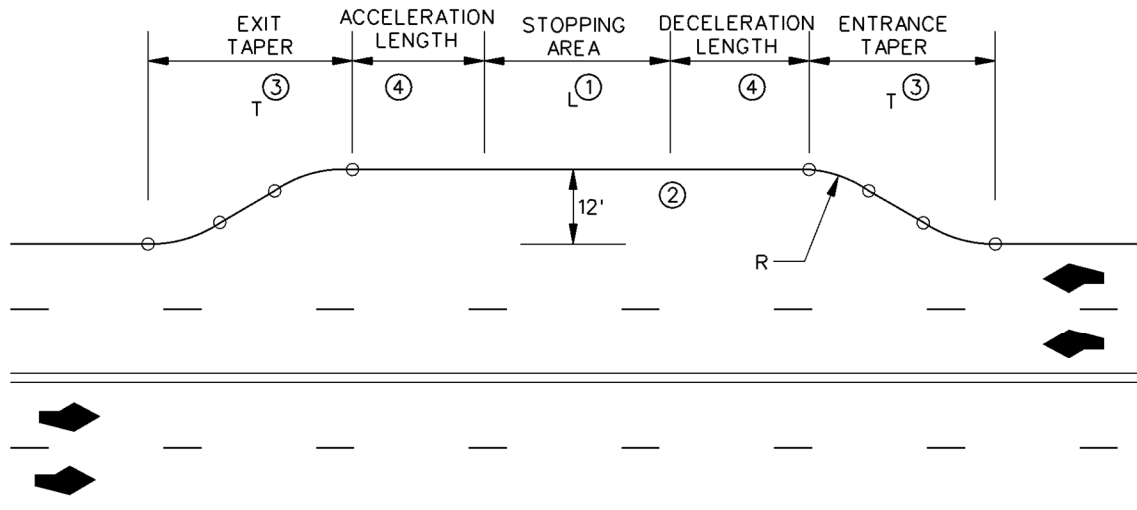

Notes:

- ① Stopping area length consists of 50 ft for each standard 40 ft bus and 70 ft for each 60 ft articulated bus expected to be at the stop simultaneously.
- ② Bus turnout width is desirably 12 ft. For posted speeds under 30 mph, a 10 ft minimum bay width is acceptable.
- ③ Suggested taper lengths are listed below. A minimum taper of 5:1 may be used for an entrance taper from an arterial street for a bus turnout while the merging or re-entry taper should not be sharper than 3:1. As an alternative, short horizontal curves (100-ft radius) may be used on the entry end and 50-ft to 100-ft curves on the re-entry end. Where a turnout is located at a far-side or near-side location, the cross street area can be assumed to fulfill the need for the exit or entry area, whichever applies.
- ④ The minimum design for a bus turnout does not include acceleration or deceleration lengths. Recommended acceleration and deceleration lengths are listed below.

Design Speed	Entering Speed*	Acceleration Lengths	Deceleration Lengths **	Suggested Taper Lengths
US CUSTOMARY				
35 mph	25 mph	250 ft	185 ft	170 ft
40 mph	30 mph	400 ft	265 ft	190 ft
45 mph	35 mph	700 ft	360 ft	210 ft
50 mph	40 mph	975 ft	470 ft	230 ft

\* Desirably, the bus speed at the end of taper should be within 10 mph of the design speed of the traveled way.

\*\* Based on a 2.5 mph/sec deceleration rate.

**BUS TURNOUT DESIGN**

**Figure 15-3B**



1. Visibility. To enhance passenger safety, the shelter sides should provide the maximum transparency as practical. In addition, do not place shelters so that it limits the general public's view of the shelter interior.
2. Selection. Contact the local transit agency to determine if they use a standardized shelter design.
3. Appearance. Shelters should be pleasing and blend with their surroundings. Shelters should also be clearly identified with "bus logo" symbols to discourage non-patron use.
4. Disabled Accessibility. Design new bus shelters to meet the accessibility criteria presented in Section 15-1.0.
5. Placement. Do not place shelters where they will restrict vehicular sight distance, pedestrian flow or disabled accessibility. It should also be placed so that waste and debris are not allowed to accumulate around the shelter.
6. Responsibility. The local transit agency is responsible for providing and maintaining the shelter.
7. Capacity. The maximum shelter size is based upon the maximum expected passenger accumulation at a bus stop between bus runs. This determination should be coordinated with the Bureau of Public Transportation. The designer can assume approximately 5.0 ft<sup>2</sup> per person to determine the appropriate shelter size. See Section 15-1.0 for minimum disabled accessibility requirements.



## 15-4.0 BIKEWAYS

The majority of bicycling will take place on public roads with no dedicated space for bicyclists. Bicyclists can be expected to ride on almost all roadways. Sometimes they use sidewalks as joint bicycle and pedestrian facilities, unless such usage is prohibited by local ordinance. This Section primarily provides information on the development of new facilities to enhance and encourage safe bicycle travel.

### 15-4.01 Bikeway Classifications

The Department has adopted the nomenclature used by AASHTO for bikeway classifications. The following definitions will apply:

1. Bikeway. Any road, path or way which in some manner is specifically designated as being open to bicycle travel, regardless of whether such facilities are designated for the exclusive use of bicycles or are to be shared with other transportation modes.
2. Shared Roadway. Any roadway upon which a bicycle lane is not designated and which may be legally used by bicycles regardless of whether such facility is specifically designated as a bikeway.
3. Bicycle Path. A bikeway physically separated from motorized vehicular traffic by an open space or barrier and either within the highway right-of-way or within an independent right-of-way. Bicycle paths may assume different forms, as conditions warrant. They may be two-direction, multilane facilities or, where the path would parallel a roadway with limited right-of-way, a single lane on both sides of the road.
4. Bicycle Lane. A portion of a roadway that has been designated by striping, signing and pavement markings for the preferential or exclusive use of bicyclists. It is distinguished from the traveled way portion of the roadway by a physical or symbolic barrier. Bicycle lanes may also assume varying forms but may generally be included in one of the following categories:
  - a. bicycle lane between parking lane and traveled way; or
  - b. bicycle lane between roadway edge and traveled way, where parking is prohibited.

### 15-4.02 Warrants

Each type of facility has its own merits and disadvantages. Care must be exercised in choosing the appropriate type of facility for a given situation. Each route is unique and must be judged on its individual conditions. The *Connecticut Statewide Bicycle and Pedestrian Transportation Plan* and *AASHTO Guide for the Development of Bicycle Facilities* provide additional guidance on the selection of bikeways.

**15-4.03      Bikeway Design Elements**

For design details of bicycle facilities, the designer is referred to the Connecticut Statewide Bicycle and Pedestrian Transportation Plan and the AASHTO *Guide for the Development of Bicycle Facilities*.

## 15-5.0 LANDSCAPING

Roadside landscaping can greatly enhance the aesthetic value of a highway. Consider landscaping treatments early in the project development so that they can be easily and inexpensively incorporated into the project design. Landscaping will be considered on a project-by-project assessment. The designer should also reference the AASHTO *A Guide for Transportation Landscape and Environmental Design* for more information on landscaping. The Department's landscaping staff within the Office of Engineering will determine the proper landscaping treatment for each project.

### 15-5.01 General Benefits

Roadside landscaping can be designed advantageously to yield several benefits. The most important objective is to fit the highway naturally into the existing terrain. Retain the existing landscape to the maximum extent practical. Following is a brief discussion of the benefits of proper landscaping:

1. Aesthetics. Gentle slopes, mountains, parks, bodies of water, and vegetation have an obvious aesthetic appeal to the highway user. Landscaping techniques can be used effectively to enhance the view from the highway. The designer should reference the FHWA publication *Visual Impact Assessment for Highway Projects* for more information.

In rural areas, the landscaping should be natural and eliminate construction scars. The planting shape and spacing should be irregular to avoid a cosmetic appearance.

In urban areas, the smaller details of the landscape predominate and plantings become more formal. The interaction between the occupants of slow-moving vehicles and pedestrians with the landscape determines the scale of the aesthetic details. In some cases, the designer may be able to provide walking areas, small parks, etc. Landscaping should be pleasant, neat, sometimes ornamental and require low maintenance.

2. Erosion. Landscaping and erosion control are interrelated. Flat and rounded slopes and vegetation serve to both prevent erosion and provide aesthetic value.
3. Screening. Landscaping can be used to effectively screen headlight glare and unsightly roadside views. It also can be used as a buffer for existing residences.
4. Maintenance. Landscaping decisions will greatly affect roadside maintenance. Maintenance activities for mowing, fertilizing and using herbicides should be considered when designing the roadside landscape.
5. Safety. The effects on roadside safety should be reflected in the landscape treatment; see Chapter Thirteen. Flat, rounded slopes are both safer and more aesthetic. Unless protected by guiderail, plant major trees outside of the clear zone; see Section 13-2.0. Shrubs and minor trees may be planted closer to the traveled way where traffic delineation

will be required. Landscaping should not be placed in ramp gore areas, near intersections or turnouts that would restrict sight distances.

## **15-5.02      Landscaping Policies**

### **15-5.02.01    Planting Policy**

All projects which include planting must have a special provision which requires the contractor to be responsible for a plant establishment period of one growing season. The time begins after all plant materials in the contract have been planted.

### **15-5.02.02    Protection of Existing Vegetation**

The Department's general policy is that, wherever practical, trees and other landscaping features will not be removed on highway projects. This objective, however, must be compatible with other considerations (e.g., roadside safety, geometric design, utilities, terrain, public acceptance, economics). The Department has placed a special emphasis on saving valuable shade trees, wherever practical. The plans should clearly designate all shade trees that will be saved.

### **15-5.02.03    Turf Establishment, Topsoil and Sodding**

In areas disturbed by construction work, the designer must ensure that the turf is reestablished. Turf establishment refers to the reseeded of disturbed areas. The designer should use the guidance in the following comments to determine the appropriate turf establishment, depending upon individual site conditions. In addition, the turf placement must reflect the requirements of the Department's *Standard Specifications for Roads, Bridges and Incidental Construction*.

1.    Topsoil. Place topsoil to a depth of 6 in at all designated locations. The following topsoil requirements apply to the indicated location:
  - a.    Freeways. Place topsoil on all fill slopes 1:5 and flatter to a width not to exceed 20 ft from the edge of shoulder. Where abutting properties are subject to intensive mowing or in other special cases, include topsoil for all areas disturbed by construction.
  - b.    All Other Highways. Topsoil should normally not be required at locations involving abutting undeveloped properties. In areas where sodding is required, include topsoil in accordance with the Department's specifications.
  - c.    Medians. In general, median areas should be topsoiled to a width not to exceed 20 ft from the edge of shoulders on both sides. Where the width remaining is 20 ft or less, include topsoil for the entire median.
  - d.    Gore Areas. Place topsoil from the end of the gore area pavement (10 ft width) at the bifurcation for a distance not to exceed 75 ft parallel to the highway for the full width between the roadways.

- e. Bridge Abutments. For structures crossing roadways, place topsoil on the approach slopes for a distance not to exceed 50 ft. This coverage is to extend from the top of slope to the toe of slope.
  - f. Other Locations. Place topsoil at any other special locations, especially in interchange areas as designated by qualified personnel.
2. Planting of Grass. Lime, seed, fertilize and mulch all areas disturbed by construction, except exposed rock surfaces and areas to be sodded, regardless of the presence or absence of topsoil. Estimate the amount of fertilizing, seeding, mulching and liming for such areas. Estimate liming at the rate of one ton per acre.
  3. Sodding. Where developed properties and/or areas of intensive mowing about the highway project (e.g., lawns of residences, hospitals, public parks), sod all adjacent areas disturbed by construction in accordance with the Department's specifications.

In addition to the above guidance for turf establishment, the designer must ensure that the project plans and quantity estimates adhere to certain criteria. The designer will determine the type of turf establishment and the areas within the construction limits that will be treated. These must be designated on the project plans. On this basis, the Office of Engineering, either by its own forces or with consulting engineers, will compute the quantities and prepare the necessary plans, special provisions and estimates for inclusion in the construction plans. In addition, the following will apply:

1. Project Plans. The requirements of turf establishment should be indicated on the plans according to the size of the project. On minor projects, these requirements generally should be reported on the detailed estimate sheet by stations. On larger projects that require Index Plans, indicate the turf establishment on these sheets where this information will not seriously conflict with the data normally reported thereon. Otherwise, prepare supplemental Index Plan sheets showing turfing requirements and include them in the contract drawings.
2. Quantity Estimates. Before preparing quantity estimates, the designer should schedule a review of the proposed turf establishment requirements with the qualified personnel in the Office of Engineering. When estimating quantities of work for turf establishment, add 10 ft to the measured length of slope to minimize the possibility of overruns. Do not indicate this additional slope length on the plans. When estimating topsoil and sodding quantities, use the measured length of the cross section and not the projected length from the plan sheets.





## **15-6.0 FENCING**

Fencing should be provided along high-speed highways to protect the driver from unexpected intrusions from outside of the right-of-way line. Fencing prevents unauthorized and unsafe entry to the highway by vehicles, pedestrians or animals. It also prevents objects from being dropped or thrown from highway overpasses.

Except where warranted for highway reasons, fencing is normally the responsibility of the abutting property owner. They may be necessary for retaining livestock, discouraging trespassing, defining property boundaries, or otherwise to keep land use activities within bounds. If private fences are impacted by a highway project, their relocation or disposition is usually reconciled as part of the property agreement.

### **15-6.01 General Warrants and Location**

In general, the following will apply:

1. Warrants. Fencing is warranted to:
  - a. keep animals off the highway,
  - b. keep children or pedestrians off the highway,
  - c. protect children and pedestrians from a precipitous slope or drop off,
  - d. prevent vehicles and people from entering or leaving the highway at unauthorized places, and
  - e. prevent stones or other objects from being dropped or thrown from highway overpasses onto vehicles passing underneath.
2. Location. Fencing is typically provided along access-controlled facilities; near schools, playgrounds and parks; near livestock areas; on some bridges; and between frontage roads and the highway mainline. Fencing is usually erected parallel to the highway centerline. Where taking lines are irregular, the fencing should still be basically parallel to the highway, provided the fencing is within the highway right-of-way. The fence line should be reasonably close to the right-of-way line; however, deviations are acceptable where existing obstructions (e.g., hedges) would have to be destroyed.

Occasionally, the fence line will intersect a stream. The fencing may cross the stream without deviation, or it may be angled in and terminated at the bridge abutment or culvert wing wall. The treatment will vary according to the size of the stream.

### **15-6.02 Freeways**

The following will apply to fencing along freeways:

1. Warrants. Provide continuous fencing on either the right-of-way or access-control line. However, engineering judgment should dictate exceptions. In addition, where a noise barrier exists, fencing may not be required to effectively preserve access control.
2. Location. Construct controlled-access fencing on State right-of-way with the face of the fencing toward the abutting property. It will be maintained by the State, delineated on contract plans and determined in the overall development of the design.
3. Type. The following will apply:
  - a. Chain link fence is generally used on freeways; see the *Connecticut Standard Drawings*. Use 6-ft high chain link fence in areas having a high concentration of children (e.g., schools, churches, playgrounds). Use 5-ft high chain link fence in areas adjacent to housing developments, single-family homes, parks, reservoirs, commercial and industrial properties, etc. During design and construction, the designer must consider impending development of this type adjacent to the highway, and chain link fence of the appropriate height may be installed to preclude replacement a short time later. In rural areas where little development is planned, wire fencing on steel posts may be used.
  - b. Normally, a coil spring tension wire is used at the top of a chain link fence. However, in areas where the fence will be subject to abuse and where there is little likelihood that it will be struck by a vehicle, a top rail may be used to provide rigidity to the installation.
  - c. Provide gates with locks, where required, to allow access by maintenance forces.
4. Payments. Fencing payments (for fencing along the right-of-way boundary) will not be made in right-of-way settlements. The Office of Right of Way will note on property agreements that fencing will be installed by the State wherever delineated on the plans.

### **15-6.03      Unlimited Access Highways**

The following will apply to fencing along unlimited access highways:

1. Location. Posts will be on the land of the abutting owner, and the face of the fencing is usually on the highway line. If by agreement with the property owner, the face of the fence may be on the other side of post. For stone walls, the face will be on the highway line, and the wall on the land of the abutting owner. The abutting owner is responsible for maintenance of all fences on unlimited access highways. The designer will include an unassigned length in the contract estimate.

2. Type. Fencing may be:
  - a. wire fencing on wood posts (steel posts as required for ledge),
  - b. stone wall or farm wall fencing, or
  - c. chain link fence.

Fencing locations and types will be determined by agreement between the property owner and Department.

#### **15-6.04      Fencing and Railings on Highway Structures**

##### **15-6.04.01    General**

A railing is required on all parapets less than 42 in in height. The railing will be a pedestrian railing, bicycle railing or protective fence. In addition to the following Sections, Section 12 of the *Bridge Design Manual* contains additional information on railing and fencing of highway overpasses.

Protective fencing should satisfy the aesthetic consideration of the structure and should be designed in conformance with the latest Department criteria for fencing. From a maintenance perspective, vinyl-coated chain-link fabric should be used on most bridges. Anodized aluminum fences should only be used with written approval. If protective fencing is provided, pedestrian and bicycle railings do not need to be provided.

##### **15-6.04.02    Highway Overpasses with Sidewalks**

The following will apply for highway overpasses with one or more sidewalks:

1. Protective Fencing. Protective fencing is required on both parapets. The height of the fencing above the top of the parapet will be a minimum of 60 in. The maximum size opening in the fence will be determined by the designer and will be approved by the Department. Also, the designer should investigate the need for a curved top fence.
2. Pedestrian Railing. A pedestrian railing is not required.
3. Bicycle Railing. A bicycle railing is not required.

##### **15-6.04.03    Highway Overpasses without Sidewalks**

The following will apply for highway overpasses without sidewalks:

1. Protective Fencing. Protective fencing is required on highway overpasses without sidewalks, which carry local or secondary roads over a limited access highway.

2. Pedestrian Railing. A pedestrian railing is required on both parapets for parapets less than 42 in high, unless protective fencing is provided.
3. Bicycle Railing. A bicycle railing is required on designated bicycle routes, unless protective fencing is provided.

#### 15-6.04.04 Stream and Wetland Overpasses

The following apply to stream and wetland overpasses with or without sidewalks:

1. Protective Fencing. In general, fencing is not required on highway overpasses without sidewalks, except where unusual conditions are present which affect public safety below.
2. Pedestrian Railing. A pedestrian railing is required on both parapets for parapets less than 42 in high.
3. Bicycle Railing. A bicycle railing is required on designated bicycle routes.

#### 15-6.04.05 Railroad Overpasses

The following will apply to all railroad overpasses:

1. Protective Fencing. Protective fencing is generally required on both parapets on the span over the railroad tracks. On long structures, protective fencing is required over the tracks plus a minimum of 25 ft beyond the outside of track, measured perpendicular to the track.

The following criteria pertain to the height of the protective fence above the top of the parapet and the maximum size of opening:

Location	Height (in)	Maximum Size Opening
Non-Electrified Zone	60 (min.)	0.5 in or as approved by the Department
Electrified Zone	60 (min.)*	Solid Barrier Required

\* Use an 84-in high protective fence with a curved top at all sidewalks.

2. Pedestrian Railing. A pedestrian railing is not required where a protective fence is provided. However on long structures, provide pedestrian railing on both parapets outside the limits for protective fencing as defined in Comment #1.
3. Bicycle Railing. A bicycle railing is not required where a protective fence is provided. However on long structures, provide bicycle railing outside the limits for protective fencing as defined in Comment #1 on designated bicycle routes.

**15-6.04.06 Pedestrian Overpasses**

Provide complete enclosures for pedestrian structures crossing over highways and railroads. The need for protective fencing on pedestrian structures at streams or woodland crossings will be determined on a case-by-case basis.

**15-6.04.07 Walls**

The following will apply to fencing and railing on structures other than overpasses:

1. U-Type Wingwalls. The warrants for pedestrian railing, bicycle railing or protective fencing on U-type wingwalls are the same as for overpasses.
2. Retaining Walls Adjacent to Traffic. A pedestrian railing is generally required for retaining walls with parapets less than 42 in high and adjacent to traffic. Retaining walls along a sidewalk generally will follow the requirements of Section 15-6.04.02.
3. Retaining Walls not Adjacent to Traffic. A pedestrian railing or protective fencing is generally required for walls that are not adjacent to traffic or for a sidewalk where the vertical drop off is greater than 60 in.
4. Concrete Barrier Walls. Pedestrian railing, bicycle railing and protective fencing are generally not required on concrete barrier walls.

**15-6.04.08 Railing and Fencing at Lighting and Signing Standards**

Where lighting and signing standards are located on structures, the railing or fencing will be continuous at these locations. Locate the lighting and signing standards outside of the continuous railing or fence. Design the protective fencing with removable panels or other means to provide access to the handhole locations. Where practical, do not locate lighting and signing standards on a span over a railroad-electrified zone.

**15-6.05 Fencing Delineation on Contract Plans**

Delineate all fencing requirements on contract plans. Show station references where needed for clarity. Where a fence is erected or replaced between a State highway and agricultural property, payment will be according to the provisions of the *Connecticut General Statutes*, Section 47-46 of Title 47, Chapter 823.



## **15-7.0 NOISE BARRIER IMPACTS**

Noise barriers are erected to reduce the environmental impact on areas adjacent to a highway. They are designed to reduce the noise level of traffic adjacent to existing buildings to an acceptable level as determined by Federal guidelines. The Office of Planning is responsible for selection, location and design as related to the environment. However, the Office of Engineering must evaluate the impacts of the noise barrier on the highway design. This Section discusses those impacts.

### **15-7.01 Roadside Safety**

Section 13-2.0 provides the Department's design criteria for clear zones. If practical, noise barrier walls should be placed outside of the applicable clear zone value. Otherwise, guiderail should be considered to shield the wall from run-off-the-road vehicles. The designer must ensure that adequate deflection distance is available between the guiderail and noise barrier. Chapter Thirteen discusses the design of guiderail in detail.

If the noise barrier is a mound of dirt, the toe of the barrier should be traversable by a run-off-the-road vehicle.

### **15-7.02 Sight Distance**

For at-grade intersections, noise barriers should not be located in the triangle required for corner sight distance. Section 11-2.0 provides the criteria to determine the required sight distance triangle.

Noise barriers can also impact sight distance along horizontal curves. Section 8-2.04 provides the detailed criteria to determine the middle ordinate value that will yield the necessary sight distance. The location of the noise barrier must be outside of this value.

### **15-7.03 Right-of-Way**

The noise barrier must be located within the highway right-of-way.

### **15-7.04 Interference with Roadside Appurtenances**

A noise barrier may be constructed on a new or on an existing highway. Its proposed location could interfere with proposed or existing roadside features, including signs, sign supports, utilities and illumination facilities. The designer must determine if these features are impacted by the noise barrier and must coordinate with the applicable Department units to resolve any conflicts.

**15-7.05      Additional Design Criteria**

In addition to the criteria in the previous Sections, the designer should also consider the following:

1.     Standard Drawings. The *Connecticut Standard Drawings* provide additional details on noise walls used by the Department.
2.     Plans. All approved noise wall options will be included in the plans, unless there is a specific noise design criteria that would suggest one design over another.
3.     Bridges. Bridge designs will not include masonry walls, or other walls with similar weight or attachment problems, which would result in additional structural loading problems.
4.     Transitions. The Contractor will be responsible for any transition details that are necessary to properly interface a structural noise wall with a ground-mounted wall of a different type, subject to the approval of the Engineer.
5.     Earth Berms. Where field conditions and right-of-way permit, earth berms will be the primary design for noise barriers.
6.     Wood Walls. The designer will design the structure mounted noise barrier walls, which will include all of the wood noise barrier walls in the *Connecticut Standard Drawings*. For other than the wood noise barrier walls, the designer will invite the manufacturer to design the wall for each structure, unless the manufacturer has requested the Department not to have its wall included in structure designs.
7.     Design Criteria. The designer will be responsible for obtaining the latest criteria for noise barrier walls immediately before submitting the project for processing. This will ensure that all of the latest criteria will be included. Where a structure is involved, the structural designer will obtain the latest criteria for noise barrier walls immediately before designing the structure to ensure that the structure is designed to accommodate all of the suitable types of walls. The structural designer is also responsible for all modifications to the design of the applicable standard walls which may be required to ensure their suitability for use as a structure mounted noise barrier wall and for the connection of the wall to the structure.



**15-8.0 ILLUMINATION (CUTOFF LIGHTING)**

For roadway illumination on State primary highways, the lighting shall be designed utilizing fixtures that are classified as "full cutoff" type. The use of "full cutoff" light fixtures will not be required if an engineering study is conducted and determines that highway safety will be compromised, the cost of the lighting installation or operation will be substantially increased, or that its use will violate any applicable Federal laws.



**15-9.0 REFERENCES**

1. *Accessibility Guidelines for Building and Facilities*, U.S. Architectural and Transportation Barriers Compliance Board, 1991, 1994.
2. FHWA-IP-84-6, *Guidelines for Making Pedestrian Crossing Structures Accessible*, August, 1984.
3. *A Policy on Geometric Design of Highways and Streets*, AASHTO, 2001.
4. *Guide for the Design of Park-and-Ride Facilities*, AASHTO, 1992.
5. *Traffic Engineering Handbook*, Institute of Transportation Engineers, 1999.
6. *The Location and Design of Bus Transfer Facilities*, Institute of Transportation Engineers, 1992.
7. *Guidelines for the Location and Design of Bus Stops*, TCRP Report 19, Transportation Research Board, 1996.
8. *Guide for the Development of Bicycle Facilities*, AASHTO, 1999.
9. *Visual Impact Assessment for Highway Projects*, FHWA, 1981.
10. *A Guide for Transportation Landscape and Environmental Design*, AASHTO, 1991.
11. *An Informational Guide on Fencing Controlled Access Highways*, AASHTO, 1990.



**APPENDIX A**ADA Resources

1. [FHWA Accessibility Resource Library](#)
2. [Accessible Public Rights-of-Way Planning and Design for Alterations](#) (Special Report, 2007)
3. FHWA-Designing Sidewalks and Trails for Access: [Part 2, Best Practices Design Guide \(2001\)](#)
4. [FHWA Public Rights-of-Way Access Advisory Memorandum](#) (January 2006)
5. [ADAAG \(2004\)](#)
6. Access Board [Draft Public Rights-of-Way Accessibility Guidelines](#)



# GLOSSARY

## General

1. Access Control. The condition where the public authority fully or partially controls the right of abutting owners to have access to and from the public highway.
2. Accessible Route. An accessible route is a continuous, unobstructed path connecting all accessible elements and spaces in a building, facility or site. A “site” is defined as a parcel of land bounded by a property line or a designated portion of a public right-of-way. A “facility” is defined as all or any portion of buildings, structures, site improvements, complexes, equipment, roads, walks, passageways, parking lots, or other real or personal property on a site.
3. Arterials. Highways that are characterized by a capacity to quickly move relatively large volumes of traffic but often provide limited access to abutting properties. The arterial system typically provides for high travel speeds and the longest trip movements.
4. Average Running Speed. The distance summation for all vehicles over a specified section of highway divided by the running time summation for all vehicles.
5. Average Travel Speed. The distance summation for all vehicles divided by the total time summation for all vehicles.
6. Bicycle Lane. A portion of a roadway that has been designated by striping, signing and pavement markings for the preferential or exclusive use of bicyclists.
7. Bicycle Path. A bikeway physically separated from motorized vehicular traffic by an open space or barrier and either within the highway right-of-way or within an independent right-of-way.
8. Bikeway. Any road, path or way which in some manner is specifically designated as being open to bicycle travel, regardless of whether such facilities are designated for the exclusive use of bicycles or will be shared with other transportation modes.
9. Bridge. A structure, including supports, erected over a depression or obstruction, such as water, a highway, or a railway, and having a track or passageway for carrying traffic or other moving loads, and having an opening measured along the center of the roadway of more than 20 ft between undercopings of abutments or spring lines or arches or extreme ends of openings for multiple boxes; may include multiple pipes where the clear distance between openings is less than half of the smaller contiguous opening.
10. Bridge Roadway Width. The clear width of the structure measured at right angles to the center of the roadway between the bottom of curbs or, if curbs are not used, between the inner faces of parapet or railing.

11. Bridge to Remain in Place. An “existing bridge to remain in place” refers to any bridge work which does not require the total replacement of both the substructure and superstructure.
12. Built-up. An urban classification that refers to the central business district within an urbanized or small urban area. The roadside development has a high density and is often commercial. Access to property is the primary function of the road network in built-up areas; the average driver rarely passes through a built-up area for mobility purposes. Pedestrian considerations may be as important as vehicular considerations, especially at intersections. Right-of-way for roadway improvements is usually not available.
13. Bus. A heavy vehicle involved in the transport of passengers on a for-hire, charter or franchised transit basis.
14. Collectors. Highways that are characterized by a roughly even distribution of their access and mobility functions.
15. Control by Regulation. Where the public authority determines where private interests may have access to and from the public road system.
16. Controlling Design Criteria. A list of geometric criteria requiring FHWA or ConnDOT approval if they are not met or exceeded.
17. Crosswalk. A marked lane for passage of pedestrians, bicycles, etc., traffic across a road or street.
18. Curb Cuts or Curb Ramps. The treatment at intersections for gradually lowering the elevation of sidewalks with curbs to the elevation of the street surface. The term “curb ramps” is used in this Manual.
19. Department. Connecticut Department of Transportation.
20. Design Exception. The process of receiving approval from the FHWA or Department for using design criteria which does not meet the criteria set forth in this Manual.
21. Design Speed. The selected speed used to determine the various geometric design features of the roadway.
22. Divided Highway. A highway with separated roadways for traffic moving in opposite directions.
23. 85th-Percentile Speed. The speed below which 85 percent of vehicles travel on a given highway.
24. Expressways. Divided highway facilities that are characterized by full or partial control of access.



25. Freeways. The highest level of arterial. Full control of access, high design speeds, and a high level of driver comfort and safety characterize these facilities.
26. Frontage Road. A road constructed adjacent and parallel to but separated from the highway for service to abutting property and for control of access.
27. Full Control (Access Controlled). Full control of access is achieved by giving priority to through traffic by providing access only at grade separation interchanges with selected public roads. No at-grade crossings or approaches are allowed. The freeway is the common term used for this type of highway. Full control of access maximizes the capacity, safety and vehicular speeds on the freeway.
28. Grade Separation. A crossing of two highways, or a highway and a railroad, at different levels.
29. High Speed. For geometric design applications, high speed is defined as greater than 45 mph.
30. Highway, Street or Road. A general term denoting a public way for purposes of vehicular travel, including the entire area within the right of way. (Recommended usage: in urban areas – highway or street, in rural areas – highway or road).
31. Intermediate. As urban classification that falls between suburban and built-up. The surrounding environment may be either residential, commercial or industrial or some combination of these. On roads and streets in intermediate areas, the extent of roadside development will have a significant impact on the selected speeds of drivers. Pedestrian activity is a significant design consideration, and sidewalks and crosswalks at intersections are common. The available right-of-way will often restrict the practical extent of roadway improvements.
32. Interchange. A system of interconnecting roadways in conjunction with one or more grade separations, providing for the movement of traffic between two or more roadways on different levels.
33. Intersection. The general area where two or more highways join or cross, within which are included the roadway and roadside facilities for traffic movements in that area.
34. Local Roads and Streets. All public roads and streets not classified as arterials or collectors.
35. Low-Moderate Density. A rural classification where the roadside development has increased to a level where the prudent driver will instinctively reduce his/her speed as compared to an open roadway. The driver must be more alert to the possibility of entering and exiting vehicles, but he/she is still able to maintain a relatively high travel speed. The estimated number of access points will average between 15 and 30 per mile per side. Right-of-way may be difficult to attain.

36. Low Speed. For geometric design applications, low speed is defined as less than or equal to 45 mph.
37. Major Strategic Highway Network Connectors. Highways that provide access between major military installations and highways that are part of the Strategic Highway Network.
38. Moderate/High Density. A rural classification where the roadside development has increased to a level that is comparable to a suburban area within an urbanized boundary. The extent of the development will have a significant impact on the selected travel speed of a prudent driver. Exiting and entering vehicles are frequent, and traffic signals are typical at major intersections. The estimated number of access points will average greater than 30 per mile per side. Right-of-way is usually quite difficult to attain.
39. National Highway System (NHS). A system of highways determined to have the greatest national importance to transportation, commerce and defense in the United States. It consists of the Interstate highway system, selected other principal arterials, and other facilities which meet the requirements of one of the subsystems within the NHS.
40. Noise Barrier. A structure designed to reduce the noise level of traffic adjacent to an existing building to an acceptable level.
41. Open. A rural classification that fits the traditional concept of a rural area. The driver has almost total freedom of movement and is generally not affected by occasional access points along the highway or road. For the purpose of determining the classification, access points will average less than 15 per mile per side. Right-of-way is usually not a problem.
42. Operating Speed. The highest overall speed at which a driver can safely travel a given highway under favorable weather conditions and prevailing traffic conditions while at no time exceeding the design speed.
43. Overpass. A grade separation where the subject highway passes over an intersecting highway or railroad.
44. Partial Control. The authority to control access is exercised to give preference to through traffic to a degree that, in addition to access connections with selected frontage or local roads, there may be some crossing at grade and some private approach connections.
45. Posted Speed Limit. The recommended speed limit for a highway as determined by engineering and traffic investigations.
46. Ramp. A short roadway connecting two or more legs of an intersection or connecting a frontage road and main lane of a highway.

47. Recreational Vehicle. A heavy vehicle, generally operated by a private motorist, engaged in the transportation of recreational equipment or facilities; examples include campers, boat trailers, motorcycle trailers, etc.
48. Right-of-Way (R/W). A general term denoting land, property, or interest therein, usually a strip acquired for or devoted to a highway use.
49. Roadway. (General) The portion of a highway including shoulders, for vehicular use. A divided highway has two or more roadways. (Construction) The portion of a highway within limits of construction.
50. Running Speed. The average speed of a vehicle over a specified section of highway. It is equal to the distance traveled divided by the running time (the time the vehicle is in motion).
51. Rural Areas. Those places outside the boundaries of urban areas.
52. Shared Roadway. Any roadway upon which a bicycle lane is not designated and which may be legally used by bicycles regardless of whether such facility is specifically designated as a bikeway.
53. Signalized Intersection. An intersection where all legs are controlled by a traffic signal.
54. State Highway System. The highway system under the jurisdiction of the Connecticut Department of Transportation consisting of those inter-municipality and Interstate highways, including their extensions through incorporated areas.
55. Stopped Controlled Intersection. An intersection where one or more legs are controlled by a stop sign.
56. Strategic Highway Network. This is a network of highways that are important to the United States strategic defense policy and which provide defense access, continuity and emergency capabilities for defense purposes.
57. Suburban. An urban classification that is usually located at the fringes of urbanized and small urban areas. The predominant character of the surrounding environment is usually residential, but it will also include a considerable number of commercial establishments. There may also be a few industrial parks in suburban areas. On suburban roads and streets, drivers usually have a significant degree of freedom, but nonetheless, they must also devote some of their attention to entering and exiting vehicles. Roadside development is characterized by low to moderate density. Pedestrian activity may or may not be a significant design factor. Right-of-way is often available for roadway improvements.
58. Surface Transportation Program (STP). A block-grant program that provides Federal-aid funds for any public road not functionally classified as a minor rural collector or a local road or street.

59. Truck. A heavy vehicle engaged primarily in the transport of goods and materials, or in the delivery of services other than public transportation.
60. Underpass. A grade separation where the subject highway passes under an intersecting highway or railroad.
61. Urban Areas. Those places within boundaries set by the responsible State and local officials having a population of 5000 or more.

### **Qualifying Words**

1. Acceptable. Design criteria that do not meet values in the upper range, but yet are considered to be reasonable and safe for design purposes.
2. Criteria. A term typically used to apply to design values, usually with no suggestion on the criticality of the design value. Because of its basically neutral implication, this Manual frequently uses “criteria” to refer to the design values presented.
3. Desirable, Preferred. An indication that the designer should make every reasonable effort to meet the criteria and should only use a “lesser” design after due consideration of the “better” design.
4. Guideline. Indicating a design value that establishes an approximate threshold that should be met if considered practical.
5. Ideal. Indicating a standard of perfection (e.g., traffic capacity under “ideal” conditions).
6. Insignificant, Minor. Indicating that the consequences from a given action are relatively small and not an important factor in the decision-making for road design.
7. May, Could, Can, Suggest, Consider. A permissive condition. Designers are allowed to apply individual judgment and discretion to the criteria when presented in this context. The decision will be based on a case-by-case assessment.
8. Minimum, Maximum. Representative of generally accepted limits within the design community, but not necessarily suggesting that these limits are inviolable. However, where the criteria presented in this context will not be met, the designer will in many cases need approval.
9. Policy. Indicating ConnDOT practice that the Department generally expects the designer to follow, unless otherwise justified.
10. Possible. Indicating that which can be accomplished. Because of its rather restrictive implication, this word will not be used in this Manual for the application of design criteria.
11. Practical, Feasible, Cost-effective, Reasonable. Advising the designer that the decision to apply the design criteria should be based on a subjective analysis of the anticipated

- benefits and costs associated with the impacts of the decision. No formal analysis (e.g., cost-effectiveness analysis) is intended, unless otherwise stated.
12. Shall, Require, Will, Must. A mandatory condition. Designers are obligated to adhere to the criteria and applications presented in this context or to perform the evaluation indicated. For the application of geometric design criteria, this Manual limits the use of these words.
  13. Should, Recommend. An advisory condition. Designers are strongly encouraged to follow the criteria and guidance presented in this context, unless there is reasonable justification not to do so.
  14. Significant, Major. Indicating that the consequences from a given action are obvious to most observers and, in many cases, can be readily measured.
  15. Standard. Indicating a design value that cannot be violated without severe consequences. This suggestion is generally inconsistent with geometric design criteria. Therefore, “standard” will not be used in this Manual to apply to geometric design criteria.
  16. Trigger Value. The minimum geometric value at which the element should be considered for improvement.
  17. Typical. Indicating a design practice that is most often used in application and which is likely to be the “best” treatment at a given site.
  18. Warranted, Justified. Indicating that some well-accepted threshold or set of conditions has been met. As used in this Manual, “warranted” or “justified” may apply to either objective or subjective evaluations. Note that, once the warranting threshold has been met, this is an indication that the design treatment should be considered and evaluated not that the design treatment is automatically required.

### **Abbreviations**

1. AASHTO. American Association of State Highway and Transportation Officials.
2. ADA. Americans with Disabilities Act.
3. CADD. Computer-Aided Drafting and Design.
4. CBD. Central Business Districts.
5. CGS. *Connecticut General Statutes*.
6. CONNDOT. Connecticut Department of Transportation.
7. FHWA. Federal Highway Administration.

8. HCM. Highway Capacity Manual.
9. ITE. Institute of Transportation Engineers.
10. MUTCD. Manual of Uniform Traffic Control Devices.
11. NCHRP. National Cooperative Highway Research Program.
12. NHS. National Highway System.
13. OSTA. Office of the State Traffic Administration.
14. PS&E. Plans, Specifications and Estimates.
15. 3R. Resurfacing, restoration and rehabilitation.
16. R/W. Right-of-way.
17. STP. Surface Transportation Program.
18. TRB. Transportation Research Board.
19. TSM. Transportation Systems Management
20. USDOT. United States Department of Transportation.

### **Planning**

1. Average Annual Daily Traffic (AADT). The total yearly volume in both directions of travel divided by the number of days in a year.
2. Average Daily Traffic (ADT). The calculation of average traffic volumes in both directions of travel in a time period greater than one day and less than one year and divided by the number of days in that time period.
3. Capacity. The maximum number of vehicles which can reasonably be expected to traverse a point or uniform section of a road during a given time period under prevailing roadway, traffic and control conditions.
4. Categorical Exclusion (CE). A classification for projects that will not induce significant environmental impacts or foreseeable alterations in land use, planned growth, development patterns, traffic volumes, travel patterns, or natural or cultural resources.
5. Delay. The criteria performance measure on interrupted flow facilities, especially at signalized intersections. For this element, average stopped-time delay is measured, which is expressed in seconds per vehicle.

6. Density. The number of vehicles occupying a given length of lane, averaged over time. It is usually expressed as vehicles per mile.
7. Design Hourly Volume (DHV). The 1-hour volume in both directions of travel in the design year selected for determining the highway design.
8. Design Service Flow Rate. The maximum hourly vehicular volume that can pass through a highway element at the selected level of service.
9. Directional Design Hourly Volume (DDHV). The 1-hour volume in one direction of travel during the DHV.
10. Directional Distribution (D). The division, by percent, of the traffic in each direction of travel during the DHV, ADT or AADT.
11. Environmental Assessment (EA). A study to determine if the environmental impacts of a project are significant, thus requiring the preparation of an EIS.
12. Environmental Impact Statement (EIS). A document which is prepared when it has been determined that a project will have a significant impact on the environment.
13. Equivalent Single-Axle Loads (ESAL's). The summation of equivalent 18-kip single-axle loads used to combine mixed traffic to design traffic for the design period.
14. Finding of No Significant Impact (FONSI). A result of an EA that shows a project will not cause a significant impact to the environment.
15. Level of Service (LOS). A qualitative concept that has been developed to characterize acceptable degrees of congestion as perceived by motorists.
16. New Construction. Horizontal and vertical alignment construction, intersections at-grade, interchanges and bridges on new locations.
17. Peak-Hour Factor (PHF). A ratio of the total hourly volume to the maximum 15-minute rate of flow within the hour.
18. Peak-Rate of Flow. The highest equivalent hourly rate at which vehicles pass over a given point or direction of a lane or roadway during a given time interval less than one-hour, usually 15 minutes.
19. Project Scope of Work. The basic intent of the highway project which determines the overall level of highway improvement.
20. Reconstruction. Reconstruction of an existing highway mainline will typically include the addition of travel lanes, reconstruction of the existing horizontal and vertical alignment, and reconstruction of intersections, interchanges and bridges.

21. 3R. Resurfacing, restoration and rehabilitation of a non-freeway facility which is mainly on an existing highway alignment.
22. Spot Improvement. Improvements that are intended to correct an identified deficiency at an isolated location on non-freeways.
23. Traffic Composition. A factor reflecting the percentage of heavy vehicles (trucks, buses and recreational vehicles) in the traffic stream during the DHV.

### **Geometric**

1. Acceleration Lanes. An auxiliary lane used by an entering vehicle to accelerate before entering the traveled way.
2. Auxiliary Lane. The portion of the roadway adjoining the through traveled way for purposes supplementary to through traffic movement including parking, speed change, turning, storage for turning, weaving or truck climbing.
3. Axis of Rotation. The superelevation axis of rotation is the line about which the pavement is revolved to superelevate the roadway. This line will maintain the normal highway profile throughout the curve. The axis of rotation is generally located at the point of grade application.
4. Back Slope. The side slope created by the connection of the ditch bottom, upward and outward, to the natural ground.
5. Broken-Back Curves. Two closely spaced horizontal curves with deflections in the same direction and a short intervening tangent.
6. Buffer Areas. The area or strip between the roadway and a sidewalk.
7. Channelization. The moving or directing of traffic through an intersection by the use of pavement markings (including striping, raised reflectors, etc.) or raised islands.
8. Cloverleaf Interchange. An interchange with loop ramps in one or more quadrants. Full cloverleaf interchanges have loop ramps in all quadrants.
9. Collector-Distributor Roads. A set of roadways at an interchange used to eliminate the weaving and reduce the number of exit and entrance points from the main through lanes of a freeway.
10. Comfort Criteria. Criteria that is based on the comfort effect of change in vertical direction in a sag vertical curve because of the combined gravitational and centrifugal forces.
11. Compound Curves. These are a series of two or more simple curves with deflections in the same direction immediately adjacent to each other.



12. Critical Length of Grade. The maximum length of a specific upgrade on which a loaded truck can operate without an unreasonable reduction in speed.
13. Critical Parallel Slope. Slopes upon which a vehicle is likely to overturn. Under the Department's roadside criteria, slopes steeper than 1:4 and 1:4 with curbing at the top are critical.
14. Crossover Line. The lane line between any two adjacent lanes of traffic.
15. Cross Slope. The slope in the cross section view of the travel lanes, expressed as a percent based on the change in vertical compared to the change in horizontal.
16. Cross Slope Rollover. The algebraic difference between the slope of the through lane and the slope of the adjacent lane or shoulder within the traveled way or gore.
17. Cuts. Sections of highway located below natural ground elevation thereby requiring excavation of earthen material.
18. Deceleration Lane. An auxiliary lane used by an exiting vehicle to reduce its speed.
19. Decision Sight Distance. Sight distance, which may be required in a complex environment, which is based on the driver's reaction time.
20. Depressed Median. A median that is lower in elevation than the traveled way and so designed to carry a certain portion of the roadway water.
21. Design Vehicle. The vehicle used to determine turning radii, off-tracking characteristics, pavement designs, climbing lanes, etc.
22. Diamond Interchange. An interchange with one-way diagonal ramps in each quadrant and two at-grade intersections on the minor road.
23. Driveway. A road providing access from a public way to a highway, street, road, etc., or abutting property.
24. Fill Slopes. Slopes extending outward and downward from the hinge point to intersect the natural ground line.
25. Flush Median. A median that is level with the surface of the adjacent roadway pavement.

26. Gore Area. The paved triangular area between the through lane and the exit lane, plus the graded area beyond the gore nose.
27. Grade Separation. A crossing of two highways, or a highway and a railroad, at different levels.
28. Grade Slopes. The rate of slope between two adjacent VPI's expressed as a percent. The numerical value for percent of grade is the vertical rise or fall in meters for each 100 m of horizontal distance. Upgrades in the direction of stationing are identified as plus (+). Downgrades are identified as minus (-).
29. Horizontal Sight Distance. The sight distance required across the inside of a horizontal curve.
30. Intersection Sight Distance (ISD). The sight distance required within the corners of intersections to safely allow a variety of vehicular maneuvers based on the type of traffic control at the intersection.
31. K-Values. The horizontal distance needed to produce a 1% change in gradient.
32. Landing Area. The area approaching an intersection for stopping and storage of vehicles.
33. Level Terrain. Level terrain is generally considered to be flat, which has minimal impact on vehicular performance. Highway sight distances are either long or could be made long without major construction expense.
34. Low-Speed Urban Streets. All streets within urbanized and small urban areas with a design speed of less than or equal to 45 mph.
35. Maximum Side Friction ( $f_{\max}$ ). Limiting values selected by AASHTO for use in the design of horizontal curves. The designated  $f_{\max}$  values represent a threshold of driver discomfort and not the point of impending skid.
36. Maximum Superelevation ( $e_{\max}$ ). The overall superelevation control used on a specific facility. Its selection depends on several factors including overall climatic conditions, terrain conditions, type of area (rural or urban) and highway functional classification.
37. Median. The portion of a divided highway separating the two traveled ways for traffic in opposite directions. The median width includes both inside shoulders.
38. Median Opening. An at-grade opening in the median to allow vehicles to cross from one roadway to the next.
39. Mountainous Terrain. Longitudinal and transverse changes in elevation are abrupt, and benching and side hill excavation are frequently required to provide the highway alignment. Mountainous terrain aggravates the performance of trucks relative to passenger cars, resulting in some trucks operating at crawl speeds.

40. Non-Recoverable Parallel Slope. Slopes that are steeper than 1:4. Most drivers will not be able to recover and return to the highway. The Department has decided to treat this range of cross slopes as critical.
41. Normal Crown (NC). The typical cross section on a tangent section (i.e., no superelevation).
42. Open Roadways. All urban facilities with a design speed greater than 45 mph and all rural facilities regardless of design speed.
43. Parking Lane. An auxiliary lane primarily for the parking of vehicles.
44. Partial Cloverleaf Interchange. An interchange with loop ramps in one, two or three quadrants.
45. PC. Point of curvature (beginning of curve).
46. PCC. Point of compound curvature.
47. Performance Curves. A set of curves that illustrate the effect grades will have on the design vehicle's acceleration and/or deceleration.
48. PI. Point of intersection of tangents.
49. Point of Grade Application. The point on the cross section where the elevation of the calculated profile grade line is located.
50. PRC. Point of reverse curvature.
51. PT. Point of tangency (end of curve).
52. PVC (Point of Vertical Curvature). The point at which a tangent grade ends and the vertical curve begins.
53. PVI (Point of Vertical Intersection). The point where the extension of two tangent grades intersect.
54. PVT (Point of Vertical Tangency). The point at which the vertical curve ends and the tangent grade begins.
55. Raised Median. A median that contains a raised portion within its limits.
56. Recoverable Parallel Slope. Slopes which can be safely traversed and upon which an errant motorist has a reasonable opportunity to stop and return to the roadway. The Department considers slopes flatter than 1:4 and slopes of 1:4 without curbing at their top recoverable.

57. Relative Longitudinal Slope. In superelevation transition sections on two-lane facilities, the relative gradient between the profile grade and edge of traveled way.
58. Reverse Adverse Crown (RC). A superelevated roadway section that is sloped across the entire traveled way in the same direction and at a rate equal to the cross slope on a tangent section.
59. Reverse Curves. These are two simple curves with deflections in opposite directions that are joined by a relatively short tangent distance.
60. Roadside. A general term denoting the area adjoining the outer edge of the roadway. Extensive areas between the roadways of a divided highway may also be considered roadside.
61. Roadway Section. The combination of the traveled way, both shoulders and any auxiliary lanes on the highway mainline.
62. Rolling Terrain. The natural slopes consistently rise above and fall below the roadway grade and, occasionally, steep slopes present some restriction to the highway alignment. In general, rolling terrain generates steeper grades, causing trucks to reduce speeds below those of passenger cars.
63. Shoulder. The portion of the roadway contiguous to the traveled way for accommodation of stopped vehicles, for emergency use, and for lateral support of base and surface courses.
64. Shoulder Slope. The slope in the cross section view of the shoulders, expressed as a percent.
65. Shoulder Width. The width of the shoulder measured from the edge of travelway to the outside edge of shoulder or face of curb.
66. Side Friction (f). The interaction between the tire and the pavement surface to counterbalance, in combination with the superelevation, the centrifugal force of a vehicle traversing a horizontal curve.
67. Sidewalk. That portion of the highway section constructed for the use of pedestrians.
68. Simple Curves. These are continuous arcs of constant radius that achieve the necessary highway deflection without an entering or exiting transition.
69. Single Point Urban Interchange. A diamond interchange where all the legs of the interchange meet at a single point on the minor road.
70. Sloping Curb. A longitudinal element placed at the roadway edge for delineation, to control drainage, to control access, etc. Sloping curbs have a height of 6 in or less with a face no steeper than 3 vertical to 1 horizontal.

71. Spiral Curves. These are curvature arrangements, used to transition between a tangent section and a simple curve, that are consistent with the transitional characteristics of vehicular turning paths. When moving from the tangent to the simple curve, the sharpness of the spiral curve gradually increases from a radius of infinity to the radius of the simple curve.
72. Stopping Sight Distance (SSD). The sum of the distance traveled during a driver's perception/reaction or brake reaction time and the distance traveled while braking to a stop.
73. Superelevation (e). The amount of cross slope or "bank" provided on a horizontal curve to help counterbalance, in combination with side friction, the centrifugal force of a vehicle traversing the curve.
74. Superelevation Rollover. The algebraic difference (A) between the superelevated travel lane slope and shoulder slope on the outside of a horizontal curve.
75. Superelevation Runoff (L). The distance needed to change in cross slope from the end of the tangent runout (adverse crown removed) to a section that is sloped at the design superelevation rate.
76. Superelevation Transition Length. The distance required to transition the roadway from a normal crown section to the full superelevation. Superelevation transition length is the sum of the tangent runout and superelevation runoff (L) distances.
77. Tangent Runout (TR). The distance needed to change from a normal crown section to a point where the adverse cross slope of the outside lane or lanes is removed.
78. Toe of Slope. The intersection of the fill slope or inslope with the natural ground or ditch bottom.
79. Top of (Cut) Slope. The intersection of the back slope with the natural ground.
80. Travel/Traffic Lane. The portion of the traveled way for the movement of a single line of vehicles.
81. Traveled Way. The portion of the roadway for the through movement of vehicles, exclusive of shoulders and auxiliary lanes.
82. Turning Roadways. Channelized (painted or raised) turn lanes at intersection at-grade.
83. Turning Template. A graphic representation of a design vehicle's turning path for various angles of turns.
84. Turn Lane. The portion of the roadway adjoining the through traveled way for speed change, turning and storage for turning vehicles.

85. Vertical Curb. A longitudinal element placed at the roadway edge for delineation, to control drainage, to control access, etc. Barrier curbs may range in height between 6 in and 12 in with a face steeper than 3 vertical to 1 horizontal.

# INDEX

## -A-

ACCESS CONTROL .....	Section 2-3.0, Chapter 4, Chapter 5, Section 6-4.0, Section 12-5.03
ACCELERATION LANES	
Interchange Ramps .....	Section 12-3.02
Turning Roadways.....	Section 11-4.02
ACCESSIBILITY, DISABLED.....	Section 15-1.0
AREA CLASSIFICATIONS.....	Section 6-1.03
ARTERIALS	
Definition.....	Section 6-1.01
Design Criteria (New Construction/Reconstruction).....	Chapter 4, Chapter 5
Design Criteria (3R).....	Section 2-3.0
AUXILIARY LANES	
Cross Slopes.....	Section 2-3.0, Chapter 4, Chapter 5
Parking Lanes.....	Section 2-3.0, Chapter 5, Section 10-1.04
Truck-Climbing Lanes .....	Section 2-7.03, Section 9-2.04
Turn Lanes .....	Section 2-3.0, Chapter 4, Chapter 5, Section 10-1.03, Section 11-5.0
Widths.....	Section 2-3.0, Chapter 4, Chapter 5, Section 11-5.0

## -B-

BARRIERS, MEDIAN	
End Treatments .....	Section 13-10.0
Glare Screens.....	Section 13-9.12
Placement.....	Section 13-9.11
Types.....	Section 13-6.0
Warrants .....	Section 13-3.0
BARRIERS, ROADSIDE	
Construction Zones .....	Section 14-4.0
Design/Layout .....	Section 13-7.0, Section 13-9.0
End Treatments .....	13-10.0

Transitions .....	Section 13-9.10
Types/Selection .....	Section 13-5.0
Warrants .....	Section 13-3.0
3R .....	Section 2-9.02
<b>BIKEWAYS</b>	
Classifications .....	Section 15-4.01
Design .....	Section 15-4.03
Warrants .....	Section 15-4.02
Widths .....	Section 2-3.0, Chapter 4, Chapter 5
<b>BRIDGES</b>	
Bridge Replacement/Rehabilitation Projects .....	Section 3-2.03, Section 6-1.02
Clearances .....	Section 2-3.0, Chapter 4, Chapter 5
Fencing and Railings .....	Section 15-6.04
Local Bridge Projects .....	Section 3.204
Underpass Width .....	Section 2-3.0, Chapter 4, Chapter 5, Section 10-4.02
Widths.....	Section 2-3.0, Section 2-7.02, Chapter 4, Chapter 5, Section 10-4.01
3R.....	Section 2-3.0, Section 2-7.02
Freeway Projects .....	Section 3-1.04
<b>BUILDINGS, ACCESSIBILITY</b> .....	Section 15-1.01
<b>BUS STOPS/TURNOUTS</b>	
Commuter Lots .....	Section 15-2.0
Design .....	Section 15-3.02
Disabled Accessibility .....	Section 15-1.02
Location .....	Section 15-3.01
<b>-C-</b>	
<b>CAPACITY</b>	
Definition.....	Section 6-3.0
Interchanges .....	Section 12-2.05
Intersections .....	Section 11-1.01
<b>CHANNELIZATION</b> .....	Section 11-7.0



## CLASSIFICATION

Area Type .....	Section 6-1.03
Functional .....	Section 6-1.01

## CLEARANCES

Horizontal .....	Section 2-9.01, Section 13-2.0
Vertical .....	Section 2-3.0, Chapter 4, Chapter 5

## CLEAR ZONES, ROADSIDE

Construction Zones .....	Section 14-4.02
New Construction/Reconstruction .....	Section 13-2.0
3R .....	Section 2-3.0, Section 2-9.01

CLIMBING LANES, TRUCK.....	Section 2-7.03, Section 9-2.04
----------------------------	--------------------------------

COLLECTOR-DISTRIBUTOR ROADS .....	Section 12-2.06
-----------------------------------	-----------------

## COLLECTOR ROADS AND STREETS

Definition.....	Section 6-1.01
Design Criteria (New Construction/Reconstruction).....	Chapter 4, Chapter 5
Design Criteria (3R).....	Section 2-3.0

COMMUTER LOTS .....	Section 15-2.0
---------------------	----------------

## CONSTRUCTION ZONES –

See Maintenance & Protection of Traffic Through Construction Zones

CONTROLLING DESIGN CRITERIA.....	Section 6-5.0
----------------------------------	---------------

## CRASH CUSHIONS – see Impact Attenuators

## CROSS SECTIONS

Ramps .....	Section 12-4.02
Transitions at Intersection .....	Section 11-1.04
Typical Sections .....	Chapter 4, Chapter 5, Section 10-6.0

## CROSS SLOPES

Auxiliary Lanes.....	Section 2-3.0, Chapter 4, Chapter 5
Shoulders.....	Section 2-3.0, Chapter 4, Chapter 5, Section 10-1.02
Travel Lanes .....	Section 2-3.0, Chapter 4, Chapter 5, Section 10-1.01

CURB RAMPS .....	Section 15-1.08
------------------	-----------------

## CURBS

Curb Ramps .....	Section 15-1.08
------------------	-----------------

Design/Application .....	Section 10-1.05
Roadside Safety .....	Section 13-9.04
Turning Radii .....	Section 11-3.03
<b>CURVES</b>	
Horizontal .....	Section 8-2.02
Intersections .....	Section 11-1.04
Vertical .....	Section 2-6.02, Section 9-3.0
<b>-D-</b>	
<b>DECELERATION LANES</b>	
Turning Roadways.....	Section 11-4.02
Interchange Ramps .....	Section 12-3.01
<b>DESIGN EXCEPTIONS</b>	
Construction Zones .....	Section 14-3.07
Procedures .....	Section 6-5.0
Spot Improvements .....	Section 3-2.02
Utilities .....	Section 13-2.03
3R .....	Section 2-4.03
Freeway Projects .....	Section 3-1.04
DESIGN HOURLY VOLUME (DHV) .....	Section 2-4.02, Section 3-1.04, Section 6-3.02
<b>DESIGN SPEED</b>	
Construction Zones .....	Section 14-3.01
Definition.....	Section 6-2.02
Design Criteria .....	Section 2-4.01, Section 3-1.04, Chapter 4, Chapter 5
Ramps .....	Section 12-4.01
Turning Roadways.....	Section 11-4.02
DESIGN VEHICLES .....	Section 9-2.02, Section 11-1.02, Section 11-3.02
DESIGN YEAR .....	Section 2-3.0, Chapter 4, Chapter 5, Section 11-1.01
DISABLED, ACCESSIBILITY .....	Section 15-1.0
DRIVEWAYS.....	Section 11-8.0
<b>-E-</b>	
ENTRANCE RAMPS .....	Section 12-3.02

EXCEPTIONS – See Design Exceptions

EXIT RAMPS.....Section 12-3.01

**-F-**

FEDERAL-AID SYSTEM.....Section 6-1.02

**FENCING**

Freeways.....Section 15-6.02

Plans.....Section 15-6.05

Structures.....Section 15-6.04

Unlimited Access Highways.....Section 15-6.03

Warrants/Location.....Section 15-6.01

**FREEWAY PROJECTS**

Approach.....Section 3-1.03

Background.....Section 3-1.01

Objectives.....Section 3-1.02

**FREEWAYS**

Definition.....Section 6-1.01

Design Criteria (New Construction/Reconstruction).....Chapter 4, Chapter 5

Design Criteria (Freeway Projects).....Section 3-1.0

Interchanges.....Chapter 12

Lane Drops.....Section 12-2.02

Median Openings.....Section 11-6.03

FUNCTIONAL CLASSIFICATION SYSTEM.....Section 6-1.01

**-G-**

GLARE SCREENS.....Section 13-9.12

**GRADES**

Critical Length of.....Section 9-2.02

Design Criteria (New Construction/Reconstruction).....Chapter 4, Chapter 5

Design Criteria (3R).....Section 2-3.0, Section 2-6.01

Driveways.....Section 11-8.01

Intersections.....Section 11-1.04

Ramps .....	Section 12-4.04
GUIDERAIL -- See Barriers, Roadside	

**-H-**

HEADLIGHT SIGHT DISTANCE – Sag Vertical Curves .....	Section 9-3.03
HIGHWAY CAPACITY .....	Section 2-4.02, Section 6-3.0
HORIZONTAL ALIGNMENT	
Construction Zones .....	Section 14-3.05
Controls .....	Section 8-2.01
Coordination with Vertical Alignment.....	Section 9-1.02
Curve Radius .....	Section 2-3.0, Chapter 4, Chapter 5
Curve Types .....	Section 8-2.02
Intersections .....	Section 11-1.03
Low-Speed Urban Streets .....	Section 2-5.02, Section 8-3.0
Ramps .....	Section 12-4.03
Rural and High-Speed Urban Highways .....	Section 2-5.01, Section 8-2.0
Superelevation.....	Section 2-3.0, Chapter 4, Chapter 5, Section 8-2.03, Section 11-4.02
Sight Distance .....	Section 8-2.04
Turning Roadways.....	Section 11-4.02
HORIZONTAL SIGHT DISTANCE .....	Section 8-2.04

**-I- -J- -K-**

ILLUMINATION .....	Section 15-8.0
IMPACT ATTENUATORS .....	Section 13-10.0
INTERCHANGES	
Access Control .....	Section 12-5.03
Capacity/Level of Service .....	Section 12-2.05
Collector-Distributor Roads .....	Section 12-2.06
Crossing Road Intersection .....	Section 12-5.0
Entrance Ramps.....	Section 12-3.02
Exit Ramps .....	Section 12-3.01
Freeway/Ramp Junctions .....	Section 12-3.0
Frontage Roads.....	Section 12-5.02

Lane Balance.....Section 12-2.01

New/Revised Access Points .....Section 12-1.01, Chapter 12 Appendix

Ramps .....Section 12-4.0

Safety Considerations .....Section 12-2.04

Types.....Section 12-1.02

Warrants .....Section 12-1.01

INTERMODAL SURFACE TRANSPORTATION EFFICIENCY ACT .....Section 6-1.02

INTERSECTIONS AT-GRADE

Alignment.....Section 11-1.03

Capacity .....Section 11-1.01

Channelization .....Section 11-7.0

Driveways .....Section 11-8.0

Intersection Sight Distance.....Section 11-2.0

Lane Extensions .....Section 11-5.06

Profile .....Section 11-1.04

Ramps .....Section 12-5.0

Spacing.....Section 11-1.05

Turn Lanes .....Section 2-3.0, Section 2-10.03, Chapter 4, Chapter 5, Section 11-5.0

Turning Radii .....Section 2-10.02, Section 11-3.0

Turning Roadways.....Section 11-4.0

INTERSECTION SIGHT DISTANCE .....Section 11-2.0

ISLANDS, CHANNELIZED.....Section 11-7.0

-L-

LANDSCAPING.....Section 15-5.0

LANES

Construction Zones .....Section 14-3.03

Cross Slope .....Section 2-3.0, Chapter 4, Chapter 5, Section 10-1.01

Drops, Freeways .....Section 12-2.02

Dual Turn Lanes .....Section 11-5.05

Extensions at Intersections.....Section 11-5.06

Parking .....Section 2-3.0 Chapter 4, Chapter 5, Section 10-1.04, Section 11-3.03

Travel.....	Section 2-3.0, Chapter 4, Chapter 5, Section 10-1.01
Turn Lanes.....	Section 2-3.0, Chapter 4, Chapter 5, Section 11-5.0
Turning Roadways.....	Section 11-4.02
Widths.....	Section 2-7.01, Chapter 4, Chapter 5
<b>LEVEL OF SERVICE</b>	
Definition.....	Section 6-3.01
Design Criteria.....	Section 2-3.0, Chapter 4, Chapter 5
Interchanges.....	Section 12-2.05
Intersections.....	Section 11-1.01
<b>LOCAL ROADS AND STREETS</b>	
Definition.....	Section 6-1.01
Design Criteria (New Construction/Reconstruction).....	Chapter 4, Chapter 5
Design Criteria (3R).....	Section 2-3.0
<b>-M-</b>	
<b>MAINTENANCE AND PROTECTION OF TRAFFIC THROUGH CONSTRUCTION ZONES</b>	
Design.....	Section 14-3.0
Plans.....	Section 14-1.02
Roadside Safety.....	Section 14-4.0
Traffic Control Management.....	Section 14-2.0
MAJOR TRAFFIC GENERATORS.....	Section 11-8.03
<b>MANUAL</b>	
Overview.....	Section 1-1.0
Summary.....	Section 1-2.0
<b>MEDIANS</b>	
Barriers.....	Figure 4I, Section 13-6.0
Design.....	Chapter 4, Chapter 5
Openings.....	Section 11-6.0
Types.....	Chapter 4, Chapter 5, Section 10-3.02
Width.....	Section 2-3.0, Chapter 4, Chapter 5, Section 10-3.01

**-N-**

NATIONAL HIGHWAY SYSTEM.....	Section 6-1.02
------------------------------	----------------

NOISE BARRIERS .....Section 15-7.0

**-O- -P-**

**PARKING**

Commuter Lots .....Section 15-2.0  
 Disabled.....Section 15-1.03  
 Near Intersections .....Section 11-3.03  
 On-Street .....Section 2-3.0, Chapter 4, Chapter 5  
 Widths .....Section 2-3.0, Chapter 4, Chapter 5

**PEDESTRIANS**

Fencing/Bridge Rails .....Section 15-6.04  
 Disabled.....Section 15-1.0  
 Intersections .....Section 11-3.03

POINT OF GRADE APPLICATION .....Chapter 4, Chapter 5

PROJECT SCOPE OF WORK.....Section 1-1.03

**-Q- -R-**

**RADII**

Intersection .....Section 11-3.0  
 Turning Roadways.....Section 11-4.02

**RAMPS**

Curb.....Section 15-1.08  
 Disabled.....Section 15-1.07  
 Interchange.....Section 12-3.0

RIGHT-OF-WAY.....Section 10-5.0

**RESURFACING, RESTORATION AND REHABILITATION (3R)**

Application .....Section 2-2.04  
 Approach .....Section 2-2.03  
 Background .....Section 2-2.01  
 Design Criteria.....Section 2-3.0  
 Evaluation .....Section 2-2.05, Section 2-5.0, Section 2-6.0  
 Objectives.....Section 2-2.02

Regulations.....	Section 2-2.01
<b>ROADSIDE SAFETY</b>	
Construction Zones .....	Section 14-4.0
New Construction/Reconstruction.....	Chapter 13
3R .....	Section 2-9.0
<b>ROCK REMOVAL .....</b>	<b>Section 2-9.01</b>

**-S-****SAFETY APPURTENANCES**

Construction Zones .....	Section 14-4.03
3R .....	Section 2-9.02
Freeway Projects .....	Section 3-1.04
<b>SCOPE OF WORK.....</b>	<b>Chapter 1-1.03</b>
<b>SEEDING/SODDING .....</b>	<b>Section 15-5.0</b>
<b>SCENIC HIGHWAYS.....</b>	<b>Chapter 1</b>

**SHOULDERS**

Construction Zones .....	Section 14-3.03
Cross Slopes .....	Section 2-3.0, Chapter 4, Chapter 5, Section 10-1.02
Widths.....	Section 2-3.0, Chapter 4, Chapter 5, Section 10-1.02

**SIDE SLOPES**

Cut Slopes .....	Chapter 4, Chapter 5, Section 2-3.0, Section 10-2.02
Clear Zones .....	Section 13-2.02
Ditches .....	Chapter 13-3.06
Fill Slopes .....	Chapter 4, Chapter 5, Section 2-3.0, Section 10-2.02
Guiderail .....	Section 13-9.03, 13-9.05

**SIDEWALKS**

Accessible Routes .....	Section 15-1.05
Design .....	Section 10-2.01
Widths.....	Section 2-3.0, Chapter 5, Section 10-2.01

**SIGHT DISTANCE**

Construction Zones .....	Section 14-3.02
Decision.....	Section 7-2.0



Horizontal .....	Section 8-2.04
Intersection .....	Section 11-2.0
Stopping .....	Section 7-1.0
SPOT IMPROVEMENTS .....	Section 3-2.0
SPEED .....	Section 6-2.0
SPEED LIMIT, POSTED .....	Section 6-2.03
STOPPING SIGHT DISTANCE.....	Section 7-1.0
SUPERELEVATION	
Axis of Rotation .....	Section 8-2.03
Definitions.....	Section 8-2.03
Design Criteria .....	Section 2-3.0, Chapter 4, Chapter 5, Section 8-2.03
Freeway Ramp Junctions .....	Section 12-3.0
Low-Speed Urban Streets .....	Section 8-3.03
Ramps .....	Section 12-4.03
Rural and High-Speed Urban Streets.....	Section 8-2.03
Shoulder .....	Figure 4H, Section 8-2.03
Transition Length.....	Section 8-2.03
Turning Roadways.....	Section 11-4.02
SURFACE TRANSPORTATION PROGRAM .....	Section 6-1.02

-T-

TAPERS

Construction Zones .....	Section 14-3.04
Ramps .....	Section 12-3.0
Truck-Climbing Lanes.....	Section 9-2.04
Turning Lanes.....	Section 11-5.03
TERRAIN DEFINITIONS.....	Section 9-2.01
TRAFFIC CALMING .....	Section 2-8.02
TRAFFIC CONTROL MANAGEMENT .....	Section 14-2

## TRAFFIC VOLUME ANALYSIS

Capacity.....	Section 6-3.03
Definitions.....	Section 6-3.01
Truck-Climbing Lanes.....	Section 9-2.04

## TRANSITIONS

Guiderail.....	Section 13-9.10
Intersections.....	Section 11-1.04
Superelevation.....	Section 8-2.03

## TRAVEL LANES

Cross Slopes.....	Section 2-3.0, Chapter 4, Chapter 5, Section 10-1.01
Widths.....	Section 2-7.01, Chapter 4, Chapter 5, Section 10-1.01

## TRUCKS

Climbing Lanes.....	Section 9-2.04
Design Vehicle.....	Section 11-3.02

## TURN LANES

At Intersections.....	Section 11-1.01, Section 11-5.0
Dual Turn Lanes.....	Section 11-5.05

TURNING RADII.....	Section 11-3.0
--------------------	----------------

TURNING ROADWAYS.....	Section 11-4.0
-----------------------	----------------

TURF ESTABLISHMENT.....	Section 15-5.0
-------------------------	----------------

TWO WAY LEFT TURN LANES (TWLTL).....	Section 11-5.07
--------------------------------------	-----------------

## TYPICAL SECTIONS

Highways.....	Chapter 4
Streets.....	Chapter 5
Ramps.....	Section 12-4.02

**-U-**

## UNDERPASSES

Cross Section Width.....	Section 2-3.0, Chapter 4, Chapter 5, Section 10-4.02
Vertical Clearances.....	Section 2-3.0, Section 3-1.04, Chapter 4, Chapter 5, Section 9-4.0

UTILITIES

Placement.....Section 10-2.03  
Setback.....Section 13-2.03

**-V-**

VERTICAL ALIGNMENT

Controls .....Section 9-1.01  
Coordination with Horizontal Alignment.....Section 9-1.02  
Crest Vertical Curves .....Section 2-6.02, Section 9-3.02  
Design Criteria .....Chapter 4, Chapter 5, Section 2-3.0, Section 9-3.0  
Driveways .....Section 11-8.0  
Grades .....Section 2-3.0, Chapter 4, Chapter 5, Section 9-2.0  
Intersections .....Section 11-1.04  
Ramps .....Section 12-4.04  
Sag Vertical Curves.....Section 2-6.03, Section 9-3.03  
Truck-Climbing Lanes.....Section 9-2.04  
VERTICAL CLEARANCES ....Section 2-3.0, Section 3-1.04, Chapter 4, Chapter 5, Section 9-4.0  
VERTICAL CURVES – See Vertical Alignment

**-W- -X- -Y- -Z-**

WORK ZONE TYPES .....Section 14-2.01

