



Filed by:

Kri Pelletier, Property Specialist - SBA Communications
134 Flanders Rd., Suite 125, Westborough, MA 01581
508.251.0720 x 3804 - kpelletier@sbsite.com

November 4, 2016

Melanie A. Bachman
Acting Executive Director
Connecticut Siting Council
Ten Franklin Square
New Britain, CT 06051

Notice of Exempt Modification

1605 Durham Hill Road, Wallingford, CT 06492

N 41° 28' 10.47"

W -72° 44' 32.10"

T-Mobile#: CT11287A_L700

Dear Ms. Bachman:

T-Mobile currently maintains three (3) antennas at the 152-foot level of the existing 165-foot Monopole Tower at 1605 Durham Hill Road, Wallingford, CT. The tower is owned by SBA Properties, LLC. The property is owned by Tilcon Mineral, Inc. T-Mobile intends to remove these (3) antennas and install (3) new L700 and (3) new L19/G19 antennas. These antennas would be installed at the 152-foot level of the tower. T-Mobile's proposed full scope of work is as follows:

Remove:

- None

Remove and Replace:

- Remove (3) L19 and G19 panel antennas and replace with (3) Commscope LNX-6515DS-A1M panel antennas

Install:

- (3) RFS APXV18-206516S-A20 panel antennas
- Upper support rail kit Commscope MT-195-14 and V-Stabilizer talley MTSVSR-MS-B
- 2-3/8" OD Mounting Pipe – 8' long
- (3) Kathrein 782 11056 Bias Ts
- (3) Ericsson KRY 112 144/1 TMAs

Existing Equipment to Remain (including Entitlements):

- (3) Allen Telecom FE15501P77/75 TMAs
- (6) EMS RR90-17-O2DP panel antennas
- (12) 1-5/8" lines



This facility was approved by the Town of Wallingford's Planning and Zoning Commission on December 13, 1999. Special Permit was given for a 165-foot tower to be battleship gray and to be constructed to support at least five carriers. This modification complies with all tower conditions.

Please accept this letter as notification pursuant to Regulations of Connecticut State Agencies §16-50j-73, for construction that constitutes an exempt modification pursuant to R.C.S.A. §16.50j-72(b)(2). In accordance with R.C.S.A. § 16.50j-73, a copy of this letter is being sent to William W. Dickinson, Jr., Mayor of the Town of Wallingford, as well as the property owner. (Separate notice is not being sent to tower owner, as it belongs to SBA.)

The planned modifications to the facility fall squarely within those activities explicitly provided for in R.C.S.A. §16.50j-72(b)(2).

1. The proposed modifications will not result in an increase in the height of the existing structure.
2. The proposed modification will not require the extension of the site boundary.
3. The proposed modifications will not increase noise levels at the facility by six decibels or more, or to levels that exceed state and local criteria.
4. The operation of the replacement antennas will not increase radio frequency emissions at the facility to a level at or above the Federal Communications Commission safety standard.
5. The proposed modification will not cause a change or alteration in the physical or environmental characteristics of the site.
6. The existing structure and its foundation can support the proposed loading.

For the foregoing reasons, T-Mobile respectfully submits that the proposed modifications to the above-referenced telecommunication facility constitute an exempt modifications under R.C.S.A. § 16-50j-72(b)(2).

Sincerely,

Kri Pelletier
Property Specialist
SBA COMMUNICATIONS CORPORATION
134 Flanders Rd., Suite 125
Westborough, MA 01581

508.251.0720 x3804 + T
508.366.2610 + F
203.446.7700 + C
kpelletier@sbsite.com

Attachments

cc: The Honorable William W. Dickinson, Jr.—as elected official
Wallingford Town Hall 45 South Main Street, Wallingford, CT 06492
Tilcon Mineral, Inc.—as property owner
PO Box 32411, Harford, CT 06150



POWER DENSITY

T-Mobile Site Inventory and Power Data

Sector:	A	Sector:	B	Sector:	C
Antenna #:	1	Antenna #:	1	Antenna #:	1
Make / Model:	RFS APXV18-206516S-A20	Make / Model:	RFS APXV18-206516S-A20	Make / Model:	RFS APXV18-206516S-A20
Gain:	16.3 dBd	Gain:	16.3 dBd	Gain:	16.3 dBd
Height (AGL):	152	Height (AGL):	152	Height (AGL):	152
Frequency Bands	1900 MHz(PCS) / 2100 MHz (AWS)	Frequency Bands	1900 MHz(PCS) / 2100 MHz (AWS)	Frequency Bands	1900 MHz(PCS) / 2100 MHz (AWS)
Channel Count	4	Channel Count	4	Channel Count	4
Total TX Power(W):	180	Total TX Power(W):	180	Total TX Power(W):	180
ERP (W):	5,251.37	ERP (W):	5,251.37	ERP (W):	5,251.37
Antenna A1 MPE%	0.89	Antenna B1 MPE%	0.89	Antenna C1 MPE%	0.89
Antenna #:	2	Antenna #:	2	Antenna #:	2
Make / Model:	Commscope LNX-6515DS-VTM	Make / Model:	Commscope LNX-6515DS-VTM	Make / Model:	Commscope LNX-6515DS-VTM
Gain:	14.6 dBd	Gain:	14.6 dBd	Gain:	14.6 dBd
Height (AGL):	152	Height (AGL):	152	Height (AGL):	152
Frequency Bands	700 MHz	Frequency Bands	700 MHz	Frequency Bands	700 MHz
Channel Count	1	Channel Count	1	Channel Count	1
Total TX Power(W):	30	Total TX Power(W):	30	Total TX Power(W):	30
ERP (W):	703.27	ERP (W):	703.27	ERP (W):	703.27
Antenna A2 MPE%	0.25	Antenna B2 MPE%	0.25	Antenna C2 MPE%	0.25

Site Composite MPE%	
Carrier	MPE%
T-Mobile (Per Sector Max)	1.14 %
Nextel	0.30 %
Verizon Wireless	2.74 %
Sprint	0.42 %
AT&T	2.39 %
Site Total MPE %:	6.99 %

T-Mobile Sector A Total:	1.14 %
T-Mobile Sector B Total:	1.14 %
T-Mobile Sector C Total:	1.14 %
Site Total:	6.99 %

T-Mobile_per sector	# Channels	Watts ERP (Per Channel)	Height (feet)	Total Power Density ($\mu\text{W}/\text{cm}^2$)	Frequency (MHz)	Allowable MPE ($\mu\text{W}/\text{cm}^2$)	Calculated % MPE
T-Mobile PCS - 1950 MHz LTE	2	1,750.46	152	5.90	PCS - 1950 MHz	1000	0.59%
T-Mobile PCS - 1950 MHz UMTS	2	875.23	152	2.95	PCS - 1950 MHz	1000	0.30%
T-Mobile UNUSED UMTS	2	0.00	152	0.00	UNUSED	1000	0.00%
T-Mobile UNUSED UMTS	0	0.00	152	0.00	UNUSED	1000	0.00%
T-Mobile UNUSED GSM	0	0.00	152	0.00	UNUSED	1000	0.00%
T-Mobile 700 MHz LTE	1	703.27	152	1.19	700 MHz	467	0.25%
						Total:	1.14%

CURRENT ASSESSMENT		CURRENT ASSESSMENT		CURRENT ASSESSMENT	
Code	Description	Code	Description	Code	Description
3-1	IND LAND	3-1	IND LAND	3-1	IND LAND
3-2	IND BLDG	3-2	IND BLDG	3-2	IND BLDG
3-3	IND IMPR	3-3	IND IMPR	3-3	IND IMPR
4-1	UTL LAND	4-1	UTL LAND	4-1	UTL LAND
Assessed Value		Assessed Value		Assessed Value	
1,053,400		1,504,900		1,053,400	
393,200		561,600		393,200	
936,100		1,337,100		936,100	
140,000		280,000		140,000	
VISION					

PREVIOUS ASSESSMENTS (HISTORY)						
Yr.	Code	Description	Assessed Value	Yr.	Code	
2015	3-1	IND LAND	1,053,400	2013	3-1	
2015	3-2	IND BLDG	393,200	2013	3-2	
2015	3-3	IND IMPR	936,100	2013	3-3	
2015	4-1	UTL LAND	140,000	2013	4-1	
Total:			2,522,700	Total:		

RECORD OF OWNERSHIP					
TOPO.	UTILITIES	STREET/ROAD	LOCATION	SALE DATE	SALE PRICE
2 Above Street	2 Public Water	1 Paved	2 Suburban	07/30/1981	0
7 Swampy					
8 Ledge					

SUPPLEMENTAL DATA					
Other ID:	ENG MAP #	Town Line:	TLI	IND PARKS	ASSOC PID#
203002010	1760				
Census:	Old MBLU	Easement			
TC MAP #	TC MAP #				
Record Lot	Record Lot				
GIS ID: 983					

OTHER ASSESSMENTS					
Year	Type	Description	Amount	Number	Comm. Int.
Total:					

ASSESSING NEIGHBORHOOD					
NBHD/SUB	Street Index Name	Tracing	Batch	Notes	Assessed Value
13/A					181,400
					9,900
					1,209,300
					1,704,900
					0
					3,603,600
Total Appraised Parcel Value					

BUILDING PERMIT RECORD					
Permit ID	Issue Date	Description	Amount	Insp. Date	% Comp.
22849	06/17/2008	Commercial	26,200	04/08/2009	100
21442	02/28/2007	Commercial	135,000	05/14/2007	100
19378	07/08/2005	Commercial	100,000	09/28/2005	100
17813	05/21/2004	Commercial	26,200	09/28/2005	100
17568	03/26/2004	Commercial	53,488	06/14/2004	100
17568	03/24/2004	C of C	0	06/14/2004	100
16621	06/11/2003	Commercial	18,900	07/25/2003	100

LAND USE EVALUATION SECTION					
B #	Use Code	Description	Zone D	Front Depth	Units
1	4100	SAND & GRAVEL M56	RU40		43,560 SF
1	4100	SAND & GRAVEL M56	RU40		10,92 AC
1	4100	SAND & GRAVEL M56	RU40		255.22 AC
1	4310	TEL REL TW M96			1.00 BL
1	4310	TEL REL TW M96			3,500 SF
Total Card Land Units: 267.22 AC Parcel Total Land Area: 267.22 AC					

VISIT CHANGE HISTORY					
Permit ID	Issue Date	Description	Amount	Insp. Date	% Comp.
Total Appraised Parcel Value					

APPRaised VALUE SUMMARY					
Appraised Bldg. Value (Card)	Appraised XF (B) Value (Bldg)	Appraised OB (L) Value (Bldg)	Appraised Land Value (Bldg)	Special Land Value	Total
181,400	9,900	1,209,300	1,704,900	0	3,603,600
Total Appraised Parcel Value					

LAND USE EVALUATION SECTION					
B #	Use Code	Description	Zone D	Front Depth	Units
1	4100	SAND & GRAVEL M56	RU40		43,560 SF
1	4100	SAND & GRAVEL M56	RU40		10,92 AC
1	4100	SAND & GRAVEL M56	RU40		255.22 AC
1	4310	TEL REL TW M96			1.00 BL
1	4310	TEL REL TW M96			3,500 SF
Total Card Land Units: 267.22 AC Parcel Total Land Area: 267.22 AC					

APPRaised VALUE SUMMARY					
Appraised Bldg. Value (Card)	Appraised XF (B) Value (Bldg)	Appraised OB (L) Value (Bldg)	Appraised Land Value (Bldg)	Special Land Value	Total
181,400	9,900	1,209,300	1,704,900	0	3,603,600
Total Appraised Parcel Value					

LAND USE EVALUATION SECTION					
B #	Use Code	Description	Zone D	Front Depth	Units
1	4100	SAND & GRAVEL M56	RU40		43,560 SF
1	4100	SAND & GRAVEL M56	RU40		10,92 AC
1	4100	SAND & GRAVEL M56	RU40		255.22 AC
1	4310	TEL REL TW M96			1.00 BL
1	4310	TEL REL TW M96			3,500 SF
Total Card Land Units: 267.22 AC Parcel Total Land Area: 267.22 AC					

RADIO FREQUENCY EMISSIONS ANALYSIS REPORT
EVALUATION OF HUMAN EXPOSURE POTENTIAL
TO NON-IONIZING EMISSIONS

T-Mobile Existing Facility

Site ID: CT11287A

Durham/Rt 68
1605 Durham Road (Rt. 68)
Wallingford, CT 06492

October 27, 2016

EBI Project Number: 6216004904

Site Compliance Summary	
Compliance Status:	COMPLIANT
Site total MPE% of FCC general public allowable limit:	6.99 %

October 27, 2016

T-Mobile USA
Attn: Jason Overbey, RF Manager
35 Griffin Road South
Bloomfield, CT 06002

Emissions Analysis for Site: **CT11287A – Durham/Rt 68**

EBI Consulting was directed to analyze the proposed T-Mobile facility located at **1605 Durham Road (Rt. 68), Wallingford, CT**, for the purpose of determining whether the emissions from the Proposed T-Mobile Antenna Installation located on this property are within specified federal limits.

All information used in this report was analyzed as a percentage of current Maximum Permissible Exposure (% MPE) as listed in the FCC OET Bulletin 65 Edition 97-01 and ANSI/IEEE Std C95.1. The FCC regulates Maximum Permissible Exposure in units of microwatts per square centimeter ($\mu\text{W}/\text{cm}^2$). The number of $\mu\text{W}/\text{cm}^2$ calculated at each sample point is called the power density. The exposure limit for power density varies depending upon the frequencies being utilized. Wireless Carriers and Paging Services use different frequency bands each with different exposure limits, therefore it is necessary to report results and limits in terms of percent MPE rather than power density.

All results were compared to the FCC (Federal Communications Commission) radio frequency exposure rules, 47 CFR 1.1307(b)(1) – (b)(3), to determine compliance with the Maximum Permissible Exposure (MPE) limits for General Population/Uncontrolled environments as defined below.

General population/uncontrolled exposure limits apply to situations in which the general public may be exposed or in which persons who are exposed as a consequence of their employment may not be made fully aware of the potential for exposure or cannot exercise control over their exposure. Therefore, members of the general public would always be considered under this category when exposure is not employment related, for example, in the case of a telecommunications tower that exposes persons in a nearby residential area.

Public exposure to radio frequencies is regulated and enforced in units of microwatts per square centimeter ($\mu\text{W}/\text{cm}^2$). The general population exposure limit for the 700 MHz Band is approximately 467 $\mu\text{W}/\text{cm}^2$, and the general population exposure limit for the 1900 MHz (PCS) band is 1000 $\mu\text{W}/\text{cm}^2$. Because each carrier will be using different frequency bands, and each frequency band has different exposure limits, it is necessary to report percent of MPE rather than power density.

Occupational/controlled exposure limits apply to situations in which persons are exposed as a consequence of their employment and in which those persons who are exposed have been made fully aware of the potential for exposure and can exercise control over their exposure. Occupational/controlled exposure limits also apply where exposure is of a transient nature as a result of incidental passage through a location where exposure levels may be above general population/uncontrolled limits (see below), as long as the exposed person has been made fully aware of the potential for exposure and can exercise control over his or her exposure by leaving the area or by some other appropriate means.

Additional details can be found in FCC OET 65.

CALCULATIONS

Calculations were done for the proposed T-Mobile Wireless antenna facility located at **1605 Durham Road (Rt. 68), Wallingford, CT**, using the equipment information listed below. All calculations were performed per the specifications under FCC OET 65. Since T-Mobile is proposing highly focused directional panel antennas, which project most of the emitted energy out toward the horizon, all calculations were performed assuming a lobe representing the maximum gain of the antenna per the antenna manufactures supplied specifications, minus 10 dB, was focused at the base of the tower. For this report the sample point is the top of a 6-foot person standing at the base of the tower.

For all calculations, all equipment was calculated using the following assumptions:

- 1) 2 GSM channels (PCS Band - 1900 MHz) were considered for each sector of the proposed installation. These Channels have a transmit power of 30 Watts per Channel.
- 2) 2 LTE channels (PCS Band - 1900 MHz) were considered for each sector of the proposed installation. These Channels have a transmit power of 60 Watts per Channel.
- 3) 1 LTE channel (700 MHz Band) was considered for each sector of the proposed installation. This channel has a transmit power of 30 Watts.
- 4) Since all radios are ground mounted there are additional cabling losses accounted for. For each ground mounted RF path the following losses were calculated. 0.90 dB of additional cable loss for all ground mounted 700 MHz Channels and 1.65 dB of additional cable loss for all ground mounted 2100 MHz channels was factored into the calculations. This is based on manufacturers Specifications for 160 feet of 1-5/8" coax cable on each path.

- 5) All radios at the proposed installation were considered to be running at full power and were uncombined in their RF transmissions paths per carrier prescribed configuration. Per FCC OET Bulletin No. 65 - Edition 97-01 recommendations to achieve the maximum anticipated value at each sample point, all power levels emitting from the proposed antenna installation are increased by a factor of 2.56 to account for possible in-phase reflections from the surrounding environment. This is rarely the case, and if so, is never continuous.
- 6) For the following calculations the sample point was the top of a 6-foot person standing at the base of the tower. The maximum gain of the antenna per the antenna manufactures supplied specifications minus 10 dB was used in this direction. This value is a very conservative estimate as gain reductions for these particular antennas are typically much higher in this direction.
- 7) The antennas used in this modeling are the **RFS APXV18-206516S-A20** for 1900 MHz (PCS) and 2100 MHz (AWS) channels and the **Commscope LNX-6515DS-VTM** for 700 MHz channels. This is based on feedback from the carrier with regards to anticipated antenna selection. The **RFS APXV18-206516S-A20** has a maximum gain of **16.3 dBd** at its main lobe at 1900 MHz and 2100 MHz. The **Commscope LNX-6515DS-VTM** has a maximum gain of **14.6 dBd** at its main lobe at 700 MHz. The maximum gain of the antenna per the antenna manufactures supplied specifications, minus 10 dB, was used for all calculations. This value is a very conservative estimate as gain reductions for these particular antennas are typically much higher in this direction.
- 8) The antenna mounting height centerline of the proposed antennas is **152 feet** above ground level (AGL).
- 9) Emissions values for additional carriers were taken from the Connecticut Siting Council active database. Values in this database are provided by the individual carriers themselves.
- 10) All calculations were done with respect to uncontrolled / general public threshold limits.

T-Mobile Site Inventory and Power Data

Sector:	A	Sector:	B	Sector:	C
Antenna #:	1	Antenna #:	1	Antenna #:	1
Make / Model:	RFS APXV18-206516S-A20	Make / Model:	RFS APXV18-206516S-A20	Make / Model:	RFS APXV18-206516S-A20
Gain:	16.3 dBd	Gain:	16.3 dBd	Gain:	16.3 dBd
Height (AGL):	152	Height (AGL):	152	Height (AGL):	152
Frequency Bands	1900 MHz(PCS) / 2100 MHz (AWS)	Frequency Bands	1900 MHz(PCS) / 2100 MHz (AWS)	Frequency Bands	1900 MHz(PCS) / 2100 MHz (AWS)
Channel Count	4	Channel Count	4	Channel Count	4
Total TX Power(W):	180	Total TX Power(W):	180	Total TX Power(W):	180
ERP (W):	5,251.37	ERP (W):	5,251.37	ERP (W):	5,251.37
Antenna A1 MPE%	0.89	Antenna B1 MPE%	0.89	Antenna C1 MPE%	0.89
Antenna #:	2	Antenna #:	2	Antenna #:	2
Make / Model:	Commscope LNX-6515DS-VTM	Make / Model:	Commscope LNX-6515DS-VTM	Make / Model:	Commscope LNX-6515DS-VTM
Gain:	14.6 dBd	Gain:	14.6 dBd	Gain:	14.6 dBd
Height (AGL):	152	Height (AGL):	152	Height (AGL):	152
Frequency Bands	700 MHz	Frequency Bands	700 MHz	Frequency Bands	700 MHz
Channel Count	1	Channel Count	1	Channel Count	1
Total TX Power(W):	30	Total TX Power(W):	30	Total TX Power(W):	30
ERP (W):	703.27	ERP (W):	703.27	ERP (W):	703.27
Antenna A2 MPE%	0.25	Antenna B2 MPE%	0.25	Antenna C2 MPE%	0.25

Site Composite MPE%	
Carrier	MPE%
T-Mobile (Per Sector Max)	1.14 %
Nextel	0.30 %
Verizon Wireless	2.74 %
Sprint	0.42 %
AT&T	2.39 %
Site Total MPE %:	6.99 %

T-Mobile Sector A Total:	1.14 %
T-Mobile Sector B Total:	1.14 %
T-Mobile Sector C Total:	1.14 %
Site Total:	6.99 %

T-Mobile _per sector	# Channels	Watts ERP (Per Channel)	Height (feet)	Total Power Density ($\mu\text{W}/\text{cm}^2$)	Frequency (MHz)	Allowable MPE ($\mu\text{W}/\text{cm}^2$)	Calculated % MPE
T-Mobile PCS - 1950 MHz LTE	2	1,750.46	152	5.90	PCS - 1950 MHz	1000	0.59%
T-Mobile PCS - 1950 MHz UMTS	2	875.23	152	2.95	PCS - 1950 MHz	1000	0.30%
T-Mobile UNUSED UMTS	2	0.00	152	0.00	UNUSED	1000	0.00%
T-Mobile UNUSED UMTS	0	0.00	152	0.00	UNUSED	1000	0.00%
T-Mobile UNUSED GSM	0	0.00	152	0.00	UNUSED	1000	0.00%
T-Mobile 700 MHz LTE	1	703.27	152	1.19	700 MHz	467	0.25%
						Total:	1.14%

Summary

All calculations performed for this analysis yielded results that were **within** the allowable limits for general public exposure to RF Emissions.

The anticipated maximum composite contributions from the T-Mobile facility as well as the site composite emissions value with regards to compliance with FCC's allowable limits for general public exposure to RF Emissions are shown here:

T-Mobile Sector	Power Density Value (%)
Sector A:	1.14 %
Sector B:	1.14 %
Sector C:	1.14 %
T-Mobile Per Sector Maximum:	1.14 %
Site Total:	6.99 %
Site Compliance Status:	COMPLIANT

The anticipated composite MPE value for this site assuming all carriers present is **6.99%** of the allowable FCC established general public limit sampled at the ground level. This is based upon values listed in the Connecticut Siting Council database for existing carrier emissions.

FCC guidelines state that if a site is found to be out of compliance (over allowable thresholds), that carriers over a 5% contribution to the composite value will require measures to bring the site into compliance. For this facility, the composite values calculated were well within the allowable 100% threshold standard per the federal government.



Tower Engineering Solutions

Phone (972) 483-0607, Fax (972) 975-9615
8445 Freeport Parkway, Suite 375, Irving, Texas 75063

Structural Analysis Report

Existing 162 ft SUMMIT Monopole

Customer Name: SBA Communications Corp

Customer Site Number: CT01698-S

Customer Site Name: Durham

Carrier Name: T-Mobile

Carrier Site ID / Name: CT11287A / Durham

Site Location: 1605 Durham Road, CT Route 68

Wallingford, Connecticut

New Haven County

Latitude: 41.469574

Longitude: -72.742250

Analysis Result:

Max Structural Usage: 75.0% [Pass]

Max Foundation Usage: 80.0% [Pass]

Report Prepared By : Fabiaye Arinyedokiari

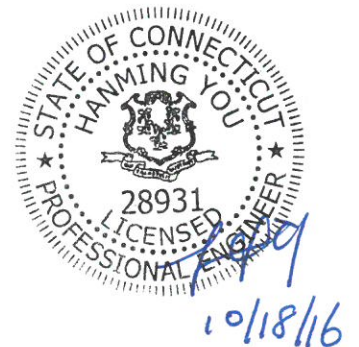

Introduction

The purpose of this report is to summarize the analysis results on the 162 ft SUMMIT Monopole to support the proposed antennas and transmission lines in addition to those currently installed. Any modification listed under Sources of Information was assumed completed and was included in this analysis.

Sources of Information

Tower Drawings	Paul J. Ford and Company Job #29299-949 dated December 22, 1999
Foundation Drawing	Paul J. Ford and Company Job #29299-949 dated December 22, 1999
Geotechnical Report	Jaworski Geotech, Inc., Project #99407G dated September 2, 1999
Modification Drawings	N/A

Analysis Criteria

The rigorous analysis was performed in accordance with the requirements and stipulations of the ANSI/TIA/EIA 222-G. In accordance with this standard, the structure was analyzed using **TESPoles**, a proprietary analysis software. The program considers the structure as an elastic 3-D model with second-order effects and temperature effects incorporated in the analysis. The analysis was performed using multiple wind directions.

Wind Speed Used in the Analysis:	Ultimate Design Wind Speed $V_{ult} = 125.0$ mph (3-Sec. Gust)/ Nominal Design Wind Speed $V_{asd} = 97.0$ mph (3-Sec. Gust)
Wind Speed with Ice:	50 mph (3-Sec. Gust) with 3/4" radial ice concurrent
Operational Wind Speed:	60 mph + 0" Radial ice
Standard/Codes:	ANSI/TIA/EIA 222-G / 2012 IBC / 2016 Connecticut State Building Code
Exposure Category:	C
Structure Class:	II
Topographic Category:	1
Crest Height:	0 ft
Seismic Parameters:	$S_S = 0.181$, $S_1 = 0.062$

Existing Antennas, Mounts and Transmission Lines

The table below summarizes the antennas, mounts and transmission lines that were considered in the analysis as existing on the tower.

Items	Elevation (ft)	Qty.	Antenna Descriptions	Mount Type & Qty.	Transmission Lines	Owner
1	162.5	3	RFS APXVTM14-C-120 - Panel	Low Profile Platform	(3) 1 1/4" (1) 1 5/8" Fiber	Sprint
2		3	RFS APXVSP18-C-A20 - Panel			
3		4	RFS ACU-A20-N RET			
4	162.0	3	Alcatel Lucent 800 MHz Filter	Collar Mount		
5		3	Alcatel Lucent 800 MHz RRU			
6		3	TD-RRH8x20-25 - RRH			
7		3	Alcatel Lucent 1900MHz RRH			
-	152.0	12	EMS RR90-17-00DP - Panel	Low Profile Platform	(12) 1 5/8"	T-Mobile
14	132.0	4	Andrew DB846F65ZAXY - Panel	Low Profile Platform	(11) 1 5/8" (2) 1 5/8" Hybrid	Verizon
15		9	Commscope SBNHH-1D65B - Panel			
16		2	Antel LPA-80080-4CF-EDIN-0 - Panel			
17		3	Alcatel Lucent RRH2x60-1900 – RRU			
18		3	Alcatel Lucent RRH2X60-700 – RRU			
19		3	Alcatel Lucent RRH2X60-AWS - RRU			
20		6	RFS FD9R6004/2C-3L - Diplexer			
21		2	RFS DB-T1-6Z-8AB-0Z – Distribution Box			
22	124.5	1	Raycap DC6-48-60-18-8F - Surge Arrestors	Low Profile Platform	(12) 1 5/8" (1) 10 mm (1) 3" Conduit (2) DC	AT&T*
23	6	Ericsson RRUS-11 RRU				
24	122.0	6	Powerwave 7770.00 - Panel			
25		3	KMW AM-X-CD-16-65-00T			
26		6	Powerwave LGP21401 TMA			
27		6	Powerwave LGP21903 - Diplexer			
-	105	-	-	Low Profile Platform	-	-
28	80.0	1	Kathrein 738-449 - Whip	Flush Mount	(1) ½"	AT&T
29	75.0	1	GPS	Flush Mount	(1) ½"	Verizon*

*Lines installed outside of pole shaft.

Proposed Carrier's Final Configuration of Antennas, Mounts and Transmission Lines

Information pertaining to the proposed carrier's final configuration of antennas and transmission lines was provided by SBA Communications Corp. The proposed antennas and lines are listed below.

Items	Elevation (ft)	Qty.	Antenna Descriptions	Mount Type & Qty.	Transmission Lines	Owner
8	152.0	6	EMS RR90-17-02DP - Panel	Platform w/ Hand Rail (Commscope MT-195-14 and VSR-MS-B)	(12) 1 5/8"	T-Mobile
9		3	RFS APXV18-206516S-A20 - Panel			
10		3	Commscope LNX-6515DS-A1M - Panel			
11		3	Allen Telecom FE15501P77/75 – TMA			
12		3	Ericsson KRY 112 144/1 – TMA			
13		3	Kathrein 782 11056 – Bias T			

All transmission lines are considered running inside of the pole shafts.

Analysis Results

The results of the structural analysis, performed for the wind and ice loading and antenna equipment as defined above, are summarized as the following:

	Pole shafts	Anchor Bolts	Base Plate
Max. Usage:	75.0%	68.2%	68.6%
Pass/Fail	Pass	Pass	Pass

Foundations

	Moment (Kip-Ft)	Shear (Kips)	Axial (Kips)
Analysis Reactions	4579.2	39.0	53.3

The foundation has been investigated using the supplied documents and soils report and was found adequate. Therefore, no modification to the foundation will be required.

Operational Condition (Rigidity):

Maximum twist/sway at the elevation of the antennas under the operational wind speed as specified in the Analysis Criteria is shown in the table:

Elevation (ft)	Antenna / Dish	Carrier	Twist (deg)	Sway (deg)
152.0	Antennas	T-Mobile	0.000	1.458

It is recommended that carriers review the twist and sway values of the antennas.

Conclusions

Based on the analysis results, the existing structure and its foundation were found to be adequate to safely support the existing and proposed equipment and meet the minimum requirements per the ANSI/TIA/EIA 222-G Standard under the design basic wind speed as specified in the Analysis Criteria.

Standard Conditions

1. This analysis was performed based on the information supplied to **(TES) Tower Engineering Solutions, LLC**. Verification of the information provided was not included in the Scope of Work for **TES**. The accuracy of the analysis is dependent on the accuracy of the information provided.
2. The analysis is based on the presumption that the tower members and components along with any existing reinforcement items have been correctly and properly designed, manufactured, installed and maintained.
3. All the existing structural members were assumed to be in good condition with no physical damage or deterioration associated with corrosion.
4. An initial tension of 10% of the break strength on all the existing guy wires was assumed in all the structural analyses of guyed towers unless different values were provided by the client. **TES** cannot take responsibility for the deviations in the analysis results because of differences in the initial tension forces of the existing guy wires.
5. Secondary component or connection secondary components, welds and bolts are assumed to be able to carry their intended original design loads. **TES** cannot take responsibility for verification of the adequacy on the connections, bolts and welds present in the structure.
6. The analyses will be performed based on the codes as specified by the client or based on the best knowledge of the engineering staff of **TES**. In the absence of information to the contrary, all work will be performed in accordance with the latest relevant revision of ANSI/TIA-222. If wind speed and/or ice loads are different from the minimum values recommended by the EIA/TIA-222 standard or other codes, **TES** should be notified in writing and the applicable minimum values provided by the client.
7. The configuration of the existing mounts, antennas, coax and other appurtenances were supplied by the customer for the current structural analysis. **TES** has not visited the tower site to verify the adequacy of the information provided. If there is any discrepancy found in the report regarding the existing conditions, **TES** should be notified immediately to evaluate the effect of the discrepancy on the analysis results.
8. The client will assume responsibility for rework associated with the differences in initially provided information, including tower and foundation information, existing and/or proposed equipment and transmission lines.
9. If a feasibility analysis was performed, final acceptance of changed conditions shall be based upon a rigorous structural analysis.

Usage Diagram - Max Ratio 75.03% at 45.0ft

Structure: CT01698-S-SBA
Site Name: Durham
Height: 162.00 (ft)
Base Elev: 0.000 (ft)

Code: EIA/TIA-222-G
Exposure: C
Gh: 1.1

10/18/2016



Page: 1

Dead Load Factor: 1.20
Wind Load Factor: 1.60

Load Case : 1.2D + 1.6W 97 mph Wind

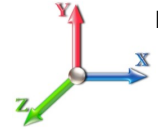

Iterations: 24

Copyright © 2016 by Tower Engineering Solutions, LLC. All rights reserved.

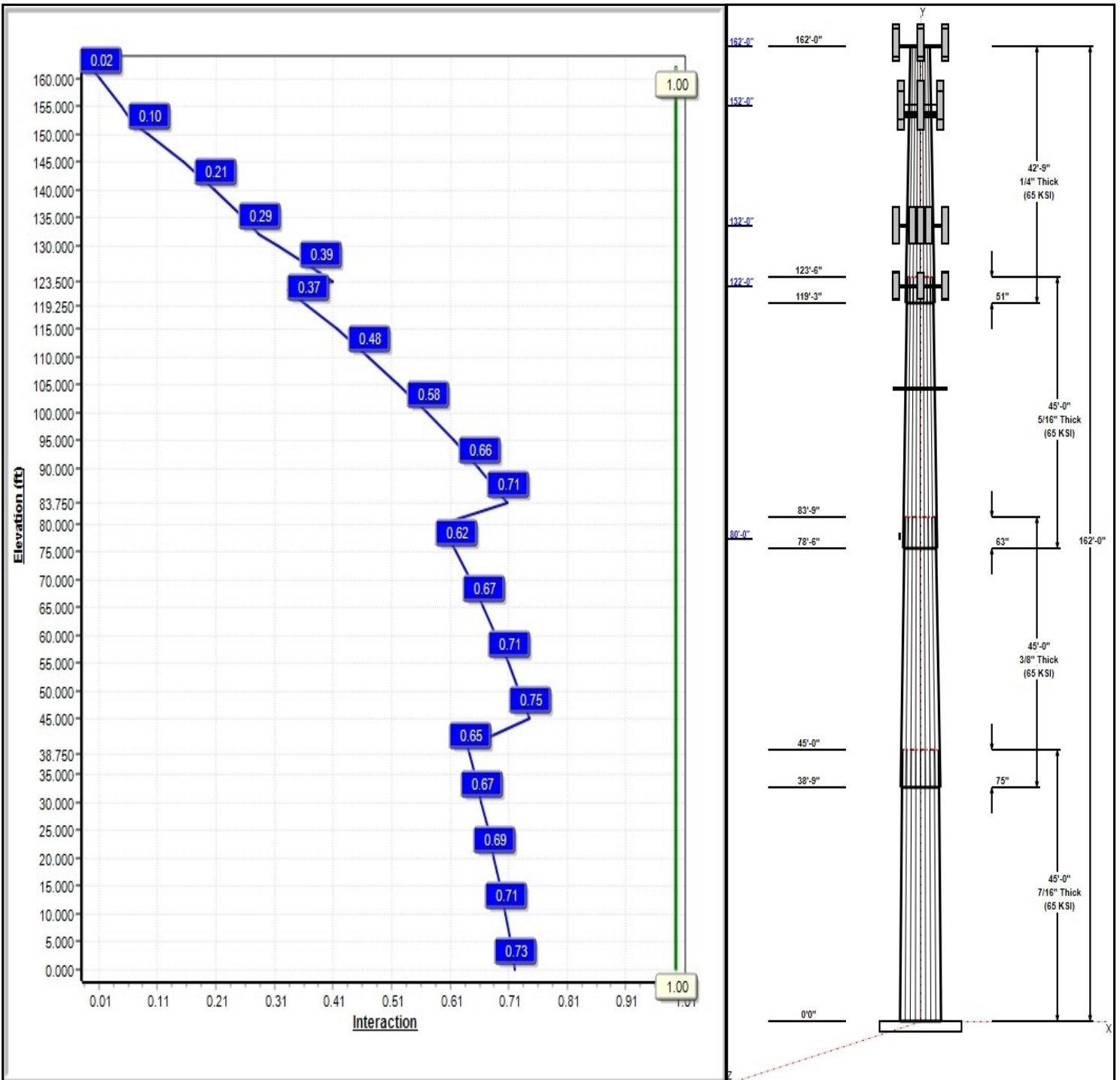

Structure: CT01698-S-SBA

Type: Tapered
Site Name: Durham
Height: 162.00 (ft)
Base Elev: 0.00 (ft)

Base Shape: 18 Sided
Taper: 0.22003

10/18/2016

Page: 2



Shaft Properties

Seq	Length (ft)	Top (in)	Bottom (in)	Thick (in)	Joint Type	Taper	Grade (ksi)
1	45.00	47.87	57.77	0.438		0.22003	65
2	45.00	40.09	49.99	0.375	Slip	0.22003	65
3	45.00	31.97	41.87	0.313	Slip	0.22003	65
4	42.75	24.00	33.41	0.250	Slip	0.22003	65

Discrete Appurtenances

Attach Elev (ft)	Force Elev (ft)	Qty	Description	Carrier
162.00	162.50	3	APXVTM14-C-120	Sprint
162.00	162.00	3	TD-RRH8x20-25	Sprint
162.00	162.50	3	APXVSP18-C-A20	Sprint
162.00	162.00	3	1900MHz RRH	Sprint
162.00	162.00	3	800 MHz RRU	Sprint
162.00	162.00	3	800 MHz Ext. Filter	Sprint
162.00	162.50	4	ACU-A20-N	Sprint
162.00	162.00	1	Low Profile Platform-flat	
162.00	160.00	1	Flush Mount	Verizon
152.00	152.00	3	APXV18-206516S-A20	T-Mobile
152.00	152.00	3	LNx-6515DS-A1M	T-Mobile
152.00	152.00	3	KRY 112 144/1	T-Mobile
152.00	152.00	3	782 11056	T-Mobile
152.00	152.00	3	FE15501P77/75	T-Mobile
152.00	152.00	1	Platform w/ Hand Rail	T-Mobile
152.00	152.00	6	RR90-17-02DP	T-Mobile
132.00	132.00	1	Low Profile Platform-flat	Verizon
132.00	132.00	9	SBNHH-1D65B	Verizon
132.00	132.00	2	LPA-80080-4CF-EDIN-0	Verizon
132.00	132.00	4	DB846F65ZAXY	Verizon
132.00	132.00	3	RRH2X60-AWS	Verizon
132.00	132.00	3	RRH2x60-1900	Verizon
132.00	132.00	3	RRH2X60-700	Verizon
132.00	132.00	6	FD9R6004/2C-3L	Verizon
132.00	132.00	2	RFS DB-T1-6Z-8AB-0Z	Verizon
124.50	124.50	1	Flush Mount	Verizon
124.50	124.50	6	RRUS-11	AT&T
124.50	124.50	1	DC6-48-60-18-8F	AT&T
122.00	122.00	6	7770.00	AT&T
122.00	122.00	6	LGP21401	AT&T
122.00	122.00	6	LGP21903	AT&T
122.00	122.00	3	AM-X-CD-16-65-00T-RET	AT&T
122.00	122.00	1	Low Profile Platform-flat	
105.00	105.00	1	Low Profile Platform-flat	
80.00	80.35	1	738-449	AT&T
75.00	75.00	1	GPS	Verizon

Linear Appurtenances

Elev From (ft)	Elev To (ft)	Placement	Description	Carrier
0.00	162.00	Inside	1 1/4" Coax	Sprint
0.00	162.00	Inside	1 5/8" Fiber	Sprint
0.00	162.00	Outside	Safety Cable	
0.00	152.00	Inside	1 5/8" Coax	T-Mobile
0.00	132.00	Inside	1 5/8" Coax	Verizon
0.00	132.00	Inside	1 5/8" Hybrid	Verizon

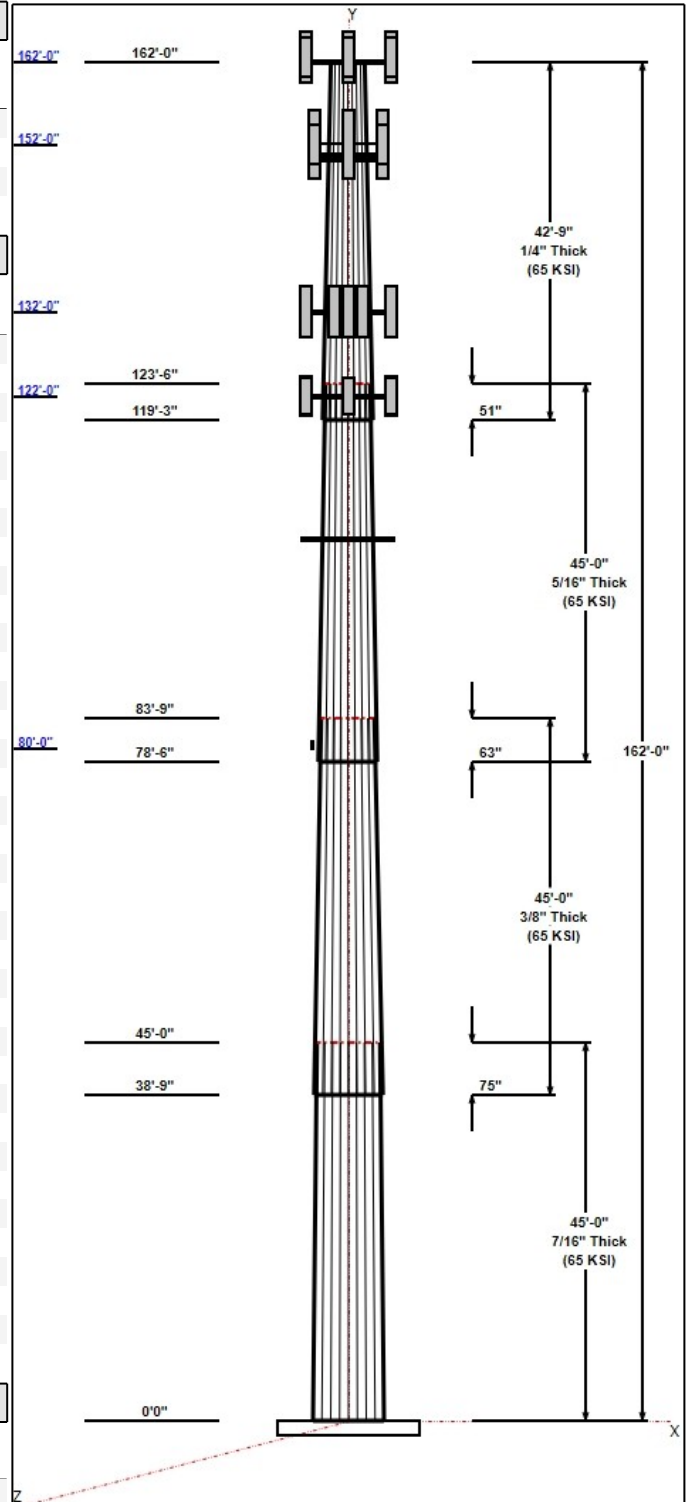

Structure: CT01698-S-SBA

Type: Tapered
Site Name: Durham
Height: 162.00 (ft)
Base Elev: 0.00 (ft)

Base Shape: 18 Sided
Taper: 0.22003

10/18/2016

Page: 3



0.00	122.00	Outside	1 5/8" Coax	AT&T
0.00	122.00	Outside	10 mm	AT&T
0.00	122.00	Outside	3" Coax	AT&T
0.00	122.00	Outside	DC	AT&T
0.00	80.00	Inside	1/2" Coax	AT&T
0.00	75.00	Outside	1/2" Coax	Verizon

Anchor Bolts

Qty	Specifications	Grade (ksi)	Arrangement
20	2.25" 18J	75.0	Cluster

Base Plate

Thickness (in)	Specifications (in)	Grade (ksi)	Geometry
3.0000	64.0	50.0	Clipped

Reactions

Load Case	Moment	Shear	Axial
1.2D + 1.6W 97 mph Wind	4579.2	39.0	53.3
0.9D + 1.6W 97 mph Wind	4532.4	39.0	39.9
1.2D + 1.0Di + 1.0Wi 50 mph Wind	1303.4	11.1	87.9
1.2D + 1.0E	227.1	1.8	53.3
0.9D + 1.0E	224.5	1.8	40.0
1.0D + 1.0W 60 mph Wind	1089.2	9.3	44.4

Structure: CT01698-S-SBA - Coax Line Placement

Type: Monopole
Site Name: Durham
Height: 162.00 (ft)

10/18/2016



Page: 4

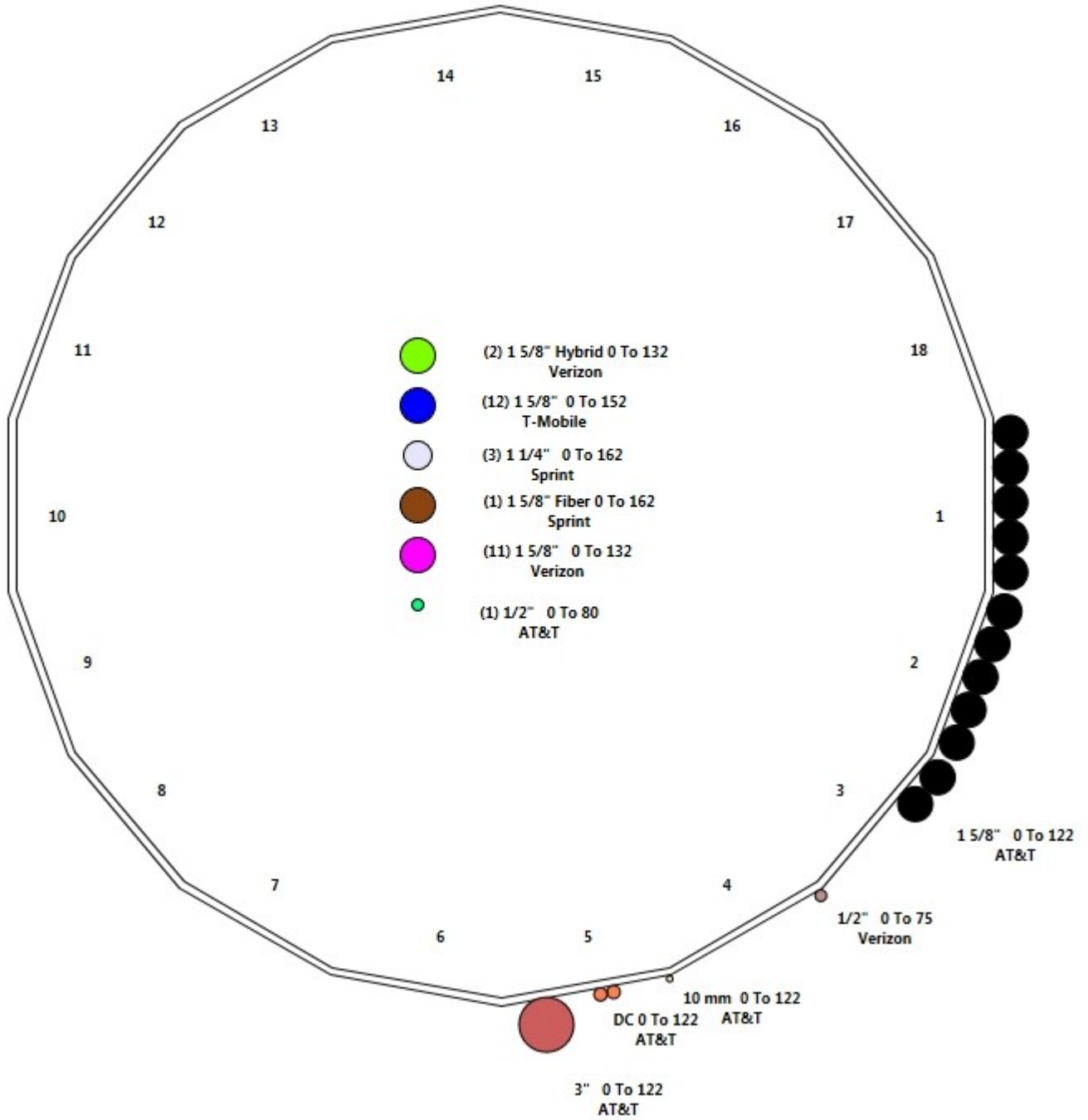

Shaft Properties

Structure: CT01698-S-SBA	Code: EIA/TIA-222-G	10/18/2016
Site Name: Durham	Exposure: C	
Height: 162.00 (ft)	Crest Height: 0.00	
Base Elev: 0.000 (ft)	Site Class: D - Stiff Soil	
Gh: 1.1	Topography: 1	Struct Class: II



Page: 5

Sec. No.	Shape	Length (ft)	Thick (in)	Fy (ksi)	Joint Type	Overlap (in)	Weight (lb)
1	18	45.000	0.4375	65		0.00	11,138
2	18	45.000	0.3750	65	Slip	75.00	8,141
3	18	45.000	0.3125	65	Slip	63.00	5,560
4	18	42.750	0.2500	65	Slip	51.00	3,284
Total Shaft Weight:							28,123

Bottom

Top

Sec. No.	Dia (in)	Elev (ft)	Area (sqin)	Ix (in^4)	W/t Ratio	D/t Ratio	Dia (in)	Elev (ft)	Area (sqin)	Ix (in^4)	W/t Ratio	D/t Ratio	Taper
1	57.77	0.00	79.61	33061.69	21.87	132.05	47.87	45.00	65.86	18720.2	17.88	109.4	0.220031
2	49.99	38.75	59.06	18370.23	22.10	133.32	40.09	83.75	47.27	9421.47	17.44	106.9	0.220031
3	41.87	78.50	41.22	8995.46	22.22	133.99	31.97	123.50	31.40	3976.25	16.63	102.3	0.220031
4	33.41	119.2	26.31	3654.12	22.15	133.63	24.00	162.00	18.84	1343.00	15.52	96.00	0.220031

Load Summary

Structure: CT01698-S-SBA	Code: EIA/TIA-222-G	10/18/2016
Site Name: Durham	Exposure: C	
Height: 162.00 (ft)	Crest Height: 0.00	
Base Elev: 0.000 (ft)	Site Class: D - Stiff Soil	
Gh: 1.1	Topography: 1	Struct Class: II



Page: 6

Discrete Appurtenances

No.	Elev (ft)	Description	Qty	No Ice			Ice			Hor. Ecc. (ft)	Vert Ecc (ft)
				Weight (lb)	CaAa (sf)	CaAa Factor	Weight (lb)	CaAa (sf)	CaAa Factor		
1	162.00	APXVTM14-C-120	3	56.00	6.34	0.79	217.90	7.463	0.79	0.00	0.50
2	162.00	TD-RRH8x20-25	3	70.00	4.05	0.69	181.50	4.870	0.69	0.00	0.00
3	162.00	APXVSP18-C-A20	3	57.00	8.02	0.83	231.19	10.835	0.83	0.00	0.50
4	162.00	1900MHz RRH	3	44.00	3.80	0.88	154.01	5.201	0.88	0.00	0.00
5	162.00	800 MHz RRU	3	53.00	2.49	0.75	127.53	3.643	0.75	0.00	0.00
6	162.00	800 MHz Ext. Filter	3	6.60	1.19	0.63	31.03	1.983	0.63	0.00	0.00
7	162.00	ACU-A20-N	4	1.00	0.14	0.75	5.33	0.439	0.75	0.00	0.50
8	162.00	Low Profile Platform-flat	1	1200.00	25.00	1.00	2255.22	46.104	1.00	0.00	0.00
9	162.00	Flush Mount	1	175.00	5.00	1.00	322.73	8.517	1.00	0.00	-2.00
10	152.00	APXV18-206516S-A20	3	18.50	4.36	0.76	87.92	6.606	0.78	0.00	0.00
11	152.00	LNx-6515DS-A1M	3	49.80	11.47	0.80	279.66	14.741	0.80	0.00	0.00
12	152.00	KRY 112 144/1	3	11.00	0.35	0.73	21.80	0.756	0.78	0.00	0.00
13	152.00	782 11056	3	1.80	0.15	0.67	6.33	0.365	0.67	0.00	0.00
14	152.00	FE15501P7775	3	17.50	0.54	0.65	23.40	0.874	0.65	0.00	0.00
15	152.00	Platform w/ Hand Rail (round)	1	2021.00	42.00	1.00	4676.88	78.698	1.00	0.00	0.00
16	152.00	RR90-17-02DP	6	13.50	4.36	0.73	112.37	5.347	0.73	0.00	0.00
17	132.00	Low Profile Platform-flat	1	1200.00	25.00	1.00	2233.83	45.677	1.00	0.00	0.00
18	132.00	SBNHH-1D65B	9	40.60	8.08	0.83	239.16	9.354	0.83	0.00	0.00
19	132.00	LPA-80080-4CF-EDIN-0	2	12.00	2.61	1.70	126.15	3.497	1.70	0.00	0.00
20	132.00	DB846F65ZAXY	4	21.00	7.05	0.93	215.40	8.264	0.93	0.00	0.00
21	132.00	RRH2X60-AWS	3	60.00	3.50	0.76	146.18	4.279	0.76	0.00	0.00
22	132.00	RRH2x60-1900	3	19.50	1.51	0.75	78.40	2.053	0.75	0.00	0.00
23	132.00	RRH2X60-700	3	60.00	3.50	0.76	146.18	4.279	0.76	0.00	0.00
24	132.00	FD9R6004/2C-3L	6	3.10	0.36	0.75	11.02	0.798	0.75	0.00	0.00
25	132.00	RFS DB-T1-6Z-8AB-0Z	2	44.00	4.33	0.71	185.58	5.662	0.71	0.00	0.00
26	124.50	Flush Mount	1	175.00	5.00	1.00	318.89	8.426	1.00	0.00	0.00
27	124.50	RRUS-11	6	55.00	4.42	0.68	143.30	5.892	0.68	0.00	0.00
28	124.50	DC6-48-60-18-8F	1	31.80	1.47	1.00	92.48	2.157	1.00	0.00	0.00
29	122.00	7770.00	6	35.00	5.50	0.73	166.79	6.542	0.73	0.00	0.00
30	122.00	LGP21401	6	14.10	1.29	0.75	38.59	2.109	0.75	0.00	0.00
31	122.00	LGP21903	6	5.50	0.27	0.75	13.76	0.660	0.75	0.00	0.00
32	122.00	AM-X-CD-16-65-00T-RET	3	33.00	6.05	0.81	174.83	8.106	0.81	0.00	0.00
33	122.00	Low Profile Platform-flat	1	1200.00	25.00	1.00	2225.72	45.514	1.00	0.00	0.00
34	105.00	Low Profile Platform-flat	1	1200.00	25.00	1.00	2210.44	45.209	1.00	0.00	0.00
35	80.00	738-449	1	0.50	0.01	1.00	2.38	0.068	1.00	0.00	0.35
36	75.00	GPS	1	10.00	1.00	1.00	37.36	1.664	1.00	0.00	0.00
Totals:			112	10,209.00			26,673.23				

Linear Appurtenances

Bottom Elev. (ft)	Top Elev. (ft)	Description	Exposed Width	Exposed
0.00	162.00	(3) 1 1/4" Coax	0.00	Inside
0.00	162.00	(1) 1 5/8" Fiber	0.00	Inside
0.00	162.00	(1) Safety Cable	0.00	Outside
0.00	152.00	(12) 1 5/8" Coax	0.00	Inside
0.00	132.00	(11) 1 5/8" Coax	0.00	Inside

Discrete Appurtenances

No.	Elev (ft)	Description	Qty	No Ice		Ice			Hor. Ecc. (ft)	Vert Ecc (ft)
				Weight (lb)	CaAa (sf)	CaAa Factor	Weight (lb)	CaAa (sf)		
0.00	132.00	(2) 1 5/8" Hybrid		0.00						
0.00	122.00	(12) 1 5/8" Coax		0.00						
0.00	122.00	(1) 10 mm		0.00						
0.00	122.00	(1) 3" Coax		3.00						
0.00	122.00	(2) DC		0.00						
0.00	80.00	(1) 1/2" Coax		0.00						
0.00	75.00	(1) 1/2" Coax		0.00						

Shaft Section Properties

Structure: CT01698-S-SBA	Code: EIA/TIA-222-G	10/18/2016
Site Name: Durham	Exposure: C	
Height: 162.00 (ft)	Crest Height: 0.00	
Base Elev: 0.000 (ft)	Site Class: D - Stiff Soil	
Gh: 1.1	Topography: 1	Struct Class: II



Page: 8

Increment Length: 5 (ft)

Elev (ft)	Description	Thick (in)	Dia (in)	Area (in ²)	Ix (in ⁴)	W/t Ratio	D/t Ratio	Fpy (ksi)	S (in ³)	Weight (lb)
0.00		0.4375	57.770	79.610	33061.7	21.87	132.05	75.7	1127.	0.0
5.00		0.4375	56.670	78.083	31194.7	21.43	129.53	76.2	1084.	1341.5
10.00		0.4375	55.570	76.555	29399.4	20.99	127.02	76.7	1042.	1315.5
15.00		0.4375	54.470	75.028	27674.3	20.54	124.50	77.2	1000.	1289.5
20.00		0.4375	53.369	73.500	26018.0	20.10	121.99	77.8	960.2	1263.5
25.00		0.4375	52.269	71.972	24429.2	19.66	119.47	78.3	920.5	1237.5
30.00		0.4375	51.169	70.445	22906.4	19.21	116.96	78.8	881.7	1211.5
35.00		0.4375	50.069	68.917	21448.3	18.77	114.44	79.3	843.7	1185.5
38.75	Bot - Section 2	0.4375	49.244	67.771	20396.2	18.44	112.56	79.7	815.8	872.1
40.00		0.4375	48.969	67.389	20053.4	18.33	111.93	79.8	806.6	538.0
45.00	Top - Section 1	0.3750	48.619	57.420	16884.8	21.45	129.65	0.0	0.0	2121.6
50.00		0.3750	47.518	56.110	15755.8	20.93	126.72	76.8	653.1	965.8
55.00		0.3750	46.418	54.801	14678.3	20.42	123.78	77.4	622.8	943.5
60.00		0.3750	45.318	53.492	13651.1	19.90	120.85	78.0	593.3	921.2
65.00		0.3750	44.218	52.182	12672.9	19.38	117.91	78.6	564.5	899.0
70.00		0.3750	43.118	50.873	11742.6	18.86	114.98	79.2	536.4	876.7
75.00		0.3750	42.018	49.563	10859.0	18.35	112.05	79.8	509.0	854.4
78.50	Bot - Section 3	0.3750	41.248	48.647	10267.7	17.98	109.99	80.2	490.3	584.8
80.00		0.3750	40.918	48.254	10020.9	17.83	109.11	80.4	482.4	456.9
83.75	Top - Section 2	0.3125	40.717	40.075	8266.0	21.56	130.30	0.0	0.0	1126.1
85.00		0.3125	40.442	39.802	8098.4	21.41	129.42	76.2	394.4	169.9
90.00		0.3125	39.342	38.711	7450.4	20.79	125.90	77.0	373.0	667.9
95.00		0.3125	38.242	37.620	6838.0	20.17	122.37	77.7	352.2	649.3
100.00		0.3125	37.142	36.529	6260.1	19.55	118.85	78.4	332.0	630.8
105.00		0.3125	36.042	35.438	5715.7	18.93	115.33	79.1	312.4	612.2
110.00		0.3125	34.942	34.347	5203.8	18.31	111.81	79.9	293.3	593.7
115.00		0.3125	33.841	33.255	4723.4	17.68	108.29	80.6	274.9	575.1
119.25	Bot - Section 4	0.3125	32.906	32.328	4339.1	17.16	105.30	81.2	259.7	474.2
120.00		0.3125	32.741	32.164	4273.5	17.06	104.77	81.3	257.1	149.3
122.00		0.3125	32.301	31.728	4101.9	16.82	103.36	81.6	250.1	394.4
123.50	Top - Section 3	0.2500	32.471	25.567	3353.6	21.49	129.88	0.0	0.0	292.3
124.50		0.2500	32.251	25.392	3285.3	21.34	129.00	76.3	200.6	86.7
125.00		0.2500	32.141	25.305	3251.6	21.26	128.56	76.4	199.3	43.1
130.00		0.2500	31.041	24.432	2926.5	20.48	124.16	77.3	185.7	423.1
132.00		0.2500	30.601	24.083	2802.9	20.17	122.40	77.7	180.4	165.1
135.00		0.2500	29.941	23.559	2623.9	19.71	119.76	78.2	172.6	243.2
140.00		0.2500	28.841	22.686	2342.9	18.93	115.36	79.1	160.0	393.4
145.00		0.2500	27.741	21.813	2082.7	18.15	110.96	80.0	147.9	378.5
150.00		0.2500	26.640	20.940	1842.6	17.38	106.56	81.0	136.2	363.7
152.00		0.2500	26.200	20.591	1751.9	17.07	104.80	81.3	131.7	141.3
155.00		0.2500	25.540	20.067	1621.6	16.60	102.16	81.9	125.1	207.5
160.00		0.2500	24.440	19.194	1419.0	15.83	97.76	82.5	114.4	334.0
162.00		0.2500	24.000	18.845	1343.0	15.52	96.00	82.5	110.2	129.4

28122.8

Wind Loading - Shaft

Structure: CT01698-S-SBA	Code: EIA/TIA-222-G	10/18/2016
Site Name: Durham	Exposure: C	
Height: 162.00 (ft)	Crest Height: 0.00	
Base Elev: 0.000 (ft)	Site Class: D - Stiff Soil	
Gh: 1.1	Topography: 1	Struct Class: II



Load Case: 1.2D + 1.6W 97 mph Wind

Dead Load Factor 1.20
Wind Load Factor 1.60

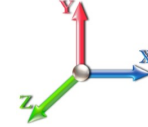

Iterations 24

Elev (ft)	Description	Kzt	Kz	qz (psf)	qzGh (psf)	C (mph-ft)	Cf	Ice Thick (in)	Tributary (ft)	Aa (sf)	CfAa (sf)	Wind Force X (lb)	Dead Load Ice (lb)	Tot Dead Load (lb)	
0.00		1.00	0.85	19.450	21.40	437.17	0.650	0.000	0.00	0.000	0.00	0.0	0.0	0.0	
5.00		1.00	0.85	19.450	21.40	428.85	0.650	0.000	5.00	24.209	15.74	538.7	0.0	1609.8	
10.00		1.00	0.85	19.450	21.40	420.52	0.650	0.000	5.00	23.744	15.43	528.3	0.0	1578.6	
15.00		1.00	0.85	19.450	21.40	412.19	0.650	0.000	5.00	23.278	15.13	518.0	0.0	1547.4	
20.00		1.00	0.90	20.638	22.70	416.01	0.650	0.000	5.00	22.813	14.83	538.6	0.0	1516.2	
25.00		1.00	0.95	21.630	23.79	417.12	0.650	0.000	5.00	22.348	14.53	553.0	0.0	1485.0	
30.00		1.00	0.98	22.477	24.72	416.25	0.650	0.000	5.00	21.882	14.22	562.7	0.0	1453.8	
35.00		1.00	1.01	23.218	25.54	413.97	0.650	0.000	5.00	21.417	13.92	568.9	0.0	1422.6	
38.75 Bot - Section 2		1.00	1.04	23.721	26.09	411.53	0.650	0.000	3.75	15.757	10.24	427.6	0.0	1046.5	
40.00		1.00	1.04	23.880	26.27	410.60	0.650	0.000	1.25	5.273	3.43	144.1	0.0	645.5	
45.00 Top - Section 1		1.00	1.07	24.479	26.93	406.38	0.650	0.000	5.00	20.803	13.52	582.6	0.0	2546.0	
50.00		1.00	1.09	25.029	27.53	407.91	0.650	0.000	5.00	20.338	13.22	582.3	0.0	1159.0	
55.00		1.00	1.12	25.536	28.09	402.48	0.650	0.000	5.00	19.872	12.92	580.5	0.0	1132.2	
60.00		1.00	1.14	26.008	28.61	396.56	0.650	0.000	5.00	19.407	12.61	577.4	0.0	1105.5	
65.00		1.00	1.16	26.450	29.09	390.21	0.650	0.000	5.00	18.941	12.31	573.1	0.0	1078.8	
70.00		1.00	1.17	26.866	29.55	383.48	0.650	0.000	5.00	18.476	12.01	567.8	0.0	1052.0	
75.00 Appurtenance(s)		1.00	1.19	27.259	29.98	376.42	0.650	0.000	5.00	18.010	11.71	561.6	0.0	1025.3	
78.50 Bot - Section 3		1.00	1.20	27.522	30.27	371.30	0.650	0.000	3.50	12.330	8.01	388.2	0.0	701.8	
80.00 Appurtenance(s)		1.00	1.21	27.632	30.39	369.06	0.650	0.000	1.50	5.294	3.44	167.3	0.0	548.2	
83.75 Top - Section 2		1.00	1.22	27.899	30.69	363.37	0.650	0.000	3.75	13.051	8.48	416.6	0.0	1351.3	
85.00		1.00	1.22	27.987	30.79	367.11	0.650	0.000	1.25	4.292	2.79	137.4	0.0	203.9	
90.00		1.00	1.24	28.325	31.16	359.28	0.650	0.000	5.00	16.878	10.97	546.9	0.0	801.5	
95.00		1.00	1.25	28.650	31.51	351.23	0.650	0.000	5.00	16.413	10.67	537.9	0.0	779.2	
100.00		1.00	1.27	28.961	31.86	342.97	0.650	0.000	5.00	15.947	10.37	528.4	0.0	756.9	
105.00 Appurtenance(s)		1.00	1.28	29.260	32.19	334.52	0.650	0.000	5.00	15.482	10.06	518.2	0.0	734.7	
110.00		1.00	1.29	29.548	32.50	325.90	0.650	0.000	5.00	15.016	9.76	507.6	0.0	712.4	
115.00		1.00	1.30	29.826	32.81	317.12	0.650	0.000	5.00	14.551	9.46	496.5	0.0	690.1	
119.25 Bot - Section 4		1.00	1.31	30.054	33.06	309.54	0.650	0.000	4.25	12.002	7.80	412.7	0.0	569.1	
120.00		1.00	1.32	30.094	33.10	308.19	0.653 *	0.000	0.75	2.115	1.38	73.1	0.0	179.1	
122.00 Appurtenance(s)		1.00	1.32	30.199	33.22	304.58	0.655 *	0.000	2.00	5.588	3.66	194.4	0.0	473.3	
123.50 Top - Section 3		1.00	1.32	30.277	33.30	301.86	0.650	0.000	1.50	4.142	2.69	143.5	0.0	350.7	
124.50 Appurtenance(s)		1.00	1.33	30.328	33.36	304.76	0.650	0.000	1.00	2.738	1.78	95.0	0.0	104.0	
125.00		1.00	1.33	30.354	33.39	303.85	0.650	0.000	0.50	1.362	0.89	47.3	0.0	51.8	
130.00		1.00	1.34	30.605	33.67	294.66	0.650	0.000	5.00	13.366	8.69	468.0	0.0	507.7	
132.00 Appurtenance(s)		1.00	1.34	30.704	33.77	290.95	0.650	0.000	2.00	5.216	3.39	183.2	0.0	198.1	
135.00		1.00	1.35	30.850	33.93	285.35	0.650	0.000	3.00	7.684	4.99	271.2	0.0	291.8	
140.00		1.00	1.36	31.087	34.20	275.92	0.650	0.000	5.00	12.435	8.08	442.2	0.0	472.1	
145.00		1.00	1.37	31.317	34.45	266.37	0.650	0.000	5.00	11.970	7.78	428.8	0.0	454.3	
150.00		1.00	1.38	31.541	34.70	256.72	0.650	0.000	5.00	11.504	7.48	415.1	0.0	436.4	
152.00 Appurtenance(s)		1.00	1.38	31.630	34.79	252.84	0.650	0.000	2.00	4.471	2.91	161.8	0.0	169.6	
155.00		1.00	1.39	31.760	34.94	246.97	0.650	0.000	3.00	6.567	4.27	238.6	0.0	249.0	
160.00		1.00	1.40	31.973	35.17	237.13	0.650	0.000	5.00	10.573	6.87	386.7	0.0	400.8	
162.00 Appurtenance(s)		1.00	1.40	32.057	35.26	233.16	0.650	0.000	2.00	4.099	2.66	150.3	0.0	155.3	
								Totals:	162.00			16,762.2			33,747.3

* Cf Adjusted by Linear Load Ra Effect

Discrete Appurtenance Forces

Structure: CT01698-S-SBA	Code: EIA/TIA-222-G	10/18/2016
Site Name: Durham	Exposure: C	
Height: 162.00 (ft)	Crest Height: 0.00	
Base Elev: 0.000 (ft)	Site Class: D - Stiff Soil	
Gh: 1.1	Topography: 1	Struct Class: II



Page: 10

Load Case: 1.2D + 1.6W 97 mph Wind

Dead Load Factor 1.20
Wind Load Factor 1.60



Iterations 24

No.	Elev (ft)	Description	Qty	qz (psf)	qzGh (psf)	CaAa x Ka	Ka	Total CaAa (sf)	Dead Load (lb)	Horiz Ecc (ft)	Vert Ecc (ft)	Wind FX (lb)	Mom Y (lb-ft)	Mom Z (lb-ft)
1	162.00	1900MHz RRH	3	32.057	35.262	0.88	1.00	10.03	158.40	0.000	0.000	566.00	0.00	0.00
2	162.00	APXVTM14-C-120	3	32.077	35.285	0.63	0.80	12.02	201.60	0.000	0.500	678.64	0.00	339.32
3	162.00	TD-RRH8x20-25	3	32.057	35.262	0.69	1.00	8.38	252.00	0.000	0.000	472.99	0.00	0.00
4	162.00	APXVSP18-C-A20	3	32.077	35.285	0.66	0.80	15.98	205.20	0.000	0.500	901.94	0.00	450.97
5	162.00	Flush Mount	1	31.973	35.170	1.00	1.00	5.00	210.00	0.000	-2.000	281.36	0.00	-562.72
6	162.00	800 MHz Ext. Filter	3	32.057	35.262	0.63	1.00	2.25	23.76	0.000	0.000	126.89	0.00	0.00
7	162.00	ACU-A20-N	4	32.077	35.285	0.75	1.00	0.42	4.80	0.000	0.500	23.71	0.00	11.86
8	162.00	Low Profile Platform-flat	1	32.057	35.262	1.00	1.00	25.00	1440.00	0.000	0.000	1410.49	0.00	0.00
9	162.00	800 MHz RRU	3	32.057	35.262	0.75	1.00	5.60	190.80	0.000	0.000	316.09	0.00	0.00
10	152.00	KRY 112 144/1	3	31.630	34.792	0.55	0.75	0.57	39.60	0.000	0.000	32.00	0.00	0.00
11	152.00	APXV18-206516S-A20	3	31.630	34.792	0.57	0.75	7.46	66.60	0.000	0.000	415.04	0.00	0.00
12	152.00	LNx-6515DS-A1M	3	31.630	34.792	0.60	0.75	20.65	179.28	0.000	0.000	1149.32	0.00	0.00
13	152.00	FE15501P77/75	3	31.630	34.792	0.49	0.75	0.79	63.00	0.000	0.000	43.96	0.00	0.00
14	152.00	782 11056	3	31.630	34.792	0.50	0.75	0.23	6.48	0.000	0.000	12.59	0.00	0.00
15	152.00	Platform w/ Hand Rail	1	31.630	34.792	1.00	1.00	42.00	2425.20	0.000	0.000	2338.06	0.00	0.00
16	152.00	RR90-17-02DP	6	31.630	34.792	0.55	0.75	14.32	97.20	0.000	0.000	797.31	0.00	0.00
17	132.00	RFS DB-T1-6Z-8AB-0Z	2	30.704	33.774	0.57	0.80	4.92	105.60	0.000	0.000	265.81	0.00	0.00
18	132.00	FD9R6004/2C-3L	6	30.704	33.774	0.60	0.80	1.30	22.32	0.000	0.000	70.03	0.00	0.00
19	132.00	RRH2X60-700	3	30.704	33.774	0.61	0.80	6.38	216.00	0.000	0.000	344.98	0.00	0.00
20	132.00	RRH2X60-AWS	3	30.704	33.774	0.61	0.80	6.38	216.00	0.000	0.000	344.98	0.00	0.00
21	132.00	DB846F65ZAXY	4	30.704	33.774	0.74	0.80	20.98	100.80	0.000	0.000	1133.78	0.00	0.00
22	132.00	LPA-80080-4CF-EDIN-0	2	30.704	33.774	1.36	0.80	7.10	28.80	0.000	0.000	383.63	0.00	0.00
23	132.00	SBNHH-1D65B	9	30.704	33.774	0.66	0.80	48.29	438.48	0.000	0.000	2609.33	0.00	0.00
24	132.00	Low Profile Platform-flat	1	30.704	33.774	1.00	1.00	25.00	1440.00	0.000	0.000	1350.97	0.00	0.00
25	132.00	RRH2x60-1900	3	30.704	33.774	0.60	0.80	2.72	70.20	0.000	0.000	146.88	0.00	0.00
26	124.50	RRUS-11	6	30.328	33.361	0.68	1.00	18.03	396.00	0.000	0.000	962.59	0.00	0.00
27	124.50	Flush Mount	1	30.328	33.361	1.00	1.00	5.00	210.00	0.000	0.000	266.89	0.00	0.00
28	124.50	DC6-48-60-18-8F	1	30.328	33.361	1.00	1.00	1.47	38.16	0.000	0.000	78.46	0.00	0.00
29	122.00	Low Profile Platform-flat	1	30.199	33.219	1.00	1.00	25.00	1440.00	0.000	0.000	1328.75	0.00	0.00
30	122.00	AM-X-CD-16-65-00T-RET	3	30.199	33.219	0.65	0.80	11.76	118.80	0.000	0.000	625.11	0.00	0.00
31	122.00	LGP21903	6	30.199	33.219	0.60	0.80	0.97	39.60	0.000	0.000	51.66	0.00	0.00
32	122.00	LGP21401	6	30.199	33.219	0.60	0.80	4.64	101.52	0.000	0.000	246.83	0.00	0.00
33	122.00	7770.00	6	30.199	33.219	0.58	0.80	19.27	252.00	0.000	0.000	1024.31	0.00	0.00
34	105.00	Low Profile Platform-flat	1	29.260	32.186	1.00	1.00	25.00	1440.00	0.000	0.000	1287.43	0.00	0.00
35	80.00	738-449	1	27.657	30.423	1.00	1.00	0.01	0.60	0.000	0.350	0.49	0.00	0.17
36	75.00	GPS	1	27.259	29.985	1.00	1.00	1.00	12.00	0.000	0.000	47.98	0.00	0.00

Totals: 12,250.80 22,137.30

Total Applied Force Summary

Structure: CT01698-S-SBA	Code: EIA/TIA-222-G	10/18/2016
Site Name: Durham	Exposure: C	
Height: 162.00 (ft)	Crest Height: 0.00	
Base Elev: 0.000 (ft)	Site Class: D - Stiff Soil	
Gh: 1.1	Topography: 1	Struct Class: II



Page: 11

Load Case: 1.2D + 1.6W 97 mph Wind

Dead Load Factor 1.20

Wind Load Factor 1.60

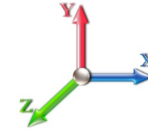

Iterations 24

Elev (ft)	Description	Lateral FX (-) (lb)	Axial FY (-) (lb)	Torsion MY (lb-ft)	Moment MZ (lb-ft)
0.00		0.00	0.00	0.00	0.00
5.00		538.69	1879.26	0.00	0.00
10.00		528.33	1848.07	0.00	0.00
15.00		517.97	1816.88	0.00	0.00
20.00		538.60	1785.70	0.00	0.00
25.00		552.99	1754.51	0.00	0.00
30.00		562.66	1723.32	0.00	0.00
35.00		568.85	1692.13	0.00	0.00
38.75		427.59	1248.63	0.00	0.00
40.00		144.06	712.91	0.00	0.00
45.00		582.58	2815.44	0.00	0.00
50.00		582.32	1428.43	0.00	0.00
55.00		580.52	1401.70	0.00	0.00
60.00		577.40	1374.97	0.00	0.00
65.00		573.13	1348.23	0.00	0.00
70.00		567.84	1321.50	0.00	0.00
75.00	(1) attachments	609.61	1306.76	0.00	0.00
78.50		388.22	889.76	0.00	0.00
80.00	(1) attachments	167.83	629.39	0.00	0.17
83.75		416.56	1551.96	0.00	0.00
85.00		137.42	270.74	0.00	0.00
90.00		546.93	1069.05	0.00	0.00
95.00		537.93	1046.77	0.00	0.00
100.00		528.35	1024.49	0.00	0.00
105.00	(1) attachments	1805.65	2442.22	0.00	0.00
110.00		507.59	979.94	0.00	0.00
115.00		496.48	957.66	0.00	0.00
119.25		412.66	796.49	0.00	0.00
120.00		73.12	219.26	0.00	0.00
122.00	(22) attachments	3471.09	2532.19	0.00	0.00
123.50		143.48	403.78	0.00	0.00
124.50	(8) attachments	1402.95	783.57	0.00	0.00
125.00		47.30	69.44	0.00	0.00
130.00		467.98	684.56	0.00	0.00
132.00	(33) attachments	6833.62	2907.04	0.00	0.00
135.00		271.20	348.80	0.00	0.00
140.00		442.23	567.08	0.00	0.00
145.00		428.83	549.26	0.00	0.00
150.00		415.11	531.43	0.00	0.00
152.00	(22) attachments	4950.07	3084.94	0.00	0.00
155.00		238.61	261.10	0.00	0.00
160.00		386.74	420.91	0.00	0.00
162.00	(24) attachments	4928.45	2849.93	0.00	239.42
Totals:		38,899.55	53,330.21	0.00	239.59

Linear Appurtenance Segment Forces (Factored)

Structure: CT01698-S-SBA	Code: EIA/TIA-222-G	10/18/2016
Site Name: Durham	Exposure: C	
Height: 162.00 (ft)	Crest Height: 0.00	
Base Elev: 0.000 (ft)	Site Class: D - Stiff Soil	
Gh: 1.1	Topography: 1	Struct Class: II



Page: 12

Load Case: 1.2D + 1.6W 97 mph Wind

Dead Load Factor 1.20

Wind Load Factor 1.60

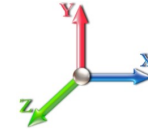

Iterations 24

Top Elev (ft)	Description	Wind Exposed	Length (ft)	Ca	Exposed Width (in)	Area (sqft)	CaAa (sqft)	Ra	Cf Adjust Factor	qz (psf)	F X (lb)	Dead Load (lb)
5.00	Safety Cable	Yes	5.00	0.000	0.38	0.16	0.00	0.058	0.000	19.450	0.00	1.64
5.00	1 5/8" Coax	Yes	5.00	0.000	0.00	0.00	0.00	0.058	0.000	19.450	0.00	74.88
5.00	10 mm	Yes	5.00	0.000	0.00	0.00	0.00	0.058	0.000	19.450	0.00	0.36
5.00	3" Coax	Yes	5.00	0.000	3.00	1.25	0.00	0.058	0.000	19.450	0.00	10.68
5.00	DC	Yes	5.00	0.000	0.00	0.00	0.00	0.058	0.000	19.450	0.00	4.80
5.00	1/2" Coax	Yes	5.00	0.000	0.00	0.00	0.00	0.058	0.000	19.450	0.00	0.96
10.00	Safety Cable	Yes	5.00	0.000	0.38	0.16	0.00	0.059	0.000	19.450	0.00	1.64
10.00	1 5/8" Coax	Yes	5.00	0.000	0.00	0.00	0.00	0.059	0.000	19.450	0.00	74.88
10.00	10 mm	Yes	5.00	0.000	0.00	0.00	0.00	0.059	0.000	19.450	0.00	0.36
10.00	3" Coax	Yes	5.00	0.000	3.00	1.25	0.00	0.059	0.000	19.450	0.00	10.68
10.00	DC	Yes	5.00	0.000	0.00	0.00	0.00	0.059	0.000	19.450	0.00	4.80
10.00	1/2" Coax	Yes	5.00	0.000	0.00	0.00	0.00	0.059	0.000	19.450	0.00	0.96
15.00	Safety Cable	Yes	5.00	0.000	0.38	0.16	0.00	0.060	0.000	19.450	0.00	1.64
15.00	1 5/8" Coax	Yes	5.00	0.000	0.00	0.00	0.00	0.060	0.000	19.450	0.00	74.88
15.00	10 mm	Yes	5.00	0.000	0.00	0.00	0.00	0.060	0.000	19.450	0.00	0.36
15.00	3" Coax	Yes	5.00	0.000	3.00	1.25	0.00	0.060	0.000	19.450	0.00	10.68
15.00	DC	Yes	5.00	0.000	0.00	0.00	0.00	0.060	0.000	19.450	0.00	4.80
15.00	1/2" Coax	Yes	5.00	0.000	0.00	0.00	0.00	0.060	0.000	19.450	0.00	0.96
20.00	Safety Cable	Yes	5.00	0.000	0.38	0.16	0.00	0.062	0.000	20.638	0.00	1.64
20.00	1 5/8" Coax	Yes	5.00	0.000	0.00	0.00	0.00	0.062	0.000	20.638	0.00	74.88
20.00	10 mm	Yes	5.00	0.000	0.00	0.00	0.00	0.062	0.000	20.638	0.00	0.36
20.00	3" Coax	Yes	5.00	0.000	3.00	1.25	0.00	0.062	0.000	20.638	0.00	10.68
20.00	DC	Yes	5.00	0.000	0.00	0.00	0.00	0.062	0.000	20.638	0.00	4.80
20.00	1/2" Coax	Yes	5.00	0.000	0.00	0.00	0.00	0.062	0.000	20.638	0.00	0.96
25.00	Safety Cable	Yes	5.00	0.000	0.38	0.16	0.00	0.063	0.000	21.630	0.00	1.64
25.00	1 5/8" Coax	Yes	5.00	0.000	0.00	0.00	0.00	0.063	0.000	21.630	0.00	74.88
25.00	10 mm	Yes	5.00	0.000	0.00	0.00	0.00	0.063	0.000	21.630	0.00	0.36
25.00	3" Coax	Yes	5.00	0.000	3.00	1.25	0.00	0.063	0.000	21.630	0.00	10.68
25.00	DC	Yes	5.00	0.000	0.00	0.00	0.00	0.063	0.000	21.630	0.00	4.80
25.00	1/2" Coax	Yes	5.00	0.000	0.00	0.00	0.00	0.063	0.000	21.630	0.00	0.96
30.00	Safety Cable	Yes	5.00	0.000	0.38	0.16	0.00	0.064	0.000	22.477	0.00	1.64
30.00	1 5/8" Coax	Yes	5.00	0.000	0.00	0.00	0.00	0.064	0.000	22.477	0.00	74.88
30.00	10 mm	Yes	5.00	0.000	0.00	0.00	0.00	0.064	0.000	22.477	0.00	0.36
30.00	3" Coax	Yes	5.00	0.000	3.00	1.25	0.00	0.064	0.000	22.477	0.00	10.68
30.00	DC	Yes	5.00	0.000	0.00	0.00	0.00	0.064	0.000	22.477	0.00	4.80
30.00	1/2" Coax	Yes	5.00	0.000	0.00	0.00	0.00	0.064	0.000	22.477	0.00	0.96
35.00	Safety Cable	Yes	5.00	0.000	0.38	0.16	0.00	0.066	0.000	23.218	0.00	1.64
35.00	1 5/8" Coax	Yes	5.00	0.000	0.00	0.00	0.00	0.066	0.000	23.218	0.00	74.88
35.00	10 mm	Yes	5.00	0.000	0.00	0.00	0.00	0.066	0.000	23.218	0.00	0.36
35.00	3" Coax	Yes	5.00	0.000	3.00	1.25	0.00	0.066	0.000	23.218	0.00	10.68
35.00	DC	Yes	5.00	0.000	0.00	0.00	0.00	0.066	0.000	23.218	0.00	4.80
35.00	1/2" Coax	Yes	5.00	0.000	0.00	0.00	0.00	0.066	0.000	23.218	0.00	0.96
38.75	Safety Cable	Yes	3.75	0.000	0.38	0.12	0.00	0.067	0.000	23.721	0.00	1.23
38.75	1 5/8" Coax	Yes	3.75	0.000	0.00	0.00	0.00	0.067	0.000	23.721	0.00	56.16
38.75	10 mm	Yes	3.75	0.000	0.00	0.00	0.00	0.067	0.000	23.721	0.00	0.27
38.75	3" Coax	Yes	3.75	0.000	3.00	0.94	0.00	0.067	0.000	23.721	0.00	8.01
38.75	DC	Yes	3.75	0.000	0.00	0.00	0.00	0.067	0.000	23.721	0.00	3.60

Linear Appurtenance Segment Forces (Factored)

Structure: CT01698-S-SBA	Code: EIA/TIA-222-G	10/18/2016
Site Name: Durham	Exposure: C	
Height: 162.00 (ft)	Crest Height: 0.00	
Base Elev: 0.000 (ft)	Site Class: D - Stiff Soil	
Gh: 1.1	Topography: 1	Struct Class: II



Page: 13

Load Case: 1.2D + 1.6W 97 mph Wind

Dead Load Factor 1.20
Wind Load Factor 1.60



Iterations 24

Top Elev (ft)	Description	Wind Exposed	Length (ft)	Ca	Exposed Width (in)	Area (sqft)	CaAa (sqft)	Ra	Cf Adjust Factor	qz (psf)	F X (lb)	Dead Load (lb)
38.75	1/2" Coax	Yes	3.75	0.000	0.00	0.00	0.00	0.067	0.000	23.721	0.00	0.72
40.00	Safety Cable	Yes	1.25	0.000	0.38	0.04	0.00	0.068	0.000	23.880	0.00	0.41
40.00	1 5/8" Coax	Yes	1.25	0.000	0.00	0.00	0.00	0.068	0.000	23.880	0.00	18.72
40.00	10 mm	Yes	1.25	0.000	0.00	0.00	0.00	0.068	0.000	23.880	0.00	0.09
40.00	3" Coax	Yes	1.25	0.000	3.00	0.31	0.00	0.068	0.000	23.880	0.00	2.67
40.00	DC	Yes	1.25	0.000	0.00	0.00	0.00	0.068	0.000	23.880	0.00	1.20
40.00	1/2" Coax	Yes	1.25	0.000	0.00	0.00	0.00	0.068	0.000	23.880	0.00	0.24
45.00	Safety Cable	Yes	5.00	0.000	0.38	0.16	0.00	0.069	0.000	24.479	0.00	1.64
45.00	1 5/8" Coax	Yes	5.00	0.000	0.00	0.00	0.00	0.069	0.000	24.479	0.00	74.88
45.00	10 mm	Yes	5.00	0.000	0.00	0.00	0.00	0.069	0.000	24.479	0.00	0.36
45.00	3" Coax	Yes	5.00	0.000	3.00	1.25	0.00	0.069	0.000	24.479	0.00	10.68
45.00	DC	Yes	5.00	0.000	0.00	0.00	0.00	0.069	0.000	24.479	0.00	4.80
45.00	1/2" Coax	Yes	5.00	0.000	0.00	0.00	0.00	0.069	0.000	24.479	0.00	0.96
50.00	Safety Cable	Yes	5.00	0.000	0.38	0.16	0.00	0.069	0.000	25.029	0.00	1.64
50.00	1 5/8" Coax	Yes	5.00	0.000	0.00	0.00	0.00	0.069	0.000	25.029	0.00	74.88
50.00	10 mm	Yes	5.00	0.000	0.00	0.00	0.00	0.069	0.000	25.029	0.00	0.36
50.00	3" Coax	Yes	5.00	0.000	3.00	1.25	0.00	0.069	0.000	25.029	0.00	10.68
50.00	DC	Yes	5.00	0.000	0.00	0.00	0.00	0.069	0.000	25.029	0.00	4.80
50.00	1/2" Coax	Yes	5.00	0.000	0.00	0.00	0.00	0.069	0.000	25.029	0.00	0.96
55.00	Safety Cable	Yes	5.00	0.000	0.38	0.16	0.00	0.071	0.000	25.536	0.00	1.64
55.00	1 5/8" Coax	Yes	5.00	0.000	0.00	0.00	0.00	0.071	0.000	25.536	0.00	74.88
55.00	10 mm	Yes	5.00	0.000	0.00	0.00	0.00	0.071	0.000	25.536	0.00	0.36
55.00	3" Coax	Yes	5.00	0.000	3.00	1.25	0.00	0.071	0.000	25.536	0.00	10.68
55.00	DC	Yes	5.00	0.000	0.00	0.00	0.00	0.071	0.000	25.536	0.00	4.80
55.00	1/2" Coax	Yes	5.00	0.000	0.00	0.00	0.00	0.071	0.000	25.536	0.00	0.96
60.00	Safety Cable	Yes	5.00	0.000	0.38	0.16	0.00	0.073	0.000	26.008	0.00	1.64
60.00	1 5/8" Coax	Yes	5.00	0.000	0.00	0.00	0.00	0.073	0.000	26.008	0.00	74.88
60.00	10 mm	Yes	5.00	0.000	0.00	0.00	0.00	0.073	0.000	26.008	0.00	0.36
60.00	3" Coax	Yes	5.00	0.000	3.00	1.25	0.00	0.073	0.000	26.008	0.00	10.68
60.00	DC	Yes	5.00	0.000	0.00	0.00	0.00	0.073	0.000	26.008	0.00	4.80
60.00	1/2" Coax	Yes	5.00	0.000	0.00	0.00	0.00	0.073	0.000	26.008	0.00	0.96
65.00	Safety Cable	Yes	5.00	0.000	0.38	0.16	0.00	0.074	0.000	26.450	0.00	1.64
65.00	1 5/8" Coax	Yes	5.00	0.000	0.00	0.00	0.00	0.074	0.000	26.450	0.00	74.88
65.00	10 mm	Yes	5.00	0.000	0.00	0.00	0.00	0.074	0.000	26.450	0.00	0.36
65.00	3" Coax	Yes	5.00	0.000	3.00	1.25	0.00	0.074	0.000	26.450	0.00	10.68
65.00	DC	Yes	5.00	0.000	0.00	0.00	0.00	0.074	0.000	26.450	0.00	4.80
65.00	1/2" Coax	Yes	5.00	0.000	0.00	0.00	0.00	0.074	0.000	26.450	0.00	0.96
70.00	Safety Cable	Yes	5.00	0.000	0.38	0.16	0.00	0.076	0.000	26.866	0.00	1.64
70.00	1 5/8" Coax	Yes	5.00	0.000	0.00	0.00	0.00	0.076	0.000	26.866	0.00	74.88
70.00	10 mm	Yes	5.00	0.000	0.00	0.00	0.00	0.076	0.000	26.866	0.00	0.36
70.00	3" Coax	Yes	5.00	0.000	3.00	1.25	0.00	0.076	0.000	26.866	0.00	10.68
70.00	DC	Yes	5.00	0.000	0.00	0.00	0.00	0.076	0.000	26.866	0.00	4.80
70.00	1/2" Coax	Yes	5.00	0.000	0.00	0.00	0.00	0.076	0.000	26.866	0.00	0.96
75.00	Safety Cable	Yes	5.00	0.000	0.38	0.16	0.00	0.078	0.000	27.259	0.00	1.64
75.00	1 5/8" Coax	Yes	5.00	0.000	0.00	0.00	0.00	0.078	0.000	27.259	0.00	74.88
75.00	10 mm	Yes	5.00	0.000	0.00	0.00	0.00	0.078	0.000	27.259	0.00	0.36
75.00	3" Coax	Yes	5.00	0.000	3.00	1.25	0.00	0.078	0.000	27.259	0.00	10.68

Linear Appurtenance Segment Forces (Factored)

Structure: CT01698-S-SBA	Code: EIA/TIA-222-G	10/18/2016
Site Name: Durham	Exposure: C	
Height: 162.00 (ft)	Crest Height: 0.00	
Base Elev: 0.000 (ft)	Site Class: D - Stiff Soil	
Gh: 1.1	Topography: 1	Struct Class: II



Page: 14

Load Case: 1.2D + 1.6W 97 mph Wind

Dead Load Factor 1.20

Wind Load Factor 1.60

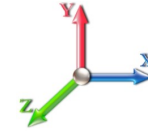

Iterations 24

Top Elev (ft)	Description	Wind Exposed	Length (ft)	Ca	Exposed Width (in)	Area (sqft)	CaAa (sqft)	Ra	Cf Adjust Factor	qz (psf)	F X (lb)	Dead Load (lb)
75.00	DC	Yes	5.00	0.000	0.00	0.00	0.00	0.078	0.000	27.259	0.00	4.80
75.00	1/2" Coax	Yes	5.00	0.000	0.00	0.00	0.00	0.078	0.000	27.259	0.00	0.96
78.50	Safety Cable	Yes	3.50	0.000	0.38	0.11	0.00	0.080	0.000	27.522	0.00	1.15
78.50	1 5/8" Coax	Yes	3.50	0.000	0.00	0.00	0.00	0.080	0.000	27.522	0.00	52.42
78.50	10 mm	Yes	3.50	0.000	0.00	0.00	0.00	0.080	0.000	27.522	0.00	0.25
78.50	3" Coax	Yes	3.50	0.000	3.00	0.88	0.00	0.080	0.000	27.522	0.00	7.48
78.50	DC	Yes	3.50	0.000	0.00	0.00	0.00	0.080	0.000	27.522	0.00	3.36
80.00	Safety Cable	Yes	1.50	0.000	0.38	0.05	0.00	0.081	0.000	27.632	0.00	0.49
80.00	1 5/8" Coax	Yes	1.50	0.000	0.00	0.00	0.00	0.081	0.000	27.632	0.00	22.46
80.00	10 mm	Yes	1.50	0.000	0.00	0.00	0.00	0.081	0.000	27.632	0.00	0.11
80.00	3" Coax	Yes	1.50	0.000	3.00	0.38	0.00	0.081	0.000	27.632	0.00	3.20
80.00	DC	Yes	1.50	0.000	0.00	0.00	0.00	0.081	0.000	27.632	0.00	1.44
83.75	Safety Cable	Yes	3.75	0.000	0.38	0.12	0.00	0.082	0.000	27.899	0.00	1.23
83.75	1 5/8" Coax	Yes	3.75	0.000	0.00	0.00	0.00	0.082	0.000	27.899	0.00	56.16
83.75	10 mm	Yes	3.75	0.000	0.00	0.00	0.00	0.082	0.000	27.899	0.00	0.27
83.75	3" Coax	Yes	3.75	0.000	3.00	0.94	0.00	0.082	0.000	27.899	0.00	8.01
83.75	DC	Yes	3.75	0.000	0.00	0.00	0.00	0.082	0.000	27.899	0.00	3.60
85.00	Safety Cable	Yes	1.25	0.000	0.38	0.04	0.00	0.082	0.000	27.987	0.00	0.41
85.00	1 5/8" Coax	Yes	1.25	0.000	0.00	0.00	0.00	0.082	0.000	27.987	0.00	18.72
85.00	10 mm	Yes	1.25	0.000	0.00	0.00	0.00	0.082	0.000	27.987	0.00	0.09
85.00	3" Coax	Yes	1.25	0.000	3.00	0.31	0.00	0.082	0.000	27.987	0.00	2.67
85.00	DC	Yes	1.25	0.000	0.00	0.00	0.00	0.082	0.000	27.987	0.00	1.20
90.00	Safety Cable	Yes	5.00	0.000	0.38	0.16	0.00	0.083	0.000	28.325	0.00	1.64
90.00	1 5/8" Coax	Yes	5.00	0.000	0.00	0.00	0.00	0.083	0.000	28.325	0.00	74.88
90.00	10 mm	Yes	5.00	0.000	0.00	0.00	0.00	0.083	0.000	28.325	0.00	0.36
90.00	3" Coax	Yes	5.00	0.000	3.00	1.25	0.00	0.083	0.000	28.325	0.00	10.68
90.00	DC	Yes	5.00	0.000	0.00	0.00	0.00	0.083	0.000	28.325	0.00	4.80
95.00	Safety Cable	Yes	5.00	0.000	0.38	0.16	0.00	0.086	0.000	28.650	0.00	1.64
95.00	1 5/8" Coax	Yes	5.00	0.000	0.00	0.00	0.00	0.086	0.000	28.650	0.00	74.88
95.00	10 mm	Yes	5.00	0.000	0.00	0.00	0.00	0.086	0.000	28.650	0.00	0.36
95.00	3" Coax	Yes	5.00	0.000	3.00	1.25	0.00	0.086	0.000	28.650	0.00	10.68
95.00	DC	Yes	5.00	0.000	0.00	0.00	0.00	0.086	0.000	28.650	0.00	4.80
100.00	Safety Cable	Yes	5.00	0.000	0.38	0.16	0.00	0.088	0.000	28.961	0.00	1.64
100.00	1 5/8" Coax	Yes	5.00	0.000	0.00	0.00	0.00	0.088	0.000	28.961	0.00	74.88
100.00	10 mm	Yes	5.00	0.000	0.00	0.00	0.00	0.088	0.000	28.961	0.00	0.36
100.00	3" Coax	Yes	5.00	0.000	3.00	1.25	0.00	0.088	0.000	28.961	0.00	10.68
100.00	DC	Yes	5.00	0.000	0.00	0.00	0.00	0.088	0.000	28.961	0.00	4.80
105.00	Safety Cable	Yes	5.00	0.000	0.38	0.16	0.00	0.091	0.000	29.260	0.00	1.64
105.00	1 5/8" Coax	Yes	5.00	0.000	0.00	0.00	0.00	0.091	0.000	29.260	0.00	74.88
105.00	10 mm	Yes	5.00	0.000	0.00	0.00	0.00	0.091	0.000	29.260	0.00	0.36
105.00	3" Coax	Yes	5.00	0.000	3.00	1.25	0.00	0.091	0.000	29.260	0.00	10.68
105.00	DC	Yes	5.00	0.000	0.00	0.00	0.00	0.091	0.000	29.260	0.00	4.80
110.00	Safety Cable	Yes	5.00	0.000	0.38	0.16	0.00	0.094	0.000	29.548	0.00	1.64
110.00	1 5/8" Coax	Yes	5.00	0.000	0.00	0.00	0.00	0.094	0.000	29.548	0.00	74.88
110.00	10 mm	Yes	5.00	0.000	0.00	0.00	0.00	0.094	0.000	29.548	0.00	0.36
110.00	3" Coax	Yes	5.00	0.000	3.00	1.25	0.00	0.094	0.000	29.548	0.00	10.68
110.00	DC	Yes	5.00	0.000	0.00	0.00	0.00	0.094	0.000	29.548	0.00	4.80

Linear Appurtenance Segment Forces (Factored)

Structure: CT01698-S-SBA	Code: EIA/TIA-222-G	10/18/2016
Site Name: Durham	Exposure: C	
Height: 162.00 (ft)	Crest Height: 0.00	
Base Elev: 0.000 (ft)	Site Class: D - Stiff Soil	
Gh: 1.1	Topography: 1	Struct Class: II



Page: 15

Load Case: 1.2D + 1.6W 97 mph Wind

Dead Load Factor 1.20

Wind Load Factor 1.60

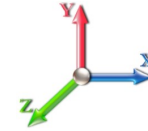

Iterations 24

Top Elev (ft)	Description	Wind Exposed	Length (ft)	Ca	Exposed Width (in)	Area (sqft)	CaAa (sqft)	Ra	Cf Adjust Factor	qz (psf)	F X (lb)	Dead Load (lb)
115.00	Safety Cable	Yes	5.00	0.000	0.38	0.16	0.00	0.097	0.000	29.826	0.00	1.64
115.00	1 5/8" Coax	Yes	5.00	0.000	0.00	0.00	0.00	0.097	0.000	29.826	0.00	74.88
115.00	10 mm	Yes	5.00	0.000	0.00	0.00	0.00	0.097	0.000	29.826	0.00	0.36
115.00	3" Coax	Yes	5.00	0.000	3.00	1.25	0.00	0.097	0.000	29.826	0.00	10.68
115.00	DC	Yes	5.00	0.000	0.00	0.00	0.00	0.097	0.000	29.826	0.00	4.80
119.25	Safety Cable	Yes	4.25	0.000	0.38	0.13	0.00	0.100	0.000	30.054	0.00	1.39
119.25	1 5/8" Coax	Yes	4.25	0.000	0.00	0.00	0.00	0.100	0.000	30.054	0.00	63.65
119.25	10 mm	Yes	4.25	0.000	0.00	0.00	0.00	0.100	0.000	30.054	0.00	0.31
119.25	3" Coax	Yes	4.25	0.000	3.00	1.06	0.00	0.100	0.000	30.054	0.00	9.08
119.25	DC	Yes	4.25	0.000	0.00	0.00	0.00	0.100	0.000	30.054	0.00	4.08
120.00	Safety Cable	Yes	0.75	0.000	0.38	0.02	0.00	0.101	1.004	30.094	0.00	0.25
120.00	1 5/8" Coax	Yes	0.75	0.000	0.00	0.00	0.00	0.101	1.004	30.094	0.00	11.23
120.00	10 mm	Yes	0.75	0.000	0.00	0.00	0.00	0.101	1.004	30.094	0.00	0.05
120.00	3" Coax	Yes	0.75	0.000	3.00	0.19	0.00	0.101	1.004	30.094	0.00	1.60
120.00	DC	Yes	0.75	0.000	0.00	0.00	0.00	0.101	1.004	30.094	0.00	0.72
122.00	Safety Cable	Yes	2.00	0.000	0.38	0.06	0.00	0.102	1.007	30.199	0.00	0.66
122.00	1 5/8" Coax	Yes	2.00	0.000	0.00	0.00	0.00	0.102	1.007	30.199	0.00	29.95
122.00	10 mm	Yes	2.00	0.000	0.00	0.00	0.00	0.102	1.007	30.199	0.00	0.14
122.00	3" Coax	Yes	2.00	0.000	3.00	0.50	0.00	0.102	1.007	30.199	0.00	4.27
122.00	DC	Yes	2.00	0.000	0.00	0.00	0.00	0.102	1.007	30.199	0.00	1.92
123.50	Safety Cable	Yes	1.50	0.000	0.38	0.05	0.00	0.012	0.000	30.277	0.00	0.49
124.50	Safety Cable	Yes	1.00	0.000	0.38	0.03	0.00	0.012	0.000	30.328	0.00	0.33
125.00	Safety Cable	Yes	0.50	0.000	0.38	0.02	0.00	0.012	0.000	30.354	0.00	0.16
130.00	Safety Cable	Yes	5.00	0.000	0.38	0.16	0.00	0.012	0.000	30.605	0.00	1.64
132.00	Safety Cable	Yes	2.00	0.000	0.38	0.06	0.00	0.012	0.000	30.704	0.00	0.66
135.00	Safety Cable	Yes	3.00	0.000	0.38	0.10	0.00	0.012	0.000	30.850	0.00	0.98
140.00	Safety Cable	Yes	5.00	0.000	0.38	0.16	0.00	0.013	0.000	31.087	0.00	1.64
145.00	Safety Cable	Yes	5.00	0.000	0.38	0.16	0.00	0.013	0.000	31.317	0.00	1.64
150.00	Safety Cable	Yes	5.00	0.000	0.38	0.16	0.00	0.014	0.000	31.541	0.00	1.64
152.00	Safety Cable	Yes	2.00	0.000	0.38	0.06	0.00	0.014	0.000	31.630	0.00	0.66
155.00	Safety Cable	Yes	3.00	0.000	0.38	0.10	0.00	0.014	0.000	31.760	0.00	0.98
160.00	Safety Cable	Yes	5.00	0.000	0.38	0.16	0.00	0.015	0.000	31.973	0.00	1.64
162.00	Safety Cable	Yes	2.00	0.000	0.38	0.06	0.00	0.015	0.000	32.057	0.00	0.66
Totals:											0.0	2,281.0

Wind Loading - Shaft

Structure: CT01698-S-SBA	Code: EIA/TIA-222-G	10/18/2016
Site Name: Durham	Exposure: C	
Height: 162.00 (ft)	Crest Height: 0.00	
Base Elev: 0.000 (ft)	Site Class: D - Stiff Soil	
Gh: 1.1	Topography: 1	Struct Class: II



Page: 17

Load Case: 0.9D + 1.6W 97 mph Wind

Dead Load Factor 0.90
Wind Load Factor 1.60

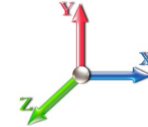

Iterations 24

Elev (ft)	Description	Kzt	Kz	qz (psf)	qzGh (psf)	C (mph-ft)	Cf	Ice Thick (in)	Tributary (ft)	Aa (sf)	CfAa (sf)	Wind Force X (lb)	Dead Load Ice (lb)	Tot Dead Load (lb)
0.00		1.00	0.85	19.450	21.40	437.17	0.650	0.000	0.00	0.000	0.00	0.0	0.0	0.0
5.00		1.00	0.85	19.450	21.40	428.85	0.650	0.000	5.00	24.209	15.74	538.7	0.0	1207.3
10.00		1.00	0.85	19.450	21.40	420.52	0.650	0.000	5.00	23.744	15.43	528.3	0.0	1183.9
15.00		1.00	0.85	19.450	21.40	412.19	0.650	0.000	5.00	23.278	15.13	518.0	0.0	1160.6
20.00		1.00	0.90	20.638	22.70	416.01	0.650	0.000	5.00	22.813	14.83	538.6	0.0	1137.2
25.00		1.00	0.95	21.630	23.79	417.12	0.650	0.000	5.00	22.348	14.53	553.0	0.0	1113.8
30.00		1.00	0.98	22.477	24.72	416.25	0.650	0.000	5.00	21.882	14.22	562.7	0.0	1090.4
35.00		1.00	1.01	23.218	25.54	413.97	0.650	0.000	5.00	21.417	13.92	568.9	0.0	1067.0
38.75 Bot - Section 2		1.00	1.04	23.721	26.09	411.53	0.650	0.000	3.75	15.757	10.24	427.6	0.0	784.9
40.00		1.00	1.04	23.880	26.27	410.60	0.650	0.000	1.25	5.273	3.43	144.1	0.0	484.2
45.00 Top - Section 1		1.00	1.07	24.479	26.93	406.38	0.650	0.000	5.00	20.803	13.52	582.6	0.0	1909.5
50.00		1.00	1.09	25.029	27.53	407.91	0.650	0.000	5.00	20.338	13.22	582.3	0.0	869.2
55.00		1.00	1.12	25.536	28.09	402.48	0.650	0.000	5.00	19.872	12.92	580.5	0.0	849.2
60.00		1.00	1.14	26.008	28.61	396.56	0.650	0.000	5.00	19.407	12.61	577.4	0.0	829.1
65.00		1.00	1.16	26.450	29.09	390.21	0.650	0.000	5.00	18.941	12.31	573.1	0.0	809.1
70.00		1.00	1.17	26.866	29.55	383.48	0.650	0.000	5.00	18.476	12.01	567.8	0.0	789.0
75.00 Appurtenance(s)		1.00	1.19	27.259	29.98	376.42	0.650	0.000	5.00	18.010	11.71	561.6	0.0	769.0
78.50 Bot - Section 3		1.00	1.20	27.522	30.27	371.30	0.650	0.000	3.50	12.330	8.01	388.2	0.0	526.3
80.00 Appurtenance(s)		1.00	1.21	27.632	30.39	369.06	0.650	0.000	1.50	5.294	3.44	167.3	0.0	411.2
83.75 Top - Section 2		1.00	1.22	27.899	30.69	363.37	0.650	0.000	3.75	13.051	8.48	416.6	0.0	1013.5
85.00		1.00	1.22	27.987	30.79	367.11	0.650	0.000	1.25	4.292	2.79	137.4	0.0	152.9
90.00		1.00	1.24	28.325	31.16	359.28	0.650	0.000	5.00	16.878	10.97	546.9	0.0	601.1
95.00		1.00	1.25	28.650	31.51	351.23	0.650	0.000	5.00	16.413	10.67	537.9	0.0	584.4
100.00		1.00	1.27	28.961	31.86	342.97	0.650	0.000	5.00	15.947	10.37	528.4	0.0	567.7
105.00 Appurtenance(s)		1.00	1.28	29.260	32.19	334.52	0.650	0.000	5.00	15.482	10.06	518.2	0.0	551.0
110.00		1.00	1.29	29.548	32.50	325.90	0.650	0.000	5.00	15.016	9.76	507.6	0.0	534.3
115.00		1.00	1.30	29.826	32.81	317.12	0.650	0.000	5.00	14.551	9.46	496.5	0.0	517.6
119.25 Bot - Section 4		1.00	1.31	30.054	33.06	309.54	0.650	0.000	4.25	12.002	7.80	412.7	0.0	426.8
120.00		1.00	1.32	30.094	33.10	308.19	0.653 *	0.000	0.75	2.115	1.38	73.1	0.0	134.3
122.00 Appurtenance(s)		1.00	1.32	30.199	33.22	304.58	0.655 *	0.000	2.00	5.588	3.66	194.4	0.0	354.9
123.50 Top - Section 3		1.00	1.32	30.277	33.30	301.86	0.650	0.000	1.50	4.142	2.69	143.5	0.0	263.0
124.50 Appurtenance(s)		1.00	1.33	30.328	33.36	304.76	0.650	0.000	1.00	2.738	1.78	95.0	0.0	78.0
125.00		1.00	1.33	30.354	33.39	303.85	0.650	0.000	0.50	1.362	0.89	47.3	0.0	38.8
130.00		1.00	1.34	30.605	33.67	294.66	0.650	0.000	5.00	13.366	8.69	468.0	0.0	380.8
132.00 Appurtenance(s)		1.00	1.34	30.704	33.77	290.95	0.650	0.000	2.00	5.216	3.39	183.2	0.0	148.6
135.00		1.00	1.35	30.850	33.93	285.35	0.650	0.000	3.00	7.684	4.99	271.2	0.0	218.9
140.00		1.00	1.36	31.087	34.20	275.92	0.650	0.000	5.00	12.435	8.08	442.2	0.0	354.1
145.00		1.00	1.37	31.317	34.45	266.37	0.650	0.000	5.00	11.970	7.78	428.8	0.0	340.7
150.00		1.00	1.38	31.541	34.70	256.72	0.650	0.000	5.00	11.504	7.48	415.1	0.0	327.3
152.00 Appurtenance(s)		1.00	1.38	31.630	34.79	252.84	0.650	0.000	2.00	4.471	2.91	161.8	0.0	127.2
155.00		1.00	1.39	31.760	34.94	246.97	0.650	0.000	3.00	6.567	4.27	238.6	0.0	186.8
160.00		1.00	1.40	31.973	35.17	237.13	0.650	0.000	5.00	10.573	6.87	386.7	0.0	300.6
162.00 Appurtenance(s)		1.00	1.40	32.057	35.26	233.16	0.650	0.000	2.00	4.099	2.66	150.3	0.0	116.5
Totals:									162.00			16,762.2	25,310.5	

* Cf Adjusted by Linear Load Ra Effect

Discrete Appurtenance Forces

Structure: CT01698-S-SBA	Code: EIA/TIA-222-G	10/18/2016
Site Name: Durham	Exposure: C	
Height: 162.00 (ft)	Crest Height: 0.00	
Base Elev: 0.000 (ft)	Site Class: D - Stiff Soil	
Gh: 1.1	Topography: 1	Struct Class: II



Page: 18

Load Case: 0.9D + 1.6W 97 mph Wind

Dead Load Factor 0.90
Wind Load Factor 1.60



Iterations 24

No.	Elev (ft)	Description	Qty	qz (psf)	qzGh (psf)	CaAa x Ka	Ka	Total CaAa (sf)	Dead Load (lb)	Horiz Ecc (ft)	Vert Ecc (ft)	Wind FX (lb)	Mom Y (lb-ft)	Mom Z (lb-ft)
1	162.00	1900MHz RRH	3	32.057	35.262	0.88	1.00	10.03	118.80	0.000	0.000	566.00	0.00	0.00
2	162.00	APXVTM14-C-120	3	32.077	35.285	0.63	0.80	12.02	151.20	0.000	0.500	678.64	0.00	339.32
3	162.00	TD-RRH8x20-25	3	32.057	35.262	0.69	1.00	8.38	189.00	0.000	0.000	472.99	0.00	0.00
4	162.00	APXVSPP18-C-A20	3	32.077	35.285	0.66	0.80	15.98	153.90	0.000	0.500	901.94	0.00	450.97
5	162.00	Flush Mount	1	31.973	35.170	1.00	1.00	5.00	157.50	0.000	-2.000	281.36	0.00	-562.72
6	162.00	800 MHz Ext. Filter	3	32.057	35.262	0.63	1.00	2.25	17.82	0.000	0.000	126.89	0.00	0.00
7	162.00	ACU-A20-N	4	32.077	35.285	0.75	1.00	0.42	3.60	0.000	0.500	23.71	0.00	11.86
8	162.00	Low Profile Platform-flat	1	32.057	35.262	1.00	1.00	25.00	1080.00	0.000	0.000	1410.49	0.00	0.00
9	162.00	800 MHz RRU	3	32.057	35.262	0.75	1.00	5.60	143.10	0.000	0.000	316.09	0.00	0.00
10	152.00	KRY 112 144/1	3	31.630	34.792	0.55	0.75	0.57	29.70	0.000	0.000	32.00	0.00	0.00
11	152.00	APXV18-206516S-A20	3	31.630	34.792	0.57	0.75	7.46	49.95	0.000	0.000	415.04	0.00	0.00
12	152.00	LNx-6515DS-A1M	3	31.630	34.792	0.60	0.75	20.65	134.46	0.000	0.000	1149.32	0.00	0.00
13	152.00	FE15501P77/75	3	31.630	34.792	0.49	0.75	0.79	47.25	0.000	0.000	43.96	0.00	0.00
14	152.00	782 11056	3	31.630	34.792	0.50	0.75	0.23	4.86	0.000	0.000	12.59	0.00	0.00
15	152.00	Platform w/ Hand Rail	1	31.630	34.792	1.00	1.00	42.00	1818.90	0.000	0.000	2338.06	0.00	0.00
16	152.00	RR90-17-02DP	6	31.630	34.792	0.55	0.75	14.32	72.90	0.000	0.000	797.31	0.00	0.00
17	132.00	RFS DB-T1-6Z-8AB-0Z	2	30.704	33.774	0.57	0.80	4.92	79.20	0.000	0.000	265.81	0.00	0.00
18	132.00	FD9R6004/2C-3L	6	30.704	33.774	0.60	0.80	1.30	16.74	0.000	0.000	70.03	0.00	0.00
19	132.00	RRH2X60-700	3	30.704	33.774	0.61	0.80	6.38	162.00	0.000	0.000	344.98	0.00	0.00
20	132.00	RRH2X60-AWS	3	30.704	33.774	0.61	0.80	6.38	162.00	0.000	0.000	344.98	0.00	0.00
21	132.00	DB846F65ZAXY	4	30.704	33.774	0.74	0.80	20.98	75.60	0.000	0.000	1133.78	0.00	0.00
22	132.00	LPA-80080-4CF-EDIN-0	2	30.704	33.774	1.36	0.80	7.10	21.60	0.000	0.000	383.63	0.00	0.00
23	132.00	SBNHH-1D65B	9	30.704	33.774	0.66	0.80	48.29	328.86	0.000	0.000	2609.33	0.00	0.00
24	132.00	Low Profile Platform-flat	1	30.704	33.774	1.00	1.00	25.00	1080.00	0.000	0.000	1350.97	0.00	0.00
25	132.00	RRH2x60-1900	3	30.704	33.774	0.60	0.80	2.72	52.65	0.000	0.000	146.88	0.00	0.00
26	124.50	RRUS-11	6	30.328	33.361	0.68	1.00	18.03	297.00	0.000	0.000	962.59	0.00	0.00
27	124.50	Flush Mount	1	30.328	33.361	1.00	1.00	5.00	157.50	0.000	0.000	266.89	0.00	0.00
28	124.50	DC6-48-60-18-8F	1	30.328	33.361	1.00	1.00	1.47	28.62	0.000	0.000	78.46	0.00	0.00
29	122.00	Low Profile Platform-flat	1	30.199	33.219	1.00	1.00	25.00	1080.00	0.000	0.000	1328.75	0.00	0.00
30	122.00	AM-X-CD-16-65-00T-RET	3	30.199	33.219	0.65	0.80	11.76	89.10	0.000	0.000	625.11	0.00	0.00
31	122.00	LGP21903	6	30.199	33.219	0.60	0.80	0.97	29.70	0.000	0.000	51.66	0.00	0.00
32	122.00	LGP21401	6	30.199	33.219	0.60	0.80	4.64	76.14	0.000	0.000	246.83	0.00	0.00
33	122.00	7770.00	6	30.199	33.219	0.58	0.80	19.27	189.00	0.000	0.000	1024.31	0.00	0.00
34	105.00	Low Profile Platform-flat	1	29.260	32.186	1.00	1.00	25.00	1080.00	0.000	0.000	1287.43	0.00	0.00
35	80.00	738-449	1	27.657	30.423	1.00	1.00	0.01	0.45	0.000	0.350	0.49	0.00	0.17
36	75.00	GPS	1	27.259	29.985	1.00	1.00	1.00	9.00	0.000	0.000	47.98	0.00	0.00

Totals: 9,188.10

22,137.30

Total Applied Force Summary

Structure: CT01698-S-SBA	Code: EIA/TIA-222-G	10/18/2016
Site Name: Durham	Exposure: C	
Height: 162.00 (ft)	Crest Height: 0.00	
Base Elev: 0.000 (ft)	Site Class: D - Stiff Soil	
Gh: 1.1	Topography: 1	Struct Class: II



Page: 19

Load Case: 0.9D + 1.6W 97 mph Wind

Dead Load Factor 0.90

Wind Load Factor 1.60

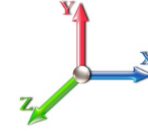

Iterations 24

Elev (ft)	Description	Lateral FX (-) (lb)	Axial FY (-) (lb)	Torsion MY (lb-ft)	Moment MZ (lb-ft)
0.00		0.00	0.00	0.00	0.00
5.00		538.69	1409.45	0.00	0.00
10.00		528.33	1386.06	0.00	0.00
15.00		517.97	1362.66	0.00	0.00
20.00		538.60	1339.27	0.00	0.00
25.00		552.99	1315.88	0.00	0.00
30.00		562.66	1292.49	0.00	0.00
35.00		568.85	1269.10	0.00	0.00
38.75		427.59	936.47	0.00	0.00
40.00		144.06	534.68	0.00	0.00
45.00		582.58	2111.58	0.00	0.00
50.00		582.32	1071.33	0.00	0.00
55.00		580.52	1051.28	0.00	0.00
60.00		577.40	1031.22	0.00	0.00
65.00		573.13	1011.17	0.00	0.00
70.00		567.84	991.12	0.00	0.00
75.00	(1) attachments	609.61	980.07	0.00	0.00
78.50		388.22	667.32	0.00	0.00
80.00	(1) attachments	167.83	472.04	0.00	0.17
83.75		416.56	1163.97	0.00	0.00
85.00		137.42	203.06	0.00	0.00
90.00		546.93	801.79	0.00	0.00
95.00		537.93	785.08	0.00	0.00
100.00		528.35	768.37	0.00	0.00
105.00	(1) attachments	1805.65	1831.66	0.00	0.00
110.00		507.59	734.95	0.00	0.00
115.00		496.48	718.25	0.00	0.00
119.25		412.66	597.37	0.00	0.00
120.00		73.12	164.44	0.00	0.00
122.00	(22) attachments	3471.09	1899.14	0.00	0.00
123.50		143.48	302.83	0.00	0.00
124.50	(8) attachments	1402.95	587.68	0.00	0.00
125.00		47.30	52.08	0.00	0.00
130.00		467.98	513.42	0.00	0.00
132.00	(33) attachments	6833.62	2180.28	0.00	0.00
135.00		271.20	261.60	0.00	0.00
140.00		442.23	425.31	0.00	0.00
145.00		428.83	411.94	0.00	0.00
150.00		415.11	398.58	0.00	0.00
152.00	(22) attachments	4950.07	2313.71	0.00	0.00
155.00		238.61	195.83	0.00	0.00
160.00		386.74	315.68	0.00	0.00
162.00	(24) attachments	4928.45	2137.45	0.00	239.42
Totals:		38,899.55	39,997.65	0.00	239.59

Linear Appurtenance Segment Forces (Factored)

Structure: CT01698-S-SBA	Code: EIA/TIA-222-G	10/18/2016	
Site Name: Durham	Exposure: C		
Height: 162.00 (ft)	Crest Height: 0.00		
Base Elev: 0.000 (ft)	Site Class: D - Stiff Soil		
Gh: 1.1	Topography: 1	Struct Class: II	Page: 20



Load Case: 0.9D + 1.6W 97 mph Wind

Dead Load Factor 0.90

Wind Load Factor 1.60

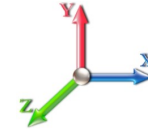

Iterations 24

Top Elev (ft)	Description	Wind Exposed	Length (ft)	Ca	Exposed Width (in)	Area (sqft)	CaAa (sqft)	Ra	Cf Adjust Factor	qz (psf)	F X (lb)	Dead Load (lb)
5.00	Safety Cable	Yes	5.00	0.000	0.38	0.16	0.00	0.058	0.000	19.450	0.00	1.23
5.00	1 5/8" Coax	Yes	5.00	0.000	0.00	0.00	0.00	0.058	0.000	19.450	0.00	56.16
5.00	10 mm	Yes	5.00	0.000	0.00	0.00	0.00	0.058	0.000	19.450	0.00	0.27
5.00	3" Coax	Yes	5.00	0.000	3.00	1.25	0.00	0.058	0.000	19.450	0.00	8.01
5.00	DC	Yes	5.00	0.000	0.00	0.00	0.00	0.058	0.000	19.450	0.00	3.60
5.00	1/2" Coax	Yes	5.00	0.000	0.00	0.00	0.00	0.058	0.000	19.450	0.00	0.72
10.00	Safety Cable	Yes	5.00	0.000	0.38	0.16	0.00	0.059	0.000	19.450	0.00	1.23
10.00	1 5/8" Coax	Yes	5.00	0.000	0.00	0.00	0.00	0.059	0.000	19.450	0.00	56.16
10.00	10 mm	Yes	5.00	0.000	0.00	0.00	0.00	0.059	0.000	19.450	0.00	0.27
10.00	3" Coax	Yes	5.00	0.000	3.00	1.25	0.00	0.059	0.000	19.450	0.00	8.01
10.00	DC	Yes	5.00	0.000	0.00	0.00	0.00	0.059	0.000	19.450	0.00	3.60
10.00	1/2" Coax	Yes	5.00	0.000	0.00	0.00	0.00	0.059	0.000	19.450	0.00	0.72
15.00	Safety Cable	Yes	5.00	0.000	0.38	0.16	0.00	0.060	0.000	19.450	0.00	1.23
15.00	1 5/8" Coax	Yes	5.00	0.000	0.00	0.00	0.00	0.060	0.000	19.450	0.00	56.16
15.00	10 mm	Yes	5.00	0.000	0.00	0.00	0.00	0.060	0.000	19.450	0.00	0.27
15.00	3" Coax	Yes	5.00	0.000	3.00	1.25	0.00	0.060	0.000	19.450	0.00	8.01
15.00	DC	Yes	5.00	0.000	0.00	0.00	0.00	0.060	0.000	19.450	0.00	3.60
15.00	1/2" Coax	Yes	5.00	0.000	0.00	0.00	0.00	0.060	0.000	19.450	0.00	0.72
20.00	Safety Cable	Yes	5.00	0.000	0.38	0.16	0.00	0.062	0.000	20.638	0.00	1.23
20.00	1 5/8" Coax	Yes	5.00	0.000	0.00	0.00	0.00	0.062	0.000	20.638	0.00	56.16
20.00	10 mm	Yes	5.00	0.000	0.00	0.00	0.00	0.062	0.000	20.638	0.00	0.27
20.00	3" Coax	Yes	5.00	0.000	3.00	1.25	0.00	0.062	0.000	20.638	0.00	8.01
20.00	DC	Yes	5.00	0.000	0.00	0.00	0.00	0.062	0.000	20.638	0.00	3.60
20.00	1/2" Coax	Yes	5.00	0.000	0.00	0.00	0.00	0.062	0.000	20.638	0.00	0.72
25.00	Safety Cable	Yes	5.00	0.000	0.38	0.16	0.00	0.063	0.000	21.630	0.00	1.23
25.00	1 5/8" Coax	Yes	5.00	0.000	0.00	0.00	0.00	0.063	0.000	21.630	0.00	56.16
25.00	10 mm	Yes	5.00	0.000	0.00	0.00	0.00	0.063	0.000	21.630	0.00	0.27
25.00	3" Coax	Yes	5.00	0.000	3.00	1.25	0.00	0.063	0.000	21.630	0.00	8.01
25.00	DC	Yes	5.00	0.000	0.00	0.00	0.00	0.063	0.000	21.630	0.00	3.60
25.00	1/2" Coax	Yes	5.00	0.000	0.00	0.00	0.00	0.063	0.000	21.630	0.00	0.72
30.00	Safety Cable	Yes	5.00	0.000	0.38	0.16	0.00	0.064	0.000	22.477	0.00	1.23
30.00	1 5/8" Coax	Yes	5.00	0.000	0.00	0.00	0.00	0.064	0.000	22.477	0.00	56.16
30.00	10 mm	Yes	5.00	0.000	0.00	0.00	0.00	0.064	0.000	22.477	0.00	0.27
30.00	3" Coax	Yes	5.00	0.000	3.00	1.25	0.00	0.064	0.000	22.477	0.00	8.01
30.00	DC	Yes	5.00	0.000	0.00	0.00	0.00	0.064	0.000	22.477	0.00	3.60
30.00	1/2" Coax	Yes	5.00	0.000	0.00	0.00	0.00	0.064	0.000	22.477	0.00	0.72
35.00	Safety Cable	Yes	5.00	0.000	0.38	0.16	0.00	0.066	0.000	23.218	0.00	1.23
35.00	1 5/8" Coax	Yes	5.00	0.000	0.00	0.00	0.00	0.066	0.000	23.218	0.00	56.16
35.00	10 mm	Yes	5.00	0.000	0.00	0.00	0.00	0.066	0.000	23.218	0.00	0.27
35.00	3" Coax	Yes	5.00	0.000	3.00	1.25	0.00	0.066	0.000	23.218	0.00	8.01
35.00	DC	Yes	5.00	0.000	0.00	0.00	0.00	0.066	0.000	23.218	0.00	3.60
35.00	1/2" Coax	Yes	5.00	0.000	0.00	0.00	0.00	0.066	0.000	23.218	0.00	0.72
38.75	Safety Cable	Yes	3.75	0.000	0.38	0.12	0.00	0.067	0.000	23.721	0.00	0.92
38.75	1 5/8" Coax	Yes	3.75	0.000	0.00	0.00	0.00	0.067	0.000	23.721	0.00	42.12
38.75	10 mm	Yes	3.75	0.000	0.00	0.00	0.00	0.067	0.000	23.721	0.00	0.20
38.75	3" Coax	Yes	3.75	0.000	3.00	0.94	0.00	0.067	0.000	23.721	0.00	6.01
38.75	DC	Yes	3.75	0.000	0.00	0.00	0.00	0.067	0.000	23.721	0.00	2.70

Linear Appurtenance Segment Forces (Factored)

Structure: CT01698-S-SBA	Code: EIA/TIA-222-G	10/18/2016
Site Name: Durham	Exposure: C	
Height: 162.00 (ft)	Crest Height: 0.00	
Base Elev: 0.000 (ft)	Site Class: D - Stiff Soil	
Gh: 1.1	Topography: 1	Struct Class: II



Page: 21

Load Case: 0.9D + 1.6W 97 mph Wind

Dead Load Factor 0.90

Wind Load Factor 1.60

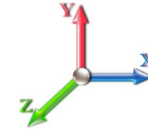

Iterations 24

Top Elev (ft)	Description	Wind Exposed	Length (ft)	Ca	Exposed Width (in)	Area (sqft)	CaAa (sqft)	Ra	Cf Adjust Factor	qz (psf)	F X (lb)	Dead Load (lb)
38.75	1/2" Coax	Yes	3.75	0.000	0.00	0.00	0.00	0.067	0.000	23.721	0.00	0.54
40.00	Safety Cable	Yes	1.25	0.000	0.38	0.04	0.00	0.068	0.000	23.880	0.00	0.31
40.00	1 5/8" Coax	Yes	1.25	0.000	0.00	0.00	0.00	0.068	0.000	23.880	0.00	14.04
40.00	10 mm	Yes	1.25	0.000	0.00	0.00	0.00	0.068	0.000	23.880	0.00	0.07
40.00	3" Coax	Yes	1.25	0.000	3.00	0.31	0.00	0.068	0.000	23.880	0.00	2.00
40.00	DC	Yes	1.25	0.000	0.00	0.00	0.00	0.068	0.000	23.880	0.00	0.90
40.00	1/2" Coax	Yes	1.25	0.000	0.00	0.00	0.00	0.068	0.000	23.880	0.00	0.18
45.00	Safety Cable	Yes	5.00	0.000	0.38	0.16	0.00	0.069	0.000	24.479	0.00	1.23
45.00	1 5/8" Coax	Yes	5.00	0.000	0.00	0.00	0.00	0.069	0.000	24.479	0.00	56.16
45.00	10 mm	Yes	5.00	0.000	0.00	0.00	0.00	0.069	0.000	24.479	0.00	0.27
45.00	3" Coax	Yes	5.00	0.000	3.00	1.25	0.00	0.069	0.000	24.479	0.00	8.01
45.00	DC	Yes	5.00	0.000	0.00	0.00	0.00	0.069	0.000	24.479	0.00	3.60
45.00	1/2" Coax	Yes	5.00	0.000	0.00	0.00	0.00	0.069	0.000	24.479	0.00	0.72
50.00	Safety Cable	Yes	5.00	0.000	0.38	0.16	0.00	0.069	0.000	25.029	0.00	1.23
50.00	1 5/8" Coax	Yes	5.00	0.000	0.00	0.00	0.00	0.069	0.000	25.029	0.00	56.16
50.00	10 mm	Yes	5.00	0.000	0.00	0.00	0.00	0.069	0.000	25.029	0.00	0.27
50.00	3" Coax	Yes	5.00	0.000	3.00	1.25	0.00	0.069	0.000	25.029	0.00	8.01
50.00	DC	Yes	5.00	0.000	0.00	0.00	0.00	0.069	0.000	25.029	0.00	3.60
50.00	1/2" Coax	Yes	5.00	0.000	0.00	0.00	0.00	0.069	0.000	25.029	0.00	0.72
55.00	Safety Cable	Yes	5.00	0.000	0.38	0.16	0.00	0.071	0.000	25.536	0.00	1.23
55.00	1 5/8" Coax	Yes	5.00	0.000	0.00	0.00	0.00	0.071	0.000	25.536	0.00	56.16
55.00	10 mm	Yes	5.00	0.000	0.00	0.00	0.00	0.071	0.000	25.536	0.00	0.27
55.00	3" Coax	Yes	5.00	0.000	3.00	1.25	0.00	0.071	0.000	25.536	0.00	8.01
55.00	DC	Yes	5.00	0.000	0.00	0.00	0.00	0.071	0.000	25.536	0.00	3.60
55.00	1/2" Coax	Yes	5.00	0.000	0.00	0.00	0.00	0.071	0.000	25.536	0.00	0.72
60.00	Safety Cable	Yes	5.00	0.000	0.38	0.16	0.00	0.073	0.000	26.008	0.00	1.23
60.00	1 5/8" Coax	Yes	5.00	0.000	0.00	0.00	0.00	0.073	0.000	26.008	0.00	56.16
60.00	10 mm	Yes	5.00	0.000	0.00	0.00	0.00	0.073	0.000	26.008	0.00	0.27
60.00	3" Coax	Yes	5.00	0.000	3.00	1.25	0.00	0.073	0.000	26.008	0.00	8.01
60.00	DC	Yes	5.00	0.000	0.00	0.00	0.00	0.073	0.000	26.008	0.00	3.60
60.00	1/2" Coax	Yes	5.00	0.000	0.00	0.00	0.00	0.073	0.000	26.008	0.00	0.72
65.00	Safety Cable	Yes	5.00	0.000	0.38	0.16	0.00	0.074	0.000	26.450	0.00	1.23
65.00	1 5/8" Coax	Yes	5.00	0.000	0.00	0.00	0.00	0.074	0.000	26.450	0.00	56.16
65.00	10 mm	Yes	5.00	0.000	0.00	0.00	0.00	0.074	0.000	26.450	0.00	0.27
65.00	3" Coax	Yes	5.00	0.000	3.00	1.25	0.00	0.074	0.000	26.450	0.00	8.01
65.00	DC	Yes	5.00	0.000	0.00	0.00	0.00	0.074	0.000	26.450	0.00	3.60
65.00	1/2" Coax	Yes	5.00	0.000	0.00	0.00	0.00	0.074	0.000	26.450	0.00	0.72
70.00	Safety Cable	Yes	5.00	0.000	0.38	0.16	0.00	0.076	0.000	26.866	0.00	1.23
70.00	1 5/8" Coax	Yes	5.00	0.000	0.00	0.00	0.00	0.076	0.000	26.866	0.00	56.16
70.00	10 mm	Yes	5.00	0.000	0.00	0.00	0.00	0.076	0.000	26.866	0.00	0.27
70.00	3" Coax	Yes	5.00	0.000	3.00	1.25	0.00	0.076	0.000	26.866	0.00	8.01
70.00	DC	Yes	5.00	0.000	0.00	0.00	0.00	0.076	0.000	26.866	0.00	3.60
70.00	1/2" Coax	Yes	5.00	0.000	0.00	0.00	0.00	0.076	0.000	26.866	0.00	0.72
75.00	Safety Cable	Yes	5.00	0.000	0.38	0.16	0.00	0.078	0.000	27.259	0.00	1.23
75.00	1 5/8" Coax	Yes	5.00	0.000	0.00	0.00	0.00	0.078	0.000	27.259	0.00	56.16
75.00	10 mm	Yes	5.00	0.000	0.00	0.00	0.00	0.078	0.000	27.259	0.00	0.27
75.00	3" Coax	Yes	5.00	0.000	3.00	1.25	0.00	0.078	0.000	27.259	0.00	8.01

Linear Appurtenance Segment Forces (Factored)

Structure: CT01698-S-SBA	Code: EIA/TIA-222-G	10/18/2016
Site Name: Durham	Exposure: C	
Height: 162.00 (ft)	Crest Height: 0.00	
Base Elev: 0.000 (ft)	Site Class: D - Stiff Soil	
Gh: 1.1	Topography: 1	Struct Class: II



Page: 22

Load Case: 0.9D + 1.6W 97 mph Wind

Dead Load Factor 0.90

Wind Load Factor 1.60

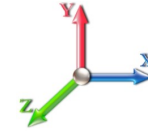

Iterations 24

Top Elev (ft)	Description	Wind Exposed	Length (ft)	Ca	Exposed Width (in)	Area (sqft)	CaAa (sqft)	Ra	Cf Adjust Factor	qz (psf)	F X (lb)	Dead Load (lb)
75.00	DC	Yes	5.00	0.000	0.00	0.00	0.00	0.078	0.000	27.259	0.00	3.60
75.00	1/2" Coax	Yes	5.00	0.000	0.00	0.00	0.00	0.078	0.000	27.259	0.00	0.72
78.50	Safety Cable	Yes	3.50	0.000	0.38	0.11	0.00	0.080	0.000	27.522	0.00	0.86
78.50	1 5/8" Coax	Yes	3.50	0.000	0.00	0.00	0.00	0.080	0.000	27.522	0.00	39.31
78.50	10 mm	Yes	3.50	0.000	0.00	0.00	0.00	0.080	0.000	27.522	0.00	0.19
78.50	3" Coax	Yes	3.50	0.000	3.00	0.88	0.00	0.080	0.000	27.522	0.00	5.61
78.50	DC	Yes	3.50	0.000	0.00	0.00	0.00	0.080	0.000	27.522	0.00	2.52
80.00	Safety Cable	Yes	1.50	0.000	0.38	0.05	0.00	0.081	0.000	27.632	0.00	0.37
80.00	1 5/8" Coax	Yes	1.50	0.000	0.00	0.00	0.00	0.081	0.000	27.632	0.00	16.85
80.00	10 mm	Yes	1.50	0.000	0.00	0.00	0.00	0.081	0.000	27.632	0.00	0.08
80.00	3" Coax	Yes	1.50	0.000	3.00	0.38	0.00	0.081	0.000	27.632	0.00	2.40
80.00	DC	Yes	1.50	0.000	0.00	0.00	0.00	0.081	0.000	27.632	0.00	1.08
83.75	Safety Cable	Yes	3.75	0.000	0.38	0.12	0.00	0.082	0.000	27.899	0.00	0.92
83.75	1 5/8" Coax	Yes	3.75	0.000	0.00	0.00	0.00	0.082	0.000	27.899	0.00	42.12
83.75	10 mm	Yes	3.75	0.000	0.00	0.00	0.00	0.082	0.000	27.899	0.00	0.20
83.75	3" Coax	Yes	3.75	0.000	3.00	0.94	0.00	0.082	0.000	27.899	0.00	6.01
83.75	DC	Yes	3.75	0.000	0.00	0.00	0.00	0.082	0.000	27.899	0.00	2.70
85.00	Safety Cable	Yes	1.25	0.000	0.38	0.04	0.00	0.082	0.000	27.987	0.00	0.31
85.00	1 5/8" Coax	Yes	1.25	0.000	0.00	0.00	0.00	0.082	0.000	27.987	0.00	14.04
85.00	10 mm	Yes	1.25	0.000	0.00	0.00	0.00	0.082	0.000	27.987	0.00	0.07
85.00	3" Coax	Yes	1.25	0.000	3.00	0.31	0.00	0.082	0.000	27.987	0.00	2.00
85.00	DC	Yes	1.25	0.000	0.00	0.00	0.00	0.082	0.000	27.987	0.00	0.90
90.00	Safety Cable	Yes	5.00	0.000	0.38	0.16	0.00	0.083	0.000	28.325	0.00	1.23
90.00	1 5/8" Coax	Yes	5.00	0.000	0.00	0.00	0.00	0.083	0.000	28.325	0.00	56.16
90.00	10 mm	Yes	5.00	0.000	0.00	0.00	0.00	0.083	0.000	28.325	0.00	0.27
90.00	3" Coax	Yes	5.00	0.000	3.00	1.25	0.00	0.083	0.000	28.325	0.00	8.01
90.00	DC	Yes	5.00	0.000	0.00	0.00	0.00	0.083	0.000	28.325	0.00	3.60
95.00	Safety Cable	Yes	5.00	0.000	0.38	0.16	0.00	0.086	0.000	28.650	0.00	1.23
95.00	1 5/8" Coax	Yes	5.00	0.000	0.00	0.00	0.00	0.086	0.000	28.650	0.00	56.16
95.00	10 mm	Yes	5.00	0.000	0.00	0.00	0.00	0.086	0.000	28.650	0.00	0.27
95.00	3" Coax	Yes	5.00	0.000	3.00	1.25	0.00	0.086	0.000	28.650	0.00	8.01
95.00	DC	Yes	5.00	0.000	0.00	0.00	0.00	0.086	0.000	28.650	0.00	3.60
100.00	Safety Cable	Yes	5.00	0.000	0.38	0.16	0.00	0.088	0.000	28.961	0.00	1.23
100.00	1 5/8" Coax	Yes	5.00	0.000	0.00	0.00	0.00	0.088	0.000	28.961	0.00	56.16
100.00	10 mm	Yes	5.00	0.000	0.00	0.00	0.00	0.088	0.000	28.961	0.00	0.27
100.00	3" Coax	Yes	5.00	0.000	3.00	1.25	0.00	0.088	0.000	28.961	0.00	8.01
100.00	DC	Yes	5.00	0.000	0.00	0.00	0.00	0.088	0.000	28.961	0.00	3.60
105.00	Safety Cable	Yes	5.00	0.000	0.38	0.16	0.00	0.091	0.000	29.260	0.00	1.23
105.00	1 5/8" Coax	Yes	5.00	0.000	0.00	0.00	0.00	0.091	0.000	29.260	0.00	56.16
105.00	10 mm	Yes	5.00	0.000	0.00	0.00	0.00	0.091	0.000	29.260	0.00	0.27
105.00	3" Coax	Yes	5.00	0.000	3.00	1.25	0.00	0.091	0.000	29.260	0.00	8.01
105.00	DC	Yes	5.00	0.000	0.00	0.00	0.00	0.091	0.000	29.260	0.00	3.60
110.00	Safety Cable	Yes	5.00	0.000	0.38	0.16	0.00	0.094	0.000	29.548	0.00	1.23
110.00	1 5/8" Coax	Yes	5.00	0.000	0.00	0.00	0.00	0.094	0.000	29.548	0.00	56.16
110.00	10 mm	Yes	5.00	0.000	0.00	0.00	0.00	0.094	0.000	29.548	0.00	0.27
110.00	3" Coax	Yes	5.00	0.000	3.00	1.25	0.00	0.094	0.000	29.548	0.00	8.01
110.00	DC	Yes	5.00	0.000	0.00	0.00	0.00	0.094	0.000	29.548	0.00	3.60

Linear Appurtenance Segment Forces (Factored)

Structure: CT01698-S-SBA	Code: EIA/TIA-222-G	10/18/2016
Site Name: Durham	Exposure: C	
Height: 162.00 (ft)	Crest Height: 0.00	
Base Elev: 0.000 (ft)	Site Class: D - Stiff Soil	
Gh: 1.1	Topography: 1	Struct Class: II



Page: 23

Load Case: 0.9D + 1.6W 97 mph Wind

Dead Load Factor 0.90

Wind Load Factor 1.60

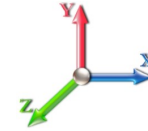

Iterations 24

Top Elev (ft)	Description	Wind Exposed	Length (ft)	Ca	Exposed Width (in)	Area (sqft)	CaAa (sqft)	Ra	Cf Adjust Factor	qz (psf)	F X (lb)	Dead Load (lb)
115.00	Safety Cable	Yes	5.00	0.000	0.38	0.16	0.00	0.097	0.000	29.826	0.00	1.23
115.00	1 5/8" Coax	Yes	5.00	0.000	0.00	0.00	0.00	0.097	0.000	29.826	0.00	56.16
115.00	10 mm	Yes	5.00	0.000	0.00	0.00	0.00	0.097	0.000	29.826	0.00	0.27
115.00	3" Coax	Yes	5.00	0.000	3.00	1.25	0.00	0.097	0.000	29.826	0.00	8.01
115.00	DC	Yes	5.00	0.000	0.00	0.00	0.00	0.097	0.000	29.826	0.00	3.60
119.25	Safety Cable	Yes	4.25	0.000	0.38	0.13	0.00	0.100	0.000	30.054	0.00	1.04
119.25	1 5/8" Coax	Yes	4.25	0.000	0.00	0.00	0.00	0.100	0.000	30.054	0.00	47.74
119.25	10 mm	Yes	4.25	0.000	0.00	0.00	0.00	0.100	0.000	30.054	0.00	0.23
119.25	3" Coax	Yes	4.25	0.000	3.00	1.06	0.00	0.100	0.000	30.054	0.00	6.81
119.25	DC	Yes	4.25	0.000	0.00	0.00	0.00	0.100	0.000	30.054	0.00	3.06
120.00	Safety Cable	Yes	0.75	0.000	0.38	0.02	0.00	0.101	1.004	30.094	0.00	0.18
120.00	1 5/8" Coax	Yes	0.75	0.000	0.00	0.00	0.00	0.101	1.004	30.094	0.00	8.42
120.00	10 mm	Yes	0.75	0.000	0.00	0.00	0.00	0.101	1.004	30.094	0.00	0.04
120.00	3" Coax	Yes	0.75	0.000	3.00	0.19	0.00	0.101	1.004	30.094	0.00	1.20
120.00	DC	Yes	0.75	0.000	0.00	0.00	0.00	0.101	1.004	30.094	0.00	0.54
122.00	Safety Cable	Yes	2.00	0.000	0.38	0.06	0.00	0.102	1.007	30.199	0.00	0.49
122.00	1 5/8" Coax	Yes	2.00	0.000	0.00	0.00	0.00	0.102	1.007	30.199	0.00	22.46
122.00	10 mm	Yes	2.00	0.000	0.00	0.00	0.00	0.102	1.007	30.199	0.00	0.11
122.00	3" Coax	Yes	2.00	0.000	3.00	0.50	0.00	0.102	1.007	30.199	0.00	3.20
122.00	DC	Yes	2.00	0.000	0.00	0.00	0.00	0.102	1.007	30.199	0.00	1.44
123.50	Safety Cable	Yes	1.50	0.000	0.38	0.05	0.00	0.012	0.000	30.277	0.00	0.37
124.50	Safety Cable	Yes	1.00	0.000	0.38	0.03	0.00	0.012	0.000	30.328	0.00	0.25
125.00	Safety Cable	Yes	0.50	0.000	0.38	0.02	0.00	0.012	0.000	30.354	0.00	0.12
130.00	Safety Cable	Yes	5.00	0.000	0.38	0.16	0.00	0.012	0.000	30.605	0.00	1.23
132.00	Safety Cable	Yes	2.00	0.000	0.38	0.06	0.00	0.012	0.000	30.704	0.00	0.49
135.00	Safety Cable	Yes	3.00	0.000	0.38	0.10	0.00	0.012	0.000	30.850	0.00	0.74
140.00	Safety Cable	Yes	5.00	0.000	0.38	0.16	0.00	0.013	0.000	31.087	0.00	1.23
145.00	Safety Cable	Yes	5.00	0.000	0.38	0.16	0.00	0.013	0.000	31.317	0.00	1.23
150.00	Safety Cable	Yes	5.00	0.000	0.38	0.16	0.00	0.014	0.000	31.541	0.00	1.23
152.00	Safety Cable	Yes	2.00	0.000	0.38	0.06	0.00	0.014	0.000	31.630	0.00	0.49
155.00	Safety Cable	Yes	3.00	0.000	0.38	0.10	0.00	0.014	0.000	31.760	0.00	0.74
160.00	Safety Cable	Yes	5.00	0.000	0.38	0.16	0.00	0.015	0.000	31.973	0.00	1.23
162.00	Safety Cable	Yes	2.00	0.000	0.38	0.06	0.00	0.015	0.000	32.057	0.00	0.49
Totals:											0.0	1,710.8

Calculated Forces

Structure: CT01698-S-SBA **Code:** EIA/TIA-222-G **10/18/2016**
Site Name: Durham **Exposure:** C
Height: 162.00 (ft) **Crest Height:** 0.00
Base Elev: 0.000 (ft) **Site Class:** D - Stiff Soil
Gh: 1.1 **Topography:** 1 **Struct Class:** II **Page:** 24



Load Case: 0.9D + 1.6W 97 mph Wind

Iterations 24

Dead Load Factor 0.90

Wind Load Factor 1.60

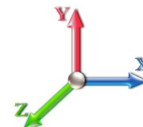

Seg Elev (ft)	Pu FY (-) (kips)	Vu FX (-) (kips)	Tu MY (-) (ft-kips)	Mu MZ (ft-kips)	Mu MX (ft-kips)	Resultant Moment (ft-kips)	phi Pn (kips)	phi Vn (kips)	phi Tn (ft-kips)	phi Mn (ft-kips)	Total Deflect (in)	Rotation Sway (deg)	Rotation Twist (deg)	Stress Ratio
0.00	-39.93	-38.97	0.00	-4532.3	0.00	4532.37	5422.04	2711.02	12776.1	6397.58	0.00	0.000	0.000	0.716
5.00	-38.39	-38.55	0.00	-4337.5	0.00	4337.54	5354.65	2677.32	12373.4	6195.90	0.10	-0.191	0.000	0.707
10.00	-36.88	-38.14	0.00	-4144.7	0.00	4144.77	5285.82	2642.91	11973.5	5995.67	0.41	-0.384	0.000	0.698
15.00	-35.39	-37.74	0.00	-3954.0	0.00	3954.05	5215.55	2607.78	11576.7	5796.99	0.91	-0.580	0.000	0.689
20.00	-33.93	-37.30	0.00	-3765.3	0.00	3765.37	5143.86	2571.93	11183.2	5599.96	1.63	-0.779	0.000	0.679
25.00	-32.49	-36.84	0.00	-3578.8	0.00	3578.86	5070.72	2535.36	10793.2	5404.66	2.55	-0.979	0.000	0.669
30.00	-31.08	-36.37	0.00	-3394.6	0.00	3394.65	4996.16	2498.08	10406.9	5211.21	3.69	-1.182	0.000	0.658
35.00	-29.71	-35.86	0.00	-3212.8	0.00	3212.82	4920.16	2460.08	10024.5	5019.70	5.04	-1.388	0.000	0.646
38.75	-28.72	-35.46	0.00	-3078.3	0.00	3078.33	4862.22	2431.11	9740.32	4877.40	6.19	-1.544	0.000	0.637
40.00	-28.11	-35.37	0.00	-3034.0	0.00	3034.00	4842.73	2421.36	9646.11	4830.22	6.60	-1.597	0.000	0.634
45.00	-25.89	-34.82	0.00	-2857.1	0.00	2857.15	3936.38	1968.19	7803.92	3907.76	8.39	-1.806	0.000	0.738
50.00	-24.71	-34.30	0.00	-2683.0	0.00	2683.05	3877.34	1938.67	7510.22	3760.69	10.39	-2.017	0.000	0.720
55.00	-23.54	-33.78	0.00	-2511.5	0.00	2511.56	3816.87	1908.43	7219.20	3614.96	12.63	-2.251	0.000	0.701
60.00	-22.40	-33.25	0.00	-2342.6	0.00	2342.68	3754.96	1877.48	6931.04	3470.67	15.11	-2.486	0.000	0.681
65.00	-21.28	-32.72	0.00	-2176.4	0.00	2176.44	3691.62	1845.81	6645.93	3327.91	17.84	-2.722	0.000	0.660
70.00	-20.18	-32.19	0.00	-2012.8	0.00	2012.85	3626.84	1813.42	6364.09	3186.77	20.82	-2.957	0.000	0.638
75.00	-19.13	-31.59	0.00	-1851.9	0.00	1851.92	3560.63	1780.31	6085.69	3047.37	24.04	-3.191	0.000	0.613
78.50	-18.42	-31.20	0.00	-1741.3	0.00	1741.36	3513.43	1756.71	5892.98	2950.87	26.44	-3.356	0.000	0.596
80.00	-17.89	-31.05	0.00	-1694.5	0.00	1694.55	3492.98	1746.49	5810.95	2909.79	27.51	-3.427	0.000	0.588
83.75	-16.70	-30.59	0.00	-1578.1	0.00	1578.14	2742.50	1371.25	4553.78	2280.28	30.27	-3.601	0.000	0.699
85.00	-16.42	-30.49	0.00	-1539.9	0.00	1539.90	2730.37	1365.18	4502.54	2254.62	31.22	-3.660	0.000	0.690
90.00	-15.52	-29.96	0.00	-1387.4	0.00	1387.46	2680.95	1340.47	4298.92	2152.65	35.19	-3.917	0.000	0.651
95.00	-14.65	-29.43	0.00	-1237.6	0.00	1237.66	2630.10	1315.05	4097.56	2051.82	39.42	-4.168	0.000	0.609
100.00	-13.80	-28.90	0.00	-1090.5	0.00	1090.52	2577.82	1288.91	3898.66	1952.23	43.92	-4.410	0.000	0.564
105.00	-12.01	-27.01	0.00	-946.00	0.00	946.00	2524.10	1262.05	3702.43	1853.97	48.66	-4.642	0.000	0.515
110.00	-11.22	-26.48	0.00	-810.98	0.00	810.98	2468.95	1234.47	3509.05	1757.13	53.63	-4.860	0.000	0.467
115.00	-10.47	-25.96	0.00	-678.58	0.00	678.58	2412.36	1206.18	3318.73	1661.83	58.83	-5.064	0.000	0.413
119.25	-9.87	-25.51	0.00	-568.26	0.00	568.26	2363.14	1181.57	3159.50	1582.10	63.41	-5.223	0.000	0.364
120.00	-9.69	-25.43	0.00	-549.13	0.00	549.13	2354.34	1177.17	3131.65	1568.15	64.23	-5.251	0.000	0.355
122.00	-8.10	-21.81	0.00	-498.27	0.00	498.27	2330.73	1165.37	3057.78	1531.16	66.44	-5.321	0.000	0.329
123.50	-7.80	-21.64	0.00	-465.56	0.00	465.56	1751.58	875.79	2319.28	1161.36	68.12	-5.371	0.000	0.406
124.50	-7.33	-20.19	0.00	-443.92	0.00	443.92	1743.79	871.89	2293.08	1148.24	69.25	-5.403	0.000	0.391
125.00	-7.25	-20.15	0.00	-433.83	0.00	433.83	1739.87	869.94	2280.00	1141.69	69.81	-5.422	0.000	0.385
130.00	-6.75	-19.65	0.00	-333.07	0.00	333.07	1699.92	849.96	2150.20	1076.70	75.58	-5.590	0.000	0.314
132.00	-5.23	-12.64	0.00	-293.77	0.00	293.77	1683.54	841.77	2098.80	1050.96	77.93	-5.651	0.000	0.283
135.00	-4.98	-12.36	0.00	-255.84	0.00	255.84	1658.53	829.27	2022.29	1012.65	81.50	-5.735	0.000	0.256
140.00	-4.57	-11.88	0.00	-194.06	0.00	194.06	1615.71	807.86	1896.47	949.64	87.57	-5.857	0.000	0.207
145.00	-4.19	-11.42	0.00	-134.66	0.00	134.66	1571.46	785.73	1772.93	887.78	93.75	-5.956	0.000	0.155
150.00	-3.83	-10.97	0.00	-77.56	0.00	77.56	1525.77	762.88	1651.87	827.16	100.01	-6.029	0.000	0.096
152.00	-2.05	-5.80	0.00	-55.63	0.00	55.63	1507.09	753.54	1604.19	803.29	102.54	-6.049	0.000	0.071
155.00	-1.88	-5.55	0.00	-38.22	0.00	38.22	1478.64	739.32	1533.49	767.89	106.34	-6.072	0.000	0.051
160.00	-1.60	-5.13	0.00	-10.49	0.00	10.49	1426.03	713.01	1413.96	708.03	112.70	-6.094	0.000	0.016
162.00	0.00	-4.93	0.00	-0.24	0.00	0.24	1400.09	700.04	1362.73	682.38	115.25	-6.096	0.000	0.000

Wind Loading - Shaft

Structure: CT01698-S-SBA	Code: EIA/TIA-222-G	10/18/2016
Site Name: Durham	Exposure: C	
Height: 162.00 (ft)	Crest Height: 0.00	
Base Elev: 0.000 (ft)	Site Class: D - Stiff Soil	
Gh: 1.1	Topography: 1	Struct Class: II



Load Case: 1.2D + 1.0Di + 1.0Wi 50 mph Wind

Iterations 24

Dead Load Factor 1.20
Wind Load Factor 1.00

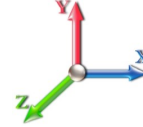

Elev (ft)	Description	Kzt	Kz	qz (psf)	qzGh (psf)	C (mph-ft)	Cf	Ice Thick (in)	Tributary (ft)	Aa (sf)	CfAa (sf)	Wind Force X (lb)	Dead Load Ice (lb)	Tot Dead Load (lb)
0.00		1.00	0.85	5.168	5.68	0.00	1.200	0.000	0.00	0.000	0.00	0.0	0.0	0.0
5.00		1.00	0.85	5.168	5.68	0.00	1.200	1.242	5.00	25.244	30.29	172.2	450.6	2060.4
10.00		1.00	0.85	5.168	5.68	0.00	1.200	1.331	5.00	24.853	29.82	169.5	474.5	2053.1
15.00		1.00	0.85	5.168	5.68	0.00	1.200	1.386	5.00	24.434	29.32	166.7	485.1	2032.5
20.00		1.00	0.90	5.483	6.03	0.00	1.200	1.427	5.00	24.002	28.80	173.7	489.7	2005.9
25.00		1.00	0.95	5.747	6.32	0.00	1.200	1.459	5.00	23.563	28.28	178.8	491.0	1976.0
30.00		1.00	0.98	5.972	6.57	0.00	1.200	1.486	5.00	23.120	27.74	182.3	490.0	1943.9
35.00		1.00	1.01	6.169	6.79	0.00	1.200	1.509	5.00	22.674	27.21	184.6	487.5	1910.1
38.75 Bot - Section 2		1.00	1.04	6.303	6.93	0.00	1.200	1.524	3.75	16.710	20.05	139.0	363.5	1410.1
40.00		1.00	1.04	6.345	6.98	0.00	1.200	1.529	1.25	5.592	6.71	46.8	122.7	768.3
45.00 Top - Section 1		1.00	1.07	6.504	7.15	0.00	1.200	1.547	5.00	22.092	26.51	189.7	486.2	3032.1
50.00		1.00	1.09	6.650	7.32	0.00	1.200	1.564	5.00	21.641	25.97	190.0	480.7	1639.7
55.00		1.00	1.12	6.785	7.46	0.00	1.200	1.579	5.00	21.188	25.43	189.8	474.6	1606.8
60.00		1.00	1.14	6.910	7.60	0.00	1.200	1.592	5.00	20.734	24.88	189.1	467.9	1573.4
65.00		1.00	1.16	7.028	7.73	0.00	1.200	1.605	5.00	20.279	24.33	188.1	460.7	1539.5
70.00		1.00	1.17	7.138	7.85	0.00	1.200	1.617	5.00	19.823	23.79	186.8	453.1	1505.1
75.00 Appurtenance(s)		1.00	1.19	7.243	7.97	0.00	1.200	1.628	5.00	19.367	23.24	185.2	445.1	1470.4
78.50 Bot - Section 3		1.00	1.20	7.313	8.04	0.00	1.200	1.636	3.50	13.284	15.94	128.2	307.5	1009.3
80.00 Appurtenance(s)		1.00	1.21	7.342	8.08	0.00	1.200	1.639	1.50	5.704	6.84	55.3	133.0	681.2
83.75 Top - Section 2		1.00	1.22	7.413	8.15	0.00	1.200	1.646	3.75	14.080	16.90	137.8	327.6	1678.9
85.00		1.00	1.22	7.436	8.18	0.00	1.200	1.649	1.25	4.636	5.56	45.5	108.7	312.5
90.00		1.00	1.24	7.526	8.28	0.00	1.200	1.658	5.00	18.260	21.91	181.4	425.8	1227.3
95.00		1.00	1.25	7.612	8.37	0.00	1.200	1.667	5.00	17.802	21.36	178.9	416.7	1195.9
100.00		1.00	1.27	7.695	8.46	0.00	1.200	1.676	5.00	17.344	20.81	176.2	407.4	1164.3
105.00 Appurtenance(s)		1.00	1.28	7.774	8.55	0.00	1.200	1.684	5.00	16.885	20.26	173.3	397.9	1132.5
110.00		1.00	1.29	7.851	8.64	0.00	1.200	1.692	5.00	16.426	19.71	170.2	388.1	1100.5
115.00		1.00	1.30	7.925	8.72	0.00	1.200	1.699	5.00	15.967	19.16	167.0	378.2	1068.3
119.25 Bot - Section 4		1.00	1.31	7.986	8.78	0.00	1.200	1.706	4.25	13.210	15.85	139.2	314.2	883.3
120.00		1.00	1.32	7.996	8.80	0.00	1.205 *	1.707	0.75	2.328	2.81	24.7	56.0	235.1
122.00 Appurtenance(s)		1.00	1.32	8.024	8.83	0.00	1.208 *	1.710	2.00	6.158	7.44	65.7	147.8	621.0
123.50 Top - Section 3		1.00	1.32	8.045	8.85	0.00	1.200	1.712	1.50	4.570	5.48	48.5	109.9	460.6
124.50 Appurtenance(s)		1.00	1.33	8.058	8.86	0.00	1.200	1.713	1.00	3.024	3.63	32.2	72.9	176.9
125.00		1.00	1.33	8.065	8.87	0.00	1.200	1.714	0.50	1.505	1.81	16.0	36.3	88.1
130.00		1.00	1.34	8.132	8.95	0.00	1.200	1.720	5.00	14.800	17.76	158.9	352.9	860.7
132.00 Appurtenance(s)		1.00	1.34	8.158	8.97	0.00	1.200	1.723	2.00	5.790	6.95	62.4	139.5	337.6
135.00		1.00	1.35	8.197	9.02	0.00	1.200	1.727	3.00	8.548	10.26	92.5	205.5	497.3
140.00		1.00	1.36	8.260	9.09	0.00	1.200	1.733	5.00	13.879	16.66	151.3	331.8	803.9
145.00		1.00	1.37	8.321	9.15	0.00	1.200	1.739	5.00	13.419	16.10	147.4	321.0	775.3
150.00		1.00	1.38	8.381	9.22	0.00	1.200	1.745	5.00	12.958	15.55	143.4	310.2	746.6
152.00 Appurtenance(s)		1.00	1.38	8.404	9.24	0.00	1.200	1.748	2.00	5.054	6.06	56.1	122.3	291.9
155.00		1.00	1.39	8.439	9.28	0.00	1.200	1.751	3.00	7.443	8.93	82.9	179.5	428.5
160.00		1.00	1.40	8.495	9.34	0.00	1.200	1.757	5.00	12.037	14.44	135.0	288.1	688.9
162.00 Appurtenance(s)		1.00	1.40	8.518	9.37	0.00	1.200	1.759	2.00	4.685	5.62	52.7	113.4	268.8
								Totals:	162.00			5,554.8	47,262.6	

* Cf Adjusted by Linear Load Ra Effect

Discrete Appurtenance Forces

Structure: CT01698-S-SBA	Code: EIA/TIA-222-G	10/18/2016
Site Name: Durham	Exposure: C	
Height: 162.00 (ft)	Crest Height: 0.00	
Base Elev: 0.000 (ft)	Site Class: D - Stiff Soil	
Gh: 1.1	Topography: 1	Struct Class: II



Page: 26

Load Case: 1.2D + 1.0Di + 1.0Wi 50 mph Wind

Dead Load Factor 1.20
Wind Load Factor 1.00

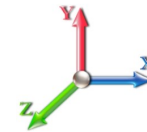

Iterations 24

No.	Elev (ft)	Description	Qty	qz (psf)	qzGh (psf)	CaAa x Ka	Ka	Total CaAa (sf)	Dead Load (lb)	Horiz Ecc (ft)	Vert Ecc (ft)	Wind FX (lb)	Mom Y (lb-ft)	Mom Z (lb-ft)
1	162.00	1900MHz RRH	3	8.518	9.369	0.88	1.00	13.73	394.82	0.000	0.000	128.64	0.00	0.00
2	162.00	APXVTM14-C-120	3	8.523	9.375	0.63	0.80	14.15	687.31	0.000	0.500	132.65	0.00	66.33
3	162.00	TD-RRH8x20-25	3	8.518	9.369	0.69	1.00	10.08	586.49	0.000	0.000	94.45	0.00	0.00
4	162.00	APXVSPP18-C-A20	3	8.523	9.375	0.66	0.80	21.58	579.26	0.000	0.500	202.36	0.00	101.18
5	162.00	Flush Mount	1	8.495	9.345	1.00	1.00	8.52	307.73	0.000	-2.000	79.59	0.00	-159.19
6	162.00	800 MHz Ext. Filter	3	8.518	9.369	0.63	1.00	3.75	76.34	0.000	0.000	35.11	0.00	0.00
7	162.00	ACU-A20-N	4	8.523	9.375	0.75	1.00	1.32	16.92	0.000	0.500	12.35	0.00	6.17
8	162.00	Low Profile Platform-flat	1	8.518	9.369	1.00	1.00	46.10	2195.22	0.000	0.000	431.97	0.00	0.00
9	162.00	800 MHz RRU	3	8.518	9.369	0.75	1.00	8.20	351.09	0.000	0.000	76.79	0.00	0.00
10	152.00	KRY 112 144/1	3	8.404	9.244	0.58	0.75	1.33	62.69	0.000	0.000	12.27	0.00	0.00
11	152.00	APXV18-206516S-A20	3	8.404	9.244	0.58	0.75	11.59	214.25	0.000	0.000	107.18	0.00	0.00
12	152.00	LNx-6515DS-A1M	3	8.404	9.244	0.60	0.75	26.53	671.45	0.000	0.000	245.29	0.00	0.00
13	152.00	FE15501P77/75	3	8.404	9.244	0.49	0.75	1.28	119.69	0.000	0.000	11.81	0.00	0.00
14	152.00	782 11056	3	8.404	9.244	0.50	0.75	0.55	11.97	0.000	0.000	5.09	0.00	0.00
15	152.00	Platform w/ Hand Rail	1	8.404	9.244	1.00	1.00	78.70	4902.08	0.000	0.000	727.52	0.00	0.00
16	152.00	RR90-17-02DP	6	8.404	9.244	0.55	0.75	17.57	690.41	0.000	0.000	162.39	0.00	0.00
17	132.00	RFS DB-T1-6Z-8AB-0Z	2	8.158	8.974	0.57	0.80	6.43	388.76	0.000	0.000	57.72	0.00	0.00
18	132.00	FD9R6004/2C-3L	6	8.158	8.974	0.60	0.80	2.87	56.07	0.000	0.000	25.77	0.00	0.00
19	132.00	RRH2X60-700	3	8.158	8.974	0.61	0.80	7.81	414.24	0.000	0.000	70.04	0.00	0.00
20	132.00	RRH2X60-AWS	3	8.158	8.974	0.61	0.80	7.81	414.24	0.000	0.000	70.04	0.00	0.00
21	132.00	DB846F65ZAXY	4	8.158	8.974	0.74	0.80	24.59	878.42	0.000	0.000	220.70	0.00	0.00
22	132.00	LPA-80080-4CF-EDIN-0	2	8.158	8.974	1.36	0.80	9.51	190.90	0.000	0.000	85.35	0.00	0.00
23	132.00	SBNHH-1D65B	9	8.158	8.974	0.66	0.80	55.90	2225.53	0.000	0.000	501.66	0.00	0.00
24	132.00	Low Profile Platform-flat	1	8.158	8.974	1.00	1.00	45.68	2173.83	0.000	0.000	409.90	0.00	0.00
25	132.00	RRH2x60-1900	3	8.158	8.974	0.60	0.80	3.69	246.89	0.000	0.000	33.16	0.00	0.00
26	124.50	RRUS-11	6	8.058	8.864	0.68	1.00	24.04	771.59	0.000	0.000	213.08	0.00	0.00
27	124.50	Flush Mount	1	8.058	8.864	1.00	1.00	8.43	303.89	0.000	0.000	74.69	0.00	0.00
28	124.50	DC6-48-60-18-8F	1	8.058	8.864	1.00	1.00	2.16	81.14	0.000	0.000	19.12	0.00	0.00
29	122.00	Low Profile Platform-flat	1	8.024	8.826	1.00	1.00	45.51	2165.72	0.000	0.000	401.72	0.00	0.00
30	122.00	AM-X-CD-16-65-00T-RET	3	8.024	8.826	0.65	0.80	15.76	419.78	0.000	0.000	139.09	0.00	0.00
31	122.00	LGP21903	6	8.024	8.826	0.60	0.80	2.37	74.73	0.000	0.000	20.96	0.00	0.00
32	122.00	LGP21401	6	8.024	8.826	0.60	0.80	7.59	205.86	0.000	0.000	67.00	0.00	0.00
33	122.00	7770.00	6	8.024	8.826	0.58	0.80	22.92	1042.76	0.000	0.000	202.33	0.00	0.00
34	105.00	Low Profile Platform-flat	1	7.774	8.552	1.00	1.00	45.21	2150.44	0.000	0.000	386.62	0.00	0.00
35	80.00	738-449	1	7.349	8.083	1.00	1.00	0.07	1.84	0.000	0.350	0.55	0.00	0.19
36	75.00	GPS	1	7.243	7.967	1.00	1.00	1.66	31.36	0.000	0.000	13.26	0.00	0.00

Totals: 26,105.69

5,478.23

Total Applied Force Summary

Structure: CT01698-S-SBA	Code: EIA/TIA-222-G	10/18/2016
Site Name: Durham	Exposure: C	
Height: 162.00 (ft)	Crest Height: 0.00	
Base Elev: 0.000 (ft)	Site Class: D - Stiff Soil	
Gh: 1.1	Topography: 1	Struct Class: II



Page: 27

Load Case: 1.2D + 1.0Di + 1.0Wi 50 mph Wind

Dead Load Factor 1.20
Wind Load Factor 1.00



Iterations 24

Elev (ft)	Description	Lateral FX (-) (lb)	Axial FY (-) (lb)	Torsion MY (lb-ft)	Moment MZ (lb-ft)
0.00		0.00	0.00	0.00	0.00
5.00		172.21	2554.00	0.00	0.00
10.00		169.54	2565.40	0.00	0.00
15.00		166.68	2556.61	0.00	0.00
20.00		173.73	2538.94	0.00	0.00
25.00		178.76	2516.15	0.00	0.00
30.00		182.26	2490.00	0.00	0.00
35.00		184.64	2461.43	0.00	0.00
38.75		139.02	1826.17	0.00	0.00
40.00		46.84	907.23	0.00	0.00
45.00		189.68	3592.19	0.00	0.00
50.00		189.97	2203.47	0.00	0.00
55.00		189.76	2174.05	0.00	0.00
60.00		189.13	2143.82	0.00	0.00
65.00		188.12	2112.89	0.00	0.00
70.00		186.79	2081.34	0.00	0.00
75.00	(1) attachments	198.42	2080.61	0.00	0.00
78.50		128.23	1400.61	0.00	0.00
80.00	(1) attachments	55.82	850.94	0.00	0.19
83.75		137.78	2099.12	0.00	0.00
85.00		45.50	452.72	0.00	0.00
90.00		181.41	1790.13	0.00	0.00
95.00		178.88	1760.69	0.00	0.00
100.00		176.17	1730.93	0.00	0.00
105.00	(1) attachments	559.90	3851.32	0.00	0.00
110.00		170.23	1670.58	0.00	0.00
115.00		167.03	1640.02	0.00	0.00
119.25		139.25	1370.37	0.00	0.00
120.00		24.68	321.14	0.00	0.00
122.00	(22) attachments	896.78	4759.42	0.00	0.00
123.50		48.53	519.82	0.00	0.00
124.50	(8) attachments	339.06	1372.99	0.00	0.00
125.00		16.02	107.82	0.00	0.00
130.00		158.86	1058.14	0.00	0.00
132.00	(33) attachments	1536.71	7405.50	0.00	0.00
135.00		92.49	566.73	0.00	0.00
140.00		151.33	919.81	0.00	0.00
145.00		147.39	891.36	0.00	0.00
150.00		143.35	862.80	0.00	0.00
152.00	(22) attachments	1327.62	7010.92	0.00	0.00
155.00		82.91	453.40	0.00	0.00
160.00		134.98	730.44	0.00	0.00
162.00	(24) attachments	1246.59	5480.60	0.00	14.49
Totals:		11,033.01	87,882.61	0.00	14.68

Linear Appurtenance Segment Forces (Factored)

Structure: CT01698-S-SBA	Code: EIA/TIA-222-G	10/18/2016
Site Name: Durham	Exposure: C	
Height: 162.00 (ft)	Crest Height: 0.00	
Base Elev: 0.000 (ft)	Site Class: D - Stiff Soil	
Gh: 1.1	Topography: 1	Struct Class: II



Page: 28

Load Case: 1.2D + 1.0Di + 1.0Wi 50 mph Wind

Dead Load Factor 1.20
Wind Load Factor 1.00



Iterations 24

Top Elev (ft)	Description	Wind Exposed	Length (ft)	Ca	Exposed Width (in)	Area (sqft)	CaAa (sqft)	Ra	Cf Adjust Factor	qz (psf)	F X (lb)	Dead Load (lb)
5.00	Safety Cable	Yes	5.00	0.000	0.38	1.19	0.00	0.058	0.000	5.168	0.00	12.93
5.00	1 5/8" Coax	Yes	5.00	0.000	0.00	0.00	0.00	0.058	0.000	5.168	0.00	218.70
5.00	10 mm	Yes	5.00	0.000	0.00	0.00	0.00	0.058	0.000	5.168	0.00	11.68
5.00	3" Coax	Yes	5.00	0.000	3.00	2.29	0.00	0.058	0.000	5.168	0.00	38.50
5.00	DC	Yes	5.00	0.000	0.00	0.00	0.00	0.058	0.000	5.168	0.00	21.94
5.00	1/2" Coax	Yes	5.00	0.000	0.00	0.00	0.00	0.058	0.000	5.168	0.00	13.70
10.00	Safety Cable	Yes	5.00	0.000	0.38	1.27	0.00	0.059	0.000	5.168	0.00	14.46
10.00	1 5/8" Coax	Yes	5.00	0.000	0.00	0.00	0.00	0.059	0.000	5.168	0.00	228.34
10.00	10 mm	Yes	5.00	0.000	0.00	0.00	0.00	0.059	0.000	5.168	0.00	13.21
10.00	3" Coax	Yes	5.00	0.000	3.00	2.36	0.00	0.059	0.000	5.168	0.00	40.94
10.00	DC	Yes	5.00	0.000	0.00	0.00	0.00	0.059	0.000	5.168	0.00	23.86
10.00	1/2" Coax	Yes	5.00	0.000	0.00	0.00	0.00	0.059	0.000	5.168	0.00	15.33
15.00	Safety Cable	Yes	5.00	0.000	0.38	1.31	0.00	0.060	0.000	5.168	0.00	15.46
15.00	1 5/8" Coax	Yes	5.00	0.000	0.00	0.00	0.00	0.060	0.000	5.168	0.00	234.34
15.00	10 mm	Yes	5.00	0.000	0.00	0.00	0.00	0.060	0.000	5.168	0.00	14.21
15.00	3" Coax	Yes	5.00	0.000	3.00	2.41	0.00	0.060	0.000	5.168	0.00	42.51
15.00	DC	Yes	5.00	0.000	0.00	0.00	0.00	0.060	0.000	5.168	0.00	25.10
15.00	1/2" Coax	Yes	5.00	0.000	0.00	0.00	0.00	0.060	0.000	5.168	0.00	16.38
20.00	Safety Cable	Yes	5.00	0.000	0.38	1.35	0.00	0.062	0.000	5.483	0.00	16.21
20.00	1 5/8" Coax	Yes	5.00	0.000	0.00	0.00	0.00	0.062	0.000	5.483	0.00	238.78
20.00	10 mm	Yes	5.00	0.000	0.00	0.00	0.00	0.062	0.000	5.483	0.00	14.96
20.00	3" Coax	Yes	5.00	0.000	3.00	2.44	0.00	0.062	0.000	5.483	0.00	43.68
20.00	DC	Yes	5.00	0.000	0.00	0.00	0.00	0.062	0.000	5.483	0.00	26.03
20.00	1/2" Coax	Yes	5.00	0.000	0.00	0.00	0.00	0.062	0.000	5.483	0.00	17.18
25.00	Safety Cable	Yes	5.00	0.000	0.38	1.37	0.00	0.063	0.000	5.747	0.00	16.83
25.00	1 5/8" Coax	Yes	5.00	0.000	0.00	0.00	0.00	0.063	0.000	5.747	0.00	242.32
25.00	10 mm	Yes	5.00	0.000	0.00	0.00	0.00	0.063	0.000	5.747	0.00	15.58
25.00	3" Coax	Yes	5.00	0.000	3.00	2.47	0.00	0.063	0.000	5.747	0.00	44.62
25.00	DC	Yes	5.00	0.000	0.00	0.00	0.00	0.063	0.000	5.747	0.00	26.78
25.00	1/2" Coax	Yes	5.00	0.000	0.00	0.00	0.00	0.063	0.000	5.747	0.00	17.83
30.00	Safety Cable	Yes	5.00	0.000	0.38	1.40	0.00	0.064	0.000	5.972	0.00	17.35
30.00	1 5/8" Coax	Yes	5.00	0.000	0.00	0.00	0.00	0.064	0.000	5.972	0.00	245.28
30.00	10 mm	Yes	5.00	0.000	0.00	0.00	0.00	0.064	0.000	5.972	0.00	16.10
30.00	3" Coax	Yes	5.00	0.000	3.00	2.49	0.00	0.064	0.000	5.972	0.00	45.42
30.00	DC	Yes	5.00	0.000	0.00	0.00	0.00	0.064	0.000	5.972	0.00	27.42
30.00	1/2" Coax	Yes	5.00	0.000	0.00	0.00	0.00	0.064	0.000	5.972	0.00	18.38
35.00	Safety Cable	Yes	5.00	0.000	0.38	1.42	0.00	0.066	0.000	6.169	0.00	17.80
35.00	1 5/8" Coax	Yes	5.00	0.000	0.00	0.00	0.00	0.066	0.000	6.169	0.00	247.84
35.00	10 mm	Yes	5.00	0.000	0.00	0.00	0.00	0.066	0.000	6.169	0.00	16.56
35.00	3" Coax	Yes	5.00	0.000	3.00	2.51	0.00	0.066	0.000	6.169	0.00	46.11
35.00	DC	Yes	5.00	0.000	0.00	0.00	0.00	0.066	0.000	6.169	0.00	27.98
35.00	1/2" Coax	Yes	5.00	0.000	0.00	0.00	0.00	0.066	0.000	6.169	0.00	18.86
38.75	Safety Cable	Yes	3.75	0.000	0.38	1.07	0.00	0.067	0.000	6.303	0.00	13.58
38.75	1 5/8" Coax	Yes	3.75	0.000	0.00	0.00	0.00	0.067	0.000	6.303	0.00	187.16
38.75	10 mm	Yes	3.75	0.000	0.00	0.00	0.00	0.067	0.000	6.303	0.00	12.65
38.75	3" Coax	Yes	3.75	0.000	3.00	1.89	0.00	0.067	0.000	6.303	0.00	34.94
38.75	DC	Yes	3.75	0.000	0.00	0.00	0.00	0.067	0.000	6.303	0.00	21.27

Linear Appurtenance Segment Forces (Factored)

Structure: CT01698-S-SBA	Code: EIA/TIA-222-G	10/18/2016
Site Name: Durham	Exposure: C	
Height: 162.00 (ft)	Crest Height: 0.00	
Base Elev: 0.000 (ft)	Site Class: D - Stiff Soil	
Gh: 1.1	Topography: 1	Struct Class: II



Page: 29

Load Case: 1.2D + 1.0Di + 1.0Wi 50 mph Wind

Dead Load Factor 1.20
Wind Load Factor 1.00



Iterations 24

Top Elev (ft)	Description	Wind Exposed	Length (ft)	Ca	Exposed Width (in)	Area (sqft)	CaAa (sqft)	Ra	Cf Adjust Factor	qz (psf)	F X (lb)	Dead Load (lb)
38.75	1/2" Coax	Yes	3.75	0.000	0.00	0.00	0.00	0.067	0.000	6.303	0.00	14.39
40.00	Safety Cable	Yes	1.25	0.000	0.38	0.36	0.00	0.068	0.000	6.345	0.00	4.55
40.00	1 5/8" Coax	Yes	1.25	0.000	0.00	0.00	0.00	0.068	0.000	6.345	0.00	62.52
40.00	10 mm	Yes	1.25	0.000	0.00	0.00	0.00	0.068	0.000	6.345	0.00	4.24
40.00	3" Coax	Yes	1.25	0.000	3.00	0.63	0.00	0.068	0.000	6.345	0.00	11.68
40.00	DC	Yes	1.25	0.000	0.00	0.00	0.00	0.068	0.000	6.345	0.00	7.12
40.00	1/2" Coax	Yes	1.25	0.000	0.00	0.00	0.00	0.068	0.000	6.345	0.00	4.82
45.00	Safety Cable	Yes	5.00	0.000	0.38	1.45	0.00	0.069	0.000	6.504	0.00	18.58
45.00	1 5/8" Coax	Yes	5.00	0.000	0.00	0.00	0.00	0.069	0.000	6.504	0.00	252.10
45.00	10 mm	Yes	5.00	0.000	0.00	0.00	0.00	0.069	0.000	6.504	0.00	17.33
45.00	3" Coax	Yes	5.00	0.000	3.00	2.54	0.00	0.069	0.000	6.504	0.00	47.28
45.00	DC	Yes	5.00	0.000	0.00	0.00	0.00	0.069	0.000	6.504	0.00	28.92
45.00	1/2" Coax	Yes	5.00	0.000	0.00	0.00	0.00	0.069	0.000	6.504	0.00	19.67
50.00	Safety Cable	Yes	5.00	0.000	0.38	1.46	0.00	0.069	0.000	6.650	0.00	18.91
50.00	1 5/8" Coax	Yes	5.00	0.000	0.00	0.00	0.00	0.069	0.000	6.650	0.00	253.93
50.00	10 mm	Yes	5.00	0.000	0.00	0.00	0.00	0.069	0.000	6.650	0.00	17.67
50.00	3" Coax	Yes	5.00	0.000	3.00	2.55	0.00	0.069	0.000	6.650	0.00	47.79
50.00	DC	Yes	5.00	0.000	0.00	0.00	0.00	0.069	0.000	6.650	0.00	29.33
50.00	1/2" Coax	Yes	5.00	0.000	0.00	0.00	0.00	0.069	0.000	6.650	0.00	20.02
55.00	Safety Cable	Yes	5.00	0.000	0.38	1.47	0.00	0.071	0.000	6.785	0.00	19.22
55.00	1 5/8" Coax	Yes	5.00	0.000	0.00	0.00	0.00	0.071	0.000	6.785	0.00	255.60
55.00	10 mm	Yes	5.00	0.000	0.00	0.00	0.00	0.071	0.000	6.785	0.00	17.98
55.00	3" Coax	Yes	5.00	0.000	3.00	2.57	0.00	0.071	0.000	6.785	0.00	48.25
55.00	DC	Yes	5.00	0.000	0.00	0.00	0.00	0.071	0.000	6.785	0.00	29.70
55.00	1/2" Coax	Yes	5.00	0.000	0.00	0.00	0.00	0.071	0.000	6.785	0.00	20.35
60.00	Safety Cable	Yes	5.00	0.000	0.38	1.49	0.00	0.073	0.000	6.910	0.00	19.51
60.00	1 5/8" Coax	Yes	5.00	0.000	0.00	0.00	0.00	0.073	0.000	6.910	0.00	257.14
60.00	10 mm	Yes	5.00	0.000	0.00	0.00	0.00	0.073	0.000	6.910	0.00	18.26
60.00	3" Coax	Yes	5.00	0.000	3.00	2.58	0.00	0.073	0.000	6.910	0.00	48.68
60.00	DC	Yes	5.00	0.000	0.00	0.00	0.00	0.073	0.000	6.910	0.00	30.05
60.00	1/2" Coax	Yes	5.00	0.000	0.00	0.00	0.00	0.073	0.000	6.910	0.00	20.65
65.00	Safety Cable	Yes	5.00	0.000	0.38	1.50	0.00	0.074	0.000	7.028	0.00	19.78
65.00	1 5/8" Coax	Yes	5.00	0.000	0.00	0.00	0.00	0.074	0.000	7.028	0.00	258.57
65.00	10 mm	Yes	5.00	0.000	0.00	0.00	0.00	0.074	0.000	7.028	0.00	18.53
65.00	3" Coax	Yes	5.00	0.000	3.00	2.59	0.00	0.074	0.000	7.028	0.00	49.08
65.00	DC	Yes	5.00	0.000	0.00	0.00	0.00	0.074	0.000	7.028	0.00	30.37
65.00	1/2" Coax	Yes	5.00	0.000	0.00	0.00	0.00	0.074	0.000	7.028	0.00	20.93
70.00	Safety Cable	Yes	5.00	0.000	0.38	1.51	0.00	0.076	0.000	7.138	0.00	20.03
70.00	1 5/8" Coax	Yes	5.00	0.000	0.00	0.00	0.00	0.076	0.000	7.138	0.00	259.91
70.00	10 mm	Yes	5.00	0.000	0.00	0.00	0.00	0.076	0.000	7.138	0.00	18.79
70.00	3" Coax	Yes	5.00	0.000	3.00	2.60	0.00	0.076	0.000	7.138	0.00	49.45
70.00	DC	Yes	5.00	0.000	0.00	0.00	0.00	0.076	0.000	7.138	0.00	30.68
70.00	1/2" Coax	Yes	5.00	0.000	0.00	0.00	0.00	0.076	0.000	7.138	0.00	21.20
75.00	Safety Cable	Yes	5.00	0.000	0.38	1.52	0.00	0.078	0.000	7.243	0.00	20.27
75.00	1 5/8" Coax	Yes	5.00	0.000	0.00	0.00	0.00	0.078	0.000	7.243	0.00	261.17
75.00	10 mm	Yes	5.00	0.000	0.00	0.00	0.00	0.078	0.000	7.243	0.00	19.02
75.00	3" Coax	Yes	5.00	0.000	3.00	2.61	0.00	0.078	0.000	7.243	0.00	49.81

Linear Appurtenance Segment Forces (Factored)

Structure: CT01698-S-SBA	Code: EIA/TIA-222-G	10/18/2016
Site Name: Durham	Exposure: C	
Height: 162.00 (ft)	Crest Height: 0.00	
Base Elev: 0.000 (ft)	Site Class: D - Stiff Soil	
Gh: 1.1	Topography: 1	Struct Class: II



Page: 30

Load Case: 1.2D + 1.0Di + 1.0Wi 50 mph Wind

Dead Load Factor 1.20
Wind Load Factor 1.00

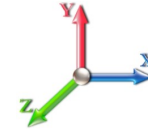

Iterations 24

Top Elev (ft)	Description	Wind Exposed	Length (ft)	Ca	Exposed Width (in)	Area (sqft)	CaAa (sqft)	Ra	Cf Adjust Factor	qz (psf)	F X (lb)	Dead Load (lb)
75.00	DC	Yes	5.00	0.000	0.00	0.00	0.00	0.078	0.000	7.243	0.00	30.97
75.00	1/2" Coax	Yes	5.00	0.000	0.00	0.00	0.00	0.078	0.000	7.243	0.00	21.45
78.50	Safety Cable	Yes	3.50	0.000	0.38	1.07	0.00	0.080	0.000	7.313	0.00	14.30
78.50	1 5/8" Coax	Yes	3.50	0.000	0.00	0.00	0.00	0.080	0.000	7.313	0.00	183.40
78.50	10 mm	Yes	3.50	0.000	0.00	0.00	0.00	0.080	0.000	7.313	0.00	13.43
78.50	3" Coax	Yes	3.50	0.000	3.00	1.83	0.00	0.080	0.000	7.313	0.00	35.03
78.50	DC	Yes	3.50	0.000	0.00	0.00	0.00	0.080	0.000	7.313	0.00	21.81
80.00	Safety Cable	Yes	1.50	0.000	0.38	0.46	0.00	0.081	0.000	7.342	0.00	6.15
80.00	1 5/8" Coax	Yes	1.50	0.000	0.00	0.00	0.00	0.081	0.000	7.342	0.00	78.71
80.00	10 mm	Yes	1.50	0.000	0.00	0.00	0.00	0.081	0.000	7.342	0.00	5.77
80.00	3" Coax	Yes	1.50	0.000	3.00	0.78	0.00	0.081	0.000	7.342	0.00	15.04
80.00	DC	Yes	1.50	0.000	0.00	0.00	0.00	0.081	0.000	7.342	0.00	9.37
83.75	Safety Cable	Yes	3.75	0.000	0.38	1.15	0.00	0.082	0.000	7.413	0.00	15.49
83.75	1 5/8" Coax	Yes	3.75	0.000	0.00	0.00	0.00	0.082	0.000	7.413	0.00	197.40
83.75	10 mm	Yes	3.75	0.000	0.00	0.00	0.00	0.082	0.000	7.413	0.00	14.56
83.75	3" Coax	Yes	3.75	0.000	3.00	1.97	0.00	0.082	0.000	7.413	0.00	37.79
83.75	DC	Yes	3.75	0.000	0.00	0.00	0.00	0.082	0.000	7.413	0.00	23.57
85.00	Safety Cable	Yes	1.25	0.000	0.38	0.38	0.00	0.082	0.000	7.436	0.00	5.18
85.00	1 5/8" Coax	Yes	1.25	0.000	0.00	0.00	0.00	0.082	0.000	7.436	0.00	65.87
85.00	10 mm	Yes	1.25	0.000	0.00	0.00	0.00	0.082	0.000	7.436	0.00	4.87
85.00	3" Coax	Yes	1.25	0.000	3.00	0.66	0.00	0.082	0.000	7.436	0.00	12.61
85.00	DC	Yes	1.25	0.000	0.00	0.00	0.00	0.082	0.000	7.436	0.00	7.87
90.00	Safety Cable	Yes	5.00	0.000	0.38	1.54	0.00	0.083	0.000	7.526	0.00	20.91
90.00	1 5/8" Coax	Yes	5.00	0.000	0.00	0.00	0.00	0.083	0.000	7.526	0.00	264.54
90.00	10 mm	Yes	5.00	0.000	0.00	0.00	0.00	0.083	0.000	7.526	0.00	19.67
90.00	3" Coax	Yes	5.00	0.000	3.00	2.63	0.00	0.083	0.000	7.526	0.00	50.76
90.00	DC	Yes	5.00	0.000	0.00	0.00	0.00	0.083	0.000	7.526	0.00	31.74
95.00	Safety Cable	Yes	5.00	0.000	0.38	1.55	0.00	0.086	0.000	7.612	0.00	21.11
95.00	1 5/8" Coax	Yes	5.00	0.000	0.00	0.00	0.00	0.086	0.000	7.612	0.00	265.55
95.00	10 mm	Yes	5.00	0.000	0.00	0.00	0.00	0.086	0.000	7.612	0.00	19.87
95.00	3" Coax	Yes	5.00	0.000	3.00	2.64	0.00	0.086	0.000	7.612	0.00	51.05
95.00	DC	Yes	5.00	0.000	0.00	0.00	0.00	0.086	0.000	7.612	0.00	31.98
100.00	Safety Cable	Yes	5.00	0.000	0.38	1.55	0.00	0.088	0.000	7.695	0.00	21.30
100.00	1 5/8" Coax	Yes	5.00	0.000	0.00	0.00	0.00	0.088	0.000	7.695	0.00	266.52
100.00	10 mm	Yes	5.00	0.000	0.00	0.00	0.00	0.088	0.000	7.695	0.00	20.05
100.00	3" Coax	Yes	5.00	0.000	3.00	2.65	0.00	0.088	0.000	7.695	0.00	51.32
100.00	DC	Yes	5.00	0.000	0.00	0.00	0.00	0.088	0.000	7.695	0.00	32.20
105.00	Safety Cable	Yes	5.00	0.000	0.38	1.56	0.00	0.091	0.000	7.774	0.00	21.48
105.00	1 5/8" Coax	Yes	5.00	0.000	0.00	0.00	0.00	0.091	0.000	7.774	0.00	267.44
105.00	10 mm	Yes	5.00	0.000	0.00	0.00	0.00	0.091	0.000	7.774	0.00	20.23
105.00	3" Coax	Yes	5.00	0.000	3.00	2.65	0.00	0.091	0.000	7.774	0.00	51.59
105.00	DC	Yes	5.00	0.000	0.00	0.00	0.00	0.091	0.000	7.774	0.00	32.42
110.00	Safety Cable	Yes	5.00	0.000	0.38	1.57	0.00	0.094	0.000	7.851	0.00	21.65
110.00	1 5/8" Coax	Yes	5.00	0.000	0.00	0.00	0.00	0.094	0.000	7.851	0.00	268.33
110.00	10 mm	Yes	5.00	0.000	0.00	0.00	0.00	0.094	0.000	7.851	0.00	20.41
110.00	3" Coax	Yes	5.00	0.000	3.00	2.66	0.00	0.094	0.000	7.851	0.00	51.84
110.00	DC	Yes	5.00	0.000	0.00	0.00	0.00	0.094	0.000	7.851	0.00	32.63

Linear Appurtenance Segment Forces (Factored)

Structure: CT01698-S-SBA	Code: EIA/TIA-222-G	10/18/2016
Site Name: Durham	Exposure: C	
Height: 162.00 (ft)	Crest Height: 0.00	
Base Elev: 0.000 (ft)	Site Class: D - Stiff Soil	
Gh: 1.1	Topography: 1	Struct Class: II



Page: 31

Load Case: 1.2D + 1.0Di + 1.0Wi 50 mph Wind

Dead Load Factor 1.20
Wind Load Factor 1.00



Iterations 24

Top Elev (ft)	Description	Wind Exposed	Length (ft)	Ca	Exposed Width (in)	Area (sqft)	CaAa (sqft)	Ra	Cf Adjust Factor	qz (psf)	F X (lb)	Dead Load (lb)
115.00	Safety Cable	Yes	5.00	0.000	0.38	1.57	0.00	0.097	0.000	7.925	0.00	21.82
115.00	1 5/8" Coax	Yes	5.00	0.000	0.00	0.00	0.00	0.097	0.000	7.925	0.00	269.18
115.00	10 mm	Yes	5.00	0.000	0.00	0.00	0.00	0.097	0.000	7.925	0.00	20.57
115.00	3" Coax	Yes	5.00	0.000	3.00	2.67	0.00	0.097	0.000	7.925	0.00	52.09
115.00	DC	Yes	5.00	0.000	0.00	0.00	0.00	0.097	0.000	7.925	0.00	32.83
119.25	Safety Cable	Yes	4.25	0.000	0.38	1.34	0.00	0.100	0.000	7.986	0.00	18.66
119.25	1 5/8" Coax	Yes	4.25	0.000	0.00	0.00	0.00	0.100	0.000	7.986	0.00	229.40
119.25	10 mm	Yes	4.25	0.000	0.00	0.00	0.00	0.100	0.000	7.986	0.00	17.61
119.25	3" Coax	Yes	4.25	0.000	3.00	2.27	0.00	0.100	0.000	7.986	0.00	44.45
119.25	DC	Yes	4.25	0.000	0.00	0.00	0.00	0.100	0.000	7.986	0.00	28.04
120.00	Safety Cable	Yes	0.75	0.000	0.38	0.24	0.00	0.101	1.004	7.996	0.00	3.30
120.00	1 5/8" Coax	Yes	0.75	0.000	0.00	0.00	0.00	0.101	1.004	7.996	0.00	40.50
120.00	10 mm	Yes	0.75	0.000	0.00	0.00	0.00	0.101	1.004	7.996	0.00	3.11
120.00	3" Coax	Yes	0.75	0.000	3.00	0.40	0.00	0.101	1.004	7.996	0.00	7.85
120.00	DC	Yes	0.75	0.000	0.00	0.00	0.00	0.101	1.004	7.996	0.00	4.95
122.00	Safety Cable	Yes	2.00	0.000	0.38	0.63	0.00	0.102	1.007	8.024	0.00	8.82
122.00	1 5/8" Coax	Yes	2.00	0.000	0.00	0.00	0.00	0.102	1.007	8.024	0.00	108.13
122.00	10 mm	Yes	2.00	0.000	0.00	0.00	0.00	0.102	1.007	8.024	0.00	8.32
122.00	3" Coax	Yes	2.00	0.000	3.00	1.07	0.00	0.102	1.007	8.024	0.00	20.97
122.00	DC	Yes	2.00	0.000	0.00	0.00	0.00	0.102	1.007	8.024	0.00	13.24
123.50	Safety Cable	Yes	1.50	0.000	0.38	0.48	0.00	0.012	0.000	8.045	0.00	6.63
124.50	Safety Cable	Yes	1.00	0.000	0.38	0.32	0.00	0.012	0.000	8.058	0.00	4.42
125.00	Safety Cable	Yes	0.50	0.000	0.38	0.16	0.00	0.012	0.000	8.065	0.00	2.21
130.00	Safety Cable	Yes	5.00	0.000	0.38	1.59	0.00	0.012	0.000	8.132	0.00	22.29
132.00	Safety Cable	Yes	2.00	0.000	0.38	0.64	0.00	0.012	0.000	8.158	0.00	8.94
135.00	Safety Cable	Yes	3.00	0.000	0.38	0.96	0.00	0.012	0.000	8.197	0.00	13.46
140.00	Safety Cable	Yes	5.00	0.000	0.38	1.60	0.00	0.013	0.000	8.260	0.00	22.57
145.00	Safety Cable	Yes	5.00	0.000	0.38	1.61	0.00	0.013	0.000	8.321	0.00	22.71
150.00	Safety Cable	Yes	5.00	0.000	0.38	1.61	0.00	0.014	0.000	8.381	0.00	22.85
152.00	Safety Cable	Yes	2.00	0.000	0.38	0.65	0.00	0.014	0.000	8.404	0.00	9.16
155.00	Safety Cable	Yes	3.00	0.000	0.38	0.97	0.00	0.014	0.000	8.439	0.00	13.79
160.00	Safety Cable	Yes	5.00	0.000	0.38	1.62	0.00	0.015	0.000	8.495	0.00	23.11
162.00	Safety Cable	Yes	2.00	0.000	0.38	0.65	0.00	0.015	0.000	8.518	0.00	9.26
Totals:											0.0	9,463.3

Calculated Forces

Structure: CT01698-S-SBA
Site Name: Durham
Height: 162.00 (ft)
Base Elev: 0.000 (ft)
Gh: 1.1

Topography: 1

Code: EIA/TIA-222-G 10/18/2016
Exposure: C
Crest Height: 0.00
Site Class: D - Stiff Soil
Struct Class: II



Page: 32

Load Case: 1.2D + 1.0Di + 1.0Wi 50 mph Wind **Iterations** 24

Dead Load Factor 1.20

Wind Load Factor 1.00

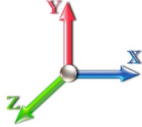

Seg Elev (ft)	Pu FY (-) (kips)	Vu FX (-) (kips)	Tu MY (-) (ft-kips)	Mu MZ (ft-kips)	Mu MX (ft-kips)	Resultant Moment (ft-kips)	phi Pn (kips)	phi Vn (kips)	phi Tn (ft-kips)	phi Mn (ft-kips)	Total Deflect (in)	Rotation Sway (deg)	Rotation Twist (deg)	Stress Ratio
0.00	-87.88	-11.08	0.00	-1303.3	0.00	1303.37	5422.04	2711.02	12776.1	6397.58	0.00	0.000	0.000	0.220
5.00	-85.31	-10.98	0.00	-1247.9	0.00	1247.99	5354.65	2677.32	12373.4	6195.90	0.03	-0.055	0.000	0.217
10.00	-82.74	-10.89	0.00	-1193.0	0.00	1193.07	5285.82	2642.91	11973.5	5995.67	0.12	-0.111	0.000	0.215
15.00	-80.17	-10.80	0.00	-1138.6	0.00	1138.61	5215.55	2607.78	11576.7	5796.99	0.26	-0.167	0.000	0.212
20.00	-77.62	-10.69	0.00	-1084.6	0.00	1084.62	5143.86	2571.93	11183.2	5599.96	0.47	-0.224	0.000	0.209
25.00	-75.09	-10.58	0.00	-1031.1	0.00	1031.15	5070.72	2535.36	10793.2	5404.66	0.73	-0.282	0.000	0.206
30.00	-72.60	-10.46	0.00	-978.24	0.00	978.24	4996.16	2498.08	10406.9	5211.21	1.06	-0.340	0.000	0.202
35.00	-70.13	-10.32	0.00	-925.95	0.00	925.95	4920.16	2460.08	10024.5	5019.70	1.45	-0.400	0.000	0.199
38.75	-68.30	-10.21	0.00	-887.24	0.00	887.24	4862.22	2431.11	9740.32	4877.40	1.78	-0.445	0.000	0.196
40.00	-67.38	-10.20	0.00	-874.48	0.00	874.48	4842.73	2421.36	9646.11	4830.22	1.90	-0.460	0.000	0.195
45.00	-63.78	-10.04	0.00	-823.50	0.00	823.50	3936.38	1968.19	7803.92	3907.76	2.41	-0.520	0.000	0.227
50.00	-61.57	-9.90	0.00	-773.29	0.00	773.29	3877.34	1938.67	7510.22	3760.69	2.99	-0.581	0.000	0.222
55.00	-59.38	-9.76	0.00	-723.78	0.00	723.78	3816.87	1908.43	7219.20	3614.96	3.64	-0.648	0.000	0.216
60.00	-57.23	-9.61	0.00	-674.99	0.00	674.99	3754.96	1877.48	6931.04	3470.67	4.35	-0.716	0.000	0.210
65.00	-55.11	-9.46	0.00	-626.93	0.00	626.93	3691.62	1845.81	6645.93	3327.91	5.14	-0.784	0.000	0.203
70.00	-53.02	-9.31	0.00	-579.63	0.00	579.63	3626.84	1813.42	6364.09	3186.77	6.00	-0.852	0.000	0.197
75.00	-50.93	-9.13	0.00	-533.10	0.00	533.10	3560.63	1780.31	6085.69	3047.37	6.93	-0.919	0.000	0.189
78.50	-49.53	-9.01	0.00	-501.15	0.00	501.15	3513.43	1756.71	5892.98	2950.87	7.62	-0.967	0.000	0.184
80.00	-48.68	-8.97	0.00	-487.64	0.00	487.64	3492.98	1746.49	5810.95	2909.79	7.92	-0.987	0.000	0.182
83.75	-46.57	-8.82	0.00	-454.02	0.00	454.02	2742.50	1371.25	4553.78	2280.28	8.72	-1.037	0.000	0.216
85.00	-46.12	-8.80	0.00	-443.00	0.00	443.00	2730.37	1365.18	4502.54	2254.62	8.99	-1.054	0.000	0.213
90.00	-44.32	-8.64	0.00	-399.00	0.00	399.00	2680.95	1340.47	4298.92	2152.65	10.14	-1.128	0.000	0.202
95.00	-42.55	-8.48	0.00	-355.79	0.00	355.79	2630.10	1315.05	4097.56	2051.82	11.36	-1.200	0.000	0.190
100.00	-40.81	-8.31	0.00	-313.40	0.00	313.40	2577.82	1288.91	3898.66	1952.23	12.65	-1.270	0.000	0.176
105.00	-36.97	-7.71	0.00	-271.82	0.00	271.82	2524.10	1262.05	3702.43	1853.97	14.02	-1.336	0.000	0.161
110.00	-35.29	-7.54	0.00	-233.28	0.00	233.28	2468.95	1234.47	3509.05	1757.13	15.45	-1.399	0.000	0.147
115.00	-33.65	-7.36	0.00	-195.60	0.00	195.60	2412.36	1206.18	3318.73	1661.83	16.95	-1.458	0.000	0.132
119.25	-32.28	-7.20	0.00	-164.32	0.00	164.32	2363.14	1181.57	3159.50	1582.10	18.27	-1.504	0.000	0.118
120.00	-31.96	-7.17	0.00	-158.92	0.00	158.92	2354.34	1177.17	3131.65	1568.15	18.51	-1.512	0.000	0.115
122.00	-27.22	-6.16	0.00	-144.58	0.00	144.58	2330.73	1165.37	3057.78	1531.16	19.15	-1.532	0.000	0.106
123.50	-26.71	-6.10	0.00	-135.34	0.00	135.34	1751.58	875.79	2319.28	1161.36	19.63	-1.547	0.000	0.132
124.50	-25.34	-5.73	0.00	-129.23	0.00	129.23	1743.79	871.89	2293.08	1148.24	19.95	-1.556	0.000	0.127
125.00	-25.23	-5.72	0.00	-126.37	0.00	126.37	1739.87	869.94	2280.00	1141.69	20.12	-1.562	0.000	0.125
130.00	-24.17	-5.55	0.00	-97.75	0.00	97.75	1699.92	849.96	2150.20	1076.70	21.78	-1.611	0.000	0.105
132.00	-16.81	-3.81	0.00	-86.65	0.00	86.65	1683.54	841.77	2098.80	1050.96	22.46	-1.629	0.000	0.092
135.00	-16.25	-3.71	0.00	-75.23	0.00	75.23	1658.53	829.27	2022.29	1012.65	23.49	-1.653	0.000	0.084
140.00	-15.33	-3.54	0.00	-56.68	0.00	56.68	1615.71	807.86	1896.47	949.64	25.24	-1.689	0.000	0.069
145.00	-14.44	-3.37	0.00	-38.98	0.00	38.98	1571.46	785.73	1772.93	887.78	27.03	-1.718	0.000	0.053
150.00	-13.58	-3.21	0.00	-22.11	0.00	22.11	1525.77	762.88	1651.87	827.16	28.84	-1.739	0.000	0.036
152.00	-6.62	-1.67	0.00	-15.70	0.00	15.70	1507.09	753.54	1604.19	803.29	29.57	-1.745	0.000	0.024
155.00	-6.17	-1.57	0.00	-10.70	0.00	10.70	1478.64	739.32	1533.49	767.89	30.67	-1.751	0.000	0.018
160.00	-5.44	-1.41	0.00	-2.84	0.00	2.84	1426.03	713.01	1413.96	708.03	32.50	-1.757	0.000	0.008
162.00	0.00	-1.25	0.00	-0.01	0.00	0.01	1400.09	700.04	1362.73	682.38	33.24	-1.758	0.000	0.000

Seismic Segment Forces (Factored)

Structure: CT01698-S-SBA	Code: EIA/TIA-222-G	10/18/2016
Site Name: Durham	Exposure: C	
Height: 162.00 (ft)	Crest Height: 0.00	
Base Elev: 0.000 (ft)	Site Class: D - Stiff Soil	
Gh: 1.1	Topography: 1	Struct Class: II



Page: 33

Load Case: 1.2D + 1.0E					Iterations 22
Gust Response Factor	1.10	Seismic Load Factor	1.00	Sds 0.19	Ss 0.18
Dead Load Factor	1.20	Structure Frequency	0.35	Sd1 0.10	S1 0.06
Wind Load Factor	0.00	Seismic Importance Factor	1.00	SA 0.03	

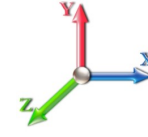

Top Elev (ft)	Description	Wz (lb)	a	b	c	Lateral Fs (lb)	R: 1.50
0.00		0.00	0.00	0.00	0.00	0.00	
5.00		1341.4	0.00	0.03	0.02	23.78	
10.00		1315.5	0.01	0.05	0.03	34.32	
15.00		1289.5	0.02	0.06	0.04	39.20	
20.00		1263.5	0.03	0.07	0.04	41.32	
25.00		1237.5	0.05	0.07	0.04	42.11	
30.00		1211.5	0.06	0.07	0.04	42.34	
35.00		1185.5	0.09	0.07	0.04	42.39	
38.75	Bot - Section 2	872.10	0.11	0.07	0.04	31.70	
40.00		537.95	0.12	0.07	0.04	19.66	
45.00	Top - Section 1	2121.6	0.15	0.07	0.03	79.08	
50.00		965.80	0.18	0.07	0.03	36.42	
55.00		943.52	0.22	0.06	0.02	35.38	
60.00		921.24	0.26	0.05	0.02	33.30	
65.00		898.96	0.30	0.04	0.01	29.71	
70.00		876.68	0.35	0.03	0.01	24.19	
75.00	Appurtenance(s)	864.41	0.41	0.02	0.01	16.73	
78.50	Bot - Section 3	584.83	0.44	0.00	0.01	7.00	
80.00	Appurtenance(s)	457.36	0.46	0.00	0.01	3.87	
83.75	Top - Section 2	1126.0	0.51	-0.02	0.01	-1.02	
85.00		169.88	0.52	-0.02	0.01	-0.70	
90.00		667.91	0.58	-0.05	0.01	-11.14	
95.00		649.35	0.65	-0.07	0.02	-17.72	
100.00		630.78	0.72	-0.09	0.03	-21.73	
105.00	Appurtenance(s)	1812.2	0.79	-0.11	0.05	-67.77	
110.00		593.65	0.87	-0.12	0.08	-21.29	
115.00		575.09	0.95	-0.12	0.11	-17.17	
119.25	Bot - Section 4	474.23	1.02	-0.10	0.14	-10.09	
120.00		149.27	1.04	-0.10	0.15	-2.90	
122.00	Appurtenance(s)	2020.9	1.07	-0.08	0.17	-28.39	
123.50	Top - Section 3	292.27	1.10	-0.07	0.19	-2.79	
124.50	Appurtenance(s)	623.50	1.12	-0.06	0.20	-3.96	
125.00		43.13	1.13	-0.05	0.20	-0.20	
130.00		423.11	1.22	0.02	0.27	6.10	
132.00	Appurtenance(s)	2363.5	1.25	0.06	0.30	54.99	
135.00		243.17	1.31	0.14	0.35	9.20	
140.00		393.40	1.41	0.31	0.44	25.85	
145.00		378.55	1.51	0.54	0.56	37.11	
150.00		363.70	1.62	0.84	0.70	49.07	
152.00	Appurtenance(s)	2539.1	1.66	0.99	0.76	383.35	
155.00		207.52	1.73	1.24	0.86	36.62	
160.00		333.99	1.84	1.74	1.05	74.42	
162.00	Appurtenance(s)	2368.2	1.89	1.98	1.14	574.77	
Totals:		38,331.8				1,627.1	Total Wind: 38,899.6

Seismic Base Shear is Less Than 50% of Wind Force - An Analysis is NOT Required

Calculated Forces

Structure: CT01698-S-SBA	Code: EIA/TIA-222-G	10/18/2016
Site Name: Durham	Exposure: C	
Height: 162.00 (ft)	Crest Height: 0.00	
Base Elev: 0.000 (ft)	Site Class: D - Stiff Soil	
Gh: 1.1	Topography: 1	Struct Class: II



Load Case: 1.2D + 1.0E						Iterations 22
Gust Response Factor	1.10			Sds	0.19	Ss 0.18
Dead Load Factor	1.20	Seismic Load Factor	1.00	Sd1	0.10	S1 0.06
Wind Load Factor	0.00	Structure Frequency	0.35	SA	0.03	Seismic Importance Factor 1.00

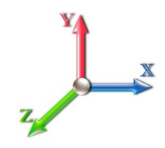

Seg Elev (ft)	Pu FY (-) (kips)	Vu FX (-) (kips)	Tu MY (-) (ft-kips)	Mu MZ (ft-kips)	Mu MX (ft-kips)	Resultant Moment (ft-kips)	phi Pn (kips)	phi Vn (kips)	phi Tn (ft-kips)	phi Mn (ft-kips)	Total Deflect (in)	Rotation Sway (deg)	Rotation Twist (deg)	Stress Ratio
0.00	-53.33	-1.84	0.00	-227.05	0.00	227.05	5422.04	2711.02	12776.1	6397.58	0.00	0.00	0.00	0.045
5.00	-51.45	-1.82	0.00	-217.86	0.00	217.86	5354.65	2677.32	12373.4	6195.90	0.01	-0.01	0.045	
10.00	-49.60	-1.80	0.00	-208.75	0.00	208.75	5285.82	2642.91	11973.5	5995.67	0.02	-0.02	0.044	
15.00	-47.78	-1.76	0.00	-199.77	0.00	199.77	5215.55	2607.78	11576.7	5796.99	0.05	-0.03	0.044	
20.00	-46.00	-1.73	0.00	-190.95	0.00	190.95	5143.86	2571.93	11183.2	5599.96	0.08	-0.04	0.043	
25.00	-44.24	-1.69	0.00	-182.30	0.00	182.30	5070.72	2535.36	10793.2	5404.66	0.13	-0.05	0.042	
30.00	-42.52	-1.66	0.00	-173.82	0.00	173.82	4996.16	2498.08	10406.9	5211.21	0.19	-0.06	0.042	
35.00	-40.83	-1.62	0.00	-165.53	0.00	165.53	4920.16	2460.08	10024.5	5019.70	0.25	-0.07	0.041	
38.75	-39.58	-1.59	0.00	-159.45	0.00	159.45	4862.22	2431.11	9740.32	4877.40	0.31	-0.08	0.041	
40.00	-38.87	-1.58	0.00	-157.47	0.00	157.47	4842.73	2421.36	9646.11	4830.22	0.33	-0.08	0.041	
45.00	-36.05	-1.50	0.00	-149.59	0.00	149.59	3936.38	1968.19	7803.92	3907.76	0.42	-0.09	0.047	
50.00	-34.62	-1.47	0.00	-142.10	0.00	142.10	3877.34	1938.67	7510.22	3760.69	0.53	-0.10	0.047	
55.00	-33.22	-1.44	0.00	-134.76	0.00	134.76	3816.87	1908.43	7219.20	3614.96	0.64	-0.12	0.046	
60.00	-31.85	-1.41	0.00	-127.58	0.00	127.58	3754.96	1877.48	6931.04	3470.67	0.77	-0.13	0.045	
65.00	-30.50	-1.38	0.00	-120.54	0.00	120.54	3691.62	1845.81	6645.93	3327.91	0.91	-0.14	0.044	
70.00	-29.17	-1.36	0.00	-113.64	0.00	113.64	3626.84	1813.42	6364.09	3186.77	1.07	-0.15	0.044	
75.00	-27.87	-1.35	0.00	-106.83	0.00	106.83	3560.63	1780.31	6085.69	3047.37	1.23	-0.17	0.043	
78.50	-26.98	-1.34	0.00	-102.13	0.00	102.13	3513.43	1756.71	5892.98	2950.87	1.36	-0.18	0.042	
80.00	-26.35	-1.34	0.00	-100.12	0.00	100.12	3492.98	1746.49	5810.95	2909.79	1.42	-0.18	0.042	
83.75	-24.80	-1.33	0.00	-95.10	0.00	95.10	2742.50	1371.25	4553.78	2280.28	1.56	-0.19	0.051	
85.00	-24.53	-1.34	0.00	-93.44	0.00	93.44	2730.37	1365.18	4502.54	2254.62	1.62	-0.20	0.050	
90.00	-23.46	-1.34	0.00	-86.75	0.00	86.75	2680.95	1340.47	4298.92	2152.65	1.83	-0.21	0.049	
95.00	-22.41	-1.34	0.00	-80.04	0.00	80.04	2630.10	1315.05	4097.56	2051.82	2.06	-0.23	0.048	
100.00	-21.38	-1.34	0.00	-73.33	0.00	73.33	2577.82	1288.91	3898.66	1952.23	2.30	-0.24	0.046	
105.00	-18.94	-1.34	0.00	-66.60	0.00	66.60	2524.10	1262.05	3702.43	1853.97	2.57	-0.26	0.043	
110.00	-17.96	-1.34	0.00	-59.91	0.00	59.91	2468.95	1234.47	3509.05	1757.13	2.85	-0.27	0.041	
115.00	-17.00	-1.34	0.00	-53.21	0.00	53.21	2412.36	1206.18	3318.73	1661.83	3.14	-0.29	0.039	
119.25	-16.21	-1.34	0.00	-47.52	0.00	47.52	2363.14	1181.57	3159.50	1582.10	3.41	-0.30	0.037	
120.00	-15.99	-1.34	0.00	-46.52	0.00	46.52	2354.34	1177.17	3131.65	1568.15	3.46	-0.31	0.036	
122.00	-13.45	-1.32	0.00	-43.84	0.00	43.84	2330.73	1165.37	3057.78	1531.16	3.59	-0.31	0.034	
123.50	-13.05	-1.32	0.00	-41.86	0.00	41.86	1751.58	875.79	2319.28	1161.36	3.68	-0.32	0.043	
124.50	-12.27	-1.32	0.00	-40.53	0.00	40.53	1743.79	871.89	2293.08	1148.24	3.75	-0.32	0.042	
125.00	-12.20	-1.32	0.00	-39.87	0.00	39.87	1739.87	869.94	2280.00	1141.69	3.78	-0.32	0.042	
130.00	-11.51	-1.31	0.00	-33.27	0.00	33.27	1699.92	849.96	2150.20	1076.70	4.13	-0.34	0.038	
132.00	-8.61	-1.24	0.00	-30.64	0.00	30.64	1683.54	841.77	2098.80	1050.96	4.27	-0.34	0.034	
135.00	-8.26	-1.23	0.00	-26.91	0.00	26.91	1658.53	829.27	2022.29	1012.65	4.49	-0.35	0.032	
140.00	-7.69	-1.20	0.00	-20.75	0.00	20.75	1615.71	807.86	1896.47	949.64	4.87	-0.36	0.027	
145.00	-7.14	-1.17	0.00	-14.73	0.00	14.73	1571.46	785.73	1772.93	887.78	5.25	-0.38	0.021	
150.00	-6.61	-1.11	0.00	-8.90	0.00	8.90	1525.77	762.88	1651.87	827.16	5.65	-0.38	0.015	
152.00	-3.53	-0.71	0.00	-6.67	0.00	6.67	1507.09	753.54	1604.19	803.29	5.81	-0.39	0.011	
155.00	-3.27	-0.67	0.00	-4.55	0.00	4.55	1478.64	739.32	1533.49	767.89	6.06	-0.39	0.008	
160.00	-2.85	-0.59	0.00	-1.19	0.00	1.19	1426.03	713.01	1413.96	708.03	6.46	-0.39	0.004	
162.00	0.00	-0.57	0.00	0.00	0.00	0.00	1400.09	700.04	1362.73	682.38	6.63	-0.39	0.000	

Seismic Segment Forces (Factored)

Structure: CT01698-S-SBA	Code: EIA/TIA-222-G	10/18/2016
Site Name: Durham	Exposure: C	
Height: 162.00 (ft)	Crest Height: 0.00	
Base Elev: 0.000 (ft)	Site Class: D - Stiff Soil	
Gh: 1.1	Topography: 1	Struct Class: II



Page: 35

Load Case: 0.9D + 1.0E					Iterations 22
Gust Response Factor	1.10	Sds	0.19	Ss	0.18
Dead Load Factor	0.90	Seismic Load Factor	1.00	Sd1	0.10
Wind Load Factor	0.00	Structure Frequency	0.35	SA	0.03
					Seismic Importance Factor 1.00

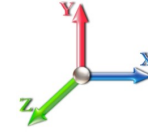

Top Elev (ft)	Description	Wz (lb)	a	b	c	Lateral Fs (lb)	R: 1.50
0.00		0.00	0.00	0.00	0.00	0.00	
5.00		1341.4	0.00	0.03	0.02	23.78	
10.00		1315.5	0.01	0.05	0.03	34.32	
15.00		1289.5	0.02	0.06	0.04	39.20	
20.00		1263.5	0.03	0.07	0.04	41.32	
25.00		1237.5	0.05	0.07	0.04	42.11	
30.00		1211.5	0.06	0.07	0.04	42.34	
35.00		1185.5	0.09	0.07	0.04	42.39	
38.75	Bot - Section 2	872.10	0.11	0.07	0.04	31.70	
40.00		537.95	0.12	0.07	0.04	19.66	
45.00	Top - Section 1	2121.6	0.15	0.07	0.03	79.08	
50.00		965.80	0.18	0.07	0.03	36.42	
55.00		943.52	0.22	0.06	0.02	35.38	
60.00		921.24	0.26	0.05	0.02	33.30	
65.00		898.96	0.30	0.04	0.01	29.71	
70.00		876.68	0.35	0.03	0.01	24.19	
75.00	Appurtenance(s)	864.41	0.41	0.02	0.01	16.73	
78.50	Bot - Section 3	584.83	0.44	0.00	0.01	7.00	
80.00	Appurtenance(s)	457.36	0.46	0.00	0.01	3.87	
83.75	Top - Section 2	1126.0	0.51	-0.02	0.01	-1.02	
85.00		169.88	0.52	-0.02	0.01	-0.70	
90.00		667.91	0.58	-0.05	0.01	-11.14	
95.00		649.35	0.65	-0.07	0.02	-17.72	
100.00		630.78	0.72	-0.09	0.03	-21.73	
105.00	Appurtenance(s)	1812.2	0.79	-0.11	0.05	-67.77	
110.00		593.65	0.87	-0.12	0.08	-21.29	
115.00		575.09	0.95	-0.12	0.11	-17.17	
119.25	Bot - Section 4	474.23	1.02	-0.10	0.14	-10.09	
120.00		149.27	1.04	-0.10	0.15	-2.90	
122.00	Appurtenance(s)	2020.9	1.07	-0.08	0.17	-28.39	
123.50	Top - Section 3	292.27	1.10	-0.07	0.19	-2.79	
124.50	Appurtenance(s)	623.50	1.12	-0.06	0.20	-3.96	
125.00		43.13	1.13	-0.05	0.20	-0.20	
130.00		423.11	1.22	0.02	0.27	6.10	
132.00	Appurtenance(s)	2363.5	1.25	0.06	0.30	54.99	
135.00		243.17	1.31	0.14	0.35	9.20	
140.00		393.40	1.41	0.31	0.44	25.85	
145.00		378.55	1.51	0.54	0.56	37.11	
150.00		363.70	1.62	0.84	0.70	49.07	
152.00	Appurtenance(s)	2539.1	1.66	0.99	0.76	383.35	
155.00		207.52	1.73	1.24	0.86	36.62	
160.00		333.99	1.84	1.74	1.05	74.42	
162.00	Appurtenance(s)	2368.2	1.89	1.98	1.14	574.77	
Totals:		38,331.8				1,627.1	Total Wind: 38,899.6

Seismic Base Shear is Less Than 50% of Wind Force - An Analysis is NOT Required

Calculated Forces

Structure: CT01698-S-SBA	Code: EIA/TIA-222-G	10/18/2016
Site Name: Durham	Exposure: C	
Height: 162.00 (ft)	Crest Height: 0.00	
Base Elev: 0.000 (ft)	Site Class: D - Stiff Soil	
Gh: 1.1	Topography: 1	Struct Class: II

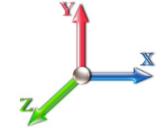

Page: 36

Load Case: 0.9D + 1.0E							Iterations 22
Gust Response Factor	1.10			Sds	0.19		Ss 0.18
Dead Load Factor	0.90	Seismic Load Factor	1.00	Sd1	0.10		S1 0.06
Wind Load Factor	0.00	Structure Frequency	0.35	SA	0.03	Seismic Importance Factor	1.00

Seg Elev (ft)	Pu FY (-) (kips)	Vu FX (-) (kips)	Tu MY (-) (ft-kips)	Mu MZ (ft-kips)	Mu MX (ft-kips)	Resultant Moment (ft-kips)	phi Pn (kips)	phi Vn (kips)	phi Tn (ft-kips)	phi Mn (ft-kips)	Total Deflect (in)	Rotation Sway (deg)	Rotation Twist (deg)	Stress Ratio
0.00	-40.00	-1.84	0.00	-224.52	0.00	224.52	5422.04	2711.02	12776.1	6397.58	0.00	0.00	0.00	0.042
5.00	-38.59	-1.82	0.00	-215.33	0.00	215.33	5354.65	2677.32	12373.4	6195.90	0.01	-0.01	0.042	
10.00	-37.20	-1.79	0.00	-206.24	0.00	206.24	5285.82	2642.91	11973.5	5995.67	0.02	-0.02	0.041	
15.00	-35.84	-1.76	0.00	-197.28	0.00	197.28	5215.55	2607.78	11576.7	5796.99	0.05	-0.03	0.041	
20.00	-34.50	-1.72	0.00	-188.50	0.00	188.50	5143.86	2571.93	11183.2	5599.96	0.08	-0.04	0.040	
25.00	-33.18	-1.68	0.00	-179.89	0.00	179.89	5070.72	2535.36	10793.2	5404.66	0.13	-0.05	0.040	
30.00	-31.89	-1.65	0.00	-171.48	0.00	171.48	4996.16	2498.08	10406.9	5211.21	0.18	-0.06	0.039	
35.00	-30.62	-1.61	0.00	-163.25	0.00	163.25	4920.16	2460.08	10024.5	5019.70	0.25	-0.07	0.039	
38.75	-29.68	-1.58	0.00	-157.22	0.00	157.22	4862.22	2431.11	9740.32	4877.40	0.31	-0.08	0.038	
40.00	-29.15	-1.56	0.00	-155.25	0.00	155.25	4842.73	2421.36	9646.11	4830.22	0.33	-0.08	0.038	
45.00	-27.04	-1.48	0.00	-147.45	0.00	147.45	3936.38	1968.19	7803.92	3907.76	0.42	-0.09	0.045	
50.00	-25.97	-1.45	0.00	-140.03	0.00	140.03	3877.34	1938.67	7510.22	3760.69	0.52	-0.10	0.044	
55.00	-24.91	-1.42	0.00	-132.78	0.00	132.78	3816.87	1908.43	7219.20	3614.96	0.63	-0.11	0.043	
60.00	-23.88	-1.39	0.00	-125.69	0.00	125.69	3754.96	1877.48	6931.04	3470.67	0.76	-0.13	0.043	
65.00	-22.87	-1.36	0.00	-118.76	0.00	118.76	3691.62	1845.81	6645.93	3327.91	0.90	-0.14	0.042	
70.00	-21.88	-1.34	0.00	-111.95	0.00	111.95	3626.84	1813.42	6364.09	3186.77	1.05	-0.15	0.041	
75.00	-20.90	-1.32	0.00	-105.26	0.00	105.26	3560.63	1780.31	6085.69	3047.37	1.22	-0.17	0.040	
78.50	-20.23	-1.32	0.00	-100.62	0.00	100.62	3513.43	1756.71	5892.98	2950.87	1.34	-0.17	0.040	
80.00	-19.76	-1.31	0.00	-98.65	0.00	98.65	3492.98	1746.49	5810.95	2909.79	1.40	-0.18	0.040	
83.75	-18.60	-1.31	0.00	-93.72	0.00	93.72	2742.50	1371.25	4553.78	2280.28	1.54	-0.19	0.048	
85.00	-18.39	-1.32	0.00	-92.08	0.00	92.08	2730.37	1365.18	4502.54	2254.62	1.59	-0.19	0.048	
90.00	-17.59	-1.32	0.00	-85.50	0.00	85.50	2680.95	1340.47	4298.92	2152.65	1.80	-0.21	0.046	
95.00	-16.81	-1.32	0.00	-78.91	0.00	78.91	2630.10	1315.05	4097.56	2051.82	2.03	-0.22	0.045	
100.00	-16.04	-1.32	0.00	-72.32	0.00	72.32	2577.82	1288.91	3898.66	1952.23	2.27	-0.24	0.043	
105.00	-14.20	-1.32	0.00	-65.72	0.00	65.72	2524.10	1262.05	3702.43	1853.97	2.53	-0.26	0.041	
110.00	-13.47	-1.32	0.00	-59.14	0.00	59.14	2468.95	1234.47	3509.05	1757.13	2.81	-0.27	0.039	
115.00	-12.75	-1.32	0.00	-52.55	0.00	52.55	2412.36	1206.18	3318.73	1661.83	3.10	-0.29	0.037	
119.25	-12.15	-1.31	0.00	-46.96	0.00	46.96	2363.14	1181.57	3159.50	1582.10	3.36	-0.30	0.035	
120.00	-11.99	-1.31	0.00	-45.98	0.00	45.98	2354.34	1177.17	3131.65	1568.15	3.41	-0.30	0.034	
122.00	-10.09	-1.31	0.00	-43.35	0.00	43.35	2330.73	1165.37	3057.78	1531.16	3.54	-0.31	0.033	
123.50	-9.79	-1.30	0.00	-41.39	0.00	41.39	1751.58	875.79	2319.28	1161.36	3.63	-0.31	0.041	
124.50	-9.20	-1.30	0.00	-40.08	0.00	40.08	1743.79	871.89	2293.08	1148.24	3.70	-0.31	0.040	
125.00	-9.15	-1.30	0.00	-39.43	0.00	39.43	1739.87	869.94	2280.00	1141.69	3.73	-0.32	0.040	
130.00	-8.63	-1.30	0.00	-32.92	0.00	32.92	1699.92	849.96	2150.20	1076.70	4.07	-0.33	0.036	
132.00	-6.45	-1.23	0.00	-30.33	0.00	30.33	1683.54	841.77	2098.80	1050.96	4.21	-0.34	0.033	
135.00	-6.19	-1.22	0.00	-26.64	0.00	26.64	1658.53	829.27	2022.29	1012.65	4.43	-0.35	0.030	
140.00	-5.77	-1.19	0.00	-20.54	0.00	20.54	1615.71	807.86	1896.47	949.64	4.80	-0.36	0.025	
145.00	-5.35	-1.15	0.00	-14.59	0.00	14.59	1571.46	785.73	1772.93	887.78	5.18	-0.37	0.020	
150.00	-4.96	-1.10	0.00	-8.82	0.00	8.82	1525.77	762.88	1651.87	827.16	5.58	-0.38	0.014	
152.00	-2.64	-0.70	0.00	-6.62	0.00	6.62	1507.09	753.54	1604.19	803.29	5.73	-0.38	0.010	
155.00	-2.45	-0.67	0.00	-4.51	0.00	4.51	1478.64	739.32	1533.49	767.89	5.97	-0.38	0.008	
160.00	-2.13	-0.59	0.00	-1.18	0.00	1.18	1426.03	713.01	1413.96	708.03	6.38	-0.39	0.003	
162.00	0.00	-0.57	0.00	0.00	0.00	0.00	1400.09	700.04	1362.73	682.38	6.54	-0.39	0.000	

Wind Loading - Shaft

Structure: CT01698-S-SBA	Code: EIA/TIA-222-G	10/18/2016
Site Name: Durham	Exposure: C	
Height: 162.00 (ft)	Crest Height: 0.00	
Base Elev: 0.000 (ft)	Site Class: D - Stiff Soil	
Gh: 1.1	Topography: 1	Struct Class: II



Page: 37

Load Case: 1.0D + 1.0W 60 mph Wind

Dead Load Factor 1.00
Wind Load Factor 1.00

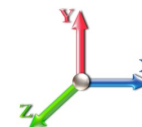

Iterations 23

Elev (ft)	Description	Kzt	Kz	qz (psf)	qzGh (psf)	C (mph-ft)	Cf	Ice Thick (in)	Tributary (ft)	Aa (sf)	CfAa (sf)	Wind Force X (lb)	Dead Load Ice (lb)	Tot Dead Load (lb)
0.00		1.00	0.85	7.442	8.19	270.41	0.650	0.000	0.00	0.000	0.00	0.0	0.0	0.0
5.00		1.00	0.85	7.442	8.19	265.27	0.650	0.000	5.00	24.209	15.74	128.8	0.0	1341.5
10.00		1.00	0.85	7.442	8.19	260.12	0.650	0.000	5.00	23.744	15.43	126.3	0.0	1315.5
15.00		1.00	0.85	7.442	8.19	254.97	0.650	0.000	5.00	23.278	15.13	123.9	0.0	1289.5
20.00		1.00	0.90	7.896	8.69	257.33	0.650	0.000	5.00	22.813	14.83	128.8	0.0	1263.5
25.00		1.00	0.95	8.276	9.10	258.01	0.650	0.000	5.00	22.348	14.53	132.2	0.0	1237.5
30.00		1.00	0.98	8.600	9.46	257.48	0.650	0.000	5.00	21.882	14.22	134.6	0.0	1211.5
35.00		1.00	1.01	8.883	9.77	256.06	0.650	0.000	5.00	21.417	13.92	136.0	0.0	1185.5
38.75 Bot - Section 2		1.00	1.04	9.076	9.98	254.56	0.650	0.000	3.75	15.757	10.24	102.3	0.0	872.1
40.00		1.00	1.04	9.137	10.05	253.98	0.650	0.000	1.25	5.273	3.43	34.5	0.0	538.0
45.00 Top - Section 1		1.00	1.07	9.366	10.30	251.37	0.650	0.000	5.00	20.803	13.52	139.3	0.0	2121.6
50.00		1.00	1.09	9.576	10.53	252.32	0.650	0.000	5.00	20.338	13.22	139.3	0.0	965.8
55.00		1.00	1.12	9.770	10.75	248.96	0.650	0.000	5.00	19.872	12.92	138.8	0.0	943.5
60.00		1.00	1.14	9.951	10.95	245.30	0.650	0.000	5.00	19.407	12.61	138.1	0.0	921.2
65.00		1.00	1.16	10.120	11.13	241.37	0.650	0.000	5.00	18.941	12.31	137.1	0.0	899.0
70.00		1.00	1.17	10.279	11.31	237.20	0.650	0.000	5.00	18.476	12.01	135.8	0.0	876.7
75.00 Appurtenance(s)		1.00	1.19	10.430	11.47	232.84	0.650	0.000	5.00	18.010	11.71	134.3	0.0	854.4
78.50 Bot - Section 3		1.00	1.20	10.530	11.58	229.67	0.650	0.000	3.50	12.330	8.01	92.8	0.0	584.8
80.00 Appurtenance(s)		1.00	1.21	10.572	11.63	228.29	0.650	0.000	1.50	5.294	3.44	40.0	0.0	456.9
83.75 Top - Section 2		1.00	1.22	10.675	11.74	224.76	0.650	0.000	3.75	13.051	8.48	99.6	0.0	1126.1
85.00		1.00	1.22	10.708	11.78	227.08	0.650	0.000	1.25	4.292	2.79	32.9	0.0	169.9
90.00		1.00	1.24	10.838	11.92	222.23	0.650	0.000	5.00	16.878	10.97	130.8	0.0	667.9
95.00		1.00	1.25	10.962	12.06	217.25	0.650	0.000	5.00	16.413	10.67	128.6	0.0	649.3
100.00		1.00	1.27	11.081	12.19	212.15	0.650	0.000	5.00	15.947	10.37	126.3	0.0	630.8
105.00 Appurtenance(s)		1.00	1.28	11.195	12.31	206.92	0.650	0.000	5.00	15.482	10.06	123.9	0.0	612.2
110.00		1.00	1.29	11.305	12.44	201.59	0.650	0.000	5.00	15.016	9.76	121.4	0.0	593.7
115.00		1.00	1.30	11.412	12.55	196.16	0.650	0.000	5.00	14.551	9.46	118.7	0.0	575.1
119.25 Bot - Section 4		1.00	1.31	11.499	12.65	191.47	0.650	0.000	4.25	12.002	7.80	98.7	0.0	474.2
120.00		1.00	1.32	11.514	12.67	190.63	0.653 *	0.000	0.75	2.115	1.38	17.5	0.0	149.3
122.00 Appurtenance(s)		1.00	1.32	11.554	12.71	188.40	0.655 *	0.000	2.00	5.588	3.66	46.5	0.0	394.4
123.50 Top - Section 3		1.00	1.32	11.584	12.74	186.71	0.650	0.000	1.50	4.142	2.69	34.3	0.0	292.3
124.50 Appurtenance(s)		1.00	1.33	11.604	12.76	188.51	0.650	0.000	1.00	2.738	1.78	22.7	0.0	86.7
125.00		1.00	1.33	11.614	12.78	187.95	0.650	0.000	0.50	1.362	0.89	11.3	0.0	43.1
130.00		1.00	1.34	11.710	12.88	182.26	0.650	0.000	5.00	13.366	8.69	111.9	0.0	423.1
132.00 Appurtenance(s)		1.00	1.34	11.748	12.92	179.97	0.650	0.000	2.00	5.216	3.39	43.8	0.0	165.1
135.00		1.00	1.35	11.803	12.98	176.50	0.650	0.000	3.00	7.684	4.99	64.9	0.0	243.2
140.00		1.00	1.36	11.894	13.08	170.67	0.650	0.000	5.00	12.435	8.08	105.8	0.0	393.4
145.00		1.00	1.37	11.982	13.18	164.77	0.650	0.000	5.00	11.970	7.78	102.5	0.0	378.5
150.00		1.00	1.38	12.068	13.27	158.80	0.650	0.000	5.00	11.504	7.48	99.3	0.0	363.7
152.00 Appurtenance(s)		1.00	1.38	12.102	13.31	156.39	0.650	0.000	2.00	4.471	2.91	38.7	0.0	141.3
155.00		1.00	1.39	12.152	13.37	152.77	0.650	0.000	3.00	6.567	4.27	57.1	0.0	207.5
160.00		1.00	1.40	12.233	13.46	146.68	0.650	0.000	5.00	10.573	6.87	92.5	0.0	334.0
162.00 Appurtenance(s)		1.00	1.40	12.265	13.49	144.22	0.650	0.000	2.00	4.099	2.66	35.9	0.0	129.4
Totals:									162.00			4,008.4		28,122.8

* Cf Adjusted by Linear Load Ra Effect

Discrete Appurtenance Forces

Structure: CT01698-S-SBA	Code: EIA/TIA-222-G	10/18/2016
Site Name: Durham	Exposure: C	
Height: 162.00 (ft)	Crest Height: 0.00	
Base Elev: 0.000 (ft)	Site Class: D - Stiff Soil	
Gh: 1.1	Topography: 1	Struct Class: II



Page: 38

Load Case: 1.0D + 1.0W 60 mph Wind

Dead Load Factor 1.00
Wind Load Factor 1.00



Iterations 23

No.	Elev (ft)	Description	Qty	qz (psf)	qzGh (psf)	CaAa x Ka	Ka	Total CaAa (sf)	Dead Load (lb)	Horiz Ecc (ft)	Vert Ecc (ft)	Wind FX (lb)	Mom Y (lb-ft)	Mom Z (lb-ft)
1	162.00	1900MHz RRH	3	12.265	13.492	0.88	1.00	10.03	132.00	0.000	0.000	135.35	0.00	0.00
2	162.00	APXVTM14-C-120	3	12.273	13.501	0.63	0.80	12.02	168.00	0.000	0.500	162.29	0.00	81.14
3	162.00	TD-RRH8x20-25	3	12.265	13.492	0.69	1.00	8.38	210.00	0.000	0.000	113.11	0.00	0.00
4	162.00	APXVSP18-C-A20	3	12.273	13.501	0.66	0.80	15.98	171.00	0.000	0.500	215.68	0.00	107.84
5	162.00	Flush Mount	1	12.233	13.457	1.00	1.00	5.00	175.00	0.000	-2.000	67.28	0.00	-134.57
6	162.00	800 MHz Ext. Filter	3	12.265	13.492	0.63	1.00	2.25	19.80	0.000	0.000	30.34	0.00	0.00
7	162.00	ACU-A20-N	4	12.273	13.501	0.75	1.00	0.42	4.00	0.000	0.500	5.67	0.00	2.84
8	162.00	Low Profile Platform-flat	1	12.265	13.492	1.00	1.00	25.00	1200.00	0.000	0.000	337.30	0.00	0.00
9	162.00	800 MHz RRU	3	12.265	13.492	0.75	1.00	5.60	159.00	0.000	0.000	75.59	0.00	0.00
10	152.00	KRY 112 144/1	3	12.102	13.312	0.55	0.75	0.57	33.00	0.000	0.000	7.65	0.00	0.00
11	152.00	APXV18-206516S-A20	3	12.102	13.312	0.57	0.75	7.46	55.50	0.000	0.000	99.25	0.00	0.00
12	152.00	LNx-6515DS-A1M	3	12.102	13.312	0.60	0.75	20.65	149.40	0.000	0.000	274.84	0.00	0.00
13	152.00	FE15501P77/75	3	12.102	13.312	0.49	0.75	0.79	52.50	0.000	0.000	10.51	0.00	0.00
14	152.00	782 11056	3	12.102	13.312	0.50	0.75	0.23	5.40	0.000	0.000	3.01	0.00	0.00
15	152.00	Platform w/ Hand Rail	1	12.102	13.312	1.00	1.00	42.00	2021.00	0.000	0.000	559.11	0.00	0.00
16	152.00	RR90-17-02DP	6	12.102	13.312	0.55	0.75	14.32	81.00	0.000	0.000	190.66	0.00	0.00
17	132.00	RFS DB-T1-6Z-8AB-0Z	2	11.748	12.922	0.57	0.80	4.92	88.00	0.000	0.000	63.56	0.00	0.00
18	132.00	FD9R6004/2C-3L	6	11.748	12.922	0.60	0.80	1.30	18.60	0.000	0.000	16.75	0.00	0.00
19	132.00	RRH2X60-700	3	11.748	12.922	0.61	0.80	6.38	180.00	0.000	0.000	82.50	0.00	0.00
20	132.00	RRH2X60-AWS	3	11.748	12.922	0.61	0.80	6.38	180.00	0.000	0.000	82.50	0.00	0.00
21	132.00	DB846F65ZAXY	4	11.748	12.922	0.74	0.80	20.98	84.00	0.000	0.000	271.12	0.00	0.00
22	132.00	LPA-80080-4CF-EDIN-0	2	11.748	12.922	1.36	0.80	7.10	24.00	0.000	0.000	91.74	0.00	0.00
23	132.00	SBNHH-1D65B	9	11.748	12.922	0.66	0.80	48.29	365.40	0.000	0.000	623.98	0.00	0.00
24	132.00	Low Profile Platform-flat	1	11.748	12.922	1.00	1.00	25.00	1200.00	0.000	0.000	323.06	0.00	0.00
25	132.00	RRH2x60-1900	3	11.748	12.922	0.60	0.80	2.72	58.50	0.000	0.000	35.12	0.00	0.00
26	124.50	RRUS-11	6	11.604	12.764	0.68	1.00	18.03	330.00	0.000	0.000	230.19	0.00	0.00
27	124.50	Flush Mount	1	11.604	12.764	1.00	1.00	5.00	175.00	0.000	0.000	63.82	0.00	0.00
28	124.50	DC6-48-60-18-8F	1	11.604	12.764	1.00	1.00	1.47	31.80	0.000	0.000	18.76	0.00	0.00
29	122.00	Low Profile Platform-flat	1	11.554	12.710	1.00	1.00	25.00	1200.00	0.000	0.000	317.75	0.00	0.00
30	122.00	AM-X-CD-16-65-00T-RET	3	11.554	12.710	0.65	0.80	11.76	99.00	0.000	0.000	149.48	0.00	0.00
31	122.00	LGP21903	6	11.554	12.710	0.60	0.80	0.97	33.00	0.000	0.000	12.35	0.00	0.00
32	122.00	LGP21401	6	11.554	12.710	0.60	0.80	4.64	84.60	0.000	0.000	59.02	0.00	0.00
33	122.00	7770.00	6	11.554	12.710	0.58	0.80	19.27	210.00	0.000	0.000	244.95	0.00	0.00
34	105.00	Low Profile Platform-flat	1	11.195	12.315	1.00	1.00	25.00	1200.00	0.000	0.000	307.87	0.00	0.00
35	80.00	738-449	1	10.582	11.640	1.00	1.00	0.01	0.50	0.000	0.350	0.12	0.00	0.04
36	75.00	GPS	1	10.430	11.473	1.00	1.00	1.00	10.00	0.000	0.000	11.47	0.00	0.00

Totals: 10,209.00

5,293.75

Total Applied Force Summary

Structure: CT01698-S-SBA	Code: EIA/TIA-222-G	10/18/2016
Site Name: Durham	Exposure: C	
Height: 162.00 (ft)	Crest Height: 0.00	
Base Elev: 0.000 (ft)	Site Class: D - Stiff Soil	
Gh: 1.1	Topography: 1	Struct Class: II



Page: 39

Load Case: 1.0D + 1.0W 60 mph Wind

Dead Load Factor 1.00
Wind Load Factor 1.00

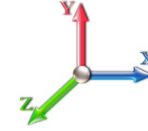

Iterations 23

Elev (ft)	Description	Lateral FX (-) (lb)	Axial FY (-) (lb)	Torsion MY (lb-ft)	Moment MZ (lb-ft)
0.00		0.00	0.00	0.00	0.00
5.00		128.82	1566.05	0.00	0.00
10.00		126.34	1540.06	0.00	0.00
15.00		123.86	1514.07	0.00	0.00
20.00		128.80	1488.08	0.00	0.00
25.00		132.24	1462.09	0.00	0.00
30.00		134.55	1436.10	0.00	0.00
35.00		136.03	1410.11	0.00	0.00
38.75		102.25	1040.52	0.00	0.00
40.00		34.45	594.09	0.00	0.00
45.00		139.31	2346.20	0.00	0.00
50.00		139.25	1190.36	0.00	0.00
55.00		138.82	1168.08	0.00	0.00
60.00		138.08	1145.81	0.00	0.00
65.00		137.05	1123.53	0.00	0.00
70.00		135.79	1101.25	0.00	0.00
75.00	(1) attachments	145.78	1088.97	0.00	0.00
78.50		92.83	741.46	0.00	0.00
80.00	(1) attachments	40.13	524.49	0.00	0.04
83.75		99.61	1293.30	0.00	0.00
85.00		32.86	225.62	0.00	0.00
90.00		130.79	890.88	0.00	0.00
95.00		128.64	872.31	0.00	0.00
100.00		126.35	853.75	0.00	0.00
105.00	(1) attachments	431.79	2035.18	0.00	0.00
110.00		121.38	816.62	0.00	0.00
115.00		118.73	798.05	0.00	0.00
119.25		98.68	663.75	0.00	0.00
120.00		17.48	182.71	0.00	0.00
122.00	(22) attachments	830.05	2110.16	0.00	0.00
123.50		34.31	336.48	0.00	0.00
124.50	(8) attachments	335.49	652.97	0.00	0.00
125.00		11.31	57.86	0.00	0.00
130.00		111.91	570.47	0.00	0.00
132.00	(33) attachments	1634.14	2422.53	0.00	0.00
135.00		64.85	290.67	0.00	0.00
140.00		105.75	472.57	0.00	0.00
145.00		102.55	457.71	0.00	0.00
150.00		99.27	442.86	0.00	0.00
152.00	(22) attachments	1183.72	2570.79	0.00	0.00
155.00		57.06	217.58	0.00	0.00
160.00		92.48	350.76	0.00	0.00
162.00	(24) attachments	1178.55	2374.94	0.00	57.25
Totals:		9,302.16	44,441.84	0.00	57.29

Linear Appurtenance Segment Forces (Factored)

Structure: CT01698-S-SBA	Code: EIA/TIA-222-G	10/18/2016
Site Name: Durham	Exposure: C	
Height: 162.00 (ft)	Crest Height: 0.00	
Base Elev: 0.000 (ft)	Site Class: D - Stiff Soil	
Gh: 1.1	Topography: 1	Struct Class: II



Page: 40

Load Case: 1.0D + 1.0W 60 mph Wind

Dead Load Factor 1.00
Wind Load Factor 1.00



Iterations 23

Top Elev (ft)	Description	Wind Exposed	Length (ft)	Ca	Exposed Width (in)	Area (sqft)	CaAa (sqft)	Ra	Cf Adjust Factor	qz (psf)	F X (lb)	Dead Load (lb)
5.00	Safety Cable	Yes	5.00	0.000	0.38	0.16	0.00	0.058	0.000	7.442	0.00	1.37
5.00	1 5/8" Coax	Yes	5.00	0.000	0.00	0.00	0.00	0.058	0.000	7.442	0.00	62.40
5.00	10 mm	Yes	5.00	0.000	0.00	0.00	0.00	0.058	0.000	7.442	0.00	0.30
5.00	3" Coax	Yes	5.00	0.000	3.00	1.25	0.00	0.058	0.000	7.442	0.00	8.90
5.00	DC	Yes	5.00	0.000	0.00	0.00	0.00	0.058	0.000	7.442	0.00	4.00
5.00	1/2" Coax	Yes	5.00	0.000	0.00	0.00	0.00	0.058	0.000	7.442	0.00	0.80
10.00	Safety Cable	Yes	5.00	0.000	0.38	0.16	0.00	0.059	0.000	7.442	0.00	1.37
10.00	1 5/8" Coax	Yes	5.00	0.000	0.00	0.00	0.00	0.059	0.000	7.442	0.00	62.40
10.00	10 mm	Yes	5.00	0.000	0.00	0.00	0.00	0.059	0.000	7.442	0.00	0.30
10.00	3" Coax	Yes	5.00	0.000	3.00	1.25	0.00	0.059	0.000	7.442	0.00	8.90
10.00	DC	Yes	5.00	0.000	0.00	0.00	0.00	0.059	0.000	7.442	0.00	4.00
10.00	1/2" Coax	Yes	5.00	0.000	0.00	0.00	0.00	0.059	0.000	7.442	0.00	0.80
15.00	Safety Cable	Yes	5.00	0.000	0.38	0.16	0.00	0.060	0.000	7.442	0.00	1.37
15.00	1 5/8" Coax	Yes	5.00	0.000	0.00	0.00	0.00	0.060	0.000	7.442	0.00	62.40
15.00	10 mm	Yes	5.00	0.000	0.00	0.00	0.00	0.060	0.000	7.442	0.00	0.30
15.00	3" Coax	Yes	5.00	0.000	3.00	1.25	0.00	0.060	0.000	7.442	0.00	8.90
15.00	DC	Yes	5.00	0.000	0.00	0.00	0.00	0.060	0.000	7.442	0.00	4.00
15.00	1/2" Coax	Yes	5.00	0.000	0.00	0.00	0.00	0.060	0.000	7.442	0.00	0.80
20.00	Safety Cable	Yes	5.00	0.000	0.38	0.16	0.00	0.062	0.000	7.896	0.00	1.37
20.00	1 5/8" Coax	Yes	5.00	0.000	0.00	0.00	0.00	0.062	0.000	7.896	0.00	62.40
20.00	10 mm	Yes	5.00	0.000	0.00	0.00	0.00	0.062	0.000	7.896	0.00	0.30
20.00	3" Coax	Yes	5.00	0.000	3.00	1.25	0.00	0.062	0.000	7.896	0.00	8.90
20.00	DC	Yes	5.00	0.000	0.00	0.00	0.00	0.062	0.000	7.896	0.00	4.00
20.00	1/2" Coax	Yes	5.00	0.000	0.00	0.00	0.00	0.062	0.000	7.896	0.00	0.80
25.00	Safety Cable	Yes	5.00	0.000	0.38	0.16	0.00	0.063	0.000	8.276	0.00	1.37
25.00	1 5/8" Coax	Yes	5.00	0.000	0.00	0.00	0.00	0.063	0.000	8.276	0.00	62.40
25.00	10 mm	Yes	5.00	0.000	0.00	0.00	0.00	0.063	0.000	8.276	0.00	0.30
25.00	3" Coax	Yes	5.00	0.000	3.00	1.25	0.00	0.063	0.000	8.276	0.00	8.90
25.00	DC	Yes	5.00	0.000	0.00	0.00	0.00	0.063	0.000	8.276	0.00	4.00
25.00	1/2" Coax	Yes	5.00	0.000	0.00	0.00	0.00	0.063	0.000	8.276	0.00	0.80
30.00	Safety Cable	Yes	5.00	0.000	0.38	0.16	0.00	0.064	0.000	8.600	0.00	1.37
30.00	1 5/8" Coax	Yes	5.00	0.000	0.00	0.00	0.00	0.064	0.000	8.600	0.00	62.40
30.00	10 mm	Yes	5.00	0.000	0.00	0.00	0.00	0.064	0.000	8.600	0.00	0.30
30.00	3" Coax	Yes	5.00	0.000	3.00	1.25	0.00	0.064	0.000	8.600	0.00	8.90
30.00	DC	Yes	5.00	0.000	0.00	0.00	0.00	0.064	0.000	8.600	0.00	4.00
30.00	1/2" Coax	Yes	5.00	0.000	0.00	0.00	0.00	0.064	0.000	8.600	0.00	0.80
35.00	Safety Cable	Yes	5.00	0.000	0.38	0.16	0.00	0.066	0.000	8.883	0.00	1.37
35.00	1 5/8" Coax	Yes	5.00	0.000	0.00	0.00	0.00	0.066	0.000	8.883	0.00	62.40
35.00	10 mm	Yes	5.00	0.000	0.00	0.00	0.00	0.066	0.000	8.883	0.00	0.30
35.00	3" Coax	Yes	5.00	0.000	3.00	1.25	0.00	0.066	0.000	8.883	0.00	8.90
35.00	DC	Yes	5.00	0.000	0.00	0.00	0.00	0.066	0.000	8.883	0.00	4.00
35.00	1/2" Coax	Yes	5.00	0.000	0.00	0.00	0.00	0.066	0.000	8.883	0.00	0.80
38.75	Safety Cable	Yes	3.75	0.000	0.38	0.12	0.00	0.067	0.000	9.076	0.00	1.02
38.75	1 5/8" Coax	Yes	3.75	0.000	0.00	0.00	0.00	0.067	0.000	9.076	0.00	46.80
38.75	10 mm	Yes	3.75	0.000	0.00	0.00	0.00	0.067	0.000	9.076	0.00	0.22
38.75	3" Coax	Yes	3.75	0.000	3.00	0.94	0.00	0.067	0.000	9.076	0.00	6.67
38.75	DC	Yes	3.75	0.000	0.00	0.00	0.00	0.067	0.000	9.076	0.00	3.00

Linear Appurtenance Segment Forces (Factored)

Structure: CT01698-S-SBA	Code: EIA/TIA-222-G	10/18/2016
Site Name: Durham	Exposure: C	
Height: 162.00 (ft)	Crest Height: 0.00	
Base Elev: 0.000 (ft)	Site Class: D - Stiff Soil	
Gh: 1.1	Topography: 1	Struct Class: II



Page: 41

Load Case: 1.0D + 1.0W 60 mph Wind

Dead Load Factor 1.00
Wind Load Factor 1.00



Iterations 23

Top Elev (ft)	Description	Wind Exposed	Length (ft)	Ca	Exposed Width (in)	Area (sqft)	CaAa (sqft)	Ra	Cf Adjust Factor	qz (psf)	F X (lb)	Dead Load (lb)
38.75	1/2" Coax	Yes	3.75	0.000	0.00	0.00	0.00	0.067	0.000	9.076	0.00	0.60
40.00	Safety Cable	Yes	1.25	0.000	0.38	0.04	0.00	0.068	0.000	9.137	0.00	0.34
40.00	1 5/8" Coax	Yes	1.25	0.000	0.00	0.00	0.00	0.068	0.000	9.137	0.00	15.60
40.00	10 mm	Yes	1.25	0.000	0.00	0.00	0.00	0.068	0.000	9.137	0.00	0.07
40.00	3" Coax	Yes	1.25	0.000	3.00	0.31	0.00	0.068	0.000	9.137	0.00	2.23
40.00	DC	Yes	1.25	0.000	0.00	0.00	0.00	0.068	0.000	9.137	0.00	1.00
40.00	1/2" Coax	Yes	1.25	0.000	0.00	0.00	0.00	0.068	0.000	9.137	0.00	0.20
45.00	Safety Cable	Yes	5.00	0.000	0.38	0.16	0.00	0.069	0.000	9.366	0.00	1.37
45.00	1 5/8" Coax	Yes	5.00	0.000	0.00	0.00	0.00	0.069	0.000	9.366	0.00	62.40
45.00	10 mm	Yes	5.00	0.000	0.00	0.00	0.00	0.069	0.000	9.366	0.00	0.30
45.00	3" Coax	Yes	5.00	0.000	3.00	1.25	0.00	0.069	0.000	9.366	0.00	8.90
45.00	DC	Yes	5.00	0.000	0.00	0.00	0.00	0.069	0.000	9.366	0.00	4.00
45.00	1/2" Coax	Yes	5.00	0.000	0.00	0.00	0.00	0.069	0.000	9.366	0.00	0.80
50.00	Safety Cable	Yes	5.00	0.000	0.38	0.16	0.00	0.069	0.000	9.576	0.00	1.37
50.00	1 5/8" Coax	Yes	5.00	0.000	0.00	0.00	0.00	0.069	0.000	9.576	0.00	62.40
50.00	10 mm	Yes	5.00	0.000	0.00	0.00	0.00	0.069	0.000	9.576	0.00	0.30
50.00	3" Coax	Yes	5.00	0.000	3.00	1.25	0.00	0.069	0.000	9.576	0.00	8.90
50.00	DC	Yes	5.00	0.000	0.00	0.00	0.00	0.069	0.000	9.576	0.00	4.00
50.00	1/2" Coax	Yes	5.00	0.000	0.00	0.00	0.00	0.069	0.000	9.576	0.00	0.80
55.00	Safety Cable	Yes	5.00	0.000	0.38	0.16	0.00	0.071	0.000	9.770	0.00	1.37
55.00	1 5/8" Coax	Yes	5.00	0.000	0.00	0.00	0.00	0.071	0.000	9.770	0.00	62.40
55.00	10 mm	Yes	5.00	0.000	0.00	0.00	0.00	0.071	0.000	9.770	0.00	0.30
55.00	3" Coax	Yes	5.00	0.000	3.00	1.25	0.00	0.071	0.000	9.770	0.00	8.90
55.00	DC	Yes	5.00	0.000	0.00	0.00	0.00	0.071	0.000	9.770	0.00	4.00
55.00	1/2" Coax	Yes	5.00	0.000	0.00	0.00	0.00	0.071	0.000	9.770	0.00	0.80
60.00	Safety Cable	Yes	5.00	0.000	0.38	0.16	0.00	0.073	0.000	9.951	0.00	1.37
60.00	1 5/8" Coax	Yes	5.00	0.000	0.00	0.00	0.00	0.073	0.000	9.951	0.00	62.40
60.00	10 mm	Yes	5.00	0.000	0.00	0.00	0.00	0.073	0.000	9.951	0.00	0.30
60.00	3" Coax	Yes	5.00	0.000	3.00	1.25	0.00	0.073	0.000	9.951	0.00	8.90
60.00	DC	Yes	5.00	0.000	0.00	0.00	0.00	0.073	0.000	9.951	0.00	4.00
60.00	1/2" Coax	Yes	5.00	0.000	0.00	0.00	0.00	0.073	0.000	9.951	0.00	0.80
65.00	Safety Cable	Yes	5.00	0.000	0.38	0.16	0.00	0.074	0.000	10.120	0.00	1.37
65.00	1 5/8" Coax	Yes	5.00	0.000	0.00	0.00	0.00	0.074	0.000	10.120	0.00	62.40
65.00	10 mm	Yes	5.00	0.000	0.00	0.00	0.00	0.074	0.000	10.120	0.00	0.30
65.00	3" Coax	Yes	5.00	0.000	3.00	1.25	0.00	0.074	0.000	10.120	0.00	8.90
65.00	DC	Yes	5.00	0.000	0.00	0.00	0.00	0.074	0.000	10.120	0.00	4.00
65.00	1/2" Coax	Yes	5.00	0.000	0.00	0.00	0.00	0.074	0.000	10.120	0.00	0.80
70.00	Safety Cable	Yes	5.00	0.000	0.38	0.16	0.00	0.076	0.000	10.279	0.00	1.37
70.00	1 5/8" Coax	Yes	5.00	0.000	0.00	0.00	0.00	0.076	0.000	10.279	0.00	62.40
70.00	10 mm	Yes	5.00	0.000	0.00	0.00	0.00	0.076	0.000	10.279	0.00	0.30
70.00	3" Coax	Yes	5.00	0.000	3.00	1.25	0.00	0.076	0.000	10.279	0.00	8.90
70.00	DC	Yes	5.00	0.000	0.00	0.00	0.00	0.076	0.000	10.279	0.00	4.00
70.00	1/2" Coax	Yes	5.00	0.000	0.00	0.00	0.00	0.076	0.000	10.279	0.00	0.80
75.00	Safety Cable	Yes	5.00	0.000	0.38	0.16	0.00	0.078	0.000	10.430	0.00	1.37
75.00	1 5/8" Coax	Yes	5.00	0.000	0.00	0.00	0.00	0.078	0.000	10.430	0.00	62.40
75.00	10 mm	Yes	5.00	0.000	0.00	0.00	0.00	0.078	0.000	10.430	0.00	0.30
75.00	3" Coax	Yes	5.00	0.000	3.00	1.25	0.00	0.078	0.000	10.430	0.00	8.90

Linear Appurtenance Segment Forces (Factored)

Structure: CT01698-S-SBA	Code: EIA/TIA-222-G	10/18/2016
Site Name: Durham	Exposure: C	
Height: 162.00 (ft)	Crest Height: 0.00	
Base Elev: 0.000 (ft)	Site Class: D - Stiff Soil	
Gh: 1.1	Topography: 1	Struct Class: II



Page: 42

Load Case: 1.0D + 1.0W 60 mph Wind

Dead Load Factor 1.00
Wind Load Factor 1.00



Iterations 23

Top Elev (ft)	Description	Wind Exposed	Length (ft)	Ca	Exposed Width (in)	Area (sqft)	CaAa (sqft)	Ra	Cf Adjust Factor	qz (psf)	F X (lb)	Dead Load (lb)
75.00	DC	Yes	5.00	0.000	0.00	0.00	0.00	0.078	0.000	10.430	0.00	4.00
75.00	1/2" Coax	Yes	5.00	0.000	0.00	0.00	0.00	0.078	0.000	10.430	0.00	0.80
78.50	Safety Cable	Yes	3.50	0.000	0.38	0.11	0.00	0.080	0.000	10.530	0.00	0.96
78.50	1 5/8" Coax	Yes	3.50	0.000	0.00	0.00	0.00	0.080	0.000	10.530	0.00	43.68
78.50	10 mm	Yes	3.50	0.000	0.00	0.00	0.00	0.080	0.000	10.530	0.00	0.21
78.50	3" Coax	Yes	3.50	0.000	3.00	0.88	0.00	0.080	0.000	10.530	0.00	6.23
78.50	DC	Yes	3.50	0.000	0.00	0.00	0.00	0.080	0.000	10.530	0.00	2.80
80.00	Safety Cable	Yes	1.50	0.000	0.38	0.05	0.00	0.081	0.000	10.572	0.00	0.41
80.00	1 5/8" Coax	Yes	1.50	0.000	0.00	0.00	0.00	0.081	0.000	10.572	0.00	18.72
80.00	10 mm	Yes	1.50	0.000	0.00	0.00	0.00	0.081	0.000	10.572	0.00	0.09
80.00	3" Coax	Yes	1.50	0.000	3.00	0.38	0.00	0.081	0.000	10.572	0.00	2.67
80.00	DC	Yes	1.50	0.000	0.00	0.00	0.00	0.081	0.000	10.572	0.00	1.20
83.75	Safety Cable	Yes	3.75	0.000	0.38	0.12	0.00	0.082	0.000	10.675	0.00	1.02
83.75	1 5/8" Coax	Yes	3.75	0.000	0.00	0.00	0.00	0.082	0.000	10.675	0.00	46.80
83.75	10 mm	Yes	3.75	0.000	0.00	0.00	0.00	0.082	0.000	10.675	0.00	0.22
83.75	3" Coax	Yes	3.75	0.000	3.00	0.94	0.00	0.082	0.000	10.675	0.00	6.67
83.75	DC	Yes	3.75	0.000	0.00	0.00	0.00	0.082	0.000	10.675	0.00	3.00
85.00	Safety Cable	Yes	1.25	0.000	0.38	0.04	0.00	0.082	0.000	10.708	0.00	0.34
85.00	1 5/8" Coax	Yes	1.25	0.000	0.00	0.00	0.00	0.082	0.000	10.708	0.00	15.60
85.00	10 mm	Yes	1.25	0.000	0.00	0.00	0.00	0.082	0.000	10.708	0.00	0.07
85.00	3" Coax	Yes	1.25	0.000	3.00	0.31	0.00	0.082	0.000	10.708	0.00	2.23
85.00	DC	Yes	1.25	0.000	0.00	0.00	0.00	0.082	0.000	10.708	0.00	1.00
90.00	Safety Cable	Yes	5.00	0.000	0.38	0.16	0.00	0.083	0.000	10.838	0.00	1.37
90.00	1 5/8" Coax	Yes	5.00	0.000	0.00	0.00	0.00	0.083	0.000	10.838	0.00	62.40
90.00	10 mm	Yes	5.00	0.000	0.00	0.00	0.00	0.083	0.000	10.838	0.00	0.30
90.00	3" Coax	Yes	5.00	0.000	3.00	1.25	0.00	0.083	0.000	10.838	0.00	8.90
90.00	DC	Yes	5.00	0.000	0.00	0.00	0.00	0.083	0.000	10.838	0.00	4.00
95.00	Safety Cable	Yes	5.00	0.000	0.38	0.16	0.00	0.086	0.000	10.962	0.00	1.37
95.00	1 5/8" Coax	Yes	5.00	0.000	0.00	0.00	0.00	0.086	0.000	10.962	0.00	62.40
95.00	10 mm	Yes	5.00	0.000	0.00	0.00	0.00	0.086	0.000	10.962	0.00	0.30
95.00	3" Coax	Yes	5.00	0.000	3.00	1.25	0.00	0.086	0.000	10.962	0.00	8.90
95.00	DC	Yes	5.00	0.000	0.00	0.00	0.00	0.086	0.000	10.962	0.00	4.00
100.00	Safety Cable	Yes	5.00	0.000	0.38	0.16	0.00	0.088	0.000	11.081	0.00	1.37
100.00	1 5/8" Coax	Yes	5.00	0.000	0.00	0.00	0.00	0.088	0.000	11.081	0.00	62.40
100.00	10 mm	Yes	5.00	0.000	0.00	0.00	0.00	0.088	0.000	11.081	0.00	0.30
100.00	3" Coax	Yes	5.00	0.000	3.00	1.25	0.00	0.088	0.000	11.081	0.00	8.90
100.00	DC	Yes	5.00	0.000	0.00	0.00	0.00	0.088	0.000	11.081	0.00	4.00
105.00	Safety Cable	Yes	5.00	0.000	0.38	0.16	0.00	0.091	0.000	11.195	0.00	1.37
105.00	1 5/8" Coax	Yes	5.00	0.000	0.00	0.00	0.00	0.091	0.000	11.195	0.00	62.40
105.00	10 mm	Yes	5.00	0.000	0.00	0.00	0.00	0.091	0.000	11.195	0.00	0.30
105.00	3" Coax	Yes	5.00	0.000	3.00	1.25	0.00	0.091	0.000	11.195	0.00	8.90
105.00	DC	Yes	5.00	0.000	0.00	0.00	0.00	0.091	0.000	11.195	0.00	4.00
110.00	Safety Cable	Yes	5.00	0.000	0.38	0.16	0.00	0.094	0.000	11.305	0.00	1.37
110.00	1 5/8" Coax	Yes	5.00	0.000	0.00	0.00	0.00	0.094	0.000	11.305	0.00	62.40
110.00	10 mm	Yes	5.00	0.000	0.00	0.00	0.00	0.094	0.000	11.305	0.00	0.30
110.00	3" Coax	Yes	5.00	0.000	3.00	1.25	0.00	0.094	0.000	11.305	0.00	8.90
110.00	DC	Yes	5.00	0.000	0.00	0.00	0.00	0.094	0.000	11.305	0.00	4.00

Linear Appurtenance Segment Forces (Factored)

Structure: CT01698-S-SBA	Code: EIA/TIA-222-G	10/18/2016
Site Name: Durham	Exposure: C	
Height: 162.00 (ft)	Crest Height: 0.00	
Base Elev: 0.000 (ft)	Site Class: D - Stiff Soil	
Gh: 1.1	Topography: 1	Struct Class: II



Page: 43

Load Case: 1.0D + 1.0W 60 mph Wind

Dead Load Factor 1.00

Wind Load Factor 1.00

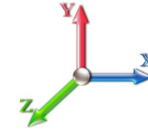

Iterations 23

Top Elev (ft)	Description	Wind Exposed	Length (ft)	Ca	Exposed Width (in)	Area (sqft)	CaAa (sqft)	Ra	Cf Adjust Factor	qz (psf)	F X (lb)	Dead Load (lb)
115.00	Safety Cable	Yes	5.00	0.000	0.38	0.16	0.00	0.097	0.000	11.412	0.00	1.37
115.00	1 5/8" Coax	Yes	5.00	0.000	0.00	0.00	0.00	0.097	0.000	11.412	0.00	62.40
115.00	10 mm	Yes	5.00	0.000	0.00	0.00	0.00	0.097	0.000	11.412	0.00	0.30
115.00	3" Coax	Yes	5.00	0.000	3.00	1.25	0.00	0.097	0.000	11.412	0.00	8.90
115.00	DC	Yes	5.00	0.000	0.00	0.00	0.00	0.097	0.000	11.412	0.00	4.00
119.25	Safety Cable	Yes	4.25	0.000	0.38	0.13	0.00	0.100	0.000	11.499	0.00	1.16
119.25	1 5/8" Coax	Yes	4.25	0.000	0.00	0.00	0.00	0.100	0.000	11.499	0.00	53.04
119.25	10 mm	Yes	4.25	0.000	0.00	0.00	0.00	0.100	0.000	11.499	0.00	0.26
119.25	3" Coax	Yes	4.25	0.000	3.00	1.06	0.00	0.100	0.000	11.499	0.00	7.57
119.25	DC	Yes	4.25	0.000	0.00	0.00	0.00	0.100	0.000	11.499	0.00	3.40
120.00	Safety Cable	Yes	0.75	0.000	0.38	0.02	0.00	0.101	1.004	11.514	0.00	0.20
120.00	1 5/8" Coax	Yes	0.75	0.000	0.00	0.00	0.00	0.101	1.004	11.514	0.00	9.36
120.00	10 mm	Yes	0.75	0.000	0.00	0.00	0.00	0.101	1.004	11.514	0.00	0.04
120.00	3" Coax	Yes	0.75	0.000	3.00	0.19	0.00	0.101	1.004	11.514	0.00	1.33
120.00	DC	Yes	0.75	0.000	0.00	0.00	0.00	0.101	1.004	11.514	0.00	0.60
122.00	Safety Cable	Yes	2.00	0.000	0.38	0.06	0.00	0.102	1.007	11.554	0.00	0.55
122.00	1 5/8" Coax	Yes	2.00	0.000	0.00	0.00	0.00	0.102	1.007	11.554	0.00	24.96
122.00	10 mm	Yes	2.00	0.000	0.00	0.00	0.00	0.102	1.007	11.554	0.00	0.12
122.00	3" Coax	Yes	2.00	0.000	3.00	0.50	0.00	0.102	1.007	11.554	0.00	3.56
122.00	DC	Yes	2.00	0.000	0.00	0.00	0.00	0.102	1.007	11.554	0.00	1.60
123.50	Safety Cable	Yes	1.50	0.000	0.38	0.05	0.00	0.012	0.000	11.584	0.00	0.41
124.50	Safety Cable	Yes	1.00	0.000	0.38	0.03	0.00	0.012	0.000	11.604	0.00	0.27
125.00	Safety Cable	Yes	0.50	0.000	0.38	0.02	0.00	0.012	0.000	11.614	0.00	0.14
130.00	Safety Cable	Yes	5.00	0.000	0.38	0.16	0.00	0.012	0.000	11.710	0.00	1.37
132.00	Safety Cable	Yes	2.00	0.000	0.38	0.06	0.00	0.012	0.000	11.748	0.00	0.55
135.00	Safety Cable	Yes	3.00	0.000	0.38	0.10	0.00	0.012	0.000	11.803	0.00	0.82
140.00	Safety Cable	Yes	5.00	0.000	0.38	0.16	0.00	0.013	0.000	11.894	0.00	1.37
145.00	Safety Cable	Yes	5.00	0.000	0.38	0.16	0.00	0.013	0.000	11.982	0.00	1.37
150.00	Safety Cable	Yes	5.00	0.000	0.38	0.16	0.00	0.014	0.000	12.068	0.00	1.37
152.00	Safety Cable	Yes	2.00	0.000	0.38	0.06	0.00	0.014	0.000	12.102	0.00	0.55
155.00	Safety Cable	Yes	3.00	0.000	0.38	0.10	0.00	0.014	0.000	12.152	0.00	0.82
160.00	Safety Cable	Yes	5.00	0.000	0.38	0.16	0.00	0.015	0.000	12.233	0.00	1.37
162.00	Safety Cable	Yes	2.00	0.000	0.38	0.06	0.00	0.015	0.000	12.265	0.00	0.55
Totals:											0.0	1,900.9

Calculated Forces

Structure: CT01698-S-SBA	Code: EIA/TIA-222-G	10/18/2016
Site Name: Durham	Exposure: C	
Height: 162.00 (ft)	Crest Height: 0.00	
Base Elev: 0.000 (ft)	Site Class: D - Stiff Soil	
Gh: 1.1	Topography: 1	Page: 44
	Struct Class: II	



Load Case: 1.0D + 1.0W 60 mph Wind

Iterations 23

Dead Load Factor 1.00
Wind Load Factor 1.00

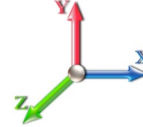

Seg Elev (ft)	Pu FY (-) (kips)	Vu FX (-) (kips)	Tu MY (-) (ft-kips)	Mu MZ (ft-kips)	Mu MX (ft-kips)	Resultant Moment (ft-kips)	phi Pn (kips)	phi Vn (kips)	phi Tn (ft-kips)	phi Mn (ft-kips)	Total Deflect (in)	Rotation Sway (deg)	Rotation Twist (deg)	Stress Ratio
0.00	-44.44	-9.32	0.00	-1089.2	0.00	1089.21	5422.04	2711.02	12776.1	6397.58	0.00	0.000	0.000	0.178
5.00	-42.86	-9.22	0.00	-1042.6	0.00	1042.62	5354.65	2677.32	12373.4	6195.90	0.02	-0.046	0.000	0.176
10.00	-41.32	-9.13	0.00	-996.49	0.00	996.49	5285.82	2642.91	11973.5	5995.67	0.10	-0.092	0.000	0.174
15.00	-39.80	-9.04	0.00	-950.85	0.00	950.85	5215.55	2607.78	11576.7	5796.99	0.22	-0.139	0.000	0.172
20.00	-38.30	-8.94	0.00	-905.67	0.00	905.67	5143.86	2571.93	11183.2	5599.96	0.39	-0.187	0.000	0.169
25.00	-36.83	-8.83	0.00	-860.99	0.00	860.99	5070.72	2535.36	10793.2	5404.66	0.61	-0.235	0.000	0.167
30.00	-35.39	-8.72	0.00	-816.85	0.00	816.85	4996.16	2498.08	10406.9	5211.21	0.89	-0.284	0.000	0.164
35.00	-33.97	-8.60	0.00	-773.26	0.00	773.26	4920.16	2460.08	10024.5	5019.70	1.21	-0.334	0.000	0.161
38.75	-32.93	-8.51	0.00	-741.01	0.00	741.01	4862.22	2431.11	9740.32	4877.40	1.49	-0.371	0.000	0.159
40.00	-32.33	-8.49	0.00	-730.38	0.00	730.38	4842.73	2421.36	9646.11	4830.22	1.59	-0.384	0.000	0.158
45.00	-29.98	-8.36	0.00	-687.95	0.00	687.95	3936.38	1968.19	7803.92	3907.76	2.02	-0.434	0.000	0.184
50.00	-28.78	-8.23	0.00	-646.17	0.00	646.17	3877.34	1938.67	7510.22	3760.69	2.50	-0.485	0.000	0.179
55.00	-27.61	-8.11	0.00	-605.01	0.00	605.01	3816.87	1908.43	7219.20	3614.96	3.04	-0.542	0.000	0.175
60.00	-26.45	-7.99	0.00	-564.45	0.00	564.45	3754.96	1877.48	6931.04	3470.67	3.64	-0.598	0.000	0.170
65.00	-25.32	-7.86	0.00	-524.50	0.00	524.50	3691.62	1845.81	6645.93	3327.91	4.29	-0.655	0.000	0.164
70.00	-24.22	-7.74	0.00	-485.18	0.00	485.18	3626.84	1813.42	6364.09	3186.77	5.01	-0.712	0.000	0.159
75.00	-23.12	-7.60	0.00	-446.49	0.00	446.49	3560.63	1780.31	6085.69	3047.37	5.79	-0.768	0.000	0.153
78.50	-22.38	-7.51	0.00	-419.89	0.00	419.89	3513.43	1756.71	5892.98	2950.87	6.36	-0.808	0.000	0.149
80.00	-21.85	-7.47	0.00	-408.63	0.00	408.63	3492.98	1746.49	5810.95	2909.79	6.62	-0.825	0.000	0.147
83.75	-20.56	-7.36	0.00	-380.62	0.00	380.62	2742.50	1371.25	4553.78	2280.28	7.29	-0.867	0.000	0.174
85.00	-20.33	-7.34	0.00	-371.42	0.00	371.42	2730.37	1365.18	4502.54	2254.62	7.51	-0.881	0.000	0.172
90.00	-19.43	-7.22	0.00	-334.72	0.00	334.72	2680.95	1340.47	4298.92	2152.65	8.47	-0.943	0.000	0.163
95.00	-18.55	-7.09	0.00	-298.64	0.00	298.64	2630.10	1315.05	4097.56	2051.82	9.49	-1.004	0.000	0.153
100.00	-17.70	-6.97	0.00	-263.19	0.00	263.19	2577.82	1288.91	3898.66	1952.23	10.57	-1.062	0.000	0.142
105.00	-15.66	-6.51	0.00	-228.35	0.00	228.35	2524.10	1262.05	3702.43	1853.97	11.72	-1.118	0.000	0.129
110.00	-14.84	-6.39	0.00	-195.80	0.00	195.80	2468.95	1234.47	3509.05	1757.13	12.92	-1.171	0.000	0.117
115.00	-14.04	-6.26	0.00	-163.86	0.00	163.86	2412.36	1206.18	3318.73	1661.83	14.17	-1.220	0.000	0.104
119.25	-13.38	-6.15	0.00	-137.25	0.00	137.25	2363.14	1181.57	3159.50	1582.10	15.28	-1.259	0.000	0.092
120.00	-13.20	-6.14	0.00	-132.63	0.00	132.63	2354.34	1177.17	3131.65	1568.15	15.47	-1.265	0.000	0.090
122.00	-11.10	-5.26	0.00	-120.36	0.00	120.36	2330.73	1165.37	3057.78	1531.16	16.01	-1.282	0.000	0.083
123.50	-10.77	-5.22	0.00	-112.47	0.00	112.47	1751.58	875.79	2319.28	1161.36	16.41	-1.294	0.000	0.103
124.50	-10.12	-4.87	0.00	-107.25	0.00	107.25	1743.79	871.89	2293.08	1148.24	16.68	-1.302	0.000	0.099
125.00	-10.06	-4.86	0.00	-104.81	0.00	104.81	1739.87	869.94	2280.00	1141.69	16.82	-1.307	0.000	0.098
130.00	-9.49	-4.74	0.00	-80.49	0.00	80.49	1699.92	849.96	2150.20	1076.70	18.21	-1.347	0.000	0.080
132.00	-7.11	-3.05	0.00	-71.00	0.00	71.00	1683.54	841.77	2098.80	1050.96	18.78	-1.362	0.000	0.072
135.00	-6.82	-2.99	0.00	-61.84	0.00	61.84	1658.53	829.27	2022.29	1012.65	19.64	-1.382	0.000	0.065
140.00	-6.35	-2.87	0.00	-46.91	0.00	46.91	1615.71	807.86	1896.47	949.64	21.11	-1.412	0.000	0.053
145.00	-5.89	-2.76	0.00	-32.55	0.00	32.55	1571.46	785.73	1772.93	887.78	22.60	-1.436	0.000	0.040
150.00	-5.45	-2.65	0.00	-18.75	0.00	18.75	1525.77	762.88	1651.87	827.16	24.11	-1.453	0.000	0.026
152.00	-2.91	-1.40	0.00	-13.44	0.00	13.44	1507.09	753.54	1604.19	803.29	24.72	-1.458	0.000	0.019
155.00	-2.69	-1.34	0.00	-9.24	0.00	9.24	1478.64	739.32	1533.49	767.89	25.64	-1.464	0.000	0.014
160.00	-2.34	-1.24	0.00	-2.54	0.00	2.54	1426.03	713.01	1413.96	708.03	27.18	-1.469	0.000	0.005
162.00	0.00	-1.18	0.00	-0.06	0.00	0.06	1400.09	700.04	1362.73	682.38	27.79	-1.469	0.000	0.000

Final Analysis Summary

Structure: CT01698-S-SBA	Code: EIA/TIA-222-G	10/18/2016
Site Name: Durham	Exposure: C	
Height: 162.00 (ft)	Crest Height: 0.00	
Base Elev: 0.000 (ft)	Site Class: D - Stiff Soil	
Gh: 1.1	Topography: 1	Struct Class: II



Page: 45

Reactions

Load Case	Shear FX (kips)	Shear FZ (kips)	Axial FY (kips)	Moment MX (ft-kips)	Moment MY (ft-kips)	Moment MZ (ft-kips)
1.2D + 1.6W 97 mph Wind	39.0	0.00	53.26	0.00	0.00	4579.18
0.9D + 1.6W 97 mph Wind	39.0	0.00	39.93	0.00	0.00	4532.37
1.2D + 1.0Di + 1.0Wi 50 mph Wind	11.1	0.00	87.88	0.00	0.00	1303.37
1.2D + 1.0E	1.8	0.00	53.33	0.00	0.00	227.05
0.9D + 1.0E	1.8	0.00	40.00	0.00	0.00	224.52
1.0D + 1.0W 60 mph Wind	9.3	0.00	44.44	0.00	0.00	1089.21

Max Stresses

Load Case	Pu FY (-) (kips)	Vu FX (-) (kips)	Tu MY (-) (ft-kips)	Mu MZ (ft-kips)	Mu MX (ft-kips)	Resultant Moment (ft-kips)	phi Pn (kips)	phi Vn (kips)	phi Tn (ft-kips)	phi Mn (ft-kips)	Elev (ft)	Stress Ratio
1.2D + 1.6W 97 mph Wind	0.00	0.00	0.00	0.00	0.00	0.00	0.00	0.00	0.00	0.00	45.00	0.750
0.9D + 1.6W 97 mph Wind	0.00	0.00	0.00	0.00	0.00	0.00	0.00	0.00	0.00	0.00	45.00	0.738
1.2D + 1.0Di + 1.0Wi 50 mph Wind	0.00	0.00	0.00	0.00	0.00	0.00	0.00	0.00	0.00	0.00	45.00	0.227
1.2D + 1.0E	0.00	0.00	0.00	0.00	0.00	0.00	0.00	0.00	0.00	0.00	83.75	0.051
0.9D + 1.0E	0.00	0.00	0.00	0.00	0.00	0.00	0.00	0.00	0.00	0.00	83.75	0.048
1.0D + 1.0W 60 mph Wind	-29.98	-8.36	0.00	-687.95	0.00	-687.95	3936.38	1968.1	7803.92	3907.76	45.00	0.184



Monopole Mat Foundation Design

Date
10/18/2016

Customer Name:	T-Mobile	EIA/TIA Standard:	EIA-222-G
Site Name:	Durham	Structure Height (Ft.):	162
Site Number:	CT01698-S-SBA	Engineer Name:	. Arinyedokia
Engr. Number:	26884_R1	Engineer Login ID:	

Foundation Info Obtained from:

Drawings/Calculations

Structure Type:

Monopole

Analysis or Design?

Analysis

Base Reactions (Factored):

Axial Load (Kips):	53.3	Shear Force (Kips):	39.0
Uplift Force (Kips):	0.0	Moment (Kips-ft):	4579.2

Allowable overstress %: 5.0%

Foundation Geometries:

		Mods required -Yes/No ?:	No
Diameter of Pier (ft.):	8.0	Depth of Base BG (ft.):	10.0
Pier Height A. G. (ft.):	0.50	Thickness of Pad (ft):	4.00
Length of Pad (ft.):	29	Width of Pad (ft.):	29

Final Length of pad (ft)	29.0	Final width of pad (ft):	29.0
Control Value for Cell D18:	0	Control Value for Cell F18:	0

Material Properties and Reabr Info:

Concrete Strength (psi):	3000	Steel Elastic Modulus:	29000	ksi
Vertical bar yield (ksi)	60	Tie steel yield (ksi):	40	
Vertical Rebar Size #:	10	Tie / Stirrup Size #:	5	
Qty. of Vertical Rebars:	44	Tie Spacing (in):	6.0	
Pad Rebar Yield (Ksi):	60	Pad Steel Rebar Size (#):	10	
Concrete Cover (in.):	3	Unit Weight of Concrete:	150.0	pcf

Rebar at the bottom of the concrete pad:

Qty. of Rebar in Pad (L):	33	Qty. of Rebar in Pad (W):	33
---------------------------	----	---------------------------	----

Rebar at the top of the concrete pad:

Qty. of Rebar in Pad (L):	33	Qty. of Rebar in Pad (W):	33
---------------------------	----	---------------------------	----

Apply 1.35 factor for e/w Per G: 1.35

Soil Design Parameters:

Soil Unit Weight (pcf):	120.0	Soil Buoyant Weight:	58.0	Pcf	
Water Table B.G.S. (ft):	13.5	Unit Weight of Water:	62.4	pcf	Angle from Top of Pad:
Ultimate Bearing Pressure (psf):	4000	Ultimate Skin Friction:	0	Psf	Angle from Bottm of Pad:
Consider Friction for O.T.M. (Y/N):	No	Consider Friction for bearing (Y/N):	No		Angle from Bottm of Pad:
Consider soil hori. force for O.T.M.:	No	Reduction factor on the maximum soil bearing pressure:	1.00		

Foundation Analysis and Design:

Uplift Strength Reduction Factor:	0.75	Compression Strength Reduction Factor:	0.75
Total Dry Soil Volume (cu. Ft.):	4744.41	Total Dry Soil Weight (Kips):	569.33
Total Buoyant Soil Volume (cu. Ft.):	0.00	Total Buoyant Soil Weight (Kips):	0.00
Total Effective Soil Weight (Kips):	569.33	Weight from the Concrete Block at Top (K):	0.00
Total Dry Concrete Volume (cu. Ft.):	3690.73	Total Dry Concrete Weight (Kips):	553.61
Total Buoyant Concrete Volume (cu. Ft.):	0.00	Total Buoyant Concrete Weight (Kips):	0.00
Total Effective Concrete Weight (Kips):	553.61	Total Vertical Load on Base (Kips):	1176.20

Check Soil Capacities:

Calculated Maxium Net Soil Pressure under the base (psf):	2387	<	Allowable Factored Soil Bearing (psf):	3000	0.80	OK!
Allowable Foundation Overturning Resistance (kips-ft.):	15426.6	>	Design Factored Momont (kips-ft):	4989	0.32	OK!
Factor of Safety Against Overturning (O. R. Moment/Design Moment):	3.09					OK!

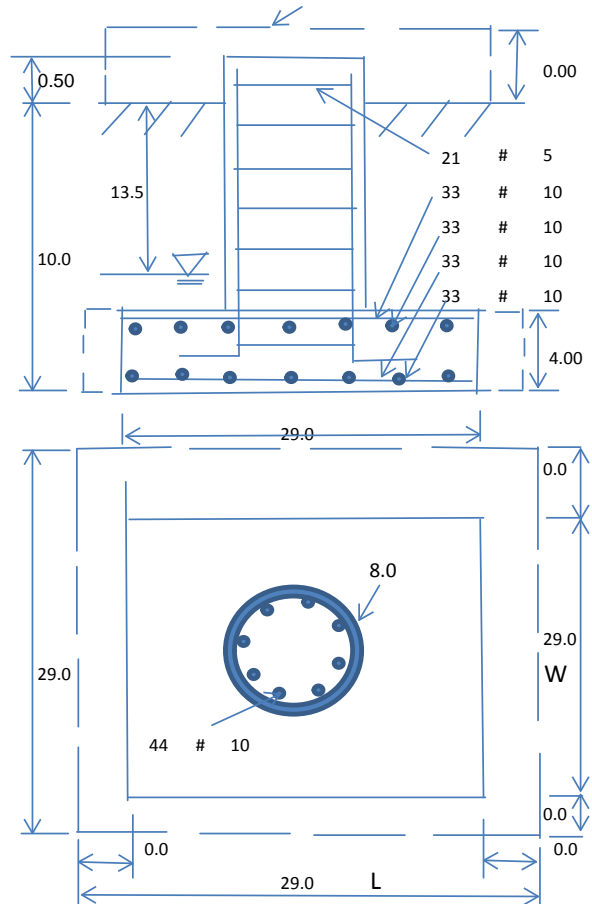

Check the capacities of Reinforcing Concrete:

Strength reduction factor (Flexure and axial tension): 0.90 Strength reduction factor (Shear): 0.75
 Strength reduction factor (Axial compression): 0.65 Wind Load Factor on Concrete Design: 1.00

Load/
Capacity
Ratio

(1) Concrete Pier:

Vertical Steel Rebar Area (sq. in./each):	1.27	Tie / Stirrup Area (sq. in./each):	0.31		
Calculated Moment Capacity (Mn,Kips-Ft):	10912.6	> Design Factored Moment (Mu, Kips-Ft)	4832.7	0.44	OK!
Calculated Shear Capacity (Kips):	912.1	> Design Factored Shear (Kips):	39.0	0.04	OK!
Calculated Tension Capacity (Tn, Kips):	3017.5	> Design Factored Tension (Tu Kips):	0.0	0.00	OK!
Calculated Compression Capacity (Pn, Kips):	9523.8	> Design Factored Axial Load (Pu Kips):	53.3	0.01	OK!
Moment & Axial Strength Combination(Pu/Pn+Mu/Mn):	0.45	OK! Check Tie Spacing (Design/Required):		0.5	OK!
Pier Reinforcement Ratio:	0.008	Reinforcement Ratio is satisfied per ACI			

(2) Concrete Pad:

One-Way Design Shear Capacity (L-Direction, Kips):	1268.7	> One-Way Factored Shear (L-D. Kips):	292.0	0.23	OK!
One-Way Design Shear Capacity (W-Direction, Kips):	1268.7	> One-Way Factored Shear (W-D., Kips)	292.0	0.23	OK!
One-Way Design Shear Capacity (Corner-Corner. Kips):	1444.3	> One-Way Factored Shear (C-C, Kips):	497.6	0.34	OK!
Lower Steel Pad Reinforcement Ratio (L-Direct.):	0.0027	OK! Lower Steel Pad Reinf. Ratio (W-Direc	0.0027		
Lower Steel Pad Moment Capacity (L-Direction. Kips-ft):	8101.7	> Moment at Bottom (L-Direct. K-Ft):	993.2	0.12	OK!
Lower Steel Pad Moment Capacity (W-Direction. Kips-ft):	8101.7	> Moment at Bottom (W-Direct. K-Ft):	993.2	0.12	OK!
Lower Steel Pad Moment Capacity (Corner-Corner,K-ft):	11366.0	> Moment at Bottom (C-C Dir. K-Ft):	1404.6	0.12	OK!
Upper Steel Pad Reinforcement Ratio (L-Direct.):	0.0027	OK! Upper Steel Reinf. Ratio (W-Direct.):	0.0027		
Upper Steel Pad Moment Capacity (L-Direction. Kips-ft):	8101.7	> Moment at the top (L-Dir Kips-Ft):	1679.2	0.21	OK!
Upper Steel Pad Moment Capacity (W-Direction. Kips-ft):	8101.7	> Moment at the top (W-Dir Kips-Ft):	1679.2	0.21	OK!
Upper Steel Pad Moment Capacity (Corner-Corner. K-ft):	11366.0	> Moment at the top (C-C Direc. K-Ft):	639.9	0.06	OK!

PROJECT INFORMATION	
SCOPE OF WORK:	UNMANNED TELECOMMUNICATIONS FACILITY T-MOBILE EQUIPMENT MODERNIZATION
ZONING JURISDICTION:	BASED ON INFORMATION PROVIDED BY T-MOBILE REGULATORY COMPLIANCE PROFESSIONALS AND LEGAL COUNSEL, THIS TELECOMMUNICATIONS EQUIPMENT DEPLOYMENT IS CONSIDERED AN ELIGIBLE FACILITY UNDER THE MIDDLE CLASS TAX RELIEF AND JOB CREATION ACT OF 2012, 47 USC 1455(A), SECTION 6409(A), AND IS SUBJECT TO AN ELIGIBLE FACILITY REQUEST, EXPEDITED REVIEW AND LIMITED/PARTIAL ZONING PRE-EMPTION FOR LOCAL DISCRETIONARY PERMITS (VARIANCE, SPECIAL PERMIT, SITE PLAN REVIEW OR ADMINISTRATIVE REVIEW).
SITE ADDRESS:	1605 DURHAM ROAD, WALLINGFORD, CT 06492
LATITUDE:	41.46956200° N
LONGITUDE:	-72.74222500° W
JURISDICTION:	NATIONAL, STATE & LOCAL CODES OR ORDINANCES
CURRENT USE:	TELECOMMUNICATIONS FACILITY
PROPOSED USE:	TELECOMMUNICATIONS FACILITY
TOWER OWNER:	SBA PROPERTIES, LLC
SBA SITE ID:	CT01698-S
SBA SITE NAME:	DURHAM
SBA REGIONAL SITE MANAGER:	STEPHEN ROTH (860)539-4920 sroth@sbasite.com

SITE NAME:
 DURHAM/Rt 68
 SITE NUMBER:
 CT11287A
 SITE ADDRESS:
 1605 DURHAM ROAD
 WALLINGFORD, CT 06492

DESIGN GUIDELINE: 704G

APPROVALS			
PROJECT MANAGER	DATE	ZONING/SITE AQC.	DATE
CONSTRUCTION	DATE	OPERATIONS	DATE
RF ENGINEERING	DATE	TOWER OWNER	DATE



SBA COMMUNICATIONS CORP.
134 FLANDERS ROAD, SUITE 125
WESTBOROUGH, MA 01581



DESIGNER:
NAME: TRYLON TSF INC.
ADDRESS: 1825 W. WALNUT HILL LANE SUITE 302
CITY, PROVINCE, IRVING, TEXAS
POSTAL CODE: TX 75038
CONTACT: KATYA SERAVALLE
PHONE: 519-465-4125



DRAWING SCALES ARE INTENDED FOR 24"x36" SIZE PRINTED MEDIA ONLY. ALL OTHER PRINTED SIZES ARE DEEMED "NOT TO SCALE".

SHEET INDEX		
SHT. #.	DESCRIPTION	REV. #.
T-1	TITLE SHEET	0
GN-1	GENERAL NOTES	0
A-1	COMPOUND, EQUIPMENT PLAN & TOWER ELEVATION PLAN TOWER EQUIPMENT DETAILS	0
A-2	TOWER EQUIPMENT DETAILS	0
A-3	TOWER EQUIPMENT DETAILS	0
E-1	ONE-LINE DIAGRAM & GROUNDING DETAILS	0

BUILDING CODES	
ALL WORK AND MATERIALS SHALL BE PERFORMED AND INSTALLED IN ACCORDANCE WITH THE CURRENT EDITIONS OF THE FOLLOWING CODES AS ADOPTED BY THE LOCAL AUTHORITIES HAVING JURISDICTION.	
1.	2003 IBC WITH 2005 CT SUPPLEMENT & 2009 CT AMENDMENTS
2.	2005 NATIONAL ELECTRICAL CODE
3.	TIA/EIA-222-G STRUCTURAL STANDARDS FOR ANTENNA SUPPORTING STRUCTURES AND ANTENNAS

GENERAL NOTES	
1.	THIS DOCUMENT IS THE CREATION, DESIGN, PROPERTY AND COPYRIGHTED WORK OF T-MOBILE NORTHEAST, LLC. ANY DUPLICATION OR USE WITHOUT EXPRESS WRITTEN CONSENT IS STRICTLY PROHIBITED. DUPLICATION AND USE BY GOVERNMENT AGENCIES FOR THE PURPOSES OF CONDUCTING THEIR LAWFULLY AUTHORIZED REGULATORY AND ADMINISTRATIVE FUNCTIONS IS SPECIFICALLY ALLOWED.
2.	THE FACILITY IS AN UNMANNED PRIVATE AND SECURED EQUIPMENT INSTALLATION. IT IS ONLY ACCESSED BY TRAINED TECHNICIANS FOR PERIODIC ROUTINE MAINTENANCE AND THEREFORE DOES NOT REQUIRE ANY WATER OR SANITARY SEWER SERVICE. THE FACILITY IS NOT GOVERNED BY REGULATIONS REQUIRING PUBLIC ACCESS PER ADA REQUIREMENTS.
3.	CONTRACTOR SHALL VERIFY ALL PLANS AND EXISTING DIMENSIONS AND CONDITIONS ON THE JOB SITE AND SHALL IMMEDIATELY NOTIFY THE T-MOBILE NORTHEAST, LLC REPRESENTATIVE IN WRITING OF DISCREPANCIES BEFORE PROCEEDING WITH THE WORK OR BE RESPONSIBLE FOR SAME.

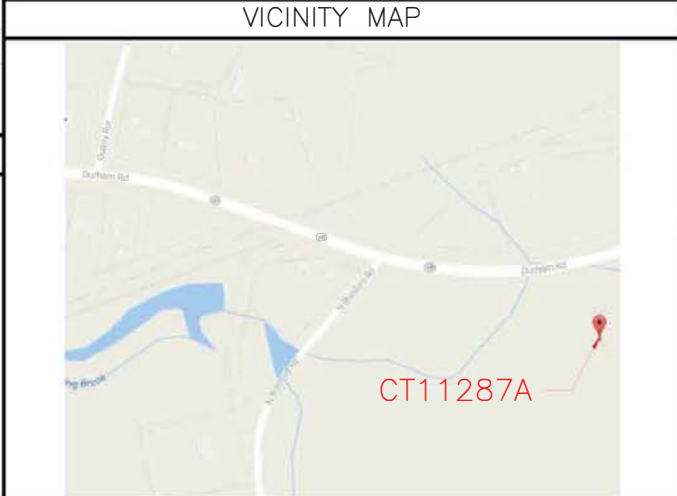

T-MOBILE TECHNICIAN SITE SAFETY NOTES	
LOCATION:	SPECIAL RESTRICTIONS
SECTOR A:	ACCESS NOT PERMITTED
SECTOR B:	ACCESS NOT PERMITTED
SECTOR C:	ACCESS NOT PERMITTED
GPS/LMU:	UNRESTRICTED
RADIO CABINETS:	UNRESTRICTED
PPC DISCONNECT:	UNRESTRICTED
MAIN CIRCUIT D/C:	UNRESTRICTED
NIU/T DEMARC:	UNRESTRICTED
OTHER/SPECIAL:	NONE

SUBMITTALS			
REV	DATE	DESCRIPTION	BY
0	10/10/16	ISSUE FOR CONSTRUCTION	gi

SPECIAL STRUCTURAL NOTES	
1.	TOWER OWNER SHALL PROVIDE GLOBAL STRUCTURAL STABILITY ANALYSIS OF EXISTING ANTENNA SUPPORT STRUCTURE. GENERAL CONTRACTOR SCOPE OF WORK SHALL INCLUDE ALL REQUIRED STRUCTURAL MODIFICATIONS, RE-BUNDLING OF COAXIAL CABLES OR OTHER SPECIAL MODIFICATIONS AS OUTLINED THEREIN.
2.	STRUCTURAL DESIGNS AND DETAILS FOR ANTENNA MOUNTS COMPLETED BY TRYLON TSF INC. ON BEHALF OF T-MOBILE ARE INCLUSIVE OF THE ENTIRE ANTENNA SUPPORT STRUCTURE (GLOBAL STRUCTURAL STABILITY ANALYSIS BY OTHERS), EXISTING TOWER PLATFORM, EXISTING ANTENNA MOUNTS AND ALL OTHER ASPECTS OF THE STRUCTURE THAT WILL SUPPORT THE T-MOBILE MODERNIZATION EQUIPMENT DEPLOYMENT AS DEPICTED HEREIN.
3.	TRYLON TSF INC. ASSUMES THAT THE TOWER IS PROPERLY CONSTRUCTED AND MAINTAINED. ALL STRUCTURAL MEMBERS AND THEIR CONNECTION ARE ASSUMED TO BE IN GOOD CONDITION AND ARE FREE FROM DEFECTS WITH NO DETERIORATION TO ITS MEMBER CAPACITIES

DIG SAFE SYSTEM
 (MA, ME, NH, RI, VT):
 1-888-344-7233
 CALL BEFORE YOU DIG
 (CT): 1-800-922-4455

Digitally signed by
 Michael Plahovinsak
 Date: 2016.10.20
 15:10:56 -0400'

Michael Plahovinsak

SITE INFO:

SITE NAME:
 DURHAM/Rt 68
 SITE NUMBER:
 CT11287A
 SITE ADDRESS:
 1605 DURHAM ROAD
 WALLINGFORD, CT 06492

SHEET TITLE:
TITLE SHEET

T-1

GROUNDING NOTES

1. THE SUBCONTRACTOR SHALL REVIEW AND INSPECT THE EXISTING FACILITY GROUNDING SYSTEM AND LIGHTNING PROTECTION SYSTEM (AS DESIGNED AND INSTALLED) FOR STRICT COMPLIANCE WITH THE NEC (AS ADOPTED BY THE AHJ), THE SITE-SPECIFIC (UL, LPL, OR NFPA) LIGHTNING PROTECTION CODE, AND GENERAL COMPLIANCE WITH TELCORDIA AND TIA GROUNDING STANDARDS. THE SUBCONTRACTOR SHALL REPORT ANY VIOLATIONS OR ADVERSE FINDINGS TO THE CONTRACTOR FOR RESOLUTION.
2. ALL GROUND ELECTRODE SYSTEMS (INCLUDING TELECOMMUNICATION, RADIO, LIGHTNING PROTECTION, AND AC POWER GES'S) SHALL BE BONDED TOGETHER, AT OR BELOW GRADE, BY TWO OR MORE COPPER BONDING CONDUCTORS IN ACCORDANCE WITH THE NEC.
3. THE SUBCONTRACTOR SHALL PERFORM IEEE FALL-OF-POTENTIAL RESISTANCE TO EARTH TESTING (PER IEEE 1100 AND 81) FOR NEW GROUND ELECTRODE SYSTEMS. THE SUBCONTRACTOR SHALL FURNISH AND INSTALL SUPPLEMENTAL GROUND ELECTRODES AS NEEDED TO ACHIEVE A TEST RESULT OF 5 OHMS OR LESS.
4. METAL RACEWAY SHALL NOT BE USED AS THE NEC REQUIRED EQUIPMENT GROUND CONDUCTOR. STRANDED COPPER CONDUCTORS WITH GREEN INSULATION, SIZED IN ACCORDANCE WITH THE NEC, SHALL BE FURNISHED AND INSTALLED WITH THE POWER CIRCUITS TO BTS EQUIPMENT.
5. EACH BTS CABINET FRAME SHALL BE DIRECTLY CONNECTED TO THE MASTER GROUND BAR WITH GREEN INSULATED SUPPLEMENTAL EQUIPMENT GROUND WIRES, 6 AWG STRANDED COPPER OR LARGER FOR INDOOR BTS 2 AWG STRANDED COPPER FOR OUTDOOR BTS.
6. EXOTHERMIC WELDS SHALL BE USED FOR ALL GROUNDING CONNECTIONS BELOW GRADE.
7. APPROVED ANTIOXIDANT COATINGS (I.E., CONDUCTIVE GEL OR PASTE) SHALL BE USED ON ALL COMPRESSION AND BOLTED GROUND CONNECTIONS.
8. ICE BRIDGE BONDING CONDUCTORS SHALL BE EXOTHERMICALLY BONDED OR BOLTED TO THE BRIDGE AND THE TOWER GROUND BAR.
9. ALUMINUM CONDUCTOR OR COPPER CLAD STEEL CONDUCTOR SHALL NOT BE USED FOR GROUNDING CONNECTIONS.
10. MISCELLANEOUS ELECTRICAL AND NON-ELECTRICAL METAL BOXES, FRAMES AND SUPPORTS SHALL BE BONDED TO THE GROUND RING, IN ACCORDANCE WITH THE NEC.
11. METAL CONDUIT SHALL BE MADE ELECTRICALLY CONTINUOUS WITH LISTED BONDING FITTINGS OR BY BONDING ACROSS THE DISCONTINUITY WITH 6 AWG COPPER WIRE UL APPROVED GROUNDING TYPE CONDUIT CLAMPS.
12. ALL NEW STRUCTURES WITH A FOUNDATION AND/OR FOOTING HAVING 20 FT. OR MORE OF 1/2 IN. OR GREATER ELECTRICALLY CONDUCTIVE REINFORCING STEEL MUST HAVE IT BONDED TO THE GROUND RING USING AN EXOTHERMIC WELD CONNECTION USING #2 AWG SOLID BARE TINNED COPPER GROUND WIRE, PER NEC 250.50

GENERAL NOTES

1. FOR THE PURPOSE OF CONSTRUCTION DRAWING, THE FOLLOWING DEFINITIONS SHALL APPLY:
 CONTRACTOR – SBA COMMUNICATIONS CORP.
 SUBCONTRACTOR – GENERAL CONTRACTOR
 (CONSTRUCTION)
 OWNER – T-MOBILE
 2. PRIOR TO THE SUBMISSION OF BIDS, THE BIDDING SUBCONTRACTOR SHALL VISIT THE CELL SITE TO FAMILIARIZE WITH THE EXISTING CONDITIONS AND TO CONFIRM THAT THE WORK CAN BE ACCOMPLISHED AS SHOWN ON THE CONSTRUCTION DRAWINGS. ANY DISCREPANCY FOUND SHALL BE BROUGHT TO THE ATTENTION OF CONTRACTOR.
 3. ALL MATERIALS FURNISHED AND INSTALLED SHALL BE IN STRICT ACCORDANCE WITH ALL APPLICABLE CODES, REGULATIONS, AND ORDINANCES. SUBCONTRACTOR SHALL ISSUE ALL APPROPRIATE NOTICES AND COMPLY WITH ALL LAWS, ORDINANCES, RULES, REGULATIONS, AND LAWFUL ORDERS OF ANY PUBLIC AUTHORITY REGARDING THE PERFORMANCE OF THE WORK. ALL WORK CARRIED OUT SHALL COMPLY WITH ALL APPLICABLE MUNICIPAL AND UTILITY COMPANY SPECIFICATIONS AND LOCAL JURISDICTIONAL CODES, ORDINANCES AND APPLICABLE REGULATIONS.
 4. DRAWINGS PROVIDED HERE ARE NOT TO BE SCALED AND ARE INTENDED TO SHOW OUTLINE ONLY.
 5. UNLESS NOTED OTHERWISE, THE WORK SHALL INCLUDE FURNISHING MATERIALS, EQUIPMENT, APPURTENANCES, AND LABOR NECESSARY TO COMPLETE ALL INSTALLATIONS AS INDICATED ON THE DRAWINGS.
 6. "KITTING LIST" SUPPLIED WITH THE BID PACKAGE IDENTIFIES ITEMS THAT WILL BE SUPPLIED BY CONTRACTOR. ITEMS NOT INCLUDED IN THE BILL OF MATERIALS AND KITTING LIST SHALL BE SUPPLIED BY THE SUBCONTRACTOR.
 7. THE SUBCONTRACTOR SHALL INSTALL ALL EQUIPMENT AND MATERIALS IN ACCORDANCE WITH MANUFACTURER'S RECOMMENDATIONS UNLESS SPECIFICALLY STATED OTHERWISE.
 8. IF THE SPECIFIED EQUIPMENT CANNOT BE INSTALLED AS SHOWN ON THESE DRAWINGS, THE SUBCONTRACTOR SHALL PROPOSE AN ALTERNATIVE INSTALLATION SPACE FOR APPROVAL BY THE CONTRACTOR.
 9. SUBCONTRACTOR SHALL DETERMINE ACTUAL ROUTING OF CONDUIT, POWER AND T1 CABLES, GROUNDING CABLES AS SHOWN ON THE POWER, GROUNDING AND TELL'D PLAN DRAWING. SUBCONTRACTOR SHALL UTILIZE EXISTING TRAYS AND/OR SHALL ADD NEW TRAYS AS NECESSARY. SUBCONTRACTOR SHALL CONFIRM THE ACTUAL ROUTING WITH THE CONTRACTOR.
 10. THE SUBCONTRACTOR SHALL PROTECT EXISTING IMPROVEMENTS, PAVEMENTS, CURBS, LANDSCAPING AND STRUCTURES. ANY DAMAGED PART SHALL BE REPAIRED AT SUBCONTRACTOR'S EXPENSE TO THE SATISFACTION OF THE OWNER.
 11. SUBCONTRACTOR SHALL LEGALLY AND PROPERLY DISPOSE OF ALL SCRAP MATERIALS SUCH AS COAXIAL CABLES AND OTHER ITEMS REMOVED FROM THE EXISTING FACILITY. ANTENNAS REMOVED SHALL BE RETURNED TO THE OWNER'S DESIGNATED LOCATION.
 12. SUBCONTRACTOR SHALL LEAVE PREMISES IN CLEAN CONDITION.
 13. ALL CONCRETE REPAIR WORK SHALL BE DONE IN ACCORDANCE WITH AMERICAN CONCRETE INSTITUTE (ACI) 301.
 14. ANY NEW CONCRETE NEEDED FOR CONSTRUCTION SHALL BE AIR-ENTRAINED AND SHALL HAVE 4000 PSI STRENGTH AT 28 DAYS. ALL CONCRETE WORK SHALL BE DONE IN ACCORDANCE WITH ACI 318 CODE REQUIREMENTS.
 15. ALL STRUCTURAL STEEL WORK SHALL BE DETAILED, FABRICATED AND ERECTED IN ACCORDANCE WITH AISC SPECIFICATIONS. ALL STRUCTURAL STEEL SHALL BE ASTM A36 (Fy = 36 ksi) UNLESS OTHERWISE NOTED. PIPES SHALL BE ASTM A53 TYPE E (Fy = 36 ksi). ALL STEEL EXPOSED TO WEATHER SHALL BE HOT DIPPED GALVANIZED. TOUCHUP ALL SCRATCHES AND OTHER MARKS IN THE FIELD AFTER STEEL IS ERECTED USING A COMPATIBLE ZINC RICH PAINT.
 16. CONSTRUCTION SHALL COMPLY WITH LTE SPECIFICATIONS AND "GENERAL CONSTRUCTION SERVICES FOR CONSTRUCTION OF T-MOBILE SITES."
 17. SUBCONTRACTOR SHALL VERIFY ALL EXISTING DIMENSIONS AND CONDITIONS PRIOR TO COMMENCING ANY WORK. ALL DIMENSIONS OF EXISTING CONSTRUCTION SHOWN ON THE DRAWINGS MUST BE VERIFIED. SUBCONTRACTOR SHALL NOTIFY THE CONTRACTOR OF ANY DISCREPANCIES PRIOR TO ORDERING MATERIAL OR PROCEEDING WITH CONSTRUCTION.
 18. THE EXISTING CELL SITE IS IN FULL COMMERCIAL OPERATION. ANY CONSTRUCTION WORK BY SUBCONTRACTOR SHALL NOT DISRUPT THE EXISTING NORMAL OPERATION. ANY WORK ON EXISTING EQUIPMENT MUST BE COORDINATED WITH CONTRACTOR. ALSO, WORK SHOULD BE SCHEDULED FOR AN APPROPRIATE MAINTENANCE WINDOW USUALLY IN LOW TRAFFIC PERIODS AFTER MIDNIGHT.
 19. SINCE THE CELL SITE IS ACTIVE, ALL SAFETY PRECAUTIONS MUST BE TAKEN WHEN WORKING AROUND HIGH LEVELS OF ELECTROMAGNETIC RADIATION. EQUIPMENT SHOULD BE SHUTDOWN PRIOR TO PERFORMING ANY WORK THAT COULD EXPOSE THE WORKERS TO DANGER. PERSONAL RF EXPOSURE MONITORS ARE ADVISED TO BE WORN TO ALERT OF ANY DANGEROUS EXPOSURE LEVELS.
 20. APPLICABLE BUILDING CODES:
 SUBCONTRACTOR'S WORK SHALL COMPLY WITH ALL APPLICABLE NATIONAL, STATE, AND LOCAL CODES AS ADOPTED BY THE LOCAL AUTHORITY HAVING JURISDICTION (AHJ) FOR THE LOCATION. THE EDITION OF THE AHJ ADOPTED CODES AND STANDARDS IN EFFECT ON THE DATE OF CONTRACT AWARD SHALL GOVERN THE DESIGN.
- SUBCONTRACTOR'S WORK SHALL COMPLY WITH THE LATEST EDITION OF THE FOLLOWING STANDARDS:
- AMERICAN CONCRETE INSTITUTE (ACI) 318; BUILDING CODE REQUIREMENTS FOR STRUCTURAL CONCRETE;
 - AMERICAN INSTITUTE OF STEEL CONSTRUCTION (AISC) MANUAL OF STEEL CONSTRUCTION, ASD, NINTH EDITION;
 - TELECOMMUNICATIONS INDUSTRY ASSOCIATION (TIA) 222-G, STRUCTURAL STANDARDS FOR STEEL
 - ANTENNA TOWER AND ANTENNA SUPPORTING STRUCTURES; REFER TO ELECTRICAL DRAWINGS FOR SPECIFIC ELECTRICAL STANDARDS.
- FOR ANY CONFLICTS BETWEEN SECTIONS OF LISTED CODES AND STANDARDS REGARDING MATERIAL, METHODS OF CONSTRUCTION, OR OTHER REQUIREMENTS, THE MOST RESTRICTIVE REQUIREMENT SHALL GOVERN. WHERE THERE IS CONFLICT BETWEEN A GENERAL REQUIREMENT AND A SPECIFIC REQUIREMENT, THE SPECIFIC REQUIREMENT SHALL GOVERN.
- ELECTRICAL DRAWING HAVE BEEN REVIEWED AND SEALED FOR STRUCTURAL PURPOSES ONLY

ABBREVIATIONS			
AGL	ABOVE GRADE LEVEL	G.C.	GENERAL CONTRACTOR
AWG	AMERICAN WIRE GAUGE	MGB	MASTER GROUND BUS
BCW	BARE COPPER WIRE	MIN	MINIMUM
BTS	BASE TRANSCIEVER STATION	PROPOSED	NEW
EXISTING	EXISTING	N.T.S.	NOT TO SCALE
EG	EQUIPMENT GROUND	REF	REFERENCE
EGR	EQUIPMENT GROUND RING	REQ	REQUIRED
		RF	RADIO FREQUENCY
		TBD	TO BE DETERMINED
		TBR	TO BE REMOVED
		TBRR	TO BE REMOVED AND REPLACED
		TYP	TYPICAL



T-MOBILE NORTHEAST, LLC
 35 GRIFFIN ROAD SOUTH
 BLOOMFIELD, CT 06002



SBA COMMUNICATIONS CORP.
 134 FLANDERS ROAD, SUITE 125
 WESTBOROUGH, MA 01581



DESIGNER:
 NAME: TRYLON TSF INC.
 ADDRESS: 1825 W. WALNUT HILL
 LANE SUITE 302
 CITY, PROVINCE, IRVING, TEXAS
 POSTAL CODE: TX 75038
 CONTACT: KATYA SERAVALLE
 PHONE: 519-465-4125



DRAWING SCALES ARE INTENDED FOR 24"x36" SIZE PRINTED MEDIA ONLY. ALL OTHER PRINTED SIZES ARE DEEMED "NOT TO SCALE".

SUBMITTALS

REV	DATE	DESCRIPTION	BY
0	10/10/16	ISSUE FOR CONSTRUCTION	GI

SITE INFO:
 SITE NAME:
 DURHAM/RT 68
 SITE NUMBER:
 CT11287A
 SITE ADDRESS:
 1605 DURHAM ROAD
 WALLINGFORD, CT 06492

SHEET TITLE:
 GENERAL NOTES

GN-1



DRAWING SCALES ARE INTENDED FOR 24" X 36" SIZE PRINTED MEDIA ONLY. ALL OTHER PRINTED SIZES ARE DEEMED "NOT TO SCALE".

SUBMITTALS

REV	DATE	DESCRIPTION	BY
0	10/10/16	ISSUE FOR CONSTRUCTION	gi

SITE INFO:
SITE NAME:
DURHAM/Rt 68
SITE NUMBER:
CT11287A
SITE ADDRESS:
1605 DURHAM ROAD
WALLINGFORD, CT 06492

SHEET TITLE:
COMPOUND, EQUIPMENT
PLAN & TOWER
ELEVATION PLAN

A-1

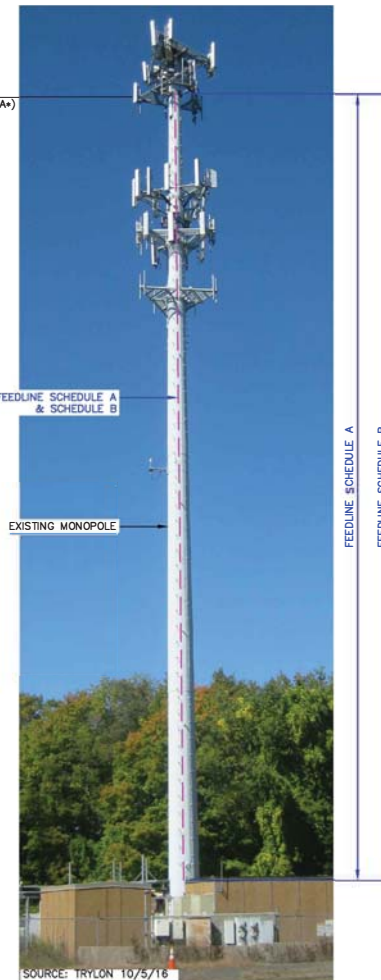

ELEVATION PHOTO DETAIL
SCALE: NTS



FEEDLINE PHOTO DETAILS
SCALE: NTS

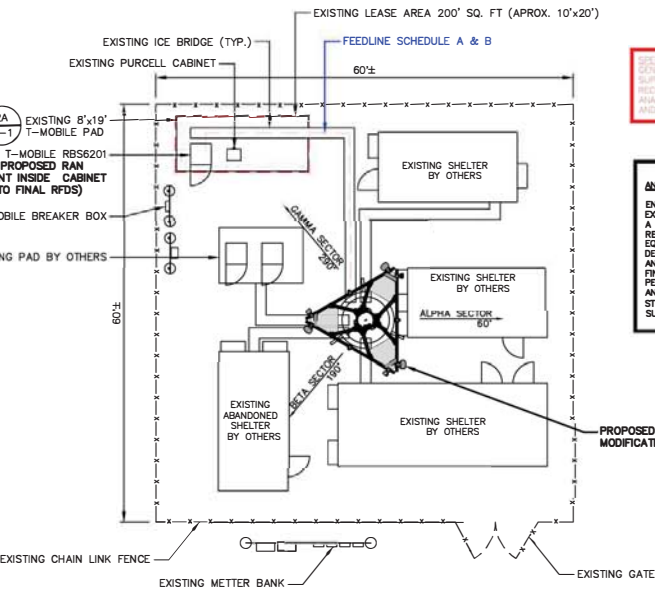

COMPOUND PLAN
22x34 SCALE: 1/8"=1'-0"
11x17 SCALE: 1/16"=1'-0"



EQUIPMENT PHOTO DETAILS
SCALE: NTS

SPECIAL PRE-CONSTRUCTION WORK NOTE
GENERAL CONTRACTOR SHALL THROUGH AND INSTALL ALL SPECIAL OR SUPPLEMENTAL ADDITIONAL TOWER-MOUNTED EQUIPMENT PER RECOMMENDATIONS FROM SBA-PROVIDED TOWER STRUCTURAL ANALYSIS FOR ANY SPECIAL SHIELDING OF TOWER TOP EQUIPMENT AND FOR ANY SPECIAL FEEDLINE BUNDLING OR RELOCATION.

ANTENNA MOUNT STRUCTURAL DESIGN NOTE
ENGINEER-OF-RECORD HAS MADE A VISUAL ASSESSMENT ONLY OF EXISTING ANTENNA MOUNT ASSEMBLIES, WITHOUT THE BENEFIT OF A RIGOROUS ANTENNA MOUNT STRUCTURAL ANALYSIS, AND RECOMMENDS THAT EXISTING AND PROPOSED TOWER TOP EQUIPMENT BE INSTALLED AS DEPICTED HEREIN. STRUCTURAL DETAILS AS DEPICTED HEREIN FOR MODIFICATION OF EXISTING ANTENNA MOUNT ASSEMBLIES ARE PRELIMINARY ONLY AND THAT FINAL CONSTRUCTION DETAILS MAY BE SUBJECT TO CHANGE. PENDING THE COMPLETION OF A SEPARATE SUPPLEMENTAL ANTENNA MOUNT STRUCTURAL ASSESSMENT, SUPPLEMENTAL STRUCTURAL MAPPING/CONDITIONS ASSESSMENT REPORT AND/OR SUPPLEMENTAL RIGOROUS ANTENNA MOUNT STRUCTURAL ANALYSIS.

FEEDLINES		
FEEDLINE SCHEDULE	FEEDLINE DESCRIPTION	LOCATION
A	(6) EXISTING 1-1/4" COAX. TO T-MOBILE RAD TO BE REMOVED	INSIDE POLE
B	(12) PROPOSED 1-5/8" COAX. TO T-MOBILE RAD	INSIDE POLE

EXISTING T-MOBILE EQUIPMENT FEEDLINE INVENTORY BASED ON OBSERVED FIELD CONDITIONS, RFDS AND FEELINE LEASING ENTIREMENTS MAY DIFFER.

T-MOBILE MOUNT
ELEV.=152'±A.G.L.(SBA)
2 A-2 3 A-2 ALL A-3

2 A-2 3 A-2 ALL A-3

2 B A-1

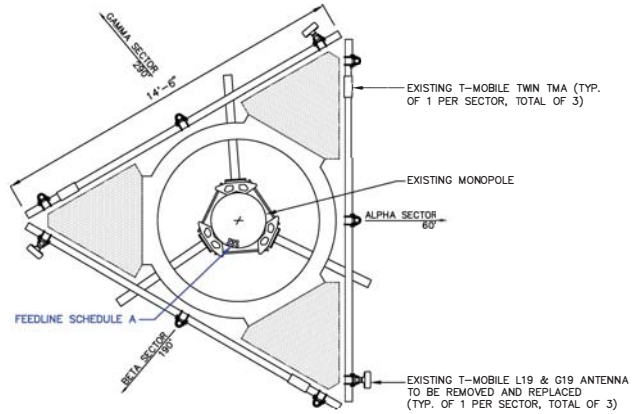

EXISTING ANTENNA PLAN 1
SCALE: NTS A-2

5
A-3 PROPOSED UPPER SUPPORT RAIL KIT FOR CO-LOCATIONS PLATFORM 14' FACE COMMSCOPE P/N MT-195-14

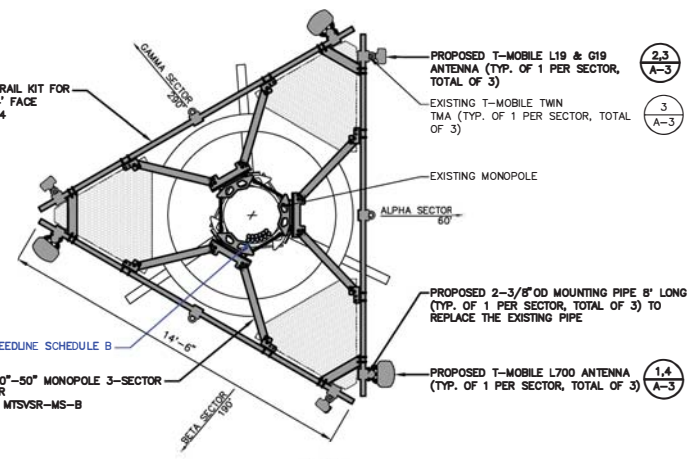

PROPOSED ANTENNA PLAN 2
SCALE: NTS A-2

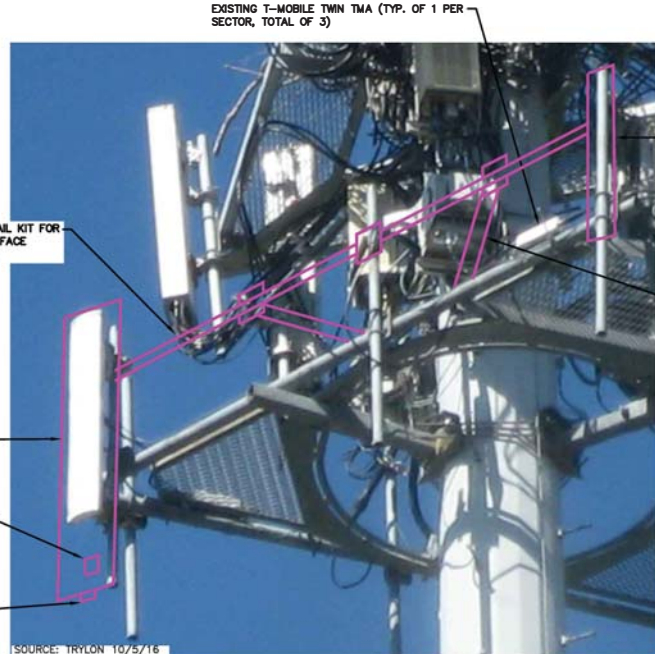

ANTENNA MOUNT PHOTO DETAIL 3
SCALE: NTS A-2



4
A-3 PROPOSED 2-3/8" OD MOUNTING PIPE 8' LONG (TYP. OF 1 PER SECTOR, TOTAL OF 3) TO REPLACE THE EXISTING PIPE

1,4
A-3 PROPOSED T-MOBILE L700 ANTENNA (1 PER SECTOR, TOTAL OF 3)

6
A-3 PROPOSED SMART BIAS TEE (TYP. OF 1 PER SECTOR, TOTAL OF 3)

5
A-3 PROPOSED UPPER SUPPORT RAIL KIT FOR CO-LOCATIONS PLATFORM 14' FACE COMMSCOPE P/N MT-195-14

2,3
A-3 PROPOSED T-MOBILE L19 & G19 ANTENNA (1 PER SECTOR, TOTAL OF 3)

5
A-3 PROPOSED 10"-50" MONOPOLE 3-SECTOR V-STABILIZER TALLEY P/N MTSVSR-MS-B

NOTE:
AT TIME OF CONSTRUCTION CONTRACTOR TO VERIFY ADMITTANCE OF EXISTING ANTENNA. IF DIFFERENT FROM ABOVE, PLEASE NOTIFY THE RF ENGINEER AND CONSTRUCTION MANAGER WITH ACTUAL ADJUSTMENTS TO ENSURE T-MOBILE'S DATABASE IS ACCURATE AND UP-TO-DATE.

SPECIAL PRE-CONSTRUCTION WORK NOTE:
GENERAL CONTRACTOR SHALL FURNISH AND INSTALL ALL SPECIAL OR SUPPLEMENTAL ADDITIONAL TOWER-MOUNTED EQUIPMENT FOR RECOMMENDATIONS FROM SBA-PROVIDED TOWER STRUCTURAL ANALYSIS FOR ANY SPECIAL SHIELDING OF TOWER TOP EQUIPMENT AND FOR ANY SPECIAL FEEDLINE BUNDLING OR RELOCATION.

ANTENNA MOUNT STRUCTURAL DESIGN NOTE:
ENGINEER-OF-RECORD HAS MADE A VISUAL ASSESSMENT ONLY OF EXISTING ANTENNA MOUNT ASSEMBLIES, WITHOUT THE BENEFIT OF A RIGOROUS ANTENNA MOUNT STRUCTURAL ANALYSIS, AND RECOMMENDS THAT EXISTING AND PROPOSED TOWER TOP EQUIPMENT BE INSTALLED AS DEPICTED HEREIN. STRUCTURAL DETAILS AS DEPICTED HEREIN FOR MODIFICATION OF EXISTING ANTENNA MOUNT ASSEMBLIES ARE PRELIMINARY ONLY AND THAT FINAL CONSTRUCTION DETAILS MAY BE SUBJECT TO CHANGE PENDING THE COMPLETION OF A SEPARATE SUPPLEMENTAL ANTENNA MOUNT STRUCTURAL ASSESSMENT, SUPPLEMENTAL STRUCTURAL MAPPING/CONDITIONS ASSESSMENT REPORT AND/OR SUPPLEMENTAL RIGOROUS ANTENNA MOUNT STRUCTURAL ANALYSIS.

T-Mobile
T-MOBILE NORTHEAST, LLC
35 GRIFFIN ROAD SOUTH
BLOOMFIELD, CT 06002

SBA
SBA COMMUNICATIONS CORP.
134 FLANDERS ROAD, SUITE 125
WESTBOROUGH, MA 01581

Trylon
DESIGNER:
NAME: TRYLON TSF INC.
ADDRESS: 1825 W. WALNUT HILL LANE SUITE 302
CITY, PROVINCE, STATE: IRVING, TEXAS TX 75038
POSTAL CODE:
CONTACT: KATYA SERAVALLE
PHONE: 519-465-4125



DRAWING SCALES ARE INTENDED FOR 24"x36" SIZE PRINTED MEDIA ONLY. ALL OTHER PRINTED SIZES ARE DEEMED "NOT TO SCALE".

SUBMITTALS			
REV	DATE	DESCRIPTION	BY
0	10/10/16	ISSUE FOR CONSTRUCTION	GI

SITE INFO:
SITE NAME:
DURHAM/Rt 68
SITE NUMBER:
CT11287A
SITE ADDRESS:
1605 DURHAM ROAD
WALLINGFORD, CT 06492

SHEET TITLE:
TOWER EQUIPMENT
DETAILS

A-2

L700 ANTENNA DIMENSIONS	
MODEL	L700-65150S-A1M
MANUF.	COMMSCOPE
WIDTH	11.9"
DEPTH	7.1"
HEIGHT	96.4"
WEIGHT	50.3 LBS

L19/G19 ANTENNA DIMENSIONS	
MODEL	APAV18-206516S-A20
MANUF.	RES
WIDTH	6.9"
DEPTH	3.15"
HEIGHT	53.1"
WEIGHT	18.7 LBS

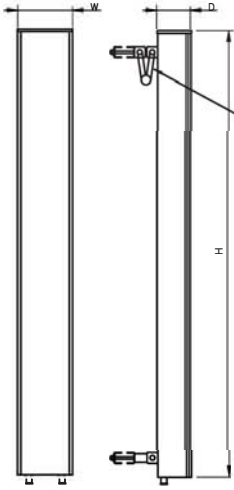

1 L700 ANTENNA DETAIL
SCALE: NTS

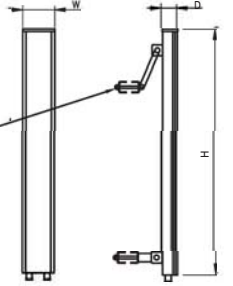

2 L19/G19 ANTENNA DETAIL
SCALE: NTS

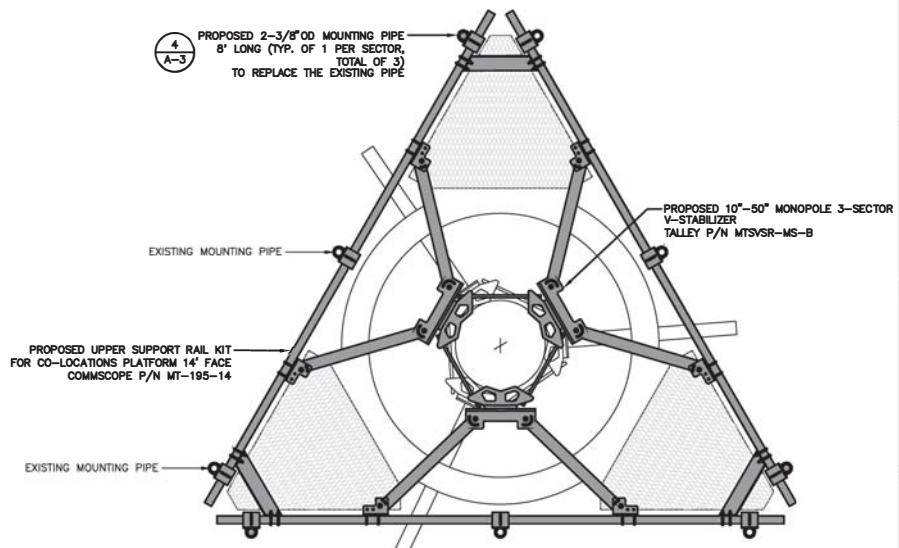

5 SUPPORT RAIL KIT DETAIL
SCALE: NTS

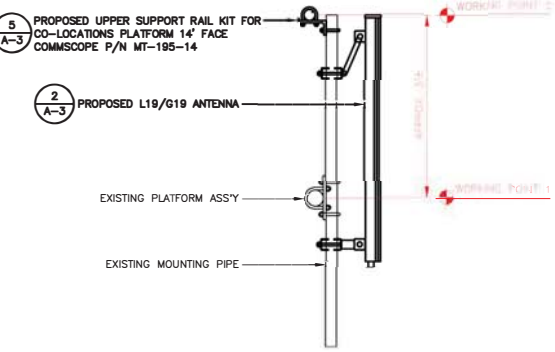

3 PROPOSED L19/G19 ANTENNA MOUNTING DETAIL
SCALE: NTS

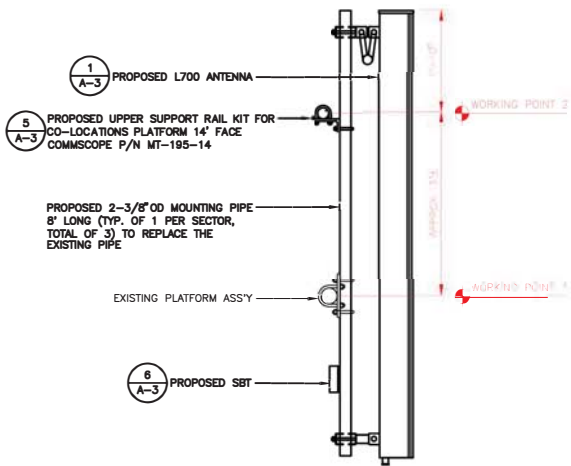

4 PROPOSED L700 ANTENNA MOUNTING DETAIL
SCALE: NTS

SBT SPECIFICATIONS	
MODEL	78211054
MANUF.	KATHREIN
WIDTH	3.2"
DEPTH	1.8"
HEIGHT	5.5"
WEIGHT	1.8 LBS

6 SMALL BIAS TEE (SBT)
SCALE: NTS

SPECIAL PRE-CONSTRUCTION WORK NOTE:
GENERAL CONTRACTOR SHALL REMOVE AND REINSTALL ALL SPECIAL OR SUPPLEMENTAL ADDITIONAL TOWER-MOUNTED EQUIPMENT PER RECOMMENDATIONS FROM SEM-PRODUCED TOWER STRUCTURAL ANALYSIS FOR ANY SPECIAL SHELLOING OF TOWER TOP EQUIPMENT AND FOR ANY SPECIAL FIELD/ON-BUILDING OR RELOCATION.

ANTENNA MOUNT STRUCTURAL DESIGN NOTE:
ENGINEER-OF-RECORD HAS MADE A VISUAL ASSESSMENT ONLY OF EXISTING ANTENNA MOUNT ASSEMBLIES. WITHOUT THE BENEFIT OF A RIGOROUS ANTENNA MOUNT STRUCTURAL ANALYSIS, AND RECOMMENDS THAT EXISTING AND PROPOSED TOWER TOP EQUIPMENT BE INSTALLED AS DEPICTED HEREIN. STRUCTURAL DETAILS AS DEPICTED HEREIN FOR MODIFICATION OF EXISTING ANTENNA MOUNT ASSEMBLIES ARE PRELIMINARY ONLY AND THAT FINAL CONSTRUCTION DETAILS MAY BE SUBJECT TO CHANGE PENDING THE COMPLETION OF A SEPARATE SUPPLEMENTAL ANTENNA MOUNT STRUCTURAL ASSESSMENT, SUPPLEMENTAL STRUCTURAL MAPPING/CONDITIONS ASSESSMENT REPORT AND/OR SUPPLEMENTAL RIGOROUS ANTENNA MOUNT STRUCTURAL ANALYSIS.

T-Mobile
T-MOBILE NORTHEAST, LLC
35 GRIFFIN ROAD SOUTH
BLOOMFIELD, CT 06002



SBA COMMUNICATIONS CORP.
134 FLANDERS ROAD, SUITE 125
WESTBOROUGH, MA 01581



DESIGNER:
NAME: TRYLON TSF INC.
ADDRESS: 1825 W. WALNUT HILL LANE SUITE 302
CITY, PROVINCE, IRVING, TEXAS
POSTAL CODE: TX 75038
CONTACT: KATYA SERAVALLE
PHONE: 519-465-4125



DRAWING SCALES ARE INTENDED FOR 24"x36" SIZE PRINTED MEDIA ONLY. ALL OTHER PRINTED SIZES ARE DEEMED "NOT TO SCALE".

SUBMITTALS			
REV	DATE	DESCRIPTION	BY
0	10/10/16	ISSUE FOR CONSTRUCTION	GI

SITE INFO:
SITE NAME:
DURHAM/RT 68
SITE NUMBER:
CT11287A
SITE ADDRESS:
1605 DURHAM ROAD
WALLINGFORD, CT 06492

SHEET TITLE:
TOWER EQUIPMENT
DETAILS

A-3

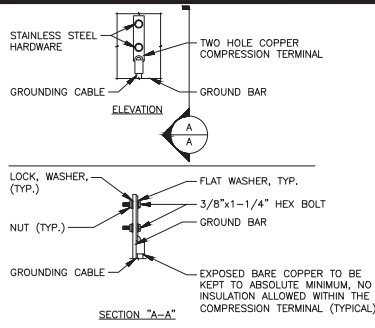

- NOTE:
- "DOUBLING UP" OR "STACKING" OF CONNECTION IS NOT PERMITTED.
 - OXIDE INHIBITING COMPOUND TO BE USED AT ALL LOCATIONS.
 - CADWELD DOWNLEADS FROM UPPER EGB, LOWER EGB, AND MGB.

TYPICAL GROUND BAR CONNECTION DETAIL (1)
SCALE: NTS

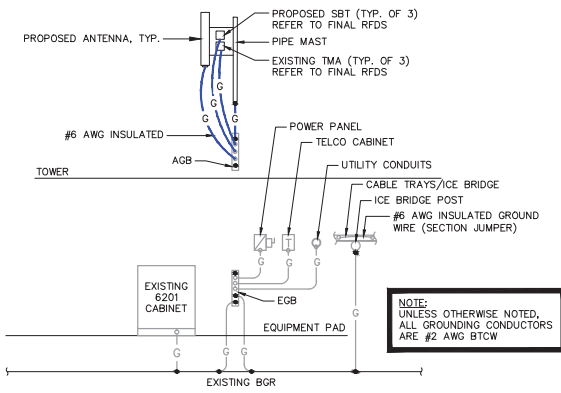

NOTE: UNLESS OTHERWISE NOTED, ALL GROUNDING CONDUCTORS ARE #2 AWG BTCW

TYPICAL GROUNDING RISER DIAGRAM (2)
SCALE: NTS

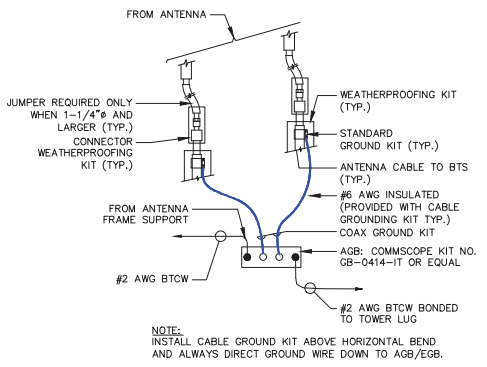

NOTE: INSTALL CABLE GROUND KIT ABOVE HORIZONTAL BEND AND ALWAYS DIRECT GROUND WIRE DOWN TO AGB/EGB.

TOWER TOP CABLE GROUNDING DETAIL (3)
SCALE: NTS

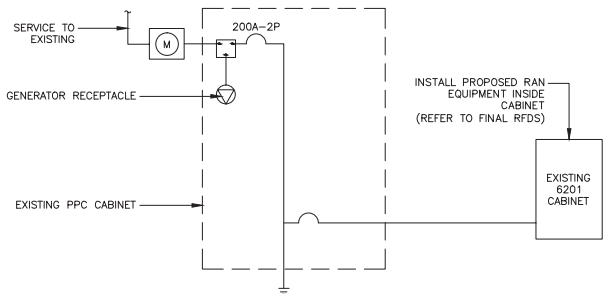

NOTE: PPC BREAKERS NOT ACCESSIBLE DURING A&E DESIGN VISIT, CONTRACTOR TO CONFIRM RBS6201 60A-2P BREAKER AVAILABLE.

ONE LINE POWER DIAGRAM (4)
SCALE: NTS



PHOTO DETAIL: PPC PANEL (5)
SCALE: NTS

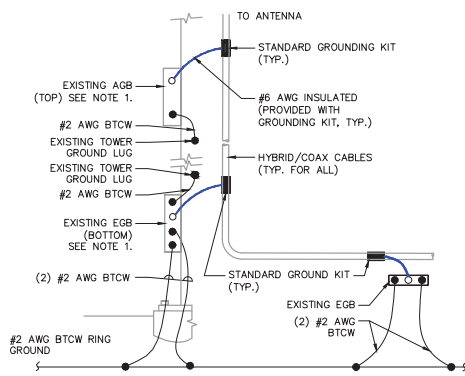

NOTE:

- NUMBER OF GROUND BARS MAY VARY DEPENDING ON THE TYPE OF TOWER, ANTENNA LOCATION, AND CONNECTION ORIENTATION. PROVIDE ADDITIONAL AGB/EGB AS REQUIRED.
- A SEPARATE GROUND BAR TO BE USED FOR GPS ANTENNA IF REQUIRED

TOWER BOTTOM CABLE GROUNDING DETAIL (6)
SCALE: NTS

ELECTRICAL LEGEND

- A AMPERE
- V VOLT
- KWH KILOWATT - HOUR
- C CONDUIT
- GRC GALVANIZED RIGID CONDUIT
- BTCW BARE TINNED (SOLID) COPPER WIRE (#2 AWG, UNLESS NOTES OTHERWISE)
- G GROUND
- MOB GROUND
- MECHANICAL CONNECTION
- CADWELDED CONNECTION
- EQUIPMENT GROUND BAR/ANTENNA GROUND BAR
- GROUND COPPER WIRE, SIZE AS NOTED
- EXPOSED WIRING
- INSULATED GROUNDING CONDUCTOR (#6 AWG STRANDED)
- 5/8"x10" COPPER CLAD STAINLESS STEEL GROUND ROD
- EXOTHERMIC (CAD WELD) OR MECHANICAL (COMPRESSION TYPE) CONNECTION
- PPC POWER PROTECTION CABINET CONNECTION
- OMNI-DIRECTIONAL ELECTRONIC MARKER SYSTEM (EMS) BALL

ELECTRICAL & GROUNDING NOTES:

- ALL ELECTRICAL WORK SHALL CONFORM TO THE REQUIREMENTS OF THE NATIONAL ELECTRICAL CODE (NEC) 2014 AS WELL AS APPLICABLE STATE AND LOCAL CODES.
- ALL ELECTRICAL ITEMS SHALL BE U.L. APPROVED OR LISTED AND PROCURED PER SPECIFICATION REQUIREMENTS.
- THE ELECTRICAL WORK INCLUDES ALL LABOR AND MATERIAL DESCRIBED BY DRAWINGS AND SPECIFICATIONS INCLUDING INCIDENTAL WORK TO PROVIDE COMPLETE OPERATING AND APPROVED ELECTRICAL SYSTEM.
- GENERAL CONTRACTOR SHALL PAY FEES FOR PERMITS, AND IS RESPONSIBLE FOR OBTAINING SAID PERMITS AND COORDINATION OF INSPECTIONS.
- ELECTRICAL AND TELCO WIRING OUTSIDE A BUILDING AND EXPOSED TO WEATHER SHALL BE IN WATER TIGHT GALVANIZED RIGID STEEL CONDUITS OR SCHEDULE 80 PVC (AS PERMITTED BY CODE) AND WHERE REQUIRED IN LIQUID TIGHT FLEXIBLE METAL OR NONMETALLIC CONDUITS.
- RIGID STEEL CONDUITS SHALL BE GROUND AT BOTH ENDS.
- ELECTRICAL WIRING SHALL BE COPPER WITH TYPE OHW, THWN, OR THHN INSULATION AS REQUIRED BY NEC.
- RUN ELECTRICAL CONDUIT OR CABLE BETWEEN ELECTRICAL ROOM AND PROPOSED CELL SITE POWER PEDESTAL AS INDICATED ON THIS DRAWING. PROVIDE FULL LENGTH FULL ROPE. COORDINATE INSTALLATION WITH UTILITY COMPANY.
- RUN TELCO CONDUIT OR CABLE BETWEEN TELEPHONE UTILITY DEMARCATION POINT AND PROPOSED CELL SITE TELCO CABINET AND BITS CABINET AS INDICATED ON DRAWING A-1. PROVIDE FULL LENGTH FULL ROPE IN INSTALLED TELCO CONDUIT. PROVIDE GREEN/LEE CONDUIT MEASURING TAPE AT EACH END.
- ALL EQUIPMENT LOCATED OUTSIDE SHALL HAVE NEMA 3R ENCLOSURE.
- GROUNDING SHALL COMPLY WITH NEC ART. 250.
- GROUND COAXIAL CABLE SHIELDS MINIMUM AT BOTH ENDS USING MANUFACTURERS COAX CABLE GROUNDING KITS SUPPLIED BY PROJECT OWNER.
- USE #6 COPPER STRANDED WIRE WITH GREEN COLOR INSULATION FOR ABOVE GRADE GROUNDING (UNLESS OTHERWISE SPECIFIED) AND #2 SOLID TINNED BARE COPPER WIRE FOR BELOW GRADE GROUNDING AS INDICATED ON THE DRAWING.
- ALL GROUND CONNECTIONS TO BE BURNED HYBRID COMPRESSION TYPE CONNECTORS OR CADWELDED EXOTHERMIC WELD. DO NOT ALLOW BARE COPPER WIRE TO BE IN CONTACT WITH GALVANIZED STEEL.
- ROUTE GROUNDING CONDUCTORS ALONG THE SHORTEST AND STRAIGHTEST PATH POSSIBLE, EXCEPT AS OTHERWISE INDICATED. GROUNDING LEADS SHOULD NEVER BE BENT AT RIGHT ANGLE. ALWAYS MAKE AT LEAST 12" RADIUS BENDS. #6 WIRE CAN BE BENT AT 6" RADIUS WHEN NECESSARY. BOND ANY METAL OBJECTS WITHIN 7 FEET OF PROPOSED EQUIPMENT OR CABINET TO MASTER GROUND BAR.
- CONNECTIONS TO MGB SHALL BE ARRANGED IN THREE MAIN GROUPS: SURGE PRODUCERS (COAXIAL CABLE GROUND KITS, TELCO AND POWER PANEL GROUND); (GROUNDING ELECTRODE RING OR BUILDING STEEL); NON-SURGING OBJECTS (EGB GROUND IN BITS UNIT).
- CONNECTIONS TO GROUND BARS SHALL BE MADE WITH TWO HOLE COMPRESSION TYPE COPPER LYGS. APPLY OXIDE INHIBITING COMPOUND TO ALL LOCATIONS.
- APPLY OXIDE INHIBITING COMPOUND TO ALL COMPRESSION TYPE GROUND CONNECTIONS.
- BOND ANTENNA MOUNTING BRACKETS, COAXIAL CABLE GROUND KITS, AND ALUM TO EGB PLACED NEAR THE ANTENNA LOCATION.
- BOND ANTENNA EGB'S AND MGB TO WATER MAIN/GROUND RING.
- TEST COMPLETED GROUND SYSTEM AND RECORD RESULTS FOR PROJECT CLOSE-OUT DOCUMENTATION.
- BOND ANY METAL OBJECTS WITHIN 7 FEET OF PROPOSED EQUIPMENT OR CABINET TO MASTER GROUND BAR.
- VERIFY PROPOSED SERVICE UPGRADE WITH LOCAL UTILITY COMPANY PRIOR TO CONSTRUCTION.

T-Mobile
T-MOBILE NORTHEAST, LLC
35 GRIFFIN ROAD SOUTH
BLOOMFIELD, CT 06002

SBA

SBA COMMUNICATIONS CORP.
134 FLANDERS ROAD, SUITE 125
WESTBOROUGH, MA 01581

Trylon

DESIGNER:
NAME: TRYLON TSF INC.
ADDRESS: 1825 W. WALNUT HILL LANE SUITE 302
CITY, PROVINCE, IRVING, TEXAS
POSTAL CODE: TX 75038
CONTACT: KATYA SERAVALLE
PHONE: 519-465-4125



DRAWING SCALES ARE INTENDED FOR 24"x36" SIZE PRINTED MEDIA ONLY. ALL OTHER PRINTED SIZES ARE DEEMED "NOT TO SCALE".

SUBMITTALS			
REV	DATE	DESCRIPTION	BY
0	10/10/16	ISSUE FOR CONSTRUCTION	GI

SITE INFO:
SITE NAME:
DURHAM/RT 68
SITE NUMBER:
CT11287A
SITE ADDRESS:
1605 DURHAM ROAD
WALLINGFORD, CT 06492

SHEET TITLE:
ELECTRICAL
DETAILS AND
NOTES