

ROBINSON & COLE LL

KENNETH C. BALDWIN

280 Trumbull Street
Hartford, CT 06103-3597
Main (860) 275-8200
Fax (860) 275-8299
kbaldwin@rc.com
Direct (860) 275-8345

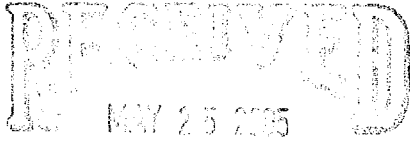

CONNECTICUT
SITING COUNCIL

May 25, 2005

Via Hand Delivery

S. Derek Phelps
Executive Director
Connecticut Siting Council
10 Franklin Square
New Britain, CT 06051

Re: **Notice of Exempt Modification – Antenna Swap
Plains Road, Haddam, CT
83 Reeds Gap Road, North Branford, CT
921-927 East Main Street, Meriden, CT
France Street, Rocky Hill, CT**

Dear Mr. Phelps:

Cellco Partnership d/b/a Verizon Wireless (“Cellco”) currently maintains a wireless telecommunications facility at each of the sites referenced above. As described below, Cellco now intends to modify each existing facility.

Please accept this letter as notification pursuant to R.C.S.A. § 16-50j-73, for construction that constitutes an exempt modification pursuant to R.C.S.A. § 16-50j-72(b)(2). In accordance with R.C.S.A. § 16-50j-73, a copy of this letter is being sent to chief executive officer in each affected municipality.

Plains Road, Haddam, CT

Cellco’s existing Plains Road facility consists of twelve (12) cellular antennas on a tower owned by Crown Atlantic Company, LLC. Cellco intends to modify its facility by replacing six (6) cellular antennas with six (6) PCS antennas at the same level on the tower. Attached behind Tab 1 are specifications for the existing cellular antennas and the proposed PCS antennas for the facility and a new general power density table.



Law Offices

- BOSTON
- HARTFORD
- NEW LONDON
- STAMFORD
- GREENWICH
- WHITE PLAINS
- NEW YORK CITY
- SARASOTA
- www.rc.com*

S. Derek Phelps
May 25, 2005
Page 2

83 Reeds Gap Road, North Branford, CT

Cellco's existing Reeds Gap Road facility consists of twelve (12) cellular antennas on a tower owned by Crown Atlantic Company, LLC. Cellco intends to modify its facility by replacing six (6) cellular antennas with six (6) PCS antennas at the same level on the tower. Attached behind Tab 2 are specifications for the existing cellular antennas and the proposed PCS antennas for the facility and a new general power density table.

921-927 East Main Street, Meriden, CT

Cellco's existing East Main Street facility consists of six (6) cellular antennas on a sign structure at the BP Gas Station. This facility was approved by the Siting Council in Petition No. 320, and therefore remain under the Council's jurisdiction. Cellco now intends to modify its facility by replacing all six (6) cellular antennas with two (2) new cellular antennas and two (2) PCS antennas, for a total of four (4) antennas, at the same level on the sign structure. Attached behind Tab 2 are specifications for the existing cellular antennas and the proposed cellular and PCS antennas for the facility and a new general power density table.

France Street, Rocky Hill CT

Cellco's existing France Street facility consists of twelve (12) cellular antennas on a tower owned by Crown Atlantic Company, LLC. Cellco intends to modify its facility by replacing six (6) cellular antennas with six (6) PCS antennas at the same level on the tower. Attached behind Tab 2 are specifications for the existing cellular antennas and the proposed PCS antennas for the facility and a new general power density table.

The planned modifications to each of these facilities fall squarely within those activities explicitly provided for in R.C.S.A. § 16-50j-72(b)(2).

1. The proposed modifications will not result in any increase in the overall height of the existing structures.
2. The proposed modifications will not affect ground-mounted equipment and will not require the extension of the site boundaries.
3. The proposed modifications will not increase noise levels at the facility by six decibels or more.



ROBINSON & COLE^{LLP}

S. Derek Phelps
May 25, 2005
Page 3

4. The proposed modifications will not result in radio frequency (RF) power density levels at the facility that exceed the Federal Communications Commission (FCC) adopted safety standard.

For the foregoing reasons, Cellco respectfully submits that the proposed modifications to the above-referenced telecommunications facilities constitute an exempt modification under R.C.S.A. § 16-50j-72(b)(2).

Sincerely,



Kenneth C. Baldwin

Enclosures

cc: Anthony Bondi, Haddam First Selectman
Michael J. Doody, North Branford Mayor
Mark Benigni, Meriden Mayor
Todd Cusano, Rocky Hill Mayor
Sandy M. Carter



ALP 9212-N

Log-Periodic Reflector Antenna

92 Degrees 12 dBd

Features:

- Broadbanded. (800-900 MHz)
- Low backlobe radiation. Front-to-back ratio better than 28 dB
- Low Intermodulation Products.
- Low Wind-load.
- Low weight.
- Small size.
- Rugged design.

Please see the following pages including radiation patterns/tables for ALP 9212-N.

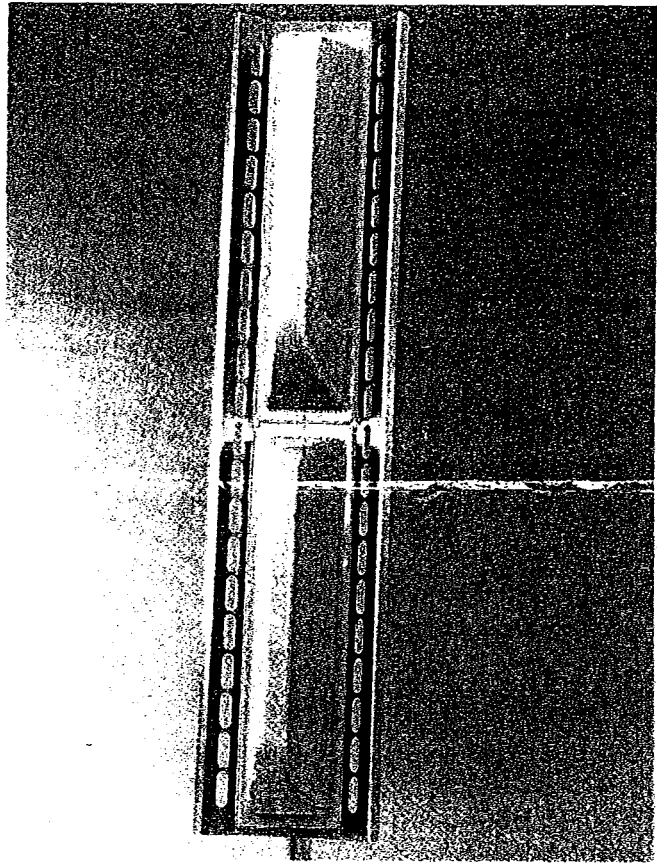

Electrical Specifications:

Frequency range:	806-896 MHz
Impedance:	50 ohm
Connector:	N-female or 7/8" EIA
VSWR:	Typ. 1.3:1 max 1.5:1
Polarization:	Vertical
Gain:	12 dBd
Front to back ratio:	>28 dB
Side-lobe suppression:	>18 dB
Intermodulation: (2x25W):	IM3 >146 dB IM5 >153 dB IM7 & IM9 >163 dB
Power Rating:	500 W
H-Plane:	-3 dB 95°
E-Plane:	-3 dB 15°
Lightning Protection:	DC Grounded

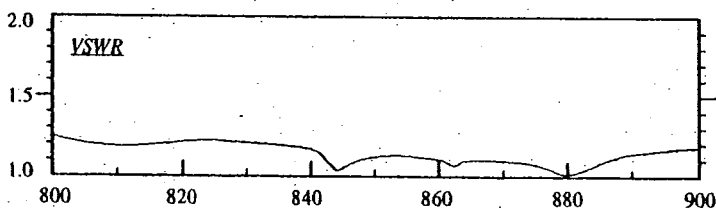

Mechanical Specifications:

Overall Height:	52 in	(1320 mm)
Width:	11.4 in	(290 mm)
Depth:	11.4 in	(290 mm)
Weight including brackets:	26.7 lbs	(12 Kg)
Rated wind velocity:	113 mph	(180 Km/h)
Wind Area (CxA/Front):	3.9 sq.ft	(0.36 sq.m)
Lateral thrust at rated wind		
Worst case:	570 N	

Materials:

Radiating elements:	Aluminum
Element housing:	Grey PVC
Back-plate:	Aluminum
Mounting hardware	
clamps:	Hot dip galvanized steel
bolts:	Stainless steel

Manufactured by: Allgon System AB

DECIBEL'

Base Station Antennas

948F85T2E-M16.1 dBi, Directed Dipole Antenna
1850-1990 MHz**1850-1990 MHz****MaxFill™****dB Director®**

- Exceptional azimuth roll-off reducing soft hand-offs and improving capacity
- Excellent upper side lobe suppression
- Deep null filling below the horizon assures improved signal intensity
- Low profile appearance and low wind loading profile for easier zoning approvals

850

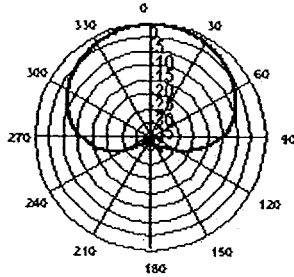

Azimuth 1850 MHz (Tilt=2)

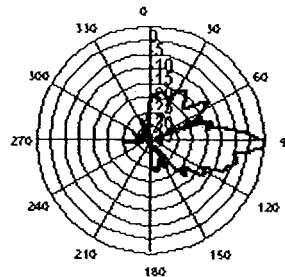

Vertical 1850 MHz (Tilt=2)

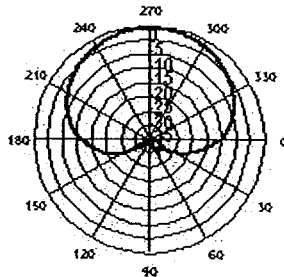

Horizontal 1850 MHz (Tilt=2)

**ELECTRICAL**

Frequency (MHz):	1850-1990
Polarization:	Vertical
Gain (dBd/dBi):	14/16.1
Azimuth BW:	85°
Elevation BW:	8°
Beam Tilt:	2°
USLS* (dB):	>18
Null Fill* (dB):	15
Front-to-Back Ratio* (dB):	40
VSWR:	<1.33:1
IM Suppression - Two 20 Watt Carriers:	-150 dBc
Impedance:	50 Ohms
Max Input Power:	250 Watts
Lightning Protection:	DC Ground
Opt Electrical Tilt:	0°, 4°, 6°

MECHANICAL

Weight:	8.5 lbs (3.9 kg)
Dimensions (LxWxD):	48 X 3.5 X 7 in (1219 X 89 X 178 mm)
Max. Wind Area:	1.18 ft ² (0.11 m ²)
Max. Wind Load (@ 100mph):	65 lbf (289 N)
Max. Wind Speed:	125 mph (201 km/h)
Radiator Material:	Low Loss Circuit Board
Reflector Material:	Aluminum
Radome Material:	ABS, UV Resistant
Mounting Hardware Material:	Galvanized Steel
Connector Type:	7-16 DIN - Female (Bottom)
Color:	Light Gray
Standard Mounting Hardware:	DB390 Pipe Mount Kit, included
Downtilt Mounting Hardware:	DB5098, optional
Opt. Mounting Hardware:	DB5094-AZ Azimuth Wall Mount



Andrew Corporation
8635 Stemmons Freeway
Dallas, Texas U.S.A 75247-3701
Tel: 214.631.0310

Fax: 214.631.4706
Toll Free Tel: 1.800.676.5342
Fax: 1.800.229.4706
www.andrew.com

Date: 4/29/2004
* - Indicates Typical Values

dbtech@andrew.com

General Power Density

Site Name: Haddam
 Tower Height: 174 FT

Operator	Operating Frequency (MHz)	Number of Trans	ERP Per Trans (watts)	Total ERP (watts)	Distance to Target (feet)	Calculated Power Density (mW/cm ²)	Maximum Permissible Exposure (mW/cm ²)	Fraction of MPE (%)
Verizon	880	9	200	1800	174	0.0214	0.586	3.65%
Verizon	1900	3	200	600	174	0.0071	1	0.71%
Total Percentage of Maximum Permissible Exposure								4.36%

*Guidelines adopted by the FCC on August 1, 1996, 47 CFR Part 1 based on NCRP Report 86, 1986 and generally on ANSI/IEEE C95.1-1992

MHz = Megahertz

mW/cm² = milliwatts per square centimeter

ERP = Effective Radiated Power



ALP 9212-N

Log-Periodic Reflector Antenna
92 Degrees 12 dBd

Features:

- Broadbanded. (800-900 MHz)
- Low backlobe radiation. Front-to-back ratio better than 28 dB
- Low Intermodulation Products.
- Low Wind-load.
- Low weight.
- Small size.
- Rugged design.

Please see the following pages including radiation patterns/tables for ALP 9212-N.

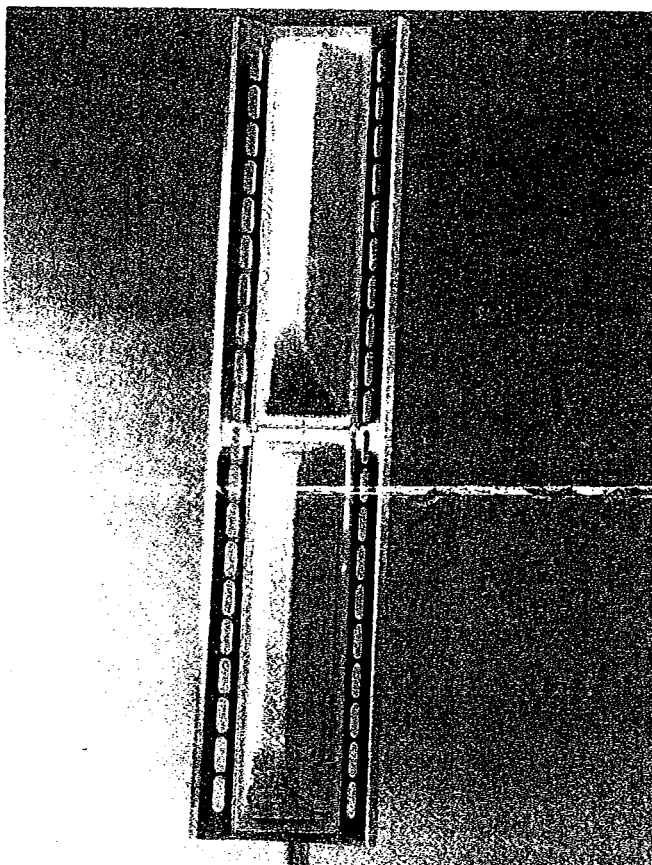

Electrical Specifications:

Frequency range:	806-896 MHz
Impedance:	50 ohm
Connector:	N-female or 7/8" EIA
VSWR:	Typ. 1.3:1 max 1.5:1
Polarization:	Vertical
Gain:	12 dBd
Front to back ratio:	>28 dB
Side-lobe suppression:	>18 dB
Intermodulation: (2x25W):	IM3 >146 dB IM5 >153 dB IM7 & IM9 >163 dB
Power Rating:	500 W
H-Plane:	-3 dB 95°
E-Plane:	-3 dB 15°
Lightning Protection:	DC Grounded

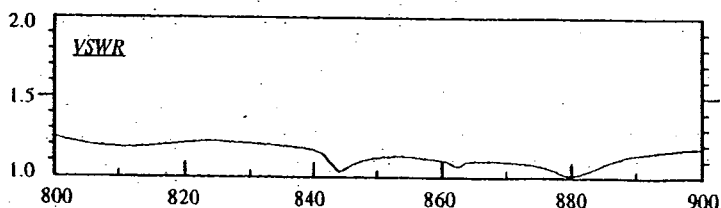

Mechanical Specifications:

Overall Height:	52 in	(1320 mm)
Width:	11.4 in	(290 mm)
Depth:	11.4 in	(290 mm)
Weight including brackets:	26.7 lbs	(12 Kg)
Rated wind velocity:	113 mph	(180 Km/h)
Wind Area (CxA/Front):	3.9 sq.ft	(0.36 sq.m)
Lateral thrust at rated wind		
Worst case:	570 N	

Materials:

Radiating elements:	Aluminum
Element housing:	Grey PVC
Back-plate:	Aluminum
Mounting hardware	
clamps:	Hot dip galvanized steel
bolts:	Stainless steel

Manufactured by: Allgon System AB

DECIBEL®
Base Station Antennas

DB844G65ZAXY

13.5 dBd, Directed Dipole, No Screen Antenna
806-896, 870-960 MHz

806-896 MHz
870-960 MHz

GEN3VPOL™
ZoneMaster™

- Excellent azimuth roll-off, reducing sector to sector interference and reducing soft hand-offs
- Air dielectric feed system, no screws, rivets, welds or solder in RF element feed path
- Strong upper side lobe suppression
- Low profile appearance and low wind loading profile for easier zoning approvals

65°

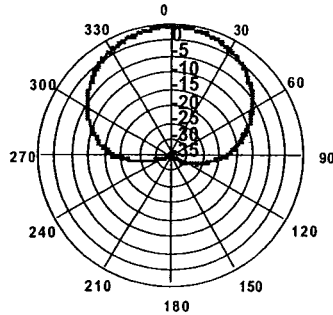

Horizontal 880 MHz (Tilt=0)

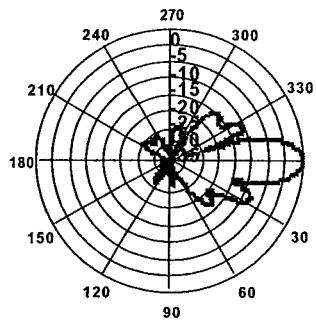

Vertical 880 MHz (Tilt=0)

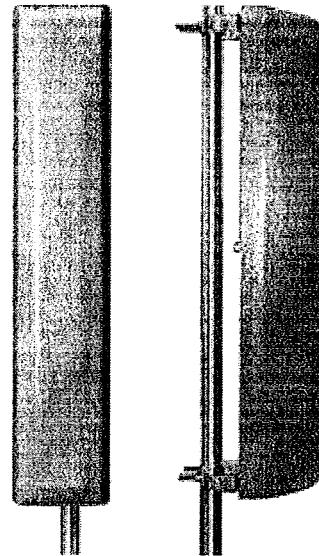

ELECTRICAL

MECHANICAL

Frequency (MHz):	806-896	870-960	Weight:	12 lbs (5.4 kg)
Polarization:	Vertical	Vertical	Dimensions (LxWxD):	48 X 10 X 8.5 in (1219 X 254 X 216 mm)
Gain (dBd/dBi):	13.5/15.6	13.8/15.9	Max. Wind Area:	0.97 ft ² (0.09 m ²)
Azimuth BW:	65°	65°	Max. Wind Load (@ 100mph):	53 lbf (236 N)
Elevation BW:	15°	15°	Max. Wind Speed:	125 mph (201 km/h)
Beam Tilt:	0°	0°	Radiator Material:	Aluminum
USLS* (dB):	>15	>15	Reflector Material:	Aluminum
Null Fill* (dB):	20-25	20-25	Radome Material:	ABS, UV Resistant
Front-to-Back Ratio* (dB):	40	40	Mounting Hardware Material:	Galvanized Steel
VSWR:	<1.33:1	<1.33:1	Connector Type:	7-16 DIN -Female (Back)
Impedance:	50 Ohms	50 Ohms	Color:	Light Gray
Max Input Power:	500 Watts	500 Watts	Standard Mounting Hardware:	DB380 Pipe Mount Kit, included
Lightning Protection:	DC Ground	DC Ground	Downtilt Mounting Hardware:	DB5083, optional
Opt Electrical Tilt:	6°	6°	Opt. Mounting Hardware:	DB5084-AZ Azimuth Wall Mount



Andrew Corporation
8635 Stemmons Freeway
Dallas, Texas U.S.A 75247-3701
Tel: 214.631.0310

Fax: 214.631.4706
Toll Free Tel: 1.800.676.5342
Fax: 1.800.229.4706
www.andrew.com

Warranty: Five years
Date: 4/23/2004
* - Indicates Typical Values

dbtech@andrew.com

DECIBEL®

948F65T2ZE-M

17.2 dBi, Log. No Screen Antenna
1850-1990 MHz

1850-1990 MHz

dB Director®
MaxFill™

- Exceptional azimuth roll-off reducing soft hand-offs and improving capacity
- Excellent upper side lobe suppression
- Deep null filling below the horizon assures improved signal intensity
- Low profile appearance and low wind loading profile for easier zoning approvals

65°

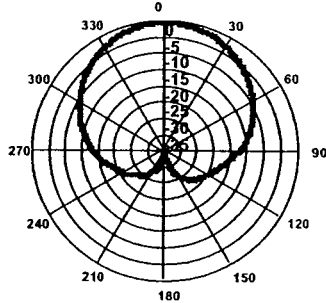

Azimuth 1950 MHz (Tilt=2)

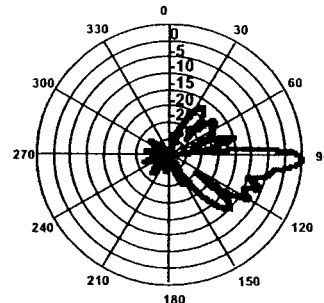

Vertical 1950 MHz (Tilt=2)

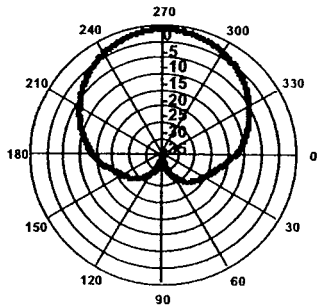

Horizontal 1950 MHz (Tilt=2)



ELECTRICAL

Frequency (MHz):	1850-1990
Polarization:	Vertical
Gain (dBd/dBi):	15.1/17.2
Azimuth BW:	65°
Elevation BW:	8°
Beam Tilt:	2°
USLS* (dB):	>16
Null Fill* (dB):	<15
Front-to-Back Ratio* (dB):	40
VSWR:	<1.33:1
IM Suppression - Two 20 Watt Carriers:	-150 dBc
Impedance:	50 Ohms
Max Input Power:	250 Watts
Lightning Protection:	DC Ground

MECHANICAL

Weight:	9.5 lbs (4.3 kg)
Dimensions (LxWxD):	48 X 6.5 X 4 in (1219 X 165 X 102 mm)
Max. Wind Area:	2.2 ft² (0.2 m²)
Max. Wind Load (@ 100mph):	88 lbf (391 N)
Max. Wind Speed:	125 mph (201 km/h)
Radiator Material:	Low Loss Circuit Board
Reflector Material:	Passivated Aluminum
Radome Material:	ABS, UV Resistant
Mounting Hardware Material:	Galvanized Steel
Connector Type:	7/16 DIN - Female (Bottom)
Color:	Light Gray
Standard Mounting Hardware:	DB390 Pipe Mount Kit, included
Downtilt Mounting Hardware:	DB5098, optional



Andrew Corporation
8635 Stemmons Freeway
Dallas, Texas U.S.A 75247-3701
Tel: 214.631.0310

Fax: 214.631.4706
Toll Free Tel: 1.800.676.5342
Fax: 1.800.229.4706
www.andrew.com

Warranty: Five Years
Date: 7/24/2003

dbtech@andrew.com

General Power Density

Site Name: North Brandford
 Tower Height: 95 FT

Operator	Operating Frequency (MHz)	Number of Trans	ERP Per Trans (watts)	Total ERP (watts)	Distance to Target (feet)	Calculated Power Density (mW/cm ²)	Maximum Permissible Exposure (mW/cm ²)	Fraction of MPE (%)
Verizon	880	9	200	1800	95	0.0717	0.586	12.24%
Verizon	1900	3	200	600	95	0.0239	1	2.39%
Total Percentage of Maximum Permissible Exposure								14.63%

*Guidelines adopted by the FCC on August 1, 1996, 47 CFR Part 1 based on NCRP Report 86, 1986 and generally on ANSI/IEEE C95.1-1992

MHz = Megahertz

mW/cm² = milliwatts per square centimeter

ERP = Effective Radiated Power



Swedcom Corporation

ALP 110 11-N

Log-Periodic Reflector Antenna

110 Degrees 11 dBd

Features:

- Broadbanded. (800-900 MHz)
- Low backlobe radiation. Front-to-back ratio better than 26 dB
- Low Intermodulation Products.
- Low Wind-load.
- Low weight.
- Small size.
- Rugged design.

Please see the following pages including radiation patterns/tables for ALP 110 11-N.

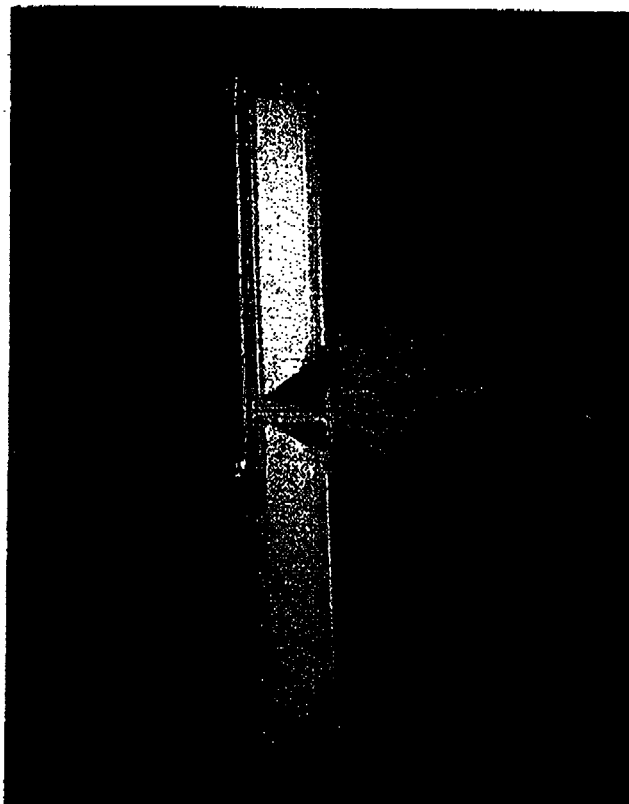

Electrical Specifications:

Frequency range:	806-896 MHz
Impedance:	50 ohm
Connector:	N-female or 7/8" EIA
VSWR:	Typ. 1.3:1 max 1.5:1
Polarization:	Vertical
Gain:	11 dBd
Front to back ratio:	>26 dB
Side-lobe suppression:	>17 dB
Intermodulation: (2x25W):	IM3 >146 dB IM5 >153 dB IM7 & IM9 >163 dB
Power Rating:	500 W
H-Plane:	-3 dB 110°
E-Plane:	-3 dB 15°
Lightning Protection:	DC Grounded

Mechanical Specifications:

Overall Height:	52 in	(1320 mm)
Width:	8.3 in	(210 mm)
Depth:	11.4 in	(290 mm)
Weight including brackets:	24.5 lbs	(11 Kg)
Rated wind velocity:	113 mph	(180 Km/h)
Wind Area (CxA/Front):	3.7 sq.ft	(0.34 sq.m)
Lateral thrust at rated wind		
Worst case:	530 N	

Materials:

Radiating elements:	Aluminum
Element housing:	Grey PVC
Back-plate:	Aluminum

Mounting hardware	
clamps:	Hot dip galvanized steel
bolts:	Stainless steel

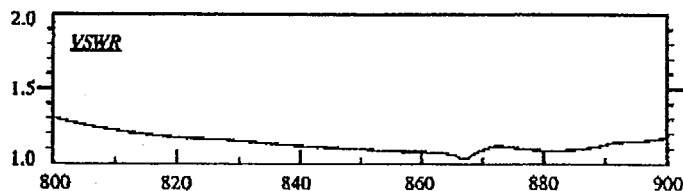

Manufactured by: Allgon System AB



DB854DG90ESX

±45° Diversity Panel Antenna

DECIBEL
Base Station Antennas

- Features air dielectric feed system for maximum array efficiency and lowest loss
- No fasteners, rivets, soldering or welding in critical element-to-transformer circuit
- Strong first upper side lobe suppression
- Excellent gain per unit length of antenna

ELECTRICAL

Frequency (MHz) :	806 - 896
Polarization :	±45°
Gain (dBd/dBi) :	11.7/13.8
Azimuth BW (Deg.):	90
Elevation BW (Deg.):	14
Beam Tilt (Deg.):	0
USLS* (dB) :	>18
Front-To-Back Ratio* (dB) :	25
Isolation (dB) :	>30
VSWR :	<1.33:1
PIM3 @ 2 x 20w (dBc) :	-150
Max. Input Power (Watts) :	500
Impedance (Ohms) :	50
Lightning Protection :	DC Ground
Opt. Electrical Tilt :	6

MECHANICAL

Weight :	8.1 kg (18 lb)
Dimensions (LxWxD) :	1,219 x 318 x 178 mm (48 x 12.5 x 7 in)
Max. Wind Area :	0.17 m ² (1.8 ft ²)
Max. Wind Load (@ 100 mph) :	444.8 N (100 lbf)
Max. Wind Speed :	241 km/h (150 mph)
Hardware Material :	Galvanized Steel
Connector Type :	7-16 DIN - Female (2, Bottom)
Color :	Light Gray
Standard Mounting Hardware :	DB380
Standard Downtilt Mounting Hardware :	DB5083

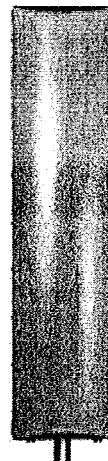

Andrew Corporation
2601 Telecom Parkway
Richardson, Texas U.S.A 75082-3521
Tel: 214.631.0310

Fax: 214.631.4706
Toll Free Tel: 1.800.676.5342
Fax: 1.800.229.4706
www.andrew.com

* - Indicates Typical
5/10/2005
dbtech@andrew.com

Information correct at date of issue but may be subject to change without notice.



DB854DG90ESX

±45° Diversity Panel Antenna

DECIBEL*
Base Station Antennas

AZIMUTH PATTERN

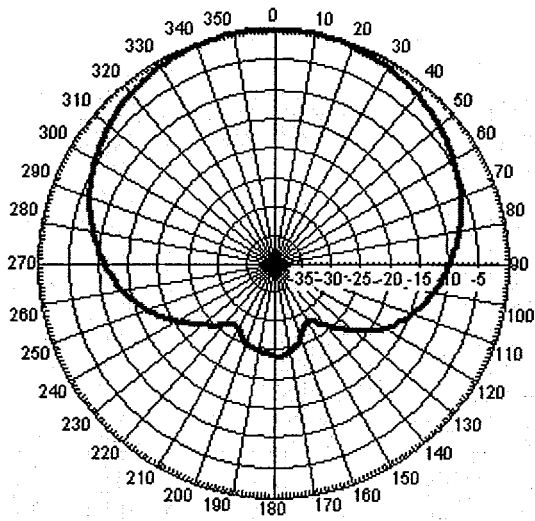

Freq: 850 MHz, Tilt: 0

ELEVATION PATTERN

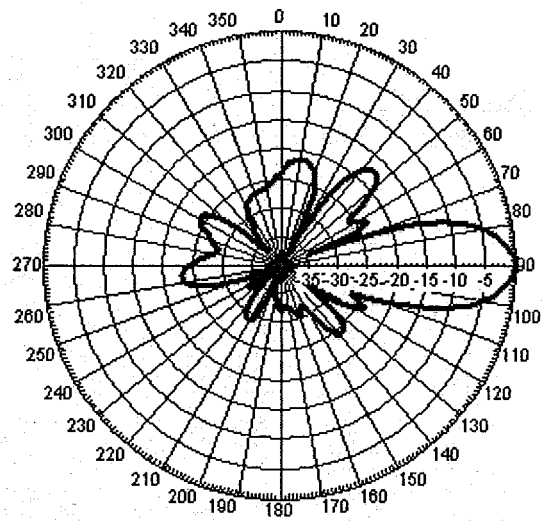

Freq: 850 MHz, Tilt: 0

DECIBEL
Base Station Antennas

932DG90T2E-M

16.7 dBi, ± 45° Diversity Panel Antenna
1850-1990 MHz

1850-1990 MHz

**Diversity Master™
GEN3XPOL™**

- Features air dielectric feed system for maximum array efficiency and lowest loss
- No fasteners, rivets, soldering or welding in critical element-to-transformer circuit
- Strong first upper side lobe suppression
- Excellent gain per unit length of antenna

90°

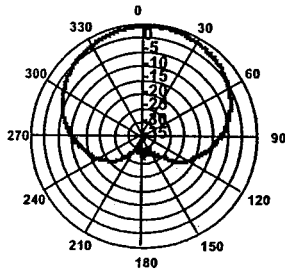

Azimuth 1850 MHz (Tilt=2)

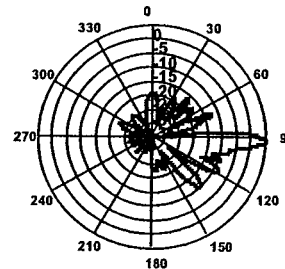

Vertical 1850 MHz (Tilt=2)

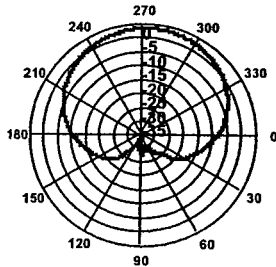

Horizontal 1850 MHz (Tilt=2)



ELECTRICAL

Frequency (MHz):	1850-1990
Polarization:	+45°/-45°
Gain (dBd/dBi):	14.6/16.7
Azimuth BW:	90°
Elevation BW:	7°
Beam Tilt:	2°
USLS* (dB):	>18
Front-to-Back Ratio* (dB):	30
Isolation (dB):	>30
VSWR:	<1.33:1
IM Suppression - Two 20 Watt Carriers:	-150 dBc
Impedance:	50 Ohms
Max Input Power:	250 Watts
Lightning Protection:	DC Ground
Opt Electrical Tilt:	0°, 4°, Variable 1-8°

MECHANICAL

Weight:	9.5 lbs (4.3 kg)
Dimensions (LxWxD):	51.5 X 7 X 3.5 in (1308 X 178 X 89 mm)
Max. Wind Area:	0.86 ft² (0.08 m²)
Max. Wind Load (@ 100mph):	50 lbf (222 N)
Max. Wind Speed:	125 mph (201 km/h)
Radiator Material:	Aluminum
Reflector Material:	Aluminum
Radome Material:	Polycarbonate, UV Resistant
Mounting Hardware Material:	Galvanized Steel
Connector Type:	7-16 DIN - Female (Bottom)
Color:	Light Gray
Standard Mounting Hardware:	DB390 Pipe Mount Kit, included
Downtilt Mounting Hardware:	DB5098, optional
Opt. Mounting Hardware:	DB5094-AZ Azimuth Wall Mount



Andrew Corporation
8635 Stemmons Freeway
Dallas, Texas U.S.A 75247-3701
Tel: 214.631.0310

Fax: 214.631.4706
Toll Free Tel: 1.800.676.5342
Fax: 1.800.229.4706
www.andrew.com

Date: 4/2/2004
* - Indicates Typical Values

dbtech@andrew.com

General Power Density

Site Name: Meriden 2, CT
 Tower Height: 48 FT

Operator	Operating Frequency (MHz)	Number of ERP/Per Channels	Total ERP (watts)	Distance to Target (feet)	Calculated Power Density (mW/cm ²)	Maximum Permissible Exposure (mW/cm ²)	Fraction of MPE (%)
Verizon	880	9	1800	48	0.2810	0.586	47.94%
Verizon	1900	3	600	48	0.0937	1	9.37%
Total Percentage of Maximum Permissible Exposure							57.31%

*Guidelines adopted by the FCC on August 1, 1996, 47 CFR Part 1 based on NCRP Report 86, 1986 and generally on ANSI/IEEE C95.1-1992

MHz = Megahertz

mW/cm² = milliwatts per square centimeter

ERP = Effective Radiated Power



ALP 9212-N

Log-Periodic Reflector Antenna

92 Degrees 12 dBd

Features:

- Broadbanded. (800-900 MHz)
- Low backlobe radiation. Front-to-back ratio better than 28 dB
- Low Intermodulation Products.
- Low Wind-load.
- Low weight.
- Small size.
- Rugged design.

Please see the following pages including radiation patterns/tables for ALP 9212-N.

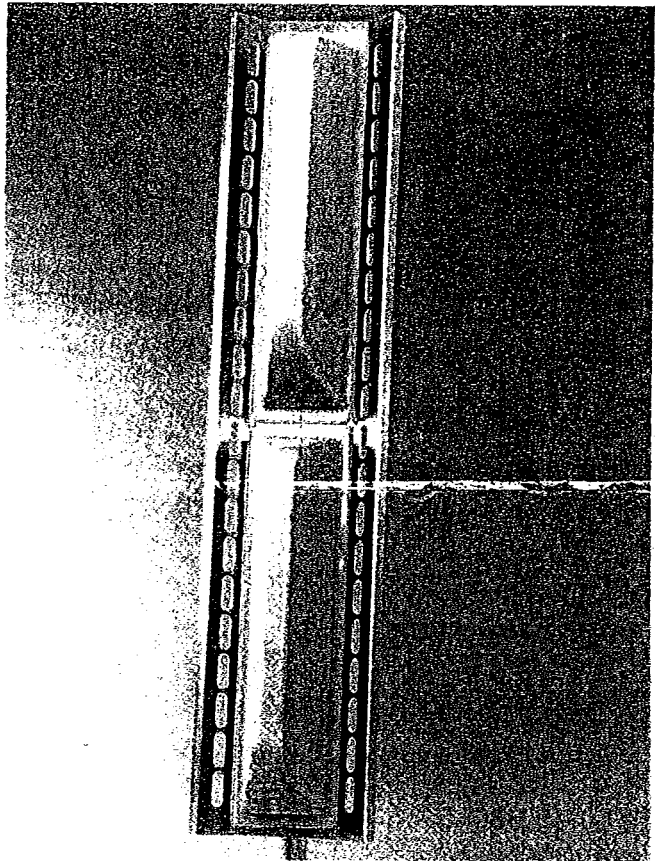

Electrical Specifications:

Frequency range:	806-896 MHz
Impedance:	50 ohm
Connector:	N-female or 7/8" EIA
VSWR:	Typ. 1.3:1 max 1.5:1
Polarization:	Vertical
Gain:	12 dBd
Front to back ratio:	>28 dB
Side-lobe suppression:	>18 dB
Intermodulation: (2x25W):	IM3 >146 dB IM5 >153 dB IM7 & IM9 >163 dB
Power Rating:	500 W
H-Plane:	-3 dB
E-Plane:	-3 dB
Lightning Protection:	DC Grounded

Mechanical Specifications:

Overall Height:	52 in	(1320 mm)
Width:	11.4 in	(290 mm)
Depth:	11.4 in	(290 mm)
Weight including brackets:	26.7 lbs	(12 Kg)
Rated wind velocity:	113 mph	(180 Km/h)
Wind Area (CxA/Front):	3.9 sq.ft	(0.36 sq.m)
Lateral thrust at rated wind		
Worst case:	570 N	

Materials:

Radiating elements:	Aluminum
Element housing:	Grey PVC
Back-plate:	Aluminum
Mounting hardware	
clamps:	Hot dip galvanized steel
bolts:	Stainless steel

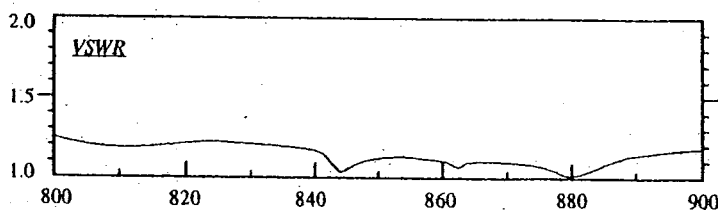

Manufactured by: Allgon System AB



950G65VTZE-M

Directed Dipole Antenna

DECIBEL
Base Station Antennas

- Field adjustable electrical downtilt, featuring linear phase shifter, no wheels or gears
- Exceptional elevation and azimuth pattern shaping
- Strong Front to Back and Front to Side ratio reduces soft hand-offs
-

ELECTRICAL

Frequency (MHz) :	1850 - 1990
Polarization :	Vertical
Gain (dBd/dBi) :	16/18.1
Azimuth BW (Deg.):	65
Elevation BW (Deg.):	6.5
Beam Tilt (Deg.):	0-7
USLS* (dB) :	>17
Null Fill (dB) :	<20
Front-To-Back Ratio* (dB) :	40
VSWR :	<1.4:1
PIM3 @ 2 x 20w (dBc) :	-145
Max. Input Power (Watts) :	250
Impedance (Ohms) :	50
Lightning Protection :	DC Ground

MECHANICAL

Weight :	4.5 kg (10 lb)
Dimensions (LxWxD) :	1,524 x 165 x 102 mm (60 x 6.5 x 4 in)
Max. Wind Area :	0.14 m ² (1.5 ft ²)
Max. Wind Load (@ 100 mph) :	378.0 N (85 lbf)
Max. Wind Speed :	201 km/h (125 mph)
Hardware Material :	Galvanized Steel
Connector Type :	7-16 DIN - Female (1, Bottom)
Color :	Light Gray
Standard Mounting Hardware :	DB390
Standard Downtilt Mounting Hardware :	DB5098

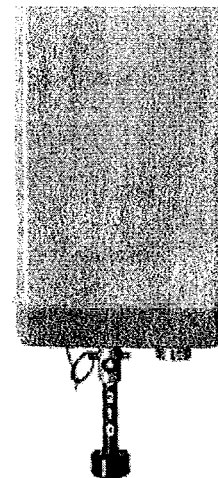

Andrew Corporation
2601 Telecom Parkway
Richardson, Texas U.S.A 75082-3521
Tel: 214.631.0310

Fax: 214.631.4706
Toll Free Tel: 1.800.676.5342
Fax: 1.800.229.4706
www.andrew.com

* - Indicates Typical
5/19/2005
dbtech@andrew.com

Information correct at date of issue but may be subject to change without notice.



950G65VTZE-M

Directed Dipole Antenna

DECIBEL*
Base Station Antennas

AZIMUTH PATTERN

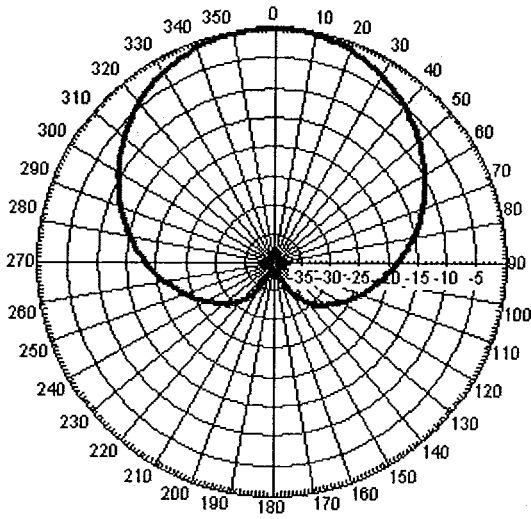

Freq: 1950 MHz, Tilt: 0

ELEVATION PATTERN

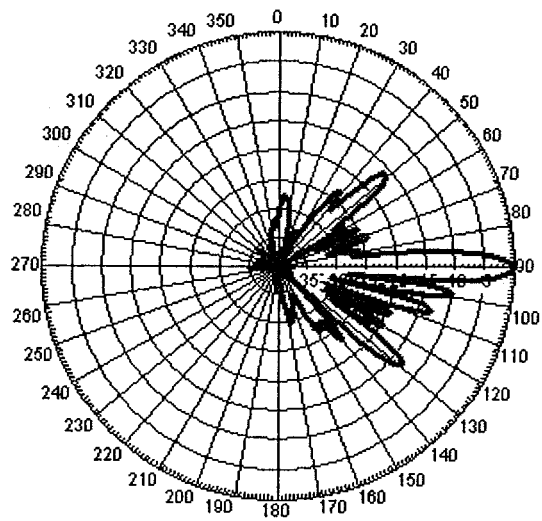

Freq: 1950 MHz, Tilt: 0

Andrew Corporation
2601 Telecom Parkway
Richardson, Texas U.S.A 75082-3521
Tel: 214.631.0310

Fax: 214.631.4706
Toll Free Tel: 1.800.676.5342
Fax: 1.800.229.4706
www.andrew.com

* - Indicates Typical
5/19/2005
dbtech@andrew.com

Information correct at date of issue but may be subject to change without notice.

General Power Density

Site Name: Rocky Hill , CT
 Tower Height: 137 ft rad center

Operator	Operating Frequency (MHz)	Number of Trans.	ERP Per Trans. (watts)	Total ERP (watts)	Distance to Target (feet)	Calculated Power Density (mW/cm ²)	Maximum Permissible Exposure* (mW/cm ²)	Fraction of MPE (%)
Verizon	869	9	200	1800	137	0.0345	0.5793	5.95%
Verizon	1900	3	200	600	137	0.0115	1	1.15%
Total Percentage of Maximum Permissible Exposure								7.10%

*Guidelines adopted by the FCC on August 1, 1996, 47 CFR Part 1 based on NCRP Report 86, 1986 and generally on ANSI/IEEE C95.1-1992

MHz = Megahertz

mW/cm² = milliwatts per square centimeter

ERP = Effective Radiated Power

Absolute worst case scenario, maximum values used.

