



Charlotte, NC 28277

[www.crowncastle.com](http://www.crowncastle.com)

September 21, 2012

Linda Roberts  
Executive Director  
Connecticut Siting Council  
10 Franklin Square  
New Britain, CT 06051

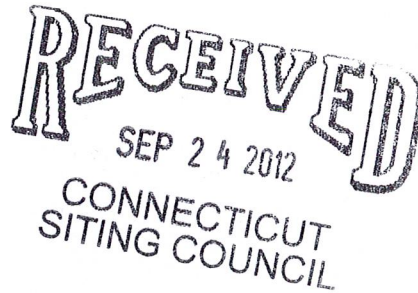

RE: **Notice of Exempt Modification – Ground Based Equipment**  
**107 Buck Road, Hebron, CT 06248**

Dear Ms. Roberts:

Sprint Spectrum, LP (“Sprint”) currently maintains wireless telecommunications antennas at the 117-foot level on an existing 119.5-foot tower at the above-referenced address. The tower is owned by Crown Castle. Sprint’s proposed work does not involve any antenna or tower work. Sprint intends to install 1 ground based RRH cabinet and 1 ground based fiber junction box to a new proposed wooden H frame. All of the proposed work is contained within the existing fenced area. Please refer to the attached drawings for site plans prepared by Infinigy Engineering.

Please accept this letter as notification pursuant to R.C.S.A. § 16-50j-73, for construction that constitutes an exempt modification pursuant to R.C.S.A. § 16-50j-72(b)(2). In accordance with R.C.S.A. § 16-50j-73, a copy of this letter is being sent to Bonnie L. Therrien, Town Manager of the City of Hebron. A copy of this letter is also being sent to Edward & Renee Ellis, the owner of the property on which the tower is located.

The planned modifications to the facility fall squarely within those activities explicitly provided for in R.C.S.A. § 16-50j-72(b)(2).

Linda Roberts  
September 21, 2012  
Page 2

1. The proposed modifications will not result in an increase in the height of the existing tower.
2. The proposed modifications will include the addition of ground base equipment as depicted on the attached drawings; however, the proposed ground based cabinets will not require the extension of the site boundaries.
3. The proposed modifications will not increase noise levels at the facility by six decibels or more.
4. The additional ground based equipment will not increase radio frequency (RF) emissions at the facility to a level at or above the Federal Communications Commission (FCC) adopted safety standard.

For the foregoing reasons, Sprint respectfully submits that the proposed modifications to the above referenced telecommunications facility constitutes an exempt modification under R.C.S.A. § 16-50j-72(b)(2).

If you have any questions or require any additional information regarding this request please do not hesitate to give me a call at (704) 405-6560 or e mail me to [kevin.savage@crowncastle.com](mailto:kevin.savage@crowncastle.com)

Sincerely,



Kevin Savage  
Property Specialist

Attachment

CC: **Property Owner:** Edward & Renee Ellis, 768 Gilead Street, Hebron, CT 06248  
**1<sup>st</sup> Selectman/Mayor:** Bonnie L. Therrien, Town of Hebron, 15 Gilead St., Hebron, CT 06248

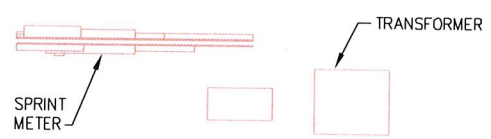
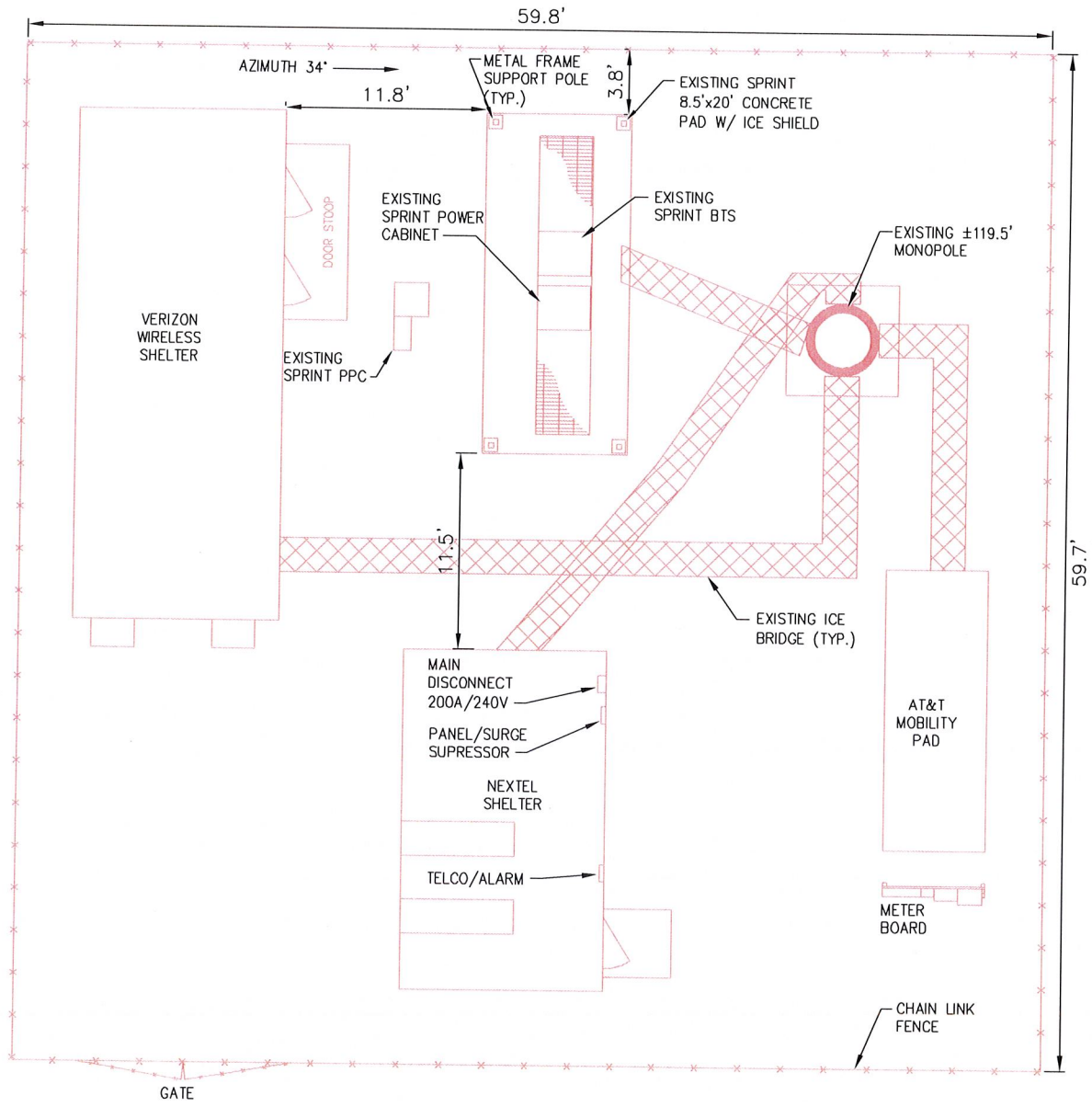

1  
 EXISTING SITE PLAN  
 (BEFORE EQUIPMENT DETAIL)  
 SCALE: AS NOTED



GRAPHIC SCALE IN FEET

<p>INTERNATIONAL BLDG.        MANHATTAN, NJ 07405</p>	<p>11 Herbert Drive        Latham, NY 12110        (518) 690-0790</p>	<b>NETWORK VISION SURVEY</b>		<b>S1</b>
		DATE: 6/25/12	REV #: (blank)	INFINIGY SITE NUMBER: 294-028
SITE NAME: SOUTH HEBRON/NED ELLIS PROP.(SSUSA) SITE NUMBER: CT33XC560		SITE ADDRESS: 107 BUCK ROAD HEBRON, CT 06248		

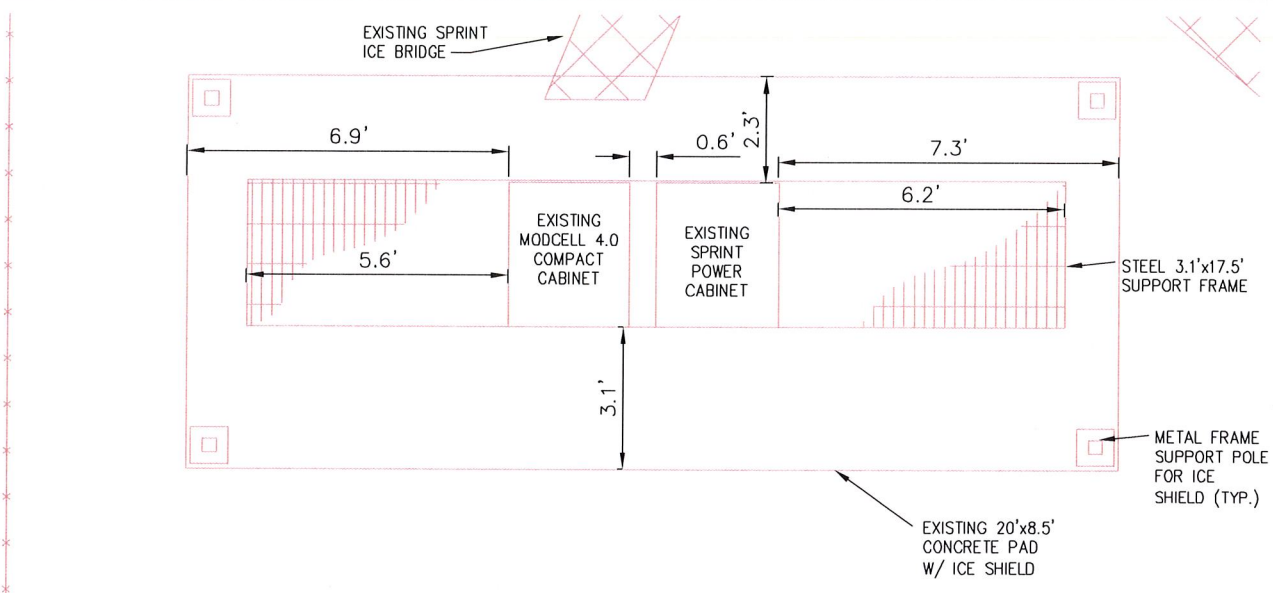

**1 BEFORE EQUIPMENT DETAIL: HOTSWAP**  
 SCALE: AS NOTED

GRAPHIC SCALE IN FEET

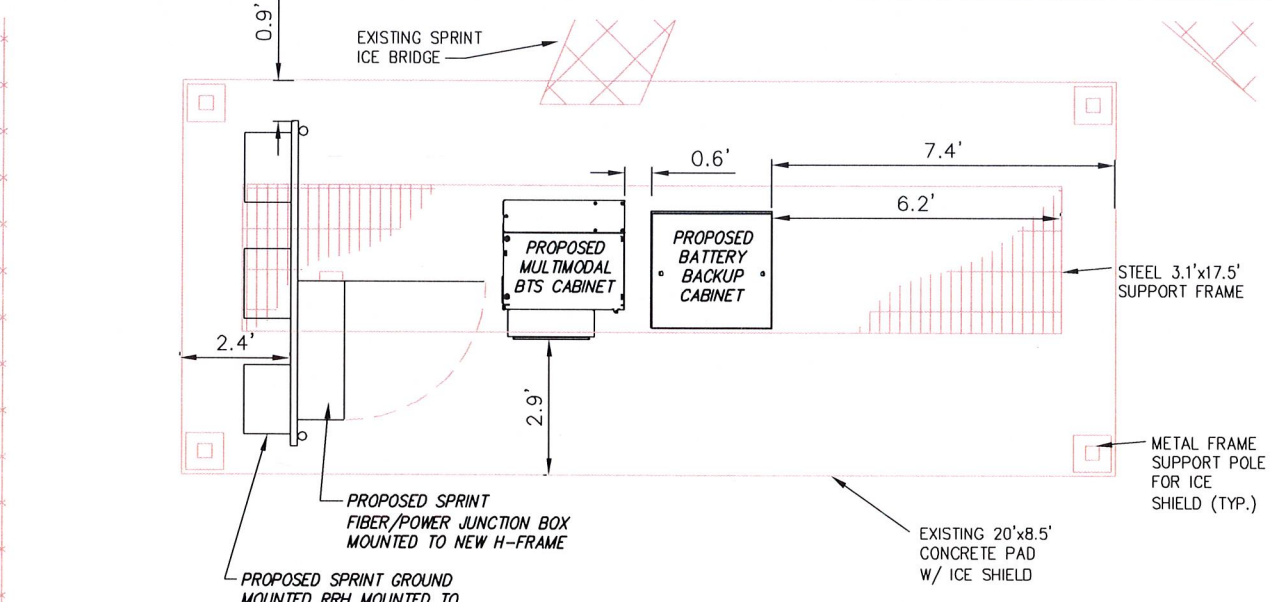

**2 DURING/AFTER EQUIPMENT DETAIL: HOTSWAP**  
 SCALE: AS NOTED

GRAPHIC SCALE IN FEET

 1 INTERNATIONAL BLVD. MAHWAH, NJ 07435	 11 Herbert Drive Latham, NY 12110 (518) 690-0790	<b>NETWORK VISION SURVEY</b>		<b>S2</b>
		DATE: 6/25/12	REV #: 294-028	INFINIGY SITE NUMBER: 294-028
SITE NAME: SOUTH HEBRON/NED ELLIS PROP.(SSUSA) SITE NUMBER: CT33XC560		SITE ADDRESS: 107 BUCK ROAD HEBRON, CT 06248		

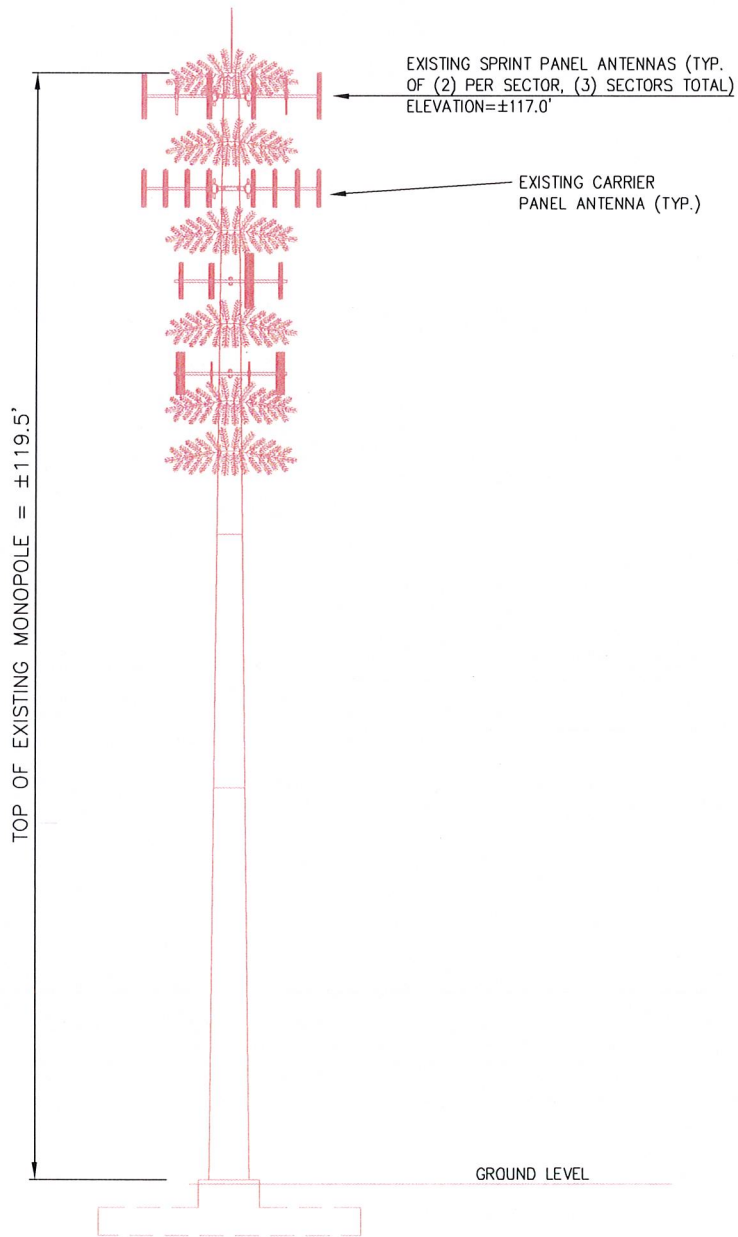

ELEVATION VIEW  
 (BEFORE/DURING/AFTER EQUIPMENT DETAIL)  
 1  
 -- NOT TO SCALE

 1 INTERNATIONAL BLVD. MAHWAH, NJ 07495	 11 Herbert Drive Latham, NY 12110 (518) 690-0790	NETWORK VISION SURVEY		S3
		DATE: 6/25/12	REV #: .	INFINIGY SITE NUMBER: 294-028
SITE NAME: SOUTH HEBRON/NED ELLIS PROP.(SSUSA) SITE NUMBER: CT33XC560		SITE ADDRESS: 107 BUCK ROAD HEBRON, CT 06248		

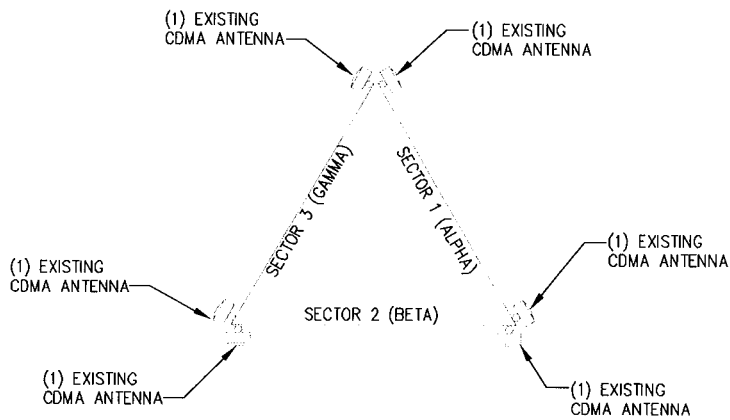

1 BEFORE/DURING/AFTER ANTENNA ARRAY  
 -- NOT TO SCALE



infinigy  
 engineering

11 Herbert Drive  
 Latham, NY 12110  
 (518) 690-0790

NETWORK VISION SURVEY

S4

DATE:  
6/25/12

REV #:

INFINIGY SITE NUMBER:  
294-028

SITE ADDRESS:  
107 BUCK ROAD  
HEBRON, CT 06248

SITE NAME: SOUTH HEBRON/NED ELLIS PROP.(SSUSA)  
 SITE NUMBER: CT33XC560