



Crown Castle
3 Corporate Park Drive, Suite 101
Clifton Park, NY 12065

June 6, 2018

Melanie A. Bachman
Acting Executive Director
Connecticut Siting Council
10 Franklin Square
New Britain, CT 06051

RE: Request of T-Mobile Northeast LLC for an Order to Approve the Shared Use of an Existing Tower at 94 East High Street East Hampton, CT 06424

Dear Ms. Bachman:

Pursuant to Connecticut General Statutes (“C.G.S.”) §16-50aa, as amended, T-Mobile Northeast LLC (“T-Mobile”) hereby requests an order from the Connecticut Siting Council (“Council”) to approve the shared use by T-Mobile of an existing telecommunication tower at 94 East High Street East Hampton, Connecticut (the “Property”). The Town of East Hampton Planning and Zoning Commission approved the tower by a Special Permit granted on May 7, 1997. The existing 117.5-foot tower is owned by Crown Castle International Corp. (“Crown Castle”). The underlying property is owned by the Pauls & Sandy's Too Inc. T-Mobile requests that the Council find that the proposed shared use of the Crown Castle tower satisfies the criteria of C.G.S. §16-50aa and issue an order approving the proposed shared use. A copy of this filing is being sent to the Honorable Melissa Engel, Chair of the Town of East Hampton Town Council, Town Manager Michael Maniscalco, to the Planning and Zoning Official Jeremy DeCarli and to the owner of the property the Pauls & Sandy's Too Inc.

Background

The existing Crown Castle facility consists of a 117.5-foot monopole tower on 62.44-acre parcel along the north east side of Route 66 also known as East High Street. Sprint PCS maintains antennas at the 118-foot level, The Town of East Hampton maintains equipment at the 117-foot level, Verizon Wireless maintains antennas at the 105-foot level, and AT&T Mobility maintains antennas at the 91-foot level. Sprint’s equipment shelter is located to the northwest of the tower, Verizon’s equipment shelter is located to the northeast of the tower, and AT&T maintains a shelter to the southeast of the tower.

T-Mobile is licensed by the Federal Communications Commission (“FCC”) to provide wireless services throughout the State of Connecticut. T-Mobile and Crown Castle have agreed to the proposed shared use of the 94 East High Street tower pursuant to mutually acceptable terms and conditions. Likewise, T-Mobile and Crown Castle have agreed to the proposed installation of equipment cabinets on the ground on the northwest side of the tower. Crown Castle has authorized T-Mobile to apply for all necessary permits and approvals that may be required to share the existing tower.

T-Mobile proposes to install twelve (12) antennas, four (4) hybrid cables, twelve (12) RRHs, eight (8) diplexers, one (1) MW Dish with an associated line and one (1) GPS. In addition, T-Mobile will install a diesel fueled 220 gallon 25 KW DC back-up generator within a 10’x 20’ concrete pad. Included in the Construction Drawings are T-Mobile’s project specifications for locations of all proposed site improvements. The Construction Drawings also contain specifications for T-Mobile’s proposed antennas and backup generator.

C.G.S. § 16-50aa(c)(1) provides that, upon written request for approval of a proposed shared use, “if the Council finds that the proposed shared use of the facility is technically, legally, environmentally and economically feasible and meets public safety concerns, the council shall issue an order approving such a shared use.” T-Mobile respectfully submits that the shared use of the tower satisfies these criteria.

A. Technical Feasibility. The existing Crown Castle tower is structurally capable of supporting T-Mobile’s proposed improvements. The proposed shared use of this tower is, therefore, technically feasible. A Feasibility Structural Analysis Report (“Structural Report”) prepared for this project confirms that this tower can support T-Mobile’s proposed loading. A copy of the Structural Report has been included in this application.

B. Legal Feasibility. Under C.G.S. § 16-50aa, the Council has been authorized to issue order approving the shared use of an existing tower such as the Crown Castle tower. This authority complements the Council’s prior-existing authority under C.G.S. § 16-50p to issue orders approving the construction of new towers that are subject to the Council’s jurisdiction. In addition, § 16-50x(a) directs the Council to “give such consideration to the other state laws and municipal regulations as it shall deem appropriate” in ruling on requests for the shared use of existing tower facilities. Under the statutory authority vested in the Council, an order by the Council approving the requested shared use would permit the Applicant to obtain a building permit for the proposed installations.

C. Environmental Feasibility. The proposed shared use of the Crown Castle tower would have a minimal environmental effect for the following reasons:

1. The proposed installation of twelve (12) antennas, four (4) hybrid cables, twelve (12) RRHs, eight (8) diplexers, one (1) MW Dish with an associated line and one (1) GPS will have no visual impact on the area of the tower. T-Mobile's cabinet and generator would be installed within an expanded facility compound. T-Mobile's shared use of this tower therefore will not cause any significant change or alteration in the physical or environmental characteristics of the existing site.
2. Operation of T-Mobile's antennas at this site would not exceed the RF emissions standard adopted by the Federal Communications Commission ("FCC"). Included in the EME report of this filing are the approximation tables that demonstrate that T-Mobile's proposed facility will operate well within the FCC RF emissions safety standards.
3. Under ordinary operating conditions, the proposed installation would not require the use of any water or sanitary facilities and would not generate air emissions or discharges to water bodies or sanitary facilities. After construction is complete the proposed installations would not generate any increased traffic to the Crown Castle facility other than periodic maintenance. The proposed shared use of the Crown Castle tower, would, therefore, have a minimal environmental effect, and is environmentally feasible.

D. Economic Feasibility. As previously mentioned, T-Mobile has entered into an agreement with Crown Castle for the shared use of the existing facility subject to mutually agreeable terms. The proposed tower sharing is, therefore, economically feasible. (Please see included authorization.)

E. Public Safety Concerns. As discussed above, the tower is structurally capable of supporting T-Mobile's full array of twelve (12) antennas and all related equipment. T-Mobile is not aware of any public safety concerns relative to the proposed sharing of the existing Crown Castle tower.

Conclusion

For the reasons discussed above, the proposed shared use of the existing Crown Castle tower at 94 East High Street satisfies the criteria state in C.G.S. §16-50aa and advances the General Assembly's and the Council's goal of preventing the unnecessary proliferation of towers in Connecticut. The Applicant, therefore, respectfully requests that the Council issue an order approving the proposed shared use.

Melanie A. Bachman

June 6, 2018

Page 4

Sincerely,

Sarah Snell

Real Estate Specialist

12 Gill Street, Suite 5800, Woburn, MA 01801

781-970-0055

sarah.snell.contractor@crowncastle.com

Attachments: Tab 1: Exhibit-1: Compound plan and elevation depicting the planned changes Tab 2: Exhibit-2: Structural Modification Report Tab 3: Exhibit-3: General Power Density Table report (RF Emissions Analysis Report)

CC: Melissa Engel, Chair Town of East Hampton Town Council (Municipality)
20 East High Street
East Hampton, CT 06424

Town Manager Michael Maniscalco (Municipality)
20 East High Street
East Hampton, CT 06424

Planning and Zoning Official Jeremy DeCarli (Planning & Zoning Official)
20 East High Street
East Hampton, CT 06424

Paul & Sandy's Too Inc. (Landowner)
93 East High Street
East Hampton, CT 06424



Summary



94 EAST HIGH ST

PAULS + SANDYS TOO INC

Parcel ID: 26/85/16 [View Details](#)

Flanders Pond

0.2km

1000ft

94 EAST HIGH ST

Location 94 EAST HIGH ST

Mblu 26/ 85/ 16/ /

Acct# R04601

Owner PAULS + SANDYS TOO INC

Assessment \$128,020

Appraisal \$475,190

PID 4364

Building Count 1

Current Value

Appraisal			
Valuation Year	Improvements	Land	Total
2015	\$83,730	\$391,460	\$475,190

Assessment			
Valuation Year	Improvements	Land	Total
2015	\$58,610	\$69,410	\$128,020

Owner of Record

Owner PAULS + SANDYS TOO INC
Co-Owner ACCT 1 OF 2
Address 93 EAST HIGH ST
EAST HAMPTON, CT 06424

Sale Price \$325,000
Certificate
Book & Page 344/ 096
Sale Date 01/28/2002
Instrument 00

Ownership History

Ownership History					
Owner	Sale Price	Certificate	Book & Page	Instrument	Sale Date
PAULS + SANDYS TOO INC	\$325,000		344/ 096	00	01/28/2002
WALL RICHARD + PHILLIP +	\$325,000		344/ 093	00	01/28/2002
WALL RICHARD + PHILLIP +	\$0		90/ 68	29	12/13/1966

Building Information

Building 1 : Section 1

Year Built: 1890
Living Area: 968
Replacement Cost: \$121,354
Building Percent 69
Good:
Replacement Cost
Less Depreciation: \$83,730

Building Attributes

Field	Description
Style	Ranch
Model	Residential
Grade:	C
Story Height	1 Story
Foundation	Conc. Block
Exterior Wall 1	Asbest Shingle
Exterior Wall 2	
Roof Structure:	Gable
Roof Cover	Asphalt Shingl
Interior Wall 1	Plastered
Interior Wall 2	
Interior Flr 1	Carpet
Interior Flr 2	
Heat Fuel	Oil
Heat Type:	Hot Water
AC Type:	None
Total Bedrooms:	2 Bedrooms
Total Bthrms:	1 Full
Total Half Baths:	0
# Extra Fixtures	
Total Rooms:	5
Bath Style:	Average
Kitchen Style:	Average
Fireplace	0
Fin Basement	0
Fin Bsmt Qual	
Bsmt. Garages	1
Gas Fireplace	

Building Photo



(<http://images.vgsi.com/photos/EastHamptonCTPhotos//00\00\3>)

Building Layout

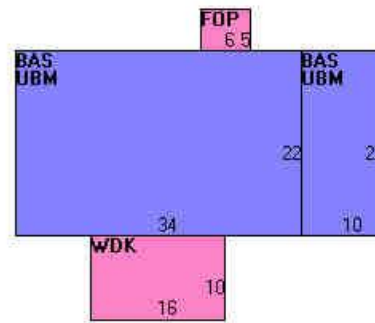

(<http://images.vgsi.com/photos/EastHamptonCTPhotos//Sketches>)

Building Sub-Areas (sq ft)			Legend
Code	Description	Gross Area	Living Area
BAS	First Floor	968	968
FOP	Framed Open Porch	30	0
UBM	Unfin Basement	968	0
WDK	Wood Deck	160	0
		2,126	968

Extra Features

Extra Features	Legend
No Data for Extra Features	

Land

Land Use

Land Line Valuation

Use Code 101
Description Single Family
Zone R-3S
Neighborhood 400
Alt Land Appr Category No

Size (Acres) 62.44
Frontage
Depth
Assessed Value \$69,410
Appraised Value \$391,460

Outbuildings

Outbuildings	<u>Legend</u>
No Data for Outbuildings	

Valuation History

Appraisal			
Valuation Year	Improvements	Land	Total
2016	\$83,730	\$391,460	\$475,190
2014	\$79,600	\$388,590	\$468,190
2012	\$79,600	\$388,590	\$468,190

Assessment			
Valuation Year	Improvements	Land	Total
2016	\$58,610	\$69,410	\$128,020
2014	\$55,720	\$62,670	\$118,390
2012	\$55,720	\$62,670	\$118,390

(c) 2016 Vision Government Solutions, Inc. All rights reserved.

10.

- 266

SPECIAL PERMIT

Applicant: Sprint Spectrum, L.P.
 Owner: Richard Wall, et al
 Location: 94 East High Street
 (Map 26, Block 85, Lot 16)
 Date Granted: May 7, 1997
 Nature of Permit: Section 7.6.1.E - Public Utility Structure
 Section 7.9.1.G - Retail/Commercial Use
 Section 7.12 - Lake Photophagy Protection Area
 Action: Subject to the provisions of the relevant regulations and written, oral and graphic testimony, the permit is approved with the following:
 Conditions:
 1. TOWN/CEA Approval
 A. All EES controls shall be in place prior to start of any work
 B. EES controls will be monitored by Town Hall
 C. Grading will be determined by Town Engineer
 D. The surface of the lower portion of the access drive shall be restored consistent with new construction as well as noted on the plans.
 2. The tower shall be disassembled and removed upon cessation of use.

UNOFFICIAL

Carol Micsek
 Carol Micsek, Clerk
 East Hampton Planning & Zoning
 Commission

May 13, 1997
 Date

RECEIVED FOR RECORD AT E. HAMPTON, NY
 ON 5/28/97 AT 11:30 A.M.
 ATTEST: PAULINE L. MARGIUM, Town Clerk
Pauline Margium
Richard Wall, Clerk



T-MOBILE SITE NUMBER: CTHA601A
T-MOBILE SITE NAME: LCTHA601A
SITE TYPE: MONOPOLE
TOWER HEIGHT: 117'-6"

BUSINESS UNIT #: 876352
SITE ADDRESS: 94 EAST HIGH ST.
 EAST HAMPTON, CT 06424
COUNTY: MIDDLESEX
JURISDICTION: TOWN OF EAST HAMPTON

T-MOBILE 2018 NSD



T-MOBILE SITE NUMBER: CTHA601A
BU #: 876352
RICHARD WALL
 94 EAST HIGH ST.
 EAST HAMPTON, CT 06424
 EXISTING 117'-6" MONOPOLE

SITE INFORMATION	
CROWN CASTLE USA INC.	RICHARD WALL
SITE NAME:	94 EAST HIGH ST. EAST HAMPTON, CT 06424
SITE ADDRESS:	MIDDLESEX
COUNTY:	26/85/16
MAP/PARCEL #:	EXISTING
AREA OF CONSTRUCTION:	41° 35' 14.20"
LATITUDE:	-72° 29' 19.60"
LONGITUDE:	NAD83
LAT/LONG TYPE:	668 FT.
GROUND ELEVATION:	R-3S
CURRENT ZONING:	TOWN OF EAST HAMPTON
JURISDICTION:	OCCUPANCY CLASSIFICATION: U
OCCUPANCY CLASSIFICATION:	TYPE OF CONSTRUCTION: IIB
TYPE OF CONSTRUCTION:	A.D.A. COMPLIANCE: FACILITY IS UNMANNED AND NOT FOR HUMAN HABITATION
A.D.A. COMPLIANCE:	PROPERTY OWNER: PAULS & SANDYS TOO INC 93 EAST HIGH STREET EAST HAMPTON, CT 06424
PROPERTY OWNER:	TOWER OWNER: GLOBAL SIGNAL ACQUISITIONS II LLC 2000 CORPORATE DRIVE CANONSBURG, PA 15317
TOWER OWNER:	CARRIER/APPLICANT: T-MOBILE 12920 SE 38TH STREET BELLEVUE, WA 98006
CARRIER/APPLICANT:	APPLICATION ID: 419731
APPLICATION ID:	ELECTRIC PROVIDER: CONNECTICUT LIGHT & POWER CO. (800) 286-2000
ELECTRIC PROVIDER:	TELCO PROVIDER: FRONTIER (877) 600-1511
TELCO PROVIDER:	

DRAWING INDEX	
SHEET #	SHEET DESCRIPTION
T-1	TITLE SHEET
T-2	GENERAL NOTES
G-1	FINAL SITE PLAN
G-2	EQUIPMENT PLAN
G-3	EQUIPMENT ELEVATIONS & DETAILS
C-4	TOWER ELEVATION & ANTENNA PLAN
C-5	EQUIPMENT DETAILS
C-6	EQUIPMENT DETAILS
C-7	EQUIPMENT DETAILS
E-1	ELECTRICAL SITE PLAN
E-2	UTILITY FRAME AND WIRING DETAILS
E-3	POWER DIAGRAM & ONE-LINE DIAGRAM
G-1	EQUIPMENT & ANTENNA GROUNDING PLANS
G-2	GROUNDING DETAILS
G-3	GROUNDING DETAILS

ALL DRAWINGS CONTAINED HEREIN ARE FORMATTED FOR 11X17. CONTRACTOR SHALL VERIFY ALL PLANS AND EXISTING DIMENSIONS AND CONDITIONS ON THE JOB SITE AND SHALL IMMEDIATELY NOTIFY THE ENGINEER IN WRITING OF ANY DISCREPANCIES BEFORE PROCEEDING WITH THE WORK OR BE RESPONSIBLE FOR SAME.

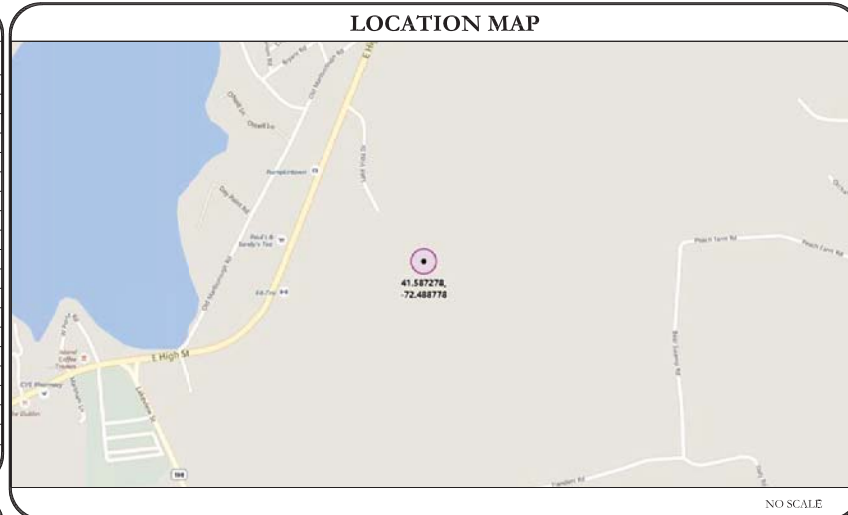

APPROVALS		
APPROVAL	SIGNATURE	DATE
PROPERTY OWNER OR REP.	_____	_____
LAND USE PLANNER	_____	_____
T-MOBILE	_____	_____
OPERATIONS	_____	_____
RF	_____	_____
NETWORK	_____	_____
BACKHAUL	_____	_____
CONSTRUCTION MANAGER	_____	_____

THE PARTIES ABOVE HEREBY APPROVE AND ACCEPT THESE DOCUMENTS AND AUTHORIZE THE CONTRACTOR TO PROCEED WITH THE CONSTRUCTION DESCRIBED HEREIN. ALL CONSTRUCTION DOCUMENTS ARE SUBJECT TO REVIEW BY THE LOCAL BUILDING DEPARTMENT AND ANY CHANGES AND MODIFICATIONS THEY MAY IMPOSE.

APPLICABLE CODES/REFERENCE DOCUMENTS

ALL WORK SHALL BE PERFORMED AND MATERIALS INSTALLED IN ACCORDANCE WITH THE CURRENT EDITIONS OF THE FOLLOWING CODES AS ADOPTED BY THE LOCAL GOVERNING AUTHORITIES. NOTHING IN THESE PLANS IS TO BE CONSTRUED TO PERMIT WORK NOT CONFORMING TO THESE CODES:

BUILDING	2016 CT STATE BUILDING CODE/2012 IBC W/ CT AMENDMENTS
MECHANICAL	2016 CT STATE BUILDING CODE/2012 IMC W/ CT AMENDMENTS
ELECTRICAL	2016 CT STATE BUILDING CODE/2014 NEC W/ CT AMENDMENTS

REFERENCE DOCUMENTS:
STRUCTURAL ANALYSIS: BY OTHERS

TOWER MODIFICATION BY OTHERS DESIGN:
CALL CONNECTICUT ONE CALL (800) 922-4455
CALL 3 WORKING-DAYS BEFORE YOU DIG!

PROJECT DESCRIPTION

THE PURPOSE OF THIS PROJECT IS TO PROPOSE AN ANTENNA MODIFICATION ON AN EXISTING WIRELESS SITE.

TOWER SCOPE OF WORK:

- INSTALL (2) PANEL ANTENNAS ON NEW ANTENNA MOUNT
- INSTALL (1) MW DISH
- INSTALL (1) GPS
- INSTALL (2) RRU's
- INSTALL (8) DIPLEXERS
- INSTALL (4) HYBRID CABLE LINES
- INSTALL (2) COAX CABLE LINES

GROUND SCOPE OF WORK:

- REMOVE EXISTING 41'-0"± CHAINLINK FENCE W/ BARBED WIRE
- INSTALLATION OF NEW 10'-0" x 20'-0" CONCRETE EQUIPMENT PAD & LEASE AREA WITHIN THE NEW 30'-0" x 44'-4" FENCED COMPOUND EXPANSION
- INSTALLATION OF NEW 25KW DIESEL GENERATOR (OPTIONAL STANDBY GENERATOR)
- INSTALLATION OF NEW ELECTRICAL SERVICE TO T-MOBILE EQUIPMENT
- INSTALLATION OF NEW FIBER SERVICE TO T-MOBILE EQUIPMENT

DESIGN PACKAGE BASED ON THE APPLICATION ID: 419731 REVISION: 2

DESIGN PACKAGE BASED ON THE RFDS REVISION: 0.1 DATE: 11/28/17

PROJECT TEAM	
A&E FIRM:	CROWN CASTLE USA INC. 2000 CORPORATE DRIVE CANONSBURG, PA 15317 CROWN.AE.APPROVAL@CROWNCastle.COM
CROWN CASTLE USA INC. CONTACTS:	3 CORPORATE PARK DRIVE, SUITE 101 CLIFTON PARK, NY 12065
	CHRISTINE TROTTA - PROJECT MANAGER (518) 373-3511 JASON D'AMICO - CONSTRUCTION MANAGER (860) 209-0104 AMANDA CORNWALL - A&E PROJECT MANAGER AMANDA.CORNWALL@CROWNCastle.COM (339) 205-7017

ISSUED FOR:				
REV	DATE	DRWN	DESCRIPTION	DES. QA
A	05/28/18	CMV	PRELIMINARY	ZTK
B	05/28/18	CMV	PRELIMINARY	ZTK
C	05/10/18	CMV	PRELIMINARY	ZTK
D	05/29/18	CMV	CONSTRUCTION	JPL

DocuSigned by:
Justin Linette
1041050237C41D...

5/30/2018 10:08:08 PM EDT

CROWN CASTLE USA INC. USA Inc.
Certificate of Registration #PEC0001001

IT IS A VIOLATION OF LAW FOR ANY PERSON, UNLESS THEY ARE ACTING UNDER THE DIRECTION OF A LICENSED PROFESSIONAL ENGINEER, TO ALTER THIS DOCUMENT.

SHEET NUMBER: T-1 **REVISION:** 0

INSTALLER NOTE:

PROPOSED GRADE INSIDE THE COMPOUND EXPANSION TO BE MAXIMUM 5%. CONTRACTOR TO GRADE SITE AS NEEDED PRIOR TO INSTALLING GRAVEL BASE.

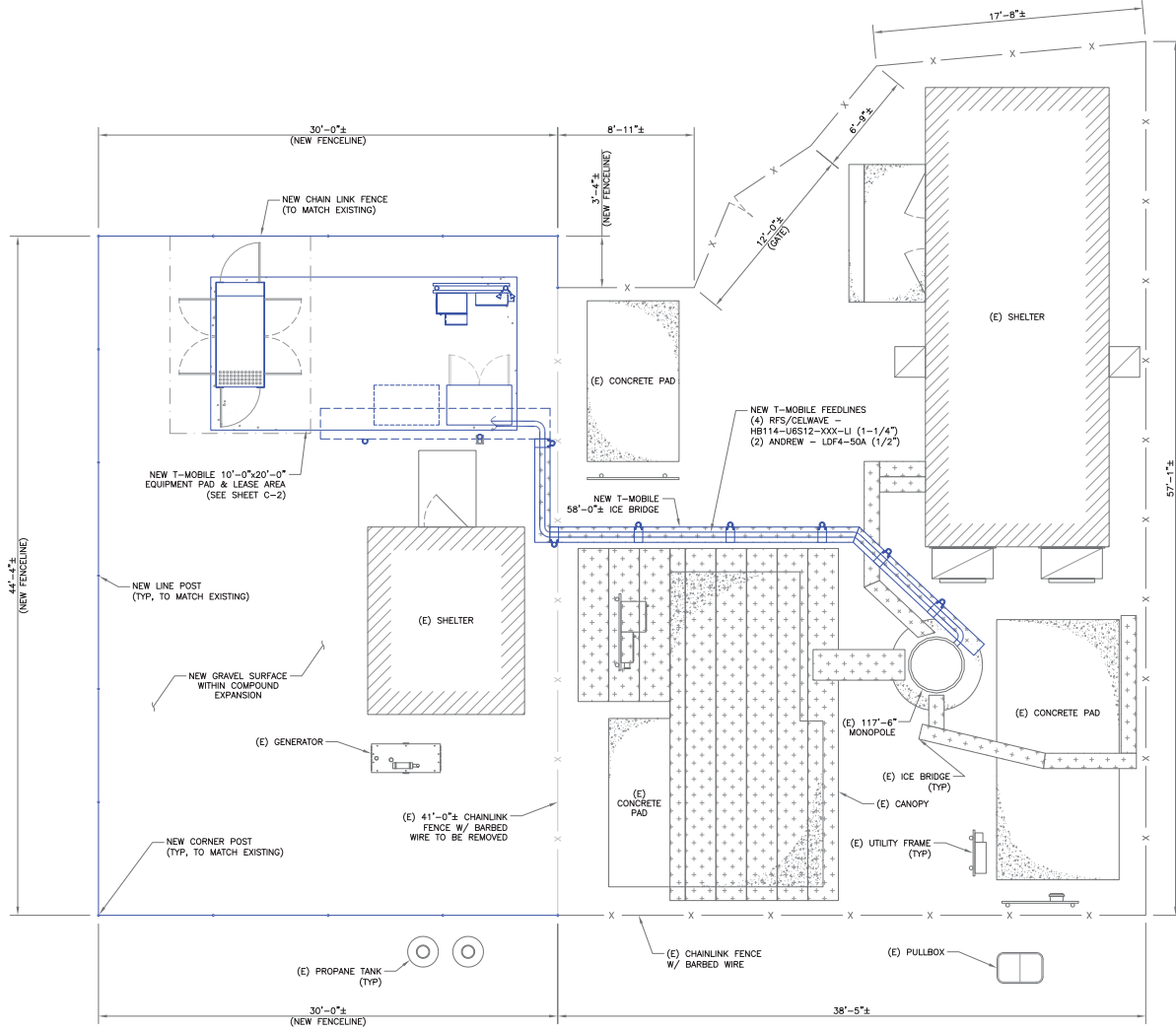
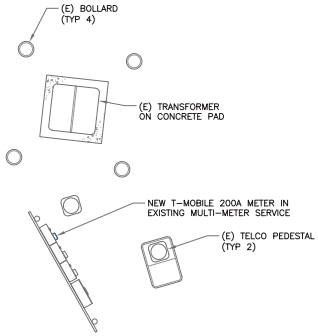

1 FINAL SITE PLAN
SCALE: 1/4"=1'-0" (FULL SIZE)
1/8"=1'-0" (1:16)



T-Mobile
12920 SE 38TH STREET
BELLEVUE, WA 98006

CROWN CASTLE
3 CORPORATE PARK DRIVE, SUITE 101
CLIFTON PARK, NY 12065

T-MOBILE SITE NUMBER:
CTHA601A

BU #: 876352
RICHARD WALL

94 EAST HIGH ST.
EAST HAMPTON, CT 06424

EXISTING 117'-6" MONOPOLE

ISSUED FOR:

REV	DATE	DRWN	DESCRIPTION	DES./QA
A	05/20/18	CMJ	PRELIMINARY	ZTK
B	05/28/18	CMJ	PRELIMINARY	ZTK
C	05/10/18	CMJ	PRELIMINARY	ZTK
D	05/29/18	CMJ	CONSTRUCTION	JPL

DocuSigned by:
Justin Linette

1041058237C41D

NO. 31965
PROFESSIONAL ENGINEER
LICENSED

5/30/2018 10:58:08 PM EDT

CROWN CASTLE USA INC. USA Inc.
Certificate of Registration #PEC-000101

IT IS A VIOLATION OF LAW FOR ANY PERSON, UNLESS THEY ARE ACTING UNDER THE DIRECTION OF A LICENSED PROFESSIONAL ENGINEER, TO ALTER THIS DOCUMENT.

SHEET NUMBER: **C-1** REVISION: **0**

INSTALLER NOTE:
 PROPOSED GRADE INSIDE THE COMPOUND
 EXPANSION TO BE MAXIMUM 5%.
 CONTRACTOR TO GRADE SITE AS NEEDED
 PRIOR TO INSTALLING GRAVEL BASE.

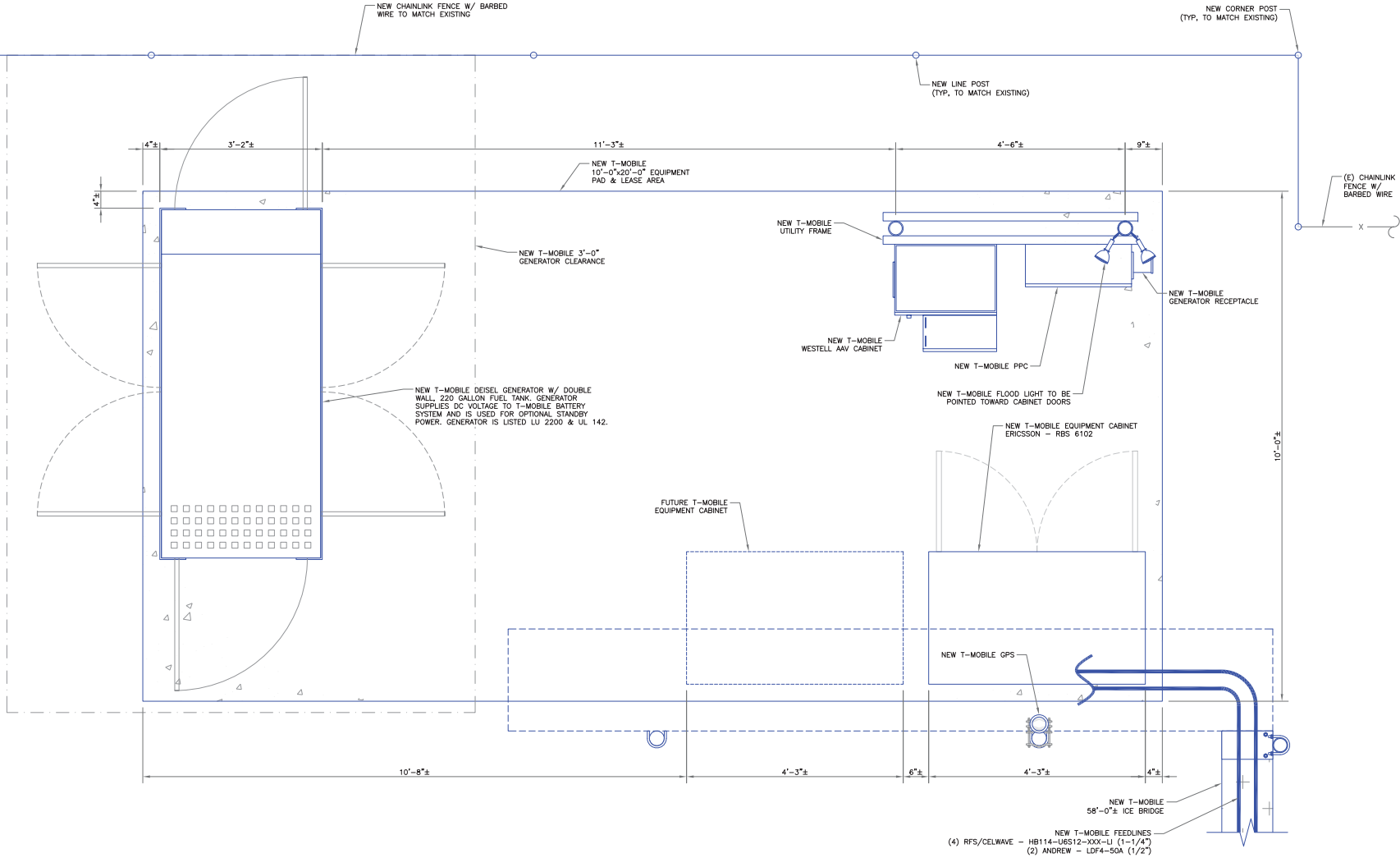

1 EQUIPMENT PLAN
 SCALE: 1"=1'-0" (FULL SIZE)
 1/2"=1'-0" (11x17)





12920 SE 38TH STREET
 BELLEVUE, WA 98006



3 CORPORATE PARK DRIVE, SUITE 101
 CLIFTON PARK, NY 12065

T-MOBILE SITE NUMBER:
CTHA601A

BU #: 876352
RICHARD WALL

94 EAST HIGH ST.
 EAST HAMPTON, CT 06424

EXISTING 117'-6" MONOPOLE

ISSUED FOR:

REV	DATE	DRWN	DESCRIPTION	DES./QA
A	05/20/18	CMJ	PRELIMINARY	ZTK
B	05/28/18	CMJ	PRELIMINARY	ZTK
C	05/10/18	CMJ	PRELIMINARY	ZTK
D	05/29/18	CMJ	CONSTRUCTION	JJG

DocuSigned by:
Justin Linette
 1041058237C41D
 No. 31965
 LICENSED PROFESSIONAL ENGINEER
 5/30/2018 10:58:08 PM EDT
 CROWN CASTLE USA INC. USA Inc.
 Certificate of Registration #PEC-000101

IT IS A VIOLATION OF LAW FOR ANY PERSON, UNLESS THEY ARE ACTING UNDER THE DIRECTION OF A LICENSED PROFESSIONAL ENGINEER, TO ALTER THIS DOCUMENT.

SHEET NUMBER: C-2 **REVISION:** 0

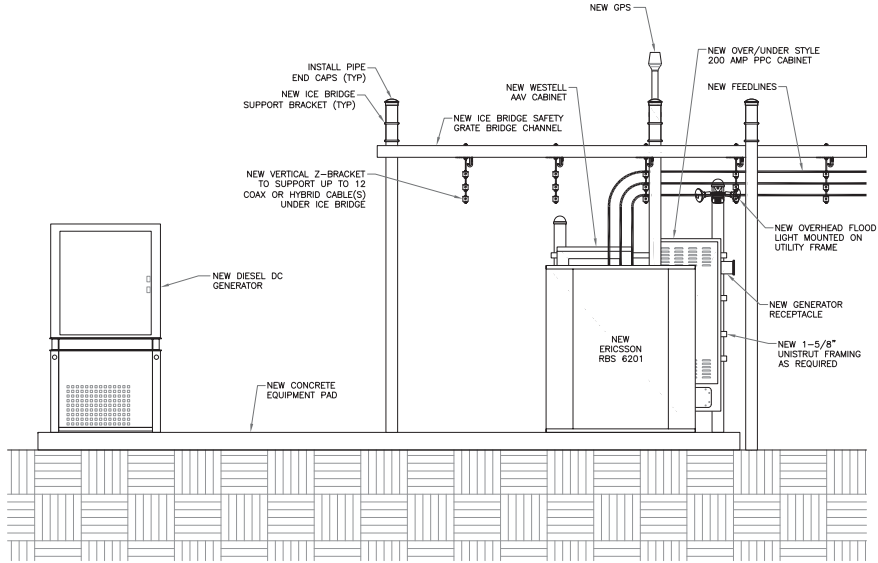

1 EQUIPMENT ELEVATION - GROUND LEVEL
SCALE: NOT TO SCALE

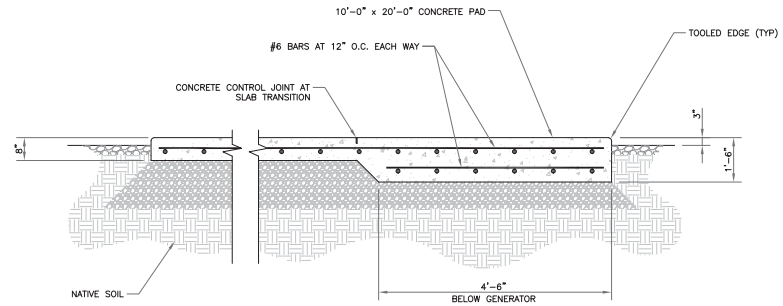

NOTES:

- 1) MINIMUM CONCRETE STRENGTH (f'_c) TO BE 4,500 psi UNLESS NOTED OTHERWISE. CONCRETE MIX SHALL BE DESIGNED BY A CERTIFIED LABORATORY. CONCRETE EXPOSED TO FREEZE-THAW CYCLES TO CONTAIN AIR ENTRAINING ADMIXTURES. AMOUNT OF AIR ENTRAINMENT TO BE BASED ON SIZE OF AGGREGATE AND F3 CLASS EXPOSURE (VERY SEVERE). CEMENT USED TO BE TYPE II PORTLAND CEMENT WITH A WATER-TO-CEMENT RATIO (W/C) NOT TO EXCEED 0.45.
- 2) CONCRETE PAD SHALL BEAR ON A MINIMUM OF 8" OF AGGREGATE BASE COURSE (ABC) MATERIAL COMPACTED TO 98% OF MAXIMUM DENSITY DETERMINED BY ASTM D1557 (MODIFIED PROCTOR). MATERIAL SHOULD BE WITHIN 3% OF OPTIMUM MOISTURE AT TIME OF COMPACTION.
- 3) ALL REINFORCING TO MAINTAIN 3" COVER WHEN CAST AGAINST AND PERMANENTLY EXPOSED TO EARTH.

2 CONCRETE PAD DETAILS
SCALE: NOT TO SCALE



T-MOBILE SITE NUMBER:
CTHA601A

BU #: 876352
RICHARD WALL

94 EAST HIGH ST.
EAST HAMPTON, CT 06424

EXISTING 117'-6" MONOPOLE

ISSUED FOR:

REV	DATE	DRWN	DESCRIPTION	DES./QA
A	05/20/18	CMJ	PRELIMINARY	ZTK
B	05/28/18	CMJ	PRELIMINARY	ZTK
C	05/10/18	CMJ	PRELIMINARY	ZTK
D	05/29/18	CMJ	CONSTRUCTION	JPL

DocuSigned by:
Justin Linette
104105823-7C41D
No. 31965
PROFESSIONAL ENGINEER
5/30/2018 10:58:08 PM EDT
CROWN CASTLE USA INC. USA Inc.
Certificate of Registration #PEC0001101

IT IS A VIOLATION OF LAW FOR ANY PERSON, UNLESS THEY ARE ACTING UNDER THE DIRECTION OF A LICENSED PROFESSIONAL ENGINEER, TO ALTER THIS DOCUMENT.

SHEET NUMBER: C-3
REVISION: 0

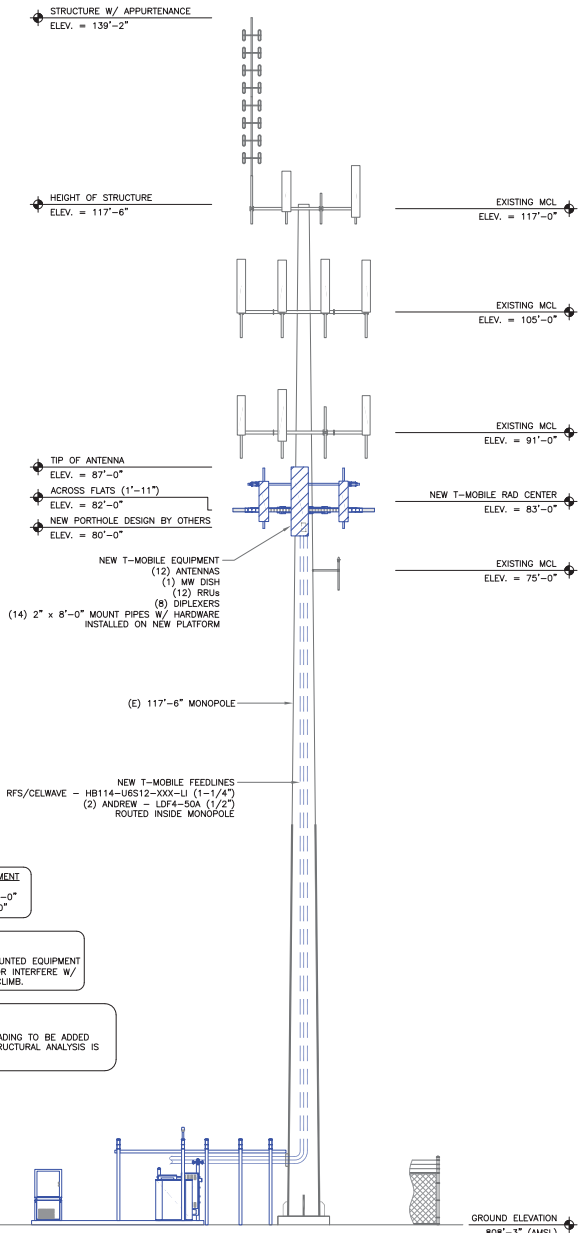

1 FINAL ELEVATION
SCALE: NOT TO SCALE

ANTENNA SCHEDULE										
SECTOR	POS.	TECHNOLOGY	RAD CENTER	AZIMUTH	ANTENNA MANUFACTURER	ANTENNA MODEL	MECH. TILT	ELECT. TILT	TOWER MOUNTED EQUIPMENT	FEEDLINE TYPE
ALPHA	A-1	LTE PCS LTE AWS	83'-0"	20°	ERICSSON	AIR 32 B2A/B66AA	0'	2'/2"	-	HYBRID (1-1/4")
ALPHA	A-2	LTE 600/700	83'-0"	20°	RFS/CELWAVE	APXVAA24_43-U-A20	0'	2'/2"	(1) RRU'S 11 B12, (1) RADIO 4478, (2) ANDREW - 641280-DF-2X	SHARED
ALPHA	A-3	UMTS AWS	83'-0"	20°	RFS/CELWAVE	APX16DW-16DW-S-E-A20	0'	2'/-	(1) RRU'S 11 B4	SHARED
BETA	B-1	LTE PCS LTE AWS	83'-0"	150°	ERICSSON	AIR 32 B2A/B66AA	0'	2'/2"	-	HYBRID (1-1/4")
BETA	B-2	LTE 600/700	83'-0"	150°	RFS/CELWAVE	APXVAA24_43-U-A20	0'	2'/2"	(1) RRU'S 11 B12, (1) RADIO 4478, (2) ANDREW - 641280-DF-2X	SHARED
BETA	B-3	UMTS AWS	83'-0"	150°	RFS/CELWAVE	APX16DW-16DW-S-E-A20	0'	2'/-	(1) RRU'S 11 B4	SHARED
GAMMA	C-1	LTE PCS LTE AWS	83'-0"	220°	ERICSSON	AIR 32 B2A/B66AA	0'	2'/2"	-	HYBRID (1-1/4")
GAMMA	C-2	LTE 600/700	83'-0"	220°	RFS/CELWAVE	APXVAA24_43-U-A20	0'	2'/2"	(1) RRU'S 11 B12, (1) RADIO 4478, (2) ANDREW - 641280-DF-2X	SHARED
GAMMA	C-3	UMTS AWS	83'-0"	220°	RFS/CELWAVE	APX16DW-16DW-S-E-A20	0'	2'/-	(1) RRU'S 11 B4	SHARED
GAMMA	D-1	LTE PCS LTE AWS	83'-0"	300°	ERICSSON	AIR 32 B2A/B66AA	0'	2'/2"	-	HYBRID (1-1/4")
GAMMA	D-2	LTE 600/700	83'-0"	300°	RFS/CELWAVE	APXVAA24_43-U-A20	0'	2'/2"	(1) RRU'S 11 B12, (1) RADIO 4478, (2) ANDREW - 641280-DF-2X	SHARED
GAMMA	D-3	UMTS AWS	83'-0"	300°	RFS/CELWAVE	APX16DW-16DW-S-E-A20	0'	2'/-	(1) RRU'S 11 B4	SHARED
GAMMA	D-4	MW	83'-0"	0°	COMMSCOPE	SHPX3-11W	0'	0'	-	COAX (1/2")

2 ANTENNA SCHEDULE
SCALE: NOT TO SCALE

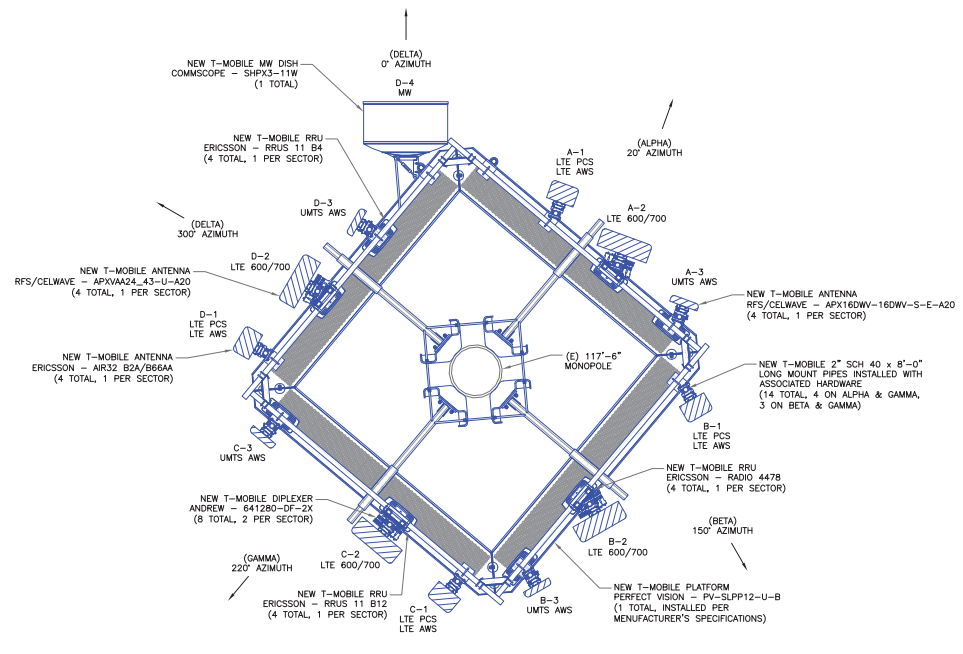

3 FINAL ANTENNA LAYOUT
SCALE: NOT TO SCALE

T-MOBILE SITE NUMBER:
CTHA601A

BU #: 876352
RICHARD WALL

94 EAST HIGH ST.
EAST HAMPTON, CT 06424

EXISTING 117'-6" MONOPOLE

ISSUED FOR:

REV	DATE	DRAWN	DESCRIPTION	DES./QA
A	05/20/18	CMJ	PRELIMINARY	ZTK
B	05/28/18	CMJ	PRELIMINARY	ZTK
C	05/10/18	CMJ	PRELIMINARY	ZTK
D	05/29/18	CMJ	CONSTRUCTION	JPL

DocuSign by: Justin Linette

104105823-7C11D

5/30/2018 09:58:08 PM EDT

CROWN CASTLE USA INC. USA Inc.
Certificate of Registration #PEC000101

IT IS A VIOLATION OF LAW FOR ANY PERSON, UNLESS THEY ARE ACTING UNDER THE DIRECTION OF A LICENSED PROFESSIONAL ENGINEER, TO ALTER THIS DOCUMENT.

SHEET NUMBER: C-4 **REVISION:** 0

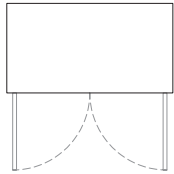
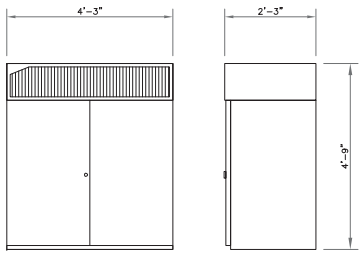

EQUIPMENT NOTES:
 HEIGHTxWIDTHxDEPTH: 57.08" x 51.00" x 27.55"
 (1450.0mm x 1300.0mm x 700.0mm)
 APPROX. MAX. WEIGHT: 859 LBS (390 kg)

1 ERICSSON - RBS 6102
 SCALE: NOT TO SCALE

EMERSON SPECIFICATIONS (CS2S2-W736 PPC)
 DIMENSIONS (WxHxD): 66.00" x 30.00" x 10.00"
 WEIGHT: APPROXIMATELY 150 LBS
 VOLTAGE: 240/120 VAC, SINGLE PHASE
 AMPERAGE: 200A
 FAULT CURRENT RATING: 65KAC
 MAIN BREAKERS: 200A SQUARE D, QG TYPE
 TRANSFER TYPE: SLIDE BAR MECHANICAL INTERLOCK
 DISTRIBUTION: 24 POSITION, 200A LOAD CENTER
 BRANCH BREAKERS: 60A, 240VAC, SQUARE D (TVSS)
 20A, 120VAC, SQUARE D (CONVENIENCE OUTLETS)
 15A, 120VAC, SQUARE D (COOLING FAN)
 200A APPLETON (LEFT OR RIGHT MOUNT)
 GENERATOR RECEPTACLE:

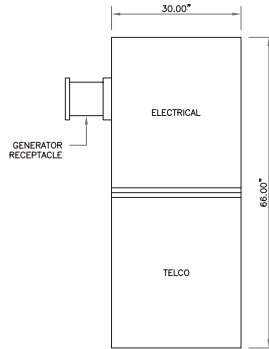

2 EMERSON - CS2S2-W736
 SCALE: NOT TO SCALE

EQUIPMENT NOTES:
 1. MOUNT PER MANUFACTURER'S SPECIFICATIONS.
 2. WESTELL BOXER CABINET TO BE INSTALLED ON UTILITY FRAME BY OTHERS AS NEEDED.

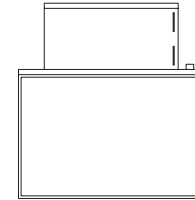

PLAN VIEW

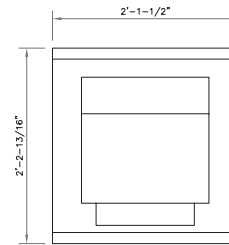

FRONT VIEW

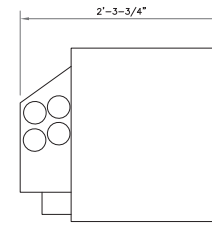

SIDE VIEW

3 WESTELL BOXER CABINET
 SCALE: NOT TO SCALE



T-MOBILE SITE NUMBER:
CTHA601A
 BU #: 876352
RICHARD WALL
 94 EAST HIGH ST.
 EAST HAMPTON, CT 06424
 EXISTING 117'-6" MONOPOLE

ISSUED FOR:

REV	DATE	DRWN	DESCRIPTION	DES./QA
A	05/20/18	CMJ	PRELIMINARY	ZTK
B	05/28/18	CMJ	PRELIMINARY	ZTK
C	05/10/18	CMJ	PRELIMINARY	ZTK
D	05/29/18	CMJ	CONSTRUCTION	JJP

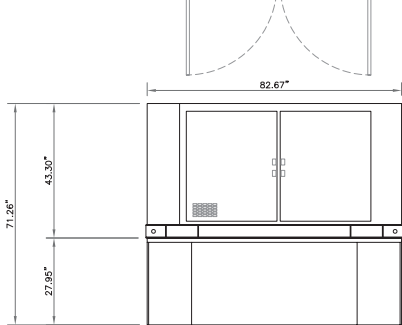
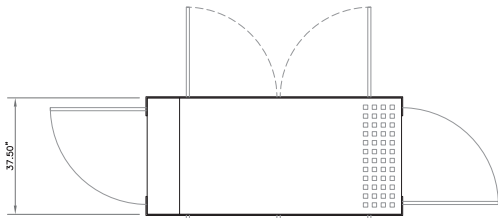

DELTA - ESOG150-PCA01:
 25KW DIESEL DC GENERATOR
 220 GALLON FUEL TANK
 WEIGHT: 5,000 LBS MAX (APPROXIMATE)
 AGENCY LISTINGS: UL 2200/UL 142

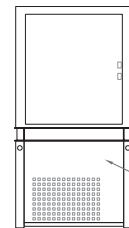

220 GALLON FUEL TANK

4 DIESEL DC GENSET 25 KW (ESOG150-PCA01)
 SCALE: NOT TO SCALE

NEPA 704 HAZARD IDENTIFICATION SYSTEM 15" DIAMOND



HAZARD RATINGS:
 NINE O'CLOCK - HEALTH (BLUE BACKGROUND, BLACK LETTERING)
 TWELVE O'CLOCK - FLAMMABILITY (RED BACKGROUND, BLACK LETTERING)
 THREE O'CLOCK - INSTABILITY (YELLOW BACKGROUND, BLACK LETTERING)
 SIX O'CLOCK - SPECIAL (WHITE BACKGROUND, BLACK LETTERING)

5 GENERATOR SIGN DETAIL
 SCALE: NOT TO SCALE

DIESEL FUEL
 COMBUSTIBLE
 NO SMOKING
 NO OPEN FLAMES
 FUEL TANK CAPACITY 110 GALS

DIESEL (WHITE LETTERING W/ RED BACKGROUND)
COMBUSTIBLE (BLACK LETTERING W/ WHITE BACKGROUND)
FLAMMABLE (BLACK LETTERING W/ WHITE BACKGROUND)
NO SMOKING (BLACK LETTERING W/ WHITE BACKGROUND)

NOTE:
 1. SIGNS MUST BE MADE OF DURABLE MATERIAL.
 2. LETTERS SHALL NOT BE LESS THAN 3" (76.2mm) MIN. IN HEIGHT & 1/2" (12.7mm) IN STROKE.
 3. SIGNS SHALL NOT BE OBSCURED OR REMOVED & SHALL BE IN ENGLISH AS A PRIMARY LANGUAGE.
 4. SIGNS TO BE PLACED ON GENERATOR/FUEL TANK PER NEPA 704.
 5. CONTRACTOR TO PROVIDE ALL REQUIRED SIGNAGE.

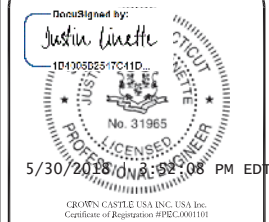

IT IS A VIOLATION OF LAW FOR ANY PERSON, UNLESS THEY ARE ACTING UNDER THE DIRECTION OF A LICENSED PROFESSIONAL ENGINEER, TO ALTER THIS DOCUMENT.

SHEET NUMBER: **C-5** REVISION: **0**

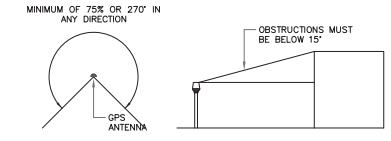
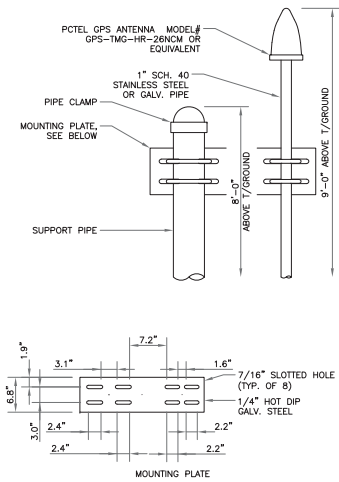

- GPS MINIMUM SKY VIEW REQUIREMENTS**
- NOTES:**
1. THE ELEVATION AND LOCATION OF THE GPS ANTENNA SHALL BE IN ACCORDANCE WITH THE FINAL RF REPORT.
 2. THE GPS ANTENNA MOUNT IS DESIGNED TO FASTEN TO A STANDARD 1-1/4" O.D. SCHEDULE 40, GALVANIZED STEEL OR STAINLESS STEEL PIPE. THE PIPE MUST NOT BE THREADED AT THE ANTENNA MOUNT END. THE PIPE SHALL BE CUT TO THE REQUIRED LENGTH (MINIMUM OF 18 INCHES) USING A HAND OR ROTARY PIPE CUTTER TO ASSURE A SMOOTH AND PERPENDICULAR CUT. A HACK SAW SHALL NOT BE USED. THE CUT PIPE END SHALL BE DEBARRED AND SMOOTH IN ORDER TO SEAL AGAINST THE NEOPRENE GASKET ATTACHED TO THE ANTENNA MOUNT.
 3. IT IS CRITICAL THAT THE GPS ANTENNA IS MOUNTED SUCH THAT IT IS WITHIN 2 DEGREES OF VERTICAL AND THE BASE OF THE ANTENNA IS WITHIN 2 DEGREES OF LEVEL.
 4. DO NOT SWEEP TEST GPS ANTENNA.

1 GPS ANTENNA DETAIL
SCALE: NOT TO SCALE

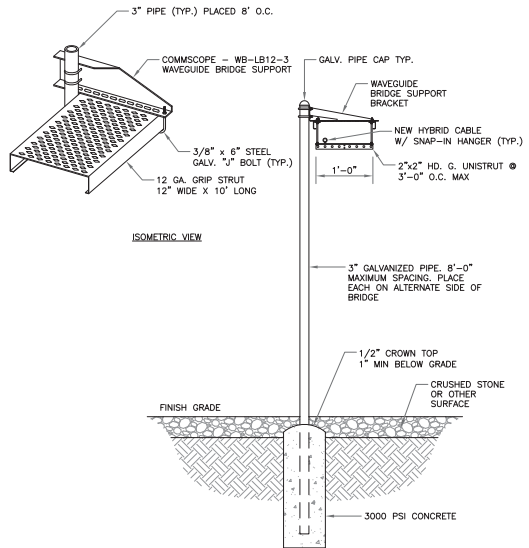

2 ICE BRIDGE DETAIL
SCALE: NOT TO SCALE

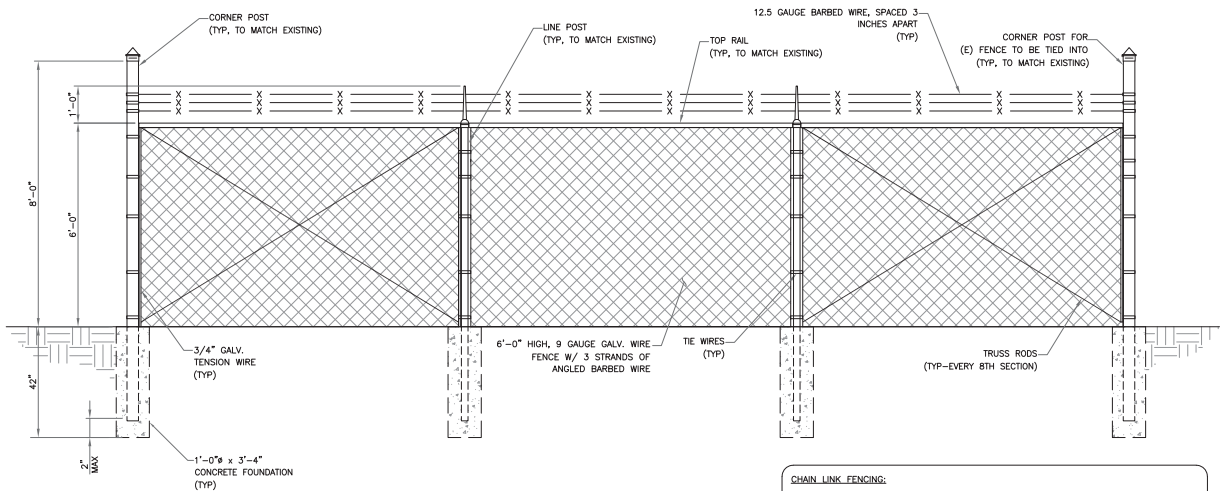
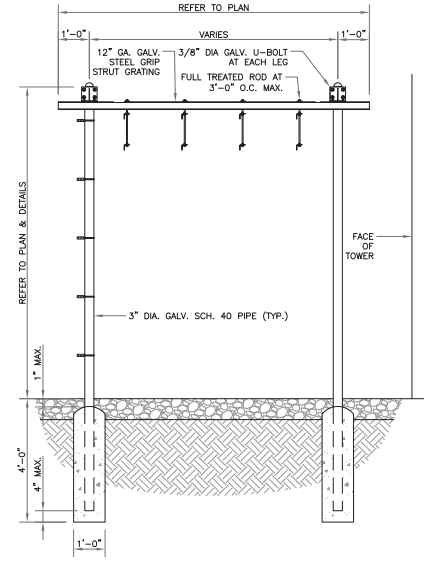

CHAIN LINK FENCING:

CHAIN LINK FENCE FABRIC TO BE GALVANIZED, 9 GAGE WIRE. FENCE FABRIC TO HAVE 2-INCH OPENINGS. SELVAJE TO BE KNUCKLED BOTH ENDS (UNLESS NOTED OTHERWISE). ZINC COATING TO BE CLASS 2 WITH MINIMUM 2 OUNCES OF ZINC PER SQUARE FOOT OF COATING - SEE ASTM A392. FENCE TO BE INSTALLED PER ASTM F567 AND THE STANDARD GUIDE FROM THE CHAIN LINK FENCE MANUFACTURER'S INSTITUTE. WHERE OCCURS, CHAIN LINK SWING GATES TO BE INSTALLED PER ASTM F900 AND CHAIN LINK HORIZONTAL SLIDING GATES TO BE INSTALLED PER ASTM F1184.

3 CHAIN LINK FENCE DETAIL
SCALE: NOT TO SCALE

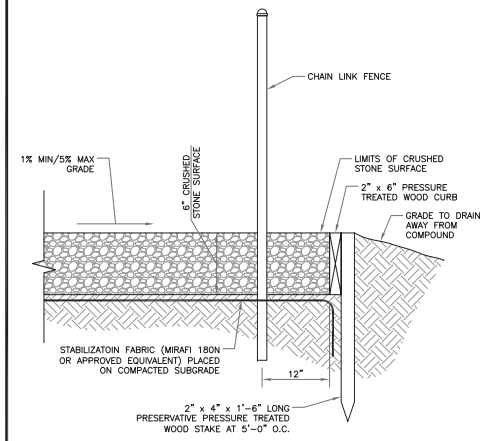

4 SECTION THROUGH COMPOUND
SCALE: NOT TO SCALE



T-MOBILE SITE NUMBER:
CTHA601A

BU #: 876352
RICHARD WALL

94 EAST HIGH ST.
EAST HAMPTON, CT 06424

EXISTING 117'-6" MONOPOLE

ISSUED FOR:

REV	DATE	DRWN	DESCRIPTION	DES./QA
A	03/20/18	CMJ	PRELIMINARY	ZTK
B	03/28/18	CMJ	PRELIMINARY	ZTK
C	05/10/18	CMJ	PRELIMINARY	ZTK
D	05/29/18	CMJ	CONSTRUCTION	JPL

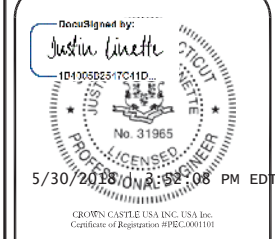

IT IS A VIOLATION OF LAW FOR ANY PERSON, UNLESS THEY ARE ACTING UNDER THE DIRECTION OF A LICENSED PROFESSIONAL ENGINEER, TO ALTER THIS DOCUMENT.

SHEET NUMBER: **C-6** REVISION: **0**

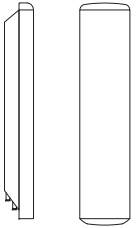

ERICSSON - AIR 32 B2A/B66AA
 WEIGHT (WITHOUT MOUNTING HARDWARE): 132.2 LBS
 SIZE (HxWxD): 56.6x12.9x8.7 IN.
 RATED WIND VELOCITY: 150.0 MPH

1 ERICSSON - AIR 32 B2A/B66AA
 SCALE: NOT TO SCALE

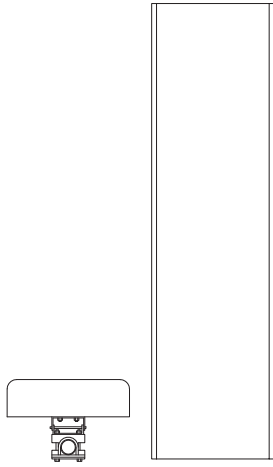

RFS/CELWAVE - APXVAA24_43-U-A20
 WEIGHT (WITHOUT MOUNTING HARDWARE): 101.4 LBS
 SIZE (HxWxD): 96.0x24.0x8.5 IN.

2 RFS/CELWAVE - APXVAA24_43-U-A20
 SCALE: NOT TO SCALE

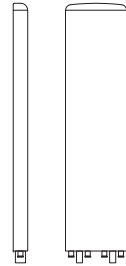

RFS/CELWAVE - APX16DW-16DW-S-E-A20
 WEIGHT (WITHOUT MOUNTING HARDWARE): 40.7 LBS
 SIZE (HxWxD): 55.9x13.3x3.15 IN.
 MOUNTING HARDWARE P/N: APMA0-2 + APMA0-E2
 RATED WIND VELOCITY: 160 MPH

3 RFS/CELWAVE - APX16DW-16DW-S-E-A20
 SCALE: NOT TO SCALE

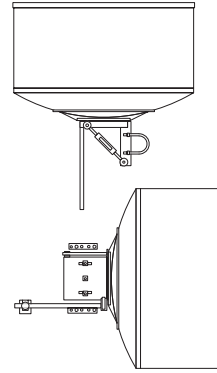

COMMSCOPE - SHPX3-11W
 WEIGHT: 67.0 LBS
 SIZE (HxWxD): 39.0x39.0x35.0 IN.

4 COMMSCOPE - SHPX3-11W
 SCALE: NOT TO SCALE

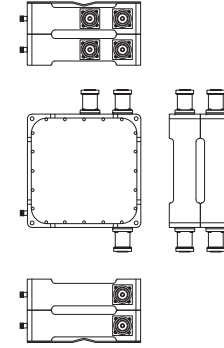

ANDREW - 641280-DF-2X
 WEIGHT: 11.0 LBS
 SIZE (HxWxD): 7.3x7.3x3.9 IN.

5 ANDREW - 641280-DF-2X
 SCALE: NOT TO SCALE

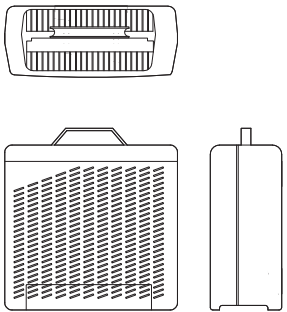

ERICSSON - RRUS 11
 WEIGHT (FULLY EQUIPPED): 50.7 LBS
 SIZE (HxWxD): 19.7x17.0x7.2 IN.

6 ERICSSON - RRUS 11
 SCALE: NOT TO SCALE

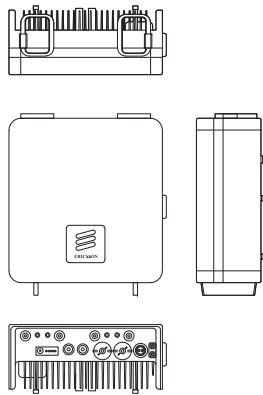

ERICSSON - RADIO 4478
 WEIGHT: 60.0 LBS
 SIZE (HxWxD): 15.0x13.0x8.0 IN.

7 ERICSSON - RADIO 4478
 SCALE: NOT TO SCALE

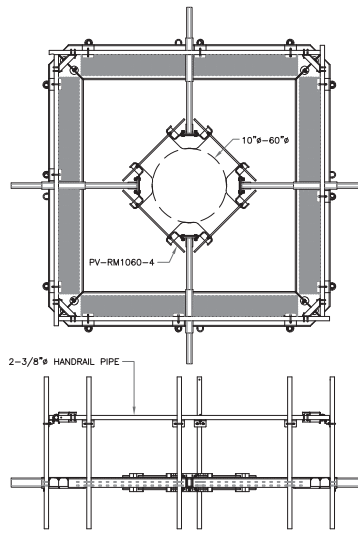

8 PERFECT VISION - PV-SLPP12U-HR-B
 SCALE: NOT TO SCALE

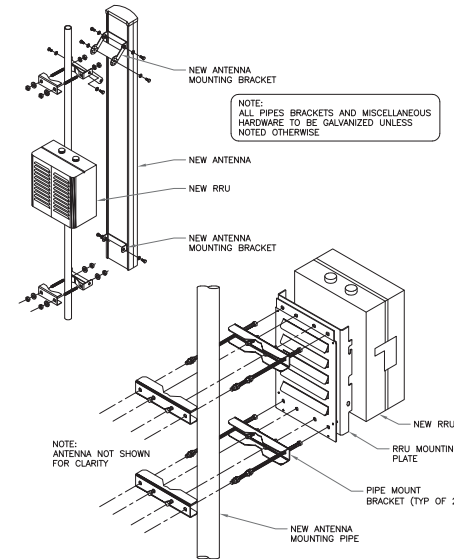

9 ANTENNA & RRU MOUNTING DETAIL
 SCALE: NOT TO SCALE



T-MOBILE SITE NUMBER:
CTHA601A

BU #: 876352
RICHARD WALL

94 EAST HIGH ST.
 EAST HAMPTON, CT 06424

EXISTING 117'-6" MONOPOLE

ISSUED FOR:

REV	DATE	DRWN	DESCRIPTION	DES./QA
A	05/20/18	CMJ	PRELIMINARY	ZTK
B	05/28/18	CMJ	PRELIMINARY	ZTK
C	05/10/18	CMJ	PRELIMINARY	ZTK
D	05/29/18	CMJ	CONSTRUCTION	JPL

DocuSigned by:

Justin Linette
 ID#1058237C11D



5/30/2018 10:58:08 PM EDT

CROWN CASTLE USA INC. USA Inc.
 Certificate of Registration #PEC000101

IT IS A VIOLATION OF LAW FOR ANY PERSON, UNLESS THEY ARE ACTING UNDER THE DIRECTION OF A LICENSED PROFESSIONAL ENGINEER, TO ALTER THIS DOCUMENT.

SHEET NUMBER: REVISION:

C-7 **0**

ELECTRICAL NOTES:

- ALL ELECTRICAL WORK SHALL CONFORM TO THE REQUIREMENTS OF THE NATIONAL ELECTRICAL CODE (NEC) AS WELL AS APPLICABLE STATE AND LOCAL CODES.
- ALL ELECTRICAL ITEMS SHALL BE U.L. APPROVED OR LISTED AND PROCURED PER SPECIFICATION REQUIREMENTS.
- THE ELECTRICAL WORK INCLUDES ALL LABOR AND MATERIAL DESCRIBED BY DRAWINGS AND SPECIFICATION INCLUDING INCIDENTAL WORK TO PROVIDE COMPLETE OPERATING AND APPROVED ELECTRICAL SYSTEM.
- GENERAL CONTRACTOR SHOULD PAY FEES FOR PERMITS, AND IS RESPONSIBLE FOR OBTAINING SAID PERMITS AND COORDINATION OF INSPECTIONS.
- ELECTRICAL AND TELCO WIRING AT EXPOSED INDOOR LOCATIONS SHALL BE IN ELECTRICAL METALLIC TUBING OR RIGID NONMETALLIC TUBING (RIGID SCHEDULE 40 PVC OR RIGID SCHEDULE 80 PVC FOR LOCATIONS SUBJECT TO PHYSICAL DAMAGE) (AS PERMITTED BY CODE).
- ELECTRICAL AND TELCO WIRING AT CONCEALED INDOOR LOCATIONS SHALL BE IN ELECTRICAL METALLIC TUBING, ELECTRICAL NONMETALLIC TUBING OR RIGID MONOMETALLIC TUBING (RIGID SCHEDULE 40 PVC (AS PERMITTED BY CODE).
- ELECTRICAL AND TELCO WIRING OUTSIDE A BUILDING, ABOVE GRADE AND EXPOSED TO WEATHER SHALL BE IN WATER TIGHT GALVANIZED RIGID STEEL CONDUCTS (RGS) AND WHERE REQUIRED IN LIQUID TIGHT FLEXIBLE METAL OR NONMETALLIC CONDUCTS.
- BURIED CONDUIT SHALL BE RIGID NONMETALLIC CONDUIT (RIGID SCHEDULE 40 PVC); DIRECT BURIED IN AREAS OF OCCASIONAL LIGHT TRAFFIC, ENCASED IN REINFORCED CONCRETE IN AREAS OF HEAVY TRAFFIC.
- LIQUIDTIGHT FLEXIBLE METAL LFMC CONDUIT SHALL BE USED INDOORS AND OUTDOORS IN AREAS WHERE VIBRATION OCCURS AND FLEXIBILITY IS NEEDED.
- RUN ELECTRICAL CONDUIT OR CABLE BETWEEN ELECTRICAL UTILITY DEMARCATION POINT AND PROJECT OWNER CELL SITE PPC AS INDICATED ON THIS DRAWING. PROVIDE FULL LENGTH PULL ROPE. COORDINATE INSTALLATION WITH UTILITY COMPANY.
- RUN TELCO CONDUIT OR CABLE BETWEEN TELEPHONE UTILITY DEMARCATION POINT (AT UTILITY POLE) AND CELL SITE TELCO CABINET AS INDICATED ON THIS DRAWING. PROVIDE FULL LENGTH PULL ROPE. INSTALLED TELCO CONDUIT, PROVIDE GREENLEE CONDUIT MEASURING TAPE AT EACH END.
- ALL EQUIPMENT LOCATED OUTSIDE SHALL HAVE NEMA 3R ENCLOSURE.
- PPC SUPPLIED BY PROJECT OWNER.
- GROUNDING SHALL COMPLY WITH NEC ART. 250. ADDITIONALLY, GROUNDING, BONDING, AND LIGHTING PROTECTION SHALL BE DONE IN ACCORDANCE WITH METRO MOD CELL SITE GROUNDING STANDARDS.
- GROUND CABLE SHIELD MINIMUM AT BOTH ENDS USING MANUFACTURERS CABLE GROUNDING KITS SUPPLIED BY T-MOBILE.
- USE #6 COPPER STRANDED WIRE WITH GREEN COLOR INSULATION FOR ABOVE GRADE GROUNDING (UNLESS OTHERWISE SPECIFIED) AND #2 SOLID TINNED BARE COPPER WIRE FOR BELOW GRADE GROUNDING AS INDICATED ON THE DRAWING.
- ALL POWER AND GROUND CONNECTIONS TO BE CRIMP-STYLE, COMPRESSION WIRE LUGS AND WIRE NUTS BY HAZZER (OR APPROVED EQUAL) RATED FOR OPERATION AT NO LESS THAN 75°C OR CADWELD EXOTHERMIC WELD. DO NOT ALLOW BARE COPPER WIRE TO BE IN CONTACT WITH GALVANIZED STEEL.
- ROUTE GROUNDING CONDUCTORS ALONG THE SHORTEST AND STRAIGHTEST PATH POSSIBLE, EXCEPT OTHERWISE INDICATED. GROUNDING LEADS SHOULD NEVER BE BENT AT RIGHT ANGLE. ALWAYS MAKE AT LEAST 12" RADIUS BENDS. #6 WIRE CAN BE BENT AT 6" RADIUS WHEN NECESSARY. BOND ANY METAL OBJECTS WITHIN 6 FEET OF PROJECT OWNER EQUIPMENT OR CABINET TO MASTER GROUND BAR OR GROUNDING RING.
- CONNECTIONS TO GROUND BARS SHALL BE MADE WITH TWO HOLE COMPRESSION TYPE COPPER LUGS. APPLY OXIDE INHABITING COMPOUND TO ALL LOCATIONS.
- APPLY OXIDE INHABITING COMPOUND TO ALL MECHANICAL GROUND CONNECTIONS.
- CONTRACTOR SHALL TEST COMPLETED GROUND SYSTEM AND RECORD RESULTS FOR PROJECT CLOSE-OUT DOCUMENTATION. 5 OHMS MINIMUM RESISTANCE REQUIRED.
- CONTRACTOR SHALL CONDUCT ANTENNA, CABLE, AND LNA RETURN-LOSS AND DISTANCE-TO-FAULT MEASUREMENTS (SWEEP TESTS) AND RECORD RESULTS FOR PROJECT CLOSE-OUT.
- THE T-MOBILE ELECTRICAL EQUIPMENT INCLUDING PANEL, SWITCH GEAR AND DISCONNECT ARE TO BE LABELED WITH ENGRAVED BAKELITE LABELS.

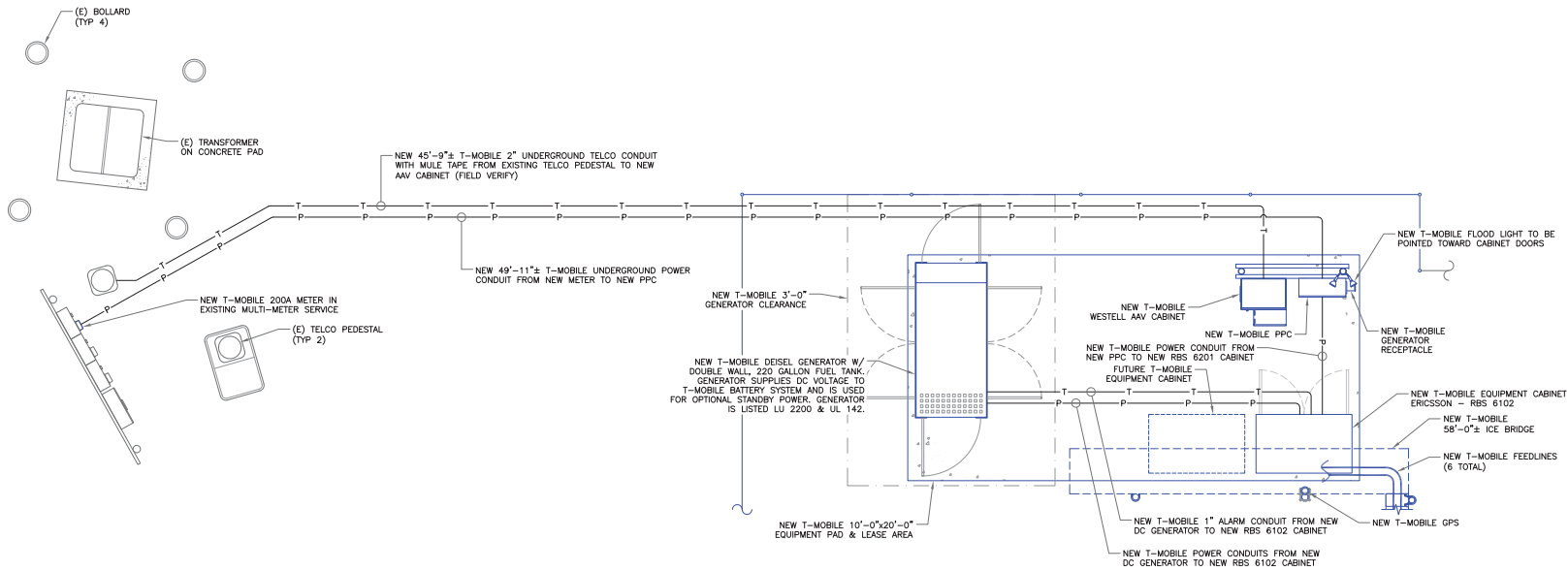

1 ELECTRICAL SITE PLAN
 SCALE: 3/8"=1'-0" (FULL SIZE)
 3/16"=1'-0" (11x17)



T-MOBILE SITE NUMBER:
CTHA601A

BU #: 876352
RICHARD WALL

94 EAST HIGH ST.
 EAST HAMPTON, CT 06424

EXISTING 117'-6" MONOPOLE

ISSUED FOR:

REV	DATE	DRWN	DESCRIPTION	DES./QA
A	05/20/18	CMJ	PRELIMINARY	ZTK
B	05/28/18	CMJ	PRELIMINARY	ZTK
C	05/10/18	CMJ	PRELIMINARY	ZTK
D	05/29/18	CMJ	CONSTRUCTION	JFJ

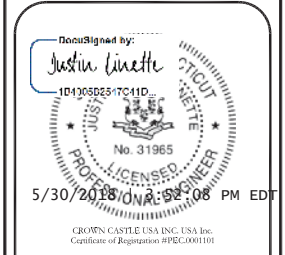

IT IS A VIOLATION OF LAW FOR ANY PERSON, UNLESS THEY ARE ACTING UNDER THE DIRECTION OF A LICENSED PROFESSIONAL ENGINEER, TO ALTER THIS DOCUMENT.

SHEET NUMBER: **E-1** REVISION: **0**

T-MOBILE PPC PANEL SCHEDULE

DESCRIPTION	CONDUCTORS & CONDUIT				LOAD (VA)	CR No.	C/B	C of NC	LOAD (VA)	CR No.	C/B	C of NC	LOAD (VA)	DESCRIPTION
	HOT	NEUTRAL/GROUND	CONDUIT											
SURGE PROTECTION DEVICE **	--	--	--	--	0	MC	60	3	4800	2	800	C	4800	RIS 602 CABINET
GFCI RECEPTACLE **	--	--	--	--	180	MC	20	5	430	6	20	NC	250	LED LIGHT & GFCI RECEPTACLE
COOLING FAN **	--	--	--	--	100	MC	10	7	0	8				
BLANK					0				0	10				
					0				0	12				
					0				0	14				
					0				0	16				
					0				0	18				
					0				0	20				
					0				0	22				
					0				0	24				
BASE LOAD (VA) =					5230				4900					
25% OF CONTINUOUS LOAD (VA) =					1200				1200					
TOTAL LOAD (VA) =					6430				6100					
TOTAL LOAD (VA) =					54				51					

** FACTORY WIRED

C AND *NC* IDENTIFIES WHETHER CONTINUOUS OR NON-CONTINUOUS LOAD

1 ELECTRICAL PANEL
SCALE: NOT TO SCALE

INSTALLER NOTE:
NORTHERN TECHNOLOGIES, INC. PPC637S2-W836-R OR APPROVAL EQUAL. SEE PPC CABINET DIAGRAM (3/E-2) FOR BREAKER REQUIREMENTS.

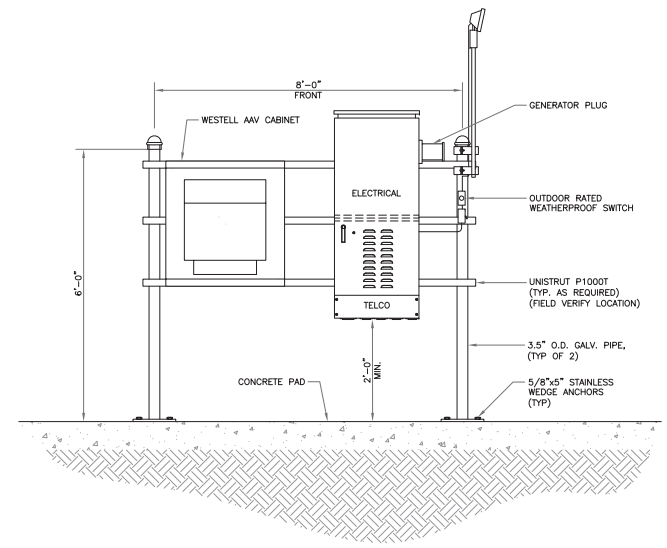

2 H-FRAME DETAIL
SCALE: NOT TO SCALE

INSTALLER NOTE:
LEAN CONCRETE, RED-COLORED TOP, MAY BE USED IN PLACE OF COMPACTED SAND

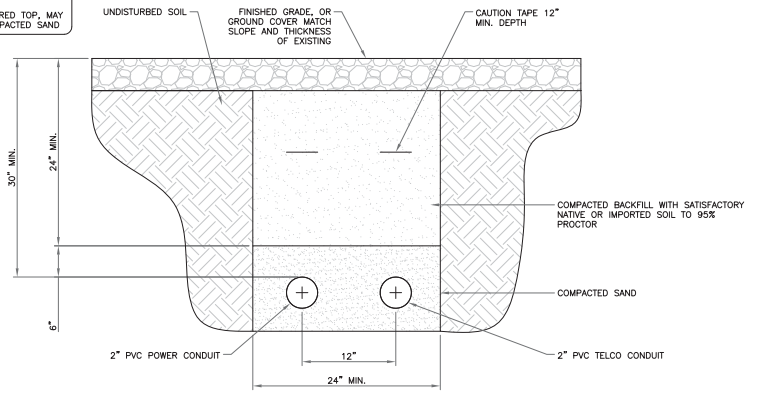

3 TYPICAL ELECTRIC & TELCO TRENCH DETAIL
SCALE: NOT TO SCALE

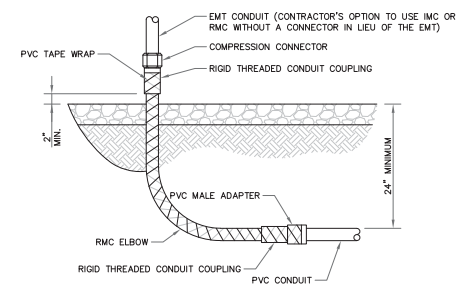

ALL METAL CONDUIT INSTALLED IN DIRECT CONTACT WITH THE EARTH SHALL BE CONSIDERED TO BE INSTALLED IN A SEVERELY CORROSIVE ENVIRONMENT AND IS REQUIRED TO HAVE SUPPLEMENTAL PROTECTION AGAINST CORROSION (NEC ARTICLE 342.10(B) & 344.10(B)(1)). THIS PROTECTION SHALL EITHER BE AN APPROVED MANUFACTURER INSTALLED PROTECTIVE COATING ON THE CONDUIT OR SHALL BE (2) LAYERS OF 10 MIL PVC PIPE WRAP TAPE INSTALLED USING OPPOSING SPIRAL WRAPS. ON VERTICAL PIPE THE OUTSIDE LAYER OF TAPE SHALL BE WRAPPED SO AS TO PROVIDE SHEDDING OF WATER (I.E. TAPE SHOULD WRAP IN AN UPWARD DIRECTION WITH LOWER WRAP BEING BENEATH THE WRAP ABOVE). SPIRAL WRAPS SHALL HAVE A MINIMUM OF 1/4" OVERLAP WITH THE PRECEDING TAPE WRAP. ANY OTHER METHODS OF CORROSION PROTECTION SHALL REQUIRE APPROVAL BY THE ENGINEER OF RECORD PRIOR TO BEING USED.

4 UNDERGROUND CONDUIT STUB UP
SCALE: NOT TO SCALE



T-MOBILE SITE NUMBER:
CTHA601A

BU #: 876352
RICHARD WALL

94 EAST HIGH ST.
EAST HAMPTON, CT 06424

EXISTING 117'-6" MONOPOLE

ISSUED FOR:

REV	DATE	DRWN	DESCRIPTION	DES. QA
A	05/20/18	CMV	PRELIMINARY	ZTK
B	05/28/18	CMV	PRELIMINARY	ZTK
C	05/10/18	CMV	PRELIMINARY	ZTK
D	05/29/18	CMV	CONSTRUCTION	JJG

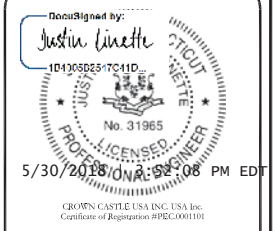

IT IS A VIOLATION OF LAW FOR ANY PERSON, UNLESS THEY ARE ACTING UNDER THE DIRECTION OF A LICENSED PROFESSIONAL ENGINEER, TO ALTER THIS DOCUMENT.

SHEET NUMBER: **E-2** REVISION: **0**

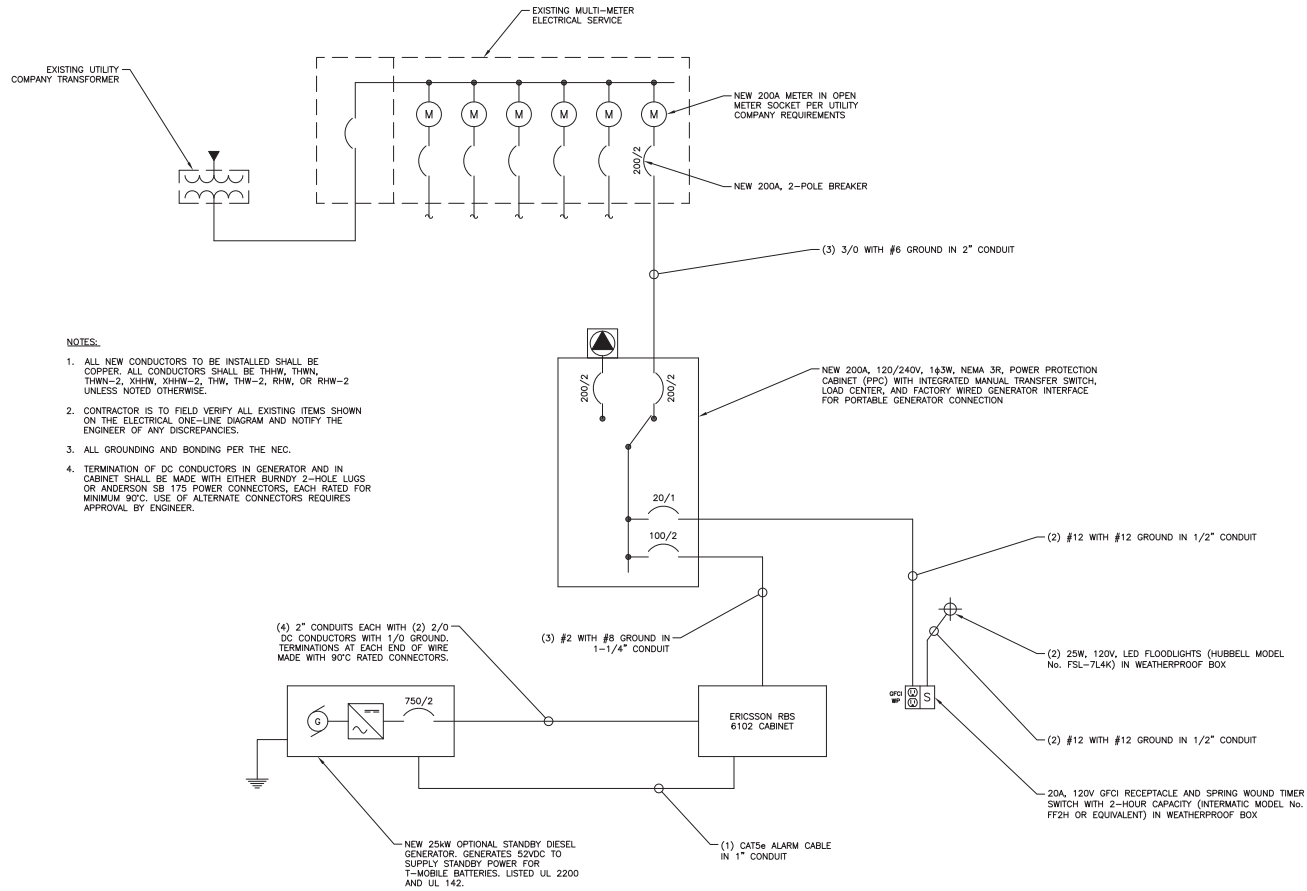

NOTES:

1. ALL NEW CONDUCTORS TO BE INSTALLED SHALL BE COPPER. ALL CONDUCTORS SHALL BE THHW, THWN, THWN-2, XHHW, XHHW-2, THW, THW-2, RHW, OR RHW-2 UNLESS NOTED OTHERWISE.
2. CONTRACTOR IS TO FIELD VERIFY ALL EXISTING ITEMS SHOWN ON THE ELECTRICAL ONE-LINE DIAGRAM AND NOTIFY THE ENGINEER OF ANY DISCREPANCIES.
3. ALL GROUNDING AND BONDING PER THE NEC.
4. TERMINATION OF DC CONDUCTORS IN GENERATOR AND IN CABINET SHALL BE MADE WITH EITHER BURNDY 2-HOLE LUGS OR ANDERSON SB 175 POWER CONNECTORS, EACH RATED FOR MINIMUM 90°C. USE OF ALTERNATE CONNECTORS REQUIRES APPROVAL BY ENGINEER.

① ONE-LINE DIAGRAM
SCALE: NOT TO SCALE



T-MOBILE SITE NUMBER:
CTHA601A

BU #: 876352
RICHARD WALL

94 EAST HIGH ST.
EAST HAMPTON, CT 06424

EXISTING 117'-6" MONOPOLE

ISSUED FOR:

REV	DATE	DRWN	DESCRIPTION	DES./QA
A	05/20/18	CVJ	PRELIMINARY	ZTK
B	05/28/18	CVJ	PRELIMINARY	ZTK
C	05/10/18	CVJ	PRELIMINARY	ZTK
D	05/29/18	CVJ	CONSTRUCTION	JFJ

DocuSigned by:
Justin Linette

104105823-7C41D

5/30/2018 10:58:08 PM EDT

CROWN CASTLE USA INC. USA Inc.
Certificate of Registration #PEC000101

IT IS A VIOLATION OF LAW FOR ANY PERSON, UNLESS THEY ARE ACTING UNDER THE DIRECTION OF A LICENSED PROFESSIONAL ENGINEER, TO ALTER THIS DOCUMENT.

SHEET NUMBER: **E-3** REVISION: **0**

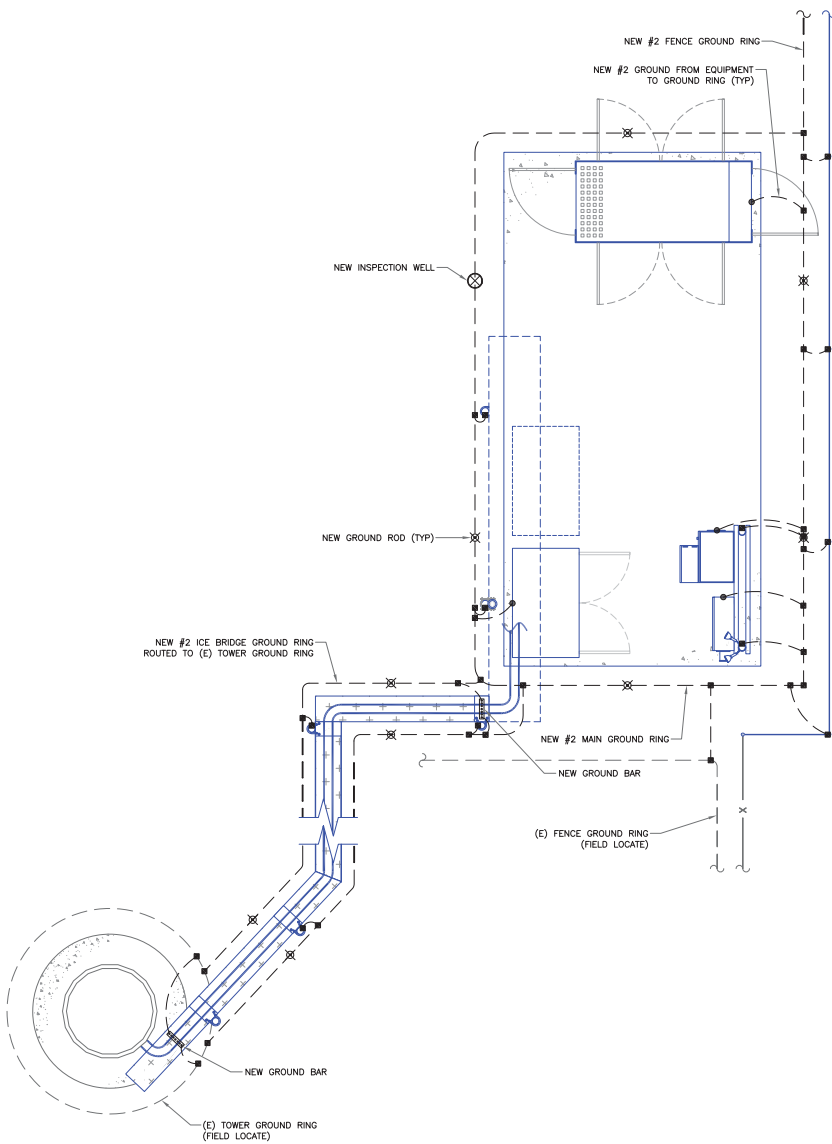

1 EQUIPMENT GROUNDING PLAN
SCALE: NOT TO SCALE

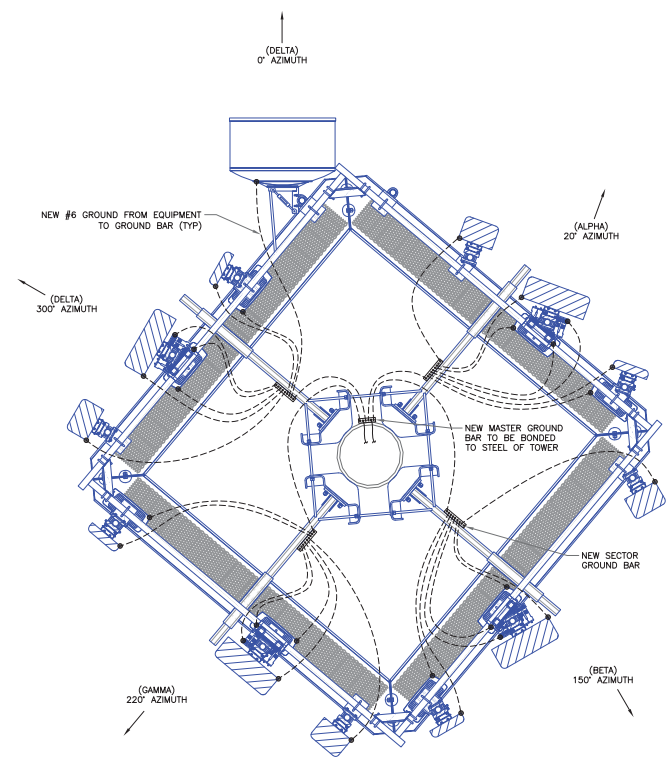
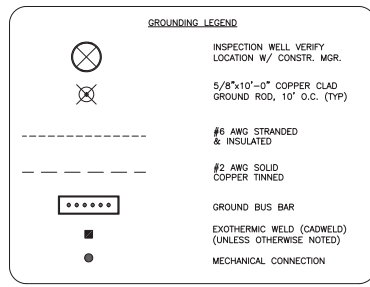

2 ANTENNA GROUNDING PLAN
SCALE: NOT TO SCALE



T-MOBILE SITE NUMBER:
CTHA601A

BU #: 876352
RICHARD WALL

94 EAST HIGH ST.
EAST HAMPTON, CT 06424

EXISTING 117'-6" MONOPOLE

ISSUED FOR:

REV	DATE	DRWN	DESCRIPTION	DES./QA
A	05/20/18	CMJ	PRELIMINARY	ZTK
B	05/28/18	CMJ	PRELIMINARY	ZTK
C	05/10/18	CMJ	PRELIMINARY	ZTK
D	05/29/18	CMJ	CONSTRUCTION	JPG

DocuSigned by:
Justin Linette

104105823-7C41D

5/30/2018 10:58:08 PM EDT

CROWN CASTLE USA INC. USA Inc.
Certificate of Registration #PEC-0001101

IT IS A VIOLATION OF LAW FOR ANY PERSON, UNLESS THEY ARE ACTING UNDER THE DIRECTION OF A LICENSED PROFESSIONAL ENGINEER, TO ALTER THIS DOCUMENT.

SHEET NUMBER: **G-1** REVISION: **0**

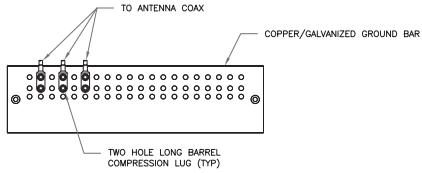

NOTES:

1. DOUBLING UP "OR STACKING" OF CONNECTIONS IS NOT PERMITTED.
2. EXTERIOR ANTIOXIDANT JOINT COMPOUND TO BE USED ON ALL EXTERIOR CONNECTIONS.
3. GROUND BAR SHALL NOT BE ISOLATED FROM TOWER. MOUNT DIRECTLY TO TOWER STEEL.

① ANTENNA GROUND BAR DETAIL
SCALE: NOT TO SCALE

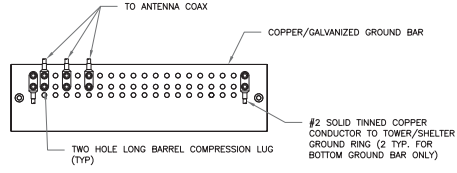

NOTES:

1. EXTERIOR ANTIOXIDANT JOINT COMPOUND TO BE USED ON ALL EXTERIOR CONNECTIONS.
2. GROUND BAR SHALL NOT BE ISOLATED FROM TOWER. MOUNT DIRECTLY TO TOWER STEEL (TOWER ONLY).
3. GROUND BAR SHALL BE ISOLATED FROM BUILDING OR SHELTER.

② TOWER/SHELTER GROUND BAR DETAIL
SCALE: NOT TO SCALE

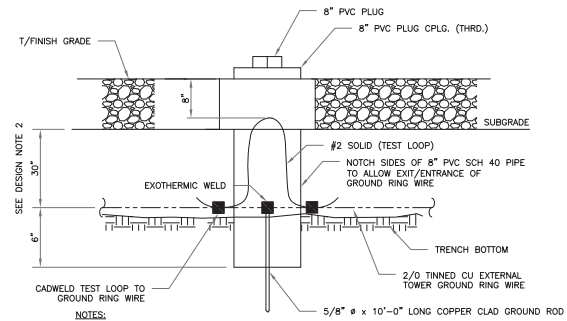

NOTES:

1. GROUND ROD SHALL BE DRIVEN VERTICALLY, NOT TO EXCEED 45 DEGREES FROM THE VERTICAL.
2. GROUND WIRE SHALL BE MIN. 30" BELOW GRADE OR 6" BELOW FROST LINE. (WHICH EVER IS GREATER) AS PER N.E.C. ARTICLE 250-50(D)

③ INSPECTION WELL DETAIL
SCALE: NOT TO SCALE

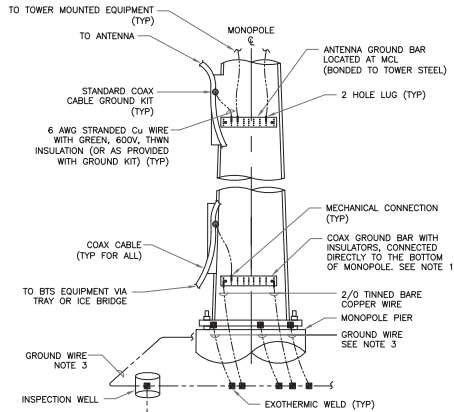

NOTES:

1. NUMBER OF GROUNDING BARS MAY VARY DEPENDING ON THE TYPE OF TOWER, ANTENNA LOCATIONS AND CONNECTION ORIENTATION. COAXIAL CABLES EXCEEDING 200 FEET ON THE TOWER SHALL HAVE GROUND KITS AT THE MIDPOINT, PROVIDE AS REQUIRED.
2. ONLY MECHANICAL CONNECTIONS ARE ALLOWED TO BE MADE TO CROWN CASTLE TOWERS. ALL MECHANICAL CONNECTIONS SHALL BE TREATED WITH AN ANTI-OXIDANT COATING.
3. ALL TOWER GROUNDING SYSTEMS SHALL COMPLY WITH THE REQUIREMENTS OF THE RECOGNIZED EDITION OF ANS/ITIA 222 AND NFPA 780.

④ TYPICAL ANTENNA CABLE GROUNDING
SCALE: NOT TO SCALE

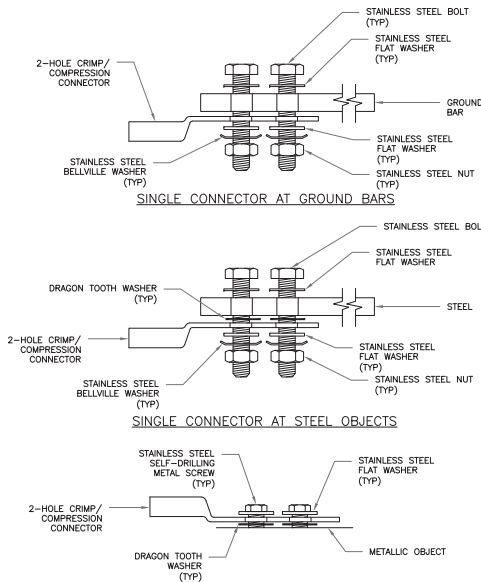

⑤ HARDWARE DETAIL FOR EXTERIOR CONNECTIONS
SCALE: NOT TO SCALE

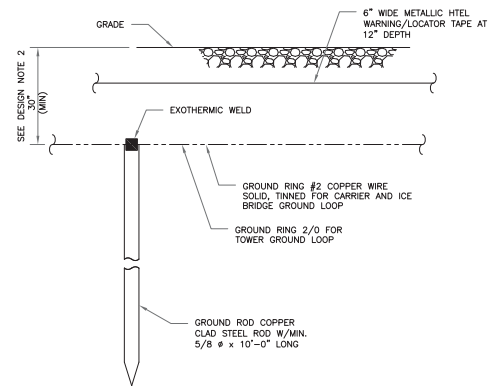

NOTES:

1. GROUND ROD SHALL BE DRIVEN VERTICALLY, NOT TO EXCEED 45 DEGREES FROM THE VERTICAL.
2. GROUND WIRE SHALL BE MIN. 30" BELOW GRADE OR 6" BELOW FROST LINE. (WHICH EVER IS GREATER) AS PER N.E.C. ARTICLE 250-50(D)

⑥ GROUND ROD DETAIL
SCALE: NOT TO SCALE



T-MOBILE SITE NUMBER:
CTHA601A

BU #: 876352
RICHARD WALL

94 EAST HIGH ST.
EAST HAMPTON, CT 06424

EXISTING 117'-6" MONOPOLE

ISSUED FOR:

REV	DATE	DRWN	DESCRIPTION	DES./QA
A	05/20/18	CMJ	PRELIMINARY	ZTK
B	05/28/18	CMJ	PRELIMINARY	ZTK
C	05/10/18	CMJ	PRELIMINARY	ZTK
D	05/29/18	CMJ	CONSTRUCTION	JPL

DocuSigned by:
Justin Linette

104105823-7C41D

NO. 31985

5/30/2018 10:58:08 PM EDT

CROWN CASTLE (USA) INC. USA Inc.
Certificate of Registration #PEC000101

IT IS A VIOLATION OF LAW FOR ANY PERSON, UNLESS THEY ARE ACTING UNDER THE DIRECTION OF A LICENSED PROFESSIONAL ENGINEER, TO ALTER THIS DOCUMENT.

SHEET NUMBER: **G-2** REVISION: **0**

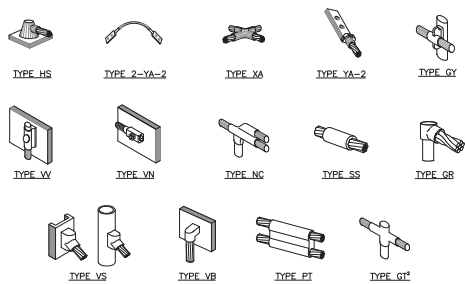

- NOTE:**
1. ERICO EXOTHERMIC "MOLD TYPES" SHOWN HERE ARE EXAMPLES. CONSULT WITH CONSTRUCTION MANAGER FOR SPECIFIC MOLDS TO BE USED FOR THIS PROJECT.
 2. MOLD TYPE ONLY TO BE USED BELOW GRADE WHEN CONNECTING GROUND RING TO GROUND ROD.

1 CADWELD GROUNDING CONNECTIONS
SCALE: NOT TO SCALE

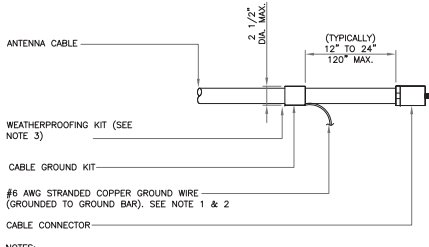

- NOTES:**
1. DO NOT INSTALL CABLE GROUND KIT AT A BEND AND ALWAYS DIRECT GROUND WIRE DOWN TO GROUND BAR.
 2. GROUNDING KIT SHALL BE TYPE AND PART NUMBER AS SUPPLIED OR RECOMMENDED BY CABLE MANUFACTURER.
 3. WEATHER PROOFING SHALL BE TWO-PART TAPE KIT, COLD SHRINK SHALL NOT BE USED.

3 CABLE GROUND KIT CONNECTION
SCALE: NOT TO SCALE

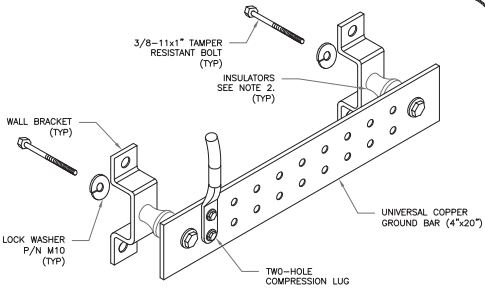

- NOTES:**
1. DOWN LEAD (HOME RUN) CONDUCTORS ARE NOT TO BE INSTALLED ON CROWN CASTLE TOWER, PER THE GROUNDING DOWN CONDUCTOR POLICY GAS-STO-10091. NO MODIFICATION OR DRILLING TO TOWER STEEL IS ALLOWED IN ANY FORM OR FASHION, CAD-WELDING ON THE TOWER AND/OR IN THE AIR ARE NOT PERMITTED.
 2. OMIT INSULATOR WHEN MOUNTING TO TOWER STEEL OR PLATFORM STEEL. USE INSULATORS WHEN ATTACHING TO BUILDING OR SHELTERS.

6 GROUND BAR DETAIL
SCALE: NOT TO SCALE

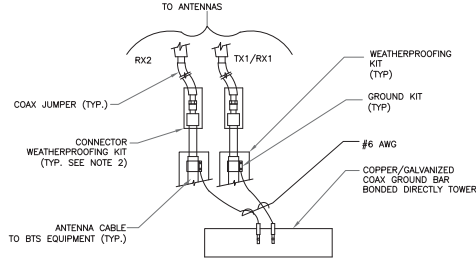

- NOTES:**
1. DO NOT INSTALL CABLE GROUND KIT AT A BEND AND ALWAYS DIRECT GROUND WIRE DOWN TO ANTENNA GROUND BAR.
 2. WEATHER PROOFING SHALL BE TWO-PART TAPE KIT, COLD SHRINK SHALL NOT BE USED.

4 GROUND CABLE CONNECTION
SCALE: NOT TO SCALE

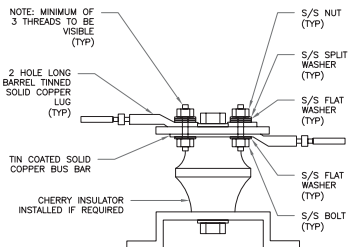

7 LUG DETAIL
SCALE: NOT TO SCALE

WIRE SIZE	BURNDY LUG	BOLT SIZE
#6 AWG GREEN INSULATED	YA6C-2TC38	3/8" - 16 NC S 2 BOLT
#2 AWG SOLID TINNED	YA3C-2TC38	3/8" - 16 NC S 2 BOLT
#2 AWG STRANDED	YA2C-2TC38	3/8" - 16 NC S 2 BOLT
#2/0 AWG STRANDED	YA26-2TC38	3/8" - 16 NC S 2 BOLT
#4/0 AWG STRANDED	YA28-2N	1/2" - 16 NC S 2 BOLT

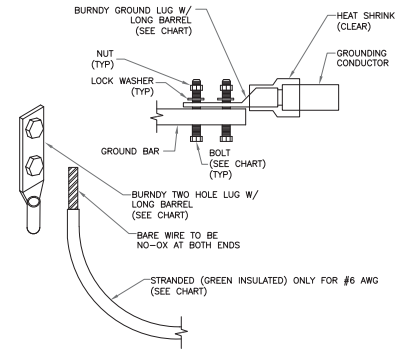

- NOTES:**
1. ALL GROUNDING LUGS ARE TO BE INSTALLED PER MANUFACTURER'S SPECIFICATIONS. ALL HARDWARE BOLTS, NUTS, LOCK WASHERS SHALL BE STAINLESS STEEL. ALL HARDWARE ARE TO BE AS FOLLOWS: BOLT, FLAT WASHER, GROUND BAR, GROUND LUG, FLAT WASHER AND NUT.

2 MECHANICAL LUG CONNECTION
SCALE: NOT TO SCALE

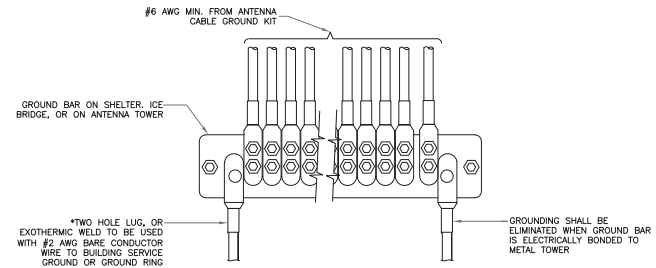

5 GROUNDWIRE INSTALLATION
SCALE: NOT TO SCALE

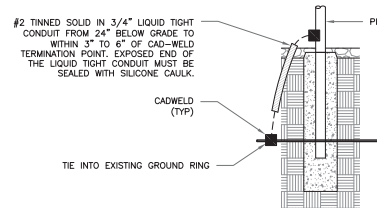

8 TRANSITIONING GROUND DETAIL
SCALE: NOT TO SCALE



T-MOBILE SITE NUMBER:
CTHA601A

BU #: 876352
RICHARD WALL

94 EAST HIGH ST.
EAST HAMPTON, CT 06424

EXISTING 117'-6" MONOPOLE

ISSUED FOR:

REV	DATE	DRWN	DESCRIPTION	DES./QA
A	05/20/18	CMV	PRELIMINARY	ZTK
B	05/28/18	CMV	PRELIMINARY	ZTK
C	05/10/18	CMV	PRELIMINARY	ZTK
D	05/29/18	CMV	CONSTRUCTION	JPL

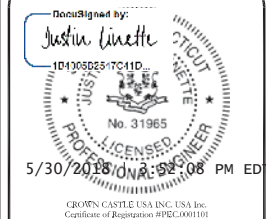

IT IS A VIOLATION OF LAW FOR ANY PERSON, UNLESS THEY ARE ACTING UNDER THE DIRECTION OF A LICENSED PROFESSIONAL ENGINEER, TO ALTER THIS DOCUMENT.

SHEET NUMBER: **G-3** REVISION: **0**

Certificate Of Completion

Envelope Id: 78C07418813040DE93B6FD684F18EE82	Status: Completed
Subject: Please DocuSign: CTHA601A_876352_RICHARD WALL_T-Mobile 2016 NSD FCD_REV 0_5.30.2018.pdf	
Source Envelope:	
Document Pages: 15	Signatures: 15
Certificate Pages: 3	Initials: 0
AutoNav: Enabled	Envelope Originator:
Envelopeld Stamping: Enabled	Whitney Flavion
Time Zone: (UTC-05:00) Eastern Time (US & Canada)	2000 Corporate Drive
	Canonsburg, PA 15317
	Whitney.Flavion.Contractor@crowncastle.com
	IP Address: 50.197.38.250

Record Tracking

Status: Original	Holder: Whitney Flavion	Location: DocuSign
5/30/2018 3:09:50 PM		
	Whitney.Flavion.Contractor@crowncastle.com	

Signer Events

Justin Linette
 justin.linette@crowncastle.com
 Crown Castle International Corp.
 Security Level: Email, Account Authentication (None)

Signature



Using IP Address: 50.197.38.250

Timestamp

Sent: 5/30/2018 | 3:18:54 PM
 Viewed: 5/30/2018 | 3:47:44 PM
 Signed: 5/30/2018 | 3:52:08 PM

Electronic Record and Signature Disclosure:
 Accepted: 4/13/2017 | 1:16:45 PM
 ID: 16e0ec22-6c96-4983-9722-bc0fa869c037

In Person Signer Events	Signature	Timestamp
Editor Delivery Events	Status	Timestamp
Agent Delivery Events	Status	Timestamp
Intermediary Delivery Events	Status	Timestamp
Certified Delivery Events	Status	Timestamp
Carbon Copy Events	Status	Timestamp
Notary Events	Signature	Timestamp
Envelope Summary Events	Status	Timestamps
Envelope Sent	Hashed/Encrypted	5/30/2018 3:18:54 PM
Certified Delivered	Security Checked	5/30/2018 3:47:44 PM
Signing Complete	Security Checked	5/30/2018 3:52:08 PM
Completed	Security Checked	5/30/2018 3:52:08 PM
Payment Events	Status	Timestamps
Electronic Record and Signature Disclosure		

ELECTRONIC RECORD AND SIGNATURE DISCLOSURE

In order to provide more efficient and faster service, Crown Castle (a company) is pleased to announce the use of DocuSign, Inc. (a DocuSign) electronic signing system. The terms for providing such documents for execution and various other documents and records to you electronically through DocuSign are set forth below. Please read the information below carefully and if you can satisfactorily access this information electronically and agree to these terms, please confirm your agreement by clicking the "I agree" button at the bottom of this document.

Getting paper copies

At any time, you may request from us a paper copy of any document for execution or other document or record provided or made available electronically to you by us. You will be able to download and print documents we send to you through the DocuSign system during and immediately after each signing session and, if you elect to create a DocuSign signer account, you may access them for a limited period of time thereafter. To request paper copies of documents previously provided by us to you electronically, send an e-mail to esignature@CrownCastle.com, requesting the subject paper copies and stating your e-mail address, name, US Postal address and telephone number.

Withdrawing your consent to receive and/or execute documents electronically

If you elect to receive documents for execution and various other documents and records from us electronically, you may at any time change your mind and tell us that thereafter you want to receive such documents only in paper format. To withdraw your consent to electronic delivery and execution of documents, use the DocuSign 'Withdraw Consent' form on the signing page of a DocuSign envelope, instead of signing it. Thereafter, you will no longer be able to use the DocuSign system to electronically receive and execute documents or other records from us. You may also send an e-mail to esignature@CrownCastle.com stating that you are withdrawing your consent to electronic delivery and execution of documents through the DocuSign system and stating your e-mail address, name, US Postal Address, and telephone number.

Consequences of withdrawing consent to receive and/or execute documents electronically

If you elect to receive documents for execution and various other documents and other records only in paper format, it will slow the speed at which we can complete the subject transactions because of the increased delivery time.

Documents for execution, and other documents and records may be sent to you electronically

Unless you tell us otherwise in accordance with the procedures described herein, we may provide documents for execution, and other documents and records electronically to you through the DocuSign system during the course of our relationship with you. To reduce the chance of you inadvertently not receiving any document for execution or other document or record, we prefer to provide all documents for execution, and other documents and records by the same method and to the same address that you have given us. If you do not agree with this process, please let us know as described below.

How to contact Crown Castle

You may contact us to let us know of any changes related to contacting you electronically, to request paper copies of documents for execution and other documents and records from us, and to withdraw your prior consent to receive documents for execution and other documents and records electronically as follows:

To contact us by phone call: 724-416-2000

To contact us by email, send messages to: esignature@CrownCastle.com

To contact us by paper mail, send correspondence to

Crown Castle
2000 Corporate Drive
Canonsburg, PA 15317

To advise Crown Castle and DocuSign of your new e-mail address

To let us know of a change to the e-mail address where we should send documents for execution and other documents and records to you, you must send an email message to esignature@CrownCastle.com and state your previous e-mail address and your new e-mail address.

In addition, you must notify DocuSign, Inc. to arrange for your new email address to be reflected in your DocuSign account by following the process for changing e-mail in the DocuSign system.

Required hardware and software

Operating Systems:	Windows® 2000, Windows® XP, Windows Vista®; Mac OS® X
Browsers:	Final release versions of Internet Explorer® 6.0 or above (Windows only); Mozilla Firefox 2.0 or above (Windows and Mac); Safari™ 3.0 or above (Mac only)
PDF Reader:	Acrobat® or similar software may be required to view and print PDF files
Screen Resolution:	800 x 600 minimum
Enabled Security Settings:	Allow per session cookies

These minimum requirements are subject to change. If these requirements change, you will be asked to re-accept the disclosure. Pre-release (e.g. beta) versions of operating systems and browsers are not supported.

Acknowledging your access and consent to receive documents electronically

Please confirm that you were able to access this disclosure electronically (which is similar to the manner in which we will deliver documents for execution and other documents and records) and that you were able to print this disclosure on paper or electronically save it for your future reference and access or that you were able to e-mail this disclosure to an address where you will be able to print it on paper or save it for your future reference and access. Further, if you consent to receiving documents for execution and other documents and records in electronic format on the terms described above, please let us know by clicking the "I agree" button below.

By checking the 'I agree' box, I confirm that:

- You can access and read this Electronic Record and Signature Disclosure; and
- As a recipient, you can read, electronically sign and act upon this message, and you agree not to forward it or any other DocuSign e-mail communications. In the event another party needs to be added to the DocuSign communication, you must make a request to the e-mail originator.



Date: **May 30, 2018**

Charles McGuirt
Crown Castle
3530 Toringdon Way Suite 300
Charlotte, NC 28277

Paul J. Ford and Company
250 East Broad st., Suite 600
Columbus, OH 43215
(614) 221-6679

Subject: Structural Analysis Report

Carrier Designation:	T-Mobile Co-Locate	
	Carrier Site Number:	CTHA601A
	Carrier Site Name:	CTHA601A
Crown Castle Designation:	Crown Castle BU Number:	876352
	Crown Castle Site Name:	RICHARD WALL
	Crown Castle JDE Job Number:	476099
	Crown Castle Work Order Number:	1579194
	Crown Castle Order Number:	419731 Rev. 2

Engineering Firm Designation: Paul J. Ford and Company Project Number: 37518-0657.002.7805

Site Data: 94 East Hight Street, EAST HAMPTON, Middlesex County, CT
Latitude 41° 35' 14.2", Longitude -72° 29' 19.6"
117.5 Foot - Monopole Tower

Dear Charles McGuirt,

Paul J. Ford and Company is pleased to submit this "Structural Analysis Report" to determine the structural integrity of the above mentioned tower. This analysis has been performed in accordance with the Crown Castle Structural 'Statement of Work' and the terms of Crown Castle Purchase Order Number 1194839, in accordance with order 419731, revision 2.

The purpose of the analysis is to determine acceptability of the tower stress level. Based on our analysis we have determined the tower stress level for the structure and foundation, under the following load case, to be:

LC4.7: Modified Structure w/ Existing + Reserved + Proposed Equipment **Sufficient Capacity**
Note: See Table I and Table II for the proposed and existing/reserved loading, respectively.

This analysis has been performed in accordance with the 2016 Connecticut State Building Code based upon an ultimate 3-second gust wind speed of 130 mph converted to a nominal 3-second gust wind speed of 101 mph per Section 1609.3 and Appendix N as required for use in the ANSI/TIA-222-G-2005 Standard, "Structural Standard for Antenna Supporting Structures and Antennas", with ANSI/TIA-222-G-1-2007 and ANSI/TIA-222-G-2-2009 Addenda per Exception #5 of Section 1609.1.1. Risk Category II and Exposure Category C were used in this analysis.

All modifications and equipment proposed in this report shall be installed in accordance with the referenced drawings for the determined available structural capacity to be effective.

We at Paul J. Ford and Company appreciate the opportunity of providing our continuing professional services to you and Crown Castle. If you have any questions or need further assistance on this or any other projects please give us a call.

Respectfully submitted by:

Gowtham Penumatsa
Structural Designer 

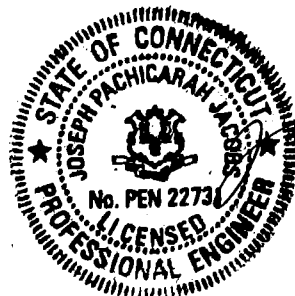

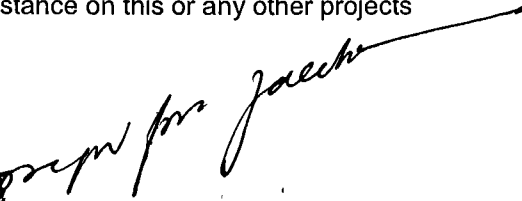

MAY 30 2018

Date: **May 30, 2018**

Charles McGuirt
Crown Castle
3530 Toringdon Way Suite 300
Charlotte, NC 28277

Paul J. Ford and Company
250 East Broad st., Suite 600
Columbus, OH 43215
(614) 221-6679

Subject: Structural Analysis Report

Carrier Designation:

T-Mobile Co-Locate

Carrier Site Number:

CTHA601A

Carrier Site Name:

CTHA601A

Crown Castle Designation:

Crown Castle BU Number:

876352

Crown Castle Site Name:

RICHARD WALL

Crown Castle JDE Job Number:

476099

Crown Castle Work Order Number:

1579194

Crown Castle Order Number:

419731 Rev. 2

Engineering Firm Designation:

Paul J. Ford and Company Project Number: 37518-0657.002.7805

Site Data:

94 East Hight Street, EAST HAMPTON, Middlesex County, CT

Latitude 41° 35' 14.2", Longitude -72° 29' 19.6"

117.5 Foot - Monopole Tower

Dear Charles McGuirt,

Paul J. Ford and Company is pleased to submit this "**Structural Analysis Report**" to determine the structural integrity of the above mentioned tower. This analysis has been performed in accordance with the Crown Castle Structural 'Statement of Work' and the terms of Crown Castle Purchase Order Number 1194839, in accordance with order 419731, revision 2.

The purpose of the analysis is to determine acceptability of the tower stress level. Based on our analysis we have determined the tower stress level for the structure and foundation, under the following load case, to be:

LC4.7: Modified Structure w/ Existing + Reserved + Proposed Equipment

Sufficient Capacity

Note: See Table I and Table II for the proposed and existing/reserved loading, respectively.

This analysis has been performed in accordance with the 2016 Connecticut State Building Code based upon an ultimate 3-second gust wind speed of 130 mph converted to a nominal 3-second gust wind speed of 101 mph per Section 1609.3 and Appendix N as required for use in the ANSI/TIA-222-G-2005 Standard, "Structural Standard for Antenna Supporting Structures and Antennas", with ANSI/TIA-222-G-1-2007 and ANSI/TIA-222-G-2-2009 Addenda per Exception #5 of Section 1609.1.1. Risk Category II and Exposure Category C were used in this analysis.

All modifications and equipment proposed in this report shall be installed in accordance with the referenced drawings for the determined available structural capacity to be effective.

We at *Paul J. Ford and Company* appreciate the opportunity of providing our continuing professional services to you and Crown Castle. If you have any questions or need further assistance on this or any other projects please give us a call.

Respectfully submitted by:

Gowtham Penumatsa
Structural Designer

TABLE OF CONTENTS

1) INTRODUCTION

2) ANALYSIS CRITERIA

Table 1 - Proposed Antenna and Cable Information

Table 2 - Existing and Reserved Antenna and Cable Information

3) ANALYSIS PROCEDURE

Table 3 - Documents Provided

3.1) Analysis Method

3.2) Assumptions

4) ANALYSIS RESULTS

Table 4 - Section Capacity (Summary)

Table 5 – Tower Components vs. Capacity

Table 6 - Microwave Dish Tilt (Sway) Results for 60 mph Rev G Service Wind

4.1) Recommendations

5) APPENDIX A

tnxTower Output

6) APPENDIX B

Base Level Drawing

7) APPENDIX C

Additional Calculations

1) INTRODUCTION

This tower is a 117.5 ft Monopole tower designed by ENGINEERED ENDEAVORS, INC. in May of 1999. The tower was originally designed for a wind speed of 89.25 mph per TIA/EIA-222-F.

2) ANALYSIS CRITERIA

This analysis has been performed in accordance with the 2016 Connecticut State Building Code based upon an ultimate 3-second gust wind speed of 130 mph converted to a nominal 3-second gust wind speed of 101 mph per Section 1609.3 and Appendix N as required for use in the ANSI/TIA-222-G-2005 Standard, "Structural Standard for Antenna Supporting Structures and Antennas", with ANSI/TIA-222-G-1-2007 and ANSI/TIA-222-G-2-2009 Addenda per Exception #5 of Section 1609.1.1. Risk Category II and Exposure Category C were used in this analysis.

Table 1 - Proposed Antenna and Cable Information

Mounting Level (ft)	Center Line Elevation (ft)	Number of Antennas	Antenna Manufacturer	Antenna Model	Number of Feed Lines	Feed Line Size (in)	Note
82.0	83.0	8	andrew	641280-DF-2X	2 4	1/2 1-1/4	-
		1	commscope	SHPX3-11W			
		4	ericsson	AIR 32 B2A/B66AA w/ Mount Pipe			
		4	ericsson	RADIO 4478			
		4	ericsson	RRUS 11 B12			
		4	ericsson	RRUS 11 B4			
		1	gps	GPS_A			
		4	rfs celwave	APX16DWV-16DWV-S-E-A20 w/ Mount Pipe			
	4	rfs celwave	APXVAA24_43-U-A20 w/ Mount Pipe				
	82.0	1	tower mounts	Platform Mount [LP 701-1]			

Table 2 - Existing and Reserved Antenna and Cable Information

Mounting Level (ft)	Center Line Elevation (ft)	Number of Antennas	Antenna Manufacturer	Antenna Model	Number of Feed Lines	Feed Line Size (in)	Note
118.0	118.0	3	alcatel lucent	800MHz 2X50W RRH W/FILTER	-	-	1
		3	alcatel lucent	PCS 1900MHz 4x45W-65MHz			
		1	tower mounts	Side Arm Mount [SO 102-3]			
117.0	130.0	1	decibel	DB264-A	1 1 2 1 3	3/8 1/2 7/8 5/8 1-1/4	1
		1	decibel	DB420-A			
	126.0	1	decibel	ASP-2011			
	119.0	3	alcatel lucent	TD-RRH8x20-25			
		1	gabriel electronics	GHF3W-23			
		3	rfs celwave	APXVSPP18-C-A20 w/ Mount Pipe			
	117.0	3	rfs celwave	APXVTM14-C-120 w/ Mount Pipe			
117.0	1	tower mounts	Platform Mount [LP 601-1]				
105.0	108.0	3	alcatel lucent	RRH2X60-AWS	2 12	1-5/8 1-1/4	1
		3	alcatel lucent	RRH2X60-PCS			
		6	andrew	HBXX-6517DS-A2M w/ Mount Pipe			
		6	andrew	LNX-6514DS-A1M w/ Mount Pipe			
		1	rfs celwave	DB-B1-6C-12AB-0Z			
	6	rfs celwave	FD9R6004/2C-3L				
105.0	1	tower mounts	Platform Mount [LP 1201-1]				
91.0	93.0	3	ericsson	RRUS 11	-	-	2
		3	ericsson	RRUS 12			
		3	powerwave technologies	1001983			
		6	powerwave technologies	LGP21901			
		6	powerwave technologies	7770.00 w/ Mount Pipe			
		6	powerwave technologies	LGP 17201			
		3	kmw communications	AM-X-CD-16-65-00T-RET w/ Mount Pipe			
	1	raycap	DC6-48-60-18-8F				
91.0	1	tower mounts	Platform Mount [LP 1201-1]				
75.0	76.0	1	lucent	KS24019-L112A	1	1/2	1
	75.0	1	tower mounts	Side Arm Mount [SO 701-1]			

- Notes:
 1) Existing Equipment
 2) Reserved Equipment

3) ANALYSIS PROCEDURE

Table 3 - Documents Provided

Document	Remarks	Reference	Source
4-GEOTECHNICAL REPORTS	CHA, 7472.07.03, 05/20/1999	1532964	CCISITES
4-POST-MODIFICATION INSPECTION	TEP, 3017571, 10/31/2005	1956331	CCISITES
4-POST-MODIFICATION INSPECTION	B+T, 84788.002, 11/02/2012	3404046	CCISITES
4-TOWER FOUNDATION DRAWINGS/DESIGN/SPECS	EEl, 5069, 05/28/1999	2122776	CCISITES
4-TOWER MANUFACTURER DRAWINGS	EEl, 5069, 05/28/1999	2122777	CCISITES
4-TOWER MANUFACTURER DRAWINGS	PJF, 37518-0657.001.7700, 3/13/2018	7420586	CCISITES

3.1) Analysis Method

tnxTower (version 7.0.5.1), a commercially available analysis software package, was used to create a three-dimensional model of the tower and calculate member stresses for various loading cases. Selected output from the analysis is included in Appendix A.

3.2) Assumptions

- 1) Tower and structures were built in accordance with the manufacturer's specifications.
- 2) The tower and structures have been maintained in accordance with the manufacturer's specification.
- 3) The configuration of antennas, transmission cables, mounts and other appurtenances are as specified in Tables 1 and 2 and the referenced drawings.
- 4) Monopole was modified in conformance with the referenced modification drawings.
- 5) The reinforcement from document #3404046 is ineffective and, therefore, not considered in this analysis.
- 6) Monopole will be modified in conformance with the referenced proposed modification drawings.
- 7) Wind loading governs. Seismic forces have been inputted as user defined loads for use within tnxTower. The foundation, anchor rods, flanges, and base plate have been analyzed for the reactions from the wind loading analysis.

This analysis may be affected if any assumptions are not valid or have been made in error. Paul J. Ford and Company should be notified to determine the effect on the structural integrity of the tower.

4) ANALYSIS RESULTS

Table 4 - Section Capacity (Summary)

Elevation (ft)	Component Type	Size	Critical Element	% Capacity	Pass / Fail
117.5 - 112.5	Pole	TP16.266x15x0.1875	Pole	19.8%	Pass
112.5 - 107.5	Pole	TP17.531x16.266x0.1875	Pole	31.2%	Pass
107.5 - 102.5	Pole	TP18.797x17.531x0.1875	Pole	50.2%	Pass
102.5 - 97.5	Pole	TP20.062x18.797x0.1875	Pole	66.0%	Pass
97.5 - 92.5	Pole	TP21.328x20.062x0.1875	Pole	78.9%	Pass
92.5 - 89.71	Pole	TP22.9x21.328x0.1875	Pole	88.7%	Pass
89.71 - 84.71	Pole	TP22.913x21.659x0.3125	Pole	61.5%	Pass
84.71 - 79.71	Pole	TP24.166x22.913x0.3125	Pole	71.9%	Pass
79.71 - 74.71	Pole	TP25.419x24.166x0.3125	Pole	81.8%	Pass
74.71 - 69.71	Pole	TP26.672x25.419x0.3125	Pole	89.7%	Pass
69.71 - 64.71	Pole	TP27.926x26.672x0.3125	Pole	96.0%	Pass
64.71 - 62.83	Pole	TP28.397x27.926x0.3125	Pole	98.1%	Pass
62.83 - 62.58	Pole + Reinf.	TP28.459x28.397x0.7375	Reinf. 2 Tension Rupture	67.2%	Pass
62.58 - 57.58	Pole + Reinf.	TP29.713x28.459x0.7125	Reinf. 2 Tension Rupture	72.3%	Pass
57.58 - 52.58	Pole + Reinf.	TP30.966x29.713x0.7	Reinf. 2 Tension Rupture	76.9%	Pass
52.58 - 47.58	Pole + Reinf.	TP32.219x30.966x0.675	Reinf. 2 Tension Rupture	81.1%	Pass
47.58 - 47.38	Pole + Reinf.	TP33.46x32.219x0.675	Reinf. 2 Tension Rupture	81.2%	Pass
47.38 - 42.38	Pole + Reinf.	TP32.896x31.644x0.675	Reinf. 2 Tension Rupture	87.5%	Pass
42.38 - 37.38	Pole + Reinf.	TP34.147x32.896x0.65	Reinf. 2 Tension Rupture	91.1%	Pass
37.38 - 32.38	Pole + Reinf.	TP35.398x34.147x0.6375	Reinf. 2 Tension Rupture	94.4%	Pass
32.38 - 31.75	Pole + Reinf.	TP35.555x35.398x0.6375	Reinf. 2 Tension Rupture	94.8%	Pass
31.75 - 31.5	Pole + Reinf.	TP35.618x35.555x0.7375	Reinf. 1 Compression	77.8%	Pass
31.5 - 26.5	Pole + Reinf.	TP36.869x35.618x0.725	Reinf. 1 Compression	80.4%	Pass
26.5 - 21.5	Pole + Reinf.	TP38.12x36.869x0.7125	Reinf. 1 Compression	82.8%	Pass
21.5 - 16.5	Pole + Reinf.	TP39.371x38.12x0.6875	Reinf. 1 Compression	85.0%	Pass
16.5 - 11.5	Pole + Reinf.	TP40.622x39.371x0.675	Reinf. 1 Compression	87.0%	Pass
11.5 - 6.5	Pole + Reinf.	TP41.874x40.622x0.6625	Reinf. 1 Compression	88.8%	Pass
6.5 - 3	Pole + Reinf.	TP42.749x41.874x0.6625	Reinf. 1 Compression	89.9%	Pass
3 - 2.75	Pole + Reinf.	TP42.812x42.749x0.8	Reinf. 3 Connection	88.9%	Pass
2.75 - 0	Pole + Reinf.	TP43.5x42.812x0.7875	Reinf. 3 Connection	89.9%	Pass
				Summary	
			Pole	98.1%	Pass
			Reinforcement	94.8%	Pass
			Overall	98.1%	Pass

Table 5 - Tower Component Stresses vs. Capacity – LC4.7

Notes	Component	Elevation (ft)	% Capacity	Pass / Fail
1	Anchor Rods	0	91.1	Pass
1	Base Plate	0	85.1	Pass
1	Base Foundation Structural Steel	0	80.5	Pass
1	Base Foundation Soil Interaction	0	89.7	Pass

Structure Rating (max from all components) =	98.1%
---	--------------

Notes:

- 1) See additional documentation in "Appendix C – Additional Calculations" for calculations supporting the % capacity consumed.

Table 6 - Microwave Dish Tilt (Sway) Results for 60 mph Rev G Service

Dish Elevation ft	Dish	Dish Diameter ft	Dish Frequency GHz	Analysis Results Tilt at Service Wind deg	Analysis Results Twist at Service Wind deg
83.0	SHPX3-11W	3.25	-	1.091	0.012

4.1) Recommendations

The monopole and its foundation will have sufficient capacity to carry the proposed loading configuration once the following load changes are met.

- monopole will be modified in conformance with the referenced proposed modification drawings.

APPENDIX A
TNXTOWER OUTPUT

Tower Input Data

There is a pole section.

This tower is designed using the TIA-222-G standard.

The following design criteria apply:

- Tower is located in Middlesex County, Connecticut.
- ASCE 7-10 Wind Data is used (wind speeds converted to nominal values).
- Basic wind speed of 101 mph.
- Structure Class II.
- Exposure Category C.
- Topographic Category 1.
- Crest Height 0.0000 ft.
- Nominal ice thickness of 0.7500 in.
- Ice thickness is considered to increase with height.
- Ice density of 56.00 pcf.
- A wind speed of 50 mph is used in combination with ice.
- Temperature drop of 50 °F.
- Deflections calculated using a wind speed of 60 mph.
- A non-linear (P-delta) analysis was used.
- Pressures are calculated at each section.
- Stress ratio used in pole design is 1.
- Local bending stresses due to climbing loads, feed line supports, and appurtenance mounts are not considered.

Options

- | | | |
|--|--|--|
| <ul style="list-style-type: none"> Consider Moments - Legs Consider Moments - Horizontals Consider Moments - Diagonals Use Moment Magnification √ Use Code Stress Ratios √ Use Code Safety Factors - Guys Escalate Ice Always Use Max Kz Use Special Wind Profile | <ul style="list-style-type: none"> Distribute Leg Loads As Uniform Assume Legs Pinned √ Assume Rigid Index Plate √ Use Clear Spans For Wind Area Use Clear Spans For KL/r Retension Guys To Initial Tension √ Bypass Mast Stability Checks √ Use Azimuth Dish Coefficients √ Project Wind Area of Appurt. | <ul style="list-style-type: none"> Use ASCE 10 X-Brace Ly Rules Calculate Redundant Bracing Forces Ignore Redundant Members in FEA SR Leg Bolts Resist Compression All Leg Panels Have Same Allowable Offset Girt At Foundation √ Consider Feed Line Torque Include Angle Block Shear Check Use TIA-222-G Bracing Resist. Exemption Use TIA-222-G Tension Splice Exemption |
| <ul style="list-style-type: none"> Include Bolts In Member Capacity | <ul style="list-style-type: none"> Autocalc Torque Arm Areas | <p style="text-align: center; background-color: #e0e0e0; margin: 0;">Poles</p> <ul style="list-style-type: none"> √ Include Shear-Torsion Interaction Always Use Sub-Critical Flow Use Top Mounted Sockets |
| <ul style="list-style-type: none"> Leg Bolts Are At Top Of Section Secondary Horizontal Braces Leg Use Diamond Inner Bracing (4 Sided) SR Members Have Cut Ends SR Members Are Concentric | <ul style="list-style-type: none"> Add IBC .6D+W Combination Sort Capacity Reports By Component Triangulate Diamond Inner Bracing Treat Feed Line Bundles As Cylinder | |

Tapered Pole Section Geometry

Section	Elevation ft	Section Length ft	Splice Length ft	Number of Sides	Top Diameter in	Bottom Diameter in	Wall Thickness in	Bend Radius in	Pole Grade
L1	117.5000-112.5000	5.0000	0.00	18	15.0000	16.2656	0.1875	0.7500	A572-65 (65 ksi)
L2	112.5000-107.5000	5.0000	0.00	18	16.2656	17.5312	0.1875	0.7500	A572-65 (65 ksi)
L3	107.5000-102.5000	5.0000	0.00	18	17.5312	18.7969	0.1875	0.7500	A572-65 (65 ksi)
L4	102.5000-97.5000	5.0000	0.00	18	18.7969	20.0625	0.1875	0.7500	A572-65 (65 ksi)
L5	97.5000-	5.0000	0.00	18	20.0625	21.3281	0.1875	0.7500	A572-65

Section	Elevation ft	Section Length ft	Splice Length ft	Number of Sides	Top Diameter in	Bottom Diameter in	Wall Thickness in	Bend Radius in	Pole Grade
L6	92.5000-86.2900	6.2100	3.42	18	21.3281	22.9000	0.1875	0.7500	(65 ksi) A572-65
L7	86.2900-84.7100	5.0000	0.00	18	21.6593	22.9126	0.3125	1.2500	(65 ksi) A572-65
L8	84.7100-79.7100	5.0000	0.00	18	22.9126	24.1658	0.3125	1.2500	(65 ksi) A572-65
L9	79.7100-74.7100	5.0000	0.00	18	24.1658	25.4191	0.3125	1.2500	(65 ksi) A572-65
L10	74.7100-69.7100	5.0000	0.00	18	25.4191	26.6724	0.3125	1.2500	(65 ksi) A572-65
L11	69.7100-64.7100	5.0000	0.00	18	26.6724	27.9256	0.3125	1.2500	(65 ksi) A572-65
L12	64.7100-62.8300	1.8800	0.00	18	27.9256	28.3968	0.3125	1.2500	(65 ksi) A572-65
L13	62.8300-62.5800	0.2500	0.00	18	28.3968	28.4595	0.7375	2.9500	(65 ksi) A572-65
L14	62.5800-57.5800	5.0000	0.00	18	28.4595	29.7128	0.7125	2.8500	(65 ksi) A572-65
L15	57.5800-52.5800	5.0000	0.00	18	29.7128	30.9660	0.7000	2.8000	(65 ksi) A572-65
L16	52.5800-47.5800	5.0000	0.00	18	30.9660	32.2193	0.6750	2.7000	(65 ksi) A572-65
L17	47.5800-42.6300	4.9500	4.75	18	32.2193	33.4600	0.6750	2.7000	(65 ksi) A572-65
L18	42.6300-42.3800	5.0000	0.00	18	31.6444	32.8955	0.6750	2.7000	(65 ksi) A572-65
L19	42.3800-37.3800	5.0000	0.00	18	32.8955	34.1466	0.6500	2.6000	(65 ksi) A572-65
L20	37.3800-32.3800	5.0000	0.00	18	34.1466	35.3978	0.6375	2.5500	(65 ksi) A572-65
L21	32.3800-31.7500	0.6300	0.00	18	35.3978	35.5554	0.6375	2.5500	(65 ksi) A572-65
L22	31.7500-31.5000	0.2500	0.00	18	35.5554	35.6180	0.7375	2.9500	(65 ksi) A572-65
L23	31.5000-26.5000	5.0000	0.00	18	35.6180	36.8691	0.7250	2.9000	(65 ksi) A572-65
L24	26.5000-21.5000	5.0000	0.00	18	36.8691	38.1202	0.7125	2.8500	(65 ksi) A572-65
L25	21.5000-16.5000	5.0000	0.00	18	38.1202	39.3713	0.6875	2.7500	(65 ksi) A572-65
L26	16.5000-11.5000	5.0000	0.00	18	39.3713	40.6224	0.6750	2.7000	(65 ksi) A572-65
L27	11.5000-6.5000	5.0000	0.00	18	40.6224	41.8735	0.6625	2.6500	(65 ksi) A572-65
L28	6.5000-3.0000	3.5000	0.00	18	41.8735	42.7493	0.6625	2.6500	(65 ksi) A572-65
L29	3.0000-2.7500	0.2500	0.00	18	42.7493	42.8119	0.8000	3.2000	(65 ksi) A572-65
L30	2.7500-0.0000	2.7500		18	42.8119	43.5000	0.7875	3.1500	(65 ksi) A572-65

Tapered Pole Properties

Section	Tip Dia. in	Area in ²	I in ⁴	r in	C in	I/C in ³	J in ⁴	It/Q in ²	w in	w/t
L1	15.2314	8.8153	244.3603	5.2584	7.6200	32.0683	489.0422	4.4085	2.3100	12.32
	16.5165	9.5685	312.5010	5.7077	8.2629	37.8196	625.4132	4.7852	2.5327	13.508
L2	16.5165	9.5685	312.5010	5.7077	8.2629	37.8196	625.4132	4.7852	2.5327	13.508
	17.8017	10.3217	392.2599	6.1570	8.9059	44.0451	785.0359	5.1618	2.7555	14.696
L3	17.8017	10.3217	392.2599	6.1570	8.9059	44.0451	785.0359	5.1618	2.7555	14.696

Section	Tip Dia. in	Area in ²	I in ⁴	r in	C in	I/C in ³	J in ⁴	It/Q in ²	w in	w/t
	19.0868	11.0749	484.5515	6.6063	9.5488	50.7447	969.7406	5.5385	2.9782	15.884
L4	19.0868	11.0749	484.5515	6.6063	9.5488	50.7447	969.7406	5.5385	2.9782	15.884
	20.3720	11.8281	590.2904	7.0556	10.1917	57.9185	1181.3576	5.9152	3.2010	17.072
L5	20.3720	11.8281	590.2904	7.0556	10.1917	57.9185	1181.3576	5.9152	3.2010	17.072
	21.6571	12.5813	710.3912	7.5049	10.8347	65.5665	1421.7171	6.2918	3.4237	18.26
L6	21.6571	12.5813	710.3912	7.5049	10.8347	65.5665	1421.7171	6.2918	3.4237	18.26
	23.2533	13.5168	880.9281	8.0629	11.6332	75.7253	1763.0154	6.7597	3.7004	19.735
L7	22.8639	21.1734	1218.9719	7.5781	11.0029	110.7861	2439.5478	10.5887	3.2620	10.439
	23.2660	22.4164	1446.5186	8.0230	11.6396	124.2758	2894.9405	11.2104	3.4826	11.144
L8	23.2660	22.4164	1446.5186	8.0230	11.6396	124.2758	2894.9405	11.2104	3.4826	11.144
	24.5386	23.6595	1700.7545	8.4679	12.2762	138.5403	3403.7469	11.8320	3.7032	11.85
L9	24.5386	23.6595	1700.7545	8.4679	12.2762	138.5403	3403.7469	11.8320	3.7032	11.85
	25.8112	24.9026	1983.1597	8.9128	12.9129	153.5797	3968.9289	12.4537	3.9238	12.556
L10	25.8112	24.9026	1983.1597	8.9128	12.9129	153.5797	3968.9289	12.4537	3.9238	12.556
	27.0838	26.1457	2295.2143	9.3577	13.5496	169.3941	4593.4487	13.0753	4.1443	13.262
L11	27.0838	26.1457	2295.2143	9.3577	13.5496	169.3941	4593.4487	13.0753	4.1443	13.262
	28.3564	27.3888	2638.3982	9.8027	14.1862	185.9833	5280.2680	13.6970	4.3649	13.968
L12	28.3564	27.3888	2638.3982	9.8027	14.1862	185.9833	5280.2680	13.6970	4.3649	13.968
	28.8349	27.8561	2775.7914	9.9699	14.4256	192.4213	5555.2352	13.9307	4.4478	14.233
L13	28.8349	64.7457	6257.9428	9.8191	14.4256	433.8084	12524.120	32.3790	3.6998	5.017
	28.8985	64.8923	6300.5718	9.8413	14.4574	435.8018	12609.434	32.4523	3.7109	5.032
L14	28.8985	62.7491	6103.4759	9.8502	14.4574	422.1690	12214.983	31.3805	3.7549	5.27
	30.1711	65.5834	6968.4270	10.2951	15.0941	461.6662	13946.023	32.7979	3.9754	5.58
L15	30.1711	64.4605	6855.0305	10.2995	15.0941	454.1536	13719.080	32.2364	3.9974	5.711
	31.4437	67.2450	7782.3032	10.7444	15.7307	494.7196	15574.846	33.6289	4.2180	6.026
L16	31.4437	64.8970	7522.9752	10.7533	15.7307	478.2342	15055.849	32.4547	4.2620	6.314
	32.7163	67.5820	8495.9070	11.1982	16.3674	519.0752	17002.993	33.7974	4.4826	6.641
L17	32.7163	67.5820	8495.9070	11.1982	16.3674	519.0752	17002.993	33.7974	4.4826	6.641
	33.9762	70.2402	9538.3600	11.6387	16.9977	561.1566	19089.270	35.1268	4.7010	6.964
L18	33.3395	66.3504	8039.8269	10.9941	16.0754	500.1336	16090.232	33.1815	4.3814	6.491
	33.4030	69.0309	9054.1123	11.4383	16.7109	541.8080	18120.138	34.5220	4.6016	6.817
L19	33.4030	66.5257	8739.0853	11.4472	16.7109	522.9564	17489.669	33.2692	4.6456	7.147
	34.6734	69.1069	9796.2867	11.8913	17.3465	564.7416	19605.463	34.5600	4.8658	7.486
L20	34.6734	67.8032	9618.6568	11.8957	17.3465	554.5015	19249.970	33.9081	4.8878	7.667
	35.9438	70.3348	10736.767	12.3399	17.9821	597.0821	21487.663	35.1741	5.1080	8.013
L21	35.9438	70.3348	10736.767	12.3399	17.9821	597.0821	21487.663	35.1741	5.1080	8.013
	36.1039	70.6538	10883.507	12.3959	18.0621	602.5591	21781.336	35.3336	5.1358	8.056
L22	36.1039	81.5026	12482.860	12.3604	18.0621	691.1063	24982.145	40.7590	4.9598	6.725
	36.1674	81.6490	12550.263	12.3826	18.0939	693.6177	25117.040	40.8323	4.9708	6.74
L23	36.1674	80.2939	12350.815	12.3870	18.0939	682.5948	24717.883	40.1546	4.9928	6.887
	37.4378	83.1729	13727.570	12.8311	18.7295	732.9388	27473.203	41.5944	5.2130	7.19
L24	37.4378	81.7672	13504.889	12.8356	18.7295	721.0495	27027.549	40.8914	5.2350	7.347
	38.7083	84.5966	14955.880	13.2797	19.3651	772.3127	29931.439	42.3063	5.4552	7.656

Section	Tip Dia. in	Area in ²	I in ⁴	r in	C in	I/C in ³	J in ⁴	It/Q in ²	w in	w/t
L25	38.7083	81.6828	14460.065 2	13.2886	19.3651	746.7091	28939.157 7	40.8492	5.4992	7.999
	39.9787	84.4129	15958.967 3	13.7328	20.0006	797.9234	31938.935 5	42.2145	5.7194	8.319
L26	39.9787	82.9049	15683.999 9	13.7372	20.0006	784.1754	31388.635 0	41.4603	5.7414	8.506
	41.2491	85.5854	17254.986 1	14.1813	20.6362	836.1516	34532.677 5	42.8008	5.9615	8.832
L27	41.2491	84.0267	16951.352 4	14.1858	20.6362	821.4379	33925.009 3	42.0214	5.9835	9.032
	42.5195	86.6576	18593.929 5	14.6299	21.2718	874.1133	37212.325 9	43.3370	6.2037	9.364
L28	42.5195	86.6576	18593.929 5	14.6299	21.2718	874.1133	37212.325 4	43.3370	6.2037	9.364
	43.4088	88.4991	19804.727 6	14.9408	21.7167	911.9601	39635.514 9	44.2580	6.3579	9.597
L29	43.4088	106.5177	23681.511 5	14.8920	21.7167	1090.4767	47394.183 7	53.2690	6.1159	7.645
	43.4723	106.6766	23787.613 0	14.9142	21.7484	1093.7619	47606.526 3	53.3484	6.1269	7.659
L30	43.4723	105.0410	23436.838 9	14.9187	21.7484	1077.6332	46904.516 6	52.5305	6.1489	7.808
	44.1711	106.7610	24607.070 3	15.1629	22.0980	1113.5429	49246.519 3	53.3906	6.2700	7.962

Tower Elevation	Gusset Area (per face)	Gusset Thickness	Gusset Grade	Adjust. Factor A _r	Adjust. Factor A _r	Weight Mult.	Double Angle Stitch Bolt Spacing Diagonals	Double Angle Stitch Bolt Spacing Horizontals	Double Angle Stitch Bolt Spacing Redundants
ft	ft ²	in					in	in	in
L1 117.5000- 112.5000				1	1	1			
L2 112.5000- 107.5000				1	1	1			
L3 107.5000- 102.5000				1	1	1			
L4 102.5000- 97.5000				1	1	1			
L5 97.5000- 92.5000				1	1	1			
L6 92.5000- 86.2900				1	1	1			
L7 86.2900- 84.7100				1	1	1			
L8 84.7100- 79.7100				1	1	1			
L9 79.7100- 74.7100				1	1	1			
L10 74.7100- 69.7100				1	1	1			
L11 69.7100- 64.7100				1	1	1			
L12 64.7100- 62.8300				1	1	1			
L13 62.8300- 62.5800				1	1	0.931072			
L14 62.5800- 57.5800				1	1	0.940216			
L15 57.5800- 52.5800				1	1	0.935469			
L16 52.5800- 47.5800				1	1	0.949198			
L17 47.5800- 42.6300				1	1	0.948426			

Tower Elevation	Gusset Area (per face)	Gusset Thickness	Gusset Grade	Adjust. Factor A_r	Adjust. Factor A_r	Weight Mult.	Double Angle Stitch Bolt Spacing Diagonals	Double Angle Stitch Bolt Spacing Horizontals	Double Angle Stitch Bolt Spacing Redundants
ft	ft ²	in					in	in	in
L18 42.6300-42.3800				1	1	0.938992			
L19 42.3800-37.3800				1	1	0.955916			
L20 37.3800-32.3800				1	1	0.956872			
L21 32.3800-31.7500				1	1	0.954765			
L22 31.7500-31.5000				1	1	0.949431			
L23 31.5000-26.5000				1	1	0.946956			
L24 26.5000-21.5000				1	1	0.945689			
L25 21.5000-16.5000				1	1	0.962447			
L26 16.5000-11.5000				1	1	0.963762			
L27 11.5000-6.5000				1	1	0.966158			
L28 6.5000-3.0000				1	1	0.955869			
L29 3.0000-2.7500				1	1	0.805291			
L30 2.7500-0.0000				1	1	0.811047			

Feed Line/Linear Appurtenances - Entered As Area

Description	Face or Leg	Allow Shield	Component Type	Placement ft	Total Number		$C_A A_A$ ft ² /ft	Weight plf

1 1/4" Flat Reinforcement	C	No	CaAa (Out Of Face)	65.5833 - 0.0000	2	No Ice 1/2" Ice 1" Ice	0.2083 0.3194 0.4306	0.00 0.00 0.00

LDF2-50A(3/8)	C	No	Inside Pole	117.0000 - 0.0000	1	No Ice 1/2" Ice 1" Ice	0.0000 0.0000 0.0000	0.08 0.08 0.08
LDF4-50A(1/2)	C	No	Inside Pole	117.0000 - 0.0000	1	No Ice 1/2" Ice 1" Ice	0.0000 0.0000 0.0000	0.15 0.15 0.15
LDF4.5-50(5/8)	C	No	Inside Pole	117.0000 - 0.0000	1	No Ice 1/2" Ice 1" Ice	0.0000 0.0000 0.0000	0.15 0.15 0.15
LDF5-50A(7/8)	C	No	Inside Pole	117.0000 - 0.0000	2	No Ice 1/2" Ice 1" Ice	0.0000 0.0000 0.0000	0.33 0.33 0.33
HB114-1-08U4-M5J(1-1/4)	C	No	CaAa (Out Of Face)	117.0000 - 0.0000	2	No Ice 1/2" Ice 1" Ice	0.0000 0.0000 0.0000	1.08 2.33 4.18
HB114-1-08U4-M5J(1-1/4)	C	No	CaAa (Out Of Face)	117.0000 - 0.0000	1	No Ice 1/2" Ice 1" Ice	0.1540 0.2540 0.3540	1.08 2.33 4.18

LDF6-50A(1-1/4)	C	No	Inside Pole	105.0000 - 0.0000	12	No Ice 1/2" Ice	0.0000 0.0000	0.60 0.60

Description	Face or Leg	Allow Shield	Component Type	Placement ft	Total Number	C _{AA}		Weight
						ft ² /ft	plf	
HB158-1-08U8-S8F18(1-5/8)	C	No	Inside Pole	105.0000 - 0.0000	1	1" Ice	0.0000	0.60
						No Ice	0.0000	1.70
						1/2" Ice	0.0000	1.70
						1" Ice	0.0000	1.70
HB158-1-08U8-S8J18(1-5/8)	C	No	Inside Pole	105.0000 - 0.0000	1	No Ice	0.0000	1.30
						1/2" Ice	0.0000	1.30
						1" Ice	0.0000	1.30

LDF6-50A(1-1/4)	C	No	CaAa (Out Of Face)	91.0000 - 0.0000	2	No Ice	0.0000	0.60
						1/2" Ice	0.0000	1.85
						1" Ice	0.0000	3.72
LDF6-50A(1-1/4)	C	No	CaAa (Out Of Face)	91.0000 - 0.0000	1	No Ice	0.1550	0.60
						1/2" Ice	0.2550	1.85
						1" Ice	0.3550	3.72
LCF158-50A(1-5/8)	C	No	Inside Pole	91.0000 - 0.0000	12	No Ice	0.0000	0.80
						1/2" Ice	0.0000	0.80
						1" Ice	0.0000	0.80

FB-L98B-002-75000(3/8)	C	No	Inside Pole	91.0000 - 0.0000	1	No Ice	0.0000	0.06
						1/2" Ice	0.0000	0.06
						1" Ice	0.0000	0.06
WR-VG86ST-BRD(3/4)	C	No	Inside Pole	91.0000 - 0.0000	2	No Ice	0.0000	0.58
						1/2" Ice	0.0000	0.58
						1" Ice	0.0000	0.58

LDF4-50A(1/2)	C	No	Inside Pole	82.0000 - 0.0000	2	No Ice	0.0000	0.15
						1/2" Ice	0.0000	0.15
						1" Ice	0.0000	0.15
HB114-U6S12-XXX-LI(1-1/4)	C	No	Inside Pole	82.0000 - 0.0000	4	No Ice	0.0000	1.70
						1/2" Ice	0.0000	1.70
						1" Ice	0.0000	1.70

LDF4-50A(1/2)	C	No	CaAa (Out Of Face)	75.0000 - 0.0000	1	No Ice	0.0000	0.15
						1/2" Ice	0.0000	0.84
						1" Ice	0.0000	2.14

Feed Line/Linear Appurtenances Section Areas

Tower Sectio n	Tower Elevation ft	Face	A _R ft ²	A _F ft ²	C _{AA} In Face ft ²	C _{AA} Out Face ft ²	Weight K
L1	117.5000-112.5000	A	0.000	0.000	0.000	0.000	0.00
		B	0.000	0.000	0.000	0.000	0.00
		C	0.000	0.000	0.000	0.693	0.02
L2	112.5000-107.5000	A	0.000	0.000	0.000	0.000	0.00
		B	0.000	0.000	0.000	0.000	0.00
		C	0.000	0.000	0.000	0.770	0.02
L3	107.5000-102.5000	A	0.000	0.000	0.000	0.000	0.00
		B	0.000	0.000	0.000	0.000	0.00
		C	0.000	0.000	0.000	0.770	0.05
L4	102.5000-97.5000	A	0.000	0.000	0.000	0.000	0.00
		B	0.000	0.000	0.000	0.000	0.00
		C	0.000	0.000	0.000	0.770	0.07
L5	97.5000-92.5000	A	0.000	0.000	0.000	0.000	0.00
		B	0.000	0.000	0.000	0.000	0.00
		C	0.000	0.000	0.000	0.770	0.07
L6	92.5000-86.2900	A	0.000	0.000	0.000	0.000	0.00
		B	0.000	0.000	0.000	0.000	0.00
		C	0.000	0.000	0.000	1.686	0.15
L7	86.2900-84.7100	A	0.000	0.000	0.000	0.000	0.00
		B	0.000	0.000	0.000	0.000	0.00
		C	0.000	0.000	0.000	0.488	0.04
L8	84.7100-79.7100	A	0.000	0.000	0.000	0.000	0.00

Tower Section n	Tower Elevation ft	Face	A _R ft ²	A _F ft ²	C _{AA} In Face ft ²	C _{AA} Out Face ft ²	Weight K
		B	0.000	0.000	0.000	0.000	0.00
		C	0.000	0.000	0.000	1.545	0.15
L9	79.7100-74.7100	A	0.000	0.000	0.000	0.000	0.00
		B	0.000	0.000	0.000	0.000	0.00
		C	0.000	0.000	0.000	1.545	0.17
L10	74.7100-69.7100	A	0.000	0.000	0.000	0.000	0.00
		B	0.000	0.000	0.000	0.000	0.00
		C	0.000	0.000	0.000	1.545	0.17
L11	69.7100-64.7100	A	0.000	0.000	0.000	0.000	0.00
		B	0.000	0.000	0.000	0.000	0.00
		C	0.000	0.000	0.000	1.909	0.17
L12	64.7100-62.8300	A	0.000	0.000	0.000	0.000	0.00
		B	0.000	0.000	0.000	0.000	0.00
		C	0.000	0.000	0.000	1.364	0.06
L13	62.8300-62.5800	A	0.000	0.000	0.000	0.000	0.00
		B	0.000	0.000	0.000	0.000	0.00
		C	0.000	0.000	0.000	0.181	0.01
L14	62.5800-57.5800	A	0.000	0.000	0.000	0.000	0.00
		B	0.000	0.000	0.000	0.000	0.00
		C	0.000	0.000	0.000	3.628	0.17
L15	57.5800-52.5800	A	0.000	0.000	0.000	0.000	0.00
		B	0.000	0.000	0.000	0.000	0.00
		C	0.000	0.000	0.000	3.628	0.17
L16	52.5800-47.5800	A	0.000	0.000	0.000	0.000	0.00
		B	0.000	0.000	0.000	0.000	0.00
		C	0.000	0.000	0.000	3.628	0.17
L17	47.5800-42.6300	A	0.000	0.000	0.000	0.000	0.00
		B	0.000	0.000	0.000	0.000	0.00
		C	0.000	0.000	0.000	3.592	0.17
L18	42.6300-42.3800	A	0.000	0.000	0.000	0.000	0.00
		B	0.000	0.000	0.000	0.000	0.00
		C	0.000	0.000	0.000	0.181	0.01
L19	42.3800-37.3800	A	0.000	0.000	0.000	0.000	0.00
		B	0.000	0.000	0.000	0.000	0.00
		C	0.000	0.000	0.000	3.628	0.17
L20	37.3800-32.3800	A	0.000	0.000	0.000	0.000	0.00
		B	0.000	0.000	0.000	0.000	0.00
		C	0.000	0.000	0.000	3.628	0.17
L21	32.3800-31.7500	A	0.000	0.000	0.000	0.000	0.00
		B	0.000	0.000	0.000	0.000	0.00
		C	0.000	0.000	0.000	0.457	0.02
L22	31.7500-31.5000	A	0.000	0.000	0.000	0.000	0.00
		B	0.000	0.000	0.000	0.000	0.00
		C	0.000	0.000	0.000	0.181	0.01
L23	31.5000-26.5000	A	0.000	0.000	0.000	0.000	0.00
		B	0.000	0.000	0.000	0.000	0.00
		C	0.000	0.000	0.000	3.628	0.17
L24	26.5000-21.5000	A	0.000	0.000	0.000	0.000	0.00
		B	0.000	0.000	0.000	0.000	0.00
		C	0.000	0.000	0.000	3.628	0.17
L25	21.5000-16.5000	A	0.000	0.000	0.000	0.000	0.00
		B	0.000	0.000	0.000	0.000	0.00
		C	0.000	0.000	0.000	3.628	0.17
L26	16.5000-11.5000	A	0.000	0.000	0.000	0.000	0.00
		B	0.000	0.000	0.000	0.000	0.00
		C	0.000	0.000	0.000	3.628	0.17
L27	11.5000-6.5000	A	0.000	0.000	0.000	0.000	0.00
		B	0.000	0.000	0.000	0.000	0.00
		C	0.000	0.000	0.000	3.628	0.17
L28	6.5000-3.0000	A	0.000	0.000	0.000	0.000	0.00
		B	0.000	0.000	0.000	0.000	0.00
		C	0.000	0.000	0.000	2.540	0.12
L29	3.0000-2.7500	A	0.000	0.000	0.000	0.000	0.00
		B	0.000	0.000	0.000	0.000	0.00
		C	0.000	0.000	0.000	0.181	0.01

Tower Section <i>n</i>	Tower Elevation <i>ft</i>	Face	A_R <i>ft²</i>	A_F <i>ft²</i>	C_{AA} <i>In Face</i> <i>ft²</i>	C_{AA} <i>Out Face</i> <i>ft²</i>	Weight <i>K</i>
L30	2.7500-0.0000	A	0.000	0.000	0.000	0.000	0.00
		B	0.000	0.000	0.000	0.000	0.00
		C	0.000	0.000	0.000	1.996	0.09

Feed Line/Linear Appurtenances Section Areas - With Ice

Tower Section <i>n</i>	Tower Elevation <i>ft</i>	Face or Leg	Ice Thickness <i>in</i>	A_R <i>ft²</i>	A_F <i>ft²</i>	C_{AA} <i>In Face</i> <i>ft²</i>	C_{AA} <i>Out Face</i> <i>ft²</i>	Weight <i>K</i>
L1	117.5000-112.5000	A	1.699	0.000	0.000	0.000	0.000	0.00
		B		0.000	0.000	0.000	0.000	0.00
		C		0.000	0.000	0.000	2.222	0.11
L2	112.5000-107.5000	A	1.692	0.000	0.000	0.000	0.000	0.00
		B		0.000	0.000	0.000	0.000	0.00
		C		0.000	0.000	0.000	2.462	0.13
L3	107.5000-102.5000	A	1.684	0.000	0.000	0.000	0.000	0.00
		B		0.000	0.000	0.000	0.000	0.00
		C		0.000	0.000	0.000	2.454	0.15
L4	102.5000-97.5000	A	1.676	0.000	0.000	0.000	0.000	0.00
		B		0.000	0.000	0.000	0.000	0.00
		C		0.000	0.000	0.000	2.446	0.18
L5	97.5000-92.5000	A	1.667	0.000	0.000	0.000	0.000	0.00
		B		0.000	0.000	0.000	0.000	0.00
		C		0.000	0.000	0.000	2.437	0.17
L6	92.5000-86.2900	A	1.657	0.000	0.000	0.000	0.000	0.00
		B		0.000	0.000	0.000	0.000	0.00
		C		0.000	0.000	0.000	5.306	0.37
L7	86.2900-84.7100	A	1.650	0.000	0.000	0.000	0.000	0.00
		B		0.000	0.000	0.000	0.000	0.00
		C		0.000	0.000	0.000	1.536	0.11
L8	84.7100-79.7100	A	1.643	0.000	0.000	0.000	0.000	0.00
		B		0.000	0.000	0.000	0.000	0.00
		C		0.000	0.000	0.000	4.832	0.35
L9	79.7100-74.7100	A	1.633	0.000	0.000	0.000	0.000	0.00
		B		0.000	0.000	0.000	0.000	0.00
		C		0.000	0.000	0.000	4.811	0.37
L10	74.7100-69.7100	A	1.622	0.000	0.000	0.000	0.000	0.00
		B		0.000	0.000	0.000	0.000	0.00
		C		0.000	0.000	0.000	4.789	0.39
L11	69.7100-64.7100	A	1.611	0.000	0.000	0.000	0.000	0.00
		B		0.000	0.000	0.000	0.000	0.00
		C		0.000	0.000	0.000	5.755	0.39
L12	64.7100-62.8300	A	1.602	0.000	0.000	0.000	0.000	0.00
		B		0.000	0.000	0.000	0.000	0.00
		C		0.000	0.000	0.000	3.908	0.15
L13	62.8300-62.5800	A	1.599	0.000	0.000	0.000	0.000	0.00
		B		0.000	0.000	0.000	0.000	0.00
		C		0.000	0.000	0.000	0.519	0.02
L14	62.5800-57.5800	A	1.593	0.000	0.000	0.000	0.000	0.00
		B		0.000	0.000	0.000	0.000	0.00
		C		0.000	0.000	0.000	10.353	0.39
L15	57.5800-52.5800	A	1.579	0.000	0.000	0.000	0.000	0.00
		B		0.000	0.000	0.000	0.000	0.00
		C		0.000	0.000	0.000	10.294	0.38
L16	52.5800-47.5800	A	1.564	0.000	0.000	0.000	0.000	0.00
		B		0.000	0.000	0.000	0.000	0.00
		C		0.000	0.000	0.000	10.231	0.38
L17	47.5800-42.6300	A	1.548	0.000	0.000	0.000	0.000	0.00
		B		0.000	0.000	0.000	0.000	0.00
		C		0.000	0.000	0.000	10.061	0.37
L18	42.6300-42.3800	A	1.538	0.000	0.000	0.000	0.000	0.00
		B		0.000	0.000	0.000	0.000	0.00

Tower Section	Tower Elevation	Face or Leg	Ice Thickness	A _R	A _F	C _A A _A In Face	C _A A _A Out Face	Weight
n	ft		in	ft ²	ft ²	ft ²	ft ²	K
L19	42.3800-37.3800	C		0.000	0.000	0.000	0.508	0.02
		A	1.529	0.000	0.000	0.000	0.000	0.00
		B		0.000	0.000	0.000	0.000	0.00
		C		0.000	0.000	0.000	10.083	0.37
L20	37.3800-32.3800	A	1.508	0.000	0.000	0.000	0.000	0.00
		B		0.000	0.000	0.000	0.000	0.00
		C		0.000	0.000	0.000	9.997	0.37
L21	32.3800-31.7500	A	1.496	0.000	0.000	0.000	0.000	0.00
		B		0.000	0.000	0.000	0.000	0.00
		C		0.000	0.000	0.000	1.253	0.05
L22	31.7500-31.5000	A	1.494	0.000	0.000	0.000	0.000	0.00
		B		0.000	0.000	0.000	0.000	0.00
		C		0.000	0.000	0.000	0.497	0.02
L23	31.5000-26.5000	A	1.481	0.000	0.000	0.000	0.000	0.00
		B		0.000	0.000	0.000	0.000	0.00
		C		0.000	0.000	0.000	9.880	0.37
L24	26.5000-21.5000	A	1.453	0.000	0.000	0.000	0.000	0.00
		B		0.000	0.000	0.000	0.000	0.00
		C		0.000	0.000	0.000	9.763	0.36
L25	21.5000-16.5000	A	1.419	0.000	0.000	0.000	0.000	0.00
		B		0.000	0.000	0.000	0.000	0.00
		C		0.000	0.000	0.000	9.621	0.35
L26	16.5000-11.5000	A	1.377	0.000	0.000	0.000	0.000	0.00
		B		0.000	0.000	0.000	0.000	0.00
		C		0.000	0.000	0.000	9.441	0.35
L27	11.5000-6.5000	A	1.317	0.000	0.000	0.000	0.000	0.00
		B		0.000	0.000	0.000	0.000	0.00
		C		0.000	0.000	0.000	9.189	0.33
L28	6.5000-3.0000	A	1.236	0.000	0.000	0.000	0.000	0.00
		B		0.000	0.000	0.000	0.000	0.00
		C		0.000	0.000	0.000	6.192	0.22
L29	3.0000-2.7500	A	1.175	0.000	0.000	0.000	0.000	0.00
		B		0.000	0.000	0.000	0.000	0.00
		C		0.000	0.000	0.000	0.430	0.02
L30	2.7500-0.0000	A	1.091	0.000	0.000	0.000	0.000	0.00
		B		0.000	0.000	0.000	0.000	0.00
		C		0.000	0.000	0.000	4.530	0.16

Feed Line Center of Pressure

Section	Elevation	CP _x	CP _z	CP _x Ice	CP _z Ice
	ft	in	in	in	in
L1	117.5000-112.5000	-0.1611	0.0930	-0.3683	0.2126
L2	112.5000-107.5000	-0.1779	0.1027	-0.4086	0.2359
L3	107.5000-102.5000	-0.1791	0.1034	-0.4181	0.2414
L4	102.5000-97.5000	-0.1801	0.1040	-0.4265	0.2462
L5	97.5000-92.5000	-0.1811	0.1046	-0.4339	0.2505
L6	92.5000-86.2900	-0.3045	0.1758	-0.6839	0.3948
L7	86.2900-84.7100	-0.3406	0.1966	-0.7538	0.4352
L8	84.7100-79.7100	-0.3422	0.1976	-0.7619	0.4399
L9	79.7100-74.7100	-0.3446	0.1989	-0.7750	0.4474
L10	74.7100-69.7100	-0.3467	0.2002	-0.7869	0.4543
L11	69.7100-64.7100	-0.4206	0.2429	-0.9150	0.5283
L12	64.7100-62.8300	-0.7116	0.4109	-1.3401	0.7737
L13	62.8300-62.5800	-0.7132	0.4118	-1.3456	0.7769
L14	62.5800-57.5800	-0.7170	0.4139	-1.3590	0.7846
L15	57.5800-52.5800	-0.7238	0.4179	-1.3830	0.7985

Section	Elevation	CP _x	CP _z	CP _x	CP _z
	ft	in	in	Ice in	Ice in
L16	52.5800-47.5800	-0.7301	0.4216	-1.4052	0.8113
L17	47.5800-42.6300	-0.7361	0.4250	-1.4254	0.8229
L18	42.6300-42.3800	-0.7362	0.4251	-1.4258	0.8232
L19	42.3800-37.3800	-0.7392	0.4268	-1.4326	0.8271
L20	37.3800-32.3800	-0.7447	0.4299	-1.4492	0.8367
L21	32.3800-31.7500	-0.7476	0.4316	-1.4575	0.8415
L22	31.7500-31.5000	-0.7481	0.4319	-1.4588	0.8422
L23	31.5000-26.5000	-0.7507	0.4334	-1.4657	0.8462
L24	26.5000-21.5000	-0.7555	0.4362	-1.4765	0.8525
L25	21.5000-16.5000	-0.7601	0.4388	-1.4838	0.8567
L26	16.5000-11.5000	-0.7644	0.4414	-1.4859	0.8579
L27	11.5000-6.5000	-0.7686	0.4437	-1.4792	0.8540
L28	6.5000-3.0000	-0.7719	0.4457	-1.4586	0.8421
L29	3.0000-2.7500	-0.7733	0.4465	-1.4378	0.8301
L30	2.7500-0.0000	-0.7745	0.4471	-1.4041	0.8106

Shielding Factor Ka

Tower Section	Feed Line Record No.	Description	Feed Line Segment Elev.	K _a No Ice	K _a Ice

Discrete Tower Loads

Description	Face or Leg	Offset Type	Offsets:		Azimuth Adjustmen t °	Placement ft	C _A A _{Front} ft ²	C _A A _{Side} ft ²	Weight K
			Horz Lateral ft	Vert ft					
Lightning Rod 5/8" x 6'	C	From Leg	0.0000	0.000	117.5000	No Ice	0.3750	0.3750	0.01
			0.00			1/2"	0.9885	0.9885	0.01
			3.00			Ice	1.6187	1.6187	0.02
						1" Ice			

800MHz 2X50W RRH W/FILTER	A	From Leg	2.0000	0.000	118.0000	No Ice	2.0583	1.9317	0.06
			0.00			1/2"	2.2398	2.1087	0.09
			0.00			Ice	2.4287	2.2931	0.11
						1" Ice			
800MHz 2X50W RRH W/FILTER	B	From Leg	2.0000	0.000	118.0000	No Ice	2.0583	1.9317	0.06
			0.00			1/2"	2.2398	2.1087	0.09
			0.00			Ice	2.4287	2.2931	0.11
						1" Ice			
800MHz 2X50W RRH W/FILTER	C	From Leg	2.0000	0.000	118.0000	No Ice	2.0583	1.9317	0.06
			0.00			1/2"	2.2398	2.1087	0.09
			0.00			Ice	2.4287	2.2931	0.11
						1" Ice			
PCS 1900MHz 4x45W-65MHz	A	From Leg	2.0000	0.000	118.0000	No Ice	2.3218	2.2381	0.06
			0.00			1/2"	2.5266	2.4407	0.08
			0.00			Ice	2.7388	2.6507	0.11
						1" Ice			
PCS 1900MHz 4x45W-65MHz	B	From Leg	2.0000	0.000	118.0000	No Ice	2.3218	2.2381	0.06
			0.00			1/2"	2.5266	2.4407	0.08
			0.00			Ice	2.7388	2.6507	0.11
						1" Ice			
PCS 1900MHz 4x45W-65MHz	C	From Leg	2.0000	0.000	118.0000	No Ice	2.3218	2.2381	0.06
			0.00			1/2"	2.5266	2.4407	0.08

Description	Face or Leg	Offset Type	Offsets: Horz Lateral Vert ft ft ft	Azimuth Adjustment °	Placement ft	C _{AA} Front ft ²	C _{AA} Side ft ²	Weight K
			0.00			Ice 2.7388	2.6507	0.11
Side Arm Mount [SO 102-3]	C	None		0.000	118.0000	1" Ice No Ice 3.0000	3.0000	0.08
						1/2" 3.4800	3.4800	0.11
						Ice 3.9600	3.9600	0.14
						1" Ice		

DB420-A	A	From Leg	4.0000 0.00 13.00	0.000	117.0000	No Ice 3.3300 1/2" 5.9940 Ice 8.6580	3.3300 5.9940 8.6580	0.03 0.04 0.05
						1" Ice		
DB264-A	B	From Leg	4.0000 0.00 13.00	0.000	117.0000	No Ice 3.1600 1/2" 5.6880 Ice 8.2160	3.1600 5.6880 8.2160	0.04 0.05 0.06
						1" Ice		
ASP-2011	C	From Leg	4.0000 0.00 9.00	0.000	117.0000	No Ice 1.0625 1/2" 1.9312 Ice 2.8167	1.0625 1.9312 2.8167	0.00 0.01 0.03
						1" Ice		
APXVSP18-C-A20 w/ Mount Pipe	A	From Leg	4.0000 0.00 2.00	0.000	117.0000	No Ice 8.2619 1/2" 8.8215 Ice 9.3462	6.9458 8.1266 9.0212	0.08 0.15 0.23
						1" Ice		
APXVSP18-C-A20 w/ Mount Pipe	B	From Leg	4.0000 0.00 2.00	0.000	117.0000	No Ice 8.2619 1/2" 8.8215 Ice 9.3462	6.9458 8.1266 9.0212	0.08 0.15 0.23
						1" Ice		
APXVSP18-C-A20 w/ Mount Pipe	C	From Leg	4.0000 0.00 2.00	0.000	117.0000	No Ice 8.2619 1/2" 8.8215 Ice 9.3462	6.9458 8.1266 9.0212	0.08 0.15 0.23
						1" Ice		
APXVTM14-C-120 w/ Mount Pipe	A	From Leg	4.0000 0.00 2.00	0.000	117.0000	No Ice 6.5799 1/2" 7.0306 Ice 7.4733	4.9591 5.7544 6.4723	0.08 0.13 0.19
						1" Ice		
APXVTM14-C-120 w/ Mount Pipe	B	From Leg	4.0000 0.00 2.00	0.000	117.0000	No Ice 6.5799 1/2" 7.0306 Ice 7.4733	4.9591 5.7544 6.4723	0.08 0.13 0.19
						1" Ice		
APXVTM14-C-120 w/ Mount Pipe	C	From Leg	4.0000 0.00 2.00	0.000	117.0000	No Ice 6.5799 1/2" 7.0306 Ice 7.4733	4.9591 5.7544 6.4723	0.08 0.13 0.19
						1" Ice		
TD-RRH8x20-25	A	From Leg	4.0000 0.00 2.00	0.000	117.0000	No Ice 4.0455 1/2" 4.2975 Ice 4.5570	1.5345 1.7142 1.9008	0.07 0.10 0.13
						1" Ice		
TD-RRH8x20-25	B	From Leg	4.0000 0.00 2.00	0.000	117.0000	No Ice 4.0455 1/2" 4.2975 Ice 4.5570	1.5345 1.7142 1.9008	0.07 0.10 0.13
						1" Ice		
TD-RRH8x20-25	C	From Leg	4.0000 0.00 2.00	0.000	117.0000	No Ice 4.0455 1/2" 4.2975 Ice 4.5570	1.5345 1.7142 1.9008	0.07 0.10 0.13
						1" Ice		
(2) 2.375" OD x 6' Mount Pipe	A	From Leg	4.0000 0.00 0.00	0.000	117.0000	No Ice 1.4250 1/2" 1.9250 Ice 2.2939	1.4250 1.9250 2.2939	0.03 0.04 0.05
						1" Ice		
(2) 2.375" OD x 6' Mount Pipe	B	From Leg	4.0000 0.00	0.000	117.0000	No Ice 1.4250 1/2" 1.9250	1.4250 1.9250	0.03 0.04

Description	Face or Leg	Offset Type	Offsets: Horz Lateral Vert ft ft ft	Azimuth Adjustment t °	Placement ft		C _{AA} Front ft ²	C _{AA} Side ft ²	Weight K
			0.00			Ice	2.2939	2.2939	0.05
(2) 2.375" OD x 6' Mount Pipe	C	From Leg	4.0000 0.00 0.00	0.000	117.0000	1" Ice No Ice 1/2" Ice	1.4250 1.9250 2.2939	1.4250 1.9250 2.2939	0.03 0.04 0.05
8-ft Ladder	C	From Leg	2.0000 0.00 -2.00	0.000	117.0000	1" Ice No Ice 1/2" Ice	7.0700 9.7300 11.1900	7.0700 9.7300 11.1900	0.04 0.07 0.08
Platform Mount [LP 601-1]	C	None		0.000	117.0000	1" Ice No Ice 1/2" Ice	28.4700 33.5900 38.7100	28.4700 33.5900 38.7100	1.12 1.51 1.91

(2) HBXX-6517DS-A2M w/ Mount Pipe	A	From Leg	4.0000 0.00 3.00	0.000	105.0000	1" Ice No Ice 1/2" Ice	8.7655 9.3417 9.8885	6.9629 8.1817 9.1436	0.07 0.14 0.21
(2) HBXX-6517DS-A2M w/ Mount Pipe	B	From Leg	4.0000 0.00 3.00	0.000	105.0000	1" Ice No Ice 1/2" Ice	8.7655 9.3417 9.8885	6.9629 8.1817 9.1436	0.07 0.14 0.21
(2) HBXX-6517DS-A2M w/ Mount Pipe	C	From Leg	4.0000 0.00 3.00	0.000	105.0000	1" Ice No Ice 1/2" Ice	8.7655 9.3417 9.8885	6.9629 8.1817 9.1436	0.07 0.14 0.21
(2) LNX-6514DS-A1M w/ Mount Pipe	A	From Leg	4.0000 0.00 3.00	0.000	105.0000	1" Ice No Ice 1/2" Ice	8.4106 8.9745 9.5048	7.0817 8.2729 9.1847	0.06 0.13 0.21
(2) LNX-6514DS-A1M w/ Mount Pipe	B	From Leg	4.0000 0.00 3.00	0.000	105.0000	1" Ice No Ice 1/2" Ice	8.4106 8.9745 9.5048	7.0817 8.2729 9.1847	0.06 0.13 0.21
(2) LNX-6514DS-A1M w/ Mount Pipe	C	From Leg	4.0000 0.00 3.00	0.000	105.0000	1" Ice No Ice 1/2" Ice	8.4106 8.9745 9.5048	7.0817 8.2729 9.1847	0.06 0.13 0.21
(2) FD9R6004/2C-3L	A	From Leg	4.0000 0.00 3.00	0.000	105.0000	1" Ice No Ice 1/2" Ice	0.3142 0.3862 0.4656	0.0762 0.1189 0.1685	0.00 0.01 0.01
(2) FD9R6004/2C-3L	B	From Leg	4.0000 0.00 3.00	0.000	105.0000	1" Ice No Ice 1/2" Ice	0.3142 0.3862 0.4656	0.0762 0.1189 0.1685	0.00 0.01 0.01
(2) FD9R6004/2C-3L	C	From Leg	4.0000 0.00 3.00	0.000	105.0000	1" Ice No Ice 1/2" Ice	0.3142 0.3862 0.4656	0.0762 0.1189 0.1685	0.00 0.01 0.01
RRH2X60-AWS	A	From Leg	4.0000 0.00 3.00	0.000	105.0000	1" Ice No Ice 1/2" Ice	1.8775 2.0551 2.2401	1.2359 1.3858 1.5441	0.04 0.06 0.08
RRH2X60-AWS	B	From Leg	4.0000 0.00 3.00	0.000	105.0000	1" Ice No Ice 1/2" Ice	1.8775 2.0551 2.2401	1.2359 1.3858 1.5441	0.04 0.06 0.08
RRH2X60-AWS	C	From Leg	4.0000 0.00	0.000	105.0000	1" Ice No Ice 1/2"	1.8775 2.0551	1.2359 1.3858	0.04 0.06

Description	Face or Leg	Offset Type	Offsets: Horz Lateral Vert ft ft ft	Azimuth Adjustment t °	Placement ft	C _{AA} Front ft ²	C _{AA} Side ft ²	Weight K	
			3.00			Ice 1" Ice No Ice	2.2401 1.5441	0.08	
RRH2X60-PCS	A	From Leg	4.0000 0.00 3.00	0.000	105.0000	1/2" Ice 1" Ice No Ice	2.2000 2.3926 2.5926	1.7233 1.9015 2.0870	0.06 0.08 0.10
RRH2X60-PCS	B	From Leg	4.0000 0.00 3.00	0.000	105.0000	1/2" Ice 1" Ice No Ice	2.2000 2.3926 2.5926	1.7233 1.9015 2.0870	0.06 0.08 0.10
RRH2X60-PCS	C	From Leg	4.0000 0.00 3.00	0.000	105.0000	1/2" Ice 1" Ice No Ice	2.2000 2.3926 2.5926	1.7233 1.9015 2.0870	0.06 0.08 0.10
DB-B1-6C-12AB-0Z	A	From Leg	4.0000 0.00 3.00	0.000	105.0000	1/2" Ice 1" Ice No Ice	3.3636 3.5972 3.8383	2.1921 2.3950 2.6056	0.03 0.06 0.09
Platform Mount [LP 1201-1]	C	None		0.000	105.0000	1/2" Ice 1" Ice No Ice	23.1000 26.8000 30.5000	23.1000 26.8000 30.5000	2.10 2.50 2.90

(2) LGP21903	A	From Leg	4.0000 0.00 2.00	0.000	91.0000	1/2" Ice 1" Ice No Ice	0.2310 0.2941 0.3647	0.1575 0.2129 0.2756	0.01 0.01 0.02
(2) LGP21903	B	From Leg	4.0000 0.00 2.00	0.000	91.0000	1/2" Ice 1" Ice No Ice	0.2310 0.2941 0.3647	0.1575 0.2129 0.2756	0.01 0.01 0.02
(2) LGP21903	C	From Leg	4.0000 0.00 2.00	0.000	91.0000	1/2" Ice 1" Ice No Ice	0.2310 0.2941 0.3647	0.1575 0.2129 0.2756	0.01 0.01 0.02
AM-X-CD-16-65-00T-RET w/ Mount Pipe	A	From Leg	4.0000 0.00 2.00	0.000	91.0000	1/2" Ice 1" Ice No Ice	8.2619 8.8215 9.3462	6.3042 7.4790 8.3676	0.07 0.14 0.21
AM-X-CD-16-65-00T-RET w/ Mount Pipe	B	From Leg	4.0000 0.00 2.00	0.000	91.0000	1/2" Ice 1" Ice No Ice	8.2619 8.8215 9.3462	6.3042 7.4790 8.3676	0.07 0.14 0.21
AM-X-CD-16-65-00T-RET w/ Mount Pipe	C	From Leg	4.0000 0.00 2.00	0.000	91.0000	1/2" Ice 1" Ice No Ice	8.2619 8.8215 9.3462	6.3042 7.4790 8.3676	0.07 0.14 0.21
(2) 7770.00 w/ Mount Pipe	A	From Leg	4.0000 0.00 2.00	0.000	91.0000	1/2" Ice 1" Ice No Ice	5.7460 6.1791 6.6067	4.2543 5.0137 5.7109	0.06 0.10 0.16
(2) 7770.00 w/ Mount Pipe	B	From Leg	4.0000 0.00 2.00	0.000	91.0000	1/2" Ice 1" Ice No Ice	5.7460 6.1791 6.6067	4.2543 5.0137 5.7109	0.06 0.10 0.16
(2) 7770.00 w/ Mount Pipe	C	From Leg	4.0000 0.00 2.00	0.000	91.0000	1/2" Ice 1" Ice No Ice	5.7460 6.1791 6.6067	4.2543 5.0137 5.7109	0.06 0.10 0.16
(2) LGP 17201	A	From Leg	4.0000 0.00	0.000	91.0000	1/2" No Ice	1.6680 1.8289	0.4669 0.5676	0.03 0.04

Description	Face or Leg	Offset Type	Offsets: Horz Lateral Vert ft ft ft	Azimuth Adjustment t °	Placement ft	C _{AA} Front ft ²	C _{AA} Side ft ²	Weight K
			2.00			Ice 1" Ice No Ice	1.9973 0.6752	0.06
(2) LGP 17201	B	From Leg	4.0000 0.00 2.00	0.000	91.0000	1" Ice No Ice 1/2" Ice	1.6680 0.4669 1.8289 0.5676 1.9973 0.6752	0.03 0.04 0.06
(2) LGP 17201	C	From Leg	4.0000 0.00 2.00	0.000	91.0000	1" Ice No Ice 1/2" Ice	1.6680 0.4669 1.8289 0.5676 1.9973 0.6752	0.03 0.04 0.06
DC6-48-60-18-8F	A	From Leg	4.0000 0.00 2.00	0.000	91.0000	1" Ice No Ice 1/2" Ice	0.9167 0.9167 1.4583 1.4583 1.6431 1.6431	0.02 0.04 0.06
(2) LGP21901	A	From Leg	4.0000 0.00 2.00	0.000	91.0000	1" Ice No Ice 1/2" Ice	0.2310 0.1575 0.2941 0.2129 0.3647 0.2756	0.01 0.01 0.01
(2) LGP21901	B	From Leg	4.0000 0.00 2.00	0.000	91.0000	1" Ice No Ice 1/2" Ice	0.2310 0.1575 0.2941 0.2129 0.3647 0.2756	0.01 0.01 0.01
(2) LGP21901	C	From Leg	4.0000 0.00 2.00	0.000	91.0000	1" Ice No Ice 1/2" Ice	0.2310 0.1575 0.2941 0.2129 0.3647 0.2756	0.01 0.01 0.01
RRUS 12	A	From Leg	4.0000 0.00 2.00	0.000	91.0000	1" Ice No Ice 1/2" Ice	3.1450 1.2854 3.3648 1.4379 3.5920 1.5998	0.06 0.08 0.11
RRUS 12	B	From Leg	4.0000 0.00 2.00	0.000	91.0000	1" Ice No Ice 1/2" Ice	3.1450 1.2854 3.3648 1.4379 3.5920 1.5998	0.06 0.08 0.11
RRUS 12	C	From Leg	4.0000 0.00 2.00	0.000	91.0000	1" Ice No Ice 1/2" Ice	3.1450 1.2854 3.3648 1.4379 3.5920 1.5998	0.06 0.08 0.11
RRUS 11	A	From Leg	4.0000 0.00 2.00	0.000	91.0000	1" Ice No Ice 1/2" Ice	2.7908 1.1923 2.9984 1.3395 3.2134 1.4957	0.05 0.07 0.10
RRUS 11	B	From Leg	4.0000 0.00 2.00	0.000	91.0000	1" Ice No Ice 1/2" Ice	2.7908 1.1923 2.9984 1.3395 3.2134 1.4957	0.05 0.07 0.10
RRUS 11	C	From Leg	4.0000 0.00 2.00	0.000	91.0000	1" Ice No Ice 1/2" Ice	2.7908 1.1923 2.9984 1.3395 3.2134 1.4957	0.05 0.07 0.10
1001983	A	From Leg	4.0000 0.00 2.00	0.000	91.0000	1" Ice No Ice 1/2" Ice	0.0524 0.1758 0.0861 0.2317 0.1272 0.2950	0.00 0.01 0.01
1001983	B	From Leg	4.0000 0.00 2.00	0.000	91.0000	1" Ice No Ice 1/2" Ice	0.0524 0.1758 0.0861 0.2317 0.1272 0.2950	0.00 0.01 0.01
1001983	C	From Leg	4.0000 0.00 2.00	0.000	91.0000	1" Ice No Ice 1/2" Ice	0.0524 0.1758 0.0861 0.2317 0.1272 0.2950	0.00 0.01 0.01

Description	Face or Leg	Offset Type	Offsets: Horz Lateral Vert ft ft ft	Azimuth Adjustment t °	Placement ft	C _{AA} Front ft ²	C _{AA} Side ft ²	Weight K	
2.375" OD x 6' Mount Pipe	A	From Leg	4.0000 0.00 0.00	0.000	91.0000	1" Ice			
						No Ice	1.4250	1.4250	0.03
						1/2" Ice	1.9250	1.9250	0.04
2.375" OD x 6' Mount Pipe	B	From Leg	4.0000 0.00 0.00	0.000	91.0000	1" Ice			
						No Ice	1.4250	1.4250	0.03
						1/2" Ice	1.9250	1.9250	0.04
2.375" OD x 6' Mount Pipe	C	From Leg	4.0000 0.00 0.00	0.000	91.0000	1" Ice			
						No Ice	1.4250	1.4250	0.03
						1/2" Ice	1.9250	1.9250	0.04
Platform Mount [LP 1201-1]	C	None		0.000	91.0000	1" Ice			
						No Ice	23.1000	23.1000	2.10
						1/2" Ice	26.8000	26.8000	2.50
*** *****									
APX16DWV-16DWV-S-E-A20 w/ Mount Pipe	A	From Leg	4.0000 0.00 1.00	20.000	82.0000	1" Ice			
						No Ice	6.8239	3.4938	0.06
						1/2" Ice	7.2751	4.2631	0.11
APX16DWV-16DWV-S-E-A20 w/ Mount Pipe	B	From Leg	4.0000 0.00 1.00	30.000	82.0000	1" Ice			
						No Ice	6.8239	3.4938	0.06
						1/2" Ice	7.2751	4.2631	0.11
APX16DWV-16DWV-S-E-A20 w/ Mount Pipe	C	From Leg	4.0000 0.00 1.00	-20.000	82.0000	1" Ice			
						No Ice	6.8239	3.4938	0.06
						1/2" Ice	7.2751	4.2631	0.11
APX16DWV-16DWV-S-E-A20 w/ Mount Pipe	A	From Leg	4.0000 0.00 1.00	-60.000	82.0000	1" Ice			
						No Ice	6.8239	3.4938	0.06
						1/2" Ice	7.2751	4.2631	0.11
GPS_A	A	From Leg	4.0000 0.00 1.00	0.000	82.0000	1" Ice			
						No Ice	0.2550	0.2550	0.00
						1/2" Ice	0.3205	0.3205	0.00
APXVAA24_43-U-A20 w/ Mount Pipe	A	From Leg	4.0000 0.00 1.00	20.000	82.0000	1" Ice			
						No Ice	20.5042	10.8819	0.13
						1/2" Ice	21.2552	12.4078	0.27
APXVAA24_43-U-A20 w/ Mount Pipe	B	From Leg	4.0000 0.00 1.00	30.000	82.0000	1" Ice			
						No Ice	20.5042	10.8819	0.13
						1/2" Ice	21.2552	12.4078	0.27
APXVAA24_43-U-A20 w/ Mount Pipe	C	From Leg	4.0000 0.00 1.00	-20.000	82.0000	1" Ice			
						No Ice	20.5042	10.8819	0.13
						1/2" Ice	21.2552	12.4078	0.27
APXVAA24_43-U-A20 w/ Mount Pipe	A	From Leg	4.0000 0.00 1.00	-60.000	82.0000	1" Ice			
						No Ice	20.5042	10.8819	0.13
						1/2" Ice	21.2552	12.4078	0.27
AIR 32 B2A/B66AA w/ Mount Pipe	A	From Leg	4.0000 0.00 1.00	20.000	82.0000	1" Ice			
						No Ice	6.7474	6.0700	0.15
						1/2" Ice	7.2017	6.8671	0.21
AIR 32 B2A/B66AA w/ Mount Pipe	B	From Leg	4.0000 0.00	30.000	82.0000	1" Ice			
						No Ice	6.7474	6.0700	0.15
						1/2" Ice	7.2017	6.8671	0.21

Description	Face or Leg	Offset Type	Offsets: Horz Lateral Vert ft ft ft	Azimuth Adjustment t °	Placement ft	C _{AA} Front ft ²	C _{AA} Side ft ²	Weight K
			1.00			Ice 1" Ice No Ice	7.6475 7.5828	0.28
AIR 32 B2A/B66AA w/ Mount Pipe	C	From Leg	4.0000 0.00 1.00	-20.000	82.0000	1/2" Ice 1" Ice	6.7474 7.2017 7.6475 7.5828	0.15 0.21 0.28
AIR 32 B2A/B66AA w/ Mount Pipe	A	From Leg	4.0000 0.00 1.00	-60.000	82.0000	No Ice 1/2" Ice 1" Ice	6.7474 7.2017 7.6475 7.5828	0.15 0.21 0.28
(3) 641280-DF-2X	A	From Leg	4.0000 0.00 1.00	0.000	82.0000	No Ice 1/2" Ice 1" Ice	0.4441 0.5289 0.6211 0.3765	0.01 0.02 0.02
(2) 641280-DF-2X	A	From Leg	4.0000 0.00 1.00	20.000	82.0000	No Ice 1/2" Ice 1" Ice	0.4441 0.5289 0.6211 0.3765	0.01 0.02 0.02
(3) 641280-DF-2X	C	From Leg	4.0000 0.00 1.00	-20.000	82.0000	No Ice 1/2" Ice 1" Ice	0.4441 0.5289 0.6211 0.3765	0.01 0.02 0.02
RRUS 11 B12	A	From Leg	4.0000 0.00 1.00	0.000	82.0000	No Ice 1/2" Ice 1" Ice	2.8333 3.0426 3.2593 1.4848	0.05 0.07 0.10
RRUS 11 B12	A	From Leg	4.0000 0.00 1.00	20.000	82.0000	No Ice 1/2" Ice 1" Ice	2.8333 3.0426 3.2593 1.4848	0.05 0.07 0.10
(2) RRUS 11 B12	C	From Leg	4.0000 0.00 1.00	-20.000	82.0000	No Ice 1/2" Ice 1" Ice	2.8333 3.0426 3.2593 1.4848	0.05 0.07 0.10
RADIO 4478	A	From Leg	4.0000 0.00 1.00	0.000	82.0000	No Ice 1/2" Ice 1" Ice	1.6250 1.7843 1.9509 1.2704	0.06 0.07 0.09
(3) RADIO 4478	A	From Leg	4.0000 0.00 1.00	20.000	82.0000	No Ice 1/2" Ice 1" Ice	1.6250 1.7843 1.9509 1.2704	0.06 0.07 0.09
RRUS 11 B4	A	From Leg	4.0000 0.00 1.00	0.000	82.0000	No Ice 1/2" Ice 1" Ice	2.8333 3.0426 3.2593 1.4848	0.05 0.07 0.10
RRUS 11 B4	A	From Leg	4.0000 0.00 1.00	20.000	82.0000	No Ice 1/2" Ice 1" Ice	2.8333 3.0426 3.2593 1.4848	0.05 0.07 0.10
(2) RRUS 11 B4	C	From Leg	4.0000 0.00 1.00	-20.000	82.0000	No Ice 1/2" Ice 1" Ice	2.8333 3.0426 3.2593 1.4848	0.05 0.07 0.10
Platform Mount [LP 701-1]	C	None		0.000	82.0000	No Ice 1/2" Ice 1" Ice	59.1500 71.1200 83.0900	2.75 3.42 4.10

KS24019-L112A	C	From Leg	3.0000 0.00	0.000	75.0000	No Ice 1/2"	0.1407 0.1979	0.01 0.01

Description	Face or Leg	Offset Type	Offsets: Horz Lateral Vert ft ft ft	Azimuth Adjustment °	Placement ft	C _{AA} Front ft ²	C _{AA} Side ft ²	Weight K
			1.00					
Side Arm Mount [SO 701-1]	C	None		0.000	75.0000	Ice 1" Ice No Ice 0.8500 1/2" 1.1400 Ice 1.4300 1" 1" Ice	0.2621 0.2621 1.6700 2.3400 3.0100	0.01 0.07 0.08 0.09

Dishes

Description	Face or Leg	Dish Type	Offset Type	Offsets: Horz Lateral Vert ft ft ft	Azimuth Adjustment °	3 dB Beam Width °	Elevation ft	Outside Diameter ft	Aperture Area ft ²	Weight K
GHF3W-23	B	Grid	From Leg	4.0000 0.00 2.00	0.000		117.0000	3.0000	No Ice 1/2" Ice 1" Ice 7.0700 7.4700 7.8600	0.06 0.09 0.13

SHPX3-11W	A	Paraboloid w/o Radome	From Leg	4.0000 0.00 1.00	0.000		82.0000	3.2500	No Ice 1/2" Ice 1" Ice 8.2958 8.7266 9.1575	0.07 0.11 0.16

Tower Pressures - No Ice

$G_H = 1.100$

Section Elevation ft	z ft	K _z	q _z psf	A _G ft ²	F a c e A _F ft ²	A _R ft ²	A _{leg} ft ²	Leg %	C _{AA} In Face ft ²	C _{AA} Out Face ft ²
L1 117.5000-112.5000	114.9663	1.303	32.33	6.614	A 0.000 B 0.000 C 0.000	6.614	6.614	100.00	0.000	0.000
L2 112.5000-107.5000	109.9688	1.291	32.03	7.150	A 0.000 B 0.000 C 0.000	7.150	7.150	100.00	0.000	0.693
L3 107.5000-102.5000	104.9710	1.279	31.72	7.685	A 0.000 B 0.000 C 0.000	7.685	7.685	100.00	0.000	0.770
L4 102.5000-97.5000	99.9729	1.266	31.40	8.221	A 0.000 B 0.000 C 0.000	8.221	8.221	100.00	0.000	0.770
L5 97.5000-92.5000	94.9745	1.252	31.06	8.756	A 0.000 B 0.000 C 0.000	8.756	8.756	100.00	0.000	0.770
L6 92.5000-86.2900	89.3582	1.236	30.66	11.621	A 0.000 B 0.000 C 0.000	11.621	11.621	100.00	0.000	1.686
L7 86.2900-84.7100	85.4977	1.225	30.38	3.037	A 0.000 B 0.000 C 0.000	3.037	3.037	100.00	0.000	0.488
L8 84.7100-	82.1878	1.214	30.13	9.959	A 0.000	9.959	9.959	100.00	0.000	0.000

Section Elevation	z	K _Z	q _z	A _G	F a c e	A _F	A _R	A _{leg}	Leg %	C _A A _A In Face ft ²	C _A A _A Out Face ft ²
ft	ft		psf	ft ²		ft ²	ft ²	ft ²			
79.7100					B	0.000	9.959		100.00	0.000	0.000
					C	0.000	9.959		100.00	0.000	1.545
L9 79.7100- 74.7100	77.1889	1.198	29.73	10.490	A	0.000	10.490	10.490	100.00	0.000	0.000
					B	0.000	10.490		100.00	0.000	0.000
					C	0.000	10.490		100.00	0.000	1.545
L10 74.7100- 69.7100	72.1900	1.182	29.32	11.020	A	0.000	11.020	11.020	100.00	0.000	0.000
					B	0.000	11.020		100.00	0.000	0.000
					C	0.000	11.020		100.00	0.000	1.545
L11 69.7100- 64.7100	67.1909	1.164	28.88	11.550	A	0.000	11.550	11.550	100.00	0.000	0.000
					B	0.000	11.550		100.00	0.000	0.000
					C	0.000	11.550		100.00	0.000	1.909
L12 64.7100- 62.8300	63.7674	1.151	28.56	4.480	A	0.000	4.480	4.480	100.00	0.000	0.000
					B	0.000	4.480		100.00	0.000	0.000
					C	0.000	4.480		100.00	0.000	1.364
L13 62.8300- 62.5800	62.7050	1.147	28.46	0.601	A	0.000	0.601	0.601	100.00	0.000	0.000
					B	0.000	0.601		100.00	0.000	0.000
					C	0.000	0.601		100.00	0.000	0.181
L14 62.5800- 57.5800	60.0620	1.137	28.20	12.306	A	0.000	12.306	12.306	100.00	0.000	0.000
					B	0.000	12.306		100.00	0.000	0.000
					C	0.000	12.306		100.00	0.000	3.628
L15 57.5800- 52.5800	55.0628	1.116	27.69	12.836	A	0.000	12.836	12.836	100.00	0.000	0.000
					B	0.000	12.836		100.00	0.000	0.000
					C	0.000	12.836		100.00	0.000	3.628
L16 52.5800- 47.5800	50.0635	1.094	27.14	13.367	A	0.000	13.367	13.367	100.00	0.000	0.000
					B	0.000	13.367		100.00	0.000	0.000
					C	0.000	13.367		100.00	0.000	3.628
L17 47.5800- 42.6300	45.0894	1.07	26.55	13.755	A	0.000	13.755	13.755	100.00	0.000	0.000
					B	0.000	13.755		100.00	0.000	0.000
					C	0.000	13.755		100.00	0.000	3.592
L18 42.6300- 42.3800	42.5050	1.057	26.22	0.695	A	0.000	0.695	0.695	100.00	0.000	0.000
					B	0.000	0.695		100.00	0.000	0.000
					C	0.000	0.695		100.00	0.000	0.181
L19 42.3800- 37.3800	39.8644	1.043	25.87	14.183	A	0.000	14.183	14.183	100.00	0.000	0.000
					B	0.000	14.183		100.00	0.000	0.000
					C	0.000	14.183		100.00	0.000	3.628
L20 37.3800- 32.3800	34.8650	1.014	25.15	14.712	A	0.000	14.712	14.712	100.00	0.000	0.000
					B	0.000	14.712		100.00	0.000	0.000
					C	0.000	14.712		100.00	0.000	3.628
L21 32.3800- 31.7500	32.0648	0.996	24.71	1.891	A	0.000	1.891	1.891	100.00	0.000	0.000
					B	0.000	1.891		100.00	0.000	0.000
					C	0.000	1.891		100.00	0.000	0.457
L22 31.7500- 31.5000	31.6250	0.993	24.64	0.753	A	0.000	0.753	0.753	100.00	0.000	0.000
					B	0.000	0.753		100.00	0.000	0.000
					C	0.000	0.753		100.00	0.000	0.181
L23 31.5000- 26.5000	28.9856	0.975	24.19	15.334	A	0.000	15.334	15.334	100.00	0.000	0.000
					B	0.000	15.334		100.00	0.000	0.000
					C	0.000	15.334		100.00	0.000	3.628
L24 26.5000- 21.5000	23.9861	0.937	23.25	15.864	A	0.000	15.864	15.864	100.00	0.000	0.000
					B	0.000	15.864		100.00	0.000	0.000
					C	0.000	15.864		100.00	0.000	3.628
L25 21.5000- 16.5000	18.9865	0.892	22.13	16.393	A	0.000	16.393	16.393	100.00	0.000	0.000
					B	0.000	16.393		100.00	0.000	0.000
					C	0.000	16.393		100.00	0.000	3.628
L26 16.5000- 11.5000	13.9870	0.85	21.09	16.922	A	0.000	16.922	16.922	100.00	0.000	0.000
					B	0.000	16.922		100.00	0.000	0.000
					C	0.000	16.922		100.00	0.000	3.628
L27 11.5000- 6.5000	8.9874	0.85	21.09	17.452	A	0.000	17.452	17.452	100.00	0.000	0.000
					B	0.000	17.452		100.00	0.000	0.000
					C	0.000	17.452		100.00	0.000	3.628
L28 6.5000- 3.0000	4.7440	0.85	21.09	12.531	A	0.000	12.531	12.531	100.00	0.000	0.000
					B	0.000	12.531		100.00	0.000	0.000
					C	0.000	12.531		100.00	0.000	2.540
L29 3.0000- 2.7500	2.8750	0.85	21.09	0.905	A	0.000	0.905	0.905	100.00	0.000	0.000
					B	0.000	0.905		100.00	0.000	0.000

Section Elevation ft	z ft	K_z	q_z psf	A_G ft ²	Face ft	A_F ft ²	A_R ft ²	A_{leg} ft ²	Leg %	C_{AA} In Face ft ²	C_{AA} Out Face ft ²
L30 2.7500-0.0000	1.3713	0.85	21.09	10.042	C	0.000	0.905	10.042	100.00	0.000	0.181
					A	0.000	10.042			0.000	
					B	0.000	10.042			0.000	
					C	0.000	10.042			1.996	

Tower Pressure - With Ice

$G_H = 1.100$

Section Elevation ft	z ft	K_z	q_z psf	t_z in	A_G ft ²	Face ft	A_F ft ²	A_R ft ²	A_{leg} ft ²	Leg %	C_{AA} In Face ft ²	C_{AA} Out Face ft ²
L1 117.5000-112.5000	114.9663	1.303	7.92	1.6994	8.030	A	0.000	8.030	8.030	100.00	0.000	0.000
						B	0.000	8.030	100.00	0.000	0.000	
						C	0.000	8.030	100.00	0.000	2.222	
L2 112.5000-107.5000	109.9688	1.291	7.85	1.6919	8.560	A	0.000	8.560	8.560	100.00	0.000	0.000
						B	0.000	8.560	100.00	0.000	0.000	
						C	0.000	8.560	100.00	0.000	2.462	
L3 107.5000-102.5000	104.9710	1.279	7.77	1.6840	9.088	A	0.000	9.088	9.088	100.00	0.000	0.000
						B	0.000	9.088	100.00	0.000	0.000	
						C	0.000	9.088	100.00	0.000	2.454	
L4 102.5000-97.5000	99.9729	1.266	7.69	1.6758	9.617	A	0.000	9.617	9.617	100.00	0.000	0.000
						B	0.000	9.617	100.00	0.000	0.000	
						C	0.000	9.617	100.00	0.000	2.446	
L5 97.5000-92.5000	94.9745	1.252	7.61	1.6672	10.145	A	0.000	10.145	10.145	100.00	0.000	0.000
						B	0.000	10.145	100.00	0.000	0.000	
						C	0.000	10.145	100.00	0.000	2.437	
L6 92.5000-86.2900	89.3582	1.236	7.51	1.6571	13.336	A	0.000	13.336	13.336	100.00	0.000	0.000
						B	0.000	13.336	100.00	0.000	0.000	
						C	0.000	13.336	100.00	0.000	5.306	
L7 86.2900-84.7100	85.4977	1.225	7.45	1.6498	3.473	A	0.000	3.473	3.473	100.00	0.000	0.000
						B	0.000	3.473	100.00	0.000	0.000	
						C	0.000	3.473	100.00	0.000	1.536	
L8 84.7100-79.7100	82.1878	1.214	7.38	1.6433	11.329	A	0.000	11.329	11.329	100.00	0.000	0.000
						B	0.000	11.329	100.00	0.000	0.000	
						C	0.000	11.329	100.00	0.000	4.832	
L9 79.7100-74.7100	77.1889	1.198	7.29	1.6330	11.850	A	0.000	11.850	11.850	100.00	0.000	0.000
						B	0.000	11.850	100.00	0.000	0.000	
						C	0.000	11.850	100.00	0.000	4.811	
L10 74.7100-69.7100	72.1900	1.182	7.18	1.6221	12.372	A	0.000	12.372	12.372	100.00	0.000	0.000
						B	0.000	12.372	100.00	0.000	0.000	
						C	0.000	12.372	100.00	0.000	4.789	
L11 69.7100-64.7100	67.1909	1.164	7.08	1.6105	12.892	A	0.000	12.892	12.892	100.00	0.000	0.000
						B	0.000	12.892	100.00	0.000	0.000	
						C	0.000	12.892	100.00	0.000	5.755	
L12 64.7100-62.8300	63.7674	1.151	7.00	1.6021	4.982	A	0.000	4.982	4.982	100.00	0.000	0.000
						B	0.000	4.982	100.00	0.000	0.000	
						C	0.000	4.982	100.00	0.000	3.908	
L13 62.8300-62.5800	62.7050	1.147	6.97	1.5994	0.668	A	0.000	0.668	0.668	100.00	0.000	0.000
						B	0.000	0.668	100.00	0.000	0.000	
						C	0.000	0.668	100.00	0.000	0.519	
L14 62.5800-57.5800	60.0620	1.137	6.91	1.5926	13.633	A	0.000	13.633	13.633	100.00	0.000	0.000
						B	0.000	13.633	100.00	0.000	0.000	
						C	0.000	13.633	100.00	0.000	10.353	
L15 57.5800-52.5800	55.0628	1.116	6.79	1.5788	14.152	A	0.000	14.152	14.152	100.00	0.000	0.000
						B	0.000	14.152	100.00	0.000	0.000	
						C	0.000	14.152	100.00	0.000	10.294	
L16 52.5800-47.5800	50.0635	1.094	6.65	1.5638	14.670	A	0.000	14.670	14.670	100.00	0.000	0.000
						B	0.000	14.670	100.00	0.000	0.000	
						C	0.000	14.670	100.00	0.000	10.231	

Section Elevation ft	z ft	K _z	q _z psf	t _z in	A _G ft ²	F a c e	A _F ft ²	A _R ft ²	A _{leg} ft ²	Leg %	C _A A _A In Face ft ²	C _A A _A Out Face ft ²
L17 47.5800-42.6300	45.0894	1.07	6.51	1.5476	15.032	A	0.000	15.032	15.032	100.00	0.000	0.000
						B	0.000	15.032		100.00	0.000	0.000
						C	0.000	15.032		100.00	0.000	10.061
L18 42.6300-42.3800	42.5050	1.057	6.43	1.5385	0.760	A	0.000	0.760	0.760	100.00	0.000	0.000
						B	0.000	0.760		100.00	0.000	0.000
						C	0.000	0.760		100.00	0.000	0.508
L19 42.3800-37.3800	39.8644	1.043	6.34	1.5286	15.456	A	0.000	15.456	15.456	100.00	0.000	0.000
						B	0.000	15.456		100.00	0.000	0.000
						C	0.000	15.456		100.00	0.000	10.083
L20 37.3800-32.3800	34.8650	1.014	6.16	1.5083	15.969	A	0.000	15.969	15.969	100.00	0.000	0.000
						B	0.000	15.969		100.00	0.000	0.000
						C	0.000	15.969		100.00	0.000	9.997
L21 32.3800-31.7500	32.0648	0.996	6.06	1.4957	2.048	A	0.000	2.048	2.048	100.00	0.000	0.000
						B	0.000	2.048		100.00	0.000	0.000
						C	0.000	2.048		100.00	0.000	1.253
L22 31.7500-31.5000	31.6250	0.993	6.04	1.4936	0.815	A	0.000	0.815	0.815	100.00	0.000	0.000
						B	0.000	0.815		100.00	0.000	0.000
						C	0.000	0.815		100.00	0.000	0.497
L23 31.5000-26.5000	28.9856	0.975	5.93	1.4807	16.568	A	0.000	16.568	16.568	100.00	0.000	0.000
						B	0.000	16.568		100.00	0.000	0.000
						C	0.000	16.568		100.00	0.000	9.880
L24 26.5000-21.5000	23.9861	0.937	5.70	1.4529	17.075	A	0.000	17.075	17.075	100.00	0.000	0.000
						B	0.000	17.075		100.00	0.000	0.000
						C	0.000	17.075		100.00	0.000	9.763
L25 21.5000-16.5000	18.9865	0.892	5.42	1.4193	17.576	A	0.000	17.576	17.576	100.00	0.000	0.000
						B	0.000	17.576		100.00	0.000	0.000
						C	0.000	17.576		100.00	0.000	9.621
L26 16.5000-11.5000	13.9870	0.85	5.17	1.3766	18.070	A	0.000	18.070	18.070	100.00	0.000	0.000
						B	0.000	18.070		100.00	0.000	0.000
						C	0.000	18.070		100.00	0.000	9.441
L27 11.5000-6.5000	8.9874	0.85	5.17	1.3171	18.549	A	0.000	18.549	18.549	100.00	0.000	0.000
						B	0.000	18.549		100.00	0.000	0.000
						C	0.000	18.549		100.00	0.000	9.189
L28 6.5000-3.0000	4.7440	0.85	5.17	1.2355	13.252	A	0.000	13.252	13.252	100.00	0.000	0.000
						B	0.000	13.252		100.00	0.000	0.000
						C	0.000	13.252		100.00	0.000	6.192
L29 3.0000-2.7500	2.8750	0.85	5.17	1.1752	0.954	A	0.000	0.954	0.954	100.00	0.000	0.000
						B	0.000	0.954		100.00	0.000	0.000
						C	0.000	0.954		100.00	0.000	0.430
L30 2.7500-0.0000	1.3713	0.85	5.17	1.0913	10.543	A	0.000	10.543	10.543	100.00	0.000	0.000
						B	0.000	10.543		100.00	0.000	0.000
						C	0.000	10.543		100.00	0.000	4.530

Tower Pressure - Service

G_H = 1.100

Section Elevation ft	z ft	K _z	q _z psf	A _G ft ²	F a c e	A _F ft ²	A _R ft ²	A _{leg} ft ²	Leg %	C _A A _A In Face ft ²	C _A A _A Out Face ft ²
L1 117.5000-112.5000	114.9663	1.303	10.21	6.614	A	0.000	6.614	6.614	100.00	0.000	0.000
					B	0.000	6.614		100.00	0.000	0.000
					C	0.000	6.614		100.00	0.000	0.693
L2 112.5000-107.5000	109.9688	1.291	10.11	7.150	A	0.000	7.150	7.150	100.00	0.000	0.000
					B	0.000	7.150		100.00	0.000	0.000
					C	0.000	7.150		100.00	0.000	0.770
L3 107.5000-102.5000	104.9710	1.279	10.02	7.685	A	0.000	7.685	7.685	100.00	0.000	0.000
					B	0.000	7.685		100.00	0.000	0.000

Section Elevation	z	K _Z	q _z	A _G	F a c e	A _F	A _R	A _{leg}	Leg %	C _A A _A In Face ft ²	C _A A _A Out Face ft ²
ft	ft		psf	ft ²		ft ²	ft ²	ft ²			
L4 102.5000- 97.5000	99.9729	1.266	9.91	8.221	C	0.000	7.685	8.221	100.00	0.000	0.770
					A	0.000	8.221		100.00	0.000	0.000
					B	0.000	8.221		100.00	0.000	0.000
L5 97.5000- 92.5000	94.9745	1.252	9.81	8.756	C	0.000	8.221	8.756	100.00	0.000	0.770
					A	0.000	8.756		100.00	0.000	0.000
					B	0.000	8.756		100.00	0.000	0.000
L6 92.5000- 86.2900	89.3582	1.236	9.68	11.621	C	0.000	8.756	11.621	100.00	0.000	0.770
					A	0.000	11.621		100.00	0.000	0.000
					B	0.000	11.621		100.00	0.000	0.000
L7 86.2900- 84.7100	85.4977	1.225	9.59	3.037	C	0.000	11.621	3.037	100.00	0.000	1.686
					A	0.000	3.037		100.00	0.000	0.000
					B	0.000	3.037		100.00	0.000	0.000
L8 84.7100- 79.7100	82.1878	1.214	9.51	9.959	C	0.000	3.037	9.959	100.00	0.000	0.488
					A	0.000	9.959		100.00	0.000	0.000
					B	0.000	9.959		100.00	0.000	0.000
L9 79.7100- 74.7100	77.1889	1.198	9.39	10.490	C	0.000	9.959	10.490	100.00	0.000	1.545
					A	0.000	10.490		100.00	0.000	0.000
					B	0.000	10.490		100.00	0.000	0.000
L10 74.7100- 69.7100	72.1900	1.182	9.26	11.020	C	0.000	10.490	11.020	100.00	0.000	1.545
					A	0.000	11.020		100.00	0.000	0.000
					B	0.000	11.020		100.00	0.000	0.000
L11 69.7100- 64.7100	67.1909	1.164	9.12	11.550	C	0.000	11.020	11.550	100.00	0.000	1.545
					A	0.000	11.550		100.00	0.000	0.000
					B	0.000	11.550		100.00	0.000	0.000
L12 64.7100- 62.8300	63.7674	1.151	9.02	4.480	C	0.000	11.550	4.480	100.00	0.000	1.909
					A	0.000	4.480		100.00	0.000	0.000
					B	0.000	4.480		100.00	0.000	0.000
L13 62.8300- 62.5800	62.7050	1.147	8.99	0.601	C	0.000	4.480	0.601	100.00	0.000	1.364
					A	0.000	0.601		100.00	0.000	0.000
					B	0.000	0.601		100.00	0.000	0.000
L14 62.5800- 57.5800	60.0620	1.137	8.91	12.306	C	0.000	0.601	12.306	100.00	0.000	0.181
					A	0.000	12.306		100.00	0.000	0.000
					B	0.000	12.306		100.00	0.000	0.000
L15 57.5800- 52.5800	55.0628	1.116	8.74	12.836	C	0.000	12.306	12.836	100.00	0.000	3.628
					A	0.000	12.836		100.00	0.000	0.000
					B	0.000	12.836		100.00	0.000	0.000
L16 52.5800- 47.5800	50.0635	1.094	8.57	13.367	C	0.000	12.836	13.367	100.00	0.000	3.628
					A	0.000	13.367		100.00	0.000	0.000
					B	0.000	13.367		100.00	0.000	0.000
L17 47.5800- 42.6300	45.0894	1.07	8.38	13.755	C	0.000	13.367	13.755	100.00	0.000	3.628
					A	0.000	13.755		100.00	0.000	0.000
					B	0.000	13.755		100.00	0.000	0.000
L18 42.6300- 42.3800	42.5050	1.057	8.28	0.695	C	0.000	13.755	0.695	100.00	0.000	3.592
					A	0.000	0.695		100.00	0.000	0.000
					B	0.000	0.695		100.00	0.000	0.000
L19 42.3800- 37.3800	39.8644	1.043	8.17	14.183	C	0.000	0.695	14.183	100.00	0.000	0.181
					A	0.000	14.183		100.00	0.000	0.000
					B	0.000	14.183		100.00	0.000	0.000
L20 37.3800- 32.3800	34.8650	1.014	7.94	14.712	C	0.000	14.183	14.712	100.00	0.000	3.628
					A	0.000	14.712		100.00	0.000	0.000
					B	0.000	14.712		100.00	0.000	0.000
L21 32.3800- 31.7500	32.0648	0.996	7.80	1.891	C	0.000	14.712	1.891	100.00	0.000	3.628
					A	0.000	1.891		100.00	0.000	0.000
					B	0.000	1.891		100.00	0.000	0.000
L22 31.7500- 31.5000	31.6250	0.993	7.78	0.753	C	0.000	1.891	0.753	100.00	0.000	0.457
					A	0.000	0.753		100.00	0.000	0.000
					B	0.000	0.753		100.00	0.000	0.000
L23 31.5000- 26.5000	28.9856	0.975	7.64	15.334	C	0.000	0.753	15.334	100.00	0.000	0.181
					A	0.000	15.334		100.00	0.000	0.000
					B	0.000	15.334		100.00	0.000	0.000
L24 26.5000- 21.5000	23.9861	0.937	7.34	15.864	C	0.000	15.334	15.864	100.00	0.000	3.628
					A	0.000	15.864		100.00	0.000	0.000
					B	0.000	15.864		100.00	0.000	0.000
					C	0.000	15.864		100.00	0.000	3.628

Section Elevation ft	z ft	K _z	q _z psf	A _G ft ²	F a c e	A _F ft ²	A _R ft ²	A _{leg} ft ²	Leg %	C _A A _A In Face ft ²	C _A A _A Out Face ft ²
L25 21.5000- 16.5000	18.9865	0.892	6.99	16.393	A	0.000	16.393	16.393	100.00	0.000	0.000
					B	0.000	16.393		100.00	0.000	0.000
					C	0.000	16.393		100.00	0.000	3.628
L26 16.5000- 11.5000	13.9870	0.85	6.66	16.922	A	0.000	16.922	16.922	100.00	0.000	0.000
					B	0.000	16.922		100.00	0.000	0.000
					C	0.000	16.922		100.00	0.000	3.628
L27 11.5000- 6.5000	8.9874	0.85	6.66	17.452	A	0.000	17.452	17.452	100.00	0.000	0.000
					B	0.000	17.452		100.00	0.000	0.000
					C	0.000	17.452		100.00	0.000	3.628
L28 6.5000- 3.0000	4.7440	0.85	6.66	12.531	A	0.000	12.531	12.531	100.00	0.000	0.000
					B	0.000	12.531		100.00	0.000	0.000
					C	0.000	12.531		100.00	0.000	2.540
L29 3.0000- 2.7500	2.8750	0.85	6.66	0.905	A	0.000	0.905	0.905	100.00	0.000	0.000
					B	0.000	0.905		100.00	0.000	0.000
					C	0.000	0.905		100.00	0.000	0.181
L30 2.7500- 0.0000	1.3713	0.85	6.66	10.042	A	0.000	10.042	10.042	100.00	0.000	0.000
					B	0.000	10.042		100.00	0.000	0.000
					C	0.000	10.042		100.00	0.000	1.996

Load Combinations

Comb. No.	Description
1	Dead Only
2	1.2 Dead+1.6 Wind 0 deg - No Ice
3	0.9 Dead+1.6 Wind 0 deg - No Ice
4	1.2 Dead+1.6 Wind 30 deg - No Ice
5	0.9 Dead+1.6 Wind 30 deg - No Ice
6	1.2 Dead+1.6 Wind 60 deg - No Ice
7	0.9 Dead+1.6 Wind 60 deg - No Ice
8	1.2 Dead+1.6 Wind 90 deg - No Ice
9	0.9 Dead+1.6 Wind 90 deg - No Ice
10	1.2 Dead+1.6 Wind 120 deg - No Ice
11	0.9 Dead+1.6 Wind 120 deg - No Ice
12	1.2 Dead+1.6 Wind 150 deg - No Ice
13	0.9 Dead+1.6 Wind 150 deg - No Ice
14	1.2 Dead+1.6 Wind 180 deg - No Ice
15	0.9 Dead+1.6 Wind 180 deg - No Ice
16	1.2 Dead+1.6 Wind 210 deg - No Ice
17	0.9 Dead+1.6 Wind 210 deg - No Ice
18	1.2 Dead+1.6 Wind 240 deg - No Ice
19	0.9 Dead+1.6 Wind 240 deg - No Ice
20	1.2 Dead+1.6 Wind 270 deg - No Ice
21	0.9 Dead+1.6 Wind 270 deg - No Ice
22	1.2 Dead+1.6 Wind 300 deg - No Ice
23	0.9 Dead+1.6 Wind 300 deg - No Ice
24	1.2 Dead+1.6 Wind 330 deg - No Ice
25	0.9 Dead+1.6 Wind 330 deg - No Ice
26	1.2 Dead+1.0 Ice+1.0 Temp
27	1.2 Dead+1.0 Wind 0 deg+1.0 Ice+1.0 Temp
28	1.2 Dead+1.0 Wind 30 deg+1.0 Ice+1.0 Temp
29	1.2 Dead+1.0 Wind 60 deg+1.0 Ice+1.0 Temp
30	1.2 Dead+1.0 Wind 90 deg+1.0 Ice+1.0 Temp
31	1.2 Dead+1.0 Wind 120 deg+1.0 Ice+1.0 Temp
32	1.2 Dead+1.0 Wind 150 deg+1.0 Ice+1.0 Temp
33	1.2 Dead+1.0 Wind 180 deg+1.0 Ice+1.0 Temp
34	1.2 Dead+1.0 Wind 210 deg+1.0 Ice+1.0 Temp
35	1.2 Dead+1.0 Wind 240 deg+1.0 Ice+1.0 Temp
36	1.2 Dead+1.0 Wind 270 deg+1.0 Ice+1.0 Temp
37	1.2 Dead+1.0 Wind 300 deg+1.0 Ice+1.0 Temp
38	1.2 Dead+1.0 Wind 330 deg+1.0 Ice+1.0 Temp

Comb. No.	Description
39	Dead+Wind 0 deg - Service
40	Dead+Wind 30 deg - Service
41	Dead+Wind 60 deg - Service
42	Dead+Wind 90 deg - Service
43	Dead+Wind 120 deg - Service
44	Dead+Wind 150 deg - Service
45	Dead+Wind 180 deg - Service
46	Dead+Wind 210 deg - Service
47	Dead+Wind 240 deg - Service
48	Dead+Wind 270 deg - Service
49	Dead+Wind 300 deg - Service
50	Dead+Wind 330 deg - Service

Maximum Member Forces

Section No.	Elevation ft	Component Type	Condition	Gov. Load Comb.	Axial K	Major Axis Moment kip-ft	Minor Axis Moment kip-ft
L1	117.5 - 112.5	Pole	Max Tension	1	0.00	-0.00	-0.00
			Max. Compression	26	-8.07	-0.53	-0.60
			Max. Mx	8	-2.33	-45.19	-0.19
			Max. My	14	-2.32	-0.54	-44.67
			Max. Vy	20	-7.55	44.54	0.06
			Max. Vx	14	7.50	-0.54	-44.67
			Max. Torque	20			0.71
L2	112.5 - 107.5	Pole	Max Tension	1	0.00	0.00	0.00
			Max. Compression	26	-8.59	-0.44	-0.60
			Max. Mx	8	-2.55	-83.72	-0.28
			Max. My	14	-2.54	-0.71	-82.95
			Max. Vy	20	-7.87	83.09	0.15
			Max. Vx	14	7.82	-0.71	-82.95
			Max. Torque	20			0.73
L3	107.5 - 102.5	Pole	Max Tension	1	0.00	0.00	0.00
			Max. Compression	26	-18.31	-0.34	0.14
			Max. Mx	8	-5.89	-154.63	-0.22
			Max. My	14	-5.86	-0.87	-153.76
			Max. Vy	20	-14.78	154.03	0.38
			Max. Vx	14	14.78	-0.87	-153.76
			Max. Torque	20			0.73
L4	102.5 - 97.5	Pole	Max Tension	1	0.00	0.00	0.00
			Max. Compression	26	-18.95	-0.22	0.18
			Max. Mx	8	-6.30	-229.27	-0.27
			Max. My	14	-6.27	-1.03	-228.46
			Max. Vy	20	-15.10	228.70	0.51
			Max. Vx	14	15.11	-1.03	-228.46
			Max. Torque	20			0.31
L5	97.5 - 92.5	Pole	Max Tension	1	0.00	0.00	0.00
			Max. Compression	26	-19.62	-0.10	0.22
			Max. Mx	8	-6.75	-305.51	-0.31
			Max. My	14	-6.71	-1.19	-304.78
			Max. Vy	20	-15.42	304.97	0.64
			Max. Vx	14	15.43	-1.19	-304.78
			Max. Torque	20			0.33
L6	92.5 - 86.29	Pole	Max Tension	1	0.00	0.00	0.00
			Max. Compression	26	-28.56	0.02	0.69
			Max. Mx	8	-10.61	-361.80	-0.22
			Max. My	2	-10.56	0.51	361.09
			Max. Vy	20	-20.71	361.29	0.82
			Max. Vx	14	20.73	-1.27	-361.01
			Max. Torque	20			0.34

Section No.	Elevation ft	Component Type	Condition	Gov. Load Comb.	Axial K	Major Axis Moment kip-ft	Minor Axis Moment kip-ft
L7	86.29 - 84.71	Pole	Max Tension	1	0.00	0.00	0.00
			Max. Compression	26	-29.94	0.24	0.73
			Max. Mx	8	-11.47	-466.37	-0.23
			Max. My	2	-11.41	0.66	465.77
			Max. Vy	20	-21.15	465.92	0.97
			Max. Vx	14	21.17	-1.41	-465.72
			Max. Torque	20			0.19
L8	84.71 - 79.71	Pole	Max Tension	1	0.00	0.00	0.00
			Max. Compression	26	-44.07	3.38	13.29
			Max. Mx	20	-17.37	599.69	4.18
			Max. My	2	-17.18	1.26	607.33
			Max. Vy	20	-30.52	599.69	4.18
			Max. Vx	14	32.05	0.21	-598.69
			Max. Torque	9			10.90
L9	79.71 - 74.71	Pole	Max Tension	1	0.00	0.00	0.00
			Max. Compression	26	-45.38	3.71	13.32
			Max. Mx	20	-18.38	753.18	3.34
			Max. My	2	-18.21	0.44	767.31
			Max. Vy	20	-30.98	753.18	3.34
			Max. Vx	14	32.51	1.10	-759.82
			Max. Torque	9			10.87
L10	74.71 - 69.71	Pole	Max Tension	1	0.00	0.00	0.00
			Max. Compression	26	-46.61	4.00	13.32
			Max. Mx	20	-19.37	908.85	2.49
			Max. My	2	-19.22	-0.40	929.50
			Max. Vy	20	-31.32	908.85	2.49
			Max. Vx	14	32.85	1.96	-923.15
			Max. Torque	9			10.80
L11	69.71 - 64.71	Pole	Max Tension	1	0.00	0.00	0.00
			Max. Compression	26	-47.86	4.29	13.28
			Max. Mx	20	-20.40	1066.29	1.61
			Max. My	2	-20.27	-1.24	1093.45
			Max. Vy	20	-31.69	1066.29	1.61
			Max. Vx	14	33.22	2.82	-1088.25
			Max. Torque	9			10.75
L12	64.71 - 62.83	Pole	Max Tension	1	0.00	0.00	0.00
			Max. Compression	26	-48.35	4.40	13.26
			Max. Mx	20	-20.76	1126.09	1.27
			Max. My	2	-20.63	-1.56	1155.70
			Max. Vy	20	-31.98	1126.09	1.27
			Max. Vx	14	33.52	3.14	-1150.94
			Max. Torque	9			10.68
L13	62.83 - 62.58	Pole	Max Tension	1	0.00	0.00	0.00
			Max. Compression	26	-48.44	4.42	13.26
			Max. Mx	20	-20.90	1134.09	1.23
			Max. My	2	-20.77	-1.60	1164.02
			Max. Vy	20	-31.99	1134.09	1.23
			Max. Vx	14	33.53	3.19	-1159.32
			Max. Torque	9			10.64
L14	62.58 - 57.58	Pole	Max Tension	1	0.00	0.00	0.00
			Max. Compression	26	-50.40	4.72	13.19
			Max. Mx	20	-22.42	1296.28	0.34
			Max. My	2	-22.30	-2.45	1332.71
			Max. Vy	20	-32.89	1296.28	0.34
			Max. Vx	14	34.42	4.04	-1329.17
			Max. Torque	9			10.63
L15	57.58 -	Pole	Max Tension	1	0.00	0.00	0.00

Section No.	Elevation ft	Component Type	Condition	Gov. Load Comb.	Axial K	Major Axis Moment kip-ft	Minor Axis Moment kip-ft			
L16	52.58 - 47.58	Pole	Max. Compression	26	-52.39	5.02	13.10			
			Max. Mx	20	-24.00	1462.91	-0.55			
			Max. My	2	-23.89	-3.29	1505.83			
			Max. Vy	20	-33.78	1462.91	-0.55			
			Max. Vx	14	35.31	4.90	-1503.45			
			Max. Torque	9			10.52			
			Max Tension	1	0.00	0.00	0.00			
			Max. Compression	26	-54.41	5.32	13.01			
			Max. Mx	20	-25.61	1633.97	-1.46			
			Max. My	2	-25.51	-4.13	1683.39			
L17	47.58 - 42.63	Pole	Max. Vy	20	-34.66	1633.97	-1.46			
			Max. Vx	14	36.20	5.76	-1682.17			
			Max. Torque	9			10.40			
			Max Tension	1	0.00	0.00	0.00			
			Max. Compression	26	-54.49	5.34	13.00			
			Max. Mx	20	-25.69	1640.90	-1.49			
			Max. My	2	-25.59	-4.17	1690.58			
			Max. Vy	20	-34.69	1640.90	-1.49			
			Max. Vx	14	36.22	5.79	-1689.41			
			Max. Torque	7			10.35			
L18	42.63 - 42.38	Pole	Max Tension	1	0.00	0.00	0.00			
			Max. Compression	26	-58.11	5.65	12.90			
			Max. Mx	20	-28.51	1816.84	-2.39			
			Max. My	2	-28.41	-5.01	1873.01			
			Max. Vy	20	-35.68	1816.84	-2.39			
			Max. Vx	14	37.21	6.65	-1873.01			
			Max. Torque	7			10.35			
			Max Tension	1	0.00	0.00	0.00			
			Max. Compression	26	-60.17	5.96	12.78			
			Max. Mx	20	-30.17	1997.33	-3.31			
L19	42.38 - 37.38	Pole	Max. My	14	-30.08	7.51	-2061.15			
			Max. Vy	20	-36.53	1997.33	-3.31			
			Max. Vx	14	38.06	7.51	-2061.15			
			Max. Torque	7			10.35			
			Max Tension	1	0.00	0.00	0.00			
			Max. Compression	26	-62.26	6.27	12.66			
			Max. Mx	20	-31.89	2182.01	-4.23			
			Max. My	14	-31.81	8.37	-2253.47			
			Max. Vy	20	-37.36	2182.01	-4.23			
			Max. Vx	14	38.89	8.37	-2253.47			
L20	37.38 - 32.38	Pole	Max. Torque	7			10.35			
			Max Tension	1	0.00	0.00	0.00			
			Max. Compression	26	-62.53	6.31	12.64			
			Max. Mx	20	-32.11	2205.57	-4.34			
			Max. My	14	-32.04	8.48	-2278.00			
			Max. Vy	20	-37.46	2205.57	-4.34			
			Max. Vx	14	38.99	8.48	-2278.00			
			Max. Torque	7			10.34			
			Max Tension	1	0.00	0.00	0.00			
			Max. Compression	26	-62.64	6.33	12.63			
L21	32.38 - 31.75	Pole	Max. Mx	20	-32.22	2214.94	-4.39			
			Max. My	14	-32.14	8.52	-2287.75			
			Max. Vy	20	-37.50	2214.94	-4.39			
			Max. Vx	14	39.03	8.52	-2287.75			
			Max. Torque	7			10.34			
			Max Tension	1	0.00	0.00	0.00			
			Max. Compression	26	-64.97	6.64	12.50			
			Max. Mx	20	-34.14	2403.94	-5.31			
			L22	31.75 - 31.5	Pole	Max. My	14	-32.04	8.48	-2278.00
						Max. Vy	20	-37.46	2205.57	-4.34
Max. Vx	14	38.99				8.48	-2278.00			
Max. Torque	7						10.34			
Max Tension	1	0.00				0.00	0.00			
Max. Compression	26	-62.53				6.31	12.64			
Max. Mx	20	-32.11				2205.57	-4.34			
Max. My	14	-32.04				8.48	-2278.00			
Max. Vy	20	-37.46				2205.57	-4.34			
Max. Vx	14	38.99				8.48	-2278.00			
L23	31.5 - 26.5	Pole	Max. Torque	7			10.34			
			Max Tension	1	0.00	0.00	0.00			
			Max. Compression	26	-64.97	6.64	12.50			
			Max. Mx	20	-34.14	2403.94	-5.31			

Section No.	Elevation ft	Component Type	Condition	Gov. Load Comb.	Axial K	Major Axis Moment kip-ft	Minor Axis Moment kip-ft
L24	26.5 - 21.5	Pole	Max. My	14	-34.07	9.38	-2484.37
			Max. Vy	20	-38.11	2403.94	-5.31
			Max. Vx	14	39.63	9.38	-2484.37
			Max. Torque	7			10.34
			Max Tension	1	0.00	0.00	0.00
			Max. Compression	26	-67.32	6.95	12.34
			Max. Mx	20	-36.11	2595.85	-6.24
			Max. My	14	-36.05	10.23	-2683.89
			Max. Vy	20	-38.68	2595.85	-6.24
			Max. Vx	14	40.20	10.23	-2683.89
L25	21.5 - 16.5	Pole	Max. Torque	7			10.34
			Max Tension	1	0.00	0.00	0.00
			Max. Compression	26	-69.69	7.24	12.16
			Max. Mx	20	-38.10	2790.51	-7.17
			Max. My	14	-38.06	11.09	-2886.13
			Max. Vy	20	-39.20	2790.51	-7.17
			Max. Vx	14	40.72	11.09	-2886.13
			Max. Torque	7			10.34
			Max Tension	1	0.00	0.00	0.00
			Max. Compression	26	-72.08	7.54	11.99
L26	16.5 - 11.5	Pole	Max. Mx	20	-40.13	2987.72	-8.10
			Max. My	14	-40.10	11.94	-3090.90
			Max. Vy	20	-39.69	2987.72	-8.10
			Max. Vx	14	41.21	11.94	-3090.90
			Max. Torque	7			10.34
			Max Tension	1	0.00	0.00	0.00
			Max. Compression	26	-74.48	7.83	11.82
			Max. Mx	20	-42.19	3187.36	-9.04
			Max. My	14	-42.17	12.79	-3298.07
			Max. Vy	20	-40.18	3187.36	-9.04
L27	11.5 - 6.5	Pole	Max. Vx	14	41.69	12.79	-3298.07
			Max. Torque	7			10.34
			Max Tension	1	0.00	0.00	0.00
			Max. Compression	26	-74.48	7.83	11.82
			Max. Mx	20	-42.19	3187.36	-9.04
			Max. My	14	-42.17	12.79	-3298.07
			Max. Vy	20	-40.18	3187.36	-9.04
			Max. Vx	14	41.69	12.79	-3298.07
			Max. Torque	7			10.34
			Max Tension	1	0.00	0.00	0.00
L28	6.5 - 3	Pole	Max. Compression	26	-76.16	8.02	11.71
			Max. Mx	20	-43.64	3328.55	-9.69
			Max. My	14	-43.64	13.38	-3444.52
			Max. Vy	20	-40.52	3328.55	-9.69
			Max. Vx	14	42.02	13.38	-3444.52
			Max. Torque	7			10.34
			Max Tension	1	0.00	0.00	0.00
			Max. Compression	26	-76.28	8.03	11.71
			Max. Mx	20	-43.77	3338.68	-9.74
			Max. My	14	-43.76	13.43	-3455.02
L29	3 - 2.75	Pole	Max. Vy	20	-40.53	3338.68	-9.74
			Max. Vx	14	42.03	13.43	-3455.02
			Max. Torque	7			10.33
			Max Tension	1	0.00	0.00	0.00
			Max. Compression	26	-76.28	8.03	11.71
			Max. Mx	20	-43.77	3338.68	-9.74
			Max. My	14	-43.76	13.43	-3455.02
			Max. Vy	20	-40.53	3338.68	-9.74
			Max. Vx	14	42.03	13.43	-3455.02
			Max. Torque	7			10.33
L30	2.75 - 0	Pole	Max. Compression	26	-77.58	8.16	11.63
			Max. Mx	20	-44.91	3450.53	-10.25
			Max. My	14	-44.90	13.89	-3571.00
			Max. Vy	20	-40.83	3450.53	-10.25
			Max. Vx	14	42.33	13.89	-3571.00
			Max. Torque	7			10.33
			Max Tension	1	0.00	0.00	0.00
			Max. Compression	26	-77.58	8.16	11.63
			Max. Mx	20	-44.91	3450.53	-10.25
			Max. My	14	-44.90	13.89	-3571.00

Maximum Reactions

Location	Condition	Gov. Load Comb.	Vertical K	Horizontal, X K	Horizontal, Z K
Pole	Max. Vert	26	77.58	-0.00	-0.00
	Max. H _x	21	33.69	40.80	-0.18

Location	Condition	Gov. Load Comb.	Vertical K	Horizontal, X K	Horizontal, Z K
	Max. H _z	2	44.93	-0.17	42.08
	Max. M _x	2	3561.04	-0.17	42.08
	Max. M _z	8	3447.21	-40.80	0.18
	Max. Torsion	7	10.33	-35.48	21.15
	Min. Vert	15	33.69	0.16	-42.30
	Min. H _x	9	33.69	-40.80	0.18
	Min. H _z	14	44.93	0.16	-42.30
	Min. M _x	14	-3571.00	0.16	-42.30
	Min. M _z	20	-3450.53	40.80	-0.18
	Min. Torsion	19	-9.55	35.37	-21.68

Tower Mast Reaction Summary

Load Combination	Vertical K	Shear _x K	Shear _z K	Overturning Moment, M _x kip-ft	Overturning Moment, M _z kip-ft	Torque kip-ft
Dead Only	37.44	0.00	0.00	-3.68	1.34	0.00
1.2 Dead+1.6 Wind 0 deg - No Ice	44.93	0.17	-42.08	-3561.04	-12.05	-3.87
0.9 Dead+1.6 Wind 0 deg - No Ice	33.69	0.17	-42.08	-3530.77	-12.39	-3.88
1.2 Dead+1.6 Wind 30 deg - No Ice	44.93	20.63	-36.43	-3081.37	-1740.88	-8.65
0.9 Dead+1.6 Wind 30 deg - No Ice	33.69	20.63	-36.43	-3055.05	-1727.03	-8.68
1.2 Dead+1.6 Wind 60 deg - No Ice	44.93	35.48	-21.15	-1791.17	-2995.65	-10.29
0.9 Dead+1.6 Wind 60 deg - No Ice	33.69	35.48	-21.15	-1775.39	-2971.49	-10.33
1.2 Dead+1.6 Wind 90 deg - No Ice	44.93	40.80	-0.18	-18.72	-3447.21	-9.13
0.9 Dead+1.6 Wind 90 deg - No Ice	33.69	40.80	-0.18	-17.43	-3419.32	-9.17
1.2 Dead+1.6 Wind 120 deg - No Ice	44.93	35.24	21.41	1807.10	-2977.98	-5.65
0.9 Dead+1.6 Wind 120 deg - No Ice	33.69	35.24	21.41	1793.52	-2953.93	-5.67
1.2 Dead+1.6 Wind 150 deg - No Ice	44.93	20.16	36.67	3096.16	-1703.14	-0.76
0.9 Dead+1.6 Wind 150 deg - No Ice	33.69	20.16	36.67	3072.04	-1689.55	-0.77
1.2 Dead+1.6 Wind 180 deg - No Ice	44.93	-0.16	42.30	3571.00	13.89	3.86
0.9 Dead+1.6 Wind 180 deg - No Ice	33.69	-0.16	42.30	3543.01	13.40	3.87
1.2 Dead+1.6 Wind 210 deg - No Ice	44.93	-20.41	36.79	3104.01	1723.85	7.52
0.9 Dead+1.6 Wind 210 deg - No Ice	33.69	-20.41	36.79	3079.87	1709.32	7.56
1.2 Dead+1.6 Wind 240 deg - No Ice	44.93	-35.37	21.68	1827.69	2989.55	9.51
0.9 Dead+1.6 Wind 240 deg - No Ice	33.69	-35.37	21.68	1814.00	2964.62	9.55
1.2 Dead+1.6 Wind 270 deg - No Ice	44.93	-40.80	0.18	10.26	3450.53	9.09
0.9 Dead+1.6 Wind 270 deg - No Ice	33.69	-40.80	0.18	11.35	3421.79	9.13
1.2 Dead+1.6 Wind 300 deg - No Ice	44.93	-35.32	-20.87	-1770.08	2986.92	6.44
0.9 Dead+1.6 Wind 300 deg - No Ice	33.69	-35.32	-20.87	-1754.43	2961.97	6.46

Load Combination	Vertical	Shear _x	Shear _z	Overturning Moment, M _x	Overturning Moment, M _z	Torque
	K	K	K	kip-ft	kip-ft	kip-ft
1.2 Dead+1.6 Wind 330 deg - No Ice	44.93	-20.34	-36.33	-3076.87	1721.00	1.92
0.9 Dead+1.6 Wind 330 deg - No Ice	33.69	-20.34	-36.33	-3050.54	1706.45	1.93
1.2 Dead+1.0 Ice+1.0 Temp	77.58	0.00	0.00	-11.63	8.16	0.00
1.2 Dead+1.0 Wind 0 deg+1.0 Ice+1.0 Temp	77.58	-0.05	-10.88	-978.86	16.81	-1.56
1.2 Dead+1.0 Wind 30 deg+1.0 Ice+1.0 Temp	77.58	5.35	-9.39	-844.49	-466.65	-2.26
1.2 Dead+1.0 Wind 60 deg+1.0 Ice+1.0 Temp	77.58	9.23	-5.45	-494.88	-811.72	-2.28
1.2 Dead+1.0 Wind 90 deg+1.0 Ice+1.0 Temp	77.58	10.63	-0.04	-15.31	-936.36	-1.67
1.2 Dead+1.0 Wind 120 deg+1.0 Ice+1.0 Temp	77.58	9.19	5.49	476.34	-809.00	-0.71
1.2 Dead+1.0 Wind 150 deg+1.0 Ice+1.0 Temp	77.58	5.26	9.44	826.72	-459.59	0.43
1.2 Dead+1.0 Wind 180 deg+1.0 Ice+1.0 Temp	77.58	-0.03	10.89	954.98	10.60	1.43
1.2 Dead+1.0 Wind 210 deg+1.0 Ice+1.0 Temp	77.58	-5.32	9.45	826.66	479.92	2.06
1.2 Dead+1.0 Wind 240 deg+1.0 Ice+1.0 Temp	77.58	-9.28	5.48	472.25	835.55	2.27
1.2 Dead+1.0 Wind 270 deg+1.0 Ice+1.0 Temp	77.58	-10.67	-0.01	-15.53	957.26	1.86
1.2 Dead+1.0 Wind 300 deg+1.0 Ice+1.0 Temp	77.58	-9.24	-5.41	-493.81	831.06	0.85
1.2 Dead+1.0 Wind 330 deg+1.0 Ice+1.0 Temp	77.58	-5.36	-9.38	-844.90	487.51	-0.41
Dead+Wind 0 deg - Service	37.44	0.03	-8.30	-703.02	-1.31	-0.15
Dead+Wind 30 deg - Service	37.44	4.07	-7.19	-608.81	-341.22	-1.38
Dead+Wind 60 deg - Service	37.44	7.00	-4.17	-355.13	-587.93	-2.07
Dead+Wind 90 deg - Service	37.44	8.05	-0.03	-6.64	-676.68	-2.19
Dead+Wind 120 deg - Service	37.44	6.95	4.23	352.34	-584.45	-1.75
Dead+Wind 150 deg - Service	37.44	3.98	7.24	605.81	-333.81	-0.87
Dead+Wind 180 deg - Service	37.44	-0.03	8.35	699.07	3.79	0.16
Dead+Wind 210 deg - Service	37.44	-4.03	7.26	607.36	340.01	1.15
Dead+Wind 240 deg - Service	37.44	-6.98	4.28	356.39	588.85	1.91
Dead+Wind 270 deg - Service	37.44	-8.05	0.04	-0.95	679.45	2.18
Dead+Wind 300 deg - Service	37.44	-6.97	-4.12	-350.98	588.31	1.91
Dead+Wind 330 deg - Service	37.44	-4.01	-7.17	-607.93	339.43	1.10

Solution Summary

Load Comb.	Sum of Applied Forces			Sum of Reactions			% Error
	PX K	PY K	PZ K	PX K	PY K	PZ K	
1	0.00	-37.44	0.00	-0.00	37.44	-0.00	0.004%
2	0.17	-44.93	-42.08	-0.17	44.93	42.08	0.000%
3	0.17	-33.69	-42.08	-0.17	33.69	42.08	0.000%
4	20.63	-44.93	-36.43	-20.63	44.93	36.43	0.000%
5	20.63	-33.69	-36.43	-20.63	33.69	36.43	0.000%
6	35.48	-44.93	-21.15	-35.48	44.93	21.15	0.000%
7	35.48	-33.69	-21.15	-35.48	33.69	21.15	0.000%

Load Comb.	Sum of Applied Forces			Sum of Reactions			% Error
	PX K	PY K	PZ K	PX K	PY K	PZ K	
8	40.80	-44.93	-0.18	-40.80	44.93	0.18	0.000%
9	40.80	-33.69	-0.18	-40.80	33.69	0.18	0.000%
10	35.24	-44.93	21.41	-35.24	44.93	-21.41	0.000%
11	35.24	-33.69	21.41	-35.24	33.69	-21.41	0.000%
12	20.16	-44.93	36.67	-20.16	44.93	-36.67	0.000%
13	20.16	-33.69	36.67	-20.16	33.69	-36.67	0.000%
14	-0.16	-44.93	42.30	0.16	44.93	-42.30	0.000%
15	-0.16	-33.69	42.30	0.16	33.69	-42.30	0.000%
16	-20.41	-44.93	36.79	20.41	44.93	-36.79	0.000%
17	-20.41	-33.69	36.79	20.41	33.69	-36.79	0.000%
18	-35.37	-44.93	21.68	35.37	44.93	-21.68	0.000%
19	-35.37	-33.69	21.68	35.37	33.69	-21.68	0.000%
20	-40.80	-44.93	0.18	40.80	44.93	-0.18	0.000%
21	-40.80	-33.69	0.18	40.80	33.69	-0.18	0.000%
22	-35.32	-44.93	-20.87	35.32	44.93	20.87	0.000%
23	-35.32	-33.69	-20.87	35.32	33.69	20.87	0.000%
24	-20.34	-44.93	-36.33	20.34	44.93	36.33	0.000%
25	-20.34	-33.69	-36.33	20.34	33.69	36.33	0.000%
26	0.00	-77.58	0.00	-0.00	77.58	-0.00	0.000%
27	-0.05	-77.58	-10.88	0.05	77.58	10.88	0.000%
28	5.35	-77.58	-9.39	-5.35	77.58	9.39	0.000%
29	9.23	-77.58	-5.45	-9.23	77.58	5.45	0.000%
30	10.63	-77.58	-0.04	-10.63	77.58	0.04	0.000%
31	9.19	-77.58	5.49	-9.19	77.58	-5.49	0.000%
32	5.26	-77.58	9.44	-5.26	77.58	-9.44	0.000%
33	-0.03	-77.58	10.89	0.03	77.58	-10.89	0.000%
34	-5.32	-77.58	9.45	5.32	77.58	-9.45	0.000%
35	-9.28	-77.58	5.48	9.28	77.58	-5.48	0.000%
36	-10.67	-77.58	-0.01	10.67	77.58	0.01	0.000%
37	-9.24	-77.58	-5.41	9.24	77.58	5.41	0.000%
38	-5.36	-77.58	-9.38	5.36	77.58	9.38	0.000%
39	0.03	-37.44	-8.30	-0.03	37.44	8.30	0.004%
40	4.07	-37.44	-7.19	-4.07	37.44	7.19	0.000%
41	7.00	-37.44	-4.17	-7.00	37.44	4.17	0.000%
42	8.05	-37.44	-0.03	-8.05	37.44	0.03	0.000%
43	6.95	-37.44	4.23	-6.95	37.44	-4.23	0.000%
44	3.98	-37.44	7.24	-3.98	37.44	-7.24	0.000%
45	-0.03	-37.44	8.35	0.03	37.44	-8.35	0.004%
46	-4.03	-37.44	7.26	4.03	37.44	-7.26	0.000%
47	-6.98	-37.44	4.28	6.98	37.44	-4.28	0.000%
48	-8.05	-37.44	0.04	8.05	37.44	-0.04	0.000%
49	-6.97	-37.44	-4.12	6.97	37.44	4.12	0.000%
50	-4.01	-37.44	-7.17	4.01	37.44	7.17	0.000%

Non-Linear Convergence Results

Load Combination	Converged?	Number of Cycles	Displacement Tolerance	Force Tolerance
1	Yes	6	0.00000001	0.00002598
2	Yes	16	0.00000001	0.00005748
3	Yes	15	0.00000001	0.00011496
4	Yes	18	0.00000001	0.00009314
5	Yes	18	0.00000001	0.00006298
6	Yes	18	0.00000001	0.00012172
7	Yes	18	0.00000001	0.00008347
8	Yes	17	0.00000001	0.00008749
9	Yes	17	0.00000001	0.00006283
10	Yes	18	0.00000001	0.00009515
11	Yes	18	0.00000001	0.00006465
12	Yes	18	0.00000001	0.00010506

13	Yes	18	0.00000001	0.00007155
14	Yes	16	0.00000001	0.00007038
15	Yes	15	0.00000001	0.00014064
16	Yes	18	0.00000001	0.00011473
17	Yes	18	0.00000001	0.00007836
18	Yes	18	0.00000001	0.00009460
19	Yes	18	0.00000001	0.00006422
20	Yes	17	0.00000001	0.00008178
21	Yes	17	0.00000001	0.00005878
22	Yes	18	0.00000001	0.00011556
23	Yes	18	0.00000001	0.00007908
24	Yes	18	0.00000001	0.00009726
25	Yes	18	0.00000001	0.00006585
26	Yes	13	0.00000001	0.00011162
27	Yes	17	0.00000001	0.00012615
28	Yes	17	0.00000001	0.00014088
29	Yes	17	0.00000001	0.00014305
30	Yes	17	0.00000001	0.00012017
31	Yes	17	0.00000001	0.00013468
32	Yes	17	0.00000001	0.00013495
33	Yes	17	0.00000001	0.00011907
34	Yes	17	0.00000001	0.00013899
35	Yes	17	0.00000001	0.00013789
36	Yes	17	0.00000001	0.00012371
37	Yes	17	0.00000001	0.00014564
38	Yes	17	0.00000001	0.00014526
39	Yes	12	0.00013239	0.00013263
40	Yes	14	0.00000001	0.00008404
41	Yes	15	0.00000001	0.00006020
42	Yes	14	0.00000001	0.00010999
43	Yes	14	0.00000001	0.00009288
44	Yes	14	0.00000001	0.00010681
45	Yes	12	0.00013219	0.00013216
46	Yes	14	0.00000001	0.00011856
47	Yes	14	0.00000001	0.00009836
48	Yes	14	0.00000001	0.00010891
49	Yes	14	0.00000001	0.00014868
50	Yes	14	0.00000001	0.00007984

Maximum Tower Deflections - Service Wind

Section No.	Elevation ft	Horz. Deflection in	Gov. Load Comb.	Tilt °	Twist °
L1	117.5 - 112.5	17.916	39	1.612	0.010
L2	112.5 - 107.5	16.237	39	1.588	0.010
L3	107.5 - 102.5	14.599	39	1.538	0.011
L4	102.5 - 97.5	13.023	39	1.466	0.011
L5	97.5 - 92.5	11.538	39	1.366	0.012
L6	92.5 - 86.29	10.167	39	1.251	0.012
L7	89.71 - 84.71	9.455	39	1.182	0.012
L8	84.71 - 79.71	8.246	39	1.118	0.012
L9	79.71 - 74.71	7.124	39	1.023	0.011
L10	74.71 - 69.71	6.108	39	0.916	0.008
L11	69.71 - 64.71	5.208	39	0.803	0.007
L12	64.71 - 62.83	4.427	39	0.687	0.005
L13	62.83 - 62.58	4.166	39	0.643	0.004
L14	62.58 - 57.58	4.132	39	0.641	0.004
L15	57.58 - 52.58	3.489	39	0.587	0.004
L16	52.58 - 47.58	2.903	39	0.532	0.003
L17	47.58 - 42.63	2.376	39	0.476	0.003
L18	47.38 - 42.38	2.356	39	0.474	0.003
L19	42.38 - 37.38	1.875	39	0.444	0.002
L20	37.38 - 32.38	1.442	39	0.384	0.002

Section No.	Elevation ft	Horz. Deflection in	Gov. Load Comb.	Tilt °	Twist °
L21	32.38 - 31.75	1.071	39	0.324	0.002
L22	31.75 - 31.5	1.029	39	0.317	0.002
L23	31.5 - 26.5	1.012	39	0.314	0.002
L24	26.5 - 21.5	0.710	39	0.263	0.001
L25	21.5 - 16.5	0.462	39	0.212	0.001
L26	16.5 - 11.5	0.268	39	0.160	0.001
L27	11.5 - 6.5	0.126	39	0.109	0.000
L28	6.5 - 3	0.038	39	0.059	0.000
L29	3 - 2.75	0.008	39	0.025	0.000
L30	2.75 - 0	0.006	39	0.023	0.000

Critical Deflections and Radius of Curvature - Service Wind

Elevation ft	Appurtenance	Gov. Load Comb.	Deflection in	Tilt °	Twist °	Radius of Curvature ft
119.0000	GHF3W-23	39	17.916	1.612	0.010	7011
118.0000	800MHz 2X50W RRH W/FILTER	39	17.916	1.612	0.010	7011
117.5000	Lightning Rod 5/8" x 6'	39	17.916	1.612	0.010	7011
117.0000	DB420-A	39	17.748	1.611	0.010	7011
105.0000	(2) HBXX-6517DS-A2M w/ Mount Pipe	39	13.801	1.505	0.012	3822
91.0000	(2) LGP21903	39	9.780	1.212	0.012	2863
83.0000	SHPX3-11W	39	7.852	1.091	0.012	3206
82.0000	APX16DWV-16DWV-S-E-A20 w/ Mount Pipe	39	7.626	1.071	0.011	3069
75.0000	KS24019-L112A	39	6.164	0.922	0.009	2610

Maximum Tower Deflections - Design Wind

Section No.	Elevation ft	Horz. Deflection in	Gov. Load Comb.	Tilt °	Twist °
L1	117.5 - 112.5	90.215	2	8.136	0.043
L2	112.5 - 107.5	81.773	2	8.011	0.047
L3	107.5 - 102.5	73.534	2	7.756	0.051
L4	102.5 - 97.5	65.612	2	7.389	0.053
L5	97.5 - 92.5	58.149	2	6.884	0.054
L6	92.5 - 86.29	51.255	2	6.301	0.055
L7	89.71 - 84.71	47.681	2	5.950	0.056
L8	84.71 - 79.71	41.608	14	5.625	0.056
L9	79.71 - 74.71	35.988	14	5.147	0.050
L10	74.71 - 69.71	30.889	14	4.616	0.040
L11	69.71 - 64.71	26.358	14	4.051	0.031
L12	64.71 - 62.83	22.423	14	3.468	0.023
L13	62.83 - 62.58	21.100	14	3.253	0.020
L14	62.58 - 57.58	20.931	14	3.240	0.020
L15	57.58 - 52.58	17.681	14	2.969	0.017
L16	52.58 - 47.58	14.718	14	2.693	0.014
L17	47.58 - 42.63	12.047	14	2.410	0.012
L18	47.38 - 42.38	11.946	14	2.399	0.012
L19	42.38 - 37.38	9.509	14	2.248	0.011
L20	37.38 - 32.38	7.314	14	1.945	0.009
L21	32.38 - 31.75	5.436	14	1.644	0.007
L22	31.75 - 31.5	5.222	14	1.606	0.007
L23	31.5 - 26.5	5.138	14	1.593	0.007
L24	26.5 - 21.5	3.606	14	1.333	0.006

Section No.	Elevation ft	Horz. Deflection in	Gov. Load Comb.	Tilt °	Twist °
L25	21.5 - 16.5	2.346	14	1.074	0.004
L26	16.5 - 11.5	1.358	14	0.814	0.003
L27	11.5 - 6.5	0.642	14	0.555	0.002
L28	6.5 - 3	0.195	14	0.300	0.001
L29	3 - 2.75	0.039	14	0.125	0.000
L30	2.75 - 0	0.033	14	0.114	0.000

Critical Deflections and Radius of Curvature - Design Wind

Elevation ft	Appurtenance	Gov. Load Comb.	Deflection in	Tilt °	Twist °	Radius of Curvature ft
119.0000	GHF3W-23	2	90.215	8.136	0.051	1483
118.0000	800MHz 2X50W RRH W/FILTER	2	90.215	8.136	0.051	1483
117.5000	Lightning Rod 5/8" x 6'	2	90.215	8.136	0.051	1483
117.0000	DB420-A	2	89.367	8.126	0.051	1483
105.0000	(2) HBXX-6517DS-A2M w/ Mount Pipe	2	69.525	7.589	0.058	789
91.0000	(2) LGP21903	2	49.313	6.101	0.058	579
83.0000	SHPX3-11W	14	39.632	5.486	0.056	650
82.0000	APX16DWV-16DWV-S-E-A20 w/ Mount Pipe	14	38.502	5.389	0.055	624
75.0000	KS24019-L112A	14	31.170	4.647	0.041	530

Compression Checks

Pole Design Data

Section No.	Elevation ft	Size	L ft	L _u ft	KI/r	A in ²	P _u K
L1	117.5 - 112.5 (1)	TP16.2656x15x0.1875	5.0000	0.0000	0.0	9.5685	-2.32
L2	112.5 - 107.5 (2)	TP17.5312x16.2656x0.1875	5.0000	0.0000	0.0	10.3217	-2.54
L3	107.5 - 102.5 (3)	TP18.7969x17.5312x0.1875	5.0000	0.0000	0.0	11.0749	-5.88
L4	102.5 - 97.5 (4)	TP20.0625x18.7969x0.1875	5.0000	0.0000	0.0	11.8281	-6.28
L5	97.5 - 92.5 (5)	TP21.3281x20.0625x0.1875	5.0000	0.0000	0.0	12.5813	-6.73
L6	92.5 - 86.29 (6)	TP22.9x21.3281x0.1875	6.2100	0.0000	0.0	13.0016	-10.59
L7	86.29 - 84.71 (7)	TP22.9126x21.6593x0.3125	5.0000	0.0000	0.0	22.4164	-11.45
L8	84.71 - 79.71 (8)	TP24.1658x22.9126x0.3125	5.0000	0.0000	0.0	23.6595	-17.24
L9	79.71 - 74.71 (9)	TP25.4191x24.1658x0.3125	5.0000	0.0000	0.0	24.9026	-18.21
L10	74.71 - 69.71 (10)	TP26.6724x25.4191x0.3125	5.0000	0.0000	0.0	26.1457	-19.22
L11	69.71 - 64.71 (11)	TP27.9256x26.6724x0.3125	5.0000	0.0000	0.0	27.3888	-20.27
L12	64.71 - 62.83 (12)	TP28.3968x27.9256x0.3125	1.8800	0.0000	0.0	27.8561	-20.63

Section No.	Elevation ft	Size	L ft	L_u ft	Kl/r	A in^2	P_u K		
L13	62.83 - 62.58 (13)	TP28.4595x28.3968x0.73 75	0.2500	0.0000	0.0	64.892 3	-20.77		
L14	62.58 - 57.58 (14)	TP29.7128x28.4595x0.71 25	5.0000	0.0000	0.0	65.583 4	-22.30		
L15	57.58 - 52.58 (15)	TP30.966x29.7128x0.7 0	5.0000	0.0000	0.0	67.245 0	-23.89		
L16	52.58 - 47.58 (16)	TP32.2193x30.966x0.675 0	5.0000	0.0000	0.0	67.582 0	-25.51		
L17	47.58 - 42.63 (17)	TP33.46x32.2193x0.675 4	4.9500	0.0000	0.0	67.689 4	-25.59		
L18	42.63 - 42.38 (18)	TP32.8955x31.6444x0.67 5	5.0000	0.0000	0.0	69.030 9	-28.40		
L19	42.38 - 37.38 (19)	TP34.1466x32.8955x0.65 9	5.0000	0.0000	0.0	69.106 9	-30.08		
L20	37.38 - 32.38 (20)	TP35.3978x34.1466x0.63 75	5.0000	0.0000	0.0	70.334 8	-31.81		
L21	32.38 - 31.75 (21)	TP35.5554x35.3978x0.63 75	0.6300	0.0000	0.0	70.653 7	-32.04		
L22	31.75 - 31.5 (22)	TP35.618x35.5554x0.737 5	0.2500	0.0000	0.0	81.649 0	-32.14		
L23	31.5 - 26.5 (23)	TP36.8691x35.618x0.725 9	5.0000	0.0000	0.0	83.172 9	-34.08		
L24	26.5 - 21.5 (24)	TP38.1202x36.8691x0.71 25	5.0000	0.0000	0.0	84.596 6	-36.05		
L25	21.5 - 16.5 (25)	TP39.3713x38.1202x0.68 75	5.0000	0.0000	0.0	84.412 9	-38.06		
L26	16.5 - 11.5 (26)	TP40.6224x39.3713x0.67 5	5.0000	0.0000	0.0	85.585 4	-40.10		
L27	11.5 - 6.5 (27)	TP41.8735x40.6224x0.66 25	5.0000	0.0000	0.0	86.657 6	-42.17		
L28	6.5 - 3 (28)	TP42.7493x41.8735x0.66 25	3.5000	0.0000	0.0	88.499 1	-43.64		
L29	3 - 2.75 (29)	TP42.8119x42.7493x0.8 70	0.2500	0.0000	0.0	106.67 70	-43.76		
L30	2.75 - 0 (30)	TP43.5x42.8119x0.7875 10	2.7500	0.0000	0.0	106.76 10	-44.90	7931.81	0.006

Pole Bending Design Data

Section No.	Elevation ft	Size	M_{ux} kip-ft
L1	117.5 - 112.5 (1)	TP16.2656x15x0.1875	45.44
L2	112.5 - 107.5 (2)	TP17.5312x16.2656x0.18 75	84.14
L3	107.5 - 102.5 (3)	TP18.7969x17.5312x0.18 75	155.22
L4	102.5 - 97.5 (4)	TP20.0625x18.7969x0.18 75	230.11
L5	97.5 - 92.5 (5)	TP21.3281x20.0625x0.18 75	306.61
L6	92.5 - 86.29 (6)	TP22.9x21.3281x0.1875	362.99
L7	86.29 - 84.71 (7)	TP22.9126x21.6593x0.31 25	467.84
L8	84.71 - 79.71 (8)	TP24.1658x22.9126x0.31 25	607.48
L9	79.71 - 74.71 (9)	TP25.4191x24.1658x0.31 25	767.31
L10	74.71 - 69.71	TP26.6724x25.4191x0.31	929.49

Section No.	Elevation	Size	M_{ux}
	ft		
	(10)	25	
L11	69.71 - 64.71	TP27.9256x26.6724x0.31	1093.45
	(11)	25	
L12	64.71 - 62.83	TP28.3968x27.9256x0.31	1155.70
	(12)	25	
L13	62.83 - 62.58	TP28.4595x28.3968x0.73	1164.02
	(13)	75	
L14	62.58 - 57.58	TP29.7128x28.4595x0.71	1332.71
	(14)	25	
L15	57.58 - 52.58	TP30.966x29.7128x0.7	1505.84
	(15)		
L16	52.58 - 47.58	TP32.2193x30.966x0.675	1683.39
	(16)		
L17	47.58 - 42.63	TP33.46x32.2193x0.675	1690.58
	(17)		
L18	42.63 - 42.38	TP32.8955x31.6444x0.67	1873.02
	(18)	5	
L19	42.38 - 37.38	TP34.1466x32.8955x0.65	2061.17
	(19)		
L20	37.38 - 32.38	TP35.3978x34.1466x0.63	2253.49
	(20)	75	
L21	32.38 - 31.75	TP35.5554x35.3978x0.63	2278.02
	(21)	75	
L22	31.75 - 31.5	TP35.618x35.5554x0.737	2287.77
	(22)	5	
L23	31.5 - 26.5	TP36.8691x35.618x0.725	2484.38
	(23)		
L24	26.5 - 21.5	TP38.1202x36.8691x0.71	2683.91
	(24)	25	
L25	21.5 - 16.5	TP39.3713x38.1202x0.68	2886.16
	(25)	75	
L26	16.5 - 11.5	TP40.6224x39.3713x0.67	3090.93
	(26)	5	
L27	11.5 - 6.5 (27)	TP41.8735x40.6224x0.66	3298.10
		25	
L28	6.5 - 3 (28)	TP42.7493x41.8735x0.66	3444.54
		25	
L29	3 - 2.75 (29)	TP42.8119x42.7493x0.8	3455.05
L30	2.75 - 0 (30)	TP43.5x42.8119x0.7875	3571.03

Pole Shear Design Data

Section No.	Elevation	Size	Actual V_u K
	ft		
L1	117.5 - 112.5	TP16.2656x15x0.1875	7.58
	(1)		
L2	112.5 - 107.5	TP17.5312x16.2656x0.18	7.91
	(2)	75	
L3	107.5 - 102.5	TP18.7969x17.5312x0.18	14.83
	(3)	75	
L4	102.5 - 97.5	TP20.0625x18.7969x0.18	15.15
	(4)	75	
L5	97.5 - 92.5 (5)	TP21.3281x20.0625x0.18	15.47
		75	
L6	92.5 - 86.29	TP22.9x21.3281x0.1875	20.76
	(6)		
L7	86.29 - 84.71	TP22.9126x21.6593x0.31	21.21
	(7)	25	
L8	84.71 - 79.71	TP24.1658x22.9126x0.31	31.38
	(8)	25	

Section No.	Elevation ft	Size	Actual V_u K
L9	79.71 - 74.71 (9)	TP25.4191x24.1658x0.31 25	32.29
L10	74.71 - 69.71 (10)	TP26.6724x25.4191x0.31 25	32.63
L11	69.71 - 64.71 (11)	TP27.9256x26.6724x0.31 25	33.00
L12	64.71 - 62.83 (12)	TP28.3968x27.9256x0.31 25	33.30
L13	62.83 - 62.58 (13)	TP28.4595x28.3968x0.73 75	33.30
L14	62.58 - 57.58 (14)	TP29.7128x28.4595x0.71 25	34.20
L15	57.58 - 52.58 (15)	TP30.966x29.7128x0.7	35.09
L16	52.58 - 47.58 (16)	TP32.2193x30.966x0.675	35.97
L17	47.58 - 42.63 (17)	TP33.46x32.2193x0.675	36.00
L18	42.63 - 42.38 (18)	TP32.8955x31.6444x0.67 5	37.21
L19	42.38 - 37.38 (19)	TP34.1466x32.8955x0.65	38.06
L20	37.38 - 32.38 (20)	TP35.3978x34.1466x0.63 75	38.89
L21	32.38 - 31.75 (21)	TP35.5554x35.3978x0.63 75	38.99
L22	31.75 - 31.5 (22)	TP35.618x35.5554x0.737 5	39.03
L23	31.5 - 26.5 (23)	TP36.8691x35.618x0.725	39.63
L24	26.5 - 21.5 (24)	TP38.1202x36.8691x0.71 25	40.20
L25	21.5 - 16.5 (25)	TP39.3713x38.1202x0.68 75	40.72
L26	16.5 - 11.5 (26)	TP40.6224x39.3713x0.67 5	41.21
L27	11.5 - 6.5 (27)	TP41.8735x40.6224x0.66 25	41.69
L28	6.5 - 3 (28)	TP42.7493x41.8735x0.66 25	42.02
L29	3 - 2.75 (29)	TP42.8119x42.7493x0.8	42.03
L30	2.75 - 0 (30)	TP43.5x42.8119x0.7875	42.33

TNX Geometry Input

Increment (ft): 5

	Section Height (ft)	Section Length (ft)	Lap Splice Length (ft)	Number of Sides	Top Diameter (in)	Bottom Diameter (in)	Wall Thickness (in)	Tapered Pole Grade	Weight Multiplier
1	117.5 - 112.5	5		18	15.000	16.266	0.1875	A572-65	1.000
2	112.5 - 107.5	5		18	16.266	17.531	0.1875	A572-65	1.000
3	107.5 - 102.5	5		18	17.531	18.797	0.1875	A572-65	1.000
4	102.5 - 97.5	5		18	18.797	20.062	0.1875	A572-65	1.000
5	97.5 - 92.5	5		18	20.062	21.328	0.1875	A572-65	1.000
6	92.5 - 89.71	6.21	3.42	18	21.328	22.900	0.1875	A572-65	1.000
7	89.71 - 84.71	5		18	21.659	22.913	0.3125	A572-65	1.000
8	84.71 - 79.71	5		18	22.913	24.166	0.3125	A572-65	1.000
9	79.71 - 74.71	5		18	24.166	25.419	0.3125	A572-65	1.000
10	74.71 - 69.71	5		18	25.419	26.672	0.3125	A572-65	1.000
11	69.71 - 64.71	5		18	26.672	27.926	0.3125	A572-65	1.000
12	64.71 - 62.83	1.88		18	27.926	28.397	0.3125	A572-65	1.000
13	62.83 - 62.58	0.25		18	28.397	28.459	0.7375	A572-65	0.931
14	62.58 - 57.58	5		18	28.459	29.713	0.7125	A572-65	0.940
15	57.58 - 52.58	5		18	29.713	30.966	0.7	A572-65	0.935
16	52.58 - 47.58	5		18	30.966	32.219	0.675	A572-65	0.949
17	47.58 - 47.38	4.95	4.75	18	32.219	33.460	0.675	A572-65	0.948
18	47.38 - 42.38	5		18	31.644	32.896	0.675	A572-65	0.939
19	42.38 - 37.38	5		18	32.896	34.147	0.65	A572-65	0.956
20	37.38 - 32.38	5		18	34.147	35.398	0.6375	A572-65	0.957
21	32.38 - 31.75	0.63		18	35.398	35.555	0.6375	A572-65	0.955
22	31.75 - 31.5	0.25		18	35.555	35.618	0.7375	A572-65	0.949
23	31.5 - 26.5	5		18	35.618	36.869	0.725	A572-65	0.947
24	26.5 - 21.5	5		18	36.869	38.120	0.7125	A572-65	0.946
25	21.5 - 16.5	5		18	38.120	39.371	0.6875	A572-65	0.962
26	16.5 - 11.5	5		18	39.371	40.622	0.675	A572-65	0.964
27	11.5 - 6.5	5		18	40.622	41.874	0.6625	A572-65	0.966
28	6.5 - 3	3.5		18	41.874	42.749	0.6625	A572-65	0.956
29	3 - 2.75	0.25		18	42.749	42.812	0.8	A572-65	0.805
30	2.75 - 0	2.75		18	42.812	43.500	0.7875	A572-65	0.811

TNX Section Forces

Increment (ft):		TNX Output				
	5	Section Height (ft)		P_u (K)	M_{ux} (kip-ft)	V_u (K)
1		117.5 - 112.5	2.32	45.44	7.58	
2		112.5 - 107.5	2.54	84.14	7.91	
3		107.5 - 102.5	5.88	155.22	14.83	
4		102.5 - 97.5	6.28	230.11	15.15	
5		97.5 - 92.5	6.73	306.61	15.47	
6		92.5 - 89.71	10.59	362.99	20.76	
7		89.71 - 84.71	11.45	467.84	21.21	
8		84.71 - 79.71	17.24	607.48	31.38	
9		79.71 - 74.71	18.21	767.31	32.29	
10		74.71 - 69.71	19.22	929.50	32.63	
11		69.71 - 64.71	20.27	1093.45	33.00	
12		64.71 - 62.83	20.63	1155.70	33.30	
13		62.83 - 62.58	20.77	1164.02	33.30	
14		62.58 - 57.58	22.30	1332.71	34.20	
15		57.58 - 52.58	23.89	1505.84	35.09	
16		52.58 - 47.58	25.51	1683.39	35.97	
17		47.58 - 47.38	25.59	1690.58	36.00	
18		47.38 - 42.38	28.40	1873.02	37.21	
19		42.38 - 37.38	30.08	2061.17	38.06	
20		37.38 - 32.38	31.81	2253.49	38.89	
21		32.38 - 31.75	32.04	2278.02	38.99	
22		31.75 - 31.5	32.14	2287.77	39.03	
23		31.5 - 26.5	34.07	2484.39	39.63	
24		26.5 - 21.5	36.05	2683.91	40.20	
25		21.5 - 16.5	38.06	2886.16	40.72	
26		16.5 - 11.5	40.10	3090.92	41.21	
27		11.5 - 6.5	42.17	3298.10	41.69	
28		6.5 - 3	43.64	3444.55	42.02	
29		3 - 2.75	43.76	3455.05	42.03	
30		2.75 - 0	44.90	3571.02	42.33	

Analysis Results

Elevation (ft)	Component Type	Size	Critical Element	% Capacity	Pass / Fail
117.5 - 112.5	Pole	TP16.266x15x0.1875	Pole	19.8%	Pass
112.5 - 107.5	Pole	TP17.531x16.266x0.1875	Pole	31.2%	Pass
107.5 - 102.5	Pole	TP18.797x17.531x0.1875	Pole	50.2%	Pass
102.5 - 97.5	Pole	TP20.062x18.797x0.1875	Pole	66.0%	Pass
97.5 - 92.5	Pole	TP21.328x20.062x0.1875	Pole	78.9%	Pass
92.5 - 89.71	Pole	TP22.9x21.328x0.1875	Pole	88.7%	Pass
89.71 - 84.71	Pole	TP22.913x21.659x0.3125	Pole	61.5%	Pass
84.71 - 79.71	Pole	TP24.166x22.913x0.3125	Pole	71.9%	Pass
79.71 - 74.71	Pole	TP25.419x24.166x0.3125	Pole	81.8%	Pass
74.71 - 69.71	Pole	TP26.672x25.419x0.3125	Pole	89.7%	Pass
69.71 - 64.71	Pole	TP27.926x26.672x0.3125	Pole	96.0%	Pass
64.71 - 62.83	Pole	TP28.397x27.926x0.3125	Pole	98.1%	Pass
62.83 - 62.58	Pole + Reinf.	TP28.459x28.397x0.7375	Reinf. 2 Tension Rupture	67.2%	Pass
62.58 - 57.58	Pole + Reinf.	TP29.713x28.459x0.7125	Reinf. 2 Tension Rupture	72.3%	Pass
57.58 - 52.58	Pole + Reinf.	TP30.966x29.713x0.7	Reinf. 2 Tension Rupture	76.9%	Pass
52.58 - 47.58	Pole + Reinf.	TP32.219x30.966x0.675	Reinf. 2 Tension Rupture	81.1%	Pass
47.58 - 47.38	Pole + Reinf.	TP33.46x32.219x0.675	Reinf. 2 Tension Rupture	81.2%	Pass
47.38 - 42.38	Pole + Reinf.	TP32.896x31.644x0.675	Reinf. 2 Tension Rupture	87.5%	Pass
42.38 - 37.38	Pole + Reinf.	TP34.147x32.896x0.65	Reinf. 2 Tension Rupture	91.1%	Pass
37.38 - 32.38	Pole + Reinf.	TP35.398x34.147x0.6375	Reinf. 2 Tension Rupture	94.4%	Pass
32.38 - 31.75	Pole + Reinf.	TP35.555x35.398x0.6375	Reinf. 2 Tension Rupture	94.8%	Pass
31.75 - 31.5	Pole + Reinf.	TP35.618x35.555x0.7375	Reinf. 1 Compression	77.8%	Pass
31.5 - 26.5	Pole + Reinf.	TP36.869x35.618x0.725	Reinf. 1 Compression	80.4%	Pass
26.5 - 21.5	Pole + Reinf.	TP38.12x36.869x0.7125	Reinf. 1 Compression	82.8%	Pass
21.5 - 16.5	Pole + Reinf.	TP39.371x38.12x0.6875	Reinf. 1 Compression	85.0%	Pass
16.5 - 11.5	Pole + Reinf.	TP40.622x39.371x0.675	Reinf. 1 Compression	87.0%	Pass
11.5 - 6.5	Pole + Reinf.	TP41.874x40.622x0.6625	Reinf. 1 Compression	88.8%	Pass
6.5 - 3	Pole + Reinf.	TP42.749x41.874x0.6625	Reinf. 1 Compression	89.9%	Pass
3 - 2.75	Pole + Reinf.	TP42.812x42.749x0.8	Reinf. 3 Connection	88.9%	Pass
2.75 - 0	Pole + Reinf.	TP43.5x42.812x0.7875	Reinf. 3 Connection	89.9%	Pass
				Summary	
			Pole	98.1%	Pass
			Reinforcement	94.8%	Pass
			Overall	98.1%	Pass

Additional Calculations

Section Elevation (ft)	Moment of Inertia (in ⁴)			Area (in ²)			% Capacity			
	Pole	Reinf.	Total	Pole	Reinf.	Total	Pole	R1	R2	R3
117.5 - 112.5	312	n/a	312	9.57	n/a	9.57	19.8%			
112.5 - 107.5	392	n/a	392	10.32	n/a	10.32	31.2%			
107.5 - 102.5	484	n/a	484	11.07	n/a	11.07	50.2%			
102.5 - 97.5	590	n/a	590	11.83	n/a	11.83	66.0%			
97.5 - 92.5	710	n/a	710	12.58	n/a	12.58	78.9%			
92.5 - 89.71	784	n/a	784	13.00	n/a	13.00	88.7%			
89.71 - 84.71	1446	n/a	1446	22.42	n/a	22.42	61.5%			
84.71 - 79.71	1700	n/a	1700	23.66	n/a	23.66	71.9%			
79.71 - 74.71	1983	n/a	1983	24.90	n/a	24.90	81.8%			
74.71 - 69.71	2294	n/a	2294	26.14	n/a	26.14	89.7%			
69.71 - 64.71	2638	n/a	2638	27.39	n/a	27.39	96.0%			
64.71 - 62.83	2775	n/a	2775	27.86	n/a	27.86	98.1%			
62.83 - 62.58	2793	3539	6332	27.92	32.50	60.42	43.5%		67.2%	
62.58 - 57.58	3183	3838	7022	29.16	32.50	61.66	46.9%		72.3%	
57.58 - 52.58	3608	4150	7758	30.40	32.50	62.90	49.9%		76.9%	
52.58 - 47.58	4069	4475	8544	31.65	32.50	64.15	53.0%		81.1%	
47.58 - 47.38	4088	4488	8576	31.70	32.50	64.20	53.1%		81.2%	
47.38 - 42.38	4333	4655	8988	32.32	32.50	64.82	57.6%		87.5%	
42.38 - 37.38	4852	4998	9849	33.56	32.50	66.06	60.6%		91.1%	
37.38 - 32.38	5410	5353	10763	34.80	32.50	67.30	63.5%		94.4%	
32.38 - 31.75	5483	5398	10882	34.96	32.50	67.46	63.9%		94.8%	
31.75 - 31.5	5513	7138	12650	35.02	42.50	77.52	55.3%	77.8%		
31.5 - 26.5	6120	7621	13741	36.26	42.50	78.76	57.8%	80.4%		
26.5 - 21.5	6770	8121	14890	37.50	42.50	80.00	60.3%	82.8%		
21.5 - 16.5	7464	8636	16101	38.74	42.50	81.24	62.6%	85.0%		
16.5 - 11.5	8205	9168	17373	39.98	42.50	82.48	64.8%	87.0%		
11.5 - 6.5	8993	9716	18709	41.22	42.50	83.72	66.9%	88.8%		
6.5 - 3	9573	10109	19682	42.09	42.50	84.59	68.3%	89.9%		
3 - 2.75	9616	14239	23855	42.15	43.75	85.90	56.8%			88.9%
2.75 - 0	10090	14618	24709	42.84	43.75	86.59	57.9%			89.9%

Note: Section capacity checked in 5 degree increments.

Site BU: 876352
Work Order: _____

Pole Geometry

	Pole Height Above Base (ft)	Section Length (ft)	Lap Splice Length (ft)	Number of Sides	Top Diameter (in)	Bottom Diameter (in)	Wall Thickness (in)	Bend Radius (in)	Pole Material
1	117.5	31.21	3.42	18	15	22.9	0.1875	0.75	A572-65
2	89.71	47.08	4.75	18	21.66	33.46	0.3125	1.25	A572-65
3	47.38	47.38	0	18	31.64	43.5	0.3125	1.25	A572-65

Reinforcement Configuration

	Bottom Effective Elevation (ft)	Top Effective Elevation (ft)	Type	Model	Number																		
						1	2	3	4	5	6	7	8	9	10	11	12	13	14	15	16	17	18
1	3	31.75	plate	CCI-SFP-085125	4		o				o					o				o			
2	31.75	62.83	plate	CCI-SFP-065125	4		o				o					o				o			
3	0	3	plate	FP 1.25 x 8.75_1	4		o				o					o				o			
4																							
5																							
6																							
7																							
8																							
9																							
10																							

Reinforcement Details

	B (in)	H (in)	Gross Area (in ²)	Pole Face to Centroid (in)	Bottom Termination Length (in)	Top Termination Length (in)	L _u (in)	Net Area (in ²)	Bolt Hole Size (in)	Reinforcement Material
1	8.5	1.25	10.625	0.625	45.000	45.000	17.000	9.063	1.1875	A572-65
2	6.5	1.25	8.125	0.625	33.000	33.000	19.000	6.563	1.1875	A572-65
3	1.25	8.75	10.9375	4.375	n/a	n/a	0.000	10.938	0.0000	A572-65

APPENDIX B
BASE LEVEL DRAWING

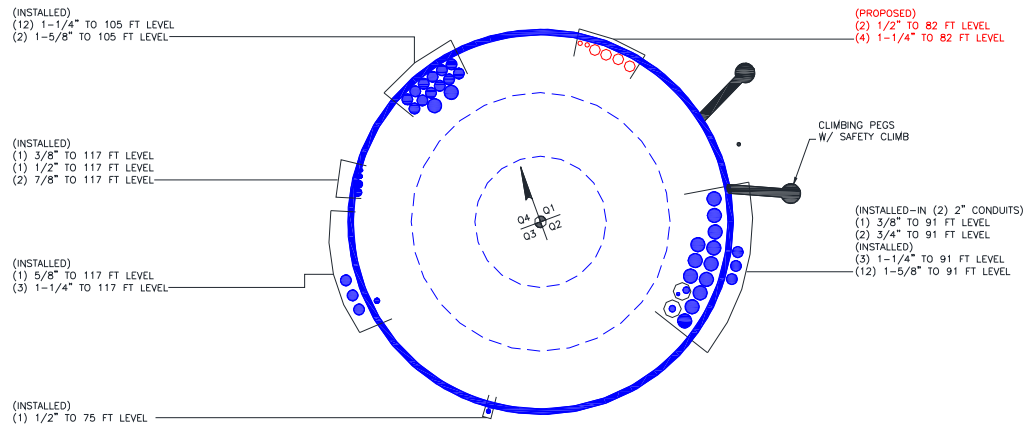

APPENDIX C
ADDITIONAL CALCULATIONS

DESIGNED APPURTENANCE LOADING

TYPE	ELEVATION	TYPE	ELEVATION
800MHz 2X50W RRH W/FILTER	118	(2) LGP 17201	91
800MHz 2X50W RRH W/FILTER	118	(2) LGP 17201	91
800MHz 2X50W RRH W/FILTER	118	(2) LGP 17201	91
PCS 1900MHz 4x45W-65MHz	118	DC6-48-60-18-8F	91
PCS 1900MHz 4x45W-65MHz	118	(2) LGP21901	91
PCS 1900MHz 4x45W-65MHz	118	(2) LGP21901	91
Side Arm Mount [SO 102-3]	118	(2) LGP21901	91
Lightning Rod 5/8" x 6"	117.5	RRUS 12	91
DB420-A	117	RRUS 12	91
DB264-A	117	RRUS 12	91
ASP-2011	117	RRUS 11	91
APXVSP18-C-A20 w/ Mount Pipe	117	RRUS 11	91
APXVSP18-C-A20 w/ Mount Pipe	117	RRUS 11	91
APXVSP18-C-A20 w/ Mount Pipe	117	1001983	91
APXVTM14-C-120 w/ Mount Pipe	117	1001983	91
APXVTM14-C-120 w/ Mount Pipe	117	1001983	91
APXVTM14-C-120 w/ Mount Pipe	117	2.375" OD x 6' Mount Pipe	91
TD-RRH8x20-25	117	2.375" OD x 6' Mount Pipe	91
TD-RRH8x20-25	117	2.375" OD x 6' Mount Pipe	91
TD-RRH8x20-25	117	Platform Mount [LP 1201-1]	91
(2) 2.375" OD x 6' Mount Pipe	117	(2) LGP21903	91
(2) 2.375" OD x 6' Mount Pipe	117	APX16DWV-16DWV-S-E-A20 w/ Mount Pipe	82
(2) 2.375" OD x 6' Mount Pipe	117	APX16DWV-16DWV-S-E-A20 w/ Mount Pipe	82
8-ft Ladder	117	APX16DWV-16DWV-S-E-A20 w/ Mount Pipe	82
Platform Mount [LP 601-1]	117	APX16DWV-16DWV-S-E-A20 w/ Mount Pipe	82
GHF3W-23	117	GPS_A	82
(2) HBXX-6517DS-A2M w/ Mount Pipe	105	APXVAA24_43-U-A20 w/ Mount Pipe	82
(2) HBXX-6517DS-A2M w/ Mount Pipe	105	APXVAA24_43-U-A20 w/ Mount Pipe	82
(2) LNX-6514DS-A1M w/ Mount Pipe	105	APXVAA24_43-U-A20 w/ Mount Pipe	82
(2) LNX-6514DS-A1M w/ Mount Pipe	105	APXVAA24_43-U-A20 w/ Mount Pipe	82
(2) LNX-6514DS-A1M w/ Mount Pipe	105	APXVAA24_43-U-A20 w/ Mount Pipe	82
(2) FD9R6004/2C-3L	105	AIR 32 B2A/B66AA w/ Mount Pipe	82
(2) FD9R6004/2C-3L	105	AIR 32 B2A/B66AA w/ Mount Pipe	82
(2) FD9R6004/2C-3L	105	AIR 32 B2A/B66AA w/ Mount Pipe	82
RRH2X60-AWS	105	(3) 641280-DF-2X	82
RRH2X60-AWS	105	(2) 641280-DF-2X	82
RRH2X60-AWS	105	(3) 641280-DF-2X	82
RRH2X60-PCS	105	RRUS 11 B12	82
RRH2X60-PCS	105	RRUS 11 B12	82
DB-B1-6C-12AB-0Z	105	(2) RRUS 11 B12	82
Platform Mount [LP 1201-1]	105	RADIO 4478	82
(2) HBXX-6517DS-A2M w/ Mount Pipe	105	(3) RADIO 4478	82
(2) LGP21903	91	RRUS 11 B4	82
(2) LGP21903	91	RRUS 11 B4	82
AM-X-CD-16-65-00T-RET w/ Mount Pipe	91	(2) RRUS 11 B4	82
AM-X-CD-16-65-00T-RET w/ Mount Pipe	91	Platform Mount [LP 701-1]	82
AM-X-CD-16-65-00T-RET w/ Mount Pipe	91	APX16DWV-16DWV-S-E-A20 w/ Mount Pipe	82
AM-X-CD-16-65-00T-RET w/ Mount Pipe	91	SHPX3-11W	82
(2) 7770.00 w/ Mount Pipe	91	KS24019-L112A	75
(2) 7770.00 w/ Mount Pipe	91	Side Arm Mount [SO 701-1]	75
(2) 7770.00 w/ Mount Pipe	91		

MATERIAL STRENGTH

GRADE	Fy	Fu	GRADE	Fy	Fu
A572-65	65 ksi	80 ksi			

TOWER DESIGN NOTES

1. Tower is located in Middlesex County, Connecticut.
2. Tower designed for Exposure C to the TIA-222-G Standard.
3. Tower designed for a 101 mph basic wind in accordance with the TIA-222-G Standard.
4. Tower is also designed for a 50 mph basic wind with 0.75 in ice. Ice is considered to increase in thickness with height.
5. Deflections are based upon a 60 mph wind.
6. Tower Structure Class II.
7. Topographic Category 1 with Crest Height of 0.0000 ft

ALL REACTIONS ARE FACTORED

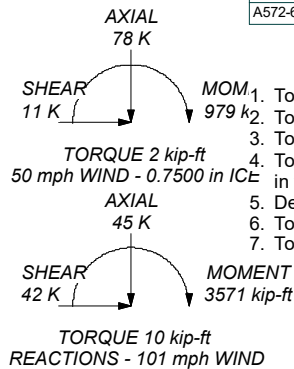

Section	Length (ft)	Number of Sides	Thickness (in)	Socket Length (ft)	Top Dia (in)	Bot Dia (in)	Grade	Weight (K)
1	5.0000	18	0.1875	3.4200	15.0000	16.2656	A572-65	0.2
2	5.0000	18	0.1875	3.4200	16.2656	17.5312	A572-65	0.2
3	5.0000	18	0.1875	3.4200	17.5312	18.7969	A572-65	0.2
4	5.0000	18	0.1875	3.4200	18.7969	20.0625	A572-65	0.2
5	5.0000	18	0.1875	3.4200	20.0625	21.3281	A572-65	0.2
6	5.0000	18	0.1875	3.4200	21.3281	22.5938	A572-65	0.2
7	5.0000	18	0.1875	3.4200	22.5938	23.8594	A572-65	0.3
8	5.0000	18	0.1875	3.4200	23.8594	25.1250	A572-65	0.4
9	5.0000	18	0.1875	3.4200	25.1250	26.3906	A572-65	0.4
10	5.0000	18	0.1875	3.4200	26.3906	27.6562	A572-65	0.4
11	5.0000	18	0.1875	3.4200	27.6562	28.9219	A572-65	0.5
12	5.0000	18	0.1875	3.4200	28.9219	30.1875	A572-65	0.5
13	5.0000	18	0.1875	3.4200	30.1875	31.4531	A572-65	1.0
14	5.0000	18	0.1875	3.4200	31.4531	32.7188	A572-65	1.0
15	5.0000	18	0.1875	3.4200	32.7188	33.9844	A572-65	1.0
16	5.0000	18	0.1875	3.4200	33.9844	35.2500	A572-65	1.1
17	5.0000	18	0.1875	3.4200	35.2500	36.5156	A572-65	1.1
18	5.0000	18	0.1875	3.4200	36.5156	37.7813	A572-65	1.1
19	5.0000	18	0.1875	3.4200	37.7813	39.0469	A572-65	1.1
20	5.0000	18	0.1875	3.4200	39.0469	40.3125	A572-65	1.1
21	5.0000	18	0.1875	3.4200	40.3125	41.5781	A572-65	1.1
22	5.0000	18	0.1875	3.4200	41.5781	42.8438	A572-65	1.1
23	5.0000	18	0.1875	3.4200	42.8438	44.1094	A572-65	1.3
24	5.0000	18	0.1875	3.4200	44.1094	45.3750	A572-65	1.3
25	5.0000	18	0.1875	3.4200	45.3750	46.6406	A572-65	1.4
26	5.0000	18	0.1875	3.4200	46.6406	47.9062	A572-65	1.4
27	5.0000	18	0.1875	3.4200	47.9062	49.1719	A572-65	1.4
28	5.0000	18	0.1875	3.4200	49.1719	50.4375	A572-65	1.4
29	5.0000	18	0.1875	3.4200	50.4375	51.7031	A572-65	1.0
30	5.0000	18	0.1875	3.4200	51.7031	52.9688	A572-65	1.0

Paul J. Ford and Compan
 250 East Broad st., Suite 600
 Columbus, OH 43215
 Phone: (614) 221-6679
 FAX:

Job: **117.5 ft Monopole / Richard Wall**
 Project: **PJF 37518-0657 / BU 876352**
 Client: Crown Castle
 Code: TIA-222-G
 Path:

Drawn by: gpenumatsa
 Date: 05/30/18
 App'd:
 Scale: NTS
 Dwg No. E-1

v4.4 - Effective 7-12-13

Asymmetric Anchor Rod Analysis

Moment =	3571	k-ft	TIA Ref.	G	Location =	Base Plate
Axial =	45.0	kips	ASIF =	1.0000	η =	0.50 for BP, Rev. G Sect. 4.9.9
Shear =	42.0	kips	Max Ratio =	100.0%	Threads =	N/A for FP, Rev. G
Anchor Qty =	16					

**** For Post Installed Anchors: Check anchors for embedment, epoxy/grout bond, and capacity based on proof load. ****

Item	Nominal Anchor Dia, in	Spec	Fy, ksi	Fu, ksi	Location, degrees	Anchor Circle, in	Area Override, in ²	Area, in ²	Max Net Compression, kips	Max Net Tension, kips	Load for Capacity Calc, kips	Capacity Override, kips	Capacity, kips	Capacity Ratio
1	2.250	#18J A615 Gr 75	75	100	0.0	52.00	0.00	3.98	231.02	224.77	236.84	0.00	260.00	91.1%
2	2.250	#18J A615 Gr 75	75	100	30.0	52.00	0.00	3.98	231.02	224.77	236.84	0.00	260.00	91.1%
3	2.250	#18J A615 Gr 75	75	100	60.0	52.00	0.00	3.98	231.02	224.77	236.84	0.00	260.00	91.1%
4	2.250	#18J A615 Gr 75	75	100	90.0	52.00	0.00	3.98	231.02	224.77	236.84	0.00	260.00	91.1%
5	2.250	#18J A615 Gr 75	75	100	120.0	52.00	0.00	3.98	231.02	224.77	236.84	0.00	260.00	91.1%
6	2.250	#18J A615 Gr 75	75	100	150.0	52.00	0.00	3.98	231.02	224.77	236.84	0.00	260.00	91.1%
7	2.250	#18J A615 Gr 75	75	100	180.0	52.00	0.00	3.98	231.02	224.77	236.84	0.00	260.00	91.1%
8	2.250	#18J A615 Gr 75	75	100	210.0	52.00	0.00	3.98	231.02	224.77	236.84	0.00	260.00	91.1%
9	2.250	#18J A615 Gr 75	75	100	240.0	52.00	0.00	3.98	231.02	224.77	236.84	0.00	260.00	91.1%
10	2.250	#18J A615 Gr 75	75	100	270.0	52.00	0.00	3.98	231.02	224.77	236.84	0.00	260.00	91.1%
11	2.250	#18J A615 Gr 75	75	100	300.0	52.00	0.00	3.98	231.02	224.77	236.84	0.00	260.00	91.1%
12	2.250	#18J A615 Gr 75	75	100	330.0	52.00	0.00	3.98	231.02	224.77	236.84	0.00	260.00	91.1%
13	1.750	A193 Gr B7	105	125	45.0	52.50	0.00	2.41	140.94	137.17	144.46	0.00	190.00	76.0%
14	1.750	A193 Gr B7	105	125	135.0	52.50	0.00	2.41	140.94	137.17	144.46	0.00	190.00	76.0%
15	1.750	A193 Gr B7	105	125	225.0	52.50	0.00	2.41	140.94	137.17	144.46	0.00	190.00	76.0%
16	1.750	A193 Gr B7	105	125	315.0	52.50	0.00	2.41	140.94	137.17	144.46	0.00	190.00	76.0%

57.38

Stiffened or Unstiffened, UngROUTed, Circular Base Plate - Any Rod Material

TIA Rev G

Assumption: Clear space between bottom of leveling nut and top of concrete not exceeding (1)*(Rod Diameter)

Site Data

BU#: 876352
Site Name: Richard Wall
App #:
Pole Manufacturer: Other

Anchor Rod Data

Qty:	12	
Diam:	2.25	in
Rod Material:	A615-J	
Strength (Fu):	100	ksi
Yield (Fy):	75	ksi
Bolt Circle:	52	in

Plate Data

Diam:	58	in
Thick:	1.75	in
Grade:	60	ksi
Single-Rod B-eff:	11.51	in

Stiffener Data (Welding at both sides)

Config:	1	*
Weld Type:	Both	
Groove Depth:	0.625	in **
Groove Angle:	45	degrees
Fillet H. Weld:	0.625	in
Fillet V. Weld:	0.375	in
Width:	6.5	in
Height:	20	in
Thick:	1.25	in
Notch:	0.75	in
Grade:	65	ksi
Weld str.:	80	ksi

Pole Data

Diam:	43.5	in
Thick:	0.3125	in
Grade:	65	ksi
# of Sides:	18	"0" IF Round
Fu	80	ksi
Reinf. Fillet Weld	0	"0" if None

Reactions

Mu:	2962.6	ft-kips
Axial, Pu:	37.5	kips
Shear, Vu:	35	kips
Eta Factor, η	0.5	TIA G (Fig. 4-4)

Reactions adjusted to account for additional anchor rods.

If No stiffeners, Criteria: AISC LRFD <-Only Applicable to Unstiffened Cases

Anchor Rod Results

Max Rod (Cu+ Vu/η): 236.9 Kips
 Allowable Axial, Φ*Fu*Anet: 260.0 Kips
 Anchor Rod Stress Ratio: 91.1% **Pass**

Stiffened
AISC LRFD
φ*Tn

Base Plate Results

Base Plate Stress: 46.0 ksi
 Allowable Plate Stress: 54.0 ksi
 Base Plate Stress Ratio: 85.1% **Pass**

Flexural Check

Stiffened
AISC LRFD
φ*Fy
Y.L. Length: N/A, Roark

Stiffener Results

Horizontal Weld : 44.4% **Pass**
 Vertical Weld: 53.1% **Pass**
 Plate Flex+Shear, fb/Fb+(fv/Fv)^2: 10.6% **Pass**
 Plate Tension+Shear, ft/Ft+(fv/Fv)^2: 44.6% **Pass**
 Plate Comp. (AISC Bracket): 45.4% **Pass**

Pole Results

Pole Punching Shear Check: 21.4% **Pass**

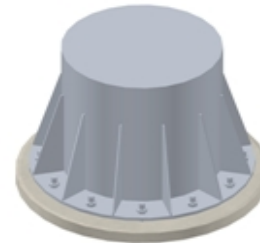
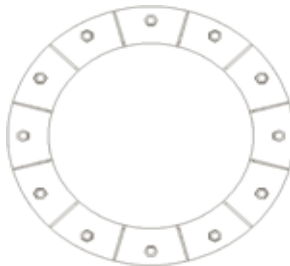

* 0 = none, 1 = every bolt, 2 = every 2 bolts, 3 = 2 per bolt

** Note: for complete joint penetration groove welds the groove depth must be exactly 1/2 the stiffener thickness for calculation purposes

Drilled Pier Foundation



BU # :	876352
Site Name:	Richard Wall
App. Number:	

TIA-222 Revison:	G
Tower Type:	Monopole

Applied Loads		
	Comp.	Uplift
Moment (kip-ft)	3571	
Axial Force (kips)	45	
Shear Force (kips)	42	

Material Properties		
Concrete Strength, f'c:	3	ksi
Rebar Strength, Fy:	60	ksi

Pier Design Data		
Depth	22	ft
Ext. Above Grade	1	ft
Pier Section 1		
<i>From 1' above grade to 22' below grade</i>		
Pier Diameter	6	ft
Rebar Quantity	14	
Rebar Size	11	
Clear Cover to Ties	4	in
Tie Size	5	

Analysis Results

Soil Lateral Capacity	Compression	Uplift
D _{v=0} (ft from TOC)	6.49	-
Soil Safety Factor	1.65	-
Max Moment (kip-ft)	3802.87	-
Rating	80.5%	-

Soil Vertical Capacity	Compression	Uplift
Skin Friction (kips)	305.36	-
End Bearing (kips)	169.65	-
Weight of Concrete (kips)	117.06	-
Total Capacity (kips)	475.01	-
Axial (kips)	162.06	-
Rating	34.1%	-

Reinforced Concrete Capacity	Compression	Uplift
Critical Depth (ft from TOC)	6.44	-
Critical Moment (kip-ft)	3802.84	-
Critical Moment Capacity	2995.47	-
Rating		-

Soil Interaction Rating	80.5%
Structural Foundation Rating	SEE NEXT SHEET

Soil Profile			
Groundwater Depth	n/a	ft	# of Layers
			4

Layer	Top (ft)	Bottom (ft)	Thickness (ft)	γ _{soil} (pcf)	γ _{concrete} (pcf)	Cohesion (ksf)	Angle of Friction (degrees)	Calculated Ultimate Skin Friction Comp (ksf)	Calculated Ultimate Skin Friction Uplift (ksf)	Ultimate Skin Friction Comp Override (ksf)	Ultimate Skin Friction Uplift Override (ksf)	Ult. Gross Bearing Capacity (ksf)	SPT Blow Count	Soil Type
1	0	3.33	3.33	120	150	0	0	0.000	0.000					Cohesionless
2	3.33	6.5	3.17	120	150	0	33	0.708	0.708				30	Cohesionless
3	6.5	11	4.5	120	150	0	33	0.616	0.616				8	Cohesionless
4	11	22	11	120	150	0	33	1.507	1.507			8	12	Cohesionless

DRILLED PIER STEEL ANALYSIS - STEEL CALCULATIONS - TIA-222-G
 BASED ON ACI 318-05, SECTIONS 9 & 10 (ASSUMING TIE REINFORCEMENT)

Factored Internal Loads from Analysis

Reference Standard =	TIA-222-G
ACI Code =	ACI 318-05
Maximum Ratio =	100.0%
Axial Load, Pu =	45.0 kips, (+Comp, -Tension)
Moment, Mu =	3802.8 k-ft (Must be Positive)
Depth to Analysis Section =	6.44 ft, from Grade

Factored Internal Loads

Load Factor =	1.0
Axial Load, Pu = ΦPn =	45.0 kips
Moment, Mu =	3802.8 k-ft

Drilled Pier Geometry and Concrete Specifications

Diameter =	72 in
fc' =	3 ksi
εc =	0.003 in/in
β1 =	0.85
Ag =	4071.5 in ²
Height Above Grade =	1 ft
Depth Below Grade =	22 ft

Nominal Axial Load and Moment

ΦPn(max) =	6438.7 kips
ΦPn(min) =	-1872.1 kips
ΦPn =	45.0 kips
Φ =	0.900
ΦMn (Resultant) =	4238.9 k-ft
at θ =	180 degrees
NA Depth =	14.69 in

Rebar Size and Specifications

	Existing	New	
Bar Size =	#11		
Override Bar Diameter =		1.7500	in
Bar Diameter =	1.4100	1.7500	in
Bar Area =	1.5600	2.4053	in ²
Effective Bar Area =	1.5600	2.4053	in ²
Number Bars =	14	4	
Spacing =	Symmetric	Symmetric	
fy =	60	80	ksi
Es =	29000	29000	ksi
εy =	0.00207	0.00276	in/in
Tie Size =	#5		
Clear Cover to Ties =	4		in
Bar Circle =	61.34	52.5	in
Adjust =	12.8571	315.0000	degrees
% of Area Effective =	100.0%	100.0%	

AXIAL RATIO = 0.7% OK

MOMENT RATIO = 89.7% OK

Minimum Required Steel

Seismic Design Category =	D	
As(min) =	13.57	sq in
As =	31.46	sq in
Stl Area Reduction Factor =	1.00	

ACI Section 10.5



RADIO FREQUENCY EMISSIONS ANALYSIS REPORT EVALUATION OF HUMAN EXPOSURE POTENTIAL TO NON-IONIZING EMISSIONS

T-Mobile Existing Facility

Site ID: CTHA601A

Crown Castle 876352 Richard Wall
94 East High Street
East Hampton, CT 06424

April 14, 2018

EBI Project Number: 6218002976

Site Compliance Summary	
Compliance Status:	COMPLIANT
Site total MPE% of FCC general population allowable limit:	22.88 %



April 14, 2018

T-Mobile USA
Attn: Jason Overbey, RF Manager
35 Griffin Road South
Bloomfield, CT 06002

Emissions Analysis for Site: **CTHA601A – Crown Castle 876352 Richard Wall**

EBI Consulting was directed to analyze the proposed T-Mobile facility located at **94 East High Street, East Hampton, CT**, for the purpose of determining whether the emissions from the Proposed T-Mobile Antenna Installation located on this property are within specified federal limits.

All information used in this report was analyzed as a percentage of current Maximum Permissible Exposure (% MPE) as listed in the FCC OET Bulletin 65 Edition 97-01 and ANSI/IEEE Std C95.1. The FCC regulates Maximum Permissible Exposure in units of microwatts per square centimeter ($\mu\text{W}/\text{cm}^2$). The number of $\mu\text{W}/\text{cm}^2$ calculated at each sample point is called the power density. The exposure limit for power density varies depending upon the frequencies being utilized. Wireless Carriers and Paging Services use different frequency bands each with different exposure limits, therefore it is necessary to report results and limits in terms of percent MPE rather than power density.

All results were compared to the FCC (Federal Communications Commission) radio frequency exposure rules, 47 CFR 1.1307(b)(1) – (b)(3), to determine compliance with the Maximum Permissible Exposure (MPE) limits for General Population/Uncontrolled environments as defined below.

General population/uncontrolled exposure limits apply to situations in which the general population may be exposed or in which persons who are exposed as a consequence of their employment may not be made fully aware of the potential for exposure or cannot exercise control over their exposure. Therefore, members of the general population would always be considered under this category when exposure is not employment related, for example, in the case of a telecommunications tower that exposes persons in a nearby residential area.

Public exposure to radio frequencies is regulated and enforced in units of microwatts per square centimeter ($\mu\text{W}/\text{cm}^2$). The general population exposure limits for the 600 MHz and 700 MHz Band are approximately $400 \mu\text{W}/\text{cm}^2$ and $467 \mu\text{W}/\text{cm}^2$ respectively. The general population exposure limit for the 1900 MHz (PCS), 2100 MHz (AWS) and 11 GHz Microwave bands is $1000 \mu\text{W}/\text{cm}^2$. Because each carrier will be using different frequency bands, and each frequency band has different exposure limits, it is necessary to report percent of MPE rather than power density.



Occupational/controlled exposure limits apply to situations in which persons are exposed as a consequence of their employment and in which those persons who are exposed have been made fully aware of the potential for exposure and can exercise control over their exposure. Occupational/controlled exposure limits also apply where exposure is of a transient nature as a result of incidental passage through a location where exposure levels may be above general population/uncontrolled limits (see below), as long as the exposed person has been made fully aware of the potential for exposure and can exercise control over his or her exposure by leaving the area or by some other appropriate means.

Additional details can be found in FCC OET 65.

CALCULATIONS

Calculations were done for the proposed T-Mobile Wireless antenna facility located at **94 East High Street, East Hampton, CT**, using the equipment information listed below. All calculations were performed per the specifications under FCC OET 65. Since T-Mobile is proposing highly focused directional panel antennas, which project most of the emitted energy out toward the horizon, all calculations were performed assuming a lobe representing the maximum gain of the antenna per the antenna manufactures supplied specifications, minus 10 dB for directional panel antennas and 20 dB for highly focused parabolic microwave dishes, was focused at the base of the tower. For this report the sample point is the top of a 6-foot person standing at the base of the tower.

For all calculations, all equipment was calculated using the following assumptions:

- 1) 2 UMTS channels (AWS Band – 2100 MHz) were considered for each sector of the proposed installation. These Channels have a transmit power of 30 Watts per Channel.
- 2) 2 LTE channels (PCS Band - 1900 MHz) were considered for each sector of the proposed installation. These Channels have a transmit power of 60 Watts per Channel.
- 3) 2 LTE channels (AWS Band – 2100 MHz) were considered for each sector of the proposed installation. These Channels have a transmit power of 60 Watts per Channel
- 4) 1 LTE channel (600 MHz Band) was considered for each sector of the proposed installation. This channel has a transmit power of 30 Watts.
- 5) 1 LTE channel (700 MHz Band) was considered for each sector of the proposed installation. This channel has a transmit power of 30 Watts.
- 6) 1 microwave backhaul channel (11 GHz) was considered for the proposed facility. This channel has a transmit power of 1 Watt.



- 7) All radios at the proposed installation were considered to be running at full power and were uncombined in their RF transmissions paths per carrier prescribed configuration. Per FCC OET Bulletin No. 65 - Edition 97-01 recommendations to achieve the maximum anticipated value at each sample point, all power levels emitting from the proposed antenna installation are increased by a factor of 2.56 to account for possible in-phase reflections from the surrounding environment. This is rarely the case, and if so, is never continuous.
- 8) For the following calculations the sample point was the top of a 6-foot person standing at the base of the tower. The maximum gain of the antenna per the antenna manufactures supplied specifications, minus 10 dB for directional panel antennas and 20 dB for highly focused parabolic microwave dishes, was used in this direction. This value is a very conservative estimate as gain reductions for these particular antennas are typically much higher in this direction.
- 9) The antennas used in this modeling are the **Ericsson AIR32 B66A/B2A & RFS APX16DWV-16DWVS-E-A20** for 1900 MHz (PCS) and 2100 MHz (AWS) channels, the **RFS APXVAA24-43-U-A20** for 600 MHz and 700 MHz channels and the **Commscope SHPX3-11W** for the proposed 11 GHz microwave backhaul. This is based on feedback from the carrier with regard to anticipated antenna selection. The **Ericsson AIR32 B66A/B2A** has a maximum gain of **15.9 dBd** at its main lobe at 1900 MHz and 2100 MHz. The **RFS APX16DWV-16DWVS-E-A20** has a maximum gain of **16.3 dBd** at its main lobe at 1900 MHz and 2100 MHz. The **RFS APXVAA24-43-U-A20** has a maximum gain of **13.15/ 13.55 dBd** at its main lobe at 600 MHz and 700 MHz respectively. The **Commscope SHPX3-11W** has a maximum gain of **36.25 dBd** at its main lobe at 10 GHz. The maximum gain of the antenna per the antenna manufactures supplied specifications, minus 10 dB for directional panel antennas and 20 dB for highly focused parabolic microwave dishes, was used for all calculations. This value is a very conservative estimate as gain reductions for these particular antennas are typically much higher in this direction.
- 10) The antenna mounting height centerline of the proposed antennas (both panel antennas and microwave dish) is **83 feet** above ground level (AGL).
- 11) Emissions values for additional carriers were taken from the Connecticut Siting Council active database. Values in this database are provided by the individual carriers themselves.
- 12) All calculations were done with respect to uncontrolled / general population threshold limits.



T-Mobile Site Inventory and Power Data

Sector:	A	Sector:	B	Sector:	C	Sector:	D
Antenna #:	1	Antenna #:	1	Antenna #:	1	Antenna #:	1
Make / Model:	Ericsson AIR32 B66A/B2A	Make / Model:	Ericsson AIR32 B66A/B2A	Make / Model:	Ericsson AIR32 B66A/B2A	Make / Model:	Ericsson AIR32 B66A/B2A
Gain:	15.9 dBd	Gain:	15.9 dBd	Gain:	15.9 dBd	Gain:	15.9 dBd
Height (AGL):	83	Height (AGL):	83	Height (AGL):	83	Height (AGL):	83
Frequency Bands	1900 MHz (PCS) / 2100 MHz (AWS)	Frequency Bands	1900 MHz (PCS) / 2100 MHz (AWS)	Frequency Bands	1900 MHz (PCS) / 2100 MHz (AWS)	Frequency Bands	1900 MHz (PCS) / 2100 MHz (AWS)
Channel Count	4	Channel Count	4	Channel Count	4	Channel Count	4
Total TX Power(W):	240	Total TX Power(W):	240	Total TX Power(W):	240	Total TX Power(W):	240
ERP (W):	9,337.08	ERP (W):	9,337.08	ERP (W):	9,337.08	ERP (W):	9,337.08
Antenna A1 MPE%	5.66	Antenna B1 MPE%	5.66	Antenna C1 MPE%	5.66	Antenna D1 MPE%	5.66
Antenna #:	2	Antenna #:	2	Antenna #:	2	Antenna #:	2
Make / Model:	RFS APX16DWV-16DWVS-E-A20	Make / Model:	RFS APX16DWV-16DWVS-E-A20	Make / Model:	RFS APX16DWV-16DWVS-E-A20	Make / Model:	RFS APX16DWV-16DWVS-E-A20
Gain:	16.3 dBd	Gain:	16.3 dBd	Gain:	16.3 dBd	Gain:	16.3 dBd
Height (AGL):	83	Height (AGL):	83	Height (AGL):	83	Height (AGL):	83
Frequency Bands	2100 MHz (AWS)	Frequency Bands	2100 MHz (AWS)	Frequency Bands	2100 MHz (AWS)	Frequency Bands	2100 MHz (AWS)
Channel Count	3	Channel Count	2	Channel Count	2	Channel Count	2
Total TX Power(W):	61	Total TX Power(W):	60	Total TX Power(W):	60	Total TX Power(W):	60
ERP (W):	6,776.44	ERP (W):	2,559.48	ERP (W):	2,559.48	ERP (W):	2,559.48
Antenna A2 MPE%	1.81	Antenna B2 MPE%	1.55	Antenna C2 MPE%	1.55	Antenna D2 MPE%	1.55
Antenna #:	3	Antenna #:	3	Antenna #:	3	Antenna #:	3
Make / Model:	RFS APXVAA24-43-U-A20	Make / Model:	RFS APXVAA24-43-U-A20	Make / Model:	RFS APXVAA24-43-U-A20	Make / Model:	RFS APXVAA24-43-U-A20
Gain:	13.15/ 13.55 dBd	Gain:	13.15/ 13.55 dBd	Gain:	13.15/ 13.55 dBd	Gain:	13.15/ 13.55 dBd
Height (AGL):	83	Height (AGL):	83	Height (AGL):	83	Height (AGL):	83
Frequency Bands	600 MHz / 700 MHz	Frequency Bands	600 MHz / 700 MHz	Frequency Bands	600 MHz / 700 MHz	Frequency Bands	600 MHz / 700 MHz
Channel Count	2	Channel Count	2	Channel Count	2	Channel Count	2
Total TX Power(W):	60	Total TX Power(W):	60	Total TX Power(W):	60	Total TX Power(W):	60
ERP (W):	1,299.01	ERP (W):	1,299.01	ERP (W):	1,299.01	ERP (W):	1,299.01
Antenna A3 MPE%	1.82	Antenna B3 MPE%	1.82	Antenna C3 MPE%	1.82	Antenna D3 MPE%	1.82

Microwave Backhaul Data

Make / Model:	Gain	Height (AGL):	Frequency Bands	Channel Count	Total TX Power(W)	ERP (W)	MPE %	Sector
Commscope SHPX3-11W	36.25 dBd	83	11 GHz	1	1	4,216.97	0.26	D



Site Composite MPE%	
Carrier	MPE%
T-Mobile (Sector D)	9.29 %
Town	1.47 %
Sprint	0.97 %
Verizon Wireless	4.88 %
AT&T	5.61 %
Nextel	0.66 %
Site Total MPE %:	22.88 %

T-Mobile Sector A Total:	9.03 %
T-Mobile Sector B Total:	9.03 %
T-Mobile Sector C Total:	9.03 %
T-Mobile Sector C Total:	9.29 %
Site Total:	
	22.88 %

T-Mobile Max Power Values (Sector D)

T-Mobile _per sector	# Channels	Watts ERP (Per Channel)	Height (feet)	Total Power Density ($\mu\text{W}/\text{cm}^2$)	Frequency (MHz)	Allowable MPE ($\mu\text{W}/\text{cm}^2$)	Calculated % MPE
T-Mobile AWS - 2100 MHz LTE	2	2,334.27	83	28.31	AWS - 2100 MHz	1000	2.83%
T-Mobile PCS - 1900 MHz LTE	2	2,334.27	83	28.31	PCS - 1900 MHz	1000	2.83%
T-Mobile AWS - 2100 MHz UMTS	2	1,279.74	83	15.52	AWS - 2100 MHz	1000	1.55%
T-Mobile 600 MHz LTE	1	619.61	83	3.76	600 MHz	1000	0.94%
T-Mobile 700 MHz LTE	1	679.39	83	4.12	700 MHz	467	0.88%
T-Mobile 11 GHz Microwave	1	1717.91	140	2.56	11 GHz	1000	0.26%
						Total:	9.29%



Summary

All calculations performed for this analysis yielded results that were **within** the allowable limits for general population exposure to RF Emissions.

The anticipated maximum composite contributions from the T-Mobile facility as well as the site composite emissions value with regards to compliance with FCC's allowable limits for general population exposure to RF Emissions are shown here:

T-Mobile Sector	Power Density Value (%)
Sector A:	9.03 %
Sector B:	9.03 %
Sector C:	9.03 %
Sector D:	9.29 %
T-Mobile Per Sector Maximum (Sector D):	9.29 %
Site Total:	22.88 %
Site Compliance Status:	COMPLIANT

The anticipated composite MPE value for this site assuming all carriers present is **22.88%** of the allowable FCC established general population limit sampled at the ground level. This is based upon values listed in the Connecticut Siting Council database for existing carrier emissions.

FCC guidelines state that if a site is found to be out of compliance (over allowable thresholds), that carriers over a 5% contribution to the composite value will require measures to bring the site into compliance. For this facility, the composite values calculated were well within the allowable 100% threshold standard per the federal government.