



# STATE OF CONNECTICUT

## CONNECTICUT SITING COUNCIL

Ten Franklin Square, New Britain, CT 06051

Phone: (860) 827-2935 Fax: (860) 827-2950

E-Mail: [siting.council@ct.gov](mailto:siting.council@ct.gov)

[www.ct.gov/csc](http://www.ct.gov/csc)

August 10, 2012

Peter LaMontagne  
New Cingular Wireless PCS, LLC  
95 Ryan Drive, Suite #1  
Raynham, MA 02767

RE: **EM-CING-040-120720** – New Cingular Wireless PCS, LLC notice of intent to modify an existing telecommunications facility located at 56 Floydville Road, East Granby, Connecticut.

Dear Mr. LaMontagne:

The Connecticut Siting Council (Council) hereby acknowledges your notice to modify this existing telecommunications facility, pursuant to Section 16-50j-73 of the Regulations of Connecticut State Agencies with the following conditions:

- The proposed coax and auxiliary equipment be installed in accordance with the recommendations made in the Structural Analysis Report prepared by FDH Engineering dated July 3, 2012 and stamped by Christopher Murphy; and
- Following the installation of the proposed equipment, AT&T shall provide documentation certifying that the installation complied with the engineer's recommendation.
- Any deviation from the proposed modification as specified in this notice and supporting materials with Council shall render this acknowledgement invalid;
- Any material changes to this modification as proposed shall require the filing of a new notice with the Council;
- Not less than 45 days after completion of construction, the Council shall be notified in writing that construction has been completed;
- The validity of this action shall expire one year from the date of this letter; and
- The applicant may file a request for an extension of time beyond the one year deadline provided that such request is submitted to the Council not less than 60 days prior to the expiration;

The proposed modifications including the placement of all necessary equipment and shelters within the tower compound are to be implemented as specified here and in your notice dated July 20, 2012. The modifications are in compliance with the exception criteria in Section 16-50j-72 (b) of the Regulations of Connecticut State Agencies as changes to an existing facility site that would not increase tower height, extend the boundaries of the tower site, increase noise levels at the tower site boundary by six decibels, and increase the total radio frequencies electromagnetic radiation power density measured at the tower site boundary to or above the standard adopted by the State Department of Environmental Protection pursuant to General Statutes § 22a-162. This facility has also been carefully modeled to ensure that radio frequency emissions are

conservatively below State and federal standards applicable to the frequencies now used on this tower.

This decision is under the exclusive jurisdiction of the Council. Please be advised that the validity of this action shall expire one year from the date of this letter. Any additional change to this facility will require explicit notice to this agency pursuant to Regulations of Connecticut State Agencies Section 16-50j-73. Such notice shall include all relevant information regarding the proposed change with cumulative worst-case modeling of radio frequency exposure at the closest point of uncontrolled access to the tower base, consistent with Federal Communications Commission, Office of Engineering and Technology, Bulletin 65. Thank you for your attention and cooperation.

Very truly yours,

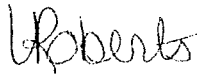

Linda Roberts  
Executive Director

LR/CDM/cm

c: The Honorable James M. Hayden, First Selectman, Town of East Granby  
Lincoln B. White, Zoning Enforcement Officer, Town of East Granby



**New Cingular Wireless  
PCS, LLC**  
500 Enterprise Drive  
Rocky Hill, Connecticut 06067

**Peter LaMontagne**  
Real Estate Consultant  
95 Ryan Drive, Suite #1  
Raynham, MA 02767  
Phone: (508)341-7854  
[plamontagne@clinell.com](mailto:plamontagne@clinell.com)

ORIGINAL

July 20, 2012

Honorable Robert Stein, Chairman,  
and Members of the Connecticut Siting Council  
Connecticut Siting Council  
10 Franklin Square  
New Britain, Connecticut 06051

RECEIVED  
JUL 20 2012  
CONNECTICUT  
SITING COUNCIL

**Re: Notice of Exempt Modification – Existing AT&T Tower Facility at 56 Floydville Road, East Granby, CT 06206**

Dear Chairman Stein and Members of the Council:

New Cingular Wireless PCS, LLC (“AT&T”) intends to modify the existing telecommunications antennas and associated equipment at an existing multicarrier telecommunications tower at 56 Floydville Road in East Granby, Connecticut. AT&T operates under licenses issued by the Federal Communications Commission (“FCC”) to provide cellular and PCS mobile telephone service in Hartford County, which includes the area to be served by AT&T’s proposed installation.

In order to accommodate technological changes, implement Long Term Evolution (“LTE”) capabilities, and enhance system performance in the State of Connecticut, New Cingular Wireless PCS, LLC (“AT&T”) plans to modify the equipment configurations at many of its existing cell sites. LTE is a new high-performance air interface for cellular mobile communications. It is designed to increase the capacity and speed of mobile telephone networks.

Please accept this letter as notification to the Council, pursuant to R.C.S.A. Section 16-50j-73, of construction which constitutes an exempt modification pursuant to R.C.S.A. Section 16-50j-72(b)(2). In compliance with R.C.S.A. Section 16-50j-73, a copy of this letter is being sent to the James Hayden, First Selectmen for the Town of East Granby.

Attached is a summary of the planned modifications, including power density calculations, reflecting the change in AT&T’s operations at the facility. Also included is documentation of the structural sufficiency of the tower to accommodate the revised antenna configuration.

### **Existing Facility**

The East Granby Facility is located at 56 Floydville Road on the east side of Route 10. Site coordinates (NAD83) are N41° 55' 42.9" and W72° 46' 34".

The facility is owned by SBA Properties, Inc of 5900 Broken Sound Parkway, N.W, Boca Raton, Florida 33487-2797.

The existing facility consists of a one hundred and twenty foot (120') monopole tower located within a fenced in compound surrounded by a chain link fence. AT&T currently operates wireless communications equipment at the facility.

### **Statutory Considerations**

The changes to the East Granby tower facility do not constitute a modification as defined in Connecticut General Statutes ("C.G.S.") Section 16-50i(d) because the general physical characteristics of the facility will not be significantly changed or altered. Rather, the planned changes to the facility fall squarely within those activities explicitly provided for in R.C.S.A. Section 16-50j-72(b)(2) because they will not result in any substantial adverse environmental effect.

1. The height of the overall structure will be unaffected.
2. The proposed changes will not affect the property boundaries. All new construction will take place inside the existing fenced compound.
3. The proposed additions will not increase the noise level at the existing facility by six decibels or more.
4. LTE will utilize additional radio frequencies newly licensed by the FCC for cellular mobile communications. However, the changes will not increase the calculated "worst case" power density for the combined operations at the site to a level at or above the applicable standard for uncontrolled environments as calculated for a mixed frequency site.

For the foregoing reasons, New Cingular Wireless respectfully submits that the proposed changes at the referenced site constitute exempt modifications under R.C.S.A Section §16-50j-72(b)(2).

Respectfully yours,



Peter LaMontagne  
Real Estate Consultant

Enclosures:

James Hayden, First Selectmen for the Town of East Granby



**New Cingular Wireless  
PCS, LLC**  
500 Enterprise Drive  
Rocky Hill, Connecticut 06067

**Peter LaMontagne**  
Real Estate Consultant  
95 Ryan Drive, Suite #1  
Raynham, MA 02767  
Phone: (508)341-7854  
[plamontagne@clinellc.com](mailto:plamontagne@clinellc.com)

July , 2012

James Hayden  
First Selectmen, East Granby  
9 Center Street  
East Granby, CT 06206

**Re: Notice of Exempt Modification – Existing Telecommunications Facility at 56  
Floydville Road, East Granby CT 06206**

Dear James Hayden, First Selectmen of East Granby,

New Cingular Wireless PCS, LLC (“AT&T”) intends to replace telecommunications antennas and associated equipment at an existing telecommunications tower, owned by SBA Properties, Inc and situated at 56 Floydville Road in East Granby, Connecticut.

A Notice of Exempt Modification has been filed with the Connecticut Siting Council as required by Regulations of Connecticut State Agencies (“R.C.S.A.”) Section 16-50j-73. Please accept this letter as notification to the Town of East Granby under Section 16-50j-73 of construction which constitutes an exempt modification pursuant to R.C.S.A. Section 16-50j-72(b)(2).

The attached letter fully sets forth the AT&T proposal. However, if you have any questions or require any further information on the plans for the site or the Siting Council’s procedures, please contact Peter LaMontagne at (508) 341-7854 or Linda Roberts, Executive Director of the Connecticut Siting Council, at (860) 827-2935.

Sincerely,

Peter LaMontagne  
Real Estate Consultant

Enclosure  
Honorable Robert Stein, Chairmen of the Connecticut Siting Council

**CT5425 – East Granby – 56 Floydville Road, East Granby, CT**

**Aerial Location Map**

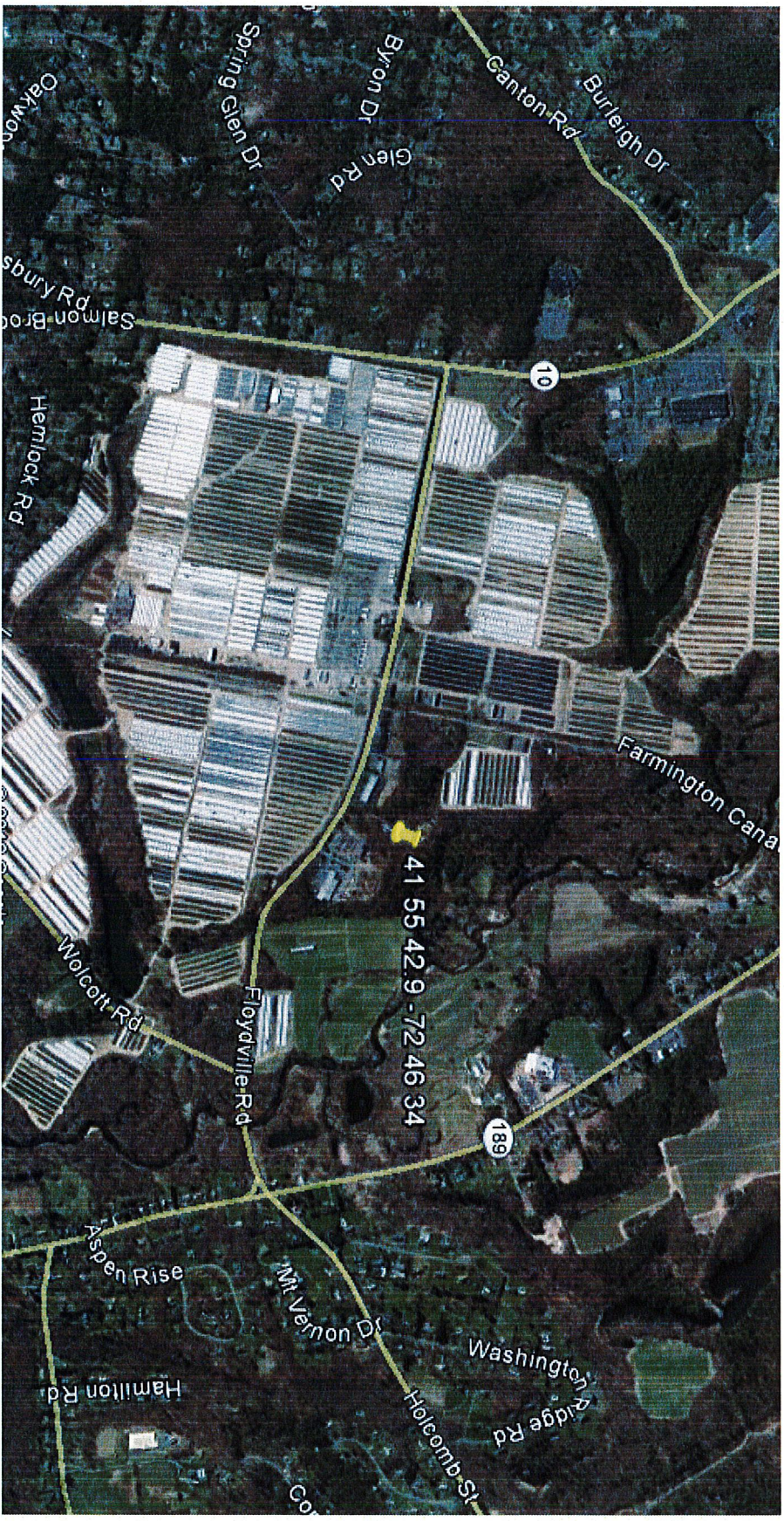

**Street Location Map**

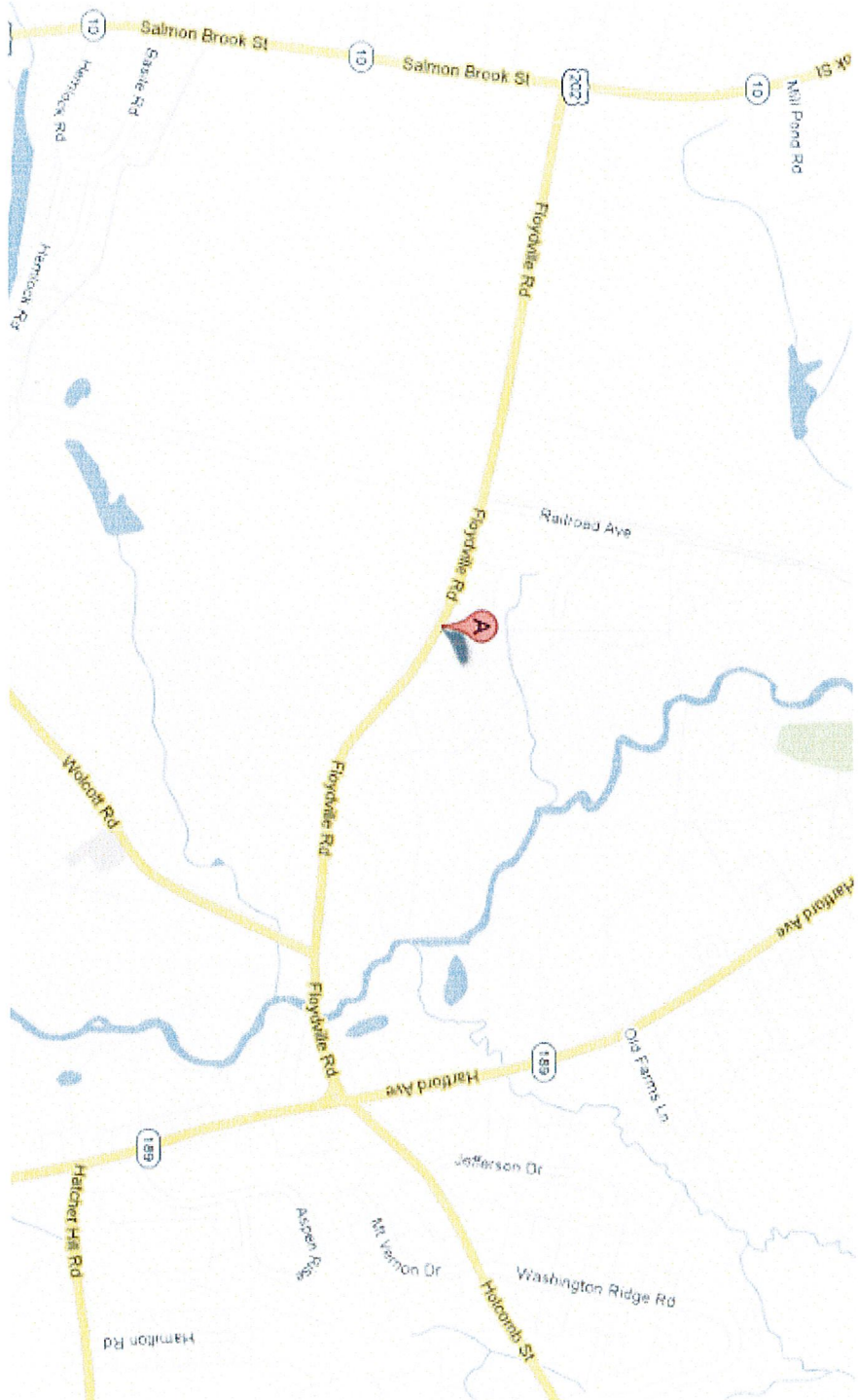



C Squared Systems, LLC  
65 Dartmouth Drive, Unit A3  
Auburn, NH 03032  
(603) 644-2800  
support@csquaredsystems.com

---

Calculated Radio Frequency Emissions



CT5425 (East Granby SW)

56 Floydville Rd, East Granby, CT 06026

---

July 13, 2012



## Table of Contents

1. Introduction.....	1
2. FCC Guidelines for Evaluating RF Radiation Exposure Limits.....	1
3. RF Exposure Prediction Methods.....	2
4. Calculation Results.....	3
5. Conclusion.....	4
6. Statement of Certification.....	4
Attachment A: References.....	5
Attachment B: FCC Limits for Maximum Permissible Exposure (MPE).....	6
Attachment C: AT&T Antenna Data Sheets and Electrical Patterns.....	8

## List of Tables

Table 1: Carrier Information.....	3
Table 2: FCC Limits for Maximum Permissible Exposure (MPE).....	6

## List of Figures

Figure 1: Graph of FCC Limits for Maximum Permissible Exposure (MPE).....	7
---	---

## 1. Introduction

The purpose of this report is to investigate compliance with applicable FCC regulations for the proposed modifications to the existing AT&T antenna arrays mounted on the monopole tower located at 56 Floydville Rd in East Granby, CT. The coordinates of the tower are 41-55-42.9 N, 72-46-34.0 W.

AT&T is proposing the following modifications:

- 1) Install three 700 MHz LTE antennas (one per sector);
- 2) Install three 700 MHz LTE Remote Radio Units (RRUs).

## 2. FCC Guidelines for Evaluating RF Radiation Exposure Limits

In 1985, the FCC established rules to regulate radio frequency (RF) exposure from FCC licensed antenna facilities. In 1996, the FCC updated these rules, which were further amended in August 1997 by OET Bulletin 65 Edition 97-01. These new rules include Maximum Permissible Exposure (MPE) limits for transmitters operating between 300 kHz and 100 GHz. The FCC MPE limits are based upon those recommended by the National Council on Radiation Protection and Measurements (NCRP), developed by the Institute of Electrical and Electronics Engineers, Inc., (IEEE) and adopted by the American National Standards Institute (ANSI).

The FCC general population/uncontrolled limits set the maximum exposure to which most people may be subjected. General population/uncontrolled exposures apply in situations in which the general public may be exposed, or in which persons that are exposed as a consequence of their employment may not be fully aware of the potential for exposure or cannot exercise control over their exposure.

Public exposure to radio frequencies is regulated and enforced in units of milliwatts per square centimeter ( $\text{mW}/\text{cm}^2$ ). The general population exposure limits for the various frequency ranges are defined in the attached "FCC Limits for Maximum Permissible Exposure (MPE)" in Attachment B of this report.

Higher exposure limits are permitted under the occupational/controlled exposure category, but only for persons who are exposed as a consequence of their employment and who have been made fully aware of the potential for exposure, and they must be able to exercise control over their exposure. General population/uncontrolled limits are five times more stringent than the levels that are acceptable for occupational, or radio frequency trained individuals. Attachment B contains excerpts from OET Bulletin 65 and defines the Maximum Exposure Limit.

Finally, it should be noted that the MPE limits adopted by the FCC for both general population/uncontrolled exposure and for occupational/controlled exposure incorporate a substantial margin of safety and have been established to be well below levels generally accepted as having the potential to cause adverse health effects.

### 3. RF Exposure Prediction Methods

The emission field calculation results displayed in the following figures were generated using the following formula as outlined in FCC bulletin OET 65:

$$\text{Power Density} = \left( \frac{1.6^2 \times EIRP}{4\pi \times R^2} \right) \times \text{Off Beam Loss}$$

Where:

EIRP = Effective Isotropic Radiated Power

R = Radial Distance =  $\sqrt{(H^2 + V^2)}$

H = Horizontal Distance from antenna in meters

V = Vertical Distance from radiation center of antenna in meters

Ground reflection factor of 1.6

Off Beam Loss is determined by the selected antenna pattern

These calculations assume that the antennas are operating at 100 percent capacity and power, and that all channels are transmitting simultaneously. Obstructions (trees, buildings, etc.) that would normally attenuate the signal are not taken into account. The calculations assume even terrain in the area of study and do not take into account actual terrain elevations which could attenuate the signal. As a result, the predicted signal levels reported below are much higher than the actual signal levels will be from the finished modifications.

#### 4. Calculation Results

Table 1 below outlines the power density information for the site. Because the proposed AT&T antennas are directional in nature, the majority of the RF power is focused out towards the horizon. As a result, there will be less RF power directed below the antennas relative to the horizon, and consequently lower power density levels around the base of the tower. Please refer to Attachment C for the vertical pattern of the proposed AT&T antennas. The calculated results for AT&T in Table 1 include a nominal 10 dB off-beam pattern loss to account for the lower relative gain below the antennas.

Carrier	Antenna Height (Feet)	Operating Frequency (MHz)	Number of Trans.	ERP Per Transmitter (Watts)	Power Density (mw/cm <sup>2</sup> )	Limit	%MPE
AT&T UMTS	89	880	1	500	0.0227	0.5867	3.87%
AT&T UMTS	89	1900	1	500	0.0227	1.0000	2.27%
AT&T GSM	89	1900	2	427	0.0388	1.0000	3.88%
AT&T GSM	89	880	4	296	0.0537	0.5867	9.16%
Voicestream	107	1935	8	238	0.0598	1.0000	5.98%
Verizon	118	869	9	200	0.0465	0.5793	8.02%
Verizon	118	1900	3	200	0.0155	1.0000	1.55%
Pocket	97	2130	3	631	0.0723	1.0000	7.23%
AT&T UMTS	87	880	2	565	0.0054	0.5867	0.92%
AT&T UMTS	87	1900	2	875	0.0083	1.0000	0.83%
AT&T LTE	87	734	1	1615	0.0077	0.4893	1.57%
AT&T GSM	87	880	1	283	0.0013	0.5867	0.23%
AT&T GSM	87	1900	4	525	0.0100	1.0000	1.00%
						<b>Total</b>	<b>27.33%</b>

**Table 1: Carrier Information**<sup>1 2 3</sup>

<sup>1</sup> The existing CSC filing for AT&T should be removed and replaced with the updated AT&T technologies and values provided in Table 1. The power density information for carriers other than AT&T was taken directly from the CSC database dated 3/29/2012. Please note that %MPE values listed are rounded to two decimal points. The total %MPE listed is a summation of each unrounded contribution. Therefore, summing each rounded value may not reflect the total value listed in the table.

<sup>2</sup> In the case where antenna models are not uniform across all 3 sectors for the same frequency band, the antenna model with the highest gain was used for the calculations.

<sup>3</sup> Antenna height listed for AT&T is in reference to the FDH Engineering, Inc Structural Analysis dated July 3, 2012.

## 5. Conclusion

The above analysis verifies that emissions from the existing site will be below the maximum power density levels as outlined by the FCC in the OET Bulletin 65 Ed. 97-01. Even when using conservative methods, the cumulative power density from the proposed transmit antennas at the existing facility is well below the limits for the general public. The highest expected percent of Maximum Permissible Exposure at ground level is **27.33% of the FCC limit**.

As noted previously, obstructions (trees, buildings, etc.) that would normally attenuate the signal are not taken into account. As a result, the predicted signal levels are more conservative (higher) than the actual signal levels will be from the finished modifications.

## 6. Statement of Certification

I certify to the best of my knowledge that the statements in this report are true and accurate. The calculations follow guidelines set forth in ANSI/IEEE Std. C95.3, ANSI/IEEE Std. C95.1 and FCC OET Bulletin 65 Edition 97-01.

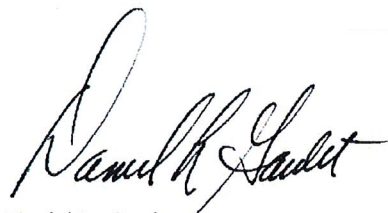

Daniel L. Goulet  
C Squared Systems, LLC

July 13, 2012

Date

### **Attachment A: References**

OET Bulletin 65 - Edition 97-01 - August 1997 Federal Communications Commission Office of Engineering & Technology

ANSI C95.1-1982, American National Standard Safety Levels With Respect to Human Exposure to Radio Frequency Electromagnetic Fields, 300 kHz to 100 GHz. IEEE-SA Standards Board

IEEE Std C95.3-1991 (Reaff 1997), IEEE Recommended Practice for the Measurement of Potentially Hazardous Electromagnetic Fields - RF and Microwave. IEEE-SA Standards Board

**Attachment B: FCC Limits for Maximum Permissible Exposure (MPE)**

**(A) Limits for Occupational/Controlled Exposure<sup>4</sup>**

Frequency Range (MHz)	Electric Field Strength (E) (V/m)	Magnetic Field Strength (E) (A/m)	Power Density (S) (mW/cm <sup>2</sup> )	Averaging Time  E  <sup>2</sup> ,  H  <sup>2</sup> or S (minutes)
0.3-3.0	614	1.63	(100)*	6
3.0-30	1842/f	4.89/f	(900/f <sup>2</sup> )*	6
30-300	61.4	0.163	1.0	6
300-1500	-	-	f/300	6
1500-100,000	-	-	5	6

**(B) Limits for General Population/Uncontrolled Exposure<sup>5</sup>**

Frequency Range (MHz)	Electric Field Strength (E) (V/m)	Magnetic Field Strength (E) (A/m)	Power Density (S) (mW/cm <sup>2</sup> )	Averaging Time  E  <sup>2</sup> ,  H  <sup>2</sup> or S (minutes)
0.3-1.34	614	1.63	(100)*	30
1.34-30	824/f	2.19/f	(180/f <sup>2</sup> )*	30
30-300	27.5	0.073	0.2	30
300-1500	-	-	f/1500	30
1500-100,000	-	-	1.0	30

f = frequency in MHz \* Plane-wave equivalent power density

**Table 2: FCC Limits for Maximum Permissible Exposure (MPE)**

<sup>4</sup> Occupational/controlled limits apply in situations in which persons are exposed as a consequence of their employment provided those persons are fully aware of the potential for exposure and can exercise control over their exposure. Limits for occupational/controlled exposure also apply in situations when an individual is transient through a location where occupational/controlled limits apply provided he or she is made aware of the potential for exposure

<sup>5</sup> General population/uncontrolled exposures apply in situations in which the general public may be exposed, or in which persons that are exposed as a consequence of their employment may not be fully aware of the potential for exposure or cannot exercise control over their exposure

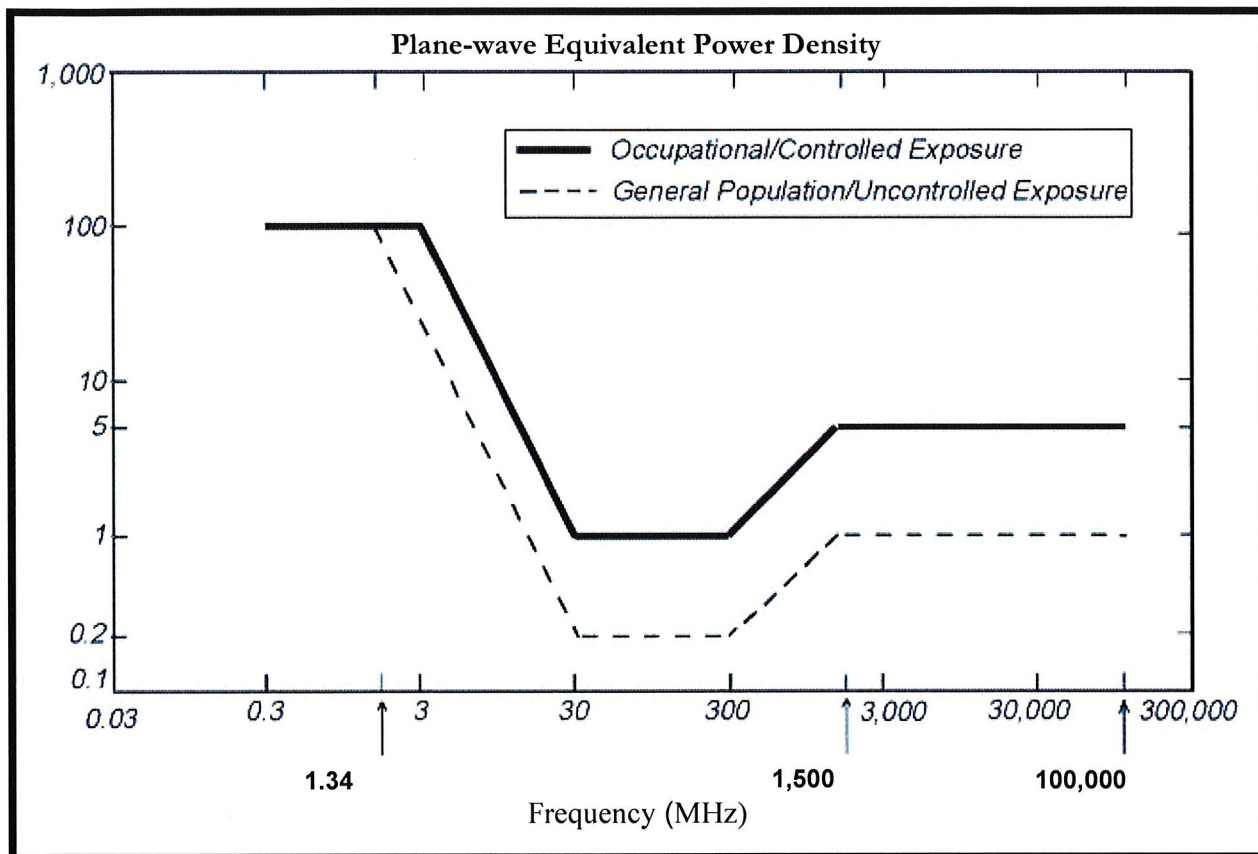
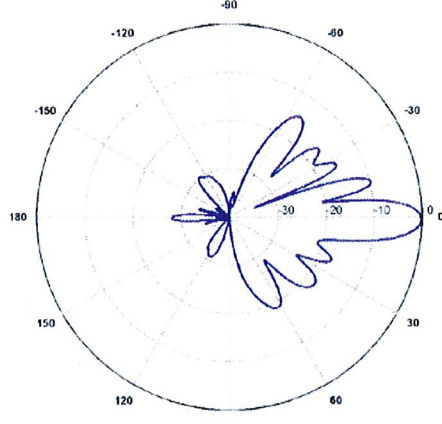
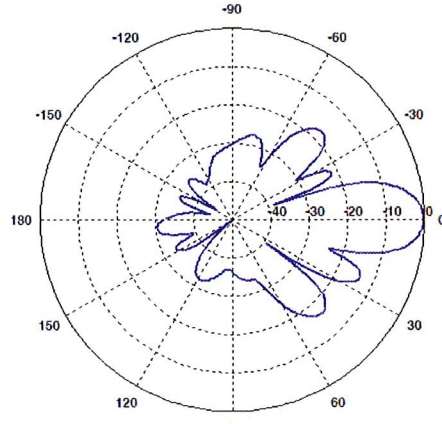
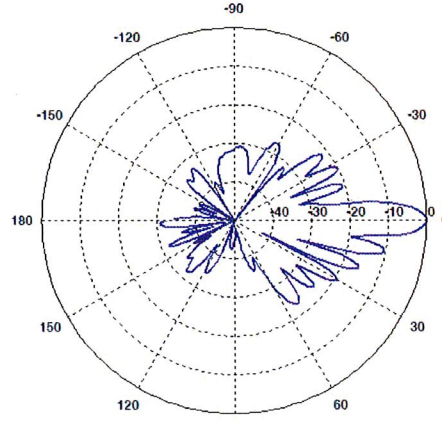

Figure 1: Graph of FCC Limits for Maximum Permissible Exposure (MPE)



**Attachment C: AT&T Antenna Data Sheets and Electrical Patterns**

<p><b>700 MHz</b></p> <p>Manufacturer: Powerwave            Model #: P65-17-XLH-RR            Frequency Band: 698-806 MHz            Gain: 14.3 dBd            Vertical Beamwidth: 8.4°            Horizontal Beamwidth: 70°            Polarization: Dual Linear ± 45°            Size L x W x D: 96.0" x 12.0" x 6.0"</p>	
<p><b>850 MHz</b></p> <p>Manufacturer: Powerwave            Model #: 7770.00            Frequency Band: 824-896 MHz            Gain: 11.4 dBd            Vertical Beamwidth: 15°            Horizontal Beamwidth: 85°            Polarization: Dual Linear ±45°            Size L x W x D: 55.0" x 11.0" x 5.0"</p>	
<p><b>1900 MHz</b></p> <p>Manufacturer: Powerwave            Model #: 7770.00            Frequency Band: 1850-1990 MHz            Gain: 13.4 dBd            Vertical Beamwidth: 7°            Horizontal Beamwidth: 90°            Polarization: Dual Linear ±45°            Size L x W x D: 55.0" x 11.0" x 5.0"</p>	



FDH Engineering, Inc., 6521 Meridien Drive Raleigh, NC 27616, Ph. 919.755.1012

**Structural Analysis for  
SBA Network Services, Inc.**

**120' Monopole Tower**

**SBA Site Name: East Granby  
SBA Site ID: CT03801-S  
AT&T Site ID: CT5425  
AT&T Site Name: East Granby SW**

**FDH Project Number 12-03651E S2**

**Analysis Results**

Tower Components	54.5%	Sufficient
Foundation	38.9%	Sufficient

Prepared By:

*Heather W Jones*

Heather W. Jones, EI  
Project Engineer

Reviewed By:

*Christopher M. Murphy*

Christopher M. Murphy, PE  
President  
CT PE License No. 25842

**FDH Engineering, Inc.**  
6521 Meridien Drive  
Raleigh, NC 27616  
(919) 755-1012  
info@fdh-inc.com

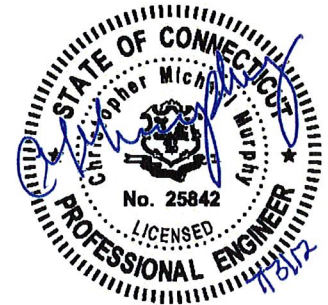

July 3, 2012

*TIA/EIA-222-F Structural Standards for Steel Antenna Towers and Antenna Supporting Structures and the 2005 Connecticut State Building Code*

**TABLE OF CONTENTS**

EXECUTIVE SUMMARY ..... 3  
    Conclusions ..... 3  
    Recommendation..... 3  
APPURTENANCE LISTING ..... 4  
RESULTS..... 5  
GENERAL COMMENTS ..... 6  
LIMITATIONS..... 6  
APPENDIX ..... 7

## EXECUTIVE SUMMARY

At the request of SBA Network Services, Inc., FDH Engineering, Inc. performed a structural analysis of the monopole located in East Granby, CT to determine whether the tower is structurally adequate to support both the existing and proposed loads pursuant to the *Structural Standards for Steel Antenna Towers and Antenna Supporting Structures, TIA/EIA-222-F* and the *2005 Connecticut State Building Code*. Information pertaining to the existing/proposed antenna loading, current tower geometry, geotechnical data, and member sizes was obtained from:

- PiRod, Inc. (Eng File No. A-118413-1) original design drawings dated June 13, 2001
- PiRod, Inc. (Eng File No. A-118413-1) Tower Calculations dated June 14, 2001
- Jaworski Geotech, Inc. (Project No. 00729G) Geotechnical Evaluation dated May 11, 2001
- SBA Network Services, Inc.

The *basic design wind speed* per the *TIA/EIA-222-F* standards and the *2005 CSBC* is 105 mph without ice and 50 mph with 1" radial ice. Ice is considered to increase in thickness with height.

## Conclusions

With the existing and proposed antennas from AT&T in place at 87 ft, the tower meets the requirements of the *TIA/EIA-222-F* standards and the *2005 CSBC* provided the **Recommendations** listed below are satisfied. Furthermore, provided the foundation was designed and constructed to support the original design reactions (see PiRod Eng File No. A-118413-1), the foundation should have the necessary capacity to support the existing and proposed loading. For a more detailed description of the analysis of the tower, see the **Results** section of this report.

Our structural analysis has been performed assuming all information provided to FDH Engineering, Inc. is accurate (i.e., the steel data, tower layout, existing antenna loading, and proposed antenna loading) and that the tower has been properly erected and maintained per the original design drawings.

## Recommendations

To ensure the requirements of the *TIA/EIA-222-F* standards and the *2005 CSBC* are met with the existing and proposed loading in place, we have the following recommendations:

1. The proposed coax should be installed inside the pole's shaft.
2. The proposed TMAs should be installed directly behind the proposed panel antennas.
3. RRU/RRH Stipulation: The equipment may be installed in any arrangement as determined by the client.

## APPURTENANCE LISTING

The proposed and existing antennas with their corresponding cables/coax lines are shown in **Table 1**. *If the actual layout determined in the field deviates from the layout, FDH Engineering, Inc. should be contacted to perform a revised analysis.*

**Table 1 - Appurtenance Loading**

### Existing Loading:

Antenna Elevation (ft)	Description	Coax and Lines	Carrier	Mount Elevation (ft)	Mount Type
117	(3) Antel BXA-70063/4CF (6) Antel LPA-80080/4CF-EDIN (6) Antel LPA-171080/8CF-EDIN (6) RFS FD9R6004/2C-3L Diplexers	(12) 1-5/8"	Verizon	117	(1) Low Profile Platform
107	(3) Thales P65Q56NS2B (3) Remec TMAs	(12) 1-5/8"	T-Mobile	107	(1) Low Profile Platform
97	(3) Kathrein 742 213	(6) 1-5/8"	Pocket	97	Flush
87	(6) Powerwave 7770.00 (6) Powerwave LGP21401 TMAs (6) Powerwave LGP21903 Diplexers	(12) 1-5/8"	AT&T	87	(1) Low Profile Platform

### Proposed Loading:

Antenna Elevation (ft)	Description	Coax and Lines	Carrier	Mount Elevation (ft)	Mount Type
88	(6) Ericsson RRUS-11 RRUs (1) Raycap DC2-48-60-18-8F Surge Arrestor	(12) 1-5/8" (1) 3' Flex Conduit	AT&T	88	(1) Universal Ring Mount (Valmont Part # LWRM)
87	(6) Powerwave 7770.00 (3) Powerwave P65-17-XLH-RR (6) Powerwave TT19-08BP111-001 TMAs (6) Powerwave LGP21903 Diplexers	(1) FB-L98B-002 (2) WR-VG86ST-BRD		87	(1) Low Profile Platform

## RESULTS

The following yield strength of steel for individual members was used for analysis:

**Table 2 - Material Strength**

Member Type	Yield Strength
Tower Shaft Sections	65 ksi
Base Plate	50 ksi
Anchor Bolts	105 ksi

**Table 3** displays the summary of the ratio (as a percentage) of force in the member to their capacities. Values greater than 100% indicate locations where the maximum force in the member exceeds its capacity. *Note: Capacities up to 100% are considered acceptable.* **Table 4** displays the maximum foundation reactions.

If the assumptions outlined in this report differ from actual field conditions, FDH Engineering, Inc. should be contacted to perform a revised analysis. Furthermore, as no information pertaining to the allowable twist and sway requirements for the existing or proposed appurtenances was provided, deflection and rotation were not taken into consideration when performing this analysis.

See the **Appendix** for detailed modeling information

**Table 3 - Summary of Working Percentage of Structural Components**

Section No.	Elevation ft	Component Type	Size	% Capacity	Pass Fail
L1	120 - 98.5	Pole	TP34.0625x24.25x0.3125	6.3	Pass
L2	98.5 - 64.8333	Pole	TP41.75x31.688x0.375	19.2	Pass
L3	64.8333 - 32	Pole	TP49.0625x39.7478x0.375	29.8	Pass
L4	32 - 0	Pole	TP56.125x46.9463x0.375	37.5	Pass
		Anchor Bolts	(39) 1.25"Ø w/ BC = 61"	35.0	Pass
		Base Plate	65"Ø x 1.5" thk.	54.5	Pass

**Table 4 - Maximum Base Reactions**

Base Reactions	Current Analysis (TIA/EIA-222-F)	Original Design (TIA/EIA-222-F)
Axial	33 k	37 k
Shear	18 k	37 k
Moment	1,447 k-ft	3,719 k-ft

## **GENERAL COMMENTS**

This engineering analysis is based upon the theoretical capacity of the structure. It is not a condition assessment of the tower and its foundation. It is the responsibility of SBA Network Services, Inc. to verify that the tower modeled and analyzed is the correct structure (with accurate antenna loading information) modeled. If there are substantial modifications to be made or the assumptions made in this analysis are not accurate, FDH Engineering, Inc. should be notified immediately to perform a revised analysis.

## **LIMITATIONS**

All opinions and conclusions are considered accurate to a reasonable degree of engineering certainty based upon the evidence available at the time of this report. All opinions and conclusions are subject to revision based upon receipt of new or additional/updated information. All services are provided exercising a level of care and diligence equivalent to the standard and care of our profession. No other warranty or guarantee, expressed or implied, is offered. Our services are confidential in nature and we will not release this report to any other party without the client's consent. The use of this engineering work is limited to the express purpose for which it was commissioned and it may not be reused, copied, or distributed for any other purpose without the written consent of FDH Engineering, Inc.

# APPENDIX



Section	1	2	3	4	22.1
Length (ft)	21.50	37.50	37.50	37.50	22.1
Number of Sides	18	18	18	18	18
Thickness (in)	0.3125	0.3750	0.3750	0.3750	0.3750
Socket Length (ft)	3.83	4.67	5.50	46.9463	56.1250
Top Dia (in)	24.2500	31.6880	39.7478	46.9463	56.1250
Bot Dia (in)	34.0625	41.7500	49.0625	46.9463	56.1250
Grade					A572-65
Weight (K)	2.1	5.5	6.7	7.8	22.1

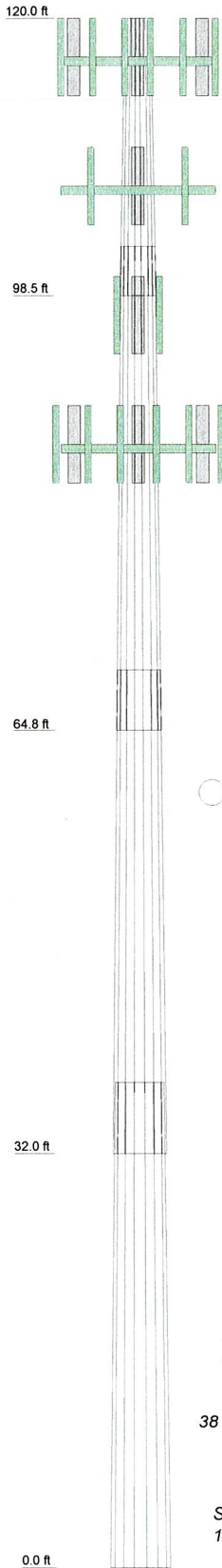

### DESIGNED APPURTENANCE LOADING

TYPE	ELEVATION	TYPE	ELEVATION
Lightning Rod	120	P65Q56NS2B w/ Mount Pipe (T-Mobile)	107
(1) Low Profile Platform mnt	117	TMA (T-Mobile)	107
BXA-70063/4CF W/ Mount Pipe (Verizon)	117	TMA (T-Mobile)	107
BXA-70063/4CF W/ Mount Pipe (Verizon)	117	TMA (T-Mobile)	107
BXA-70063/4CF W/ Mount Pipe (Verizon)	117	(1) Low Profile Platform mnt	107
(2) LPA-80080/4CF W/ Mount Pipe (Verizon)	117	742 213 w/ Mount Pipe (Pocket)	97
(2) LPA-80080/4CF W/ Mount Pipe (Verizon)	117	742 213 w/ Mount Pipe (Pocket)	97
(2) LPA-80080/4CF W/ Mount Pipe (Verizon)	117	(2) RRUS-11 (ATT)	88
(2) LPA-80080/4CF W/ Mount Pipe (Verizon)	117	(2) RRUS-11 (ATT)	88
(2) LPA-80080/4CF W/ Mount Pipe (Verizon)	117	(2) RRUS-11 (ATT)	88
(2) LPA-171080/8CF w/ Mount Pipe (Verizon)	117	DC2-48-60-18-8F Surge Arrestor (ATT)	88
(2) LPA-171080/8CF w/ Mount Pipe (Verizon)	117	Ring Mount (ATT)	88
(2) LPA-171080/8CF w/ Mount Pipe (Verizon)	117	(2) LGP21903 Diplexer (ATT)	87
(2) LPA-171080/8CF w/ Mount Pipe (Verizon)	117	(1) Low Profile Platform mnt	87
(2) FD9R6004/2C-3L Diplexer (Verizon)	117	P65-17-XLH-RR w/ Mount Pipe (ATT)	87
(2) FD9R6004/2C-3L Diplexer (Verizon)	117	P65-17-XLH-RR w/ Mount Pipe (ATT)	87
(2) FD9R6004/2C-3L Diplexer (Verizon)	117	P65-17-XLH-RR w/ Mount Pipe (ATT)	87
(2) FD9R6004/2C-3L Diplexer (Verizon)	117	(2) TT19-08BP111-001 TMA (ATT)	87
(2) FD9R6004/2C-3L Diplexer (Verizon)	117	(2) TT19-08BP111-001 TMA (ATT)	87
(2) FD9R6004/2C-3L Diplexer (Verizon)	117	(2) TT19-08BP111-001 TMA (ATT)	87
P65Q56NS2B w/ Mount Pipe (T-Mobile)	107	(2) 7770.00 w/ Mount Pipe (ATT)	87
P65Q56NS2B w/ Mount Pipe (T-Mobile)	107	(2) 7770.00 w/ Mount Pipe (ATT)	87
		(2) LGP21903 Diplexer (ATT)	87
		(2) LGP21903 Diplexer (ATT)	87

### MATERIAL STRENGTH

GRADE	Fy	Fu	GRADE	Fy	Fu
A572-65	65 ksi	80 ksi			

### TOWER DESIGN NOTES

1. Tower is located in Hartford County, Connecticut.
2. Tower designed for a 80 mph basic wind in accordance with the TIA/EIA-222-F Standard.
3. Tower is also designed for a 38 mph basic wind with 1.00 in ice. Ice is considered to increase in thickness with height.
4. Deflections are based upon a 60 mph wind.
5. TOWER RATING: 37.5%

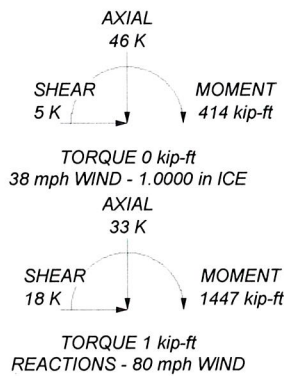

**FDH Engineering, Inc.**  
 6521 Meridian Drive  
 Raleigh, NC 27616  
 Phone: (919) 755-1012  
 FAX: (919) 755-1031

Job: <b>East Granby, CT03801-S</b>			
Project: <b>12-03651E S2</b>			
Client: <b>SBA Network Services, Inc.</b>	Drawn by: <b>Heather Jones</b>	App'd:	
Code: <b>TIA/EIA-222-F</b>	Date: <b>07/03/12</b>	Scale: <b>NTS</b>	
Path:		Dwg No. <b>E-1</b>	

**PROJECT INFORMATION**

SCOPE OF WORK: UNMANNED TELECOMMUNICATIONS FACILITY MODIFICATIONS  
 SITE ADDRESS: 56 FLOYDVILLE RD  
 EAST GRANBY, CT 06026  
 LATITUDE: 41.928592 N 41° 55' 42.9" N  
 LONGITUDE: -72.776099 W -72° 46' 34" W  
 JURISDICTION: NATIONAL, STATE & LOCAL CODES OR ORDINANCES  
 CURRENT USE: TELECOMMUNICATIONS FACILITY  
 PROPOSED USE: TELECOMMUNICATIONS FACILITY



**SITE NUMBER: CT5425**  
**SITE NAME: EAST GRANBY SW**

**DRAWING INDEX**

**REV**

**VICINITY MAP**

**GENERAL NOTES**

- T-1 TITLE SHEET**
- GN-1 GENERAL NOTES**
- A-1 COMPOUND PLAN & EQUIPMENT PLAN**
- A-2 ANTENNA LAYOUT, ELEVATION & DETAILS**
- A-3 DETAILS**
- G-1 PLUMBING DIAGRAM & GROUNDING DETAILS**

- 1
- 1
- 1
- 1
- 1
- 1
- 1

**DIRECTION TO SITE:**  
 START OUT GOING NORTHEAST ON ENTERPRISE DR TOWARD CAPITOL BLVD. 0.4 MI. TURN LEFT ONTO CAPITOL BLVD. 0.3 MI. TURN LEFT ONTO WEST ST. 0.2 MI. MERGE ONTO I-91 N VIA THE RAMP ON THE LEFT TOWARD HARTFORD. 15.3 MI. TAKE THE CT-305/BLOOMFIELD AVE EXIT, EXIT 37, TOWARD WINDSOR CENTER. 0.2 MI. TURN LEFT ONTO CT-305 W/BLOOMFIELD AVE. CONTINUE TO FOLLOW CT-305 W. 2.5 MI. TURN RIGHT ONTO BLUE HILLS AVE/CT-187. CONTINUE TO FOLLOW CT-187 N. 3.3 MI. STAY STRAIGHT TO GO ONTO CT-189 N. 2.9 MI. TURN LEFT ONTO FLOYDVILLE RD. 0.6 MI. END AT 56 FLOYDVILLE RD EAST GRANBY, CT 06026.

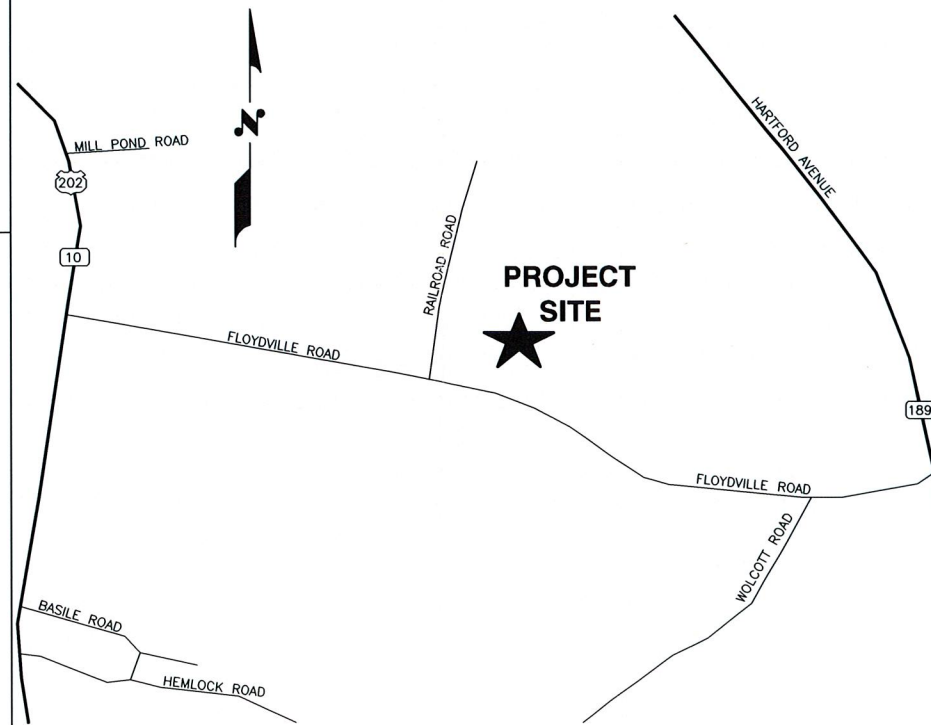

1. THIS DOCUMENT IS THE CREATION, DESIGN, PROPERTY AND COPYRIGHTED WORK OF AT&T. ANY DUPLICATION OR USE WITHOUT EXPRESS WRITTEN CONSENT IS STRICTLY PROHIBITED. DUPLICATION AND USE BY GOVERNMENT AGENCIES FOR THE PURPOSES OF CONDUCTING THEIR LAWFULLY AUTHORIZED REGULATORY AND ADMINISTRATIVE FUNCTIONS IS SPECIFICALLY ALLOWED.
2. THE FACILITY IS AN UNMANNED PRIVATE AND SECURED EQUIPMENT INSTALLATION. IT IS ONLY ACCESSED BY TRAINED TECHNICIANS FOR PERIODIC ROUTINE MAINTENANCE AND THEREFORE DOES NOT REQUIRE ANY WATER OR SANITARY SEWER SERVICE. THE FACILITY IS NOT GOVERNED BY REGULATIONS REQUIRING PUBLIC ACCESS PER ADA REQUIREMENTS.
3. CONTRACTOR SHALL VERIFY ALL PLANS AND EXISTING DIMENSIONS AND CONDITIONS ON THE JOB SITE AND SHALL IMMEDIATELY NOTIFY THE AT&T REPRESENTATIVE IN WRITING OF DISCREPANCIES BEFORE PROCEEDING WITH THE WORK OR BE RESPONSIBLE FOR SAME.

72 HOURS  
 BEFORE YOU DIG   
 CALL TOLL FREE 800-922-4455

UNDERGROUND SERVICE ALERT

**Hudson Design Group**  
 1600 OSGOOD STREET  
 BUILDING 20 NORTH, SUITE 2-101  
 N. ANDOVER, MA 01845  
 TEL: (978) 557-5553  
 FAX: (978) 336-5586

**NEXLINK GLOBAL SERVICES**  
 a UniTek GLOBAL SERVICES company  
 800 MARSHALL PHELPS ROAD UNIT#: 2A  
 WINDSOR, CT 06095

**SITE NUMBER: CT5425**  
**SITE NAME: EAST GRANBY SW**  
 56 FLOYDVILLE RD  
 EAST GRANBY, CT 06026  
 HARTFORD COUNTY

**at&t**  
 500 ENTERPRISE DRIVE, SUITE 3A  
 ROCKY HILL, CT 06067

		STATE OF CONNECTICUT DANIEL P. HARTZ LICENSED PROFESSIONAL ENGINEER No. 1173		AT&T	
				TITLE SHEET (LTE)	
NO.	DATE	REVISIONS	BY	JOB NUMBER	DRAWING NUMBER
1	04/10/12	ISSUED FOR CONSTRUCTION	HC	8425.01	T-1
0	03/08/12	ISSUED FOR REVIEW	JG		
SCALE: AS SHOWN		DESIGNED BY: DC	DRAWN BY: JG		REV 1

**GROUNDING NOTES**

- THE SUBCONTRACTOR SHALL REVIEW AND INSPECT THE EXISTING FACILITY GROUNDING SYSTEM AND LIGHTNING PROTECTION SYSTEM (AS DESIGNED AND INSTALLED) FOR STRICT COMPLIANCE WITH THE NEC (AS ADOPTED BY THE AHJ), THE SITE-SPECIFIC (UL, LPI, OR NFPA) LIGHTNING PROTECTION CODE, AND GENERAL COMPLIANCE WITH TELCORDIA AND TIA GROUNDING STANDARDS. THE SUBCONTRACTOR SHALL REPORT ANY VIOLATIONS OR ADVERSE FINDINGS TO THE CONTRACTOR FOR RESOLUTION.
- ALL GROUND ELECTRODE SYSTEMS (INCLUDING TELECOMMUNICATION, RADIO, LIGHTNING PROTECTION, AND AC POWER GES'S) SHALL BE BONDED TOGETHER, AT OR BELOW GRADE, BY TWO OR MORE COPPER BONDING CONDUCTORS IN ACCORDANCE WITH THE NEC.
- THE SUBCONTRACTOR SHALL PERFORM IEEE FALL-OFF-POTENTIAL RESISTANCE TO EARTH TESTING (PER IEEE 1100 AND 81) FOR NEW GROUND ELECTRODE SYSTEMS. THE SUBCONTRACTOR SHALL FURNISH AND INSTALL SUPPLEMENTAL GROUND ELECTRODES AS NEEDED TO ACHIEVE A TEST RESULT OF 5 OHMS OR LESS.
- METAL RACEWAY SHALL NOT BE USED AS THE NEC REQUIRED EQUIPMENT GROUND CONDUCTOR. STRANDED COPPER CONDUCTORS WITH GREEN INSULATION, SIZED IN ACCORDANCE WITH THE NEC, SHALL BE FURNISHED AND INSTALLED WITH THE POWER CIRCUITS TO BTS EQUIPMENT.
- EACH BTS CABINET FRAME SHALL BE DIRECTLY CONNECTED TO THE MASTER GROUND BAR WITH GREEN INSULATED SUPPLEMENTAL EQUIPMENT GROUND WIRES, 6 AWG STRANDED COPPER OR LARGER FOR INDOOR BTS 2 AWG STRANDED COPPER FOR OUTDOOR BTS.
- EXOTHERMIC WELDS SHALL BE USED FOR ALL GROUNDING CONNECTIONS BELOW GRADE.
- APPROVED ANTIOXIDANT COATINGS (I.E., CONDUCTIVE GEL OR PASTE) SHALL BE USED ON ALL COMPRESSION AND BOLTED GROUND CONNECTIONS.
- ICE BRIDGE BONDING CONDUCTORS SHALL BE EXOTHERMICALLY BONDED OR BOLTED TO THE BRIDGE AND THE TOWER GROUND BAR.
- ALUMINUM CONDUCTOR OR COPPER CLAD STEEL CONDUCTOR SHALL NOT BE USED FOR GROUNDING CONNECTIONS.
- MISCELLANEOUS ELECTRICAL AND NON-ELECTRICAL METAL BOXES, FRAMES AND SUPPORTS SHALL BE BONDED TO THE GROUND RING, IN ACCORDANCE WITH THE NEC.
- METAL CONDUIT SHALL BE MADE ELECTRICALLY CONTINUOUS WITH LISTED BONDING FITTINGS OR BY BONDING ACROSS THE DISCONTINUITY WITH 6 AWS COPPER WIRE UL APPROVED GROUNDING TYPE CONDUIT CLAMPS.
- ALL NEW STRUCTURES WITH A FOUNDATION AND/OR FOOTING HAVING 20 FT. OR MORE OF 1/2 IN. OR GREATER ELECTRICALLY CONDUCTIVE REINFORCING STEEL MUST HAVE IT BONDED TO THE GROUND RING USING AN EXOTHERMIC WELD CONNECTION USING #2 AWG SOLID BARE TINNED COPPER GROUND WIRE, PER NEC 250.50

**GENERAL NOTES**

- FOR THE PURPOSE OF CONSTRUCTION DRAWING, THE FOLLOWING DEFINITIONS SHALL APPLY:  
 CONTRACTOR - NEXLINK  
 SUBCONTRACTOR - GENERAL CONTRACTOR (CONSTRUCTION)  
 OWNER - AT&T MOBILITY
  - PRIOR TO THE SUBMISSION OF BIDS, THE BIDDING SUBCONTRACTOR SHALL VISIT THE CELL SITE TO FAMILIARIZE WITH THE EXISTING CONDITIONS AND TO CONFIRM THAT THE WORK CAN BE ACCOMPLISHED AS SHOWN ON THE CONSTRUCTION DRAWINGS. ANY DISCREPANCY FOUND SHALL BE BROUGHT TO THE ATTENTION OF CONTRACTOR.
  - ALL MATERIALS FURNISHED AND INSTALLED SHALL BE IN STRICT ACCORDANCE WITH ALL APPLICABLE CODES, REGULATIONS, AND ORDINANCES. SUBCONTRACTOR SHALL ISSUE ALL APPROPRIATE NOTICES AND COMPLY WITH ALL LAWS, ORDINANCES, RULES, REGULATIONS, AND LAWFUL ORDERS OF ANY PUBLIC AUTHORITY REGARDING THE PERFORMANCE OF THE WORK. ALL WORK CARRIED OUT SHALL COMPLY WITH ALL APPLICABLE MUNICIPAL AND UTILITY COMPANY SPECIFICATIONS AND LOCAL JURISDICTIONAL CODES, ORDINANCES AND APPLICABLE REGULATIONS.
  - DRAWINGS PROVIDED HERE ARE NOT TO BE SCALED AND ARE INTENDED TO SHOW OUTLINE ONLY.
  - UNLESS NOTED OTHERWISE, THE WORK SHALL INCLUDE FURNISHING MATERIALS, EQUIPMENT, APPURTENANCES, AND LABOR NECESSARY TO COMPLETE ALL INSTALLATIONS AS INDICATED ON THE DRAWINGS.
  - "KITTING LIST" SUPPLIED WITH THE BID PACKAGE IDENTIFIES ITEMS THAT WILL BE SUPPLIED BY CONTRACTOR. ITEMS NOT INCLUDED IN THE BILL OF MATERIALS AND KITTING LIST SHALL BE SUPPLIED BY THE SUBCONTRACTOR.
  - THE SUBCONTRACTOR SHALL INSTALL ALL EQUIPMENT AND MATERIALS IN ACCORDANCE WITH MANUFACTURER'S RECOMMENDATIONS UNLESS SPECIFICALLY STATED OTHERWISE.
  - IF THE SPECIFIED EQUIPMENT CANNOT BE INSTALLED AS SHOWN ON THESE DRAWINGS, THE SUBCONTRACTOR SHALL PROPOSE AN ALTERNATIVE INSTALLATION SPACE FOR APPROVAL BY THE CONTRACTOR.
  - SUBCONTRACTOR SHALL DETERMINE ACTUAL ROUTING OF CONDUIT, POWER AND T1 CABLES, GROUNDING CABLES AS SHOWN ON THE POWER, GROUNDING AND TELCO PLAN DRAWING. SUBCONTRACTOR SHALL UTILIZE EXISTING TRAYS AND/OR SHALL ADD NEW TRAYS AS NECESSARY. SUBCONTRACTOR SHALL CONFIRM THE ACTUAL ROUTING WITH THE CONTRACTOR.
  - THE SUBCONTRACTOR SHALL PROTECT EXISTING IMPROVEMENTS, PAVEMENTS, CURBS, LANDSCAPING AND STRUCTURES. ANY DAMAGED PART SHALL BE REPAIRED AT SUBCONTRACTOR'S EXPENSE TO THE SATISFACTION OF OWNER.
  - SUBCONTRACTOR SHALL LEGALLY AND PROPERLY DISPOSE OF ALL SCRAP MATERIALS SUCH AS COAXIAL CABLES AND OTHER ITEMS REMOVED FROM THE EXISTING FACILITY. ANTENNAS REMOVED SHALL BE RETURNED TO THE OWNER'S DESIGNATED LOCATION.
  - SUBCONTRACTOR SHALL LEAVE PREMISES IN CLEAN CONDITION.
  - ALL CONCRETE REPAIR WORK SHALL BE DONE IN ACCORDANCE WITH AMERICAN CONCRETE INSTITUTE (ACI) 301.
  - ANY NEW CONCRETE NEEDED FOR THE CONSTRUCTION SHALL BE AIR-ENTRAINED AND SHALL HAVE 4000 PSI STRENGTH AT 28 DAYS. ALL CONCRETE WORK SHALL BE DONE IN ACCORDANCE WITH ACI 318 CODE REQUIREMENTS.
  - ALL STRUCTURAL STEEL WORK SHALL BE DETAILED, FABRICATED AND ERECTED IN ACCORDANCE WITH AISC SPECIFICATIONS. ALL STRUCTURAL STEEL SHALL BE ASTM A36 (Fy = 36 ksi) UNLESS OTHERWISE NOTED. PIPES SHALL BE ASTM A53 TYPE E (Fy = 36 ksi). ALL STEEL EXPOSED TO WEATHER SHALL BE HOT DIPPED GALVANIZED. TOUCHUP ALL SCRATCHES AND OTHER MARKS IN THE FIELD AFTER STEEL IS ERECTED USING A COMPATIBLE ZINC RICH PAINT.
  - CONSTRUCTION SHALL COMPLY WITH UMS SPECIFICATIONS AND "GENERAL CONSTRUCTION SERVICES FOR CONSTRUCTION OF AT&T MOBILITY SITES."
  - SUBCONTRACTOR SHALL VERIFY ALL EXISTING DIMENSIONS AND CONDITIONS PRIOR TO COMMENCING ANY WORK. ALL DIMENSIONS OF EXISTING CONSTRUCTION SHOWN ON THE DRAWINGS MUST BE VERIFIED. SUBCONTRACTOR SHALL NOTIFY THE CONTRACTOR OF ANY DISCREPANCIES PRIOR TO ORDERING MATERIAL OR PROCEEDING WITH CONSTRUCTION.
  - THE EXISTING CELL SITE IS IN FULL COMMERCIAL OPERATION. ANY CONSTRUCTION WORK BY SUBCONTRACTOR SHALL NOT DISRUPT THE EXISTING NORMAL OPERATION. ANY WORK ON EXISTING EQUIPMENT MUST BE COORDINATED WITH CONTRACTOR. ALSO, WORK SHOULD BE SCHEDULED FOR AN APPROPRIATE MAINTENANCE WINDOW USUALLY IN LOW TRAFFIC PERIODS AFTER MIDNIGHT.
  - SINCE THE CELL SITE IS ACTIVE, ALL SAFETY PRECAUTIONS MUST BE TAKEN WHEN WORKING AROUND HIGH LEVELS OF ELECTROMAGNETIC RADIATION. EQUIPMENT SHOULD BE SHUTDOWN PRIOR TO PERFORMING ANY WORK THAT COULD EXPOSE THE WORKERS TO DANGER. PERSONAL RF EXPOSURE MONITORS ARE ADVISED TO BE WORN TO ALERT OF ANY DANGEROUS EXPOSURE LEVELS.
  - APPLICABLE BUILDING CODES:  
 SUBCONTRACTOR'S WORK SHALL COMPLY WITH ALL APPLICABLE NATIONAL, STATE, AND LOCAL CODES AS ADOPTED BY THE LOCAL AUTHORITY HAVING JURISDICTION (AHJ) FOR THE LOCATION. THE EDITION OF THE AHJ ADOPTED CODES AND STANDARDS IN EFFECT ON THE DATE OF CONTRACT AWARD SHALL GOVERN THE DESIGN.  
 BUILDING CODE: 2003 IBC WITH 2005 CT SUPPLEMENT & 2009 CT AMENDMENTS  
 ELECTRICAL CODE: REFER TO ELECTRICAL DRAWINGS  
 LIGHTNING CODE: REFER TO ELECTRICAL DRAWINGS
- SUBCONTRACTOR'S WORK SHALL COMPLY WITH THE LATEST EDITION OF THE FOLLOWING STANDARDS:
- AMERICAN CONCRETE INSTITUTE (ACI) 318; BUILDING CODE REQUIREMENTS FOR STRUCTURAL CONCRETE;
- AMERICAN INSTITUTE OF STEEL CONSTRUCTION (AISC)  
 MANUAL OF STEEL CONSTRUCTION, ASD, NINTH EDITION;
- TELECOMMUNICATIONS INDUSTRY ASSOCIATION (TIA) 222-F,  
 STRUCTURAL STANDARDS FOR STEEL
- ANTENNA TOWER AND ANTENNA SUPPORTING STRUCTURES; REFER TO ELECTRICAL DRAWINGS FOR SPECIFIC ELECTRICAL STANDARDS.
- FOR ANY CONFLICTS BETWEEN SECTIONS OF LISTED CODES AND STANDARDS REGARDING MATERIAL, METHODS OF CONSTRUCTION, OR OTHER REQUIREMENTS, THE MOST RESTRICTIVE REQUIREMENT SHALL GOVERN. WHERE THERE IS CONFLICT BETWEEN A GENERAL REQUIREMENT AND A SPECIFIC REQUIREMENT, THE SPECIFIC REQUIREMENT SHALL GOVERN.

**ABBREVIATIONS**

AGL	ABOVE GRADE LEVEL	G.C.	GENERAL CONTRACTOR	RF	RADIO FREQUENCY
AWG	AMERICAN WIRE GAUGE	MGB	MASTER GROUND BUS		
BCW	BARE COPPER WIRE	MIN	MINIMUM	TBD	TO BE DETERMINED
BTS	BASE TRANSCEIVER STATION	PROPOSED NEW		TBR	TO BE REMOVED
EXISTING	EXISTING	N.T.S.	NOT TO SCALE	TBRR	TO BE REMOVED AND REPLACED
EG	EQUIPMENT GROUND			TYP	TYPICAL
EGR	EQUIPMENT GROUND RING				

**Hudson**  
Design Group, Inc.

1600 OSGOOD STREET  
BUILDING 20 NORTH, SUITE 2-101  
N. ANDOVER, MA 01845

TEL: (978) 557-5553  
FAX: (978) 336-5386

**NEXLINK**  
GLOBAL SERVICES

a UniTek GLOBAL SERVICES company  
800 MARSHALL PHELPS ROAD UNIT#: 2A  
WINDSOR, CT 06095

**SITE NUMBER: CT5425**  
**SITE NAME: EAST GRANBY SW**

56 FLOYDVILLE RD  
EAST GRANBY, CT 06026  
HARTFORD COUNTY

**at&t**

500 ENTERPRISE DRIVE, SUITE 3A  
ROCKY HILL, CT 06067

				AT&T	
1	04/10/12	ISSUED FOR CONSTRUCTION	HC	HC	DPH
0	03/08/12	ISSUED FOR REVIEW	IG	HC	DPH
NO.	DATE	REVISIONS	BY	CHK	APP'D
SCALE: AS SHOWN		DESIGNED BY: DC	DRAWN BY: JG		
				GENERAL NOTES (LTE)	
			DRAWING NUMBER		REV
			GN-1		1

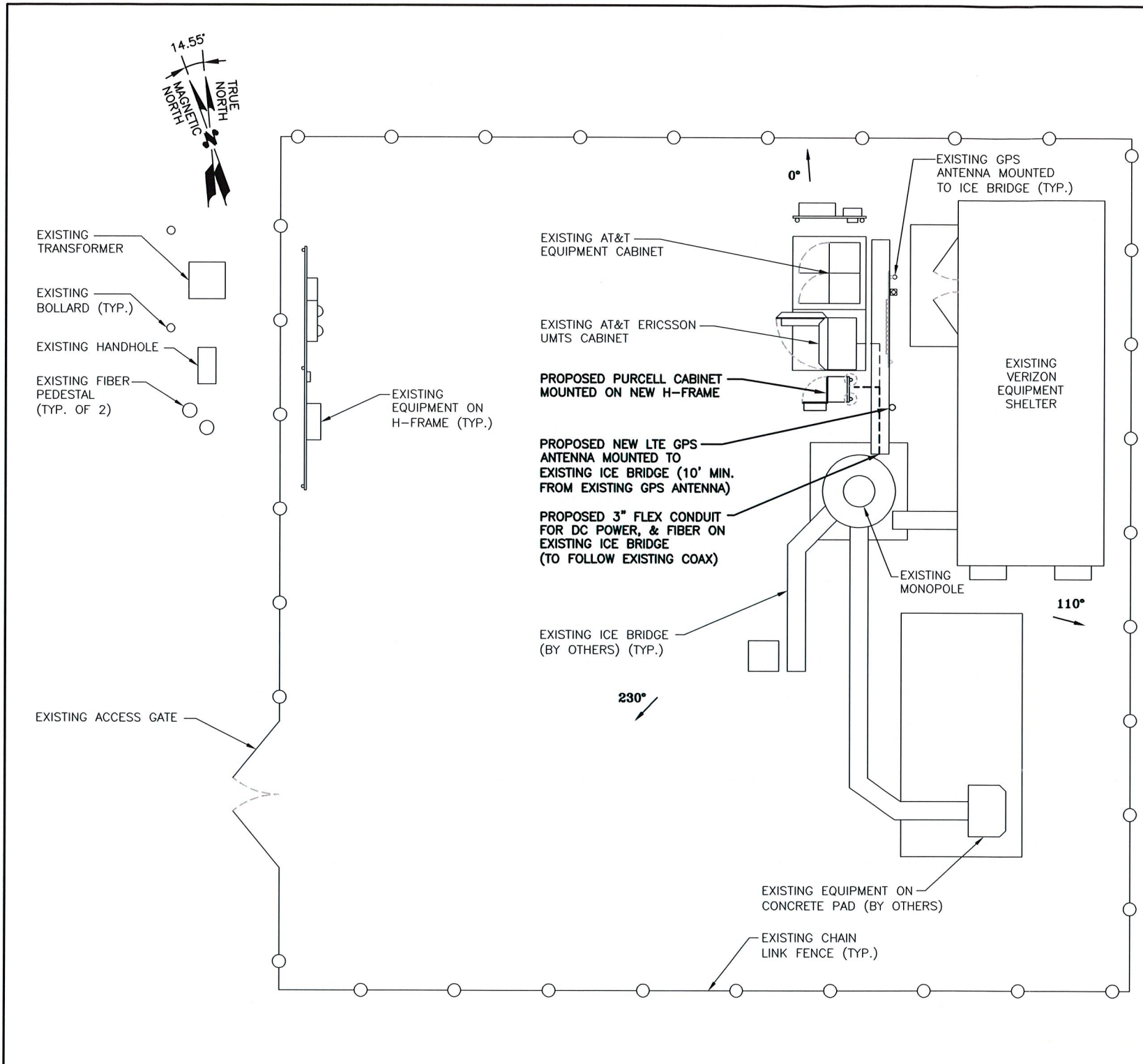

**COMPOUND PLAN**

SCALE: 1/8"=1'-0"

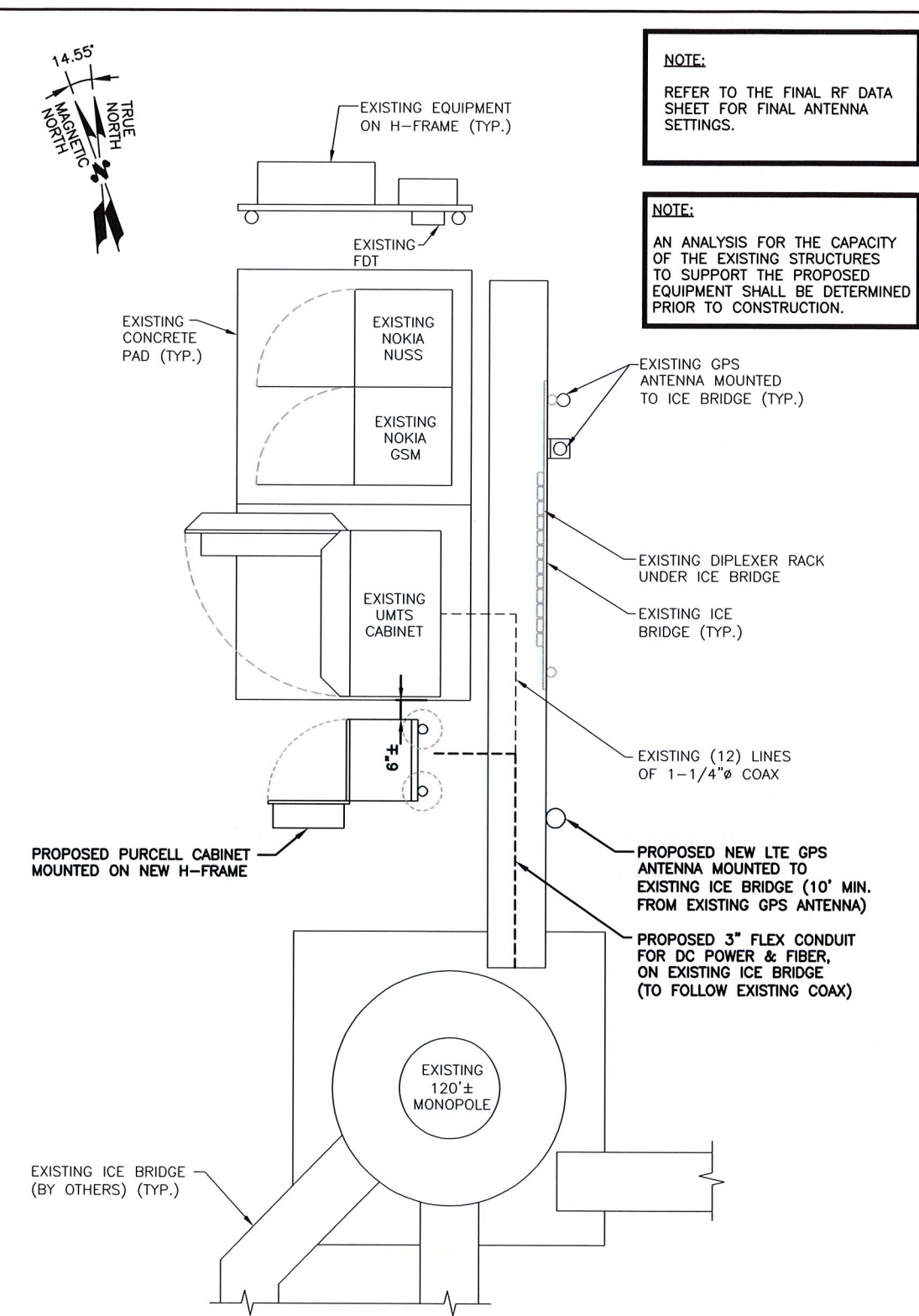

**EQUIPMENT PLAN**

SCALE: 1/2"=1'-0"



**NOTE:**  
REFER TO THE FINAL RF DATA SHEET FOR FINAL ANTENNA SETTINGS.

**NOTE:**  
AN ANALYSIS FOR THE CAPACITY OF THE EXISTING STRUCTURES TO SUPPORT THE PROPOSED EQUIPMENT SHALL BE DETERMINED PRIOR TO CONSTRUCTION.

**Hudson Design Group**

1600 OSGOOD STREET  
BUILDING 20 NORTH, SUITE 2-101  
N. ANDOVER, MA 01845

TEL: (978) 557-5553  
FAX: (978) 336-5586

**NEXLINK**  
GLOBAL SERVICES

a UniTek GLOBAL SERVICES company

800 MARSHALL PHELPS ROAD UNIT#: 2A  
WINDSOR, CT 06095

**SITE NUMBER: CT5425**  
**SITE NAME: EAST GRANBY SW**

56 FLOYDVILLE RD  
EAST GRANBY, CT 06026  
HARTFORD COUNTY

**at&t**

500 ENTERPRISE DRIVE, SUITE 3A  
ROCKY HILL, CT 06067

						AT&T	
1	04/10/12	ISSUED FOR CONSTRUCTION	HC	HC	DP/ML	COMPOUND PLAN & EQUIPMENT PLAN (LTE)	
0	03/08/12	ISSUED FOR REVIEW	JG	AC	BS/1		
NO.	DATE	REVISIONS	BY	CHK	APP'D	JOB NUMBER	DRAWING NUMBER
SCALE: AS SHOWN		DESIGNED BY: DC	DRAWN BY: JG			5425.01	A-1
							1

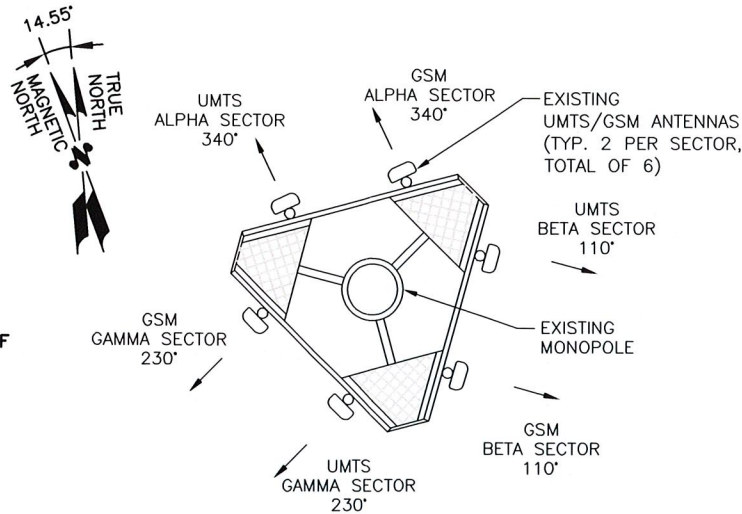
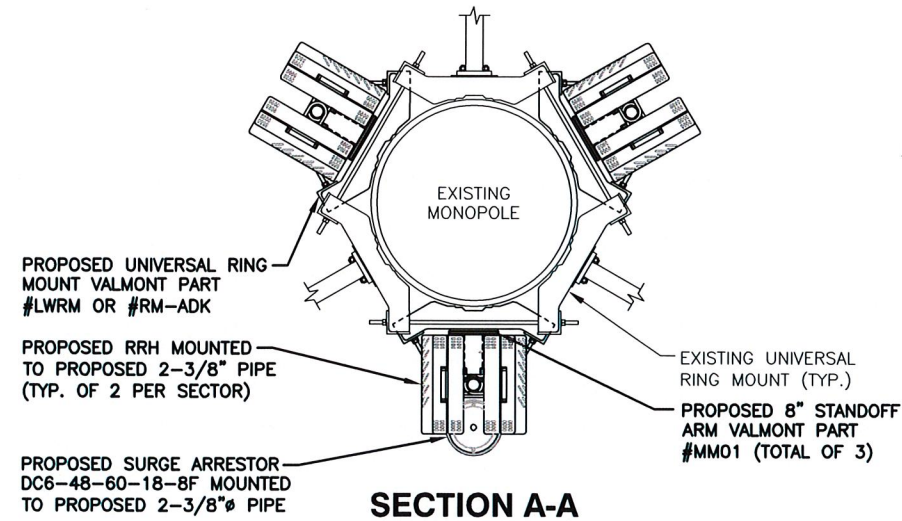

TOP OF MONOPOLE  
120'-0"± AGL

**NOTE:**  
REFER TO THE FINAL RF DATA SHEET FOR FINAL ANTENNA SETTINGS.

**NOTE:**  
AN ANALYSIS FOR THE CAPACITY OF THE EXISTING STRUCTURES TO SUPPORT THE PROPOSED EQUIPMENT SHALL BE DETERMINED PRIOR TO CONSTRUCTION.

EXISTING ANTENNA (BY OTHERS) (TYP.)

CENTER OF PROPOSED AT&T ANTENNAS, RRH'S & SURGE ARRESTOR (LTE)  
ELEV. 89'-0"± (AGL)

PROPOSED LTE ANTENNA  
ALPHA SECTOR: P65-17-XLH-RR  
BETA SECTOR: P65-17-XLH-RR  
GAMMA SECTOR: P65-17-XLH-RR  
MOUNTED TO NEW MOUNTING PIPE AT POSITION 3 (TYP. 1 PER SECTOR, TOTAL OF 3)

PROPOSED DC POWER & FIBER LINES WITHIN EXISTING MONOPOLE (TO FOLLOW EXISTING COAX)

EXISTING (12) LINES OF 1-1/4" COAX

EXISTING 120'± MONOPOLE

PROPOSED NEW LTE GPS ANTENNA MOUNTED TO EXISTING ICE BRIDGE (10' MIN. FROM EXISTING GPS ANTENNA)

PROPOSED PURCELL CABINET MOUNTED TO NEW H-FRAME

EXISTING GPS ANTENNA MOUNTED TO ICE BRIDGE (TYP.)

EXISTING AT&T EQUIPMENT (TYP.)

EXISTING CHAIN LINK FENCE (TYP.)

GROUND REF. 0'-0" AGL

PROPOSED RRH MOUNTED TO PROPOSED 2-3/8" PIPE (TYP. OF 2 PER SECTOR)(BEYOND)

PROPOSED ROTATE EXISTING AT&T GSM/UMTS ANTENNAS TO MATCH NEW LTE AZIMUTH (TYP. OF 2)

PROPOSED SLIDE EXISTING UMTS/GSM ANTENNAS AND TMA'S TO POSITIONS 1 & 4 (TYP. 2 PER SECTOR, TOTAL OF 6)

PROPOSED SURGE ARRESTOR DC6-48-60-18-8F MOUNTED TO PROPOSED 2-3/8" PIPE

EXISTING VERIZON EQUIPMENT SHELTER

EXISTING ICE BRIDGE (TYP.)

EXISTING EQUIPMENT (BY OTHERS)

**WEST ELEVATION**

SCALE: 1/8" = 1'-0" 0 4'-0" 8'-0" 16'-0" 24'-0"

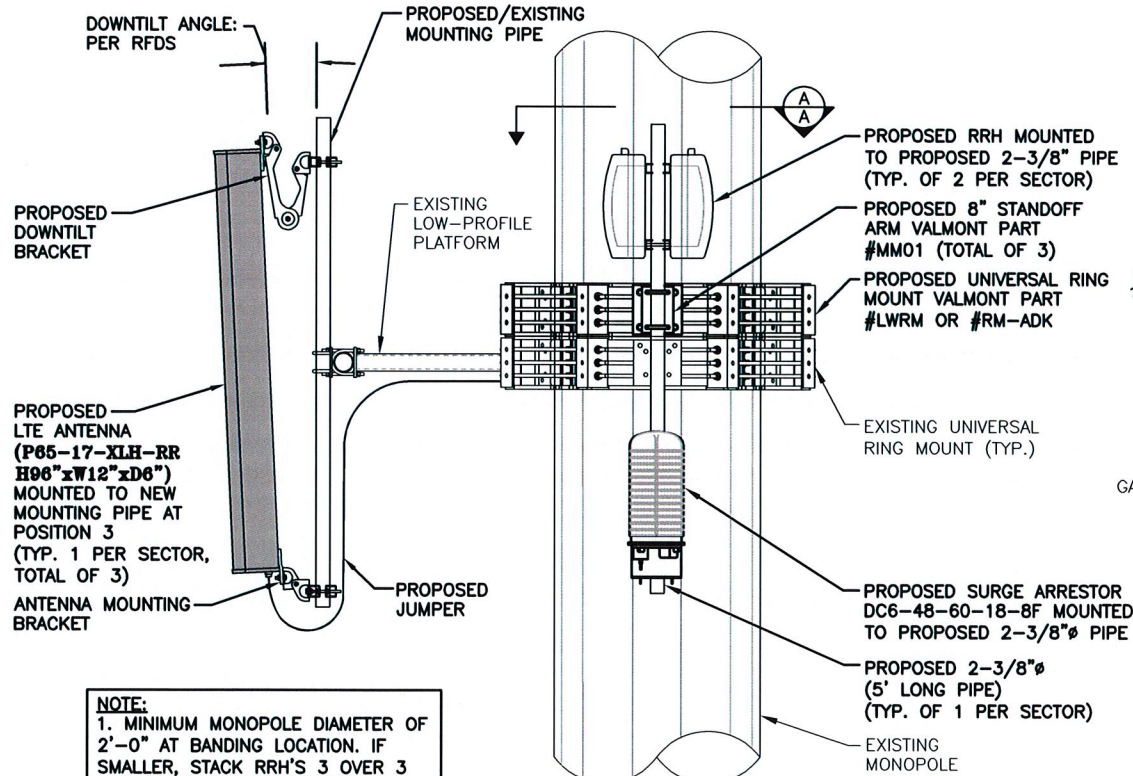

**NOTE:**  
1. MINIMUM MONOPOLE DIAMETER OF 2'-0" AT BANDING LOCATION. IF SMALLER, STACK RRH'S 3 OVER 3  
2. CONTRACTOR TO ENSURE THAT RRH MOUNTING DOES NOT INTERFERE WITH CLIMBING LADDER

PART #	VMI PART #	SIZE RANGE
LWRM	801068	12"-45"
RM-ADK	157286	36"-60" ADAPTER KIT

**NOTES:**  
1. REFER TO RFDS & SECTOR SCHEMATICS FOR ANTENNA MODEL, TYPE & QUANTITY REQUIRED PER SECTOR

**PROPOSED RRH & SURGE ARRESTOR MOUNTING DETAIL**  
SCALE: N.T.S.

**EXISTING GSM/UMTS ANTENNA PLAN**  
SCALE: N.T.S.

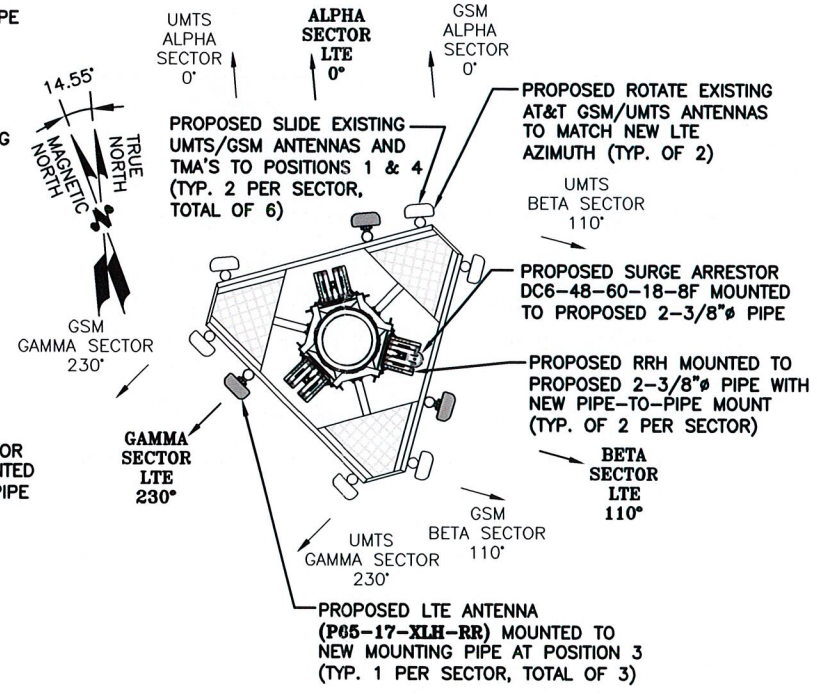

**PROPOSED LTE ANTENNA PLAN**  
SCALE: N.T.S.

**Hudson Design Group**  
1600 OSGOOD STREET  
BUILDING 20 NORTH, SUITE 2-101  
N. ANDOVER, MA 01845  
TEL: (978) 557-5553  
FAX: (978) 336-5586

**NEXLINK GLOBAL SERVICES**  
a UniTek GLOBAL SERVICES company  
800 MARSHALL PHELPS ROAD UNIT#: 2A  
WINDSOR, CT 06095

**SITE NUMBER: CT5425**  
**SITE NAME: EAST GRANBY SW**  
56 FLOYDVILLE RD  
EAST GRANBY, CT 06026  
HARTFORD COUNTY

**at&t**  
500 ENTERPRISE DRIVE, SUITE 3A  
ROCKY HILL, CT 06067

NO.	DATE	REVISIONS	BY	CHK	APP	SCALE	DESIGNED BY	DRAWN BY	DWG NUMBER	REV
1	04/10/12	ISSUED FOR CONSTRUCTION	HC	HG	DPH	AS SHOWN	DC	JG	5425.01	
0	03/08/12	ISSUED FOR REVIEW	JG	HC	DPH					

STATE OF CONNECTICUT  
JAMES P. JAMES  
REGISTERED PROFESSIONAL ENGINEER  
No. 12173

AT&T  
ANTENNA LAYOUT, ELEVATION & DETAILS (LTE)

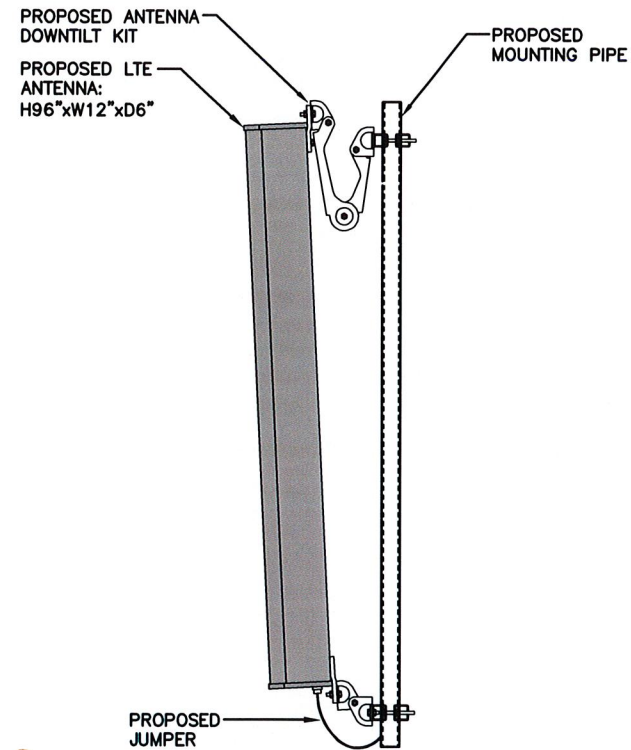

**PROPOSED LTE ANTENNA, MOUNTING DETAIL**

SCALE: N.T.S.

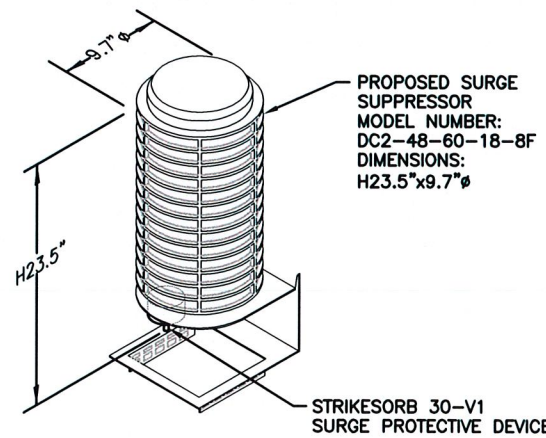

NOTE: MOUNT PER MANUFACTURER'S SPECIFICATIONS.

**DC SURGE SUPPRESSOR DETAIL**

SCALE: N.T.S.

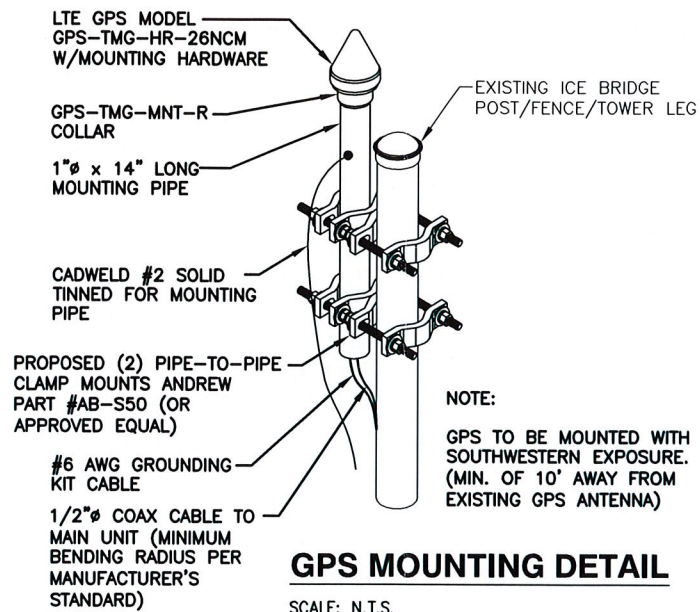

**GPS MOUNTING DETAIL**

SCALE: N.T.S.

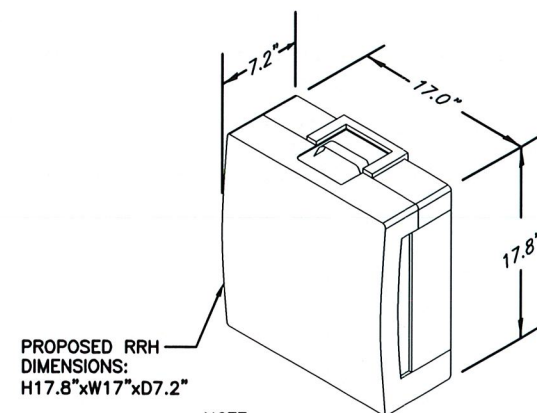

NOTE: MOUNT PER MANUFACTURER'S SPECIFICATIONS.

**RRH DETAIL**

SCALE: N.T.S.

NOTE:  
 AN ANALYSIS FOR THE CAPACITY OF THE EXISTING STRUCTURES TO SUPPORT THE PROPOSED EQUIPMENT SHALL BE DETERMINED PRIOR TO CONSTRUCTION.

NOTE:  
 REFER TO THE FINAL RF DATA SHEET FOR FINAL ANTENNA SETTINGS.

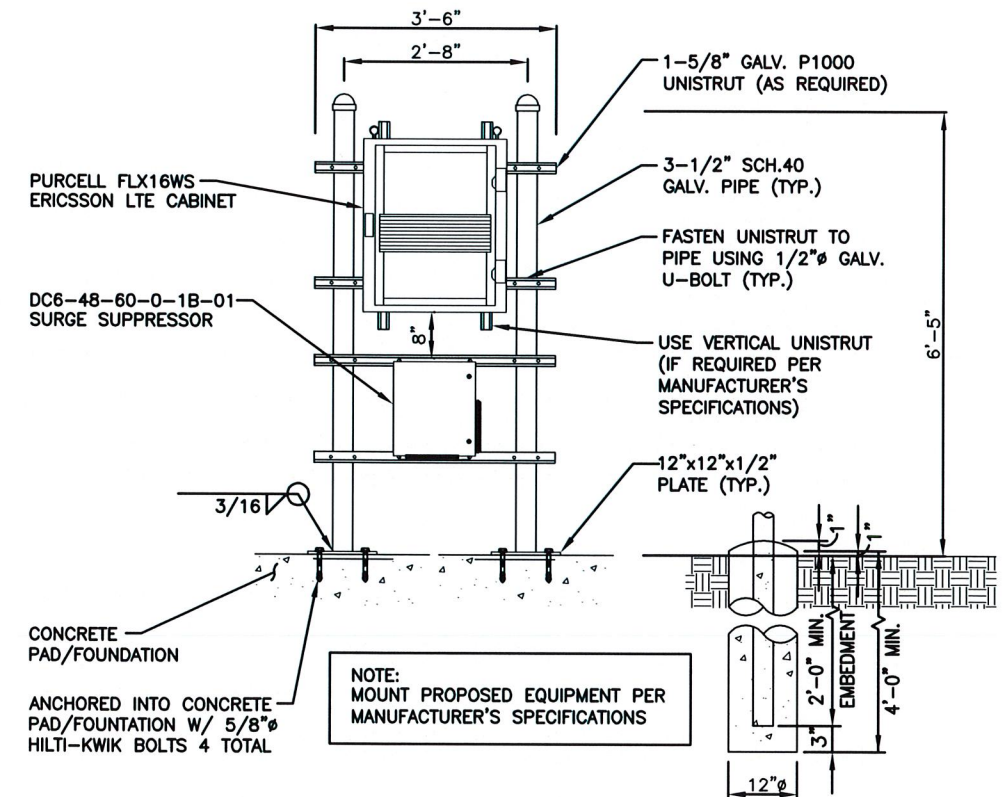
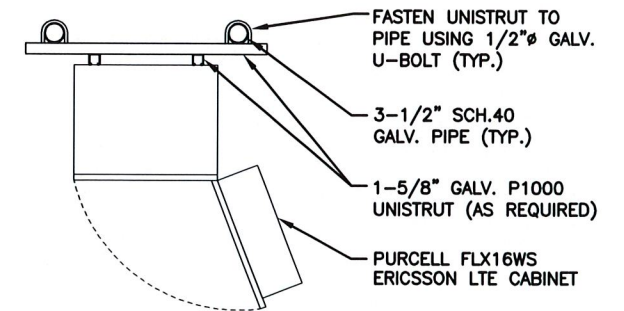

**PROPOSED EQUIPMENT MOUNTING DETAIL**

SCALE: N.T.S.

**Hudson Design Group LLC**  
 1600 OSGOOD STREET  
 BUILDING 20 NORTH, SUITE 2-101  
 N. ANDOVER, MA 01845  
 TEL: (978) 557-5553  
 FAX: (978) 336-5386

**NEXLINK GLOBAL SERVICES**  
 a UniTek GLOBAL SERVICES company  
 800 MARSHALL PHELPS ROAD UNIT#: 2A  
 WINDSOR, CT 06095

**SITE NUMBER: CT5425**  
**SITE NAME: EAST GRANBY SW**  
 56 FLOYDVILLE RD  
 EAST GRANBY, CT 06026  
 HARTFORD COUNTY

**at&t**  
 500 ENTERPRISE DRIVE, SUITE 3A  
 ROCKY HILL, CT 06067

						AT&T	
						DETAILS (LTE)	
1	04/10/12	ISSUED FOR CONSTRUCTION	HC	HC	DPH		
0	03/08/12	ISSUED FOR REVIEW	JG	HC	DPH		
NO.	DATE	REVISIONS	BY	CHK	APP		
SCALE: AS SHOWN		DESIGNED BY: DC	DRAWN BY: JG		JOB NUMBER: 6425.01	DRAWING NUMBER: A-3	REV: 1

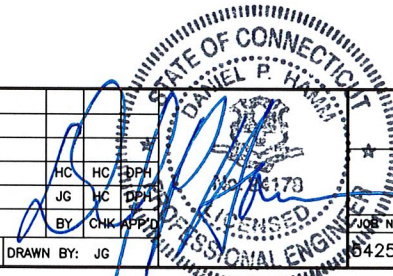

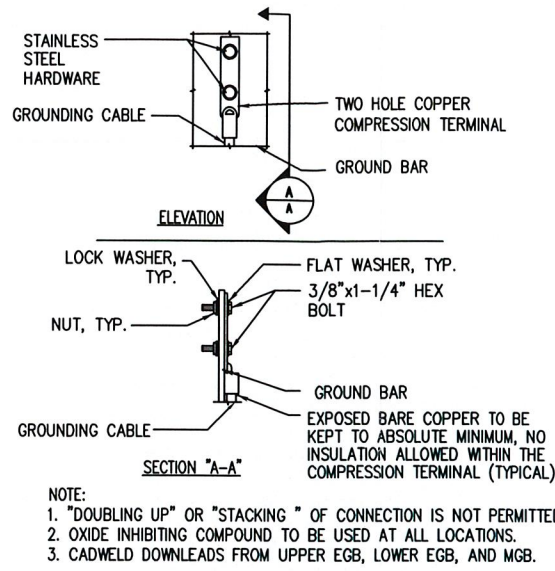

**TYPICAL GROUND BAR CONNECTION DETAIL**

2  
N.T.S.

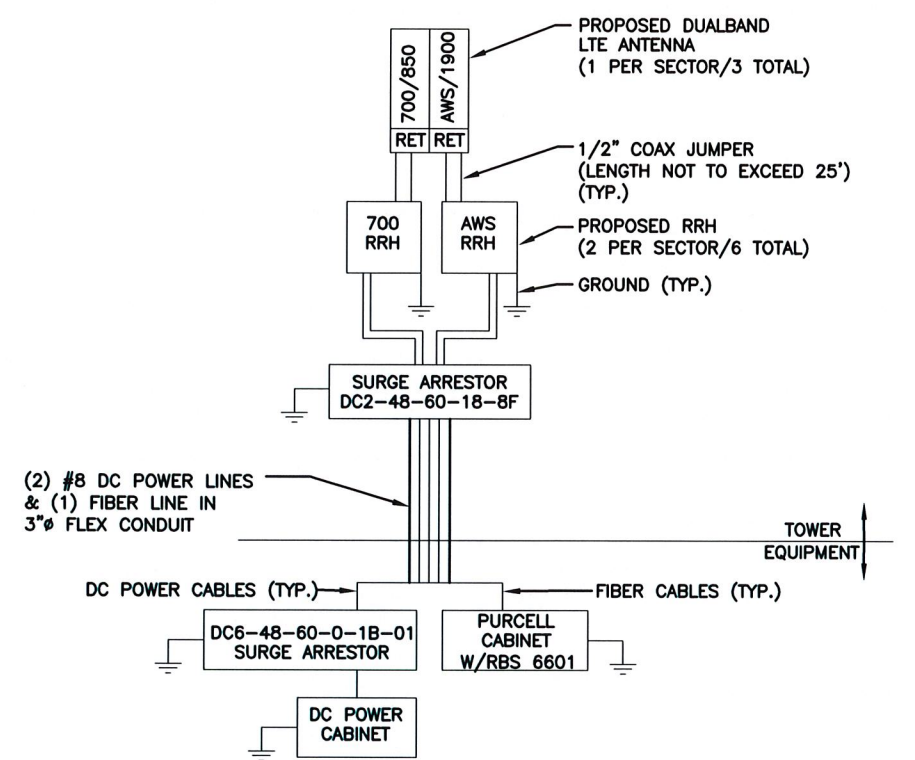

**NOTES:**  
 1. CONTRACTOR TO CONFIRM ALL PARTS.  
 2. INSTALL ALL EQUIPMENT TO MANUFACTURER'S RECOMMENDATIONS.

**PLUMBING DIAGRAM**

3  
N.T.S.

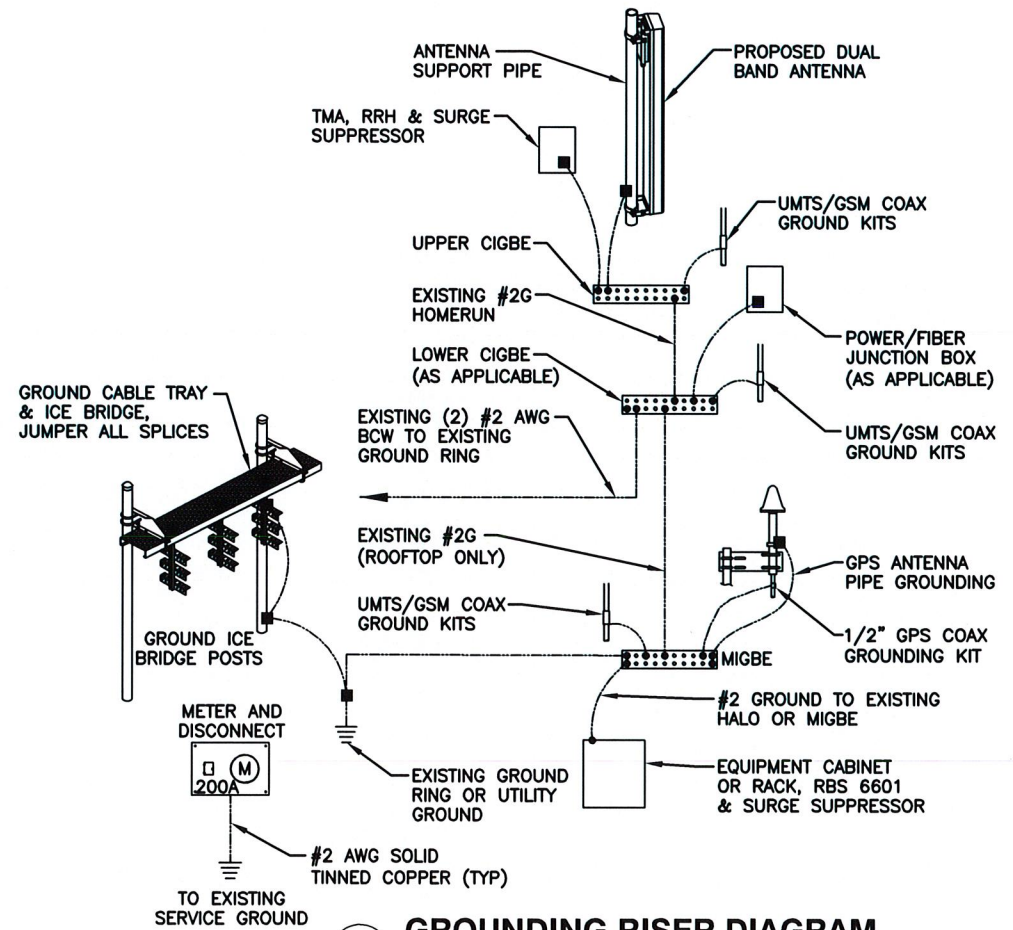

**GROUNDING RISER DIAGRAM**

1  
N.T.S.

WIRELESS SOLUTIONS INC.			
NO.	REQ.	PART NO.	DESCRIPTION
1	1	HLGB-0420-IS	SOLID GND. BAR (20"x4"x1/4")
2	2		WALL MTG. BRKT.
3	2		INSULATORS
4	4		5/8"-11x1" H.H.C.S.
5	4		5/8 LOCKWASHER

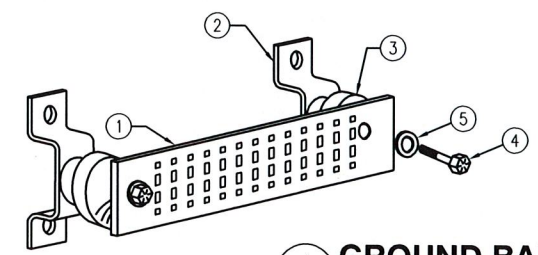

**GROUND BAR - DETAIL**

4  
N.T.S.

EACH GROUND CONDUCTOR TERMINATING ON ANY GROUND BAR SHALL HAVE AN IDENTIFICATION TAG ATTACHED AT EACH END THAT WILL IDENTIFY ITS ORIGIN AND DESTINATION.

**SECTION "P" - SURGE PRODUCERS**

- CABLE ENTRY PORTS (HATCH PLATES) (#2)
- GENERATOR FRAMEWORK (IF AVAILABLE) (#2)
- TELCO GROUND BAR
- COMMERCIAL POWER COMMON NEUTRAL/GROUND BOND (#2)
- +24V POWER SUPPLY RETURN BAR (#2)
- 48V POWER SUPPLY RETURN BAR (#2)
- RECTIFIER FRAMES.

**SECTION "A" - SURGE ABSORBERS**

- INTERIOR GROUND RING (#2)
- EXTERNAL EARTH GROUND FIELD (BURIED GROUND RING) (#2)
- METALLIC COLD WATER PIPE (IF AVAILABLE) (#2)
- BUILDING STEEL (IF AVAILABLE) (#2)

**Hudson Design Group**  
 1600 OSGOOD STREET  
 BUILDING 20 NORTH, SUITE 2-101  
 N. ANDOVER, MA 01845  
 TEL: (978) 557-5553  
 FAX: (978) 336-5586

**NEXLINK GLOBAL SERVICES**  
 a UniTek GLOBAL SERVICES company  
 800 MARSHALL PHELPS ROAD UNIT#: 2A  
 WINDSOR, CT 06095

**SITE NUMBER: CT5425**  
**SITE NAME: EAST GRANBY SW**  
 56 FLOYDVILLE RD  
 EAST GRANBY, CT 06026  
 HARTFORD COUNTY

**at&t**  
 500 ENTERPRISE DRIVE, SUITE 3A  
 ROCKY HILL, CT 06067

1 04/10/12 ISSUED FOR CONSTRUCTION		HC MC DPH		AT&T	
0 03/08/12 ISSUED FOR REVIEW		JG HC DPH		PLUMBING DIAGRAM & GROUNDING DETAILS (LTE)	
NO.	DATE	REVISIONS	BY	CHK APPR	NO.
SCALE: AS SHOWN			DESIGNED BY: DC	DRAWN BY: JG	PROJECT NUMBER: 0425.01
				DRAWING NUMBER: G-1	REV: 1