



STATE OF CONNECTICUT
CONNECTICUT SITING COUNCIL

10 Franklin Square
New Britain, Connecticut 06051
Phone: (860) 827-2935
Fax: (860) 827-2950

March 28, 2000

Sandy M. Carter
Bell Atlantic Mobile
20 Alexander Drive, P.O. Box 5029
Wallingford, CT 06492

RE: TS-BAM-028-000309 - Cellco Partnership d/b/a Bell Atlantic Mobile request for an order to approve tower sharing at an existing telecommunications facility located at 48 Westchester Road in Colchester, Connecticut.

Dear Ms. Carter:

At a public meeting held March 22, 2000, the Connecticut Siting Council (Council) ruled that the shared use of this existing tower site is technically, legally, environmentally, and economically feasible and meets public safety concerns, and therefore, in compliance with General Statutes § 16-50aa, the Council has ordered the shared use of this facility to avoid the unnecessary proliferation of tower structures. This facility has also been carefully modeled to ensure that radio frequency emissions are conservatively below State and federal standards applicable to the frequencies now used on this tower.

This decision is under the exclusive jurisdiction of the Council. Any additional change to this facility may require an explicit request to this agency pursuant to General Statutes § 16-50aa or notice pursuant to Regulations of Connecticut State Agencies Section 16-50j-73, as applicable. Such request or notice shall include all relevant information regarding the proposed change with cumulative worst-case modeling of radio frequency exposure at the closest point uncontrolled access to the tower base, consistent with Federal Communications Commission, Office of Engineering and Technology, Bulletin 65. Any deviation from this format may result in the Council implementing enforcement proceedings pursuant to General Statutes § 16-50u including, without limitation, imposition of expenses resulting from such failure and of civil penalties in an amount not less than one thousand dollars per day for each day of construction or operation in material violation.

This decision applies only to this request for tower sharing and is not applicable to any other request or construction.

The proposed shared use is to be implemented as specified in your letter dated March 9, 2000.

Thank you for your attention and cooperation.

Very truly yours,

Mortimer A. Gelston
Chairman

MAG/RKE/grg

c: Honorable Jenny Contois, First Selectman, Town of Colchester
J. Brendan Sharkey, VoiceStream Wireless

RECEIVED

© Bell Atlantic Mobile

20 Alexander Drive
P.O. Box 5029
Wallingford, CT 06492-2430
203-269-8858

MAR - 9 2000

CONNECTICUT
SITING COUNCIL



March 9, 2000

HAND DELIVERED

Mr. Mortimer A. Gelston, Chairman
Connecticut Siting Council
10 Franklin Square
New Britain, Connecticut 06051

Re: Request by Cellco Partnership d/b/a Bell Atlantic Mobile for an Order to Approve the Shared Use of a Tower Facility located at 48 Westchester Road, Colchester, Connecticut.

Dear Chairman Gelston:

Pursuant to Connecticut General Statutes (C.G.S.) Sec. 16-50aa, Cellco Partnership d/b/a Bell Atlantic Mobile ("BAM") hereby requests an order from the Connecticut Siting Council ("Council") to approve the proposed shared use by BAM of an existing tower located at 48 Westchester Road (Route 149), Colchester, Connecticut. The property is owned by Margus Properties, LLC, from which SBA Towers, Inc. leases property for the tower facility. Omnipoint Communications is proposing to mount antennas on the existing tower and has leased space for its equipment cabinet. As shown on the attached drawing and as further described below, BAM proposes to install antennas on the existing tower and to locate an equipment shelter at the base of the tower. BAM requests that the Council finds that the proposed shared use of the tower facility satisfy the criteria stated in C.G.S. Sec. 16-50aa, and to issue an order approving the proposed shared use.

Background

BAM is licensed by the Federal Communications Commission to provide cellular telephone service in the New London County New England County Metropolitan Area (NECMA), which includes the area to be served by the proposed Colchester installation.

The facility at 48 Westchester Road in Colchester, consists of a 180 foot AGL monopole type tower located on a leased parcel in which Omnipoint has proposed to locate its equipment. The monopole tower will support several Omnipoint antennas, which provide mobile communications service to the public pursuant to a FCC license. BAM and SBA Towers, Inc. have agreed to the proposed shared use of this tower pursuant to mutually acceptable terms and conditions. SBA Towers, Inc. has authorized BAM to apply for all necessary permits, approvals and authorizations which may be required for the proposed shared use of this facility.

BAM proposes to install twelve (8) Allgon Model 7129.16 antennas, approximately 52 inches in height and four (4) Allgon Model 7125.18 antennas, approximately 102" in height, on a platform with their center of radiation at approximately 167.5 feet above ground level ("AGL"). BAM will also install one (1) GPS antenna on the tower. Equipment associated with these antennas, as well as a 40 KW diesel-fueled emergency stand-by generator, would be located in a new approximately 12-foot x 30-foot equipment building located at the base of the tower.

C.G.S. Sec. 16-50aa provides that, upon written request for approval of a proposed shared use, "if the Council finds that the proposed shared use of the facility is technically, legally, environmentally and economically feasible and meets public safety concerns, the Council shall issue an order approving such shared use" (C.G.S. Sec. 16-50aa(c)(1).)

Discussion

A. Technical Feasibility. The existing tower is structurally sound and capable of supporting the proposed BAM antennas. Enclosed is the structural analysis performed on the tower. BAM engineers have determined that the proposed antenna installations present minimal potential for interference to or from existing radio transmissions from this location. In addition, the applicant is unaware of any occasion where its operations have caused interference with AM, FM, or television reception. The proposed shared use of this tower therefore is technically feasible.

B. Legal Feasibility. Under C.G.S. Sec. 16-50aa, the Council has been authorized to issue an order approving the proposed shared use of an existing communications tower facility such as the facility at 48 Westchester Road (C.G.S. Sec. 16-50aa(c)(1).) This authority complements the Council's prior-existing authority under C.G.S. Sec. 16-50p to issue orders approving the construction of new towers that are subject to the Council's jurisdiction. C.G.S. Section 16-50x(a) directs the Council to "give consideration to other state laws and municipal regulations as it shall deem appropriate" in ruling on requests for the shared use of existing tower facilities. Under the authority vested in the Council by C.G.S. Sec. 16-50aa, an order by the Council approving the shared use would permit the applicant to obtain a building permit for the proposed installations.

C. Environmental Feasibility. The proposed shared use would have a minimal environmental effect, for the following reasons:

1. The proposed installations would have an insignificant incremental visual impact, and would not cause any significant change or alteration in the physical or environmental characteristics of the existing site. The addition of the proposed antennas would not increase the height of the tower, and would not extend the boundaries of the tower site, including the placement of the equipment building near the base of the existing tower.
2. The proposed installation would not increase the noise levels at the existing facility by six decibels or more. The only additional noise will occur during emergency use or periodic exercising of the generator.

3. Operation of the additional antennas will not increase the total radio frequency electromagnetic radiation power density, measured at the tower base to a level at or above the applicable standard. "Worst-case" exposure calculations for a point at the base of the tower in relation to operation of each of BAM's and Omnipoint's antenna arrays are as follows:

	<u>Applicable ANSI Stnd.</u>	<u>Calculated "Worst-Case"</u>	<u>Percentage of Stnd.</u>
<u>BAM</u>	0.583 mW/cm ²	0.0243 mW/cm ²	4.17%
<u>Omnipoint</u>	1.000 mW/cm ²	0.0111 mW/cm ²	1.11%
		Total	<u>5.28%</u>

The collective "worst-case" exposure would be only 5.28 % of the ANSI standard, as calculated for mixed frequency sites. Power density levels from shared use of the tower facility would thus be well below applicable ANSI standards.

4. The proposed installations would not require any water or sanitary facilities, or generate discharges to water bodies. Operation of the emergency back-up generator will result in limited air emission; pursuant to R.C.S.A. Section 22a-174-3, the generator will require the issuance of a permit from the Department of Environmental Protection Bureau of Air Management. After construction is complete, the proposed installation would not generate any traffic other than periodic maintenance visits. The proposed use of this facility would therefore have a minimal environmental effect, and is environmentally feasible.

D. Economic Feasibility. As previously mentioned, the tower owner and the applicant have entered into a mutual agreement to share use of the existing tower on terms agreeable to the parties, and the proposed tower sharing is thus economically feasible.

Mr. Mortimer A. Gelston
March 9, 2000
Page 4

E. Public Safety Concerns. As stated above, the existing tower is structurally capable of supporting the proposed BAM antennas. The Applicant is not aware of any other public safety concerns relative to the proposed tower sharing of the existing tower. In fact, the provision of new or improved cellular phone service in the Colchester area, especially along the heavily traveled Routes 2 and 149 and surrounding area, through shared use of the tower is expected to enhance the safety and welfare of area residents and travelers. The public safety benefits of wireless service are further illustrated by the decision of local authorities elsewhere in Connecticut to provide cellular phones to the residents to improve local public safety and emergency communications. The proposed shared use of this facility would likewise improve public safety in the Colchester area.

Conclusion

For the reasons discussed above, the proposed shared use of the existing telecommunications tower facility at 48 Westchester Road satisfies the criteria stated in C.G.S. Sec. 16-50aa, and advances the General Assembly's and the Council's goal of preventing the proliferation of towers in Connecticut. The Applicant therefore requests that the Council issue an order approving the proposed shared use.

Thank you for your consideration of this matter.

Pursuant to Connecticut General Statutes, Section 16-50v and Section 16-50v-1(a) of the Regulations of Connecticut State Agencies, BAM has enclosed a check in the amount of \$500.00 for the required filing fee.

Respectfully yours,

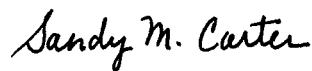

Sandy M. Carter
Manager – Regulatory
Bell Atlantic Mobile

Attachment
cc: Honorable Jenny Contois, First Selectman

© Bell Atlantic Mobile

20 Alexander Drive
P.O. Box 5029
Wallingford, CT 06492-2430
203-269-8858



March 9, 2000

Honorable Jenny Contois
First Selectman
Town Hall
127 Norwich Avenue
Colchester, Connecticut 06415

Dear Ms. Contois:

This letter is to inform you that Celco Partnership d/b/a Bell Atlantic Mobile plans to install antennas and associated equipment at the existing tower facility located at 48 Westchester Road, Colchester, Connecticut. I am enclosing a copy of Bell Atlantic Mobile's tower sharing application to the Connecticut Siting Council.

The application fully sets forth the Company's proposal. However, if you have any questions or require further information on our plans or the Siting Council's procedures, please contact me at (203) 294-8519 or Mr. Joel Rinebold, Executive Director of the Connecticut Siting Council at (860) 827-2935.

Sincerely,

Sandy M. Carter

Sandy M. Carter
Manager - Regulatory
Bell Atlantic Mobile

Enclosure



March 6, 2000

Sandy Carter
Manager Real Estate-Zoning
Bell Atlantic
20 Alexander Drive
Wallingford, CT 06492

Re: Existing Tower Facility

Dear Sandy Carter,

Please be advised that Bell Atlantic Mobile is authorized to proceed in seeking Connecticut Siting Council approval for the above referenced tower site owned by SBA Inc. located at 48 Westchester Road, Colchester, CT 06415.

Regards,

A handwritten signature in black ink, appearing to read "Edward Dupont", written over a light blue horizontal line.

Edward Dupont
Construction Project Manager
SBA Inc.
EGD/egd

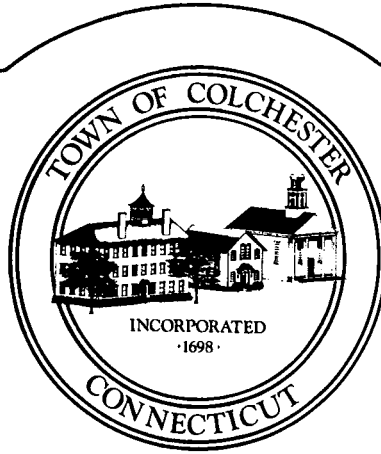

Planning and Zoning

Planning Director
Town Engineer
Code Administration
Health Director
Building Official
Fire Marshal
Registered Sanitarian
Zoning Enforcement
Wetlands Enforcement

CERTIFIED MAIL
RETURN RECEIPT REQUESTED

November 4, 1999

Ms. Esther McNany
SBA Inc.
125 Shaw Street
New London, CT 06320

RE: SDP#99-235, SBA/Omnipoint Communications, 48 Westchester Road,
Communications Tower, Site Development Plan prepared by Goodkind & O'Dea
Inc (Job#CT10125-018) dated 8/25/99 revised through 9/28/99

Dear Ms. McNany:

The above referenced site development plan was approved by the Zoning & Planning Commission at their regular meeting held November 3, 1999.

Per Section 12.10.1 of the Zoning Regulations, a bond in the amount of 25% of the total cost of site improvements must be posted prior to the endorsement of this plan and/or commencement of work. A bond estimate must be submitted to the Town Engineer for his review and approval.

If you have any questions, please call me at 537-7283.

Very truly yours,

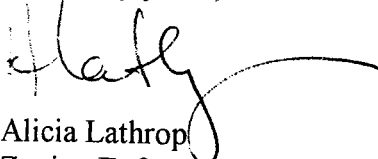
Alicia Lathrop
Zoning Enforcement Officer

Electrical Specifications	7125.16	7125.18
Polarization	linear, vertical	linear, vertical
Gain dBd (dBi)	14 (16)	16 (18)
Horizontal -3dB beamwidth	60°	60°
Front-to-back ratio	>30 dB	>30 dB
Vertical -3dB beamwidth	15°	8°
Electrical Downfilt	0	0
Nominal Impedance	50 ohm	50 ohm
VSWR	<1.5:1	<1.5:1
Maximum input power	500W	500W
Intermodulation products(2Tx@20 W)	<-103 dBm	<-103 dBm

Mechanical Specifications	7125.16	7125.18
Height	52" (1.32m)	102.1" (2.6m)
Width	17.3" (.44m)	17.3" (.44m)
Depth	11.4" (.29m)	12.6" (.32m)
Weight	18.9 lb (8.6 kg)	38.5 lb (17.5kg)
Survival wind speed	156 mph (70m/s)	156 mph (70m/s)
Maximum wind area	5.4 sq ft (.5 sq m)	10.2 sq ft (.92 sq m)
Max. wind load @ 100 mph (C=1)	87 lbf. (388N)	161 lbf. (714N)

Allgon Log Periodic 60°

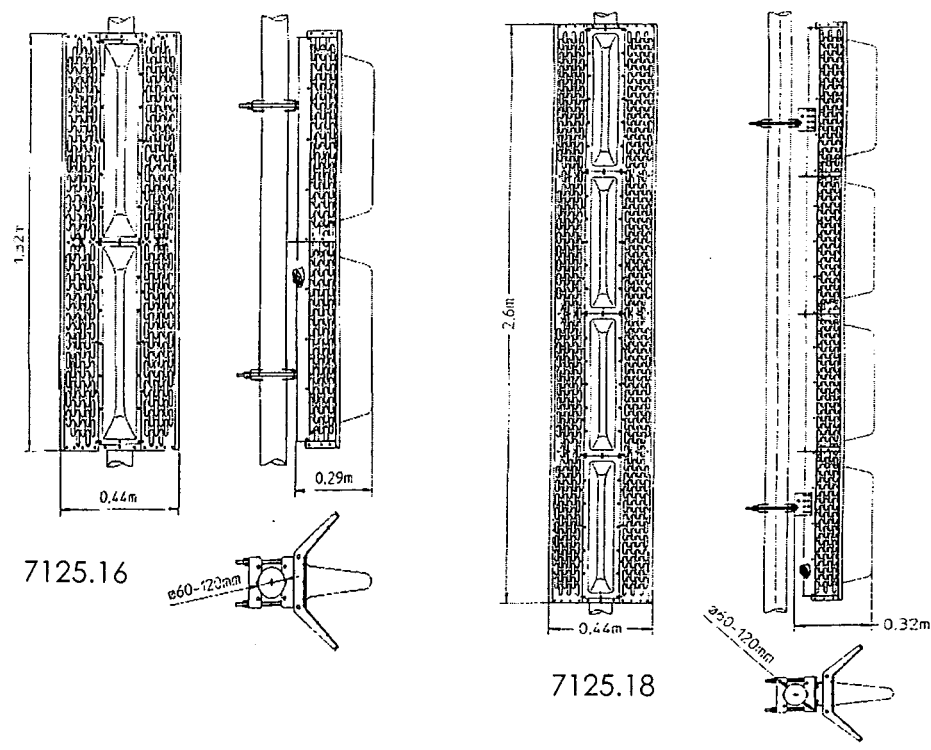

Part Number Guide:
 ex: 7129.14.XX.00 ——— **Electrical Downfilt**

Type of Connector
.05 - N Connector
.22 - E Connector
.33 - 7/16 DIN Connector

INFORMATION:
 Call 1-888-Allgon 1

ALLGON
 Base Station
 Antennas
 Page 21

Alpha & Beta

Electrical Specifications	7129.20	7129.16
Polarization	linear, vertical	linear, vertical
Gain dBd (dBi)	11 (13)	13 (15)
Horizontal -3dB beamwidth	85°	85°
Front-to-back ratio	>30 dB	>30 dB
Vertical -3dB beamwidth	25°	15°
Electrical Downtilt	0	0
Nominal Impedance	50 ohm	50 ohm
VSWR	<1.5:1	<1.5:1
Maximum input power	500W	500 W
Intermodulation products(2Tx@20 W)	<-103 dBm	<-103 dBm

Mechanical Specifications	7129.20	7129.16
Height	31.5" (.8m)	52" (1.32m)
Width	13" (.33m)	13" (.33m)
Depth	11.4" (.29m)	11.4" (.29m)
Weight	12.1 lb (5.1 kg)	17.4 lb (7.9kg)
Survival wind speed	156 mph (70m/s)	156 mph (70m/s)
Maximum wind area	2.7 sq ft (.25 sq m)	4.5 sq ft (.42 sq m)
Max. wind load @ 100 mph (C=1)	44 lbf. (194N)	73 lbf. (326N)

Allgon Log Periodic 85°

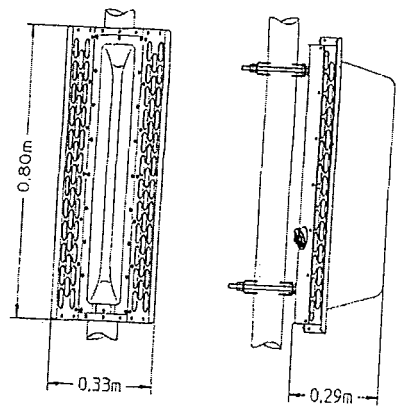

7129.20

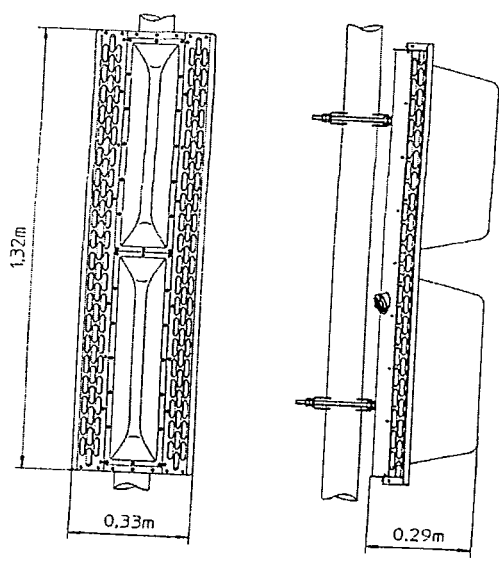
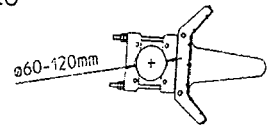

7129.16

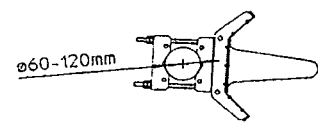

Part Number Guide:
 ex: 7129.14.XX.00

Electrical Downtilt

Type of Connector

- .05 - N Connector
- .22 - E Connector
- .33 - 7/16 DIN Connector

INFORMATION:
 Call 1-888-Allgon 1

valmont

MICROFLECT

VALMONT/MICROFLECT
3575 25TH ST. SE - P.O. BOX 12985
SALEM, OREGON 97302-1190
PHONE: 1-800-547-2151

ENGINEER: Adrian McJunkin, P.E. (ext. 246)

FILE COPY

SITE # 10125-018
FILE TYPE CONST.
SECTION TOWER

Ed Dupont
SBA
18 PG. 5

COMMUNICATION POLE DESIGN CALCULATIONS

FILE COPY



[Handwritten signature]
11/23/99

SBA
VALMONT ORDER #19487-99
SITE NAME: 10125-018/Colchester, CT
POLE HEIGHT: 180

AM

valmont

MICROFLECT

11/1/99
ENGINEERING DATA
 for
SBA
10125-018/Colchester, CT
VALMONT ORDER 19487-99

- 1) STRUCTURE DESIGN CONFORMS TO EIA/TIA-222-F INCLUDING:
 HIGH WIND WITH 85 MPH BASIC VELOCITY
 73.6 MPH WIND WITH 0.5 INCH RADIAL ICE
 TWIST AND SWAY EVALUATION NOT REQUIRED
- 2) FEEDLINES ARE ASSUMED TO BE PLACED INTERIOR TO THE POLE.
- 3) ALL MICROWAVE ASSUMED TO BE 6 GHz UNLESS OTHERWISE NOTED.
- 4) LOADING AS FOLLOWS:
 - 180' POLE
 - 1 - Lightning Rod, 7' @ 180.0'
 - 12 - DB896 @ 177.0'
 - 1 - Platform, Valmont w/o rails, 13.42' @ 177.0'
 - 12 - DB896 @ 170.0'
 - 1 - Platform, Valmont w/o rails, 13.42' @ 170.0'
 - 12 - DB896 @ 160.0'
 - 1 - Platform, Valmont w/o rails, 13.42' @ 160.0'
 - 12 - DB896 @ 150.0'
 - 1 - Platform, Valmont w/o rails, 13.42' @ 150.0'
 - 12 - DB896 @ 140.0'
 - 1 - Platform, Valmont w/o rails, 13.42' @ 140.0'

NOTE: Monopole structure designed to meet Connecticut State Building Code.

DRILLED PIER ESTIMATE PER EIA 'NORMAL' SOILS

POLE HEIGHT(FT):	180	NUMBER OF A.B.'s:	20
BOLT CIRCLE(IN):	68.62	DIA. OF A.B.'s(IN):	2.25
BASE VERTICAL(K):	56.10	LENGTH OF A.B.'s(IN):	120.00
BASE SHEAR(K):	39.46	PROJECTION LENGTH(IN):	9.75
BASE MOMENT(IN-K):	60542	TEMPLATE OD(IN):	72.12

PIER DIAMETER(FT): 6.89
 USE 7.00

$$\text{PIER DEPTH}(L_d) = 2.0 + \text{SHEAR}/4.5 \cdot \text{DIA.} + 2(\text{SHEAR}^2/40.5 \cdot \text{DIA.}^2 + \text{SHEAR}/3 + \text{MOM}/12 \cdot 4.5 \cdot \text{DIA.})^{1/2}$$

$$= 29.7$$

SUMMARY: DIAMETER 7.0 FEET
 DEPTH = 29.6 FEET
 LENGTH = 30.1 FEET
 CONCRETE VOLUME = 43.0 CUBIC YARDS

valmont

MICROFLECT

BY _____ DATE _____
 CHKD. BY _____ DATE _____

SHEET NO. _____

11/1/99
ENGINEERING DATA
 for
SBA
 10125-018/Colchester, CT
 VALMONT ORDER 19487-99

EIA/TIA-222-F
 BASIC WIND: 85.0 MPH
 WIND & ICE: 73.6 MPH AND 0.5 IN. ICE
 TWIST & SWAY: NOT REQUIRED

QTY DESCRIPTION	HEIGHT	DATA W.O. ICE		DATA W/ ICE	
		EPA	WT	EPA	WT
1 Lightning Rod, 7'	@ 180.0'	1.05	35	1.73	44
12 DB896	@ 177.0'	54.60	264	58.92	660
1 Platform, Valmont w/o rails, 13.42'	@ 177.0'	24.80	2000	26.20	2500
12 DB896	@ 170.0'	54.60	264	58.92	660
1 Platform, Valmont w/o rails, 13.42'	@ 170.0'	24.80	2000	26.20	2500
12 DB896	@ 160.0'	54.60	264	58.92	660
1 Platform, Valmont w/o rails, 13.42'	@ 160.0'	24.80	2000	26.20	2500
12 DB896	@ 150.0'	54.60	264	58.92	660
1 Platform, Valmont w/o rails, 13.42'	@ 150.0'	24.80	2000	26.20	2500
12 DB896	@ 140.0'	54.60	264	58.92	660
1 Platform, Valmont w/o rails, 13.42'	@ 140.0'	24.80	2000	26.20	2500

NOTE: Monopole structure designed to meet Connecticut State Building Code.

BY VALMONT INDUSTRIES FOR: SBA 180' POLE, SITE: 10125-018/COLCHESTER, CT 19487-99 DATE 11/01/99
 *** SUMMARY *** VERSION CPL-01

----- DESIGN SUMMARY (DOES NOT INCLUDE EMBEDMENT) -----

HEIGHT (FT)	POLE SHAFT WEIGHT (LBS)	POLE TAPER (IN/FT)	GROUND LINE DIAMETER (IN)	TOP DIAMETER (IN)	SHAPE
180.00	32239.	0.2050	60.000	24.912	16-SIDED SYMMETRICAL POLYGON

CONNECTIONS BETWEEN SECTIONS	/FIRST/	/SECOND/	/THIRD/
HEIGHT TYPE OVERLAP LENGTH	53.00'	98.90'	132.27'
	LAP SPLICE 85"	LAP SPLICE 72"	LAP SPLICE 63"

SECTION CHARACTERISTICS	/FIRST/	/SECOND/	/THIRD/	/FOURTH/
BASE DIAMETER (IN)	60.000**	51.345	42.339	35.769
TOP DIAMETER (IN)	49.135	40.475	34.259	24.912
THICKNESS (IN)	0.43750	0.37500	0.31250	0.21875
LENGTH	53' 0"	53' 0"	39' 5"	53' 0"
WEIGHT (LBS)	13591.	9804.	5066.	3779.

** AT GROUNDLINE

----- ANALYSIS SUMMARY -----

GROUND LINE	MAX. STRESS 1ST SECTION	MAX. STRESS 2ND SECTION	MAX. STRESS 3RD SECTION	MAX. STRESS 4TH SECTION	POLE TOP
LOD1	LOD1	LOD1	LOD1	LOD1	LOD1
0.00	0.00	53.00	98.90	132.27	180.00
60543.	60543.	37023.	19701.	8904.	3.
39458.	39458.	32739.	27111.	23483.	54.
43594.	43594.	28550.	19353.	14700.	35.
49.21	49.21	50.77	47.79	43.31	0.03
52.00	52.00	52.00	52.00	49.71	52.00
1.06	1.06	1.02	1.09	1.15	999.99
0.00	0.00	11.79	43.35	80.21	150.42

NOTE: DIAMETERS ARE OUTSIDE, MEASURED ACROSS THE FLATS

BY VALMONT INDUSTRIES

FOR:

SBA 180' POLE, SITE: 10125-018/COLCHESTER, CT

19487-99

DATE 11/01/99

FOR: 180.00 FOOT

*** GROUNDLINE REACTIONS ***

LOADING CASE IDENTIFIER	***** ABOUT X-AXIS *****	***** ABOUT Y-AXIS *****	MOMENTS (IN-KIPS) RESULTANT (X & Y)	TORSIONAL	***** AXIAL FORCE (LBS) *****	***** X-DIRECTION IN *****	***** Y-DIRECTION IN *****	SHEAR (LBS) IN Y-DIRECTION	***** RESULTANT (X & Y) *****	NOTES
LOD1	42810.	42810.	60543.	-143.	43594.	27901.	27901.	27901.	39458.	A C
LOD2	35023.	35023.	49530.	-116.	53112.	22171.	22171.	22171.	31354.	B

NOTE: POSITIVE AXIAL FORCE IS DOWNWARD. AXIAL FORCE INCLUDES THE WEIGHT OF THE ABOVE-GROUND PORTION OF THE POLE SHAFT TIMES THE APPROPRIATE OVERLOAD FACTOR, IN ADDITION TO THE CONCENTRATED VERTICAL LOADING.

KEY TO THE SPECIAL NOTE ENTRIES

- A INDICATES LOAD CASE WITH MAXIMUM OVERTURNING MOMENT
- B INDICATES LOAD CASE WITH MAXIMUM AXIAL FORCE
- C INDICATES LOAD CASE WITH MAXIMUM RESULTANT SHEAR

BY VALMONT INDUSTRIES FOR: SBA 180' POLE, SITE: 10125-018/COLCHESTER, CT 19487-99 DATE 11/01/99

LOADING CASE LOD1

*** INPUT LOADS ***

BASIC VELOCITY IS 85.00 M.P.H.; ICE THICKNESS 0.00 INCHES
 FORCE COEFFICIENT INCREASED TO ACCOUNT FOR PROJECTIONS (EIA NOTE #3)
 - MULTIPLIER IS 1.3, BUT RESULT NOT TO EXCEED 1.2-
 WIND ORIENTATION IS 45.0 DEGREES CLOCKWISE FROM -X- AXIS
 POLE WEIGHT OVERLOAD FACTOR IS 1.000 EXPOSURE C GUST FACTOR 1.69
 ARM LOCATION IS MEASURED CLOCKWISE FROM -X- AXIS
 POSITIVE -Y- AXIS IS 90 DEGREES CLOCKWISE FROM -X- AXIS

ARM NO.	FOUNDATION ROTATION OF 0.50 DEGREES			ARM LENGTH (FT)	LOCATION OF ARM IN XY PLANE (DEGREES)	ORIENTATION OF SYSTEM		
	ARM MOUNTING HEIGHT (FT)	HEIGHT OF LOAD APPLICATION POINT (FT)	(LONGITUDINAL) * (VERTICAL) +Y-AXIS * +Z-AXIS			FORCE-X (LBS)	FORCE-Y (LBS)	FORCE-Z (LBS)
1	180.00	183.50	0.00	0.00	45.00	38	35	1.0
2	177.00	180.10	0.00	0.00	45.00	1966	264	54.6
3	177.00	178.50	0.00	0.00	45.00	891	2000	24.8
4	170.00	173.10	0.00	0.00	45.00	1944	264	54.6
5	170.00	171.50	0.00	0.00	45.00	881	2000	24.8
6	160.00	163.10	0.00	0.00	45.00	1911	264	54.6
7	160.00	161.50	0.00	0.00	45.00	866	2000	24.8
8	150.00	153.10	0.00	0.00	45.00	1877	264	54.6
9	150.00	151.50	0.00	0.00	45.00	850	2000	24.8
10	140.00	143.10	0.00	0.00	45.00	1841	264	54.6
11	140.00	141.50	0.00	0.00	45.00	834	2000	24.8

BY VALMONT INDUSTRIES

FOR: SBA 180' POLE, SITE: 10125-018/COLCHESTER, CT

19487-99

DATE 11/01/99

LOADING CASE LOD2

*** INPUT LOADS ***

BASIC VELOCITY IS 74.00 M.P.H.; ICE THICKNESS 0.50 INCHES
 FORCE COEFFICIENT INCREASED TO ACCOUNT FOR PROJECTIONS (EIA NOTE #3)
 - MULTIPLIER IS 1.3, BUT RESULT NOT TO EXCEED 1.2-
 WIND ORIENTATION IS 45.0 DEGREES CLOCKWISE FROM -X- AXIS
 POLE WEIGHT OVERLOAD FACTOR IS 1.000 EXPOSURE C GUST FACTOR 1.69
 ARM LOCATION IS MEASURED CLOCKWISE FROM -X- AXIS
 POSITIVE -Y- AXIS IS 90 DEGREES CLOCKWISE FROM -X- AXIS

FOUNDATION ROTATION OF 0.50 DEGREES

ARM NO.	ARM MOUNTING HEIGHT (FT)	APPLICATION POINT HEIGHT OF LOAD (FT)	ARM LENGTH (FT)	LOCATION OF ARM IN XY PLANE (DEGREES)	FORCE-Y (LBS)	FORCE-X (LBS)	FORCE-Z (LBS)	EPA (SQ. FT.)
1	180.00	183.50	0.00	45.00	47	47	44	1.7
2	177.00	180.10	0.00	45.00	1608	1608	660	58.9
3	177.00	178.50	0.00	45.00	713	713	2500	26.2
4	170.00	173.10	0.00	45.00	1590	1590	660	58.9
5	170.00	171.50	0.00	45.00	705	705	2500	26.2
6	160.00	163.10	0.00	45.00	1563	1563	660	58.9
7	160.00	161.50	0.00	45.00	693	693	2500	26.2
8	150.00	153.10	0.00	45.00	1535	1535	660	58.9
9	150.00	151.50	0.00	45.00	681	681	2500	26.2
10	140.00	143.10	0.00	45.00	1506	1506	660	58.9
11	140.00	141.50	0.00	45.00	667	667	2500	26.2

ORIENTATION OF SYSTEM

+***** +X-AXIS
 * * * * *
 * * * * * (TRANSVERSE)

(LONGITUDINAL) * * * * * (VERTICAL)
 +Y-AXIS * * * * * +Z-AXIS

CONNECTION LOCATIONS	HEIGHT (FEET)	DIAMETER ACROSS FLATS (IN)	WALL THK. (IN)	D/T ACROSS FLATS	W/T ACROSS FLATS	MOMENTS OF INERTIA (IN4)	AREA (IN2)
BASE	0.00	60.000	0.4375	137.1	25.31	37335.	83.00
	5.00	58.975	0.4375	134.8	24.85	35441.	81.57
	10.00	57.950	0.4375	132.5	24.38	33611.	80.14
	15.00	56.925	0.4375	130.1	23.91	31846.	78.71
	20.00	55.900	0.4375	127.8	23.45	30144.	77.29
	25.00	54.875	0.4375	125.4	22.98	28503.	75.86
	30.00	53.850	0.4375	123.1	22.51	26923.	74.43
	35.00	52.825	0.4375	120.7	22.05	25403.	73.00
	40.00	51.800	0.4375	118.4	21.58	23941.	71.57
	45.00	50.775	0.4375	116.1	21.11	22536.	70.14
SEC BASE	45.88	50.595	0.4375	115.6	21.03	22295.	69.89
	50.00	49.750	0.4375	113.7	20.65	21187.	68.72
SEC TOP	53.00	49.885	0.3750	133.0	24.49	18379.	59.14
	55.00	49.475	0.3750	131.9	24.27	17927.	58.65
	60.00	48.450	0.3750	129.2	23.73	16827.	57.42
	65.00	47.425	0.3750	126.5	23.19	15774.	56.20
	70.00	46.400	0.3750	123.7	22.64	14765.	54.97
	75.00	45.375	0.3750	121.0	22.10	13800.	53.75
	80.00	44.350	0.3750	118.3	21.55	12879.	52.52
	85.00	43.325	0.3750	115.5	21.01	11999.	51.30
	90.00	42.300	0.3750	112.8	20.47	11160.	50.08
SEC BASE	92.86	41.714	0.3750	111.2	20.15	10699.	49.38
	95.00	41.275	0.3750	110.1	19.92	10361.	48.85
SEC TOP	98.90	41.100	0.3125	131.5	24.19	8564.	40.60
	100.00	40.875	0.3125	130.8	24.05	8423.	40.37
	105.00	39.850	0.3125	127.5	23.40	7800.	39.35
	110.00	38.825	0.3125	124.2	22.74	7209.	38.33
	115.00	37.800	0.3125	121.0	22.09	6649.	37.31
	120.00	36.775	0.3125	117.7	21.44	6118.	36.29
	125.00	35.750	0.3125	114.4	20.78	5616.	35.27
SEC BASE	127.04	35.332	0.3125	113.1	20.52	5420.	34.86
	130.00	34.725	0.3125	111.1	20.13	5143.	34.25
SEC TOP	132.27	34.697	0.2188	158.6	29.59	3621.	24.02
	135.00	34.137	0.2188	156.1	29.08	3447.	23.63
ARM	140.00	33.112	0.2188	151.4	28.14	3144.	22.92
ARM	140.00	33.112	0.2188	151.4	28.14	3144.	22.92
	145.00	32.087	0.2188	146.7	27.21	2859.	22.20
ARM	150.00	31.062	0.2188	142.0	26.28	2592.	21.49
ARM	150.00	31.062	0.2188	142.0	26.28	2592.	21.49
	155.00	30.037	0.2188	137.3	25.35	2342.	20.78
ARM	160.00	29.012	0.2188	132.6	24.41	2109.	20.06
ARM	160.00	29.012	0.2188	132.6	24.41	2109.	20.06
	165.00	27.987	0.2188	127.9	23.48	1892.	19.35
ARM	170.00	26.962	0.2188	123.3	22.55	1690.	18.63
ARM	170.00	26.962	0.2188	123.3	22.55	1690.	18.63
	175.00	25.937	0.2188	118.6	21.61	1503.	17.92
ARM	177.00	25.527	0.2188	116.7	21.24	1432.	17.63

*** PROPERTIES ***

ARM
ARM
TOP

177.00
180.00
180.00

25.527
24.912
24.912

0.2188
0.2188
0.2188

116.7
113.9
113.9

21.24
20.68
20.68

1432.
1330.
1330.

17.63
17.21
17.21

BY VALMONT INDUSTRIES
LOADING CASE LODI

SBA 180' POLE, SITE: 10125-018/COLCHESTER, CT

19487-99

DATE 11/01/99

SHEAR FORCE AT BASE (LB) = 39458.
TOTAL VERTICAL FORCE AT BASE (LB) = 43594.

*** REACTIONS ***

*** MOMENTS ABOUT -X- AXIS (IN-KIPS) ***
LOAD WIND DEFL TOTAL

*** MOMENTS ABOUT -Y- AXIS (IN-KIPS) ***
LOAD WIND DEFL TOTAL

SHEAR FORCE AT BASE (LB) = 39458.
TOTAL VERTICAL FORCE AT BASE (LB) = 43594.

HEIGHT	LOAD	WIND	DEFL	TOTAL	LOAD	WIND	DEFL	TOTAL
0.00	27198.	13640.	1973.	42810.	27198.	13640.	1973.	42810.
5.00	26364.	12814.	1954.	41132.	26364.	12814.	1954.	41132.
10.00	25530.	12017.	1929.	39477.	25530.	12017.	1929.	39477.
15.00	24696.	11249.	1900.	37845.	24696.	11249.	1900.	37845.
20.00	23862.	10508.	1866.	36236.	23862.	10508.	1866.	36236.
25.00	23028.	9794.	1827.	34650.	23028.	9794.	1827.	34650.
30.00	22194.	9107.	1785.	33086.	22194.	9107.	1785.	33086.
35.00	21361.	8445.	1738.	31544.	21361.	8445.	1738.	31544.
40.00	20527.	7809.	1688.	30024.	20527.	7809.	1688.	30024.
45.00	19693.	7199.	1635.	28526.	19693.	7199.	1635.	28526.
45.88	19546.	7094.	1625.	28266.	19546.	7094.	1625.	28266.
50.00	18859.	6614.	1579.	27052.	18859.	6614.	1579.	27052.
53.00	18358.	6277.	1544.	26179.	18358.	6277.	1544.	26179.
55.00	18025.	6057.	1521.	25603.	18025.	6057.	1521.	25603.
60.00	17191.	5526.	1462.	24179.	17191.	5526.	1462.	24179.
65.00	16357.	5022.	1400.	22779.	16357.	5022.	1400.	22779.
70.00	15523.	4545.	1336.	21404.	15523.	4545.	1336.	21404.
75.00	14689.	4094.	1270.	20053.	14689.	4094.	1270.	20053.
80.00	13855.	3669.	1202.	18726.	13855.	3669.	1202.	18726.
85.00	13021.	3270.	1132.	17424.	13021.	3270.	1132.	17424.
90.00	12188.	2897.	1061.	16146.	12188.	2897.	1061.	16146.
92.86	11711.	2695.	1020.	15426.	11711.	2695.	1020.	15426.
95.00	11354.	2549.	989.	14892.	11354.	2549.	989.	14892.
98.90	10703.	2295.	933.	13931.	10703.	2295.	933.	13931.
100.00	10520.	2226.	917.	13663.	10520.	2226.	917.	13663.
105.00	9686.	1927.	846.	12459.	9686.	1927.	846.	12459.
110.00	8852.	1653.	774.	11279.	8852.	1653.	774.	11279.
115.00	8018.	1403.	701.	10121.	8018.	1403.	701.	10121.
120.00	7184.	1176.	627.	8987.	7184.	1176.	627.	8987.
125.00	6350.	971.	553.	7874.	6350.	971.	553.	7874.
127.04	6010.	894.	523.	7427.	6010.	894.	523.	7427.
130.00	5516.	788.	479.	6783.	5516.	788.	479.	6783.
132.27	5138.	712.	446.	6296.	5138.	712.	446.	6296.
135.00	4682.	627.	407.	5716.	4682.	627.	407.	5716.
140.00	3849.	486.	334.	4669.	3849.	486.	334.	4669.
140.00	3849.	486.	334.	4669.	3849.	486.	334.	4669.
145.00	3065.	366.	266.	3698.	3065.	366.	266.	3698.
150.00	2392.	266.	205.	2863.	2392.	266.	205.	2863.
150.00	266.	266.	205.	2863.	266.	266.	205.	2863.
155.00	1772.	184.	151.	2107.	1772.	184.	151.	2107.
160.00	1262.	117.	104.	1483.	1262.	117.	104.	1483.
160.00	1262.	117.	104.	1483.	1262.	117.	104.	1483.
165.00	809.	65.	64.	939.	809.	65.	64.	939.
170.00	466.	29.	33.	528.	466.	29.	33.	528.
170.00	466.	29.	33.	528.	466.	29.	33.	528.
175.00	182.	7.	10.	200.	182.	7.	10.	200.
177.00	113.	3.	4.	120.	113.	3.	4.	120.
177.00	113.	3.	4.	120.	113.	3.	4.	120.

2. 2.

0. 0.

0. 0.

2. 2.

2. 2.

0. 0.

0. 0.

2. 2.

180.00
180.00

DATE 11/01/99

19487-99

SBA 180' POLE, SITE: 10125-018/COLCHESTER, CT

FOR: BY VALMONT INDUSTRIES

LOADING CASE LOD1

***** DEFECTIONS AND STRESSES **												
*****	*****	*****	*****	*****	*****	*****	*****	*****	*****	*****		
LOADING CASE LOD1	DEFLECTIONS	DEFLECTIONS	DEFLECTIONS	DEFLECTIONS	DEFLECTIONS	DEFLECTIONS	DEFLECTIONS	DEFLECTIONS	DEFLECTIONS	DEFLECTIONS		
0.00	0.0	0.0	0.0	0.0	0.00	48.69	0.53	-0.07	0.96	49.21	52.00	1.057
5.00	0.1	0.1	0.1	0.1	0.19	48.44	0.52	-0.07	0.96	48.95	52.00	1.062
10.00	0.4	0.3	0.3	0.4	0.39	48.16	0.51	-0.07	0.96	48.67	52.00	1.068
15.00	0.9	0.6	0.6	0.9	0.59	47.87	0.50	-0.08	0.96	48.37	52.00	1.075
20.00	1.6	1.2	1.2	1.6	0.79	47.55	0.49	-0.08	0.96	48.05	52.00	1.082
25.00	2.4	1.8	1.8	2.6	0.99	47.21	0.49	-0.08	0.96	47.73	52.00	1.090
30.00	3.5	2.6	2.6	3.7	1.20	46.83	0.48	-0.09	0.96	47.31	52.00	1.099
35.00	4.8	3.6	3.6	5.1	1.40	46.42	0.47	-0.09	0.97	46.89	52.00	1.109
40.00	6.3	4.7	4.7	6.7	1.61	45.97	0.46	-0.09	0.97	46.43	52.00	1.120
45.00	8.0	6.0	6.0	8.4	1.82	45.48	0.45	-0.10	0.97	45.94	52.00	1.132
45.88	8.3	6.2	6.2	8.8	1.86	45.39	0.45	-0.10	0.97	45.84	52.00	1.134
50.00	9.9	7.4	7.4	10.5	2.04	44.95	0.45	-0.10	0.97	45.40	52.00	1.145
53.00	11.2	8.3	8.3	11.8	2.17	50.28	0.48	-0.12	1.12	50.77	52.00	1.024
55.00	12.1	9.0	9.0	12.7	2.27	50.00	0.48	-0.12	1.12	50.48	52.00	1.030
60.00	14.4	10.8	10.8	15.2	2.51	49.27	0.47	-0.12	1.12	49.74	52.00	1.045
65.00	17.0	12.7	12.7	18.0	2.75	48.47	0.47	-0.13	1.12	48.93	52.00	1.063
70.00	19.9	14.8	14.8	21.0	2.99	47.60	0.46	-0.13	1.12	48.06	52.00	1.082
75.00	23.0	17.1	17.1	24.2	3.23	46.66	0.45	-0.14	1.13	47.11	52.00	1.104
80.00	26.3	19.6	19.6	27.8	3.48	45.63	0.45	-0.15	1.13	46.08	52.00	1.128
85.00	29.8	22.3	22.3	31.5	3.72	44.52	0.44	-0.15	1.13	44.96	52.00	1.157
90.00	33.6	25.1	25.1	35.5	3.97	43.31	0.43	-0.16	1.14	43.74	52.00	1.189
92.86	35.9	26.8	26.8	38.0	4.10	42.56	0.43	-0.17	1.14	42.99	52.00	1.210
95.00	37.7	28.2	28.2	39.8	4.21	41.98	0.43	-0.17	1.14	42.41	52.00	1.226
98.90	41.0	30.7	30.7	43.3	4.41	47.31	0.48	-0.21	1.35	47.79	52.00	1.088
100.00	41.9	31.4	31.4	44.4	4.47	46.92	0.48	-0.21	1.35	47.40	52.00	1.097
105.00	46.5	34.8	34.8	49.2	4.74	45.04	0.47	-0.22	1.36	45.52	52.00	1.142
110.00	51.3	38.4	38.4	54.3	5.00	42.99	0.47	-0.22	1.36	43.45	52.00	1.197
115.00	56.3	42.2	42.2	59.7	5.26	40.72	0.46	-0.24	1.37	41.18	52.00	1.263
120.00	61.6	46.2	46.2	65.3	5.51	38.23	0.46	-0.26	1.38	38.69	52.00	1.344
125.00	67.2	50.3	50.3	71.2	5.75	35.47	0.45	-0.27	1.39	35.92	52.00	1.448
127.04	69.5	52.1	52.1	73.7	5.85	34.26	0.45	-0.28	1.39	34.71	52.00	1.498
130.00	72.9	54.7	54.7	77.3	5.98	32.41	0.45	-0.29	1.40	32.86	52.00	1.562
132.27	75.6	56.7	56.7	80.2	6.10	42.69	0.61	-0.41	1.97	43.31	49.71	1.148
135.00	78.9	59.2	59.2	83.7	6.25	40.05	0.61	-0.42	1.98	40.67	50.13	1.232
140.00	85.2	63.9	63.9	90.4	6.52	34.79	0.61	-0.45	2.00	35.42	50.89	1.437
140.00	85.2	63.9	63.9	90.4	6.52	34.79	0.61	-0.45	2.00	35.42	50.89	1.437
145.00	91.7	68.9	68.9	97.4	6.75	29.37	0.52	-0.38	1.68	29.89	51.65	1.728
150.00	98.5	73.9	73.9	104.5	6.95	24.28	0.51	-0.40	1.69	24.80	52.00	2.096
150.00	98.5	73.9	73.9	104.5	6.95	24.28	0.51	-0.40	1.69	24.80	52.00	2.096
155.00	105.4	79.1	79.1	111.9	7.12	19.12	0.41	-0.31	1.34	19.53	52.00	2.663
160.00	112.4	84.5	84.5	119.4	7.25	14.43	0.40	-0.34	1.35	14.85	52.00	3.502
160.00	112.4	84.5	84.5	119.4	7.25	14.43	0.40	-0.34	1.35	14.85	52.00	3.502
165.00	119.6	89.9	89.9	127.1	7.35	9.83	0.28	-0.24	0.95	10.12	52.00	5.138
170.00	126.8	95.3	95.3	134.8	7.42	5.96	0.28	-0.25	0.95	6.25	52.00	8.314
170.00	126.8	95.3	95.3	134.8	7.42	5.96	0.28	-0.25	0.95	6.25	52.00	8.314
175.00	134.1	100.8	100.8	142.6	7.46	2.44	0.14	-0.14	0.50	2.60	52.00	20.017

BY VALMONT INDUSTRIES FOR: SBA 180' POLE, SITE: 10125-018/COLCHESTER, CT
LOADING CASE LOD2

19487-99 DATE 11/01/99
SHEAR FORCE AT BASE (LB) = 31354.
TOTAL VERTICAL FORCE AT BASE (LB) = 53112.

HEIGHT	*** REACTIONS ***			*** MOMENTS ABOUT -Y- AXIS (IN-KIPS) ***			TOTAL
	LOAD	WIND	DEFL	LOAD	WIND	DEFL	
0.00	22205.	10614.	2204.	22205.	10614.	2204.	35023.
5.00	21526.	9974.	2181.	21526.	9974.	2181.	33682.
10.00	20848.	9356.	2154.	20848.	9356.	2154.	32357.
15.00	20169.	8759.	2121.	20169.	8759.	2121.	31049.
20.00	19491.	8184.	2083.	19491.	8184.	2083.	29758.
25.00	18812.	7630.	2041.	18812.	7630.	2041.	28483.
30.00	18133.	7096.	1995.	18133.	7096.	1995.	27224.
35.00	17455.	6582.	1945.	17455.	6582.	1945.	25982.
40.00	16776.	6087.	1891.	16776.	6087.	1891.	24755.
45.00	16098.	5613.	1834.	16098.	5613.	1834.	23545.
45.88	15979.	5532.	1824.	15979.	5532.	1824.	23334.
50.00	15419.	5159.	1774.	15419.	5159.	1774.	22352.
53.00	15012.	4896.	1737.	15012.	4896.	1737.	21645.
55.00	14741.	4725.	1712.	14741.	4725.	1712.	21178.
60.00	14062.	4312.	1648.	14062.	4312.	1648.	20022.
65.00	13383.	3920.	1581.	13383.	3920.	1581.	18884.
70.00	12705.	3548.	1511.	12705.	3548.	1511.	17764.
75.00	12026.	3197.	1439.	12026.	3197.	1439.	16662.
80.00	11348.	2867.	1364.	11348.	2867.	1364.	15579.
85.00	10669.	2556.	1288.	10669.	2556.	1288.	14513.
90.00	9991.	2265.	1210.	9991.	2265.	1210.	13465.
92.86	9603.	2107.	1165.	9603.	2107.	1165.	12875.
95.00	9312.	1994.	1130.	9312.	1994.	1130.	12436.
98.90	8783.	1795.	1068.	8783.	1795.	1068.	11646.
100.00	8633.	1741.	1051.	8633.	1741.	1051.	11426.
105.00	7955.	1508.	971.	7955.	1508.	971.	10434.
110.00	7276.	1294.	890.	7276.	1294.	890.	9461.
115.00	6598.	1099.	807.	6598.	1099.	807.	8504.
120.00	5919.	921.	724.	5919.	921.	724.	7564.
125.00	5241.	761.	640.	5241.	761.	640.	6641.
127.04	4964.	701.	606.	4964.	701.	606.	6270.
130.00	4562.	618.	556.	4562.	618.	556.	5735.
132.27	4254.	559.	518.	4254.	559.	518.	5330.
135.00	3883.	492.	472.	3883.	492.	472.	4847.
140.00	3205.	382.	388.	3205.	382.	388.	3974.
140.00	3205.	382.	388.	3205.	382.	388.	3974.
145.00	2552.	288.	310.	2552.	288.	310.	3149.
150.00	2003.	209.	203.	2003.	209.	203.	2451.
150.00	2003.	209.	239.	2003.	209.	239.	2451.
155.00	1484.	145.	176.	1484.	145.	176.	1804.
160.00	1069.	92.	121.	1069.	92.	121.	1282.
160.00	1069.	92.	121.	1069.	92.	121.	1282.
165.00	686.	51.	75.	686.	51.	75.	813.
170.00	406.	23.	39.	406.	23.	39.	468.
170.00	406.	23.	39.	406.	23.	39.	468.
175.00	162.	6.	12.	162.	6.	12.	180.
177.00	105.	2.	5.	105.	2.	5.	113.
177.00	105.	2.	5.	105.	2.	5.	113.

2: 2:

0: 0:

0: 0:

2: 2:

2: 2:

0: 0:

0: 0:

2: 2:

180.00
180.00

Bell Atlantic Mobile

WIRELESS COMMUNICATIONS FACILITY

COLCHESTER WESTCHESTER ROAD (ROUTE 149) COLCHESTER, CT.

REVISIONS		
01	03/07/00	CT SITTING COUNCIL
02		
03		
04		
05		



NATCOMM
 Natcomm, LLC - Engineering Consultants
 63-2 North Branford Road
 Branford, Connecticut 06405
 Tel. (203) 498-0580
 Fax (203) 498-0587
 Consulting Engineers - Project Management
 Site Acquisition - Communications Installations



COLCHESTER
BAM PROJECT
NO. 993359
 48 WESTCHESTER RD. (CT. RTE 149)
 COLCHESTER, CONNECTICUT

PROJECT NO:	161A
DRAWN BY:	CTW
CHECKED BY:	CFC
SCALE:	AS NOTED
DATE:	02/15/00

TITLE SHEET

T-1
 DWG. 1 OF 2

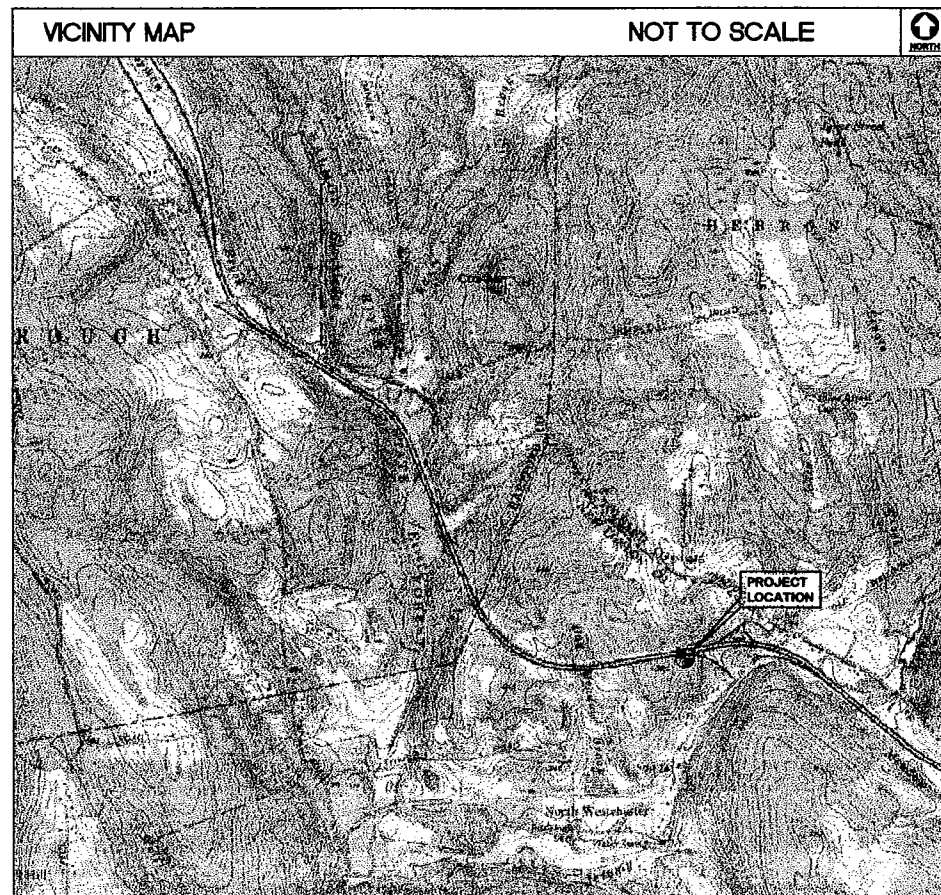

PROJECT SUMMARY	
SEARCH AREA:	NOT AVAILABLE
SITE NAME:	COLCHESTER
SITE ADDRESS:	COLCHESTER WESTCHESTER ROAD (ROUTE 149) COLCHESTER, CT
CONTACT PERSON:	WAYNE LUKACEK, BAM
SITE PARCEL NO.:	NOT AVAILABLE
DEED BOOK / PAGE:	NOT AVAILABLE
CURRENT ZONING:	NOT AVAILABLE
GOVERNING CODE:	CONNECTICUT BUILDING CODE CONNECTICUT LIFE SAFETY CODES
LEASOR:	-
APPLICANT:	BELL ATLANTIC MOBILE 20 ALEXANDER DRIVE WALLINGFORD, CT. 06492
ENGINEER:	NATCOMM LLC. 63-2 NORTH BRANFORD RD. BRANFORD, CT. 06405

SHEET INDEX		
SHT. NO.	DESCRIPTION	REV. NO.
T-1	TITLE SHEET	00
C-1	SITE PLAN AND ELEVATION	00

EXISTING 100' X 100' SBA, INC. LEASE AREA WITH FENCED COMPOUND.

EXISTING 70'X80', 6' HIGH CHAIN LINK FENCE

EXISTING 6" GRAVEL SURFACE OVER STABILIZATION FABRIC ACCESS DISTURBED, TO BE RESTORED TO ORIGINAL CONDITION.

BAM ICE BRIDGE AND ICE BRIDGE SUPPORT POST, TYPICAL.

180' MONOPOLE.

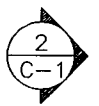

FUTURE EQUIPMENT BY OTHERS. TYPICAL.

12' WIDE DOUBLE SWING GATE BY OTHERS.

EXISTING 12' WIDE BITUMINOUS DRIVE.

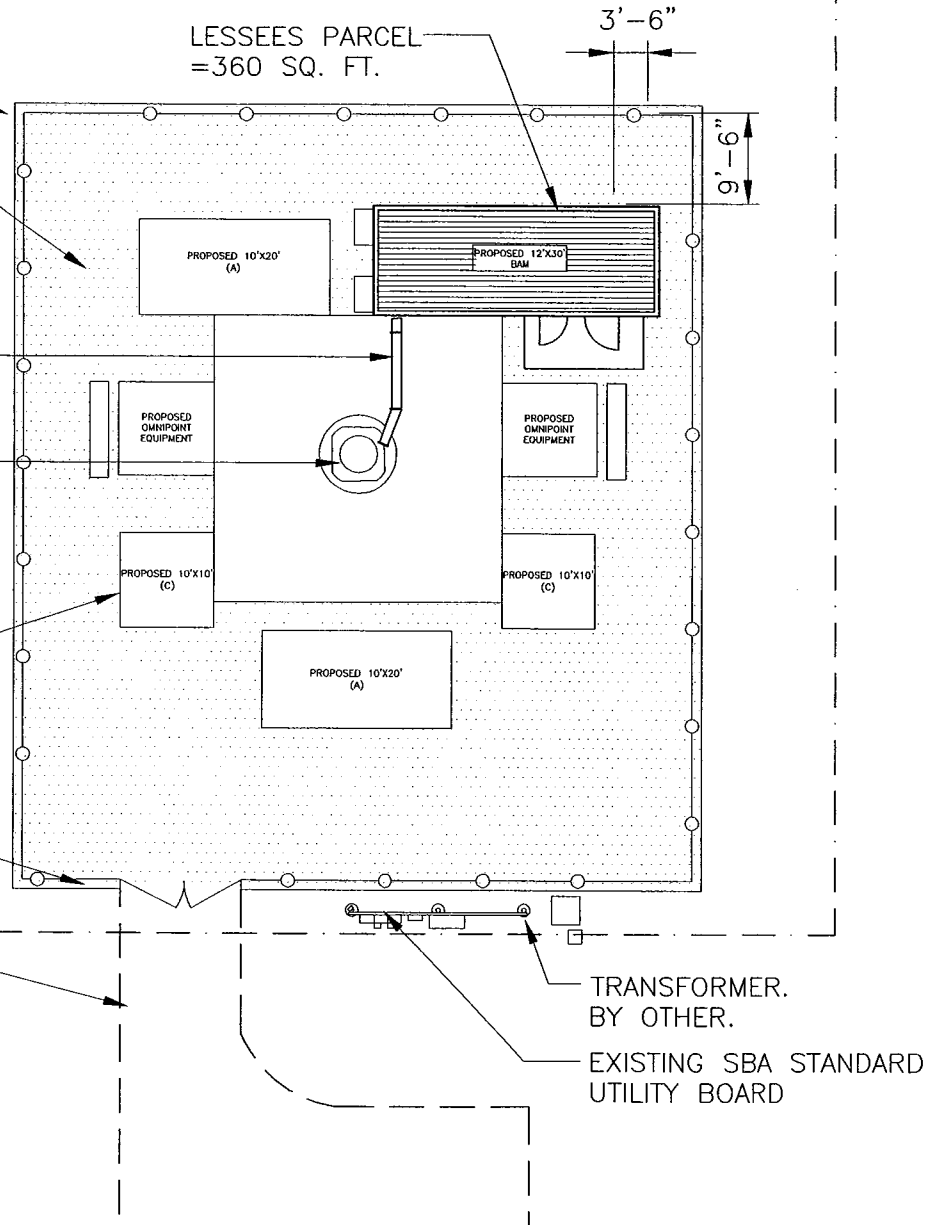

1
C-1 **COMPOUND PLAN**
SCALE: NOT TO SCALE

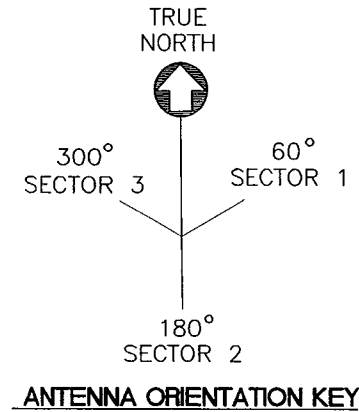
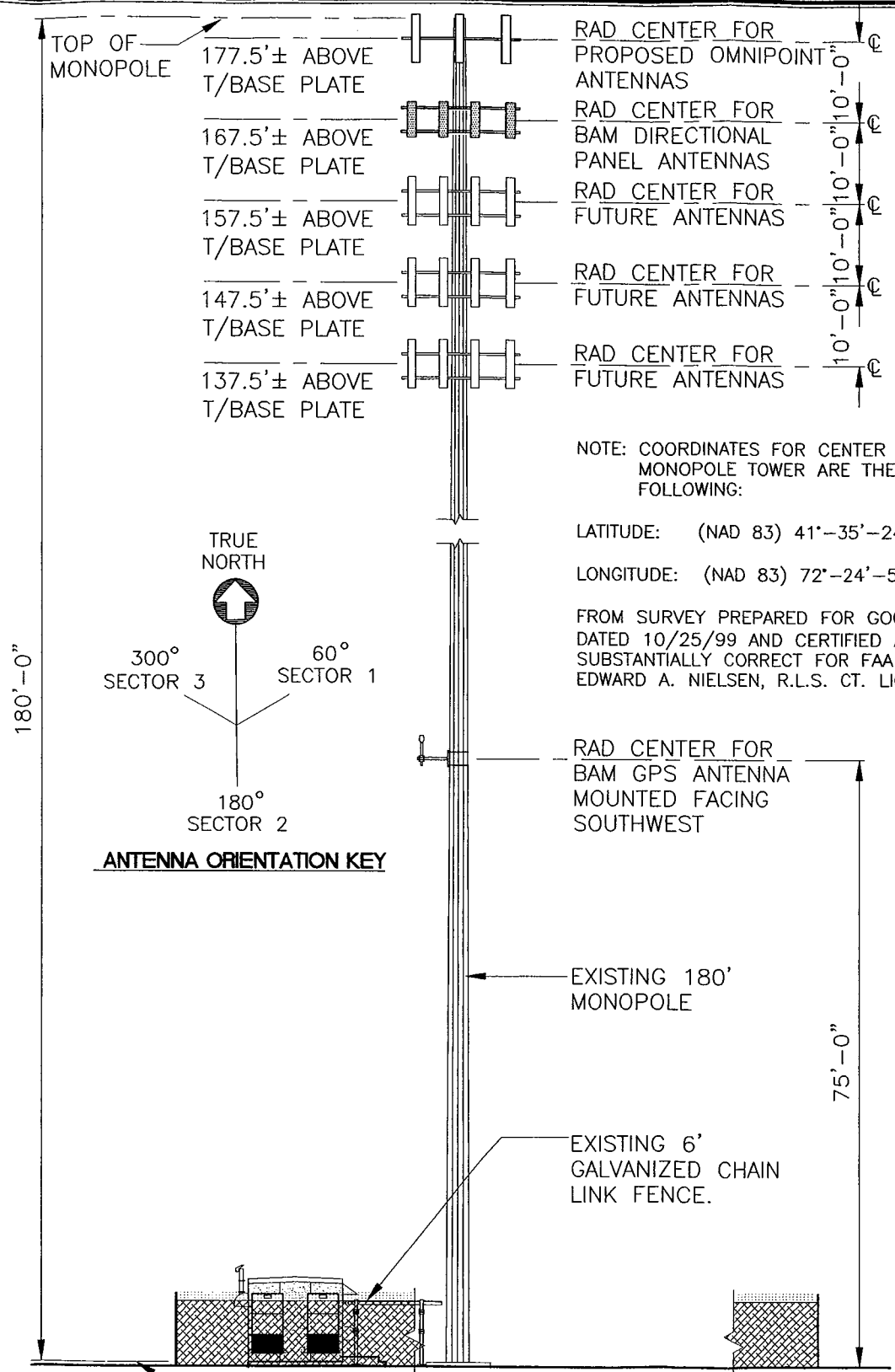

ANTENNA ORIENTATION KEY

2
C-1 **TOWER ELEVATION**
SCALE: NOT TO SCALE

- 177.5'± ABOVE T/BASE PLATE RAD CENTER FOR PROPOSED OMNIPOINT ANTENNAS
- 167.5'± ABOVE T/BASE PLATE RAD CENTER FOR BAM DIRECTIONAL PANEL ANTENNAS
- 157.5'± ABOVE T/BASE PLATE RAD CENTER FOR FUTURE ANTENNAS
- 147.5'± ABOVE T/BASE PLATE RAD CENTER FOR FUTURE ANTENNAS
- 137.5'± ABOVE T/BASE PLATE RAD CENTER FOR FUTURE ANTENNAS

NOTE: COORDINATES FOR CENTER OF MONOPOLE TOWER ARE THE FOLLOWING:

LATITUDE: (NAD 83) 41°-35'-24.58"
LONGITUDE: (NAD 83) 72°-24'-5.28"

FROM SURVEY PREPARED FOR GOODKIND & O'DEA DATED 10/25/99 AND CERTIFIED AS BEING SUBSTANTIALLY CORRECT FOR FAA A-2 SURVEY BY EDWARD A. NIELSEN, R.L.S. CT. LICENSE NO. 6404.

RAD CENTER FOR BAM GPS ANTENNA MOUNTED FACING SOUTHWEST

EXISTING 180' MONOPOLE

EXISTING 6' GALVANIZED CHAIN LINK FENCE.

REVISIONS		
01	03/07/00	CT SITING COUNCIL
02		
03		
04		
05		



NATCOMM
NATCOMM, L.L.C. Engineering Consultants
63-2 North Branford Road
Branford, Connecticut 06405
Tel: (203) 486-0680
Fax: (203) 486-8087
Consulting Engineers-Project Management
Site Acquisition-Communications Installations



COLCHESTER
BAM PROJECT
NO. 993359
48 WESTCHESTER RD. (CT. RTE 149)
COLCHESTER, CONNECTICUT

PROJECT NO:	161A
DRAWN BY:	CTW
CHECKED BY:	CFC
SCALE:	AS NOTED
DATE:	02/15/00

COMPOUND PLAN & TOWER ELEVATION

C-1
DWG. 2 OF 2