



STATE OF CONNECTICUT

CONNECTICUT SITING COUNCIL

Ten Franklin Square, New Britain, CT 06051

Phone: (860) 827-2935 Fax: (860) 827-2950

E-Mail: siting.council@ct.gov

www.ct.gov/csc

VIA ELECTRONIC MAIL

April 17, 2019

Jennifer Iliades
Site Acquisition Consultant
Centerline Communications, LLC
750 West Center Street, Suite 301
West Bridgewater, MA 02379

RE: **EM-CING-028-190315** – New Cinglar Wireless PCS, LLC (AT&T) notice of intent to modify an existing telecommunications facility located 355 Route 85 (a/k/a New London Road), Colchester, Connecticut.

Dear Ms. Iliades:

The Connecticut Siting Council (Council) is in receipt of your correspondence of April 12, 2019 submitted in response to the Council's March 19, 2019 notification of an incomplete request for exempt modification with regard to the above-referenced matter.

The submission renders the request for exempt modification complete and the Council will process the request in accordance with the Federal Communications Commission 60-day timeframe.

Thank you for your attention and cooperation.

Sincerely,

Melanie A. Bachman
Executive Director

MAB/IN/emr



Robidoux, Evan

From: Jennifer Iliades <jiliades@clinellc.com>
Sent: Friday, April 12, 2019 3:19 PM
To: Robidoux, Evan; CSC-DL Siting Council
Cc: David Ford
Subject: RE: Council incomplete Letter for EM-CING-028-190315-Route85_a/k/a_NewLondonRd-Colchester
Attachments: em-cing-028-190315_incompleteltr_Rte85(akaNewLondonRd).pdf; CT5730 - Notice of Exempt Modification - Supplemental Info 4.12.19.pdf
Follow Up Flag: Follow up
Flag Status: Flagged

Good afternoon,

Attached please find our letter, revised CDs and EME pursuant to your request on 3/25/2019 regarding the above-referenced exempt modification notification.

Please do not hesitate to contact us should you have any questions or require additional information. A hard copy has been sent out and should arrive shortly.

Thank you,



Jennifer Iliades | Site Acquisition Consultant
750 West Center Street, Suite 301 | West Bridgewater, MA 02379
Phone: 978.944.1304 | Fax: 508.319.3017
jiliades@clinellc.com | www.centerlinecommunications.com

From: Robidoux, Evan <Evan.Robidoux@ct.gov>
Sent: Monday, March 25, 2019 8:55 AM
To: Jennifer Iliades <jiliades@clinellc.com>
Cc: CSC-DL Siting Council <Siting.Council@ct.gov>
Subject: Council incomplete Letter for EM-CING-028-190315-Route85_a/k/a_NewLondonRd-Colchester

Please see the attached correspondence.

Evan Robidoux
Clerk Typist
Connecticut Siting Council
10 Franklin Square
New Britain, CT 06051

April 12, 2019

Melanie A. Bachman
Executive Director
Connecticut Siting Council
10 Franklin Square
New Britain, CT 06051

**Regarding: EM-CING-028-190315 Notice of Incompletion
Notice of Exempt Modification – AT&T Site CT5730
Address: 355 Route 85 (a/k/a 355 New London Road), Colchester, CT 06415**

Dear Ms. Bachman:

Pursuant to your correspondence dated March 19, 2019, your staff had identified deficiencies in the Construction Drawings and Radio Frequency Emissions Analysis (RF) Report in our original submission dated March 11, 2019 and delivered to your office on March 14, 2019. Accordingly, enclosed herewith please find both the revised Construction Drawings and revised RF Report per your request.

Please do not hesitate to contact me should you have any questions, concerns or require additional information. Thank you for your assistance to this matter.

Sincerely,



Jennifer Iliades
Site Acquisition Consultant
Centerline Communications, LLC
750 West Center Street, Suite 301
West Bridgewater, MA 02379
jiliades@clinellc.com

Enclosures

cc: The Honorable Arthur P. Shilosky, First Selectman, Town of Colchester
Randall Benson, Town Planner, Town of Colchester



STATE OF CONNECTICUT

CONNECTICUT SITING COUNCIL

Ten Franklin Square, New Britain, CT 06051

Phone: (860) 827-2935 Fax: (860) 827-2950

E-Mail: siting.council@ct.gov

www.ct.gov/csc

March 19, 2019

Jennifer Iliades
Site Acquisition Consultant
Centerline Communications, LLC
750 West Center Street, Suite 301
West Bridgewater, MA 02379

RE: **EM-CING-028-190315** – New Cingular Wireless PCS, LLC (AT&T) notice of intent to modify an existing telecommunications facility located at 355 Route 85 (a/k/a New London Road), Colchester, Connecticut.

Dear Ms. Iliades:

The Connecticut Siting Council (Council) received a notice of intent to modify the above-referenced facility on March 15, 2019.

According to Section 16-50j-71 of the Regulations of Connecticut State Agencies, "...any modification, as defined in Section 16-50j-2a of the Regulations of Connecticut State Agencies, to an existing tower site, except as specified in Sections 16-50j-72 and 16-50j-88 of the Regulations of Connecticut State Agencies, may have a substantial adverse environmental effect."

Staff has reviewed this exempt modification request for completeness and has identified a deficiency in the Construction Drawings (CD) dated January 30, 2019 and prepared by Hudson Design Group. The CD is not stamped and signed by a Professional Engineer duly licensed in the State of Connecticut. Also the CD and the Radio Frequency Emissions Analysis (RF) Report dated March 4, 2019 and prepared by Centerline Communications, list the site address as "285 West Road" on their respective cover pages. This is inconsistent with the site address as listed on the town's property card.

Therefore, the exempt modification request is incomplete at this time. The Council recommends that Centerline Communications provide a CD that is stamped and signed by a Professional Engineer duly licensed in the state of Connecticut, and an RF Report that both cite the correct address for the facility, on or before April 16, 2019. If additional time is needed to gather the requested information, please submit a written request for an extension of time prior to April 16, 2019.

This notice of incompleteness shall have the effect of tolling the Federal Communications Commission (FCC) 60-day timeframe in accordance with Paragraph 217 of the FCC Wireless Infrastructure Report and Order issued on October 21, 2014 (FCC 14-153).

Thank you for your attention to this matter. Should you have any questions, please feel free to contact me at 860-827-2951.

Sincerely,

Melanie Bachman
Executive Director

MAB/IN/emr

c: The Honorable Arthur P. Shilosky, First Selectman, Town of Colchester
Randall Benson, Town Planner, Town of Colchester



S:\EMS_TS\1_BYTOWN\Colchester\Rte85_aka_NewLondonRd\AT&T\CD\CD\emr\0315_incompletlr_Rte85(aka_NewLondonRd).docx

PROJECT INFORMATION

SCOPE OF WORK: **ITEMS TO BE MOUNTED ON THE EXISTING MONOPOLE:**

- NEW AT&T LTE ANTENNA (800-10965) @ POS. 1 (TOTAL OF 1 FOR ALPHA SECTOR).
- NEW AT&T LTE ANTENNA (HPA-65R-BU6AA) @ POS. 2 (TOTAL OF 1 FOR ALPHA SECTOR).
- NEW AT&T LTE ANTENNA (800-10966) @ POS. 1 (TYP OF 1 PER BETA & GAMMA SECTOR, TOTAL OF 2)
- NEW AT&T LTE ANTENNA (HPA-65R-BU8AA) @ POS. 2 (TYP OF 1 PER BETA & GAMMA SECTOR, TOTAL OF 2)
- NEW AT&T RRUS 4449 B5/B12 (850/700) (TYP OF 1 PER SECTOR, TOTAL OF 3).
- NEW AT&T RRUS 8843 B2/B66A (AWS/PCS) (TYP OF 1 PER SECTOR, TOTAL OF 3).
- NEW AT&T SURGE ARRESTOR DC6-48-60-18-8C (TOTAL OF 1) WITH (2) DC POWER, & (1) FIBER.
- INSTALL MOUNT MODIFICATIONS AS SHOWN ON "S" SHEETS.

ITEMS TO BE MOUNTED AT EQUIPMENT LOCATION:

- SWAP BB WITH (2) 6630.
- ADD (1) XMU.
- INSTALL NEW AT&T LOW BAND COMBINERS (DBCT108F1V92-1) (TOTAL OF 3).
- INSTALL NEW AT&T RRUS 4478 B14 (700) (TYP. OF 1 FOR ALPHA, & 1 SHARED BETWEEN BETA & GAMMA, TOTAL OF 2)
- INSTALL NEW SURGE ARRESTORS (TSXDC-4310FM) (TYP. OF 4 PER RRU, TOTAL OF 8)

ITEMS TO REMAIN:

- (3) ANTENNAS, (6) TMA'S, (1) SURGE ARRESTOR, (12) COAX CABLES, (2) DC POWER & (1) FIBER.

SQUID ALARMING (NOT TO BE DAISY CHAINED).

- THE 1ST SQUID INSTALLED WILL BE ALARMED TO THE LOWEST BAND (OR FIRST INSTALLED RRH/RRU ON THE ALPHA SECTOR, IN THE EVENT THE ALARM CABLE CANNOT BE CONNECTED TO ALPHA IT WILL BE ACCEPTABLE TO ALARM TO THE CLOSEST PHYSICAL SECTOR ON AN EXCEPTION BASIS.
- 2ND SQUID INSTALLED WILL BE ALARMED TO THE LOWEST BAND (OR FIRST INSTALLED) RRH/RRU ON THE BETA SECTOR.
- 3RD SQUID INSTALLED WILL BE ALARMED TO THE LOWEST BAND (OR FIRST INSTALLED) RRH/RRU ON THE GAMMA SECTOR.

SITE ADDRESS: 335 NEW LONDON ROAD
COLCHESTER, CT 06415

LATITUDE: 41.545000 N, 41° 32' 42.00" N
LONGITUDE: 72.304200 W, 72° 18' 15.12" W
TYPE OF SITE: MONOPOLE/ OUTDOOR EQUIPMENT
STRUCTURE HEIGHT: 180'±
RAD CENTER: 150'±
CURRENT USE: TELECOMMUNICATIONS FACILITY
PROPOSED USE: TELECOMMUNICATIONS FACILITY



SITE NUMBER: CT5730

SITE NAME: COLCHESTER SOUTH

FA CODE: 10070974

**PACE ID: MRCTB035138, MRCTB035154, MRCTB035199,
MRCTB035222, MRCTB035354**

PROJECT: LTE 2C/3C/4C/5C/4TX4RX 2019 UPGRADE

VICINITY MAP

DIRECTIONS TO SITE:

START OUT GOING NORTHEAST ON ENTERPRISE DR TOWARD CAPITOL BLVD. TURN LEFT ONTO CAPITOL BLVD. TURN LEFT ONTO WEST ST. MERGE ONTO I-91 N VIA THE RAMP IN THE LEFT TOWARD HARTFORD 4.5 MILES. MERGE ONTO CT-3 N VIA EXIT 25 TOWARD GLASTONBURY. MERGE ONTO CT-2 E TOWARD NORWICH 20.0 MILES. MERGE ONTO CT-11 S VIA EXIT 19 TOWARD NEW LONDON. TAKE THE LAKE HAYWARD RD EXIT, EXIT 6, TOWARD CT-85/CT-354. TURN LEFT ONTO LAKE HAYWARD RD. TURN RIGHT ONTO NEW LONDON RD/CT-85. TURN SLIGHT RIGHT ONTO WEST RD. 285 WEST RD IS ON THE LEFT.

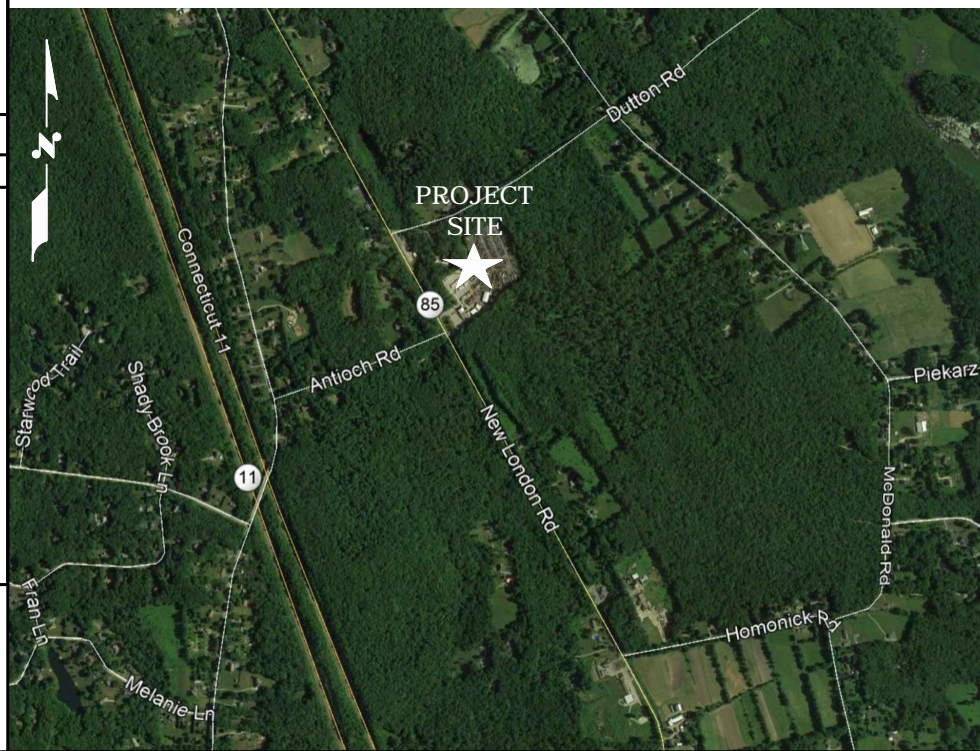

GENERAL NOTES

1. THIS DOCUMENT IS THE CREATION, DESIGN, PROPERTY AND COPYRIGHTED WORK OF AT&T. ANY DUPLICATION OR USE WITHOUT EXPRESS WRITTEN CONSENT IS STRICTLY PROHIBITED. DUPLICATION AND USE BY GOVERNMENT AGENCIES FOR THE PURPOSES OF CONDUCTING THEIR LAWFULLY AUTHORIZED REGULATORY AND ADMINISTRATIVE FUNCTIONS IS SPECIFICALLY ALLOWED.
2. THE FACILITY IS AN UNMANNED PRIVATE AND SECURED EQUIPMENT INSTALLATION. IT IS ONLY ACCESSED BY TRAINED TECHNICIANS FOR PERIODIC ROUTINE MAINTENANCE AND THEREFORE DOES NOT REQUIRE ANY WATER OR SANITARY SEWER SERVICE. THE FACILITY IS NOT GOVERNED BY REGULATIONS REQUIRING PUBLIC ACCESS PER ADA REQUIREMENTS.
3. CONTRACTOR SHALL VERIFY ALL PLANS AND EXISTING DIMENSIONS AND CONDITIONS ON THE JOB SITE AND SHALL IMMEDIATELY NOTIFY THE AT&T MOBILITY REPRESENTATIVE IN WRITING OF DISCREPANCIES BEFORE PROCEEDING WITH THE WORK OR BE RESPONSIBLE FOR SAME.
4. CONSTRUCTION DRAWINGS ARE VALID FOR SIX MONTHS AFTER ENGINEER OF RECORD'S STAMPED AND SIGNED SUBMITTAL DATE LISTED HEREIN.

DRAWING INDEX

SHEET NO.	DESCRIPTION	REV.
T-1	TITLE SHEET	1
GN-1	GENERAL NOTES	1
A-1	COMPOUND & EQUIPMENT PLANS	1
A-2	ANTENNA LAYOUTS & ELEVATION	1
A-3	DETAILS	1
A-4	DETAILS	1
SN-1	STRUCTURAL NOTES	1
S-1	STRUCTURAL DETAILS	1
RF-1	RF PLUMBING DIAGRAM	1
G-1	GROUNDING DETAILS	1

ATC SITE NAME: COLCHESTER CT 6
ATC SITE #: 302465

72 HOURS



CALL BEFORE YOU DIG
CALL TOLL FREE 1-800-922-4455
OR CALL 811

UNDERGROUND SERVICE ALERT

HGD HUDSON Design Group LLC
45 BEECHWOOD DRIVE
NORTH ANDOVER, MA 01845
TEL: (978) 557-5553
FAX: (978) 336-5586

CENTERLINE COMMUNICATIONS
750 WEST CENTER STREET., SUITE #301
WEST BRIDGEWATER, MA 02379

SITE NUMBER: CT5730
SITE NAME: COLCHESTER SOUTH
ATC SITE #: 302465
335 NEW LONDON ROAD
COLCHESTER, CT 06415
NEW LONDON COUNTY

at&t
550 COCHITUATE ROAD
FRAMINGHAM, MA 01701

NO.	DATE	REVISIONS	BY	CHK	APP'D
1	04/12/19	ISSUED FOR CONSTRUCTION	SG	AT	DJC
A	03/26/19	ISSUED FOR REVIEW	ET	AT	DJC

SCALE: AS SHOWN DESIGNED BY: AT DRAWN BY: ET

AT&T
TITLE SHEET
(LTE 2C/3C/4C/5C/4TX4RX)
SITE NUMBER: CT5730
DRAWING NUMBER: T-1
REV: 1

GROUNDING NOTES

1. THE SUBCONTRACTOR SHALL REVIEW AND INSPECT THE EXISTING FACILITY GROUNDING SYSTEM AND LIGHTNING PROTECTION SYSTEM (AS DESIGNED AND INSTALLED) FOR STRICT COMPLIANCE WITH THE NEC (AS ADOPTED BY THE AHJ), THE SITE-SPECIFIC (UL, LPI, OR NFPA) LIGHTING PROTECTION CODE, AND GENERAL COMPLIANCE WITH TELCORDIA AND TIA GROUNDING STANDARDS. THE SUBCONTRACTOR SHALL REPORT ANY VIOLATIONS OR ADVERSE FINDINGS TO THE CONTRACTOR FOR RESOLUTION.
2. ALL GROUND ELECTRODE SYSTEMS (INCLUDING TELECOMMUNICATION, RADIO, LIGHTNING PROTECTION, AND AC POWER GES'S) SHALL BE BONDED TOGETHER, AT OR BELOW GRADE, BY TWO OR MORE COPPER BONDING CONDUCTORS IN ACCORDANCE WITH THE NEC.
3. THE SUBCONTRACTOR SHALL PERFORM IEEE FALL-OF-POTENTIAL RESISTANCE TO EARTH TESTING (PER IEEE 1100 AND 81) FOR NEW GROUND ELECTRODE SYSTEMS. THE SUBCONTRACTOR SHALL FURNISH AND INSTALL SUPPLEMENTAL GROUND ELECTRODES AS NEEDED TO ACHIEVE A TEST RESULT OF 5 OHMS OR LESS.
4. METAL RACEWAY SHALL NOT BE USED AS THE NEC REQUIRED EQUIPMENT GROUND CONDUCTOR. STRANDED COPPER CONDUCTORS WITH GREEN INSULATION, SIZED IN ACCORDANCE WITH THE NEC, SHALL BE FURNISHED AND INSTALLED WITH THE POWER CIRCUITS TO BTS EQUIPMENT.
5. EACH BTS CABINET FRAME SHALL BE DIRECTLY CONNECTED TO THE MASTER GROUND BAR WITH GREEN INSULATED SUPPLEMENTAL EQUIPMENT GROUND WIRES, 6 AWG STRANDED COPPER OR LARGER FOR INDOOR BTS 2 AWG STRANDED COPPER FOR OUTDOOR BTS.
6. EXOTHERMIC WELDS SHALL BE USED FOR ALL GROUNDING CONNECTIONS BELOW GRADE.
7. APPROVED ANTIOXIDANT COATINGS (I.E., CONDUCTIVE GEL OR PASTE) SHALL BE USED ON ALL COMPRESSION AND BOLTED GROUND CONNECTIONS.
8. ICE BRIDGE BONDING CONDUCTORS SHALL BE EXOTHERMICALLY BONDED OR BOLTED TO GROUND BAR.
9. ALUMINUM CONDUCTOR OR COPPER CLAD STEEL CONDUCTOR SHALL NOT BE USED FOR GROUNDING CONNECTIONS.
10. MISCELLANEOUS ELECTRICAL AND NON-ELECTRICAL METAL BOXES, FRAMES AND SUPPORTS SHALL BE BONDED TO THE GROUND RING, IN ACCORDANCE WITH THE NEC.
11. METAL CONDUIT SHALL BE MADE ELECTRICALLY CONTINUOUS WITH LISTED BONDING FITTINGS OR BY BONDING ACROSS THE DISCONTINUITY WITH 6 AWS COPPER WIRE UL APPROVED GROUNDING TYPE CONDUIT CLAMPS.
12. ALL NEW STRUCTURES WITH A FOUNDATION AND/OR FOOTING HAVING 20 FT. OR MORE OF 1/2 IN. OR GREATER ELECTRICALLY CONDUCTIVE REINFORCING STEEL MUST HAVE IT BONDED TO THE GROUND RING USING AN EXOTHERMIC WELD CONNECTION USING #2 AWG SOLID BARE TINNED COPPER GROUND WIRE, PER NEC 250.50

GENERAL NOTES

1. FOR THE PURPOSE OF CONSTRUCTION DRAWING, THE FOLLOWING DEFINITIONS SHALL APPLY:
 CONTRACTOR – CENTERLINE
 SUBCONTRACTOR – GENERAL CONTRACTOR (CONSTRUCTION)
 OWNER – AT&T MOBILITY
2. PRIOR TO THE SUBMISSION OF BIDS, THE BIDDING SUBCONTRACTOR SHALL VISIT THE CELL SITE TO FAMILIARIZE WITH THE EXISTING CONDITIONS AND TO CONFIRM THAT THE WORK CAN BE ACCOMPLISHED AS SHOWN ON THE CONSTRUCTION DRAWINGS. ANY DISCREPANCY FOUND SHALL BE BROUGHT TO THE ATTENTION OF CONTRACTOR.
3. ALL MATERIALS FURNISHED AND INSTALLED SHALL BE IN STRICT ACCORDANCE WITH ALL APPLICABLE CODES, REGULATIONS, AND ORDINANCES. SUBCONTRACTOR SHALL ISSUE ALL APPROPRIATE NOTICES AND COMPLY WITH ALL LAWS, ORDINANCES, RULES, REGULATIONS, AND LAWFUL ORDERS OF ANY PUBLIC AUTHORITY REGARDING THE PERFORMANCE OF THE WORK. ALL WORK CARRIED OUT SHALL COMPLY WITH ALL APPLICABLE MUNICIPAL AND UTILITY COMPANY SPECIFICATIONS AND LOCAL JURISDICTIONAL CODES, ORDINANCES AND APPLICABLE REGULATIONS.
4. DRAWINGS PROVIDED HERE ARE NOT TO BE SCALED AND ARE INTENDED TO SHOW OUTLINE ONLY.
5. UNLESS NOTED OTHERWISE, THE WORK SHALL INCLUDE FURNISHING MATERIALS, EQUIPMENT, APPURTENANCES, AND LABOR NECESSARY TO COMPLETE ALL INSTALLATIONS AS INDICATED ON THE DRAWINGS.
6. "KITTING LIST" SUPPLIED WITH THE BID PACKAGE IDENTIFIES ITEMS THAT WILL BE SUPPLIED BY CONTRACTOR. ITEMS NOT INCLUDED IN THE BILL OF MATERIALS AND KITTING LIST SHALL BE SUPPLIED BY THE SUBCONTRACTOR.
7. THE SUBCONTRACTOR SHALL INSTALL ALL EQUIPMENT AND MATERIALS IN ACCORDANCE WITH MANUFACTURER'S RECOMMENDATIONS UNLESS SPECIFICALLY STATED OTHERWISE.
8. IF THE SPECIFIED EQUIPMENT CANNOT BE INSTALLED AS SHOWN ON THESE DRAWINGS, THE SUBCONTRACTOR SHALL PROPOSE AN ALTERNATIVE INSTALLATION SPACE FOR APPROVAL BY THE CONTRACTOR.
9. SUBCONTRACTOR SHALL DETERMINE ACTUAL ROUTING OF CONDUIT, POWER AND T1 CABLES, GROUNDING CABLES AS SHOWN ON THE POWER, GROUNDING AND TELCO PLAN DRAWING. SUBCONTRACTOR SHALL UTILIZE EXISTING TRAYS AND/OR SHALL ADD NEW TRAYS AS NECESSARY. SUBCONTRACTOR SHALL CONFIRM THE ACTUAL ROUTING WITH THE CONTRACTOR.
10. THE SUBCONTRACTOR SHALL PROTECT EXISTING IMPROVEMENTS, PAVEMENTS, CURBS, LANDSCAPING AND STRUCTURES. ANY DAMAGED PART SHALL BE REPAIRED AT SUBCONTRACTOR'S EXPENSE TO THE SATISFACTION OF OWNER.
11. SUBCONTRACTOR SHALL LEGALLY AND PROPERLY DISPOSE OF ALL SCRAP MATERIALS SUCH AS COAXIAL CABLES AND OTHER ITEMS REMOVED FROM THE EXISTING FACILITY. ANTENNAS REMOVED SHALL BE RETURNED TO THE OWNER'S DESIGNATED LOCATION.
12. SUBCONTRACTOR SHALL LEAVE PREMISES IN CLEAN CONDITION.
13. ALL CONCRETE REPAIR WORK SHALL BE DONE IN ACCORDANCE WITH AMERICAN CONCRETE INSTITUTE (ACI) 301.

14. ANY NEW CONCRETE NEEDED FOR THE CONSTRUCTION SHALL BE AIR-ENTRAINED AND SHALL HAVE 4000 PSI STRENGTH AT 28 DAYS. ALL CONCRETE WORK SHALL BE DONE IN ACCORDANCE WITH ACI 318 CODE REQUIREMENTS.
15. ALL STRUCTURAL STEEL WORK SHALL BE DETAILED, FABRICATED AND ERECTED IN ACCORDANCE WITH AISC SPECIFICATIONS. ALL STRUCTURAL STEEL SHALL BE ASTM A36 (Fy = 36 ksi) UNLESS OTHERWISE NOTED. PIPES SHALL BE ASTM A53 TYPE E (Fy = 36 ksi). ALL STEEL EXPOSED TO WEATHER SHALL BE HOT DIPPED GALVANIZED. TOUCHUP ALL SCRATCHES AND OTHER MARKS IN THE FIELD AFTER STEEL IS ERECTED USING A COMPATIBLE ZINC RICH PAINT.
16. CONSTRUCTION SHALL COMPLY WITH SPECIFICATIONS AND "GENERAL CONSTRUCTION SERVICES FOR CONSTRUCTION OF AT&T SITES."
17. SUBCONTRACTOR SHALL VERIFY ALL EXISTING DIMENSIONS AND CONDITIONS PRIOR TO COMMENCING ANY WORK. ALL DIMENSIONS OF EXISTING CONSTRUCTION SHOWN ON THE DRAWINGS MUST BE VERIFIED. SUBCONTRACTOR SHALL NOTIFY THE CONTRACTOR OF ANY DISCREPANCIES PRIOR TO ORDERING MATERIAL OR PROCEEDING WITH CONSTRUCTION.
18. THE EXISTING CELL SITE IS IN FULL COMMERCIAL OPERATION. ANY CONSTRUCTION WORK BY SUBCONTRACTOR SHALL NOT DISRUPT THE EXISTING NORMAL OPERATION. ANY WORK ON EXISTING EQUIPMENT MUST BE COORDINATED WITH CONTRACTOR. ALSO, WORK SHOULD BE SCHEDULED FOR AN APPROPRIATE MAINTENANCE WINDOW USUALLY IN LOW TRAFFIC PERIODS AFTER MIDNIGHT.
19. SINCE THE CELL SITE IS ACTIVE, ALL SAFETY PRECAUTIONS MUST BE TAKEN WHEN WORKING AROUND HIGH LEVELS OF ELECTROMAGNETIC RADIATION. EQUIPMENT SHOULD BE SHUTDOWN PRIOR TO PERFORMING ANY WORK THAT COULD EXPOSE THE WORKERS TO DANGER. PERSONAL RF EXPOSURE MONITORS ARE ADVISED TO BE WORN TO ALERT OF ANY DANGEROUS EXPOSURE LEVELS.
20. APPLICABLE BUILDING CODES:
 SUBCONTRACTOR'S WORK SHALL COMPLY WITH ALL APPLICABLE NATIONAL, STATE, AND LOCAL CODES AS ADOPTED BY THE LOCAL AUTHORITY HAVING JURISDICTION (AHJ) FOR THE LOCATION. THE EDITION OF THE AHJ ADOPTED CODES AND STANDARDS IN EFFECT ON THE DATE OF CONTRACT AWARD SHALL GOVERN THE DESIGN.

BUILDING CODE: IBC 2015 WITH 2018 CT STATE BUILDING CODE AMENDMENTS
 ELECTRICAL CODE: 2017 NATIONAL ELECTRICAL CODE (NFPA 70-2017)

SUBCONTRACTOR'S WORK SHALL COMPLY WITH THE LATEST EDITION OF THE FOLLOWING STANDARDS:

AMERICAN CONCRETE INSTITUTE (ACI) 318; BUILDING CODE REQUIREMENTS FOR STRUCTURAL CONCRETE;

AMERICAN INSTITUTE OF STEEL CONSTRUCTION (AISC) MANUAL OF STEEL CONSTRUCTION, ASD, FOURTEENTH EDITION;

TELECOMMUNICATIONS INDUSTRY ASSOCIATION (TIA) 222-G, STRUCTURAL STANDARDS FOR STEEL

FOR ANY CONFLICTS BETWEEN SECTIONS OF LISTED CODES AND STANDARDS REGARDING MATERIAL, METHODS OF CONSTRUCTION, OR OTHER REQUIREMENTS, THE MOST RESTRICTIVE REQUIREMENT SHALL GOVERN. WHERE THERE IS CONFLICT BETWEEN A GENERAL REQUIREMENT AND A SPECIFIC REQUIREMENT, THE SPECIFIC REQUIREMENT SHALL GOVERN.

ABBREVIATIONS					
AGL	ABOVE GRADE LEVEL	EQ	EQUAL	REQ	REQUIRED
AWG	AMERICAN WIRE GAUGE	GC	GENERAL CONTRACTOR	RF	RADIO FREQUENCY
BBU	BATTERY BACKUP UNIT	GRC	GALVANIZED RIGID CONDUIT	TBD	TO BE DETERMINED
BTCW	BARE TINNED SOLID COPPER WIRE	MGB	MASTER GROUND BAR	TBR	TO BE REMOVED
BGR	BURIED GROUND RING	MIN	MINIMUM	TBRR	TO BE REMOVED AND REPLACED
BTS	BASE TRANSCEIVER STATION	P	PROPOSED	TYP	TYPICAL
E	EXISTING	NTS	NOT TO SCALE	UG	UNDER GROUND
EGB	EQUIPMENT GROUND BAR	RAD	RADIATION CENTER LINE (ANTENNA)	VIF	VERIFY IN FIELD
EGR	EQUIPMENT GROUND RING	REF	REFERENCE		

45 BEECHWOOD DRIVE
NORTH ANDOVER, MA 01845
TEL: (978) 557-5553
FAX: (978) 336-5586

750 WEST CENTER STREET., SUITE #301
WEST BRIDGEWATER, MA 02379

SITE NUMBER: CT5730
 SITE NAME: COLCHESTER SOUTH
 ATC SITE #: 302465
 335 NEW LONDON ROAD
 COLCHESTER, CT 06415
 NEW LONDON COUNTY

550 COCHITUATE ROAD
FRAMINGHAM, MA 01701

NO.	DATE	REVISIONS	BY	CHK	APP'D
1	04/12/19	ISSUED FOR CONSTRUCTION	SG	AT	DJC
A	03/26/19	ISSUED FOR REVIEW	ET	AT	DJC

SCALE: AS SHOWN DESIGNED BY: AT DRAWN BY: ET

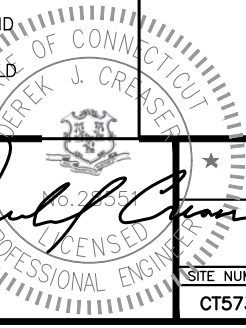

AT&T
 GENERAL NOTES
 (LTE 2C/3C/4C/5C/4TX4RX)
 SITE NUMBER: CT5730 DRAWING NUMBER: GN-1 REV: 1

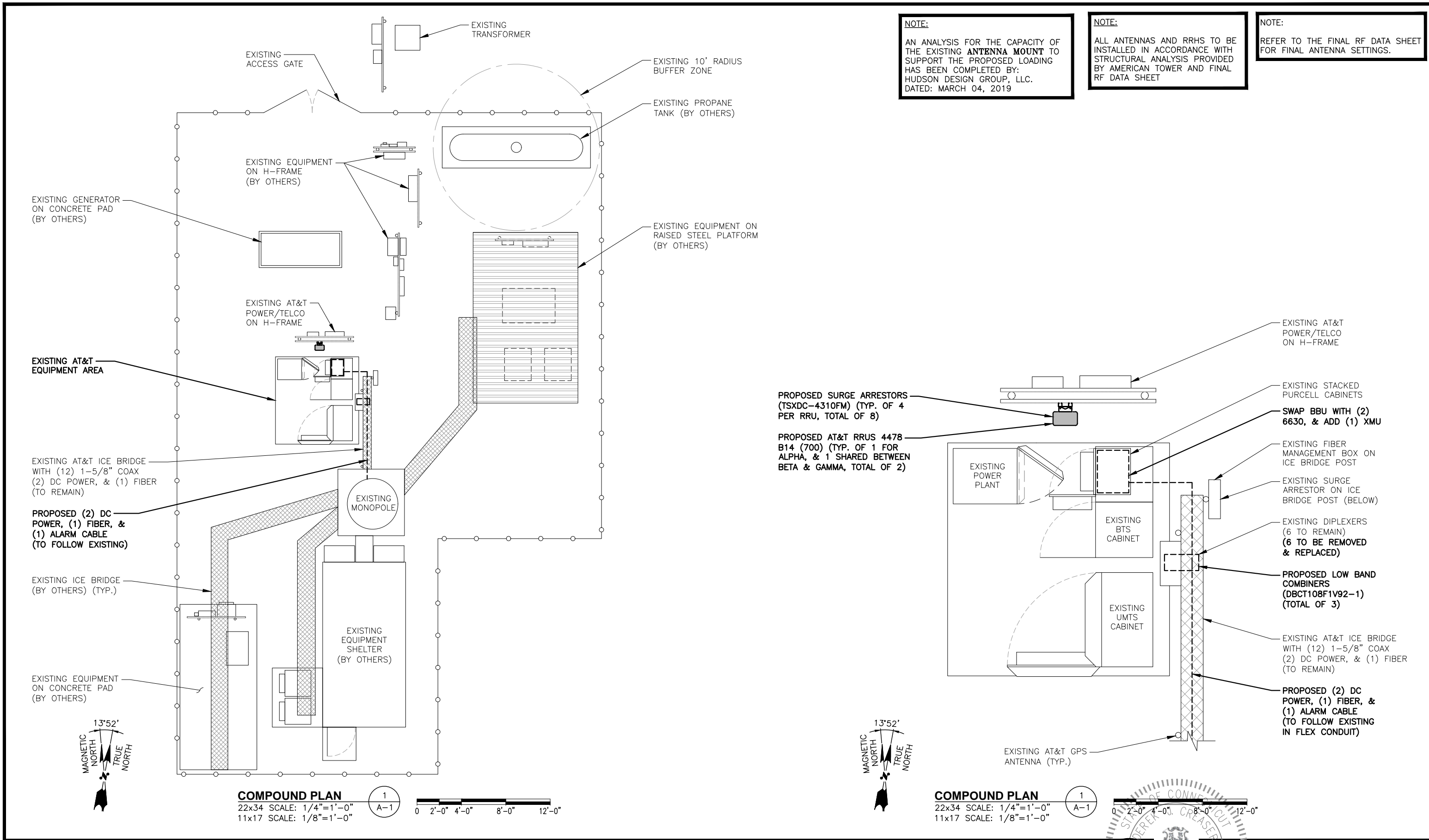

HGD HUDSON Design Group LLC
45 BEECHWOOD DRIVE
NORTH ANDOVER, MA 01845
TEL: (978) 557-5553
FAX: (978) 336-5586

CENTERLINE COMMUNICATIONS
750 WEST CENTER STREET., SUITE #301
WEST BRIDGEWATER, MA 02379

SITE NUMBER: CT5730
SITE NAME: COLCHESTER SOUTH
ATC SITE #: 302465
335 NEW LONDON ROAD
COLCHESTER, CT 06415
NEW LONDON COUNTY

at&t
550 COCHITUATE ROAD
FRAMINGHAM, MA 01701

NO.	DATE	REVISIONS	BY	CHK	APP'D
1	04/12/19	ISSUED FOR CONSTRUCTION	SG	AT	DJC
A	03/26/19	ISSUED FOR REVIEW	ET	AT	DJC

SCALE: AS SHOWN DESIGNED BY: AT DRAWN BY: ET

AT&T
COMPOUND & EQUIPMENT PLANS
(LTE 2C/3C/4C/5C/4TX4RX)

SITE NUMBER	DRAWING NUMBER	REV
CT5730	A-1	1

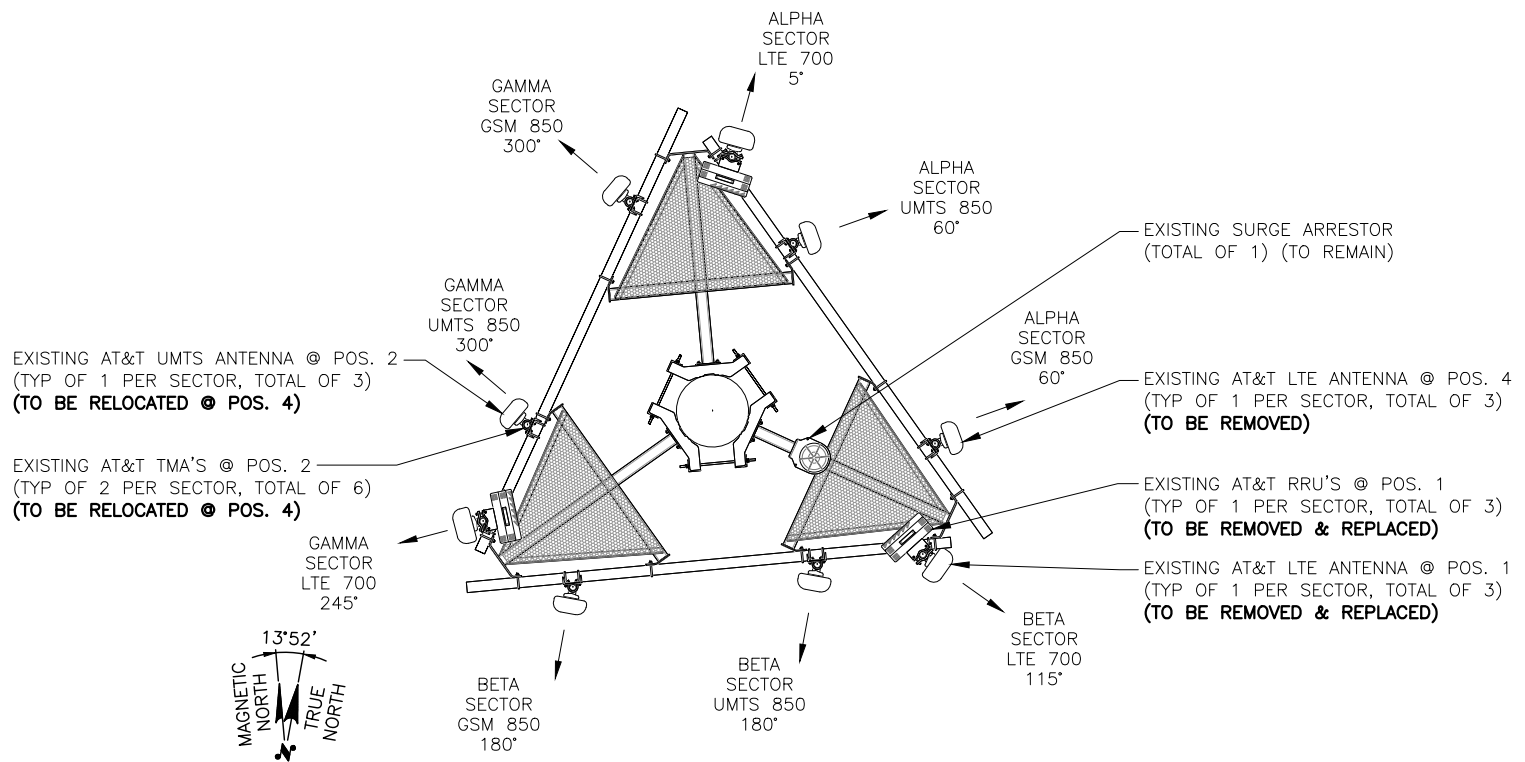

EXISTING ANTENNA LAYOUT
SCALE: N.T.S.

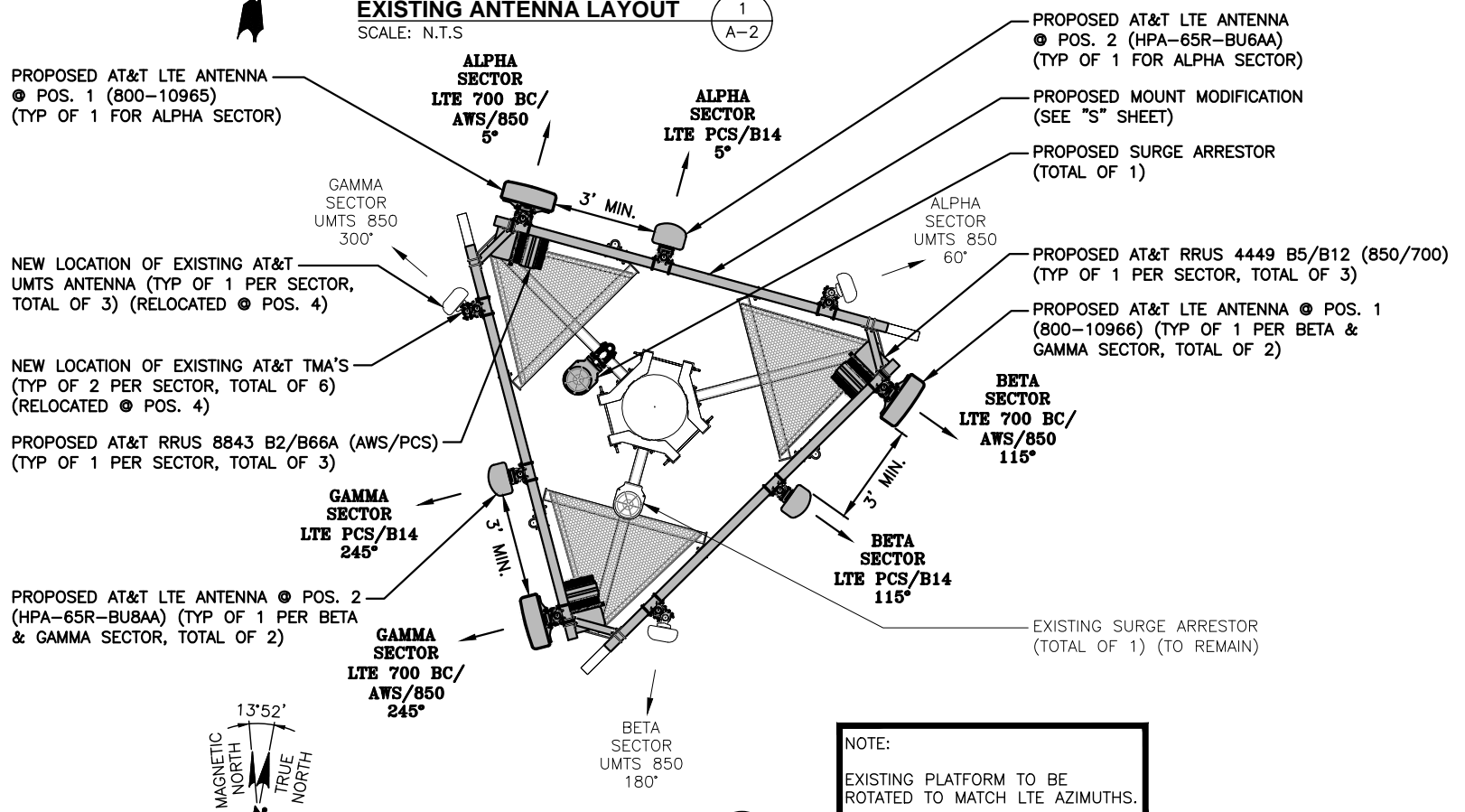

PROPOSED ANTENNA LAYOUT
SCALE: N.T.S.

NOTE:
REFER TO THE FINAL RF DATA SHEET FOR FINAL ANTENNA SETTINGS.

NOTE:
ALL ANTENNAS AND RRHS TO BE INSTALLED IN ACCORDANCE WITH STRUCTURAL ANALYSIS PROVIDED BY AMERICAN TOWER AND FINAL RF DATA SHEET

NOTE:
AN ANALYSIS FOR THE CAPACITY OF THE EXISTING ANTENNA MOUNT TO SUPPORT THE PROPOSED LOADING HAS BEEN COMPLETED BY: HUDSON DESIGN GROUP, LLC. DATED: MARCH 04, 2019

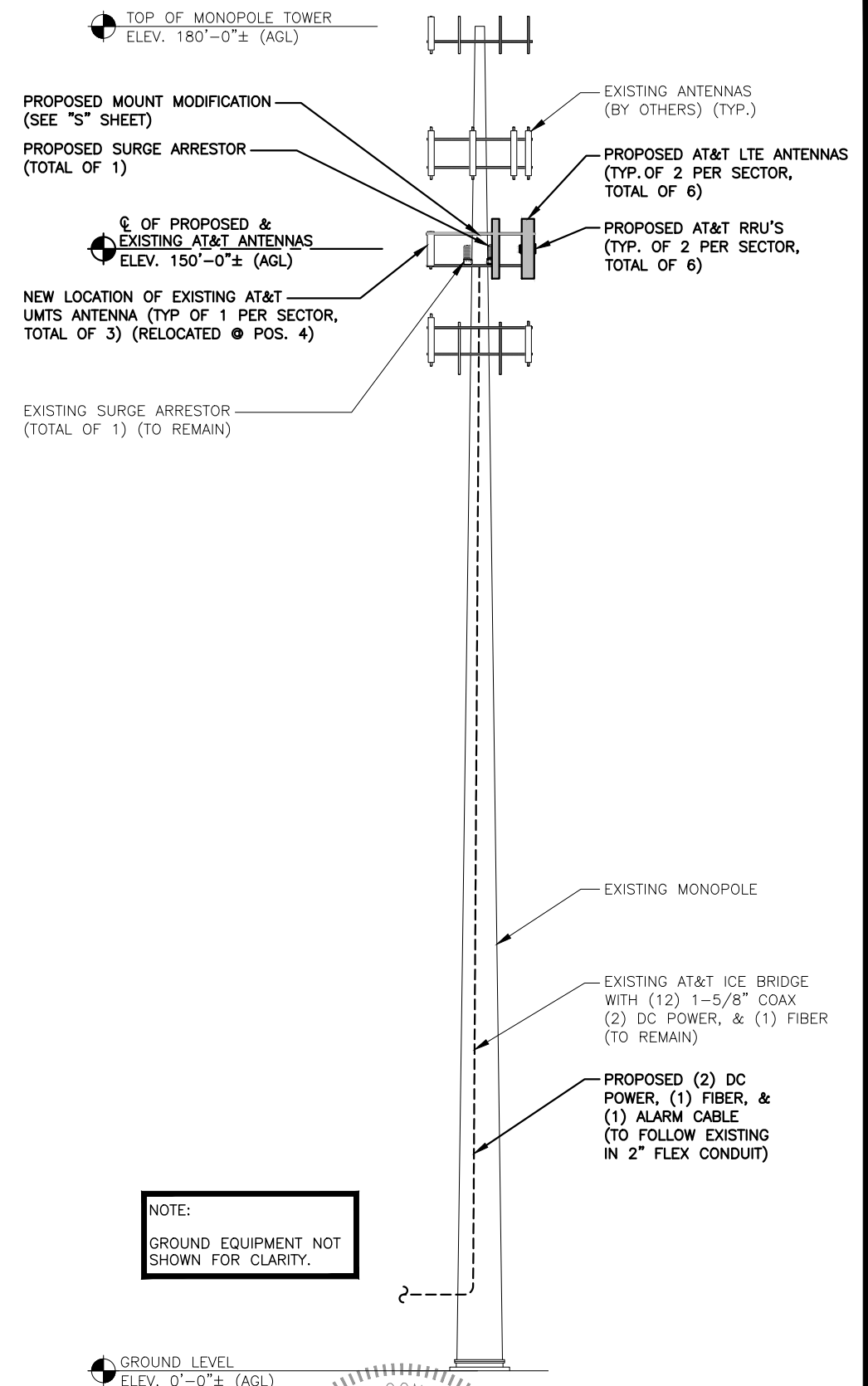

NOTE:
GROUND EQUIPMENT NOT SHOWN FOR CLARITY.

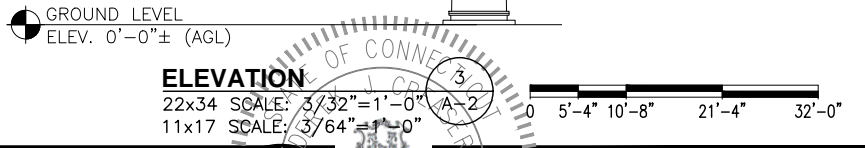

HGD HUDSON Design Group LLC
45 BEECHWOOD DRIVE
NORTH ANDOVER, MA 01845
TEL: (978) 557-5553
FAX: (978) 336-5586

CENTERLINE COMMUNICATIONS
750 WEST CENTER STREET., SUITE #301
WEST BRIDGEWATER, MA 02379

SITE NUMBER: CT5730
SITE NAME: COLCHESTER SOUTH
ATC SITE #: 302465
335 NEW LONDON ROAD
COLCHESTER, CT 06415
NEW LONDON COUNTY

at&t
550 COCHITUATE ROAD
FRAMINGHAM, MA 01701

1	04/12/19	ISSUED FOR CONSTRUCTION	SG	AT	DJC
A	03/26/19	ISSUED FOR REVIEW	ET	AT	DJC
NO.	DATE	REVISIONS	BY	CHK	APP'D
SCALE: AS SHOWN		DESIGNED BY: AT	DRAWN BY: ET		

AT&T
ANTENNA LAYOUTS & ELEVATION
(LTE 2C/3C/4C/5C/4TX4RX)
SITE NUMBER: CT5730
DRAWING NUMBER: A-2
REV: 1

NOTE:
REFER TO THE FINAL RF DATA SHEET FOR FINAL ANTENNA SETTINGS.

NOTE:
ALL ANTENNAS AND RRHS TO BE INSTALLED IN ACCORDANCE WITH STRUCTURAL ANALYSIS PROVIDED BY AMERICAN TOWER AND FINAL RF DATA SHEET

NOTE:
AN ANALYSIS FOR THE CAPACITY OF THE EXISTING **ANTENNA MOUNT** TO SUPPORT THE PROPOSED LOADING HAS BEEN COMPLETED BY: HUDSON DESIGN GROUP, LLC. DATED: MARCH 04, 2019

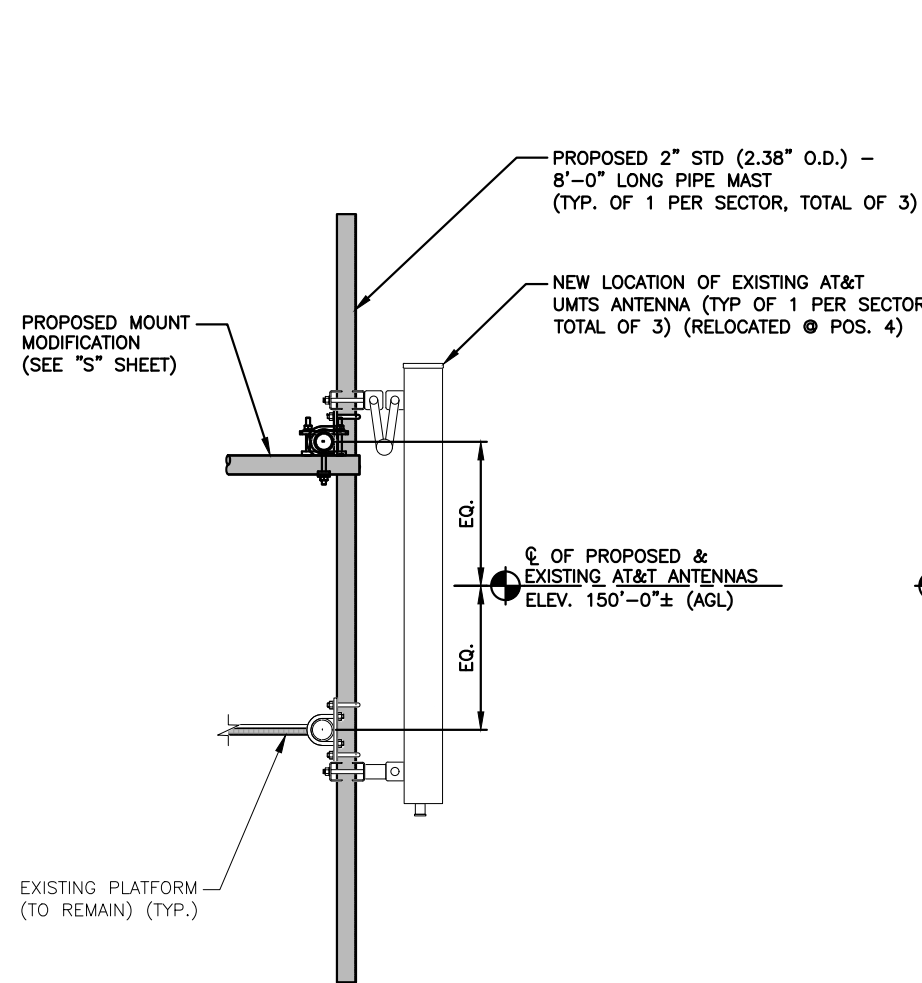

EXISTING UMTS ANTENNA MOUNTING DETAIL
22x34 SCALE: 1"=1'-0"
11x17 SCALE: 1/2"=1'-0"

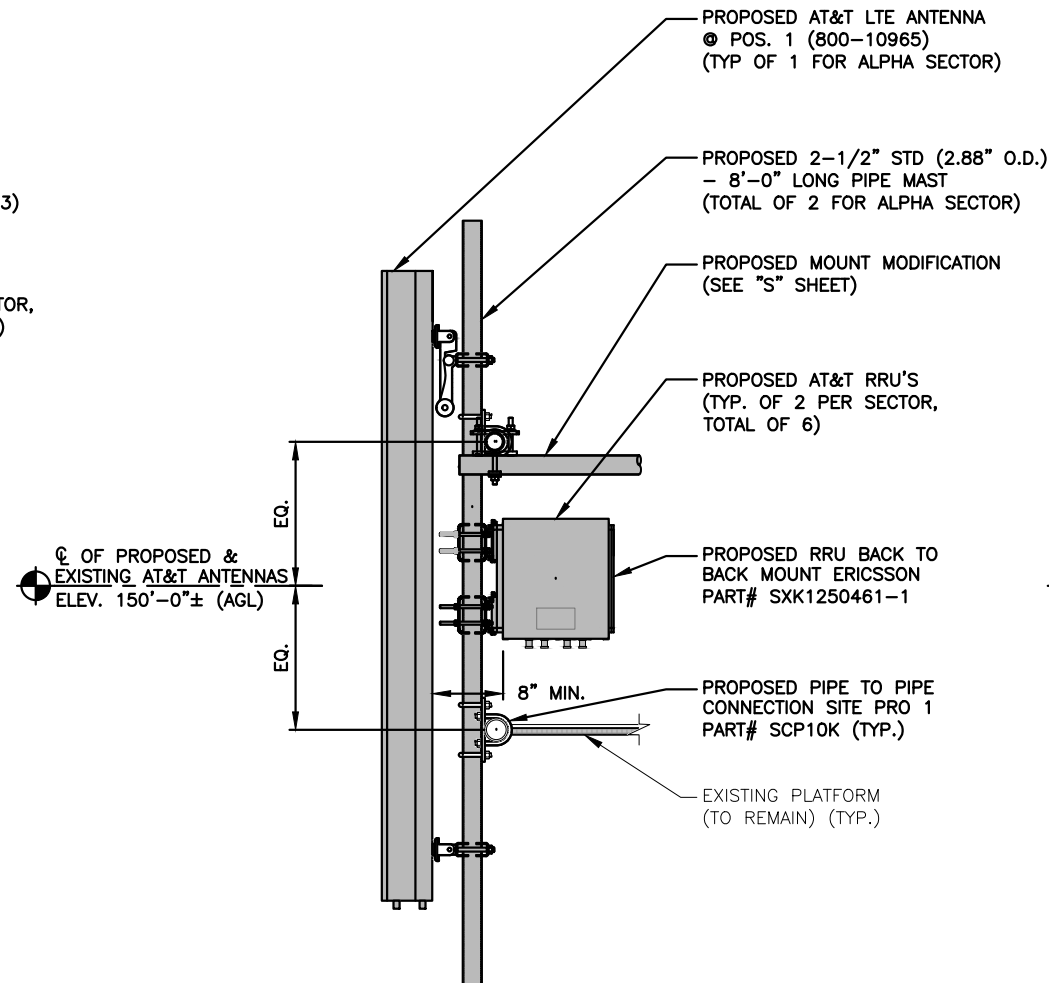
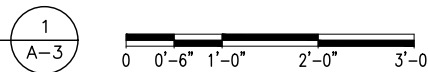

PROPOSED LTE ANTENNA & RRH MOUNTING DETAIL (ALPHA SECTOR)
22x34 SCALE: 1"=1'-0"
11x17 SCALE: 1/2"=1'-0"

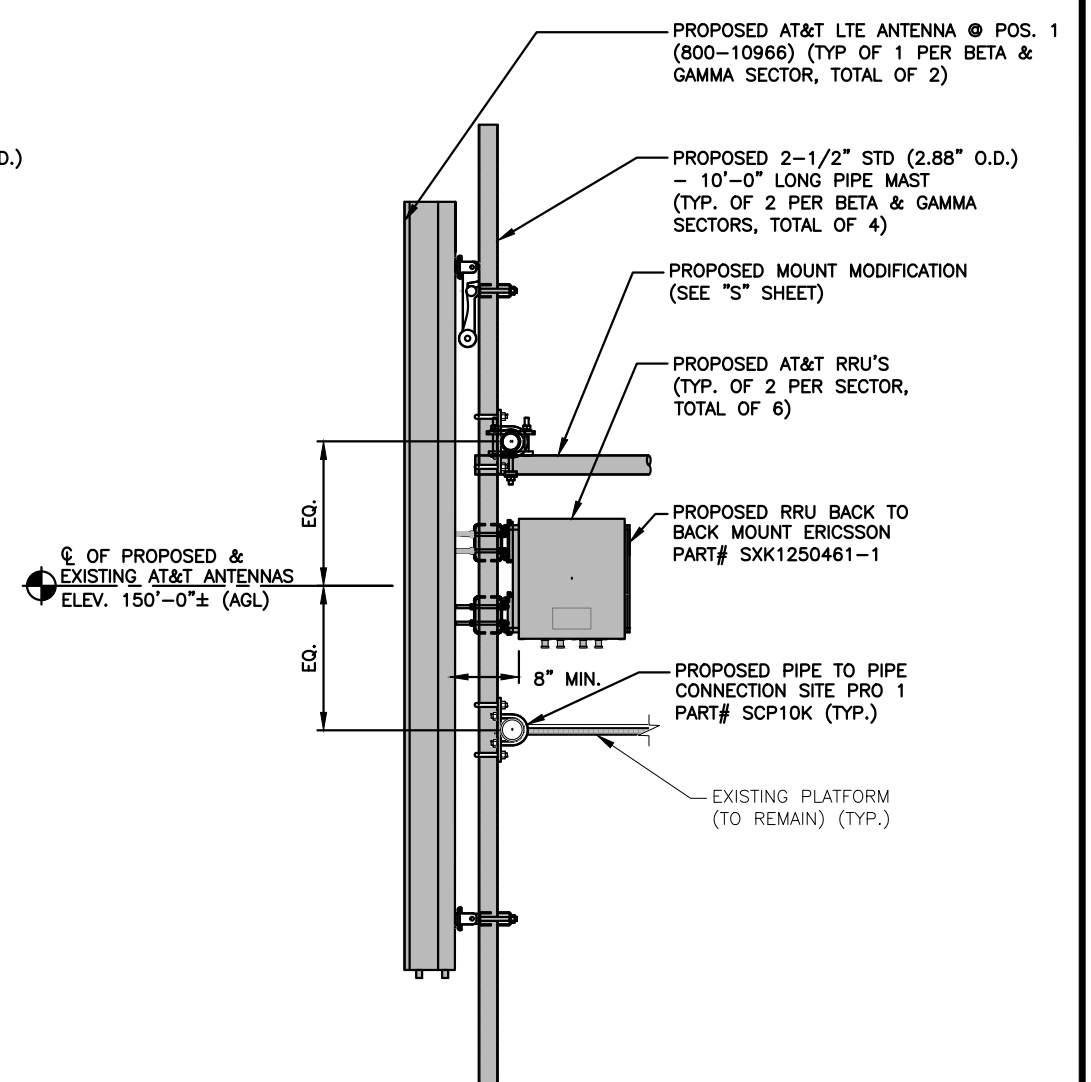
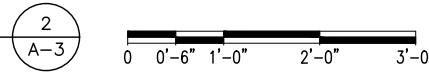

PROPOSED LTE ANTENNA & RRH MOUNTING DETAIL (BETA & GAMMA SECTORS)
22x34 SCALE: 1"=1'-0"
11x17 SCALE: 1/2"=1'-0"



NO.	DATE	REVISIONS	BY	CHK	APP'D
1	04/12/19	ISSUED FOR CONSTRUCTION	SG	AT	DJC
A	03/26/19	ISSUED FOR REVIEW	ET	AT	DJC

SCALE: AS SHOWN DESIGNED BY: AT DRAWN BY: ET

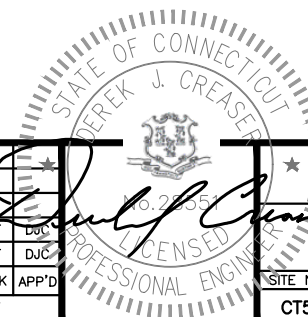

NOTE:
REFER TO THE FINAL RF DATA SHEET FOR FINAL ANTENNA SETTINGS.

NOTE:
ALL ANTENNAS AND RRHS TO BE INSTALLED IN ACCORDANCE WITH STRUCTURAL ANALYSIS PROVIDED BY AMERICAN TOWER AND FINAL RF DATA SHEET

ANTENNA SCHEDULE											
SECTOR	EXISTING/PROPOSED	BAND	ANTENNA	SIZE (INCHES) (L x W x D)	ANTENNA ϕ HEIGHT	AZIMUTH	TMA/DIPLEXER	RRU	SIZE (INCHES) (L x W x D)	FEEDER	RAYCAP
A1	PROPOSED	LTE 700 BC /AWS/850	800-10965	78.7X20X6.9	$\pm 150'$	5°	-	(1)(P) 4449 B5/B12 (700BC/850)	17.9X13.2X9.4	-	(E) RAYCAP DC6-48-60-18-8C
A2	PROPOSED	LTE PCS/B14	HPA-65R-BU6AA	71.2X11.7X8.4	$\pm 150'$	5°	(1)(P)(G) KAEIUS DBCT106F1V92-1	(1)(P)(G) 4478 B14 (700) (1)(P) 8843 B2/B66A (AWS/PCS)	18.1X13.4X8.3 14.9X13.2X10.9	(2) 1-5/8 COAX (LENGTH 210' \pm)	
A3	-	-	-	-	-	-	-	-	-	-	
A4	EXISTING	UMTS 850	7770	55X11X5	$\pm 150'$	60°	(2)(E)(G) POWERWAVE LGP21901 (2)(E) POWERWAVE LGP21401	-	-	(2) 1-5/8 COAX (TO BE CAPPED)	(P)(1) RAYCAP DC6-48-60-18-8C
B1	PROPOSED	LTE 700 BC /AWS/850	800-10966	96X20X6.9	$\pm 150'$	115°	-	(1)(P) 4449 B5/B12 (700BC/850)	17.9X13.2X9.4	-	
B2	PROPOSED	LTE PCS/B14	HPA-65R-BU8AA	96X11.7X7.6	$\pm 150'$	115°	(1)(P)(G) KAEIUS DBCT106F1V92-1	(1)(P)(G) 4478 B14 (700) (1)(P) 8843 B2/B66A (AWS/PCS)	18.1X13.4X8.3 14.9X13.2X10.9	(2) 1-5/8 COAX (LENGTH 210' \pm)	
B3	-	-	-	-	-	-	-	-	-	-	
B4	EXISTING	UMTS 850	7770	55X11X5	$\pm 150'$	180°	(2)(E)(G) POWERWAVE LGP21901 (2)(E) POWERWAVE LGP21401	-	-	(2) 1-5/8 COAX (TO BE CAPPED)	
C1	PROPOSED	LTE 700 BC /AWS/850	800-10966	96X20X6.9	$\pm 150'$	245°	-	(1)(P) 4449 B5/B12 (700BC/850)	17.9X13.2X9.4	-	SHARED
C2	PROPOSED	LTE PCS/B14	HPA-65R-BU8AA	96X11.7X7.6	$\pm 150'$	245°	(1)(P)(G) KAEIUS DBCT106F1V92-1	4478 B14 (SHARED) (1)(P) 8843 B2/B66A (AWS/PCS)	- 14.9X13.2X10.9	(2) 1-5/8 COAX (LENGTH 210' \pm)	
C3	-	-	-	-	-	-	-	-	-	-	
C4	EXISTING	UMTS 850	7770	55X11X5	$\pm 150'$	300°	(2)(E)(G) POWERWAVE LGP21901 (2)(E) POWERWAVE LGP21401	-	-	(2) 1-5/8 COAX (TO BE CAPPED)	

FINAL ANTENNA SCHEDULE 1
SCALE: N.T.S. A-4

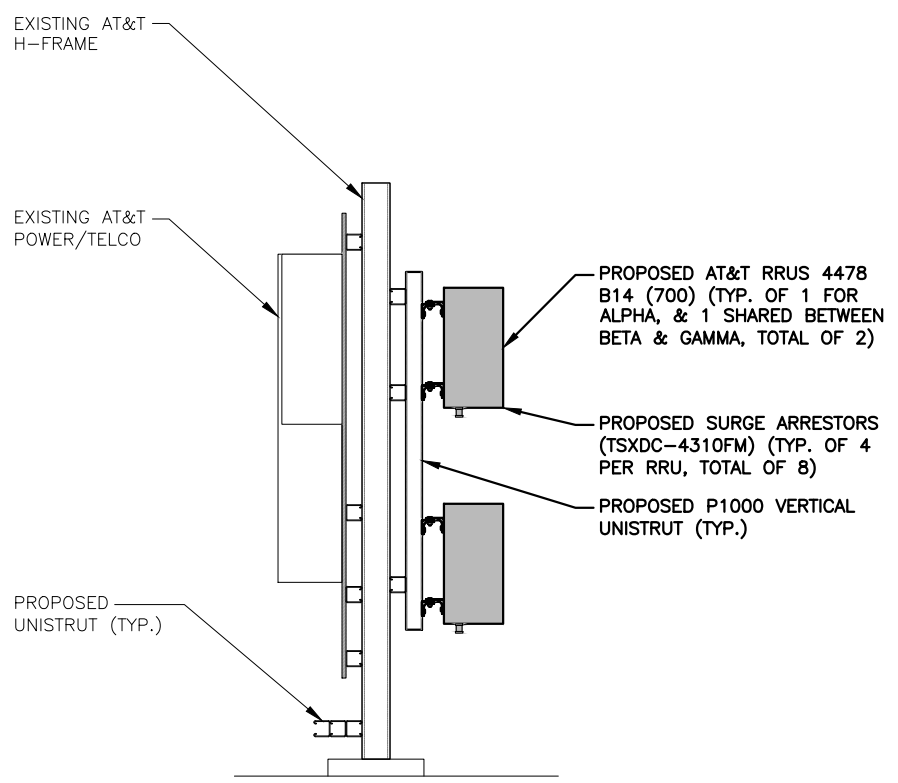

PROPOSED RRH MOUNTING DETAIL 2
22x34 SCALE: 1"=1'-0"
11x17 SCALE: 1/2"=1'-0" A-4

RRU CHART				
QUANTITY	MODEL	L	W	D
2(P)(G)	4478 B14	18.1"	13.4"	8.3"
3(P)	4449	17.9"	13.2"	9.4"
3(P)	8843	14.9"	13.2"	10.9"

NOTE:
MOUNT PER MANUFACTURER'S SPECIFICATIONS

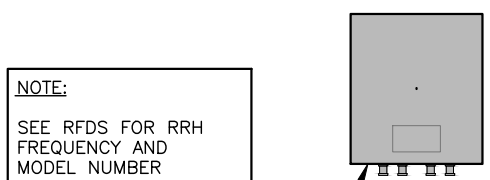

PROPOSED RRU REFER TO THE FINAL RFDS AND CHART FOR QUANTITY, MODEL AND DIMENSIONS

NOTE:
MOUNT PER MANUFACTURER'S SPECIFICATIONS.

PROPOSED RRUS DETAIL 3
SCALE: N.T.S. A-4

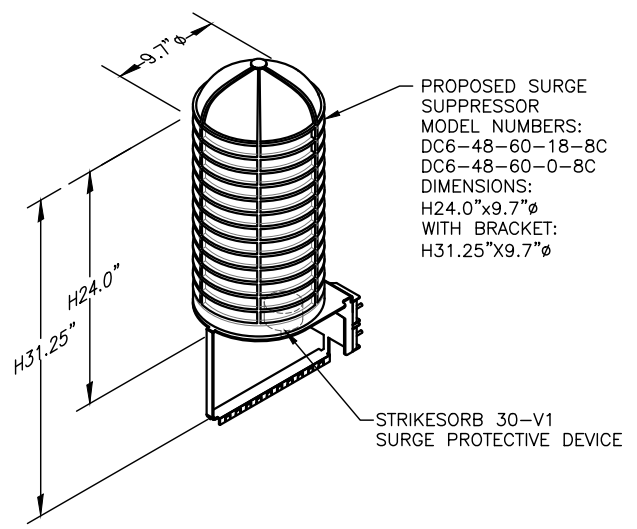

NOTE:
MOUNT PER MANUFACTURER'S SPECIFICATIONS.

DC SURGE SUPPRESSOR DETAIL 4
SCALE: N.T.S. A-4

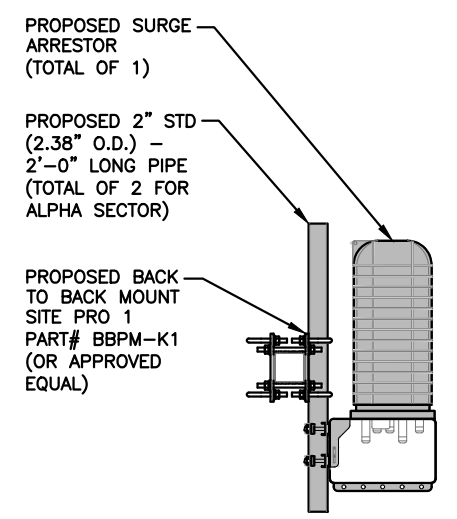

PROPOSED SURGE ARRESTOR MOUNTING DETAIL 5
SCALE: N.T.S. A-4

STRUCTURAL NOTES:

- DESIGN REQUIREMENTS ARE PER STATE BUILDING CODE AND APPLICABLE SUPPLEMENTS, INTERNATIONAL BUILDING CODE, EIA/TIA-222-G STRUCTURAL STANDARDS FOR STEEL ANTENNA, TOWERS AND ANTENNA SUPPORTING STRUCTURES.
- CONTRACTOR SHALL VERIFY ALL DIMENSIONS AND CONDITIONS IN THE FIELD PRIOR TO FABRICATION AND ERECTION OF ANY MATERIAL. ANY UNUSUAL CONDITIONS SHALL BE REPORTED TO THE ATTENTION OF THE CONSTRUCTION MANAGER AND ENGINEER OF RECORD.
- DESIGN AND CONSTRUCTION OF STRUCTURAL STEEL SHALL CONFORM TO THE AMERICAN INSTITUTE OF STEEL CONSTRUCTION "SPECIFICATION FOR THE DESIGN, FABRICATION AND ERECTION OF STRUCTURAL STEEL FOR BUILDINGS".
- STRUCTURAL STEEL SHALL CONFORM TO ASTM A992 (Fy=50 ksi), MISCELLANEOUS STEEL SHALL CONFORM TO ASTM A36 UNLESS OTHERWISE INDICATED.
- STEEL PIPE SHALL CONFORM TO ASTM A500 "COLD-FORMED WELDED & SEAMLESS CARBON STEEL STRUCTURAL TUBING", GRADE B, OR ASTM A53 PIPE STEEL BLACK AND HOT-DIPPED ZINC-COATED WELDED AND SEAMLESS TYPE E OR S, GRADE B. PIPE SIZES INDICATED ARE NOMINAL. ACTUAL OUTSIDE DIAMETER IS LARGER.
- STRUCTURAL CONNECTION BOLTS SHALL BE HIGH STRENGTH BOLTS (BEARING TYPE) AND CONFORM TO ASTM A325 TYPE-X "HIGH STRENGTH BOLTS FOR STRUCTURAL JOINTS, INCLUDING SUITABLE NUTS AND PLAIN HARDENED WASHERS". ALL BOLTS SHALL BE 3/4" DIA UON.
- ALL STEEL MATERIALS SHALL BE GALVANIZED AFTER FABRICATION IN ACCORDANCE WITH ASTM A123 "ZINC (HOT-DIP GALVANIZED) COATINGS ON IRON AND STEEL PRODUCTS", UNLESS OTHERWISE NOTED.
- ALL BOLTS, ANCHORS AND MISCELLANEOUS HARDWARE SHALL BE GALVANIZED IN ACCORDANCE WITH ASTM A153 "ZINC-COATING (HOT-DIP) ON IRON AND STEEL HARDWARE", UNLESS OTHERWISE NOTED.
- FIELD WELDS, DRILL HOLES, SAW CUTS AND ALL DAMAGED GALVANIZED SURFACES SHALL BE REPAIRED WITH AN ORGANIC ZINC REPAIR PAINT COMPLYING WITH REQUIREMENTS OF ASTM A780. GALVANIZING REPAIR PAINT SHALL HAVE 65 PERCENT ZINC BY WEIGHT, ZIRP BY DUNCAN GALVANIZING, GALVA BRIGHT PREMIUM BY CROWN OR EQUAL. THICKNESS OF APPLIED GALVANIZING REPAIR PAINT SHALL BE NOT LESS THAN 4 COATS (ALLOW TIME TO DRY BETWEEN COATS) WITH A RESULTING COATING THICKNESS REQUIRED BY ASTM A123 OR A153 AS APPLICABLE.
- CONTRACTOR SHALL COMPLY WITH AWS CODE FOR PROCEDURES, APPEARANCE AND QUALITY OF WELDS, AND FOR METHODS USED IN CORRECTING WELDING. ALL WELDERS AND WELDING PROCESSES SHALL BE QUALIFIED IN ACCORDANCE WITH AWS "STANDARD QUALIFICATION PROCEDURES". ALL WELDING SHALL BE DONE USING E70XX ELECTRODES AND WELDING SHALL CONFORM TO AISC AND D.I. WHERE FILLET WELD SIZES ARE NOT SHOWN, PROVIDE THE MINIMUM SIZE PER TABLE J2.4 IN THE AISC "STEEL CONSTRUCTION MANUAL". 14TH EDITION.
- INCORRECTLY FABRICATED, DAMAGED OR OTHERWISE MISFITTING OR NON-CONFORMING MATERIALS OR CONDITIONS SHALL BE REPORTED TO THE CONSTRUCTION MANAGER PRIOR TO REMEDIAL OR CORRECTIVE ACTION. ANY SUCH ACTION SHALL REQUIRE CONSTRUCTION MANAGER APPROVAL.
- UNISTRUT SHALL BE FORMED STEEL CHANNEL STRUT FRAMING AS MANUFACTURED BY UNISTRUT CORP., WAYNE, MI OR EQUAL. STRUT MEMBERS SHALL BE 1 5/8"x1 5/8"x12GA, UNLESS OTHERWISE NOTED, AND SHALL BE HOT-DIP GALVANIZED AFTER FABRICATION.
- EPOXY ANCHOR ASSEMBLY SHALL CONSIST OF STAINLESS STEEL ANCHOR ROD WITH NUTS & WASHERS. AN INTERNALLY THREADED INSERT, A SCREEN TUBE AND A EPOXY ADHESIVE. THE ANCHORING SYSTEM SHALL BE THE HILTI-HIT HY-270 AND OR HY-200 SYSTEMS (AS SPECIFIED IN DWG.) OR ENGINEERS APPROVED EQUAL.
- EXPANSION BOLTS SHALL CONFORM TO FEDERAL SPECIFICATION FF-S-325, GROUP II, TYPE 4, CLASS I, HILTI KWIK BOLT III OR APPROVED EQUAL. INSTALLATION SHALL BE IN ACCORDANCE WITH THE MANUFACTURER'S RECOMMENDATIONS.
- LUMBER SHALL COMPLY WITH THE REQUIREMENTS OF THE AMERICAN INSTITUTE OF TIMBER CONSTRUCTION AND THE NATIONAL FOREST PRODUCTS ASSOCIATION'S NATIONAL DESIGN SPECIFICATION FOR WOOD CONSTRUCTION. ALL LUMBER SHALL BE PRESSURE TREATED AND SHALL BE STRUCTURAL GRADE NO. 2 OR BETTER.
- WHERE ROOF PENETRATIONS ARE REQUIRED, THE CONTRACTOR SHALL CONTACT AND COORDINATE RELATED WORK WITH THE BUILDING OWNER AND THE EXISTING ROOF INSTALLER. WORK SHALL BE PERFORMED IN SUCH A MANNER AS TO NOT VOID THE EXISTING ROOF WARRANTY. ROOF SHALL BE WATERTIGHT.
- ALL FIBERGLASS MEMBERS USED ARE AS MANUFACTURED BY STRONGWELL COMPANY OF BRISTOL, VA 24203. ALL DESIGN CRITERIA FOR THESE MEMBERS IS BASED ON INFORMATION PROVIDED IN THE DESIGN MANUAL. ALL REQUIREMENTS PUBLISHED IN SAID MANUAL MUST BE STRICTLY ADHERED TO.
- NO MATERIALS TO BE ORDERED AND NO WORK TO BE COMPLETED UNTIL SHOP DRAWINGS HAVE BEEN REVIEWED AND APPROVED IN WRITING.
- SUBCONTRACTOR SHALL FIREPROOF ALL STEEL TO PRE-EXISTING CONDITIONS.

SPECIAL INSPECTIONS (REFERENCE IBC CHAPTER 17):

GENERAL: WHERE APPLICATION IS MADE FOR CONSTRUCTION, THE OWNER OR THE REGISTERED DESIGN PROFESSIONAL IN RESPONSIBLE CHARGE ACTING AS THE OWNER'S AGENT SHALL EMPLOY ONE OR MORE APPROVED AGENCIES TO PERFORM INSPECTIONS DURING CONSTRUCTION ON THE TYPES OF WORK LISTED IN THE INSPECTION CHECKLIST ABOVE.

THE REGISTERED DESIGN PROFESSIONAL IN RESPONSIBLE CHARGE AND ENGINEERS OF RECORD INVOLVED IN THE DESIGN OF THE PROJECT ARE PERMITTED TO ACT AS THE APPROVED AGENCY AND THEIR PERSONNEL ARE PERMITTED TO ACT AS THE SPECIAL INSPECTOR FOR THE WORK DESIGNED BY THEM, PROVIDED THOSE PERSONNEL MEET THE QUALIFICATION REQUIREMENTS.

STATEMENT OF SPECIAL INSPECTIONS: THE APPLICANT SHALL SUBMIT A STATEMENT OF SPECIAL INSPECTIONS PREPARED BY THE REGISTERED DESIGN PROFESSIONAL IN RESPONSIBLE CHARGE IN ACCORDANCE WITH SECTION 107.1 AS A CONDITION FOR ISSUANCE. THIS STATEMENT SHALL BE IN ACCORDANCE WITH SECTION 1705.

REPORT REQUIREMENT: SPECIAL INSPECTORS SHALL KEEP RECORDS OF INSPECTIONS. THE SPECIAL INSPECTOR SHALL FURNISH INSPECTION REPORTS TO THE BUILDING OFFICIAL, AND TO THE REGISTERED DESIGN PROFESSIONAL IN RESPONSIBLE CHARGE. REPORTS SHALL INDICATE THAT WORK INSPECTED WAS OR WAS NOT COMPLETED IN CONFORMANCE TO APPROVED CONSTRUCTION DOCUMENTS. DISCREPANCIES SHALL BE BROUGHT TO THE IMMEDIATE ATTENTION OF THE CONTRACTOR FOR CORRECTION. IF THEY ARE NOT CORRECTED, THE DISCREPANCIES SHALL BE BROUGHT TO THE ATTENTION OF THE BUILDING OFFICIAL AND TO THE REGISTERED DESIGN PROFESSIONAL IN RESPONSIBLE CHARGE. A FINAL REPORT DOCUMENTING REQUIRED SPECIAL INSPECTIONS SHALL BE SUBMITTED.

SPECIAL INSPECTION CHECKLIST	
BEFORE CONSTRUCTION	
CONSTRUCTION/INSTALLATION INSPECTIONS AND TESTING REQUIRED (COMPLETED BY ENGINEER OF RECORD)	REPORT ITEM
N/A	ENGINEER OF RECORD APPROVED SHOP DRAWINGS ¹
N/A	MATERIAL SPECIFICATIONS REPORT ²
N/A	FABRICATOR NDE INSPECTION
N/A	PACKING SLIPS ³
ADDITIONAL TESTING AND INSPECTIONS:	
DURING CONSTRUCTION	
CONSTRUCTION/INSTALLATION INSPECTIONS AND TESTING REQUIRED (COMPLETED BY ENGINEER OF RECORD)	REPORT ITEM
REQUIRED	STEEL INSPECTIONS
N/A	HIGH STRENGTH BOLT INSPECTIONS
N/A	HIGH WIND ZONE INSPECTIONS ⁴
N/A	FOUNDATION INSPECTIONS
N/A	CONCRETE COMP. STRENGTH, SLUMP TESTS AND PLACEMENT
N/A	POST INSTALLED ANCHOR VERIFICATION ⁵
N/A	GROUT VERIFICATION
REQUIRED	CERTIFIED WELD INSPECTION
N/A	EARTHWORK: LIFT AND DENSITY
N/A	ON SITE COLD GALVANIZING VERIFICATION
N/A	GUY WIRE TENSION REPORT
ADDITIONAL TESTING AND INSPECTIONS:	
AFTER CONSTRUCTION	
CONSTRUCTION/INSTALLATION INSPECTIONS AND TESTING REQUIRED (COMPLETED BY ENGINEER OF RECORD)	REPORT ITEM
REQUIRED	MODIFICATION INSPECTOR REDLINE OR RECORD DRAWINGS ⁶
N/A	POST INSTALLED ANCHOR PULL-OUT TESTING
REQUIRED	PHOTOGRAPHS
ADDITIONAL TESTING AND INSPECTIONS:	

NOTES:

- REQUIRED FOR ANY NEW SHOP FABRICATED FRP OR STEEL.
- PROVIDED BY MANUFACTURER, REQUIRED IF HIGH STRENGTH BOLTS OR STEEL.
- PROVIDED BY GENERAL CONTRACTOR; PROOF OF MATERIALS.
- HIGH WIND ZONE INSPECTION CATB 120MPH OR CAT C,D 110MPH INSPECT FRAMING OF WALLS, ANCHORING, FASTENING SCHEDULE.
- ADHESIVE FOR REBAR AND ANCHORS SHALL HAVE BEEN TESTED IN ACCORDANCE WITH ACI 355.4 AND ICC-ES AC308 FOR CRACKED CONCRETE AND SEISMIC APPLICATIONS. DESIGN ADHESIVE BOND STRENGTH HAS BEEN BASED ON ACI 355.4 TEMPERATURE CATEGORY B WITH INSTALLATIONS INTO DRY HOLES DRILLED USING A CARBIDE BIT INTO CRACKED CONCRETE THAT HAS CURED FOR AT LEAST 21 DAYS. ADHESIVE ANCHORS REQUIRING CERTIFIED INSTALLATIONS SHALL BE INSTALLED BY A CERTIFIED ADHESIVE ANCHOR INSTALLER PER ACI 318-11 D.9.2.2. INSTALLATIONS REQUIRING CERTIFIED INSTALLERS SHALL BE INSPECTED PER ACI 318-11 D.8.2.4.
- AS REQUIRED; FOR ANY FIELD CHANGES TO THE ITEMS IN THIS TABLE.

NOTES:

- ALL CONNECTIONS TO BE SHOP WELDED & FIELD BOLTED USING 3/4"Ø A325-X BOLTS, UNLESS OTHERWISE NOTIFIED.
- SHOP DRAWING ENGINEER REVIEW & APPROVAL REQUIRED BEFORE ORDERING MATERIAL.
- SHOP DRAWING ENGINEER REVIEW & APPROVAL REQUIRED PRIOR TO STEEL FABRICATION.
- VERIFICATION OF EXISTING ROOF CONSTRUCTION IS REQUIRED PRIOR TO THE INSTALLATION OF THE ROOF PLATFORM. ENGINEER OF RECORD IS TO APPROVE EXISTING CONDITIONS IN ORDER TO MOVE FORWARD.
- CENTERLINE OF PROPOSED STEEL PLATFORM SUPPORT COLUMNS TO BE CENTRALLY LOCATED OVER THE EXISTING BUILDING COLUMNS.
- EXISTING BRICK MASONRY COLUMNS/BEARING TO BE REPAIRED/REPLACED AT ALL PROPOSED PLATFORM SUPPORT POINTS. ENGINEER OF RECORD TO REVIEW AND APPROVE.

45 BEECHWOOD DRIVE
NORTH ANDOVER, MA 01845
TEL: (978) 557-5553
FAX: (978) 336-5586

750 WEST CENTER STREET., SUITE #301
WEST BRIDGEWATER, MA 02379

SITE NUMBER: CT5730
SITE NAME: COLCHESTER SOUTH
ATC SITE #: 302465
335 NEW LONDON ROAD
COLCHESTER, CT 06415
NEW LONDON COUNTY

550 COCHITUATE ROAD
FRAMINGHAM, MA 01701

NO.	DATE	REVISIONS	BY	CHK	APP'D
1	04/12/19	ISSUED FOR CONSTRUCTION	SG	AT	DJC
A	03/26/19	ISSUED FOR REVIEW	ET	AT	DJC

SCALE: AS SHOWN DESIGNED BY: AT DRAWN BY: ET

AT&T
STRUCTURAL NOTES
(LTE 2C/3C/4C/5C/4TX4RX)
SITE NUMBER: CT5730 DRAWING NUMBER: SN-1 REV: 1

NOTE:
REFER TO THE FINAL RF DATA SHEET FOR FINAL ANTENNA SETTINGS.

NOTE:
ALL ANTENNAS AND RRHS TO BE INSTALLED IN ACCORDANCE WITH STRUCTURAL ANALYSIS PROVIDED BY AMERICAN TOWER AND FINAL RF DATA SHEET

NOTE:
AN ANALYSIS FOR THE CAPACITY OF THE EXISTING ANTENNA MOUNT TO SUPPORT THE PROPOSED LOADING HAS BEEN COMPLETED BY: HUDSON DESIGN GROUP, LLC. DATED: MARCH 04, 2019

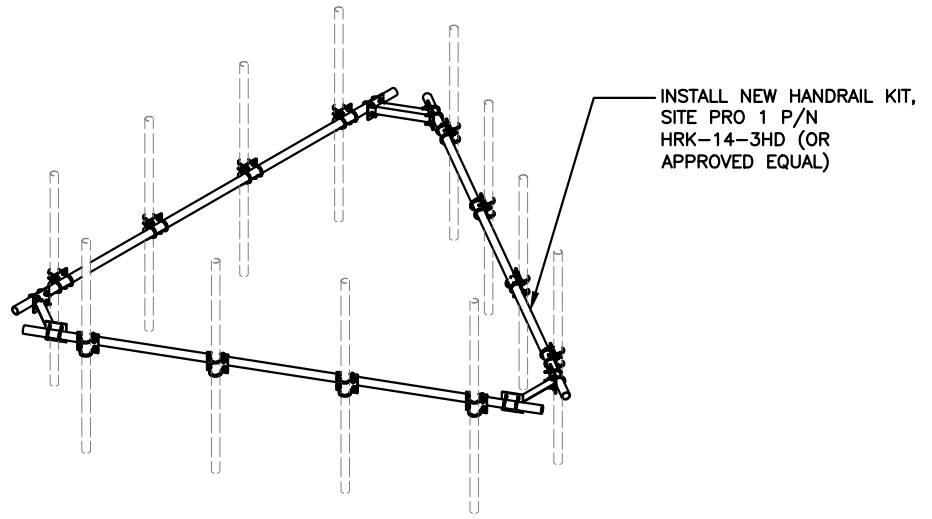

PROPOSED HANDRAIL KIT
SCALE: N.T.S.

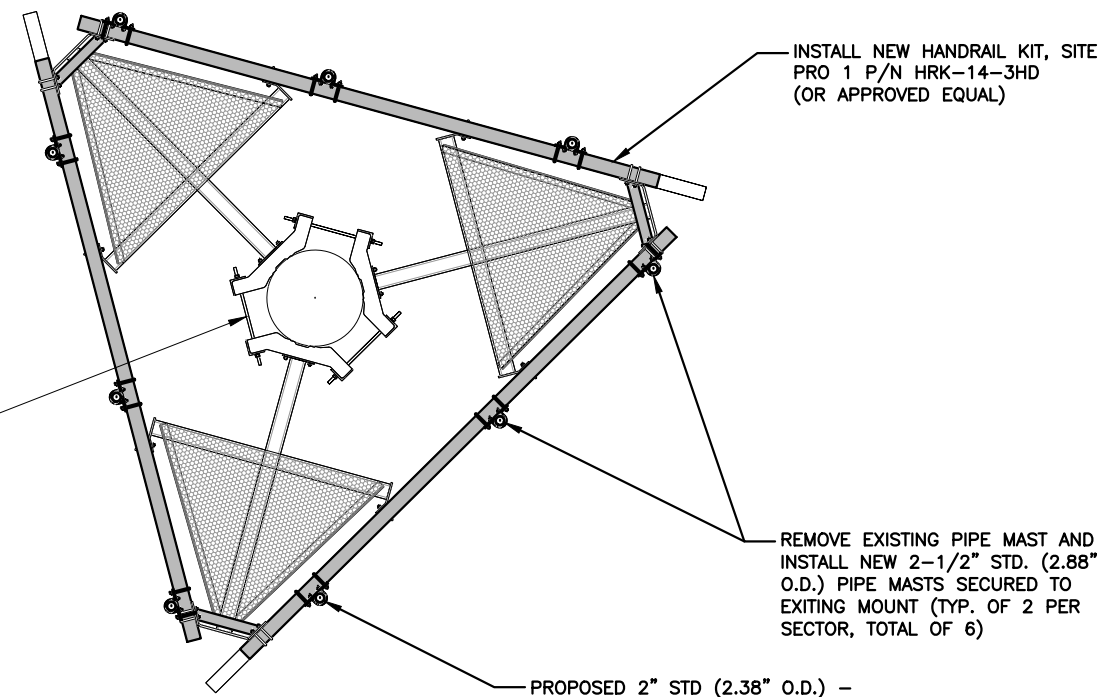

PLATFORM REINFORCEMENT PLAN
22x34 SCALE: 1"=1'-0"
11x17 SCALE: 1/2"=1'-0"

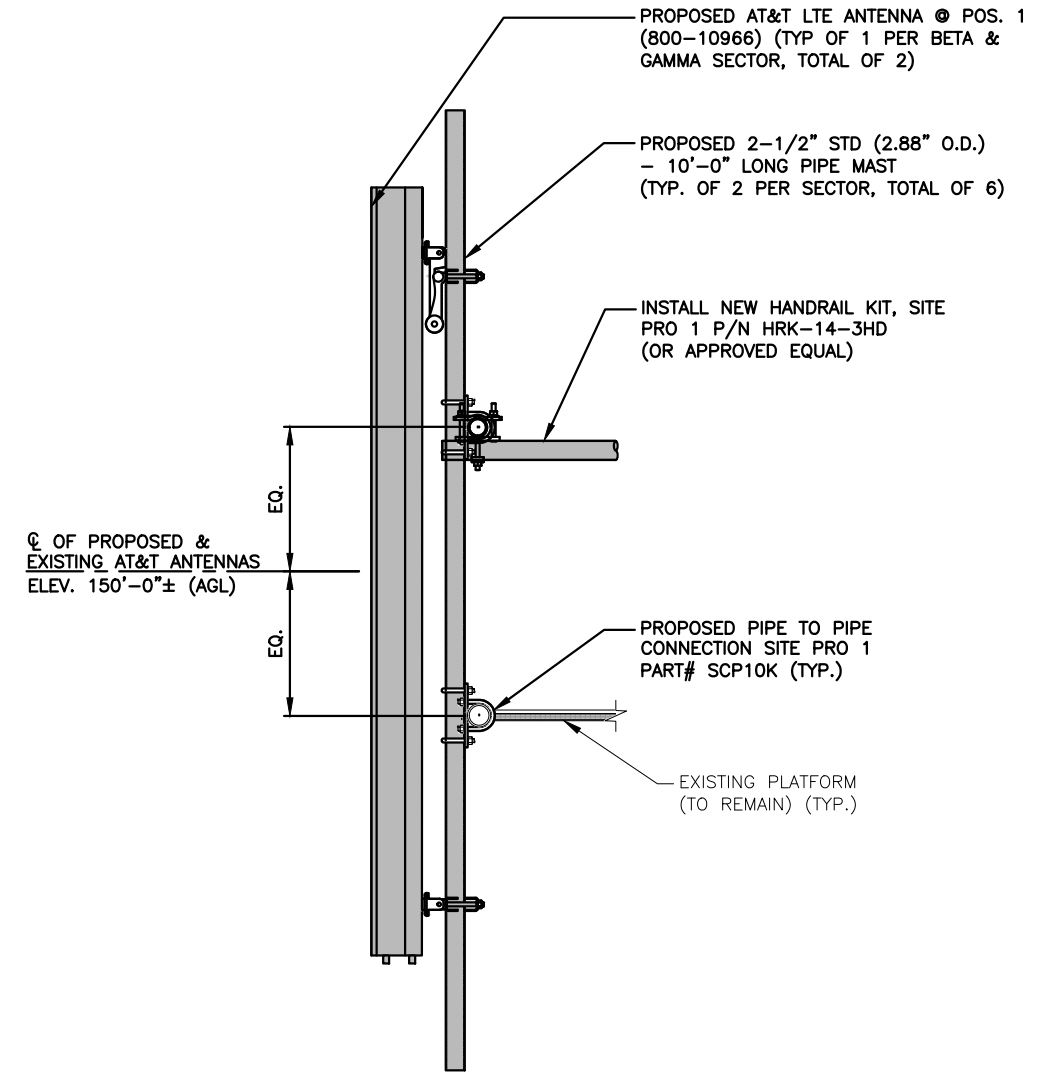
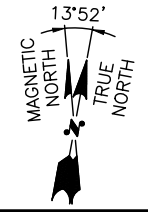

PROPOSED MOUNT MODIFICATION DETAIL
22x34 SCALE: 1"=1'-0"
11x17 SCALE: 1/2"=1'-0"

HG HUDSON Design Group LLC
45 BEECHWOOD DRIVE
NORTH ANDOVER, MA 01845
TEL: (978) 557-5553
FAX: (978) 336-5586

CENTERLINE COMMUNICATIONS
750 WEST CENTER STREET., SUITE #301
WEST BRIDGEWATER, MA 02379

SITE NUMBER: CT5730
SITE NAME: COLCHESTER SOUTH
ATC SITE #: 302465
335 NEW LONDON ROAD
COLCHESTER, CT 06415
NEW LONDON COUNTY

at&t
550 COCHITUATE ROAD
FRAMINGHAM, MA 01701

				AT&T			
				STRUCTURAL DETAILS (LTE 2C/3C/4C/5C/4TX4RX)			
NO.	DATE	REVISIONS	BY	CHK	APP'D	SITE NUMBER	DRAWING NUMBER
1	04/12/19	ISSUED FOR CONSTRUCTION	SG	AT	DJC	CT5730	S-1
A	03/26/19	ISSUED FOR REVIEW	ET	AT	DJC		
SCALE: AS SHOWN		DESIGNED BY: AT		DRAWN BY: ET			1

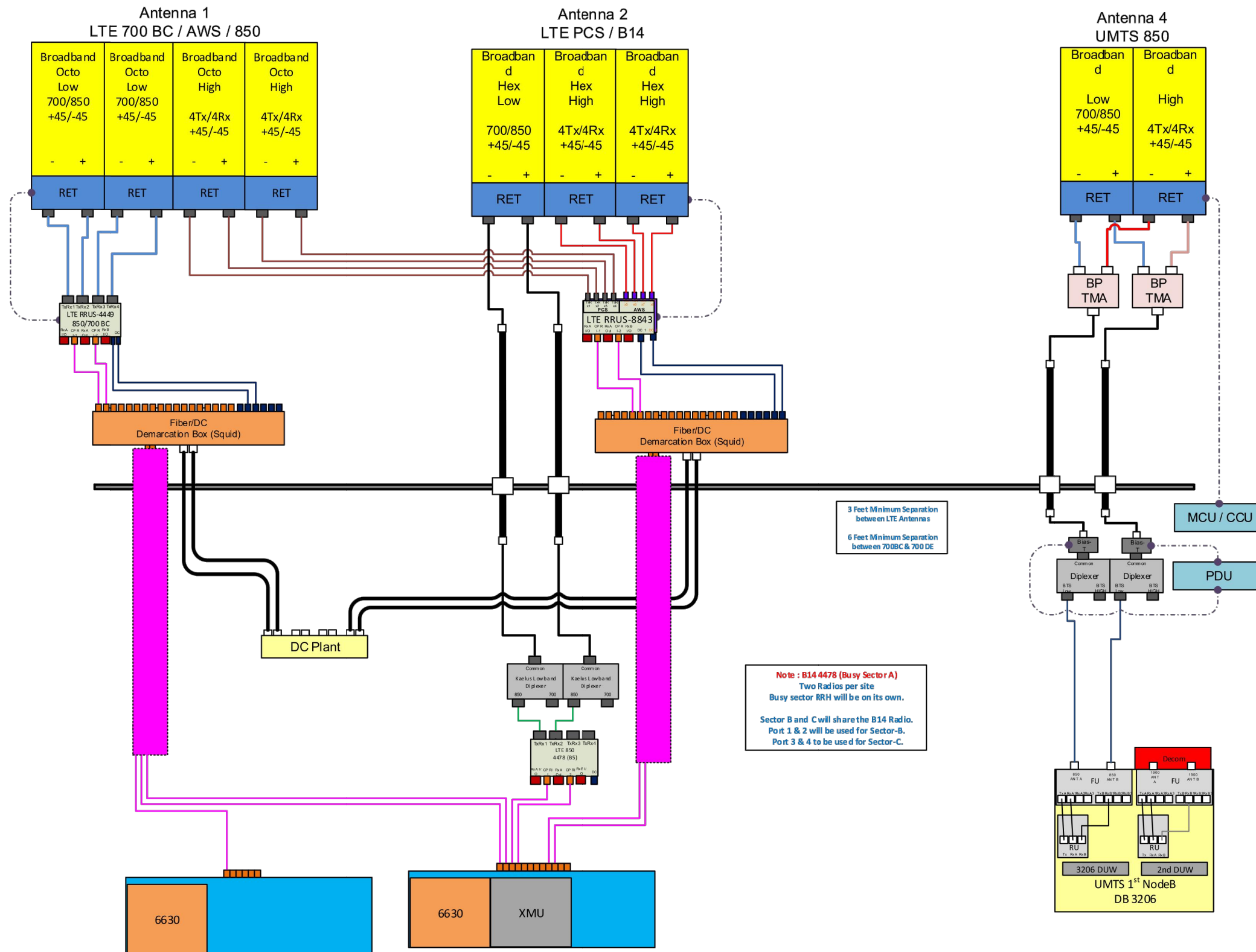

NOTE:
1. CONTRACTOR TO CONFIRM ALL PARTS.
2. INSTALL ALL EQUIPMENT TO MANUFACTURER'S RECOMMENDATIONS

NOTE:
REFER TO THE FINAL RF DATA SHEET FOR FINAL ANTENNA SETTINGS.

RF PLUMBING DIAGRAM 1
SCALE: N.T.S. RF-1

<p>45 BEECHWOOD DRIVE NORTH ANDOVER, MA 01845 TEL: (978) 557-5553 FAX: (978) 336-5586</p>	<p>750 WEST CENTER STREET., SUITE #301 WEST BRIDGEWATER, MA 02379</p>	<p>SITE NUMBER: CT5730 SITE NAME: COLCHESTER SOUTH ATC SITE #: 302465</p> <p>335 NEW LONDON ROAD COLCHESTER, CT 06415 NEW LONDON COUNTY</p>	<p>550 COCHITUATE ROAD FRAMINGHAM, MA 01701</p>	<table border="1"> <tr> <th>NO.</th> <th>DATE</th> <th>REVISIONS</th> <th>BY</th> <th>CHK</th> <th>APP'D</th> </tr> <tr> <td>1</td> <td>04/12/19</td> <td>ISSUED FOR CONSTRUCTION</td> <td>SG</td> <td>AT</td> <td>DJC</td> </tr> <tr> <td>A</td> <td>03/26/19</td> <td>ISSUED FOR REVIEW</td> <td>ET</td> <td>AT</td> <td>DJC</td> </tr> </table>	NO.	DATE	REVISIONS	BY	CHK	APP'D	1	04/12/19	ISSUED FOR CONSTRUCTION	SG	AT	DJC	A	03/26/19	ISSUED FOR REVIEW	ET	AT	DJC	<p>AT&T</p> <p>RF PLUMBING DIAGRAM (LTE 2C/3C/4C/5C/4TX4RX)</p>
				NO.	DATE	REVISIONS	BY	CHK	APP'D														
1	04/12/19	ISSUED FOR CONSTRUCTION	SG	AT	DJC																		
A	03/26/19	ISSUED FOR REVIEW	ET	AT	DJC																		
<p>SCALE: AS SHOWN</p>	<p>DESIGNED BY: AT</p>	<p>DRAWN BY: ET</p>	<table border="1"> <tr> <th>SITE NUMBER</th> <th>DRAWING NUMBER</th> <th>REV</th> </tr> <tr> <td>CT5730</td> <td>RF-1</td> <td>1</td> </tr> </table>	SITE NUMBER	DRAWING NUMBER	REV	CT5730	RF-1	1														
SITE NUMBER	DRAWING NUMBER	REV																					
CT5730	RF-1	1																					

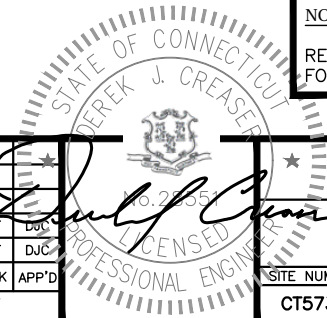

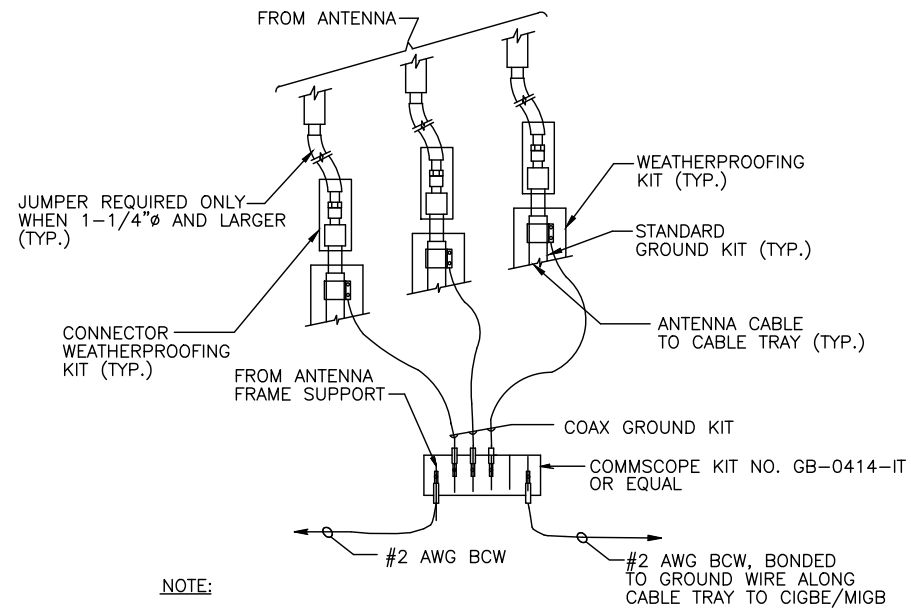

NOTE:
 1. DO NOT INSTALL CABLE GROUND KIT AT A BEND AND ALWAYS DIRECT GROUND WIRE DOWN TO CIGBE.

GROUND WIRE TO GROUND BAR CONNECTION DETAIL 1
 SCALE: N.T.S. G-1

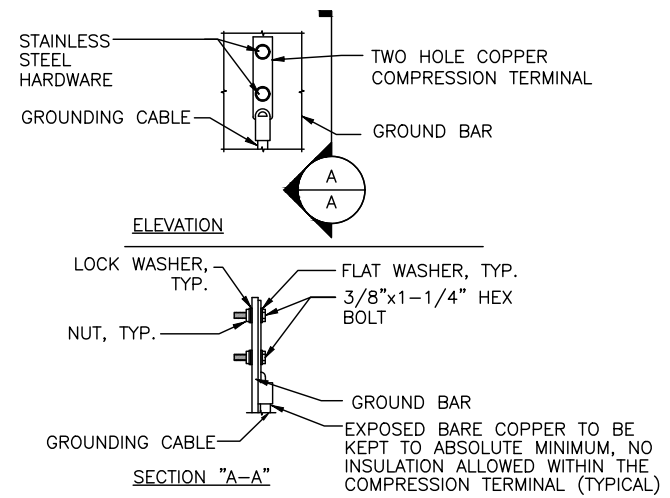

NOTE:
 1. "DOUBLING UP" OR "STACKING" OF CONNECTION IS NOT PERMITTED.
 2. OXIDE INHIBITING COMPOUND TO BE USED AT ALL LOCATION.
 3. CADWELD DOWNLEADS FROM UPPER EGB, LOWER EGB, AND MGB

TYPICAL GROUND BAR CONNECTION DETAIL 3
 SCALE: N.T.S. G-1

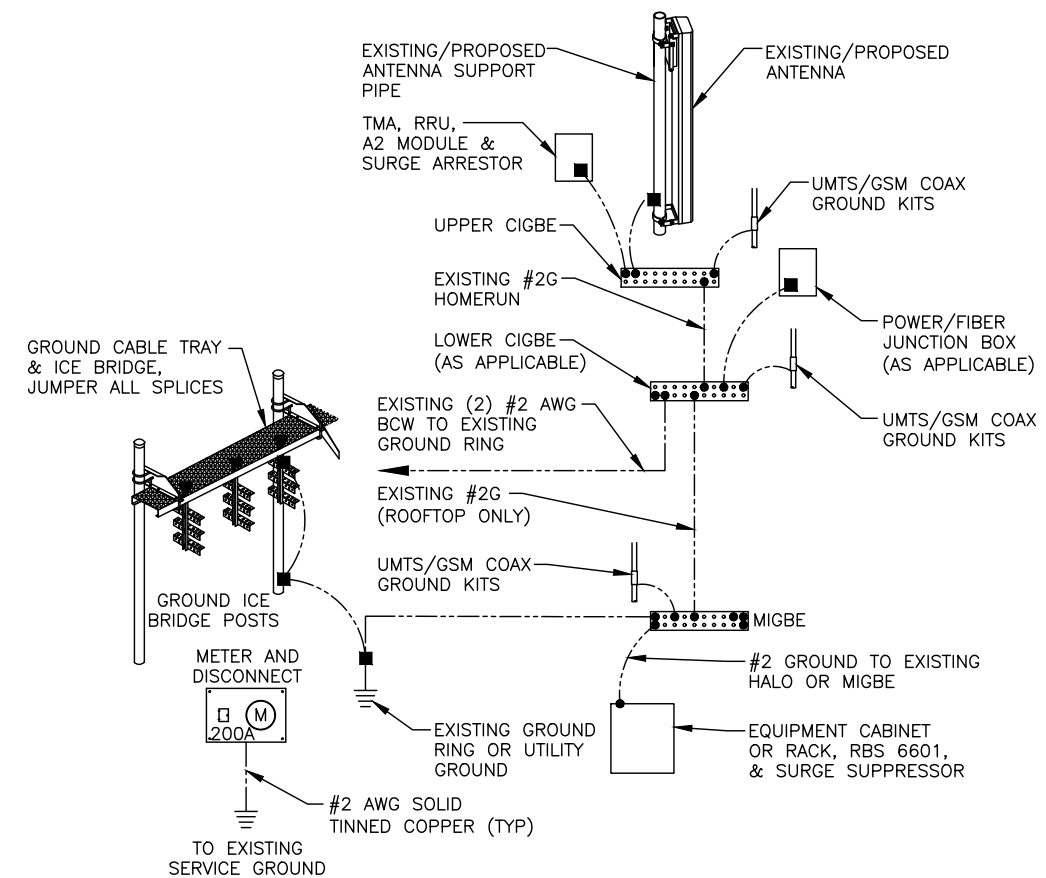

GROUNDING RISER DIAGRAM 2
 SCALE: N.T.S. G-1

EACH GROUND CONDUCTOR TERMINATING ON ANY GROUND BAR SHALL HAVE AN IDENTIFICATION TAG ATTACHED AT EACH END THAT WILL IDENTIFY ITS ORIGIN AND DESTINATION.

SECTION "P" - SURGE PRODUCERS

- CABLE ENTRY PORTS (HATCH PLATES) (#2)
- GENERATOR FRAMEWORK (IF AVAILABLE) (#2)
- TELCO GROUND BAR
- COMMERCIAL POWER COMMON NEUTRAL/GROUND BOND (#2)
- +24V POWER SUPPLY RETURN BAR (#2)
- 48V POWER SUPPLY RETURN BAR (#2)
- RECTIFIER FRAMES.

SECTION "A" - SURGE ABSORBERS

- INTERIOR GROUND RING (#2)
- EXTERNAL EARTH GROUND FIELD (BURIED GROUND RING) (#2)
- METALLIC COLD WATER PIPE (IF AVAILABLE) (#2)
- BUILDING STEEL (IF AVAILABLE) (#2)

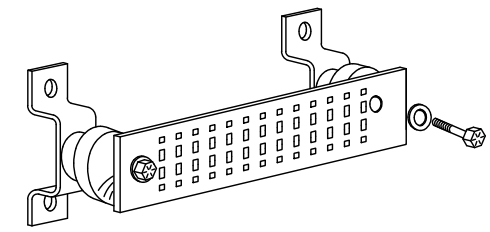

GROUND BAR - DETAIL 4
 SCALE: N.T.S. G-1



Radio Frequency Emissions Analysis Report

AT&T Existing Facility

Site ID: CT5730

FA#: 10070974

Colchester South
335 New London Road
Colchester, CT 06415

March 4, 2019

Centerline Communications Project Number: 950012-202

Site Compliance Summary	
Compliance Status:	COMPLIANT
Site total MPE% of FCC general population allowable limit:	9.32 %



March 4, 2019

AT&T Mobility – New England
Attn: John Benedetto, RF Manager
550 Cochituate Road
Suite 550 – 13&14
Framingham, MA 06040

Emissions Analysis for Site: **CT5730 – Colchester South**

Centerline Communications, LLC (“Centerline”) was directed to analyze the proposed AT&T facility located at **335 New London Road, Colchester, CT**, for the purpose of determining whether the emissions from the Proposed AT&T Antenna Installation located on this property are within specified federal limits.

All information used in this report was analyzed as a percentage of current Maximum Permissible Exposure (% MPE) as listed in the FCC OET Bulletin 65 Edition 97-01 and ANSI/IEEE Std C95.1. The FCC regulates Maximum Permissible Exposure in units of microwatts per square centimeter ($\mu\text{W}/\text{cm}^2$). The number of $\mu\text{W}/\text{cm}^2$ calculated at each sample point is called the power density. The exposure limit for power density varies depending upon the frequencies being utilized. Wireless Carriers and Paging Services use different frequency bands each with different exposure limits, therefore it is necessary to report results and limits in terms of percent MPE rather than power density.

All results were compared to the FCC (Federal Communications Commission) radio frequency exposure rules, 47 CFR 1.1307(b)(1) – (b)(3), to determine compliance with the Maximum Permissible Exposure (MPE) limits for General Population/Uncontrolled environments as defined below.

General population/uncontrolled exposure limits apply to situations in which the general population may be exposed or in which persons who are exposed as a consequence of their employment may not be made fully aware of the potential for exposure or cannot exercise control over their exposure. Therefore, members of the general population would always be considered under this category when exposure is not employment related, for example, in the case of a telecommunications tower that exposes persons in a nearby residential area.

Population exposure to radio frequencies is regulated and enforced in units of microwatts per square centimeter ($\mu\text{W}/\text{cm}^2$). The general population exposure limits for the 700 and 850 MHz Bands are approximately $467 \mu\text{W}/\text{cm}^2$ and $567 \mu\text{W}/\text{cm}^2$ respectively. The general population exposure limit for the 1900 MHz (PCS), 2100 MHz (AWS) and 2300 MHz (WCS) bands is $1000 \mu\text{W}/\text{cm}^2$. Because each carrier will be using different frequency bands, and each frequency band has different exposure limits, it is necessary to report percent of MPE rather than power density.



Occupational/controlled exposure limits apply to situations in which persons are exposed as a consequence of their employment and in which those persons who are exposed have been made fully aware of the potential for exposure and can exercise control over their exposure. Occupational/controlled exposure limits also apply where exposure is of a transient nature as a result of incidental passage through a location where exposure levels may be above general population/uncontrolled limits (see below), as long as the exposed person has been made fully aware of the potential for exposure and can exercise control over his or her exposure by leaving the area or by some other appropriate means.

Additional details can be found in FCC OET 65.



CALCULATIONS

Calculations were performed for the proposed AT&T Wireless antenna facility located at **335 New London Road, Colchester, CT**, using the equipment information listed below. All calculations were performed per the specifications under FCC OET 65. Since AT&T is proposing highly focused directional panel antennas, which project most of the emitted energy out toward the horizon, all calculations were performed assuming a lobe representing the maximum gain of the antenna per the antenna manufactures supplied specifications, minus 10 dB, was focused at the base of the tower. For this report the sample point is the top of a 6-foot person standing at the base of the tower.

Per FCC OET Bulletin No. 65 - Edition 97-01 recommendations to achieve the maximum anticipated value at each sample point, all power levels emitting from the proposed antenna installation are increased by a factor of 2.56 to account for possible in-phase reflections from the surrounding environment. All power values expressed and analyzed are maximum power levels expected to be used on all radios.

All emissions values for additional carriers were taken from the Connecticut Siting Council (CSC) active MPE database. Values in this database are provided by the individual carriers themselves

For each sector the following channel counts, frequency bands and power levels were utilized as shown in *Table 1*:

Technology	Frequency Band	Channel Count	Transmit Power per Channel (W)
UMTS	850 MHz	2	30
LTE	700 MHz	2	40
LTE	2100 MHz (AWS)	4	30
5G	850 MHz	2	25
LTE	700 MHz (Band 14)	2	40
LTE	1900 MHz (PCS)	4	40

Table 1: Channel Data Table



The following antennas listed in *Table 2* were used in the modeling for transmission in the 700 MHz, 850 MHz, 1900 MHz (PCS), 2100 MHz (AWS) and 2300 MHz (WCS) frequency bands. This is based on feedback from the carrier with regards to anticipated antenna selection. Maximum gain values for all antennas are listed in the Inventory and Power Data table below. The maximum gain of the antenna per the antenna manufactures supplied specifications, minus 10 dB, was used for all calculations. This value is a very conservative estimate as gain reductions for these particular antennas are typically much higher in this direction.

Sector	Antenna Number	Antenna Make / Model	Antenna Centerline (ft)
A	1	Powerwave 7770	150
A	2	Kathrein 800-10965	150
A	3	CCI HPA-65R-BU6AA	150
B	1	Powerwave 7770	150
B	2	Kathrein 800-10966	150
B	3	CCI HPA-65R-BU8AA	150
C	1	Powerwave 7770	150
C	2	Kathrein 800-10966	150
C	3	CCI HPA-65R-BU8AA	150

Table 2: Antenna Data

All calculations were done with respect to uncontrolled / general population threshold limits.



RESULTS

Per the calculations completed for the proposed AT&T configurations *Table 3* shows resulting emissions power levels and percentages of the FCC’s allowable general population limit.

Antenna ID	Antenna Make / Model	Frequency Bands	Antenna Gain (dBd)	Channel Count	Total TX Power (W)	ERP (W)	MPE %
Antenna A1	Powerwave 7770	850 MHz	11.4	2	60	828.23	0.25
Antenna A2	Kathrein 800-10965	700 MHz / 2100 MHz (AWS) / 850 MHz	12.65 / 15.95 / 13.45	6	190	4,940.47	1.29
Antenna A3	CCI HPA-65R-BU6AA	700 MHz (Band 14) / 1900 MHz (PCS)	12.45 / 15.95	6	240	7,703.14	1.61
Sector A Composite MPE%							3.16
Antenna B1	Powerwave 7770	850 MHz	11.4	2	60	828.23	0.25
Antenna B2	Kathrein 800-10966	700 MHz / 2100 MHz (AWS) / 850 MHz	13.55 / 16.15 / 14.25	6	190	5,614.66	1.51
Antenna B3	CCI HPA-65R-BU8AA	700 MHz (Band 14) / 1900 MHz (PCS)	13.35 / 15.95	6	240	8,026.98	1.73
Sector B Composite MPE%							3.50
Antenna C1	Powerwave 7770	850 MHz	11.4	2	60	828.23	0.25
Antenna C2	Kathrein 800-10966	700 MHz / 2100 MHz (AWS) / 850 MHz	13.55 / 16.15 / 14.25	6	190	5,614.66	1.51
Antenna C3	CCI HPA-65R-BU8AA	700 MHz (Band 14) / 1900 MHz (PCS)	13.35 / 15.95	6	240	8,026.98	1.73
Sector C Composite MPE%							3.50

Table 3: AT&T Emissions Levels



The Following table (*table 4*) shows all additional carriers on site and their MPE% as recorded in the CSC active MPE database for this facility along with the newly calculated maximum AT&T MPE contributions per this report. FCC OET 65 specifies that for carriers utilizing directional antennas that the highest recorded sector value be used for composite site MPE values due to their greatly reduced emissions contributions in the directions of the adjacent sectors. For this site, the sectors with the largest calculated MPE% are Sectors B & C. *Table 5* below shows a summary for each AT&T Sector as well as the composite MPE value for the site.

Site Composite MPE%	
Carrier	MPE%
AT&T – Max Per Sector Value (Sectors B & C)	3.50 %
T-Mobile	1.97 %
Verizon Wireless	2.03 %
Enertrac (Receive Only)	0.00 %
Sprint	1.82 %
Site Total MPE %:	9.32 %

Table 4: All Carrier MPE Contributions

AT&T Sector A Total:	3.16 %
AT&T Sector B Total:	3.50 %
AT&T Sector C Total:	3.50 %
Site Total:	9.32 %

Table 5: Site MPE Summary



FCC OET 65 specifies that for carriers utilizing directional antennas that the highest recorded sector value be used for composite site MPE values due to their greatly reduced emissions contributions in the directions of the adjacent sectors. *Table 6* below details a breakdown by frequency band and technology for the MPE power values for the maximum calculated AT&T sector(s). For this site, the sectors with the largest calculated MPE% are Sectors B & C.

AT&T _ Frequency Band / Technology Max Power Values (Sectors B & C)	# Channels	Watts ERP (Per Channel)	Height (feet)	Total Power Density ($\mu\text{W}/\text{cm}^2$)	Frequency (MHz)	Allowable MPE ($\mu\text{W}/\text{cm}^2$)	Calculated % MPE
AT&T 850 MHz UMTS – Antenna 1	2	414.12	150	1.44	850 MHz	567	0.25%
AT&T 700 MHz LTE – Antenna 2	2	905.86	150	3.14	700 MHz	467	0.67%
AT&T 2100 MHz (AWS) LTE – Antenna 2	2	1,236.29	150	4.29	2100 MHz (AWS)	1000	0.43%
AT&T 850 MHz 5G – Antenna 2	2	665.18	150	2.31	850 MHz	567	0.41%
AT&T 700 MHz LTE – Antenna 3	2	865.09	150	3.00	700 MHz	467	0.64%
AT&T 1900 MHz (PCS) LTE – Antenna 3	4	1,574.20	150	10.92	1900 MHz (PCS)	1000	1.09%
						Total:	3.50%

Table 6: AT&T Maximum Sector MPE Power Values



Summary

All calculations performed for this analysis yielded results that were **within** the allowable limits for general population exposure to RF Emissions.

The anticipated maximum composite contributions from the AT&T facility as well as the site composite emissions value with regards to compliance with FCC's allowable limits for general population exposure to RF Emissions are shown here:

AT&T Sector	Power Density Value (%)
Sector A:	3.16 %
Sector B:	3.50 %
Sector C:	3.50 %
AT&T Maximum Total (per sector):	3.50 %
Site Total:	9.32 %
Site Compliance Status:	COMPLIANT

The anticipated composite MPE value for this site assuming all carriers present is **9.32 %** of the allowable FCC established general population limit sampled at the ground level. This is based upon values listed in the Connecticut Siting Council database for existing carrier emissions.

FCC guidelines state that if a site is found to be out of compliance (over allowable thresholds), that carriers over a 5% contribution to the composite value will require measures to bring the site into compliance. For this facility, the composite values calculated were well within the allowable 100% threshold standard per the federal government.

A handwritten signature in black ink, appearing to read 'Scott Heffernan', is written over a light blue horizontal line.

Scott Heffernan

RF Engineering Director

Centerline Communications, LLC

95 Ryan Drive, Suite 1

Raynham, MA 02767