



**NSS** **NORTHEAST**  
SITE SOLUTIONS  
*Turnkey Wireless Development*

Northeast Site Solutions  
Denise Sabo  
199 Brickyard Rd Farmington, CT 06032  
860-209-4690  
[denise@northeastsitesolutions.com](mailto:denise@northeastsitesolutions.com)

February 24, 2017

Members of the Siting Council  
Connecticut Siting Council  
Ten Franklin Square  
New Britain, CT 06051

RE: Notice of Exempt Modification  
1119 Summit Road, Cheshire CT 06410  
Latitude: 41.53640000  
Longitude: -72.95730000  
T-Mobile Site#: CT11352C\_L1900

Dear Ms. Bachman:

T-Mobile currently maintains six (6) antennas at the 138-foot level of the existing 167-foot monopole at 1119 Summit Road, Cheshire CT 06410. The tower is owned by Crown Castle. The property is owned by Joanne Didomizio. T-Mobile now intends to add (3) new 1900/2100 MHz antenna and add (1) hybrid cable. The new antennas would be installed at the 138-foot level of the tower.

**Planned Modifications:**

Remove:

NONE

Remove and Replace:

NONE

Install New:

(1) 1-1/2" Hybrid Cable

(3)AIR32 B66Aa/B2a

Existing to Remain:

(3)APX16-PV-16PVL Antenna

(3) Commscope LNX-6515 Antenna

(3) Smart Bias Tee

(3) Twin TMA

(18) 1-5/8" Coax

This facility was approved by the Connecticut Siting Council. Docket No. 199: Tower height was approved not to exceed 170 feet. Please see attached.



**NSS** **NORTHEAST**  
SITE SOLUTIONS  
*Turnkey Wireless Development*

Please accept this letter as notification pursuant to Regulations of Connecticut State Agencies § 16-50j-73, for construction that constitutes an exempt modification pursuant to R.C.S.A. § 16-50j-72(b)(2). In accordance with R.C.S.A. § 16-50j-73, a copy of this letter is being sent to Town Manager Michael A. Milone, Elected Official and William S. Voelker, Town Planner for the Town of Cheshire, as well as the property owner and the tower owner.

The planned modifications to the facility fall squarely within those activities explicitly provided for in R.C.S.A. § 16-50j-72(b)(2).

1. The proposed modifications will not result in an increase in the height of the existing structure.
2. The proposed modifications will not require the extension of the site boundary.
3. The proposed modifications will not increase noise levels at the facility by six decibels or more, or to levels that exceed state and local criteria.
4. The operation of the replacement antennas will not increase radio frequency emissions at the facility to a level at or above the Federal Communications Commission safety standard.
5. The proposed modifications will not cause a change or alteration in the physical or environmental characteristics of the site.
6. The existing structure and its foundation can support the proposed loading.

For the foregoing reasons, T-Mobile respectfully submits that the proposed modifications to the above referenced telecommunications facility constitute an exempt modification under R.C.S.A. § 16-50j-72(b)(2).

Sincerely,

**Denise Sabo**

Mobile: 860-209-4690

Fax: 413-521-0558

Office: 199 Brickyard Rd, Farmington, CT 06032

Email: [denise@northeastsitesolutions.com](mailto:denise@northeastsitesolutions.com)

Attachments

cc: Michael A. Milone- Town Manager - as elected official  
William S. Voelker – Town Planner  
Crown Castle - as tower owner  
Joanne Didomizio - as property owner

# Exhibit A



# CONNECTICUT SITING COUNCIL

- [Home](#)
- [About Us](#)
- [Pending Matters](#)
- [Decisions](#)
- [Forms](#)
- [Contact Us](#)



**Robert Stein**  
Chairman

- [Filing Guides](#)
- [Meetings & Minutes](#)
- [Public Participation](#)
- [Audio Link to New Britain Hearing Rooms](#)
- [Programs & Services](#)
- [Telecommunications Database](#)
- [Publications](#)
- [Other Resources](#)
- [Statutes & Regulations](#)
- [Electric Transmission Upgrade Projects](#)
- [Frequently Asked Questions](#)



[Robert Stein](#),  
Chairman

Melanie Bachman,  
Acting Executive Director

**NOTICE TO USERS**

The Connecticut Siting Council posts filed documents to this site as a public service. The Council disclaims any liability for the content of submissions made by parties, intervenors, public officials, and the general public. Further, while the Council seeks to be complete in its postings, the Council urges users of this site to confirm with the submitter the completeness of the postings made. The posting of any document does not constitute or imply endorsement by the Connecticut Siting Council. Finally, the

<p><b>DOCKET NO. 199</b> - Crown Atlantic Company LLC and Cellco Partnership d/b/a Verizon Wireless application for a Certificate of Environmental Compatibility and Public Need for the construction, maintenance and operation of a cellular telecommunications facility at 1119 Summit Road, Cheshire, Connecticut.</p>	Connecticut } Siting } Council } April 12, } 2001
--	---

**Decision and Order**

Pursuant to the foregoing Findings of Fact and Opinion, the Connecticut Siting Council (Council) finds that the effects associated with the construction, operation, and maintenance of a telecommunications facility at the proposed alternate site in Cheshire, Connecticut, including effects on the natural environment; ecological integrity and balance; public health and safety; scenic, historic, and recreational values; forests and parks; air and water purity; and fish and wildlife are not disproportionate either alone or cumulatively with other effects when compared to need, are not in conflict with the policies of the State concerning such effects, and are not sufficient reason to deny the application and therefore directs that a Certificate of Environmental Compatibility and Public Need, as provided by General Statutes § 16-50k, be issued to Crown Atlantic Company LLC and Cellco Partnership d/b/a Verizon Wireless for the construction, maintenance and operation of a cellular telecommunications facility at the proposed alternate site located at 1119 Summit Road, Cheshire, Connecticut. We deny certification of the proposed prime site located at 1119 Summit Road, Cheshire, Connecticut.

The facility shall be constructed, operated, and maintained substantially as specified in the Council's record in this matter, and subject to the following conditions:

1. The tower shall be constructed as a monopole, no taller than necessary to provide the proposed telecommunications services, sufficient to accommodate the antennas of AT&T, Voicestream, Sprint, the Town of Cheshire and other entities, both public and private, but such tower shall not exceed a height of 170 feet above ground level.
2. The Certificate Holder shall prepare a Development and Management (D&M) Plan for this site in compliance with Sections 16-50j-75 through 16-50j-77 of the Regulations of Connecticut State Agencies. The D&M Plan shall be submitted to and approved by the Council prior to the commencement of facility construction and shall include: a final site plan(s) for site development to include the location and specifications for the tower, tower foundation, antennas, a single equipment building capable to house all proposed users including the Town of Cheshire, security fence, access road, utility line, and landscaping plan. The D&M Plan shall also include construction plans to be submitted prior to construction for site clearing, water drainage, and erosion and sedimentation control consistent with the Connecticut Guidelines for Soil Erosion and Sediment Control, as amended.
3. The Certificate Holder shall, prior to the commencement of operation, provide the Council worst-case modeling of electromagnetic radio frequency power density of all proposed entities' antennas at the closest point of uncontrolled access to the tower base, consistent with Federal Communications Commission, Office of Engineering and Technology, Bulletin No. 65, August 1997. The Certificate Holder shall provide a recalculated report of electromagnetic radio frequency power density if and when circumstances in operation cause a change in power density above the levels calculated and provided pursuant to this Decision and Order.
4. Upon the establishment of any new State or federal radio frequency standards applicable to frequencies of this facility, the facility granted herein shall be brought into compliance with such standards.
5. The Certificate Holder shall permit public or private entities to share space on the proposed tower for fair consideration, or shall provide any requesting entity with specific legal, technical, environmental, or economic reasons precluding such tower sharing.
6. If the facility does not initially provide, or permanently ceases to provide cellular services following completion of construction, this Decision and Order shall be void, and the Certificate Holder shall dismantle the tower and remove all associated equipment or reapply for any continued or new use to the Council before any such use is made.
7. Any antenna that becomes obsolete and ceases to function shall be removed within 60 days after such antennas become obsolete and ceases to function.

Connecticut Siting Council assumes no responsibility for the use of documents posted on this site.

For further information about the proper use of material posted on this site, please see the State of Connecticut [disclaimer](#).

8. Unless otherwise approved by the Council, this Decision and Order shall be void if all construction authorized herein is not completed within three years of the effective date of this Decision and Order or within three years after all appeals to this Decision and Order have been resolved.

Pursuant to General Statutes § 16-50p, we hereby direct that a copy of the Findings of Fact, Opinion, and Decision and Order be served on each person listed below, and notice of issuance shall be published in [The Hartford Courant](#), [The Cheshire Herald](#), [The Waterbury Republican-American](#) and [The Record Journal](#).

By this Decision and Order, the Council disposes of the legal rights, duties, and privileges of each party named or admitted to the proceeding in accordance with Section 16-50j-17 of the Regulations of Connecticut State Agencies.

The parties and intervenors to this proceeding are:

Crown Atlantic Company LLC Robert Stanford, Project Manager  
And Cellco Partnership d/b/a Crown Atlantic Company LLC  
Verizon Wireless 703 Hebron Avenue  
Glastonbury, CT 06033

Kenneth C. Baldwin, Esq.  
Robinson & Cole LLP  
280 Trumbull Street  
Hartford, CT 06103-3597

AT&T Wireless Services, Inc. Anthony B. Gioffre III, Esq.  
Cuddy & Feder & Worby  
90 Maple Avenue  
White Plains, NY 10601

Content Last Modified on 10/9/2002 1:52:54 PM

**Ten Franklin Square New Britain, CT 06051 / 860- 827-2935**

[Home](#) | [CT.gov Home](#) | [Send Feedback](#) | [Login](#) | [Register](#)

State of Connecticut [Disclaimer](#), [Privacy Policy](#), and [Web Site Accessibility Policy](#). Copyright © 2002-2016 State of Connecticut.



# Exhibit B

The Assessor's office is responsible for the maintenance of records on the ownership of properties. Assessments are computed at 70% of the estimated market value of real property at the time of the last revaluation which was 2013.



# Town of Cheshire

*The bedding plant capital of Connecticut*

Information on the Property Records for the Municipality of Cheshire was last updated on 10/27/2016.

## Parcel Information

Location:	1119 SUMMIT RD	Property Use:	Residential	Primary Use:	Residential
Unique ID:	00087800	Map Block Lot:	24 2	Acres:	22.52
Zone:	R-80	Volume / Page:	0798/0074	Developers Map / Lot:	15809
Census:	3432				

## Value Information

	Appraised Value	70% Assessed Value
Land	377,245	264,070
Buildings	311,951	218,370

	Appraised Value	70% Assessed Value
Detached Outbuildings	6,370	4,460
Total	695,566	486,900

### Owner's Information

#### Owner's Data

DIDOMIZIO JOANNE M  
1115 SUMMIT RD  
CHESHIRE CT 06410

### Building 1





0087800 03/08/2012

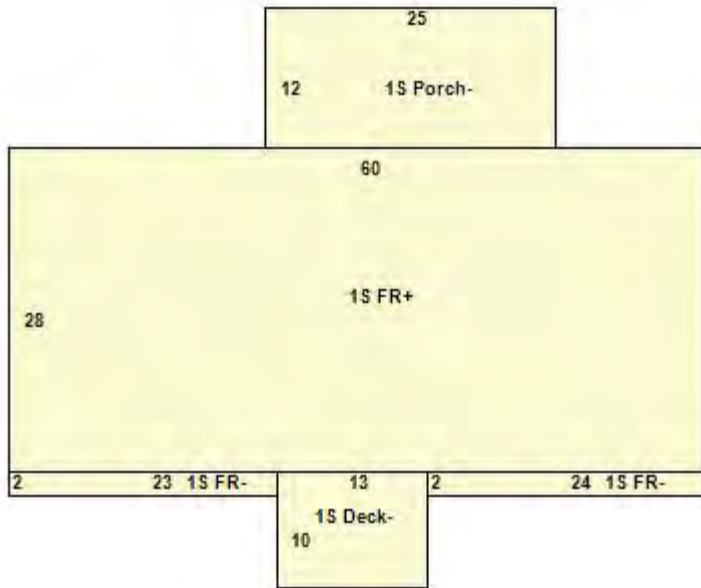

Building Use:	Single Family	Style:	Raised Ranch	Living Area:	1,774
Stories:	1.00	Construction:	Wood Frame	Year Built:	1990
Total Rooms:	7	Bedrooms:	2	Full Baths:	3
Heating:	FHA	Fireplaces:	0	Half Baths:	1
Fuel:	Oil	Cooling Percent:	0%	Basement Area:	1,680

Basement Finished Area:	840	Basement Garages:	2	Roof Material:	Asphalt
Siding:	Clapboards				

### Special Features

Whirlpool	1
-----------	---

### Attached Components

Type:	Year Built:	Area:
Wood Deck	1990	130
Open Porch	1990	300

### Building 2

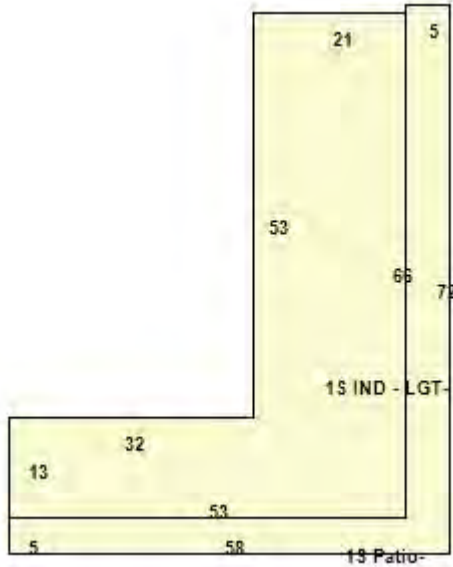

Category:	Industrial	Use:	Light Industrial	Stories:	1.00
Above Grade:	1,802	Below Grade:	0	Below Grade Finish:	0
Construction:	Good	Year Built:	2002	Heating:	
Fuel:		Cooling Percent:	0%	Siding:	Stone
Roof Material:		Beds/Units:	0		

### Special Features

### Attached Components

Type:	Year Built:	Area:
Concrete Patio	2002	625

### Building 3

Photo Not Available

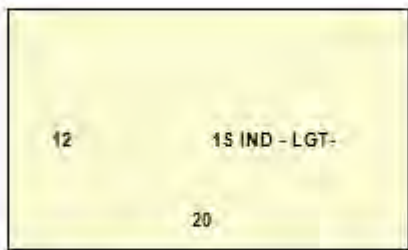

Category:	Industrial	Use:	Light Industrial	Stories:	1.00
Above Grade:	240	Below Grade:	0	Below Grade Finish:	0

Construction:	Good	Year Built:	2004	Heating:	
Fuel:		Cooling Percent:	0%	Siding:	Concrete Block
Roof Material:		Beds/Units:	0		

### Special Features

### Attached Components

### Detached Outbuildings

Type:	Year Built:	Length:	Width:	Area:
Fencing	2002			1,600

Information Published With Permission From The Assessor

# Town of Cheshire, Connecticut - Assessment Parcel Map

Unique ID: 00087800

Address: 1119 SUMMIT RD

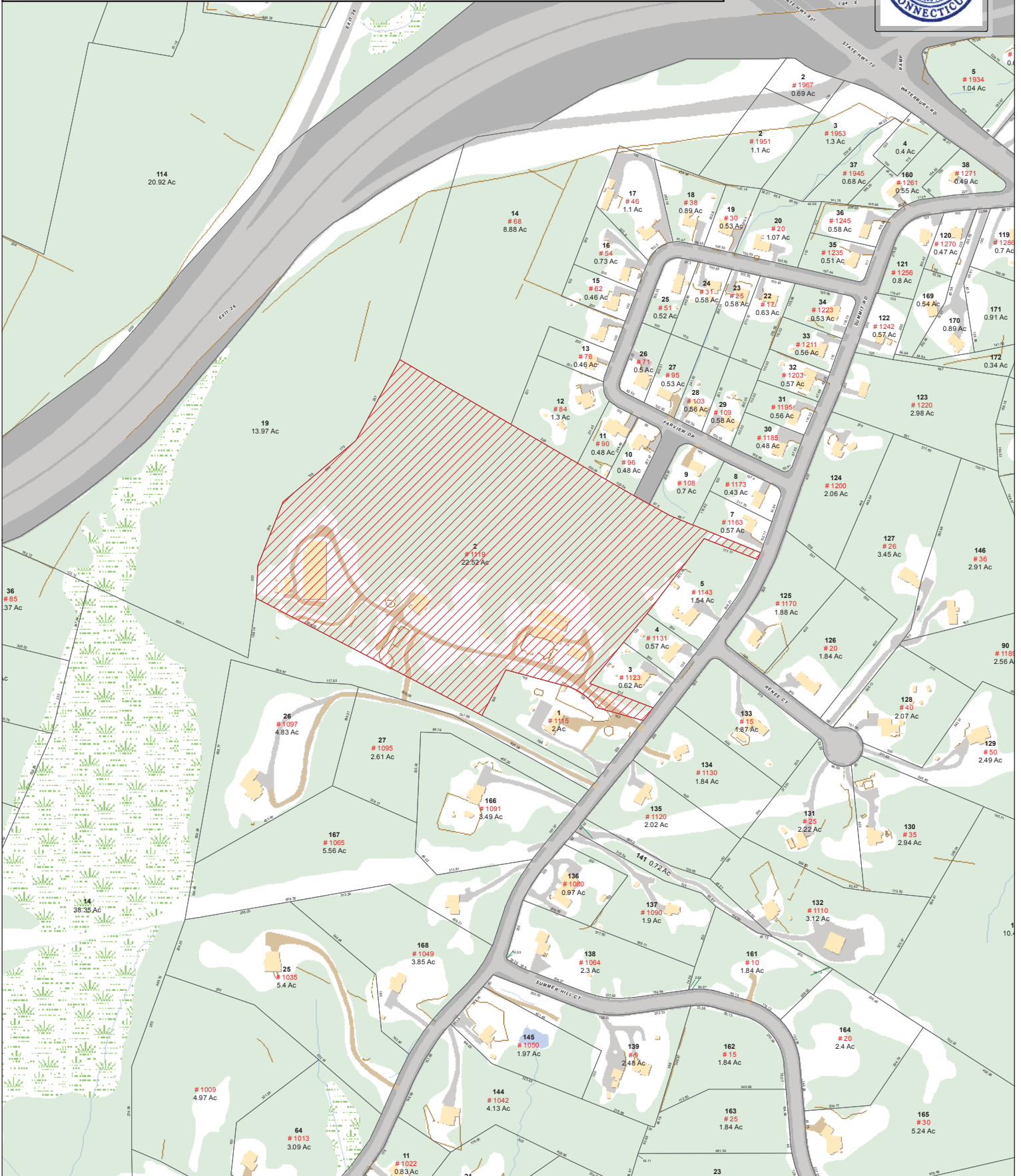

Approximate Scale:

1 inch = 400 feet

**Disclaimer:**  
This map is for informational purposes only.  
All information is subject to verification by any user.  
The Town of Cheshire and its mapping contractors  
assume no legal responsibility for the information contained herein.

Map Produced January 2016

# Exhibit C



# T-Mobile

T-MOBILE NORTHEAST LLC

SITE NUMBER:

**CT11352C**

SITE NAME:

**CROWN CHESHIRE**

SITE ADDRESS:

**1119 SUMMIT ROAD  
CHESHIRE, CT 06410**

(794DB CONFIGURATION)

**T-Mobile**

T-MOBILE NORTHEAST LLC

35 GRIFFIN ROAD SOUTH  
BLOOMFIELD, CT 06002  
O: 860-692-7100  
F: 860-692-7159

**NSS**  
NORTHEAST  
SITE SOLUTIONS

Turnkey Wireless Development  
420 MAIN STREET  
STURBRIDGE, MA 01566  
O: 860-692-7100  
F: 860-692-7159

**VRG**

VERTICAL RESOURCES GRP.

489 WASHINGTON STREET  
AUBURN, MA 01501  
TEL: 508-981-9590  
FAX: 508-519-8939



THIS DOCUMENT IS THE CREATION, DESIGN, PROPERTY AND COPYRIGHTED WORK OF T-MOBILE COMMUNICATIONS. ANY DUPLICATION OR USE WITHOUT EXPRESS WRITTEN CONSENT IS STRICTLY PROHIBITED. DUPLICATION AND USE BY GOVERNMENT AGENCIES FOR THE PURPOSES OF CONDUCTING THEIR LAWFULLY AUTHORIZED REGULATORY AND ADMINISTRATIVE FUNCTIONS IS SPECIFICALLY ALLOWED.

**SUBMITTALS**

NO	DATE	DESCRIPTION	BY
2	02/20/17	FOR PERMITTING	MN
1	02/13/17	GENERAL REVISIONS	MN
0	02/06/17	ISSUED FOR REVIEW	MN

**SITE INFORMATION**

SITE NUMBER:	CT11352C	TOWER OWNER:	CROWN CASTLE INTERNATIONAL 500 W CUMMINGS PARK WOBURN, MA 01801
SITE NAME:	CROWN CHESHIRE	LOCAL POWER COMPANY:	EVERSOURCE
SITE ADDRESS:	119 SUMMIT ROAD CHESHIRE, CT 06410	LOCAL TELCO COMPANY:	LIGHT TOWER
COUNTY:	NEW HAVEN	APPLICANT:	T-MOBILE NORTHEAST LLC 35 GRIFFIN ROAD SOUTH BLOOMFIELD, CT 06002 P: (860) 648-1116
ZONING:	N/A	SITE ACQUISITION REPRESENTATIVE:	NORTHEAST SITE SOLUTIONS 420 MAIN STREET UNIT #2 STURBRIDGE, MA 01566 P: (860) 394-7021
PARCEL ID:	N/A	ARCHITECT/ENGINEER:	VERTICAL RESOURCES GROUP 489 WASHINGTON STREET AUBURN, MA 01501 TEL:508-981-9590 FAX:508-519-8939
FAA 2-C COORDINATES:	N 41° 32' 11.2" W 72° 57' 26.3"		
GROUND ELEV:	630'-0"± AMSL		
STRUCTURE TYPE:	MONOPOLE		
STRUCTURE HEIGHT:	167'-0"± AGL		
ANTENNA RAD CENTER:	138'-0"± AGL		

**VICINITY MAP (NOT TO SCALE)**

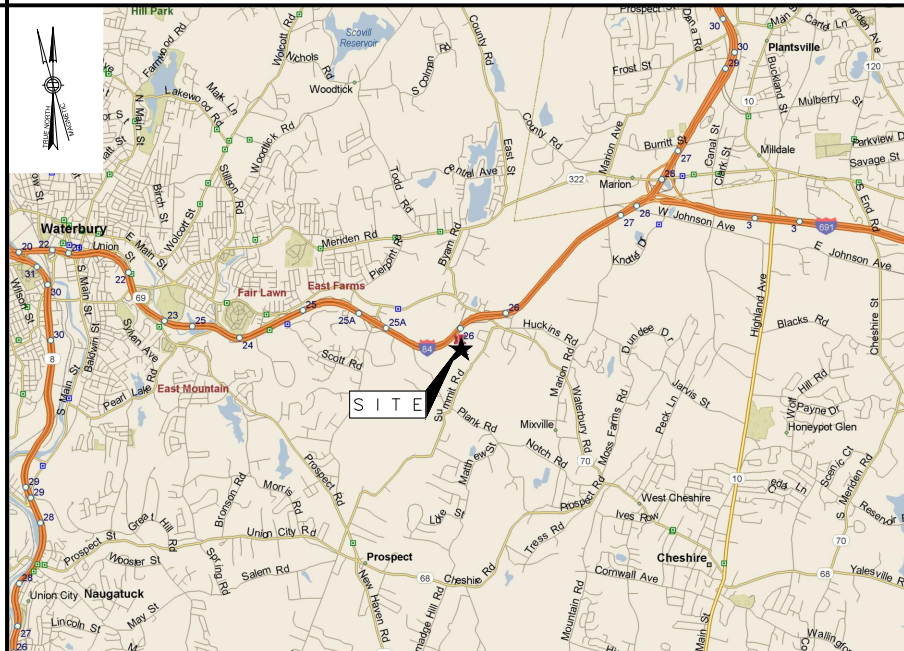

**DRAWING INDEX**

SHT #	SHEET DESCRIPTION
01	TITLE SHEET
02	GENERAL NOTES
03	ROOF PLAN & ELEVATIONS
04	ANTENNA DETAILS
05	GROUNDING & RF PLUMBING DIAGRAM
06	GROUNDING DETAILS

**GENERAL NOTES**

- THIS IS AN UNMANNED TELECOMMUNICATION FACILITY AND NOT FOR HUMAN HABITATION:  
-HANDICAP ACCESS REQUIREMENTS ARE NOT REQUIRED.  
-FACILITY HAS NO PLUMBING OR REFRIGERANTS.  
-THIS FACILITY SHALL MEET OR EXCEED ALL FAA AND FCC REGULATOR REQUIREMENTS.
- CONTRACTOR SHALL VERIFY ALL PLANS AND EXISTING DIMENSIONS AND CONDITIONS ON THE JOB SITE AND SHALL IMMEDIATELY NOTIFY THE PROJECT OWNER'S REPRESENTATIVE IN WRITING OF DISCREPANCIES BEFORE PROCEEDING WITH THE WORK OR BE RESPONSIBLE FOR SAME.
- DEVELOPMENT AND USE OF THIS SITE WILL CONFORM TO ALL APPLICABLE CODES AND ORDINANCES.  
BUILDING CODE: CONNECTICUT STATE BUILDING CODE  
ELECTRICAL CODE: 2008 (OR LATEST) NATIONAL ELECTRICAL CODE  
STRUCTURAL CODE: TIA/EIA-222-G OR LATEST EDITION

**DIRECTIONS:**  
FROM BLOOMFIELD, CT PROCEED SOUTH ON I-91. CONTINUE THROUGH HARTFORD. TAKE I-91 SOUTH EXIT 32 TOWARDS I-84 WEST. CONTINUE ON I-84 WEST. TAKE I-84 WEST EXIT 26 TOWARDS WATERBURY ROAD. AT END OF OFF RAMP TURN LEFT ONTO WATERBURY RD. TURN RIGHT ONTO SUMMIT RD. SITE WILL BE ON RIGHT.



**CALL BEFORE YOU DIG  
C.B.Y.D.COM**

CONNECTICUT LAW REQUIRES TWO WORKING DAYS NOTICE PRIOR TO ANY EARTH MOVING ACTIVITIES BY CALLING 800-922-4455 OR DIAL 811

**APPROVALS**

THE FOLLOWING PARTIES HEREBY APPROVE AND ACCEPT THESE DOCUMENTS AND AUTHORIZE THE CONTRACTOR TO PROCEED WITH THE CONSTRUCTION DESCRIBED HEREIN. ALL DOCUMENTS ARE SUBJECT TO REVIEW BY THE LOCAL BUILDING DEPARTMENT AND MAY IMPOSE CHANGES OR MODIFICATIONS.

CONSTRUCTION:	_____	DATE:	_____
SITE ACQUISITION:	_____	DATE:	_____
LEASING/	_____	DATE:	_____
R.F. ENGINEER:	_____	DATE:	_____
LANDLORD/ PROPERTY OWNER:	_____	DATE:	_____

SITE NUMBER:  
**CT11352-C**  
SITE NAME:  
**CROWN CHESHIRE**  
SITE ADDRESS:  
**1119 SUMMIT ROAD  
CHESHIRE, CT 06410**

SHEET TITLE:  
**TITLE SHEET**

SHEET NUMBER:  
**01**



**GENERAL NOTES**

- FOR THE PURPOSE OF CONSTRUCTION DRAWING, THE FOLLOWING DEFINITIONS SHALL APPLY:  
 CONTRACTOR – PRIME CONTRACTOR  
 SUBCONTRACTOR – GENERAL CONTRACTOR (CONSTRUCTION)  
 OWNER – AT&T WIRELESS  
 OEM – ORIGINAL EQUIPMENT MANUFACTURER
- PRIOR TO THE SUBMISSION OF BIDS, THE BIDDING SUBCONTRACTOR SHALL VISIT THE CELL SITE TO FAMILIARIZE WITH THE EXISTING CONDITIONS AND TO CONFIRM THAT THE WORK CAN BE ACCOMPLISHED AS SHOWN ON THE CONSTRUCTION DRAWINGS. ANY DISCREPANCY FOUND SHALL BE BROUGHT TO THE ATTENTION OF CONTRACTOR.
- ALL MATERIALS FURNISHED AND INSTALLED SHALL BE IN STRICT ACCORDANCE WITH ALL APPLICABLE CODES, REGULATIONS, AND ORDINANCES. SUBCONTRACTOR SHALL ISSUE ALL APPROPRIATE NOTICES AND COMPLY WITH ALL LAWS, ORDINANCES, RULES, REGULATIONS, AND LAWFUL ORDERS OF ANY PUBLIC AUTHORITY REGARDING THE PERFORMANCE OF THE WORK.
- ALL WORK CARRIED OUT SHALL COMPLY WITH ALL APPLICABLE MUNICIPAL AND UTILITY COMPANY SPECIFICATIONS AND LOCAL JURISDICTIONAL CODES, ORDINANCES AND APPLICABLE REGULATIONS.
- DRAWINGS PROVIDED HERE ARE NOT TO SCALE UNLESS OTHERWISE NOTED AND ARE INTENDED TO SHOW OUTLINE ONLY.
- UNLESS NOTED OTHERWISE, THE WORK SHALL INCLUDE FURNISHING MATERIALS, EQUIPMENT, APPURTENANCES, AND LABOR NECESSARY TO COMPLETE ALL INSTALLATIONS AS INDICATED ON THE DRAWINGS.
- THE SUBCONTRACTOR SHALL INSTALL ALL EQUIPMENT AND MATERIALS IN ACCORDANCE WITH MANUFACTURER'S RECOMMENDATIONS UNLESS SPECIFICALLY STATED OTHERWISE.
- IF THE SPECIFIED EQUIPMENT CANNOT BE INSTALLED AS SHOWN ON THESE DRAWINGS, THE SUBCONTRACTOR SHALL PROPOSE AN ALTERNATIVE INSTALLATION FOR APPROVAL BY THE CONTRACTOR.
- SUBCONTRACTOR SHALL DETERMINE ACTUAL ROUTING OF CONDUIT, POWER AND T1 CABLES, GROUNDING CABLES AS SHOWN ON THE POWER, GROUNDING AND TELCO PLAN DRAWING. ROUTING OF CONDUIT FOR POWER AND TELCO SHALL BE APPROVED BY OWNER OF SITE.
- THE SUBCONTRACTOR SHALL PROTECT EXISTING IMPROVEMENTS, PAVEMENTS, CURBS, LANDSCAPING AND STRUCTURES. ANY DAMAGED PART SHALL BE REPAIRED AT SUBCONTRACTOR'S EXPENSE TO THE SATISFACTION OF OWNER.
- SUBCONTRACTOR SHALL LEGALLY AND PROPERLY DISPOSE OF ALL SCRAP MATERIALS SUCH AS COAXIAL CABLES AND OTHER ITEMS REMOVED FROM THE EXISTING FACILITY. ANTENNAS REMOVED SHALL BE RETURNED TO THE OWNER'S DESIGNATED LOCATION.
- SUBCONTRACTOR SHALL LEAVE PREMISES IN CLEAN CONDITION.

**SITE WORK GENERAL NOTES**

- THE SUBCONTRACTOR SHALL CONTACT UTILITY LOCATING SERVICES PRIOR TO THE START OF CONSTRUCTION.
- ALL EXISTING ACTIVE SEWER, WATER, GAS, ELECTRIC, AND OTHER UTILITIES WHERE ENCOUNTERED IN THE WORK, SHALL BE PROTECTED AT ALL TIMES, AND WHERE REQUIRED FOR THE PROPER EXECUTION OF THE WORK, SHALL BE RELOCATED AS DIRECTED BY CONTRACTOR. EXTREME CAUTION SHOULD BE USED BY THE SUBCONTRACTOR WHEN EXCAVATING OR DRILLING PIERS AROUND OR NEAR UTILITIES. SUBCONTRACTOR SHALL PROVIDE SAFETY TRAINING FOR THE WORKING CREW. THIS WILL INCLUDE BUT NOT BE LIMITED TO A) FALL PROTECTION B) CONFINED SPACE C) ELECTRICAL SAFETY D) TRENCHING & EXCAVATION.
- ALL SITE WORK SHALL BE AS INDICATED ON THE DRAWINGS AND PROJECT SPECIFICATIONS.
- IF NECESSARY, RUBBISH, STUMPS, DEBRIS, STICKS, STONES, TOP SOIL AND OTHER REFUSE SHALL BE REMOVED FROM THE SITE AND DISPOSED OF LEGALLY.
- ALL EXISTING INACTIVE SEWER, WATER, GAS, ELECTRIC AND OTHER UTILITIES, WHICH INTERFERE WITH THE EXECUTION OF THE WORK, SHALL BE REMOVED AND/OR CAPPED, PLUGGED OR OTHERWISE DISCONTINUED AT POINTS WHICH WILL NOT INTERFERE WITH THE EXECUTION OF THE WORK, SUBJECT TO THE APPROVAL OF CONTRACTOR, OWNER AND/OR LOCAL UTILITIES.
- SUBCONTRACTOR SHALL MINIMIZE DISTURBANCE TO EXISTING SITE DURING CONSTRUCTION.
- THE SUBCONTRACTOR SHALL PROVIDE SITE SIGNAGE IN ACCORDANCE WITH THE OWNER SPECIFICATION FOR SITE SIGNAGE.
- THE SITE SHALL BE GRADED TO CAUSE SURFACE WATER TO FLOW AWAY FROM THE TRANSMISSION EQUIPMENT AND TOWER AREAS.
- NO FILL OR EMBANKMENT MATERIAL SHALL BE PLACED ON FROZEN GROUND. FROZEN MATERIALS, SNOW OR ICE SHALL NOT BE PLACED IN ANY FILL OR EMBANKMENT.
- THE SUB GRADE SHALL BE COMPACTED AND BROUGHT TO A SMOOTH UNIFORM GRADE PRIOR TO FINISHED SURFACE APPLICATION, SEE DETAIL 303.
- THE AREAS OF THE OWNERS PROPERTY DISTURBED BY THE WORK AND NOT COVERED BY THE TOWER, EQUIPMENT OR DRIVEWAY, SHALL BE GRADED TO A UNIFORM SLOPE, AND STABILIZED TO PREVENT EROSION.
- EROSION CONTROL MEASURES, IF REQUIRED DURING CONSTRUCTION, SHALL BE IN CONFORMANCE WITH THE LOCAL JURISDICTION'S GUIDELINES FOR EROSION AND SEDIMENT CONTROL.
- ALL EARTH WORK SHALL BE PERFORMED IN ACCORDANCE WITH TECHNICAL SPECIFICATION FOR CONSTRUCTION OF RADIO ACCESS NETWORK SITES.

**CONCRETE AND REINFORCING STEEL NOTES:**

- ALL CONCRETE WORK SHALL BE IN ACCORDANCE WITH THE ACI 301, ACI 318, ACI 336, ASTM A184, ASTM A185 AND THE DESIGN AND CONSTRUCTION SPECIFICATION FOR CAST-IN-PLACE CONCRETE.
- ALL CONCRETE SHALL HAVE A MINIMUM COMPRESSIVE STRENGTH OF 4000 PSI AT 28 DAYS, UNLESS NOTED OTHERWISE. A HIGHER STRENGTH (4000 PSI) MAY BE USED.
- REINFORCING STEEL SHALL CONFORM TO ASTM A 615, GRADE 60, DEFORMED UNLESS NOTED OTHERWISE. WELDED WIRE FABRIC SHALL CONFORM TO ASTM A 185 WELDED STEEL WIRE FABRIC UNLESS NOTED OTHERWISE. SPLICES SHALL BE CLASS "B" AND ALL HOOKS SHALL BE STANDARD, UNO.
- THE FOLLOWING MINIMUM CONCRETE COVER SHALL BE PROVIDED FOR REINFORCING STEEL UNLESS SHOWN OTHERWISE ON DRAWINGS:  
 CONCRETE CAST AGAINST EARTH.....3 IN.  
 CONCRETE EXPOSED TO EARTH OR WEATHER:  
 #6 AND LARGER .....2 INCH  
 #5 AND SMALLER & WWF.....1 1/2 INCH  
 CONCRETE NOT EXPOSED TO EARTH OR WEATHER OR NOT CAST AGAINST THE GROUND:  
 SLAB AND WALL .....3/4 INCH  
 BEAMS AND COLUMNS.....1 1/2 INCH
- A 3/4" CHAMFER SHALL BE PROVIDED AT ALL EXPOSED EDGES OF CONCRETE, UNO, IN ACCORDANCE WITH ACI 301 SECTION 4.2.4.
- INSTALLATION OF CONCRETE EXPANSION/WEDGE ANCHOR, SHALL BE PER MANUFACTURER'S WRITTEN RECOMMENDED PROCEDURE. THE ANCHOR BOLT, DOWEL OR ROD SHALL CONFORM TO MANUFACTURER'S RECOMMENDATION FOR EMBEDMENT DEPTH OR AS SHOWN ON THE DRAWINGS. NO REBAR SHALL BE CUT WITHOUT PRIOR CONTRACTOR APPROVAL WHEN DRILLING HOLES IN CONCRETE. SPECIAL INSPECTIONS, REQUIRED BY GOVERNING CODES, SHALL BE PERFORMED IN ORDER TO MAINTAIN MANUFACTURER'S MAXIMUM ALLOWABLE LOADS. ALL EXPANSION/WEDGE ANCHORS SHALL BE STAINLESS STEEL OR HOT DIPPED GALVANIZED. EXPANSION BOLTS SHALL BE PROVIDED BY RAMSET/REDHEAD HILTI OR APPROVED EQUAL.
- CONCRETE CYLINDER TEST IS NOT REQUIRED FOR SLAB ON GRADE WHEN CONCRETE IS LESS THAN 50 CUBIC YARDS (IBC 1905.6.2.3) IN THAT EVENT THE FOLLOWING RECORDS SHALL BE PROVIDED BY THE CONCRETE SUPPLIER:  
 (A) RESULTS OF CONCRETE CYLINDER TESTS PERFORMED AT THE SUPPLIER'S PLANT,  
 (B) CERTIFICATION OF MINIMUM COMPRESSIVE STRENGTH FOR THE CONCRETE GRADE SUPPLIED.  
 FOR GREATER THAN 50 CUBIC YARDS THE GC SHALL PERFORM THE CONCRETE CYLINDER TEST.
- AS AN ALTERNATIVE TO ITEM 7, TEST CYLINDERS SHALL BE TAKEN INITIALLY AND THEREAFTER FOR EVERY 50 YARDS OF CONCRETE FROM EACH DIFFERENT BATCH PLANT.
- EQUIPMENT SHALL NOT BE PLACED ON NEW PADS FOR SEVEN DAYS AFTER PAD IS POURED, UNLESS IT IS VERIFIED BY TESTS THAT COMPRESSIVE STRENGTH HAS BEEN ATTAINED.
- ALL CONCRETE SHALL BE SUPPLIED IN ACCORDANCE WITH TECHNICAL SPECIFICATION FOR CONSTRUCTION OF RADIO ACCESS NETWORK SITES.

**SOIL COMPACTION NOTES FOR SLAB ON GRADE:**

- EXCAVATE AS REQUIRED TO REMOVE VEGETATION AND TOPSOIL, EXPOSE UNDISTURBED NATURAL SUBGRADE AND PLACE CRUSHED STONE AS REQUIRED.
- COMPACTION CERTIFICATION: AN INSPECTION AND WRITTEN CERTIFICATION BY A QUALIFIED GEOTECHNICAL TECHNICIAN OR ENGINEER IS ACCEPTABLE.
- AS AN ALTERNATIVE TO INSPECTION AND WRITTEN CERTIFICATION, THE "UNDISTURBED SOIL" BASE SHALL BE COMPACTED WITH "COMPACTION EQUIPMENT", LISTED BELOW, TO AT LEAST 90% MODIFIED PROCTOR MAXIMUM DENSITY PER ASTM D 1557 METHOD C.
- COMPACTED SUBBASE SHALL BE UNIFORM AND LEVELED. PROVIDE 6" MINIMUM CRUSHED STONE OR GRAVEL COMPACTED IN 3" LIFTS ABOVE COMPACTED SOIL. GRAVEL SHALL BE NATURAL OR CRUSHED WITH 100% PASSING 1" SIEVE.
- AS AN ALTERNATIVE TO ITEMS 2 AND 3 PROOF ROLL THE SUBGRADE SOILS WITH 5 PASSES OF A MEDIUM SIZED VIBRATORY PLATE COMPACTOR (SUCH AS BOMAG BPR 30/38) OR HAND-OPERATED SINGLE DRUM VIBRATORY ROLLER (SUCH AS BOMAG BW 55E). ANY SOFT AREAS THAT ARE ENCOUNTERED SHOULD BE REMOVED AND REPLACED WITH A WELL-GRADED GRANULAR FILL, AND COMPACTED AS STATED ABOVE.
- COMPACTION CRITERIA FOR OTHER FILL AREAS ON SITE SHALL MEET THE SAME REQUIREMENTS AS NOTED ABOVE.
- SOIL COMPACTION SHALL BE PERFORMED IN ACCORDANCE WITH TECHNICAL SPECIFICATION FOR CONSTRUCTION OF RADIO ACCESS NETWORK SITES.

**COMPACTION EQUIPMENT:**

HAND OPERATED DOUBLE DRUM, VIBRATORY ROLLER, VIBRATORY PLATE COMPACTOR OR JUMPING JACK COMPACTOR.

**ELECTRICAL INSTALLATION NOTES**

- ALL ELECTRICAL WORK SHALL BE PERFORMED IN ACCORDANCE WITH THE PROJECT SPECIFICATIONS, NEC AND ALL APPLICABLE LOCAL CODES.
- CONDUIT ROUTINGS ARE SCHEMATIC. SUBCONTRACTOR SHALL INSTALL CONDUITS SO THAT ACCESS TO EQUIPMENT IS NOT BLOCKED.
- WIRING, RACEWAY AND SUPPORT METHODS AND MATERIALS SHALL COMPLY WITH THE REQUIREMENTS OF THE NEC AND TELCORDIA.
- ALL CIRCUITS SHALL BE SEGREGATED AND MAINTAIN MINIMUM CABLE SEPARATION AS REQUIRED BY THE NEC AND TELCORDIA.
- CABLES SHALL NOT BE ROUTED THROUGH LADDER-STYLE CABLE TRAY RUNGS.
- EACH END OF EVERY POWER, POWER PHASE CONDUCTOR (I.E., HOTS), GROUNDING, AND T1 CONDUCTOR AND CABLE SHALL BE LABELED WITH COLOR-CODED INSULATION OR ELECTRICAL TAPE (3M BRAND, 1/2 INCH PLASTIC ELECTRICAL TAPE WITH UV PROTECTION, OR EQUAL). THE IDENTIFICATION METHOD SHALL CONFORM WITH NEC & OSHA.
- ALL ELECTRICAL COMPONENTS SHALL BE CLEARLY LABELED WITH PERMANENT LABELS. ALL EQUIPMENT SHALL BE LABELED WITH THEIR VOLTAGE RATING, PHASE CONFIGURATION, WIRE CONFIGURATION, POWER OR AMPACITY RATING, AND BRANCH CIRCUIT ID NUMBERS (I.E., PANELBOARD AND CIRCUIT ID'S). NO HAND WRITTEN LABELS ALLOWED.
- PANELBOARDS (ID NUMBERS) AND INTERNAL CIRCUIT BREAKERS (CIRCUIT ID NUMBERS) SHALL BE CLEARLY LABELED. NO HAND WRITTEN LABELS ALLOWED.
- ALL TIE WRAPS SHALL BE CUT FLUSH WITH APPROVED CUTTING TOOL TO REMOVE SHARP EDGES.
- POWER, CONTROL, AND EQUIPMENT GROUND WIRING IN TUBING OR CONDUIT SHALL BE SINGLE CONDUCTOR (SIZE 14 AWG OR LARGER), 600V, OIL RESISTANT THHN OR THWN-2, CLASS B STRANDED COPPER CABLE RATED FOR 90 °C (WET AND DRY) OPERATION; LISTED OR LABELED FOR THE LOCATION AND RACEWAY SYSTEM USED, UNLESS OTHERWISE SPECIFIED.
- SUPPLEMENTAL EQUIPMENT GROUND WIRING LOCATED INDOORS SHALL BE SINGLE CONDUCTOR (SIZE 6 AWG OR LARGER), 600V, OIL RESISTANT THHN OR THWN-2 GREEN INSULATION, CLASS B STRANDED COPPER CABLE RATED FOR 90 °C (WET AND DRY) OPERATION; LISTED OR LABELED FOR THE LOCATION AND RACEWAY SYSTEM USED, UNLESS OTHERWISE SPECIFIED.
- POWER AND CONTROL WIRING, NOT IN TUBING OR CONDUIT, SHALL BE MULTI-CONDUCTOR, TYPE TC CABLE (SIZE 14 AWG OR LARGER), 600V, OIL RESISTANT THHN OR THWN-2, CLASS B STRANDED COPPER CABLE RATED FOR 90 °C (WET AND DRY) OPERATION; WITH OUTER JACKET; LISTED OR LABELED FOR THE LOCATION USED, UNLESS OTHERWISE SPECIFIED.
- ALL POWER AND POWER GROUNDING CONNECTIONS SHALL BE CRIMP-STYLE, COMPRESSION WIRE LUGS AND WIRENUTS BY THOMAS AND BETTS (OR EQUAL). LUGS AND WIRENUTS SHALL BE RATED FOR OPERATION AT NO LESS THAN 75°C (90°C IF AVAILABLE).
- RACEWAY AND CABLE TRAY SHALL BE LISTED OR LABELED FOR ELECTRICAL USE IN ACCORDANCE WITH NEMA, UL, ANSI/IEEE, AND NEC.
- ELECTRICAL METALLIC TUBING (EMT) OR RIGID NONMETALLIC CONDUIT (I.E., RIGID PVC SCHEDULE 40, OR RIGID PVC SCHEDULE 80 FOR LOCATIONS SUBJECT TO PHYSICAL DAMAGE) SHALL BE USED FOR EXPOSED INDOOR LOCATIONS.
- ELECTRICAL METALLIC TUBING (EMT), ELECTRICAL NONMETALLIC TUBING (ENT), OR RIGID NONMETALLIC CONDUIT (RIGID PVC, SCHEDULE 40) SHALL BE USED FOR CONCEALED INDOOR LOCATIONS.
- GALVANIZED STEEL INTERMEDIATE METALLIC CONDUIT (IMC) SHALL BE USED FOR OUTDOOR LOCATIONS ABOVE GRADE.
- RIGID NONMETALLIC CONDUIT (I.E., RIGID PVC SCHEDULE 40 OR RIGID PVC SCHEDULE 80) SHALL BE USED UNDERGROUND; DIRECT BURIED, IN AREAS OF OCCASIONAL LIGHT VEHICLE TRAFFIC OR ENCASED IN REINFORCED CONCRETE IN AREAS OF HEAVY VEHICLE TRAFFIC.
- LIQUID-TIGHT FLEXIBLE METALLIC CONDUIT (LIQUID-TITE FLEX) SHALL BE USED INDOORS AND OUTDOORS, WHERE VIBRATION OCCURS OR FLEXIBILITY IS NEEDED.
- CONDUIT AND TUBING FITTINGS SHALL BE THREADED OR COMPRESSION-TYPE AND APPROVED FOR THE LOCATION USED. SETSCREW FITTINGS ARE NOT ACCEPTABLE.
- CABINETS, BOXES, AND WIREWAYS SHALL BE LISTED OR LABELED FOR ELECTRICAL USE IN ACCORDANCE WITH NEMA, UL, ANSI/IEEE, AND NEC.
- WIREWAYS SHALL BE EPOXY-COATED (GRAY) AND INCLUDE A HINGED COVER, DESIGNED TO SWING OPEN DOWNWARD; SHALL BE PANDUIT TYPE E (OR EQUAL); AND RATED NEMA 1 (OR BETTER) INDOORS, OR NEMA 3R (OR BETTER) OUTDOORS.
- EQUIPMENT CABINETS, TERMINAL BOXES, JUNCTION BOXES, AND PULL BOXES SHALL BE GALVANIZED OR EPOXY-COATED SHEET STEEL, SHALL MEET OR EXCEED UL 50, AND RATED NEMA 1 (OR BETTER) INDOORS, OR NEMA 3R (OR BETTER) OUTDOORS

**ELECTRICAL INSTALLATION NOTES (cont.)**

- METAL RECEPTACLE, SWITCH, AND DEVICE BOXES SHALL BE GALVANIZED, EPOXY-COATED, OR NON-CORRODING; SHALL MEET OR EXCEED UL 514A AND NEMA OS 1; AND RATED NEMA 1 (OR BETTER) INDOORS, OR WEATHER PROTECTED (WP OR BETTER) OUTDOORS.
- NONMETALLIC RECEPTACLE, SWITCH, AND DEVICE BOXES SHALL MEET OR EXCEED NEMA OS 2; AND RATED NEMA 1 (OR BETTER) INDOORS, OR WEATHER PROTECTED (WP OR BETTER) OUTDOORS.
- THE SUBCONTRACTOR SHALL NOTIFY AND OBTAIN NECESSARY AUTHORIZATION FROM THE CONTRACTOR BEFORE COMMENCING WORK ON THE AC POWER DISTRIBUTION PANELS.
- THE SUBCONTRACTOR SHALL PROVIDE NECESSARY TAGGING ON THE BREAKERS, CABLES AND DISTRIBUTION PANELS IN ACCORDANCE WITH THE APPLICABLE CODES AND STANDARDS TO SAFEGUARD AGAINST LIFE AND PROPERTY.

**STRUCTURAL STEEL NOTES:**

- ALL STEEL WORK SHALL BE GALVANIZED IN ACCORDANCE WITH ASTM A123 (HOT-DIP) UNLESS NOTED OTHERWISE. STRUCTURAL STEEL SHALL BE ASTM-A-36 UNLESS OTHERWISE NOTED ON THE SITE SPECIFIC DRAWINGS. STEEL DESIGN, INSTALLATION AND BOLTING SHALL BE PERFORMED IN ACCORDANCE WITH THE AMERICAN INSTITUTE OF STEEL CONSTRUCTION (AISC) "MANUAL OF STEEL CONSTRUCTION".
- ALL WELDING SHALL BE PERFORMED USING E70XX ELECTRODES AND WELDING SHALL CONFORM TO AISC. WHERE FILLET WELD SIZES ARE NOT SHOWN, PROVIDE THE MINIMUM SIZE PER TABLE J2.4 IN THE AISC "MANUAL OF STEEL CONSTRUCTION". PAINTED SURFACES SHALL BE TOUCHED UP.
- BOLTED CONNECTIONS SHALL BE ASTM A325 BEARING TYPE (3/4") CONNECTIONS AND SHALL HAVE MINIMUM OF TWO BOLTS UNLESS NOTED OTHERWISE. STEEL FASTENER HARDWARE SHALL BE GALVANIZED IN ACCORDANCE WITH ASTM A153 (HOT-DIP)
- NON-STRUCTURAL CONNECTIONS FOR STEEL GRATING MAY USE 5/8" DIA. ASTM A 307 BOLTS UNLESS NOTED OTHERWISE.
- INSTALLATION OF CONCRETE EXPANSION/WEDGE ANCHOR, SHALL BE PER MANUFACTURER'S WRITTEN RECOMMENDED PROCEDURE. THE ANCHOR BOLT, DOWEL OR ROD SHALL CONFORM TO MANUFACTURER'S RECOMMENDATION FOR EMBEDMENT DEPTH OR AS SHOWN ON THE DRAWINGS. NO REBAR SHALL BE CUT WITHOUT PRIOR CONTRACTOR APPROVAL WHEN DRILLING HOLES IN CONCRETE. SPECIAL INSPECTIONS, REQUIRED BY GOVERNING CODES, SHALL BE PERFORMED IN ORDER TO MAINTAIN MANUFACTURER'S MAXIMUM ALLOWABLE LOADS. ALL EXPANSION/WEDGE ANCHORS SHALL BE STAINLESS STEEL OR HOT DIPPED GALVANIZED. EXPANSION BOLTS SHALL BE PROVIDED BY RAMSET/REDHEAD, HILTI OR APPROVED EQUAL.
- ALL STRUCTURAL STEEL SHALL BE SUPPLIED IN ACCORDANCE WITH TECHNICAL SPECIFICATION FOR CONSTRUCTION OF RADIO ACCESS NETWORK SITES.



T-MOBILE NORTHEAST LLC

35 GRIFFIN ROAD SOUTH  
 BLOOMFIELD, CT 06002  
 O: 860-692-7100  
 F: 860-692-7159



420 MAIN STREET  
 STURBRIDGE, MA 01566  
 O: 860-692-7100  
 F: 860-692-7159



489 WASHINGTON STREET  
 AUBURN, MA 01501  
 TEL: 508-981-9590  
 FAX: 508-519-8939



THIS DOCUMENT IS THE CREATION, DESIGN, PROPERTY AND COPYRIGHTED WORK OF T-MOBILE COMMUNICATIONS. ANY DUPLICATION OR USE WITHOUT EXPRESS WRITTEN CONSENT IS STRICTLY PROHIBITED. DUPLICATION AND USE BY GOVERNMENT AGENCIES FOR THE PURPOSES OF CONDUCTING THEIR LAWFULLY AUTHORIZED REGULATORY AND ADMINISTRATIVE FUNCTIONS IS SPECIFICALLY ALLOWED.

SUBMITTALS			
NO	DATE	DESCRIPTION	BY
2	02/20/17	FOR PERMITTING	MN
1	02/13/17	GENERAL REVISIONS	MN
0	02/06/17	ISSUED FOR REVIEW	MN

SITE NUMBER:  
**CT11352-C**  
 SITE NAME:  
**CROWN CHESHIRE**  
 SITE ADDRESS:  
**1119 SUMMIT ROAD  
 CHESHIRE, CT 06410**

SHEET TITLE:  
**GENERAL NOTES**

SHEET NUMBER:  
**02**

**GENERAL NOTES**

1. THE TYPE, DIMENSIONS, MOUNTING HARDWARE, AND THE POSITIONS OF ALL EQUIPMENT IN THE COMPOUND ARE SHOWN IN ILLUSTRATIVE FASHION. THESE DRAWINGS ARE NOT INTENDED FOR CONSTRUCTION. ACTUAL HARDWARE DETAILS AND FINAL LOCATIONS MAY DIFFER SLIGHTLY FROM WHAT IS SHOWN.

2. THE CELLULAR INSTALLATION IS AN UNMANNED PRIVATE AND SECURED COMPOUND. IT IS ONLY ACCESSED BY TRAINED TECHNICIANS FOR PERIODIC ROUTINE MAINTENANCE AND THEREFORE DOES NOT REQUIRE ANY WATER OR SANITARY SEWER SERVICE. THE FACILITY IS NOT GOVERNED BY REGULATIONS REQUIRING PUBLIC ACCESS PER ADA REQUIREMENTS.

3. CONSTRUCTION, MAINTENANCE & OPERATION OF PROPOSED TOWER FACILITY WILL BE HELD IN ACCORDANCE WITH ALL APPLICABLE LOCAL, STATE & FEDERAL REGULATIONS AND GUIDELINES.



(E) T-MOBILE PANEL IN BETA SECTOR POSITION #3 (1/SECT., 3 TOT.) WITH EXISTING 2 TMA'S TO REMAIN (2/SECT., 6 TOT.)

(P) T-MOBILE LTE ERICSSON AIR32 DB B66Aa B2a PANEL IN BETA SECTOR POSITION #2 (1/SECT., 3 TOT.)

(E) T-MOBILE LTE PANEL IN BETA SECTOR POSITION #1 (1/SECT., 3 TOT.) WITH (E) SMART BIAS T ON L700 ANTENNA (1/SECT., 3 TOT.)

(P) T-MOBILE 6x12 HYBRID FIBER CABLE TO FOLLOW EXISTING CABLE ROUTE

(E) T-MOBILE CABINETS INSIDE EQUIPMENT ROOM

(E) T-MOBILE LTE PANEL IN GAMMA SECTOR POSITION #1 (1/SECT., 3 TOT.) WITH (E) SMART BIAS T ON L700 ANTENNA (1/SECT., 3 TOT.)

(P) T-MOBILE LTE ERICSSON AIR32 DB B66Aa B2a PANEL IN GAMMA SECTOR POSITION #2 (1/SECT., 3 TOT.)

(E) T-MOBILE PANEL IN GAMMA SECTOR POSITION #3 (1/SECT., 3 TOT.) WITH EXISTING 2 TMA'S TO REMAIN (2/SECT., 6 TOT.)

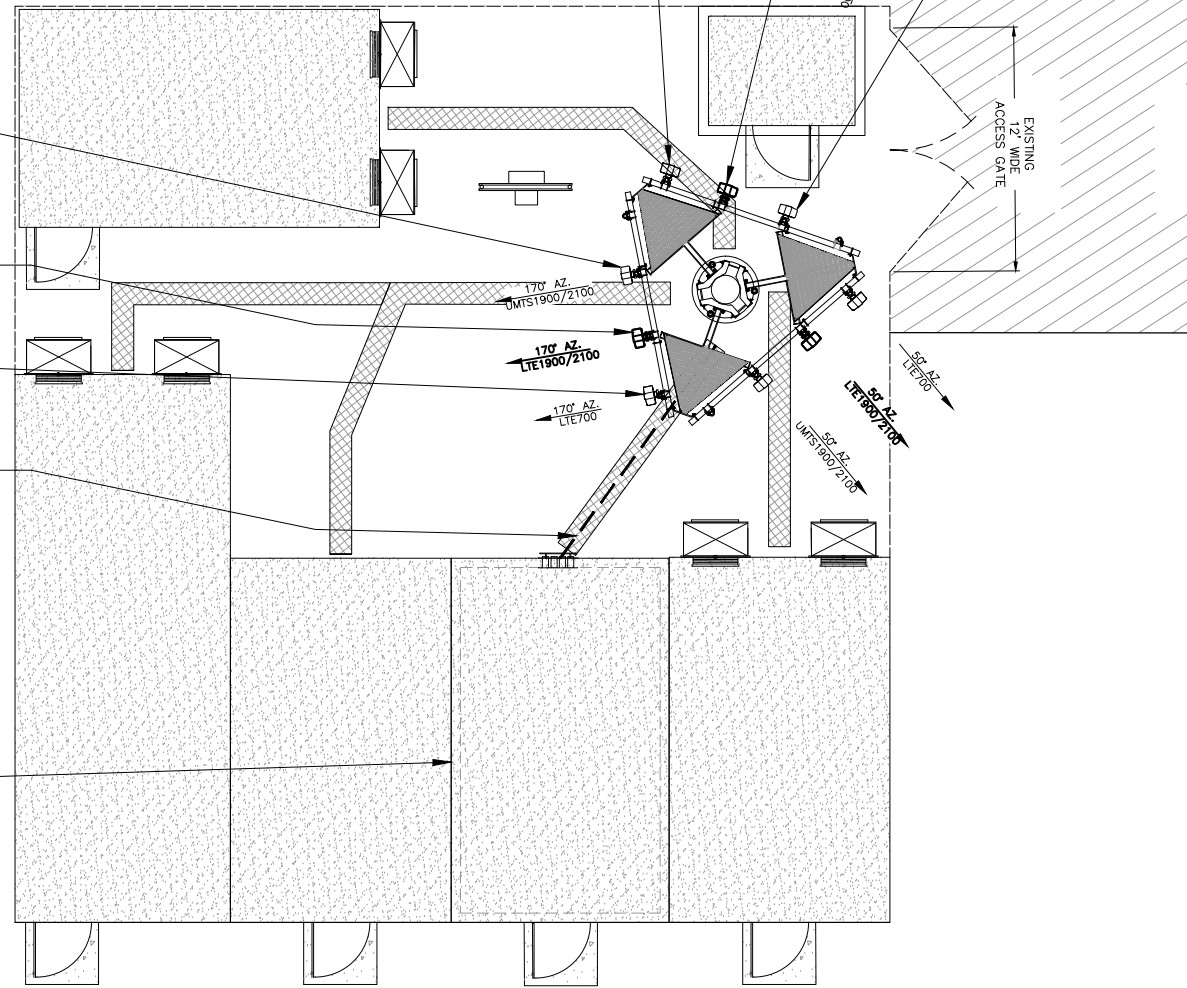

**SITE PLAN** 2  
SCALE: 1" = 5'

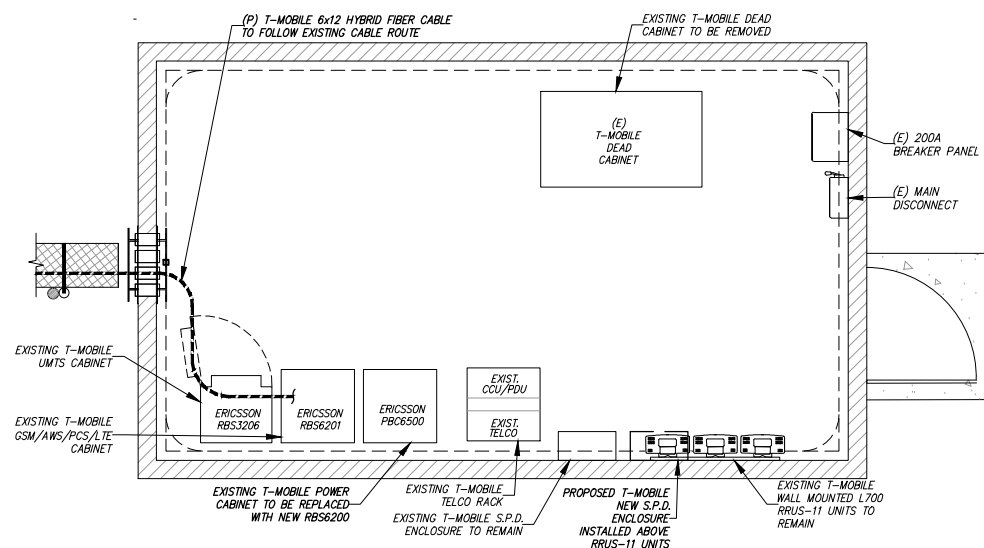
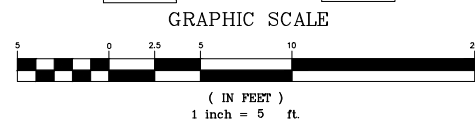

**EQUIPMENT ROOM LAYOUT** 1  
SCALE: 1" = 2.5'

(E) CARRIER ANTENNAS ELEV.= ±167'-0" ± AGL.

(E) CARRIER ANTENNAS ELEV.= ±158'-0" ± AGL.

(E) CARRIER ANTENNAS ELEV.= ±148'-0" ± AGL.

(E) T-MOBILE (6) EXISTING LTE/UMTS ANTENNAS, (3) NEW ERICSSON AIR32 DB B66Aa B2a ELEV. = ±138'-0" ± AGL.

(E) T-MOBILE PANEL RFS APX16PV-16PVL IN POSITION #3 TO REMAIN (1/SECT., 3 TOT.) WITH EXISTING 2 TMA'S TO REMAIN (2/SECT., 6 TOT.)

(P) T-MOBILE LTE ERICSSON AIR32 DB B66Aa B2a PANEL IN POSITION #2 (1/SECT., 3 TOT.)

(E) T-MOBILE LTE700 COMMSCOPE LNX-6515DS-AIM PANEL IN POSITION #1 TO REMAIN IN PLACE (1/SECT., 3 TOT.) WITH (E) SMART BIAS T ON L700 ANTENNA (1/SECT., 3 TOT.)

(E) T-MOBILE ERICSSON DUAL BAND TMA'S KRY112134/KRY11289 TO REMAIN IN PLACE (2/SECT., 6 TOT.)

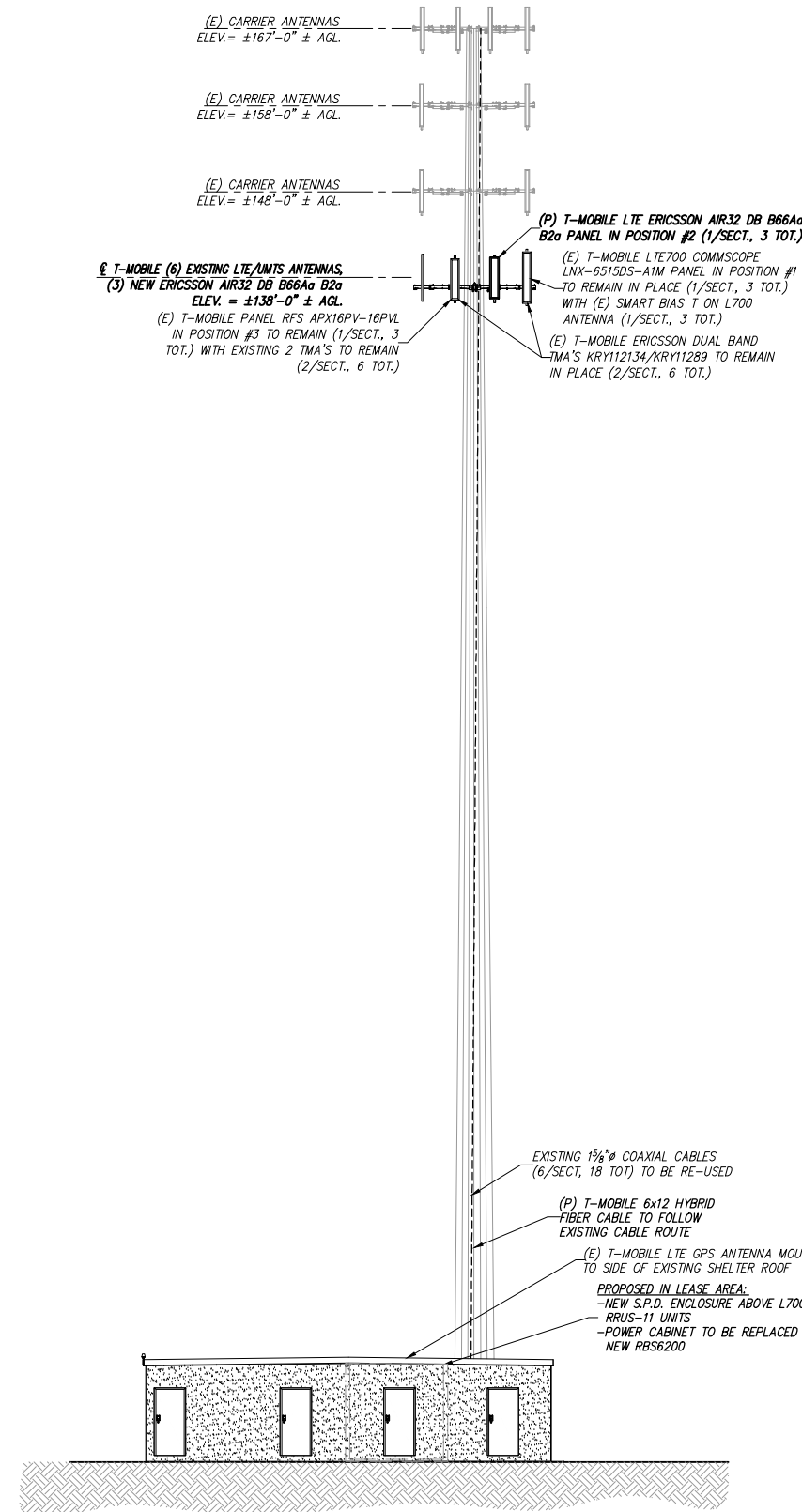

**TOWER ELEVATION VIEW** 3  
SCALE: N.T.S.

**T-Mobile**  
T-MOBILE NORTHEAST LLC

35 GRIFFIN ROAD SOUTH  
BLOOMFIELD, CT 06002  
O: 860-692-7100  
F: 860-692-7159

**NSS**  
NORTHEAST  
SITE SOLUTIONS  
Turnkey Wireless Development

420 MAIN STREET  
STURBRIDGE, MA 01566  
O: 860-692-7100  
F: 860-692-7159

**VRG**  
VERTICAL RESOURCES GRP.

489 WASHINGTON STREET  
AUBURN, MA 01501  
TEL: 508-981-9590  
FAX: 508-519-8939



THIS DOCUMENT IS THE CREATION, DESIGN, PROPERTY AND COPYRIGHTED WORK OF T-MOBILE COMMUNICATIONS. ANY DUPLICATION OR USE WITHOUT EXPRESS WRITTEN CONSENT IS STRICTLY PROHIBITED. DUPLICATION AND USE BY GOVERNMENT AGENCIES FOR THE PURPOSES OF CONDUCTING THEIR LAWFULLY AUTHORIZED REGULATORY AND ADMINISTRATIVE FUNCTIONS IS SPECIFICALLY ALLOWED.

SUBMITTALS			
NO	DATE	DESCRIPTION	BY
2	02/20/17	FOR PERMITTING	MN
1	02/13/17	GENERAL REVISIONS	MN
0	02/06/17	ISSUED FOR REVIEW	MN

SITE NUMBER:  
**CT11352-C**  
SITE NAME:  
**CROWN CHESHIRE**  
SITE ADDRESS:  
**1119 SUMMIT ROAD  
CHESHIRE, CT 06410**

SHEET TITLE:  
**SITE PLAN &  
ELEVATIONS**

SHEET NUMBER:  
**03**



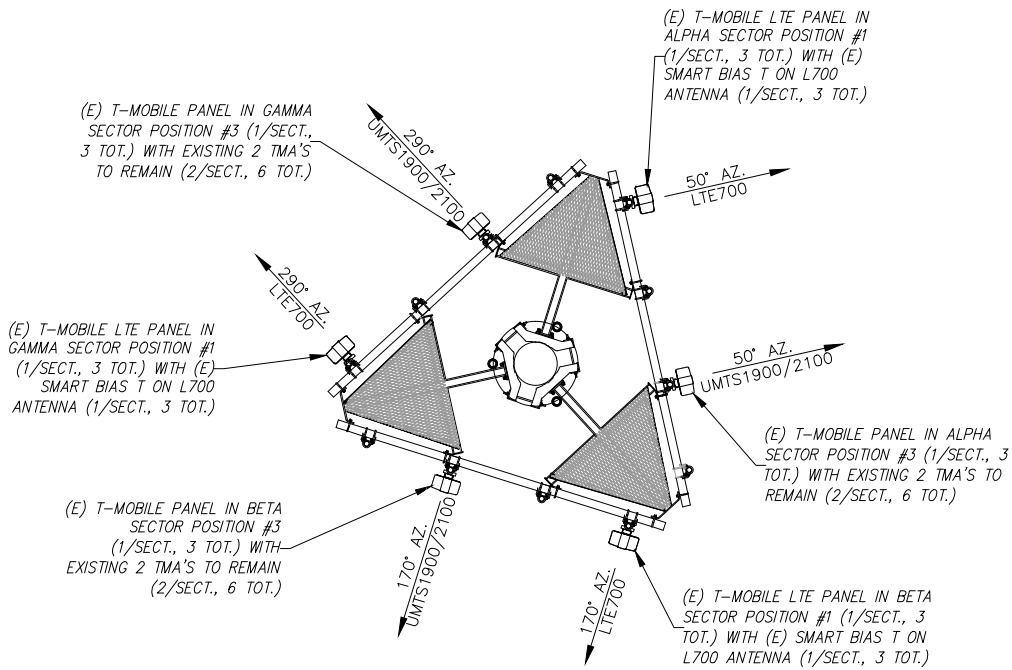

EXISTING ANTENNA CONDITIONS 1  
SCALE: N.T.S. 04

NOTES:  
REFER TO FINAL RF DATA SHEET FOR FINAL ANTENNA SETTINGS AND CONFIGURATIONS

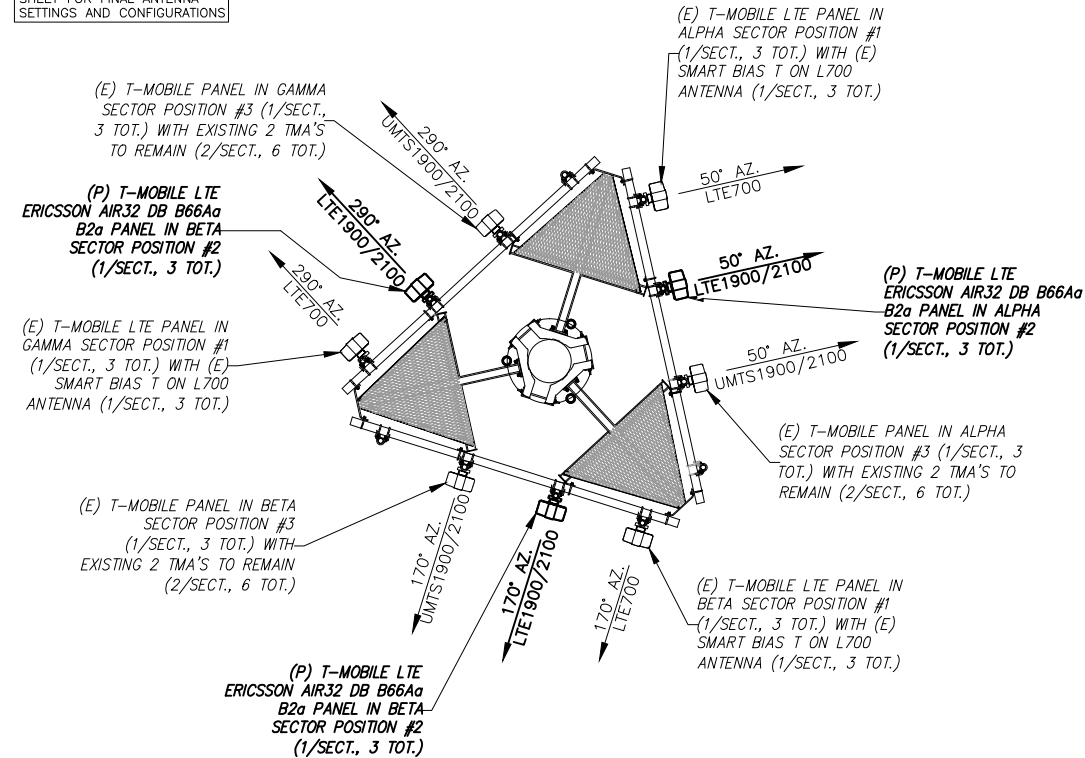

PROPOSED ANTENNA CONFIGURATION 2  
SCALE: N.T.S. 04

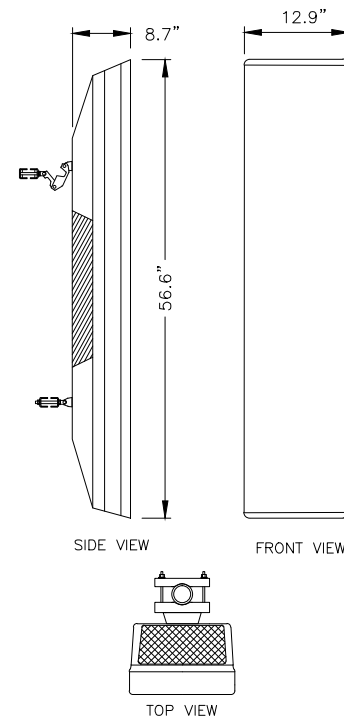

MANUFACTURER:	ERICSSON
MODEL:	AIR32 B66Aa B2A
DIMENSIONS:	HxWxD 56.6"x12.9"x8.7"

ANTENNA DETAILS 3  
ERICSSON AIR32 B66Aa/B2A 04  
SCALE: N.T.S.

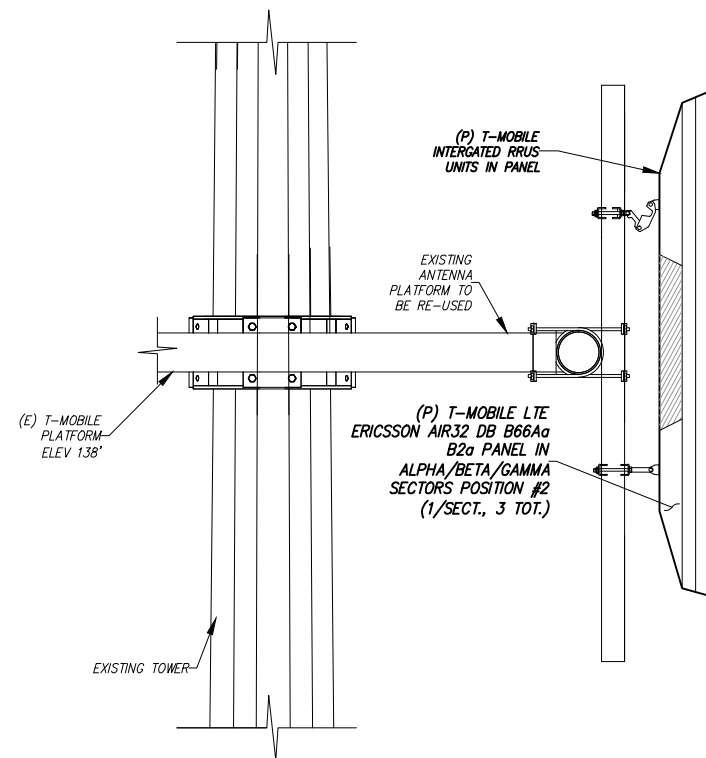

ANTENNA & PIPE MAST ATTACHMENT 4  
SCALE: N.T.S. 04

**T-Mobile**  
T-MOBILE NORTHEAST LLC  
35 GRIFFIN ROAD SOUTH  
BLOOMFIELD, CT 06002  
O: 860-692-7100  
F: 860-692-7159

**NSS**  
NORTHEAST  
SITE SOLUTIONS  
*Turnkey Wireless Development*  
420 MAIN STREET  
STURBRIDGE, MA 01566  
O: 860-692-7100  
F: 860-692-7159

**VRG**  
VERTICAL RESOURCES GRP.  
489 WASHINGTON STREET  
AUBURN, MA 01501  
TEL: 508-981-9590  
FAX: 508-519-8939



THIS DOCUMENT IS THE CREATION, DESIGN, PROPERTY AND COPYRIGHTED WORK OF T-MOBILE COMMUNICATIONS. ANY DUPLICATION OR USE WITHOUT EXPRESS WRITTEN CONSENT IS STRICTLY PROHIBITED. DUPLICATION AND USE BY GOVERNMENT AGENCIES FOR THE PURPOSES OF CONDUCTING THEIR LAWFULLY AUTHORIZED REGULATORY AND ADMINISTRATIVE FUNCTIONS IS SPECIFICALLY ALLOWED.

SUBMITTALS			
NO	DATE	DESCRIPTION	BY
2	02/20/17	FOR PERMITTING	MN
1	02/13/17	GENERAL REVISIONS	MN
0	02/06/17	ISSUED FOR REVIEW	MN

SITE NUMBER:  
**CT11352-C**  
SITE NAME:  
**CROWN CHESHIRE**  
SITE ADDRESS:  
**1119 SUMMIT ROAD  
CHESHIRE, CT 06410**

SHEET TITLE:  
**ANTENNA DETAILS**

SHEET NUMBER:  
**04**

# AIR32 DB

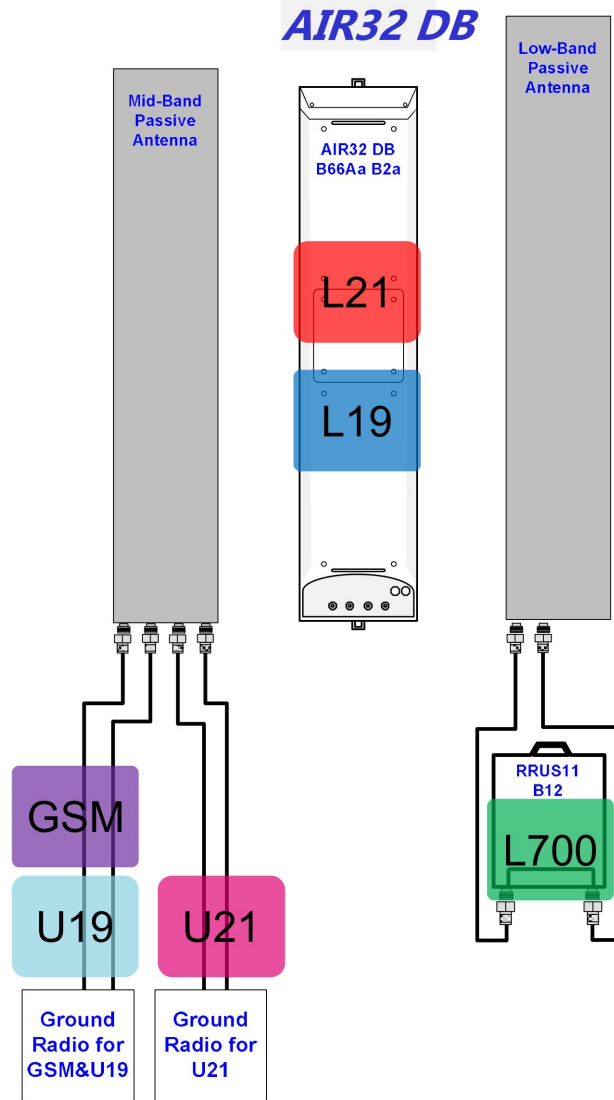

COAX/FIBER  
CABLE PLUMBING DIAGRAM  
SCALE: N.T.S.

1  
05

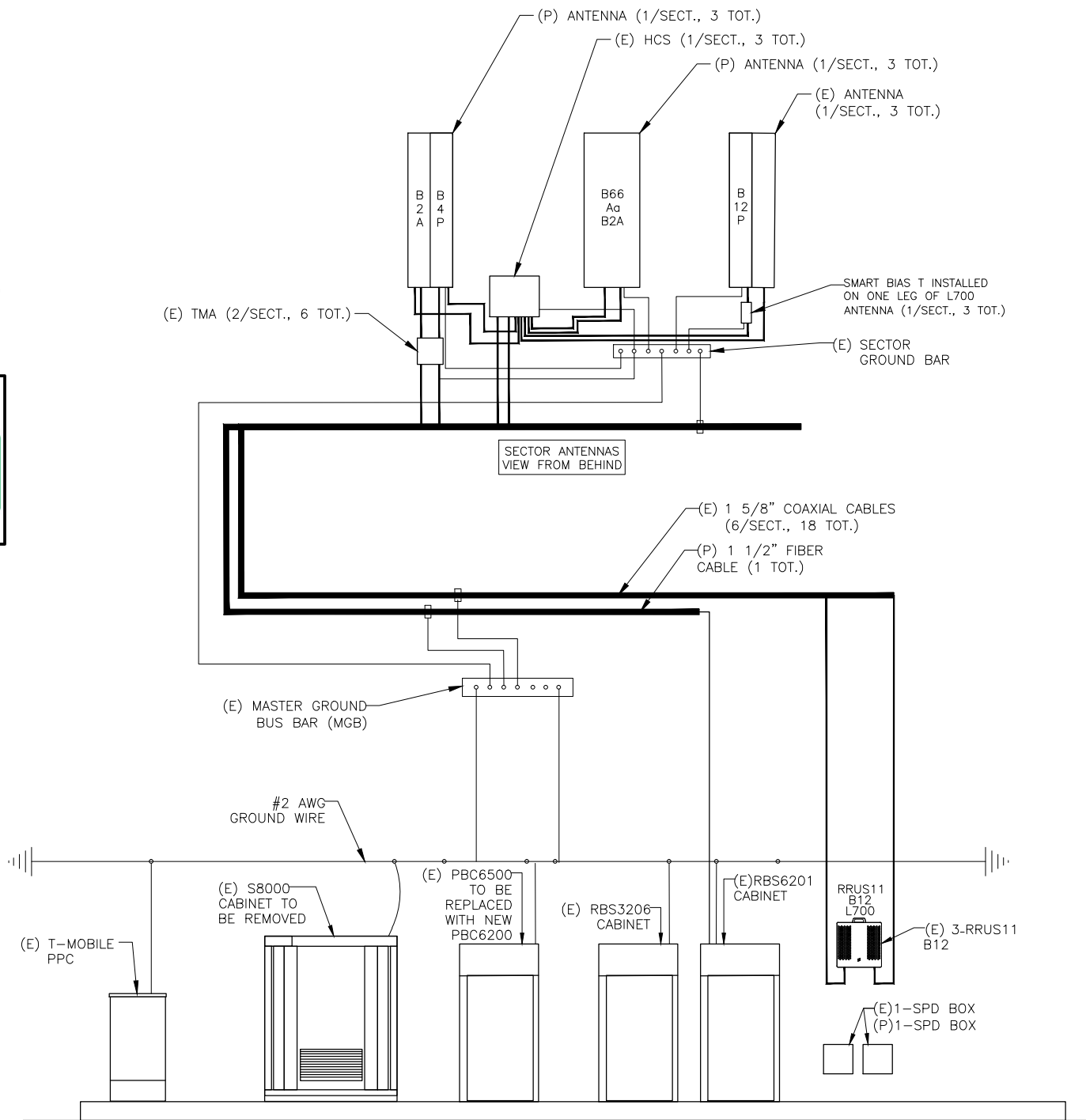

GROUNDING PLUMBING DIAGRAM  
SCALE: N.T.S.

2  
05

### HYBRID FIBER/POWER JUMPER NOTES:

1. IN GENERAL THIS CABLE WILL HANDLE SIMILARLY TO A " COAXIAL CABLE. 38" COAXIAL CABLE.
2. THE TERMINATED FIBER ENDS HOWEVER ARE FRAGILE AND MUST BE PROTECTED DURING INSTALLATION. LEAVE THE PACKAGING AROUND THE FIBER ENDS IN PLACE UNTIL READY TO CONNECT THE JUMPER BETWEEN OVP AND RRU OR BBU.
3. DO NOT BEND THE FIBER BREAKOUT CABLE (BETWEEN THE MAIN CABLE AND THE FIBER CONNECTOR) TIGHTER THAN " (19MM) RADIUS, ELSE THERE IS A RISK OF BREAKING THE GLASS. 34" (19MM) RADIUS, ELSE THERE IS A RISK OF BREAKING THE GLASS.
4. ATTACH THE MAIN CABLE SECURELY TO THE STRUCTURE OR EQUIPMENT USING HANGERS AND/OR CABLE TIES TO PREVENT STRAIN ON CONNECTIONS FROM MOVEMENT IN WIND OR SNOW/ICE CONDITIONS.
5. ENSURE THE LC FIBER CONNECTORS ARE SEATED FIRMLY IN PANEL IN OVP OR IN EQUIPMENT.
6. INSTALLATION TEMPERATURE RANGE IS -22F TO 158F (-30C TO 70C).
7. MINIMUM CABLE BEND RADII ARE 10.3 INCH (265MM) LOADED (WITH TENSION ON THE CABLE) AND 5.2 INCH (130MM) UNLOADED.
8. MAXIMUM CABLE TENSILE LOAD IS 350 LB (1560N) SHORT TERM (DURING INSTALLATION) AND 105 LB (470N) LONG TERM.
9. STANDARD LENGTHS AVAILABLE ARE 6 FEET, 15 FEET AND 20 FEET

### TRUNK FIBER NOTES:

1. IN GENERAL THIS CABLE WILL HANDLE SIMILARLY TO " COAXIAL CABLE, AND SIMILAR INSTALLATION TECHNIQUES APPLY. ALL 78" COAXIAL CABLE, AND SIMILAR INSTALLATION TECHNIQUES APPLY. ALL CABLES ARE INDIVIDUALLY SERIALIZED, BE SURE TO WRITE DOWN THE CABLE SERIAL NUMBER FOR FUTURE REFERENCE.
2. THE TERMINATED FIBER ENDS (THE BROKEN OUT FIBERS PLUS CONNECTORS) HOWEVER ARE FRAGILE, AND THESE MUST BE PROTECTED DURING THE INSTALLATION PROCESS.
3. LEAVE THE PROTECTIVE TUBE AND SOCK AROUND THE FIBER TAILS AND CONNECTORS IN PLACE DURING HOISTING AND SECURING THE CABLE. REMOVE THIS ONLY JUST PRIOR TO MAKING THE FINAL CONNECTIONS TO THE OVP BOX.
4. DO NOT BEND THE FIBER ENDS (IN THE ORANGE FURCATION TUBES) TIGHTER THAN " (19MM) BEND RADIUS, ELSE THERE IS 34" (19MM) BEND RADIUS, ELSE THERE IS A RISK OF BREAKING THE GLASS FIBERS.
5. BE SURE THAT THE LACE UP ENDS AND FIBER CONNECTORS ARE NOT DAMAGED BY ATTACHMENT OF A HOISTING GRIP OR DURING THE HOISTING PROCESS. ATTACH A HOISTING GRIP ON THE JACKETED CABLE NO LESS THAN 6 INCHES BELOW THE FIBER BREAKOUT POINT. IF A HOISTING GRIP IS NOT EASILY ATTACHED, USE A SIMPLE LINE ATTACHED BELOW THE FIBER BREAK-OUT POINT (I.E. AT THE CABLE OUTER JACKET). PREVENT THE FIBER TAILS (IN PROTECTIVE TUBE) AT THE CABLE END FROM UNDUE MOVEMENT DURING HOISTING BY SECURING THE PROTECTIVE TUBE (WITH OUTER SOCK) TO THE HOISTING LINE.
6. DURING HOISTING ENSURE THAT THERE IS A FREE PATH AND THAT THE CABLE, AND ESPECIALLY THE FIBER ENDS, WILL NOT CATCH ON TOWER MEMBERS OR OTHER OBSTACLES.
7. INSTALLATION TEMPERATURE RANGE IS -22F TO 158F (-30C TO +70C).
8. MINIMUM CABLE BEND RADII ARE 22.2" (565MM) LOADED (WITH TENSION ON THE CABLE) AND 11.1" (280MM) UNLOADED.
9. MAXIMUM CABLE TENSILE LOAD IS 3560 N (800 LB) SHORT TERM (DURING INSTALLATION) AND 1070 N (240 LB) LONG TERM.
10. COMMSCOPE NON LACE UP GRIP RECOMMENDED FOR MONOPOLE INSTALLATIONS. 11. MAXIMUM HANGER SPACING 3FT (0.9 M).

**T-Mobile**  
T-MOBILE NORTHEAST LLC  
35 GRIFFIN ROAD SOUTH  
BLOOMFIELD, CT 06002  
O: 860-692-7100  
F: 860-692-7159

**NSS**  
NORTHEAST  
SITE SOLUTIONS  
Turnkey Wireless Development  
420 MAIN STREET  
STURBRIDGE, MA 01566  
O: 860-692-7100  
F: 860-692-7159

**VRG**  
VERTICAL RESOURCES GRP.  
489 WASHINGTON STREET  
AUBURN, MA 01501  
TEL: 508-981-9590  
FAX: 508-519-8939

THIS DOCUMENT IS THE CREATION, DESIGN, PROPERTY AND COPYRIGHTED WORK OF T-MOBILE COMMUNICATIONS. ANY DUPLICATION OR USE WITHOUT EXPRESS WRITTEN CONSENT IS STRICTLY PROHIBITED. DUPLICATION AND USE BY GOVERNMENT AGENCIES FOR THE PURPOSES OF CONDUCTING THEIR LAWFULLY AUTHORIZED REGULATORY AND ADMINISTRATIVE FUNCTIONS IS SPECIFICALLY ALLOWED.

SUBMITTALS			
NO	DATE	DESCRIPTION	BY
2	02/20/17	FOR PERMITTING	MN
1	02/13/17	GENERAL REVISIONS	MN
0	02/06/17	ISSUED FOR REVIEW	MN

SITE NUMBER:  
**CT11352-C**  
SITE NAME:  
**CROWN CHESHIRE**  
SITE ADDRESS:  
**1119 SUMMIT ROAD  
CHESHIRE, CT 06410**

SHEET TITLE:  
**GROUNDING & RF  
PLUMBING DIAGRAM**

SHEET NUMBER:  
**05**

NOTE:  
DO NOT INSTALL CABLE  
GROUND KIT AT A BEND  
AND ALWAYS DIRECT  
GROUND WIRE DOWN TO  
CIGBE

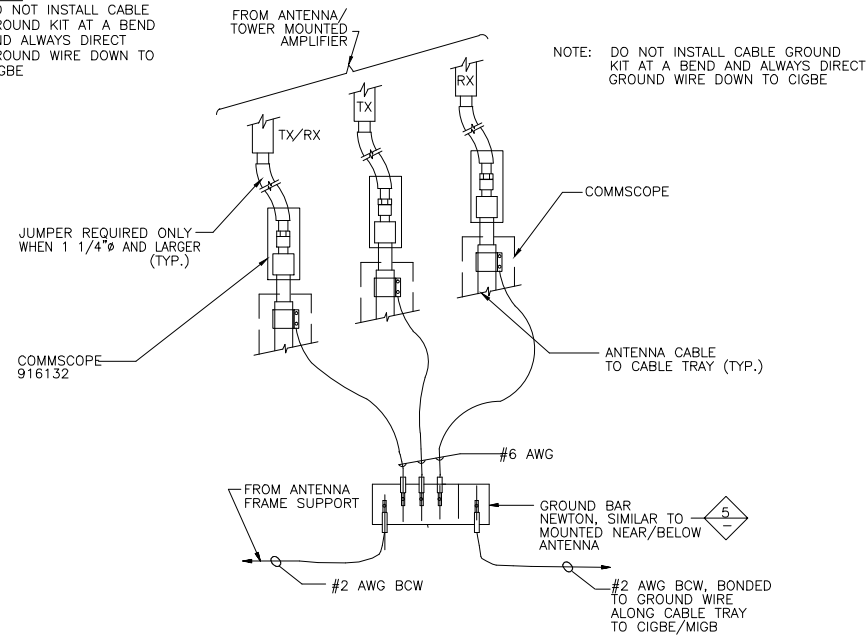

CONNECTION OF GROUND WIRES TO GROUNDING BAR 1  
SCALE: N.T.S. 06

NOTE: DO NOT INSTALL CABLE  
GROUND KIT AT A BEND AND ALWAYS  
DIRECT GROUND WIRE DOWN TO  
CIGBE

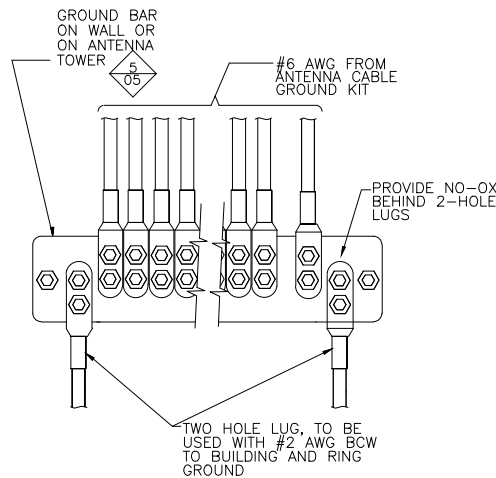

INSTALLATION OF GROUND  
WIRE TO GROUND BAR 2  
SCALE: N.T.S. 06

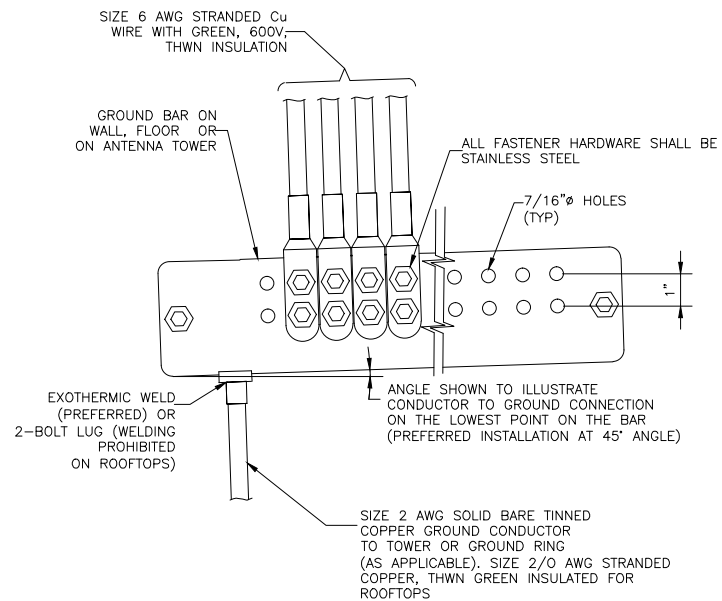

INSTALLATION OF GROUND WIRE  
TO ANTENNA CABLE GROUND BAR 5  
SCALE: N.T.S. 06

CONNECTION OF GROUND WIRES TO GROUNDING BAR 1  
SCALE: N.T.S. 06

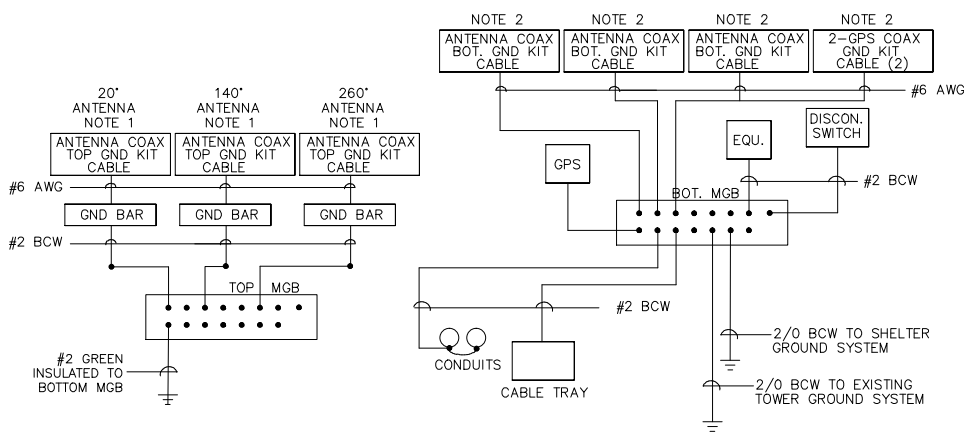

NOTE:  
1. BOND ANTENNA GROUNDING KIT CABLE TO TOP CIGBE  
2. BOND ANTENNA GROUNDING KIT CABLE TO BOTTOM CIGBE

GROUNDING ONE-LINE DIAGRAM 3  
SCALE: N.T.S. 06

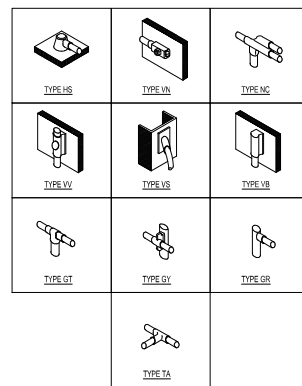

GROUNDING CONNECTION DETAIL 4  
SCALE: N.T.S. 06

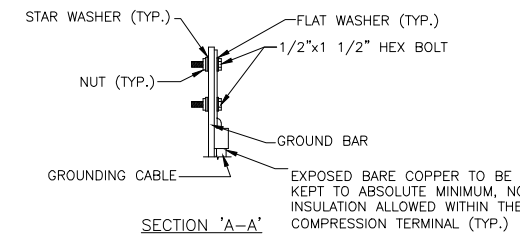
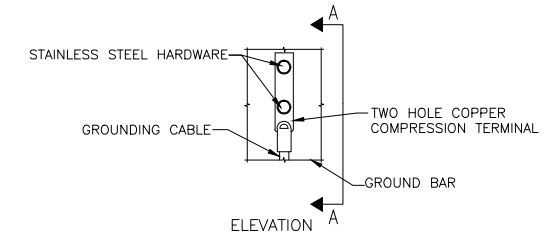

NOTES:  
1. DOUBLING UP OR STACKING OF CONNECTIONS IS NOT PERMITTED  
2. OXIDE INHIBITING COMPOUND TO BE USED AT ALL LOCATIONS.

TYP. MECHANICAL CONNECTION 6  
SCALE: N.T.S. 06

NEWTON INSTRUMENT COMPANY, INC. BUTNER, N.C. OR APPROVED EQUAL			
ITEM	REQ.	PART NO.	DESCRIPTION
①	1	1/4"x4"x12"	PRE DRILLED GND. BAR
②	2	A-6056	WALL MTG. BRKT.
③	2	3061-4	INSULATORS
④	2	3012-13	5/8"-11x4" H.H.C.S.
⑤	4	3015-8	5/8 LOCKWASHER
⑥	2	3014-8	5/8"-11 HEX NUT

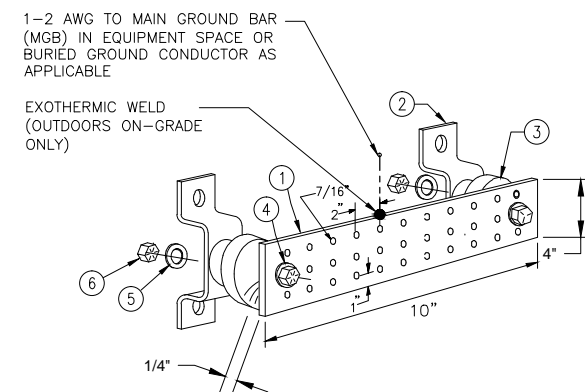

GROUND BAR DETAIL 7  
SCALE: N.T.S. 06

**T-Mobile**  
T-MOBILE NORTHEAST LLC  
35 GRIFFIN ROAD SOUTH  
BLOOMFIELD, CT 06002  
O: 860-692-7100  
F: 860-692-7159

**NSS**  
NORTHEAST  
SITE SOLUTIONS  
Turnkey Wireless Development  
420 MAIN STREET  
STURBRIDGE, MA 01566  
O: 860-692-7100  
F: 860-692-7159

**VRG**  
VERTICAL RESOURCES GRP.  
489 WASHINGTON STREET  
AUBURN, MA 01501  
TEL: 508-981-9590  
FAX: 508-519-8939

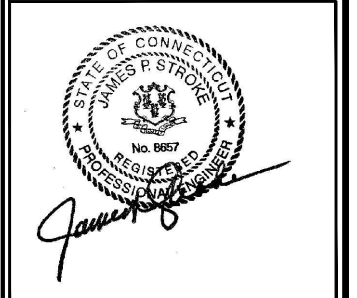

THIS DOCUMENT IS THE CREATION, DESIGN, PROPERTY AND COPYRIGHTED WORK OF T-MOBILE COMMUNICATIONS. ANY DUPLICATION OR USE WITHOUT EXPRESS WRITTEN CONSENT IS STRICTLY PROHIBITED. DUPLICATION AND USE BY GOVERNMENT AGENCIES FOR THE PURPOSES OF CONDUCTING THEIR LAWFULLY AUTHORIZED REGULATORY AND ADMINISTRATIVE FUNCTIONS IS SPECIFICALLY ALLOWED.

SUBMITTALS			
NO	DATE	DESCRIPTION	BY
2	02/20/17	FOR PERMITTING	MN
1	02/13/17	GENERAL REVISIONS	MN
0	02/06/17	ISSUED FOR REVIEW	MN

SITE NUMBER:  
**CT11352-C**  
SITE NAME:  
**CROWN CHESHIRE**  
SITE ADDRESS:  
**1119 SUMMIT ROAD  
CHESHIRE, CT 06410**

SHEET TITLE:  
**GROUNDING DETAILS**

SHEET NUMBER:  
**06**

# Exhibit D

Date: **January 30, 2017**

Charles McGuirt  
Crown Castle  
3530 Toringdon Way, Suite 300  
Charlotte, NC 28277  
(704) 405-6607



Tower Engineering Professionals  
326 Tryon Road  
Raleigh, NC 27603  
(919) 661-6351  
[crown@tepgroup.net](mailto:crown@tepgroup.net)

**Subject: Structural Analysis Report**

**Carrier Designation:** *T-Mobile Co-Locate*  
**Carrier Site Number:** CT11352C  
**Carrier Site Name:** Crowne Cheshire

**Crown Castle Designation:**  
**Crown Castle BU Number:** 801367  
**Crown Castle Site Name:** CT NHV-2075 CAC 801367  
**Crown Castle JDE Job Number:** 417155  
**Crown Castle Work Order Number:** 1353714  
**Crown Castle Application Number:** 374826 Rev. 0

**Engineering Firm Designation:** **TEP Project Number:** 25630.106836

**Site Data:** **1121 Summit Road, Cheshire, New Haven County, CT 06410**  
**Latitude 41° 32' 11.2", Longitude -72° 57' 26.3"**  
**167 Foot - Monopole Tower**

Dear Charles McGuirt,

*Tower Engineering Professionals* is pleased to submit this "**Structural Analysis Report**" to determine the structural integrity of the above mentioned tower. This analysis has been performed in accordance with the Crown Castle Structural 'Statement of Work' and the terms of Crown Castle Purchase Order Number 994397, in accordance with application 374826, revision 0.

The purpose of the analysis is to determine acceptability of the tower stress level. Based on our analysis we have determined the tower stress level for the structure and foundation, under the following load case, to be:

LC7: Existing + Reserved + Proposed Equipment

**Sufficient Capacity**

Note: See Table I and Table II for the proposed and existing/reserved loading, respectively.

This analysis has been performed in accordance with the 2016 Connecticut State Building Code (2012 International Building Code) based upon an ultimate 3-second gust wind speed of 125 mph converted to a nominal 3-second gust wind speed of 97 mph per Section 1609.3 and Appendix N as required for use in the TIA-222-G Standard per Exception #5 of Section 1609.1.1. Exposure Category B and Risk Category II were used in this analysis.

All modifications and equipment proposed in this report shall be installed in accordance with the appurtenances listed in Tables 1 and 2 and the attached drawing for the determined available structural capacity to be effective.

We at *Tower Engineering Professionals* appreciate the opportunity of providing our continuing professional services to you and *Crown Castle*. If you have any questions or need further assistance on this or any other projects please give us a call.

Structural analysis prepared by: Matthew T. Weavil, E.I. / ZRH

Respectfully submitted by:

Graham M. Andres, P.E.



## TABLE OF CONTENTS

### 1) INTRODUCTION

### 2) ANALYSIS CRITERIA

Table 1 - Proposed Antenna and Cable Information

Table 2 - Existing and Reserved Antenna and Cable Information

Table 3 - Design Antenna and Cable Information

### 3) ANALYSIS PROCEDURE

Table 4 - Documents Provided

3.1) Analysis Method

3.2) Assumptions

### 4) ANALYSIS RESULTS

Table 5 - Section Capacity (Summary)

Table 6 - Tower Component Stresses vs. Capacity

4.1) Recommendations

### 5) APPENDIX A

tnxTower Output

### 6) APPENDIX B

Base Level Drawing

### 7) APPENDIX C

Additional Calculations



## 1) INTRODUCTION

This tower is a 167-ft monopole tower designed by Paul J. Ford and Company in June of 2001. The tower was originally designed for a wind speed of 85 mph per TIA/EIA-222-F for the appurtenances listed in Table 3. The tower has been modified multiple times in the past to accommodate additional loading. TEP visited the site in November of 2012 and May of 2013 to perform post modification inspections. All information provided to TEP was assumed to be accurate and complete.

## 2) ANALYSIS CRITERIA

The analysis has been performed in accordance with the ANSI/TIA-222-G-2-2009 Structural Standard for Antenna Supporting Structures and Antennas – Addendum 2 using a nominal 3-second gust wind speed of 97 mph with no ice, 50 mph with 0.75 inch ice thickness and 60 mph under service loads with the following design criteria:

Type of Analysis: **Rigorous Structural Analysis**

Classification of Structure: **Class II**

Exposure Category: **Exposure B**

Topographic Category: **Category 1**

Earthquake Category: **Not Considered**

Earthquake effects may be ignored per this standard for site locations where  $S_s$  does not exceed 1.0. (New Haven County Max  $S_s = 0.32$ ).

**Table 1 - Proposed Antenna and Cable Information**

Mounting Level (ft)	Center Line Elevation (ft)	Number of Antennas	Antenna Manufacturer	Antenna Model	Number of Feed Lines	Feed Line Size (in)	Note
138.0	138.0	3	Ericsson	AIR -32 B2A/B66AA w/ Mount Pipe	1	1-1/2	1
		3	Commscope	LNx-6515DS-A1M w/ Mount Pipe			

Notes:

- 1) See "Appendix B – Base Level Drawing" for assumed feed line configuration.

**Table 2 - Existing and Reserved Antenna and Cable Information**

Mounting Level (ft)	Center Line Elevation (ft)	Number of Antennas	Antenna Manufacturer	Antenna Model	Number of Feed Lines	Feed Line Size (in)	Note
167.0	171.0	1	GPS	GPS_A	19 1	1-5/8 1/2	1
	168.0	6	Antel	LPA-80063-6CF-EDIN w/ Mount Pipe			
		3	Antel	BXA-70063-6CF-EDIN-2 w/ Mount Pipe			
		3	Antel	BXA-171063-8BF-2 w/ Mount Pipe			
		3	Antel	BXA-171063-8CF-EDIN-X w/ Mount Pipe			
		3	Alcatel Lucent	RRH2X40-AWS			
	1	RFS Celwave	DB-T1-6Z-8AB-0Z				
167.0	1	Tower Mounts	Platform Mount [LP 1201-1]				

Mounting Level (ft)	Center Line Elevation (ft)	Number of Antennas	Antenna Manufacturer	Antenna Model	Number of Feed Lines	Feed Line Size (in)	Note
158.0	160.0	3	CCI Antennas	TPA-65R-LCUUUU-H8 w/ Mount Pipe	2 1	3/4 3/8	2
		6	CCI Antennas	TPX-070821			
		3	Ericsson	RRUS 32			
		3	Ericsson	RRUS 32 B2			
		1	Raycap	DC6-48-60-18-8F			
		1	Tower Mounts	Handrail Kit [NA 510-1]			
	3	Andrew	SBNH-1D6565C w/ Mount Pipe	12 2 1	1-5/8 3/4 3/8	1	
	3	Powerwave Technologies	7770.00 w/ Mount Pipe				
	1	Raycap	DC6-48-60-18-8F				
	3	Ericsson	RRUS-11				
6	Powerwave Technologies	LGP21401	-	-	2		
1	Tower Mounts	Platform Mount [LP 1201-1]					
157.0	1	Tower Mounts	Kicker Support Kit [NA 509-3]	-	-	2	
150.0	151.0	3	Alcatel Lucent	PCS 1900MHz 4x45W-65MHz	-	-	1
	150.0	3	Alcatel Lucent	TME-800MHZ RRH			
		2	Tower Mounts	Pipe Mount [PM 601-3]			
148.0	148.0	1	Tower Mounts	Platform Mount [LP 1201-1]	3 1	1/2 5/8	1
	147.0	3	RFS Celwave	APXVTM14-C-120 w/ Mount Pipe			
		3	RFS Celwave	APXVSP18-C-A20 w/ Mount Pipe			
		3	Alcatel Lucent	TD-RRH8x20-25			
		3	Alcatel Lucent	800 External Notch Filter			
		9	RFS Celwave	ACU-A20-N			
138.0	138.0	3	Commscope	LNx-6515DS-VTM w/ Mount Pipe	18	1-5/8	1
		3	RFS Celwave	APX16PV-16PVL w/ Mount Pipe			
		3	Ericsson	KRY 112 134/1			
		3	Ericsson	KRY 112 89/5			
		3	Commscope	ATBT-BOTTOM-24V			
		1	Tower Mounts	Platform Mount [LP 1201-1]			

Notes:

- 1) Existing equipment
- 2) Reserved equipment
- 3) Existing equipment to be removed; not considered in this analysis

**Table 3 - Design Antenna and Cable Information**

Mounting Level (ft)	Center Line Elevation (ft)	Number of Antennas	Antenna Manufacturer	Antenna Model	Number of Feed Lines	Feed Line Size (in)
168.0	168.0	1	Generic	Panel Antennas (Total CaAa = 40 sq. ft.)	-	-
158.0	158.0	1	Generic	Panel Antennas (Total CaAa = 40 sq. ft.)	-	-
148.0	148.0	1	Generic	Panel Antennas (Total CaAa = 40 sq. ft.)	-	-
138.0	138.0	1	Generic	Panel Antennas (Total CaAa = 40 sq. ft.)	-	-
128.0	128.0	1	Generic	Panel Antennas (Total CaAa = 40 sq. ft.)	-	-
118.0	118.0	1	Generic	Panel Antennas (Total CaAa = 40 sq. ft.)	-	-

### 3) ANALYSIS PROCEDURE

**Table 4 - Documents Provided**

Document	Remarks	Reference	Source
Geotechnical Report	Clough, Harbour & Associates, LLP	445076	CCISites
Tower Foundation Drawings	Paul J. Ford and Company	842573	CCISites
Foundation Mapping	FDH Velocitel	842573	CCISites
Tower Manufacturer Drawings	Paul J. Ford and Company	799210	CCISites
Tower Reinforcement Drawings	Paul J. Ford and Company	3245562	CCISites
Post Modification Inspection	Tower Engineering Professionals	3379750	CCISites
Tower Reinforcement Drawings	Paul J. Ford and Company	3461318	CCISites
Post Modification Inspection	Tower Engineering Professionals	3847627	CCISites

#### 3.1) Analysis Method

tnxTower (version 7.0.5.1), a commercially available analysis software package, was used to create a three-dimensional model of the tower and calculate member stresses for various loading cases. Selected output from the analysis is included in Appendix A.

For analysis of monopole shaft reinforcements, the plates are modeled as linear appurtenances along the exterior of the pole. The loads calculated from tnxTower are then exported to a proprietary calculation sheet created by Tower Engineering Professionals, Inc. that analyzes each reinforcing element along each critical axis and presents percent capacities for each element and the pole shaft along each critical axis. The actual percent capacity of the tower structure including the reinforcing elements is reported in Table 5 - Section Capacity (Summary).

### 3.2) Assumptions

- 1) The tower and foundation were built in accordance with the manufacturer's specifications.
- 2) The tower and foundation have been maintained in accordance with the manufacturer's specification.
- 3) The configuration of antennas, transmission cables, mounts and other appurtenances are as specified in Tables 1 and 2, and "Appendix B – Base Level Drawing".
- 4) All tower components are in sufficient condition to carry their full design capacity.
- 5) Serviceability with respect to antenna twist, tilt, roll, or lateral translation, is not checked and is left to the carrier or tower owner to ensure conformance.
- 6) All antenna mounts and mounting hardware are structurally sufficient to carry the full design capacity requirements of appurtenance wind area and weight as provided by the original manufacturer specifications. It is the carrier's responsibility to ensure compliance to the structural limitations of the existing and/or proposed antenna mounts. TEP did not perform a site visit to verify the size, condition or capacity of the antenna mounts and did not analyze antennas supporting mounts as part of this structural analysis report.

This analysis may be affected if any assumptions are not valid or have been made in error. Tower Engineering Professionals should be notified to determine the effect on the structural integrity of the tower.

### 4) ANALYSIS RESULTS

**Table 5 - Section Capacity (Summary)**

Section No.	Elevation (ft)	Component Type	Size	Critical Element	P (lb)	$\Phi P_{allow}$ (lb)	% Capacity	Pass / Fail
L1	167.00-118.25	Pole	TP35.36x24.00x0.2500	1	Note 1	Note 1	61.9	Pass
L2	122.75-77.75	Pole	TP44.30x33.81x0.3125	2	Note 1	Note 1	70.1	Pass
L3	83.25-38.25	Pole	TP52.88x42.39x0.3750	3	Note 1	Note 1	65.3	Pass
L4	45.00-0.00	Pole	TP61.04x50.55x0.4375	4	Note 1	Note 1	63.8	Pass
M1	53.00-43.00	Mod (Ex)	(Aero) MP304	1	Note 1	Note 1	76.0	Pass
M2	91.50-81.50	Mod (Ex)	(Aero) MP303	2	Note 1	Note 1	80.6	Pass
M3	65.50-50.50	Mod (Ex)	(Aero) MP304	3	Note 1	Note 1	74.9	Pass
							Summary	
							Pole (L2)	70.1 Pass
							Mod (M2)	80.6 Pass
							<b>RATING =</b>	<b>80.6 Pass</b>

**Table 6 - Tower Component Stresses vs. Capacity**

Notes	Component	Elevation (ft)	% Capacity	Pass / Fail
1	Anchor Rods	-	62.5	Pass
1	Base Plate	-	50.3	Pass
1	Base Foundation Soil Interaction	-	81.7	Pass
1	Base Foundation Structural	-	42.7	Pass

<b>Structure Rating (max from all components) =</b>	<b>81.7%</b>
---	--------------

Notes:

- 1) See additional documentation in "Appendix C - Additional Calculations" for calculations supporting the % capacity listed.

#### **4.1) Recommendations**

- 1) If the load differs from that described in Tables 1 and 2 of this report, "Appendix B – Base Level Drawing" or the provisions of this analysis are found to be invalid, another structural analysis should be performed.
- 2) The tower and its foundation have sufficient capacity to carry the proposed load configuration. No modifications are required at this time.

**APPENDIX A**  
**TNXTOWER OUTPUT**

167.0 ft

**DESIGNED APPURTENANCE LOADING**

TYPE	ELEVATION	TYPE	ELEVATION
Lightning Rod 5/8" x 6"	167	Platform Mount [LP 1201-1]	158
(2) LPA-80063-6CF-EDIN w/ Mount Pipe	167	Miscellaneous [NA 509-3]	157
(2) LPA-80063-6CF-EDIN w/ Mount Pipe	167	PCS 1900MHz 4x45W-65MHz	150
(2) LPA-80063-6CF-EDIN w/ Mount Pipe	167	PCS 1900MHz 4x45W-65MHz	150
BXA-70063-6CF-EDIN-2 w/ Mount Pipe	167	PCS 1900MHz 4x45W-65MHz	150
BXA-70063-6CF-EDIN-2 w/ Mount Pipe	167	TME-800MHz RRH	150
BXA-70063-6CF-EDIN-2 w/ Mount Pipe	167	TME-800MHz RRH	150
BXA-171063-8BF-2 w/ Mount Pipe	167	TME-800MHz RRH	150
BXA-171063-8BF-2 w/ Mount Pipe	167	(2) Pipe Mount [PM 601-3]	150
BXA-171063-8BF-2 w/ Mount Pipe	167	APXVTM14-C-120 w/ Mount Pipe	148
BXA-171063-8CF-EDIN-X w/ Mount Pipe	167	APXVTM14-C-120 w/ Mount Pipe	148
BXA-171063-8CF-EDIN-X w/ Mount Pipe	167	APXVTM14-C-120 w/ Mount Pipe	148
BXA-171063-8CF-EDIN-X w/ Mount Pipe	167	APXVSP18-C-A20 w/ Mount Pipe	148
GPS_A	167	APXVSP18-C-A20 w/ Mount Pipe	148
RRH2X40-AWS	167	APXVSP18-C-A20 w/ Mount Pipe	148
RRH2X40-AWS	167	TD-RRH8x20-25	148
RRH2X40-AWS	167	TD-RRH8x20-25	148
DB-T1-6Z-8AB-OZ	167	TD-RRH8x20-25	148
2.4" Dia x 4-ft Mount Pipe	167	800 EXTERNAL NOTCH FILTER	148
Platform Mount [LP 1201-1]	167	800 EXTERNAL NOTCH FILTER	148
Miscellaneous [NA 510-1]	160	800 EXTERNAL NOTCH FILTER	148
TPA-65R-LCUUUU-H8 w/ Mount Pipe	158	(3) ACU-A20-N	148
TPA-65R-LCUUUU-H8 w/ Mount Pipe	158	(3) ACU-A20-N	148
SBNH-1D6565C w/ Mount Pipe	158	(3) ACU-A20-N	148
SBNH-1D6565C w/ Mount Pipe	158	2.4" Dia x 6-ft Pipe	148
SBNH-1D6565C w/ Mount Pipe	158	2.4" Dia x 6-ft Pipe	148
7770.00 w/ Mount Pipe	158	2.4" Dia x 6-ft Pipe	148
7770.00 w/ Mount Pipe	158	Platform Mount [LP 1201-1]	148
7770.00 w/ Mount Pipe	158	AIR -32 B2A/B66AA w/ Mount Pipe	138
(2) TPX-070821	158	AIR -32 B2A/B66AA w/ Mount Pipe	138
(2) TPX-070821	158	AIR -32 B2A/B66AA w/ Mount Pipe	138
(2) TPX-070821	158	LNX-6515DS-A1M w/ Mount Pipe	138
RRUS 32	158	LNX-6515DS-A1M w/ Mount Pipe	138
RRUS 32	158	LNX-6515DS-A1M w/ Mount Pipe	138
RRUS 32	158	APX16PV-16PVL w/ Mount Pipe	138
RRUS 32 B2	158	APX16PV-16PVL w/ Mount Pipe	138
RRUS 32 B2	158	APX16PV-16PVL w/ Mount Pipe	138
RRUS 32 B2	158	KRY 112 89/5	138
DC6-48-60-18-8F	158	KRY 112 89/5	138
DC6-48-60-18-8F	158	KRY 112 89/5	138
(2) LGP21401	158	KRY 112 134/1	138
(2) LGP21401	158	KRY 112 134/1	138
(2) LGP21401	158	KRY 112 134/1	138
RRUS-11	158	ATBT-BOTTOM-24V	138
RRUS-11	158	ATBT-BOTTOM-24V	138
RRUS-11	158	ATBT-BOTTOM-24V	138
2.4" Dia x 6-ft Pipe	158	2.4" Dia x 6-ft Pipe	138
2.4" Dia x 6-ft Pipe	158	2.4" Dia x 6-ft Pipe	138
2.4" Dia x 6-ft Pipe	158	2.4" Dia x 6-ft Pipe	138
TPA-65R-LCUUUU-H8 w/ Mount Pipe	158	Platform Mount [LP 1201-1]	138

**MATERIAL STRENGTH**

GRADE	Fy	Fu	GRADE	Fy	Fu
MPRF-Fy=65ksi, Density=100%	65 ksi	80 ksi			

**TOWER DESIGN NOTES**

1. Tower is located in New Haven County, Connecticut.
2. Tower designed for Exposure B to the TIA-222-G Standard.
3. Tower designed for a 97 mph basic wind in accordance with the TIA-222-G Standard.
4. Tower is also designed for a 50 mph basic wind with 0.75 in ice. Ice is considered to increase in thickness with height.
5. Deflections are based upon a 60 mph wind.
6. Tower Structure Class II.
7. Topographic Category 1 with Crest Height of 0.00 ft

Section	Length (ft)	Number of Sides	Thickness (in)	Socket Length (ft)	Top Dia (in)	Bot Dia (in)	Grade	Weight (lb)
1	48.75	18	0.2500	4.50	24.0000	35.3600		3873.9
2	32.50	18	0.3125	33.8114	41.3843			4089.9
3	12.50	18	0.3832	5.50	41.3843	44.2970		1794.2
4	19.25	18	0.3750	42.3904	46.8763			3450.6
5	12.50	18	0.4611	46.8763	49.7893			2427.8
6	13.25	18	0.4583	49.7893	52.8770			2734.6
7	45.00	18	0.4375	50.5540	61.0400			11771.3
								30142.4

MPRF-Fy=65ksi, Density=100%

118.3 ft

90.3 ft

77.8 ft

64.0 ft

51.5 ft

38.3 ft

0.0 ft

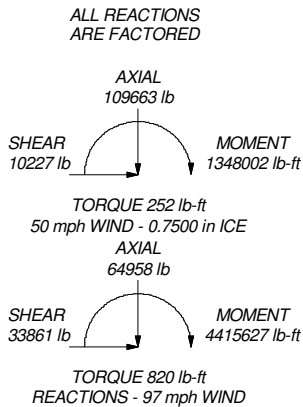

 Tower Engineering Professionals	<b>Tower Engineering Professionals</b> 326 Tryon Road Raleigh, NC 27603 Phone: (919) 661-6351 FAX: (919) 661-6350		Job: <b>CT NHV-2075 CAC 801367 (BU 801367)</b>
	Project: <b>TEP No. 25630.106836</b>		Drawn by: mtweavil    App'd:
	Code: TIA-222-G	Date: 01/30/17	Scale: NTS
	Path: C:\Users\mtweavil\Desktop\S&S\Monopolis\CT NHV-2075_25630.106836\801367_LC7.dwg		Dwg No. E-1

<b>tnxTower</b>  <b>Tower Engineering Professionals</b> 326 Tryon Road Raleigh, NC 27603 Phone: (919) 661-6351 FAX: (919) 661-6350	<b>Job</b> CT NHV-2075 CAC 801367 (BU 801367)	<b>Page</b> 1 of 13
	<b>Project</b> TEP No. 25630.106836	<b>Date</b> 13:41:40 01/30/17
	<b>Client</b> Crown Castle	<b>Designed by</b> mtweavil

## Tower Input Data

There is a pole section.

This tower is designed using the TIA-222-G standard.

The following design criteria apply:

Tower is located in New Haven County, Connecticut.

Basic wind speed of 97 mph.

Structure Class II.

Exposure Category B.

Topographic Category 1.

Crest Height 0.00 ft.

Nominal ice thickness of 0.7500 in.

Ice thickness is considered to increase with height.

Ice density of 56 pcf.

A wind speed of 50 mph is used in combination with ice.

Temperature drop of 50 °F.

Deflections calculated using a wind speed of 60 mph.

A non-linear (P-delta) analysis was used.

Pressures are calculated at each section.

Stress ratio used in pole design is 1.

Local bending stresses due to climbing loads, feed line supports, and appurtenance mounts are not considered.

## Options

<ul style="list-style-type: none"> <li>Consider Moments - Legs</li> <li>Consider Moments - Horizontals</li> <li>Consider Moments - Diagonals</li> <li>Use Moment Magnification</li> <li>√ Use Code Stress Ratios</li> <li>√ Use Code Safety Factors - Guys</li> <li>Escalate Ice</li> <li>Always Use Max Kz</li> <li>Use Special Wind Profile</li> <li>Include Bolts In Member Capacity</li> <li>Leg Bolts Are At Top Of Section</li> <li>Secondary Horizontal Braces Leg</li> <li>Use Diamond Inner Bracing (4 Sided)</li> <li>SR Members Have Cut Ends</li> <li>SR Members Are Concentric</li> </ul>	<ul style="list-style-type: none"> <li>Distribute Leg Loads As Uniform</li> <li>Assume Legs Pinned</li> <li>√ Assume Rigid Index Plate</li> <li>√ Use Clear Spans For Wind Area</li> <li>Use Clear Spans For KL/r</li> <li>Retension Guys To Initial Tension</li> <li>√ Bypass Mast Stability Checks</li> <li>√ Use Azimuth Dish Coefficients</li> <li>√ Project Wind Area of Appurt.</li> <li>Autocalc Torque Arm Areas</li> <li>Add IBC .6D+W Combination</li> <li>√ Sort Capacity Reports By Component</li> <li>Triangulate Diamond Inner Bracing</li> <li>Treat Feed Line Bundles As Cylinder</li> </ul>	<ul style="list-style-type: none"> <li>Use ASCE 10 X-Brace Ly Rules</li> <li>Calculate Redundant Bracing Forces</li> <li>Ignore Redundant Members in FEA</li> <li>SR Leg Bolts Resist Compression</li> <li>All Leg Panels Have Same Allowable</li> <li>Offset Girt At Foundation</li> <li>√ Consider Feed Line Torque</li> <li>Include Angle Block Shear Check</li> <li>Use TIA-222-G Bracing Resist. Exemption</li> <li>Use TIA-222-G Tension Splice Exemption</li> <li style="background-color: #cccccc;">Poles</li> <li>√ Include Shear-Torsion Interaction</li> <li>Always Use Sub-Critical Flow</li> <li>Use Top Mounted Sockets</li> </ul>
--	--	--

## Tapered Pole Section Geometry

Section	Elevation	Section Length	Splice Length	Number of Sides	Top Diameter	Bottom Diameter	Wall Thickness	Bend Radius	Pole Grade
	ft	ft	ft		in	in	in	in	
L1	167.00-118.25	48.75	4.50	18	24.0000	35.3600	0.2500	1.0000	MPRF-Fy=65ksi, Density=100% (65 ksi)



<b>tnxTower</b>  <b>Tower Engineering Professionals</b> 326 Tryon Road Raleigh, NC 27603 Phone: (919) 661-6351 FAX: (919) 661-6350	<b>Job</b> CT NHV-2075 CAC 801367 (BU 801367)	<b>Page</b> 2 of 13
	<b>Project</b> TEP No. 25630.106836	<b>Date</b> 13:41:40 01/30/17
	<b>Client</b> Crown Castle	<b>Designed by</b> mtweavil

Section	Elevation ft	Section Length ft	Splice Length ft	Number of Sides	Top Diameter in	Bottom Diameter in	Wall Thickness in	Bend Radius in	Pole Grade
L2	118.25-90.25	32.50	0.00	18	33.8114	41.3843	0.3125	1.2500	MPRF-Fy=65ksi, Density=100% (65 ksi)
L3	90.25-77.75	12.50	5.50	18	41.3843	44.2970	0.3832	1.5330	MPRF-Fy=65ksi, Density=100% (65 ksi)
L4	77.75-64.00	19.25	0.00	18	42.3904	46.8763	0.3750	1.5000	MPRF-Fy=65ksi, Density=100% (65 ksi)
L5	64.00-51.50	12.50	0.00	18	46.8763	49.7893	0.4611	1.8444	MPRF-Fy=65ksi, Density=100% (65 ksi)
L6	51.50-38.25	13.25	6.75	18	49.7893	52.8770	0.4583	1.8331	MPRF-Fy=65ksi, Density=100% (65 ksi)
L7	38.25-0.00	45.00		18	50.5540	61.0400	0.4375	1.7500	MPRF-Fy=65ksi, Density=100% (65 ksi)

### Tapered Pole Properties

Section	Tip Dia. in	Area in <sup>2</sup>	I in <sup>4</sup>	r in	C in	I/C in <sup>3</sup>	J in <sup>4</sup>	I/Q in <sup>2</sup>	w in	w/t
L1	24.3702	18.8456	1342.9976	8.4313	12.1920	110.1540	2687.7623	9.4246	3.7840	15.136
	35.9055	27.8598	4338.8723	12.4641	17.9629	241.5466	8683.4538	13.9325	5.7834	23.133
L2	35.3977	33.2267	4710.7064	11.8921	17.1762	274.2579	9427.6112	16.6165	5.4008	17.283
	42.0228	40.7381	8682.1373	14.5805	21.0232	412.9781	17375.6988	20.3729	6.7336	21.548
L3	42.0228	49.8743	10592.6546	14.5554	21.0232	503.8545	21199.2473	24.9419	6.6091	17.245
	44.9804	53.4173	13014.2872	15.5894	22.5029	578.3388	26045.6990	26.7137	7.1218	18.583
L4	44.3458	50.0088	11153.2426	14.9155	21.5343	517.9286	22321.1609	25.0092	6.8007	18.135
	47.5995	55.3482	15120.6993	16.5080	23.8132	634.9719	30261.2947	27.6794	7.5902	20.241
L5	47.5995	67.9285	18488.9001	16.4774	23.8132	776.4147	37002.1284	33.9707	7.4387	16.133
	50.5574	72.1916	22192.9316	17.5115	25.2930	877.4353	44415.0652	36.1027	7.9514	17.245
L6	50.5574	71.7536	22060.7965	17.5125	25.2930	872.2112	44150.6213	35.8836	7.9564	17.362
	53.6927	76.2448	26467.9722	18.6087	26.8615	985.3492	52970.7717	38.1296	8.4998	18.548
L7	52.9310	69.5930	22083.3335	17.7914	25.6814	859.8949	44195.7247	34.8031	8.1275	18.577
	61.9816	84.1541	39047.5735	21.5139	31.0083	1259.2612	78146.5267	42.0851	9.9730	22.796

Tower Elevation ft	Gusset Area (per face) ft <sup>2</sup>	Gusset Thickness in	Gusset Grade	Adjust. Factor A <sub>f</sub>	Adjust. Factor A <sub>r</sub>	Weight Mult.	Double Angle Stitch Bolt Spacing Diagonals in	Double Angle Stitch Bolt Spacing Horizontals in	Double Angle Stitch Bolt Spacing Redundants in
L1 167.00-118.25				1	1	1			
L2 118.25-90.25				1	1	1			
L3 90.25-77.75				1	1	0.816763			
L4 77.75-64.00				1	1	1			

<b>tnxTower</b>  <b>Tower Engineering Professionals</b> 326 Tryon Road Raleigh, NC 27603 Phone: (919) 661-6351 FAX: (919) 661-6350	<b>Job</b> CT NHV-2075 CAC 801367 (BU 801367)	<b>Page</b> 3 of 13
	<b>Project</b> TEP No. 25630.106836	<b>Date</b> 13:41:40 01/30/17
	<b>Client</b> Crown Castle	<b>Designed by</b> mtweavil

Tower Elevation	Gusset Area (per face)	Gusset Thickness	Gusset Grade	Adjust. Factor $A_f$	Adjust. Factor $A_r$	Weight Mult.	Double Angle Stitch Bolt Spacing Diagonals	Double Angle Stitch Bolt Spacing Horizontals	Double Angle Stitch Bolt Spacing Redundants
ft	ft <sup>2</sup>	in					in	in	in
L5 64.00-51.50				1	1	0.814712			
L6 51.50-38.25				1	1	0.819643			
L7 38.25-0.00				1	1	1			

### Feed Line/Linear Appurtenances - Entered As Round Or Flat

Description	Sector	Component Type	Placement	Total Number	Number Per Row	Start/End Position	Width or Diameter	Perimeter	Weight
			ft				in	in	plf
561(1-5/8")	B	Surface Ar (CaAa)	167.00 - 0.00	7	6	0.250 0.250	1.6250		1.35
FLC 158-50J(1-5/8")	C	Surface Ar (CaAa)	138.00 - 0.00	4	4	0.000 0.000	2.0150		0.92
***									
Step Pegs (5/8" SR) 7-in. w/30" step	A	Surface Ar (CaAa)	167.00 - 0.00	1	1	-0.250 -0.250	0.3500		0.49
Safety Line 3/8	A	Surface Ar (CaAa)	167.00 - 0.00	1	1	-0.250 -0.250	0.3750		0.22
*									
Aero MP3-04	A	Surface Ar (CaAa)	53.00 - 43.00	1	1	-0.250 -0.250	1.6100		14.10
Aero MP3-04	A	Surface Ar (CaAa)	53.00 - 43.00	1	1	0.500 0.500	1.6100		14.10
Aero MP3-04	A	Surface Ar (CaAa)	65.50 - 53.00	1	1	-0.250 -0.250	1.6100		14.10
Aero MP3-04	A	Surface Ar (CaAa)	65.50 - 53.00	1	1	0.500 0.500	1.6100		14.10
*									
Aero MP3-03	A	Surface Ar (CaAa)	91.50 - 81.50	1	1	-0.250 -0.250	1.5700		9.90
Aero MP3-03	A	Surface Ar (CaAa)	91.50 - 81.50	1	1	0.500 0.500	1.5700		9.90
*									

### Feed Line/Linear Appurtenances - Entered As Area

Description	Face or Leg	Allow Shield	Component Type	Placement	Total Number		$C_{AA}$	Weight
				ft			ft <sup>2</sup> /ft	plf
LDF4-50A(1/2")	C	No	Inside Pole	167.00 - 0.00	1	No Ice 1/2" Ice 1" Ice	0.00 0.00 0.00	0.15 0.15 0.15
HB158-1-08U8-S8J18(1-5/8")	C	No	Inside Pole	167.00 - 0.00	1	No Ice 1/2" Ice 1" Ice	0.00 0.00 0.00	1.30 1.30 1.30
561(1-5/8")	C	No	Inside Pole	167.00 - 0.00	11	No Ice 1/2" Ice 1" Ice	0.00 0.00 0.00	1.35 1.35 1.35
***								
LDF7-50A(1-5/8")	B	No	Inside Pole	158.00 - 0.00	12	No Ice 1/2" Ice 1" Ice	0.00 0.00 0.00	0.82 0.82 0.82

<b>tnxTower</b>  <b>Tower Engineering Professionals</b> 326 Tryon Road Raleigh, NC 27603 Phone: (919) 661-6351 FAX: (919) 661-6350	<b>Job</b> CT NHV-2075 CAC 801367 (BU 801367)	<b>Page</b> 4 of 13
	<b>Project</b> TEP No. 25630.106836	<b>Date</b> 13:41:40 01/30/17
	<b>Client</b> Crown Castle	<b>Designed by</b> mtweavil

Description	Face or Leg	Allow Shield	Component Type	Placement ft	Total Number		C <sub>AA</sub> ft <sup>2</sup> /ft	Weight plf
FB-L98B-002-75000(3/8")	B	No	Inside Pole	158.00 - 0.00	1	No Ice	0.00	0.06
						1/2" Ice	0.00	0.06
						1" Ice	0.00	0.06
WR-VG86ST-BRD(3/4")	B	No	Inside Pole	158.00 - 0.00	2	No Ice	0.00	0.58
						1/2" Ice	0.00	0.58
						1" Ice	0.00	0.58
2" Flexible Conduit	B	No	Inside Pole	158.00 - 0.00	1	No Ice	0.00	0.34
						1/2" Ice	0.00	0.34
						1" Ice	0.00	0.34
FB-L98B-034-XXX(3/8")	B	No	Inside Pole	158.00 - 0.00	1	No Ice	0.00	0.06
						1/2" Ice	0.00	0.06
						1" Ice	0.00	0.06
WR-VG86ST-BRD(3/4")	B	No	Inside Pole	158.00 - 0.00	2	No Ice	0.00	0.58
						1/2" Ice	0.00	0.58
						1" Ice	0.00	0.58
***								
HB058-M12-XXXF(5/8")	C	No	Inside Pole	148.00 - 0.00	1	No Ice	0.00	0.24
						1/2" Ice	0.00	0.24
						1" Ice	0.00	0.24
HYBRIFLEX RRH 1-SECTOR(1/2")	C	No	Inside Pole	148.00 - 0.00	3	No Ice	0.00	0.15
						1/2" Ice	0.00	0.15
						1" Ice	0.00	0.15
***								
FLC 158-50J(1-5/8")	C	No	Inside Pole	138.00 - 0.00	14	No Ice	0.00	0.92
						1/2" Ice	0.00	0.92
						1" Ice	0.00	0.92
MLC HYBRID 6x12 6AWGx6(1-1/2)	C	No	CaAa (Out Of Face)	138.00 - 0.00	1	No Ice	0.00	0.59
						1/2" Ice	0.00	1.83
						1" Ice	0.00	3.68
Aero MP3-04	C	No	CaAa (Out Of Face)	53.00 - 43.00	1	No Ice	0.00	14.10
						1/2" Ice	0.00	15.30
						1" Ice	0.00	16.85
*								
Aero MP3-04	A	No	CaAa (Out Of Face)	53.00 - 50.50	1	No Ice	0.00	14.10
						1/2" Ice	0.00	15.30
						1" Ice	0.00	16.85
Aero MP3-04	A	No	CaAa (Out Of Face)	53.00 - 50.50	1	No Ice	0.00	14.10
						1/2" Ice	0.00	15.30
						1" Ice	0.00	16.85
Aero MP3-04	C	No	CaAa (Out Of Face)	65.50 - 50.50	1	No Ice	0.00	14.10
						1/2" Ice	0.00	15.30
						1" Ice	0.00	16.85
Aero MP3-03	C	No	CaAa (Out Of Face)	91.50 - 81.50	1	No Ice	0.00	9.90
						1/2" Ice	0.00	11.06
						1" Ice	0.00	12.57
*								

### Feed Line/Linear Appurtenances Section Areas

Tower Section	Tower Elevation ft	Face	A <sub>R</sub> ft <sup>2</sup>	A <sub>F</sub> ft <sup>2</sup>	C <sub>AA</sub> In Face ft <sup>2</sup>	C <sub>AA</sub> Out Face ft <sup>2</sup>	Weight lb
L1	167.00-118.25	A	0.000	0.000	3.534	0.000	34
		B	0.000	0.000	47.531	0.000	963
		C	0.000	0.000	15.919	0.000	1154
L2	118.25-90.25	A	0.000	0.000	2.422	0.000	45
		B	0.000	0.000	27.300	0.000	618
		C	0.000	0.000	22.568	0.000	968

<b>tnxTower</b>  <b>Tower Engineering Professionals</b> 326 Tryon Road Raleigh, NC 27603 Phone: (919) 661-6351 FAX: (919) 661-6350	<b>Job</b> CT NHV-2075 CAC 801367 (BU 801367)	<b>Page</b> 5 of 13
	<b>Project</b> TEP No. 25630.106836	<b>Date</b> 13:41:40 01/30/17
	<b>Client</b> Crown Castle	<b>Designed by</b> mtweavil

Tower Section	Tower Elevation ft	Face	A <sub>R</sub> ft <sup>2</sup>	A <sub>F</sub> ft <sup>2</sup>	C <sub>AA</sub> In Face ft <sup>2</sup>	C <sub>AA</sub> Out Face ft <sup>2</sup>	Weight lb
L3	90.25-77.75	A	0.000	0.000	3.654	0.000	182
		B	0.000	0.000	12.188	0.000	276
		C	0.000	0.000	10.075	0.000	513
L4	77.75-64.00	A	0.000	0.000	1.480	0.000	52
		B	0.000	0.000	13.406	0.000	304
		C	0.000	0.000	11.083	0.000	491
L5	64.00-51.50	A	0.000	0.000	4.931	0.000	404
		B	0.000	0.000	12.188	0.000	276
		C	0.000	0.000	10.075	0.000	624
L6	51.50-38.25	A	0.000	0.000	3.698	0.000	277
		B	0.000	0.000	12.919	0.000	293
		C	0.000	0.000	10.680	0.000	586
L7	38.25-0.00	A	0.000	0.000	2.773	0.000	27
		B	0.000	0.000	37.294	0.000	845
		C	0.000	0.000	30.829	0.000	1306

### Feed Line/Linear Appurtenances Section Areas - With Ice

Tower Section	Tower Elevation ft	Face or Leg	Ice Thickness in	A <sub>R</sub> ft <sup>2</sup>	A <sub>F</sub> ft <sup>2</sup>	C <sub>AA</sub> In Face ft <sup>2</sup>	C <sub>AA</sub> Out Face ft <sup>2</sup>	Weight lb
L1	167.00-118.25	A	1.735	0.000	0.000	37.365	0.000	468
		B		0.000	0.000	80.558	0.000	1990
		C		0.000	0.000	28.464	0.000	1633
L2	118.25-90.25	A	1.682	0.000	0.000	22.721	0.000	311
		B		0.000	0.000	46.269	0.000	1208
		C		0.000	0.000	40.354	0.000	1655
L3	90.25-77.75	A	1.647	0.000	0.000	17.651	0.000	396
		B		0.000	0.000	20.381	0.000	525
		C		0.000	0.000	17.740	0.000	845
L4	77.75-64.00	A	1.619	0.000	0.000	11.525	0.000	183
		B		0.000	0.000	22.419	0.000	577
		C		0.000	0.000	19.514	0.000	812
L5	64.00-51.50	A	1.586	0.000	0.000	20.793	0.000	668
		B		0.000	0.000	20.191	0.000	515
		C		0.000	0.000	17.551	0.000	969
L6	51.50-38.25	A	1.547	0.000	0.000	17.153	0.000	484
		B		0.000	0.000	21.272	0.000	539
		C		0.000	0.000	18.472	0.000	914
L7	38.25-0.00	A	1.417	0.000	0.000	26.436	0.000	303
		B		0.000	0.000	61.406	0.000	1556
		C		0.000	0.000	53.326	0.000	2114

### Feed Line Center of Pressure

Section	Elevation ft	CP <sub>X</sub> in	CP <sub>Z</sub> in	CP <sub>X</sub> Ice in	CP <sub>Z</sub> Ice in
L1	167.00-118.25	0.9628	0.3684	0.5841	0.3810
L2	118.25-90.25	0.9141	0.7866	0.5420	0.8133
L3	90.25-77.75	0.8110	0.6871	0.3707	0.6313
L4	77.75-64.00	0.9431	0.8144	0.5819	0.8700
L5	64.00-51.50	0.7725	0.6492	0.3040	0.5689
L6	51.50-38.25	0.8600	0.7337	0.4456	0.7231

<b>tnxTower</b>  <b>Tower Engineering Professionals</b> 326 Tryon Road Raleigh, NC 27603 Phone: (919) 661-6351 FAX: (919) 661-6350	<b>Job</b> CT NHV-2075 CAC 801367 (BU 801367)	<b>Page</b> 6 of 13
	<b>Project</b> TEP No. 25630.106836	<b>Date</b> 13:41:40 01/30/17
	<b>Client</b> Crown Castle	<b>Designed by</b> mtweavil

Section	Elevation	CP <sub>x</sub>	CP <sub>z</sub>	CP <sub>x</sub> Ice	CP <sub>z</sub> Ice
	ft	in	in	in	in
L7	38.25-0.00	1.0203	0.8889	0.7112	1.0248

### Shielding Factor Ka

Tower Section	Feed Line Record No.	Description	Feed Line Segment Elev.	K <sub>a</sub> No Ice	K <sub>a</sub> Ice
L1	4	561(1-5/8")	118.25 - 167.00	1.0000	1.0000
L1	17	FLC 158-50J(1-5/8")	118.25 - 138.00	1.0000	1.0000
L1	20	Step Pegs (5/8" SR) 7-in. w/30" step	118.25 - 167.00	1.0000	1.0000
L1	21	Safety Line 3/8	118.25 - 167.00	1.0000	1.0000
L1	33	Aero MP3-03	118.25 - 91.50	1.0000	1.0000
L1	34	Aero MP3-03	118.25 - 91.50	1.0000	1.0000
L3	4	561(1-5/8")	77.75 - 90.25	1.0000	1.0000
L3	17	FLC 158-50J(1-5/8")	77.75 - 90.25	1.0000	1.0000
L3	20	Step Pegs (5/8" SR) 7-in. w/30" step	77.75 - 90.25	1.0000	1.0000
L3	21	Safety Line 3/8	77.75 - 90.25	1.0000	1.0000
L3	33	Aero MP3-03	81.50 - 90.25	1.0000	1.0000
L3	34	Aero MP3-03	81.50 - 90.25	1.0000	1.0000
L3	28	Aero MP3-04	77.75 - 65.50	1.0000	1.0000
L3	30	Aero MP3-04	77.75 - 65.50	1.0000	1.0000
L5	4	561(1-5/8")	51.50 - 64.00	1.0000	1.0000
L5	17	FLC 158-50J(1-5/8")	51.50 - 64.00	1.0000	1.0000
L5	20	Step Pegs (5/8" SR) 7-in. w/30" step	51.50 - 64.00	1.0000	1.0000
L5	21	Safety Line 3/8	51.50 - 64.00	1.0000	1.0000
L5	23	Aero MP3-04	51.50 - 53.00	1.0000	1.0000
L5	24	Aero MP3-04	51.50 - 53.00	1.0000	1.0000
L5	28	Aero MP3-04	53.00 - 64.00	1.0000	1.0000
L5	30	Aero MP3-04	53.00 - 64.00	1.0000	1.0000
L6	4	561(1-5/8")	38.25 - 51.50	1.0000	1.0000
L6	17	FLC 158-50J(1-5/8")	38.25 - 51.50	1.0000	1.0000
L6	20	Step Pegs (5/8" SR) 7-in. w/30" step	38.25 - 51.50	1.0000	1.0000
L6	21	Safety Line 3/8	38.25 - 51.50	1.0000	1.0000
L6	23	Aero MP3-04	43.00 - 51.50	1.0000	1.0000
L6	24	Aero MP3-04	43.00 - 51.50	1.0000	1.0000

### Discrete Tower Loads

<b>tnxTower</b>  <b>Tower Engineering Professionals</b> 326 Tryon Road Raleigh, NC 27603 Phone: (919) 661-6351 FAX: (919) 661-6350	<b>Job</b>	CT NHV-2075 CAC 801367 (BU 801367)	<b>Page</b>	7 of 13
	<b>Project</b>	TEP No. 25630.106836	<b>Date</b>	13:41:40 01/30/17
	<b>Client</b>	Crown Castle	<b>Designed by</b>	mtweavil

Description	Face or Leg	Offset Type	Offsets:		Azimuth Adjustment	Placement	C <sub>AA</sub> Front	C <sub>AA</sub> Side	Weight	
			Horz	Vert						
			ft	ft	°	ft	ft <sup>2</sup>	ft <sup>2</sup>	lb	
Lightning Rod 5/8" x 6'	C	From Leg	0.00	0.00	0.0000	167.00	No Ice	0.38	0.38	7
			0.00	0.00			1/2" Ice	0.99	0.99	11
			3.00	3.00			1" Ice	1.62	1.62	19
***										
(2) LPA-80063-6CF-EDIN w/ Mount Pipe	A	From Centroid-Fa	4.00	-1.00	0.0000	167.00	No Ice	9.97	10.25	52
			1.00	1.00			1/2" Ice	10.54	11.42	145
			1.00	1.00			1" Ice	11.08	12.31	247
(2) LPA-80063-6CF-EDIN w/ Mount Pipe	B	From Centroid-Fa	4.00	0.00	0.0000	167.00	No Ice	9.97	10.25	52
			0.00	0.00			1/2" Ice	10.54	11.42	145
			1.00	1.00			1" Ice	11.08	12.31	247
(2) LPA-80063-6CF-EDIN w/ Mount Pipe	C	From Centroid-Fa	4.00	0.00	0.0000	167.00	No Ice	9.97	10.25	52
			0.00	0.00			1/2" Ice	10.54	11.42	145
			1.00	1.00			1" Ice	11.08	12.31	247
BXA-70063-6CF-EDIN-2 w/ Mount Pipe	A	From Centroid-Fa	4.00	-2.00	0.0000	167.00	No Ice	7.81	5.80	42
			1.00	1.00			1/2" Ice	8.36	6.95	103
			1.00	1.00			1" Ice	8.87	7.82	171
BXA-70063-6CF-EDIN-2 w/ Mount Pipe	B	From Centroid-Fa	4.00	-3.00	0.0000	167.00	No Ice	7.81	5.80	42
			1.00	1.00			1/2" Ice	8.36	6.95	103
			1.00	1.00			1" Ice	8.87	7.82	171
BXA-70063-6CF-EDIN-2 w/ Mount Pipe	C	From Centroid-Fa	4.00	-3.00	0.0000	167.00	No Ice	7.81	5.80	42
			1.00	1.00			1/2" Ice	8.36	6.95	103
			1.00	1.00			1" Ice	8.87	7.82	171
BXA-171063-8BF-2 w/ Mount Pipe	A	From Centroid-Fa	4.00	-5.00	0.0000	167.00	No Ice	3.18	3.35	29
			1.00	1.00			1/2" Ice	3.56	3.97	61
			1.00	1.00			1" Ice	3.93	4.60	99
BXA-171063-8BF-2 w/ Mount Pipe	B	From Centroid-Fa	4.00	0.00	0.0000	167.00	No Ice	3.18	3.35	29
			0.00	0.00			1/2" Ice	3.56	3.97	61
			1.00	1.00			1" Ice	3.93	4.60	99
BXA-171063-8BF-2 w/ Mount Pipe	C	From Centroid-Fa	4.00	0.00	0.0000	167.00	No Ice	3.18	3.35	29
			0.00	0.00			1/2" Ice	3.56	3.97	61
			1.00	1.00			1" Ice	3.93	4.60	99
BXA-171063-8CF-EDIN-X w/ Mount Pipe	A	From Centroid-Fa	4.00	2.00	0.0000	167.00	No Ice	3.16	3.33	28
			1.00	1.00			1/2" Ice	3.53	3.94	60
			1.00	1.00			1" Ice	3.90	4.56	97
BXA-171063-8CF-EDIN-X w/ Mount Pipe	B	From Centroid-Fa	4.00	3.00	0.0000	167.00	No Ice	3.16	3.33	28
			1.00	1.00			1/2" Ice	3.53	3.94	60
			1.00	1.00			1" Ice	3.90	4.56	97
BXA-171063-8CF-EDIN-X w/ Mount Pipe	C	From Centroid-Fa	4.00	3.00	0.0000	167.00	No Ice	3.16	3.33	28
			1.00	1.00			1/2" Ice	3.53	3.94	60
			1.00	1.00			1" Ice	3.90	4.56	97
GPS_A	A	From Centroid-Fa	4.00	7.00	0.0000	167.00	No Ice	0.26	0.26	1
			1.00	1.00			1/2" Ice	0.32	0.32	5
			1.00	1.00			1" Ice	0.39	0.39	10
RRH2X40-AWS	A	From Centroid-Fa	4.00	2.00	0.0000	167.00	No Ice	2.16	1.42	44
			1.00	1.00			1/2" Ice	2.36	1.59	61
			1.00	1.00			1" Ice	2.57	1.77	82
RRH2X40-AWS	B	From Centroid-Fa	4.00	3.00	0.0000	167.00	No Ice	2.16	1.42	44
			1.00	1.00			1/2" Ice	2.36	1.59	61
			1.00	1.00			1" Ice	2.57	1.77	82
RRH2X40-AWS	C	From Centroid-Fa	4.00	3.00	0.0000	167.00	No Ice	2.16	1.42	44
			1.00	1.00			1/2" Ice	2.36	1.59	61
			1.00	1.00			1" Ice	2.57	1.77	82
DB-T1-6Z-8AB-0Z	A	From Centroid-Fa	4.00	2.00	0.0000	167.00	No Ice	4.80	2.00	44
			1.00	1.00			1/2" Ice	5.07	2.19	80
			1.00	1.00			1" Ice	5.35	2.39	120
2.4" Dia x 4-ft Mount Pipe	A	From Centroid-Fa	4.00	7.00	0.0000	167.00	No Ice	0.87	0.87	15
			1.00	1.00			1/2" Ice	1.12	1.12	22

<b>tnxTower</b>  <b>Tower Engineering Professionals</b> 326 Tryon Road Raleigh, NC 27603 Phone: (919) 661-6351 FAX: (919) 661-6350	<b>Job</b>	CT NHV-2075 CAC 801367 (BU 801367)	<b>Page</b>	8 of 13
	<b>Project</b>	TEP No. 25630.106836	<b>Date</b>	13:41:40 01/30/17
	<b>Client</b>	Crown Castle	<b>Designed by</b>	mtweavil

Description	Face or Leg	Offset Type	Offsets:		Azimuth Adjustment	Placement	C <sub>AA</sub> Front	C <sub>AA</sub> Side	Weight
			Horz	Vert					
			ft	ft	°	ft	ft <sup>2</sup>	ft <sup>2</sup>	lb
Platform Mount [LP 1201-1]	C	ce None	0.00		0.0000	167.00	1" Ice 1.37 No Ice 23.10 1/2" Ice 26.80 1" Ice 30.50	1.37 23.10 26.80 30.50	32 2100 2500 2900
***									
TPA-65R-LCUUUU-H8 w/ Mount Pipe	A	From Centroid-Fa ce	4.00 -3.00 2.00		-30.0000	158.00	No Ice 13.54 1/2" Ice 14.24 1" Ice 14.95	10.96 12.49 14.04	114 218 331
TPA-65R-LCUUUU-H8 w/ Mount Pipe	B	From Centroid-Fa ce	4.00 -3.00 2.00		-30.0000	158.00	No Ice 13.54 1/2" Ice 14.24 1" Ice 14.95	10.96 12.49 14.04	114 218 331
TPA-65R-LCUUUU-H8 w/ Mount Pipe	C	From Centroid-Fa ce	4.00 -3.00 2.00		-30.0000	158.00	No Ice 13.54 1/2" Ice 14.24 1" Ice 14.95	10.96 12.49 14.04	114 218 331
SBNH-1D6565C w/ Mount Pipe	A	From Centroid-Fa ce	4.00 -7.00 2.00		-30.0000	158.00	No Ice 11.69 1/2" Ice 12.42 1" Ice 13.16	9.85 11.38 12.94	99 189 289
SBNH-1D6565C w/ Mount Pipe	B	From Centroid-Fa ce	4.00 -7.00 2.00		-30.0000	158.00	No Ice 11.69 1/2" Ice 12.42 1" Ice 13.16	9.85 11.38 12.94	99 189 289
SBNH-1D6565C w/ Mount Pipe	C	From Centroid-Fa ce	4.00 -7.00 2.00		-30.0000	158.00	No Ice 11.69 1/2" Ice 12.42 1" Ice 13.16	9.85 11.38 12.94	99 189 289
7770.00 w/ Mount Pipe	A	From Centroid-Fa ce	4.00 7.00 2.00		-10.0000	158.00	No Ice 5.75 1/2" Ice 6.18 1" Ice 6.61	4.25 5.01 5.71	55 103 157
7770.00 w/ Mount Pipe	B	From Centroid-Fa ce	4.00 7.00 2.00		-10.0000	158.00	No Ice 5.75 1/2" Ice 6.18 1" Ice 6.61	4.25 5.01 5.71	55 103 157
7770.00 w/ Mount Pipe	C	From Centroid-Fa ce	4.00 7.00 2.00		-10.0000	158.00	No Ice 5.75 1/2" Ice 6.18 1" Ice 6.61	4.25 5.01 5.71	55 103 157
(2) TPX-070821	A	From Centroid-Fa ce	4.00 -3.00 2.00		-30.0000	158.00	No Ice 0.47 1/2" Ice 0.56 1" Ice 0.66	0.10 0.15 0.20	8 11 16
(2) TPX-070821	B	From Centroid-Fa ce	4.00 -3.00 2.00		-30.0000	158.00	No Ice 0.47 1/2" Ice 0.56 1" Ice 0.66	0.10 0.15 0.20	8 11 16
(2) TPX-070821	C	From Centroid-Fa ce	4.00 -3.00 2.00		-30.0000	158.00	No Ice 0.47 1/2" Ice 0.56 1" Ice 0.66	0.10 0.15 0.20	8 11 16
RRUS 32	A	From Centroid-Fa ce	4.00 -3.00 2.00		-30.0000	158.00	No Ice 2.86 1/2" Ice 3.08 1" Ice 3.32	1.78 1.97 2.17	55 77 103
RRUS 32	B	From Centroid-Fa ce	4.00 -3.00 2.00		-30.0000	158.00	No Ice 2.86 1/2" Ice 3.08 1" Ice 3.32	1.78 1.97 2.17	55 77 103
RRUS 32	C	From Centroid-Fa ce	4.00 -3.00 2.00		-30.0000	158.00	No Ice 2.86 1/2" Ice 3.08 1" Ice 3.32	1.78 1.97 2.17	55 77 103
RRUS 32 B2	A	From Centroid-Fa ce	4.00 -3.00 2.00		-30.0000	158.00	No Ice 2.73 1/2" Ice 2.95 1" Ice 3.18	1.67 1.86 2.05	53 74 98
RRUS 32 B2	B	From Centroid-Fa ce	4.00 -3.00 2.00		-30.0000	158.00	No Ice 2.73 1/2" Ice 2.95 1" Ice 3.18	1.67 1.86 2.05	53 74 98
RRUS 32 B2	C	From	4.00		-30.0000	158.00	No Ice 2.73	1.67	53

<b>tnxTower</b>  <b>Tower Engineering Professionals</b> 326 Tryon Road Raleigh, NC 27603 Phone: (919) 661-6351 FAX: (919) 661-6350	<b>Job</b>	CT NHV-2075 CAC 801367 (BU 801367)	<b>Page</b>	9 of 13
	<b>Project</b>	TEP No. 25630.106836	<b>Date</b>	13:41:40 01/30/17
	<b>Client</b>	Crown Castle	<b>Designed by</b>	mtweavil

Description	Face or Leg	Offset Type	Offsets:		Azimuth Adjustment	Placement	C <sub>AA</sub> Front	C <sub>AA</sub> Side	Weight	
			Horz	Vert						
			ft	ft	°	ft	ft <sup>2</sup>	ft <sup>2</sup>	lb	
DC6-48-60-18-8F	B	Centroid-Face	-3.00			1/2" Ice	2.95	1.86	74	
		ce	2.00			1" Ice	3.18	2.05	98	
		From	4.00		-30.0000	158.00	No Ice	0.92	0.92	19
DC6-48-60-18-8F	B	Centroid-Face	-3.00			1/2" Ice	1.46	1.46	37	
		ce	2.00			1" Ice	1.64	1.64	57	
		From	4.00		-30.0000	158.00	No Ice	0.92	0.92	19
(2) LGP21401	A	Centroid-Face	-7.00			1/2" Ice	1.46	1.46	37	
		ce	0.00			1" Ice	1.64	1.64	57	
		From	4.00		-10.0000	158.00	No Ice	1.10	0.21	14
(2) LGP21401	B	Centroid-Face	7.00			1/2" Ice	1.24	0.27	21	
		ce	0.00			1" Ice	1.38	0.35	30	
		From	4.00		-10.0000	158.00	No Ice	1.10	0.21	14
(2) LGP21401	C	Centroid-Face	7.00			1/2" Ice	1.24	0.27	21	
		ce	0.00			1" Ice	1.38	0.35	30	
		From	4.00		-10.0000	158.00	No Ice	1.10	0.21	14
RRUS-11	A	Centroid-Face	7.00			1/2" Ice	1.24	0.27	21	
		ce	0.00			1" Ice	1.38	0.35	30	
		From	4.00		-30.0000	158.00	No Ice	2.79	1.19	50
RRUS-11	B	Centroid-Face	-7.00			1/2" Ice	3.00	1.34	71	
		ce	0.00			1" Ice	3.21	1.50	95	
		From	4.00		-30.0000	158.00	No Ice	2.79	1.19	50
RRUS-11	C	Centroid-Face	-7.00			1/2" Ice	3.00	1.34	71	
		ce	0.00			1" Ice	3.21	1.50	95	
		From	4.00		-30.0000	158.00	No Ice	2.79	1.19	50
2.4" Dia x 6-ft Pipe	A	Centroid-Face	-7.00			1/2" Ice	3.00	1.34	71	
		ce	0.00			1" Ice	3.21	1.50	95	
		From	4.00		0.0000	158.00	No Ice	1.43	1.43	22
2.4" Dia x 6-ft Pipe	B	Centroid-Face	3.00			1/2" Ice	1.93	1.93	33	
		ce	0.00			1" Ice	2.30	2.30	48	
		From	4.00		0.0000	158.00	No Ice	1.43	1.43	22
2.4" Dia x 6-ft Pipe	C	Centroid-Face	3.00			1/2" Ice	1.93	1.93	33	
		ce	0.00			1" Ice	2.30	2.30	48	
		From	4.00		0.0000	158.00	No Ice	1.43	1.43	22
Miscellaneous [NA 509-3]	C	Centroid-Face	3.00			1/2" Ice	1.93	1.93	33	
		ce	0.00			1" Ice	2.30	2.30	48	
		None			0.0000	157.00	No Ice	11.84	11.84	275
Miscellaneous [NA 510-1]	C	None			0.0000	160.00	No Ice	6.00	6.00	256
		None			0.0000	160.00	1/2" Ice	8.50	8.50	340
		None			0.0000	160.00	1" Ice	11.00	11.00	409
Platform Mount [LP 1201-1]	C	None			0.0000	158.00	No Ice	23.10	23.10	2100
		None			0.0000	158.00	1/2" Ice	26.80	26.80	2500
		None			0.0000	158.00	1" Ice	30.50	30.50	2900
***										
PCS 1900MHz 4x45W-65MHz	A	From Face	1.00		-30.0000	150.00	No Ice	2.32	2.24	60
		From Face	0.00		-30.0000	150.00	1/2" Ice	2.53	2.44	83
		From Face	1.00		-30.0000	150.00	1" Ice	2.74	2.65	110
PCS 1900MHz 4x45W-65MHz	B	From Face	1.00		-30.0000	150.00	No Ice	2.32	2.24	60
		From Face	0.00		-30.0000	150.00	1/2" Ice	2.53	2.44	83
		From Face	1.00		-30.0000	150.00	1" Ice	2.74	2.65	110
PCS 1900MHz 4x45W-65MHz	C	From Face	1.00		10.0000	150.00	No Ice	2.32	2.24	60
		From Face	0.00		10.0000	150.00	1/2" Ice	2.53	2.44	83
		From Face	1.00		10.0000	150.00	1" Ice	2.74	2.65	110
TME-800MHz RRH	A	From Face	1.00		-30.0000	150.00	No Ice	2.13	1.77	53
		From Face	0.00		-30.0000	150.00	1/2" Ice	2.32	1.95	74
		From Face	0.00		-30.0000	150.00	1" Ice	2.51	2.13	98



<b>tnxTower</b>  <b>Tower Engineering Professionals</b> 326 Tryon Road Raleigh, NC 27603 Phone: (919) 661-6351 FAX: (919) 661-6350	<b>Job</b>	CT NHV-2075 CAC 801367 (BU 801367)	<b>Page</b>	10 of 13
	<b>Project</b>	TEP No. 25630.106836	<b>Date</b>	13:41:40 01/30/17
	<b>Client</b>	Crown Castle	<b>Designed by</b>	mtweavil

Description	Face or Leg	Offset Type	Offsets:		Azimuth Adjustment	Placement	C <sub>AA</sub> Front	C <sub>AA</sub> Side	Weight
			Horz	Vert					
			ft	ft	°	ft	ft <sup>2</sup>	ft <sup>2</sup>	lb
TME-800MHZ RRH	B	From Face	1.00		-30.0000	150.00	No Ice	2.13	53
			0.00				1/2" Ice	2.32	74
			0.00				1" Ice	2.51	98
TME-800MHZ RRH	C	From Face	1.00		10.0000	150.00	No Ice	2.13	53
			0.00				1/2" Ice	2.32	74
			0.00				1" Ice	2.51	98
(2) Pipe Mount [PM 601-3]	C	None			0.0000	150.00	No Ice	4.39	195
							1/2" Ice	5.48	237
							1" Ice	6.57	280
***									
APXVTM14-C-120 w/ Mount Pipe	A	From Centroid-Fa ce	4.00 -7.00 -1.00		-10.0000	148.00	No Ice	6.34	56
							1/2" Ice	6.72	96
							1" Ice	7.10	140
APXVTM14-C-120 w/ Mount Pipe	B	From Centroid-Fa ce	4.00 -7.00 -1.00		-10.0000	148.00	No Ice	6.34	56
							1/2" Ice	6.72	96
							1" Ice	7.10	140
APXVTM14-C-120 w/ Mount Pipe	C	From Centroid-Fa ce	4.00 -7.00 -1.00		-10.0000	148.00	No Ice	6.34	56
							1/2" Ice	6.72	96
							1" Ice	7.10	140
APXVSPP18-C-A20 w/ Mount Pipe	A	From Centroid-Fa ce	4.00 1.00 -1.00		-10.0000	148.00	No Ice	8.26	83
							1/2" Ice	8.82	151
							1" Ice	9.35	227
APXVSPP18-C-A20 w/ Mount Pipe	B	From Centroid-Fa ce	4.00 1.00 -1.00		-10.0000	148.00	No Ice	8.26	83
							1/2" Ice	8.82	151
							1" Ice	9.35	227
APXVSPP18-C-A20 w/ Mount Pipe	C	From Centroid-Fa ce	4.00 1.00 -1.00		-10.0000	148.00	No Ice	8.26	83
							1/2" Ice	8.82	151
							1" Ice	9.35	227
TD-RRH8x20-25	A	From Centroid-Fa ce	4.00 -7.00 -1.00		-10.0000	148.00	No Ice	4.05	70
							1/2" Ice	4.30	97
							1" Ice	4.56	128
TD-RRH8x20-25	B	From Centroid-Fa ce	4.00 -7.00 -1.00		-10.0000	148.00	No Ice	4.05	70
							1/2" Ice	4.30	97
							1" Ice	4.56	128
TD-RRH8x20-25	C	From Centroid-Fa ce	4.00 -7.00 -1.00		-10.0000	148.00	No Ice	4.05	70
							1/2" Ice	4.30	97
							1" Ice	4.56	128
800 EXTERNAL NOTCH FILTER	A	From Centroid-Fa ce	4.00 1.00 -1.00		-10.0000	148.00	No Ice	0.66	11
							1/2" Ice	0.76	17
							1" Ice	0.87	24
800 EXTERNAL NOTCH FILTER	B	From Centroid-Fa ce	4.00 1.00 -1.00		-10.0000	148.00	No Ice	0.66	11
							1/2" Ice	0.76	17
							1" Ice	0.87	24
800 EXTERNAL NOTCH FILTER	C	From Centroid-Fa ce	4.00 1.00 -1.00		-10.0000	148.00	No Ice	0.66	11
							1/2" Ice	0.76	17
							1" Ice	0.87	24
(3) ACU-A20-N	A	From Centroid-Fa ce	4.00 1.00 -1.00		-10.0000	148.00	No Ice	0.07	1
							1/2" Ice	0.10	2
							1" Ice	0.15	4
(3) ACU-A20-N	B	From Centroid-Fa ce	4.00 1.00 -1.00		-10.0000	148.00	No Ice	0.07	1
							1/2" Ice	0.10	2
							1" Ice	0.15	4
(3) ACU-A20-N	C	From Centroid-Fa ce	4.00 1.00 -1.00		-10.0000	148.00	No Ice	0.07	1
							1/2" Ice	0.10	2
							1" Ice	0.15	4
2.4" Dia x 6-ft Pipe	A	From Centroid-Fa	4.00		0.0000	148.00	No Ice	1.43	22
			7.00				1/2" Ice	1.93	33

<b>tnxTower</b>  <b>Tower Engineering Professionals</b> 326 Tryon Road Raleigh, NC 27603 Phone: (919) 661-6351 FAX: (919) 661-6350	<b>Job</b>	CT NHV-2075 CAC 801367 (BU 801367)	<b>Page</b>	11 of 13
	<b>Project</b>	TEP No. 25630.106836	<b>Date</b>	13:41:40 01/30/17
	<b>Client</b>	Crown Castle	<b>Designed by</b>	mtweavil

Description	Face or Leg	Offset Type	Offsets:		Azimuth Adjustment	Placement	C <sub>AA</sub> Front	C <sub>AA</sub> Side	Weight	
			Horz	Vert						
			ft	ft	°	ft	ft <sup>2</sup>	ft <sup>2</sup>	lb	
2.4" Dia x 6-ft Pipe	B	ce	0.00		0.0000	148.00	1" Ice	2.30	2.30	48
		From	4.00				No Ice	1.43	1.43	22
		Centroid-Fa	7.00				1/2" Ice	1.93	1.93	33
2.4" Dia x 6-ft Pipe	C	ce	0.00		0.0000	148.00	1" Ice	2.30	2.30	48
		From	4.00				No Ice	1.43	1.43	22
		Centroid-Fa	7.00				1/2" Ice	1.93	1.93	33
Platform Mount [LP 1201-1]	C	ce	0.00		0.0000	148.00	1" Ice	2.30	2.30	48
		None					No Ice	23.10	23.10	2100
							1/2" Ice	26.80	26.80	2500
							1" Ice	30.50	30.50	2900
***										
AIR -32 B2A/B66AA w/ Mount Pipe	A	From	4.00		-10.0000	138.00	No Ice	6.75	6.07	153
		Centroid-Fa	-7.00				1/2" Ice	7.20	6.87	214
		ce	0.00				1" Ice	7.65	7.58	282
AIR -32 B2A/B66AA w/ Mount Pipe	B	From	4.00		-10.0000	138.00	No Ice	6.75	6.07	153
		Centroid-Fa	-7.00				1/2" Ice	7.20	6.87	214
		ce	0.00				1" Ice	7.65	7.58	282
AIR -32 B2A/B66AA w/ Mount Pipe	C	From	4.00		-10.0000	138.00	No Ice	6.75	6.07	153
		Centroid-Fa	-7.00				1/2" Ice	7.20	6.87	214
		ce	0.00				1" Ice	7.65	7.58	282
LNX-6515DS-A1M w/ Mount Pipe	A	From	4.00		-10.0000	138.00	No Ice	11.68	9.84	83
		Centroid-Fa	3.00				1/2" Ice	12.40	11.37	173
		ce	0.00				1" Ice	13.14	12.91	273
LNX-6515DS-A1M w/ Mount Pipe	B	From	4.00		-10.0000	138.00	No Ice	11.68	9.84	83
		Centroid-Fa	3.00				1/2" Ice	12.40	11.37	173
		ce	0.00				1" Ice	13.14	12.91	273
LNX-6515DS-A1M w/ Mount Pipe	C	From	4.00		-10.0000	138.00	No Ice	11.68	9.84	83
		Centroid-Fa	3.00				1/2" Ice	12.40	11.37	173
		ce	0.00				1" Ice	13.14	12.91	273
APX16PV-16PVL w/ Mount Pipe	A	From	4.00		-10.0000	138.00	No Ice	6.27	3.27	59
		Centroid-Fa	-3.00				1/2" Ice	6.70	3.97	105
		ce	0.00				1" Ice	7.13	4.64	156
APX16PV-16PVL w/ Mount Pipe	B	From	4.00		-10.0000	138.00	No Ice	6.27	3.27	59
		Centroid-Fa	-3.00				1/2" Ice	6.70	3.97	105
		ce	0.00				1" Ice	7.13	4.64	156
APX16PV-16PVL w/ Mount Pipe	C	From	4.00		-10.0000	138.00	No Ice	6.27	3.27	59
		Centroid-Fa	-3.00				1/2" Ice	6.70	3.97	105
		ce	0.00				1" Ice	7.13	4.64	156
KRY 112 89/5	A	From	4.00		-10.0000	138.00	No Ice	0.20	0.37	15
		Centroid-Fa	-3.00				1/2" Ice	0.26	0.45	20
		ce	0.00				1" Ice	0.33	0.55	27
KRY 112 89/5	B	From	4.00		-10.0000	138.00	No Ice	0.20	0.37	15
		Centroid-Fa	-3.00				1/2" Ice	0.26	0.45	20
		ce	0.00				1" Ice	0.33	0.55	27
KRY 112 89/5	C	From	4.00		-10.0000	138.00	No Ice	0.20	0.37	15
		Centroid-Fa	-3.00				1/2" Ice	0.26	0.45	20
		ce	0.00				1" Ice	0.33	0.55	27
KRY 112 134/1	A	From	4.00		-10.0000	138.00	No Ice	0.86	0.43	10
		Centroid-Fa	-3.00				1/2" Ice	0.98	0.53	17
		ce	0.00				1" Ice	1.11	0.63	26
KRY 112 134/1	B	From	4.00		-10.0000	138.00	No Ice	0.86	0.43	10
		Centroid-Fa	-3.00				1/2" Ice	0.98	0.53	17
		ce	0.00				1" Ice	1.11	0.63	26
KRY 112 134/1	C	From	4.00		-10.0000	138.00	No Ice	0.86	0.43	10
		Centroid-Fa	-3.00				1/2" Ice	0.98	0.53	17
		ce	0.00				1" Ice	1.11	0.63	26
ATBT-BOTTOM-24V	A	From	4.00		-10.0000	138.00	No Ice	0.10	0.06	3

<b>tnxTower</b>  <b>Tower Engineering Professionals</b> 326 Tryon Road Raleigh, NC 27603 Phone: (919) 661-6351 FAX: (919) 661-6350	<b>Job</b>	CT NHV-2075 CAC 801367 (BU 801367)	<b>Page</b>	12 of 13
	<b>Project</b>	TEP No. 25630.106836	<b>Date</b>	13:41:40 01/30/17
	<b>Client</b>	Crown Castle	<b>Designed by</b>	mtweavil

Description	Face or Leg	Offset Type	Offsets:		Azimuth Adjustment	Placement	C <sub>AA</sub> Front	C <sub>AA</sub> Side	Weight	
			Horz	Vert						
			ft	ft	°	ft	ft <sup>2</sup>	ft <sup>2</sup>	lb	
ATBT-BOTTOM-24V	B	Centroid-Face	3.00			1/2" Ice	0.15	0.10	4	
		ce	0.00			1" Ice	0.20	0.15	6	
		From	4.00		-10.0000	138.00	No Ice	0.10	0.06	3
ATBT-BOTTOM-24V	C	Centroid-Face	3.00			1/2" Ice	0.15	0.10	4	
		ce	0.00			1" Ice	0.20	0.15	6	
		From	4.00		-10.0000	138.00	No Ice	0.10	0.06	3
2.4" Dia x 6-ft Pipe	A	Centroid-Face	3.00			1/2" Ice	0.15	0.10	4	
		ce	0.00			1" Ice	0.20	0.15	6	
		From	4.00		0.0000	138.00	No Ice	1.43	1.43	22
2.4" Dia x 6-ft Pipe	B	Centroid-Face	7.00			1/2" Ice	1.93	1.93	33	
		ce	0.00			1" Ice	2.30	2.30	48	
		From	4.00		0.0000	138.00	No Ice	1.43	1.43	22
2.4" Dia x 6-ft Pipe	C	Centroid-Face	7.00			1/2" Ice	1.93	1.93	33	
		ce	0.00			1" Ice	2.30	2.30	48	
		From	4.00		0.0000	138.00	No Ice	1.43	1.43	22
Platform Mount [LP 1201-1]	C	Centroid-Face	7.00			1/2" Ice	1.93	1.93	33	
		ce	0.00			1" Ice	2.30	2.30	48	
		None			0.0000	138.00	No Ice	23.10	23.10	2100
							1/2" Ice	26.80	26.80	2500
							1" Ice	30.50	30.50	2900

\*

### Compression Checks

### Pole Design Data

Section No.	Elevation	Size	L	L <sub>u</sub>	Kl/r	A	P <sub>u</sub>	φP <sub>n</sub>	Ratio P <sub>u</sub> /φP <sub>n</sub>
			ft	ft		in <sup>2</sup>	lb	lb	
L1	167 - 118.25 (1)	TP35.36x24x0.25	48.75	0.00	0.0	27.0277	-20983	1825830	0.011
L2	118.25 - 90.25 (2)	TP41.3843x33.8114x0.3125	32.50	0.00	0.0	40.7381	-29106	2788570	0.010
L3	90.25 - 77.75 (3)	TP44.297x41.3843x0.3832	12.50	0.00	0.0	51.8584	-31065	3744820	0.008
L4	77.75 - 64 (4)	TP46.8763x42.3904x0.375	19.25	0.00	0.0	55.3482	-37991	3865220	0.010
L5	64 - 51.5 (5)	TP49.7893x46.8763x0.4611	12.50	0.00	0.0	72.1916	-42665	5270410	0.008
L6	51.5 - 38.25 (6)	TP52.877x49.7893x0.4583	13.25	0.00	0.0	73.9568	-45037	5344570	0.008
L7	38.25 - 0 (7)	TP61.04x50.554x0.4375	45.00	0.00	0.0	84.1541	-64938	5649280	0.011

### Pole Bending Design Data

<b>tnxTower</b>  <b>Tower Engineering Professionals</b> 326 Tryon Road Raleigh, NC 27603 Phone: (919) 661-6351 FAX: (919) 661-6350	<b>Job</b>	CT NHV-2075 CAC 801367 (BU 801367)	<b>Page</b>	13 of 13
	<b>Project</b>	TEP No. 25630.106836	<b>Date</b>	13:41:40 01/30/17
	<b>Client</b>	Crown Castle	<b>Designed by</b>	mtweavil

Section No.	Elevation ft	Size	$M_{ux}$	$\phi M_{rx}$	Ratio	$M_{uy}$	$\phi M_{ry}$	Ratio
			lb-ft	lb-ft	$\frac{M_{ux}}{\phi M_{rx}}$	lb-ft	lb-ft	$\frac{M_{uy}}{\phi M_{ry}}$
L1	167 - 118.25 (1)	TP35.36x24x0.25	776852	1279492	0.607	0	1279492	0.000
L2	118.25 - 90.25 (2)	TP41.3843x33.8114x0.3125	1625750	2355733	0.690	0	2355733	0.000
L3	90.25 - 77.75 (3)	TP44.297x41.3843x0.3832	1819542	3279242	0.555	0	3279242	0.000
L4	77.75 - 64 (4)	TP46.8763x42.3904x0.375	2374750	3695250	0.643	0	3695250	0.000
L5	64 - 51.5 (5)	TP49.7893x46.8763x0.4611	2750642	5338158	0.515	0	5338158	0.000
L6	51.5 - 38.25 (6)	TP52.877x49.7893x0.4583	2950942	5581650	0.529	0	5581650	0.000
L7	38.25 - 0 (7)	TP61.04x50.554x0.4375	4415625	7044541	0.627	0	7044541	0.000

### Pole Shear Design Data

Section No.	Elevation ft	Size	Actual $V_u$	$\phi V_n$	Ratio	Actual $T_u$	$\phi T_n$	Ratio
			lb	lb	$\frac{V_u}{\phi V_n}$	lb-ft	lb-ft	$\frac{T_u}{\phi T_n}$
L1	167 - 118.25 (1)	TP35.36x24x0.25	24791	912914	0.027	825	2562117	0.000
L2	118.25 - 90.25 (2)	TP41.3843x33.8114x0.3125	27414	1394280	0.020	822	4717233	0.000
L3	90.25 - 77.75 (3)	TP44.297x41.3843x0.3832	27988	1872410	0.015	813	6566508	0.000
L4	77.75 - 64 (4)	TP46.8763x42.3904x0.375	29588	1932610	0.015	812	7399541	0.000
L5	64 - 51.5 (5)	TP49.7893x46.8763x0.4611	30595	2635200	0.012	820	10689333	0.000
L6	51.5 - 38.25 (6)	TP52.877x49.7893x0.4583	31054	2672280	0.012	820	11177000	0.000
L7	38.25 - 0 (7)	TP61.04x50.554x0.4375	33898	2824640	0.012	811	14106333	0.000

**APPENDIX B**  
**BASE LEVEL DRAWING**

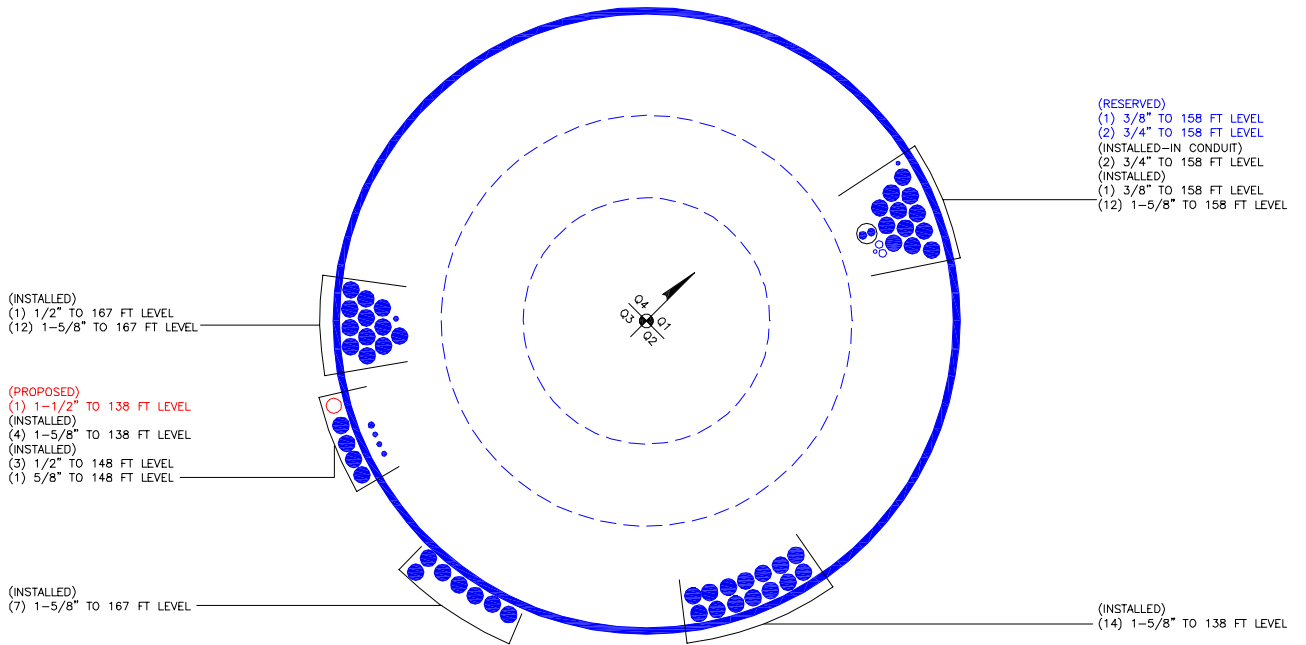

**APPENDIX C**  
**ADDITIONAL CALCULATIONS**





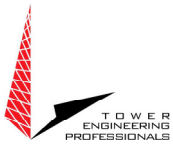

CT NHV-2075 CAC 801367 (BU 801367)

Pole (L2)	70.1%	Pass
Mod (M2)	80.6%	Pass

TEP #: 25630.106836

Analysis: MTW 1/30/2017

Check: ZRH 1/30/2017

**Monopole Reinforcement\_v1.8.11 - TIA-222-G - Capacities**

Section No.	Elevation (ft)	Type	Size	Critical Element	Pu (lb)	$\phi Pn$ (lb)	% Capacity	Pass/Fail
L1	167.00-118.25	Pole	TP35.36x24.00x0.2500	1	Note 1	Note 1	61.9	Pass
L2	122.75-77.75	Pole	TP44.30x33.81x0.3125	2	Note 1	Note 1	70.1	Pass
L3	83.25-38.25	Pole	TP52.88x42.39x0.3750	3	Note 1	Note 1	65.3	Pass
L4	45.00-0.00	Pole	TP61.04x50.55x0.4375	4	Note 1	Note 1	63.8	Pass
M1	53.00-43.00	Mod (Ex)	(Aero) MP304	1	Note 1	Note 1	76.0	Pass
M2	91.50-81.50	Mod (Ex)	(Aero) MP303	2	Note 1	Note 1	80.6	Pass
M3	65.50-50.50	Mod (Ex)	(Aero) MP304	3	Note 1	Note 1	74.9	Pass

Summary		
Pole (L2)	70.1	Pass
Mod (M2)	80.6	Pass
<b>RATING =</b>	<b>80.6</b>	<b>Pass</b>

\*Note 1: See additional documentation in following sheets for details.



Reinforcement Layout

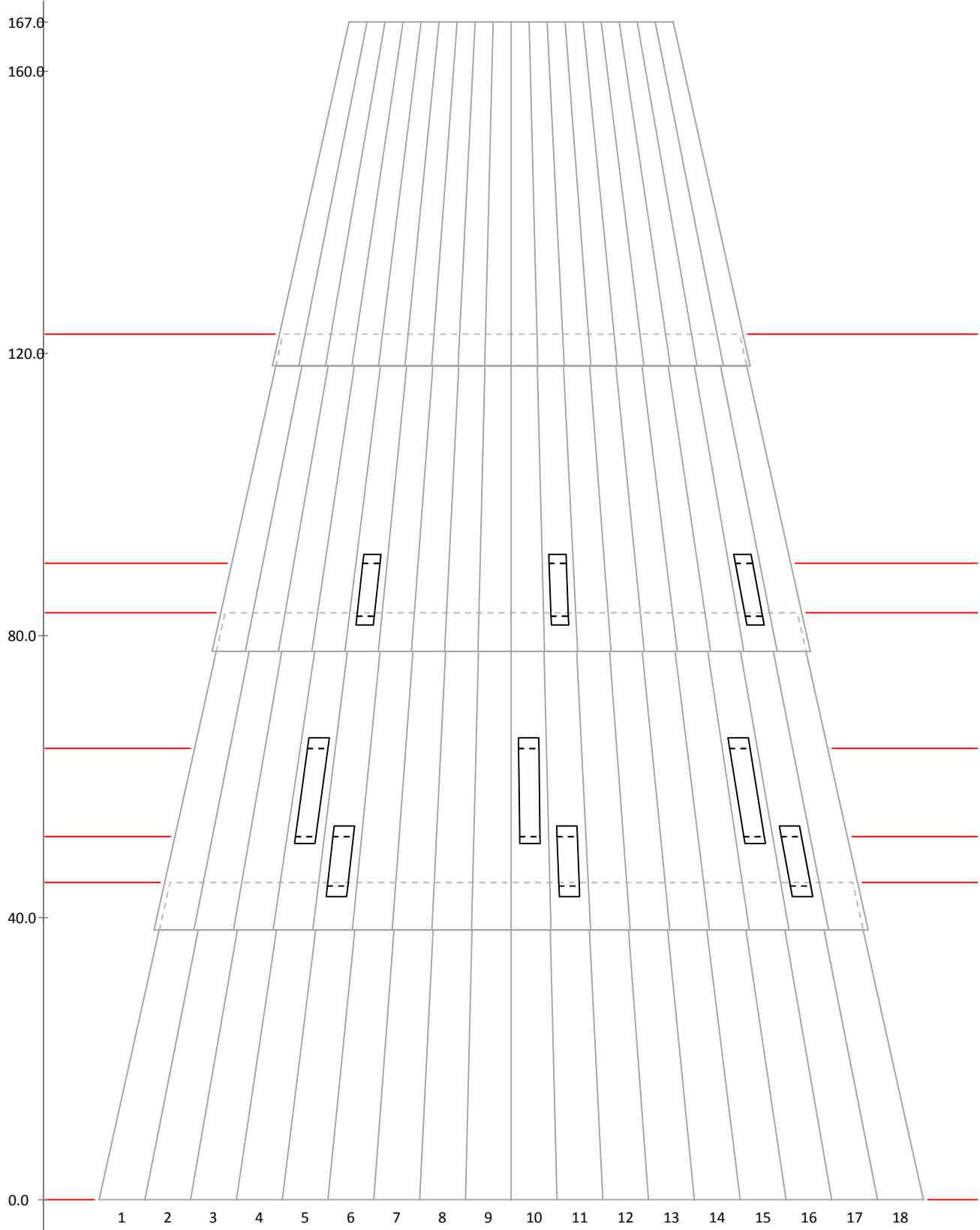



Elevation: 0.00-ft

Loads	
Axial:	64.9 k
Moment:	4,415.6 k-ft
Shear:	33.9 k
Torsion:	0.8 k-ft
Equivalent Loads to Pole	
Axial:	64.9 k
Moment:	4,415.6 k-ft
Shear:	33.9 k
Torsion:	0.8 k-ft
Shear Flow N/A	

Pole Info	
OD:	61.04 in
t:	0.4375 in
Pole $A_G$ :	84.15 in <sup>2</sup>
Pole $I_G$ :	39,047.6 in <sup>4</sup>
Controlling	
Angle:	10.00°
$I_{CONT}$ :	39,047.6 in <sup>4</sup>
$A_G$ :	84.15 in <sup>2</sup>
Minimum	
Angle:	0.00°
$I_{MIN}$ :	39,047.6 in <sup>4</sup>
$t_{EFF}$ :	0.4375 in

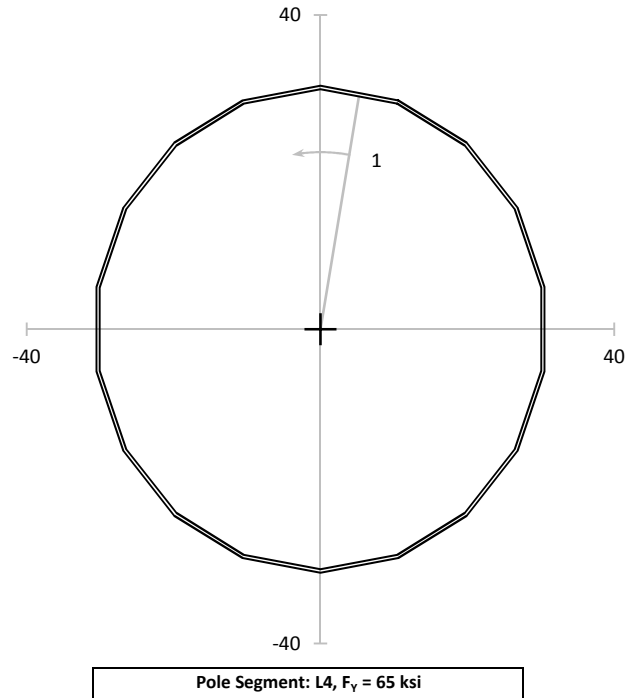

POLE CAPACITY											
Angle (°)	$Y_{CONT}$ (in)	$I$ (in <sup>4</sup> )	$\sigma_A$ (ksi)	$\sigma_B$ (ksi)	$\sigma_V$ (ksi)	$\sigma_T$ (ksi)	$\phi F_A$ (ksi)	$\phi F_B$ (ksi)	$\phi F_V$ (ksi)	$\phi F_T$ (ksi)	Capacity
10.00	31.01	39047.6	0.772	42.078	0.403	0.004	67.130	67.130	33.565	67.130	63.8%

MODIFICATION CAPACITIES											
Mod Number	#	Angle (°)	$Y_{CONT}$ (in)	$I$ (in <sup>4</sup> )	$\sigma_A$ (ksi)	$\sigma_B$ (ksi)	$\sigma_V$ (ksi)	$\phi F_A$ (ksi)	$\phi F_B$ (ksi)	$\phi F_V$ (ksi)	Capacity



Elevation: 45.00-ft

Loads	
Axial:	45.0 k
Moment:	2,950.9 k-ft
Shear:	31.1 k
Torsion:	0.8 k-ft
Equivalent Loads to Pole	
Axial:	37.4 k
Moment:	2,426.6 k-ft
Shear:	25.8 k
Torsion:	0.8 k-ft
Shear Flow	
Controlling Mod:	1
q:	0.139 k/in
Bolt/Weld Cap:	36.0 k/bolt
Max Spacing:	258.18 in
Stitch:	18.00 in
Capacity:	7.0%

Pole Info	
OD:	51.30 in
t:	0.3750 in
Pole $A_G$ :	60.62 in <sup>2</sup>
Pole $I_G$ :	19,864.2 in <sup>4</sup>
Controlling	
Angle:	200.00°
$I_G$ :	24,156.0 in <sup>4</sup>
$A_G$ :	73.01 in <sup>2</sup>
Minimum	
Angle:	10.05°
$I_{MIN}$ :	24,156.0 in <sup>4</sup>
$t_{EFF}$ :	0.4583 in

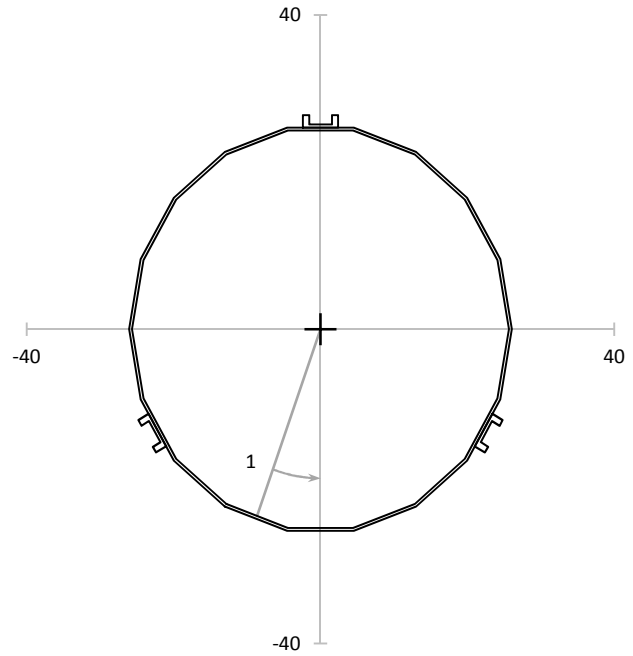

Pole Segment: L3, F<sub>y</sub> = 65 ksi

POLE CAPACITY											
Angle (°)	$Y_{CONT}$ (in)	$I$ (in <sup>4</sup> )	$\sigma_A$ (ksi)	$\sigma_B$ (ksi)	$\sigma_V$ (ksi)	$\sigma_T$ (ksi)	$\phi F_A$ (ksi)	$\phi F_B$ (ksi)	$\phi F_V$ (ksi)	$\phi F_T$ (ksi)	Capacity
190.00	26.06	24156.0	0.617	38.206	0.425	0.006	67.635	67.635	33.817	67.635	57.4%

MODIFICATION CAPACITIES											
Mod Number	#	Angle (°)	$Y_{CONT}$ (in)	$I$ (in <sup>4</sup> )	$\sigma_A$ (ksi)	$\sigma_B$ (ksi)	$\sigma_V$ (ksi)	$\phi F_A$ (ksi)	$\phi F_B$ (ksi)	$\phi F_V$ (ksi)	Capacity
1	1	80.00	26.26	24156.0	0.617	38.499	0.425	53.494	49.881	29.250	76.0%
1	2	200.00	26.26	24156.0	0.617	38.499	0.425	53.494	49.881	29.250	76.0%
1	3	320.00	26.26	24156.0	0.617	38.499	0.425	53.494	49.881	29.250	76.0%

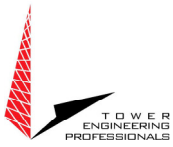

Elevation: 51.50-ft

Loads	
Axial:	42.7 k
Moment:	2,750.6 k-ft
Shear:	30.6 k
Torsion:	0.8 k-ft
Equivalent Loads to Pole	
Axial:	35.2 k
Moment:	2,248.8 k-ft
Shear:	25.3 k
Torsion:	0.8 k-ft
Shear Flow	
Controlling Mod:	3
q:	0.145 k/in
Bolt/Weld Cap:	36.0 k/bolt
Max Spacing:	247.91 in
Stitch:	18.00 in
Capacity:	7.3%

Pole Info	
OD:	49.79 in
t:	0.3750 in
Pole $A_G$ :	58.82 in <sup>2</sup>
Pole $I_G$ :	18,144.0 in <sup>4</sup>
Controlling	
Angle:	180.00°
$I_G$ :	22,192.9 in <sup>4</sup>
$A_G$ :	71.21 in <sup>2</sup>
Minimum	
Angle:	173.00°
$I_{MIN}$ :	22,192.9 in <sup>4</sup>
$t_{EFF}$ :	0.4611 in

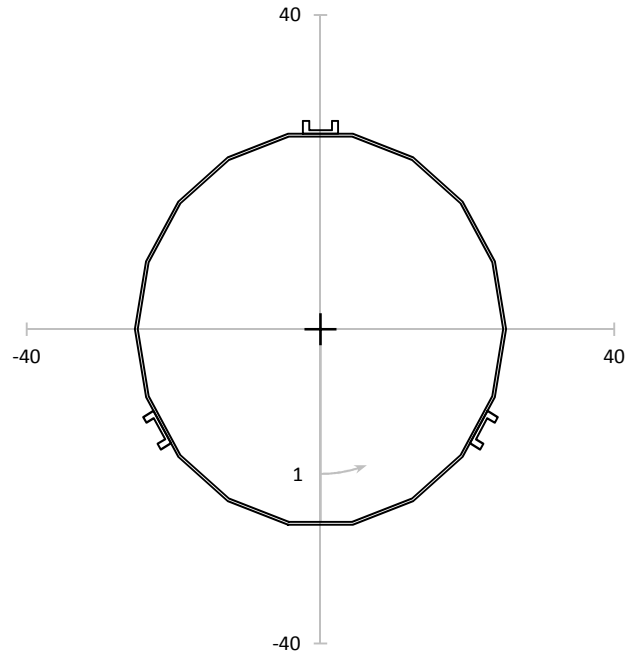

POLE CAPACITY											
Angle (°)	$Y_{CONT}$ (in)	$I$ (in <sup>4</sup> )	$\sigma_A$ (ksi)	$\sigma_B$ (ksi)	$\sigma_V$ (ksi)	$\sigma_T$ (ksi)	$\phi F_A$ (ksi)	$\phi F_B$ (ksi)	$\phi F_V$ (ksi)	$\phi F_T$ (ksi)	Capacity
10.00	25.29	22192.9	0.599	37.618	0.430	0.007	68.387	68.387	34.194	68.387	55.9%

MODIFICATION CAPACITIES											
Mod Number	#	Angle (°)	$Y_{CONT}$ (in)	$I$ (in <sup>4</sup> )	$\sigma_A$ (ksi)	$\sigma_B$ (ksi)	$\sigma_V$ (ksi)	$\phi F_A$ (ksi)	$\phi F_B$ (ksi)	$\phi F_V$ (ksi)	Capacity
3	1	60.00	25.50	22192.9	0.599	37.933	0.430	53.494	49.881	29.250	74.9%
3	2	180.00	25.50	22192.9	0.599	37.933	0.430	53.494	49.881	29.250	74.9%
3	3	300.00	25.50	22192.9	0.599	37.933	0.430	53.494	49.881	29.250	74.9%

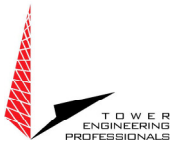

Elevation: 64.00-ft

Loads	
Axial:	38.0 k
Moment:	2,374.7 k-ft
Shear:	29.6 k
Torsion:	0.8 k-ft
Equivalent Loads to Pole	
Axial:	38.0 k
Moment:	2,374.7 k-ft
Shear:	29.6 k
Torsion:	0.8 k-ft
Shear Flow N/A	

Pole Info	
OD:	46.88 in
t:	0.3750 in
Pole $A_G$ :	55.35 in <sup>2</sup>
Pole $I_G$ :	15,120.7 in <sup>4</sup>
Controlling	
Angle:	10.00°
$I_G$ :	15,120.7 in <sup>4</sup>
$A_G$ :	55.35 in <sup>2</sup>
Minimum	
Angle:	0.00°
$I_{MIN}$ :	15,120.7 in <sup>4</sup>
$t_{EFF}$ :	0.3750 in

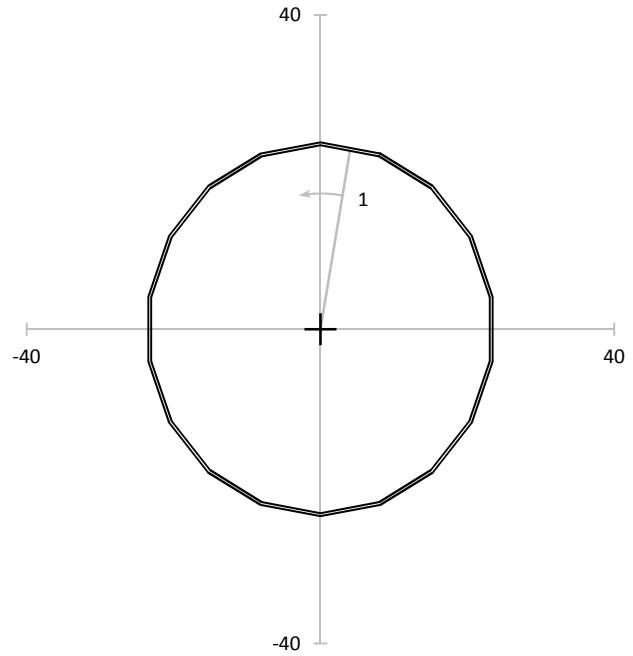

POLE CAPACITY											
Angle (°)	$Y_{CONT}$ (in)	$I$ (in <sup>4</sup> )	$\sigma_A$ (ksi)	$\sigma_B$ (ksi)	$\sigma_V$ (ksi)	$\sigma_T$ (ksi)	$\phi F_A$ (ksi)	$\phi F_B$ (ksi)	$\phi F_V$ (ksi)	$\phi F_T$ (ksi)	Capacity
10.00	23.81	15120.7	0.686	44.879	0.535	0.008	69.835	69.835	34.917	69.835	65.3%

MODIFICATION CAPACITIES											
Mod Number	#	Angle (°)	$Y_{CONT}$ (in)	$I$ (in <sup>4</sup> )	$\sigma_A$ (ksi)	$\sigma_B$ (ksi)	$\sigma_V$ (ksi)	$\phi F_A$ (ksi)	$\phi F_B$ (ksi)	$\phi F_V$ (ksi)	Capacity

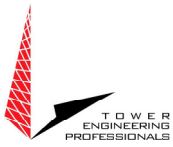

Elevation: 83.25-ft

Loads	
Axial:	31.1 k
Moment:	1,819.5 k-ft
Shear:	28.0 k
Torsion:	0.8 k-ft
Equivalent Loads to Pole	
Axial:	25.7 k
Moment:	1,491.1 k-ft
Shear:	23.2 k
Torsion:	0.8 k-ft
Shear Flow	
Controlling Mod:	2
q:	0.152 k/in
Bolt/Weld Cap:	36.0 k/bolt
Max Spacing:	237.38 in
Stitch:	18.00 in
Capacity:	7.6%

Pole Info	
OD:	43.02 in
t:	0.3125 in
Pole $A_G$ :	42.36 in <sup>2</sup>
Pole $I_G$ :	9,758.1 in <sup>4</sup>
Controlling	
Angle:	200.00°
$I_G$ :	11,907.8 in <sup>4</sup>
$A_G$ :	51.12 in <sup>2</sup>
Minimum	
Angle:	23.60°
$I_{MIN}$ :	11,907.8 in <sup>4</sup>
$t_{EFF}$ :	0.3832 in

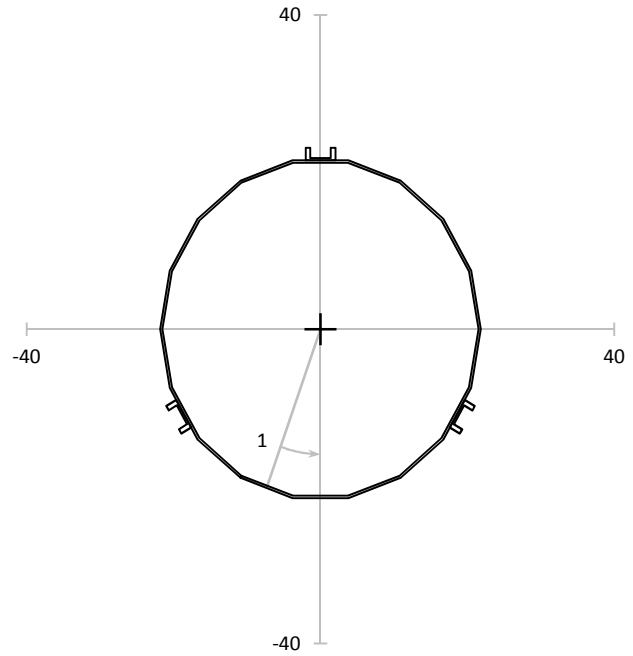

POLE CAPACITY											
Angle (°)	$Y_{CONT}$ (in)	$I$ (in <sup>4</sup> )	$\sigma_A$ (ksi)	$\sigma_B$ (ksi)	$\sigma_V$ (ksi)	$\sigma_T$ (ksi)	$\phi F_A$ (ksi)	$\phi F_B$ (ksi)	$\phi F_V$ (ksi)	$\phi F_T$ (ksi)	Capacity
10.00	21.85	11907.8	0.608	40.068	0.548	0.011	67.479	67.479	33.739	67.479	60.3%

MODIFICATION CAPACITIES											
Mod Number	#	Angle (°)	$Y_{CONT}$ (in)	$I$ (in <sup>4</sup> )	$\sigma_A$ (ksi)	$\sigma_B$ (ksi)	$\sigma_V$ (ksi)	$\phi F_A$ (ksi)	$\phi F_B$ (ksi)	$\phi F_V$ (ksi)	Capacity
2	1	80.00	22.10	11907.8	0.608	40.519	0.548	53.615	49.540	29.250	80.6%
2	2	200.00	22.10	11907.8	0.608	40.519	0.548	53.615	49.540	29.250	80.6%
2	3	320.00	22.10	11907.8	0.608	40.519	0.548	53.615	49.540	29.250	80.6%

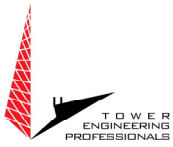

Elevation: 90.25-ft

Loads	
Axial:	29.1 k
Moment:	1,625.8 k-ft
Shear:	27.4 k
Torsion:	0.8 k-ft
Equivalent Loads to Pole	
Axial:	29.1 k
Moment:	1,625.8 k-ft
Shear:	27.4 k
Torsion:	0.8 k-ft
Shear Flow N/A	

Pole Info	
OD:	41.38 in
t:	0.3125 in
Pole $A_G$ :	40.74 in <sup>2</sup>
Pole $I_G$ :	8,682.1 in <sup>4</sup>
Controlling	
Angle:	10.00°
$I_G$ :	8,682.1 in <sup>4</sup>
$A_G$ :	40.74 in <sup>2</sup>
Minimum	
Angle:	0.00°
$I_{MIN}$ :	8,682.1 in <sup>4</sup>
$t_{EFF}$ :	0.3125 in

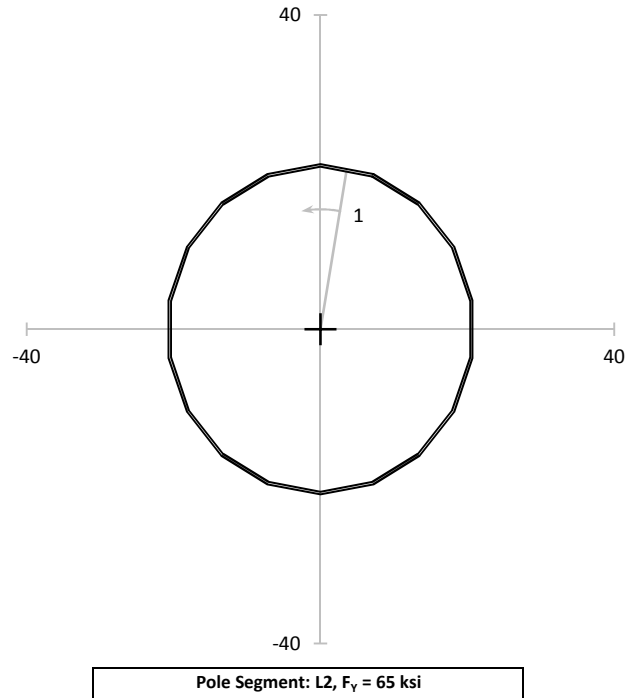

POLE CAPACITY											
Angle (°)	$Y_{CONT}$ (in)	$I$ (in <sup>4</sup> )	$\sigma_A$ (ksi)	$\sigma_B$ (ksi)	$\sigma_V$ (ksi)	$\sigma_T$ (ksi)	$\phi F_A$ (ksi)	$\phi F_B$ (ksi)	$\phi F_V$ (ksi)	$\phi F_T$ (ksi)	Capacity
10.00	21.02	8682.1	0.714	47.240	0.673	0.012	68.451	68.451	34.226	68.451	70.1%

MODIFICATION CAPACITIES											
Mod Number	#	Angle (°)	$Y_{CONT}$ (in)	$I$ (in <sup>4</sup> )	$\sigma_A$ (ksi)	$\sigma_B$ (ksi)	$\sigma_V$ (ksi)	$\phi F_A$ (ksi)	$\phi F_B$ (ksi)	$\phi F_V$ (ksi)	Capacity



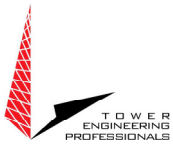

Elevation: 122.75-ft

Loads	
Axial:	21.0 k
Moment:	776.9 k-ft
Shear:	24.8 k
Torsion:	0.8 k-ft
Equivalent Loads to Pole	
Axial:	21.0 k
Moment:	776.9 k-ft
Shear:	24.8 k
Torsion:	0.8 k-ft
Shear Flow N/A	

Pole Info	
OD:	34.31 in
t:	0.2500 in
Pole $A_G$ :	27.03 in <sup>2</sup>
Pole $I_G$ :	3,961.6 in <sup>4</sup>
Controlling	
Angle:	10.00°
$I_G$ :	3,961.6 in <sup>4</sup>
$A_G$ :	27.03 in <sup>2</sup>
Minimum	
Angle:	0.00°
$I_{MIN}$ :	3,961.6 in <sup>4</sup>
$t_{EFF}$ :	0.2500 in

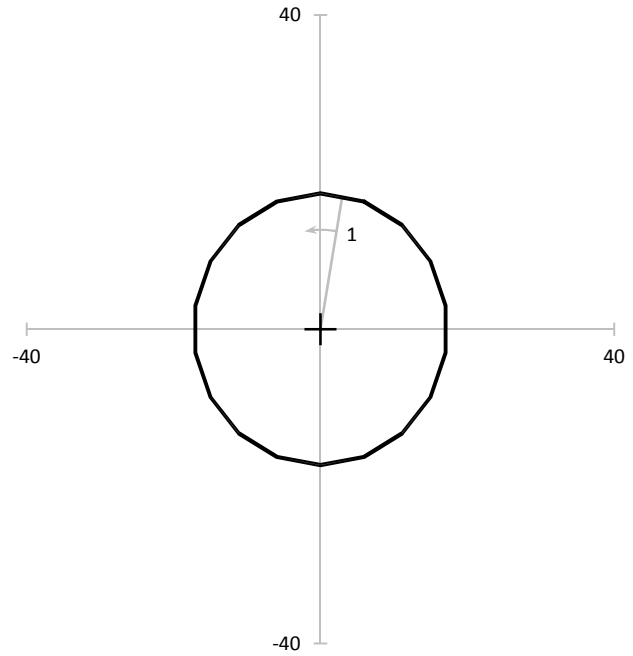

Pole Segment: L1,  $F_y = 65$  ksi

POLE CAPACITY											
Angle (°)	$Y_{CONT}$ (in)	$I$ (in <sup>4</sup> )	$\sigma_A$ (ksi)	$\sigma_B$ (ksi)	$\sigma_V$ (ksi)	$\sigma_T$ (ksi)	$\phi F_A$ (ksi)	$\phi F_B$ (ksi)	$\phi F_V$ (ksi)	$\phi F_T$ (ksi)	Capacity
10.00	17.43	3961.6	0.776	41.016	0.917	0.022	67.554	67.554	33.777	67.554	61.9%

MODIFICATION CAPACITIES											
Mod Number	#	Angle (°)	$Y_{CONT}$ (in)	$I$ (in <sup>4</sup> )	$\sigma_A$ (ksi)	$\sigma_B$ (ksi)	$\sigma_V$ (ksi)	$\phi F_A$ (ksi)	$\phi F_B$ (ksi)	$\phi F_V$ (ksi)	Capacity

## Square, Stiffened / Unstiffened Base Plate, Any Rod Material - Rev. F / G

- Assumptions: 1) Rod groups at corners. Total # rods divisible by 4. Maximum total # of rods = 48 (12 per Corner).  
 2) Rod Spacing = Straight Center-to-Center distance between any (2) adjacent rods (same corner)  
 3) Clear space between bottom of leveling nut and top of concrete **not** exceeding  $(1) \times (\text{Rod Diameter})$

### Site Data

BU#: 801367  
 Site Name: CT NHV-2075 CAC 801367  
 App #: 374826 Rev. 0

### Anchor Rod Data

Eta Factor, $\eta$	0.5	TIA G (Fig. 4-4)
Qty:	20	
Diam:	2.25	in
Rod Material:	A615-J	
Yield, Fy:	75	ksi
Strength, Fu:	100	ksi
Bolt Circle:	68	in
Anchor Spacing:	6	in

### Plate Data

W=Side:	67	in
Thick:	3	in
Grade:	55	ksi
Clip Distance:	14	in

### Stiffener Data (Welding at both sides)

Configuration:	Unstiffened	
Weld Type:	**	
Groove Depth:		in **
Groove Angle:		degrees
Fillet H. Weld:		<-- Disregard
Fillet V. Weld:		in
Width:		in
Height:		in
Thick:		in
Notch:		in
Grade:		ksi
Weld str.:		ksi

### Pole Data

Diam:	61.04	in
Thick:	0.4375	in
Grade:	65	ksi
# of Sides:	18	"0" IF Round

### Base Reactions

TIA Revision:	G	
Factored Moment, Mu:	4415.627	ft-kips
Factored Axial, Pu:	64.958	kips
Factored Shear, Vu:	33.861	kips

### Anchor Rod Results

TIA G --> Max Rod  $(C_u + V_u/\eta)$ : 162.5 Kips  
 Axial Design Strength,  $\Phi * F_u * A_{net}$ : 260.0 Kips  
 Anchor Rod Stress Ratio: 62.5% **Pass**

### Base Plate Results

Base Plate Stress: 24.9 ksi  
 PL Design Bending Strength,  $\Phi * F_y$ : 49.5 ksi  
 Base Plate Stress Ratio: 50.3% **Pass**

### Flexural Check

### PL Ref. Data

Yield Line (in):	33.71
Max PL Length:	33.71

### N/A - Unstiffened

### Stiffener Results

Horizontal Weld : N/A  
 Vertical Weld: N/A  
 Plate Flex+Shear,  $f_b/F_b + (f_v/F_v)^2$ : N/A  
 Plate Tension+Shear,  $f_t/F_t + (f_v/F_v)^2$ : N/A  
 Plate Comp. (AISC Bracket): N/A

### Pole Results

Pole Punching Shear Check: N/A

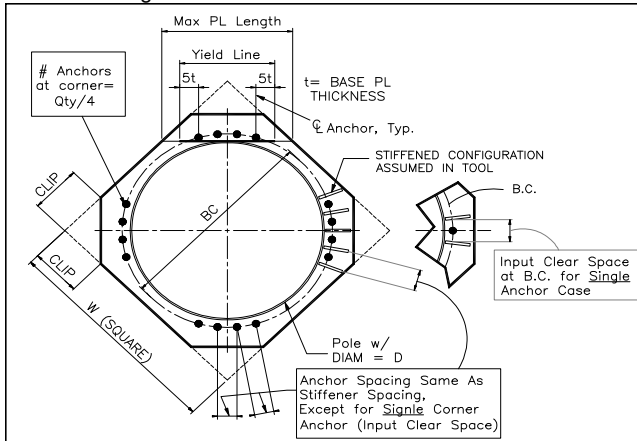

\*\* Note: for complete joint penetration groove welds the groove depth must be exactly 1/2 the stiffener thickness for calculation purposes

JOB: CT NHV-2075 CAC 801367 (BU 801367)  
 SHEET NUMBER: 1 OF 2  
 CALCULATED BY: MTW DATE 1/30/2017  
 CHECKED BY: ZRH DATE 1/30/2017

**Pad and Pier Foundation for Monopole - TIA-222-G**

(For pads of unequal side dimensions and eccentric tower location)

q <sub>a</sub> , ALLOWABLE SOIL PRESS. (ksf)	8.00
NET or GROSS	NET
SAFETY FACTOR IN q <sub>a</sub>	2
SOIL DENSITY (pcf)	100

F <sub>c</sub> (ksi)	3
F <sub>y</sub> (ksi)	60

φ\*q<sub>n</sub> = 12.0 ksf

**Base Reactions LC1: 1.2D + 1.6W**

M, MOMENT (k-ft)	4415.6
P <sub>t</sub> , TOTAL DOWNLOAD (k)	65.0
H, HORIZONTAL SHEAR (k)	33.9
Tower Eccentricity, e <sub>LT</sub> (ft)	0.0
Tower Eccentricity, e <sub>BT</sub> (ft)	0.0

**Base Reaction LC2: 0.9D + 1.6W**

M (k-ft)	4415.6
P <sub>t</sub> (k)	48.7
H (k)	33.9

Try:	L (ft.)	B (ft.)	t (ft.)	Depth to top of pad (ft.)	Pier dia./width (ft.)	Pier Height, h (cu.ft.)	Pier Shape
	28	25	2.5	2.9	8.00	3.50	Round

W <sub>m</sub> , Weight of Mat (k) =	262.5
W <sub>p</sub> , Weight of Pier (k) =	26.4
W <sub>s</sub> , Weight of Soil (k) =	188.4

Concrete Vol. (cu ft) 71.33

**CHECK BEARING PRESSURE for LC1: 1.2D + 1.6W**

P = P <sub>t</sub> + W <sub>f</sub> + W <sub>s</sub> =	637.7 k
e <sub>L</sub> =	7.24 ft
L/6 =	4.67 ft
e <sub>B</sub> =	7.24 ft
B/6 =	4.17 ft
Orthogonal: q <sub>max</sub> =	2.28 ksf
Diag. Axis: q <sub>max</sub> =	3.06 ksf

**Capacity:** 25.5%

**CHECK BEARING STABILITY FOR LC2: 0.9D + 1.6W**

90° Axis	M <sub>φqn</sub> <sup>1</sup> =	5654.6 k-ft
	M <sub>ot</sub> /M <sub>φqn</sub> =	0.82
Diag. Axis	M <sub>φqn</sub> =	6767.9 k-ft
	M <sub>ot</sub> /M <sub>φqn</sub> =	0.68

**Capacity:** 81.7%

<sup>1</sup> M<sub>φqn</sub> is the overturning moment at which q<sub>max</sub> = φq<sub>n</sub>

**CHECK OVERTURNING: LC2 WITH WIND PARALLEL TO SIDE B CONTROLS**

M <sub>st</sub> =(P <sub>t</sub> +0.9W <sub>p</sub> )*(B/2-e <sub>BT</sub> )+(0.9W <sub>m+s</sub> *B/2) =	5978.7 k-ft
M <sub>ot</sub> = M+H*(t+h) =	4618.8 k-ft
M <sub>ot</sub> /M <sub>st</sub> =	0.77

**Capacity:** 77.3%

JOB: CT NHV-2075 CAC 801367 (BU 801367)  
 SHEET NUMBER: 2 OF 2  
 CALCULATED BY: MTW DATE 1/30/2017  
 CHECKED BY: ZRH DATE 1/30/2017

**CHECK ONE WAY SHEAR**

$V_u = 286.0 \text{ k}$   
 $V_c = 710.8 \text{ k}$

**Capacity:** 40.24%

**CALCULATE REINFORCING REQUIRED**

$F'_c = 3.0 \text{ ksi}$        $F'_y = 60.0 \text{ ksi}$

Temp & Shrinkage reinforcing,  $A_{s,t} = 0.32 \text{ in}^2/\text{ft}$  (ACI 318 Sec. 10.5.4)

**BOTTOM REINFORCING**

Bar Size = 10  
 Bar Spacing, c-c: 9.0  
 d = 25.1 in.

$\mu = 475.9 \text{ in-k/ft}$

$\phi M_n = 0.9 * A_s * F_y * d (1 - 0.59 * A_s * F_y / (b * d * F'_c))$

Solution:  $A_{s,req} = 0.36 \text{ in}^2/\text{ft}$

Check,  $A_s = 1.69 \text{ in}^2/\text{ft}$

**Capacity:** 21.01%

**TOP REINFORCING**

Bar Size = 10  
 Bar Spacing, c-c: 9.0  
 d = 25.1 in.

$\mu = 952.1 \text{ in-k/ft}$

$\phi M_n = 0.9 * A_s * F_y * d (1 - 0.59 * A_s * F_y / (b * d * F'_c))$

Solution:  $A_{s,req} = 0.72 \text{ in}^2/\text{ft}$

Check,  $A_s = 1.69 \text{ in}^2/\text{ft}$

**Capacity:** 42.65%

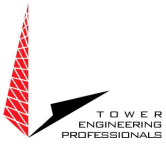

PASS PASS

CT NHV-2075 CAC 801367 (BU 801367)

Results Summary: LC1 LC2  
 Soil Interaction: N/A N/A  
 Foundation Structural: 41.2% 12.5%

TEP #: 25630.106836  
 Analysis: MTW 1/30/2017  
 Check: ZRH 1/30/2017

Drilled Caisson Tool - Input

Code Revisions: TIA-222-G ACI 318-11

Tower Type: Monopole

	LC1	LC2	
Moment:	4,534.14	1,383.80	kip-ft
Axial (download):	64.96	109.66	kip
Shear:	33.86	10.23	kip
Axial (uplift):			kip

Shaft Information		
Diameter:	8.00	ft
Projection:	0.60	ft
Caisson Length:	3.50	ft
f'c:	3.000	ksi
Max $\epsilon_c$ :	0.003	in/in

Cage 1 Reinforcement

Tie Bar Size:	4	(fy = 40.0 ksi)
Clear Cover to Tie:	3.00	in (Cage $\phi$ = 87.59in)
Tie Bar Spacing:	6.00	in
Vertical Bar Size:	11	
Vertical Bar Quantity:	40	( $\rho$ = 0.862%)
fy:	60.0	ksi
E:	29,000	ksi

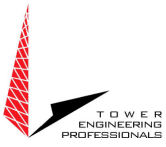

Reinforcement Capacity

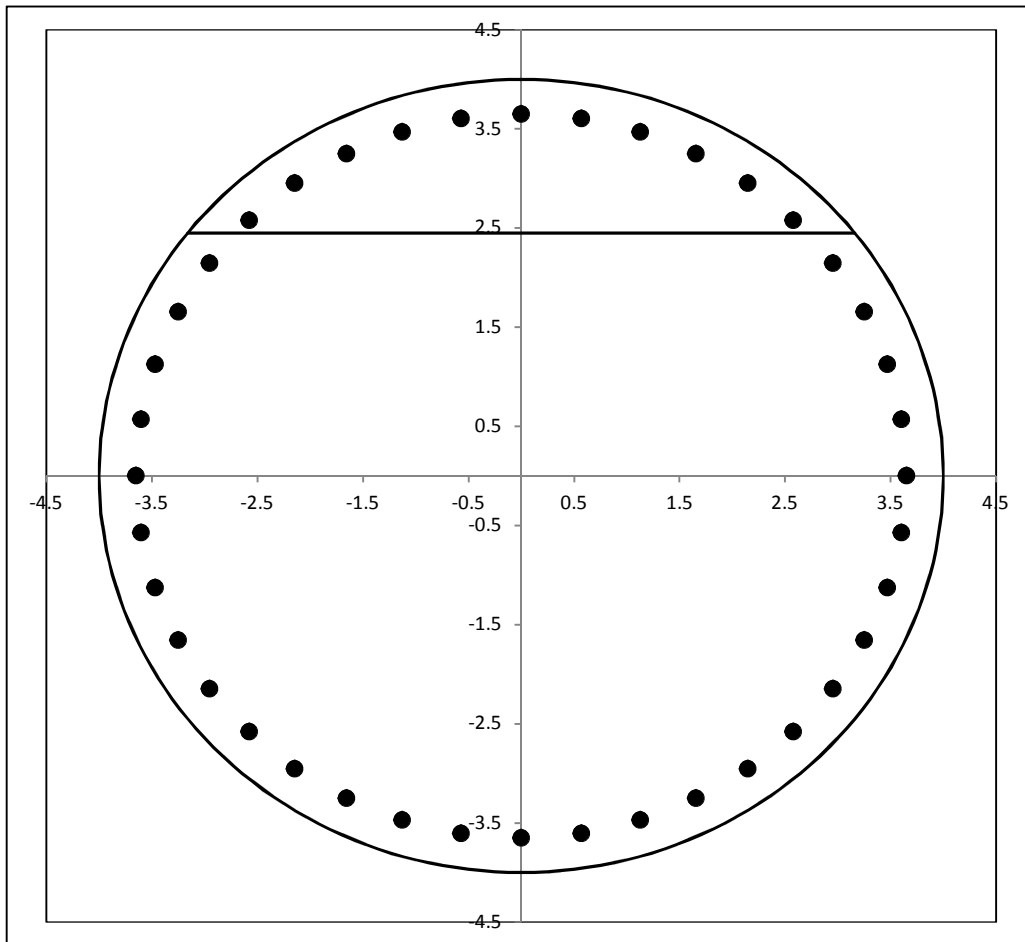

	LC1	LC2
$V_u$ =	33.9	33.9 kip
$V_c$ =	796.5	798.9 kip
$f_{y,tie}$ = 40.0 $V_s$ =	244.4	244.4 kip
$\phi V_n$ =	780.7	782.5 kip
Capacity =	4.3%	4.3%
	PASS	PASS

	LC1	LC2
$M_u$ =	4534.1	1383.8 kip-ft
$\phi M_n$ =	10993.4	11109.1 kip-ft
Capacity =	41.2%	12.5%
	PASS	PASS

# Exhibit E

**RADIO FREQUENCY EMISSIONS ANALYSIS REPORT  
EVALUATION OF HUMAN EXPOSURE POTENTIAL  
TO NON-IONIZING EMISSIONS**

**T-Mobile Existing Facility**

**Site ID: CT11352C**

**Crown Cheshire  
1119 Summit Road  
Cheshire, CT 06410**

**February 9, 2017**

**EBI Project Number: 6217000475**

<b>Site Compliance Summary</b>	
Compliance Status:	<b>COMPLIANT</b>
Site total MPE% of FCC general public allowable limit:	<b>7.01 %</b>



February 9, 2017

T-Mobile USA  
Attn: Jason Overbey, RF Manager  
35 Griffin Road South  
Bloomfield, CT 06002

Emissions Analysis for Site: **CT11352C – Crown Cheshire**

EBI Consulting was directed to analyze the proposed T-Mobile facility located at **1119 Summit Road, Cheshire, CT**, for the purpose of determining whether the emissions from the Proposed T-Mobile Antenna Installation located on this property are within specified federal limits.

All information used in this report was analyzed as a percentage of current Maximum Permissible Exposure (% MPE) as listed in the FCC OET Bulletin 65 Edition 97-01 and ANSI/IEEE Std C95.1. The FCC regulates Maximum Permissible Exposure in units of microwatts per square centimeter ( $\mu\text{W}/\text{cm}^2$ ). The number of  $\mu\text{W}/\text{cm}^2$  calculated at each sample point is called the power density. The exposure limit for power density varies depending upon the frequencies being utilized. Wireless Carriers and Paging Services use different frequency bands each with different exposure limits, therefore it is necessary to report results and limits in terms of percent MPE rather than power density.

All results were compared to the FCC (Federal Communications Commission) radio frequency exposure rules, 47 CFR 1.1307(b)(1) – (b)(3), to determine compliance with the Maximum Permissible Exposure (MPE) limits for General Population/Uncontrolled environments as defined below.

General population/uncontrolled exposure limits apply to situations in which the general public may be exposed or in which persons who are exposed as a consequence of their employment may not be made fully aware of the potential for exposure or cannot exercise control over their exposure. Therefore, members of the general public would always be considered under this category when exposure is not employment related, for example, in the case of a telecommunications tower that exposes persons in a nearby residential area.

Public exposure to radio frequencies is regulated and enforced in units of microwatts per square centimeter ( $\mu\text{W}/\text{cm}^2$ ). The general population exposure limit for the 700 MHz Band is approximately 467  $\mu\text{W}/\text{cm}^2$ , and the general population exposure limit for the 1900 MHz (PCS) and 2100 MHz (AWS) bands is 1000  $\mu\text{W}/\text{cm}^2$ . Because each carrier will be using different frequency bands, and each frequency band has different exposure limits, it is necessary to report percent of MPE rather than power density.

Occupational/controlled exposure limits apply to situations in which persons are exposed as a consequence of their employment and in which those persons who are exposed have been made fully aware of the potential for exposure and can exercise control over their exposure. Occupational/controlled exposure limits also apply where exposure is of a transient nature as a result of incidental passage through a location where exposure levels may be above general population/uncontrolled limits (see below), as long as the exposed person has been made fully aware of the potential for exposure and can exercise control over his or her exposure by leaving the area or by some other appropriate means.

Additional details can be found in FCC OET 65.

## **CALCULATIONS**

Calculations were done for the proposed T-Mobile Wireless antenna facility located at **1119 Summit Road, Cheshire, CT**, using the equipment information listed below. All calculations were performed per the specifications under FCC OET 65. Since T-Mobile is proposing highly focused directional panel antennas, which project most of the emitted energy out toward the horizon, all calculations were performed assuming a lobe representing the maximum gain of the antenna per the antenna manufactures supplied specifications, minus 10 dB, was focused at the base of the tower. For this report the sample point is the top of a 6-foot person standing at the base of the tower.

For all calculations, all equipment was calculated using the following assumptions:

- 1) 2 GSM channels (PCS Band - 1900 MHz) were considered for each sector of the proposed installation. These Channels have a transmit power of 30 Watts per Channel.
- 2) 2 UMTS channels (PCS Band - 1900 MHz) were considered for each sector of the proposed installation. These Channels have a transmit power of 30 Watts per Channel.
- 3) 2 UMTS channels (AWS Band – 2100 MHz) were considered for each sector of the proposed installation. These Channels have a transmit power of 30 Watts per Channel.
- 4) 2 LTE channels (PCS Band - 1900 MHz) were considered for each sector of the proposed installation. These Channels have a transmit power of 60 Watts per Channel.
- 5) 2 LTE channels (AWS Band – 2100 MHz) were considered for each sector of the proposed installation. These Channels have a transmit power of 60 Watts per Channel.
- 6) 1 LTE channel (700 MHz Band) was considered for each sector of the proposed installation. This channel has a transmit power of 30 Watts.

- 7) Since The 2100 MHz UMTS & 1900 MHz UMTS and GSM radios are ground mounted there are additional cabling losses accounted for. For each ground mounted RF path the following losses were calculated. 1.70 dB of additional cable loss for all ground mounted 1900 MHz UMTS & GSM channels and 1.75 dB of additional cable loss for all ground mounted 2100 MHz UMTS channels were factored into the calculations used for this analysis. This is based on manufacturers Specifications for 165 feet of 1-5/8" coax cable on each path.
- 8) All radios at the proposed installation were considered to be running at full power and were uncombined in their RF transmissions paths per carrier prescribed configuration. Per FCC OET Bulletin No. 65 - Edition 97-01 recommendations to achieve the maximum anticipated value at each sample point, all power levels emitting from the proposed antenna installation are increased by a factor of 2.56 to account for possible in-phase reflections from the surrounding environment. This is rarely the case, and if so, is never continuous.
- 9) For the following calculations the sample point was the top of a 6-foot person standing at the base of the tower. The maximum gain of the antenna per the antenna manufactures supplied specifications minus 10 dB was used in this direction. This value is a very conservative estimate as gain reductions for these particular antennas are typically much higher in this direction.
- 10) The antennas used in this modeling are the **Ericsson AIR32 B2A / B66Aa & RFS APX16PV-16PVL** for 1900 MHz (PCS) and 2100 MHz (AWS) channels and the **Commscope LNX-6515DS-A1M** for 700 MHz channels. This is based on feedback from the carrier with regards to anticipated antenna selection. The **Ericsson AIR32 B2A / B66Aa** has a maximum gain of **15.9 dBd** at its main lobe at 1900 MHz and 2100 MHz. The **RFS APX16PV-16PVL** has a maximum gain of **16.3 dBd** at its main lobe at 1900 MHz and 2100 MHz. The **Commscope LNX-6515DS-A1M** has a maximum gain of **14.6 dBd** at its main lobe at 700 MHz. The maximum gain of the antenna per the antenna manufactures supplied specifications, minus 10 dB, was used for all calculations. This value is a very conservative estimate as gain reductions for these particular antennas are typically much higher in this direction.
- 11) The antenna mounting height centerline of the proposed antennas is **138 feet** above ground level (AGL).
- 12) Emissions values for additional carriers were taken from the Connecticut Siting Council active database. Values in this database are provided by the individual carriers themselves.
- 13) All calculations were done with respect to uncontrolled / general public threshold limits.

### T-Mobile Site Inventory and Power Data

Sector:	A	Sector:	B	Sector:	C
Antenna #:	1	Antenna #:	1	Antenna #:	1
Make / Model:	Ericsson AIR32 B2A / B66Aa	Make / Model:	Ericsson AIR32 B2A / B66Aa	Make / Model:	Ericsson AIR32 B2A / B66Aa
Gain:	15.9 dBd	Gain:	15.9 dBd	Gain:	15.9 dBd
Height (AGL):	138	Height (AGL):	138	Height (AGL):	138
Frequency Bands	1900 MHz (PCS) / 2100 MHz (AWS)	Frequency Bands	1900 MHz (PCS) / 2100 MHz (AWS)	Frequency Bands	1900 MHz (PCS) / 2100 MHz (AWS)
Channel Count	4	Channel Count	4	Channel Count	4
Total TX Power(W):	240	Total TX Power(W):	240	Total TX Power(W):	240
ERP (W):	9,337.08	ERP (W):	9,337.08	ERP (W):	9,337.08
Antenna A1 MPE%	1.93	Antenna B1 MPE%	1.93	Antenna C1 MPE%	1.93
Antenna #:	2	Antenna #:	2	Antenna #:	2
Make / Model:	RFS APX16PV-16PVL	Make / Model:	RFS APX16PV-16PVL	Make / Model:	RFS APX16PV-16PVL
Gain:	16.3 dBd	Gain:	16.3 dBd	Gain:	16.3 dBd
Height (AGL):	138	Height (AGL):	138	Height (AGL):	138
Frequency Bands	1900 MHz(PCS) / 2100 MHz (AWS)	Frequency Bands	1900 MHz(PCS) / 2100 MHz (AWS)	Frequency Bands	1900 MHz(PCS) / 2100 MHz (AWS)
Channel Count	6	Channel Count	6	Channel Count	6
Total TX Power(W):	180	Total TX Power(W):	180	Total TX Power(W):	180
ERP (W):	5,171.45	ERP (W):	5,171.45	ERP (W):	5,171.45
Antenna A2 MPE%	1.07	Antenna B2 MPE%	1.07	Antenna C2 MPE%	1.07
Antenna #:	3	Antenna #:	3	Antenna #:	3
Make / Model:	Commscope LNX-6515DS-A1M	Make / Model:	Commscope LNX-6515DS-A1M	Make / Model:	Commscope LNX-6515DS-A1M
Gain:	14.6 dBd	Gain:	14.6 dBd	Gain:	14.6 dBd
Height (AGL):	138	Height (AGL):	138	Height (AGL):	138
Frequency Bands	700 MHz	Frequency Bands	700 MHz	Frequency Bands	700 MHz
Channel Count	1	Channel Count	1	Channel Count	1
Total TX Power(W):	30	Total TX Power(W):	30	Total TX Power(W):	30
ERP (W):	865.21	ERP (W):	865.21	ERP (W):	865.21
Antenna A3 MPE%	0.38	Antenna B3 MPE%	0.38	Antenna C3 MPE%	0.38

Site Composite MPE%	
Carrier	MPE%
T-Mobile (Per Sector Max)	3.38 %
Verizon Wireless	1.41 %
Sprint	0.77 %
AT&T	1.45 %
<b>Site Total MPE %:</b>	<b>7.01 %</b>

T-Mobile Sector A Total:	3.38 %
T-Mobile Sector B Total:	3.38 %
T-Mobile Sector C Total:	3.38 %
<b>Site Total:</b>	<b>7.01 %</b>

T-Mobile_Max Values per sector	# Channels	Watts ERP (Per Channel)	Height (feet)	Total Power Density ( $\mu\text{W}/\text{cm}^2$ )	Frequency (MHz)	Allowable MPE ( $\mu\text{W}/\text{cm}^2$ )	Calculated % MPE
T-Mobile AWS - 2100 MHz LTE	2	2,334.27	138	9.63	AWS - 2100 MHz	1000	0.96%
T-Mobile PCS - 1900 MHz LTE	2	2,334.27	138	9.63	PCS - 1900 MHz	1000	0.96%
T-Mobile AWS - 2100 MHz UMTS	2	855.31	138	3.53	AWS - 2100 MHz	1000	0.35%
T-Mobile PCS - 1950 MHz UMTS	2	865.21	138	3.57	PCS - 1950 MHz	1000	0.36%
T-Mobile PCS - 1950 MHz GSM	2	865.21	138	3.57	PCS - 1950 MHz	1000	0.36%
T-Mobile 700 MHz LTE	1	865.21	138	1.79	700 MHz	467	0.38%
						<b>Total*:</b>	<b>3.38%</b>

\*NOTE: Totals may vary by 0.01% due to summing of remainders

## Summary

All calculations performed for this analysis yielded results that were **within** the allowable limits for general public exposure to RF Emissions.

The anticipated maximum composite contributions from the T-Mobile facility as well as the site composite emissions value with regards to compliance with FCC's allowable limits for general public exposure to RF Emissions are shown here:

T-Mobile Sector	Power Density Value (%)
Sector A:	3.38 %
Sector B:	3.38 %
Sector C:	3.38 %
T-Mobile Per Sector Maximum:	3.38 %
Site Total:	7.01 %
Site Compliance Status:	<b>COMPLIANT</b>

The anticipated composite MPE value for this site assuming all carriers present is **7.01%** of the allowable FCC established general public limit sampled at the ground level. This is based upon values listed in the Connecticut Siting Council database for existing carrier emissions.

FCC guidelines state that if a site is found to be out of compliance (over allowable thresholds), that carriers over a 5% contribution to the composite value will require measures to bring the site into compliance. For this facility, the composite values calculated were well within the allowable 100% threshold standard per the federal government.