



STATE OF CONNECTICUT
CONNECTICUT SITING COUNCIL

Ten Franklin Square, New Britain, CT 06051

Phone: (860) 827-2935 Fax: (860) 827-2950

E-Mail: siting.council@ct.gov

Web Site: portal.ct.gov/csc

VIA ELECTRONIC MAIL

October 16, 2020

Kyle Richers
Transcend Wireless
10 Industrial Avenue, Suite 3
Mahwah, NJ 07430

RE: **EM-T-MOBILE-018-200902** – T-Mobile notice of intent to modify an existing telecommunications facility located at 39 Carmen Hill Road, Brookfield, Connecticut.

Dear Mr. Richers:

The Connecticut Siting Council (Council) is in receipt of your correspondence of October 14, 2020 submitted in response to the Council's October 6, 2020 notification of an incomplete request for exempt modification with regard to the above-referenced matter.

The submission renders the request for exempt modification complete and the Council will process the request in accordance with the Federal Communications Commission 60-day timeframe.

Thank you for your attention and cooperation.

Sincerely,

s/Melanie A. Bachman

Melanie A. Bachman
Executive Director

MAB/IN/laf

From: Kyle Richers <krichers@transcendwireless.com>
Sent: Wednesday, October 14, 2020 8:54 AM
To: Robidoux, Evan <Evan.Robidoux@ct.gov>
Cc: CSC-DL Siting Council <Siting.Council@ct.gov>
Subject: RE: Council Incomplete Letter for EM-T-MOBILE-018-200902 (39 Carmen Hill Road, Brookfield)

Good Morning,

In response, please find the attached revised structural analysis, that specifically references the new mount in the loading section. Also attached are the CDs. The mount analysis dated 7/7/2020 is referenced on page 4. Let me know if you need anything else.



Structural Analysis Report

Structure : 492 Foot Guyed Tower
VB Site Name : WRKI-FM
VB Site Number : US-CT-5009
Proposed Carrier : T-Mobile
Carrier Site Name : Brookfield/Junction Rd.
Carrier Site Number : CT11196A
Site Location : 0.3 Mi. Sse of Intersection of Carmen Hill Rd. & Se Trail
Brookfield, CT 06804 (Fairfield County)
41.4934, -73.4288
Date : June 1, 2020
Max Member Stress Level : 83%
Result : PASS

Prepared by:



VERTICAL BRIDGE ENGINEERING, LLC



06/01/2020

Table of Contents

Introduction1

Existing Structural Information1

Final Proposed Equipment Loading for T-Mobile1

Design Criteria2

Analysis Results2

Assumptions2

Conclusions3

Standard Conditions4

Disclaimer of Warranties4

Calculations..... Attached

Collocation Application Attached

Introduction

We have completed our structural analysis of the proposed equipment installation on the foregoing tower to determine its ability to support the new loads proposed by **T-Mobile**. The objective of the analysis was to determine if the tower meets the current structural codes and standards with the proposed equipment installation.

Existing Structural Information

The following documents for the existing structure were made available for our structural analysis.

Tower Information	Structural Components Tower Mapping Dated June 12, 2015.
Foundation Information	Structural Components Foundation Mapping Dated April 7, 2016.
Geotechnical Information	Delta Oaks Group Job No. GEO16-00237-03 dated April 11, 2016.
Existing Equipment Information	Vertical Bridge Collocation Application dated May 21, 2020.
Tower Reinforcement Information	Tower has been reinforced and is included in this analysis. ETS Modification Drawings Job No. 192640.14 dated May 10, 2019.

Final Proposed Equipment Loading for T-Mobile

The following proposed loading was obtained from the Vertical Bridge Collocation Application:

Antenna/Equipment					Coax	
Mount (ft.)	RAD (ft.)	Qty.	Antenna	Type	Qty.	Size/Type
280.0	-	3	Site Pro 1 VFA14-HD	Mount	12 1 4	1-5/8" Coax 1-5/8" Hybrid 1-5/8" Fiber
	280.0	3	RFS APX16DWV-16DWV-S-E-ACU	Panel		
		3	RFS APXVAARR24_43-U-NA-20	Panel		
		3	Ericsson KRY 112144	TMA		
		3	Ericsson KRY 112 89-4	TMA		
		3	Ericsson RRU 4449 B71B85	RRU		
		3	Ericsson AIR6488 2.5GHz	Panel		
		3	Ericsson AIR 32	Panel		
		3	Ericsson 4415 B25	RRU		

Note: Proposed equipment shown in bold.

Note: Other existing loading can be found on the tower profile attached.

Design Criteria

The tower was analyzed using tnxTower (Version 8.0.7.4) tower analysis software using the following design criteria.

State	Connecticut
City/County Building Code	Fairfield County (IBC 2018)
TIA/EIA Standard Code	TIA-222-H
Basic Wind Speed	115 MPH (V_{ult})
Basic Wind Speed w/ Ice	50 MPH w/ 1.0" Ice
Steel Grade	50 ksi Legs / 36 ksi All Other Members / A325 Bolts
Exposure Category	C
Topographic Category (height)	1 (0.0 ft)
Risk Category	II
Ss	0.21
Seismic Design Category	B

Analysis Results

Based on the foregoing information, our structural analysis determined that **the existing tower is structurally capable of supporting the proposed equipment loads without modification.** The existing tower base, inner, and outer anchor foundations have also been evaluated. The tower base, inner, and outer anchor foundations **are structurally capable of supporting the proposed equipment loads.** A seismic analysis has been performed on this tower and is not controlling.

Assumptions

The below assumptions are true, complete and accurate.

1. The existing tower has been maintained to manufacturer's specifications and is in good condition.
2. Foundations are considered to have been properly designed for the original design loads.
3. All member connections are considered to have been designed to meet the load carrying capacity of the connected member.
4. Antenna mount loads have been estimated based on generally accepted industry standards.
5. The mounts for the proposed antennas have been analyzed and designed by others.
6. See additional assumptions contained in the report attached.
7. Tower is within acceptable engineering tolerance at 105%.
8. Foundations are within acceptable engineering tolerance at 110%.

Conclusions

The existing tower described above **has sufficient capacity** to support the proposed loading based on the governing Building Code. The tower base, inner, and outer anchor foundations have also been evaluated and are acceptable. A seismic analysis has been performed on this tower and is not controlling.

We appreciate the opportunity of providing our continuing professional services to you. If you have any questions or need further assistance, please call us anytime at 561-948-6367.

Sincerely,

Analysis by:

Jesse Wagner
Modifications and Safety Manager

Reviewed by:

Michael T. DeBoer, PE
Vice President of Structural Engineering 06/01/2020



Standard Conditions

All engineering services are performed on the basis that the information used is current and correct. This information may consist of, but not necessarily limited, to:

- Information supplied by the client regarding the structure itself, the antenna and transmission line loading on the structure and its components, or relevant information.
- Information from drawings in possession of Vertical Bridge Engineering, LLC, or generated by field inspections or measurements of the structure.

It is the responsibility of the client to ensure that the information provided to Vertical Bridge Engineering, LLC and used in the performance of our engineering services is correct and complete. In the absence of information contrary, we consider that all structures were constructed in accordance with the drawings and specifications and are in a un- corroded condition and have not deteriorated; and we, therefore consider that their capacity has not significantly changed from the original design condition.

All services will be performed to the codes and standards specified by the client, and we do not imply to meet any other code and standard requirements unless explicitly agreed to in writing. If wind and ice loads or other relevant parameters are to be different from the minimum values recommended by the codes and standards, the client shall specify the exact requirements. In the absence of information to the contrary, all work will be performed in accordance with the revision of ANSI/TIA/EIA-222-H requested.

All services are performed, results obtained, and recommendations made in accordance with the generally accepted engineering principles and practices. Vertical Bridge Engineering LLC is not responsible for the conclusions, opinions and recommendations made by others based on the information we supply.

Disclaimer of Warranties

The engineering services by Vertical Bridge Engineering, LLC in connection with this Structural Analysis are limited to a computer analysis of the tower structure, size and capacity of its members. Vertical Bridge Engineering, LLC does not analyze the fabrication, including welding, except as may be expressly included in this report.

The purpose of this report is to assess the feasibility of adding appurtenances usually accompanied by transmission lines. Any mention of structural modifications are reasonable estimates and should not be used a precise construction document. Precise modification drawings are obtainable from Vertical Bridge Engineering, LLC but are beyond the scope of this report.

Vertical Bridge Engineering, LLC makes no warranties, express or implied, in connection with this report and disclaims any liability arising from material, fabrication and erection of this tower, or installation and compliance with legal and permitting requirements of the proposed equipment. Vertical Bridge Engineering, LLC will not be responsible whatsoever for or on account of, consequential or incidental damages sustained by any person, firm, or organization as a result of any data or conclusions contained in this report. The maximum liability of Vertical Bridge Engineering, LLC pursuant to this report will be limited to the total fee received for preparation of this report.

Attachment 1: Calculations

Section	T25	T24	T23	T22	T21	T20	T19	T18	T17	T16	T15	T14	T13	T12	T11	T10	T9	T8	T7	T6	T5	T4	T3	T2	T1	L2	L1	
Legs																												
Leg Grade																												
Diagonals																												
Top Girts																												
Bottom Girts																												
Horizontalis																												
Top Guy Pull-Offs																												
Face Width (ft)																												
# Panels @ (ft)																												
Weight (K)	39.3	1.9	1.9	2.0	1.9	2.0	1.9	2.0	1.9	2.0	1.9	2.0	1.9	2.2	1.7	1.9	1.4	1.2	1.2	1.3	1.2	1.2	1.3	0.6	0.4	0.7	0.5	

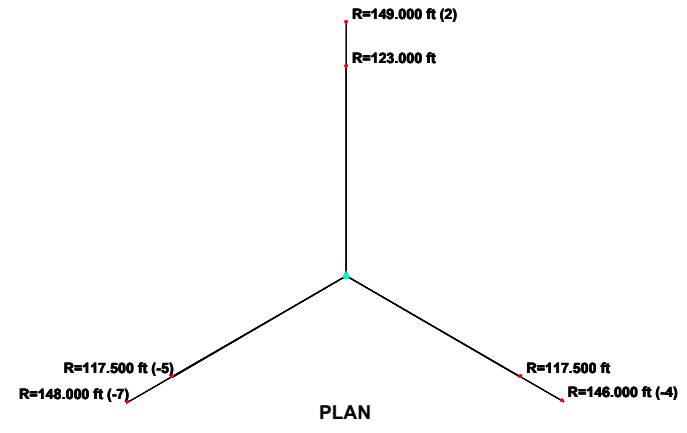
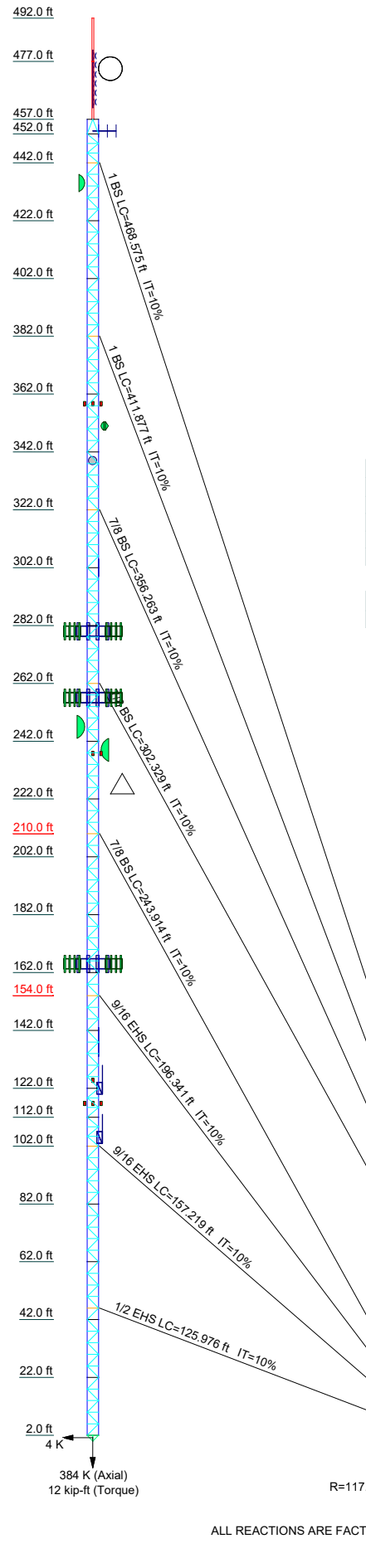

SYMBOL LIST

MARK	SIZE	MARK	SIZE
A	L2 1/2x2x3/16	F	L2x2x3/16
B	L1 3/4x1 3/4x3/16	G	2L2 1/2x2 1/2x3/8x1/4
C	L2 1/2x2 1/2x3/8	H	1 @ 5
D	L1 3/4x1 3/4x3/16 w/ L2x2x1/4	I	3 @ 3.33333
E	C6x10.5		

MATERIAL STRENGTH

GRADE	Fy	Fu	GRADE	Fy	Fu
A572-50	50 ksi	65 ksi	A36	36 ksi	58 ksi

TOWER DESIGN NOTES

1. Tower is located in Fairfield County, Connecticut.
2. Tower designed for Exposure C to the TIA-222-H Standard.
3. Tower designed for a 115 mph basic wind in accordance with the TIA-222-H Standard.
4. Tower is also designed for a 50 mph basic wind with 1.00 in ice. Ice is considered to increase in thickness with height.
5. Deflections are based upon a 60 mph wind.
6. Tower Risk Category II.
7. Topographic Category 1 with Crest Height of 0.000 ft
8. TOWER RATING: 83%

ALL REACTIONS ARE FACTORED

<p>Vertical Bridge 750 Park of Commerce Drive Boca Raton, FL 33487 Phone: 561-948-6367 FAX:</p>			<p>Job: US-CT-5009 Project: Guyed Tower Structural Analysis Client: _____ Drawn by: JWagner App'd: _____ Code: TIA-222-H Date: 05/29/20 Scale: NTS Path: _____ Dwg No. E-1</p>		
--	--	--	--	--	--

Section	T25	T24	T23	T22	T21	T20	T19	T18	T17	T16	T15	T14	T13	T12	T11	T10	T9	T8	T7	T6	T5	T4	T3	T2	T1	L2	L1	
Legs																											P8x.406	A53-B-35
Leg Grade																												
Diagonals																												
Diagonal Grade																												
Top Girts																												
Bottom Girts																												
Horizontalis																												
Top Guy Pull-Offs																												
Face Width (ft)																												
# Panels @ (ft)																												
Weight (K)	39.3																											

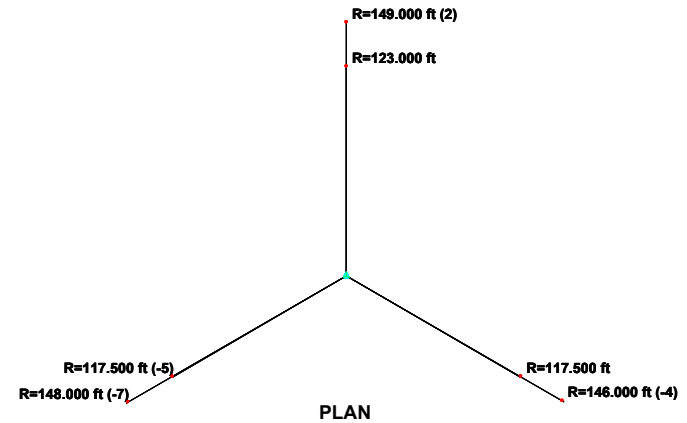
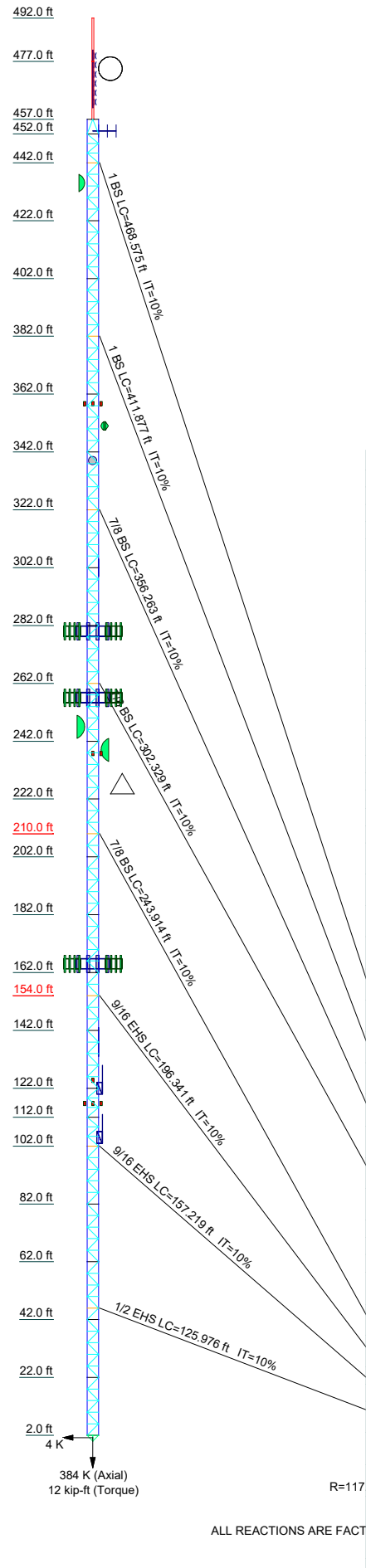

DESIGNED APPURTENANCE LOADING

TYPE	ELEVATION	TYPE	ELEVATION
Beacon (.075k 2.250CAAA) (Tower)	490	Nokia AAHC MIMO (25.6x19.7x9.64) (Sprint)	257
2 Bay FM Antenna	471	Nokia AAHC MIMO (25.6x19.7x9.64) (Sprint)	257
3' Yagi(.03k,2.08CAAA)	453	CommScope NNVV-65B-R4 (72x19.6x7.8) (Sprint)	257
6' Grid Dish	435	CommScope NNVV-65B-R4 (72x19.6x7.8) (Sprint)	257
Obstruction Light(.01k,.8CAAA) (Tower)	358	CommScope NNVV-65B-R4 (72x19.6x7.8) (Sprint)	257
Obstruction Light(.01k,.8CAAA) (Tower)	358	CommScope NNVV-65B-R4 (72x19.6x7.8) (Sprint)	257
Obstruction Light(.01k,.8CAAA) (Tower)	358	CommScope NNVV-65B-R4 (72x19.6x7.8) (Sprint)	257
3' Dish w/ Radomes	351	8' Grid Dish (140lbs 20.1CaAa)	247
3' Grid Dish	339	8' Grid Dish (140lbs 20.1CaAa)	239
6' Omni	302	Beacon (.075k 2.250CAAA) (Tower)	237
2' Side arm (25lbs 0.5CaAa)	302	Beacon (.075k 2.250CAAA) (Tower)	237
Kathrein CA5-FM/CP/RM	300	Ericsson RRUS-4483 (15x13.2x9) (ATI)	165
KRY 112 89/4 (T-Mobile)	280	Ericsson RRUS-4483 (15x13.2x9) (ATI)	165
KRY 112 89/4 (T-Mobile)	280	Ericsson RRUS-4483 (15x13.2x9) (ATI)	165
KRY 112 89/4 (T-Mobile)	280	Raycap DC6-48-60-0-8C-EV (31.4x18.28x10.24) (ATI)	165
Sector Frames (T-Mobile)	280	Raycap DC6-48-60-0-8C-EV (31.4x18.28x10.24) (ATI)	165
KRY 112 144/1 (T-Mobile)	280	Raycap DC6-48-60-0-8C-EV (31.4x18.28x10.24) (ATI)	165
KRY 112 144/1 (T-Mobile)	280	Ice Bridge (2x2) (ATI)	165
RFS APX16DWV-16DWV-S-E-A20 (55.9x13.3x3.15) (T-Mobile)	280	CCI HPA65R-BU8A (96x11.7x7.6) (ATI)	165
RFS APX16DWV-16DWV-S-E-A20 (55.9x13.3x3.15) (T-Mobile)	280	Ericsson RRUS-4483 (15x13.2x9) (ATI)	165
RFS APX16DWV-16DWV-S-E-A20 (55.9x13.3x3.15) (T-Mobile)	280	(2) CCI TPA65R-BU8DA-K (96.0x21.0x7.8) (ATI)	165
RFS APXVAARR24 43-U-NA20 (95.9x24x8.7) (T-Mobile)	280	Ericsson 8843 (15x13.1x10.9) (ATI)	165
RFS APXVAARR24 43-U-NA20 (95.9x24x8.7) (T-Mobile)	280	Ericsson 8843 (15x13.1x10.9) (ATI)	165
RFS APXVAARR24 43-U-NA20 (95.9x24x8.7) (T-Mobile)	280	Ericsson 8843 (15x13.1x10.9) (ATI)	165
Ericsson RRU 4449 B71B12 (14.9x13.2x10.4) (T-Mobile)	280	Ericsson RRUS E2 (20.4x18.5x7.5) (ATI)	165
Ericsson RRU 4449 B71B12 (14.9x13.2x10.4) (T-Mobile)	280	Ericsson RRUS E2 (20.4x18.5x7.5) (ATI)	165
Ericsson RRU 4449 B71B12 (14.9x13.2x10.4) (T-Mobile)	280	Ericsson RRUS E2 (20.4x18.5x7.5) (ATI)	165
Ericsson AIR6488 2.5GHz (34.8x20.5x7.2) (T-Mobile)	280	Ericsson 4415 B30 (16.5x13.4x5.9) (ATI)	165
Ericsson AIR6488 2.5GHz (34.8x20.5x7.2) (T-Mobile)	280	Ericsson 4415 B30 (16.5x13.4x5.9) (ATI)	165
Ericsson AIR6488 2.5GHz (34.8x20.5x7.2) (T-Mobile)	280	Ericsson 4415 B30 (16.5x13.4x5.9) (ATI)	165
Ericsson AIR 32 (T-Mobile)	280	Ericsson 4449 (18x13.2x9.4) (ATI)	165
Ericsson AIR 32 (T-Mobile)	280	Ericsson 4449 (18x13.2x9.4) (ATI)	165
Ericsson AIR 32 (T-Mobile)	280	Ericsson 4449 (18x13.2x9.4) (ATI)	165
Ericsson AIR 32 (T-Mobile)	280	Sector Frames (ATI)	165
Ericsson 4415 B25 (15x13.2x5.4) (T-Mobile)	280	(2) CCI TPA65R-BU8DA-K (96.0x21.0x7.8) (ATI)	165
Ericsson 4415 B25 (15x13.2x5.4) (T-Mobile)	280	(2) CCI TPA65R-BU8DA-K (96.0x21.0x7.8) (ATI)	165
Ericsson 4415 B25 (15x13.2x5.4) (T-Mobile)	280	CCI HPA65R-BU8A (96x11.7x7.6) (ATI)	165
SM 408-3 (Sprint)	257	CCI HPA65R-BU8A (96x11.7x7.6) (ATI)	165
PCS 1900MHz 4x45W-65MHz (Sprint)	257	3' Side Arm	138
800 EXTERNAL NOTCH FILTER (Sprint)	257	10' Dipole	138
Alcatel Lucent RRR-4x45-1900 (25x12x12) (Sprint)	257	3' Side Arm	125
Alcatel Lucent RRR-4x45-1900 (25x12x12) (Sprint)	257	10' Dipole	125
Alcatel Lucent RRR 2x50-800 (16x13x10) (Sprint)	257	Beacon (.075k 2.250CAAA) (Tower)	124
Alcatel Lucent RRR 2x50-800 (16x13x10) (Sprint)	257	Obstruction Light(.01k,.8CAAA) (Tower)	116
Alcatel Lucent RRR 2x50-800 (16x13x10) (Sprint)	257	Obstruction Light(.01k,.8CAAA) (Tower)	116
Nokia AAHC MIMO (25.6x19.7x9.64) (Sprint)	257	Obstruction Light(.01k,.8CAAA) (Tower)	116

Vertical Bridge

750 Park of Commerce Drive
Boca Raton, FL 33487
Phone: 561-948-6367
FAX:

Job: **US-CT-5009**

Project: **Guyed Tower Structural Analysis**

Client:	Drawn by: JWagner	App'd:
Code: TIA-222-H	Date: 05/29/20	Scale: NTS
Path:	Dwg No. E-1	

C:\Users\lwagner\Desktop\Operations\US-CT-5009\US-CT-5009_SA_052820_T-Mobile.dwg

tnxTower Vertical Bridge 750 Park of Commerce Drive Boca Raton, FL 33487 Phone: 561-948-6367 FAX:	Job US-CT-5009	Page 1 of 83
	Project Guyed Tower Structural Analysis	Date 11:53:35 05/29/20
	Client	Designed by JWagner

Tower Input Data

The main tower is a 3x guyed tower with an overall height of 492.000 ft above the ground line.

The base of the tower is set at an elevation of 0.000 ft above the ground line.

The face width of the tower is 4.000 ft at the top and 4.000 ft at the base.

An index plate is provided at the 3x guyed -tower connection.

There is a pole section.

This tower is designed using the TIA-222-H standard.

The following design criteria apply:

Tower is located in Fairfield County, Connecticut.

Tower base elevation above sea level: 718.000 ft.

Basic wind speed of 115 mph.

Risk Category II.

Exposure Category C.

Simplified Topographic Factor Procedure for wind speed-up calculations is used.

Topographic Category: 1.

Crest Height: 0.000 ft.

Nominal ice thickness of 1.0000 in.

Ice thickness is considered to increase with height.

Ice density of 56.000 pcf.

A wind speed of 50 mph is used in combination with ice.

Temperature drop of 50.000 °F.

Deflections calculated using a wind speed of 60 mph.

I-Beam base is 2.000 ft above the pivot.

Pressures are calculated at each section.

Stress ratio used in pole design is 1.

Safety factor used in guy design is 1.

Stress ratio used in tower member design is 1.

Local bending stresses due to climbing loads, feed line supports, and appurtenance mounts are not considered.

Options

<ul style="list-style-type: none"> Consider Moments - Legs Consider Moments - Horizontals Consider Moments - Diagonals Use Moment Magnification √ Use Code Stress Ratios √ Use Code Safety Factors - Guys Escalate Ice Always Use Max Kz Use Special Wind Profile √ Include Bolts In Member Capacity Leg Bolts Are At Top Of Section Secondary Horizontal Braces Leg Use Diamond Inner Bracing (4 Sided) √ SR Members Have Cut Ends √ SR Members Are Concentric 	<ul style="list-style-type: none"> Distribute Leg Loads As Uniform Assume Legs Pinned √ Assume Rigid Index Plate √ Use Clear Spans For Wind Area √ Use Clear Spans For KL/r √ Retension Guys To Initial Tension Bypass Mast Stability Checks √ Use Azimuth Dish Coefficients √ Project Wind Area of Appurt. √ Autocalc Torque Arm Areas Add IBC .6D+W Combination √ Sort Capacity Reports By Component Triangulate Diamond Inner Bracing Treat Feed Line Bundles As Cylinder Ignore KL/ry For 60 Deg. Angle Legs 	<ul style="list-style-type: none"> Use ASCE 10 X-Brace Ly Rules √ Calculate Redundant Bracing Forces Ignore Redundant Members in FEA √ SR Leg Bolts Resist Compression √ All Leg Panels Have Same Allowable Offset Girt At Foundation √ Consider Feed Line Torque √ Include Angle Block Shear Check Use TIA-222-H Bracing Resist. Exemption Use TIA-222-H Tension Splice Exemption <li style="text-align: center;">Poles Include Shear-Torsion Interaction Always Use Sub-Critical Flow Use Top Mounted Sockets Pole Without Linear Attachments Pole With Shroud Or No Appurtenances Outside and Inside Corner Radii Are Known
--	---	--

tnxTower Vertical Bridge 750 Park of Commerce Drive Boca Raton, FL 33487 Phone: 561-948-6367 FAX:	Job US-CT-5009	Page 2 of 83
	Project Guyed Tower Structural Analysis	Date 11:53:35 05/29/20
	Client	Designed by JWagner

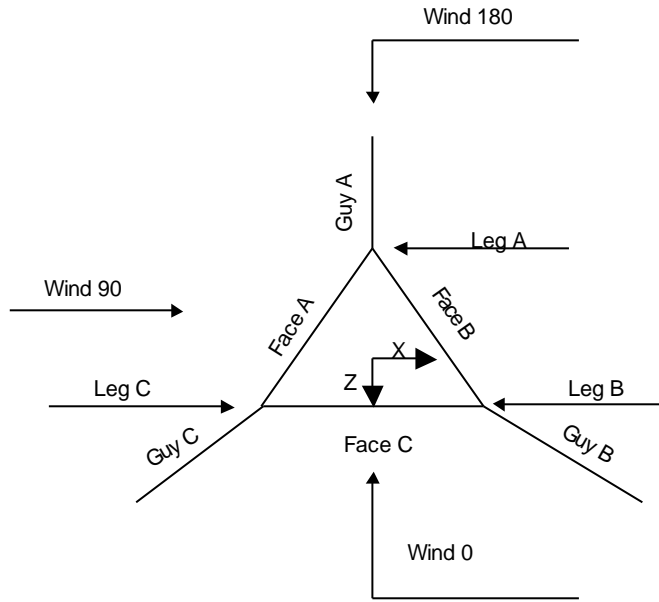

Corner & Starmount Guyed Tower

Pole Section Geometry

Section	Elevation ft	Section Length ft	Pole Size	Pole Grade	Socket Length ft
L1	492.000-477.000	15.000	P8x.406	A53-B-35 (35 ksi)	
L2	477.000-457.000	20.000	P8x.406	A53-B-35 (35 ksi)	

Tower Elevation ft	Gusset Area (per face) ft ²	Gusset Thickness in	Gusset Grade	Adjust. Factor A _f	Adjust. Factor A _r	Weight Mult.	Double Angle Stitch Bolt Spacing Diagonals in	Double Angle Stitch Bolt Spacing Horizontals in	Double Angle Stitch Bolt Spacing Redundants in
L1 492.000-477.000				1	1	1			
L2 477.000-457.000				1	1	1			

tnxTower Vertical Bridge 750 Park of Commerce Drive Boca Raton, FL 33487 Phone: 561-948-6367 FAX:	Job US-CT-5009	Page 3 of 83
	Project Guyed Tower Structural Analysis	Date 11:53:35 05/29/20
	Client	Designed by JWagner

Tower Section Geometry

Tower Section	Tower Elevation	Assembly Database	Description	Section Width	Number of Sections	Section Length
	<i>ft</i>			<i>ft</i>		<i>ft</i>
T1	457.000-452.000			4.000	1	5.000
T2	452.000-442.000			4.000	1	10.000
T3	442.000-422.000			4.000	1	20.000
T4	422.000-402.000			4.000	1	20.000
T5	402.000-382.000			4.000	1	20.000
T6	382.000-362.000			4.000	1	20.000
T7	362.000-342.000			4.000	1	20.000
T8	342.000-322.000			4.000	1	20.000
T9	322.000-302.000			4.000	1	20.000
T10	302.000-282.000			4.000	1	20.000
T11	282.000-262.000			4.000	1	20.000
T12	262.000-242.000			4.000	1	20.000
T13	242.000-222.000			4.000	1	20.000
T14	222.000-202.000			4.000	1	20.000
T15	202.000-182.000			4.000	1	20.000
T16	182.000-162.000			4.000	1	20.000
T17	162.000-142.000			4.000	1	20.000
T18	142.000-122.000			4.000	1	20.000
T19	122.000-112.000			4.000	1	10.000
T20	112.000-102.000			4.000	1	10.000
T21	102.000-82.000			4.000	1	20.000
T22	82.000-62.000			4.000	1	20.000
T23	62.000-42.000			4.000	1	20.000
T24	42.000-22.000			4.000	1	20.000
T25	22.000-2.000			4.000	1	20.000

Tower Section Geometry (cont'd)

Tower Section	Tower Elevation	Diagonal Spacing	Bracing Type	Has K Brace End Panels	Has Horizontals	Top Girt Offset	Bottom Girt Offset
	<i>ft</i>	<i>ft</i>				<i>in</i>	<i>in</i>
T1	457.000-452.000	5.000	K Brace Down	No	Yes	0.0000	0.0000
T2	452.000-442.000	3.333	K Brace Right	No	Yes	0.0000	0.0000
T3	442.000-422.000	4.000	K Brace Left	No	Yes	0.0000	0.0000
T4	422.000-402.000	4.000	K Brace Right	No	Yes	0.0000	0.0000
T5	402.000-382.000	4.000	K Brace Left	No	Yes	0.0000	0.0000
T6	382.000-362.000	4.000	K Brace Right	No	Yes	0.0000	0.0000
T7	362.000-342.000	4.000	K Brace Left	No	Yes	0.0000	0.0000
T8	342.000-322.000	4.000	K Brace Right	No	Yes	0.0000	0.0000
T9	322.000-302.000	4.000	K Brace Left	No	Yes	0.0000	0.0000
T10	302.000-282.000	4.000	K Brace Right	No	Yes	0.0000	0.0000
T11	282.000-262.000	4.000	K Brace Left	No	Yes	0.0000	0.0000
T12	262.000-242.000	4.000	K Brace Right	No	Yes	0.0000	0.0000
T13	242.000-222.000	4.000	K Brace Left	No	Yes	0.0000	0.0000
T14	222.000-202.000	4.000	K Brace Right	No	Yes	0.0000	0.0000
T15	202.000-182.000	4.000	K Brace Left	No	Yes	0.0000	0.0000
T16	182.000-162.000	4.000	K Brace Right	No	Yes	0.0000	0.0000
T17	162.000-142.000	4.000	K Brace Left	No	Yes	0.0000	0.0000
T18	142.000-122.000	4.000	K Brace Right	No	Yes	0.0000	0.0000
T19	122.000-112.000	3.333	K Brace Left	No	Yes	0.0000	0.0000

tnxTower Vertical Bridge 750 Park of Commerce Drive Boca Raton, FL 33487 Phone: 561-948-6367 FAX:	Job	US-CT-5009	Page	4 of 83
	Project	Guyed Tower Structural Analysis	Date	11:53:35 05/29/20
	Client		Designed by	JWagner

Tower Section	Tower Elevation	Diagonal Spacing	Bracing Type	Has K Brace End Panels	Has Horizontals	Top Girt Offset	Bottom Girt Offset
	ft	ft				in	in
T20	112.000-102.000	3.333	K Brace Right	No	Yes	0.0000	0.0000
T21	102.000-82.000	4.000	K Brace Left	No	Yes	0.0000	0.0000
T22	82.000-62.000	4.000	K Brace Right	No	Yes	0.0000	0.0000
T23	62.000-42.000	4.000	K Brace Left	No	Yes	0.0000	0.0000
T24	42.000-22.000	4.000	K Brace Right	No	Yes	0.0000	0.0000
T25	22.000-2.000	4.000	K Brace Left	No	Yes	0.0000	0.0000

Tower Section Geometry (cont'd)

Tower Elevation	Leg Type	Leg Size	Leg Grade	Diagonal Type	Diagonal Size	Diagonal Grade
ft						
T1 457.000-452.000	Solid Round	2 1/4	A572-50 (50 ksi)	Single Angle	L2 1/2x2x3/16	A36 (36 ksi)
T2 452.000-442.000	Solid Round	2 1/4	A572-50 (50 ksi)	Single Angle	L2x2x1/4	A36 (36 ksi)
T3 442.000-422.000	Solid Round	2 1/4	A572-50 (50 ksi)	Single Angle	L2x2x1/4	A36 (36 ksi)
T4 422.000-402.000	Solid Round	2 1/4	A572-50 (50 ksi)	Single Angle	L2x2x1/4	A36 (36 ksi)
T5 402.000-382.000	Solid Round	2 1/4	A572-50 (50 ksi)	Single Angle	L2x2x1/4	A36 (36 ksi)
T6 382.000-362.000	Solid Round	2 1/4	A572-50 (50 ksi)	Single Angle	L2x2x1/4	A36 (36 ksi)
T7 362.000-342.000	Solid Round	2 1/4	A572-50 (50 ksi)	Single Angle	L2x2x1/4	A36 (36 ksi)
T8 342.000-322.000	Solid Round	2 1/4	A572-50 (50 ksi)	Single Angle	L2x2x1/4	A36 (36 ksi)
T9 322.000-302.000	Solid Round	2 1/2	A572-50 (50 ksi)	Single Angle	L1 3/4x1 3/4x3/16	A36 (36 ksi)
T10 302.000-282.000	Solid Round	2 1/2	A572-50 (50 ksi)	Single Angle	L2x2x1/4	A36 (36 ksi)
T11 282.000-262.000	Solid Round	2 3/4	A572-50 (50 ksi)	Single Angle	L2 1/2x2 1/2x3/8	A36 (36 ksi)
T12 262.000-242.000	Solid Round	2 3/4	A572-50 (50 ksi)	Single Angle	L2x2x1/4	A36 (36 ksi)
T13 242.000-222.000	Solid Round	2 3/4	A572-50 (50 ksi)	Single Angle	L2x2x1/4	A36 (36 ksi)
T14 222.000-202.000	Solid Round	3	A572-50 (50 ksi)	Single Angle	L2 1/2x2 1/2x3/8	A36 (36 ksi)
T15 202.000-182.000	Solid Round	3	A572-50 (50 ksi)	Equal Angle	L2x2x1/4	A36 (36 ksi)
T16 182.000-162.000	Solid Round	3	A572-50 (50 ksi)	Equal Angle	L2x2x1/4	A36 (36 ksi)
T17 162.000-142.000	Solid Round	3	A572-50 (50 ksi)	Equal Angle	L2x2x1/4	A36 (36 ksi)
T18 142.000-122.000	Solid Round	3	A572-50 (50 ksi)	Equal Angle	L2x2x1/4	A36 (36 ksi)
T19 122.000-112.000	Solid Round	3	A572-50 (50 ksi)	Equal Angle	L2x2x1/4	A36 (36 ksi)
T20 112.000-102.000	Solid Round	3	A572-50 (50 ksi)	Arbitrary Shape	L1 3/4x1 3/4x3/16 w/ L2x2x1/4	A36 (36 ksi)
T21 102.000-82.000	Solid Round	3	A572-50 (50 ksi)	Equal Angle	L2x2x1/4	A36 (36 ksi)
T22 82.000-62.000	Solid Round	3	A572-50 (50 ksi)	Equal Angle	L2x2x1/4	A36 (36 ksi)
T23	Solid Round	3	A572-50	Equal Angle	L2x2x1/4	A36

tnxTower Vertical Bridge 750 Park of Commerce Drive Boca Raton, FL 33487 Phone: 561-948-6367 FAX:	Job	US-CT-5009	Page	5 of 83
	Project	Guyed Tower Structural Analysis	Date	11:53:35 05/29/20
	Client		Designed by	JWagner

Tower Elevation ft	Leg Type	Leg Size	Leg Grade	Diagonal Type	Diagonal Size	Diagonal Grade
62.000-42.000	Solid Round	3	(50 ksi)	Equal Angle	L2x2x1/4	(36 ksi)
T24			A572-50			A36
42.000-22.000	Solid Round	3	(50 ksi)	Equal Angle	L2x2x1/4	(36 ksi)
T25			A572-50			A36
22.000-2.000			(50 ksi)			(36 ksi)

Tower Section Geometry (cont'd)

Tower Elevation ft	Top Girt Type	Top Girt Size	Top Girt Grade	Bottom Girt Type	Bottom Girt Size	Bottom Girt Grade
T1	Channel	C6x10.5	A36	Single Angle	L2x2x3/16	A36
457.000-452.000			(36 ksi)			(36 ksi)
T2	Single Angle	L2x2x3/16	A36	Single Angle	L2x2x3/16	A36
452.000-442.000			(36 ksi)			(36 ksi)
T3	Single Angle	L2x2x3/16	A36	Single Angle	L2x2x3/16	A36
442.000-422.000			(36 ksi)			(36 ksi)
T4	Single Angle	L2x2x3/16	A36	Single Angle	L2x2x3/16	A36
422.000-402.000			(36 ksi)			(36 ksi)
T5	Single Angle	L2x2x3/16	A36	Single Angle	L2x2x3/16	A36
402.000-382.000			(36 ksi)			(36 ksi)
T6	Single Angle	L2x2x3/16	A36	Single Angle	L2x2x3/16	A36
382.000-362.000			(36 ksi)			(36 ksi)
T7	Single Angle	L2x2x3/16	A36	Single Angle	L2x2x3/16	A36
362.000-342.000			(36 ksi)			(36 ksi)
T8	Single Angle	L2x2x3/16	A36	Single Angle	L2x2x3/16	A36
342.000-322.000			(36 ksi)			(36 ksi)
T9	Single Angle	L2x2x3/16	A36	Single Angle	L2x2x3/16	A36
322.000-302.000			(36 ksi)			(36 ksi)
T10	Single Angle	L2x2x3/16	A36	Single Angle	L2x2x3/16	A36
302.000-282.000			(36 ksi)			(36 ksi)
T11	Single Angle	L2x2x3/16	A36	Single Angle	L2x2x3/16	A36
282.000-262.000			(36 ksi)			(36 ksi)
T12	Single Angle	L2x2x3/16	A36	Single Angle	L2x2x3/16	A36
262.000-242.000			(36 ksi)			(36 ksi)
T13	Single Angle	L2x2x3/16	A36	Single Angle	L2x2x3/16	A36
242.000-222.000			(36 ksi)			(36 ksi)
T14	Single Angle	L2x2x3/16	A36	Single Angle	L2x2x3/16	A36
222.000-202.000			(36 ksi)			(36 ksi)
T15	Single Angle	L2x2x3/16	A36	Single Angle	L2x2x3/16	A36
202.000-182.000			(36 ksi)			(36 ksi)
T16	Single Angle	L2x2x3/16	A36	Single Angle	L2x2x3/16	A36
182.000-162.000			(36 ksi)			(36 ksi)
T17	Single Angle	L2x2x3/16	A36	Single Angle	L2x2x3/16	A36
162.000-142.000			(36 ksi)			(36 ksi)
T18	Single Angle	L2x2x3/16	A36	Single Angle	L2x2x3/16	A36
142.000-122.000			(36 ksi)			(36 ksi)
T19	Single Angle	L2x2x3/16	A36	Single Angle	L2x2x3/16	A36
122.000-112.000			(36 ksi)			(36 ksi)
T20	Single Angle	L2x2x3/16	A36	Single Angle	L2x2x3/16	A36
112.000-102.000			(36 ksi)			(36 ksi)
T21	Single Angle	L2x2x3/16	A36	Single Angle	L2x2x3/16	A36
102.000-82.000			(36 ksi)			(36 ksi)
T22	Single Angle	L2x2x3/16	A36	Single Angle	L2x2x3/16	A36
82.000-62.000			(36 ksi)			(36 ksi)
T23	Single Angle	L2x2x3/16	A36	Single Angle	L2x2x3/16	A36

tnxTower Vertical Bridge 750 Park of Commerce Drive Boca Raton, FL 33487 Phone: 561-948-6367 FAX:	Job	US-CT-5009	Page	6 of 83
	Project	Guyed Tower Structural Analysis	Date	11:53:35 05/29/20
	Client		Designed by	JWagner

Tower Elevation ft	Top Girt Type	Top Girt Size	Top Girt Grade	Bottom Girt Type	Bottom Girt Size	Bottom Girt Grade
62.000-42.000			(36 ksi)			(36 ksi)
T24	Single Angle	L2x2x3/16	A36	Single Angle	L2x2x3/16	A36
42.000-22.000			(36 ksi)			(36 ksi)
T25	Single Angle	L2x2x3/16	A36	Single Angle	L2x2x3/16	A36
22.000-2.000			(36 ksi)			(36 ksi)

Tower Section Geometry (cont'd)

Tower Elevation ft	No. of Mid Girts	Mid Girt Type	Mid Girt Size	Mid Girt Grade	Horizontal Type	Horizontal Size	Horizontal Grade
T1	None	Solid Round		A572-50	Single Angle	L2x2x3/16	A36
457.000-452.000				(50 ksi)			(36 ksi)
T2	None	Solid Round		A572-50	Single Angle	L2x2x3/16	A36
452.000-442.000				(50 ksi)			(36 ksi)
T3	None	Solid Round		A572-50	Single Angle	L2x2x3/16	A36
442.000-422.000				(50 ksi)			(36 ksi)
T4	None	Solid Round		A572-50	Single Angle	L2x2x3/16	A36
422.000-402.000				(50 ksi)			(36 ksi)
T5	None	Solid Round		A572-50	Single Angle	L2x2x3/16	A36
402.000-382.000				(50 ksi)			(36 ksi)
T6	None	Solid Round		A572-50	Single Angle	L2x2x3/16	A36
382.000-362.000				(50 ksi)			(36 ksi)
T7	None	Solid Round		A572-50	Single Angle	L2x2x3/16	A36
362.000-342.000				(50 ksi)			(36 ksi)
T8	None	Solid Round		A572-50	Single Angle	L2x2x3/16	A36
342.000-322.000				(50 ksi)			(36 ksi)
T9	None	Solid Round		A572-50	Single Angle	L2x2x3/16	A36
322.000-302.000				(50 ksi)			(36 ksi)
T10	None	Solid Round		A572-50	Single Angle	L2x2x3/16	A36
302.000-282.000				(50 ksi)			(36 ksi)
T11	None	Solid Round		A572-50	Single Angle	L2x2x3/16	A36
282.000-262.000				(50 ksi)			(36 ksi)
T12	None	Solid Round		A572-50	Single Angle	L2x2x3/16	A36
262.000-242.000				(50 ksi)			(36 ksi)
T13	None	Solid Round		A572-50	Single Angle	L2x2x3/16	A36
242.000-222.000				(50 ksi)			(36 ksi)
T14	None	Solid Round		A572-50	Single Angle	L2x2x3/16	A36
222.000-202.000				(50 ksi)			(36 ksi)
T15	None	Solid Round		A572-50	Single Angle	L2x2x3/16	A36
202.000-182.000				(50 ksi)			(36 ksi)
T16	None	Solid Round		A572-50	Single Angle	L2x2x3/16	A36
182.000-162.000				(50 ksi)			(36 ksi)
T17	None	Solid Round		A572-50	Single Angle	L2x2x3/16	A36
162.000-142.000				(50 ksi)			(36 ksi)
T18	None	Solid Round		A572-50	Single Angle	L2x2x3/16	A36
142.000-122.000				(50 ksi)			(36 ksi)
T19	None	Solid Round		A572-50	Single Angle	L2x2x3/16	A36
122.000-112.000				(50 ksi)			(36 ksi)
T20	None	Solid Round		A572-50	Single Angle	L2x2x3/16	A36
112.000-102.000				(50 ksi)			(36 ksi)
T21	None	Solid Round		A572-50	Single Angle	L2x2x3/16	A36
102.000-82.000				(50 ksi)			(36 ksi)
T22	None	Solid Round		A572-50	Single Angle	L2x2x3/16	A36
82.000-62.000				(50 ksi)			(36 ksi)

<p>tnxTower</p> <p>Vertical Bridge 750 Park of Commerce Drive Boca Raton, FL 33487 Phone: 561-948-6367 FAX:</p>	<p>Job</p> <p>US-CT-5009</p>	<p>Page</p> <p>7 of 83</p>
	<p>Project</p> <p>Guyed Tower Structural Analysis</p>	<p>Date</p> <p>11:53:35 05/29/20</p>
	<p>Client</p>	<p>Designed by</p> <p>JWagner</p>

Tower Elevation ft	No. of Mid Girts	Mid Girt Type	Mid Girt Size	Mid Girt Grade	Horizontal Type	Horizontal Size	Horizontal Grade
T23 62.000-42.000	None	Solid Round		A572-50 (50 ksi)	Single Angle	L2x2x3/16	A36 (36 ksi)
T24 42.000-22.000	None	Solid Round		A572-50 (50 ksi)	Single Angle	L2x2x3/16	A36 (36 ksi)
T25 22.000-2.000	None	Solid Round		A572-50 (50 ksi)	Single Angle	L2x2x3/16	A36 (36 ksi)

Tower Section Geometry (cont'd)

Tower Elevation ft	Gusset Area (per face) ft ²	Gusset Thickness in	Gusset Grade	Adjust. Factor A _f	Adjust. Factor A _r	Weight Mult.	Double Angle Stitch Bolt Spacing Diagonals in	Double Angle Stitch Bolt Spacing Horizontals in	Double Angle Stitch Bolt Spacing Redundants in
T1 457.000-452.000	0.000	0.0000	A36 (36 ksi)	1	1	1	36.0000	36.0000	36.0000
T2 452.000-442.000	0.000	0.0000	A36 (36 ksi)	1	1	1	36.0000	36.0000	36.0000
T3 442.000-422.000	0.000	0.0000	A36 (36 ksi)	1	1	1	36.0000	36.0000	36.0000
T4 422.000-402.000	0.000	0.0000	A36 (36 ksi)	1	1	1	36.0000	36.0000	36.0000
T5 402.000-382.000	0.000	0.0000	A36 (36 ksi)	1	1	1	36.0000	36.0000	36.0000
T6 382.000-362.000	0.000	0.0000	A36 (36 ksi)	1	1	1	36.0000	36.0000	36.0000
T7 362.000-342.000	0.000	0.0000	A36 (36 ksi)	1	1	1	36.0000	36.0000	36.0000
T8 342.000-322.000	0.000	0.0000	A36 (36 ksi)	1	1	1	36.0000	36.0000	36.0000
T9 322.000-302.000	0.000	0.0000	A36 (36 ksi)	1	1	1	36.0000	36.0000	36.0000
T10 302.000-282.000	0.000	0.0000	A36 (36 ksi)	1	1	1	36.0000	36.0000	36.0000
T11 282.000-262.000	0.000	0.0000	A36 (36 ksi)	1	1	1	36.0000	36.0000	36.0000
T12 262.000-242.000	0.000	0.0000	A36 (36 ksi)	1	1	1	36.0000	36.0000	36.0000
T13 242.000-222.000	0.000	0.0000	A36 (36 ksi)	1	1	1	36.0000	36.0000	36.0000
T14 222.000-202.000	0.000	0.0000	A36 (36 ksi)	1	1	1	36.0000	36.0000	36.0000

tnxTower Vertical Bridge 750 Park of Commerce Drive Boca Raton, FL 33487 Phone: 561-948-6367 FAX:	Job	US-CT-5009	Page	9 of 83
	Project	Guyed Tower Structural Analysis	Date	11:53:35 05/29/20
	Client		Designed by	JWagner

Tower Elevation	Calc K Single Angles	Calc K Solid Rounds	K Factors ¹									
			Legs	X Brace Diags	K Brace Diags	Single Diags	Girts	Horiz.	Sec. Horiz.	Inner Brace		
				X Y	X Y	X Y	X Y	X Y	X Y	X Y		
382.000-362.000				1	1	1	1	1	1	1	1	1
T7	Yes	Yes	1	1	1	1	1	1	1	1	1	1
362.000-342.000				1	1	1	1	1	1	1	1	1
T8	Yes	Yes	1	1	1	1	1	1	1	1	1	1
342.000-322.000				1	1	1	1	1	1	1	1	1
T9	Yes	Yes	1	1	1	1	1	1	1	1	1	1
322.000-302.000				1	1	1	1	1	1	1	1	1
T10	Yes	Yes	1	1	1	1	1	1	1	1	1	1
302.000-282.000				1	1	1	1	1	1	1	1	1
T11	Yes	Yes	1	1	1	1	1	1	1	1	1	1
282.000-262.000				1	1	1	1	1	1	1	1	1
T12	Yes	Yes	1	1	1	1	1	1	1	1	1	1
262.000-242.000				1	1	1	1	1	1	1	1	1
T13	Yes	Yes	1	1	1	1	1	1	1	1	1	1
242.000-222.000				1	1	1	1	1	1	1	1	1
T14	Yes	Yes	1	1	1	1	1	1	1	1	1	1
222.000-202.000				1	1	1	1	1	1	1	1	1
T15	Yes	Yes	1	1	1	1	1	1	1	1	1	1
202.000-182.000				1	1	1	1	1	1	1	1	1
T16	Yes	Yes	1	1	1	1	1	1	1	1	1	1
182.000-162.000				1	1	1	1	1	1	1	1	1
T17	Yes	Yes	1	1	1	1	1	1	1	1	1	1
162.000-142.000				1	1	1	1	1	1	1	1	1
T18	Yes	Yes	1	1	1	1	1	1	1	1	1	1
142.000-122.000				1	1	1	1	1	1	1	1	1
T19	Yes	Yes	1	1	1	1	1	1	1	1	1	1
122.000-112.000				1	1	1	1	1	1	1	1	1
T20	Yes	Yes	1	1	1	1	1	1	1	1	1	1
112.000-102.000				1	1	1	1	1	1	1	1	1
T21	Yes	Yes	1	1	1	1	1	1	1	1	1	1
102.000-82.000				1	1	1	1	1	1	1	1	1
T22	Yes	Yes	1	1	1	1	1	1	1	1	1	1
82.000-62.000				1	1	1	1	1	1	1	1	1
T23	Yes	Yes	1	1	1	1	1	1	1	1	1	1
62.000-42.000				1	1	1	1	1	1	1	1	1
T24	Yes	Yes	1	1	1	1	1	1	1	1	1	1
42.000-22.000				1	1	1	1	1	1	1	1	1
T25	Yes	Yes	1	1	1	1	1	1	1	1	1	1
22.000-2.000				1	1	1	1	1	1	1	1	1

¹Note: K factors are applied to member segment lengths. K-braces without inner supporting members will have the K factor in the out-of-plane direction applied to the overall length.

Job	US-CT-5009	Page	12 of 83
Project	Guyed Tower Structural Analysis	Date	11:53:35 05/29/20
Client		Designed by	JWagner

Tower Elevation ft	Leg Connection Type	Leg		Diagonal		Top Girt		Bottom Girt		Mid Girt		Long Horizontal		Short Horizontal	
		Bolt Size in	No.	Bolt Size in	No.	Bolt Size in	No.	Bolt Size in	No.	Bolt Size in	No.	Bolt Size in	No.	Bolt Size in	No.
T8 342.000-322.000	Sleeve DS	0.7500 A325N	0	0.6250 A325N	1	0.6250 A325N	1	0.6250 A325N	0	0.6250 A325N	0	0.6250 A325N	1	0.6250 A325N	0
T9 322.000-302.000	Sleeve DS	0.7500 A325N	0	0.6250 A325N	1	0.6250 A325N	1	0.6250 A325N	0	0.6250 A325N	0	0.6250 A325N	1	0.6250 A325N	0
T10 302.000-282.000	Sleeve DS	0.7500 A325N	0	0.6250 A325N	1	0.6250 A325N	1	0.6250 A325N	0	0.6250 A325N	0	0.6250 A325N	1	0.6250 A325N	0
T11 282.000-262.000	Sleeve DS	0.7500 A325N	0	0.6250 A325N	1	0.6250 A325N	1	0.6250 A325N	0	0.6250 A325N	0	0.6250 A325N	1	0.6250 A325N	0
T12 262.000-242.000	Sleeve DS	0.7500 A325N	0	0.6250 A325N	1	0.6250 A325N	1	0.6250 A325N	0	0.6250 A325N	0	0.6250 A325N	1	0.6250 A325N	0
T13 242.000-222.000	Sleeve DS	0.7500 A325N	0	0.6250 A325N	1	0.6250 A325N	1	0.6250 A325N	0	0.6250 A325N	0	0.6250 A325N	1	0.6250 A325N	0
T14 222.000-202.000	Sleeve DS	0.7500 A325N	0	0.6250 A325N	1	0.6250 A325N	1	0.6250 A325N	0	0.6250 A325N	0	0.6250 A325N	1	0.6250 A325N	0
T15 202.000-182.000	Sleeve DS	0.7500 A325N	0	0.6250 A325N	1	0.6250 A325N	1	0.6250 A325N	0	0.6250 A325N	0	0.6250 A325N	1	0.6250 A325N	0
T16 182.000-162.000	Sleeve DS	0.7500 A325N	0	0.6250 A325N	1	0.6250 A325N	1	0.6250 A325N	0	0.6250 A325N	0	0.6250 A325N	1	0.6250 A325N	0
T17 162.000-142.000	Sleeve DS	0.7500 A325N	0	0.6250 A325N	1	0.6250 A325N	1	0.6250 A325N	0	0.6250 A325N	0	0.6250 A325N	1	0.6250 A325N	0
T18 142.000-122.000	Sleeve DS	0.7500 A325N	0	0.6250 A325N	1	0.6250 A325N	1	0.6250 A325N	0	0.6250 A325N	0	0.6250 A325N	1	0.6250 A325N	0
T19 122.000-112.000	Sleeve DS	0.7500 A325N	0	0.6250 A325N	1	0.6250 A325N	1	0.6250 A325N	0	0.6250 A325N	0	0.6250 A325N	1	0.6250 A325N	0
T20 112.000-102.000	Sleeve DS	0.7500 A325N	0	0.6250 A325N	1	0.6250 A325N	1	0.6250 A325N	0	0.6250 A325N	0	0.6250 A325N	1	0.6250 A325N	0
T21 102.000-82.000	Sleeve DS	0.7500 A325N	0	0.6250 A325N	1	0.6250 A325N	1	0.6250 A325N	0	0.6250 A325N	0	0.6250 A325N	1	0.6250 A325N	0
T22 82.000-62.000	Sleeve DS	0.7500 A325N	0	0.6250 A325N	1	0.6250 A325N	1	0.6250 A325N	0	0.6250 A325N	0	0.6250 A325N	1	0.6250 A325N	0
T23 62.000-42.000	Sleeve DS	0.7500 A325N	0	0.6250 A325N	1	0.6250 A325N	1	0.6250 A325N	0	0.6250 A325N	0	0.6250 A325N	1	0.6250 A325N	0
T24 42.000-22.000	Sleeve DS	0.7500 A325N	0	0.6250 A325N	1	0.6250 A325N	1	0.6250 A325N	0	0.6250 A325N	0	0.6250 A325N	1	0.6250 A325N	0
T25 22.000-2.000	Sleeve DS	0.7500 A325N	0	0.6250 A325N	1	0.6250 A325N	1	0.6250 A325N	0	0.6250 A325N	0	0.6250 A325N	1	0.6250 A325N	0

tnxTower Vertical Bridge 750 Park of Commerce Drive Boca Raton, FL 33487 Phone: 561-948-6367 FAX:	Job	US-CT-5009	Page	13 of 83
	Project	Guyed Tower Structural Analysis	Date	11:53:35 05/29/20
	Client		Designed by	JWagner

Guy Elevation	Guy Grade	Guy Size	Initial Tension	%	Guy Modulus	Guy Weight	L _a	Anchor Radius	Anchor Azimuth Adj.	Anchor Elevation	End Fitting Efficiency	
ft			K		ksi	plf	ft	ft	°	ft	%	
442	BS	A	1	12.200	10%	24000.000	2.100	463.412	149.000	0.0000	2.000	100%
		B	1	12.200	10%	24000.000	2.100	468.175	146.000	0.0000	-4.000	100%
		C	1	12.200	10%	24000.000	2.100	471.642	148.000	0.0000	-7.000	100%
382	BS	A	1	12.200	10%	24000.000	2.100	406.985	149.000	0.0000	2.000	100%
		B	1	12.200	10%	24000.000	2.100	411.527	146.000	0.0000	-4.000	100%
		C	1	12.200	10%	24000.000	2.100	415.034	148.000	0.0000	-7.000	100%
322	BS	A	7/8	9.200	10%	24000.000	1.610	351.727	149.000	0.0000	2.000	100%
		B	7/8	9.200	10%	24000.000	1.610	355.966	146.000	0.0000	-4.000	100%
		C	7/8	9.200	10%	24000.000	1.610	359.515	148.000	0.0000	-7.000	100%
262	BS	A	7/8	9.200	10%	24000.000	1.610	298.280	149.000	0.0000	2.000	100%
		B	7/8	9.200	10%	24000.000	1.610	302.079	146.000	0.0000	-4.000	100%
		C	7/8	9.200	10%	24000.000	1.610	305.666	148.000	0.0000	-7.000	100%
210	BS	A	7/8	9.200	10%	24000.000	1.610	242.010	123.000	0.0000	0.000	100%
		B	7/8	9.200	10%	24000.000	1.610	239.318	117.500	0.0000	0.000	100%
		C	7/8	9.200	10%	24000.000	1.610	243.710	117.500	0.0000	-5.000	100%
154	EHS	A	9/16	3.500	10%	21000.000	0.671	195.493	123.000	0.0000	0.000	100%
		B	9/16	3.500	10%	21000.000	0.671	192.151	117.500	0.0000	0.000	100%
		C	9/16	3.500	10%	21000.000	0.671	196.174	117.500	0.0000	-5.000	100%
102	EHS	A	9/16	3.500	10%	21000.000	0.671	157.886	123.000	0.0000	0.000	100%
		B	9/16	3.500	10%	21000.000	0.671	153.730	117.500	0.0000	0.000	100%
		C	9/16	3.500	10%	21000.000	0.671	157.086	117.500	0.0000	-5.000	100%
46	EHS	A	1/2	2.690	10%	21000.000	0.517	129.052	123.000	0.0000	0.000	100%
		B	1/2	2.690	10%	21000.000	0.517	123.932	117.500	0.0000	0.000	100%
		C	1/2	2.690	10%	21000.000	0.517	125.870	117.500	0.0000	-5.000	100%

Guy Data(cont'd)

Guy Elevation	Mount Type	Torque-Arm Spread	Torque-Arm Leg Angle	Torque-Arm Style	Torque-Arm Grade	Torque-Arm Type	Torque-Arm Size
ft		ft	°				
442	Corner						
382	Corner						
322	Corner						
262	Corner						
210	Corner						
154	Corner						
102	Corner						
46	Corner						

Guy Data (cont'd)

Guy Elevation	Diagonal Grade	Diagonal Type	Upper Diagonal Size	Lower Diagonal Size	Is Strap.	Pull-Off Grade	Pull-Off Type	Pull-Off Size
ft								
442.000	A572-50 (50 ksi)	Solid Round			No	A36 (36 ksi)	Double Equal Angle	2L2 1/2x2 1/2x3/8x1/4
382.000	A572-50 (50 ksi)	Solid Round			No	A36 (36 ksi)	Double Equal Angle	2L2 1/2x2 1/2x3/8x1/4

tnxTower Vertical Bridge 750 Park of Commerce Drive Boca Raton, FL 33487 Phone: 561-948-6367 FAX:	Job US-CT-5009	Page 14 of 83
	Project Guyed Tower Structural Analysis	Date 11:53:35 05/29/20
	Client	Designed by JWagner

Guy Elevation ft	Diagonal Grade	Diagonal Type	Upper Diagonal Size	Lower Diagonal Size	Is Strap.	Pull-Off Grade	Pull-Off Type	Pull-Off Size
322.000	A572-50 (50 ksi)	Solid Round			No	A36 (36 ksi)	Double Equal Angle	2L2 1/2x2 1/2x3/8x1/4
262.000	A572-50 (50 ksi)	Solid Round			No	A36 (36 ksi)	Double Equal Angle	2L2 1/2x2 1/2x3/8x1/4
210.000	A572-50 (50 ksi)	Solid Round			No	A36 (36 ksi)	Double Equal Angle	2L2 1/2x2 1/2x3/8x1/4
154.000	A572-50 (50 ksi)	Solid Round			No	A36 (36 ksi)	Double Equal Angle	2L2 1/2x2 1/2x3/8x1/4
102.000	A572-50 (50 ksi)	Solid Round			No	A36 (36 ksi)	Double Equal Angle	2L2 1/2x2 1/2x3/8x1/4
46.000	A572-50 (50 ksi)	Solid Round			No	A36 (36 ksi)	Double Equal Angle	2L2 1/2x2 1/2x3/8x1/4

Guy Data (cont'd)

Guy Elevation ft	Cable Weight A K	Cable Weight B K	Cable Weight C K	Cable Weight D K	Tower Intercept A ft	Tower Intercept B ft	Tower Intercept C ft	Tower Intercept D ft
442	0.973	0.983	0.990		17.825	18.185	18.450	
					7.3 sec/pulse	7.4 sec/pulse	7.4 sec/pulse	
382	0.855	0.864	0.872		13.817	14.120	14.359	
					6.4 sec/pulse	6.5 sec/pulse	6.5 sec/pulse	
322	0.566	0.573	0.579		10.540	10.790	11.003	
					5.6 sec/pulse	5.7 sec/pulse	5.7 sec/pulse	
262	0.480	0.486	0.492		7.619	7.810	7.995	
					4.8 sec/pulse	4.8 sec/pulse	4.9 sec/pulse	
210	0.390	0.385	0.392		5.037	4.925	5.106	
					3.9 sec/pulse	3.8 sec/pulse	3.9 sec/pulse	
154	0.131	0.129	0.132		3.613	3.491	3.637	
					3.3 sec/pulse	3.2 sec/pulse	3.3 sec/pulse	
102	0.106	0.103	0.105		2.369	2.245	2.344	
					2.7 sec/pulse	2.6 sec/pulse	2.6 sec/pulse	
46	0.067	0.064	0.065		1.595	1.471	1.516	
					2.2 sec/pulse	2.1 sec/pulse	2.1 sec/pulse	

Guy Data (cont'd)

Guy Elevation ft	Calc K Single Angles	Calc K Solid Rounds	Torque Arm		Pull Off		Diagonal	
			K _x	K _y	K _x	K _y	K _x	K _y
442	No	No			1	1	1	1
382	No	No			1	1	1	1
322	No	No			1	1	1	1

tnxTower Vertical Bridge 750 Park of Commerce Drive Boca Raton, FL 33487 Phone: 561-948-6367 FAX:	Job US-CT-5009	Page 15 of 83
	Project Guyed Tower Structural Analysis	Date 11:53:35 05/29/20
	Client	Designed by JWagner

Guy Elevation ft	Calc K Single Angles	Calc K Solid Rounds	Torque Arm		Pull Off		Diagonal	
			K _x	K _y	K _x	K _y	K _x	K _y
262	No	No			1	1	1	1
210	No	No			1	1	1	1
154	No	No			1	1	1	1
102	No	No			1	1	1	1
46	No	No			1	1	1	1

Guy Data (cont'd)

Guy Elevation ft	Torque-Arm				Pull Off				Diagonal			
	Bolt Size in	Number	Net Width Deduct in	U	Bolt Size in	Number	Net Width Deduct in	U	Bolt Size in	Number	Net Width Deduct in	U
442	0.0000 A325N	0	0.0000	1	0.7500 A325N	2	0.0000	0.75	0.6250 A325N	0	0.0000	0.75
382	0.0000 A325N	0	0.0000	1	0.7500 A325N	2	0.0000	0.75	0.6250 A325N	0	0.0000	0.75
322	0.0000 A325N	0	0.0000	1	0.7500 A325N	2	0.0000	0.75	0.6250 A325N	0	0.0000	0.75
262	0.0000 A325N	0	0.0000	1	0.7500 A325N	2	0.0000	0.75	0.6250 A325N	0	0.0000	0.75
210	0.0000 A325N	0	0.0000	1	0.7500 A325N	2	0.0000	0.75	0.6250 A325N	0	0.0000	0.75
154	0.0000 A325N	0	0.0000	1	0.7500 A325N	2	0.0000	0.75	0.6250 A325N	0	0.0000	0.75
102	0.0000 A325N	0	0.0000	1	0.7500 A325N	2	0.0000	0.75	0.6250 A325N	0	0.0000	0.75
46	0.0000 A325N	0	0.0000	1	0.7500 A325N	2	0.0000	0.75	0.6250 A325N	0	0.0000	0.75

Guy Pressures

Guy Elevation ft	Guy Location	z ft	q _z ksf	q _z Ice ksf	Ice Thickness in
442	A	222.000	0.042	0.008	1.2100
	B	219.000	0.042	0.008	1.2084
	C	217.500	0.042	0.008	1.2075
382	A	192.000	0.041	0.008	1.1926
	B	189.000	0.041	0.008	1.1907
	C	187.500	0.041	0.008	1.1897
322	A	162.000	0.039	0.007	1.1725
	B	159.000	0.039	0.007	1.1703
	C	157.500	0.039	0.007	1.1692
262	A	132.000	0.038	0.007	1.1487
	B	129.000	0.037	0.007	1.1461
	C	127.500	0.037	0.007	1.1447
210	A	105.000	0.036	0.007	1.1227
	B	105.000	0.036	0.007	1.1227
	C	102.500	0.036	0.007	1.1200
154	A	77.000	0.034	0.006	1.0884
	B	77.000	0.034	0.006	1.0884

Job	US-CT-5009	Page	16 of 83
Project	Guyed Tower Structural Analysis	Date	11:53:35 05/29/20
Client		Designed by	JWagner

Guy Elevation ft	Guy Location	z ft	qz ksf	qz Ice ksf	Ice Thickness in
102	C	74.500	0.033	0.006	1.0848
	A	51.000	0.031	0.006	1.0445
	B	51.000	0.031	0.006	1.0445
46	C	48.500	0.030	0.006	1.0393
	A	23.000	0.026	0.005	0.9645
	B	23.000	0.026	0.005	0.9645
	C	20.500	0.025	0.005	0.9535

Guy-Tensioning Information

Temperature At Time Of Tensioning																	
Guy Elevation ft	H ft	V ft	0 F		20 F		40 F		60 F		80 F		100 F		120 F		
			Initial Tension K	Intercept ft	Initial Tension K	Intercept ft	Initial Tension K	Intercept ft	Initial Tension K	Intercept ft	Initial Tension K	Intercept ft	Initial Tension K	Intercept ft	Initial Tension K	Intercept ft	
			442	A	146.69	440.00	12.735	17.10	12.556	17.33	12.378	17.58	12.200	17.83	12.023	18.08	11.846
	B	143.69	446.00	12.704	17.48	12.535	17.71	12.367	17.95	12.200	18.18	12.033	18.43	11.866	18.68	11.700	18.94
	C	145.69	449.00	12.709	17.73	12.539	17.96	12.369	18.20	12.200	18.45	12.031	18.70	11.862	18.96	11.694	19.22
382	A	146.69	380.00	12.893	13.09	12.662	13.33	12.430	13.57	12.200	13.82	11.970	14.08	11.741	14.34	11.513	14.62
	B	143.69	386.00	12.852	13.42	12.634	13.65	12.417	13.88	12.200	14.12	11.984	14.37	11.769	14.62	11.554	14.89
	C	145.69	389.00	12.858	13.64	12.638	13.87	12.419	14.11	12.200	14.36	11.982	14.61	11.765	14.88	11.548	15.15
322	A	146.69	320.00	9.909	9.80	9.672	10.04	9.435	10.28	9.200	10.54	8.966	10.81	8.733	11.09	8.501	11.39
	B	143.69	326.00	9.865	10.08	9.643	10.30	9.421	10.54	9.200	10.79	8.980	11.05	8.761	11.32	8.543	11.60
	C	145.69	329.00	9.869	10.27	9.645	10.51	9.422	10.75	9.200	11.00	8.979	11.27	8.758	11.54	8.539	11.83
262	A	146.69	260.00	10.187	6.89	9.856	7.12	9.527	7.36	9.200	7.62	8.875	7.89	8.552	8.18	8.232	8.50
	B	143.69	266.00	10.125	7.11	9.815	7.33	9.507	7.56	9.200	7.81	8.895	8.07	8.592	8.35	8.291	8.65
	C	145.69	269.00	10.127	7.28	9.817	7.50	9.507	7.74	9.200	7.99	8.894	8.26	8.591	8.55	8.289	8.85
210	A	120.69	210.00	10.231	4.54	9.886	4.69	9.542	4.86	9.200	5.04	8.859	5.23	8.520	5.43	8.184	5.65
	B	115.19	210.00	10.163	4.46	9.841	4.61	9.520	4.76	9.200	4.93	8.881	5.10	8.564	5.29	8.249	5.48
	C	115.19	215.00	10.129	4.64	9.818	4.79	9.508	4.94	9.200	5.11	8.893	5.28	8.587	5.46	8.282	5.66
154	A	120.69	154.00	4.083	3.10	3.887	3.26	3.693	3.43	3.500	3.61	3.308	3.82	3.119	4.05	2.931	4.30
	B	115.19	154.00	4.052	3.02	3.867	3.16	3.683	3.32	3.500	3.49	3.318	3.68	3.138	3.89	2.961	4.12
	C	115.19	159.00	4.029	3.16	3.852	3.31	3.675	3.47	3.500	3.64	3.326	3.83	3.153	4.03	2.981	4.26
102	A	120.69	102.00	4.397	1.89	4.096	2.03	3.796	2.18	3.500	2.37	3.207	2.58	2.919	2.84	2.638	3.13
	B	115.19	102.00	4.364	1.80	4.074	1.93	3.786	2.08	3.500	2.25	3.217	2.44	2.939	2.67	2.666	2.94
	C	115.19	107.00	4.328	1.90	4.050	2.03	3.774	2.17	3.500	2.34	3.229	2.54	2.962	2.76	2.700	3.03
46	A	120.69	46.00	3.729	1.15	3.379	1.27	3.033	1.42	2.690	1.59	2.354	1.82	2.027	2.11	1.717	2.49
	B	115.19	46.00	3.719	1.06	3.373	1.17	3.030	1.31	2.690	1.47	2.356	1.68	2.031	1.95	1.721	2.29
	C	115.19	51.00	3.687	1.11	3.352	1.22	3.019	1.35	2.690	1.52	2.366	1.72	2.051	1.99	1.749	2.33

Feed Line/Linear Appurtenances - Entered As Round Or Flat

Description	Face or Leg	Allow Shield	Exclude From Torque Calculation	Component Type	Placement ft	Face Offset in	Lateral Offset (Frac FW)	#	# Per Row	Clear Spacing in	Width or Diameter in	Perimeter in	Weight klf
3" Coax	B	No	No	Ar (CaAa)	435.000 - 8.000	-1.0000	-0.3	1	1	0.0000	3.0100		0.002
AVA5-50(7/8")	B	No	No	Ar (CaAa)	435.000 - 8.000	-1.0000	-0.2	1	1	0.0000	1.1020		0.000
1" Conduit (Tower)	C	No	No	Ar (CaAa)	435.000 - 8.000	-1.0000	-0.25	1	1	0.0000	1.1630		0.001
LDF4.5-50(5/8")	C	No	No	Ar (CaAa)	351.000 - 8.000	-1.0000	0	1	1	0.0000	0.8650		0.000
1 5/8" OD Conduit	C	No	No	Ar (CaAa)	430.000 - 8.000	-1.0000	0.4	1	1	0.0000	1.6250		0.001
LDF5-50A(7/8")	A	No	No	Ar (CaAa)	108.000 - 8.000	-1.0000	0.31	1	1	0.0000	1.0900		0.000
LDF5-50A(7/8")	A	No	No	Ar (CaAa)	124.000 - 8.000	-1.0000	0.38	1	1	0.0000	1.0900		0.000

tnxTower Vertical Bridge 750 Park of Commerce Drive Boca Raton, FL 33487 Phone: 561-948-6367 FAX:	Job US-CT-5009	Page 17 of 83
	Project Guyed Tower Structural Analysis	Date 11:53:35 05/29/20
	Client	Designed by JWagner

Description	Face or Leg	Allow Shield	Exclude From Torque Calculation	Component Type	Placement ft	Face Offset in	Lateral Offset (Frac FW)	#	# Per Row	Clear Spacing in	Width or Diameter in	Perimeter in	Weight klf
LDF5-50A(7/8")	A	No	No	Ar (CaAa)	138.000 - 8.000	-1.0000	0.32	1	1	0.0000	1.0900		0.000
LDF5-50A(7/8")	A	No	No	Ar (CaAa)	239.000 - 8.000	-1.0000	0.33	1	1	0.0000	1.0900		0.000
LDF5-50A(7/8")	A	No	No	Ar (CaAa)	247.000 - 8.000	-1.0000	0.34	1	1	0.0000	1.0900		0.000
LDF5-50A(7/8")	A	No	No	Ar (CaAa)	339.000 - 8.000	-1.0000	0.37	1	1	0.0000	1.0900		0.000
LDF5-50A(7/8")	A	No	No	Ar (CaAa)	435.000 - 8.000	-1.0000	0.36	1	1	0.0000	1.0900		0.000
LDF5-50A(7/8")	A	No	No	Ar (CaAa)	435.000 - 8.000	-1.0000	0.35	1	1	0.0000	1.0900		0.000
LDF6-50A(1-1/4") (Berkshire)	A	No	No	Ar (CaAa)	302.000 - 8.000	0.0000	0.35	1	1	0.0000	1.5500		0.001
LDF2-50A(3/8") SC (Tower)	C	No	No	Ar (CaAa)	445.000 - 8.000	-5.0000	0.35	1	1	0.0000	0.4400		0.000
LDF4.5-50(5/8")	A	No	No	Ar (CaAa)	455.000 - 8.000	0.0000	0	1	1	0.0000	0.8650		0.000
LDF4-50A(1/2")	C	No	No	Ar (CaAa)	289.000 - 8.000	-1.0000	-0.35	1	1	0.0000	0.6300		0.000
1.625' Fiber Cables (T-Mobile)	A	No	No	Ar (CaAa)	280.000 - 8.000	0.0000	0.25	4	4	0.0000	1.5500		0.001
LDF7-50A(1-5/8") (T-Mobile)	B	No	No	Ar (CaAa)	280.000 - 8.000	-1.0000	0	6	3	0.0000	1.9800		0.001
LDF7-50A(1-5/8") (T-Mobile)	A	No	No	Ar (CaAa)	280.000 - 8.000	0.0000	0.25	6	3	0.0000	1.9800		0.001
1.625" Hybrid Cable (T-Mobile)	C	No	No	Ar (CaAa)	280.000 - 8.000	0.0000	0	1	1	0.0000	1.9800		0.001
LDF6-50A(1-1/4") (Sprint)	C	No	No	Ar (CaAa)	257.000 - 8.000	-1.0000	-0.35	1	1	0.0000	1.5500		0.001
LDF6-50A(1-1/4") (Sprint)	C	No	No	Ar (CaAa)	257.000 - 8.000	-1.0000	0.35	3	3	0.0000	1.5500		0.001
LDF2-50(3/8") (AT&T)	C	No	No	Ar (CaAa)	165.000 - 8.000	0.0000	0.4	2	2	0.0000	0.4400		0.000
LDF4.5-50(5/8") (AT&T)	C	No	No	Ar (CaAa)	165.000 - 8.000	0.0000	0.1	6	3	0.0000	0.8650		0.000

Feed Line/Linear Appurtenances Section Areas

Tower Section	Tower Elevation ft	Face	A _R ft ²	A _F ft ²	C _{AA} In Face ft ²	C _{AA} Out Face ft ²	Weight K
L1	492.000-477.000	A	0.000	0.000	0.000	0.000	0.000
		B	0.000	0.000	0.000	0.000	0.000
		C	0.000	0.000	0.000	0.000	0.000
L2	477.000-457.000	A	0.000	0.000	0.000	0.000	0.000
		B	0.000	0.000	0.000	0.000	0.000

Job	US-CT-5009
Project	Guyed Tower Structural Analysis
Client	

Page	18 of 83
Date	11:53:35 05/29/20
Designed by	JWagner

Tower Section	Tower Elevation ft	Face	A _R ft ²	A _F ft ²	C _{AA} In Face ft ²	C _{AA} Out Face ft ²	Weight K
T1	457.000-452.000	C	0.000	0.000	0.000	0.000	0.000
		A	0.000	0.000	0.260	0.000	0.000
		B	0.000	0.000	0.000	0.000	0.000
T2	452.000-442.000	C	0.000	0.000	0.000	0.000	0.000
		A	0.000	0.000	0.865	0.000	0.002
		B	0.000	0.000	0.000	0.000	0.000
T3	442.000-422.000	C	0.000	0.000	0.132	0.000	0.000
		A	0.000	0.000	4.564	0.000	0.012
		B	0.000	0.000	5.346	0.000	0.027
T4	422.000-402.000	C	0.000	0.000	3.692	0.000	0.017
		A	0.000	0.000	6.090	0.000	0.016
		B	0.000	0.000	8.224	0.000	0.042
T5	402.000-382.000	C	0.000	0.000	6.456	0.000	0.031
		A	0.000	0.000	6.090	0.000	0.016
		B	0.000	0.000	8.224	0.000	0.042
T6	382.000-362.000	C	0.000	0.000	6.456	0.000	0.031
		A	0.000	0.000	6.090	0.000	0.016
		B	0.000	0.000	8.224	0.000	0.042
T7	362.000-342.000	C	0.000	0.000	6.456	0.000	0.031
		A	0.000	0.000	6.090	0.000	0.016
		B	0.000	0.000	8.224	0.000	0.042
T8	342.000-322.000	C	0.000	0.000	7.235	0.000	0.033
		A	0.000	0.000	7.943	0.000	0.022
		B	0.000	0.000	8.224	0.000	0.042
T9	322.000-302.000	C	0.000	0.000	8.186	0.000	0.034
		A	0.000	0.000	8.270	0.000	0.023
		B	0.000	0.000	8.224	0.000	0.042
T10	302.000-282.000	C	0.000	0.000	8.186	0.000	0.034
		A	0.000	0.000	11.370	0.000	0.036
		B	0.000	0.000	8.224	0.000	0.042
T11	282.000-262.000	C	0.000	0.000	8.627	0.000	0.035
		A	0.000	0.000	43.914	0.000	0.172
		B	0.000	0.000	29.608	0.000	0.130
T12	262.000-242.000	C	0.000	0.000	13.010	0.000	0.052
		A	0.000	0.000	48.075	0.000	0.189
		B	0.000	0.000	31.984	0.000	0.140
T13	242.000-222.000	C	0.000	0.000	22.706	0.000	0.093
		A	0.000	0.000	51.563	0.000	0.199
		B	0.000	0.000	31.984	0.000	0.140
T14	222.000-202.000	C	0.000	0.000	25.806	0.000	0.107
		A	0.000	0.000	51.890	0.000	0.200
		B	0.000	0.000	31.984	0.000	0.140
T15	202.000-182.000	C	0.000	0.000	25.806	0.000	0.107
		A	0.000	0.000	51.890	0.000	0.200
		B	0.000	0.000	31.984	0.000	0.140
T16	182.000-162.000	C	0.000	0.000	25.806	0.000	0.107
		A	0.000	0.000	51.890	0.000	0.200
		B	0.000	0.000	31.984	0.000	0.140
T17	162.000-142.000	C	0.000	0.000	27.627	0.000	0.110
		A	0.000	0.000	51.890	0.000	0.200
		B	0.000	0.000	31.984	0.000	0.140
T18	142.000-122.000	C	0.000	0.000	37.946	0.000	0.128
		A	0.000	0.000	53.852	0.000	0.206
		B	0.000	0.000	31.984	0.000	0.140
T19	122.000-112.000	C	0.000	0.000	37.946	0.000	0.128
		A	0.000	0.000	28.125	0.000	0.107
		B	0.000	0.000	15.992	0.000	0.070
T20	112.000-102.000	C	0.000	0.000	18.973	0.000	0.064
		A	0.000	0.000	28.779	0.000	0.109
		B	0.000	0.000	15.992	0.000	0.070
		C	0.000	0.000	18.973	0.000	0.064

<p>tnxTower</p> <p>Vertical Bridge 750 Park of Commerce Drive Boca Raton, FL 33487 Phone: 561-948-6367 FAX:</p>	Job	US-CT-5009	Page	19 of 83
	Project	Guyed Tower Structural Analysis	Date	11:53:35 05/29/20
	Client		Designed by	JWagner

Tower Section	Tower Elevation ft	Face	A _R ft ²	A _F ft ²	C _{AA} In Face ft ²	C _{AA} Out Face ft ²	Weight K
T21	102.000-82.000	A	0.000	0.000	58.430	0.000	0.220
		B	0.000	0.000	31.984	0.000	0.140
		C	0.000	0.000	37.946	0.000	0.128
T22	82.000-62.000	A	0.000	0.000	58.430	0.000	0.220
		B	0.000	0.000	31.984	0.000	0.140
		C	0.000	0.000	37.946	0.000	0.128
T23	62.000-42.000	A	0.000	0.000	58.430	0.000	0.220
		B	0.000	0.000	31.984	0.000	0.140
		C	0.000	0.000	37.946	0.000	0.128
T24	42.000-22.000	A	0.000	0.000	58.430	0.000	0.220
		B	0.000	0.000	31.984	0.000	0.140
		C	0.000	0.000	37.946	0.000	0.128
T25	22.000-2.000	A	0.000	0.000	40.901	0.000	0.154
		B	0.000	0.000	22.389	0.000	0.098
		C	0.000	0.000	26.562	0.000	0.089

Feed Line/Linear Appurtenances Section Areas - With Ice

Tower Section	Tower Elevation ft	Face or Leg	Ice Thickness in	A _R ft ²	A _F ft ²	C _{AA} In Face ft ²	C _{AA} Out Face ft ²	Weight K
L1	492.000-477.000	A	1.308	0.000	0.000	0.000	0.000	0.000
		B		0.000	0.000	0.000	0.000	0.000
		C		0.000	0.000	0.000	0.000	0.000
L2	477.000-457.000	A	1.303	0.000	0.000	0.000	0.000	0.000
		B		0.000	0.000	0.000	0.000	0.000
		C		0.000	0.000	0.000	0.000	0.000
T1	457.000-452.000	A	1.300	0.000	0.000	1.039	0.000	0.011
		B		0.000	0.000	0.000	0.000	0.000
		C		0.000	0.000	0.000	0.000	0.000
T2	452.000-442.000	A	1.298	0.000	0.000	3.460	0.000	0.036
		B		0.000	0.000	0.000	0.000	0.000
		C		0.000	0.000	0.911	0.000	0.009
T3	442.000-422.000	A	1.293	0.000	0.000	16.462	0.000	0.178
		B		0.000	0.000	12.071	0.000	0.165
		C		0.000	0.000	14.297	0.000	0.159
T4	422.000-402.000	A	1.287	0.000	0.000	21.536	0.000	0.233
		B		0.000	0.000	18.521	0.000	0.252
		C		0.000	0.000	21.902	0.000	0.254
T5	402.000-382.000	A	1.281	0.000	0.000	21.459	0.000	0.232
		B		0.000	0.000	18.470	0.000	0.250
		C		0.000	0.000	21.825	0.000	0.253
T6	382.000-362.000	A	1.274	0.000	0.000	21.379	0.000	0.230
		B		0.000	0.000	18.417	0.000	0.249
		C		0.000	0.000	21.745	0.000	0.251
T7	362.000-342.000	A	1.267	0.000	0.000	21.295	0.000	0.228
		B		0.000	0.000	18.361	0.000	0.247
		C		0.000	0.000	24.720	0.000	0.280
T8	342.000-322.000	A	1.260	0.000	0.000	27.342	0.000	0.293
		B		0.000	0.000	18.301	0.000	0.246
		C		0.000	0.000	28.341	0.000	0.315
T9	322.000-302.000	A	1.252	0.000	0.000	28.300	0.000	0.302
		B		0.000	0.000	18.239	0.000	0.244
		C		0.000	0.000	28.216	0.000	0.313
T10	302.000-282.000	A	1.244	0.000	0.000	36.242	0.000	0.398
		B		0.000	0.000	18.173	0.000	0.242
		C		0.000	0.000	30.266	0.000	0.331
T11	282.000-262.000	A	1.235	0.000	0.000	81.386	0.000	0.916

tnxTower Vertical Bridge 750 Park of Commerce Drive Boca Raton, FL 33487 Phone: 561-948-6367 FAX:	Job	US-CT-5009	Page	20 of 83
	Project	Guyed Tower Structural Analysis	Date	11:53:35 05/29/20
	Client		Designed by	JWagner

Tower Section	Tower Elevation ft	Face or Leg	Ice Thickness in	A _R ft ²	A _F ft ²	C _{AA} In Face ft ²	C _{AA} Out Face ft ²	Weight K
		B		0.000	0.000	41.921	0.000	0.548
		C		0.000	0.000	42.152	0.000	0.468
T12	262.000-242.000	A	1.225	0.000	0.000	87.876	0.000	0.986
		B		0.000	0.000	44.427	0.000	0.578
		C		0.000	0.000	64.100	0.000	0.689
T13	242.000-222.000	A	1.215	0.000	0.000	98.793	0.000	1.097
		B		0.000	0.000	44.275	0.000	0.574
		C		0.000	0.000	70.843	0.000	0.753
T14	222.000-202.000	A	1.204	0.000	0.000	99.395	0.000	1.098
		B		0.000	0.000	44.111	0.000	0.570
		C		0.000	0.000	70.463	0.000	0.745
T15	202.000-182.000	A	1.193	0.000	0.000	98.900	0.000	1.086
		B		0.000	0.000	43.933	0.000	0.565
		C		0.000	0.000	70.050	0.000	0.736
T16	182.000-162.000	A	1.180	0.000	0.000	98.357	0.000	1.074
		B		0.000	0.000	43.737	0.000	0.559
		C		0.000	0.000	73.610	0.000	0.754
T17	162.000-142.000	A	1.165	0.000	0.000	97.754	0.000	1.060
		B		0.000	0.000	43.520	0.000	0.553
		C		0.000	0.000	95.648	0.000	0.901
T18	142.000-122.000	A	1.149	0.000	0.000	103.172	0.000	1.107
		B		0.000	0.000	43.275	0.000	0.547
		C		0.000	0.000	94.850	0.000	0.886
T19	122.000-112.000	A	1.135	0.000	0.000	54.970	0.000	0.584
		B		0.000	0.000	21.534	0.000	0.270
		C		0.000	0.000	47.089	0.000	0.437
T20	112.000-102.000	A	1.125	0.000	0.000	56.724	0.000	0.599
		B		0.000	0.000	21.458	0.000	0.268
		C		0.000	0.000	46.842	0.000	0.432
T21	102.000-82.000	A	1.108	0.000	0.000	115.215	0.000	1.204
		B		0.000	0.000	42.664	0.000	0.530
		C		0.000	0.000	92.860	0.000	0.849
T22	82.000-62.000	A	1.081	0.000	0.000	113.777	0.000	1.173
		B		0.000	0.000	42.261	0.000	0.519
		C		0.000	0.000	91.548	0.000	0.825
T23	62.000-42.000	A	1.047	0.000	0.000	111.922	0.000	1.133
		B		0.000	0.000	41.742	0.000	0.505
		C		0.000	0.000	89.857	0.000	0.794
T24	42.000-22.000	A	0.997	0.000	0.000	109.264	0.000	1.078
		B		0.000	0.000	40.998	0.000	0.486
		C		0.000	0.000	87.434	0.000	0.751
T25	22.000-2.000	A	0.904	0.000	0.000	72.993	0.000	0.684
		B		0.000	0.000	27.721	0.000	0.315
		C		0.000	0.000	58.020	0.000	0.471

Feed Line Center of Pressure

Section	Elevation ft	CP _x in	CP _z in	CP _x Ice in	CP _z Ice in
L1	492.000-477.000	0.0000	0.0000	0.0000	0.0000
L2	477.000-457.000	0.0000	0.0000	0.0000	0.0000
T1	457.000-452.000	-0.1574	-0.1028	-0.3653	-0.2258
T2	452.000-442.000	-0.4381	-0.1893	-1.1561	-0.3513
T3	442.000-422.000	-0.3372	-2.6140	-1.3071	-2.4156
T4	422.000-402.000	-0.5234	-3.3319	-1.4863	-2.9577
T5	402.000-382.000	-0.5234	-3.3319	-1.4843	-2.9566

tnxTower Vertical Bridge 750 Park of Commerce Drive Boca Raton, FL 33487 Phone: 561-948-6367 FAX:	Job	US-CT-5009	Page	21 of 83
	Project	Guyed Tower Structural Analysis	Date	11:53:35 05/29/20
	Client		Designed by	JWagner

Section	Elevation ft	CP _x	CP _z	CP _x	CP _z
		in	in	Ice in	Ice in
T6	382.000-362.000	-0.5195	-3.3097	-1.4775	-2.9471
T7	362.000-342.000	-0.5182	-3.1649	-1.4495	-2.6270
T8	342.000-322.000	-0.5409	-3.4168	-1.4261	-3.0176
T9	322.000-302.000	-0.5465	-3.4837	-1.4257	-3.1399
T10	302.000-282.000	-0.5823	-4.0432	-1.3140	-3.8291
T11	282.000-262.000	-0.3522	-6.0738	-0.7800	-5.1484
T12	262.000-242.000	-0.9327	-5.7228	-1.2230	-4.5172
T13	242.000-222.000	-1.1468	-5.8794	-1.4085	-4.9066
T14	222.000-202.000	-1.1050	-5.7035	-1.3856	-4.8777
T15	202.000-182.000	-1.1395	-5.8524	-1.4082	-4.9470
T16	182.000-162.000	-1.1985	-5.7344	-1.5128	-4.7625
T17	162.000-142.000	-1.5087	-5.0747	-2.0556	-3.7645
T18	142.000-122.000	-1.5314	-5.2854	-2.0742	-4.1193
T19	122.000-112.000	-1.4987	-5.4302	-2.0246	-4.4810
T20	112.000-102.000	-1.5127	-5.5447	-2.0338	-4.6965
T21	102.000-82.000	-1.5540	-5.7207	-2.0876	-4.8956
T22	82.000-62.000	-1.6711	-5.4019	-2.0892	-4.9087
T23	62.000-42.000	-1.6650	-5.3852	-2.0836	-4.9106
T24	42.000-22.000	-1.6711	-5.4019	-2.0835	-4.9301
T25	22.000-2.000	-1.4125	-4.6221	-1.8232	-4.3731

Note: For pole sections, center of pressure calculations do not consider feed line shielding.

Shielding Factor Ka

Tower Section	Feed Line Record No.	Description	Feed Line Segment Elev.	K _a No Ice	K _a Ice
T1	16	LDF4.5-50(5/8")	452.00 - 455.00	0.6000	0.4943
T2	15	LDF2-50A(3/8") SC	442.00 - 445.00	0.6000	0.5877
T2	16	LDF4.5-50(5/8")	442.00 - 452.00	0.6000	0.5877
T3	1	3" Coax	422.00 - 435.00	1.0000	0.6000
T3	2	AVA5-50(7/8")	422.00 - 435.00	0.6000	0.6000
T3	3	1" Conduit	422.00 - 435.00	0.6000	0.6000
T3	5	1 5/8" OD Conduit	422.00 - 430.00	0.6000	0.6000
T3	12	LDF5-50A(7/8")	422.00 - 435.00	0.6000	0.6000
T3	13	LDF5-50A(7/8")	422.00 - 435.00	0.6000	0.6000
T3	15	LDF2-50A(3/8") SC	422.00 - 442.00	0.6000	0.6000
T3	16	LDF4.5-50(5/8")	422.00 - 442.00	0.6000	0.6000
T4	1	3" Coax	402.00 - 422.00	1.0000	0.6000
T4	2	AVA5-50(7/8")	402.00 - 422.00	0.6000	0.6000
T4	3	1" Conduit	402.00 -	0.6000	0.6000

Job	US-CT-5009	Page	22 of 83
Project	Guyed Tower Structural Analysis	Date	11:53:35 05/29/20
Client		Designed by	JWagner

Tower Section	Feed Line Record No.	Description	Feed Line Segment Elev.	K_a No Ice	K_a Ice
			422.00		
T4	5	1 5/8" OD Conduit	402.00 - 422.00	0.6000	0.6000
T4	12	LDF5-50A(7/8")	402.00 - 422.00	0.6000	0.6000
T4	13	LDF5-50A(7/8")	402.00 - 422.00	0.6000	0.6000
T4	15	LDF2-50A(3/8") SC	402.00 - 422.00	0.6000	0.6000
T4	16	LDF4.5-50(5/8")	402.00 - 422.00	0.6000	0.6000
T5	1	3" Coax	382.00 - 402.00	1.0000	0.6000
T5	2	AVA5-50(7/8")	382.00 - 402.00	0.6000	0.6000
T5	3	1" Conduit	382.00 - 402.00	0.6000	0.6000
T5	5	1 5/8" OD Conduit	382.00 - 402.00	0.6000	0.6000
T5	12	LDF5-50A(7/8")	382.00 - 402.00	0.6000	0.6000
T5	13	LDF5-50A(7/8")	382.00 - 402.00	0.6000	0.6000
T5	15	LDF2-50A(3/8") SC	382.00 - 402.00	0.6000	0.6000
T5	16	LDF4.5-50(5/8")	382.00 - 402.00	0.6000	0.6000
T6	1	3" Coax	362.00 - 382.00	1.0000	0.6000
T6	2	AVA5-50(7/8")	362.00 - 382.00	0.6000	0.6000
T6	3	1" Conduit	362.00 - 382.00	0.6000	0.6000
T6	5	1 5/8" OD Conduit	362.00 - 382.00	0.6000	0.6000
T6	12	LDF5-50A(7/8")	362.00 - 382.00	0.6000	0.6000
T6	13	LDF5-50A(7/8")	362.00 - 382.00	0.6000	0.6000
T6	15	LDF2-50A(3/8") SC	362.00 - 382.00	0.6000	0.6000
T6	16	LDF4.5-50(5/8")	362.00 - 382.00	0.6000	0.6000
T7	1	3" Coax	342.00 - 362.00	1.0000	0.6000
T7	2	AVA5-50(7/8")	342.00 - 362.00	0.6000	0.6000
T7	3	1" Conduit	342.00 - 362.00	0.6000	0.6000
T7	4	LDF4.5-50(5/8")	342.00 - 351.00	0.6000	0.6000
T7	5	1 5/8" OD Conduit	342.00 - 362.00	0.6000	0.6000
T7	12	LDF5-50A(7/8")	342.00 - 362.00	0.6000	0.6000
T7	13	LDF5-50A(7/8")	342.00 - 362.00	0.6000	0.6000
T7	15	LDF2-50A(3/8") SC	342.00 - 362.00	0.6000	0.6000
T7	16	LDF4.5-50(5/8")	342.00 - 362.00	0.6000	0.6000
T8	1	3" Coax	322.00 -	1.0000	0.6000

Job	US-CT-5009	Page	23 of 83
Project	Guyed Tower Structural Analysis	Date	11:53:35 05/29/20
Client		Designed by	JWagner

Tower Section	Feed Line Record No.	Description	Feed Line Segment Elev.	K_a No Ice	K_a Ice
T8	2	AVA5-50(7/8")	342.00 322.00 - 342.00	0.6000	0.6000
T8	3	1" Conduit	322.00 - 342.00	0.6000	0.6000
T8	4	LDF4.5-50(5/8")	322.00 - 342.00	0.6000	0.6000
T8	5	1 5/8" OD Conduit	322.00 - 342.00	0.6000	0.6000
T8	11	LDF5-50A(7/8")	322.00 - 339.00	0.6000	0.6000
T8	12	LDF5-50A(7/8")	322.00 - 342.00	0.6000	0.6000
T8	13	LDF5-50A(7/8")	322.00 - 342.00	0.6000	0.6000
T8	15	LDF2-50A(3/8") SC	322.00 - 342.00	0.6000	0.6000
T8	16	LDF4.5-50(5/8")	322.00 - 342.00	0.6000	0.6000
T9	1	3" Coax	302.00 - 322.00	1.0000	0.6000
T9	2	AVA5-50(7/8")	302.00 - 322.00	0.6000	0.6000
T9	3	1" Conduit	302.00 - 322.00	0.6000	0.6000
T9	4	LDF4.5-50(5/8")	302.00 - 322.00	0.6000	0.6000
T9	5	1 5/8" OD Conduit	302.00 - 322.00	0.6000	0.6000
T9	11	LDF5-50A(7/8")	302.00 - 322.00	0.6000	0.6000
T9	12	LDF5-50A(7/8")	302.00 - 322.00	0.6000	0.6000
T9	13	LDF5-50A(7/8")	302.00 - 322.00	0.6000	0.6000
T9	15	LDF2-50A(3/8") SC	302.00 - 322.00	0.6000	0.6000
T9	16	LDF4.5-50(5/8")	302.00 - 322.00	0.6000	0.6000
T10	1	3" Coax	282.00 - 302.00	1.0000	0.6000
T10	2	AVA5-50(7/8")	282.00 - 302.00	0.6000	0.6000
T10	3	1" Conduit	282.00 - 302.00	0.6000	0.6000
T10	4	LDF4.5-50(5/8")	282.00 - 302.00	0.6000	0.6000
T10	5	1 5/8" OD Conduit	282.00 - 302.00	0.6000	0.6000
T10	11	LDF5-50A(7/8")	282.00 - 302.00	0.6000	0.6000
T10	12	LDF5-50A(7/8")	282.00 - 302.00	0.6000	0.6000
T10	13	LDF5-50A(7/8")	282.00 - 302.00	0.6000	0.6000
T10	14	LDF6-50A(1-1/4")	282.00 - 302.00	0.6000	0.6000
T10	15	LDF2-50A(3/8") SC	282.00 - 302.00	0.6000	0.6000
T10	16	LDF4.5-50(5/8")	282.00 - 302.00	0.6000	0.6000
T10	17	LDF4-50A(1/2")	282.00 -	0.6000	0.6000

<i>Tower Section</i>	<i>Feed Line Record No.</i>	<i>Description</i>	<i>Feed Line Segment Elev.</i>	<i>K_a No Ice</i>	<i>K_a Ice</i>
			289.00		
T11	1	3" Coax	262.00 - 282.00	1.0000	0.6000
T11	2	AVA5-50(7/8")	262.00 - 282.00	0.6000	0.6000
T11	3	1" Conduit	262.00 - 282.00	0.6000	0.6000
T11	4	LDF4.5-50(5/8")	262.00 - 282.00	0.6000	0.6000
T11	5	1 5/8" OD Conduit	262.00 - 282.00	0.6000	0.6000
T11	11	LDF5-50A(7/8")	262.00 - 282.00	0.6000	0.6000
T11	12	LDF5-50A(7/8")	262.00 - 282.00	0.6000	0.6000
T11	13	LDF5-50A(7/8")	262.00 - 282.00	0.6000	0.6000
T11	14	LDF6-50A(1-1/4")	262.00 - 282.00	0.6000	0.6000
T11	15	LDF2-50A(3/8") SC	262.00 - 282.00	0.6000	0.6000
T11	16	LDF4.5-50(5/8")	262.00 - 282.00	0.6000	0.6000
T11	17	LDF4-50A(1/2")	262.00 - 282.00	0.6000	0.6000
T11	21	1.625' Fiber Cables	262.00 - 280.00	0.6000	0.6000
T11	22	LDF7-50A(1-5/8")	262.00 - 280.00	0.6000	0.6000
T11	23	LDF7-50A(1-5/8")	262.00 - 280.00	0.6000	0.6000
T11	24	1.625" Hybrid Cable	262.00 - 280.00	0.6000	0.6000
T12	1	3" Coax	242.00 - 262.00	1.0000	0.6000
T12	2	AVA5-50(7/8")	242.00 - 262.00	0.6000	0.6000
T12	3	1" Conduit	242.00 - 262.00	0.6000	0.6000
T12	4	LDF4.5-50(5/8")	242.00 - 262.00	0.6000	0.6000
T12	5	1 5/8" OD Conduit	242.00 - 262.00	0.6000	0.6000
T12	10	LDF5-50A(7/8")	242.00 - 247.00	0.6000	0.6000
T12	11	LDF5-50A(7/8")	242.00 - 262.00	0.6000	0.6000
T12	12	LDF5-50A(7/8")	242.00 - 262.00	0.6000	0.6000
T12	13	LDF5-50A(7/8")	242.00 - 262.00	0.6000	0.6000
T12	14	LDF6-50A(1-1/4")	242.00 - 262.00	0.6000	0.6000
T12	15	LDF2-50A(3/8") SC	242.00 - 262.00	0.6000	0.6000
T12	16	LDF4.5-50(5/8")	242.00 - 262.00	0.6000	0.6000
T12	17	LDF4-50A(1/2")	242.00 - 262.00	0.6000	0.6000
T12	21	1.625' Fiber Cables	242.00 - 262.00	0.6000	0.6000
T12	22	LDF7-50A(1-5/8")	242.00 -	0.6000	0.6000

Job	US-CT-5009	Page	25 of 83
Project	Guyed Tower Structural Analysis	Date	11:53:35 05/29/20
Client		Designed by	JWagner

Tower Section	Feed Line Record No.	Description	Feed Line Segment Elev.	K_a No Ice	K_a Ice
			262.00		
T12	23	LDF7-50A(1-5/8")	242.00 - 262.00	0.6000	0.6000
T12	24	1.625" Hybrid Cable	242.00 - 262.00	0.6000	0.6000
T12	25	LDF6-50A(1-1/4")	242.00 - 257.00	0.6000	0.6000
T12	26	LDF6-50A(1-1/4")	242.00 - 257.00	0.6000	0.6000
T13	1	3" Coax	222.00 - 242.00	1.0000	0.6000
T13	2	AVA5-50(7/8")	222.00 - 242.00	0.6000	0.6000
T13	3	1" Conduit	222.00 - 242.00	0.6000	0.6000
T13	4	LDF4.5-50(5/8")	222.00 - 242.00	0.6000	0.6000
T13	5	1 5/8" OD Conduit	222.00 - 242.00	0.6000	0.6000
T13	9	LDF5-50A(7/8")	222.00 - 239.00	0.6000	0.6000
T13	10	LDF5-50A(7/8")	222.00 - 242.00	0.6000	0.6000
T13	11	LDF5-50A(7/8")	222.00 - 242.00	0.6000	0.6000
T13	12	LDF5-50A(7/8")	222.00 - 242.00	0.6000	0.6000
T13	13	LDF5-50A(7/8")	222.00 - 242.00	0.6000	0.6000
T13	14	LDF6-50A(1-1/4")	222.00 - 242.00	0.6000	0.6000
T13	15	LDF2-50A(3/8") SC	222.00 - 242.00	0.6000	0.6000
T13	16	LDF4.5-50(5/8")	222.00 - 242.00	0.6000	0.6000
T13	17	LDF4-50A(1/2")	222.00 - 242.00	0.6000	0.6000
T13	21	1.625' Fiber Cables	222.00 - 242.00	0.6000	0.6000
T13	22	LDF7-50A(1-5/8")	222.00 - 242.00	0.6000	0.6000
T13	23	LDF7-50A(1-5/8")	222.00 - 242.00	0.6000	0.6000
T13	24	1.625" Hybrid Cable	222.00 - 242.00	0.6000	0.6000
T13	25	LDF6-50A(1-1/4")	222.00 - 242.00	0.6000	0.6000
T13	26	LDF6-50A(1-1/4")	222.00 - 242.00	0.6000	0.6000
T14	1	3" Coax	202.00 - 222.00	1.0000	0.5965
T14	2	AVA5-50(7/8")	202.00 - 222.00	0.6000	0.5965
T14	3	1" Conduit	202.00 - 222.00	0.6000	0.5965
T14	4	LDF4.5-50(5/8")	202.00 - 222.00	0.6000	0.5965
T14	5	1 5/8" OD Conduit	202.00 - 222.00	0.6000	0.5965
T14	9	LDF5-50A(7/8")	202.00 - 222.00	0.6000	0.5965
T14	10	LDF5-50A(7/8")	202.00 -	0.6000	0.5965

Job	US-CT-5009	Page	26 of 83
Project	Guyed Tower Structural Analysis	Date	11:53:35 05/29/20
Client		Designed by	JWagner

Tower Section	Feed Line Record No.	Description	Feed Line Segment Elev.	K_a No Ice	K_a Ice
			222.00		
T14	11	LDF5-50A(7/8")	202.00 - 222.00	0.6000	0.5965
T14	12	LDF5-50A(7/8")	202.00 - 222.00	0.6000	0.5965
T14	13	LDF5-50A(7/8")	202.00 - 222.00	0.6000	0.5965
T14	14	LDF6-50A(1-1/4")	202.00 - 222.00	0.6000	0.5965
T14	15	LDF2-50A(3/8") SC	202.00 - 222.00	0.6000	0.5965
T14	16	LDF4.5-50(5/8")	202.00 - 222.00	0.6000	0.5965
T14	17	LDF4-50A(1/2")	202.00 - 222.00	0.6000	0.5965
T14	21	1.625' Fiber Cables	202.00 - 222.00	0.6000	0.5965
T14	22	LDF7-50A(1-5/8")	202.00 - 222.00	0.6000	0.5965
T14	23	LDF7-50A(1-5/8")	202.00 - 222.00	0.6000	0.5965
T14	24	1.625" Hybrid Cable	202.00 - 222.00	0.6000	0.5965
T14	25	LDF6-50A(1-1/4")	202.00 - 222.00	0.6000	0.5965
T14	26	LDF6-50A(1-1/4")	202.00 - 222.00	0.6000	0.5965
T15	1	3" Coax	182.00 - 202.00	1.0000	0.6000
T15	2	AVA5-50(7/8")	182.00 - 202.00	0.6000	0.6000
T15	3	1" Conduit	182.00 - 202.00	0.6000	0.6000
T15	4	LDF4.5-50(5/8")	182.00 - 202.00	0.6000	0.6000
T15	5	1 5/8" OD Conduit	182.00 - 202.00	0.6000	0.6000
T15	9	LDF5-50A(7/8")	182.00 - 202.00	0.6000	0.6000
T15	10	LDF5-50A(7/8")	182.00 - 202.00	0.6000	0.6000
T15	11	LDF5-50A(7/8")	182.00 - 202.00	0.6000	0.6000
T15	12	LDF5-50A(7/8")	182.00 - 202.00	0.6000	0.6000
T15	13	LDF5-50A(7/8")	182.00 - 202.00	0.6000	0.6000
T15	14	LDF6-50A(1-1/4")	182.00 - 202.00	0.6000	0.6000
T15	15	LDF2-50A(3/8") SC	182.00 - 202.00	0.6000	0.6000
T15	16	LDF4.5-50(5/8")	182.00 - 202.00	0.6000	0.6000
T15	17	LDF4-50A(1/2")	182.00 - 202.00	0.6000	0.6000
T15	21	1.625' Fiber Cables	182.00 - 202.00	0.6000	0.6000
T15	22	LDF7-50A(1-5/8")	182.00 - 202.00	0.6000	0.6000
T15	23	LDF7-50A(1-5/8")	182.00 - 202.00	0.6000	0.6000
T15	24	1.625" Hybrid Cable	182.00 -	0.6000	0.6000

Job	US-CT-5009	Page	27 of 83
Project	Guyed Tower Structural Analysis	Date	11:53:35 05/29/20
Client		Designed by	JWagner

Tower Section	Feed Line Record No.	Description	Feed Line Segment Elev.	K_a No Ice	K_a Ice
			202.00		
T15	25	LDF6-50A(1-1/4")	182.00 - 202.00	0.6000	0.6000
T15	26	LDF6-50A(1-1/4")	182.00 - 202.00	0.6000	0.6000
T16	1	3" Coax	162.00 - 182.00	1.0000	0.6000
T16	2	AVA5-50(7/8")	162.00 - 182.00	0.6000	0.6000
T16	3	1" Conduit	162.00 - 182.00	0.6000	0.6000
T16	4	LDF4.5-50(5/8")	162.00 - 182.00	0.6000	0.6000
T16	5	1 5/8" OD Conduit	162.00 - 182.00	0.6000	0.6000
T16	9	LDF5-50A(7/8")	162.00 - 182.00	0.6000	0.6000
T16	10	LDF5-50A(7/8")	162.00 - 182.00	0.6000	0.6000
T16	11	LDF5-50A(7/8")	162.00 - 182.00	0.6000	0.6000
T16	12	LDF5-50A(7/8")	162.00 - 182.00	0.6000	0.6000
T16	13	LDF5-50A(7/8")	162.00 - 182.00	0.6000	0.6000
T16	14	LDF6-50A(1-1/4")	162.00 - 182.00	0.6000	0.6000
T16	15	LDF2-50A(3/8") SC	162.00 - 182.00	0.6000	0.6000
T16	16	LDF4.5-50(5/8")	162.00 - 182.00	0.6000	0.6000
T16	17	LDF4-50A(1/2")	162.00 - 182.00	0.6000	0.6000
T16	21	1.625' Fiber Cables	162.00 - 182.00	0.6000	0.6000
T16	22	LDF7-50A(1-5/8")	162.00 - 182.00	0.6000	0.6000
T16	23	LDF7-50A(1-5/8")	162.00 - 182.00	0.6000	0.6000
T16	24	1.625" Hybrid Cable	162.00 - 182.00	0.6000	0.6000
T16	25	LDF6-50A(1-1/4")	162.00 - 182.00	0.6000	0.6000
T16	26	LDF6-50A(1-1/4")	162.00 - 182.00	0.6000	0.6000
T16	27	LDF2-50(3/8")	162.00 - 165.00	0.6000	0.6000
T16	28	LDF4.5-50(5/8")	162.00 - 165.00	0.6000	0.6000
T17	1	3" Coax	142.00 - 162.00	1.0000	0.6000
T17	2	AVA5-50(7/8")	142.00 - 162.00	0.6000	0.6000
T17	3	1" Conduit	142.00 - 162.00	0.6000	0.6000
T17	4	LDF4.5-50(5/8")	142.00 - 162.00	0.6000	0.6000
T17	5	1 5/8" OD Conduit	142.00 - 162.00	0.6000	0.6000
T17	9	LDF5-50A(7/8")	142.00 - 162.00	0.6000	0.6000
T17	10	LDF5-50A(7/8")	142.00 -	0.6000	0.6000

Job	US-CT-5009	Page	28 of 83
Project	Guyed Tower Structural Analysis	Date	11:53:35 05/29/20
Client		Designed by	JWagner

Tower Section	Feed Line Record No.	Description	Feed Line Segment Elev.	K_a No Ice	K_a Ice
T17	11	LDF5-50A(7/8")	162.00 142.00 - 162.00	0.6000	0.6000
T17	12	LDF5-50A(7/8")	142.00 - 162.00	0.6000	0.6000
T17	13	LDF5-50A(7/8")	142.00 - 162.00	0.6000	0.6000
T17	14	LDF6-50A(1-1/4")	142.00 - 162.00	0.6000	0.6000
T17	15	LDF2-50A(3/8") SC	142.00 - 162.00	0.6000	0.6000
T17	16	LDF4.5-50(5/8")	142.00 - 162.00	0.6000	0.6000
T17	17	LDF4-50A(1/2")	142.00 - 162.00	0.6000	0.6000
T17	21	1.625' Fiber Cables	142.00 - 162.00	0.6000	0.6000
T17	22	LDF7-50A(1-5/8")	142.00 - 162.00	0.6000	0.6000
T17	23	LDF7-50A(1-5/8")	142.00 - 162.00	0.6000	0.6000
T17	24	1.625" Hybrid Cable	142.00 - 162.00	0.6000	0.6000
T17	25	LDF6-50A(1-1/4")	142.00 - 162.00	0.6000	0.6000
T17	26	LDF6-50A(1-1/4")	142.00 - 162.00	0.6000	0.6000
T17	27	LDF2-50(3/8")	142.00 - 162.00	0.6000	0.6000
T17	28	LDF4.5-50(5/8")	142.00 - 162.00	0.6000	0.6000
T18	1	3" Coax	122.00 - 142.00	1.0000	0.6000
T18	2	AVA5-50(7/8")	122.00 - 142.00	0.6000	0.6000
T18	3	1" Conduit	122.00 - 142.00	0.6000	0.6000
T18	4	LDF4.5-50(5/8")	122.00 - 142.00	0.6000	0.6000
T18	5	1 5/8" OD Conduit	122.00 - 142.00	0.6000	0.6000
T18	7	LDF5-50A(7/8")	122.00 - 124.00	0.6000	0.6000
T18	8	LDF5-50A(7/8")	122.00 - 138.00	0.6000	0.6000
T18	9	LDF5-50A(7/8")	122.00 - 142.00	0.6000	0.6000
T18	10	LDF5-50A(7/8")	122.00 - 142.00	0.6000	0.6000
T18	11	LDF5-50A(7/8")	122.00 - 142.00	0.6000	0.6000
T18	12	LDF5-50A(7/8")	122.00 - 142.00	0.6000	0.6000
T18	13	LDF5-50A(7/8")	122.00 - 142.00	0.6000	0.6000
T18	14	LDF6-50A(1-1/4")	122.00 - 142.00	0.6000	0.6000
T18	15	LDF2-50A(3/8") SC	122.00 - 142.00	0.6000	0.6000
T18	16	LDF4.5-50(5/8")	122.00 - 142.00	0.6000	0.6000
T18	17	LDF4-50A(1/2")	122.00 -	0.6000	0.6000

Job	US-CT-5009	Page	29 of 83
Project	Guyed Tower Structural Analysis	Date	11:53:35 05/29/20
Client		Designed by	JWagner

Tower Section	Feed Line Record No.	Description	Feed Line Segment Elev.	K_a No Ice	K_a Ice
T18	21	1.625' Fiber Cables	142.00 - 122.00	0.6000	0.6000
T18	22	LDF7-50A(1-5/8")	142.00 - 122.00	0.6000	0.6000
T18	23	LDF7-50A(1-5/8")	142.00 - 122.00	0.6000	0.6000
T18	24	1.625" Hybrid Cable	142.00 - 122.00	0.6000	0.6000
T18	25	LDF6-50A(1-1/4")	142.00 - 122.00	0.6000	0.6000
T18	26	LDF6-50A(1-1/4")	142.00 - 122.00	0.6000	0.6000
T18	27	LDF2-50(3/8")	142.00 - 122.00	0.6000	0.6000
T18	28	LDF4.5-50(5/8")	142.00 - 122.00	0.6000	0.6000
T19	1	3" Coax	112.00 - 122.00	1.0000	0.5946
T19	2	AVA5-50(7/8")	112.00 - 122.00	0.6000	0.5946
T19	3	1" Conduit	112.00 - 122.00	0.6000	0.5946
T19	4	LDF4.5-50(5/8")	112.00 - 122.00	0.6000	0.5946
T19	5	1 5/8" OD Conduit	112.00 - 122.00	0.6000	0.5946
T19	7	LDF5-50A(7/8")	112.00 - 122.00	0.6000	0.5946
T19	8	LDF5-50A(7/8")	112.00 - 122.00	0.6000	0.5946
T19	9	LDF5-50A(7/8")	112.00 - 122.00	0.6000	0.5946
T19	10	LDF5-50A(7/8")	112.00 - 122.00	0.6000	0.5946
T19	11	LDF5-50A(7/8")	112.00 - 122.00	0.6000	0.5946
T19	12	LDF5-50A(7/8")	112.00 - 122.00	0.6000	0.5946
T19	13	LDF5-50A(7/8")	112.00 - 122.00	0.6000	0.5946
T19	14	LDF6-50A(1-1/4")	112.00 - 122.00	0.6000	0.5946
T19	15	LDF2-50A(3/8") SC	112.00 - 122.00	0.6000	0.5946
T19	16	LDF4.5-50(5/8")	112.00 - 122.00	0.6000	0.5946
T19	17	LDF4-50A(1/2")	112.00 - 122.00	0.6000	0.5946
T19	21	1.625' Fiber Cables	112.00 - 122.00	0.6000	0.5946
T19	22	LDF7-50A(1-5/8")	112.00 - 122.00	0.6000	0.5946
T19	23	LDF7-50A(1-5/8")	112.00 - 122.00	0.6000	0.5946
T19	24	1.625" Hybrid Cable	112.00 - 122.00	0.6000	0.5946
T19	25	LDF6-50A(1-1/4")	112.00 - 122.00	0.6000	0.5946
T19	26	LDF6-50A(1-1/4")	112.00 - 122.00	0.6000	0.5946
T19	27	LDF2-50(3/8")	112.00 -	0.6000	0.5946

Job	US-CT-5009	Page	30 of 83
Project	Guyed Tower Structural Analysis	Date	11:53:35 05/29/20
Client		Designed by	JWagner

Tower Section	Feed Line Record No.	Description	Feed Line Segment Elev.	K_a No Ice	K_a Ice
			122.00		
T19	28	LDF4.5-50(5/8")	112.00 - 122.00	0.6000	0.5946
T20	1	3" Coax	102.00 - 112.00	1.0000	0.6000
T20	2	AVA5-50(7/8")	102.00 - 112.00	0.6000	0.6000
T20	3	1" Conduit	102.00 - 112.00	0.6000	0.6000
T20	4	LDF4.5-50(5/8")	102.00 - 112.00	0.6000	0.6000
T20	5	1 5/8" OD Conduit	102.00 - 112.00	0.6000	0.6000
T20	6	LDF5-50A(7/8")	102.00 - 108.00	0.6000	0.6000
T20	7	LDF5-50A(7/8")	102.00 - 112.00	0.6000	0.6000
T20	8	LDF5-50A(7/8")	102.00 - 112.00	0.6000	0.6000
T20	9	LDF5-50A(7/8")	102.00 - 112.00	0.6000	0.6000
T20	10	LDF5-50A(7/8")	102.00 - 112.00	0.6000	0.6000
T20	11	LDF5-50A(7/8")	102.00 - 112.00	0.6000	0.6000
T20	12	LDF5-50A(7/8")	102.00 - 112.00	0.6000	0.6000
T20	13	LDF5-50A(7/8")	102.00 - 112.00	0.6000	0.6000
T20	14	LDF6-50A(1-1/4")	102.00 - 112.00	0.6000	0.6000
T20	15	LDF2-50A(3/8") SC	102.00 - 112.00	0.6000	0.6000
T20	16	LDF4.5-50(5/8")	102.00 - 112.00	0.6000	0.6000
T20	17	LDF4-50A(1/2")	102.00 - 112.00	0.6000	0.6000
T20	21	1.625' Fiber Cables	102.00 - 112.00	0.6000	0.6000
T20	22	LDF7-50A(1-5/8")	102.00 - 112.00	0.6000	0.6000
T20	23	LDF7-50A(1-5/8")	102.00 - 112.00	0.6000	0.6000
T20	24	1.625" Hybrid Cable	102.00 - 112.00	0.6000	0.6000
T20	25	LDF6-50A(1-1/4")	102.00 - 112.00	0.6000	0.6000
T20	26	LDF6-50A(1-1/4")	102.00 - 112.00	0.6000	0.6000
T20	27	LDF2-50(3/8")	102.00 - 112.00	0.6000	0.6000
T20	28	LDF4.5-50(5/8")	102.00 - 112.00	0.6000	0.6000
T21	1	3" Coax	82.00 - 102.00	1.0000	0.6000
T21	2	AVA5-50(7/8")	82.00 - 102.00	0.6000	0.6000
T21	3	1" Conduit	82.00 - 102.00	0.6000	0.6000
T21	4	LDF4.5-50(5/8")	82.00 - 102.00	0.6000	0.6000
T21	5	1 5/8" OD Conduit	82.00 - 102.00	0.6000	0.6000
T21	6	LDF5-50A(7/8")	82.00 - 102.00	0.6000	0.6000
T21	7	LDF5-50A(7/8")	82.00 - 102.00	0.6000	0.6000
T21	8	LDF5-50A(7/8")	82.00 - 102.00	0.6000	0.6000
T21	9	LDF5-50A(7/8")	82.00 - 102.00	0.6000	0.6000

Job	US-CT-5009	Page	31 of 83
Project	Guyed Tower Structural Analysis	Date	11:53:35 05/29/20
Client		Designed by	JWagner

Tower Section	Feed Line Record No.	Description	Feed Line Segment Elev.	K_a No Ice	K_a Ice
T21	10	LDF5-50A(7/8")	82.00 - 102.00	0.6000	0.6000
T21	11	LDF5-50A(7/8")	82.00 - 102.00	0.6000	0.6000
T21	12	LDF5-50A(7/8")	82.00 - 102.00	0.6000	0.6000
T21	13	LDF5-50A(7/8")	82.00 - 102.00	0.6000	0.6000
T21	14	LDF6-50A(1-1/4")	82.00 - 102.00	0.6000	0.6000
T21	15	LDF2-50A(3/8") SC	82.00 - 102.00	0.6000	0.6000
T21	16	LDF4.5-50(5/8")	82.00 - 102.00	0.6000	0.6000
T21	17	LDF4-50A(1/2")	82.00 - 102.00	0.6000	0.6000
T21	21	1.625' Fiber Cables	82.00 - 102.00	0.6000	0.6000
T21	22	LDF7-50A(1-5/8")	82.00 - 102.00	0.6000	0.6000
T21	23	LDF7-50A(1-5/8")	82.00 - 102.00	0.6000	0.6000
T21	24	1.625" Hybrid Cable	82.00 - 102.00	0.6000	0.6000
T21	25	LDF6-50A(1-1/4")	82.00 - 102.00	0.6000	0.6000
T21	26	LDF6-50A(1-1/4")	82.00 - 102.00	0.6000	0.6000
T21	27	LDF2-50(3/8")	82.00 - 102.00	0.6000	0.6000
T21	28	LDF4.5-50(5/8")	82.00 - 102.00	0.6000	0.6000
T22	1	3" Coax	62.00 - 82.00	0.6000	0.6000
T22	2	AVA5-50(7/8")	62.00 - 82.00	0.6000	0.6000
T22	3	1" Conduit	62.00 - 82.00	0.6000	0.6000
T22	4	LDF4.5-50(5/8")	62.00 - 82.00	0.6000	0.6000
T22	5	1 5/8" OD Conduit	62.00 - 82.00	0.6000	0.6000
T22	6	LDF5-50A(7/8")	62.00 - 82.00	0.6000	0.6000
T22	7	LDF5-50A(7/8")	62.00 - 82.00	0.6000	0.6000
T22	8	LDF5-50A(7/8")	62.00 - 82.00	0.6000	0.6000
T22	9	LDF5-50A(7/8")	62.00 - 82.00	0.6000	0.6000
T22	10	LDF5-50A(7/8")	62.00 - 82.00	0.6000	0.6000
T22	11	LDF5-50A(7/8")	62.00 - 82.00	0.6000	0.6000
T22	12	LDF5-50A(7/8")	62.00 - 82.00	0.6000	0.6000
T22	13	LDF5-50A(7/8")	62.00 - 82.00	0.6000	0.6000
T22	14	LDF6-50A(1-1/4")	62.00 - 82.00	0.6000	0.6000
T22	15	LDF2-50A(3/8") SC	62.00 - 82.00	0.6000	0.6000
T22	16	LDF4.5-50(5/8")	62.00 - 82.00	0.6000	0.6000
T22	17	LDF4-50A(1/2")	62.00 - 82.00	0.6000	0.6000
T22	21	1.625' Fiber Cables	62.00 - 82.00	0.6000	0.6000
T22	22	LDF7-50A(1-5/8")	62.00 - 82.00	0.6000	0.6000
T22	23	LDF7-50A(1-5/8")	62.00 - 82.00	0.6000	0.6000
T22	24	1.625" Hybrid Cable	62.00 - 82.00	0.6000	0.6000
T22	25	LDF6-50A(1-1/4")	62.00 - 82.00	0.6000	0.6000
T22	26	LDF6-50A(1-1/4")	62.00 - 82.00	0.6000	0.6000
T22	27	LDF2-50(3/8")	62.00 - 82.00	0.6000	0.6000
T22	28	LDF4.5-50(5/8")	62.00 - 82.00	0.6000	0.6000
T23	1	3" Coax	42.00 - 62.00	0.6000	0.6000
T23	2	AVA5-50(7/8")	42.00 - 62.00	0.6000	0.6000
T23	3	1" Conduit	42.00 - 62.00	0.6000	0.6000
T23	4	LDF4.5-50(5/8")	42.00 - 62.00	0.6000	0.6000
T23	5	1 5/8" OD Conduit	42.00 - 62.00	0.6000	0.6000
T23	6	LDF5-50A(7/8")	42.00 - 62.00	0.6000	0.6000
T23	7	LDF5-50A(7/8")	42.00 - 62.00	0.6000	0.6000
T23	8	LDF5-50A(7/8")	42.00 - 62.00	0.6000	0.6000
T23	9	LDF5-50A(7/8")	42.00 - 62.00	0.6000	0.6000
T23	10	LDF5-50A(7/8")	42.00 - 62.00	0.6000	0.6000
T23	11	LDF5-50A(7/8")	42.00 - 62.00	0.6000	0.6000
T23	12	LDF5-50A(7/8")	42.00 - 62.00	0.6000	0.6000
T23	13	LDF5-50A(7/8")	42.00 - 62.00	0.6000	0.6000
T23	14	LDF6-50A(1-1/4")	42.00 - 62.00	0.6000	0.6000
T23	15	LDF2-50A(3/8") SC	42.00 - 62.00	0.6000	0.6000
T23	16	LDF4.5-50(5/8")	42.00 - 62.00	0.6000	0.6000
T23	17	LDF4-50A(1/2")	42.00 - 62.00	0.6000	0.6000
T23	21	1.625' Fiber Cables	42.00 - 62.00	0.6000	0.6000
T23	22	LDF7-50A(1-5/8")	42.00 - 62.00	0.6000	0.6000
T23	23	LDF7-50A(1-5/8")	42.00 - 62.00	0.6000	0.6000
T23	24	1.625" Hybrid Cable	42.00 - 62.00	0.6000	0.6000

tnxTower

Vertical Bridge
750 Park of Commerce Drive
Boca Raton, FL 33487
Phone: 561-948-6367
FAX:

Job	US-CT-5009	Page	32 of 83
Project	Guyed Tower Structural Analysis	Date	11:53:35 05/29/20
Client		Designed by	JWagner

<i>Tower Section</i>	<i>Feed Line Record No.</i>	<i>Description</i>	<i>Feed Line Segment Elev.</i>	<i>K_a No Ice</i>	<i>K_a Ice</i>
T23	25	LDF6-50A(1-1/4")	42.00 - 62.00	0.6000	0.6000
T23	26	LDF6-50A(1-1/4")	42.00 - 62.00	0.6000	0.6000
T23	27	LDF2-50(3/8")	42.00 - 62.00	0.6000	0.6000
T23	28	LDF4.5-50(5/8")	42.00 - 62.00	0.6000	0.6000
T24	1	3" Coax	22.00 - 42.00	0.6000	0.6000
T24	2	AVA5-50(7/8")	22.00 - 42.00	0.6000	0.6000
T24	3	1" Conduit	22.00 - 42.00	0.6000	0.6000
T24	4	LDF4.5-50(5/8")	22.00 - 42.00	0.6000	0.6000
T24	5	1 5/8" OD Conduit	22.00 - 42.00	0.6000	0.6000
T24	6	LDF5-50A(7/8")	22.00 - 42.00	0.6000	0.6000
T24	7	LDF5-50A(7/8")	22.00 - 42.00	0.6000	0.6000
T24	8	LDF5-50A(7/8")	22.00 - 42.00	0.6000	0.6000
T24	9	LDF5-50A(7/8")	22.00 - 42.00	0.6000	0.6000
T24	10	LDF5-50A(7/8")	22.00 - 42.00	0.6000	0.6000
T24	11	LDF5-50A(7/8")	22.00 - 42.00	0.6000	0.6000
T24	12	LDF5-50A(7/8")	22.00 - 42.00	0.6000	0.6000
T24	13	LDF5-50A(7/8")	22.00 - 42.00	0.6000	0.6000
T24	14	LDF6-50A(1-1/4")	22.00 - 42.00	0.6000	0.6000
T24	15	LDF2-50A(3/8") SC	22.00 - 42.00	0.6000	0.6000
T24	16	LDF4.5-50(5/8")	22.00 - 42.00	0.6000	0.6000
T24	17	LDF4-50A(1/2")	22.00 - 42.00	0.6000	0.6000
T24	21	1.625' Fiber Cables	22.00 - 42.00	0.6000	0.6000
T24	22	LDF7-50A(1-5/8")	22.00 - 42.00	0.6000	0.6000
T24	23	LDF7-50A(1-5/8")	22.00 - 42.00	0.6000	0.6000
T24	24	1.625" Hybrid Cable	22.00 - 42.00	0.6000	0.6000
T24	25	LDF6-50A(1-1/4")	22.00 - 42.00	0.6000	0.6000
T24	26	LDF6-50A(1-1/4")	22.00 - 42.00	0.6000	0.6000
T24	27	LDF2-50(3/8")	22.00 - 42.00	0.6000	0.6000
T24	28	LDF4.5-50(5/8")	22.00 - 42.00	0.6000	0.6000
T25	1	3" Coax	8.00 - 22.00	0.6000	0.6000
T25	2	AVA5-50(7/8")	8.00 - 22.00	0.6000	0.6000
T25	3	1" Conduit	8.00 - 22.00	0.6000	0.6000
T25	4	LDF4.5-50(5/8")	8.00 - 22.00	0.6000	0.6000
T25	5	1 5/8" OD Conduit	8.00 - 22.00	0.6000	0.6000
T25	6	LDF5-50A(7/8")	8.00 - 22.00	0.6000	0.6000
T25	7	LDF5-50A(7/8")	8.00 - 22.00	0.6000	0.6000
T25	8	LDF5-50A(7/8")	8.00 - 22.00	0.6000	0.6000
T25	9	LDF5-50A(7/8")	8.00 - 22.00	0.6000	0.6000
T25	10	LDF5-50A(7/8")	8.00 - 22.00	0.6000	0.6000
T25	11	LDF5-50A(7/8")	8.00 - 22.00	0.6000	0.6000
T25	12	LDF5-50A(7/8")	8.00 - 22.00	0.6000	0.6000
T25	13	LDF5-50A(7/8")	8.00 - 22.00	0.6000	0.6000
T25	14	LDF6-50A(1-1/4")	8.00 - 22.00	0.6000	0.6000
T25	15	LDF2-50A(3/8") SC	8.00 - 22.00	0.6000	0.6000
T25	16	LDF4.5-50(5/8")	8.00 - 22.00	0.6000	0.6000
T25	17	LDF4-50A(1/2")	8.00 - 22.00	0.6000	0.6000
T25	21	1.625' Fiber Cables	8.00 - 22.00	0.6000	0.6000
T25	22	LDF7-50A(1-5/8")	8.00 - 22.00	0.6000	0.6000
T25	23	LDF7-50A(1-5/8")	8.00 - 22.00	0.6000	0.6000
T25	24	1.625" Hybrid Cable	8.00 - 22.00	0.6000	0.6000
T25	25	LDF6-50A(1-1/4")	8.00 - 22.00	0.6000	0.6000
T25	26	LDF6-50A(1-1/4")	8.00 - 22.00	0.6000	0.6000
T25	27	LDF2-50(3/8")	8.00 - 22.00	0.6000	0.6000
T25	28	LDF4.5-50(5/8")	8.00 - 22.00	0.6000	0.6000

tnxTower Vertical Bridge 750 Park of Commerce Drive Boca Raton, FL 33487 Phone: 561-948-6367 FAX:	Job	US-CT-5009	Page	33 of 83
	Project	Guyed Tower Structural Analysis	Date	11:53:35 05/29/20
	Client		Designed by	JWagner

Discrete Tower Loads

Description	Face or Leg	Offset Type	Offsets:		Azimuth Adjustment	Placement	C _{AA} Front	C _{AA} Side	Weight	
			Horz	Vert						
			ft	ft	°	ft	ft ²	ft ²	K	
10' Dipole	B	From Face	1.500	0.000	0.0000	108.000	No Ice	3.000	3.000	0.030
			0.000	0.000			1/2" Ice	4.000	4.000	0.055
			0.000	0.000			1" Ice	5.000	5.000	0.080
10' Dipole	B	From Face	1.500	0.000	0.0000	125.000	No Ice	3.000	3.000	0.030
			0.000	0.000			1/2" Ice	4.000	4.000	0.055
			0.000	0.000			1" Ice	5.000	5.000	0.080
Obstruction Light(.01k,.8CAAA) (Tower)	A	From Leg	1.000	0.000	0.0000	116.000	No Ice	0.800	0.800	0.010
			0.000	0.000			1/2" Ice	1.000	1.000	0.016
			0.000	0.000			1" Ice	1.200	1.200	0.022
Obstruction Light(.01k,.8CAAA) (Tower)	B	From Leg	1.000	0.000	0.0000	116.000	No Ice	0.800	0.800	0.010
			0.000	0.000			1/2" Ice	1.000	1.000	0.016
			0.000	0.000			1" Ice	1.200	1.200	0.022
Obstruction Light(.01k,.8CAAA) (Tower)	C	From Leg	1.000	0.000	0.0000	116.000	No Ice	0.800	0.800	0.010
			0.000	0.000			1/2" Ice	1.000	1.000	0.016
			0.000	0.000			1" Ice	1.200	1.200	0.022
3' Side Arm	B	From Leg	1.500	0.000	0.0000	108.000	No Ice	0.450	2.750	0.040
			0.000	0.000			1/2" Ice	0.570	3.860	0.060
			0.000	0.000			1" Ice	0.690	4.970	0.080
3' Side Arm	B	From Leg	1.500	0.000	0.0000	125.000	No Ice	0.450	2.750	0.040
			0.000	0.000			1/2" Ice	0.570	3.860	0.060
			0.000	0.000			1" Ice	0.690	4.970	0.080
Beacon (.075k 2.250CAAA) (Tower)	A	From Leg	1.000	0.000	0.0000	124.000	No Ice	2.250	2.250	0.075
			0.000	0.000			1/2" Ice	2.500	2.500	0.100
			0.000	0.000			1" Ice	2.750	2.750	0.125
10' Dipole	A	From Leg	1.500	0.000	0.0000	138.000	No Ice	3.000	3.000	0.030
			0.000	0.000			1/2" Ice	4.000	4.000	0.055
			0.000	0.000			1" Ice	5.000	5.000	0.080
3' Side Arm	A	From Leg	1.500	0.000	0.0000	138.000	No Ice	0.450	2.750	0.040
			0.000	0.000			1/2" Ice	0.570	3.860	0.060
			0.000	0.000			1" Ice	0.690	4.970	0.080
Beacon (.075k 2.250CAAA) (Tower)	A	From Leg	1.000	0.000	0.0000	237.000	No Ice	2.250	2.250	0.075
			0.000	0.000			1/2" Ice	2.500	2.500	0.100
			0.000	0.000			1" Ice	2.750	2.750	0.125
Beacon (.075k 2.250CAAA) (Tower)	B	From Leg	1.000	0.000	0.0000	237.000	No Ice	2.250	2.250	0.075
			0.000	0.000			1/2" Ice	2.500	2.500	0.100
			0.000	0.000			1" Ice	2.750	2.750	0.125
6' Omni	A	From Leg	2.000	0.000	0.0000	302.000	No Ice	2.250	2.250	0.010
			0.000	0.000			1/2" Ice	2.619	2.619	0.029
			0.000	0.000			1" Ice	2.998	2.998	0.052
2' Side arm (25lbs 0.5CaAa)	A	From Leg	1.000	0.000	0.0000	302.000	No Ice	0.500	0.500	0.025
			0.000	0.000			1/2" Ice	0.000	0.000	0.033
			0.000	0.000			1" Ice	0.000	0.000	0.040
3' Yagi(.03k,2.08CAAA)	A	From Leg	2.000	0.000	0.0000	453.000	No Ice	2.080	2.080	0.030
			0.000	0.000			1/2" Ice	3.790	3.790	0.050
			0.000	0.000			1" Ice	5.500	5.500	0.070
2 Bay FM Antenna	A	From Leg	2.000	0.000	0.0000	471.000	No Ice	5.000	5.000	0.050
			0.000	0.000			1/2" Ice	8.000	8.000	0.090
			0.000	0.000			1" Ice	11.000	11.000	0.130
Beacon (.075k 2.250CAAA) (Tower)	C	None			0.0000	490.000	No Ice	2.250	2.250	0.075
							1/2" Ice	2.500	2.500	0.100
							1" Ice	2.750	2.750	0.125
Obstruction Light(.01k,.8CAAA) (Tower)	A	From Leg	1.000	0.000	0.0000	358.000	No Ice	0.800	0.800	0.010
			0.000	0.000			1/2" Ice	1.000	1.000	0.016
			0.000	0.000			1" Ice	1.200	1.200	0.022

tnxTower Vertical Bridge 750 Park of Commerce Drive Boca Raton, FL 33487 Phone: 561-948-6367 FAX:	Job	US-CT-5009	Page	34 of 83
	Project	Guyed Tower Structural Analysis	Date	11:53:35 05/29/20
	Client		Designed by	JWagner

Description	Face or Leg	Offset Type	Offsets:		Azimuth Adjustment	Placement	C _{AA} Front	C _{AA} Side	Weight	
			Horz	Lateral						Vert
Obstruction	B	From Leg	1.000	0.000	0.0000	358.000	No Ice	0.800	0.800	0.010
Light(.01k,.8CAAA)			0.000	0.000			1/2" Ice	1.000	1.000	0.016
(Tower)			0.000	0.000			1" Ice	1.200	1.200	0.022
Obstruction	C	From Leg	1.000	0.000	0.0000	358.000	No Ice	0.800	0.800	0.010
Light(.01k,.8CAAA)			0.000	0.000			1/2" Ice	1.000	1.000	0.016
(Tower)			0.000	0.000			1" Ice	1.200	1.200	0.022
Kathrein CA5-FM/CP/RM	C	From Leg	1.500	0.000	0.0000	300.000	No Ice	4.500	3.500	0.018
			0.000	0.000			1/2" Ice	5.500	4.400	0.023
			0.000	0.000			1" Ice	6.500	5.300	0.029
SM 408-3	A	From Leg	2.000	0.000	0.0000	257.000	No Ice	22.450	22.450	1.000
(Sprint)			0.000	0.000			1/2" Ice	33.500	33.500	1.500
			0.000	0.000			1" Ice	44.550	44.550	2.000
PCS 1900MHz	A	From Leg	4.000	0.000	0.0000	257.000	No Ice	2.322	2.238	0.060
4x45W-65MHz			0.000	0.000			1/2" Ice	2.527	2.441	0.083
(Sprint)			0.000	0.000			1" Ice	2.739	2.651	0.110
800 EXTERNAL NOTCH	A	From Leg	4.000	0.000	0.0000	257.000	No Ice	0.660	0.321	0.011
FILTER			0.000	0.000			1/2" Ice	0.763	0.398	0.017
(Sprint)			0.000	0.000			1" Ice	0.873	0.483	0.024
Alcatel Lucent	B	From Leg	4.000	0.000	0.0000	257.000	No Ice	2.500	2.500	0.070
RRH-4x45-1900 (25x12x12)			0.000	0.000			1/2" Ice	2.709	2.709	0.095
(Sprint)			0.000	0.000			1" Ice	2.926	2.926	0.124
Alcatel Lucent	C	From Leg	4.000	0.000	0.0000	257.000	No Ice	2.500	2.500	0.070
RRH-4x45-1900 (25x12x12)			0.000	0.000			1/2" Ice	2.709	2.709	0.095
(Sprint)			0.000	0.000			1" Ice	2.926	2.926	0.124
Alcatel Lucent RRH	B	From Leg	4.000	0.000	0.0000	257.000	No Ice	1.701	1.282	0.053
2x50-800 (16x13x10)			0.000	0.000			1/2" Ice	1.864	1.428	0.070
(Sprint)			0.000	0.000			1" Ice	2.035	1.580	0.090
Alcatel Lucent RRH	C	From Leg	4.000	0.000	0.0000	257.000	No Ice	1.701	1.282	0.053
2x50-800 (16x13x10)			0.000	0.000			1/2" Ice	1.864	1.428	0.070
(Sprint)			0.000	0.000			1" Ice	2.035	1.580	0.090
Nokia AAHC MIMO	A	From Leg	4.000	0.000	0.0000	257.000	No Ice	4.203	2.068	0.103
(25.6x19.7x9.64)			0.000	0.000			1/2" Ice	4.458	2.260	0.135
(Sprint)			0.000	0.000			1" Ice	4.721	2.463	0.171
Nokia AAHC MIMO	B	From Leg	4.000	0.000	0.0000	257.000	No Ice	4.203	2.068	0.103
(25.6x19.7x9.64)			0.000	0.000			1/2" Ice	4.458	2.260	0.135
(Sprint)			0.000	0.000			1" Ice	4.721	2.463	0.171
Nokia AAHC MIMO	C	From Leg	4.000	0.000	0.0000	257.000	No Ice	4.203	2.068	0.103
(25.6x19.7x9.64)			0.000	0.000			1/2" Ice	4.458	2.260	0.135
(Sprint)			0.000	0.000			1" Ice	4.721	2.463	0.171
CommScope NNVV-65B-R4	A	From Leg	4.000	0.000	0.0000	257.000	No Ice	12.271	5.750	0.085
(72x19.6x7.8)			0.000	0.000			1/2" Ice	12.766	6.207	0.157
(Sprint)			0.000	0.000			1" Ice	13.268	6.671	0.236
CommScope NNVV-65B-R4	B	From Leg	4.000	0.000	0.0000	257.000	No Ice	12.271	5.750	0.085
(72x19.6x7.8)			0.000	0.000			1/2" Ice	12.766	6.207	0.157
(Sprint)			0.000	0.000			1" Ice	13.268	6.671	0.236
CommScope NNVV-65B-R4	C	From Leg	4.000	0.000	0.0000	257.000	No Ice	12.271	5.750	0.085
(72x19.6x7.8)			0.000	0.000			1/2" Ice	12.766	6.207	0.157
(Sprint)			0.000	0.000			1" Ice	13.268	6.671	0.236
Sector Frames	C	None		0.0000	0.0000	165.000	No Ice	30.000	30.000	1.000
(AT&T)							1/2" Ice	35.000	35.000	1.250
							1" Ice	40.000	40.000	1.500
(2) CCI TPA65R-BU8DA-K	A	From Leg	4.000	0.000	0.0000	165.000	No Ice	18.089	8.200	0.087
(96.0x21.0x7.8)			0.000	0.000			1/2" Ice	18.722	8.794	0.185
(AT&T)			0.000	0.000			1" Ice	19.362	9.395	0.283
(2) CCI TPA65R-BU8DA-K	B	From Leg	4.000	0.000	0.0000	165.000	No Ice	18.089	8.200	0.087
(96.0x21.0x7.8)			0.000	0.000			1/2" Ice	18.722	8.794	0.185
(AT&T)			0.000	0.000			1" Ice	19.362	9.395	0.283

tnxTower Vertical Bridge 750 Park of Commerce Drive Boca Raton, FL 33487 Phone: 561-948-6367 FAX:	Job	US-CT-5009	Page	35 of 83
	Project	Guyed Tower Structural Analysis	Date	11:53:35 05/29/20
	Client		Designed by	JWagner

Description	Face or Leg	Offset Type	Offsets:		Azimuth Adjustment °	Placement ft	C _{AA} Front ft ²	C _{AA} Side ft ²	Weight K
			Horz Lateral ft	Vert ft					
(2) CCI TPA65R-BU8DA-K (96.0x21.0x7.8) (AT&T)	C	From Leg	4.000	0.000	0.0000	165.000	No Ice 18.089	8.200	0.087
			0.000				1/2" Ice 18.722	8.794	0.185
			0.000				1" Ice 19.362	9.395	0.283
Ericsson 8843 (15x13.1x10.9) (AT&T)	A	From Leg	4.000	0.000	0.0000	165.000	No Ice 1.638	1.363	0.071
			0.000				1/2" Ice 1.797	1.510	0.089
			0.000				1" Ice 1.965	1.665	0.109
Ericsson 8843 (15x13.1x10.9) (AT&T)	B	From Leg	4.000	0.000	0.0000	165.000	No Ice 1.638	1.363	0.071
			0.000				1/2" Ice 1.797	1.510	0.089
			0.000				1" Ice 1.965	1.665	0.109
Ericsson 8843 (15x13.1x10.9) (AT&T)	C	From Leg	4.000	0.000	0.0000	165.000	No Ice 1.638	1.363	0.071
			0.000				1/2" Ice 1.797	1.510	0.089
			0.000				1" Ice 1.965	1.665	0.109
Ericsson RRUS E2 (20.4x18.5x7.5) (AT&T)	A	From Leg	4.000	0.000	0.0000	165.000	No Ice 3.145	1.285	0.060
			0.000				1/2" Ice 3.365	1.438	0.083
			0.000				1" Ice 3.592	1.600	0.110
Ericsson RRUS E2 (20.4x18.5x7.5) (AT&T)	B	From Leg	4.000	0.000	0.0000	165.000	No Ice 3.145	1.285	0.060
			0.000				1/2" Ice 3.365	1.438	0.083
			0.000				1" Ice 3.592	1.600	0.110
Ericsson RRUS E2 (20.4x18.5x7.5) (AT&T)	C	From Leg	4.000	0.000	0.0000	165.000	No Ice 3.145	1.285	0.060
			0.000				1/2" Ice 3.365	1.438	0.083
			0.000				1" Ice 3.592	1.600	0.110
Ericsson 4415 B30 (16.5x13.4x5.9) (AT&T)	A	From Leg	4.000	0.000	0.0000	165.000	No Ice 1.843	0.820	0.046
			0.000				1/2" Ice 2.012	0.943	0.060
			0.000				1" Ice 2.190	1.075	0.077
Ericsson 4415 B30 (16.5x13.4x5.9) (AT&T)	B	From Leg	4.000	0.000	0.0000	165.000	No Ice 1.843	0.820	0.046
			0.000				1/2" Ice 2.012	0.943	0.060
			0.000				1" Ice 2.190	1.075	0.077
Ericsson 4415 B30 (16.5x13.4x5.9) (AT&T)	C	From Leg	4.000	0.000	0.0000	165.000	No Ice 1.843	0.820	0.046
			0.000				1/2" Ice 2.012	0.943	0.060
			0.000				1" Ice 2.190	1.075	0.077
Ericsson 4449 (18x13.2x9.4) (AT&T)	A	From Leg	4.000	0.000	0.0000	165.000	No Ice 1.980	1.410	0.070
			0.000				1/2" Ice 2.157	1.566	0.089
			0.000				1" Ice 2.341	1.729	0.110
Ericsson 4449 (18x13.2x9.4) (AT&T)	B	From Leg	4.000	0.000	0.0000	165.000	No Ice 1.980	1.410	0.070
			0.000				1/2" Ice 2.157	1.566	0.089
			0.000				1" Ice 2.341	1.729	0.110
Ericsson 4449 (18x13.2x9.4) (AT&T)	C	From Leg	4.000	0.000	0.0000	165.000	No Ice 1.980	1.410	0.070
			0.000				1/2" Ice 2.157	1.566	0.089
			0.000				1" Ice 2.341	1.729	0.110
CCI HPA65R-BU8A (96x11.7x7.6) (AT&T)	A	From Leg	4.000	0.000	0.0000	165.000	No Ice 11.233	8.044	0.054
			0.000				1/2" Ice 11.848	8.637	0.121
			0.000				1" Ice 12.471	9.238	0.195
CCI HPA65R-BU8A (96x11.7x7.6) (AT&T)	B	From Leg	4.000	0.000	0.0000	165.000	No Ice 11.233	8.044	0.054
			0.000				1/2" Ice 11.848	8.637	0.121
			0.000				1" Ice 12.471	9.238	0.195
CCI HPA65R-BU8A (96x11.7x7.6) (AT&T)	C	From Leg	4.000	0.000	0.0000	165.000	No Ice 11.233	8.044	0.054
			0.000				1/2" Ice 11.848	8.637	0.121
			0.000				1" Ice 12.471	9.238	0.195
Ericsson RRUS-4483 (15x13.2x9) (AT&T)	A	From Leg	4.000	0.000	0.0000	165.000	No Ice 1.650	1.125	0.072
			0.000				1/2" Ice 1.810	1.262	0.088
			0.000				1" Ice 1.978	1.406	0.106
Ericsson RRUS-4483 (15x13.2x9) (AT&T)	B	From Leg	4.000	0.000	0.0000	165.000	No Ice 1.650	1.125	0.072
			0.000				1/2" Ice 1.810	1.262	0.088
			0.000				1" Ice 1.978	1.406	0.106
Ericsson RRUS-4483 (15x13.2x9) (AT&T)	C	From Leg	4.000	0.000	0.0000	165.000	No Ice 1.650	1.125	0.072
			0.000				1/2" Ice 1.810	1.262	0.088
			0.000				1" Ice 1.978	1.406	0.106

tnxTower Vertical Bridge 750 Park of Commerce Drive Boca Raton, FL 33487 Phone: 561-948-6367 FAX:	Job						Page		
	US-CT-5009						36 of 83		
	Project						Date		
Guyed Tower Structural Analysis						11:53:35 05/29/20			
Client						Designed by			
						JWagner			

Description	Face or Leg	Offset Type	Offsets:			Azimuth Adjustment	Placement	C _{AA} Front	C _{AA} Side	Weight	
			Horz	Lateral	Vert						°
Raycap DC6-48-60-0-8C-EV (31.4x18.28x10.24) (AT&T)	A	From Leg	1.000	0.000	0.000	0.0000	165.000	No Ice	4.783	2.736	0.026
			0.000	0.000	0.000			1/2" Ice	5.063	2.962	0.063
			0.000	0.000	0.000			1" Ice	5.350	3.195	0.104
Raycap DC6-48-60-0-8C-EV (31.4x18.28x10.24) (AT&T)	B	From Leg	1.000	0.000	0.000	0.0000	165.000	No Ice	4.783	2.736	0.026
			0.000	0.000	0.000			1/2" Ice	5.063	2.962	0.063
			0.000	0.000	0.000			1" Ice	5.350	3.195	0.104
Raycap DC6-48-60-0-8C-EV (31.4x18.28x10.24) (AT&T)	C	From Leg	1.000	0.000	0.000	0.0000	165.000	No Ice	4.783	2.736	0.026
			0.000	0.000	0.000			1/2" Ice	5.063	2.962	0.063
			0.000	0.000	0.000			1" Ice	5.350	3.195	0.104
Ice Bridge (2'x2') (AT&T)	C	From Leg	1.000	0.000	0.000	0.0000	165.000	No Ice	2.850	3.000	0.030
			0.000	0.000	0.000			1/2" Ice	3.500	4.000	0.045
			0.000	0.000	0.000			1" Ice	4.150	5.000	0.060
KRY 112 89/4 (T-Mobile)	A	From Leg	4.000	0.000	0.000	0.0000	280.000	No Ice	0.559	0.362	0.015
			0.000	0.000	0.000			1/2" Ice	0.658	0.445	0.020
			0.000	0.000	0.000			1" Ice	0.764	0.538	0.027
KRY 112 89/4 (T-Mobile)	B	From Leg	4.000	0.000	0.000	0.0000	280.000	No Ice	0.559	0.362	0.015
			0.000	0.000	0.000			1/2" Ice	0.658	0.445	0.020
			0.000	0.000	0.000			1" Ice	0.764	0.538	0.027
KRY 112 89/4 (T-Mobile)	C	From Leg	4.000	0.000	0.000	0.0000	280.000	No Ice	0.559	0.362	0.015
			0.000	0.000	0.000			1/2" Ice	0.658	0.445	0.020
			0.000	0.000	0.000			1" Ice	0.764	0.538	0.027
Sector Frames (T-Mobile)	C	None				0.0000	280.000	No Ice	25.000	25.000	1.000
								1/2" Ice	30.000	30.000	1.250
								1" Ice	35.000	35.000	1.500
KRY 112 144/1 (T-Mobile)	A	From Leg	4.000	0.000	0.000	0.0000	280.000	No Ice	0.350	0.175	0.011
			0.000	0.000	0.000			1/2" Ice	0.426	0.234	0.014
			0.000	0.000	0.000			1" Ice	0.509	0.301	0.019
KRY 112 144/1 (T-Mobile)	B	From Leg	4.000	0.000	0.000	0.0000	280.000	No Ice	0.350	0.175	0.011
			0.000	0.000	0.000			1/2" Ice	0.426	0.234	0.014
			0.000	0.000	0.000			1" Ice	0.509	0.301	0.019
KRY 112 144/1 (T-Mobile)	C	From Leg	4.000	0.000	0.000	0.0000	280.000	No Ice	0.350	0.175	0.011
			0.000	0.000	0.000			1/2" Ice	0.426	0.234	0.014
			0.000	0.000	0.000			1" Ice	0.509	0.301	0.019
RFS APX16DWV-16DWV-S-E-A 20 (55.9x13.3x3.15) (T-Mobile)	A	From Leg	4.000	0.000	0.000	0.0000	280.000	No Ice	6.586	2.150	0.041
			0.000	0.000	0.000			1/2" Ice	6.962	2.490	0.074
			0.000	0.000	0.000			1" Ice	7.344	2.837	0.113
RFS APX16DWV-16DWV-S-E-A 20 (55.9x13.3x3.15) (T-Mobile)	B	From Leg	4.000	0.000	0.000	0.0000	280.000	No Ice	6.586	2.150	0.041
			0.000	0.000	0.000			1/2" Ice	6.962	2.490	0.074
			0.000	0.000	0.000			1" Ice	7.344	2.837	0.113
RFS APX16DWV-16DWV-S-E-A 20 (55.9x13.3x3.15) (T-Mobile)	C	From Leg	4.000	0.000	0.000	0.0000	280.000	No Ice	6.586	2.150	0.041
			0.000	0.000	0.000			1/2" Ice	6.962	2.490	0.074
			0.000	0.000	0.000			1" Ice	7.344	2.837	0.113
RFS APXVAARR24_43-U-NA20 (95.9x24x8.7) (T-Mobile)	A	From Leg	4.000	0.000	0.000	0.0000	280.000	No Ice	20.267	8.744	0.101
			0.000	0.000	0.000			1/2" Ice	20.915	9.342	0.213
			0.000	0.000	0.000			1" Ice	21.570	9.947	0.334
RFS APXVAARR24_43-U-NA20 (95.9x24x8.7) (T-Mobile)	B	From Leg	4.000	0.000	0.000	0.0000	280.000	No Ice	20.267	8.744	0.101
			0.000	0.000	0.000			1/2" Ice	20.915	9.342	0.213
			0.000	0.000	0.000			1" Ice	21.570	9.947	0.334
RFS APXVAARR24_43-U-NA20 (95.9x24x8.7) (T-Mobile)	C	From Leg	4.000	0.000	0.000	0.0000	280.000	No Ice	20.267	8.744	0.101
			0.000	0.000	0.000			1/2" Ice	20.915	9.342	0.213
			0.000	0.000	0.000			1" Ice	21.570	9.947	0.334

tnxTower Vertical Bridge 750 Park of Commerce Drive Boca Raton, FL 33487 Phone: 561-948-6367 FAX:	Job	US-CT-5009	Page	37 of 83
	Project	Guyed Tower Structural Analysis	Date	11:53:35 05/29/20
	Client		Designed by	JWagner

Description	Face or Leg	Offset Type	Offsets:		Azimuth Adjustment	Placement	CAAA		Weight	
			Horz Lateral	Vert			Front	Side		
			ft	ft	°	ft	ft ²	ft ²	K	
Ericsson RRU 4449 B71B12 (14.9x13.2x10.4) (T-Mobile)	A	From Leg	4.000	0.000	0.0000	280.000	No Ice	1.639	1.291	0.074
			0.000	0.000			1/2" Ice	1.799	1.436	0.091
			0.000	0.000			1" Ice	1.966	1.587	0.111
Ericsson RRU 4449 B71B12 (14.9x13.2x10.4) (T-Mobile)	B	From Leg	4.000	0.000	0.0000	280.000	No Ice	1.639	1.291	0.074
			0.000	0.000			1/2" Ice	1.799	1.436	0.091
			0.000	0.000			1" Ice	1.966	1.587	0.111
Ericsson RRU 4449 B71B12 (14.9x13.2x10.4) (T-Mobile)	C	From Leg	4.000	0.000	0.0000	280.000	No Ice	1.639	1.291	0.074
			0.000	0.000			1/2" Ice	1.799	1.436	0.091
			0.000	0.000			1" Ice	1.966	1.587	0.111
Ericsson AIR6488 2.5GHz (34.8x20.5x7.2) (T-Mobile)	A	From Leg	4.000	0.000	0.0000	280.000	No Ice	5.945	2.268	0.128
			0.000	0.000			1/2" Ice	6.256	2.498	0.166
			0.000	0.000			1" Ice	6.574	2.735	0.208
Ericsson AIR6488 2.5GHz (34.8x20.5x7.2) (T-Mobile)	B	From Leg	4.000	0.000	0.0000	280.000	No Ice	5.945	2.268	0.128
			0.000	0.000			1/2" Ice	6.256	2.498	0.166
			0.000	0.000			1" Ice	6.574	2.735	0.208
Ericsson AIR6488 2.5GHz (34.8x20.5x7.2) (T-Mobile)	C	From Leg	4.000	0.000	0.0000	280.000	No Ice	5.945	2.268	0.128
			0.000	0.000			1/2" Ice	6.256	2.498	0.166
			0.000	0.000			1" Ice	6.574	2.735	0.208
Ericsson AIR 32 (T-Mobile)	A	From Leg	4.000	0.000	0.0000	280.000	No Ice	6.510	4.712	0.132
			0.000	0.000			1/2" Ice	6.887	5.068	0.178
			0.000	0.000			1" Ice	7.271	5.431	0.229
Ericsson AIR 32 (T-Mobile)	B	From Leg	4.000	0.000	0.0000	280.000	No Ice	6.510	4.712	0.132
			0.000	0.000			1/2" Ice	6.887	5.068	0.178
			0.000	0.000			1" Ice	7.271	5.431	0.229
Ericsson AIR 32 (T-Mobile)	C	From Leg	4.000	0.000	0.0000	280.000	No Ice	6.510	4.712	0.132
			0.000	0.000			1/2" Ice	6.887	5.068	0.178
			0.000	0.000			1" Ice	7.271	5.431	0.229
Ericsson 4415 B25 (15x13.2x5.4) (T-Mobile)	A	From Leg	4.000	0.000	0.0000	280.000	No Ice	1.650	0.682	0.000
			0.000	0.000			1/2" Ice	1.810	0.794	0.013
			0.000	0.000			1" Ice	1.978	0.916	0.027
Ericsson 4415 B25 (15x13.2x5.4) (T-Mobile)	B	From Leg	4.000	0.000	0.0000	280.000	No Ice	1.650	0.682	0.000
			0.000	0.000			1/2" Ice	1.810	0.794	0.013
			0.000	0.000			1" Ice	1.978	0.916	0.027
Ericsson 4415 B25 (15x13.2x5.4) (T-Mobile)	C	From Leg	4.000	0.000	0.0000	280.000	No Ice	1.650	0.682	0.000
			0.000	0.000			1/2" Ice	1.810	0.794	0.013
			0.000	0.000			1" Ice	1.978	0.916	0.027

Dishes

Description	Face or Leg	Dish Type	Offset Type	Offsets:		Azimuth Adjustment	3 dB Beam Width	Elevation	Outside Diameter	Aperture Area	Weight	
				Horz Lateral	Vert							
				ft	°	°	ft	ft	ft ²	K		
8' Grid Dish (140lbs 20.1CaAa)	B	Grid	From Leg	1.000	0.000	0.0000		239.000	8.000	No Ice	20.106	0.140
				0.000	0.000					1/2" Ice	23.000	0.320
				0.000	0.000					1" Ice	25.894	0.590
8' Grid Dish (140lbs 20.1CaAa)	C	Grid	From Leg	1.000	0.000	0.0000		247.000	8.000	No Ice	20.106	0.140
				0.000	0.000					1/2" Ice	23.000	0.320
				0.000	0.000					1" Ice	25.894	0.590
3' Grid Dish	A	Grid	From	1.000	0.000	0.0000		339.000	3.000	No Ice	2.830	0.030

tnxTower Vertical Bridge 750 Park of Commerce Drive Boca Raton, FL 33487 Phone: 561-948-6367 FAX:	Job	US-CT-5009	Page	38 of 83
	Project	Guyed Tower Structural Analysis	Date	11:53:35 05/29/20
	Client		Designed by	JWagner

Description	Face or Leg	Dish Type	Offset Type	Offsets: Horz Lateral Vert ft	Azimuth Adjustment °	3 dB Beam Width °	Elevation ft	Outside Diameter ft	Aperture Area ft ²	Weight K	
3' Dish w/ Radomes	B	Paraboloid w/Radome	Leg	0.000	0.0000		351.000	3.000	1/2" Ice	7.467	0.068
			From	0.000					1" Ice	12.103	0.107
			Leg	0.000					No Ice	7.069	0.035
				0.000					1/2" Ice	7.467	0.073
6' Grid Dish	C	Grid	From	0.000	0.0000		435.000	6.000	1" Ice	7.865	0.112
			Leg	0.000					No Ice	11.000	0.250
				0.000					1/2" Ice	14.000	0.399
				0.000					1" Ice	18.000	0.548

Tower Pressures - No Ice

G_H = 0.850 (base tower), 1.350 (upper structure)

Section Elevation ft	z ft	K _Z	q _z ksf	A _G ft ²	F _a c e	A _F ft ²	A _R ft ²	A _{leg} ft ²	Leg %	C _{AA} In Face ft ²	C _{AA} Out Face ft ²
L1 492.000-477.000	484.500	1.764	0.049	10.781	A	0.000	10.781	10.781	100.00	0.000	0.000
					B	0.000	10.781	100.00	0.000	0.000	
					C	0.000	10.781	100.00	0.000	0.000	
L2 477.000-457.000	467.000	1.751	0.049	14.375	A	0.000	14.375	14.375	100.00	0.000	0.000
					B	0.000	14.375	100.00	0.000	0.000	
					C	0.000	14.375	100.00	0.000	0.000	
T1 457.000-452.000	454.500	1.741	0.049	20.938	A	4.045	1.875	1.875	31.67	0.260	0.000
					B	4.045	1.875	31.67	0.000	0.000	
					C	4.045	1.875	31.67	0.000	0.000	
T2 452.000-442.000	447.000	1.735	0.049	41.875	A	4.388	3.750	3.750	46.08	0.865	0.000
					B	4.388	3.750	46.08	0.000	0.000	
					C	4.388	3.750	46.08	0.132	0.000	
T3 442.000-422.000	432.000	1.722	0.048	83.750	A	7.829	7.500	7.500	48.93	4.564	0.000
					B	7.829	7.500	48.93	5.346	0.000	
					C	7.829	7.500	48.93	3.692	0.000	
T4 422.000-402.000	412.000	1.705	0.048	83.750	A	7.670	7.500	7.500	49.44	6.090	0.000
					B	7.670	7.500	49.44	8.224	0.000	
					C	7.670	7.500	49.44	6.456	0.000	
T5 402.000-382.000	392.000	1.687	0.047	83.750	A	7.670	7.500	7.500	49.44	6.090	0.000
					B	7.670	7.500	49.44	8.224	0.000	
					C	7.670	7.500	49.44	6.456	0.000	
T6 382.000-362.000	372.000	1.669	0.047	83.750	A	7.829	7.500	7.500	48.93	6.090	0.000
					B	7.829	7.500	48.93	8.224	0.000	
					C	7.829	7.500	48.93	6.456	0.000	
T7 362.000-342.000	352.000	1.65	0.046	83.750	A	7.670	7.500	7.500	49.44	6.090	0.000
					B	7.670	7.500	49.44	8.224	0.000	
					C	7.670	7.500	49.44	7.235	0.000	
T8 342.000-322.000	332.000	1.629	0.046	83.750	A	7.670	7.500	7.500	49.44	7.943	0.000
					B	7.670	7.500	49.44	8.224	0.000	
					C	7.670	7.500	49.44	8.186	0.000	
T9 322.000-302.000	312.000	1.608	0.045	84.167	A	7.228	8.333	8.333	53.55	8.270	0.000
					B	7.228	8.333	53.55	8.224	0.000	
					C	7.228	8.333	53.55	8.186	0.000	
T10 302.000-282.000	292.000	1.586	0.044	84.167	A	7.628	8.333	8.333	52.21	11.370	0.000
					B	7.628	8.333	52.21	8.224	0.000	
					C	7.628	8.333	52.21	8.627	0.000	
T11 282.000-262.000	272.000	1.562	0.044	84.583	A	8.697	9.167	9.167	51.31	43.914	0.000
					B	8.697	9.167	51.31	29.608	0.000	

tnxTower Vertical Bridge 750 Park of Commerce Drive Boca Raton, FL 33487 Phone: 561-948-6367 FAX:	Job US-CT-5009	Page 39 of 83
	Project Guyed Tower Structural Analysis	Date 11:53:35 05/29/20
	Client	Designed by JWagner

Section Elevation ft	z ft	K _Z	q _z ksf	A _G ft ²	F a c e	A _F ft ²	A _R ft ²	A _{leg} ft ²	Leg %	C _{AA} In Face ft ²	C _{AA} Out Face ft ²
00					C	8.697	9.167		51.31	13.010	0.000
T12	252.000	1.537	0.043	84.583	A	7.743	9.167	9.167	54.21	48.075	0.000
262.000-242.0					B	7.743	9.167		54.21	31.984	0.000
00					C	7.743	9.167		54.21	22.706	0.000
T13	232.000	1.511	0.042	84.583	A	7.586	9.167	9.167	54.72	51.563	0.000
242.000-222.0					B	7.586	9.167		54.72	31.984	0.000
00					C	7.586	9.167		54.72	25.806	0.000
T14	212.000	1.483	0.042	85.000	A	8.806	10.000	10.000	53.18	51.890	0.000
222.000-202.0					B	8.806	10.000		53.18	31.984	0.000
00					C	8.806	10.000		53.18	25.806	0.000
T15	192.000	1.452	0.041	85.000	A	7.544	10.000	10.000	57.00	51.890	0.000
202.000-182.0					B	7.544	10.000		57.00	31.984	0.000
00					C	7.544	10.000		57.00	25.806	0.000
T16	172.000	1.419	0.040	85.000	A	7.544	10.000	10.000	57.00	51.890	0.000
182.000-162.0					B	7.544	10.000		57.00	31.984	0.000
00					C	7.544	10.000		57.00	27.627	0.000
T17	152.000	1.382	0.039	85.000	A	7.701	10.000	10.000	56.50	51.890	0.000
162.000-142.0					B	7.701	10.000		56.50	31.984	0.000
00					C	7.701	10.000		56.50	37.946	0.000
T18	132.000	1.342	0.038	85.000	A	7.544	10.000	10.000	57.00	53.852	0.000
142.000-122.0					B	7.544	10.000		57.00	31.984	0.000
00					C	7.544	10.000		57.00	37.946	0.000
T19	117.000	1.308	0.037	42.500	A	4.316	5.000	5.000	53.67	28.125	0.000
122.000-112.0					B	4.316	5.000		53.67	15.992	0.000
00					C	4.316	5.000		53.67	18.973	0.000
T20	107.000	1.284	0.036	42.500	A	4.319	5.000	5.000	53.65	28.779	0.000
112.000-102.0					B	4.319	5.000		53.65	15.992	0.000
00					C	4.319	5.000		53.65	18.973	0.000
T21	92.000	1.244	0.035	85.000	A	7.701	10.000	10.000	56.50	58.430	0.000
102.000-82.0					B	7.701	10.000		56.50	31.984	0.000
0					C	7.701	10.000		56.50	37.946	0.000
T22	72.000	1.181	0.033	85.000	A	7.544	10.000	10.000	57.00	58.430	0.000
82.000-62.000					B	7.544	10.000		57.00	31.984	0.000
					C	7.544	10.000		57.00	37.946	0.000
T23	52.000	1.103	0.031	85.000	A	7.701	10.000	10.000	56.50	58.430	0.000
62.000-42.000					B	7.701	10.000		56.50	31.984	0.000
					C	7.701	10.000		56.50	37.946	0.000
T24	32.000	0.996	0.028	85.000	A	7.544	10.000	10.000	57.00	58.430	0.000
42.000-22.000					B	7.544	10.000		57.00	31.984	0.000
					C	7.544	10.000		57.00	37.946	0.000
T25	12.000	0.85	0.024	85.000	A	8.169	10.000	10.000	55.04	40.901	0.000
22.000-2.000					B	8.169	10.000		55.04	22.389	0.000
					C	8.169	10.000		55.04	26.562	0.000

Tower Pressure - With Ice

G_H = 0.850 (base tower), 1.350 (upper structure)

Section Elevation ft	z ft	K _Z	q _z ksf	t _z in	A _G ft ²	F a c e	A _F ft ²	A _R ft ²	A _{leg} ft ²	Leg %	C _{AA} In Face ft ²	C _{AA} Out Face ft ²
L1	484.500	1.764	0.009	1.3082	14.052	A	0.000	14.052	14.052	100.00	0.000	0.000
492.000-477.000						B	0.000	14.052		100.00	0.000	0.000
						C	0.000	14.052		100.00	0.000	0.000
L2	467.000	1.751	0.009	1.3034	18.720	A	0.000	18.720	18.720	100.00	0.000	0.000

tnxTower

Vertical Bridge
 750 Park of Commerce Drive
 Boca Raton, FL 33487
 Phone: 561-948-6367
 FAX:

Job	US-CT-5009	Page	40 of 83
Project	Guyed Tower Structural Analysis	Date	11:53:35 05/29/20
Client		Designed by	JWagner

Section Elevation ft	z ft	Kz	qz ksf	tz in	AG ft ²	F a c e	AF ft ²	AR ft ²	Aleg ft ²	Leg %	CAAA In Face ft ²	CAAA Out Face ft ²
477.000-457.000						B	0.000	18.720		100.00	0.000	0.000
						C	0.000	18.720		100.00	0.000	0.000
T1 457.000-452.000	454.500	1.741	0.009	1.2999	22.021	A	4.045	7.091	4.041	36.29	1.039	0.000
						B	4.045	7.091		36.29	0.000	0.000
						C	4.045	7.091		36.29	0.000	0.000
T2 452.000-442.000	447.000	1.735	0.009	1.2977	44.038	A	4.388	13.770	8.076	44.48	3.460	0.000
						B	4.388	13.770		44.48	0.000	0.000
						C	4.388	13.770		44.48	0.911	0.000
T3 442.000-422.000	432.000	1.722	0.009	1.2933	88.061	A	7.829	26.042	16.122	47.60	16.462	0.000
						B	7.829	26.042		47.60	12.071	0.000
						C	7.829	26.042		47.60	14.297	0.000
T4 422.000-402.000	412.000	1.705	0.009	1.2872	88.041	A	7.670	25.954	16.081	47.83	21.536	0.000
						B	7.670	25.954		47.83	18.521	0.000
						C	7.670	25.954		47.83	21.902	0.000
T5 402.000-382.000	392.000	1.687	0.009	1.2808	88.019	A	7.670	25.862	16.039	47.83	21.459	0.000
						B	7.670	25.862		47.83	18.470	0.000
						C	7.670	25.862		47.83	21.825	0.000
T6 382.000-362.000	372.000	1.669	0.009	1.2741	87.997	A	7.829	25.767	15.994	47.61	21.379	0.000
						B	7.829	25.767		47.61	18.417	0.000
						C	7.829	25.767		47.61	21.745	0.000
T7 362.000-342.000	352.000	1.65	0.009	1.2671	87.974	A	7.670	25.666	15.947	47.84	21.295	0.000
						B	7.670	25.666		47.84	18.361	0.000
						C	7.670	25.666		47.84	24.720	0.000
T8 342.000-322.000	332.000	1.629	0.009	1.2597	87.949	A	7.670	25.560	15.898	47.84	27.342	0.000
						B	7.670	25.560		47.84	18.301	0.000
						C	7.670	25.560		47.84	28.341	0.000
T9 322.000-302.000	312.000	1.608	0.009	1.2519	88.340	A	7.228	26.229	16.679	49.85	28.300	0.000
						B	7.228	26.229		49.85	18.239	0.000
						C	7.228	26.229		49.85	28.216	0.000
T10 302.000-282.000	292.000	1.586	0.008	1.2436	88.312	A	7.628	26.111	16.624	49.27	36.242	0.000
						B	7.628	26.111		49.27	18.173	0.000
						C	7.628	26.111		49.27	30.266	0.000
T11 282.000-262.000	272.000	1.562	0.008	1.2348	88.699	A	8.697	26.767	17.399	49.06	81.386	0.000
						B	8.697	26.767		49.06	41.921	0.000
						C	8.697	26.767		49.06	42.152	0.000
T12 262.000-242.000	252.000	1.537	0.008	1.2254	88.668	A	7.743	26.633	17.336	50.43	87.876	0.000
						B	7.743	26.633		50.43	44.427	0.000
						C	7.743	26.633		50.43	64.100	0.000
T13 242.000-222.000	232.000	1.511	0.008	1.2153	88.634	A	7.586	26.489	17.269	50.68	98.793	0.000
						B	7.586	26.489		50.68	44.275	0.000
						C	7.586	26.489		50.68	70.843	0.000
T14 222.000-202.000	212.000	1.483	0.008	1.2044	89.015	A	8.806	27.116	18.030	50.19	99.395	0.000
						B	8.806	27.116		50.19	44.111	0.000
						C	8.806	27.116		50.19	70.463	0.000
T15 202.000-182.000	192.000	1.452	0.008	1.1926	88.975	A	7.544	26.948	17.950	52.04	98.900	0.000
						B	7.544	26.948		52.04	43.933	0.000
						C	7.544	26.948		52.04	70.050	0.000
T16 182.000-162.000	172.000	1.419	0.008	1.1795	88.932	A	7.544	26.762	17.863	52.07	98.357	0.000
						B	7.544	26.762		52.07	43.737	0.000
						C	7.544	26.762		52.07	73.610	0.000
T17 162.000-142.000	152.000	1.382	0.007	1.1650	88.883	A	7.701	26.556	17.767	51.86	97.754	0.000
						B	7.701	26.556		51.86	43.520	0.000
						C	7.701	26.556		51.86	95.648	0.000
T18 142.000-122.000	132.000	1.342	0.007	1.1487	88.829	A	7.544	26.324	17.658	52.14	103.172	0.000
						B	7.544	26.324		52.14	43.275	0.000
						C	7.544	26.324		52.14	94.850	0.000
T19 122.000-112.000	117.000	1.308	0.007	1.1349	44.392	A	4.316	13.681	8.783	48.80	54.970	0.000
						B	4.316	13.681		48.80	21.534	0.000
						C	4.316	13.681		48.80	47.089	0.000
T20	107.000	1.284	0.007	1.1248	44.375	A	6.150	10.858	8.749	51.44	56.724	0.000

tnxTower Vertical Bridge 750 Park of Commerce Drive Boca Raton, FL 33487 Phone: 561-948-6367 FAX:	Job	US-CT-5009	Page	41 of 83
	Project	Guyed Tower Structural Analysis	Date	11:53:35 05/29/20
	Client		Designed by	JWagner

Section Elevation ft	z ft	K _Z	q _z ksf	t _z in	A _G ft ²	F a c e	A _F ft ²	A _R ft ²	A _{leg} ft ²	Leg %	C _{AA} In Face ft ²	C _{AA} Out Face ft ²
112.000-102.000						B	6.150	10.858		51.44	21.458	0.000
						C	6.150	10.858		51.44	46.842	0.000
T21	92.000	1.244	0.007	1.1080	88.693	A	7.701	25.745	17.386	51.98	115.215	0.000
102.000-82.000						B	7.701	25.745		51.98	42.664	0.000
						C	7.701	25.745		51.98	92.860	0.000
T22	72.000	1.181	0.006	1.0811	88.604	A	7.544	25.364	17.208	52.29	113.777	0.000
82.000-62.000						B	7.544	25.364		52.29	42.261	0.000
						C	7.544	25.364		52.29	91.548	0.000
T23	52.000	1.103	0.006	1.0465	88.488	A	7.701	24.872	16.977	52.12	111.922	0.000
62.000-42.000						B	7.701	24.872		52.12	41.742	0.000
						C	7.701	24.872		52.12	89.857	0.000
T24	32.000	0.996	0.005	0.9969	88.323	A	7.544	24.167	16.646	52.49	109.264	0.000
42.000-22.000						B	7.544	24.167		52.49	40.998	0.000
						C	7.544	24.167		52.49	87.434	0.000
T25	12.000	0.85	0.005	0.9038	88.013	A	8.169	23.409	16.025	50.75	72.993	0.000
22.000-2.000						B	8.169	23.409		50.75	27.721	0.000
						C	8.169	23.409		50.75	58.020	0.000

Tower Pressure - Service

G_H = 0.850 (base tower), 1.350 (upper structure)

Section Elevation ft	z ft	K _Z	q _z ksf	A _G ft ²	F a c e	A _F ft ²	A _R ft ²	A _{leg} ft ²	Leg %	C _{AA} In Face ft ²	C _{AA} Out Face ft ²
L1	484.500	1.764	0.013	10.781	A	0.000	10.781	10.781	100.00	0.000	0.000
492.000-477.000					B	0.000	10.781		100.00	0.000	0.000
					C	0.000	10.781		100.00	0.000	0.000
L2	467.000	1.751	0.013	14.375	A	0.000	14.375	14.375	100.00	0.000	0.000
477.000-457.000					B	0.000	14.375		100.00	0.000	0.000
					C	0.000	14.375		100.00	0.000	0.000
T1	454.500	1.741	0.013	20.938	A	4.045	1.875	1.875	31.67	0.260	0.000
457.000-452.000					B	4.045	1.875		31.67	0.000	0.000
					C	4.045	1.875		31.67	0.000	0.000
T2	447.000	1.735	0.013	41.875	A	4.388	3.750	3.750	46.08	0.865	0.000
452.000-442.000					B	4.388	3.750		46.08	0.000	0.000
					C	4.388	3.750		46.08	0.132	0.000
T3	432.000	1.722	0.013	83.750	A	7.829	7.500	7.500	48.93	4.564	0.000
442.000-422.000					B	7.829	7.500		48.93	5.346	0.000
					C	7.829	7.500		48.93	3.692	0.000
T4	412.000	1.705	0.013	83.750	A	7.670	7.500	7.500	49.44	6.090	0.000
422.000-402.000					B	7.670	7.500		49.44	8.224	0.000
					C	7.670	7.500		49.44	6.456	0.000
T5	392.000	1.687	0.013	83.750	A	7.670	7.500	7.500	49.44	6.090	0.000
402.000-382.000					B	7.670	7.500		49.44	8.224	0.000
					C	7.670	7.500		49.44	6.456	0.000
T6	372.000	1.669	0.013	83.750	A	7.829	7.500	7.500	48.93	6.090	0.000
382.000-362.000					B	7.829	7.500		48.93	8.224	0.000
					C	7.829	7.500		48.93	6.456	0.000
T7	352.000	1.65	0.013	83.750	A	7.670	7.500	7.500	49.44	6.090	0.000
362.000-342.000					B	7.670	7.500		49.44	8.224	0.000
					C	7.670	7.500		49.44	7.235	0.000
T8	332.000	1.629	0.012	83.750	A	7.670	7.500	7.500	49.44	7.943	0.000
342.000-322.000					B	7.670	7.500		49.44	8.224	0.000

tnxTower Vertical Bridge 750 Park of Commerce Drive Boca Raton, FL 33487 Phone: 561-948-6367 FAX:	Job	US-CT-5009	Page	42 of 83
	Project	Guyed Tower Structural Analysis	Date	11:53:35 05/29/20
	Client		Designed by	JWagner

Section Elevation ft	z ft	K _Z	q _z ksf	A _G ft ²	F a c e	A _F ft ²	A _R ft ²	A _{leg} ft ²	Leg %	C _{AA} In Face ft ²	C _{AA} Out Face ft ²
00					C	7.670	7.500		49.44	8.186	0.000
T9	312.000	1.608	0.012	84.167	A	7.228	8.333	8.333	53.55	8.270	0.000
322.000-302.0					B	7.228	8.333		53.55	8.224	0.000
00					C	7.228	8.333		53.55	8.186	0.000
T10	292.000	1.586	0.012	84.167	A	7.628	8.333	8.333	52.21	11.370	0.000
302.000-282.0					B	7.628	8.333		52.21	8.224	0.000
00					C	7.628	8.333		52.21	8.627	0.000
T11	272.000	1.562	0.012	84.583	A	8.697	9.167	9.167	51.31	43.914	0.000
282.000-262.0					B	8.697	9.167		51.31	29.608	0.000
00					C	8.697	9.167		51.31	13.010	0.000
T12	252.000	1.537	0.012	84.583	A	7.743	9.167	9.167	54.21	48.075	0.000
262.000-242.0					B	7.743	9.167		54.21	31.984	0.000
00					C	7.743	9.167		54.21	22.706	0.000
T13	232.000	1.511	0.012	84.583	A	7.586	9.167	9.167	54.72	51.563	0.000
242.000-222.0					B	7.586	9.167		54.72	31.984	0.000
00					C	7.586	9.167		54.72	25.806	0.000
T14	212.000	1.483	0.011	85.000	A	8.806	10.000	10.000	53.18	51.890	0.000
222.000-202.0					B	8.806	10.000		53.18	31.984	0.000
00					C	8.806	10.000		53.18	25.806	0.000
T15	192.000	1.452	0.011	85.000	A	7.544	10.000	10.000	57.00	51.890	0.000
202.000-182.0					B	7.544	10.000		57.00	31.984	0.000
00					C	7.544	10.000		57.00	25.806	0.000
T16	172.000	1.419	0.011	85.000	A	7.544	10.000	10.000	57.00	51.890	0.000
182.000-162.0					B	7.544	10.000		57.00	31.984	0.000
00					C	7.544	10.000		57.00	27.627	0.000
T17	152.000	1.382	0.011	85.000	A	7.701	10.000	10.000	56.50	51.890	0.000
162.000-142.0					B	7.701	10.000		56.50	31.984	0.000
00					C	7.701	10.000		56.50	37.946	0.000
T18	132.000	1.342	0.010	85.000	A	7.544	10.000	10.000	57.00	53.852	0.000
142.000-122.0					B	7.544	10.000		57.00	31.984	0.000
00					C	7.544	10.000		57.00	37.946	0.000
T19	117.000	1.308	0.010	42.500	A	4.316	5.000	5.000	53.67	28.125	0.000
122.000-112.0					B	4.316	5.000		53.67	15.992	0.000
00					C	4.316	5.000		53.67	18.973	0.000
T20	107.000	1.284	0.010	42.500	A	4.319	5.000	5.000	53.65	28.779	0.000
112.000-102.0					B	4.319	5.000		53.65	15.992	0.000
00					C	4.319	5.000		53.65	18.973	0.000
T21	92.000	1.244	0.009	85.000	A	7.701	10.000	10.000	56.50	58.430	0.000
102.000-82.0					B	7.701	10.000		56.50	31.984	0.000
0					C	7.701	10.000		56.50	37.946	0.000
T22	72.000	1.181	0.009	85.000	A	7.544	10.000	10.000	57.00	58.430	0.000
82.000-62.000					B	7.544	10.000		57.00	31.984	0.000
					C	7.544	10.000		57.00	37.946	0.000
T23	52.000	1.103	0.008	85.000	A	7.701	10.000	10.000	56.50	58.430	0.000
62.000-42.000					B	7.701	10.000		56.50	31.984	0.000
					C	7.701	10.000		56.50	37.946	0.000
T24	32.000	0.996	0.008	85.000	A	7.544	10.000	10.000	57.00	58.430	0.000
42.000-22.000					B	7.544	10.000		57.00	31.984	0.000
					C	7.544	10.000		57.00	37.946	0.000
T25	12.000	0.85	0.006	85.000	A	8.169	10.000	10.000	55.04	40.901	0.000
22.000-2.000					B	8.169	10.000		55.04	22.389	0.000
					C	8.169	10.000		55.04	26.562	0.000

Tower Forces - No Ice - Wind Normal To Face

tnxTower

Vertical Bridge
 750 Park of Commerce Drive
 Boca Raton, FL 33487
 Phone: 561-948-6367
 FAX:

Job	US-CT-5009	Page	43 of 83
Project	Guyed Tower Structural Analysis	Date	11:53:35 05/29/20
Client		Designed by	JWagner

Section Elevation	Add Weight	Self Weight	F a c e	e	C _F	q _z	D _F	D _R	A _E	F	w	Ctrl. Face
ft	K	K				ksf			ft ²	K	klf	
L1 492.000-477.0 00	0.000	0.535	A	1	0.6	0.049	1	1	10.781	0.432	0.029	C
			B	1	0.6		1	1	10.781			
			C	1	0.6		1	1	10.781			
L2 477.000-457.0 00	0.000	0.713	A	1	0.6	0.049	1	1	14.375	0.572	0.029	C
			B	1	0.6		1	1	14.375			
			C	1	0.6		1	1	14.375			
T1 457.000-452.0 00	0.000	0.418	A	0.283	2.343	0.049	1	1	5.158	0.508	0.102	C
			B	0.283	2.343		1	1	5.158			
			C	0.283	2.343		1	1	5.158			
T2 452.000-442.0 00	0.002	0.643	A	0.194	2.615	0.049	1	1	6.538	0.732	0.073	C
			B	0.194	2.615		1	1	6.538			
			C	0.194	2.615		1	1	6.538			
T3 442.000-422.0 00	0.055	1.341	A	0.183	2.654	0.048	1	1	12.117	1.719	0.086	C
			B	0.183	2.654		1	1	12.117			
			C	0.183	2.654		1	1	12.117			
T4 422.000-402.0 00	0.089	1.229	A	0.181	2.66	0.048	1	1	11.956	1.897	0.095	C
			B	0.181	2.66		1	1	11.956			
			C	0.181	2.66		1	1	11.956			
T5 402.000-382.0 00	0.089	1.229	A	0.181	2.66	0.047	1	1	11.956	1.877	0.094	C
			B	0.181	2.66		1	1	11.956			
			C	0.181	2.66		1	1	11.956			
T6 382.000-362.0 00	0.089	1.341	A	0.183	2.654	0.047	1	1	12.117	1.870	0.094	C
			B	0.183	2.654		1	1	12.117			
			C	0.183	2.654		1	1	12.117			
T7 362.000-342.0 00	0.091	1.229	A	0.181	2.66	0.046	1	1	11.956	1.853	0.093	C
			B	0.181	2.66		1	1	11.956			
			C	0.181	2.66		1	1	11.956			
T8 342.000-322.0 00	0.098	1.229	A	0.181	2.66	0.046	1	1	11.956	1.896	0.095	C
			B	0.181	2.66		1	1	11.956			
			C	0.181	2.66		1	1	11.956			
T9 322.000-302.0 00	0.099	1.440	A	0.185	2.647	0.045	1	1	11.994	1.877	0.094	C
			B	0.185	2.647		1	1	11.994			
			C	0.185	2.647		1	1	11.994			
T10 302.000-282.0 00	0.113	1.419	A	0.19	2.631	0.044	1	1	12.401	1.964	0.098	C
			B	0.19	2.631		1	1	12.401			
			C	0.19	2.631		1	1	12.401			
T11 282.000-262.0 00	0.354	1.858	A	0.211	2.559	0.044	1	1	13.982	2.922	0.146	A
			B	0.211	2.559		1	1	13.982			
			C	0.211	2.559		1	1	13.982			
T12 262.000-242.0 00	0.422	1.742	A	0.2	2.596	0.043	1	1	13.009	3.054	0.153	A
			B	0.2	2.596		1	1	13.009			
			C	0.2	2.596		1	1	13.009			
T13 242.000-222.0 00	0.446	1.629	A	0.198	2.602	0.042	1	1	12.849	3.113	0.156	A
			B	0.198	2.602		1	1	12.849			
			C	0.198	2.602		1	1	12.849			
T14 222.000-202.0 00	0.447	2.201	A	0.221	2.527	0.042	1	1	14.591	3.182	0.159	A
			B	0.221	2.527		1	1	14.591			
			C	0.221	2.527		1	1	14.591			
T15 202.000-182.0 00	0.447	1.860	A	0.206	2.575	0.041	1	1	13.301	3.026	0.151	A
			B	0.206	2.575		1	1	13.301			
			C	0.206	2.575		1	1	13.301			
T16 182.000-162.0 00	0.450	1.860	A	0.206	2.575	0.040	1	1	13.301	2.976	0.149	A
			B	0.206	2.575		1	1	13.301			
			C	0.206	2.575		1	1	13.301			
T17 162.000-142.0 00	0.468	1.972	A	0.208	2.569	0.039	1	1	13.460	3.015	0.151	A
			B	0.208	2.569		1	1	13.460			
			C	0.208	2.569		1	1	13.460			
T18 142.000-122.0 00	0.474	1.860	A	0.206	2.575	0.038	1	1	13.301	2.954	0.148	A
			B	0.206	2.575		1	1	13.301			
			C	0.206	2.575		1	1	13.301			

tnxTower Vertical Bridge 750 Park of Commerce Drive Boca Raton, FL 33487 Phone: 561-948-6367 FAX:	Job	US-CT-5009	Page	44 of 83
	Project	Guyed Tower Structural Analysis	Date	11:53:35 05/29/20
	Client		Designed by	JWagner

Section Elevation ft	Add Weight K	Self Weight K	F a c e	e	C _F	q _z ksf	D _F	D _R	A _E ft ²	F K	w klf	Ctrl. Face
T19 122.000-112.000	0.241	0.959	A	0.219	2.533	0.037	1	1	7.206	1.498	0.150	A
			B	0.219	2.533		1	1	7.206			
			C	0.219	2.533		1	1	7.206			
T20 112.000-102.000	0.243	1.060	A	0.219	2.533	0.036	1	1	7.210	1.482	0.148	A
			B	0.219	2.533		1	1	7.210			
			C	0.219	2.533		1	1	7.210			
T21 102.000-82.000	0.488	1.972	A	0.208	2.569	0.035	1	1	13.460	2.829	0.141	A
			B	0.208	2.569		1	1	13.460			
			C	0.208	2.569		1	1	13.460			
T22 82.000-62.000	0.488	1.860	A	0.206	2.575	0.033	1	1	13.301	2.610	0.130	A
			B	0.206	2.575		1	1	13.301			
			C	0.206	2.575		1	1	13.301			
T23 62.000-42.000	0.488	1.972	A	0.208	2.569	0.031	1	1	13.460	2.446	0.122	A
			B	0.208	2.569		1	1	13.460			
			C	0.208	2.569		1	1	13.460			
T24 42.000-22.000	0.488	1.860	A	0.206	2.575	0.028	1	1	13.301	2.200	0.110	A
			B	0.206	2.575		1	1	13.301			
			C	0.206	2.575		1	1	13.301			
T25 22.000-2.000	0.342	1.889	A	0.214	2.551	0.024	1	1	13.940	1.549	0.077	A
			B	0.214	2.551		1	1	13.940			
			C	0.214	2.551		1	1	13.940			
Sum Weight:	7.012	39.321								56.053		

Tower Forces - No Ice - Wind 60 To Face

Section Elevation ft	Add Weight K	Self Weight K	F a c e	e	C _F	q _z ksf	D _F	D _R	A _E ft ²	F K	w klf	Ctrl. Face
L1 492.000-477.000	0.000	0.535	A	1	0.6	0.049	1	1	10.781	0.432	0.029	C
			B	1	0.6		1	1	10.781			
			C	1	0.6		1	1	10.781			
L2 477.000-457.000	0.000	0.713	A	1	0.6	0.049	1	1	14.375	0.572	0.029	C
			B	1	0.6		1	1	14.375			
			C	1	0.6		1	1	14.375			
T1 457.000-452.000	0.000	0.418	A	0.283	2.343	0.049	0.8	1	4.349	0.429	0.086	C
			B	0.283	2.343		0.8	1	4.349			
			C	0.283	2.343		0.8	1	4.349			
T2 452.000-442.000	0.002	0.643	A	0.194	2.615	0.049	0.8	1	5.661	0.637	0.064	C
			B	0.194	2.615		0.8	1	5.661			
			C	0.194	2.615		0.8	1	5.661			
T3 442.000-422.000	0.055	1.341	A	0.183	2.654	0.048	0.8	1	10.551	1.548	0.077	C
			B	0.183	2.654		0.8	1	10.551			
			C	0.183	2.654		0.8	1	10.551			
T4 422.000-402.000	0.089	1.229	A	0.181	2.66	0.048	0.8	1	10.422	1.731	0.087	C
			B	0.181	2.66		0.8	1	10.422			
			C	0.181	2.66		0.8	1	10.422			
T5 402.000-382.000	0.089	1.229	A	0.181	2.66	0.047	0.8	1	10.422	1.713	0.086	C
			B	0.181	2.66		0.8	1	10.422			
			C	0.181	2.66		0.8	1	10.422			
T6 382.000-362.000	0.089	1.341	A	0.183	2.654	0.047	0.8	1	10.551	1.705	0.085	C
			B	0.183	2.654		0.8	1	10.551			
			C	0.183	2.654		0.8	1	10.551			
T7	0.091	1.229	A	0.181	2.66	0.046	0.8	1	10.422	1.693	0.085	C

tnxTower

Vertical Bridge
 750 Park of Commerce Drive
 Boca Raton, FL 33487
 Phone: 561-948-6367
 FAX:

Job	US-CT-5009	Page	45 of 83
Project	Guyed Tower Structural Analysis	Date	11:53:35 05/29/20
Client		Designed by	JWagner

Section Elevation ft	Add Weight K	Self Weight K	F a c e	e	C _F	q _z ksf	D _F	D _R	A _E ft ²	F K	w klf	Ctrl. Face
362.000-342.000			B	0.181	2.66		0.8	1	10.422			
00			C	0.181	2.66		0.8	1	10.422			
T8	0.098	1.229	A	0.181	2.66	0.046	0.8	1	10.422	1.738	0.087	C
342.000-322.000			B	0.181	2.66		0.8	1	10.422			
00			C	0.181	2.66		0.8	1	10.422			
T9	0.099	1.440	A	0.185	2.647	0.045	0.8	1	10.549	1.730	0.087	C
322.000-302.000			B	0.185	2.647		0.8	1	10.549			
00			C	0.185	2.647		0.8	1	10.549			
T10	0.113	1.419	A	0.19	2.631	0.044	0.8	1	10.875	1.813	0.091	C
302.000-282.000			B	0.19	2.631		0.8	1	10.875			
00			C	0.19	2.631		0.8	1	10.875			
T11	0.354	1.858	A	0.211	2.559	0.044	0.8	1	12.243	2.757	0.138	B
282.000-262.000			B	0.211	2.559		0.8	1	12.243			
00			C	0.211	2.559		0.8	1	12.243			
T12	0.422	1.742	A	0.2	2.596	0.043	0.8	1	11.461	2.907	0.145	B
262.000-242.000			B	0.2	2.596		0.8	1	11.461			
00			C	0.2	2.596		0.8	1	11.461			
T13	0.446	1.629	A	0.198	2.602	0.042	0.8	1	11.332	2.971	0.149	B
242.000-222.000			B	0.198	2.602		0.8	1	11.332			
00			C	0.198	2.602		0.8	1	11.332			
T14	0.447	2.201	A	0.221	2.527	0.042	0.8	1	12.830	3.025	0.151	B
222.000-202.000			B	0.221	2.527		0.8	1	12.830			
00			C	0.221	2.527		0.8	1	12.830			
T15	0.447	1.860	A	0.206	2.575	0.041	0.8	1	11.792	2.892	0.145	B
202.000-182.000			B	0.206	2.575		0.8	1	11.792			
00			C	0.206	2.575		0.8	1	11.792			
T16	0.450	1.860	A	0.206	2.575	0.040	0.8	1	11.792	2.845	0.142	B
182.000-162.000			B	0.206	2.575		0.8	1	11.792			
00			C	0.206	2.575		0.8	1	11.792			
T17	0.468	1.972	A	0.208	2.569	0.039	0.8	1	11.920	2.885	0.144	B
162.000-142.000			B	0.208	2.569		0.8	1	11.920			
00			C	0.208	2.569		0.8	1	11.920			
T18	0.474	1.860	A	0.206	2.575	0.038	0.8	1	11.792	2.830	0.141	B
142.000-122.000			B	0.206	2.575		0.8	1	11.792			
00			C	0.206	2.575		0.8	1	11.792			
T19	0.241	0.959	A	0.219	2.533	0.037	0.8	1	6.343	1.430	0.143	B
122.000-112.000			B	0.219	2.533		0.8	1	6.343			
00			C	0.219	2.533		0.8	1	6.343			
T20	0.243	1.060	A	0.219	2.533	0.036	0.8	1	6.346	1.415	0.142	B
112.000-102.000			B	0.219	2.533		0.8	1	6.346			
00			C	0.219	2.533		0.8	1	6.346			
T21	0.488	1.972	A	0.208	2.569	0.035	0.8	1	11.920	2.712	0.136	B
102.000-82.000			B	0.208	2.569		0.8	1	11.920			
0			C	0.208	2.569		0.8	1	11.920			
T22	0.488	1.860	A	0.206	2.575	0.033	0.8	1	11.792	2.500	0.125	B
82.000-62.000			B	0.206	2.575		0.8	1	11.792			
00			C	0.206	2.575		0.8	1	11.792			
T23	0.488	1.972	A	0.208	2.569	0.031	0.8	1	11.920	2.342	0.117	B
62.000-42.000			B	0.208	2.569		0.8	1	11.920			
00			C	0.208	2.569		0.8	1	11.920			
T24	0.488	1.860	A	0.206	2.575	0.028	0.8	1	11.792	2.108	0.105	B
42.000-22.000			B	0.206	2.575		0.8	1	11.792			
00			C	0.206	2.575		0.8	1	11.792			
T25	0.342	1.889	A	0.214	2.551	0.024	0.8	1	12.306	1.465	0.073	B
22.000-2.000			B	0.214	2.551		0.8	1	12.306			
00			C	0.214	2.551		0.8	1	12.306			
Sum Weight:	7.012	39.321								52.822		

tnxTower Vertical Bridge 750 Park of Commerce Drive Boca Raton, FL 33487 Phone: 561-948-6367 FAX:	Job US-CT-5009	Page 46 of 83
	Project Guyed Tower Structural Analysis	Date 11:53:35 05/29/20
	Client	Designed by JWagner

Tower Forces - No Ice - Wind 90 To Face

Section Elevation	Add Weight	Self Weight	F a c e	e	C _F	q _z	D _F	D _R	A _E	F	w	Ctrl. Face
ft	K	K				ksf			ft ²	K	klf	
L1 492.000-477.000	0.000	0.535	A B C	1 1 1	0.6 0.6 0.6	0.049	1 1 1	1 1 1	10.781 10.781 10.781	0.432	0.029	C
L2 477.000-457.000	0.000	0.713	A B C	1 1 1	0.6 0.6 0.6	0.049	1 1 1	1 1 1	14.375 14.375 14.375	0.572	0.029	C
T1 457.000-452.000	0.000	0.418	A B C	0.283 0.283 0.283	2.343 2.343 2.343	0.049	0.85 0.85 0.85	1 1 1	4.551 4.551 4.551	0.449	0.090	C
T2 452.000-442.000	0.002	0.643	A B C	0.194 0.194 0.194	2.615 2.615 2.615	0.049	0.85 0.85 0.85	1 1 1	5.880 5.880 5.880	0.660	0.066	C
T3 442.000-422.000	0.055	1.341	A B C	0.183 0.183 0.183	2.654 2.654 2.654	0.048	0.85 0.85 0.85	1 1 1	10.943 10.943 10.943	1.591	0.080	C
T4 422.000-402.000	0.089	1.229	A B C	0.181 0.181 0.181	2.66 2.66 2.66	0.048	0.85 0.85 0.85	1 1 1	10.805 10.805 10.805	1.772	0.089	C
T5 402.000-382.000	0.089	1.229	A B C	0.181 0.181 0.181	2.66 2.66 2.66	0.047	0.85 0.85 0.85	1 1 1	10.805 10.805 10.805	1.754	0.088	C
T6 382.000-362.000	0.089	1.341	A B C	0.183 0.183 0.183	2.654 2.654 2.654	0.047	0.85 0.85 0.85	1 1 1	10.943 10.943 10.943	1.746	0.087	C
T7 362.000-342.000	0.091	1.229	A B C	0.181 0.181 0.181	2.66 2.66 2.66	0.046	0.85 0.85 0.85	1 1 1	10.805 10.805 10.805	1.733	0.087	C
T8 342.000-322.000	0.098	1.229	A B C	0.181 0.181 0.181	2.66 2.66 2.66	0.046	0.85 0.85 0.85	1 1 1	10.805 10.805 10.805	1.777	0.089	C
T9 322.000-302.000	0.099	1.440	A B C	0.185 0.185 0.185	2.647 2.647 2.647	0.045	0.85 0.85 0.85	1 1 1	10.910 10.910 10.910	1.767	0.088	C
T10 302.000-282.000	0.113	1.419	A B C	0.19 0.19 0.19	2.631 2.631 2.631	0.044	0.85 0.85 0.85	1 1 1	11.257 11.257 11.257	1.850	0.093	C
T11 282.000-262.000	0.354	1.858	A B C	0.211 0.211 0.211	2.559 2.559 2.559	0.044	0.85 0.85 0.85	1 1 1	12.678 12.678 12.678	2.823	0.141	C
T12 262.000-242.000	0.422	1.742	A B C	0.2 0.2 0.2	2.596 2.596 2.596	0.043	0.85 0.85 0.85	1 1 1	11.848 11.848 11.848	2.947	0.147	B
T13 242.000-222.000	0.446	1.629	A B C	0.198 0.198 0.198	2.602 2.602 2.602	0.042	0.85 0.85 0.85	1 1 1	11.711 11.711 11.711	3.028	0.151	B
T14 222.000-202.000	0.447	2.201	A B C	0.221 0.221 0.221	2.527 2.527 2.527	0.042	0.85 0.85 0.85	1 1 1	13.270 13.270 13.270	3.086	0.154	B
T15 202.000-182.000	0.447	1.860	A B C	0.206 0.206 0.206	2.575 2.575 2.575	0.041	0.85 0.85 0.85	1 1 1	12.169 12.169 12.169	2.946	0.147	B
T16 182.000-162.000	0.450	1.860	A B C	0.206 0.206 0.206	2.575 2.575 2.575	0.040	0.85 0.85 0.85	1 1 1	12.169 12.169 12.169	2.902	0.145	B

tnxTower Vertical Bridge 750 Park of Commerce Drive Boca Raton, FL 33487 Phone: 561-948-6367 FAX:	Job	US-CT-5009	Page	47 of 83
	Project	Guyed Tower Structural Analysis	Date	11:53:35 05/29/20
	Client		Designed by	JWagner

Section Elevation ft	Add Weight K	Self Weight K	F a c e	e	C _F	q _z ksf	D _F	D _R	A _E ft ²	F K	w klf	Ctrl. Face
T17 162.000-142.000	0.468	1.972	A	0.208	2.569	0.039	0.85	1	12.305	2.966	0.148	B
			B	0.208	2.569		0.85	1	12.305			
			C	0.208	2.569		0.85	1	12.305			
T18 142.000-122.000	0.474	1.860	A	0.206	2.575	0.038	0.85	1	12.169	2.908	0.145	B
			B	0.206	2.575		0.85	1	12.169			
			C	0.206	2.575		0.85	1	12.169			
T19 122.000-112.000	0.241	0.959	A	0.219	2.533	0.037	0.85	1	6.559	1.470	0.147	B
			B	0.219	2.533		0.85	1	6.559			
			C	0.219	2.533		0.85	1	6.559			
T20 112.000-102.000	0.243	1.060	A	0.219	2.533	0.036	0.85	1	6.562	1.455	0.145	B
			B	0.219	2.533		0.85	1	6.562			
			C	0.219	2.533		0.85	1	6.562			
T21 102.000-82.000	0.488	1.972	A	0.208	2.569	0.035	0.85	1	12.305	2.785	0.139	B
			B	0.208	2.569		0.85	1	12.305			
			C	0.208	2.569		0.85	1	12.305			
T22 82.000-62.000	0.488	1.860	A	0.206	2.575	0.033	0.85	1	12.169	2.569	0.128	B
			B	0.206	2.575		0.85	1	12.169			
			C	0.206	2.575		0.85	1	12.169			
T23 62.000-42.000	0.488	1.972	A	0.208	2.569	0.031	0.85	1	12.305	2.407	0.120	B
			B	0.208	2.569		0.85	1	12.305			
			C	0.208	2.569		0.85	1	12.305			
T24 42.000-22.000	0.488	1.860	A	0.206	2.575	0.028	0.85	1	12.169	2.166	0.108	B
			B	0.206	2.575		0.85	1	12.169			
			C	0.206	2.575		0.85	1	12.169			
T25 22.000-2.000	0.342	1.889	A	0.214	2.551	0.024	0.85	1	12.714	1.507	0.075	B
			B	0.214	2.551		0.85	1	12.714			
			C	0.214	2.551		0.85	1	12.714			
Sum Weight:	7.012	39.321								54.071		

Tower Forces - With Ice - Wind Normal To Face

Section Elevation ft	Add Weight K	Self Weight K	F a c e	e	C _F	q _z ksf	D _F	D _R	A _E ft ²	F K	w klf	Ctrl. Face
L1 492.000-477.000	0.000	0.773	A	1	1.2	0.009	1	1	14.052	0.213	0.014	C
			B	1	1.2		1	1	14.052			
			C	1	1.2		1	1	14.052			
L2 477.000-457.000	0.000	1.030	A	1	1.2	0.009	1	1	18.720	0.281	0.014	C
			B	1	1.2		1	1	18.720			
			C	1	1.2		1	1	18.720			
T1 457.000-452.000	0.011	0.879	A	0.506	1.893	0.009	1	1	8.925	0.137	0.027	C
			B	0.506	1.893		1	1	8.925			
			C	0.506	1.893		1	1	8.925			
T2 452.000-442.000	0.044	1.354	A	0.412	2.04	0.009	1	1	13.223	0.231	0.023	C
			B	0.412	2.04		1	1	13.223			
			C	0.412	2.04		1	1	13.223			
T3 442.000-422.000	0.501	2.666	A	0.385	2.095	0.009	1	1	24.228	0.593	0.030	C
			B	0.385	2.095		1	1	24.228			
			C	0.385	2.095		1	1	24.228			
T4 422.000-402.000	0.740	2.500	A	0.382	2.101	0.009	1	1	23.985	0.673	0.034	C
			B	0.382	2.101		1	1	23.985			
			C	0.382	2.101		1	1	23.985			
T5 402.000-382.000	0.735	2.491	A	0.381	2.103	0.009	1	1	23.917	0.664	0.033	C

tnxTower

Vertical Bridge
 750 Park of Commerce Drive
 Boca Raton, FL 33487
 Phone: 561-948-6367
 FAX:

Job	US-CT-5009	Page	48 of 83
Project	Guyed Tower Structural Analysis	Date	11:53:35 05/29/20
Client		Designed by	JWagner

Section Elevation ft	Add Weight K	Self Weight K	F a c e	e	C _F	q _z ksf	D _F	D _R	A _E ft ²	F K	w klf	Ctrl. Face
402.000-382.000			B	0.381	2.103		1	1	23.917			
00			C	0.381	2.103		1	1	23.917			
T6	0.730	2.640	A	0.382	2.101	0.009	1	1	24.024	0.657	0.033	C
382.000-362.000			B	0.382	2.101		1	1	24.024			
00			C	0.382	2.101		1	1	24.024			
T7	0.756	2.474	A	0.379	2.107	0.009	1	1	23.772	0.659	0.033	C
362.000-342.000			B	0.379	2.107		1	1	23.772			
00			C	0.379	2.107		1	1	23.772			
T8	0.855	2.464	A	0.378	2.11	0.009	1	1	23.694	0.693	0.035	C
342.000-322.000			B	0.378	2.11		1	1	23.694			
00			C	0.378	2.11		1	1	23.694			
T9	0.859	2.687	A	0.379	2.108	0.009	1	1	23.681	0.687	0.034	C
322.000-302.000			B	0.379	2.108		1	1	23.681			
00			C	0.379	2.108		1	1	23.681			
T10	0.971	2.656	A	0.382	2.101	0.008	1	1	24.043	0.724	0.036	C
302.000-282.000			B	0.382	2.101		1	1	24.043			
00			C	0.382	2.101		1	1	24.043			
T11	1.933	3.197	A	0.4	2.064	0.008	1	1	25.725	1.009	0.050	A
282.000-262.000			B	0.4	2.064		1	1	25.725			
00			C	0.4	2.064		1	1	25.725			
T12	2.253	3.022	A	0.388	2.089	0.008	1	1	24.549	1.076	0.054	A
262.000-242.000			B	0.388	2.089		1	1	24.549			
00			C	0.388	2.089		1	1	24.549			
T13	2.425	2.852	A	0.384	2.096	0.008	1	1	24.265	1.117	0.056	A
242.000-222.000			B	0.384	2.096		1	1	24.265			
00			C	0.384	2.096		1	1	24.265			
T14	2.412	3.563	A	0.404	2.057	0.008	1	1	26.100	1.111	0.056	A
222.000-202.000			B	0.404	2.057		1	1	26.100			
00			C	0.404	2.057		1	1	26.100			
T15	2.387	3.075	A	0.388	2.089	0.008	1	1	24.548	1.073	0.054	A
202.000-182.000			B	0.388	2.089		1	1	24.548			
00			C	0.388	2.089		1	1	24.548			
T16	2.387	3.058	A	0.386	2.093	0.008	1	1	24.410	1.053	0.053	A
182.000-162.000			B	0.386	2.093		1	1	24.410			
00			C	0.386	2.093		1	1	24.410			
T17	2.515	3.193	A	0.385	2.094	0.007	1	1	24.432	1.079	0.054	A
162.000-142.000			B	0.385	2.094		1	1	24.432			
00			C	0.385	2.094		1	1	24.432			
T18	2.540	3.018	A	0.381	2.102	0.007	1	1	24.085	1.061	0.053	A
142.000-122.000			B	0.381	2.102		1	1	24.085			
00			C	0.381	2.102		1	1	24.085			
T19	1.291	1.586	A	0.405	2.053	0.007	1	1	13.052	0.533	0.053	A
122.000-112.000			B	0.405	2.053		1	1	13.052			
00			C	0.405	2.053		1	1	13.052			
T20	1.299	1.590	A	0.383	2.098	0.007	1	1	12.981	0.534	0.053	A
112.000-102.000			B	0.383	2.098		1	1	12.981			
00			C	0.383	2.098		1	1	12.981			
T21	2.583	3.117	A	0.377	2.111	0.007	1	1	23.834	1.015	0.051	A
102.000-82.000			B	0.377	2.111		1	1	23.834			
0			C	0.377	2.111		1	1	23.834			
T22	2.517	2.931	A	0.371	2.123	0.006	1	1	23.380	0.951	0.048	A
82.000-62.000			B	0.371	2.123		1	1	23.380			
00			C	0.371	2.123		1	1	23.380			
T23	2.433	3.038	A	0.368	2.131	0.006	1	1	23.197	0.876	0.044	A
62.000-42.000			B	0.368	2.131		1	1	23.197			
00			C	0.368	2.131		1	1	23.197			
T24	2.315	2.827	A	0.359	2.151	0.005	1	1	22.516	0.772	0.039	A
42.000-22.000			B	0.359	2.151		1	1	22.516			
00			C	0.359	2.151		1	1	22.516			
T25	1.471	2.794	A	0.359	2.151	0.005	1	1	22.669	0.503	0.025	A

tnxTower Vertical Bridge 750 Park of Commerce Drive Boca Raton, FL 33487 Phone: 561-948-6367 FAX:	Job	US-CT-5009	Page	49 of 83
	Project	Guyed Tower Structural Analysis	Date	11:53:35 05/29/20
	Client		Designed by	JWagner

Section Elevation	Add Weight	Self Weight	F a c e	e	C _F	q _z	D _F	D _R	A _E	F	w	Ctrl. Face
ft	K	K				ksf			ft ²	K	klf	
22.000-2.000			B	0.359	2.151		1	1	22.669			
			C	0.359	2.151		1	1	22.669			
Sum Weight:	38.962	67.476								19.975		

Tower Forces - With Ice - Wind 60 To Face

Section Elevation	Add Weight	Self Weight	F a c e	e	C _F	q _z	D _F	D _R	A _E	F	w	Ctrl. Face
ft	K	K				ksf			ft ²	K	klf	
L1	0.000	0.773	A	1	1.2	0.009	1	1	14.052	0.213	0.014	C
492.000-477.0			B	1	1.2		1	1	14.052			
00			C	1	1.2		1	1	14.052			
L2	0.000	1.030	A	1	1.2	0.009	1	1	18.720	0.281	0.014	C
477.000-457.0			B	1	1.2		1	1	18.720			
00			C	1	1.2		1	1	18.720			
T1	0.011	0.879	A	0.506	1.893	0.009	0.8	1	8.116	0.124	0.025	C
457.000-452.0			B	0.506	1.893		0.8	1	8.116			
00			C	0.506	1.893		0.8	1	8.116			
T2	0.044	1.354	A	0.412	2.04	0.009	0.8	1	12.345	0.217	0.022	C
452.000-442.0			B	0.412	2.04		0.8	1	12.345			
00			C	0.412	2.04		0.8	1	12.345			
T3	0.501	2.666	A	0.385	2.095	0.009	0.8	1	22.662	0.568	0.028	C
442.000-422.0			B	0.385	2.095		0.8	1	22.662			
00			C	0.385	2.095		0.8	1	22.662			
T4	0.740	2.500	A	0.382	2.101	0.009	0.8	1	22.451	0.648	0.032	C
422.000-402.0			B	0.382	2.101		0.8	1	22.451			
00			C	0.382	2.101		0.8	1	22.451			
T5	0.735	2.491	A	0.381	2.103	0.009	0.8	1	22.383	0.640	0.032	C
402.000-382.0			B	0.381	2.103		0.8	1	22.383			
00			C	0.381	2.103		0.8	1	22.383			
T6	0.730	2.640	A	0.382	2.101	0.009	0.8	1	22.459	0.632	0.032	C
382.000-362.0			B	0.382	2.101		0.8	1	22.459			
00			C	0.382	2.101		0.8	1	22.459			
T7	0.756	2.474	A	0.379	2.107	0.009	0.8	1	22.238	0.635	0.032	C
362.000-342.0			B	0.379	2.107		0.8	1	22.238			
00			C	0.379	2.107		0.8	1	22.238			
T8	0.855	2.464	A	0.378	2.11	0.009	0.8	1	22.160	0.669	0.033	C
342.000-322.0			B	0.378	2.11		0.8	1	22.160			
00			C	0.378	2.11		0.8	1	22.160			
T9	0.859	2.687	A	0.379	2.108	0.009	0.8	1	22.235	0.665	0.033	C
322.000-302.0			B	0.379	2.108		0.8	1	22.235			
00			C	0.379	2.108		0.8	1	22.235			
T10	0.971	2.656	A	0.382	2.101	0.008	0.8	1	22.517	0.701	0.035	C
302.000-282.0			B	0.382	2.101		0.8	1	22.517			
00			C	0.382	2.101		0.8	1	22.517			
T11	1.933	3.197	A	0.4	2.064	0.008	0.8	1	23.986	0.983	0.049	B
282.000-262.0			B	0.4	2.064		0.8	1	23.986			
00			C	0.4	2.064		0.8	1	23.986			
T12	2.253	3.022	A	0.388	2.089	0.008	0.8	1	23.000	1.053	0.053	B
262.000-242.0			B	0.388	2.089		0.8	1	23.000			
00			C	0.388	2.089		0.8	1	23.000			
T13	2.425	2.852	A	0.384	2.096	0.008	0.8	1	22.748	1.096	0.055	B
242.000-222.0			B	0.384	2.096		0.8	1	22.748			

tnxTower Vertical Bridge 750 Park of Commerce Drive Boca Raton, FL 33487 Phone: 561-948-6367 FAX:	Job	US-CT-5009	Page	50 of 83
	Project	Guyed Tower Structural Analysis	Date	11:53:35 05/29/20
	Client		Designed by	JWagner

Section Elevation	Add Weight	Self Weight	F a c e	e	C _F	q _z	D _F	D _R	A _E	F	w	Ctrl. Face
ft	K	K				ksf			ft ²	K	klf	
00			C	0.384	2.096		0.8	1	22.748			
T14	2.412	3.563	A	0.404	2.057	0.008	0.8	1	24.339	1.087	0.054	B
222.000-202.0			B	0.404	2.057		0.8	1	24.339			
00			C	0.404	2.057		0.8	1	24.339			
T15	2.387	3.075	A	0.388	2.089	0.008	0.8	1	23.039	1.052	0.053	B
202.000-182.0			B	0.388	2.089		0.8	1	23.039			
00			C	0.388	2.089		0.8	1	23.039			
T16	2.387	3.058	A	0.386	2.093	0.008	0.8	1	22.901	1.033	0.052	B
182.000-162.0			B	0.386	2.093		0.8	1	22.901			
00			C	0.386	2.093		0.8	1	22.901			
T17	2.515	3.193	A	0.385	2.094	0.007	0.8	1	22.892	1.059	0.053	B
162.000-142.0			B	0.385	2.094		0.8	1	22.892			
00			C	0.385	2.094		0.8	1	22.892			
T18	2.540	3.018	A	0.381	2.102	0.007	0.8	1	22.576	1.042	0.052	B
142.000-122.0			B	0.381	2.102		0.8	1	22.576			
00			C	0.381	2.102		0.8	1	22.576			
T19	1.291	1.586	A	0.405	2.053	0.007	0.8	1	12.189	0.523	0.052	B
122.000-112.0			B	0.405	2.053		0.8	1	12.189			
00			C	0.405	2.053		0.8	1	12.189			
T20	1.299	1.590	A	0.383	2.098	0.007	0.8	1	11.751	0.519	0.052	B
112.000-102.0			B	0.383	2.098		0.8	1	11.751			
00			C	0.383	2.098		0.8	1	11.751			
T21	2.583	3.117	A	0.377	2.111	0.007	0.8	1	22.293	0.996	0.050	B
102.000-82.0			B	0.377	2.111		0.8	1	22.293			
0			C	0.377	2.111		0.8	1	22.293			
T22	2.517	2.931	A	0.371	2.123	0.006	0.8	1	21.871	0.934	0.047	B
82.000-62.000			B	0.371	2.123		0.8	1	21.871			
			C	0.371	2.123		0.8	1	21.871			
T23	2.433	3.038	A	0.368	2.131	0.006	0.8	1	21.657	0.860	0.043	B
62.000-42.000			B	0.368	2.131		0.8	1	21.657			
			C	0.368	2.131		0.8	1	21.657			
T24	2.315	2.827	A	0.359	2.151	0.005	0.8	1	21.007	0.758	0.038	B
42.000-22.000			B	0.359	2.151		0.8	1	21.007			
			C	0.359	2.151		0.8	1	21.007			
T25	1.471	2.794	A	0.359	2.151	0.005	0.8	1	21.035	0.489	0.024	B
22.000-2.000			B	0.359	2.151		0.8	1	21.035			
			C	0.359	2.151		0.8	1	21.035			
Sum Weight:	38.962	67.476								19.478		

Tower Forces - With Ice - Wind 90 To Face

Section Elevation	Add Weight	Self Weight	F a c e	e	C _F	q _z	D _F	D _R	A _E	F	w	Ctrl. Face
ft	K	K				ksf			ft ²	K	klf	
L1	0.000	0.773	A	1	1.2	0.009	1	1	14.052	0.213	0.014	C
492.000-477.0			B	1	1.2		1	1	14.052			
00			C	1	1.2		1	1	14.052			
L2	0.000	1.030	A	1	1.2	0.009	1	1	18.720	0.281	0.014	C
477.000-457.0			B	1	1.2		1	1	18.720			
00			C	1	1.2		1	1	18.720			
T1	0.011	0.879	A	0.506	1.893	0.009	0.85	1	8.318	0.127	0.025	C
457.000-452.0			B	0.506	1.893		0.85	1	8.318			
00			C	0.506	1.893		0.85	1	8.318			

Job	US-CT-5009	Page	51 of 83
Project	Guyed Tower Structural Analysis	Date	11:53:35 05/29/20
Client		Designed by	JWagner

Section Elevation	Add Weight	Self Weight	F a c e	e	C _F	q _z	D _F	D _R	A _E	F	w	Ctrl. Face
ft	K	K				ksf			ft ²	K	klf	
T2 452.000-442.000	0.044	1.354	A B C	0.412 0.412 0.412	2.04 2.04 2.04	0.009	0.85 0.85 0.85	1 1 1	12.565 12.565 12.565	0.220	0.022	C
T3 442.000-422.000	0.501	2.666	A B C	0.385 0.385 0.385	2.095 2.095 2.095	0.009	0.85 0.85 0.85	1 1 1	23.054 23.054 23.054	0.574	0.029	C
T4 422.000-402.000	0.740	2.500	A B C	0.382 0.382 0.382	2.101 2.101 2.101	0.009	0.85 0.85 0.85	1 1 1	22.834 22.834 22.834	0.654	0.033	C
T5 402.000-382.000	0.735	2.491	A B C	0.381 0.381 0.381	2.103 2.103 2.103	0.009	0.85 0.85 0.85	1 1 1	22.767 22.767 22.767	0.646	0.032	C
T6 382.000-362.000	0.730	2.640	A B C	0.382 0.382 0.382	2.101 2.101 2.101	0.009	0.85 0.85 0.85	1 1 1	22.850 22.850 22.850	0.639	0.032	C
T7 362.000-342.000	0.756	2.474	A B C	0.379 0.379 0.379	2.107 2.107 2.107	0.009	0.85 0.85 0.85	1 1 1	22.622 22.622 22.622	0.641	0.032	C
T8 342.000-322.000	0.855	2.464	A B C	0.378 0.378 0.378	2.11 2.11 2.11	0.009	0.85 0.85 0.85	1 1 1	22.544 22.544 22.544	0.675	0.034	C
T9 322.000-302.000	0.859	2.687	A B C	0.379 0.379 0.379	2.108 2.108 2.108	0.009	0.85 0.85 0.85	1 1 1	22.597 22.597 22.597	0.670	0.034	C
T10 302.000-282.000	0.971	2.656	A B C	0.382 0.382 0.382	2.101 2.101 2.101	0.008	0.85 0.85 0.85	1 1 1	22.899 22.899 22.899	0.707	0.035	C
T11 282.000-262.000	1.933	3.197	A B C	0.4 0.4 0.4	2.064 2.064 2.064	0.008	0.85 0.85 0.85	1 1 1	24.421 24.421 24.421	0.983	0.049	C
T12 262.000-242.000	2.253	3.022	A B C	0.388 0.388 0.388	2.089 2.089 2.089	0.008	0.85 0.85 0.85	1 1 1	23.387 23.387 23.387	1.048	0.052	B
T13 242.000-222.000	2.425	2.852	A B C	0.384 0.384 0.384	2.096 2.096 2.096	0.008	0.85 0.85 0.85	1 1 1	23.127 23.127 23.127	1.095	0.055	B
T14 222.000-202.000	2.412	3.563	A B C	0.404 0.404 0.404	2.057 2.057 2.057	0.008	0.85 0.85 0.85	1 1 1	24.779 24.779 24.779	1.087	0.054	B
T15 202.000-182.000	2.387	3.075	A B C	0.388 0.388 0.388	2.089 2.089 2.089	0.008	0.85 0.85 0.85	1 1 1	23.416 23.416 23.416	1.052	0.053	B
T16 182.000-162.000	2.387	3.058	A B C	0.386 0.386 0.386	2.093 2.093 2.093	0.008	0.85 0.85 0.85	1 1 1	23.278 23.278 23.278	1.033	0.052	B
T17 162.000-142.000	2.515	3.193	A B C	0.385 0.385 0.385	2.094 2.094 2.094	0.007	0.85 0.85 0.85	1 1 1	23.277 23.277 23.277	1.064	0.053	B
T18 142.000-122.000	2.540	3.018	A B C	0.381 0.381 0.381	2.102 2.102 2.102	0.007	0.85 0.85 0.85	1 1 1	22.953 22.953 22.953	1.047	0.052	B
T19 122.000-112.000	1.291	1.586	A B C	0.405 0.405 0.405	2.053 2.053 2.053	0.007	0.85 0.85 0.85	1 1 1	12.405 12.405 12.405	0.526	0.053	B
T20 112.000-102.000	1.299	1.590	A B C	0.383 0.383 0.383	2.098 2.098 2.098	0.007	0.85 0.85 0.85	1 1 1	12.059 12.059 12.059	0.523	0.052	B
T21 102.000-82.000	2.583	3.117	A B C	0.377 0.377 0.377	2.111 2.111 2.111	0.007	0.85 0.85 0.85	1 1 1	22.678 22.678 22.678	1.001	0.050	B

tnxTower Vertical Bridge 750 Park of Commerce Drive Boca Raton, FL 33487 Phone: 561-948-6367 FAX:	Job US-CT-5009	Page 52 of 83
	Project Guyed Tower Structural Analysis	Date 11:53:35 05/29/20
	Client	Designed by JWagner

Section Elevation ft	Add Weight K	Self Weight K	F a c e	e	C _F	q _z ksf	D _F	D _R	A _E ft ²	F K	w klf	Ctrl. Face
T22 82.000-62.000	2.517	2.931	A	0.371	2.123	0.006	0.85	1	22.249	0.939	0.047	B
			B	0.371	2.123		0.85	1	22.249			
			C	0.371	2.123		0.85	1	22.249			
T23 62.000-42.000	2.433	3.038	A	0.368	2.131	0.006	0.85	1	22.042	0.864	0.043	B
			B	0.368	2.131		0.85	1	22.042			
			C	0.368	2.131		0.85	1	22.042			
T24 42.000-22.000	2.315	2.827	A	0.359	2.151	0.005	0.85	1	21.384	0.762	0.038	B
			B	0.359	2.151		0.85	1	21.384			
			C	0.359	2.151		0.85	1	21.384			
T25 22.000-2.000	1.471	2.794	A	0.359	2.151	0.005	0.85	1	21.443	0.493	0.025	B
			B	0.359	2.151		0.85	1	21.443			
			C	0.359	2.151		0.85	1	21.443			
Sum Weight:	38.962	67.476								19.566		

Tower Forces - Service - Wind Normal To Face

Section Elevation ft	Add Weight K	Self Weight K	F a c e	e	C _F	q _z ksf	D _F	D _R	A _E ft ²	F K	w klf	Ctrl. Face
L1 492.000-477.000	0.000	0.535	A	1	0.828	0.013	1	1	10.781	0.162	0.011	C
			B	1	0.828		1	1	10.781			
			C	1	0.828		1	1	10.781			
L2 477.000-457.000	0.000	0.713	A	1	0.831	0.013	1	1	14.375	0.215	0.011	C
			B	1	0.831		1	1	14.375			
			C	1	0.831		1	1	14.375			
T1 457.000-452.000	0.000	0.418	A	0.283	2.343	0.013	1	1	5.158	0.138	0.028	C
			B	0.283	2.343		1	1	5.158			
			C	0.283	2.343		1	1	5.158			
T2 452.000-442.000	0.002	0.643	A	0.194	2.615	0.013	1	1	6.538	0.199	0.020	C
			B	0.194	2.615		1	1	6.538			
			C	0.194	2.615		1	1	6.538			
T3 442.000-422.000	0.055	1.341	A	0.183	2.654	0.013	1	1	12.117	0.468	0.023	C
			B	0.183	2.654		1	1	12.117			
			C	0.183	2.654		1	1	12.117			
T4 422.000-402.000	0.089	1.229	A	0.181	2.66	0.013	1	1	11.956	0.516	0.026	C
			B	0.181	2.66		1	1	11.956			
			C	0.181	2.66		1	1	11.956			
T5 402.000-382.000	0.089	1.229	A	0.181	2.66	0.013	1	1	11.956	0.511	0.026	C
			B	0.181	2.66		1	1	11.956			
			C	0.181	2.66		1	1	11.956			
T6 382.000-362.000	0.089	1.341	A	0.183	2.654	0.013	1	1	12.117	0.509	0.025	C
			B	0.183	2.654		1	1	12.117			
			C	0.183	2.654		1	1	12.117			
T7 362.000-342.000	0.091	1.229	A	0.181	2.66	0.013	1	1	11.956	0.505	0.025	C
			B	0.181	2.66		1	1	11.956			
			C	0.181	2.66		1	1	11.956			
T8 342.000-322.000	0.098	1.229	A	0.181	2.66	0.012	1	1	11.956	0.516	0.026	C
			B	0.181	2.66		1	1	11.956			
			C	0.181	2.66		1	1	11.956			
T9 322.000-302.000	0.099	1.440	A	0.185	2.647	0.012	1	1	11.994	0.511	0.026	C
			B	0.185	2.647		1	1	11.994			
			C	0.185	2.647		1	1	11.994			
T10	0.113	1.419	A	0.19	2.631	0.012	1	1	12.401	0.535	0.027	C

tnxTower Vertical Bridge 750 Park of Commerce Drive Boca Raton, FL 33487 Phone: 561-948-6367 FAX:	Job US-CT-5009	Page 53 of 83
	Project Guyed Tower Structural Analysis	Date 11:53:35 05/29/20
	Client	Designed by JWagner

Section Elevation ft	Add Weight K	Self Weight K	F a c e	e	C _F	q _z ksf	D _F	D _R	A _E ft ²	F K	w klf	Ctrl. Face
302.000-282.000			B	0.19	2.631		1	1	12.401			
			C	0.19	2.631		1	1	12.401			
T11	0.354	1.858	A	0.211	2.559	0.012	1	1	13.982	0.796	0.040	A
282.000-262.000			B	0.211	2.559		1	1	13.982			
			C	0.211	2.559		1	1	13.982			
T12	0.422	1.742	A	0.2	2.596	0.012	1	1	13.009	0.831	0.042	A
262.000-242.000			B	0.2	2.596		1	1	13.009			
			C	0.2	2.596		1	1	13.009			
T13	0.446	1.629	A	0.198	2.602	0.012	1	1	12.849	0.847	0.042	A
242.000-222.000			B	0.198	2.602		1	1	12.849			
			C	0.198	2.602		1	1	12.849			
T14	0.447	2.201	A	0.221	2.527	0.011	1	1	14.591	0.866	0.043	A
222.000-202.000			B	0.221	2.527		1	1	14.591			
			C	0.221	2.527		1	1	14.591			
T15	0.447	1.860	A	0.206	2.575	0.011	1	1	13.301	0.824	0.041	A
202.000-182.000			B	0.206	2.575		1	1	13.301			
			C	0.206	2.575		1	1	13.301			
T16	0.450	1.860	A	0.206	2.575	0.011	1	1	13.301	0.810	0.041	A
182.000-162.000			B	0.206	2.575		1	1	13.301			
			C	0.206	2.575		1	1	13.301			
T17	0.468	1.972	A	0.208	2.569	0.011	1	1	13.460	0.821	0.041	A
162.000-142.000			B	0.208	2.569		1	1	13.460			
			C	0.208	2.569		1	1	13.460			
T18	0.474	1.860	A	0.206	2.575	0.010	1	1	13.301	0.804	0.040	A
142.000-122.000			B	0.206	2.575		1	1	13.301			
			C	0.206	2.575		1	1	13.301			
T19	0.241	0.959	A	0.219	2.533	0.010	1	1	7.206	0.408	0.041	A
122.000-112.000			B	0.219	2.533		1	1	7.206			
			C	0.219	2.533		1	1	7.206			
T20	0.243	1.060	A	0.219	2.533	0.010	1	1	7.210	0.403	0.040	A
112.000-102.000			B	0.219	2.533		1	1	7.210			
			C	0.219	2.533		1	1	7.210			
T21	0.488	1.972	A	0.208	2.569	0.009	1	1	13.460	0.770	0.039	A
102.000-82.000			B	0.208	2.569		1	1	13.460			
			C	0.208	2.569		1	1	13.460			
T22	0.488	1.860	A	0.206	2.575	0.009	1	1	13.301	0.710	0.036	A
82.000-62.000			B	0.206	2.575		1	1	13.301			
			C	0.206	2.575		1	1	13.301			
T23	0.488	1.972	A	0.208	2.569	0.008	1	1	13.460	0.666	0.033	A
62.000-42.000			B	0.208	2.569		1	1	13.460			
			C	0.208	2.569		1	1	13.460			
T24	0.488	1.860	A	0.206	2.575	0.008	1	1	13.301	0.599	0.030	A
42.000-22.000			B	0.206	2.575		1	1	13.301			
			C	0.206	2.575		1	1	13.301			
T25	0.342	1.889	A	0.214	2.551	0.006	1	1	13.940	0.422	0.021	A
22.000-2.000			B	0.214	2.551		1	1	13.940			
			C	0.214	2.551		1	1	13.940			
Sum Weight:	7.012	39.321								15.363		

Tower Forces - Service - Wind 60 To Face

tnxTower

Vertical Bridge
 750 Park of Commerce Drive
 Boca Raton, FL 33487
 Phone: 561-948-6367
 FAX:

Job	US-CT-5009	Page	54 of 83
Project	Guyed Tower Structural Analysis	Date	11:53:35 05/29/20
Client		Designed by	JWagner

Section Elevation	Add Weight	Self Weight	F a c e	e	C _F	q _z	D _F	D _R	A _E	F	w	Ctrl. Face
ft	K	K				ksf			ft ²	K	klf	
L1	0.000	0.535	A	1	0.828	0.013	1	1	10.781	0.162	0.011	C
492.000-477.0			B	1	0.828		1	1	10.781			
00			C	1	0.828		1	1	10.781			
L2	0.000	0.713	A	1	0.831	0.013	1	1	14.375	0.215	0.011	C
477.000-457.0			B	1	0.831		1	1	14.375			
00			C	1	0.831		1	1	14.375			
T1	0.000	0.418	A	0.283	2.343	0.013	0.8	1	4.349	0.117	0.023	C
457.000-452.0			B	0.283	2.343		0.8	1	4.349			
00			C	0.283	2.343		0.8	1	4.349			
T2	0.002	0.643	A	0.194	2.615	0.013	0.8	1	5.661	0.173	0.017	C
452.000-442.0			B	0.194	2.615		0.8	1	5.661			
00			C	0.194	2.615		0.8	1	5.661			
T3	0.055	1.341	A	0.183	2.654	0.013	0.8	1	10.551	0.422	0.021	C
442.000-422.0			B	0.183	2.654		0.8	1	10.551			
00			C	0.183	2.654		0.8	1	10.551			
T4	0.089	1.229	A	0.181	2.66	0.013	0.8	1	10.422	0.471	0.024	C
422.000-402.0			B	0.181	2.66		0.8	1	10.422			
00			C	0.181	2.66		0.8	1	10.422			
T5	0.089	1.229	A	0.181	2.66	0.013	0.8	1	10.422	0.466	0.023	C
402.000-382.0			B	0.181	2.66		0.8	1	10.422			
00			C	0.181	2.66		0.8	1	10.422			
T6	0.089	1.341	A	0.183	2.654	0.013	0.8	1	10.551	0.464	0.023	C
382.000-362.0			B	0.183	2.654		0.8	1	10.551			
00			C	0.183	2.654		0.8	1	10.551			
T7	0.091	1.229	A	0.181	2.66	0.013	0.8	1	10.422	0.461	0.023	C
362.000-342.0			B	0.181	2.66		0.8	1	10.422			
00			C	0.181	2.66		0.8	1	10.422			
T8	0.098	1.229	A	0.181	2.66	0.012	0.8	1	10.422	0.473	0.024	C
342.000-322.0			B	0.181	2.66		0.8	1	10.422			
00			C	0.181	2.66		0.8	1	10.422			
T9	0.099	1.440	A	0.185	2.647	0.012	0.8	1	10.549	0.471	0.024	C
322.000-302.0			B	0.185	2.647		0.8	1	10.549			
00			C	0.185	2.647		0.8	1	10.549			
T10	0.113	1.419	A	0.19	2.631	0.012	0.8	1	10.875	0.493	0.025	C
302.000-282.0			B	0.19	2.631		0.8	1	10.875			
00			C	0.19	2.631		0.8	1	10.875			
T11	0.354	1.858	A	0.211	2.559	0.012	0.8	1	12.243	0.750	0.038	B
282.000-262.0			B	0.211	2.559		0.8	1	12.243			
00			C	0.211	2.559		0.8	1	12.243			
T12	0.422	1.742	A	0.2	2.596	0.012	0.8	1	11.461	0.791	0.040	B
262.000-242.0			B	0.2	2.596		0.8	1	11.461			
00			C	0.2	2.596		0.8	1	11.461			
T13	0.446	1.629	A	0.198	2.602	0.012	0.8	1	11.332	0.809	0.040	B
242.000-222.0			B	0.198	2.602		0.8	1	11.332			
00			C	0.198	2.602		0.8	1	11.332			
T14	0.447	2.201	A	0.221	2.527	0.011	0.8	1	12.830	0.824	0.041	B
222.000-202.0			B	0.221	2.527		0.8	1	12.830			
00			C	0.221	2.527		0.8	1	12.830			
T15	0.447	1.860	A	0.206	2.575	0.011	0.8	1	11.792	0.787	0.039	B
202.000-182.0			B	0.206	2.575		0.8	1	11.792			
00			C	0.206	2.575		0.8	1	11.792			
T16	0.450	1.860	A	0.206	2.575	0.011	0.8	1	11.792	0.774	0.039	B
182.000-162.0			B	0.206	2.575		0.8	1	11.792			
00			C	0.206	2.575		0.8	1	11.792			
T17	0.468	1.972	A	0.208	2.569	0.011	0.8	1	11.920	0.785	0.039	B
162.000-142.0			B	0.208	2.569		0.8	1	11.920			
00			C	0.208	2.569		0.8	1	11.920			
T18	0.474	1.860	A	0.206	2.575	0.010	0.8	1	11.792	0.770	0.039	B
142.000-122.0			B	0.206	2.575		0.8	1	11.792			
00			C	0.206	2.575		0.8	1	11.792			

tnxTower Vertical Bridge 750 Park of Commerce Drive Boca Raton, FL 33487 Phone: 561-948-6367 FAX:	Job	US-CT-5009	Page	55 of 83
	Project	Guyed Tower Structural Analysis	Date	11:53:35 05/29/20
	Client		Designed by	JWagner

Section Elevation ft	Add Weight K	Self Weight K	F a c e	e	C _F	q _z ksf	D _F	D _R	A _E ft ²	F K	w klf	Ctrl. Face
T19 122.000-112.000	0.241	0.959	A	0.219	2.533	0.010	0.8	1	6.343	0.389	0.039	B
			B	0.219	2.533		0.8	1	6.343			
			C	0.219	2.533		0.8	1	6.343			
T20 112.000-102.000	0.243	1.060	A	0.219	2.533	0.010	0.8	1	6.346	0.385	0.039	B
			B	0.219	2.533		0.8	1	6.346			
			C	0.219	2.533		0.8	1	6.346			
T21 102.000-82.000	0.488	1.972	A	0.208	2.569	0.009	0.8	1	11.920	0.738	0.037	B
			B	0.208	2.569		0.8	1	11.920			
			C	0.208	2.569		0.8	1	11.920			
T22 82.000-62.000	0.488	1.860	A	0.206	2.575	0.009	0.8	1	11.792	0.681	0.034	B
			B	0.206	2.575		0.8	1	11.792			
			C	0.206	2.575		0.8	1	11.792			
T23 62.000-42.000	0.488	1.972	A	0.208	2.569	0.008	0.8	1	11.920	0.637	0.032	B
			B	0.208	2.569		0.8	1	11.920			
			C	0.208	2.569		0.8	1	11.920			
T24 42.000-22.000	0.488	1.860	A	0.206	2.575	0.008	0.8	1	11.792	0.574	0.029	B
			B	0.206	2.575		0.8	1	11.792			
			C	0.206	2.575		0.8	1	11.792			
T25 22.000-2.000	0.342	1.889	A	0.214	2.551	0.006	0.8	1	12.306	0.399	0.020	B
			B	0.214	2.551		0.8	1	12.306			
			C	0.214	2.551		0.8	1	12.306			
Sum Weight:	7.012	39.321								14.483		

Tower Forces - Service - Wind 90 To Face

Section Elevation ft	Add Weight K	Self Weight K	F a c e	e	C _F	q _z ksf	D _F	D _R	A _E ft ²	F K	w klf	Ctrl. Face
L1 492.000-477.000	0.000	0.535	A	1	0.828	0.013	1	1	10.781	0.162	0.011	C
			B	1	0.828		1	1	10.781			
			C	1	0.828		1	1	10.781			
L2 477.000-457.000	0.000	0.713	A	1	0.831	0.013	1	1	14.375	0.215	0.011	C
			B	1	0.831		1	1	14.375			
			C	1	0.831		1	1	14.375			
T1 457.000-452.000	0.000	0.418	A	0.283	2.343	0.013	0.85	1	4.551	0.122	0.024	C
			B	0.283	2.343		0.85	1	4.551			
			C	0.283	2.343		0.85	1	4.551			
T2 452.000-442.000	0.002	0.643	A	0.194	2.615	0.013	0.85	1	5.880	0.180	0.018	C
			B	0.194	2.615		0.85	1	5.880			
			C	0.194	2.615		0.85	1	5.880			
T3 442.000-422.000	0.055	1.341	A	0.183	2.654	0.013	0.85	1	10.943	0.433	0.022	C
			B	0.183	2.654		0.85	1	10.943			
			C	0.183	2.654		0.85	1	10.943			
T4 422.000-402.000	0.089	1.229	A	0.181	2.66	0.013	0.85	1	10.805	0.482	0.024	C
			B	0.181	2.66		0.85	1	10.805			
			C	0.181	2.66		0.85	1	10.805			
T5 402.000-382.000	0.089	1.229	A	0.181	2.66	0.013	0.85	1	10.805	0.477	0.024	C
			B	0.181	2.66		0.85	1	10.805			
			C	0.181	2.66		0.85	1	10.805			
T6 382.000-362.000	0.089	1.341	A	0.183	2.654	0.013	0.85	1	10.943	0.475	0.024	C
			B	0.183	2.654		0.85	1	10.943			
			C	0.183	2.654		0.85	1	10.943			
T7	0.091	1.229	A	0.181	2.66	0.013	0.85	1	10.805	0.472	0.024	C

tnxTower Vertical Bridge 750 Park of Commerce Drive Boca Raton, FL 33487 Phone: 561-948-6367 FAX:	Job	US-CT-5009	Page	56 of 83
	Project	Guyed Tower Structural Analysis	Date	11:53:35 05/29/20
	Client		Designed by	JWagner

Section Elevation ft	Add Weight K	Self Weight K	F a c e	e	C _F	q _z ksf	D _F	D _R	A _E ft ²	F K	w klf	Ctrl. Face
362.000-342.000			B	0.181	2.66		0.85	1	10.805			
			C	0.181	2.66		0.85	1	10.805			
T8	0.098	1.229	A	0.181	2.66	0.012	0.85	1	10.805	0.484	0.024	C
342.000-322.000			B	0.181	2.66		0.85	1	10.805			
			C	0.181	2.66		0.85	1	10.805			
T9	0.099	1.440	A	0.185	2.647	0.012	0.85	1	10.910	0.481	0.024	C
322.000-302.000			B	0.185	2.647		0.85	1	10.910			
			C	0.185	2.647		0.85	1	10.910			
T10	0.113	1.419	A	0.19	2.631	0.012	0.85	1	11.257	0.504	0.025	C
302.000-282.000			B	0.19	2.631		0.85	1	11.257			
			C	0.19	2.631		0.85	1	11.257			
T11	0.354	1.858	A	0.211	2.559	0.012	0.85	1	12.678	0.768	0.038	C
282.000-262.000			B	0.211	2.559		0.85	1	12.678			
			C	0.211	2.559		0.85	1	12.678			
T12	0.422	1.742	A	0.2	2.596	0.012	0.85	1	11.848	0.802	0.040	B
262.000-242.000			B	0.2	2.596		0.85	1	11.848			
			C	0.2	2.596		0.85	1	11.848			
T13	0.446	1.629	A	0.198	2.602	0.012	0.85	1	11.711	0.824	0.041	B
242.000-222.000			B	0.198	2.602		0.85	1	11.711			
			C	0.198	2.602		0.85	1	11.711			
T14	0.447	2.201	A	0.221	2.527	0.011	0.85	1	13.270	0.840	0.042	B
222.000-202.000			B	0.221	2.527		0.85	1	13.270			
			C	0.221	2.527		0.85	1	13.270			
T15	0.447	1.860	A	0.206	2.575	0.011	0.85	1	12.169	0.802	0.040	B
202.000-182.000			B	0.206	2.575		0.85	1	12.169			
			C	0.206	2.575		0.85	1	12.169			
T16	0.450	1.860	A	0.206	2.575	0.011	0.85	1	12.169	0.790	0.040	B
182.000-162.000			B	0.206	2.575		0.85	1	12.169			
			C	0.206	2.575		0.85	1	12.169			
T17	0.468	1.972	A	0.208	2.569	0.011	0.85	1	12.305	0.807	0.040	B
162.000-142.000			B	0.208	2.569		0.85	1	12.305			
			C	0.208	2.569		0.85	1	12.305			
T18	0.474	1.860	A	0.206	2.575	0.010	0.85	1	12.169	0.792	0.040	B
142.000-122.000			B	0.206	2.575		0.85	1	12.169			
			C	0.206	2.575		0.85	1	12.169			
T19	0.241	0.959	A	0.219	2.533	0.010	0.85	1	6.559	0.400	0.040	B
122.000-112.000			B	0.219	2.533		0.85	1	6.559			
			C	0.219	2.533		0.85	1	6.559			
T20	0.243	1.060	A	0.219	2.533	0.010	0.85	1	6.562	0.396	0.040	B
112.000-102.000			B	0.219	2.533		0.85	1	6.562			
			C	0.219	2.533		0.85	1	6.562			
T21	0.488	1.972	A	0.208	2.569	0.009	0.85	1	12.305	0.758	0.038	B
102.000-82.000			B	0.208	2.569		0.85	1	12.305			
			C	0.208	2.569		0.85	1	12.305			
T22	0.488	1.860	A	0.206	2.575	0.009	0.85	1	12.169	0.699	0.035	B
82.000-62.000			B	0.206	2.575		0.85	1	12.169			
			C	0.206	2.575		0.85	1	12.169			
T23	0.488	1.972	A	0.208	2.569	0.008	0.85	1	12.305	0.655	0.033	B
62.000-42.000			B	0.208	2.569		0.85	1	12.305			
			C	0.208	2.569		0.85	1	12.305			
T24	0.488	1.860	A	0.206	2.575	0.008	0.85	1	12.169	0.590	0.029	B
42.000-22.000			B	0.206	2.575		0.85	1	12.169			
			C	0.206	2.575		0.85	1	12.169			
T25	0.342	1.889	A	0.214	2.551	0.006	0.85	1	12.714	0.410	0.021	B
22.000-2.000			B	0.214	2.551		0.85	1	12.714			
			C	0.214	2.551		0.85	1	12.714			
Sum Weight:	7.012	39.321								14.823		

tnxTower Vertical Bridge 750 Park of Commerce Drive Boca Raton, FL 33487 Phone: 561-948-6367 FAX:	Job	US-CT-5009	Page	57 of 83
	Project	Guyed Tower Structural Analysis	Date	11:53:35 05/29/20
	Client		Designed by	JWagner

Force Totals (Does not include forces on guys)

Load Case	Vertical Forces	Sum of Forces X	Sum of Forces Z	Sum of Torques
	K	K	K	kip-ft
Leg Weight	28.245			
Bracing Weight	11.075			
Total Member Self-Weight	39.321			
Guy Weight	10.784			
Total Weight	65.550			
Wind 0 deg - No Ice		0.058	-67.542	-4.483
Wind 30 deg - No Ice		32.407	-55.995	-12.405
Wind 60 deg - No Ice		55.763	-32.166	-19.039
Wind 90 deg - No Ice		66.458	-0.051	-23.599
Wind 120 deg - No Ice		59.792	34.400	-18.223
Wind 150 deg - No Ice		33.323	57.785	-6.505
Wind 180 deg - No Ice		-0.111	64.255	4.481
Wind 210 deg - No Ice		-32.442	55.974	12.298
Wind 240 deg - No Ice		-58.686	33.828	19.014
Wind 270 deg - No Ice		-66.535	0.100	23.651
Wind 300 deg - No Ice		-57.027	-32.767	18.250
Wind 330 deg - No Ice		-33.443	-57.805	6.560
Member Ice	28.156			
Guy Ice	19.068			
Total Weight Ice	156.105			
Wind 0 deg - Ice		0.205	-23.399	-2.385
Wind 30 deg - Ice		11.628	-19.604	-4.930
Wind 60 deg - Ice		19.763	-11.405	-7.276
Wind 90 deg - Ice		23.118	-0.277	-8.276
Wind 120 deg - Ice		20.660	11.573	-6.222
Wind 150 deg - Ice		11.431	19.973	-1.503
Wind 180 deg - Ice		-0.042	22.726	2.702
Wind 210 deg - Ice		-11.294	19.673	5.563
Wind 240 deg - Ice		-20.215	11.552	7.599
Wind 270 deg - Ice		-23.065	-0.121	7.931
Wind 300 deg - Ice		-20.031	-11.511	5.582
Wind 330 deg - Ice		-11.657	-19.904	1.215
Total Weight	65.550			
Wind 0 deg - Service		0.016	-18.490	-1.220
Wind 30 deg - Service		8.874	-15.333	-3.377
Wind 60 deg - Service		15.270	-8.808	-5.183
Wind 90 deg - Service		18.195	-0.014	-6.424
Wind 120 deg - Service		16.367	9.416	-4.960
Wind 150 deg - Service		9.123	15.820	-1.771
Wind 180 deg - Service		-0.030	17.596	1.220
Wind 210 deg - Service		-8.883	15.327	3.348
Wind 240 deg - Service		-16.066	9.261	5.176
Wind 270 deg - Service		-18.216	0.027	6.438
Wind 300 deg - Service		-15.614	-8.972	4.968
Wind 330 deg - Service		-9.156	-15.826	1.786

Load Combinations

tnxTower Vertical Bridge 750 Park of Commerce Drive Boca Raton, FL 33487 Phone: 561-948-6367 FAX:	Job	US-CT-5009	Page	58 of 83
	Project	Guyed Tower Structural Analysis	Date	11:53:35 05/29/20
	Client		Designed by	JWagner

<i>Comb. No.</i>	<i>Description</i>
1	Dead Only
2	1.2 Dead+1.0 Wind 0 deg - No Ice+1.0 Guy
3	1.2 Dead+1.0 Wind 30 deg - No Ice+1.0 Guy
4	1.2 Dead+1.0 Wind 60 deg - No Ice+1.0 Guy
5	1.2 Dead+1.0 Wind 90 deg - No Ice+1.0 Guy
6	1.2 Dead+1.0 Wind 120 deg - No Ice+1.0 Guy
7	1.2 Dead+1.0 Wind 150 deg - No Ice+1.0 Guy
8	1.2 Dead+1.0 Wind 180 deg - No Ice+1.0 Guy
9	1.2 Dead+1.0 Wind 210 deg - No Ice+1.0 Guy
10	1.2 Dead+1.0 Wind 240 deg - No Ice+1.0 Guy
11	1.2 Dead+1.0 Wind 270 deg - No Ice+1.0 Guy
12	1.2 Dead+1.0 Wind 300 deg - No Ice+1.0 Guy
13	1.2 Dead+1.0 Wind 330 deg - No Ice+1.0 Guy
14	1.2 Dead+1.0 Ice+1.0 Temp+Guy
15	1.2 Dead+1.0 Wind 0 deg+1.0 Ice+1.0 Temp+1.0 Guy
16	1.2 Dead+1.0 Wind 30 deg+1.0 Ice+1.0 Temp+1.0 Guy
17	1.2 Dead+1.0 Wind 60 deg+1.0 Ice+1.0 Temp+1.0 Guy
18	1.2 Dead+1.0 Wind 90 deg+1.0 Ice+1.0 Temp+1.0 Guy
19	1.2 Dead+1.0 Wind 120 deg+1.0 Ice+1.0 Temp+1.0 Guy
20	1.2 Dead+1.0 Wind 150 deg+1.0 Ice+1.0 Temp+1.0 Guy
21	1.2 Dead+1.0 Wind 180 deg+1.0 Ice+1.0 Temp+1.0 Guy
22	1.2 Dead+1.0 Wind 210 deg+1.0 Ice+1.0 Temp+1.0 Guy
23	1.2 Dead+1.0 Wind 240 deg+1.0 Ice+1.0 Temp+1.0 Guy
24	1.2 Dead+1.0 Wind 270 deg+1.0 Ice+1.0 Temp+1.0 Guy
25	1.2 Dead+1.0 Wind 300 deg+1.0 Ice+1.0 Temp+1.0 Guy
26	1.2 Dead+1.0 Wind 330 deg+1.0 Ice+1.0 Temp+1.0 Guy
27	Dead+Wind 0 deg - Service+Guy
28	Dead+Wind 30 deg - Service+Guy
29	Dead+Wind 60 deg - Service+Guy
30	Dead+Wind 90 deg - Service+Guy
31	Dead+Wind 120 deg - Service+Guy
32	Dead+Wind 150 deg - Service+Guy
33	Dead+Wind 180 deg - Service+Guy
34	Dead+Wind 210 deg - Service+Guy
35	Dead+Wind 240 deg - Service+Guy
36	Dead+Wind 270 deg - Service+Guy
37	Dead+Wind 300 deg - Service+Guy
38	Dead+Wind 330 deg - Service+Guy

Maximum Reactions

<i>Location</i>	<i>Condition</i>	<i>Gov. Load Comb.</i>	<i>Vertical K</i>	<i>Horizontal, X K</i>	<i>Horizontal, Z K</i>
Guy C @ 148 ft Elev -7 ft Azimuth 240 deg	Max. Vert	10	-13.168	-2.834	1.637
	Max. H _x	10	-13.168	-2.834	1.637
	Max. H _z	3	-108.948	-41.335	25.754
	Min. Vert	5	-110.336	-43.556	23.318
	Min. H _x	5	-110.336	-43.556	23.318
	Min. H _z	9	-17.169	-5.024	1.532
Guy B @ 146 ft Elev -4 ft Azimuth 120 deg	Max. Vert	6	-13.214	2.818	1.627
	Max. H _x	11	-111.048	43.552	23.313
	Max. H _z	13	-109.925	41.545	25.870
	Min. Vert	11	-111.048	43.552	23.313
	Min. H _x	6	-13.214	2.818	1.627

tnxTower Vertical Bridge 750 Park of Commerce Drive Boca Raton, FL 33487 Phone: 561-948-6367 FAX:	Job US-CT-5009	Page 59 of 83
	Project Guyed Tower Structural Analysis	Date 11:53:35 05/29/20
	Client	Designed by JWagner

Location	Condition	Gov. Load Comb.	Vertical K	Horizontal, X K	Horizontal, Z K
Guy A @ 149 ft Elev 2 ft Azimuth 0 deg	Min. H _z	7	-17.246	4.997	1.525
	Max. Vert	2	-12.226	-0.000	-3.096
	Max. H _x	11	-61.369	2.844	-26.978
	Max. H _z	2	-12.226	-0.000	-3.096
	Min. Vert	8	-106.595	0.012	-49.083
Guy C @ 117.5 ft Elev -5 ft Azimuth 240 deg	Min. H _x	5	-61.034	-2.839	-26.842
	Min. H _z	8	-106.595	0.012	-49.083
	Max. Vert	10	-1.317	-0.535	0.308
	Max. H _x	10	-1.317	-0.535	0.308
	Max. H _z	3	-57.797	-40.680	24.228
Guy B @ 117.5 ft Elev 0 ft Azimuth 120 deg	Min. Vert	5	-59.831	-42.680	23.920
	Min. H _x	5	-59.831	-42.680	23.920
	Min. H _z	10	-1.317	-0.535	0.308
	Max. Vert	6	-1.168	0.486	0.281
	Max. H _x	11	-58.036	42.633	23.912
Guy A @ 123 ft Elev 0 ft Azimuth 0 deg	Max. H _z	13	-58.404	42.458	25.290
	Min. Vert	13	-58.404	42.458	25.290
	Min. H _x	6	-1.168	0.486	0.281
	Min. H _z	6	-1.168	0.486	0.281
	Max. Vert	2	-1.081	-0.000	-0.565
Mast	Max. H _x	10	-47.861	0.994	-42.211
	Max. H _z	2	-1.081	-0.000	-0.565
	Min. Vert	7	-55.744	-0.645	-49.257
	Min. H _x	6	-49.164	-1.041	-43.453
	Min. H _z	7	-55.744	-0.645	-49.257
	Max. Vert	6	384.152	3.357	1.664
	Max. H _x	6	384.152	3.357	1.664
	Max. H _z	6	384.152	3.357	1.664
	Max. M _x	1	0.000	0.001	-0.030
	Max. M _z	1	0.000	0.001	-0.030
	Max. Torsion	5	11.589	2.753	0.954
	Min. Vert	1	225.460	0.001	-0.030
	Min. H _x	10	380.372	-3.032	1.607
	Min. H _z	2	383.769	0.121	-3.747
	Min. M _x	1	0.000	0.001	-0.030
Min. M _z	1	0.000	0.001	-0.030	
Min. Torsion	11	-11.302	-2.558	0.986	

Tower Mast Reaction Summary

Load Combination	Vertical K	Shear _x K	Shear _z K	Overturning Moment, M _x kip-ft	Overturning Moment, M _z kip-ft	Torque kip-ft
Dead Only	225.460	-0.001	0.030	0.000	0.000	-0.059
1.2 Dead+1.0 Wind 0 deg - No Ice+1.0 Guy	383.769	-0.121	3.747	0.000	0.000	-2.369
1.2 Dead+1.0 Wind 30 deg - No Ice+1.0 Guy	352.814	-0.467	2.766	0.000	0.000	-5.391
1.2 Dead+1.0 Wind 60 deg - No Ice+1.0 Guy	311.676	-1.053	0.596	0.000	0.000	-9.684

tnxTower Vertical Bridge 750 Park of Commerce Drive Boca Raton, FL 33487 Phone: 561-948-6367 FAX:	Job US-CT-5009	Page 60 of 83
	Project Guyed Tower Structural Analysis	Date 11:53:35 05/29/20
	Client	Designed by JWagner

Load Combination	Vertical K	Shear _x K	Shear _z K	Overturning Moment, M _x kip-ft	Overturning Moment, M _z kip-ft	Torque kip-ft
Ice+1.0 Guy						
1.2 Dead+1.0 Wind 90 deg - No Ice+1.0 Guy	355.358	-2.753	-0.954	0.000	0.000	-11.589
1.2 Dead+1.0 Wind 120 deg - No Ice+1.0 Guy	384.152	-3.357	-1.664	0.000	0.000	-8.118
1.2 Dead+1.0 Wind 150 deg - No Ice+1.0 Guy	352.302	-2.191	-1.445	0.000	0.000	-2.406
1.2 Dead+1.0 Wind 180 deg - No Ice+1.0 Guy	308.715	0.035	-0.837	0.000	0.000	2.336
1.2 Dead+1.0 Wind 210 deg - No Ice+1.0 Guy	348.326	1.988	-1.362	0.000	0.000	5.059
1.2 Dead+1.0 Wind 240 deg - No Ice+1.0 Guy	380.372	3.032	-1.607	0.000	0.000	8.068
1.2 Dead+1.0 Wind 270 deg - No Ice+1.0 Guy	354.798	2.558	-0.986	0.000	0.000	11.302
1.2 Dead+1.0 Wind 300 deg - No Ice+1.0 Guy	312.712	0.960	0.518	0.000	0.000	9.170
1.2 Dead+1.0 Wind 330 deg - No Ice+1.0 Guy	356.488	0.299	2.876	0.000	0.000	2.098
1.2 Dead+1.0 Ice+1.0 Temp+Guy	335.896	0.015	0.093	0.000	0.000	-0.103
1.2 Dead+1.0 Wind 0 deg+1.0 Ice+1.0 Temp+1.0 Guy	344.240	0.000	0.400	0.000	0.000	-1.477
1.2 Dead+1.0 Wind 30 deg+1.0 Ice+1.0 Temp+1.0 Guy	347.693	-0.170	0.369	0.000	0.000	-2.554
1.2 Dead+1.0 Wind 60 deg+1.0 Ice+1.0 Temp+1.0 Guy	350.351	-0.303	0.266	0.000	0.000	-3.980
1.2 Dead+1.0 Wind 90 deg+1.0 Ice+1.0 Temp+1.0 Guy	347.837	-0.341	0.108	0.000	0.000	-4.767
1.2 Dead+1.0 Wind 120 deg+1.0 Ice+1.0 Temp+1.0 Guy	344.296	-0.270	-0.026	0.000	0.000	-3.437
1.2 Dead+1.0 Wind 150 deg+1.0 Ice+1.0 Temp+1.0 Guy	347.680	-0.148	-0.145	0.000	0.000	-0.655
1.2 Dead+1.0 Wind 180 deg+1.0 Ice+1.0 Temp+1.0 Guy	350.093	0.028	-0.192	0.000	0.000	1.335
1.2 Dead+1.0 Wind 210 deg+1.0 Ice+1.0 Temp+1.0 Guy	347.404	0.181	-0.141	0.000	0.000	2.574
1.2 Dead+1.0 Wind 240 deg+1.0 Ice+1.0 Temp+1.0 Guy	343.852	0.277	-0.024	0.000	0.000	3.941
1.2 Dead+1.0 Wind 270 deg+1.0 Ice+1.0 Temp+1.0 Guy	347.788	0.350	0.090	0.000	0.000	4.426
1.2 Dead+1.0 Wind 300 deg+1.0 Ice+1.0 Temp+1.0 Guy	350.607	0.313	0.246	0.000	0.000	2.925
1.2 Dead+1.0 Wind 330 deg+1.0 Ice+1.0 Temp+1.0 Guy	347.976	0.171	0.368	0.000	0.000	0.284
Dead+Wind 0 deg - Service+Guy	227.432	-0.011	0.010	0.000	0.000	-0.819
Dead+Wind 30 deg - Service+Guy	227.958	-0.032	0.035	0.000	0.000	-1.907
Dead+Wind 60 deg - Service+Guy	228.555	-0.051	0.045	0.000	0.000	-3.065
Dead+Wind 90 deg - Service+Guy	228.287	-0.044	0.040	0.000	0.000	-3.964
Dead+Wind 120 deg - Service+Guy	227.943	-0.011	0.046	0.000	0.000	-2.972
Dead+Wind 150 deg - Service+Guy	228.647	-0.007	0.034	0.000	0.000	-0.920
Dead+Wind 180 deg - Service+Guy	229.174	0.008	0.020	0.000	0.000	0.692
Dead+Wind 210 deg - Service+Guy	228.724	0.021	0.024	0.000	0.000	1.761

tnxTower Vertical Bridge 750 Park of Commerce Drive Boca Raton, FL 33487 Phone: 561-948-6367 FAX:	Job	US-CT-5009	Page	61 of 83
	Project	Guyed Tower Structural Analysis	Date	11:53:35 05/29/20
	Client		Designed by	JWagner

Load Combination	Vertical K	Shear _x K	Shear _z K	Overturning Moment, M _x kip-ft	Overturning Moment, M _z kip-ft	Torque kip-ft
Dead+Wind 240 deg - Service+Guy	228.122	0.017	0.034	0.000	0.000	2.937
Dead+Wind 270 deg - Service+Guy	228.575	0.039	0.027	0.000	0.000	3.842
Dead+Wind 300 deg - Service+Guy	228.862	0.036	0.031	0.000	0.000	2.851
Dead+Wind 330 deg - Service+Guy	228.176	0.011	0.026	0.000	0.000	0.813

Solution Summary

Load Comb.	Sum of Applied Forces			Sum of Reactions			% Error
	PX K	PY K	PZ K	PX K	PY K	PZ K	
1	0.000	-65.547	0.000	0.000	65.547	-0.013	0.020%
2	0.059	-76.685	-83.778	-0.059	76.684	83.706	0.063%
3	40.554	-76.494	-70.057	-40.562	76.493	69.999	0.053%
4	69.898	-76.306	-40.291	-69.871	76.306	40.260	0.037%
5	82.787	-76.522	-0.050	-82.741	76.522	0.085	0.052%
6	73.930	-76.733	42.525	-73.869	76.732	-42.491	0.061%
7	41.471	-76.529	71.846	-41.418	76.528	-71.827	0.049%
8	-0.112	-76.316	80.491	0.103	76.315	-80.454	0.035%
9	-40.590	-76.507	70.037	40.539	76.506	-70.017	0.049%
10	-72.821	-76.695	41.953	72.760	76.693	-41.919	0.061%
11	-82.864	-76.479	0.098	82.818	76.478	-0.063	0.052%
12	-71.165	-76.268	-40.893	71.131	76.268	40.867	0.037%
13	-41.591	-76.473	-71.866	41.600	76.472	71.808	0.052%
14	0.000	-167.051	0.000	-0.009	167.051	-0.037	0.023%
15	0.208	-167.195	-34.457	-0.204	167.195	34.465	0.005%
16	17.185	-167.045	-29.190	-17.172	167.045	29.185	0.008%
17	29.405	-166.901	-16.945	-29.392	166.901	16.936	0.009%
18	34.256	-167.065	-0.277	-34.246	167.065	0.268	0.008%
19	30.302	-167.226	17.110	-30.304	167.226	-17.121	0.007%
20	16.986	-167.071	29.556	-16.988	167.071	-29.543	0.007%
21	-0.045	-166.911	33.793	0.043	166.911	-33.779	0.008%
22	-16.851	-167.057	29.260	16.850	167.057	-29.247	0.007%
23	-29.857	-167.201	17.093	29.857	167.201	-17.104	0.006%
24	-34.203	-167.037	-0.121	34.192	167.037	0.113	0.008%
25	-29.673	-166.876	-17.048	29.659	166.876	17.040	0.009%
26	-17.211	-167.031	-29.487	17.198	167.031	29.482	0.008%
27	0.016	-65.596	-22.914	-0.017	65.596	22.906	0.012%
28	11.092	-65.546	-19.161	-11.085	65.546	19.156	0.012%
29	19.117	-65.495	-11.020	-19.110	65.495	11.015	0.013%
30	22.640	-65.553	-0.014	-22.632	65.553	0.010	0.012%
31	20.211	-65.613	11.626	-20.204	65.613	-11.622	0.011%
32	11.341	-65.555	19.648	-11.340	65.555	-19.640	0.011%
33	-0.031	-65.497	22.015	0.030	65.497	-22.008	0.011%
34	-11.101	-65.549	19.155	11.100	65.549	-19.148	0.011%
35	-19.910	-65.602	11.471	19.903	65.602	-11.468	0.012%
36	-22.661	-65.542	0.027	22.653	65.542	-0.030	0.012%
37	-19.462	-65.484	-11.184	19.455	65.484	11.179	0.013%
38	-11.374	-65.540	-19.653	11.367	65.540	19.648	0.012%

Non-Linear Convergence Results

tnxTower Vertical Bridge 750 Park of Commerce Drive Boca Raton, FL 33487 Phone: 561-948-6367 FAX:	Job	US-CT-5009	Page	62 of 83
	Project	Guyed Tower Structural Analysis	Date	11:53:35 05/29/20
	Client		Designed by	JWagner

<i>Load Combination</i>	<i>Converged?</i>	<i>Number of Cycles</i>	<i>Displacement Tolerance</i>	<i>Force Tolerance</i>
1	Yes	22	0.00020000	0.00001044
2	Yes	158	0.00019683	0.00007239
3	Yes	144	0.00019791	0.00006348
4	Yes	66	0.00019246	0.00006473
5	Yes	136	0.00019610	0.00006374
6	Yes	150	0.00019691	0.00007177
7	Yes	135	0.00019877	0.00006058
8	Yes	62	0.00019847	0.00005967
9	Yes	141	0.00019538	0.00006063
10	Yes	154	0.00019604	0.00007218
11	Yes	139	0.00019596	0.00006406
12	Yes	65	0.00019767	0.00006697
13	Yes	142	0.00019593	0.00006215
14	Yes	16	0.00020000	0.00002753
15	Yes	38	0.00019866	0.00001627
16	Yes	79	0.00019565	0.00002000
17	Yes	86	0.00019846	0.00002298
18	Yes	80	0.00019463	0.00002025
19	Yes	42	0.00019824	0.00001507
20	Yes	76	0.00019769	0.00001829
21	Yes	84	0.00019687	0.00002047
22	Yes	76	0.00019731	0.00001889
23	Yes	33	0.00019486	0.00001638
24	Yes	80	0.00019249	0.00002026
25	Yes	86	0.00019897	0.00002301
26	Yes	79	0.00019683	0.00001996
27	Yes	28	0.00019520	0.00001917
28	Yes	41	0.00019608	0.00001845
29	Yes	46	0.00019885	0.00001959
30	Yes	40	0.00019540	0.00001849
31	Yes	28	0.00019061	0.00001938
32	Yes	41	0.00019050	0.00001648
33	Yes	47	0.00019284	0.00001697
34	Yes	42	0.00019053	0.00001678
35	Yes	30	0.00019629	0.00001904
36	Yes	41	0.00019695	0.00001899
37	Yes	47	0.00019419	0.00001935
38	Yes	41	0.00019887	0.00001870

Maximum Tower Deflections - Service Wind

<i>Section No.</i>	<i>Elevation</i>	<i>Horz. Deflection</i>	<i>Gov. Load Comb.</i>	<i>Tilt</i>	<i>Twist</i>
	<i>ft</i>	<i>in</i>		<i>°</i>	<i>°</i>
L1	492 - 477	7.811	37	0.4469	0.8574
L2	477 - 457	6.433	37	0.4161	0.8574
T1	457 - 452	5.190	37	0.0948	0.8450
T2	452 - 442	5.090	37	0.0922	0.8427
T3	442 - 422	4.901	37	0.0825	0.8362
T4	422 - 402	4.568	37	0.0779	0.8479
T5	402 - 382	4.249	37	0.0703	0.8454
T6	382 - 362	3.980	37	0.0486	0.8464
T7	362 - 342	3.806	37	0.0391	0.8729
T8	342 - 322	3.652	37	0.0334	0.8631
T9	322 - 302	3.528	37	0.0181	0.8780
T10	302 - 282	3.474	37	0.0194	0.8802

tnxTower Vertical Bridge 750 Park of Commerce Drive Boca Raton, FL 33487 Phone: 561-948-6367 FAX:	Job	US-CT-5009	Page	63 of 83
	Project	Guyed Tower Structural Analysis	Date	11:53:35 05/29/20
	Client		Designed by	JWagner

Section No.	Elevation ft	Horz. Deflection in	Gov. Load Comb.	Tilt °	Twist °
T11	282 - 262	3.376	37	0.0304	0.8989
T12	262 - 242	3.226	37	0.0312	0.8716
T13	242 - 222	3.108	29	0.0347	0.8854
T14	222 - 202	2.972	29	0.0337	0.8300
T15	202 - 182	2.874	30	0.0246	0.8349
T16	182 - 162	2.797	30	0.0346	0.7781
T17	162 - 142	2.629	30	0.0543	0.7525
T18	142 - 122	2.368	30	0.0692	0.6760
T19	122 - 112	2.041	30	0.0828	0.6312
T20	112 - 102	1.859	27	0.0850	0.5655
T21	102 - 82	1.686	27	0.0823	0.5761
T22	82 - 62	1.373	27	0.0803	0.4548
T23	62 - 42	1.036	27	0.0816	0.3912
T24	42 - 22	0.690	27	0.0788	0.2453
T25	22 - 2	0.369	27	0.0787	0.1707

Critical Deflections and Radius of Curvature - Service Wind

Elevation ft	Appurtenance	Gov. Load Comb.	Deflection in	Tilt °	Twist °	Radius of Curvature ft
490.000	Beacon (.075k 2.250CAAA)	37	7.621	0.4525	0.8577	29251
471.000	2 Bay FM Antenna	37	5.946	0.3173	0.8544	5301
453.000	3' Yagi(.03k,2.08CAAA)	37	5.107	0.0913	0.8432	13733
442.000	Guy	37	4.901	0.0825	0.8362	44268
435.000	6' Grid Dish	37	4.776	0.0771	0.8316	53778
382.000	Guy	37	3.980	0.0486	0.8464	37822
358.000	Obstruction Light(.01k.,8CAAA)	37	3.775	0.0385	0.8691	402961
351.000	3' Dish w/ Radomes	37	3.721	0.0371	0.8505	382381
339.000	3' Grid Dish	37	3.629	0.0313	0.8604	121643
322.000	Guy	37	3.528	0.0181	0.8780	41195
302.000	6' Omni	37	3.474	0.0194	0.8802	67328
300.000	Kathrein CA5-FM/CP/RM	37	3.468	0.0205	0.8798	62094
280.000	KRY 112 89/4	37	3.362	0.0309	0.8982	84106
262.000	Guy	37	3.226	0.0312	0.8716	74164
257.000	SM 408-3	37	3.193	0.0317	0.8625	117770
247.000	8' Grid Dish (140lbs 20.1CaAa)	29	3.136	0.0336	0.8846	94538
239.000	8' Grid Dish (140lbs 20.1CaAa)	29	3.089	0.0352	0.8785	71041
237.000	Beacon (.075k 2.250CAAA)	29	3.076	0.0354	0.8714	91308
210.000	Guy	29	2.906	0.0273	0.8284	88485
165.000	Sector Frames	30	2.660	0.0515	0.7581	50003
154.000	Guy	30	2.534	0.0606	0.7125	60631
138.000	10' Dipole	30	2.308	0.0722	0.6557	73740
125.000	10' Dipole	30	2.094	0.0812	0.6439	65980
124.000	Beacon (.075k 2.250CAAA)	30	2.076	0.0818	0.6407	66266
116.000	Obstruction Light(.01k.,8CAAA)	30	1.930	0.0848	0.5867	139204
108.000	10' Dipole	27	1.789	0.0842	0.5662	105237
102.000	Guy	27	1.686	0.0823	0.5761	54968
46.000	Guy	27	0.757	0.0794	0.2615	109615

Maximum Tower Deflections - Design Wind

tnxTower Vertical Bridge 750 Park of Commerce Drive Boca Raton, FL 33487 Phone: 561-948-6367 FAX:	Job	US-CT-5009	Page	64 of 83
	Project	Guyed Tower Structural Analysis	Date	11:53:35 05/29/20
	Client		Designed by	JWagner

Section No.	Elevation ft	Horz. Deflection in	Gov. Load Comb.	Tilt °	Twist °
L1	492 - 477	45.767	10	1.4326	2.3212
L2	477 - 457	41.388	2	1.3399	2.3213
T1	457 - 452	37.355	2	0.4132	2.2763
T2	452 - 442	36.961	2	0.4055	2.2677
T3	442 - 422	36.201	2	0.3768	2.2478
T4	422 - 402	34.807	2	0.3716	2.2813
T5	402 - 382	33.407	2	0.3530	2.2786
T6	382 - 362	32.148	2	0.2753	2.2818
T7	362 - 342	31.229	2	0.2391	2.3363
T8	342 - 322	30.361	2	0.2154	2.3432
T9	322 - 302	29.599	2	0.1540	2.3645
T10	302 - 282	29.105	2	0.1563	2.4246
T11	282 - 262	28.422	2	0.1994	2.4599
T12	262 - 242	27.527	2	0.2049	2.4258
T13	242 - 222	26.705	6	0.2316	2.4292
T14	222 - 202	25.805	6	0.2505	2.3244
T15	202 - 182	24.907	6	0.2418	2.3042
T16	182 - 162	23.914	6	0.3204	2.2019
T17	162 - 142	22.374	6	0.4439	2.0960
T18	142 - 122	20.269	6	0.5508	1.9328
T19	122 - 112	17.700	6	0.6485	1.7708
T20	112 - 102	16.266	6	0.6764	1.6209
T21	102 - 82	14.805	6	0.6815	1.6041
T22	82 - 62	11.957	6	0.6957	1.3245
T23	62 - 42	8.982	6	0.7111	1.0869
T24	42 - 22	5.993	6	0.6920	0.7195
T25	22 - 2	3.156	6	0.6831	0.4386

Critical Deflections and Radius of Curvature - Design Wind

Elevation ft	Appurtenance	Gov. Load Comb.	Deflection in	Tilt °	Twist °	Radius of Curvature ft
490.000	Beacon (.075k 2.250CAAA)	10	45.161	1.4481	2.3224	9826
471.000	2 Bay FM Antenna	2	39.847	1.0546	2.3105	1817
453.000	3' Yagi(.03k.2.08CAAA)	2	37.031	0.4029	2.2694	4748
442.000	Guy	2	36.201	0.3768	2.2478	15436
435.000	6' Grid Dish	2	35.693	0.3628	2.2468	19514
382.000	Guy	2	32.148	0.2753	2.2818	10116
358.000	Obstruction Light(.01k,.8CAAA)	2	31.057	0.2362	2.3355	130688
351.000	3' Dish w/ Radomes	2	30.752	0.2304	2.3154	99346
339.000	3' Grid Dish	2	30.233	0.2071	2.3396	30752
322.000	Guy	2	29.599	0.1540	2.3645	10748
302.000	6' Omni	2	29.105	0.1563	2.4246	16319
300.000	Kathrein CA5-FM/CP/RM	2	29.051	0.1603	2.4278	15090
280.000	KRY 112 89/4	2	28.337	0.2015	2.4591	19672
262.000	Guy	2	27.527	0.2049	2.4258	18950
257.000	SM 408-3	2	27.317	0.2089	2.4083	30056
247.000	8' Grid Dish (140lbs 20.1CaAa)	2	26.903	0.2232	2.4331	17390
239.000	8' Grid Dish (140lbs 20.1CaAa)	6	26.585	0.2365	2.4150	13337
237.000	Beacon (.075k 2.250CAAA)	6	26.500	0.2395	2.4014	15634
210.000	Guy	6	25.260	0.2409	2.3019	22395
165.000	Sector Frames	6	22.644	0.4257	2.1134	8211
154.000	Guy	6	21.593	0.4887	2.0106	9249
138.000	10' Dipole	6	19.790	0.5715	1.8876	10848
125.000	10' Dipole	6	18.113	0.6362	1.8046	11083
124.000	Beacon (.075k 2.250CAAA)	6	17.977	0.6405	1.7950	11202

tnxTower Vertical Bridge 750 Park of Commerce Drive Boca Raton, FL 33487 Phone: 561-948-6367 FAX:	Job US-CT-5009	Page 65 of 83
	Project Guyed Tower Structural Analysis	Date 11:53:35 05/29/20
	Client	Designed by JWagner

Elevation	Appurtenance	Gov. Load Comb.	Deflection in	Tilt °	Twist °	Radius of Curvature ft
116.000	Obstruction Light(.01k.,8CAAA)	6	16.847	0.6682	1.6718	20086
108.000	10' Dipole	6	15.680	0.6802	1.6081	28633
102.000	Guy	6	14.805	0.6815	1.6041	14936
46.000	Guy	6	6.579	0.6875	0.7756	22321

Bolt Design Data

Section No.	Elevation ft	Component Type	Bolt Grade	Bolt Size in	Number Of Bolts	Maximum Load per Bolt K	Allowable Load per Bolt K	Ratio Load Allowable	Allowable Ratio	Criteria	
T1	457	Diagonal	A325N	0.6250	1	1.788	9.914	0.180	✓	1	Member Block Shear
		Top Girt	A325N	0.6250	1	0.000	13.806	0.000	✓	1	Bolt Shear
T2	452	Diagonal	A325N	0.6250	1	2.352	10.500	0.224	✓	1	Member Block Shear
		Horizontal	A325N	0.6250	1	0.291	7.875	0.037	✓	1	Member Block Shear
T3	442	Top Girt	A325N	0.6250	1	0.814	7.875	0.103	✓	1	Member Block Shear
		Diagonal	A325N	0.6250	1	1.157	10.500	0.110	✓	1	Member Block Shear
T4	422	Horizontal	A325N	0.6250	1	0.405	7.875	0.051	✓	1	Member Block Shear
		Top Guy Pull-Off@442	A325N	0.7500	2	2.940	32.477	0.091	✓	1	Member Block Shear
T5	402	Diagonal	A325N	0.6250	1	2.046	10.500	0.195	✓	1	Member Block Shear
		Horizontal	A325N	0.6250	1	0.514	7.875	0.065	✓	1	Member Block Shear
T6	382	Top Girt	A325N	0.6250	1	0.240	7.875	0.031	✓	1	Member Block Shear
		Diagonal	A325N	0.6250	1	3.635	10.500	0.346	✓	1	Member Block Shear
T7	362	Horizontal	A325N	0.6250	1	0.838	7.875	0.106	✓	1	Member Block Shear
		Top Girt	A325N	0.6250	1	0.248	7.875	0.032	✓	1	Member Block Shear
T8	342	Diagonal	A325N	0.6250	1	1.994	10.500	0.190	✓	1	Member Block Shear
		Horizontal	A325N	0.6250	1	0.935	7.875	0.119	✓	1	Member Block Shear
T9	322	Top Guy Pull-Off@382	A325N	0.7500	2	3.485	32.477	0.107	✓	1	Member Block Shear
		Diagonal	A325N	0.6250	1	1.770	13.806	0.128	✓	1	Bolt Shear
T10	302	Horizontal	A325N	0.6250	1	0.860	7.875	0.109	✓	1	Member Block Shear
		Top Girt	A325N	0.6250	1	0.323	7.875	0.041	✓	1	Member Block Shear
T11	282	Diagonal	A325N	0.6250	1	2.539	10.500	0.242	✓	1	Member Block Shear
		Horizontal	A325N	0.6250	1	1.099	7.875	0.140	✓	1	Member Block Shear
T12	262	Top Girt	A325N	0.6250	1	0.333	7.875	0.042	✓	1	Member Block Shear

tnxTower Vertical Bridge 750 Park of Commerce Drive Boca Raton, FL 33487 Phone: 561-948-6367 FAX:	Job	US-CT-5009	Page	66 of 83
	Project	Guyed Tower Structural Analysis	Date	11:53:35 05/29/20
	Client		Designed by	JWagner

Section No.	Elevation ft	Component Type	Bolt Grade	Bolt Size in	Number Of Bolts	Maximum Load per Bolt K	Allowable Load per Bolt K	Ratio Load Allowable	Allowable Ratio	Criteria	
T9	322	Diagonal	A325N	0.6250	1	3.368	6.855	0.491	✓	1	Member Block Shear
		Horizontal	A325N	0.6250	1	1.137	7.875	0.144	✓	1	Member Block Shear
		Top Guy Pull-Off@322	A325N	0.7500	2	3.484	32.477	0.107	✓	1	Member Block Shear
T10	302	Diagonal	A325N	0.6250	1	2.265	13.806	0.164	✓	1	Bolt Shear
		Horizontal	A325N	0.6250	1	1.182	7.875	0.150	✓	1	Member Block Shear
		Top Girt	A325N	0.6250	1	0.569	7.875	0.072	✓	1	Member Block Shear
T11	282	Diagonal	A325N	0.6250	1	6.707	13.806	0.486	✓	1	Bolt Shear
		Horizontal	A325N	0.6250	1	1.476	7.875	0.187	✓	1	Member Block Shear
		Top Girt	A325N	0.6250	1	1.319	7.875	0.167	✓	1	Member Block Shear
T12	262	Diagonal	A325N	0.6250	1	4.003	10.500	0.381	✓	1	Member Block Shear
		Horizontal	A325N	0.6250	1	1.552	7.875	0.197	✓	1	Member Block Shear
		Top Guy Pull-Off@262	A325N	0.7500	2	4.948	32.477	0.152	✓	1	Member Block Shear
T13	242	Diagonal	A325N	0.6250	1	4.898	13.806	0.355	✓	1	Bolt Shear
		Horizontal	A325N	0.6250	1	1.534	7.875	0.195	✓	1	Member Block Shear
		Top Girt	A325N	0.6250	1	0.762	7.875	0.097	✓	1	Member Block Shear
T14	222	Diagonal	A325N	0.6250	1	8.249	13.806	0.598	✓	1	Bolt Shear
		Horizontal	A325N	0.6250	1	1.943	7.875	0.247	✓	1	Member Block Shear
		Top Girt	A325N	0.6250	1	0.828	7.875	0.105	✓	1	Member Block Shear
		Top Guy Pull-Off@210	A325N	0.7500	2	5.501	32.477	0.169	✓	1	Member Block Shear
T15	202	Diagonal	A325N	0.6250	1	7.462	13.806	0.541	✓	1	Bolt Shear
		Horizontal	A325N	0.6250	1	2.186	7.875	0.278	✓	1	Member Block Shear
		Top Girt	A325N	0.6250	1	1.038	7.875	0.132	✓	1	Member Block Shear
T16	182	Diagonal	A325N	0.6250	1	5.556	13.806	0.402	✓	1	Bolt Shear
		Horizontal	A325N	0.6250	1	2.438	7.875	0.310	✓	1	Member Block Shear
		Top Girt	A325N	0.6250	1	1.035	7.875	0.131	✓	1	Member Block Shear
T17	162	Diagonal	A325N	0.6250	1	7.545	13.806	0.547	✓	1	Bolt Shear
		Horizontal	A325N	0.6250	1	2.394	7.875	0.304	✓	1	Member Block Shear
		Top Girt	A325N	0.6250	1	1.527	7.875	0.194	✓	1	Member Block Shear
T18	142	Top Guy Pull-Off@154	A325N	0.7500	2	3.359	32.477	0.103	✓	1	Member Block Shear
		Diagonal	A325N	0.6250	1	6.396	13.806	0.463	✓	1	Bolt Shear
		Horizontal	A325N	0.6250	1	2.380	7.875	0.302	✓	1	Member Block Shear
		Top Girt	A325N	0.6250	1	1.086	7.875	0.138	✓	1	Member Block Shear

tnxTower Vertical Bridge 750 Park of Commerce Drive Boca Raton, FL 33487 Phone: 561-948-6367 FAX:	Job	US-CT-5009	Page	67 of 83
	Project	Guyed Tower Structural Analysis	Date	11:53:35 05/29/20
	Client		Designed by	JWagner

Section No.	Elevation ft	Component Type	Bolt Grade	Bolt Size in	Number Of Bolts	Maximum Load per Bolt K	Allowable Load per Bolt K	Ratio Load Allowable	Allowable Ratio	Criteria
T19	122	Diagonal	A325N	0.6250	1	7.785	13.806	0.564 ✓	1	Bolt Shear
		Horizontal	A325N	0.6250	1	2.207	7.875	0.280 ✓	1	Member Block Shear
		Top Girt	A325N	0.6250	1	1.151	7.875	0.146 ✓	1	Member Block Shear
T20	112	Diagonal	A325N	0.6250	1	9.036	13.806	0.655 ✓	1	Bolt Shear
		Horizontal	A325N	0.6250	1	2.106	7.875	0.267 ✓	1	Member Block Shear
		Top Girt	A325N	0.6250	1	1.173	7.875	0.149 ✓	1	Member Block Shear
T21	102	Diagonal	A325N	0.6250	1	6.410	13.806	0.464 ✓	1	Bolt Shear
		Horizontal	A325N	0.6250	1	2.198	7.875	0.279 ✓	1	Member Block Shear
		Top Guy Pull-Off@102	A325N	0.7500	2	4.254	32.477	0.131 ✓	1	Member Block Shear
T22	82	Diagonal	A325N	0.6250	1	6.340	13.806	0.459 ✓	1	Bolt Shear
		Horizontal	A325N	0.6250	1	2.227	7.875	0.283 ✓	1	Member Block Shear
		Top Girt	A325N	0.6250	1	1.041	7.875	0.132 ✓	1	Member Block Shear
T23	62	Diagonal	A325N	0.6250	1	8.330	13.806	0.603 ✓	1	Bolt Shear
		Horizontal	A325N	0.6250	1	2.407	7.875	0.306 ✓	1	Member Block Shear
		Top Girt	A325N	0.6250	1	1.016	7.875	0.129 ✓	1	Member Block Shear
		Top Guy Pull-Off@46	A325N	0.7500	2	3.031	32.477	0.093 ✓	1	Member Block Shear
T24	42	Diagonal	A325N	0.6250	1	8.122	13.806	0.588 ✓	1	Bolt Shear
		Horizontal	A325N	0.6250	1	2.360	7.875	0.300 ✓	1	Member Block Shear
		Top Girt	A325N	0.6250	1	0.955	7.875	0.121 ✓	1	Member Block Shear
T25	22	Diagonal	A325N	0.6250	1	6.643	13.806	0.481 ✓	1	Bolt Shear
		Horizontal	A325N	0.6250	1	2.262	7.875	0.287 ✓	1	Member Block Shear
		Top Girt	A325N	0.6250	1	0.998	7.875	0.127 ✓	1	Member Block Shear

Guy Design Data

Section No.	Elevation ft	Size	Initial Tension K	Breaking Load K	Actual T_u K	Allowable ϕT_n K	Required S.F.	Actual S.F.
T3	442.000 (A) (776)	1 BS	12.200	122.000	32.171	73.200	1.000	2.275 ✓
	442.000 (B) (775)	1 BS	12.200	122.000	32.763	73.200	1.000	2.234 ✓
	442.000 (C) (774)	1 BS	12.200	122.000	32.637	73.200	1.000	2.243 ✓
T6	382.000 (A) (779)	1 BS	12.200	122.000	32.272	73.200	1.000	2.268 ✓

tnxTower Vertical Bridge 750 Park of Commerce Drive Boca Raton, FL 33487 Phone: 561-948-6367 FAX:	Job	US-CT-5009	Page	68 of 83
	Project	Guyed Tower Structural Analysis	Date	11:53:35 05/29/20
	Client		Designed by	JWagner

Section No.	Elevation ft	Size	Initial Tension K	Breaking Load K	Actual T_u K	Allowable ϕT_n K	Required S.F.	Actual S.F.
	382.000 (B) (778)	1 BS	12.200	122.000	33.237	73.200	1.000	2.202 ✓
	382.000 (C) (777)	1 BS	12.200	122.000	32.980	73.200	1.000	2.220 ✓
T9	322.000 (A) (782)	7/8 BS	9.200	92.000	26.398	55.200	1.000	2.091 ✓
	322.000 (B) (781)	7/8 BS	9.200	92.000	27.582	55.200	1.000	2.001 ✓
	322.000 (C) (780)	7/8 BS	9.200	92.000	27.407	55.200	1.000	2.014 ✓
T12	262.000 (A) (785)	7/8 BS	9.200	92.000	31.118	55.200	1.000	1.774 ✓
	262.000 (B) (784)	7/8 BS	9.200	92.000	32.299	55.200	1.000	1.709 ✓
	262.000 (C) (783)	7/8 BS	9.200	92.000	32.535	55.200	1.000	1.697 ✓
T14	210.000 (A) (788)	7/8 BS	9.200	92.000	34.207	55.200	1.000	1.614 ✓
	210.000 (B) (787)	7/8 BS	9.200	92.000	35.404	55.200	1.000	1.559 ✓
	210.000 (C) (786)	7/8 BS	9.200	92.000	35.630	55.200	1.000	1.549 ✓
T17	154.000 (A) (791)	9/16 EHS	3.500	35.000	16.110	21.000	1.000	1.304 ✓
	154.000 (B) (790)	9/16 EHS	3.500	35.000	16.511	21.000	1.000	1.272 ✓
	154.000 (C) (789)	9/16 EHS	3.500	35.000	16.658	21.000	1.000	1.261 ✓
T21	102.000 (A) (794)	9/16 EHS	3.500	35.000	16.905	21.000	1.000	1.242 ✓
	102.000 (B) (793)	9/16 EHS	3.500	35.000	17.294	21.000	1.000	1.214 ✓
	102.000 (C) (792)	9/16 EHS	3.500	35.000	17.427	21.000	1.000	1.205 ✓
T23	46.000 (A) (797)	1/2 EHS	2.690	26.900	9.635	16.140	1.000	1.675 ✓
	46.000 (B) (796)	1/2 EHS	2.690	26.900	9.878	16.140	1.000	1.634 ✓
	46.000 (C) (795)	1/2 EHS	2.690	26.900	9.984	16.140	1.000	1.617 ✓

Compression Checks

Pole Design Data

Section No.	Elevation ft	Size	L ft	L_u ft	Kl/r	A in^2	P_u K	ϕP_n K	Ratio $\frac{P_u}{\phi P_n}$
L1	492 - 477 (1)	P8x.406	15.000	35.000	144.4	10.4832	-0.720	113.643	0.006
L2	477 - 457 (2)	P8x.406	20.000	35.000	144.4	10.4832	-1.638	113.643	0.014

tnxTower Vertical Bridge 750 Park of Commerce Drive Boca Raton, FL 33487 Phone: 561-948-6367 FAX:	Job US-CT-5009	Page 69 of 83
	Project Guyed Tower Structural Analysis	Date 11:53:35 05/29/20
	Client	Designed by JWagner

Pole Bending Design Data

Section No.	Elevation ft	Size	M_{ux} kip-ft	ϕM_{nx} kip-ft	Ratio $\frac{M_{ux}}{\phi M_{nx}}$	M_{uy} kip-ft	ϕM_{ny} kip-ft	Ratio $\frac{M_{uy}}{\phi M_{ny}}$
L1	492 - 477 (1)	P8x.406	5.284	72.052	0.073	0.000	72.052	0.000
L2	477 - 457 (2)	P8x.406	27.352	72.052	0.380	0.000	72.052	0.000

Pole Shear Design Data

Section No.	Elevation ft	Size	Actual V_u K	ϕV_n K	Ratio $\frac{V_u}{\phi V_n}$	Actual T_u kip-ft	ϕT_n kip-ft	Ratio $\frac{T_u}{\phi T_n}$
L1	492 - 477 (1)	P8x.406	0.691	99.067	0.007	0.000	71.586	0.000
L2	477 - 457 (2)	P8x.406	1.451	99.067	0.015	0.384	71.586	0.005

Pole Interaction Design Data

Section No.	Elevation ft	Ratio $\frac{P_u}{\phi P_n}$	Ratio $\frac{M_{ux}}{\phi M_{nx}}$	Ratio $\frac{M_{uy}}{\phi M_{ny}}$	Ratio $\frac{V_u}{\phi V_n}$	Ratio $\frac{T_u}{\phi T_n}$	Comb. Stress Ratio	Allow. Stress Ratio	Criteria
L1	492 - 477 (1)	0.006	0.073	0.000	0.007	0.000	0.080	1.000	4.8.2 ✓
L2	477 - 457 (2)	0.014	0.380	0.000	0.015	0.005	0.394 ✓ ✓	1.000	4.8.2 ✓

Leg Design Data (Compression)

Section No.	Elevation ft	Size	L ft	L_u ft	Kl/r	A in ²	Mast Stability Index	P_u K	ϕP_n K	Ratio $\frac{P_u}{\phi P_n}$
T1	457 - 452	2 1/4	5.000	5.000	106.7 K=1.00	3.9761	1.00	-7.837	77.870	0.101 ¹
T2	452 - 442	2 1/4	10.000	3.333	71.1 K=1.00	3.9761	1.00	-16.787	123.621	0.136 ¹
T3	442 - 422	2 1/4	20.000	4.000	85.3 K=1.00	3.9761	1.00	-23.369	105.060	0.222 ¹
T4	422 - 402	2 1/4	20.000	4.000	85.3 K=1.00	3.9761	1.00	-29.666	105.060	0.282 ¹
T5	402 - 382	2 1/4	20.000	4.000	85.3 K=1.00	3.9761	1.00	-48.369	105.060	0.460 ¹
T6	382 - 362	2 1/4	20.000	4.000	85.3 K=1.00	3.9761	1.00	-53.975	105.060	0.514 ¹
T7	362 - 342	2 1/4	20.000	4.000	85.3 K=1.00	3.9761	1.00	-49.660	105.060	0.473 ¹

tnxTower Vertical Bridge 750 Park of Commerce Drive Boca Raton, FL 33487 Phone: 561-948-6367 FAX:	Job US-CT-5009	Page 70 of 83
	Project Guyed Tower Structural Analysis	Date 11:53:35 05/29/20
	Client	Designed by JWagner

Section No.	Elevation ft	Size	L ft	L _u ft	Kl/r	A in ²	Mast Stability Index	P _u K	φP _n K	Ratio $\frac{P_u}{\phi P_n}$
T8	342 - 322	2 1/4	20.000	4.000	K=1.00 85.3	3.9761	1.00	-63.432	105.060	0.604 ¹
T9	322 - 302	2 1/2	20.000	4.000	K=1.00 76.8	4.9087	1.00	-65.638	143.512	0.457 ¹
T10	302 - 282	2 1/2	20.000	4.000	K=1.00 76.8	4.9087	1.00	-68.222	143.512	0.475 ¹
T11	282 - 262	2 3/4	20.000	4.000	K=1.00 69.8	5.9396	1.00	-72.502	187.145	0.387 ¹
T12	262 - 242	2 3/4	20.000	4.000	K=1.00 69.8	5.9396	1.00	-88.770	187.145	0.474 ¹
T13	242 - 222	2 3/4	20.000	4.000	K=1.00 69.8	5.9396	1.00	-88.576	187.145	0.473 ¹
T14	222 - 202	3	20.000	4.000	K=1.00 64.0	7.0686	1.00	-112.190	235.765	0.476 ¹
T15	202 - 182	3	20.000	4.000	K=1.00 64.0	7.0686	1.00	-126.183	235.765	0.535 ¹
T16	182 - 162	3	20.000	4.000	K=1.00 64.0	7.0686	1.00	-135.004	235.765	0.573 ¹
T17	162 - 142	3	20.000	4.000	K=1.00 64.0	7.0686	1.00	-138.208	235.765	0.586 ¹
T18	142 - 122	3	20.000	4.000	K=1.00 64.0	7.0686	1.00	-137.418	235.765	0.583 ¹
T19	122 - 112	3	10.000	3.333	K=1.00 53.3	7.0686	1.00	-127.409	258.358	0.493 ¹
T20	112 - 102	3	10.000	3.333	K=1.00 53.3	7.0686	1.00	-121.613	258.358	0.471 ¹
T21	102 - 82	3	20.000	4.000	K=1.00 64.0	7.0686	1.00	-126.922	235.765	0.538 ¹
T22	82 - 62	3	20.000	4.000	K=1.00 64.0	7.0686	1.00	-128.590	235.765	0.545 ¹
T23	62 - 42	3	20.000	4.000	K=1.00 64.0	7.0686	1.00	-138.956	235.765	0.589 ¹
T24	42 - 22	3	20.000	4.000	K=1.00 64.0	7.0686	1.00	-136.263	235.765	0.578 ¹
T25	22 - 2	3	20.000	4.000	K=1.00 64.0	7.0686	1.00	-130.589	235.765	0.554 ¹

¹ P_u / φP_n controls

Leg Bending Design Data (Compression)

Section No.	Elevation ft	Size	M _{ux} kip-ft	φM _{ux} kip-ft	Ratio $\frac{M_{ux}}{\phi M_{ux}}$	M _{uy} kip-ft	φM _{uy} kip-ft	Ratio $\frac{M_{uy}}{\phi M_{uy}}$
T1	457 - 452	2 1/4	0.000	7.119	0.000	0.000	7.119	0.000
T2	452 - 442	2 1/4	0.000	7.119	0.000	0.000	7.119	0.000
T3	442 - 422	2 1/4	0.000	7.119	0.000	0.000	7.119	0.000
T4	422 - 402	2 1/4	0.000	7.119	0.000	0.000	7.119	0.000
T5	402 - 382	2 1/4	0.000	7.119	0.000	0.000	7.119	0.000
T6	382 - 362	2 1/4	0.000	7.119	0.000	0.000	7.119	0.000
T7	362 - 342	2 1/4	0.000	7.119	0.000	0.000	7.119	0.000
T8	342 - 322	2 1/4	0.000	7.119	0.000	0.000	7.119	0.000
T9	322 - 302	2 1/2	0.000	9.766	0.000	0.000	9.766	0.000
T10	302 - 282	2 1/2	0.000	9.766	0.000	0.000	9.766	0.000
T11	282 - 262	2 3/4	0.000	12.998	0.000	0.000	12.998	0.000

tnxTower Vertical Bridge 750 Park of Commerce Drive Boca Raton, FL 33487 Phone: 561-948-6367 FAX:	Job	US-CT-5009	Page	71 of 83
	Project	Guyed Tower Structural Analysis	Date	11:53:35 05/29/20
	Client		Designed by	JWagner

Section No.	Elevation ft	Size	M_{ux} kip-ft	ϕM_{nx} kip-ft	Ratio $\frac{M_{ux}}{\phi M_{nx}}$	M_{uy} kip-ft	ϕM_{ny} kip-ft	Ratio $\frac{M_{uy}}{\phi M_{ny}}$
T12	262 - 242	2 3/4	0.000	12.998	0.000	0.000	12.998	0.000
T13	242 - 222	2 3/4	0.000	12.998	0.000	0.000	12.998	0.000
T14	222 - 202	3	0.000	16.875	0.000	0.000	16.875	0.000
T15	202 - 182	3	0.000	16.875	0.000	0.000	16.875	0.000
T16	182 - 162	3	0.000	16.875	0.000	0.000	16.875	0.000
T17	162 - 142	3	0.000	16.875	0.000	0.000	16.875	0.000
T18	142 - 122	3	0.000	16.875	0.000	0.000	16.875	0.000
T19	122 - 112	3	0.000	16.875	0.000	0.000	16.875	0.000
T20	112 - 102	3	0.000	16.875	0.000	0.000	16.875	0.000
T21	102 - 82	3	0.000	16.875	0.000	0.000	16.875	0.000
T22	82 - 62	3	0.000	16.875	0.000	0.000	16.875	0.000
T23	62 - 42	3	0.000	16.875	0.000	0.000	16.875	0.000
T24	42 - 22	3	0.000	16.875	0.000	0.000	16.875	0.000
T25	22 - 2	3	0.000	16.875	0.000	0.000	16.875	0.000

Leg Interaction Design Data (Compression)

Section No.	Elevation ft	Size	Ratio $\frac{P_u}{\phi P_n}$	Ratio $\frac{M_{ux}}{\phi M_{nx}}$	Ratio $\frac{M_{uy}}{\phi M_{ny}}$	Comb. Stress Ratio	Allow. Stress Ratio	Criteria
T1	457 - 452	2 1/4	0.101	0.000	0.000	0.101 ¹	1.000	4.8.1 ✓
T2	452 - 442	2 1/4	0.136	0.000	0.000	0.136 ¹	1.000	4.8.1 ✓
T3	442 - 422	2 1/4	0.222	0.000	0.000	0.222 ¹	1.000	4.8.1 ✓
T4	422 - 402	2 1/4	0.282	0.000	0.000	0.282 ¹	1.000	4.8.1 ✓
T5	402 - 382	2 1/4	0.460	0.000	0.000	0.460 ¹	1.000	4.8.1 ✓
T6	382 - 362	2 1/4	0.514	0.000	0.000	0.514 ¹	1.000	4.8.1 ✓
T7	362 - 342	2 1/4	0.473	0.000	0.000	0.473 ¹	1.000	4.8.1 ✓
T8	342 - 322	2 1/4	0.604	0.000	0.000	0.604 ¹	1.000	4.8.1 ✓
T9	322 - 302	2 1/2	0.457	0.000	0.000	0.457 ¹	1.000	4.8.1 ✓
T10	302 - 282	2 1/2	0.475	0.000	0.000	0.475 ¹	1.000	4.8.1 ✓
T11	282 - 262	2 3/4	0.387	0.000	0.000	0.387 ¹	1.000	4.8.1 ✓
T12	262 - 242	2 3/4	0.474	0.000	0.000	0.474 ¹	1.000	4.8.1 ✓
T13	242 - 222	2 3/4	0.473	0.000	0.000	0.473 ¹	1.000	4.8.1 ✓
T14	222 - 202	3	0.476	0.000	0.000	0.476 ¹	1.000	4.8.1 ✓
T15	202 - 182	3	0.535	0.000	0.000	0.535 ¹	1.000	4.8.1 ✓
T16	182 - 162	3	0.573	0.000	0.000	0.573 ¹	1.000	4.8.1 ✓

tnxTower Vertical Bridge 750 Park of Commerce Drive Boca Raton, FL 33487 Phone: 561-948-6367 FAX:	Job US-CT-5009	Page 72 of 83
	Project Guyed Tower Structural Analysis	Date 11:53:35 05/29/20
	Client	Designed by JWagner

Section No.	Elevation ft	Size	Ratio	Ratio	Ratio	Comb. Stress Ratio	Allow. Stress Ratio	Criteria
			$\frac{P_u}{\phi P_n}$	$\frac{M_{ux}}{\phi M_{nx}}$	$\frac{M_{uy}}{\phi M_{ny}}$			
T17	162 - 142	3	0.586	0.000	0.000	0.586 ¹	1.000	4.8.1 ✓
T18	142 - 122	3	0.583	0.000	0.000	0.583 ¹	1.000	4.8.1 ✓
T19	122 - 112	3	0.493	0.000	0.000	0.493 ¹	1.000	4.8.1 ✓
T20	112 - 102	3	0.471	0.000	0.000	0.471 ¹	1.000	4.8.1 ✓
T21	102 - 82	3	0.538	0.000	0.000	0.538 ¹	1.000	4.8.1 ✓
T22	82 - 62	3	0.545	0.000	0.000	0.545 ¹	1.000	4.8.1 ✓
T23	62 - 42	3	0.589	0.000	0.000	0.589 ¹	1.000	4.8.1 ✓
T24	42 - 22	3	0.578	0.000	0.000	0.578 ¹	1.000	4.8.1 ✓
T25	22 - 2	3	0.554	0.000	0.000	0.554 ¹	1.000	4.8.1 ✓

¹ $P_u / \phi P_n$ controls

Diagonal Design Data (Compression)

Section No.	Elevation ft	Size	L	L _u	Kl/r	A	P _u	ϕP_n	Ratio
			ft	ft		in ²	K	K	$\frac{P_u}{\phi P_n}$
T1	457 - 452	L2 1/2x2x3/16	5.385	4.841	136.0 K=1.00	0.8090	-1.957	12.510	0.156 ¹ ✓
T2	452 - 442	L2x2x1/4	5.207	4.671	143.4 K=1.00	0.9380	-2.459	13.063	0.188 ¹ ✓
T3	442 - 422	L2x2x1/4	5.657	5.100	156.5 K=1.00	0.9380	-1.374	10.958	0.125 ¹ ✓
T4	422 - 402	L2x2x1/4	5.657	5.100	156.5 K=1.00	0.9380	-2.309	10.958	0.211 ¹ ✓
T5	402 - 382	L2x2x1/4	5.657	5.100	156.5 K=1.00	0.9380	-4.078	10.958	0.372 ¹ ✓
T6	382 - 362	L2x2x1/4	5.657	5.100	156.5 K=1.00	0.9380	-2.423	10.958	0.221 ¹ ✓
T7	362 - 342	L2x2x1/4	5.657	5.100	156.5 K=1.00	0.9380	-1.770	10.958	0.162 ¹ ✓
T8	342 - 322	L2x2x1/4	5.657	5.100	156.5 K=1.00	0.9380	-3.199	10.958	0.292 ¹ ✓
T9	322 - 302	L1 3/4x1 3/4x3/16	5.657	5.071	177.2 K=1.00	0.6211	-3.997	5.664	0.706 ¹ ✓
T10	302 - 282	L2x2x1/4	5.657	5.071	155.6 K=1.00	0.9380	-2.265	11.086	0.204 ¹ ✓
T11	282 - 262	L2 1/2x2 1/2x3/8	5.657	5.041	124.2 K=1.00	1.7300	-6.707	32.063	0.209 ¹ ✓

tnxTower Vertical Bridge 750 Park of Commerce Drive Boca Raton, FL 33487 Phone: 561-948-6367 FAX:	Job US-CT-5009	Page 73 of 83
	Project Guyed Tower Structural Analysis	Date 11:53:35 05/29/20
	Client	Designed by JWagner

Section No.	Elevation ft	Size	L ft	L _u ft	Kl/r	A in ²	P _u K	φP _n K	Ratio P _u / φP _n
T12	262 - 242	L2x2x1/4	5.657	5.041	154.7 K=1.00	0.9380	-5.256	11.216	0.469 ¹ ✓
T13	242 - 222	L2x2x1/4	5.657	5.041	154.7 K=1.00	0.9380	-4.898	11.216	0.437 ¹ ✓
T14	222 - 202	L2 1/2x2 1/2x3/8	5.657	5.012	123.5 K=1.00	1.7300	-8.249	32.415	0.254 ¹ ✓
T15	202 - 182	L2x2x1/4	5.657	5.012	153.8 K=1.00	0.9380	-7.462	11.348	0.658 ¹ ✓
T16	182 - 162	L2x2x1/4	5.657	5.012	153.8 K=1.00	0.9380	-5.556	11.348	0.490 ¹ ✓
T17	162 - 142	L2x2x1/4	5.657	5.012	153.8 K=1.00	0.9380	-7.545	11.348	0.665 ¹ ✓
T18	142 - 122	L2x2x1/4	5.657	5.012	153.8 K=1.00	0.9380	-6.396	11.348	0.564 ¹ ✓
T19	122 - 112	L2x2x1/4	5.207	4.590	140.9 K=1.00	0.9380	-7.785	13.531	0.575 ¹ ✓
T20	112 - 102	L1 3/4x1 3/4x3/16 w/ L2x2x1/4	5.207	4.881	99.8 K=1.00	1.5710	-9.036	30.133	0.300 ¹ ✓
T21	102 - 82	L2x2x1/4	5.657	5.012	153.8 K=1.00	0.9380	-6.410	11.348	0.565 ¹ ✓
T22	82 - 62	L2x2x1/4	5.657	5.012	153.8 K=1.00	0.9380	-6.340	11.348	0.559 ¹ ✓
T23	62 - 42	L2x2x1/4	5.657	5.012	153.8 K=1.00	0.9380	-8.330	11.348	0.734 ¹ ✓
T24	42 - 22	L2x2x1/4	5.657	5.012	153.8 K=1.00	0.9380	-8.122	11.348	0.716 ¹ ✓
T25	22 - 2	L2x2x1/4	5.657	5.012	153.8 K=1.00	0.9380	-6.643	11.348	0.585 ¹ ✓

¹ P_u / φP_n controls

Horizontal Design Data (Compression)

Section No.	Elevation ft	Size	L ft	L _u ft	Kl/r	A in ²	P _u K	φP _n K	Ratio P _u / φP _n
T2	452 - 442	L2x2x3/16	4.000	3.521	113.6 K=1.06	0.7150	-0.291	15.292	0.019 ¹ ✓
T3	442 - 422	L2x2x3/16	4.000	3.521	113.6 K=1.06	0.7150	-0.405	15.292	0.026 ¹ ✓
T4	422 - 402	L2x2x3/16	4.000	3.521	113.6 K=1.06	0.7150	-0.514	15.292	0.034 ¹ ✓
T5	402 - 382	L2x2x3/16	4.000	3.521	113.6 K=1.06	0.7150	-0.838	15.292	0.055 ¹ ✓
T6	382 - 362	L2x2x3/16	4.000	3.521	113.6 K=1.06	0.7150	-0.935	15.292	0.061 ¹ ✓
T7	362 - 342	L2x2x3/16	4.000	3.521	113.6 K=1.06	0.7150	-0.860	15.292	0.056 ¹ ✓
T8	342 - 322	L2x2x3/16	4.000	3.521	113.6 K=1.06	0.7150	-1.099	15.292	0.072 ¹ ✓

tnxTower Vertical Bridge 750 Park of Commerce Drive Boca Raton, FL 33487 Phone: 561-948-6367 FAX:	Job	US-CT-5009	Page	74 of 83
	Project	Guyed Tower Structural Analysis	Date	11:53:35 05/29/20
	Client		Designed by	JWagner

Section No.	Elevation ft	Size	L ft	L _u ft	Kl/r	A in ²	P _u K	φP _n K	Ratio $\frac{P_u}{\phi P_n}$
T9	322 - 302	L2x2x3/16	4.000	3.500	113.3 K=1.06	0.7150	-1.137	15.350	0.074 ¹ ✓
T10	302 - 282	L2x2x3/16	4.000	3.500	113.3 K=1.06	0.7150	-1.182	15.350	0.077 ¹ ✓
T11	282 - 262	L2x2x3/16	4.000	3.479	113.0 K=1.07	0.7150	-1.256	15.408	0.081 ¹ ✓
T12	262 - 242	L2x2x3/16	4.000	3.479	113.0 K=1.07	0.7150	-1.538	15.408	0.100 ¹ ✓
T13	242 - 222	L2x2x3/16	4.000	3.479	113.0 K=1.07	0.7150	-1.534	15.408	0.100 ¹ ✓
T14	222 - 202	L2x2x3/16	4.000	3.458	112.7 K=1.07	0.7150	-1.943	15.466	0.126 ¹ ✓
T15	202 - 182	L2x2x3/16	4.000	3.458	112.7 K=1.07	0.7150	-2.186	15.466	0.141 ¹ ✓
T16	182 - 162	L2x2x3/16	4.000	3.458	112.7 K=1.07	0.7150	-2.338	15.466	0.151 ¹ ✓
T17	162 - 142	L2x2x3/16	4.000	3.458	112.7 K=1.07	0.7150	-2.394	15.466	0.155 ¹ ✓
T18	142 - 122	L2x2x3/16	4.000	3.458	112.7 K=1.07	0.7150	-2.380	15.466	0.154 ¹ ✓
T19	122 - 112	L2x2x3/16	4.000	3.458	112.7 K=1.07	0.7150	-2.207	15.466	0.143 ¹ ✓
T20	112 - 102	L2x2x3/16	4.000	3.458	112.7 K=1.07	0.7150	-2.106	15.466	0.136 ¹ ✓
T21	102 - 82	L2x2x3/16	4.000	3.458	112.7 K=1.07	0.7150	-2.198	15.466	0.142 ¹ ✓
T22	82 - 62	L2x2x3/16	4.000	3.458	112.7 K=1.07	0.7150	-2.227	15.466	0.144 ¹ ✓
T23	62 - 42	L2x2x3/16	4.000	3.458	112.7 K=1.07	0.7150	-2.407	15.466	0.156 ¹ ✓
T24	42 - 22	L2x2x3/16	4.000	3.458	112.7 K=1.07	0.7150	-2.360	15.466	0.153 ¹ ✓
T25	22 - 2	L2x2x3/16	4.000	3.458	112.7 K=1.07	0.7150	-2.262	15.466	0.146 ¹ ✓

¹ P_u / φP_n controls

Top Girt Design Data (Compression)

Section No.	Elevation ft	Size	L ft	L _u ft	Kl/r	A in ²	P _u K	φP _n K	Ratio $\frac{P_u}{\phi P_n}$
T1	457 - 452	C6x10.5	4.000	2.859	64.9 K=1.00	3.0900	-0.000	80.226	0.000 ¹ ✓
T2	452 - 442	L2x2x3/16	4.000	3.521	113.6 K=1.06	0.7150	-0.744	15.292	0.049 ¹ ✓
T4	422 - 402	L2x2x3/16	4.000	3.521	113.6 K=1.06	0.7150	-0.037	15.292	0.002 ¹ ✓

tnxTower Vertical Bridge 750 Park of Commerce Drive Boca Raton, FL 33487 Phone: 561-948-6367 FAX:	Job US-CT-5009	Page 75 of 83
	Project Guyed Tower Structural Analysis	Date 11:53:35 05/29/20
	Client	Designed by JWagner

Section No.	Elevation ft	Size	L ft	L _u ft	Kl/r	A in ²	P _u K	φP _n K	Ratio $\frac{P_u}{\phi P_n}$
T5	402 - 382	L2x2x3/16	4.000	3.521	113.6 K=1.06	0.7150	-0.037	15.292	0.002 ¹ ✓
T11	282 - 262	L2x2x3/16	4.000	3.479	113.0 K=1.07	0.7150	-0.611	15.408	0.040 ¹ ✓
T17	162 - 142	L2x2x3/16	4.000	3.458	112.7 K=1.07	0.7150	-0.124	15.466	0.008 ¹ ✓

¹ P_u / φP_n controls

Tension Checks

Leg Design Data (Tension)

Section No.	Elevation ft	Size	L ft	L _u ft	Kl/r	A in ²	P _u K	φP _n K	Ratio $\frac{P_u}{\phi P_n}$
T1	457 - 452	2 1/4	5.000	5.000	106.7	3.9761	6.867	178.924	0.038 ¹
T2	452 - 442	2 1/4	10.000	3.333	71.1	3.9761	14.902	178.924	0.083 ¹
T5	402 - 382	2 1/4	20.000	4.000	85.3	3.9761	4.448	178.924	0.025 ¹

¹ P_u / φP_n controls

Leg Bending Design Data (Tension)

Section No.	Elevation ft	Size	M _{ux} kip-ft	φM _{ux} kip-ft	Ratio $\frac{M_{ux}}{\phi M_{ux}}$	M _{uy} kip-ft	φM _{uy} kip-ft	Ratio $\frac{M_{uy}}{\phi M_{uy}}$
T1	457 - 452	2 1/4	0.000	7.119	0.000	0.000	7.119	0.000
T2	452 - 442	2 1/4	0.000	7.119	0.000	0.000	7.119	0.000
T5	402 - 382	2 1/4	0.000	7.119	0.000	0.000	7.119	0.000

Leg Interaction Design Data (Tension)

Section No.	Elevation ft	Size	Ratio $\frac{P_u}{\phi P_n}$	Ratio $\frac{M_{ux}}{\phi M_{ux}}$	Ratio $\frac{M_{uy}}{\phi M_{uy}}$	Comb. Stress Ratio	Allow. Stress Ratio	Criteria
T1	457 - 452	2 1/4	0.038	0.000	0.000	0.038 ¹ ✓	1.000	4.8.1 ✓
T2	452 - 442	2 1/4	0.083	0.000	0.000	0.083 ¹ ✓	1.000	4.8.1 ✓
T5	402 - 382	2 1/4	0.025	0.000	0.000	0.025 ¹ ✓	1.000	4.8.1 ✓

tnxTower Vertical Bridge 750 Park of Commerce Drive Boca Raton, FL 33487 Phone: 561-948-6367 FAX:	Job US-CT-5009	Page 76 of 83
	Project Guyed Tower Structural Analysis	Date 11:53:35 05/29/20
	Client	Designed by JWagner

¹ $P_u / \phi P_n$ controls

Diagonal Design Data (Tension)

Section No.	Elevation ft	Size	L ft	L_u ft	Kl/r	A in ²	P_u K	ϕP_n K	Ratio $\frac{P_u}{\phi P_n}$
T1	457 - 452	L2 1/2x2x3/16	5.385	4.841	102.7	0.5013	1.788	21.806	0.082 ¹
T2	452 - 442	L2x2x1/4	5.207	4.671	97.8	0.5629	2.352	24.485	0.096 ¹
T3	442 - 422	L2x2x1/4	5.657	5.100	106.2	0.5629	1.157	24.485	0.047 ¹
T4	422 - 402	L2x2x1/4	5.657	5.100	106.2	0.5629	2.046	24.485	0.084 ¹
T5	402 - 382	L2x2x1/4	5.657	5.100	106.2	0.5629	3.635	24.485	0.148 ¹
T6	382 - 362	L2x2x1/4	5.657	5.100	106.2	0.5629	1.994	24.485	0.081 ¹
T7	362 - 342	L2x2x1/4	5.657	5.100	106.2	0.5629	1.230	24.485	0.050 ¹
T8	342 - 322	L2x2x1/4	5.657	5.100	106.2	0.5629	2.539	24.485	0.104 ¹
T9	322 - 302	L1 3/4x1 3/4x3/16	5.657	5.071	119.8	0.3604	3.368	15.675	0.215 ¹
T10	302 - 282	L2x2x1/4	5.657	5.071	105.7	0.5629	1.342	24.485	0.055 ¹
T11	282 - 262	L2 1/2x2 1/2x3/8	5.657	5.041	85.0	1.0866	5.505	47.266	0.116 ¹
T12	262 - 242	L2x2x1/4	5.657	5.041	105.1	0.5629	4.003	24.485	0.163 ¹
T13	242 - 222	L2x2x1/4	5.657	5.041	105.1	0.5629	3.630	24.485	0.148 ¹
T14	222 - 202	L2 1/2x2 1/2x3/8	5.657	5.012	84.5	1.0866	6.232	47.266	0.132 ¹
T15	202 - 182	L2x2x1/4	5.657	5.012	104.5	0.5629	5.380	24.485	0.220 ¹
T16	182 - 162	L2x2x1/4	5.657	5.012	104.5	0.5629	3.803	24.485	0.155 ¹
T17	162 - 142	L2x2x1/4	5.657	5.012	104.5	0.5629	5.716	24.485	0.233 ¹
T18	142 - 122	L2x2x1/4	5.657	5.012	104.5	0.5629	4.488	24.485	0.183 ¹
T19	122 - 112	L2x2x1/4	5.207	4.590	96.2	0.5629	5.211	24.485	0.213 ¹
T20	112 - 102	L1 3/4x1 3/4x3/16 w/ L2x2x1/4	5.207	4.881	99.8	1.5710	6.576	50.900	0.129 ¹
T21	102 - 82	L2x2x1/4	5.657	5.012	104.5	0.5629	4.234	24.485	0.173 ¹
T22	82 - 62	L2x2x1/4	5.657	5.012	104.5	0.5629	4.128	24.485	0.169 ¹
T23	62 - 42	L2x2x1/4	5.657	5.012	104.5	0.5629	5.869	24.485	0.240 ¹

tnxTower Vertical Bridge 750 Park of Commerce Drive Boca Raton, FL 33487 Phone: 561-948-6367 FAX:	Job US-CT-5009	Page 77 of 83
	Project Guyed Tower Structural Analysis	Date 11:53:35 05/29/20
	Client	Designed by JWagner

Section No.	Elevation ft	Size	L ft	L _u ft	Kl/r	A in ²	P _u K	φP _n K	Ratio $\frac{P_u}{\phi P_n}$
T24	42 - 22	L2x2x1/4	5.657	5.012	104.5	0.5629	5.837	24.485	0.238 ¹ ✓
T25	22 - 2	L2x2x1/4	5.657	5.012	104.5	0.5629	4.152	24.485	0.170 ¹ ✓

¹ P_u / φP_n controls

Horizontal Design Data (Tension)

Section No.	Elevation ft	Size	L ft	L _u ft	Kl/r	A in ²	P _u K	φP _n K	Ratio $\frac{P_u}{\phi P_n}$
T2	452 - 442	L2x2x3/16	4.000	3.521	74.1	0.4308	0.291	18.739	0.016 ¹ ✓
T3	442 - 422	L2x2x3/16	4.000	3.521	74.1	0.4308	0.405	18.739	0.022 ¹ ✓
T4	422 - 402	L2x2x3/16	4.000	3.521	74.1	0.4308	0.514	18.739	0.027 ¹ ✓
T5	402 - 382	L2x2x3/16	4.000	3.521	74.1	0.4308	0.838	18.739	0.045 ¹ ✓
T6	382 - 362	L2x2x3/16	4.000	3.521	74.1	0.4308	0.935	18.739	0.050 ¹ ✓
T7	362 - 342	L2x2x3/16	4.000	3.521	74.1	0.4308	0.860	18.739	0.046 ¹ ✓
T8	342 - 322	L2x2x3/16	4.000	3.521	74.1	0.4308	1.099	18.739	0.059 ¹ ✓
T9	322 - 302	L2x2x3/16	4.000	3.500	73.7	0.4308	1.137	18.739	0.061 ¹ ✓
T10	302 - 282	L2x2x3/16	4.000	3.500	73.7	0.4308	1.182	18.739	0.063 ¹ ✓
T11	282 - 262	L2x2x3/16	4.000	3.479	73.3	0.4308	1.476	18.739	0.079 ¹ ✓
T12	262 - 242	L2x2x3/16	4.000	3.479	73.3	0.4308	1.552	18.739	0.083 ¹ ✓
T13	242 - 222	L2x2x3/16	4.000	3.479	73.3	0.4308	1.534	18.739	0.082 ¹ ✓
T14	222 - 202	L2x2x3/16	4.000	3.458	72.9	0.4308	1.943	18.739	0.104 ¹ ✓
T15	202 - 182	L2x2x3/16	4.000	3.458	72.9	0.4308	2.186	18.739	0.117 ¹ ✓
T16	182 - 162	L2x2x3/16	4.000	3.458	72.9	0.4308	2.438	18.739	0.130 ¹ ✓
T17	162 - 142	L2x2x3/16	4.000	3.458	72.9	0.4308	2.394	18.739	0.128 ¹ ✓
T18	142 - 122	L2x2x3/16	4.000	3.458	72.9	0.4308	2.380	18.739	0.127 ¹ ✓
T19	122 - 112	L2x2x3/16	4.000	3.458	72.9	0.4308	2.207	18.739	0.118 ¹ ✓

tnxTower Vertical Bridge 750 Park of Commerce Drive Boca Raton, FL 33487 Phone: 561-948-6367 FAX:	Job	US-CT-5009	Page	78 of 83
	Project	Guyed Tower Structural Analysis	Date	11:53:35 05/29/20
	Client		Designed by	JWagner

Section No.	Elevation ft	Size	L ft	L _u ft	Kl/r	A in ²	P _u K	φP _n K	Ratio $\frac{P_u}{\phi P_n}$
T20	112 - 102	L2x2x3/16	4.000	3.458	72.9	0.4308	2.106	18.739	0.112 ¹
T21	102 - 82	L2x2x3/16	4.000	3.458	72.9	0.4308	2.198	18.739	0.117 ¹
T22	82 - 62	L2x2x3/16	4.000	3.458	72.9	0.4308	2.227	18.739	0.119 ¹
T23	62 - 42	L2x2x3/16	4.000	3.458	72.9	0.4308	2.407	18.739	0.128 ¹
T24	42 - 22	L2x2x3/16	4.000	3.458	72.9	0.4308	2.360	18.739	0.126 ¹
T25	22 - 2	L2x2x3/16	4.000	3.458	72.9	0.4308	2.262	18.739	0.121 ¹

¹ P_u / φP_n controls

Top Girt Design Data (Tension)

Section No.	Elevation ft	Size	L ft	L _u ft	Kl/r	A in ²	P _u K	φP _n K	Ratio $\frac{P_u}{\phi P_n}$
T1	457 - 452	C6x10.5	4.000	2.859	64.9	2.1409	0.000	93.128	0.000 ¹
T2	452 - 442	L2x2x3/16	4.000	3.521	74.1	0.4308	0.814	18.739	0.043 ¹
T4	422 - 402	L2x2x3/16	4.000	3.521	74.1	0.4308	0.240	18.739	0.013 ¹
T5	402 - 382	L2x2x3/16	4.000	3.521	74.1	0.4308	0.248	18.739	0.013 ¹
T7	362 - 342	L2x2x3/16	4.000	3.521	74.1	0.4308	0.323	18.739	0.017 ¹
T8	342 - 322	L2x2x3/16	4.000	3.521	74.1	0.4308	0.333	18.739	0.018 ¹
T10	302 - 282	L2x2x3/16	4.000	3.500	73.7	0.4308	0.569	18.739	0.030 ¹
T11	282 - 262	L2x2x3/16	4.000	3.479	73.3	0.4308	1.319	18.739	0.070 ¹
T13	242 - 222	L2x2x3/16	4.000	3.479	73.3	0.4308	0.762	18.739	0.041 ¹
T14	222 - 202	L2x2x3/16	4.000	3.458	72.9	0.4308	0.828	18.739	0.044 ¹
T15	202 - 182	L2x2x3/16	4.000	3.458	72.9	0.4308	1.038	18.739	0.055 ¹
T16	182 - 162	L2x2x3/16	4.000	3.458	72.9	0.4308	1.035	18.739	0.055 ¹
T17	162 - 142	L2x2x3/16	4.000	3.458	72.9	0.4308	1.527	18.739	0.082 ¹
T18	142 - 122	L2x2x3/16	4.000	3.458	72.9	0.4308	1.086	18.739	0.058 ¹
T19	122 - 112	L2x2x3/16	4.000	3.458	72.9	0.4308	1.151	18.739	0.061 ¹

tnxTower Vertical Bridge 750 Park of Commerce Drive Boca Raton, FL 33487 Phone: 561-948-6367 FAX:	Job US-CT-5009	Page 79 of 83
	Project Guyed Tower Structural Analysis	Date 11:53:35 05/29/20
	Client	Designed by JWagner

Section No.	Elevation ft	Size	L ft	L _u ft	Kl/r	A in ²	P _u K	φP _n K	Ratio $\frac{P_u}{\phi P_n}$
T20	112 - 102	L2x2x3/16	4.000	3.458	72.9	0.4308	1.173	18.739	0.063 ¹ ✓
T22	82 - 62	L2x2x3/16	4.000	3.458	72.9	0.4308	1.041	18.739	0.056 ¹ ✓
T23	62 - 42	L2x2x3/16	4.000	3.458	72.9	0.4308	1.016	18.739	0.054 ¹ ✓
T24	42 - 22	L2x2x3/16	4.000	3.458	72.9	0.4308	0.955	18.739	0.051 ¹ ✓
T25	22 - 2	L2x2x3/16	4.000	3.458	72.9	0.4308	0.998	18.739	0.053 ¹ ✓

¹ P_u / φP_n controls

Bottom Girt Design Data (Tension)

Section No.	Elevation ft	Size	L ft	L _u ft	Kl/r	A in ²	P _u K	φP _n K	Ratio $\frac{P_u}{\phi P_n}$
T25	22 - 2	L2x2x3/16	4.000	3.750	72.9	0.7150	3.176	23.166	0.137 ¹ ✓

¹ P_u / φP_n controls

Top Guy Pull-Off Design Data (Tension)

Section No.	Elevation ft	Size	L ft	L _u ft	Kl/r	A in ²	P _u K	φP _n K	Ratio $\frac{P_u}{\phi P_n}$
T3	442 - 422	2L2 1/2x2 1/2x3/8x1/4	4.000	3.813	60.7	2.1094	5.880	91.758	0.064 ¹ ✓
T6	382 - 362	2L 'a' > 22.1987 in - 22 2L2 1/2x2 1/2x3/8x1/4	4.000	3.813	60.7	2.1094	6.970	91.758	0.076 ¹ ✓
T9	322 - 302	2L 'a' > 22.1987 in - 110 2L2 1/2x2 1/2x3/8x1/4	4.000	3.792	60.4	2.1094	6.969	91.758	0.076 ¹ ✓
T12	262 - 242	2L 'a' > 22.0773 in - 208 2L2 1/2x2 1/2x3/8x1/4	4.000	3.771	60.1	2.1094	9.897	91.758	0.108 ¹ ✓
T14	222 - 202	2L 'a' > 21.9560 in - 308 2L2 1/2x2 1/2x3/8x1/4	4.000	3.750	59.7	2.1094	11.002	91.758	0.120 ¹ ✓
T17	162 - 142	2L 'a' > 21.8347 in - 418 2L2 1/2x2 1/2x3/8x1/4	4.000	3.750	59.7	2.1094	6.719	91.758	0.073 ¹ ✓
		2L 'a' > 21.8347 in - 523							✓

tnxTower Vertical Bridge 750 Park of Commerce Drive Boca Raton, FL 33487 Phone: 561-948-6367 FAX:	Job	US-CT-5009	Page	80 of 83
	Project	Guyed Tower Structural Analysis	Date	11:53:35 05/29/20
	Client		Designed by	JWagner

Section No.	Elevation ft	Size	L ft	L_u ft	Kl/r	A in^2	P_u K	ϕP_n K	Ratio $\frac{P_u}{\phi P_n}$
T21	102 - 82	2L2 1/2x2 1/2x3/8x1/4	4.000	3.750	59.7	2.1094	8.508	91.758	0.093 ¹ ✓
T23	62 - 42	2L 'a' > 21.8347 in - 592 2L2 1/2x2 1/2x3/8x1/4	4.000	3.750	59.7	2.1094	6.062	91.758	0.066 ¹ ✓
		2L 'a' > 21.8347 in - 685							

¹ $P_u / \phi P_n$ controls

Section Capacity Table

Section No.	Elevation ft	Component Type	Size	Critical Element	P K	ϕP_{allow} K	% Capacity	Pass Fail
L1	492 - 477	Pole	P8x.406	1	-0.720	113.643	8.0	Pass
L2	477 - 457	Pole	P8x.406	2	-1.638	113.643	39.4	Pass
T1	457 - 452	Leg	2 1/4	5	-7.837	77.870	10.1	Pass
T2	452 - 442	Leg	2 1/4	19	-16.787	123.621	13.6	Pass
T3	442 - 422	Leg	2 1/4	40	-23.369	105.060	22.2	Pass
T4	422 - 402	Leg	2 1/4	72	-29.666	105.060	28.2	Pass
T5	402 - 382	Leg	2 1/4	105	-48.369	105.060	46.0	Pass
T6	382 - 362	Leg	2 1/4	138	-53.975	105.060	51.4	Pass
T7	362 - 342	Leg	2 1/4	171	-49.660	105.060	47.3	Pass
T8	342 - 322	Leg	2 1/4	204	-63.432	105.060	60.4	Pass
T9	322 - 302	Leg	2 1/2	238	-65.638	143.512	45.7	Pass
T10	302 - 282	Leg	2 1/2	271	-68.222	143.512	47.5	Pass
T11	282 - 262	Leg	2 3/4	303	-72.502	187.145	38.7	Pass
T12	262 - 242	Leg	2 3/4	336	-88.770	187.145	47.4	Pass
T13	242 - 222	Leg	2 3/4	369	-88.576	187.145	47.3	Pass
T14	222 - 202	Leg	3	402	-112.190	235.765	47.6	Pass
T15	202 - 182	Leg	3	435	-126.183	235.765	53.5	Pass
T16	182 - 162	Leg	3	468	-135.004	235.765	57.3	Pass
T17	162 - 142	Leg	3	501	-138.208	235.765	58.6	Pass
T18	142 - 122	Leg	3	534	-137.418	235.765	58.3	Pass
T19	122 - 112	Leg	3	567	-127.409	258.358	49.3	Pass
T20	112 - 102	Leg	3	590	-121.613	258.358	47.1	Pass
T21	102 - 82	Leg	3	611	-126.922	235.765	53.8	Pass
T22	82 - 62	Leg	3	644	-128.590	235.765	54.5	Pass
T23	62 - 42	Leg	3	675	-138.956	235.765	58.9	Pass
T24	42 - 22	Leg	3	709	-136.263	235.765	57.8	Pass
T25	22 - 2	Leg	3	743	-130.589	235.765	55.4	Pass
T1	457 - 452	Diagonal	L2 1/2x2x3/16	14	-1.957	12.510	15.6	Pass
T2	452 - 442	Diagonal	L2x2x1/4	26	-2.459	13.063	18.8	Pass
							22.4 (b)	
T3	442 - 422	Diagonal	L2x2x1/4	71	-1.374	10.958	12.5	Pass
T4	422 - 402	Diagonal	L2x2x1/4	80	-2.309	10.958	21.1	Pass
T5	402 - 382	Diagonal	L2x2x1/4	113	-4.078	10.958	37.2	Pass
T6	382 - 362	Diagonal	L2x2x1/4	169	-2.423	10.958	22.1	Pass
T7	362 - 342	Diagonal	L2x2x1/4	177	-1.770	10.958	16.2	Pass
T8	342 - 322	Diagonal	L2x2x1/4	211	-3.199	10.958	29.2	Pass
T9	322 - 302	Diagonal	L1 3/4x1 3/4x3/16	269	-3.997	5.664	70.6	Pass
T10	302 - 282	Diagonal	L2x2x1/4	301	-2.265	11.086	20.4	Pass
T11	282 - 262	Diagonal	L2 1/2x2 1/2x3/8	311	-6.707	32.063	20.9	Pass
							48.6 (b)	
T12	262 - 242	Diagonal	L2x2x1/4	367	-5.256	11.216	46.9	Pass

Job	US-CT-5009	Page	81 of 83
Project	Guyed Tower Structural Analysis	Date	11:53:35 05/29/20
Client		Designed by	JWagner

Section No.	Elevation ft	Component Type	Size	Critical Element	P K	ϕP_{allow} K	% Capacity	Pass Fail
T13	242 - 222	Diagonal	L2x2x1/4	377	-4.898	11.216	43.7	Pass
T14	222 - 202	Diagonal	L2 1/2x2 1/2x3/8	414	-8.249	32.415	25.4	Pass
							59.8 (b)	
T15	202 - 182	Diagonal	L2x2x1/4	465	-7.462	11.348	65.8	Pass
T16	182 - 162	Diagonal	L2x2x1/4	475	-5.556	11.348	49.0	Pass
T17	162 - 142	Diagonal	L2x2x1/4	527	-7.545	11.348	66.5	Pass
T18	142 - 122	Diagonal	L2x2x1/4	542	-6.396	11.348	56.4	Pass
T19	122 - 112	Diagonal	L2x2x1/4	574	-7.785	13.531	57.5	Pass
T20	112 - 102	Diagonal	L1 3/4x1 3/4x3/16 w/ L2x2x1/4	596	-9.036	30.133	30.0	Pass
							65.5 (b)	
T21	102 - 82	Diagonal	L2x2x1/4	639	-6.410	11.348	56.5	Pass
T22	82 - 62	Diagonal	L2x2x1/4	650	-6.340	11.348	55.9	Pass
T23	62 - 42	Diagonal	L2x2x1/4	681	-8.330	11.348	73.4	Pass
T24	42 - 22	Diagonal	L2x2x1/4	738	-8.122	11.348	71.6	Pass
T25	22 - 2	Diagonal	L2x2x1/4	771	-6.643	11.348	58.5	Pass
T2	452 - 442	Horizontal	L2x2x3/16	27	-0.291	15.292	1.9	Pass
							3.7 (b)	
T3	442 - 422	Horizontal	L2x2x3/16	55	-0.405	15.292	2.6	Pass
							5.1 (b)	
T4	422 - 402	Horizontal	L2x2x3/16	81	-0.514	15.292	3.4	Pass
							6.5 (b)	
T5	402 - 382	Horizontal	L2x2x3/16	114	-0.838	15.292	5.5	Pass
							10.6 (b)	
T6	382 - 362	Horizontal	L2x2x3/16	153	-0.935	15.292	6.1	Pass
							11.9 (b)	
T7	362 - 342	Horizontal	L2x2x3/16	180	-0.860	15.292	5.6	Pass
							10.9 (b)	
T8	342 - 322	Horizontal	L2x2x3/16	215	-1.099	15.292	7.2	Pass
							14.0 (b)	
T9	322 - 302	Horizontal	L2x2x3/16	246	-1.137	15.350	7.4	Pass
							14.4 (b)	
T10	302 - 282	Horizontal	L2x2x3/16	285	-1.182	15.350	7.7	Pass
							15.0 (b)	
T11	282 - 262	Horizontal	L2x2x3/16	312	-1.256	15.408	8.1	Pass
							18.7 (b)	
T12	262 - 242	Horizontal	L2x2x3/16	345	-1.538	15.408	10.0	Pass
							19.7 (b)	
T13	242 - 222	Horizontal	L2x2x3/16	378	-1.534	15.408	10.0	Pass
							19.5 (b)	
T14	222 - 202	Horizontal	L2x2x3/16	423	-1.943	15.466	12.6	Pass
							24.7 (b)	
T15	202 - 182	Horizontal	L2x2x3/16	452	-2.186	15.466	14.1	Pass
							27.8 (b)	
T16	182 - 162	Horizontal	L2x2x3/16	483	-2.338	15.466	15.1	Pass
							31.0 (b)	
T17	162 - 142	Horizontal	L2x2x3/16	510	-2.394	15.466	15.5	Pass
							30.4 (b)	
T18	142 - 122	Horizontal	L2x2x3/16	551	-2.380	15.466	15.4	Pass
							30.2 (b)	
T19	122 - 112	Horizontal	L2x2x3/16	576	-2.207	15.466	14.3	Pass
							28.0 (b)	
T20	112 - 102	Horizontal	L2x2x3/16	598	-2.106	15.466	13.6	Pass
							26.7 (b)	
T21	102 - 82	Horizontal	L2x2x3/16	619	-2.198	15.466	14.2	Pass
							27.9 (b)	
T22	82 - 62	Horizontal	L2x2x3/16	652	-2.227	15.466	14.4	Pass
							28.3 (b)	
T23	62 - 42	Horizontal	L2x2x3/16	692	-2.407	15.466	15.6	Pass
							30.6 (b)	
T24	42 - 22	Horizontal	L2x2x3/16	717	-2.360	15.466	15.3	Pass
							30.0 (b)	

tnxTower Vertical Bridge 750 Park of Commerce Drive Boca Raton, FL 33487 Phone: 561-948-6367 FAX:	Job	US-CT-5009	Page	82 of 83
	Project	Guyed Tower Structural Analysis	Date	11:53:35 05/29/20
	Client		Designed by	JWagner

Section No.	Elevation ft	Component Type	Size	Critical Element	P K	ϕP_{allow} K	% Capacity	Pass Fail
T25	22 - 2	Horizontal	L2x2x3/16	757	-2.262	15.466	14.6	Pass
							28.7 (b)	
T1	457 - 452	Top Girt	C6x10.5	7	-0.000	80.226	1.6	Pass
T2	452 - 442	Top Girt	L2x2x3/16	11	-0.744	15.292	4.9	Pass
							10.3 (b)	
T4	422 - 402	Top Girt	L2x2x3/16	43	0.240	18.739	1.3	Pass
							3.1 (b)	
T5	402 - 382	Top Girt	L2x2x3/16	77	0.248	18.739	1.3	Pass
							3.2 (b)	
T7	362 - 342	Top Girt	L2x2x3/16	143	0.323	18.739	1.7	Pass
							4.1 (b)	
T8	342 - 322	Top Girt	L2x2x3/16	175	0.333	18.739	1.8	Pass
							4.2 (b)	
T10	302 - 282	Top Girt	L2x2x3/16	241	0.569	18.739	3.0	Pass
							7.2 (b)	
T11	282 - 262	Top Girt	L2x2x3/16	275	1.319	18.739	7.0	Pass
							16.7 (b)	
T13	242 - 222	Top Girt	L2x2x3/16	341	0.762	18.739	4.1	Pass
							9.7 (b)	
T14	222 - 202	Top Girt	L2x2x3/16	373	0.828	18.739	4.4	Pass
							10.5 (b)	
T15	202 - 182	Top Girt	L2x2x3/16	407	1.038	18.739	5.5	Pass
							13.2 (b)	
T16	182 - 162	Top Girt	L2x2x3/16	439	1.035	18.739	5.5	Pass
							13.1 (b)	
T17	162 - 142	Top Girt	L2x2x3/16	473	1.527	18.739	8.2	Pass
							19.4 (b)	
T18	142 - 122	Top Girt	L2x2x3/16	505	1.086	18.739	5.8	Pass
							13.8 (b)	
T19	122 - 112	Top Girt	L2x2x3/16	539	1.151	18.739	6.1	Pass
							14.6 (b)	
T20	112 - 102	Top Girt	L2x2x3/16	571	1.173	18.739	6.3	Pass
							14.9 (b)	
T22	82 - 62	Top Girt	L2x2x3/16	613	1.041	18.739	5.6	Pass
							13.2 (b)	
T23	62 - 42	Top Girt	L2x2x3/16	647	1.016	18.739	5.4	Pass
							12.9 (b)	
T24	42 - 22	Top Girt	L2x2x3/16	680	0.955	18.739	5.1	Pass
							12.1 (b)	
T25	22 - 2	Top Girt	L2x2x3/16	713	0.998	18.739	5.3	Pass
							12.7 (b)	
T25	22 - 2	Bottom Girt	L2x2x3/16	746	3.176	23.166	13.7	Pass
T3	442 - 422	Guy A@442	1	776	32.171	73.200	44.0	Pass
T6	382 - 362	Guy A@382	1	779	32.272	73.200	44.1	Pass
T9	322 - 302	Guy A@322	7/8	782	26.398	55.200	47.8	Pass
T12	262 - 242	Guy A@262	7/8	785	31.118	55.200	56.4	Pass
T14	222 - 202	Guy A@210	7/8	788	34.207	55.200	62.0	Pass
T17	162 - 142	Guy A@154	9/16	791	16.110	21.000	76.7	Pass
T21	102 - 82	Guy A@102	9/16	794	16.905	21.000	80.5	Pass
T23	62 - 42	Guy A@46	1/2	797	9.635	16.140	59.7	Pass
T3	442 - 422	Guy B@442	1	775	32.763	73.200	44.8	Pass
T6	382 - 362	Guy B@382	1	778	33.237	73.200	45.4	Pass
T9	322 - 302	Guy B@322	7/8	781	27.582	55.200	50.0	Pass
T12	262 - 242	Guy B@262	7/8	784	32.299	55.200	58.5	Pass
T14	222 - 202	Guy B@210	7/8	787	35.404	55.200	64.1	Pass
T17	162 - 142	Guy B@154	9/16	790	16.511	21.000	78.6	Pass
T21	102 - 82	Guy B@102	9/16	793	17.294	21.000	82.4	Pass
T23	62 - 42	Guy B@46	1/2	796	9.878	16.140	61.2	Pass
T3	442 - 422	Guy C@442	1	774	32.637	73.200	44.6	Pass
T6	382 - 362	Guy C@382	1	777	32.980	73.200	45.1	Pass
T9	322 - 302	Guy C@322	7/8	780	27.407	55.200	49.6	Pass

tnxTower Vertical Bridge 750 Park of Commerce Drive Boca Raton, FL 33487 Phone: 561-948-6367 FAX:	Job	US-CT-5009	Page	83 of 83
	Project	Guyed Tower Structural Analysis	Date	11:53:35 05/29/20
	Client		Designed by	JWagner

Section No.	Elevation ft	Component Type	Size	Critical Element	P K	ϕP_{allow} K	% Capacity	Pass Fail	
T12	262 - 242	Guy C@262	7/8	783	32.535	55.200	58.9	Pass	
T14	222 - 202	Guy C@210	7/8	786	35.630	55.200	64.5	Pass	
T17	162 - 142	Guy C@154	9/16	789	16.658	21.000	79.3	Pass	
T21	102 - 82	Guy C@102	9/16	792	17.427	21.000	83.0	Pass	
T23	62 - 42	Guy C@46	1/2	795	9.984	16.140	61.9	Pass	
T3	442 - 422	Top Guy Pull-Off@442	2L2 1/2x2 1/2x3/8x1/4	22	5.880	91.758	6.4 9.1 (b)	Pass	
T6	382 - 362	Top Guy Pull-Off@382	2L2 1/2x2 1/2x3/8x1/4	110	6.970	91.758	7.6 10.7 (b)	Pass	
T9	322 - 302	Top Guy Pull-Off@322	2L2 1/2x2 1/2x3/8x1/4	208	6.969	91.758	7.6 10.7 (b)	Pass	
T12	262 - 242	Top Guy Pull-Off@262	2L2 1/2x2 1/2x3/8x1/4	308	9.897	91.758	10.8 15.2 (b)	Pass	
T14	222 - 202	Top Guy Pull-Off@210	2L2 1/2x2 1/2x3/8x1/4	418	11.002	91.758	12.0 16.9 (b)	Pass	
T17	162 - 142	Top Guy Pull-Off@154	2L2 1/2x2 1/2x3/8x1/4	523	6.719	91.758	7.3 10.3 (b)	Pass	
T21	102 - 82	Top Guy Pull-Off@102	2L2 1/2x2 1/2x3/8x1/4	592	8.508	91.758	9.3 13.1 (b)	Pass	
T23	62 - 42	Top Guy Pull-Off@46	2L2 1/2x2 1/2x3/8x1/4	685	6.062	91.758	6.6 9.3 (b)	Pass	
							Summary		
							Pole (L2)	39.4	Pass
							Leg (T8)	60.4	Pass
							Diagonal (T23)	73.4	Pass
							Horizontal (T16)	31.0	Pass
							Top Girt (T17)	19.4	Pass
							Bottom Girt (T25)	13.7	Pass
							Guy A (T21)	80.5	Pass
							Guy B (T21)	82.4	Pass
							Guy C (T21)	83.0	Pass
							Top Guy Pull-Off (T14)	16.9	Pass
							Bolt Checks	65.5	Pass
							RATING =	83.0	Pass

PROJECT No: US-CT-5009
 PROJECT NAME: _____
Vertical Bridge
 DATE: May 29, 2020

ENG: LM
 CHK: MD
 PAGE: _____ of _____

TIA-222-G

TOWER BASE CHECKS - GUYED TOWER

Tower Reactions		Factored Loads		Factored Resistance		% Capacity	Column Rebar
<input checked="" type="radio"/> TIA-G	Download	384.00 kips	Bearing Capacity	2847.10 kips	pass	13.5%	PCA COL 384.0 kips 26.0 k-ft Max. Pier Moment @ 6.5 ft
<input type="radio"/> EIA-F	Horizontal	4.00 kips	Horizontal Capacity	66.31 kips	pass	6.0%	
	Overturning Check (q_{max})	3.46 ksf	Overturning Capacity	14.53 ksf	pass	23.8% [GOVERNS]	
	Punching Shear Check	234.00 kips	2-way Capacity	2277.43 kips	pass	10.3%	
	Flexural Shear Check	34.29 kips	1-way Capacity	455.49 kips	pass	7.5%	
	Pier Rebar Required	(minimum only, use PCACOL for total quantity)		#N/A			
	Mat Rebar Required	(checked rebar for 6" min to 24" max spacing)		#N/A		SF=8.40	

Soil Parameters	Soils Report	Foundation Geometry	FDN Dwgs
ϕ	28 °	B (width)	14.00 ft
water level	8.00 ft (2.44 m)	T (thickness)	3.00 ft
Soil Dry Density (γ_{dry})	0.105 kcf (16.5 kN/m ³)	L (length)	14.00 ft
Soil Sub Density (γ_{sub})	0.050 kcf (7.85 kN/m ³)	D (depth to bottom surface)	9.00 ft
Passive earth coefficient	2.770	ϕ (pier diameter)	6.00 ft
Allowable bearing pressure	12.105 ksf (579.6 kPa)	<input checked="" type="checkbox"/> Check if Square Pier	

Concrete parameters

f'_c = **3.000** ksi (20.7 MPa)
 Dry Density (γ_{dry}) = 0.150 kcf
 Sub Density (γ_{sub}) = 0.087 kcf

Volume of concrete **822.0 cuft (30.5 cuyd)**

Mat	d (dry)	2.00 ft	392.00
	d (sub)	1.00 ft	196.00
Pier	d (above)	0.50 ft	18.00
	d (dry)	6.00 ft	216.00
	d (sub)	0.00 ft	0.00

Passive Earth pressure resistance

press. - top of concrete	1.74	--	ksf
press. - bottom of concr.	2.47	--	ksf
Total resistance =	88.41	--	kips
Horizontal resistance =	66.31	--	kips

(x 0.75, Cl 9.4.1)

Depth of Soil

d (overall)	6.00	2.D.Tan ϕ	Area
d (dry)	6.00	6.381	415.37
d (submerged)	0.00	0.000	196.00

Volume of Soil **196.00**

Bearing capacity

contact area =	196.00	--	ft ²
allowable net pressure =	12.105	--	ksf
Download resistance =	2847.10	--	kips

(2 • 0.60, Cl 9.4)

Vol (total)	1577.4 ft ³	Frustum Volume Method
Vol (dry)	1577.4 ft ³	
Vol (submerged)	0.0 ft ³	

Overturning - Bearing

Moment = Shear x Arm **28.000** -- k-ft

ORTHO $q_{max} = P/A + M/S (S=b^3/6)$ **3.432** -- ksf

DIAG $q_{max} = P/A + M/S (S=b^3/6\sqrt{2})$ **3.457** -- ksf

(not factored)

Concrete Reinforcing (Already Factored Loads)

f'_c **3.00** ksi
 f_y **60** ksi
 Steel (Metric/ASTM) **ASTM**
 Bar size **0** #
 Bar area **#N/A** in²

PIER **ASTM**
0
#N/A

Check for 2-Way Shear **d=33.000"**

Shear Area ($b_o \times d$) =	96.25	--	ft ²
Factored bearing stress =	1.959	--	ksf
Factored shear force =	234.00	--	kips
Factored shear resistance	2277.4	--	kips
Check for 2-way shear	Pass	--	

Slab Reinforcing

Download	1.96 ksf	Wgt of Rebar #N/A lbs
l_v	4.0 ft	
$M_u = \frac{1}{2} wL \cdot l_v^2$	219.43 kip-ft	
K_u	14.3925	
ρ	0.00027	choose larger of ρ or ρ_{min}
$\rho_{min} \geq 0.0018$	0.00180	
$4/3 \cdot \rho$ if $\rho < \rho_{min}$	0.00036	
As Required	9.9792 in ²	
Number of bars	#N/A bars	
spacing =	#N/A in	

Check for 1-Way Shear **d=33.000"**

Shear Area ($b \times d$) =	38.50	--	ft ²
Factored bearing stress =	1.959	--	ksf
Factored shear force =	34.29	--	kips
Factored shear resistance	455.5	--	kips
Check for 2-way shear	Pass	--	

PROJECT No: US-CT-5009
 PROJECT NAME: _____
Vertical Bridge
 DATE: May 29, 2020

ENG: LM
 CHK: MD
 PAGE: _____ of _____

TIA-222-G

GUY ANCHOR - DEADMAN CHECKS

Tower Reactions		Factored Loads	Factored Resistance	% Capacity	SF=3.03
<input checked="" type="radio"/> TIA-G	Uplift	60.0 kips	Uplift Capacity 128.69 kips	pass 46.6%	
<input type="radio"/> EIA-F	Horizontal	49.0 kips	Horizontal Capacity 74.25 kips	pass 66.0% [GOVERNS]	

Soil Parameters	From Soils Report				Dead-man geometry	From Fdn Dwgs
	Depth (ft)	ϕ (°)	C (psf)	γ (pcf)		
Layer 1	4.0	28.0	0.0	105.0	B (width)	4.50 ft
Layer 2	6.0	0.0	1250.0	110.0	T (thickness / height)	2.50 ft
Layer 3	8.0	0.0	400.0	105.0	L (length)	15.00 ft
Layer 4	9.5	0.0	750.0	105.0	D (depth to bottom surface)	9.50 ft
Layer 5						
All. Top Friction	138	psf (FS=2)			f'c (compressive strength)	3.00 ksi (20.7 MPa)
All. Side Friction	138	psf (FS=2)			Water Table	30.00 ft (9.15 m)
Frost Depth	4.00	ft				
Ignored Depth	0.00	ft				

Depth is taken to bottom of layer

Depth (ft)	Kp	1/2Cu (psf)	tan (% ϕ)	Ca (Kulhawy)	γ -d (psf)	Kp Pressure	Cu Pressure	Total Layer Pressure	Front of Block Area	1/2Cu Thickness	1/2Cu Area	1/2Cu Area
0.00					0.0	0.000	0.000	0.000	0.00	0.00	0.000	0.000
4.00	2.770	0.0	0.338	0.000	420.0	1.163	0.000	1.163	0.00	0.00	0.000	0.000
4.00	1.000	625.0	0.000	0.582	420.0	0.420	2.500	2.920	0.00	2.00	78.000	48.750
6.00	1.000	200.0	0.000	1.000	640.0	0.640	0.800	1.440	15.00	1.00	39.000	7.800
8.00	1.000	375.0	0.000	0.763	850.0	0.850	1.500	2.350	22.50	0.00	0.000	0.000
9.50	1.000	375.0	0.000	0.763	1007.5	1.008	1.500	2.508				
9.50												

Uplift Resistance	Factored		
Weight of concrete	25.31	--	kips
	(x 0.90, Cl 2.3.2)		
Weight of soil (all layers)	69.92	--	kips
	(x 0.75, Cl 9.4.1)		
1/2Cu Resistance	56.55	--	kips
	(x 0.75, Cl 9.4.1)		
Total Side Friction (2 x BT)	4.39	--	kips
	(x 0.75, Cl 9.4.1)		
Total Front Friction (T x L)	10.35	--	kips
	(x 0.75, Cl 9.4.1)		
Total Uplift Resistance	166.52	--	kips
Factored Uplift Resistance	128.69	--	kips

Concrete Parameters	Depth	Weight	Volume
Dry Density (γ_{dry})	0.150	2.50	25.31
Sub Density (γ_{sub})	0.087	0.00	0.00
		168.8 cuft (6.3 cuyd)	

Depth of Soil	2 · D · Tan ϕ	Area	Volume
d (top of layer 1)	0.00	4.254	168.54
d (top of layer 2)	4.00	0.000	67.50
d (top of layer 3)	6.00	0.000	67.50
d (top of layer 4)		0.000	0.00
d (top of layer 5)		0.000	0.00
d (top of deadman)	7.00	67.50	659.4

Depth of Deadman	Depth	Pressure	
d (top of deadman)	7.00	1.545	
d (above boundary)	7.00	1.545	(overwrite if applicable)
d (below boundary)	9.50	2.508	(overwrite if applicable)
d (bot of deadman)	9.50	2.508	

(Frustum Volume Method)

(/ft of length)

Horizontal Pressure Resistance			
Total Front Pressure (P x L)	75.98	--	kips
Total Side Friction (2 x BT)	4.39	--	kips
Total Top Friction (B x L)	18.63	--	kips
Total Horiz Resistance	99.01	--	kips
Factored Horiz Resistance	74.25	--	kips
	(x 0.75, Cl 9.4.1)		

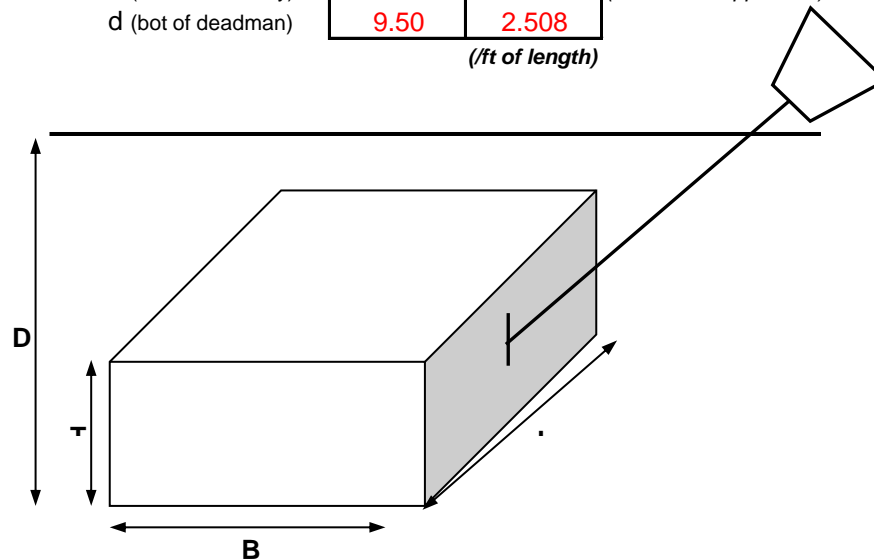

PROJECT No: US-CT-5009
 PROJECT NAME: _____
Vertical Bridge
 DATE: May 29, 2020

ENG: LM
 CHK: MD
 PAGE: _____ of _____

TIA-222-G

GUY ANCHOR - DEADMAN CHECKS

Tower Reactions		Factored Loads	Factored Resistance	% Capacity	SF=9.23
<input checked="" type="radio"/> TIA-G	Uplift	111.0 kips	Uplift Capacity 512.45 kips	pass 21.7% [GOVERNS]	
<input type="radio"/> EIA-F	Horizontal	49.0 kips	Horizontal Capacity 279.65 kips	pass 17.5%	

Soil Parameters	From Soils Report				Dead-man geometry	From Fdn Dwgs
	Depth (ft)	ϕ (°)	C (psf)	γ (pcf)		
Layer 1	4.0	28.0	0.0	105.0	B (width)	11.00 ft
Layer 2	6.0	0.0	1250.0	110.0	T (thickness / height)	4.50 ft
Layer 3	8.0	0.0	400.0	105.0	L (length)	28.00 ft
Layer 4	11.5	0.0	750.0	105.0	D (depth to bottom surface)	11.50 ft
Layer 5						
All. Top Friction	138	psf (FS=2)			f'c (compressive strength)	3.00 ksi (20.7 MPa)
All. Side Friction	138	psf (FS=2)			Water Table	30.00 ft (9.15 m)
Frost Depth	3.33	ft				
Ignored Depth	0.00	ft				

Depth is taken to bottom of layer

Depth (ft)	Kp	1/2Cu (psf)	tan (% ϕ)	Ca (Kulhawy)	γ -d (psf)	Kp Pressure	Cu Pressure	Total Layer Pressure	Front of Block Area	1/2Cu Thickness	1/2Cu Area	1/2Cu Area
0.00					0.0	0.000	0.000	0.000	0.00	0.67	52.260	0.000
4.00	2.770	0.0	0.338	0.000	420.0	1.163	0.000	1.163	0.00	2.00	156.000	97.500
4.00	1.000	625.0	0.000	0.582	420.0	0.420	2.500	2.920	0.00	1.00	78.000	15.600
6.00	1.000	200.0	0.000	1.000	640.0	0.640	0.800	1.440	28.00	0.00	0.000	0.000
6.00	1.000	375.0	0.000	0.763	850.0	0.850	1.500	2.350	98.00			
8.00	1.000	375.0	0.000	0.763	850.0	0.850	1.500	2.350	98.00			
11.50	1.000	375.0	0.000	0.763	1217.5	1.218	1.500	2.718				
11.50												

Uplift Resistance	Factored		
Weight of concrete	207.90	--	kips
	(x 0.90, Cl 2.3.2)		
Weight of soil (all layers)	266.60	--	kips
	(x 0.75, Cl 9.4.1)		
1/2Cu Resistance	113.10	--	kips
	(x 0.75, Cl 9.4.1)		
Total Side Friction (2 x BT)	19.32	--	kips
	(x 0.75, Cl 9.4.1)		
Total Front Friction (T x L)	34.78	--	kips
	(x 0.75, Cl 9.4.1)		
Total Uplift Resistance	641.69	--	kips
Factored Uplift Resistance	512.45	--	kips

Concrete Parameters	Depth	Weight	Volume
Dry Density (γ_{dry})	0.150	4.50	207.90
Sub Density (γ_{sub})	0.087	0.00	0.00
			1386.0 cuft (51.4 cuyd)

Depth of Soil	2 · D · Tan ϕ	Area	Volume
d (top of layer 1)	0.00	4.254	491.99
d (top of layer 2)	4.00	0.000	308.00
d (top of layer 3)	6.00	0.000	308.00
d (top of layer 4)		0.000	0.00
d (top of layer 5)		0.000	0.00
d (top of deadman)	7.00	308.00	2509.7

Depth of Deadman	Depth	Pressure
d (top of deadman)	7.00	1.545
d (above boundary)	7.00	1.545
d (below boundary)	11.50	2.718
d (bot of deadman)	11.50	2.718

(overwrite if applicable)
(overwrite if applicable)
(/ft of length)

Horizontal Pressure Resistance			
Total Front Pressure (P x L)	268.54	--	kips
Total Side Friction (2 x BT)	19.32	--	kips
Total Top Friction (B x L)	85.01	--	kips
Total Horiz Resistance	372.87	--	kips
Factored Horiz Resistance	279.65	--	kips
	(x 0.75, Cl 9.4.1)		

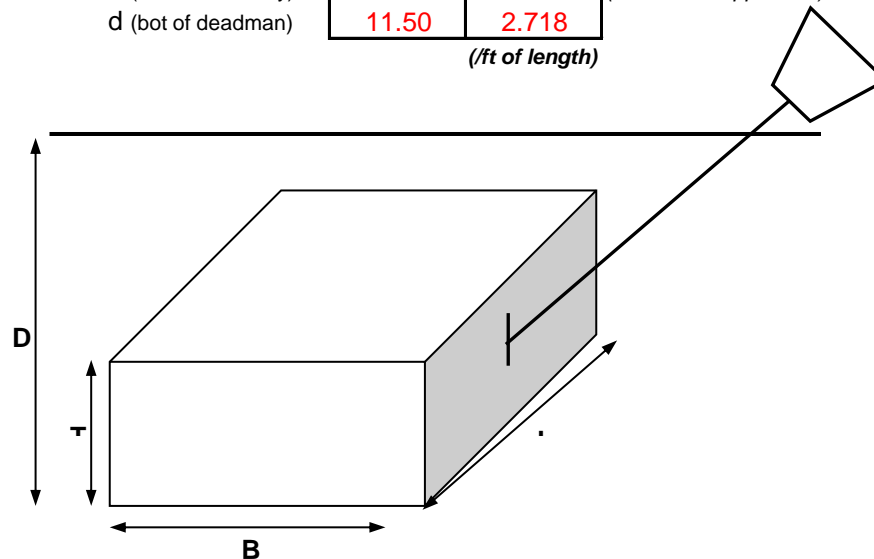



BU: US-CT-5009
 WO:
 Order:

Structure: A
 Rev:

Location

	Decimal Degrees	Deg	Min	Sec	
Lat:	41.493439	+	41	29	36.38
Long:	-73.428817	-	73	25	43.74

Code and Site Parameters

Seismic Design Code:	TIA-222-H	
Site Soil:	D (Default)	Default
Risk Category:	II	
<u>USGS Seismic Reference</u>		
S _s :	0.2100	g
S ₁ :	0.0550	g
T _L :	6	s

Seismic Design Category Determination

Importance Factor, I _e :	1
Acceleration-based site coefficient, F _a :	1.6000
Velocity-based site coefficient, F _v :	2.4000
Design spectral response acceleration short period, S _{DS} :	0.2240 g
Design spectral response acceleration 1 s period, S _{D1} :	0.0880 g
Seismic Design Category Based on S _{DS} :	B
Seismic Design Category Based on S _{D1} :	B
Seismic Design Category Based on S ₁ :	N/A
Controlling Seismic Design Category:	B

ASCE 7 Hazards Report

Address:
No Address at This Location

Standard: ASCE/SEI 7-16
Risk Category: II
Soil Class: D - Default (see Section 11.4.3)

Elevation: 718.96 ft (NAVD 88)
Latitude: 41.493439
Longitude: -73.428817

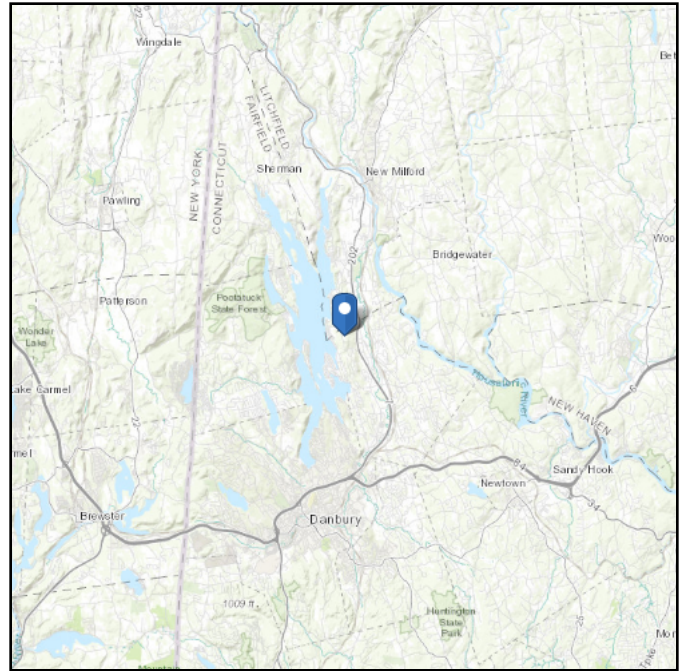
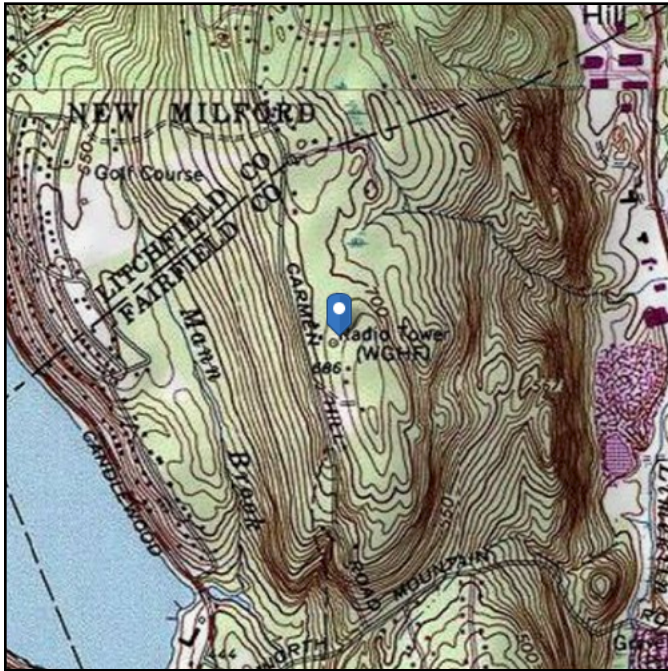

Wind

Results:

Wind Speed:	115 Vmph
10-year MRI	75 Vmph
25-year MRI	84 Vmph
50-year MRI	89 Vmph
100-year MRI	95 Vmph

Data Source: ASCE/SEI 7-16, Fig. 26.5-1B and Figs. CC.2-1–CC.2-4

Date Accessed: Fri May 29 2020

Value provided is 3-second gust wind speeds at 33 ft above ground for Exposure C Category, based on linear interpolation between contours. Wind speeds are interpolated in accordance with the 7-16 Standard. Wind speeds correspond to approximately a 7% probability of exceedance in 50 years (annual exceedance probability = 0.00143, MRI = 700 years).

Site is not in a hurricane-prone region as defined in ASCE/SEI 7-16 Section 26.2.

Mountainous terrain, gorges, ocean promontories, and special wind regions should be examined for unusual wind conditions.

Site Soil Class: D - Default (see Section 11.4.3)

Results:

S_s :	0.21	S_{D1} :	0.089
S_1 :	0.055	T_L :	6
F_a :	1.6	PGA :	0.119
F_v :	2.4	PGA _M :	0.186
S_{MS} :	0.337	F_{PGA} :	1.562
S_{M1} :	0.133	I_e :	1
S_{DS} :	0.224	C_v :	0.721

Seismic Design Category B

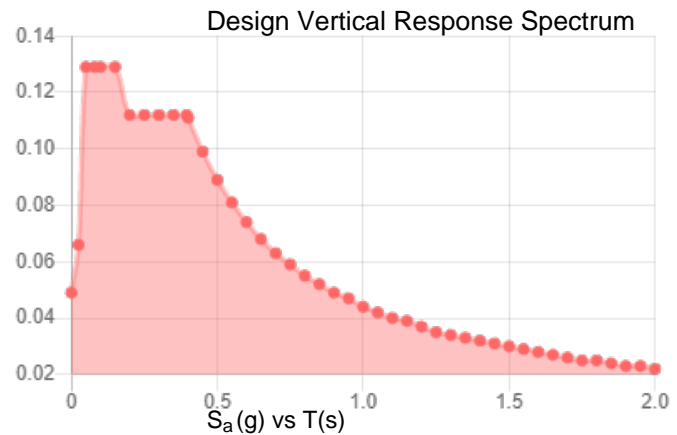
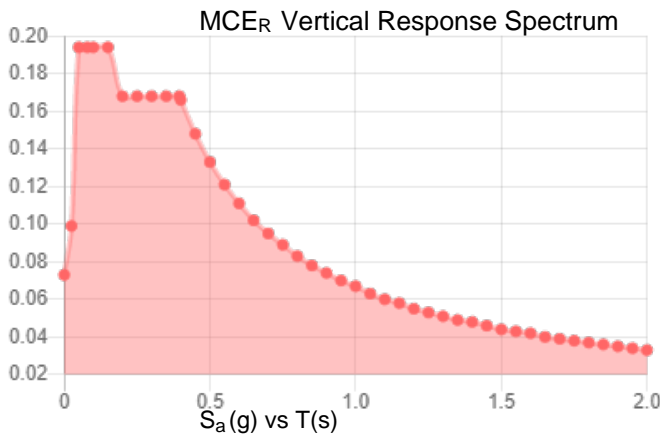
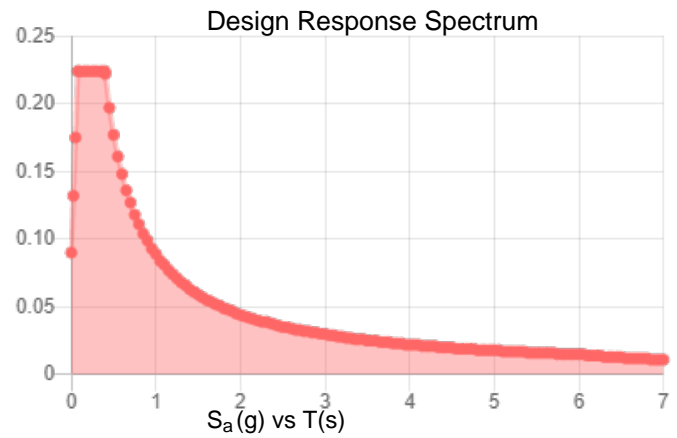
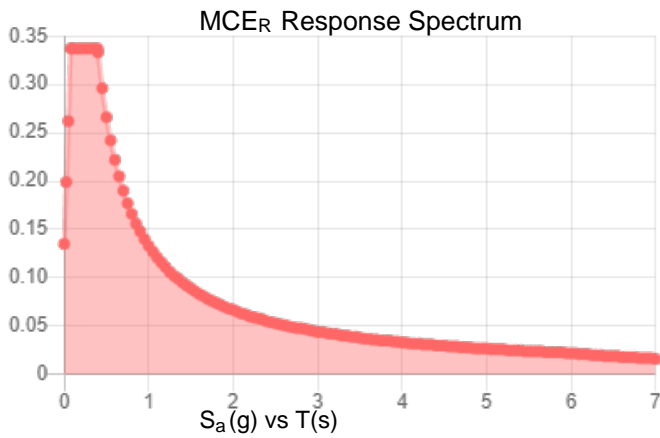

Data Accessed:

Fri May 29 2020

Date Source:

USGS Seismic Design Maps based on ASCE/SEI 7-16 and ASCE/SEI 7-16 Table 1.5-2. Additional data for site-specific ground motion procedures in accordance with ASCE/SEI 7-16 Ch. 21 are available from USGS.

Ice

Results:

Ice Thickness: 1.00 in.
Concurrent Temperature: 15 F
Gust Speed: 50 mph

Data Source: Standard ASCE/SEI 7-16, Figs. 10-2 through 10-8

Date Accessed: Fri May 29 2020

Ice thicknesses on structures in exposed locations at elevations higher than the surrounding terrain and in valleys and gorges may exceed the mapped values.

Values provided are equivalent radial ice thicknesses due to freezing rain with concurrent 3-second gust speeds, for a 500-year mean recurrence interval, and temperatures concurrent with ice thicknesses due to freezing rain. Thicknesses for ice accretions caused by other sources shall be obtained from local meteorological studies. Ice thicknesses in exposed locations at elevations higher than the surrounding terrain and in valleys and gorges may exceed the mapped values.

The ASCE 7 Hazard Tool is provided for your convenience, for informational purposes only, and is provided “as is” and without warranties of any kind. The location data included herein has been obtained from information developed, produced, and maintained by third party providers; or has been extrapolated from maps incorporated in the ASCE 7 standard. While ASCE has made every effort to use data obtained from reliable sources or methodologies, ASCE does not make any representations or warranties as to the accuracy, completeness, reliability, currency, or quality of any data provided herein. Any third-party links provided by this Tool should not be construed as an endorsement, affiliation, relationship, or sponsorship of such third-party content by or from ASCE.

ASCE does not intend, nor should anyone interpret, the results provided by this Tool to replace the sound judgment of a competent professional, having knowledge and experience in the appropriate field(s) of practice, nor to substitute for the standard of care required of such professionals in interpreting and applying the contents of this Tool or the ASCE 7 standard.

In using this Tool, you expressly assume all risks associated with your use. Under no circumstances shall ASCE or its officers, directors, employees, members, affiliates, or agents be liable to you or any other person for any direct, indirect, special, incidental, or consequential damages arising from or related to your use of, or reliance on, the Tool or any information obtained therein. To the fullest extent permitted by law, you agree to release and hold harmless ASCE from any and all liability of any nature arising out of or resulting from any use of data provided by the ASCE 7 Hazard Tool.

Attachment 2:
Collocation Application



<input type="checkbox"/> NEW LEASE <input type="checkbox"/> AMENDMENT TO EXISTING LEASE <input type="checkbox"/> RECONTRACT <input type="checkbox"/> BTS ANCHOR TENANT	INTERNAL USE ONLY
	APP VERSION #
	LEASE #
	AMENDMENT #

PLEASE RETURN THIS APPLICATION VIA EMAIL TO: Vertical Bridge 750 Park of Commerce Drive Suite 200 Boca Raton, FL 33487 Attn: Regional Leasing Manager	E-Mail: Phone:	VB Site Number: VB Site Name: Application Date: Revision Dates: RSM Approval:	
--	-------------------------------	---	--

APPLICANT / CARRIER INFORMATION

Carrier Name:		Contact Name:	
Carrier Site Number:		Contact Number:	
Carrier Site Name:		Contact Fax:	
Carrier Legal Entity Name:		Contact Address:	
State of registration:			
Type of entity (LP, LLC, Corp) d/b/a (if applicable)			
Notice Address for Lease:		Contact E-mail:	
With copies to:		Additional E-mail:	
Carrier Invoice Address:		Other:	
Carrier Invoice Contact - Name, Title, Phone No.		Carrier NOC#	

ADDITIONAL CONTACT INFORMATION

Leasing Contact Name/Number:	
RF Contact Name/Number:	
Construction Contact Name/Number:	
Emergency Contact Name/Number:	

SITE INFORMATION – This information can be found and should match the information on www.verticalbridge.com

Latitude:		N	Existing Structure Type:	
Longitude:		W	Existing Structure Height:	
Site Address:				

FREQUENCY/TECHNOLOGY INFORMATION

Type of Technology for all equipment (i.e., 3G, LTE, CMDA, MW, WiFi, TV, etc.)	
TX Frequency (MHz)	
RX Frequency (MHz)	
Tenants using an unlicensed band must provide exact Frequency Channels and Call Sign(s) to be utilized. (Providing the band range only will not be accepted.)	

PLEASE PROVIDE BRIEF DESCRIPTION OF GENERAL SCOPE OF WORK



EXISTING EQUIPMENT
Applicant's Existing Equipment Configuration and Specifications

Equipment Type (ex: panel, TMA, RRU)	RAD (feet)	Mount Height (feet)	Mount Type	Equip Qty	Equipment Manufacturer	Equipment Model #	Equip Dim (HxWxD) (ft or in)	Equip Weight (lbs)	Az	Remain

EXISTING LINES
Applicant's Existing Lines and Specifications

Line Type	Line Size (Inches)	Total # of Lines	Coax interior or exterior (for monopoles)	Remain	Comments:

PROPOSED EQUIPMENT									
Applicant's Proposed Equipment Configuration and Specifications									
Equipment Type (ex: panel, TMA, RRU, ice shields)	RAD (feet)	Mount Height (feet)	Mount Type	Equip Qty	Equipment Manufacturer	Equipment Model #	Equip Dim (HxWxD) (ft or in)	Equip Weight (lbs)	Azimuth

PROPOSED LINES				
Applicant's Proposed Lines and Specifications				
Line Type	Line Size (Inches)	Total # of Lines	Coax interior or exterior (for monopoles)	Comments:
Coax				
RET Home Run Cable				
Fiber				
DC Power				



PROPOSED FINAL CONFIGURATION TOTALS	
EQUIPMENT TYPE	TOTAL
Panel Antennas	
Omni/Whip Antennas	
RRU	
TMA	
Diplexer / Triplexer	
Bias T	
Surge Suppressor	
MW Dish	
Ice Shield	
ODU	
Filter	
Combiner	
Junction Box	
RET	
Equipment Cabinets	
Other (Please specify)	
Other (Please specify)	
Other (Please specify)	
Other (Please specify)	
Other (Please specify)	

PROPOSED FINAL CONFIGURATION TOTALS	
LINE TYPE	TOTAL
Coax	
Hybrid	
CAT5	
DC/Power	
RET	
Fiber	

ADDITIONAL EQUIPMENT INFORMATION
<ul style="list-style-type: none"> • RRUs, TMAs and ODUs are required to be installed directly behind the antennas / MW dish. Otherwise there will be an additional charge. • All equipment lines are required to be installed inside the tower when space is available. Carriers will be charged an additional \$25.00 per line per month if equipment lines are installed on the outside of the tower even though there is available space inside the tower. Vertical Bridge must approve any installation of lines on the outside of the tower. • All tenant equipment must be installed within one continuous 10 ft vertical envelope. Exceeding this vertical space will be subject to additional rent.



GROUND / INTERIOR SPACE REQUIREMENTS					
Total Ground / Interior Area Dimensions: L' x W' = Total Square Feet Required	X	(Including all Equipment (i.e., Shelter, Equipment Platform or Pad, Generator Pad, Generator Fuel Tank Pad, Antenna Sleds, etc. – provide details below)			
Cabinet Area Dimensions (Pad/Platform)	X	Cabinet Installation Type			
Shelter Pad Dimensions	X	Shelter Manufacturer			
Rooftop Antenna Total Area Required	X	Antenna Sled Dimensions (per sector)	X	Antenna Wall Mount Dimensions (per sector)	X

EQUIPMENT CABINET REQUIREMENTS (Required for rooftops or Vertical Bridge interior space)					
Number of Cabinets Required		Cabinet Dimensions (L' x W' x H')		Manufacturer:	
Number of Cabinets Required		Cabinet Dimensions (L' x W' x H')		Manufacturer:	
Number of Cabinets Required		Cabinet Dimensions (L' x W' x H')		Manufacturer:	
Equipment Cabinet Comments					

GENERATOR REQUIREMENTS					
Generator Required?:		Generator Fuel Type		Generator Size	
Generator Pad Dimensions			Generator Manufacturer		
Generator Fuel Tank Pad Dimensions			Fuel Tank Manufacturer		

AC POWER REQUIREMENTS			
Meter Type		Estimated Monthly Utility Usage Amount	
Voltage		Total Amperage	

FIBER / BACKHAUL					
Fiber Installation Status		Fiber Provider			
Cable Type		Number of Points of Entry		Conduit/Riser Size (in inches)	

STRUCTURAL ANALYSIS DETAILS			
Structural Hardcopies Required?		If wet seals required, please provide address:	

ADDITIONAL COMMENTS



WIRELESS COMMUNICATIONS FACILITY

BROOKFIELD/JUNCTION RD

SITE ID: CT1196A

39 CARMEN HILL ROAD BROOKFIELD, CT 06804

T-MOBILE RF CONFIGURATION

67D5994DB_2xAIR+1QP+1OP

GENERAL NOTES

- ALL WORK SHALL BE IN ACCORDANCE WITH THE 2015 INTERNATIONAL BUILDING CODE AS MODIFIED BY THE 2018 CONNECTICUT SUPPLEMENT, INCLUDING THE TIA/EIA-222 REVISION "G" STRUCTURAL STANDARDS FOR STEEL ANTENNA TOWERS AND SUPPORTING STRUCTURES." 2018 CONNECTICUT FIRE SAFETY CODE, 2017 NATIONAL ELECTRICAL CODE AND LOCAL CODES.
- CONTRACTOR SHALL REVIEW ALL DRAWINGS AND SPECIFICATIONS IN THE CONTRACT DOCUMENT SET. CONTRACTOR SHALL COORDINATE ALL WORK SHOWN IN THE SET OF DRAWINGS. THE CONTRACTOR SHALL PROVIDE A COMPLETE SET OF DRAWINGS TO ALL SUBCONTRACTORS AND ALL RELATED PARTIES. THE SUBCONTRACTORS SHALL EXAMINE ALL THE DRAWINGS AND SPECIFICATIONS FOR THE INFORMATION THAT AFFECTS THEIR WORK.
- CONTRACTOR SHALL PROVIDE A COMPLETE BUILD-OUT WITH ALL FINISHES, STRUCTURAL, MECHANICAL, AND ELECTRICAL COMPONENTS AND PROVIDE ALL ITEMS AS SHOWN OR INDICATED ON THE DRAWINGS OR IN THE WRITTEN SPECIFICATIONS.
- CONTRACTOR SHALL FURNISH ALL MATERIAL, LABOR AND EQUIPMENT TO COMPLETE THE WORK AND FURNISH A COMPLETED JOB ALL IN ACCORDANCE WITH LOCAL AND STATE GOVERNING AUTHORITIES AND OTHER AUTHORITIES HAVING LAWFUL JURISDICTION OVER THE WORK.
- CONTRACTOR SHALL SECURE AND PAY FOR ALL PERMITS AND ALL INSPECTIONS REQUIRED AND SHALL ALSO PAY FEES REQUIRED FOR THE GENERAL CONSTRUCTION, PLUMBING, ELECTRICAL AND HVAC. PERMITS SHALL BE PAID FOR BY THE RESPECTIVE SUBCONTRACTORS.
- CONTRACTOR SHALL MAINTAIN A CURRENT SET OF DRAWINGS AND SPECIFICATIONS ON SITE AT ALL TIMES AND INSURE DISTRIBUTION OF NEW DRAWINGS TO SUBCONTRACTORS AND OTHER RELEVANT PARTIES AS SOON AS THEY ARE MADE AVAILABLE. ALL OLD DRAWINGS SHALL BE MARKED VOID AND REMOVED FROM THE CONTRACT AREA. THE CONTRACTOR SHALL FURNISH AN 'AS-BUILT' SET OF DRAWINGS TO OWNER UPON COMPLETION OF PROJECT.
- LOCATION OF EQUIPMENT, AND WORK SUPPLIED BY OTHERS THAT IS DIAGRAMMATICALLY INDICATED ON THE DRAWINGS SHALL BE DETERMINED BY THE CONTRACTOR. THE CONTRACTOR SHALL DETERMINE LOCATIONS AND DIMENSIONS SUBJECT TO STRUCTURAL CONDITIONS AND WORK OF THE SUBCONTRACTORS.
- THE CONTRACTOR IS SOLELY RESPONSIBLE TO DETERMINE CONSTRUCTION PROCEDURE AND SEQUENCE, AND TO ENSURE THE SAFETY OF THE EXISTING STRUCTURES AND ITS COMPONENT PARTS DURING CONSTRUCTION. THIS INCLUDES THE ADDITION OF WHATEVER SHORING, BRACING, UNDERPINNING, ETC. THAT MAY BE NECESSARY.
- DRAWINGS INDICATE THE MINIMUM STANDARDS, BUT IF ANY WORK SHOULD BE INDICATED TO BE SUBSTANDARD TO ANY ORDINANCES, LAWS, CODES, RULES, OR REGULATIONS BEARING ON THE WORK, THE CONTRACTOR SHALL INCLUDE IN HIS WORK AND SHALL EXECUTE THE WORK CORRECTLY IN ACCORDANCE WITH SUCH ORDINANCES, LAWS, CODES, RULES OR REGULATIONS WITH NO INCREASE IN COSTS.
- ALL UTILITY WORK SHALL BE IN ACCORDANCE WITH LOCAL UTILITY COMPANY REQUIREMENTS AND SPECIFICATIONS.
- ALL EQUIPMENT AND PRODUCTS PURCHASED ARE TO BE REVIEWED BY CONTRACTOR AND ALL APPLICABLE SUBCONTRACTORS FOR ANY CONDITION PER MFR.'S RECOMMENDATIONS. CONTRACTOR TO SUPPLY THESE ITEMS AT NO COST TO OWNER OR CONSTRUCTION MANAGER.
- ANY AND ALL ERRORS, DISCREPANCIES, AND "MISSED" ITEMS ARE TO BE BROUGHT TO THE ATTENTION OF THE T-MOBILE CONSTRUCTION MANAGER DURING THE BIDDING PROCESS BY THE CONTRACTOR. ALL THESE ITEMS ARE TO BE INCLUDED IN THE BID. NO 'EXTRA' WILL BE ALLOWED FOR MISSED ITEMS.
- CONTRACTOR SHALL BE RESPONSIBLE FOR ALL ON-SITE SAFETY FROM THE TIME THE JOB IS AWARDED UNTIL ALL WORK IS COMPLETE AND ACCEPTED BY THE OWNER.
- CONTRACTOR TO REVIEW ALL SHOP DRAWINGS AND SUBMIT COPY TO ENGINEER FOR APPROVAL. DRAWINGS MUST BEAR THE CHECKER'S INITIALS BEFORE SUBMITTING TO THE CONSTRUCTION MANAGER FOR REVIEW.
- THE CONTRACTOR SHALL FIELD VERIFY ALL DIMENSIONS, ELEVATIONS, ANGLES, AND EXISTING CONDITIONS AT THE SITE, PRIOR TO FABRICATION AND/OR INSTALLATION OF ANY WORK IN THE CONTRACT AREA.
- COORDINATION, LAYOUT, FURNISHING AND INSTALLATION OF CONDUIT AND ALL APPURTENANCES REQUIRED FOR PROPER INSTALLATION OF ELECTRICAL AND TELECOMMUNICATION SERVICE SHALL BE THE SOLE RESPONSIBILITY OF THE CONTRACTOR.
- ALL DAMAGE CAUSED TO ANY EXISTING STRUCTURE SHALL BE THE SOLE RESPONSIBILITY OF THE CONTRACTOR. THE CONTRACTOR WILL BE HELD LIABLE FOR ALL REPAIRS REQUIRED FOR EXISTING STRUCTURES IF DAMAGED DURING CONSTRUCTION ACTIVITIES.
- THE CONTRACTOR SHALL CONTACT "CALL BEFORE YOU DIG" AT LEAST 48 HOURS PRIOR TO ANY EXCAVATIONS AT 1-800-922-4455. ALL UTILITIES SHALL BE IDENTIFIED AND CLEARLY MARKED. CONTRACTOR SHALL MAINTAIN AND PROTECT MARKED UTILITIES THROUGHOUT PROJECT COMPLETION.
- CONTRACTOR SHALL COMPLY WITH OWNERS ENVIRONMENTAL ENGINEER ON ALL METHODS AND PROVISIONS FOR ALL EXCAVATION ACTIVITIES INCLUDING SOIL DISPOSAL. ALL BACKFILL MATERIALS TO BE PROVIDED BY THE CONTRACTOR.

SITE DIRECTIONS

FROM: 35 GRIFFIN ROAD SOUTH BLOOMFIELD, CT 06002	TO: 39 CARMEN HILL ROAD BROOKFIELD, CT 06804														
<ol style="list-style-type: none"> START OUT GOING SOUTH ON GRIFFIN RD TOWARD W NEWBERRY RD. TURN LEFT ONTO W NEWBERRY RD. TURN RIGHT ONTO WOODLAND AVE. TURN RIGHT ONTO WINTONBURY AVE. TURN LEFT ONTO TUNXIS AVE/CT-189. CONTINUE TO FOLLOW CT-189. TURN RIGHT ONTO COTTAGE GROVE RD/CT-218. CONTINUE TO FOLLOW CT-218. CT-218 BECOMES N MAIN ST. MERGE ONTO I-84 W TOWARD WATERBURY. TAKE THE CT-25 EXIT, EXIT 9, TOWARD BROOKFIELD. MERGE ONTO CT-25 TOWARD BROOKFIELD/HAWLEYVILLE. CT-25 BECOMES STATION RD. TURN RIGHT ONTO LAUREL HILL RD. TAKE THE 1ST LEFT ONTO N MOUNTAIN RD. TAKE THE 1ST RIGHT ONTO CARMEN HILL RD. 37 CARMEN HILL RD, BROOKFIELD, CT 06804-1004, 37 CARMEN HILL RD IS ON THE RIGHT. 	<table border="1"> <tr><td>0.07 MI.</td></tr> <tr><td>0.51 MI.</td></tr> <tr><td>2.49 MI.</td></tr> <tr><td>0.22 MI.</td></tr> <tr><td>1.03 MI.</td></tr> <tr><td>2.69 MI.</td></tr> <tr><td>3.52 MI.</td></tr> <tr><td>45.41 MI.</td></tr> <tr><td>0.31 MI.</td></tr> <tr><td>5.22 MI.</td></tr> <tr><td>0.18 MI.</td></tr> <tr><td>0.20 MI.</td></tr> <tr><td>0.82 MI.</td></tr> <tr><td>0.49 MI.</td></tr> </table>	0.07 MI.	0.51 MI.	2.49 MI.	0.22 MI.	1.03 MI.	2.69 MI.	3.52 MI.	45.41 MI.	0.31 MI.	5.22 MI.	0.18 MI.	0.20 MI.	0.82 MI.	0.49 MI.
0.07 MI.															
0.51 MI.															
2.49 MI.															
0.22 MI.															
1.03 MI.															
2.69 MI.															
3.52 MI.															
45.41 MI.															
0.31 MI.															
5.22 MI.															
0.18 MI.															
0.20 MI.															
0.82 MI.															
0.49 MI.															

SITE COORDINATES: LATITUDE: 41°-29'-36.39" N LONGITUDE: 73°-25'-43.43" W GROUND ELEVATION: 722'± AMSL	COORDINATES AND GROUND ELEVATION ARE REFERENCED FROM GOOGLE EARTH
---	---

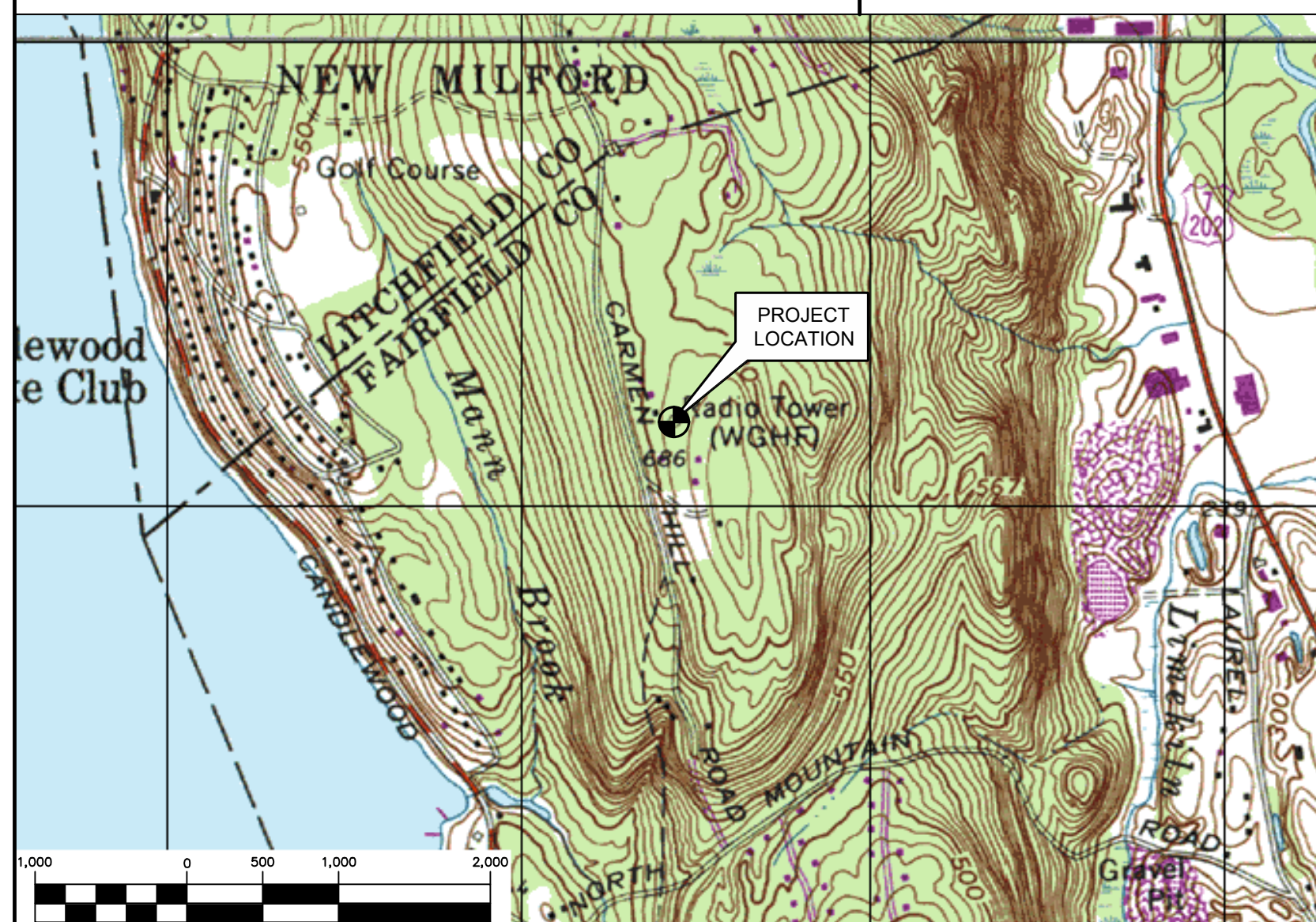

PROJECT SUMMARY

- THE PROPOSED SCOPE OF WORK CONSISTS OF A MODIFICATION TO THE EXISTING UNMANNED TELECOMMUNICATIONS FACILITY INCLUDING THE FOLLOWING:
 - INSTALLATION OF (3) NEW ANTENNAS, (1) PER SECTOR
 - INSTALL (1) IXRE ROUTER IN EXISTING 6160 CABINET
 - INSTALL (3) BB6630'S FOR L2500 IN EXISTING 6160 CABINET
 - INSTALL (1) BB6630 FOR N2500 IN EXISTING 6160 CABINET
 - REMOVE EXISTING EXCESSIVE COAX CABLES
 - INSTALL (2) 6X12 HCS
 - INSTALL (1) 200A PPC CABINET

PROJECT INFORMATION

SITE NAME:	BROOKFIELD/JUNCTION RD.
SITE ID:	CT11196A
SITE ADDRESS:	39 CARMEN HILL ROAD BROOKFIELD, CT 06804
APPLICANT:	T-MOBILE NORTHEAST, LLC 35 GRIFFIN ROAD SOUTH BLOOMFIELD, CT 06002
CONTACT PERSON:	DAN REID (PROJECT MANAGER) TRANSCEND WIRELESS, LLC (203) 592-8291
ENGINEER:	CENTEK ENGINEERING, INC. 63-2 NORTH BRANFORD RD. BRANFORD, CT 06405
PROJECT COORDINATES:	CARLO F. CENTORE, PE (203) 488-0580 EXT. 122 LATITUDE: 41°-29'-36.39" N LONGITUDE: 73°-25'-43.43" W GROUND ELEVATION: 722'± AMSL SITE COORDINATES AND GROUND ELEVATION REFERENCED FROM GOOGLE EARTH.

SHEET INDEX

SHT. NO.	DESCRIPTION	REV.
T-1	TITLE SHEET	2
N-1	DESIGN BASIS AND SITE NOTES	2
C-1	SITE LOCATION PLAN	2
C-2	COMPOUND PLAN AND ELEVATION	2
C-3	EQUIPMENT LAYOUT PLANS	2
C-4	ANTENNA PLANS AND ELEVATIONS	2
C-5	TYPICAL DETAILS	2
S-1	STRUCTURAL DETAILS	2
E-1	TYPICAL ELECTRICAL DETAILS	2

REV.	DATE	DESCRIPTION
2	09/16/20	TJR RIS 09/15/20
0	09/19/20	TJR RIS 09/19/20

PROFESSIONAL ENGINEER SEAL

T-Mobile
T-Mobile Northeast, LLC
35 Griffin Road South
Bloomfield, CT 06002

CENTEK engineering
Centek Solutions
(203) 488-0580
(203) 488-8587 Fax
632 North Branford Road
Branford, CT 06405
www.CentekEng.com

T-MOBILE NORTHEAST LLC
WIRELESS COMMUNICATIONS FACILITY
BROOKFIELD/JUNCTION RD.
SITE ID: CT1196A
39 CARMEN HILL ROAD
BROOKFIELD, CT 06804

DATE:	05/06/20
SCALE:	AS NOTED
JOB NO.	20074.01

TITLE SHEET

T-1
Sheet No. 1 of 8

NOTES AND SPECIFICATIONS

DESIGN BASIS:

GOVERNING CODE: 2015 INTERNATIONAL BUILDING (IBC) AS MODIFIED BY THE 2018 CT STATE BUILDING CODE AND AMENDMENTS.

1. DESIGN CRITERIA:
- RISK CATEGORY: II (BASED ON IBC TABLE 1604.5)
 - NOMINAL DESIGN SPEED (OTHER STRUCTURE): 93 MPH (V_{wsd}) (EXPOSURE C/IMPORTANCE FACTOR 1.0 BASED ON ASCE 7-10) PER 2015 INTERNATIONAL BUILDING CODE (IBC) AS MODIFIED BY THE 2018 CONNECTICUT STATE BUILDING CODE.
 - SEISMIC LOAD (DOES NOT CONTROL): PER ASCE 7-10 MINIMUM DESIGN LOADS FOR BUILDING AND OTHER STRUCTURES.

SITE NOTES

- THE CONTRACTOR SHALL CALL UTILITIES PRIOR TO THE START OF CONSTRUCTION.
- ACTIVE EXISTING UTILITIES, WHERE ENCOUNTERED IN THE WORK, SHALL BE PROTECTED AT ALL TIMES. THE ENGINEER SHALL BE NOTIFIED IMMEDIATELY, PRIOR TO PROCEEDING, SHOULD ANY UNCOVERED EXISTING UTILITY PRECLUDE COMPLETION OF THE WORK IN ACCORDANCE WITH THE CONTRACT DOCUMENTS.
- THE AREAS OF THE COMPOUND DISTURBED BY THE WORK SHALL BE RETURNED TO THEIR ORIGINAL CONDITION.
- CONTRACTOR SHALL MINIMIZE DISTURBANCE TO EXISTING SITE DURING CONSTRUCTION. EROSION CONTROL MEASURES, SHALL BE IN CONFORMANCE WITH THE LOCAL GUIDELINES FOR EROSION AND SEDIMENT CONTROL.
- IF ANY FIELD CONDITIONS EXIST WHICH PRECLUDE COMPLIANCE WITH THE DRAWINGS, THE CONTRACTOR SHALL IMMEDIATELY NOTIFY THE ENGINEER AND SHALL PROCEED WITH AFFECTED WORK AFTER CONFLICT IS SATISFACTORILY RESOLVED.

GENERAL NOTES

- ALL WORK SHALL BE IN ACCORDANCE WITH THE 2015 INTERNATIONAL BUILDING CODE AS MODIFIED BY THE 2018 CONNECTICUT SUPPLEMENT, INCLUDING THE TIA/EIA-222 REVISION "G" "STRUCTURAL STANDARDS FOR STEEL ANTENNA TOWERS AND SUPPORTING STRUCTURES." 2017 CONNECTICUT FIRE SAFETY CODE, NATIONAL ELECTRICAL CODE AND LOCAL CODES.
- CONTRACTOR SHALL REVIEW ALL DRAWINGS AND SPECIFICATIONS IN THE CONTRACT DOCUMENT SET. CONTRACTOR SHALL COORDINATE ALL WORK SHOWN IN THE SET OF DRAWINGS. THE CONTRACTOR SHALL PROVIDE A COMPLETE SET OF DRAWINGS TO ALL SUBCONTRACTORS AND ALL RELATED PARTIES. THE SUBCONTRACTORS SHALL EXAMINE ALL THE DRAWINGS AND SPECIFICATIONS FOR THE INFORMATION THAT AFFECTS THEIR WORK.
- CONTRACTOR SHALL PROVIDE A COMPLETE BUILD-OUT WITH ALL FINISHES, STRUCTURAL, MECHANICAL, AND ELECTRICAL COMPONENTS AND PROVIDE ALL ITEMS AS SHOWN OR INDICATED ON THE DRAWINGS OR IN THE WRITTEN SPECIFICATIONS.
- CONTRACTOR SHALL FURNISH ALL MATERIAL, LABOR AND EQUIPMENT TO COMPLETE THE WORK AND FURNISH A COMPLETED JOB ALL IN ACCORDANCE WITH LOCAL AND STATE GOVERNING AUTHORITIES AND OTHER AUTHORITIES HAVING LAWFUL JURISDICTION OVER THE WORK.
- CONTRACTOR SHALL SECURE AND PAY FOR ALL PERMITS AND ALL INSPECTIONS REQUIRED AND SHALL ALSO PAY FEES REQUIRED FOR THE GENERAL CONSTRUCTION, PLUMBING, ELECTRICAL AND HVAC. PERMITS SHALL BE PAID FOR BY THE RESPECTIVE SUBCONTRACTORS.
- CONTRACTOR SHALL MAINTAIN A CURRENT SET OF DRAWINGS AND SPECIFICATIONS ON SITE AT ALL TIMES AND INSURE DISTRIBUTION OF NEW DRAWINGS TO SUBCONTRACTORS AND OTHER RELEVANT PARTIES AS SOON AS THEY ARE MADE AVAILABLE. ALL OLD DRAWINGS SHALL BE MARKED VOID AND REMOVED FROM THE CONTRACT AREA. THE CONTRACTOR SHALL FURNISH AN "AS-BUILT" SET OF DRAWINGS TO OWNER UPON COMPLETION OF PROJECT.
- LOCATION OF EQUIPMENT AND WORK SUPPLIED BY OTHERS THAT IS DIAGRAMMATICALLY INDICATED ON THE DRAWINGS, SHALL BE DETERMINED BY THE CONTRACTOR. THE CONTRACTOR SHALL DETERMINE LOCATIONS AND DIMENSIONS SUBJECT TO STRUCTURAL CONDITIONS AND WORK OF THE SUBCONTRACTORS.
- THE CONTRACTOR IS SOLELY RESPONSIBLE TO DETERMINE CONSTRUCTION PROCEDURE AND SEQUENCE, AND TO ENSURE THE SAFETY OF THE EXISTING STRUCTURES AND IT'S COMPONENT PARTS DURING CONSTRUCTION. THIS INCLUDES THE ADDITION OF WHATEVER SHORING, BRACING, UNDERPINNING, ETC. THAT MAY BE NECESSARY.
- DRAWINGS INDICATE THE MINIMUM STANDARDS, BUT IF ANY WORK SHOULD BE INDICATED TO BE SUBSTANDARD TO ANY ORDINANCES, LAWS, CODES, RULES, OR REGULATIONS BEARING ON THE WORK, THE CONTRACTOR SHALL INCLUDE IN HIS WORK AND SHALL EXECUTE THE WORK CORRECTLY IN ACCORDANCE WITH SUCH ORDINANCES, LAWS, CODES, RULES OR REGULATIONS WITH NO INCREASE IN COSTS.
- ALL UTILITY WORK SHALL BE IN ACCORDANCE WITH LOCAL UTILITY COMPANY REQUIREMENTS AND SPECIFICATIONS.
- ALL EQUIPMENT AND PRODUCTS PURCHASED ARE TO BE REVIEWED BY CONTRACTOR AND ALL APPLICABLE SUBCONTRACTORS FOR ANY CONDITION PER MFR.'S RECOMMENDATIONS. CONTRACTOR TO SUPPLY THESE ITEMS AT NO COST TO OWNER OR CONSTRUCTION MANAGER.
- ANY AND ALL ERRORS, DISCREPANCIES, AND "MISSED" ITEMS, ARE TO BE BROUGHT TO THE ATTENTION OF THE SITE OWNER'S CONSTRUCTION MANAGER DURING THE BIDDING PROCESS BY THE CONTRACTOR. ALL THESE ITEMS ARE TO BE INCLUDED IN THE BID. NO 'EXTRA' WILL BE ALLOWED FOR MISSED ITEMS.
- CONTRACTOR SHALL BE RESPONSIBLE FOR ALL ON-SITE SAFETY FROM THE TIME THE JOB IS AWARDED UNTIL ALL WORK IS COMPLETE AND ACCEPTED BY THE OWNER.
- CONTRACTOR TO REVIEW ALL SHOP DRAWINGS AND SUBMIT COPY TO ENGINEER FOR APPROVAL. DRAWINGS MUST BEAR THE CHECKER'S INITIALS BEFORE SUBMITTING TO THE CONSTRUCTION MANAGER FOR REVIEW.
- THE CONTRACTOR SHALL FIELD VERIFY ALL DIMENSIONS, ELEVATIONS, ANGLES, AND EXISTING CONDITIONS AT THE SITE, PRIOR TO FABRICATION AND/OR INSTALLATION OF ANY WORK IN THE CONTRACT AREA.
- COORDINATION, LAYOUT, FURNISHING AND INSTALLATION OF CONDUIT AND ALL APPURTENANCES REQUIRED FOR PROPER INSTALLATION OF ELECTRICAL AND TELECOMMUNICATION SERVICE SHALL BE THE SOLE RESPONSIBILITY OF THE CONTRACTOR.
- ALL DAMAGE CAUSED TO ANY EXISTING STRUCTURE SHALL BE THE SOLE RESPONSIBILITY OF THE CONTRACTOR. THE CONTRACTOR WILL BE HELD LIABLE FOR ALL REPAIRS REQUIRED FOR EXISTING STRUCTURES IF DAMAGED DURING CONSTRUCTION ACTIVITIES.
- THE CONTRACTOR SHALL CONTACT "DIG SAFE" (DIAL 811) AT LEAST 48 HOURS PRIOR TO ANY EXCAVATIONS. ALL UTILITIES SHALL BE IDENTIFIED AND CLEARLY MARKED. CONTRACTOR SHALL MAINTAIN AND PROTECT MARKED UTILITIES THROUGHOUT PROJECT COMPLETION.
- CONTRACTOR SHALL COMPLY WITH OWNER'S ENVIRONMENTAL ENGINEER ON ALL METHODS AND PROVISIONS FOR ALL EXCAVATION ACTIVITIES INCLUDING SOIL DISPOSAL. ALL BACKFILL MATERIALS TO BE PROVIDED BY THE CONTRACTOR.
- THE COUNTY/CITY/TOWN WILL MAKE PERIODIC FIELD OBSERVATION AND INSPECTIONS TO MONITOR THE INSTALLATION, MATERIALS, WORKMANSHIP AND EQUIPMENT INCORPORATED INTO THE PROJECT TO ENSURE COMPLIANCE WITH THE DESIGN PLANS, SPECIFICATIONS, CONTRACT DOCUMENTS AND APPROVED SHOP DRAWINGS.
- THE COUNTY/CITY/TOWN MUST BE NOTIFIED (2) WORKING DAYS PRIOR TO CONCEALMENT/BURIAL OF ANY SYSTEM OR MATERIAL THAT WILL PREVENT THE DIRECT INSPECTION OF MATERIALS, METHODS OR WORKMANSHIP. EXAMPLES OF THESE PROCESSES ARE BACKFILLING A GROUND RING OR TOWER FOUNDATION, POURING TOWER FOUNDATIONS, BURYING GROUND RODS, PLATES OR GRIDS, ETC. THE CONTRACTOR MAY PROCEED WITH THE SCHEDULED PROCESS (2) WORKING DAYS AFTER PROVIDING NOTICE UNLESS NOTIFIED OTHERWISE BY THE COUNTY/CITY/TOWN.

REV.	DATE	DESCRIPTION
2	09/16/20	TJR
1	09/15/20	RTS
0	09/19/20	TJR

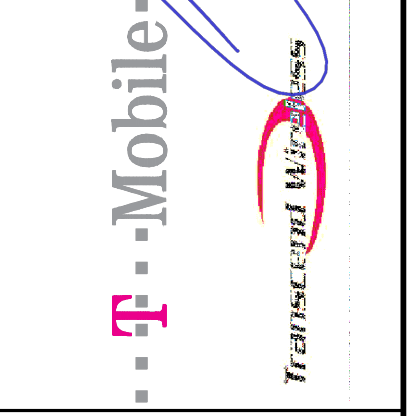
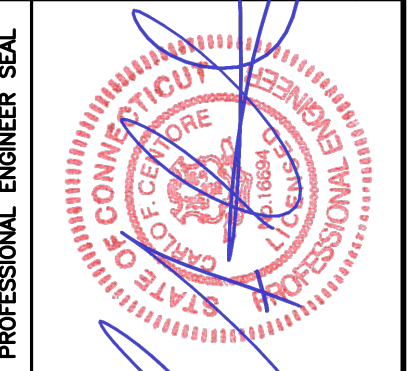

CEN TEK engineering
 Center on Solutions
 (203) 488-0380
 (203) 488-8587 Fax
 632 North Branford Road
 Branford, CT 06405
 www.CenTelEng.com

T-MOBILE NORTHEAST LLC
 WIRELESS COMMUNICATIONS FACILITY
BROOKFIELD/JUNCTION RD.
SITE ID: CT1196A
 39 CAPMEN HILL ROAD
 BROOKFIELD, CT 06804

DATE: 05/06/20
 SCALE: AS NOTED
 JOB NO. 20074.01

DESIGN BASIS
 AND SITE NOTES

NOTE:
ALL COAX LENGTHS TO BE MEASURED
AND VERIFIED IN FIELD BEFORE ORDERING

ANTENNA SCHEDULE								
SECTOR	EXISTING/PROPOSED	ANTENNA	SIZE (INCHES) (L x W x D)	ANTENNA HEIGHT	AZIMUTH	(E/P) RRU (QTY)	(E/P) TMA (QTY)	(QTY) PROPOSED COAX (LENGTH)
A1	EXISTING	RFS (APX16DWV-16DWV-S-E-A20)	55.9 x 13.0 x 3.15	280'	10°		(E) GENERIC TWIN STYLE 1B (2)	(1) 6x12 HYBRID CABLE (±310')
A2	EXISTING	ERICSSON (AIR6488 B41)	34.8 x 20.5 x 7.2	280'	10°			
A3	PROPOSED	ERICSSON (AIR32 KRD901146-1_B66A_B2A)	56.6 x 12.9 x 8.7	280'	10°			
A4	EXISTING	RFS (APXVAARR24_43-U-NA20)	95.9 x 24 x 8.7	280'	10°	(E) RADIO 4449 B71 (1), (E) RADIO 4415 B25 (1)		
B1	EXISTING	RFS (APX16DWV-16DWV-S-E-A20)	55.9 x 13.0 x 3.15	280'	130°		(E) GENERIC TWIN STYLE 1B (2)	(1) 6x12 HYBRID CABLE (±310')
B2	EXISTING	ERICSSON (AIR6488 B41)	34.8 x 20.5 x 7.2	280'	130°			
B3	PROPOSED	ERICSSON (AIR32 KRD901146-1_B66A_B2A)	56.6 x 12.9 x 8.7	280'	130°			
B4	EXISTING	RFS (APXVAARR24_43-U-NA20)	95.9 x 24 x 8.7	280'	130°	(E) RADIO 4449 B71 (1), (E) RADIO 4415 B25 (1)		
C1	EXISTING	RFS (APX16DWV-16DWV-S-E-A20)	55.9 x 13.0 x 3.15	280'	250°		(E) GENERIC TWIN STYLE 1B (2)	
C2	EXISTING	ERICSSON (AIR6488 B41)	34.8 x 20.5 x 7.2	280'	250°			
C3	PROPOSED	ERICSSON (AIR32 KRD901146-1_B66A_B2A)	56.6 x 12.9 x 8.7	280'	250°			
C4	EXISTING	RFS (APXVAARR24_43-U-NA20)	95.9 x 24 x 8.7	280'	250°	(E) RADIO 4449 B71 (1), (E) RADIO 4415 B25 (1)		

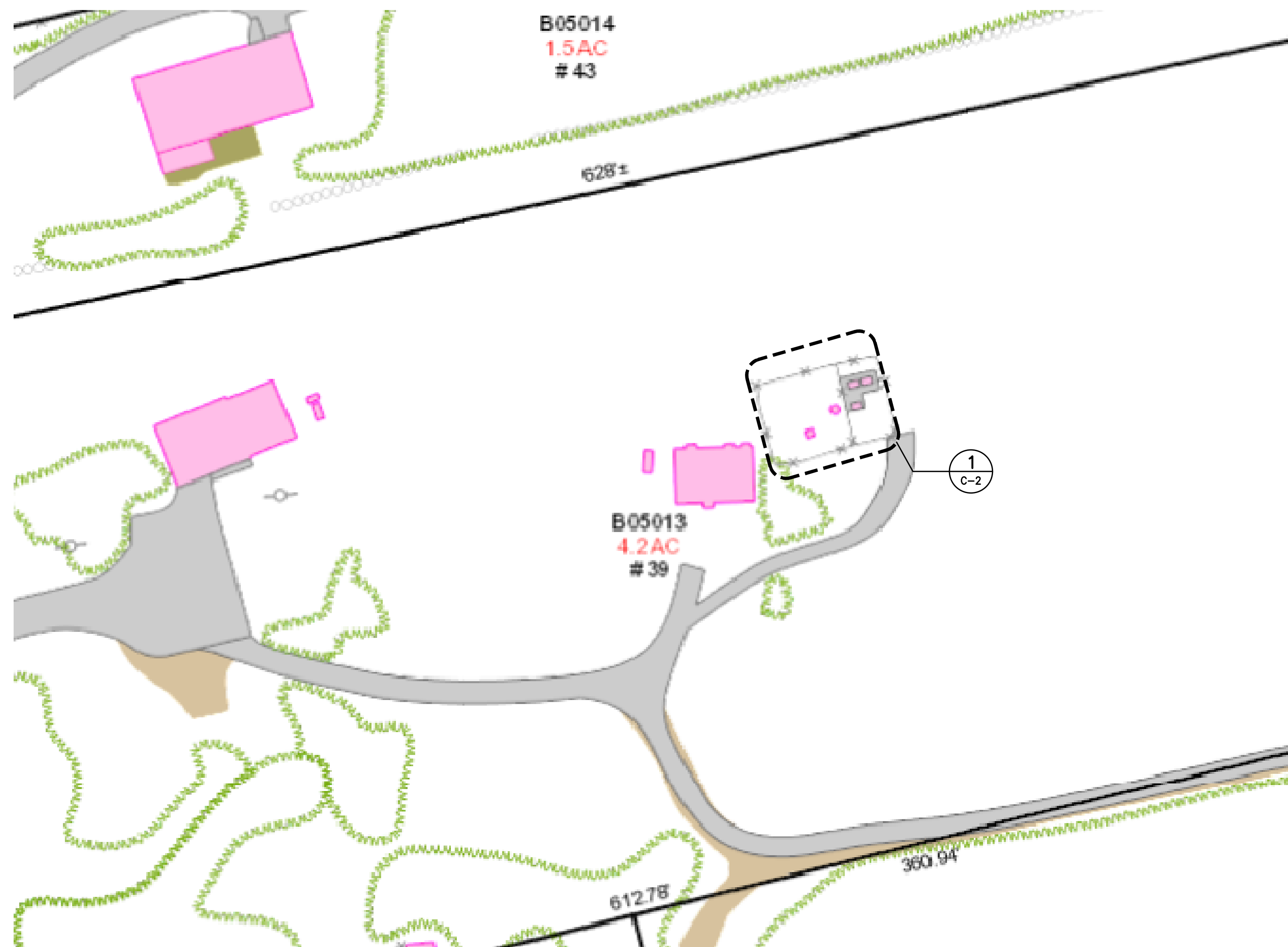

1 SITE LOCATION PLAN
C-1 SCALE: 1" = 50'

APPROX. NORTH

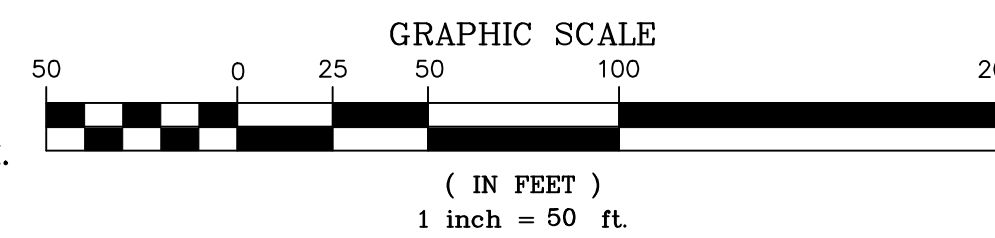

PROFESSIONAL ENGINEER SEAL 	CONSTRUCTION DRAWINGS - REISED GIS MAP CONSTRUCTION DRAWINGS - REISED ADDRESS CONSTRUCTION DRAWINGS - ISSUED FOR CONSTRUCTION
	T.J.R. T.J.R. T.J.R. T.J.R. DATE DRAWN BY/CHK'D BY
	2 09/16/20 09/15/20 09/19/20 REV.
	DESCRIPTION
<p> CENTEK engineering Center on Solutions (203) 488-0380 (203) 488-8587 Fax 652 North Branford Road Branford, CT 06405 www.CentekEng.com </p>	
<p> T-MOBILE NORTHEAST LLC WIRELESS COMMUNICATIONS FACILITY BROOKFIELD/JUNCTION RD. SITE ID: CT1196A 39 CARMEN HILL ROAD BROOKFIELD, CT 06804 </p>	
DATE: 05/06/20 SCALE: AS NOTED JOB NO. 20074.01	
SITE LOCATION PLAN	
<p style="font-size: 2em; font-weight: bold;">C-1</p>	
Sheet No. 3 of 8	

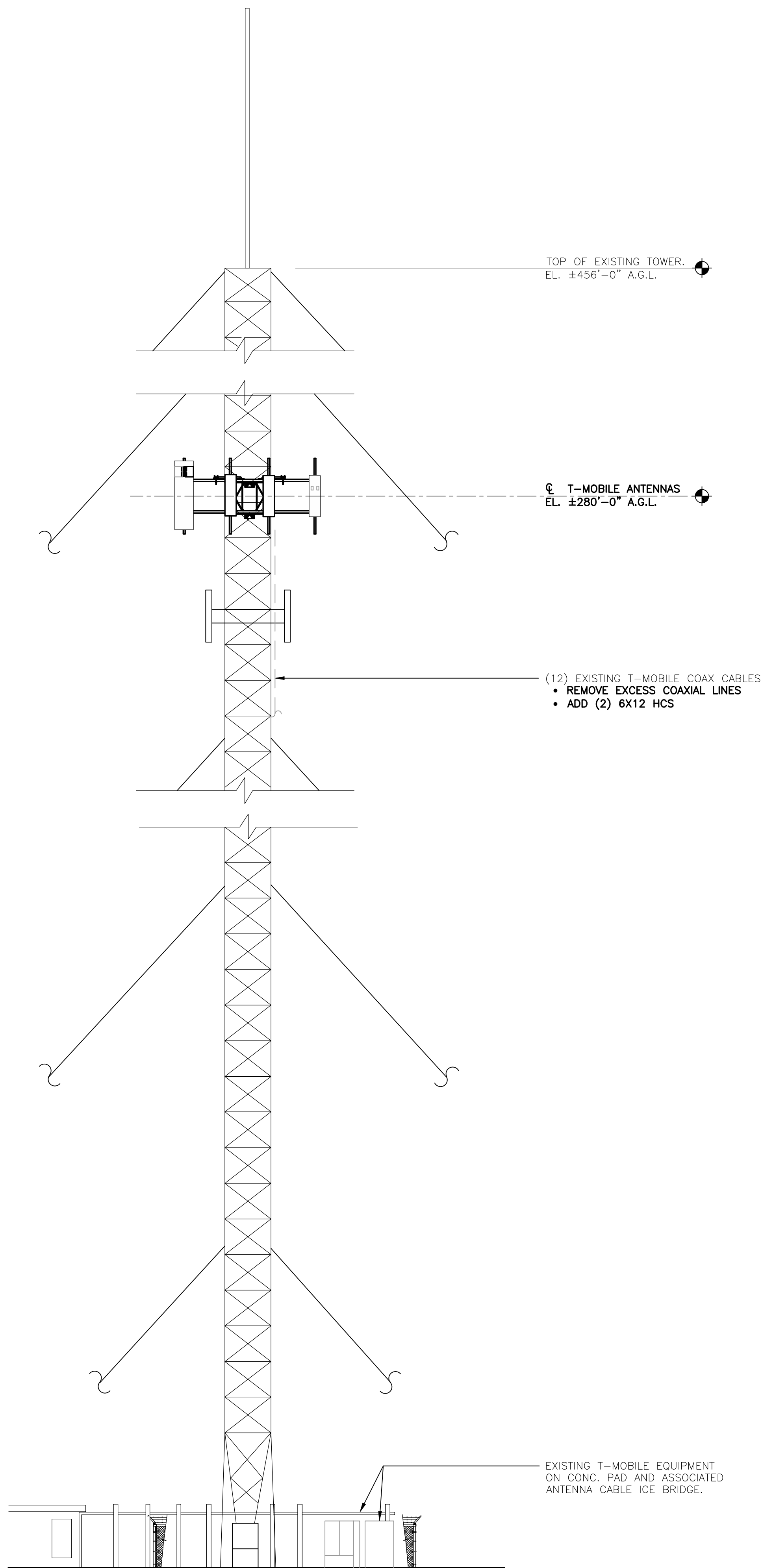

2 TOWER ELEVATION
C-2 SCALE: NOT TO SCALE

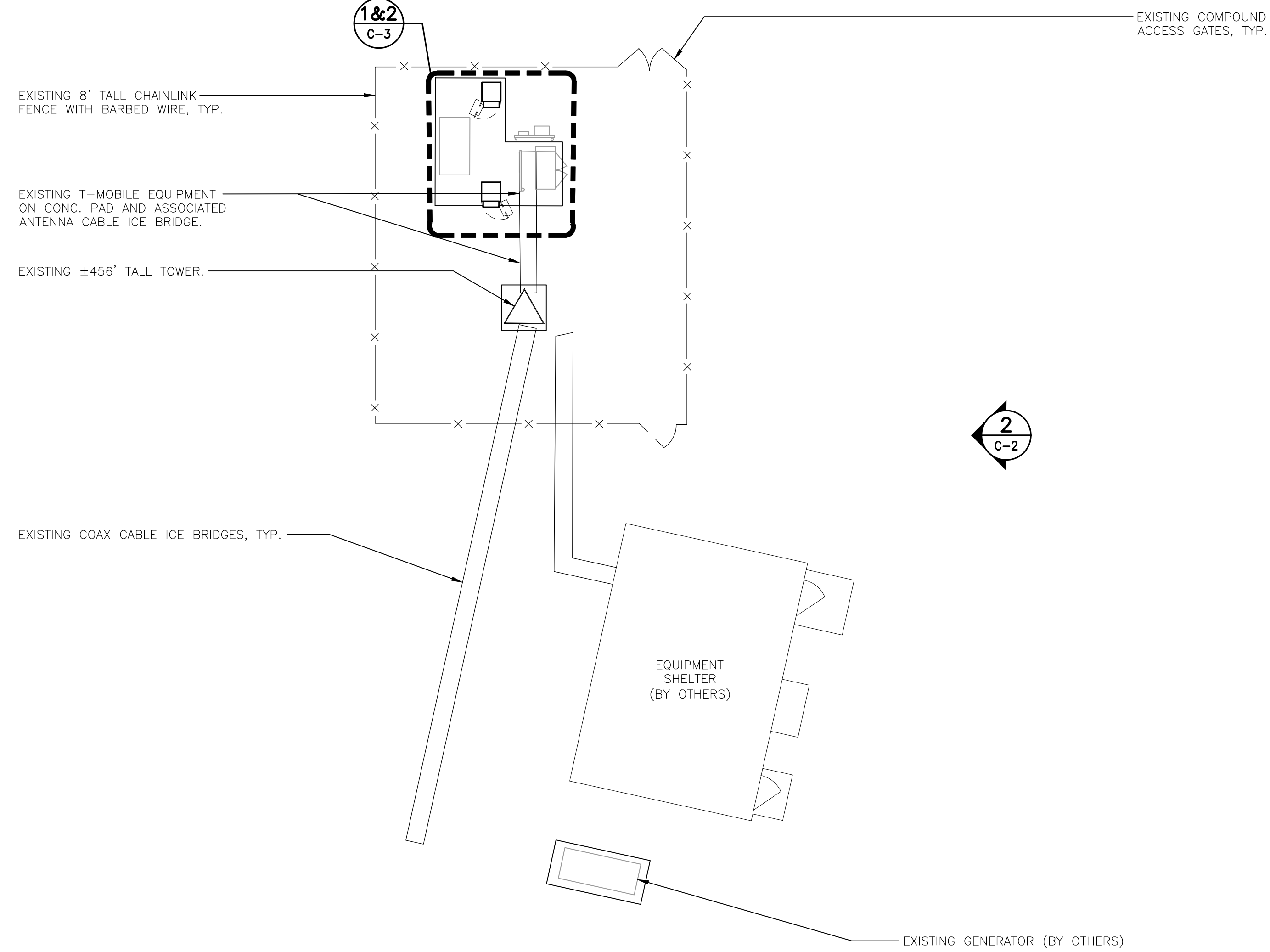

1 COMPOUND PLAN
C-2 SCALE: 1" = 10'

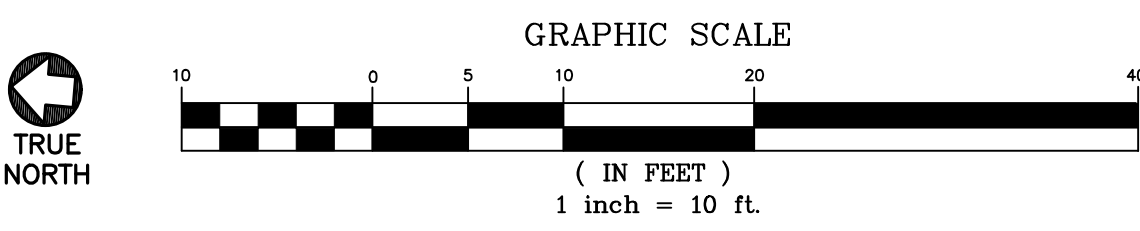

STRUCTURAL COMPLIANCE

ANTENNA MOUNTS
A STRUCTURAL ANALYSIS OF THE ANTENNA MOUNTS WAS PERFORMED FOR THE PROPOSED EQUIPMENT INSTALLATION AND THEY WERE FOUND TO BE STRUCTURALLY SUFFICIENT TO ACCOMMODATE THE PROPOSED LOADING.
REFER TO THE ANTENNA MOUNT ANALYSIS REPORT PREPARED BY CENTEK ENGINEERING (PROJECT # 20074.01) DATED 07/07/20 FOR ADDITIONAL INFORMATION AND REQUIREMENTS.

TOWER AND TOWER FOUNDATION
A STRUCTURAL ANALYSIS OF THE TOWER AND TOWER FOUNDATION WAS PERFORMED FOR THE PROPOSED EQUIPMENT INSTALLATION AND THEY WERE FOUND TO BE STRUCTURALLY SUFFICIENT TO ACCOMMODATE THE PROPOSED LOADING.
REFER TO THE STRUCTURAL ANALYSIS REPORT PREPARED BY VERTICAL BRIDGE ENGINEERING, LLC (PROJECT # US-CT-5009) DATED 06/01/20 FOR ADDITIONAL INFORMATION AND REQUIREMENTS.

NOTE: NO EQUIPMENT SHALL BE INSTALLED ON THE HOSTING STRUCTURE WITHOUT A PASSING STRUCTURAL ANALYSIS REPORT AND CONTRACTOR PRIOR CONFIRMATION THAT ANY AND ALL REQUISITE MODIFICATIONS HAVE BEEN COMPLETED.

<p>PROFESSIONAL ENGINEER SEAL</p>	
<p>T-Mobile T-Mobile USA, Inc.</p>	
<p>CENTEK engineering Centek on Solutions (203) 488-0380 (203) 488-8887 Fax 652 North Branford Road Branford, CT 06405 www.CentekEng.com</p>	
<p>T-MOBILE NORTHEAST LLC WIRELESS COMMUNICATIONS FACILITY BROOKFIELD/JUNCTION RD. SITE ID: CT1196A 39 CARMEN HILL ROAD BROOKFIELD, CT 06804</p>	
DATE:	05/06/20
SCALE:	AS NOTED
JOB NO.	20074.01
<p>COMPOUND PLAN, AND ELEVATION</p>	
<p>C-2</p>	
<p>Sheet No. 4 of 8</p>	

REV.	DATE	DRAWN BY	CHK'D BY	DESCRIPTION
2	09/16/20	RTS	TJR	CONSTRUCTION DRAWINGS - REVISED GIS MAP
1	09/15/20	RTS	TJR	CONSTRUCTION DRAWINGS - REVISED ADDRESS
0	09/19/20	RTS	TJR	CONSTRUCTION DRAWINGS - ISSUED FOR CONSTRUCTION

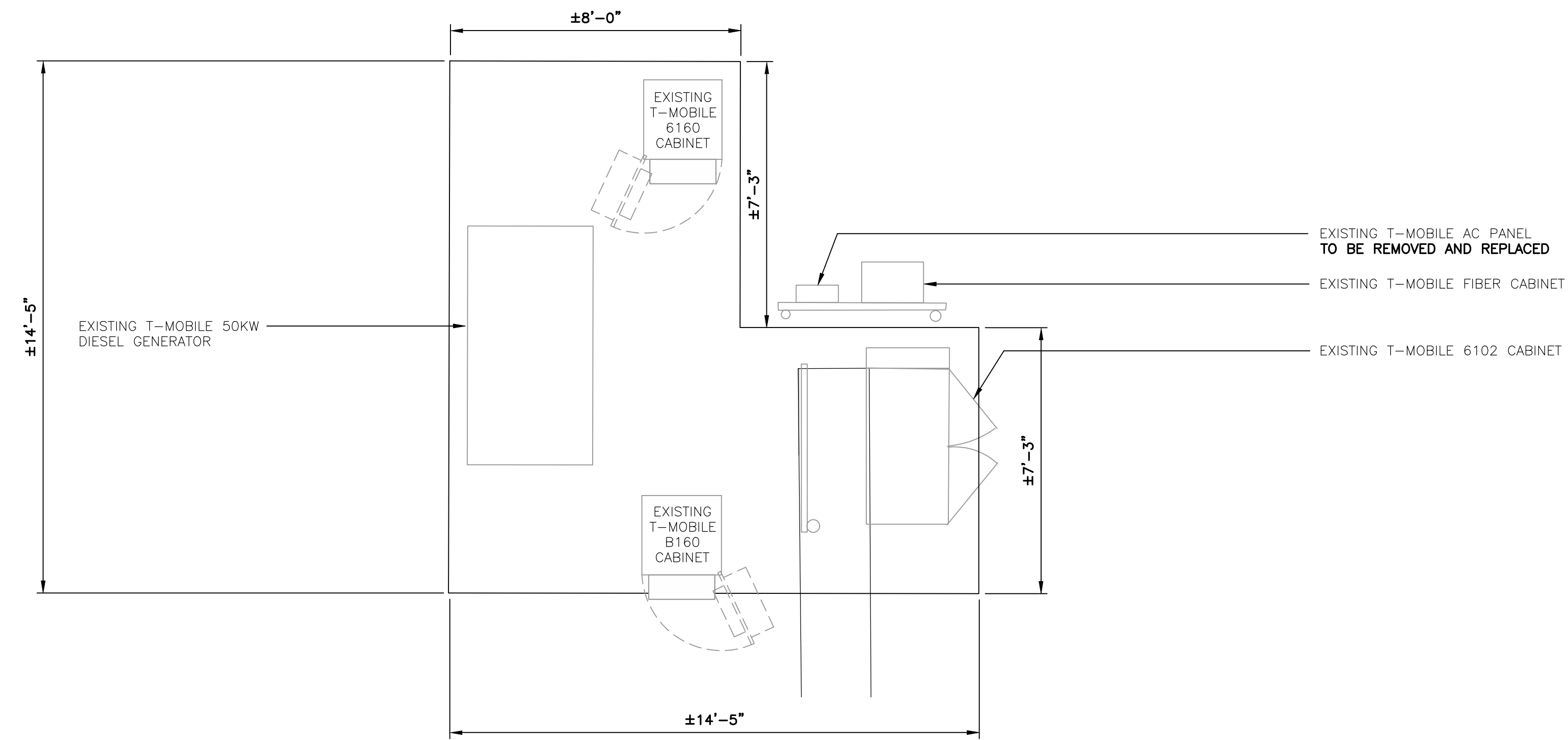

1
C-3 **EQUIPMENT PLAN - EXISTING**
SCALE: 3/8" = 1'
TRUE NORTH

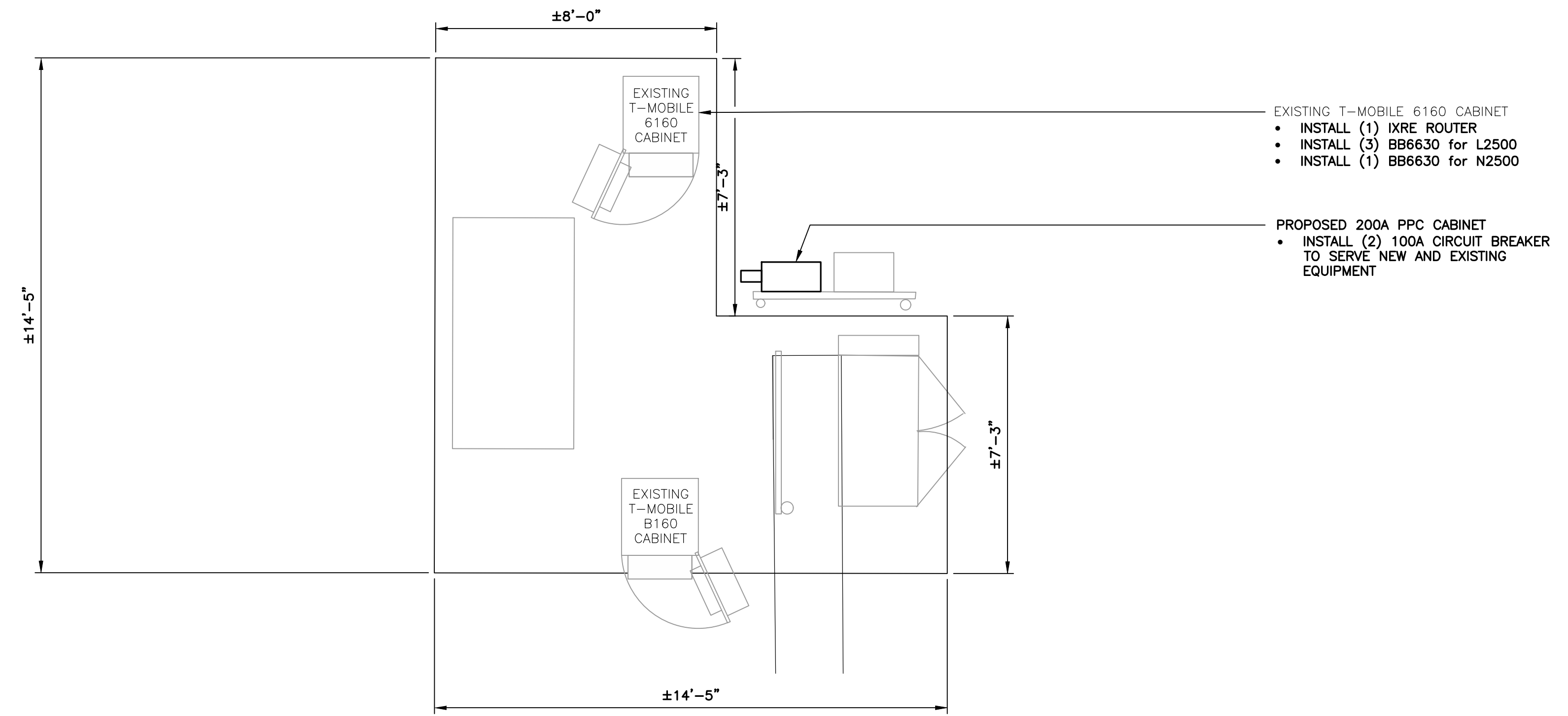

2
C-3 **EQUIPMENT PLAN - PROPOSED**
SCALE: 3/8" = 1'
TRUE NORTH

<p>CENTEK engineering Centek on Solutions (203) 488-0380 (203) 488-8587 Fax 652 North Branford Road Branford, CT 06405 www.CentekEng.com</p>	
<p>T-MOBILE NORTHEAST LLC WIRELESS COMMUNICATIONS FACILITY BROOKFIELD/JUNCTION RD. SITE ID: CT1196A 39 CARMEN HILL ROAD BROOKFIELD, CT 06804</p>	
DATE:	05/06/20
SCALE:	AS NOTED
JOB NO.	20074.01
EQUIPMENT LAYOUT PLANS	
C-3	
Sheet No. 5 of 8	

REV.	DATE	DRAWN BY/CHK'D BY	DESCRIPTION
2	09/16/20	RTS	CONSTRUCTION DRAWINGS - REISED GIS MAP
1	09/15/20	RTS	CONSTRUCTION DRAWINGS - REISED ADDRESS
0	09/19/20	RTS	CONSTRUCTION DRAWINGS - ISSUED FOR CONSTRUCTION

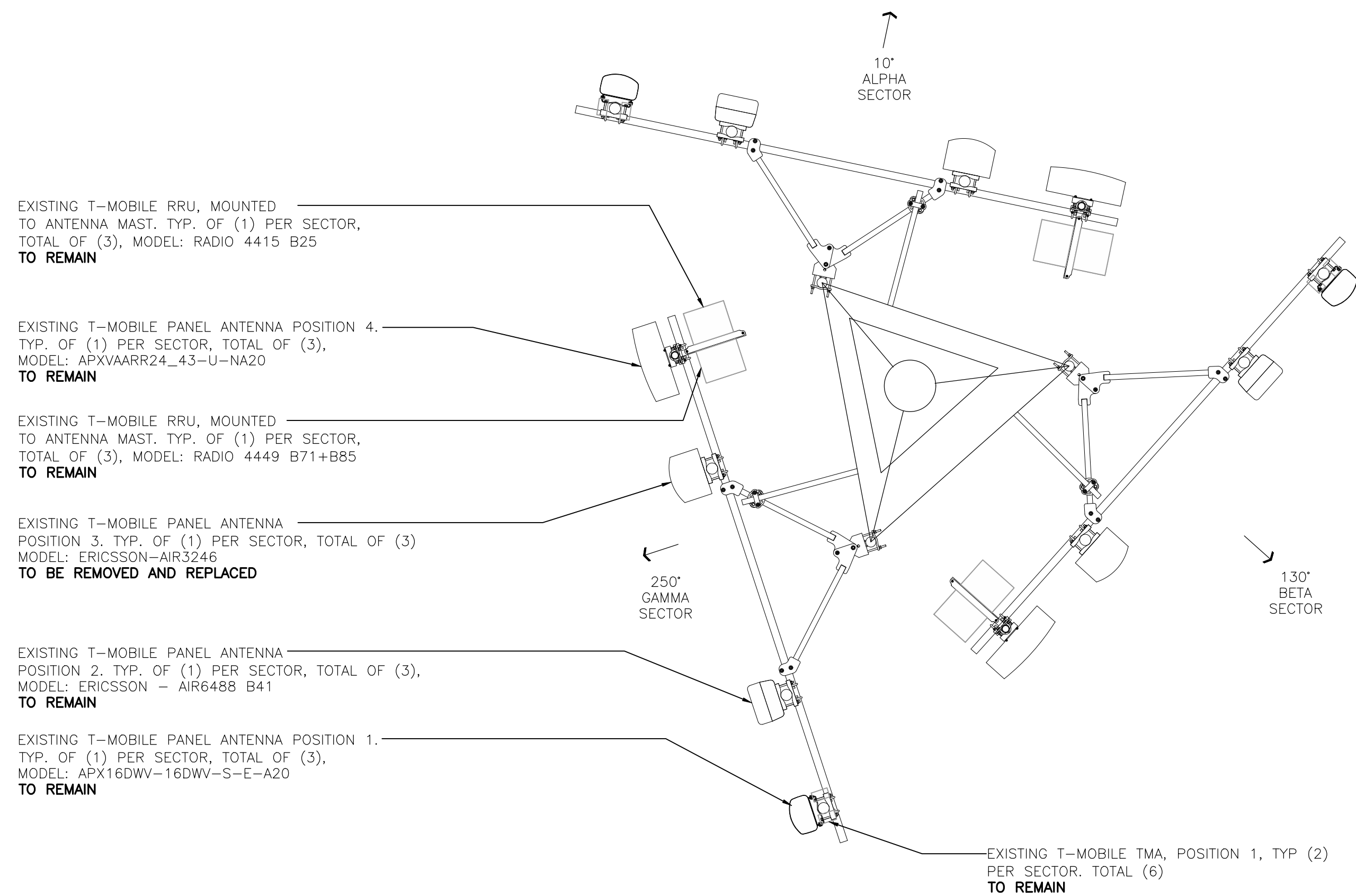

EXISTING T-MOBILE RRU, MOUNTED TO ANTENNA MAST. TYP. OF (1) PER SECTOR, TOTAL OF (3), MODEL: RADIO 4415 B25
TO REMAIN

EXISTING T-MOBILE PANEL ANTENNA POSITION 4. TYP. OF (1) PER SECTOR, TOTAL OF (3), MODEL: APXVAARR24_43-U-NA20
TO REMAIN

EXISTING T-MOBILE RRU, MOUNTED TO ANTENNA MAST. TYP. OF (1) PER SECTOR, TOTAL OF (3), MODEL: RADIO 4449 B71+B85
TO REMAIN

EXISTING T-MOBILE PANEL ANTENNA POSITION 3. TYP. OF (1) PER SECTOR, TOTAL OF (3), MODEL: ERICSSON-AIR3246
TO BE REMOVED AND REPLACED

EXISTING T-MOBILE PANEL ANTENNA POSITION 2. TYP. OF (1) PER SECTOR, TOTAL OF (3), MODEL: ERICSSON - AIR6488 B41
TO REMAIN

EXISTING T-MOBILE PANEL ANTENNA POSITION 1. TYP. OF (1) PER SECTOR, TOTAL OF (3), MODEL: APX16DW-16DW-S-E-A20
TO REMAIN

EXISTING T-MOBILE TMA, POSITION 1, TYP (2) PER SECTOR, TOTAL (6)
TO REMAIN

1 EXISTING ANTENNA MOUNTING CONFIGURATION
C-4 SCALE: 3/8" = 1' 280' ELEVATION TRUE NORTH

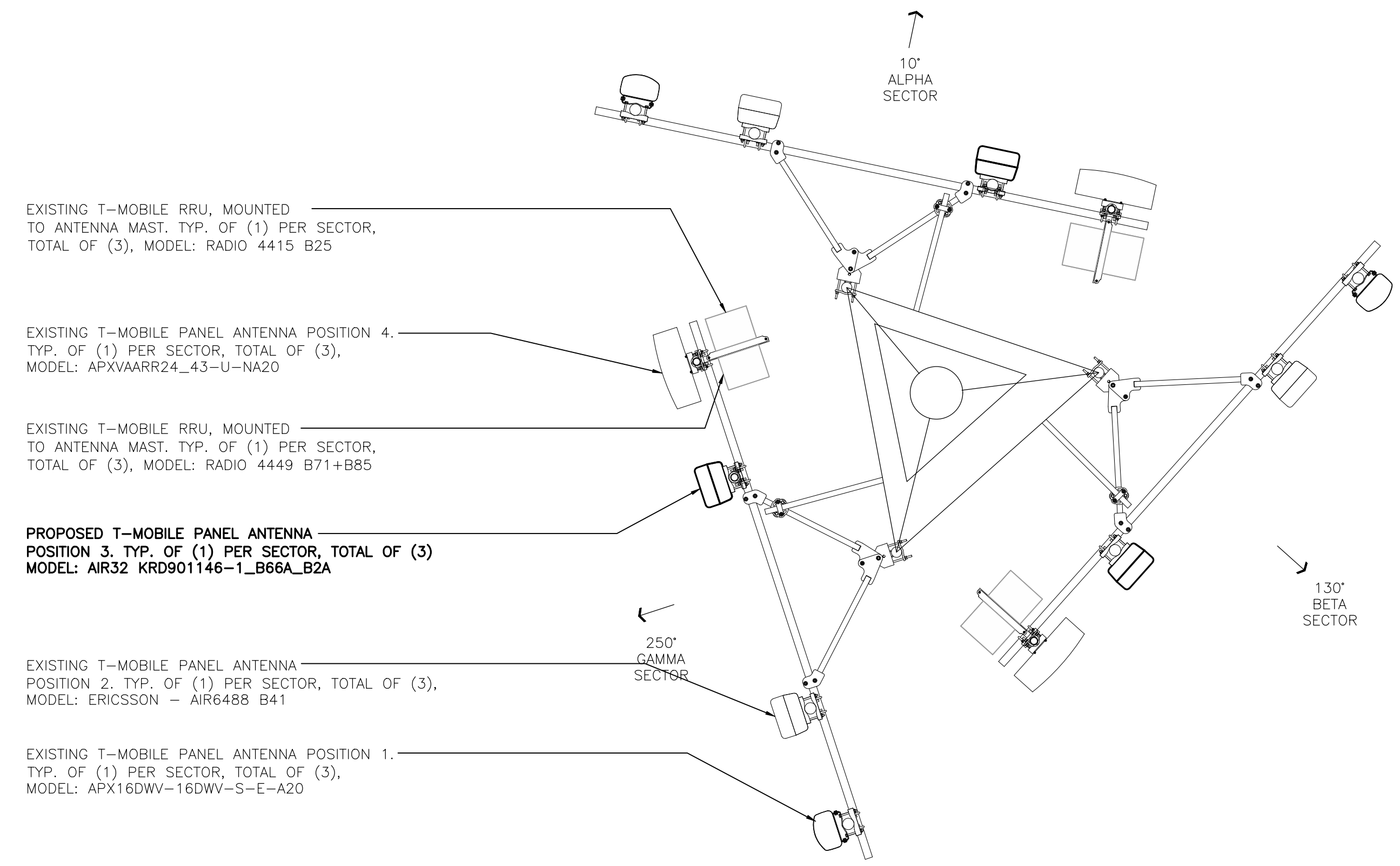

EXISTING T-MOBILE RRU, MOUNTED TO ANTENNA MAST. TYP. OF (1) PER SECTOR, TOTAL OF (3), MODEL: RADIO 4415 B25

EXISTING T-MOBILE PANEL ANTENNA POSITION 4. TYP. OF (1) PER SECTOR, TOTAL OF (3), MODEL: APXVAARR24_43-U-NA20

EXISTING T-MOBILE RRU, MOUNTED TO ANTENNA MAST. TYP. OF (1) PER SECTOR, TOTAL OF (3), MODEL: RADIO 4449 B71+B85

PROPOSED T-MOBILE PANEL ANTENNA POSITION 3. TYP. OF (1) PER SECTOR, TOTAL OF (3) MODEL: AIR32 KRD901146-1_B66A_B2A

EXISTING T-MOBILE PANEL ANTENNA POSITION 2. TYP. OF (1) PER SECTOR, TOTAL OF (3), MODEL: ERICSSON - AIR6488 B41

EXISTING T-MOBILE PANEL ANTENNA POSITION 1. TYP. OF (1) PER SECTOR, TOTAL OF (3), MODEL: APX16DW-16DW-S-E-A20

2 PROPOSED ANTENNA MOUNTING CONFIGURATION
C-4 SCALE: 3/8" = 1' 240' ELEVATION TRUE NORTH

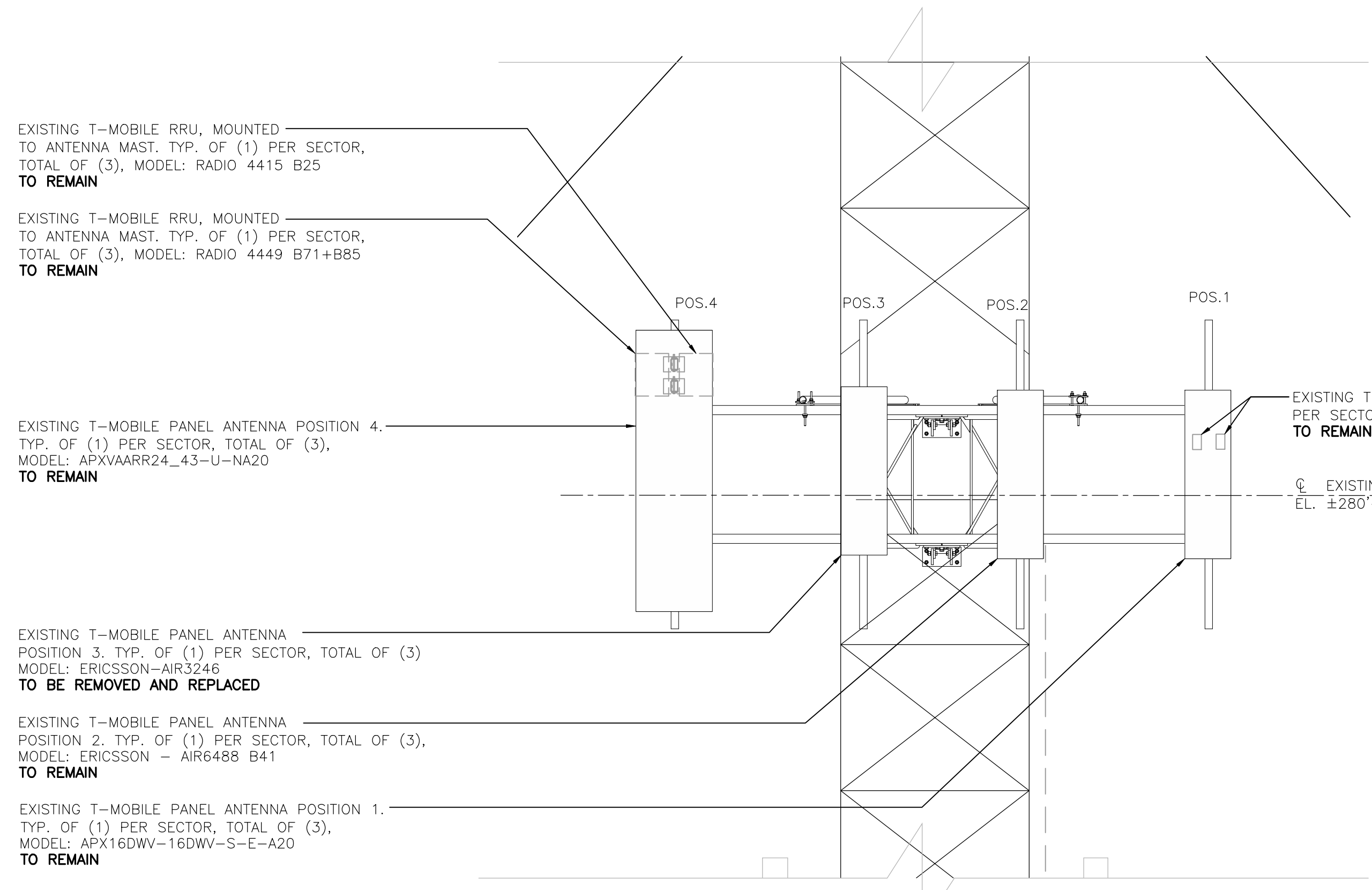

EXISTING T-MOBILE RRU, MOUNTED TO ANTENNA MAST. TYP. OF (1) PER SECTOR, TOTAL OF (3), MODEL: RADIO 4415 B25
TO REMAIN

EXISTING T-MOBILE RRU, MOUNTED TO ANTENNA MAST. TYP. OF (1) PER SECTOR, TOTAL OF (3), MODEL: RADIO 4449 B71+B85
TO REMAIN

EXISTING T-MOBILE PANEL ANTENNA POSITION 4. TYP. OF (1) PER SECTOR, TOTAL OF (3), MODEL: APXVAARR24_43-U-NA20
TO REMAIN

EXISTING T-MOBILE PANEL ANTENNA POSITION 3. TYP. OF (1) PER SECTOR, TOTAL OF (3), MODEL: ERICSSON-AIR3246
TO BE REMOVED AND REPLACED

EXISTING T-MOBILE PANEL ANTENNA POSITION 2. TYP. OF (1) PER SECTOR, TOTAL OF (3), MODEL: ERICSSON - AIR6488 B41
TO REMAIN

EXISTING T-MOBILE PANEL ANTENNA POSITION 1. TYP. OF (1) PER SECTOR, TOTAL OF (3), MODEL: APX16DW-16DW-S-E-A20
TO REMAIN

EXISTING T-MOBILE TMA, POSITION 1, TYP (2) PER SECTOR, TOTAL (6)
TO REMAIN

EXISTING T-MOBILE ANTENNAS
EL. ±280'-0" A.G.L.

1A EXISTING ANTENNA ELEVATION
C-4 SCALE: 3/8" = 1'

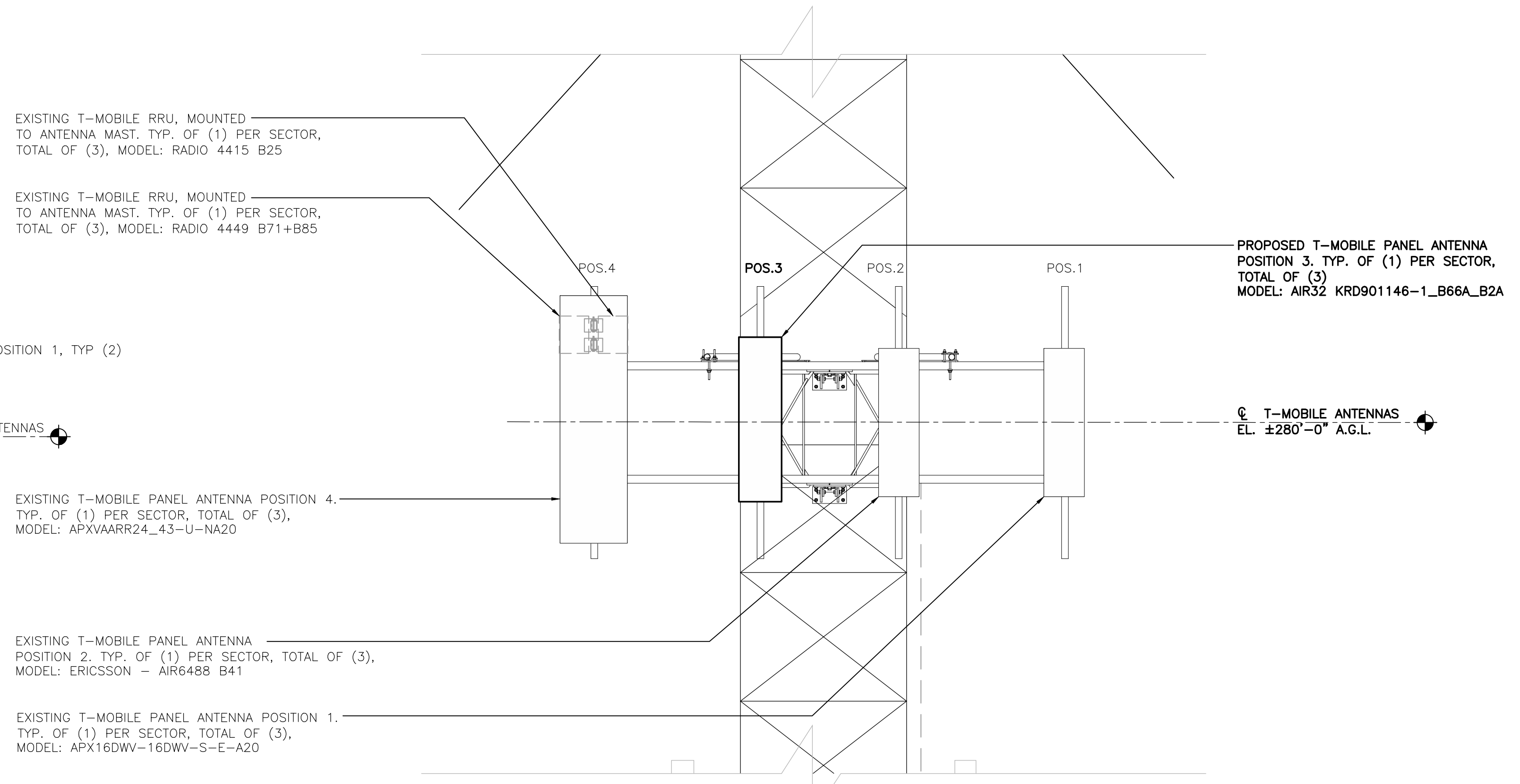

EXISTING T-MOBILE RRU, MOUNTED TO ANTENNA MAST. TYP. OF (1) PER SECTOR, TOTAL OF (3), MODEL: RADIO 4415 B25

EXISTING T-MOBILE RRU, MOUNTED TO ANTENNA MAST. TYP. OF (1) PER SECTOR, TOTAL OF (3), MODEL: RADIO 4449 B71+B85

EXISTING T-MOBILE PANEL ANTENNA POSITION 4. TYP. OF (1) PER SECTOR, TOTAL OF (3), MODEL: APXVAARR24_43-U-NA20

EXISTING T-MOBILE PANEL ANTENNA POSITION 2. TYP. OF (1) PER SECTOR, TOTAL OF (3), MODEL: ERICSSON - AIR6488 B41

EXISTING T-MOBILE PANEL ANTENNA POSITION 1. TYP. OF (1) PER SECTOR, TOTAL OF (3), MODEL: APX16DW-16DW-S-E-A20

PROPOSED T-MOBILE PANEL ANTENNA POSITION 3. TYP. OF (1) PER SECTOR, TOTAL OF (3) MODEL: AIR32 KRD901146-1_B66A_B2A

T-MOBILE ANTENNAS
EL. ±280'-0" A.G.L.

2A PROPOSED ANTENNA ELEVATION
C-4 SCALE: 3/8" = 1'

CONSTRUCTION DRAWINGS - REVISIONS	TJR	DATE	DESCRIPTION
CONSTRUCTION DRAWINGS - REVISIONS	RIS	09/16/20	2
CONSTRUCTION DRAWINGS - REVISIONS	TJR	09/15/20	0
CONSTRUCTION DRAWINGS - REVISIONS	RIS	09/19/20	0
CONSTRUCTION DRAWINGS - REVISIONS	TJR	09/19/20	0

PROFESSIONAL ENGINEER SEAL

T-Mobile

CENITEK engineering
Centerline Solutions
(203) 488-0880
(203) 488-8887 Fax
652 North Branford Road
Branford, CT 06405
www.CenterEng.com

T-MOBILE NORTHEAST LLC
WIRELESS COMMUNICATIONS FACILITY
BROOKFIELD/JUNCTION RD.
SITE ID: CT1196A
39 CARMEN HILL ROAD
BROOKFIELD, CT 06804

DATE: 05/06/20
SCALE: AS NOTED
JOB NO. 20074.01

ANTENNA PLANS AND ELEVATIONS

C-4

Sheet No. 6 of 8

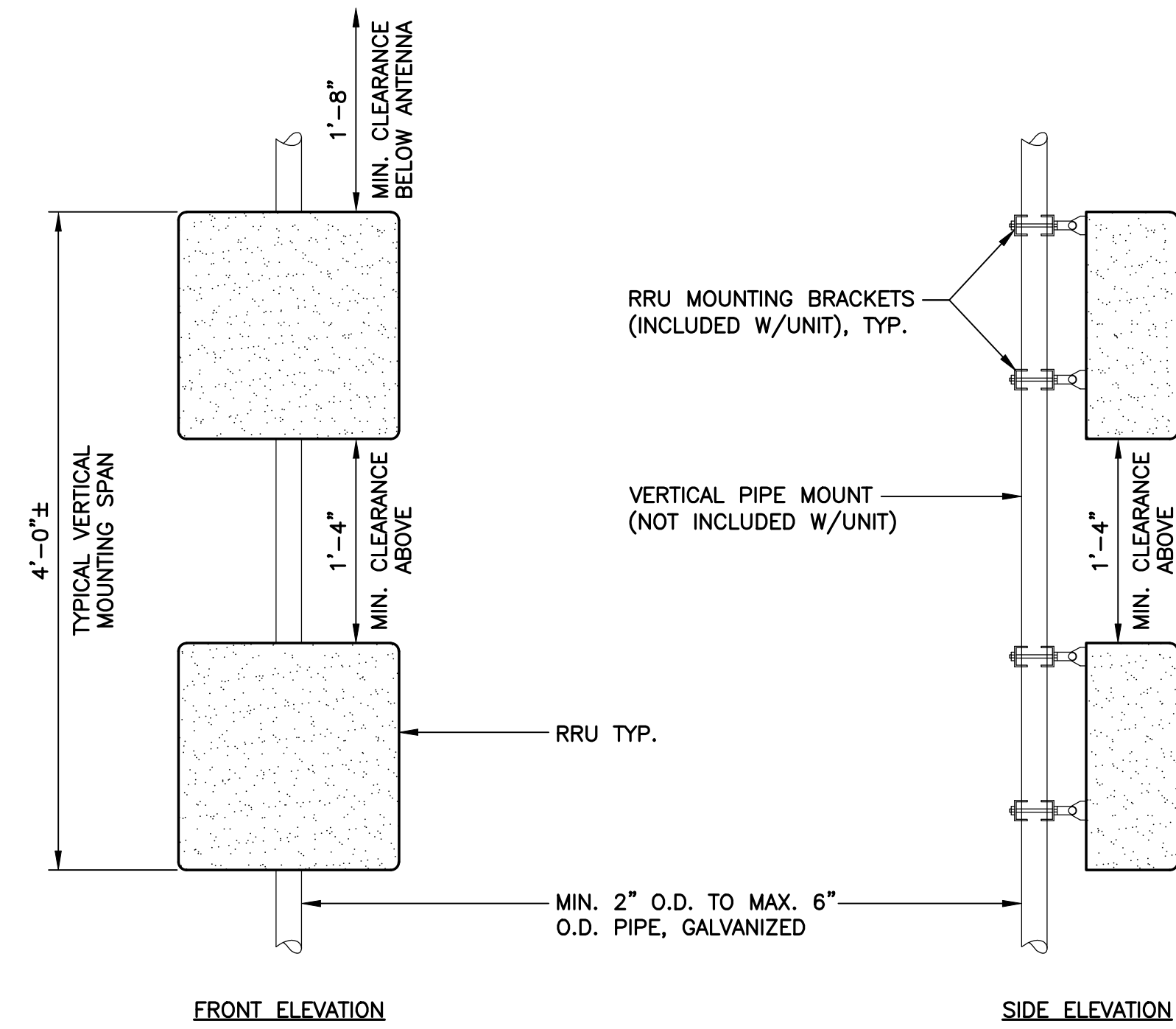

- NOTES:**
1. T-MOBILE SHALL SUPPLY RRU, AND RRU POLE-MOUNTING BRACKET. CONTRACTOR SHALL SUPPLY POLE/PIPE AND INSTALL ALL MOUNTING HARDWARE INCLUDING ERICSSON RRU POLE-MOUNTING BRACKET. CONTRACTOR SHALL INSTALLS RRU AND MAKES CABLE TERMINATIONS.
 2. NO PAINTING OF THE RRU OR SOLAR SHIELD IS ALLOWED.

1 TYPICAL RRUS MOUNTING DETAILS
C-5 SCALE: NOT TO SCALE

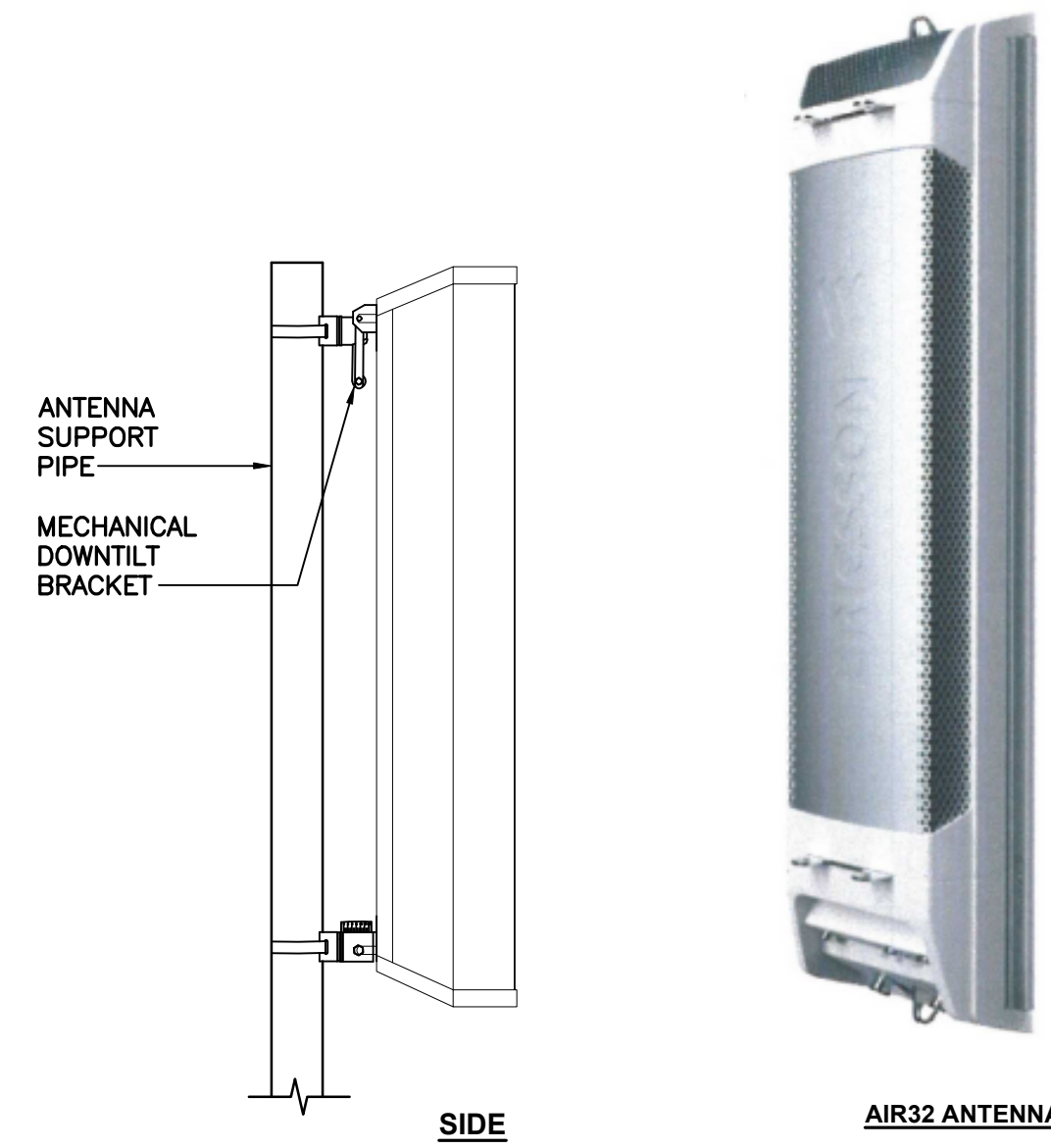

ALPHA/BETA/GAMMA ANTENNA		
EQUIPMENT	DIMENSIONS	WEIGHT
MAKE: ERICSSON MODEL: AIR32 KRD901146-1 B66A_B2A	56.6"L x 12.9"W x 8.7"D	±132 LBS.

NOTES:
1. CONTRACTOR TO COORDINATE FINAL EQUIPMENT MODEL SELECTION WITH T-MOBILE CONSTRUCTION MANAGER PRIOR TO ORDERING.

2 PROPOSED ANTENNA DETAIL
C-5 SCALE: NOT TO SCALE

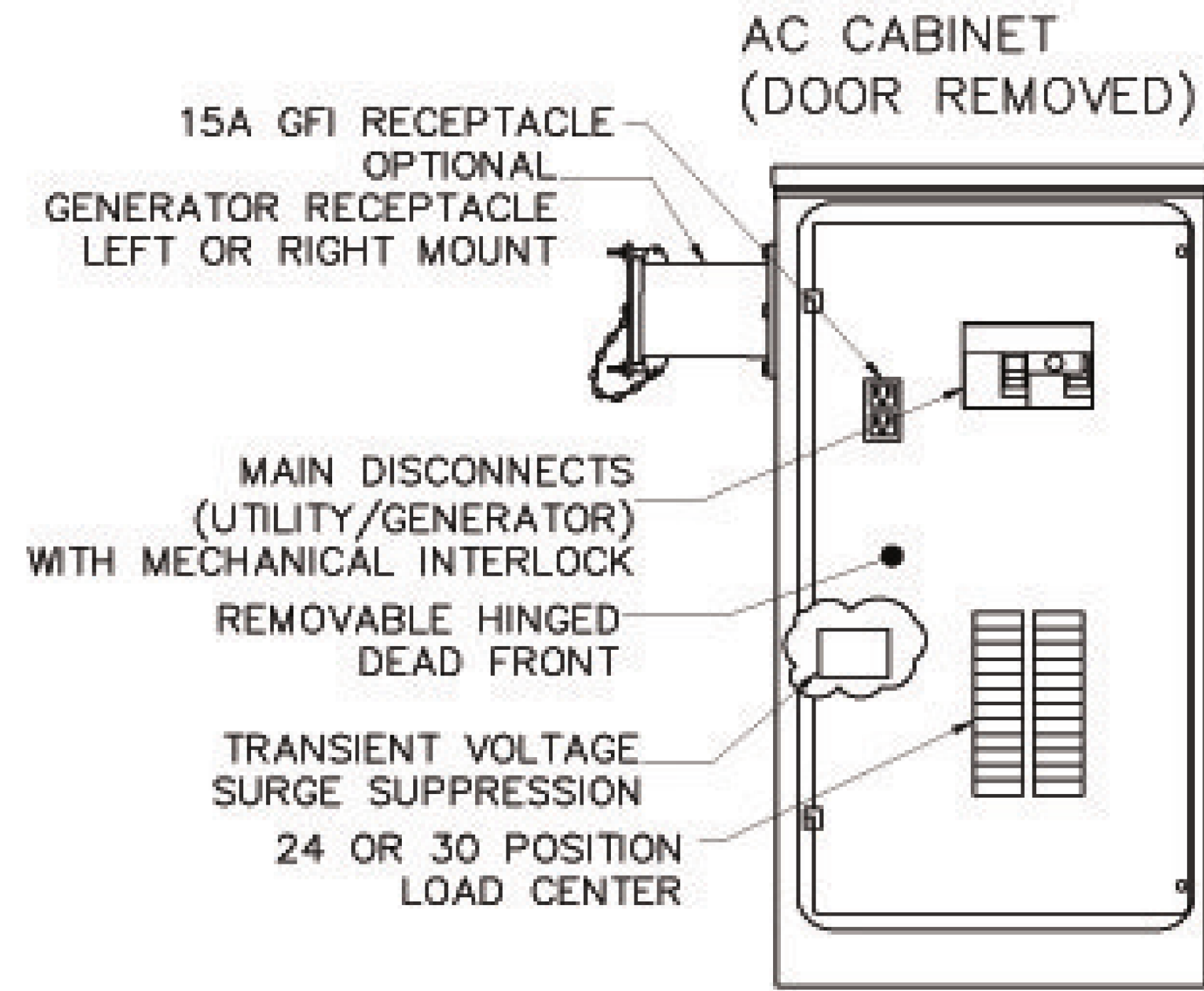

PPC CABINET		
EQUIPMENT	DIMENSIONS	WEIGHT
MAKE: EMERSON MODEL: CAC-A75201090	40.0"H x 20.0"W x 10.0"D	±80 LBS

3 PPC CABINET DETAIL
C-6 NOT TO SCALE



EQUIPMENT CABINET		
EQUIPMENT	DIMENSIONS	WEIGHT
MAKE: ERICSSON MODEL: ENCLOSURE 6160	62.0"H x 26.0"W x 26.0"D	±1200 LBS

4 ENCLOSURE 6160 (OUTDOOR)
C-5 SCALE: NOT TO SCALE



EQUIPMENT CABINET		
EQUIPMENT	DIMENSIONS	WEIGHT
MAKE: ERICSSON MODEL: BATTERY CABINET B160	62.0"H x 26.0"W x 26.0"D	±1883 LBS

5 BATTERY CABINET DETAIL
C-5 NOT TO SCALE

REV.	DATE	DESCRIPTION
2	09/16/20	TJR
	09/15/20	RIS
0	09/19/20	RIS

CONSTRUCTION DRAWINGS - REISED GIS MAP
CONSTRUCTION DRAWINGS - REISED ADDRESS
CONSTRUCTION DRAWINGS - ISSUED FOR CONSTRUCTION

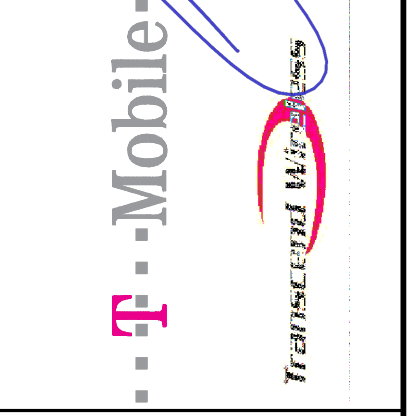
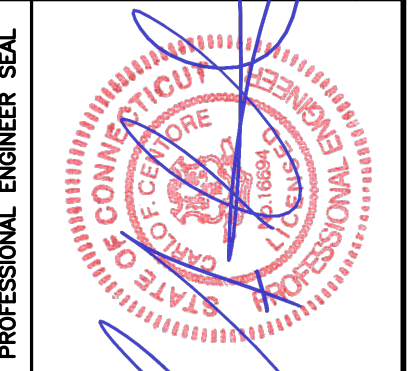

CEN TEK engineering
Center on Solutions
(203) 488-0380
(203) 488-8587 Fax
652 North Branford Road
Branford, CT 06405
www.CentekEng.com

T-MOBILE NORTHEAST LLC
WIRELESS COMMUNICATIONS FACILITY
BROOKFIELD/JUNCTION RD.
SITE ID: CT1196A
39 CARMEN HILL ROAD
BROOKFIELD, CT 06804

DATE: 05/06/20
SCALE: AS NOTED
JOB NO. 20074.01

TYPICAL DETAILS

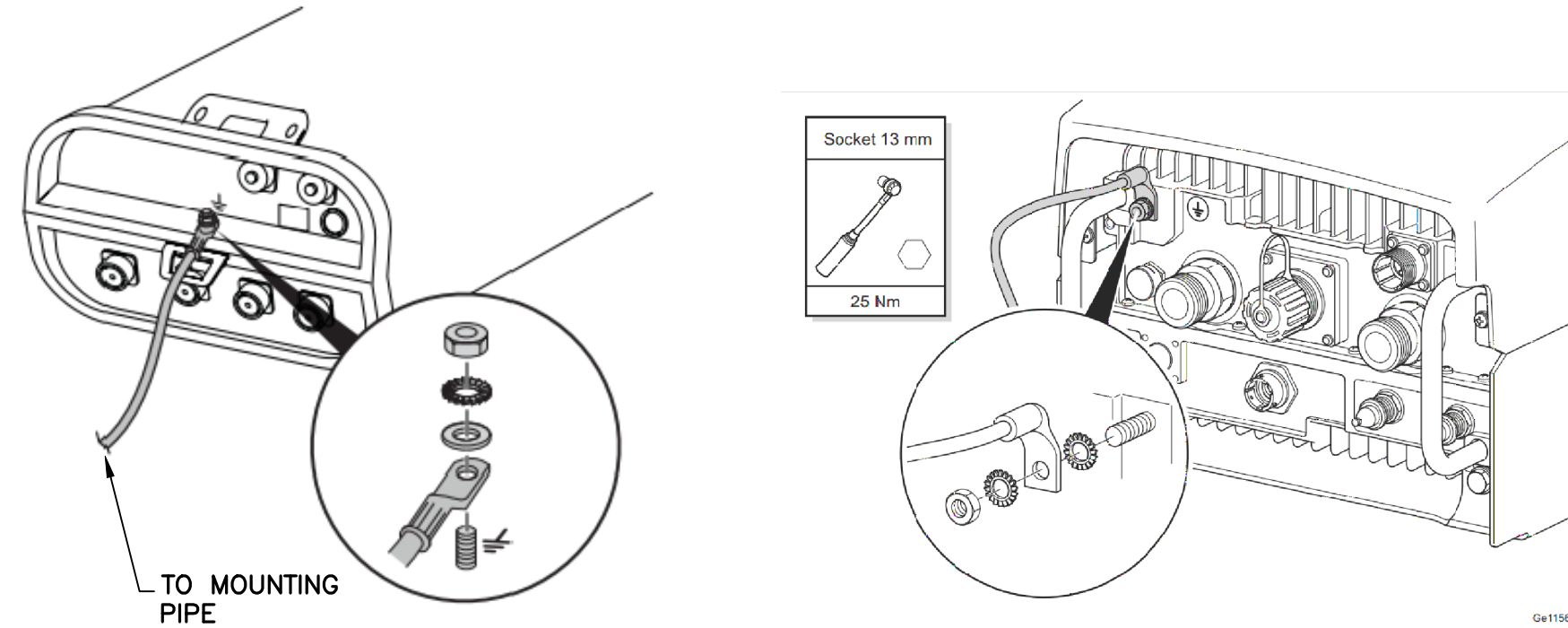

1 TYPICAL ANTENNA/RRU GROUNDING DETAILS
E-1 SCALE: NOT TO SCALE

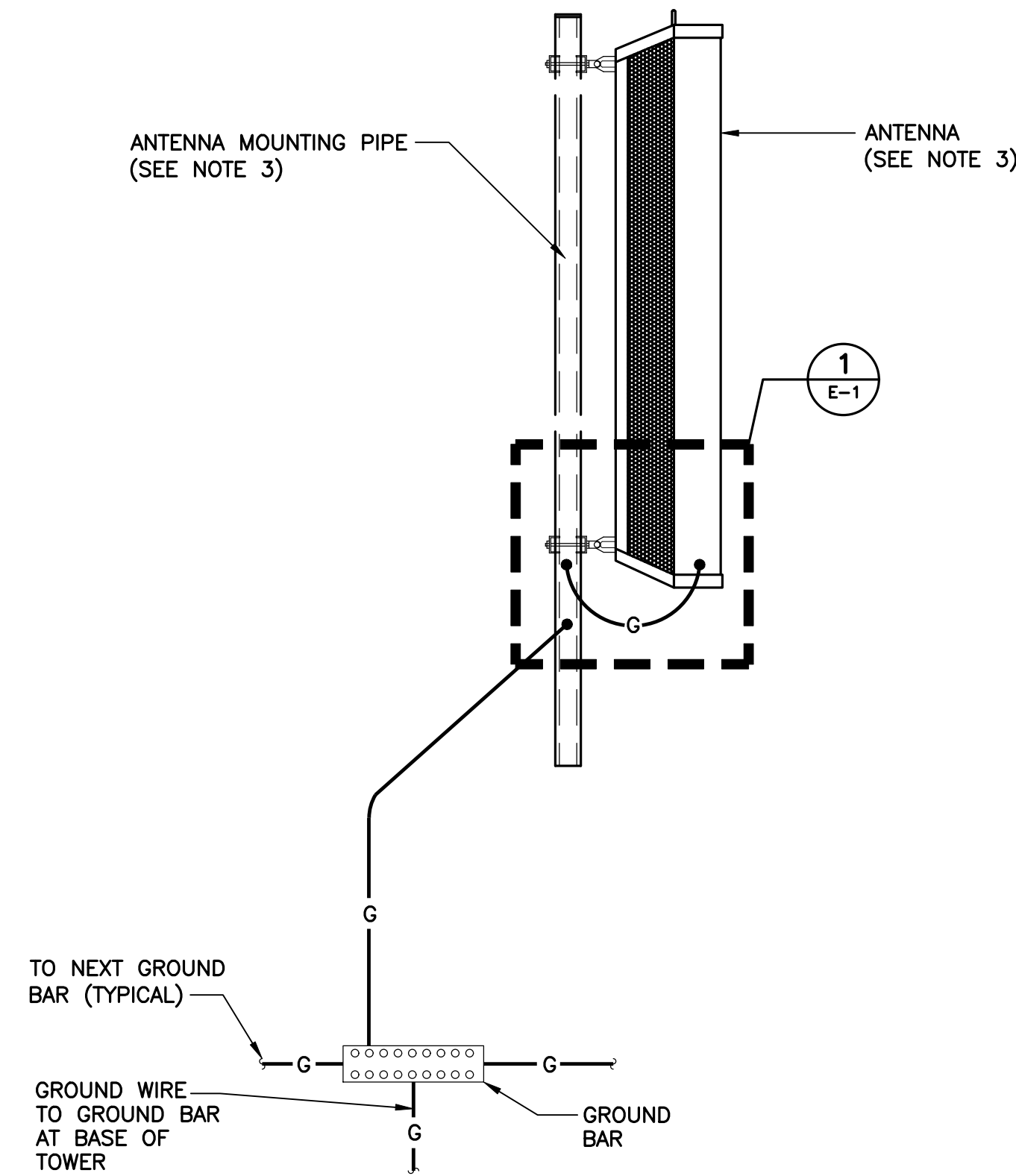

- NOTES:**
- BOND COAXIAL CABLE GROUND KITS TO EACH OWNER'S GROUND BAR ALONG ENTIRE COAX RUN FROM ANTENNA TO SHELTER.
 - BOND ALL EQUIPMENT TO GROUND PER NEC AND MANUFACTURERS' SPECIFICATIONS.
 - DETAIL IS TYPICAL FOR ALL ANTENNA SECTORS, INCLUDING GPS ANTENNA.

2 TYPICAL ANTENNA GROUNDING DETAIL
E-1 SCALE: NOT TO SCALE

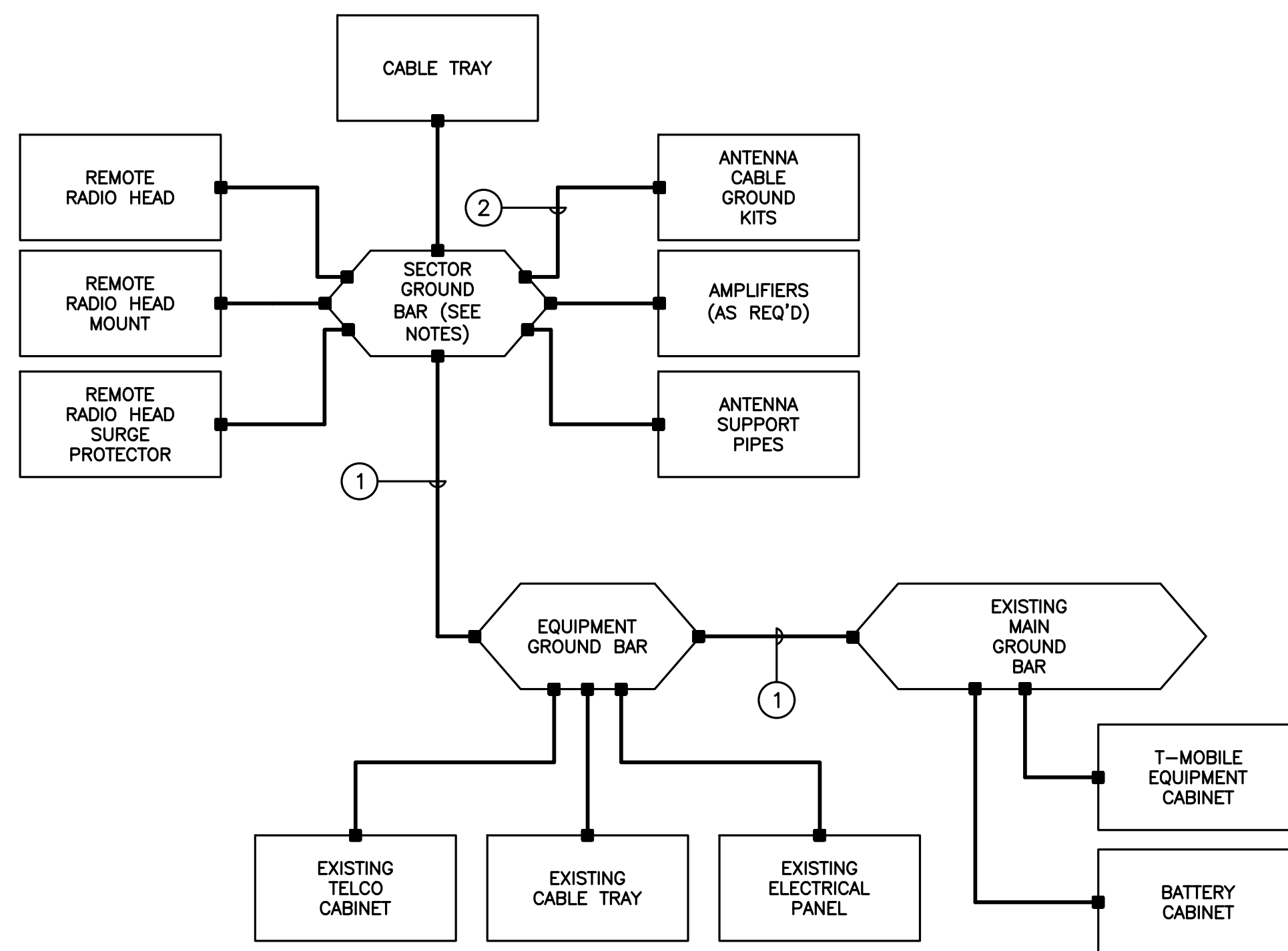

GROUNDING SCHEMATIC NOTES

- #2 AWG
 - #6 AWG
- GENERAL NOTES:**
- ALL SURGE SUPPRESSION EQUIPMENT SHALL BE BONDED TO GROUND PER MANUFACTURER'S SPECIFICATIONS
 - UNLESS OTHERWISE NOTED OR REQUIRED BY CODE, GROUND CONDUCTORS SHOWN SHALL BE #2 AWG (SOLID TINNED BCW - EXTERIOR; STRANDED GREEN INSULATED - INTERIOR).
 - ALL SECTOR GROUND BARS SHALL BE BONDED TOGETHER WITH #2 AWG SOLID TINNED BCW.
 - BOND ALL EQUIPMENT CABINETS AND BATTERY CABINETS TO GROUND PER MANUFACTURER'S SPECIFICATIONS.
 - COORDINATE ALL ROOF MOUNTED EQUIPMENT WITH OWNER.
 - ALL ROOF MOUNTED AMPLIFIERS AND ASSOCIATED EQUIPMENT SHALL BE BONDED TO THE SECTOR GROUND BAR PER MANUFACTURER'S SPECIFICATIONS.
 - ALL GROUNDING SHALL BE IN ACCORDANCE WITH NEC AND OWNER'S REQUIREMENTS.

4 TYPICAL GROUNDING SCHEMATIC DETAIL
E-1 SCALE: NOT TO SCALE

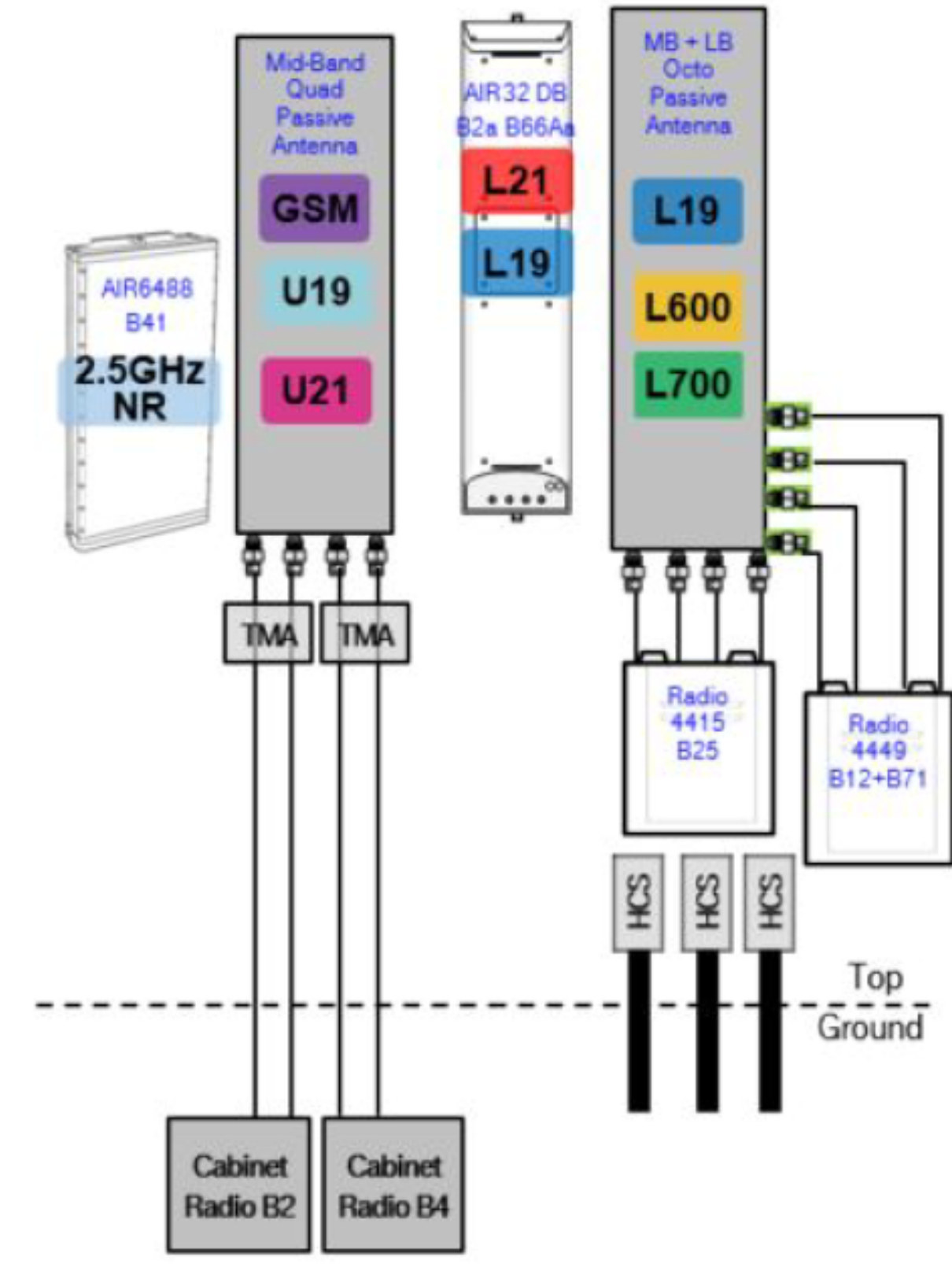

3 PROPOSED PLUMBING DIAGRAM
E-1 SCALE: NOT TO SCALE

RISER DIAGRAM NOTES

- EXISTING 200A, 120/240V, SINGLE PHASE PANEL TO BE REMOVED. RELOCATE ALL EXISTING CIRCUITS TO NEW PPC CABINET.
- SECTION OF EXISTING CONDUITS AND CONDUCTORS TO REMAIN.
- EXISTING EQUIPMENT CABINET TO REMAIN.
- NEW 200A PPC CABINET
- JUNCTION BOX SIZED PER NEC REQUIREMENTS
- SECTION OF CONDUITS AND CONDUCTORS TO BE REMOVED.
- EXPANSION COUPLING TYP.
- EXTEND EXISTING CONDUITS AND CONDUCTORS TO NEW PPC CABINET
- NEW 100A/2P CIRCUIT BREAKER TO SERVE EXISTING EQUIPMENT CABINET. COORDINATE CABINET DOWNGRADE WITH CONSTRUCTION MANAGER.
- NEW 100A/2P CIRCUIT BREAKER TO SERVE NEW EQUIPMENT CABINET.
- (3) #1 AWG, (1) #8 AWG GROUND, 1-1/4" CONDUIT.
- NEW RADIO EQUIPMENT CABINET.
- NEW BATTERY CABINET.
- DC CONDUIT AND CONDUCTORS FOR BATTERY CABINET CONNECTION PER MANUFACTURERS SPECIFICATIONS.

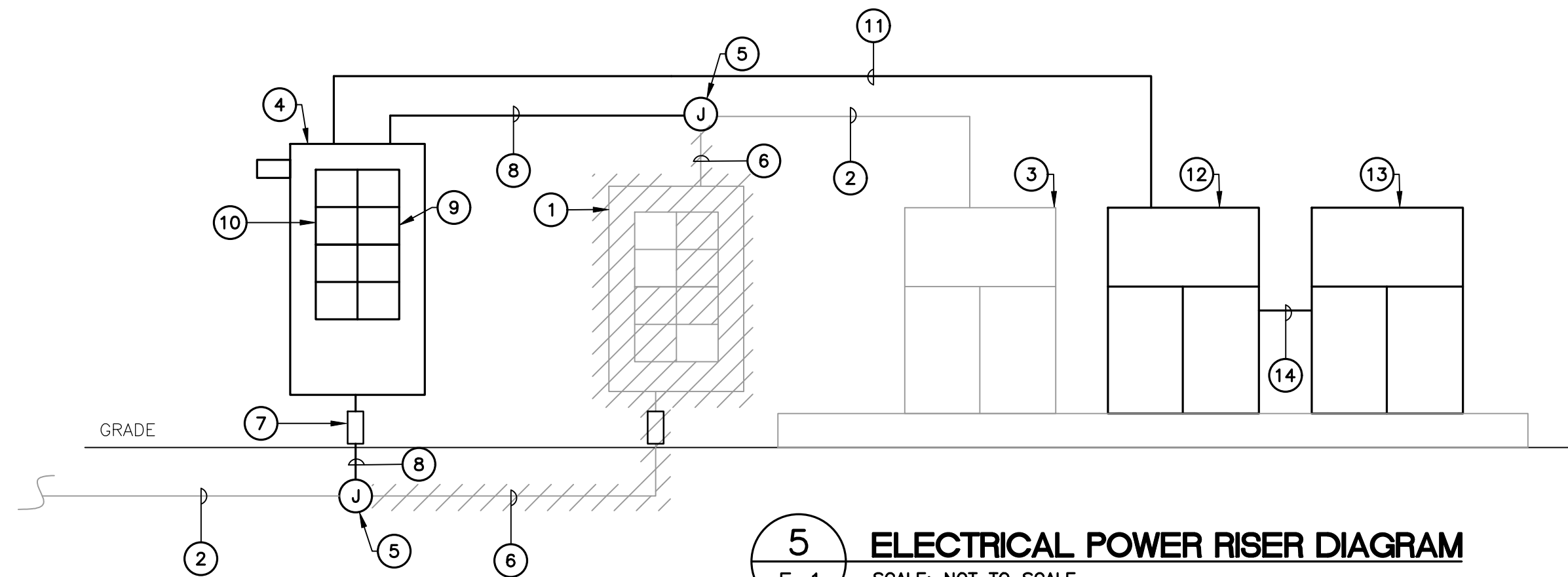

5 ELECTRICAL POWER RISER DIAGRAM
E-1 SCALE: NOT TO SCALE

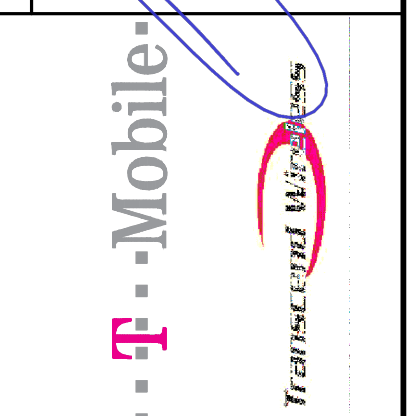
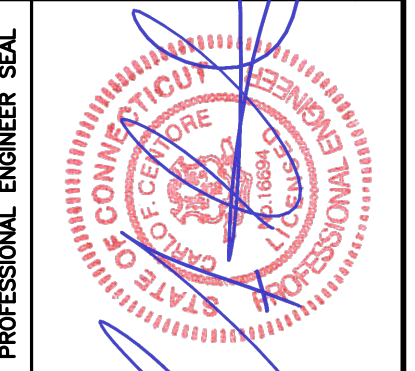

CEN TEK engineering
Center on Solutions
(203) 488-0380
(203) 488-8587 Fax
652 North Branford Road
Branford, CT 06405
www.CenTekEng.com

T-MOBILE NORTHEAST LLC
WIRELESS COMMUNICATIONS FACILITY
BROOKFIELD/JUNCTION RD.
SITE ID: CT1196A
39 CARMEN HILL ROAD
BROOKFIELD, CT 06804

DATE: 05/06/20
SCALE: AS NOTED
JOB NO. 20074.01

TYPICAL ELECTRICAL DETAILS

E-1
Sheet No. 8 of 8

REV.	DATE	DRAWN BY	CHK'D BY	DESCRIPTION
2	09/16/20	RIS	TJR	CONSTRUCTION DRAWINGS - REVISED GIS MAP
1	09/15/20	RIS	TJR	CONSTRUCTION DRAWINGS - REVISED ADDRESS
0	09/19/20	RIS	TJR	CONSTRUCTION DRAWINGS - ISSUED FOR CONSTRUCTION