



**CROWN
CASTLE**

Crown Castle
3530 Toringdon Way Suite 300
Charlotte NC 28277

Tel (704) 405-6600

February 5, 2015

Melanie A. Bachman
Connecticut Siting Council
10 Franklin Square
New Britain, CT 06051

RE: T-Mobile-Exempt Modification - Crown Site BU: 826217
T-Mobile Site ID: CT11004B
Located at: 240 Kensington Rd., Berlin, CT 06037

Dear Ms. Bachman:

This letter and exhibits are submitted on behalf of T-Mobile. T-Mobile is making modifications to certain existing sites in its Connecticut system in order to implement their 700MHz technology. Please accept this letter and exhibits as notification, pursuant to § 16-50j-73 of the Regulations of Connecticut State Agencies ("R.C.S.A."), of construction that constitutes an exempt modification pursuant to R.C.S.A. § 16-50j-72(b)(2). In compliance with R.C.S.A. § 16-50j-73, a copy of this letter is being sent to Denise McNair, Town Manager for the Town of Berlin and Town of Berlin Connecticut, Property owner.

T-Mobile plans to modify the existing wireless communications facility owned by Crown Castle and located at **240 Kensington Rd., Berlin, CT**. Attached are a compound plan and elevation depicting the planned changes (Exhibit-1), and documentation of the structural sufficiency of the structure to accommodate the revised antenna configuration (Exhibit-2). Also included is a power density table report reflecting the modification to T-Mobile's operations at the site (Exhibit-3).

The changes to the facility do not constitute a modification as defined in Connecticut General Statutes ("C.G.S.") § 16-50i(d) because the general physical characteristics of the facility will not be significantly changed. Rather, the planned changes to the facility fall squarely within those activities explicitly provided for in the R.C.S.A. § 16-50j-72(b)(2).

1. The proposed modifications will not result in an increase in the height of the existing tower. T-Mobile's replacement antennas will be located at the same elevation on the existing tower.
2. There will be no proposed modifications to the ground and no extension of boundaries.
3. The proposed modifications will not increase noise levels at the facility by six decibels or more.

4. The operation of the replacement antennas will not increase radio frequency (RF) emissions at the facility to a level at or above the Federal Communications Commission (FCC) adopted safety standard. A cumulative General Power Density table report for T-Mobile's modified facility is included as Exhibit-3.
5. A Structural Modification Report confirming that the tower and foundation can support T-Mobile's proposed modifications is included as Exhibit-2.

For the foregoing reasons, T-Mobile respectfully submits the proposed modifications to the above-reference telecommunications facility constitutes an exempt modification under R.C.S.A. § 16-50j-72(b)(2).

Sincerely,



Jerry Feathers
Real Estate Specialist

Enclosure

Tab 1: Exhibit-1: Compound plan and elevation depicting the planned changes

Tab 2: Exhibit-2: Structural Modification Report

Tab 3: Exhibit-3: General Power Density Table Report (RF Emissions Analysis Report)

cc: Denise McNair, Town Manager
Town of Berlin
240 Kensington Road
Berlin, CT 06037

cc: Town of Berlin Connecticut c/o Town Manager
240 Kensington Road
Berlin, CT 06037



T-MOBILE NORTHEAST LLC

T-MOBILE SITE #: CT11004B
CROWN CASTLE BU #: 826217
SITE NAME: NEWINGTON_1
240 KENSINGTON ROAD
BERLIN, CT 06037
HARTFORD COUNTY

SITE CONFIGURATION: 704G



Dewberry Engineers Inc.
 600 PARSIPPANY ROAD
 SUITE 301
 PARSIPPANY, NJ 07054
 PHONE: 973.739.9400
 FAX: 973.739.9710



T-MOBILE NORTHEAST LLC

4 SYLVAN WAY
 PARSIPPANY, NJ 07054
 PHONE: (973) 397-4800
 FAX: (973) 292-8893

NEWINGTON_1

CT11004B

240 KENSINGTON ROAD
 BERLIN, CT 06037
 HARTFORD COUNTY

SITE INFORMATION

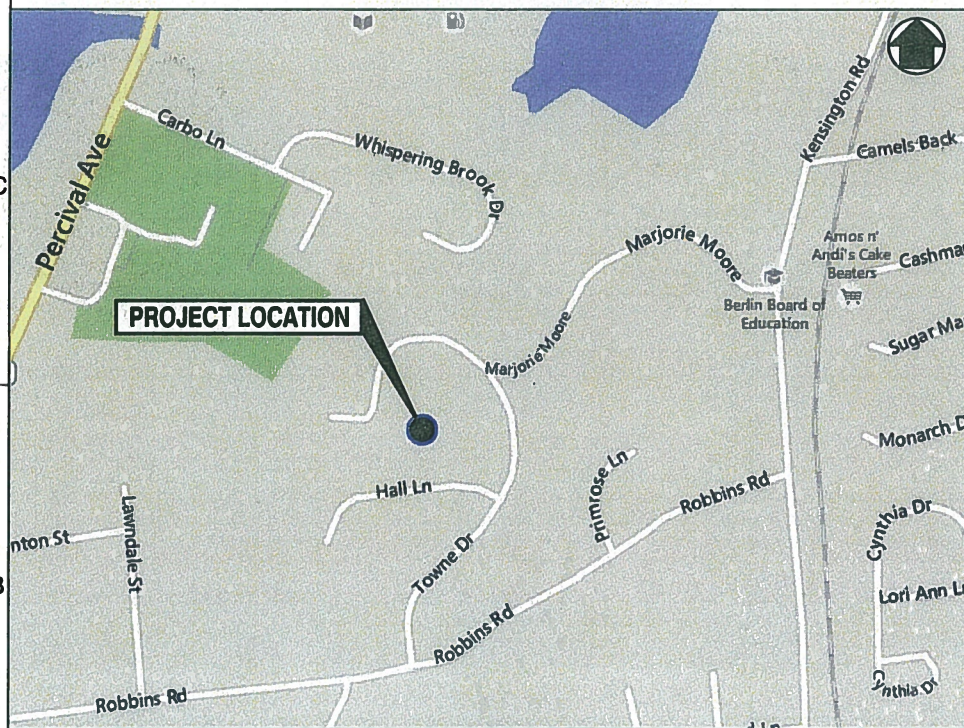

KEY MAP

N.T.S.

DIRECTIONS: (FROM PARSIPPANY):

START OUT GOING WEST ON SYLVAN WAY TOWARD CENTURY DR.. TURN RIGHT ONTO LITTLETON RD/US-202 N. KEEP LEFT AT THE FORK TO GO ON LITTLETON RD E. MERGE ONTO I-287 N. MERGE ONTO I-87 S/I-287 E/NEW YORK TRWY S TOWARD I-87 S/TAPPAN ZEE BRG/NEW YORK CITY. TAKE THE I-87 S EXIT TOWARD SAW MILL PKWY S/NEW YORK CITY. TAKE THE NY-119/SAW MILL PKWY N EXIT 8A TOWARD ELMSFORD. MERGE ONTO SAW MILL RIVER PKWY N VIA THE RAMP ON THE LEFT TOWARD KATONAH. MERGE ONTO I-684 N VIA THE EXIT ON THE LEFT. MERGE ONTO I-84 E VIA EXIT 9E TOWARD DANBURY. MERGE ONTO I-691 E VIA EXIT 27 TOWARD MERIDEN. TAKE THE CT-71/CHAMBERLAIN HWY EXIT 5 TOWARD KENSINGTON. TURN LEFT ONTO CHAMBERLAIN HWY/CT-71. TURN RIGHT ONTO NORTON RD. TURN LEFT ONTO KENSINGTON RD. 240 KENSINGTON RD IS ON THE LEFT.

PROJECT INFORMATION

T-MOBILE SITE #: CT11004B
 CROWN CASTLE BU #: 826217
 SITE ADDRESS: 240 KENSINGTON ROAD
 BERLIN, CT 06037
 HARTFORD COUNTY
 LATITUDE: N 41° 37' 34.3"
 LONGITUDE: W 72° 46' 32.33"
 TOWER OWNER: CROWN CASTLE
 1200 MACARTHUR BLVD., SUITE 200
 MAHWAH, NJ 07430
 CONTACT: PETER TISI
 (201) 236-9224
 APPLICANT: T-MOBILE NORTHEAST, LLC
 4 SYLVAN WAY
 PARSIPPANY, NJ 07054
 CONTACT: PHONE #: (973) 397-4800
 FAX #: (973) 292-8893
 ENGINEER: DEWBERRY ENGINEERS INC.
 600 PARSIPPANY ROAD, SUITE 301
 PARSIPPANY, NJ 07054
 CONTACT: GREG NAWROTZKI
 (973) 576-9653
 SCOPE OF WORK: REMOVE AND REPLACE (3) EXISTING ANTENNAS WITH (3) NEW ANTENNAS, ADD (3) NEW BIAS TEES, ADD (3) NEW RRU'S AT GRADE

SHEET INDEX

SHEET NO.	SHEET DESCRIPTION
T-1	TITLE SHEET
G-1	GENERAL NOTES
C-1	COMPOUND PLAN & EQUIPMENT PLANS
C-2	ANTENNA LAYOUTS & ELEVATIONS
C-3	CONSTRUCTION DETAILS
E-1	GROUNDING NOTES & DETAILS

APPROVALS

T-MOBILE	DATE
OWNER/ LANDLORD	DATE
RF ENGINEER	DATE
ZONING	DATE
CONSTRUCTION	DATE

THIS DOCUMENT WAS DEVELOPED TO REFLECT A SPECIFIC SITE AND ITS SITE CONDITIONS AND IS NOT TO BE USED FOR ANOTHER SITE OR WHEN OTHER CONDITIONS PERTAIN. REUSE OF THIS DOCUMENT IS AT THE SOLE RISK OF THE USER.

SEAL



THIS DOCUMENT WAS DEVELOPED TO REFLECT A SPECIFIC SITE AND ITS SITE CONDITIONS AND IS NOT TO BE USED FOR ANOTHER SITE OR WHEN OTHER CONDITIONS PERTAIN. REUSE OF THIS DOCUMENT IS AT THE SOLE RISK OF THE USER.

SCALE

AS SHOWN

REV.	DATE	BY	DESCRIPTION
0	10/28/14	HMP	ISSUED AS FINAL
A	09/05/14	HMP	ISSUED FOR REVIEW

REVISIONS

DRAWN BY: HMP
 CHECKED BY: BSH
 APPROVED BY: GHN
 DATE: 09/05/14

TITLE

TITLE SHEET

PROJECT NO. 50066258/50066266

T-1

SHEET NO.

1

2

3

4

5

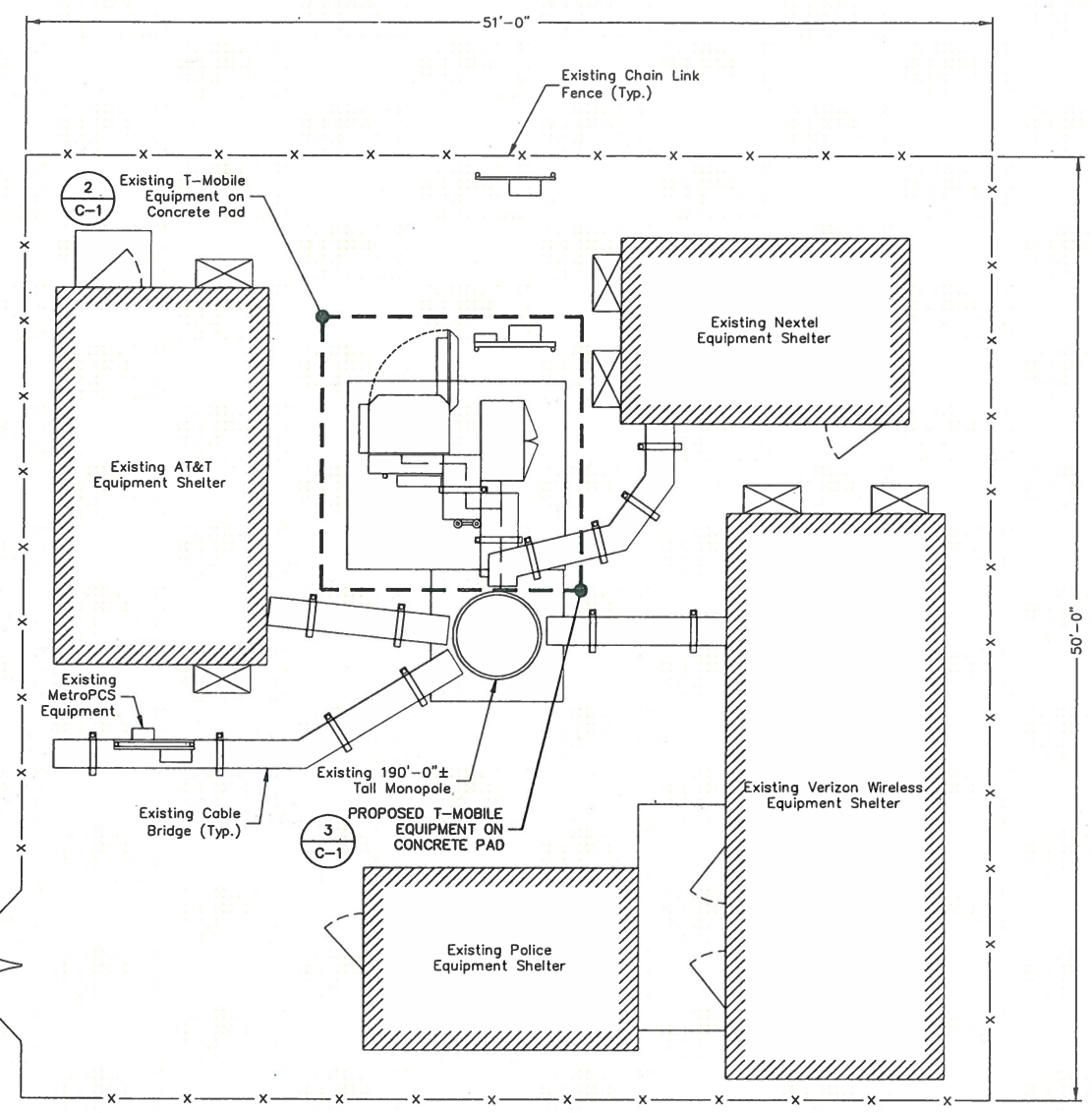

COMPOUND PLAN
SCALE: 1"=10' FOR 11"x17"
1"=5' FOR 22"x34"
0' 5' 10'

- NOTES:**
1. NORTH SHOWN AS APPROXIMATE.
 2. NOT ALL INFORMATION IS SHOWN FOR CLARITY.
 3. MOUNT ALL ANTENNAS, RRU'S, BIAS TEES, COAX, ETC. IN ACCORDANCE WITH STRUCTURAL ANALYSIS TO BE COMPLETED BY OTHERS.

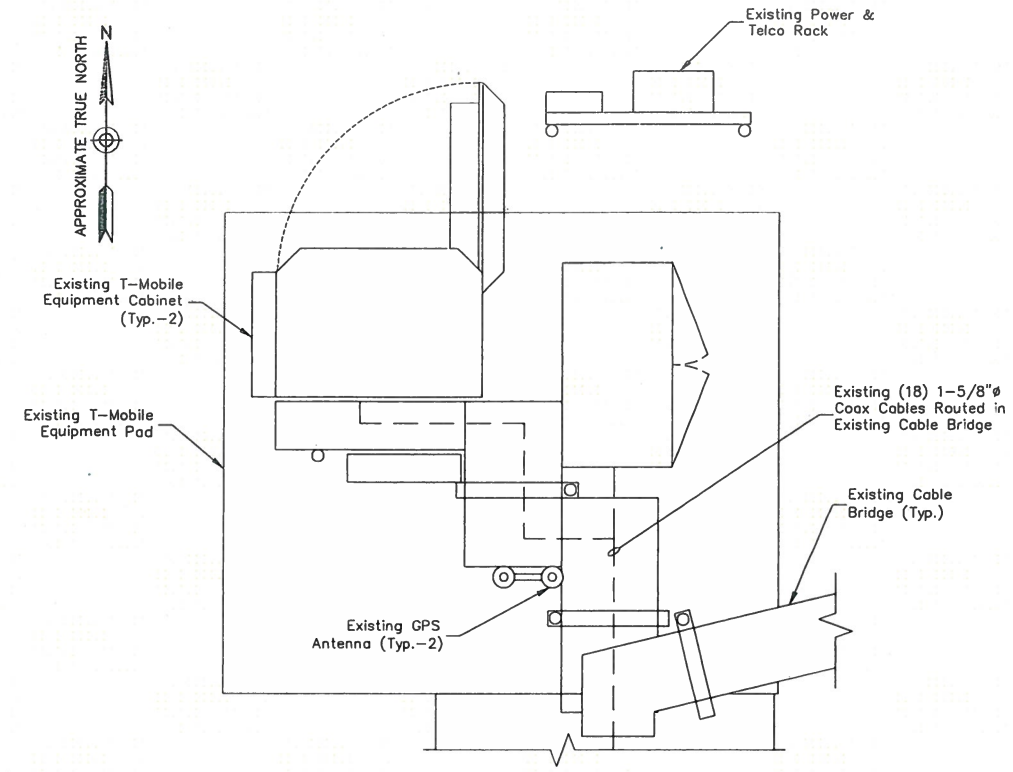

EXISTING EQUIPMENT PLAN
SCALE: 1/4"=1' FOR 11"x17"
1/2"=1' FOR 22"x34"
0' 2' 4'

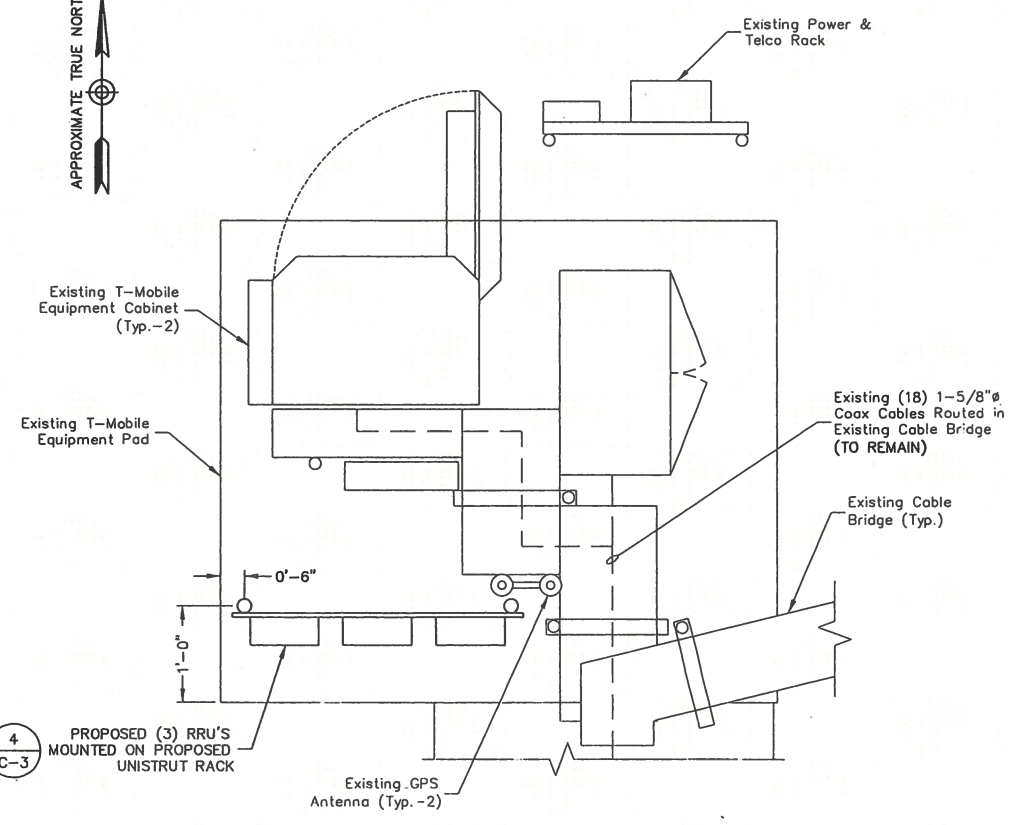

PROPOSED EQUIPMENT PLAN
SCALE: 1/4"=1' FOR 11"x17"
1/2"=1' FOR 22"x34"
0' 2' 4'

Dewberry
Dewberry Engineers Inc.
600 PARSIPPANY ROAD
SUITE 301
PARSIPPANY, NJ 07054
PHONE: 973.739.9400
FAX: 973.739.9710

T-Mobile
T-MOBILE NORTHEAST LLC
4 SYLVAN WAY
PARSIPPANY, NJ 07054
PHONE: (973) 397-4800
FAX: (973) 292-6893

NEWINGTON_1

CT11004B

240 KENSINGTON ROAD
BERLIN, CT 06037
HARTFORD COUNTY

THIS DOCUMENT WAS DEVELOPED TO REFLECT A SPECIFIC SITE AND ITS SITE CONDITIONS AND IS NOT TO BE USED FOR ANOTHER SITE OR WHEN OTHER CONDITIONS PERTAIN. REUSE OF THIS DOCUMENT IS AT THE SOLE RISK OF THE USER.



SCALE
AS SHOWN

REV.	DATE	BY	DESCRIPTION
0	10/28/14	HMP	ISSUED AS FINAL
A	09/05/14	HMP	ISSUED FOR REVIEW

REVISIONS

DRAWN BY HMP
CHECKED BY BSH
APPROVED BY CHN
DATE 09/05/14

COMPOUND PLAN & EQUIPMENT PLANS

PROJECT NO. 50066258/50066266

C - 1

SHEET NO.

1

2

3

4

5

E
D
C
B
A

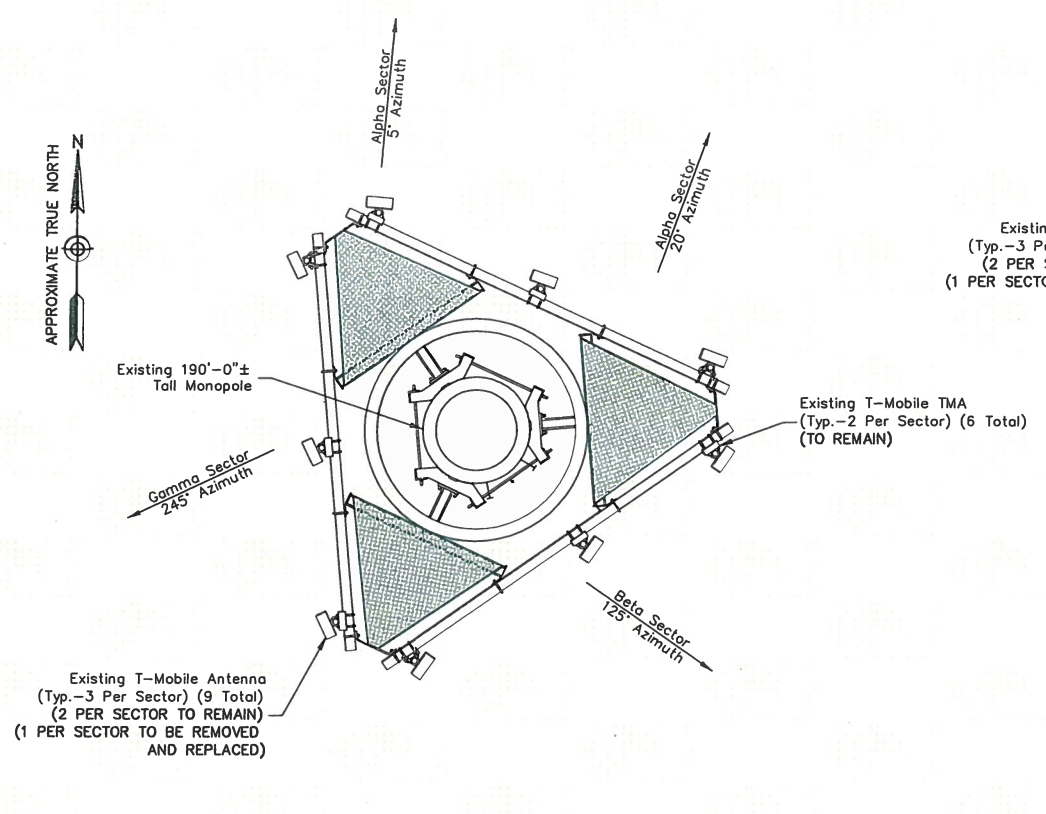

EXISTING ANTENNA LAYOUT (1)
SCALE: N.T.S.

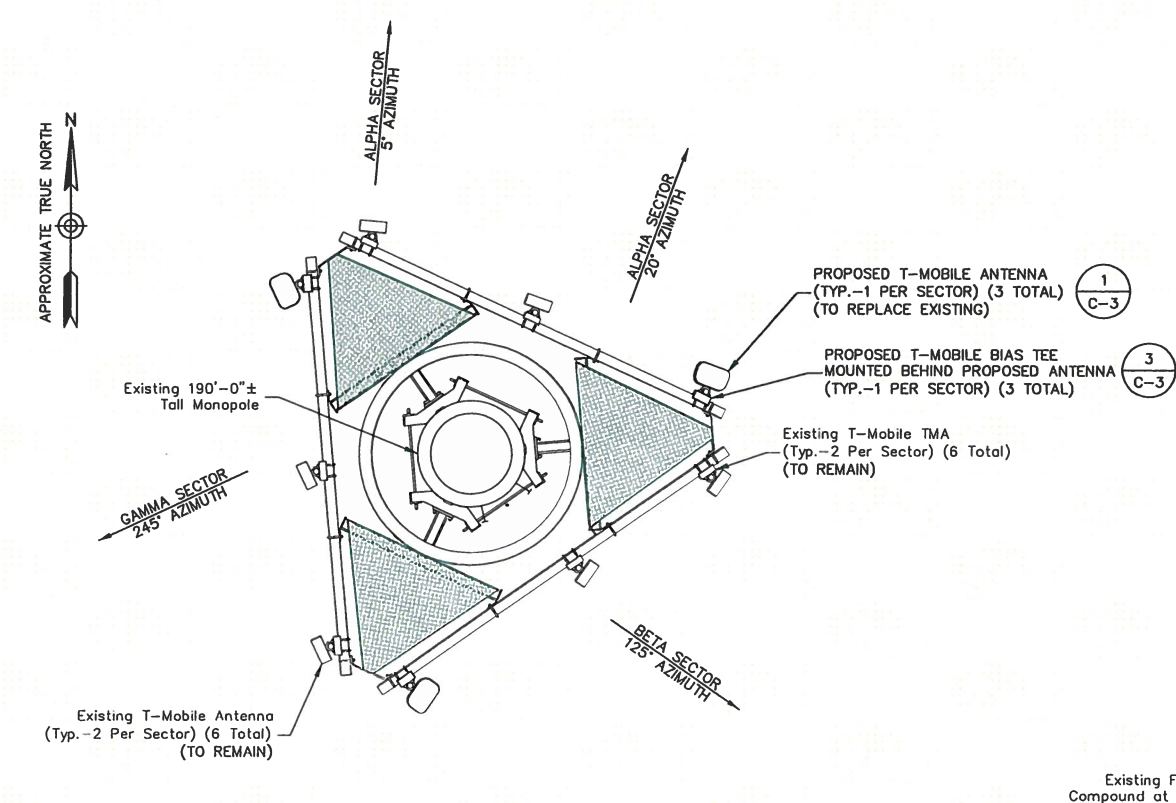

PROPOSED ANTENNA LAYOUT (2)
SCALE: N.T.S.

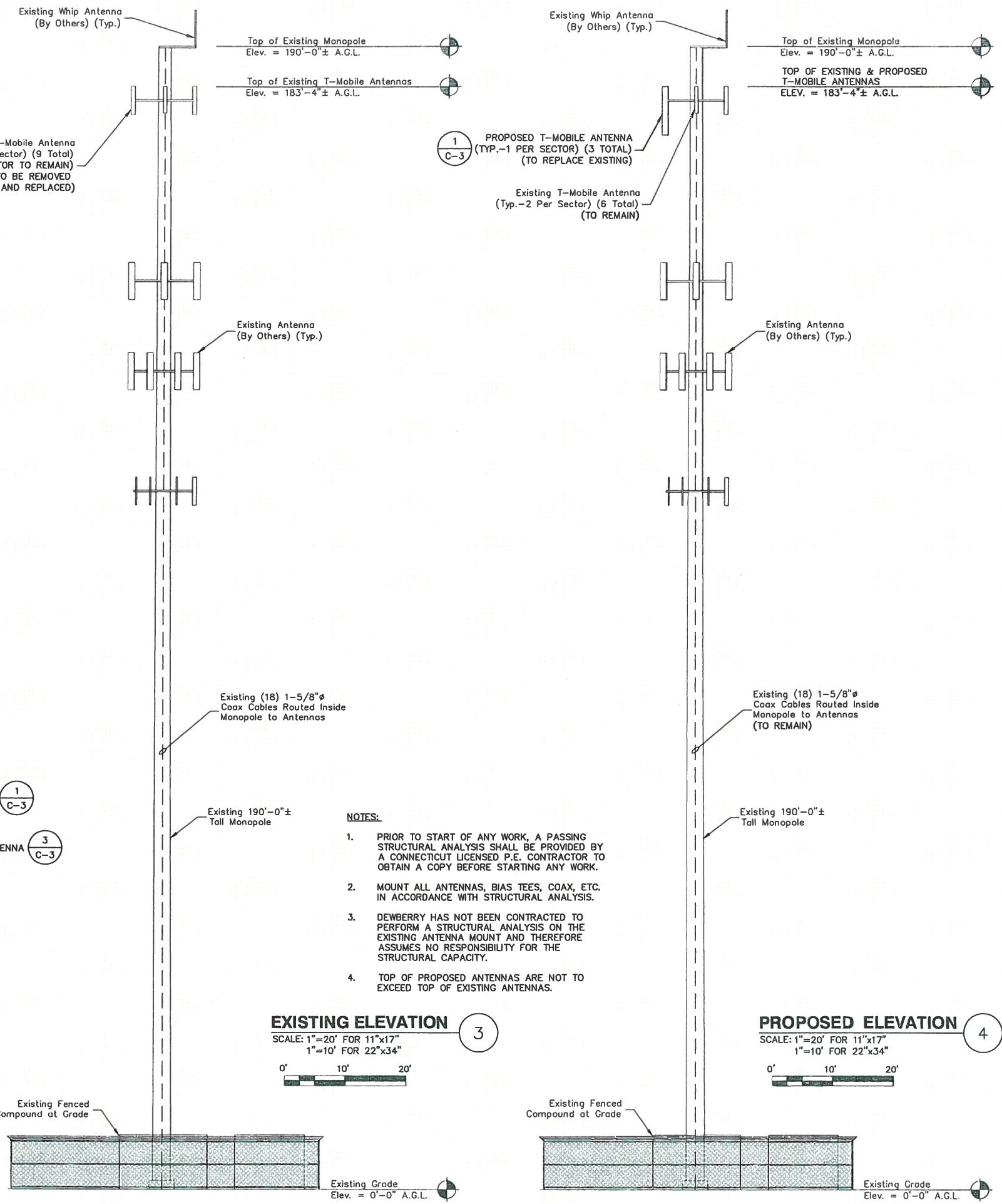

EXISTING ELEVATION (3)
SCALE: 1"=20' FOR 11"x17"
1"=10' FOR 22"x34"

PROPOSED ELEVATION (4)
SCALE: 1"=20' FOR 11"x17"
1"=10' FOR 22"x34"

- NOTES:**
1. PRIOR TO START OF ANY WORK, A PASSING STRUCTURAL ANALYSIS SHALL BE PROVIDED BY A CONNECTICUT LICENSED P.E. CONTRACTOR TO OBTAIN A COPY BEFORE STARTING ANY WORK.
 2. MOUNT ALL ANTENNAS, BIAS TEES, COAX, ETC. IN ACCORDANCE WITH STRUCTURAL ANALYSIS.
 3. DEWBERRY HAS NOT BEEN CONTRACTED TO PERFORM A STRUCTURAL ANALYSIS ON THE EXISTING ANTENNA MOUNT AND THEREFORE ASSUMES NO RESPONSIBILITY FOR THE STRUCTURAL CAPACITY.
 4. TOP OF PROPOSED ANTENNAS ARE NOT TO EXCEED TOP OF EXISTING ANTENNAS.

Dewberry
Dewberry Engineers Inc.
600 PARSIPPANY ROAD
SUITE 301
PARSIPPANY, NJ 07054
PHONE: 973.739.9400
FAX: 973.739.9710

T-Mobile
T-MOBILE NORTHEAST LLC
4 SYLVAN WAY
PARSIPPANY, NJ 07054
PHONE: (973) 397-4800
FAX: (973) 292-4893

NEWINGTON_1
CT11004B
240 KENSINGTON ROAD
BERLIN, CT 06037
HARTFORD COUNTY

THIS DOCUMENT WAS DEVELOPED TO REFLECT A SPECIFIC SITE AND ITS SITE CONDITIONS AND IS NOT TO BE USED FOR ANOTHER SITE OR WHEN OTHER CONDITIONS PERTAIN. REUSE OF THIS DOCUMENT IS AT THE SOLE RISK OF THE USER.

SEAL
STATE OF CONNECTICUT
Professional Engineer
J. M. DEWBERRY
No. 25522
CONNECTION LICENSE NO. 102322
THIS DOCUMENT IS THE PROPERTY OF DEWBERRY ENGINEERS, INC. AND IS TO BE USED ONLY FOR THE PROJECT AND SITE SPECIFICALLY IDENTIFIED HEREON. IT IS TO BE KEPT IN THE OFFICE OF THE ENGINEER WHO PREPARED IT. IT IS TO BE RETURNED TO HIM OR HER UPON THE COMPLETION OF THE PROJECT. IT IS TO BE DESTROYED AFTER THE PROJECT IS COMPLETED. REPRODUCTION OR TRANSMISSION OF THIS DRAWING AND/OR THE INFORMATION CONTAINED IN IT IS FORBIDDEN WITHOUT THE WRITTEN PERMISSION OF T-MOBILE.

SCALE AS SHOWN

REV.	DATE	BY	DESCRIPTION
0	10/28/14	HMP	ISSUED AS FINAL
A	09/05/14	HMP	ISSUED FOR REVIEW

REVISIONS

DRAWN BY HMP
CHECKED BY BSH
APPROVED BY GHN
DATE 09/05/14

ANTENNA LAYOUTS & ELEVATIONS

PROJECT NO. 50066258/50066266

C - 2

SHEET NO.

1

2

3

4

5

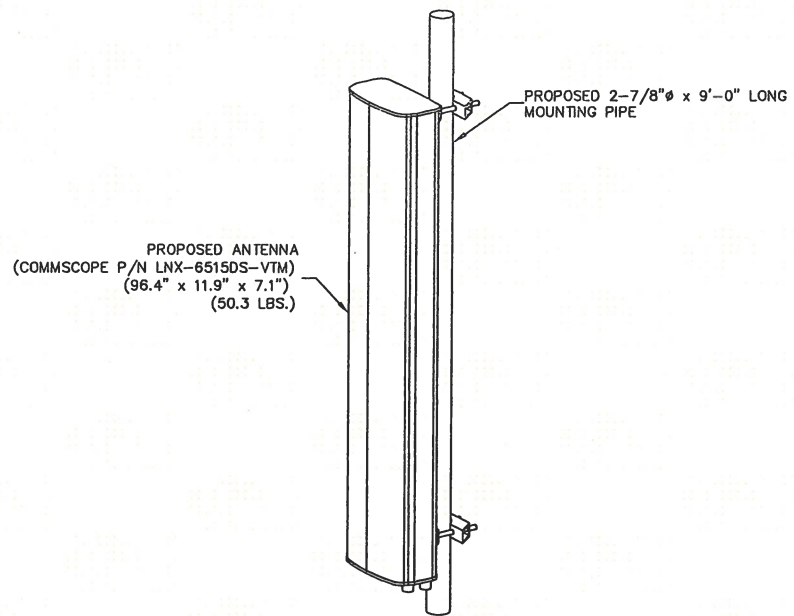

NOTES:

1. MOUNT ANTENNAS PER MANUFACTURER'S RECOMMENDATIONS.
2. GROUND ANTENNAS AND MOUNTS PER MANUFACTURER'S RECOMMENDATIONS AND T-MOBILE STANDARDS.
3. CONFIRM REQUIRED ANTENNAS WITH THE LATEST RFDS.

ISOMETRIC ANTENNA DETAILS

SCALE: N.T.S.

1

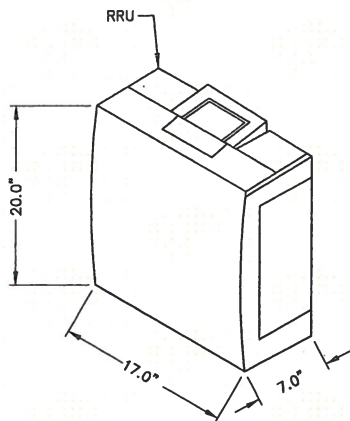

SPECIFICATIONS
 HEIGHT: 20.0"
 WIDTH: 17.0"
 DEPTH: 7.0"
 WEIGHT: 50.7 LBS

ERICSSON RRUS-11 B12

NOTES:

1. MOUNT EQUIPMENT PER MANUFACTURER'S RECOMMENDATIONS.
2. GROUND EQUIPMENT AND MOUNTS PER MANUFACTURER'S RECOMMENDATIONS AND T-MOBILE STANDARDS.
3. CONFIRM REQUIRED EQUIPMENT WITH THE LATEST RFDS.

RRUS-11 - REMOTE RADIO UNIT

SCALE: N.T.S.

2

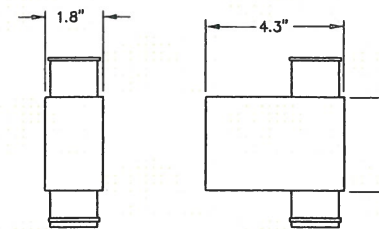

SIDE

FRONT

ANDREW ATBT-BOTTOM-24V

NOTES:

1. MOUNT EQUIPMENT PER MANUFACTURER'S RECOMMENDATIONS.
2. GROUND EQUIPMENT AND MOUNTS PER MANUFACTURER'S RECOMMENDATIONS AND T-MOBILE STANDARDS.
3. CONFIRM REQUIRED EQUIPMENT WITH THE LATEST RFDS.

BIAS TEE DETAIL

SCALE: N.T.S.

3

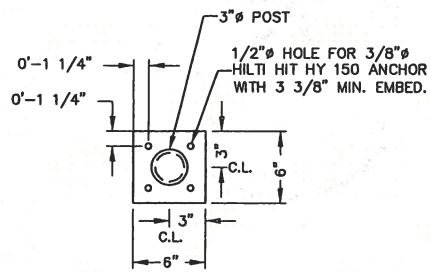

BASE PLATE

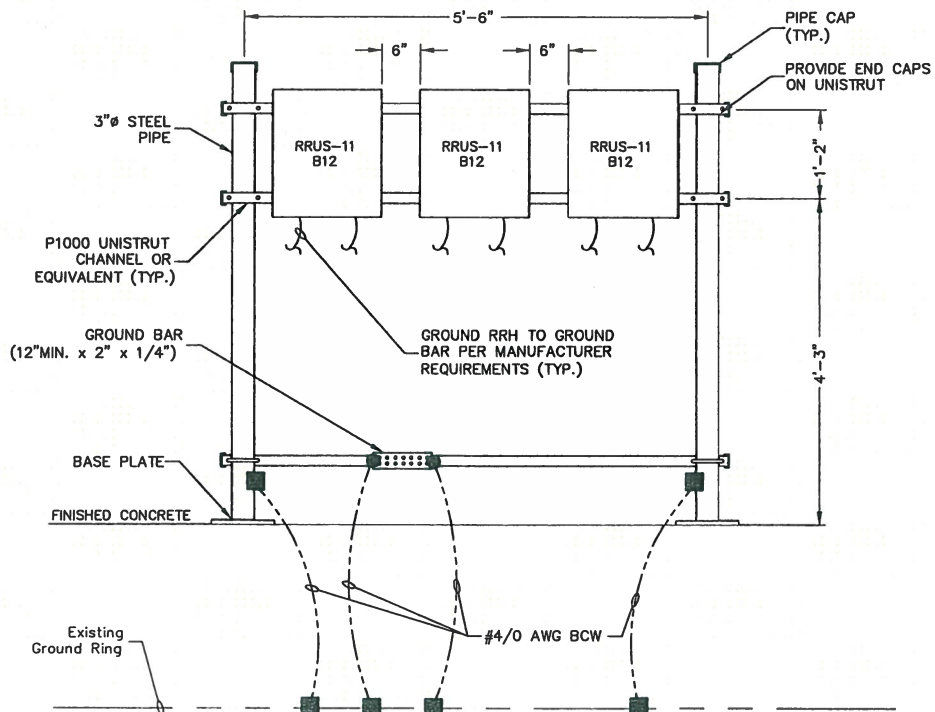

NOTES:

1. CONTRACTOR SHALL SUPPLY AND INSTALL UNISTRUT (OR EQUIVALENT) MOUNTING CHANNELS.
2. CONTRACTOR SHALL SUPPLY (BUT NOT INSTALL) 3/8" UNISTRUT BOLTING HARDWARE AND SPRING NUTS. TYPICAL FOUR PER RRU. CONTRACTOR SHALL BAG THE BOLTING HARDWARE AND HANG FROM INSTALLED UNISTRUT FRAME.
3. SPACING MAY VARY BASED ON SELECTED EQUIPMENT. ADJUSTMENTS TO SPACING WILL BE MADE BY RRU INSTALLER.
4. NO PAINTING OF THE RRU OR SOLAR SHIELD IS ALLOWED.

RRU RACK DETAIL

SCALE: N.T.S.

4

DESIGN CONFIGURATION

ANTENNAS	EXISTING	PROPOSED	COAX		COAX LENGTH
			EXISTING	PROPOSED	
ALPHA	EMS RR90-17-02DP	EXISTING TO REMAIN	(6) 1-5/8"	-	231'
	RFS APXV18-206516L-A	EXISTING TO REMAIN			
	EMS RR90-17-02DP	COMMSCOPE LNX-6515DS-VTM			
BETA	EMS RR90-17-02DP	EXISTING TO REMAIN	(6) 1-5/8"	-	231'
	RFS APXV18-206516L-A	EXISTING TO REMAIN			
	EMS RR90-17-02DP	COMMSCOPE LNX-6515DS-VTM			
GAMMA	EMS RR90-17-02DP	EXISTING TO REMAIN	(6) 1-5/8"	-	231'
	RFS APXV18-206516L-A	EXISTING TO REMAIN			
	EMS RR90-17-02DP	COMMSCOPE LNX-6515DS-VTM			



Dewberry Engineers Inc.
 600 PARSIPPANY ROAD
 SUITE 301
 PARSIPPANY, NJ 07054
 PHONE: 973.739.9400
 FAX: 973.739.9710



T-MOBILE NORTHEAST LLC

4 SYLVAN WAY
 PARSIPPANY, NJ 07054
 PHONE: (973) 397-4860
 FAX: (973) 292-4893

NEWINGTON_1

CT11004B

240 KENSINGTON ROAD
 BERLIN, CT 06037
 HARTFORD COUNTY

THIS DOCUMENT WAS DEVELOPED TO REFLECT A SPECIFIC SITE AND ITS SITE CONDITIONS AND IS NOT TO BE USED FOR ANOTHER SITE OR WHEN OTHER CONDITIONS PERTAIN. REUSE OF THIS DOCUMENT IS AT THE SOLE RISK OF THE USER.

SEAL



THIS DRAWING IS THE PROPERTY OF T-MOBILE. IT IS TO BE USED ONLY FOR THE PROJECT AND SITE SPECIFICALLY IDENTIFIED HEREIN. IT IS TO BE KEPT IN CONFIDENCE AND NOT TO BE REPRODUCED OR TRANSMITTED IN ANY FORM OR BY ANY MEANS, ELECTRONIC OR MECHANICAL, INCLUDING PHOTOCOPYING, RECORDING, OR BY ANY INFORMATION STORAGE AND RETRIEVAL SYSTEM, WITHOUT THE WRITTEN PERMISSION OF T-MOBILE.

SCALE

AS SHOWN

REV.	DATE	BY	DESCRIPTION
0	10/28/14	HMP	ISSUED AS FINAL
A	09/05/14	HMP	ISSUED FOR REVIEW

REVISIONS

DRAWN BY: HMP
 CHECKED BY: BSH
 APPROVED BY: GHN
 DATE: 09/05/14

TITLE

CONSTRUCTION DETAILS

PROJECT NO. 5006258/5006266

C - 3

SHEET NO.

GROUNDING NOTES:

- THE CONTRACTOR SHALL REVIEW AND INSPECT THE EXISTING FACILITY GROUNDING SYSTEM AND LIGHTNING PROTECTION SYSTEM (AS DESIGNED AND INSTALLED) FOR STRICT COMPLIANCE WITH THE NEC (AS ADOPTED BY THE AHJ), THE SITE-SPECIFIC (UL, LPI, OR NFPA) LIGHTING PROTECTION CODE, AND GENERAL COMPLIANCE WITH TELCORDIA AND TIA GROUNDING STANDARDS. THE CONTRACTOR SHALL REPORT ANY VIOLATIONS OR ADVERSE FINDINGS TO THE ENGINEER FOR RESOLUTION.
- ALL GROUND ELECTRODE SYSTEMS (INCLUDING TELECOMMUNICATION, RADIO, LIGHTNING PROTECTION, AND AC POWER GES'S) SHALL BE BONDED TOGETHER, AT OR BELOW GRADE, BY TWO OR MORE COPPER BONDING CONDUCTORS. ALL AVAILABLE GROUNDING ELECTRODES SHALL BE CONNECTED TOGETHER IN ACCORDANCE WITH THE NEC.
- THE CONTRACTOR SHALL PERFORM IEEE FALL-OF-POTENTIAL RESISTANCE TO EARTH TESTING (PER IEEE 1100 AND 81) FOR GROUND ELECTRODE SYSTEMS. USE OF OTHER METHODS MUST BE PRE-APPROVED BY THE ENGINEER IN WRITING.
- THE CONTRACTOR SHALL FURNISH AND INSTALL SUPPLEMENTAL GROUND ELECTRODES AS NEEDED TO ACHIEVE A TEST RESULT OF 5 OHMS OR LESS ON TOWER SITES AND 10 OHMS OR LESS ON ROOFTOP SITES. WHEN ADDING ELECTRODES, CONTRACTOR SHALL MAINTAIN A MINIMUM DISTANCE BETWEEN THE ADDED ELECTRODE AND ANY OTHER EXISTING ELECTRODE EQUAL TO THE BURIED LENGTH OF THE ROD. IDEALLY, CONTRACTOR SHALL STRIVE TO KEEP THE SEPARATION DISTANCE EQUAL TO TWICE THE BURIED LENGTH OF THE RODS.
- THE CONTRACTOR IS RESPONSIBLE FOR PROPERLY SEQUENCING GROUNDING AND UNDERGROUND CONDUIT INSTALLATION AS TO PREVENT ANY LOSS OF CONTINUITY IN THE GROUNDING SYSTEM OR DAMAGE TO THE CONDUIT.
- METAL CONDUIT AND TRAY SHALL BE GROUNDED AND MADE ELECTRICALLY CONTINUOUS WITH LISTED BONDING FITTINGS OR BY BONDING ACROSS THE DISCONTINUITY WITH 6 AWG COPPER WIRE AND UL APPROVED GROUNDING TYPE CONDUIT CLAMPS.
- METAL RACEWAY SHALL NOT BE USED AS THE NEC REQUIRED EQUIPMENT GROUND CONDUCTOR. STRANDED COPPER CONDUCTORS WITH GREEN INSULATION, SIZED IN ACCORDANCE WITH THE NEC, SHALL BE FURNISHED AND INSTALLED WITH THE POWER CIRCUITS TO TRANSMISSION EQUIPMENT.
- CONNECTIONS TO THE GROUND BUS SHALL NOT BE DOUBLED UP OR STACKED. BACK-TO-BACK CONNECTIONS ON OPPOSITE SIDES OF THE GROUND BUS ARE PERMITTED.
- ALUMINUM CONDUCTOR OR COPPER CLAD STEEL CONDUCTOR SHALL NOT BE USED FOR GROUNDING CONNECTIONS.
- USE OF 90° BENDS IN THE PROTECTION GROUNDING CONDUCTORS SHALL BE AVOIDED WHEN 45° BENDS CAN BE ADEQUATELY SUPPORTED. IN ALL CASES, BENDS SHALL BE MADE WITH A MINIMUM BEND RADIUS OF 8 INCHES.
- EACH INTERIOR TRANSMISSION CABINET FRAME/PLINTH SHALL BE DIRECTLY CONNECTED TO THE MASTER GROUND BAR WITH 6 AWG STRANDED, GREEN INSULATED SUPPLEMENTAL EQUIPMENT GROUND WIRE UNLESS NOTED OTHERWISE IN THE DETAILS. EACH OUTDOOR CABINET FRAME/PLINTH SHALL BE DIRECTLY CONNECTED TO THE BURIED GROUND RING WITH 2 AWG SOLID TIN-PLATED COPPER WIRE UNLESS NOTED OTHERWISE IN THE DETAILS.
- ALL EXTERIOR GROUND CONDUCTORS BETWEEN EQUIPMENT/GROUND BARS AND THE GROUND RING, SHALL BE 2 AWG SOLID TIN-PLATED COPPER UNLESS OTHERWISE INDICATED.
- EXOTHERMIC WELDS SHALL BE USED FOR ALL GROUNDING CONNECTIONS BELOW GRADE. CONNECTIONS TO ABOVE GRADE UNITS SHALL BE MADE WITH EXOTHERMIC WELDS WHERE PRACTICAL OR WITH 2 HOLE MECHANICAL TYPE BRASS CONNECTORS WITH STAINLESS STEEL HARDWARE, INCLUDING SET SCREWS. HIGH PRESSURE CRIMP CONNECTORS MAY ONLY BE USED WITH WRITTEN PERMISSION FROM T-MOBILE MARKET REPRESENTATIVE.
- EXOTHERMIC WELDS SHALL BE PERMITTED ON TOWERS ONLY WITH THE EXPRESS APPROVAL OF THE TOWER MANUFACTURER OR THE CONTRACTOR'S STRUCTURAL ENGINEER.
- ALL WIRE TO WIRE GROUND CONNECTIONS TO THE INTERIOR GROUND RING SHALL BE FORMED USING HIGH PRESS CRIMPS OR SPLIT BOLT CONNECTORS WHERE INDICATED IN THE DETAILS.
- ON ROOFTOP SITES WHERE EXOTHERMIC WELDS ARE A FIRE HAZARD COPPER COMPRESSION CAP CONNECTORS MAY BE USED FOR WIRE TO WIRE CONNECTIONS. 2 HOLE MECHANICAL TYPE BRASS CONNECTORS WITH STAINLESS STEEL HARDWARE, INCLUDING SET SCREWS SHALL BE USED FOR CONNECTION TO ALL ROOFTOP TRANSMISSION EQUIPMENT AND STRUCTURAL STEEL.
- COAX BRIDGE BONDING CONDUCTORS SHALL BE EXOTHERMICALLY BONDED OR BOLTED TO THE BRIDGE AND THE TOWER GROUND BAR USING TWO-HOLE MECHANICAL TYPE BRASS CONNECTORS AND STAINLESS STEEL HARDWARE.
- APPROVED ANTIOXIDANT COATINGS (I.E., CONDUCTIVE GEL OR PASTE) SHALL BE USED ON ALL COMPRESSION AND BOLTED GROUND CONNECTIONS.
- ALL EXTERIOR GROUND CONNECTIONS SHALL BE COATED WITH A CORROSION RESISTANT MATERIAL.
- MISCELLANEOUS ELECTRICAL AND NON-ELECTRICAL METAL BOXES, FRAMES AND SUPPORTS SHALL BE BONDED TO THE GROUND RING, IN ACCORDANCE WITH THE NEC.
- BOND ALL METALLIC OBJECTS WITHIN 6 FT OF THE BURIED GROUND RING WITH 2 AWG SOLID TIN-PLATED COPPER GROUND CONDUCTOR. DURING EXCAVATION FOR NEW GROUND CONDUCTORS, IF EXISTING GROUND CONDUCTORS ARE ENCOUNTERED, BOND EXISTING GROUND CONDUCTORS TO NEW CONDUCTORS.
- GROUND CONDUCTORS USED IN THE FACILITY GROUND AND LIGHTNING PROTECTION SYSTEMS SHALL NOT BE ROUTED THROUGH METALLIC OBJECTS THAT FORM A RING AROUND THE CONDUCTOR, SUCH AS METALLIC CONDUITS, METAL SUPPORT CLIPS OR SLEEVES THROUGH WALLS OR FLOORS. WHEN IT IS REQUIRED TO BE HOUSED IN CONDUIT TO MEET CODE REQUIREMENTS OR LOCAL CONDITIONS, NON-METALLIC MATERIAL SUCH AS PVC PLASTIC CONDUIT SHALL BE USED. WHERE USE OF METAL CONDUIT IS UNAVOIDABLE (E.G., NON-METALLIC CONDUIT PROHIBITED BY LOCAL CODE) THE GROUND CONDUCTOR SHALL BE BONDED TO EACH END OF THE METAL CONDUIT WITH LISTED BONDING FITTINGS.

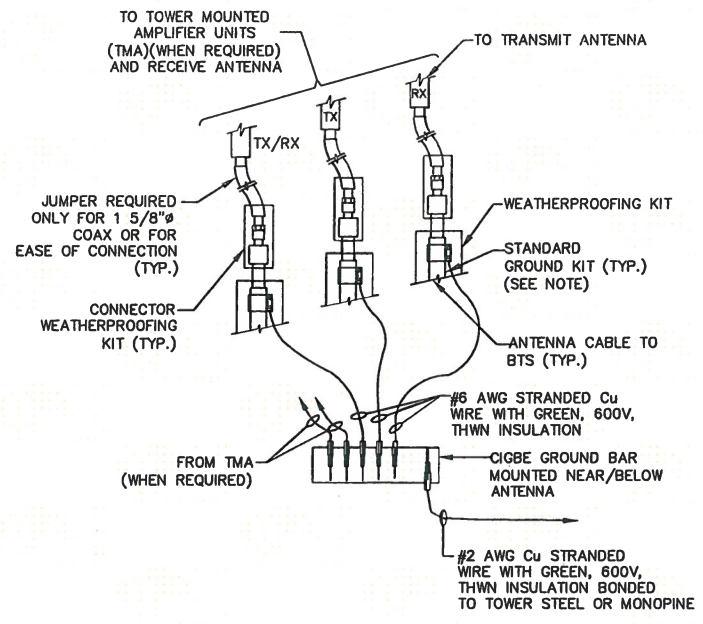

- NOTE:**
- DO NOT INSTALL CABLE GROUND KIT AT A BEND AND ALWAYS DIRECT GROUND WIRE DOWN TO CIGBE.

CONNECTION OF GROUND WIRES TO GROUNDING BAR (CIGBE)
SCALE: N.T.S.

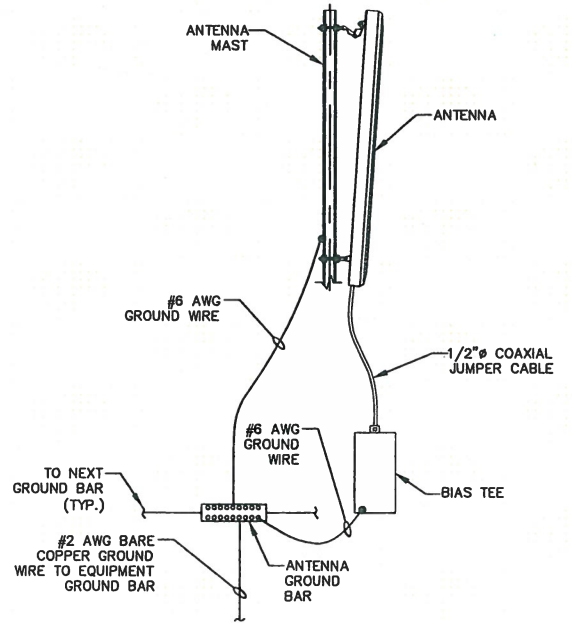

TYPICAL ANTENNA GROUNDING DETAIL
SCALE: N.T.S.

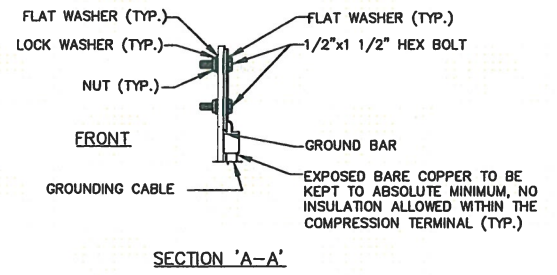
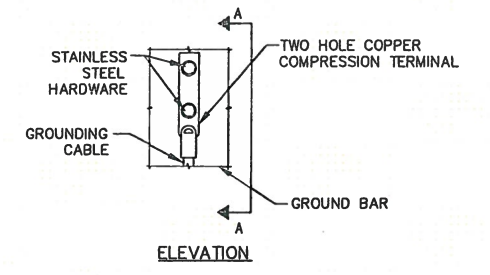

- NOTES:**
- DOUBLING UP OR STACKING OF CONNECTIONS IS NOT PERMITTED.
 - OXIDE INHIBITING COMPOUND TO BE USED AT ALL LOCATIONS.

TYPICAL GROUND BAR MECHANICAL CONNECTION DETAIL
SCALE: N.T.S.

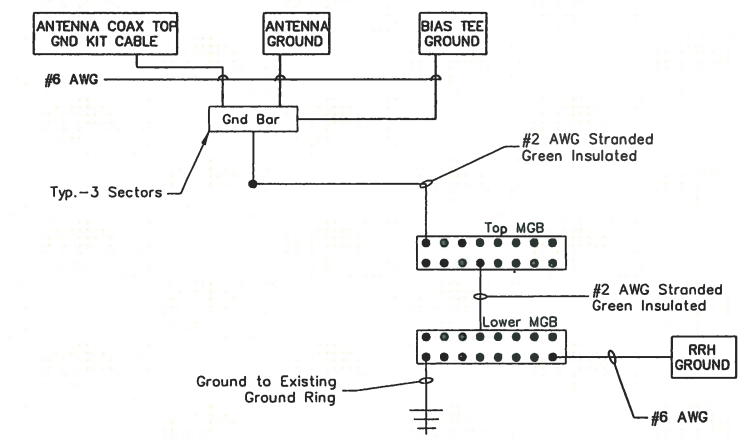

- NOTES:**
- BOND ANTENNA GROUNDING KIT CABLE TO TOP CIGBE
 - BOND ANTENNA GROUNDING KIT CABLE TO BOTTOM CIGBE.
 - SCHEMATIC GROUNDING DIAGRAM IS TYPICAL FOR EACH SECTOR.
 - VERIFY EXISTING GROUND SYSTEM IS INSTALLED PER T-MOBILE STANDARDS.

SCHEMATIC GROUNDING DIAGRAM
SCALE: N.T.S.

Dewberry
Dewberry Engineers Inc.
600 PARSIPPANY ROAD
SUITE 301
PARSIPPANY, NJ 07054
PHONE: 973.739.9400
FAX: 973.739.9710

T-Mobile
T-MOBILE NORTHEAST LLC
4 SYLVAN WAY
PARSIPPANY, NJ 07054
PHONE: (973) 397-4889
FAX: (973) 232-4883

NEWINGTON_1

CT11004B

240 KENSINGTON ROAD
BERLIN, CT 06037
HARTFORD COUNTY

THIS DOCUMENT WAS DEVELOPED TO REFLECT A SPECIFIC SITE AND ITS SITE CONDITIONS AND IS NOT TO BE USED FOR ANOTHER SITE OR WHEN OTHER CONDITIONS PERTAIN. REUSE OF THIS DOCUMENT IS AT THE SOLE RISK OF THE USER.



THIS DRAWING IS THE PROPERTY OF DEWBERRY ENGINEERS INC. AND ITS AFFILIATES. REPRODUCTION OR USE OF THIS DRAWING AND/OR THE INFORMATION CONTAINED IN IT IS FORBIDDEN WITHOUT THE WRITTEN PERMISSION OF T-MOBILE.

SCALE: AS SHOWN

REV.	DATE	BY	DESCRIPTION
0	10/28/14	HMP	ISSUED AS FINAL
A	09/05/14	HMP	ISSUED FOR REVIEW

DRAWN BY: HMP
CHECKED BY: BSH
APPROVED BY: GHN
DATE: 09/05/14
TITLE:

GROUNDING NOTES & DETAILS

PROJECT NO. 50066258/50066266

January 30, 2015

Mr. Mitchell Abbott
Crown Castle
3530 Toringdon Way Suite 300
Charlotte, NC 28277
(704) 405-6612

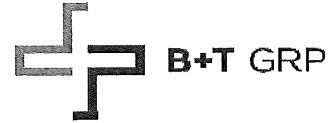

B+T Group
1717 S. Boulder, Suite 300
Tulsa, OK 74119
(918) 587-4630
ModDwgs@btgrp.com

Subject: Structural Modification Report

Carrier Designation: *T-Mobile Co-Locate*
Carrier Site Number: CT11004B
Carrier Site Name: N/A

Crown Castle Designation:
Crown Castle BU Number: 826217
Crown Castle Site Name: Newington_1
Crown Castle JDE Job Number: 268610
Crown Castle Work Order Number: 996578
Crown Castle Application Number: 261440 Rev. 2

Engineering Firm Designation: **B+T Group Project Number:** 87581.010.01

Site Data: **240 Kensington Road, Berlin, CT, Hartford County**
Latitude 41° 37' 34.3", Longitude -72° 46' 32.33"
190 Foot - Monopole

Dear Mr. Abbott,

B+T Group is pleased to submit this “**Structural Modification Report**” to determine the structural integrity of the above mentioned tower. This analysis has been performed in accordance with the Crown Castle Structural ‘Statement of Work’ and the terms of Crown Castle Purchase Order Number 748355, in accordance with application 261440, revision 2.

The purpose of the analysis is to determine acceptability of the tower stress level. Based on our analysis we have determined the tower stress level for the structure and foundation, under the following load case, to be:

LC4.7: TSA specified load case with proposed modifications **Sufficient Capacity**
Note: See Table 1 and Table 2 for the proposed and existing/reserved loading, respectively.

The analysis has been performed in accordance with the TIA/EIA-222-F standard and 2005 CT State Building Code based upon a wind speed of 80 mph fastest mile.

All modifications and equipment proposed in this report shall be installed in accordance with the attached drawings for the determined available structural capacity to be effective.

We at B+T Group appreciate the opportunity of providing our continuing professional services to you and Crown Castle. If you have any questions or need further assistance on this or any other projects please give us a call.

Respectfully submitted by:
B+T Engineering, Inc.

Ali Habibi
Project Engineer

Chad E. Tuttle, P.E.
President

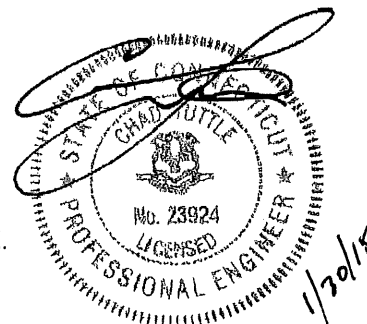

TABLE OF CONTENTS

1) INTRODUCTION

2) ANALYSIS CRITERIA

Table 1 - Proposed Antenna and Cable Information

Table 2 - Existing and Reserved Antenna and Cable Information

Table 3 - Design Antenna and Cable Information

3) ANALYSIS PROCEDURE

Table 4 - Documents Provided

3.1) Analysis Method

3.2) Assumptions

4) ANALYSIS RESULTS

Table 5 - Section Capacity (Summary)

Table 6 - Tower Components vs. Capacity

4.1) Recommendations

5) APPENDIX A

tnxTower Output

6) APPENDIX B

Base Level Drawing

7) APPENDIX C

Additional Calculations

8) APPENDIX D

Tower Modification Drawings

1) INTRODUCTION

This is a 190 ft. Monopole designed by Pirod in February of 1999. The monopole was originally designed for a wind speed of 80 mph per TIA/EIA-222-F. This monopole was reinforced in 2008 by Natcomm and those modifications were found to be ineffective and were not considered in this analysis. This monopole has been modified by B+T Group in 2014 and those modifications were incorporated in this analysis.

2) ANALYSIS CRITERIA

The structural analysis was performed for this monopole in accordance with the requirements of TIA/EIA-222-F Structural Standards for Steel Antenna Towers and Antenna Supporting Structures using a fastest mile wind speed of 80 mph with no ice, 37.6 mph with 1 inch ice thickness and 50 mph under service loads.

Table 1 - Proposed Antenna and Cable Information

Mounting Level (ft)	Center Line Elevation (ft)	Number of Antennas	Antenna Manufacturer	Antenna Model	Number of Feed Lines	Feed Line Size (in)	Note
184.0	184.0	3	Commscope	ATBT-BOTTOM-24V	--	--	--
		3	Commscope	LNx-6515DS-VTM			

Table 2 - Existing and Reserved Antenna and Cable Information

Mounting Level (ft)	Center Line Elevation (ft)	Number of Antennas	Antenna Manufacturer	Antenna Model	Number of Feed Lines	Feed Line Size (in)	Note
192.0	196.0	1	Kathrein	OGB4-900D	1	7/8	1
		1	Mti Wireless Edge	MT-485002			
	192.0	2	--	Side Arm Mount [SO 701-1]	1	1/2	
191.0	196.0	1	Andrew	DB589-A	1	5/16	1
	190.0	1	Motorola	WB2623	1	1/2	
184.0	181.0	3	Powerwave Tech	LGP21401	18	1 5/8	1
		3	EMS Wireless	RR90-17-02DP			
		3	EMS Wireless	RR90-17-02DP			
		6	Ericsson	KRY 112 144/1			
		3	RFS Celwave	APXV18-206516L-A			
		1	--	Platform Mount [LP 405-1]			
160.0	160.0	6	Commscope	HBXX-6517DS-VTM	7	1 5/8	2
		2	Commscope	LNx-8514DS-VTM			
		3	Antel	BXA-70063-6CF-2			
		1	Commscope	LNx-6514DS-VTM			
		3	Alcatel Lucent	RRH2X60-AWS			
		3	Alcatel Lucent	RRH2X60-PCS			
		1	RFS Celwave	DB-T1-6Z-8AB-0Z			
		1	--	Platform Mount [LP 303-1]			
158.0	158.0	1	Decibel	DB205-A	2	7/8	1
		1	Sinclair	SRL-224NM-4			
		2	--	Side Arm Mount [SO 702-1]			

Mounting Level (ft)	Center Line Elevation (ft)	Number of Antennas	Antenna Manufacturer	Antenna Model	Number of Feed Lines	Feed Line Size (in)	Note
151.0	151.0	2	Andrew	SBNH-1D6565C	2	3/8 7/16	2
		6	Communication Components Inc.	DTMABP7819VG12A			
		1	KMW	AM-X-CD-16-65-00T-RET			
		6	Powerwave	CM1007-DBPXBC-003			
		6	Powerwave	LGP21901	12	1 1/4	
		2	Andrew	SBNH-1D6565C			
		1	KMW	AM-X-CD-16-65-00T-RET			
		3	Powerwave	7770.00			
1	--	Platform Mount [LP 403-1]					
148.0	148.0	6	Ericsson	RRU-11	--	--	2
		1	Raycap	DC6-48-60-18-8F			
		1	--	Pipe Mount [PM 601-1]			
		2	--	Pipe Mount [PM 601-3]			
132.0	132.0	1	Sinclair	SRL-235-2	1	7/8	1
		1	--	Side Arm Mount [SO 702-1]			
124.0	124.0	1	Decibel	DB205-A	1	1/2 1 5/8	1
		1	Decibel	PCS 1900 TMA RX			
		1	--	Side Arm Mount [SO 701-1]			
116.0	120.0	1	Andrew	VHLP2.5-10W	9	1 1/4 5/16 1/2	1
		1	Dragonwave	HORIZON DUO			
	118.0	3	Argus	LLPX310R			
		9	Decibel	DB844G90A-XY			
		3	Samsung	WIMAX DAP HEAD			
	116.0	1	--	Platform Mount [LP 405-1]			
100.0	100.0	3	Kathrein	742 213	6	1 5/8	1
		1	--	Pipe Mount [PM 601-3]			
90.0	99.0	2	Decibel	DB205-A	1	5/16 1/2 7/8	1
		1	Andrew	KP2F-34			
	90.0	1	Mti Wireless Edge	MT-485002			
		2	--	Side Arm Mount [SO 702-1]			
87.0	87.0	2	GPS	GPS_A	2	1/2	1
		2	--	Side Arm Mount [SO 701-1]			
70.0	70.0	1	Sinclair	SRL-235-2	1	7/8	1
		1	--	Side Arm Mount [SO 702-1]			
58.0	58.0	1	Decibel	DB583	1	1/2	1
		1	--	Side Arm Mount [SO 702-1]			
43.0	43.0	1	Decibel	DB909XVTE-M	1	1/2	1
		1	--	Side Arm Mount [SO 702-1]			
33.0	33.0	1	Decibel	DB909XVTE-M	1	1/2	1
		1	--	Side Arm Mount [SO 702-1]			

- Notes:
 1) Existing Equipment
 2) Reserved Equipment
 3) **Equipment To Be Removed**

Table 3 - Design Antenna and Cable Information

Mounting Level (ft)	Center Line Elevation (ft)	Number of Antennas	Antenna Manufacturer	Antenna Model	Number of Feed Lines	Feed Line Size (in)
190	190	1	Decibel	DB809	1	1-5/8
177.667	177.667	12	EMS Wireless	RR90-17-00DP	12	1-5/8
155	155	2	Decibel	DB205	2	1-5/8
140	140	2	Decibel	DB205	2	1-5/8
127.667	127.667	12	EMS Wireless	RR90-17-00DP	12	1-5/8
117.667	117.667	12	EMS Wireless	RR90-17-00DP	12	1-5/8
25	25	1	Decibel	DB516	2	1-5/8
		1	Decibel	DB809M		
20	20	1	Decibel	DB205	1	1-5/8

3) ANALYSIS PROCEDURE

Table 4 - Documents Provided

Document	Remarks	Reference	Source
Online Application	T-Mobile Co-Locate, Rev # 2	261440	CCI Sites
Tower Manufacturer Drawings	Pirod, File No. A-115400	3438498	CCI Sites
Tower Modification Drawings	B+T Group, Project No. 87581.005.01	Date: 10/17/14	CCI Sites
Foundation Drawings	Pirod, File No. A-115400	3463552	CCI Sites
Geotech Report	FPA, Job No. 98A209ERI	3438510	CCI Sites
Antenna Configuration	Crown CAD Package	Date: 09/10/14	CCI Sites

3.1) Analysis Method

tnxTower (version 6.1.4.1), a commercially available analysis software package, was used to create a three-dimensional model of the tower and calculate member stresses for various loading cases. Selected output from the analysis is included in Appendix A.

3.2) Assumptions

- 1) Tower and structures were built in accordance with the manufacturer's specifications.
- 2) The tower and structures have been maintained in accordance with the manufacturer's specification.
- 3) The configuration of antennas, transmission cables, mounts and other appurtenances are as specified in Tables 1 and 2 and the referenced drawings.
- 4) When applicable, transmission cables are considered as structural components for calculating wind loads as allowed by TIA/EIA-222-F.
- 5) Mount areas and weights are assumed based on photographs provided.

This analysis may be affected if any assumptions are not valid or have been made in error. B+T Group should be notified to determine the effect on the structural integrity of the tower.

4) ANALYSIS RESULTS

Table 5 - Section Capacity (Summary) - LC4.7

Section No.	Elevation (ft)	Component Type	Size	Critical Element	P (K)	SF*P_allow (K)	% Capacity	Pass / Fail
L1	190 - 180	Pole	P18x3/8	1	-3.090	-	6.9	Pass ¹
L2	180 - 140	Pole	P24x3/8	2	-13.011	-	93.3	Pass ¹
L3	140 - 120	Pole	P36x3/8	3	-17.101	-	91.5	Pass ¹
L4	120 - 109	Pole	P42x3/8	4	-21.863	-	92.3	Pass ¹
L5	109 - 104	Pole	P42x3/8 [0.449926]	5	-23.182	-	85.6	Pass ¹
L6	104 - 100	Pole	P42x3/8 [0.525959]	6	-24.358	-	80.9	Pass ¹
L7	100 - 89	Pole	P48x3/8 [0.43965]	7	-28.055	-	93.0	Pass ¹
L8	89 - 80	Pole	P48x3/8 [0.53914]	8	-31.244	-	88.8	Pass ¹
L9	80 - 69	Pole	P54x3/8 [0.490666]	9	-35.194	-	92.4	Pass ¹
L10	69 - 60	Pole	P54x3/8 [0.578486]	10	-38.754	-	89.1	Pass ¹
L11	60 - 49	Pole	P60x3/8 [0.516129]	11	-43.148	-	93.8	Pass ¹
L12	49 - 40	Pole	P60x3/8 [0.594533]	12	-47.190	-	90.7	Pass ¹
L13	40 - 29	Pole	P60x1/2 [0.604293]	13	-52.264	-	93.5	Pass ¹
L14	29 - 20	Pole	P60x1/2 [0.683417]	14	-56.784	-	90.7	Pass ¹
L15	20 - 9	Pole	P60x5/8 [0.703867]	15	-62.516	-	91.1	Pass ¹
L16	9 - 0	Pole	P60x5/8 [0.756633]	16	-67.491	-	92.2	Pass ¹
							Summary	
						Pole (L11)	93.8	Pass ¹
						RATING =	93.8	Pass¹

Table 6 - Tower Component Stresses vs. Capacity - LC4.7

Notes	Component	Elevation (ft)	% Capacity	Pass / Fail
1	Flange Bolts	180	5.1	Pass
1,2	Flange Plate	180	4.2	Pass
1	Flange Bolts	140	75.7	Pass
1,2	Flange Plate	140	64.0	Pass
1	Bridge Stiffeners	120	80.7	Pass
1	Flange Bolts	120	46.6	Pass
1	Flange Plate	120	32.7	Pass
1	Bridge Stiffeners	100	74.3	Pass
1	Flange Bolts	100	43.0	Pass
1	Flange Plate	100	55.2	Pass
1	Bridge Stiffeners	80	85.4	Pass
1	Flange Bolts	80	54.6	Pass
1	Flange Plate	80	69.5	Pass
1	Bridge Stiffeners	60	51.2	Pass
1	Flange Bolts	60	32.4	Pass
1	Flange Plate	60	51.2	Pass
1	Bridge Stiffeners	40	67.8	Pass
1	Flange Bolts	40	30.6	Pass
1	Flange Plate	40	54.4	Pass
1	Bridge Stiffeners	20	92.6	Pass
1	Flange Bolts	20	43.6	Pass
1	Flange Plate	20	76.1	Pass
1	Anchor Rods	Base	36.7	Pass
1	Base Plate	Base	96.7	Pass
1	Base Foundation	Base	98.1	Pass

Structure Rating (max from all components) =	98.1%
---	--------------

Notes:

- 1) See additional documentation in "Appendix C - Additional Calculations" for calculations supporting the % capacity listed.
- 2) Base plate design methodology of the manufacturer has been reviewed and found to be an acceptable means of designing to resist the full capacity of the bolts and shaft.
- 3) The percent capacities shown above (excluding foundations) include the 1/3 increase in allowable stresses as allowed by TIA/EIA-222-F.

4.1) Recommendations

- 1) All modifications proposed in this report shall be installed in accordance with the attached drawings (Appendix D) for the determined available structural capacity to be effective.

APPENDIX A
tnxTOWER OUTPUT

1	P16x3/8	10.000	A53-B-42	45.9
2	P24x3/8	40.000		
3	P36x3/8	20.000		
4	P42x3/8	11.000		
5	P48x3/8 [0.439926] [0.449926]	5.000		
6	P48x3/8 [0.53914]	4.000		
7	P48x3/8 [0.53914]	11.000		
8	P48x3/8 [0.53914]	9.000		
9	P54x3/8 [0.490666]	11.000		
10	P54x3/8 [0.578486]	9.000		
11	P60x3/8 [0.516129]	11.000		
12	P60x3/8 [0.594533]	9.000		
13	P60x1/2 [0.604293]	11.000		
14	P60x1/2 [0.683417]	9.000		
15	P60x5/8 [0.703867]	11.000		
16	P60x5/8 [0.756633]	9.000		
Section				45.9
Size				
Length (ft)				
Grade				
Weight (K)				

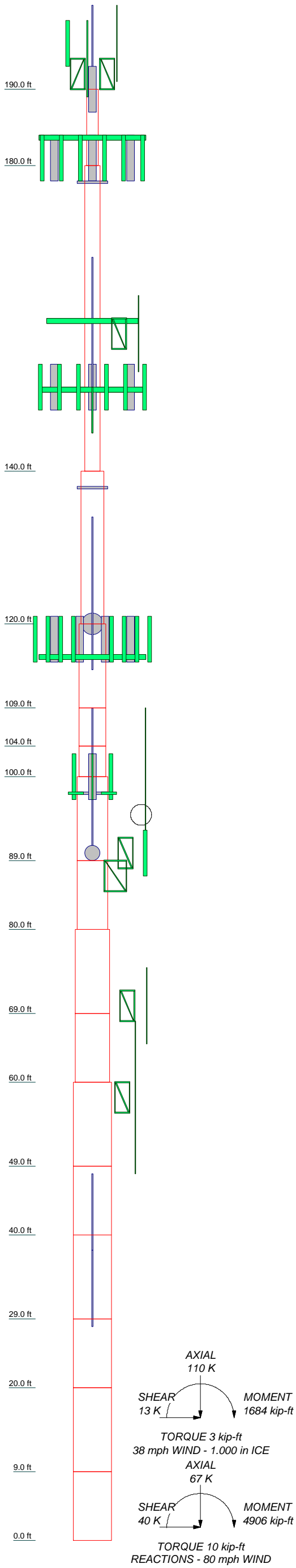

DESIGNED APPURTENANCE LOADING

TYPE	ELEVATION	TYPE	ELEVATION
OGB4-900D (E)	192	(2) DTMABP7819VG12A (R)	151
MT-485002 w/ Mount Pipe (E)	192	Platform Mount [LP 403-1] (E)	151
Side Arm Mount [SO 701-1] (E)	192	(2) SBNH-1D6565C w/ Mount Pipe (E)	151
Side Arm Mount [SO 701-1] (E)	192	(2) RRU-11 (R)	148
DB589-A (E)	191	(2) RRU-11 (R)	148
WB2623 w/ Mount Pipe (E)	191	DC6-48-60-18-8F (R)	148
6' x 2" Mount Pipe (E)	191	(2) Pipe Mount [PM 601-3] (R)	148
Lightning Rod 5/8" x 4' on 4' Pole (E)	190	Pipe Mount [PM 601-1] (R)	148
RR90-17-02DP w/ Mount Pipe (E)	184	(2) RRU-11 (R)	148
RR90-17-02DP w/ Mount Pipe (E)	184	4' ICE SHIELDS (E)	138
RR90-17-02DP w/ Mount Pipe (E)	184	Side Arm Mount [SO 702-1] (E)	132
APXV18-206516L-A w/ Mount Pipe (E)	184	SRL-235-2 (E)	132
APXV18-206516L-A w/ Mount Pipe (E)	184	4' x 2" Pipe Mount (E)	132
APXV18-206516L-A w/ Mount Pipe (E)	184	Side Arm Mount [SO 701-1] (E)	124
(2) KRY 112 144/1 (E)	184	6' x 2" Mount Pipe (E)	124
(2) KRY 112 144/1 (E)	184	DB205-A (E)	124
(2) KRY 112 144/1 (E)	184	PCS 1900 TMA RX (E)	124
LNX-6515DS-VTM w/ Mount Pipe (p)	184	LLPX310R w/ Mount Pipe (E)	116
LNX-6515DS-VTM w/ Mount Pipe (p)	184	(3) DB844G90A-XY w/ Mount Pipe (E)	116
LNX-6515DS-VTM w/ Mount Pipe (p)	184	(3) DB844G90A-XY w/ Mount Pipe (E)	116
ATBT-BOTTOM-24V (p)	184	(3) DB844G90A-XY w/ Mount Pipe (E)	116
ATBT-BOTTOM-24V (p)	184	HORIZON DUO (E)	116
ATBT-BOTTOM-24V (p)	184	WIMAX DAP HEAD (E)	116
Platform Mount [LP 405-1] (E)	184	WIMAX DAP HEAD (E)	116
4' ICE SHIELDS (E)	178	WIMAX DAP HEAD (E)	116
(2) HBXX-6517DS-VTM w/ Mount Pipe (R)	160	Platform Mount [LP 405-1] (E)	116
(2) HBXX-6517DS-VTM w/ Mount Pipe (R)	160	LLPX310R w/ Mount Pipe (E)	116
LNX-8514DS-VTM w/ Mount Pipe (R)	160	LLPX310R w/ Mount Pipe (E)	116
LNX-8514DS-VTM w/ Mount Pipe (R)	160	VHLP2.5-10W (E)	116
LNX-6514DS-VTM w/ Mount Pipe (R)	160	Pipe Mount [PM 601-3] (E)	100
BXA-70063-6CF-2 w/ Mount Pipe (R)	160	742 213 (E)	100
BXA-70063-6CF-2 w/ Mount Pipe (R)	160	742 213 (E)	100
BXA-70063-6CF-2 w/ Mount Pipe (R)	160	742 213 (E)	100
RRH2X60-PCS (R)	160	4' ICE SHIELDS (E)	98
RRH2X60-PCS (R)	160	4' ICE SHIELDS (E)	98
RRH2X60-PCS (R)	160	4' ICE SHIELDS (E)	98
RRH2X60-AWS (R)	160	DB205-A (E)	90
RRH2X60-AWS (R)	160	DB205-A (E)	90
RRH2X60-AWS (R)	160	Side Arm Mount [SO 702-1] (E)	90
DB-T1-6Z-8AB-OZ (R)	160	Side Arm Mount [SO 702-1] (E)	90
Platform Mount [LP 303-1] (E)	160	6' x 2" Mount Pipe (E)	90
(2) HBXX-6517DS-VTM w/ Mount Pipe (R)	160	MT-485002 w/ Mount Pipe (E)	90
SRL-224NM-4 (E)	158	KP2F-34 (E)	90
Side Arm Mount [SO 702-1] (E)	158	GPS_A (E)	87
Side Arm Mount [SO 702-1] (E)	158	GPS_A (E)	87
4' x 2" Pipe Mount (E)	158	Side Arm Mount [SO 701-1] (E)	87
4' x 2" Pipe Mount (E)	158	Side Arm Mount [SO 701-1] (E)	87
DB205-A (E)	158	SRL-235-2 (E-B Leg per Photo)	70
(3) 7770.00 w/ Mount Pipe (E)	151	6' x 2" Mount Pipe (E-B Leg per Photo)	70
AM-X-CD-16-65-00T-RET w/ Mount Pipe (E)	151	Side Arm Mount [SO 702-1] (E-B Leg per Photo)	70
AM-X-CD-16-65-00T-RET w/ Mount Pipe (R)	151	DB583 (E)	58
(2) SBNH-1D6565C w/ Mount Pipe (R)	151	4' x 2" Pipe Mount (E)	58
(2) CM1007-DBPXBC-003 (R)	151	Side Arm Mount [SO 702-1] (E)	58
(2) CM1007-DBPXBC-003 (R)	151	DB909XVTE-M (E-A Leg per Photo)	43
(2) CM1007-DBPXBC-003 (R)	151	4' x 2" Pipe Mount (E-A Leg per Photo)	43
(2) LGP21901 (R)	151	Side Arm Mount [SO 702-1] (E-A Leg per Photo)	43
(2) LGP21901 (R)	151	4' x 2" Pipe Mount (E-A Leg per Photo)	33
(2) LGP21901 (R)	151	Side Arm Mount [SO 702-1] (E-A Leg per Photo)	33
(4) DTMABP7819VG12A (R)	151	DB909XVTE-M (E-A Leg per Photo)	33

TOWER DESIGN NOTES

1. Tower is located in Hartford County, Connecticut.
2. Tower designed for a 80 mph basic wind in accordance with the TIA/EIA-222-F Standard.
3. Tower is also designed for a 38 mph basic wind with 1.00 in ice. Ice is considered to increase in thickness with height.
4. Deflections are based upon a 50 mph wind.
5. TOWER RATING 93.8%

ABC Engineering		Job: 87581.010.01 - Newington_1, CT (BU# 82621)	
1234 W. Jones St.		Project:	
Smallville, PA 12345		Client: Crown Castle	Drawn by: ahabibi
Consulting Engineers	Phone: (555) 555-1234	Date: 01/30/15	Scale: NTS
	FAX: (555) 555-1235	Path:	Dwg No. E-1

Vx

Vz

Mx

Mz

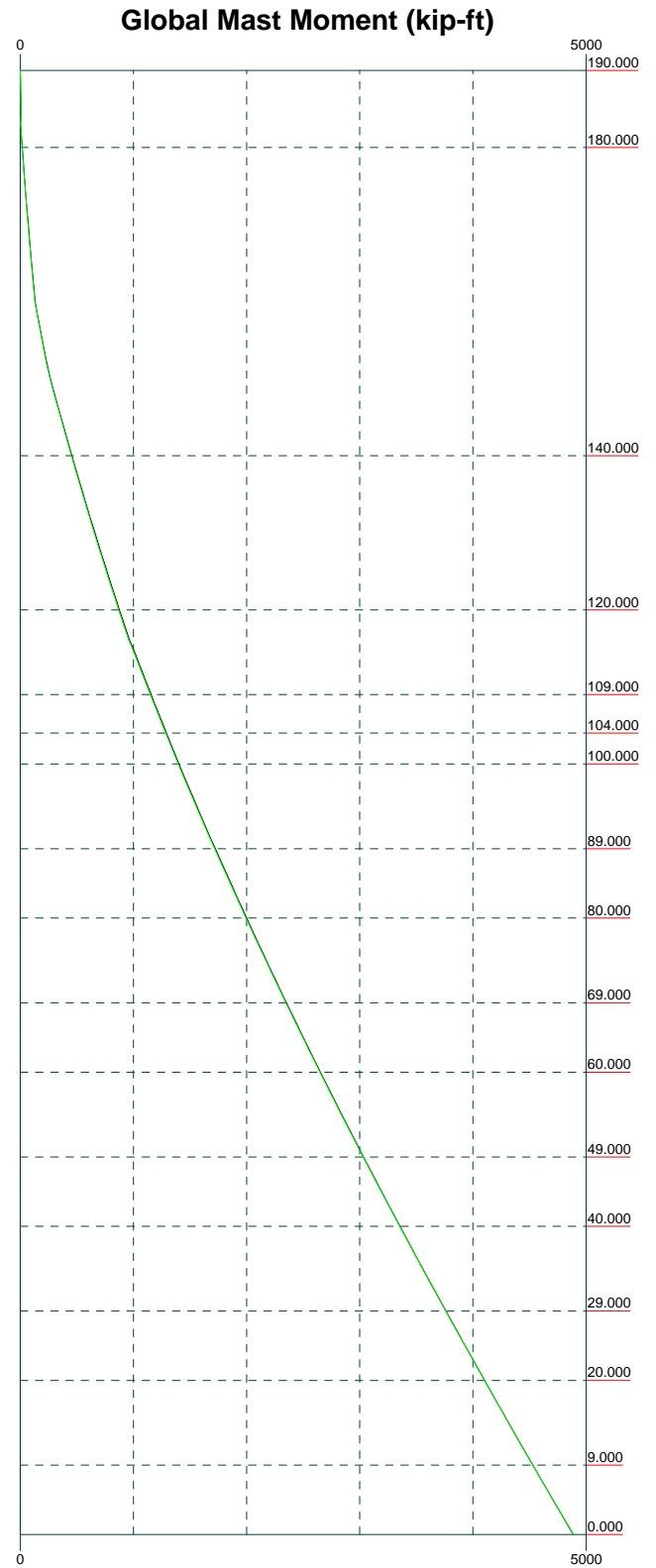
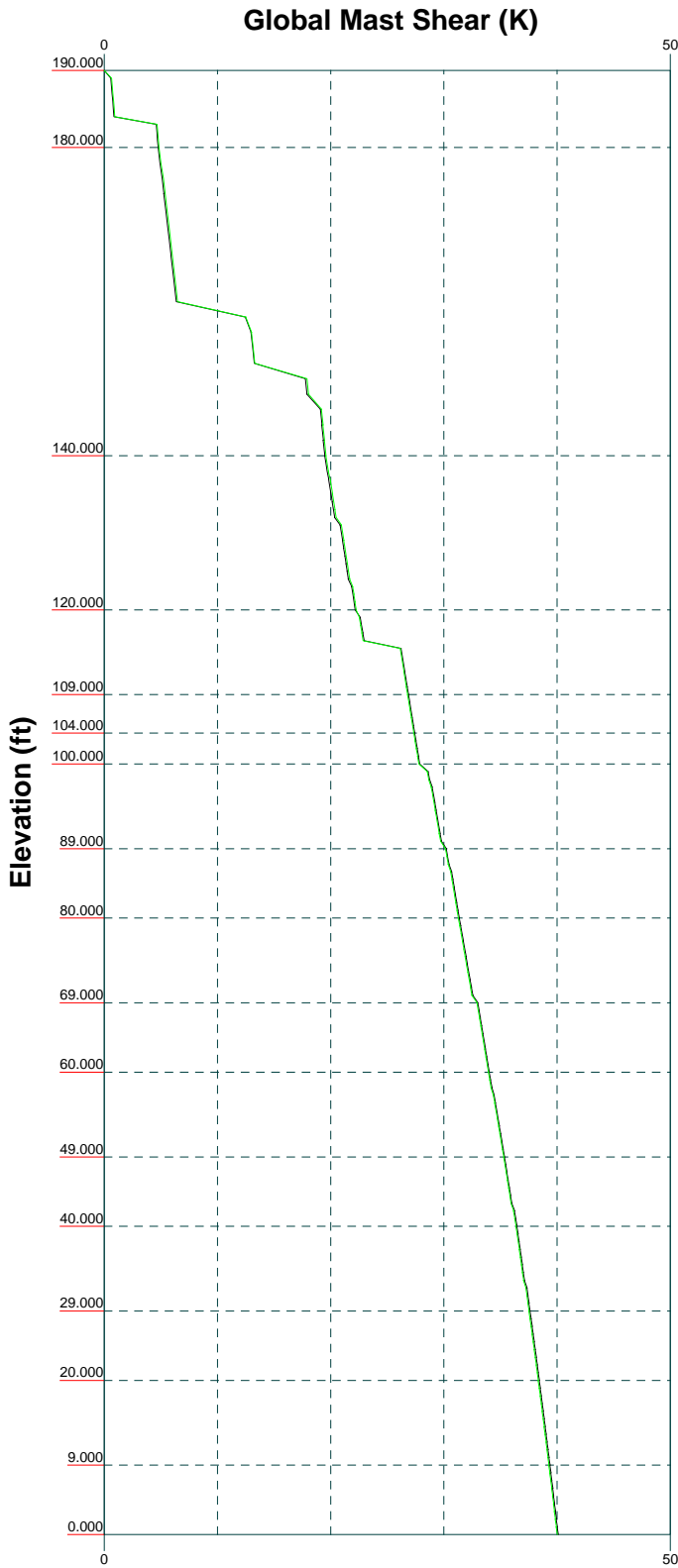

B+T Group
 1717 S. Boulder, Suite 300
 Tulsa, OK 74119
 Phone: (918) 587-4630
 FAX: (918) 295-0265

Job: 87581.009.01 - Newington_1, CT (BU# 82621)		
Project:		
Client: Crown Castle	Drawn by: APatil	App'd:
Code: TIA/EIA-222-F	Date: 10/26/14	Scale: NTS
Path:	Dwg No. E-4	

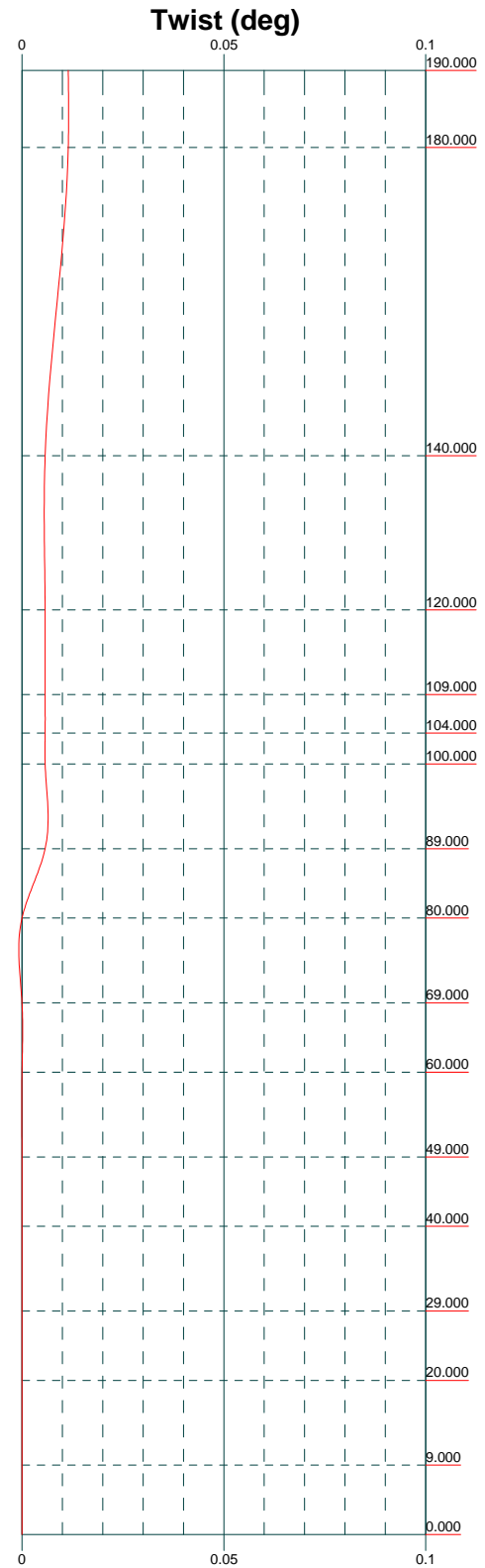
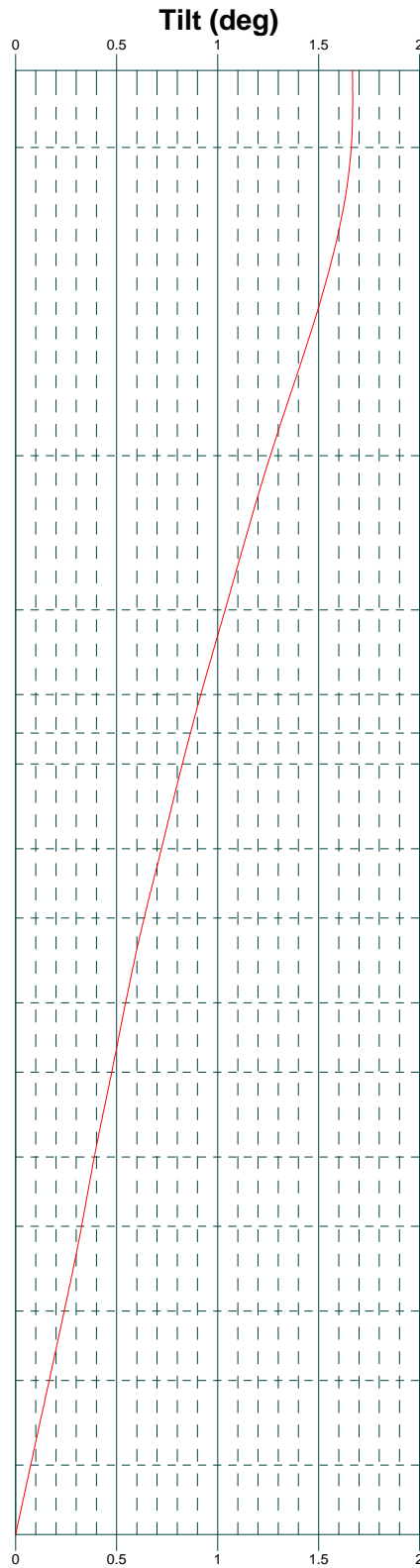
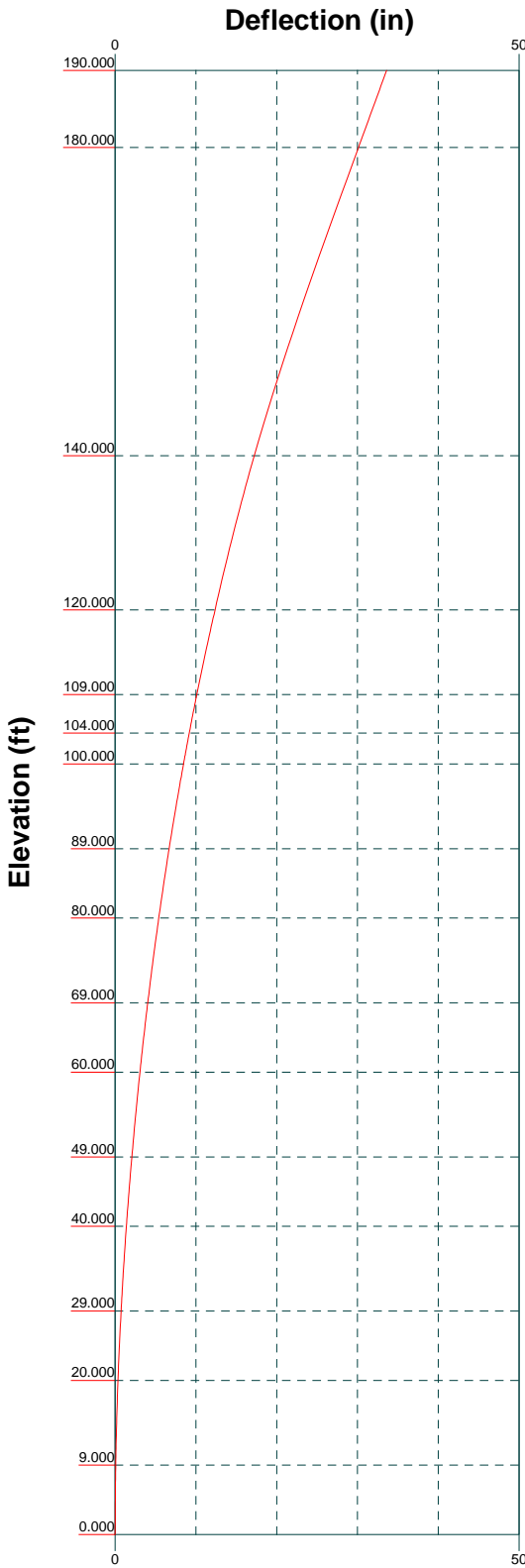

B+T Group
 1717 S. Boulder, Suite 300
 Tulsa, OK 74119
 Phone: (918) 587-4630
 FAX: (918) 295-0265

Job: 87581.009.01 - Newington_1, CT (BU# 82621)		
Project:		
Client: Crown Castle	Drawn by: APatil	App'd:
Code: TIA/EIA-222-F	Date: 10/26/14	Scale: NTS
Path:	Dwg No. E-5	

Feed Line Distribution Chart

0' - 190'

— Round
 — Flat
 — App In Face
 — App Out Face
 — Truss Leg

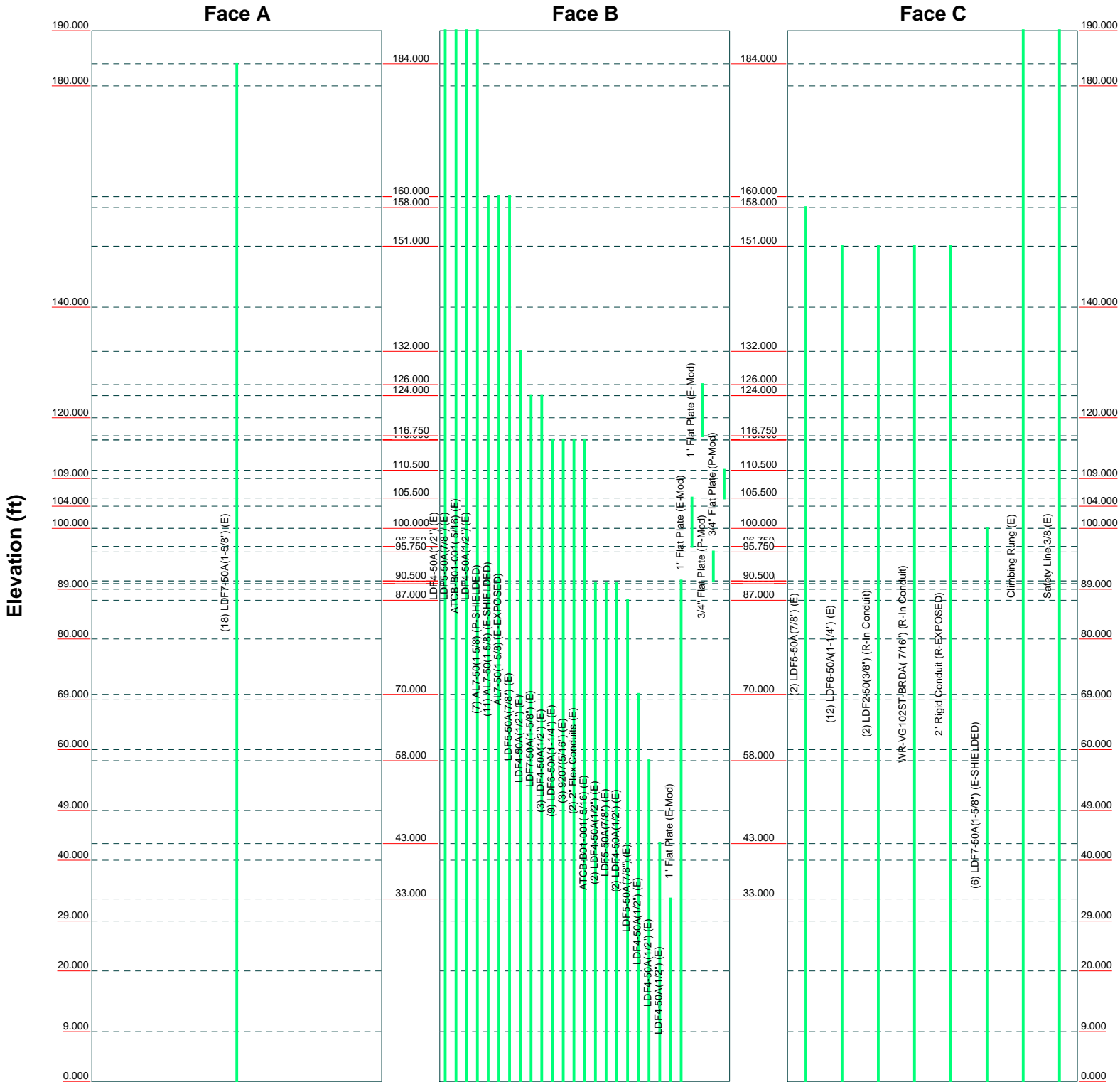

B+T Group
 1717 S. Boulder, Suite 300
 Tulsa, OK 74119
 Phone: (918) 587-4630
 FAX: (918) 295-0265

Job: 87581.009.01 - Newington 1, CT (BU# 82621)		
Project:		
Client: Crown Castle	Drawn by: APatil	App'd:
Code: TIA/EIA-222-F	Date: 10/26/14	Scale: NTS
Path:	Dwg No. E-7	

tnxTower ABC Engineering 1234 W. Jones St. Smallville, PA 12345 Phone: (555) 555-1234 FAX: (555) 555-1235	Job 87581.010.01 - Newington_1, CT (BU# 826217)	Page 1 of 38
	Project	Date 14:49:48 01/30/15
	Client Crown Castle	Designed by ahabibi

Tower Input Data

There is a pole section.

This tower is designed using the TIA/EIA-222-F standard.

The following design criteria apply:

Tower is located in Hartford County, Connecticut.

Basic wind speed of 80 mph.

Nominal ice thickness of 1.000 in.

Ice thickness is considered to increase with height.

Ice density of 56.000 pcf.

A wind speed of 38 mph is used in combination with ice.

Temperature drop of 50.000 °F.

Deflections calculated using a wind speed of 50 mph.

TOWER RATING 93.8%.

A non-linear (P-delta) analysis was used.

Pressures are calculated at each section.

Stress ratio used in pole design is 1.333.

Local bending stresses due to climbing loads, feed line supports, and appurtenance mounts are not considered.

Options

- | | | |
|--|--|---|
| <ul style="list-style-type: none"> Consider Moments - Legs Consider Moments - Horizontals Consider Moments - Diagonals Use Moment Magnification √ Use Code Stress Ratios √ Use Code Safety Factors - Guys √ Escalate Ice Always Use Max Kz Use Special Wind Profile Include Bolts In Member Capacity Leg Bolts Are At Top Of Section Secondary Horizontal Braces Leg Use Diamond Inner Bracing (4 Sided) Add IBC .6D+W Combination | <ul style="list-style-type: none"> Distribute Leg Loads As Uniform Assume Legs Pinned √ Assume Rigid Index Plate √ Use Clear Spans For Wind Area Use Clear Spans For KL/r Retension Guys To Initial Tension √ Bypass Mast Stability Checks √ Use Azimuth Dish Coefficients √ Project Wind Area of Appurt. Autocalc Torque Arm Areas SR Members Have Cut Ends Sort Capacity Reports By Component Triangulate Diamond Inner Bracing Use TIA-222-G Tension Splice Capacity Exemption | <ul style="list-style-type: none"> Treat Feedline Bundles As Cylinder Use ASCE 10 X-Brace Ly Rules Calculate Redundant Bracing Forces Ignore Redundant Members in FEA SR Leg Bolts Resist Compression All Leg Panels Have Same Allowable Offset Girt At Foundation √ Consider Feedline Torque Include Angle Block Shear Check <li style="text-align: center;">Poles √ Include Shear-Torsion Interaction Always Use Sub-Critical Flow Use Top Mounted Sockets |
|--|--|---|

Pole Section Geometry

Section	Elevation <i>ft</i>	Section Length <i>ft</i>	Pole Size	Pole Grade	Socket Length <i>ft</i>
L1	190.000-180.000	10.000	P18x3/8	A53-B-42 (42 ksi)	
L2	180.000-140.000	40.000	P24x3/8	A53-B-42 (42 ksi)	
L3	140.000-120.000	20.000	P36x3/8	A53-B-42 (42 ksi)	
L4	120.000-109.000	11.000	P42x3/8	A53-B-42 (42 ksi)	

tnxTower ABC Engineering 1234 W. Jones St. Smallville, PA 12345 Phone: (555) 555-1234 FAX: (555) 555-1235	Job 87581.010.01 - Newington_1, CT (BU# 826217)	Page 2 of 38
	Project	Date 14:49:48 01/30/15
	Client Crown Castle	Designed by ahabibi

Section	Elevation ft	Section Length ft	Pole Size	Pole Grade	Socket Length ft
L5	109.000-104.000	5.000	P42x3/8 [0.449926]	39.923929ksi (40 ksi)	
L6	104.000-100.000	4.000	P42x3/8 [0.525959]	38.016952ksi (38 ksi)	
L7	100.000-89.000	11.000	P48x3/8 [0.43965]	40.362076ksi (40 ksi)	
L8	89.000-80.000	9.000	P48x3/8 [0.53914]	38.076921ksi (38 ksi)	
L9	80.000-69.000	11.000	P54x3/8 [0.490666]	39.389682ksi (39 ksi)	
L10	69.000-60.000	9.000	P54x3/8 [0.578486]	37.614698ksi (38 ksi)	
L11	60.000-49.000	11.000	P60x3/8 [0.516129]	39.092679ksi (39 ksi)	
L12	49.000-40.000	9.000	P60x3/8 [0.594533]	37.644985ksi (38 ksi)	
L13	40.000-29.000	11.000	P60x1/2 [0.604293]	39.940562ksi (40 ksi)	
L14	29.000-20.000	9.000	P60x1/2 [0.683417]	38.508049ksi (39 ksi)	
L15	20.000-9.000	11.000	P60x5/8 [0.703867]	40.5123ksi (41 ksi)	
L16	9.000-0.000	9.000	P60x5/8 [0.756633]	39.574431ksi (40 ksi)	

Tower Elevation ft	Gusset Area (per face) ft ²	Gusset Thickness in	Gusset Grade	Adjust. Factor A _f	Adjust. Factor A _r	Weight Mult.	Double Angle Stitch Bolt Spacing Diagonals in	Double Angle Stitch Bolt Spacing Horizontals in
L1 190.000-180.000				1	1	1		
L2 180.000-140.000				1	1	1		
L3 140.000-120.000				1	1	1		
L4 120.000-109.000				1	1	1		
L5 109.000-104.000				1	1	0.988718		
L6 104.000-100.000				1	1	0.978734		
L7 100.000-89.000				1	1	0.991619		
L8 89.000-80.000				1	1	0.978348		
L9 80.000-69.000				1	1	0.984646		
L10 69.000-60.000				1	1	0.97566		
L11				1	1	0.981503		

tnxTower ABC Engineering 1234 W. Jones St. Smallville, PA 12345 Phone: (555) 555-1234 FAX: (555) 555-1235	Job 87581.010.01 - Newington_1, CT (BU# 826217)	Page 3 of 38
	Project	Date 14:49:48 01/30/15
	Client Crown Castle	Designed by ahabibi

Tower Elevation	Gusset Area (per face)	Gusset Thickness	Gusset Grade	Adjust. Factor A_f	Adjust. Factor A_r	Weight Mult.	Double Angle Stitch Bolt Spacing Diagonals in	Double Angle Stitch Bolt Spacing Horizontals in
ft	ft ²	in						
60.000-49.000								
L12				1	1	0.974922		
49.000-40.000								
L13				1	1	0.988999		
40.000-29.000								
L14				1	1	0.98172		
29.000-20.000								
L15				1	1	0.992596		
20.000-9.000								
L16				1	1	0.988139		
9.000-0.000								

Feed Line/Linear Appurtenances - Entered As Round Or Flat

Description	Face or Leg	Allow Shield	Component Type	Placement	Total Number	Number Per Row	Clear Spacing in	Width or Diameter in	Perimeter in	Weight klf
***				ft						

Feed Line/Linear Appurtenances - Entered As Area

Description	Face or Leg	Allow Shield	Component Type	Placement	Total Number		C_{AA}	Weight
				ft			ft ² /ft	klf
LDF4-50A(1/2") (E)	B	No	Inside Pole	190.000 - 0.000	1	No Ice	0.000	0.000
						1/2" Ice	0.000	0.000
						1" Ice	0.000	0.000
						2" Ice	0.000	0.000
						4" Ice	0.000	0.000
LDF5-50A(7/8") (E)	B	No	Inside Pole	190.000 - 0.000	1	No Ice	0.000	0.000
						1/2" Ice	0.000	0.000
						1" Ice	0.000	0.000
						2" Ice	0.000	0.000
						4" Ice	0.000	0.000
ATCB-B01-001(5/16) (E)	B	No	Inside Pole	190.000 - 0.000	1	No Ice	0.000	0.000
						1/2" Ice	0.000	0.000
						1" Ice	0.000	0.000
						2" Ice	0.000	0.000
						4" Ice	0.000	0.000
LDF4-50A(1/2") (E)	B	No	Inside Pole	190.000 - 0.000	1	No Ice	0.000	0.000
						1/2" Ice	0.000	0.000
						1" Ice	0.000	0.000
						2" Ice	0.000	0.000
						4" Ice	0.000	0.000

LDF7-50A(1-5/8") (E)	A	No	Inside Pole	184.000 - 0.000	18	No Ice	0.000	0.001
						1/2" Ice	0.000	0.001
						1" Ice	0.000	0.001
						2" Ice	0.000	0.001
						4" Ice	0.000	0.001

AL7-50(1 5/8)	B	No	CaAa (Out Of	160.000 - 0.000	7	No Ice	0.000	0.001

tnxTower ABC Engineering 1234 W. Jones St. Smallville, PA 12345 Phone: (555) 555-1234 FAX: (555) 555-1235	Job		87581.010.01 - Newington_1, CT (BU# 826217)		Page		4 of 38	
	Project				Date		14:49:48 01/30/15	
	Client		Crown Castle		Designed by		ahabibi	

Description	Face or Leg	Allow Shield	Component Type	Placement ft	Total Number		C _A A _A ft ² /ft	Weight klf
(R-SHIELDED)			Face)			1/2" Ice	0.000	0.002
						1" Ice	0.000	0.004
						2" Ice	0.000	0.010
						4" Ice	0.000	0.030
AL7-50(1 5/8) (E-SHIELDED)	B	No	CaAa (Out Of Face)	160.000 - 0.000	11	No Ice	0.000	0.001
						1/2" Ice	0.000	0.002
						1" Ice	0.000	0.004
						2" Ice	0.000	0.010
						4" Ice	0.000	0.030
AL7-50(1 5/8) (E-EXPOSED)	B	No	CaAa (Out Of Face)	160.000 - 0.000	1	No Ice	0.196	0.001
						1/2" Ice	0.296	0.002
						1" Ice	0.396	0.004
						2" Ice	0.596	0.010
						4" Ice	0.996	0.030
*** LDF5-50A(7/8") (E)	C	No	Inside Pole	158.000 - 0.000	2	No Ice	0.000	0.000
						1/2" Ice	0.000	0.000
						1" Ice	0.000	0.000
						2" Ice	0.000	0.000
						4" Ice	0.000	0.000
*** LDF6-50A(1-1/4") (E)	C	No	Inside Pole	151.000 - 0.000	12	No Ice	0.000	0.001
						1/2" Ice	0.000	0.001
						1" Ice	0.000	0.001
						2" Ice	0.000	0.001
						4" Ice	0.000	0.001
LDF2-50(3/8") (R-In Conduit)	C	No	Inside Pole	151.000 - 0.000	2	No Ice	0.000	0.000
						1/2" Ice	0.000	0.000
						1" Ice	0.000	0.000
						2" Ice	0.000	0.000
						4" Ice	0.000	0.000
WR-VG102ST-BRDA(7/16") (R-In Conduit)	C	No	Inside Pole	151.000 - 0.000	1	No Ice	0.000	0.000
						1/2" Ice	0.000	0.000
						1" Ice	0.000	0.000
						2" Ice	0.000	0.000
						4" Ice	0.000	0.000
2" Rigid Conduit (R-EXPOSED)	C	No	CaAa (Out Of Face)	151.000 - 0.000	1	No Ice	0.200	0.003
						1/2" Ice	0.300	0.004
						1" Ice	0.400	0.006
						2" Ice	0.600	0.013
						4" Ice	1.000	0.032
*** LDF5-50A(7/8") (E)	B	No	Inside Pole	132.000 - 0.000	1	No Ice	0.000	0.000
						1/2" Ice	0.000	0.000
						1" Ice	0.000	0.000
						2" Ice	0.000	0.000
						4" Ice	0.000	0.000
*** LDF4-50A(1/2") (E)	B	No	Inside Pole	124.000 - 0.000	1	No Ice	0.000	0.000
						1/2" Ice	0.000	0.000
						1" Ice	0.000	0.000
						2" Ice	0.000	0.000
						4" Ice	0.000	0.000
LDF7-50A(1-5/8") (E)	B	No	Inside Pole	124.000 - 0.000	1	No Ice	0.000	0.001
						1/2" Ice	0.000	0.001
						1" Ice	0.000	0.001
						2" Ice	0.000	0.001
						4" Ice	0.000	0.001
*** LDF4-50A(1/2") (E)	B	No	Inside Pole	116.000 - 0.000	3	No Ice	0.000	0.000
						1/2" Ice	0.000	0.000

tnxTower ABC Engineering 1234 W. Jones St. Smallville, PA 12345 Phone: (555) 555-1234 FAX: (555) 555-1235	Job		87581.010.01 - Newington_1, CT (BU# 826217)		Page		5 of 38	
	Project				Date		14:49:48 01/30/15	
	Client		Crown Castle		Designed by		ahabibi	

Description	Face or Leg	Allow Shield	Component Type	Placement ft	Total Number		C _{AA} ft ² /ft	Weight klf
						1" Ice	0.000	0.000
						2" Ice	0.000	0.000
						4" Ice	0.000	0.000
LDF6-50A(1-1/4") (E)	B	No	Inside Pole	116.000 - 0.000	9	No Ice	0.000	0.001
						1/2" Ice	0.000	0.001
						1" Ice	0.000	0.001
						2" Ice	0.000	0.001
						4" Ice	0.000	0.001
9207(5/16") (E)	B	No	Inside Pole	116.000 - 0.000	3	No Ice	0.000	0.001
						1/2" Ice	0.000	0.001
						1" Ice	0.000	0.001
						2" Ice	0.000	0.001
						4" Ice	0.000	0.001
2" Flex Conduits (E)	B	No	Inside Pole	116.000 - 0.000	2	No Ice	0.000	0.003
						1/2" Ice	0.000	0.003
						1" Ice	0.000	0.003
						2" Ice	0.000	0.003
						4" Ice	0.000	0.003

LDF7-50A(1-5/8") (E-SHIELDED)	C	No	CaAa (Out Of Face)	100.000 - 0.000	6	No Ice	0.000	0.001
						1/2" Ice	0.000	0.002
						1" Ice	0.000	0.004
						2" Ice	0.000	0.011
						4" Ice	0.000	0.030

ATCB-B01-001(5/16) (E)	B	No	Inside Pole	90.000 - 0.000	1	No Ice	0.000	0.000
						1/2" Ice	0.000	0.000
						1" Ice	0.000	0.000
						2" Ice	0.000	0.000
						4" Ice	0.000	0.000
LDF4-50A(1/2") (E)	B	No	Inside Pole	90.000 - 0.000	2	No Ice	0.000	0.000
						1/2" Ice	0.000	0.000
						1" Ice	0.000	0.000
						2" Ice	0.000	0.000
						4" Ice	0.000	0.000
LDF5-50A(7/8") (E)	B	No	Inside Pole	90.000 - 0.000	1	No Ice	0.000	0.000
						1/2" Ice	0.000	0.000
						1" Ice	0.000	0.000
						2" Ice	0.000	0.000
						4" Ice	0.000	0.000

LDF4-50A(1/2") (E)	B	No	Inside Pole	87.000 - 0.000	2	No Ice	0.000	0.000
						1/2" Ice	0.000	0.000
						1" Ice	0.000	0.000
						2" Ice	0.000	0.000
						4" Ice	0.000	0.000

LDF5-50A(7/8") (E)	B	No	Inside Pole	70.000 - 0.000	1	No Ice	0.000	0.000
						1/2" Ice	0.000	0.000
						1" Ice	0.000	0.000
						2" Ice	0.000	0.000
						4" Ice	0.000	0.000

LDF4-50A(1/2") (E)	B	No	Inside Pole	58.000 - 0.000	1	No Ice	0.000	0.000
						1/2" Ice	0.000	0.000
						1" Ice	0.000	0.000
						2" Ice	0.000	0.000
						4" Ice	0.000	0.000

LDF4-50A(1/2") (E)	B	No	Inside Pole	43.000 - 0.000	1	No Ice	0.000	0.000
						1/2" Ice	0.000	0.000

tnxTower ABC Engineering 1234 W. Jones St. Smallville, PA 12345 Phone: (555) 555-1234 FAX: (555) 555-1235	Job 87581.010.01 - Newington_1, CT (BU# 826217)	Page 6 of 38
	Project	Date 14:49:48 01/30/15
	Client Crown Castle	Designed by ahabibi

Description	Face or Leg	Allow Shield	Component Type	Placement ft	Total Number		C _{AA} ft ² /ft	Weight klf
						1" Ice	0.000	0.000
						2" Ice	0.000	0.000
						4" Ice	0.000	0.000
*** LDF4-50A(1/2") (E)	B	No	Inside Pole	33.000 - 0.000	1	No Ice	0.000	0.000
						1/2" Ice	0.000	0.000
						1" Ice	0.000	0.000
						2" Ice	0.000	0.000
						4" Ice	0.000	0.000
*** Climbing Rung (E)	C	No	CaAa (Out Of Face)	190.000 - 0.000	1	No Ice	0.234	0.005
						1/2" Ice	0.547	0.008
						1" Ice	0.859	0.013
						2" Ice	1.484	0.029
						4" Ice	2.734	0.087
Safety Line 3/8 (E)	C	No	CaAa (Out Of Face)	190.000 - 0.000	1	No Ice	0.037	0.000
						1/2" Ice	0.137	0.001
						1" Ice	0.238	0.001
						2" Ice	0.437	0.002
						4" Ice	0.838	0.004
*** 1" Flat Plate (E-Mod)	B	No	CaAa (Out Of Face)	90.500 - 0.000	1	No Ice	0.167	0.000
						1/2" Ice	0.250	0.000
						1" Ice	0.333	0.000
						2" Ice	0.500	0.000
						4" Ice	0.833	0.000
1" Flat Plate (E-Mod)	B	No	CaAa (Out Of Face)	105.500 - 96.750	1	No Ice	0.167	0.000
						1/2" Ice	0.250	0.000
						1" Ice	0.333	0.000
						2" Ice	0.500	0.000
						4" Ice	0.833	0.000
1" Flat Plate (E-Mod)	B	No	CaAa (Out Of Face)	126.000 - 116.750	1	No Ice	0.167	0.000
						1/2" Ice	0.250	0.000
						1" Ice	0.333	0.000
						2" Ice	0.500	0.000
						4" Ice	0.833	0.000
*** 3/4" Flat Plate (P-Mod)	B	No	CaAa (Out Of Face)	95.750 - 90.500	1	No Ice	0.125	0.000
						1/2" Ice	0.208	0.000
						1" Ice	0.292	0.000
						2" Ice	0.458	0.000
						4" Ice	0.792	0.000
3/4" Flat Plate (P-Mod)	B	No	CaAa (Out Of Face)	110.500 - 105.500	1	No Ice	0.125	0.000
						1/2" Ice	0.208	0.000
						1" Ice	0.292	0.000
						2" Ice	0.458	0.000
						4" Ice	0.792	0.000

Feed Line/Linear Appurtenances Section Areas

Tower Section	Tower Elevation ft	Face	A _R ft ²	A _F ft ²	C _{AA} In Face ft ²	C _{AA} Out Face ft ²	Weight K
L1	190.000-180.000	A	0.000	0.000	0.000	0.000	0.059
		B	0.000	0.000	0.000	0.000	0.007
		C	0.000	0.000	0.000	2.719	0.055
L2	180.000-140.000	A	0.000	0.000	0.000	0.000	0.590

tnxTower ABC Engineering 1234 W. Jones St. Smallville, PA 12345 Phone: (555) 555-1234 FAX: (555) 555-1235	Job	Page
	87581.010.01 - Newington_1, CT (BU# 826217)	7 of 38
	Project	Date
		14:49:48 01/30/15
	Client	Designed by
	Crown Castle	ahabibi

Tower Section	Tower Elevation ft	Face	A _R ft ²	A _F ft ²	C _A A _A In Face ft ²	C _A A _A Out Face ft ²	Weight K
		B	0.000	0.000	0.000	3.920	0.226
		C	0.000	0.000	0.000	13.076	0.353
L3	140.000-120.000	A	0.000	0.000	0.000	0.000	0.295
		B	0.000	0.000	0.000	4.920	0.220
		C	0.000	0.000	0.000	9.438	0.344
L4	120.000-109.000	A	0.000	0.000	0.000	0.000	0.162
		B	0.000	0.000	0.000	2.885	0.227
		C	0.000	0.000	0.000	5.191	0.189
L5	109.000-104.000	A	0.000	0.000	0.000	0.000	0.074
		B	0.000	0.000	0.000	1.667	0.128
		C	0.000	0.000	0.000	2.359	0.086
L6	104.000-100.000	A	0.000	0.000	0.000	0.000	0.059
		B	0.000	0.000	0.000	1.451	0.103
		C	0.000	0.000	0.000	1.888	0.069
L7	100.000-89.000	A	0.000	0.000	0.000	0.000	0.162
		B	0.000	0.000	0.000	3.604	0.283
		C	0.000	0.000	0.000	5.191	0.244
L8	89.000-80.000	A	0.000	0.000	0.000	0.000	0.133
		B	0.000	0.000	0.000	3.264	0.240
		C	0.000	0.000	0.000	4.247	0.199
L9	80.000-69.000	A	0.000	0.000	0.000	0.000	0.162
		B	0.000	0.000	0.000	3.989	0.294
		C	0.000	0.000	0.000	5.191	0.244
L10	69.000-60.000	A	0.000	0.000	0.000	0.000	0.133
		B	0.000	0.000	0.000	3.264	0.243
		C	0.000	0.000	0.000	4.247	0.199
L11	60.000-49.000	A	0.000	0.000	0.000	0.000	0.162
		B	0.000	0.000	0.000	3.989	0.298
		C	0.000	0.000	0.000	5.191	0.244
L12	49.000-40.000	A	0.000	0.000	0.000	0.000	0.133
		B	0.000	0.000	0.000	3.264	0.245
		C	0.000	0.000	0.000	4.247	0.199
L13	40.000-29.000	A	0.000	0.000	0.000	0.000	0.162
		B	0.000	0.000	0.000	3.989	0.301
		C	0.000	0.000	0.000	5.191	0.244
L14	29.000-20.000	A	0.000	0.000	0.000	0.000	0.133
		B	0.000	0.000	0.000	3.264	0.247
		C	0.000	0.000	0.000	4.247	0.199
L15	20.000-9.000	A	0.000	0.000	0.000	0.000	0.162
		B	0.000	0.000	0.000	3.989	0.302
		C	0.000	0.000	0.000	5.191	0.244
L16	9.000-0.000	A	0.000	0.000	0.000	0.000	0.133
		B	0.000	0.000	0.000	3.264	0.247
		C	0.000	0.000	0.000	4.247	0.199

Feed Line/Linear Appurtenances Section Areas - With Ice

Tower Section	Tower Elevation ft	Face or Leg	Ice Thickness in	A _R ft ²	A _F ft ²	C _A A _A In Face ft ²	C _A A _A Out Face ft ²	Weight K
L1	190.000-180.000	A	1.230	0.000	0.000	0.000	0.000	0.059
		B		0.000	0.000	0.000	0.000	0.007
		C		0.000	0.000	0.000	12.865	0.179
L2	180.000-140.000	A	1.209	0.000	0.000	0.000	0.000	0.590
		B		0.000	0.000	0.000	8.755	2.081
		C		0.000	0.000	0.000	55.624	0.892
L3	140.000-120.000	A	1.179	0.000	0.000	0.000	0.000	0.295
		B		0.000	0.000	0.000	10.814	2.005

tnxTower ABC Engineering 1234 W. Jones St. Smallville, PA 12345 Phone: (555) 555-1234 FAX: (555) 555-1235	Job 87581.010.01 - Newington_1, CT (BU# 826217)	Page 8 of 38
	Project	Date 14:49:48 01/30/15
	Client Crown Castle	Designed by ahabibi

Tower Section	Tower Elevation ft	Face or Leg	Ice Thickness in	A _R ft ²	A _F ft ²	C _A A _A In Face ft ²	C _A A _A Out Face ft ²	Weight K
L4	120.000-109.000	C	1.161	0.000	0.000	0.000	33.604	0.672
		A		0.000	0.000	0.000	0.000	0.162
		B		0.000	0.000	0.000	6.359	1.187
L5	109.000-104.000	C	1.151	0.000	0.000	0.000	18.281	0.365
		A		0.000	0.000	0.000	0.000	0.074
		B		0.000	0.000	0.000	3.778	0.559
L6	104.000-100.000	C	1.145	0.000	0.000	0.000	8.258	0.165
		A		0.000	0.000	0.000	0.000	0.059
		B		0.000	0.000	0.000	3.130	0.444
L7	100.000-89.000	C	1.135	0.000	0.000	0.000	6.582	0.131
		A		0.000	0.000	0.000	0.000	0.162
		B		0.000	0.000	0.000	7.991	1.209
L8	89.000-80.000	C	1.119	0.000	0.000	0.000	17.983	0.707
		A		0.000	0.000	0.000	0.000	0.133
		B		0.000	0.000	0.000	6.958	0.982
L9	80.000-69.000	C	1.103	0.000	0.000	0.000	14.574	0.570
		A		0.000	0.000	0.000	0.000	0.162
		B		0.000	0.000	0.000	8.437	1.180
L10	69.000-60.000	C	1.084	0.000	0.000	0.000	17.623	0.686
		A		0.000	0.000	0.000	0.000	0.133
		B		0.000	0.000	0.000	6.840	0.948
L11	60.000-49.000	C	1.062	0.000	0.000	0.000	14.245	0.551
		A		0.000	0.000	0.000	0.000	0.162
		B		0.000	0.000	0.000	8.273	1.133
L12	49.000-40.000	C	1.037	0.000	0.000	0.000	17.166	0.659
		A		0.000	0.000	0.000	0.000	0.133
		B		0.000	0.000	0.000	6.685	0.901
L13	40.000-29.000	C	1.005	0.000	0.000	0.000	13.809	0.525
		A		0.000	0.000	0.000	0.000	0.162
		B		0.000	0.000	0.000	8.044	1.064
L14	29.000-20.000	C	1.000	0.000	0.000	0.000	16.526	0.622
		A		0.000	0.000	0.000	0.000	0.133
		B		0.000	0.000	0.000	6.564	0.865
L15	20.000-9.000	C	1.000	0.000	0.000	0.000	13.472	0.506
		A		0.000	0.000	0.000	0.000	0.162
		B		0.000	0.000	0.000	8.023	1.058
L16	9.000-0.000	C	1.000	0.000	0.000	0.000	16.466	0.618
		A		0.000	0.000	0.000	0.000	0.133
		B		0.000	0.000	0.000	6.564	0.865
		C		0.000	0.000	0.000	13.472	0.506

Feed Line Center of Pressure

Section	Elevation ft	CP _X in	CP _Z in	CP _X Ice in	CP _Z Ice in
L1	190.000-180.000	-0.299	0.173	-0.838	0.484
L2	180.000-140.000	-0.245	0.263	-0.799	0.633
L3	140.000-120.000	-0.237	0.434	-0.820	0.922
L4	120.000-109.000	-0.225	0.455	-0.831	0.991
L5	109.000-104.000	-0.146	0.491	-0.668	1.036
L6	104.000-100.000	-0.115	0.505	-0.641	1.042
L7	100.000-89.000	-0.156	0.500	-0.721	1.081
L8	89.000-80.000	-0.117	0.518	-0.668	1.091
L9	80.000-69.000	-0.120	0.528	-0.692	1.134
L10	69.000-60.000	-0.120	0.528	-0.685	1.126
L11	60.000-49.000	-0.122	0.536	-0.701	1.158

tnxTower ABC Engineering 1234 W. Jones St. Smallville, PA 12345 Phone: (555) 555-1234 FAX: (555) 555-1235	Job 87581.010.01 - Newington_1, CT (BU# 826217)	Page 9 of 38
	Project	Date 14:49:48 01/30/15
	Client Crown Castle	Designed by ahabibi

Section	Elevation	CP _X	CP _Z	CP _X	CP _Z
	ft	in	in	Ice in	Ice in
L12	49.000-40.000	-0.122	0.536	-0.690	1.146
L13	40.000-29.000	-0.122	0.536	-0.677	1.132
L14	29.000-20.000	-0.122	0.536	-0.674	1.129
L15	20.000-9.000	-0.122	0.536	-0.674	1.129
L16	9.000-0.000	-0.122	0.536	-0.674	1.129

Discrete Tower Loads

Description	Face or Leg	Offset Type	Offsets: Horz Lateral Vert ft ft ft	Azimuth Adjustment °	Placement ft	C _A A _A Front ft ²	C _A A _A Side ft ²	Weight K	
Lightning Rod 5/8" x 4' on 4' Pole (E)	C	From Leg	0.000	0.000	190.000	No Ice	1.465	1.465	0.066
			0.000			1/2" Ice	2.131	2.131	0.087
			4.000			1" Ice	2.702	2.702	0.112
						2" Ice	3.805	3.805	0.175
						4" Ice	6.417	6.417	0.373
*** OGB4-900D (E)	B	From Leg	3.000	0.000	192.000	No Ice	0.785	0.785	0.010
			0.000			1/2" Ice	1.028	1.028	0.016
			4.000			1" Ice	1.281	1.281	0.025
						2" Ice	1.814	1.814	0.053
						4" Ice	3.111	3.111	0.148
MT-485002 w/ Mount Pipe (E)	C	From Leg	3.000	0.000	192.000	No Ice	1.572	0.473	0.011
			0.000			1/2" Ice	1.797	0.681	0.022
			4.000			1" Ice	2.044	0.932	0.037
						2" Ice	2.587	1.512	0.075
						4" Ice	3.843	2.909	0.209
Side Arm Mount [SO 701-1] (E)	B	From Leg	1.500	0.000	192.000	No Ice	0.850	1.670	0.065
			0.000			1/2" Ice	1.140	2.340	0.079
			0.000			1" Ice	1.430	3.010	0.093
						2" Ice	2.010	4.350	0.121
						4" Ice	3.170	7.030	0.177
Side Arm Mount [SO 701-1] (E)	C	From Leg	1.500	0.000	192.000	No Ice	0.850	1.670	0.065
			0.000			1/2" Ice	1.140	2.340	0.079
			0.000			1" Ice	1.430	3.010	0.093
						2" Ice	2.010	4.350	0.121
						4" Ice	3.170	7.030	0.177
*** DB589-A (E)	A	From Leg	1.000	0.000	191.000	No Ice	2.763	2.763	0.012
			0.000			1/2" Ice	4.170	4.170	0.033
			5.000			1" Ice	5.593	5.593	0.063
						2" Ice	8.490	8.490	0.150
						4" Ice	12.440	12.440	0.437
WB2623 w/ Mount Pipe (E)	A	From Leg	1.000	0.000	191.000	No Ice	2.221	0.919	0.020
			0.000			1/2" Ice	2.477	1.183	0.038
			-1.000			1" Ice	2.751	1.475	0.058
						2" Ice	3.354	2.151	0.111
						4" Ice	4.725	3.740	0.281
6' x 2" Mount Pipe (E)	A	From Leg	0.500	0.000	191.000	No Ice	1.425	1.425	0.022
			0.000			1/2" Ice	1.925	1.925	0.033
			0.000			1" Ice	2.294	2.294	0.048
						2" Ice	3.060	3.060	0.090

tnxTower ABC Engineering 1234 W. Jones St. Smallville, PA 12345 Phone: (555) 555-1234 FAX: (555) 555-1235	Job		87581.010.01 - Newington_1, CT (BU# 826217)		Page		10 of 38	
	Project				Date		14:49:48 01/30/15	
	Client		Crown Castle		Designed by		ahabibi	

Description	Face or Leg	Offset Type	Offsets:		Azimuth Adjustment	Placement	C _{AA} Front	C _{AA} Side	Weight	
			Horz	Vert						
			ft	ft	°	ft	ft ²	ft ²	K	
						4" Ice	4.702	4.702	0.231	

RR90-17-02DP w/ Mount Pipe (E)	A	From Leg	4.000 0.000 -3.000		0.000	184.000	No Ice 1/2" Ice 1" Ice 2" Ice 4" Ice	4.593 5.088 4.784 6.225 9.308	3.319 4.089 4.784 6.225 9.308	0.034 0.072 0.115 0.224 0.557
RR90-17-02DP w/ Mount Pipe (E)	B	From Leg	4.000 0.000 -3.000		0.000	184.000	No Ice 1/2" Ice 1" Ice 2" Ice 4" Ice	4.593 5.088 4.784 6.225 9.308	3.319 4.089 4.784 6.225 9.308	0.034 0.072 0.115 0.224 0.557
RR90-17-02DP w/ Mount Pipe (E)	C	From Leg	4.000 0.000 -3.000		0.000	184.000	No Ice 1/2" Ice 1" Ice 2" Ice 4" Ice	4.593 5.088 5.578 6.588 8.731	3.319 4.089 4.784 6.225 9.308	0.034 0.072 0.115 0.224 0.557
APXV18-206516L-A w/ Mount Pipe (E)	A	From Leg	4.000 0.000 -3.000		0.000	184.000	No Ice 1/2" Ice 1" Ice 2" Ice 4" Ice	3.808 4.221 4.666 5.622 7.659	3.289 3.995 4.661 6.044 9.023	0.038 0.073 0.113 0.213 0.526
APXV18-206516L-A w/ Mount Pipe (E)	B	From Leg	4.000 0.000 -3.000		0.000	184.000	No Ice 1/2" Ice 1" Ice 2" Ice 4" Ice	3.808 4.221 4.666 5.622 7.659	3.289 3.995 4.661 6.044 9.023	0.038 0.073 0.113 0.213 0.526
APXV18-206516L-A w/ Mount Pipe (E)	C	From Leg	4.000 0.000 -3.000		0.000	184.000	No Ice 1/2" Ice 1" Ice 2" Ice 4" Ice	3.808 4.221 4.666 5.622 7.659	3.289 3.995 4.661 6.044 9.023	0.038 0.073 0.113 0.213 0.526
(2) KRY 112 144/1 (E)	A	From Leg	4.000 0.000 -3.000		0.000	184.000	No Ice 1/2" Ice 1" Ice 2" Ice 4" Ice	0.408 0.497 0.594 0.815 1.359	0.204 0.273 0.351 0.533 0.999	0.011 0.014 0.019 0.032 0.082
(2) KRY 112 144/1 (E)	B	From Leg	4.000 0.000 -3.000		0.000	184.000	No Ice 1/2" Ice 1" Ice 2" Ice 4" Ice	0.408 0.497 0.594 0.815 1.359	0.204 0.273 0.351 0.533 0.999	0.011 0.014 0.019 0.032 0.082
(2) KRY 112 144/1 (E)	C	From Leg	4.000 0.000 -3.000		0.000	184.000	No Ice 1/2" Ice 1" Ice 2" Ice 4" Ice	0.408 0.497 0.594 0.815 1.359	0.204 0.273 0.351 0.533 0.999	0.011 0.014 0.019 0.032 0.082
LNx-6515DS-VTM w/ Mount Pipe (p)	A	From Leg	4.000 0.000 -3.000		0.000	184.000	No Ice 1/2" Ice 1" Ice 2" Ice 4" Ice	11.683 12.404 13.135 14.601 17.875	9.842 11.366 12.914 15.267 20.139	0.083 0.173 0.273 0.506 1.151
LNx-6515DS-VTM w/ Mount Pipe (p)	B	From Leg	4.000 0.000 -3.000		0.000	184.000	No Ice 1/2" Ice 1" Ice 2" Ice 4" Ice	11.683 12.404 13.135 14.601 17.875	9.842 11.366 12.914 15.267 20.139	0.083 0.173 0.273 0.506 1.151

tnxTower ABC Engineering 1234 W. Jones St. Smallville, PA 12345 Phone: (555) 555-1234 FAX: (555) 555-1235	Job 87581.010.01 - Newington_1, CT (BU# 826217)	Page 11 of 38
	Project	Date 14:49:48 01/30/15
	Client Crown Castle	Designed by ahabibi

Description	Face or Leg	Offset Type	Offsets: Horz Lateral Vert ft ft ft	Azimuth Adjustment °	Placement ft	CAAA Front ft ²	CAAA Side ft ²	Weight K	
LNX-6515DS-VTM w/ Mount Pipe (p)	C	From Leg	4.000	0.000	184.000	No Ice	11.683	9.842	0.083
			0.000			1/2" Ice	12.404	11.366	0.173
			-3.000			1" Ice	13.135	12.914	0.273
						2" Ice	14.601	15.267	0.506
						4" Ice	17.875	20.139	1.151
ATBT-BOTTOM-24V (p)	A	From Leg	4.000	0.000	184.000	No Ice	0.121	0.075	0.003
			0.000			1/2" Ice	0.172	0.119	0.004
			-3.000			1" Ice	0.232	0.172	0.006
						2" Ice	0.377	0.303	0.013
						4" Ice	0.771	0.668	0.045
ATBT-BOTTOM-24V (p)	B	From Leg	4.000	0.000	184.000	No Ice	0.121	0.075	0.003
			0.000			1/2" Ice	0.172	0.119	0.004
			-3.000			1" Ice	0.232	0.172	0.006
						2" Ice	0.377	0.303	0.013
						4" Ice	0.771	0.668	0.045
ATBT-BOTTOM-24V (p)	C	From Leg	4.000	0.000	184.000	No Ice	0.121	0.075	0.003
			0.000			1/2" Ice	0.172	0.119	0.004
			-3.000			1" Ice	0.232	0.172	0.006
						2" Ice	0.377	0.303	0.013
						4" Ice	0.771	0.668	0.045
Platform Mount [LP 405-1] (E)	C	None		0.000	184.000	No Ice	20.800	20.800	1.800
						1/2" Ice	28.100	28.100	2.066
						1" Ice	35.400	35.400	2.332
						2" Ice	50.000	50.000	2.864
						4" Ice	79.200	79.200	3.928

(2) HBXX-6517DS-VTM w/ Mount Pipe (R)	A	From Leg	4.000	0.000	160.000	No Ice	8.976	6.963	0.069
			0.000			1/2" Ice	9.647	8.182	0.139
			0.000			1" Ice	10.291	9.144	0.217
						2" Ice	11.595	11.022	0.401
						4" Ice	14.321	15.027	0.916
(2) HBXX-6517DS-VTM w/ Mount Pipe (R)	B	From Leg	4.000	0.000	160.000	No Ice	8.976	6.963	0.069
			0.000			1/2" Ice	9.647	8.182	0.139
			0.000			1" Ice	10.291	9.144	0.217
						2" Ice	11.595	11.022	0.401
						4" Ice	14.321	15.027	0.916
(2) HBXX-6517DS-VTM w/ Mount Pipe (R)	C	From Leg	4.000	0.000	160.000	No Ice	8.976	6.963	0.069
			0.000			1/2" Ice	9.647	8.182	0.139
			0.000			1" Ice	10.291	9.144	0.217
						2" Ice	11.595	11.022	0.401
						4" Ice	14.321	15.027	0.916
LNX-8514DS-VTM w/ Mount Pipe (R)	A	From Leg	4.000	0.000	160.000	No Ice	11.683	9.842	0.084
			0.000			1/2" Ice	12.404	11.366	0.174
			0.000			1" Ice	13.135	12.914	0.273
						2" Ice	14.601	15.267	0.507
						4" Ice	17.875	20.139	1.152
LNX-8514DS-VTM w/ Mount Pipe (R)	C	From Leg	4.000	0.000	160.000	No Ice	11.683	9.842	0.084
			0.000			1/2" Ice	12.404	11.366	0.174
			0.000			1" Ice	13.135	12.914	0.273
						2" Ice	14.601	15.267	0.507
						4" Ice	17.875	20.139	1.152
LNX-6514DS-VTM w/ Mount Pipe (R)	B	From Leg	4.000	0.000	160.000	No Ice	8.648	7.082	0.065
			0.000			1/2" Ice	9.305	8.273	0.134
			0.000			1" Ice	9.930	9.185	0.211
						2" Ice	11.204	11.023	0.393
						4" Ice	13.872	15.063	0.902
BXA-70063-6CF-2 w/ Mount	A	From Leg	4.000	0.000	160.000	No Ice	7.969	5.801	0.042

tnxTower ABC Engineering 1234 W. Jones St. Smallville, PA 12345 Phone: (555) 555-1234 FAX: (555) 555-1235	Job		87581.010.01 - Newington_1, CT (BU# 826217)		Page		12 of 38	
	Project				Date		14:49:48 01/30/15	
	Client		Crown Castle		Designed by		ahabibi	

Description	Face or Leg	Offset Type	Offsets:			Azimuth Adjustment °	Placement ft	C _{AA} Front ft ²	C _{AA} Side ft ²	Weight K
			Horz ft	Lateral ft	Vert ft					
Pipe (R)			0.000				1/2" Ice 8.609	6.953	0.103	
			0.000				1" Ice 9.216	7.819	0.171	
							2" Ice 10.459	9.601	0.335	
							4" Ice 13.066	13.366	0.804	
BXA-70063-6CF-2 w/ Mount Pipe (R)	B	From Leg	4.000	0.000	160.000		No Ice 7.969	5.801	0.042	
			0.000				1/2" Ice 8.609	6.953	0.103	
			0.000				1" Ice 9.216	7.819	0.171	
							2" Ice 10.459	9.601	0.335	
							4" Ice 13.066	13.366	0.804	
BXA-70063-6CF-2 w/ Mount Pipe (R)	C	From Leg	4.000	0.000	160.000		No Ice 7.969	5.801	0.042	
			0.000				1/2" Ice 8.609	6.953	0.103	
			0.000				1" Ice 9.216	7.819	0.171	
							2" Ice 10.459	9.601	0.335	
							4" Ice 13.066	13.366	0.804	
RRH2X60-PCS (R)	A	From Leg	4.000	0.000	160.000		No Ice 2.567	2.011	0.055	
			0.000				1/2" Ice 2.791	2.218	0.075	
			0.000				1" Ice 3.025	2.435	0.099	
							2" Ice 3.517	2.894	0.155	
							4" Ice 4.606	3.915	0.313	
RRH2X60-PCS (R)	B	From Leg	4.000	0.000	160.000		No Ice 2.567	2.011	0.055	
			0.000				1/2" Ice 2.791	2.218	0.075	
			0.000				1" Ice 3.025	2.435	0.099	
							2" Ice 3.517	2.894	0.155	
							4" Ice 4.606	3.915	0.313	
RRH2X60-PCS (R)	C	From Leg	4.000	0.000	160.000		No Ice 2.567	2.011	0.055	
			0.000				1/2" Ice 2.791	2.218	0.075	
			0.000				1" Ice 3.025	2.435	0.099	
							2" Ice 3.517	2.894	0.155	
							4" Ice 4.606	3.915	0.313	
RRH2X60-AWS (R)	A	From Leg	4.000	0.000	160.000		No Ice 3.957	2.158	0.060	
			0.000				1/2" Ice 4.272	2.441	0.084	
			0.000				1" Ice 4.596	2.733	0.112	
							2" Ice 5.271	3.342	0.180	
							4" Ice 6.722	4.665	0.369	
RRH2X60-AWS (R)	B	From Leg	4.000	0.000	160.000		No Ice 3.957	2.158	0.060	
			0.000				1/2" Ice 4.272	2.441	0.084	
			0.000				1" Ice 4.596	2.733	0.112	
							2" Ice 5.271	3.342	0.180	
							4" Ice 6.722	4.665	0.369	
RRH2X60-AWS (R)	C	From Leg	4.000	0.000	160.000		No Ice 3.957	2.158	0.060	
			0.000				1/2" Ice 4.272	2.441	0.084	
			0.000				1" Ice 4.596	2.733	0.112	
							2" Ice 5.271	3.342	0.180	
							4" Ice 6.722	4.665	0.369	
DB-T1-6Z-8AB-0Z (R)	C	From Leg	4.000	0.000	160.000		No Ice 5.600	2.333	0.044	
			0.000				1/2" Ice 5.915	2.558	0.080	
			0.000				1" Ice 6.240	2.791	0.120	
							2" Ice 6.914	3.284	0.213	
							4" Ice 8.365	4.373	0.455	
Platform Mount [LP 303-1] (E)	C	None		0.000	160.000		No Ice 14.660	14.660	1.250	
							1/2" Ice 18.870	18.870	1.481	
							1" Ice 23.080	23.080	1.713	
							2" Ice 31.500	31.500	2.175	
							4" Ice 48.340	48.340	3.101	
*** DB205-A (E)	A	From Leg	6.000	0.000	158.000		No Ice 1.200	1.200	0.038	
			0.000				1/2" Ice 2.160	2.160	0.049	

tnxTower ABC Engineering 1234 W. Jones St. Smallville, PA 12345 Phone: (555) 555-1234 FAX: (555) 555-1235	Job		87581.010.01 - Newington_1, CT (BU# 826217)		Page		13 of 38	
	Project				Date		14:49:48 01/30/15	
	Client		Crown Castle		Designed by		ahabibi	

Description	Face or Leg	Offset Type	Offsets:			Azimuth Adjustment	Placement	C _{AA} Front	C _{AA} Side	Weight
			Horz	Lateral	Vert					
					0.000					
							1" Ice	3.120	3.120	0.061
							2" Ice	5.040	5.040	0.084
							4" Ice	8.880	8.880	0.129
SRL-224NM-4 (E)	B	From Leg	6.000	0.000	158.000	No Ice	2.600	2.600	0.035	
			0.000			1/2" Ice	4.680	4.680	0.045	
			0.000			1" Ice	6.760	6.760	0.056	
						2" Ice	10.920	10.920	0.077	
						4" Ice	19.240	19.240	0.119	
Side Arm Mount [SO 702-1] (E)	A	From Leg	3.000	0.000	158.000	No Ice	1.000	1.430	0.027	
			0.000			1/2" Ice	1.000	2.050	0.038	
			0.000			1" Ice	1.000	2.670	0.049	
						2" Ice	1.000	3.910	0.071	
						4" Ice	1.000	6.390	0.115	
Side Arm Mount [SO 702-1] (E)	B	From Leg	3.000	0.000	158.000	No Ice	1.000	1.430	0.027	
			0.000			1/2" Ice	1.000	2.050	0.038	
			0.000			1" Ice	1.000	2.670	0.049	
						2" Ice	1.000	3.910	0.071	
						4" Ice	1.000	6.390	0.115	
4' x 2" Pipe Mount (E)	A	From Leg	6.000	0.000	158.000	No Ice	0.866	0.866	0.015	
			0.000			1/2" Ice	1.111	1.111	0.022	
			0.000			1" Ice	1.365	1.365	0.032	
						2" Ice	1.901	1.901	0.062	
						4" Ice	3.228	3.228	0.161	
4' x 2" Pipe Mount (E)	B	From Leg	6.000	0.000	158.000	No Ice	0.866	0.866	0.015	
			0.000			1/2" Ice	1.111	1.111	0.022	
			0.000			1" Ice	1.365	1.365	0.032	
						2" Ice	1.901	1.901	0.062	
						4" Ice	3.228	3.228	0.161	

(2) SBNH-1D6565C w/ Mount Pipe (E)	A	From Leg	4.000	0.000	151.000	No Ice	11.644	9.842	0.094	
			0.000			1/2" Ice	12.365	11.366	0.183	
			0.000			1" Ice	13.095	12.914	0.283	
						2" Ice	14.553	15.267	0.516	
						4" Ice	17.825	20.139	1.160	
(3) 7770.00 w/ Mount Pipe (E)	C	From Leg	4.000	0.000	151.000	No Ice	6.119	4.254	0.055	
			0.000			1/2" Ice	6.626	5.014	0.103	
			0.000			1" Ice	7.128	5.711	0.157	
						2" Ice	8.164	7.155	0.287	
						4" Ice	10.360	10.412	0.665	
AM-X-CD-16-65-00T-RET w/ Mount Pipe (E)	A	From Leg	4.000	0.000	151.000	No Ice	8.498	6.304	0.074	
			0.000			1/2" Ice	9.149	7.479	0.139	
			0.000			1" Ice	9.767	8.368	0.212	
						2" Ice	11.031	10.179	0.385	
						4" Ice	13.679	14.024	0.874	
AM-X-CD-16-65-00T-RET w/ Mount Pipe (R)	B	From Leg	4.000	0.000	151.000	No Ice	8.498	6.304	0.074	
			0.000			1/2" Ice	9.149	7.479	0.139	
			0.000			1" Ice	9.767	8.368	0.212	
						2" Ice	11.031	10.179	0.385	
						4" Ice	13.679	14.024	0.874	
(2) SBNH-1D6565C w/ Mount Pipe (R)	B	From Leg	4.000	0.000	151.000	No Ice	11.644	9.842	0.094	
			0.000			1/2" Ice	12.365	11.366	0.183	
			0.000			1" Ice	13.095	12.914	0.283	
						2" Ice	14.553	15.267	0.516	
						4" Ice	17.825	20.139	1.160	
(2) CM1007-DBPXC-003 (R)	A	From Leg	4.000	0.000	151.000	No Ice	0.429	0.156	0.007	
			0.000			1/2" Ice	0.523	0.214	0.010	
			0.000			1" Ice	0.626	0.280	0.015	

tnxTower ABC Engineering 1234 W. Jones St. Smallville, PA 12345 Phone: (555) 555-1234 FAX: (555) 555-1235	Job		87581.010.01 - Newington_1, CT (BU# 826217)		Page		14 of 38	
	Project				Date		14:49:48 01/30/15	
	Client		Crown Castle		Designed by		ahabibi	

Description	Face or Leg	Offset Type	Offsets:		Azimuth Adjustment	Placement	C _{AA} Front	C _{AA} Side	Weight	
			Horz	Lateral						Vert
(2) CM1007-DBPXBC-003 (R)	B	From Leg	4.000	0.000	0.000	151.000	2" Ice	0.858	0.438	0.029
							4" Ice	1.425	0.858	0.082
							No Ice	0.429	0.156	0.007
							1/2" Ice	0.523	0.214	0.010
							1" Ice	0.626	0.280	0.015
(2) CM1007-DBPXBC-003 (R)	C	From Leg	4.000	0.000	0.000	151.000	2" Ice	0.858	0.438	0.029
							4" Ice	1.425	0.858	0.082
							No Ice	0.429	0.156	0.007
							1/2" Ice	0.523	0.214	0.010
							1" Ice	0.626	0.280	0.015
(2) LGP21901 (R)	A	From Leg	4.000	0.000	0.000	151.000	2" Ice	0.858	0.438	0.029
							4" Ice	1.425	0.858	0.082
							No Ice	0.270	0.184	0.006
							1/2" Ice	0.343	0.248	0.008
							1" Ice	0.425	0.322	0.011
(2) LGP21901 (R)	B	From Leg	4.000	0.000	0.000	151.000	2" Ice	0.616	0.494	0.022
							4" Ice	1.101	0.943	0.066
							No Ice	0.270	0.184	0.006
							1/2" Ice	0.343	0.248	0.008
							1" Ice	0.425	0.322	0.011
(2) LGP21901 (R)	C	From Leg	4.000	0.000	0.000	151.000	2" Ice	0.616	0.494	0.022
							4" Ice	1.101	0.943	0.066
							No Ice	0.270	0.184	0.006
							1/2" Ice	0.343	0.248	0.008
							1" Ice	0.425	0.322	0.011
(4) DTMABP7819VG12A (R)	A	From Leg	4.000	0.000	0.000	151.000	2" Ice	0.616	0.494	0.022
							4" Ice	1.101	0.943	0.066
							No Ice	1.139	0.391	0.019
							1/2" Ice	1.284	0.488	0.026
							1" Ice	1.437	0.595	0.036
(2) DTMABP7819VG12A (R)	B	From Leg	4.000	0.000	0.000	151.000	2" Ice	1.769	0.833	0.060
							4" Ice	2.538	1.414	0.140
							No Ice	1.139	0.391	0.019
							1/2" Ice	1.284	0.488	0.026
							1" Ice	1.437	0.595	0.036
Platform Mount [LP 403-1] (E)	C	None			0.000	151.000	2" Ice	1.769	0.833	0.060
							4" Ice	2.538	1.414	0.140
							No Ice	18.850	18.850	1.500
							1/2" Ice	24.300	24.300	1.797
							1" Ice	29.750	29.750	2.093
*** (2) RRU-11 (R)	A	From Leg	1.000	0.000	0.000	148.000	2" Ice	40.650	40.650	2.686
							4" Ice	62.450	62.450	3.872
							No Ice	1.912	1.472	0.044
							1/2" Ice	2.102	1.645	0.060
							1" Ice	2.301	1.827	0.078
(2) RRU-11 (R)	B	From Leg	1.000	0.000	0.000	148.000	2" Ice	2.725	2.218	0.123
							4" Ice	3.676	3.102	0.254
							No Ice	1.912	1.472	0.044
							1/2" Ice	2.102	1.645	0.060
							1" Ice	2.301	1.827	0.078
(2) RRU-11 (R)	C	From Leg	1.000	0.000	0.000	148.000	2" Ice	2.725	2.218	0.123
							4" Ice	3.676	3.102	0.254
							No Ice	1.912	1.472	0.044
							1/2" Ice	2.102	1.645	0.060
							1" Ice	2.301	1.827	0.078
(2) RRU-11 (R)							2" Ice	2.725	2.218	0.123
							4" Ice	3.676	3.102	0.254
							No Ice	1.912	1.472	0.044
							1/2" Ice	2.102	1.645	0.060
							1" Ice	2.301	1.827	0.078

tnxTower ABC Engineering 1234 W. Jones St. Smallville, PA 12345 Phone: (555) 555-1234 FAX: (555) 555-1235	Job		87581.010.01 - Newington_1, CT (BU# 826217)		Page		15 of 38	
	Project				Date		14:49:48 01/30/15	
	Client		Crown Castle		Designed by		ahabibi	

Description	Face or Leg	Offset Type	Offsets:		Azimuth Adjustment	Placement	C _{AA}		Weight	
			Horz	Lateral			Front	Side		
			ft	ft	°	ft	ft ²	ft ²	K	
DC6-48-60-18-8F (R)	C	From Leg	1.000	0.000	0.000	148.000	4" Ice	3.676	3.102	0.254
			0.000	0.000			No Ice	2.567	2.567	0.019
			0.000	0.000			1/2" Ice	2.798	2.798	0.041
							1" Ice	3.038	3.038	0.067
							2" Ice	3.543	3.543	0.129
(2) Pipe Mount [PM 601-3] (R)	C	None			0.000	148.000	4" Ice	4.658	4.658	0.299
							No Ice	4.390	4.390	0.195
							1/2" Ice	5.480	5.480	0.237
							1" Ice	6.570	6.570	0.280
							2" Ice	8.750	8.750	0.365
Pipe Mount [PM 601-1] (R)	C	From Leg	0.500	0.000	0.000	148.000	4" Ice	13.110	13.110	0.534
			0.000	0.000			No Ice	3.000	0.900	0.065
			0.000	0.000			1/2" Ice	3.740	1.120	0.079
							1" Ice	4.480	1.340	0.093
							2" Ice	5.960	1.780	0.122
**** SRL-235-2 (E)	A	From Leg	6.000	0.000	0.000	132.000	4" Ice	8.920	2.660	0.178
			0.000	0.000			No Ice	7.000	7.000	0.076
			0.000	0.000			1/2" Ice	9.037	9.037	0.125
							1" Ice	11.092	11.092	0.187
							2" Ice	15.250	15.250	0.351
4' x 2" Pipe Mount (E)	A	From Leg	6.000	0.000	0.000	132.000	4" Ice	22.255	22.255	0.836
			0.000	0.000			No Ice	0.866	0.866	0.015
			0.000	0.000			1/2" Ice	1.111	1.111	0.022
							1" Ice	1.365	1.365	0.032
							2" Ice	1.901	1.901	0.062
Side Arm Mount [SO 702-1] (E)	A	From Leg	3.000	0.000	0.000	132.000	4" Ice	3.228	3.228	0.161
			0.000	0.000			No Ice	1.000	1.430	0.027
			0.000	0.000			1/2" Ice	1.000	2.050	0.038
							1" Ice	1.000	2.670	0.049
							2" Ice	1.000	3.910	0.071
**** DB205-A (E)	A	From Leg	3.000	0.000	0.000	124.000	4" Ice	1.000	6.390	0.115
			0.000	0.000			No Ice	1.200	1.200	0.038
			0.000	0.000			1/2" Ice	2.160	2.160	0.049
							1" Ice	3.120	3.120	0.061
							2" Ice	5.040	5.040	0.084
PCS 1900 TMA RX (E)	A	From Leg	3.000	0.000	0.000	124.000	4" Ice	8.880	8.880	0.129
			0.000	0.000			No Ice	0.628	0.617	0.018
			0.000	0.000			1/2" Ice	0.744	0.732	0.023
							1" Ice	0.869	0.856	0.031
							2" Ice	1.145	1.131	0.052
Side Arm Mount [SO 701-1] (E)	A	From Leg	1.500	0.000	0.000	124.000	4" Ice	1.799	1.783	0.122
			0.000	0.000			No Ice	0.850	1.670	0.065
			0.000	0.000			1/2" Ice	1.140	2.340	0.079
							1" Ice	1.430	3.010	0.093
							2" Ice	2.010	4.350	0.121
6' x 2" Mount Pipe (E)	A	From Leg	3.000	0.000	0.000	124.000	4" Ice	3.170	7.030	0.177
			0.000	0.000			No Ice	1.425	1.425	0.022
			0.000	0.000			1/2" Ice	1.925	1.925	0.033
							1" Ice	2.294	2.294	0.048
							2" Ice	3.060	3.060	0.090
**** LLPX310R w/ Mount Pipe (E)	A	From Leg	4.000	0.000	0.000	116.000	4" Ice	4.702	4.702	0.231
			0.000	0.000			No Ice	5.904	3.857	0.058
			2.000	0.000			1/2" Ice	6.722	4.954	0.105
						1" Ice	7.462	5.903	0.158	

tnxTower ABC Engineering 1234 W. Jones St. Smallville, PA 12345 Phone: (555) 555-1234 FAX: (555) 555-1235	Job		87581.010.01 - Newington_1, CT (BU# 826217)		Page		16 of 38	
	Project				Date		14:49:48 01/30/15	
	Client		Crown Castle		Designed by		ahabibi	

Description	Face or Leg	Offset Type	Offsets:		Azimuth Adjustment	Placement	C _{AA} Front	C _{AA} Side	Weight
			Horz	Lateral					
						2" Ice	8.772	7.531	0.287
						4" Ice	11.557	11.049	0.670
LLPX310R w/ Mount Pipe (E)	B	From Leg	4.000	0.000	116.000	No Ice	5.904	3.857	0.058
			0.000			1/2" Ice	6.722	4.954	0.105
			2.000			1" Ice	7.462	5.903	0.158
						2" Ice	8.772	7.531	0.287
						4" Ice	11.557	11.049	0.670
LLPX310R w/ Mount Pipe (E)	C	From Leg	4.000	0.000	116.000	No Ice	5.904	3.857	0.058
			0.000			1/2" Ice	6.722	4.954	0.105
			2.000			1" Ice	7.462	5.903	0.158
						2" Ice	8.772	7.531	0.287
						4" Ice	11.557	11.049	0.670
(3) DB844G90A-XY w/ Mount Pipe (E)	A	From Leg	4.000	0.000	116.000	No Ice	3.299	4.921	0.032
			0.000			1/2" Ice	3.690	5.596	0.072
			2.000			1" Ice	4.119	6.284	0.117
						2" Ice	5.007	7.712	0.228
						4" Ice	6.920	10.833	0.557
(3) DB844G90A-XY w/ Mount Pipe (E)	B	From Leg	4.000	0.000	116.000	No Ice	3.299	4.921	0.032
			0.000			1/2" Ice	3.690	5.596	0.072
			2.000			1" Ice	4.119	6.284	0.117
						2" Ice	5.007	7.712	0.228
						4" Ice	6.920	10.833	0.557
(3) DB844G90A-XY w/ Mount Pipe (E)	C	From Leg	4.000	0.000	116.000	No Ice	3.299	4.921	0.032
			0.000			1/2" Ice	3.690	5.596	0.072
			2.000			1" Ice	4.119	6.284	0.117
						2" Ice	5.007	7.712	0.228
						4" Ice	6.920	10.833	0.557
HORIZON DUO (E)	A	From Leg	4.000	0.000	116.000	No Ice	0.547	0.343	0.007
			0.000			1/2" Ice	0.648	0.426	0.012
			4.000			1" Ice	0.759	0.518	0.018
						2" Ice	1.005	0.728	0.036
						4" Ice	1.601	1.252	0.097
WIMAX DAP HEAD (E)	A	From Leg	4.000	0.000	116.000	No Ice	1.804	0.778	0.033
			0.000			1/2" Ice	1.988	0.918	0.045
			2.000			1" Ice	2.180	1.067	0.058
						2" Ice	2.589	1.391	0.094
						4" Ice	3.512	2.143	0.201
WIMAX DAP HEAD (E)	B	From Leg	4.000	0.000	116.000	No Ice	1.804	0.778	0.033
			0.000			1/2" Ice	1.988	0.918	0.045
			2.000			1" Ice	2.180	1.067	0.058
						2" Ice	2.589	1.391	0.094
						4" Ice	3.512	2.143	0.201
WIMAX DAP HEAD (E)	C	From Leg	4.000	0.000	116.000	No Ice	1.804	0.778	0.033
			0.000			1/2" Ice	1.988	0.918	0.045
			2.000			1" Ice	2.180	1.067	0.058
						2" Ice	2.589	1.391	0.094
						4" Ice	3.512	2.143	0.201
Platform Mount [LP 405-1] (E)	C	None		0.000	116.000	No Ice	20.800	20.800	1.800
						1/2" Ice	28.100	28.100	2.066
						1" Ice	35.400	35.400	2.332
						2" Ice	50.000	50.000	2.864
						4" Ice	79.200	79.200	3.928

742 213 (E)	A	From Leg	1.000	0.000	100.000	No Ice	5.135	2.869	0.022
			0.000			1/2" Ice	5.609	3.483	0.047
			0.000			1" Ice	6.090	3.946	0.078
						2" Ice	7.074	4.893	0.158

tnxTower ABC Engineering 1234 W. Jones St. Smallville, PA 12345 Phone: (555) 555-1234 FAX: (555) 555-1235	Job	87581.010.01 - Newington_1, CT (BU# 826217)	Page	17 of 38
	Project		Date	14:49:48 01/30/15
	Client	Crown Castle		Designed by

Description	Face or Leg	Offset Type	Offsets:		Azimuth Adjustment	Placement	C _{AA} Front	C _{AA} Side	Weight	
			Horz	Lateral						
			ft	ft	°	ft	ft ²	ft ²	K	
742 213 (E)	B	From Leg	1.000	0.000	0.000	100.000	4" Ice	9.130	6.876	0.394
			0.000	0.000			No Ice	5.135	2.869	0.022
			0.000	0.000			1/2" Ice	5.609	3.483	0.047
							1" Ice	6.090	3.946	0.078
							2" Ice	7.074	4.893	0.158
742 213 (E)	C	From Leg	1.000	0.000	0.000	100.000	4" Ice	9.130	6.876	0.394
			0.000	0.000			No Ice	5.135	2.869	0.022
			0.000	0.000			1/2" Ice	5.609	3.483	0.047
							1" Ice	6.090	3.946	0.078
							2" Ice	7.074	4.893	0.158
Pipe Mount [PM 601-3] (E)	C	None			0.000	100.000	4" Ice	9.130	6.876	0.394
							No Ice	4.390	4.390	0.195
							1/2" Ice	5.480	5.480	0.237
							1" Ice	6.570	6.570	0.280
							2" Ice	8.750	8.750	0.365
*** DB205-A (E)	A	From Leg	6.000	0.000	0.000	90.000	4" Ice	13.110	13.110	0.534
			0.000	0.000			No Ice	1.200	1.200	0.038
			9.000	0.000			1/2" Ice	2.160	2.160	0.049
							1" Ice	3.120	3.120	0.061
							2" Ice	5.040	5.040	0.084
DB205-A (E)	B	From Leg	6.000	0.000	0.000	90.000	4" Ice	8.880	8.880	0.129
			0.000	0.000			No Ice	1.200	1.200	0.038
			9.000	0.000			1/2" Ice	2.160	2.160	0.049
							1" Ice	3.120	3.120	0.061
							2" Ice	5.040	5.040	0.084
MT-485002 w/ Mount Pipe (E)	B	From Leg	6.000	0.000	0.000	90.000	4" Ice	8.880	8.880	0.129
			0.000	0.000			No Ice	1.572	0.473	0.011
			0.000	0.000			1/2" Ice	1.797	0.681	0.022
							1" Ice	2.044	0.932	0.037
							2" Ice	2.587	1.512	0.075
Side Arm Mount [SO 702-1] (E)	A	From Leg	3.000	0.000	0.000	90.000	4" Ice	3.843	2.909	0.209
			0.000	0.000			No Ice	1.000	1.430	0.027
			0.000	0.000			1/2" Ice	1.000	2.050	0.038
							1" Ice	1.000	2.670	0.049
							2" Ice	1.000	3.910	0.071
Side Arm Mount [SO 702-1] (E)	B	From Leg	3.000	0.000	0.000	90.000	4" Ice	1.000	6.390	0.115
			0.000	0.000			No Ice	1.000	1.430	0.027
			0.000	0.000			1/2" Ice	1.000	2.050	0.038
							1" Ice	1.000	2.670	0.049
							2" Ice	1.000	3.910	0.071
6' x 2" Mount Pipe (E)	A	From Leg	6.000	0.000	0.000	90.000	4" Ice	1.000	6.390	0.115
			0.000	0.000			No Ice	1.425	1.425	0.022
			0.000	0.000			1/2" Ice	1.925	1.925	0.033
							1" Ice	2.294	2.294	0.048
							2" Ice	3.060	3.060	0.090
*** GPS_A (E)	A	From Leg	3.000	0.000	0.000	87.000	4" Ice	4.702	4.702	0.231
			0.000	0.000			No Ice	0.297	0.297	0.001
			0.000	0.000			1/2" Ice	0.374	0.374	0.005
							1" Ice	0.459	0.459	0.010
							2" Ice	0.655	0.655	0.025
GPS_A (E)	B	From Leg	3.000	0.000	0.000	87.000	4" Ice	1.151	1.151	0.079
			0.000	0.000			No Ice	0.297	0.297	0.001
			0.000	0.000			1/2" Ice	0.374	0.374	0.005
							1" Ice	0.459	0.459	0.010
							2" Ice	0.655	0.655	0.025

tnxTower ABC Engineering 1234 W. Jones St. Smallville, PA 12345 Phone: (555) 555-1234 FAX: (555) 555-1235	Job		87581.010.01 - Newington_1, CT (BU# 826217)		Page		18 of 38	
	Project				Date		14:49:48 01/30/15	
	Client		Crown Castle		Designed by		ahabibi	

Description	Face or Leg	Offset Type	Offsets:		Azimuth Adjustment	Placement	C _{AA} Front	C _{AA} Side	Weight	
			Horz	Lateral						Vert
Side Arm Mount [SO 701-1] (E)	A	From Leg	1.500	0.000	0.000	87.000	4" Ice	1.151	1.151	0.079
							No Ice	0.850	1.670	0.065
							1/2" Ice	1.140	2.340	0.079
							1" Ice	1.430	3.010	0.093
							2" Ice	2.010	4.350	0.121
Side Arm Mount [SO 701-1] (E)	B	From Leg	1.500	0.000	0.000	87.000	4" Ice	3.170	7.030	0.177
							No Ice	0.850	1.670	0.065
							1/2" Ice	1.140	2.340	0.079
							1" Ice	1.430	3.010	0.093
							2" Ice	2.010	4.350	0.121
*** SRL-235-2 (E-B Leg per Photo)	B	From Leg	6.000	0.000	0.000	70.000	4" Ice	3.170	7.030	0.177
							No Ice	7.000	7.000	0.076
							1/2" Ice	9.037	9.037	0.125
							1" Ice	11.092	11.092	0.187
							2" Ice	15.250	15.250	0.351
6' x 2" Mount Pipe (E-B Leg per Photo)	B	From Leg	6.000	0.000	0.000	70.000	4" Ice	22.255	22.255	0.836
							No Ice	1.425	1.425	0.022
							1/2" Ice	1.925	1.925	0.033
							1" Ice	2.294	2.294	0.048
							2" Ice	3.060	3.060	0.090
Side Arm Mount [SO 702-1] (E-B Leg per Photo)	B	From Leg	3.000	0.000	0.000	70.000	4" Ice	4.702	4.702	0.231
							No Ice	1.000	1.430	0.027
							1/2" Ice	1.000	2.050	0.038
							1" Ice	1.000	2.670	0.049
							2" Ice	1.000	3.910	0.071
*** DB583 (E)	B	From Leg	4.000	0.000	0.000	58.000	4" Ice	1.000	6.390	0.115
							No Ice	0.537	0.537	0.006
							1/2" Ice	0.711	0.711	0.012
							1" Ice	0.894	0.894	0.019
							2" Ice	1.336	1.336	0.041
4' x 2" Pipe Mount (E)	B	From Leg	4.000	0.000	0.000	58.000	4" Ice	2.392	2.392	0.116
							No Ice	0.866	0.866	0.015
							1/2" Ice	1.111	1.111	0.022
							1" Ice	1.365	1.365	0.032
							2" Ice	1.901	1.901	0.062
Side Arm Mount [SO 702-1] (E)	B	From Leg	2.000	0.000	0.000	58.000	4" Ice	3.228	3.228	0.161
							No Ice	1.000	1.430	0.027
							1/2" Ice	1.000	2.050	0.038
							1" Ice	1.000	2.670	0.049
							2" Ice	1.000	3.910	0.071
*** DB909XVTE-M (E-A Leg per Photo)	A	From Leg	4.000	0.000	0.000	43.000	4" Ice	1.000	6.390	0.115
							No Ice	2.301	2.301	0.024
							1/2" Ice	2.622	2.622	0.047
							1" Ice	2.952	2.952	0.073
							2" Ice	3.733	3.733	0.139
4' x 2" Pipe Mount (E-A Leg per Photo)	A	From Leg	4.000	0.000	0.000	43.000	4" Ice	5.478	5.478	0.323
							No Ice	0.866	0.866	0.015
							1/2" Ice	1.111	1.111	0.022
							1" Ice	1.365	1.365	0.032
							2" Ice	1.901	1.901	0.062
Side Arm Mount [SO 702-1] (E-A Leg per Photo)	A	From Leg	2.000	0.000	0.000	43.000	4" Ice	3.228	3.228	0.161
							No Ice	1.000	1.430	0.027
							1/2" Ice	1.000	2.050	0.038
							1" Ice	1.000	2.670	0.049

tnxTower ABC Engineering 1234 W. Jones St. Smallville, PA 12345 Phone: (555) 555-1234 FAX: (555) 555-1235	Job 87581.010.01 - Newington_1, CT (BU# 826217)	Page 19 of 38
	Project	Date 14:49:48 01/30/15
	Client Crown Castle	Designed by ahabibi

Description	Face or Leg	Offset Type	Offsets: Horz Lateral Vert ft ft ft	Azimuth Adjustment °	Placement ft		C _{AA} Front ft ²	C _{AA} Side ft ²	Weight K
						2" Ice	1.000	3.910	0.071
						4" Ice	1.000	6.390	0.115

DB909XVTE-M (E-A Leg per Photo)	A	From Leg	4.000 0.000 0.000	0.000	33.000	No Ice	2.301	2.301	0.024
						1/2" Ice	2.622	2.622	0.047
						1" Ice	2.952	2.952	0.073
						2" Ice	3.733	3.733	0.139
						4" Ice	5.478	5.478	0.323
4' x 2" Pipe Mount (E-A Leg per Photo)	A	From Leg	4.000 0.000 0.000	0.000	33.000	No Ice	0.866	0.866	0.015
						1/2" Ice	1.111	1.111	0.022
						1" Ice	1.365	1.365	0.032
						2" Ice	1.901	1.901	0.062
						4" Ice	3.228	3.228	0.161
Side Arm Mount [SO 702-1] (E-A Leg per Photo)	A	From Leg	2.000 0.000 0.000	0.000	33.000	No Ice	1.000	1.430	0.027
						1/2" Ice	1.000	2.050	0.038
						1" Ice	1.000	2.670	0.049
						2" Ice	1.000	3.910	0.071
						4" Ice	1.000	6.390	0.115

4' ICE SHIELDS (E)	A	From Leg	0.500 0.000 0.000	0.000	178.000	No Ice	1.400	0.467	0.030
						1/2" Ice	1.884	0.640	0.095
						1" Ice	2.377	0.821	0.167
						2" Ice	3.388	1.210	0.332
						4" Ice	5.514	2.091	0.748
4' ICE SHIELDS (E)	A	From Leg	0.500 0.000 0.000	0.000	138.000	No Ice	1.400	0.467	0.030
						1/2" Ice	1.884	0.640	0.095
						1" Ice	2.377	0.821	0.167
						2" Ice	3.388	1.210	0.332
						4" Ice	5.514	2.091	0.748
4' ICE SHIELDS (E)	A	From Leg	0.500 0.000 0.000	0.000	98.000	No Ice	1.400	0.467	0.030
						1/2" Ice	1.884	0.640	0.095
						1" Ice	2.377	0.821	0.167
						2" Ice	3.388	1.210	0.332
						4" Ice	5.514	2.091	0.748
4' ICE SHIELDS (E)	B	From Leg	0.500 0.000 0.000	0.000	98.000	No Ice	1.400	0.467	0.030
						1/2" Ice	1.884	0.640	0.095
						1" Ice	2.377	0.821	0.167
						2" Ice	3.388	1.210	0.332
						4" Ice	5.514	2.091	0.748
4' ICE SHIELDS (E)	C	From Leg	0.500 0.000 0.000	0.000	98.000	No Ice	1.400	0.467	0.030
						1/2" Ice	1.884	0.640	0.095
						1" Ice	2.377	0.821	0.167
						2" Ice	3.388	1.210	0.332
						4" Ice	5.514	2.091	0.748

Dishes

tnxTower ABC Engineering 1234 W. Jones St. Smallville, PA 12345 Phone: (555) 555-1234 FAX: (555) 555-1235	Job 87581.010.01 - Newington_1, CT (BU# 826217)	Page 20 of 38
	Project	Date 14:49:48 01/30/15
	Client Crown Castle	Designed by ahabibi

Description	Face or Leg	Dish Type	Offset Type	Offsets: Horz Lateral Vert ft	Azimuth Adjustment °	3 dB Beam Width °	Elevation ft	Outside Diameter ft	Aperture Area ft ²	Weight K	
VHLP2.5-10W (E)	A	Paraboloid w/Shroud (HP)	From Leg	4.000 0.000 4.000	90.000		116.000	2.917	No Ice 1/2" Ice 1" Ice 2" Ice 4" Ice	6.680 7.070 7.460 8.230 9.780	0.050 0.090 0.120 0.200 0.340
**** KP2F-34 (E)	A	Grid	From Leg	6.000 0.000 0.000	0.000		90.000	2.000	No Ice 1/2" Ice 1" Ice 2" Ice 4" Ice	3.140 3.410 3.680 4.276 5.600	0.005 0.023 0.040 0.075 0.100

Compression Checks

Pole Design Data

Section No.	Elevation ft	Size	L ft	L _a ft	Kl/r	F _a ksi	A in ²	Actual P K	Allow. P _a K	Ratio P/P _a
L1	190 - 189	P18x3/8	10.000	0.000	0.0	25.200	20.764	-0.307	523.252	0.001
	189 - 188					25.200	20.764	-0.385	523.252	0.001
	188 - 187					25.200	20.764	-0.464	523.252	0.001
	187 - 186					25.200	20.764	-0.543	523.252	0.001
	186 - 185					25.200	20.764	-0.621	523.252	0.001
	185 - 184					25.200	20.764	-0.700	523.252	0.001
	184 - 183					25.200	20.764	-2.853	523.252	0.005
	183 - 182					25.200	20.764	-2.932	523.252	0.006
	182 - 181					25.200	20.764	-3.010	523.252	0.006
	181 - 180					25.200	20.764	-3.090	523.252	0.006
	L2					180 - 178	P24x3/8	40.000	0.000	0.0
178 - 176		25.200	27.833	-3.590	701.380	0.005				
176 - 174		25.200	27.833	-3.828	701.380	0.005				
174 - 172		25.200	27.833	-4.066	701.380	0.006				
172 - 170		25.200	27.833	-4.305	701.380	0.006				
170 - 168		25.200	27.833	-4.544	701.380	0.006				
168 - 166		25.200	27.833	-4.783	701.380	0.007				
166 - 164		25.200	27.833	-5.023	701.380	0.007				
164 - 162		25.200	27.833	-5.264	701.380	0.008				
162 - 160		25.200	27.833	-5.505	701.380	0.008				
160 - 158		25.200	27.833	-7.748	701.380	0.011				
158 - 156		25.200	27.833	-8.129	701.380	0.012				
156 - 154		25.200	27.833	-8.379	701.380	0.012				
154 - 152		25.200	27.833	-8.631	701.380	0.012				
L3	152 - 150	P36x3/8	20.000	0.000	0.0	25.200	27.833	-10.978	701.380	0.016
	150 - 148					25.200	27.833	-11.241	701.380	0.016
	148 - 146					25.200	27.833	-12.180	701.380	0.017
	146 - 144					25.200	27.833	-12.453	701.380	0.018
	144 - 142					25.200	27.833	-12.730	701.380	0.018
	142 - 140					25.200	27.833	-13.011	701.380	0.019
	140 - 139					23.696	41.970	-13.217	994.507	0.013
	139 - 138					23.696	41.970	-13.404	994.507	0.013
138 - 137	23.696	41.970	-13.618	994.507	0.014					

tnxTower ABC Engineering 1234 W. Jones St. Smallville, PA 12345 Phone: (555) 555-1234 FAX: (555) 555-1235	Job 87581.010.01 - Newington_1, CT (BU# 826217)	Page 21 of 38
	Project	Date 14:49:48 01/30/15
	Client Crown Castle	Designed by ahabibi

Section No.	Elevation ft	Size	L ft	L _a ft	Kl/r	F _a ksi	A in ²	Actual P K	Allow. P _a K	Ratio P P _a
	137 - 136					23.696	41.970	-13.806	994.507	0.014
	136 - 135					23.696	41.970	-13.994	994.507	0.014
	135 - 134					23.696	41.970	-14.182	994.507	0.014
	134 - 133					23.696	41.970	-14.371	994.507	0.014
	133 - 132					23.696	41.970	-14.560	994.507	0.015
	132 - 131					23.696	41.970	-14.848	994.507	0.015
	131 - 130					23.696	41.970	-15.039	994.507	0.015
	130 - 129					23.696	41.970	-15.229	994.507	0.015
	129 - 128					23.696	41.970	-15.420	994.507	0.016
	128 - 127					23.696	41.970	-15.612	994.507	0.016
	127 - 126					23.696	41.970	-15.804	994.507	0.016
	126 - 125					23.696	41.970	-15.996	994.507	0.016
	125 - 124					23.696	41.970	-16.189	994.507	0.016
	124 - 123					23.696	41.970	-16.517	994.507	0.017
	123 - 122					23.696	41.970	-16.711	994.507	0.017
	122 - 121					23.696	41.970	-16.906	994.507	0.017
	121 - 120					23.696	41.970	-17.101	994.507	0.017
L4	120 - 119	P42x3/8	11.000	0.000	0.0	22.711	49.038	-17.368	1113.690	0.016
	119 - 118					22.711	49.038	-17.592	1113.690	0.016
	118 - 117					22.711	49.038	-17.816	1113.690	0.016
	117 - 116					22.711	49.038	-18.040	1113.690	0.016
	116 - 115					22.711	49.038	-20.496	1113.690	0.018
	115 - 114					22.711	49.038	-20.723	1113.690	0.019
	114 - 113					22.711	49.038	-20.950	1113.690	0.019
	113 - 112					22.711	49.038	-21.177	1113.690	0.019
	112 - 111					22.711	49.038	-21.405	1113.690	0.019
	111 - 110					22.711	49.038	-21.634	1113.690	0.019
	110 - 109					22.711	49.038	-21.863	1113.690	0.020
L5	109 - 108	P42x3/8 [0.449926]	5.000	0.000	0.0	23.061	58.730	-22.127	1354.400	0.016
	108 - 107					23.061	58.730	-22.390	1354.400	0.017
	107 - 106					23.061	58.730	-22.653	1354.400	0.017
	106 - 105					23.061	58.730	-22.917	1354.400	0.017
	105 - 104					23.061	58.730	-23.182	1354.400	0.017
L6	104 - 103	P42x3/8 [0.525959]	4.000	0.000	0.0	22.810	68.530	-23.476	1563.170	0.015
	103 - 102					22.810	68.530	-23.770	1563.170	0.015
	102 - 101					22.810	68.530	-24.064	1563.170	0.015
	101 - 100					22.810	68.530	-24.358	1563.170	0.016
L7	100 - 99	P48x3/8 [0.43965]	11.000	0.000	0.0	22.208	65.690	-24.888	1458.870	0.017
	99 - 98					22.208	65.690	-25.179	1458.870	0.017
	98 - 97					22.208	65.690	-25.556	1458.870	0.018
	97 - 96					22.208	65.690	-25.848	1458.870	0.018
	96 - 95					22.208	65.690	-26.140	1458.870	0.018
	95 - 94					22.208	65.690	-26.432	1458.870	0.018
	94 - 93					22.208	65.690	-26.724	1458.870	0.018
	93 - 92					22.208	65.690	-27.017	1458.870	0.019
	92 - 91					22.208	65.690	-27.310	1458.870	0.019
	91 - 90					22.208	65.690	-27.604	1458.870	0.019
	90 - 89					22.208	65.690	-28.055	1458.870	0.019
L8	89 - 88	P48x3/8 [0.53914]	9.000	0.000	0.0	22.666	80.387	-28.395	1822.090	0.016
	88 - 87					22.666	80.387	-28.734	1822.090	0.016
	87 - 86					22.666	80.387	-29.202	1822.090	0.016
	86 - 85					22.666	80.387	-29.541	1822.090	0.016
	85 - 84					22.666	80.387	-29.881	1822.090	0.016
	84 - 83					22.666	80.387	-30.222	1822.090	0.017
	83 - 82					22.666	80.387	-30.562	1822.090	0.017
	82 - 81					22.666	80.387	-30.903	1822.090	0.017
	81 - 80					22.666	80.387	-31.244	1822.090	0.017
L9	80 - 79	P54x3/8 [0.490666]	11.000	0.000	0.0	21.771	82.483	-31.593	1795.750	0.018
	79 - 78					21.771	82.483	-31.940	1795.750	0.018
	78 - 77					21.771	82.483	-32.288	1795.750	0.018

Section No.	Elevation ft	Size	L ft	L _a ft	Kl/r	F _a ksi	A in ²	Actual P K	Allow. P _a K	Ratio P P _a
	77 - 76					21.771	82.483	-32.635	1795.750	0.018
	76 - 75					21.771	82.483	-32.983	1795.750	0.018
	75 - 74					21.771	82.483	-33.332	1795.750	0.019
	74 - 73					21.771	82.483	-33.680	1795.750	0.019
	73 - 72					21.771	82.483	-34.029	1795.750	0.019
	72 - 71					21.771	82.483	-34.378	1795.750	0.019
	71 - 70					21.771	82.483	-34.727	1795.750	0.019
	70 - 69					21.771	82.483	-35.194	1795.750	0.020
L10	69 - 68	P54x3/8 [0.578486]	9.000	0.000	0.0	22.138	97.087	-35.589	2149.270	0.017
	68 - 67					22.138	97.087	-35.984	2149.270	0.017
	67 - 66					22.138	97.087	-36.379	2149.270	0.017
	66 - 65					22.138	97.087	-36.774	2149.270	0.017
	65 - 64					22.138	97.087	-37.169	2149.270	0.017
	64 - 63					22.138	97.087	-37.565	2149.270	0.017
	63 - 62					22.138	97.087	-37.961	2149.270	0.018
	62 - 61					22.138	97.087	-38.357	2149.270	0.018
	61 - 60					22.138	97.087	-38.754	2149.270	0.018
L11	60 - 59	P60x3/8 [0.516129]	11.000	0.000	0.0	21.332	96.451	-39.149	2057.470	0.019
	59 - 58					21.332	96.451	-39.543	2057.470	0.019
	58 - 57					21.332	96.451	-39.984	2057.470	0.019
	57 - 56					21.332	96.451	-40.379	2057.470	0.020
	56 - 55					21.332	96.451	-40.774	2057.470	0.020
	55 - 54					21.332	96.451	-41.169	2057.470	0.020
	54 - 53					21.332	96.451	-41.564	2057.470	0.020
	53 - 52					21.332	96.451	-41.960	2057.470	0.020
	52 - 51					21.332	96.451	-42.356	2057.470	0.021
	51 - 50					21.332	96.451	-42.752	2057.470	0.021
	50 - 49					21.332	96.451	-43.148	2057.470	0.021
L12	49 - 48	P60x3/8 [0.594533]	9.000	0.000	0.0	21.618	110.956	-43.590	2398.620	0.018
	48 - 47					21.618	110.956	-44.031	2398.620	0.018
	47 - 46					21.618	110.956	-44.473	2398.620	0.019
	46 - 45					21.618	110.956	-44.914	2398.620	0.019
	45 - 44					21.618	110.956	-45.356	2398.620	0.019
	44 - 43					21.618	110.956	-45.798	2398.620	0.019
	43 - 42					21.618	110.956	-46.305	2398.620	0.019
	42 - 41					21.618	110.956	-46.747	2398.620	0.019
	41 - 40					21.618	110.956	-47.190	2398.620	0.020
L13	40 - 39	P60x1/2 [0.604293]	11.000	0.000	0.0	22.644	112.759	-47.645	2553.280	0.019
	39 - 38					22.644	112.759	-48.099	2553.280	0.019
	38 - 37					22.644	112.759	-48.554	2553.280	0.019
	37 - 36					22.644	112.759	-49.009	2553.280	0.019
	36 - 35					22.644	112.759	-49.463	2553.280	0.019
	35 - 34					22.644	112.759	-49.919	2553.280	0.020
	34 - 33					22.644	112.759	-50.374	2553.280	0.020
	33 - 32					22.644	112.759	-50.895	2553.280	0.020
	32 - 31					22.644	112.759	-51.351	2553.280	0.020
	31 - 30					22.644	112.759	-51.807	2553.280	0.020
	30 - 29					22.644	112.759	-52.264	2553.280	0.020
L14	29 - 28	P60x1/2 [0.683417]	9.000	0.000	0.0	22.944	127.354	-52.766	2921.950	0.018
	28 - 27					22.944	127.354	-53.268	2921.950	0.018
	27 - 26					22.944	127.354	-53.769	2921.950	0.018
	26 - 25					22.944	127.354	-54.271	2921.950	0.019
	25 - 24					22.944	127.354	-54.773	2921.950	0.019
	24 - 23					22.944	127.354	-55.276	2921.950	0.019
	23 - 22					22.944	127.354	-55.778	2921.950	0.019
	22 - 21					22.944	127.354	-56.281	2921.950	0.019
	21 - 20					22.944	127.354	-56.784	2921.950	0.019
L15	20 - 19	P60x5/8 [0.703867]	11.000	0.000	0.0	23.971	131.119	-57.304	3143.050	0.018
	19 - 18					23.971	131.119	-57.824	3143.050	0.018
	18 - 17					23.971	131.119	-58.345	3143.050	0.019

Section No.	Elevation ft	Size	L ft	L _a ft	Kl/r	F _a ksi	A in ²	Actual P K	Allow. P _a K	Ratio P P _a
	17 - 16					23.971	131.119	-58.865	3143.050	0.019
	16 - 15					23.971	131.119	-59.386	3143.050	0.019
	15 - 14					23.971	131.119	-59.907	3143.050	0.019
	14 - 13					23.971	131.119	-60.429	3143.050	0.019
	13 - 12					23.971	131.119	-60.950	3143.050	0.019
	12 - 11					23.971	131.119	-61.472	3143.050	0.020
	11 - 10					23.971	131.119	-61.994	3143.050	0.020
	10 - 9					23.971	131.119	-62.516	3143.050	0.020
L16	9 - 8	P60x5/8 [0.756633]	9.000	0.000	0.0	23.745	140.823	-63.069	3343.800	0.019
	8 - 7					23.745	140.823	-63.621	3343.800	0.019
	7 - 6					23.745	140.823	-64.173	3343.800	0.019
	6 - 5					23.745	140.823	-64.726	3343.800	0.019
	5 - 4					23.745	140.823	-65.278	3343.800	0.020
	4 - 3					23.745	140.823	-65.831	3343.800	0.020
	3 - 2					23.745	140.823	-66.384	3343.800	0.020
	2 - 1					23.745	140.823	-66.938	3343.800	0.020
	1 - 0					23.745	140.823	-67.491	3343.800	0.020

Pole Bending Design Data

Section No.	Elevation ft	Size	Actual M _x kip-ft	Actual f _{bx} ksi	Allow. F _{bx} ksi	Ratio f _{bx} F _{bx}	Actual M _y kip-ft	Actual f _{by} ksi	Allow. F _{by} ksi	Ratio f _{by} F _{by}
L1	190 - 189	P18x3/8	2.675	0.358	27.720	0.013	0.000	0.000	27.720	0.000
	189 - 188		3.352	0.449	27.720	0.016	0.000	0.000	27.720	0.000
	188 - 187		4.086	0.547	27.720	0.020	0.000	0.000	27.720	0.000
	187 - 186		4.880	0.653	27.720	0.024	0.000	0.000	27.720	0.000
	186 - 185		5.732	0.767	27.720	0.028	0.000	0.000	27.720	0.000
	185 - 184		6.642	0.889	27.720	0.032	0.000	0.000	27.720	0.000
	184 - 183		3.588	0.480	27.720	0.017	0.000	0.000	27.720	0.000
	183 - 182		8.284	1.109	27.720	0.040	0.000	0.000	27.720	0.000
	182 - 181		13.037	1.746	27.720	0.063	0.000	0.000	27.720	0.000
	181 - 180		17.849	2.390	27.720	0.086	0.000	0.000	27.720	0.000
L2	180 - 178	P24x3/8	27.695	2.053	27.720	0.074	0.000	0.000	27.720	0.000
	178 - 176		37.931	2.812	27.720	0.101	0.000	0.000	27.720	0.000
	176 - 174		48.526	3.598	27.720	0.130	0.000	0.000	27.720	0.000
	174 - 172		59.438	4.407	27.720	0.159	0.000	0.000	27.720	0.000
	172 - 170		70.667	5.239	27.720	0.189	0.000	0.000	27.720	0.000
	170 - 168		82.211	6.095	27.720	0.220	0.000	0.000	27.720	0.000
	168 - 166		94.067	6.974	27.720	0.252	0.000	0.000	27.720	0.000
	166 - 164		106.236	7.876	27.720	0.284	0.000	0.000	27.720	0.000
	164 - 162		118.714	8.801	27.720	0.318	0.000	0.000	27.720	0.000
	162 - 160		131.500	9.749	27.720	0.352	0.000	0.000	27.720	0.000
	160 - 158		156.693	11.617	27.720	0.419	0.000	0.000	27.720	0.000
	158 - 156		182.302	13.516	27.720	0.488	0.000	0.000	27.720	0.000
	156 - 154		208.619	15.467	27.720	0.558	0.000	0.000	27.720	0.000
	154 - 152		235.229	17.440	27.720	0.629	0.000	0.000	27.720	0.000
	152 - 150		267.174	19.808	27.720	0.715	0.000	0.000	27.720	0.000
	150 - 148		303.163	22.476	27.720	0.811	0.000	0.000	27.720	0.000
	148 - 146		341.430	25.313	27.720	0.913	0.000	0.000	27.720	0.000
	146 - 144		380.077	28.179	27.720	1.017	0.000	0.000	27.720	0.000
	144 - 142		418.978	31.063	27.720	1.121	0.000	0.000	27.720	0.000
	142 - 140		458.124	33.965	27.720	1.225	0.000	0.000	27.720	0.000
L3	140 - 139	P36x3/8	477.807	15.499	23.696	0.654	0.000	0.000	23.696	0.000
	139 - 138		497.596	16.141	23.696	0.681	0.000	0.000	23.696	0.000
	138 - 137		517.595	16.790	23.696	0.709	0.000	0.000	23.696	0.000

Section No.	Elevation ft	Size	Actual M_x kip-ft	Actual f_{bx} ksi	Allow. F_{bx} ksi	Ratio $\frac{f_{bx}}{F_{bx}}$	Actual M_y kip-ft	Actual f_{by} ksi	Allow. F_{by} ksi	Ratio $\frac{f_{by}}{F_{by}}$
	137 - 136		537.648	17.440	23.696	0.736	0.000	0.000	23.696	0.000
	136 - 135		557.808	18.094	23.696	0.764	0.000	0.000	23.696	0.000
	135 - 134		578.073	18.751	23.696	0.791	0.000	0.000	23.696	0.000
	134 - 133		598.444	19.412	23.696	0.819	0.000	0.000	23.696	0.000
	133 - 132		618.921	20.076	23.696	0.847	0.000	0.000	23.696	0.000
	132 - 131		640.574	20.779	23.696	0.877	0.000	0.000	23.696	0.000
	131 - 130		661.634	21.462	23.696	0.906	0.000	0.000	23.696	0.000
	130 - 129		682.799	22.148	23.696	0.935	0.000	0.000	23.696	0.000
	129 - 128		704.068	22.838	23.696	0.964	0.000	0.000	23.696	0.000
	128 - 127		725.439	23.532	23.696	0.993	0.000	0.000	23.696	0.000
	127 - 126		746.913	24.228	23.696	1.022	0.000	0.000	23.696	0.000
	126 - 125		768.490	24.928	23.696	1.052	0.000	0.000	23.696	0.000
	125 - 124		790.168	25.631	23.696	1.082	0.000	0.000	23.696	0.000
	124 - 123		812.601	26.359	23.696	1.112	0.000	0.000	23.696	0.000
	123 - 122		834.658	27.075	23.696	1.143	0.000	0.000	23.696	0.000
	122 - 121		856.825	27.793	23.696	1.173	0.000	0.000	23.696	0.000
	121 - 120		879.083	28.515	23.696	1.203	0.000	0.000	23.696	0.000
L4	120 - 119	P42x3/8	901.883	21.398	22.711	0.942	0.000	0.000	22.711	0.000
	119 - 118		924.567	21.936	22.711	0.966	0.000	0.000	22.711	0.000
	118 - 117		947.350	22.476	22.711	0.990	0.000	0.000	22.711	0.000
	117 - 116		970.258	23.020	22.711	1.014	0.000	0.000	22.711	0.000
	116 - 115		1000.96	23.748	22.711	1.046	0.000	0.000	22.711	0.000
			7							
	115 - 114		1027.25	24.372	22.711	1.073	0.000	0.000	22.711	0.000
			0							
	114 - 113		1053.64	24.998	22.711	1.101	0.000	0.000	22.711	0.000
			2							
	113 - 112		1080.14	25.627	22.711	1.128	0.000	0.000	22.711	0.000
			2							
	112 - 111		1106.75	26.258	22.711	1.156	0.000	0.000	22.711	0.000
			8							
	111 - 110		1133.47	26.892	22.711	1.184	0.000	0.000	22.711	0.000
			5							
	110 - 109		1160.30	27.529	22.711	1.212	0.000	0.000	22.711	0.000
			8							
L5	109 - 108	P42x3/8 [0.449926]	1187.24	23.603	23.061	1.023	0.000	0.000	23.061	0.000
			2							
	108 - 107		1214.29	24.141	23.061	1.047	0.000	0.000	23.061	0.000
			2							
	107 - 106		1241.45	24.681	23.061	1.070	0.000	0.000	23.061	0.000
			0							
	106 - 105		1268.72	25.223	23.061	1.094	0.000	0.000	23.061	0.000
			5							
	105 - 104		1296.10	25.767	23.061	1.117	0.000	0.000	23.061	0.000
			0							
L6	104 - 103	P42x3/8 [0.525959]	1323.59	22.633	25.091	0.902	0.000	0.000	25.091	0.000
			2							
	103 - 102		1351.19	23.105	25.091	0.921	0.000	0.000	25.091	0.000
			2							
	102 - 101		1378.90	23.579	25.091	0.940	0.000	0.000	25.091	0.000
			0							
	101 - 100		1406.72	24.055	25.091	0.959	0.000	0.000	25.091	0.000
			5							
L7	100 - 99	P48x3/8 [0.43965]	1435.28	22.253	22.208	1.002	0.000	0.000	22.208	0.000
			3							
	99 - 98		1463.95	22.698	22.208	1.022	0.000	0.000	22.208	0.000
			8							
	98 - 97		1492.86	23.146	22.208	1.042	0.000	0.000	22.208	0.000
			7							
	97 - 96		1521.89	23.596	22.208	1.062	0.000	0.000	22.208	0.000

tnxTower ABC Engineering 1234 W. Jones St. Smallville, PA 12345 Phone: (555) 555-1234 FAX: (555) 555-1235	Job 87581.010.01 - Newington_1, CT (BU# 826217)	Page 25 of 38
	Project	Date 14:49:48 01/30/15
	Client Crown Castle	Designed by ahabibi

Section No.	Elevation ft	Size	Actual M_x kip-ft	Actual f_{bx} ksi	Allow. F_{bx} ksi	Ratio $\frac{f_{bx}}{F_{bx}}$	Actual M_y kip-ft	Actual f_{by} ksi	Allow. F_{by} ksi	Ratio $\frac{f_{by}}{F_{by}}$
	96 - 95		2 1551.02	24.048	22.208	1.083	0.000	0.000	22.208	0.000
	95 - 94		5 1580.28	24.501	22.208	1.103	0.000	0.000	22.208	0.000
	94 - 93		3 1609.65	24.957	22.208	1.124	0.000	0.000	22.208	0.000
	93 - 92		8 1639.15	25.414	22.208	1.144	0.000	0.000	22.208	0.000
	92 - 91		0 1668.75	25.873	22.208	1.165	0.000	0.000	22.208	0.000
	91 - 90		8 1698.47	26.334	22.208	1.186	0.000	0.000	22.208	0.000
	90 - 89		5 1730.01	26.823	22.208	1.208	0.000	0.000	22.208	0.000
L8	89 - 88	P48x3/8 [0.53914]	7 1760.29	22.395	22.666	0.988	0.000	0.000	22.666	0.000
	88 - 87		2 1790.67	22.782	22.666	1.005	0.000	0.000	22.666	0.000
	87 - 86		5 1821.50	23.174	22.666	1.022	0.000	0.000	22.666	0.000
	86 - 85		0 1852.24	23.565	22.666	1.040	0.000	0.000	22.666	0.000
	85 - 84		2 1883.10	23.958	22.666	1.057	0.000	0.000	22.666	0.000
	84 - 83		0 1914.06	24.351	22.666	1.074	0.000	0.000	22.666	0.000
	83 - 82		7 1945.14	24.747	22.666	1.092	0.000	0.000	22.666	0.000
	82 - 81		2 1976.33	25.144	22.666	1.109	0.000	0.000	22.666	0.000
	81 - 80		3 2007.64	25.542	22.666	1.127	0.000	0.000	22.666	0.000
L9	80 - 79	P54x3/8 [0.490666]	2 2039.05	22.377	21.771	1.028	0.000	0.000	21.771	0.000
	79 - 78		8 2070.60	22.723	21.771	1.044	0.000	0.000	21.771	0.000
	78 - 77		0 2102.25	23.071	21.771	1.060	0.000	0.000	21.771	0.000
	77 - 76		8 2134.03	23.419	21.771	1.076	0.000	0.000	21.771	0.000
	76 - 75		3 2165.93	23.769	21.771	1.092	0.000	0.000	21.771	0.000
	75 - 74		3 2197.95	24.121	21.771	1.108	0.000	0.000	21.771	0.000
	74 - 73		0 2230.08	24.473	21.771	1.124	0.000	0.000	21.771	0.000
	73 - 72		3 2262.33	24.827	21.771	1.140	0.000	0.000	21.771	0.000
	72 - 71		3 2294.70	25.183	21.771	1.157	0.000	0.000	21.771	0.000
	71 - 70		8 2327.19	25.539	21.771	1.173	0.000	0.000	21.771	0.000
	70 - 69		2 2360.14	25.901	21.771	1.190	0.000	0.000	21.771	0.000
L10	69 - 68	P54x3/8 [0.578486]	2 2393.20	22.386	22.138	1.011	0.000	0.000	22.138	0.000
	68 - 67		0 2426.37	22.696	22.138	1.025	0.000	0.000	22.138	0.000
	67 - 66		5 2459.66	23.008	22.138	1.039	0.000	0.000	22.138	0.000

tnxTower ABC Engineering 1234 W. Jones St. Smallville, PA 12345 Phone: (555) 555-1234 FAX: (555) 555-1235	Job 87581.010.01 - Newington_1, CT (BU# 826217)	Page 26 of 38
	Project	Date 14:49:48 01/30/15
	Client Crown Castle	Designed by ahabibi

Section No.	Elevation ft	Size	Actual M_x kip-ft	Actual f_{bx} ksi	Allow. F_{bx} ksi	Ratio $\frac{f_{bx}}{F_{bx}}$	Actual M_y kip-ft	Actual f_{by} ksi	Allow. F_{by} ksi	Ratio $\frac{f_{by}}{F_{by}}$
	66 - 65		2493.06	23.320	22.138	1.053	0.000	0.000	22.138	0.000
	65 - 64		2526.58	23.633	22.138	1.068	0.000	0.000	22.138	0.000
	64 - 63		2560.20	23.948	22.138	1.082	0.000	0.000	22.138	0.000
	63 - 62		2593.95	24.264	22.138	1.096	0.000	0.000	22.138	0.000
	62 - 61		2627.80	24.580	22.138	1.110	0.000	0.000	22.138	0.000
	61 - 60		2661.75	24.898	22.138	1.125	0.000	0.000	22.138	0.000
L11	60 - 59	P60x3/8 [0.516129]	2695.83	22.748	21.332	1.066	0.000	0.000	21.332	0.000
	59 - 58		2730.01	23.037	21.332	1.080	0.000	0.000	21.332	0.000
	58 - 57		2764.41	23.327	21.332	1.094	0.000	0.000	21.332	0.000
	57 - 56		2798.93	23.618	21.332	1.107	0.000	0.000	21.332	0.000
	56 - 55		2833.55	23.910	21.332	1.121	0.000	0.000	21.332	0.000
	55 - 54		2868.30	24.204	21.332	1.135	0.000	0.000	21.332	0.000
	54 - 53		2903.16	24.498	21.332	1.148	0.000	0.000	21.332	0.000
	53 - 52		2938.14	24.793	21.332	1.162	0.000	0.000	21.332	0.000
	52 - 51		2973.22	25.089	21.332	1.176	0.000	0.000	21.332	0.000
	51 - 50		3008.42	25.386	21.332	1.190	0.000	0.000	21.332	0.000
	50 - 49		3043.74	25.684	21.332	1.204	0.000	0.000	21.332	0.000
L12	49 - 48	P60x3/8 [0.594533]	3079.15	22.645	21.618	1.048	0.000	0.000	21.618	0.000
	48 - 47		3114.69	22.907	21.618	1.060	0.000	0.000	21.618	0.000
	47 - 46		3150.33	23.169	21.618	1.072	0.000	0.000	21.618	0.000
	46 - 45		3186.07	23.432	21.618	1.084	0.000	0.000	21.618	0.000
	45 - 44		3221.92	23.695	21.618	1.096	0.000	0.000	21.618	0.000
	44 - 43		3257.88	23.960	21.618	1.108	0.000	0.000	21.618	0.000
	43 - 42		3294.40	24.228	21.618	1.121	0.000	0.000	21.618	0.000
	42 - 41		3330.70	24.495	21.618	1.133	0.000	0.000	21.618	0.000
	41 - 40		3367.10	24.763	21.618	1.145	0.000	0.000	21.618	0.000
L13	40 - 39	P60x1/2 [0.604293]	3403.60	24.639	22.644	1.088	0.000	0.000	22.644	0.000
	39 - 38		3440.20	24.904	22.644	1.100	0.000	0.000	22.644	0.000
	38 - 37		3476.90	25.170	22.644	1.112	0.000	0.000	22.644	0.000
	37 - 36		3513.69	25.436	22.644	1.123	0.000	0.000	22.644	0.000

tnxTower

ABC Engineering
 1234 W. Jones St.
 Smallville, PA 12345
 Phone: (555) 555-1234
 FAX: (555) 555-1235

Job
 87581.010.01 - Newington_1, CT (BU# 826217)

Page
 27 of 38

Project
 Date
 14:49:48 01/30/15

Client
 Crown Castle
 Designed by
 ahabibi

Section No.	Elevation ft	Size	Actual M_x kip-ft	Actual f_{bx} ksi	Allow. F_{bx} ksi	Ratio $\frac{f_{bx}}{F_{bx}}$	Actual M_y kip-ft	Actual f_{by} ksi	Allow. F_{by} ksi	Ratio $\frac{f_{by}}{F_{by}}$
	36 - 35		2 3550.51	25.703	22.644	1.135	0.000	0.000	22.644	0.000
	35 - 34		7 3587.62	25.971	22.644	1.147	0.000	0.000	22.644	0.000
	34 - 33		5 3624.81	26.240	22.644	1.159	0.000	0.000	22.644	0.000
	33 - 32		7 3662.04	26.510	22.644	1.171	0.000	0.000	22.644	0.000
	32 - 31		2 3699.55	26.781	22.644	1.183	0.000	0.000	22.644	0.000
	31 - 30		0 3737.15	27.054	22.644	1.195	0.000	0.000	22.644	0.000
	30 - 29		0 3774.84	27.326	22.644	1.207	0.000	0.000	22.644	0.000
L14	29 - 28	P60x1/2 [0.683417]	2 3812.62	24.502	22.944	1.068	0.000	0.000	22.944	0.000
	28 - 27		5 3850.50	24.745	22.944	1.079	0.000	0.000	22.944	0.000
	27 - 26		0 3888.45	24.989	22.944	1.089	0.000	0.000	22.944	0.000
	26 - 25		8 3926.51	25.234	22.944	1.100	0.000	0.000	22.944	0.000
	25 - 24		7 3964.66	25.479	22.944	1.110	0.000	0.000	22.944	0.000
	24 - 23		7 4002.90	25.724	22.944	1.121	0.000	0.000	22.944	0.000
	23 - 22		0 4041.23	25.971	22.944	1.132	0.000	0.000	22.944	0.000
	22 - 21		3 4079.64	26.218	22.944	1.143	0.000	0.000	22.944	0.000
	21 - 20		2 4118.15	26.465	22.944	1.153	0.000	0.000	22.944	0.000
L15	20 - 19	P60x5/8 [0.703867]	0 4156.74	25.964	23.971	1.083	0.000	0.000	23.971	0.000
	19 - 18		2 4195.42	26.205	23.971	1.093	0.000	0.000	23.971	0.000
	18 - 17		5 4234.19	26.447	23.971	1.103	0.000	0.000	23.971	0.000
	17 - 16		2 4273.04	26.690	23.971	1.113	0.000	0.000	23.971	0.000
	16 - 15		2 4311.98	26.933	23.971	1.124	0.000	0.000	23.971	0.000
	15 - 14		3 4351.00	27.177	23.971	1.134	0.000	0.000	23.971	0.000
	14 - 13		8 4390.11	27.421	23.971	1.144	0.000	0.000	23.971	0.000
	13 - 12		7 4429.31	27.666	23.971	1.154	0.000	0.000	23.971	0.000
	12 - 11		7 4468.59	27.912	23.971	1.164	0.000	0.000	23.971	0.000
	11 - 10		2 4507.95	28.157	23.971	1.175	0.000	0.000	23.971	0.000
	10 - 9		8 4547.40	28.404	23.971	1.185	0.000	0.000	23.971	0.000
L16	9 - 8	P60x5/8 [0.756633]	0 4586.92	26.723	26.119	1.023	0.000	0.000	26.119	0.000
	8 - 7		5 4626.54	26.954	26.119	1.032	0.000	0.000	26.119	0.000
	7 - 6		2 4666.23	27.185	26.119	1.041	0.000	0.000	26.119	0.000

tnxTower ABC Engineering 1234 W. Jones St. Smallville, PA 12345 Phone: (555) 555-1234 FAX: (555) 555-1235	Job 87581.010.01 - Newington_1, CT (BU# 826217)	Page 28 of 38
	Project	Date 14:49:48 01/30/15
	Client Crown Castle	Designed by ahabibi

Section No.	Elevation ft	Size	Actual M_x kip-ft	Actual f_{bx} ksi	Allow. F_{bx} ksi	Ratio $\frac{f_{bx}}{F_{bx}}$	Actual M_y kip-ft	Actual f_{by} ksi	Allow. F_{by} ksi	Ratio $\frac{f_{by}}{F_{by}}$
	6 - 5		3 4706.00	27.417	26.119	1.050	0.000	0.000	26.119	0.000
	5 - 4		8 4745.86	27.649	26.119	1.059	0.000	0.000	26.119	0.000
	4 - 3		7 4785.80	27.882	26.119	1.067	0.000	0.000	26.119	0.000
	3 - 2		0 4825.81	28.115	26.119	1.076	0.000	0.000	26.119	0.000
	2 - 1		7 4865.91	28.349	26.119	1.085	0.000	0.000	26.119	0.000
	1 - 0		7 4906.09	28.583	26.119	1.094	0.000	0.000	26.119	0.000
			2							

Pole Shear Design Data

Section No.	Elevation ft	Size	Actual V K	Actual f_v ksi	Allow. F_v ksi	Ratio $\frac{f_v}{F_v}$	Actual T kip-ft	Actual f_{vt} ksi	Allow. F_{vt} ksi	Ratio $\frac{f_{vt}}{F_{vt}}$		
L1	190 - 189	P18x3/8	0.645	0.062	16.800	0.004	0.039	0.003	16.800	0.000		
	189 - 188		0.703	0.068	16.800	0.004	0.040	0.003	16.800	0.000		
	188 - 187		0.761	0.073	16.800	0.004	0.041	0.003	16.800	0.000		
	187 - 186		0.820	0.079	16.800	0.005	0.042	0.003	16.800	0.000		
	186 - 185		0.878	0.085	16.800	0.005	0.042	0.003	16.800	0.000		
	185 - 184		0.937	0.090	16.800	0.005	0.043	0.003	16.800	0.000		
	184 - 183		4.663	0.449	16.800	0.027	0.044	0.003	16.800	0.000		
	183 - 182		4.721	0.455	16.800	0.027	0.045	0.003	16.800	0.000		
	182 - 181		4.780	0.460	16.800	0.027	0.046	0.003	16.800	0.000		
	181 - 180		4.838	0.466	16.800	0.028	0.047	0.003	16.800	0.000		
	L2		180 - 178	P24x3/8	4.998	0.359	16.800	0.021	0.048	0.002	16.800	0.000
			178 - 176		5.213	0.375	16.800	0.022	0.066	0.002	16.800	0.000
			176 - 174		5.372	0.386	16.800	0.023	0.067	0.002	16.800	0.000
			174 - 172		5.531	0.397	16.800	0.024	0.068	0.003	16.800	0.000
172 - 170		5.689	0.409		16.800	0.024	0.069	0.003	16.800	0.000		
170 - 168		5.846	0.420		16.800	0.025	0.070	0.003	16.800	0.000		
168 - 166		6.002	0.431		16.800	0.026	0.071	0.003	16.800	0.000		
166 - 164		6.158	0.442		16.800	0.026	0.072	0.003	16.800	0.000		
164 - 162		6.312	0.454		16.800	0.027	0.073	0.003	16.800	0.000		
162 - 160		6.466	0.465		16.800	0.028	0.074	0.003	16.800	0.000		
160 - 158		12.575	0.904		16.800	0.054	0.940	0.035	16.800	0.002		
158 - 156		13.084	0.940		16.800	0.056	0.067	0.002	16.800	0.000		
156 - 154		13.232	0.951		16.800	0.057	0.067	0.003	16.800	0.000		
154 - 152		13.377	0.961		16.800	0.057	0.068	0.003	16.800	0.000		
L3	152 - 150	P36x3/8	17.938	1.289	16.800	0.077	1.349	0.050	16.800	0.003		
	150 - 148		18.076	1.299	16.800	0.077	1.349	0.050	16.800	0.003		
	148 - 146		19.274	1.385	16.800	0.082	1.206	0.045	16.800	0.003		
	146 - 144		19.405	1.394	16.800	0.083	1.205	0.045	16.800	0.003		
	144 - 142		19.531	1.403	16.800	0.084	1.204	0.045	16.800	0.003		
	142 - 140		19.654	1.412	16.800	0.084	1.203	0.045	16.800	0.003		
	140 - 139		19.750	0.941	16.800	0.056	1.202	0.019	11.901	0.002		
	139 - 138		19.857	0.946	16.800	0.056	1.202	0.019	11.901	0.002		
	138 - 137		20.015	0.954	16.800	0.057	1.181	0.019	11.901	0.002		
	137 - 136		20.121	0.959	16.800	0.057	1.181	0.019	11.901	0.002		
	136 - 135		20.228	0.964	16.800	0.057	1.181	0.019	11.901	0.002		
	135 - 134		20.334	0.969	16.800	0.058	1.181	0.019	11.901	0.002		
134 - 133	20.439	0.974	16.800	0.058	1.181	0.019	11.901	0.002				

Section No.	Elevation ft	Size	Actual V K	Actual f_v ksi	Allow. F_v ksi	Ratio $\frac{f_v}{F_v}$	Actual T kip-ft	Actual f_{vr} ksi	Allow. F_{vr} ksi	Ratio $\frac{f_{vr}}{F_{vr}}$
	133 - 132		20.544	0.979	16.800	0.058	1.181	0.019	11.901	0.002
	132 - 131		21.024	1.002	16.800	0.060	0.184	0.003	11.901	0.000
	131 - 130		21.128	1.007	16.800	0.060	0.184	0.003	11.901	0.000
	130 - 129		21.232	1.012	16.800	0.060	0.184	0.003	11.901	0.000
	129 - 128		21.336	1.017	16.800	0.061	0.184	0.003	11.901	0.000
	128 - 127		21.439	1.022	16.800	0.061	0.184	0.003	11.901	0.000
	127 - 126		21.541	1.027	16.800	0.061	0.184	0.003	11.901	0.000
	126 - 125		21.644	1.031	16.800	0.061	0.183	0.003	11.901	0.000
	125 - 124		21.745	1.036	16.800	0.062	0.183	0.003	11.901	0.000
	124 - 123		22.027	1.050	16.800	0.062	0.592	0.010	11.901	0.001
	123 - 122		22.128	1.054	16.800	0.063	0.592	0.010	11.901	0.001
	122 - 121		22.228	1.059	16.800	0.063	0.592	0.010	11.901	0.001
	121 - 120		22.328	1.064	16.800	0.063	0.592	0.010	11.901	0.001
L4	120 - 119	P42x3/8	22.638	0.923	16.800	0.055	1.561	0.019	9.619	0.002
	119 - 118		22.751	0.928	16.800	0.055	1.561	0.019	9.619	0.002
	118 - 117		22.864	0.932	16.800	0.056	1.561	0.019	9.619	0.002
	117 - 116		22.976	0.937	16.800	0.056	1.561	0.019	9.619	0.002
	116 - 115		26.246	1.070	16.800	0.064	1.602	0.019	9.619	0.002
	115 - 114		26.357	1.075	16.800	0.064	1.602	0.019	9.619	0.002
	114 - 113		26.467	1.079	16.800	0.064	1.601	0.019	9.619	0.002
	113 - 112		26.576	1.084	16.800	0.065	1.601	0.019	9.619	0.002
	112 - 111		26.685	1.088	16.800	0.065	1.601	0.019	9.619	0.002
	111 - 110		26.794	1.093	16.800	0.065	1.600	0.019	9.619	0.002
	110 - 109		26.902	1.097	16.800	0.065	1.600	0.019	9.619	0.002
L5	109 - 108	P42x3/8 [0.449926]	27.012	0.920	15.970	0.058	1.600	0.016	12.412	0.001
	108 - 107		27.124	0.924	15.970	0.058	1.598	0.016	12.412	0.001
	107 - 106		27.234	0.927	15.970	0.058	1.597	0.016	12.412	0.001
	106 - 105		27.344	0.931	15.970	0.058	1.596	0.016	12.412	0.001
	105 - 104		27.453	0.935	15.970	0.059	1.595	0.016	12.412	0.001
L6	104 - 103	P42x3/8 [0.525959]	27.564	0.804	15.207	0.053	1.594	0.014	15.207	0.001
	103 - 102		27.675	0.808	15.207	0.053	1.593	0.014	15.207	0.001
	102 - 101		27.786	0.811	15.207	0.053	1.591	0.014	15.207	0.001
	101 - 100		27.896	0.814	15.207	0.054	1.590	0.014	15.207	0.001
L7	100 - 99	P48x3/8 [0.43965]	28.647	0.872	16.145	0.054	1.588	0.012	9.813	0.001
	99 - 98		28.765	0.876	16.145	0.054	1.587	0.012	9.813	0.001
	98 - 97		28.993	0.883	16.145	0.055	1.586	0.012	9.813	0.001
	97 - 96		29.111	0.886	16.145	0.055	1.585	0.012	9.813	0.001
	96 - 95		29.228	0.890	16.145	0.055	1.584	0.012	9.813	0.001
	95 - 94		29.345	0.893	16.145	0.055	1.583	0.012	9.813	0.001
	94 - 93		29.462	0.897	16.145	0.056	1.581	0.012	9.813	0.001
	93 - 92		29.578	0.901	16.145	0.056	1.580	0.012	9.813	0.001
	92 - 91		29.694	0.904	16.145	0.056	1.579	0.012	9.813	0.001
	91 - 90		29.809	0.908	16.145	0.056	1.578	0.012	9.813	0.001
	90 - 89		30.243	0.921	16.145	0.057	1.524	0.012	9.813	0.001
L8	89 - 88	P48x3/8 [0.53914]	30.357	0.755	15.231	0.050	1.523	0.010	13.325	0.001
	88 - 87		30.472	0.758	15.231	0.050	1.522	0.010	13.325	0.001
	87 - 86		30.712	0.764	15.231	0.050	1.383	0.009	13.325	0.001
	86 - 85		30.827	0.767	15.231	0.050	1.381	0.009	13.325	0.001
	85 - 84		30.940	0.770	15.231	0.051	1.380	0.009	13.325	0.001
	84 - 83		31.054	0.773	15.231	0.051	1.378	0.009	13.325	0.001
	83 - 82		31.166	0.775	15.231	0.051	1.377	0.009	13.325	0.001
	82 - 81		31.278	0.778	15.231	0.051	1.375	0.009	13.325	0.001
	81 - 80		31.390	0.781	15.231	0.051	1.374	0.009	13.325	0.001
L9	80 - 79	P54x3/8 [0.490666]	31.510	0.764	15.756	0.048	1.372	0.008	10.275	0.001
	79 - 78		31.630	0.767	15.756	0.049	1.370	0.008	10.275	0.001
	78 - 77		31.750	0.770	15.756	0.049	1.369	0.008	10.275	0.001
	77 - 76		31.870	0.773	15.756	0.049	1.367	0.008	10.275	0.001
	76 - 75		31.989	0.776	15.756	0.049	1.366	0.007	10.275	0.001
	75 - 74		32.108	0.779	15.756	0.049	1.364	0.007	10.275	0.001
	74 - 73		32.227	0.781	15.756	0.050	1.362	0.007	10.275	0.001

tnxTower ABC Engineering 1234 W. Jones St. Smallville, PA 12345 Phone: (555) 555-1234 FAX: (555) 555-1235	Job 87581.010.01 - Newington_1, CT (BU# 826217)	Page 30 of 38
	Project	Date 14:49:48 01/30/15
	Client Crown Castle	Designed by ahabibi

Section No.	Elevation ft	Size	Actual V K	Actual f_v ksi	Allow. F_v ksi	Ratio $\frac{f_v}{F_v}$	Actual T kip-ft	Actual f_{vr} ksi	Allow. F_{vr} ksi	Ratio $\frac{f_{vr}}{F_{vr}}$
L10	73 - 72	P54x3/8 [0.578486]	32.344	0.784	15.756	0.050	1.361	0.007	10.275	0.001
	72 - 71		32.462	0.787	15.756	0.050	1.359	0.007	10.275	0.001
	71 - 70		32.579	0.790	15.756	0.050	1.357	0.007	10.275	0.001
	70 - 69		33.037	0.801	15.756	0.051	1.312	0.007	10.275	0.001
	69 - 68		33.151	0.683	15.046	0.045	1.314	0.006	12.624	0.000
	68 - 67		33.264	0.685	15.046	0.046	1.315	0.006	12.624	0.000
	67 - 66		33.378	0.688	15.046	0.046	1.317	0.006	12.624	0.000
	66 - 65		33.491	0.690	15.046	0.046	1.318	0.006	12.624	0.000
	65 - 64		33.604	0.692	15.046	0.046	1.320	0.006	12.624	0.000
	64 - 63		33.716	0.695	15.046	0.046	1.321	0.006	12.624	0.000
L11	63 - 62	P60x3/8 [0.516129]	33.828	0.697	15.046	0.046	1.323	0.006	12.624	0.000
	62 - 61		33.939	0.699	15.046	0.046	1.324	0.006	12.624	0.000
	61 - 60		34.050	0.701	15.046	0.047	1.326	0.006	12.624	0.000
	60 - 59		34.165	0.708	15.637	0.045	1.328	0.006	10.115	0.001
	59 - 58		34.282	0.711	15.637	0.045	1.329	0.006	10.115	0.001
	58 - 57		34.491	0.715	15.637	0.046	1.842	0.008	10.115	0.001
	57 - 56		34.607	0.718	15.637	0.046	1.844	0.008	10.115	0.001
	56 - 55		34.722	0.720	15.637	0.046	1.845	0.008	10.115	0.001
	55 - 54		34.837	0.722	15.637	0.046	1.847	0.008	10.115	0.001
	54 - 53		34.952	0.725	15.637	0.046	1.849	0.008	10.115	0.001
L12	53 - 52	P60x3/8 [0.594533]	35.066	0.727	15.637	0.046	1.850	0.008	10.115	0.001
	52 - 51		35.180	0.729	15.637	0.047	1.852	0.008	10.115	0.001
	51 - 50		35.293	0.732	15.637	0.047	1.853	0.008	10.115	0.001
	50 - 49		35.406	0.734	15.637	0.047	1.855	0.008	10.115	0.001
	49 - 48		35.513	0.640	15.058	0.043	1.857	0.007	12.070	0.001
	48 - 47		35.621	0.642	15.058	0.043	1.858	0.007	12.070	0.001
	47 - 46		35.728	0.644	15.058	0.043	1.860	0.007	12.070	0.001
	46 - 45		35.835	0.646	15.058	0.043	1.861	0.007	12.070	0.001
	45 - 44		35.942	0.648	15.058	0.043	1.863	0.007	12.070	0.001
	44 - 43		36.048	0.650	15.058	0.043	1.864	0.007	12.070	0.001
L13	43 - 42	P60x1/2 [0.604293]	36.282	0.654	15.058	0.043	1.459	0.005	12.070	0.000
	42 - 41		36.387	0.656	15.058	0.044	1.461	0.005	12.070	0.000
	41 - 40		36.492	0.658	15.058	0.044	1.462	0.005	12.070	0.000
	40 - 39		36.588	0.649	15.976	0.041	1.464	0.005	12.318	0.000
	39 - 38		36.685	0.651	15.976	0.041	1.465	0.005	12.318	0.000
	38 - 37		36.780	0.652	15.976	0.041	1.467	0.005	12.318	0.000
	37 - 36		36.876	0.654	15.976	0.041	1.468	0.005	12.318	0.000
	36 - 35		37.043	0.657	15.976	0.041	3.475	0.013	12.318	0.001
	35 - 34		37.137	0.659	15.976	0.041	3.471	0.013	12.318	0.001
	34 - 33		37.231	0.660	15.976	0.041	3.467	0.013	12.318	0.001
L14	33 - 32	P60x1/2 [0.683417]	37.449	0.664	15.976	0.042	4.116	0.015	12.318	0.001
	32 - 31		37.542	0.666	15.976	0.042	4.112	0.015	12.318	0.001
	31 - 30		37.634	0.668	15.976	0.042	4.108	0.015	12.318	0.001
	30 - 29		37.725	0.669	15.976	0.042	4.105	0.015	12.318	0.001
	29 - 28		37.817	0.594	15.403	0.039	4.101	0.013	14.367	0.001
	28 - 27		37.909	0.595	15.403	0.039	4.098	0.013	14.367	0.001
	27 - 26		38.000	0.597	15.403	0.039	4.094	0.013	14.367	0.001
	26 - 25		38.091	0.598	15.403	0.039	4.090	0.013	14.367	0.001
	25 - 24		38.181	0.600	15.403	0.039	4.087	0.013	14.367	0.001
	24 - 23		38.271	0.601	15.403	0.039	4.083	0.013	14.367	0.001
L15	23 - 22	P60x5/8 [0.703867]	38.361	0.602	15.403	0.039	4.080	0.013	14.367	0.001
	22 - 21		38.449	0.604	15.403	0.039	4.076	0.013	14.367	0.001
	21 - 20		38.537	0.605	15.403	0.039	4.073	0.013	14.367	0.001
	20 - 19		38.626	0.589	16.205	0.036	4.069	0.013	14.906	0.001
	19 - 18		38.713	0.591	16.205	0.036	4.066	0.013	14.906	0.001
	18 - 17		38.801	0.592	16.205	0.037	4.062	0.013	14.906	0.001
	17 - 16		38.887	0.593	16.205	0.037	4.058	0.013	14.906	0.001
	16 - 15		38.973	0.594	16.205	0.037	4.055	0.013	14.906	0.001
	15 - 14		39.059	0.596	16.205	0.037	4.051	0.013	14.906	0.001
	14 - 13		39.144	0.597	16.205	0.037	4.048	0.013	14.906	0.001

tnxTower ABC Engineering 1234 W. Jones St. Smallville, PA 12345 Phone: (555) 555-1234 FAX: (555) 555-1235	Job 87581.010.01 - Newington_1, CT (BU# 826217)	Page 31 of 38
	Project	Date 14:49:48 01/30/15
	Client Crown Castle	Designed by ahabibi

Section No.	Elevation ft	Size	Actual V K	Actual f _v ksi	Allow. F _v ksi	Ratio f _v / F _v	Actual T kip-ft	Actual f _{vt} ksi	Allow. F _{vt} ksi	Ratio f _{vt} / F _{vt}
L16	13 - 12	P60x5/8 [0.756633]	39.228	0.598	16.205	0.037	4.044	0.013	14.906	0.001
	12 - 11		39.312	0.600	16.205	0.037	4.041	0.013	14.906	0.001
	11 - 10		39.395	0.601	16.205	0.037	4.037	0.013	14.906	0.001
	10 - 9		39.478	0.602	16.205	0.037	4.034	0.013	14.906	0.001
	9 - 8		39.560	0.562	15.830	0.035	4.030	0.012	15.830	0.001
	8 - 7		39.644	0.563	15.830	0.036	4.027	0.012	15.830	0.001
	7 - 6		39.726	0.564	15.830	0.036	4.023	0.012	15.830	0.001
	6 - 5		39.808	0.565	15.830	0.036	4.020	0.012	15.830	0.001
	5 - 4		39.889	0.567	15.830	0.036	4.016	0.012	15.830	0.001
	4 - 3		39.970	0.568	15.830	0.036	4.012	0.012	15.830	0.001
	3 - 2		40.050	0.569	15.830	0.036	4.009	0.012	15.830	0.001
	2 - 1		40.129	0.570	15.830	0.036	4.005	0.012	15.830	0.001
	1 - 0		40.208	0.571	15.830	0.036	4.002	0.012	15.830	0.001

Pole Interaction Design Data

Section No.	Elevation ft	Ratio P P _a	Ratio f _{bx} F _{bx}	Ratio f _{by} F _{by}	Ratio f _v F _v	Ratio f _{vt} F _{vt}	Comb. Stress Ratio	Allow. Stress Ratio	Criteria
L1	190 - 189	0.001	0.013	0.000	0.004	0.000	0.014	1.333	H1-3+VT ✓
	189 - 188	0.001	0.016	0.000	0.004	0.000	0.017	1.333	H1-3+VT ✓
	188 - 187	0.001	0.020	0.000	0.004	0.000	0.021	1.333	H1-3+VT ✓
	187 - 186	0.001	0.024	0.000	0.005	0.000	0.025	1.333	H1-3+VT ✓
	186 - 185	0.001	0.028	0.000	0.005	0.000	0.029	1.333	H1-3+VT ✓
	185 - 184	0.001	0.032	0.000	0.005	0.000	0.033	1.333	H1-3+VT ✓
	184 - 183	0.005	0.017	0.000	0.027	0.000	0.024	1.333	H1-3+VT ✓
	183 - 182	0.006	0.040	0.000	0.027	0.000	0.046	1.333	H1-3+VT ✓
	182 - 181	0.006	0.063	0.000	0.027	0.000	0.069	1.333	H1-3+VT ✓
	181 - 180	0.006	0.086	0.000	0.028	0.000	0.093	1.333	H1-3+VT ✓
L2	180 - 178	0.005	0.074	0.000	0.021	0.000	0.079	1.333	H1-3+VT ✓
	178 - 176	0.005	0.101	0.000	0.022	0.000	0.107	1.333	H1-3+VT ✓
	176 - 174	0.005	0.130	0.000	0.023	0.000	0.136	1.333	H1-3+VT ✓
	174 - 172	0.006	0.159	0.000	0.024	0.000	0.165	1.333	H1-3+VT ✓
	172 - 170	0.006	0.189	0.000	0.024	0.000	0.196	1.333	H1-3+VT ✓
	170 - 168	0.006	0.220	0.000	0.025	0.000	0.227	1.333	H1-3+VT ✓

tnxTower ABC Engineering 1234 W. Jones St. Smallville, PA 12345 Phone: (555) 555-1234 FAX: (555) 555-1235	Job 87581.010.01 - Newington_1, CT (BU# 826217)	Page 32 of 38
	Project	Date 14:49:48 01/30/15
	Client Crown Castle	Designed by ahabibi

Section No.	Elevation ft	Ratio	Ratio	Ratio	Ratio	Ratio	Comb. Stress Ratio	Allow. Stress Ratio	Criteria
		$\frac{P}{P_a}$	$\frac{f_{bx}}{F_{bx}}$	$\frac{f_{by}}{F_{by}}$	$\frac{f_v}{F_v}$	$\frac{f_{vt}}{F_{vt}}$			
	168 - 166	0.007	0.252	0.000	0.026	0.000	0.259	1.333	H1-3+VT ✓
	166 - 164	0.007	0.284	0.000	0.026	0.000	0.292	1.333	H1-3+VT ✓
	164 - 162	0.008	0.318	0.000	0.027	0.000	0.326	1.333	H1-3+VT ✓
	162 - 160	0.008	0.352	0.000	0.028	0.000	0.360	1.333	H1-3+VT ✓
	160 - 158	0.011	0.419	0.000	0.054	0.002	0.433	1.333	H1-3+VT ✓
	158 - 156	0.012	0.488	0.000	0.056	0.000	0.502	1.333	H1-3+VT ✓
	156 - 154	0.012	0.558	0.000	0.057	0.000	0.573	1.333	H1-3+VT ✓
	154 - 152	0.012	0.629	0.000	0.057	0.000	0.645	1.333	H1-3+VT ✓
	152 - 150	0.016	0.715	0.000	0.077	0.003	0.737	1.333	H1-3+VT ✓
	150 - 148	0.016	0.811	0.000	0.077	0.003	0.833	1.333	H1-3+VT ✓
	148 - 146	0.017	0.913	0.000	0.082	0.003	0.938	1.333	H1-3+VT ✓
	146 - 144	0.018	1.017	0.000	0.083	0.003	1.042	1.333	H1-3+VT ✓
	144 - 142	0.018	1.121	0.000	0.084	0.003	1.146	1.333	H1-3+VT ✓
	142 - 140	0.019	1.225	0.000	0.084	0.003	1.251	1.333	H1-3+VT ✓
L3	140 - 139	0.013	0.654	0.000	0.056	0.002	0.671	1.333	H1-3+VT ✓
	139 - 138	0.013	0.681	0.000	0.056	0.002	0.698	1.333	H1-3+VT ✓
	138 - 137	0.014	0.709	0.000	0.057	0.002	0.726	1.333	H1-3+VT ✓
	137 - 136	0.014	0.736	0.000	0.057	0.002	0.753	1.333	H1-3+VT ✓
	136 - 135	0.014	0.764	0.000	0.057	0.002	0.781	1.333	H1-3+VT ✓
	135 - 134	0.014	0.791	0.000	0.058	0.002	0.809	1.333	H1-3+VT ✓
	134 - 133	0.014	0.819	0.000	0.058	0.002	0.837	1.333	H1-3+VT ✓
	133 - 132	0.015	0.847	0.000	0.058	0.002	0.865	1.333	H1-3+VT ✓
	132 - 131	0.015	0.877	0.000	0.060	0.000	0.895	1.333	H1-3+VT ✓
	131 - 130	0.015	0.906	0.000	0.060	0.000	0.924	1.333	H1-3+VT ✓
	130 - 129	0.015	0.935	0.000	0.060	0.000	0.954	1.333	H1-3+VT ✓
	129 - 128	0.016	0.964	0.000	0.061	0.000	0.983	1.333	H1-3+VT ✓

tnxTower ABC Engineering 1234 W. Jones St. Smallville, PA 12345 Phone: (555) 555-1234 FAX: (555) 555-1235	Job 87581.010.01 - Newington_1, CT (BU# 826217)	Page 33 of 38
	Project	Date 14:49:48 01/30/15
	Client Crown Castle	Designed by ahabibi

Section No.	Elevation ft	Ratio P P_a	Ratio f_{bx} F_{bx}	Ratio f_{by} F_{by}	Ratio f_v F_v	Ratio f_{vt} F_{vt}	Comb. Stress Ratio	Allow. Stress Ratio	Criteria
	128 - 127	0.016	0.993	0.000	0.061	0.000	1.012	1.333	H1-3+VT ✓
	127 - 126	0.016	1.022	0.000	0.061	0.000	1.042	1.333	H1-3+VT ✓
	126 - 125	0.016	1.052	0.000	0.061	0.000	1.072	1.333	H1-3+VT ✓
	125 - 124	0.016	1.082	0.000	0.062	0.000	1.102	1.333	H1-3+VT ✓
	124 - 123	0.017	1.112	0.000	0.062	0.001	1.133	1.333	H1-3+VT ✓
	123 - 122	0.017	1.143	0.000	0.063	0.001	1.163	1.333	H1-3+VT ✓
	122 - 121	0.017	1.173	0.000	0.063	0.001	1.194	1.333	H1-3+VT ✓
	121 - 120	0.017	1.203	0.000	0.063	0.001	1.225	1.333	H1-3+VT ✓
L4	120 - 119	0.016	0.942	0.000	0.055	0.002	0.961	1.333	H1-3+VT ✓
	119 - 118	0.016	0.966	0.000	0.055	0.002	0.985	1.333	H1-3+VT ✓
	118 - 117	0.016	0.990	0.000	0.056	0.002	1.009	1.333	H1-3+VT ✓
	117 - 116	0.016	1.014	0.000	0.056	0.002	1.033	1.333	H1-3+VT ✓
	116 - 115	0.018	1.046	0.000	0.064	0.002	1.068	1.333	H1-3+VT ✓
	115 - 114	0.019	1.073	0.000	0.064	0.002	1.096	1.333	H1-3+VT ✓
	114 - 113	0.019	1.101	0.000	0.064	0.002	1.124	1.333	H1-3+VT ✓
	113 - 112	0.019	1.128	0.000	0.065	0.002	1.152	1.333	H1-3+VT ✓
	112 - 111	0.019	1.156	0.000	0.065	0.002	1.180	1.333	H1-3+VT ✓
	111 - 110	0.019	1.184	0.000	0.065	0.002	1.208	1.333	H1-3+VT ✓
	110 - 109	0.020	1.212	0.000	0.065	0.002	1.236	1.333	H1-3+VT ✓
L5	109 - 108	0.016	1.023	0.000	0.058	0.001	1.043	1.333	H1-3+VT ✓
	108 - 107	0.017	1.047	0.000	0.058	0.001	1.067	1.333	H1-3+VT ✓
	107 - 106	0.017	1.070	0.000	0.058	0.001	1.090	1.333	H1-3+VT ✓
	106 - 105	0.017	1.094	0.000	0.058	0.001	1.114	1.333	H1-3+VT ✓
	105 - 104	0.017	1.117	0.000	0.059	0.001	1.138	1.333	H1-3+VT ✓
L6	104 - 103	0.015	0.902	0.000	0.053	0.001	0.920	1.333	H1-3+VT ✓
	103 - 102	0.015	0.921	0.000	0.053	0.001	0.939	1.333	H1-3+VT ✓

tnxTower ABC Engineering 1234 W. Jones St. Smallville, PA 12345 Phone: (555) 555-1234 FAX: (555) 555-1235	Job 87581.010.01 - Newington_1, CT (BU# 826217)	Page 34 of 38
	Project	Date 14:49:48 01/30/15
	Client Crown Castle	Designed by ahabibi

Section No.	Elevation ft	Ratio	Ratio	Ratio	Ratio	Ratio	Comb. Stress Ratio	Allow. Stress Ratio	Criteria
		$\frac{P}{P_a}$	$\frac{f_{bx}}{F_{bx}}$	$\frac{f_{by}}{F_{by}}$	$\frac{f_v}{F_v}$	$\frac{f_{vt}}{F_{vt}}$			
	102 - 101	0.015	0.940	0.000	0.053	0.001	0.958	1.333	H1-3+VT ✓
	101 - 100	0.016	0.959	0.000	0.054	0.001	0.977	1.333	H1-3+VT ✓
L7	100 - 99	0.017	1.002	0.000	0.054	0.001	1.022	1.333	H1-3+VT ✓
	99 - 98	0.017	1.022	0.000	0.054	0.001	1.042	1.333	H1-3+VT ✓
	98 - 97	0.018	1.042	0.000	0.055	0.001	1.063	1.333	H1-3+VT ✓
	97 - 96	0.018	1.062	0.000	0.055	0.001	1.083	1.333	H1-3+VT ✓
	96 - 95	0.018	1.083	0.000	0.055	0.001	1.104	1.333	H1-3+VT ✓
	95 - 94	0.018	1.103	0.000	0.055	0.001	1.125	1.333	H1-3+VT ✓
	94 - 93	0.018	1.124	0.000	0.056	0.001	1.145	1.333	H1-3+VT ✓
	93 - 92	0.019	1.144	0.000	0.056	0.001	1.166	1.333	H1-3+VT ✓
	92 - 91	0.019	1.165	0.000	0.056	0.001	1.187	1.333	H1-3+VT ✓
	91 - 90	0.019	1.186	0.000	0.056	0.001	1.208	1.333	H1-3+VT ✓
	90 - 89	0.019	1.208	0.000	0.057	0.001	1.230	1.333	H1-3+VT ✓
L8	89 - 88	0.016	0.988	0.000	0.050	0.001	1.006	1.333	H1-3+VT ✓
	88 - 87	0.016	1.005	0.000	0.050	0.001	1.023	1.333	H1-3+VT ✓
	87 - 86	0.016	1.022	0.000	0.050	0.001	1.041	1.333	H1-3+VT ✓
	86 - 85	0.016	1.040	0.000	0.050	0.001	1.058	1.333	H1-3+VT ✓
	85 - 84	0.016	1.057	0.000	0.051	0.001	1.076	1.333	H1-3+VT ✓
	84 - 83	0.017	1.074	0.000	0.051	0.001	1.094	1.333	H1-3+VT ✓
	83 - 82	0.017	1.092	0.000	0.051	0.001	1.111	1.333	H1-3+VT ✓
	82 - 81	0.017	1.109	0.000	0.051	0.001	1.129	1.333	H1-3+VT ✓
	81 - 80	0.017	1.127	0.000	0.051	0.001	1.147	1.333	H1-3+VT ✓
L9	80 - 79	0.018	1.028	0.000	0.048	0.001	1.048	1.333	H1-3+VT ✓
	79 - 78	0.018	1.044	0.000	0.049	0.001	1.064	1.333	H1-3+VT ✓
	78 - 77	0.018	1.060	0.000	0.049	0.001	1.080	1.333	H1-3+VT ✓
	77 - 76	0.018	1.076	0.000	0.049	0.001	1.096	1.333	H1-3+VT ✓

tnxTower ABC Engineering 1234 W. Jones St. Smallville, PA 12345 Phone: (555) 555-1234 FAX: (555) 555-1235	Job 87581.010.01 - Newington_1, CT (BU# 826217)	Page 35 of 38
	Project	Date 14:49:48 01/30/15
	Client Crown Castle	Designed by ahabibi

Section No.	Elevation ft	Ratio $\frac{P}{P_a}$	Ratio $\frac{f_{bx}}{F_{bx}}$	Ratio $\frac{f_{by}}{F_{by}}$	Ratio $\frac{f_v}{F_v}$	Ratio $\frac{f_{vt}}{F_{vt}}$	Comb. Stress Ratio	Allow. Stress Ratio	Criteria
	76 - 75	0.018	1.092	0.000	0.049	0.001	1.113	1.333	H1-3+VT ✓
	75 - 74	0.019	1.108	0.000	0.049	0.001	1.129	1.333	H1-3+VT ✓
	74 - 73	0.019	1.124	0.000	0.050	0.001	1.145	1.333	H1-3+VT ✓
	73 - 72	0.019	1.140	0.000	0.050	0.001	1.162	1.333	H1-3+VT ✓
	72 - 71	0.019	1.157	0.000	0.050	0.001	1.178	1.333	H1-3+VT ✓
	71 - 70	0.019	1.173	0.000	0.050	0.001	1.195	1.333	H1-3+VT ✓
	70 - 69	0.020	1.190	0.000	0.051	0.001	1.212	1.333	H1-3+VT ✓
L10	69 - 68	0.017	1.011	0.000	0.045	0.000	1.030	1.333	H1-3+VT ✓
	68 - 67	0.017	1.025	0.000	0.046	0.000	1.044	1.333	H1-3+VT ✓
	67 - 66	0.017	1.039	0.000	0.046	0.000	1.058	1.333	H1-3+VT ✓
	66 - 65	0.017	1.053	0.000	0.046	0.000	1.073	1.333	H1-3+VT ✓
	65 - 64	0.017	1.068	0.000	0.046	0.000	1.087	1.333	H1-3+VT ✓
	64 - 63	0.017	1.082	0.000	0.046	0.000	1.101	1.333	H1-3+VT ✓
	63 - 62	0.018	1.096	0.000	0.046	0.000	1.116	1.333	H1-3+VT ✓
	62 - 61	0.018	1.110	0.000	0.046	0.000	1.130	1.333	H1-3+VT ✓
	61 - 60	0.018	1.125	0.000	0.047	0.000	1.145	1.333	H1-3+VT ✓
L11	60 - 59	0.019	1.066	0.000	0.045	0.001	1.088	1.333	H1-3+VT ✓
	59 - 58	0.019	1.080	0.000	0.045	0.001	1.101	1.333	H1-3+VT ✓
	58 - 57	0.019	1.094	0.000	0.046	0.001	1.115	1.333	H1-3+VT ✓
	57 - 56	0.020	1.107	0.000	0.046	0.001	1.129	1.333	H1-3+VT ✓
	56 - 55	0.020	1.121	0.000	0.046	0.001	1.143	1.333	H1-3+VT ✓
	55 - 54	0.020	1.135	0.000	0.046	0.001	1.157	1.333	H1-3+VT ✓
	54 - 53	0.020	1.148	0.000	0.046	0.001	1.171	1.333	H1-3+VT ✓
	53 - 52	0.020	1.162	0.000	0.046	0.001	1.185	1.333	H1-3+VT ✓
	52 - 51	0.021	1.176	0.000	0.047	0.001	1.199	1.333	H1-3+VT ✓
	51 - 50	0.021	1.190	0.000	0.047	0.001	1.213	1.333	H1-3+VT ✓

tnxTower ABC Engineering 1234 W. Jones St. Smallville, PA 12345 Phone: (555) 555-1234 FAX: (555) 555-1235	Job 87581.010.01 - Newington_1, CT (BU# 826217)	Page 36 of 38
	Project	Date 14:49:48 01/30/15
	Client Crown Castle	Designed by ahabibi

Section No.	Elevation ft	Ratio $\frac{P}{P_a}$	Ratio $\frac{f_{bx}}{F_{bx}}$	Ratio $\frac{f_{by}}{F_{by}}$	Ratio $\frac{f_v}{F_v}$	Ratio $\frac{f_{vt}}{F_{vt}}$	Comb. Stress Ratio	Allow. Stress Ratio	Criteria
L12	50 - 49	0.021	1.204	0.000	0.047	0.001	1.227	1.333	H1-3+VT ✓
	49 - 48	0.018	1.048	0.000	0.043	0.001	1.068	1.333	H1-3+VT ✓
	48 - 47	0.018	1.060	0.000	0.043	0.001	1.080	1.333	H1-3+VT ✓
	47 - 46	0.019	1.072	0.000	0.043	0.001	1.092	1.333	H1-3+VT ✓
	46 - 45	0.019	1.084	0.000	0.043	0.001	1.105	1.333	H1-3+VT ✓
	45 - 44	0.019	1.096	0.000	0.043	0.001	1.117	1.333	H1-3+VT ✓
	44 - 43	0.019	1.108	0.000	0.043	0.001	1.129	1.333	H1-3+VT ✓
L13	43 - 42	0.019	1.121	0.000	0.043	0.000	1.142	1.333	H1-3+VT ✓
	42 - 41	0.019	1.133	0.000	0.044	0.000	1.155	1.333	H1-3+VT ✓
	41 - 40	0.020	1.145	0.000	0.044	0.000	1.167	1.333	H1-3+VT ✓
	40 - 39	0.019	1.088	0.000	0.041	0.000	1.108	1.333	H1-3+VT ✓
	39 - 38	0.019	1.100	0.000	0.041	0.000	1.120	1.333	H1-3+VT ✓
	38 - 37	0.019	1.112	0.000	0.041	0.000	1.132	1.333	H1-3+VT ✓
	37 - 36	0.019	1.123	0.000	0.041	0.000	1.144	1.333	H1-3+VT ✓
	36 - 35	0.019	1.135	0.000	0.041	0.001	1.156	1.333	H1-3+VT ✓
	35 - 34	0.020	1.147	0.000	0.041	0.001	1.168	1.333	H1-3+VT ✓
	34 - 33	0.020	1.159	0.000	0.041	0.001	1.180	1.333	H1-3+VT ✓
L14	33 - 32	0.020	1.171	0.000	0.042	0.001	1.193	1.333	H1-3+VT ✓
	32 - 31	0.020	1.183	0.000	0.042	0.001	1.205	1.333	H1-3+VT ✓
	31 - 30	0.020	1.195	0.000	0.042	0.001	1.217	1.333	H1-3+VT ✓
	30 - 29	0.020	1.207	0.000	0.042	0.001	1.229	1.333	H1-3+VT ✓
	29 - 28	0.018	1.068	0.000	0.039	0.001	1.088	1.333	H1-3+VT ✓
	28 - 27	0.018	1.079	0.000	0.039	0.001	1.098	1.333	H1-3+VT ✓
	27 - 26	0.018	1.089	0.000	0.039	0.001	1.109	1.333	H1-3+VT ✓
26 - 25	0.019	1.100	0.000	0.039	0.001	1.120	1.333	H1-3+VT ✓	
25 - 24	0.019	1.110	0.000	0.039	0.001	1.131	1.333	H1-3+VT ✓	

tnxTower ABC Engineering 1234 W. Jones St. Smallville, PA 12345 Phone: (555) 555-1234 FAX: (555) 555-1235	Job 87581.010.01 - Newington_1, CT (BU# 826217)	Page 37 of 38
	Project	Date 14:49:48 01/30/15
	Client Crown Castle	Designed by ahabibi

Section No.	Elevation ft	Ratio $\frac{P}{P_a}$	Ratio $\frac{f_{bx}}{F_{bx}}$	Ratio $\frac{f_{by}}{F_{by}}$	Ratio $\frac{f_v}{F_v}$	Ratio $\frac{f_{vt}}{F_{vt}}$	Comb. Stress Ratio	Allow. Stress Ratio	Criteria
	24 - 23	0.019	1.121	0.000	0.039	0.001	1.142	1.333	H1-3+VT ✓
	23 - 22	0.019	1.132	0.000	0.039	0.001	1.153	1.333	H1-3+VT ✓
	22 - 21	0.019	1.143	0.000	0.039	0.001	1.164	1.333	H1-3+VT ✓
	21 - 20	0.019	1.153	0.000	0.039	0.001	1.175	1.333	H1-3+VT ✓
L15	20 - 19	0.018	1.083	0.000	0.036	0.001	1.103	1.333	H1-3+VT ✓
	19 - 18	0.018	1.093	0.000	0.036	0.001	1.113	1.333	H1-3+VT ✓
	18 - 17	0.019	1.103	0.000	0.037	0.001	1.123	1.333	H1-3+VT ✓
	17 - 16	0.019	1.113	0.000	0.037	0.001	1.134	1.333	H1-3+VT ✓
	16 - 15	0.019	1.124	0.000	0.037	0.001	1.144	1.333	H1-3+VT ✓
	15 - 14	0.019	1.134	0.000	0.037	0.001	1.154	1.333	H1-3+VT ✓
	14 - 13	0.019	1.144	0.000	0.037	0.001	1.165	1.333	H1-3+VT ✓
	13 - 12	0.019	1.154	0.000	0.037	0.001	1.175	1.333	H1-3+VT ✓
	12 - 11	0.020	1.164	0.000	0.037	0.001	1.185	1.333	H1-3+VT ✓
	11 - 10	0.020	1.175	0.000	0.037	0.001	1.196	1.333	H1-3+VT ✓
	10 - 9	0.020	1.185	0.000	0.037	0.001	1.206	1.333	H1-3+VT ✓
L16	9 - 8	0.019	1.023	0.000	0.035	0.001	1.043	1.333	H1-3+VT ✓
	8 - 7	0.019	1.032	0.000	0.036	0.001	1.052	1.333	H1-3+VT ✓
	7 - 6	0.019	1.041	0.000	0.036	0.001	1.061	1.333	H1-3+VT ✓
	6 - 5	0.019	1.050	0.000	0.036	0.001	1.070	1.333	H1-3+VT ✓
	5 - 4	0.020	1.059	0.000	0.036	0.001	1.079	1.333	H1-3+VT ✓
	4 - 3	0.020	1.067	0.000	0.036	0.001	1.089	1.333	H1-3+VT ✓
	3 - 2	0.020	1.076	0.000	0.036	0.001	1.098	1.333	H1-3+VT ✓
	2 - 1	0.020	1.085	0.000	0.036	0.001	1.107	1.333	H1-3+VT ✓
	1 - 0	0.020	1.094	0.000	0.036	0.001	1.116	1.333	H1-3+VT ✓

tnxTower ABC Engineering 1234 W. Jones St. Smallville, PA 12345 Phone: (555) 555-1234 FAX: (555) 555-1235	Job 87581.010.01 - Newington_1, CT (BU# 826217)	Page 38 of 38
	Project	Date 14:49:48 01/30/15
	Client Crown Castle	Designed by ahabibi

Section Capacity Table

Section No.	Elevation ft	Component Type	Size	Critical Element	P K	SF*P _{allow} K	% Capacity	Pass Fail
L1	190 - 180	Pole	P18x3/8	1	-3.090	697.495	6.9	Pass
L2	180 - 140	Pole	P24x3/8	2	-13.011	934.940	93.3	Pass
L3	140 - 120	Pole	P36x3/8	3	-17.101	1325.678	91.5	Pass
L4	120 - 109	Pole	P42x3/8	4	-21.863	1484.549	92.3	Pass
L5	109 - 104	Pole	P42x3/8 [0.449926]	5	-23.182	1805.415	85.6	Pass
L6	104 - 100	Pole	P42x3/8 [0.525959]	6	-24.358	2083.706	80.9	Pass
L7	100 - 89	Pole	P48x3/8 [0.43965]	7	-28.055	1944.674	93.0	Pass
L8	89 - 80	Pole	P48x3/8 [0.53914]	8	-31.244	2428.846	88.8	Pass
L9	80 - 69	Pole	P54x3/8 [0.490666]	9	-35.194	2393.735	92.4	Pass
L10	69 - 60	Pole	P54x3/8 [0.578486]	10	-38.754	2864.977	89.1	Pass
L11	60 - 49	Pole	P60x3/8 [0.516129]	11	-43.148	2742.607	93.8	Pass
L12	49 - 40	Pole	P60x3/8 [0.594533]	12	-47.190	3197.360	90.7	Pass
L13	40 - 29	Pole	P60x1/2 [0.604293]	13	-52.264	3403.522	93.5	Pass
L14	29 - 20	Pole	P60x1/2 [0.683417]	14	-56.784	3894.959	90.7	Pass
L15	20 - 9	Pole	P60x5/8 [0.703867]	15	-62.516	4189.685	91.1	Pass
L16	9 - 0	Pole	P60x5/8 [0.756633]	16	-67.491	4457.285	92.2	Pass
						Summary		
						Pole (L2)	93.8	Pass
						RATING =	93.8	Pass

APPENDIX B
BASE LEVEL DRAWING

(RESERVED)
 (7) 1-5/8" TO 160 FT LEVEL
 (INSTALLED)
 (12) 1-5/8" TO 160 FT LEVEL

(INSTALLED)
 (9) 1-1/4" TO 116 FT LEVEL
 (INSTALLED)
 (3) 5/16" TO 116 FT LEVEL
 (3) 1/2" TO 116 FT LEVEL
 (2) 2" FLEX CONDUITS

(INSTALLED)
 (1) 7/8" TO 184 FT LEVEL
 (18) 1-5/8" TO 184 FT LEVEL

(INSTALLED)
 (1) 1/2" TO 33 FT LEVEL
 (1) 1/2" TO 43 FT LEVEL
 (1) 1/2" TO 58 FT LEVEL
 (1) 7/8" TO 70 FT LEVEL
 (2) 1/2" TO 87 FT LEVEL
 (1) 5/16" TO 90 FT LEVEL
 (2) 1/2" TO 90 FT LEVEL
 (1) 7/8" TO 90 FT LEVEL
 (1) 1/2" TO 124 FT LEVEL
 (1) 1-5/8" TO 124 FT LEVEL
 (1) 7/8" TO 132 FT LEVEL
 (2) 7/8" TO 158 FT LEVEL
 (1) 5/16" TO 191 FT LEVEL
 (1) 1/2" TO 191 FT LEVEL
 (1) 1/2" TO 192 FT LEVEL
 (1) 7/8" TO 192 FT LEVEL

(INSTALLED)
 (6) 7/8" TO 100 FT LEVEL

(INSTALLED)
 (2) 7/8" TO 158 FT LEVEL

(RESERVED-IN CONDUIT)
 (2) 3/8" TO 151 FT LEVEL
 (1) 7/16" TO 151 FT LEVEL
 (INSTALLED)
 (12) 1-1/4" TO 151 FT LEVEL

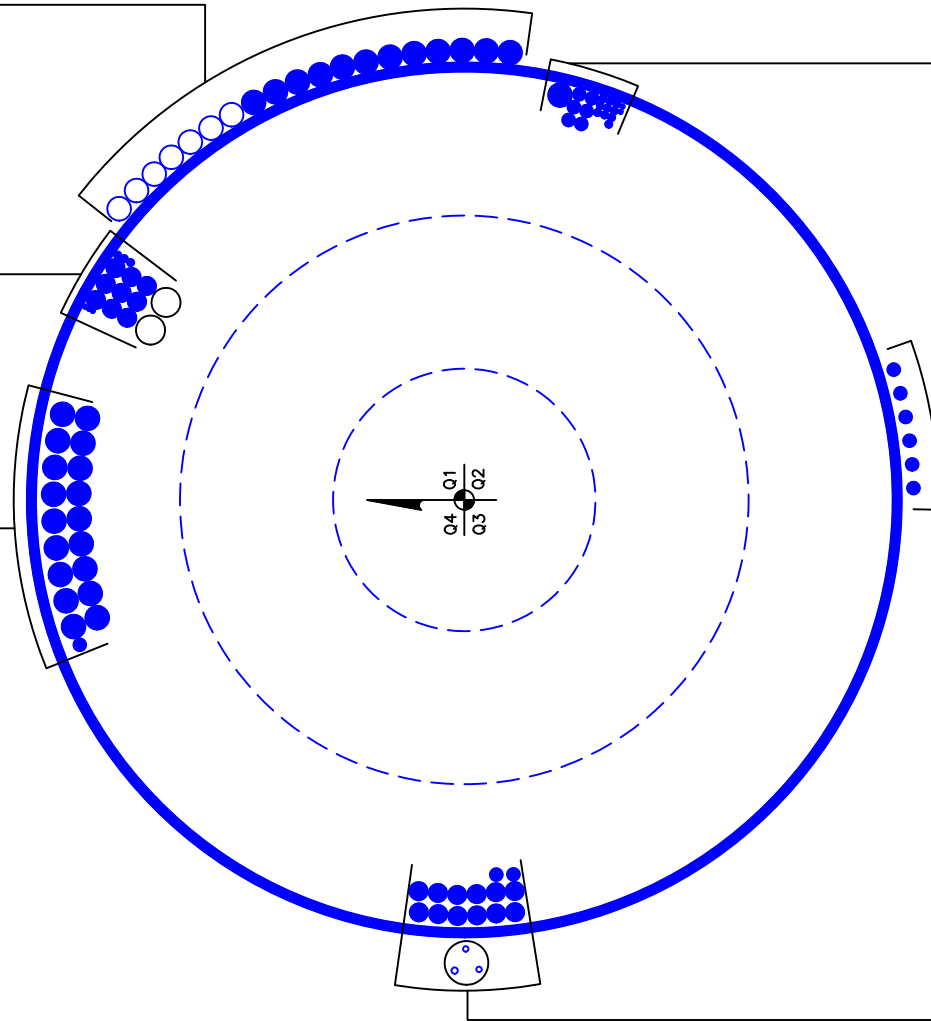

BUSINESS UNIT: 826217 TOWER ID: C_BASELEVEL

APPENDIX C
ADDITIONAL CALCULATIONS

Reinforcement Capacity

Dimensions and Properties														Compression				Axial				
Model	Weight (lb/ft)	Area (in ²)	Moment of Inertia (in ⁴)	Moment of Inertia (in ⁴)	Centroid from Mating Edge (in)	Centroid from Bolt Hole Center (in)	Web Thickness (in)	Width (in)	Flange Width (in)	Flange Thickness (in)	Hole Diameter (in)	Yield Stress (ksi)	Ultimate Stress (ksi)	Slender. Ratio Coefficient	Unbraced Length (in)	Slender. Ratio Coefficient	Unbraced Length (in)	ASD-9			LRFD	
																		Allowable Axial (kip)	Allowable Axial w/ increase (kip)	Governing Axial	Design Axial Strength (kip)	Governing Axial
CCI-0.75x4	10.2	3.00	0.14	4.00	0.375	0	0.75	4	0	0	1.21875	65	80	0.80	16	1.00	16	81.6	108.8	Rupture	122.3	Rupture
CCI-1x4.5	15.3	4.50	0.38	7.59	0.5	0	1	4.5	0	0	1.21875	65	80	0.80	20	1.00	20	128.8	171.7	Rupture	193.1	Rupture
CCI-1x6	20.4	6.00	0.50	18.00	0.5	0	1	6	0	0	1.21875	65	80	0.80	16	1.00	16	188.8	251.7	Rupture	283.1	Rupture
CCI-1.25x6.5	27.6	8.13	1.06	28.61	0.625	0	1.25	6.5	0	0	1.21875	65	80	0.80	19	1.00	19	260.4	347.2	Compress.	391.4	Rupture

Stiffened or Unstiffened, Exterior Flange Plate - Any Bolt Material TIA Rev F

Site Data

BU#: 826217
 Site Name: Newington ,CT
 App #: 261440 Rev# 2

Reactions		
Moment:	17.849	ft-kips
Axial:	3.09	kips
Shear:	4.838	kips
Elevation:	180	feet

Pole Manufacturer:	Pirod
--------------------	-------

If No stiffeners, Criteria: **AISC ASD** <-Only Applicable to Unstiffened Cases

Bolt Data		
Qty:	16	
Diameter (in.):	1	Bolt Fu: 120
Bolt Material:	A325	Bolt Fy: 92
N/A:		Bolt Fty: 44.00
N/A:		<-- Disregard
N/A:		<-- Disregard
Circle (in.):	21	

Flange Bolt Results

Bolt Tension Capacity, **B**: 46.07 kips
 Max Bolt directly applied T: 2.36 Kips
 Min. PL "tc" for **B** cap. **w/o** Pry: 1.474 in
 Min PL "treq" for actual **T w/ Pry**: 0.256 in
 Min PL "t1" for actual **T w/o Pry**: 0.333 in
 T allowable with Prying: 41.75 kips
 Prying Force, Q: 0.00 kips
 Total Bolt Tension=T+Q: 2.36 kips
 Prying Bolt Stress Ratio=(T+Q)/(B): 5.1% **Pass**

Rigid
Service, ASD
Fty*ASIF

Plate Data		
Diam:	24	in
Thick, t:	1.25	in
Grade (Fy):	36	ksi
Strength, Fu:	58	ksi
Single-Rod B-eff:	3.53	in

Exterior Flange Plate Results

Flexural Check
 Compression Side Plate Stress: Rohn/Pirod, OK
 Allowable Plate Stress: 36.0 ksi
 Compression Plate Stress Ratio: Rohn/Pirod, OK

Rigid
Service ASD
0.75*Fy*ASIF
Comp. Y.L. Length: 10.82

No Prying

Tension Side Stress Ratio, (treq/t)^2: 4.2% **Pass**

Stiffener Data (Welding at Both Sides)		
Config:	0	*
Weld Type:		
Groove Depth:		in **
Groove Angle:		degrees
Fillet H. Weld:		<-- Disregard
Fillet V. Weld:		in
Width:		in
Height:		in
Thick:		in
Notch:		in
Grade:		ksi
Weld str.:		ksi

n/a

Stiffener Results

N/A for Rohn / Pirod
 Horizontal Weld : N/A
 Vertical Weld: N/A
 Plate Flex+Shear, fb/Fb+(fv/Fv)^2: N/A
 Plate Tension+Shear, ft/Ft+(fv/Fv)^2: N/A
 Plate Comp. (AISC Bracket): N/A

Pole Results

Pole Punching Shear Check: N/A

Pole Data		
Diam:	18	in
Thick:	0.375	in
Grade:	42	ksi
# of Sides:	0	"0" IF Round
Fu	63	ksi
Reinf. Fillet Weld	0	"0" if None

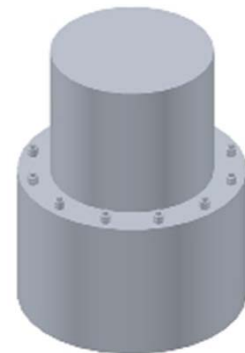
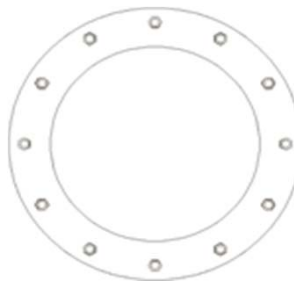

Stress Increase Factor		
ASIF:	1.333	

* 0 = none, 1 = every bolt, 2 = every 2 bolts, 3 = 2 per bolt

** Note: for complete joint penetration groove welds the groove depth must be exactly 1/2 the stiffener thickness for calculation purposes

Stiffened or Unstiffened, Exterior Flange Plate - Any Bolt Material TIA Rev F

Site Data

BU#: 826217
 Site Name: Newington ,CT
 App #: 261440 Rev# 2

Reactions		
Moment:	458.124	ft-kips
Axial:	13.011	kips
Shear:	19.654	kips
Elevation:	140	feet

Pole Manufacturer:	Pirod
--------------------	-------

If No stiffeners, Criteria: **AISC ASD** <-Only Applicable to Unstiffened Cases

Bolt Data		
Qty:	24	
Diameter (in.):	1	Bolt Fu: 120
Bolt Material:	A325	Bolt Fy: 92
N/A:		Bolt Fty: 44.00
N/A:		<-- Disregard
N/A:		<-- Disregard
Circle (in.):	27	

Flange Bolt Results

Bolt Tension Capacity, B: 46.07 kips
 Max Bolt directly applied T: 33.39 Kips
 Min. PL "tc" for B cap. w/o Pry: 1.503 in
 Min PL "treq" for actual T w/ Pry: 1.000 in
 Min PL "t1" for actual T w/o Pry: 1.280 in
 T allowable with Prying: 39.05 kips
 Prying Force, Q: 1.49 kips
 Total Bolt Tension=T+Q: 34.88 kips
 Prying Bolt Stress Ratio=(T+Q)/(B): 75.7% **Pass**

Non-Rigid
Service, ASD
Fty*ASIF

Plate Data		
Diam:	36.375	in
Thick, t:	1.25	in
Grade (Fy):	36	ksi
Strength, Fu:	58	ksi
Single-Rod B-eff:	-17.00	in

Exterior Flange Plate Results

Flexural Check: Rohn/Pirod, OK
 Compression Side Plate Stress: 36.0 ksi
 Allowable Plate Stress: Rohn/Pirod, OK
 Compression Plate Stress Ratio: Rohn/Pirod, OK

Non-Rigid
Service ASD
0.75*Fy*ASIF
Comp. Y.L. Length: #NUM!

Prying Occurs, PL Check:

Tension Side Stress Ratio, (treq/t)^2: 64.0% **Pass**

Stiffener Data (Welding at Both Sides)		
Config:	0	*
Weld Type:		
Groove Depth:		in **
Groove Angle:		degrees
Fillet H. Weld:		<-- Disregard
Fillet V. Weld:		in
Width:		in
Height:		in
Thick:		in
Notch:		in
Grade:		ksi
Weld str.:		ksi

n/a

Stiffener Results

N/A for Rohn / Pirod
 Horizontal Weld : N/A
 Vertical Weld: N/A
 Plate Flex+Shear, fb/Fb+(fv/Fv)^2: N/A
 Plate Tension+Shear, ft/Ft+(fv/Fv)^2: N/A
 Plate Comp. (AISC Bracket): N/A

Pole Results

Pole Punching Shear Check: N/A

Pole Data		
Diam:	36	in
Thick:	0.375	in
Grade:	42	ksi
# of Sides:	0	"0" IF Round
Fu	63	ksi
Reinf. Fillet Weld	0	"0" if None

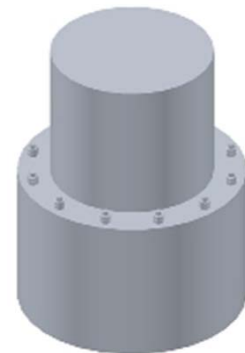
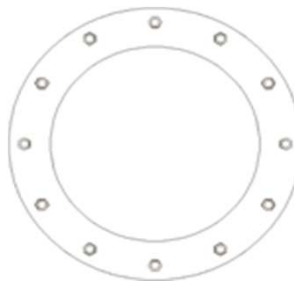

Stress Increase Factor		
ASIF:	1.333	

* 0 = none, 1 = every bolt, 2 = every 2 bolts, 3 = 2 per bolt

** Note: for complete joint penetration groove welds the groove depth must be exactly 1/2 the stiffener thickness for calculation purposes

PROJECT	87581.010.01 - Newington_1, CT - BU# 826217		
SUBJECT	Existing Bolt-on Bridge Stiffeners @ 120'		
DATE	01/28/15	PAGE	1 OF 1



SSC

Global Section Properties:

Step Width	3.00 in
Pole Thickness	0.38 in
Pole Grade	42.00 ksi
BS Material Grade	65.00 ksi
BS Ultimate Stress	80.00 ksi
BS Width	4.50 in
BS Thickness	1.00 in
BS Height	110.00 in
I	7314.58 in ⁴
Moment	879.08 k-ft
Ybar	21.50 in
S	340.21 in ³
fb	31.01 ksi
Area	4.50 in ²
P	139.53 k

Bolt Circle	39
Number of Bolts	28
Bolt Size	1

Global MOI, Taken from AutoCAD
Moment at Flange Under Consideration
Dist. CL Pole to CL BS
Global Section Modulus; I/Ybar
M/S
BS Cross Sectional Area Below Flange
Load to BS

Check Bridge Stiffener Span:

Lu	16.00 in	
ly	0.38 in ⁴	
A	4.50 in ²	
ry	0.2887 in	
Cc	93.84414701	
kl/r	55.42562584	
Fa	28.81 ksi	
Fa w/ 1/3 Increase	38.42 ksi	80.71%

Plate Tension Analysis:

Hole Size	1.25 in	
Ag	4.50 in ²	
An	3.25 in ²	
U	1	
Ae	3.25 in ²	
Ta (Yielding)	234.00 k	
Ta (Rupture)	173.33 k	
Ft (Equiv)	38.52 ksi	80.50%

Moment to Existing Bolt Group:

S _{BG} =	375.11 in ³	# Bolts Acting	7
ft =	28.12 ksi		
Ab =	.785 in ²		
T =	154.61 k		
Arm =	39.00 in		
M _{EQ} =	502.5 k-ft	<-----Insert into Crown Spreadsheet	

Stiffened or Unstiffened, Exterior Flange Plate - Any Bolt Material TIA Rev F

Site Data

BU#: 826217
 Site Name: Newington ,CT
 App #: 261440 Rev# 2

Reactions		
Moment:	502.5	ft-kips
Axial:	17.101	kips
Shear:	22.328	kips
Elevation:	120	feet

Pole Manufacturer:	Pirod
--------------------	-------

If No stiffeners, Criteria: **AISC ASD** <-Only Applicable to Unstiffened Cases

Bolt Data		
Qty:	28	
Diameter (in.):	1	Bolt Fu: 120
Bolt Material:	A325	Bolt Fy: 92
N/A:		Bolt Fty: 44.00
N/A:		<-- Disregard
N/A:		<-- Disregard
Circle (in.):	39	

Flange Bolt Results

Bolt Tension Capacity, **B**: 46.07 kips
 Max Bolt directly applied T: 21.48 Kips
 Min. PL "tc" for **B** cap. **w/o** Pry: 1.379 in
 Min PL "treq" for actual **T w/ Pry**: 0.714 in
 Min PL "t1" for actual **T w/o Pry**: 0.941 in
 T allowable with Prying: 43.33 kips
 Prying Force, Q: 0.00 kips
 Total Bolt Tension=T+Q: 21.48 kips
 Prying Bolt Stress Ratio=(T+Q)/(B): 46.6% **Pass**

Rigid
Service, ASD
Fty*ASIF

Plate Data		
Diam:	42	in
Thick, t:	1.25	in
Grade (Fy):	36	ksi
Strength, Fu:	58	ksi
Single-Rod B-eff:	4.04	in

Exterior Flange Plate Results

Flexural Check
 Compression Side Plate Stress: Rohn/Pirod, OK
 Allowable Plate Stress: 36.0 ksi
 Compression Plate Stress Ratio: Rohn/Pirod, OK

Rigid
Service ASD
0.75*Fy*ASIF
Comp. Y.L. Length:
15.00

Stiffener Data (Welding at Both Sides)

Config:	0	*
Weld Type:		
Groove Depth:		in **
Groove Angle:		degrees
Fillet H. Weld:		<-- Disregard
Fillet V. Weld:		in
Width:		in
Height:		in
Thick:		in
Notch:		in
Grade:		ksi
Weld str.:		ksi

No Prying

Tension Side Stress Ratio, (treq/t)^2: 32.7% **Pass**

n/a

Stiffener Results

N/A for Rohn / Pirod
 Horizontal Weld : N/A
 Vertical Weld: N/A
 Plate Flex+Shear, fb/Fb+(fv/Fv)^2: N/A
 Plate Tension+Shear, ft/Ft+(fv/Fv)^2: N/A
 Plate Comp. (AISC Bracket): N/A

Pole Results

Pole Punching Shear Check: N/A

Pole Data		
Diam:	36	in
Thick:	0.375	in
Grade:	42	ksi
# of Sides:	0	"0" IF Round
Fu	63	ksi
Reinf. Fillet Weld	0	"0" if None

Stress Increase Factor	
ASIF:	1.333

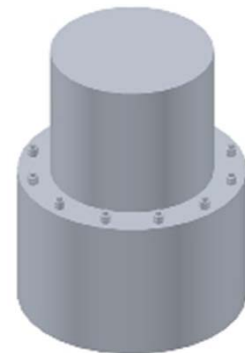
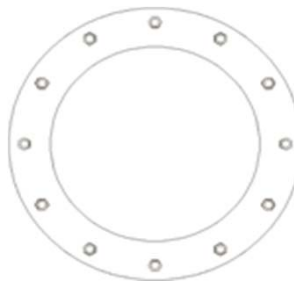

* 0 = none, 1 = every bolt, 2 = every 2 bolts, 3 = 2 per bolt

** Note: for complete joint penetration groove welds the groove depth must be exactly 1/2 the stiffener thickness for calculation purposes

PROJECT	87581.010.01 - Newington_1, CT - BU# 826217		
SUBJECT	Existing and New Bolt-on Bridge Stiffeners @ 100'		
DATE	01/28/15	PAGE	1 OF 1



SSC

Global Section Properties:

Step Width	3.00 in
Pole Thickness	0.38 in
Pole Grade	42.00 ksi
BS Material Grade	65.00 ksi
BS Ultimate Stress	80.00 ksi
BS Width	4.50 in
BS Thickness	1.00 in
BS Height	110.00 in
I	14490.58 in ⁴
Moment	1406.73 k-ft
Ybar	24.50 in
S	591.45 in ³
fb	28.54 ksi
Area	4.50 in ²
P	128.43 k

Bolt Circle	45
Number of Bolts	32
Bolt Size	1

Global MOI, Taken from AutoCAD
Moment at Flange Under Consideration
Dist. CL Pole to CL BS
Global Section Modulus; I/Ybar
M/S
BS Cross Sectional Area Below Flange
Load to BS

Check Bridge Stiffener Span:

Lu	16.00 in	
ly	0.38 in ⁴	
A	4.50 in ²	
ry	0.2887 in	
Cc	93.84414701	
kl/r	55.42562584	
Fa	28.81 ksi	
Fa w/ 1/3 Increase	38.42 ksi	74.29%

Plate Tension Analysis:

Hole Size	1.25 in	
Ag	4.50 in ²	
An	3.25 in ²	
U	1	
Ae	3.25 in ²	
Ta (Yielding)	234.00 k	
Ta (Rupture)	173.33 k	
Ft (Equiv)	38.52 ksi	74.10%

Moment to Existing Bolt Group:

S _{BG} =	644.03 in ³	# Bolts Acting	8
ft =	26.21 ksi		
Ab =	.785 in ²		
T =	164.69 k		
Arm =	45.00 in		
M _{EQ} =	617.6 k-ft	<-----Insert into Crown Spreadsheet	

Stiffened or Unstiffened, Exterior Flange Plate - Any Bolt Material TIA Rev F

Site Data

BU#: 826217
 Site Name: Newington ,CT
 App #: 261440 Rev# 2

Reactions		
Moment:	617.6	ft-kips
Axial:	24.358	kips
Shear:	27.896	kips
Elevation:	100	feet

Pole Manufacturer:	Other
--------------------	-------

If No stiffeners, Criteria: **AISC ASD** <-Only Applicable to Unstiffened Cases

Bolt Data		
Qty:	32	
Diameter (in.):	1	Bolt Fu: 120
Bolt Material:	A325	Bolt Fy: 92
N/A:		Bolt Fty: 44.00
N/A:		<-- Disregard
N/A:		<-- Disregard
Circle (in.):	45	

Flange Bolt Results

Bolt Tension Capacity, **B**: 46.07 kips
 Max Bolt directly applied T: 19.83 Kips
 Min. PL "tc" for **B** cap. **w/o** Pry: 1.365 in
 Min PL "treq" for actual **T w/ Pry**: 0.678 in
 Min PL "t1" for actual **T w/o Pry**: 0.895 in
 T allowable with Prying: 43.59 kips
 Prying Force, Q: 0.00 kips
 Total Bolt Tension=T+Q: 19.83 kips
 Prying Bolt Stress Ratio=(T+Q)/(B): 43.0% **Pass**

Rigid
Service, ASD
Fty*ASIF

Plate Data		
Diam:	48	in
Thick, t:	1.25	in
Grade (Fy):	36	ksi
Strength, Fu:	58	ksi
Single-Rod B-eff:	4.12	in

Exterior Flange Plate Results

Flexural Check
 Compression Side Plate Stress: 19.2 ksi
 Allowable Plate Stress: 36.0 ksi
 Compression Plate Stress Ratio: 53.4% **Pass**
No Prying
 Tension Side Stress Ratio, (treq/t)^2: 29.4% **Pass**

Rigid
Service ASD
0.75*Fy*ASIF
Comp. Y.L. Length:
16.16

Stiffener Data (Welding at Both Sides)		
Config:	0	*
Weld Type:		
Groove Depth:		in **
Groove Angle:		degrees
Fillet H. Weld:		<-- Disregard
Fillet V. Weld:		in
Width:		in
Height:		in
Thick:		in
Notch:		in
Grade:		ksi
Weld str.:		ksi

n/a

Stiffener Results

Horizontal Weld : n/a
 Vertical Weld: n/a
 Plate Flex+Shear, fb/Fb+(fv/Fv)^2: n/a
 Plate Tension+Shear, ft/Ft+(fv/Fv)^2: n/a
 Plate Comp. (AISC Bracket): n/a

Pole Results

Pole Punching Shear Check: n/a

Pole Data		
Diam:	42	in
Thick:	0.375	in
Grade:	42	ksi
# of Sides:	0	"0" IF Round
Fu	63	ksi
Reinf. Fillet Weld	0	"0" if None

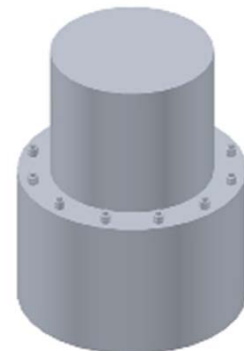
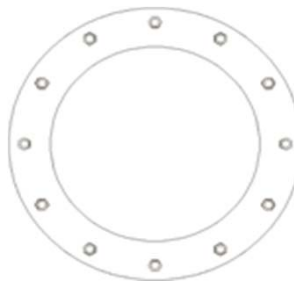

Stress Increase Factor	
ASIF:	1.333

* 0 = none, 1 = every bolt, 2 = every 2 bolts, 3 = 2 per bolt

** Note: for complete joint penetration groove welds the groove depth must be exactly 1/2 the stiffener thickness for calculation purposes

Stiffened or Unstiffened, Interior Flange Plate - Any Bolt Material TIA Rev F

Site Data

BU#: 826217
 Site Name: *Newington, CT*
 App #: 261440 Rev# 2

Manufacturer: **Other**

Bolt Data

Qty:	32		
Diam:	1	Bolt Fu:	120
Bolt Material:	A325	Bolt Fy:	92
N/A:		<-- Disregard	Bolt Fty:
N/A:		<-- Disregard	44.00
Circle:	45	in	

Reactions

Moment:	617.6	ft-kips
Axial:	24.358	kips
Shear:	27.896	kips
Exterior Flange Run, T+Q:	19.83	kips

Elevation: **100** feet

Interior Flange Bolt Results

Maximum Bolt Tension: 19.8 Kips, Ext. Flange T+Q
 Allowable Tension: 46.1 Kips
 Bolt Stress Ratio: 43.0% **Pass**

Plate Data

Plate Outer Diam:	47.25	in
Plate Inner Diam:	42	in (Hole @ Ctr)
Thick:	1.25	in
Grade:	36	ksi
Effective Width:	4.64	in

Interior Flange Plate Results

Flexural Check
 Controlling Bolt Axial Force: 21.3 Kips, Ext. C= Interior C
 Plate Stress: 19.9 ksi
 Allowable Plate Stress: 36.0 ksi
 Plate Stress Ratio: 55.2% **Pass**

Stiffener Data (Welding at Both Sides)

Config:	0	*
Weld Type:		
Groove Depth:		in **
Groove Angle:		degrees
Fillet H. Weld:		<-- Disregard
Fillet V. Weld:		in
Width:		in
Height:		in
Thick:		in
Notch:		in
Grade:		ksi
Weld str.:		ksi

n/a

Stiffener Results

Horizontal Weld : n/a
 Vertical Weld: n/a
 Plate Flex+Shear, $f_b/F_b + (f_v/F_v)^2$: n/a
 Plate Tension+Shear, $f_t/F_t + (f_v/F_v)^2$: n/a
 Plate Comp. (AISC Bracket): n/a

Pole Results

Pole Punching Shear Check: n/a

Pole Data

Pole OuterDiam:	48	in
Thick:	0.375	in
Pole Inner Diam:	47.25	in
Grade:	42	ksi
# of Sides:	0	"0" IF Round
Fu	63	ksi

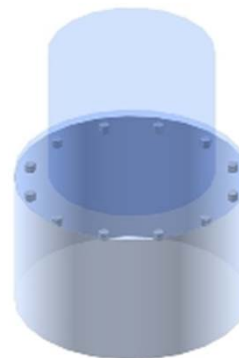
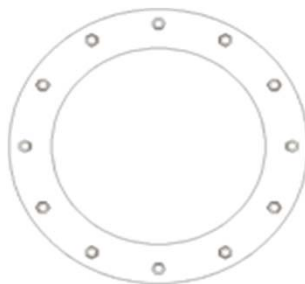

Stress Increase Factor

ASIF:	1.333
-------	-------

* 0 = none, 1 = every bolt, 2 = every 2 bolts, 3 = 2 per bolt

** Note: for complete joint penetration groove welds the groove depth must be exactly 1/2 the stiffener thickness for calculation purposes

PROJECT	87581.010.01 - Newington_1, CT - BU# 826217		
SUBJECT	Existing Bolt-on Bridge Stiffeners @ 80'		
DATE	01/28/15	PAGE	1 OF 1



SSC

Global Section Properties:

Step Width	3.00 in
Pole Thickness	0.38 in
Pole Grade	42.00 ksi
BS Material Grade	65.00 ksi
BS Ultimate Stress	80.00 ksi
BS Width	6.50 in
BS Thickness	1.25 in
BS Height	128.00 in
I	18539.73 in ⁴
Moment	2007.64 k-ft
Ybar	27.63 in
S	671.12 in ³
fb	35.90 ksi
Area	8.13 in ²
P	291.67 k

Bolt Circle	51
Number of Bolts	36
Bolt Size	1

Global MOI, Taken from AutoCAD
Moment at Flange Under Consideration
Dist. CL Pole to CL BS
Global Section Modulus; I/Ybar
M/S
BS Cross Sectional Area Below Flange
Load to BS

Check Bridge Stiffener Span:

Lu	16.00 in	
ly	1.06 in ⁴	
A	8.13 in ²	
ry	0.3608 in	
Cc	93.84414701	
kl/r	44.34050067	
Fa	31.54 ksi	
Fa w/ 1/3 Increase	42.06 ksi	85.35%

Plate Tension Analysis:

Hole Size	1.25 in	
Ag	8.13 in ²	
An	6.56 in ²	
U	1	
Ae	6.56 in ²	
Ta (Yielding)	422.50 k	
Ta (Rupture)	350.00 k	
Ft (Equiv)	43.08 ksi	83.33%

Moment to Existing Bolt Group:

S _{BG} =	727.05 in ³	# Bolts Acting	9
ft =	33.14 ksi		
Ab =	.785 in ²		
T =	234.23 k		
Arm =	51.00 in		
M _{EQ} =	995.5 k-ft	<-----Insert into Crown Spreadsheet	

Stiffened or Unstiffened, Exterior Flange Plate - Any Bolt Material TIA Rev F

Site Data

BU#: 826217
 Site Name: Newington ,CT
 App #: 261440 Rev# 2

Reactions

Moment:	995.5	ft-kips
Axial:	31.244	kips
Shear:	31.39	kips
Elevation:	80	feet

Pole Manufacturer: Other

Bolt Data

Qty:	36	Bolt Fu:	120
Diameter (in.):	1	Bolt Fy:	92
Bolt Material:	A325	Bolt Fty:	44.00
N/A:		<-- Disregard	
N/A:		<-- Disregard	
Circle (in.):	51		

If No stiffeners, Criteria: AISC ASD <--Only Applicable to Unstiffened Cases

Flange Bolt Results

Bolt Tension Capacity, B: 46.07 kips
 Max Bolt directly applied T: 25.16 Kips
 Min. PL "tc" for B cap. w/o Pry: 1.354 in
 Min PL "treq" for actual T w/ Pry: 0.757 in
 Min PL "t1" for actual T w/o Pry: 1.001 in
 T allowable with Prying: 43.80 kips
 Prying Force, Q: 0.00 kips
 Total Bolt Tension=T+Q: 25.16 kips
 Prying Bolt Stress Ratio=(T+Q)/(B): 54.6% **Pass**

Rigid
Service, ASD
Fty*ASIF

Plate Data

Diam:	54	in
Thick, t:	1.25	in
Grade (Fy):	36	ksi
Strength, Fu:	58	ksi
Single-Rod B-eff:	4.19	in

Exterior Flange Plate Results

Flexural Check
 Compression Side Plate Stress: 24.1 ksi
 Allowable Plate Stress: 36.0 ksi
 Compression Plate Stress Ratio: 66.9% **Pass**
No Prying
 Tension Side Stress Ratio, (treq/t)^2: 36.7% **Pass**

Rigid
Service ASD
0.75*Fy*ASIF
Comp. Y.L. Length: 17.23

Stiffener Data (Welding at Both Sides)

Config:	0	*
Weld Type:		
Groove Depth:		in **
Groove Angle:		degrees
Fillet H. Weld:		<-- Disregard
Fillet V. Weld:		in
Width:		in
Height:		in
Thick:		in
Notch:		in
Grade:		ksi
Weld str.:		ksi

n/a

Stiffener Results

Horizontal Weld : n/a
 Vertical Weld: n/a
 Plate Flex+Shear, fb/Fb+(fv/Fv)^2: n/a
 Plate Tension+Shear, ft/Ft+(fv/Fv)^2: n/a
 Plate Comp. (AISC Bracket): n/a

Pole Results

Pole Punching Shear Check: n/a

Pole Data

Diam:	48	in
Thick:	0.375	in
Grade:	42	ksi
# of Sides:	0	"0" IF Round
Fu	63	ksi
Reinf. Fillet Weld	0	"0" if None

Stress Increase Factor

ASIF:	1.333
-------	-------

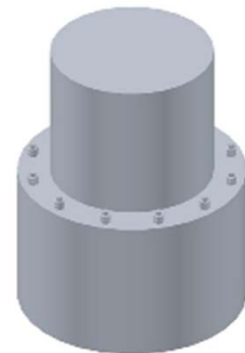
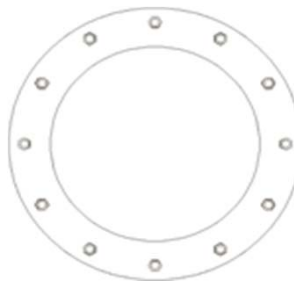

* 0 = none, 1 = every bolt, 2 = every 2 bolts, 3 = 2 per bolt

** Note: for complete joint penetration groove welds the groove depth must be exactly 1/2 the stiffener thickness for calculation purposes

Stiffened or Unstiffened, Interior Flange Plate - Any Bolt Material TIA Rev F

Site Data	
BU#:	826217
Site Name:	Newington, CT
App #:	261440 Rev# 2
Manufacturer:	Other

Reactions		
Moment:	995.5	ft-kips
Axial:	31.244	kips
Shear:	31.39	kips
Exterior Flange Run, T+Q:	25.16	kips

Elevation: 80 feet

Bolt Data			
Qty:	36		
Diam:	1	Bolt Fu:	120
Bolt Material:	A325	Bolt Fy:	92
N/A:		Bolt Fty:	44.00
N/A:			
Circle:	51		

Interior Flange Bolt Results

Maximum Bolt Tension: 25.2 Kips, Ext. Flange T+Q
 Allowable Tension: 46.1 Kips
 Bolt Stress Ratio: 54.6% **Pass**

Plate Data		
Plate Outer Diam:	53.25	in
Plate Inner Diam:	48	in (Hole @ Ctr)
Thick:	1.25	in
Grade:	36	ksi
Effective Width:	4.65	in

Interior Flange Plate Results

Controlling Bolt Axial Force: 26.9 Kips, Ext. C= Interior C
 Plate Stress: 25.0 ksi
 Allowable Plate Stress: 36.0 ksi
 Plate Stress Ratio: 69.5% **Pass**

Flexural Check

Stiffener Data (Welding at Both Sides)		
Config:	0	*
Weld Type:		
Groove Depth:		in **
Groove Angle:		degrees
Fillet H. Weld:		<-- Disregard
Fillet V. Weld:		in
Width:		in
Height:		in
Thick:		in
Notch:		in
Grade:		ksi
Weld str.:		ksi

n/a

Stiffener Results

Horizontal Weld : n/a
 Vertical Weld: n/a
 Plate Flex+Shear, $f_b/F_b + (f_v/F_v)^2$: n/a
 Plate Tension+Shear, $f_t/F_t + (f_v/F_v)^2$: n/a
 Plate Comp. (AISC Bracket): n/a

Pole Results

Pole Punching Shear Check: n/a

Pole Data		
Pole OuterDiam:	54	in
Thick:	0.375	in
Pole Inner Diam:	53.25	in
Grade:	42	ksi
# of Sides:	0	"0" IF Round
Fu	63	ksi

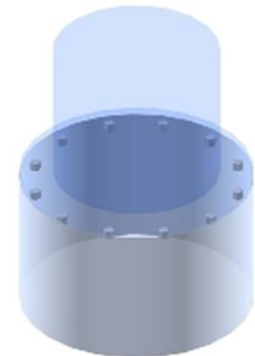
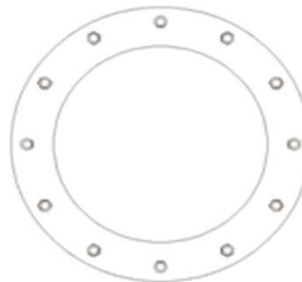

Stress Increase Factor	
ASIF:	1.333

* 0 = none, 1 = every bolt, 2 = every 2 bolts, 3 = 2 per bolt

** Note: for complete joint penetration groove welds the groove depth must be exactly 1/2 the stiffener thickness for calculation purposes

PROJECT	87581.010.01 - Newington_1, CT - BU# 826217		
SUBJECT	Existing Bolt-on Bridge Stiffeners @ 60'		
DATE	01/28/15	PAGE	1 OF 1



SSC

Global Section Properties:

Step Width	3.00 in
Pole Thickness	0.38 in
Pole Grade	42.00 ksi
BS Material Grade	65.00 ksi
BS Ultimate Stress	80.00 ksi
BS Width	8.50 in
BS Thickness	1.25 in
BS Height	128.00 in
I	45404.24 in ⁴
Moment	2661.76 k-ft
Ybar	30.63 in
S	1482.59 in ³
fb	21.54 ksi
Area	10.63 in ²
P	228.91 k

Bolt Circle	57
Number of Bolts	48
Bolt Size	1

Global MOI, Taken from AutoCAD
Moment at Flange Under Consideration
Dist. CL Pole to CL BS
Global Section Modulus; I/Ybar
M/S
BS Cross Sectional Area Below Flange
Load to BS

Check Bridge Stiffener Span:

Lu	16.00 in	
ly	1.38 in ⁴	
A	10.63 in ²	
ry	0.3608 in	
Cc	93.84414701	
kl/r	44.34050067	
Fa	31.54 ksi	
Fa w/ 1/3 Increase	42.06 ksi	51.23%

Plate Tension Analysis:

Hole Size	1.25 in	
Ag	10.63 in ²	
An	9.06 in ²	
U	1	
Ae	9.06 in ²	
Ta (Yielding)	552.50 k	
Ta (Rupture)	483.33 k	
Ft (Equiv)	45.49 ksi	47.36%

Moment to Existing Bolt Group:

S _{BG} =	1593.13 in ³	# Bolts Acting	12
ft =	20.05 ksi		
Ab =	.785 in ²		
T =	188.96 k		
Arm =	57.00 in		
M _{EQ} =	897.6 k-ft	<-----Insert into Crown Spreadsheet	

Stiffened or Unstiffened, Exterior Flange Plate - Any Bolt Material TIA Rev F

Site Data

BU#: 826217
 Site Name: Newington ,CT
 App #: 261440 Rev# 2

Reactions

Moment:	897.6	ft-kips
Axial:	38.754	kips
Shear:	34.05	kips
Elevation:	60	feet

Pole Manufacturer: Other

Bolt Data

Qty:	48	Bolt Fu:	120
Diameter (in.):	1	Bolt Fy:	92
Bolt Material:	A325	Bolt Fty:	44.00
N/A:		<-- Disregard	
N/A:		<-- Disregard	
Circle (in.):	57		

If No stiffeners, Criteria: AISC ASD <--Only Applicable to Unstiffened Cases

Flange Bolt Results

Bolt Tension Capacity, B: 46.07 kips
 Max Bolt directly applied T: 14.94 Kips
 Min. PL "tc" for B cap. w/o Pry: 1.474 in
 Min PL "treq" for actual T w/ Pry: 0.644 in
 Min PL "t1" for actual T w/o Pry: 0.839 in
 T allowable with Prying: 41.75 kips
 Prying Force, Q: 0.00 kips
 Total Bolt Tension=T+Q: 14.94 kips
 Prying Bolt Stress Ratio=(T+Q)/(B): 32.4% **Pass**

Rigid
Service, ASD
Fty*ASIF

Plate Data

Diam:	60	in
Thick, t:	1.25	in
Grade (Fy):	36	ksi
Strength, Fu:	58	ksi
Single-Rod B-eff:	3.53	in

Exterior Flange Plate Results

Flexural Check
 Compression Side Plate Stress: 17.5 ksi
 Allowable Plate Stress: 36.0 ksi
 Compression Plate Stress Ratio: 48.5% **Pass**
No Prying
 Tension Side Stress Ratio, (treq/t)^2: 26.5% **Pass**

Rigid
Service ASD
0.75*Fy*ASIF
Comp. Y.L. Length: 18.25

Stiffener Data (Welding at Both Sides)

Config:	0	*
Weld Type:		
Groove Depth:		in **
Groove Angle:		degrees
Fillet H. Weld:		<-- Disregard
Fillet V. Weld:		in
Width:		in
Height:		in
Thick:		in
Notch:		in
Grade:		ksi
Weld str.:		ksi

n/a

Stiffener Results

Horizontal Weld : n/a
 Vertical Weld: n/a
 Plate Flex+Shear, fb/Fb+(fv/Fv)^2: n/a
 Plate Tension+Shear, ft/Ft+(fv/Fv)^2: n/a
 Plate Comp. (AISC Bracket): n/a

Pole Results

Pole Punching Shear Check: n/a

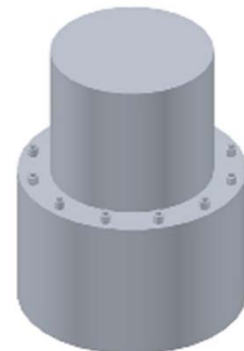
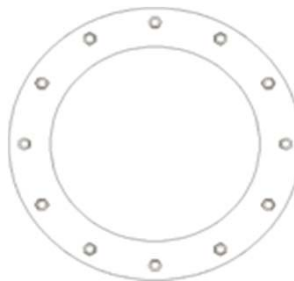

Pole Data

Diam:	54	in
Thick:	0.375	in
Grade:	42	ksi
# of Sides:	0	"0" IF Round
Fu	63	ksi
Reinf. Fillet Weld	0	"0" if None

Stress Increase Factor

ASIF:	1.333
-------	-------

* 0 = none, 1 = every bolt, 2 = every 2 bolts, 3 = 2 per bolt

** Note: for complete joint penetration groove welds the groove depth must be exactly 1/2 the stiffener thickness for calculation purposes

Stiffened or Unstiffened, Interior Flange Plate - Any Bolt Material TIA Rev F

Site Data

BU#: 826217
 Site Name: *Newington, CT*
 App #: 261440 Rev# 2

Manufacturer: **Other**

Bolt Data

Qty:	48		
Diam:	1	Bolt Fu:	120
Bolt Material:	A325	Bolt Fy:	92
N/A:		Bolt Fty:	44.00
N/A:			
Circle:	57		

Reactions		
Moment:	897.6	ft-kips
Axial:	38.754	kips
Shear:	34.05	kips
Exterior Flange Run, T+Q:	14.94	kips

Elevation: **60** feet

Interior Flange Bolt Results

Maximum Bolt Tension: 14.9 Kips, Ext. Flange T+Q
 Allowable Tension: 46.1 Kips
 Bolt Stress Ratio: 32.4% **Pass**

Plate Data

Plate Outer Diam:	59.25	in
Plate Inner Diam:	54	in (Hole @ Ctr)
Thick:	1.25	in
Grade:	36	ksi
Effective Width:	3.88	in

Interior Flange Plate Results

Flexural Check
 Controlling Bolt Axial Force: 16.6 Kips, Ext. C= Interior C
 Plate Stress: 18.4 ksi
 Allowable Plate Stress: 36.0 ksi
 Plate Stress Ratio: 51.2% **Pass**

Stiffener Data (Welding at Both Sides)

Config:	0	*
Weld Type:		
Groove Depth:		in **
Groove Angle:		degrees
Fillet H. Weld:		<-- Disregard
Fillet V. Weld:		in
Width:		in
Height:		in
Thick:		in
Notch:		in
Grade:		ksi
Weld str.:		ksi

n/a

Stiffener Results

Horizontal Weld : n/a
 Vertical Weld: n/a
 Plate Flex+Shear, $f_b/F_b + (f_v/F_v)^2$: n/a
 Plate Tension+Shear, $f_t/F_t + (f_v/F_v)^2$: n/a
 Plate Comp. (AISC Bracket): n/a

Pole Results

Pole Punching Shear Check: n/a

Pole Data

Pole OuterDiam:	60	in
Thick:	0.375	in
Pole Inner Diam:	59.25	in
Grade:	42	ksi
# of Sides:	0	"0" IF Round
Fu	63	ksi

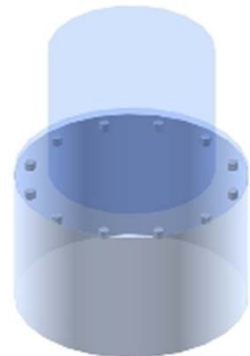
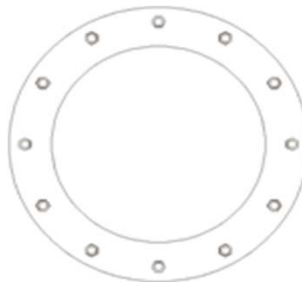

Stress Increase Factor

ASIF:	1.333
-------	-------

* 0 = none, 1 = every bolt, 2 = every 2 bolts, 3 = 2 per bolt

** Note: for complete joint penetration groove welds the groove depth must be exactly 1/2 the stiffener thickness for calculation purposes

PROJECT	87581.010.01 - Newington_1, CT - BU# 826217		
SUBJECT	Existing Bolt-on Bridge Stiffeners @ 40'		
DATE	01/28/15	PAGE	1 OF 1



SSC

Global Section Properties:

Step Width	0.00 in
Pole Thickness	0.50 in
Pole Grade	42.00 ksi
BS Material Grade	65.00 ksi
BS Ultimate Stress	80.00 ksi
BS Width	8.50 in
BS Thickness	1.25 in
BS Height	128.00 in
I	55715.20 in ⁴
Moment	3367.11 k-ft
Ybar	31.13 in
S	1790.05 in ³
fb	22.57 ksi
Area	10.63 in ²
P	239.83 k

Bolt Circle	50
Number of Bolts	64
Bolt Size	1.25

Global MOI, Taken from AutoCAD
Moment at Flange Under Consideration
Dist. CL Pole to CL BS
Global Section Modulus; I/Ybar
M/S
BS Cross Sectional Area Below Flange
Load to BS

Check Bridge Stiffener Span:

Lu	25.00 in	
ly	1.38 in ⁴	
A	10.63 in ²	
ry	0.3608 in	
Cc	93.84414701	
kl/r	69.2820323	
Fa	24.98 ksi	
Fa w/ 1/3 Increase	33.30 ksi	67.78%

Plate Tension Analysis:

Hole Size	1.25 in	
Ag	10.63 in ²	
An	9.06 in ²	
U	1	
Ae	9.06 in ²	
Ta (Yielding)	552.50 k	
Ta (Rupture)	483.33 k	
Ft (Equiv)	45.49 ksi	49.62%

Moment to Existing Bolt Group:

S _{BG} =	2228.61 in ³	# Bolts Acting	16
ft =	18.13 ksi		
Ab =	1.227 in ²		
T =	355.99 k		
Arm =	50.00 in		
M _{EQ} =	1483.3 k-ft	<-----Insert into Crown Spreadsheet	

Stiffened or Unstiffened, Interior Flange Plate - Any Bolt Material TIA Rev F

Site Data	
BU#:	826217
Site Name:	Newington, CT
App #:	261440 Rev# 2

Reactions		
Moment:	652.97	ft-kips
Axial:	47.19	kips
Shear:	36.492	kips
Exterior Flange Run, T+Q:	0	kips

Manufacturer:	Other
---------------	-------

Elevation: 40-47BC feet

Bolt Data			
Qty:	32		
Diam:	1.25	Bolt Fu:	105
Bolt Material:	A325	Bolt Fy:	81
N/A:		Bolt Fty:	44.00
N/A:			
Circle:	47		

Interior Flange Bolt Results
 Maximum Bolt Tension: 19.4 Kips, Ext. T=Interior T
 Allowable Tension: 72.0 Kips
 Bolt Stress Ratio: 26.9% **Pass**

Plate Data		
Plate Outer Diam:	59	in
Plate Inner Diam:	45	in (Hole @ Ctr)
Thick:	1.25	in
Grade:	36	ksi
Effective Width:	5.79	in

Interior Flange Plate Results Flexural Check
 Controlling Bolt Axial Force: 22.3 Kips, Ext. C= Interior C
 Plate Stress: 17.5 ksi
 Allowable Plate Stress: 36.0 ksi
 Plate Stress Ratio: 48.7% **Pass**

Stiffener Data (Welding at Both Sides)		
Config:	1	*
Weld Type:	Fillet	
Groove Depth:		<-- Disregard
Groove Angle:		<-- Disregard
Fillet H. Weld:	0.3125	in
Fillet V. Weld:	0.3125	in
Width:	3	in
Height:	6	in
Thick:	0.5	in
Notch:	0.5	in
Grade:	36	ksi
Weld str.:	70	ksi

Stiffener Results
 Horizontal Weld : 18.4% **Pass**
 Vertical Weld: 9.9% **Pass**
 Plate Flex+Shear, fb/Fb+(fv/Fv)^2: 6.3% **Pass**
 Plate Tension+Shear, ft/Ft+(fv/Fv)^2: 15.4% **Pass**
 Plate Comp. (AISC Bracket): 21.0% **Pass**

Pole Results
 Pole Punching Shear Check: 3.4% **Pass**

Pole Data		
Pole OuterDiam:	60	in
Thick:	0.5	in
Pole Inner Diam:	59	in
Grade:	42	ksi
# of Sides:	0	"0" IF Round
Fu	63	ksi

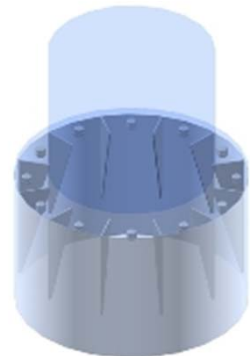
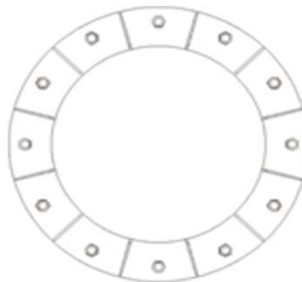

Stress Increase Factor	
ASIF:	1.333

* 0 = none, 1 = every bolt, 2 = every 2 bolts, 3 = 2 per bolt

** Note: for complete joint penetration groove welds the groove depth must be exactly 1/2 the stiffener thickness for calculation purposes

Stiffened or Unstiffened, Interior Flange Plate - Any Bolt Material TIA Rev F

Site Data	
BU#:	826217
Site Name:	Newington, CT
App #:	261440 Rev# 2

Manufacturer:	Other
---------------	-------

Bolt Data	
Qty:	32
Diam:	1.25
Bolt Material:	A325
N/A:	<-- Disregard
N/A:	<-- Disregard
Circle:	53 in

Bolt Fu:	105
Bolt Fy:	81
Bolt Fty:	44.00

Reactions	
Moment:	830.33 ft-kips
Axial:	47.19 kips
Shear:	36.492 kips
Exterior Flange Run, T+Q:	0 kips

Elevation: 40-53BC feet

Interior Flange Bolt Results

Maximum Bolt Tension:	22.0 Kips, Ext. T=Interior T
Allowable Tension:	72.0 Kips
Bolt Stress Ratio:	30.6% Pass

Plate Data	
Plate Outer Diam:	59 in
Plate Inner Diam:	45 in (Hole @ Ctr)
Thick:	1.25 in
Grade:	36 ksi
Effective Width:	5.79 in

Interior Flange Plate Results

Controlling Bolt Axial Force:	25.0 Kips, Ext. C= Interior C
Plate Stress:	19.6 ksi
Allowable Plate Stress:	36.0 ksi
Plate Stress Ratio:	54.4% Pass

Flexural Check

Stiffener Data (Welding at Both Sides)	
Config:	1 *
Weld Type:	Fillet
Groove Depth:	<-- Disregard
Groove Angle:	<-- Disregard
Fillet H. Weld:	0.3125 in
Fillet V. Weld:	0.3125 in
Width:	3 in
Height:	6 in
Thick:	0.5 in
Notch:	0.5 in
Grade:	36 ksi
Weld str.:	70 ksi

Stiffener Results

Horizontal Weld :	23.0% Pass
Vertical Weld:	12.3% Pass
Plate Flex+Shear, fb/Fb+(fv/Fv)^2:	8.1% Pass
Plate Tension+Shear, ft/Ft+(fv/Fv)^2:	19.5% Pass
Plate Comp. (AISC Bracket):	26.2% Pass

Pole Results

Pole Punching Shear Check:	4.3% Pass
----------------------------	------------------

Pole Data	
Pole OuterDiam:	60 in
Thick:	0.5 in
Pole Inner Diam:	59 in
Grade:	42 ksi
# of Sides:	0 "0" IF Round
Fu	63 ksi

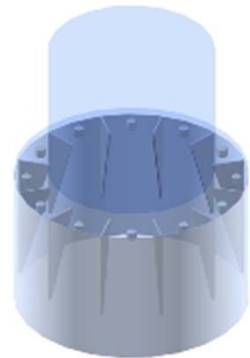
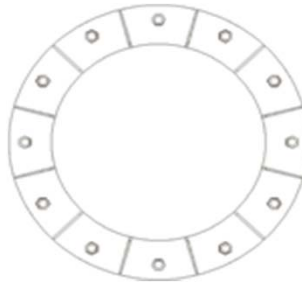

Stress Increase Factor	
ASIF:	1.333

* 0 = none, 1 = every bolt, 2 = every 2 bolts, 3 = 2 per bolt

** Note: for complete joint penetration groove welds the groove depth must be exactly 1/2 the stiffener thickness for calculation purposes

PROJECT	87581.010.01 - Newington_1, CT - BU# 826217		
SUBJECT	Existing Bolt-on Bridge Stiffeners @ 20'		
DATE	01/28/15	PAGE	1 OF 1



SSC

Global Section Properties:

Step Width	0.00 in
Pole Thickness	0.63 in
Pole Grade	42.00 ksi
BS Material Grade	65.00 ksi
BS Ultimate Stress	80.00 ksi
BS Width	6.50 in
BS Thickness	1.25 in
BS Height	128.00 in
I	48342.38 in ⁴
Moment	4118.15 k-ft
Ybar	31.13 in
S	1553.17 in ³
fb	31.82 ksi
Area	8.13 in ²
P	258.52 k

Bolt Circle	50
Number of Bolts	64
Bolt Size	1.25

Global MOI, Taken from AutoCAD
Moment at Flange Under Consideration
Dist. CL Pole to CL BS
Global Section Modulus; I/Ybar
M/S
BS Cross Sectional Area Below Flange
Load to BS

Check Bridge Stiffener Span:

Lu	24.00 in	
ly	1.06 in ⁴	
A	8.13 in ²	
ry	0.3608 in	
Cc	93.84414701	
kl/r	66.51075101	
Fa	25.78 ksi	
Fa w/ 1/3 Increase	34.38 ksi	92.56%

Plate Tension Analysis:

Hole Size	1.25 in	
Ag	8.13 in ²	
An	6.56 in ²	
U	1	
Ae	6.56 in ²	
Ta (Yielding)	422.50 k	
Ta (Rupture)	350.00 k	
Ft (Equiv)	43.08 ksi	73.86%

Moment to Existing Bolt Group:

S _{BG} =	1933.70 in ³	# Bolts Acting	16
ft =	25.56 ksi		
Ab =	1.227 in ²		
T =	501.79 k		
Arm =	50.00 in		
M _{EQ} =	2090.8 k-ft	<-----Insert into Crown Spreadsheet	

Stiffened or Unstiffened, Interior Flange Plate - Any Bolt Material TIA Rev F

Site Data

BU#: 826217
 Site Name: *Newington, CT*
 App #: 261440 Rev# 2

Manufacturer: **Other**

Bolt Data

Qty:	32		
Diam:	1.25	Bolt Fu:	105
Bolt Material:	A325	Bolt Fy:	81
N/A:		<-- Disregard	Bolt Fty:
N/A:		<-- Disregard	44.00
Circle:	47	in	

Reactions

Moment:	920.4	ft-kips
Axial:	56.784	kips
Shear:	38.537	kips
Exterior Flange Run, T+Q:	0	kips

Elevation: **20-47BC** feet

Interior Flange Bolt Results

Maximum Bolt Tension: 27.6 Kips, Ext. T=Interior T
 Allowable Tension: 72.0 Kips
 Bolt Stress Ratio: 38.3% **Pass**

Plate Data

Plate Outer Diam:	58.75	in
Plate Inner Diam:	45	in (Hole @ Ctr)
Thick:	1.25	in
Grade:	36	ksi
Effective Width:	5.77	in

Interior Flange Plate Results

Flexural Check
 Controlling Bolt Axial Force: 31.1 Kips, Ext. C= Interior C
 Plate Stress: 24.5 ksi
 Allowable Plate Stress: 36.0 ksi
 Plate Stress Ratio: 67.9% **Pass**

Stiffener Data (Welding at Both Sides)

Config:	1	*
Weld Type:	Fillet	
Groove Depth:		<-- Disregard
Groove Angle:		<-- Disregard
Fillet H. Weld:	0.3125	in
Fillet V. Weld:	0.3125	in
Width:	3	in
Height:	6	in
Thick:	0.5	in
Notch:	0.5	in
Grade:	36	ksi
Weld str.:	70	ksi

Stiffener Results

Horizontal Weld : 21.8% **Pass**
 Vertical Weld: 11.6% **Pass**
 Plate Flex+Shear, $f_b/F_b+(f_v/F_v)^2$: 7.6% **Pass**
 Plate Tension+Shear, $f_t/F_t+(f_v/F_v)^2$: 18.4% **Pass**
 Plate Comp. (AISC Bracket): 24.8% **Pass**

Pole Results

Pole Punching Shear Check: 3.2% **Pass**

Pole Data

Pole OuterDiam:	60	in
Thick:	0.625	in
Pole Inner Diam:	58.75	in
Grade:	42	ksi
# of Sides:	0	"0" IF Round
Fu	63	ksi

Stress Increase Factor

ASIF:	1.333
-------	-------

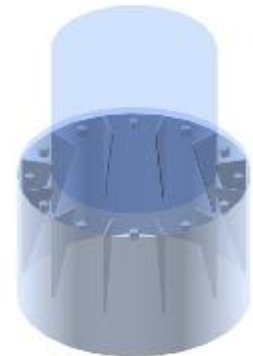
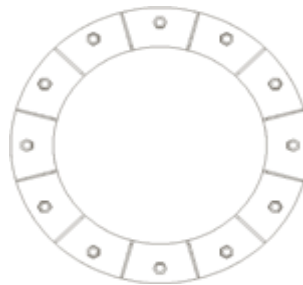

* 0 = none, 1 = every bolt, 2 = every 2 bolts, 3 = 2 per bolt

** Note: for complete joint penetration groove welds the groove depth must be exactly 1/2 the stiffener thickness for calculation purposes

Stiffened or Unstiffened, Interior Flange Plate - Any Bolt Material TIA Rev F

Site Data	
BU#:	826217
Site Name:	Newington, CT
App #:	261440 Rev# 2

Reactions		
Moment:	1170.4	ft-kips
Axial:	56.784	kips
Shear:	38.537	kips
Exterior Flange Run, T+Q:	0	kips

Manufacturer:	Other
---------------	-------

Elevation: 20-53BC feet

Bolt Data		
Qty:	32	
Diam:	1.25	Bolt Fu: 105
Bolt Material:	A325	Bolt Fy: 81
N/A:		Bolt Fty: 44.00
N/A:		
Circle:	53	in

Interior Flange Bolt Results
 Maximum Bolt Tension: 31.4 Kips, Ext. T=Interior T
 Allowable Tension: 72.0 Kips
 Bolt Stress Ratio: 43.6% **Pass**

Plate Data		
Plate Outer Diam:	58.75	in
Plate Inner Diam:	45	in (Hole @ Ctr)
Thick:	1.25	in
Grade:	36	ksi
Effective Width:	5.77	in

Interior Flange Plate Results Flexural Check
 Controlling Bolt Axial Force: 34.9 Kips, Ext. C= Interior C
 Plate Stress: 27.4 ksi
 Allowable Plate Stress: 36.0 ksi
 Plate Stress Ratio: 76.1% **Pass**

Stiffener Data (Welding at Both Sides)		
Config:	1	*
Weld Type:	Fillet	
Groove Depth:		<-- Disregard
Groove Angle:		<-- Disregard
Fillet H. Weld:	0.3125	in
Fillet V. Weld:	0.3125	in
Width:	3	in
Height:	6	in
Thick:	0.5	in
Notch:	0.5	in
Grade:	36	ksi
Weld str.:	70	ksi

Stiffener Results
 Horizontal Weld : 27.3% **Pass**
 Vertical Weld: 14.6% **Pass**
 Plate Flex+Shear, fb/Fb+(fv/Fv)^2: 10.0% **Pass**
 Plate Tension+Shear, ft/Ft+(fv/Fv)^2: 23.4% **Pass**
 Plate Comp. (AISC Bracket): 31.1% **Pass**

Pole Data		
Pole OuterDiam:	60	in
Thick:	0.625	in
Pole Inner Diam:	58.75	in
Grade:	42	ksi
# of Sides:	0	"0" IF Round
Fu	63	ksi

Pole Results
 Pole Punching Shear Check: 4.0% **Pass**

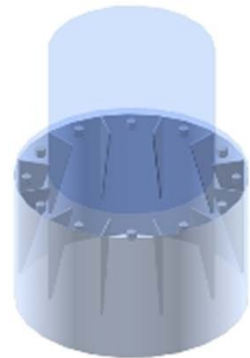
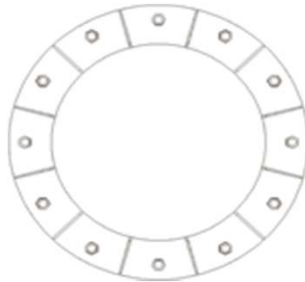

Stress Increase Factor	
ASIF:	1.333

* 0 = none, 1 = every bolt, 2 = every 2 bolts, 3 = 2 per bolt

** Note: for complete joint penetration groove welds the groove depth must be exactly 1/2 the stiffener thickness for calculation purposes

Anchor Rod Information for TIA/EIA-222-F and TIA-222-G-2

Site Information	
ID:	826217
Name:	Newington_1
App. #:	221161; Revision # 5



Base Reactions	
Moment:	4906 ft-kip
Axial:	67 kip
Shear:	40 kip
Base Plate Type:	Circular

Design Information	
TIA Code:	F
ASIF:	1.333
Failure:	95%
eta Factor:	0.50

Original Anchor Rod Data	
Quantity:	52
Diameter:	1.25 in
Material:	A687
Bolt Circle:	67.0 in
Bolt Spacing:	in
Bolt Group Area:	63.81 in ²
Bolt Group MOIx:	35807 in ⁴
<u>Reactions Seen by Original AR Group</u>	
Moment:	2249.3 kip-ft
Axial:	67.5 kip
Shear:	40.2 kip
<u>Original AR Capacity Check</u>	
Tension Load:	29.7 kip
Allowable load:	81.0 kip
AR Capacity:	36.7% Pass

First Added Anchor Rod Data	
Quantity:	10
Diameter:	2.25 in
Material:	A193 B7
Bolt Circle:	92.3 in
Bolt Group Area:	39.76 in ²
Bolt Group MOIx:	42296 in ⁴
<u>Reactions Seen by First Added AR Group</u>	
Moment:	2656.8 kip-ft
Axial:	0.0 kip
Shear:	0.0 kip
<u>First Added AR Capacity Check</u>	
Tension Load:	138.2 kip
Allowable load:	218.6 kip
AR Capacity:	63.2% Pass

Second Added Anchor Rod Data	
Quantity:	
Diameter:	in
Material:	
Bolt Circle:	in
Bolt Group Area:	0.00 in ²
Bolt Group MOIx:	0 in ⁴
<u>Reactions Seen by Second Added AR Group</u>	
Moment:	0.0 kip-ft
Axial:	0.0 kip
Shear:	0.0 kip
<u>Second Added AR Capacity Check</u>	
Tension Load:	0.0 kip
Allowable load:	0.0 kip
AR Capacity:	0.0%

Third Added Anchor Rod Data	
Quantity:	
Diameter:	in
Material:	
Bolt Circle:	in
Bolt Group Area:	0.00 in ²
Bolt Group MOIx:	0 in ⁴
<u>Reactions Seen by Second Added AR Group</u>	
Moment:	0.0 kip-ft
Axial:	0.0 kip
Shear:	0.0 kip
<u>Second Added AR Capacity Check</u>	
Tension Load:	0.0 kip
Allowable load:	0.0 kip
AR Capacity:	0.0%

Stiffened or Unstiffened, Ungrouted, Circular Base Plate - Any Rod Material

TIA Rev F

Site Data

BU#:	826217
Site Name:	Newington_1
App #:	261440; Revision # 2
Pole Manufacturer:	Other

Reactions

Moment:	2249.3	ft-kips
Axial:	67.4913	kips
Shear:	40.20778	kips

Anchor Rod Data

Qty:	52	
Diam:	1.25	in
Rod Material:	Other	
Strength (Fu):	150	ksi
Yield (Fy):	105	ksi
Bolt Circle:	67	in

If No stiffeners, Criteria: **AISC ASD** <-Only Applicable to Unstiffened Cases

Anchor Rod Results

Maximum Rod Tension:	29.7 Kips
Allowable Tension:	81.0 Kips
Anchor Rod Stress Ratio:	36.7% Pass

Stiffened
Service, ASD
Ft*ASIF

Plate Data

Diam:	70	in
Thick:	1	in
Grade:	36	ksi
Single-Rod B-eff:	3.62	in

Base Plate Results

Base Plate Stress:	34.8 ksi	Flexural Check
Allowable Plate Stress:	36.0 ksi	
Base Plate Stress Ratio:	96.7% Pass	

Stiffened
Service, ASD
0.75*Fy*ASIF
Y.L. Length:
N/A, Roark

Stiffener Data (Welding at both sides)

Config:	1	*
Weld Type:	Fillet	
Groove Depth:		<-- Disregard
Groove Angle:		<-- Disregard
Fillet H. Weld:	0.3125	in
Fillet V. Weld:	0.3125	in
Width:	3	in
Height:	6	in
Thick:	0.5	in
Notch:	0.5	in
Grade:	36	ksi
Weld str.:	70	ksi

Stiffener Results

Horizontal Weld :	46.5% Pass
Vertical Weld:	24.9% Pass
Plate Flex+Shear, fb/Fb+(fv/Fv)^2:	19.6% Pass
Plate Tension+Shear, ft/Ft+(fv/Fv)^2:	42.4% Pass
Plate Comp. (AISC Bracket):	53.0% Pass

Pole Results

Pole Punching Shear Check:	6.9% Pass
----------------------------	------------------

Pole Data

Diam:	60	in
Thick:	0.625	in
Grade:	42	ksi
# of Sides:	0	"0" IF Round
Fu	63	ksi
Reinf. Fillet Weld	0	"0" if None

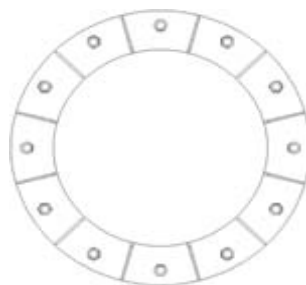

Stress Increase Factor

ASIF:	1.333
-------	-------

* 0 = none, 1 = every bolt, 2 = every 2 bolts, 3 = 2 per bolt

** Note: for complete joint penetration groove welds the groove depth must be exactly 1/2 the stiffener thickness for calculation purposes

PROJECT	826217 - Newington_1	JEB
SUBJECT	261440 Rev # 2	
DATE	01/28/15	PAGE 1 OF 9



B+T GRP
 1717 S. Boulder, Suite 300
 Tulsa, OK 74159
 (918) 587-4630

87581_009_01_MP_FDN_Monopole Pier and Pad Unified.xls

B&T Proj. No.: 87581.009.01

Monopole Pad & Pier Foundation Analysis

Rev. Type: **F**

Design Loads:

	Input unfactored loads	
Shear:	<u>40.0</u>	kips
Moment:	<u>3,706.0</u>	ft-kips
Tower Height:	<u>190.0</u>	ft
Tower Weight:	<u>67.0</u>	kips

Pad & Pier Dimensions / Properties:

Pole Diameter at Base:	<u>60.00</u>	in
Bearing Depth:	<u>9.0</u>	ft
Pad Width:	<u>20.5</u>	ft
Neglected Depth:	<u>3.3</u>	ft
Thickness:	<u>2.5</u>	ft
Pier Diameter:	<u>7.0</u>	ft
Pier Height Above Grade:	<u>0.5</u>	ft
BP Dist. Above Pier:	<u>3.0</u>	in
Clear Cover:	<u>3.0</u>	in
Pier Rebar Size:	<u>9</u>	
Pier Rebar Quantity:	<u>34</u>	
Pad Rebar Size:	<u>11</u>	
Pad Rebar Quantity:	<u>30</u>	
Pier Tie Size:	<u>4</u>	
Tie Quantity:	<u>11</u>	
Rebar Yield Strength:	<u>60000</u>	psi
Concrete Strength:	<u>3000</u>	psi
Concrete Unit Weight:	<u>0.15</u>	kcf
Seismic Zone:	<u>1</u>	

20.5 FT

Plan View

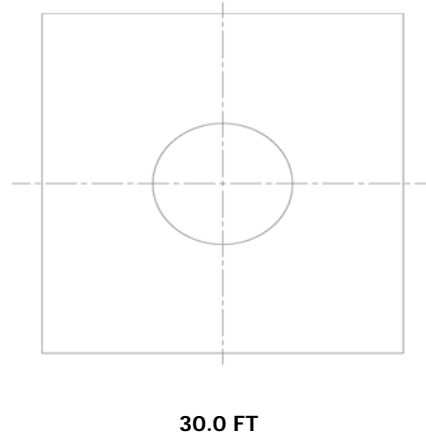

Elevation Overview

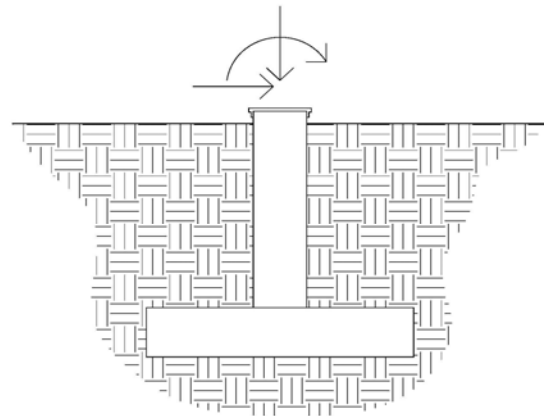

Soil Data:

	Allowable Values	
Soil Unit Weight:	<u>0.130</u>	kcf
Ult. Bearing Capacity:	<u>16.000</u>	ksf
Angle of Friction:	<u>36.000</u>	deg
Cohesion:	<u>0.000</u>	ksf
Passive Pressure:	<u>0.000</u>	ksf
Base Friction:	<u>0.350</u>	

** Notes:

The moment was reduced to account for the rock anchor modifaicton.

Summary of Results

Req'd Pier Diam.	OK
Overtuning	84.4%
Shear Capacity	29.4%
Bearing	64.6%
Pad Shear - 1-way	98.1%
Pad Shear - 2-way	10.6%
Pad Moment Capacity	51.5%
Pier Moment Capacity	93.4%

APPENDIX D
TOWER MODIFICATION DRAWINGS

TOWER MODIFICATION DRAWINGS PREPARED FOR: CROWN CASTLE

PROJECT CONTACTS:

1. CROWN TOWER STRUCTURAL ANALYST

MITCHELL ABBOTT
(704) 405-6612
MITCHELL.ABBOTT@CROWNCastle.COM
3530 TORINGDON WAY, SUITE 300
CHARLOTTE, NC 28277

2. CROWN PROJECT MANAGER

JERRY BRUNO
(781) 970-0069
JERRY.BRUNO@CROWNCastle.COM

3. CROWN CONSTRUCTION MANAGER

N/A

4. B+T GROUP PROJECT ENGINEER

ALI HABIBI
(918) 587-4630
AHABIBI@BTGRP.COM
1717 S BOULDER AVENUE, SUITE 300
TULSA, OK 74119

5. B+T GROUP ENGINEER (EOR)

CHAD E TUTTLE, P.E.
(918) 587-4630
CTUTTLE@BTGRP.COM
1717 S BOULDER AVENUE, SUITE 300
TULSA, OK 74119

TOWER INFORMATION

TOWER MANUFACTURER / DWG #: PIROD INC. / 204566-B
TOWER HEIGHT / TYPE: 190' MONOPOLE
TOWER LOCATION: LAT. 41° 37' 34.3"
DATUM: (NAD 1983) LONG. -72° 46' 32.33"
ELEV. 140 FT AMSL
STRUCTURAL DESIGN DRAWING REPORT: B+T GROUP / WO. # 996578
STRUCTURAL ANALYSIS REPORT: B+T GROUP / WO. # 926907
STRUCTURAL ANALYSIS DATE: 09/16/14
APPLICATION ID / REVISION #: 2614401 / 2
CCSITES DOCUMENT ID: 5299086

CODE COMPLIANCE

THIS REINFORCEMENT DESIGN IS BASED ON THE REQUIREMENTS OF TIA/EIA-222-F STRUCTURAL STANDARDS FOR STEEL ANTENNA TOWERS AND ANTENNA SUPPORTING STRUCTURES USING FASTEST MILE WIND SPEED OF 80 MPH WITH NO ICE, 37.6 MPH WITH 1 INCH ICE THICKNESS AND 50 MPH UNDER SERVICE LOADS.

DRAWINGS INCLUDED

SHEET NUMBER	DESCRIPTION
S1	TITLE SHEET
S2	MODIFICATION INSPECTION NOTES AND CHECKLIST
S3	GENERAL NOTES, AJAX BOLT NOTES AND DETAIL
S4	TOWER ELEV., SCHEDULE AND TX LINE DIST. DIAGRAM
S5	TOWER SECTION (0'-19.5')
S6	TOWER SECTIONS (20'-30.5' AND 40'-50.5')
S7	TOWER SECTIONS (60'-70.5' AND 80'-99.5')
S8	FLAT PLATE BRIDGE STIFFENER DETAIL, SCHEDULE AND TOWER SECTION (100'-110.5')
D1	PART DETAIL

SITE NAME: NEWINGTON_1
BU NUMBER: 826217

SITE ADDRESS:
240 KENSINGTON ROAD,
BERLIN, CT 06037
HARTFORD COUNTY, USA

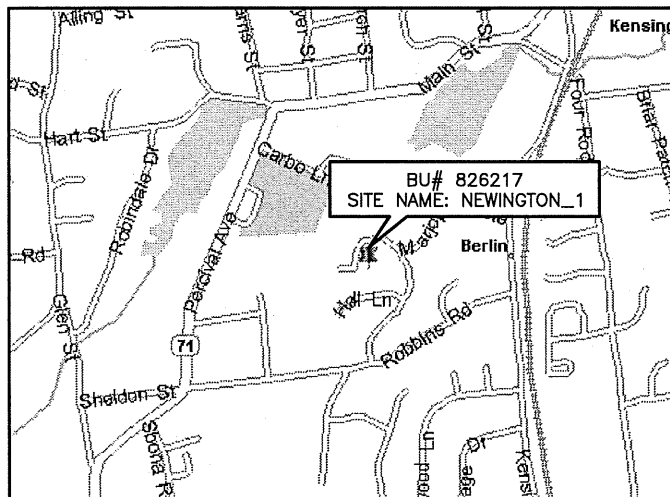

MAP

DIRECTIONS

FROM RT 9 TO EXIT 22. TURN RIGHT ON TO MILL ST. RT 372 FOLLOW 3/4 MI AT SET OF LIGHTS TURN LEFT ONTO KENSINGO RD. 1/4 MI ON RIGHT WILL BE TOWN BUILDINGS COMPLEX AND ACCESS RD. FOLLOW TO TOP OF HILL. TOWER IS BEHIND TOWN HALL AND POLICE STATION.

B+T GRP
1717 S. BOULDER AVE.
SUITE 300
TULSA, OK 74119
PH: (918) 587-4630
www.btgrp.com

**CROWN
CASTLE**

ISSUED FOR:

REV	DATE	DESCRIPTION
0	01/30/15	ISSUED FOR CONSTRUCTION

PROJECT NO: 87581.010.01
PROJECT ENG: ALI HABIBI
DRAWN BY: UJJ / GLS
CHECKED BY: SSC

B+T ENGINEERING, INC.

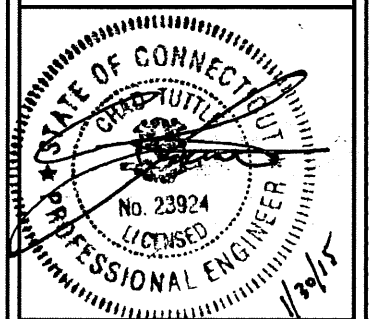

IT IS A VIOLATION OF LAW FOR ANY PERSON, UNLESS THEY ARE ACTING UNDER THE DIRECTION OF A LICENSED PROFESSIONAL ENGINEER, TO ALTER THIS DOCUMENT.

NEWINGTON_1
826217

240 KENSINGTON ROAD,
BERLIN, CT

EXISTING 190' MONOPOLE

SHEET TITLE

TITLE SHEET

SHEET NUMBER:

S1

REVISION:

0

NOTES:

1. ALL STRUCTURAL BOLTS SHALL BE INSTALLED AND TIGHTENED TO THE PRE-TENSIONED CONDITION ACCORDING TO THE REQUIREMENTS OF THE AISC 'SPECIFICATION FOR STRUCTURAL JOINTS USING HIGH-STRENGTH BOLTS', DEC. 31, 2009.
2. ALL STRUCTURAL BOLTS SHALL BE INSPECTED ACCORDING TO THE REQUIREMENTS OF THE AISC 'SPECIFICATION FOR STRUCTURAL JOINTS USING HIGH-STRENGTH BOLTS', DEC. 31, 2009.
3. ALL AJAX M20 BOLTS WITH SHEAR SLEEVES SHALL BE PRE-TENSIONED AND TIGHTENED UNTIL THE DIRECT TENSION INDICATOR (DTI) WASHERS SHOW THAT THE PROPER BOLT TENSION HAS BEEN REACHED. SEE NOTES AND DETAIL BELOW FOR THE USE OF DIRECT TENSION INDICATOR (DTI) WASHERS WITH THE AJAX M20 BOLTS.
4. ALL AJAX BOLTS SHALL BE INSTALLED USING DIRECT TENSION INDICATORS (DTI'S) AND HARDENED WASHERS. DTI'S SHALL BE THE SQUIRTER® STYLE, MADE TO ASTM F959 LATEST REVISION; AND HARDENED WASHERS SHALL CONFORM TO ASTM F436 AND HAVE A HARDNESS OF HRC 38 OR HIGHER.
5. AS AN ALTERNATIVE TO USING DTI WASHERS, AJAX BOLTS MAY BE PRETENSIONED PER AISC TURN-OF-NUT METHOD.

NOTES FOR AJAX M20 'ONE-SIDE' BOLTS WITH DIRECT TENSION INDICATORS (DTI'S):

DTI'S REQUIRED: DTI'S SHALL BE "SELF-INDICATING" SQUIRTER® STYLE DTI'S MADE WITH SILICONE EMBEDDED IN THEM, INSPECTED BY MEANS OF THE VISUAL EJECTION OF SILICONE AS THE DTI PROTRUSIONS COMPRESS. SQUIRTER® DTI'S SHALL BE CALIBRATED PER MANUFACTURER'S INSTRUCTIONS PRIOR TO USE.

THE DIRECT TENSION INDICATOR (DTI) WASHERS SHALL BE THE "SQUIRTER® STYLE" AS MANUFACTURED BY:

APPLIED BOLTING TECHNOLOGY PRODUCTS, INC.
1413 ROCKINGHAM ROAD
BELLOWS FALLS, VERMONT 05101, USA
PHONE 1-800-552-1999
WEBSITE: WWW.APPLIEDBOLTING.COM

DISTRIBUTORS OF SQUIRTER® DTI'S:
HTTP://WWW.APPLIEDBOLTING.COM/APPLIED-BOLTING-DISTRIBUTORS.HTML

DTI: USE DIRECT TENSION INDICATOR (DTI) WASHERS COMPATIBLE WITH 3/4" NOMINAL A325 BOLTS FOR THE AJAX M20 BOLTS. DTI'S SHALL NOT BE HOT-DIP GALVANIZED. DTI'S SHALL BE MECHANICALLY GALVANIZED (MG) BY THE COLD MECHANICAL PROCESS ONLY AS PROVIDED BY THE DTI MANUFACTURER.

HARDENED WASHERS REQUIRED: USE A HARDENED WASHER FOR A 3/4" NOMINAL BOLT BETWEEN THE TOP OF THE DIRECT TENSION INDICATOR (DTI) WASHER AND THE NUT OF THE AJAX M20 BOLT. HARDENED WASHERS SHALL CONFORM TO ASTM F436 AND HAVE A MINIMUM HARDNESS OF HRC 38 OR HIGHER. THE HARDENED WASHERS SHALL BE MECHANICALLY GALVANIZED BY THE COLD MECHANICAL PROCESS. ALTERNATIVELY, CORRECTLY MADE HOT DIP GALVANIZED HARDENED FLAT WASHERS HAVING A MINIMUM HARDNESS OF HRC 38 CAN BE USED; CONTRACTOR SHALL PROVIDE DOCUMENTATION OF WASHER SPECIFICATION AND HARDNESS.

NUT LUBRICATION REQUIRED: PROPERLY LUBRICATE THE THREADS OF THE NUT OF THE AJAX BOLT SO THAT IT CAN BE PROPERLY TIGHTENED WITHOUT GALLING AND/OR LOCKING UP ON THE BOLT THREADS. CONTRACTOR SHALL FOLLOW DTI MANUFACTURER INSTRUCTIONS FOR PROPER LUBRICATION AND TIGHTENING.

NOTE: COMPLETELY COMPRESSED DTI'S SHOWING NO VISIBLE REMAINING GAP ARE ACCEPTABLE. DTI WASHERS SHALL BE PLACED DIRECTLY AGAINST THE OUTER AJAX WASHER WITH THE DTI BUMPS FACING AWAY FROM THE AJAX WASHER. PLACE A HARDENED WASHER BETWEEN THE DTI AND AJAX NUT. THE DTI BUMPS SHALL BEAR AGAINST THE UNDERSIDE OF A HARDENED FLAT WASHER, NEVER DIRECTLY AGAINST THE NUT.

CONTRACTOR SHALL FOLLOW DTI MANUFACTURER'S INSTRUCTIONS FOR INSTALLATION, LUBRICATION, TIGHTENING AND INSPECTION.

INSPECTION REQUIRED: ALL AJAX BOLTS SHALL BE INSPECTED ACCORDING TO THE REQUIREMENTS OF THE AISC 'SPECIFICATION FOR STRUCTURAL JOINTS USING HIGH-STRENGTH BOLTS', DEC. 32, 2009, BY A QUALIFIED BOLT INSPECTOR. DURING INSTALLATION, THE BOLT INSPECTOR SHALL VERIFY AND DOCUMENT THE SHOP-DRILLED AND FIELD-DRILLED HOLE SIZES; THE INSTALLATION OF THE AJAX BOLT ASSEMBLY, INCLUDING THE SHEAR SLEEVE PLACEMENT AND NUT LUBRICATION AND THE CONTRACTOR'S TENSIONING PROCEDURE. IN ADDITION, ALL AJAX BOLTS AND DTI'S SHALL BE VISUALLY INSPECTED ACCORDING TO THE DTI MANUFACTURER'S INSTRUCTIONS. THE BOLT INSPECTOR SHALL PROVIDE COMPLETE PHOTO DOCUMENTATION OF ALL BOLTS AFTER TIGHTENING CLEARLY SHOWING THE CONDITION OF THE DTI'S.

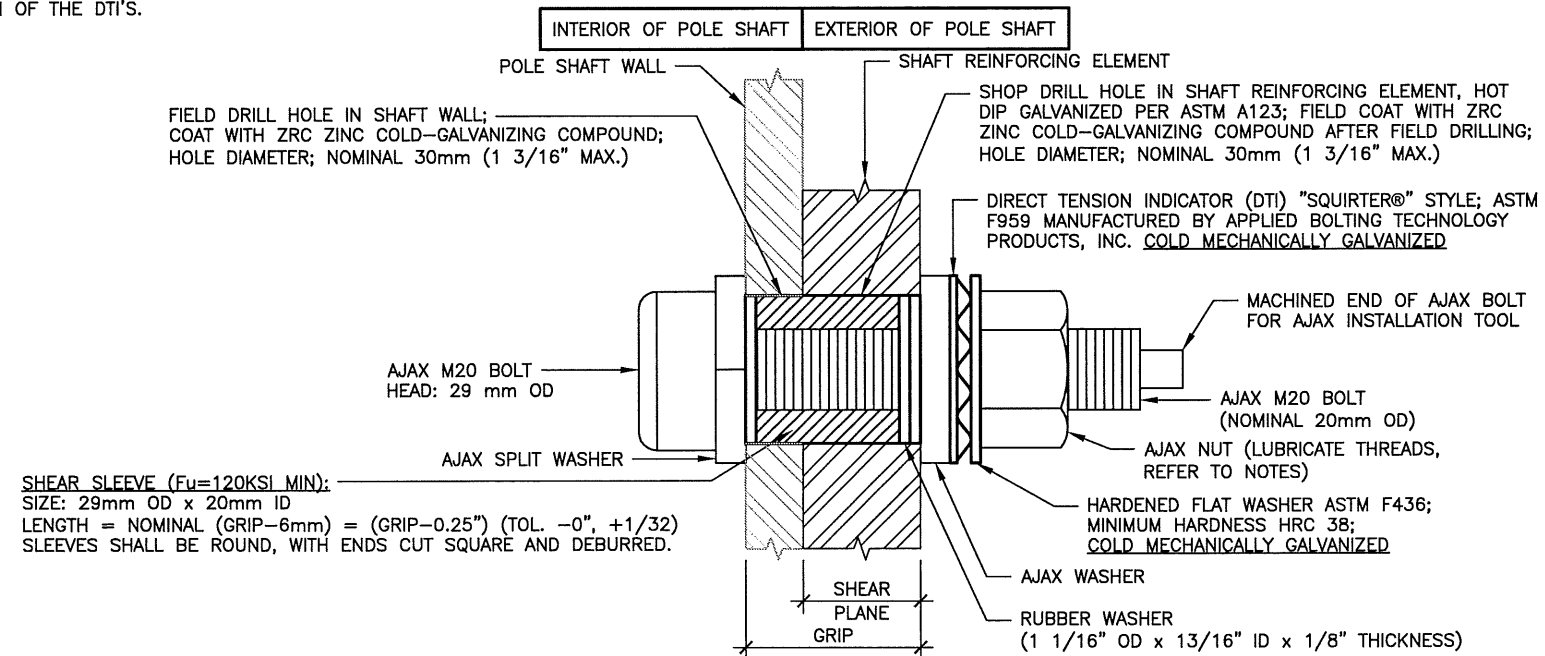

1 TYPICAL AJAX BOLT DETAIL
SCALE: N.T.S.

GENERAL NOTES

- 1.1 ALL WORK SHALL COMPLY WITH THE TIA/EIA-222-F STANDARD AS WELL AS ANY OTHER GOVERNING BUILDING CODES.
- 1.2 FIELD WORK WILL BE DONE AROUND EXISTING COAXIAL CABLE AND EQUIPMENT. ALL WORK SHALL BE DONE IN A MANNER SUCH THAT NO DAMAGE OCCURS TO THE EXISTING EQUIPMENT OR THE STRUCTURE.
- 1.3 A MINIMUM OF TWO COATS OF ZINGA COLD GALVANIZING COMPOUND (OR APPROVED EQUIVALENT) SHALL BE APPLIED TO ANY FIELD CUTS OR FIELD DRILLED HOLES.
- 1.4 THE USE OF A GAS TORCH OR WELDER WILL NOT BE PERMITTED ON THE TOWER WITHOUT THE CONSENT OF THE OWNER.
- 1.5 IN LIEU OF TEMPORARY BRACING CONTRACTOR MAY HAVE A STABILITY ANALYSIS PERFORMED BY AN ENGINEER LICENSED IN THE STATE THE TOWER IS LOCATED. THE ANALYSIS SHALL USE A MINIMUM WIND SPEED OF 45 mph (3-SEC) PER TIA-1019.

FABRICATION

- 2.1 ALL WORK SHALL BE DONE IN ACCORDANCE WITH A.I.S.C. "SPECIFICATIONS FOR THE DESIGN, FABRICATION AND ERECTION OF STRUCTURAL STEEL FOR BUILDINGS."
- 2.2 STRUCTURAL STEEL SHALL MEET THE FOLLOWING SPECIFICATIONS:

	YIELD	ASTM SPECS
A. STEEL SHAPES AND PLATES, U.N.O.	65ksi	A572
B. STEEL PIPE	50ksi	---
- 2.3 ALL NEW MATERIAL INCLUDING STRUCTURAL STEEL AND FASTENERS SHALL BE HOT DIPPED GALVANIZED AFTER FABRICATION IN ACCORDANCE WITH ASTM A123 AND A153.
- 2.4 WELDING SHALL MEET ANSI/AWS D1.1 STRUCTURAL WELDING CODE (LATEST REVISION). ELECTRODES SHALL BE E80 SERIES.
- 2.5 CONTRACTOR SHALL PROVIDE SHOP FABRICATION DRAWINGS TO B+T GROUP 5 DAYS PRIOR TO FABRICATION.

KEY NOTES

TOWER MODIFICATION I.D.

B+T GRP
1717 S. BOULDER AVE.
SUITE 300
TULSA, OK 74119
PH: (918) 587-4630
www.btgrp.com

CROWN CASTLE

ISSUED FOR:

REV	DATE	DESCRIPTION
0	01/30/15	ISSUED FOR CONSTRUCTION

PROJECT NO:	87581.010.01
PROJECT ENG:	ALI HABIBI
DRAWN BY:	UUJ / GLS
CHECKED BY:	SSC

B+T ENGINEERING, INC.

IT IS A VIOLATION OF LAW FOR ANY PERSON, UNLESS THEY ARE ACTING UNDER THE DIRECTION OF A LICENSED PROFESSIONAL ENGINEER, TO ALTER THIS DOCUMENT.

NEWINGTON_1
826217
240 KENSINGTON ROAD,
BERLIN, CT
EXISTING 190' MONOPOLE

SHEET TITLE
GENERAL NOTES,
AJAX BOLT NOTES
AND DETAIL

SHEET NUMBER:	REVISION:
S3	0

I:\Projects\Crown Castle\87581_010_01_NEWINGTON_1\TOW_MOD_REV1.dwg - User: LSIMPSON - January 30, 2015 - 4:14 PM

CROWN CASTLE

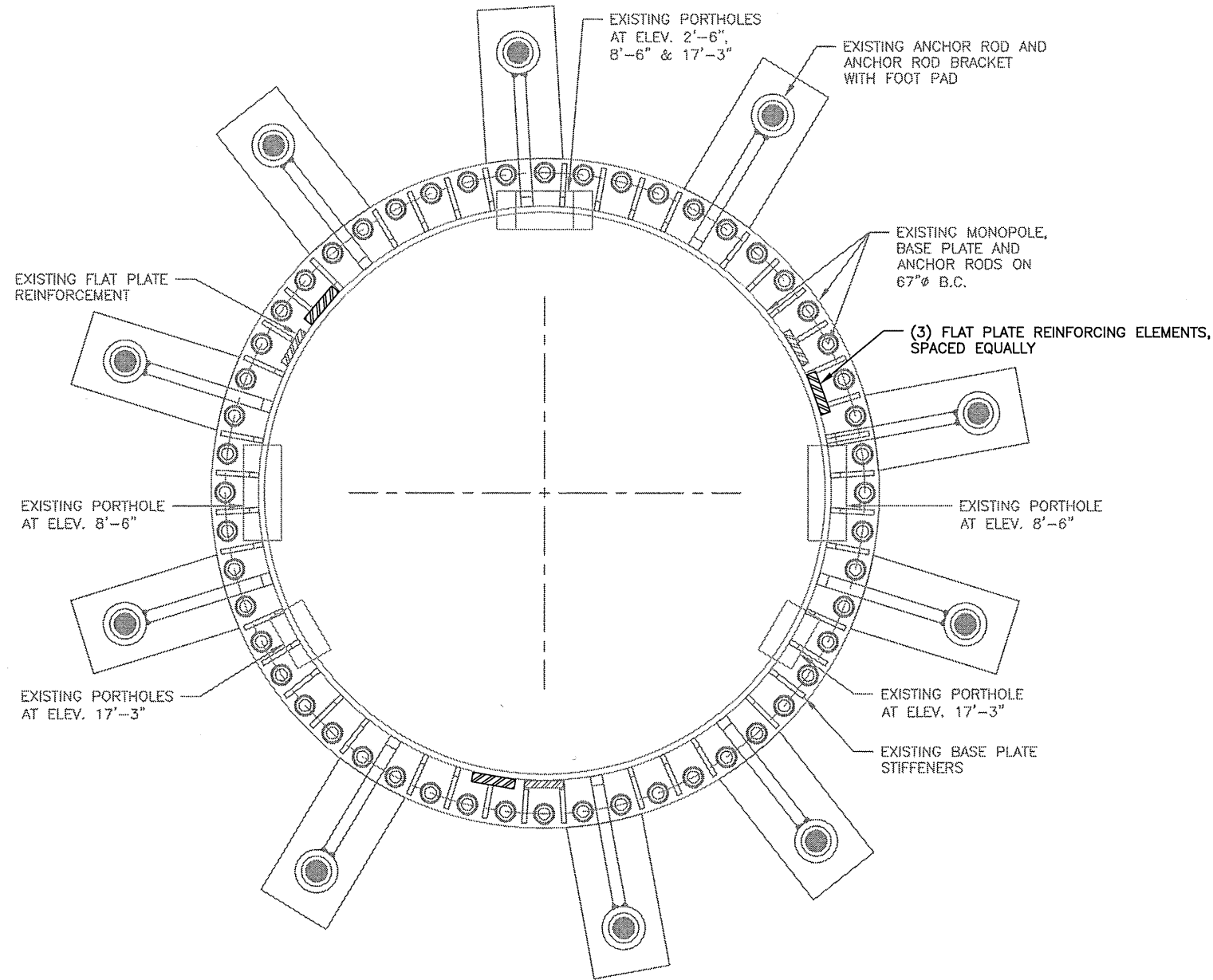

1 TOWER SECTION (0'-19.5')
 SCALE: N.T.S.

NOTE:
 CONTRACTOR CAN CHOOSE ANY SYMMETRICAL LOCATIONS TO SUIT FIELD CONDITIONS. NOTIFY B+T GROUP IMMEDIATELY FOR ANY DISCREPANCIES.

ISSUED FOR:

REV	DATE	DESCRIPTION
0	01/30/15	ISSUED FOR CONSTRUCTION

PROJECT NO:	87581.010.01
PROJECT ENG:	ALI HABIBI
DRAWN BY:	UUJ / GLS
CHECKED BY:	SSC

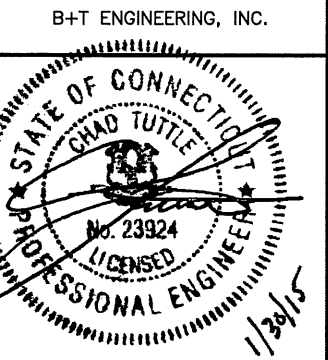

IT IS A VIOLATION OF LAW FOR ANY PERSON, UNLESS THEY ARE ACTING UNDER THE DIRECTION OF A LICENSED PROFESSIONAL ENGINEER, TO ALTER THIS DOCUMENT.

NEWINGTON_1
 826217
 240 KENSINGTON ROAD,
 BERLIN, CT
 EXISTING 190' MONOPOLE

SHEET TITLE
 TOWER SECTION
 (0'-19.5')

SHEET NUMBER: **S5** REVISION: **0**

CROWN CASTLE

ISSUED FOR:

REV	DATE	DESCRIPTION
0	01/30/15	ISSUED FOR CONSTRUCTION

PROJECT NO:	87581.010.01
PROJECT ENG:	ALI HABIBI
DRAWN BY:	UUJ / GLS
CHECKED BY:	SSC

B+T ENGINEERING, INC.

STATE OF CONNECTICUT
 CHAD TUTTLE
 No. 23924
 LICENSED PROFESSIONAL ENGINEER
 1/30/15

IT IS A VIOLATION OF LAW FOR ANY PERSON, UNLESS THEY ARE ACTING UNDER THE DIRECTION OF A LICENSED PROFESSIONAL ENGINEER, TO ALTER THIS DOCUMENT.

NEWINGTON_1
 826217
 240 KENSINGTON ROAD,
 BERLIN, CT
 EXISTING 190' MONOPOLE

SHEET TITLE
 TOWER SECTIONS
 (20'-30.5' AND 40'-50.5')

SHEET NUMBER: **S6** REVISION: **0**

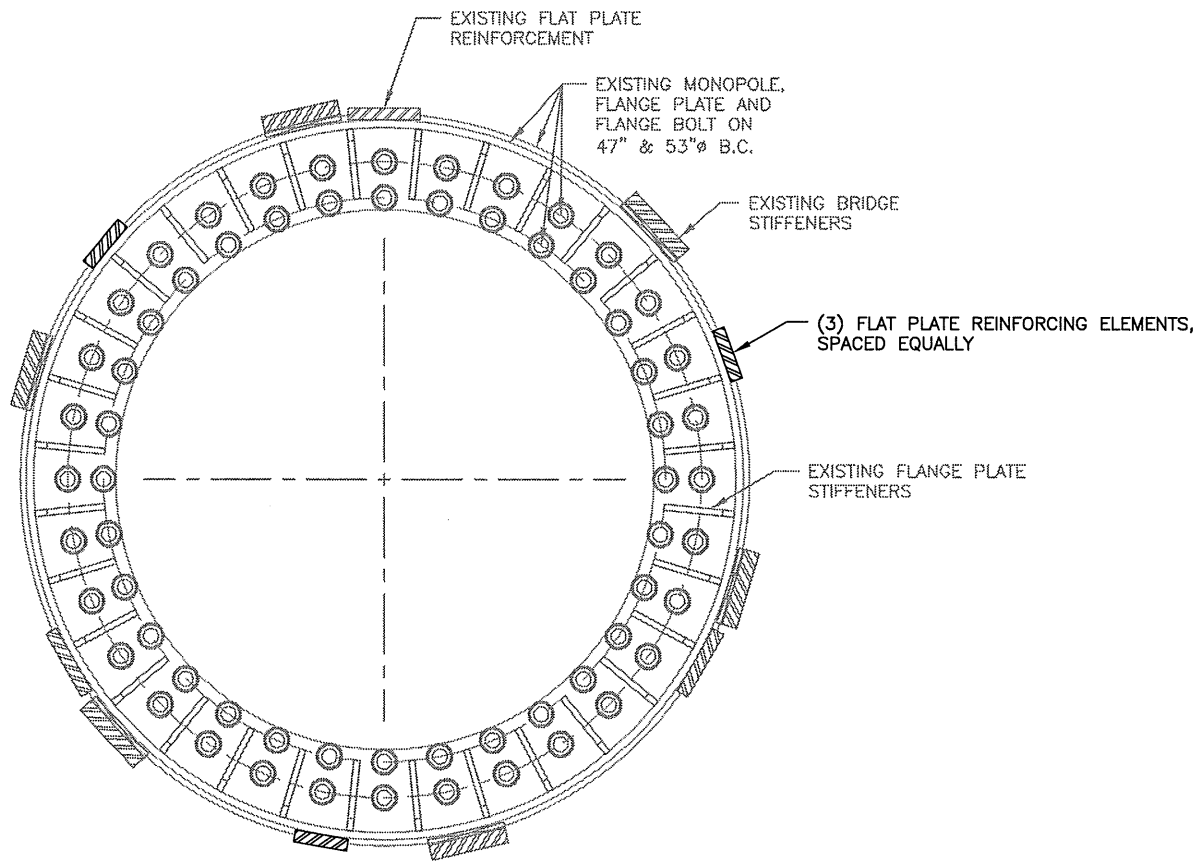

1 TOWER SECTION (20'-30.5')
 SCALE: N.T.S.

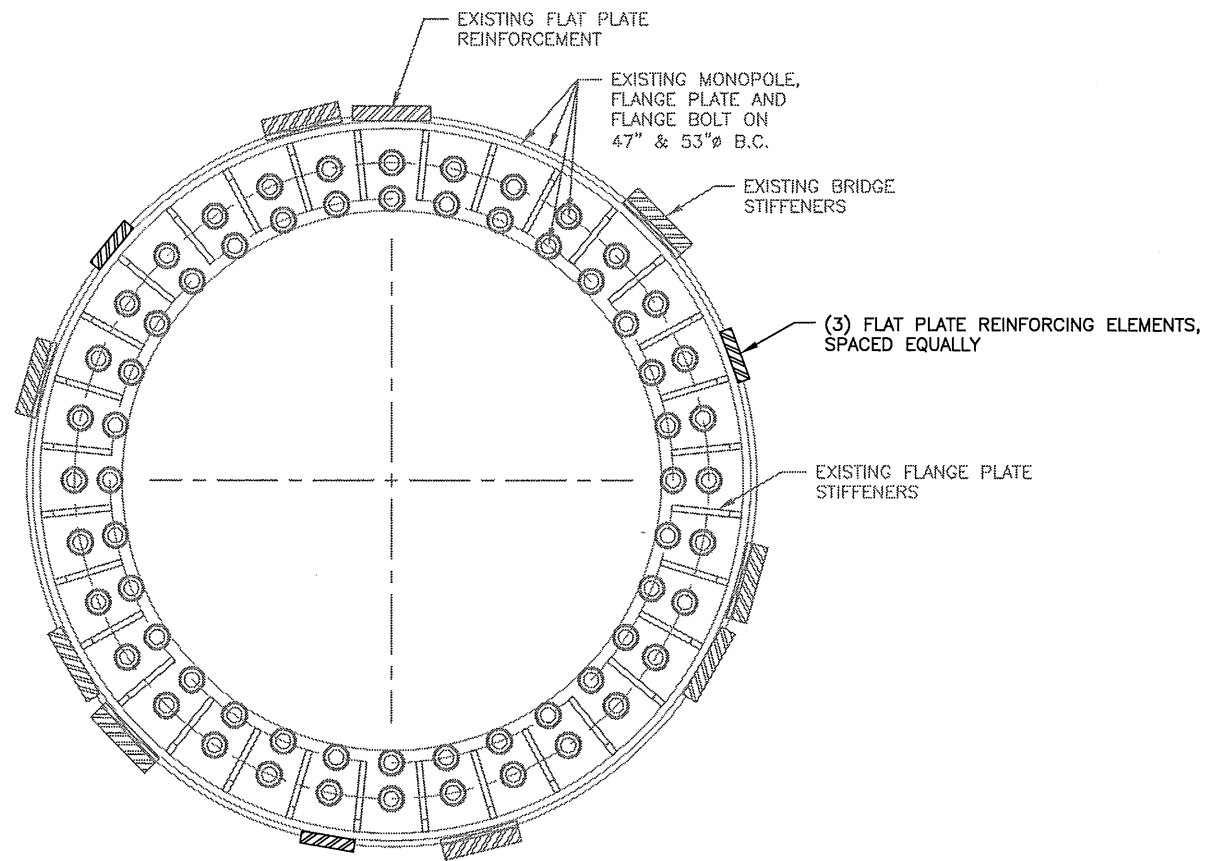

2 TOWER SECTION (40'-50.5')
 SCALE: N.T.S.

NOTE:
 CONTRACTOR CAN CHOOSE ANY SYMMETRICAL LOCATIONS TO SUIT FIELD CONDITIONS. NOTIFY B+T GROUP IMMEDIATELY FOR ANY DISCREPANCIES.

CROWN CASTLE

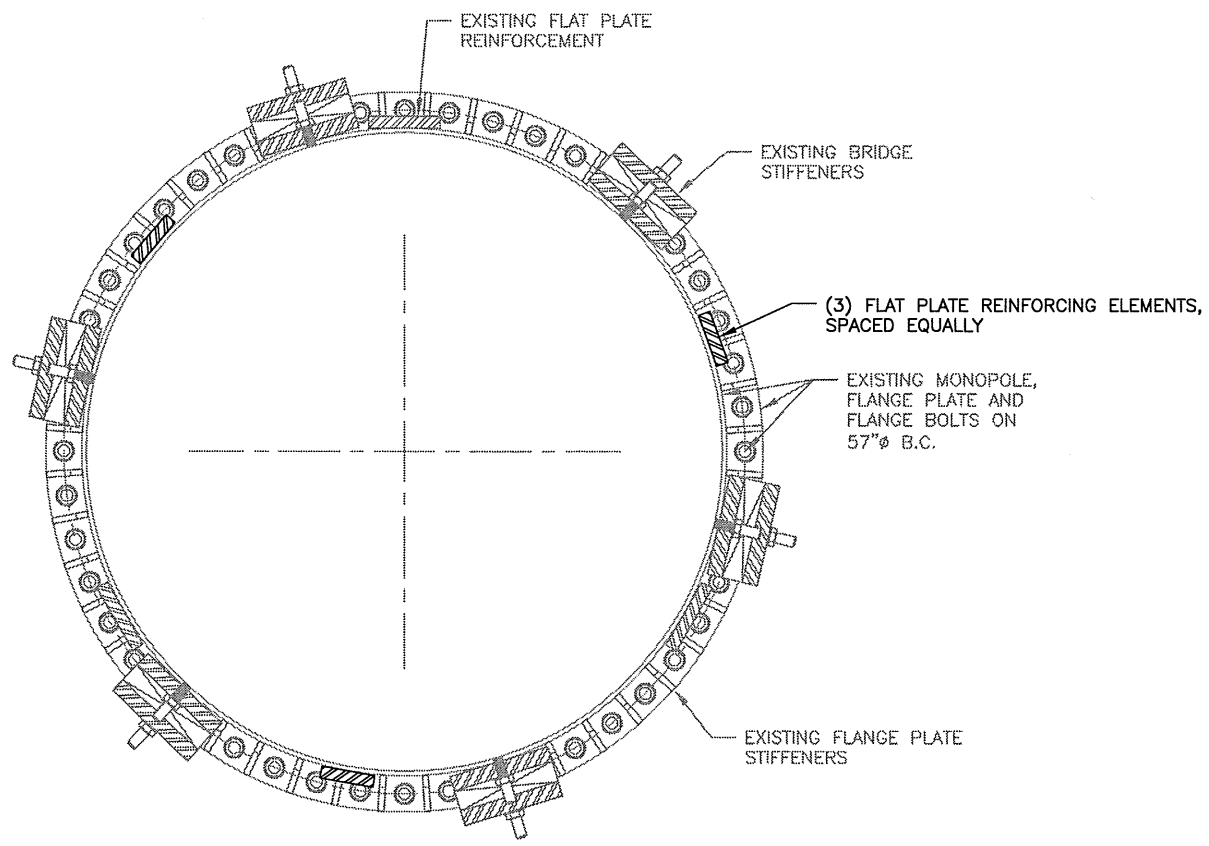

1 TOWER SECTION (60'-70.5')
 SCALE: N.T.S.

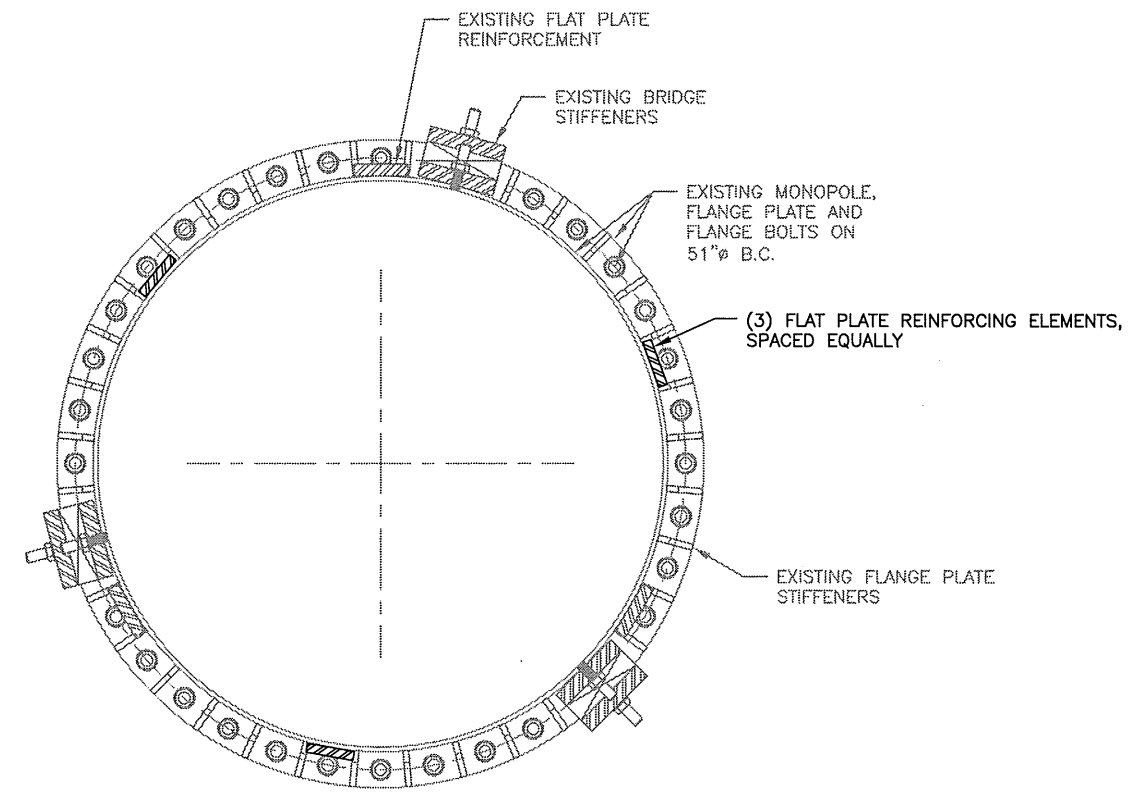

2 TOWER SECTION (80'-99.5')
 SCALE: N.T.S.

NOTE:
 CONTRACTOR CAN CHOOSE ANY SYMMETRICAL LOCATIONS TO SUIT FIELD CONDITIONS. NOTIFY B+T GROUP IMMEDIATELY FOR ANY DISCREPANCIES.

ISSUED FOR:

REV	DATE	DESCRIPTION
0	01/30/15	ISSUED FOR CONSTRUCTION

PROJECT NO:	87581.010.01
PROJECT ENG:	ALI HABIBI
DRAWN BY:	UUJ / GLS
CHECKED BY:	SSC

B+T ENGINEERING, INC.

STATE OF CONNECTICUT
 CHAS TUTTLE
 No. 23924
 LICENSED PROFESSIONAL ENGINEER
 1/29/15

IT IS A VIOLATION OF LAW FOR ANY PERSON, UNLESS THEY ARE ACTING UNDER THE DIRECTION OF A LICENSED PROFESSIONAL ENGINEER, TO ALTER THIS DOCUMENT.

NEWINGTON_1
 826217
 240 KENSINGTON ROAD,
 BERLIN, CT
 EXISTING 190' MONOPOLE

SHEET TITLE
 TOWER SECTIONS
 (60'-70.5' AND 80'-99.5')

SHEET NUMBER: S7	REVISION: 0
----------------------------	-----------------------

S:\Projects\Crown Castle\87581_01\TOW MOD\87581_0101_NEWINGTON_1_826217_TOW MOD REV1.dwg -- Sheet:SS -- User: LSIMPSON -- January 30, 2015 -- 4:14 PM

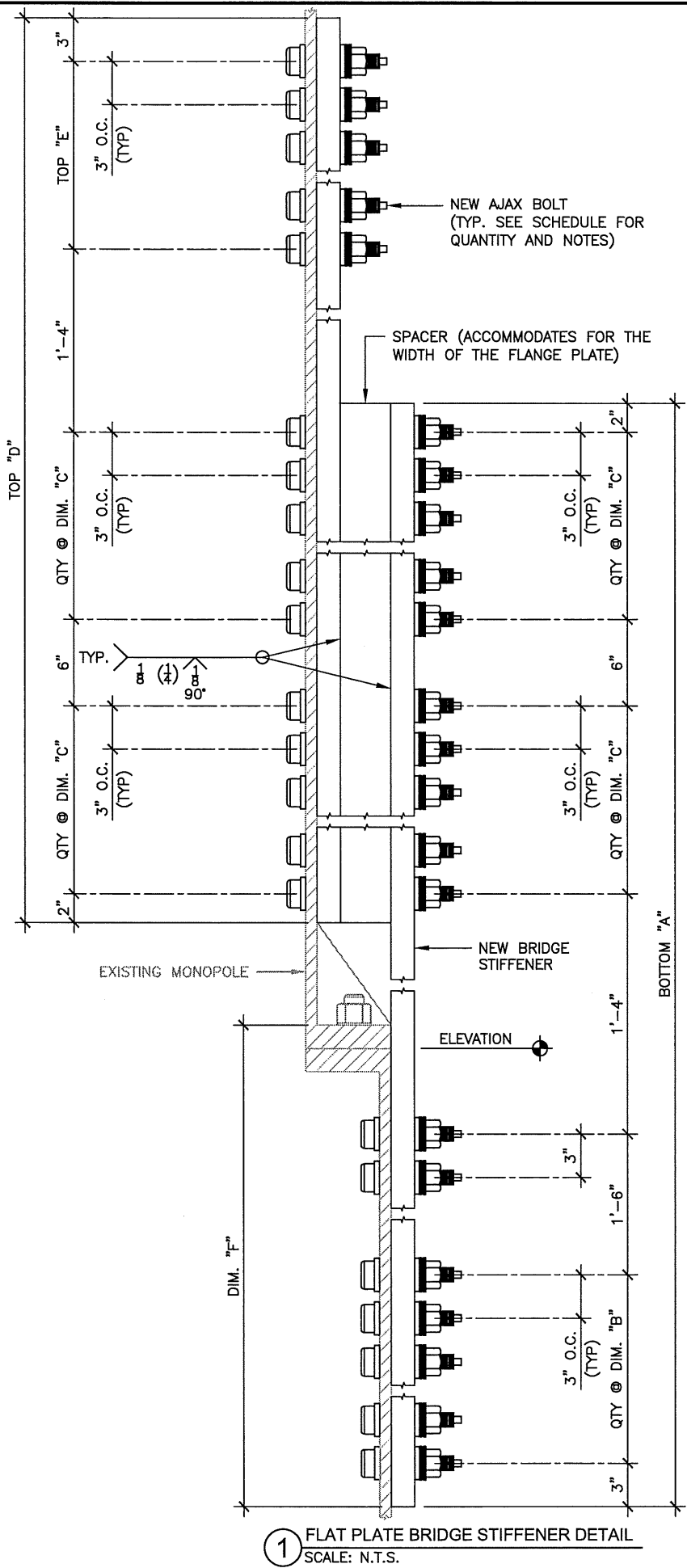

1 FLAT PLATE BRIDGE STIFFENER DETAIL
SCALE: N.T.S.

FLAT PLATE BRIDGE STIFFENER-SCHEDULE (65KSI)										
ELEVATION	NO. OF BRIDGE STIFFENERS	FLAT PLATE SIZE	BOTTOM "A"	QTY @ DIM. "B"	QTY @ DIM. "C"	TOP "D"	QTY @ DIM. "E"	DIM. "F"	AJAX BOLT QTY PER STIFFENER	TOTAL AJAX BOLT QTY
100'	3	1"x4 1/2"	7'-0"	6 HOLES @ 1'-3"	5 HOLES @ 1'-0"	5'-6"	6 HOLES @ 1'-3"	3'-9"	24	72

NOTE:
CONTRACTOR CAN CHOOSE ANY SYMMETRICAL LOCATIONS TO SUIT FIELD CONDITIONS NOTIFY B-T GROUP IMMEDIATELY FOR ANY DISCREPANCIES.

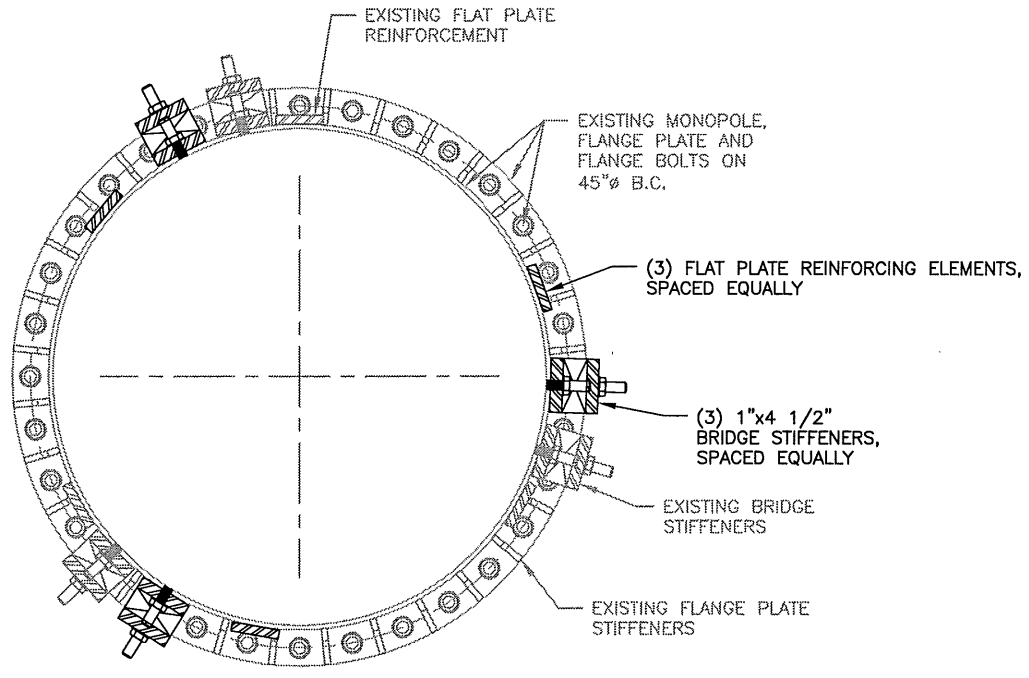

2 TOWER SECTION (100'-110.5')
SCALE: N.T.S.

B+T GRP
1717 S. BOULDER AVE.
SUITE 300
TULSA, OK 74119
PH: (918) 587-4630
www.btgrp.com

**CROWN
CASTLE**

ISSUED FOR:

REV	DATE	DESCRIPTION
0	01/30/15	ISSUED FOR CONSTRUCTION

PROJECT NO:	87581.010.01
PROJECT ENG:	ALI HABIBI
DRAWN BY:	UUJ / GLS
CHECKED BY:	SSC

B-T ENGINEERING, INC.

IT IS A VIOLATION OF LAW FOR ANY PERSON, UNLESS THEY ARE ACTING UNDER THE DIRECTION OF A LICENSED PROFESSIONAL ENGINEER, TO ALTER THIS DOCUMENT.

NEWINGTON_1
826217
240 KENSINGTON ROAD,
BERLIN, CT
EXISTING 190' MONOPOLE

SHEET TITLE
FLAT PLATE BRIDGE STIFFENER
DETAIL, SCHEDULE AND
TOWER SECTION (100'-110.5')

SHEET NUMBER: **S8** REVISION: **0**

S:\Projects\Crown Castle\826217_Newington_1\TOW MOD\826217_Newington_1_826217_TOW MOD REV1.dwg -- User: LSMFSON -- January 30, 2015 -- 4:14 PM

B+T GRP
 1717 S. BOULDER AVE.
 SUITE 300
 TULSA, OK 74119
 PH: (918) 587-4630
 www.btgrp.com

CROWN CASTLE

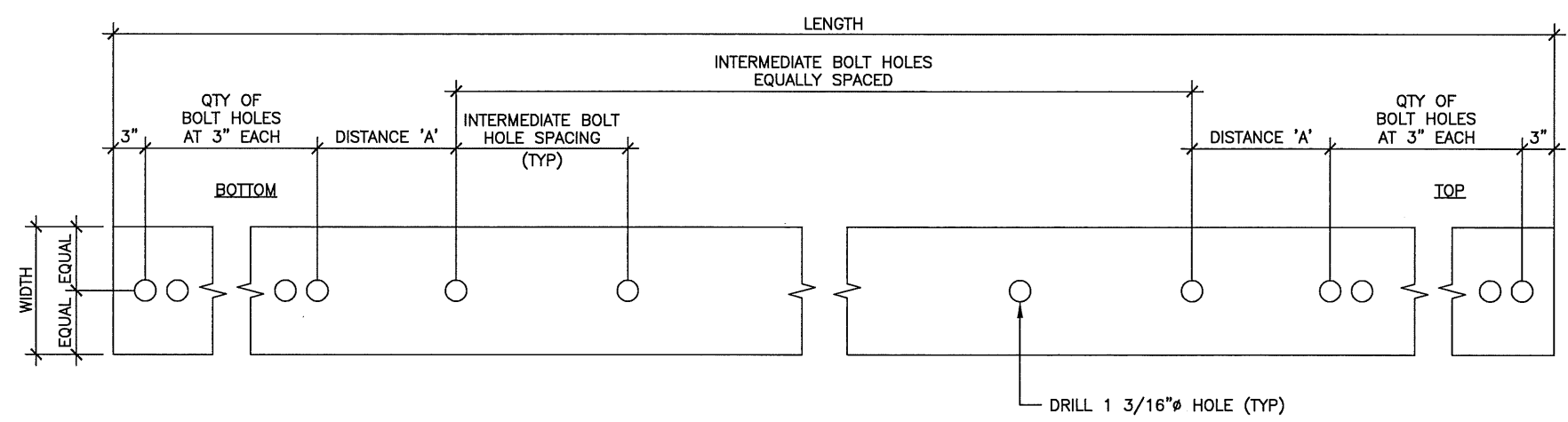

1 PART DETAIL
 SCALE: N.T.S.

PART NUMBER	BLACK WEIGHT (LBS)	WIDTH	THICKNESS	LENGTH	DISTANCE 'A'	TOTAL QTY OF 1 3/16" Ø BOLT HOLES	QTY OF BOLT HOLES (BOTTOM END)	QTY OF BOLT HOLES (TOP END)	INTERMEDIATE BOLT HOLE SPACING
FP1	291	4 1/2"	1"	19'-0"	1'-4"	21	6	6	1'-8"
FP2	194	4"	3/4"	19'-0"	1'-2"	20	4	4	1'-4"

ISSUED FOR:

REV	DATE	DESCRIPTION
0	01/30/15	ISSUED FOR CONSTRUCTION

PROJECT NO:	87581.010.01
PROJECT ENG:	ALI HABIBI
DRAWN BY:	UUJ / GLS
CHECKED BY:	SSC

B+T ENGINEERING, INC.

STATE OF CONNECTICUT
 CHAS TUTTLE
 No. 23924
 LICENSED PROFESSIONAL ENGINEER
 1/30/15

IT IS A VIOLATION OF LAW FOR ANY PERSON, UNLESS THEY ARE ACTING UNDER THE DIRECTION OF A LICENSED PROFESSIONAL ENGINEER, TO ALTER THIS DOCUMENT.

NEWINGTON_1
 826217
 240 KENSINGTON ROAD,
 BERLIN, CT
 EXISTING 190' MONOPOLE

SHEET TITLE
 PART DETAIL

SHEET NUMBER: **D1** REVISION: **0**

**RADIO FREQUENCY EMISSIONS ANALYSIS REPORT
EVALUATION OF HUMAN EXPOSURE POTENTIAL
TO NON-IONIZING EMISSIONS**

T-Mobile Existing Facility

Site ID: CT11004B

**Newington 1
240 Kensington Road
Berlin, CT 06037**

February 5, 2015

EBI Project Number: 62150651

Site Compliance Summary	
Compliance Status:	COMPLIANT
Site total MPE% of FCC general public allowable limit:	97.29 %

February 5, 2015

T-Mobile USA
Attn: Jason Overbey, RF Manager
35 Griffin Road South
Bloomfield, CT 06002

Emissions Analysis for Site: **CT11004B – Newington 1**

EBI Consulting was directed to analyze the proposed T-Mobile facility located at **240 Kensington Road, Berlin, CT**, for the purpose of determining whether the emissions from the Proposed T-Mobile Antenna Installation located on this property are within specified federal limits.

All information used in this report was analyzed as a percentage of current Maximum Permissible Exposure (% MPE) as listed in the FCC OET Bulletin 65 Edition 97-01 and ANSI/IEEE Std C95.1. The FCC regulates Maximum Permissible Exposure in units of microwatts per square centimeter ($\mu\text{W}/\text{cm}^2$). The number of $\mu\text{W}/\text{cm}^2$ calculated at each sample point is called the power density. The exposure limit for power density varies depending upon the frequencies being utilized. Wireless Carriers and Paging Services use different frequency bands each with different exposure limits, therefore it is necessary to report results and limits in terms of percent MPE rather than power density.

All results were compared to the FCC (Federal Communications Commission) radio frequency exposure rules, 47 CFR 1.1307(b)(1) – (b)(3), to determine compliance with the Maximum Permissible Exposure (MPE) limits for General Population/Uncontrolled environments as defined below.

General population/uncontrolled exposure limits apply to situations in which the general public may be exposed or in which persons who are exposed as a consequence of their employment may not be made fully aware of the potential for exposure or cannot exercise control over their exposure. Therefore, members of the general public would always be considered under this category when exposure is not employment related, for example, in the case of a telecommunications tower that exposes persons in a nearby residential area.

Public exposure to radio frequencies is regulated and enforced in units of microwatts per square centimeter ($\mu\text{W}/\text{cm}^2$). The general population exposure limit for the 700 MHz Band is $467 \mu\text{W}/\text{cm}^2$, and the general population exposure limit for the PCS and AWS bands is $1000 \mu\text{W}/\text{cm}^2$. Because each carrier will be using different frequency bands, and each frequency band has different exposure limits, it is necessary to report percent of MPE rather than power density.

Occupational/controlled exposure limits apply to situations in which persons are exposed as a consequence of their employment and in which those persons who are exposed have been made fully aware of the potential for exposure and can exercise control over their exposure. Occupational/controlled exposure limits also apply where exposure is of a transient nature as a result of incidental passage through a location where exposure levels may be above general population/uncontrolled limits (see below), as long as the exposed person has been made fully aware of the potential for exposure and can exercise control over his or her exposure by leaving the area or by some other appropriate means.

Additional details can be found in FCC OET 65.

CALCULATIONS

Calculations were done for the proposed T-Mobile Wireless antenna facility located at **240 Kensington Road, Berlin, CT**, using the equipment information listed below. All calculations were performed per the specifications under FCC OET 65. Since T-Mobile is proposing highly focused directional panel antennas, which project most of the emitted energy out toward the horizon, all calculations were performed assuming a lobe representing the maximum gain of the antenna per the antenna manufactures supplied specifications, minus 10 dB, was focused at the base of the tower. For this report the sample point is the top of a 6 foot person standing at the base of the tower.

For all calculations, all equipment was calculated using the following assumptions:

- 1) 2 GSM channels (PCS Band - 1900 MHz) were considered for each sector of the proposed installation. These Channels have a transmit power of 30 Watts per Channel
- 2) 2 UMTS channels (AWS Band – 2100 MHz) were considered for each sector of the proposed installation. These Channels have a transmit power of 30 Watts per Channel.
- 3) 2 LTE channels (AWS Band – 2100 MHz) were considered for each sector of the proposed installation. These Channels have a transmit power of 60 Watts per Channel.
- 4) 1 LTE channel (700 MHz Band) was considered for each sector of the proposed installation. This channel has a transmit power of 30 Watts.
- 5) All radios at the proposed installation were considered to be running at full power and were uncombined in their RF transmissions paths per carrier prescribed configuration. Per FCC OET Bulletin No. 65 - Edition 97-01 recommendations to achieve the maximum anticipated value at each sample point, all power levels emitting from the proposed antenna installation are increased by a factor of 2.56 to account for possible in-phase reflections from the surrounding environment. This is rarely the case, and if so, is never continuous.

- 6) For the following calculations the sample point was the top of a six foot person standing at the base of the tower. The maximum gain of the antenna per the antenna manufactures supplied specifications minus 10 dB was used in this direction. This value is a very conservative estimate as gain reductions for these particular antennas are typically much higher in this direction.
- 7) The antennas used in this modeling are the **EMS RR90_17_02DP** for 1900 MHz (PCS), the **RFS APXV18-206516L** for 2100 MHz (AWS) channels and the **Commscope LNX-6515DS-VTM** for 700 MHz channels. This is based on feedback from the carrier with regards to anticipated antenna selection. The **EMS RR90_17_02DP** has a maximum gain of **14.4 dBd** at its main lobe at 1900 MHz. The **RFS APXV18-206516L** has a maximum gain of **16.3 dBd** at its main lobe at 2100 MHz. The **Commscope LNX-6515DS-VTM** has a maximum gain of **14.6 dBd** at its main lobe at 700 MHz. The maximum gain of the antenna per the antenna manufactures supplied specifications, minus 10 dB, was used for all calculations. This value is a very conservative estimate as gain reductions for these particular antennas are typically much higher in this direction.
- 8) The antenna mounting height centerline of the proposed antennas is **184 feet** above ground level (AGL).
- 9) Emissions values for additional carriers were taken from the Connecticut Siting Council active database. Values in this database are provided by the individual carriers themselves.

All calculations were done with respect to uncontrolled / general public threshold limits.

T-Mobile Site Inventory and Power Data

Sector:	A	Sector:	B	Sector:	C
Antenna #:	1	Antenna #:	1	Antenna #:	1
Make / Model:	EMS RR90_17_02DP	Make / Model:	EMS RR90_17_02DP	Make / Model:	EMS RR90_17_02DP
Gain:	14.4 dBd	Gain:	14.4 dBd	Gain:	14.4 dBd
Height (AGL):	184	Height (AGL):	184	Height (AGL):	184
Frequency Bands	1900 MHz(PCS) / 2100 MHz (AWS)	Frequency Bands	1900 MHz(PCS) / 2100 MHz (AWS)	Frequency Bands	1900 MHz(PCS) / 2100 MHz (AWS)
Channel Count	2	Channel Count	2	# PCS Channels:	2
Total TX Power:	60	Total TX Power:	60	# AWS Channels:	60
ERP (W):	1,652.54	ERP (W):	1,652.54	ERP (W):	1,652.54
Antenna A1 MPE%	0.19	Antenna B1 MPE%	0.19	Antenna C1 MPE%	0.19
Antenna #:	2	Antenna #:	2	Antenna #:	2
Make / Model:	RFS APXV18-206516L	Make / Model:	RFS APXV18-206516L	Make / Model:	RFS APXV18-206516L
Gain:	16.3 dBd	Gain:	16.3 dBd	Gain:	16.3 dBd
Height (AGL):	184	Height (AGL):	184	Height (AGL):	184
Frequency Bands	1900 MHz(PCS) / 2100 MHz (AWS)	Frequency Bands	1900 MHz(PCS) / 2100 MHz (AWS)	Frequency Bands	1900 MHz(PCS) / 2100 MHz (AWS)
Channel Count	4	Channel Count	4	Channel Count	4
Total TX Power:	180	Total TX Power:	180	Total TX Power:	180
ERP (W):	7,678.43	ERP (W):	7,678.43	ERP (W):	7,678.43
Antenna A2 MPE%	0.87	Antenna B2 MPE%	0.87	Antenna C2 MPE%	0.87
Antenna #:	3	Antenna #:	3	Antenna #:	3
Make / Model:	Commscope LNX- 6515DS-VTM	Make / Model:	Commscope LNX- 6515DS-VTM	Make / Model:	Commscope LNX- 6515DS-VTM
Gain:	14.6 dBd	Gain:	14.6 dBd	Gain:	14.6 dBd
Height (AGL):	184	Height (AGL):	184	Height (AGL):	184
Frequency Bands	700 Mhz	Frequency Bands	700 Mhz	Frequency Bands	700 Mhz
Channel Count	1	Channel Count	1	Channel Count	1
Total TX Power:	30	Total TX Power:	30	Total TX Power:	30
ERP (W):	865.21	ERP (W):	865.21	ERP (W):	865.21
Antenna A3 MPE%	0.21	Antenna B3 MPE%	0.21	Antenna C3 MPE%	0.21

Site Composite MPE%	
Carrier	MPE%
T-Mobile	3.81
AT&T	18.04 %
Clearwire	1.30 %
MetroPCS	6.06 %
Nextel	4.24 %
Town of Berlin	56.06 %
Verizon Wireless	7.78 %
Site Total MPE %:	97.29 %

T-Mobile Sector 1 Total:	1.27 %
T-Mobile Sector 2 Total:	1.27 %
T-Mobile Sector 3 Total:	1.27 %
Site Total:	97.29 %

Summary

All calculations performed for this analysis yielded results that were **within** the allowable limits for general public exposure to RF Emissions.

The anticipated maximum composite contributions from the T-Mobile facility as well as the site composite emissions value with regards to compliance with FCC's allowable limits for general public exposure to RF Emissions are shown here:

T-Mobile Sector	Power Density Value (%)
Sector 1:	1.27 %
Sector 2:	1.27 %
Sector 3 :	1.27 %
T-Mobile Total:	3.81 %
Site Total:	97.29 %
Site Compliance Status:	COMPLIANT

The anticipated composite MPE value for this site assuming all carriers present is **97.29%** of the allowable FCC established general public limit sampled at the ground level. This is based upon values listed in the Connecticut Siting Council database for existing carrier emissions.

FCC guidelines state that if a site is found to be out of compliance (over allowable thresholds), that carriers over a 5% contribution to the composite value will require measures to bring the site into compliance. For this facility, the composite values calculated were well within the allowable 100% threshold standard per the federal government.



Scott Heffernan
RF Engineering Director

EBI Consulting
21 B Street
Burlington, MA 01803