



STATE OF CONNECTICUT

CONNECTICUT SITING COUNCIL

Ten Franklin Square, New Britain, CT 06051

Phone: (860) 827-2935 Fax: (860) 827-2950

E-Mail: siting.council@po.state.ct.us

Web Site: www.state.ct.us/csc/index.htm

April 16, 2001

Stephen J. Humes
LeBoeuf, Lamb, Greene & MacRae
Goodwin Square
225 Asylum Street
Hartford, CT 06103

RE: **TS-VOICESTREAM-004-010328** - VoiceStream Wireless Corporation request for an order to approve tower sharing at an existing telecommunications facility located at Redwood Lane, Avon, Connecticut.

Dear Attorney Humes:

At a public meeting held April 12, 2001, the Connecticut Siting Council (Council) ruled that the shared use of this existing tower site is technically, legally, environmentally, and economically feasible and meets public safety concerns, and therefore, in compliance with General Statutes § 16-50aa, the Council has ordered the shared use of this facility to avoid the unnecessary proliferation of tower structures. This facility has also been carefully modeled to ensure that radio frequency emissions are conservatively below State and federal standards applicable to the frequencies now used on this tower.

This decision is under the exclusive jurisdiction of the Council. Any additional change to this facility may require an explicit request to this agency pursuant to General Statutes § 16-50aa or notice pursuant to Regulations of Connecticut State Agencies Section 16-50j-73, as applicable. Such request or notice shall include all relevant information regarding the proposed change with cumulative worst-case modeling of radio frequency exposure at the closest point uncontrolled access to the tower base, consistent with Federal Communications Commission, Office of Engineering and Technology, Bulletin 65. Any deviation from this format may result in the Council implementing enforcement proceedings pursuant to General Statutes § 16-50u including, without limitation, imposition of expenses resulting from such failure and of civil penalties in an amount not less than one thousand dollars per day for each day of construction or operation in material violation.

This decision applies only to this request for tower sharing and is not applicable to any other request or construction.

The proposed shared use is to be implemented as specified in your letter dated March 28, 2001.

Thank you for your attention and cooperation.

Very truly yours,

Mortimer A. Gelston
Chairman

MAG/RKE/laf

- c: Honorable Richard W. Hines, Chairman Town Council, Town of Avon
- Philip K. Schenck, Jr., Town Manager, Town of Avon
- Steven M. Kushner, Town Planner, Town of Avon
- Esther McNany, SBA, Inc.
- Christopher B. Fisher, Esq., Cuddy & Feder & Worby LLP
- Julie M. Donaldson, Esq., Hurwitz & Sagarin LLC

LEBOEUF, LAMB, GREENE & MACRAE L.L.P.

A LIMITED LIABILITY PARTNERSHIP INCLUDING PROFESSIONAL CORPORATIONS

NEW YORK
WASHINGTON, D.C.
ALBANY
BOSTON
DENVER
HARRISBURG
HARTFORD
HOUSTON
JACKSONVILLE
LOS ANGELES
NEWARK
PITTSBURGH
SALT LAKE CITY
SAN FRANCISCO

GOODWIN SQUARE
225 ASYLUM STREET
HARTFORD, CT 06103

(860) 293-3500

FACSIMILE: (860) 293-3555

WRITER'S DIRECT DIAL:
(860) 293-3744

LONDON
(A LONDON-BASED
MULTINATIONAL PARTNERSHIP)

PARIS

BRUSSELS

MOSCOW

RIYADH
(AFFILIATED OFFICE)

TASHKENT

BISHKEK

ALMATY

BEIJING

March 28, 2001

Mortimer A. Gelston, Chairman
Connecticut Siting Council
10 Franklin Square
New Britain, CT 06051



**Re: Request by VoiceStream Wireless Corp. for an Order
to Approve the Shared Use of a Tower Facility
Redwood Lane, Avon, Connecticut**

Dear Chairman Gelston and Members of the Council:

Please be advised that LeBoeuf, Lamb, Greene & MacRae, L.L.P. represents VoiceStream Wireless Corporation ("VoiceStream") in the above-referenced matter. Pursuant to Connecticut General Statutes §16-50aa, VoiceStream hereby requests an order from the Connecticut Siting Council ("Council") to approve the proposed shared use by the applicant of an existing tower located at Redwood Lane, in the Farmington Woods condominium complex in Avon, Connecticut. VoiceStream proposes to install antennas on the existing tower, and the equipment associated with this facility would be located near the base of the tower within the existing compound (see "Exhibit A"). VoiceStream requests that the Council find that the proposed shared use of the tower satisfies the criteria stated in §16-50aa and issue an order approving the proposed use.

Background

In February 2000, VoiceStream acquired from Omnipoint Communications, Inc. the "A block" "Wideband PCS" license for the 2-GHz PCS frequencies for the greater New York City area, including the entire State of Connecticut. VoiceStream is licensed by the Federal Communications Commission (FCC) to provide PCS wireless telecommunications service in the State of Connecticut, which includes the area to be served by the proposed installation.

The tower at Redwood Lane is a 105 foot monopole. The coordinates for the site are 41°-46'-21" N and 72°-52'-48" W. The tower is owned by SBA, Inc. and the surrounding land is owed by The Avon Water Company. An existing Avon Water Company water tower is located slightly southwest of the monopole and surrounding equipment compound. An existing access drive goes around the water tower and is

adjacent to the tower and equipment compound. VoiceStream and the owner have agreed to mutually acceptable terms and conditions for the proposed shared use of this tower, and the owner has authorized VoiceStream to act on its behalf to apply for all necessary local, state and federal permits, approvals and authorizations which may be required for the proposed shared use of this facility.

The SBA monopole is newly constructed. VoiceStream is projected to be the first carrier to locate on the structure. SBA has created a seventy foot by fifty foot (70'-0" x 50'-0") leased parcel compound with room for existing and future equipment. The compound layout is shown in the attached Exhibit A. AT&T and Sprint currently have leased equipment areas within the compound. Details regarding the planned elevations and types of future antennas are supplied in the structural analysis attached as Exhibit C. VoiceStream proposes to install an antenna cluster comprised of three sectors, with two antennas per sector. The model number for each sector is EMS RR90-17-02 DP. The proposed antennas would be mounted on a thirteen foot (13'-0") low profile platform fed by six coax lines not exceeding 1-5/8" diameter with centerlines at the 106-foot elevation. The radio transmission equipment associated with these antennas, two Nortel S8000 cabinets, would be located near the base of the tower on an existing concrete pad in a ten foot by twenty foot (10'-0" x 20'-0") leased equipment area within the larger SBA compound. Exhibit B contains specifications for the proposed antennas and equipment cabinet.

C.G.S. §16-50aa (c) (1) provides in pertinent part that upon written request for approval of a proposed shared use, "if the council finds that the proposed shared use of the facility is technically, legally, environmentally and economically feasible and meets public safety concerns, the council shall issue an order approving such shared use." The shared use of the tower satisfies those criteria as follows:

A. Technical Feasibility - The existing tower was designed to accommodate multiple carriers. A structural analysis of the tower with the proposed VoiceStream installation has been performed and is attached as Exhibit C. The proposed shared use of this tower therefore is technically feasible.

B. Legal Feasibility Under C.G.S. § 16-50aa, the Council has been authorized to issue orders approving the proposed shared use of an existing tower facility such as the facility at Redwood Lane in Avon. This authority complements the Council's prior-existing authority under C.G.S. § 16-50p to issue orders approving the construction of new towers that are subject to the Council's jurisdiction. C.G.S. § 16-50x(a) vests exclusive jurisdiction over these facilities in the Council, which shall "give such consideration to other state laws and municipal regulations as it shall deem appropriate" in ruling on requests for the shared use of existing tower facilities. Under this statutory authority vested in the Council, an order by the Council approving the shared use would permit the applicant to obtain a building permit for the proposed installations.

C. Environmental Feasibility The proposed shared use would have minimal environmental effects, if any, for the following reasons:

1. The proposed installations (i.e., three sectors with two antennas per sector) would have an insignificant incremental visual impact, and would not cause any significant change or alteration in the physical or environmental characteristics of the existing site. In particular, the proposed installations would not increase the height of the existing tower, and would not extend the boundaries of the existing compound area.

2. The proposed installations would not increase the noise levels at the existing facility by six decibels or more.
3. Operation of antennas at this site would not exceed the total radio frequency electromagnetic radiation power density level adopted by the American National Standards Institute ("ANSI"). The "worst-case" exposure calculated for operation of this facility (i.e., calculated at the base of the tower, which represents the closest publicly accessible point within the broadcast field of the antennas) will be 0.024046 mW/cm², which is 2.4046% of the Maximum Permissible Emission (MPE). These calculations are attached as Exhibit D.
4. The proposed installations would not require any water or sanitary facilities, or generate air emissions or discharges to water bodies or sanitary facilities. After construction is complete (approximately two weeks), the proposed installations would not generate any traffic other than periodic maintenance visits.

The proposed use of this facility would therefore have a minimal environmental effect, if any, and is environmentally feasible.

D. Economic Feasibility As previously mentioned, the owner and VoiceStream have entered into a mutual agreement to share the use of the existing tower on terms agreeable to the parties. The proposed tower sharing is therefore economically feasible.

E. Public Safety Concerns As stated above, the existing tower is structurally capable of supporting the proposed VoiceStream antennas. The tower stands on a compound accessible from Redwood Lane. VoiceStream is not aware of any other public safety concerns relative to the proposed sharing of the existing tower. In fact, the provision of new or improved phone service through shared use of the existing tower will enhance the safety and welfare of area residents.

Conclusion

For the reasons discussed above, the proposed shared use of the existing tower facility at Redwood Lane, in Avon, Connecticut satisfies the criteria stated in C.G.S. §16-50aa, and advances the General Assembly's and the Siting Council's goal of preventing the proliferation of towers in Connecticut. VoiceStream therefore respectfully requests that the Council issue an order approving the proposed shared use of this tower.

Thank you for your consideration of this matter.

Respectfully submitted,

VOICESTREAM WIRELESS CORPORATION

By: _____

Its Counsel

Stephen J. Humes

Diane W. Whitney

Redwood Lane, Avon, CT
Page 4

Attachments

cc: Philip K. Schenck, Town Manager, Town of Avon

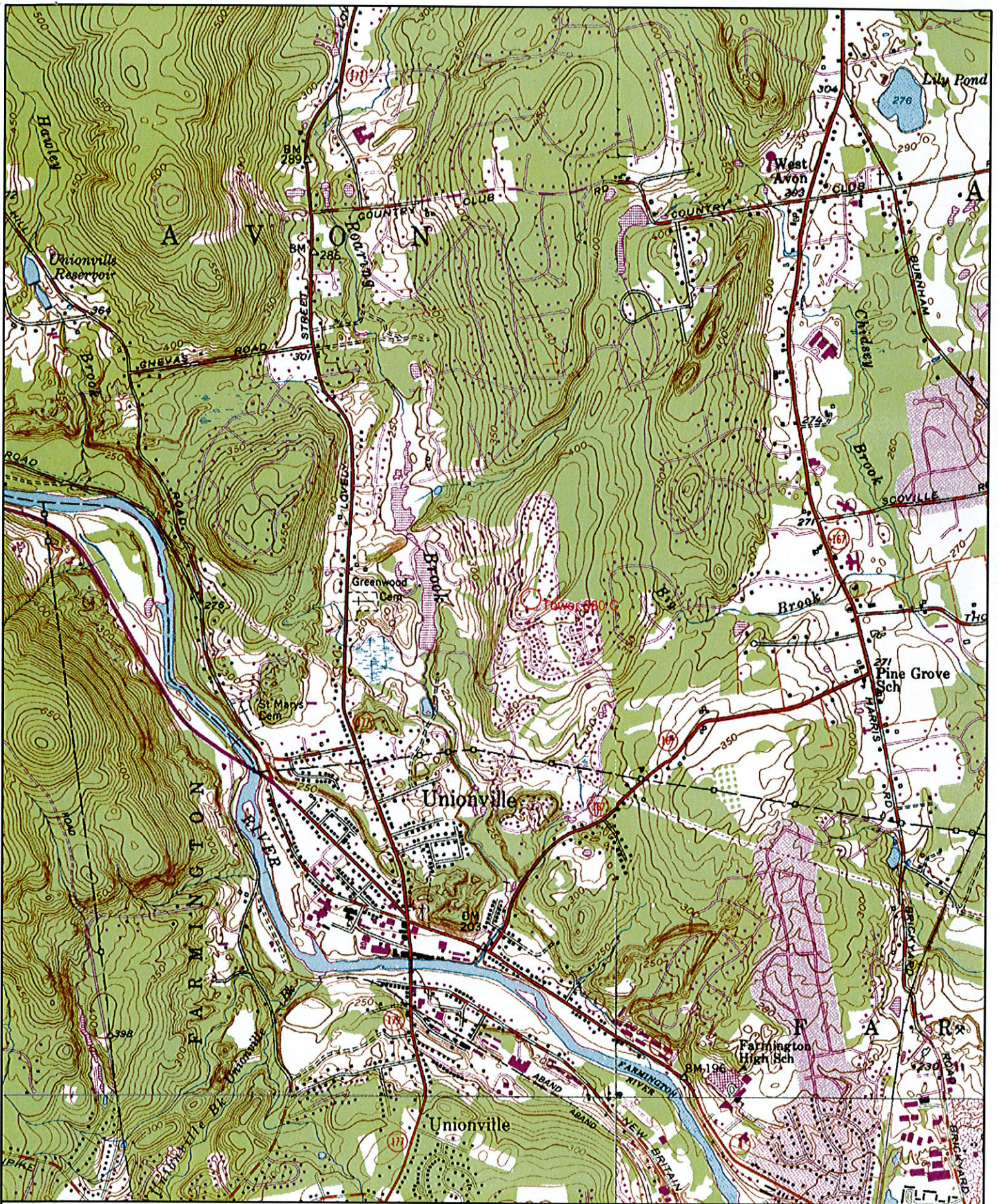

Name: COLLINSVILLE
 Date: 3/27/2001
 Scale: 1 inch equals 2000 feet

Location: 041° 46' 18.5" N 072° 52' 56.2" W
 Caption: VoiceStream
 Tower 380C
 Avon

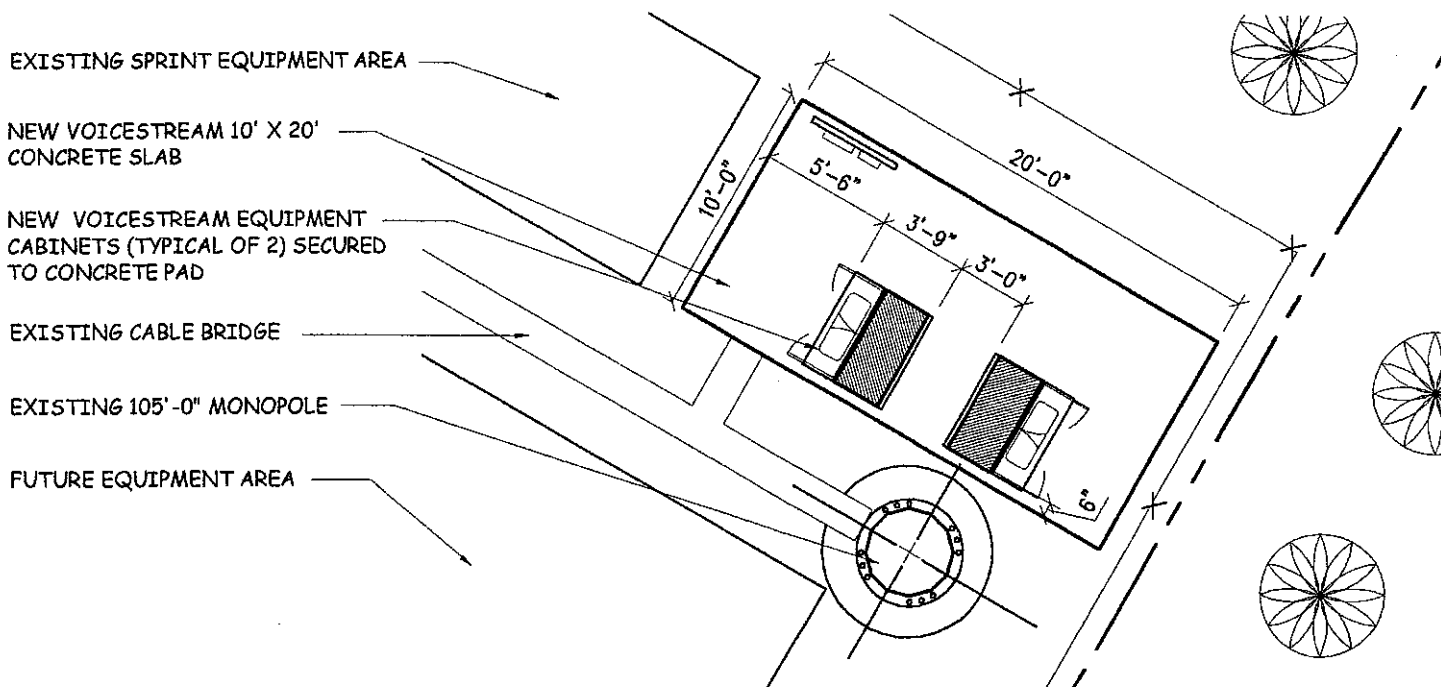
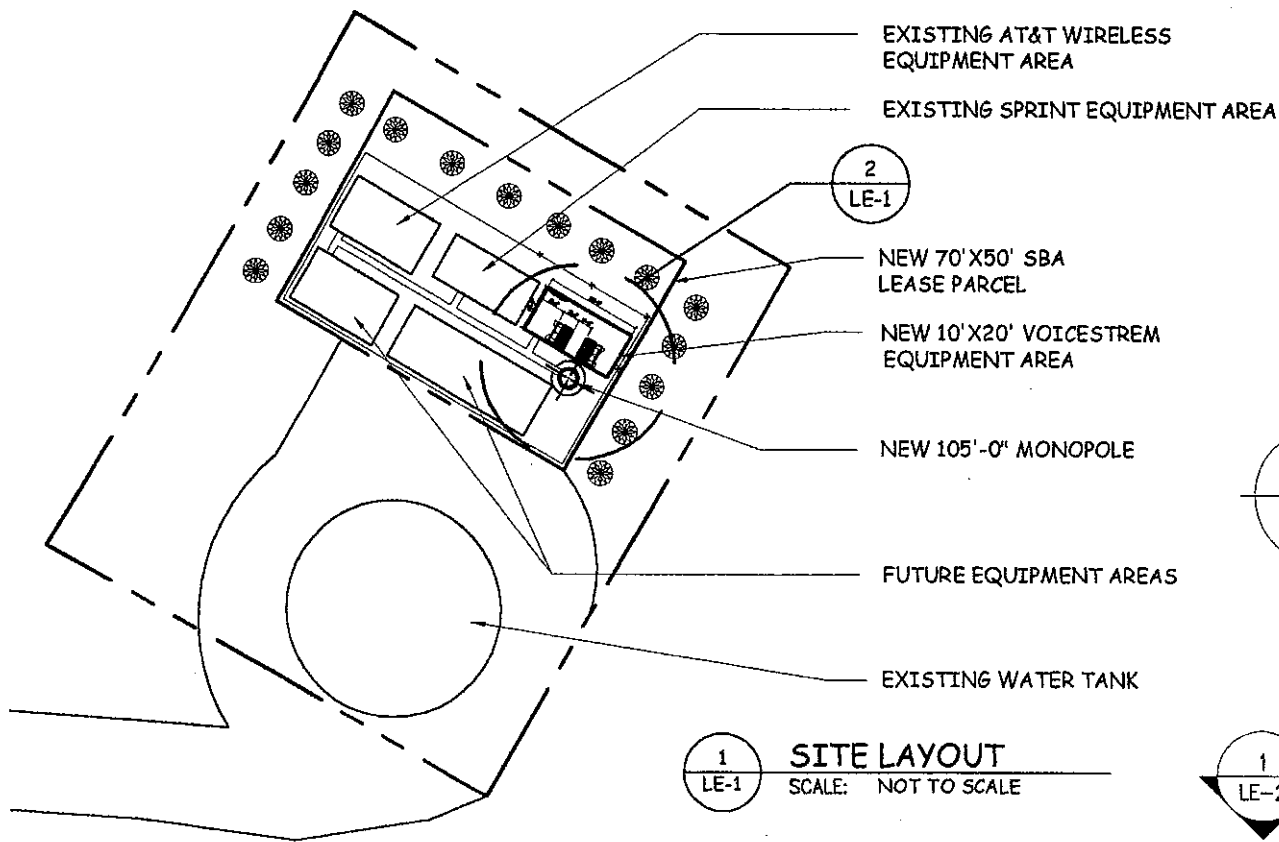

NOTE: EXHIBITS SUBMITTED ARE A CONCEPTUAL REPRESENTATION OF THE LEASE AGREEMENT ONLY. ACTUAL CONSTRUCTION DOCUMENTATION MAY VARY TO COMPLY WITH ALL APPLICABLE CODES.

Approved By: RF ENGINEER: _____ DATE: _____	 140 PILLEY STREET, BLOOMFIELD, CT, 06002	Project: THE AVON WATER COMPANY				
Approved By: CONST MNGR: _____ DATE: _____		Address: REDWOD LANE AVON, CT				
Approved By: S.A.C. : _____ DATE: _____		Project No: CT-11-380C Search Area: AVON				
ON AIR ENGINEERING 201 WALNUT STREET, WASHINGTON TOWNSHIP, NJ 07675	P.M.: DWe	Drawn: RSa	Chgd by:	Date: 9/21/00	Drawing Title: SITE LAYOUT	Drawing No: LE-1

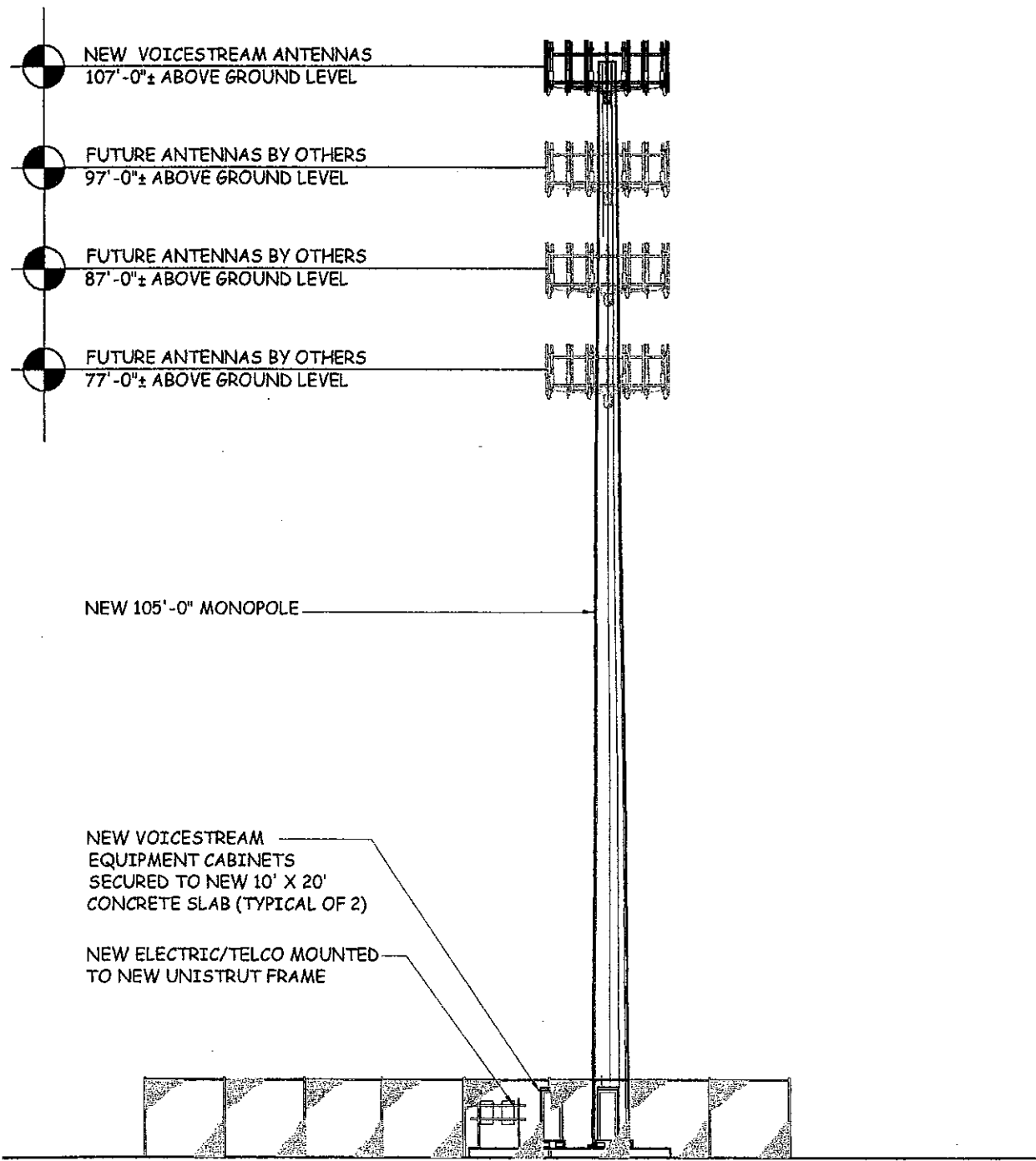

1
LE-2 ELEVATION
SCALE: 1/16" = 1'-0"

NOTE: EXHIBITS SUBMITTED ARE A CONCEPTUAL REPRESENTATION OF THE LEASE AGREEMENT ONLY. ACTUAL CONSTRUCTION DOCUMENTATION MAY VARY TO COMPLY WITH ALL APPLICABLE CODES.

Approved By: RF ENGINEER: _____ DATE: _____	Client:  100 FAILEY STREET, BLOOMFIELD, CT, 06002	Project: THE AVON WATER COMPANY
Approved By: CONST MNGR: _____ DATE: _____		Address: REDWOD LANE AVON, CT
Approved By: S.A.C. : _____ DATE: _____		Project No: CT-11-380C Search Area: AVON
ON AIR ENGINEERING 201 WALNUT STREET, WASHINGTON TOWNSHIP, NJ 07675	P.M.: DWe Drawn: RSa Chkd. by: _____ Date: 9/21/00	Drawing Title: ELEVATION Drawing No. LE-2

Exhibit B

Equipment Specifications **Redwood Lane, Avon, CT**

NORTEL
NETWORKS™

S8000 BTS

Site Specifications

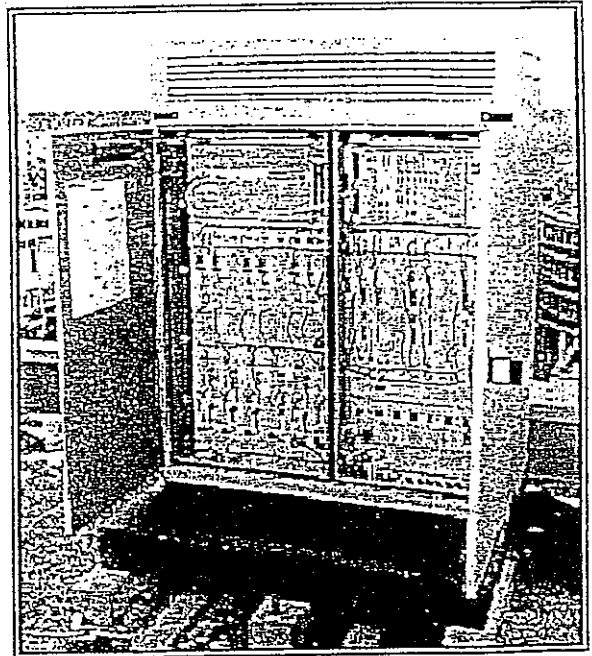
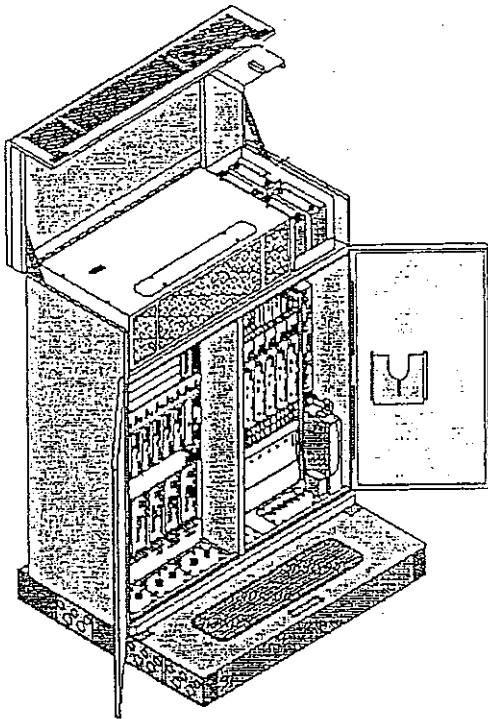

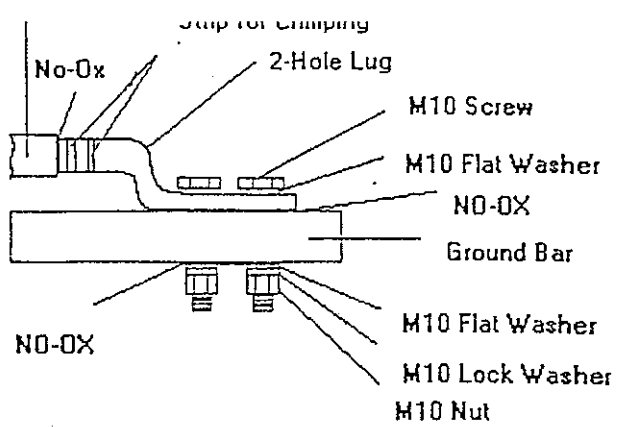
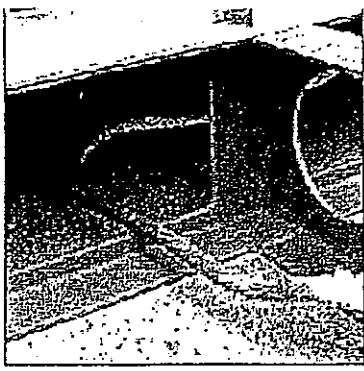

Apply a light coating of No Oxidation (NO-OX) to the ground bar area.

Dimensions, Weights & Clearances

BTS

Weight: 915 pounds
 Dimensions: 53.2"W x 26"D x 63"H

Clearances while transporting in building:

Door Access:
 Height: 6.6 feet
 Width 3 feet

Corridor Access:
 Height: 6.6 feet
 Width: 3.6 feet (straight), 6.6 feet (right angle)

Clearances when installed:

Above: 28 inches for opening of hood
 Rear: 8 inches for installation of outer skin
 Sides: 8 inches for adjustment of door hinges
 Front: 54 inches to open door and technician access

Plinth

Weight:
 87 pounds
 Dimensions:
 53.2"W x 44"D x 10.2"H

Floor Characteristics

Minimum Floor Resistance:
 123 pounds/foot²

Flatness:
 ¼ inch over 78 inches

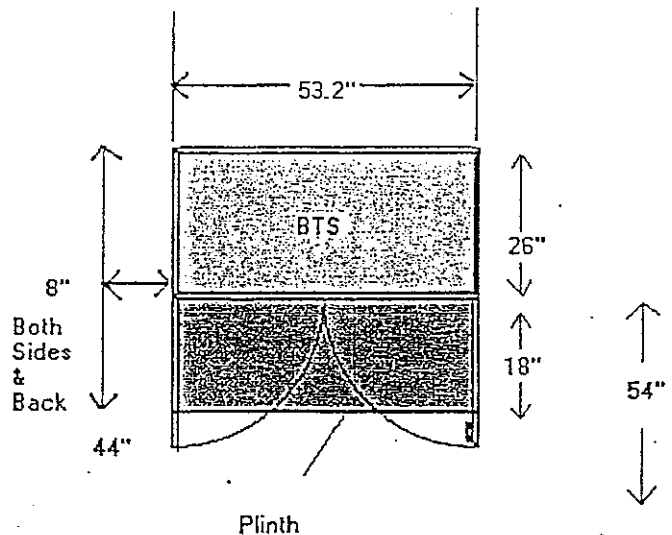

Electrical Specifications

Split Single-Phase

3 wires plus ground

L1: Black 6 gauge

L2: Red 6 gauge

Neutral: White 6 gauge

Ground: Yellow/Green 6 gauge

Maximum distance between AC box and BTS: 105 feet

187 ~ 254 VAC between L1 and L2

99 ~ 127 VAC between Neutral and L1 or L2

45 ~ 65 Hertz

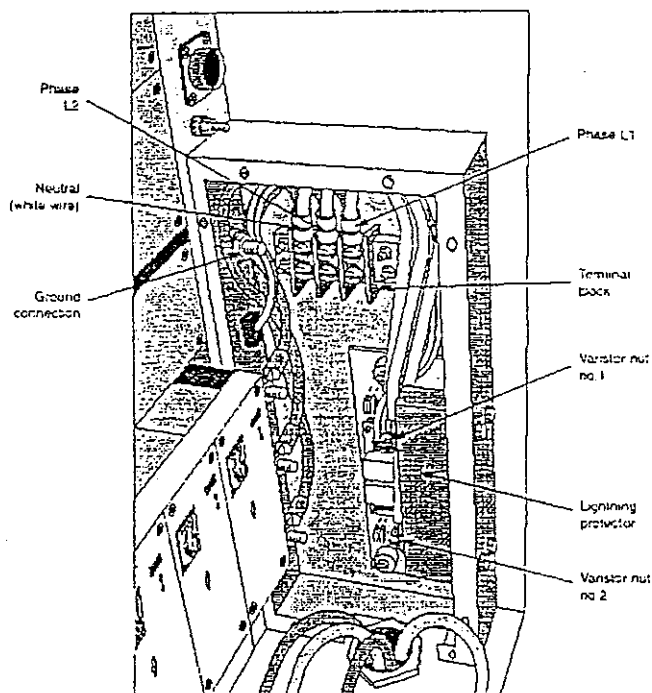

AC connection to BTS located at the front, lower, right-hand side of BTS

Circuit Breaker in AC Box

Up to 4 transmitters

30 A, bipolar, C curve

5 or more transmitters

40A, bipolar, C curve

BTS to Ground connection

Minimum 2 AWG, run in most direct route as possible towards true earth, minimizing bends. No bend shall be less than 90 degrees.

1850 MHz - 1990 MHz (P)

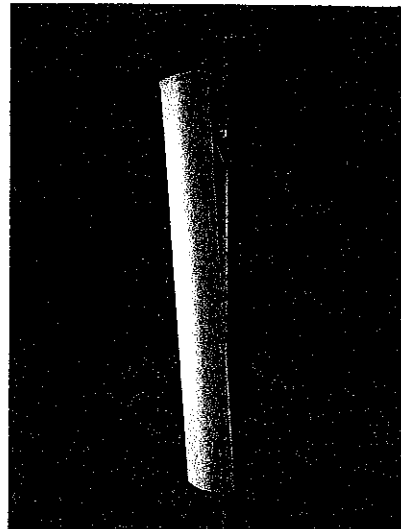
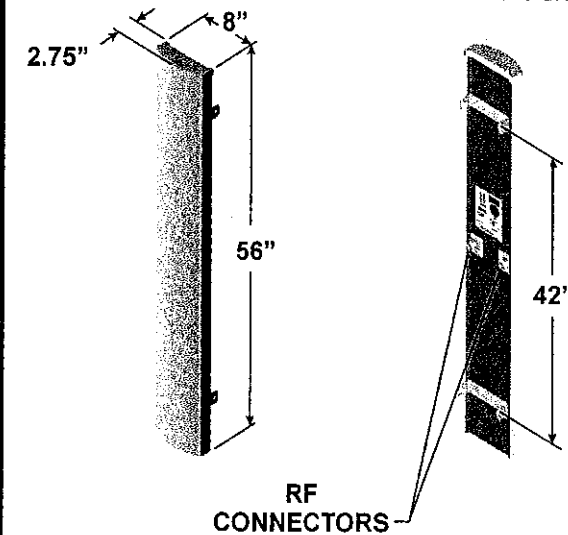

- 90° beamwidth
- 16.5 dBi gain
- ±45° DualPol™
- 56 inch

SPECIFICATIONS

Electrical		Mechanical	
Azimuth Beamwidth	90°	Dimensions (L x W x D)	56in x 8in x 2.75in (142 cm x 20.3 cm x 7.0 cm)
Elevation Beamwidth	6°	Rated Wind Velocity	150 mph (241 km/hr)
Gain	16.5 dBi (14.4 dBd)	Equivalent Flat Plate Area	3.1ft ² (.29 m ²)
Polarization	Slant, ±45°	Front Wind Load @ 100 mph (161 kph)	90 lbs (400 N)
Port-to-Port Isolation	≥ 30 dB	Side Wind Load @ 100 mph (161 kph)	31 lbs (139 N)
Front-to-Back Ratio	≥ 25 dB (≥ 30 dB Typ.)	Weight	18 lbs (8.2 kg)
Electrical Downtilt Options	0°, 2°, 4°, 6°	<p>Note: Patent Pending and US Patent number 5, 757, 246.</p> <p>Values and patterns are representative and variations may occur. Specifications may change without notice due to continuous product enhancements. Digitized pattern data is available from the factory or via the web site www.emswireless.com and reflect all updates.</p>	
VSWR	1.35:1 Max		
Connectors	2; Type N or 7-16 DIN (female)		
Power Handling	250 Watts CW		
Passive Intermodulation	<-147 dBc (2 tone @ +43 dBm (20W) ea.)		
Lightning Protection	Chassis Ground		

MOUNTING OPTIONS

Model Number	Description	Comments
MTG-P00-10	Standard Mount (Supplied with antenna)	Mounts to Wall or 1.5 inch to 5.0 inch O.D. Pole (3.8 cm to 12.7 cm)
MTG-S02-10	Swivel Mount	Mounting kit providing azimuth adjustment.
MTG-DXX-20*	Mechanical Downtilt Kits	0° - 10° or 0° - 15° Mechanical Downtilt
MTG-CXX-10*	Cluster Mount Kits	3 antennas 120° apart or 2 antennas 180° apart
MTG-C02-10	U-Bolt Cluster Mount Kit	3 antennas 120° apart, 4.5" O.D. pole.
MTG-TXX-10*	Steel Band Mount	Pole diameters 7.5" - 45"

* Model number shown represents a series of products. See mounting options section for specific model number.

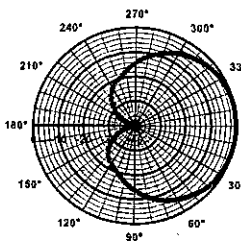

Azimuth

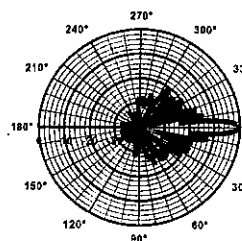

Elevation
0° Downtilt

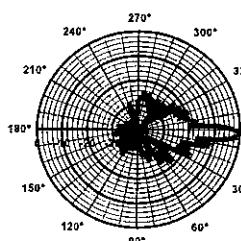

Elevation
2° Downtilt

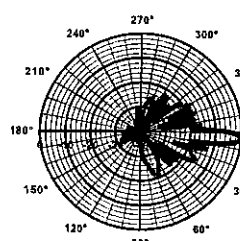

Elevation
4° Downtilt

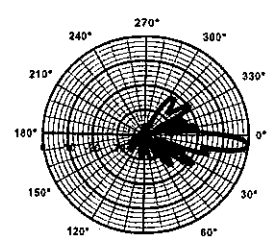

Elevation
6° Downtilt

Exhibit C

Structural Analysis **Redwood Lane, Avon, CT**

On Air Engineering, LLC

201 Walnut Street
Township of Washington, NJ 07676
(201) 358-9541
(201) 358-9542 fax

March 21, 2001

Ms. Karina Hansen
VoiceStream Wireless
100 Filley Street
Bloomfield, CT 06002

Re: CT-11-380-C
Redwood Lane, Avon, CT
Structural Analysis for SBA Monopole

Dear Ms. Hansen:

Our office has completed a structural assessment and loading conditions for the above referenced SBA monopole to determine the adequacy of the structure for carrying proposed VoiceStream antennas, mounts and cables.

VoiceStream provided our office with Pirod Inc. monopole and foundation design drawings dated 9/26/00. The drawings indicate that the monopole has been designed for 5 carriers and one GPS antenna for the following loads and elevations:

106'-0"	(12) DB896, 13' low profile platform, 1-5/8" coax lines
98'-0"	(12) DB896, 13' low profile platform, 1-5/8" coax lines
90'-0"	(12) DB896, 13' low profile platform, 1-5/8" coax lines
82'-0"	(12) DB896, 13' low profile platform, 1-5/8" coax lines
74'-0"	(12) DB896, 13' low profile platform, 1-5/8" coax lines
69'-0"	(1) GPS antenna

VoiceStream is proposing to install (6) antennas manufactured by EMS Wireless, model # RR90-17-02DP on a 13' low profile platform fed by (6) coax lines not exceeding 1-5/8" diameter at the 107'-0" centerline elevation. The pole is currently under construction with VoiceStream projected to be the first carrier to locate on the structure.

Based on the proposed VoiceStream loading in comparison to the overall Pirod design loading, this monopole is determined to be structurally adequate. This analysis assumes that the pole and foundation upon completion shall be installed in accordance with Pirod Inc. design drawings and in compliance with all local and state building codes.

Very truly yours,



David A. Weinpahl, P.E.
President
On Air Engineering, LLC

cc: Sherry Sukow - VoiceStream Wireless

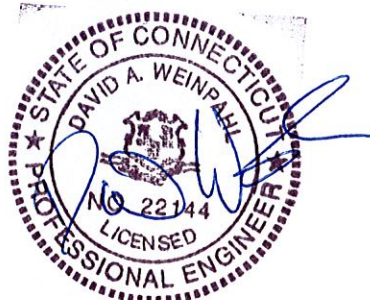

Exhibit D

Power Density Calculations

Redwood Lane, Avon, CT

Technical Memo

To: Karina Hansen
From: Enrique Ramos, Jr. (Radio Engineering Consultant)
cc: Mike Fulton
Subject: Power Density Report for CT-11-380C
Date: 03/09/01

1. Introduction:

This report is the result of an Electromagnetic Field Intensities (EMF - Power Densities) study for the proposed VoiceStream Wireless PCS antenna installation on a monopole at Redwood Lane, Avon, CT. This study incorporates the most conservative considerations for determining the practical combined worst-case power density levels that would be theoretically encountered from several locations surrounding the transmitting location.

2. Discussion:

The following assumptions were used in the calculations:

- 1) The emissions from the Voicestream transmitters are in the 1930-1945 MHz frequency band.
- 2) The antenna cluster consists of 3 sectors, with 2 antennas per sector. The model number for each antenna is EMS-RR90-17-02DP.
- 3) The antenna height is 107 feet centerline.
- 4) The maximum transmit power from each sector is 1254.84 watts Effective Isotropic Radiated Power (EiRP) assuming 4 channels per sector.
- 5) All the antennas are simultaneously transmitting and receiving, 24 hours a day.
- 6) Power levels emitting from the antennas are increased by a factor of 2.56 to account for possible in-phase reflections from the surrounding environment. This is rarely the case, and if so, is never continuous.
- 7) The average ground level of the studied area does not significantly change with respect to the transmitting location.

Equations given in "FCC OET Bulletin 65, Edition 97-01" were then used with the above information to perform the calculations.

3. Conclusion:

Based on the above worse case assumptions, the power density calculations from the proposed VoiceStream Wireless, PCS antenna installation on Redwood Lane, Avon, CT is 0.024046 mw/cm². This value represents only 2.4046% of the Maximum Permissible Emission (MPE) standard of 1000 microwatts per square centimeter ($\mu\text{w}/\text{cm}^2$) set forth in the FCC/ANSI/IEEE C95.1-1991. Details are shown in the attachment. Furthermore, the proposed antenna location for VoiceStream Wireless will not interfere with existing public safety telecommunications, AM band and FM band radio broadcast, TV, Police Communication, HAM Radio communications and other signals in the area.

Worst Case Power Density

Region 11 - Connecticut Power Density Calculation Site: CT-11-380C Site Address: Redwood Lane Town: Avon Pole Height: 110FT Tower Style: Monopole	
Base Station TX output	20 W
Number of channels	4
Antenna Model	EMS-RR90-17-02DP
Cable Size	1-1/4 "
Cable Length	125.0 ft
Antenna Height	107.0 ft
Ground Reflection	1
Frequency	1930.00 MHz
Jumper & Connector loss	2.62 dB
Antenna Gain	16.5 dBi
Cable Loss per foot	0.0154 dB (loss per ft)
Total Cable Loss	1.925 dB
Total Attenuation	4.545 dB
Total EIRP per channel (In Watts)	54.97 dB
Total EIRP per sector (In Watts)	313.71 W
	60.99 dB
	1254.84 W
	nsg
	11.955
Power Density (S) =	0.024046 mW / cm²
% MPE =	2.4046%
Equation Used:	$S = \frac{(1000 \text{ (grf)})^2 (\text{Power})^{10} \text{ (nsg/10)}}{4\pi (R)^2}$
Office of Engineering and Technology (OET) Bulletin 65, Edition 97-01, August 1997	



STATE OF CONNECTICUT

CONNECTICUT SITING COUNCIL

Ten Franklin Square, New Britain, CT 06051

Phone: (860) 827-2935 Fax: (860) 827-2950

E-Mail: siting.council@po.state.ct.us

Web Site: www.state.ct.us/csc/index.htm

March 29, 2001

Mr. Philip K. Schenck, Jr.
Town Manager
Town of Avon
60 West Main Street
Avon, CT 06001-3743

RE: **TS-VOICESTREAM-004-010328** - VoiceStream Wireless Corporation request for an order to approve tower sharing at an existing telecommunications facility located at Redwood Lane, Avon, Connecticut.

Dear Mr. Schenck:

The Connecticut Siting Council (Council) received this request for tower sharing, pursuant to Connecticut General Statutes § 16-50aa.

The Council will consider this item at the next meeting scheduled for April 12, 2001, at 1:30 p.m. in Hearing Room Two, Ten Franklin Square, New Britain, Connecticut.

Please call me or inform the Council if you have any questions or comments regarding this proposal.

Thank you for your cooperation and consideration.

Very truly yours,

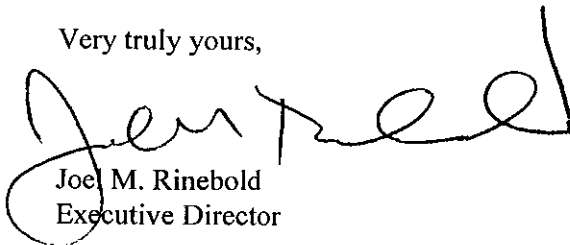

Joel M. Rinebold
Executive Director

JMR/RKE/grg

Enclosure: Notice of Tower Sharing

c: Honorable Richard W. Hines, Chairman Town Council, Town of Avon

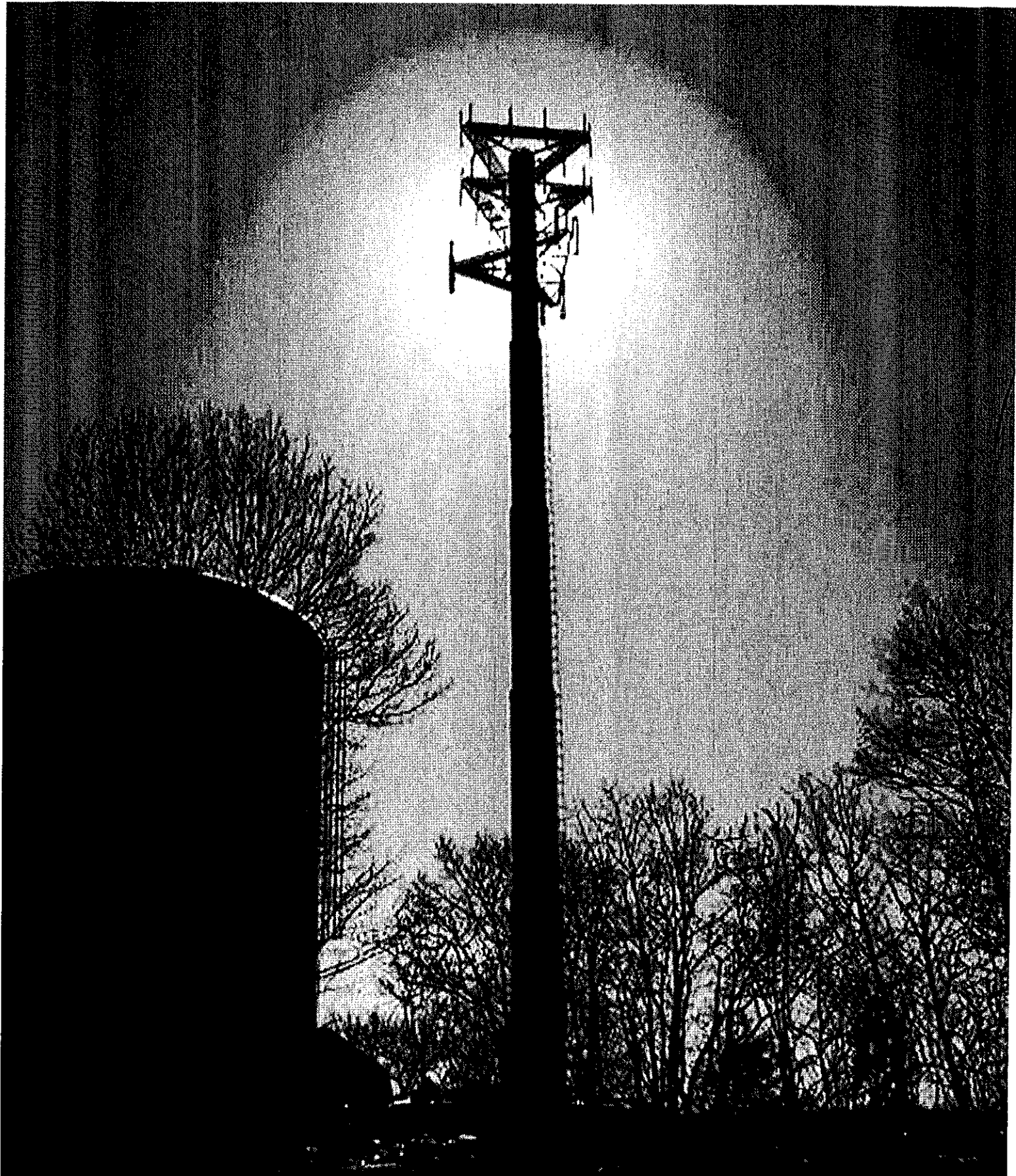

Voicestream Redwood Lane Avon 4/05/01