

December 16, 2015

*Via Hand Delivery*

Stephen C. Dunn, First Selectman  
Town of Brookfield  
100 Pocono Road  
Brookfield, CT 06804

Re: **Submission of Technical Information Concerning a Proposal to Construct a  
Wireless Telecommunications Facility at 100 Pocono Road, Brookfield, Connecticut**

Dear Mr. Dunn:

This firm represents Homeland Towers, LLC (“Homeland”) and Cellco Partnership d/b/a Verizon Wireless (“Cellco”) (collectively, the “Applicant”), in its proposal to construct a new wireless telecommunications facility in the southwest corner of the 43.28 acre municipal facilities complex at 100 Pocono Road in Brookfield, Connecticut (the “Property”). As you are aware, the Property is owned by the Town of Brookfield (“Town”). For the purposes of this filing, Cellco has identified the proposed telecommunications facility as its “Brookfield South Facility”.

This Technical Report is submitted by the Applicant pursuant to Connecticut General Statutes (“Conn. Gen. Stat.”) § 16-50I(g), which establishes local input requirements for the siting of a wireless telecommunications facility under the jurisdiction of the Connecticut Siting Council (the “Council”). This statutory provision requires the submission of technical information to the municipality where a proposed facility will be located and any municipality within 2,500 feet of the proposed facility location.

# Robinson + Cole

Stephen C. Dunn  
December 16, 2015  
Page 2

Correspondence and/or communications regarding the information contained in this report should be directed to:

Raymond Vergati  
Homeland Towers  
22 Shelter Rock Lane - Building C  
Danbury, CT 06810

Anthony Befera  
Verizon Wireless  
99 East River Drive  
East Hartford, CT 06108

A copy of all such correspondence or communications should also be sent to the Applicant's attorney:

Kenneth C. Baldwin, Esq.  
Robinson & Cole LLP  
280 Trumbull Street  
Hartford, CT 06103-3597

The Applicant intends to submit an application to the Council for a Certificate of Environmental Compatibility and Public Need ("Certificate") for the construction, maintenance and operation of a wireless telecommunications facility at the Property. The Brookfield South Facility would interact with Cellco's existing wireless facilities in Brookfield, Danbury, Bethel and Newtown. The Brookfield South Facility would provide improved coverage to existing service gaps along portions of Routes 7, 202, 25 and 133 in Brookfield. Plots showing coverage from Cellco's existing cell sites in the area, alone and together with the predicted coverage from the proposed Brookfield South Facility are included in Attachment 1. The Brookfield South Facility will also off-load voice and data traffic from Cellco's existing Brookfield cell site (Beta sector) and Bethel North cell site (Alpha sector), which are currently operating at or near their respective capacity limits.

## **Cell Site Information**

The proposed Brookfield South Facility would be located in the southwest corner of an approximately 43.28-acre Town-owned parcel, directly behind and west of, the Brookfield Fire Department. The Property is Town's Restricted Industrial/Commercial (IR/C – 80/40) zone district and is currently used for municipal purposes, including Town Hall offices, the Brookfield Senior Center, the Town's Police and Fire Departments, and the Public Works Departments materials storage area. Portions of the Property to the north of the tower site have also been developed with athletic fields and a playground area. (See Site Schematic included in Attachment 2).

Stephen C. Dunn  
December 16, 2015  
Page 3

The proposed wireless facility will consist of a 150-foot monopole tower located in the middle of a 62' x 75' fenced and gravel compound. Cellco will install twelve (12) panel-type antennas at the centerline height of 146 feet above ground level ("AGL"). Equipment associated with Cellco's antennas and a propane fueled back-up generator would be located on a 12' x 30' concrete pad located near the base of the tower. A 500 gallon propane fuel tank will also be installed in the southwest corner of the cell site compound. Town antennas will be attached to the top of the tower and extend to an overall height of approximately 175 feet AGL. Access to the Brookfield South Facility would extend from Pocono Road over a portion of an existing paved driveway a distance of approximately 420 feet then over a gravel driveway extension, a distance of approximately 300 feet to the cell site. Project plans for the Brookfield South Facility are included in Attachment 3.

## **Connecticut Siting Council Jurisdiction**

Municipal jurisdiction over the siting of the proposed telecommunications facility described in this report is pre-empted by provisions of the Public Utilities Environmental Standards Act ("PUESA"), Conn. Gen. Stat. § 16-50g *et seq.* The PUESA gives exclusive jurisdiction over the location, type and modification of telecommunications towers, to the Council (Conn. Gen. Stat. § 16-50x(a); 16-50i(a)(6)). Accordingly, the telecommunications facility described in this report is exempt from the Town's land use regulations.

Upon receipt of an application, the Council will assign a docket number and, following a completeness review, set a docket schedule, including a hearing date. At that time, the Town may choose to become an intervenor or party in the proceeding. Other procedures followed by the Council include serving the applicant and other participants with interrogatories, holding a pre-hearing conference, and conducting a public hearing. The public hearing would be held at a location in the Town. Following the public hearing, the Council will issue findings of fact, an opinion and a decision and order. Prior to construction, the Council will also require the Applicant to submit a development and management plan ("D&M Plan") which is, in essence, a final site development plan showing the details of the facility incorporating any conditions imposed by the Council. These procedures are also outside the scope of the Town's jurisdiction and are governed by the Connecticut General Statutes, the Regulations of Connecticut State Agencies, and the Council's Rules of Practice. If the Council approves the cell site described in this report, Cellco will submit to the Building Official an application for approval of a building permit. Under Section 16-50x of the General Statutes, which provides for the exclusive jurisdiction of the Council, the building official must honor the Council's decision.

Stephen C. Dunn  
December 16, 2015  
Page 4

## **Municipal Consultation Process**

Pursuant to Section 16-50 $\bar{l}$  of the General Statutes, Town officials are entitled to receive technical information regarding the proposed telecommunications facility at least ninety (90) days prior to the filing of an application with the Council. This Technical Report is provided to the Town in accordance with these provisions and includes information on the need for improved reliable wireless service in the area; the location of existing wireless facilities in and around Brookfield; details of the proposed facility; the location of alternative sites considered and rejected; the location of schools and commercial day care facilities in the area and the aesthetic impacts of the facility on those schools and day care facilities, if any; a description of the site selection process; and a discussion of potential environmental effects associated with the proposed facility.

Not later than sixty (60) days after the initial consultation meeting, the municipality may, in cooperation with Cellco, hold a public information hearing on the facility proposal. If such a hearing is held, the applicant must notify all abutting landowners and publish notice of the hearing in a newspaper of general circulation in the municipality, at least fifteen (15) days prior to the hearing.

Not later than thirty (30) days after the initial consultation meeting, the municipality may present Cellco with alternative sites, including municipal parcels, for its consideration. If not previously considered, these alternatives will be evaluated and discussed in its application to the Council.

Pursuant to Section 16-50 $\bar{l}$ (e) of the General Statutes, Cellco must provide a summary of the Town's comments and recommendations, if any, to the Council within fifteen (15) days of the filing of an application.

## **Need for the Proposed Wireless Facility**

The proposed Brookfield South Facility described in this Technical Report would allow Cellco to provide enhanced wireless voice and data services in portions of Brookfield, Danbury and Bethel, Connecticut. More particularly, the Brookfield South Facility will provide additional wireless "coverage" along portions of Routes 7, 202 (Federal Road), 25 and 133 as well as local roads in the area. The Brookfield South Facility will also provide capacity relief to Cellco's existing Brookfield and Bethel North cell sites which are currently operating at or beyond their respective capacity limits (exhausting).

# Robinson + Cole

Stephen C. Dunn  
December 16, 2015  
Page 5

## Environmental Effects

In our experience, the primary impact of a wireless facility such as the proposed Brookfield South Facility is visual. The visual impact of the proposed facility will vary from place to place around the site location, depending upon factors such as vegetation, topography, distance from the tower, and the location of buildings in the sight-line of the cell site.

To more fully assess the visual impact of the Brookfield South Facility, All-Points Technology Corporation (“APT”) has prepared a Visibility Analysis. This analysis indicates that the area where the proposed 150-foot tower at the Property would be visible, year-round, consists of approximately 348 acres, primarily limited to the east and north along Pocono Road and Silvermine Road and to the south and west along Route 7, Junction Road and Federal Road. When the leaves are off the trees, views of the proposed tower through the trees (a/k/a seasonal views) may occur over a larger area (approximately 752 acres) around the tower site. (*See Attachment 4*).

Pursuant to the provisions of Conn. Gen. Stat. § 16-50p(a)(3)(G), new telecommunications facilities must be located at least 250 feet from schools (defined in C.G.S. §10-154a) and commercial day care facilities (defined in C.G.S. §19a-77(a)(1)) unless the location selected is acceptable to the Town’s chief elected official or the Council finds that the facility will not have a substantial adverse effect on the aesthetics or scenic quality of the neighborhood where the school or commercial day care use is located. The proposed Brookfield South Facility is not located within 250 feet of any building containing a school or commercial day care facility.

Based on field surveys and related environmental investigations, the Applicant has determined that the construction of the Brookfield South Facility will have no direct impact on inland wetlands or watercourses, within or near the tower compound. Cellco anticipates that all other physical environmental effects associated with the proposed facility would be minimal.

## Radio Frequency Emissions

The Federal Communications Commission (“FCC”) has adopted a standard (the “Standard”) for exposure of radio frequency (“RF”) emissions from telecommunications base stations like the Brookfield South Facility. To ensure compliance with the Standard, Cellco has performed a worst-case RF emissions calculation for the proposed facility according to the methodology described in FCC Office of Science and Technology Bulletin No. 65 (“OST Bulletin 65”). This calculation is a conservative, worst-case approximation of RF emissions at

Stephen C. Dunn  
December 16, 2015  
Page 6

the closest accessible point to the antenna (i.e., the base of the tower), and with all antennas transmitting simultaneously on all channels at full power. The worst-case calculated RF emissions level for Cellco's antennas at the 146-foot level on the proposed tower would be 21.05% of the FCC Standard. (See Attachment 5.) Actual RF emissions levels from this facility will be far less than this "worst-case" approximation.

### **Scenic Natural Historic or Recreational Impacts**

To further assess the environmental impacts of the proposed facility, Cellco is working with its consultant team to prepare a National Environmental Policy Act ("NEPA") Environmental Screening Checklist (the "NEPA Checklist") and other related environmental reviews to determine if the facility will have any significant adverse environmental effects. The NEPA Checklist will include information from the Environmental and Geographic Information Center of the Connecticut Department of Energy and Environmental Protection ("DEEP"), the U.S. Fish and Wildlife Service ("USFWS") and the State Historic Preservation Officer ("SHPO"). Copies of the DEEP, USFWS and the SHPO determinations will also be submitted as a part of the Council Application.

### **Site Search Process**

The Applicant conducted a search for suitable cell site locations in Brookfield and identified the Property as a site that would satisfy Cellco's wireless service objectives in the area. In addition to the proposed location, the Applicant identified and investigated three (3) alternative facility locations in the area. With the exception of the Property, each of the alternative sites considered were either rejected by the landowner, eliminated due to some concerns for significant environmental effects or failed to meet Cellco's wireless service objectives. A complete list of other potential cell sites investigated is included in Attachment 6.

### **Tower Sharing**

As stated above, Homeland, as the tower owner, intends to build a tower that is capable of supporting antennas of multiple wireless telecommunications providers, including the Town of Brookfield emergency service providers. The provision to share the tower is consistent with the intent of the General Assembly when it adopted Conn. Gen. Stat. § 16-50aa and with Council policy. The availability of space on the proposed tower may reduce, if not eliminate, the need for additional towers in Brookfield for the foreseeable future.

# Robinson + Cole

Stephen C. Dunn  
December 16, 2015  
Page 7

## Conclusion

This Technical Report is submitted in accordance with Conn. Gen. Stat. § 16-50~~l~~ which requires Cellco to supply the Town with information regarding its proposed Brookfield South Facility. This report includes information regarding the site selection process, public need, and the potential environmental impacts of the facility. The Applicant submits that its proposed Brookfield South Facility would not have any significant adverse environmental effects. Moreover, the Applicant submits that the public need for high quality wireless service, and a competitive framework for providing such service has been determined by the FCC to be in the public interest and that such public need far outweighs any perceived environmental effects of the proposed facility.

Please contact me if you have any additional questions regarding the proposed facility.

Sincerely,

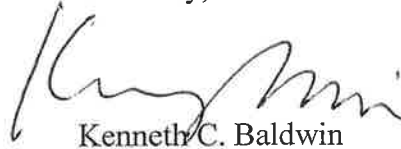

Kenneth C. Baldwin

KCB/kmd  
Enclosures

Copy to (*via hand delivery*):

Jon Van Hise, Chairman, Brookfield Planning Commission  
Ryan Blessey, Chairman, Brookfield Zoning Commission  
Sharon Fox, Chairman, Brookfield Inland-Wetlands Commission  
Raymond Vergati, Homeland Towers  
Anthony R. Befera, Verizon Wireless

# **ATTACHMENT 1**



**Existing Verizon Wireless 700 MHz Coverage with an Antenna Centerline Height of 146' AGL Brookfield, Connecticut and Surrounding Area (\*Map Scale is 1:30,000)**

Coverage is depicted at a signal threshold of 120 dB Operational Path Loss

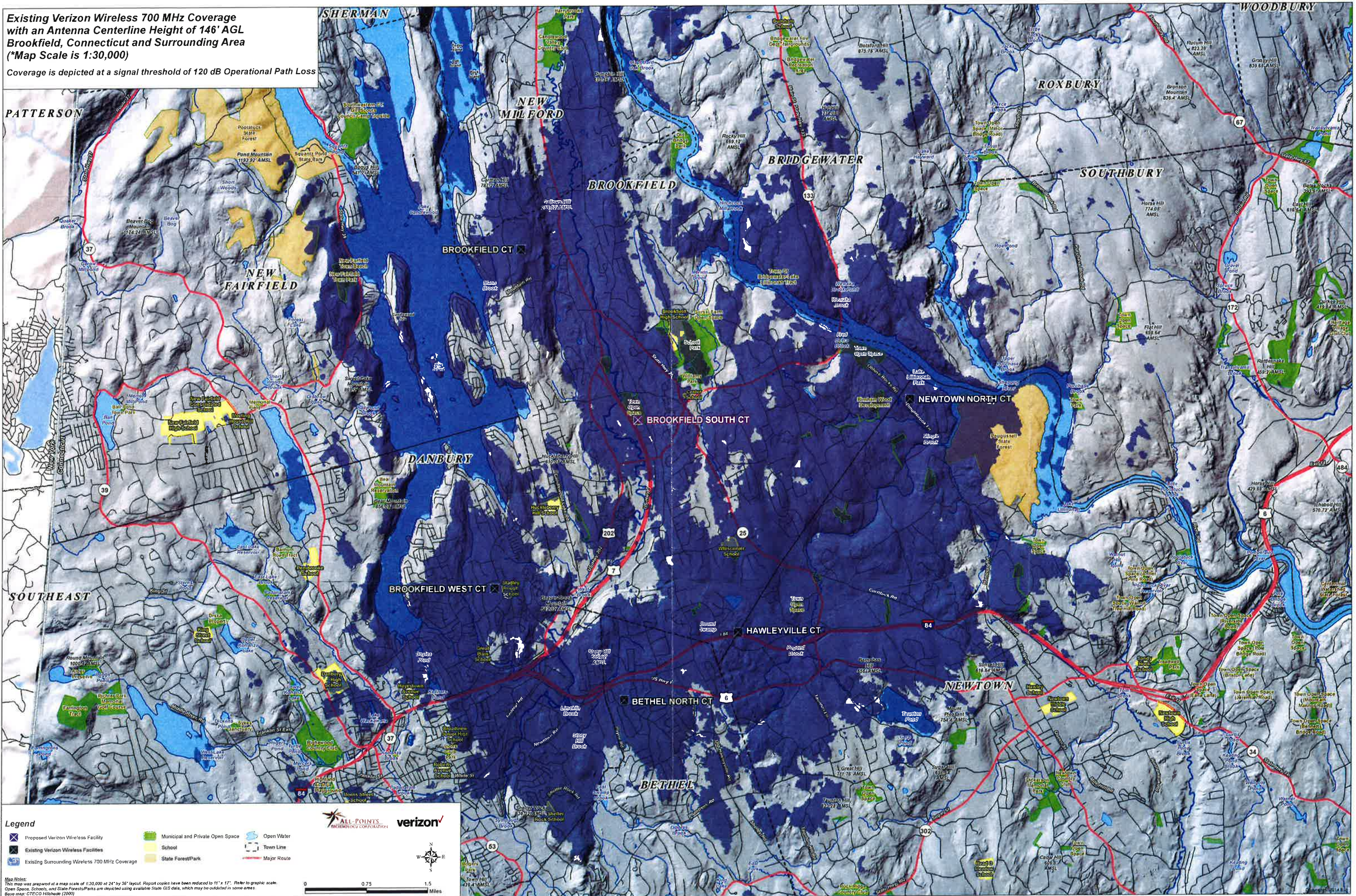

**Legend**

- ✖ Proposed Verizon Wireless Facility
- ✖ Existing Verizon Wireless Facilities
- ✖ Existing Surrounding Wireless 700 MHz Coverage
- Municipal and Private Open Space
- School
- State Forest/Park
- Open Water
- Town Line
- Major Route

**Map Notes:**  
 This map was prepared at a map scale of 1:30,000 at 24" by 36" layout. Report copies have been reduced to 11" x 17". Refer to graphic scale.  
 Open Space, Schools, and State Forests/Parks are depicted using available State GIS data, which may be outdated in some areas.  
 Base map: CT/CTD Hillshade (2007)

**Scale:** 0 0.75 1.5 Miles

**Logos:** ALL-POINTS COMMUNICATIONS CORPORATION, verizon

Proposed Verizon Wireless 700 MHz Coverage with an Antenna Centerline Height of 146' AGL Brookfield, Connecticut and Surrounding Area (\*Map Scale is 1:30,000)

Coverage is depicted at a signal threshold of 120 dB Operational Path Loss

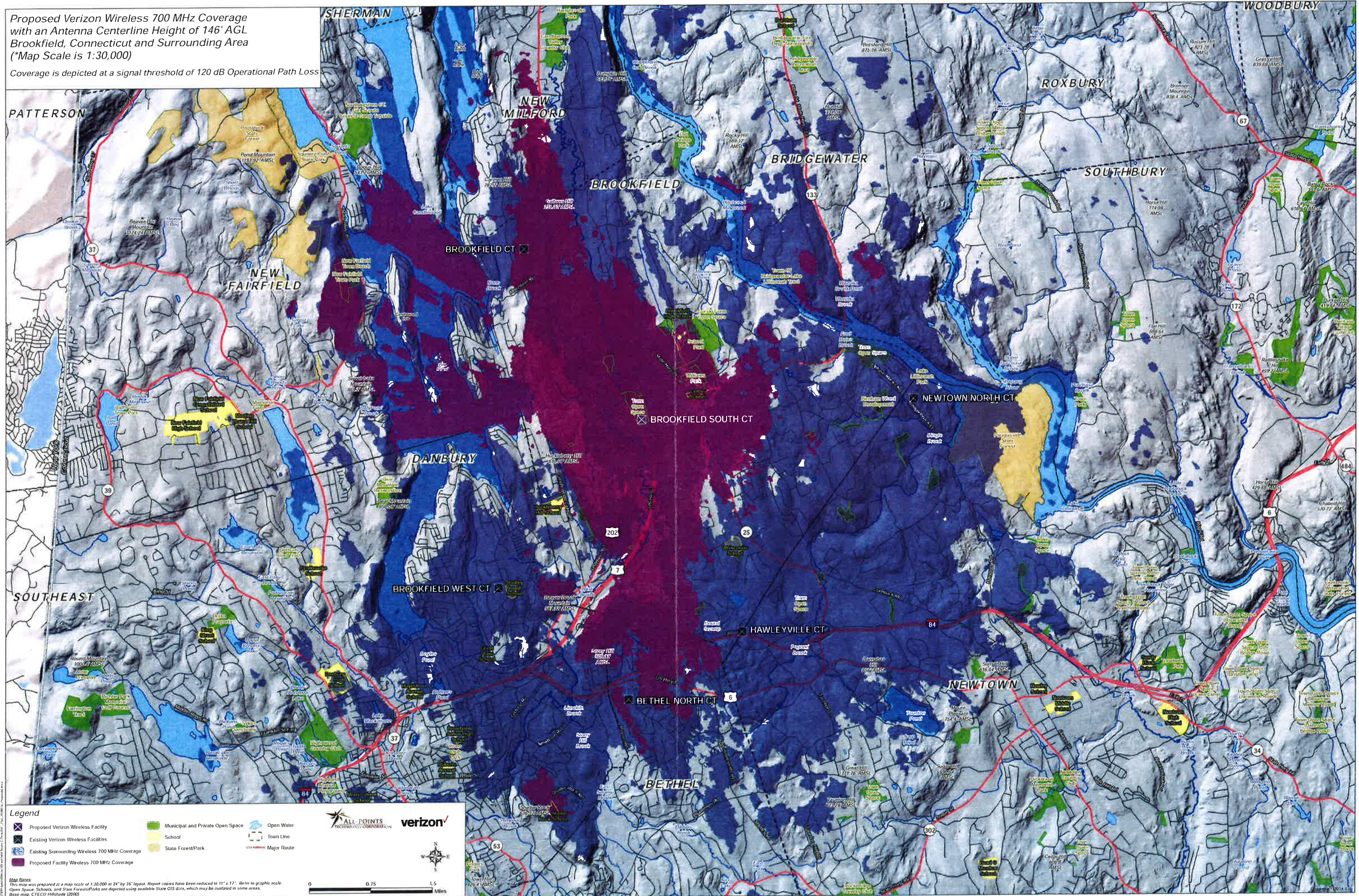

**Legend**

- Proposed Verizon Wireless Facility
- Municipal and Private Open Space
- Open Water
- Existing Verizon Wireless Facilities
- School
- Town Line
- Existing Surrounding Wireless 700 MHz Coverage
- State Forest/Park
- Major Route
- Proposed Facility Wireless 700 MHz Coverage

**Map Notes:**  
 This map was prepared at a map scale of 1:30,000 at 24" by 36" layout. Report copies have been reduced to 11" x 17". Refer to graphic scale.  
 Open Space, Schools, and State Forests/Parks are depicted using available State GIS data, which may be outdated in some areas.  
 Base map: CT/CO Hillshade (2000)

0 0.75 1.5 Miles

©2011 Verizon Wireless. All rights reserved. This map is a service mark of Verizon Wireless.

Existing Verizon Wireless 850 MHz Coverage  
with an Antenna Centerline Height of 146' AGL  
Brookfield, Connecticut and Surrounding Area  
(\*Map Scale is 1:30,000)  
Coverage plot assumes 55% site loading on the Cellco system  
Coverage is depicted at a signal threshold of -85 dBm

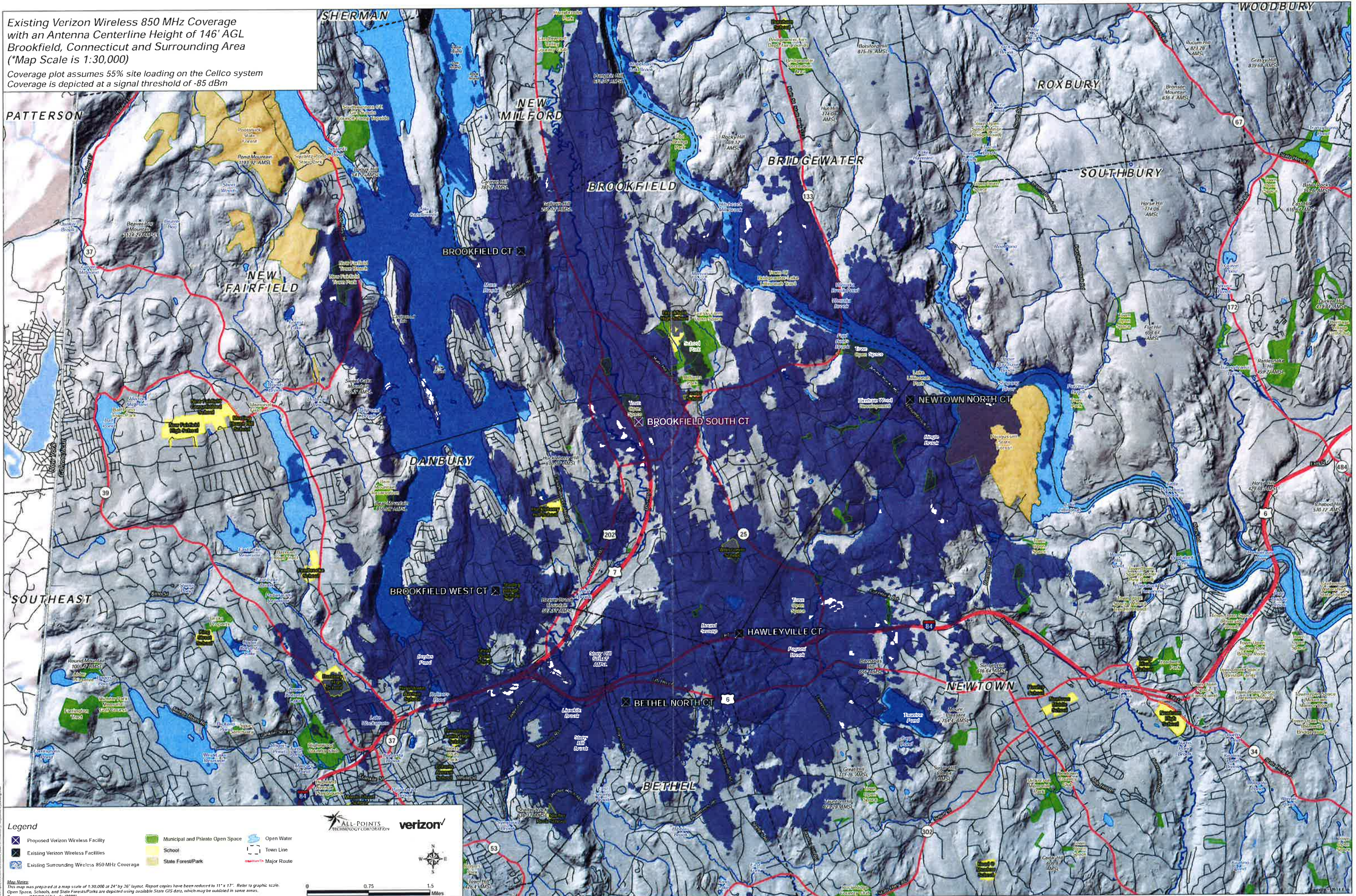

**Legend**

- Proposed Verizon Wireless Facility
- Existing Verizon Wireless Facilities
- Existing Surrounding Wireless 850 MHz Coverage
- Municipal and Private Open Space
- School
- State Forest/Park
- Open Water
- Town Line
- Major Route

**Map Notes:**  
This map was prepared at a map scale of 1:30,000 at 24" by 36" layout. Report copies have been reduced to 11" x 17". Refer to graphic scale.  
Open Space, Schools, and State Forests/Parks are depicted using available State GIS data, which may be outdated in some areas.  
Base map: CTECO Hillshade (2000)

**Scale:** 0 0.75 1.5 Miles

**Logos:** ALL-POINTS TECHNOLOGY CORPORATION, verizon

Proposed Verizon Wireless 850 MHz Coverage with an Antenna Centerline Height of 146' AGL  
 Brookfield, Connecticut and Surrounding Area  
 (\*Map Scale is 1:30,000)  
 Coverage plot assumes 55% site loading on the Cellco system  
 Coverage is depicted at a signal threshold of -85 dBm

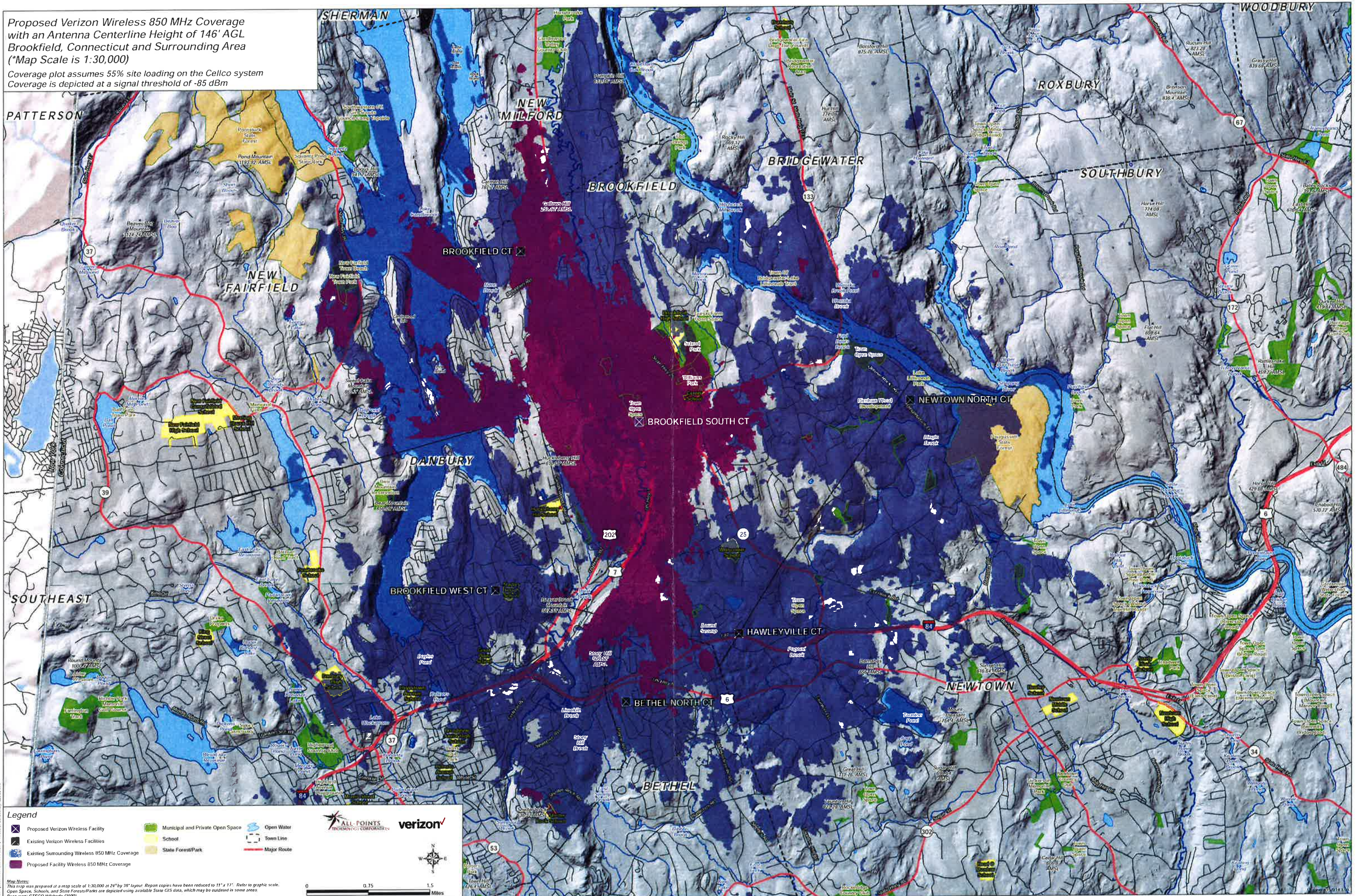

**Legend**

- Proposed Verizon Wireless Facility
- Existing Verizon Wireless Facilities
- Existing Surrounding Wireless 850 MHz Coverage
- Proposed Facility Wireless 850 MHz Coverage
- Municipal and Private Open Space
- School
- State Forest/Park
- Open Water
- Town Line
- Major Route

**ALL POINTS**  
 A VERIZON WIRELESS COMPANY

**verizon**

**Map Notes:**  
 This map was prepared at a map scale of 1:30,000 at 24" by 36" layout. Report copies have been reduced to 11" x 17". Refer to graphic scale.  
 Open Space, Schools, and State Forests/Parks are depicted using available State GIS data, which may be outdated in some areas.  
 Base map: CTECO Hishade (2000)

0 0.75 1.5 Miles

**Existing Verizon Wireless 1900 MHz Coverage with an Antenna Centerline Height of 146' AGL Brookfield, Connecticut and Surrounding Area (\*Map Scale is 1:30,000)**

Coverage plot assumes 55% site loading on the Cellco system  
Coverage is depicted at a signal threshold of -85 dBm

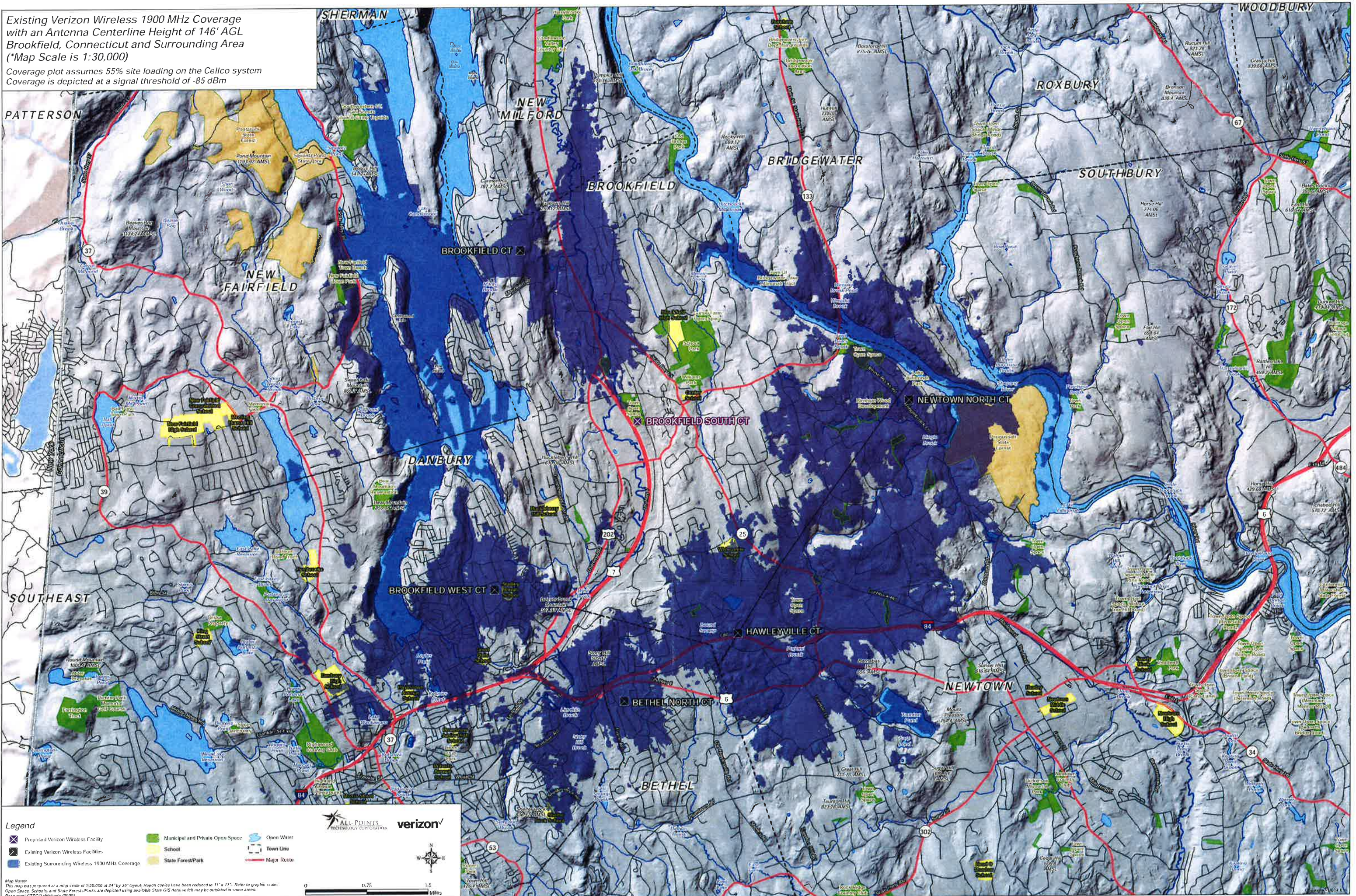

- Legend**
- X Proposed Verizon Wireless Facility
  - Municipal and Private Open Space
  - Existing Verizon Wireless Facilities
  - School
  - Existing Surrounding Wireless 1900 MHz Coverage
  - State Forest/Park
  - Open Water
  - Town Line
  - Major Route



**Map Notes:**  
This map was prepared at a map scale of 1:30,000 at 24" by 36" layout. Repro copies have been reduced to 11" x 17". Refer to graphic scale.  
Open Space, Schools, and State Forests/Parks are depicted using available State GIS data, which may be outdated in some areas.  
Base map: CTGEO Hillshade (2000)



**Proposed Verizon Wireless 1900 MHz Coverage with an Antenna Centerline Height of 146' AGL Brookfield, Connecticut and Surrounding Area (\*Map Scale is 1:30,000)**

Coverage plot assumes 55% site loading on the Cellco system  
Coverage is depicted at a signal threshold of -85 dBm

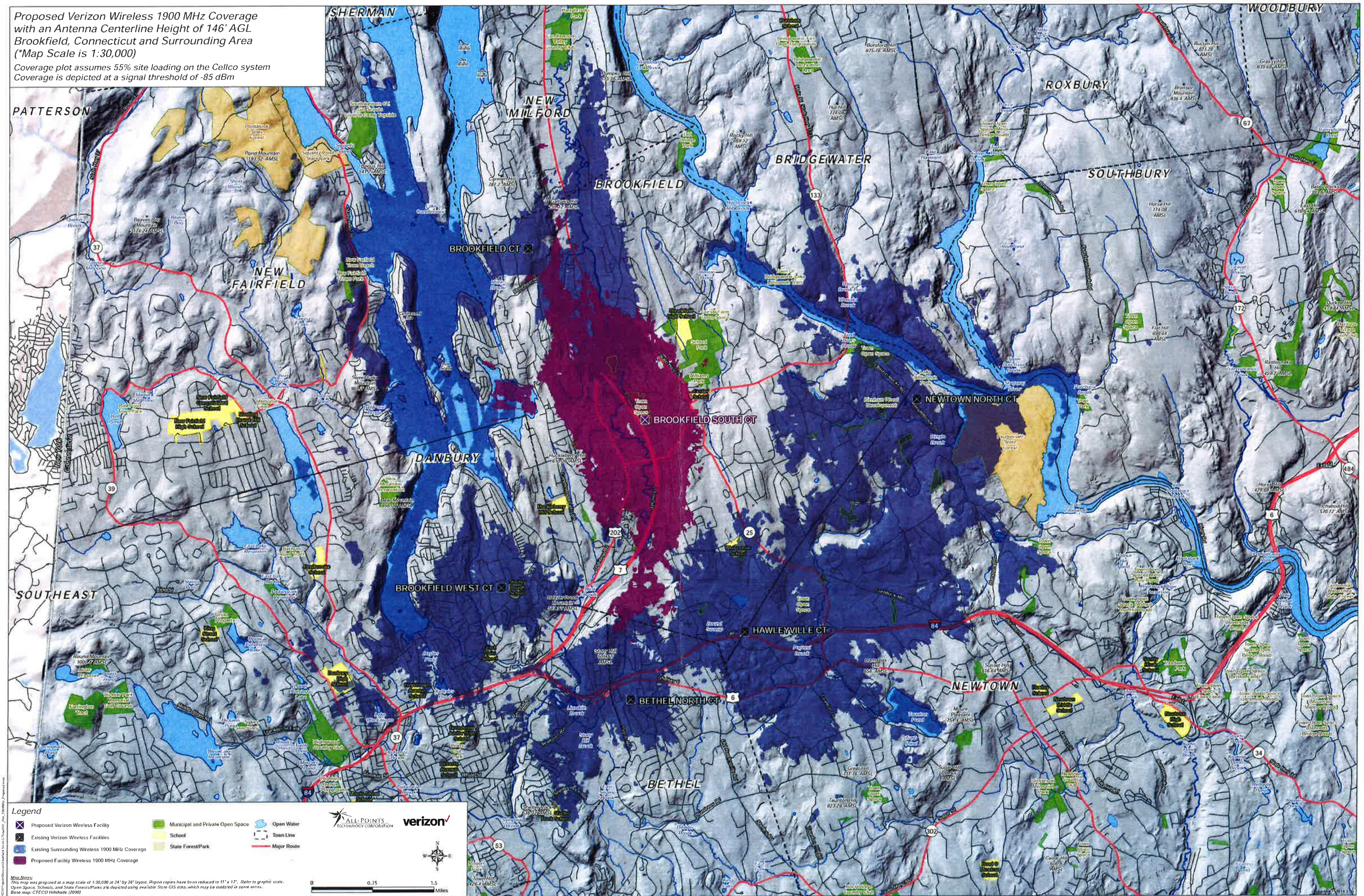

**Legend**

- Proposed Verizon Wireless Facility
- Existing Verizon Wireless Facilities
- Existing Surrounding Wireless 1900 MHz Coverage
- Proposed Facility Wireless 1900 MHz Coverage
- Municipal and Private Open Space
- School
- State Forest/Park
- Open Water
- Town Line
- Major Route

**Map Notes:**  
This map was prepared at a map scale of 1:30,000 at 24" by 36" layout. Report copies have been reduced to 11" x 17". Refer to graphic scale.  
Open Space, Schools, and State Forest/Parks are depicted using available State GIS data, which may be outdated in some areas.  
Base map: CTECO Hatched (2000)

0 0.75 1.5 Miles

Copyright 2009 Verizon Wireless. All rights reserved. This document is the property of Verizon Wireless. It is not to be distributed, copied, or reproduced in any form without the prior written permission of Verizon Wireless.

Existing Verizon Wireless 2100 MHz Coverage  
with an Antenna Centerline Height of 146' AGL  
Brookfield, Connecticut and Surrounding Area  
(\*Map Scale is 1:30,000)

Coverage is depicted at a signal threshold of 120 dB Operational Path Loss

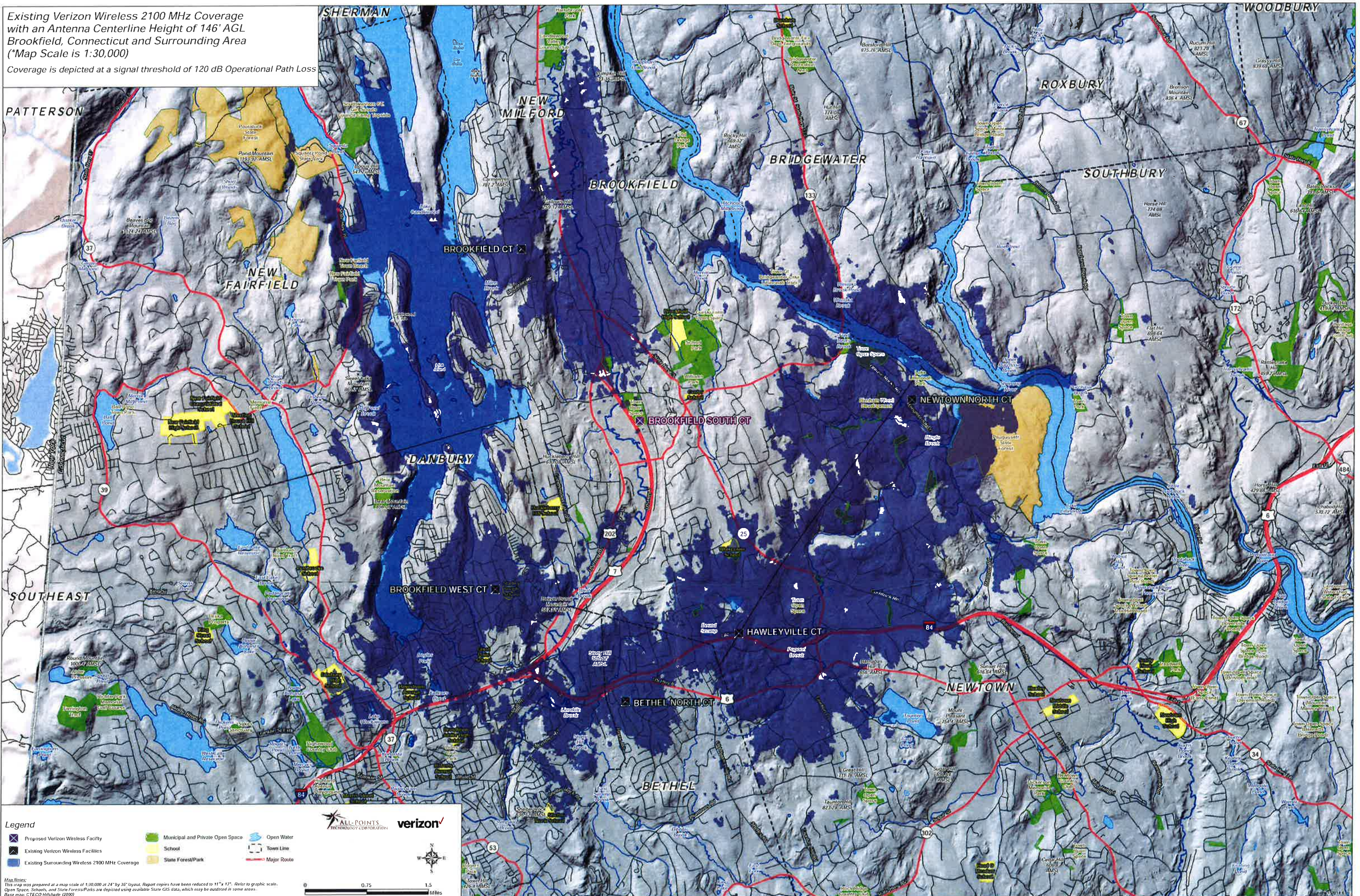

- Legend**
- Proposed Verizon Wireless Facility
  - Municipal and Private Open Space
  - Open Water
  - Existing Verizon Wireless Facilities
  - School
  - Town Line
  - Existing Surrounding Wireless 2100 MHz Coverage
  - State Forest/Park
  - Major Route



**Map Notes:**  
This map was prepared at a map scale of 1:30,000 at 24" by 36" layout. Repert copies have been reduced to 11" x 17". Refer to graphic scale.  
Open Space, Schools, and State Forest/Parks are depicted using available State GIS data, which may be outdated in some areas.  
Base map: CTECO Hillshade (2009)



Copyright 2010 Verizon Wireless. All rights reserved. The Verizon logo is a registered trademark of Verizon Wireless.

Proposed Verizon Wireless 2100 MHz Coverage  
with an Antenna Centerline Height of 146' AGL  
Brookfield, Connecticut and Surrounding Area  
(\*Map Scale is 1:30,000)

Coverage is depicted at a signal threshold of 120 dB Operational Path Loss

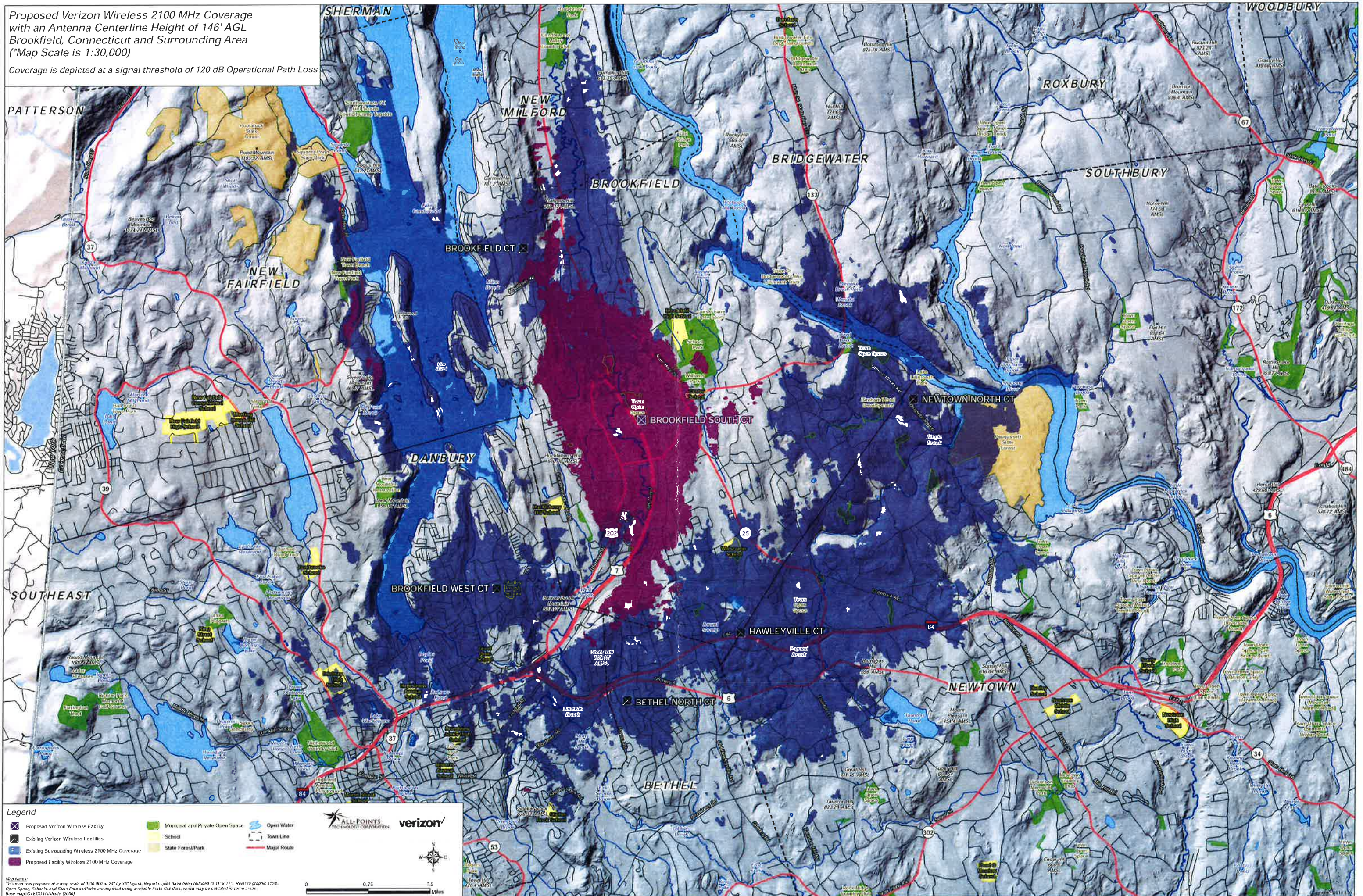



# **ATTACHMENT 2**

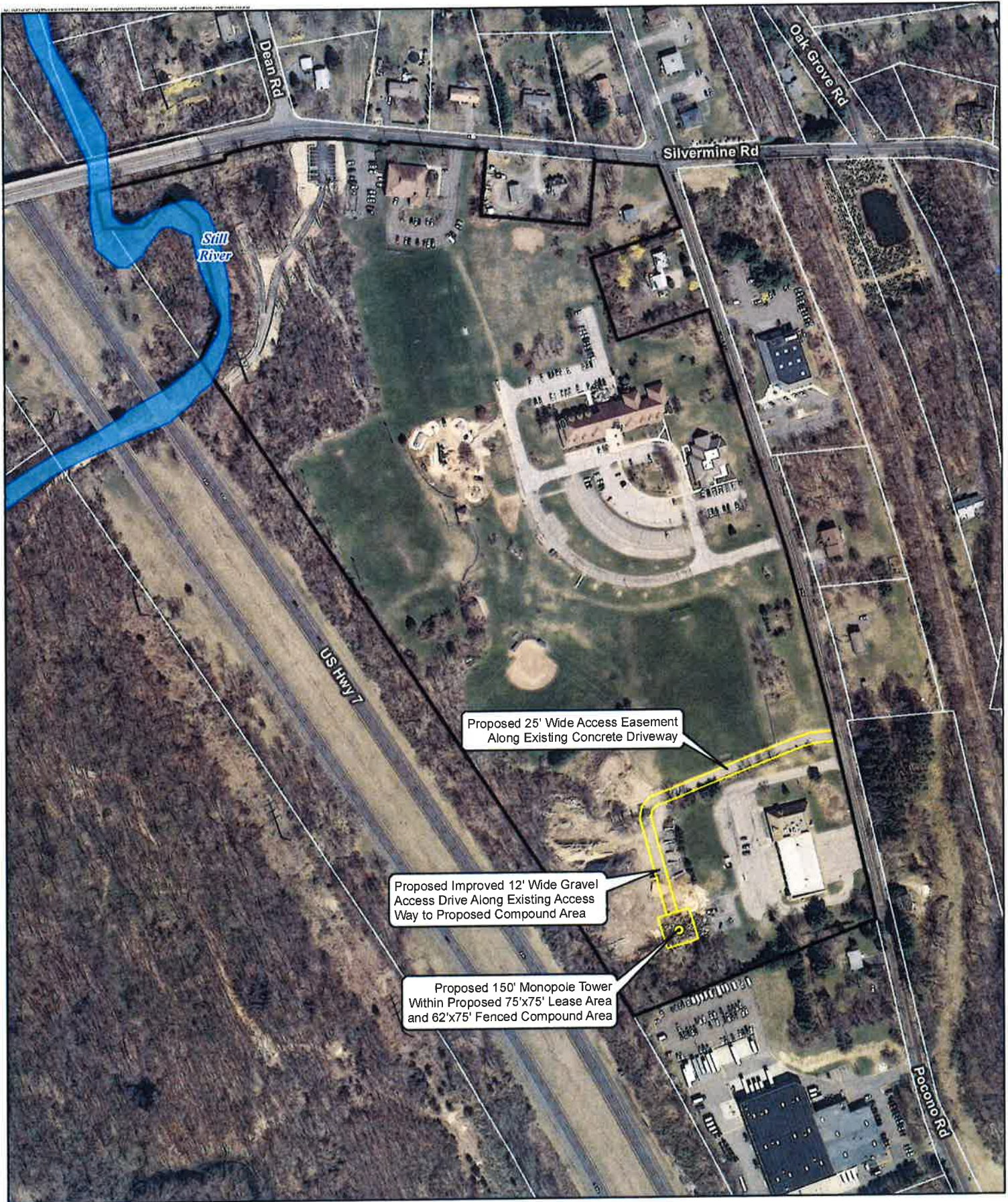

**Legend**

- ⊙ Proposed 150' Tall Monopole Tower
- Approximate Proposed Facility Layout
- ⬜ Host Property
- ⬜ Approximate Parcel Boundary (CTDEEP GIS)

**Site Schematic**

Proposed Wireless Telecommunications Facility  
 Brookfield  
 100 Pocono Road  
 Brookfield, Connecticut



**Map Notes:**  
 Base Map Source: 2012 Aerial Photograph (CTECO)  
 Map Scale: 1 inch = 300 feet  
 Map Date: October 2015



# **ATTACHMENT 3**

### LOCATION MAP

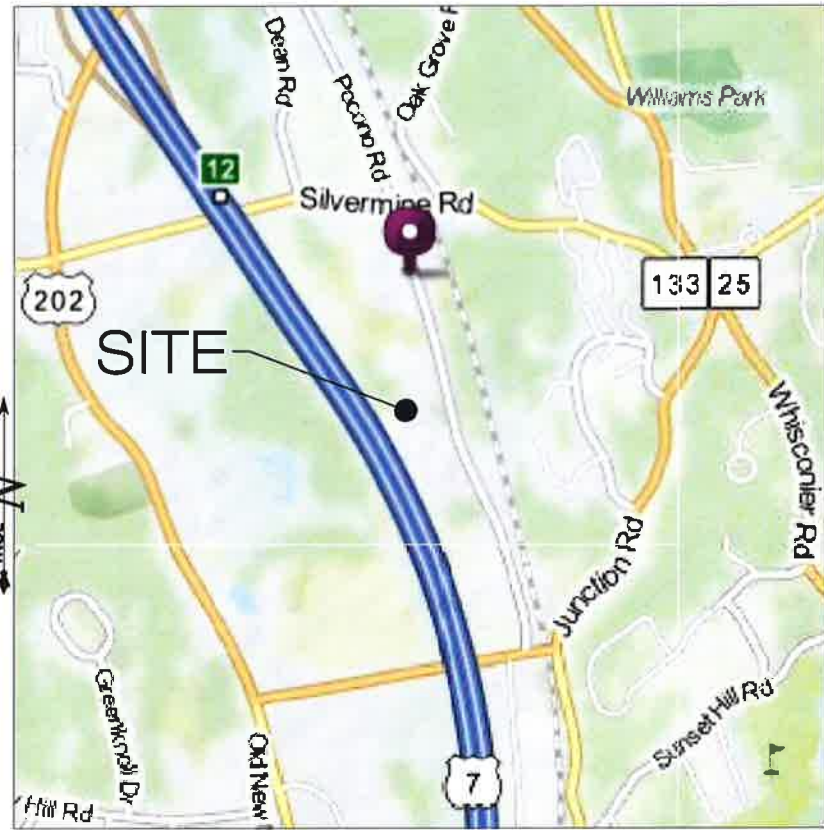

SCALE : NTS SOURCE: GOOGLE MAPS

### USGS TOPOGRAPHIC MAP

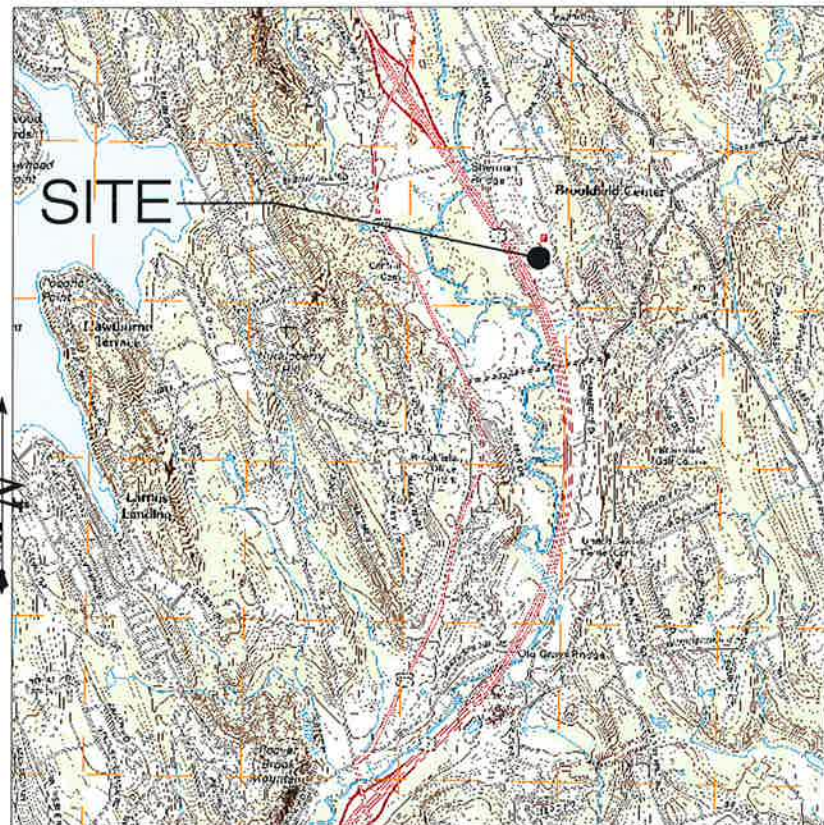

SCALE : 1" = 2000' SOURCE: USGS 7.5 QUADRANGLE FOR DANBURY

Cellco Partnership d/b/a



99 EAST RIVER DRIVE  
9TH FLOOR  
EAST HARTFORD, CT 06108



3 SADDLEBROOK DRIVE  
KILLINGWORTH, CT 06419  
WWW.ALLPOINTSTECH.COM  
PHONE: (860)-663-1697  
FAX: (860)-663-0935

### CONTACT PERSONNEL

**APPLICANTS:**  
HOMELAND TOWERS  
22 SHELTER ROCK LANE  
BUILDING C  
DANBURY, CONNECTICUT 06810

**CO-APPLICANTS**  
CELLCO PARTNERSHIP D/B/A  
VERIZON WIRELESS  
99 EAST RIVER DRIVE - 9TH FLOOR  
EAST HARTFORD, CT 06108

**LANDLORD**  
TOWN OF BROOKFIELD  
TOWN HALL COMPLEX  
PO BOX 5106  
BROOKFIELD, CT 06804

**HOMELAND PROJECT MANAGER:**  
RAYMOND VERGATI  
(203) 297-6345

**HOMELAND PROJECT ATTORNEY:**  
ROBINSON & COLE, LLP  
280 TRUMBULL STREET  
HARTFORD, CT 06103

**POWER PROVIDER:**  
EVERSOURCE (203) 270-5808  
ROBERT RONCARTI - CASE #2511619

**TELCO PROVIDER:**  
FRONTIER: (800) 921-8102

**CALL BEFORE YOU DIG:**  
(800) 922-4455

**GOVERNING CODES:**  
2009 CONNECTICUT BUILDING CODE (2003 IBC BASIS)  
2011 NATIONAL ELECTRIC CODE  
EIA/TIA 222F

### SITE INFORMATION

**BROOKFIELD  
100 POCONO ROAD  
BROOKFIELD, CT 06804**

### DRAWING INDEX

- T-1 TITLE SHEET & INDEX
- A-1 ABUTTERS MAP
- EX-1 PARTIAL TOPOGRAPHIC SURVEY
- EX-2 COMPILATION PLAN
- SP-1 SITE PLAN
- SP-2 COMPOUND PLAN & TOWER ELEVATION
- SP-3 SITE DETAILS

**\*SITE INFORMATION:**

-SITE NAME:.....	BROOKFIELD	-ZONE:.....	IRC 80/40 & R-40
-SITE ID NUMBER:.....	CT-777	-LATITUDE - .....	41° 27' 46.72" N
		-LONGITUDE - .....	73° 23' 53.97" W
-SITE ADDRESS:.....	100 POCONO ROAD BROOKFIELD, CT 06804	-ELEVATION - .....	337± AMSL
		-FEMA/FIRM DESIGNATION:.....	PANEL #09001C0134F - ZONE X
-MAP:.....	E10	-ACREAGE:.....	43.28± Ac (VOL. 137, PAGE 1144)
-LOTS:.....	014		

**PERMITTING DOCUMENTS**

**BROOKFIELD  
100 POCONO ROAD  
BROOKFIELD, CT 06804**

**DESIGN TYPE:  
RAW LAND**

**REVISIONS:**

- REV.0: 07/17/15: FOR REVIEW: SMC
- REV.1: 11/19/15: COMPOUND REVISIONS: RCB
- REV.2: 12/04/15: CLIENT REVISIONS: RCB
- REV.3: 12/15/15: EQUIP. REVISIONS: RCB
- REV.4:
- REV.5:

**TITLE SHEET  
& INDEX**

APT FILING NUMBER: CT-283-150  
APT DRAWING NUMBER: CT-777 T-1  
DRAWN BY: RCB  
CHECKED BY: SMC  
SCALE: AS NOTED  
DATE: 07/17/15

**SHEET NUMBER:**

**T-1**

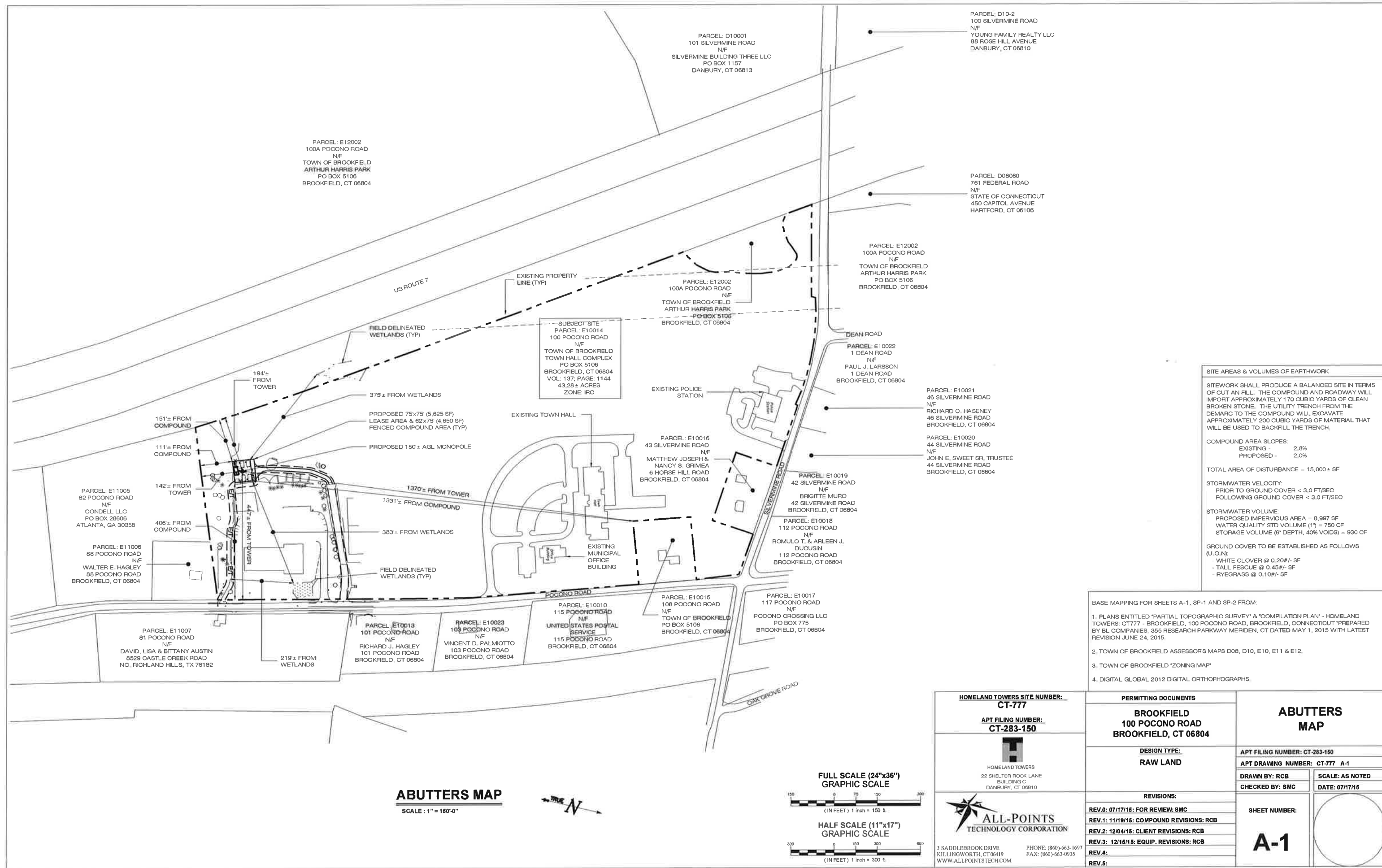

**SITE AREAS & VOLUMES OF EARTHWORK**

SITework SHALL PRODUCE A BALANCED SITE IN TERMS OF CUT AND FILL. THE COMPOUND AND ROADWAY WILL IMPORT APPROXIMATELY 170 CUBIC YARDS OF CLEAN BROKEN STONE. THE UTILITY TRENCH FROM THE DEMARC TO THE COMPOUND WILL EXCAVATE APPROXIMATELY 200 CUBIC YARDS OF MATERIAL THAT WILL BE USED TO BACKFILL THE TRENCH.

COMPOUND AREA SLOPES:  
 EXISTING - 2.6%  
 PROPOSED - 2.0%

TOTAL AREA OF DISTURBANCE = 15,000± SF

STORMWATER VELOCITY:  
 PRIOR TO GROUND COVER < 3.0 FT/SEC  
 FOLLOWING GROUND COVER < 3.0 FT/SEC

STORMWATER VOLUME:  
 PROPOSED IMPERVIOUS AREA = 8,997 SF  
 WATER QUALITY STD VOLUME (1") = 750 CF  
 STORAGE VOLUME (6" DEPTH, 40% VOIDS) = 930 CF

GROUND COVER TO BE ESTABLISHED AS FOLLOWS (U.O.N):  
 - WHITE CLOVER @ 0.20#/- SF  
 - TALL FESCUE @ 0.45#/- SF  
 - RYEGRASS @ 0.10#/- SF

- BASE MAPPING FOR SHEETS A-1, SP-1 AND SP-2 FROM:
1. PLANS ENTITLED "PARTIAL TOPOGRAPHIC SURVEY" & "COMPILATION PLAN" - HOMELAND TOWERS: CT777 - BROOKFIELD, 100 POCONO ROAD, BROOKFIELD, CONNECTICUT "PREPARED BY BL COMPANIES, 355 RESEARCH PARKWAY MERIDEN, CT DATED MAY 1, 2015 WITH LATEST REVISION JUNE 24, 2015.
  2. TOWN OF BROOKFIELD ASSESSOR'S MAPS D08, D10, E10, E11 & E12.
  3. TOWN OF BROOKFIELD "ZONING MAP"
  4. DIGITAL GLOBAL 2012 DIGITAL ORTHOPHOGRAPHS.

**ABUTTERS MAP**  
 SCALE: 1" = 150'-0"

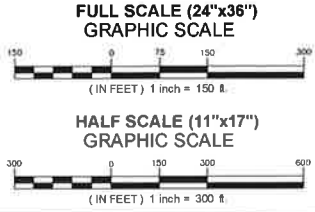

<b>HOMELAND TOWERS SITE NUMBER:</b> <b>CT-777</b>  <b>APT FILING NUMBER:</b> <b>CT-283-150</b>	<b>PERMITTING DOCUMENTS</b>  <b>BROOKFIELD</b> <b>100 POCONO ROAD</b> <b>BROOKFIELD, CT 06804</b>	<b>ABUTTERS MAP</b>  <b>APT FILING NUMBER: CT-283-150</b> <b>APT DRAWING NUMBER: CT-777 A-1</b> <b>DRAWN BY: RCB</b> <b>CHECKED BY: SMC</b> <b>SCALE: AS NOTED</b> <b>DATE: 07/17/16</b>
	<b>DESIGN TYPE:</b> <b>RAW LAND</b>	
 HOMELAND TOWERS 22 SHELTER ROCK LANE BUILDING C DANBURY, CT 06810	<b>REVISIONS:</b> <b>REV.0: 07/17/15: FOR REVIEW: SMC</b> <b>REV.1: 11/19/15: COMPOUND REVISIONS: RCB</b> <b>REV.2: 12/04/15: CLIENT REVISIONS: RCB</b> <b>REV.3: 12/16/15: EQUIP. REVISIONS: RCB</b> <b>REV.4:</b> <b>REV.5:</b>	 <b>ALL-POINTS TECHNOLOGY CORPORATION</b>  3 SADDLEBROOK DRIVE KILLINGWORTH, CT 06419 WWW.ALLPOINTSTECH.COM PHONE: (860)-663-1697 FAX: (860)-663-0935



LOCATION MAP

NOT TO SCALE

GENERAL NOTES

- THIS MAP HAS BEEN PREPARED IN ACCORDANCE WITH THE REGULATIONS OF CONNECTICUT STATE AGENCIES, SECTIONS 20-300b-1 THROUGH 20-300b-20 AND THE "STANDARDS FOR SURVEYS AND MAPS IN THE STATE OF CONNECTICUT" AS ADOPTED BY THE CONNECTICUT ASSOCIATION OF LAND SURVEYORS, INC. ON SEPTEMBER 26, 1996.
  - THIS PLAN CONFORMS TO HORIZONTAL ACCURACY CLASS A-2 AND A TOPOGRAPHIC ACCURACY OF T-2.
  - THE TYPE OF SURVEY PERFORMED IS A TOPOGRAPHIC SURVEY AND IS INTENDED TO DEPICT THE EXISTING CONDITIONS WITH RESPECT TO MONUMENTATION FOUND, STRUCTURES, VISIBLE UTILITIES, ROADWAYS AND CONTOURS.
- NORTH ARROW REFERS TO NAD 83 USING GPS METHODS.
- ELEVATIONS REFER TO NAVD 88 USING GPS METHODS.
- PARCEL IS LOCATED IN A FLOOD ZONE X, (AREAS DETERMINED TO BE OUTSIDE THE 0.2% ANNUAL CHANCE FLOODPLAIN) AS DEPICTED ON F.I.R.M. MAP NO. 090010134F PANEL 134 OF 626 EFFECTIVE DATE: JUNE 18, 2010.
- THE UNDERGROUND UTILITIES DEPICTED HAVE BEEN PLOTTED FROM FIELD SURVEY INFORMATION AND EXISTING DRAWINGS. THE SURVEYOR MAKES NO GUARANTEES THAT THE UNDERGROUND UTILITIES DEPICTED COMPRISE ALL SUCH UTILITIES IN THE AREA, EITHER IN SERVICE OR ABANDONED. THE SURVEYOR FURTHER DOES NOT WARRANT THAT THE UNDERGROUND UTILITIES DEPICTED ARE IN THE EXACT LOCATION INDICATED THOUGH THEY ARE PLOTTED AS ACCURATELY AS POSSIBLE FROM INFORMATION AVAILABLE. THE SURVEYOR HAS NOT PHYSICALLY EXPOSED THE UNDERGROUND UTILITIES. PER CONNECTICUT STATE LAW THE CONTRACTOR SHALL CONFIRM THE LOCATION OF ALL UTILITIES PRIOR TO THE COMMENCEMENT OF EXCAVATION. CALL BEFORE YOU DIG 1-800-922-4455.
- WETLAND LOCATIONS PROVIDED BY ALL-POINTS TECHNOLOGY CORPORATION ON MAY 11, 2015.

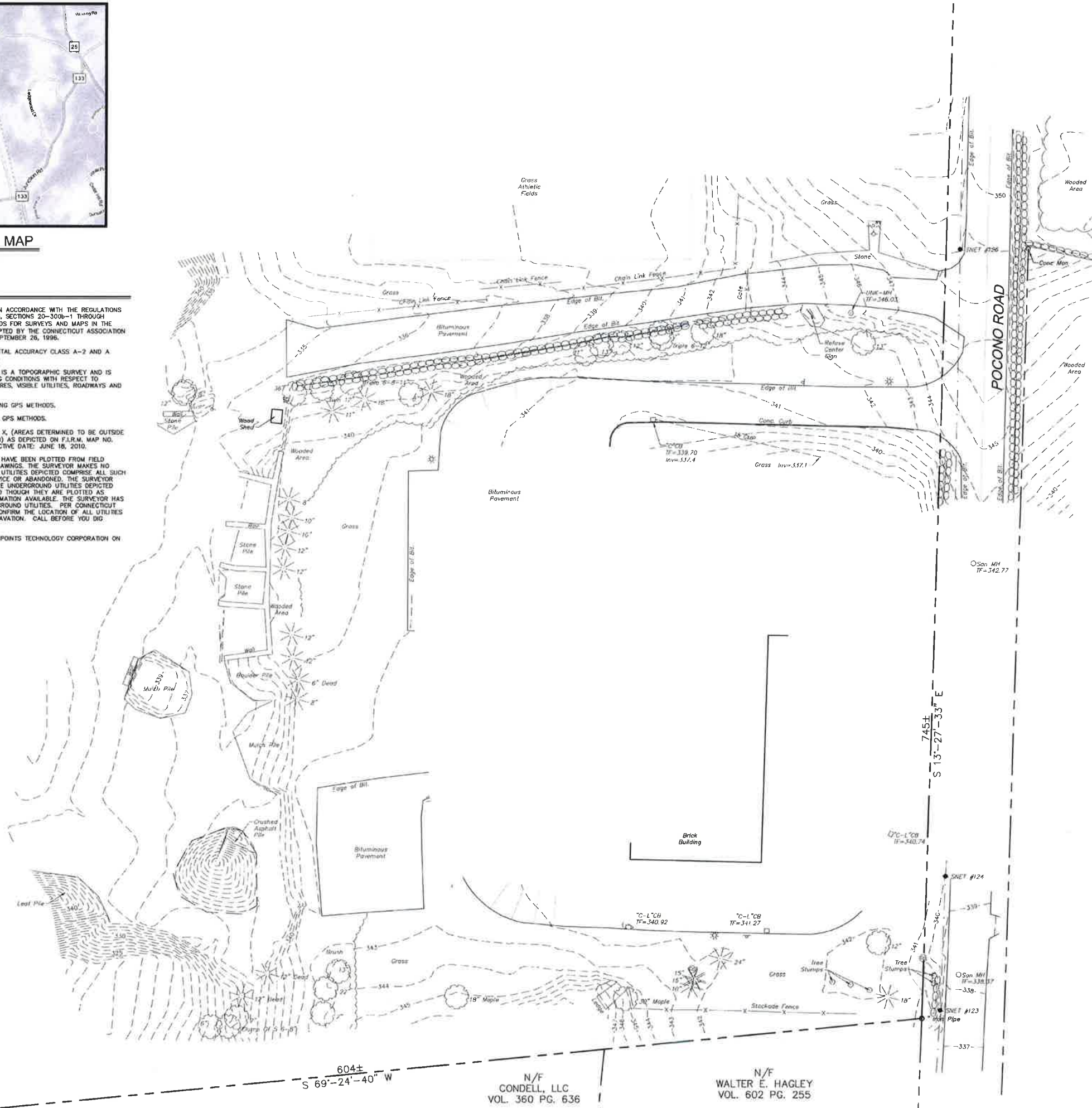

LEGEND

	Property Line
	Treelines
	Major Contour
	Minor Contour
	Stone Wall
	Guide Rail
	Fence
	Overhead Wires
	Underground Electric Line
	Sanitary Sewer
	Storm Sewer
	Handhole
	Electric Meter
	Utility Pole
	Utility Pole w/ Light
	Light Pole
	Gas Valve
	Cleanout
	Catch Basin
	Manhole
	Fire Hydrant
	Water Valve
	Sign
	Ballard
	Deciduous Tree
	Coniferous Tree

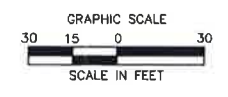

TO MY KNOWLEDGE AND BELIEF THIS MAP IS SUBSTANTIALLY CORRECT AS NOTED HEREON.

*Robert H. Roper*

ROBERT H. ROPER L.S. #18469

NO CERTIFICATION IS EXPRESSED OR IMPLIED UNLESS THIS MAP BEARS THE ORIGINAL SIGNATURE AND EMBOSSED SEAL OF THE ABOVE NAMED LAND SURVEYOR.



ARCHITECTURE  
ENGINEERING  
ENVIRONMENTAL  
LAND SURVEYING

355 Research Parkway  
Meriden, CT 06450  
(203) 636-1400  
(203) 636-2615 Fax

HOMELAND TOWERS: CT777 - BROOKFIELD  
100 POCONO ROAD  
TOWN OF BROOKFIELD, FAIRFIELD COUNTY, CONNECTICUT

REVISIONS	Date	Desc.	Additional Topography
No.	05/12/15	Revised Boundary Line	
2.	06/16/15		
Surveyed	TDH		
Drawn	EEB		
Checked	TDH		
Approved	RHR		
Scale	1" = 30'		
Project No.	15S2629		
Date	05/01/15		
Field Book	TDH		
CAD File:	EX15S262901		
Title	Partial Topographic Survey		
Sheet No.	EX-1		

Jul 10, 2015 8:28am browser: C:\Users\j\Documents\DWG\EX15S262901.dwg  
Project: Ex15S262901  
B.L. COMPANIES, INC. THESE DRAWINGS SHALL NOT BE UTILIZED BY ANY PERSON FROM AN ORGANIZATION WITHOUT THE EXPRESS WRITTEN PERMISSION OF B.L. COMPANIES

N/F CONDELL, LLC  
VOL. 360 PG. 636

N/F WALTER E. HAGLEY  
VOL. 602 PG. 255



LOCATION MAP  
NOT TO SCALE

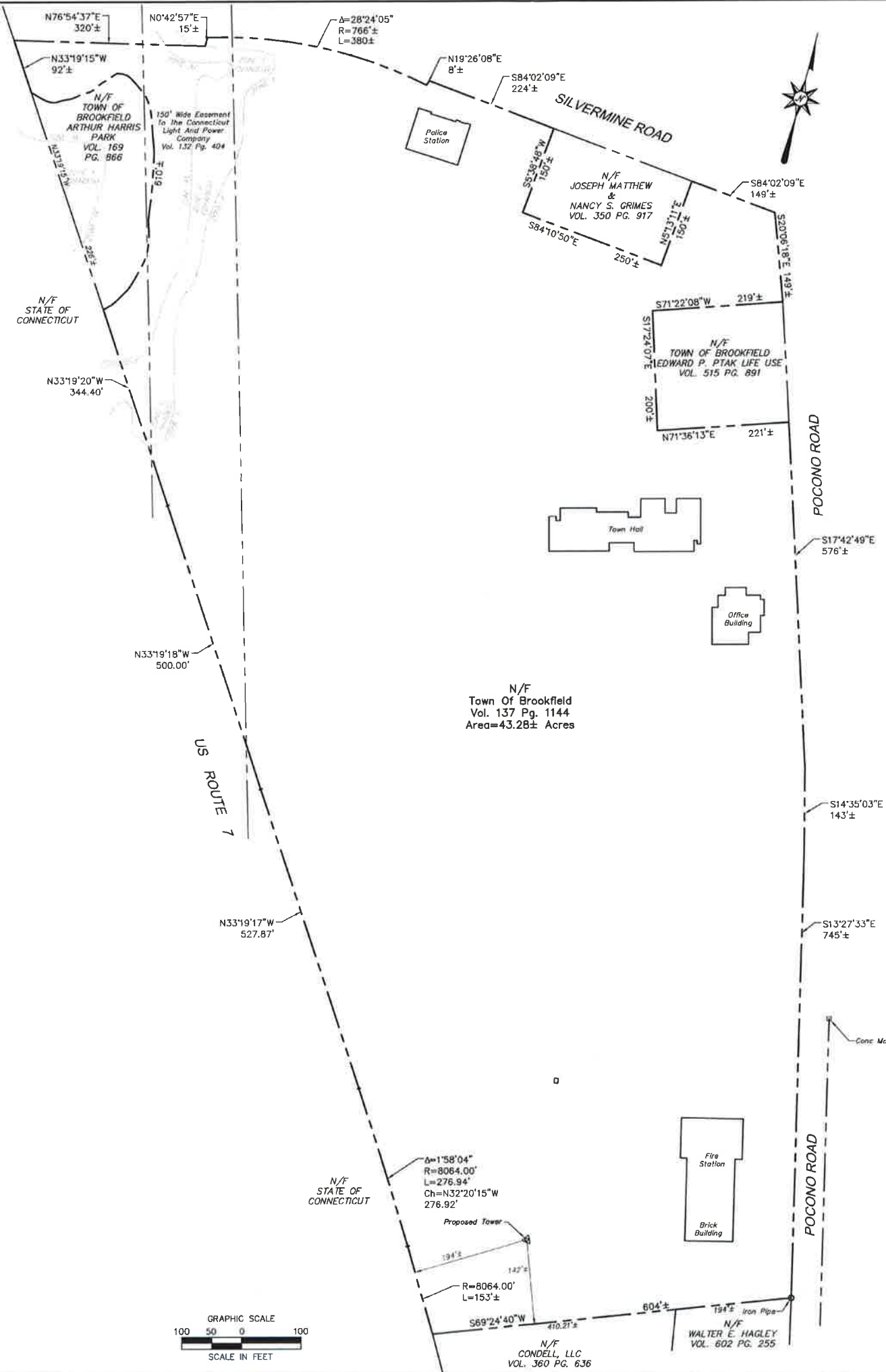

**GENERAL NOTES**

1. A) THIS MAP HAS BEEN PREPARED IN ACCORDANCE WITH THE REGULATIONS OF CONNECTICUT STATE AGENCIES, SECTIONS 20-300b-1 THROUGH 20-300b-20 AND THE "STANDARDS FOR SURVEYS AND MAPS IN THE STATE OF CONNECTICUT" AS ADOPTED BY THE CONNECTICUT ASSOCIATION OF LAND SURVEYORS, INC. ON SEPTEMBER 26, 1996.
- B) THIS PLAN CONFORMS TO HORIZONTAL ACCURACY CLASS D.
- C) THIS MAP WAS COMPILED FROM OTHER MAPS, RECORD RESEARCH OR OTHER SOURCES OF INFORMATION. IT IS NOT TO BE CONSTRUED AS HAVING BEEN OBTAINED AS THE RESULT OF A FIELD SURVEY, AND IS SUBJECT TO SUCH CHANGE AS AN ACCURATE FIELD SURVEY MAY DISCLOSE.
2. NORTH ARROW REFERS TO NAD 83 USING GPS METHODS.
3. REFERENCE IS MADE TO THE FOLLOWING MAPS:
  - A. "TOWN OF BROOKFIELD MAP SHOWING LAND TO BE CONVEYED TO UPS THIRTY PLAN CORPORATION POCOMO ROAD, BROOKFIELD, CONNECTICUT" SCALE: 1"=40' DATE: 8/14/81 PREPARED BY CARROCCIO-COVILL & ASSOCIATES, INC., BROOKFIELD, CONN. AND FILED IN THE TOWN CLERK'S OFFICE AS MAP BOOK 18 AT PAGE 10.
  - B. "STATE OF CONNECTICUT DEPARTMENT OF TRANSPORTATION RIGHT OF WAY MAP TOWN OF BROOKFIELD FROM THE DANBURY TOWN LINE NORTHERLY TO THE DANBURY - NEW MILFORD ROAD, STAMPED PRELIMINARY, SCALE 1"=80', NUMBER 18-08, SHEET NO. 6 OF 8 & 7 OF 8.
4. PARCEL IS ALSO SUBJECT TO THE FOLLOWING:
  - VOL. 137 AT PAGE 1144, RESTRICTIVE COVENANTS.
  - VOL. 101 AT PAGE 941, SLOPE EASEMENT TO THE STATE OF CONNECTICUT AND A 125' WIDE EASEMENT TO THE CONNECTICUT LIGHT AND POWER COMPANY.
  - VOL. 132 AT PAGE 404, RIGHTS AND A 150' WIDE EASEMENT TO THE CONNECTICUT LIGHT AND POWER COMPANY.
  - VOL. 314 AT PAGE 882, OPEN SPACE GRANT AND IMPROVEMENTS TO THE TOWN HALL RECREATION AREA.
  - VOL. 591 AT PAGE 814, USE RESTRICTIONS INCLUDING THOSE SET FORTH IN VOL. 137 AT PAGE 1144.
5. PORTIONS OF THE PARCEL ARE LOCATED IN THE FOLLOWING FLOOD HAZARD AREAS: ZONE X, ZONE X SHADED & ZONE AE AS DEPICTED ON F.L.R.M. COMMUNITY PANEL NO. 09001C0134F PANEL 134 OF 626 EFFECTIVE DATE: JUNE 18, 2010.

**LEGEND**

	Property Line
	Easement Line
	Stone Wall
	Fence
	Utility Pole
	Light Pole
	Catch Basin
	Manhole
	Fire Hydrant
	Water Valve
	Deciduous Tree
	Coniferous Tree



355 Florence Parkway  
Meriden, CT 06450  
(203) 630-1406  
(203) 630-2615 Fax

**HOMELAND TOWERS: CT777 - BROOKFIELD**  
100 POCOMO ROAD  
TOWN OF BROOKFIELD, FAIRFIELD COUNTY, CONNECTICUT

REVISIONS	Desc.
No.	Date
Surveyed	TDH
Drawn	RHR
Checked	TDH
Approved	RHR
Scale	1" = 100'
Project No.	1552629
Date	06/24/2015
Field Book	
CAD File:	EX155262902
Title	COMPILATION PLAN
Sheet No.	EX-2



TO MY KNOWLEDGE AND BELIEF THIS MAP IS SUBSTANTIALLY CORRECT AS NOTED HEREON.

ROBERT H. ROPER L.S. #18469

NO CERTIFICATION IS EXPRESSED OR IMPLIED UNLESS THIS MAP BEARS THE ORIGINAL SIGNATURE AND EMBOSSED SEAL OF THE ABOVE NAMED LAND SURVEYOR.

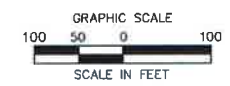

©2015 BL COMPANIES, INC. THESE DRAWINGS SHALL NOT BE UTILIZED BY ANY PERSON, FIRM OR CORPORATION WITHOUT THE SPECIFIC WRITTEN PERMISSION OF BL COMPANIES.

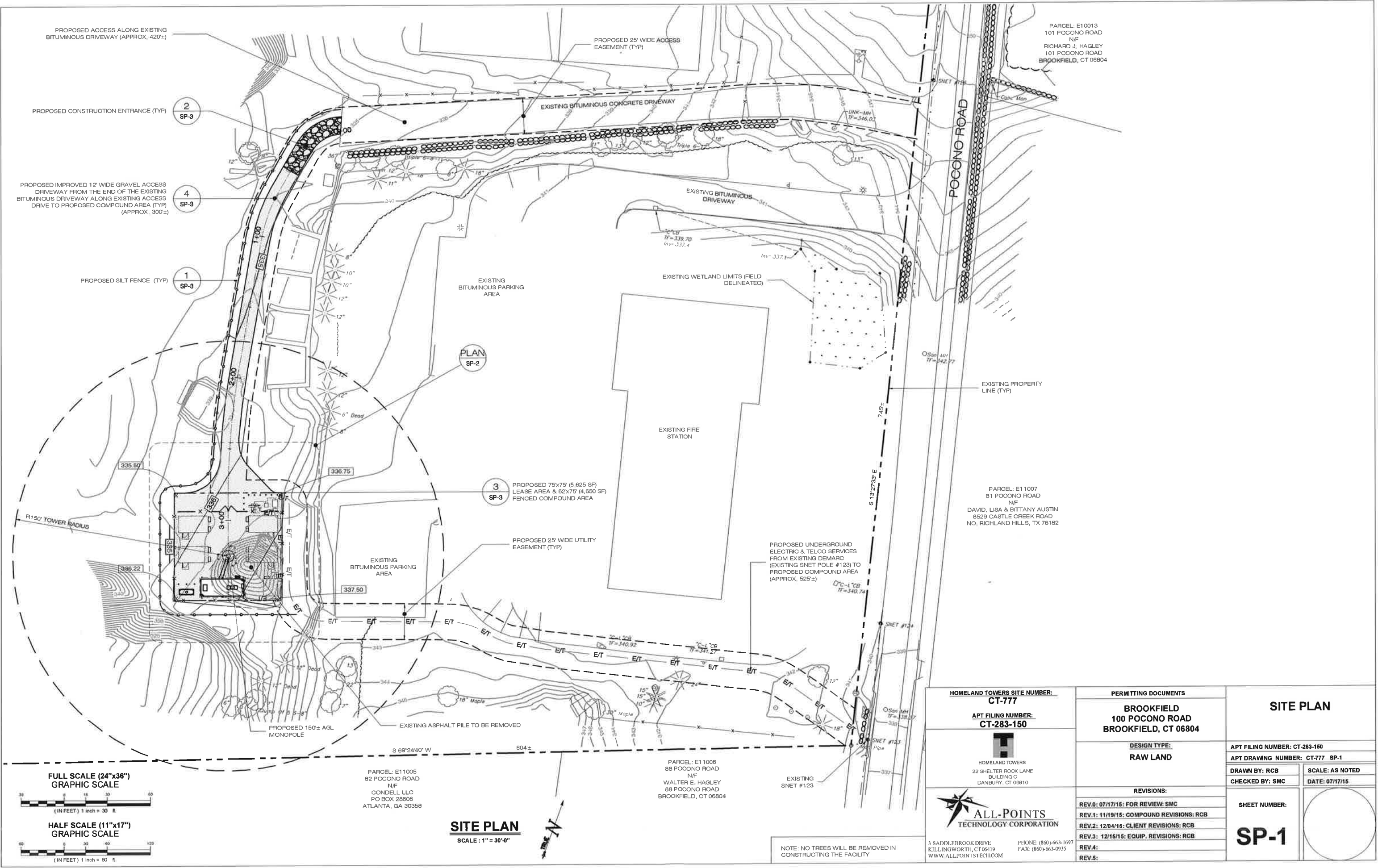



PARCEL: E10013  
 101 POCONO ROAD  
 N/F  
 RICHARD J. HAGLEY  
 101 POCONO ROAD  
 BROOKFIELD, CT 06804

PARCEL: E11007  
 81 POCONO ROAD  
 N/F  
 DAVID, LISA & BITTANY AUSTIN  
 8529 CASTLE CREEK ROAD  
 NO. RICHLAND HILLS, TX 76182

PARCEL: E11006  
 88 POCONO ROAD  
 N/F  
 WALTER E. HAGLEY  
 88 POCONO ROAD  
 BROOKFIELD, CT 06804

PARCEL: E11005  
 82 POCONO ROAD  
 N/F  
 CONDELL LLC  
 PO BOX 28606  
 ATLANTA, GA 30358

HOMELAND TOWERS SITE NUMBER: <b>CT-777</b>	PERMITTING DOCUMENTS <b>BROOKFIELD 100 POCONO ROAD BROOKFIELD, CT 06804</b>	<b>SITE PLAN</b>	
APT FILING NUMBER: <b>CT-283-150</b>	DESIGN TYPE: <b>RAW LAND</b>	APT FILING NUMBER: CT-283-150	
 HOMELAND TOWERS 22 SHELTER ROCK LANE BUILDING C DANBURY, CT 06810	REVISIONS: REV.0: 07/17/15: FOR REVIEW: SMC REV.1: 11/19/15: COMPOUND REVISIONS: RCB REV.2: 12/04/16: CLIENT REVISIONS: RCB REV.3: 12/16/16: EQUIP. REVISIONS: RCB REV.4: REV.5:	APT DRAWING NUMBER: CT-777 SP-1	
		DRAWN BY: RCB	
 ALL-POINTS TECHNOLOGY CORPORATION 3 SADDLEBROOK DRIVE KILLINGWORTH, CT 06419 WWW.ALLPOINTSTECH.COM		CHECKED BY: SMC	DATE: 07/17/15
		SHEET NUMBER: <b>SP-1</b>	

NOTE: NO TREES WILL BE REMOVED IN CONSTRUCTING THE FACILITY

**SITE PLAN**  
 SCALE: 1" = 30'-0"

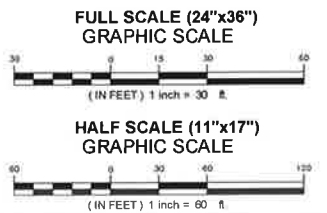



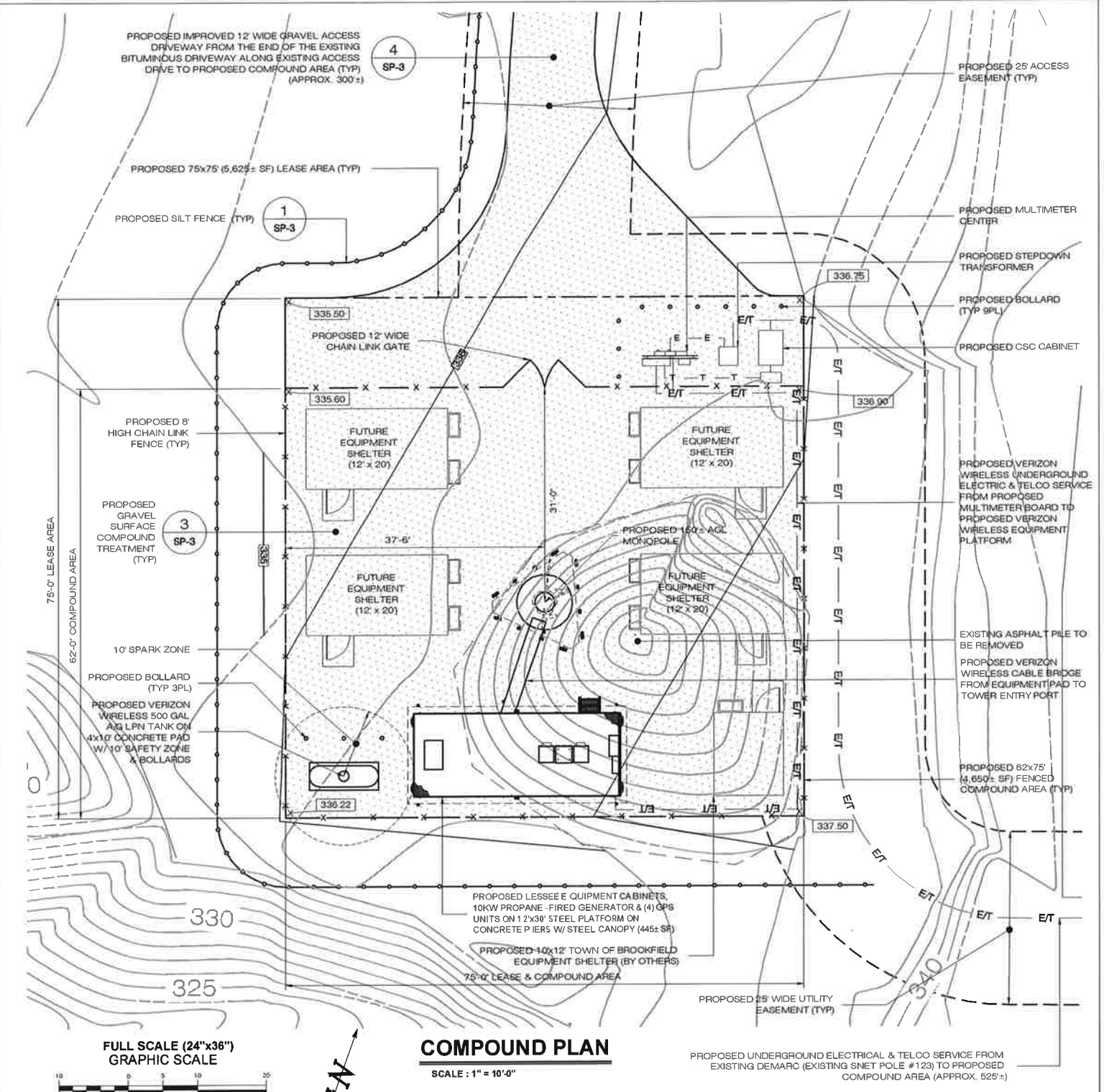
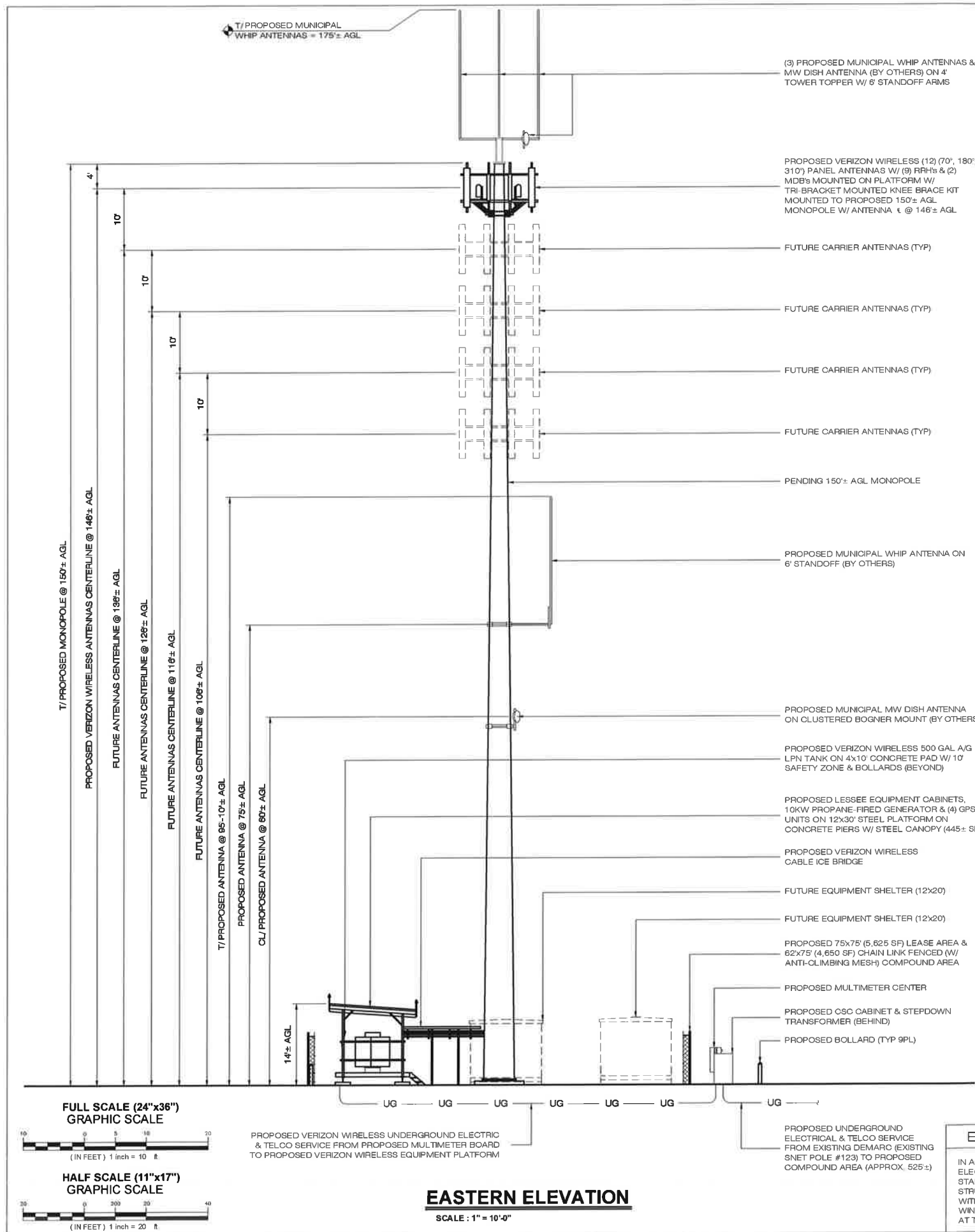

**ENGINEERING ANALYSIS AND CERTIFICATION**

IN ACCORDANCE WITH THE 2009 CONNECTICUT STATE BUILDING CODE AND THE ELECTRONIC INDUSTRIES ASSOCIATION STANDARD EIA/ITA-222-F "STRUCTURAL STANDARDS FOR STEEL ANTENNA TOWERS AND ANTENNA SUPPORT STRUCTURES" FOR FAIRFIELD COUNTY, THE TOWER WOULD BE DESIGNED TO WITHSTAND PRESSURES EQUIVALENT TO A MAXIMUM 85 MPH FASTEST MILE WIND SPEED. THE FOUNDATION DESIGN WOULD BE BASED ON SOIL CONDITIONS AT THE SITE.

<b>HOMELAND TOWERS SITE NUMBER:</b> CT-777  <b>APT FILING NUMBER:</b> CT-283-150   HOMELAND TOWERS 22 SHELTER ROCK LANE BUILDING C DANEBURY, CT 06810	<b>PERMITTING DOCUMENTS</b>  <b>BROOKFIELD</b> <b>100 POCONO ROAD</b> <b>BROOKFIELD, CT 06804</b>  <b>DESIGN TYPE:</b> <b>RAW LAND</b>	<b>COMPOUND PLAN &amp; TOWER ELEVATION</b>  <b>APT FILING NUMBER: CT-283-150</b> <b>APT DRAWING NUMBER: CT-777 SP-2</b> <b>DRAWN BY: RCB</b> <b>CHECKED BY: SMC</b> <b>SCALE: AS NOTED</b> <b>DATE: 07/17/15</b>
	<b>REVISIONS:</b> REV.0: 07/17/15: FOR REVIEW: SMC REV.1: 11/19/15: COMPOUND REVISIONS: RCB REV.2: 12/04/15: CLIENT REVISIONS: RCB REV.3: 12/15/15: EQUIP. REVISIONS: RCB REV.4: REV.5:	<b>SHEET NUMBER:</b>  <b>SP-2</b>

**ALL-POINTS TECHNOLOGY CORPORATION**  
 3 SADDLEBROOK DRIVE  
 KILLINGWORTH, CT 06419  
 WWW.ALLPOINTSCT.COM  
 PHONE: (860)-663-1697  
 FAX: (860)-663-0935

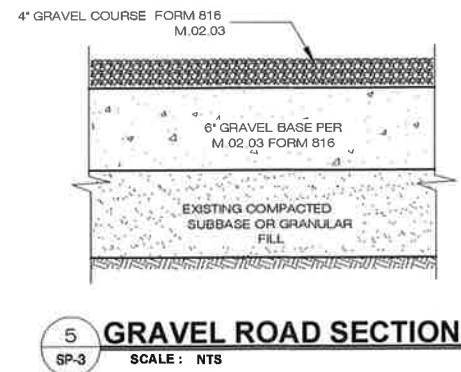
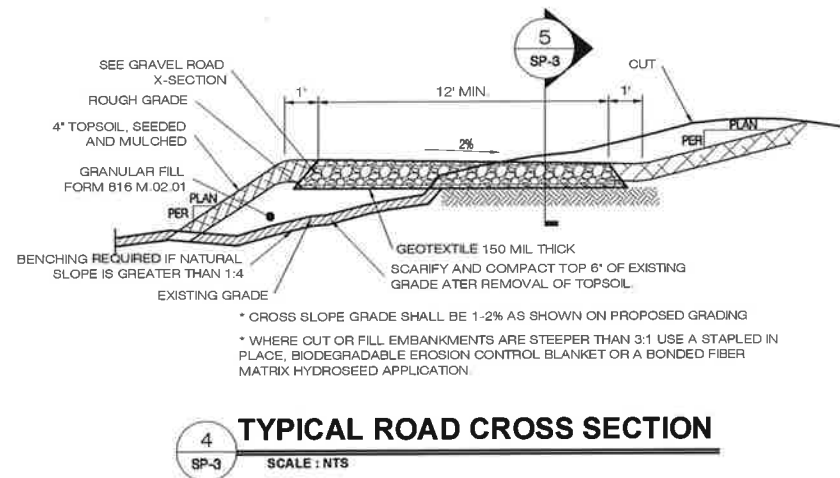
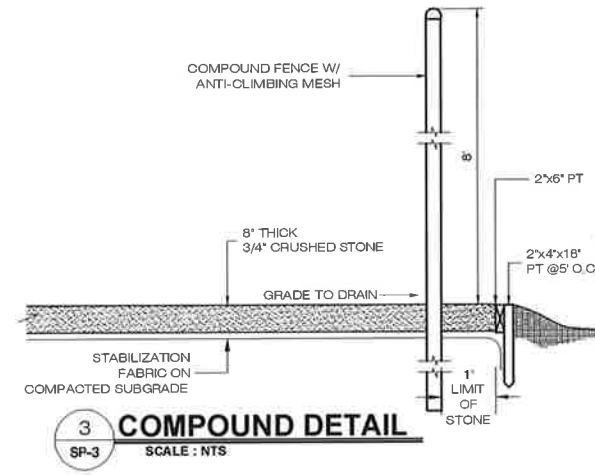
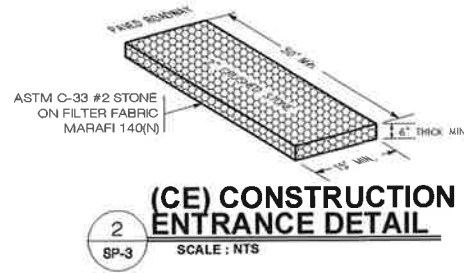
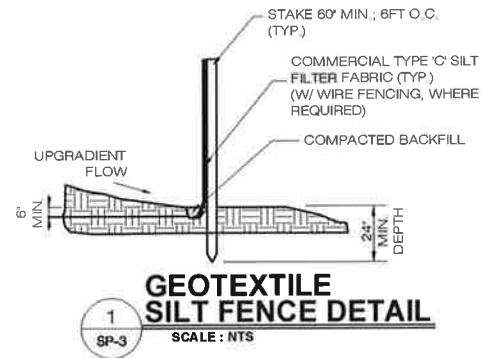

HOMELAND TOWERS SITE NUMBER: <b>CT-777</b> APT FILING NUMBER: <b>CT-283-150</b>	PERMITTING DOCUMENTS <b>BROOKFIELD</b> <b>100 POCONO ROAD</b> <b>BROOKFIELD, CT 06804</b>	<b>SITE DETAILS</b> APT FILING NUMBER: CT-283-150 APT DRAWING NUMBER: CT-777 SP-3	
	DESIGN TYPE: <b>RAW LAND</b>		
 HOMELAND TOWERS 22 SHELTER ROCK LANE BUILDING C DANBURY, CT 06810  <b>ALL-POINTS</b> TECHNOLOGY CORPORATION 3 SADDLEBROOK DRIVE KILLINGWORTH, CT 06419 WWW.ALLPOINTSTECH.COM PHONE: (800)-663-1697 FAX: (800)-663-0935	REVISIONS:		SHEET NUMBER: <b>SP-3</b>
	REV.0: 07/17/15: FOR REVIEW: SMC		
	REV.1: 11/19/15: COMPOUND REVISIONS: RCB		
	REV.2: 12/04/15: CLIENT REVISIONS: RCB		
	REV.3: 12/15/15: EQUIP. REVISIONS: RCB		
REV.4: REV.5:			

# **ATTACHMENT 4**

# **Visibility Analysis**

**100 Pocono Road  
Brookfield, Connecticut**

**Prepared For:**

**Homeland Towers LLC  
22 Shelter Rock Lane  
Building C  
Danbury, CT 06810**

**Prepared By:**

**All-Points TECHNOLOGY Corporation, P.C.  
3 Saddlebrook Drive  
Killingworth, CT 06141**

**December 2015**

## **Project Introduction**

Homeland Towers is considering the development of a new wireless communications facility ("Facility") at 100 Pocono Road in Brookfield, Connecticut (the "Property"). At the request of Homeland Towers, All-Points Technology Corporation, P.C. ("APT") prepared this Visibility Analysis to evaluate the potential visual impacts associated with the proposed Facility from within a two-mile radius (the "Study Area"). Parts of the neighboring municipalities of New Fairfield and Danbury are located in the western portion of the Study Area.

### **Site Description and Setting**

The approximately 43.28-acre Property is located west of Pocono Road and east of State Route 7 in Brookfield Center. The Property is developed with the Brookfield Municipal Center complex. The municipal complex includes the town hall, police department, fire department, and senior center buildings and various athletic fields, playgrounds, residential yard refuse center, and supporting infrastructure.

The area proposed for the Facility (the "Site") is located in the southwestern portion of the Property, in a portion of the refuse center area, at an approximate ground elevation of 337 feet Above Mean Sea Level ("AMSL"). The proposed Facility would include a 150-foot tall steel monopole surrounded by a 62-foot by 75-foot, gravel base equipment compound. Cellco Partnership d/b/a Verizon Wireless would utilize the upper portion of the monopole by affixing an antenna platform at a centerline height of 146 feet above ground level ("AGL"). The Town of Brookfield plans to install three (3) 21-foot tall whip antennas and one (1) microwave dish mounted on a four (4) foot extension at the top of the monopole, one (1) 21-foot tall whip antenna mounted at 75 feet AGL, and one (1) microwave dish mounted at 60' AGL.

Land use within the immediate vicinity of the Property is primarily a mix of industrial and commercial development to the south, west (along Federal Road aka Route 202) and northwest; with residential development occurring to the north (beyond Silvermine Road), east (across a railroad corridor), and farther south. An electrical transmission corridor extends south to north immediately beyond Route 7 followed by a large expanse of undeveloped wooded land bordering the Still River.

The topography within the Study Area is characterized as generally by gradual to steep rolling hills and valleys; ground elevations range from approximately 200 feet AMSL to 730 feet AMSL. The tree cover within the Study Area (consisting of mixed deciduous hardwoods with interspersed stands of conifers) occupies approximately 5,735 acres of the 8,042-acre study area ( $\pm 71\%$ ).

# Methodology

APT used the combination of a predictive computer model and in-field analysis to evaluate the visibility associated with the proposed Facility on both a quantitative and qualitative basis. The predictive model provides a measurable assessment of potential visibility throughout the entire Study Area including private properties and other areas inaccessible for direct observations. The in-field analyses included a balloon float and reconnaissance of the Study Area to record existing conditions, verify results of the model, inventory visible and nonvisible locations, and provide photographic documentation from publicly accessible areas. A description of the procedures used in the analysis is provided below.

## Preliminary Computer Modeling

Computer modeling tools were used to predict those areas where at least a portion of the Facility is estimated to be visible including TerrSet, an image analysis program developed by Clark Labs at Clark University. Project- and Study Area-specific data were incorporated into the computer model, including the site location, its ground elevation and the proposed Facility height, as well as the surrounding topography and existing vegetation, which are the primary features that can block direct lines of sight.

Information used in the model included lidar<sup>1</sup>-based digital elevation data and customized land use data layers developed specifically for this analysis. Lidar is a remote-sensing technology that develops elevation data in meters by measuring the time it takes for laser light to return from the surface to the instrument's sensors. The varying reflectivity of objects also means that the returns can be classified based on the characteristics of the reflected light, normally into categories such as "bare earth," "vegetation," "road," or "building." The system is also designed to capture many more data points than older radar-based systems. Thus, lidar-based digital elevation models ("DEM"s) have a much finer resolution and can also identify the different features of the landscape at the time that it was captured.

Viewshed analysis using lidar data provide a much more detailed view of the potential obstacles (especially trees and buildings), and therefore the viewshed modeling produces results with many smaller areas of visibility than those produced by using radar-based DEMs. Its precision makes lidar a superior source of data, but at present it is only available for limited areas of the state. The viewshed results are also checked against the most current aerial photographs in case significant changes (a new housing development, for example) have occurred since the time the lidar data was captured.

The lidar-based DEM created for this analysis represents topographic information for the state of Connecticut that was derived through the spatial interpolation of airborne LiDAR-based data collected in the years 2007 through 2012 and has a horizontal resolution of approximately two (2) feet. In addition, multiple land use data layers were created from the Natural Resources Conservation Service (through the USDA) aerial

---

<sup>1</sup> Lidar (a word invented to mean "light radar") may also be referred to as LiDAR, an acronym for Light Detection and Ranging. It is a technology that utilized lasers to determine the distance to an object or surface. LiDAR is similar to radar, but incorporates laser pulses rather than sound waves. It measures the time delay between transmission and reflection of the laser pulse.

photography (1-meter resolution, flown in 2012) using IDRISI image processing tools. The IDRISI tools develops light reflective classes defined by statistical analysis of individual pixels, which are then grouped based on common reflective values such that distinctions can be made automatically between deciduous and coniferous tree species, as well as grassland, impervious surface areas, surface water and other distinct land use features.

With these data inputs, the model is then queried to determine where the top of the Facility can be seen from any point(s) within the Study Area, given the intervening existing topography and vegetation. The results of the preliminary analysis are depicted on the attached maps and are intended to provide a representation of those areas where portions of the Facility may potentially be visible to the human eye without the aid of magnification, based on a viewer eye-height of 5 feet above the ground and the combination of intervening topography and tree canopy (year-round) and tree trunks (seasonally, when the leaves are off the deciduous trees). The shaded areas of predicted visibility shown on the map denote locations from within the Study Area which the proposed Facility may potentially be visible year-round (in yellow) above the tree canopy and/or seasonally, through the trees (during "leaf-off" conditions; depicted in orange). The Facility however may not necessarily be visible from all locations within those shaded areas. It is important to note that the computer model cannot account for mass density, the height, diameter and branching variability of the trees, or the degradation of views that occur with distance. In addition, each point – or pixel - represents about one square meter in area, and thus is not predicting visibility from all viewpoints through all possible obstacles. Although large portions of the predicted viewshed may theoretically offer visibility of the Facility, because of these unavoidable limitations the quality of those views may not be sufficient for the human eye to recognize the tower or discriminate it from other surrounding objects. Visibility also varies seasonally with increased, albeit obstructed, views occurring during "leaf-off" conditions. Beyond the density of woodlands found within the given Study Area, each individual tree has its own unique trunk, pole timber and branching pattern characteristics that provide varying degrees of screening in leafless conditions which cannot be precisely modeled.

Once the data layers were entered, image processing tools were applied and overlaid onto USGS topographic base maps and aerial photographs to achieve an estimate of locations where the Facility might be visible. Additional data was reviewed and incorporated into the visibility analysis, including protected private and public open space, parks, recreational facilities, hiking trails, schools, and historic districts. The Still River Linear Park trail system is located approximately 600 feet west of the Site, beyond Federal Road; this system extends northward, crossing Route 7 and Silvermine Road. The William Gurski Open Space trails are located approximately one mile to the northeast. Based on a review of publicly-available information, no designated state scenic roads exist within the Study Area.

## **Field Reconnaissance**

To supplement and fine tune the results of the computer modeling efforts, APT completed in-field verification activities consisting of a balloon float, vehicular and pedestrian reconnaissance, and photo-documentation.

### **Balloon Float and Field Reconnaissance**

A balloon float and field reconnaissance were conducted July 13, 2015 to evaluate the visibility associated with the proposed Facility and to obtain photographs for use in this report. The balloon float consisted of raising an approximately four-foot diameter, red helium-filled balloon tethered to a string height of 150 feet

above ground level ("AGL") at the proposed Facility location. Weather conditions were favorable for the in-field activities, with calm winds (less than 3 miles per hour) and partly cloudy skies. Once the balloon was secured, APT conducted a Study Area reconnaissance by driving along the local and State roads and other publicly accessible locations to document and inventory where the balloon could be seen above/through the tree canopy. Visual observations from the reconnaissance were also used to evaluate the results of the preliminary visibility mapping and identify any discrepancies in the initial modeling.

## **Photographic Documentation and Simulations**

During the balloon float and field reconnaissance, APT drove the public roads within the Study Area and recorded observations, including photo-documentation, of those areas where the balloon was and was not visible. Photographs were obtained from several vantage points to document the views of a proposed Facility. The geographic coordinates of the camera's position at each photo location were logged using global positioning system ("GPS") technology. Photographs were taken with a Canon EOS 6D digital camera body and Canon EF 24 to 105 millimeter ("mm") zoom lens, with the lens set to 50 mm.

*"The lens that most closely approximates the view of the unaided human eye is known as the normal focal-length lens. For the 35 mm camera format, which gives a 24x36 mm image, the normal focal length is about 50 mm."<sup>2</sup>*

## **Final Visibility Mapping**

Information obtained during the field reconnaissance was incorporated into the mapping data layers, including observations of the balloon float, the photo locations, areas that experienced recent land use changes and those places where the initial model was found to over-predict visibility. Once the additional data was integrated into the model, APT re-calculated the visibility of the proposed Facility from within the Study Area to assist in producing the final viewshed map.

## **Photographic Simulations**

One (1) photographic simulation was generated to portray a scaled rendering of the proposed Facility from where it will be visible on a year-round basis. Using field data, site plan information and 3-dimension (3D) modeling software, spatially referenced models of the site area and Facility were generated and merged. The geographic coordinates obtained in the field for the photograph locations were incorporated into the model to produce virtual camera positions within the spatial 3D model. Photo simulations were then created using a combination of renderings generated in the 3D model and photo-rendering software programs<sup>3</sup>.

For presentation purposes in this report, the photographs were taken with a 50 mm focal length and produced in an approximate 7-inch by 10.5-inch format. When viewing in this format size, we believe it is important to

---

<sup>2</sup> Warren, Bruce. Photography, West Publishing Company, Eagan, MN, c. 1993, (page 70).

<sup>3</sup> As a final step, the accuracy and scale of select simulations are tested against photographs of similar existing facilities with recorded camera position, focal length, photo location, and tower location.



provide the largest representational image while maintaining an accurate relation of sizes between objects within the frame of the photograph.

Photo-documentation of the balloon float and the photo-simulation of the proposed Facility are presented in the attachment at the end of this report. The balloon float photos are intended to provide visual reference points for the approximate height and location of the proposed Facility relative to the scene. The photo-simulation is intended to provide the reader with a general understanding of the different views that might be achieved of the Facility.

### Photograph Locations

The table below summarizes characteristics of the photographs and simulations presented in the attachment to this report including a description of each location, view orientation, the distance from where the photo was taken relative to the proposed Facility and the general characteristics of that view. The photo locations are depicted on the visibility analysis maps provided as attachments to this report.

View	Location	Orientation	Distance to Site	View Characteristics
1	Elbow Hill Road	Southeast	±0.69 Mile	Year-round
2	Silvermine Road	Southeast	±0.62 Mile	Year-round
3	Silvermine Road	Southeast	±0.46 Mile	Year-round
4	Dean Road	Southeast	±0.41 Mile	Year-round
5	Brookfield Police Department	Southeast	±0.32 Mile	Year-round
6	Brookfield Parks and Recreation	Southeast	±0.25 Mile	Year-round
7	Brookfield Parks and Recreation	Southeast	±0.16 Mile	Year-round
8	Pocono Road	Southwest	±0.20 Mile	Year-round
9	Pocono Road	Southwest	±0.16 Mile	Year-round
10	Pocono Road	Southwest	±0.16 Mile	Not Visible
11	Pocono Road	Southeast	±0.12 Mile	Year-round
12	Pocono Road	Southwest	±0.09 Mile	Year-round
13	Junction Road	Northwest	±0.49 Mile	Year-round
14	Junction Road	Northeast	±0.54 Mile	Year-round
15	Junction Road	Northeast	±0.58 Mile	Year-round
16	Federal Road	Northeast	±0.61 Mile	Year-round
17	Federal Road	Northeast	±0.61 Mile	Not Visible
18	Federal Road	Northeast	±0.54 Mile	Year-round
19	Central Cemetery	Northeast	±0.57 Mile	Year-round
20	Old Oak Drive	East	±0.62 Mile	Year-round
21	Federal Road	Southeast	±0.73 Mile	Not Visible
22	Federal Road	Southeast	±0.80 Mile	Year-round
23	Federal Road	Southeast	±0.83 Mile	Year-round

## **Visibility Analysis Results**

Results of this analysis are graphically displayed on the viewshed maps provided in the attachment at the end of this report. Areas from where the proposed Facility would be visible year-round comprise a total of approximately 348 acres and are primarily limited to the Property, locations to the east and north along Pocono Road and Silvermine Road, and to the south and west on Junction Road and Federal Road.

When the leaves are off the trees, seasonal views through intervening tree trunks and branches are anticipated to occur over some locations within an area of 752± additional acres. This estimate is based solely on computer modeling (APT did not have access to private properties for confirmation) which over predicts seasonal visibility. Therefore, although the "footprint" of seasonal visibility depicted on the viewshed maps covers several acres, views will not be achieved from all locations within those areas. The majority of potential seasonal views would be obstructed during leaf-off conditions by intervening tree trunks and branches or structures.

Views of the Facility from several locations on the Property would be unobstructed such that the majority of the tower would be visible. Other near-range views (within less than 0.25 mile) of the Facility would occur primarily along Pocono Road and offer similar profiles. Beyond approximately 0.35 mile from the Facility, views of the whip antennas and microwave dish will not be readily apparent.

Views of the Facility may be achieved from portions of the Still River Linear Park trail system. Areas immediately west of the Property are heavily wooded and any views from this portion of the trail would be limited to seasonal times of the year when the leaves are off the trees. Farther north along the trail, as it crosses Route 7 and Silvermine Road, year-round views of the top of the Facility may occur in some locations.

### **Proximity to Schools And Commercial Child Day Care Centers**

No views of the proposed Facility would occur at schools or commercial child day care centers. The nearest school, Brookfield High School is located approximately 1.16 miles to the northeast. The nearest commercial child day care center, Prince of Peace Pre-School, is located approximately 0.57 mile to the south.

## **Limitations**

The viewshed maps presented in the attachment to this report depict areas where the proposed Facility may potentially be visible to the human eye without the aid of magnification based on a viewer eye-height of 5 feet above the ground and intervening topography, tree canopy and structures. This analysis may not necessarily account for all visible locations, as it is based on the combination of computer modeling, incorporating 2012 aerial photographs, and in-field observations from publicly-accessible locations. No access to private properties was provided to APT personnel. This analysis does not claim to depict the only areas, or all locations, where visibility may occur; it is intended to provide a representation of those areas where the Facility is likely to be seen.

The simulations provide a representation of the Facility under similar settings as those encountered during the balloon float and reconnaissance. Views of the Facility can change throughout the seasons and the time of day, and are dependent on weather and other atmospheric conditions (e.g., haze, fog, clouds); the location, angle and intensity of the sun; and the specific viewer location. Weather conditions on the day of the balloon float included partly cloudy skies and the photo-simulation presented in this report provides an accurate portrayal of the Facility during comparable conditions.

## **ATTACHMENTS**

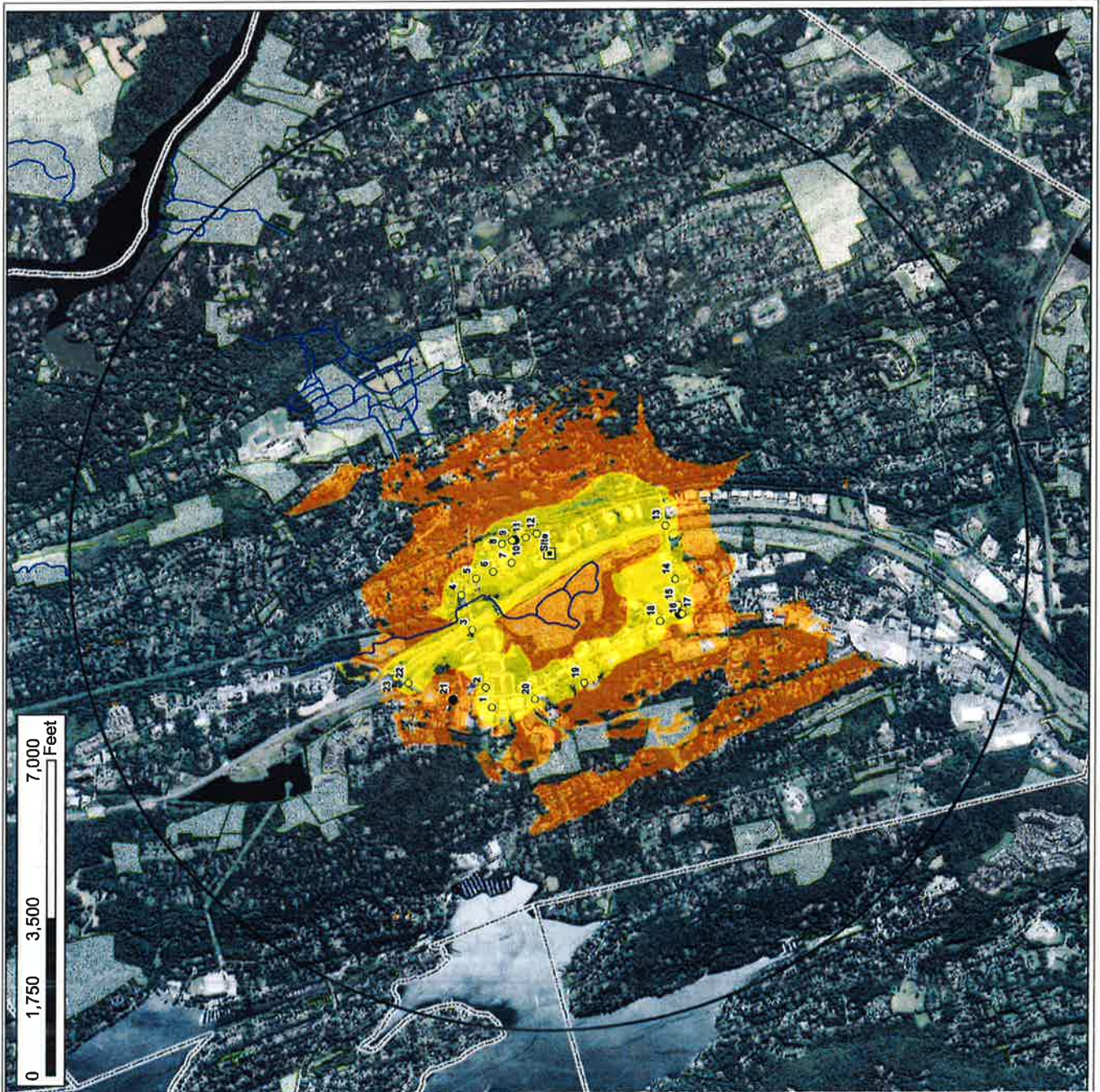

**Viewshed Map – Aerial Base**  
 Proposed Wireless Telecommunications Facility  
 Brookfield  
 100 Pocono Road, Brookfield, CT

Proposed facility height is 150 feet AGL. Study area encompasses a two-mile radius and includes 8,042 acres of land.

Map compiled 11/20/2015

Map information field verified by APT on 7/13/2015.

Only those resources located within the extent of the map are depicted. For a complete list of data sources consulted for this analysis, please refer to the Documentation Page.

**Legend**

- Proposed Tower
- Photo Locations
- Not Visible
- Year-round Views
- Trails
- Predicted Seasonal Visibility (752 Acres)
- Predicted Year-Round Visibility (348 Acres)
- ▭ Towns
- ▭ 2-Mile Study Area
- ▭ Open Space



**Location**



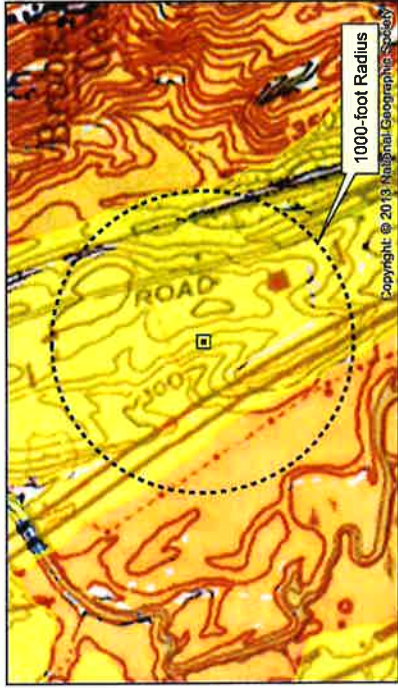
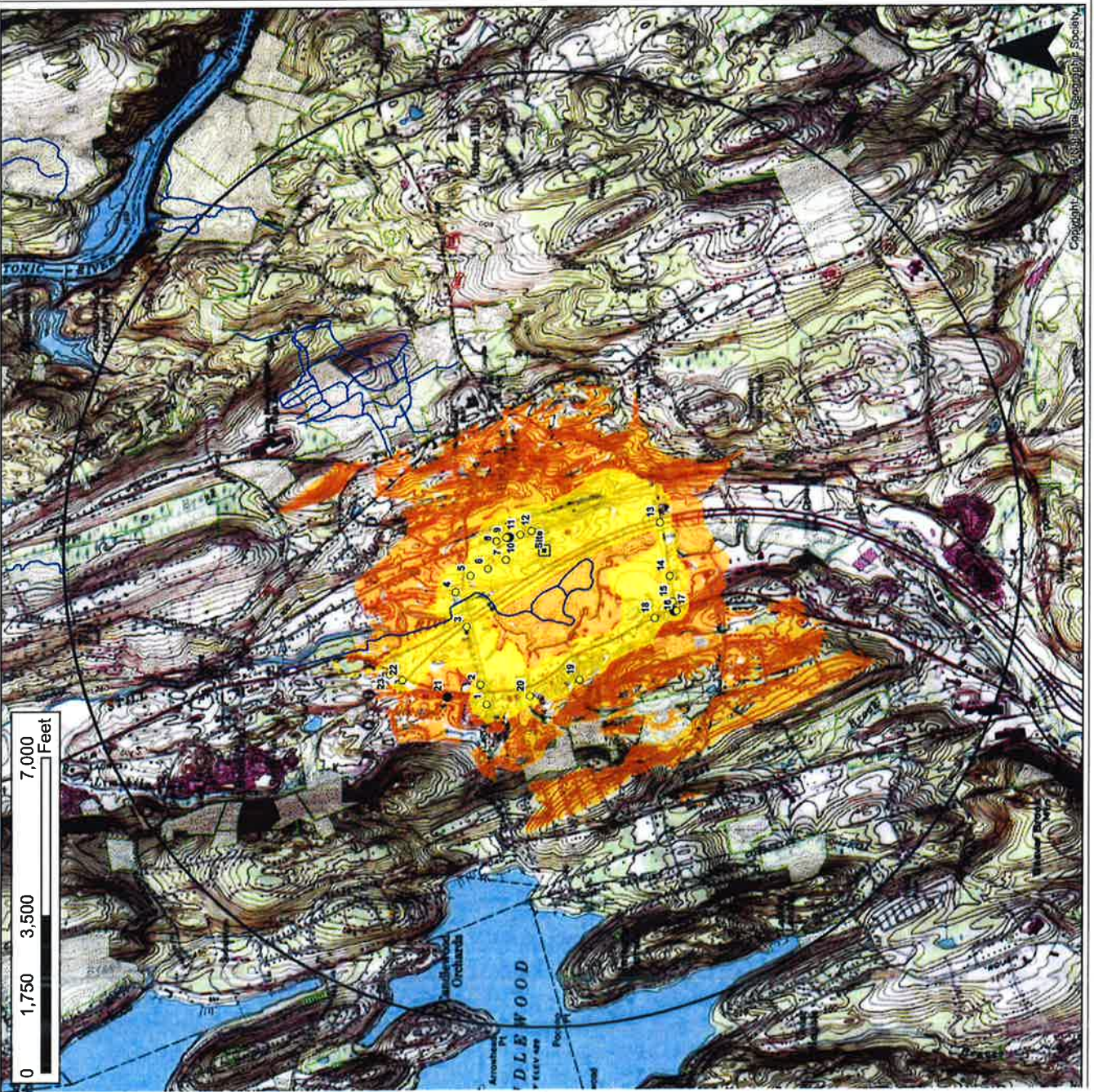

**Viewshed Map – Topo Base**

Proposed Wireless Telecommunications Facility  
 Brookfield  
 100 Pocono Road, Brookfield, CT

Proposed facility height is 150 feet AGL.  
 Study area encompasses a two-mile radius and includes 8,042 acres of land.

Map compiled 11/20/2015

Map information field verified by APT on 7/13/2015.

Only those resources located within the extent of the map are depicted. For a complete list of data sources consulted for this analysis, please refer to the Documentation Page.

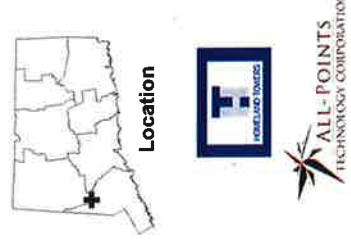

ALL-POINTS  
 TECHNOLOGY CORPORATION



# PHOTO LOG

- Legend
- Site
  - Year-Round Visibility
  - Not Visible



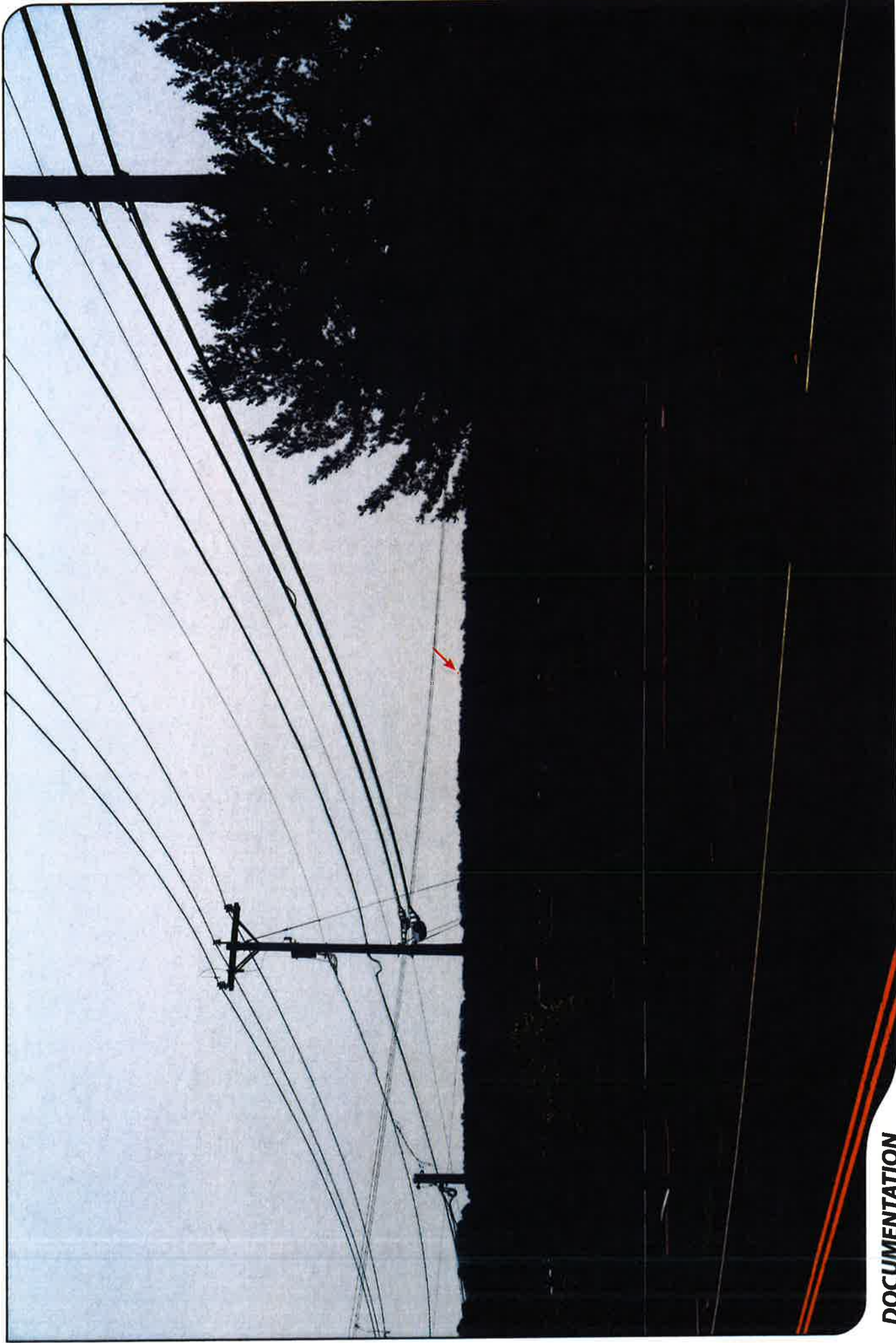

**DOCUMENTATION**

PHOTO	LOCATION	ORIENTATION	DISTANCE TO SITE	VISIBILITY
1	ELBOW HILL ROAD	SOUTHEAST	+/- 0.69 MILE	YEAR ROUND



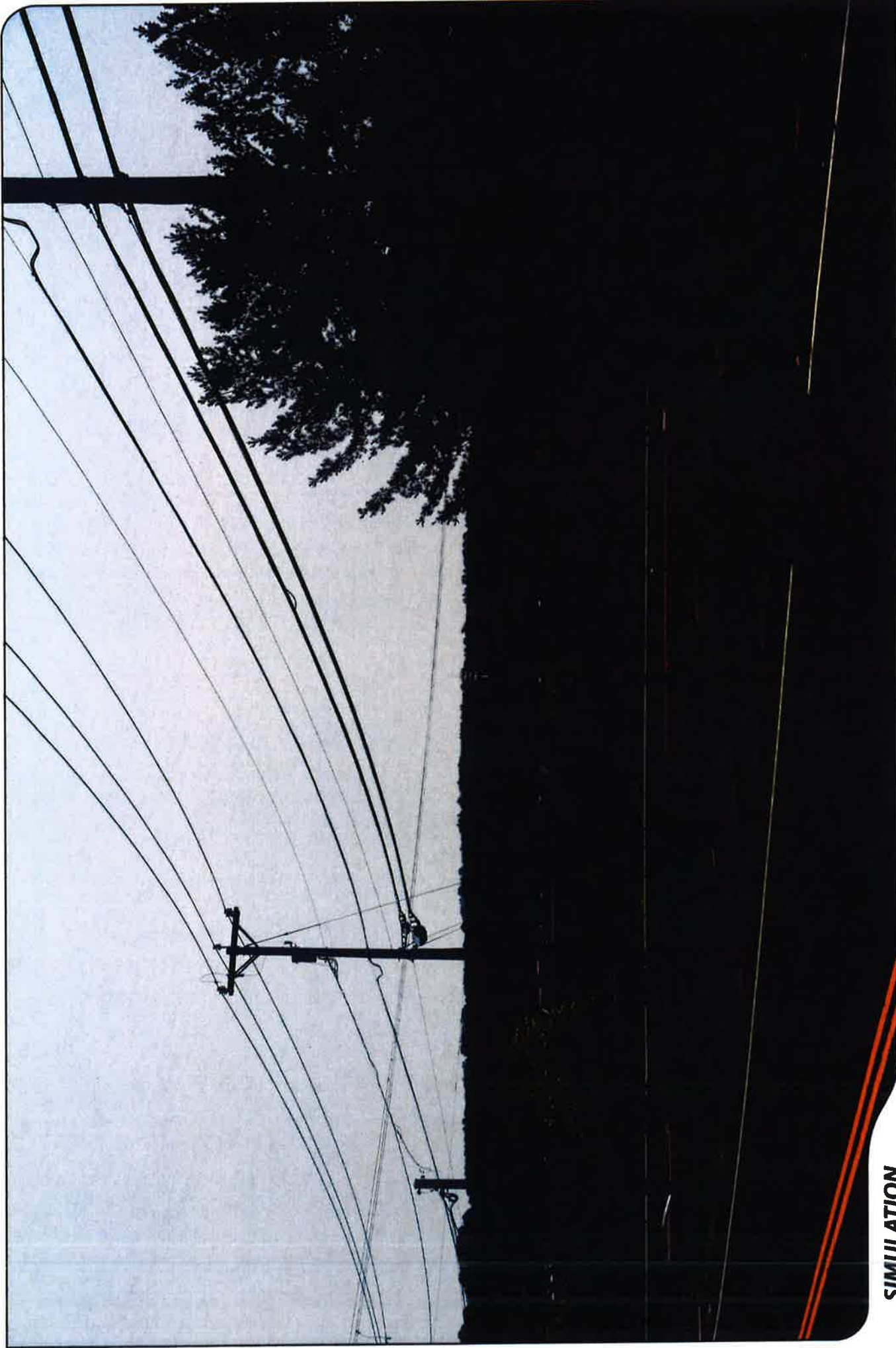

**SIMULATION**

PHOTO	LOCATION	ORIENTATION	DISTANCE TO SITE	VISIBILITY
1	ELBOW HILL ROAD	SOUTHEAST	+/- 0.69 MILE	YEAR ROUND



**DOCUMENTATION**

PHOTO	LOCATION	ORIENTATION	DISTANCE TO SITE	VISIBILITY
2	SILVERMINE ROAD	SOUTHEAST	+/- 0.62 MILE	YEAR ROUND



**SIMULATION**

PHOTO	LOCATION	ORIENTATION	DISTANCE TO SITE	VISIBILITY
2	SILVERMINE ROAD	SOUTHEAST	+/- 0.62 MILE	YEAR ROUND

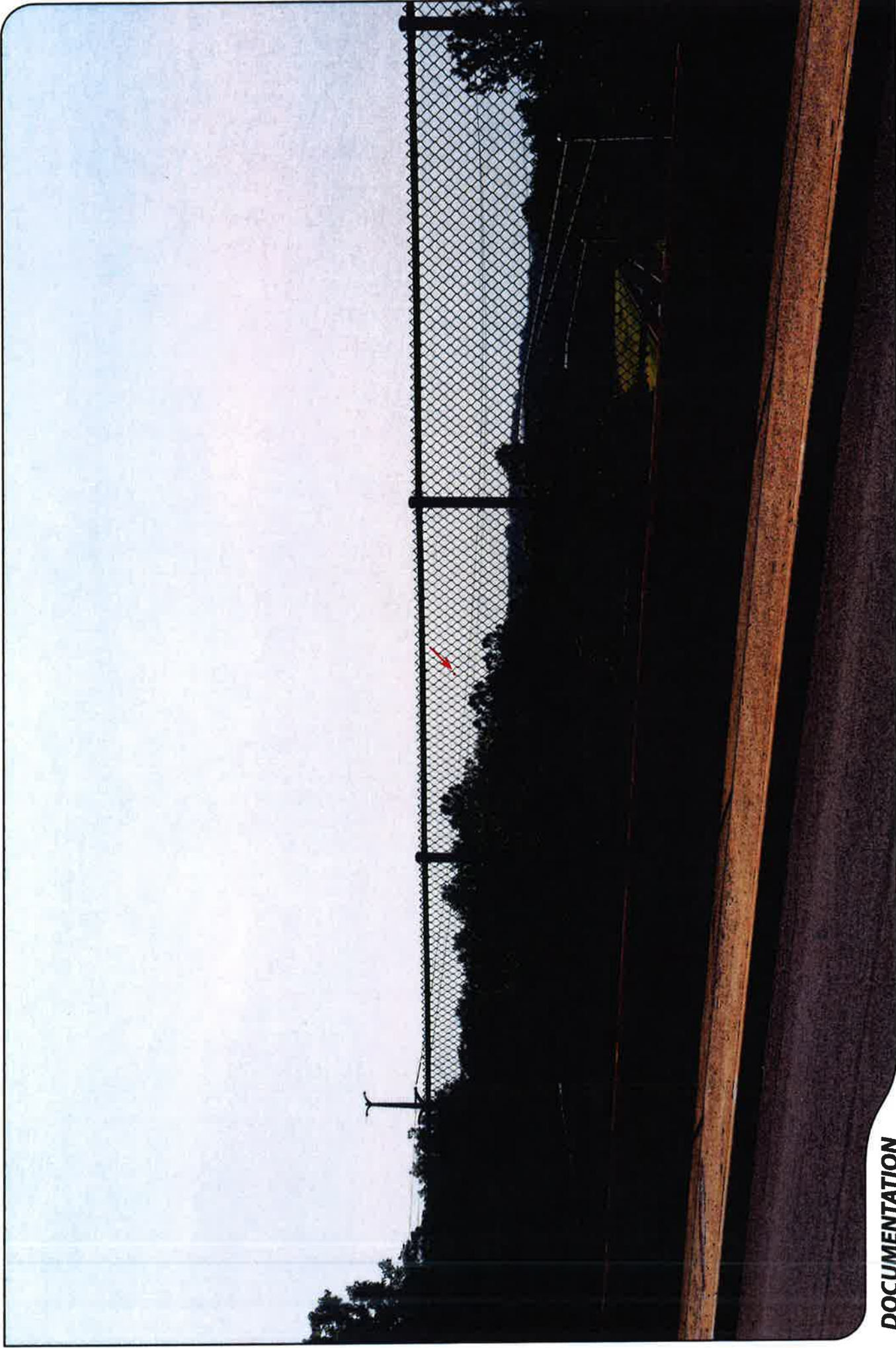

**DOCUMENTATION**

PHOTO	LOCATION	ORIENTATION	DISTANCE TO SITE	VISIBILITY
3	SILVERMINE ROAD	SOUTHEAST	+/- 0.46 MILE	YEAR ROUND

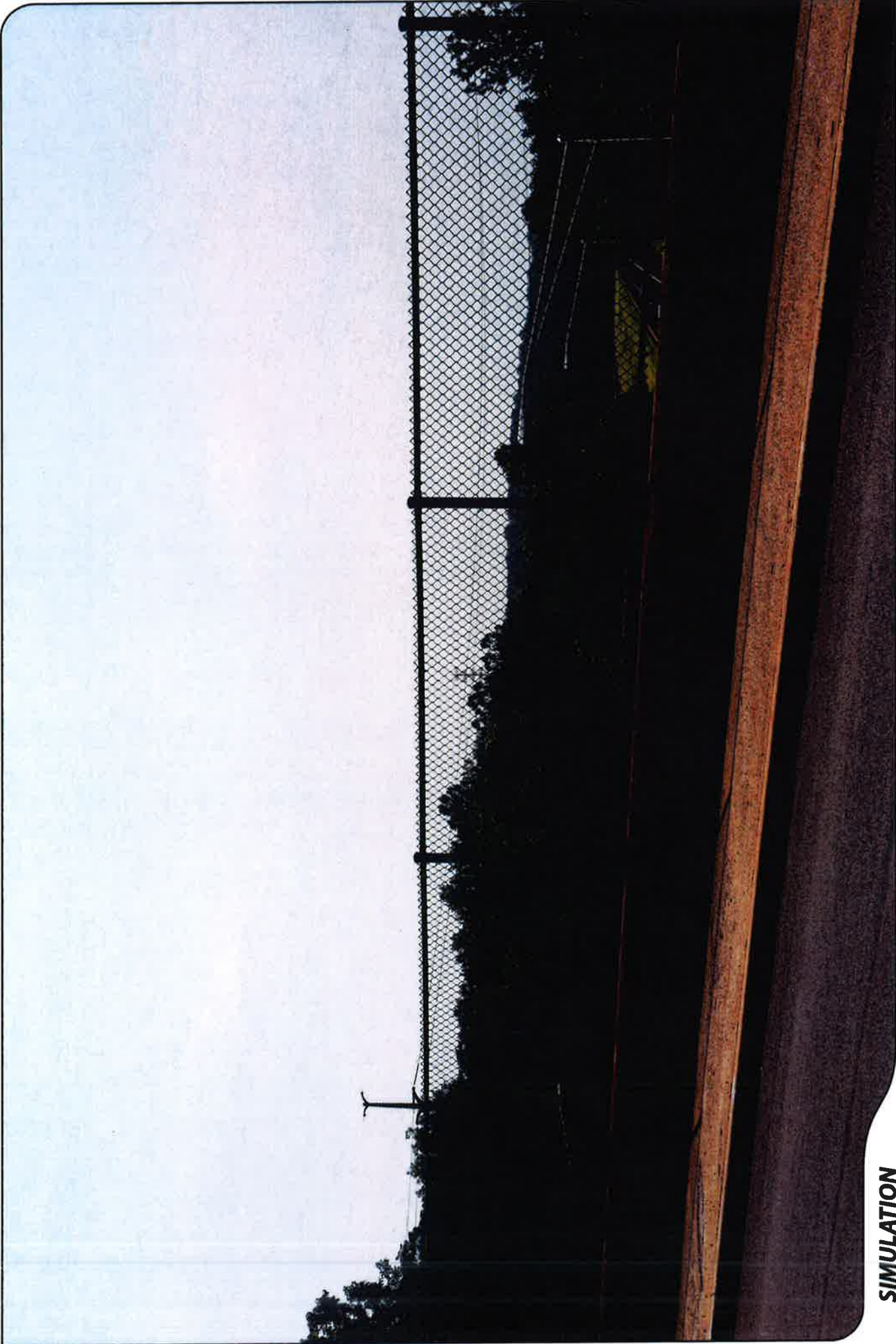

**SIMULATION**

PHOTO	LOCATION	ORIENTATION	DISTANCE TO SITE	VISIBILITY
3	SILVERMINE ROAD	SOUTHEAST	+/- 0.46 MILE	YEAR ROUND



**DOCUMENTATION**

PHOTO  
**4**

LOCATION  
**DEAN ROAD**

ORIENTATION  
**SOUTHEAST**

DISTANCE TO SITE  
**+/- 0.41 MILE**

VISIBILITY  
**YEAR ROUND**



**ALL-POINTS**  
TECHNOLOGY CORPORATION



**SIMULATION**

PHOTO	LOCATION	ORIENTATION	DISTANCE TO SITE	VISIBILITY
4	DEAN ROAD	SOUTHEAST	+/- 0.41 MILE	YEAR ROUND



**DOCUMENTATION**

PHOTO	LOCATION	ORIENTATION	DISTANCE TO SITE	VISIBILITY
5	BROOKFIELD POLICE DEPARTMENT	SOUTHEAST	+/- 0.32 MILE	YEAR ROUND





**SIMULATION**

PHOTO

5

LOCATION

**BROOKFIELD POLICE DEPARTMENT**

ORIENTATION

**SOUTHEAST**

DISTANCE TO SITE

**+/- 0.32 MILE**

VISIBILITY

**YEAR ROUND**



**DOCUMENTATION**

PHOTO	LOCATION	ORIENTATION	DISTANCE TO SITE	VISIBILITY
6	BROOKFIELD PARKS AND RECREATION	SOUTHEAST	+/- 0.25 MILE	YEAR ROUND



**SIMULATION**

PHOTO

6

LOCATION

**BROOKFIELD PARKS AND RECREATION**

ORIENTATION

**SOUTHEAST**

DISTANCE TO SITE

**+/- 0.25 MILE**

VISIBILITY

**YEAR ROUND**



**DOCUMENTATION**

PHOTO

7

LOCATION

**BROOKFIELD PARKS AND RECREATION**

ORIENTATION

**SOUTHEAST**

DISTANCE TO SITE

**+/- 0.16 MILE**

VISIBILITY

**YEAR ROUND**



**SIMULATION**

PHOTO  
7

LOCATION

**BROOKFIELD PARKS AND RECREATION**

ORIENTATION  
**SOUTHEAST**

DISTANCE TO SITE  
**+/- 0.16 MILE**

VISIBILITY  
**YEAR ROUND**



**DOCUMENTATION**

PHOTO	LOCATION	ORIENTATION	DISTANCE TO SITE	VISIBILITY
8	POCONO ROAD	SOUTHWEST	+/- 0.20 MILE	YEAR ROUND



**SIMULATION**

PHOTO

8

LOCATION

**POCONO ROAD**

ORIENTATION

**SOUTHWEST**

DISTANCE TO SITE

**+/- 0.20 MILE**

VISIBILITY

**YEAR ROUND**





**DOCUMENTATION**

PHOTO

9

LOCATION

POCONO ROAD

ORIENTATION

SOUTHWEST

DISTANCE TO SITE

+/- 0.16 MILE

VISIBILITY

YEAR ROUND



ALL-POINTS  
TECHNOLOGY CORPORATION







**SIMULATION**

PHOTO

9

LOCATION

POCONO ROAD

ORIENTATION

SOUTHWEST

DISTANCE TO SITE

+/- 0.16 MILE

VISIBILITY

YEAR ROUND

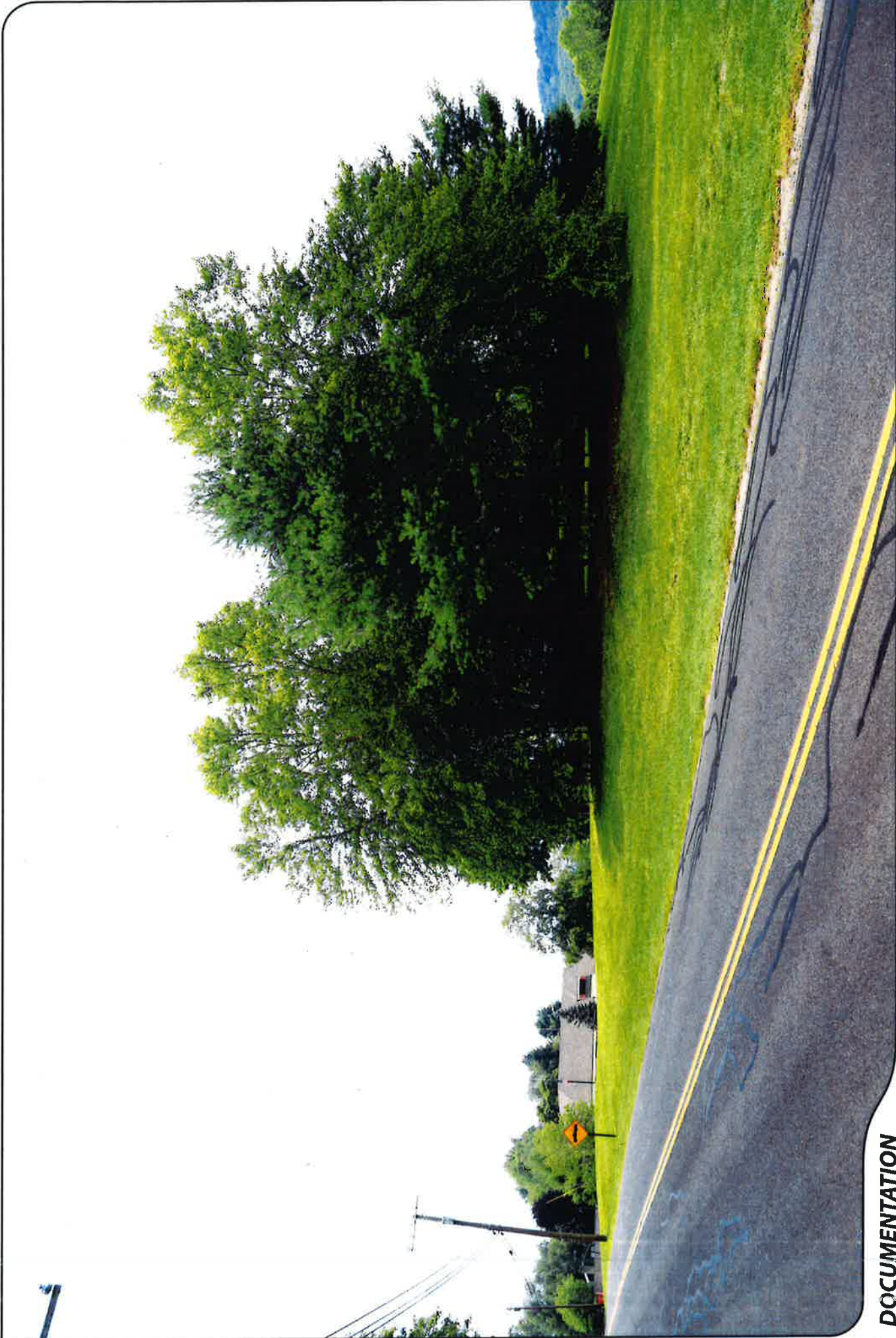

**DOCUMENTATION**

PHOTO	LOCATION	ORIENTATION	DISTANCE TO SITE	VISIBILITY
10	POCONO ROAD	SOUTHWEST	+/- 0.16 MILE	NOT VISIBLE



**DOCUMENTATION**

PHOTO

11

LOCATION

POCONO ROAD

ORIENTATION

SOUTHWEST

DISTANCE TO SITE

+/- 0.12 MILE

VISIBILITY

YEAR ROUND



**SIMULATION**

PHOTO	LOCATION	ORIENTATION	DISTANCE TO SITE	VISIBILITY
11	POCONO ROAD	SOUTHWEST	+/- 0.12 MILE	YEAR ROUND



**DOCUMENTATION**

PHOTO	LOCATION	ORIENTATION	DISTANCE TO SITE	VISIBILITY
12	POCONO ROAD	SOUTHWEST	+/- 0.09 MILE	YEAR ROUND



**SIMULATION**

PHOTO  
12

LOCATION  
**POCONO ROAD**

ORIENTATION  
**SOUTHWEST**

DISTANCE TO SITE  
**+/- 0.09 MILE**

VISIBILITY  
**YEAR ROUND**



**DOCUMENTATION**

PHOTO

13

LOCATION

JUNCTION ROAD

ORIENTATION

**NORTHWEST**

DISTANCE TO SITE

**+/- 0.49 MILE**

VISIBILITY

**YEAR ROUND**



**ALL-POINTS**  
TECHNOLOGY CORPORATION



**SIMULATION**

PHOTO	LOCATION	ORIENTATION	DISTANCE TO SITE	VISIBILITY
13	JUNCTION ROAD	NORTHWEST	+/- 0.49 MILE	YEAR ROUND





**DOCUMENTATION**

PHOTO	LOCATION	ORIENTATION	DISTANCE TO SITE	VISIBILITY
14	JUNCTION ROAD	NORTHEAST	+/- 0.54 MILE	YEAR ROUND



**SIMULATION**

PHOTO	LOCATION	ORIENTATION	DISTANCE TO SITE	VISIBILITY
14	JUNCTION ROAD	NORTHEAST	+/- 0.54 MILE	YEAR ROUND



**DOCUMENTATION**

PHOTO	LOCATION	ORIENTATION	DISTANCE TO SITE	VISIBILITY
15	JUNCTION ROAD	NORTHEAST	+/- 0.58 MILE	YEAR ROUND



**SIMULATION**

PHOTO	LOCATION	ORIENTATION	DISTANCE TO SITE	VISIBILITY
15	JUNCTION ROAD	NORTHEAST	+/- 0.58 MILE	YEAR ROUND



**DOCUMENTATION**

PHOTO

16

LOCATION

**FEDERAL ROAD**

ORIENTATION

**NORTHEAST**

DISTANCE TO SITE

**+/- 0.61 MILE**

VISIBILITY

**YEAR ROUND**



**SIMULATION**

PHOTO	LOCATION	ORIENTATION	DISTANCE TO SITE	VISIBILITY
16	FEDERAL ROAD	NORTHEAST	+/- 0.61 MILE	YEAR ROUND



**DOCUMENTATION**

PHOTO	LOCATION	ORIENTATION	DISTANCE TO SITE	VISIBILITY
17	FEDERAL ROAD	NORTHEAST	+/- 0.61 MILE	NOT VISIBLE

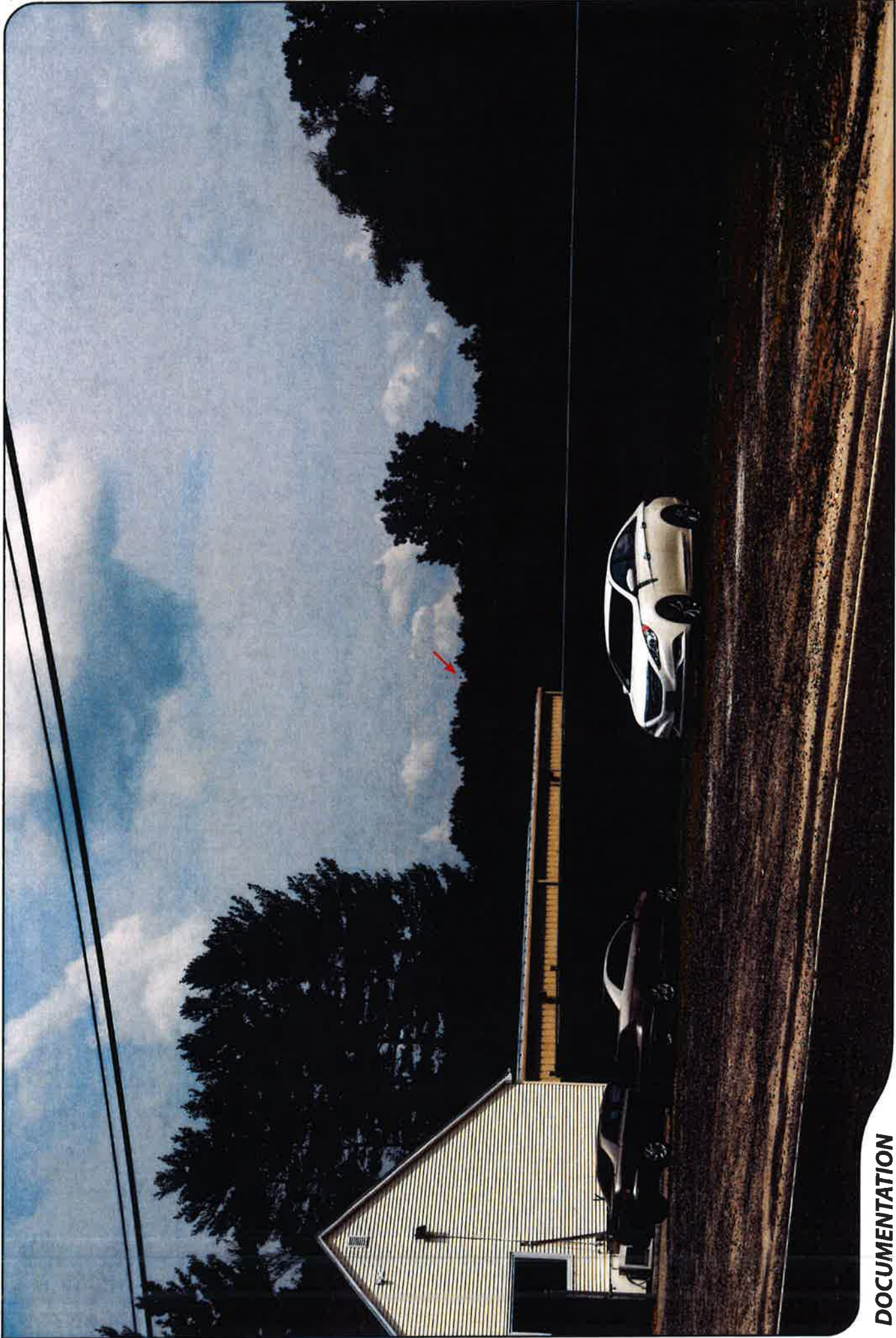

**DOCUMENTATION**

PHOTO

18

LOCATION

FEDERAL ROAD

ORIENTATION

NORTHEAST

DISTANCE TO SITE

+/- 0.54 MILE

VISIBILITY

YEAR ROUND



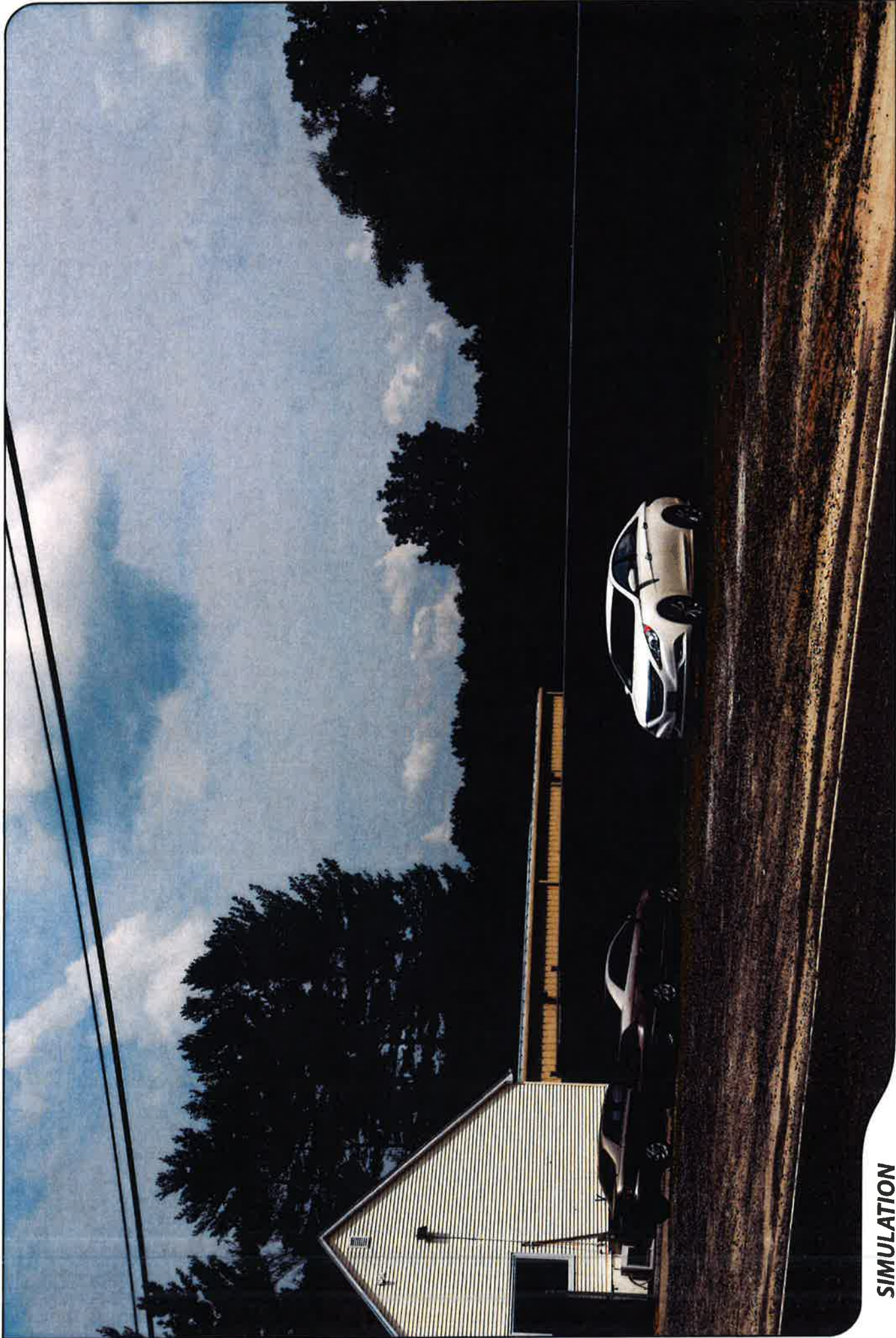

**SIMULATION**

PHOTO

18

LOCATION

**FEDERAL ROAD**

ORIENTATION

**NORTHEAST**

DISTANCE TO SITE

**+/- 0.54 MILE**

VISIBILITY

**YEAR ROUND**



**DOCUMENTATION**

PHOTO	LOCATION	ORIENTATION	DISTANCE TO SITE	VISIBILITY
19	CENTRAL CEMETERY	NORTHEAST	+/- 0.57 MILE	YEAR ROUND



**SIMULATION**

PHOTO	LOCATION	ORIENTATION	DISTANCE TO SITE	VISIBILITY
19	CENTRAL CEMETERY	NORTHEAST	+/- 0.57 MILE	YEAR ROUND



**DOCUMENTATION**

PHOTO	LOCATION	ORIENTATION	DISTANCE TO SITE	VISIBILITY
20	OLD OAK DRIVE	EAST	+/- 0.62 MILE	YEAR ROUND



**SIMULATION**

PHOTO	LOCATION	ORIENTATION	DISTANCE TO SITE	VISIBILITY
20	OLD OAK DRIVE	EAST	+/- 0.62 MILE	YEAR ROUND



**DOCUMENTATION**

PHOTO

21

LOCATION

**FEDERAL ROAD**

ORIENTATION

**SOUTHEAST**

DISTANCE TO SITE

**+/- 0.73 MILE**

VISIBILITY

**NOT VISIBLE**

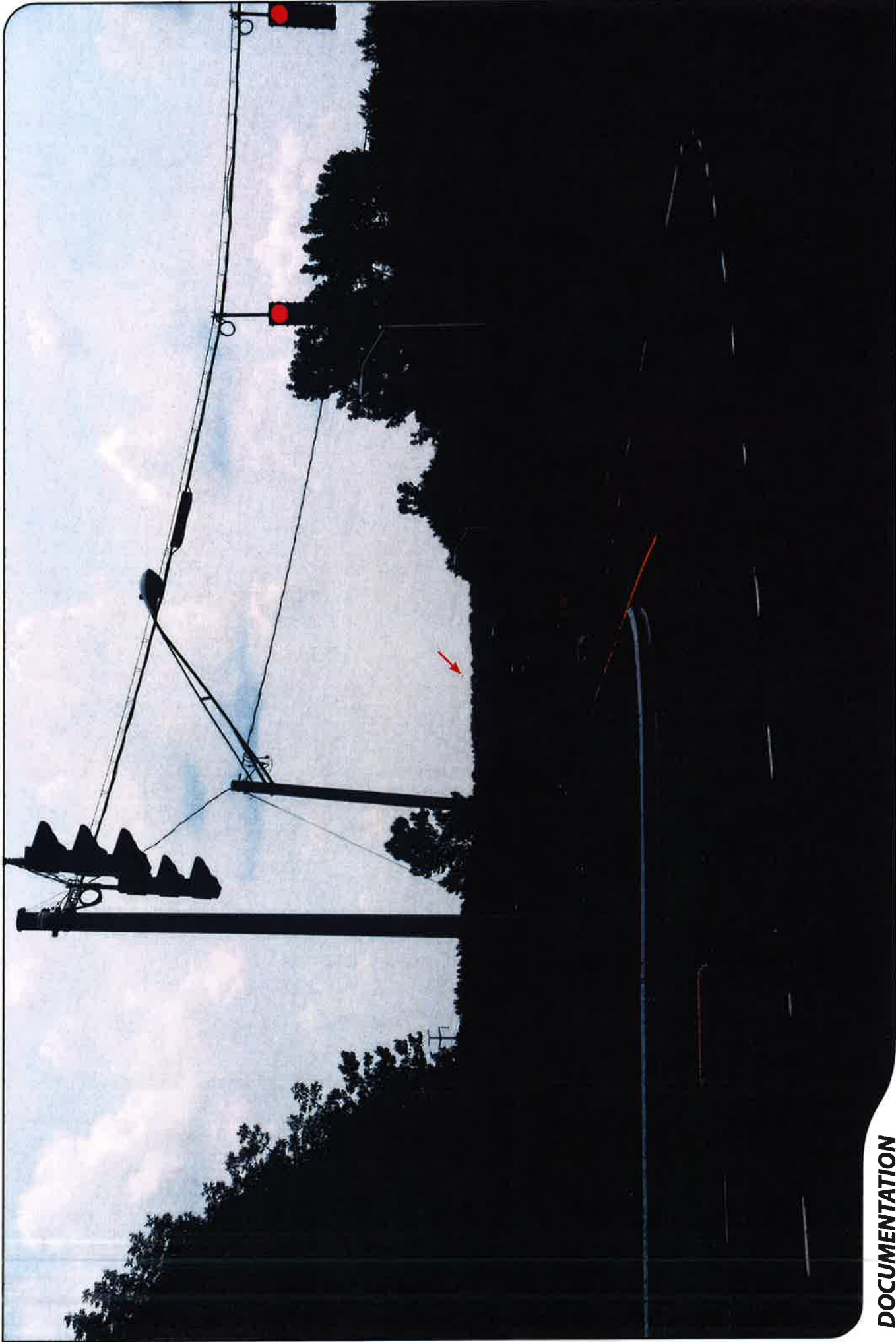

**DOCUMENTATION**

PHOTO	LOCATION	ORIENTATION	DISTANCE TO SITE	VISIBILITY
22	FEDERAL ROAD	SOUTHEAST	+/- 0.80 MILE	YEAR ROUND

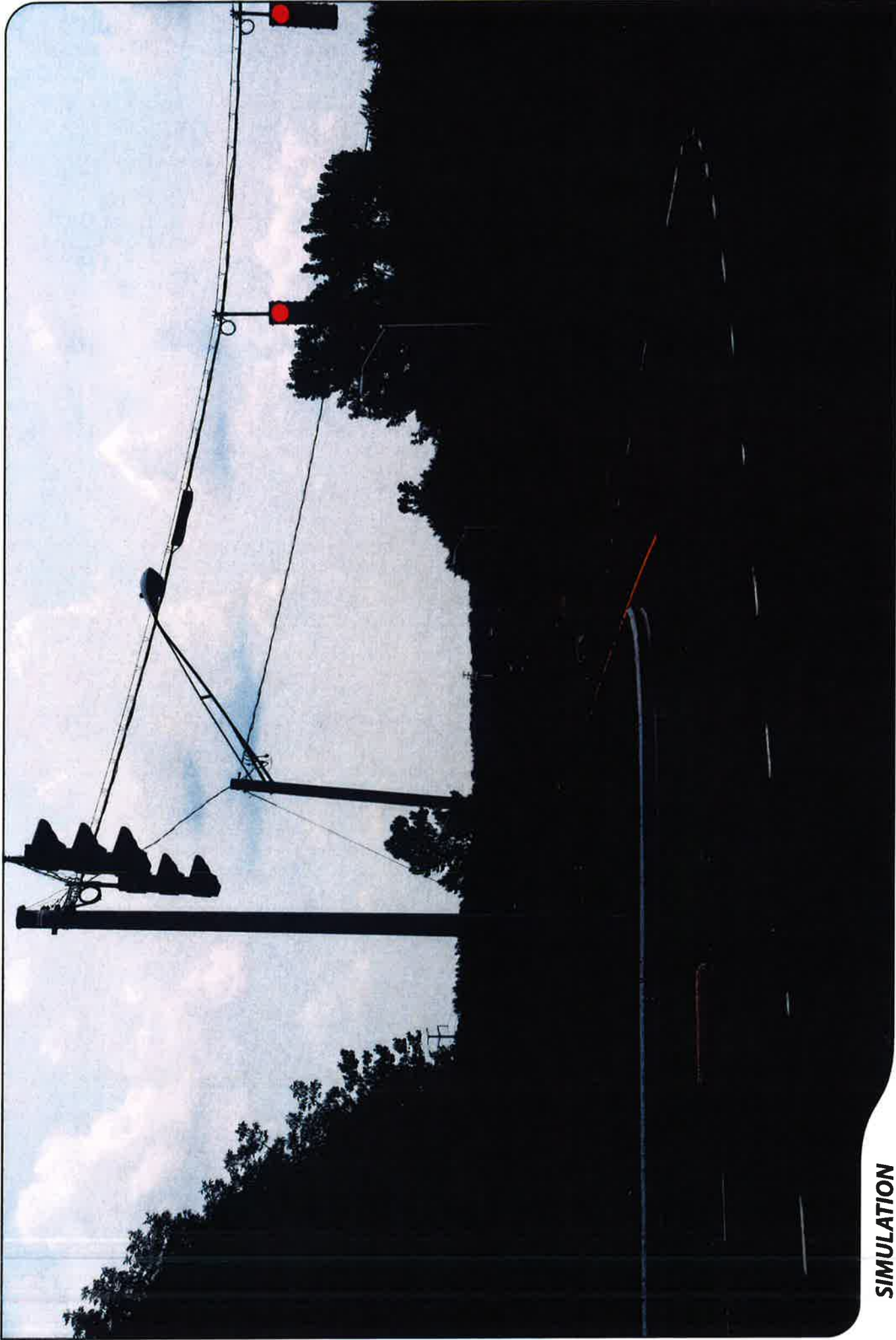

**SIMULATION**

PHOTO

22

LOCATION

**FEDERAL ROAD**

ORIENTATION

**SOUTHEAST**

DISTANCE TO SITE

**+/- 0.80 MILE**

VISIBILITY

**YEAR ROUND**





**DOCUMENTATION**

PHOTO	LOCATION	ORIENTATION	DISTANCE TO SITE	VISIBILITY
23	FEDERAL ROAD	SOUTHEAST	+/- 0.83 MILE	YEAR ROUND



**SIMULATION**

PHOTO

23

LOCATION

**FEDERAL ROAD**

ORIENTATION

**SOUTHEAST**

DISTANCE TO SITE

**+/- 0.83 MILE**

VISIBILITY

**YEAR ROUND**

# DOCUMENTATION

## SOURCES CONSULTED FOR VIEWSHED MAPS

100 Pocono Road  
Brookfield, Connecticut

### *Physical Geography / Background Data*

Center for Land Use Education and Research, University of Connecticut (<http://clear.uconn.edu>)

\*Land Use / Land Cover (2006)

\*Coniferous and Deciduous Forest (2006)

^LiDAR data – topography (2007-2012)

United States Geological Survey

\*USGS topographic quadrangle maps – Danbury, Newtown (1984)

National Resource Conservation Service

\*NAIP aerial photography (2012)

Department of Transportation data

^State Scenic Highways (updated monthly)

Heritage Consultants

^Municipal Scenic Roads

### *Cultural Resources*

Heritage Consultants

^National Register

^ Local Survey Data

### *Dedicated Open Space & Recreation Areas*

Connecticut Department of Energy and Environmental Protection (DEEP)

\*DEEP Property (May 2007)

\*Federal Open Space (1997)

\*Municipal and Private Open Space (1997)

\*DEEP Boat Launches (1994)

Connecticut Forest & Parks Association

^Connecticut Walk Books East –

*The Guide to the Blue-Blazed Hiking Trails of Western Connecticut, 19th Edition, 2006.*

### *Other*

^ConnDOT Scenic Strips (based on Department of Transportation data)

\*Available to the public in GIS-compatible format (some require fees).

^ Data not available to general public in GIS format. Reviewed independently and, where applicable, GIS data later prepared specifically for this Study Area.

**NOTE** Not all the sources listed above appear on the Viewshed Maps. Only those features within the scale of the graphic are shown.

### **LIMITATIONS**

The visibility analysis map(s) presented in this report depict areas where the proposed Facility may potentially be visible to the human eye without the aid of magnification based on a viewer eye-height of 5 feet above the ground and intervening topography, tree canopy heights and structures. This analysis may not necessarily account for all visible locations, as it is based on the combination of computer modeling, incorporating 2012 aerial photographs, and in-field observations from publicly-accessible locations. No access to private properties beyond the host Property was provided to APT personnel. This analysis does not claim to depict the only areas, or all locations, where visibility may occur; it is intended to provide a representation of those areas where the Facility is likely to be seen.

The photo-simulations in this report are provided for visual representation only. Actual visibility depends on various environmental conditions, including (but not necessarily limited to) weather, season, time of day, and viewer location.

# **ATTACHMENT 5**

General Power Density

Site Name: BROOKFIELD SOUTH, CT  
 Cumulative Power Density

Operator	Operating Frequency (MHz)	Number of Trans.	ERP Per Trans. (watts)	Total ERP (watts)	Distance to Target (feet)	Calculated Power Density (mW/cm <sup>2</sup> )	Maximum Permissible Exposure* (mW/cm <sup>2</sup> )	Fraction of MPE (%)
VZW PCS	1970	1	2389	2389	146	0.0403	1.0	4.03%
VZW Cellular	869	9	340	3060	146	0.0516	0.5793333333	8.91%
VZW AWS	2145	1	2619	2619	146	0.0442	1.0	4.42%
VZW 700	746	1	1087	1087	146	0.0183	0.4973333333	3.69%

**Total Percentage of Maximum Permissible Exposure**

21.05%

\*Guidelines adopted by the FCC on August 1, 1996, 47 CFR Part 1 based on NCRP Report 86, 1986 and generally on ANSI/IEEE C95.1-1992

MHz = Megahertz

mW/cm<sup>2</sup> = milliwatts per square centimeter

ERP = Effective Radiated Power

Absolute worst case maximum values used.

# **ATTACHMENT 6**

**Homeland Towers  
and  
Cellco Partnership d/b/a Verizon Wireless**

**Brookfield South Facility  
100 Pocono Road  
Brookfield, Connecticut**

**Site Search Summary**

Section 16-50j-74(j) of the Regulations of Connecticut State Agencies requires the submission of a statement that describes “the narrowing process by which other possible sites were considered and eliminated.” In accordance with this requirement, descriptions of the general site search process, the identification of the applicable search area and the alternative locations considered for development of the proposed telecommunications facility in Brookfield are provided below.

**Site Search Process**

To initiate its site selection process in an area where wireless service problems have been identified a carrier first establishes a site search area. In any search area a carrier would seek to avoid the unnecessary proliferation of towers and to reduce the potential adverse environmental effects of a new tower site while at the same time maximizing the quality of service provided from a particular facility. These objectives are achieved by initially locating existing towers and other sufficiently tall structures within and near a site search area. If any are found they are evaluated to determine whether they are capable of supporting telecommunications antennas and related equipment at a location and elevation that satisfies the wireless carriers technical requirements.

The list of available locations maybe further reduced if after preliminary negotiations a property owner withdraws a site from further consideration. From among the remaining locations, the proposed sites are selected by eliminating those that have a greater potential for adverse environmental effects and fewer benefits to the public. In any given site search area the weight afforded to factors considered in the site selection process will vary depending upon availability nature of sites within the search area.

**Need for the Brookfield South Facility**

Within approximately four (4) miles of the proposed Brookfield South Facility, Cellco maintains five (5) macro-cell telecommunications facilities. The macro-cell facilities are identified as Cellco’s Brookfield, Brookfield West, Bethel North, Hawleyville and Newtown North cell sites.

Cellco’s Brookfield facility consists of antennas on a tower at 37 Carmen Hill Road in Brookfield. Cellco’s Brookfield West facility consists of flush-mounted antennas on a tower at 52

Stadley Rough Road in Danbury. Cellco's Bethel North facility consists of antennas on a Eversource (CL&P) transmission line structure at 8 Sky Edge Lane in Bethel. Cellco's Hawleyville facility consists of antennas on a tower at 6 Fairfield Drive in Newtown. Cellco's Newtown North facility consists of antennas on a tower at 24 Dinglebrook Lane in Newtown.

The proposed Brookfield South Facility will provide service to existing coverage gaps along Routes 7, 202, 25 and 133 and the surrounding areas in portions of Brookfield and Danbury and capacity relief to Cellco's existing Brookfield and Bethel North facilities, which are currently operating at or near their current capacity limits.

#### Properties Investigated by Homeland Towers and Cellco

Homeland Towers and Cellco identified and investigated a total of four (4) sites in and around the Brookfield South search area. Descriptions of the sites investigated are provided below. Also, attached is a map depicting the approximate location of the alternative sites investigated.

**A. Town of Brookfield, 100 Pocono Road, Brookfield, CT**

Homeland Towers approached the Town of Brookfield's previous First Selectman, William Davidson, back in November of 2011, regarding its search for a suitable tower site in the area of Pocono Road and Route 7. The Town asked Homeland to consider the Town-owned parcel at 100 Pocono Road as an option since the Town was already interested in the possibility of siting a new tower on its property as a part of its public safety communications network. Homeland entered into a lease with the Town of Brookfield for a new tower site in March of 2014.

**B. Eversource, 100 Pocono Road, Brookfield, CT**

Homeland investigated the potential use of an existing Eversource transmission line tower in the northerly portion of the 43.28-acre Town-owned parcel at 100 Pocono Road. These towers carry an Eversource 345 kV transmission line through Brookfield. This structure was rejected by Eversource due to its outage category rating of a 4. This rating makes it difficult to obtain an outage to permit the installation of antennas and related equipment on this structure.

**C. Existing Flagpole Tower, 2 Huckleberry Hill Road (YMCA), Brookfield, CT**

Cellco investigated the use of an existing flagpole tower at 2 Huckleberry Hill Road. This site was rejected because it did not meet Cellco's RF objectives nor was the tower capable of supporting Cellco's antennas. In addition, the owner was not interested in rebuilding the tower.

**D. 60 Old New Milford Road, Brookfield, CT (Rooftop)**

This existing rooftop was investigated and rejected because the height of the building did not meet Cellco's RF wireless service objective.



**Aerial Map of Homeland Towers and Cellco's search and proposed site**

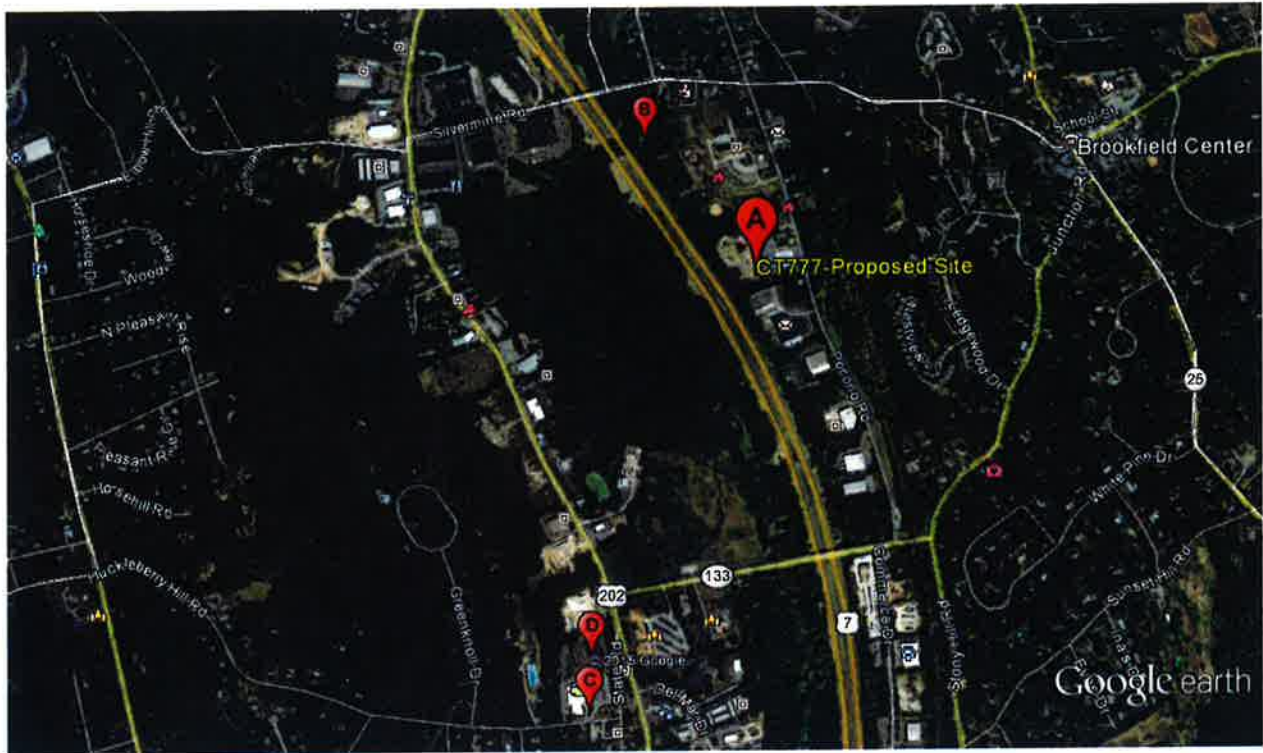

**Topographical Map of Homeland Towers and Cellco's search and proposed site**

