

**THE CONNECTICUT PORTION
OF THE INTERSTATE RELIABILITY PROJECT**

BY

THE CONNECTICUT LIGHT AND POWER COMPANY

**VOLUME 3: ENVIRONMENTAL – CULTURAL
RESOURCES**

DECEMBER 2011

VOLUME 3: ENVIRONMENTAL – CULTURAL RESOURCES

- EX. 1: Supplement to the Historical and Archaeological Assessment for the Interstate Reliability Project Connecticut Portion, October 2011**
- EX. 2: Historical and Archaeological Assessment for The Connecticut Light & Power Company Interstate Reliability Project, May 2008**

**EX. 1: Supplement to the Historical and Archaeological Assessment for
the Interstate Reliability Project Connecticut Portion,
October 2011**

SUPPLEMENT
to the
HISTORICAL AND ARCHAEOLOGICAL ASSESSMENT
for the
INTERSTATE RELIABILITY PROJECT
CONNECTICUT PORTION

October 2011

By:

The Public Archaeology Laboratory
210 Lonsdale Avenue
Pawtucket, Rhode Island 02860

Prepared for:

The Connecticut Light and Power Company

TABLE OF CONTENTS

| <u>Section</u> | <u>Page No.</u> |
|---|------------------------|
| 1. INTRODUCTION AND STUDY OBJECTIVES | 1 |
| 1.1 Purpose of the Supplement | 1 |
| 1.2 Project Background | 1 |
| 1.3 Cultural Resources Consultants and Tribal Interactions | 2 |
| 2. SUMMARY OF CULTURAL RESOURCE STUDIES: 2008 – SUMMER 2011 | 4 |
| 3. REVIEW OF ONGOING AND FUTURE CULTURAL RESOURCE STUDIES | 6 |

LIST OF FIGURES

| | |
|---|---|
| Figure 1-1: General Location of the Connecticut Portion of the Interstate Reliability Project | 3 |
|---|---|

1. INTRODUCTION

1.1 PURPOSE OF THE SUPPLEMENT

The purpose of this Supplement is to augment the *Historical and Archaeological Assessment* that was prepared by Raber Associates in 2008 for the Connecticut portion of the Interstate Reliability Project (Project). Specifically, the Supplement summarizes the additional cultural resources research and field studies conducted for the Connecticut portion of the project since the publication of the 2008 report, and the additional studies that will be performed, in consultation with the state and federal regulatory agencies, Connecticut State Historic Preservation Office [SHPO] and the U.S. Army Corps of Engineers [Corps] and Native American Tribes.

1.2 PROJECT BACKGROUND

The Interstate Reliability Project, which is needed to address electric transmission system problems in Southern New England, will consist of facilities in northeastern Connecticut, northwestern Rhode Island, and south-central Massachusetts. These proposed facilities include approximately 75 miles of new 345-kilovolt (kV) overhead transmission lines and related improvements to substations and switching stations. The Connecticut Light and Power Company (CL&P), a wholly-owned subsidiary of Northeast Utilities (NU), would build and operate the Connecticut portion of the Project, while the Narragansett Electric Company and New England Power Company (wholly-owned subsidiaries of National Grid USA [National Grid]) will construct and operate the Rhode Island and Massachusetts portions of the Project, respectively.

In Connecticut, CL&P proposes to construct and operate approximately 36.8 miles of new 345-kV overhead transmission lines aligned adjacent to existing 345-kV transmission lines. The proposed 36.8-mile route will extend through 11 towns in New London, Tolland, and Windham counties. Except for 1.4 miles through federally-owned lands in the Mansfield Hollow area of the towns of Mansfield and Chaplin, the new 345-kV lines would be aligned entirely within presently un-used portions of CL&P's existing rights-of-way (ROWs). As part of the Project, CL&P also proposes to modify two existing substations (Card Street Substation and Killingly Substation) and the Lake Road Switching Station; these modifications would be localized within the developed portions of the station sites. Figure 1-1 generally illustrates the proposed location of the Connecticut portion of the Project.

Since the publication of the 2008 *Historical and Archaeological Assessment*, the following Project elements have changed:

- The 310 Line Loop has been eliminated from the Project. The 310 Line Loop would have involved the construction of new 345-kV transmission lines on a 1-mile segment of existing CL&P ROW in the Town of Lebanon between Card Street Substation and Village Hill Junction and an expansion of the existing Card Street Substation to interconnect these new lines.
- CL&P has selected the Proposed Route and proposed overhead configurations for the new 345-kV transmission line based on the results of further studies and public outreach conducted between 2008 and the fall 2011. (All of the identified route variations were determined to be less preferable than the portions of the Proposed Route that will be replaced.)
- Three configuration options have been identified along the 1.4 miles where the Proposed Route traverses federally-owned properties administered by the Corps. Along this 1.4 miles, the existing CL&P easement is only 150 feet wide, substantially less than most other portions of ROW. Consequently, CL&P identified a proposed transmission line configuration that will match the existing structure heights and appearance, but will require 11 additional acres of easement acquisition. In addition, two other feasible configuration options were identified. One of the options would involve less easement expansion (4.8 acres), but would use new 345-kV structures that would not match the existing 345-kV structure heights and appearance. The other option would not require any additional easement, but would entail a more complex construction sequence involving removal and reconstruction of the existing 345-kV line as well as the development of the new 345-kV line. Under the no ROW expansion option, extensive electrical outages would be required and neither the rebuilt existing 345-kV line nor the new 345-kV line would match the existing 345-kV structures in appearance and height.

1.3 CULTURAL RESOURCE CONSULTANTS AND TRIBAL INTERACTIONS

Raber Associates prepared the 2008 *Historical and Archaeological Assessment* and subsequently performed some Phase 1b cultural resource studies between 2008 and 2011 for the Connecticut portion of the Project. In the summer of 2011, CL&P retained The Public Archaeology Laboratory, Inc. (PAL) to assume primary responsibility for further cultural resource studies and to assist in consultation with the SHPO, the Corps, and Native American Tribes for the Connecticut portion of the Project. The Native American Tribes that potentially could choose to be involved in the Project include the Mashantucket Pequot Tribal Nation, Mashpee Wampanoag Tribe, Mohegan Tribe, Narragansett Indian Tribe, Nipmuc National Tribal Council (Hassananesit Band), Stockbridge Munsee Tribe, and Wampanoag Tribe of Gay Head (Aquinnah).

National Grid has previously retained PAL to perform these functions for the Rhode Island and Massachusetts portions of the Project. As a result, all cultural resources work in the three-state Project area now will be uniformly and consistently managed by PAL.

**Figure 1-1
General Location of Connecticut Portion of the Proposed Interstate Reliability Project**

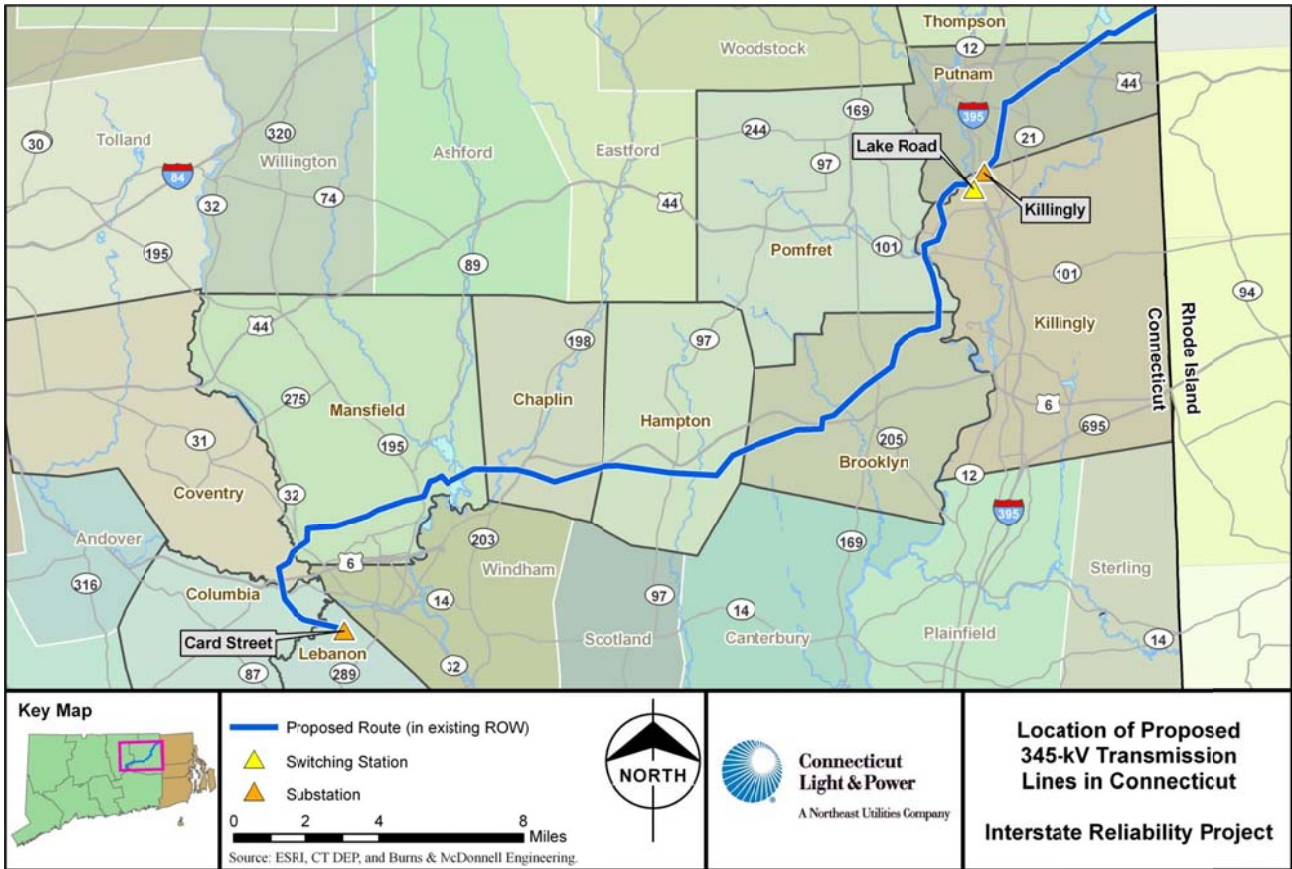

2. SUMMARY OF CULTURAL RESOURCE STUDIES: 2008 – SUMMER 2011

The 2008 *Historical and Archaeological Assessment* describes the results of research performed along the 36.8-mile Proposed CT Route, as well as along variations to portions of this Proposed Route. The research consisted of a review of archaeological and historic sites recorded in the vicinity of the Proposed Route and route variations, including sites listed in the National Register of Historic Places (National Register, NRHP) and State Register of Historic Places (State Register, SRHP). The assessment identifies and maps areas of potential sensitivity for locating unidentified Native American archaeological sites. In addition, a visual analysis to assess the potential effects of the Project on standing historic structures was conducted and documented in the *Assessment* report.

After the completion of the 2008 *Assessment*, CL&P commissioned Raber Associates to conduct additional cultural resources studies, consisting of archaeological reconnaissance/Phase 1b testing of potentially archaeologically-sensitive Project areas that could be affected by the Project activities (i.e., clearing, access road and staging area development, etc.). In 2009 and 2010, Raber Associates performed Phase 1b testing along approximately 90% of the sensitive areas identified in the 2008 *Assessment* of the proposed 36.8-mile transmission line route.

These investigations, which were performed using methods consistent with the *Environmental Primer for Connecticut's Archaeological Resources*, began with hand-excavated, 50-centimeter-square shovel test pits at intervals not exceeding 15 meters/50 feet and additional shovel test pits where material was located at intervals of 2 to 4 meters to confirm the presence of sites potentially eligible for the NRHP/SRHP. Surface features, including foundations and unidentified human-built stone piles, walls, or rings were also noted, mapped, and photographed. This testing resulted in the following:

- Approximately 115 potentially-significant Native American archaeological sites were identified. More detailed field investigations will be required to determine the eligibility of these sites to the NRHP/SRHP.
- Seven pre-twentieth-century Euro-American archaeological sites were located by surface inspection and/or subsurface testing. The sites include a water-powered mill and an eighteenth-nineteenth century homestead. More detailed studies will be required to determine the functions of most of these sites and their significance and eligibility for listing in the NRHP/SRHP.

- Five human-built stone piles, walls, or rings were located, with considerable variations in size. More detailed studies will be required to assess the age, function, cultural affiliation, and eligibility of these features to the NRHP/SRHP (none appear to be field walls).

As part of the Phase 1b work, Raber Associates tested the proposed 11-acre transmission line easement expansion area along the 1.4-miles of federally-owned lands in the Mansfield Hollow area. This work was performed pursuant to a permit issued by the Corps under the Archaeological Resources Protection Act of 1979.

Additional Phase 1b testing (and subsequent cultural resource studies) will be performed as discussed in Section 3. Upon completion of the Phase 1b testing and artifact analyses, a management summary documenting the testing results and providing recommendations for Phase 2 testing will be submitted to the SHPO, the Corps, and the consulting Native American Tribes.

3. REVIEW OF ONGOING AND FUTURE CULTURAL RESOURCE STUDIES

As plans for the Project continue to evolve, CL&P has commissioned PAL to manage the cultural resource program, including coordination with the SHPO, Corps, and Native American Tribes. Other potentially involved groups, such as those related to the Quinebaug-Shetucket National Heritage Corridor (which encompasses 10 of the 11 towns traversed by the proposed transmission line route in Connecticut) also may be consulted.

This program will be performed in conformance with federal and state historic preservation regulations (e.g., the National Historic Preservation Act¹). As part of this process, cultural resource investigations (i.e., additional Phase 1b, Phase 2, Phase 3) will be developed in consultation with the SHPO, the Corps, and the consulting Native American Tribes. Accordingly, the following types of activities will be performed:

- Conduct ROW walkovers with representatives of the SHPO, the Corps, and Native American Tribes, as appropriate. The purpose of the walkovers will be to discuss the already completed Phase 1b testing, to determine the need for additional Phase 1b testing, and to identify Areas of Interest (AOIs) to the Tribes.
- Develop agreements with Native American Tribes relating to Tribal involvement in the Project's cultural resource review.
- Complete Phase 1b testing and prepare and submit to the SHPO, the Corps, and the consulting Native American Tribes a Phase 1b report with recommendations for Phase 2 testing.
- Conduct Phase 2 testing of the sites as recommended after consultation with the SHPO, the Corps, and the consulting Native American Tribes.
- Prepare Phase 2 reports, including recommendations on sites that are eligible for listing in the National Register.
- Following Determinations of Eligibility on sites recommended as eligible in the Phase 2 report, by the Corps in consultation with the SHPO and the Native American Tribes, Determinations of Effect from the Project on the sites will be made. Eligible sites that can be avoided during

¹ Section 106 of the National Historic Preservation Act of 1966 (NHPA) requires federal agencies to take into account the effects of their undertakings on historic properties, and afford the Advisory Council on Historic Preservation (ACHP) a reasonable opportunity to comment. The historic preservation review process mandated by Section 106 is outlined in regulations issued by ACHP. Revised regulations, "Protection of Historic Properties" (36 CFR Part 800), became effective January 11, 2001. Part of the Section 106 process encourages consultation with Native American Tribes at an early stage in project planning.

construction will be identified. Sites that cannot be avoided and therefore will require mitigation (e.g., data recovery) also will be determined.

If necessary, a Memorandum of Agreement among the Corps, the SHPO, the Native American Tribes, and other interested parties may be developed. The Advisory Council on Historic Preservation will be invited to participate in the consultation. Archaeological Site Avoidance and Protection Plans will be developed for those sites that can be avoided.

- Complete Phase 3 reports and conduct any agreed-upon cultural resource mitigation and public information programs.
- Complete artifact curation.

**EX. 2: Historical and Archaeological Assessment for The Connecticut
Light & Power Company Interstate Reliability Project,
May 2008**

RABER ASSOCIATES

CONSULTANTS IN THE HISTORICAL AND SOCIAL SCIENCES



Final Report

**HISTORICAL AND ARCHAEOLOGICAL ASSESSMENT
FOR THE CONNECTICUT LIGHT & POWER COMPANY
INTERSTATE RELIABILITY PROJECT
MUNICIPAL CONSULTATION FILING**

**TOWNS OF LEBANON, COLUMBIA, COVENTRY, MANSFIELD, CHAPLIN, HAMPTON,
BROOKLYN, POMFRET, KILLINGLY, PUTNAM, THOMPSON, AND WINDHAM,
CONNECTICUT**

Michael S. Raber

Prepared for:

Burns & McDonnell Engineering Company, Inc.
9400 Ward Parkway
Kansas City, MO 64114

May 2008

81 Dayton Road • P.O. Box 46
South Glastonbury • CT 06073
(860) 633-9026(voice/fax)/msraber@aol.com (e-mail)

ABSTRACT

The Connecticut Light and Power Company (CL&P) in Connecticut, the Narragansett Electric Company in Rhode Island, and The New England Power Company in Massachusetts propose to enhance electric service and reliability by the construction and operation of the Interstate Reliability Project (IRP, or Project). Connecticut sections of the project require approval of the Connecticut Siting Council. The location, size, and nature of associated new structures remain undetermined, pending Siting Council approval of a route and completion of a CL&P Development and Management Plan (D&M Plan). The Connecticut portion of the Project will include construction and operation of a new 345-kV transmission line and associated facilities or improvements from the Card Street Substation in Lebanon, Connecticut to the Rhode Island border in Thompson, Connecticut, via the Lake Road Substation in Killingly, Connecticut (see Appendix 1: Project Overview and Index Map).

The Primary Route Under Consideration would consist of an approximately 36.5-mile overhead 345-kV transmission line, parallel to an existing 345-kV transmission line and constructed entirely within the of existing CL&P ROW except for two segments traversing the Mansfield Hollow Reservoir and State Park. To avoid groups of homes and Statutory Facilities as defined by CSC, a total of four overhead and five underground variations to the Primary Route were identified. An assessment of cultural resources was made on behalf of CL&P to identify known or potential archaeological sites within possible project areas, and to evaluate the potential for adverse visual effects on significant historic properties. Depending on an approved D&M Plan, additional assessment or reconnaissance investigations will be made in consultation with the Connecticut State Historic Preservation Office.

Five documented Native American archaeological sites exist close to, or within, the limits of the Primary Route Under Consideration. Of the two sites located within these limits, one has been determined not eligible for the National Register of Historic Places. The second site within these limits, and the three sites located just beyond these limits, have insufficient reported data to make such determination. Background research and field inspection indicated areas sensitive for potential Native American sites along discontinuous areas totaling approximately 64.2 percent of the Primary Route Under Consideration, and 50.8-80.0% of overhead route variations. Native American sites are not expected in most alternative underground routes, although sites are possible alongside roadways where off-road facilities are required. With the exception of one National Register property traversed by the Willimantic South Overhead Variation in Windham, there are no reported or likely Euroamerican archaeological sites listed on, or eligible for listing on, the National Register of Historic Places or the State Register of Historic Places in, or adjacent to, the Primary Route Under Consideration or any of the variation routes.

Twelve significant historic resources and a National Scenic Byway were identified within approximately 0.25 mile of the Primary Route Under Consideration. Many of these resources are historic districts which lie wholly or partially beyond the 0.25-mile limit, so that the total number of individual sites or structures within approximately 0.25 mile is 21. The 0.25 mile distance was selected to evaluate possible visual effects of new overhead transmission structures. Based on digital topographic profiles, and simulations shown on photographs of possible new transmission structures, adverse visual effects on these resources appear unlikely. Comparable totals relative to the Willimantic South Overhead Variation are 4 historic resources and 29 individual sites. Most of the approximately dozen structures within the Mansfield Hollow Historic District are within 0.25 mile of the Mount Hope Montessori School Overhead Variation. With the possible exception of part of the Windham Center Historic District along the Willimantic South Overhead Variation, digital topographic profiles and photographs taken to simulate views of new transmission structures suggest no likely adverse visual effects on significant resources within 0.25 miles of any variation routes.

For the Willimantic South Underground Variation, there are 7 significant resources with 32 individual structures within approximately 500 feet, and there is one cemetery subject to Ancient Burying Ground protection under Connecticut law adjacent to the Putnam North Underground Variation. The 500 foot distance was chosen to plan for any necessary protective measures against blasting effects.

CONTENTS

| | |
|--|-----------|
| I. INTRODUCTION | 1 |
| A. Purpose of Study | 1 |
| B. Summary Project Description | 2 |
| 1. Primary Route Under Consideration | 2 |
| 2. Related Improvements | 3 |
| 3. Route Variations | 3 |
| 4. Proposed Facilities and Construction Methods | 4 |
| C. Study Issues and Definitions | 6 |
| 1. Overhead Construction | 6 |
| a. Visual Effects | 6 |
| b. Archaeological Resources | 7 |
| 2. Underground Construction | 8 |
| 3. Cemeteries | 8 |
| II. ASSESSMENT STUDY METHODS | 9 |
| III. PROJECT AREA ENVIRONMENTS | 11 |
| IV. NATIVE AMERICAN ARCHAEOLOGICAL SENSITIVITY | 14 |
| A. Known Resources and Research Context | 14 |
| 1. Prehistoric and Contact Period Background | 15 |
| B. Project Area Sensitivity and Future Actions | 29 |
| V. EUROAMERICAN RESOURCE SENSITIVITY AND POTENTIAL VISUAL EFFECTS | 31 |
| A. Summary of Background Information | 31 |
| B. Known or Potential Archaeological Resources | 35 |
| 1. Overhead Routes | 35 |
| 2. Underground Routes | 36 |
| C. Historic Properties and Visual Effects | 39 |
| 1. Resource Identification | 39 |
| 2. Preliminary Identification of Resources Subject to Project Effects | 40 |
| 3. Possible Future Needed Actions | 41 |
| REFERENCES | 44 |
| PERSONAL COMMUNICATIONS | 56 |

TABLES

| | |
|--|----|
| 1. REPORTED NATIVE AMERICAN ARCHAEOLOGICAL SITES WITHIN ONE MILE OF PRIMARY ROUTE | 16 |
| 2. REPORTED NATIVE AMERICAN ARCHAEOLOGICAL SITES WITHIN ONE MILE OF WILLIMANTIC SOUTH OVERHEAD VARIATION | 18 |
| 3. REPORTED NATIVE AMERICAN ARCHAEOLOGICAL SITES WITHIN ONE MILE OF MOUNT HOPE MONTESSORI SCHOOL OVERHEAD VARIATION | 18 |
| 4. REPORTED NATIVE AMERICAN ARCHAEOLOGICAL SITES WITHIN ONE MILE OF PUTNAM NORTH OVERHEAD VARIATION | 18 |
| 5. REPORTED NATIVE AMERICAN ARCHAEOLOGICAL SITES WITHIN ONE MILE OF WILLIMANTIC SOUTH UNDERGROUND VARIATION | 19 |
| 6. REPORTED NATIVE AMERICAN ARCHAEOLOGICAL SITES WITHIN ONE MILE OF MOUNT HOPE MONTESSORI SCHOOL UNDERGROUND VARIATION | 19 |
| 7. REPORTED NATIVE AMERICAN ARCHAEOLOGICAL SITES WITHIN ONE MILE OF PUTNAM NORTH UNDERGROUND VARIATION | 20 |
| 8. REPORTED EUROAMERICAN ARCHAEOLOGICAL SITES WITHIN ONE MILE OF PRIMARY ROUTE | 37 |
| 9. REPORTED EUROAMERICAN ARCHAEOLOGICAL SITES WITHIN ONE MILE OF WILLIMANTIC SOUTH OVERHEAD VARIATION | 37 |
| 10. REPORTED EUROAMERICAN ARCHAEOLOGICAL SITES WITHIN ONE MILE OF MOUNT HOPE MONTESSORI SCHOOL OVERHEAD VARIATION | 38 |
| 11. REPORTED EUROAMERICAN ARCHAEOLOGICAL SITES WITHIN ONE MILE OF WILLIMANTIC SOUTH UNDERGROUND VARIATION | 38 |

| | |
|---|-----------|
| 12. REPORTED EUROAMERICAN ARCHAEOLOGICAL SITES WITHIN ONE MILE OF MOUNT HOPE MONTESSORI SCHOOL UNDERGROUND VARIATION | 38 |
| 13. KNOWN SIGNIFICANT ABOVEGROUND HISTORIC RESOURCES WITHIN APPROXIMATELY ONE QUARTER MILE OF PRIMARY ROUTE | 42 |
| 14. KNOWN SIGNIFICANT ABOVEGROUND HISTORIC RESOURCES WITHIN APPROXIMATELY ONE QUARTER MILE OF WILLIMANTIC SOUTH OVERHEAD VARIATION | 43 |
| 15. KNOWN SIGNIFICANT ABOVEGROUND HISTORIC RESOURCES WITHIN 500 FEET OF WILLIMANTIC SOUTH UNDERGROUND VARIATION | 43 |

APPENDICES

- 1. MARCH 2008 PROJECT OVERVIEW MAPS, SIGNIFICANT HISTORIC RESOURCES & AREAS OF ARCHAEOLOGICAL SENSITIVITY**
- 2. DIGITALLY-GENERATED TOPOGRAPHIC PROFILES SAMPLING POSSIBLE LINES OF SIGHT FROM SIGNIFICANT HISTORIC PROPERTIES TO POSSIBLE OVERHEAD TRANSMISSION STRUCTURES ON PRIMARY ROUTE UNDER CONSIDERATION**
- 3. PHOTOGRAPHS OF SIGNIFICANT HISTORIC PROPERTIES WITHIN ONE QUARTER MILE OF EXISTING TRANSMISSION STRUCTURES ON PRIMARY ROUTE, WITH SIMULATIONS OF PROPOSED OVERHEAD TRANSMISSION STRUCTURES**

I. INTRODUCTION

A. Purpose of Study

The Connecticut Light and Power Company (CL&P) in Connecticut, the Narragansett Electric Company in Rhode Island, and The New England Power Company in Massachusetts propose to enhance electric service and reliability by the construction and operation of the Interstate Reliability Project (IRP, or Project). National Grid USA (National Grid) owns the Rhode Island and Massachusetts companies. The Project will increase the ability of the Connecticut system to import power generated outside of the state in order to meet growing demands within the state and comply with mandatory federal and regional reliability standards and criteria. At the same time, the IRP improvements will advance a comprehensive regional plan for improving electric transmission in New England, through extensive coordinated improvements in Connecticut, Rhode Island, and Massachusetts. This comprehensive plan is known as the New England East – West Solution (NEEWS). The Connecticut portion of the Project will include construction and operation of a new 345-kV transmission line and associated facilities from the Card Street Substation in Lebanon, Connecticut to the Rhode Island border in Thompson, Connecticut, via the Lake Road Substation in Killingly, Connecticut. The new transmission line would supplement CL&P's existing 345-kV transmission line that extends between the 310 Loop to Card Street and Lake Road substations and interconnects to the National Grid system at the Rhode Island border. The existing CL&P right-of-way (ROW) is located within portions of the Towns of Lebanon, Columbia, Coventry, Mansfield, Chaplin, Hampton, Brooklyn, Pomfret, Killingly, Putnam, and Thompson. The Primary Route Under Consideration and several variations for the new transmission line would cross the same municipalities; in addition, one of the route variations would cross portions of the Town of Windham.

CL&P is in the process of submitting an application to the Connecticut Siting Council ("Siting Council"/"Council") for a Certificate of Environmental Compatibility and Public Need (Certificate) for the construction and operation of the proposed 345-kV electric transmission facilities. In addition to the Council, CL&P will seek approvals and/or certifications from the Connecticut Department of Environmental Protection (DEP), the Connecticut State Historic Preservation Office (SHPO), and other agencies as may be required depending upon the final project design. The location, size, and nature of associated new transmission structures and facilities remain undetermined, pending completion of a CL&P Development and Management Plan (D&M Plan) approved by the Siting Council.

CL&P is presently conducting initial planning for the Project. Part of this planning process involves the identification and evaluation of alternative routes for the transmission line, and the subsequent presentation of such information to the public for review and comment as part of the Siting Council's Municipal Consultation Filing (MCF). CL&P commissioned this Cultural Resource Assessment as part of the initial Project planning process. The purpose of the assessment, as described further below, is to provide input to the MCF process. After the MCF process, and based on consultations with project area municipalities and state agencies, the final application to the Siting Council will include a proposed route. CL&P has not yet identified a proposed route for the Project, but has determined the general configuration of a Primary Route Under Consideration along with several possible variations.

Among the issues to be addressed for approval of the Project's environmental compatibility, potential Project effects on cultural resources must be reviewed by the State Historic Preservation Office (SHPO) under the Connecticut Environmental Policy Act (Connecticut General Statutes Chapter 439 Section 22a) and under the Connecticut Public Utilities Environmental Standards Act (PUESA; Connecticut General Statutes Chapter 277a, Section 16-50p(a)(2)). Cultural resources subject to review under these acts include historic architectural properties, historic industrial or engineering resources, and prehistoric or historic archaeological sites.

Northeast Utilities subsidiary Northeast Utilities Service Company (NUSCO) provides services to CL&P including oversight or implementation of transmission planning, design, and permitting work required for the Project. CL&P retained Burns & McDonnell Engineering Company, Inc. (B&M) to manage IRP engineering and construction, in coordination with NUSCO. As agent for the utility companies, B&M retained Raber Associates to identify known or possible cultural resources subject to potential effects of project construction, and to recommend future actions needed to avoid adverse effects on cultural resources eligible for the State or National registers of historic places.

Based on consultations among NUSCO, Raber Associates, SHPO, and B&M, Raber Associates prepared a cultural resources assessment of current IRP alternatives. Assessment methods, summarized in Section II, are iterations and enhancements of methods developed by Raber Associates, NUSCO, and SHPO on similar recent projects (Raber and Wiegand 2002, 2003). During earlier stages of Project planning in 2004, Raber Associates prepared a draft of the present assessment, assisted by Luc Litwinionek and Daniel Forrest of the Public Archaeology Survey Team, Inc..

CL&P's application to the Siting Council for a Certificate will include a similar assessment covering the route that is ultimately proposed for the Project, as well as any other potentially viable alternatives or variations identified during CL&P's consultations with municipalities and state agencies.

B. Summary Project Description

Within the Connecticut portion of the Project, CL&P and its consultants identified an overhead Primary Route Under Consideration for new transmission facilities, related improvements to existing lines and substations, and potential overhead and underground variations to the Primary Route Under Consideration to avoid the potential alignment of overhead structures near certain Statutory Facilities, including schools, residential areas and day care centers as required by Public Act No. 04-246. In addition, there is a group of homes that may be determined by the CSC to be Statutory Facilities. Appendix 1 shows these routes and their variations.

1. Primary Route Under Consideration (Primary Route)

In 1971, CL&P constructed the existing 36.5-mile 345-kV transmission line between Card Street Substation and Lake Road Substation and from Lake Road Substation to the Rhode Island border. The existing transmission line is supported predominantly on wood H-frame structures 75-110 feet high. Steel monopoles in the Mansfield State Park and Mansfield Reservoir area are 105-135 feet high, and there is a 145-foot-high steel monopole at Lake Road Substation. The right-of-way (ROW) previously acquired for this existing line varies between 150-400 feet, which is generally enough to accommodate the proposed new 345-kV circuit. The Primary Route Under Consideration would parallel the existing 345-kV transmission line and would be constructed entirely within the existing CL&P ROW except for two segments (5175 and 2745 feet) traversing the Mansfield Hollow Reservoir and State Park. The ROW within Mansfield Hollow State Park is 150 feet wide and would need to be expanded to accommodate the proposed 345-kV transmission line. Construction of the Primary Route Under Consideration could require as much as approximately 27 acres of new ROW, crossing of 66 streams, and clearing of forested and shrub vegetation to provide minimum conductor clearances and access to structures for construction and maintenance.

2. Related Improvements

The arrangement of one of the two existing CL&P 345-kV lines from Manchester Substation to Millstone Substation, the 310 circuit, currently bypasses the Card Street Substation. A part of the Project is to add short 345-kV line segments to loop the 310 circuit through the Card Street Substation. CL&P is proposing the relocation/rebuild within the existing ROW of the 368 line segment and the 383 line segment from Village Hill Road Junction to Card Street Substation, a distance of approximately 1 mile, to allow adequate ROW for the new 310 line connections. The existing 368 and 383 lines between Village Hill Road Junction and Card Street Substation are both currently configured on single-circuit wood-pole H-frame structures. These line segments would be rebuilt on steel monopoles with vertical configurations of the conductors. The two new 345-kV line segments for the 310 loop will also be built on steel monopoles with vertical configurations of the conductors. The modifications to the structure configurations will allow CL&P to re-position four single circuit 345-kV lines and stay primarily within CL&P's existing ROW. Additional ROW for this 310 line-loop work would be required at Card Street Substation for the overhead line entry. Card Street Substation would have to expand, but could do so on CL&P property. Additional engineering will be required to quantify the impacts in the area.

Related work at the Killingly and Lake Road substations will be required, but will not involve work beyond the existing fenced enclosures of these facilities, and does not appear to require any further cultural resource review.

3. Route Variations

a. Willimantic South Overhead Variation

The Willimantic South Overhead Variation would provide an overhead alternative to avoid the Mount Hope Montessori School, several areas with residences in Mansfield, and Mansfield Hollow State Park. This would be approximately 9.3 miles in length. Based on a ROW width of 150 feet (minimum width required for H-frame construction), the Willimantic South Overhead Variation would require the acquisition of 169 acres of new ROW, crossing of 6 streams and the Shetucket River, and the clearing of of forested and shrub vegetation to provide minimum conductor clearances and access to structures for construction and maintenance.

b. Mount Hope (M.H.) Montessori School Overhead Variation

To avoid the Mount Hope Montessori School and several areas with residences in Mansfield, this variation would extend approximately 2650 feet, east of existing ROW, and would probably require acquisition of 9 acres of new ROW, some of which would require clearing.

c. Brooklyn Overhead Variation

To avoid isolated areas with residences and a residential day care facility, the Brooklyn Overhead Variation in Brooklyn and Pomfret would extend 3.3 miles north and east from the existing CL&P 345-kV ROW from a location approximately 0.3 miles northeast of State Route 169. The route crosses CL&P's existing distribution ROW, Barrett Hill Road and Spaulding Road, turns east crossing Searles Road before ending at the existing ROW. This variation would require approximately 59 acres of new ROW, almost all of which would require clearing.

d. Putnam North Overhead Variation

This variation would extend 1.3 miles northeast from the existing CL&P 345-kV ROW before rejoining it on the east of an isolated group of homes, and would require approximately 23 acres of new ROW, all of which would require clearing.

e. Willimantic South Underground Variation

Underground variation 1 would provide an underground alternative to avoid the Mount Hope Montessori School, several areas with residences in Mansfield, and Mansfield Hollow State Park. This variation would total 10.7 miles, constructed largely within public roadways, and would include one rail crossing and one crossing of the Shetucket River. One transition station covering approximately 2-4 acres would be required where overhead and underground sections meet.

f. Mansfield Underground Variation

This variation to avoid an isolated group of homes would be approximately 0.7 miles long, beginning at a new transition station west of Highland Road and adjacent to CL&P's existing ROW. This route would leave the transition station to the north along the existing ROW, turn north, and cross Highland Road before ending at a second new transition station located adjacent to the existing ROW. This variation would require the acquisition of approximately 14 or 10? acres of property for the transition stations.

g. Mount Hope (M.H.) Montessori School Underground Variation

To avoid the Mount Hope Montessori School, this variation would be approximately 1.1 miles long and would begin at a new transition station located west of State Route 195 and adjacent to CL&P's existing ROW. This route would leave the transition station to the east along the existing ROW, cross State Route 195, turn north, cross Bassetts Bridge Road, and turn east before ending at a new transition station. This variation would require the acquisition of approximately 4-20 acres of property for the transition stations.

h. Brooklyn Underground Variation

This variation, located in Brooklyn to avoid an isolated group of homes, would be approximately one mile long and would begin at a new transition station west of Church Street and adjacent to CL&P's existing ROW. This route would leave the transition station to the east along the existing ROW, cross Church Street and turn north at Day Street Junction before ending at a new transition station.. This variation would require the acquisition of approximately 7-10 acres of property for the transition stations.

i. Putnam North Underground Variation

This variation to avoid an isolated group of homes would be approximately 3.4 miles long and would begin at a new transition station south of State Route 44 and adjacent to the existing CL&P ROW. It would exit the transition station to the south along State Route 44, turn northeast on Munyon Road, turn north along East Putnam Road/Quaddick Town Farm Road, and turn east along the existing CL&P ROW before ending at a new transition station located adjacent to the ROW and north of Elmwood Hill Road. This variation would require the acquisition of approximately 8-10 acres of property for the transition stations

4. Proposed Facilities and Construction Methods

a. Overhead Facilities

New overhead structures would be slightly higher than existing structures, and would include wood or steel H-frames typically 90 feet in height, steel delta-style monopoles averaging 120 feet high, and 130-foot-high vertical steel monopoles approximately 110-130 feet high. New structures would in some cases require concrete footings. Construction of reinforced concrete foundations for new 345-kV structures would include mechanical excavation, pneumatic hammers, or controlled rock drilling and blasting.

Construction and vegetation clearance methods will be developed to minimize site disturbance and to protect residual forests, wetlands, watercourses, soils, and cultural resources including stone walls, old cemeteries and old foundations that are commonly found in wooded areas in Connecticut. Impacts to stone walls will be limited to equipment bar-ways generally not exceeding 15 feet in width, and other aboveground cultural resources will be avoided.

Construction vehicles including large cranes will require access to each structure location, and stable pads or work areas. Existing access roads will form the backbone of the construction road network and will be used as much as possible to limit ground disturbance. However, additional spur roads will have to be constructed to provide access to the new structure locations and pad sites.

Existing access roads are in various conditions, and in many places will require improvements to achieve appropriate grades (10% or less), sufficient surface widths (at least 15 feet), and stable bases. Existing access road improvements will range from light to extensive grading. New spur roads may only require minor grading to level the ground surface before applying stone and gravel, but in some cases extensive cuts and fills may be necessary to prepare a stable road base. The amount of work necessary will depend on topography, soil conditions, and type of vehicles that will need access through the area.

A range of construction pad preparation methods will include light surface grading, extensive cuts and fills, and/or use of wooden mats in wetlands. Pad sizes will vary with activity requirements, but may reach 100-foot-square areas at sites of new overhead structures. Smaller pads could be utilized if site conditions allow. Construction sites may frequently require 20-foot-square dewatering pits outside pad limits. At sites where existing structures would be dismantled, pad size would depend on the type of structure to be removed, existing topography, and other natural features. A cleared area typically at least 25 feet from all structure surfaces, including all poles of a multiple pole structure and all guy wires, would be needed but different sizes and configurations are likely. If necessary, gravel would be used to level and stabilize the area. Typically these sites would not exceed the size of the cleared area.

Equipment storage and/or staging areas, along with pole stockpile sites and wire stringing locations (for pulling and tensioning), will be necessary to support the construction of the 345-kV overhead transmission line and the reconstruction of certain of the existing transmission facilities. The locations of such areas will not be determined until a final route for the Project is certified.

Mechanical equipment to remove herbaceous vegetation, shrubs, small diameter trees and other low growing vegetation could include many types of brush mowers, most of which have rubber or steel tracks and a cutting head mounted directly on the front or on a boom. The cutting head is typically a steel drum spinning at a very high speed.

Larger-diameter trees would be removed by directionally-controlled hand-held chainsaw felling, or by mechanical felling with a “feller buncher.” This type of machine has a cutting head mounted directly on the front or on a boom, and will have rubber tires or steel tracks. A feller buncher is designed to work as part of a “cut-to-length” system, in which the feller buncher severs the tree with the saw head, and the operator holds the tree for a short time to direct the tree to a desired place on the ground. The operator can then cut off tree limbs and cut the main stem of the tree into shorter logs. All the cut material is grouped into piles so that the next phase of the work can begin.

Regardless of the method used to fell the trees, all the material will need to be brought to a central location (loading or landing area) for further processing and removal from the site. There are two types of machines commonly used during this phase of the work. The most likely equipment would be a skidder, a large, articulated tractor with a grapple and/or winch on the rear of the machine which the operator uses to drag material to a loading area. The second type of machine is a forwarder, an articulated tractor with a loading boom that can pick up the material and place it in a bunk on the rear. The material can then be transported to the loading area without being dragged over the ground surface. This type of machine is less common than a skidder, particularly in land clearing operations.

b. Underground Facilities

Any underground construction required for the Project would involve the use of underground XLPE (cross-linked polyethylene) cable technology. The 345-kV cable system would consist of 9 cables (three parallel sets of three), contained within approximately 3-foot-wide by 3-foot-tall concrete-encased duct banks, as well as large concrete splice vaults. Cable installation, largely within or adjacent to existing roadways, would

typically require 4-foot-wide trenches averaging 5-7 feet in depth, excavated mechanically with supplementary blasting where necessary. Size limits of the spools carrying the large underground cable, and cable-pulling considerations, would limit continuous lengths of installed cable to approximately 1800 linear feet. Cable sections would be joined by concrete splice vaults, with inside dimensions approximately 10 feet wide, 10 feet high and up to 32 feet long. Trench excavations for splice vaults would exceed these dimensions by at least several feet in any direction. Vaults may be installed within public roadways or, in order to avoid conflicts with other utilities buried beneath the roadways, may be installed in other suitable locations adjacent to such roads (e.g., beneath parking lots, sidewalks, road shoulders, or road medians). However, when vaults are installed off-road for this reason while duct banks are within the road, the duct bank must cross other parallel buried utilities twice for each vault, which greatly complicates the design and construction.

c. Stream and Railroad Crossings

The Project may require both overhead and underground crossings of streams, rivers, lakes and railroad tracks. Overhead transmission lines would be designed to span railroads and water crossings. Underground cable systems would be installed below railroad crossings using trenchless techniques such as horizontal directional drilling (HDD) or jack and bore methods. Crossing watercourses could include such trenchless methods, attaching cables to existing bridges, or open trenching across the stream channel. For smaller, culverted watercourses, the cable could be installed in a trench above or below the existing culverts.

HDD and jack and bore methods would involve cable and cable casing diameters totaling several feet, as well as staging or pit areas on either side of a watercourse or railroad crossing. HDD staging areas for drilling would be up to 150 by 250 feet, with shallow pits approximately 10 feet wide, 8 feet long, and 5 feet deep required to collect the drilling fluid. The jack and bore method, typically used for short crossings of shallow waterways or for railroad crossings, would require digging a pit approximately 16 feet wide, 30 feet long, and deep enough to allow the installation of the cable system under the waterway or railroad.

d. Transition Stations

Each of the possible transition stations at junctions of underground and overhead facilities would be over 2 acres in area and would require up to 10 acres of property acquisition (Appendix 1). Structure heights within transition station would range between 22 and 90 feet. There would also be some expansion of the Card Street Substation, presently not defined, to accommodate the junction of underground and overhead facilities.

C. Study Issues and Definitions

1. Overhead Construction

a. Visual Effects

Any potential effects on historic architectural or engineering resources associated with overhead transmission lines would be limited to the visual intrusion of taller and/or closer transmission line structures, heights of which will vary depending on Project alternatives. Available guidelines for SHPO assessment of visual effects on cultural resources appear in Section 16-50p(a)(4)(C) of PUESA, and in regulations of the federal Advisory Council on Historic Preservation (36CFR 800.5). Both sets of guidelines apply to properties listed, or eligible for listing, on the National Register of Historic Places. Based on Federal Power Commission guidelines to which it refers, PUESA mandates avoidance of effects on National Register properties where possible, or, if avoidance is not possible, minimization of transmission structure visibility or effects on the character of National Register property environ. Advisory Council on Historic Preservation (ACHP) regulations, while not required in SHPO review of projects subject to Connecticut Siting Council approval, provide *de facto* guidelines commonly used by SHPO. Criteria for findings of adverse effects on historic properties include change of the physical features within a property's setting which contribute to property significance, and introduction of visual elements which diminish the integrity of a property's significant features.

These guidelines provide no established or objective criteria for determining when a visual effect is adverse, leaving identification of adverse effects to the judgment of the reviewer (personal communications, Dr. David A. Poirier, SHPO). In general, visual effects will be diminished if new structures are as low as possible relative to existing structure heights, and/or if new structures are located further from historic properties. Based on results of a similar, recent studies for proposed 345-kV transmission facilities (Raber and Wiegand 2002, 2003), and discussions with SHPO Staff Archaeologist Dr. David A. Poirier, this assessment distinguishes among three categories of visibility:

- Visibility with No Effect: the structure is too far from a historic property, and/or too masked by forest cover or built environments, to be perceived as a distinct landscape feature;
- Visibility with Non-Adverse Effect: the structure can be perceived as a distinct landscape feature, but because of distance, forest cover, or built environments there is no significant change to the visual environment of a historic property;
- Visibility with Adverse Effect: by virtue of proximity, size, or appearance, the structure degrades the existing visual environment which contributes to the significance of a historic property.

For historic architectural and engineering resources along the Primary Route Under Consideration and route variations, assessment objectives included:

- Identifying all historic properties listed on, or eligible for listing on, the State or National registers of historic places within 0.25 mile of proposed new structures; and
- Providing graphic evidence of the extent of potential visual effects for each such historic property.

The universe of inventoried historic properties, and the choice of a 0.25-mile distance as a viewshed corridor from proposed new structures, is also based on results of the recent study for upgraded transmission facilities from Plumtree Substation in Bethel, CT to the Norwalk, CT Substation (Raber and Wiegand 2002), and on discussions with SHPO Staff Archaeologist Dr. David A. Poirier and Historical Architect Susan R. Chandler.

In addition to the types of historic resources noted above, SHPO has expressed interest in State Route 169, which has been designated a National Scenic Byway and is crossed by the Primary Route Under Consideration in Brooklyn. Although consultations with the Connecticut Department of Transportation did not indicate any clear guidelines on how to evaluate visual effects on the scenic byway beyond the state right-of-way, SHPO suggested that for preliminary planning purposes, Route 169 in the Project area be treated as equivalent to a listed or eligible historic property (personal communications, Robert Cless and David A. Poirier).

Data developed to meet these visual effects evaluation objectives can be used by CL&P, the Connecticut Siting Council, and interested local parties to determine which potential visual effects are adverse, and to identify possible means of mitigating or avoiding adverse effects.

b. Archaeological Resources

The potential for prehistoric or historic archaeological resources has not been previously evaluated along most of alternative routes under consideration. As a result, the present study included an archaeological assessment, from which recommendations for future reconnaissance investigations have been developed. These recommendations can be implemented when a proposed route is selected and the final project configuration is determined. The assessment was conducted to meet all standards of the SHPO *Environmental Primer for Connecticut's Archaeological Resources*, with the following objectives:

- Identification of any known or possible archaeological resources in project areas, based on available background material and surface inspection;
- Assessment of the known or potential eligibility of such resources to the National or State registers of historic places;
- Development of recommendations on the need for any additional investigations to confirm or identify such resources, or to determine their eligibility to the National or State registers.

To be eligible for the National or State registers, cultural resources must possess physical integrity and meet at least one of the following criteria:

- A. Association with important historic events or activities;
- B. Association with important persons;
- C. Distinctive design or physical characteristics, including representation of a significant entity whose individual components may lack distinction;
- D. Potential to provide important information about prehistory or history.

2. Underground Construction

Possible effects on cultural resources from underground transmission facility construction include:

- Direct effects on belowground prehistoric or historic archaeological resources, the potential for which has not previously been evaluated in most project areas
- Direct effects on nearby significant historic structures, including foundation damage from blasting during construction

In the upland environment of the Project area with generally shallow soils away from floodplains, it was assumed that historical roadbed construction episodes have removed all soils sensitive for Native American resources, or severely limited the integrity of such resources by removing most sensitive strata, where underground construction would follow existing road rights-of-way. The same disturbance, and the relative antiquity of the roads along the underground variations, also suggested that no Euroamerican resources other than perhaps older utilities would be found in or below existing roadbeds. Although most areas immediately adjacent to paved roadways may already be disturbed, pockets of archaeological material may survive in such areas. Conversely, undocumented disturbance associated with generations of road and utility construction, maintenance, and improvement may have removed all archaeologically-sensitive soils within surrounding level, well-drained areas.

Archaeological assessment objectives for possible off-road underground routes were similar to those summarized above for overhead construction. Reconnaissance archaeological testing will be necessary to locate sites if any underground routes are defined in areas not within developed roadbeds.

To address any possible effects on significant historic structures, assessment objectives included identifying all historic properties within 500 feet of underground construction which are listed on or eligible for the State or National registers of historic places.

3. Cemeteries

Resource identification for overhead and underground construction also included cemeteries used in whole or in part more than 100 years ago (within distances of 0.25 miles and 500 feet from the alternative routes, respectively). Cemetery areas 100 years or older are protected as Ancient Burying Grounds under Connecticut General Statutes 19a-315, and historic cemeteries are frequently determined eligible for the State or National registers of historic places.

II. ASSESSMENT STUDY METHODS

A. Background Research

Background research focused on two objectives:

- Identifying known or potential archaeological sites, and collecting information on environmental, prehistoric, historic, and technological contexts of such sites as appropriate;
- Identifying all significant historic architectural and engineering properties within 0.25 miles of overhead routes, and within 500 feet of underground routes.

Background sources included:

- Listings on the State and National registers of historic places;
- Listings of sites eligible for the National Register maintained by SHPO, including historic bridges identified in surveys made for the Connecticut Department of Transportation;
- Lists of other potentially significant properties in townwide architectural surveys completed for SHPO or in local historic districts;
- Prehistoric and historic archaeological site files maintained by the Connecticut State Archaeologist;
- Unpublished cultural resource management studies and other pertinent reports filed with SHPO, the Connecticut State Archaeologist, or University of Connecticut Special Collections at the Dodd Center, including historic resource documentations conducted to standards of SHPO or the National Park Service;
- Published and unpublished studies of project vicinity geology, hydrology, soils, prehistoric or historic archaeological sites, and local or regional history and geography;
- Historic maps and aerial photographs available at the Connecticut State Library and the University of Connecticut;
- Maps, plans, drawings, and other pertinent documents held by CL&P.

B. Analysis and Field Inspections

Initial field assessment was conducted along the Primary Route Under Consideration, where CL&P has ownership and/or access rights, and along all underground variations. Field assessment was not feasible along most portions of the Willimantic South Overhead Variation or any of the other overhead variations due to lack of access to private property. Field inspection of the 310 Loop section of CL&P right-of-way was not conducted because of the very recent addition of this IRP component to the Project, but can be completed during subsequent investigations.

1. Historic Architectural and Engineering Properties

a. Overhead Routes and Route Variations

For significant aboveground historic properties within 0.25 mile of the existing CL&P ROW along the Primary Route Under Consideration, Raber Associates developed digital topographic profiles to eliminate those properties visually shielded from the corridor by hills, forest cover, or large structures. Profile contours were based on U.S. Geological Survey quadrangle base maps as reproduced in TOPO! CD-ROM format, from which preliminary profiles were generated between specific transmission line structures and historic properties. Profile data were re-plotted for graphic clarity, with the addition of typical forest cover paralleling ground contours where such cover exists. Recent aerial photographs were used as needed to identify the

horizontal extent of forest cover. Although tree heights in forested project area vicinities average 60-80 feet, plotted profiles conservatively assumed only a 50-foot-high average cover.

Photographic documentation for identification of potential visual effects was conducted for historic properties, clusters of properties, and the National Scenic Byway within 0.25 miles of the existing CL&P ROW, unless digital topographic profile analysis indicated no proposed transmission structures would be visible, or where field inspection indicated a lack of visibility. For preliminary simulation purposes, photographs of existing transmission structures along the Primary Route Under Consideration were used to introduce prospective new simulated structures at the same locations. Following completion of the CL&P Development and Management Plan with identification of new structure locations, more detailed visual analyses will be conducted as needed, including coverage of historic resources near overhead variations selected for Project design.

b. Underground Route and Route Variations

Brief inspection of significant aboveground historic properties along the Willimantic South and Putnam North underground variations was conducted to confirm the current survival or location of such properties.

2. Historic and Prehistoric Archaeological Sites

Along the Primary Route Under Consideration and the underground portion of underground variation 1, aerial, walkover, and/or automobile inspections were conducted as discussed below in Section IV.B.

Based on environmental criteria and known site distributions, all areas within the existing right-of-way and the variations sensitive for Native American sites were plotted in Geographic Information System (GIS) format, along with known prehistoric and historic sites within 1 mile.

Site assessments were framed in terms of National Register criteria. For Native American sites, background and field data were used to create a bi-modal classification of all Project areas: sensitive for known or possible resources with at least potential National Register eligibility, or not sensitive. Designation of non-sensitive areas incorporated negative findings made in previous archaeological surveys. Any planned project actions involving ground disturbance in sensitive areas would require reconnaissance studies. Areas with potential for few sites could include important information in the form of small, undisturbed satellite or special-purpose sites within larger Native American settlement systems. Site assessments addressed National Register significance criteria C (important example of typical site) and D (having potential for important new historical information). For unreported or previously reported historic sites, we classified data from background and field investigations as follows:

- Listed on the National or State registers of historic places;
- Eligible for National or State register listing, based on SHPO findings and/or finding in previous surveys;
- Potentially eligible for National or State register listing, pending additional research, based on previous studies and/or assessment research;
- Known or possible site with undetermined potential for National or State register listing;
- Known site with no potential eligibility, based on based on previous studies and/or assessment research.

III. PROJECT AREA ENVIRONMENTS

The environment of northeastern Connecticut is an upland of moderate relief, consisting of a mass of resistant crystalline rocks lying in north-south trending belts (e.g., Dowan and Craig 1976; Flint 1930). The relief is greatest at the northern border of Connecticut, with the general level of hills being 800 to 1000 feet, and decreases southward as the upland surface slopes gently to the coast (Flint 1930).

Drainage. Most of eastern Connecticut lies within the Thames River drainage basin. Project routes cross or are in proximity to a number the rivers within this basin including the Willimantic, Shetucket, Natchaug, Quinebaug and Fivemile rivers. Each of these rivers are fed by numerous smaller tributaries which form a relatively dense and complicated drainage network.

Biotic Environment. The vegetational and climatic history of Connecticut have been documented by the palynological work of Deevey (1939), Davis (1969), Beetham and Niering (1961), Gaudreau (1988), and, using archaeobotanical evidence, by McWeeney (1994, 1999). Four major stages of vegetation cover have been identified. Tundra vegetation immediately followed the retreat of the ice as interpreted by a zone of herbaceous pollen laid down in Roger's Lake in Lyme 14,000 to 12,000 years ago. Plants whose pollen was abundantly represented include sedges, grasses, *Artemesia*, *Rumex*, *Thalictrum*, and shrubby willows (*Salix spp.*) (Davis 1969). The dominance of non-arboreal pollen during this period suggests the climatic instability. The climate was once thought to have been uniformly cold and wet, similar to present subarctic conditions (e.g., Davis 1969); however, recent evidence indicates significant shifts in weather patterns on a decadal or even annual time scale, and a greater contrast between winter and summer temperature extremes likely supported diverse floral and faunal communities with no modern-day analogue (e.g., Kutzbach 1987). Megafauna which roamed the tundra at this time likely included mammoth (*Mammuthus primigenius*), though infrequently in the Northeast, mastodon (*Mammut americanum*), caribou (*Rangifer tarandus*), moose (*Alces alces*), musk ox (*Ovibos moschatus*), bison (*Bison spp.*), and horse (*Equus sp.*) (Flint 1971).

About 12,000 years ago the climate ameliorated, favoring the development of spruce forest in southern New England (Davis 1967). White pine, fir, and larch, along with mixed temperate deciduous tree pollen recovered from several locations, suggest a significant degree of species-level diversity within the spruce-dominated forest communities between 12,000 and 11,000 B.P. (years before present). Colder climatic conditions returned during the Younger Dryas event (ca. 11,200 to 10,500 B.P.), followed by a period of significantly warmer and moister weather regimes (McWeeney 1999: 7).

A pine-hardwood forest, perhaps analogous to the present vegetation of the Great Lakes region, replaced the mixed spruce-deciduous woodland around 9,500 years ago and persisted to about 8,000 years ago (Davis 1969). Hardwood trees, particularly temperate nut-bearing or mast species such as red and white oak, hickory, and walnut, increased in relative abundance during this period. This vegetation succession has been interpreted as indicating a change to a notably warmer and drier climate in the Northeast (Beetham and Niering 1961), and increasing forest fire frequency (McWeeney 1999).

A temperate oak forest broadly similar to present forest cover succeeded the pine-hardwood forest (Davis 1969) in three substages. Hemlock co-dominated with oak from 7,000-5,000 B.P., when it suddenly disappeared due to a possible hemlock-specific blight. Hickory replaced hemlock as an important component until about 2,000 years ago, when it in turn was succeeded by chestnut (Deevey 1939). Since European settlement in the early 17th century, the pollen of ragweed and other weedy species in the sediment profile is correlated with clearing for agriculture. As deciduous forests replaced the spruce and pine, boreal mammals were replaced by temperate species.

Wetlands and upland vegetation have changed since the retreat of glaciers (Golet 1976). Ponds and lakes originating from glacial times gradually collected sediment washed in from the uplands, as well as the remains of dead plants and animals that lived in the water or around its edges. First, aquatic plants colonized the water bodies, and later, as the ponds continued to fill in with sediments and organic remains, emergent plants expanded from wetland margins to colonize the shallow water bodies. With a further decrease in water depth, shrubs invaded, eventually replaced by swamp forest (Golet 1976).

The regional forest cover on well-drained uplands in northeastern Connecticut is classified as Central Hardwoods-Hemlock-White Pine or Central Hardwoods-White Pine (Westveld (1956), Dowhan and Craig (1976), Egler and Niering (1965). Central hardwood tree species include oak (*Quercus spp.*) especially red (*Q. rubra*), black (*Q. velutina*) and white (*Q. alba*), hickories (*Carya spp.*), red maple (*Acer rubrum*) and black birch (*Betula lenta*). Hemlock (*Tsuga canadensis*) and white pine (*Pinus strobus*) are generally frequent and locally abundant to dominant, especially in the northern part of the region. Scarlet oak (*Q. coccinea*) and chestnut oak (*Q. prinus*) dominate on many of the drier ridges. Chestnut (*Castanea dentata*) formerly a major forest tree species was virtually eliminated in the 1920s by the chestnut blight (*Endothia parasitica*) (Dowhan and Craig 1976). Early phases of old-field vegetation development are characterized by white pine (*Pinus Strobus*), red cedar (*Juniperus virginiana*) and gray birch (*B. populifolia*), with pine predominating in northern regions and cedar in southern parts (Dowhan and Craig 1976; Egler and Niering 1965; Raup 1940).

Topography. The topography of the area is the end result of several interrelated factors, including glacial deposition and erosion related to the distribution of underlying bedrock masses, Holocene modification of the glacial terrain, and late historic to modern period earth-moving activity. During glacial advances, the valleys in eastern Connecticut were widened and deepened, while sharper features such as ridges and hilltops were eroded to more rounded forms. Retreat of the ice to the north resulted in the deposition of large quantities of glacial debris in the meltwater streams (outwash), which filled some valleys in the area and created broad flat plains composed of stratified sands and gravels. Hills bounding the valley margins are underlain by crystalline bedrock (or in the case of drumlinoid hills, sediments predating the final glaciation) covered in a thin mantle of late Pleistocene age glacial till. The varied topography and complex sedimentary history of the area has contributed to the formation of streams and inland wetlands. The terrain consists of rolling hills and ridges, interspersed with many small swamps and streams. Larger swamps and complex wetland basins are found along the margins of the Quinebaug River, marking the former locations of glacial lake beds within the valley bottom.

Geology. Eastern Connecticut straddles the Honey Hill Fault, which separates the Avalonian Terrain to the east from the Merrimack Synclinorium to the west (Rodgers 1985). Bedrock on both sides of the fault is composed of complexly-folded metamorphic rocks including quartzite, schist, gneiss, and greenstone. Plainfield Formation quartzite, which outcrops along much of the length of the Honey Hill Fault and ranges in color from tan to dark green, is one of the most common lithic materials found in prehistoric sites in eastern Connecticut and western Rhode Island. Plainfield quartzite has been found at Terminal Archaic Period sites (circa 3,400 years ago) from Rhode Island westward to the Connecticut River Valley (McBride 1984a; McBride and Soulsby 1989). The quality of Plainfield quartzite is highly variable, but often superior to other locally available materials.

Soils. Soils within river valleys are generally developed on Wisconsinan-age glacial outwash sediments. The river valley land system of eastern Connecticut is distinguished by its relatively flat to undulating topography underlain by stratified sands and gravels deposited during the melting of the glacier. Outwash sediments are primarily restricted to valleys along present-day streams and rivers. Natural Resource Conservation Service (NRCS) mapping of the soil units shows a gradient of fine- to coarse-grained loams. Soils within the Project area include excessively drained Hinckley gravelly sandy loams along the stream terraces. Finer-grained Charlton-Chatfield loams occur on the uplands blanketing glacial till. Rock outcrops cover up to ten percent of the surface in these areas. Canton and Charlton fine sandy loams also are common throughout the Project vicinity on upland hills, plains and ridges. Agawam fine sandy loams and Merrimac sandy loams are found on stream terraces and outwash plains. Compacted glacial till is found in association with drumlins throughout the higher elevations. Udorthentic soils, which are disturbed soil units, were identified commonly throughout the Project area. The most encountered soil along the alternative routes is associated with the Hinckley gravelly sandy loam.

Vegetation and Wildlife. Northeastern Connecticut is included in the temperate deciduous forest biome of the Northeast Upland region defined by Shelford (1974). Forest associations are primarily red and white oak types within the encompassing hemlock-white pine northern hardwoods communities (Braun 1950; Cronan and Brooks 1968; Shelford 1963).

The vegetation is characterized by an open oak forest dominated by black oak and white oak with a well-developed ericaceous shrub layer. White pine may be locally abundant. Hollows frequently support a poorly developed oak-viburnum association. Localized variations in forest composition within and adjacent to the Project area depend on the extent and nature of historic period land use. Most frequently found are second-growth forest types in varying stages of succession as a result of clearing land for pasture and firewood. Second-growth cover over former open lands consists primarily of red cedar, grey birch, red maple, poplar, white pine, and hemlock. Most mature secondary growth consists of red and white oak, birch, hickory, beech, and dogwood. Wooded wetlands are characterized by red maple, swamp white oak, brown ash, yellow birch and alder.

Three major habitats can be identified in the vicinity of the Project areas for purposes of this assessment: 1) woodland, 2) wetlands, and 3) streams. Woodland habitats consist of both hardwoods and conifers in varying frequencies. Hardwood forests and their associated understory vegetation provide cover for wildlife and produce nuts and other fruits and foliage which can be eaten by a variety of wildlife. Wildlife attracted to this type of habitat includes white-tailed deer (*Odocoileus virginianus*), gray squirrel (*Sciurus carolinensis*), raccoon (*Procyon lotor*), and gray fox (*Urocyon cinereoargenteus*).

Wetland habitats consist of open swamps or marshy shallow water area that supports wild herbaceous annual and perennial plants. Wildlife attracted to this habitat include duck, geese, muskrat (*Ondatra zibethica*), mink (*Mustela vison*), and beaver (*Castor canadensis*). The deeper streams and rivers also support many animal species, including waterfowl and a variety of fish.

Climate. Climatic conditions within Connecticut demonstrate considerable variability. Interior regions of the state, most notably the northwestern and northeastern highlands, experience greater seasonal contrasts than southern areas along Long Island Sound. In general, the mean annual temperature in northeastern portions of the state is one to two degrees colder than the Connecticut River Valley and coastal areas, with extreme temperature differences in shorter duration. The average climatic conditions for this region are as follows: average annual temperature is 49 degrees Fahrenheit, mean July maximum temperature is approximately 60 degrees, mean January maximum temperature is 26 degrees, average January minimum is 9 to 10 degrees, average precipitation is 48 inches per year, average annual snowfall is 40 to 50 inches, and average number of frost-free days is 160 or nearly three weeks shorter than along coastal sections and within the Connecticut River Valley (Dowhan and Craig 1976).

Wetland/Riverine Use. The larger rivers within the Northeast Hills ecoregion were significant sources of food and important transportation routes in the past. Anadromous fish, including both shad (*Alosa sapissima*) and Atlantic salmon (*Salmo salar*), were seasonally abundant in the Quinebaug River prior to the construction of mill dams in the 19th century. Riverine wetlands bordering the Quinebaug and other major rivers would have offered numerous economically important plant species, such as cattail (*Typha spp.*), bulrush (*Scirpus spp.*), water lily (*Nymphaea spp.*) and goosefoot (*Chenopodiaceae*). Moderate-sized watercourses are less easily characterized. High water levels during the spring snow-melt season may have allowed for travel on watercraft in some smaller rivers, though numerous falls and rapids may have precluded this on many of the steeply descending streams. Even discounting water travel, the incised valleys occupied by many upland streams and small rivers offered the easiest travel routes through more rugged sections of the landscape. Associated wetlands and shallow water marshes would have provided an abundance of edible aquatic and emergent flora, including cattail (*Typha spp.*), bulrush (*Scirpus spp.*), water lily (*Nymphaea spp.*), blue flag (*Iris versicolor*), smartweed and knotweed (*Polygonum spp.*), as well as game animals like moose (*Alces alces*), beaver (*Castor canadensis*) and muskrat (*Ondatra zibethica*) and migratory water fowl.

Wetlands have been demonstrated to have been important foci in aboriginal settlement patterns throughout the prehistoric period in northeastern Connecticut (McBride and Soulsby 1989; Nicholas 1988; Wadleigh et al. 1978). The Northeast Highlands Archaeological Survey, conducted in Mansfield, Tolland and Willington, and discussed below, identified a correlation between wetlands and prehistoric settlement and subsistence in this ecoregion (Wadleigh et al. 1978).

IV. NATIVE AMERICAN ARCHAEOLOGICAL SENSITIVITY

A. Known Resources and Research Context

Northeastern Connecticut was the scene of some of the earliest archaeological investigations in Connecticut (Basto 1938, 1939; Pope 1952; Praus 1945), but these investigations were primarily concerned with simply describing archaeological sites and artifact assemblages. Some of the earliest compliance-related (i.e., legally mandated) archaeological work in southern New England was conducted in eastern Connecticut (Jordan 1965). Generally speaking, however, most archaeological work conducted in Connecticut concentrated either along the coast or in the major riverine areas, where deeply stratified or large, highly visible sites were located. As a result of the intensive (and largely successful) focus on lowland and coastal sections of Connecticut and the relative lack of work in upland sections, the archaeological potential of the northeastern part of the state was long assumed to be relatively poor. However, in the past 15 years archaeological data from compliance and cultural resource management-related projects in northeastern Connecticut began to change this view of the highlands. These more recent archaeological projects were not isolated single-site excavations, but regional site surveys which covered relatively large areas. The resultant data significantly improved the understanding of the prehistory of northeastern Connecticut, and suggest that the complexity and density of prehistoric archaeological sites in this part of the state are far greater than once thought. Furthermore, several of these studies suggest that this region once supported year-round Native American settlements and was not just used on a seasonal basis by groups operating out of the Connecticut River Valley and Long Island Sound areas (e.g. McBride and Soulsby 1989).

Between 1980 and 1985, the Public Archaeology Survey Team, Inc. (PAST) conducted several large-scale archaeological surveys in northeastern Connecticut. In 1978 a survey was conducted of Mansfield, Tolland and Willington. In the same year an archaeological survey of approximately 200 acres surrounding the West Thompson Dam was also conducted (McBride *et al.* 1980a), and in the next two years more intensive archaeological surveys were conducted in the towns of Coventry (McBride *et al.* 1980b) and Woodstock (Wadleigh *et al.* 1981). These surveys were important for developing a culture history for the region because they were the first attempts in southern New England to survey highland areas away from large riverine areas.

In general, the surveys refuted the traditional assumption that upland/interior areas were peripheral with respect to prehistoric subsistence and settlement patterns and were used primarily on a temporary basis for hunting by groups operating out of coastal or larger riverine systems such as the Connecticut River. Increasing numbers of archaeological sites continue to be identified as more cultural resource management-related projects are conducted. Data from these projects have resulted in upward revisions of estimates of site complexity and density in the eastern Connecticut uplands.

The vicinities of most of the alternative routes have many reported Native American archaeological sites, which collectively span the entire known period of Native American habitation in the region. Despite the relatively large number of prehistoric archaeological sites discovered and studied in Connecticut over the past 30 years, however, there remain serious gaps in the archaeological record, both in terms of culture history and regional prehistory chronology. In some cases, these gaps coincide with time periods for which very few sites have been found, notably the earlier millennia of prehistory from Paleo-Indian to Middle Archaic times. In addition, sites of the Terminal Archaic and Woodland periods are not commonly encountered away from the coast and major streams. It remains unclear whether this pattern of site distribution reflects changing settlement and subsistence patterns after the Late Archaic, a change in prehistoric population sizes, or the loss of many sites to recent development (especially before the recent increase in cultural resource management studies). The Contact period of early historic times is especially poorly represented, in large part due to its extremely short duration and the fact that Native American populations declined rapidly during this period, with the surviving groups moving outside the area or perhaps assimilating to such a degree as to make their archaeological identity difficult to recognize.

Problems common to researchers working elsewhere in the northeastern United States appear in this part of Connecticut: poorly defined stratigraphic relationships of components, lack of many sites from single chronological periods, poor preservation of organic materials, and site disturbance or destruction by both cultural and natural forces. The increasing pace and scope of development in northeastern Connecticut is

perhaps the most destructive local factor, responsible for the loss of many potentially valuable archaeological sites. This situation, together with the highly variable nature of information about prehistoric cultural resources in this portion of the state, makes comparison of the study area with research results from the Northeast region necessary in assessing study area potential for such resources.

This section integrates data from the Connecticut River Valley, the Connecticut eastern highlands, and the Connecticut western highlands, with additional data from eastern New York and western Massachusetts. The intent is to propose a regional cultural-historical sequence for the Project area. It is necessary first to define the archaeological terminology that will be used in the culture history.

When archaeological units are defined, three important elements must be considered: content, distribution, and temporal duration. These elements must be defined for the smallest archaeological units (the site and site components) as well as for larger ones (periods, phases, and traditions). The fundamental unit of analysis is the *site*, which is defined as any locale at which human activity took place. A more formal definition is a spatial clustering of archaeological data, comprising artifacts (objects manufactured or altered by humans), ecofacts (bone, seeds, nuts), and features (non-portable artifacts such as hearths and storage pits). Archaeological sites frequently contain remains from more than one time period. In such cases, each artifact-bearing zone of a site that can be chronologically distinguished from another is referred to as a *component*. Thus, a multi-component site consists of occupations from more than one time period. An archaeological component is assumed to represent a discrete occurrence in space and time.

Larger conceptual units are also used. The term *period* refers to a chronological unit of prehistory as defined for a region. Terms such as Paleo-Indian Period and Late Archaic Period define archaeologically discrete spans of time. The term *phase*, used for a similar purpose, refers to a shorter span of time defined by local groupings of similar artifact assemblages. The primary difference between the period and the phase is that the former is a term generally applicable to a large region (the eastern or northeastern United States) while the latter denotes a smaller geographical and chronological unit.

The term *tradition* is used to describe archaeological manifestations which exhibit long time depth and share characteristics with other sites of a discrete regional cultural group. For example, the Laurentian tradition is an archaeological unit in the northeastern United States that is characterized by specific artifact types dated to a period between 5,500 and 4,200 years ago. The Laurentian tradition is an aspect of the Late Archaic Period.

In most archaeological studies conducted to date in southern New England, the basic units of study have been the site and component. A prehistoric site or component is assigned to a particular time period (e.g., Late Archaic, Middle Woodland) and a cultural tradition (e.g., Laurentian, Susquehanna) according to the diagnostic artifacts recovered. Diagnostic artifacts such as projectile points or ceramics possess distinct characteristics that allow them to be used as temporal markers for inter-site comparisons.

1. Prehistoric and Contact Period Background

The prehistoric Native American occupation of northeastern Connecticut took place over a long period beginning between about 10,000 BC to about 1600 AD, when the Contact period of early historic times began. The prehistory of the region is divided into several time periods based on changing ecological conditions and corresponding cultural adaptation. These major periods are the Paleoindian, Archaic, Woodland, and Contact periods, some of which are subdivided into shorter periods based on distinctive technological and/or stylistic changes.

Hundreds of prehistoric Native American sites are known for eastern Connecticut. For assessment of Project area Native American resource sensitivity, data on 52 sites reported within about a mile of the Primary Route Under Consideration were collected from Office of the State Archeologist (OSA) files and cultural resource management reports on file at the University of Connecticut's Special Collections in the Dodd Center (Table 1). Only one of these sites (State Site No. 112-8 in Pomfret) has been determined eligible for the National Register of Historic Places, and it is a quarter mile east of the Primary Route Under Consideration. The other reported sites have insufficient reported data to make such determination or are not eligible, including 5

shown in Table 1 within approximately 300 feet of the existing CL&P ROW centerline. Of these 5 sites, 2 are reported within the existing ROW: Site 78-2 in Mansfield with undetermined eligibility, and Site 69-90 in Killingly which has been determined not eligible. Most of the reported sites near the Mount Hope Montessori School Overhead Variation, and the Mansfield, Mount Hope Montessori School, and Putnam North underground variations, are the same as those reported in Table 1, including several which are adjacent to the existing ROW. Reported sites within about a mile of the other routes total 4 near the Willimantic South Overhead Variation, 4 near the Putnam North Overhead Variation, and 16 near the Willimantic South Underground Variation (Tables 2-7). Site 32-11 shown in Table 1 is within a mile of the Mansfield Underground Variation. There are no reported sites within a mile of the Brooklyn Overhead and Brooklyn Underground variations. Site 163-5 shown in Table 5 is within a mile of the 310 Loop Route and the Card Street Substation..

Table 1. REPORTED NATIVE AMERICAN ARCHAEOLOGICAL SITES WITHIN ONE MILE OF PRIMARY ROUTE
(SHADED ENTRIES ARE REPORTEDLY WITHIN APPROXIMATELY 300 FEET OF EXISTING CL&P CENTERLINE)

| TOWN | NO. | NAME | DATE | DESCRIPTION | NR STATUS | SOURCES |
|-----------|--------|---------------------------------|---------------|---|-----------|--------------------------|
| COLUMBIA | 30-1 | POTTER'S PLAIN | LA/LW | Snook Kill, narrow-stemmed, Orient fishtail, Squibnocket, Levanna projectile points; | UNK | OSA |
| COLUMBIA | 30-9 | HOP RIVER & WILLIMANTIC RIVER | LA/LW | Brewerton, Lamoka, Snook Kill, Rossville, Levanna projectile points; stone grinding tools, debitage | UNK | OSA |
| COVENTRY | 32-10 | BRAINARD ROCKSHELTER | UNK | no data | UNK | OSA |
| COVENTRY | 32-11 | POPPLES FARM SITE | LA? | no data | UNK | OSA |
| COVENTRY | 32-12 | FLANDERS RIVER ROAD ROCKSHELTER | UNK | rockshelter; quartz debitage | UNK | OSA |
| COVENTRY | 32-14 | RAISCH POINT SITE | EA/MA/LA/WOOD | campsite; Squibnocket, small-stemmed, bifurcate base, Snook Kill, Rossville, Levanna projectile points; untyped projectile points; scrapers | UNK | OSA |
| COVENTRY | 32-15 | RAISCH SITE | LA | campsite; quartz, flint bifaces; quartz retouched flakes; quartz, flint debitage | UNK | OSA |
| COVENTRY | 32-18 | SQUIRES SITE | LA | campsite; Snook Kill projectile points; untyped projectile point; quartz debitage | UNK | OSA |
| COVENTRY | 32-20 | POLLANSKY | LA | campsite; Brewerton, Squibnocket projectile points | UNK | OSA |
| COVENTRY | 32-21 | HASMANN | LA | campsite; Susquehanna, Brewerton projectile points; pipestem; flint, quartz, & felsite debitage | UNK | OSA |
| MANSFIELD | 78-2 | WARREN SARGEANT SITE | WOOD | clay extraction area?; aboriginal ceramics; steatite bowl | UNK | OSA; Russo & Cherau 1994 |
| MANSFIELD | 78-3 | MOUNT HOPE RIVER SITE | WOOD | campsite; quartz biface; quartzite, quartz, argillite, jasper debitage; calcined bone | UNK | OSA; Russo & Cherau 1994 |
| MANSFIELD | 78-7 | POPELESKI | UNK | projectile point? | UNK | OSA |
| MANSFIELD | 78-11 | TURNIP MEADOW | PAL?/LA/ UNK | campsite?; fluted projectile point?/Snook Kill projectile points | UNK | OSA |
| MANSFIELD | 78-12 | BASSETT BRIDGE ROAD | UNK | campsite?; chert, felsite, mudstone, quartz, quartzite, hornfels debitage | UNK | OSA; Russo & Cherau 1994 |
| MANSFIELD | 78-14 | MANSFIELD HOLLOW DAM | UNK | campsite?; no data on artifacts | UNK | OSA |
| MANSFIELD | 78-15 | WILLIMANTIC RESERVOIR | WOOD | campsite?; untyped projectile points; aboriginal ceramics; broken pestle?; quartz preform; quartz, chert debitage | UNK | OSA |
| MANSFIELD | 78-17 | ECHO LAKE | UNK | no data | UNK | OSA |
| MANSFIELD | 78-137 | HALL SITE | LA/EW/MW/LW | campsite; Orient Fishtail, Susquehanna, Levanna, Brewerton, Jack's Reef, small stemmed projectile points; drills; scrapers | UNK | OSA |
| MANSFIELD | 78-155 | TURNIP MEADOW 2 | LA | campsite; narrow-stemmed projectile point; jasper thumbnail scraper; quartzite, quartz, felsite, chert debitage; charcoal | UNK | OSA; Russo & Cherau 1994 |
| MANSFIELD | 78-156 | KNOTTY PINE | UNK | campsite; hornfels, quartzite, quartz, jasper debitage | UNK | OSA; Russo & Cherau 1994 |
| MANSFIELD | 78-157 | PICNIC AREA | UNK | campsite; quartz, quartzite debitage | UNK | OSA; Russo & Cherau 1994 |
| MANSFIELD | 78-160 | FIND SPOT 7 | UNK | 1 quartz debris | UNK | OSA; Russo & Cherau 1994 |
| MANSFIELD | 78-161 | MOUNT HOPE RIVER | UNK | campsite; quartz, felsite debitage | UNK | OSA; Russo & Cherau 1994 |
| MANSFIELD | 78-162 | TURNIP TERRACE | UNK | campsite; quartzite, quartz, chert debitage | UNK | OSA; Russo & Cherau 1994 |
| MANSFIELD | 78-163 | SCREAMING HAWK | UNK | campsite; quartzite, quartz, chert debitage | UNK | OSA; Russo & Cherau 1994 |
| MANSFIELD | 78-164 | BASSETT ROAD | UNK | quartz debitage | UNK | OSA; Russo & Cherau 1994 |

| TOWN | NO. | NAME | DATE | DESCRIPTION | NR STATUS | SOURCES |
|-----------|--------|------------------------------------|---------|--|-----------|---|
| MANSFIELD | 78-165 | FIND SPOT 8 | UNK | 1 quartzite flake | UNK | OSA; Russo & Cherau 1994 |
| CHAPLIN | 24-64 | FIND SPOT 3 | UNK | 1 quartz flake | UNK | OSA; Russo & Cherau 1994 |
| CHAPLIN | 24-65 | SHUBA ROAD | LA | campsite; Brewerton, Vosburg projectile points; untyped slate projectile point; quartzite preform; quartzite & slate debitage | UNK | OSA; Russo & Cherau 1994 |
| CHAPLIN | 24-66 | MANSURE LANE | UNK | campsite; Levanna-type projectile point; quartz biface fragment; quartzite, quartz, chert debitage | UNK | OSA; Russo & Cherau 1994 |
| CHAPLIN | 24-67 | NATCHAUG RIVER 1 | UNK | campsite; quartz, chert debitage | UNK | OSA; Russo & Cherau 1994 |
| CHAPLIN | 24-68 | NATCHAUG RIVER 2 | UNK | campsite; quartz, chert debitage | UNK | OSA; Russo & Cherau 1994 |
| CHAPLIN | 24-69 | BEDLAM ROAD SOUTH | UNK | campsite; quartzite debitage | UNK | OSA; Russo & Cherau 1994 |
| CHAPLIN | 24-70 | FIND SPOT 2 | UNK | 1 quartzite flake | UNK | OSA; Russo & Cherau 1994 |
| CHAPLIN | 24-71 | NATCHAUG TERRACE | UNK | quartzite, quartz, felsite, mudstone debitage | UNK | OSA; Russo & Cherau 1994 |
| CHAPLIN | 24-72 | NATCHAUG BEND | UNK | chert, quartz debitage | UNK | OSA; Russo & Cherau 1994 |
| POMFRET | 112-1 | | WOOD | campsite; quartzite narrow-stemmed projectile point; quartzite knife; quartz, flint, argillite debitage; bone fragments; charred botanical fragments; possible feature | UNK | OSA; McBride & Soulsby 1990 |
| POMFRET | 112-2 | | UNK | campsite; quartz, quartzite, flint debitage | UNK | OSA; McBride & Soulsby 1990 |
| POMFRET | 112-3 | | MA | campsite; quartzite Neville projectile point; quartzite, quartz debitage | UNK | OSA; McBride & Soulsby 1990 |
| POMFRET | 112-4 | | UNK | campsite; quartz, rhyolite debitage | UNK | OSA; McBride & Soulsby 1990 |
| POMFRET | 112-5 | | UNK | campsite; quartzite, quartz debitage | UNK | OSA; McBride & Soulsby 1990 |
| POMFRET | 112-6 | | UNK | 1 quartzite flake | UNK | OSA; McBride & Soulsby 1990 |
| POMFRET | 112-8 | IDLE WILD FARM | EW | campsite; quartzite projectile point; aboriginal ceramics; quartz, quartzite bifaces; quartz, quartzite debitage | NRE | OSA; McBride 1992; Soulsby 1992; McBride 1993 |
| KILLINGLY | 69-2 | KILLINGLY WOOD POWER PROJECT | LA | campsite; Wading River projectile point; flint, quartz, rhyolite debitage | UNK | OSA; McBride 1988 |
| KILLINGLY | 69-90 | KILLINGLY 2G | UNK | quartzite, quartz debitage ; quartzite biface | NOT NRE | Heritage Consultants, LLC 2004 |
| PUTNAM | 116-1 | MUNYON ROAD SITE | UNK | campsite; quartz core; quartzite debitage | UNK | OSA |
| PUTNAM | 116-2 | EAST PUTNAM GRAVEL PIT SITE | ARC? | campsite; quartzite biface; quartz, quartzite debitage | UNK | OSA |
| PUTNAM | 116-3 | FIVE MILE RIVER SWIMMING HOLE SITE | LA | campsite; Squibnocket, Brewerton projectile points; biface; quartz scrapers; quartz, quartzite cores; quartz, quartzite debitage | UNK | OSA |
| PUTNAM | 116-4 | GREAT MEADOW | UNK | campsite; 1 quartzite scraper | UNK | OSA |
| PUTNAM | 116-8 | HAYDEN GRIST MILL SITE | LA | campsite; Levanna, Squibnocket, Stuebenville, Rossville projectile points; scrapers; bowl manufacturing tool? | UNK | OSA |
| WINDHAM | 163-1 | BOYD SITE | LA/WOOD | campsite; pont tip fragment; biface; drill; quartz, quartzite, flint debitage | UNK | OSA |

ABBREVIATIONS

| | | | |
|-----------|-----------------------|----------------|--|
| DATE: UNK | Unknown | NR STATUS: NRE | Eligible for National Register listing |
| PAL | Paleoindian | UNK | National Register eligibility not determined |
| ARC | Unidentified Archaic | NOT NRE | Not eligible for National Register listing |
| MA | Middle Archaic | | |
| LA | Late Archaic | SOURCES: OSA | Office of Connecticut State Archaeology |
| WOOD | Unidentified Woodland | | |
| EW | Early Woodland | | |
| MW | Middle Woodland | | |
| LW | Late Woodland | | |

Table 2. REPORTED NATIVE AMERICAN ARCHAEOLOGICAL SITES WITHIN ONE MILE OF WILLIMANTIC SOUTH OVERHEAD VARIATION

| TOWN | NO. | NAME | DATE | DESCRIPTION | NR STATUS | SOURCES |
|---------|-------|------------------|--------------------|--|-----------|--------------------------|
| LEBANON | 71-11 | BENDER | MA/LA/EW/ MW/LW | campsite; Broadspear, Narrow-Stemmed, Levanna, Jack's Reef projectile points; celts; grooved netstone; scrapers; spokeshaves; stone knives; kaolin pipe fragment | UNK | OSA |
| CHAPLIN | 24-67 | NATCHAUG RIVER 1 | UNK | campsite; quartz, chert debitage | UNK | OSA; Russo & Cherau 1994 |
| CHAPLIN | 24-68 | NATCHAUG RIVER 2 | UNK | campsite; quartz, chert debitage | UNK | OSA; Russo & Cherau 1994 |
| WINDHAM | 163-1 | BOYD SITE | LA/WOOD | campsite; pont tip fragment; biface; drill; quartz, quartzite, flint debitage | UNK | OSA |

Table 3. REPORTED NATIVE AMERICAN ARCHAEOLOGICAL SITES WITHIN ONE MILE OF M.H. MONTESSORI SCHOOL OVERHEAD VARIATION

| TOWN | NO. | NAME | DATE | DESCRIPTION | NR STATUS | SOURCES |
|-----------|--------|-----------------------|------|---|-----------|--------------------------|
| MANSFIELD | 78-2 | WARREN SARGEANT SITE | WOOD | clay extraction area?; aboriginal ceramics; steatite bowl | UNK | OSA; Russo & Cherau 1994 |
| MANSFIELD | 78-3 | MOUNT HOPE RIVER SITE | WOOD | campsite; quartz biface; quartzite, quartz, argillite, jasper debitage; calcined bone | UNK | OSA; Russo & Cherau 1994 |
| MANSFIELD | 78-12 | BA SSETT BRIDGE ROAD | UNK | campsite?; chert, felsite, mudstone, quartz, quartzite, hornfels debitage | UNK | OSA; Russo & Cherau 1994 |
| MANSFIELD | 78-14 | MANSFIELD HOLLOW DAM | UNK | campsite?; no data on artifacts | UNK | OSA |
| MANSFIELD | 78-15 | WILLIMANTIC RESERVOIR | WOOD | campsite?; untyped projectile points; aboriginal ceramics; broken pestle?; quartz preform; quartz, chert debitage | UNK | OSA |
| MANSFIELD | 78-17 | ECHO LAKE | UNK | no data | UNK | OSA |
| MANSFIELD | 78-156 | KNOTTY PINE | UNK | campsite; hornfels, quartzite, quartz, jasper debitage | UNK | OSA; Russo & Cherau 1994 |
| MANSFIELD | 78-162 | TURNIP TERRACE | UNK | campsite; quartzite, quartz, chert debitage | UNK | OSA; Russo & Cherau 1994 |
| MANSFIELD | 78-164 | BASSETT ROAD | UNK | quartz debitage | UNK | OSA; Russo & Cherau 1994 |

Table 4. REPORTED NATIVE AMERICAN ARCHAEOLOGICAL SITES WITHIN ONE MILE OF PUTNAM NORTH OVERHEAD VARIATION

| TOWN | NO. | NAME | DATE | DESCRIPTION | NR STATUS | SOURCES |
|--------|-------|------------------------------------|------|--|-----------|---------|
| PUTNAM | 116-1 | MUNYON ROAD SITE | UNK | campsite; quartz core; quartzite debitage | UNK | OSA |
| PUTNAM | 116-2 | EAST PUTNAM GRAVEL PIT SITE | ARC? | campsite; quartzite biface; quartz, quartzite debitage | UNK | OSA |
| PUTNAM | 116-3 | FIVE MILE RIVER SWIMMING HOLE SITE | LA | campsite; Squibnocket, Brewerton projectile points; biface; quartz scrapers; quartz, quartzite cores; quartz, quartzite debitage | UNK | OSA |
| PUTNAM | 116-8 | HAYDEN GRIST MILL SITE | LA | campsite; Levanna, Squibnocket, Stuebenville, Rossville projectile points; scrapers; bowl manufacturing tool? | UNK | OSA |

ABBREVIATIONS

DATE: UNK Unknown
 ARC Unidentified Archaic
 MA Middle Archaic
 LA Late Archaic
 WOOD Unidentified Woodland
 EW Early Woodland
 MW Middle Woodland
 LW Late Woodland

NR STATUS: UNK National Register eligibility not determined

SOURCES: OSA Office of Connecticut State Archaeology

Table 5. REPORTED NATIVE AMERICAN ARCHAEOLOGICAL SITES WITHIN ONE MILE OF WILLIMANTIC SOUTH UNDERGROUND VARIATION

| TOWN | NO. | NAME | DATE | DESCRIPTION | NR STATUS | SOURCES |
|-----------|--------|-------------------|---------|---|-----------|-------------------------------|
| WINDHAM | 163-1 | BOYD SITE | LA/WOOD | campsite; point tip fragment; biface; drill; quartz, quartzite, flint debitage | UNK | OSA |
| WINDHAM | 163-2 | BALLYMAHOCK WEST | LW/UNK | campsite; projectile point; bifaces; unifaces; drills; cobbles; chunks; quartz, quartzite, flint debitage; calcined mammal bone; charred nutshell fragments; features | UNK | OSA; McBride and Soulsby 1989 |
| WINDHAM | 163-4 | | UNK | no data | UNK | OSA |
| WINDHAM | 163-5 | | UNK | no data | UNK | OSA |
| MANSFIELD | 78-156 | KNOTTY PINE | UNK | campsite; hornfels, quartzite, quartz, jasper debitage | UNK | OSA; Russo & Cherau 1994 |
| MANSFIELD | 78-163 | SCREAMING HAWK | UNK | campsite; quartzite, quartz, chert debitage | UNK | OSA; Russo & Cherau 1994 |
| MANSFIELD | 78-165 | FIND SPOT 8 | UNK | 1 quartzite flake | UNK | OSA; Russo & Cherau 1994 |
| CHAPLIN | 24-64 | FIND SPOT 3 | UNK | 1 quartz flake | UNK | OSA; Russo & Cherau 1994 |
| CHAPLIN | 24-65 | SHUBA ROAD | LA | campsite; Brewerton, Vosburg projectile points; untyped slate projectile point; quartzite preform; quartzite & slate debitage | UNK | OSA; Russo & Cherau 1994 |
| CHAPLIN | 24-66 | MANSURE LANE | UNK | campsite; Levanna-type projectile point; quartz biface fragment; quartzite, quartz, chert debitage | UNK | OSA; Russo & Cherau 1994 |
| CHAPLIN | 24-67 | NATCHAUG RIVER 1 | UNK | campsite; quartz, chert debitage | UNK | OSA; Russo & Cherau 1994 |
| CHAPLIN | 24-68 | NATCHAUG RIVER 2 | UNK | campsite; quartz, chert debitage | UNK | OSA; Russo & Cherau 1994 |
| CHAPLIN | 24-69 | BEDLAM ROAD SOUTH | UNK | campsite; quartzite debitage | UNK | OSA; Russo & Cherau 1994 |
| CHAPLIN | 24-70 | FIND SPOT 2 | UNK | 1 quartzite flake | UNK | OSA; Russo & Cherau 1994 |
| CHAPLIN | 24-71 | NATCHAUG TERRACE | UNK | quartzite, quartz, felsite, mudstone debitage | UNK | OSA; Russo & Cherau 1994 |
| CHAPLIN | 24-72 | NATCHAUG BEND | UNK | chert, quartz debitage | UNK | OSA; Russo & Cherau 1994 |

Table 6. REPORTED NATIVE AMERICAN ARCHAEOLOGICAL SITES WITHIN ONE MILE OF MOUNT HOPE MONTESSORI SCHOOL UNDERGROUND VARIATION

| TOWN | NO. | NAME | DATE | DESCRIPTION | NR STATUS | SOURCES |
|-----------|--------|-----------------------|--------------|---|-----------|--------------------------|
| MANSFIELD | 78-2 | WARREN SARGEANT SITE | WOOD | clay extraction area?; aboriginal ceramics; steatite bowl | UNK | OSA; Russo & Cherau 1994 |
| MANSFIELD | 78-7 | POPELESKI | UNK | projectile point? | UNK | OSA |
| MANSFIELD | 78-11 | TURNIP MEADOW | PAL?/LA/ UNK | campsite?; fluted projectile point?/Snook Kill projectile points | UNK | OSA |
| MANSFIELD | 78-12 | BASSETT BRIDGE ROAD | UNK | campsite?; chert, felsite, mudstone, quartz, quartzite, hornfels debitage | UNK | OSA; Russo & Cherau 1994 |
| MANSFIELD | 78-14 | MANSFIELD HOLLOW DAM | UNK | campsite?; no data on artifacts | UNK | OSA |
| MANSFIELD | 78-15 | WILLIMANTIC RESERVOIR | WOOD | campsite?; untyped projectile points; aboriginal ceramics; broken pestle?; quartz preform; quartz, chert debitage | UNK | OSA |
| MANSFIELD | 78-17 | ECHO LAKE | UNK | no data | UNK | OSA |
| MANSFIELD | 78-156 | KNOTTY PINE | UNK | campsite; hornfels, quartzite, quartz, jasper debitage | UNK | OSA; Russo & Cherau 1994 |
| MANSFIELD | 78-164 | BASSETT ROAD | UNK | quartz debitage | UNK | OSA; Russo & Cherau 1994 |

ABBREVIATIONS

DATE: UNK Unknown NR STATUS: UNK National Register eligibility not determined
 PAL Paleoindian NOT NRE Not eligible for National Register listing
 ARC Unidentified Archaic
 WOOD Unidentified Woodland SOURCES: OSA Office of Connecticut State Archaeology
 LW Late Woodland
 LA Late Archaic

Table 7. REPORTED NATIVE AMERICAN ARCHAEOLOGICAL SITES WITHIN ONE MILE OF PUTNAM NORTH UNDERGROUND VARIATION

| TOWN | NO. | NAME | DATE | DESCRIPTION | NR STATUS | SOURCES |
|--------|-------|------------------------------------|------|--|-----------|---------|
| PUTNAM | 116-1 | MUNYON ROAD SITE | UNK | campsite; quartz core; quartzite debitage | UNK | OSA |
| PUTNAM | 116-2 | EAST PUTNAM GRAVEL PIT SITE | ARC? | campsite; quartzite biface; quartz, quartzite debitage | UNK | OSA |
| PUTNAM | 116-3 | FIVE MILE RIVER SWIMMING HOLE SITE | LA | campsite; Squibnocket, Brewerton projectile points; biface; quartz scrapers; quartz, quartzite cores; quartz, quartzite debitage | UNK | OSA |
| PUTNAM | 116-4 | GREAT MEADOW | UNK | campsite; 1 quartzite scraper | UNK | OSA |
| PUTNAM | 116-8 | HAYDEN GRIST MILL SITE | LA | campsite; Levanna, Squibnocket, Stuebenville, Rossville projectile points; scrapers; bowl manufacturing tool? | UNK | OSA |

ABBREVIATIONS

| | | | | | |
|-------|-----|----------------------|------------|---------|--|
| DATE: | UNK | Unknown | NR STATUS: | UNK | National Register eligibility not determined |
| | ARC | Unidentified Archaic | | NOT NRE | Not eligible for National Register listing |
| | LA | Late Archaic | SOURCES: | OSA | Office of Connecticut State Archaeology |

Paleo-Indian Period (11,000-9,500 B.P.)

In the Northeast, the Paleo-Indian period dates from 11,000 to 9,500 (Gramly and Funk 1990; Meltzer 1988; Petersen 1995). Sites from this period are characterized by distinctive fluted points and flaked stone assemblages dominated by unifacial tools. The exploitation of a wide range of food resources, possibly including megafauna as well as large and small game, fish and wild plant foods, is hypothesized, but poorly documented to date (Eisenberg 1978). Caribou and beaver bone have, however, been recovered from the Whipple Site in southern New Hampshire and the Bull Brook Site in northeastern Massachusetts (Spiess et al. 1985). The Shawnee-Minisink Site, situated near the Delaware River, contained preserved fish and nut remains (McNett 1985). These observations suggest a generalist foraging pattern, which may have included seasonal specialization on certain game types (such as caribou) in some regions (e.g., Meltzer 1988).

The settlement pattern of the Paleo-Indians is not well understood. However, the existence of both small and very large sites suggests that small, highly mobile family groups exploited a wide range of seasonally available resources and may have aggregated annually for communal hunting. The distant bedrock sources for stone materials utilized at most northeastern Paleo-Indian sites suggest a very high degree of annual mobility (Meltzer 1988). Some of the better-known and best-dated Paleo-Indian sites (Haynes et al. 1984; Levine 1990; Meltzer 1988) include the Vail Site in northwestern Maine, with dates averaging 10,500 +/- 300 years B.P. (Haynes et al. 1984); the Shawnee-Minisink Site in Pennsylvania, dated to 10,590 +/- 300 B.P. (McNett 1985); the Templeton Site in northwestern Connecticut, dated to 10,190 +/- 300 B.P. (Moeller 1980); and the Debert Site in Nova Scotia, with a tight cluster of dates around 10,600 years B.P. (MacDonald 1968; Stuckenrath 1966; Wilmeth 1978).

Few intact habitation sites from the Paleo-Indian Period have been excavated in Connecticut; most consist of surface finds in plowed fields (Brennan 1982; Curran and Dincauze 1977; Swigart 1974). Exceptions to this pattern include the Liebman Site in Lebanon (Parkos and Pfeiffer 1995), and the Hidden Creek Site on the Mashantucket Pequot Reservation (Jones 1997). The Turnip Meadow site in Mansfield contains a possible paleoindian component, as a fluted point was reported to have been collected by a local avocational archaeologist (OSA Site Form).

Archaic Period (9,500-2,700 B.P.)

The Archaic Period dates from 9,500 to 2,700 B.P. in the Northeast and is characterized by generalist hunter-gatherer cultures (e.g., Petersen 1995). The Archaic is subdivided into the Early, Middle, Late and Terminal periods on the basis of associated changes in projectile point styles, ceremonialism and inferred subsistence adaptations (McBride 1984a; Snow 1980). Each sub-period is discussed below.

Early Archaic Period (9,500-8,000 B.P.)

Pollen evidence indicates a rapid shift toward a warmer climate beginning around 10,000 B.P. at the end of the Pleistocene (Gaudreau and Webb 1985; McWeeney 1999). As the climate warmed, temperate forest species such as deer, turkey and beaver became more abundant (e.g., Spiess 1992) and seasonally available resources became more predictable. This permitted Early Archaic populations to schedule more efficiently their subsistence activities such as nut-gathering and the exploitation of anadromous fish.

Recent excavations in northern New England indicate that two separate cultural groups may have been present in the area during this time period (Petersen and Putnam 1992). The first tradition is characterized archaeologically by projectile points with strong stylistic affinities to materials recovered in the Southeast. These include stemmed and corner-notched points such as Palmer/Kirk types, and bifurcate-based styles such as MacCorkle, St. Albans, LeCroy, and Kanawha (Dincauze and Mulholland 1977). These point styles are well-dated in the Southeast between 9,500 and 8,000 years B.P. (Anderson and Sassaman 1996). The second tradition, termed the Gulf of Maine Archaic, is characterized by a quartz cobble lithic industry dominated by steep-edged unifacial scrapers and a distinct lack of projectile points (Robinson and Petersen 1993). The presence of a well-developed ground-stone technology may indicate a greater emphasis on plant food processing and woodworking within this tradition. Recent excavations in southeastern Connecticut have yielded significant evidence that the Gulf of Maine Archaic may extend well south of its currently accepted boundaries (Forrest 1999). The Sandy Hill Site on the Mashantucket Pequot Reservation has produced scores of steep-edged quartz scrapers, hundreds of quartz micro-cores and several ground-stone tools. Several pit-house features have yielded dates between 9,300 and 8,500 B.P., along with many wetland plant species, including cattail, bulrush, and water lily (Forrest 1999, 2000), suggesting the importance of hunting in Early Archaic subsistence patterns may be exaggerated in conventional reconstructions.

Well-dated Early Archaic sites in the Northeast include the Richmond Hill Site in New York, dated to 9,360 +/- 120 B.P. (Ritchie and Funk 1973); the Ward's Point Site in New York, dated to 8,250 +/- 140 B.P. (Ritchie and Funk 1973); the Hollowell Site in New York, at 8,160 B.P. (Ritchie and Funk 1973); and the Haviland Bifurcate Site in central New York, dated to 8,405 +/- 65 (Ferguson 1995). One of Connecticut's best-known manifestations of this period is the Dill Farm Site in East Haddam. This site produced radiocarbon dates between 8,560 +/- 270 B.P. and 8,050 +/- 90 B.P., and yielded quartz debitage, retouched tools, bifurcate-based points, and cooking and refuse features which contained carbonized hazelnut and walnut and calcined mammal bone (McBride 1984a; Pfeiffer 1986).

The rarity and small size of most Early Archaic sites indicate that between 9,500 and 8,500 years ago the population density of the Northeast remained very low. These known occupations are best accounted for by the presence of small and highly mobile groups. While very little data concerning subsistence has been recovered from Connecticut, better information is available from outside the state. Evidence from these sites indicate the use of beaver, muskrat, deer, turtle, and fish (including anadromous shad and salmon) (Petersen 1995; Spiess 1992).

The River Road II site in Putnam was documented as possibly containing an Early Archaic component based on the presence of diagnostic stone tools on the surface of the site (OSA Site Form).

Middle Archaic Period (8,000-6,000 B.P.)

The Middle Archaic Period in the Northeast dates from 8,000 to 6,000 B.P. Pollen evidence indicates a trend toward a warmer climate in this period (Gaudreau and Webb 1985; McWeeney 1999). Projectile point types typical of the period include Neville, Stark and Merrimack varieties (Snow 1980).

The best-documented Middle Archaic assemblage in New England is the Neville Site, located in Manchester, New Hampshire (Dincauze 1976). This is a multi-component Middle and Late Archaic site which has yielded radiocarbon dates ranging from 7,740 to 7,015 B.P. associated with the Middle Archaic components. The analysis of lithic materials and preserved subsistence remains indicates that this site may represent a series of successive seasonal camps, possibly associated with anadromous fish harvests.

Middle Archaic data from the Northeast indicate a trend toward more special-purpose camps, reflecting more specialized seasonal activity in different resource zones. New tool classes during this period include grooved axes, which indicate woodworking tasks. The presence of netsinkers and plummets attests to the growing importance of marine resources such as fish (Dincauze 1976; Snow 1980). Multiple short-term camps have been identified along major interior wetlands, but there is currently little evidence of large aggregation sites in these ecological settings (cf. Jones 1999).

Few sites in Connecticut have yielded information on Middle Archaic subsistence and land use patterns. Archaeological assemblages are characterized by Neville and Stark projectile points, and possibly a quartz cobble industry (McBride 1984a). The Dill Farm Site in East Haddam yielded Neville points, basin-shaped hearths, post molds, pit features, nuts and mammal bone, caches of quarry blocks, and stone tool manufacturing debris. The pattern suggests seasonal reuse of this locale over a long period of time. Charcoal deposits from this site were radiocarbon-dated to 7,720 +/- 260 B.P. and 7,305 +/- 280 B.P. (Pfeiffer 1986).

The River Road I site in Putnam is the only occupation within one mile of the proposed route with a Middle Archaic component (OSA Site Form). One projectile point of the Stark variety was recovered from the surface of the site. Stark points have been dated between 7,500 and 6,500 B.P. at the Neville site in New Hampshire (Dincauze 1976).

Late Archaic Period (6,000-2,700 B.P.)

The Late Archaic Period in the Northeast dates from approximately 6,000 to 2,700 B.P. This period was characterized by a distribution of plant and animal populations which was very similar to the present (Snow 1980). The Late Archaic is thought to have been a time of cultural florescence, as reflected by evidence for population growth, long-distance exchange networks and burial ritual (Ritchie 1969; Snow 1980).

Presently, the Late Archaic Period is divided into a chronological sequence of three major cultural traditions: the Laurentian tradition (ca. 5,500-4,200 B.P.), the Narrow-stemmed tradition (ca. 4,300-3,500 B.P.), and the Susquehanna tradition (ca. 3,800-2,700 B.P.) (Ritchie 1969; Snow 1980). Each tradition is marked by a distinct complex of projectile point types. Phases within the traditions have been proposed following the investigation of a series of well-dated archaeological sites. The traditions and phases are outlined below.

Laurentian Tradition

The Laurentian tradition is considered the earliest manifestation of the Late Archaic Period in southern New England. The earliest site assigned to this tradition in the Northeast is the Schafer Site, located in the Mohawk Valley of New York. This site yielded cultural deposits radiocarbon-dated to 6,290 +/- 100 B.P. (Wellman 1975). Very little is known about possible Laurentian tradition sites predating 5,500 B.P. in Connecticut.

The majority of data defining the Laurentian tradition in the Northeast come from work done by William Ritchie in New York State and on Martha's Vineyard (Ritchie 1969 and 1994). Sites assigned to the Laurentian tradition are characterized by Vosburg, Brewerton and Otter Creek projectile points, bannerstones, gouges, adzes, plummets, ulus (semilunar slate knives), and a settlement system in which large camps were located in riverine areas. Smaller, more temporary and special-purpose sites were situated in the interior (Ritchie 1969a and 1994). Presently, the Laurentian tradition in Connecticut is defined by a series of sites, dated between 4,800 and 4,300 B.P., which exhibit several of the diagnostic elements of the tradition as defined by Ritchie in New York. Diagnostic aspects of Laurentian assemblages include projectile points of the Brewerton type, ground-stone tools, ulus, and a preference for lithic materials other than quartz.

Few Laurentian occupation sites in Connecticut have been tested intensively enough to address subsistence and land use patterns. McBride (1984b) noted that Laurentian occupations tend to be small, usually not more than 500 square meters in size, and are distributed across a wide range of ecological zones, with an emphasis towards the uplands. Laurentian settlement patterns are believed to reflect the movement of small, mobile groups of hunters and gatherers (perhaps 10-20 people per group) moving periodically to take advantage of seasonally abundant resources. Large seasonal camps suggest increased aggregation of population for at least part of the year. The Bliss Site in Old Lyme, dated at approximately 4,700 B.P. (Pfeiffer 1984), is the earliest reported cremation burial site in southern New England. Twenty-one burial features have been reported from this site, including grave offerings of Brewerton projectile points, bannerstones, axes, pestles, blades, scrapers, animal bones, and carbonized seeds and nut remains.

Narrow-Stemmed Tradition

Sites of the Narrow-stemmed tradition date between 4,300 and 3,500 B.P. in southern New England. This tradition is characterized by: 1) small triangular and narrow-stemmed projectile point forms, regional variants of which include Squibnocket, Beekman, Sylvan Lake, Lamoka, Bare Island, Wading River, and Poplar Island projectile points (Ritchie 1971; Snow 1980); 2) a quartz cobble lithic industry; 3) the use of adzes, plummets, and gouges; and 4) a settlement pattern of seasonal camps along rivers and interior wetlands and temporary and task-specific sites found across a variety of environmental zones (McBride 1984a). Large seasonal camps located along major rivers indicate multiple, long-term seasonal occupations of site locations, suggesting a degree of stability and territoriality not seen in earlier time periods. The Narrow-stemmed tradition in Connecticut is characterized by stemmed point and triangular forms and the presence of an almost exclusively quartz cobble lithic industry (McBride 1984a).

The Woodchuck Knoll Site on the Connecticut River in South Windsor, Connecticut, is one of the most extensively researched large riverine base camps of its time period (McBride 1978). At this site, a shallow Laurentian deposit underlies extensive Narrow-stemmed tradition deposits. Radiocarbon dates from the Narrow-stemmed component range from 3,760 to 3,500 B.P. The component includes numerous hearths and storage pits, artifact caches, and habitation remains. Macrobotanical remains of hickory, walnut, and *Chenopodium sp.* indicate summer and fall occupation. The presence of charred weevil (*Sitophili sp.*) associated with the botanical remains suggests that wild plant food gathering and storage was a recurrent activity at the site (McBride 1978).

Narrow-stemmed occupations in Connecticut are distributed over a wide range of ecozones and environmental locales, including riverine areas, lakes, upland streams and interior wetlands; this indicates the exploitation of a variety of habitats and their resources. Base camps tend to be situated along major rivers, whereas seasonal camps have been discovered in a variety of environmental contexts. Smaller, more specialized occupations tend to be located in terrace and upland zones (McBride 1984a). The nature and distribution of sites suggest aggregation during summer months, with seasonal dispersal into smaller groups during the cold weather (McBride 1984a; McBride and Soulsby 1989).

McBride (1984a) noted a high frequency of seasonal camps and task-specific Narrow-stemmed sites in the Connecticut River Valley, implying frequent residential moves by multi-family groups to extract seasonally available resources from specific microenvironments. The high number of task-specific sites indicates frequent movement out of seasonal base camps on a daily or temporary basis to procure resources and then a return to the base camp. The settlement data suggest less mobile populations than in previous time periods, with larger seasonal aggregations of people. Population aggregations are indicated both near the Connecticut River and along the major rivers and inland wetlands of the eastern and western highlands. Seasonal movement from the river to the uplands is still poorly understood, but the high frequency of seasonal camps throughout the Connecticut River Valley and adjacent highlands suggests movement of groups to upland areas on a seasonal basis.

Susquehanna Tradition

Sites of the Susquehanna tradition date between 3,900 and 2,700 B.P. in southern New England, and are characterized by broadspear projectile point forms. These include the Snook Kill, Susquehanna Broad and Orient Fishtail varieties. Lithic assemblages typically consist of flint, chert, argillite, felsite, rhyolite and quartzite (local quartz was used infrequently). Additional diagnostic artifacts include ground-stone tools (including wing-shaped atlatl weights, grooved axes and adzes), carved soapstone bowls, and occasionally cord-marked and grit-tempered ceramics. The larger sites appear to be oriented toward coastal and riverine locales (Dincauze 1975; Pagoulatos 1986; Pfeiffer 1990; Snow 1980).

A number of Susquehanna tradition cremation burial sites have been identified in southern New England. The earliest dated mortuary site is the Litchfield Site in New Hampshire, which dates to 3,670 +/- 111 B.P. and yielded Susquehanna broad points and calcined bone (Finch 1964). It is unclear whether a nearby habitation area was occupied at the same time as the cremation. The Flat River Cremation Site in Rhode Island was radiocarbon-dated to 3,430 +/- 100 B.P. (Fowler 1968).

Cremation burial sites have also been found in the Charles River and Sudbury valleys of southeastern Massachusetts, including the Mansion Inn Site, the Watertown Arsenal Site, and the Vincent Site (Dincauze 1968). The Vincent Site has been radiocarbon-dated to 3,470 +/- 125 B.P. and is characterized by the presence of Mansion Inn blades and Susquehanna broad points. A wide variety of ground-stone and retouched tools were also found at the site. Other mortuary sites include the Sugar Loaf and Jamesport Sites on Long Island (Ritchie 1959). The Sugar Loaf Site yielded Orient Fishtail points, calcined human bone, steatite and a date of 3,000 +/- 300 B.P. The Jamesport Site included caches of implements, steatite bowl fragments, quartz Orient Fishtail points, hammerstones, and crude ceramics, and was radiocarbon-dated to 2,720 +/- 220 B.P. (Ritchie 1959).

Burial ritual in this period has received a great deal of attention in Connecticut (Pagoulatos 1986; Pfeiffer 1980, 1983, 1984). Extensively studied Susquehanna cremation sites include the Schwartz, Carrier and Griffin Sites. The best-documented of these sites is the Griffin Site, with a range of radiocarbon dates between 3,495 and 2,985 B.P. (Pfeiffer 1983). The Carrier Site, located on a terrace edge overlooking the Connecticut River floodplain, has been radiocarbon-dated to 3,550 +/- 90 B.P. (Pagoulatos 1986). Both sites yielded caches of blades, form tools, steatite vessels and human bone. Numerous habitation sites have also been identified in the Connecticut Valley, eastern highlands, and surrounding areas.

The Timothy Stevens Site, situated on the terrace edge overlooking the Connecticut River floodplain in Glastonbury, may represent a typical larger occupation or seasonal camp. This site dates to between 2,740 +/- 60 B.P. and 2,460 +/- 60 B.P. (Pagoulatos 1986) and yielded a wide range of features, including hearths, trash pits, activity areas, house remains, storage pits, and caches of points. Remains of white-tailed deer, beaver, small mammals, turtle, fish, lamb's-quarters, hickory, and walnut were found, suggesting at least summer and fall occupancy. Other seasonal camps, such as the Parkos, Horse Barn and Blaschick Sites, also adjacent to

the Connecticut River, have yielded similar cultural remains. The Horse Barn Site contained aquatic remains, freshwater clamshells, and charred hickory, walnut and lamb's-quarters, reflecting late summer and fall occupation. The Parkos and Blaschick Sites, on a cove off the Connecticut River in East Haddam, included unidentified mammal remains, huckleberry, blackberry and a variety of other berries, suggesting spring and summer occupation (Pagoulatos 1986).

An example of interior upland Susquehanna tradition sites is Site 32-59, located along the Willimantic River in Coventry, Connecticut. This site includes two small loci, each measuring about 100 to 250 square meters in size (McBride and Pagoulatos 1988). One locus consists primarily of quartzite blade fragments and steatite bowl debris; the other locus yielded flint and argillite chipping debris, a Genesee point, and a hearth with a radiocarbon date of 3,890 +/- 80 B.P. Site 72-55 in Ledyard is another interior upland camp. It yielded numerous features, including hearths, refuse pits and post molds, broadspear points, retouched tools, argillite flake scatters, and a date of 3,840 +/- 70 B.P. (OSA site files).

In summary, the data demonstrate differences in land use patterns and seasonal movements associated with the Susquehanna tradition. Data from interior uplands suggest that temporary occupations were somewhat specialized and were established near streams and swamps. Less frequent group movements and more specialized procurement strategies are inferred. Population aggregations near major rivers during certain times of the year are suggested, perhaps coinciding with burial ceremonies and the harvesting of floodplain plant resources (Pagoulatos 1986). Groups may have dispersed into smaller domestic units or specialized task groups and moved into the highlands during other times of the year.

The Late Archaic period is well documented in the northeastern corner of Connecticut. Ten sites within one mile of the proposed corridor have been documented as containing diagnostics dating to the Late Archaic period. All of them are designated as campsites (OSA Site Forms).

The Woodland Period (2,700-350 B.P.)

In the Northeast, the Woodland Period is characterized by the increased use of pottery, the introduction of tropical cultigens (maize, beans, and squash), and an increase in site size and complexity, suggesting a trend toward increased sedentism and social complexity. The Woodland Period has been subdivided into early, middle, and late periods on the basis of ceramic styles and political and social developments (Ritchie 1969a; Snow 1980).

Early Woodland Period (2,700-2,000 B.P.)

In the Northeast, the Early Woodland Period dates between 2,700 to 2,000 B.P. The period was characterized by the widespread use of ceramics and increasingly complex burial ritual (Dragoo 1976; Griffin 1967; Snow 1980). Ceramics were commonly thick, grit-tempered, and cord-marked on the interior and exterior.

Several Early Woodland regional phases have been recognized in southern New England. These include the Meadowood phase and the Lagoon complex of Martha's Vineyard (Ritchie 1969a and 1994; Snow 1980). These regional expressions of the Early Woodland Period are generally characterized by: 1) Lagoon, Meadowood, and Rossville point forms; 2) thick, grit-tempered, cord-marked ceramics; 3) a settlement pattern oriented toward riverine locales; 4) burial ritual; and 5) long-distance trade/exchange networks.

In Connecticut, this period is characterized by a quartz cobble lithic industry, narrow-stemmed points, occasional Meadowood projectile points, thick cord-marked ceramics, and human cremations. Associated Artifact assemblages have been dated between 2,700 and 2,000 B.P. Little data are available regarding Early Woodland settlement and subsistence patterns. The Waldo-Hennessey Site, a collection of small, seasonal camps in a tidal estuary locale in Branford, provides information on Early Woodland subsistence procurement and land use patterns. Ceramics were found in association with narrow-stemmed quartz points and Meadowood and Rossville point forms. Subsistence remains include oyster, soft- and hard-shelled clams, and white-tailed deer. The combination of food remains and numerous superimposed features indicates that the site was re-occupied on a seasonal basis by small groups of people (McBride 1984a).

Early Woodland sites elsewhere in Connecticut are distributed across a variety of ecozones, although there appears to be an orientation toward floodplain wetlands and upland lakes. Large sites are located on the floodplain and terraces, as in the Narrow-stemmed tradition (McBride 1984a); however, even though there is a tendency toward the use of the floodplain, Early Woodland settlement patterns may still be characterized by seasonal group movements throughout the lowlands and highlands, with population aggregations along major rivers, interior lakes, and wetlands (McBride 1984a).

In the Connecticut River Valley, Early Woodland seasonal camps are found along the river as well as near large interior wetlands and lakes. A similar pattern is indicated in the eastern uplands, where most of the sites tend to be earlier than their counterparts along the Connecticut River. In fact, the few well-dated Early Woodland sites in the uplands tend to overlap in time and space with Susquehanna tradition sites. The different nature of interior/upland sites between these two cultural traditions (i.e., Early Woodland Narrow-stemmed tradition sites are seasonal, Susquehanna tradition sites are more temporary and specialized) argues for two overlapping settlement systems--one, the Susquehanna, centered along the major rivers with seasonal and specialized use of the uplands, and the second, the Early Woodland, staying year-round in the uplands.

Excavations at the Idle Wild Farm Site in Pomfret during a Phase III Data Recovery (McBride 1993), revealed an occupation dating to the Early Woodland Period based on a radiocarbon date of $2,280 \pm 100$ B.P. Based on the investigations at the site, the site was interpreted as representing a seasonal camp reflecting activities related to tool production and maintenance, food processing, and cooking.

Middle Woodland Period (2,000-1,000 B.P.)

The Middle Woodland Period in the Northeast dates from 2,000 to 1,000 B.P. and is characterized by increased diversity in ceramic style and form and long-distance exchange networks (Snow 1980). Much of our knowledge of this period in southern New England is extrapolated from work done in New York State by Ritchie (1994), who noted an increased use of plant foods such as goosefoot (*Chenopodium sp.*) in the Kipp Island Phase, which he suggests had a substantial impact upon social and settlement patterns. Ritchie further noted an increase in the frequency and size of storage facilities, which may reflect a growing trend toward sedentism (Ritchie 1994; Snow 1980).

In the Connecticut River valley, the Middle Woodland Period is dated between 2,000 and 1,200 B.P. and is defined on the basis of 1) straight-walled, pointed-bottomed, dentate-stamped ceramics; 2) a quartz cobble lithic industry, but with an increased amount of flint from New York, ranging from 5 to 15% of a site's lithic assemblage; 3) narrow-stemmed and occasionally Jack's Reef projectile point varieties; and 4) a settlement pattern characterized by population aggregations along major rivers and the coast.

Larger riverine aggregations include sites such as Hamburg Cove in Lyme, radiocarbon-dated to $1,490 \pm 100$ B.P. (McBride 1984a). The site includes post molds, hearths and the remains of turtle, deer and small mammals, reflecting spring and summer occupancy. Numerous other seasonal camps along the river yielded roasting features, storage pits and subsistence remains such as beaver, turtle, bayberry and sturgeon, suggesting summer and fall occupation.

Middle Woodland occupations are found across riverine and upland zones. Large seasonal camps are mostly found along major rivers and temporary camps tend to be away from the river in the uplands. The data suggest a settlement pattern of the aggregation of populations near major rivers for much of the year. McBride (1984a) suggests that organized task groups may have established temporary camps in the uplands to exploit specific resources. The pattern reflects a strategy in which collectors made fewer residential moves; task groups would collect resources in upland zones and transport them to the riverine base camps.

Late Woodland Period (1,000-350 B.P.)

The Late Woodland Period in the Northeast dates from 1,000 to 350 B.P. and has been characterized by the intensive use of maize, beans, and squash; changes in ceramic technology, form, style, and function; population aggregations in villages along coastal and riverine locales; increased sedentism; and the use of upland zones by smaller, domestic units or organized task groups. Not all of these regional developments have been identified in southern New England. Late Woodland Period artifact assemblages include Levanna projectile points and finely made, brushed, stamped, incised and cord-marked ceramics (Ritchie 1969b; Snow 1980). Late Woodland settlement patterns suggest a trend toward fewer, larger villages near the coast and river, reflecting a continued reduction in residential mobility and increased sedentism. It has been hypothesized that these changes can be attributed to the introduction of maize, beans and squash, but it is unclear how important cultigens were in aboriginal diet of southern New England groups (Ceci 1980; McBride 1984a; Ritchie 1994).

Dating from 1,200 to 450 B.P., this period is characterized by the following: 1) brushed, cord-marked, stamped, fabric-marked and incised Windsor, Sebonac and Hollister ceramics; 2) an increase in nonlocal lithic utilization, ranging from 60 to 80% of assemblage context; 3) the presence of Levanna and Madison point varieties; and 4) a settlement pattern which reflects the establishment of semi-sedentary villages near rivers and temporary encampments in the uplands (McBride 1984a).

Village sites are identified along estuaries and along major rivers. Preserved subsistence remains from such occupations have included white-tailed deer, woodchuck, fish, birds and small mammals; plant remains include berries, hickory nuts, lamb's-quarters, hazelnuts and acorns. Domesticated plants have included maize, beans and sunflower (Bendremer and Dewar 1993; McBride 1984a). These food remains suggest that these horticulturalists utilized a wide variety of microenvironments, throughout the spring, summer and fall to supplement domestic crops.

Recent work by Lavin and Cooke at the Morgan Site (6-HT-120) on the Connecticut River floodplain in Rocky Hill has provided valuable information on subsistence activities. Large quantities of maize have been recovered from undisturbed cultural deposits which also yielded a wide range of ceramics, Levanna projectile points and radiocarbon dates of 675 +/- 75 B.P. and 630 +/- 70 B.P. (Lavin 1988). The 6-HT-116 Site, located in South Windsor, has been radiocarbon-dated to 460 +/- 100 B.P. and 445 +/- 90 B.P., and yielded a single kernel of maize (McBride 1984a). This site also produced wild plant remains, including walnut, hickory, goosefoot, purslane, carpetweed, and elderberry. Although cultigens are present, wild plant foods clearly contributed significantly to the aboriginal diet.

Late Woodland occupations are found distributed across a range of riverine and upland zones, with larger settlements along the major rivers. Micro-environments utilized include floodplain wetlands, coves, tidal marshes, upland streams and interior wetlands. Large villages tend to be situated along major rivers, estuaries and tidal marshes. Smaller, temporary camps are situated along upland streams and inland wetlands. Populations appear to have aggregated in large villages during much of the year. Temporary camps were established on a seasonal basis by smaller domestic units or organized task groups in upland zones. The settlement pattern reflects that of a collecting strategy (Binford 1980; McBride 1984a).

Two sites near Columbia and within one mile of the proposed corridor have been documented as containing a Late Woodland component (OSA Site Forms). Both sites represent large multi-component occupations with extensive artifact assemblages collected from local avocational archaeologists. The Late Woodland occupations at both sites appear to be associated with villages.

Contact Period (350-250 B.P.)

The archaeological record of the contact period in northeastern Connecticut is quite poorly documented with respect to Native occupation. The general area was occupied mainly by a subgroup of the Nipmuck Tribe known as the Quinebaugs, but was also frequented by the Mohegans, Narragansetts, and Pequots (Bickford 1999; DeForest 1991). According to historical accounts, several Native trails ran north-south through the Quinebaug valley. The Quinebaug Nipmuck also had a village on the east bank of the Quinebaug River, in present-day Danielson (Barber 1838; Weaver et al. 1976).

Unlike many of the more prominent Native American tribes in southern New England, the Quinebaug never negotiated as a sovereign nation with the Connecticut Colony, and as a consequence, left a more fragmentary documentary record of their contacts with English settlers during the 17th century (Bickford 1999:3). The Nipmuck appear to have been a more loosely organized group than their Mohegan, Pequot, or Narragansett contemporaries to the south and east, with numerous small villages scattered across much of interior southeastern New England. The fluid social boundaries separating the bands within the Nipmuck tribe may have been a reaction to the consistent interference from neighboring groups. As Frank Speck noted: "Their local sub-divisions seem to have had vacillating associations with adjacent groups whose hereditary chiefs often assumed authority to sanction their land transactions with the English" (cited in Bickford 1999: 4).

The Quinebaug sub-group established several villages along the Quinebaug River and its major tributaries. They erected a palisaded village called Acquiunk, in the south part of Danielson, and had a burying ground that was located in the same town between Dyer Street and the railroad. The village was later burned by the English during King Philips War (1675-1676) (Weaver et al. 1976).

The importance of the Quinebaug River to the Contact period Native Americans living in the area is underscored by several historical accounts. According to DeForest (1991), one of several conflicts between the Nipmuck (most likely part of the Quinebaug group) and the Narragansett occurred when the former invited the latter to a feast of lamprey one spring. The lamprey were served undressed, according to Nipmuck tradition, which greatly offended the visiting Narragansett, who "were more fastidious than their inland neighbors, [and] took such a disgust at this circumstance that they refused to eat" (DeForest 1991: 267). A violent struggle ensued, and all but two of the Narragansett guests were killed. The feasting on lamprey is notable, as this species is anadromous, and was likely taken at one or more fish weirs constructed across the Quinebaug River. Such weirs have been documented along the river course (e.g. Russo 1994) and probably provided an important source of food to local Quinebaug groups. Other resources were also available along the banks of the river and its major tributaries. The convergence of the Quinebaug and Assawaga or Five Mile River in the town of Killingly contained an abundance of reeds which were used by the local Nipmuck groups to make mats and baskets. Interestingly, the name of the convergence was also known as Wabbaquasset, which means the "mat producing country" (Weaver et al. 1976).

Historical transactions which changed Native American culture began as early as the 17th century when European settlement and trade moved into the area. Land purchases, diseases, and conflict became the norm in Native American communities after European settlement. Additional changes to Native American perception occurred through religious conversion activities that occurred in the 17th century, a task that was readily undertaken locally by a number of pastors, deacons and priests. Over time, indigenous people in the area lost or traded control of their lands and slowly faded into the background.

By the 1670s, the hunting and trapping grounds of southern New England were probably depleted as sources of Indian income, and those groups which had survived the disease and warfare of the early Contact period had begun trading land rights for money, goods, or political security. After the Pequot War of 1637, the Mohegans under Uncas secured most of Connecticut east of the Connecticut River as their hunting ground. Uncas and his sons sold, granted, or were otherwise divested by the English of all of this area between 1659 and 1699. Uncas's son, Attawanhood, also known as Joshua, had control of much of present Tolland and Windham Counties before his death in 1676. Joshua bequeathed the lands east of Bolton Notch in parcels to several groups of prominent Hartford, Saybrook, and Norwich men in his will, as well as to his son Abimelech.

B. Project Area Sensitivity and Future Actions

As discussed above, many prehistoric sites from a wide time range exist within the vicinity of the Primary Routes Under Consideration. Most Project areas are in relatively undeveloped parts of Tolland and Windham counties, where Native American site possibilities are high in certain environments. The overhead and underground routes cross-cut virtually every topographic and environmental setting in the region, including many streams or rivers. Undisturbed areas matching certain environmental characteristics are sensitive for possible Native American archaeological sites, which could contribute to knowledge of local and regional prehistory.

Environmental characteristics of known Native American sites in the vicinities of the alternative Project routes allowed for identification of areas sensitive for undiscovered sites, based on both surface inspection and information about slope and drainage conditions. Slope, drainage and proximity to streams and wetlands are generally the indicators of Native American site sensitivity. The vast majority of sites are located in areas of less than 12-15% slopes, in well-drained soils. While some fairly large sites that may have been used as permanent, semi-permanent or seasonal sites may be located along major streams and wetlands, previous experience has shown that uplands settings with small level areas adjacent to smaller streams and wetlands do contain prehistoric sites. The smaller sites encountered in such settings would probably have been used as temporary camps, hunting camps and stations, resource acquisition sites for the obtaining of workable stone or food items, or temporary refuges. It would be expected that rock overhangs in many of the areas with steeper, rocky topography would have also been used as short-term shelters. Rockshelters are reported in Coventry near the western end of the existing CL&P ROW (Sites 32-10, 32-12).

While proximity to available water in the form of streams, wetlands and ponds with their associated floral and faunal resources would usually be a good indication of potential Native American sites, the absence of nearby water should not be considered great enough to exclude some site locations, particularly in the steeper portions of the Project area. As many sites in such locations are small temporary camps or hunting sites, they may have been occupied during the late fall through early spring, when the presence of snow may have eliminated the need for a stream or wetlands. Conversely, it is important to understand if areas now poorly drained have been either created or enlarged due to modern land use. It is possible that some sites may now lie within wet areas that were formerly well-drained, although we are presently not aware of any such areas among those identified as non-sensitive.

Other factors that may have been important in prehistoric times include the presence of rocks and minerals used for tools. Outcrops of quartz and steatite may exist in surficial exposures of bedrock that were once used as quarry-workshops by prehistoric Native Americans. The presence of steep, narrow gorges and stream valleys and natural rock enclosures may have also been used as natural ambush and game drive sites for hunters. Absent potential for rockshelters, however, areas with extensive exposed rock outcrops will rarely retain any data from Native American occupations in this region.

Based on these considerations, areas with Native American resource sensitivity were identified for the routes under consideration. Identification procedures included:

- For all routes, assessment of slope, drainage, rock outcrop and disturbance characteristics from topographic and soil maps, recent aerial photographs, digital data available from the Connecticut Department of Environmental Protection, detailed plan and profile data for the existing CL&P ROW, and wetlands identifications made for this Project (U.S. Department of Agriculture 1966, 1981: Northeast Utilities Service Company 1969-1991; Connecticut Department of Environmental Protection 2003);
- Visual inspection by helicopter of the Primary Route Under Consideration, primarily to identify rock outcrops with possible rockshelters and any unmapped disturbed areas, followed by visual inspection from truck or on foot to assess rockshelter potential;

- Visual inspection by automobile or on foot along existing roadway portions of the Willimantic South and Putnam North underground variations.

Five possible rockshelter areas were identified by helicopter in the Primary Route Under Consideration, but detailed walkover inspection did not find any overhangs at these locations indicating rockshelter potential. The extremely overgrown nature of most of the Primary Route Under Consideration precluded comprehensive walkover inspection, and lack of access to the Willimantic South Overhead Variation sections not within existing ROW precluded any ground inspection.

Appendix 1 shows Project areas with known or likely sensitivity for possible Native American sites. Along the Primary Route Under Consideration approximately 64.2 percent appears to be sensitive. Comparable percentages for other overhead routes and related improvements are:

| | |
|---|-------|
| Willimantic South Overhead Variation | 71.6% |
| Mount Hope Montessori School Overhead Variation | 80.0% |
| Brooklyn Overhead Variation | 80.0% |
| Putnam North Overhead Variation | 50.8% |
| 310 Loop | 83.0% |

For the underground route variations within existing ROW, percentages which appear sensitive for possible Native American sites including transition station areas are:

| | |
|--|-------|
| Mansfield Underground Variation | 73.5% |
| Mount Hope Montessori School Underground Variation | 68.9% |
| Brooklyn Underground Variation | 77.2% |

Any underground Project routes within existing roadways are assumed to have no archaeological sensitivity. Along such roadways, however, adjacent unpaved areas may be sensitive, although undocumented disturbance may have removed archaeologically-sensitive soils within some of these off-road areas (Appendix 2). For the Willimantic South Underground Variation, which would be constructed largely within existing roadways, 71.2% of adjacent unpaved areas appear sensitive for Native American resources including the transition station sites. The comparable percentage for the Putnam North Underground Variation is 79.0%.

Most or all of the area presently intended for Card Street Substation expansion appears to be sensitive for possible Native American sites, as do most or all areas identified for potential transition stations. Precise locations of future transmission structures and any transition stations remain undetermined, as does the nature and extent of associated land disturbance.

Detailed surface inspection and reconnaissance archaeological testing will be necessary to confirm the presence or absence of Native American sites at future structures, new access routes, off-road underground routes, or other Project-related disturbance in the sensitive areas shown in Appendix 2. Current standards for reconnaissance testing in Connecticut call for hand-excavated shovel tests at least 50 cm. square at intervals of no more than 15 m./50 ft.

V. EUROAMERICAN RESOURCE SENSITIVITY AND POTENTIAL VISUAL EFFECTS

A. Summary of Background Information

Euroamerican settlement in Project area towns began in the late 17th century. A large number of readily-exploited waterpower privileges along smaller rivers powered grist, saw, and fulling mills, allowing these upland towns to develop as agricultural communities based primarily on grain, forest, and livestock products. The region played an important role during the American Revolution, in part as a section of the route traveled by the French army under comte de Rochambeau from Rhode Island to Yorktown. Although farmers and merchants in some of these towns were able to participate in the West Indies trade by moving products or animals to the nearest coastal or river ports, limited road development and distance from navigable waterways generally inhibited economic and population growth until the early 19th century. Communities on larger streams or rivers then began to emerge around textile manufacture, which by the mid 19th century stimulated rail construction into some towns. Towns without manufacturing or rail access remained small and agrarian well into the 20th century. This section provides brief summaries of town histories as general background to an analysis of cultural resources along the Primary Routes Under Consideration.

Brooklyn

Along the Quinebaug River, the area including Brooklyn was part of an enormous tract deeded by Uncas' son Owaneco to James Fitch, Jr. between 1680 and 1687. Fitch's claims conflicted with those of John Winthrop, Jr., who had purchased a vaguely-defined area from the Mohegan in 1653, but Fitch sold off large areas including a 3000-acre tract in present Brooklyn deeded in 1703 to Richard Adams. Originally part of Canterbury and Pomfret -- both areas settled by Fitch or his grantees -- Brooklyn became a separate ecclesiastical society in 1731 and a separate township in 1786. Most of the original Adams land was acquired by William Danielson between 1769 and 1795, who sought to secure large areas in proximity to the river. Brooklyn served briefly as Windham County's shire town in the early 19th century and had some half dozen saw mills and grist mills by 1811.

Beginning in 1820, the East Brooklyn area along the Quinebaug River opposite Danielson became a textile manufacturing center, but most of the town remained an agricultural community with a small population into the 20th century (Warren and Gillet 1812; Gerrish *et al.* 1856; Gray 1869; Larned 1874, I: 6-18; Bayles 1889: 564-70; Daniels 1979: 20-21; Raber and Soulsby 1996: 16).

Chaplin

The lands including present Chaplin were deeded by one of the sons of Uncas to a group of colonists from Norwich. The first settler, Deacon Benjamin Chaplin, a wealthy landowner from Pomfret, obtained large tracts of lands along the Natchaug River. An expert surveyor, Chaplin took advantage of the ignorance of absent landowners to acquire lands that he suggested were not habitable. Chaplin became the Deacon of the First Church of Mansfield and settlement in Chaplin following 1740 came mostly from residents from the towns of Mansfield and Windham. At Chaplin's request, a meeting house was built after his death attracting surrounding villagers. Local mill owners and their workers set up residence in Chaplin Village, which was focused around the church, as a separate ecclesiastical society or parish was formed in 1809. Chaplin became a town in 1822, incorporating lands from Mansfield, Windham and Hampton.

Several industrial sites sprung along the Natchaug River and Stonehouse Brook including wood processing, paper, textile industries as well as a tannery and a boot factory. However, the lack of direct rail connections, relative to other nearby towns which obtained rail transport, eventually led to the demise of the local industries in Chaplin, eventually pushing the local inhabitants to revert to an agrarian economic base. Population steadily declined in Chaplin until the introduction of motorized vehicles in the 1920s, providing local residents with much needed transportation to neighboring work places. Even today, Chaplin remains a rural community and over 90% of the town's residents are employed outside of the town (Naser 1972).

Columbia and Lebanon

Uncas' sons deeded land in these present towns to colonists from Norwich and New London in the 1690s. Columbia was initially settled as part of Lebanon as disputes over original ownership rights arose when settlers purchased tract from local Native groups where Uncas and his sons asserted their rights as rightful owners. The lands were repurchased separately from the Nehantic tribe in 1699 and the Mohegans in 1700.

Lebanon was incorporated as a separate town in 1700, from which Columbia was established in 1804 with the Ten Mile River as part of the boundary. Lebanon is well known as its role in the American Revolution as it served as an encampment and command post for revolutionary forces. William Williams, one of the signers of the Declaration of Independence, and Jonathan Trumbull, the only sitting colonial governor to support the Revolution, were both from Lebanon. Both towns were largely bypassed by 19th-century industrial development and remained primarily agricultural into the 20th century, with tributaries of the Willimantic and Yantic rivers powering grist mills, saw mills, and other small-scale industries (Caulkins 1866: 151-2; Cole 1888: 731-2; Warren and Gillet 1812; Beers 1868; Gray 1869; Anonymous 1954: 55). Today both towns remain largely rural communities. As of the 1980s, Lebanon still contained 60 dairy farms and 20 poultry farms (O'Brien 1982).

Coventry

Uncas' son Joshua deeded land in present Coventry to a group of entrepreneurs from Hartford, known as the Hartford Legatees. Following Joshua's death, the grantees began surveying the various tracts of lands and in 1709 formed a committee to survey allotments and offer titled deeds to would be settlers. These settlers arrived from Northampton, Massachusetts and from the Hartford area. In 1712, since the Connecticut Colony imposed taxes on the settlers, a request to have the town officially incorporated was presented to the Connecticut General Assembly. The local economy centered around agriculture well into the 19th century as local industries supported domestic production of grains, meat and wool. However, Coventry underwent a rapid transformation from an agricultural to an industrial center by the mid 19th century. The Willimantic and Hop Rivers, as well as the watersheds associated with Lake Wangumbaug, provided excellent sources of hydraulic power that could be harnessed to operate mills and factories. Textiles, metal products, glass and munitions were manufactured at industrial sites powered by these mills. The construction of the railroad along the Willimantic River provided the means to transport goods from these production sites to distribution centers. However, Coventry could not compete with better-sited operations found across the Willimantic River and by the end of the 19th century, Coventry had mostly returned to its agrarian roots. The early 20th century saw a steady increase in summer houses being built around Lake Wangumbaug and Coventry became known as a resort community. Today, Coventry remains mostly a residential center, though it still has retained much of its rural landscape with scattered farming complexes throughout the area.

Hampton

Joshua bequeathed the lands east of Bolton Notch in parcels to several groups of prominent Hartford, Saybrook, and Norwich men in his will, as well as to his son Abimelech. One such group from Norwich received an area first incorporated as the Town of Windham in 1692, including the present towns of Windham, Mansfield, Hampton, Scotland, and Chaplin (Daniels 1979: 20-25; Raber and Soulsby 1996: 16). English families first settled in the Hampton area c1708-09, with the first authorized land purchases in 1712. Fairly rapid growth in settlement led to establishment of a separate Canada Parish within Windham in 1717. Following another three generations of agricultural development, Hampton was incorporated as a town in 1786, with boundaries reaching the Natchaug River to the west. Hampton remained focused geographically around Little River. Farmers along the Natchaug incorporated the Town of Chaplin in 1822, reducing Hampton's area (Bayles 1889: 373; Griggs c1940: 1-11). Hampton's rolling terrain dotted with wetlands encouraged dairy-based agriculture into the present century, but the town's relatively poor transportation links and waterpower limitations inhibited industrial development. There was no rail link through Hampton until the 1872 completion of the New York and New England Railroad's line between Putnam and Willimantic, by which time many of Hampton's small, often multi-purpose country mills had begun to disappear in the face of flood, fire, and limited opportunities for growth (Bayles 1889: 380-9; Turner and Jacobus 1986: 180-2).

Killingly

Killingly was settled by the English around 1700 and for the next century developed as an agricultural community. In the early years of the 19th century, however, textile manufacturers began to exploit the town's many fine waterpower opportunities along the Quinebaug and Five Mile rivers and Whetstone Brook. At each waterfall, small villages grew up around the mills, with stores, churches, and homes for workers. Two of the villages, Dayville and Danielson (originally called (Danielsonville), outpaced the others as a result of the Norwich and Worcester Railroad, which was built through Killingly around 1840. Another nearby mill village was Williamsville. In the early 20th century, the Williamsville cotton mill was purchased by the Goodyear Rubber Company, which renamed the village "Goodyear" and greatly expanded both the mill itself and the number of employee houses in the village. For many years, cotton duck (canvas) formed the base upon which automobile tires were made, and Killingly (which had another tire-duck mill in Danielson) rode the wave of automobile-production prosperity. Today the village is known as Rogers after the specialty-paper manufacturer which occupies the mill buildings.

Outside the mill villages, most of Killingly remained almost entirely agricultural until modern times. Except for low-lying areas which were swampy or wooded, most of the land was plowed for crops, fenced in to pasture animals, or cut for hay. The farms were not entirely divorced from nearby manufacturing activities: farm families supplemented their income by working in the mills, and the mill villages undoubtedly provided Killingly farmers with an enhanced market for milk, eggs, butter, and vegetables.

The movement of eastern European immigrants onto Connecticut farmland in the early 20th century is an important chapter in state history. These farms, no longer valued by Yankee families who had found opportunities elsewhere, represented a chance at property ownership for the immigrant industrial working class. Throughout the eastern part of the state, Polish, Slovak, Czech, and Eastern European Jewish farmers worked on their newly acquired farms and thereby gave one or two more generations of life to the land.

Mansfield

Joshua deeded a large parcel of land including present Mansfield to a group of colonists from Norwich in the late 17th century. In 1692, the area was first incorporated as part of Windham, becoming the Town of Mansfield in 1703. Until 1822, the town included portions west of the Natchaug River within present-day Chaplin. Prior to being included in Tolland County in the 1820s, Mansfield was part of Hartford County and subsequently Windham County. The occupants of the Mansfield area, as others in the general vicinity, primarily focused on small-scale farming, with most families living on scattered farmsteads. Abundant small waterpower privileges on Stonehouse Brook and the Mount Hope, Fenton, and Natchaug rivers drove equipment or provided process water for saw, grist, powder, fulling, clover-seed and textile mills as well as a few tanneries and metal works. The construction of a silk mill in 1810, based on a locally-invented mechanical device for spinning silk, brought an economic impetus to the area until the 1840s, when economic depression, uncontrolled speculation on mulberry trees, and ravaging diseases had drastic effects on overall silk production. The importation of silk from the Orient allowed these mills to recover rapidly and be again profitable. Following the Civil War, the tendency towards centralized industries in larger towns struck a significant economic blow to these small mills which eventually failed, and Mansfield's population dropped rapidly. The founding of an agricultural school in the 1880s and its subsequent expansion culminating into the University of Connecticut in the late 1930s channeled new growth in the area as the academic community relocated in the surrounding villages.

Pomfret

As in other parts of northeastern Connecticut, Captain James Fitch was the first Euro-American to claim the area of present day Pomfret, as Owaneco and his son Josiah deeded the land in 1684. Fitch in turn, as part of the Mashamoquet Purchase, deeded the property to a group of settlers from Massachusetts (Sellers 1942). Between 1691 and 1696, John Sabin of Bristol County, Massachusetts became the first settler and in 1713 the town was incorporated as Pomfret. Settlement was relatively slow in the area compared to neighboring communities, with only a few saw and grist mills put into operation. Pomfret remained mostly a rural farming

community, which by the early 19th century also became known as a summer resort community for wealthy Newport and Providence businessmen and their families. The influx of the upper class into the area led to the construction of large residential estates in the 20th century.

Putnam

One of last incorporated areas in northeastern Connecticut, Putnam was officially recognized as a town only in 1855. However, its location along the Quinebaug River allowed for its recognition as a distinct entity long before its incorporation, as a series of manufacturing sites developed around Cargill Falls just north of present-day Pomfret street. The first grist mill was built as early as 1730, followed by a distillery, a trip hammer shop, a scythe-sharpening shop and a butter churning operation after purchase of the privilege by Benjamin Cargill in 1760. In the early 1800s, saw and linseed oil mills were opened around the falls and in 1807 the first mechanized cotton mill went into operation. At the time, the area around the falls came to be known as Pomfretville. The presence of houses for mill workers, a general store, a schoolhouse, also used for religious services allowed for the area to develop as a small village. Turnpikes, added in the early 19th century, further enhanced the area's accessibility and economic prosperity.

In the next forty years, several other textile enterprises sprouted around the falls, each ancillary mill becoming the center of a village, with attendant houses, stores and associated buildings. Railroad construction enhanced industrial activity and as the community grew larger, residents recognized the need for their own schools, public services and local government. The town as incorporated in 1855, named for Revolutionary War figure Israel Putnam, contained within its bounds parts of Pomfret, Thompson and Killingly. The town continued to prosper following the Civil War as large textile factories and smaller non-textile enterprises, including shoe factories, machine shops and forges were added to its already strong industrial base. The presence of numerous churches, a central business district, a newspaper, sidewalks, and street lights provided the residents of Putnam a flavor akin to city life. Extensive residential neighborhoods arose around the center of town, reflecting the upper classes of businessmen owning or running the various enterprises, and working class populations including French Canadian immigrants.

The Great Depression ended Putnam's wealth and economic success, forcing many companies to permanently close their operations. Subsequent events would add to the decline of Putnam's prosperity. Floods in 1936 and a hurricane in 1938 damaged industrial sites further affecting local employment and in the summer of 1955, a terrible flood caused by the surging of the Quinebaug River, would severely damage large portions of the town, sweeping away houses, commercial buildings and infrastructures. Several mills were flooded or caught on fire and were destroyed. Putnam recovered eventually though never again reached its affluence of years past. Today, Putnam is mostly a residential center with small commercial businesses.

Thompson

The area including Thompson was claimed by Connecticut and Massachusetts into the early 17th century, but the town originated as the northern part of Killingly. Thompson's Mechanicville area was the first part of the present town settled in this period, and enough families followed so that an ecclesiastical society or parish was established in 1728 corresponding to later town boundaries. The town was incorporated in 1785. Settlement on the French River in Thompson was limited until the early 19th century, when Rhode Island merchants began taking advantage of eastern Connecticut's waterpower and President Jefferson's 1808 embargo on manufactured goods to build textile mills. The Mason family from Providence built Thompson's first cotton mill c1812 on the French River about a mile downstream of the project area, expanding their operations with additional mills in 1826 and 1831 in a growing village named for them. Upriver, William Fisher and others established the Thompson Village Company in 1828, and built a cotton mill and waterpower system within the project area. After Fisher became sole owner in 1830, the growing village around his mill was known as Fisherville. He retained control until 1855, after which time there were a series of owners through most of the Civil War. There were at least five other small cotton mills in Thompson by 1845, many of which benefited from the 1840 opening of the Norwich and Worcester Railroad along the east side of the French River (Warren and Gillet 1812; Larned 1880: 533; Bayles 1889: 626, 633, 683, 688-9; Roth *et al.* 1981: 244-5; Thompson Bicentennial Book Committee 1985: 5, 29; Spencer 1993: 27-8).

In 1848, Providence physician William Grosvenor purchased the Masonville mills and waterpower privileges, adding a new mill soon after the Civil War increased demand for cotton goods. With Lucius Briggs, he bought all of Fisherville and its industrial resources in 1864. The new owners consolidated both operations in 1868 under the aegis of the new Grosvenor Dale Company, and renamed their villages Grosvenor-Dale and North Grosvenor-Dale. The company became one of the largest examples of the greatly expanded textile industry in eastern Connecticut after the Civil War. North Grosvenordale was transformed into a large mill village surrounding one of the region's largest cotton factories beginning in 1872, when the company completed most of the present mill and greatly enlarged the dam and headrace. The new dam was 11.5 feet higher than the old one, had a 26.5-foot fall with a rollway and high-water spillway, and, in conjunction with two dams below North Grosvenordale, controlled flows into the mills in both villages (Porter 1885: 41; Bayles 1889: 689-90; Clouette and Cronin 1992; Spencer 1993: 47-8).

Windham

Uncas' son Owaneco deeded lands including present Windham to James Fitch, who in turn sold these lands to the Massachusetts Colony. Not long after the first settlers arrived in the area, Windham was established as the county seat in 1726, rapidly acquiring the status as an important center for business and governmental activities. The location of the courthouse, county jail and other judicial offices stimulated businesses, including a newspaper office, taverns, and associated residential buildings to be set up in the area. In the early 19th century, because of its importance in the area, turnpike roads were laid out through and near the town. The Windham Turnpike Company was established spurring major stagecoach and teamster operations in Windham. As well, these turnpikes helped move manufactured goods as well as agricultural staples from the area to other parts of the state. Staple production of grain, pork, beef, hemp, wool, flax, and tobacco contributed to the town's economic prosperity.

Beginning in the 1820s, cotton production created the beginnings of the small urban center of Willimantic, where the Willimantic Linen Company emerged as a very large maker of thread in the 1850s. The opening of the New London, Willimantic, and Palmer Railroad in 1849, and later railroad lines, promoted Willimantic as a transportation center and a major interchange in the eastern portion of the state. The railroad-related industries provided employment for a large number of residents in the stations, freight offices and round houses. Willimantic became a separate city in 1893. The Windham area also continued to develop as an industrial, commercial, and regional financial center through the 19th century. Windham's relative affluence in turn attracted a larger contingent of immigrants, mostly Irish but also French-Canadians and Swedes who contributed significantly to the local manpower and to the growth of the town. In the 20th century, the advent of two World Wars and the Depression Era, contributed in slowing the area's economic growth. Beginning in the 1950s, the Windham area increasingly became a suburban center of the greater Hartford area and helped in its revitalization (Bayles 1889; Clouette and Roth 2001; Larned 2000; Lincoln 1920).

B. Known or Potential Archaeological Resources

1. Overhead Routes

Identification of known or potential archaeological resources included review of historic maps, files held by the Connecticut State Archaeologist, selected cultural resource management surveys, and limited field inspection. Near the Primary Route Under Consideration, 24 previously-reported sites were identified 400-6000 feet away, none of which were listed or eligible for the National or State registers of historic places (Table 8). In addition, two former rail lines cross this route in three places. The Air Line Railroad, completed in 1873, crosses the route as a flat trackbed just west of Card Substation in Lebanon. The New York & New England Railroad, opened in 1872, crosses the route as a flat trackbed north of Route 6 in Coventry, and as a cut through rock 25-30 feet deep east of South Brook Road in Hampton. The latter site has no well-defined engineering features, and like the other two former crossings does not appear to be a potentially significant resource. Although undocumented historic waterpower resources could survive at some stream or river crossings, historic maps do not suggest mill sites at such crossings within the Primary Route Under Consideration. The closest reported site is a partly-documented 19th- century mill ruin on Stony Brook in

Brooklyn about 400 feet east of the existing line. Small undocumented domestic, commercial, or recreational sites remain a possibility along or near roads crossed by the Primary Route Under Consideration, including ruins of small structures probably associated with a Boy Scout camp c1935-1965 south of Route 44 in Putnam (Fairchild Aerial Survey 1934; Northeast Utilities Service Co. 1969-1991). The significance of any recovered historic artifacts at such sites would depend primarily on the integrity of apparent depositional episodes, and the age and rarity of the materials. This route generally appears to have limited sensitivity for significant belowground historic resources, a characterization which also applies to the Mount Hope Montessori School Overhead Variation which includes 5 of the sites reported along the Primary Route (Table 10), the Putnam North Overhead Variation and the 310 Loop each within a mile of 1 site (respectively 69-68, and 30-12 shown on Table 8), and the Brooklyn and Putnam North overhead variations for which there are no reported sites nearby.

Along the Willimantic South Overhead Variation, 3 previously-reported sites were identified, two of which are listed on the National Register of Historic Places (Table 9). All but one of these sites is 400-5100 feet away from the route, and most of the limits on sensitivity for significant below-ground resources noted for the existing CL&P ROW apply to the overhead alternative. An additional former New York and New England Railroad trackbed crossing of the Primary Route Under Consideration in Chaplin has not been inspected for this assessment. The notable exception to these findings is the Fourth Camp of Rochambeau's Army, a 16-acre National Register site in Windham traversed by the Willimantic South Overhead Variation. This site, significant largely for known and potential below-ground remains of the 1781 encampment, should be avoided in any project planning.

2. Underground Routes

Historical maps and secondary sources indicate that virtually all of the Willimantic South Underground Variation consists of roadways built on previously undeveloped land. There are 16 previously-reported archaeological sites 850-4600 feet from this route (Table 11). These sites include two Rochambeau Army camps listed on the National Register of Historic Places, both of which are over 800 feet from the Willimantic South Underground Variation. Most roads along the Willimantic South Underground Variation were established between the late 17th and late 19th centuries. Generations of road and utility construction have probably removed, or severely damaged, remains of original unpaved roads. Any undisturbed off-road segments of underground variations near stream crossings could be sensitive for undocumented historic sites, although historic maps do not suggest mill sites at such crossings. The former New York and New England Railroad once crossed this route near the Windham Airport, but recent maps and aerial photographs suggest this crossing has been completely removed.

The four other underground variations generally appear to have little sensitivity for significant belowground historic resources. There are 4 reported sites within a 1-mile radius of the Mount Hope Montessori School Underground Variation, all at least 2000 feet away; no sites are reported near the remaining routes.

It is possible that undisturbed soils near existing or demolished historic structures could contain artifact deposits associated with residential, commercial, or industrial disposal of trash or other waste products, including hazardous materials. Given the long history of road development and nearby historic occupation near most underground route segments, it is difficult to anticipate the nature or extent of possible historic artifacts. The significance of any recovered historic artifacts will depend primarily on the integrity of apparent depositional episodes, and the age and rarity of the materials. In general, widely-distributed household or commercial materials post-dating the mid 19th century will be too well documented to yield significant new information. It should also be noted that undisturbed rural sections of the Willimantic South Underground Variation may retain sufficient remains of historic landscape features to warrant future eligibility to the National or State registers of historic places. Such features could include combinations of stone walls, open fields, and historic structures. No inspection of offroad underground routes or route variations was made for this assessment, and as noted below there may be a number of historic structures of undetermined eligibility in Project areas.

Table 8. REPORTED EUROAMERICAN ARCHAEOLOGICAL SITES WITHIN ONE MILE OF PRIMARY ROUTE

| TOWN | NO. | NAME | DATE | DESCRIPTION | DISTANCE | NR STATUS | SOURCES |
|-----------|--------|---|--|---|----------|-----------|---------------------------------|
| COLUMBIA | 30-12 | MILL | UNK | stone-lined mill races; midden | 2900' | UNK | OSA; Lizee et al. 1994 |
| COLUMBIA | | SAWMILL | 18 th - 19 th c. | dam abutments | 2200' | UNK | Raber and Gordon 1996 |
| COLUMBIA | | CARD'S MILL | c. 1855-75 | dam, mill foundations | 2500' | UNK | Raber and Gordon 1996 |
| MANSFIELD | 78-39 | TREMBLE TANNERY | 19th c. | tannery; dam | 4000' | UNK | OSA |
| MANSFIELD | 78-88 | SCHOOL HOUSE BROOK NO. 88 | 19th c. | dam; canal channel | 4600' | UNK | OSA |
| MANSFIELD | 78-94 | OLD UNCLE HALL PLACE | 17th c. | altered house; barn outbuilding | 4000' | UNK | OSA |
| MANSFIELD | 78-95 | | UNK | cellar hole | 3200' | UNK | OSA |
| MANSFIELD | 78-150 | R.M. JOHNSON FARM | 19th-20th c. | foundations (house, outbuilding, barns (2)) | 4600' | UNK | OSA; Russo & Cherau 1994 |
| WINDHAM | 163-6 | MANSFIELD HOLLOW DAM | 18th-20th c. | saw and grist mill; archaeed stone dam and stone textile dam | 2100' | UNK | OSA |
| WINDHAM | 163-12 | A. HARTSON RESIDENCE | 19th c. | house foundations | 4400' | UNK | OSA; Russo & Cherau 1994 |
| WINDHAM | 163-13 | J. SWIFT SAW AND GRIST MILL | 19th c. | mill; dam | 4500' | UNK | OSA; Russo & Cherau 1994 |
| WINDHAM | 163-14 | E.H. HALL AND SON THREAD MILL | 19th c. | mill; dam | 4300' | UNK | OSA; Russo & Cherau 1994 |
| CHAPLIN | 24-16 | ROSS MILLS | 19th c. | crib dam, canal | 3500' | UNK | OSA; Bayles 1889 |
| CHAPLIN | 24-26 | DEANS MILL | 18th-19th c. | foundations, crib dam | 4900' | UNK | OSA; Bayles 1889 |
| CHAPLIN | 24-27 | LYONS PAPER MILL | 19th c. | foundations, crib dam | 6000' | UNK | OSA; Bayles 1889 |
| BROOKLYN | 19-21 | TRINITY CHURCH | 18th-19th c. | stone capped pit feature, ceramics, machine cut and hand wrought nails | 3400' | UNK | OSA; Fragola 2000a, 2000b |
| BROOKLYN | 19-20 | GRIFFIN-BAKER HOUSE | 19th c. | ceramic, bone, plastic, nails, metal | 2800' | UNK | OSA; Fragola 2000a, 2000b |
| BROOKLYN | 19-22 | BENNETT'S MILL | 19th c. | fieldstone alignment and walls, dam footings, linear depression | 400' | UNK | OSA; Fragola 2000a, 2000b |
| BROOKLYN | 19-23 | GRANT TERRY HOUSE | c1845-1972 | foundation | 2800' | UNK | TAMS/Earth Tech 2005 |
| BROOKLYN | 19-24 | 23 WAUREGAN ROAD | c1833-1900 | house foundation | 4800' | UNK | TAMS/Earth Tech 2002 |
| BROOKLYN | 19-25 | 28 WAUREGAN ROAD | c1855-1900 | house foundation | 4800' | UNK | TAMS/Earth Tech 2002 |
| KILLINGLY | 69-27 | ARNOLD'S MILL | 19th c. | mill race, mill ruins | 2000' | UNK | OSA |
| KILLINGLY | 69-42 | ROGERS MILL SOUTH | 19th-20th c. | coal, whiteware, creamware, pearlware, stoneware, glass, nails, kaolin shell, slag, metal | 1800' | NOT NRE | OSA; McBride 1992; Soulsby 1992 |
| KILLINGLY | 69-68 | PEOPLES TRAMWAY COMPANY STONE ARCH BRIDGE | ca. 1900 | stone bridge | 1100' | UNK | CONNDOT HBIF |

Table 9. REPORTED EUROAMERICAN ARCHAEOLOGICAL SITES WITHIN ONE MILE OF WILLIMANTIC SOUTH OVERHEAD VARIATION

| TOWN | NO. | NAME | DATE | DESCRIPTION | DISTANCE | NR STATUS | SOURCES |
|----------|--------|--|------|--|----------|-----------|-----------------------------|
| WINDHAM | 163-24 | 47 th CAMP OF ROCHAMBEAU'S ARMY | 1782 | 16 acres: uniform, kettle, sword fragments; coins, musket balls, artillery gauge | 3400' | LISTED | OSA; Harper & Clouette 2001 |
| WINDHAM | 163-25 | FOURTH CAMP OF ROCHAMBEAU'S ARMY | 1781 | 16 acres; uniform fragments; coins; musket balls; stone bridge abutment on former road | 0' | LISTED | OSA; Harper & Clouette 2001 |
| SCOTLAND | 123-5 | | UNK. | no data | 5100' | UNK | OSA |

ABBREVIATION

NR STATUS: LISTED Listed on the National Register of Historic Places SOURCES: OSA Office of Connecticut State Archaeology
 UNK National Register eligibility not determined HBIF Historic Bridge Inventory Form
 NOT NRE Not eligible for National Register listing

Table 10. REPORTED EUROAMERICAN ARCHAEOLOGICAL SITES WITHIN ONE MILE OF M.H. MONTESSORI SCHOOL OVERHEAD VARIATION

| TOWN | NO. | NAME | DATE | DESCRIPTION | DISTANCE | NR STATUS | SOURCES |
|-----------|-------|---------------------------|--------------|---|----------|-----------|---------|
| MANSFIELD | 78-39 | TREMBLE TANNERY | 19th c. | tannery; dam | 4000' | UNK | OSA |
| MANSFIELD | 78-88 | SCHOOL HOUSE BROOK NO. 88 | 19th c. | dam; canal channel | 4600' | UNK | OSA |
| MANSFIELD | 78-94 | OLD UNCLE HALL PLACE | 17th c. | altered house; barn outbuilding | 4000' | UNK | OSA |
| MANSFIELD | 78-95 | | UNK | cellar hole | 3200' | UNK | OSA |
| WINDHAM | 163-6 | MANSFIELD HOLLOW DAM | 18th-20th c. | saw and grist mill; archaed stone dam and stone textile dam | 2100' | UNK | OSA |

Table 11. REPORTED EUROAMERICAN ARCHAEOLOGICAL SITES WITHIN ONE MILE OF WILLIMANTIC SOUTH UNDERGROUND VARIATION

| TOWN | NO. | NAME | DATE | DESCRIPTION | DISTANCE | NR STATUS | SOURCES |
|-----------|--------|---|--------------|---|----------|-----------|-----------------------------|
| WINDHAM | 163-9 | BARN | 19th c. | barn foundations and associated remains | 1200' | UNK | OSA; Russo & Cherau 1994 |
| WINDHAM | 163-10 | LINCOLN WOOLEN MILL | 19th c. | mill; flow-blue ironstone; earthenware; bottle glass | 1200' | UNK | OSA; Russo & Cherau 1994 |
| WINDHAM | 163-11 | W.S. BURNHAM RESIDENCE | 19th-20th c. | house foundations | 700' | UNK | OSA; Russo & Cherau 1994 |
| WINDHAM | 163-12 | A. HARTSON RESIDENCE | 19th c. | house foundations | 850' | UNK | OSA; Russo & Cherau 1994 |
| WINDHAM | 163-13 | J. SWIFT SAW AND GRIST MILL | 19th c. | mill; dam | 950' | UNK | OSA; Russo & Cherau 1994 |
| WINDHAM | 163-14 | E.H. HALL AND SON THREAD MILL | 19th c. | mill; dam | 1200' | UNK | OSA; Russo & Cherau 1994 |
| WINDHAM | 163-15 | H. SPAFFORD/J.F. MCCARTHY RESIDENCE | 19th-20th c. | house foundations | 950' | UNK | OSA; Russo & Cherau 1994 |
| WINDHAM | 163-16 | H. SPAFFORD WAGON/MACHINE SHOP | 19th-20th c. | remains of shop commercial building | 650' | UNK | OSA; Russo & Cherau 1994 |
| WINDHAM | 163-17 | O.L. MOSELEY RESIDENCE | 19th-20th c. | house foundations | 650' | UNK | OSA; Russo & Cherau 1994 |
| WINDHAM | 163-18 | K.G. KOENNICKE | 19th-20th c. | house foundations; outbuildings (3) | 650' | UNK | OSA; Russo & Cherau 1994 |
| WINDHAM | 163-19 | W.G. STEVENS DOUBLE BAY GARAGE | 20th c. | garage foundations; outbuilding | 750' | UNK | OSA; Russo & Cherau 1994 |
| WINDHAM | 163-20 | W.G. STEVENS RESIDENCE | 19th-20th c. | house foundations; well; privy? | 650' | UNK | OSA; Russo & Cherau 1994 |
| WINDHAM | 163-21 | L.J. POTVIN CHICKEN FARM | 19th-20th c. | chicken farm outbuildings (coop foundations (2); silo; shed foundations (2); barn foundation) | 750' | UNK | OSA; Russo & Cherau 1994 |
| WINDHAM | 163-24 | 47 th CAMP OF ROCHAMBEA'S ARMY | 1782 | 16 acres; uniform, kettle, sword fragments; coins, musket balls, artillerist gauge | 2300' | LISTED | OSA; Harper & Clouette 2001 |
| WINDHAM | 163-25 | FOURTH CAMP OF ROCHAMBEAU'S ARMY | 1781 | 16 acres; uniform fragments; coins; musket balls; stone bridge abutment on former road | 850' | LISTED | OSA; Harper & Clouette 2001 |
| MANSFIELD | 78-150 | R.M. JOHNSON FARM | 19th-20th c. | foundations (house, outbuilding, barns (2)) | 4600' | UNK | OSA; Russo & Cherau 1994 |

Table 12. REPORTED EUROAMERICAN ARCHAEOLOGICAL SITES WITHIN ONE MILE OF MOUNT HOPE MONTESSORI SCHOOL UNDERGROUND VARIATION

| TOWN | NO. | NAME | DATE | DESCRIPTION | DISTANCE | NR STATUS | SOURCES |
|-----------|-------|---------------------------|--------------|---|----------|-----------|---------|
| MANSFIELD | 78-39 | TREMBLE TANNERY | 19th c. | tannery; dam | 4000' | UNK | OSA |
| MANSFIELD | 78-88 | SCHOOL HOUSE BROOK NO. 88 | 19th c. | dam; canal channel | 4600' | UNK | OSA |
| MANSFIELD | 78-95 | | UNK | cellar hole | 3200' | UNK | OSA |
| WINDHAM | 163-6 | MANSFIELD HOLLOW DAM | 18th-20th c. | saw and grist mill; archaed stone dam and stone textile dam | 2100' | UNK | OSA |

ABBREVIATION

NR STATUS: LISTED Listed on the National Register of Historic Places SOURCES: OSA Office of Connecticut State Archaeology
 UNK National Register eligibility not determined HBIF Historic Bridge Inventory Form
 NOT NRE Not eligible for National Register listing

C. Historic Properties and Visual Effects

1. Resource Identification

For this assessment, significant aboveground historic properties included resources which have been listed on the National or State registers of historic places, identified as eligible for these registers in previous surveys and cultural resource studies, identified as historic cemeteries subject to State protection and potentially eligible for register listing, or designated a National Scenic Byway. Identification of significant historic properties within 0.25 mile of possible overhead route segments and 500 feet of possible underground route segments was based primarily on:

- Maps available with National Register of Historic Places nomination forms, State Register of Historic Places nominations or other materials, townwide surveys of historic architectural or industrial resources, and other cultural resource management studies;
- Lists with addresses of properties considered eligible for National Register listing in townwide surveys of historic architectural or industrial resources;
- A statewide inventory of many historic bridges (Connecticut Department of Transportation 1994, 2001; Historic Resource Consultants 1990, 1991).

All Project area towns except Putnam have had some degree of townwide historic resource survey, with only the more urbanized area in Putnam surveyed. This area is far beyond the distance limits of concern for this assessment. In Windham, detailed survey of Willimantic focused on areas north of the Willimantic River which did not fall within the limits of assessment concern (Clouette and Roth 1983). Sufficient detail was available in surveys of Killingly and Thompson to locate resources identified as eligible for the National Register (Clouette and Roth 1982; McDonough 1986; McCahon 1990). In other Project area towns with townwide surveys, including Windham outside Willimantic, the surveys were all done with minimal funding in the late 1970s, lack any identification of specific eligible properties, and in many cases lack maps of inventoried properties (Anonymous 1978; Law 1978a, 1978b; Denegre 1978; Lazarius 1978; Munhall 1978a, 1978b; Old Houses Committee 1978; Woisard 1978). While subsequent research identified significant properties which became National Register districts in many of these towns, there are probably over fifty inventoried structures within 0.25 mile of possible overhead routes **S**and a much smaller number within 500 feet of possible underground routes **S**for which no findings of eligibility have been made.

With these caveats, a total of 12 significant historic resources and a National Scenic Byway were identified within approximately 0.25 mile of the Primary Route Under Consideration (Table 13). Many of these resources are historic districts which lie wholly or partially beyond the 0.25-mile limit, so that the total number of individual sites or structures within approximately 0.25 mile is 21. Comparable totals relative to the Willimantic South Overhead Variation are 4 resources and 29 individual sites (Table 14). For the Willimantic South Underground Variation, comparable totals include 7 resources and 32 structures within 500 feet (Table 15). Most of the individual structures noted above for tables 14 and 15 are within the Windham Center National Register District. Most structures within the Mansfield Hollow Historic District (shown in Table 13) are within 0.25 mile of the Mount Hope Montessori School Overhead Variation.

No significant historic resources were identified within approximately 0.25 mile of the Brooklyn Overhead Variation or the 310 Loop, or within approximately 500 feet of the Mansfield and Brooklyn underground variations. Along the Montessori School Underground Variation, the edge of the Mansfield Hollow Historic District is just over 500 feet to the east, but the nearest historic structures within the district are approximately 1000 feet from this variation. The Munyan Cemetery (shown in Table 13) is adjacent to the Putnam North Underground Variation.

Appendix 1 maps show the locations of the historic resources noted above.

2. Preliminary Identification of Resources Subject to Potential Effects

No direct Project effects are presently anticipated on known significant aboveground historic properties along any possible routes. Any potential effects of blasting on significant properties along underground routes would be evaluated during D&M planning following final route determination, and protective measures developed as needed.

For all overhead routes, a total of 14 significant historic resources and the National Scenic Byway were identified within approximately 0.25 mile of the Primary Route Under Consideration or the Willimantic South and Mount Hope Montessori School overhead variations, as noted above and detailed in Tables 13-14. One of these resources, the Brooklyn Green Historic District, is over 0.4 mile from the existing CL&P ROW of 80-to-90-foot structures with the intervening areas largely undeveloped and wooded. Experience with recent transmission line visual effects issues suggests that even with full visibility, a new structure 80-90 feet high at such a distance will have no adverse effects (e.g., Raber and Wiegand 2003).

For 10 of the remaining 11 significant historic resources along the Primary Route Under Consideration, transects between specific properties and specific existing transmission structure locations were identified on U.S. Geological Survey maps and digitally profiled to assess visibility (Table 15, Appendix 2). Digital results included in Appendix 2 indicate that for 9 of these profiles, new structures at heights of up to 100 feet would not be visible because of terrain or forest cover obstructions, regardless of any additional vegetation clearing for new construction. One profile, No. 5, suggests possible visibility from a small portion of the Mansfield Center Cemetery, but such visibility would be greatly limited by distance and intervening tree cover (Appendix 3). For these resources, Project impacts appear to be Visibility with No Effect or Visibility with Non-Adverse Effect.

No profiles were needed to show that new structures would have some visual effect on the Mansfield Hollow Dam, the remaining significant historic resource along the Primary Route Under Consideration, as shown with existing and simulated conditions in Appendix 3. The Primary Route crosses the dam with transmission structures adjacent or close to the historic resource. Although additional structures would be placed near existing ones, the currently-anticipated similarity of scale, design and height between existing and proposed structures appear to present limited overall landscape changes to the dam and its immediate vicinity. The Primary Route Under Consideration appears to present a potential Non-Adverse Effect visual effect on Mansfield Hollow Dam.

Generally similar conclusions seem to apply to the Primary Route Under Consideration crossing of State Route 169 in Brooklyn. Existing and proposed structures southwest of the Scenic Byway are approximately 400 feet from the road, on a steep, heavily vegetated hillside. Even if some of the vegetation is cleared for Project construction, potential visual effects on the roadside landscape appear limited. Depending on the placement of a new structure southwest of the road, vegetation clearing could also be designed to minimize visibility. To the northeast of the road, there is an existing structure approximately 130 feet away in an open field. Adding a second structure at this distance would have some visual effect on a short stretch of roadside landscape with a fieldstone wall, open field, and more distant pond. However, as the general character of the scenic byway is maintained for automobile travel, traveler perception to the northwest of landscape effects along a roadway distance of less than 400 feet appear to be limited, especially if new structures built in this area are made of wood rather than steel. The Primary Route Under Consideration appears to present a potential Non-Adverse Effect visual effect on State Route 169 (Appendix 3).

On the Willimantic South Overhead Variation, two closely-related significant resources are within approximately 0.25 mile: parts of the Windham Center National Register District, and the Dr. Chester Hunt Office which remains part of this district despite being moved twice since 1968. Profile No. 11 suggests that new structures 130 feet high would not be visible from the latter property. Profiles No. 12 and 13 suggest that south of the Windham Center Elementary School on Route 14/203 (a non-contributing complex within the historic district), most new structures would not be visible due to terrain and forest cover, even if 130 feet high. From Weir Court south of the center of the district, Profile No. 14 suggests possible limited visibility of new structures 130 feet high, and probable lack of visibility for new structures under approximately 100 feet high (Appendix 2). Immediately west of Weir Court, this same profile suggests visibility of new structures would increase from private property adjacent to historic district residences, but at the distances currently under consideration it is likely such visibility would have no adverse effect on district landscapes. North of the elementary school, however, the variation route crosses the north end of the historic district 200-500 feet from four contributing historic residences, in an area of limited tree cover. At these close distances, no profiles were needed to show that new structures might have adverse visual effects on these latter historic buildings. Photographic simulations of possible structures for the Willimantic South Overhead Variation have not been completed to date, but may be necessary if this variation becomes a likely alternative during Project planning, public comment, and CSC review.

The same tree cover which shields the Mansfield Hollow Historic District from the Primary Route Under Consideration also appears to shield most of the district from potential visibility of possible new structures along the Mount Hope Montessori School Overhead Variation. Photographic simulation of new structures west of the district, where the variation route is over 800 feet from district homes at the only notable break in tree cover in the vicinity, suggests that Project impacts of new 90-foot-tall structures anticipated for this variation would be Visibility with No Effect or Visibility with Non-Adverse Effect. Placing new structures behind tree cover, as shown in Appendix 3, would provide maximum protection from many visual effects.

3. Possible Future Needed Actions

CL&P will continue to coordinate with SHPO regarding cultural resources and will perform further archaeological and visual effect studies as necessary. For overhead Project areas in which no previous historic resource surveys have been conducted to identify significant historic properties, additional studies may be needed to locate and evaluate such properties and any related Project effects. To define further the universe of historic properties subject to potential visual effects, a proposed Project route and transmission line configuration must be selected, and designed in conjunction with a draft CL&P Development and Management Plan. For resources already identified as significant, it is recognized that the simulations in Appendix 3 may not account for all possible conditions of future right-of-way tree clearances, but together with digital profiles the simulations may identify conditions under which future remaining forest cover would continue to create conditions of Visibility with Non-Adverse Effect. For new structures in the Willimantic South and Mount Hope Montessori School Overhead Variations, visual simulations may be needed to evaluate effects on some resources in the Mansfield Hollow and Windham Center historic districts. For the numerous historic resources previously inventoried but of undetermined significance in Project vicinities, digital profiles and simulations can be used to identify properties subject to possible adverse effects following selection of a proposed route and transmission line plan. Additional research may be required to determine the significance of properties subject to possible adverse effects, and Development and Management planning may have to include measures to minimize or mitigate such effects.

TABLE 13. KNOWN SIGNIFICANT ABOVEGROUND HISTORIC RESOURCES WITHIN APPROXIMATELY ONE QUARTER MILE OF PRIMARY ROUTE UNDER CONSIDERATION

| TOWN | NAME | SUMMARY DESCRIPTION | STATUS | RESOURCES W/IN ± 0.25 MILE | PROFILE/ RESULT | PHOTO | SOURCES | REMARKS |
|-----------|------------------------------------|--|-----------------------|----------------------------|---------------------|------------------|--|---|
| COVENTRY | FLANDERS ROAD BRIDGE (No. 4622) | 1914 steel pony truss | NRE | 1 | 1: BLOCKED | | Historic Resource Consultants 1990; Clouette 1994 | 0.3 miles from center of existing right-of-way |
| MANSFIELD | 3 JEWISH CEMETERIES | early 20 th century | CGS 19a-315 | 1 | 2: BLOCKED | | Hale 1932; Mansfield Planning & Zoning Commission 1993 | nearest point 0.33 miles from center of existing right-of-way |
| MANSFIELD | MANSFIELD HOLLOW HISTORIC DISTRICT | 19 th century mill, 10 houses, store, barn | LISTED | 8 | 3: BLOCKED | | Clouette 1978a | also adjacent to Mount Hope Montessori School Overhead Variation – see Appendix 3: 2-3 |
| MANSFIELD | MANSFIELD CENTER CEMETERY | 18th-19th century | LISTED; CGS 19a-315 | 1 | 5: OPEN | Appendix 3: 1 | Clouette 1992 | nearest point 0.32 miles from center of existing right-of-way |
| MANSFIELD | MANSFIELD HOLLOW DAM | 1949-52 flood control dam & associated structures | NR LISTING PENDING | 1 | NONE: OPEN | Appendix 3: 4-7 | Atwood 2002 | CL&P structure 9081 is immediately east of the dam, & structures 9080 & 9082 are 600-850 feet from dam with no tree cover |
| MANSFIELD | MANSFIELD CENTER HISTORIC DISTRICT | ± 20 houses, 10 sites or structures, town hall, church, library, & New Cemetery - 18th-19th c. | LISTED; CGS 19a-315 | 1 (New Cemetery) | 4: BLOCKED | | Bigelow 1967; Babbitt 1972 | |
| CHAPLIN | CHEWINK CEMETERY | 19 th -20 th centuries | CGS 19a-315 | 1 | 6: BLOCKED | | Hale 1932, 1934; Law 1978 | |
| CHAPLIN | OLD CEMETERY | 18 th -19 th centuries | CGS 19a-315 | 1 | 7: BLOCKED | | Hale 1932, 1934 | |
| HAMPTON | SOUTH CEMETERY | 19 th century | CGS 19a-315 | 1 | 8: BLOCKED | | Hale 1932; Law 1978 | |
| BROOKLYN | STATE ROUTE 169 | | NATIONAL SCENIC BYWAY | 1 | NONE: OPEN | Appendix 3: 8-11 | | crossed by Primary Route |
| BROOKLYN | BROOKLYN GREEN HISTORIC DISTRICT | 18th-19th c. village: 4 churches, post office, library, town hall, ± 64 homes | LISTED | 0 | NONE see remarks | | Keiner 1979a | nearest points approximately 0.4 miles from center of existing right-of-way |
| KILLINGLY | ROGERS VILLAGE | 19th-20th c. mill village: 1 mill, hotel, church, social club, 57 homes, 1 site | NRE | 4 | 9: BLOCKED | | Clouette and Roth 1982 | |
| PUTNAM | MUNYAN CEMETERY | 19 th -20 th centuries | CGS 19a-315 | 1 | 10: BLOCKED | | Hale 1932, 1934 | 0.3 miles from center of existing right-of-way |

ABBREVIATIONS

STATUS: LISTED
NRE
CGS 19a-315

Listed on the National Register of Historic Places
Eligible for National Register listing
Wholly or Partially Protected under Connecticut Statute as Ancient Burying Ground

PROFILE RESULT: BLOCKED No Likely Visibility assuming 50'-high forest
OPEN Possible Visibility assuming 50'-high forest

TABLE 14. KNOWN SIGNIFICANT ABOVEGROUND HISTORIC RESOURCES WITHIN APPROXIMATELY ONE QUARTER MILE OF WILLIMANTIC SOUTH OVERHEAD VARIATION

| TOWN | NAME | SUMMARY DESCRIPTION | STATUS | RESOURCES W/IN ± 0.25 MILE | PROFILE/ RESULT | SOURCES | REMARKS |
|---------|----------------------------------|--|-------------|-------------------------------|--|---------------------------|--|
| WINDHAM | DR CHESTER HUNT OFFICE | c1800-1810 structure, used as medical office mid-19th century | LISTED | 1 | 11: BLOCKED | Luyster 1970 | 0.25 miles from variation route; included within Windham Center National Register District; moved 1984 within district |
| WINDHAM | WINDHAM CENTER HISTORIC DISTRICT | 18th-20th century town center/village: 2 churches, library, 2 former stores, 1 former inn, 1 hat shop, 53 other residences | LISTED | 26 | 12: BLOCKED 13: BLOCKED 14: See remarks | Keiner 1979b | visibility would vary with new structure heights and locations, with structures up to about 100' high probably blocked at most locations; visual effects likely north of non-contributing school on Route 14/203 |
| CHAPLIN | CHEWINK CEMETERY | 19 th -20 th centuries | CGS 19a-315 | 1 | 6: BLOCKED | Hale 1932, 1934; Law 1978 | approximately 1300' from center of Primary Route and 1000' from Variation 1 representative centerline |
| CHAPLIN | OLD CEMETERY | 18 th -19 th centuries | CGS 19a-315 | 1 | 7: BLOCKED | Hale 1932, 1934 | approximately 800' from center of Primary Route and 1400' from Variation 1 representative centerline |

ABBREVIATIONS

STATUS: LISTED Listed on the National Register of Historic Places
 CGS 19a-315 Wholly or Partially Protected under Connecticut Statute as Ancient Burying Ground

TABLE 15. KNOWN SIGNIFICANT ABOVEGROUND HISTORIC RESOURCES WITHIN 500 FEET OF WILLIMANTIC SOUTH UNDERGROUND VARIATION

| TOWN | NAME | SUMMARY DESCRIPTION | STATUS | RESOURCES W/IN " 500 FEET | SOURCES | REMARKS |
|---------|----------------------------------|--|-------------|------------------------------|--|--|
| WINDHAM | WILLIMANTIC ARMORY | 1912 head house & drill house, Romanesque Revival influences | LISTED | 1 | Clouette & Roth 1984 | adjacent to underground alternative |
| WINDHAM | WILLIMANTIC ELKS CLUB | 1925-1927 Gothic Revival lodge | LISTED | 1 | Clouette 2005 | adjacent to underground alternative |
| WINDHAM | WILLIMANTIC FOOTBRIDGE | 1906 600'-long, 5-span structure of steel through trusses | LISTED | 1 | Clouette 1978b | 200 feet from underground alternative |
| WINDHAM | WINDHAM ROAD BRIDGE (No. 01850) | 1869 130'-long 2-span ashlar stone arch structure | NRE | 1 | Historic Resource Consultants 1990, 1991; SHPO | 200 feet from underground alternative; designated for pedestrian use only |
| WINDHAM | DR CHESTER HUNT OFFICE | c1800-1810 structure, used as medical office mid-19th century | LISTED | 1 | Luyster 1980 | adjacent to underground alternative; included within Windham Center National Register District |
| WINDHAM | WINDHAM CENTER HISTORIC DISTRICT | 18th-20th century town center/village: 2 churches, library, 2 former stores, 1 former inn, 1 hat shop, 53 other residences | LISTED | 26 | Keiner 1979a | portions are adjacent to underground alternative |
| WINDHAM | NORTH WINDHAM CEMETERY | 19 th -20 th centuries | CGS 19a-315 | 1 | Hale 1932, 1934 | 400 feet from underground alternative |

ABBREVIATIONS

STATUS: LISTED Listed on the National Register of Historic Places
 NRE Eligible for National Register listing
 CGS 19a-315 Wholly or Partially Protected under Connecticut Statute as Ancient Burying Ground

SOURCES: SHPO State Historic Preservation Office

REFERENCES

- Anderson, David G. and Kenneth E. Sassaman
1996 *The Paleoindians and Early Archaic Southeast*. Tuscaloosa: University of Alabama Press.
- Anonymous
1954 *The Story of Columbia*. Columbia: Women's Guild of the Congregational Church.
1978 [Pomfret townwide reconnaissance-level historic resource survey]. Prepared for Connecticut Historical Commission and Regional Planning Agency. On file, Connecticut Historic Preservation Collection, Dodd Center, University of Connecticut, Storrs.
- Atwood, Kathleen A.
2002 Mansfield Hollow Dam. National Register of Historic Places Registration Form. On file, Connecticut State Historic Preservation Office.
- Babbitt, Susan
1972 Mansfield Center Historic District. National Register of Historic Places Inventory—Nomination Form. On file, Connecticut State Historic Preservation Office.
- Barber, John W.
1838 *Connecticut Historical Collections*. New Haven, CT: Durrie & Peck and John W. Barber.
- Basto, A.
1938 A Cross-section of an Algonquin Village Site Located at South Woodstock, Windham County, Connecticut. *Bulletin of the Archaeological Society of Connecticut* 6: 12-34.
1939 A Second Summer's Field Work on the Village Site in South Woodstock, Connecticut. *Bulletin of the Archaeological Society of Connecticut* 8: 27-44.
- Bayles, Richard M.
1889 *History of Windham County, Connecticut*. New York: W.W. Preston & Co.
- Beers, F.W., A.D. Ellis, and G.G. Soule
1868 *Atlas of New London County, Connecticut*. New York.
- Beetham, N. and W. Niering
1961 A Pollen Diagram from Southeastern Connecticut. *American Journal of Science* 259: 69-75.
- Bendremer, Jeffrey and Robert E. Dewar
1993 The Advent of Prehistoric Maize in New England. In *Corn and Culture in the New World*, Sissel Johannsen and Christine Hastorf, editors. Minneapolis: University of Minnesota Press.
- Bickford, Christopher P.
1999 *Plainfield Transformed: Three Centuries of Life in a Connecticut Town 1699-1999*. Plainfield, Connecticut: Plainfield Historical Society.
- Bigelow, Seymour
1967 Historic District, Mansfield Centre [sic] Conn. Map on file, Connecticut State Historic Preservation Office.
- Binford, Lewis R.
1980 Willow Smoke and Dogs' Tails: Hunter-Gatherer Settlement Systems and Archaeological Site Formation. *American Antiquity* 45(1): 4-20.

- Blodget, William
1792 A New and Correct Map of Connecticut, One of the United States of America. Middletown, CT.
- Braun, Emma L.
1950 *Deciduous Forests of Eastern North America*. New York: Hafner.
- Brennan, L.
1982 Compilation of Fluted Points of Eastern North America by Count and Distribution: an AENA Project. *Archaeology of Eastern North America* 10:27-46.
- Caulkins, Frances M.
1866 *History of Norwich, Connecticut from its possession by the Indians to the year 1866*. Hartford.
- Ceci, Lynn
1980 Maize Cultivation in Coastal New York: The Archaeological, Agronomical and Documentary Evidence. *North American Archaeologist* 1(1): 45-74.
- Clouette, Bruce
1978a Mansfield Hollow National Register District. National Register of Historic Places Inventory—Nomination Form. On file, Connecticut State Historic Preservation Office.
1978b Willimantic Footbridge. National Register of Historic Places Inventory—Nomination Form. On file, Connecticut State Historic Preservation Office.
1992 Mansfield Center Cemetery. National Register of Historic Places Inventory—Nomination Form. On file, Connecticut State Historic Preservation Office.
1994 Perkins Corner Bridge (CONNDOT No. 4622). Historic American Engineering Record Documentation HAER No. CT-150. On file, Connecticut Historic Preservation Collection, Dodd Center, University of Connecticut, Storrs.
2005 Willimantic Elks Club. National Register of Historic Places Registration Form. On file, Connecticut State Historic Preservation Office.
- Clouette, Bruce and Matthew Roth
1982 Historic Resource Survey of the Killingly Community Development Areas. Prepared for Town of Killingly. On file, Connecticut Historic Preservation Collection, Dodd Center, University of Connecticut, Storrs.
1984 Willimantic Armory. National Register of Historic Places Inventory—Nomination Form. On file, Connecticut State Historic Preservation Office.
1983 Historic and Architectural Resource Survey in the Town of Windham. Willimantic Community Development Areas. Three Volumes. Sponsored by the Willimantic Community Development Agency and the Connecticut Historical Commission. On file, Connecticut Historic Preservation Collection, Dodd Center, University of Connecticut, Storrs.
- Cole, J.R.
1888 *History of Tolland County, Connecticut*. New York: W.W. Preston & Co.

- Connecticut Department of Environmental Protection
2003 Environmental GIS Data for Connecticut 2003 Edition. Environmental and Geographic Information Center. DEP Bulletin 37.
- Cronan, John M. and Albert Brooks
1968 *The Mammals of Rhode Island*. Revised edition. Wildlife Pamphlet No. 6. Rhode Island Department of Natural Resources, Division of Conservation. 133 pp.
- Curran, Mary L. and Dena F. Dincauze
1977 Paleo-Indians and Paleo-Lakes: New Data from the Connecticut Drainage. In Amerinds and their Paleoenvironments in Northeastern North America. *Annals of the New York Academy of Sciences* Vol. 288.
- Daniels, Bruce C.
1979 *The Connecticut Town: Growth and Development, 1635-1790*. Middletown, CT: Wesleyan University Press.
- Davis, Alison
1976 *Hampton Remembers*. Hampton: published by the author.
- Davis, Margaret B.
1967 Late Glacial Climate in the Northern U.S.: A Comparison of New England and the Great Lakes Region. In *Quaternary Paleology*, pp. 11-44, Edward J. Cushing and Herbert E. Wright, Jr., editors. Volume 7 of the Proceedings of the VII Congress of the International Association for Quaternary Research. New Haven: Yale University Press.

1969 Climatic Changes in Southern Connecticut recorded by Pollen Deposition at Roger Lake. *Ecology* 50: 409-442.
- Deevey, E.S.
1939 Studies on Connecticut Lake Sediments. *American Journal of Science* 237: 691-724.
- DeForest, James W.
1991 *History of the Indians of Connecticut from the Earliest Known Period to 1850*. Native American Book Publishers. Brighton, Michigan. [Originally published 1852]
- Denegre, Joseph
1978 [Coventry townwide reconnaissance-level historic resource survey]. Prepared for Connecticut Historical Commission and Regional Planning Agency. On file, Connecticut Historic Preservation Collection, Dodd Center, University of Connecticut, Storrs.
- Dincauze, Dena F.
1968 *Cremation Cemeteries in Eastern Massachusetts*. Papers of the Peabody Museum of Archaeology and Ethnology. Harvard University, Cambridge.

1975 The Late Archaic Period in Southern New England. *Arctic Anthropology* 12(2): 23-24.

1976 The Neville site: 8,000 years at Amoskeag, Manchester, New Hampshire. *Cambridge: Peabody Museum Monographs*, No. 4: 150 pp.
- Dincauze Dena F. and M. Mulholland
1977 Early and Middle Archaic Site Distributions and Habitat in Southern New England. In *Amerinds and Their Paleoenvironments in Northeastern North America*, Walter S. Newman and Bert Salwen, editors, pp. 439-456. *Annals of the New York Academy of Sciences*.

- Dowhan, Joseph J. and Robert J. Craig
1976 *Rare and Endangered Species of Connecticut and Their Habitats*. Connecticut Geological Survey, Natural History Survey, Report of Investigation No. 6.
- Dragoo, Don W.
1976 Some Aspects of Eastern North American Prehistory. A Review. *American Antiquity* 41(1): 13-35.
- Eisenberg, Leonard
1978 *Paleo-Indian Settlement Pattern in the Hudson and Delaware River Drainages*. Occasional Publications in Northeastern Anthropology, Franklin Pierce College.
- Egler, Frank E., and William A. Niering
1965 *The Vegetation of Connecticut's Natural Areas*. State Geological & Natural History Survey of Connecticut. New Haven: Yale Natural Preserve.
- Fairchild Aerial Survey
1934 Aerial survey of the State of Connecticut. Record Group 89, Records of the Department of Transportation. Connecticut State Archives.
- Ferguson, J.P.
1995 The Haviland Site: The Early Archaic in Schoharie County. *The Bulletin Journal of the New York State Archaeological Association* 110: 1-15.
- Finch, Eugene
1964 Recent Archaeological Work in New Hampshire. *Eastern States Archaeological Federation Bulletin* 24: 14-15.
- Flint, Richard F.
1930 The Glacial Geology of Connecticut. *Connecticut Geological and Natural History Survey Bulletin, No. 47*.

1971 *Glacial and Quaternary Geology*. New York: J. Wiley and Sons.
- Forrest, Daniel T.
1999 Beyond Presence and Absence: Establishing Diversity in Connecticut's Early Holocene Archaeological Record. *Bulletin of the Connecticut Archaeological Society* 62: 79-100.

2000 Looking for a More Substantial Early Archaic. Paper given at the joint meetings of the Archaeological Society of Connecticut, the Massachusetts Archaeological Society, and the New Hampshire Archaeological Society, Spring 2000.
- Fowler, William S.
1968 A Case for an Early Archaic in New England. *Massachusetts Archaeological Society Bulletin* 29: 53-58.
- Fragola, Patricia
2000a Supplemental Phase I Archaeological Reconnaissance Survey Reconstruction of Route 6. Pawtucket, RI: Public Archaeology Laboratory, Inc. Report on file as CHPC #900, Connecticut Historic Preservation Collection, Dodd Center, University of Connecticut, Storrs.

- 2000b Phase II Archaeological Intensive Survey and Supplemental Phase I Archaeological Reconnaissance Survey. Reconstruction of Route 6. Pawtucket, RI: Public Archaeology Laboratory, Inc. Report on file as CHPC #930, Connecticut Historic Preservation Collection, Dodd Center, University of Connecticut, Storrs.
- Gaudreau, Denise C. and Thompson Webb III
 1985 Late Quaternary Pollen Stratigraphy and Isochrone Maps for the Northeastern United States. In *Pollen Records of Late Quaternary North America*, Vaughn M. Bryant, Jr. and Richard G. Holloway, editors, pp. 247-280. Dallas: American Association of Palynologists Foundation.
- Gerrish, E. P., and others
 1856 Windham County, Connecticut, From Actual Survey. Philadelphia: Woodford and Bartlett.
- Golet, Francis C.
 1976 Wildlife Wetland Evaluation Model. In *Models for Assessment of Freshwater Wetlands*, pp. 13-34, J.S. Larson, editor. Publication No. 32. Amherst, MA: Water Resources Research Center, University of Massachusetts.
- Gramly, Richard M. and Robert E. Funk
 1990 What is Known and Not Known About the Human Occupation of the Northeastern United States Until 10,000 B.P. *Archaeology of Eastern North America* 18: 5-31.
- Gray, O.W.
 1969 *Atlas of Windham and Tolland Counties...* Hartford: D.G. Keeney.
- Griffin, James B.
 1967 Eastern North American Archaeology: A Summary. *Science* 156(3772): 125-191.
- Griggs, Susan J.
 c1940 *Folklore and Families of Hampton and Vicinity*.
- Hale, Charles R., ed.
 1932 Cemeteries and Burial Plots in Connecticut, Under Auspices of Connecticut State Library. Connecticut State Library.
 1934 Connecticut State Tombstone Collection. Connecticut State Library.
- Haynes, C.V., D.J. Donahue, A.J.T. Jull and T.H. Zabel
 1984 Application of Accelerator Dating to Fluted Point Paleoindian Sites. *Archaeology of Eastern North America* 12: 184-191.
- Heritage Consultants, LLC
 2004 Phase I Cultural Resources Reconnaissance Survey of the Proposed Tracy Substation and Associated Access Road, Killingly and Putnam, Connecticut. Report prepared for Vanasse Hangen Brustlin, Inc. and Northeast Utilities.
- Historic Resource Consultants
 1990 Connecticut Historic Bridge Survey/Inventory-Phase Final Report: Project Narrative, Inventory and Recommendations. Report prepared for Connecticut Department of Transportation. Hartford.
 1991 Connecticut Historic Bridge Inventory/Final Report: Preservation Plan. Report prepared for Connecticut Department of Transportation. Hartford.

- Jones, Brian D.
 1997 The Hidden Creek Site in Southeastern Connecticut. *Archaeology of Eastern North America* 25: 45-80.
- Jordan, D.F.
 1965 *An Archaeological Reconnaissance of Seven Flood Control Reservoir Areas in New Hampshire, Massachusetts, and Connecticut*. Report prepared for the National Park Service: Region Five.
- Keiner, Harry
 1979a Brooklyn Green Historic District. National Register of Historic Places Inventory—Nomination Form. On file, Connecticut State Historic Preservation Office.
 1979b Windham Center National Register District. National Register of Historic Places Inventory – Nomination Form. On file, Connecticut State Historic Preservation Office.
- Kutzbach, John E.
 1987 Model Simulations of the Climatic Patterns During the Deglaciation of North America. In *North America and Adjacent Oceans During the Last Deglaciation (Geology of North America)*, William F. Ruddiman and Herbert E. Wright, Jr., editors, v. k-3: 425-446. Geological Society of America.
- Larned, Ellen D.
 2000 *History of Windham County, Connecticut*. Volume I: 1600-1760. Pomfret, CT: Swordsmith Productions.
- Lavin, Lucianne
 1988 The Morgan Site, Rocky Hill, Connecticut: A Late Woodland Farming Community in the Lower Connecticut River Valley. *Bulletin of the Archaeological Society of Connecticut* 51: 7-21.
- Lazarius, David
 1978 [Columbia townwide reconnaissance-level historic resource survey]. Prepared for Connecticut Historical Commission and Regional Planning Agency. On file, Connecticut Historic Preservation Collection, Dodd Center, University of Connecticut, Storrs.
- Law, Pamela
 1978a [Chaplin townwide reconnaissance-level historic resource survey]. Prepared for Connecticut Historical Commission and Regional Planning Agency. On file, Connecticut Historic Preservation Collection, Dodd Center, University of Connecticut, Storrs.
 1978b [Hampton townwide reconnaissance-level historic resource survey]. Prepared for Connecticut Historical Commission and Regional Planning Agency. On file, Connecticut Historic Preservation Collection, Dodd Center, University of Connecticut, Storrs.
- Levine, Mary
 1990 Accommodating Age: Radiocarbon Results and Fluted Point Sites in Eastern North America. *Archaeology of Eastern North America* 18: 33-64.
- Lincoln, Allen B.
 1920 *A Modern History of Windham County, Connecticut*. Two Volumes. Chicago: S.J. Clark Publishing Company.

Lizee, Jonathan M., Mary G. Soulsby and Kevin A. McBride

- 1994 Phase II Report, Algonquin Gas Transmission Company 7.5-mile Replacement Loop in Coventry, Columbia and Lebanon, CT. Storrs, CT: Public Archaeology Survey Team, Inc. Report on file as CHPC #614, Connecticut Historic Preservation Collection, Dodd Center, University of Connecticut, Storrs.

Luyster, Constance

- 1970 Dr. Chester Hunt Office. National Register of Historic Places Inventory—Nomination Form. On file, Connecticut State Historic Preservation Office.

MacDonald, George F.

- 1968 *Debert, a Paleoindian Site in Central Nova Scotia*. Anthropology Papers 16, National Museums of Canada, Ottawa.

Mansfield Planning and Zoning Commission

- 1993 Plan of Development, Mansfield, Connecticut.

McBride, Kevin A.

- 1978 Subsistence and Settlement in the Lower Connecticut River Valley: An Example from Woodchuck Knoll. *Man in the Northeast* Nos. 15-16.

- 1984a Prehistory of the Lower Connecticut River Valley. Ph.D. dissertation, University of Connecticut.

- 1984b Phase I and II Archaeological Surveys for Rapid Infiltration/Percolation Land Treatment System, Coventry, Connecticut. Prepared for Fuss & O'Neill, Inc. Storrs, CT: PAST, Inc. Report on file as CHPC #268, Connecticut Historic Preservation Collection, Dodd Center, University of Connecticut, Storrs.

- 1988 Phase I Archaeological Reconnaissance Survey, A.R.S. Killingly Siting Project. Storrs, CT: Public Archaeology Survey Team, Inc. Report on file as CHPC #340, Connecticut Historic Preservation Collection, Dodd Center, University of Connecticut, Storrs.

- 1992 Report on Phase I Archaeological Reconnaissance Survey of the Idle Wild Farm, Inc./Town of Pomfret Sewer. Storrs, CT: Public Archaeology Research Team, Inc. Report on file as CHPC #514, Connecticut Historic Preservation Collection, Dodd Center, University of Connecticut, Storrs.

- 1993 Phase III Data Recovery Report, Site 112-8, Town of Pomfret Sewer. Storrs, CT: Public Archaeology Survey Team, Inc. Report on file as CHPC #641, Connecticut Historic Preservation Collection, Dodd Center, University of Connecticut, Storrs.

McBride, Kevin A. and Peter Pagoulatos

- 1988 Report: Phase III Archaeological Data Recovery of Sites 32-59, 32-60 and 32-61 in the Coventry Sewer Project. Storrs, Connecticut: PAST, Inc. Prepared for Fuss and O'Neill Engineers. Report on file as CHPC #641, Connecticut Historic Preservation Collection, Dodd Center, University of Connecticut, Storrs.

McBride, Kevin A. and Mary G. Soulsby

- 1989 Prehistory of Eastern Connecticut: Phase I, II and III Archaeological Surveys of the Relocation of Route 6/I-84 Project. Two volumes. Prepared for the Connecticut Department of Transportation. Storrs, Connecticut: PAST, Inc. Report on file as CHPC #399, Connecticut Historic Preservation Collection, Dodd Center, University of Connecticut, Storrs.

- 1990 Report on an Archaeological Resources Survey of the Rainbow Creek Development in Pomfret, CT. Storrs, CT: Public Archaeology Survey Team, Inc.
- McBride, Kevin A., Mary G. Soulsby, Robert R. Gradie, and Nicholas Bellantoni
 1980a Phase I Archaeological Reconnaissance, West Thompson Reservoir, West Thompson, Connecticut. *Archaeological Research Monographs*, No. 14. Prepared for the Army Corps of Engineers, New England Division. Report on file as CHPC #155, Connecticut Historic Preservation Collection, Dodd Center, University of Connecticut, Storrs.
- McBride, Kevin A., William M. Wadleigh, and Robert E. Dewar
 1980 Prehistoric Settlement in Eastern Connecticut: the North-Central Lowlands and Northeastern Highlands Surveys: 1979. *Archaeology Research Monographs*, No. 15. Prepared for the Connecticut Historical Commission. Report on file as CHPC #8, Connecticut Historic Preservation Collection, Dodd Center, University of Connecticut, Storrs.
- McCahon, Mary E.
 1990 Cultural Resources Survey of Killingly, Connecticut. 1990 Survey of Outlying Villages and Rural Properties, Phase 3. Prepared for Town of Killingly and Connecticut Historical Commission. On file, Connecticut Historic Preservation Collection, Dodd Center, University of Connecticut, Storrs.
- McDonough, Mark
 1986 Townwide Historical and Architectural Survey of Thompson, Connecticut. Sponsored by Town of Thompson and Connecticut Historical Commission. On file, Connecticut Historic Preservation Collection, Dodd Center, University of Connecticut, Storrs.
- McNett, Charles W.
 1985 *Shawnee Minisink: A Stratified Paleoindian-Archaic Site in the Upper Delaware River Valley of Pennsylvania*. Orlando: Academic Press.
- McWeeney, Lucinda
 1994 Archaeological Settlement Patterns and Vegetation Dynamics in Southern New England in the Late Quaternary. Ph.D. dissertation, Yale University.
 1999 A Review of Late Pleistocene and Holocene Climate Changes in Southern New England. *Bulletin of the Connecticut Archaeological Society* 62: 3-18.
- Meltzer, David J.
 1988 Late Pleistocene Human Adaptation in Eastern North America. *Journal of World Prehistory* 2:1-52.
- Millis, Heather
 1998 Phase I Cultural Resource Survey and Phase II Evaluation for the Proposed Lake Road Power Plant Interconnect Corridor, Killingly and Putnam. TRC Garrow and Associates, Inc. Report on file as CHPC #810, Connecticut Historic Preservation Collection, Dodd Center, University of Connecticut, Storrs.
- Moeller, Roger
 1980 6-LF-21: A Paleo-Indian Site in Western Connecticut. *American Indian Archaeological Institute Occasional Paper* No. 2.
- Munhall, Robert
 1978a [Lebanon townwide reconnaissance-level historic resource survey]. Prepared for Connecticut Historical Commission and Regional Planning Agency. On file, Connecticut Historic Preservation Collection, Dodd Center, University of Connecticut, Storrs.

- 1978b [Windham townwide reconnaissance-level historic resource survey]. Prepared for Connecticut Historical Commission and Regional Planning Agency. On file, Connecticut Historic Preservation Collection, Dodd Center, University of Connecticut, Storrs.
- Naser, G.R.
1972 *Ben Chaplin's Town: 1822-1972*. Chaplin, CT: Chaplin Historical Society.
- Nicholas, George
1988 Ecological Leveling: The Archaeology and Environmental Dynamics of Early Post-glacial Land Use. In *Holocene Human Ecology in Northeastern North America*, George Nicholas, editor, pp. 257-296. New York: Plenum Press.
- Northeast Utilities Service Co.
1969-
1991 Card Street - Rhode Island 345KV Line Plan & Profile. Drawing No. 01017-10002. 39 sheets.
- O'Brien, Robert
1982 *The Connecticut Almanac*. West Hartford, CT: Imprint.
- Old Houses Committee/Mansfield Historical Society
1978 Historic and Architectural Resource Survey, Mansfield, Connecticut. [updated 1985 by Louise Blaney] On file, Connecticut Historic Preservation Collection, Dodd Center, University of Connecticut, Storrs.
- Pagoulatos, Peter
1986 Terminal Archaic Settlement and Subsistence in the Connecticut River Valley. Unpublished Ph.D. dissertation, University of Connecticut.
- Parkos, J. and J. Pfeiffer
1995 A Paleoindian Site in Lebanon, Connecticut. Paper presented at the Archaeological Society of Connecticut Annual Spring Meeting, Essex, Connecticut.
- Petersen, James B.
1995 Preceramic Archaeological Manifestations in the Far Northeast: a Review of Current Research. *Archaeology of Eastern North America* 23: 207-230.
- Petersen James B. and David E. Putnam
1992 Early Holocene Occupation in the Central Gulf of Maine Region. In *Early Holocene Occupation of Northern New England*, Brian S. Robinson, James B. Petersen, and Ann K. Robinson, editors, pp. 13-63. Occasional Publications of the Maine Archaeological Society 9. Maine Historic Preservation Commission, Augusta.
- Pfeiffer, John
1980 The Griffin Site. *Man in the Northeast* No. 19: 129-133.

1983 Bashan Lake:4500 Years of Prehistory. *Archaeological Society of Connecticut Bulletin* 46:45-53.

1984 The Late and Terminal Archaic Periods of Connecticut Prehistory. *Bulletin of the Archaeological Society of Connecticut* 47: 73-88.

1986 Dill Farm Locus 1: Early and Middle Archaic Components in Southern New England. *Bulletin of the Archaeological Society of Connecticut* 49: 19-35.

- 1990 The Late and Terminal Archaic Periods of Connecticut Prehistory. In *Experiments and Observations on the Terminal Archaic of the Middle Atlantic Region*, Roger Moeller, editor, pp. 85-104. Bethlehem, Connecticut: Archaeological Services.
- Pomo, Eric, Bruce Clouette and Mary Harper
 2004 Phase I Archaeological Reconnaissance Survey and Phase II intensive Survey of the Elderly Housing Development 1009 Maple Street, Killingly, Connecticut. Unpublished manuscript. Storrs, CT: Public Archaeology Survey Team, Inc.
- Pope, Gustavus D.
 1948 Fieldwork in Northeastern Connecticut. *Newsletter of the Archaeological Society of Connecticut* 50:2-3.
 1952 Excavation of the Charles Tyler Site. *Bulletin of the Archaeological Society of Connecticut* 26: 3-29.
- Porter, Dwight
 1885 The Region Tributary to Long Island Sound, in U.S. Bureau of the Census, *Tenth Census of the United States, Report on the Water Power of the United States, Part 1*. Washington: Government Printing Office, 1885.
- Praus, Alexis A.
 1945 The South Woodstock Site. *Bulletin of the Archaeological Society of Connecticut* 17: 1-52.
- Raber, Michael S., and Robert B. Gordon
 1996 Archaeological Assessment of the Vicinity of the Village Hill Road Bridge, State Project No. 30-94, Bridge No. 04619, Towns of Columbia and Lebanon, Connecticut. Report prepared for Close, Jensen & Miller. South Glastonbury, CT: Raber Associates. Report on file as CHPC #667, Connecticut Historic Preservation Collection, Dodd Center, University of Connecticut, Storrs.
- Raber, Michael S., and Mary G. Soulsby
 1996 Archaeological and Historical Reconnaissance Survey, Replacement of Depot Road Bridge, Coventry, Connecticut. Report prepared for the Town of Coventry and Nathan L. Jacobson and Associates, Inc. Public Archaeology Survey Team, Inc., and Raber Associates. Report on file as CHPC #644, Connecticut Historic Preservation Collection, Dodd Center, University of Connecticut, Storrs.
- Raber, Michael S., and Ernest A. Wiegand
 2002 Cultural Resources Assessment in Support of Proposed Electric Transmission Line Facilities Between Plumtree and Norwalk Substations Bethel, Redding, Weston, Wilton, and Norwalk, Connecticut. Report prepared for Northeast Utilities Service Company. South Glastonbury, CT: Raber Associates. Report on file as CHPC #1070, Connecticut Historic Preservation Collection, Dodd Center, University of Connecticut, Storrs.
 2003 Cultural Resources Assessment of Proposed Middletown-Norwalk 345 Kv Transmission Project: Proposed Route with Supported Changes and Alternative Routes. Report prepared for Northeast Utilities Service Company. South Glastonbury, CT: Raber Associates. Report on file as CHPC #1283, Connecticut Historic Preservation Collection, Dodd Center, University of Connecticut, Storrs.
- Raup, Hugh M.
 1940 Old Field Forests of Southeastern New England. *Journal of the Arnold Arboretum* 21: 266-273.

- Ritchie, William A.
 1959 *The Stony Brook Site and its Relation to Archaic and Transitional Cultures on Long Island*. The New York State Museum and Science Service, Bulletin 372.
- 1969 *The Archaeology of Martha's Vineyard*. New York: Natural History Press.
- 1971 *A Typology and Nomenclature for New York Projectile Points*. New York State Museum and Science Service Bulletin No. 384.
- 1994 *The Archaeology of New York State*. Revised Edition. Garden City, NY: Natural History Press.
- Ritchie, William A. and Robert E. Funk
 1973 *Aboriginal Settlement Patterns in the Northeast*. The University of the State of New York State Education Department, New York State Museum and Science Service.
- Robertson, James O., and Janet C.
 1993 *All Our Yesterdays*. New York: Harper Collins.
- Robinson, Brian S. and James B. Petersen
 1993 Perceptions of Marginality: The Case of the Early Holocene in Northern New England. *Northeast Anthropology* 46: 61-75.
- Rogers, John (compiler)
 1985 *Bedrock geological map of Connecticut*. Connecticut Geologic and Natural History Survey, Natural Resource Atlas Map Series, 2 map sheets, 1:125,000.
- Roth, Matthew, Bruce Clouette, and Victor Darnell
 1981 *Connecticut, An Inventory of Historic Engineering and Industrial Sites*. Washington: Society for Industrial Archeology.
- Russo, Paul A. and Suzanne Cherau
 1994 Historic and Archaeological Reconnaissance/Inventory Survey, Cultural Resource Management Plan, Mansfield Hollow Lake. 2 volumes. Pawtucket, RI: Public Archaeology Laboratory, Inc. Report on file as CHPC #568, Connecticut Historic Preservation Collection, Dodd Center, University of Connecticut, Storrs.
- Sellers, Helen E.
 1942 *Connecticut Town Origins: Their Names, Boundaries, Early Histories and First Families*. Chester: Pequot Press Inc.
- Shelford, Victor E.
 1963 *The Ecology of North America*. Urbana: University of Illinois Press.
- Snow, Dean
 1980 *The Archaeology of New England*. New York: Academic Press.
- Soulsby, Mary G.
 1992 Report on Phase II investigations of Sites 69-42 and 112-8. Storrs, CT: Public Archaeology Survey Team, Inc.
- Spencer, Linda
 1993 Historic Preservation in Connecticut/Vol. II/Eastern Highlands: Historical and Architectural Overview and Management Guide. Hartford: Connecticut Historical Commission.

- Spiess, Arthur
 1992 Archaic Period Subsistence in New England and the Atlantic Provinces. In *Early Holocene Occupations in Northern New England*, Brian S. Robinson, James B. Petersen and Ann K. Robinson, editors, pp. 163-185. Occasional Publications of the Maine Archaeological Society 9. Augusta: Maine Historic Preservation Commission.
- Spiess, Arthur, Mary L. Curran, and Jonathan Grimes
 1985 Caribou (*Rangifer tarandus L.*) Bones from New England Paleoindian Sites. *North American Archaeologist* 6:145-159.
- Stuckenrath, Robert
 1966 The Debert Archaeological Project, Nova Scotia: Radiocarbon Dating. *Quaternaria* 8: 75-80.
- Swigart, Edmund K.
 1974 *The Prehistory of the Indians of Western Connecticut, Part I*. Washington, Connecticut: The Shepaug Valley Archaeological Society.
- TAMS/Earth Tech
 2002 Assessment & Archaeological Reconnaissance Survey, Realignment of Connecticut Route 169 at Route 205, and Intensive Archaeological Survey, CONNDOT Project #19-105. Report prepared for Connecticut Department of Transportation. Report on file as CHPC #1129, Connecticut Historic Preservation Collection, Dodd Center, University of Connecticut, Storrs.
- 2004 Supplemental Archaeological Reconnaissance Survey and Intensive Archaeological Survey, 10 Tatnic Road and 136 Hartford Road, Brooklyn, Connecticut. CONNDOT Project #19-93. Report prepared for Connecticut Department of Transportation. Report on file as CHPC #1409, Connecticut Historic Preservation Collection, Dodd Center, University of Connecticut, Storrs.
- Thompson Bicentennial Book Committee
 1985 *Thompson Bicentennial Memory Book 1785-1985*. Thompson.
- Turner, Gregg, and Melancthon W. Jacobus
 1986 *Connecticut's Railroads...An Illustrated History*. Hartford: Connecticut Historical Society.
- U.S. Department of Agriculture, Soil Conservation Service
 1966 *Soil Survey of Tolland County, Connecticut*. Washington: Government Printing Office.
- 1981 *Soil Survey of Windham County, Connecticut*. Washington: Government Printing Office.
- Wadleigh, William M., Karen K. Furbish, Kevin A. McBride, and Robert E. Dewar
 1978 The Northeast Highlands Archaeological Survey: Tolland, Mansfield, and Willington. *Archaeological Research Monograph No. 2*, Storrs, CT: PAST, Inc. Report on file as CHPC #5, Connecticut Historic Preservation Collection, Dodd Center, University of Connecticut, Storrs.
- Wadleigh, William M., Kevin A. McBride and Mary G. Soulsby
 1981 Prehistoric Settlement in Eastern Connecticut: the South-Central Lowlands and Northeastern Highlands Survey, 1980. *Archaeology Research Monographs No. 20*, PAST, Inc. Report on file as CHPC #12, Connecticut Historic Preservation Collection, Dodd Center, University of Connecticut, Storrs.

- Warren, Moses and George Gillet
1812 Connecticut, from Actual Survey, Made in 1811... East Windsor: Abner Reed.
- Weaver, Margaret, Geraldine A. Wood, and Raymond H. Wood
1976 *Miles of Millstreams (A Chronicle of Killingly, Connecticut): An Official Bicentennial History (1976)*. Killingly: American Revolution Bicentennial Commission of Killingly.
- Wellman, B.
1975 Prehistoric Site Survey and Salvage in the Upper Schoharie Valley, New York. *Eastern States Archaeological Federation Bulletin* 34: 15.
- Westveld, M.
1956 Natural Forest Vegetation Zones of New England. *Journal of Forestry* 54: 332-338.
- Wilmeth, R.
1978 Canadian archaeological radiocarbon dates (revised version). *Archaeological Survey of Canada Mercury Series Paper No. 77*. Ottawa: National Museum of Man.
- Woisard, Kenneth
1978 [Brooklyn townwide reconnaissance-level historic resource survey]. Prepared for Connecticut Historical Commission and Regional Planning Agency. On file, Connecticut Historic Preservation Collection, Dodd Center, University of Connecticut, Storrs.

PERSONAL COMMUNICATIONS

Nicholas F. Bellantoni, Connecticut State Archaeologist

Susan Chandler, Historical Architect, Connecticut State Historic Preservation Office

Robert Cless, Transportation Planner, Connecticut Department of Transportation

David A. Poirier, Staff Archaeologist, Connecticut State Historic Preservation Office

APPENDIX 1

**MARCH 2008 PROJECT OVERVIEW MAPS, SIGNIFICANT HISTORIC RESOURCES & AREAS OF
ARCHAEOLOGICAL SENSITIVITY**

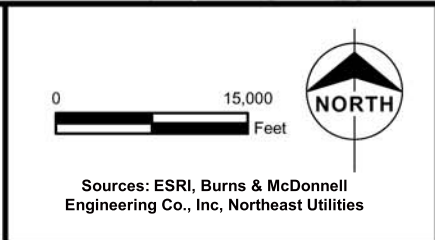
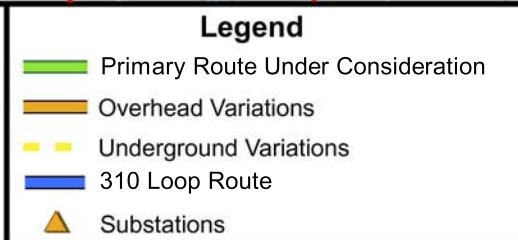
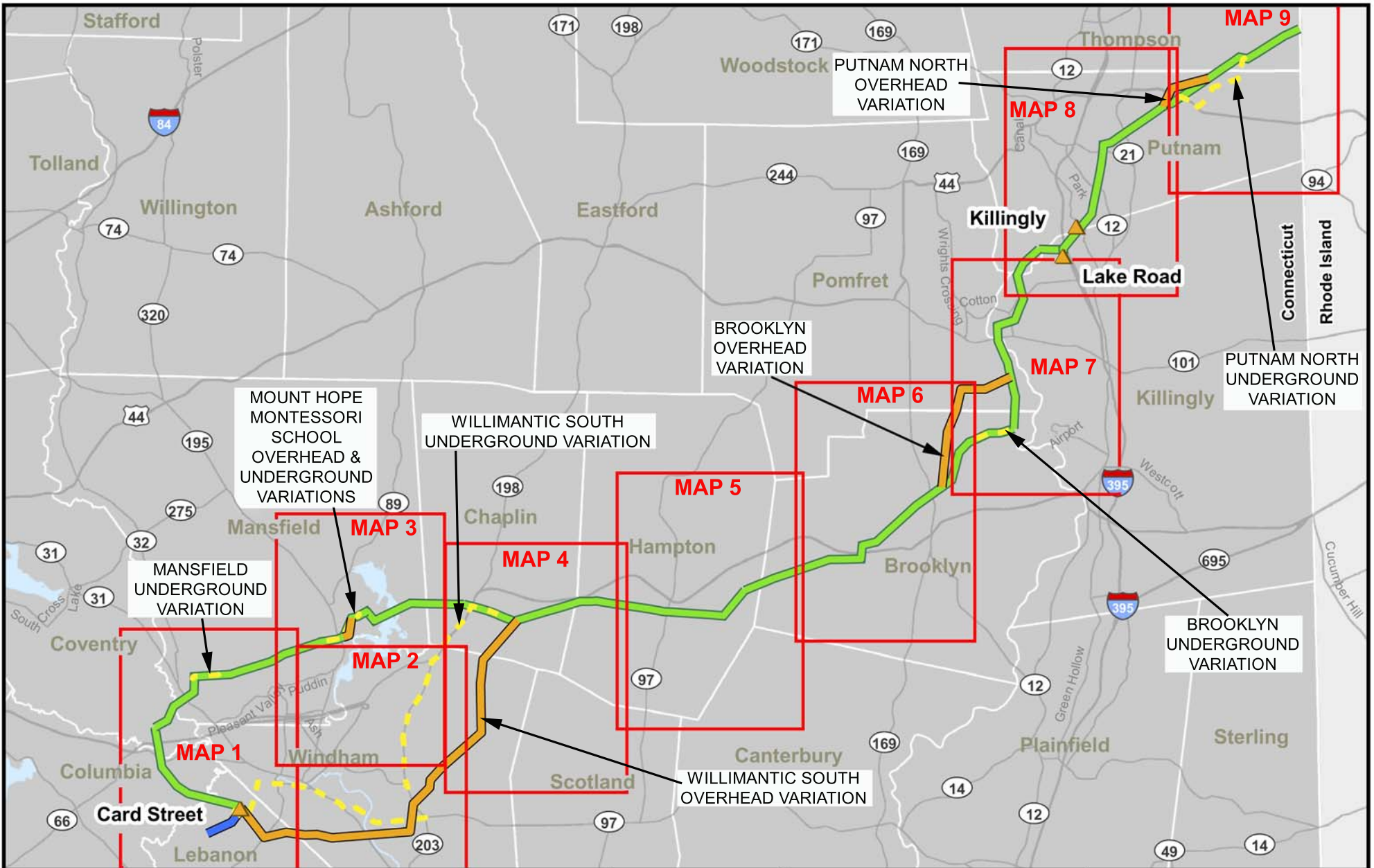

CULTURAL RESOURCES & ARCHAEOLOGICAL SENSITIVITY

INTERSTATE RELIABILITY PROJECT
APPENDIX 1, PROJECT OVERVIEW
& INDEX MAP

Raber Associates - March 2008

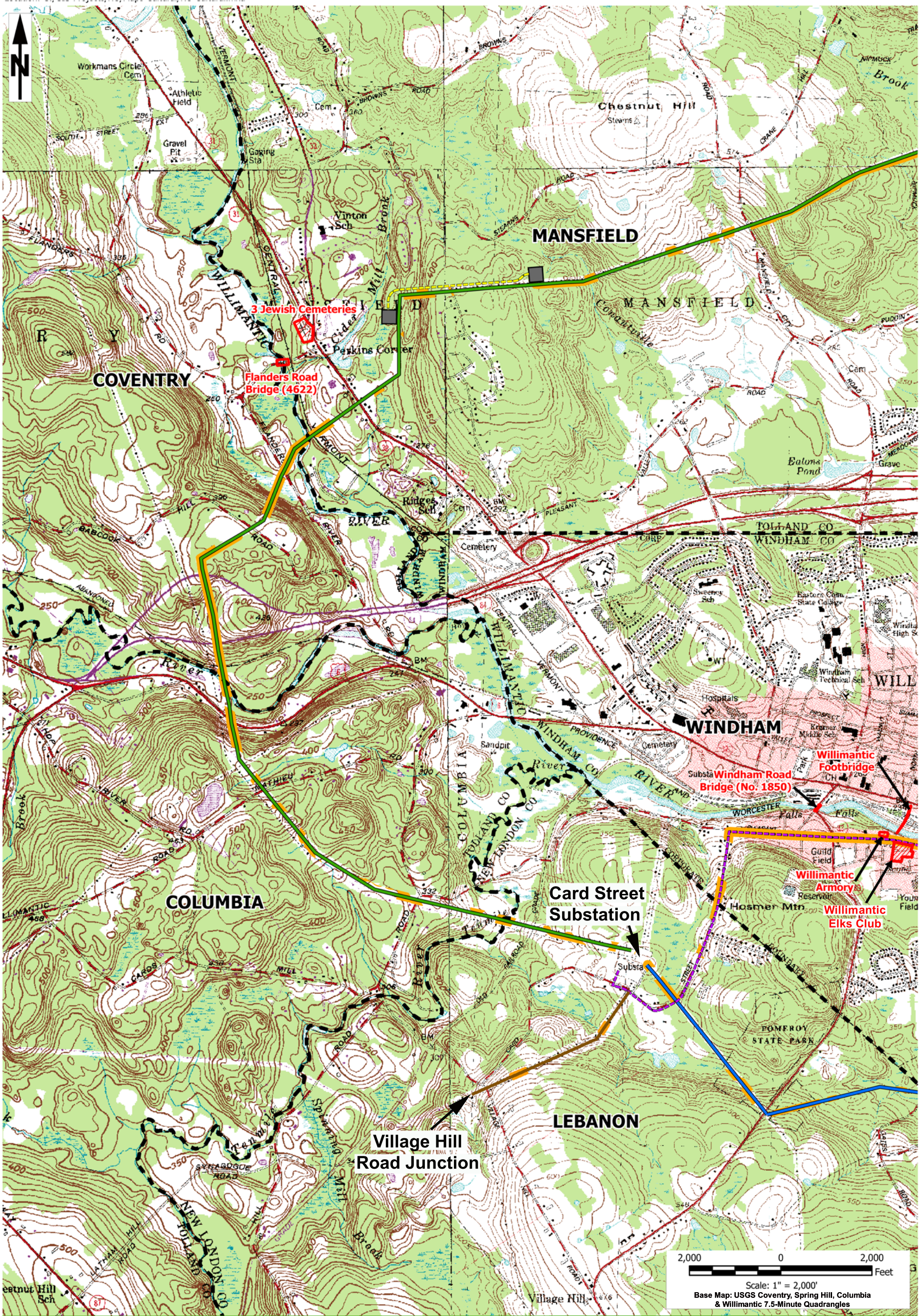

| LEGEND | | |
|---|---------------------------------|---|
| Primary Route under Consideration | Mansfield Underground Variation | Historic Cemetery and/or Historic Resource Listed/Eligible for National Register of Historic Places |
| Willimantic South Overhead Variation | Potential Transition Station | Area of Low Archaeological Sensitivity |
| Willimantic South Underground Variation | 310 Loop | Town Boundaries |

Connecticut Light & Power
The Northeast Utilities System

CULTURAL RESOURCES & ARCHAEOLOGICAL SENSITIVITY

INTERSTATE RELIABILITY PROJECT
APPENDIX 1, MAP 1 OF 9

Raber Associates - March 2008

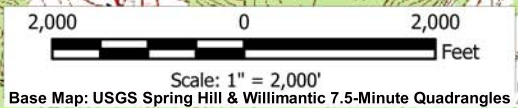
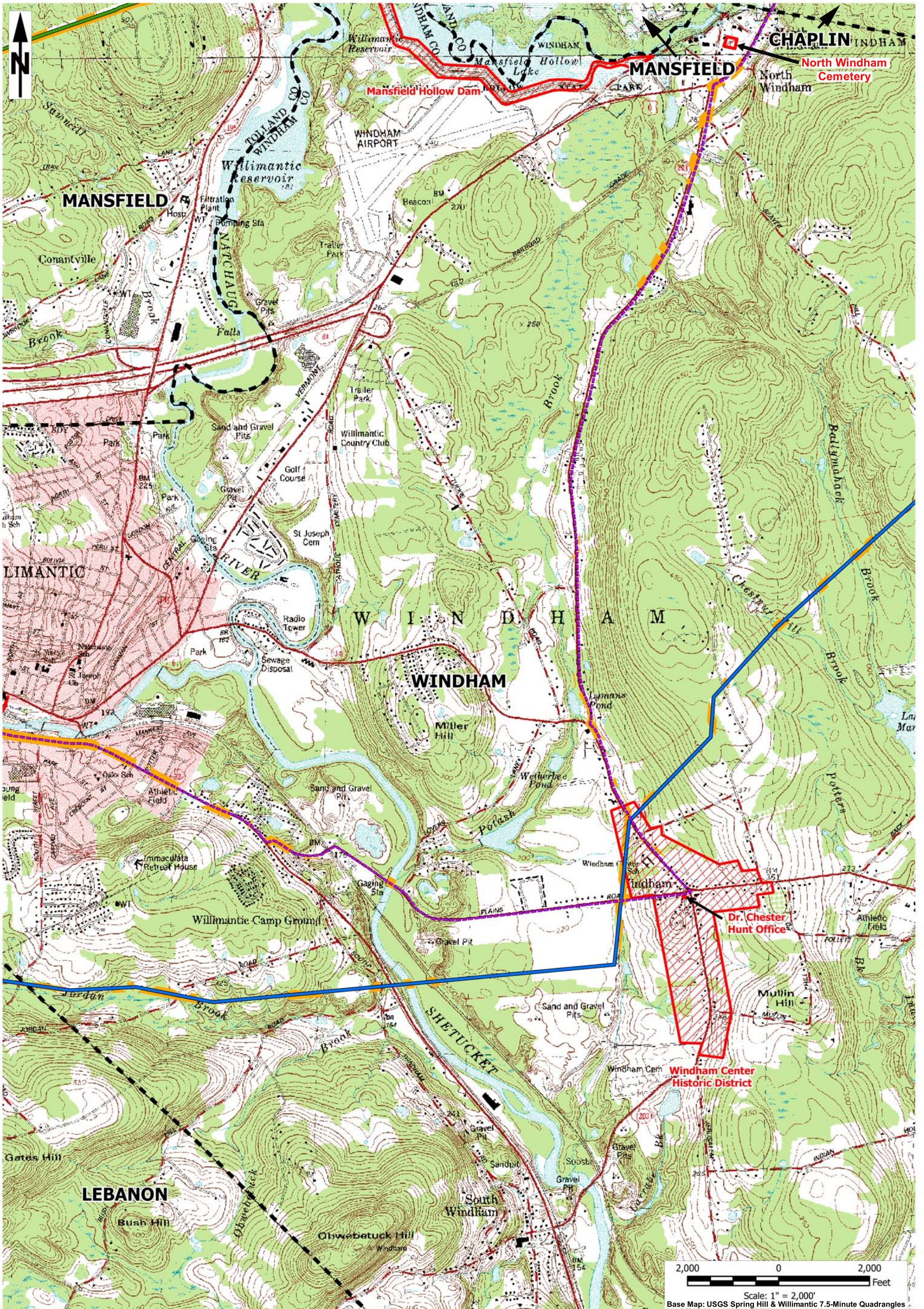

| | | | |
|--|---|--|---|
| <p>LEGEND</p> <ul style="list-style-type: none"> — Primary Route under Consideration — Willimantic South Overhead Variation — Willimantic South Underground Variation | <ul style="list-style-type: none"> Historic Cemetery and/or Historic Resource Listed/Eligible for National Register of Historic Places Area of Low Archaeological Sensitivity Town Boundaries |  <p>Connecticut Light & Power The Northeast Utilities System</p> | <p>CULTURAL RESOURCES & ARCHAEOLOGICAL SENSITIVITY</p> <p>INTERSTATE RELIABILITY PROJECT APPENDIX 1, MAP 2 OF 9</p> <p>Raber Associates - March 2008</p> |
|--|---|--|---|

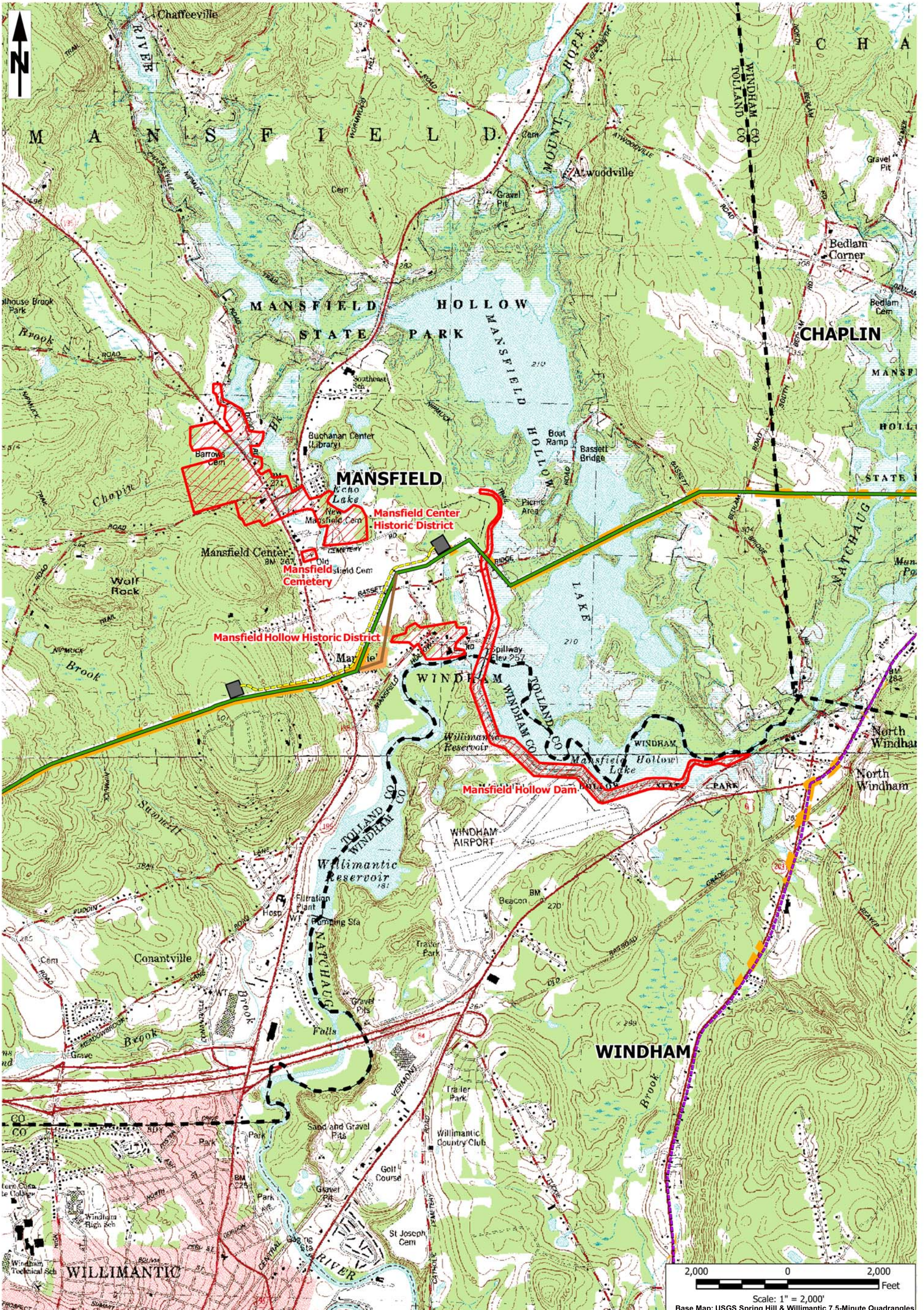

| | | | | |
|--|--|--|--|---|
| <p>LEGEND</p> <ul style="list-style-type: none"> Primary Route under Consideration Mount Hope Montessori School Overhead Variation Willimantic South Underground Variation | <ul style="list-style-type: none"> Mount Hope Montessori School Underground Variation Potential Transition Station | <ul style="list-style-type: none"> Historic Cemetery and/or Historic Resource Listed/Eligible for National Register of Historic Places Area of Low Archaeological Sensitivity Town Boundaries |  <p>Connecticut Light & Power The Northeast Utilities System</p> | <p>CULTURAL RESOURCES & ARCHAEOLOGICAL SENSITIVITY</p> <p>INTERSTATE RELIABILITY PROJECT APPENDIX 1, MAP 3 OF 9</p> <p>Raber Associates - March 2008</p> |
|--|--|--|--|---|

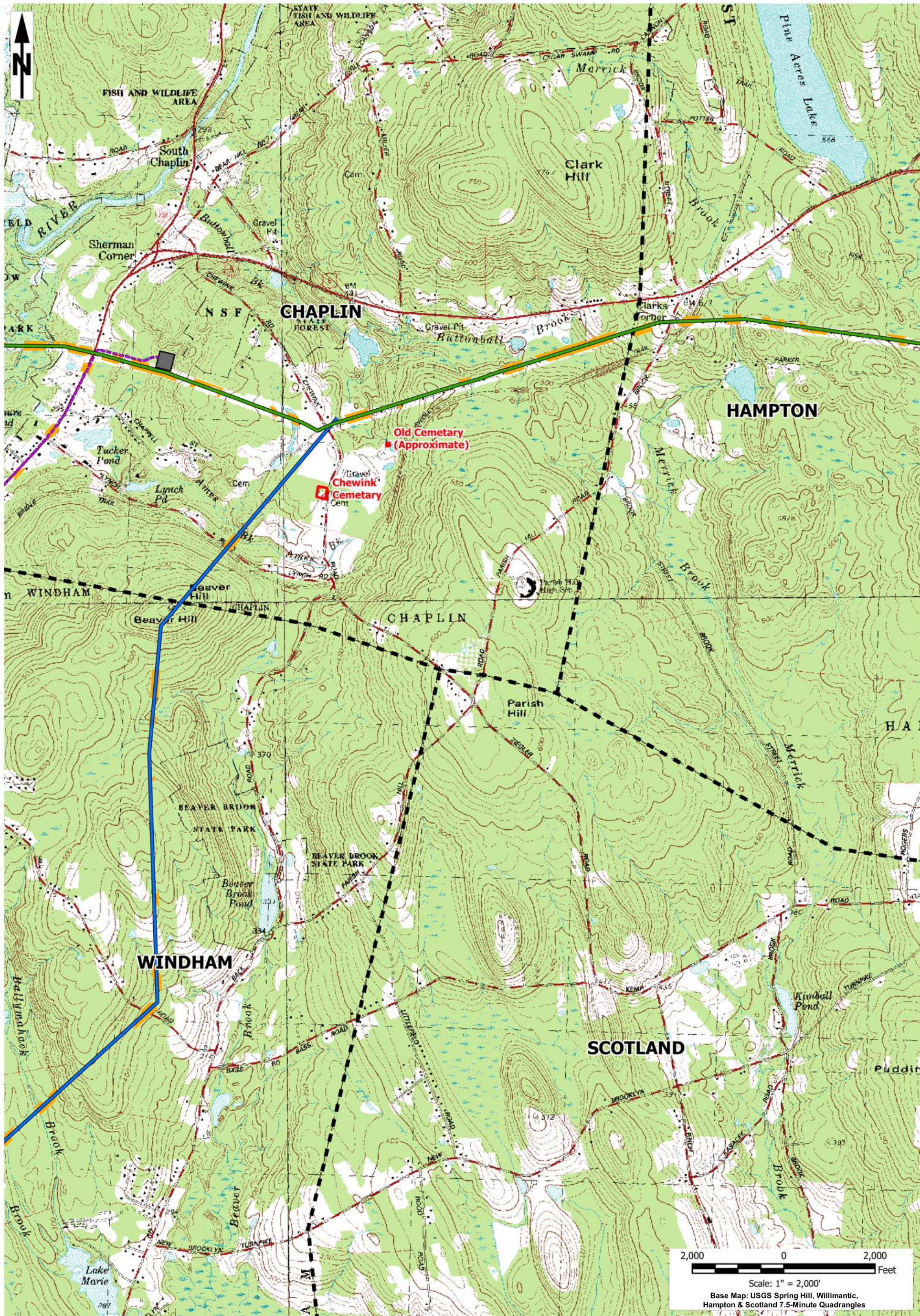

| | | | | |
|--|---|--|--|---|
| <p>LEGEND</p> <ul style="list-style-type: none"> Primary Route under Consideration Willimantic South Overhead Variation | <ul style="list-style-type: none"> Willimantic South Underground Variation Potential Transition Station | <ul style="list-style-type: none"> Historic Cemetery and/or Historic Resource Listed/Eligible for National Register of Historic Places Area of Low Archaeological Sensitivity Town Boundaries |  <p>Connecticut Light & Power The Northeast Utilities System</p> | <p>CULTURAL RESOURCES & ARCHAEOLOGICAL SENSITIVITY</p> <p>INTERSTATE RELIABILITY PROJECT APPENDIX 1, MAP 4 OF 9</p> <p>Raber Associates - March 2008</p> |
|--|---|--|--|---|

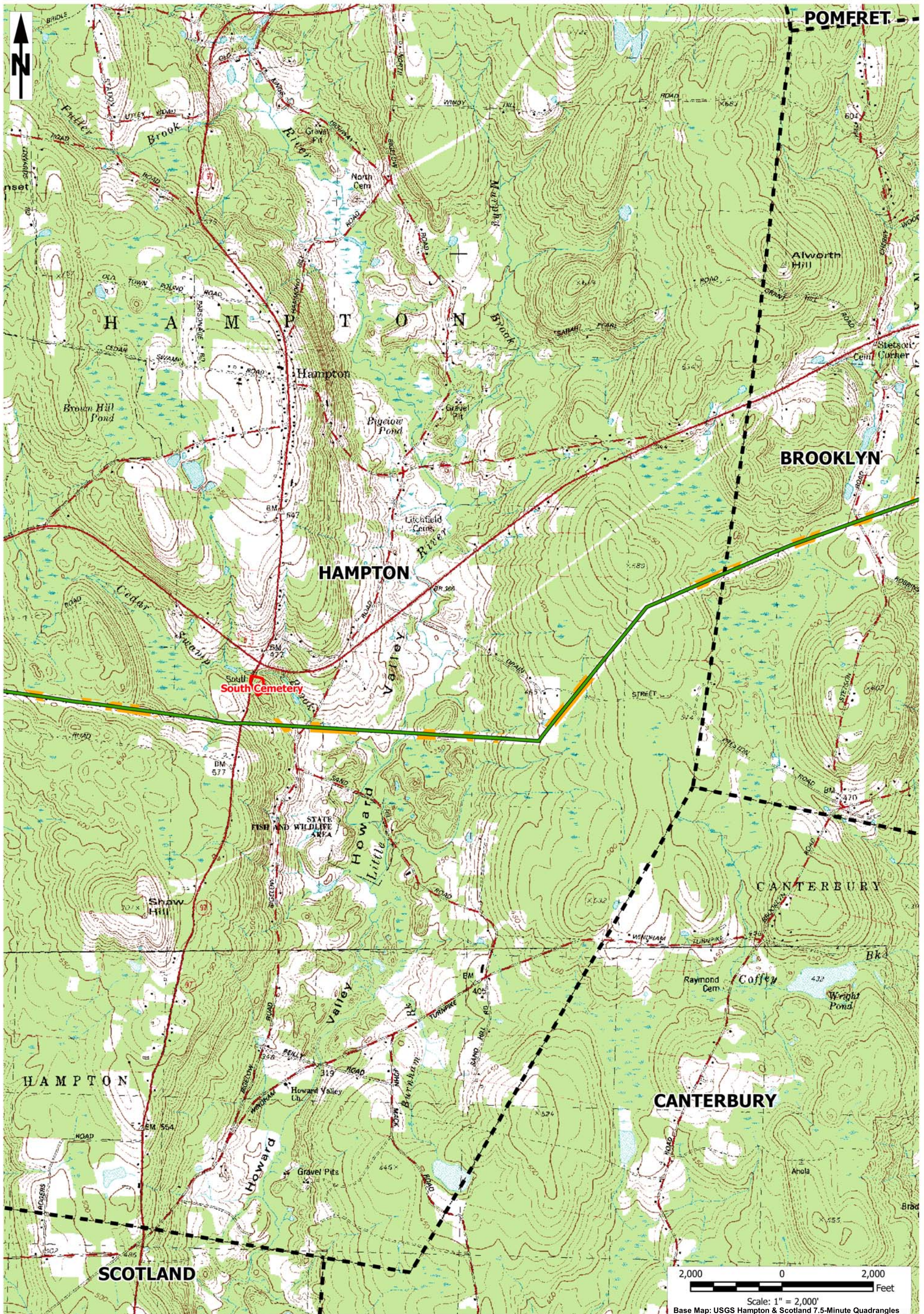

2,000 0 2,000
 Feet
 Scale: 1" = 2,000'
 Base Map: USGS Hampton & Scotland 7.5-Minute Quadrangles

LEGEND

— Primary Route under Consideration

- Historic Cemetery and/or Historic Resource Listed/Eligible for National Register of Historic Places
- Area of Low Archaeological Sensitivity
- Town Boundaries



**Connecticut
 Light & Power**
 The Northeast Utilities System

**CULTURAL RESOURCES &
 ARCHAEOLOGICAL SENSITIVITY**

INTERSTATE RELIABILITY PROJECT
 APPENDIX 1, MAP 5 OF 9

Raber Associates - March 2008

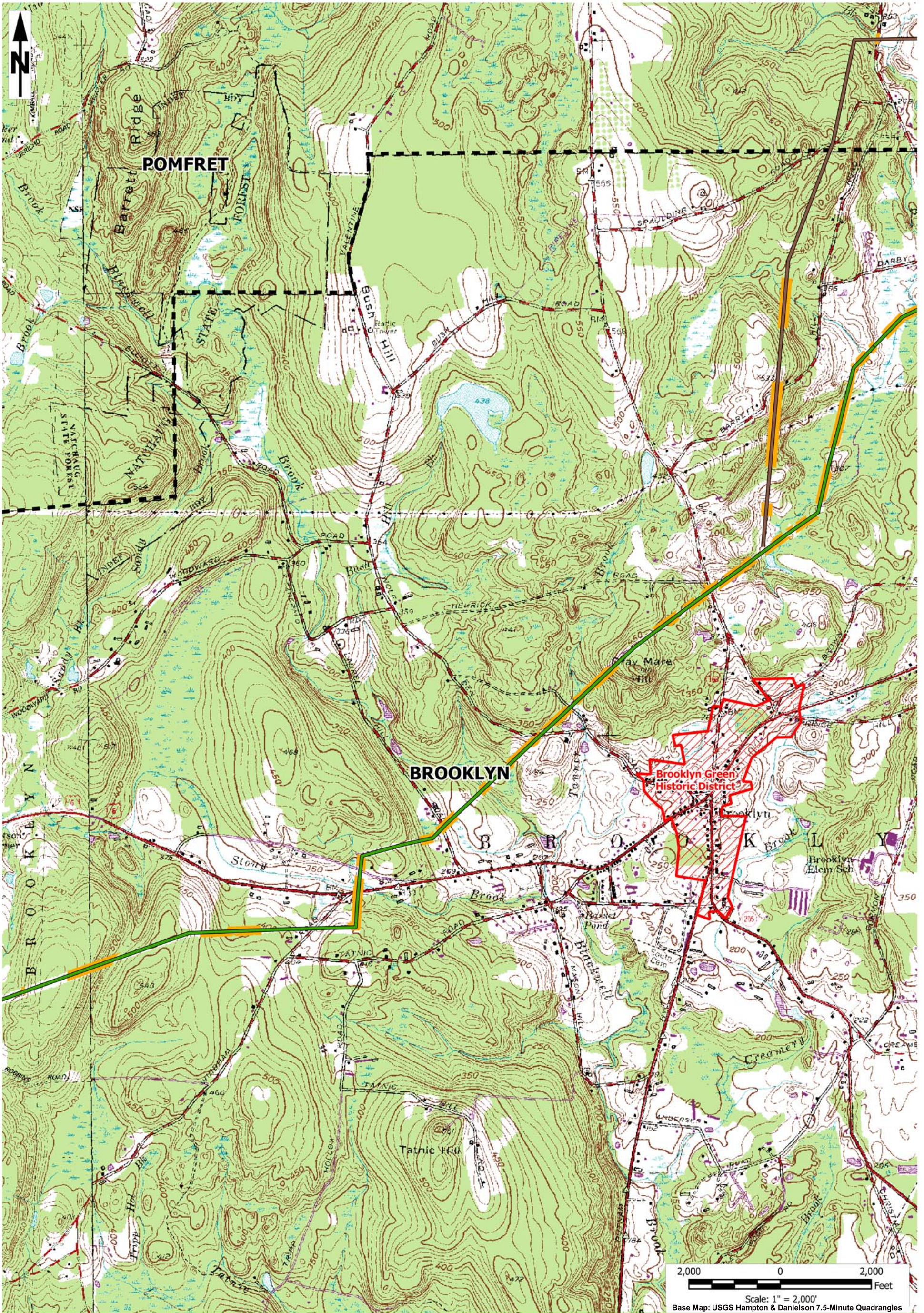

LEGEND

-  Primary Route under Consideration
-  Brooklyn Overhead Variation
-  Historic Cemetery and/or Historic Resource Listed/Eligible for National Register of Historic Places
-  Area of Low Archaeological Sensitivity
-  Town Boundaries



**Connecticut
Light & Power**
The Northeast Utilities System

CULTURAL RESOURCES & ARCHAEOLOGICAL SENSITIVITY

INTERSTATE RELIABILITY PROJECT
APPENDIX 1, MAP 6 OF 9

Raber Associates - March 2008

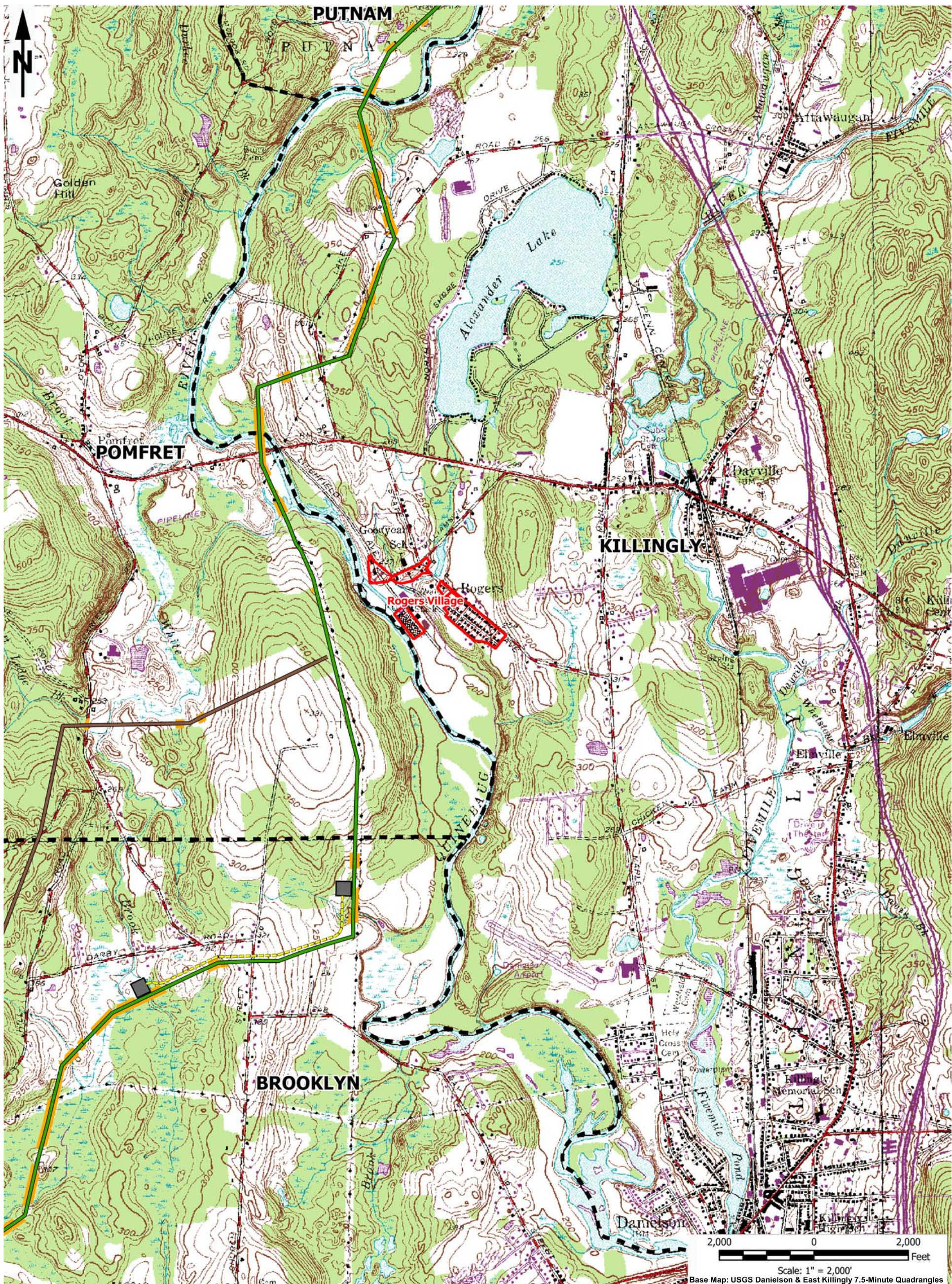

LEGEND

- Primary Route under Consideration
- Brooklyn Underground Variation
- Brooklyn Overhead Variation
- Potential Transition Station
- Historic Cemetery and/or Historic Resource Listed/Eligible for National Register of Historic Places
- Area of Low Archaeological Sensitivity
- Town Boundaries



CULTURAL RESOURCES & ARCHAEOLOGICAL SENSITIVITY
INTERSTATE RELIABILITY PROJECT
 APPENDIX 1, MAP 7 OF 9
 Raber Associates - March 2008

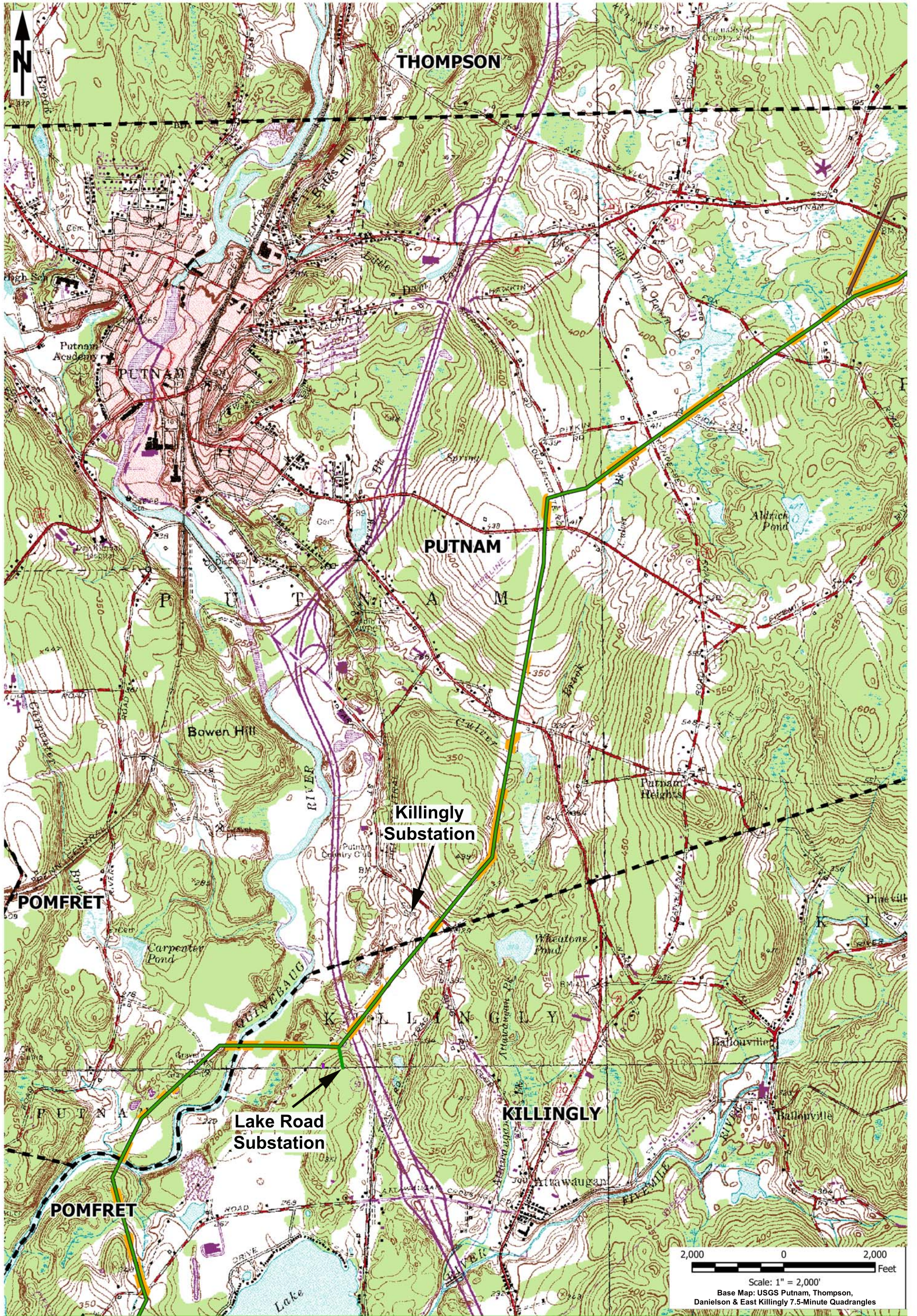

2,000 0 2,000 Feet
 Scale: 1" = 2,000'
 Base Map: USGS Putnam, Thompson, Danielson & East Killingly 7.5-Minute Quadrangles

LEGEND

Primary Route under Consideration

Putnam North Overhead Variation

- Historic Cemetery and/or Historic Resource Listed/Eligible for National Register of Historic Places
- Area of Low Archaeological Sensitivity
- Town Boundaries



CULTURAL RESOURCES & ARCHAEOLOGICAL SENSITIVITY

INTERSTATE RELIABILITY PROJECT
 APPENDIX 1, MAP 8 OF 9

Raber Associates - March 2008

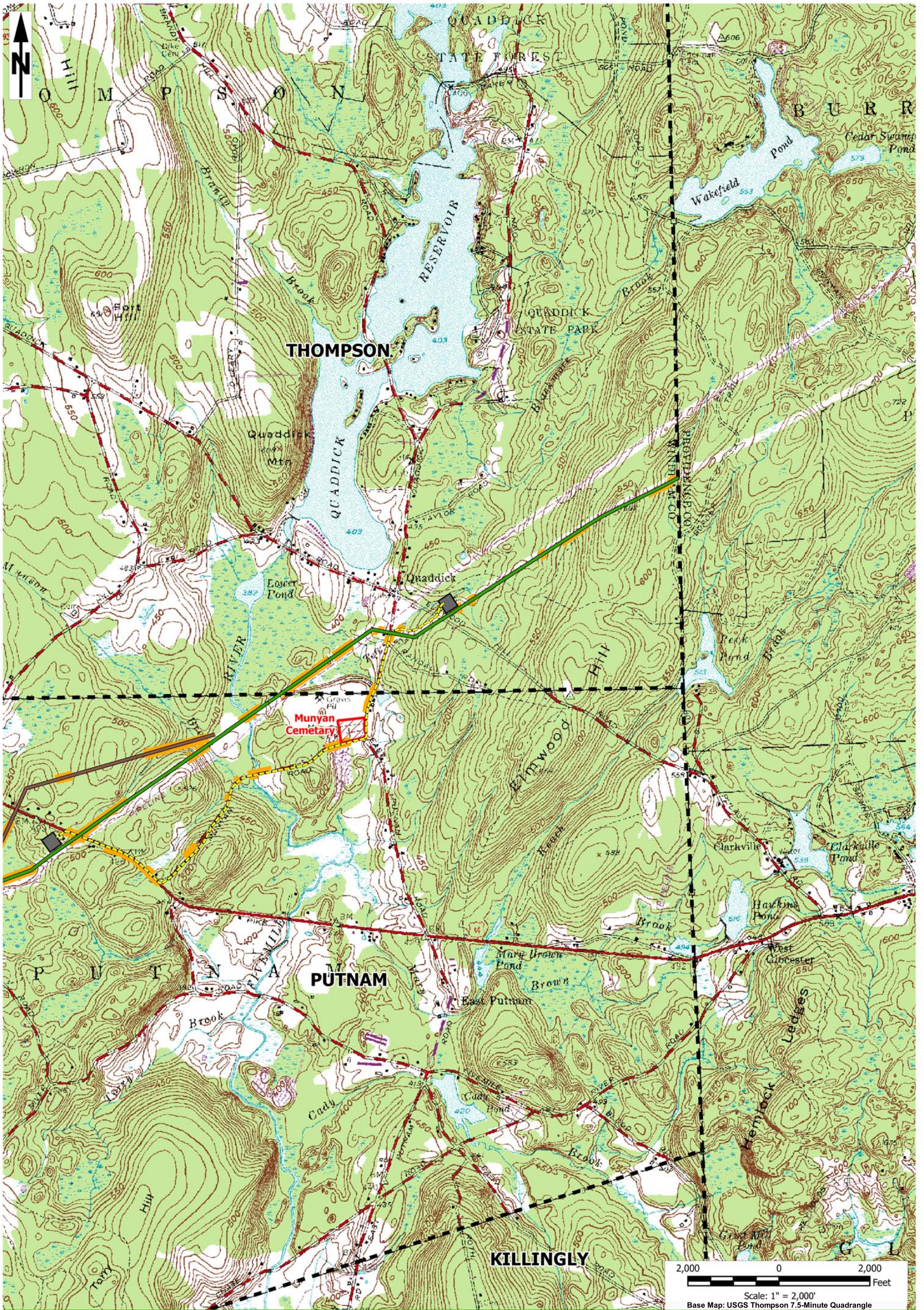

LEGEND

- Primary Route under Consideration
- Putnam North Overhead Variation
- Putnam North Underground Variation
- Potential Transition Station
- Historic Cemetery and/or Historic Resource Listed/Eligible for National Register of Historic Places
- Area of Low Archaeological Sensitivity
- Town Boundaries



**Connecticut
Light & Power**
The Northeast Utilities System

CULTURAL RESOURCES & ARCHAEOLOGICAL SENSITIVITY

INTERSTATE RELIABILITY PROJECT
APPENDIX 1, MAP 9 OF 9

Raber Associates - March 2008

APPENDIX 2

**DIGITALLY-GENERATED TOPOGRAPHIC PROFILES SAMPLING POSSIBLE LINES OF SIGHT FROM
SIGNIFICANT HISTORIC PROPERTIES TO POSSIBLE OVERHEAD TRANSMISSION
STRUCTURES ON PRIMARY ROUTE**

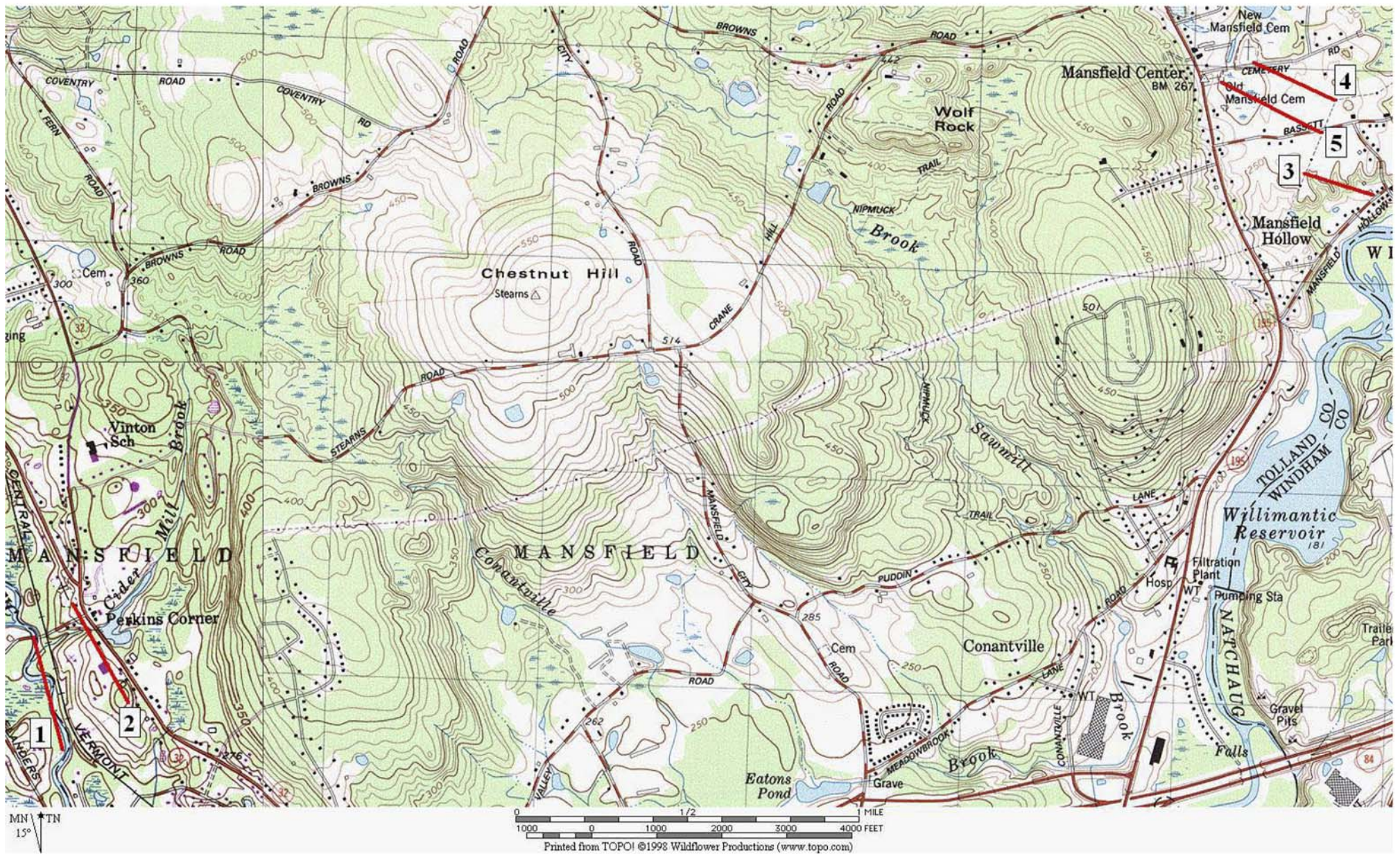

KEY TO PROFILES 1-5 ON COVENTRY, COLUMBIA, WILLIMANTIC AND SPRING HILL QUADRANGLES

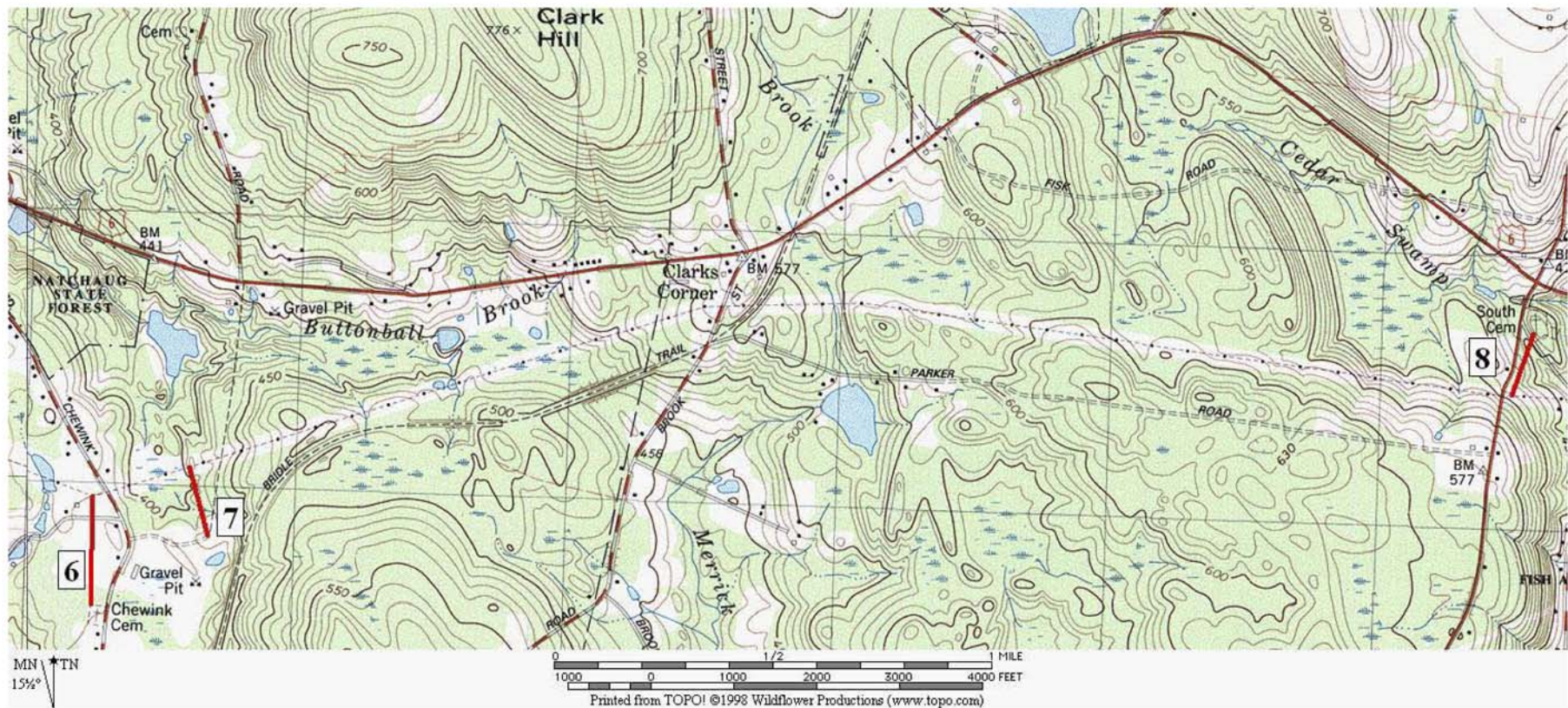

KEY TO PROFILES 6-8 ON HAMPTON QUADRANGLE

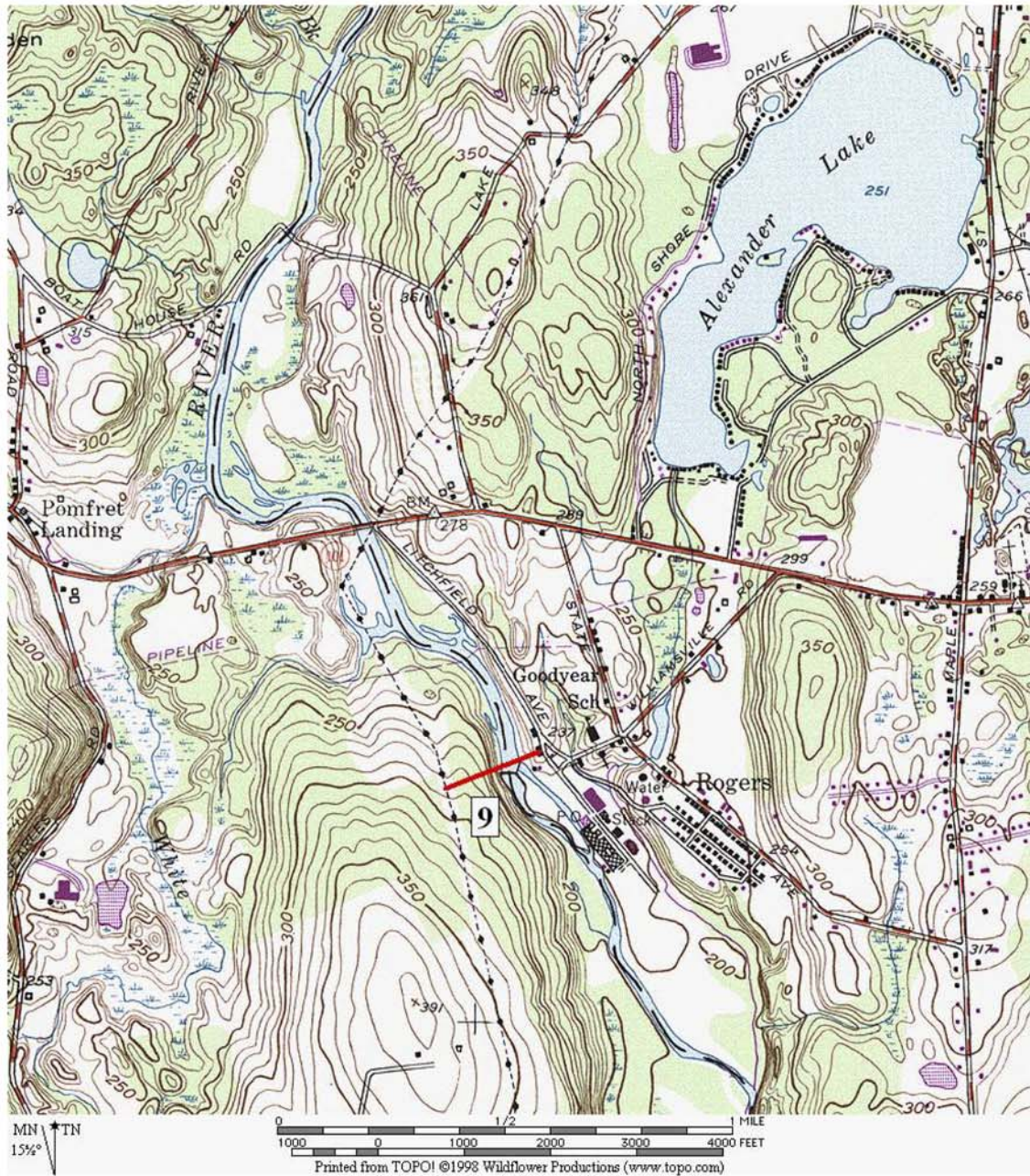

KEY TO PROFILE 9 ON DANIELSON QUADRANGLE

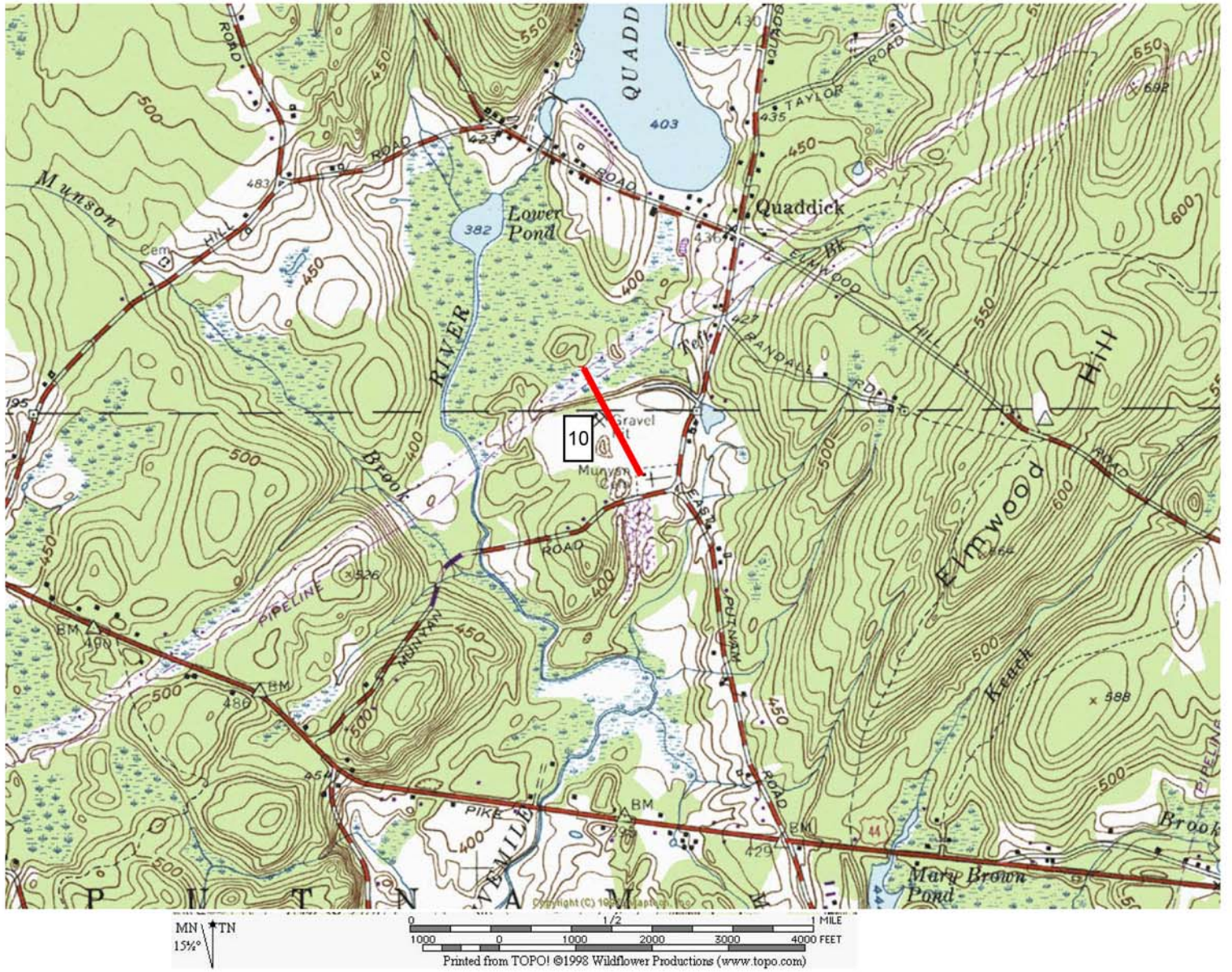

KEY TO PROFILE 10 ON THOMPSON QUADRANGLE

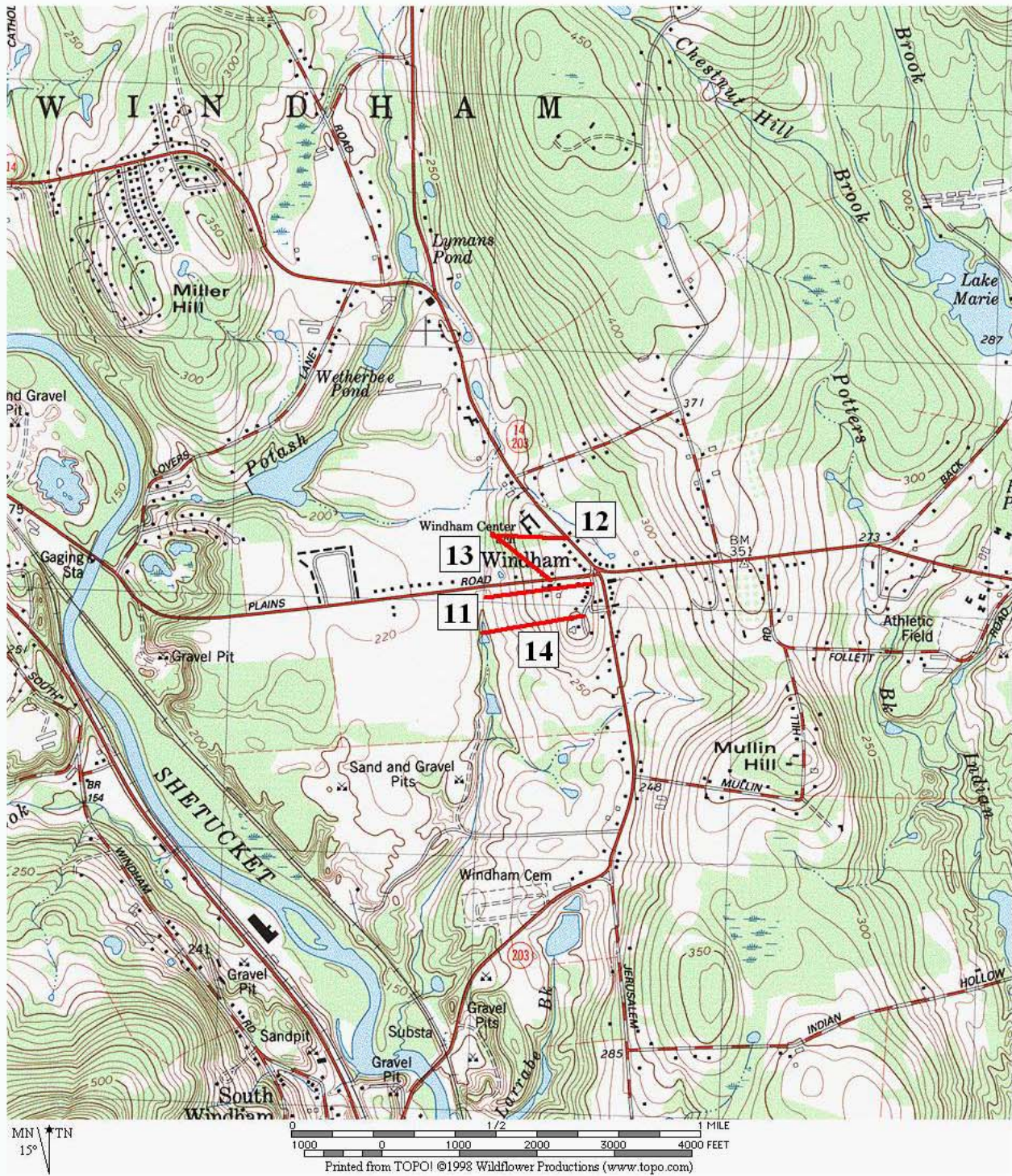

KEY TO PROFILES 11-14 ON WILLIMANTIC QUADRANGLE

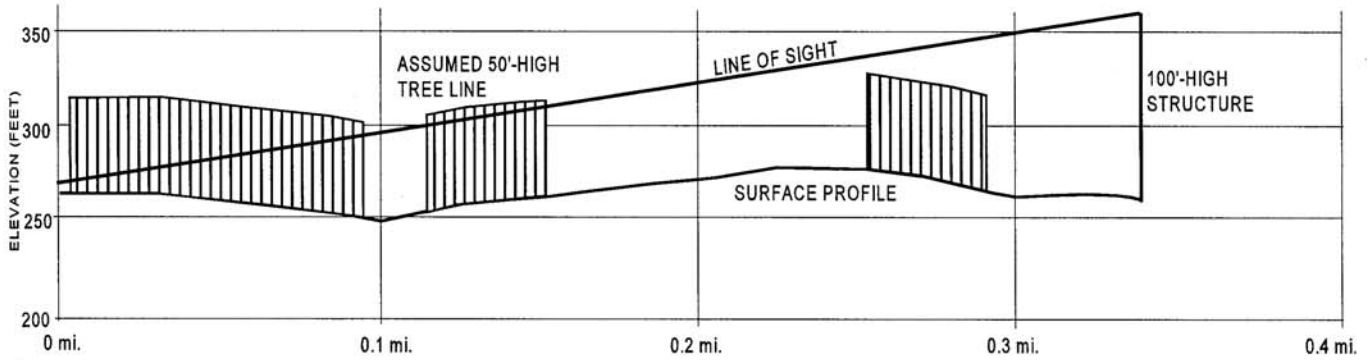

PROFILE 1: FLANDERS ROAD BRIDGE TO STRUCTURE 9034

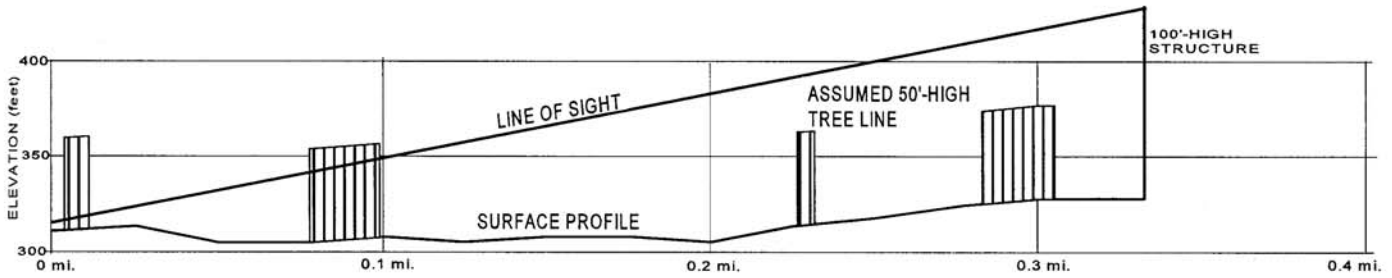

PROFILE 2: JEWISH CEMETERIES TO STRUCTURE 9036

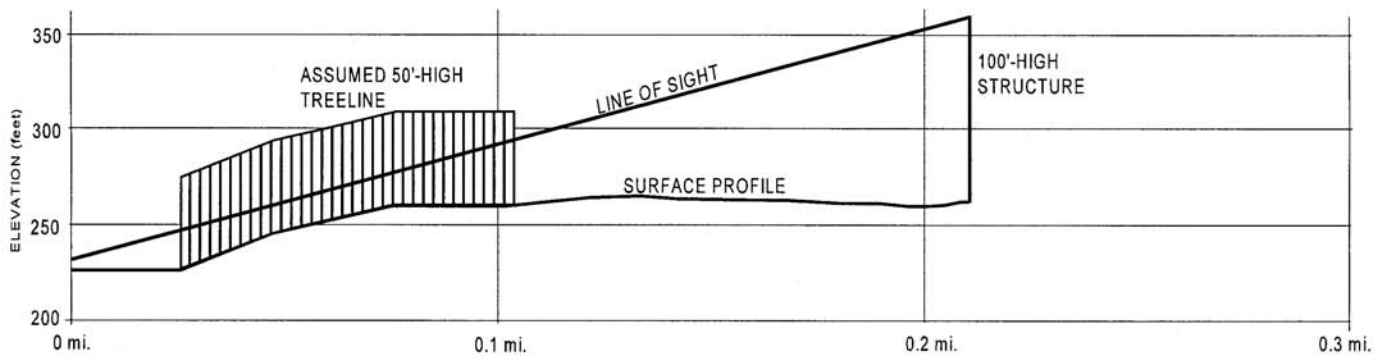

PROFILE 3: 89 MANSFIELD HOLLOW ROAD TO STRUCTURE 9075

1" = 100' (VERT.)

BASE PROFILES ADAPTED FROM TOPO! ©1998 WILDFLOWER PRODUCTIONS

RABER ASSOCIATES: CULTURAL RESOURCES ASSESSMENT FOR INTERSTATE RELIABILITY PROJECT, MAY 2008

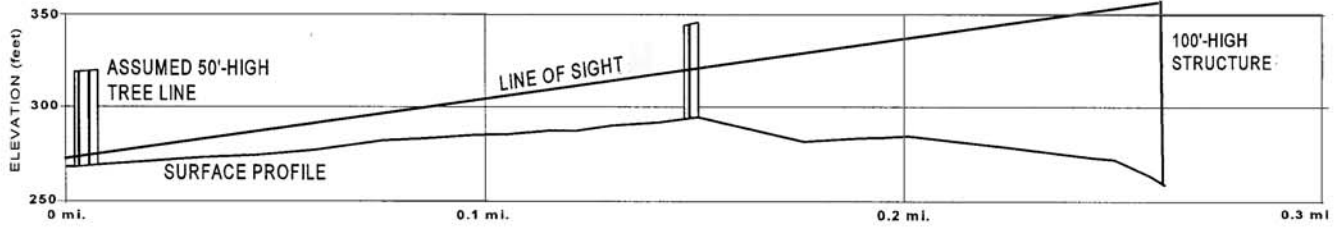

PROFILE 4: MANSFIELD NEW CEMETERY TO STRUCTURE 9077

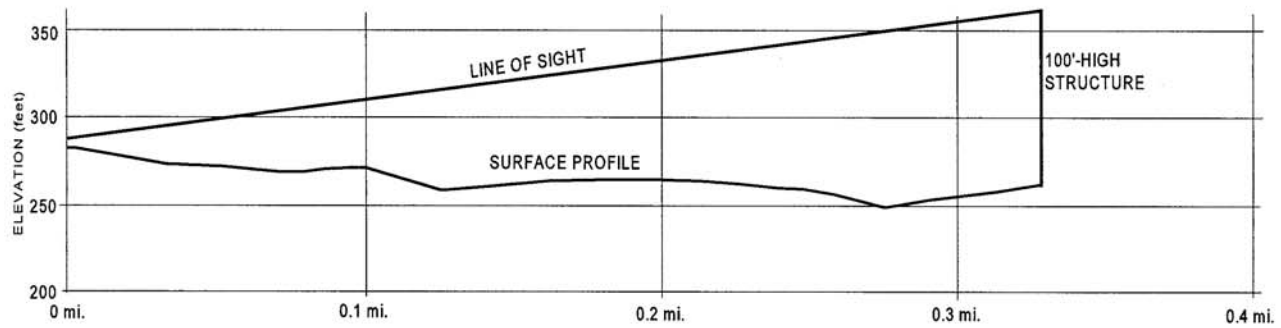

PROFILE 5: MANSFIELD OLD CEMETERY TO STRUCTURE 9076

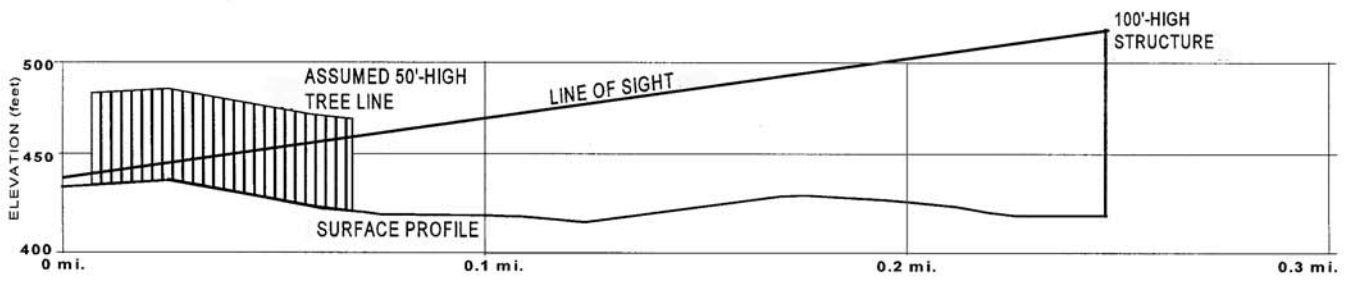

PROFILE 6: CHEWINK CEMETERY TO STRUCTURE 9110

1" = 100' (VERT.)

BASE PROFILES ADAPTED FROM TOPO! ©1998 WILDFLOWER PRODUCTIONS

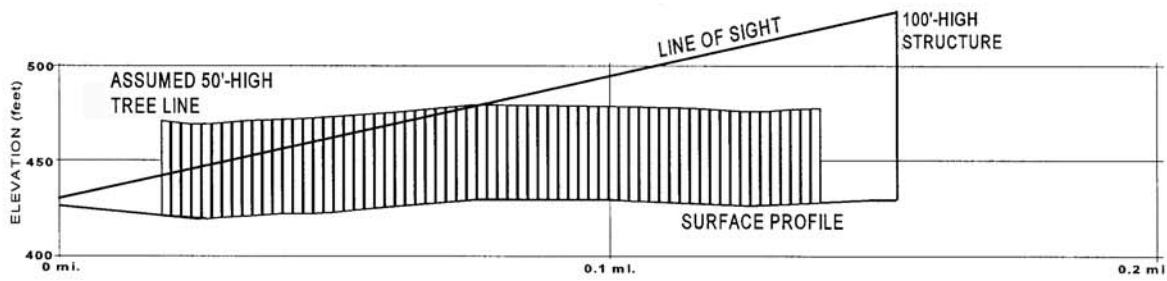

PROFILE 7: CHAPLIN OLD CEMETERY TO STRUCTURE 9112

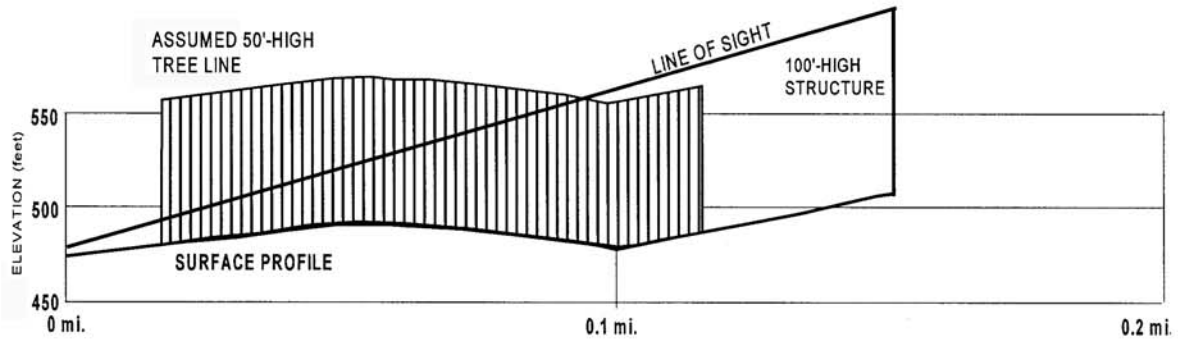

PROFILE 8: HAMPTON SOUTH CEMETERY TO STRUCTURE 9140

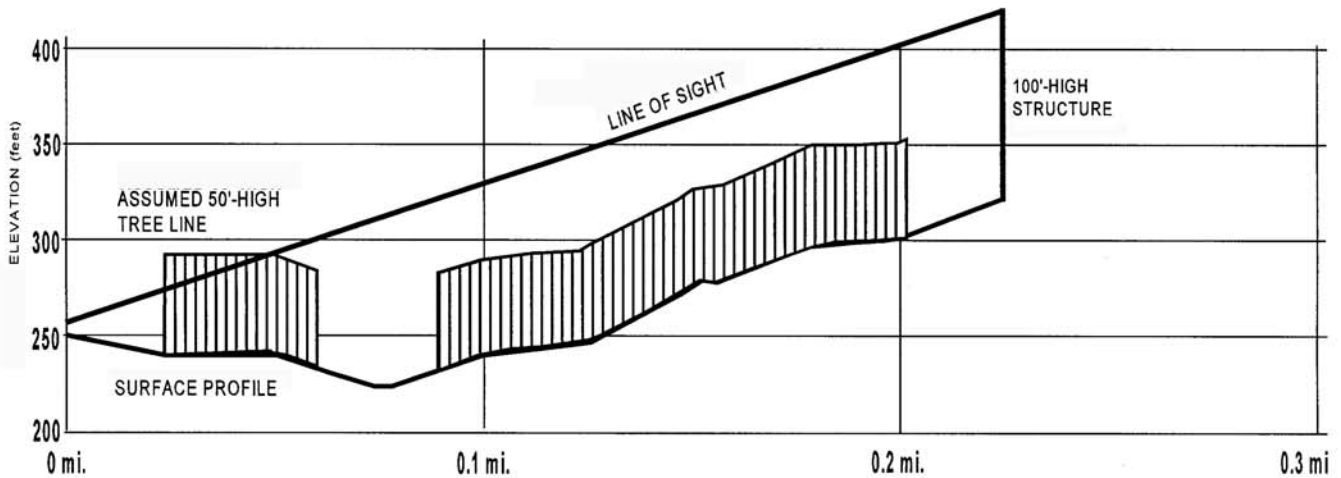

PROFILE 9: ROGERS VILLAGE TO STRUCTURE 9232

1" = 100' (VERT.)

BASE PROFILES ADAPTED FROM TOPO! ©1998 WILDFLOWER PRODUCTIONS

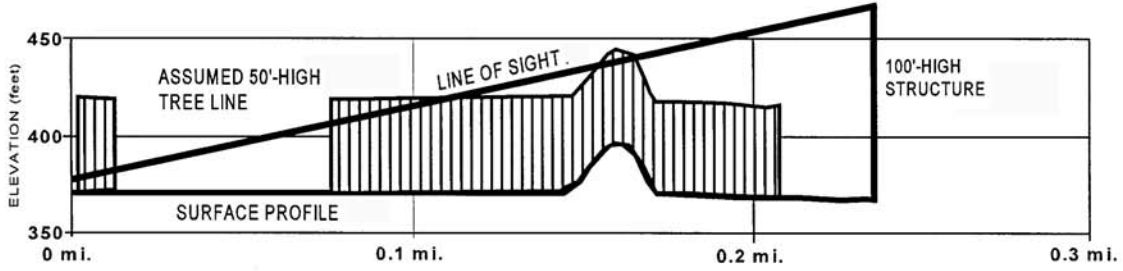

PROFILE 10: MUNYAN CEMETERY TO STRUCTURE 9316

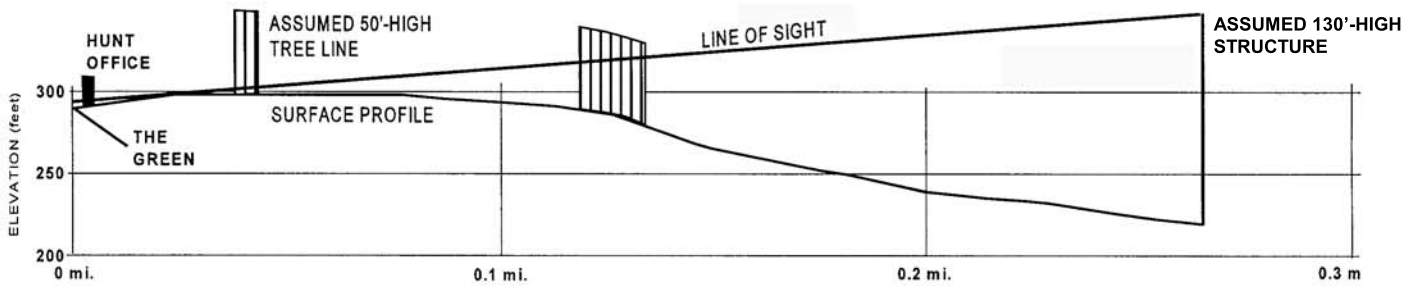

PROFILE 11: DR. CHESTER HUNT OFFICE TO WILLIMANTIC SOUTH OVERHEAD VARIATION

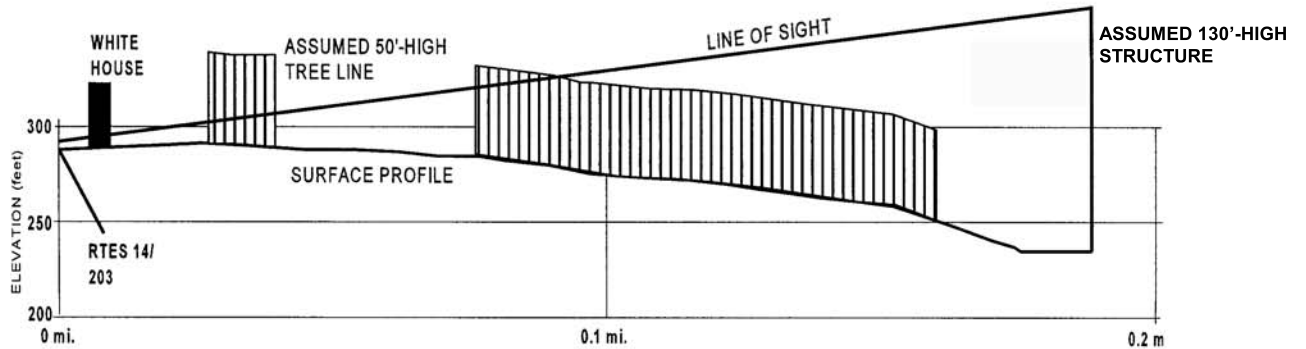

PROFILE 12: ELISHA WHITE HOUSE TO WILLIMANTIC SOUTH OVERHEAD VARIATION

1" = 100' (VERT.)

BASE PROFILES ADAPTED FROM TOPO! ©1998 WILDFLOWER PRODUCTIONS

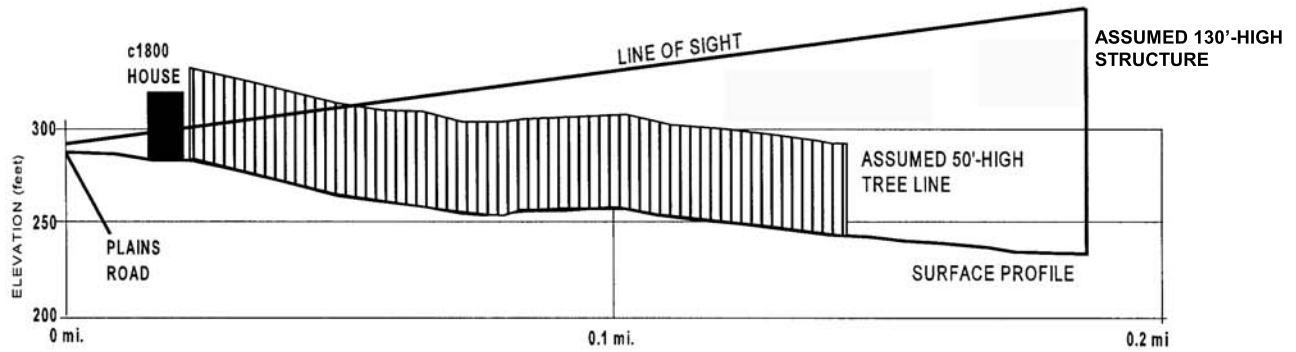

PROFILE 13: c1800 HOUSE TO WILLIMANTIC SOUTH OVERHEAD VARIATION

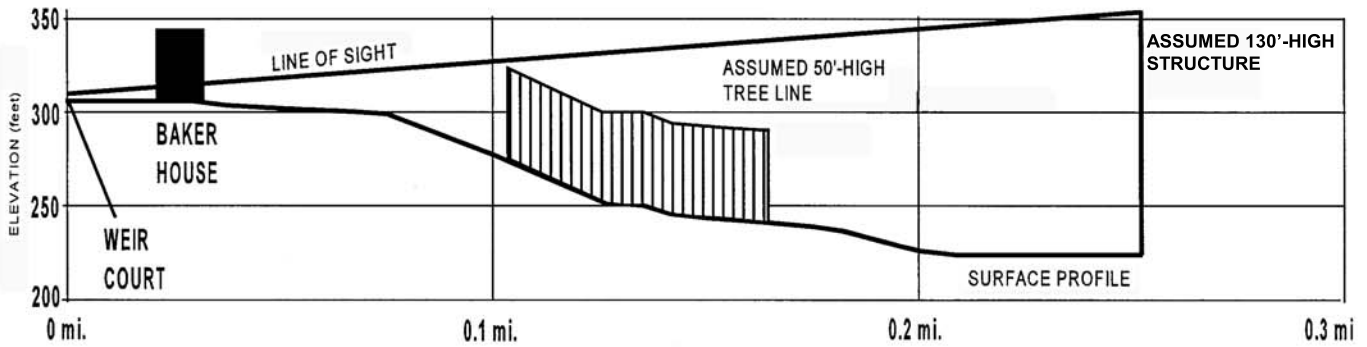

PROFILE 14: BAKER HOUSE TO WILLIMANTIC SOUTH OVERHEAD VARIATION

1" = 100' (VERT.)

BASE PROFILES ADAPTED FROM TOPO! ©1998 WILDFLOWER PRODUCTIONS

APPENDIX 3

**PHOTOGRAPHS OF SELECTED SIGNIFICANT HISTORIC PROPERTIES WITHIN ONE QUARTER
MILE OF EXISTING TRANSMISSION STRUCTURES ON PRIMARY ROUTE, WITH SIMULATIONS OF
PROPOSED OVERHEAD TRANSMISSION STRUCTURES**

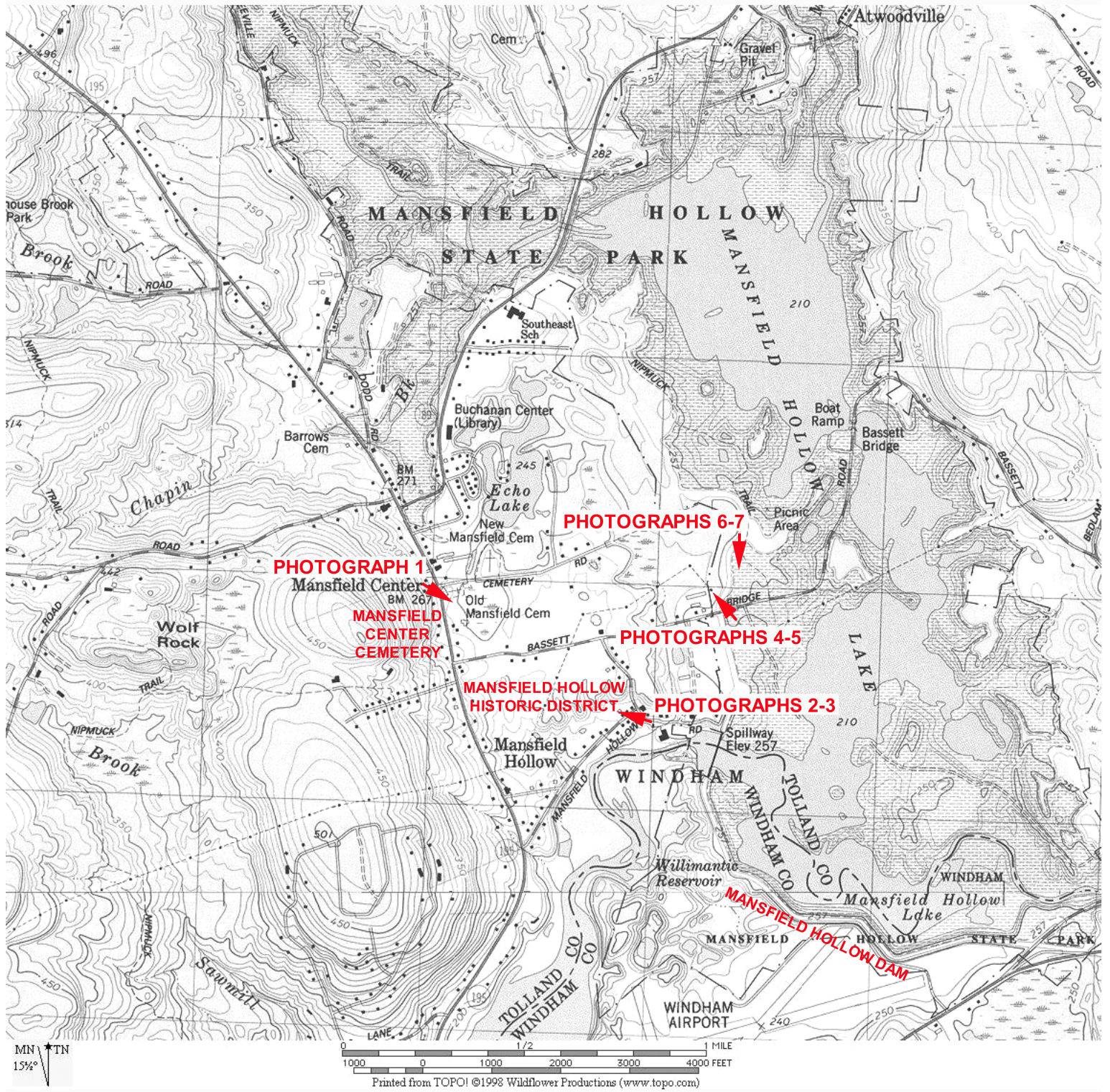

KEY TO PHOTOGRAPHS 1-7 ON SPRING HILL QUADRANGLE



Photograph 1. VIEW SOUTHEAST FROM MANSFIELD CENTER CEMETERY 1900 FEET TO EXISTING STRUCTURE 9076

Existing 60-foot-high wooden H-frame structure, located just south of Bassett Bridge Road, is barely visible. A similar new structure, even if 90 feet high, would not have an adverse visual effect.



Photograph 2. VIEW WEST FROM WESTERNMOST HOUSE IN MANSFIELD HOLLOW HISTORIC DISTRICT APPROXIMATELY 800 FEET TO MOUNT HOPE MONTESSORI SCHOOL OVERHEAD VARIATION ALIGNMENT



Photograph 3. VIEW WEST FROM WESTERNMOST HOUSE IN MANSFIELD HOLLOW HISTORIC DISTRICT WITH SIMULATED MOUNT HOPE MONTESSORI SCHOOL OVERHEAD VARIATION STRUCTURE AND CONDUCTORS



**Photograph 4. VIEW NORTHWEST FROM MANSFIELD HOLLOW DAM
DAM 630 FEET TO EXISTING STRUCTURE 9080**



**Photograph 5. VIEW NORTHWEST FROM MANSFIELD HOLLOW
DAM WITH EXISTING AND SIMULATED
STRUCTURES**



Photograph 6. VIEW SOUTHEAST FROM MANSFIELD HOLLOW DAM 430 FEET TO EXISTING STRUCTURE 9081 (RIGHT) AND 1000 FEET TO EXISTING STRUCTURE 9082 (LEFT)



Photograph 7. VIEW SOUTHEAST FROM MANSFIELD HOLLOW DAM WITH EXISTING AND SIMULATED STRUCTURES

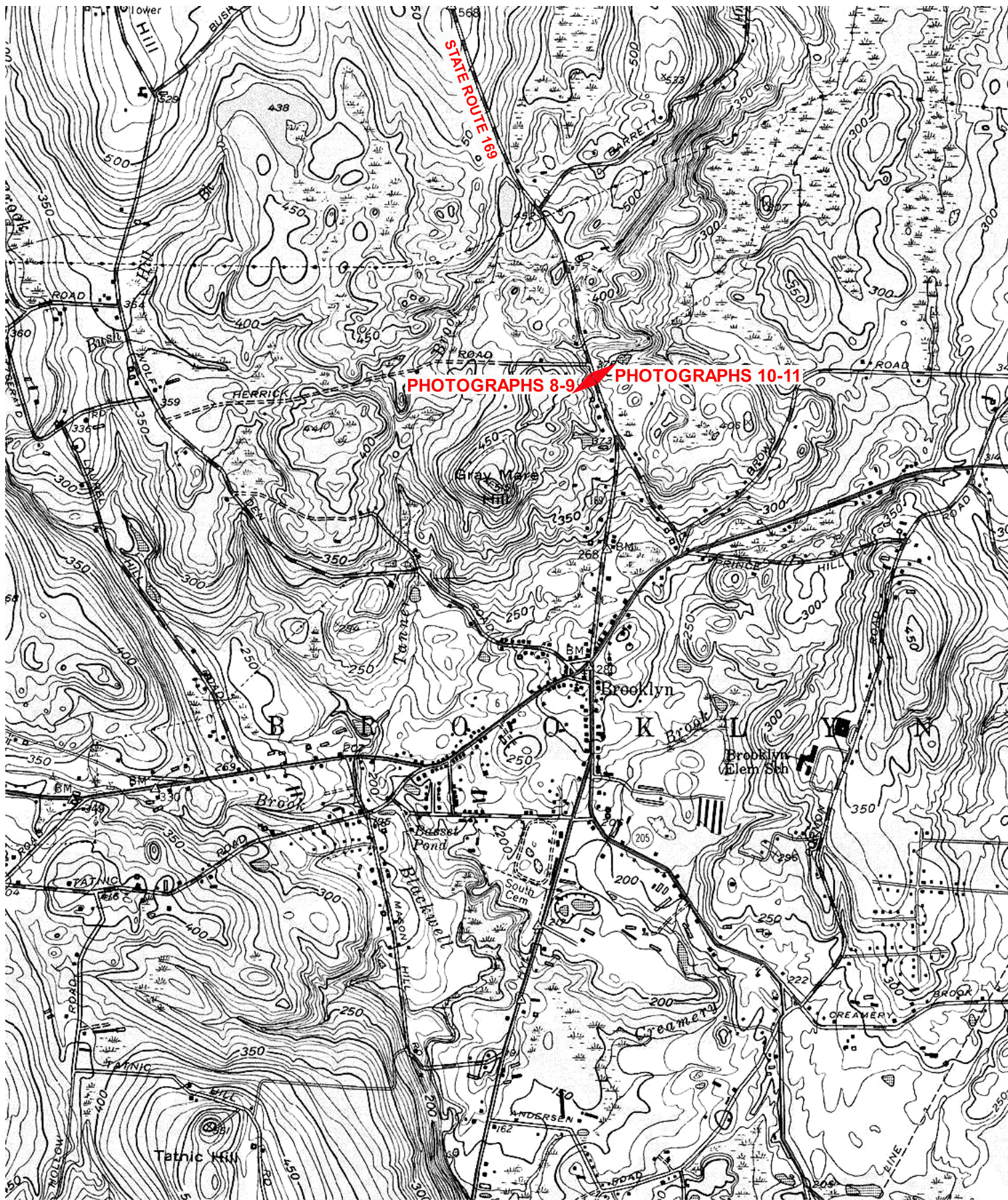

KEY TO PHOTOGRAPHS 8-11 ON DANIELSON QUADRANGLE



Photograph 8. VIEW SOUTHWEST FROM STATE ROUTE 169 400 FEET TO EXISTING STRUCTURE 9198



Photograph 9. VIEW SOUTHWEST FROM STATE ROUTE 169 TO EXISTING AND SIMULATED STRUCTURE



Photograph 10. VIEW NORTHEAST FROM STATE ROUTE 169 130 FEET TO EXISTING STRUCTURE 9199



Photograph 11. VIEW NORTHEAST FROM STATE ROUTE 169 WITH EXISTING & SIMULATED STRUCTURES