

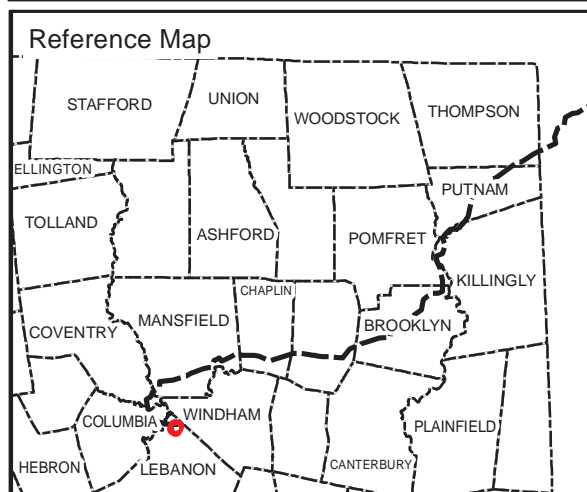

Path: U:\Projects\us\45547\GIS\Datasets\ArcDocs\SRP_DM_Existing_Substation_2.mxd

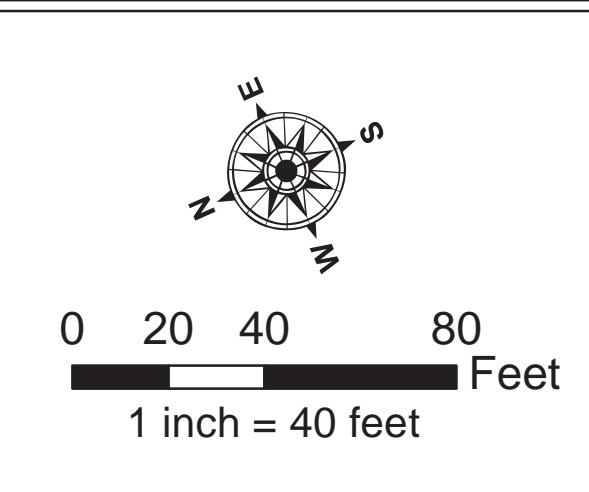

Legend:
 Parcel (white outline)
 NU Owned Property (orange outline)
 Existing ROW (dashed line)
 Fence (line with cross-ticks)
 Existing Contour Line (10' Interval) (grey line)
 Wetland (green fill)



NO.	DATE	REVISIONS	BY	CHK	APP	APP

 DATE: 8/1/2013 DESIGNED: M.Kasinskas		DETAILED: J.Francis	
		CHECKED: M.Kasinskas	

Northeast Utilities Service Co.
 THE CONNECTICUT LIGHT & POWER CO.
Interstate Reliability Project
Development & Management Plan

BY: J.Francis	CHKD: M.Kasinskas	APP	APP
DATE: 8/1/2013	DATE: 8/1/2013	DATE	DATE
SCALE 1 inch = 40ft	Mapsheet A-3	Card Street Substation Existing Conditions	

Image Source: State of Connecticut 2012 Imagery Mosaic Dataset

- NOTES:**
- SITE DEVELOPMENT CONTRACTOR SHALL PROVIDE TEMPORARY CONSTRUCTION ENTRANCES AS SPECIFIED.
 - SITE DEVELOPMENT CONTRACTOR SHALL BE RESPONSIBLE FOR COMPLIANCE WITH ALL EROSION AND SEDIMENT CONTROL PRACTICES AS SPECIFIED IN THE FOLLOWING:
 - 2002 CONNECTICUT GUIDELINES FOR SOIL EROSION AND SEDIMENT CONTROL
 - NORTHEAST UTILITIES' CONSTRUCTION & MAINTENANCE ENVIRONMENTAL REQUIREMENTS - BEST MANAGEMENT PRACTICES MANUAL: CONNECTICUT DECEMBER 2011
 - CT DEEP'S GENERAL PERMIT FOR THE DISCHARGE OF STORMWATER AND DEWATERING WASTEWATERS ASSOCIATED WITH CONSTRUCTION ACTIVITIES
 - EROSION AND SEDIMENT CONTROL PRACTICES ARE TO BE INSTALLED PRIOR TO ANY MAJOR SOIL DISTURBANCES AND MAINTAINED AS SPECIFIED UNTIL PERMANENT PROTECTION IS ESTABLISHED.
 - LIMITS OF WORK AREA DISTURBANCE ARE DEFINED BY THE EROSION CONTROLS. NO WORK AREA DISTURBANCE SHALL TAKE PLACE OUTSIDE OF THE EROSION CONTROL LIMITS.
 - CONSTRUCTION ENTRANCES, THE SURFACE OF WORK AREAS WITHIN THE SUBSTATION, AND OTHER AREAS TO BE GRAVELED, AS SHOWN, SHALL BE SURFACED WITH 2" THICK WORKING SURFACE AGGREGATE AS SPECIFIED.
 - AREAS AFFECTED BY CONSTRUCTION WITHIN THE SUBSTATION FENCE LINES SHALL BE PERMANENTLY STABILIZED WITH GRAVEL. OTHER DISTURBED AREAS SHALL BE RESEED TO ESTABLISH A UNIFORM VEGETATIVE COVER OF 70% DENSITY, OR PERMANENTLY STABILIZED WITH GRAVEL.

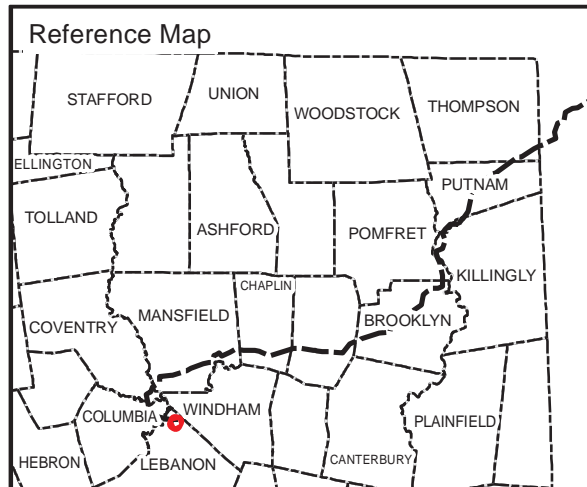
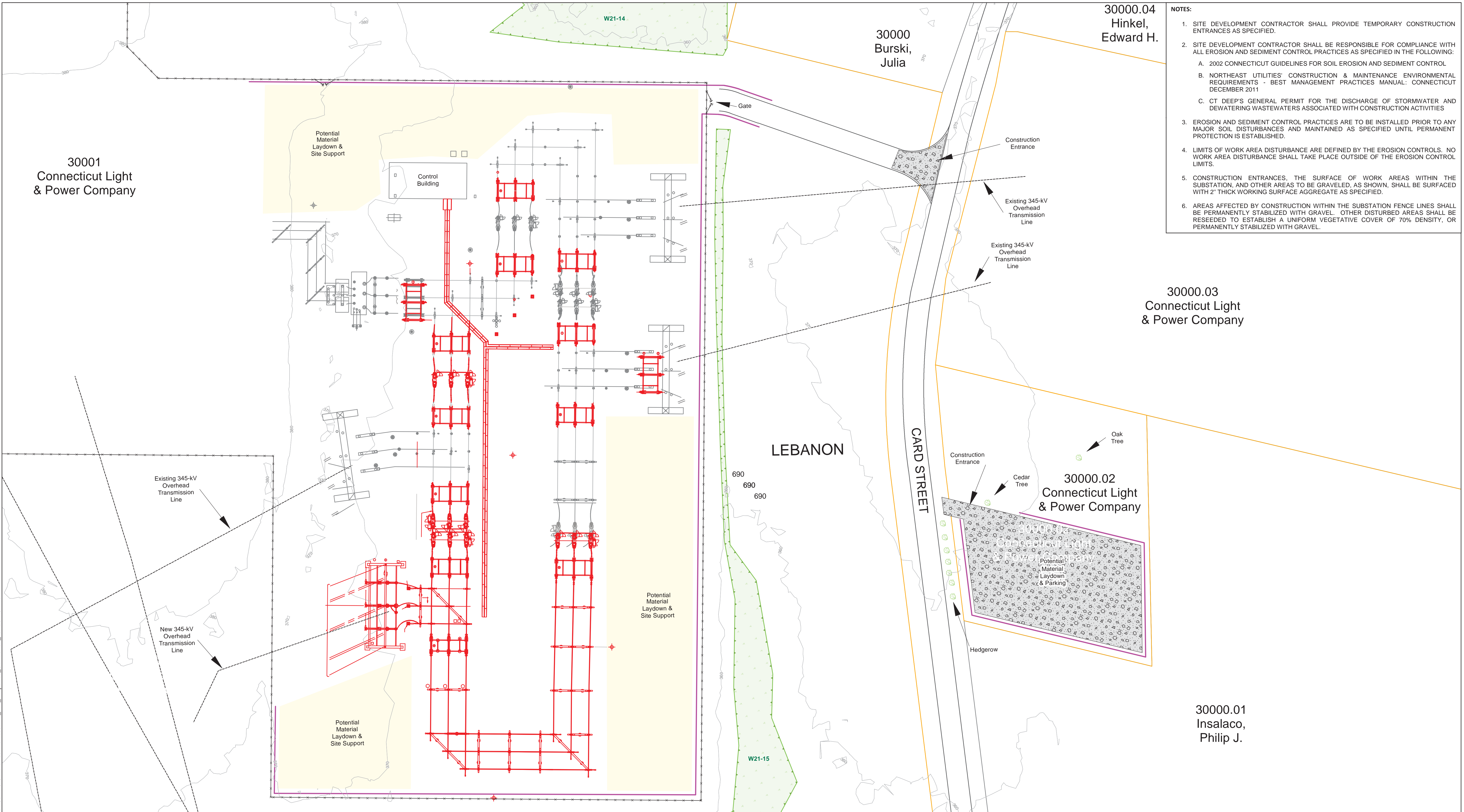

- Existing ROW
- Existing Contour Line (10' Interval)
- Existing Transmission Line
- Proposed Transmission Line
- Ground Grid Additions
- Substation Additions
- Erosion & Sedimentation Controls
- Parcel
- NU Owned Property
- Gravel
- Pavement

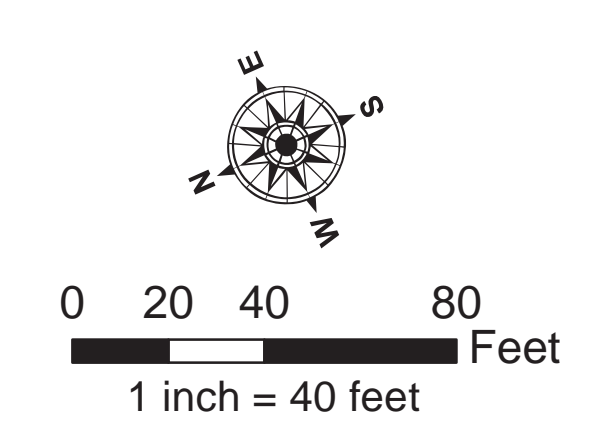

NO.	DATE	REVISIONS	BY	CHK	APP	APP

DATE	8/1/2013	DESIGNED	M.Kasinskas
DATE	8/1/2013	CHECKED	M.Kasinskas

Burns & McDonnell
SINCE 1898

Northeast Utilities Service Co.
THE CONNECTICUT LIGHT & POWER CO.

**Interstate Reliability Project
Development & Management Plan**

BY: J.Francis	CHKD: M.Kasinskas	APP	APP
DATE: 8/1/2013	DATE: 8/1/2013	DATE	DATE
SCALE 1 inch = 40ft	Mapsheet A-4	Card Street Substation Proposed Conditions	
45547			

Path: U:\Projects\us\45547\GIS\Drawfiles\ArcDocs\SRP_DM_Proposed_Substation_20130710.mxd



AERIAL VIEW

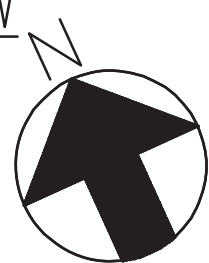

CARD STREET D&M PLAN - NOT FOR CONSTRUCTION CONTRACTOR
AERIAL

Burns & McDonnell
SINCE 1925

NOT FOR CONSTRUCTION
REVISION(S) ^w

W-2	03/05/13	ISSUED FOR D&M PLAN				date	DECEMBER 3, 2012	detailed	J. EICHENBERGER
W-1	12/05/12	ISSUED FOR NUSCO REVIEW				designed	X. XXX	checked	
no.	date	revisions	det.	dsn	chk	app.			

Burns & McDonnell
SINCE 1925

46650

REVISIONS DURING CONSTRUCTION			
NO.	DATE	DESCRIPTION	BY

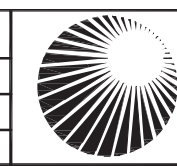

Northeast Utilities Service Co.

BY	REV. NO.	DATE	SIZE	DWG. NO.

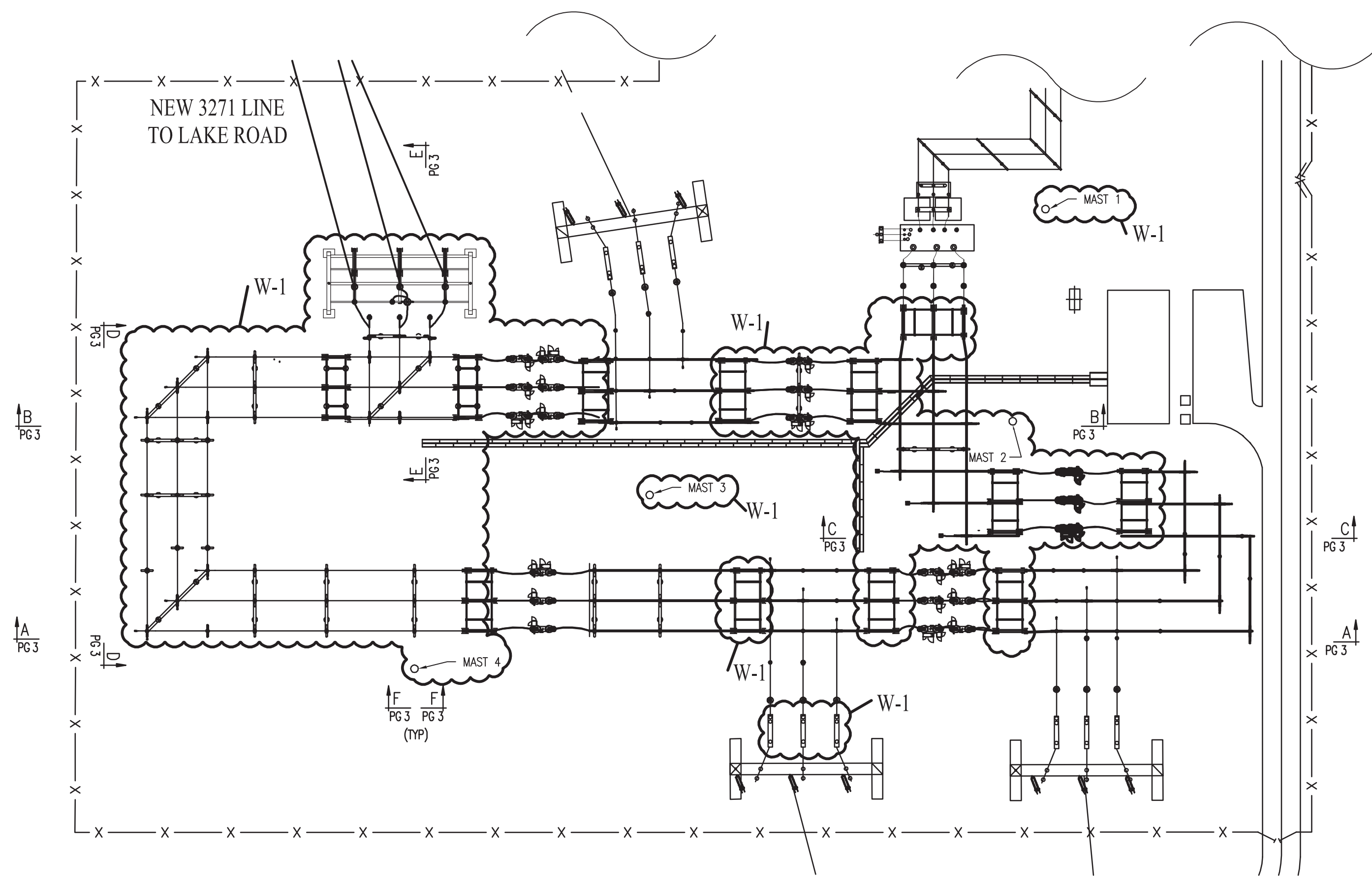

PLAN VIEW

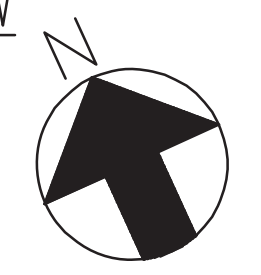

CARD STREET D&M PLAN - NOT FOR CONSTRUCTION CONTRACTOR
PROPOSED GENERAL ARRANGEMENT PLAN

Burns & McDonnell
NOT FOR CONSTRUCTION
REVISION(S) W

no.	date	revisions	det.	dsn.	chk.	app.
W-2	03/05/13	ISSUED FOR D&M PLAN	-	-	-	-
W-1	12/05/12	ISSUED FOR NUSCO REVIEW	-	-	-	-

date	designed	checked	detailed
DECEMBER 3, 2012	X. XXX		J. EICHENBERGER



REVISIONS DURING CONSTRUCTION			
no.	date	description	approved

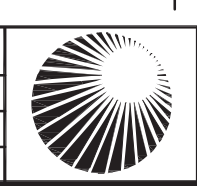

Northeast Utilities Service Co.
BY: _____ REV. NO. _____ DATE _____ SIZE D DWG. NO. EXHIBIT-1 PG 2

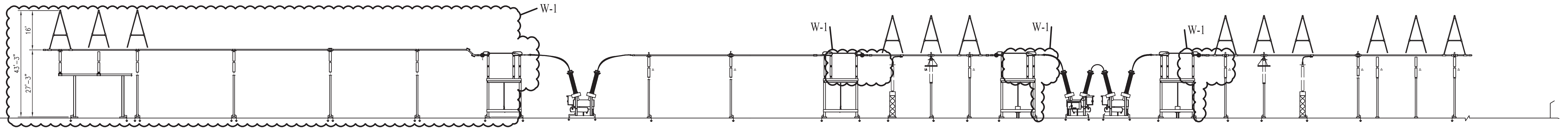

SECTION A-A
1" = 20'-0"
PG 2

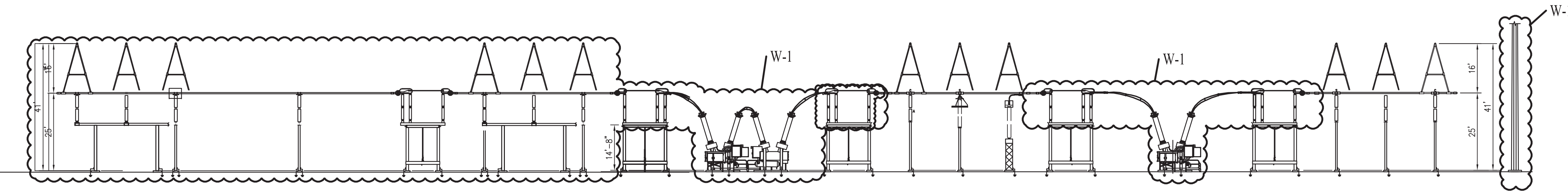

SECTION B-B
1" = 20'-0"
PG 2

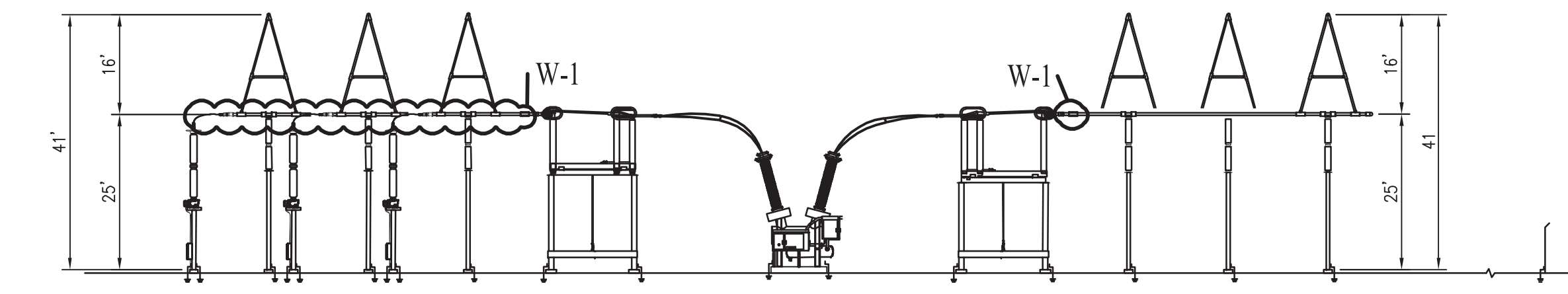

SECTION C-C
1" = 20'-0"
PG 2

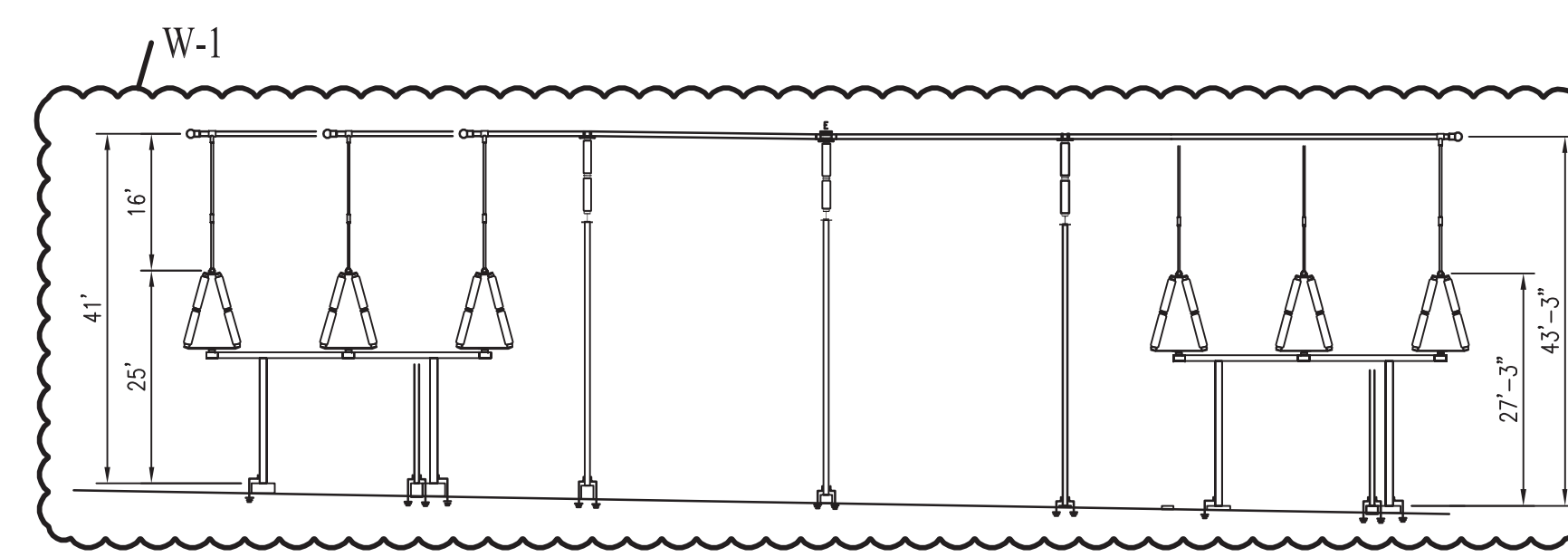

SECTION D-D
1" = 20'-0"
PG 2

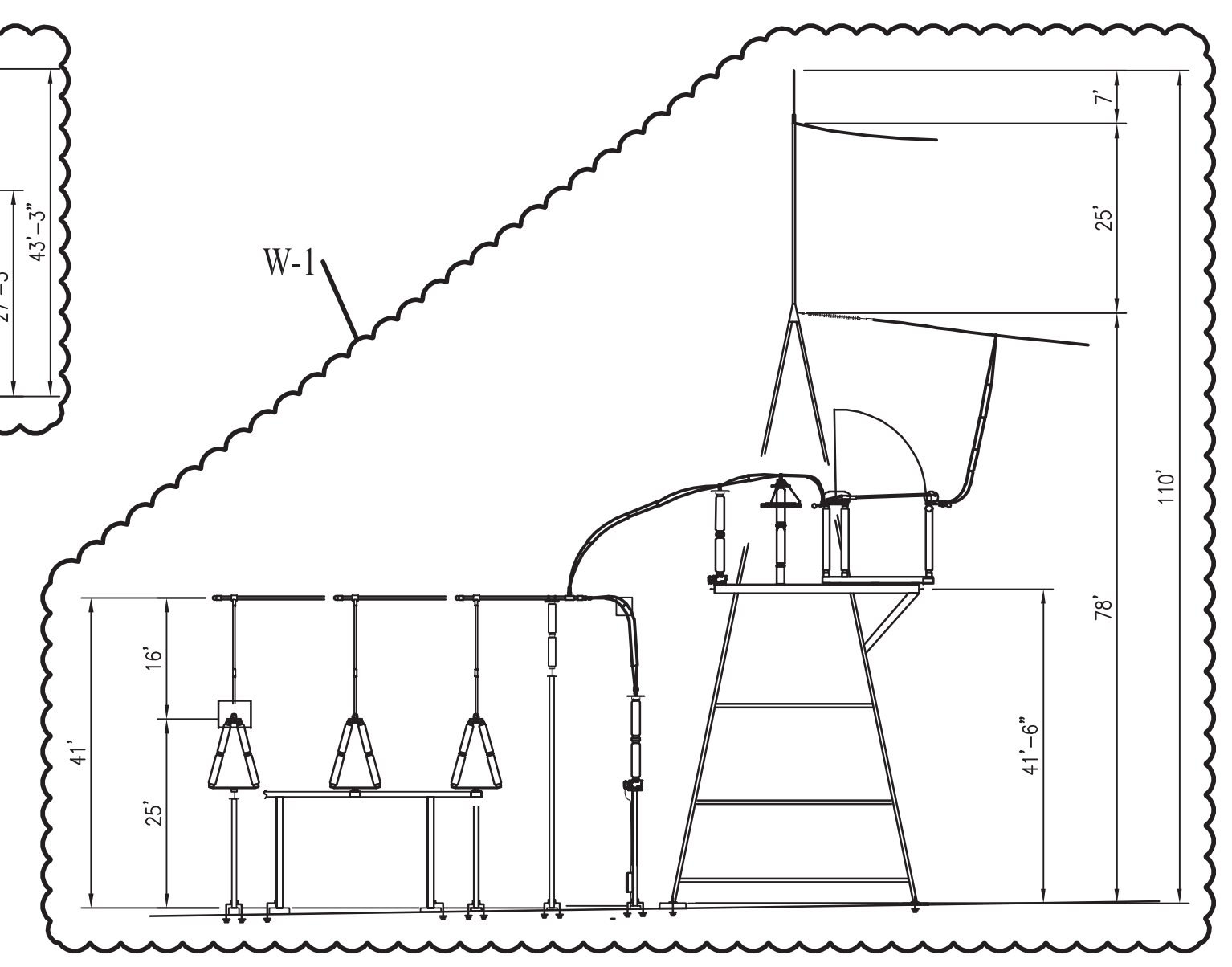

SECTION E-E
1" = 20'-0"
PG 2

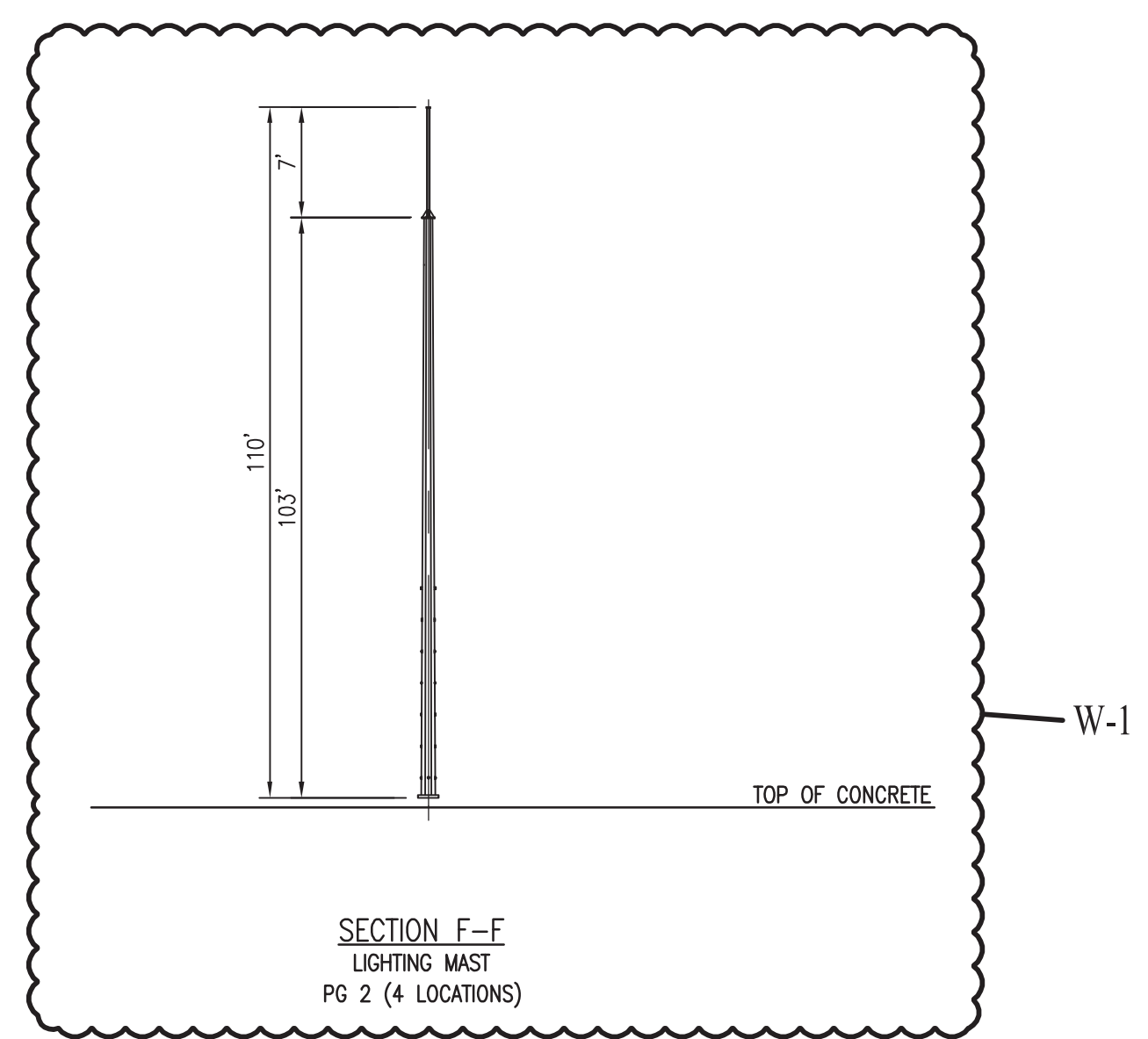

SECTION F-F
LIGHTING MAST
PG 2 (4 LOCATIONS)

CARD STREET D&M PLAN - NOT FOR CONSTRUCTION CONTRACTOR
PROPOSED SECTIONS

NOT FOR CONSTRUCTION
REVISION(S) W

W-2	03/05/13	ISSUED FOR D&M PLAN				date	DECEMBER 3, 2012	detailed	J. EICHENBERGER
W-1	12/05/12	ISSUED FOR NUSCO REVIEW				designed	X. XXX	checked	
no.	date	revisions	det.	dsn	chk	app.			



REVISIONS DURING CONSTRUCTION			

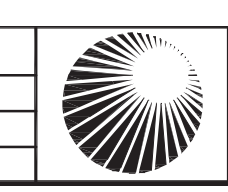

Northeast Utilities Service Co.
BY: REV. NO. DATE SIZE DWG. NO.
D EXHIBIT-1 PG 3

- NOTES:**
- SITE DEVELOPMENT CONTRACTOR SHALL PROVIDE TEMPORARY CONSTRUCTION ENTRANCES AS SPECIFIED.
 - SITE DEVELOPMENT CONTRACTOR SHALL BE RESPONSIBLE FOR COMPLIANCE WITH ALL EROSION AND SEDIMENT CONTROL PRACTICES AS SPECIFIED IN THE FOLLOWING:
 - 2002 CONNECTICUT GUIDELINES FOR SOIL EROSION AND SEDIMENT CONTROL
 - NORTHEAST UTILITIES' CONSTRUCTION & MAINTENANCE ENVIRONMENTAL REQUIREMENTS - BEST MANAGEMENT PRACTICES MANUAL: CONNECTICUT DECEMBER 2011
 - CT DEEP'S GENERAL PERMIT FOR THE DISCHARGE OF STORMWATER AND DEWATERING WASTEWATERS ASSOCIATED WITH CONSTRUCTION ACTIVITIES
 - EROSION AND SEDIMENT CONTROL PRACTICES ARE TO BE INSTALLED PRIOR TO ANY MAJOR SOIL DISTURBANCES AND MAINTAINED AS SPECIFIED UNTIL PERMANENT PROTECTION IS ESTABLISHED.
 - LIMITS OF WORK AREA DISTURBANCE ARE DEFINED BY THE EROSION CONTROLS. NO WORK AREA DISTURBANCE SHALL TAKE PLACE OUTSIDE OF THE EROSION CONTROL LIMITS.
 - CONSTRUCTION ENTRANCES, THE SURFACE OF THE AREA WITHIN THE SWITCHING STATION, THE AREA EXTENDING 3' BEYOND THE GROUND GRID, AND OTHER AREAS TO BE GRAVELED, AS SHOWN, SHALL BE SURFACED WITH 2" THICK WORKING SURFACE AGGREGATE AS SPECIFIED.
 - AREAS AFFECTED BY CONSTRUCTION WITHIN THE SWITCHING STATION FENCE LINES AND THE AREA EXTENDING 3' BEYOND THE GROUND GRID SHALL BE PERMANENTLY STABILIZED WITH GRAVEL. OTHER DISTURBED AREAS SHALL BE RESEED TO ESTABLISH A UNIFORM VEGETATIVE COVER OF 70% DENSITY, OR PERMANENTLY STABILIZED WITH GRAVEL. TEMPORARY STAGING AREAS WILL BE RESTORED TO PRE-CONSTRUCTION CONDITIONS, OR AS OTHERWISE SPECIFIED PURSUANT TO AGREEMENT WITH THE LAKE ROAD GENERATING STATION.

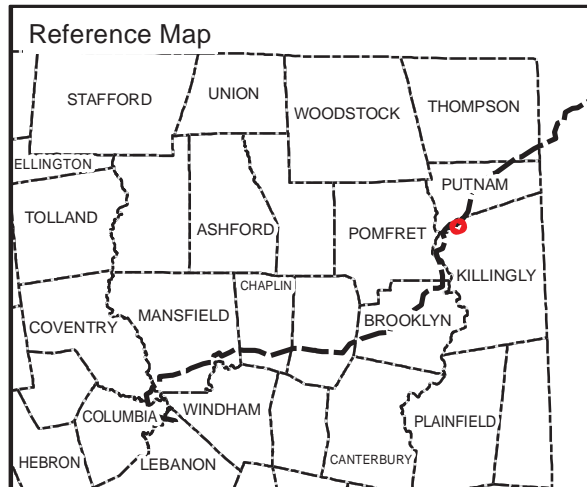
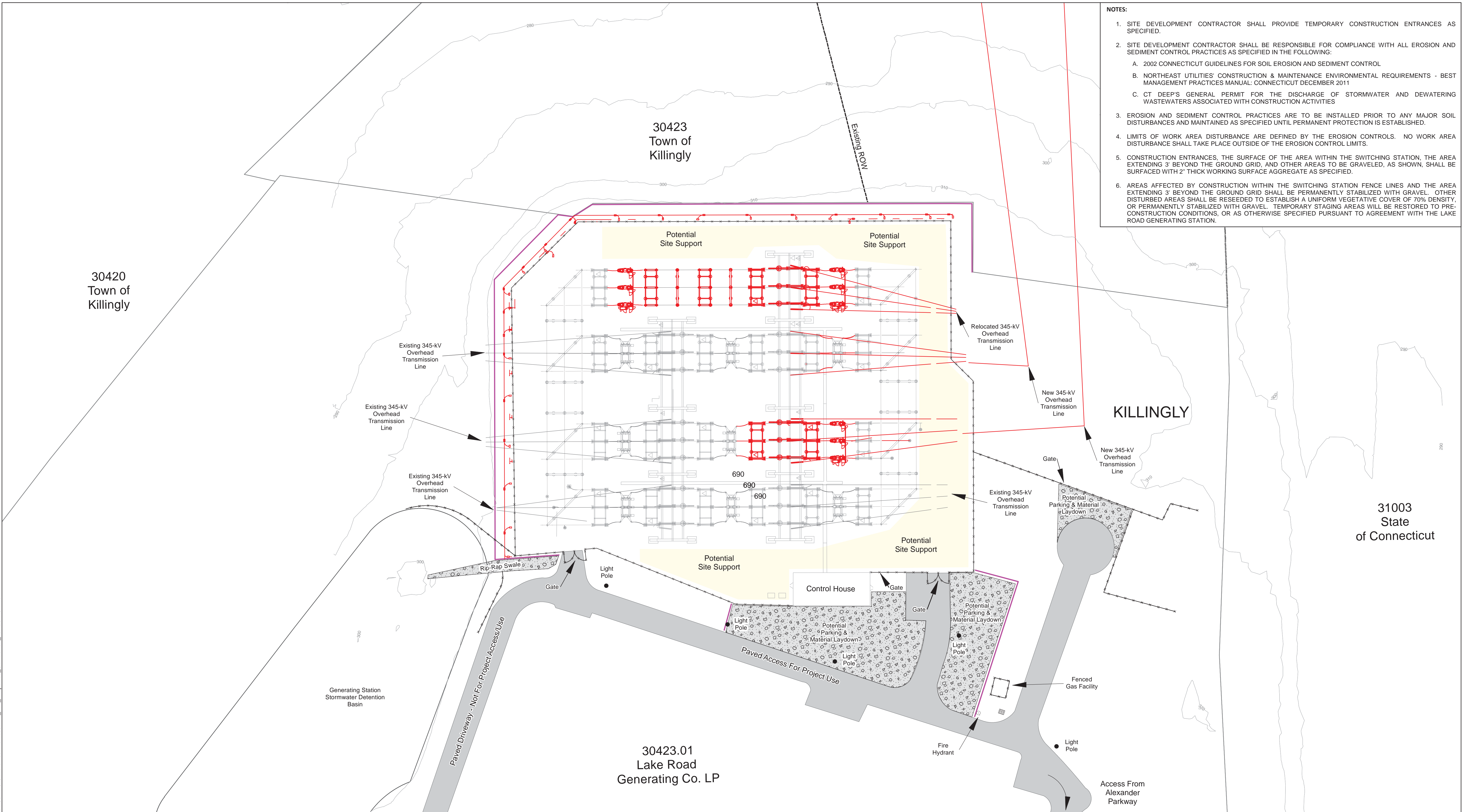

- Existing ROW
- Existing Contour Line (10' Interval)
- Existing Transmission Line
- Proposed Transmission Line
- Ground Grid Additions
- Switching Station Additions
- Erosion & Sedimentation Controls
- Parcel
- NU Owned Property
- Gravel
- Pavement

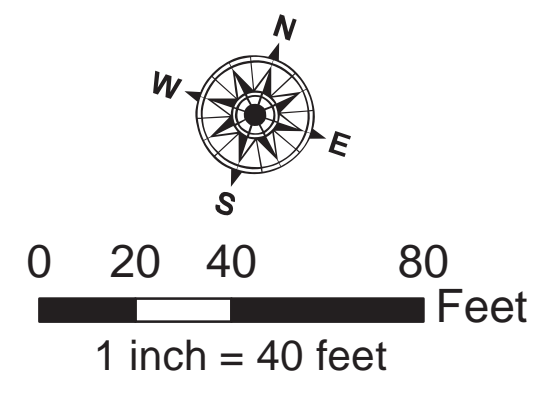

NO.	DATE	REVISIONS	BY	CHK	APP	APP

		DATE	DETAILED
		8/1/2013	J.Francis
		DESIGNED	CHECKED
		M.Kasinskaskas	M.Kasinskaskas

Northeast Utilities Service Co. THE CONNECTICUT LIGHT & POWER CO.			
Interstate Reliability Project Development & Management Plan			
BY: J.Francis	CHKD: M.Kasinskaskas	APP	APP
DATE: 8/1/2013	DATE: 8/1/2013	DATE	DATE
SCALE 1 inch = 40ft	Mapsheet B-4	Lake Road Switching Station Proposed Conditions	
45547			

Path: U:\Projects\us\45547\GIS\Drawings\ArcDocs\SRP_DM_Proposed_Substation_20130710.mxd

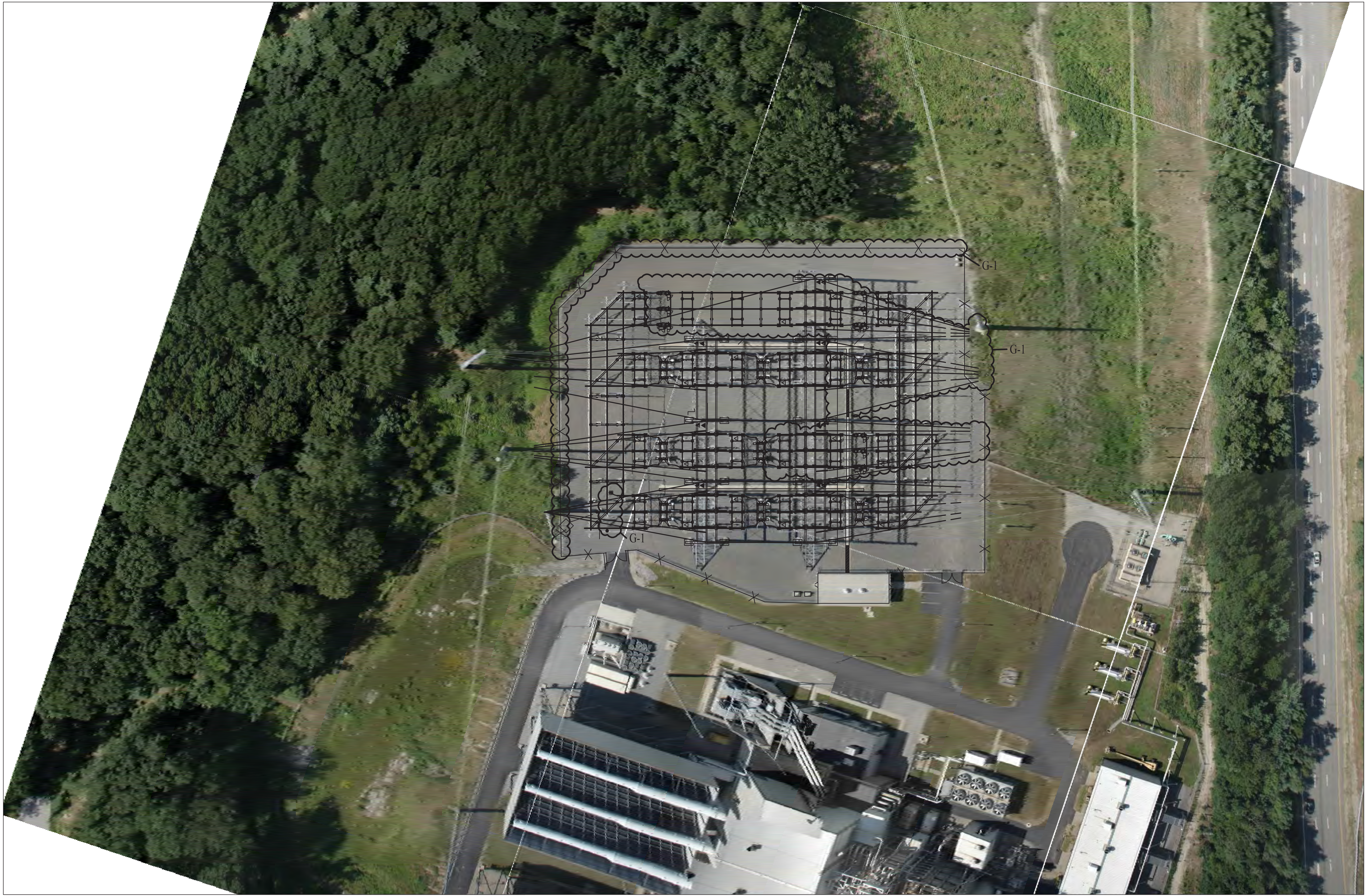

AERIAL VIEW

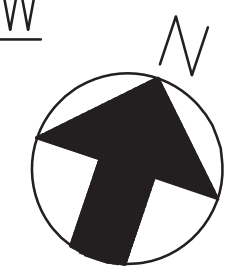

NOT FOR CONSTRUCTION
 REVISION(S) ⁰

no.	date	revisions	det.	dsn	chk	app.
G-1	12/04/12	ISSUED FOR MUSCO REVIEW				

date
DECEMBER 3, 2012
 designed
X. XXX
 detailed
J. EICHENBERGER
 checked



REVISIONS DURING CONSTRUCTION			
no.	date	description	status

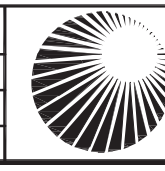

Northeast Utilities Service Co.
 BY: _____ REV. NO. _____ DATE _____ SIZE: D DWG. NO. EXHIBIT-1 PG 1

LAKE ROAD D&M PLAN - NOT FOR CONSTRUCTION CONTRACTOR
 AERIAL

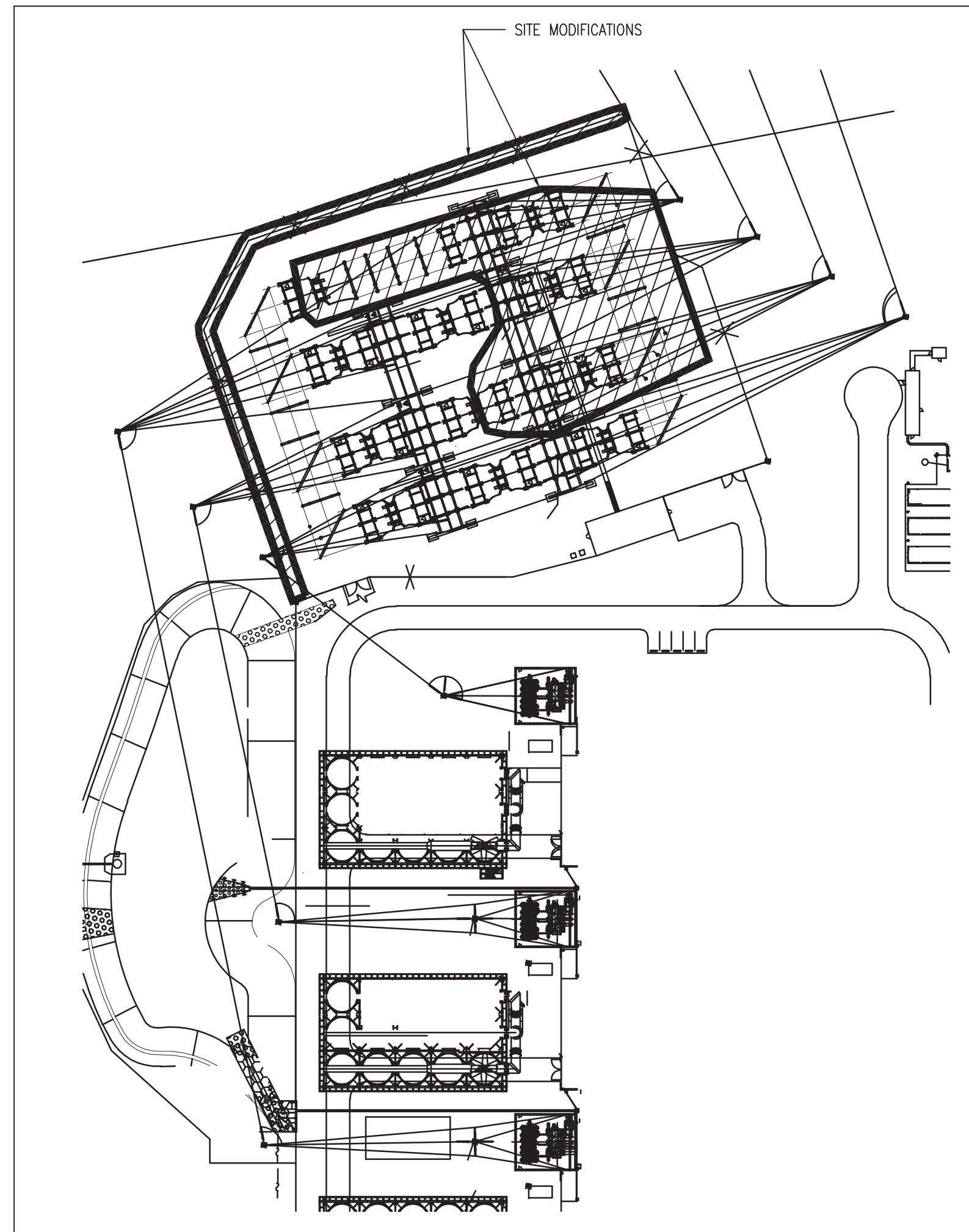

LOCATION PLAN

0 200' 400'
SCALE IN FEET

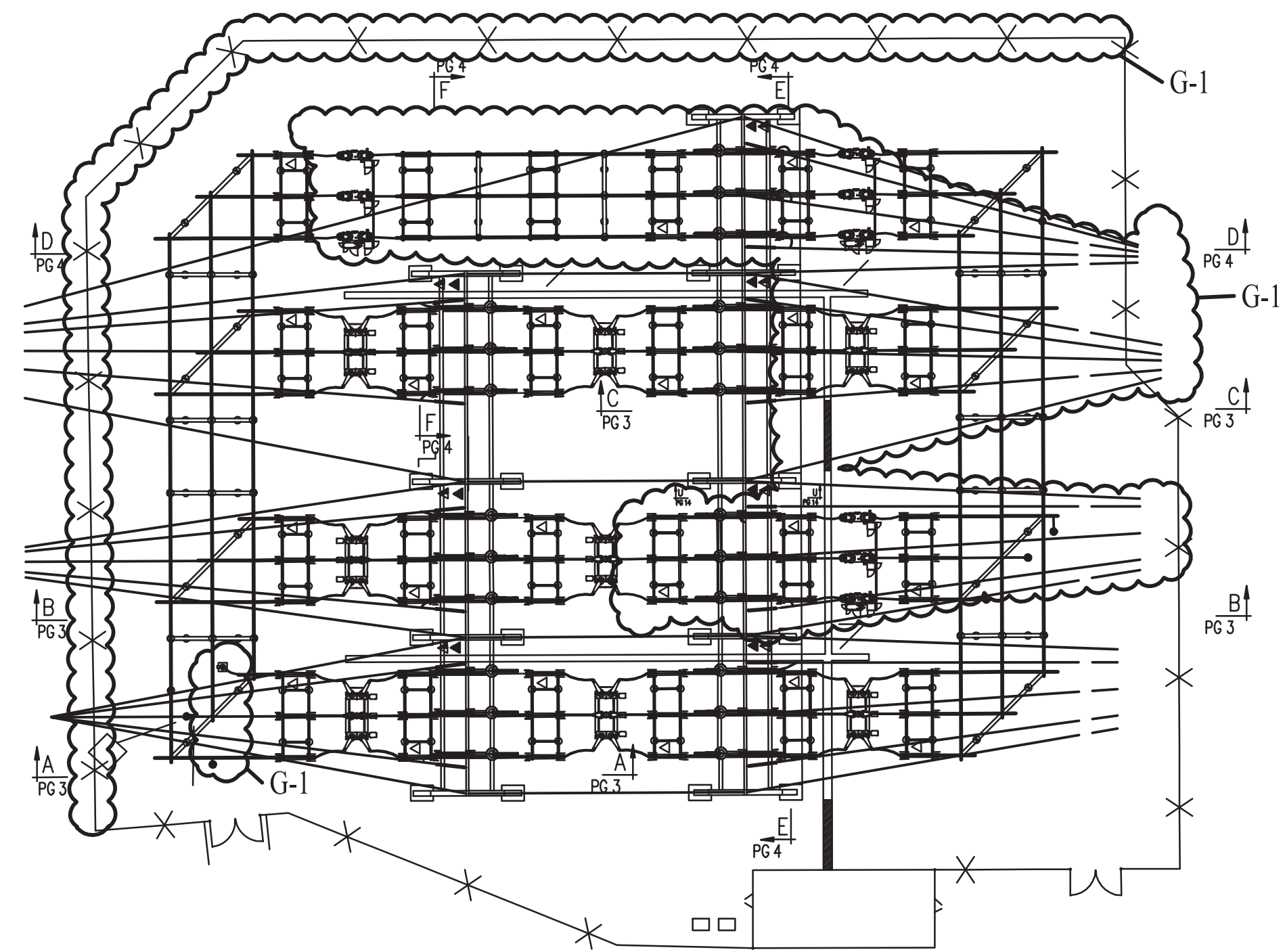

PLAN VIEW

0 50' 100'
SCALE IN FEET



LAKE ROAD D&M PLAN - NOT FOR CONSTRUCTION CONTRACTOR
PROPOSED GENERAL ARRANGEMENT PLAN

Burns & McDonnell
SINCE 1878

NOT FOR CONSTRUCTION
REVISION(S) ^g

no.	date	revisions	det.	dsn.	chk.	app.
G-1	12/04/12	ISSUED FOR NUSCO REVIEW				

date	DECEMBER 3, 2012	detailed	J. EICHENBERGER
designed	X. XXX	checked	

Burns & McDonnell
SINCE 1878
46650

REVISIONS DURING CONSTRUCTION			
no.	date	description	approved

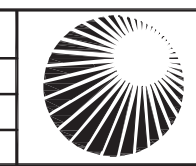

Northeast Utilities Service Co.
BY: _____ REV. NO.: _____ DATE: _____ SIZE: D DWG. NO.: EXHIBIT-1 PG 2

12/7/2012 3:15 PM - j.eichenberger - N:\USCO\46650 - IRP_SS\3.9 - Lake_Rd\Cadd\CSC\Exhibit-1.dwg - D&M - Sections-1
 NU VER: 02/2012

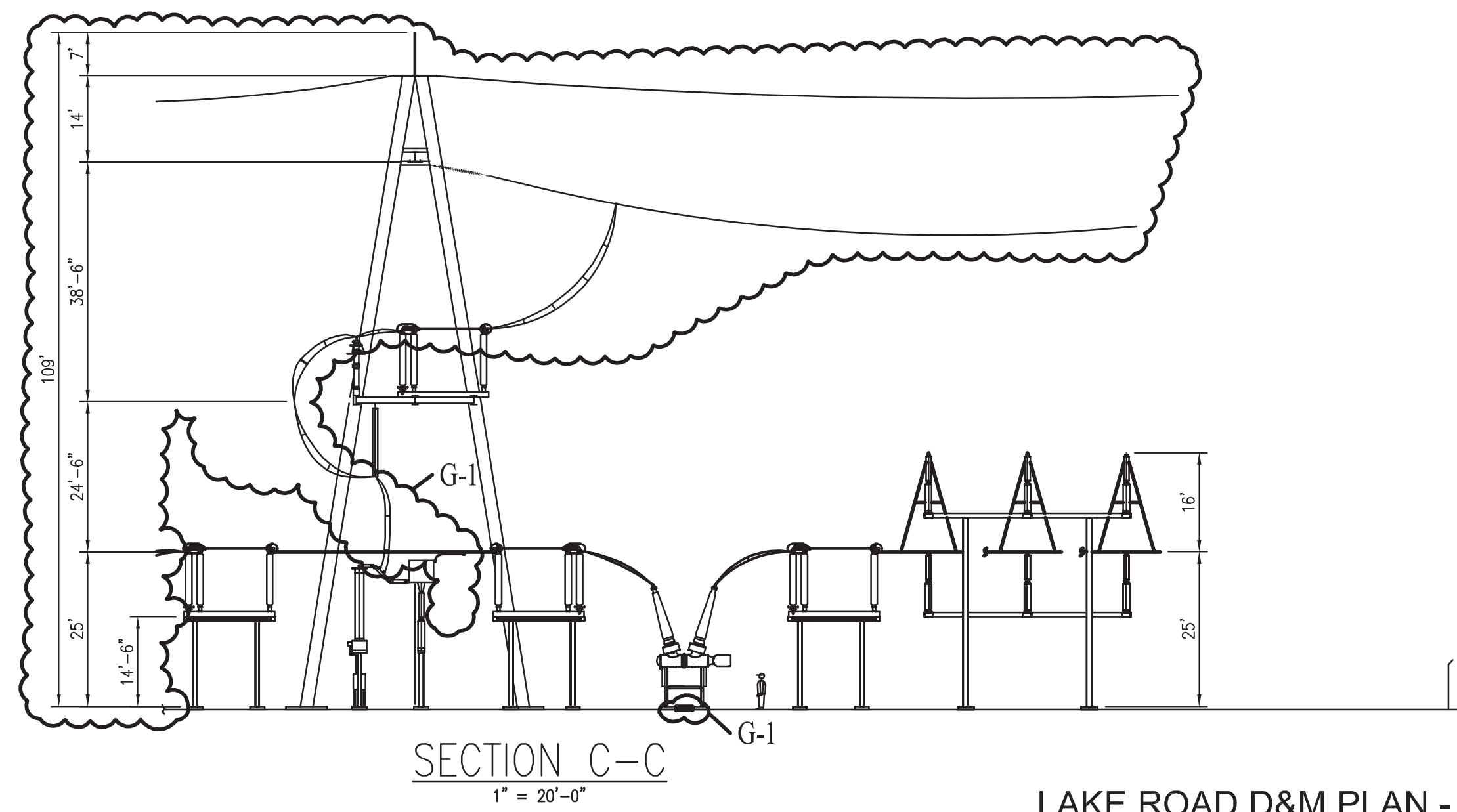
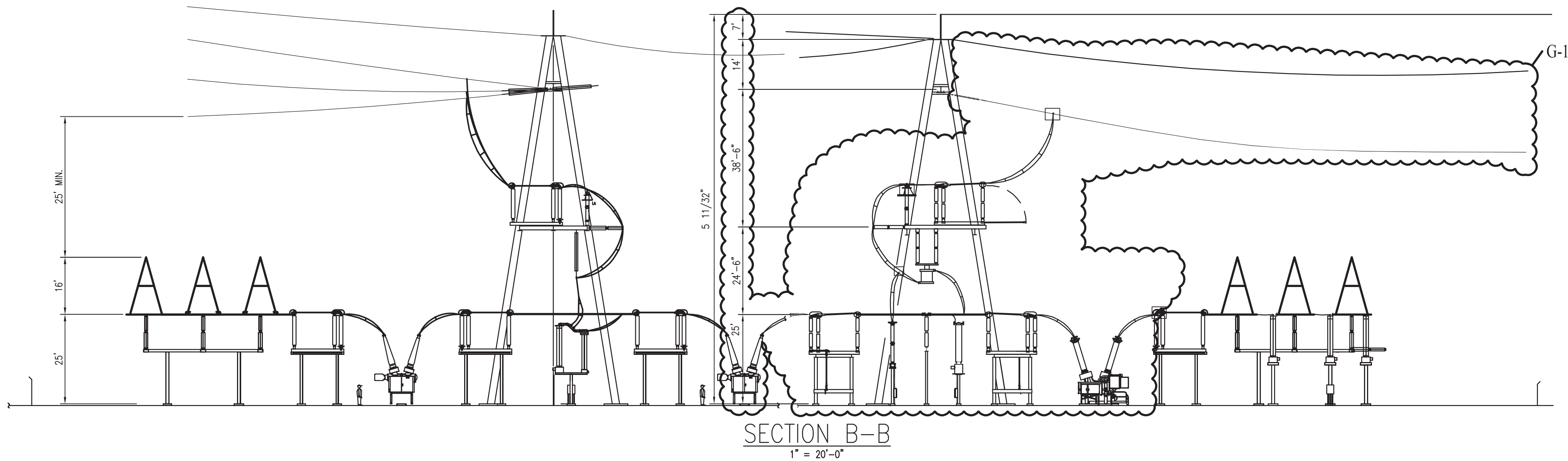
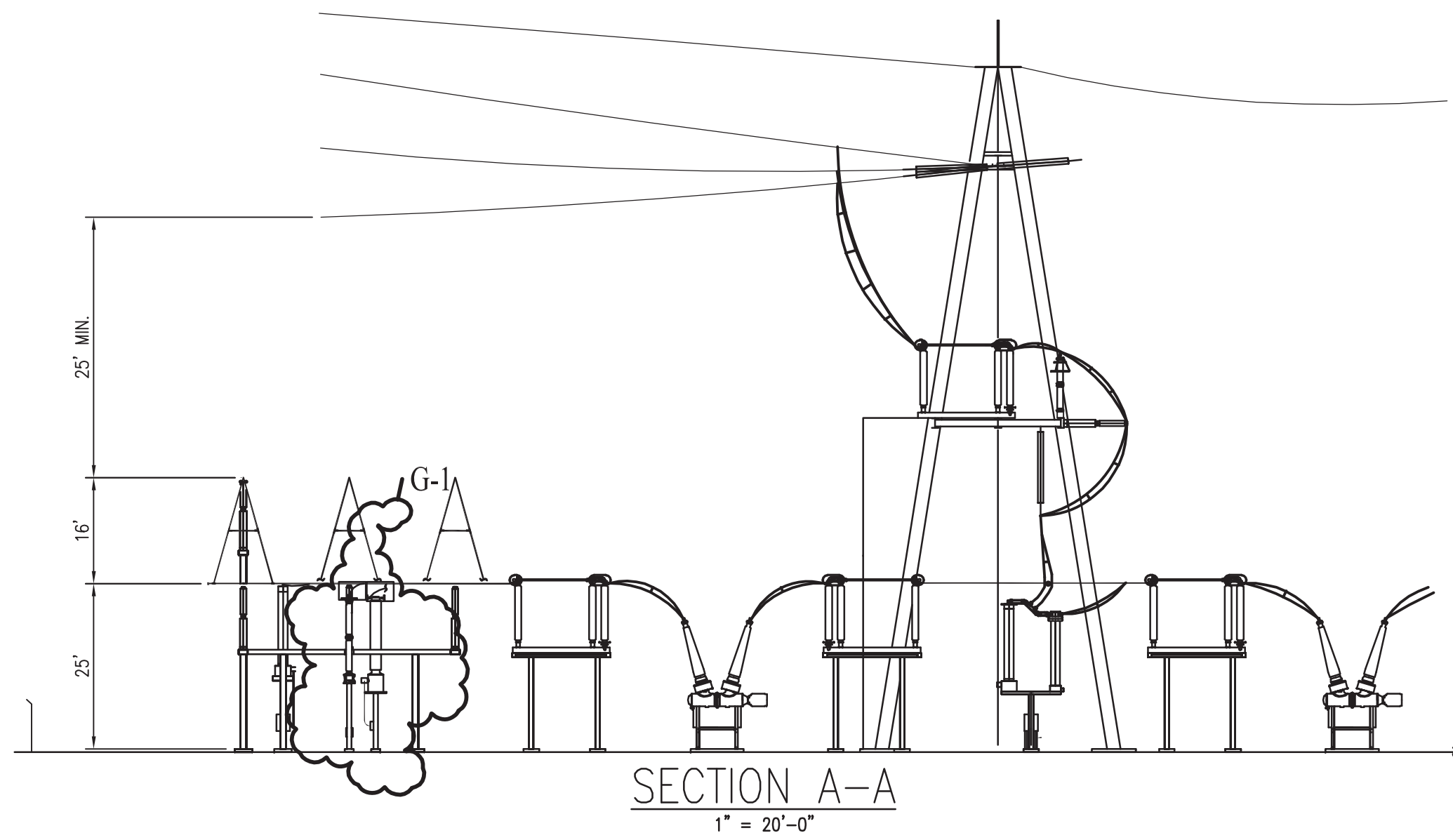

LAKE ROAD D&M PLAN - NOT FOR CONSTRUCTION CONTRACTOR
PROPOSED SECTIONS - 1 OF 2

NOT FOR CONSTRUCTION
 REVISION(S) ^G

no.	date	revisions	det.	dsn	chk	app.
G-1	12/04/12	ISSUED FOR MUSCO REVIEW				

date DECEMBER 3, 2012	detailed J. EICHENBERGER
designed X. XXX	checked

46650

REVISIONS DURING CONSTRUCTION			
no.	date	description	by

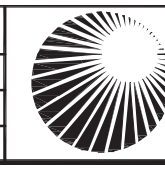

Northeast Utilities Service Co.
 BY: _____ REV. NO.: _____ DATE: _____ SIZE: D DWG. NO.: EXHIBIT-1 PG 3

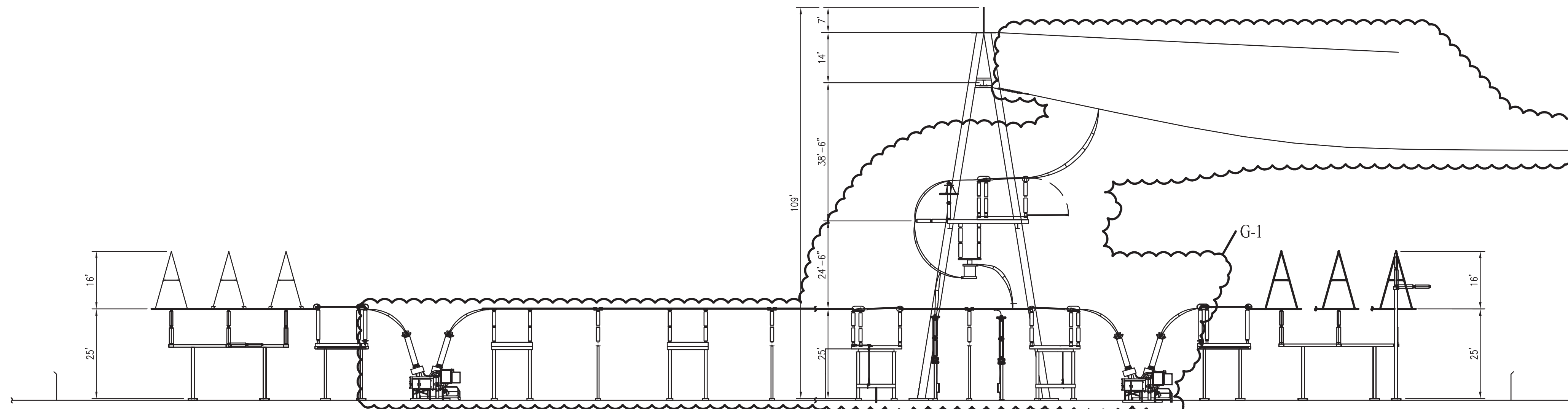

SECTION D-D
1" = 20'-0"

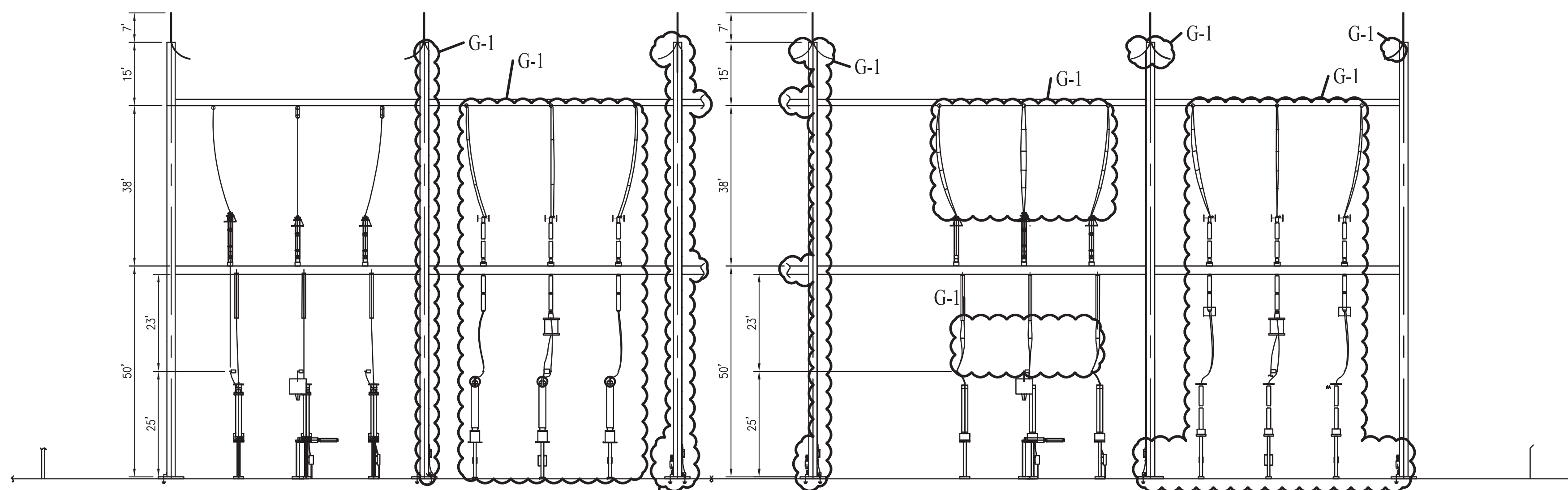

SECTION E-E
1" = 20'-0"

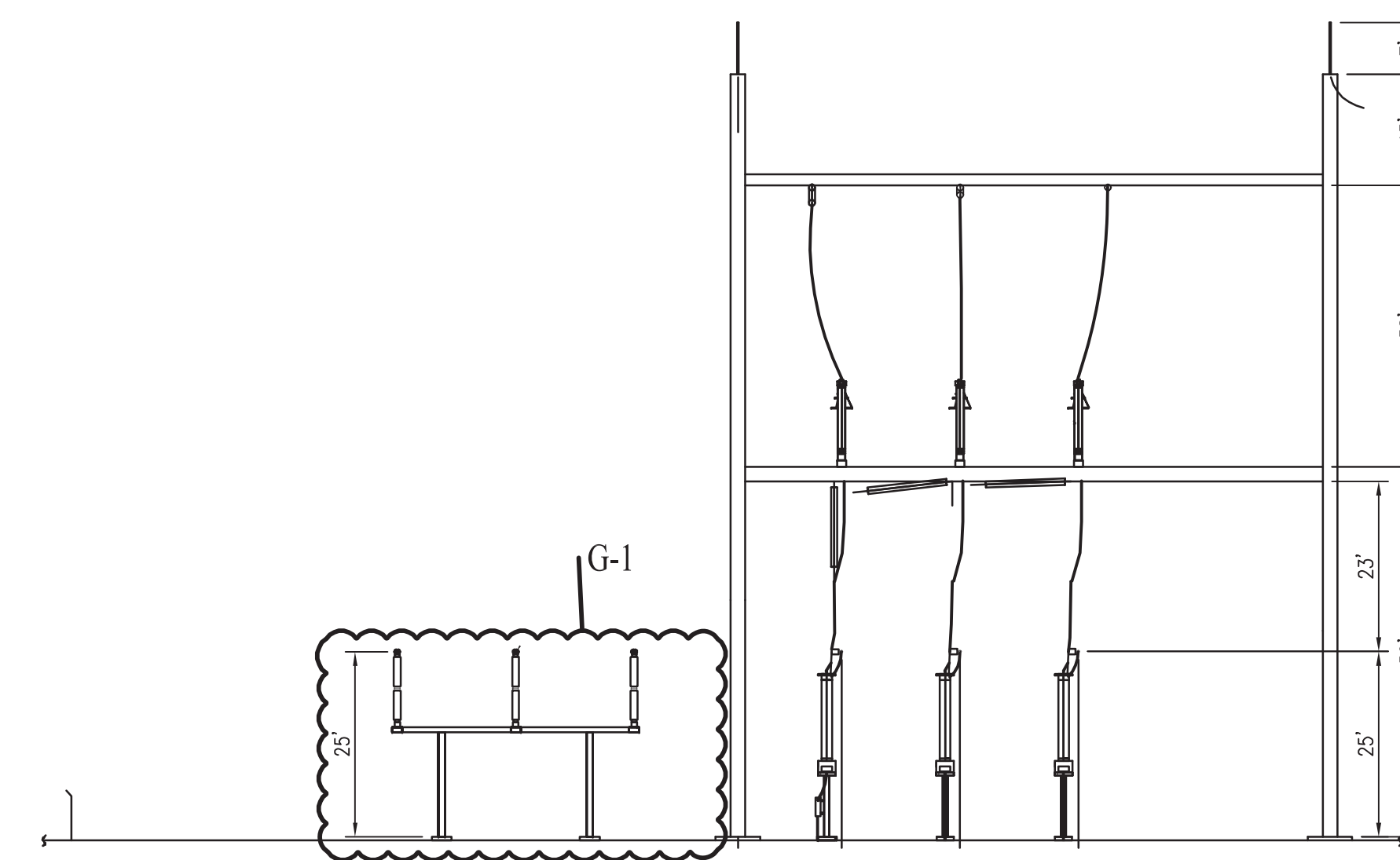

SECTION F-F
1" = 20'-0"

LAKE ROAD D&M PLAN - NOT FOR CONSTRUCTION CONTRACTOR
PROPOSED SECTIONS - 2 OF 2

Burns & McDonnell
NOT FOR CONSTRUCTION
 REVISION(S) ^G

no.	date	revisions	det.	dsn	chk	app.
G-1	12/04/12	ISSUED FOR MUSCO REVIEW				

date	DECEMBER 3, 2012	detailed	J. EICHENBERGER
designed	X. XXX	checked	

Burns & McDonnell
 46650

REVISIONS DURING CONSTRUCTION			
no.	date	description	status

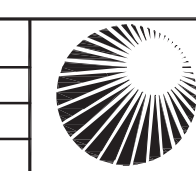

Northeast Utilities Service Co.
 BY: _____ REV. NO.: _____ DATE: _____ SIZE: D DWG. NO.: EXHIBIT-1 PG 4

5/12/2013 11:05 AM - Revise - N:\MS20146650 - RFP 5513.9 - Lake Rd\Code\1699-33004\001.dwg - REV G Additions

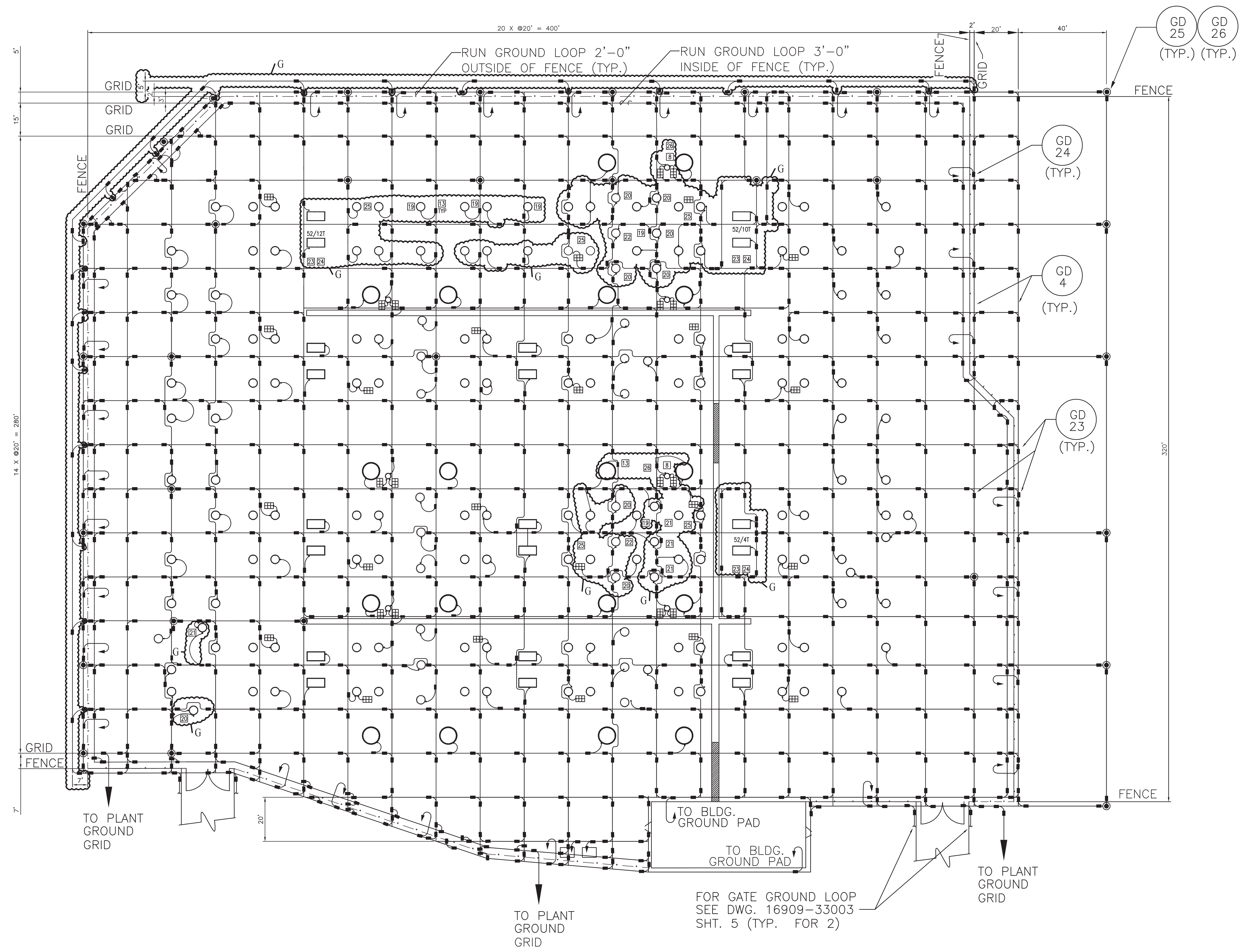
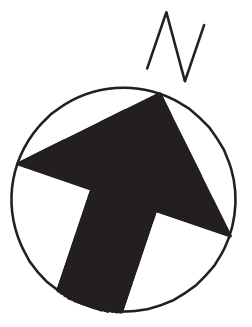

BILL OF MATERIAL (W.O.#40079801)		
ITEM NUMBER	QUANTITY	DESCRIPTION
GD4	27500 FT.	CABLE, BARE, 4/0 19 STRAND SOFT-DRAWN COPPER.
GD23	441	GROUND GRID CONNECTOR, CAST COPPER, FOR DIRECT BURIAL CROSS & TEE CONNECTIONS, 4/0 MAIN CABLE 4/0 BRANCH CABLE, THOMAS & BETTS CAT. NO 53065.
GD24	135	GROUND CABLE PARALLEL CONNECTOR, WROUGHT COPPER, FOR DIRECT BURIAL, 4/0 MAIN CABLE, 4/0 TAP, THOMAS & BETTS CAT. NO. 54765
GD25	31	TWO CABLES TO GROUND ROD CONNECTOR, DIRECT BURIAL, CAST COPPER, 4/0 MAIN CABLE, 4/0 TAP CABLE, 5/8" DIA. GROUND ROD, THOMAS & BETTS CAT. NO 53065-58 GR.
GD26	31	GROUND ROD, 5/8" DIA., 8 FT. SINGLE LENGTH, COPPERWELD.

NOTES:
 1. SEE DWG. 16909-95001 FOR GROUNDING MATERIAL FOR W.O. #402662LR
 2. SEE DWG 16909-33004 PG.2 FOR GROUND GRID DATA.

CONSTRUCTION NOTES:
 1. CONTRACTOR SHALL REPAIR ALL DAMAGE TO THE EXISTING GROUND GRID CAUSED BY THE INSTALLATION OF FOUNDATIONS, CONDUIT OR OTHER CONSTRUCTION ACTIVITY.
 2. ALL REPAIRS TO THE GROUND GRID MUST MAINTAIN THE SAME CONTINUITY AS THE ORIGINAL, PRECONSTRUCTION GROUND GRID.

LEGEND:
 [Symbol] TYP. 3' X 4' SWITCH EQUALIZING MAT REQUIRED FOR EACH DISCONNECT SWITCH
 [Symbol] 5/8" DIA. 8 FT LONG COPPERWELD GROUND ROD
 [Symbol] 3/4" DIA., 10 FT. LONG, COPPERBONDED GROUND ROD (DETAIL 14 TYP. W.O. #402662LR)
 [Symbol] GRID CROSS AND TEE CONNECTOR FOR 4/0 - 19 STRAND, BARE, SOFT-DRAWN COPPER CABLE (DETAIL 12 TYP. W.O. #402662LR)
 [Symbol] COMPRESSION TYPE CONNECTION 4/0 COPPER TO 4/0 COPPER (DETAIL 13 TYP. W.O. # 402662LR)
 [Symbol] DETAIL DESIGNATION, SEE DWG 33003 PG 6 THRU 8
 [Symbol] CONNECTION FROM BARE GROUND CABLE TO FENCE

REFERENCE DRAWINGS:

345KV PLAN VIEW	16909-33001
345KV GROUNDING DETAILS 11 TO 24	16909-33003 PG 6
345KV GROUNDING DETAIL 25	16909-33003 PG 7
345KV GROUNDING DETAIL 26	16909-33003 PG 8
345KV MATERIAL LIST	16909-95001

Burns & McDonnell
 THE REGISTRANT OF THE NEWLY APPLIED SEAL, DATED 05/17/13, ONLY ASSUMES RESPONSIBILITY FOR THE CHANGES AS INDICATED BY THE FOLLOWING REVISION(S) G.

REV G - ADDITIONS

REVISIONS DURING CONSTRUCTION						
NO.	DATE	DESCRIPTION	BY	CHK	APP	TYP.
G	05/13	NEWS ADDITIONS 345KV W.O.# 402662LR (CON-2002B)	DJK	JSE	TLF	



46650
 date APRIL 1, 2009 detailed R. DAVY
 designed T. FLIEH checked A. GROLL

no.	date	revisions	by	chk	app	app

NO.	DATE	AS BUILT PER	C.M.	BY	CHK	APP	APP
1	7/05	W.O. #40079801					
		AS BUILT REVISIONS					

Northeast Utilities Service Co.
 THE CONNECTICUT LIGHT AND POWER COMPANY

LAKE ROAD 27E
 345KV GROUNDING PLAN
 GROUNDING PLAN
 KILLINGLY, CT

DATE 6/7/00
 BY R. DAVY
 CHECKED A. GROLL
 DATE 6/7/00

FILE NO. 16909-33004 PG 1

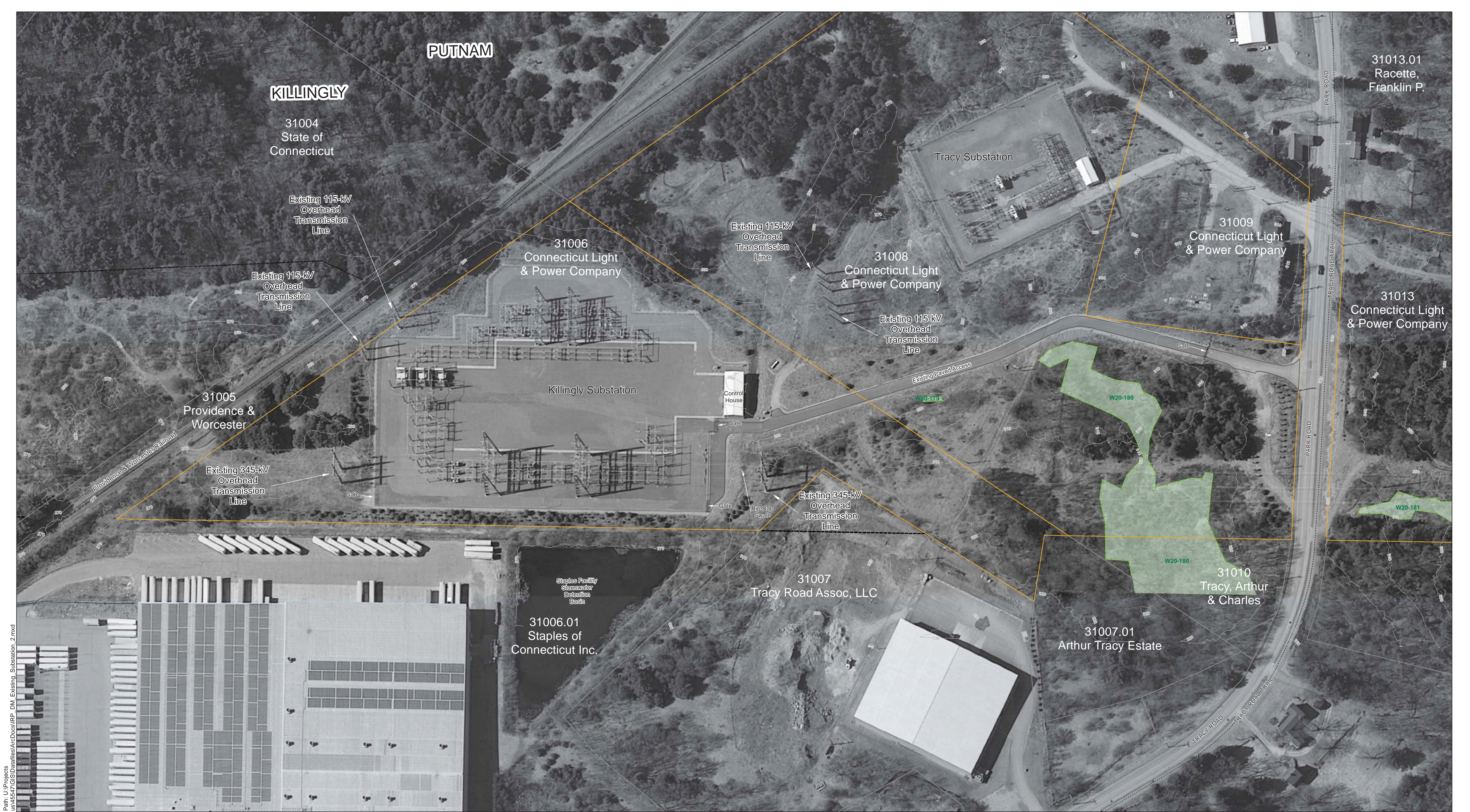

Path: U:\Projects\us\46547\GIS\MapFiles\ArcDocs\SRP_DM_Existing_Substation_2.mxd

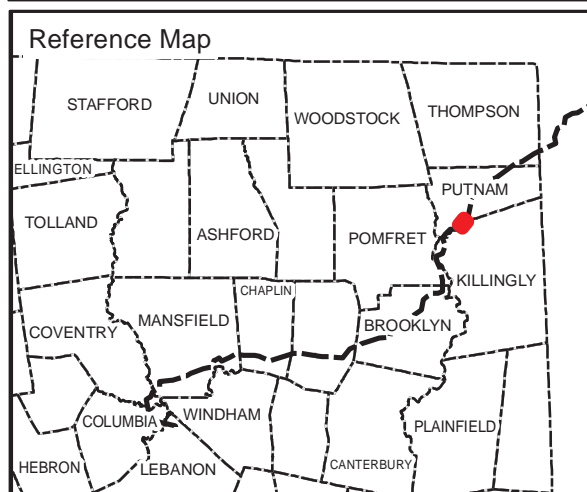

Parcel
 NU Owned Property
 Existing ROW
 Fence
 Existing Contour Line (10' Interval)
 Wetland

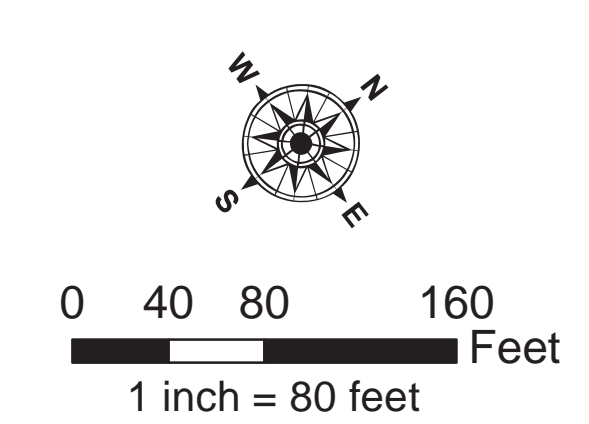

NO.	DATE	REVISIONS	BY	CHK	APP	APP

 SINCE 1898	
DATE	DETAILED
8/1/2013	J.Francis
DESIGNED	CHECKED
M.Kasinskas	M.Kasinskas

Northeast Utilities Service Co.
 THE CONNECTICUT LIGHT & POWER CO.

Interstate Reliability Project
Development & Management Plan

BY: J.Francis	CHKD: M.Kasinskas	APP	APP
DATE: 8/1/2013	DATE: 8/1/2013	DATE	DATE
SCALE 1 inch = 80ft	Mapsheet	Killingly Substation	
45547	C-3	Existing Conditions	

Image Source: State of Connecticut 2012 Imagery Mosaic Dataset

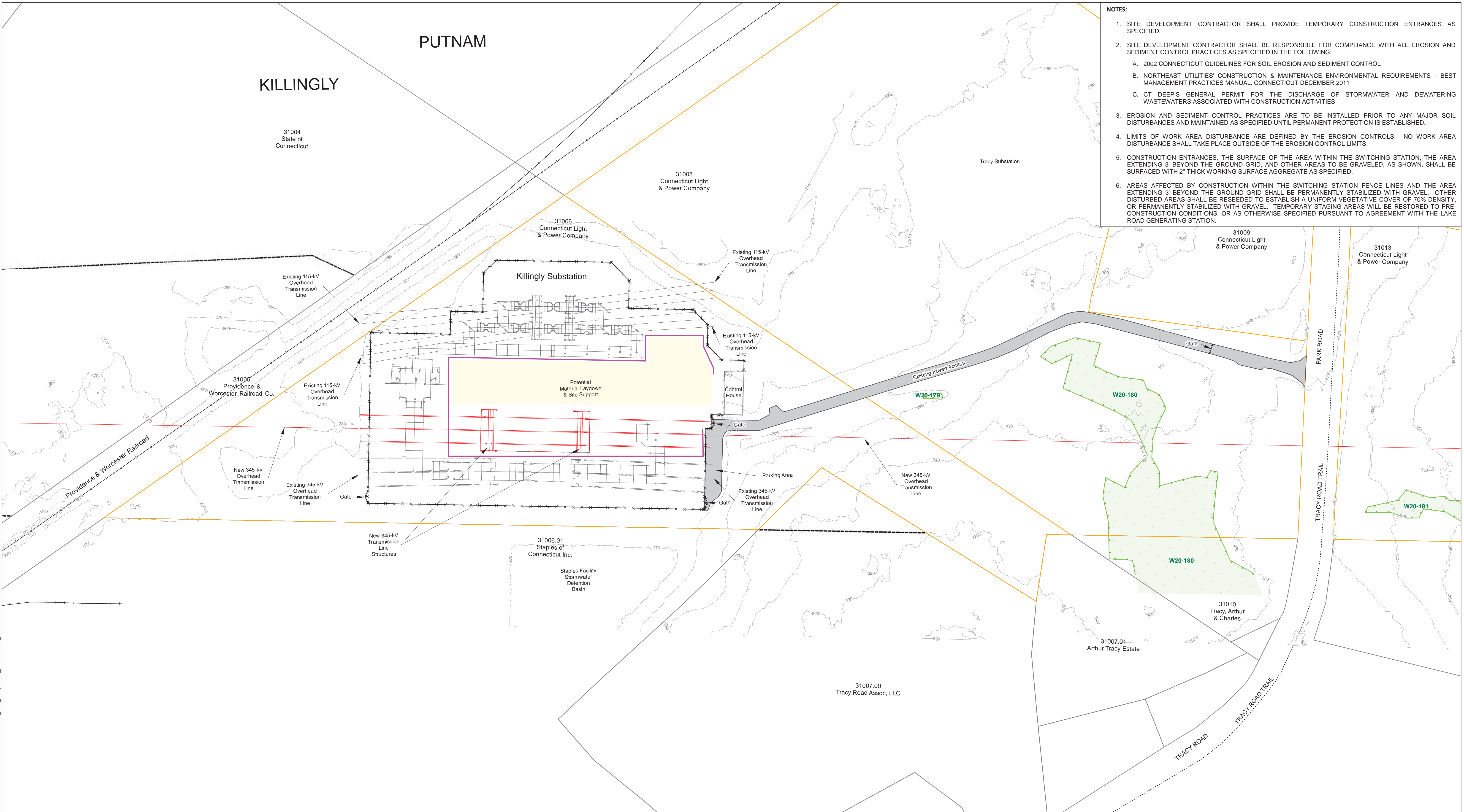

- NOTES:**
- SITE DEVELOPMENT CONTRACTOR SHALL PROVIDE TEMPORARY CONSTRUCTION ENTRANCES AS SPECIFIED.
 - SITE DEVELOPMENT CONTRACTOR SHALL BE RESPONSIBLE FOR COMPLIANCE WITH ALL EROSION AND SEDIMENT CONTROL PRACTICES AS SPECIFIED IN THE FOLLOWING:
 - 2002 CONNECTICUT GUIDELINES FOR SOIL EROSION AND SEDIMENT CONTROL
 - NORTHEAST UTILITIES' CONSTRUCTION & MAINTENANCE ENVIRONMENTAL REQUIREMENTS - BEST MANAGEMENT PRACTICES MANUAL: CONNECTICUT DECEMBER 2011
 - CT DEEP'S GENERAL PERMIT FOR THE DISCHARGE OF STORMWATER AND DEWATERING WASTEWATERS ASSOCIATED WITH CONSTRUCTION ACTIVITIES
 - EROSION AND SEDIMENT CONTROL PRACTICES ARE TO BE INSTALLED PRIOR TO ANY MAJOR SOIL DISTURBANCES AND MAINTAINED UNTIL PERMANENT PROTECTION IS ESTABLISHED.
 - LIMITS OF WORK AREA DISTURBANCE ARE DEFINED BY THE EROSION CONTROLS. NO WORK AREA DISTURBANCE SHALL TAKE PLACE OUTSIDE OF THE EROSION CONTROL LIMITS.
 - CONSTRUCTION ENTRANCES, THE SURFACE OF THE AREA WITHIN THE SWITCHING STATION, THE AREA EXTENDING 3' BEYOND THE GROUND GRID, AND OTHER AREAS TO BE GRAVELED, AS SHOWN, SHALL BE SURFACED WITH 2" THICK WORKING SURFACE AGGREGATE AS SPECIFIED.
 - AREAS AFFECTED BY CONSTRUCTION WITHIN THE SWITCHING STATION FENCE LINES AND THE AREA EXTENDING 3' BEYOND THE GROUND GRID SHALL BE PERMANENTLY STABILIZED WITH GRAVEL. OTHER DISTURBED AREAS SHALL BE RESEED TO ESTABLISH A UNIFORM VEGETATIVE COVER OF 70% DENSITY, OR PERMANENTLY STABILIZED WITH GRAVEL. TEMPORARY STAGING AREAS WILL BE RESTORED TO PRE-CONSTRUCTION CONDITIONS, OR AS OTHERWISE SPECIFIED PURSUANT TO AGREEMENT WITH THE LAKE ROAD GENERATING STATION.

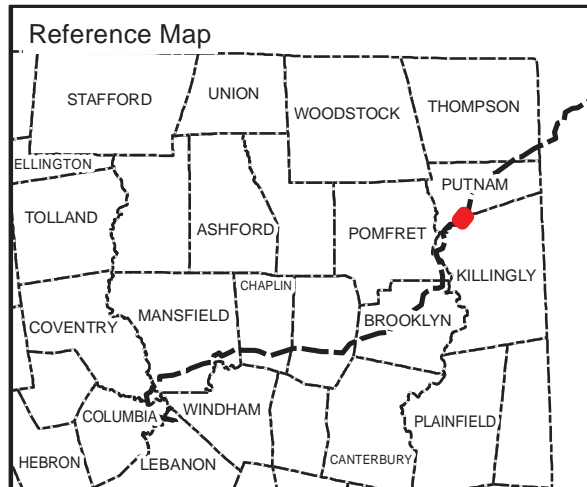

- Existing ROW
- - - Existing Contour Line (10' Interval)
- - - Existing Transmission Line
- Proposed Transmission Line
- Substation Additions
- Erosion & Sedimentation Controls
- Parcel
- NU Owned Property
- Gravel
- Pavement
- Wetland

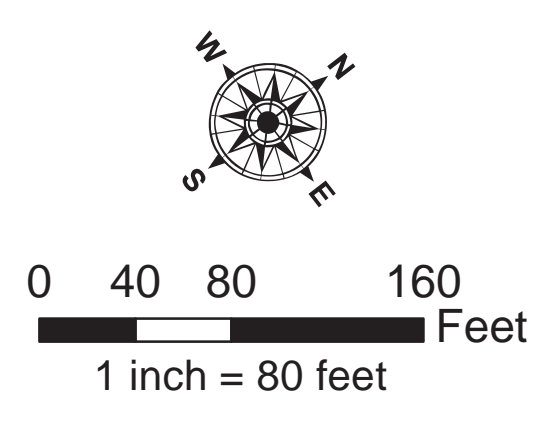

NO.	DATE	REVISIONS	BY	CHK	APP	APP

		DATE	8/1/2013	DETAILED	J.Francis
		DESIGNED	M.Kasinskas	CHECKED	M.Kasinskas

Northeast Utilities Service Co.
THE CONNECTICUT LIGHT & POWER CO.

**Interstate Reliability Project
Development & Management Plan**

BY: J.Francis	CHKD: M.Kasinskas	APP	APP
DATE: 8/1/2013	DATE: 8/1/2013	DATE	DATE
SCALE 1 inch = 40ft	45547	Mapsheet C-4	Killingly Substation Proposed Conditions

Path: U:\Projects\us\45547\GIS\Drawings\ArcDocs\IRP_DM_Proposed_Substation_20130710.mxd

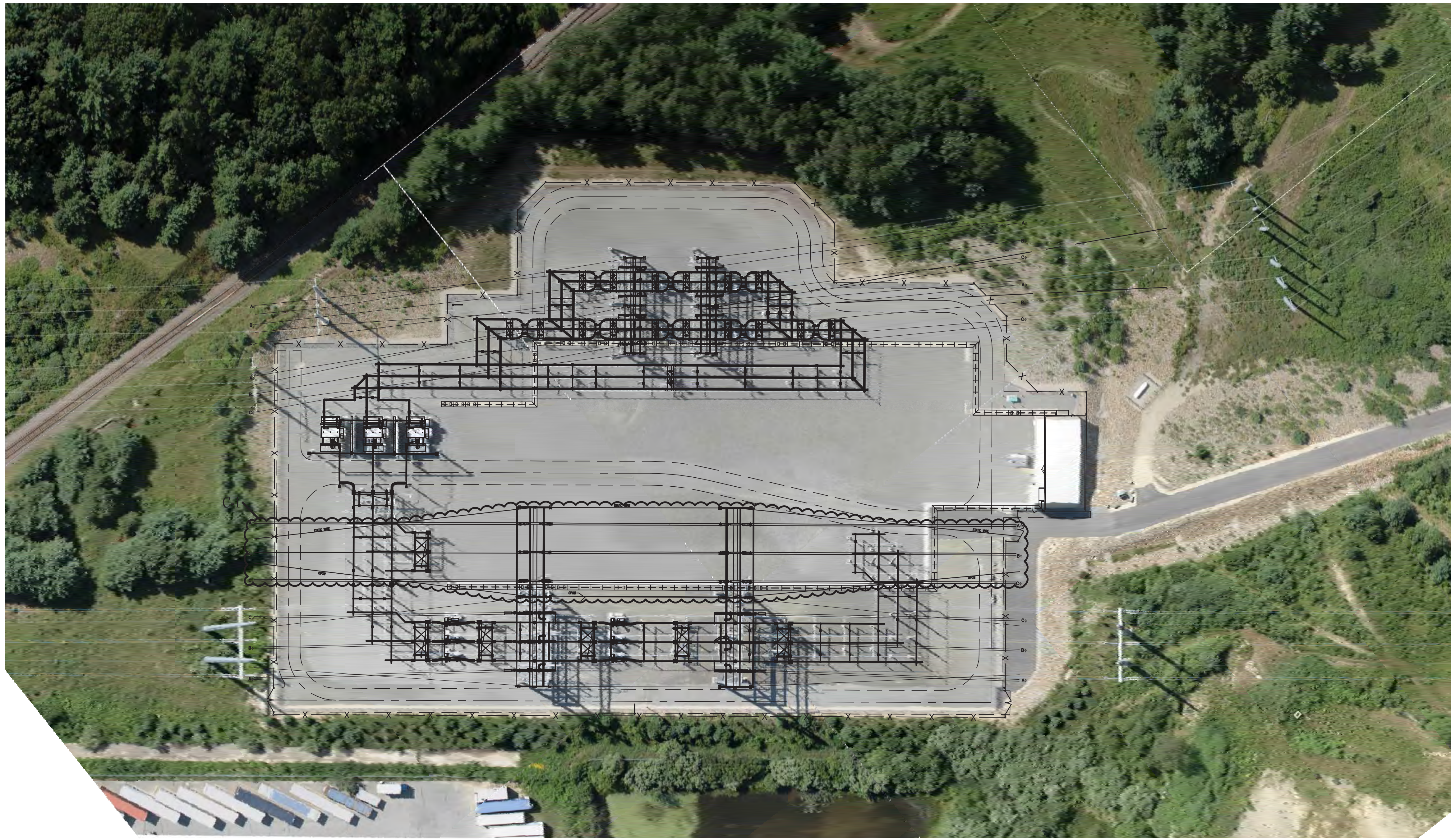

AERIAL VIEW

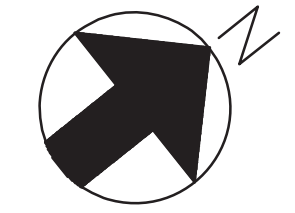

Burns & McDonnell
NOT FOR CONSTRUCTION
 REVISION(S) C

no.	date	revisions	det.	dsn	chk	app
C-2	03/05/13	ISSUED FOR D&M PLAN	-	-	-	-
C-1	12/04/12	ISSUED FOR NUSCO REVIEW	-	-	-	-

date
DECEMBER 3, 2012
 detailed
J. EICHENBERGER
 designed
X. XXX
 checked



REVISIONS DURING CONSTRUCTION			
NO.	DATE	DESCRIPTION	BY



Northeast Utilities Service Co.
 BY REV. NO. DATE SIZE DWG. NO.
 D EXHIBIT-1 PG 1

KILLINGLY D&M PLAN - NOT FOR CONSTRUCTION CONTRACTOR
 PROPOSED GENERAL ARRANGEMENT PLAN AND AERIAL

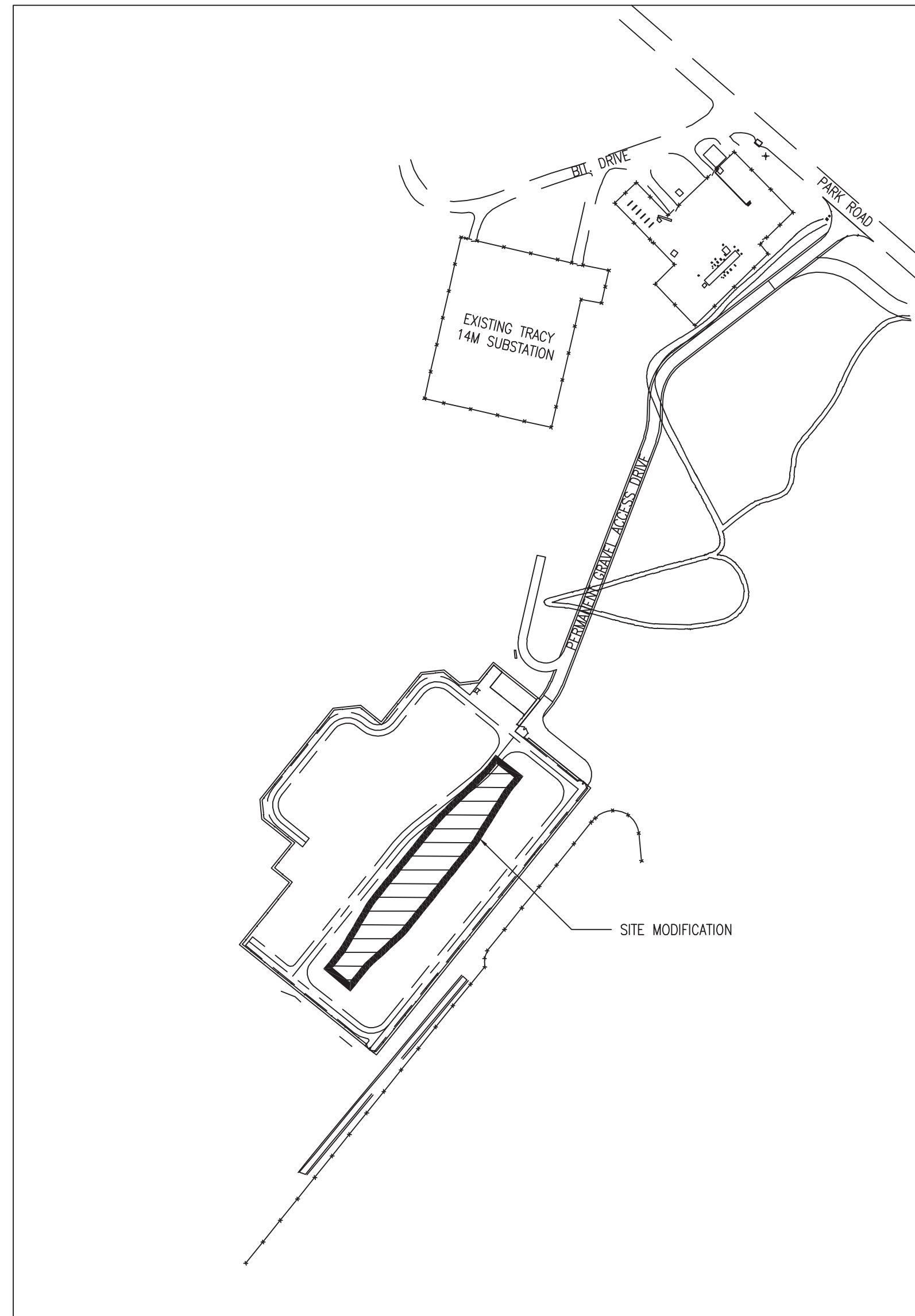

LOCATION PLAN

0 200' 400'
SCALE IN FEET

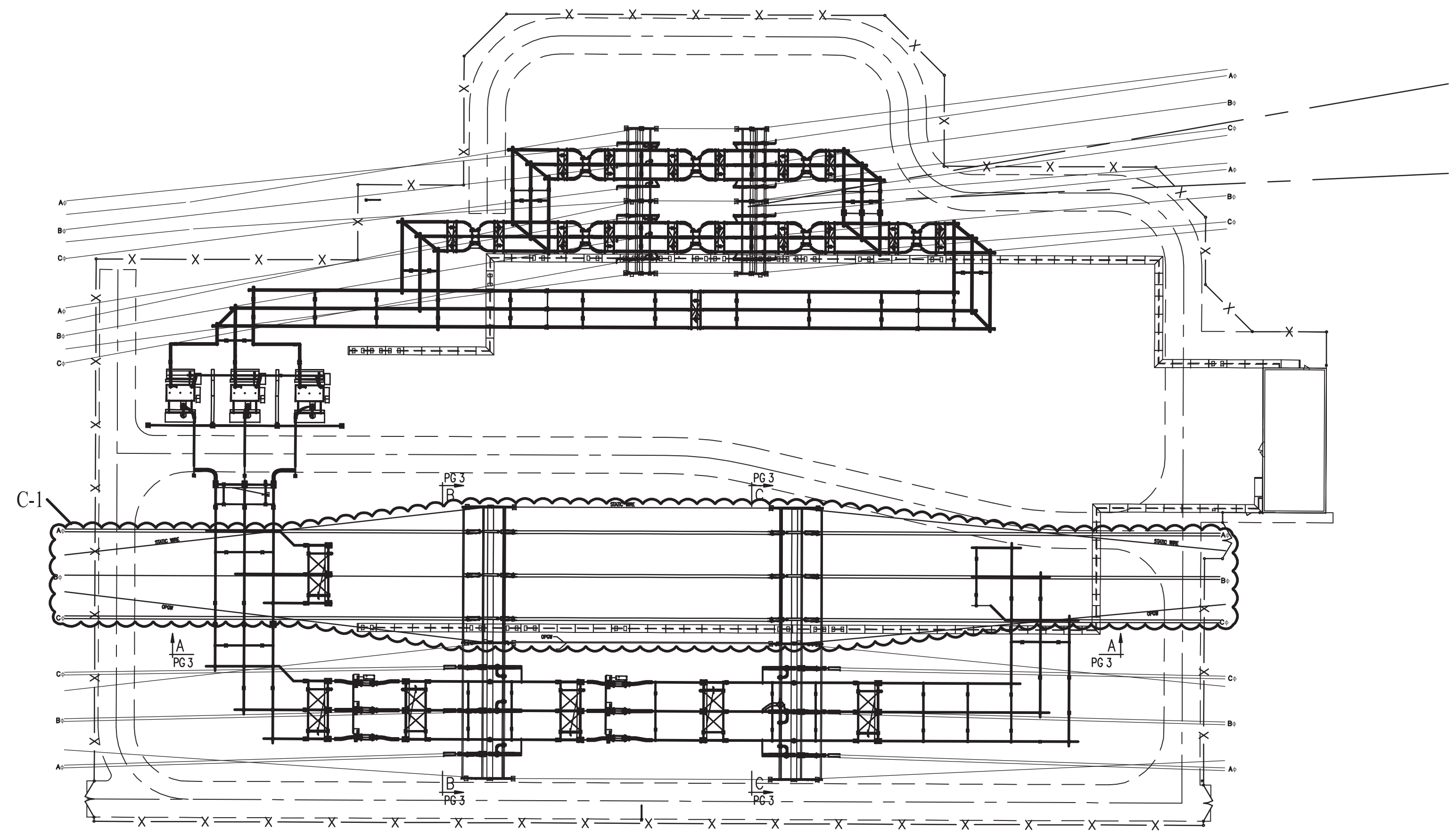

PLAN VIEW

0 50' 100'
SCALE IN FEET

KILLINGLY D&M PLAN - NOT FOR CONSTRUCTION CONTRACTOR
PROPOSED GENERAL ARRANGEMENT PLAN

Burns & McDonnell
NOT FOR CONSTRUCTION
REVISION(S) C

no	date	revisions	det	dsn	chk	app	date	designed	checked	detailed
C-2	03/05/13	ISSUED FOR D&M PLAN					DECEMBER 3, 2012	J. EICHENBERGER		
C-1	12/04/12	ISSUED FOR NUSCO REVIEW					X. XXX			

Burns & McDonnell
46650

REVISIONS DURING CONSTRUCTION			
NO.	DATE	DESCRIPTION	BY

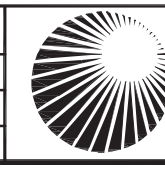

Northeast Utilities Service Co.
BY: _____ REV. NO.: _____ DATE: _____ SIZE: D DWG. NO.: EXHIBIT-1 PG 2

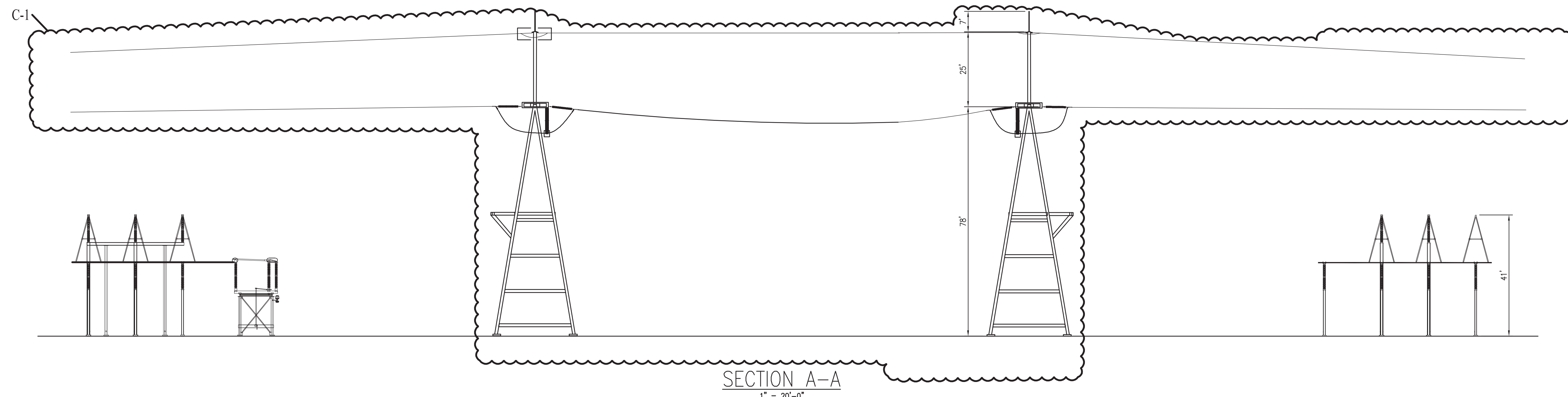

SECTION A-A
1" = 20'-0"

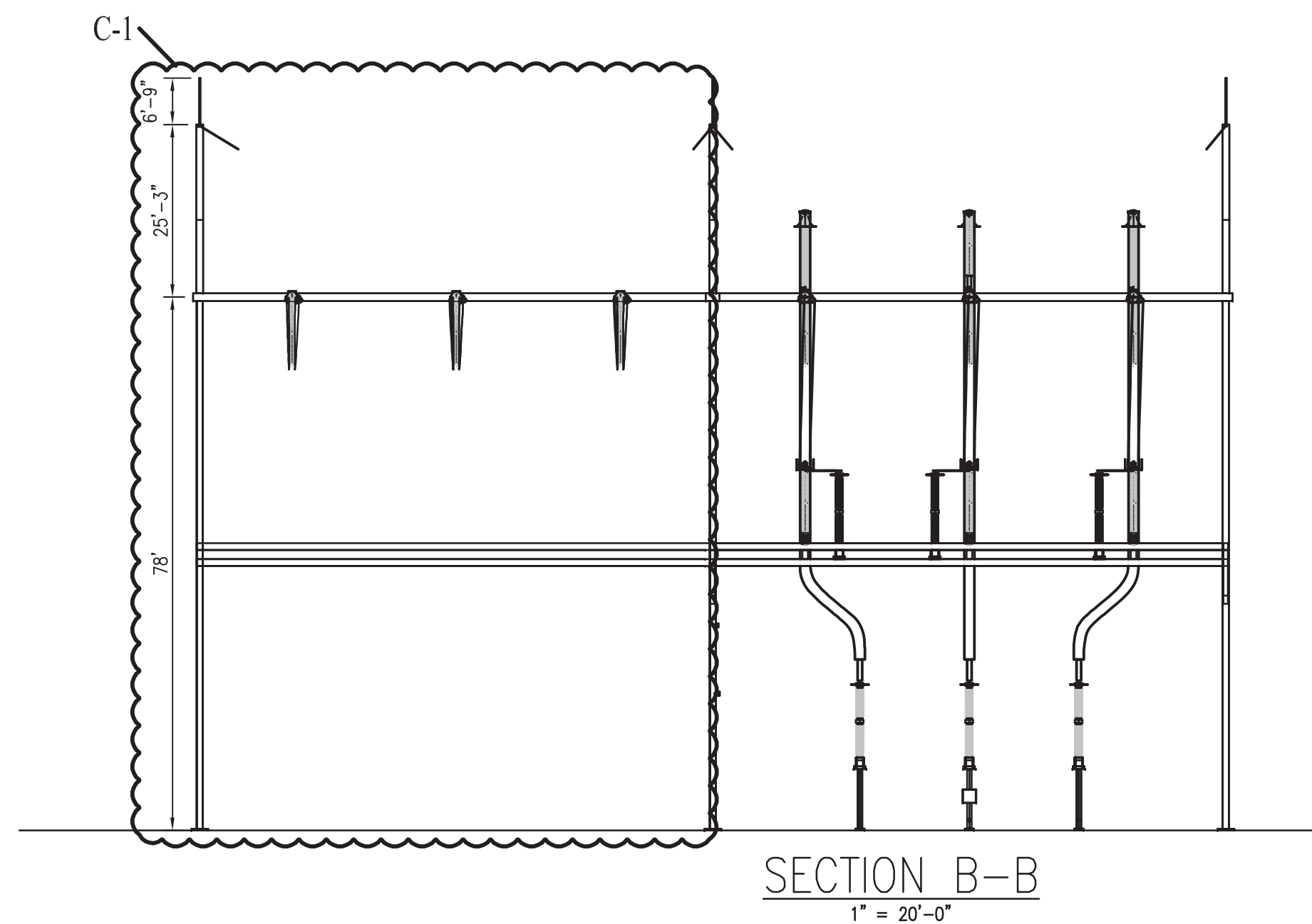

SECTION B-B
1" = 20'-0"

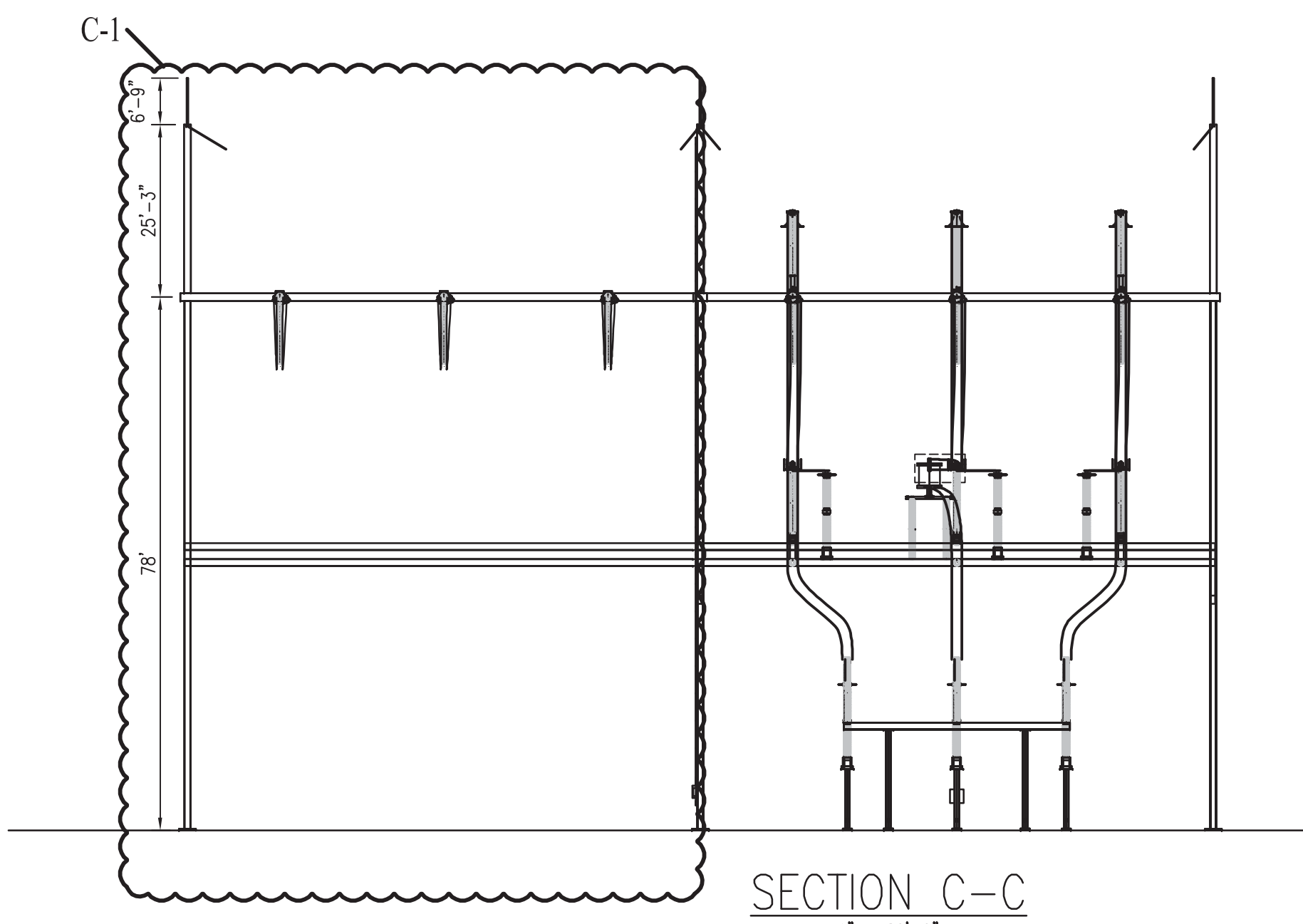

SECTION C-C
1" = 20'-0"

KILLINGLY D&M PLAN - NOT FOR CONSTRUCTION CONTRACTOR
PROPOSED SECTIONS

Burns & McDonnell
NOT FOR CONSTRUCTION
 REVISION(S) C

no.	date	revisions	det.	dsn.	chk.	app.
C-1	12/04/12	ISSUED FOR NUSCO REVIEW				

date	DECEMBER 3, 2012	detailed	J. EICHENBERGER
designed	X. XXX	checked	

Burns & McDonnell
 46650

REVISIONS DURING CONSTRUCTION			
no.	date	description	approved

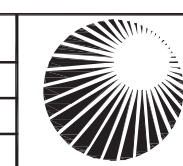

Northeast Utilities Service Co.
 BY: _____ REV. NO. _____ DATE _____ SIZE: D DWG. NO. EXHIBIT-1 PG 3

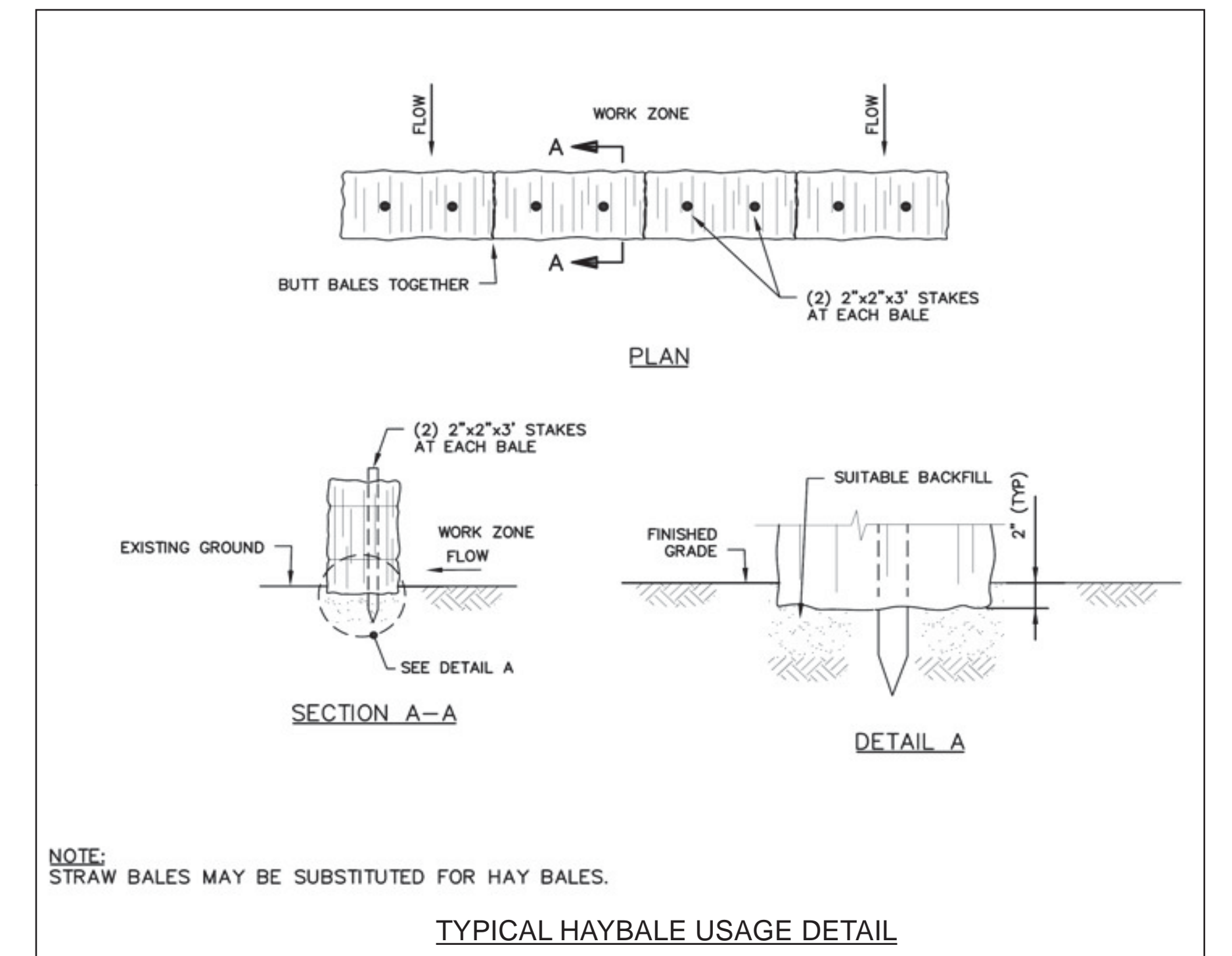
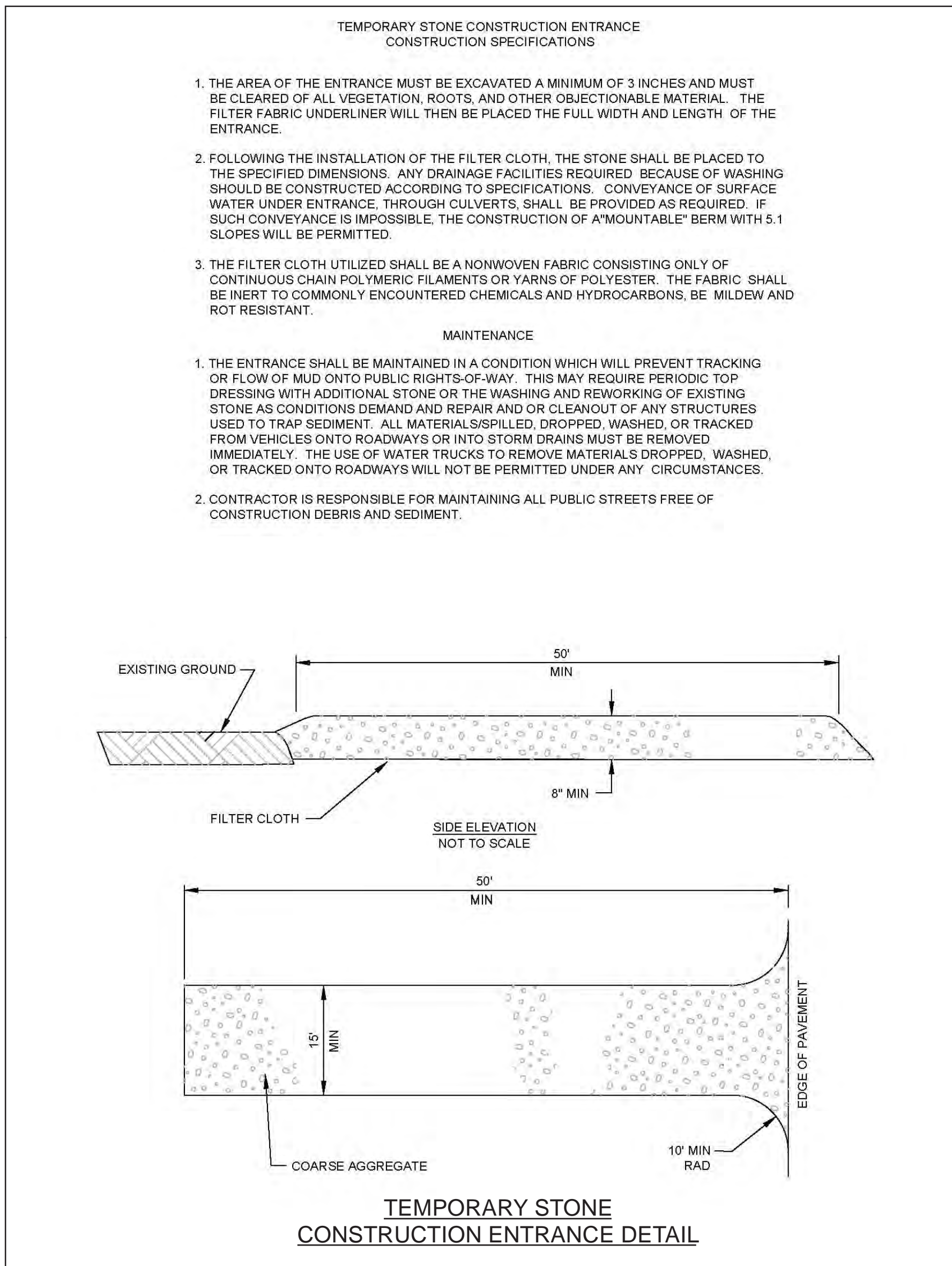
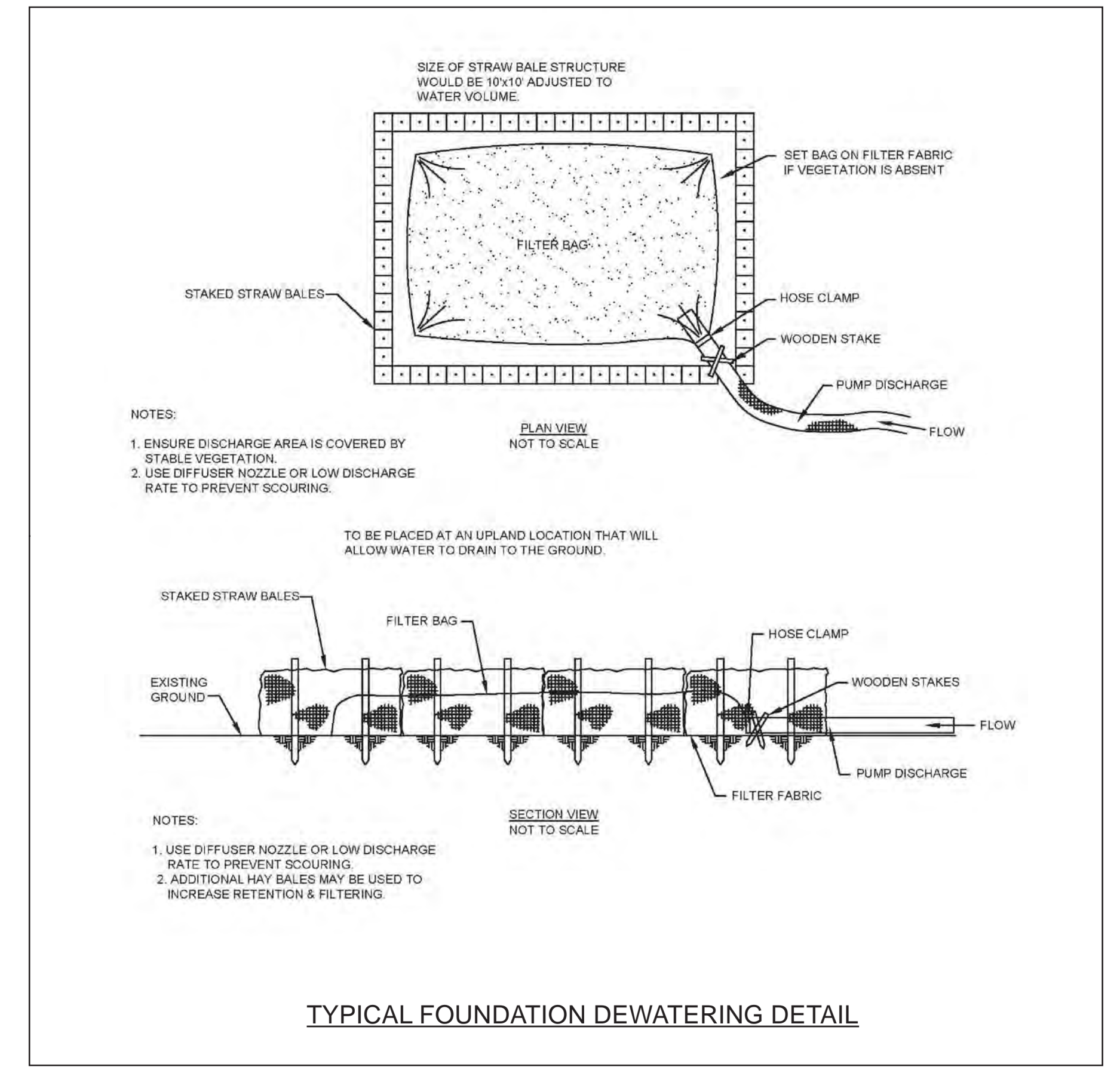
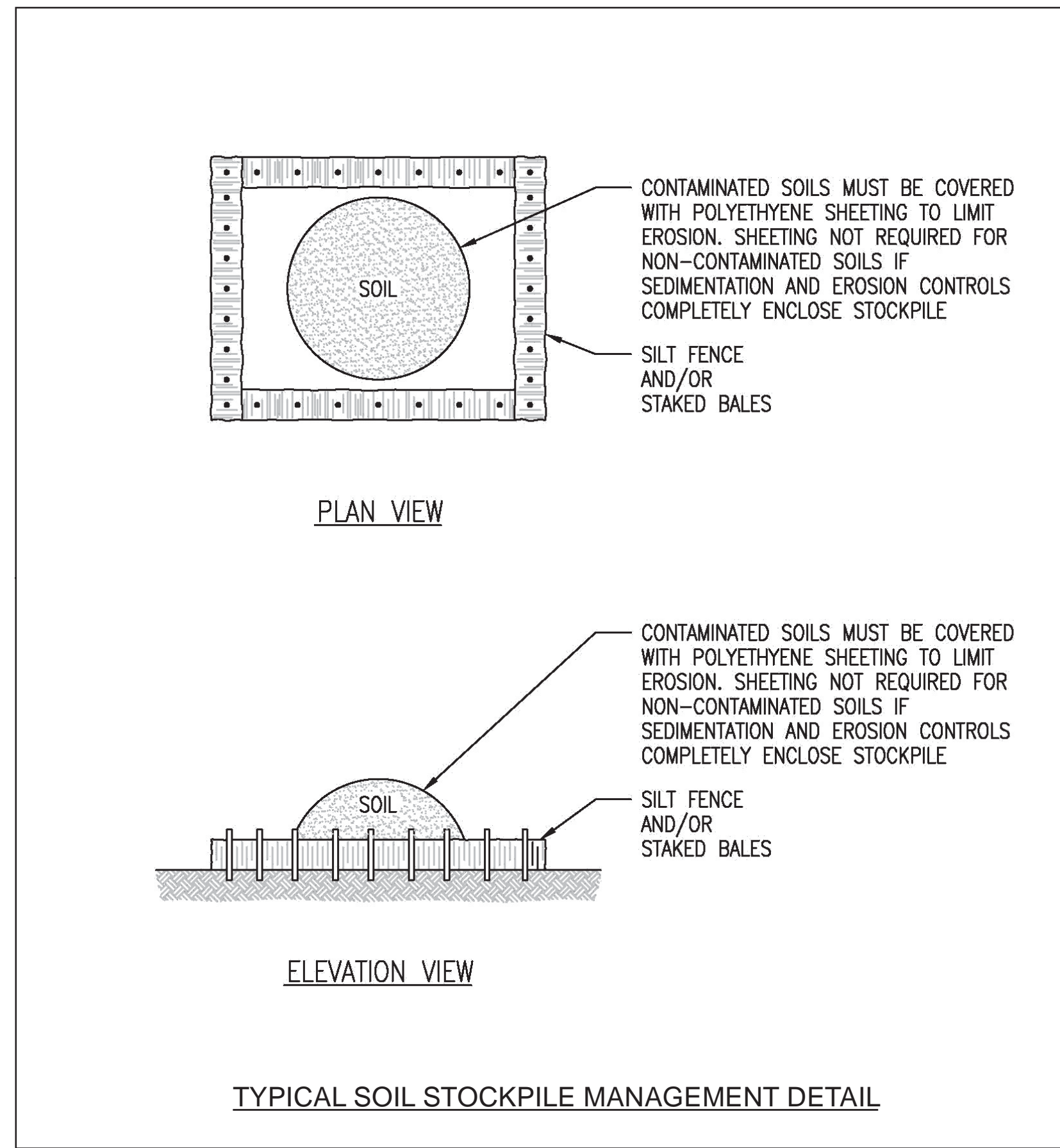
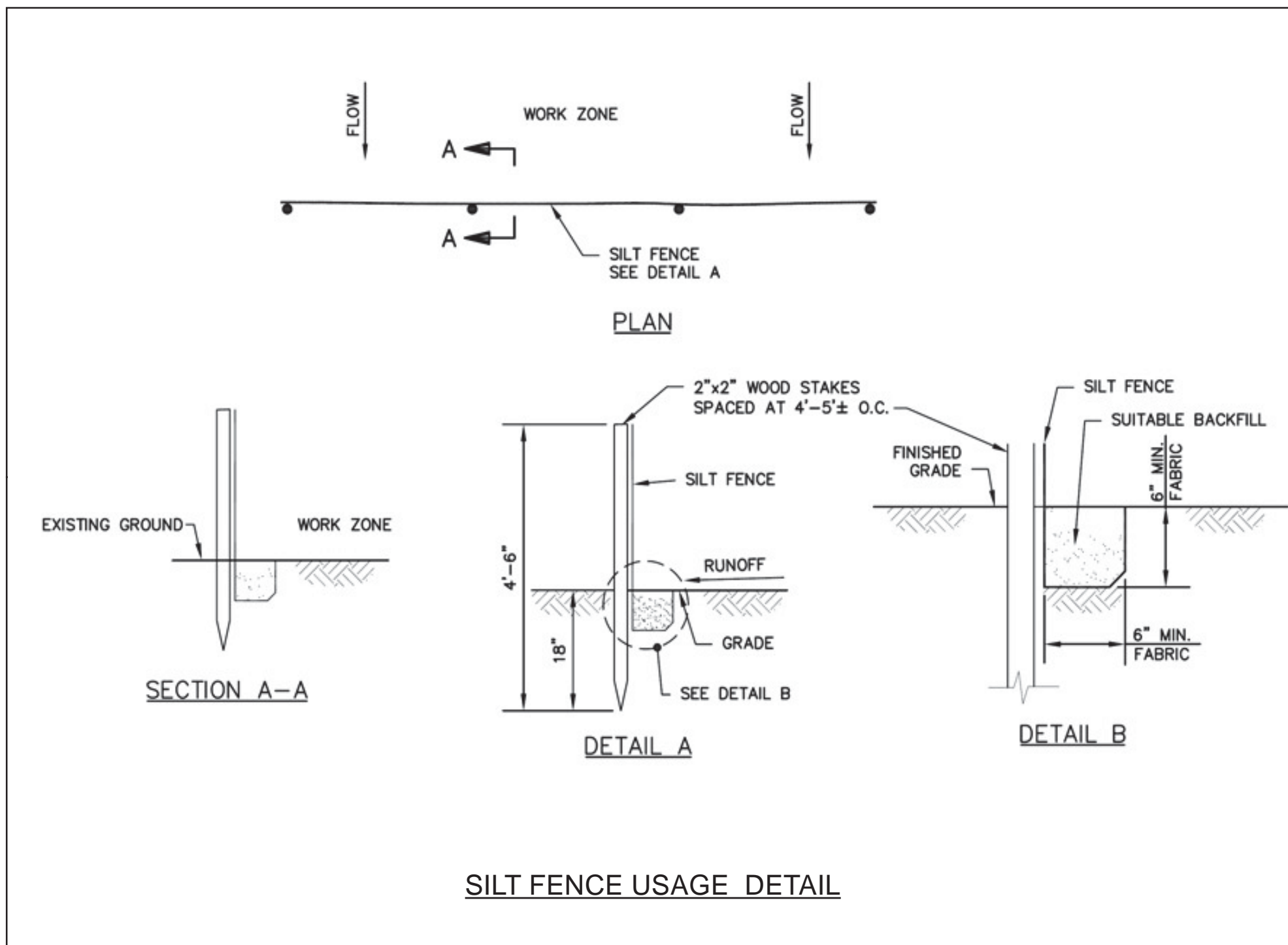

							DATE DETAILED		THE CONNECTICUT LIGHT & POWER CO.			
							DESIGNED CHECKED		Interstate Reliability Project Development & Management Plan			
							NO. DATE REVISIONS BY CHK APP APP		BY: CHKD APP APP DATE: DATE DATE DATE SCALE: NONE 47547 D Sheet 1 of 1			