



August 10, 2018

Melanie A. Bachman  
Executive Director  
Connecticut Siting Council  
10 Franklin Square  
New Britain, CT 06051

Regarding: Notice of Exempt Modification – Antenna Modification  
Property Address: 440 Hayden Station Rd., Windsor, CT 06095  
AT&T Site: CT5140 – Windsor Breakneck

Dear Ms. Bachman:

AT&T currently maintains a wireless telecommunications facility on an existing 95-foot monopole at the above-referenced address, latitude 41°-53'-52.05084", longitude -72°-38'-41.99604". Said monopole is owned by Crown Castle.

AT&T desires to modify its existing telecommunications facility by adding three (3) antennas, adding three (3) remote-radio heads ("RRHs"), adding one (1) Surge Suppressor and replacing equipment inside equipment shelter at base of tower. The centerline height of the existing antennas is and will remain at 94 feet.

Please accept this application as notification pursuant to R.C.S.A. §16-50j-73, for construction that constitutes an exempt modification pursuant to R.C.S.A. §16-50j-72 (b)(2). In accordance with R.C.S.A. §16-50j-73, a copy of this letter is being sent to Peter Souza, as Manager for the Town of Windsor, Robert Ruzzo, as Building Official and Zoning Enforcement Officer for the Town of Windsor, Crown Castle, LLC, as owner of the Cellular Phone Tower.

The planned modifications to AT&T's facility fall squarely within those activities explicitly provided for in R.C.S.A. §16-50j-72 (b)(2). Specifically:

1. The planned modification will not result in an increase in the height of the existing structure. The added antennas and accessory equipment along with equipment to be swapped will be installed at the existing height of 94 feet on the 95-foot monopole.
2. The proposed modifications will not involve any changes to ground-mounted equipment, and therefore will not require an extension of the site boundary.
3. The proposed modification will not increase the noise level at the facility by six decibels or more, or to levels that exceed state and local criteria.

4. The operation of the modified facility will not increase radio frequency (RF) emissions at the facility to a level at or above Federal Communications Commission (FCC) safety standard. An RF emissions calculation (enclosed) for AT&T's modified facility is herein provided.
5. The proposed modifications will not cause a change or alteration in the physical or environmental characteristics of the site.
6. The existing structure and its foundation can support AT&T's proposed modifications (please see enclosed structural analysis completed by FDH Velocitel, dated February 16<sup>th</sup>, 2018).

For the foregoing reasons, AT&T respectfully requests that the proposed remote-radio head installation be allowed within the exempt modifications under R.C.S.A. §16-50j-72 (b)(2).

Sincerely,

*Robert C. Wilson*

Robert C. Wilson  
Site Acquisition Manager

Enclosures: Exhibit 1 – Field Card and GIS Map  
Exhibit 2 – Construction Drawings  
Exhibit 3 – Structural Analysis  
Exhibit 4 – RF Emissions Analysis Report Evaluation

cc: Peter Souza, as Manager for the Town of Windsor, Robert Ruzzo, as Building Official and Zoning Enforcement Officer for the Town of Windsor, Crown Castle, LLC, as owner of the Cellular Phone Tower.

### Property Cards

Address Search :   [Clear Search](#)

**Your search returned multiple addresses**

Additional addresses:  
[440 HAYDEN STATION RD](#)

**440 Hayden Station Rd**

**Property Owner:**  
Cb Baggs Llp

**Property Co-Owner**

**Mailing Address:**  
440 Hayden Station Rd  
Windsor, CT  
06095

**File Code**  
6739

**Map:**  
49

**Block:**  
471

**Lot:**  
109

**Census Tract:**  
4735.02

**Property Type:**  
Ind Whses

**Land Area (Acres):**  
3.71

**Zone:**  
I



[Click to Enlarge](#)

**Construction Details**

<b>Year Built:</b> 1982	<b>Total Rooms:</b>
<b>Building Style:</b> Warehouse	<b>Bedrooms:</b>
<b>Stories:</b> 1	<b>Bathrooms:</b>
<b>Living Area:</b> 0 Sq/Ft	<b>Half Baths:</b>
<b>Building ID</b> 4624	<b>Heating Type</b> Hot Air-No Duc
<b>Grade</b> Average	<b>Heating Fuel</b> Gas
<b>Exterior Wall</b> Pre-Finsh Metl	<b>AC Type</b> Central

Valuation	
<b>Assessed Land Value:</b>	\$246,050
<b>Assessed Building Value:</b>	\$786,380
<b>Total Assessed Value:</b>	\$1,032,430
<hr/>	
<b>Appraised Land Value:</b>	\$351,500
<b>Appraised Building Value:</b>	\$1,123,400
<b>Total Appraised Value:</b>	\$1,474,900

Last Sale	
<b>Last Sale Date:</b>	Friday, October 6th, 2000
<b>Last Sale Price:</b>	\$1,500,000
<b>Qualified Sale:</b>	Q
<b>Book / Page:</b>	1243/ 531

Prior Owners			
Sale Date	Owner Name	Sale Price	Book / Page
2000/10/6	ADFM ASSOCIATES LLC	666483	1243/ 522
1994/4/15	COAST DISTRIBUTION SYSTEM INC	0	998/ 108
1989/8/31	COAST DISTRIBUTION SYS	0	758/ 213

**Parcel Sketch**

**Sub Area Detail**

Code	Gross Area (Sq Ft)	Living Area (Sq Ft)
BAS	42720	42720

**Outbuildings & Extra Features**

Code	Description	Appraised Value	Assessed Value
PAV1	PAVING-ASPHALT	\$20800.00	\$14560.00
LDL1	LOAD LEVELERS	\$17000.00	\$11900.00
SPR1	SPRINKLERS-WET	\$70900.00	\$49630.00
VLT2	VAULT-GOOD	\$60800.00	\$42560.00

**Legend:**

<b>AOF</b> Office Area	<b>APT</b> Apartment	<b>BAS</b> First Floor
<b>CAN</b> Canopy	<b>CDN</b> Canopy (Det)	<b>CLP</b> Loading Platform (Finished)
<b>EAF</b> Attic (Expan)(Finished)	<b>EAU</b> Attic (Expan)(Unfinished)	<b>FAT</b> Attic (Finished)
<b>FBM</b> Basement (Finished)	<b>FCB</b> Cabana (Encl)(Finished)	<b>FCP</b> Carport (Framed)
<b>FDC</b> Carport (Det)(Framed)	<b>FDS</b> Porch (Scr)(Det)(Finished)	<b>FDU</b> Utility (Det)(Finished)

<del><b>FEP</b> Porch (Encl)(Finished)</del>	<del><b>FGR</b> Garage (Framed)</del>	<del><b>FHS</b> Half-Story (Finished)</del>
<b>FLL</b> Lower Level (Finished)	<b>FOP</b> Porch (Open)(Finished)	<b>FSP</b> Porch (Screen)(Finished)
<b>FST</b> Utility (Finished)	<b>FUS</b> Upper-Story (Finished)	<b>PTO</b> Patio
<b>SDA</b> Store Display Area	<b>SFB</b> Base (Semi-Finished)	<b>SPA</b> Service Prod Area
<b>TQS</b> Three-Qtr Story	<b>UAT</b> Attic (Unfinished)	<b>UBM</b> Basement (Unfinished)
<b>UCB</b> Cabana (Encl)(Unfinished)	<b>UDS</b> Porch (Scrn)(Dedt)(Unfinished)	<b>UDU</b> Utility (Det)(Unfinished)
<b>UEP</b> Porch (Encl)(Unfinished)	<b>UHS</b> Half-Story (Unfinished)	<b>ULP</b> Loading Platform (Unfinished)
<b>UOP</b> Porch (Open)(Unfinished)	<b>USP</b> Porch (Scrn)(Unfinished)	<b>UST</b> Utility (Strg)(Unfinished)
<b>UUS</b> Upper-Story (Unfinished)	<b>WDK</b> Wood Deck	

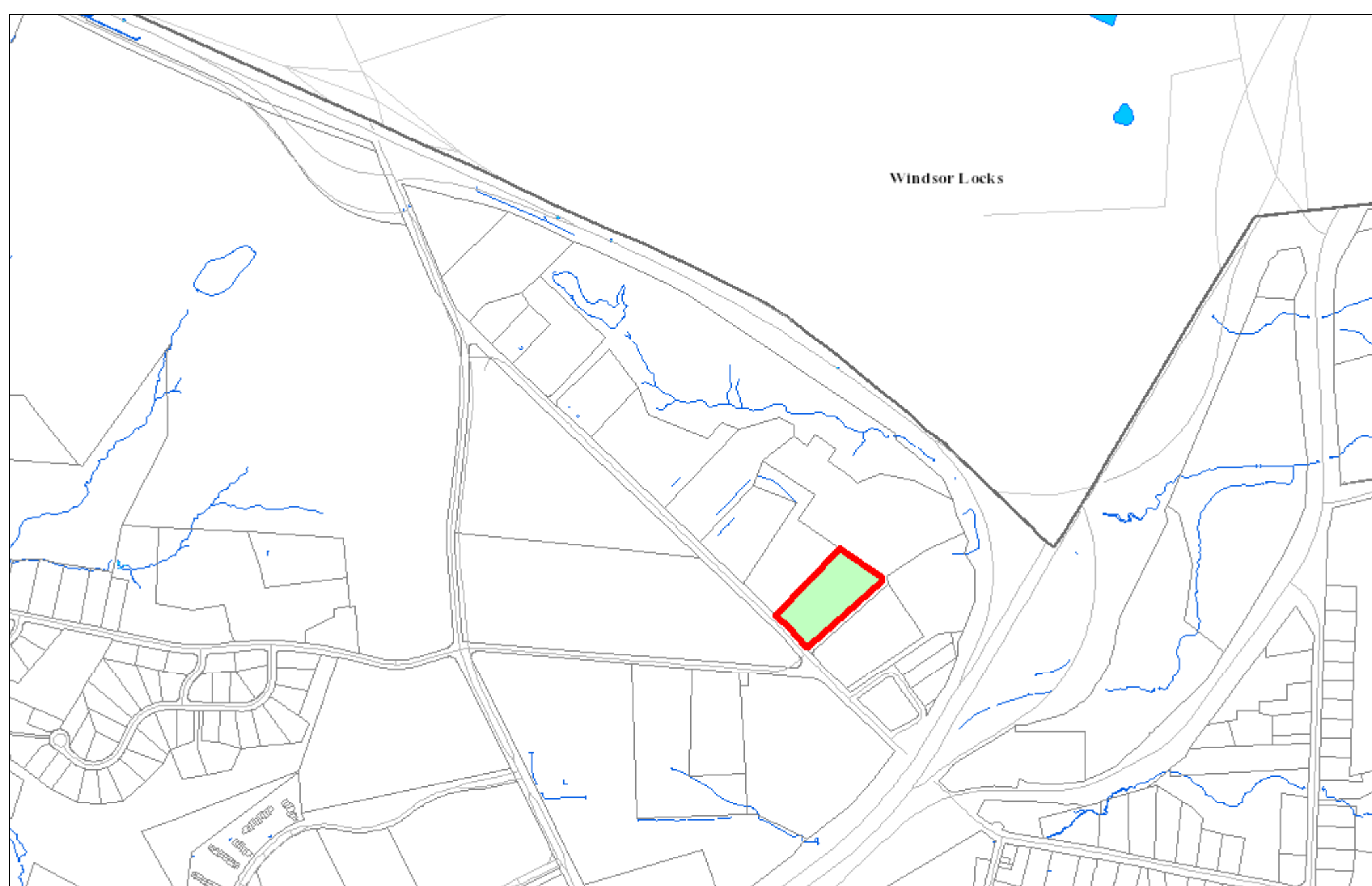

Windsor Locks

Hartford County, Connecticut

Horizontal Datum is Connecticut State Plane Feet, NAD83

1 inch = 987 feet

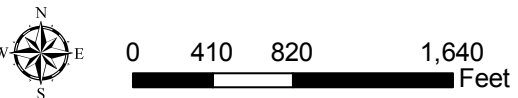

Property Boundaries not legally binding for title or zoning purposes.

The Town of Windsor makes no warranty as to the accuracy, reliability, or completeness of the information and is not responsible for any error or omissions for results obtained from the use of the information.







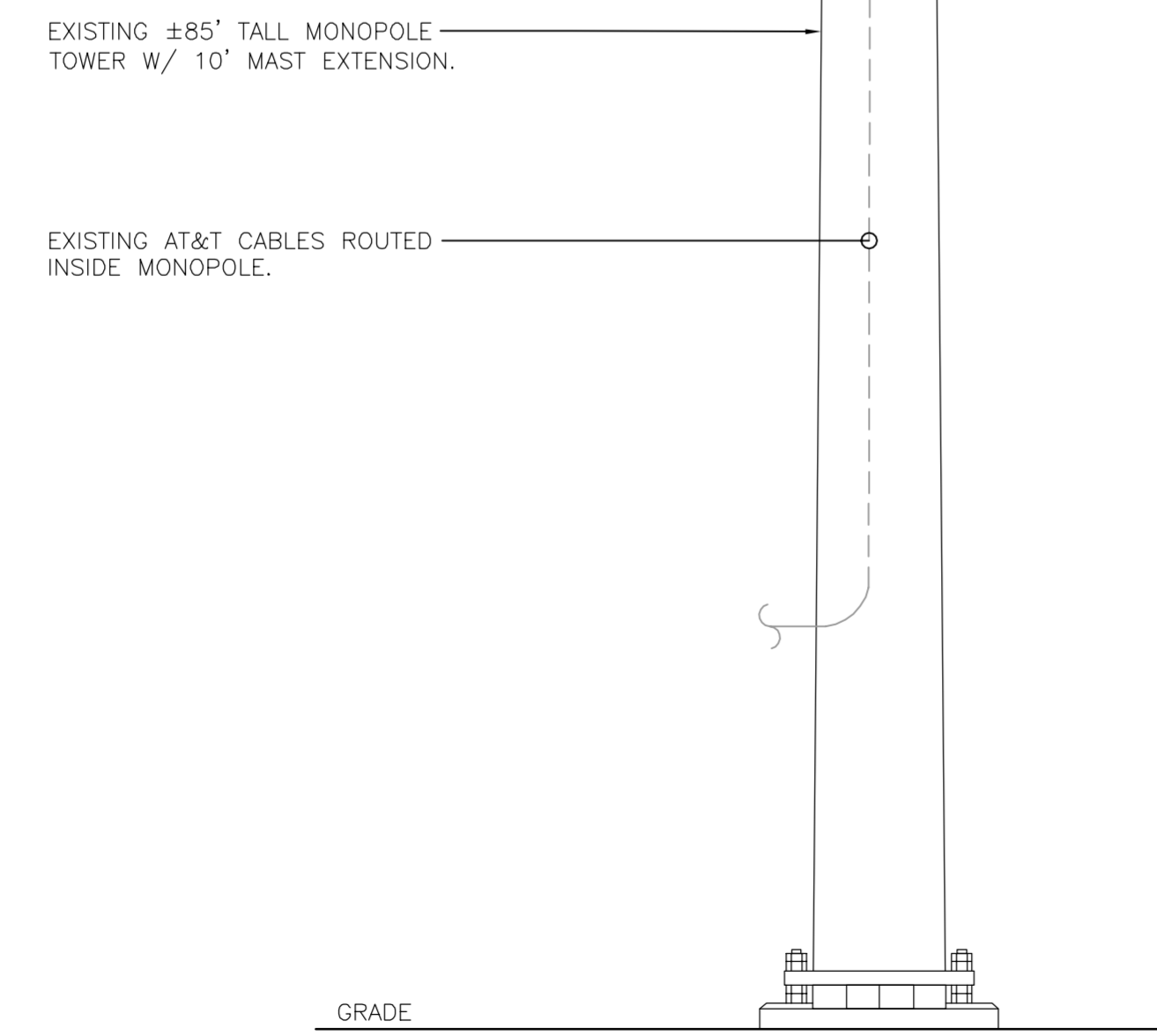
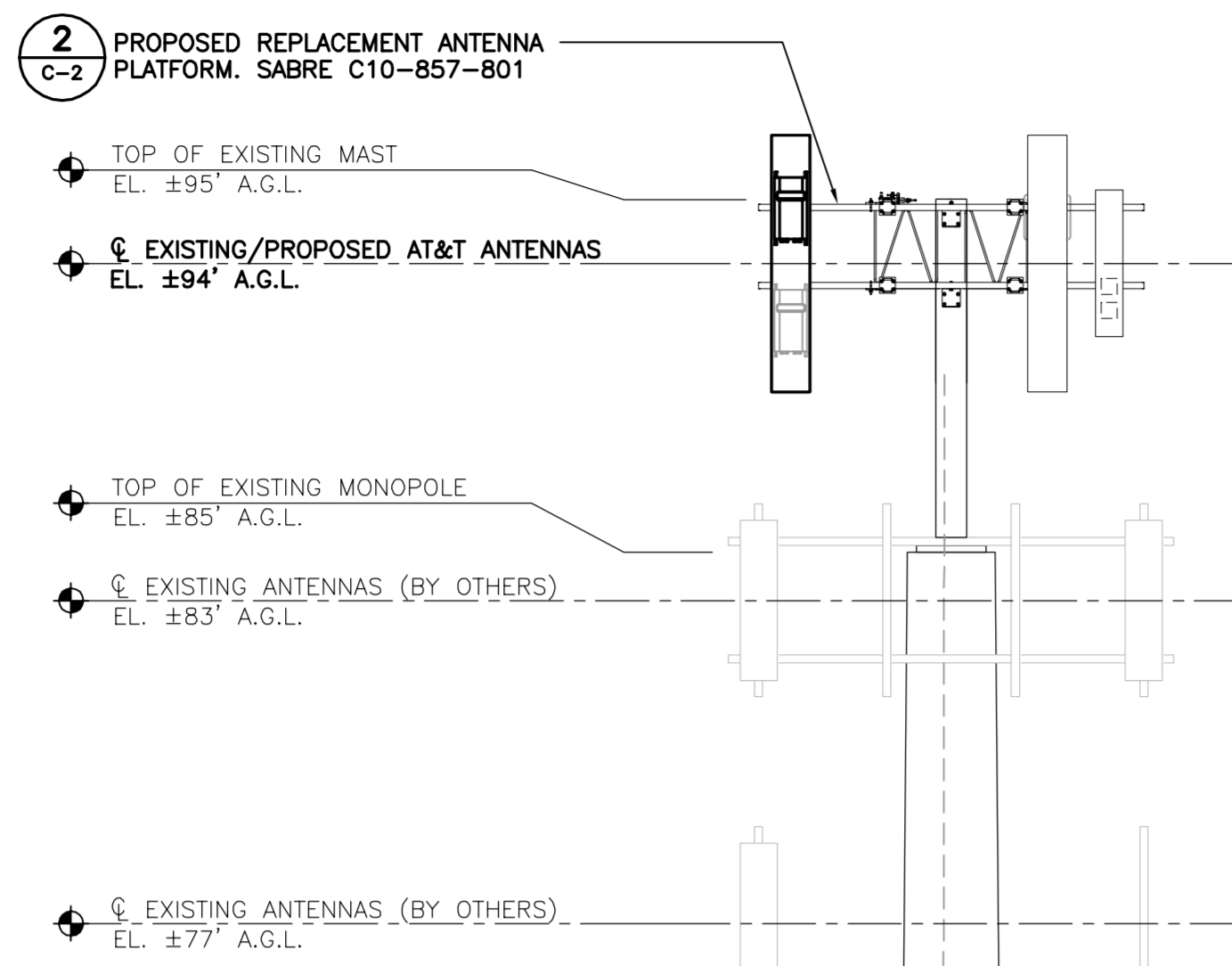

**3 TOWER ELEVATION - PROPOSED**  
C-1 SCALE: 3/16" = 1'-0"

**TOWER STRUCTURAL NOTES:**

1. TOWER STRUCTURAL ANALYSIS SIGNED AND SEALED BY A STRUCTURAL ENGINEER LICENSED IN THE STATE OF CONNECTICUT TO BE PROVIDED PRIOR TO INSTALLATION OF THE ADDITIONAL TOWER LOADING DEPICTED HEREIN.
2. ALL ANTENNAS AND COAX TO BE INSTALLED IN ACCORDANCE WITH STRUCTURAL ANALYSIS PROVIDED BY CROWN CASTLE, INC. AND FINAL AT&T RF DATA SHEET.

**NOTES:**

1. OTHER CARRIER EQUIPMENT NOT SHOWN FOR CLARITY
2. A.G.L. = ABOVE GRADE LEVEL

**NOTE:**  
GROUND EQUIPMENT NOT SHOWN FOR CLARITY.

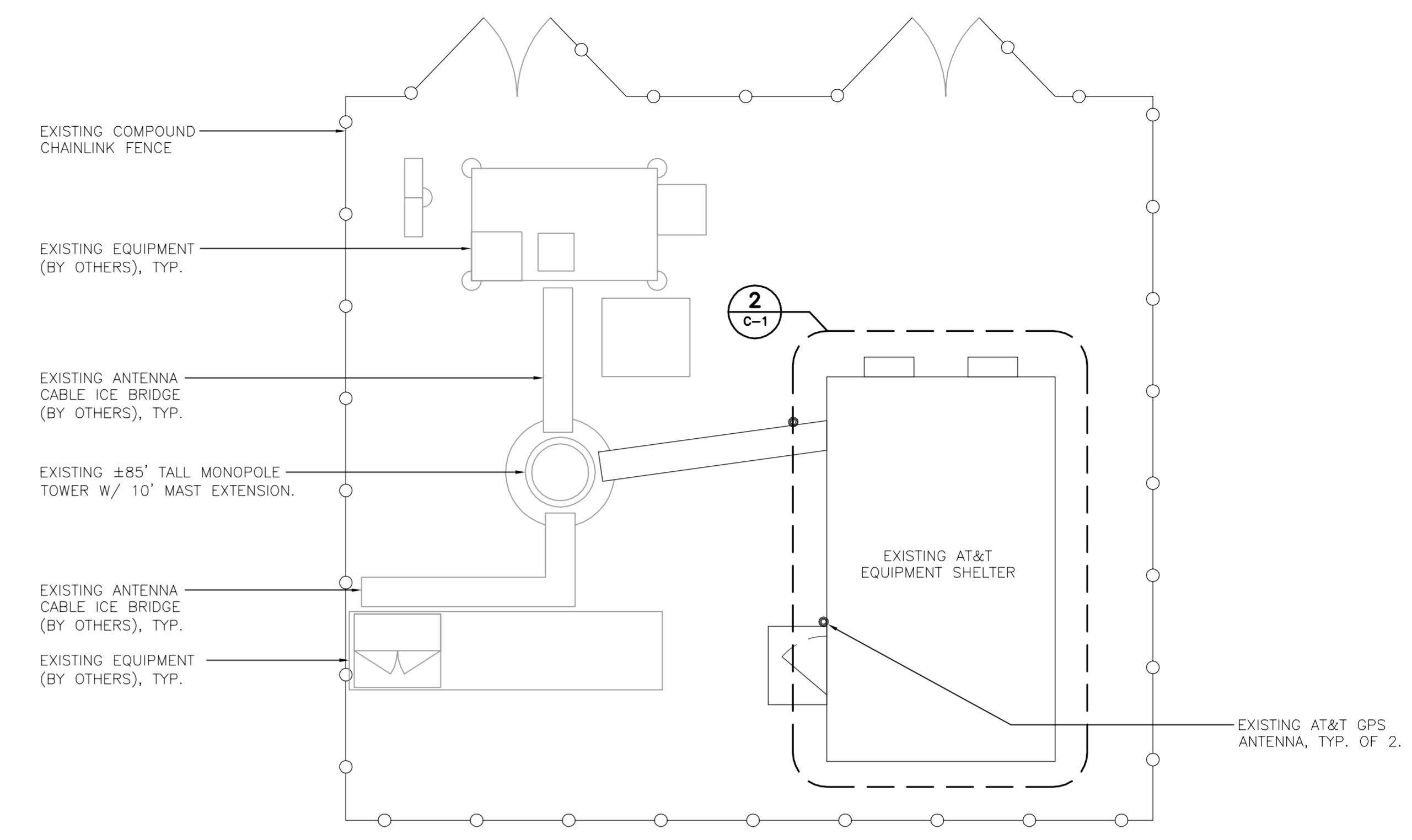

**1 COMPOUND PLAN**  
C-1 SCALE: 3/16" = 1'-0" TRUE NORTH

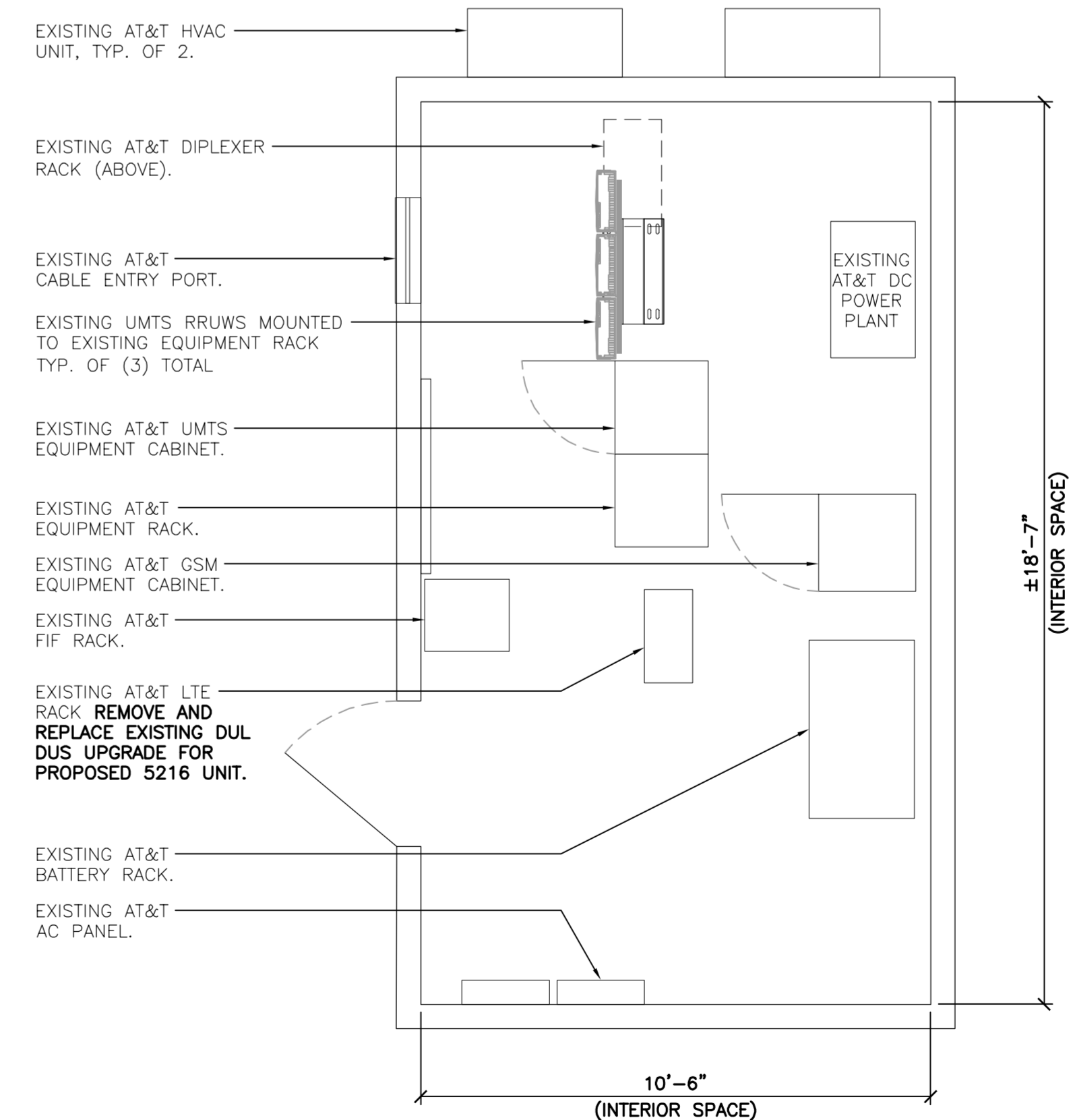

**2 EQUIPMENT LAYOUT PLAN**  
C-1 SCALE: 3/8" = 1'-0" TRUE NORTH

REV.	DATE	DMD	CAG	CONSTRUCTION DRAWINGS -	ISSUED FOR CONSTRUCTION
0	06/14/18				

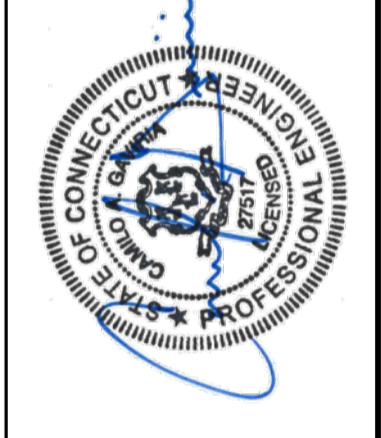

**CENITEK** engineering  
Centered on Solutions™  
203) 488-0580  
203) 488-8387 Fax  
63-2 North Branford Road  
Branford, CT 06405  
www.CenitekEng.com

**AT&T MOBILITY**  
WIRELESS COMMUNICATIONS FACILITY  
**WINDSOR BREAKNECK**  
CT5140 - LTE 3C WCS  
440 HAYDEN STATION RD  
WINDSOR, CT 06095

DATE: 02/28/18  
SCALE: AS NOTED  
JOB NO. 18000.06

PLANS AND ELEVATION

**C-1**  
Sheet No. 3 of 8

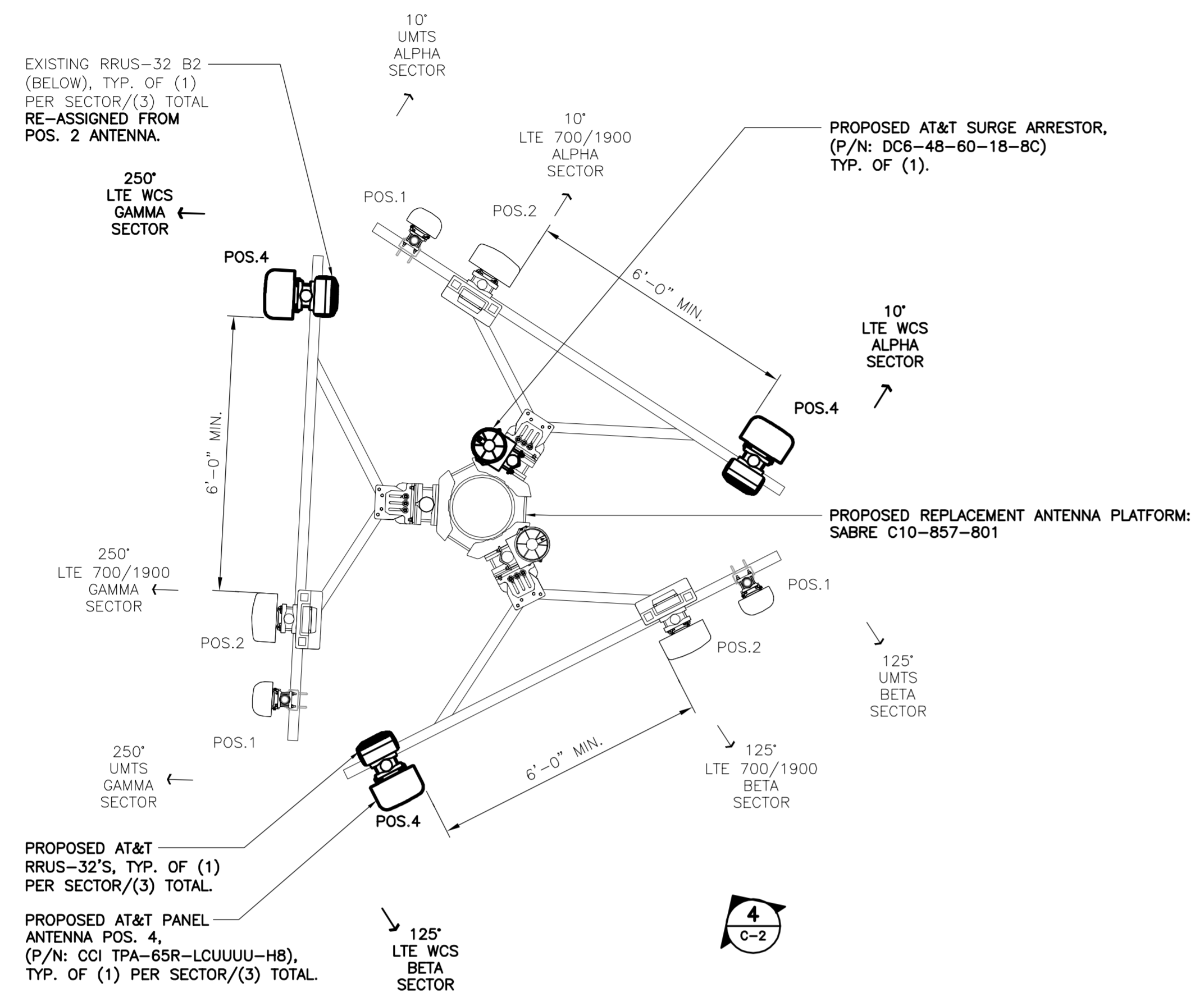

**2 PROPOSED ANTENNA PLAN**  
 SCALE: 3/8" = 1'-0" NORTH

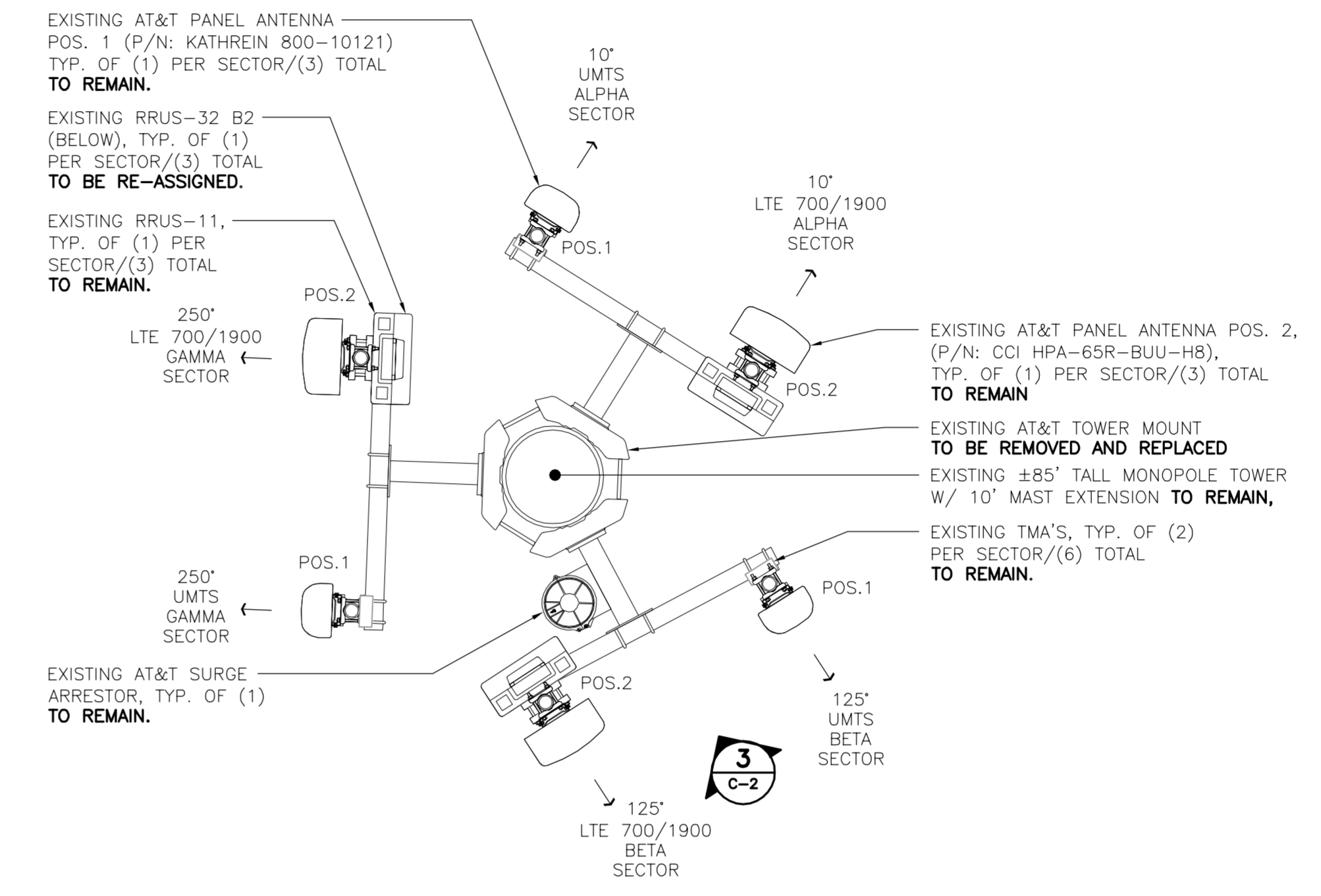

**1 EXISTING ANTENNA PLAN**  
 SCALE: 1/2" = 1'-0" NORTH

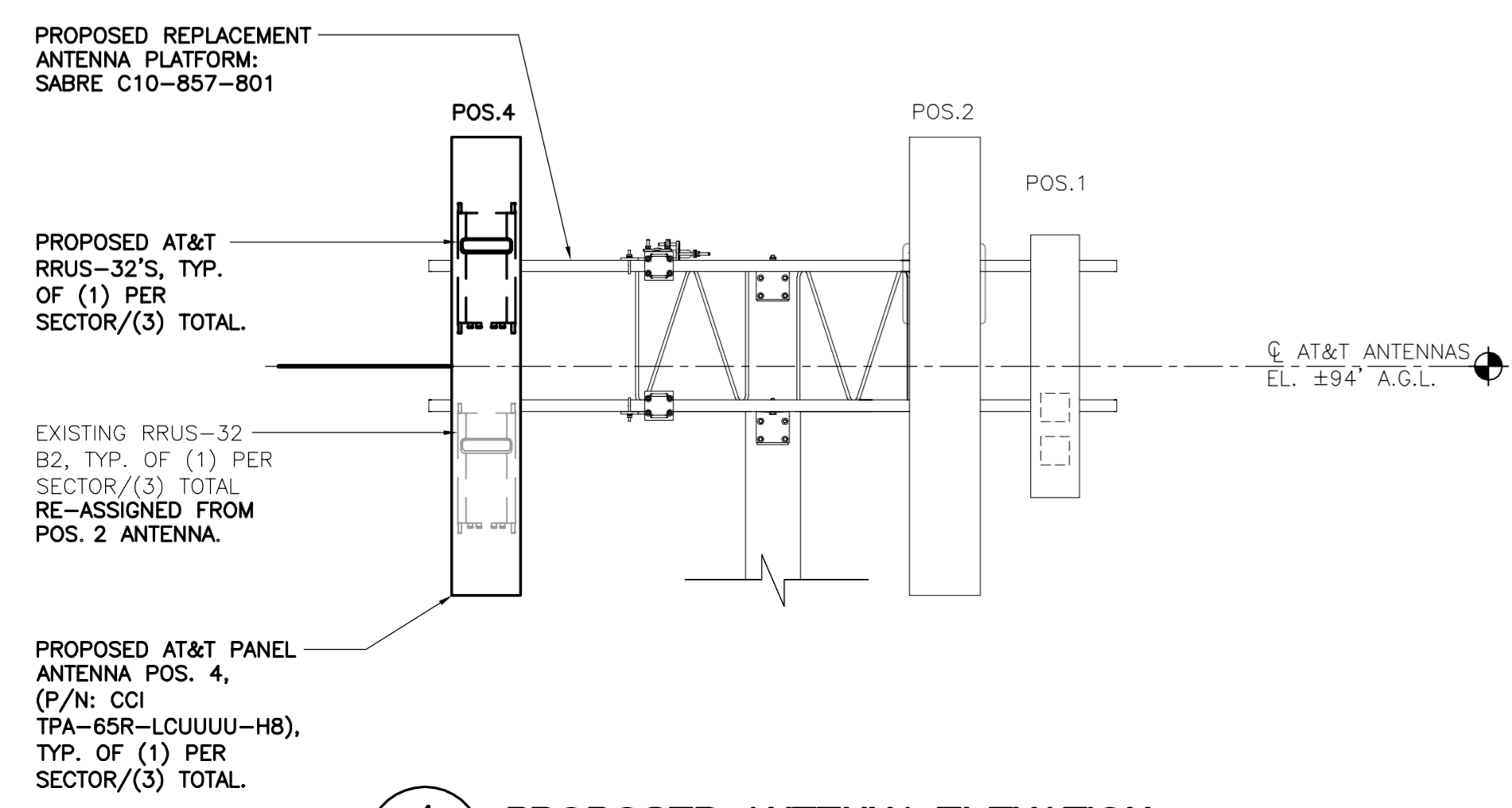

**4 PROPOSED ANTENNA ELEVATION**  
 SCALE: 3/8" = 1'-0"

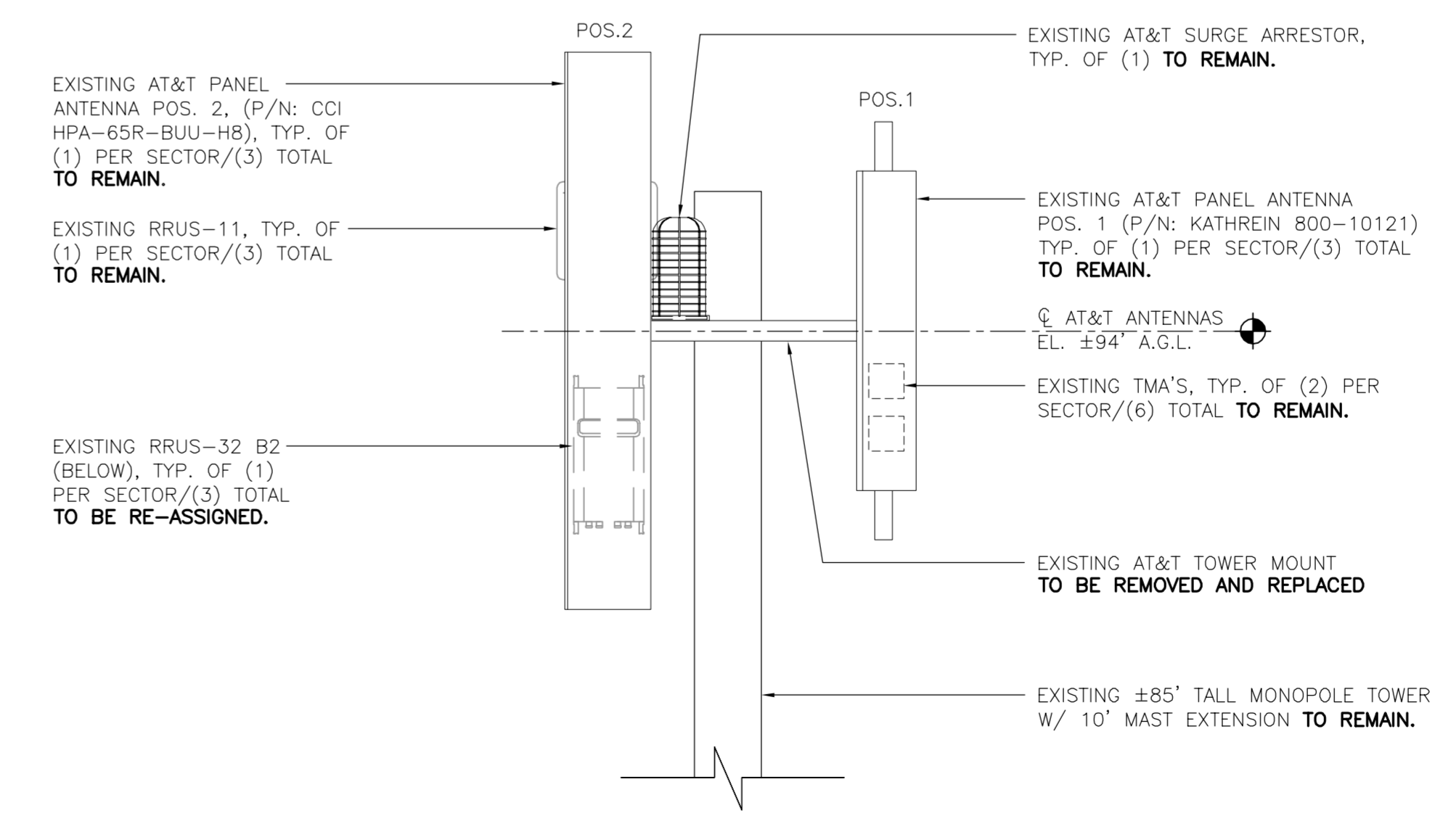

**3 EXISTING ANTENNA ELEVATION**  
 SCALE: 1/2" = 1'-0"

REV.	DATE	DRAWN BY	CAG	CONSTRUCTION DRAWINGS	ISSUED FOR CONSTRUCTION
0	06/14/18	DMD	CAG	CONSTRUCTION DRAWINGS	ISSUED FOR CONSTRUCTION

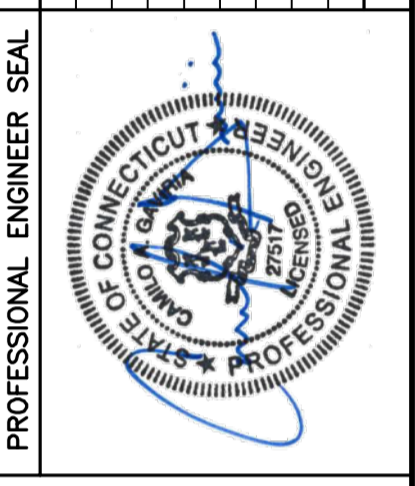

**CENTEK** engineering  
 Centered on Solutions™  
 (203) 488-0360  
 (203) 488-8387 Fax  
 63-2 North Branford Road  
 Branford, CT 06405  
 www.CentekEng.com

**AT&T MOBILITY**  
 WIRELESS COMMUNICATIONS FACILITY  
**WINDSOR BREAKNECK**  
 CT5140 - LTE 3C WCS  
 440 HAYDEN STATION RD  
 WINDSOR, CT 06095

DATE: 02/28/18  
 SCALE: AS NOTED  
 JOB NO. 18000.06

LTE 3C WCS  
 ANTENNA  
 LAYOUT PLANS

**C-2**  
 Sheet No. 4 of 8

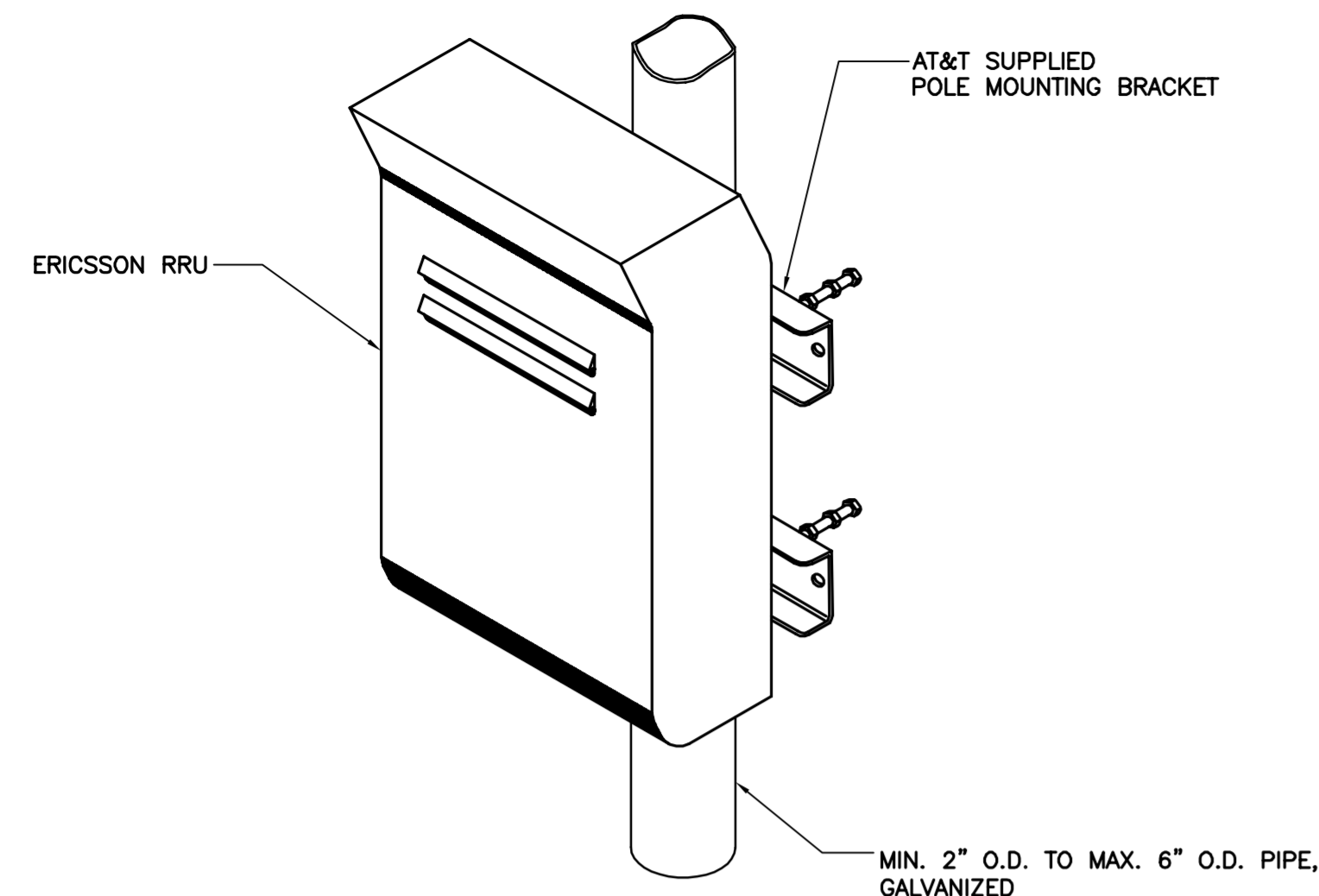

ISOMETRIC VIEW

NOTES:

1. AT&T SHALL SUPPLY RRU, AND RRU POLE-MOUNTING BRACKET. CONTRACTOR SHALL SUPPLY POLE/PIPE AND INSTALL ALL MOUNTING HARDWARE INCLUDING ERICSSON RRU POLE-MOUNTING BRACKET. CONTRACTOR SHALL INSTALLS RRU AND MAKES CABLE TERMINATIONS.
2. NO PAINTING OF THE RRU OR SOLAR SHIELD IS ALLOWED.

**1 TYPICAL RRUS MOUNTING DETAILS**  
C-3 SCALE: NTS

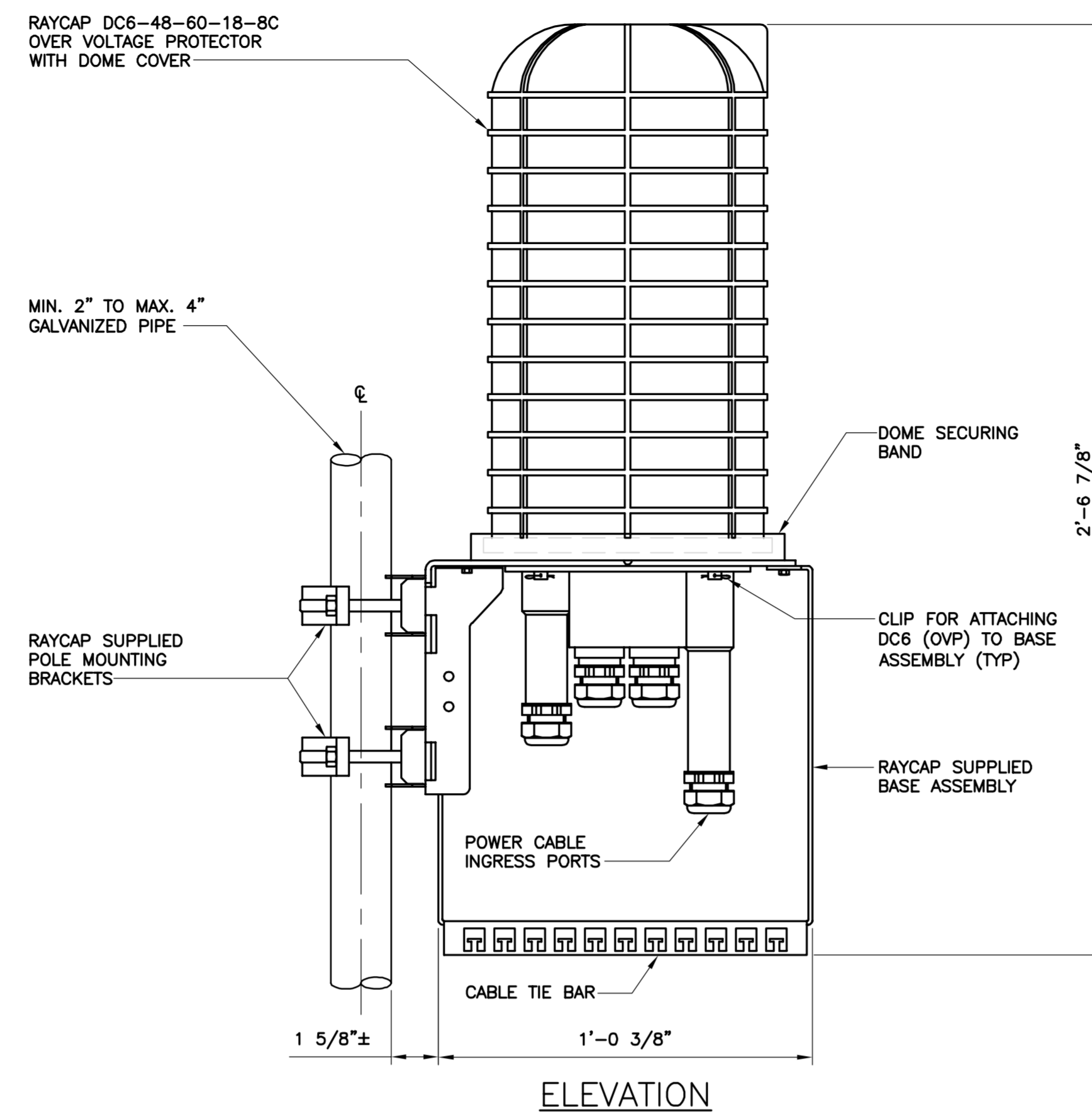

ELEVATION

NOTES:

1. RAYCAP VIA AT&T SUPPLIES THE DC6 OVER VOLTAGE PROTECTOR AND PIPE MOUNTING BRACKETS. SUBCONTRACTOR SHALL SUPPLY THE PIPE.

**2 RAYCAP DC6 MOUNTING DETAIL**  
C-3 SCALE: 3" = 1'-0"

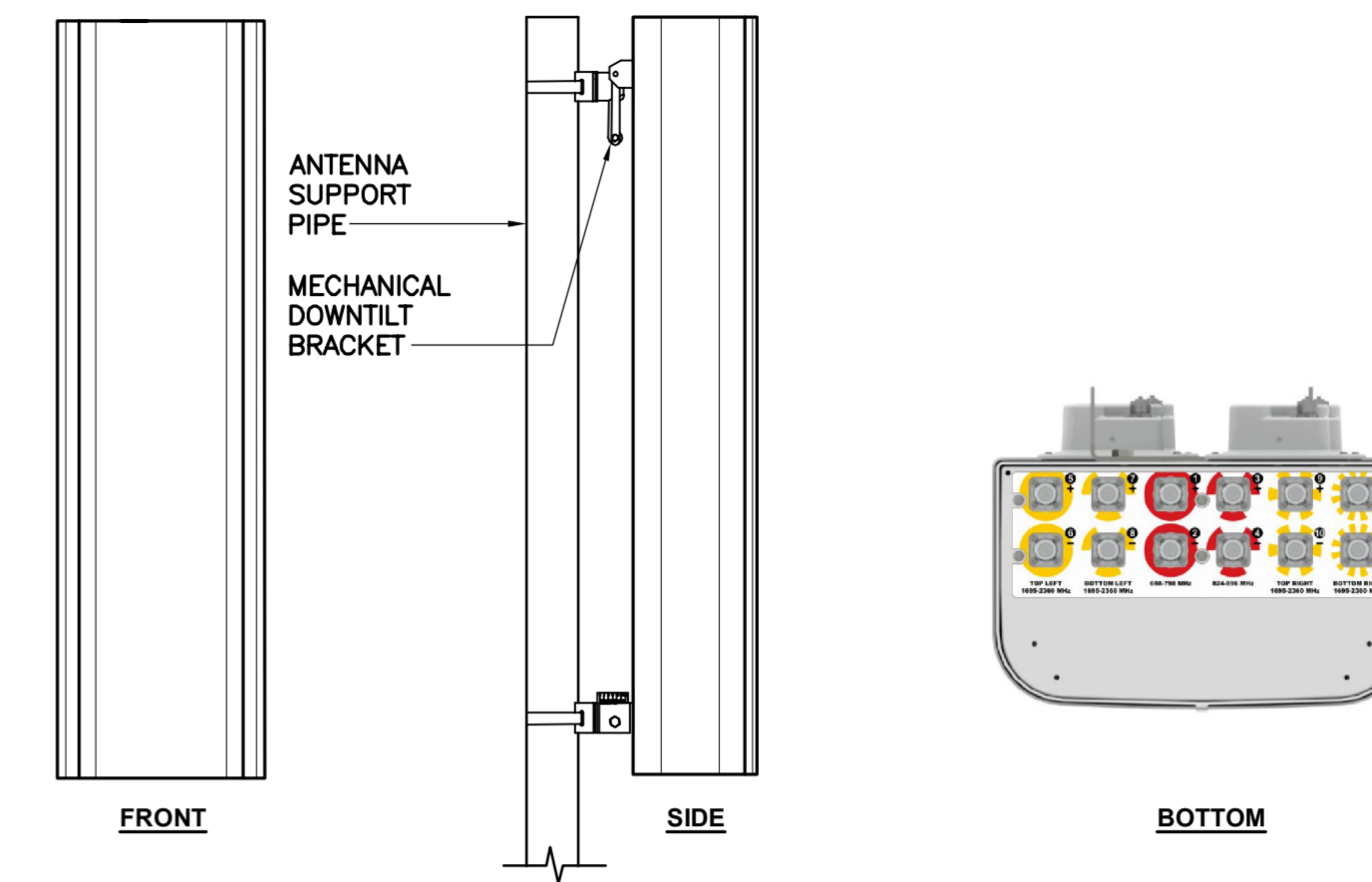

ALPHA/BETA/GAMMA ANTENNA		
EQUIPMENT	DIMENSIONS	WEIGHT
MAKE: CCI	96"L x 14.4"W x 8.6"D	75 LBS.
MODEL: TPA-65R-LCUUUU-HB		

**3 PROPOSED ANTENNA DETAIL**  
C-3 SCALE: NTS

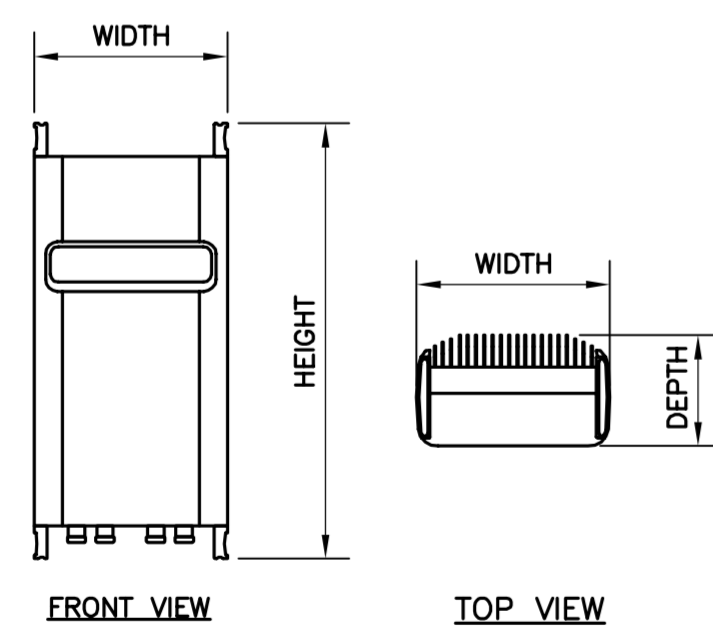

FRONT VIEW TOP VIEW

RRU (REMOTE RADIO UNIT)			
EQUIPMENT	DIMENSIONS	WEIGHT	CLEARANCES
MAKE: ERICSSON MODEL: RRUS-32	27.17"H x 12.05"W x 7.01"D	52.91 LBS.	ABOVE: 16" MIN. BELOW: 12" MIN. FRONT: 36" MIN.

NOTES:

1. CONTRACTOR TO COORDINATE FINAL EQUIPMENT MODEL SELECTION WITH AT&T CONSTRUCTION MANAGER PRIOR TO ORDERING.

**4 ERICSSON RRUS 32 DETAIL**  
C-3 SCALE: 1" = 1'-0"

REV.	DATE	BY	DESCRIPTION
0	06/14/18	DMD	CONSTRUCTION DRAWINGS - ISSUED FOR CONSTRUCTION

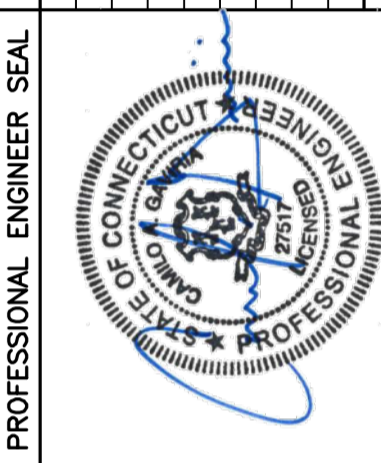

**CEN TEK** engineering  
Centered on Solutions™  
(203) 488-0360  
(203) 488-8387 Fax  
63-2 North Branford Road  
Branford, CT 06405  
www.CentekEng.com

AT&T MOBILITY  
WIRELESS COMMUNICATIONS FACILITY  
**WINDSOR BREAKNECK**  
CT5140 - LTE 3C WCS  
440 HAYDEN STATION RD  
WINDSOR, CT 06095

DATE: 02/28/18  
SCALE: AS NOTED  
JOB NO. 18000.06

DETAILS

**C-3**  
Sheet No. 5 of 8





EACH RRH CABINET SHALL BE GROUNDED IN THE FOLLOWING MANNER:  
 1. AT TOP OF THE CABINET  
 2. AT RIGHT SIDE OF THE CABINET.

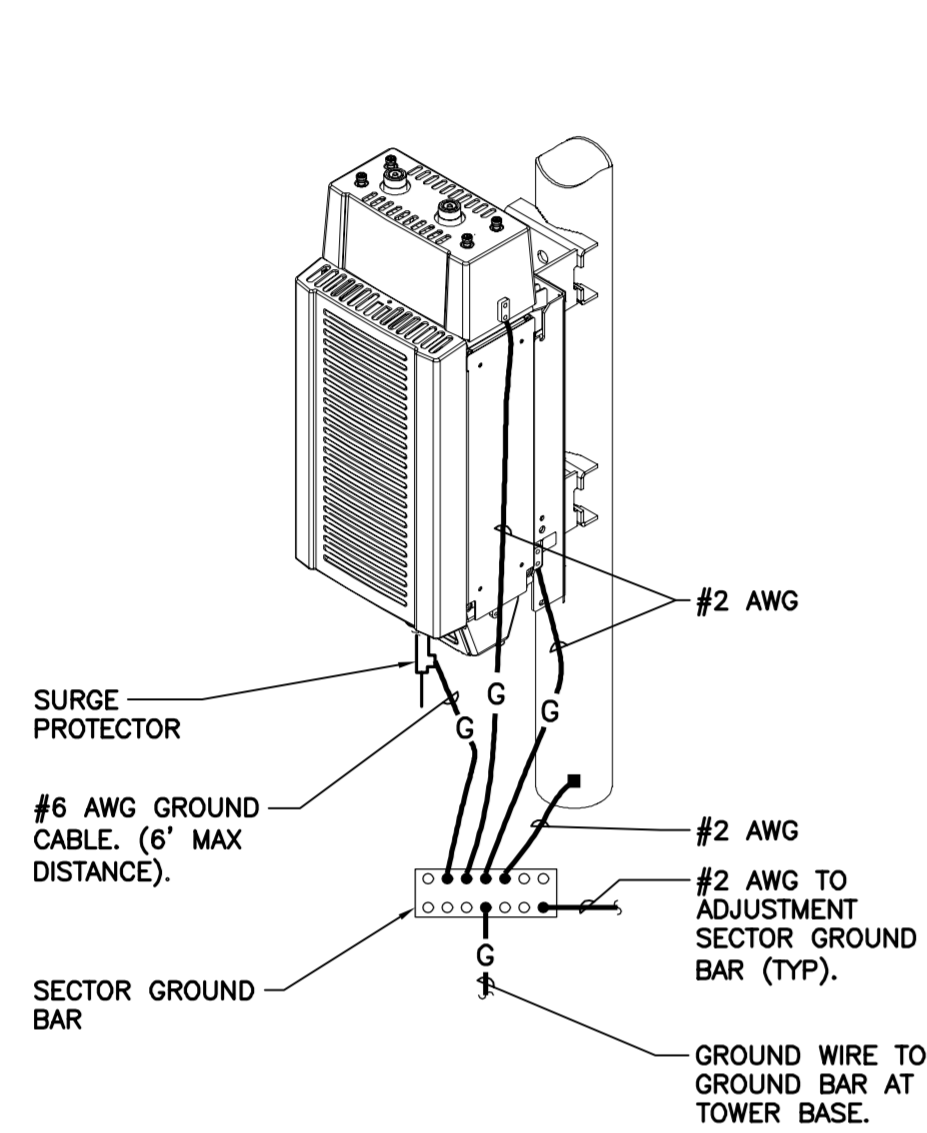

**4 RRU POLE MOUNT GROUNING**  
 E-3 NOT TO SCALE

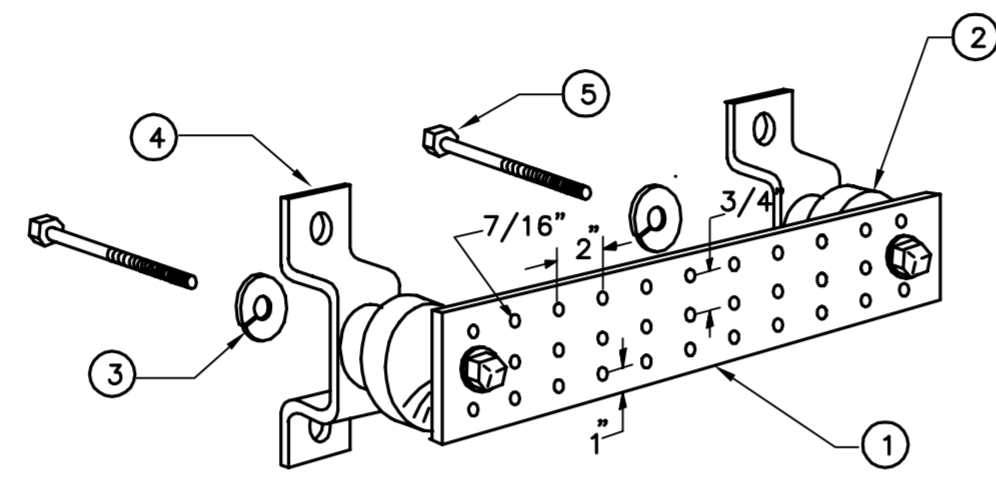

**LEGEND**

1. TINNED COPPER GROUND BAR, 1/4" x 4" x 20", NEWTON INSTRUMENT CO. HOLE CENTERS TO MATCH NEMA DOUBLE LUG.
2. INSULATORS, NEWTON INSTRUMENT CAT. NO. 2. 3061-4.
3. 5/8" LOCK WASHERS, NEWTON INSTRUMENT CO. CAT. NO. 3015-8.
4. WALL MOUNTING BRACKET, NEWTON INSTRUMENT CO. CAT. NO. A-6056.
5. STAINLESS STEEL SECURITY SCREWS.

**3 GROUND BAR DETAIL**  
 E-3 NOT TO SCALE

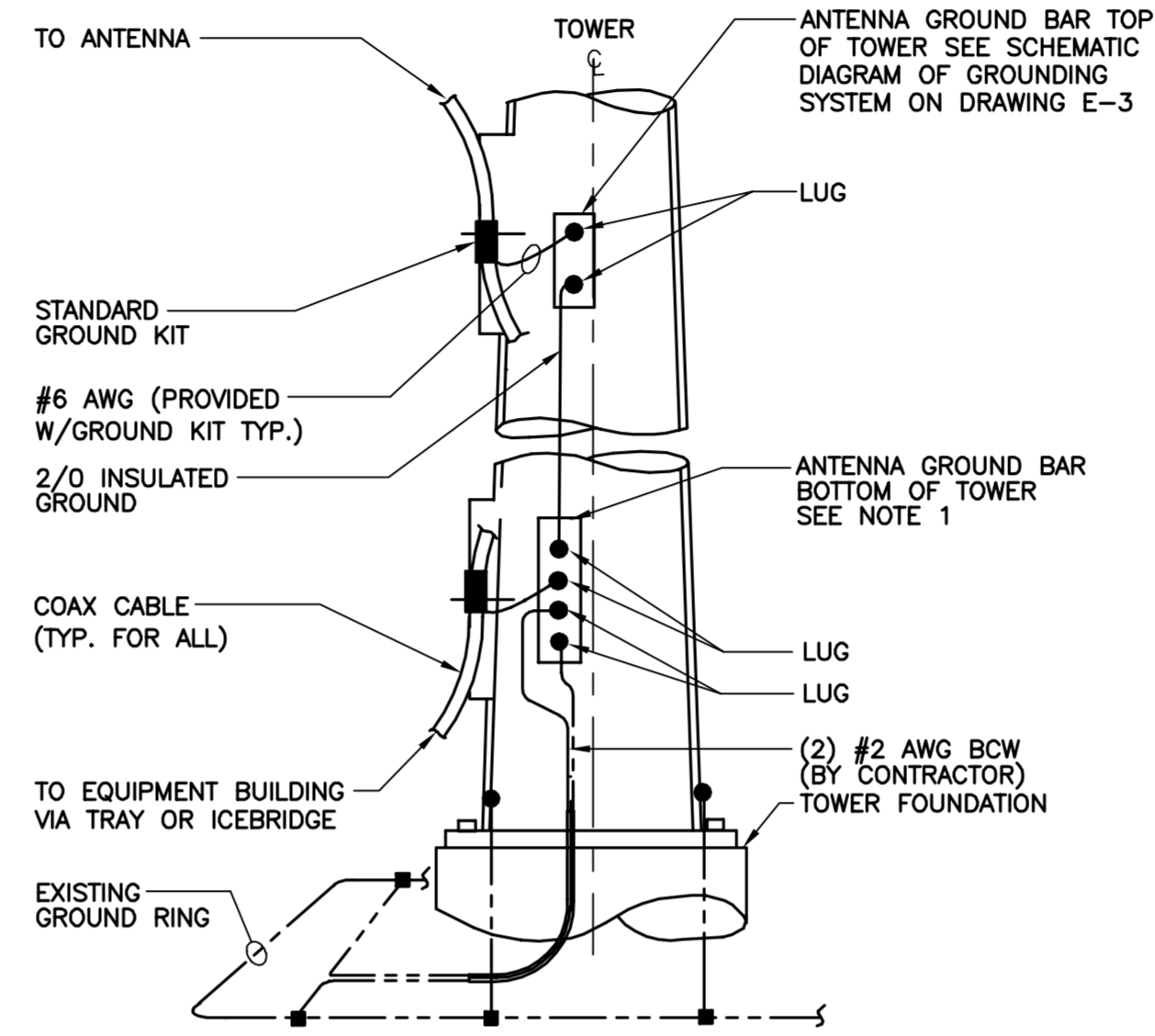

**NOTES:**

1. NUMBER OF GROUND BARS MAY VARY DEPENDING ON THE TYPE OF TOWER, LOCATION AND CONNECTION ORIENTATION. PROVIDE AS REQUIRED.
2. A SEPARATE GROUND BAR TO BE USED FOR GPS ANTENNA IF REQUIRED.

**2 ANTENNA CABLE GROUNING - TOWER**  
 E-3 NOT TO SCALE

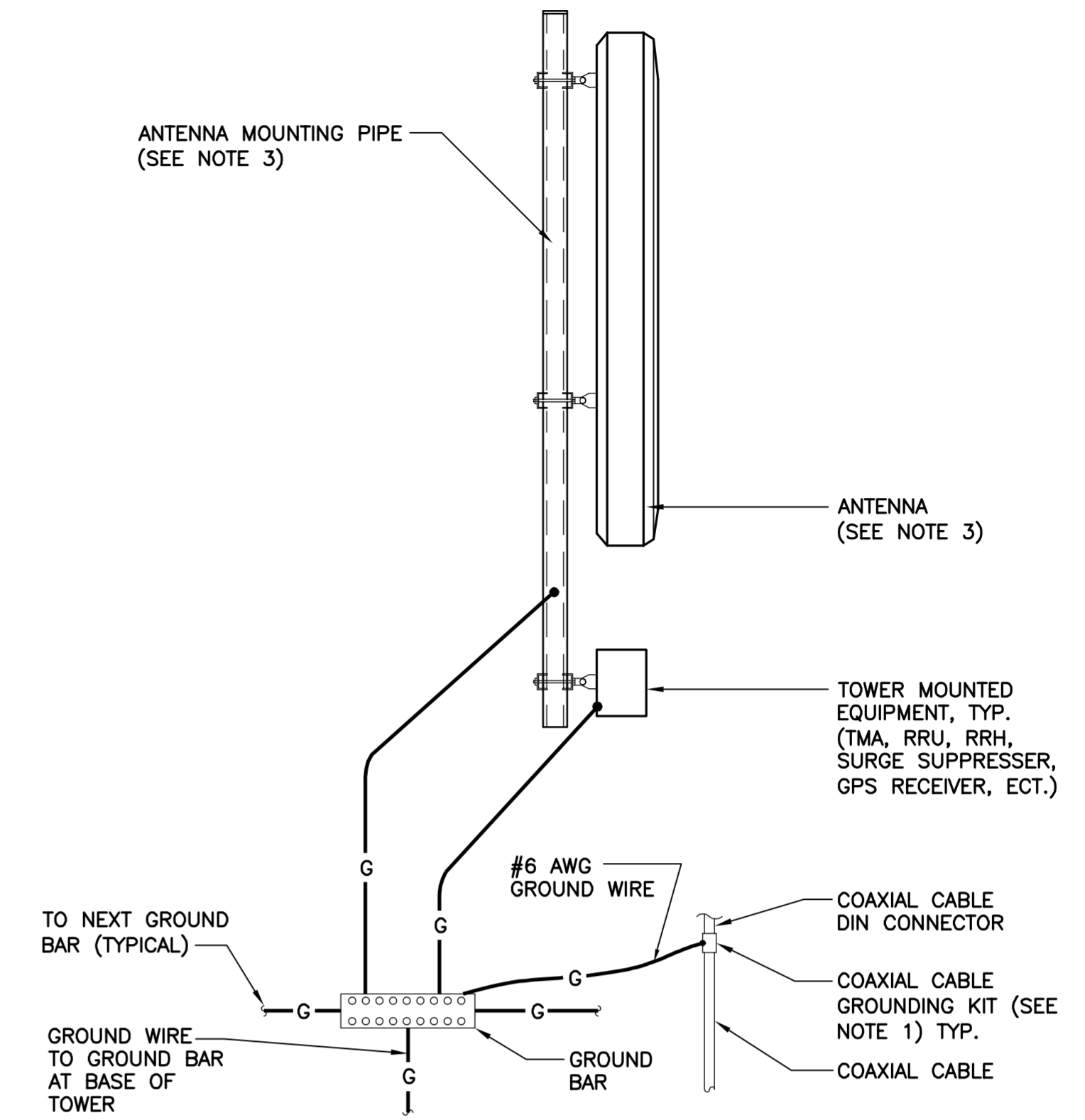

**NOTES:**

1. BOND COAXIAL CABLE GROUND KITS TO EACH OWNER'S GROUND BAR ALONG ENTIRE COAX RUN FROM ANTENNA TO SHELTER.
2. BOND ALL EQUIPMENT TO GROUND PER NEC AND MANUFACTURERS SPECIFICATIONS.
3. DETAIL IS TYPICAL FOR ALL ANTENNA SECTORS, INCLUDING GPS ANTENNA.

**1 TYPICAL ANTENNA GROUNING DETAIL**  
 E-3 NOT TO SCALE

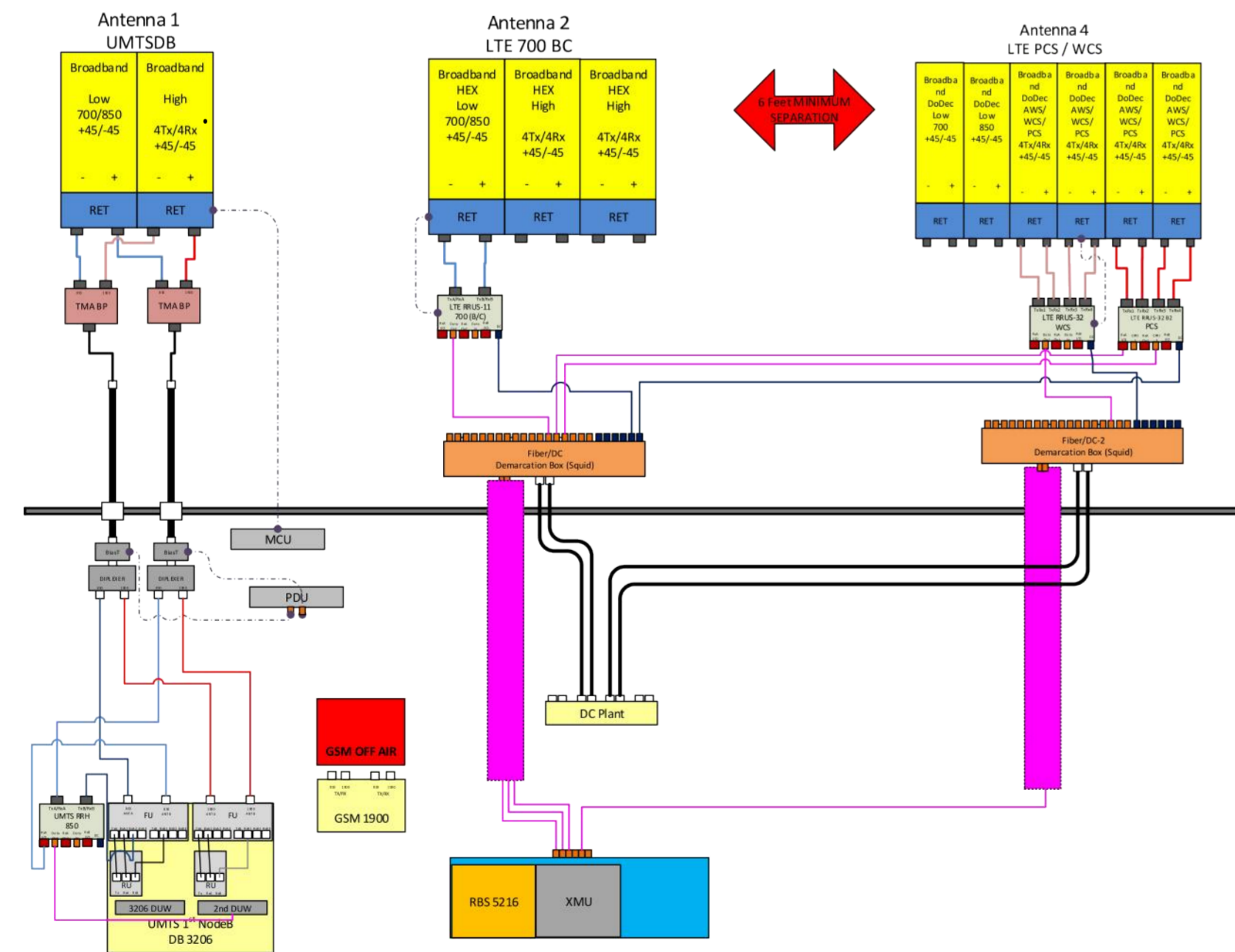

**7 RF PLUMBING DIAGRAM**  
 E-3 NOT TO SCALE

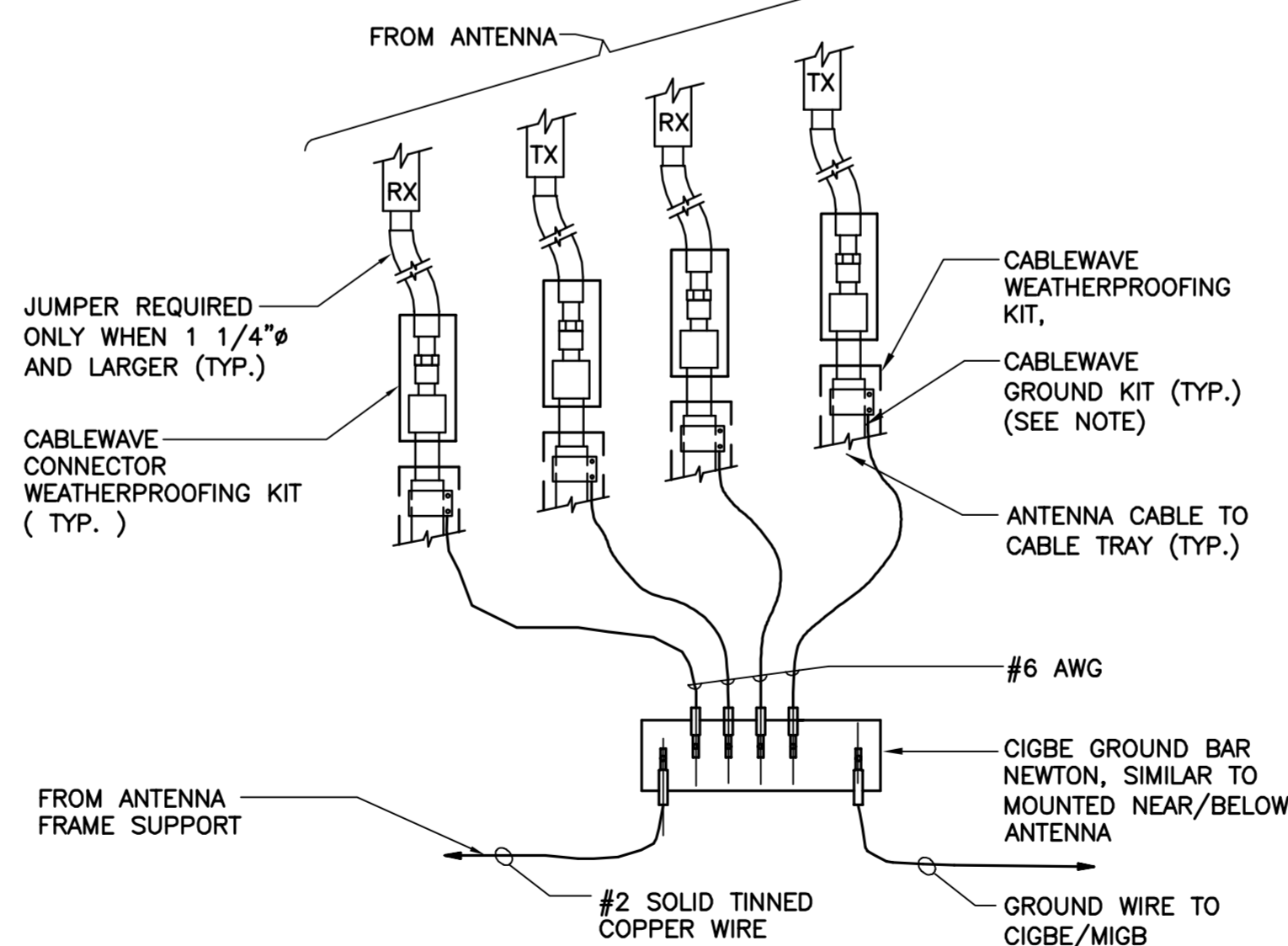

**NOTE:**

1. DO NOT INSTALL CABLE GROUND KIT AT A BEND AND ALWAYS DIRECT GROUND WIRE DOWN TO CIGBE

**6 CONNECTION OF GROUND WIRES TO GROUND BAR**  
 E-3 NOT TO SCALE

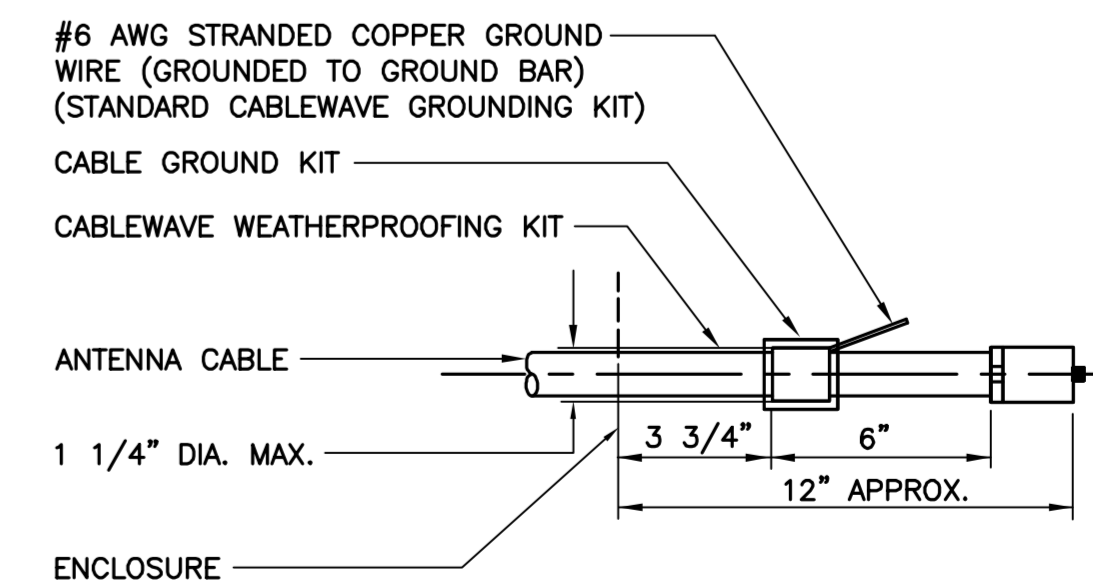

**NOTE:**

1. DO NOT INSTALL CABLE GROUND KIT AT A BEND AND ALWAYS DIRECT GROUND WIRE DOWN TO GROUND BAR.

**5 ANTENNA CABLE GROUNING DETAIL**  
 E-3 NOT TO SCALE

REV.	DATE	DMD	CAG	CONSTRUCTION DRAWINGS	ISSUED FOR CONSTRUCTION
0	06/14/18				

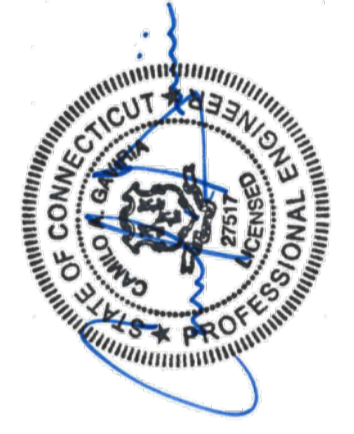

**CENTEK engineering**  
 Centered on Solutions™  
 (203) 489-0360  
 (203) 489-8387 Fax  
 63-2 North Branford Road  
 Branford, CT 06405  
 www.CentekEng.com

**AT&T MOBILITY**  
 WIRELESS COMMUNICATIONS FACILITY  
**WINDSOR BREAKNECK**  
 CT5140 - LTE 3C WCS  
 440 HAYDEN STATION RD  
 WINDSOR, CT 06095

DATE: 02/28/18  
 SCALE: AS NOTED  
 JOB NO. 18000.06

TYPICAL ELECTRICAL DETAILS

**E-3**



ENGINEERING INNOVATION  
 Velocitel, Inc. d.b.a. FDH Velocitel  
 6521 Meridien Drive, Suite 107  
 Raleigh, North Carolina 27616  
 (919) 755-1012

Date: **February 16, 2018**

Marianne Dunst  
 Crown Castle  
 3530 Toringdon Way Suite 300  
 Charlotte, NC 28277

**Subject: Structural Analysis Report**

**Carrier Designation:** **AT&T Mobility Co-Locate**  
**Carrier Site Number:** CT5140  
**Carrier Site Name:** 10071329

**Crown Castle Designation:** **Crown Castle BU Number:** 876326  
**Crown Castle Site Name:** HAYDEN STATION  
**Crown Castle JDE Job Number:** 480523  
**Crown Castle Work Order Number:** 1522662  
**Crown Castle Application Number:** 422595 Rev. 1

**Engineering Firm Designation:** **FDH Velocitel Project Number:** 18PDVZ1400

**Site Data:** **440 Hayden Station Road, WINDSOR, Hartford County, CT**  
**Latitude 41° 53' 52.2", Longitude -72° 38' 38.7"**  
**96 Foot - Monopole Tower**

Dear Marianne Dunst,

FDH Velocitel is pleased to submit this “**Structural Analysis Report**” to determine the structural integrity of the above mentioned tower. This analysis has been performed in accordance with the Crown Castle Structural ‘Statement of Work’ and the terms of Crown Castle Purchase Order Number 1140982, in accordance with application 422595, revision 1.

The purpose of the analysis is to determine acceptability of the tower stress level. Based on our analysis we have determined the tower stress level for the structure and foundation, under the following load case, to be:

LC5: Existing + Proposed Equipment **Sufficient Capacity**  
 Note: See Table I and Table II for the proposed and existing loading, respectively.

This analysis has been performed in accordance with the 2016 Connecticut State Building Code based upon an ultimate 3-second gust wind speed of 125 mph converted to a nominal 3-second gust wind speed of 97 mph per section 1609.3 and Appendix N as required for use in the TIA-222-G Standard per Exception #5 of Section 1609.1.1. Exposure Category C with a topographic category 1 and Risk Category II were used in this analysis.

We at FDH Velocitel appreciate the opportunity of providing our continuing professional services to you and Crown Castle. If you have any questions or need further assistance on this or any other projects please give us a call.

Respectfully submitted by:

Reviewed by:

Jack B. Deeken, EI  
 Project Engineer I

Dennis D. Abel, PE  
 Director of New Product Development  
 CT PE License No. 23247



## TABLE OF CONTENTS

### 1) INTRODUCTION

### 2) ANALYSIS CRITERIA

Table 1 - Proposed Antenna and Cable Information

Table 2 - Existing Antenna and Cable Information

Table 3 - Design Antenna and Cable Information

### 3) ANALYSIS PROCEDURE

Table 4 - Documents Provided

3.1) Analysis Method

3.2) Assumptions

### 4) ANALYSIS RESULTS

Table 5 - Section Capacity (Summary)

Table 6 – Tower Components vs. Capacity

4.1) Recommendations

### 5) APPENDIX A

tnxTower Output

### 6) APPENDIX B

Base Level Drawing

### 7) APPENDIX C

Additional Calculations



**1) INTRODUCTION**

This tower is a 96 ft Monopole tower designed by ROHN in January of 1997. The tower was originally designed for a wind speed of 80 mph per TIA/EIA-222-F.

**2) ANALYSIS CRITERIA**

The structural analysis was performed for this tower in accordance with the requirements of TIA-222-G Structural Standard for Antenna Supporting Structures and Antennas using a 3-second gust wind speed of 97 mph with no ice, 50 mph with 1 inch ice thickness and 60 mph under service loads, exposure category C with topographic category 1.

**Table 1 - Proposed Antenna and Cable Information**

Mounting Level (ft)	Center Line Elevation (ft)	Number of Antennas	Antenna Manufacturer	Antenna Model	Number of Feed Lines	Feed Line Size (in)	Note
92.0	92.0	3	cci antennas	TPA-65R-LCUUUU-H8	1 2	3/8 3/4	-
		3	ericsson	RRUS 32			
		1	raycap	DC6-48-60-18-8F			
		1	-	Sector Mount [SM 502-3]			

**Table 2 - Existing Antenna and Cable Information**

Mounting Level (ft)	Center Line Elevation (ft)	Number of Antennas	Antenna Manufacturer	Antenna Model	Number of Feed Lines	Feed Line Size (in)	Note
92.0	92.0	3	cci antennas	HPA-65R-BUU-H8	1 1 2 6	2" Conduit 3/8 3/4 1-5/8	1
		3	ericsson	RRUS 32 B2			
		3	ericsson	RRUS-11			
		3	kathrein	800 10121			
		6	kathrein	860 10025			
		6	powerwave technologies	LGP21401			
		1	raycap	DC6-48-60-18-8F			
		1	-	T-Arm Mount [TA 702-3]			
83.0	86.0	1	andrew	VHLP2-180	2 6 4 1 3	2" Conduit 5/16 1/2 5/8 1-1/4	1
		2	dragonwave	A-ANT-11G-4-C			
	83.0	3	alcatel lucent	TD-RRH8x20-25			
		3	dragonwave	Horizon DUO			
		3	rfs celwave	APXVSP18-C-A20			
		3	rfs celwave	APXVTM14-C-120			
		3	samsung telecommunications	WIMAX DAP HEAD			
		1	-	Platform Mount [LP 502-1]			
82.0	3	kathrein	840 10045				
79.0	80.0	3	alcatel lucent	800MHz 2X50W RRH W/FILTER			
	79.0	1	-	Side Arm Mount [SO 104-3]			
	77.0	3	alcatel lucent	PCS 1900MHz 4x45W-65MHz			

Mounting Level (ft)	Center Line Elevation (ft)	Number of Antennas	Antenna Manufacturer	Antenna Model	Number of Feed Lines	Feed Line Size (in)	Note
75.0	75.0	3	andrew	LNX-6515DS-A1M	12 1	7/8 1-5/8	1
		3	ericsson	ERICSSON AIR 21 B2A B4P			
		3	ericsson	ERICSSON AIR 21 B4A B2P			
		3	ericsson	KRY 112 144/1			
		3	ericsson	RRUS 11 B12			
		1	-	Platform Mount [LP 303-1]			
57.0	57.0	1	gps	GPS_A	1	1/2	1
		1	-	4.5' x 2" horizontal mount pipe			

Notes:

- 1) Existing Equipment
- 2) Reserved Equipment
- 3) Equipment To Be Removed; Not considered

**Table 3 - Design Antenna and Cable Information**

Mounting Level (ft)	Center Line Elevation (ft)	Number of Antennas	Antenna Manufacturer	Antenna Model	Number of Feed Lines	Feed Line Size (in)
85	85	12	swedcom	ALP9212	12	1 5/8
75	75	12	swedcom	ALP9212	12	1 5/8
60	60	12	swedcom	ALP9212	12	1 5/8

**3) ANALYSIS PROCEDURE**

**Table 4 - Documents Provided**

Document	Remarks	Reference	Source
4-GEOTECHNICAL REPORTS	Clough, Harbor, & Associates LLP	1530918	CCISITES
4-TOWER FOUNDATION DRAWINGS/DESIGN/SPECS	Rohn, Inc.	1640630	CCISITES
4-TOWER MANUFACTURER DRAWINGS	Rohn, Inc.	1639483	CCISITES
4-TOWER STRUCTURAL ANALYSIS REPORTS	URS	1771083	CCISITES

**3.1) Analysis Method**

tnxTower (version 7.0.5.1), a commercially available analysis software package, was used to create a three-dimensional model of the tower and calculate member stresses for various loading cases. Selected output from the analysis is included in Appendix A.

**3.2) Assumptions**

- 1) Tower and structures were built in accordance with the manufacturer's specifications.
- 2) The tower and structures have been maintained in accordance with the manufacturer's specification.
- 3) The configuration of antennas, transmission cables, mounts and other appurtenances are as specified in Tables 1 and 2 and the referenced drawings.
- 4) Tower extension geometry was taken from the previous analysis
- 5) Base and flange plate design methodology of the manufacturer has been reviewed and found to be an acceptable means of designing to resist the full capacity of the bolts and shaft.

This analysis may be affected if any assumptions are not valid or have been made in error. FDH Velocitel should be notified to determine the effect on the structural integrity of the tower.

**4) ANALYSIS RESULTS**

**Table 5 - Section Capacity (Summary)**

Section No.	Elevation (ft)	Component Type	Size	Critical Element	P (K)	SF*P_allow (K)	% Capacity	Pass / Fail
L1	96 - 85	Pole	P12x.5	1	-5.11	606.13	26.0	Pass
L2	85 - 65	Pole	P42x3/8	2	-15.81	1668.87	21.1	Pass
L3	65 - 32.5	Pole	P48x3/8	3	-24.33	1847.49	46.5	Pass
L4	32.5 - 0	Pole	P48x1/2	4	-35.35	2649.06	59.5	Pass
							Summary	
						Pole (L4)	59.5	Pass
						Rating =	59.5	Pass

**Table 6 - Tower Component Stresses vs. Capacity – LC5**

Notes	Component	Elevation (ft)	% Capacity	Pass / Fail
1	Anchor Rods	0	70.8	Pass
1	Base Plate	0	60.7	Pass
1	Base Foundation Structural	0	41.7	Pass
1	Base Foundation Soil Interaction	0	31.8	Pass
1	Flange Plate	32.5	32.3	Pass
1	Flange Bolts	32.5	41.2	Pass
1	Flange Plate	65	21.9	Pass
1	Flange Bolts	65	13.9	Pass
1	Flange Plate	85	25.3	Pass
1	Flange Bolts	85	3.6	Pass

<b>Structure Rating (max from all components) =</b>	<b>70.8%</b>
---	--------------

Notes:

- 1) See additional documentation in "Appendix C – Additional Calculations" for calculations supporting the % capacity consumed.

**4.1) Recommendations**

The tower and its foundation have sufficient capacity to carry the proposed load configuration. No modifications are required at this time.

**APPENDIX A**  
**TNXTOWER OUTPUT**

1	P12x.5	11.00	A53-B-35	0.7
2	P42x3/8	20.00		3.3
3	P48x3/8	32.50	A53-B-42	6.2
4	P48x1/2	32.50		8.3
Section	Size	Length (ft)	Grade	Weight (K)
				18.5

96.0 ft  
85.0 ft  
65.0 ft  
32.5 ft  
0.0 ft

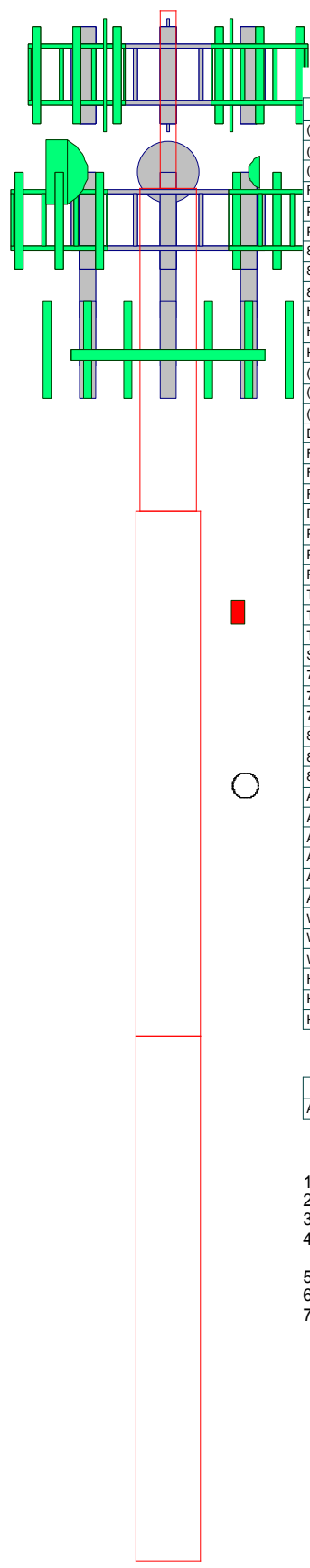

### DESIGNED APPURTENANCE LOADING

TYPE	ELEVATION	TYPE	ELEVATION
(2) 860 10025	92	TD-RRH8x20-25	83
(2) 860 10025	92	TD-RRH8x20-25	83
(2) 860 10025	92	TD-RRH8x20-25	83
RRUS 32 B2	92	(2) 4' x 2" Pipe Mount	83
RRUS 32 B2	92	(2) 4' x 2" Pipe Mount	83
RRUS 32 B2	92	(2) 4' x 2" Pipe Mount	83
800 10121 w/ Mount Pipe	92	Platform Mount [LP 502-1]	83
800 10121 w/ Mount Pipe	92	A-ANT-11G-4-C	83
800 10121 w/ Mount Pipe	92	VHLP2-180	83
HPA-65R-BUU-H8 w/ Mount Pipe	92	A-ANT-11G-4-C	83
HPA-65R-BUU-H8 w/ Mount Pipe	92	PCS 1900MHz 4x45W-65MHz	79
HPA-65R-BUU-H8 w/ Mount Pipe	92	PCS 1900MHz 4x45W-65MHz	79
(2) LGP21401	92	PCS 1900MHz 4x45W-65MHz	79
(2) LGP21401	92	4' x 2" Pipe Mount	79
(2) LGP21401	92	4' x 2" Pipe Mount	79
DC6-48-60-18-8F	92	4' x 2" Pipe Mount	79
RRUS-11	92	Side Arm Mount [SO 104-3]	79
RRUS-11	92	800MHz 2X50W RRH W/FILTER	79
RRUS-11	92	800MHz 2X50W RRH W/FILTER	79
DC6-48-60-18-8F	92	800MHz 2X50W RRH W/FILTER	79
RRUS 32	92	ERICSSON AIR 21 B4A B2P w/ Mount Pipe	75
RRUS 32	92	ERICSSON AIR 21 B4A B2P w/ Mount Pipe	75
RRUS 32	92	ERICSSON AIR 21 B4A B2P w/ Mount Pipe	75
TPA-65R-LCUUUU-H8 w/ Mount Pipe	92	ERICSSON AIR 21 B4A B2P w/ Mount Pipe	75
TPA-65R-LCUUUU-H8 w/ Mount Pipe	92	ERICSSON AIR 21 B4A B2P w/ Mount Pipe	75
TPA-65R-LCUUUU-H8 w/ Mount Pipe	92	KRY 112 144/1	75
Sector Mount [SM 502-3]	92	KRY 112 144/1	75
7'x2 1/2" Pipe Mount	92	KRY 112 144/1	75
7'x2 1/2" Pipe Mount	92	LNX-6515DS-A1M w/ Mount Pipe	75
7'x2 1/2" Pipe Mount	92	LNX-6515DS-A1M w/ Mount Pipe	75
840 10045 w/ Mount Pipe	83	LNX-6515DS-A1M w/ Mount Pipe	75
840 10045 w/ Mount Pipe	83	RRUS 11 B12	75
840 10045 w/ Mount Pipe	83	RRUS 11 B12	75
APXVSP18-C-A20 w/ Mount Pipe	83	RRUS 11 B12	75
APXVSP18-C-A20 w/ Mount Pipe	83	Platform Mount [LP 303-1]	75
APXVSP18-C-A20 w/ Mount Pipe	83	ERICSSON AIR 21 B2A B4P w/ Mount Pipe	75
APXVTM14-C-120 w/ Mount Pipe	83	ERICSSON AIR 21 B2A B4P w/ Mount Pipe	75
APXVTM14-C-120 w/ Mount Pipe	83	ERICSSON AIR 21 B2A B4P w/ Mount Pipe	75
APXVTM14-C-120 w/ Mount Pipe	83	ERICSSON AIR 21 B2A B4P w/ Mount Pipe	75
WIMAX DAP HEAD	83	4.5' x 2" horizontal mount pipe	57
WIMAX DAP HEAD	83	GPS_A	57
Horizon DUO	83		
Horizon DUO	83		
Horizon DUO	83		

### MATERIAL STRENGTH

GRADE	Fy	Fu	GRADE	Fy	Fu
A53-B-35	35 ksi	63 ksi	A53-B-42	42 ksi	63 ksi

### TOWER DESIGN NOTES

1. Tower is located in Hartford County, Connecticut.
2. Tower designed for Exposure C to the TIA-222-G Standard.
3. Tower designed for a 97 mph basic wind in accordance with the TIA-222-G Standard.
4. Tower is also designed for a 50 mph basic wind with 1.00 in ice. Ice is considered to increase in thickness with height.
5. Deflections are based upon a 60 mph wind.
6. Tower Structure Class II.
7. Topographic Category 1 with Crest Height of 0.00 ft

 <b>FDH Velocitel</b> ENGINEERING INNOVATION Tower Analysis	<b>6521 Meridien Drive, Suite 107</b> <b>Raleigh, North Carolina 27616</b> Phone: (919) 755-1012 FAX: 9197551031		<b>Job: BU# 876326 - Hayden Station</b> Project: <b>18PDVZ1400</b>	
	Client: Crown Castle Code: TIA-222-G Path:	Drawn by: Jack B. Deeken, EI Date: 02/16/18	App'd: Scale: NTS Dwg No. E-1	

Section	1	P12x.5	11.00	A53-B-35	0.7
Section	2	P42x3/8	20.00	A53-B-42	3.3
Section	3	P48x3/8	32.50		6.2
Section	4	P48x1/2	32.50		8.3
Section					18.5
Length (ft)					
Grade					
Weight (K)					

96.0 ft  
85.0 ft  
65.0 ft  
32.5 ft  
0.0 ft

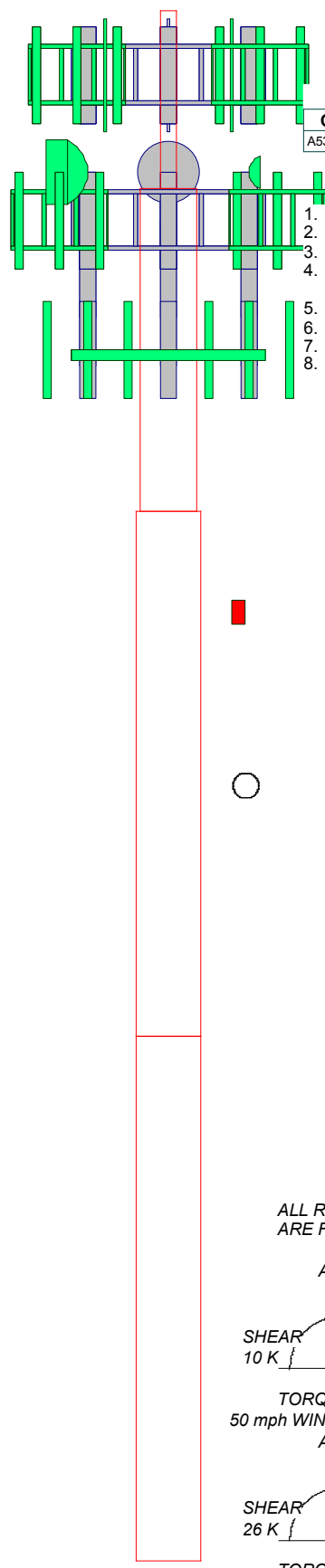

**MATERIAL STRENGTH**

GRADE	Fy	Fu	GRADE	Fy	Fu
A53-B-35	35 ksi	63 ksi	A53-B-42	42 ksi	63 ksi

**TOWER DESIGN NOTES**

1. Tower is located in Hartford County, Connecticut.
2. Tower designed for Exposure C to the TIA-222-G Standard.
3. Tower designed for a 97 mph basic wind in accordance with the TIA-222-G Standard.
4. Tower is also designed for a 50 mph basic wind with 1.00 in ice. Ice is considered to increase in thickness with height.
5. Deflections are based upon a 60 mph wind.
6. Tower Structure Class II.
7. Topographic Category 1 with Crest Height of 0.00 ft
8. TOWER RATING: 59.5%

ALL REACTIONS ARE FACTORED

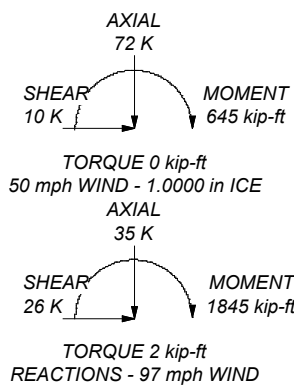

<p>ENGINEERING INNOVATION</p> <p>Tower Analysis</p>	<p><b>FDH Velocitel</b></p> <p>6521 Meridien Drive, Suite 107 Raleigh, North Carolina 27616 Phone: (919) 755-1012 FAX: 9197551031</p>			<p>Job: <b>BU# 876326 - Hayden Station</b></p>		
	<p>Project: <b>18PDVZ1400</b></p>			<p>Client: Crown Castle</p>		<p>Drawn by: Jack B. Deeken, EI</p>
	<p>Code: TIA-222-G</p>			<p>Date: 02/16/18</p>		<p>App'd: NTS</p>
	<p>Path:</p>			<p>Scale: NTS</p>		<p>Dwg No. E-1</p>

## Tower Input Data

There is a pole section.

This tower is designed using the TIA-222-G standard.

The following design criteria apply:

- 4) Tower is located in Hartford County, Connecticut.
- 5) ASCE 7-10 Wind Data is used (wind speeds converted to nominal values).
- 6) Basic wind speed of 97 mph.
- 7) Structure Class II.
- 8) Exposure Category C.
- 9) Topographic Category 1.
- 10) Crest Height 0.00 ft.
- 11) Nominal ice thickness of 1.0000 in.
- 12) Ice thickness is considered to increase with height.
- 13) Ice density of 56 pcf.
- 14) A wind speed of 50 mph is used in combination with ice.
- 15) Temperature drop of 50 °F.
- 16) Deflections calculated using a wind speed of 60 mph.
- 17) A non-linear (P-delta) analysis was used.
- 18) Pressures are calculated at each section.
- 19) Stress ratio used in pole design is 1.
- 20) Local bending stresses due to climbing loads, feed line supports, and appurtenance mounts are not considered.

## Options

Consider Moments - Legs Consider Moments - Horizontals Consider Moments - Diagonals Use Moment Magnification ✓ Use Code Stress Ratios ✓ Use Code Safety Factors - Guys Escalate Ice Always Use Max Kz Use Special Wind Profile  Include Bolts In Member Capacity  Leg Bolts Are At Top Of Section Secondary Horizontal Braces Leg Use Diamond Inner Bracing (4 Sided) SR Members Have Cut Ends SR Members Are Concentric	Distribute Leg Loads As Uniform Assume Legs Pinned ✓ Assume Rigid Index Plate ✓ Use Clear Spans For Wind Area Use Clear Spans For KL/r Retension Guys To Initial Tension ✓ Bypass Mast Stability Checks ✓ Use Azimuth Dish Coefficients ✓ Project Wind Area of Appurt.  Autocalc Torque Arm Areas  Add IBC .6D+W Combination ✓ Sort Capacity Reports By Component Triangulate Diamond Inner Bracing Treat Feed Line Bundles As Cylinder	Use ASCE 10 X-Brace Ly Rules Calculate Redundant Bracing Forces Ignore Redundant Members in FEA SR Leg Bolts Resist Compression All Leg Panels Have Same Allowable Offset Girt At Foundation ✓ Consider Feed Line Torque Include Angle Block Shear Check Use TIA-222-G Bracing Resist. Exemption Use TIA-222-G Tension Splice Exemption  <div style="text-align: center; background-color: #e0e0e0; padding: 2px;"><b>Poles</b></div> ✓ Include Shear-Torsion Interaction Always Use Sub-Critical Flow Use Top Mounted Sockets
--	--	---

## Pole Section Geometry

Section	Elevation ft	Section Length ft	Pole Size	Pole Grade	Socket Length ft
L1	96.00-85.00	11.00	P12x.5	A53-B-35 (35 ksi)	
L2	85.00-65.00	20.00	P42x3/8	A53-B-42 (42 ksi)	
L3	65.00-32.50	32.50	P48x3/8	A53-B-42 (42 ksi)	
L4	32.50-0.00	32.50	P48x1/2	A53-B-42 (42 ksi)	

Tower Elevation	Gusset Area (per face)	Gusset Thickness	Gusset Grade	Adjust. Factor $A_r$	Adjust. Factor $A_r$	Weight Mult.	Double Angle Stitch Bolt Spacing Diagonals	Double Angle Stitch Bolt Spacing Horizontals	Double Angle Stitch Bolt Spacing Redundants
ft	ft <sup>2</sup>	in					in	in	in
L1 96.00-85.00				1	1	1			
L2 85.00-65.00				1	1	1			
L3 65.00-32.50				1	1	1			
L4 32.50-0.00				1	1	1			

**Feed Line/Linear Appurtenances - Entered As Round Or Flat**

Description	Sector	Component Type	Placement	Total Number	Number Per Row	Start/End Position	Width or Diameter	Perimeter	Weight
			ft				in	in	plf
FSJ4-50B(1/2")	A	Surface Ar (CaAa)	83.00 - 0.00	3	3	-0.180 -0.150	0.5200		0.14
HB058-M12-XXXF(5/8")	A	Surface Ar (CaAa)	83.00 - 0.00	1	1	-0.210	0.8400		0.24
HB114-1-08U4-M5J(1-1/4")	A	Surface Ar (CaAa)	83.00 - 0.00	3	3	-0.230 -0.200	1.5400		1.08
2" Rigid Conduit	A	Surface Ar (CaAa)	83.00 - 2.00	2	2	-0.130 -0.100	2.0000		2.80
****									
AVA5-50( 7/8)	B	Surface Ar (CaAa)	75.00 - 2.00	6	6	0.080 0.200	1.1020		0.30
AVA7-50(1-5/8)	B	Surface Ar (CaAa)	75.00 - 2.00	1	1	0.200 0.210	2.0100		0.70

**Feed Line/Linear Appurtenances - Entered As Area**

Description	Face or Leg	Allow Shield	Component Type	Placement	Total Number		$C_{AA}$	Weight
				ft			ft <sup>2</sup> /ft	plf
LDF7-50A(1-5/8")	A	No	Inside Pole	92.00 - 8.00	6	No Ice 1/2" Ice 1" Ice	0.00 0.00 0.00	0.82 0.82 0.82
FB-L98B-002-75000( 3/8")	A	No	Inside Pole	92.00 - 8.00	1	No Ice 1/2" Ice 1" Ice	0.00 0.00 0.00	0.06 0.06 0.06
FB-L98B-002-75000( 3/8")	A	No	Inside Pole	92.00 - 8.00	1	No Ice 1/2" Ice 1" Ice	0.00 0.00 0.00	0.06 0.06 0.06
WR-VG86ST-BRD( 3/4)	A	No	Inside Pole	92.00 - 8.00	2	No Ice 1/2" Ice 1" Ice	0.00 0.00 0.00	0.58 0.58 0.58
WR-VG86ST-BRD( 3/4)	A	No	Inside Pole	92.00 - 8.00	2	No Ice 1/2" Ice 1" Ice	0.00 0.00 0.00	0.58 0.58 0.58
2" Rigid Conduit	A	No	Inside Pole	92.00 - 0.00	1	No Ice 1/2" Ice 1" Ice	0.00 0.00 0.00	2.80 2.80 2.80
*								
ATCB-B01-001(5/16")	A	No	Inside Pole	83.00 - 0.00	6	No Ice 1/2" Ice 1" Ice	0.00 0.00 0.00	0.07 0.07 0.07
LDF4-50A(1/2")	A	No	Inside Pole	83.00 - 0.00	1	No Ice 1/2" Ice 1" Ice	0.00 0.00 0.00	0.15 0.15 0.15
AVA5-50( 7/8)	B	No	Inside Pole	75.00 - 2.00	6	No Ice	0.00	0.30



Description	Face or Leg	Allow Shield	Component Type	Placement ft	Total Number	C <sub>AA</sub> A ft <sup>2</sup> /ft	Weight plf
						1/2" Ice 0.00	0.30
						1" Ice 0.00	0.30

**Feed Line/Linear Appurtenances Section Areas**

Tower Sectio n	Tower Elevation ft	Face	A <sub>R</sub> ft <sup>2</sup>	A <sub>F</sub> ft <sup>2</sup>	C <sub>AA</sub> A In Face ft <sup>2</sup>	C <sub>AA</sub> A Out Face ft <sup>2</sup>	Weight K
L1	96.00-85.00	A	0.000	0.000	0.000	0.000	0.07
		B	0.000	0.000	0.000	0.000	0.00
		C	0.000	0.000	0.000	0.000	0.00
L2	85.00-65.00	A	0.000	0.000	19.836	0.000	0.39
		B	0.000	0.000	8.622	0.000	0.04
		C	0.000	0.000	0.000	0.000	0.00
L3	65.00-32.50	A	0.000	0.000	35.815	0.000	0.66
		B	0.000	0.000	28.022	0.000	0.14
		C	0.000	0.000	0.000	0.000	0.00
L4	32.50-0.00	A	0.000	0.000	35.015	0.000	0.59
		B	0.000	0.000	26.297	0.000	0.13
		C	0.000	0.000	0.000	0.000	0.00

**Feed Line/Linear Appurtenances Section Areas - With Ice**

Tower Sectio n	Tower Elevation ft	Face or Leg	Ice Thickness in	A <sub>R</sub> ft <sup>2</sup>	A <sub>F</sub> ft <sup>2</sup>	C <sub>AA</sub> A In Face ft <sup>2</sup>	C <sub>AA</sub> A Out Face ft <sup>2</sup>	Weight K
L1	96.00-85.00	A	2.212	0.000	0.000	0.000	0.000	0.07
		B		0.000	0.000	0.000	0.000	0.00
		C		0.000	0.000	0.000	0.000	0.00
L2	85.00-65.00	A	2.171	0.000	0.000	61.543	0.000	1.23
		B		0.000	0.000	20.045	0.000	0.34
		C		0.000	0.000	0.000	0.000	0.00
L3	65.00-32.50	A	2.081	0.000	0.000	108.331	0.000	2.10
		B		0.000	0.000	63.826	0.000	1.05
		C		0.000	0.000	0.000	0.000	0.00
L4	32.50-0.00	A	1.868	0.000	0.000	99.823	0.000	1.80
		B		0.000	0.000	56.975	0.000	0.87
		C		0.000	0.000	0.000	0.000	0.00

**Feed Line Center of Pressure**

Section	Elevation ft	CP <sub>x</sub> in	CP <sub>z</sub> in	CP <sub>x</sub> Ice in	CP <sub>z</sub> Ice in
L1	96.00-85.00	0.0000	0.0000	0.0000	0.0000
L2	85.00-65.00	-0.6061	-0.2744	-1.0837	-0.3640
L3	65.00-32.50	-0.2369	-0.3648	-0.6603	-0.4527
L4	32.50-0.00	-0.2705	-0.3513	-0.6822	-0.4376

**Shielding Factor Ka**

Tower Section	Feed Line Record No.	Description	Feed Line Segment Elev.	K <sub>a</sub> No Ice	K <sub>a</sub> Ice

Tower Section	Feed Line Record No.	Description	Feed Line Segment Elev.	K <sub>a</sub> No Ice	K <sub>a</sub> Ice
L2	11	FSJ4-50B(1/2")	65.00 - 83.00	1.0000	1.0000
L2	13	HB058-M12-XXXF(5/8")	65.00 - 83.00	1.0000	1.0000
L2	14	HB114-1-08U4-M5J(1-1/4")	65.00 - 83.00	1.0000	1.0000
L2	15	2" Rigid Conduit	65.00 - 83.00	1.0000	1.0000
L2	17	AVA5-50( 7/8)	65.00 - 75.00	1.0000	1.0000
L2	19	AVA7-50(1-5/8)	65.00 - 75.00	1.0000	1.0000
L3	11	FSJ4-50B(1/2")	32.50 - 65.00	1.0000	1.0000
L3	13	HB058-M12-XXXF(5/8")	32.50 - 65.00	1.0000	1.0000
L3	14	HB114-1-08U4-M5J(1-1/4")	32.50 - 65.00	1.0000	1.0000
L3	15	2" Rigid Conduit	32.50 - 65.00	1.0000	1.0000
L3	17	AVA5-50( 7/8)	32.50 - 65.00	1.0000	1.0000
L3	19	AVA7-50(1-5/8)	32.50 - 65.00	1.0000	1.0000
L4	11	FSJ4-50B(1/2")	0.00 - 32.50	1.0000	1.0000
L4	13	HB058-M12-XXXF(5/8")	0.00 - 32.50	1.0000	1.0000
L4	14	HB114-1-08U4-M5J(1-1/4")	0.00 - 32.50	1.0000	1.0000
L4	15	2" Rigid Conduit	2.00 - 32.50	1.0000	1.0000
L4	17	AVA5-50( 7/8)	2.00 - 32.50	1.0000	1.0000
L4	19	AVA7-50(1-5/8)	2.00 - 32.50	1.0000	1.0000

### Discrete Tower Loads

Description	Face or Leg	Offset Type	Offsets: Horz Lateral	Azimuth Adjustment	Placement	C <sub>AA</sub> Front	C <sub>AA</sub> Side	Weight
			ft ft ft	°	ft	ft <sup>2</sup>	ft <sup>2</sup>	K
*92FT*								
(2) 860 10025	A	From Leg	4.00 0.00 0.00	0.0000	92.00	No Ice 1/2" Ice 1" Ice	0.14 0.20 0.26 0.12 0.17 0.23	0.00 0.00 0.01
(2) 860 10025	B	From Leg	4.00 0.00 0.00	0.0000	92.00	No Ice 1/2" Ice 1" Ice	0.14 0.20 0.26 0.12 0.17 0.23	0.00 0.00 0.01
(2) 860 10025	C	From Leg	4.00 0.00 0.00	0.0000	92.00	No Ice 1/2" Ice 1" Ice	0.14 0.20 0.26 0.12 0.17 0.23	0.00 0.00 0.01
RRUS 32 B2	A	From Leg	4.00 0.00 0.00	0.0000	92.00	No Ice 1/2" Ice 1" Ice	2.76 2.98 3.22 1.69 1.88 2.07	0.05 0.07 0.10
RRUS 32 B2	B	From Leg	4.00 0.00 0.00	0.0000	92.00	No Ice 1/2" Ice 1" Ice	2.76 2.98 3.22 1.69 1.88 2.07	0.05 0.07 0.10

Description	Face or Leg	Offset Type	Offsets:		Azimuth Adjustment	Placement	C <sub>AA</sub> Front	C <sub>AA</sub> Side	Weight
			Horz	Lateral					
			ft	ft	°	ft	ft <sup>2</sup>	ft <sup>2</sup>	K
RRUS 32 B2	C	From Leg	4.00	0.0000	92.00	No Ice	2.76	1.69	0.05
			0.00			1/2"	2.98	1.88	0.07
			0.00			Ice	3.22	2.07	0.10
						1" Ice			
800 10121 w/ Mount Pipe	A	From Leg	4.00	0.0000	92.00	No Ice	5.39	4.60	0.07
			0.00			1/2"	5.81	5.35	0.11
			0.00			Ice	6.23	6.05	0.17
						1" Ice			
800 10121 w/ Mount Pipe	B	From Leg	4.00	0.0000	92.00	No Ice	5.39	4.60	0.07
			0.00			1/2"	5.81	5.35	0.11
			0.00			Ice	6.23	6.05	0.17
						1" Ice			
800 10121 w/ Mount Pipe	C	From Leg	4.00	0.0000	92.00	No Ice	5.39	4.60	0.07
			0.00			1/2"	5.81	5.35	0.11
			0.00			Ice	6.23	6.05	0.17
						1" Ice			
HPA-65R-BUU-H8 w/ Mount Pipe	A	From Leg	4.00	0.0000	92.00	No Ice	12.98	9.18	0.10
			0.00			1/2"	13.56	10.48	0.19
			0.00			Ice	14.15	11.49	0.29
						1" Ice			
HPA-65R-BUU-H8 w/ Mount Pipe	B	From Leg	4.00	0.0000	92.00	No Ice	12.98	9.18	0.10
			0.00			1/2"	13.56	10.48	0.19
			0.00			Ice	14.15	11.49	0.29
						1" Ice			
HPA-65R-BUU-H8 w/ Mount Pipe	C	From Leg	4.00	0.0000	92.00	No Ice	12.98	9.18	0.10
			0.00			1/2"	13.56	10.48	0.19
			0.00			Ice	14.15	11.49	0.29
						1" Ice			
(2) LGP21401	A	From Leg	4.00	0.0000	92.00	No Ice	1.10	0.35	0.01
			0.00			1/2"	1.24	0.44	0.02
			0.00			Ice	1.38	0.54	0.03
						1" Ice			
(2) LGP21401	B	From Leg	4.00	0.0000	92.00	No Ice	1.10	0.35	0.01
			0.00			1/2"	1.24	0.44	0.02
			0.00			Ice	1.38	0.54	0.03
						1" Ice			
(2) LGP21401	C	From Leg	4.00	0.0000	92.00	No Ice	1.10	0.35	0.01
			0.00			1/2"	1.24	0.44	0.02
			0.00			Ice	1.38	0.54	0.03
						1" Ice			
DC6-48-60-18-8F	A	From Leg	4.00	0.0000	92.00	No Ice	1.21	1.21	0.03
			0.00			1/2"	1.89	1.89	0.05
			0.00			Ice	2.11	2.11	0.08
						1" Ice			
RRUS-11	B	From Leg	4.00	0.0000	92.00	No Ice	2.52	1.07	0.06
			0.00			1/2"	2.72	1.21	0.07
			0.00			Ice	2.92	1.36	0.10
						1" Ice			
RRUS-11	C	From Leg	4.00	0.0000	92.00	No Ice	2.52	1.07	0.06
			0.00			1/2"	2.72	1.21	0.07
			0.00			Ice	2.92	1.36	0.10
						1" Ice			
RRUS-11	A	From Leg	4.00	0.0000	92.00	No Ice	2.52	1.07	0.06
			0.00			1/2"	2.72	1.21	0.07
			0.00			Ice	2.92	1.36	0.10
						1" Ice			
DC6-48-60-18-8F	A	From Leg	4.00	0.0000	92.00	No Ice	1.21	1.21	0.03
			0.00			1/2"	1.89	1.89	0.05
			0.00			Ice	2.11	2.11	0.08
						1" Ice			
RRUS 32	A	From Leg	4.00	0.0000	92.00	No Ice	2.86	1.78	0.06
			0.00			1/2"	3.08	1.97	0.08
			0.00			Ice	3.32	2.17	0.10
						1" Ice			
RRUS 32	B	From Leg	4.00	0.0000	92.00	No Ice	2.86	1.78	0.06

Description	Face or Leg	Offset Type	Offsets: Horz Lateral Vert ft ft ft	Azimuth Adjustment t °	Placement ft	C <sub>AA</sub> Front ft <sup>2</sup>	C <sub>AA</sub> Side ft <sup>2</sup>	Weight K	
			0.00			1/2"	3.08	1.97	0.08
			0.00			Ice	3.32	2.17	0.10
RRUS 32	C	From Leg	4.00	0.0000	92.00	1" Ice	2.86	1.78	0.06
			0.00			No Ice	3.08	1.97	0.08
			0.00			1/2"	3.32	2.17	0.10
			0.00			Ice			
			0.00			1" Ice			
TPA-65R-LCUUUU-H8 w/ Mount Pipe	A	From Leg	4.00	0.0000	92.00	No Ice	13.59	11.41	0.13
			0.00			1/2"	14.29	12.94	0.24
			0.00			Ice	14.98	14.29	0.36
			0.00			1" Ice			
TPA-65R-LCUUUU-H8 w/ Mount Pipe	B	From Leg	4.00	0.0000	92.00	No Ice	13.59	11.41	0.13
			0.00			1/2"	14.29	12.94	0.24
			0.00			Ice	14.98	14.29	0.36
			0.00			1" Ice			
TPA-65R-LCUUUU-H8 w/ Mount Pipe	C	From Leg	4.00	0.0000	92.00	No Ice	13.59	11.41	0.13
			0.00			1/2"	14.29	12.94	0.24
			0.00			Ice	14.98	14.29	0.36
			0.00			1" Ice			
Sector Mount [SM 502-3]	C	None		0.0000	92.00	No Ice	33.02	33.02	1.67
						1/2"	47.36	47.36	2.22
						Ice	61.70	61.70	2.77
						1" Ice			
7'x2 1/2" Pipe Mount	A	From Leg	4.00	0.0000	92.00	No Ice	2.01	2.01	0.04
			0.00			1/2"	2.59	2.59	0.06
			0.00			Ice	3.02	3.02	0.07
			0.00			1" Ice			
7'x2 1/2" Pipe Mount	B	From Leg	4.00	0.0000	92.00	No Ice	2.01	2.01	0.04
			0.00			1/2"	2.59	2.59	0.06
			0.00			Ice	3.02	3.02	0.07
			0.00			1" Ice			
7'x2 1/2" Pipe Mount	C	From Leg	4.00	0.0000	92.00	No Ice	2.01	2.01	0.04
			0.00			1/2"	2.59	2.59	0.06
			0.00			Ice	3.02	3.02	0.07
			0.00			1" Ice			
*83FT*						1" Ice			
840 10045 w/ Mount Pipe	A	From Leg	4.00	0.0000	83.00	No Ice	3.58	3.58	0.06
			0.00			1/2"	5.31	5.31	0.11
			-1.00			Ice	6.02	6.02	0.17
			-1.00			1" Ice			
840 10045 w/ Mount Pipe	B	From Leg	4.00	0.0000	83.00	No Ice	3.58	3.58	0.06
			0.00			1/2"	5.31	5.31	0.11
			-1.00			Ice	6.02	6.02	0.17
			-1.00			1" Ice			
840 10045 w/ Mount Pipe	C	From Leg	4.00	0.0000	83.00	No Ice	3.58	3.58	0.06
			0.00			1/2"	5.31	5.31	0.11
			-1.00			Ice	6.02	6.02	0.17
			-1.00			1" Ice			
APXVSP18-C-A20 w/ Mount Pipe	A	From Leg	4.00	0.0000	83.00	No Ice	8.26	7.47	0.09
			0.00			1/2"	8.82	8.66	0.16
			0.00			Ice	9.35	9.56	0.24
			0.00			1" Ice			
APXVSP18-C-A20 w/ Mount Pipe	B	From Leg	4.00	0.0000	83.00	No Ice	8.26	7.47	0.09
			0.00			1/2"	8.82	8.66	0.16
			0.00			Ice	9.35	9.56	0.24
			0.00			1" Ice			
APXVSP18-C-A20 w/ Mount Pipe	C	From Leg	4.00	0.0000	83.00	No Ice	8.26	7.47	0.09
			0.00			1/2"	8.82	8.66	0.16
			0.00			Ice	9.35	9.56	0.24
			0.00			1" Ice			
APXVTM14-C-120 w/ Mount Pipe	A	From Leg	4.00	0.0000	83.00	No Ice	6.58	4.96	0.08
			0.00			1/2"	7.03	5.75	0.13
			0.00			Ice	7.47	6.47	0.19
			0.00			1" Ice			
APXVTM14-C-120 w/ Mount Pipe	B	From Leg	4.00	0.0000	83.00	No Ice	6.58	4.96	0.08

Description	Face or Leg	Offset Type	Offsets: Horz Lateral Vert ft ft ft	Azimuth Adjustment °	Placement ft	C <sub>AA</sub> Front ft <sup>2</sup>	C <sub>AA</sub> Side ft <sup>2</sup>	Weight K
Mount Pipe			0.00 0.00			1/2" 7.03 Ice 7.47	5.75 6.47	0.13 0.19
APXVTM14-C-120 w/ Mount Pipe	C	From Leg	4.00 0.00 0.00	0.0000	83.00	1" Ice No Ice 6.58 1/2" 7.03 Ice 7.47	4.96 5.75 6.47	0.08 0.13 0.19
WIMAX DAP HEAD	A	From Leg	4.00 0.00 0.00	0.0000	83.00	1" Ice No Ice 1.55 1/2" 1.70 Ice 1.87	0.68 0.80 0.92	0.03 0.04 0.06
WIMAX DAP HEAD	B	From Leg	4.00 0.00 0.00	0.0000	83.00	1" Ice No Ice 1.55 1/2" 1.70 Ice 1.87	0.68 0.80 0.92	0.03 0.04 0.06
WIMAX DAP HEAD	C	From Leg	4.00 0.00 0.00	0.0000	83.00	1" Ice No Ice 1.55 1/2" 1.70 Ice 1.87	0.68 0.80 0.92	0.03 0.04 0.06
Horizon DUO	A	From Leg	4.00 0.00 0.00	0.0000	83.00	1" Ice No Ice 0.47 1/2" 0.56 Ice 0.65	0.29 0.37 0.44	0.01 0.01 0.02
Horizon DUO	B	From Leg	4.00 0.00 0.00	0.0000	83.00	1" Ice No Ice 0.47 1/2" 0.56 Ice 0.65	0.29 0.37 0.44	0.01 0.01 0.02
Horizon DUO	C	From Leg	4.00 0.00 0.00	0.0000	83.00	1" Ice No Ice 0.47 1/2" 0.56 Ice 0.65	0.29 0.37 0.44	0.01 0.01 0.02
TD-RRH8x20-25	A	From Leg	4.00 0.00 0.00	0.0000	83.00	1" Ice No Ice 3.70 1/2" 3.95 Ice 4.20	1.29 1.46 1.64	0.07 0.09 0.12
TD-RRH8x20-25	B	From Leg	4.00 0.00 0.00	0.0000	83.00	1" Ice No Ice 3.70 1/2" 3.95 Ice 4.20	1.29 1.46 1.64	0.07 0.09 0.12
TD-RRH8x20-25	C	From Leg	4.00 0.00 0.00	0.0000	83.00	1" Ice No Ice 3.70 1/2" 3.95 Ice 4.20	1.29 1.46 1.64	0.07 0.09 0.12
(2) 4' x 2" Pipe Mount	A	From Leg	4.00 0.00 0.00	0.0000	83.00	1" Ice No Ice 0.79 1/2" 1.03 Ice 1.28	0.79 1.03 1.28	0.03 0.04 0.04
(2) 4' x 2" Pipe Mount	B	From Leg	4.00 0.00 0.00	0.0000	83.00	1" Ice No Ice 0.79 1/2" 1.03 Ice 1.28	0.79 1.03 1.28	0.03 0.04 0.04
(2) 4' x 2" Pipe Mount	C	From Leg	4.00 0.00 0.00	0.0000	83.00	1" Ice No Ice 0.79 1/2" 1.03 Ice 1.28	0.79 1.03 1.28	0.03 0.04 0.04
Platform Mount [LP 502-1]	C	None		0.0000	83.00	1" Ice No Ice 32.35 1/2" 45.67 Ice 58.99 1" Ice	32.35 45.67 58.99	0.93 1.19 1.46
*79FT* 800MHz 2X50W RRH W/FILTER	A	From Leg	1.00 0.00 1.00	0.0000	79.00	No Ice 2.06 1/2" 2.24 Ice 2.43 1" Ice	1.93 2.11 2.29	0.06 0.09 0.11
800MHz 2X50W RRH	B	From Leg	1.00	0.0000	79.00	No Ice 2.06	1.93	0.06

Description	Face or Leg	Offset Type	Offsets: Horz Lateral Vert ft ft ft	Azimuth Adjustment t °	Placement ft	C <sub>AA</sub> Front ft <sup>2</sup>	C <sub>AA</sub> Side ft <sup>2</sup>	Weight K
W/FILTER			0.00 1.00			1/2" Ice 2.24 2.43	2.11 2.29	0.09 0.11
800MHz 2X50W RRH W/FILTER	C	From Leg	1.00 0.00 1.00	0.0000	79.00	1" Ice No Ice 1/2" Ice 2.06 2.24 2.43	1.93 2.11 2.29	0.06 0.09 0.11
PCS 1900MHz 4x45W- 65MHz	A	From Leg	1.00 0.00 -2.00	0.0000	79.00	1" Ice No Ice 1/2" Ice 2.32 2.53 2.74	2.24 2.44 2.65	0.06 0.08 0.11
PCS 1900MHz 4x45W- 65MHz	B	From Leg	1.00 0.00 -2.00	0.0000	79.00	1" Ice No Ice 1/2" Ice 2.32 2.53 2.74	2.24 2.44 2.65	0.06 0.08 0.11
PCS 1900MHz 4x45W- 65MHz	C	From Leg	1.00 0.00 -2.00	0.0000	79.00	1" Ice No Ice 1/2" Ice 2.32 2.53 2.74	2.24 2.44 2.65	0.06 0.08 0.11
4' x 2" Pipe Mount	A	From Leg	1.00 0.00 0.00	0.0000	79.00	1" Ice No Ice 1/2" Ice 0.79 1.03 1.28	0.79 1.03 1.28	0.03 0.04 0.04
4' x 2" Pipe Mount	B	From Leg	1.00 0.00 0.00	0.0000	79.00	1" Ice No Ice 1/2" Ice 0.79 1.03 1.28	0.79 1.03 1.28	0.03 0.04 0.04
4' x 2" Pipe Mount	C	From Leg	1.00 0.00 0.00	0.0000	79.00	1" Ice No Ice 1/2" Ice 0.79 1.03 1.28	0.79 1.03 1.28	0.03 0.04 0.04
Side Arm Mount [SO 104- 3]	C	None		0.0000	79.00	1" Ice No Ice 1/2" Ice 3.30 4.13 4.96	3.30 4.13 4.96	0.29 0.32 0.35
*75FT*						1" Ice		
ERICSSON AIR 21 B2A B4P w/ Mount Pipe	A	From Leg	4.00 0.00 0.00	0.0000	75.00	1" Ice No Ice 1/2" Ice 6.33 6.78 7.21	5.64 6.43 7.13	0.11 0.17 0.23
ERICSSON AIR 21 B2A B4P w/ Mount Pipe	B	From Leg	4.00 0.00 0.00	0.0000	75.00	1" Ice No Ice 1/2" Ice 6.33 6.78 7.21	5.64 6.43 7.13	0.11 0.17 0.23
ERICSSON AIR 21 B2A B4P w/ Mount Pipe	C	From Leg	4.00 0.00 0.00	0.0000	75.00	1" Ice No Ice 1/2" Ice 6.33 6.78 7.21	5.64 6.43 7.13	0.11 0.17 0.23
ERICSSON AIR 21 B4A B2P w/ Mount Pipe	A	From Leg	4.00 0.00 0.00	0.0000	75.00	1" Ice No Ice 1/2" Ice 6.33 6.78 7.21	5.64 6.43 7.13	0.11 0.17 0.23
ERICSSON AIR 21 B4A B2P w/ Mount Pipe	B	From Leg	4.00 0.00 0.00	0.0000	75.00	1" Ice No Ice 1/2" Ice 6.33 6.78 7.21	5.64 6.43 7.13	0.11 0.17 0.23
ERICSSON AIR 21 B4A B2P w/ Mount Pipe	C	From Leg	4.00 0.00 0.00	0.0000	75.00	1" Ice No Ice 1/2" Ice 6.33 6.78 7.21	5.64 6.43 7.13	0.11 0.17 0.23
KRY 112 144/1	A	From Leg	4.00 0.00 0.00	0.0000	75.00	1" Ice No Ice 1/2" Ice 0.35 0.43 0.51	0.16 0.22 0.28	0.01 0.01 0.02
KRY 112 144/1	B	From Leg	4.00	0.0000	75.00	1" Ice No Ice 0.35	0.16	0.01

Description	Face or Leg	Offset Type	Offsets:		Azimuth Adjustment	Placement	C <sub>AA</sub> <sub>Front</sub>	C <sub>AA</sub> <sub>Side</sub>	Weight	
			Horz Lateral	Vert						ft
				0.00			1/2"	0.43	0.22	0.01
				0.00			Ice	0.51	0.28	0.02
							1" Ice			
KRY 112 144/1	C	From Leg	4.00	0.0000	75.00	No Ice	0.35	0.16	0.01	
			0.00			1/2"	0.43	0.22	0.01	
			0.00			Ice	0.51	0.28	0.02	
						1" Ice				
LNX-6515DS-A1M w/ Mount Pipe	A	From Leg	4.00	0.0000	75.00	No Ice	11.78	10.85	0.12	
			0.00			1/2"	12.50	12.32	0.22	
			0.00			Ice	13.18	13.46	0.33	
						1" Ice				
LNX-6515DS-A1M w/ Mount Pipe	B	From Leg	4.00	0.0000	75.00	No Ice	11.78	10.85	0.12	
			0.00			1/2"	12.50	12.32	0.22	
			0.00			Ice	13.18	13.46	0.33	
						1" Ice				
LNX-6515DS-A1M w/ Mount Pipe	C	From Leg	4.00	0.0000	75.00	No Ice	11.78	10.85	0.12	
			0.00			1/2"	12.50	12.32	0.22	
			0.00			Ice	13.18	13.46	0.33	
						1" Ice				
RRUS 11 B12	A	From Leg	4.00	0.0000	75.00	No Ice	2.83	1.18	0.05	
			0.00			1/2"	3.04	1.33	0.07	
			0.00			Ice	3.26	1.48	0.10	
						1" Ice				
RRUS 11 B12	B	From Leg	4.00	0.0000	75.00	No Ice	2.83	1.18	0.05	
			0.00			1/2"	3.04	1.33	0.07	
			0.00			Ice	3.26	1.48	0.10	
						1" Ice				
RRUS 11 B12	C	From Leg	4.00	0.0000	75.00	No Ice	2.83	1.18	0.05	
			0.00			1/2"	3.04	1.33	0.07	
			0.00			Ice	3.26	1.48	0.10	
						1" Ice				
Platform Mount [LP 303-1]	C	None		0.0000	75.00	No Ice	14.66	14.66	1.25	
						1/2"	18.87	18.87	1.48	
						Ice	23.08	23.08	1.71	
						1" Ice				
*57FT* GPS_A	B	From Leg	3.00	0.0000	57.00	No Ice	0.26	0.26	0.00	
			0.00			1/2"	0.32	0.32	0.00	
			1.00			Ice	0.39	0.39	0.01	
						1" Ice				
4.5' x 2" horizontal mount pipe	B	From Leg	0.00	0.0000	57.00	No Ice	0.90	0.90	0.03	
			0.00			1/2"	1.21	1.21	0.04	
			0.00			Ice	1.49	1.49	0.05	
						1" Ice				
*****										

### Dishes

Description	Face or Leg	Dish Type	Offset Type	Offsets:		Azimuth Adjustment	3 dB Beam Width	Elevation	Outside Diameter	Aperture Area	Weight	
				Horz Lateral	Vert							ft
A-ANT-11G-4-C	A	Paraboloid w/Shroud (HP)	From Leg	4.00	-5.0000			83.00	3.92	No Ice	14.08	0.12
				0.00						1/2" Ice	14.63	0.20
				3.00						1" Ice	15.19	0.27
VHLP2-180	B	Paraboloid w/o Radome	From Leg	4.00	-35.0000			83.00	2.00	No Ice	3.14	0.03
				0.00						1/2" Ice	3.41	0.04
				3.00						1" Ice	3.68	0.06

Description	Face or Leg	Dish Type	Offset Type	Offsets: Horz Lateral Vert ft	Azimuth Adjustment °	3 dB Beam Width °	Elevation ft	Outside Diameter ft	Aperture Area ft <sup>2</sup>	Weight K	
A-ANT-11G-4-C	C	Paraboloid w/Shroud (HP)	From Leg	4.00 0.00 3.00	25.0000		83.00	3.92	No Ice 1/2" Ice 1" Ice	14.08 14.63 15.19	0.12 0.20 0.27
***											

## Load Combinations

Comb. No.	Description
1	Dead Only
2	1.2 Dead+1.6 Wind 0 deg - No Ice
3	0.9 Dead+1.6 Wind 0 deg - No Ice
4	1.2 Dead+1.6 Wind 30 deg - No Ice
5	0.9 Dead+1.6 Wind 30 deg - No Ice
6	1.2 Dead+1.6 Wind 60 deg - No Ice
7	0.9 Dead+1.6 Wind 60 deg - No Ice
8	1.2 Dead+1.6 Wind 90 deg - No Ice
9	0.9 Dead+1.6 Wind 90 deg - No Ice
10	1.2 Dead+1.6 Wind 120 deg - No Ice
11	0.9 Dead+1.6 Wind 120 deg - No Ice
12	1.2 Dead+1.6 Wind 150 deg - No Ice
13	0.9 Dead+1.6 Wind 150 deg - No Ice
14	1.2 Dead+1.6 Wind 180 deg - No Ice
15	0.9 Dead+1.6 Wind 180 deg - No Ice
16	1.2 Dead+1.6 Wind 210 deg - No Ice
17	0.9 Dead+1.6 Wind 210 deg - No Ice
18	1.2 Dead+1.6 Wind 240 deg - No Ice
19	0.9 Dead+1.6 Wind 240 deg - No Ice
20	1.2 Dead+1.6 Wind 270 deg - No Ice
21	0.9 Dead+1.6 Wind 270 deg - No Ice
22	1.2 Dead+1.6 Wind 300 deg - No Ice
23	0.9 Dead+1.6 Wind 300 deg - No Ice
24	1.2 Dead+1.6 Wind 330 deg - No Ice
25	0.9 Dead+1.6 Wind 330 deg - No Ice
26	1.2 Dead+1.0 Ice+1.0 Temp
27	1.2 Dead+1.0 Wind 0 deg+1.0 Ice+1.0 Temp
28	1.2 Dead+1.0 Wind 30 deg+1.0 Ice+1.0 Temp
29	1.2 Dead+1.0 Wind 60 deg+1.0 Ice+1.0 Temp
30	1.2 Dead+1.0 Wind 90 deg+1.0 Ice+1.0 Temp
31	1.2 Dead+1.0 Wind 120 deg+1.0 Ice+1.0 Temp
32	1.2 Dead+1.0 Wind 150 deg+1.0 Ice+1.0 Temp
33	1.2 Dead+1.0 Wind 180 deg+1.0 Ice+1.0 Temp
34	1.2 Dead+1.0 Wind 210 deg+1.0 Ice+1.0 Temp
35	1.2 Dead+1.0 Wind 240 deg+1.0 Ice+1.0 Temp
36	1.2 Dead+1.0 Wind 270 deg+1.0 Ice+1.0 Temp
37	1.2 Dead+1.0 Wind 300 deg+1.0 Ice+1.0 Temp
38	1.2 Dead+1.0 Wind 330 deg+1.0 Ice+1.0 Temp
39	Dead+Wind 0 deg - Service
40	Dead+Wind 30 deg - Service
41	Dead+Wind 60 deg - Service
42	Dead+Wind 90 deg - Service
43	Dead+Wind 120 deg - Service
44	Dead+Wind 150 deg - Service
45	Dead+Wind 180 deg - Service
46	Dead+Wind 210 deg - Service
47	Dead+Wind 240 deg - Service
48	Dead+Wind 270 deg - Service
49	Dead+Wind 300 deg - Service
50	Dead+Wind 330 deg - Service

## Maximum Member Forces



Section No.	Elevation ft	Component Type	Condition	Gov. Load Comb.	Axial K	Major Axis Moment kip-ft	Minor Axis Moment kip-ft
L1	96 - 85	Pole	Max Tension	14	0.00	-0.00	-0.00
			Max. Compression	26	-14.97	1.47	2.32
			Max. Mx	20	-5.11	49.18	0.63
			Max. My	2	-5.11	0.38	49.14
			Max. Vy	8	8.30	-48.42	0.59
			Max. Vx	14	8.22	0.54	-48.19
L2	85 - 65	Pole	Max. Torque	24			1.80
			Max Tension	1	0.00	0.00	0.00
			Max. Compression	26	-40.30	2.80	2.79
			Max. Mx	8	-15.81	-359.65	1.18
			Max. My	14	-15.81	3.50	-359.12
			Max. Vy	8	19.16	-359.65	1.18
L3	65 - 32.5	Pole	Max. Vx	14	19.18	3.50	-359.12
			Max. Torque	24			1.80
			Max Tension	1	0.00	0.00	0.00
			Max. Compression	26	-55.30	4.11	3.63
			Max. Mx	8	-24.34	-1039.82	2.16
			Max. My	14	-24.33	8.29	-1047.35
L4	32.5 - 0	Pole	Max. Vy	8	22.61	-1039.82	2.16
			Max. Vx	14	23.05	8.29	-1047.35
			Max. Torque	24			1.80
			Max Tension	1	0.00	0.00	0.00
			Max. Compression	26	-71.71	5.57	4.48
			Max. Mx	8	-35.35	-1817.37	3.16
			Max. My	14	-35.35	13.10	-1844.67
			Max. Vy	8	25.16	-1817.37	3.16
			Max. Vx	14	25.90	13.10	-1844.67
			Max. Torque	24			1.73

### Maximum Reactions

Location	Condition	Gov. Load Comb.	Vertical K	Horizontal, X K	Horizontal, Z K
Pole	Max. Vert	26	71.71	-0.00	-0.00
	Max. H <sub>x</sub>	21	26.52	25.06	0.07
	Max. H <sub>z</sub>	3	26.52	-0.02	25.69
	Max. M <sub>x</sub>	2	1829.74	-0.02	25.69
	Max. M <sub>z</sub>	8	1817.37	-25.14	0.02
	Max. Torsion	24	1.73	12.71	21.50
	Min. Vert	15	26.52	0.13	-25.89
	Min. H <sub>x</sub>	9	26.52	-25.14	0.02
	Min. H <sub>z</sub>	15	26.52	0.13	-25.89
	Min. M <sub>x</sub>	14	-1844.67	0.13	-25.89
	Min. M <sub>z</sub>	20	-1814.06	25.06	0.07
	Min. Torsion	12	-1.06	-12.72	-21.66

### Tower Mast Reaction Summary

Load Combination	Vertical K	Shear <sub>x</sub> K	Shear <sub>z</sub> K	Overtuning Moment, M <sub>x</sub> kip-ft	Overtuning Moment, M <sub>z</sub> kip-ft	Torque kip-ft
Dead Only	29.47	-0.00	-0.00	-0.83	1.46	0.00
1.2 Dead+1.6 Wind 0 deg - No Ice	35.36	0.02	-25.69	-1829.74	0.02	-1.31
0.9 Dead+1.6 Wind 0 deg - No Ice	26.52	0.02	-25.69	-1824.33	-0.43	-1.31
1.2 Dead+1.6 Wind 30 deg - No Ice	35.36	12.68	-21.55	-1557.21	-916.87	0.27
0.9 Dead+1.6 Wind 30 deg - No Ice	26.52	12.68	-21.55	-1552.53	-914.71	0.28

Load Combination	Vertical K	Shear <sub>x</sub> K	Shear <sub>z</sub> K	Overturning Moment, M <sub>x</sub> kip-ft	Overturning Moment, M <sub>z</sub> kip-ft	Torque kip-ft
No Ice						
1.2 Dead+1.6 Wind 60 deg - No Ice	35.36	21.77	-12.59	-911.91	-1573.61	-0.19
0.9 Dead+1.6 Wind 60 deg - No Ice	26.52	21.77	-12.59	-909.07	-1569.58	-0.18
1.2 Dead+1.6 Wind 90 deg - No Ice	35.36	25.14	-0.02	-3.16	-1817.37	-0.40
0.9 Dead+1.6 Wind 90 deg - No Ice	26.52	25.14	-0.02	-2.90	-1812.66	-0.39
1.2 Dead+1.6 Wind 120 deg - No Ice	35.36	21.75	12.69	918.83	-1571.86	0.50
0.9 Dead+1.6 Wind 120 deg - No Ice	26.52	21.75	12.69	916.47	-1567.83	0.51
1.2 Dead+1.6 Wind 150 deg - No Ice	35.36	12.72	21.66	1564.33	-920.99	1.06
0.9 Dead+1.6 Wind 150 deg - No Ice	26.52	12.72	21.66	1560.14	-918.81	1.06
1.2 Dead+1.6 Wind 180 deg - No Ice	35.36	-0.13	25.89	1844.67	13.10	1.01
0.9 Dead+1.6 Wind 180 deg - No Ice	26.52	-0.13	25.89	1839.71	12.62	1.00
1.2 Dead+1.6 Wind 210 deg - No Ice	35.36	-12.73	21.71	1568.39	924.75	0.01
0.9 Dead+1.6 Wind 210 deg - No Ice	26.52	-12.73	21.71	1564.19	921.68	0.00
1.2 Dead+1.6 Wind 240 deg - No Ice	35.36	-21.66	12.62	912.35	1566.91	0.14
0.9 Dead+1.6 Wind 240 deg - No Ice	26.52	-21.66	12.62	910.01	1562.02	0.13
1.2 Dead+1.6 Wind 270 deg - No Ice	35.36	-25.06	-0.07	-6.94	1814.06	0.51
0.9 Dead+1.6 Wind 270 deg - No Ice	26.52	-25.06	-0.07	-6.66	1808.48	0.51
1.2 Dead+1.6 Wind 300 deg - No Ice	35.36	-21.73	-12.43	-897.87	1573.49	-0.64
0.9 Dead+1.6 Wind 300 deg - No Ice	26.52	-21.73	-12.43	-895.07	1568.58	-0.64
1.2 Dead+1.6 Wind 330 deg - No Ice	35.36	-12.71	-21.50	-1552.91	923.80	-1.73
0.9 Dead+1.6 Wind 330 deg - No Ice	26.52	-12.71	-21.50	-1548.25	920.73	-1.73
1.2 Dead+1.0 Ice+1.0 Temp	71.71	0.00	0.00	-4.48	5.57	0.00
1.2 Dead+1.0 Wind 0 deg+1.0 Ice+1.0 Temp	71.71	0.00	-9.47	-645.08	5.28	-0.23
1.2 Dead+1.0 Wind 30 deg+1.0 Ice+1.0 Temp	71.71	4.03	-6.91	-500.72	-284.78	0.04
1.2 Dead+1.0 Wind 60 deg+1.0 Ice+1.0 Temp	71.71	6.95	-4.02	-293.56	-494.34	-0.08
1.2 Dead+1.0 Wind 90 deg+1.0 Ice+1.0 Temp	71.71	8.03	-0.00	-5.04	-571.75	-0.14
1.2 Dead+1.0 Wind 120 deg+1.0 Ice+1.0 Temp	71.71	6.95	4.03	286.10	-493.95	0.02
1.2 Dead+1.0 Wind 150 deg+1.0 Ice+1.0 Temp	71.71	4.04	6.93	493.28	-285.63	0.15
1.2 Dead+1.0 Wind 180 deg+1.0 Ice+1.0 Temp	71.71	-0.03	9.51	639.24	8.12	0.17
1.2 Dead+1.0 Wind 210 deg+1.0 Ice+1.0 Temp	71.71	-4.05	6.93	494.04	297.62	0.00
1.2 Dead+1.0 Wind 240 deg+1.0 Ice+1.0 Temp	71.71	-6.93	4.02	284.69	504.08	0.07
1.2 Dead+1.0 Wind 270 deg+1.0 Ice+1.0 Temp	71.71	-8.01	-0.01	-5.71	582.06	0.15
1.2 Dead+1.0 Wind 300 deg+1.0 Ice+1.0 Temp	71.71	-6.95	-3.98	-290.52	505.39	-0.07
1.2 Dead+1.0 Wind 330 deg+1.0 Ice+1.0 Temp	71.71	-4.05	-6.89	-499.74	297.39	-0.30
Dead+Wind 0 deg - Service	29.47	0.00	-5.50	-391.38	1.10	-0.28
Dead+Wind 30 deg - Service	29.47	2.71	-4.61	-333.17	-194.71	0.06
Dead+Wind 60 deg - Service	29.47	4.66	-2.69	-195.36	-334.96	-0.04

Load Combination	Vertical	Shear <sub>x</sub>	Shear <sub>z</sub>	Overturning Moment, M <sub>x</sub>	Overturning Moment, M <sub>z</sub>	Torque
	K	K	K	kip-ft	kip-ft	kip-ft
Dead+Wind 90 deg - Service	29.47	5.38	-0.01	-1.30	-387.02	-0.08
Dead+Wind 120 deg - Service	29.47	4.65	2.71	195.60	-334.58	0.11
Dead+Wind 150 deg - Service	29.47	2.72	4.63	333.45	-195.59	0.23
Dead+Wind 180 deg - Service	29.47	-0.03	5.54	393.33	3.89	0.22
Dead+Wind 210 deg - Service	29.47	-2.72	4.64	334.32	198.58	0.00
Dead+Wind 240 deg - Service	29.47	-4.63	2.70	194.22	335.72	0.03
Dead+Wind 270 deg - Service	29.47	-5.36	-0.01	-2.10	388.50	0.11
Dead+Wind 300 deg - Service	29.47	-4.65	-2.66	-192.37	337.12	-0.14
Dead+Wind 330 deg - Service	29.47	-2.72	-4.60	-332.25	198.38	-0.37

## Solution Summary

Load Comb.	Sum of Applied Forces			Sum of Reactions			% Error
	PX K	PY K	PZ K	PX K	PY K	PZ K	
1	0.00	-29.47	0.00	0.00	29.47	0.00	0.000%
2	0.02	-35.36	-25.69	-0.02	35.36	25.69	0.001%
3	0.02	-26.52	-25.69	-0.02	26.52	25.69	0.001%
4	12.68	-35.36	-21.55	-12.68	35.36	21.55	0.000%
5	12.68	-26.52	-21.55	-12.68	26.52	21.55	0.000%
6	21.77	-35.36	-12.59	-21.77	35.36	12.59	0.000%
7	21.77	-26.52	-12.59	-21.77	26.52	12.59	0.000%
8	25.14	-35.36	-0.02	-25.14	35.36	0.02	0.001%
9	25.14	-26.52	-0.02	-25.14	26.52	0.02	0.001%
10	21.75	-35.36	12.69	-21.75	35.36	-12.69	0.000%
11	21.75	-26.52	12.69	-21.75	26.52	-12.69	0.000%
12	12.72	-35.36	21.66	-12.72	35.36	-21.66	0.000%
13	12.72	-26.52	21.66	-12.72	26.52	-21.66	0.000%
14	-0.13	-35.36	25.89	0.13	35.36	-25.89	0.001%
15	-0.13	-26.52	25.89	0.13	26.52	-25.89	0.001%
16	-12.73	-35.36	21.71	12.73	35.36	-21.71	0.000%
17	-12.73	-26.52	21.71	12.73	26.52	-21.71	0.000%
18	-21.66	-35.36	12.62	21.66	35.36	-12.62	0.000%
19	-21.66	-26.52	12.62	21.66	26.52	-12.62	0.000%
20	-25.07	-35.36	-0.07	25.06	35.36	0.07	0.001%
21	-25.07	-26.52	-0.07	25.06	26.52	0.07	0.001%
22	-21.73	-35.36	-12.43	21.73	35.36	12.43	0.000%
23	-21.73	-26.52	-12.43	21.73	26.52	12.43	0.000%
24	-12.71	-35.36	-21.50	12.71	35.36	21.50	0.000%
25	-12.71	-26.52	-21.50	12.71	26.52	21.50	0.000%
26	0.00	-71.71	0.00	-0.00	71.71	-0.00	0.000%
27	0.00	-71.71	-9.47	-0.00	71.71	9.47	0.000%
28	4.03	-71.71	-6.91	-4.03	71.71	6.91	0.000%
29	6.95	-71.71	-4.02	-6.95	71.71	4.02	0.000%
30	8.03	-71.71	-0.00	-8.03	71.71	0.00	0.000%
31	6.95	-71.71	4.03	-6.95	71.71	-4.03	0.000%
32	4.04	-71.71	6.93	-4.04	71.71	-6.93	0.000%
33	-0.03	-71.71	9.51	0.03	71.71	-9.51	0.000%
34	-4.05	-71.71	6.93	4.05	71.71	-6.93	0.000%
35	-6.93	-71.71	4.02	6.93	71.71	-4.02	0.000%
36	-8.01	-71.71	-0.01	8.01	71.71	0.01	0.000%
37	-6.95	-71.71	-3.98	6.95	71.71	3.98	0.000%
38	-4.05	-71.71	-6.89	4.05	71.71	6.89	0.000%
39	0.00	-29.47	-5.50	-0.00	29.47	5.50	0.001%
40	2.71	-29.47	-4.61	-2.71	29.47	4.61	0.001%
41	4.66	-29.47	-2.69	-4.66	29.47	2.69	0.001%
42	5.38	-29.47	-0.01	-5.38	29.47	0.01	0.001%
43	4.65	-29.47	2.72	-4.65	29.47	-2.71	0.001%

Load Comb.	Sum of Applied Forces			Sum of Reactions			% Error
	PX K	PY K	PZ K	PX K	PY K	PZ K	
44	2.72	-29.47	4.63	-2.72	29.47	-4.63	0.001%
45	-0.03	-29.47	5.54	0.03	29.47	-5.54	0.001%
46	-2.72	-29.47	4.64	2.72	29.47	-4.64	0.001%
47	-4.63	-29.47	2.70	4.63	29.47	-2.70	0.001%
48	-5.36	-29.47	-0.01	5.36	29.47	0.01	0.001%
49	-4.65	-29.47	-2.66	4.65	29.47	2.66	0.001%
50	-2.72	-29.47	-4.60	2.72	29.47	4.60	0.001%

### Non-Linear Convergence Results

Load Combination	Converged?	Number of Cycles	Displacement Tolerance	Force Tolerance
1	Yes	6	0.00000001	0.00000001
2	Yes	9	0.00000001	0.00010416
3	Yes	9	0.00000001	0.00008850
4	Yes	10	0.00000001	0.00009792
5	Yes	10	0.00000001	0.00008032
6	Yes	10	0.00000001	0.00009875
7	Yes	10	0.00000001	0.00008086
8	Yes	9	0.00000001	0.00004794
9	Yes	9	0.00000001	0.00004236
10	Yes	10	0.00000001	0.00010204
11	Yes	10	0.00000001	0.00008373
12	Yes	10	0.00000001	0.00008915
13	Yes	10	0.00000001	0.00007289
14	Yes	9	0.00000001	0.00009011
15	Yes	9	0.00000001	0.00007670
16	Yes	10	0.00000001	0.00009824
17	Yes	10	0.00000001	0.00008036
18	Yes	10	0.00000001	0.00009466
19	Yes	10	0.00000001	0.00007750
20	Yes	9	0.00000001	0.00005531
21	Yes	9	0.00000001	0.00004827
22	Yes	10	0.00000001	0.00008978
23	Yes	10	0.00000001	0.00007331
24	Yes	10	0.00000001	0.00011478
25	Yes	10	0.00000001	0.00009443
26	Yes	6	0.00000001	0.00001167
27	Yes	10	0.00000001	0.00012848
28	Yes	10	0.00000001	0.00012193
29	Yes	10	0.00000001	0.00012168
30	Yes	10	0.00000001	0.00011631
31	Yes	10	0.00000001	0.00012006
32	Yes	10	0.00000001	0.00011980
33	Yes	10	0.00000001	0.00012643
34	Yes	10	0.00000001	0.00012197
35	Yes	10	0.00000001	0.00012236
36	Yes	10	0.00000001	0.00011906
37	Yes	10	0.00000001	0.00012391
38	Yes	10	0.00000001	0.00012389
39	Yes	8	0.00000001	0.00005353
40	Yes	8	0.00000001	0.00004749
41	Yes	8	0.00000001	0.00004763
42	Yes	8	0.00000001	0.00005043
43	Yes	8	0.00000001	0.00004850
44	Yes	8	0.00000001	0.00004683
45	Yes	8	0.00000001	0.00005254
46	Yes	8	0.00000001	0.00004723
47	Yes	8	0.00000001	0.00004686
48	Yes	8	0.00000001	0.00005090
49	Yes	8	0.00000001	0.00004666
50	Yes	8	0.00000001	0.00005540

### Maximum Tower Deflections - Service Wind

Section No.	Elevation ft	Horz. Deflection in	Gov. Load Comb.	Tilt °	Twist °
L1	96 - 85	3.342	45	0.2705	0.0009
L2	85 - 65	2.737	45	0.2413	0.0005
L3	65 - 32.5	1.758	45	0.2204	0.0003
L4	32.5 - 0	0.501	45	0.1347	0.0001

### Critical Deflections and Radius of Curvature - Service Wind

Elevation ft	Appurtenance	Gov. Load Comb.	Deflection in	Tilt °	Twist °	Radius of Curvature ft
92.00	(2) 860 10025	45	3.119	0.2584	0.0008	46088
86.00	A-ANT-11G-4-C	45	2.791	0.2432	0.0008	24501
83.00	840 10045 w/ Mount Pipe	45	2.632	0.2381	0.0007	23122
79.00	800MHz 2X50W RRH W/FILTER	45	2.428	0.2331	0.0007	26616
75.00	ERICSSON AIR 21 B2A B4P w/ Mount Pipe	45	2.230	0.2294	0.0006	32458
57.00	GPS_A	45	1.397	0.2073	0.0004	31238

### Maximum Tower Deflections - Design Wind

Section No.	Elevation ft	Horz. Deflection in	Gov. Load Comb.	Tilt °	Twist °
L1	96 - 85	15.696	14	1.2631	0.0044
L2	85 - 65	12.849	14	1.1338	0.0022
L3	65 - 32.5	8.248	14	1.0346	0.0014
L4	32.5 - 0	2.350	14	0.6319	0.0006

### Critical Deflections and Radius of Curvature - Design Wind

Elevation ft	Appurtenance	Gov. Load Comb.	Deflection in	Tilt °	Twist °	Radius of Curvature ft
92.00	(2) 860 10025	14	14.644	1.2108	0.0039	10211
86.00	A-ANT-11G-4-C	14	13.100	1.1429	0.0036	5426
83.00	840 10045 w/ Mount Pipe	14	12.355	1.1179	0.0034	5114
79.00	800MHz 2X50W RRH W/FILTER	14	11.394	1.0938	0.0032	5867
75.00	ERICSSON AIR 21 B2A B4P w/ Mount Pipe	14	10.466	1.0766	0.0029	7119
57.00	GPS_A	14	6.554	0.9733	0.0019	6699

### Compression Checks

### Pole Design Data

Section No.	Elevation ft	Size	L ft	L <sub>u</sub> ft	Kl/r	A in <sup>2</sup>	P <sub>u</sub> K	φP <sub>n</sub> K	Ratio $\frac{P_u}{\phi P_n}$
L1	96 - 95	P12x.5	11.00	0.00	0.0	19.242	-0.13	606.13	0.000 <sup>1</sup>
						3			
	95 - 94					19.242	-0.17	606.13	0.000
						3			
	94 - 93					19.242	-0.26	606.13	0.000
						3			
	93 - 92					19.242	-0.34	606.13	0.001
						3			
	92 - 91					19.242	-4.28	606.13	0.007
						3			
	91 - 90					19.242	-4.37	606.13	0.007
	3								
90 - 89	19.242	-4.46	606.13	0.007					
	3								
89 - 88	19.242	-4.54	606.13	0.007					
	3								
88 - 87	19.242	-4.63	606.13	0.008					
	3								
87 - 86	19.242	-4.72	606.13	0.008					
	3								
86 - 85	19.242	-5.11	606.13	0.008					
	3								
L2	85 - 84	P42x3/8	20.00	0.00	0.0	49.038	-5.33	1668.87	0.003
						3			
	84 - 83					49.038	-5.56	1668.87	0.003
						3			
	83 - 82					49.038	-8.24	1668.87	0.005
						3			
	82 - 81					49.038	-8.46	1668.87	0.005
						3			
	81 - 80					49.038	-8.69	1668.87	0.005
						3			
	80 - 79					49.038	-8.91	1668.87	0.005
						3			
	79 - 78					49.038	-10.01	1668.87	0.006
						3			
	78 - 77					49.038	-10.23	1668.87	0.006
						3			
	77 - 76					49.038	-10.45	1668.87	0.006
	3								
76 - 75	49.038	-10.68	1668.87	0.006					
	3								
75 - 74	49.038	-13.77	1668.87	0.008					
	3								
74 - 73	49.038	-14.00	1668.87	0.008					
	3								
73 - 72	49.038	-14.22	1668.87	0.009					
	3								
72 - 71	49.038	-14.45	1668.87	0.009					
	3								
71 - 70	49.038	-14.68	1668.87	0.009					
	3								
70 - 69	49.038	-14.90	1668.87	0.009					
	3								
69 - 68	49.038	-15.13	1668.87	0.009					
	3								
68 - 67	49.038	-15.36	1668.87	0.009					
	3								
67 - 66	49.038	-15.58	1668.87	0.009					
	3								
66 - 65	49.038	-15.81	1668.87	0.009					
	3								
L3	65 - 63.375	P48x3/8	32.50	0.00	0.0	56.106	-16.23	1847.49	0.009
						9			
	63.375 - 61.75					56.106	-16.65	1847.49	0.009
						9			
	61.75 - 60.125					56.106	-17.07	1847.49	0.009
	9								
60.125 - 58.5	56.106	-17.49	1847.49	0.009					
	9								

Section No.	Elevation ft	Size	L ft	L <sub>u</sub> ft	Kl/r	A in <sup>2</sup>	P <sub>u</sub> K	φP <sub>n</sub> K	Ratio $\frac{P_u}{\phi P_n}$
	58.5 - 56.875					9 56.106	-17.95	1847.49	0.010
	56.875 - 55.25					9 56.106	-18.37	1847.49	0.010
	55.25 - 53.625					9 56.106	-18.80	1847.49	0.010
	53.625 - 52					9 56.106	-19.22	1847.49	0.010
	52 - 50.375					9 56.106	-19.64	1847.49	0.011
	50.375 - 48.75					9 56.106	-20.06	1847.49	0.011
	48.75 - 47.125					9 56.106	-20.49	1847.49	0.011
	47.125 - 45.5					9 56.106	-20.91	1847.49	0.011
	45.5 - 43.875					9 56.106	-21.34	1847.49	0.012
	43.875 - 42.25					9 56.106	-21.76	1847.49	0.012
	42.25 - 40.625					9 56.106	-22.19	1847.49	0.012
	40.625 - 39					9 56.106	-22.62	1847.49	0.012
	39 - 37.375					9 56.106	-23.05	1847.49	0.012
	37.375 - 35.75					9 56.106	-23.48	1847.49	0.013
	35.75 - 34.125					9 56.106	-23.91	1847.49	0.013
	34.125 - 32.5					9 56.106	-24.33	1847.49	0.013
L4	32.5 - 30.875	P48x1/2	32.50	0.00	0.0	8 74.612	-24.88	2649.06	0.009
	30.875 - 29.25					8 74.612	-25.43	2649.06	0.010
	29.25 - 27.625					8 74.612	-25.97	2649.06	0.010
	27.625 - 26					8 74.612	-26.52	2649.06	0.010
	26 - 24.375					8 74.612	-27.07	2649.06	0.010
	24.375 - 22.75					8 74.612	-27.62	2649.06	0.010
	22.75 - 21.125					8 74.612	-28.17	2649.06	0.011
	21.125 - 19.5					8 74.612	-28.72	2649.06	0.011
	19.5 - 17.875					8 74.612	-29.27	2649.06	0.011
	17.875 - 16.25					8 74.612	-29.82	2649.06	0.011
	16.25 - 14.625					8 74.612	-30.37	2649.06	0.011
	14.625 - 13					8 74.612	-30.92	2649.06	0.012
	13 - 11.375					8 74.612	-31.47	2649.06	0.012
	11.375 - 9.75					8 74.612	-32.02	2649.06	0.012
	9.75 - 8.125					8 74.612	-32.58	2649.06	0.012
	8.125 - 6.5					8 74.612	-33.13	2649.06	0.013
	6.5 - 4.875					8 74.612	-33.68	2649.06	0.013
	4.875 - 3.25					8 74.612	-34.24	2649.06	0.013

Section No.	Elevation ft	Size	L ft	L <sub>u</sub> ft	KI/r	A in <sup>2</sup>	P <sub>u</sub> K	φP <sub>n</sub> K	Ratio $\frac{P_u}{\phi P_n}$
	3.25 - 1.625					74.6128	-34.79	2649.06	0.013
	1.625 - 0					74.6128	-35.35	2649.06	0.013

<sup>1</sup> P<sub>u</sub> / φP<sub>n</sub> controls

### Pole Bending Design Data

Section No.	Elevation ft	Size	M <sub>ux</sub> kip-ft	φM <sub>nx</sub> kip-ft	Ratio $\frac{M_{ux}}{\phi M_{nx}}$	M <sub>uy</sub> kip-ft	φM <sub>ny</sub> kip-ft	Ratio $\frac{M_{uy}}{\phi M_{ny}}$		
L1	96 - 95	P12x.5	0.01	197.07	0.000	0.00	197.07	0.000		
	95 - 94		0.07	197.07	0.000	0.00	197.07	0.000		
	94 - 93		0.15	197.07	0.001	0.00	197.07	0.000		
	93 - 92		0.27	197.07	0.001	0.00	197.07	0.000		
	92 - 91		7.23	197.07	0.037	0.00	197.07	0.000		
	91 - 90		13.89	197.07	0.071	0.00	197.07	0.000		
	90 - 89		20.59	197.07	0.104	0.00	197.07	0.000		
	89 - 88		27.32	197.07	0.139	0.00	197.07	0.000		
	88 - 87		34.09	197.07	0.173	0.00	197.07	0.000		
	87 - 86		40.88	197.07	0.207	0.00	197.07	0.000		
	86 - 85		49.38	197.07	0.251	0.00	197.07	0.000		
	L2		85 - 84	P42x3/8	57.64	1796.56	0.032	0.00	1796.56	0.000
			84 - 83		66.00	1796.56	0.037	0.00	1796.56	0.000
			83 - 82		78.37	1796.56	0.044	0.00	1796.56	0.000
82 - 81		91.25	1796.56		0.051	0.00	1796.56	0.000		
81 - 80		104.25	1796.56		0.058	0.00	1796.56	0.000		
80 - 79		117.34	1796.56		0.065	0.00	1796.56	0.000		
79 - 78		131.04	1796.56		0.073	0.00	1796.56	0.000		
78 - 77		145.22	1796.56		0.081	0.00	1796.56	0.000		
77 - 76		159.52	1796.56		0.089	0.00	1796.56	0.000		
76 - 75		173.91	1796.56		0.097	0.00	1796.56	0.000		
75 - 74		192.12	1796.56		0.107	0.00	1796.56	0.000		
74 - 73		210.42	1796.56		0.117	0.00	1796.56	0.000		
73 - 72		228.83	1796.56		0.127	0.00	1796.56	0.000		
72 - 71		247.34	1796.56		0.138	0.00	1796.56	0.000		
71 - 70		265.96	1796.56		0.148	0.00	1796.56	0.000		
70 - 69		284.68	1796.56		0.158	0.00	1796.56	0.000		
69 - 68		303.50	1796.56		0.169	0.00	1796.56	0.000		
68 - 67		322.43	1796.56		0.179	0.00	1796.56	0.000		
67 - 66		341.45	1796.56		0.190	0.00	1796.56	0.000		
66 - 65		360.58	1796.56		0.201	0.00	1796.56	0.000		
L3	65 - 63.375	P48x3/8	391.90	2321.11	0.169	0.00	2321.11	0.000		
	63.375 - 61.75		423.51	2321.11	0.182	0.00	2321.11	0.000		
	61.75 - 60.125		455.42	2321.11	0.196	0.00	2321.11	0.000		
	60.125 - 58.5		487.62	2321.11	0.210	0.00	2321.11	0.000		
	58.5 - 56.875		520.13	2321.11	0.224	0.00	2321.11	0.000		
	56.875 - 55.25		552.99	2321.11	0.238	0.00	2321.11	0.000		
	55.25 - 53.625		586.14	2321.11	0.253	0.00	2321.11	0.000		
	53.625 - 52		619.57	2321.11	0.267	0.00	2321.11	0.000		
	52 - 50.375		653.27	2321.11	0.281	0.00	2321.11	0.000		
	50.375 - 48.75		687.59	2321.11	0.296	0.00	2321.11	0.000		
	48.75 - 47.125		722.22	2321.11	0.311	0.00	2321.11	0.000		
	47.125 - 45.5		757.16	2321.11	0.326	0.00	2321.11	0.000		
	45.5 - 43.875		792.40	2321.11	0.341	0.00	2321.11	0.000		
	43.875 - 42.25		827.94	2321.11	0.357	0.00	2321.11	0.000		



Section No.	Elevation ft	Size	$M_{ux}$	$\phi M_{nx}$	Ratio	$M_{uy}$	$\phi M_{ny}$	Ratio
			kip-ft	kip-ft	$\frac{M_{ux}}{\phi M_{nx}}$	kip-ft	kip-ft	$\frac{M_{uy}}{\phi M_{ny}}$
L4	42.25 - 40.625	P48x1/2	863.79	2321.11	0.372	0.00	2321.11	0.000
	40.625 - 39		899.92	2321.11	0.388	0.00	2321.11	0.000
	39 - 37.375		936.36	2321.11	0.403	0.00	2321.11	0.000
	37.375 - 35.75		973.08	2321.11	0.419	0.00	2321.11	0.000
	35.75 - 34.125		1010.09	2321.11	0.435	0.00	2321.11	0.000
	34.125 - 32.5		1047.38	2321.11	0.451	0.00	2321.11	0.000
	32.5 - 30.875		1084.96	3173.47	0.342	0.00	3173.47	0.000
	30.875 - 29.25		1122.78	3173.47	0.354	0.00	3173.47	0.000
	29.25 - 27.625		1160.88	3173.47	0.366	0.00	3173.47	0.000
	27.625 - 26		1199.22	3173.47	0.378	0.00	3173.47	0.000
	26 - 24.375		1237.82	3173.47	0.390	0.00	3173.47	0.000
	24.375 - 22.75		1276.67	3173.47	0.402	0.00	3173.47	0.000
	22.75 - 21.125		1315.76	3173.47	0.415	0.00	3173.47	0.000
	21.125 - 19.5		1355.10	3173.47	0.427	0.00	3173.47	0.000
	19.5 - 17.875		1394.68	3173.47	0.439	0.00	3173.47	0.000
	17.875 - 16.25		1434.48	3173.47	0.452	0.00	3173.47	0.000
	16.25 - 14.625		1474.53	3173.47	0.465	0.00	3173.47	0.000
	14.625 - 13		1514.79	3173.47	0.477	0.00	3173.47	0.000
	13 - 11.375		1555.29	3173.47	0.490	0.00	3173.47	0.000
	11.375 - 9.75		1596.01	3173.47	0.503	0.00	3173.47	0.000
	9.75 - 8.125		1636.93	3173.47	0.516	0.00	3173.47	0.000
	8.125 - 6.5		1678.08	3173.47	0.529	0.00	3173.47	0.000
	6.5 - 4.875		1719.43	3173.47	0.542	0.00	3173.47	0.000
	4.875 - 3.25		1761.00	3173.47	0.555	0.00	3173.47	0.000
3.25 - 1.625	1802.76	3173.47	0.568	0.00	3173.47	0.000		
1.625 - 0	1844.72	3173.47	0.581	0.00	3173.47	0.000		

### Pole Shear Design Data

Section No.	Elevation ft	Size	Actual	$\phi V_n$	Ratio	Actual	$\phi T_n$	Ratio		
			$V_u$ K	K	$\frac{V_u}{\phi V_n}$	$T_u$ kip-ft	kip-ft	$\frac{T_u}{\phi T_n}$		
L1	96 - 95	P12x.5	0.02	303.07	0.000	0.00	297.74	0.000		
	95 - 94		0.07	303.07	0.000	0.00	297.74	0.000		
	94 - 93		0.10	303.07	0.000	0.00	297.74	0.000		
	93 - 92		0.13	303.07	0.000	0.00	297.74	0.000		
	92 - 91		6.65	303.07	0.022	0.00	297.74	0.000		
	91 - 90		6.68	303.07	0.022	0.00	297.74	0.000		
	90 - 89		6.72	303.07	0.022	0.00	297.74	0.000		
	89 - 88		6.75	303.07	0.022	0.00	297.74	0.000		
	88 - 87		6.78	303.07	0.022	0.00	297.74	0.000		
	87 - 86		6.81	303.07	0.022	0.00	297.74	0.000		
	86 - 85		8.14	303.07	0.027	1.80	297.74	0.006		
	L2		85 - 84	P42x3/8	8.30	834.44	0.010	0.64	2868.84	0.000
			84 - 83		8.40	834.44	0.010	0.64	2868.84	0.000
			83 - 82		12.82	834.44	0.015	0.64	2868.84	0.000
82 - 81		12.93	834.44		0.015	0.64	2868.84	0.000		
81 - 80		13.03	834.44		0.016	0.64	2868.84	0.000		
80 - 79		13.13	834.44		0.016	0.64	2868.84	0.000		
79 - 78		14.04	834.44		0.017	0.58	2868.84	0.000		
78 - 77		14.24	834.44		0.017	0.13	2868.84	0.000		
77 - 76		14.34	834.44		0.017	0.13	2868.84	0.000		
76 - 75		14.45	834.44		0.017	0.13	2868.84	0.000		
75 - 74	18.25	834.44	0.022	0.13	2868.84	0.000				
74 - 73	18.36	834.44	0.022	0.13	2868.84	0.000				
73 - 72	18.46	834.44	0.022	0.13	2868.84	0.000				

Section No.	Elevation ft	Size	Actual $V_u$ K	$\phi V_n$ K	Ratio $V_u$ $\phi V_n$	Actual $T_u$ kip-ft	$\phi T_n$ kip-ft	Ratio $T_u$ $\phi T_n$
	72 - 71		18.56	834.44	0.022	0.13	2868.84	0.000
	71 - 70		18.67	834.44	0.022	0.13	2868.84	0.000
	70 - 69		18.77	834.44	0.022	0.13	2868.84	0.000
	69 - 68		18.87	834.44	0.023	0.13	2868.84	0.000
	68 - 67		18.97	834.44	0.023	0.13	2868.84	0.000
	67 - 66		19.08	834.44	0.023	0.13	2868.84	0.000
	66 - 65		19.18	834.44	0.023	0.13	2868.84	0.000
L3	65 - 63.375	P48x3/8	19.36	923.75	0.021	0.13	3637.70	0.000
	63.375 - 61.75		19.54	923.75	0.021	0.13	3637.70	0.000
	61.75 - 60.125		19.73	923.75	0.021	0.13	3637.70	0.000
	60.125 - 58.5		19.91	923.75	0.022	0.13	3637.70	0.000
	58.5 - 56.875		20.13	923.75	0.022	0.13	3637.70	0.000
	56.875 - 55.25		20.31	923.75	0.022	0.01	3637.70	0.000
	55.25 - 53.625		20.49	923.75	0.022	0.01	3637.70	0.000
	53.625 - 52		20.66	923.75	0.022	0.01	3637.70	0.000
	52 - 50.375		21.03	923.75	0.023	1.01	3637.70	0.000
	50.375 - 48.75		21.23	923.75	0.023	1.01	3637.70	0.000
	48.75 - 47.125		21.42	923.75	0.023	1.01	3637.70	0.000
	47.125 - 45.5		21.60	923.75	0.023	1.01	3637.70	0.000
	45.5 - 43.875		21.79	923.75	0.024	1.01	3637.70	0.000
	43.875 - 42.25		21.98	923.75	0.024	1.01	3637.70	0.000
	42.25 - 40.625		22.16	923.75	0.024	1.01	3637.70	0.000
	40.625 - 39		22.34	923.75	0.024	1.01	3637.70	0.000
	39 - 37.375		22.52	923.75	0.024	1.01	3637.70	0.000
	37.375 - 35.75		22.70	923.75	0.025	1.01	3637.70	0.000
	35.75 - 34.125		22.88	923.75	0.025	1.01	3637.70	0.000
L4	34.125 - 32.5	P48x1/2	23.05	923.75	0.025	1.01	3637.70	0.000
	32.5 - 30.875		23.21	1324.53	0.018	1.01	5188.89	0.000
	30.875 - 29.25		23.37	1324.53	0.018	1.01	5188.89	0.000
	29.25 - 27.625		23.53	1324.53	0.018	1.01	5188.89	0.000
	27.625 - 26		23.69	1324.53	0.018	1.01	5188.89	0.000
	26 - 24.375		23.84	1324.53	0.018	1.01	5188.89	0.000
	24.375 - 22.75		23.99	1324.53	0.018	1.01	5188.89	0.000
	22.75 - 21.125		24.15	1324.53	0.018	1.01	5188.89	0.000
	21.125 - 19.5		24.29	1324.53	0.018	1.01	5188.89	0.000
	19.5 - 17.875		24.44	1324.53	0.018	1.01	5188.89	0.000
	17.875 - 16.25		24.58	1324.53	0.019	1.01	5188.89	0.000
	16.25 - 14.625		24.73	1324.53	0.019	1.01	5188.89	0.000
	14.625 - 13		24.87	1324.53	0.019	1.01	5188.89	0.000
	13 - 11.375		25.00	1324.53	0.019	1.01	5188.89	0.000
	11.375 - 9.75		25.14	1324.53	0.019	1.01	5188.89	0.000
	9.75 - 8.125		25.27	1324.53	0.019	1.01	5188.89	0.000
	8.125 - 6.5		25.40	1324.53	0.019	1.01	5188.89	0.000
	6.5 - 4.875		25.53	1324.53	0.019	1.01	5188.89	0.000
	4.875 - 3.25		25.65	1324.53	0.019	1.01	5188.89	0.000
	3.25 - 1.625		25.78	1324.53	0.019	1.01	5188.89	0.000
	1.625 - 0		25.90	1324.53	0.020	1.01	5188.89	0.000

### Pole Interaction Design Data

Section No.	Elevation ft	Ratio	Ratio	Ratio	Ratio	Ratio	Comb. Stress Ratio	Allow. Stress Ratio	Criteria	
		$P_u$	$M_{ux}$	$M_{uy}$	$V_u$	$T_u$				
		$\phi P_n$	$\phi M_{nx}$	$\phi M_{ny}$	$\phi V_n$	$\phi T_n$				
L1	96 - 95	0.000	0.000	0.000	0.000	0.000	0.000	1.000	4.8.2	
	95 - 94	0.000	0.000	0.000	0.000	0.000	0.001	1.000	4.8.2	
	94 - 93	0.000	0.001	0.000	0.000	0.000	0.001	1.000	4.8.2	
	93 - 92	0.001	0.001	0.000	0.000	0.000	0.002	1.000	4.8.2	
	92 - 91	0.007	0.037	0.000	0.022	0.000	0.044	1.000	4.8.2	
	91 - 90	0.007	0.071	0.000	0.022	0.000	0.078	1.000	4.8.2	
	90 - 89	0.007	0.104	0.000	0.022	0.000	0.112	1.000	4.8.2	
	89 - 88	0.007	0.139	0.000	0.022	0.000	0.147	1.000	4.8.2	
	88 - 87	0.008	0.173	0.000	0.022	0.000	0.181	1.000	4.8.2	
	87 - 86	0.008	0.207	0.000	0.022	0.000	0.216	1.000	4.8.2	
	86 - 85	0.008	0.251	0.000	0.027	0.006	0.260	1.000	4.8.2	
	L2	85 - 84	0.003	0.032	0.000	0.010	0.000	0.035	1.000	4.8.2
		84 - 83	0.003	0.037	0.000	0.010	0.000	0.040	1.000	4.8.2
		83 - 82	0.005	0.044	0.000	0.015	0.000	0.049	1.000	4.8.2
82 - 81		0.005	0.051	0.000	0.015	0.000	0.056	1.000	4.8.2	
81 - 80		0.005	0.058	0.000	0.016	0.000	0.063	1.000	4.8.2	
80 - 79		0.005	0.065	0.000	0.016	0.000	0.071	1.000	4.8.2	
79 - 78		0.006	0.073	0.000	0.017	0.000	0.079	1.000	4.8.2	
78 - 77		0.006	0.081	0.000	0.017	0.000	0.087	1.000	4.8.2	
77 - 76		0.006	0.089	0.000	0.017	0.000	0.095	1.000	4.8.2	
76 - 75		0.006	0.097	0.000	0.017	0.000	0.104	1.000	4.8.2	
75 - 74		0.008	0.107	0.000	0.022	0.000	0.116	1.000	4.8.2	
74 - 73		0.008	0.117	0.000	0.022	0.000	0.126	1.000	4.8.2	
73 - 72		0.009	0.127	0.000	0.022	0.000	0.136	1.000	4.8.2	
72 - 71		0.009	0.138	0.000	0.022	0.000	0.147	1.000	4.8.2	
71 - 70		0.009	0.148	0.000	0.022	0.000	0.157	1.000	4.8.2	
70 - 69		0.009	0.158	0.000	0.022	0.000	0.168	1.000	4.8.2	
69 - 68		0.009	0.169	0.000	0.023	0.000	0.179	1.000	4.8.2	
68 - 67	0.009	0.179	0.000	0.023	0.000	0.189	1.000	4.8.2		
67 - 66	0.009	0.190	0.000	0.023	0.000	0.200	1.000	4.8.2		
66 - 65	0.009	0.201	0.000	0.023	0.000	0.211	1.000	4.8.2		
L3	65 - 63.375	0.009	0.169	0.000	0.021	0.000	0.178	1.000	4.8.2	
	63.375 - 61.75	0.009	0.182	0.000	0.021	0.000	0.192	1.000	4.8.2	
	61.75 - 60.125	0.009	0.196	0.000	0.021	0.000	0.206	1.000	4.8.2	
	60.125 - 58.5	0.009	0.210	0.000	0.022	0.000	0.220	1.000	4.8.2	
	58.5 - 56.875	0.010	0.224	0.000	0.022	0.000	0.234	1.000	4.8.2	
	56.875 - 55.25	0.010	0.238	0.000	0.022	0.000	0.249	1.000	4.8.2	
	55.25 - 53.625	0.010	0.253	0.000	0.022	0.000	0.263	1.000	4.8.2	
	53.625 - 52	0.010	0.267	0.000	0.022	0.000	0.278	1.000	4.8.2	
	52 - 50.375	0.011	0.281	0.000	0.023	0.000	0.293	1.000	4.8.2	
	50.375 - 48.75	0.011	0.296	0.000	0.023	0.000	0.308	1.000	4.8.2	
	48.75 - 47.125	0.011	0.311	0.000	0.023	0.000	0.323	1.000	4.8.2	
	47.125 - 45.5	0.011	0.326	0.000	0.023	0.000	0.338	1.000	4.8.2	
	45.5 - 43.875	0.012	0.341	0.000	0.024	0.000	0.354	1.000	4.8.2	
	43.875 - 42.25	0.012	0.357	0.000	0.024	0.000	0.369	1.000	4.8.2	
	42.25 - 40.625	0.012	0.372	0.000	0.024	0.000	0.385	1.000	4.8.2	
	40.625 - 39	0.012	0.388	0.000	0.024	0.000	0.401	1.000	4.8.2	
	39 - 37.375	0.012	0.403	0.000	0.024	0.000	0.416	1.000	4.8.2	
37.375 - 35.75	0.013	0.419	0.000	0.025	0.000	0.433	1.000	4.8.2		
35.75 - 34.125	0.013	0.435	0.000	0.025	0.000	0.449	1.000	4.8.2		
34.125 - 32.5	0.013	0.451	0.000	0.025	0.000	0.465	1.000	4.8.2		
L4	32.5 - 30.875	0.009	0.342	0.000	0.018	0.000	0.352	1.000	4.8.2	
	30.875 - 29.25	0.010	0.354	0.000	0.018	0.000	0.364	1.000	4.8.2	
	29.25 - 27.625	0.010	0.366	0.000	0.018	0.000	0.376	1.000	4.8.2	
	27.625									

Section No.	Elevation ft	Ratio	Ratio	Ratio	Ratio	Ratio	Comb. Stress Ratio	Allow. Stress Ratio	Criteria
		$P_u$	$M_{ux}$	$M_{uy}$	$V_u$	$T_u$			
		$\phi P_n$	$\phi M_{nx}$	$\phi M_{ny}$	$\phi V_n$	$\phi T_n$			
	27.625 - 26	0.010	0.378	0.000	0.018	0.000	0.388	1.000	4.8.2
	26 - 24.375	0.010	0.390	0.000	0.018	0.000	0.401	1.000	4.8.2
	24.375 - 22.75	0.010	0.402	0.000	0.018	0.000	0.413	1.000	4.8.2
	22.75 - 21.125	0.011	0.415	0.000	0.018	0.000	0.426	1.000	4.8.2
	21.125 - 19.5	0.011	0.427	0.000	0.018	0.000	0.438	1.000	4.8.2
	19.5 - 17.875	0.011	0.439	0.000	0.018	0.000	0.451	1.000	4.8.2
	17.875 - 16.25	0.011	0.452	0.000	0.019	0.000	0.464	1.000	4.8.2
	16.25 - 14.625	0.011	0.465	0.000	0.019	0.000	0.476	1.000	4.8.2
	14.625 - 13	0.012	0.477	0.000	0.019	0.000	0.489	1.000	4.8.2
	13 - 11.375	0.012	0.490	0.000	0.019	0.000	0.502	1.000	4.8.2
	11.375 - 9.75	0.012	0.503	0.000	0.019	0.000	0.515	1.000	4.8.2
	9.75 - 8.125	0.012	0.516	0.000	0.019	0.000	0.528	1.000	4.8.2
	8.125 - 6.5	0.013	0.529	0.000	0.019	0.000	0.542	1.000	4.8.2
	6.5 - 4.875	0.013	0.542	0.000	0.019	0.000	0.555	1.000	4.8.2
	4.875 - 3.25	0.013	0.555	0.000	0.019	0.000	0.568	1.000	4.8.2
	3.25 - 1.625	0.013	0.568	0.000	0.019	0.000	0.582	1.000	4.8.2
	1.625 - 0	0.013	0.581	0.000	0.020	0.000	0.595	1.000	4.8.2

<sup>1</sup>  $P_u / \phi P_n$  controls

### Section Capacity Table

Section No.	Elevation ft	Component Type	Size	Critical Element	P K	$\phi P_{allow}$ K	% Capacity	Pass Fail	
L1	96 - 85	Pole	P12x.5	1	-5.11	606.13	26.0	Pass	
L2	85 - 65	Pole	P42x3/8	2	-15.81	1668.87	21.1	Pass	
L3	65 - 32.5	Pole	P48x3/8	3	-24.33	1847.49	46.5	Pass	
L4	32.5 - 0	Pole	P48x1/2	4	-35.35	2649.06	59.5	Pass	
							Summary		
							Pole (L4)	59.5	Pass
							<b>RATING =</b>	<b>59.5</b>	<b>Pass</b>

**APPENDIX B**  
**BASE LEVEL DRAWING**

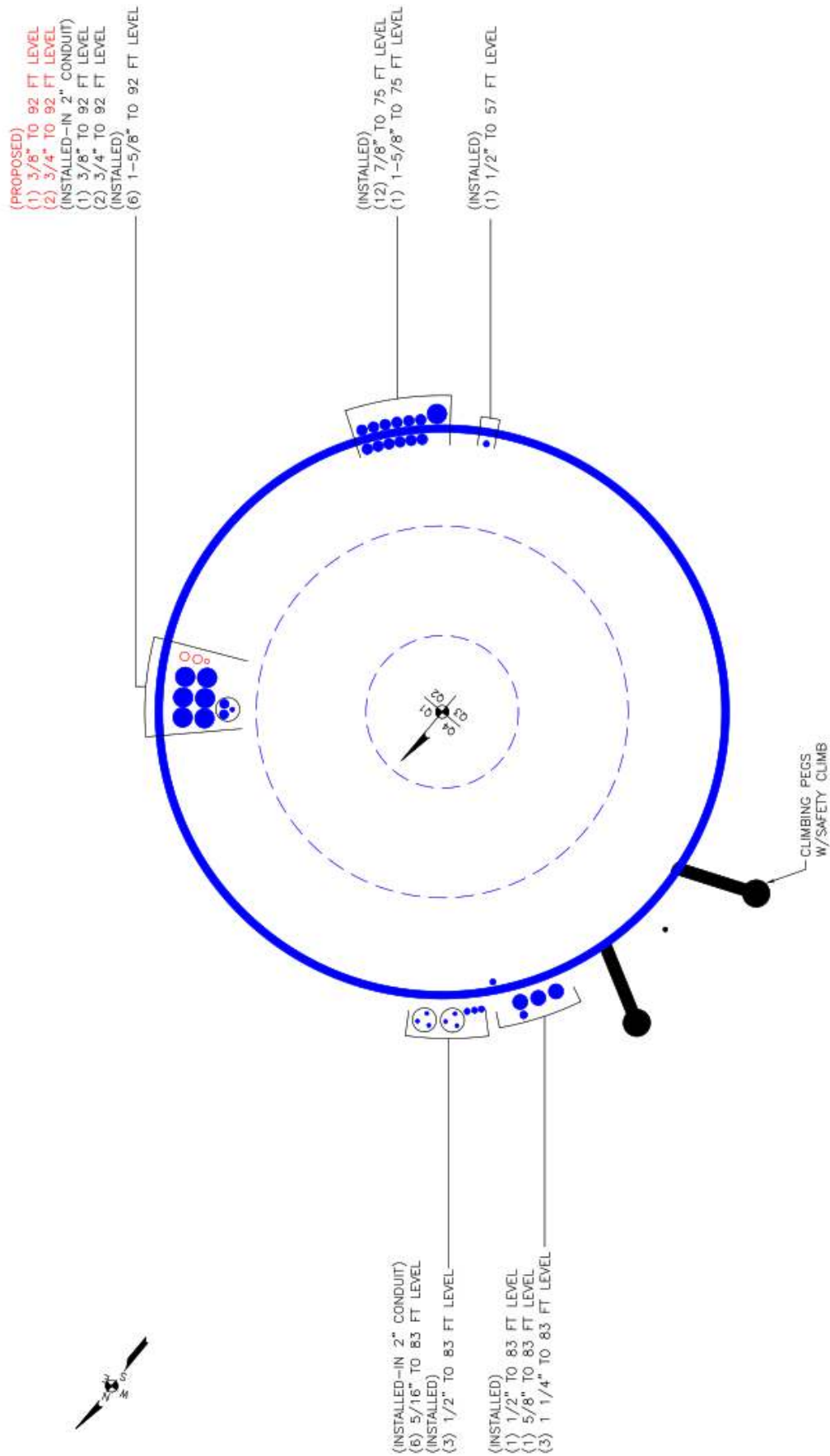

**APPENDIX C**  
**ADDITIONAL CALCULATIONS**

## Stiffened or Unstiffened, UngROUTED, Circular Base Plate - Any Rod Material

**TIA Rev G** Assumption: Clear space between bottom of leveling nut and top of concrete **not** exceeding (1)\*(Rod Diameter)

### Site Data

BU#: 876326
Site Name: Hayden Station
App #: 18PDVZ1400
Pole Manufacturer: <b>Other</b>

### Anchor Rod Data

Qty:	20	
Diam:	1.5	in
Rod Material:	Other	
Strength (Fu):	109	ksi
Yield (Fy):	125	ksi
Bolt Circle:	53.5	in

### Plate Data

Diam:	59	in
Thick:	2	in
Grade:	36	ksi
Single-Rod B-eff:	7.54	in

### Stiffener Data (Welding at both sides)

Config:	0	*
Weld Type:		
Groove Depth:		<-- Disregard
Groove Angle:		<-- Disregard
Fillet H. Weld:		in
Fillet V. Weld:		in
Width:		in
Height:		in
Thick:		in
Notch:		in
Grade:		ksi
Weld str.:		ksi

### Pole Data

Diam:	48	in
Thick:	0.5	in
Grade:	42	ksi
# of Sides:	0	"0" IF Round
Fu	63	ksi
Reinf. Fillet Weld	0	"0" if None

### Reactions

Mu:	1845	ft-kips
Axial, Pu:	35	kips
Shear, Vu:	26	kips
Eta Factor, η	0.5	TIA G (Fig. 4-4)

If No stiffeners, Criteria: **AISC LRFD** <-Only Applicable to Unstiffened Cases

### Anchor Rod Results

Max Rod (Cu+ Vu/η): 87.1 Kips  
 Allowable Axial, Φ\*Fu\*Anet: 123.0 Kips  
 Anchor Rod Stress Ratio: 70.8% **Pass**

Rigid
AISC LRFD
φ*Tn

### Base Plate Results

Base Plate Stress: 19.7 ksi  
 Allowable Plate Stress: 32.4 ksi  
 Base Plate Stress Ratio: 60.7% **Pass**

### Flexural Check

Rigid
AISC LRFD
φ*Fy
Y.L. Length:
23.63

**n/a**

### Stiffener Results

Horizontal Weld : n/a  
 Vertical Weld: n/a  
 Plate Flex+Shear, fb/Fb+(fv/Fv)^2: n/a  
 Plate Tension+Shear, ft/Ft+(fv/Fv)^2: n/a  
 Plate Comp. (AISC Bracket): n/a

### Pole Results

Pole Punching Shear Check: n/a

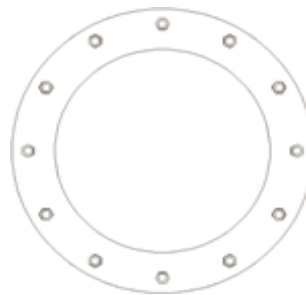

\* 0 = none, 1 = every bolt, 2 = every 2 bolts, 3 = 2 per bolt

\*\* Note: for complete joint penetration groove welds the groove depth must be exactly 1/2 the stiffener thickness for calculation purposes



# Stiffened or Unstiffened, Exterior Flange Plate - Any Bolt Material TIA Rev G

Site Data	
BU#:	876326
Site Name:	Hayden Station
App #:	18PDVZ1400

Reactions		
Mu	1047.39	ft-kips
Axial, Pu:	24.33	kips
Shear, Vu:	23.05	kips
Elevation:	32.5	feet

Bolt Threads:
X-Excluded
$\phi V_n = \phi(0.55 \cdot A_b \cdot F_u)$
$\phi = 0.75, \phi \cdot V_n$ (kips):
76.54

Pole Manufacturer:	Other
--------------------	-------

If No stiffeners, Criteria: **TIA G** <-Only Applicable to Unstiffened Cases

Bolt Data			
Qty:	20		
Diameter (in.):	1.5	Bolt Fu:	105
Bolt Material:	A325	Bolt Fy:	81
N/A:	100	<-- Disregard	
N/A:	75	<-- Disregard	
Circle (in.):	53.5		

Flange Bolt Results	
Bolt Tension Capacity, $\phi \cdot T_n, B1$ :	111.04 kips
Adjusted $\phi \cdot T_n$ (due to $V_u = V_u / Q_t$ ), <b>B</b> :	111.02 kips
Max Bolt <u>directly</u> applied $T_u$ :	45.77 Kips
Min. PL "tc" for <b>B</b> cap. <b>w/o Pry</b> :	1.501 in
Min PL "treq" for actual <b>T w/ Pry</b> :	0.720 in
Min PL "t1" for actual <b>T w/o Pry</b> :	0.964 in
T allowable w/o Prying:	111.04 kips
Prying Force, q:	0.00 kips
Total Bolt Tension= $T_u + q$ :	45.77 kips
Non-Prying Bolt Stress Ratio, $T_u / B$ :	41.2% <b>Pass</b>

Rigid
$\phi \cdot T_n$
$\phi T_n [1 - (V_u / \phi V_n)^2]^{0.5}$

Plate Data		
Diam:	59	in
Thick, t:	2	in
Grade (Fy):	36	ksi
Strength, Fu:	58	ksi
Single-Rod B-eff:	7.54	in

Exterior Flange Plate Results	
Flexural Check	
Compression Side Plate Stress:	10.5 ksi
Allowable Plate Stress:	32.4 ksi
Compression Plate Stress Ratio:	32.3% <b>Pass</b>
<b>No Prying</b>	
Tension Side Stress Ratio, $(t_{req} / t)^2$ :	13.0% <b>Pass</b>

$\alpha' < 0$  case

Rigid
TIA G
$\phi \cdot F_y$
Comp. Y.L. Length:
23.63

Stiffener Data (Welding at Both Sides)		
Config:	0	*
Weld Type:		
Groove Depth:		<-- Disregard
Groove Angle:		<-- Disregard
Fillet H. Weld:		in
Fillet V. Weld:		in
Width:		in
Height:		in
Thick:		in
Notch:		in
Grade:		ksi
Weld str.:		ksi

**n/a**

Stiffener Results	
Horizontal Weld :	n/a
Vertical Weld:	n/a
Plate Flex+Shear, $f_b / F_b + (f_v / F_v)^2$ :	n/a
Plate Tension+Shear, $f_t / F_t + (f_v / F_v)^2$ :	n/a
Plate Comp. (AISC Bracket):	n/a
<b>Pole Results</b>	
Pole Punching Shear Check:	n/a

Pole Data		
Diam:	48	in
Thick:	0.375	in
Grade:	42	ksi
# of Sides:	0	"0" IF Round
Fu	63	ksi
Reinf. Fillet Weld	0	"0" if None

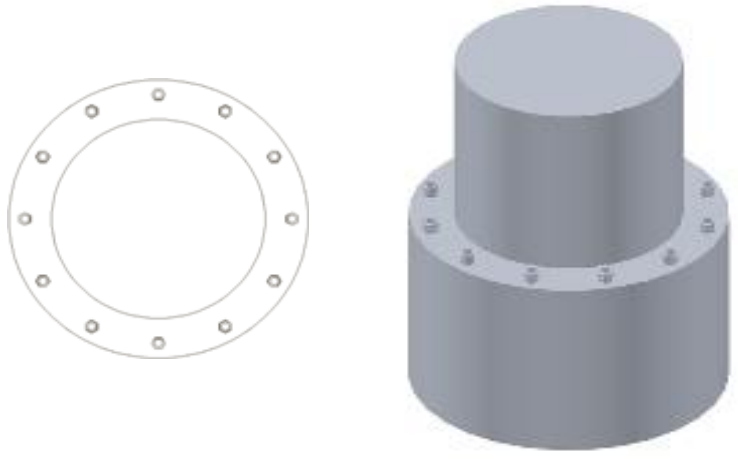

\* 0 = none, 1 = every bolt, 2 = every 2 bolts, 3 = 2 per bolt  
 \*\* Note: for complete joint penetration groove welds the groove depth must be exactly 1/2 the stiffener thickness for calculation purposes

## Stiffened or Unstiffened, Exterior Flange Plate - Any Bolt Material TIA Rev G

### Site Data

BU#: 876326  
 Site Name: Hayden Station  
 App #: 18PDVZ1400

Reactions		
Mu	1047.39	ft-kips
Axial, Pu:	24.33	kips
Shear, Vu:	23.05	kips
Elevation:	32.5	feet

Bolt Threads:
X-Excluded
$\phi V_n = \phi(0.55 \cdot A_b \cdot F_u)$
$\phi = 0.75, \phi \cdot V_n$ (kips):
76.54

Pole Manufacturer:	Other
--------------------	-------

If No stiffeners, Criteria: TIA G <-Only Applicable to Unstiffened Cases

Bolt Data		
Qty:	20	
Diameter (in.):	1.5	Bolt Fu: 105
Bolt Material:	A325	Bolt Fy: 81
N/A:	100	<-- Disregard
N/A:	75	<-- Disregard
Circle (in.):	53.5	

### Flange Bolt Results

Bolt Tension Capacity,  $\phi \cdot T_n, B1$ : 111.04 kips  
 Adjusted  $\phi \cdot T_n$  (due to  $V_u = V_u / Q_{ty}$ ), **B**: 111.02 kips  
 Max Bolt directly applied  $T_u$ : 45.77 Kips  
 Min. PL "tc" for **B** cap. **w/o Pry**: 1.501 in  
 Min PL "treq" for actual **T w/ Pry**: 0.720 in  
 Min PL "t1" for actual **T w/o Pry**: 0.964 in  
 T allowable w/o Prying: 111.04 kips  
 Prying Force, q: 0.00 kips  
 Total Bolt Tension= $T_u + q$ : 45.77 kips  
 Non-Prying Bolt Stress Ratio,  $T_u / B$ : 41.2% **Pass**

Rigid
$\phi \cdot T_n$
$\phi T_n [(1 - (V_u / \phi V_n)^2)^{0.5}]$

$\alpha' < 0$  case

Plate Data		
Diam:	59	in
Thick, t:	2	in
Grade (Fy):	36	ksi
Strength, Fu:	58	ksi
Single-Rod B-eff:	7.54	in

### Exterior Flange Plate Results

Flexural Check  
 Compression Side Plate Stress: 10.5 ksi  
 Allowable Plate Stress: 32.4 ksi  
 Compression Plate Stress Ratio: 32.3% **Pass**  
**No Prying**  
 Tension Side Stress Ratio,  $(t_{req}/t)^2$ : 13.0% **Pass**

Rigid
TIA G
$\phi \cdot F_y$
Comp. Y.L. Length:
23.63

Stiffener Data (Welding at Both Sides)		
Config:	0	*
Weld Type:		
Groove Depth:		<-- Disregard
Groove Angle:		<-- Disregard
Fillet H. Weld:		in
Fillet V. Weld:		in
Width:		in
Height:		in
Thick:		in
Notch:		in
Grade:		ksi
Weld str.:		ksi

n/a

### Stiffener Results

Horizontal Weld : n/a  
 Vertical Weld: n/a  
 Plate Flex+Shear,  $f_b / F_b + (f_v / F_v)^2$ : n/a  
 Plate Tension+Shear,  $f_t / F_t + (f_v / F_v)^2$ : n/a  
 Plate Comp. (AISC Bracket): n/a

### Pole Results

Pole Punching Shear Check: n/a

Pole Data		
Diam:	48	in
Thick:	0.5	in
Grade:	42	ksi
# of Sides:	0	"0" IF Round
Fu	63	ksi
Reinf. Fillet Weld	0	"0" if None

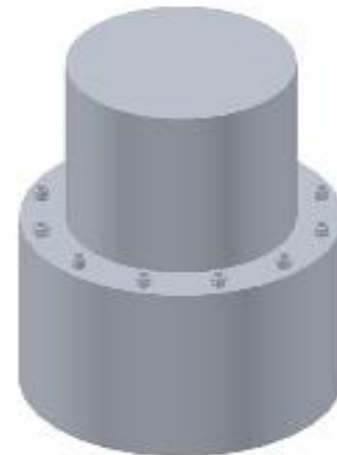
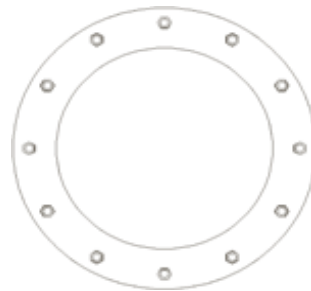

\* 0 = none, 1 = every bolt, 2 = every 2 bolts, 3 = 2 per bolt

\*\* Note: for complete joint penetration groove welds the groove depth must be exactly 1/2 the stiffener thickness for calculation purposes

## Stiffened or Unstiffened, Exterior Flange Plate - Any Bolt Material TIA Rev G

### Site Data

BU#: 876326  
 Site Name: *Hayden Station*  
 App #: 18PDVZ1400

Pole Manufacturer: **Other**

### Bolt Data

Qty:	20		
Diameter (in.):	1.5	Bolt Fu:	105
Bolt Material:	A325	Bolt Fy:	81
N/A:	100	<-- Disregard	
N/A:	75	<-- Disregard	
Circle (in.):	53.5		

### Plate Data

Diam:	59	in
Thick, t:	2	in
Grade (Fy):	36	ksi
Strength, Fu:	58	ksi
Single-Rod B-eff:	6.60	in

### Stiffener Data (Welding at Both Sides)

Config:	0	*
Weld Type:		
Groove Depth:		<-- Disregard
Groove Angle:		<-- Disregard
Fillet H. Weld:		in
Fillet V. Weld:		in
Width:		in
Height:		in
Thick:		in
Notch:		in
Grade:		ksi
Weld str.:		ksi

### Pole Data

Diam:	42	in
Thick:	0.375	in
Grade:	42	ksi
# of Sides:	0	"0" IF Round
Fu:	63	ksi
Reinf. Fillet Weld:	0	"0" if None

### Reactions

Mu	360.58	ft-kips
Axial, Pu:	15.81	kips
Shear, Vu:	19.18	kips
Elevation:	65	feet

### Bolt Threads:

X-Excluded
$\phi V_n = \phi(0.55 \cdot A_b \cdot F_u)$
$\phi = 0.75, \phi \cdot V_n$ (kips):
76.54

If No stiffeners, Criteria: **TIA G** <-Only Applicable to Unstiffened Cases

### Flange Bolt Results

Bolt Tension Capacity, $\phi \cdot T_n, B1$ :	111.04 kips
Adjusted $\phi \cdot T_n$ (due to $V_u = V_u / Q_t$ ), <b>B</b> :	111.03 kips
Max Bolt <u>directly</u> applied $T_u$ :	15.39 Kips
Min. PL "tc" for <b>B cap. w/o Pry</b> :	2.538 in
Min PL "treq" for actual <b>T w/ Pry</b> :	0.712 in
Min PL "t1" for actual <b>T w/o Pry</b> :	0.945 in
T allowable with Prying:	86.27 kips
Prying Force, q:	0.00 kips
Total Bolt Tension= $T_u + q$ :	15.39 kips
Prying Bolt Stress Ratio= $(T_u + q) / (B)$ :	13.9% <b>Pass</b>

Rigid
$\phi \cdot T_n$
$\phi T_n [1 - (V_u / \phi V_n)^2]^{0.5}$

$0 \leq \alpha \leq 1$  case

### Exterior Flange Plate Results

Flexural Check	
Compression Side Plate Stress:	7.1 ksi
Allowable Plate Stress:	32.4 ksi
Compression Plate Stress Ratio:	21.9% <b>Pass</b>
<b>No Prying</b>	
Tension Side Stress Ratio, $(t_{req}/t)^2$ :	12.7% <b>Pass</b>

Rigid
TIA G
$\phi \cdot F_y$
Comp. Y.L. Length:
33.14

**n/a**

### Stiffener Results

Horizontal Weld :	n/a
Vertical Weld:	n/a
Plate Flex+Shear, $f_b / F_b + (f_v / F_v)^2$ :	n/a
Plate Tension+Shear, $f_t / F_t + (f_v / F_v)^2$ :	n/a
Plate Comp. (AISC Bracket):	n/a

### Pole Results

Pole Punching Shear Check: n/a

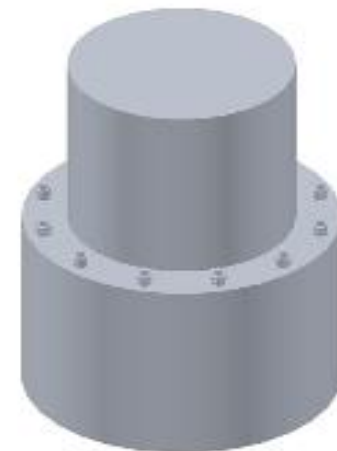
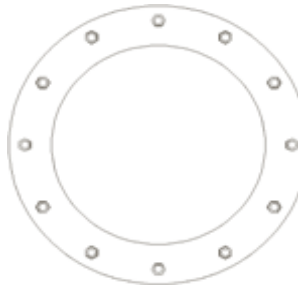

\* 0 = none, 1 = every bolt, 2 = every 2 bolts, 3 = 2 per bolt

\*\* Note: for complete joint penetration groove welds the groove depth must be exactly 1/2 the stiffener thickness for calculation purposes

## Stiffened or Unstiffened, Exterior Flange Plate - Any Bolt Material TIA Rev G

### Site Data

BU#: 876326  
 Site Name: Hayden Station  
 App #: 18PDVZ1400

Reactions		
Mu	360.58	ft-kips
Axial, Pu:	15.81	kips
Shear, Vu:	19.18	kips
Elevation:	65	feet

Bolt Threads:
X-Excluded
$\phi V_n = \phi(0.55 \cdot A_b \cdot F_u)$
$\phi = 0.75, \phi \cdot V_n$ (kips):
76.54

Pole Manufacturer: Other

If No stiffeners, Criteria: TIA G <-Only Applicable to Unstiffened Cases

Bolt Data		
Qty:	20	
Diameter (in.):	1.5	Bolt Fu: 105
Bolt Material:	A325	Bolt Fy: 81
N/A:	100	<-- Disregard
N/A:	75	<-- Disregard
Circle (in.):	53.5	

### Flange Bolt Results

Bolt Tension Capacity,  $\phi \cdot T_n, B1$ : 111.04 kips  
 Adjusted  $\phi \cdot T_n$  (due to  $V_u = V_u / Q_t$ ), **B**: 111.03 kips  
 Max Bolt directly applied  $T_u$ : 15.39 Kips  
 Min. PL "tc" for **B** cap. **w/o Pry**: 1.502 in  
 Min PL "treq" for actual **T w/ Pry**: 0.417 in  
 Min PL "t1" for actual **T w/o Pry**: 0.559 in  
 T allowable w/o Prying: 111.04 kips  
 Prying Force, q: 0.00 kips  
 Total Bolt Tension= $T_u + q$ : 15.39 kips  
 Non-Prying Bolt Stress Ratio,  $T_u / B$ : 13.9% **Pass**

Rigid
$\phi \cdot T_n$
$\phi T_n [(1 - (V_u / \phi V_n)^2)^{0.5}]$

$\alpha' < 0$  case

Plate Data		
Diam:	59	in
Thick, t:	2	in
Grade (Fy):	36	ksi
Strength, Fu:	58	ksi
Single-Rod B-eff:	7.54	in

### Exterior Flange Plate Results

Flexural Check  
 Compression Side Plate Stress: 3.7 ksi  
 Allowable Plate Stress: 32.4 ksi  
 Compression Plate Stress Ratio: 11.4% **Pass**  
**No Prying**  
 Tension Side Stress Ratio,  $(treq/t)^2$ : 4.4% **Pass**

Rigid
TIA G
$\phi \cdot F_y$
Comp. Y.L. Length:
23.63

Stiffener Data (Welding at Both Sides)		
Config:	0	*
Weld Type:		
Groove Depth:		<-- Disregard
Groove Angle:		<-- Disregard
Fillet H. Weld:		in
Fillet V. Weld:		in
Width:		in
Height:		in
Thick:		in
Notch:		in
Grade:		ksi
Weld str.:		ksi

n/a

### Stiffener Results

Horizontal Weld : n/a  
 Vertical Weld: n/a  
 Plate Flex+Shear,  $f_b / F_b + (f_v / F_v)^2$ : n/a  
 Plate Tension+Shear,  $f_t / F_t + (f_v / F_v)^2$ : n/a  
 Plate Comp. (AISC Bracket): n/a

### Pole Results

Pole Punching Shear Check: n/a

Pole Data		
Diam:	48	in
Thick:	0.375	in
Grade:	42	ksi
# of Sides:	0	"0" IF Round
Fu	63	ksi
Reinf. Fillet Weld	0	"0" if None

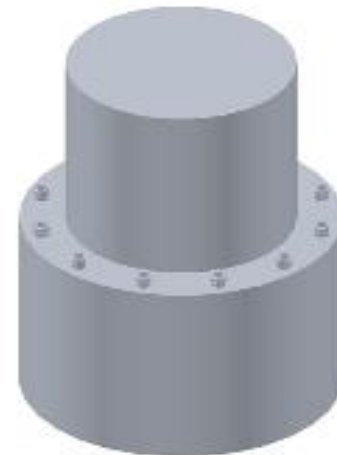
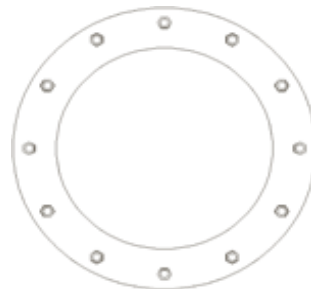

\* 0 = none, 1 = every bolt, 2 = every 2 bolts, 3 = 2 per bolt

\*\* Note: for complete joint penetration groove welds the groove depth must be exactly 1/2 the stiffener thickness for calculation purposes

## Stiffened or Unstiffened, Exterior Flange Plate - Any Bolt Material TIA Rev G

### Site Data

BU#: 876326  
 Site Name: *Hayden Station*  
 App #: 18PDVZ1400

Pole Manufacturer: **Other**

### Bolt Data

Qty:	20		
Diameter (in.):	1	Bolt Fu:	120
Bolt Material:	A325	Bolt Fy:	92
N/A:	100	<-- Disregard	
N/A:	75	<-- Disregard	
Circle (in.):	53		

### Plate Data

Diam:	59	in
Thick, t:	2	in
Grade (Fy):	36	ksi
Strength, Fu:	58	ksi
Single-Rod B-eff:	2.00	in

### Stiffener Data (Welding at Both Sides)

Config:	0	*
Weld Type:		
Groove Depth:		<-- Disregard
Groove Angle:		<-- Disregard
Fillet H. Weld:		in
Fillet V. Weld:		in
Width:		in
Height:		in
Thick:		in
Notch:		in
Grade:		ksi
Weld str.:		ksi

### Pole Data

Diam:	12.75	in
Thick:	0.5	in
Grade:	35	ksi
# of Sides:	0	"0" IF Round
Fu	63	ksi
Reinf. Fillet Weld	0	"0" if None

### Reactions

Mu	49.38	ft-kips
Axial, Pu:	5.11	kips
Shear, Vu:	8.14	kips
Elevation:	85	feet

### Bolt Threads:

X-Excluded
$\phi V_n = \phi(0.55 \cdot A_b \cdot F_u)$
$\phi = 0.75, \phi \cdot V_n$ (kips):
38.88

If No stiffeners, Criteria: **TIA G** <-Only Applicable to Unstiffened Cases

### Flange Bolt Results

Bolt Tension Capacity, $\phi \cdot T_n, B1$ :	54.54 kips
Adjusted $\phi \cdot T_n$ (due to $V_u = V_u / Q_t$ ), <b>B</b> :	54.54 kips
Max Bolt <u>directly</u> applied $T_u$ :	1.98 Kips
Min. PL "tc" for <b>B</b> cap. <b>w/o Pry</b> :	6.396 in
Min PL "treq" for actual <b>T w/ Pry</b> :	1.006 in
Min PL "t1" for actual <b>T w/o Pry</b> :	1.219 in
T allowable with Prying:	7.84 kips
Prying Force, q:	0.00 kips
Total Bolt Tension= $T_u + q$ :	1.98 kips
Prying Bolt Stress Ratio= $(T_u + q) / (B)$ :	3.6% <b>Pass</b>

Non-Rigid
$\phi \cdot T_n$
$\phi T_n [1 - (V_u / \phi V_n)^2]^{0.5}$

$\alpha > 1$  case

### Exterior Flange Plate Results

Flexural Check	
Compression Side Plate Stress:	4.6 ksi
Allowable Plate Stress:	32.4 ksi
Compression Plate Stress Ratio:	14.1% <b>Pass</b>
<b>No Prying</b>	
Tension Side Stress Ratio, $(t_{req} / t)^2$ :	25.3% <b>Pass</b>

Non-Rigid
TIA G
$\phi \cdot F_y$
Comp. Y.L. Length:
51.44

**n/a**

### Stiffener Results

Horizontal Weld :	n/a
Vertical Weld:	n/a
Plate Flex+Shear, $f_b / F_b + (f_v / F_v)^2$ :	n/a
Plate Tension+Shear, $f_t / F_t + (f_v / F_v)^2$ :	n/a
Plate Comp. (AISC Bracket):	n/a

### Pole Results

Pole Punching Shear Check: n/a

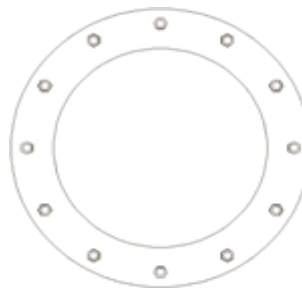

\* 0 = none, 1 = every bolt, 2 = every 2 bolts, 3 = 2 per bolt

\*\* Note: for complete joint penetration groove welds the groove depth must be exactly 1/2 the stiffener thickness for calculation purposes

## Stiffened or Unstiffened, Exterior Flange Plate - Any Bolt Material TIA Rev G

### Site Data

BU#: 876326  
 Site Name: Hayden Station  
 App #: 18PDVZ1400

Reactions		
Mu	49.38	ft-kips
Axial, Pu:	5.11	kips
Shear, Vu:	8.14	kips
Elevation:	85	feet

Bolt Threads:
X-Excluded
$\phi V_n = \phi(0.55 \cdot A_b \cdot F_u)$
$\phi = 0.75, \phi \cdot V_n$ (kips):
38.88

Pole Manufacturer: Other

If No stiffeners, Criteria: TIA G <-Only Applicable to Unstiffened Cases

Bolt Data		
Qty:	20	
Diameter (in.):	1	Bolt Fu: 120
Bolt Material:	A325	Bolt Fy: 92
N/A:	100	<-- Disregard
N/A:	75	<-- Disregard
Circle (in.):	53	

### Flange Bolt Results

Bolt Tension Capacity,  $\phi \cdot T_n, B1$ : 54.54 kips  
 Adjusted  $\phi \cdot T_n$  (due to  $V_u = V_u / Q_t$ ), **B**: 54.54 kips  
 Max Bolt directly applied  $T_u$ : 1.98 Kips  
 Min. PL "tc" for **B** cap. **w/o Pry**: 1.779 in  
 Min PL "treq" for actual **T w/ Pry**: 0.250 in  
 Min PL "t1" for actual **T w/o Pry**: 0.339 in  
 T allowable with Prying: 31.70 kips  
 Prying Force, q: 0.00 kips  
 Total Bolt Tension= $T_u + q$ : 1.98 kips  
 Prying Bolt Stress Ratio= $(T_u + q) / (B)$ : 3.6% **Pass**

Non-Rigid
$\phi \cdot T_n$
$\phi T_n [(1 - (V_u / \phi V_n)^2)^{0.5}]$

$\alpha > 1$  case

Plate Data		
Diam:	59	in
Thick, t:	1	in
Grade (Fy):	36	ksi
Strength, Fu:	58	ksi
Single-Rod B-eff:	6.60	in

### Exterior Flange Plate Results

Flexural Check  
 Compression Side Plate Stress: 4.6 ksi  
 Allowable Plate Stress: 32.4 ksi  
 Compression Plate Stress Ratio: 14.2% **Pass**  
**No Prying**  
 Tension Side Stress Ratio,  $(t_{req}/t)^2$ : 6.2% **Pass**

Non-Rigid
TIA G
$\phi \cdot F_y$
Comp. Y.L. Length:
32.33

Stiffener Data (Welding at Both Sides)		
Config:	0	*
Weld Type:		
Groove Depth:		<-- Disregard
Groove Angle:		<-- Disregard
Fillet H. Weld:		in
Fillet V. Weld:		in
Width:		in
Height:		in
Thick:		in
Notch:		in
Grade:		ksi
Weld str.:		ksi

n/a

### Stiffener Results

Horizontal Weld : n/a  
 Vertical Weld: n/a  
 Plate Flex+Shear,  $f_b / F_b + (f_v / F_v)^2$ : n/a  
 Plate Tension+Shear,  $f_t / F_t + (f_v / F_v)^2$ : n/a  
 Plate Comp. (AISC Bracket): n/a

### Pole Results

Pole Punching Shear Check: n/a

Pole Data		
Diam:	42	in
Thick:	0.375	in
Grade:	42	ksi
# of Sides:	0	"0" IF Round
Fu	63	ksi
Reinf. Fillet Weld	0	"0" if None

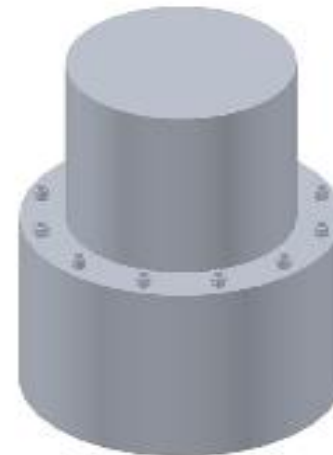
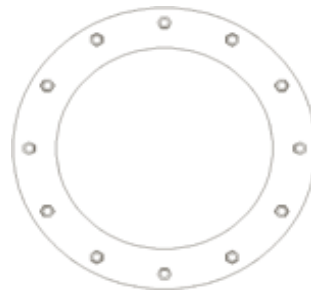

\* 0 = none, 1 = every bolt, 2 = every 2 bolts, 3 = 2 per bolt

\*\* Note: for complete joint penetration groove welds the groove depth must be exactly 1/2 the stiffener thickness for calculation purposes

## Drilled Pier Foundation

BU #:	876326
Site Name:	HAYDEN STATION
App. Number:	422595 Rev. 1

TIA-222 Revison:	G
Tower Type:	Monopole



Applied Loads		
	Comp.	Uplift
Moment (kip-ft)	1844.71	
Axial Force (kips)	35.35	
Shear Force (kips)	25.9	

Material Properties		
Concrete Strength, $f_c$ :	3	ksi
Rebar Strength, $F_y$ :	60	ksi

Pier Design Data		
Depth	30	ft
Ext. Above Grade	0.5	ft
Pier Section 1		
<i>From 0.5' above grade to 30' below grade</i>		
Pier Diameter	7	ft
Rebar Quantity	24	
Rebar Size	10	
Clear Cover to Ties	3	in
Tie Size	5	

Analysis Results		
Soil Lateral Capacity		
$D_{v=0}$ (ft from TOC)	8.80	-
Soil Safety Factor	8.37	-
Max Moment (kip-ft)	2040.09	-
Rating	15.9%	-
Soil Vertical Capacity		
Skin Friction (kips)	774.36	-
End Bearing (kips)	0.00	-
Weight of Concrete (kips)	211.28	-
Total Capacity (kips)	774.36	-
Axial (kips)	246.63	-
Rating	31.8%	-
Reinforced Concrete Capacity		
Critical Depth (ft from TOC)	9.04	-
Critical Moment (kip-ft)	2039.84	-
Critical Moment Capacity	4896.79	-
Rating	41.7%	-
<b>Soil Interaction Rating</b>		<b>31.8%</b>
<b>Structural Foundation Rating</b>		<b>41.7%</b>

Soil Profile			
Groundwater Depth	31	ft	# of Layers 3

Layer	Top (ft)	Bottom (ft)	Thickness (ft)	$\gamma_{soil}$ (pcf)	$\gamma_{concrete}$ (pcf)	Cohesion (ksf)	Angle of Friction (degrees)	Calculated Ultimate Skin Friction Comp (ksf)	Calculated Ultimate Skin Friction Uplift (ksf)	Ultimate Skin Friction Comp Override (ksf)	Ultimate Skin Friction Uplift Override (ksf)	Ult. Gross Bearing Capacity (ksf)	SPT Blow Count	Soil Type
1	0	4	4	120	150	0	0	0.000	0.000					Cohesionless
2	4	20	16	120	150	0	32	1.387	1.387				14	Cohesionless
3	20	30	10	120	150	0	32	2.475	2.475			0	16	Cohesionless



# Radio Frequency Emissions Analysis Report

AT&T Existing Facility

Site ID: CT5140

FA#: 10071329

Windsor Breakneck  
440 Hayden Station Road  
Windsor, CT 6095

**March 14, 2018**

**Centerline Communications Project Number: 950006-104**

Site Compliance Summary	
Compliance Status:	<b>COMPLIANT</b>
Site total MPE% of FCC general population allowable limit:	<b>21.65 %</b>





March 14, 2018

AT&T Mobility – New England  
Attn: John Benedetto, RF Manager  
550 Cochituate Road  
Suite 550 – 13&14  
Framingham, MA 06040

### Emissions Analysis for Site: **CT5140 – Windsor Breakneck**

Centerline Communications, LLC (“Centerline”) was directed to analyze the proposed AT&T facility located at **440 Hayden Station Road, Windsor, CT**, for the purpose of determining whether the emissions from the Proposed AT&T Antenna Installation located on this property are within specified federal limits.

All information used in this report was analyzed as a percentage of current Maximum Permissible Exposure (% MPE) as listed in the FCC OET Bulletin 65 Edition 97-01 and ANSI/IEEE Std C95.1. The FCC regulates Maximum Permissible Exposure in units of microwatts per square centimeter ( $\mu\text{W}/\text{cm}^2$ ). The number of  $\mu\text{W}/\text{cm}^2$  calculated at each sample point is called the power density. The exposure limit for power density varies depending upon the frequencies being utilized. Wireless Carriers and Paging Services use different frequency bands each with different exposure limits, therefore it is necessary to report results and limits in terms of percent MPE rather than power density.

All results were compared to the FCC (Federal Communications Commission) radio frequency exposure rules, 47 CFR 1.1307(b)(1) – (b)(3), to determine compliance with the Maximum Permissible Exposure (MPE) limits for General Population/Uncontrolled environments as defined below.

General population/uncontrolled exposure limits apply to situations in which the general population may be exposed or in which persons who are exposed as a consequence of their employment may not be made fully aware of the potential for exposure or cannot exercise control over their exposure. Therefore, members of the general population would always be considered under this category when exposure is not employment related, for example, in the case of a telecommunications tower that exposes persons in a nearby residential area.

Population exposure to radio frequencies is regulated and enforced in units of microwatts per square centimeter ( $\mu\text{W}/\text{cm}^2$ ). The general population exposure limits for the 700 and 850 MHz Bands are approximately  $467 \mu\text{W}/\text{cm}^2$  and  $567 \mu\text{W}/\text{cm}^2$  respectively. The general population exposure limit for the 1900 MHz (PCS), 2100 MHz (AWS) and 2300 MHz (WCS) bands is  $1000 \mu\text{W}/\text{cm}^2$ . Because each carrier will be using different frequency bands, and each frequency band has different exposure limits, it is necessary to report percent of MPE rather than power density.



Occupational/controlled exposure limits apply to situations in which persons are exposed as a consequence of their employment and in which those persons who are exposed have been made fully aware of the potential for exposure and can exercise control over their exposure. Occupational/controlled exposure limits also apply where exposure is of a transient nature as a result of incidental passage through a location where exposure levels may be above general population/uncontrolled limits (see below), as long as the exposed person has been made fully aware of the potential for exposure and can exercise control over his or her exposure by leaving the area or by some other appropriate means.

Additional details can be found in FCC OET 65.



## CALCULATIONS

Calculations were performed for the proposed AT&T Wireless antenna facility located at **440 Hayden Station Road, Windsor, CT**, using the equipment information listed below. All calculations were performed per the specifications under FCC OET 65. Since AT&T is proposing highly focused directional panel antennas, which project most of the emitted energy out toward the horizon, all calculations were performed assuming a lobe representing the maximum gain of the antenna per the antenna manufactures supplied specifications, minus 10 dB, was focused at the base of the tower. For this report the sample point is the top of a 6-foot person standing at the base of the tower.

Per FCC OET Bulletin No. 65 - Edition 97-01 recommendations to achieve the maximum anticipated value at each sample point, all power levels emitting from the proposed antenna installation are increased by a factor of 2.56 to account for possible in-phase reflections from the surrounding environment. All power values expressed and analyzed are maximum power levels expected to be used on all radios.

All emissions values for additional carriers were taken from the Connecticut Siting Council (CSC) active MPE database. Values in this database are provided by the individual carriers themselves

For each sector the following channel counts, frequency bands and power levels were utilized as shown in *Table 1*:

Technology	Frequency Band	Channel Count	Transmit Power per Channel (W)
UMTS	850 MHz	1	30
UMTS	850 MHz	1	30
LTE	700 MHz	2	40
LTE	1900 MHz (PCS)	4	40
LTE	2300 MHz (WCS)	4	30

*Table 1: Channel Data Table*



The following antennas listed in *Table 2* were used in the modeling for transmission in the 700 MHz, 850 MHz, 1900 MHz (PCS) and 2300 MHz (WCS) frequency bands. This is based on feedback from the carrier with regards to anticipated antenna selection. Maximum gain values for all antennas are listed in the Inventory and Power Data table below. The maximum gain of the antenna per the antenna manufactures supplied specifications, minus 10 dB, was used for all calculations. This value is a very conservative estimate as gain reductions for these particular antennas are typically much higher in this direction.

Sector	Antenna Number	Antenna Make / Model	Antenna Centerline (ft)
A	1	Kathrein 800-10121	92
A	2	CCI HPA-65R-BUU-H8	92
A	3	CCI TPA-65R-LCUUUU-H8	92
B	1	Kathrein 800-10121	92
B	2	CCI HPA-65R-BUU-H8	92
B	3	CCI TPA-65R-LCUUUU-H8	92
C	1	Kathrein 800-10121	92
C	2	CCI HPA-65R-BUU-H8	92
C	3	CCI TPA-65R-LCUUUU-H8	92

*Table 2: Antenna Data*

All calculations were done with respect to uncontrolled / general population threshold limits.



## RESULTS

Per the calculations completed for the proposed AT&T configurations *Table 3* shows resulting emissions power levels and percentages of the FCC’s allowable general population limit.

Antenna ID	Antenna Make / Model	Frequency Bands	Antenna Gain (dBd)	Channel Count	Total TX Power (W)	ERP (W)	MPE %
Antenna A1	Kathrein 800-10121	850 MHz / 1900 MHz (PCS)	11.45 / 14.35	2	60	1,235.72	0.76
Antenna A2	CCI HPA-65R-BUU-H8	700 MHz	13.15	2	80	1,652.30	1.72
Antenna A3	CCI TPA-65R-LCUUUU-H8	1900 MHz (PCS) / 2100 MHz (AWS)	13.75 / 14.25	8	280	6,987.07	3.40
Sector A Composite MPE%							<b>5.87</b>
Antenna B1	Kathrein 800-10121	850 MHz / 1900 MHz (PCS)	11.45 / 14.35	2	60	1,235.72	0.76
Antenna B2	CCI HPA-65R-BUU-H8	700 MHz	13.15	2	80	1,652.30	1.72
Antenna B3	CCI TPA-65R-LCUUUU-H8	1900 MHz (PCS) / 2100 MHz (AWS)	13.75 / 14.25	8	280	6,987.07	3.40
Sector B Composite MPE%							<b>5.87</b>
Antenna C1	Kathrein 800-10121	850 MHz / 1900 MHz (PCS)	11.45 / 14.35	2	60	1,235.72	0.76
Antenna C2	CCI HPA-65R-BUU-H8	700 MHz	13.15	2	80	1,652.30	1.72
Antenna C3	CCI TPA-65R-LCUUUU-H8	1900 MHz (PCS) / 2100 MHz (AWS)	13.75 / 14.25	8	280	6,987.07	3.40
Sector C Composite MPE%							<b>5.87</b>

*Table 3: AT&T Emissions Levels*



The Following table (*table 4*) shows all additional carriers on site and their MPE% as recorded in the CSC active MPE database for this facility along with the newly calculated maximum AT&T MPE contributions per this report. FCC OET 65 specifies that for carriers utilizing directional antennas that the highest recorded sector value be used for composite site MPE values due to their greatly reduced emissions contributions in the directions of the adjacent sectors. For this site, all three sectors have the same configuration yielding the same results on all three sectors. *Table 5* below shows a summary for each AT&T Sector as well as the composite MPE value for the site.

<b>Site Composite MPE%</b>	
<b>Carrier</b>	<b>MPE%</b>
AT&T – Max Sector Value	<b>5.87 %</b>
T-Mobile	13.74 %
Clearwire	0.31 %
Sprint	1.73 %
<b>Site Total MPE %:</b>	<b>21.65 %</b>

*Table 4: All Carrier MPE Contributions*

AT&T Sector A Total:	5.87 %
AT&T Sector B Total:	5.87 %
AT&T Sector C Total:	5.87 %
<b>Site Total:</b>	<b>21.65 %</b>

*Table 5: Site MPE Summary*



FCC OET 65 specifies that for carriers utilizing directional antennas that the highest recorded sector value be used for composite site MPE values due to their greatly reduced emissions contributions in the directions of the adjacent sectors. *Table 6* below details a breakdown by frequency band and technology for the MPE power values for the maximum calculated AT&T sector(s). For this site, all three sectors have the same configuration yielding the same results on all three sectors.

AT&T _ Frequency Band / Technology Max Power Values (Per Sector)	# Channels	Watts ERP (Per Channel)	Height (feet)	Total Power Density ( $\mu\text{W}/\text{cm}^2$ )	Frequency (MHz)	Allowable MPE ( $\mu\text{W}/\text{cm}^2$ )	Calculated % MPE
AT&T 850 MHz UMTS (Antenna 1)	1	418.91	92	2.04	850 MHz	567	0.36%
AT&T 1900 MHz (PCS) UMTS (Antenna 1)	1	816.81	92	3.97	1900 MHz (PCS)	1000	0.40%
AT&T 700 MHz LTE (Antenna 2)	2	826.15	92	8.03	700 MHz	467	1.72%
AT&T 1900 MHz (PCS) LTE (Antenna 3)	4	948.55	92	18.44	1900 MHz (PCS)	1000	1.84%
AT&T 2100 MHz (AWS) LTE (Antenna 3)	4	798.22	92	15.52	2100 MHz (AWS)	1000	1.55%
						<b>Total:</b>	<b>5.87%</b>

*Table 6: AT&T Maximum Sector MPE Power Values*



## Summary

All calculations performed for this analysis yielded results that were **within** the allowable limits for general population exposure to RF Emissions.

The anticipated maximum composite contributions from the AT&T facility as well as the site composite emissions value with regards to compliance with FCC's allowable limits for general population exposure to RF Emissions are shown here:

AT&T Sector	Power Density Value (%)
Sector A:	5.87 %
Sector B:	5.87 %
Sector C:	5.87 %
AT&T Maximum Total (per sector):	5.87 %
Site Total:	21.65 %
Site Compliance Status:	<b>COMPLIANT</b>

The anticipated composite MPE value for this site assuming all carriers present is **21.65 %** of the allowable FCC established general population limit sampled at the ground level. This is based upon values listed in the Connecticut Siting Council database for existing carrier emissions.

FCC guidelines state that if a site is found to be out of compliance (over allowable thresholds), that carriers over a 5% contribution to the composite value will require measures to bring the site into compliance. For this facility, the composite values calculated were well within the allowable 100% threshold standard per the federal government.

A handwritten signature in black ink, appearing to read 'Scott Heffernan', is positioned above the contact information.

Scott Heffernan  
RF Engineering Director  
**Centerline Communications, LLC**  
95 Ryan Drive, Suite 1  
Raynham, MA 02767



SENDER: COMPLETE THIS SECTION

- Complete items 1, 2, and 3.
- Print your name and address on the reverse so that we can return the card to you.
- Attach this card to the back of the mailpiece, or on the front if space permits.

1. Article Addressed to:  
**Crown Castle**  
**Paul Pedicone, Project Manager**  
**3 Corporate Drive, Suite 101**  
**Clifton Park, NY 12065**



9590 9402 3845 8032 6732 96

2. Article Number (Transfer from service label)  
**7014 2120 0001 6938 3548**

PS Form 3811, July 2015 PSN 7530-02-000-9053

SENDER: COMPLETE THIS SECTION

- Complete items 1, 2, and 3.
- Print your name and address on the reverse so that we can return the card to you.
- Attach this card to the back of the mailpiece, or on the front if space permits.

1. Article Addressed to:  
**Peter Souza, Town Manager**  
**Town of Windsor**  
**275 Broad Street**  
**Windsor, CT 06095**



9590 9402 3845 8032 6732 65

2. Article Number (Transfer from service label)  
**7014 2120 0001 6938 3517**

PS Form 3811, July 2015 PSN 7530-02-000-9053

COMPLETE THIS SECTION ON DELIVERY

A. Signature  Agent  
 Addressee  
 B. Received by (Printed Name) **Laurie Hawes**  
 C. Date of Delivery **8/16/18**  
 D. Is delivery address different from item 1?  Yes  
 If YES, enter delivery address below:  No

3. Service Type
- Adult Signature
  - Adult Signature Restricted Delivery
  - Certified Mail®
  - Certified Mail Restricted Delivery
  - Collect on Delivery
  - Collect on Delivery Restricted Delivery
  - Mail Restricted Delivery
  - Priority Mail Express®
  - Registered Mail™
  - Registered Mail Restricted Delivery
  - Return Receipt for Merchandise
  - Signature Confirmation™
  - Signature Confirmation Restricted Delivery

Domestic Return Receipt

COMPLETE THIS SECTION ON DELIVERY

A. Signature  Agent  
 Addressee  
 B. Received by (Printed Name) **Dawn Howard**  
 C. Date of Delivery **8/16/18**  
 D. Is delivery address different from item 1?  Yes  
 If YES, enter delivery address below:  No

3. Service Type
- Adult Signature
  - Adult Signature Restricted Delivery
  - Certified Mail®
  - Certified Mail Restricted Delivery
  - Collect on Delivery
  - Collect on Delivery Restricted Delivery
  - Mail Restricted Delivery
  - Priority Mail Express®
  - Registered Mail™
  - Registered Mail Restricted Delivery
  - Return Receipt for Merchandise
  - Signature Confirmation™
  - Signature Confirmation Restricted Delivery

Domestic Return Receipt

COMPLETE THIS SECTION ON DELIVERY

A. Signature  Agent  
 Addressee  
 B. Received by (Printed Name) **Laurie Hawes**  
 C. Date of Delivery **8/16/18**  
 D. Is delivery address different from item 1?  Yes  
 If YES, enter delivery address below:  No

3. Service Type
- Adult Signature
  - Adult Signature Restricted Delivery
  - Certified Mail®
  - Certified Mail Restricted Delivery
  - Collect on Delivery
  - Collect on Delivery Restricted Delivery
  - Mail Restricted Delivery
  - Priority Mail Express®
  - Registered Mail™
  - Registered Mail Restricted Delivery
  - Return Receipt for Merchandise
  - Signature Confirmation™
  - Signature Confirmation Restricted Delivery

SENDER: COMPLETE THIS SECTION

- Complete items 1, 2, and 3.
- Print your name and address on the reverse so that we can return the card to you.
- Attach this card to the back of the mailpiece, or on the front if space permits.

1. Article Addressed to:  
**Robert Ruzzo,**  
**Building Official/Zoning**  
**Enforcement Officer**  
**275 Broad Street**  
**Windsor, CT 06095**



9590 9402 3845 8032 6732 89

2. Article Number (Transfer from service label)  
**7014 2120 0001 6938 3531**

PS Form 3811, July 2015 PSN 7530-02-000-9053

Domestic Return Receipt