



STATE OF CONNECTICUT

CONNECTICUT SITING COUNCIL

Ten Franklin Square, New Britain, CT 06051

Phone: (860) 827-2935 Fax: (860) 827-2950

E-Mail: siting.council@ct.gov

www.ct.gov/csc

VIA ELECTRONIC MAIL

June 4, 2019

Nicole Caplan-Mason
Site Acquisition Supervisor
Empire Telecom
16 Esquire Road
Billerica, MA 01862

RE: **EM-AT&T-103-190507** – AT&T Mobility, LLC notice of intent to modify an existing telecommunications facility located at 29 Willruss Court (a/k/a 2 Willruss Street), Norwalk, Connecticut.

Dear Ms. Caplan-Mason:

The Connecticut Siting Council (Council) is in receipt of your correspondence of May 31, 2019 submitted in response to the Council's May 8, 2019 notification of an incomplete request for exempt modification with regard to the above-referenced matter.

The submission renders the request for exempt modification complete and the Council will process the request in accordance with the Federal Communications Commission 60-day timeframe.

Thank you for your attention and cooperation.

Sincerely,

Melanie A. Bachman
Executive Director

MAB/IN/emr



file copy

Nicole Caplan

From: Nicole Caplan
Sent: Friday, May 31, 2019 8:39 AM
To: 'Siting.Council@ct.gov'
Cc: Lauren Groppi
Subject: EM-AT&T-103-190507 29 Willruss Court (CT5046)-Revised Structural and Construction Drawings
Attachments: 18000.55 CT5046 Norwalk Center - Rev2 CDs 19.05.21 (S&S).pdf; 18000.55 - CT5046 Structural Analysis Rev2 19.05.21.pdf

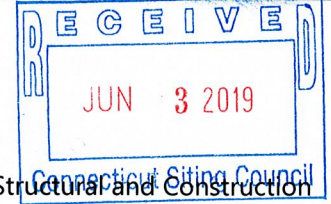

Dear Sir/Madam,

In response to your letter dated May 8, 2019, attached please find the revised structural analysis and construction CDs that account for T-Mobile's modification to the tower located at 29 Willruss Court. These have been reviewed and approved by Eversource, the owner of the tower.

One copy of the structural and one copy of the construction CDs were mailed out today and should be received by your office in the coming days. Please let me know if you have any questions or need any additional information.

Thanks,

Nicole Caplan-Mason
 Site Acquisition Supervisor
 Empire Telecom
 16 Esquire Road
 Billerica, MA 01862

Phone: 978-284-3906
Fax: 978-923-7909
Email: ncaplan@empiretelecomm.com
Website: <http://empiretelecomm.com/>



Disclaimer: This E-Mail is intended only for the use of the individual or entity to which it is addressed, and may contain information that is privileged, confidential and exempt from disclosure under applicable law. If you have received this communication in error, please do not distribute it and delete the original message. Unless expressly stated in this e-mail, nothing in this message or any attachment should be construed as a digital or electronic signature.

**Structural Analysis of
Antenna Mast and Tower**

AT&T Site Ref: CT5046

*Eversource Structure No. 1102
94' Electric Transmission Lattice Tower*

*Willruss Court
Norwalk, CT*

CEN TEK Project No. 18000.55

~~*Date: November 21, 2018*~~

Rev 2: May 21, 2019

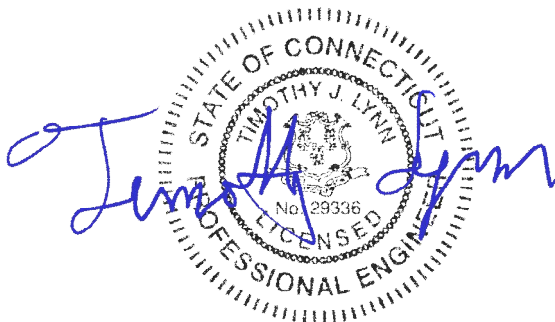

Prepared for:
AT&T Mobility
500 Enterprise Drive, Suite 3A
Rocky Hill, CT 06067

Table of Contents

SECTION 1 - REPORT

- INTRODUCTION
- PRIMARY ASSUMPTIONS USED IN THE ANALYSIS
- ANALYSIS
- DESIGN BASIS
- RESULTS
- CONCLUSION

SECTION 2 - CONDITIONS & SOFTWARE

- STANDARD ENGINEERING CONDITIONS
- GENERAL DESCRIPTION OF STRUCTURAL ANALYSIS PROGRAMS
 - RISA 3-D
 - PLS TOWER

SECTION 3 - DESIGN CRITERIA

- CRITERIA FOR DESIGN OF PCS FACILITIES ON OR EXTENDING ABOVE METAL ELECTRIC TRANSMISSION TOWERS
- NU DESIGN CRITERIA TABLE
- PCS SHAPE FACTOR CRITERIA

SECTION 4 - DRAWINGS

- TOWER ELEVATION AND FEEDLINE PLAN

SECTION 5 - TIA-222-G LOAD CALCULATIONS

- EQUIPMENT WIND LOAD CALCULATION

SECTION 6 - ANTENNA MAST ANALYSIS PER TIA-222G

- RISA 3-D ANALYSIS REPORT
- ANTENNA MAST CONNECTION TO TOWER

SECTION 7 - NESC/EVERSOURCE LOAD CALCULATIONS

- EQUIPMENT WIND LOAD CALCULATION

SECTION 8 - ANTENNA MAST ANALYSIS PER NESC/EVERSOURCE

- RISA 3-D ANALYSIS REPORT

SECTION 9 - UTILITY TOWER ANALYSIS

- COAX CABLE LOAD ON TOWER CALCULATION
- PLS REPORT
- FOUNDATION ANALYSIS
- LOCAL STRESS CHECK

SECTION 10 - REFERENCE MATERIAL

- RFDS DATA SHEET
- EQUIPMENT CUT SHEETS

Introduction

The purpose of this report is to analyze the existing antenna mast and 94' utility tower located on Willruss Court in Norwalk, CT for the proposed antenna and equipment upgrade by AT&T.

The existing and proposed loads consist of the following:

- **T-MOBILE (Existing):**
Antennas: Three (3) RFS APX16DWV-16DWVS-E-A20 panel antennas and three (3) Bias Tees mounted the existing North mast with a RAD center elevation of 114-ft above tower base plate.
Coax Cables: Twelve (12) 1-1/4" Ø coax cables running on the Northeast leg of the tower.
- **T-MOBILE (Existing):**
Antennas: Three (3) RFS APXVAARR24_43 panel antennas and three (3) Bias Tees mounted the existing South mast with a RAD center elevation of 114-ft above tower base plate.
Coax Cables: Twenty-Four (24) 1-1/4" Ø coax cables running on the Southwest leg of the tower.
- **AT&T (Existing to Remain):**
Antennas: Three (3) KMW AM-X-CD-14-65 panel antennas and three (3) Kaelus TMA2093F00V1-1 TMAs mounted on the existing South mast with a RAD center elevation of 105-ft above tower base plate.
Coax Cables: Six (6) 1-1/4" Ø coax cables running on the Southeast leg of the tower and six (6) 1-1/4" Ø coax cables running on the Northwest leg of the tower.
- **AT&T (Existing to Remove):**
Antennas: Three (3) Powerwave 7770 panel antennas and three (3) Powerwave TT19-08BP111-001 TMAs mounted on the existing North mast with a RAD center elevation of 105-ft above tower base plate.
- **AT&T (Proposed):**
Antennas: Three (3) Quintel QS46512-2 panel antennas and six (6) Commscope TMAT21X23B68-31-43 TMAs mounted on the existing North mast with a RAD center elevation of 105-ft above tower base plate.
Coax Cables: Six (6) 1-1/4" Ø coax cables running on the Northwest leg of the tower.

Primary assumptions used in the analysis

- ASCE Manual No. 10-97, "Design of Latticed Steel Transmission Structures", defines steel stresses for evaluation of the utility tower.
- All utility tower members are adequately protected to prevent corrosion of steel members.
- All proposed antenna mounts are modeled as listed above.
- All coaxial cable will be installed within the antenna mast unless specified otherwise.
- Antenna mast will be properly installed and maintained.
- No residual stresses exist due to incorrect tower erection.
- All bolts are appropriately tightened providing the necessary connection continuity.
- All welds conform to the requirements of AWS D1.1.
- Antenna mast and utility tower will be in plumb condition.
- Utility tower was properly installed and maintained and all members were properly designed, detailed, fabricated, and installed and have been properly maintained since erection.
- Any deviation from the analyzed loading will require a new analysis for verification of structural adequacy.

A n a l y s i s

Structural analysis of the existing antenna mast was independently completed using the current version of RISA-3D computer program licensed to CENTEK Engineering, Inc.

The existing mast consisting of a 12” sch. 80 pipe conforming to ASTM A53 Grade B (Fy = 35ksi) connected at four points to the existing tower was analyzed for its ability to resist loads prescribed by the TIA standard. Section 5 of this report details these gravity and lateral wind loads. NESC prescribed loads were also applied to the mast in order to obtain reactions needed for analyzing the utility tower structure. These loads are developed in Section 7 of this report. Load cases and combinations used in RISA-3D for TIA loading and for NESC loading are listed in report Sections 6 and 8 respectively.

Structural analysis of the existing utility tower structure was completed using the current version of PLS-Tower computer program licensed to CENTEK Engineering, Inc. The NESC program contains a library of all AISC angle shapes and corresponding section properties are computed and applied directly within the program. The program’s Steel Code Check option was also utilized.

D e s i g n B a s i s

Our analysis was performed in accordance with TIA-222-G, ASCE Manual No. 10-97, “Design of Latticed Steel Transmission Structures”, NESC C2-2012 and Eversource Design Criteria.

▪ UTILITY TOWER ANALYSIS

The purpose of this analysis is to determine the adequacy of the existing utility structure to support the proposed antenna loads. The loading and design requirements were analyzed in accordance with the NU Design Criteria Table, NESC C2-2012 ~ Construction Grade B, and ASCE Manual No. 10-97, “Design of Latticed Steel Transmission Structures”.

Load cases considered:

Load Case 1: NESC Heavy

Wind Pressure.....	4.0 psf
Radial Ice Thickness.....	0.5”
Vertical Overload Capacity Factor.....	1.50
Wind Overload Capacity Factor.....	2.50
Wire Tension Overload Capacity Factor.....	1.65

Load Case 2: NESC Extreme

Wind Speed.....	110 mph ⁽¹⁾
Radial Ice Thickness.....	0”

Note 1: NESC C2-2012, Section 25, Rule 250C: Extreme Wind Loading, 1.25 x Gust Response Factor (wind speed: 3-second gust)

Load Case 1: NESC Heavy Broken Wire

Wind Pressure.....	4.0 psf
Radial Ice Thickness.....	0.5”
Vertical Overload Capacity Factor.....	1.50
Wind Overload Capacity Factor.....	2.50
Wire Tension Overload Capacity Factor.....	1.65

▪ **MAST ASSEMBLY ANALYSIS**

Mast, appurtenances and connections to the utility tower were analyzed and designed in accordance with the Eversource Design Criteria Table, TIA-222-G and AISC standards.

Load cases considered:

Load Case 1:

Wind Speed..... 93 mph ^(2018 CSBC Appendix-N)
 Radial Ice Thickness..... 0"

Load Case 2:

Wind Pressure..... 50 mph wind pressure
 Radial Ice Thickness..... 0.75"

Results

▪ **ANTENNA MAST**

The existing antenna mast was determined to be structurally **adequate**.

Component	Design Limit	Stress Ratio (percentage of capacity)	Result
12" Sch. X-Strong	Bending	45.6%	PASS
HSS6x6x1/4	Bending	65.6%	PASS
Connection	Shear	5.9%	PASS

▪ **UTILITY TOWER**

This analysis finds that the subject utility structure is adequate to support the proposed antenna mast and related appurtenances. The tower stresses meet the requirements set forth by the ASCE Manual No. 10-97, "Design of Latticed Steel Transmission Structures", for the applied NESC Heavy and Hi-Wind load cases. The detailed analysis results are provided in Section 8 of this report. The analysis results are summarized as follows:

A maximum usage of **98.47%** occurs in the utility tower under the **NESC Heavy Broken Wire** loading condition.

TOWER SECTION:

The utility structure was found to be within allowable limits.

Tower Member	Stress Ratio (% of capacity)	Result
Angle g80XY	98.47%	PASS

▪ FOUNDATION AND ANCHORS

The existing foundation consists of four (4) 3-ft square tapering to 6-ft square x 9.5-ft long reinforced concrete piers and four (4) 11-ft square x 3-ft thick reinforced concrete pads. The base of the tower is connected to the foundation by one (1) anchor stub per leg. Foundation information was obtained from NUSCO drawing # 01135-60003.

BASE REACTIONS:

From PLS-Tower analysis of utility tower based on NESC/NU prescribed loads.

Load Case	Shear	Uplift	Compression
NESC Heavy Wind	42.96 kips	70.77 kips	128.21 kips
NESC Extreme Wind	39.56 kips	88.56 kips	116.21 kips
NESC Heavy Broken Wire	44.51 kips	89.01 kips	127.70 kips

Note 1 – 10% increase to be applied to the above tower base reactions for foundation verification per OTRM 051

FOUNDATION:

The foundation was found to be within allowable limits.

Foundation	Design Limit	Required FS ⁽¹⁾	Proposed Loading FS ⁽²⁾	Result
Reinf. Conc. Pad & Pier	Uplift	1.0	2.56	PASS
	Bearing Pressure	9 ksf	1.86 ksf	PASS

Note 1: FS denotes Factor of Safety

Note 2: 10% increase to PLS base reactions used in foundation analysis per OTRM 051.

Conclusion

This analysis shows that the subject utility tower **is adequate** to support the proposed AT&T equipment upgrade.

The analysis is based, in part on the information provided to this office by Eversource and AT&T. If the existing conditions are different than the information in this report, CENTEK engineering, Inc. must be contacted for resolution of any potential issues.

Please feel free to call with any questions or comments.

Respectfully Submitted by:

Timothy J. Lynn, PE
 Structural Engineer

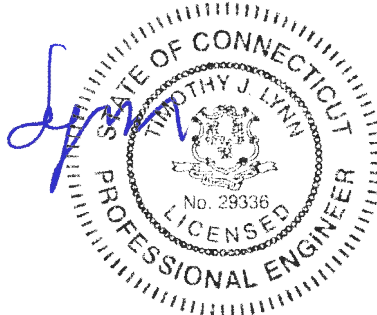

STANDARD CONDITIONS FOR FURNISHING OF
PROFESSIONAL ENGINEERING SERVICES ON
EXISTING STRUCTURES

All engineering services are performed on the basis that the information used is current and correct. This information may consist of, but is not necessarily limited to:

- Information supplied by the client regarding the structure itself, its foundations, the soil conditions, the antenna and feed line loading on the structure and its components, or other relevant information.
- Information from the field and/or drawings in the possession of CENTEK engineering, Inc. or generated by field inspections or measurements of the structure.
- It is the responsibility of the client to ensure that the information provided to CENTEK engineering, Inc. and used in the performance of our engineering services is correct and complete. In the absence of information to the contrary, we assume that all structures were constructed in accordance with the drawings and specifications and are in an un-corroded condition and have not deteriorated. It is therefore assumed that its capacity has not significantly changed from the “as new” condition.
- All services will be performed to the codes specified by the client, and we do not imply to meet any other codes or requirements unless explicitly agreed in writing. If wind and ice loads or other relevant parameters are to be different from the minimum values recommended by the codes, the client shall specify the exact requirement. In the absence of information to the contrary, all work will be performed in accordance with the latest revision of ANSI/ASCE10 & ANSI/EIA-222.
- All services are performed, results obtained, and recommendations made in accordance with generally accepted engineering principles and practices. CENTEK engineering, Inc. is not responsible for the conclusions, opinions and recommendations made by others based on the information we supply.

GENERAL DESCRIPTION OF STRUCTURAL ANALYSIS PROGRAM ~ RISA - 3 D

RISA-3D Structural Analysis Program is an integrated structural analysis and design software package for buildings, bridges, tower structures, etc.

Modeling Features:

- Comprehensive CAD-like graphic drawing/editing capabilities that let you draw, modify and load elements as well as snap, move, rotate, copy, mirror, scale, split, merge, mesh, delete, apply, etc.
- Versatile drawing grids (orthogonal, radial, skewed)
- Universal snaps and object snaps allow drawing without grids
- Versatile general truss generator
- Powerful graphic select/unselect tools including box, line, polygon, invert, criteria, spreadsheet selection, with locking
- Saved selections to quickly recall desired selections
- Modification tools that modify single items or entire selections
- Real spreadsheets with cut, paste, fill, math, sort, find, etc.
- Dynamic synchronization between spreadsheets and views so you can edit or view any data in the plotted views or in the spreadsheets
- Simultaneous view of multiple spreadsheets
- Constant in-stream error checking and data validation
- Unlimited undo/redo capability
- Generation templates for grids, disks, cylinders, cones, arcs, trusses, tanks, hydrostatic loads, etc.
- Support for all units systems & conversions at any time
- Automatic interaction with RISASection libraries
- Import DXF, RISA-2D, STAAD and ProSteel 3D files
- Export DXF, SDNF and ProSteel 3D files

Analysis Features:

- Static analysis and P-Delta effects
- Multiple simultaneous dynamic and response spectra analysis using Gupta, CQC or SRSS mode combinations
- Automatic inclusion of mass offset (5% or user defined) for dynamic analysis
- Physical member modeling that does not require members to be broken up at intermediate joints
- State of the art 3 or 4 node plate/shell elements
- High-end automatic mesh generation — draw a polygon with any number of sides to create a mesh of well-formed quadrilateral (NOT triangular) elements.
- Accurate analysis of tapered wide flanges - web, top and bottom flanges may all taper independently
- Automatic rigid diaphragm modeling
- Area loads with one-way or two-way distributions
- Multiple simultaneous moving loads with standard AASHTO loads and custom moving loads for bridges, cranes, etc.
- Torsional warping calculations for stiffness, stress and design
- Automatic Top of Member offset modeling
- Member end releases & rigid end offsets
- Joint master-slave assignments
- Joints detachable from diaphragms
- Enforced joint displacements
- 1-Way members, for tension only bracing, slipping, etc.

- 1-Way springs, for modeling soils and other effects
- Euler members that take compression up to their buckling load, then turn off.
- Stress calculations on any arbitrary shape
- Inactive members, plates, and diaphragms allows you to quickly remove parts of structures from consideration
- Story drift calculations provide relative drift and ratio to height
- Automatic self-weight calculations for members and plates
- Automatic subgrade soil spring generator

Graphics Features:

- Unlimited simultaneous model view windows
- Extraordinary “true to scale” rendering, even when drawing
- High-speed redraw algorithm for instant refreshing
- Dynamic scrolling stops right where you want
- Plot & print virtually everything with color coding & labeling
- Rotate, zoom, pan, scroll and snap views
- Saved views to quickly restore frequent or desired views
- Full render or wire-frame animations of deflected model and dynamic mode shapes with frame and speed control
- Animation of moving loads with speed control
- High quality customizable graphics printing

Design Features:

- Designs concrete, hot rolled steel, cold formed steel and wood
- ACI 1999/2002, BS 8110-97, CSA A23.3-94, IS456:2000, EC 2-1992 with consistent bar sizes through adjacent spans
- Exact integration of concrete stress distributions using parabolic or rectangular stress blocks
- Concrete beam detailing (Rectangular, T and L)
- Concrete column interaction diagrams
- Steel Design Codes: AISC ASD 9th, LRFD 2nd & 3rd, HSS Specification, CAN/CSA-S16.1-1994 & 2004, BS 5950-1-2000, IS 800-1984, Euro 3-1993 including local shape databases
- AISI 1999 cold formed steel design
- NDS 1991/1997/2001 wood design, including Structural Composite Lumber, multi-ply, full sawn
- Automatic spectra generation for UBC 1997, IBC 2000/2003
- Generation of load combinations: ASCE, UBC, IBC, BOCA, SBC, ACI
- Unbraced lengths for physical members that recognize connecting elements and full lengths of members
- Automatic approximation of K factors
- Tapered wide flange design with either ASD or LRFD codes
- Optimization of member sizes for all materials and all design codes, controlled by standard or user-defined lists of available sizes and criteria such as maximum depths
- Automatic calculation of custom shape properties
- Steel Shapes: AISC, HSS, CAN, ARBED, British, Euro, Indian, Chilean
- Light Gage Shapes: AISI, SSMA, Dale / Incor, Dietrich, Marino\WARE
- Wood Shapes: Complete NDS species/grade database
- Full seamless integration with RISAFoot (Ver 2 or better) for advanced footing design and detailing
- Plate force summation tool

Results Features:

- Graphic presentation of color-coded results and plotted designs
- Color contours of plate stresses and forces with quadratic smoothing, the contours may also be animated
- Spreadsheet results with sorting and filtering of: reactions, member & joint deflections, beam & plate forces/stresses, optimized sizes, code designs, concrete reinforcing, material takeoffs, frequencies and mode shapes
- Standard and user-defined reports
- Graphic member detail reports with force/stress/deflection diagrams and detailed design calculations and expanded diagrams that display magnitudes at any dialed location
- Saved solutions quickly restore analysis and design results.

GENERAL DESCRIPTION OF STRUCTURAL ANALYSIS PROGRAM ~ PLS - TOWER

PLS-TOWER is a Microsoft Windows program for the analysis and design of steel latticed towers used in electric power lines or communication facilities. Both self-supporting and guyed towers can be modeled. The program performs design checks of structures under user specified loads. For electric power structures it can also calculate maximum allowable wind and weight spans and interaction diagrams between different ratios of allowable wind and weight spans.

Modeling Features:

- Powerful graphics module (stress usages shown in different colors)
- Graphical selection of joints and members allows graphical editing and checking
- Towers can be shown as lines, wire frames or can be rendered as 3-d polygon surfaces
- Can extract geometry and connectivity information from a DXF CAD drawing
- CAD design drawings, title blocks, drawing borders or photos can be tied to structure model
- XML based post processor interface
- Steel Detailing Neutral File (SDNF) export to link with detailing packages
- Can link directly to line design program PLS-CADD
- Automatic generation of structure files for PLS-CADD
- Databases of steel angles, rounds, bolts, guys, etc.
- Automatic generation of joints and members by symmetries and interpolations
- Automated mast generation (quickly builds model for towers that have regular repeating sections) via graphical copy/paste
- Steel angles and rounds modeled either as truss, beam or tension-only elements
- Guys are easily handled (can be modeled as exact cable elements)

Analysis Features:

- Automatic handling of tension-only members
- Automatic distribution of loads in 2-part suspension insulators (v-strings, horizontal vees, etc.)
- Automatic calculation of tower dead, ice, and wind loads as well as drag coefficients according to:
 - ASCE 74-1991
 - NESC 2002
 - NESC 2007
 - IEC 60826:2003
 - EN50341-1:2001 (CENELEC)
 - EN50341-3-9:2001 (UK NNA)
 - EN50341-3-17:2001 (Portugal NNA)
 - ESAA C(b)1-2003 (Australia)
 - TPNZ (New Zealand)
 - REE (Spain)
 - EIA/TIA 222-F
 - ANSI/TIA 222-G
 - CSA S37-01
- Automated microwave antenna loading as per EIA/TIA 222-F and ANSI/TIA 222-G
- Minimization of problems caused by unstable joints and mechanisms
- Automatic bandwidth minimization and ability to solve large problems
- Design checks according to (other standards can be added easily):
 - ASCE Standard 10-90

- AS 3995 (Australian Standard 3995)
- BS 8100 (British Standard 8100)
- EN50341-1 (CENELEC, both empirical and analytical methods are available)
- ECCS 1985
- NGT-ECCS
- PN-90/B-03200
- EIA/TIA 222-F
- ANSI/TIA 222-G
- CSA S37-01
- EDF/RTE Resal
- IS 802 (India Standard 802)

Results Features:

- Design summaries printed for each group of members
 - Easy to interpret text, spreadsheet and graphics design summaries
 - Automatic determination of allowable wind and weight spans
 - Automatic determination of interaction diagrams between allowable wind and weight spans
 - Capability to batch run multiple tower configurations and consolidate the results
 - Automated optimum angle member size selection and bolt quantity determination
- Tool for interactive angle member sizing and bolt quantity determination.

*Criteria for Design of PCS Facilities On or
Extending Above Metal Electric Transmission
Towers & Analysis of Transmission Towers
Supporting PCS Masts* ⁽¹⁾

Introduction

This criteria is the result from an evaluation of the methods and loadings specified by the separate standards, which are used in designing telecommunications towers and electric transmission towers. That evaluation is detailed elsewhere, but in summary; the methods and loadings are significantly different. This criteria specifies the manner in which the appropriate standard is used to design PCS facilities including masts and brackets (hereafter referred to as “masts”), and to evaluate the electric transmission towers to support PCS masts. The intent is to achieve an equivalent level of safety and security under the extreme design conditions expected in Connecticut and Massachusetts.

ANSI Standard TIA-222 covering the design of telecommunications structures specifies a working strength/allowable stress design approach. This approach applies the loads from extreme weather loading conditions, and designs the structure so that it does not exceed some defined percentage of failure strength (allowable stress).

ANSI Standard C2-2007 (National Electrical Safety Code) covering the design of electric transmission metal structures is based upon an ultimate strength/yield stress design approach. This approach applies a multiplier (overload capacity factor) to the loads possible from extreme weather loading conditions, and designs the structure so that it does not exceed its ultimate strength (yield stress).

Each standard defines the details of how loads are to be calculated differently. Most of the NU effort in “unifying” both codes was to establish what level of strength each approach would provide, and then increasing the appropriate elements of each to achieve a similar level of security under extreme weather loadings.

Two extreme weather conditions are considered. The first is an extreme wind condition (hurricane) based upon a 50-year recurrence (2% annual probability). The second is a winter condition combining wind and ice loadings.

The following sections describe the design criteria for any PCS mast extending above the top of an electric transmission tower, and the analysis criteria for evaluating the loads on the transmission tower from such a mast from the lower portions of such a mast, and loads on the pre-existing electric lower portions of such a mast, and loads on the pre-existing electric transmission tower and the conductors it supports.

| Note 1: Prepared from documentation provide from Northeast Utilities.

PCS Mast

The PCS facility (mast, external cable/trays, including the initial and any planned future support platforms, antennas, etc. extending the full height above the top level of the electric transmission structure) shall be designed in accordance with the provisions of TIA 222-G:

ELECTRIC TRANSMISSION TOWER

The electric transmission tower shall be analyzed using yield stress theory in accordance with the attached table titled “NU Design Criteria”. This specifies uniform loadings (different from the TIA loadings) on the each of the following components of the installed facility:

- PCS mast for its total height above ground level, including the initial and planned future support platforms, antennas, etc. above the top of an electric transmission structure.
- Conductors are related devices and hardware.
- Electric transmission structure. The loads from the PCS facility and from the electric conductors shall be applied to the structure at conductor and PCS mast attachment points, where those load transfer to the tower.

The uniform loadings and factors specified for the above components in the table are based upon the National Electrical Safety Code 2007 Edition Extreme Wind (Rule 250C) and Combined Ice and Wind (Rule 250B-Heavy) Loadings. These provide equivalent loadings compared to TIA and its loads and factors with the exceptions noted above. (Note that the NESC does not require the projected wind surfaces of structures and equipment to be increased by the ice covering.)

In the event that the electric transmission tower is not sufficient to support the additional loadings of the PCS mast, reinforcement will be necessary to upgrade the strength of the overstressed members.

Eversource Overhead Transmission Standards

Attachment A Eversource Design Criteria

Attachment A NU Design Criteria		Basic Wind Speed	Pressure	Height factor	Gust Factor	Load or Stress Factor	Force Coef. - Shape Factor	
		V (MPH)	Q (PSF)	Kz	Gh			
Ice Condition	TIA/EIA	Antenna Mount	TIA	TIA (0.75Wi)	TIA	TIA	TIA, Section 3.1.1.1 disallowed for connection design	TIA
	NESC Heavy	Tower/Pole Analysis with antennas extending above top of Tower/Pole (Yield Stress)	—	4	1	1	2.50	1.6 Flat Surfaces 1.3 Round Surfaces
		Tower/Pole Analysis with antennas below top of Tower/Pole (on two faces)	—	4	1	1	2.50	1.6 Flat Surfaces 1.3 Round Surfaces
		Conductor Loads Provided by NU						
High Wind Condition	TIA/EIA	Antenna Mount	85	TIA	TIA	TIA	TIA, Section 3.1.1.1 disallowed for connection design	TIA
	NESC Extreme Wind	Tower/Pole Analysis with antennas extending above top of Tower/Pole	For wind speed use OTRM 060 Map 1, Rule 250C: Extreme Wind Loading Apply a 1.25 X Gust Response Factor to all telecommunication equipment projected above top of tower/pole and apply a 1.0 x Gust Response Factor to the tower/pole structure					1.6 Flat Surfaces 1.3 Round Surfaces
		Tower/Pole Analysis with antennas below top of Tower/Pole	For wind speed use OTRM 060 Map 1, Rule 250C: Extreme Wind Loading Height above ground is based on overall height to top of tower/pole					1.6 Flat Surfaces 1.3 Round Surfaces
		Conductor Loads Provided by NU						
NESC Extreme Ice with Wind Condition *		Tower/Pole Analysis with antennas extending above top of Tower/Pole	For wind speed use OTRM 060 Map 1, Rule 250D: Extreme Ice with Wind Loading 4 PSF Wind Load 1.25 X Gust Response Factor Apply a 1.25 X Gust Response Factor to all telecommunication equipment projected above top of tower/pole and apply a 1.0 x Gust Response Factor to the tower/pole structure					1.6 Flat Surfaces 1.3 Round Surfaces
		Tower/Pole Analysis with antennas below top of Tower/Pole	For wind speed use OTRM 060 Map 1, Rule 250D: Extreme Ice with Wind Loading 4 PSF Wind Load Height above ground is based on overall height to top of tower/pole					1.6 Flat Surfaces 1.3 Round Surfaces
			Conductor Loads Provided by NU					
		* Only for structures installed after 2007						

Communication Antennas on Transmission Structures

Eversource Overhead Transmission Standards

mount as specified below, and shall include the wireless communication mast and antenna loads per NESC criteria)

The strength reduction factor obtained from the field investigation shall be applied to the members or connections that are showing signs of deterioration from their original condition

With the written approval of Eversource Transmission Line Engineering on a case by case the existing structures may be analyzed initially using the current NESC code, then it is permitted to use the original design code with the original conductor load should the existing tower fail the current NESC code.

The structure shall be analyzed using yield stress theory in accordance with Attachment A, "Eversource Design Criteria." This specifies uniform loadings (different from the TIA loadings) on each of the following components of the installed facility:

- a) Wireless communication mast for its total height above ground level, including the initial and any planned future equipment (Support Platforms, Antennas, TMA's etc.) above the top of an electric transmission structure.
- b) Conductors and related devices and hardware (wire loads will be provided by Eversource).
- c) Electric Transmission Structure
 - i) The loads from the wireless communication equipment components based on NESC and Eversource Criteria in Attachment A, and from the electric conductors shall be applied to the structure at conductor and wireless communication mast attachment points, where those loads transfer to the tower.
 - ii) Shape Factor Multiplier:

NESC Structure Shape	Cd
Polyround (for polygonal steel poles)	1.3
Flat	1.6
Open Lattice	3.2
Pole with Coaxial Cable	1.6

- iii) When Coaxial Cables are mounted alongside the pole structure, the shape multiplier shall be:

Mount Type	Cable Cd	Pole Cd
Coaxial Cables on outside periphery (One layer)	1.45	1.45
Coaxial Cables mounted on stand offs	1.6	1.6

- d) The uniform loadings and factors specified for the above components in Attachment A, "Eversource Design Criteria" are based upon the National Electric Safety Code 2007 Edition Extreme Wind (Rule 250C) and Combined Ice and Wind (Rule 250B-Heavy) Loadings. These provide equivalent loadings compared to the TIA and its loads and factors with the exceptions noted above.

Note: The NESC does not require ice load be included in the supporting structure. (Ice on conductors and shield wire only, and Eversource will provide these loads).

- e) Mast reaction loads shall be evaluated for local effects on the transmission structure members at the attachment points.

Communication Antennas on Transmission Structures			
Eversource Approved by: CPS (CT/WMA) JCC (NH/EMA)	Design	OTRM 059	Rev. 0
		Page 3 of 10	06/07/2018

EXISTING THREE (3) RFS APX16DWV-16DWVS PANEL ANTENNAS AND THREE (3) BIAS TEES FLUSH MOUNTED.

☉ T-MOBILE ANTENNAS
EL. ±114'-0" ATB

☉ AT&T ANTENNAS
EL. ±105'-0" ATB

PROPOSED THREE (3) QUINTEL QS46512-2 AND SIX (6) COMMSCOPE TMA21X23B68-31-43 TMAs FLUSH MOUNTED.

☉ TOP CONNECTION
EL. ±83'-6" ATB

EXISTING 12" SCH. 80 (O.D. = 12.75") X 55' LONG PIPE MAST

☉ BOTTOM CONNECTION
EL. ±62'-0" ATB

T-MOBILE EXISTING (12) 1-1/4" DIA. COAX CABLES MOUNTED ON A COAX SUPPORT BRACKET ON NE LEG

AT&T EXISTING SIX (6) AND PROPOSED (6) 1-1/4" DIA. COAX CABLES MOUNTED ON A COAX SUPPORT BRACKET ON NW LEG

EXIST. GRADE

EXISTING THREE (3) RFS APXVAARR24_43 PANEL ANTENNAS AND THREE (3) BIAS TEES MOUNTED ON (2) UNIVERSAL RING MOUNTS (P/N LWR4).

☉ T-MOBILE ANTENNAS
EL. ±114'-0" ATB

☉ AT&T ANTENNAS
EL. ±105'-0" ATB

EXISTING THREE (3) KMW AM-X-CD-14-65 PANEL ANTENNAS AND THREE (3) KAELUS TMA2093F00V1-1 TMAS MOUNTED ON UNIVERSAL TRI-BRACKET.

EXISTING 12" SCH. 80 (O.D. = 12.75") X 55' LONG PIPE MAST

EXISTING 94' TALL STEEL TRANSMISSION STRUCTURE NO. 1102

T-MOBILE EXISTING (24) 1-1/4" DIA. COAX CABLES MOUNTED ON A COAX SUPPORT BRACKET ON SW LEG

AT&T EXISTING (6) 1-1/4" DIA. COAX CABLES MOUNTED ON A COAX SUPPORT BRACKET ON SE LEG

1 TOWER & MAST ELEVATION
SK-1 SCALE: NOT TO SCALE

REVISIONS	
00	11/21/18 ISSUED FOR REVIEW
01	5/21/19 CONSTRUCTION

CEN TEK engineering
Centered on Solutions™
www.CentekEng.com
(203) 488-0580
(203) 488-8387 Fax
63-2 North Branford Road, Branford, CT 06405

CT5046
EVERSOURCE 1102
WILLRUSS COURT
NORWALK, CT 06850

PROJECT NO: 18000.55
DRAWN BY: TJL
CHECKED BY: CAG
SCALE: AS NOTED
DATE: 11/21/18

TOWER AND MAST ELEVATION
SK-1
DWG. 1 OF 2

T-MOBILE EXISTING (12)
1-1/4" DIA. COAX CABLES
MOUNTED ON A COAX
SUPPORT BRACKET ON NE LEG

AT&T EXISTING (6) 1-1/4"
DIA. COAX CABLES MOUNTED
ON A COAX SUPPORT
BRACKET ON SE LEG

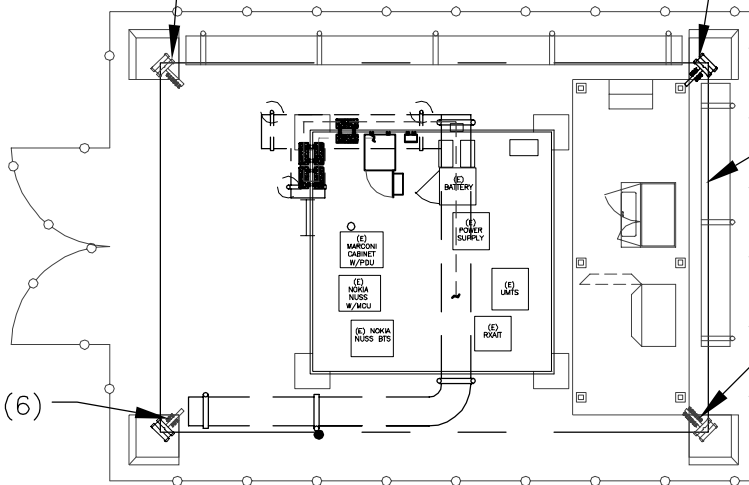

EXISTING 94' TALL CL&P
STEEL TRANSMISSION
STRUCTURE NO. 1102

T-MOBILE EXISTING
(24) 1-1/4" DIA.
COAX CABLES MOUNTED
ON A COAX SUPPORT
BRACKET ON SW LEG

AT&T EXISTING SIX (6)
AND PROPOSED (6)
1-1/4" DIA. COAX
CABLES MOUNTED ON A
COAX SUPPORT
BRACKET ON NW LEG

1
SK-2

TOWER PLAN

SCALE: NOT TO SCALE



TRUE
NORTH

REVISIONS	
00	11/21/18 ISSUED FOR REVIEW
01	5/21/19 CONSTRUCTION

CEN TEK engineering
Centered on Solutions™
www.CentekEng.com

(203) 488-0580
(203) 488-8587 Fax
63-2 North Branford Road, Branford, CT 06405

CT5046
EVERSOURCE 1102

WILLRUSS COURT
NORWALK, CT 06850

PROJECT NO:	18000.55
DRAWN BY:	TJL
CHECKED BY:	CFC
SCALE:	AS NOTED
DATE:	11/21/18

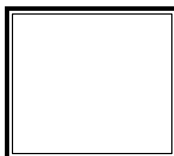

TOWER AND COAX
PLAN

SK-2

DWG. 2 OF 2

**Development of Design Heights, Exposure Coefficients,
 and Velocity Pressures Per TIA-222-G**

Wind Speeds

Basic Wind Speed $V := 93$ mph (User Input - 2016 CSBC Appendix N)
 Basic Wind Speed with Ice $V_i := 50$ mph (User Input per Annex B of TIA-222-G)

Input

Structure Type = Structure_Type := Lattice (User Input)
 Structure Category = SC := III (User Input)
 Exposure Category = Exp := C (User Input)
 Structure Height = h := 94 ft (User Input)
 Height to Center of Antennas = $z_{TMO} := 114$ ft (User Input)
 Height to Center of Antennas = $z_{ATT} := 105$ ft (User Input)
 Height to Center of Mast = $z_{Mast1} := 90$ ft (User Input)
 Radial Ice Thickness = $t_i := 0.75$ in (User Input per Annex B of TIA-222-G)
 Radial Ice Density = $\rho_d := 56.00$ pcf (User Input)
 Topographic Factor = $K_{zt} := 1.0$ (User Input)
 $K_a := 1.0$ (User Input)
 Gust Response Factor = $G_H := 1.35$ (User Input)

Output

Wind Direction Probability Factor = $K_d := \begin{cases} 0.95 & \text{if Structure_Type = Pole} \\ 0.85 & \text{if Structure_Type = Lattice} \end{cases} = 0.85$ (Per Table 2-2 of TIA-222-G)
 Importance Factors = $I_{Wind} := \begin{cases} 0.87 & \text{if SC = 1} \\ 1.00 & \text{if SC = 2} \\ 1.15 & \text{if SC = 3} \end{cases} = 1.15$ (Per Table 2-3 of TIA-222-G)
 $I_{Wind_w_Ice} := \begin{cases} 0 & \text{if SC = 1} \\ 1.00 & \text{if SC = 2} \\ 1.00 & \text{if SC = 3} \end{cases} = 1$
 $I_{ice} := \begin{cases} 0 & \text{if SC = 1} \\ 1.00 & \text{if SC = 2} \\ 1.25 & \text{if SC = 3} \end{cases} = 1.25$

$$K_{iz} := \left(\frac{z_{TMo}}{33} \right)^{0.1} = 1.132$$

Velocity Pressure Coefficient Antennas =

Velocity Pressure w/o Ice Antennas =

Velocity Pressure with Ice Antennas =

$$t_{izTMo} := 2.0 \cdot t_{ice} \cdot K_{iz} \cdot K_{zt}^{0.35} = 2.122$$

$$K_{zTMo} := 2.01 \left(\left(\frac{z_{TMo}}{z_g} \right) \right)^{\frac{2}{\alpha}} = 1.301$$

$$q_{zTMo} := 0.00256 \cdot K_d \cdot K_{zTMo} \cdot V_{Wind}^2 = 28.158$$

$$q_{z_{ice.TMo}} := 0.00256 \cdot K_d \cdot K_{zTMo} \cdot V_{i}^2 \cdot I_{Wind_w_Ice} = 7.078$$

$$K_{iz} := \left(\frac{z_{ATT}}{33} \right)^{0.1} = 1.123$$

Velocity Pressure Coefficient Antennas =

Velocity Pressure w/o Ice Antennas =

Velocity Pressure with Ice Antennas =

$$t_{izATT} := 2.0 \cdot t_{ice} \cdot K_{iz} \cdot K_{zt}^{0.35} = 2.105$$

$$K_{zATT} := 2.01 \left(\left(\frac{z_{ATT}}{z_g} \right) \right)^{\frac{2}{\alpha}} = 1.279$$

$$q_{zATT} := 0.00256 \cdot K_d \cdot K_{zATT} \cdot V_{Wind}^2 = 27.675$$

$$q_{z_{ice.ATT}} := 0.00256 \cdot K_d \cdot K_{zATT} \cdot V_{i}^2 \cdot I_{Wind_w_Ice} = 6.956$$

$$K_{izMast1} := \left(\frac{z_{Mast1}}{33} \right)^{0.1} = 1.106$$

Velocity Pressure Coefficient Mast =

Velocity Pressure w/o Ice Mast =

Velocity Pressure with Ice Mast =

$$t_{izMast1} := 2.0 \cdot t_{ice} \cdot K_{izMast1} \cdot K_{zt}^{0.35} = 2.073$$

$$K_{zMast1} := 2.01 \left(\left(\frac{z_{Mast1}}{z_g} \right) \right)^{\frac{2}{\alpha}} = 1.238$$

$$q_{zMast1} := 0.00256 \cdot K_d \cdot K_{zMast1} \cdot V_{Wind}^2 = 26.791$$

$$q_{z_{ice.Mast1}} := 0.00256 \cdot K_d \cdot K_{zMast1} \cdot V_{i}^2 \cdot I_{Wind_w_Ice} = 6.734$$

Development of Wind & Ice Load on Mast

Mast Data:

	(12" Sch. 80 Pipe)	(User Input)
Mast Shape =	Round	(User Input)
Mast Diameter =	$D_{mast} := 12.75$ in	(User Input)
Mast Length =	$L_{mast} := 55$ ft	(User Input)
Mast Thickness =	$t_{mast} := 0.5$ in	(User Input)
Velocity Coefficient =	$C := \sqrt{I \cdot K_z Mast1} \cdot V \cdot \frac{D_{mast}}{12} = 110$	
Mast Force Coefficient =	$CF_{mast} = 0.6$	

Wind Load (without ice)

Mast Projected Surface Area = $A_{mast} := \frac{D_{mast}}{12} = 1.063$ s/ft

Total Mast Wind Force = $qZ_{Mast1} \cdot G_H \cdot CF_{mast} \cdot A_{mast} = 23$ plf **BLC 5,7**

Wind Load (with ice)

Mast Projected Surface Area w/ Ice = $A_{ICE_{mast}} := \frac{(D_{mast} + 2 \cdot t_{izMast1})}{12} = 1.408$ s/ft

Total Mast Wind Force w/ Ice = $qZ_{ice.Mast1} \cdot G_H \cdot CF_{mast} \cdot A_{ICE_{mast}} = 8$ plf **BLC 4,6**

Gravity Loads (without ice)

Weight of the mast = Self Weight (Computed internally by Risa-3D) plf **BLC 1**

Gravity Loads (ice only)

Ice Area per Linear Foot = $A_{i_{mast}} := \frac{\pi}{4} [(D_{mast} + t_{izMast1} \cdot 2)^2 - D_{mast}^2] = 96.5$ sq in

Weight of Ice on Mast = $W_{ICE_{mast1}} := I_d \cdot \frac{A_{i_{mast}}}{144} = 38$ plf **BLC 3**

Development of Wind & Ice Load on Antennas

Antenna Data:

	(AT&T)	
Antenna Model =	Quintel QS46512-2	
Antenna Shape =	Flat	(User Input)
Antenna Height =	$L_{ant} := 52$	in (User Input)
Antenna Width =	$W_{ant} := 12$	in (User Input)
Antenna Thickness =	$T_{ant} := 10.8$	in (User Input)
Antenna Weight =	$WT_{ant} := 75$	lbs (User Input)
Number of Antennas =	$N_{ant} := 3$	(User Input)
Antenna Aspect Ratio =	$Ar_{ant} := \frac{L_{ant}}{W_{ant}} = 4.3$	
Antenna Force Coefficient =	$Ca_{ant} = 1.28$	

Wind Load (without ice)

Surface Area for One Antenna =	$SA_{ant} := \frac{L_{ant} \cdot W_{ant}}{144} = 4.3$	sf
Antenna Projected Surface Area =	$A_{ant} := SA_{ant} \cdot N_{ant} = 13$	sf
Total Antenna Wind Force =	$F_{ant} := qz_{ATT} \cdot G_H \cdot Ca_{ant} \cdot K_a \cdot A_{ant} = 622$	lbs BLC 5,7

Wind Load (with ice)

Surface Area for One Antenna w/ Ice =	$SA_{ICEant} := \frac{(L_{ant} + 2 \cdot t_{izATT}) \cdot (W_{ant} + 2 \cdot t_{izATT})}{144} = 6.3$	sf
Antenna Projected Surface Area w/ Ice =	$A_{ICEant} := SA_{ICEant} \cdot N_{ant} = 19$	sf
Total Antenna Wind Force w/ Ice =	$F_{ant} := qz_{ice.ATT} \cdot G_H \cdot Ca_{ant} \cdot K_a \cdot A_{ICEant} = 228$	lbs BLC 4,6

Gravity Load (without ice)

Weight of All Antennas =	$WT_{ant} \cdot N_{ant} = 225$	lbs BLC 2
---------------------------------	--	------------------

Gravity Loads (ice only)

Volume of Each Antenna =	$V_{ant} := L_{ant} \cdot W_{ant} \cdot T_{ant} = 6739$	cu in
Volume of Ice on Each Antenna =	$V_{ice} := (L_{ant} + 2 \cdot t_{izATT}) \cdot (W_{ant} + 2 \cdot t_{izATT}) \cdot (T_{ant} + 2 \cdot t_{izATT}) - V_{ant} = 6938$	
Weight of Ice on Each Antenna =	$W_{ICEant} := \frac{V_{ice}}{1728} \cdot Id = 225$	lbs
Weight of Ice on All Antennas =	$W_{ICEant} \cdot N_{ant} = 674$	lbs BLC 3

Development of Wind & Ice Load on Antennas

Antenna Data:

(AT&T)

Antenna Model =	Commscope TMAT21x23B68-31-43
Antenna Shape =	Flat (User Input)
Antenna Height =	$L_{ant} := 9.7$ in (User Input)
Antenna Width =	$W_{ant} := 11$ in (User Input)
Antenna Thickness =	$T_{ant} := 3.9$ in (User Input)
Antenna Weight =	$WT_{ant} := 22$ lbs (User Input)
Number of Antennas =	$N_{ant} := 6$ (User Input)
Antenna Aspect Ratio =	$Ar_{ant} := \frac{L_{ant}}{W_{ant}} = 0.9$
Antenna Force Coefficient =	$Ca_{ant} = 1.2$

Wind Load (without ice)

Surface Area for One Antenna =	$SA_{ant} := \frac{L_{ant} \cdot W_{ant}}{144} = 0.7$	sf
Antenna Projected Surface Area =	$A_{ant} := SA_{ant} \cdot N_{ant} = 4.4$	sf

Total Antenna Wind Force =

$F_{ant} := qz_{ATT} \cdot G_H \cdot Ca_{ant} \cdot K_a \cdot A_{ant} = 199$ lbs **BLC 5,7**

Wind Load (with ice)

Surface Area for One Antenna w/ Ice =	$SA_{ICEant} := \frac{(L_{ant} + 2 \cdot t_{zATT}) \cdot (W_{ant} + 2 \cdot t_{zATT})}{144} = 1.5$	sf
Antenna Projected Surface Area w/ Ice =	$A_{ICEant} := SA_{ICEant} \cdot N_{ant} = 8.8$	sf

Total Antenna Wind Force w/ Ice =

$F_{ant} := qz_{ice} \cdot ATT \cdot G_H \cdot Ca_{ant} \cdot K_a \cdot A_{ICEant} = 99$ lbs **BLC 4,6**

Gravity Load (without ice)

Weight of All Antennas =

$WT_{ant} \cdot N_{ant} = 132$ lbs **BLC 2**

Gravity Loads (ice only)

Volume of Each Antenna =	$V_{ant} := L_{ant} \cdot W_{ant} \cdot T_{ant} = 416$	cu in
Volume of Ice on Each Antenna =	$V_{ice} := (L_{ant} + 2 \cdot t_{zATT}) \cdot (W_{ant} + 2 \cdot t_{zATT}) \cdot (T_{ant} + 2 \cdot t_{zATT}) - V_{ant} = 1300$	
Weight of Ice on Each Antenna =	$W_{ICEant} := \frac{V_{ice}}{1728} \cdot Id = 42$	lbs
Weight of Ice on All Antennas =	$W_{ICEant} \cdot N_{ant} = 253$	lbs BLC 3

Development of Wind & Ice Load on Antenna Mounts

Subject:

Loads on North Mast on Structure #1102

Location:

Norwalk, CT

Rev. 0: 11/21/18

Prepared by: T.J.L. Checked by: C.A.G.
 Job No. 18000.55

Mount Data:

(AT&T)

Mount Type:

Tri-Bracket and Pipes

Mount Shape =

Flat

(User Input)

Mount Projected Surface Area =

CaAa := 0

sf

(User Input)

Mount Projected Surface Area w/ Ice =

CaAa_{ice} := 0

sf

(User Input)

Mount Weight =

WT_{mnt} := 265

lbs

(User Input)

Mount Weight w/ Ice =

WT_{mnt.ice} := 300

lbs

Wind Load (without ice)

Total Mount Wind Force =

$$F_{mnt} := qZ_{ATT} \cdot G_H \cdot CaAa = 0$$

lbs

BLC 5,7

Wind Load (with ice)

Total Mount Wind Force =

$$F_{mnt} := qZ_{ice.ATT} \cdot G_H \cdot CaAa_{ice} = 0$$

lbs

BLC 4,6

Gravity Loads (without ice)

Weight of All Mounts =

$$WT_{mnt} = 265$$

lbs

BLC 2

Gravity Loads (ice only)

Weight of Ice on All Mounts =

$$WT_{mnt.ice} - WT_{mnt} = 35$$

lbs

BLC 3

Development of Wind & Ice Load on Antennas

Antenna Data:

	(T-Mobile)	
Antenna Model =	RFSAPX16DWV-16DWVS	
Antenna Shape =	Flat	(User Input)
Antenna Height =	$L_{ant} := 55.9$ in	(User Input)
Antenna Width =	$W_{ant} := 13$ in	(User Input)
Antenna Thickness =	$T_{ant} := 3.15$ in	(User Input)
Antenna Weight =	$WT_{ant} := 41$ lbs	(User Input)
Number of Antennas =	$N_{ant} := 3$	(User Input)
Antenna Aspect Ratio =	$Ar_{ant} := \frac{L_{ant}}{W_{ant}} = 4.3$	
Antenna Force Coefficient =	$Ca_{ant} = 1.28$	

Wind Load (without ice)

Surface Area for One Antenna =	$SA_{ant} := \frac{L_{ant} \cdot W_{ant}}{144} = 5$	sf
Antenna Projected Surface Area =	$A_{ant} := SA_{ant} \cdot N_{ant} = 15.1$	sf

Total Antenna Wind Force = $F_{ant} := qz_{TMO} \cdot G_H \cdot Ca_{ant} \cdot K_a \cdot A_{ant} = 737$ lbs **BLC 5,7**

Wind Load (with ice)

Surface Area for One Antenna w/ Ice =	$SA_{ICEant} := \frac{(L_{ant} + 2 \cdot t_{izTMO}) \cdot (W_{ant} + 2 \cdot t_{izTMO})}{144} = 7.2$	sf
Antenna Projected Surface Area w/ Ice =	$A_{ICEant} := SA_{ICEant} \cdot N_{ant} = 21.6$	sf

Total Antenna Wind Force w/ Ice = $F_{ant} := qz_{ice.TMO} \cdot G_H \cdot Ca_{ant} \cdot K_a \cdot A_{ICEant} = 264$ lbs **BLC 4,6**

Gravity Load (without ice)

Weight of All Antennas = $WT_{ant} \cdot N_{ant} = 123$ lbs **BLC 2**

Gravity Loads (ice only)

Volume of Each Antenna =	$V_{ant} := L_{ant} \cdot W_{ant} \cdot T_{ant} = 2289$	cu in
Volume of Ice on Each Antenna =	$V_{ice} := (L_{ant} + 2 \cdot t_{izTMO}) \cdot (W_{ant} + 2 \cdot t_{izTMO}) \cdot (T_{ant} + 2 \cdot t_{izTMO}) - V_{ant} = 5381$	
Weight of Ice on Each Antenna =	$W_{ICEant} := \frac{V_{ice}}{1728} \cdot \rho_d = 174$	lbs
Weight of Ice on All Antennas =	$W_{ICEant} \cdot N_{ant} = 523$	lbs BLC 3

Development of Wind & Ice Load on Antennas

Antenna Data:

	(T-Mbble)	
Antenna Model =	CommscopeATSBT-TOP-FM-4G Bias Tee	
Antenna Shape =	Flat	(User Input)
Antenna Height =	$L_{ant} := 5.63$	in (User Input)
Antenna Width =	$W_{ant} := 3.7$	in (User Input)
Antenna Thickness =	$T_{ant} := 2$	in (User Input)
Antenna Weight =	$WT_{ant} := 2$	lbs (User Input)
Number of Antennas =	$N_{ant} := 3$	(User Input)
Antenna Aspect Ratio =	$Ar_{ant} := \frac{L_{ant}}{W_{ant}} = 1.5$	
Antenna Force Coefficient =	$Ca_{ant} = 1.2$	

Wind Load (without ice)

Surface Area for One Antenna =	$SA_{ant} := \frac{L_{ant} \cdot W_{ant}}{144} = 0.1$	sf
Antenna Projected Surface Area =	$A_{ant} := SA_{ant} \cdot N_{ant} = 0.4$	sf

Total Antenna Wind Force = $F_{ant} := qz_{TMO} \cdot G_H \cdot Ca_{ant} \cdot K_a \cdot A_{ant} = 20$ lbs **BLC 5,7**

Wind Load (with ice)

Surface Area for One Antenna w/ Ice =	$SA_{ICEant} := \frac{(L_{ant} + 2 \cdot t_{izTMO}) \cdot (W_{ant} + 2 \cdot t_{izTMO})}{144} = 0.5$	sf
Antenna Projected Surface Area w/ Ice =	$A_{ICEant} := SA_{ICEant} \cdot N_{ant} = 1.6$	sf

Total Antenna Wind Force w/ Ice = $F_{ant} := qz_{ice.TMO} \cdot G_H \cdot Ca_{ant} \cdot K_a \cdot A_{ICEant} = 19$ lbs **BLC 4,6**

Gravity Load (without ice)

Weight of All Antennas = $WT_{ant} \cdot N_{ant} = 6$ lbs **BLC 2**

Gravity Loads (ice only)

Volume of Each Antenna =	$V_{ant} := L_{ant} \cdot W_{ant} \cdot T_{ant} = 42$	cu in
Volume of Ice on Each Antenna =	$V_{ice} := (L_{ant} + 2 \cdot t_{izTMO}) \cdot (W_{ant} + 2 \cdot t_{izTMO}) \cdot (T_{ant} + 2 \cdot t_{izTMO}) - V_{ant} = 448$	
Weight of Ice on Each Antenna =	$W_{ICEant} := \frac{V_{ice}}{1728} \cdot Id = 15$	lbs

Weight of Ice on All Antennas = $W_{ICEant} \cdot N_{ant} = 44$ lbs **BLC 3**

Development of Wind & Ice Load on Antenna Mounts

Mount Data:

(T-Mbble)

Mount Type:

Tri-Bracket and Pipes

Mount Shape =

Flat (User Input)

Mount Projected Surface Area =

CaAa := 0 sf (User Input)

Mount Projected Surface Area w/ Ice =

CaAa_{ice} := 0 sf (User Input)

Mount Weight =

WT_{mnt} := 265 lbs (User Input)

Mount Weight w/ Ice =

WT_{mnt.ice} := 300 lbs

Wind Load (without ice)

Total Mount Wind Force =

$F_{mnt} := qZ_{TMO} \cdot G_H \cdot CaAa = 0$ lbs **BLC 5,7**

Wind Load (with ice)

Total Mount Wind Force =

$F_{mnt} := qZ_{ice.TMO} \cdot G_H \cdot CaAa_{ice} = 0$ lbs **BLC 4,6**

Gravity Loads (without ice)

Weight of All Mounts =

WT_{mnt} = 265 lbs **BLC 2**

Gravity Loads (ice only)

Weight of Ice on All Mounts =

WT_{mnt.ice} - WT_{mnt} = 35 lbs **BLC 3**

Development of Wind & Ice Load on Coax Cables

Coax Cable Data:

Coax Type =	HELIX 1-1/4"	
Shape =	Round	(User Input)
Coax Outside Diameter =	$D_{\text{coax}} := 1.55$	in (User Input)
Coax Cable Length =	$L_{\text{coax}} := 20$	ft (User Input)
Weight of Coax per foot =	$Wt_{\text{coax}} := 0.66$	plf (User Input)
Total Number of Coax =	$N_{\text{coax}} := 24$	(User Input)
Total Number of Exterior Coax =	$Ne_{\text{coax}} := 24$	(User Input) (12AT&T & 12 T-Mobile)
No. of Coax Projecting Outside Face of Mast =	$NP_{\text{coax}} := 4$	(User Input)
Coax aspect ratio,	$Ar_{\text{coax}} := \frac{(L_{\text{coax}} \cdot 12)}{D_{\text{coax}}} = 154.8$	
Coax Cable Force Factor Coefficient =	$Ca_{\text{coax}} = 1.2$	

Wind Load (without ice)

Coax projected surface area = $A_{\text{coax}} := \frac{(NP_{\text{coax}} \cdot D_{\text{coax}})}{12} = 0.5$ s/ft

Total Coax Wind Force = $F_{\text{coax}} := Ca_{\text{coax}} \cdot qz_{\text{Mast1}} \cdot G_H \cdot A_{\text{coax}} = 22$ plf **BLC 5,7**

Wind Load (with ice)

Coax projected surface area w/ Ice = $A_{\text{ICE}_{\text{coax}}} := \frac{(NP_{\text{coax}} \cdot D_{\text{coax}} + 2 \cdot t_{\text{izMast1}})}{12} = 0.9$ s/ft

Total Coax Wind Force w/ Ice = $Fi_{\text{coax}} := Ca_{\text{coax}} \cdot qz_{\text{Ice.Mast1}} \cdot G_H \cdot A_{\text{ICE}_{\text{coax}}} = 9$ plf **BLC 4,6**

Gravity Loads (without ice)

Weight of all cables w/o ice $WT_{\text{coax}} := Wt_{\text{coax}} \cdot N_{\text{coax}} = 16$ plf **BLC 2**

Gravity Loads (ice only)

Ice Area per Linear Foot = $Ai_{\text{coax}} := \frac{\pi}{4} [(D_{\text{coax}} + 2 \cdot t_{\text{izMast1}})^2 - D_{\text{coax}}^2] = 23.6$ sq in

Ice Weight All Coax per foot = $WTi_{\text{coax}} := Ne_{\text{coax}} \cdot Id \cdot \frac{Ai_{\text{coax}}}{144} = 220$ plf **BLC 3**

Development of Wind & Ice Load on Brace Member

Member Data:

HSS6x6x1/4

Antenna Shape = Flat (User Input)

Height = $H_{mem} := 6$ in (User Input)

Width = $W_{mem} := 6$ in (User Input)

Thickness = $t_{mem} := 0.25$ in (User Input)

Length = $L_{mem} := 42$ in (User Input)

Member Aspect Ratio = $Ar_{mem} := \frac{L_{mem}}{W_{mem}} = 7.0$

Member Force Coefficient = $Ca_{mem} = 1.4$

Wind Load (without ice)

Member Projected Surface Area = $A_{mem} := \frac{H_{mem}}{12} = 0.5$ sq ft

Total Member Wind Force = $F_{mem} := qz_{Mast1} \cdot G_H \cdot Ca_{mem} \cdot A_{mem} = 25$ plf **BLC 5,7**

Wind Load (with ice)

Member Projected Surface Area w/ ice = $A_{ICEmem} := \frac{(H_{mem} + 2 \cdot t_{izMast1})}{12} = 0.8$ sq ft

Total Member Wind Force w/ Ice = $F_{i_{mem}} := qz_{ice.Mast1} \cdot G_H \cdot Ca_{mem} \cdot A_{ICEmem} = 11$ plf **BLC 4,6**

Gravity Load (without ice)

Weight of Member = Self Weight plf **BLC 1**

Gravity Loads (ice only)

Ice Area per Linear foot = $Ai_{mem} := (W_{mem} + 2 \cdot t_{izMast1}) \cdot (H_{mem} + 2 \cdot t_{izMast1}) - W_{mem} \cdot H_{mem} = 67$ sq in

Weight of Ice on Member = $W_{ICE.mem} := Id \cdot \frac{Ai_{mem}}{144} = 26$ plf **BLC 3**

(Global) Model Settings

Display Sections for Member Calcs	5
Max Internal Sections for Member Calcs	97
Include Shear Deformation?	Yes
Increase Nailing Capacity for Wind?	Yes
Include Warping?	Yes
Trans Load Btwn Intersecting Wood Wall?	Yes
Area Load Mesh (in^2)	144
Merge Tolerance (in)	.12
P-Delta Analysis Tolerance	0.50%
Include P-Delta for Walls?	Yes
Automatically Iterate Stiffness for Walls?	No
Max Iterations for Wall Stiffness	3
Gravity Acceleration (ft/sec^2)	32.2
Wall Mesh Size (in)	12
Eigensolution Convergence Tol. (1.E-)	4
Vertical Axis	Y
Global Member Orientation Plane	XZ
Static Solver	Sparse Accelerated
Dynamic Solver	Standard Solver

Hot Rolled Steel Code	AISC 14th(360-10): LRFD
Adjust Stiffness?	Yes(Iterative)
RISAConnection Code	AISC 14th(360-10): ASD
Cold Formed Steel Code	AISI 1999: ASD
Wood Code	AF&PA NDS-91/97: ASD
Wood Temperature	< 100F
Concrete Code	ACI 318-02
Masonry Code	ACI 530-05: ASD
Aluminum Code	AA ADM1-05: ASD - Building
Stainless Steel Code	AISC 14th(360-10): ASD
Adjust Stiffness?	Yes(Iterative)

Number of Shear Regions	4
Region Spacing Increment (in)	4
Biaxial Column Method	PCA Load Contour
Parme Beta Factor (PCA)	.65
Concrete Stress Block	Rectangular
Use Cracked Sections?	Yes
Use Cracked Sections Slab?	Yes
Bad Framing Warnings?	No
Unused Force Warnings?	Yes
Min 1 Bar Diam. Spacing?	No
Concrete Rebar Set	REBAR_SET_ASTMA615
Min % Steel for Column	1
Max % Steel for Column	8

(Global) Model Settings, Continued

Seismic Code	UBC 1997
Seismic Base Elevation (ft)	Not Entered
Add Base Weight?	No
Ct X	.035
Ct Z	.035
T X (sec)	Not Entered
T Z (sec)	Not Entered
R X	8.5
R Z	8.5
Ca	.36
Cv	.54
Nv	1
Occupancy Category	4
Seismic Zone	3
Om Z	1
Om X	1
Rho Z	1
Rho X	1
Footing Overturning Safety Factor	1.5
Optimize for OTM/Sliding	No
Check Concrete Bearing	No
Footing Concrete Weight (k/ft^3)	0
Footing Concrete f'c (ksi)	3
Footing Concrete Ec (ksi)	4000
Lambda	1
Footing Steel fy (ksi)	60
Minimum Steel	0.0018
Maximum Steel	0.0075
Footing Top Bar	#3
Footing Top Bar Cover (in)	3.5
Footing Bottom Bar	#3
Footing Bottom Bar Cover (in)	3.5
Pedestal Bar	#3
Pedestal Bar Cover (in)	1.5
Pedestal Ties	#3

Hot Rolled Steel Properties

	Label	E [ksi]	G [ksi]	Nu	Therm (\1...	Density[k/ft^3]	Yield[ksi]	Ry	Fu[ksi]	Rt
1	A36 Gr.36	29000	11154	.3	.65	.49	36	1.5	58	1.2
2	A572 Gr.50	29000	11154	.3	.65	.49	50	1.1	58	1.2
3	A992	29000	11154	.3	.65	.49	50	1.1	58	1.2
4	A500 Gr.42	29000	11154	.3	.65	.49	42	1.3	58	1.1
5	A500 Gr.46	29000	11154	.3	.65	.49	46	1.2	58	1.1
6	A53 Gr. B	29000	11154	.3	.65	.49	35	1.5	58	1.2

Hot Rolled Steel Section Sets

	Label	Shape	Type	Design List	Material	Design ...	A [in ²]	I _{yy} [in ⁴]	I _{zz} [in ⁴]	J [in ⁴]
1	Mast	PIPE 12.0X	Column	Pipe	A53 Gr. B	Typical	17.5	339	339	678
2	Brace	HSS6X6X4	Beam	Tube	A500 Gr.46	Typical	5.24	28.6	28.6	45.6

Hot Rolled Steel Design Parameters

	Label	Shape	Length[ft]	L _{byy} [ft]	L _{bzz} [ft]	L _{comp top} [ft]	L _{comp bot} [ft]	L-torqu...	K _{yy}	K _{zz}	C _b	Function
1	M1	Mast	33	Segment	Segment	L _{byy}						Lateral
2	M2	Brace	2.25			L _{byy}						Lateral
3	M3	Brace	7			L _{byy}						Lateral
4	M4	Brace	2.25			L _{byy}						Lateral
5	M5	Brace	2.25			L _{byy}						Lateral
6	M6	Brace	7			L _{byy}						Lateral
7	M7	Brace	2.25			L _{byy}						Lateral
8	M8	Mast	22									Lateral

Member Primary Data

	Label	I Joint	J Joint	K Joint	Rotate(d...	Section/Shape	Type	Design List	Material	Design Ru...
1	M1	N1	N3			Mast	Column	Pipe	A53 Gr. B	Typical
2	M2	N8	N12			Brace	Beam	Tube	A500 Gr...	Typical
3	M3	N12	N11			Brace	Beam	Tube	A500 Gr...	Typical
4	M4	N11	N7			Brace	Beam	Tube	A500 Gr...	Typical
5	M5	N6	N10			Brace	Beam	Tube	A500 Gr...	Typical
6	M6	N10	N9			Brace	Beam	Tube	A500 Gr...	Typical
7	M7	N9	N5			Brace	Beam	Tube	A500 Gr...	Typical
8	M8	N3	N4			Mast	Column	Pipe	A53 Gr. B	Typical

Joint Coordinates and Temperatures

	Label	X [ft]	Y [ft]	Z [ft]	Temp [F]	Detach From Dia...
1	N1	0	0	0	0	
2	N2	0	21.5	0	0	
3	N3	0	33	0	0	
4	N4	0	55	0	0	
5	N5	-2.25	0	3.5	0	
6	N6	-2.25	0	-3.5	0	
7	N7	-2.25	21.5	3.5	0	
8	N8	-2.25	21.5	-3.5	0	
9	N9	0	0	3.5	0	
10	N10	0	0	-3.5	0	
11	N11	0	21.5	3.5	0	
12	N12	0	21.5	-3.5	0	

Joint Boundary Conditions

	Joint Label	X [k/in]	Y [k/in]	Z [k/in]	X Rot.[k-ft/rad]	Y Rot.[k-ft/rad]	Z Rot.[k-ft/rad]
1	N8	Reaction	Reaction	Reaction			
2	N7	Reaction	Reaction	Reaction			
3	N5	Reaction	Reaction	Reaction			
4	N6	Reaction	Reaction	Reaction			

Member Point Loads (BLC 2 : Weight of Appurtenances)

	Member Label	Direction	Magnitude[k,k-ft]	Location[ft,%]
1	M8	Y	-.225	10
2	M8	Y	-.132	10
3	M8	Y	-.265	10
4	M8	Y	-.123	19
5	M8	Y	-.006	19
6	M8	Y	-.265	19

Member Point Loads (BLC 3 : Weight of Ice Only)

	Member Label	Direction	Magnitude[k,k-ft]	Location[ft,%]
1	M8	Y	-.674	10
2	M8	Y	-.253	10
3	M8	Y	-.035	10
4	M8	Y	-.523	19
5	M8	Y	-.044	19
6	M8	Y	-.035	19

Member Point Loads (BLC 4 : (x) TIA Wind with Ice)

	Member Label	Direction	Magnitude[k,k-ft]	Location[ft,%]
1	M8	X	.228	10
2	M8	X	.099	10
3	M8	X	.264	19
4	M8	X	.019	19

Member Point Loads (BLC 5 : (x) TIA Wind)

	Member Label	Direction	Magnitude[k,k-ft]	Location[ft,%]
1	M8	X	.622	10
2	M8	X	.199	10
3	M8	X	.737	19
4	M8	X	.02	19

Member Point Loads (BLC 6 : (z) TIA Wind with Ice)

	Member Label	Direction	Magnitude[k,k-ft]	Location[ft,%]
1	M8	Z	.228	10
2	M8	Z	.099	10
3	M8	Z	.264	19
4	M8	Z	.019	19

Member Point Loads (BLC 7 : (z) TIA Wind)

	Member Label	Direction	Magnitude[k,k-ft]	Location[ft,%]
1	M8	Z	.622	10
2	M8	Z	.199	10
3	M8	Z	.737	19
4	M8	Z	.02	19

Member Distributed Loads (BLC 2 : Weight of Appurtenances)

	Member Label	Direction	Start Magnitude[k/ft,F,ksf]	End Magnitude[k/...]	Start Location[ft,%]	End Location[ft,%]
1	M1	Y	-.016	-.016	23	33
2	M8	Y	-.016	-.016	0	8

Member Distributed Loads (BLC 3 : Weight of Ice Only)

	Member Label	Direction	Start Magnitude[k/ft,F,ksf]	End Magnitude[k/...]	Start Location[ft,%]	End Location[ft,%]
1	M1	Y	-.038	-.038	0	0
2	M8	Y	-.038	-.038	0	0
3	M1	Y	-.22	-.22	23	33
4	M8	Y	-.22	-.22	0	8
5	M2	Y	-.026	-.026	0	0
6	M3	Y	-.026	-.026	0	0
7	M4	Y	-.026	-.026	0	0
8	M5	Y	-.026	-.026	0	0
9	M6	Y	-.026	-.026	0	0
10	M7	Y	-.026	-.026	0	0

Member Distributed Loads (BLC 4 : (x) TIA Wind with Ice)

	Member Label	Direction	Start Magnitude[k/ft,F,ksf]	End Magnitude[k/...]	Start Location[ft,%]	End Location[ft,%]
1	M1	X	.008	.008	0	0
2	M8	X	.008	.008	0	8
3	M1	X	.012	.012	23	33
4	M8	X	.012	.012	0	8
5	M3	X	.011	.011	0	0
6	M6	X	.011	.011	0	0

Member Distributed Loads (BLC 5 : (x) TIA Wind)

	Member Label	Direction	Start Magnitude[k/ft,F,ksf]	End Magnitude[k/...]	Start Location[ft,%]	End Location[ft,%]
1	M1	X	.023	.023	0	0
2	M8	X	.023	.023	0	8
3	M1	X	.034	.034	23	33
4	M8	X	.034	.034	0	8
5	M3	X	.025	.025	0	0
6	M6	X	.025	.025	0	0

Member Distributed Loads (BLC 6 : (z) TIA Wind with Ice)

	Member Label	Direction	Start Magnitude[k/ft,F,ksf]	End Magnitude[k/...]	Start Location[ft,%]	End Location[ft,%]
1	M1	Z	.008	.008	0	0
2	M8	Z	.008	.008	0	8
3	M1	Z	.012	.012	23	33
4	M8	Z	.012	.012	0	8
5	M2	Z	.011	.011	0	0
6	M5	Z	.011	.011	0	0

Member Distributed Loads (BLC 7 : (z) TIA Wind)

	Member Label	Direction	Start Magnitude[k/ft,F,ksf]	End Magnitude[k/...]	Start Location[ft,%]	End Location[ft,%]
1	M1	Z	.023	.023	0	0
2	M8	Z	.023	.023	0	8
3	M1	Z	.034	.034	23	33



Member Distributed Loads (BLC 7 : (z) TIA Wind) (Continued)

	Member Label	Direction	Start Magnitude[k/ft,F,ksf]	End Magnitude[k/...	Start Location[ft,%]	End Location[ft,%]
4	M8	Z	.034	.034	0	8
5	M2	Z	.013	.013	0	0
6	M5	Z	.013	.013	0	0

Basic Load Cases

	BLC Description	Category	X Gravity	Y Gravity	Z Gravity	Joint	Point	Distribu...	Area(M...	Surface...
1	Self Weight	None		-1						
2	Weight of Appurtenances	None					6	2		
3	Weight of Ice Only	None					6	10		
4	(x) TIA Wind with Ice	None					4	6		
5	(x) TIA Wind	None					4	6		
6	(z) TIA Wind with Ice	None					4	6		
7	(z) TIA Wind	None					4	6		

Load Combinations

	Description	So...P...	S...	BLCFac..	BLCFac..	BLCFac..	BLCFac..	BLCFac..	BLCFac..	BLCFac..	BLCFac..	BLCFac..	BLCFac..	BLCFac..
1	1.2D + 1.6W (X-direction)	Yes	Y	1	1.2	2	1.2	5	1.6					
2	0.9D + 1.6W (X-direction)	Yes	Y	1	.9	2	.9	5	1.6					
3	1.2D + 1.0Di + 1.0Wi (X-...	Yes	Y	1	1.2	2	1.2	3	1	4	1			
4	1.2D + 1.6W (Z-direction)	Yes	Y	1	1.2	2	1.2	7	1.6					
5	0.9D + 1.6W (Z-direction)	Yes	Y	1	.9	2	.9	7	1.6					
6	1.2D + 1.0Di + 1.0Wi (Z-d...	Yes	Y	1	1.2	2	1.2	3	1	6	1			

Envelope Joint Reactions

	Joint		X [k]	LC	Y [k]	LC	Z [k]	LC	MX [k-ft]	LC	MY [k-ft]	LC	MZ [k-ft]	LC
1	N8	max	-1.403	6	3.18	3	-1.107	3	0	6	0	6	0	6
2		min	-4.708	1	-1.936	5	-4.147	4	0	1	0	1	0	1
3	N7	max	2.569	5	4.567	4	2.912	1	0	6	0	6	0	6
4		min	-4.708	1	-.454	2	-3.756	5	0	1	0	1	0	1
5	N5	max	1.922	1	3.92	3	1.238	5	0	6	0	6	0	6
6		min	-.944	5	.213	5	-1.232	1	0	1	0	1	0	1
7	N6	max	1.922	1	3.92	3	1.562	4	0	6	0	6	0	6
8		min	1.024	6	2.033	5	.714	3	0	1	0	1	0	1
9	Totals:	max	0	6	14.199	6	0	3						
10		min	-5.573	1	4.49	2	-5.103	4						

Envelope Joint Displacements

	Joint		X [in]	LC	Y [in]	LC	Z [in]	LC	X Rotation [...	LC	Y Rotation [...	LC	Z Rotation [...	LC
1	N1	max	-.004	5	-.13	5	0	3	0	3	0	3	3.013e-03	2
2		min	-.033	1	-.429	3	-.035	4	-2.402e-03	4	-8.935e-05	4	-1.121e-03	6
3	N2	max	.077	1	-.131	5	.104	4	8.052e-03	4	7.402e-04	4	-3.746e-04	5
4		min	.004	5	-.433	3	0	1	0	1	0	1	-1.022e-02	1
5	N3	max	2.486	1	-.132	5	2.212	4	2.087e-02	4	7.402e-04	4	-3.777e-04	5
6		min	.056	5	-.436	3	0	1	0	1	0	1	-2.307e-02	1
7	N4	max	9.668	1	-.132	5	8.812	4	2.639e-02	4	7.402e-04	4	-3.796e-04	5
8		min	.156	5	-.438	3	0	1	0	1	0	1	-2.859e-02	1



Envelope Joint Displacements (Continued)

	Joint		X [in]	LC	Y [in]	LC	Z [in]	LC	X Rotation [...]	LC	Y Rotation [...]	LC	Z Rotation [...]	LC
9	N5	max	0	6	0	6	0	6	-2.596e-03	5	1.452e-03	4	-8.991e-04	5
10		min	0	1	0	1	0	1	-4.998e-03	3	-1.64e-04	1	-1.108e-02	3
11	N6	max	0	6	0	6	0	6	4.998e-03	3	1.501e-03	4	-4.461e-03	2
12		min	0	1	0	1	0	1	2.396e-04	5	9.507e-05	3	-1.146e-02	6
13	N7	max	0	6	0	6	0	6	2.554e-03	5	3.876e-04	1	-8.635e-03	2
14		min	0	1	0	1	0	1	-4.008e-03	3	-4.351e-03	4	-1.321e-02	4
15	N8	max	0	6	0	6	0	6	5.83e-03	4	-1.473e-04	3	5.013e-03	5
16		min	0	1	0	1	0	1	-6.744e-04	2	-4.405e-03	4	-1.218e-02	3
17	N9	max	0	5	-.023	5	0	3	-2.596e-03	5	7.949e-04	4	-7.89e-04	5
18		min	0	1	-.284	3	-.034	4	-4.998e-03	3	2.974e-04	3	-8.939e-03	3
19	N10	max	0	6	-.11	2	0	1	4.998e-03	3	6.502e-04	5	-2.981e-03	2
20		min	0	1	-.295	6	-.034	4	2.396e-04	5	-5.128e-04	1	-9.406e-03	6
21	N11	max	.001	1	-.235	2	.103	4	2.554e-03	5	-4.607e-04	3	-8.913e-03	2
22		min	0	5	-.339	4	0	3	-4.008e-03	3	-2.305e-03	4	-1.07e-02	4
23	N12	max	.001	1	.128	5	.103	4	5.83e-03	4	1.212e-03	1	3.95e-03	5
24		min	0	6	-.317	3	-.001	1	-6.744e-04	2	-2.158e-03	5	-1.047e-02	3

Envelope AISC 14th(360-10): LRFD Steel Code Checks

Member	Shape	Code Check	Loc...	LC	Shea..	Loc.....	L..phi*Pn..	phi*Pn..	phi*M...	phi*M....	Eqn			
1	M1	PIPE_12.0X	.456	21....	1	.034	21....	4	524.199	551.25	184.275	184.275	1..H1-1b	
2	M2	HSS6X6X4	.356	2.25	5	.067	0	z	4	214.996	216.936	38.64	38.64	1..H1-1b
3	M3	HSS6X6X4	.656	3.5	4	.394	7	y	4	198.868	216.936	38.64	38.64	1..H3-6
4	M4	HSS6X6X4	.489	0	4	.075	2.25	y	4	214.996	216.936	38.64	38.64	1..H1-1b
5	M5	HSS6X6X4	.270	2.25	3	.064	0	y	3	214.996	216.936	38.64	38.64	1..H1-1b
6	M6	HSS6X6X4	.528	3.5	3	.334	0	y	3	198.868	216.936	38.64	38.64	1..H3-6
7	M7	HSS6X6X4	.270	0	3	.064	2.25	y	3	214.996	216.936	38.64	38.64	1..H1-1b
8	M8	PIPE_12.0X	.220	0	1	.020	0		1	458.537	551.25	184.275	184.275	2..H1-1b

Joint Reactions

	LC	Joint Label	X [k]	Y [k]	Z [k]	MX [k-ft]	MY [k-ft]	MZ [k-ft]
1	1	N8	-4.708	-.083	-2.912	0	0	0
2	1	N7	-4.708	-.083	2.912	0	0	0
3	1	N5	1.922	3.077	-1.232	0	0	0
4	1	N6	1.922	3.077	1.232	0	0	0
5	1	Totals:	-5.573	5.987	0			
6	1	COG (ft):	X: -.036	Y: 30.25	Z: 0			

Joint Reactions

	LC	Joint Label	X [k]	Y [k]	Z [k]	MX [k-ft]	MY [k-ft]	MZ [k-ft]
1	2	N8	-4.622	-.454	-2.858	0	0	0
2	2	N7	-4.622	-.454	2.858	0	0	0
3	2	N5	1.836	2.699	-1.178	0	0	0
4	2	N6	1.836	2.699	1.178	0	0	0
5	2	Totals:	-5.573	4.49	0			
6	2	COG (ft):	X: -.036	Y: 30.25	Z: 0			

Joint Reactions

	LC	Joint Label	X [k]	Y [k]	Z [k]	MX [k-ft]	MY [k-ft]	MZ [k-ft]
1	3	N8	-1.783	3.18	-1.107	0	0	0
2	3	N7	-1.783	3.18	1.107	0	0	0
3	3	N5	1.129	3.92	-.714	0	0	0
4	3	N6	1.129	3.92	.714	0	0	0
5	3	Totals:	-1.308	14.199	0			
6	3	COG (ft):	X: -.034	Y: 31.298	Z: 0			

Joint Reactions

	LC	Joint Label	X [k]	Y [k]	Z [k]	MX [k-ft]	MY [k-ft]	MZ [k-ft]
1	4	N8	-3.121	-1.572	-4.147	0	0	0
2	4	N7	2.497	4.567	-3.714	0	0	0
3	4	N5	-.872	.583	1.197	0	0	0
4	4	N6	1.495	2.41	1.562	0	0	0
5	4	Totals:	0	5.987	-5.103			
6	4	COG (ft):	X: -.036	Y: 30.25	Z: 0			

Joint Reactions

	LC	Joint Label	X [k]	Y [k]	Z [k]	MX [k-ft]	MY [k-ft]	MZ [k-ft]
1	5	N8	-3.038	-1.936	-4.092	0	0	0
2	5	N7	2.569	4.18	-3.756	0	0	0
3	5	N5	-.944	.213	1.238	0	0	0
4	5	N6	1.412	2.033	1.506	0	0	0
5	5	Totals:	0	4.49	-5.103			
6	5	COG (ft):	X: -.036	Y: 30.25	Z: 0			

Joint Reactions

	LC	Joint Label	X [k]	Y [k]	Z [k]	MX [k-ft]	MY [k-ft]	MZ [k-ft]
1	6	N8	-1.403	2.822	-1.402	0	0	0
2	6	N7	-.072	4.305	-.466	0	0	0
3	6	N5	.451	3.313	-.123	0	0	0
4	6	N6	1.024	3.758	.787	0	0	0
5	6	Totals:	0	14.199	-1.204			
6	6	COG (ft):	X: -.034	Y: 31.298	Z: 0			



Code Check (Env)	
Black	No Calc
Red	> 1.0
Magenta	.90-1.0
Green	.75-.90
Cyan	.50-.75
Blue	0-.50

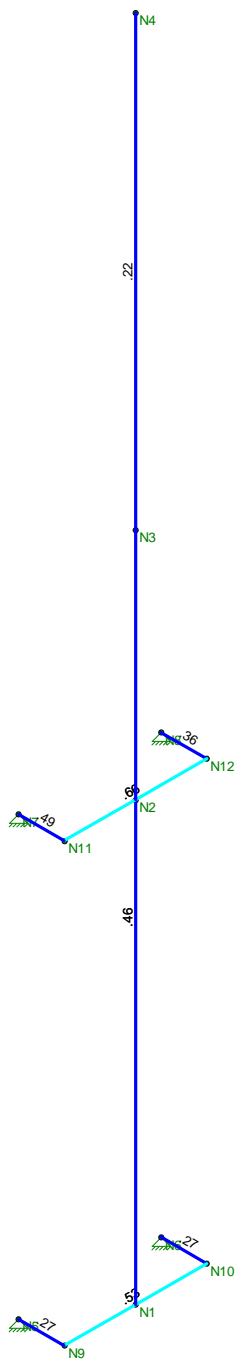

Member Code Checks Displayed (Enveloped)
Envelope Only Solution

CENTEK Engineering, INC.	North Mast - Tower # 1102 Unity Check	Nov 21, 2018 at 9:14 AM
TJL		TIA North Mast.r3d
18000.55		

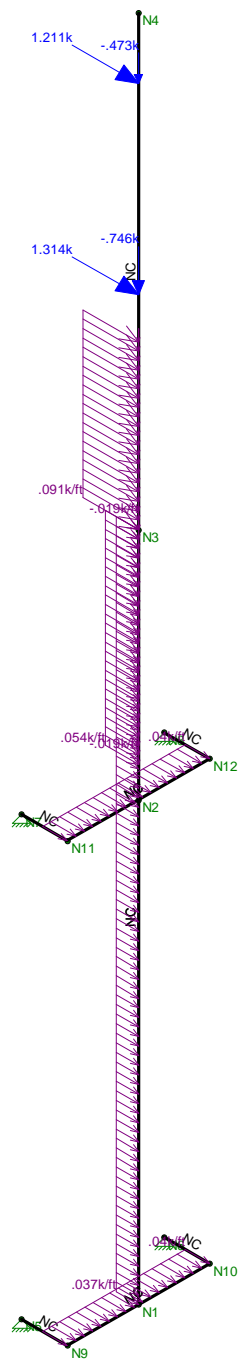

Member Code Checks Displayed
 Loads: LC 1, 1.2D + 1.6W (X-direction)

CENTEK Engineering, INC.	North Mast - Tower # 1102 LC #1 Loads	
TJL		Nov 21, 2018 at 9:14 AM
18000.55		TIA North Mast.r3d



Code Check (LC 1)

Black	No Calc
Red	> 1.0
Magenta	.90-1.0
Green	.75-.90
Cyan	.50-.75
Blue	0-.50

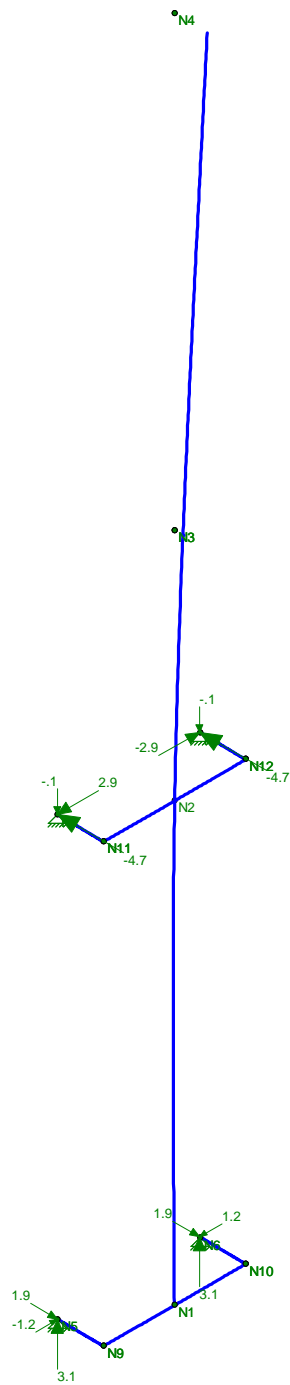

Member Code Checks Displayed
 Results for LC 1, 1.2D + 1.6W (X-direction)
 Reaction and Moment Units are k and k-ft

CENTEK Engineering, INC.		
TJL	North Mast - Tower # 1102	Nov 21, 2018 at 9:16 AM
18000.55	LC #1 Reactions and Deflected Shape	TIA North Mast.r3d

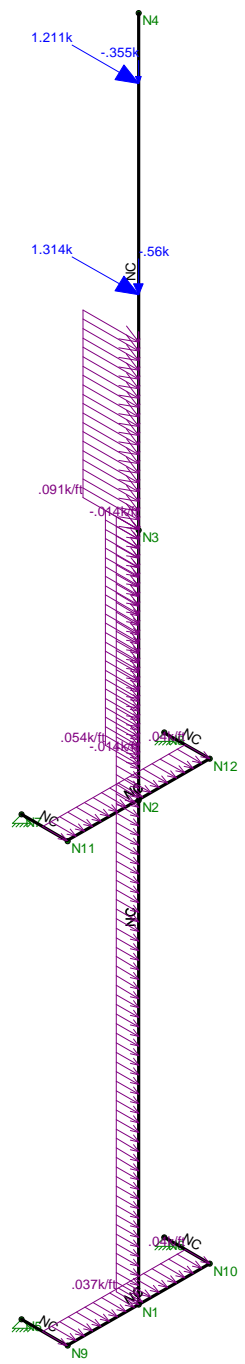

Member Code Checks Displayed
 Loads: LC 2, 0.9D + 1.6W (X-direction)

CENTEK Engineering, INC.	North Mast - Tower # 1102 LC #2 Loads	
TJL		Nov 21, 2018 at 9:14 AM
18000.55		TIA North Mast.r3d



Code Check (LC 2)

Black	No Calc
Red	> 1.0
Magenta	.90-1.0
Green	.75-.90
Cyan	.50-.75
Blue	0-.50

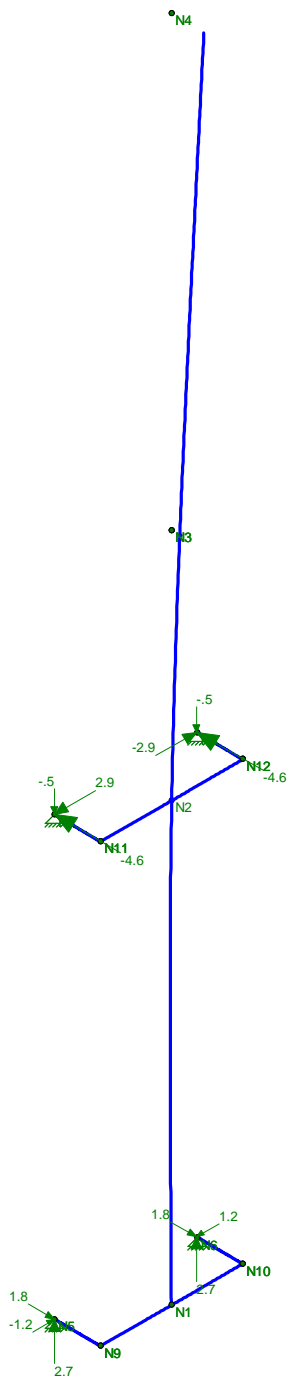

Member Code Checks Displayed
 Results for LC 2, 0.9D + 1.6W (X-direction)
 Reaction and Moment Units are k and k-ft

CENTEK Engineering, INC.		
TJL	North Mast - Tower # 1102 LC #2 Reactions and Deflected Shape	Nov 21, 2018 at 9:16 AM
18000.55		TIA North Mast.r3d

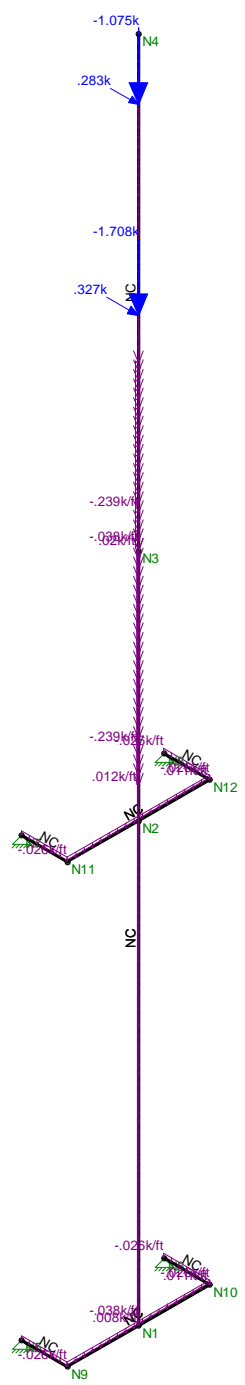

Member Code Checks Displayed
 Loads: LC 3, 1.2D + 1.0Di + 1.0Wi (X-direction)

CENTEK Engineering, INC.	North Mast - Tower # 1102 LC #3 Loads	
TJL		Nov 21, 2018 at 9:15 AM
18000.55		TIA North Mast.r3d



Code Check (LC 3)

Black	No Calc
Red	> 1.0
Magenta	.90-1.0
Green	.75-.90
Cyan	.50-.75
Blue	0-.50

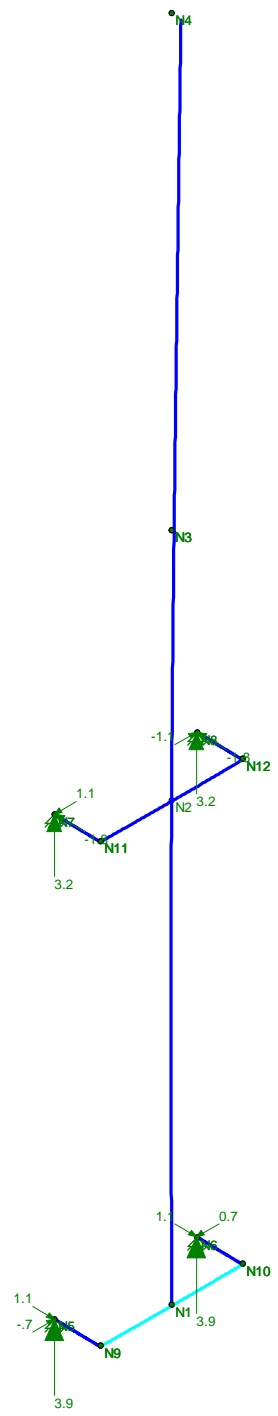

Member Code Checks Displayed
 Results for LC 3, 1.2D + 1.0Di + 1.0Wi (X-direction)
 Reaction and Moment Units are k and k-ft

CENTEK Engineering, INC.	North Mast - Tower # 1102 LC #3 Reactions and Deflected Shape	
TJL		Nov 21, 2018 at 9:17 AM
18000.55		TIA North Mast.r3d

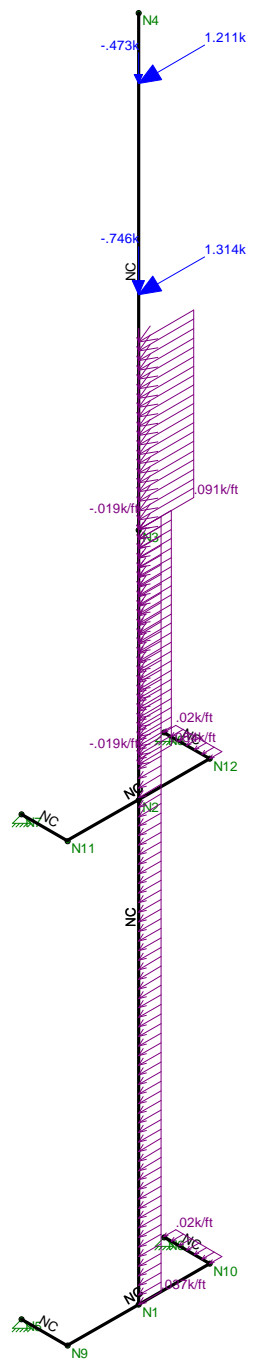

Member Code Checks Displayed
 Loads: LC 4, 1.2D + 1.6W (Z-direction)

CENTEK Engineering, INC.	North Mast - Tower # 1102 LC #4 Loads	
TJL		Nov 21, 2018 at 9:15 AM
18000.55		TIA North Mast.r3d



Code Check (LC 4)

Black	No Calc
Red	> 1.0
Magenta	.90-1.0
Green	.75-.90
Cyan	.50-.75
Blue	0-.50

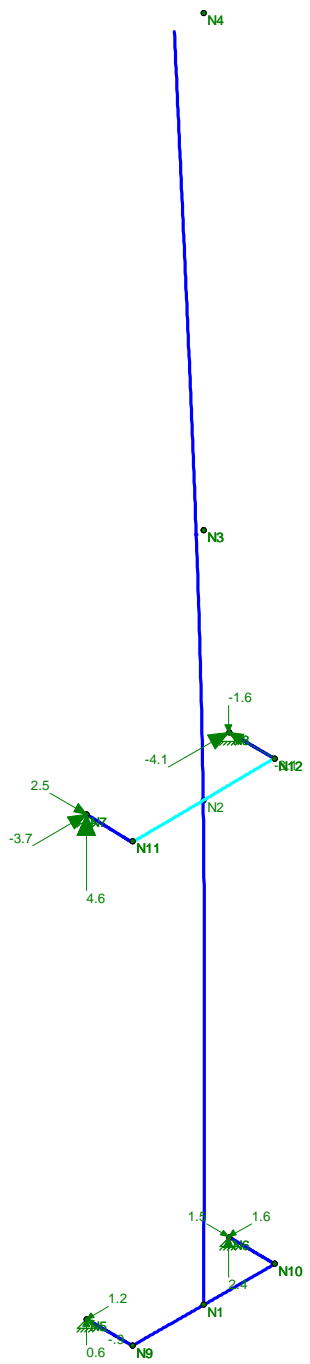

Member Code Checks Displayed
 Results for LC 4, 1.2D + 1.6W (Z-direction)
 Reaction and Moment Units are k and k-ft

CENTEK Engineering, INC.		
TJL	North Mast - Tower # 1102	Nov 21, 2018 at 9:17 AM
18000.55	LC #4 Reactions and Deflected Shape	TIA North Mast.r3d

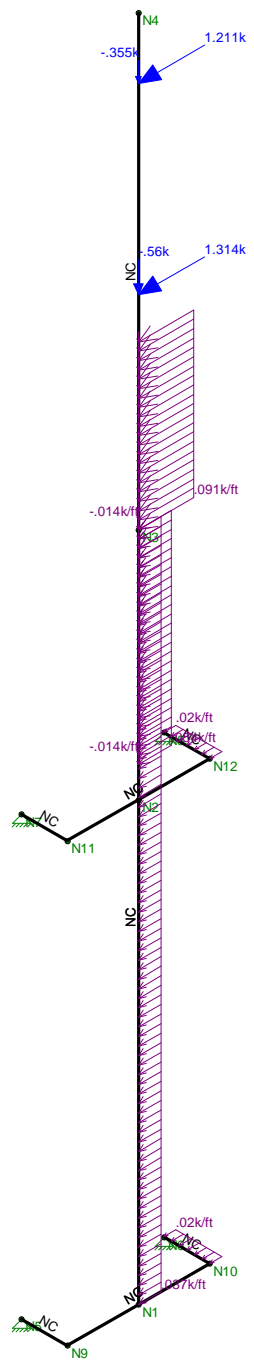

Member Code Checks Displayed
 Loads: LC 5, 0.9D + 1.6W (Z-direction)

CENTEK Engineering, INC.	North Mast - Tower # 1102 LC #5 Loads	
TJL		Nov 21, 2018 at 9:15 AM
18000.55		TIA North Mast.r3d



Code Check (LC 5)

Black	No Calc
Red	> 1.0
Magenta	.90-1.0
Green	.75-.90
Cyan	.50-.75
Blue	0-.50

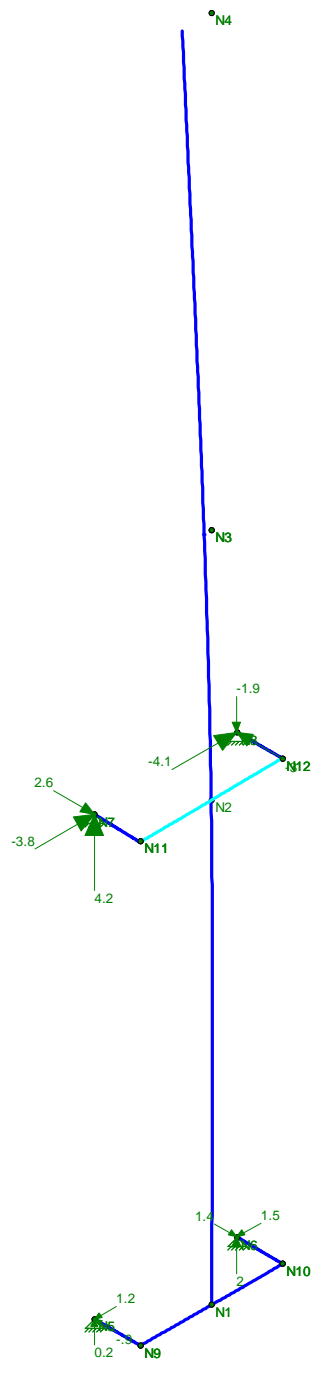

Member Code Checks Displayed
 Results for LC 5, 0.9D + 1.6W (Z-direction)
 Reaction and Moment Units are k and k-ft

CENTEK Engineering, INC.		
TJL	North Mast - Tower # 1102 LC #5 Reactions and Deflected Shape	Nov 21, 2018 at 9:17 AM
18000.55		TIA North Mast.r3d

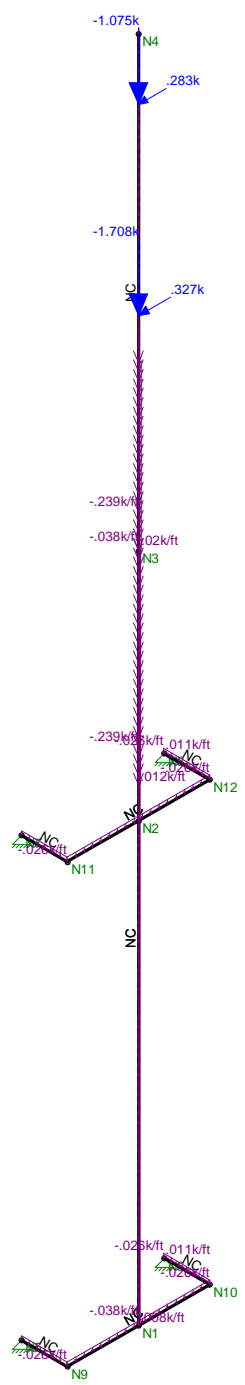

Member Code Checks Displayed
 Loads: LC 6, 1.2D + 1.0Di + 1.0Wi (Z-direction)

CENTEK Engineering, INC.	North Mast - Tower # 1102 LC #6 Loads	
TJL		Nov 21, 2018 at 9:15 AM
18000.55		TIA North Mast.r3d



Code Check (LC 6)

Black	No Calc
Red	> 1.0
Magenta	.90-1.0
Green	.75-.90
Cyan	.50-.75
Blue	0-.50

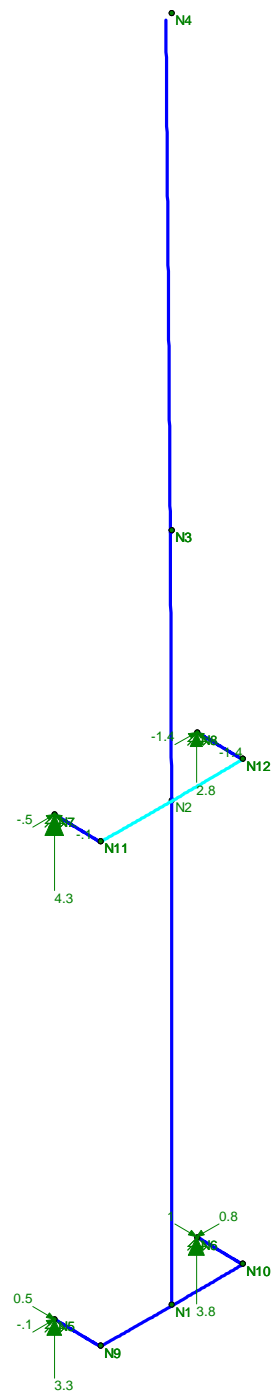

Member Code Checks Displayed
 Results for LC 6, 1.2D + 1.0Di + 1.0Wi (Z-direction)
 Reaction and Moment Units are k and k-ft

CENTEK Engineering, INC.		
TJL	North Mast - Tower # 1102 LC #6 Reactions and Deflected Shape	Nov 21, 2018 at 9:18 AM
18000.55		TIA North Mast.r3d

Column: **M8**

Shape: **PIPE_12.0X**

Material: **A53 Gr. B**

Length: **22 ft**

I Joint: **N3**

J Joint: **N4**

LC 1: 1.2D + 1.6W (X-direction)

Code Check: **0.220 (bending)**

Report Based On 97 Sections

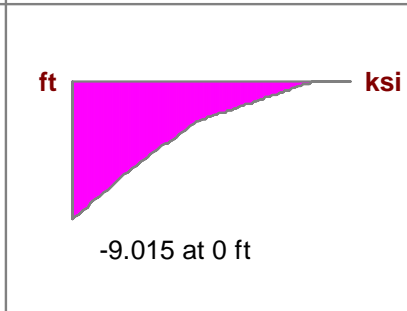
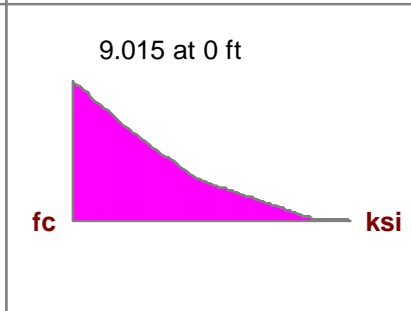
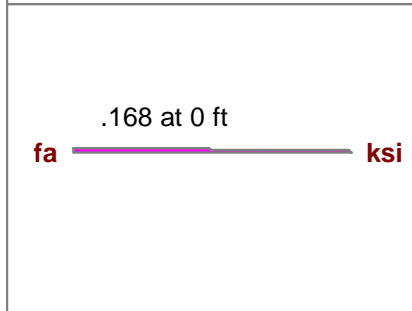
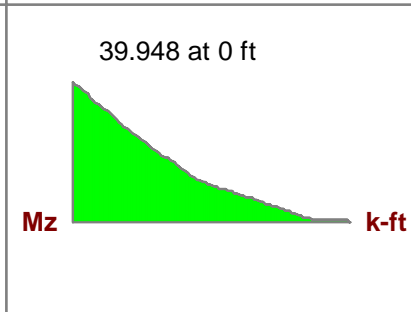
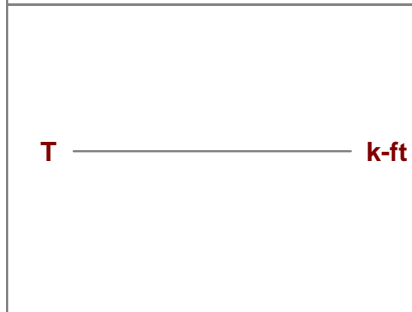
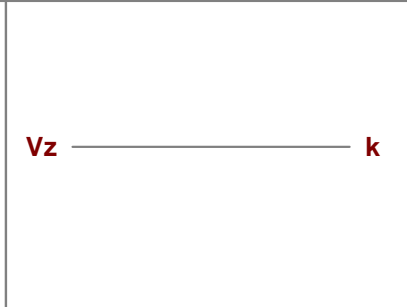
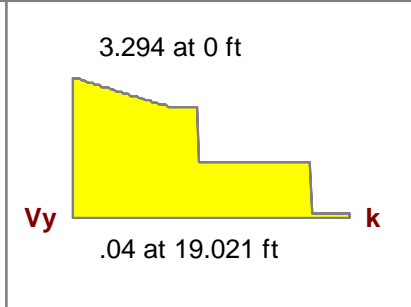
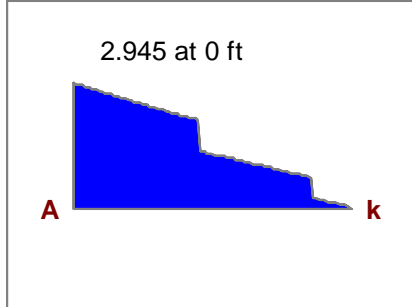
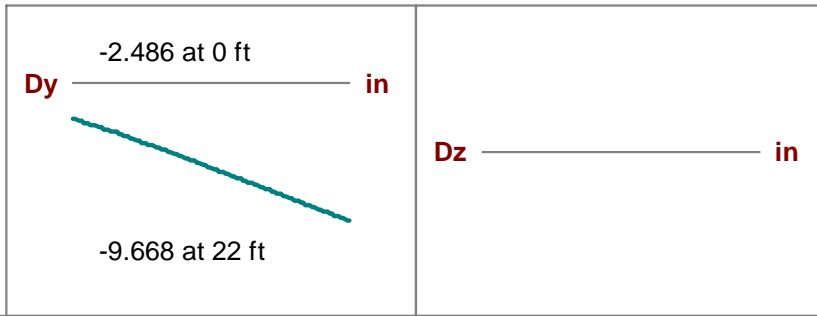

AISC 14th(360-10): LRFD Code Check

Direct Analysis Method

Max Bending Check **0.220**
 Location **0 ft**
 Equation **H1-1b**

Max Shear Check **0.020 (s)**
 Location **0 ft**
 Max Defl Ratio **L/36**

Bending

Compact

Compression

Non-Slender

Fy **35 ksi**
 phi*Pnc **458.537 k**
 phi*Pnt **551.25 k**
 phi*Mny **184.275 k-ft**
 phi*Mnz **184.275 k-ft**
 phi*Vny **165.375 k**
 phi*Vnz **165.375 k**
 phi*Tn **173.622 k-ft**
 Cb **2.272**

y-y z-z
 Lb **22 ft** **22 ft**
 KL/r **59.982** **59.982**
 L Comp Flange **22 ft**
 L-torque **22 ft**
 Tau_b **1**

Flange Bolt and Flange Plate Analysis:**Input Data:**Tower Reactions:

Overturing Moment =	OM := 39.9-ft-kips	(Input From RisaTower)
Shear Force =	Shear := 3.3-kips	(Input From RisaTower)
Axial Force =	Axial := 3.0-kips	(Input From RisaTower)

Flange Bolt Data:

UseASTMA325

Number of Flange Bolts =	N := 8	(User Input)
Diameter of Bolt Circle =	D_{bc} := 17-in	(User Input)
Bolt Minimum Tensile Strength =	F_{ub} := 120-ksi	(User Input)
Bolt Modulus =	E := 29000-ksi	(User Input)
Diameter of Flange Bolts =	D := 1.125-in	(User Input)
Threads per Inch =	n := 7	(User Input)

Flange Plate Data:

UseASTMA36

Plate Yield Strength =	F_{ybp} := 50-ksi	(User Input)
Flange Plate Thickness =	t_{bp} := 1.5-in	(User Input)
Flange Plate Diameter =	D_{bp} := 20-in	(User Input)
Outer Pole Diameter =	D_{pole} := 12.8-in	(User Input)

Geometric Layout Data:

Distance from Bolts to Centroid of Pole:

Radius of Bolt Circle = $R_{bc} := \frac{D_{bc}}{2} = 8.5 \cdot \text{in}$

Distance to Bolts = $i := 1..N$

$$d_i := \begin{cases} \theta \leftarrow 2\pi \cdot \left(\frac{i}{N}\right) & d_1 = 6.01 \cdot \text{in} & d_7 = -6.01 \cdot \text{in} \\ d \leftarrow R_{bc} \cdot \sin(\theta) & d_2 = 8.50 \cdot \text{in} & d_8 = -0.00 \cdot \text{in} \\ & d_3 = 6.01 \cdot \text{in} \\ & d_4 = 0.00 \cdot \text{in} \\ & d_5 = -6.01 \cdot \text{in} \\ & d_6 = -8.50 \cdot \text{in} \end{cases}$$

Critical Distances For Bending in Plate:

Outer Pole Radius = $R_{pole} := \frac{D_{pole}}{2} = 6.4 \cdot \text{in}$

Moment Arms of Bolts about Neutral Axis = $MA_i := \text{if}(d_i \geq R_{pole}, d_i - R_{pole}, 0 \cdot \text{in})$

$MA_1 = 0.00 \cdot \text{in} \quad MA_7 = 0.00 \cdot \text{in}$
 $MA_2 = 2.10 \cdot \text{in} \quad MA_8 = 0.00 \cdot \text{in}$
 $MA_3 = 0.00 \cdot \text{in}$
 $MA_4 = 0.00 \cdot \text{in}$
 $MA_5 = 0.00 \cdot \text{in}$
 $MA_6 = 0.00 \cdot \text{in}$

Effective Width of Flangeplate for Bending = $B_{eff} := .8 \cdot 2 \cdot \sqrt{\left(\frac{D_{bp}}{2}\right)^2 - \left(\frac{D_{pole}}{2}\right)^2} = 12.3 \cdot \text{in}$

Flange Bolt Analysis :

Calculated Flange Bolt Properties:

Polar Moment of Inertia = $I_p := \sum_i (d_i)^2 = 289 \cdot \text{in}^2$

Gross Area of Bolt = $A_g := \frac{\pi}{4} \cdot D^2 = 0.994 \cdot \text{in}^2$

Net Area of Bolt = $A_n := \frac{\pi}{4} \cdot \left(D - \frac{0.9743 \cdot \text{in}}{n} \right)^2 = 0.763 \cdot \text{in}^2$

Net Diameter = $D_n := \frac{2 \cdot \sqrt{A_n}}{\sqrt{\pi}} = 0.986 \cdot \text{in}$

Radius of Gyration of Bolt = $r := \frac{D_n}{4} = 0.246 \cdot \text{in}$

Section Modulus of Bolt = $S_x := \frac{\pi \cdot D_n^3}{32} = 0.094 \cdot \text{in}^3$

Check Flange Bolt Tension Force:

Maximum Tensile Force = $T_{\text{Max}} := \text{OM} \cdot \frac{R_{bc}}{I_p} - \frac{\text{Axial}}{N} = 13.7 \cdot \text{kips}$

Maximum Shear Force = $V_{\text{Max}} := \frac{\text{Shear}}{N} = 0.4 \cdot \text{kips}$

Design Tensile Strength = $\Phi R_{nt} := (0.75 \cdot F_{ub} \cdot 0.75 \cdot A_g) = 67.1 \cdot \text{kips}$

Bolt Tension % of Capacity = $\frac{T_{\text{Max}}}{\Phi R_{nt}} = 20.43 \cdot \%$

Condition1 = $\text{Condition1} := \text{if} \left(\frac{T_{\text{Max}}}{\Phi R_{nt}} \leq 1.00, \text{"OK"}, \text{"Overstressed"} \right)$

Condition1 = "OK"

Design Shear Strength = $\Phi R_{nv} := (0.75 \cdot 0.45 \cdot F_{ub} \cdot A_g) = 40.3 \cdot \text{kips}$

Condition2 = $\text{Condition2} := \text{if} \left[\left(\frac{V_{\text{Max}}}{\Phi R_{nv}} \right)^2 + \left(\frac{T_{\text{Max}}}{\Phi R_{nt}} \right)^2 \leq 1.00, \text{"OK"}, \text{"Overstressed"} \right]$

Condition2 = "OK"

Flange Plate Analysis:

Force from Bolts= $C_i := \frac{OM \cdot d_i}{I_p} + \frac{Axial}{N}$

$C_1 = 10.3\text{-kips}$ $C_7 = -9.6\text{-kips}$
 $C_2 = 14.5\text{-kips}$ $C_8 = 0.4\text{-kips}$
 $C_3 = 10.3\text{-kips}$
 $C_4 = 0.4\text{-kips}$
 $C_5 = -9.6\text{-kips}$
 $C_6 = -13.7\text{-kips}$

Maximum Bending Stress in Plate =

$$f_{bp} := \sum_i \frac{4 \cdot C_i \cdot MA_i}{(B_{eff} \cdot t_{bp}^2)} = 4.4\text{-ksi}$$

Allowable Bending Stress in Plate =

$$F_{bp} := 0.9 \cdot F_{y_{bp}} = 45\text{-ksi}$$

Plate Bending Stress % of Capacity =

$$\frac{f_{bp}}{F_{bp}} = 9.8\%$$

Condition3 =

$$\text{Condition2} := \text{if} \left(\frac{f_{bp}}{F_{bp}} < 1.00, \text{"Ok"}, \text{"Overstressed"} \right)$$

Condition2 = "Ok"

Mast Connection to Tower:

Reactions:

Moment = Moment := 0-kips (Input From Risa-3D)

Vertical = Vertical := 3.1-kips (Input From Risa-3D)

Horizontal x-dir = Horizontal_x := 4.7-kips (Input From Risa-3D)

Horizontal z-dir = Horizontal_z := 2.9-kips (Input From Risa-3D)

Bolt Data:

Bolt Type = ASTMA325 (User Input)

Bolt Diameter = D := 0.75-in (User Input)

Number of Bolts = N_b := 4 (User Input)

Design Tensile Strength = F_t := 29.8-kips (User Input)

Design Shear Strength = F_v := 17.9-kips (User Input)

Shear Force =
$$f_v := \frac{\sqrt{\text{Horizontal}_z^2 + \text{Vertical}^2}}{N_b} = 1.1 \cdot \text{kips}$$

Bolt Shear % of Capacity =
$$\frac{f_v}{F_v} = 5.93\%$$

Check Bolt Shear = Bolt_Shear := if $\left(\frac{f_v}{F_v} \leq 1.00, \text{"OK"}, \text{"Overstressed"} \right)$

Bolt_Shear = "OK"

Tension Force =
$$f_t := \frac{\text{Horizontal}_x}{N_b} = 1.2 \cdot \text{kips}$$

Bolt Tension % of Capacity =
$$\frac{f_t}{F_t} = 3.94\%$$

Check Bolt Tension = Bolt_Tension := if $\left(\frac{f_t}{F_t} \leq 1.00, \text{"OK"}, \text{"Overstressed"} \right)$

Bolt_Tension = "OK"

Basic Components

Heavy Wind Pressure =	p := 4.00	psf	(User Input NESC 2012 Figure 250-1 & Table 250-1)
Basic Windspeed =	V := 110	mph	(User Input NESC 2012 Figure 250-2(e))
Radial Ice Thickness =	Ir := 0.50	in	(User Input)
Radial Ice Density =	Id := 56.0	pcf	(User Input)

Factors for Extreme Wind Calculation

Elevation of Top of PCS Mast Above Grade =	TME := 117	ft	(User Input)
Multiplier Gust Response Factor =	m := 1.25		(User Input - Only for NESC Extreme wind case)
NESC Factor =	kv := 1.43		(User Input from NESC 2012 Table 250-3 equation)
Importance Factor =	I := 1.0		(User Input from NESC 2012 Section 250.C.2)
Velocity Pressure Coefficient =	$Kz := 2.01 \cdot \left(\frac{TME}{900} \right)^{\frac{2}{9.5}} = 1.308$		(NESC 2012 Table 250-2)
Exposure Factor =	$Es := 0.346 \left[\frac{33}{(0.67 \cdot TME)} \right]^{\frac{1}{7}} = 0.306$		(NESC 2012 Table 250-3)
Response Term =	$Bs := \frac{1}{\left(1 + 0.375 \cdot \frac{TME}{220} \right)} = 0.834$		(NESC 2012 Table 250-3)
Gust Response Factor =	$Grf := \frac{\left[1 + \left(2.7 \cdot Es \cdot Bs \cdot \frac{1}{2} \right) \right]}{kv^2} = 0.858$		(NESC 2012 Table 250-3)
Wind Pressure =	$qz := 0.00256 \cdot Kz \cdot V^2 \cdot Grf \cdot I = 34.8$	psf	(NESC 2012 Section 250.C.2)

Shape Factors

Shape Factor for Round Members =	Cd _R := 1.3	(User Input)
Shape Factor for Flat Members =	Cd _F := 1.6	(User Input)
Shape Factor for Coax Cables Attached to Outside of Pole =	Cd _{coax} := 1.6	(User Input)

Overload Factors

Overload Factors for Wind Loads:

NESC Heavy Loading =	2.5	(User Input)	Apply in Risa-3D Analysis
NESC Extreme Loading =	1.0	(User Input)	Apply in Risa-3D Analysis

Overload Factors for Vertical Loads:

NESC Heavy Loading =	1.5	(User Input)	Apply in Risa-3D Analysis
NESC Extreme Loading =	1.0	(User Input)	Apply in Risa-3D Analysis

Development of Wind & Ice Load on Mast

Mast Data:

(12" Sch. 80)

Mast Shape =	Round	(User Input)
Mast Diameter =	$D_{mast} := 12.8$ in	(User Input)
Mast Length =	$L_{mast} := 55$ ft	(User Input)
Mast Thickness =	$t_{mast} := 0.5$ in	(User Input)

Wind Load (NESC Extreme)

Mast Projected Surface Area = $A_{mast} := \frac{D_{mast}}{12} = 1.067$

Total Mast Wind Force (Below Top of Tower) = $qz \cdot C_{dR} \cdot A_{mast} = 48$ plf **BLC 5**

Total Mast Wind Force (Below Top of Tower) = $qz \cdot C_{d_{coax}} \cdot A_{mast} = 59$ Coax on Mast plf **BLC 5**

Total Mast Wind Force (Above Top of Tower) = $qz \cdot C_{d_{coax}} \cdot A_{mast} \cdot m = 74$ Coax on Mast plf **BLC 5**

Wind Load (NESE Heavy)

Mast Projected Surface Area w/ Ice = $A_{ICE_{mast}} := \frac{(D_{mast} + 2 \cdot Ir)}{12} = 1.15$

Total Mast Wind Force w/ Ice = $p \cdot C_{dR} \cdot A_{ICE_{mast}} = 6$ plf **BLC 4**

Total Mast Wind Force w/ Ice = $p \cdot C_{d_{coax}} \cdot A_{ICE_{mast}} = 7$ Coax on Mast plf **BLC 4**

Gravity Loads (without ice)

Weight of the Mast = Self Weight (Computed internally by Risa-3D) plf **BLC 1**

Gravity Loads (ice only)

Ice Area per Linear Foot = $A_{i_{mast}} := \frac{\pi}{4} [(D_{mast} + Ir \cdot 2)^2 - D_{mast}^2] = 20.9$ sq in

Weight of Ice on Mast = $W_{ICE_{mast}} := Id \cdot \frac{A_{i_{mast}}}{144} = 8$ plf **BLC 3**

Development of Wind & Ice Load on Antennas

Antenna Data:

Antenna Model =	KMW AM-X-CD-14-65	(AT&T)
Antenna Shape =	Flat	(User Input)
Antenna Height =	$L_{ant} := 48$ in	(User Input)
Antenna Width =	$W_{ant} := 11.8$ in	(User Input)
Antenna Thickness =	$T_{ant} := 5.9$ in	(User Input)
Antenna Weight =	$WT_{ant} := 36.4$ lbs	(User Input)
Number of Antennas =	$N_{ant} := 3$	(User Input)

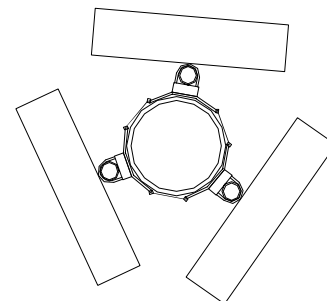

Wind Load (NESC Extreme)

Assumes Maximum Possible Wind Pressure Applied to all Antennas Simultaneously

Surface Area for One Antenna =

$$SA_{ant} := \frac{L_{ant} \cdot W_{ant}}{144} = 3.9 \quad sf$$

Antenna Projected Surface Area =

$$A_{ant} := SA_{ant} \cdot N_{ant} = 11.8 \quad sf$$

Total Antenna Wind Force =

$$F_{ant} := qz \cdot Cd_F \cdot A_{ant} \cdot m = 820 \quad lbs \quad \text{BLC 5}$$

Wind Load (NESC Heavy)

Assumes Maximum Possible Wind Pressure Applied to all Antennas Simultaneously

Surface Area for One Antenna w/ Ice =

$$SA_{ICEant} := \frac{(L_{ant} + 1) \cdot (W_{ant} + 1)}{144} = 4.4 \quad sf$$

Antenna Projected Surface Area w/ Ice =

$$A_{ICEant} := SA_{ICEant} \cdot N_{ant} = 13.1 \quad sf$$

Total Antenna Wind Force w/ Ice =

$$F_{ant} := p \cdot Cd_F \cdot A_{ICEant} = 84 \quad lbs \quad \text{BLC 4}$$

Gravity Load (without ice)

Weight of All Antennas =

$$WT_{ant} \cdot N_{ant} = 109 \quad lbs \quad \text{BLC 2}$$

Gravity Load (ice only)

Volume of Each Antenna =

$$V_{ant} := L_{ant} \cdot W_{ant} \cdot T_{ant} = 3342 \quad cu \text{ in}$$

Volume of Ice on Each Antenna =

$$V_{ice} := (L_{ant} + 1) \cdot (W_{ant} + 1) \cdot (T_{ant} + 1) - V_{ant} = 986 \quad cu \text{ in}$$

Weight of Ice on Each Antenna =

$$W_{ICEant} := \frac{V_{ice}}{1728} \cdot \rho_d = 32 \quad lbs$$

Weight of Ice on All Antennas =

$$W_{ICEant} \cdot N_{ant} = 96 \quad lbs \quad \text{BLC 3}$$

Development of Wind & Ice Load on TMA's

TMA Data:

TMA Model =	Kaleus TMA2093F00V1-1	(AT&T)
TMA Shape =	Flat	(User Input)
TMA Height =	$L_{TMA} := 11.8$ in	(User Input)
TMA Width =	$W_{TMA} := 9.8$ in	(User Input)
TMA Thickness =	$T_{TMA} := 3.7$ in	(User Input)
TMA Weight =	$W_{TMA} := 23$ lbs	(User Input)
Number of TMA's =	$N_{TMA} := 3$	(User Input)

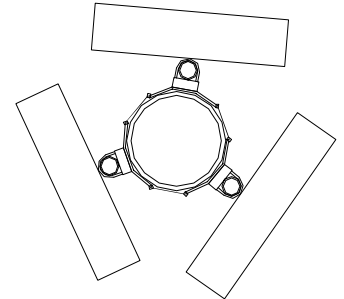

Wind Load (NESC Extreme Wind)

Assumes Maximum Possible Wind Pressure Applied to All TMA's Simultaneously

Surface Area for One TMA = $SA_{TMA} := \frac{L_{TMA} \cdot W_{TMA}}{144} = 0.8$ sf

TMA Projected Surface Area = $A_{TMA} := SA_{TMA} \cdot N_{TMA} = 2.4$ sf

Total TMA Wind Force = $F_{TMA} := qz \cdot C_d \cdot A_{TMA} \cdot m = 167$ lbs **BLC 5**

Wind Load (NESC Heavy Wind)

Assumes Maximum Possible Wind Pressure Applied to All TMA's Simultaneously

Surface Area for One TMA w/ Ice = $SA_{ICETMA} := \frac{(L_{TMA} + 2 \cdot I_r) \cdot (W_{TMA} + 2 \cdot I_r)}{144} = 1$ sf

TMA Projected Surface Area w/ Ice = $A_{ICETMA} := SA_{ICETMA} \cdot N_{TMA} = 2.9$ sf

Total TMA Wind Force w/ Ice = $F_{iTMA} := p \cdot C_d \cdot A_{ICETMA} = 18$ lbs **BLC 4**

Gravity Load (without ice)

Weight of All TMA's = $Wgt_{TMA} := (W_{TMA} \cdot N_{TMA}) = 69$ lbs **BLC 2**

Gravity Load (ice)

Volume of Each TMA = $V_{TMA} := L_{TMA} \cdot W_{TMA} \cdot T_{TMA} = 428$ cu in

Volume of Ice on Each TMA = $V_{ice} := (L_{TMA} + 2 \cdot I_r) \cdot (W_{TMA} + 2 \cdot I_r) \cdot (T_{TMA} + 2 \cdot I_r) - V_{TMA} = 222$ cu in

Weight of Ice on Each TMA = $W_{ICETMA} := \frac{V_{ice}}{1728} \cdot I_d = 7$ lbs

Weight of Ice on All TMA's = $Wgt_{ice.TMA} := (W_{ICETMA} \cdot N_{TMA}) = 22$ lbs **BLC 3**

Development of Wind & Ice Load on Antenna Mounts

Mount Data:

Mount Type:
 Mount Shape =
 Pipe Mount Length =
 2 inch Pipe Mount Linear Weight =
 Pipe Mount Outside Diameter =
 Number of Mounting Pipes =
 Tri-Bracket Weight =

(AT&T)
 Microflex Universal Tri-Bracket
 Flat (User Input)
 $L_{mnt} := 72$ in (User Input)
 $W_{mnt} := 3.66$ plf (User Input)
 $D_{mnt} := 2.375$ in (User Input)
 $N_{mnt} := 3$ (User Input)
 $W_{tb.mnt} := 197$ lbs (User Input)

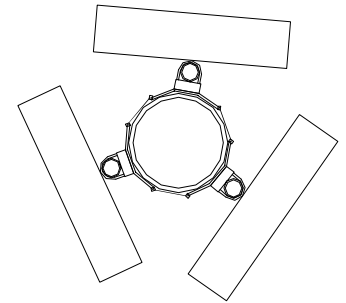

Wind Load (NESC Extreme)

Assumes Mount is Shielded by Antenna

Mount Projected Surface Area =

$A_{mnt} := 0.0$ sf

Total Mount Wind Force =

$F_{mnt} := qz \cdot C_d \cdot A_{mnt} \cdot m = 0$ lbs **BLC 5**

Wind Load (NESC Heavy)

Assumes Mount is Shielded by Antenna

Mount Projected Surface Area w/ Ice =

$A_{ICEmnt} := 0.0$ sf

Total Mount Wind Force =

$F_{mnt} := p \cdot C_d \cdot A_{ICEmnt} = 0$ lbs **BLC 4**

Gravity Loads (without ice)

Weight Each Pipe Mount =

$W_{Tmnt} := W_{mnt} \cdot \frac{L_{mnt}}{12} = 22$ lbs

Weight of All Mounts =

$W_{Tmnt} \cdot N_{mnt} + W_{tb.mnt} = 263$ lbs **BLC 2**

Gravity Load (ice only)

Volume of Each Pipe =

$V_{mnt} := \frac{\pi}{4} \cdot D_{mnt}^2 \cdot L_{mnt} = 319$ cu in

Volume of Ice on Each Pipe =

$V_{ice} := \left[\frac{\pi}{4} \cdot \left[(D_{mnt} + 1)^2 \right] \cdot (L_{mnt} + 1) \right] - V_{mnt} = 334$ cu in

Weight of Ice each mount (incl. hardware) =

$W_{ICEmnt} := \frac{V_{ice}}{1728} \cdot \rho_{ice} = 11$ lbs

Weight of Ice on All Mounts =

$W_{ICEmnt} \cdot N_{mnt} + 5 = 37$ lbs **BLC 3**

Development of Wind & Ice Load on Antennas

Antenna Data:

Antenna Model =	(T-Mobile)	RFSAPXVAARR24_43
Antenna Shape =	Flat	(User Input)
Antenna Height =	$L_{ant} := 95.9$	in (User Input)
Antenna Width =	$W_{ant} := 24$	in (User Input)
Antenna Thickness =	$T_{ant} := 8.7$	in (User Input)
Antenna Weight =	$WT_{ant} := 153$	lbs (User Input)
Number of Antennas =	$N_{ant} := 3$	(User Input)

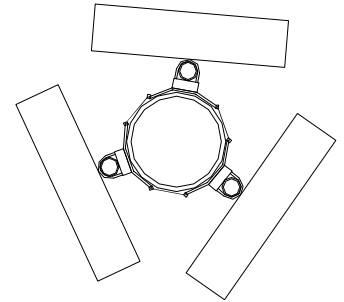

Wind Load (NESC Extreme)

Assumes Maximum Possible Wind Pressure Applied to all Antennas Simultaneously

Surface Area for One Antenna =

$$SA_{ant} := \frac{L_{ant} \cdot W_{ant}}{144} = 16 \quad sf$$

Antenna Projected Surface Area =

$$A_{ant} := SA_{ant} \cdot N_{ant} = 48 \quad sf$$

Total Antenna Wind Force =

$$F_{ant} := qz \cdot Cd_F \cdot A_{ant} = 3333 \quad lbs \quad \text{BLC 5}$$

Wind Load (NESC Heavy)

Assumes Maximum Possible Wind Pressure Applied to all Antennas Simultaneously

Surface Area for One Antenna w/ Ice =

$$SA_{ICEant} := \frac{(L_{ant} + 1) \cdot (W_{ant} + 1)}{144} = 16.8 \quad sf$$

Antenna Projected Surface Area w/ Ice =

$$A_{ICEant} := SA_{ICEant} \cdot N_{ant} = 50.5 \quad sf$$

Total Antenna Wind Force w/ Ice =

$$F_{i_{ant}} := p \cdot Cd_F \cdot A_{ICEant} = 323 \quad lbs \quad \text{BLC 4}$$

Gravity Load (without ice)

Weight of All Antennas =

$$WT_{ant} \cdot N_{ant} = 459 \quad lbs \quad \text{BLC 2}$$

Gravity Load (ice only)

Volume of Each Antenna =

$$V_{ant} := L_{ant} \cdot W_{ant} \cdot T_{ant} = 2 \times 10^4 \quad cu \text{ in}$$

Volume of Ice on Each Antenna =

$$V_{ice} := (L_{ant} + 1) \cdot (W_{ant} + 1) \cdot (T_{ant} + 1) - V_{ant} = 3474 \quad cu \text{ in}$$

Weight of Ice on Each Antenna =

$$W_{ICEant} := \frac{V_{ice}}{1728} \cdot \rho_d = 113 \quad lbs$$

Weight of Ice on All Antennas =

$$W_{ICEant} \cdot N_{ant} = 338 \quad lbs \quad \text{BLC 3}$$

Development of Wind & Ice Load on Antennas

Antenna Data:

	(T-Mobile)
Antenna Model =	Commscope ATSBT-TOP-FM-4G Bias Tee
Antenna Shape =	Flat (User Input)
Antenna Height =	$L_{ant} := 5.63$ in (User Input)
Antenna Width =	$W_{ant} := 3.7$ in (User Input)
Antenna Thickness =	$T_{ant} := 2.0$ in (User Input)
Antenna Weight =	$WT_{ant} := 2$ lbs (User Input)
Number of Antennas =	$N_{ant} := 3$ (User Input)

Wind Load (NESC Extreme)

Assumes Maximum Possible Wind Pressure Applied to all Antennas Simultaneously

Surface Area for One Antenna =	$SA_{ant} := \frac{L_{ant} \cdot W_{ant}}{144} = 0.1$	sf
Antenna Projected Surface Area =	$A_{ant} := SA_{ant} \cdot N_{ant} = 0.4$	sf

Total Antenna Wind Force =

$F_{ant} := qz \cdot C_d \cdot A_{ant} \cdot m = 30$ lbs **BLC 5**

Wind Load (NESC Heavy)

Assumes Maximum Possible Wind Pressure Applied to all Antennas Simultaneously

Surface Area for One Antenna w/ Ice =	$SA_{ICEant} := \frac{(L_{ant} + 1) \cdot (W_{ant} + 1)}{144} = 0.2$	sf
Antenna Projected Surface Area w/ Ice =	$A_{ICEant} := SA_{ICEant} \cdot N_{ant} = 0.6$	sf

Total Antenna Wind Force w/ Ice =

$F_{ant} := p \cdot C_d \cdot A_{ICEant} = 4$ lbs **BLC 4**

Gravity Load (without ice)

Weight of All Antennas =

$WT_{ant} \cdot N_{ant} = 6$ lbs **BLC 2**

Gravity Load (ice only)

Volume of Each Antenna =	$V_{ant} := L_{ant} \cdot W_{ant} \cdot T_{ant} = 42$	cu in
Volume of Ice on Each Antenna =	$V_{ice} := (L_{ant} + 1) \cdot (W_{ant} + 1) \cdot (T_{ant} + 1) - V_{ant} = 52$	cu in
Weight of Ice on Each Antenna =	$W_{ICEant} := \frac{V_{ice}}{1728} \cdot \rho = 2$	lbs

Weight of Ice on All Antennas =

$W_{ICEant} \cdot N_{ant} = 5$ lbs **BLC 3**

Subject:

Load Analysis of South Mast on Structure #1102

Location:

Norwalk, CT

Rev. 2: 5/21/19

Prepared by: T.J.L Checked by: C.A.G.
 Job No. 18000.55

Development of Wind & Ice Load on Antenna Mounts

Mount Data:

(T-Mobile)

Mount Type:

SitePro Universal Ring Mount x2 w/ (3) 2 Std. x 9' long pipe masts

Mount Shape =

Flat (User Input)

Mount Projected Surface Area =

$C_{aA} := 0$ sf (User Input)

Mount Projected Surface Area w/ Ice =

$C_{aA}_{ice} := 0$ sf (User Input)

Mount Weight =

$W_{T_{mnt}} := 650$ lbs (User Input)

Mount Weight w/ Ice =

$W_{T_{mnt.ice}} := 725$ lbs

Wind Load (NESC Extreme)

Assumes Mount is Shielded by Antenna

Mount Projected Surface Area =

$A_{mnt} := 0.0$ sf

Total Mount Wind Force =

$F_{mnt} := qz \cdot C_d \cdot F \cdot A_{mnt} = 0$ lbs **BLC 5**

Wind Load (NESC Heavy)

Assumes Mount is Shielded by Antenna

Mount Projected Surface Area w/ Ice =

$A_{ICE_{mnt}} := 0.0$ sf

Total Mount Wind Force =

$F_{i_{mnt}} := p \cdot C_d \cdot F \cdot A_{ICE_{mnt}} = 0$ lbs **BLC 4**

Gravity Loads (without ice)

Weight of All Mounts =

$W_{T_{mnt}} = 650$ lbs **BLC 2**

Gravity Loads (ice only)

Weight of Ice on All Mounts =

$W_{T_{mnt.ice}} - W_{T_{mnt}} = 75$ lbs **BLC 3**

Development of Wind & Ice Load on Coax Cables

Coax Cable Data:

Coax Type =	HELIAX 1-1/4"	
Shape =	Round	(User Input)
Coax Outside Diameter =	$D_{\text{coax}} := 1.55$	in (User Input)
Coax Cable Length =	$L_{\text{coax}} := 20$	ft (User Input)
Weight of Coax per foot =	$Wt_{\text{coax}} := 0.66$	plf (User Input)
Total Number of Coax =	$N_{\text{coax}} := 30$	(User Input) (6AT&T & 24 T-Mobile)
No. of Coax Projecting Outside Face of PCS Mast =	$NP_{\text{coax}} := 6$	(User Input)

Wind Load (NESC Extreme)

Coax projected surface area = $A_{\text{coax}} := \frac{(NP_{\text{coax}} \cdot D_{\text{coax}})}{12} = 0.8$ ft

Total Coax Wind Force (Above NU Structure) =

$F_{\text{coax}} := qz \cdot Cd_{\text{coax}} \cdot A_{\text{coax}} \cdot m = 54$ plf **BLC 5**

Wind Load (NESC Heavy)

Coax projected surface area w/ Ice = $A_{\text{ICE}_{\text{coax}}} := \frac{(NP_{\text{coax}} \cdot D_{\text{coax}} + 2 \cdot 1r)}{12} = 0.9$ ft

Total Coax Wind Force w/ Ice =

$F_{\text{coax}} := p \cdot Cd_{\text{coax}} \cdot A_{\text{ICE}_{\text{coax}}} = 5$ plf **BLC 4**

Gravity Loads (without ice)

Weight of all cables w/o ice

$WT_{\text{coax}} := Wt_{\text{coax}} \cdot N_{\text{coax}} = 20$ plf **BLC 2**

Gravity Load (ice only)

Ice Area per Linear Foot =

$A_{\text{ice}_{\text{coax}}} := \frac{\pi}{4} [(D_{\text{coax}} + 2 \cdot 1r)^2 - D_{\text{coax}}^2] = 3.2$ sq in

Ice Weight All Coax per foot =

$WT_{\text{ice}_{\text{coax}}} := Id \cdot \left(N_{\text{coax}} \cdot \frac{A_{\text{ice}_{\text{coax}}}}{144} \right) = 38$ plf **BLC 3**

Development of Wind & Ice Load on Coax Cables

Coax Cable Data:

Coax Type =	HELIX 1-1/4"	
Shape =	Round	(User Input)
Coax Outside Diameter =	$D_{\text{coax}} := 1.55$	in (User Input)
Coax Cable Length =	$L_{\text{coax}} := 20$	ft (User Input)
Weight of Coax per foot =	$Wt_{\text{coax}} := 0.66$	plf (User Input)
Total Number of Coax =	$N_{\text{coax}} := 24$	(User Input) (24 T-Mobile)
No. of Coax Projecting Outside Face of PCS Mast =	$NP_{\text{coax}} := 6$	(User Input)

Wind Load (NESC Extreme)

Coax projected surface area = $A_{\text{coax}} := \frac{(NP_{\text{coax}} \cdot D_{\text{coax}})}{12} = 0.8$ ft

Total Coax Wind Force (Above NU Structure) =

$F_{\text{coax}} := qz \cdot C_d \cdot A_{\text{coax}} \cdot m = 54$ plf **BLC 5**

Wind Load (NESC Heavy)

Coax projected surface area w/ Ice = $A_{\text{ICE}_{\text{coax}}} := \frac{(NP_{\text{coax}} \cdot D_{\text{coax}} + 2 \cdot 1r)}{12} = 0.9$ ft

Total Coax Wind Force w/ Ice =

$F_{\text{coax}} := p \cdot C_d \cdot A_{\text{ICE}_{\text{coax}}} = 5$ plf **BLC 4**

Gravity Loads (without ice)

Weight of all cables w/o ice

$WT_{\text{coax}} := Wt_{\text{coax}} \cdot N_{\text{coax}} = 16$ plf **BLC 2**

Gravity Load (ice only)

Ice Area per Linear Foot =

$A_{\text{ice}_{\text{coax}}} := \frac{\pi}{4} [(D_{\text{coax}} + 2 \cdot 1r)^2 - D_{\text{coax}}^2] = 3.2$ sq in

Ice Weight All Coax per foot =

$WT_{\text{ice}_{\text{coax}}} := Id \cdot \left(N_{\text{coax}} \cdot \frac{A_{\text{ice}_{\text{coax}}}}{144} \right) = 30$ plf **BLC 3**

Development of Wind & Ice Load on Brace Member

Member Data:

	HSS6x6x1/4	
Shape =	Flat	(User Input)
Width =	$W_{mem} := 6$	in (User Input)
Length =	$L_{mem} := 5$	ft (User Input)
Height =	$H_{mem} := 6$	in (User Input)

Wind Load (NESC Extreme)

Member Projected Surface Area = $A_{mem} := \frac{W_{mem}}{12} = 0.5$

Total Member Wind Force = $qz \cdot C_dF \cdot A_{mem} = 28$ plf **BLC 5,7**

Wind Load (NESE Heavy)

Member Projected Surface Area w/ Ice = $A_{ICE_{mem}} := \frac{(W_{mem} + 2 \cdot lr)}{12} = 0.583$

Total Member Wind Force w/ Ice = $p \cdot C_dF \cdot A_{ICE_{mem}} = 4$ plf **BLC 4,6**

Gravity Loads (without ice)

Weight of the Member = Self Weight (Computed internally by Risa-3D) plf **BLC 1**

Gravity Loads (ice only)

Ice Area per Linear Foot = $A_{i_{mem}} := (W_{mem} + 2 \cdot lr) \cdot (H_{mem} + 2 \cdot lr) - W_{mem} \cdot H_{mem} = 13$ sq in

Weight of Ice on Member = $W_{ICE_{mem}} := Id \cdot \frac{A_{i_{mem}}}{144} = 5$ plf **BLC 3**

Basic Components

Heavy Wind Pressure =	p := 4.00	psf	(User Input NESC 2012 Figure 250-1 & Table 250-1)
Basic Windspeed =	V := 110	mph	(User Input NESC 2012 Figure 250-2(e))
Radial Ice Thickness =	Ir := 0.50	in	(User Input)
Radial Ice Density =	Id := 56.0	pcf	(User Input)

Factors for Extreme Wind Calculation

Elevation of Top of PCS Mast Above Grade =	TME := 118	ft	(User Input)
Multiplier Gust Response Factor =	m := 1.25		(User Input - Only for NESC Extreme wind case)
NESC Factor =	kv := 1.43		(User Input from NESC 2012 Table 250-3 equation)
Importance Factor =	I := 1.0		(User Input from NESC 2012 Section 250.C.2)
Velocity Pressure Coefficient =	$Kz := 2.01 \cdot \left(\frac{TME}{900} \right)^{\frac{2}{9.5}} = 1.31$		(NESC 2012 Table 250-2)
Exposure Factor =	$Es := 0.346 \left[\frac{33}{(0.67 \cdot TME)} \right]^{\frac{1}{7}} = 0.305$		(NESC 2012 Table 250-3)
Response Term =	$Bs := \frac{1}{\left(1 + 0.375 \cdot \frac{TME}{220} \right)} = 0.833$		(NESC 2012 Table 250-3)
Gust Response Factor =	$Grf := \frac{\left[1 + \left(2.7 \cdot Es \cdot Bs \cdot \frac{1}{2} \right) \right]}{kv^2} = 0.857$		(NESC 2012 Table 250-3)
Wind Pressure =	$qz := 0.00256 \cdot Kz \cdot V^2 \cdot Grf \cdot I = 34.8$	psf	(NESC 2012 Section 250.C.2)

Shape Factors

Shape Factor for Round Members =	Cd _R := 1.3	(User Input)
Shape Factor for Flat Members =	Cd _F := 1.6	(User Input)
Shape Factor for Coax Cables Attached to Outside of Pole =	Cd _{coax} := 1.6	(User Input)

Overload Factors

Overload Factors for Wind Loads:

NESC Heavy Loading =	2.5	(User Input)	Apply in Risa-3D Analysis
NESC Extreme Loading =	1.0	(User Input)	Apply in Risa-3D Analysis

Overload Factors for Vertical Loads:

NESC Heavy Loading =	1.5	(User Input)	Apply in Risa-3D Analysis
NESC Extreme Loading =	1.0	(User Input)	Apply in Risa-3D Analysis

Development of Wind & Ice Load on Mast

Mast Data:

(12" Sch. 80)

Mast Shape =	Round	(User Input)
Mast Diameter =	$D_{mast} := 12.8$ in	(User Input)
Mast Length =	$L_{mast} := 55$ ft	(User Input)
Mast Thickness =	$t_{mast} := 0.5$ in	(User Input)

Wind Load (NESC Extreme)

Mast Projected Surface Area = $A_{mast} := \frac{D_{mast}}{12} = 1.067$

Total Mast Wind Force (Below Top of Tower) = $qz \cdot C_{dR} \cdot A_{mast} = 48$ plf **BLC 5**

Total Mast Wind Force (Below Top of Tower) = $qz \cdot C_{d_{coax}} \cdot A_{mast} = 59$ Coax on Mast plf **BLC 5**

Total Mast Wind Force (Above Top of Tower) = $qz \cdot C_{d_{coax}} \cdot A_{mast} \cdot m = 74$ Coax on Mast plf **BLC 5**

Wind Load (NESE Heavy)

Mast Projected Surface Area w/ Ice = $A_{ICE_{mast}} := \frac{(D_{mast} + 2 \cdot Ir)}{12} = 1.15$

Total Mast Wind Force w/ Ice = $p \cdot C_{dR} \cdot A_{ICE_{mast}} = 6$ plf **BLC 4**

Total Mast Wind Force w/ Ice = $p \cdot C_{d_{coax}} \cdot A_{ICE_{mast}} = 7$ Coax on Mast plf **BLC 4**

Gravity Loads (without ice)

Weight of the Mast = Self Weight (Computed internally by Risa-3D) plf **BLC 1**

Gravity Loads (ice only)

Ice Area per Linear Foot = $A_{i_{mast}} := \frac{\pi}{4} [(D_{mast} + Ir \cdot 2)^2 - D_{mast}^2] = 20.9$ sq in

Weight of Ice on Mast = $W_{ICE_{mast}} := Id \cdot \frac{A_{i_{mast}}}{144} = 8$ plf **BLC 3**

Development of Wind & Ice Load on Antennas

Antenna Data:

Antenna Model =	Quintel QS46512-2	(AT&T)
Antenna Shape =	Flat	(User Input)
Antenna Height =	$L_{ant} := 52$ in	(User Input)
Antenna Width =	$W_{ant} := 12$ in	(User Input)
Antenna Thickness =	$T_{ant} := 10.8$ in	(User Input)
Antenna Weight =	$WT_{ant} := 75$ lbs	(User Input)
Number of Antennas =	$N_{ant} := 3$	(User Input)

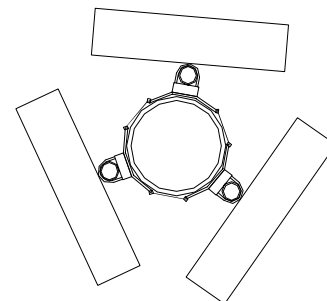

Wind Load (NESC Extreme)

Assumes Maximum Possible Wind Pressure Applied to all Antennas Simultaneously

Surface Area for One Antenna =

$$SA_{ant} := \frac{L_{ant} \cdot W_{ant}}{144} = 4.3 \quad sf$$

Antenna Projected Surface Area =

$$A_{ant} := SA_{ant} \cdot N_{ant} = 13 \quad sf$$

Total Antenna Wind Force =

$$F_{ant} := qz \cdot Cd_F \cdot A_{ant} \cdot m = 904 \quad lbs \quad \text{BLC 5}$$

Wind Load (NESC Heavy)

Assumes Maximum Possible Wind Pressure Applied to all Antennas Simultaneously

Surface Area for One Antenna w/ Ice =

$$SA_{ICEant} := \frac{(L_{ant} + 1) \cdot (W_{ant} + 1)}{144} = 4.8 \quad sf$$

Antenna Projected Surface Area w/ Ice =

$$A_{ICEant} := SA_{ICEant} \cdot N_{ant} = 14.4 \quad sf$$

Total Antenna Wind Force w/ Ice =

$$F_{ant} := p \cdot Cd_F \cdot A_{ICEant} = 92 \quad lbs \quad \text{BLC 4}$$

Gravity Load (without ice)

Weight of All Antennas =

$$WT_{ant} \cdot N_{ant} = 225 \quad lbs \quad \text{BLC 2}$$

Gravity Load (ice only)

Volume of Each Antenna =

$$V_{ant} := L_{ant} \cdot W_{ant} \cdot T_{ant} = 6739 \quad cu \text{ in}$$

Volume of Ice on Each Antenna =

$$V_{ice} := (L_{ant} + 1) \cdot (W_{ant} + 1) \cdot (T_{ant} + 1) - V_{ant} = 1391 \quad cu \text{ in}$$

Weight of Ice on Each Antenna =

$$W_{ICEant} := \frac{V_{ice}}{1728} \cdot Id = 45 \quad lbs$$

Weight of Ice on All Antennas =

$$W_{ICEant} \cdot N_{ant} = 135 \quad lbs \quad \text{BLC 3}$$

Development of Wind & Ice Load on TMA's

TMA Data:

TMA Model =
 TMA Shape =
 TMA Height =
 TMA Width =
 TMA Thickness =
 TMA Weight =
 Number of TMA's =

(AT&T)

Commscope TMAT21X23B68-31-43

Flat (User Input)

$L_{TMA} := 9.7$ in (User Input)

$W_{TMA} := 11.0$ in (User Input)

$T_{TMA} := 3.9$ in (User Input)

$W_{TMA} := 22$ lbs (User Input)

$N_{TMA} := 6$ (User Input)

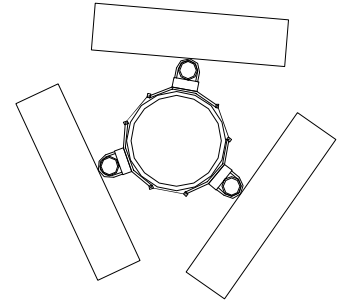

Wind Load (NESC Extreme Wind)

Assumes Maximum Possible Wind Pressure Applied to All TMA's Simultaneously

Surface Area for One TMA =

$$SA_{TMA} := \frac{L_{TMA} \cdot W_{TMA}}{144} = 0.7 \quad \text{sf}$$

TMA Projected Surface Area =

$$A_{TMA} := SA_{TMA} \cdot N_{TMA} = 4.4 \quad \text{sf}$$

Total TMA Wind Force =

$$F_{TMA} := qz \cdot C_d \cdot A_{TMA} \cdot m = 309 \quad \text{lbs} \quad \text{BLC 5}$$

Wind Load (NESC Heavy Wind)

Assumes Maximum Possible Wind Pressure Applied to All TMA's Simultaneously

Surface Area for One TMA w/ Ice =

$$SA_{ICETMA} := \frac{(L_{TMA} + 2 \cdot Ir) \cdot (W_{TMA} + 2 \cdot Ir)}{144} = 0.9 \quad \text{sf}$$

TMA Projected Surface Area w/ Ice =

$$A_{ICETMA} := SA_{ICETMA} \cdot N_{TMA} = 5.3 \quad \text{sf}$$

Total TMA Wind Force w/ Ice =

$$F_{iTMA} := p \cdot C_d \cdot A_{ICETMA} = 34 \quad \text{lbs} \quad \text{BLC 4}$$

Gravity Load (without ice)

Weight of All TMA's =

$$Wgt_{TMA} := (W_{TMA} \cdot N_{TMA}) = 132 \quad \text{lbs} \quad \text{BLC 2}$$

Gravity Load (ice)

Volume of Each TMA =

$$V_{TMA} := L_{TMA} \cdot W_{TMA} \cdot T_{TMA} = 416 \quad \text{cu in}$$

Volume of Ice on Each TMA =

$$V_{ice} := (L_{TMA} + 2 \cdot Ir) \cdot (W_{TMA} + 2 \cdot Ir) \cdot (T_{TMA} + 2 \cdot Ir) - V_{TMA} = 213 \quad \text{cu in}$$

Weight of Ice on Each TMA =

$$W_{ICETMA} := \frac{V_{ice}}{1728} \cdot Id = 7 \quad \text{lbs}$$

Weight of Ice on All TMA's =

$$Wgt_{ice.TMA} := (W_{ICETMA} \cdot N_{TMA}) = 41 \quad \text{lbs} \quad \text{BLC 3}$$

Development of Wind & Ice Load on Antenna Mounts

Mount Data:

Mount Type:
 Mount Shape =
 Pipe Mount Length =
 2 inch Pipe Mount Linear Weight =
 Pipe Mount Outside Diameter =
 Number of Mounting Pipes =
 Tri-Bracket Weight =

(AT&T)
 Microflect Universal Tri-Bracket
 Flat (User Input)
 $L_{mnt} := 72$ in (User Input)
 $W_{mnt} := 3.66$ plf (User Input)
 $D_{mnt} := 2.375$ in (User Input)
 $N_{mnt} := 3$ (User Input)
 $W_{tb.mnt} := 197$ lbs (User Input)

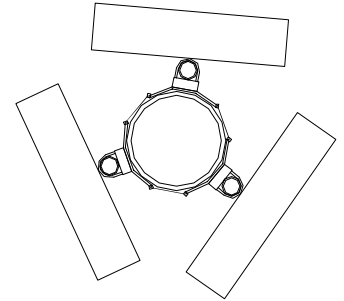

Wind Load (NESC Extreme)

Assumes Mount is Shielded by Antenna

Mount Projected Surface Area =

$A_{mnt} := 0.0$ sf

Total Mount Wind Force =

$F_{mnt} := qz \cdot C_d \cdot A_{mnt} \cdot m = 0$ lbs **BLC 5**

Wind Load (NESC Heavy)

Assumes Mount is Shielded by Antenna

Mount Projected Surface Area w/ Ice =

$A_{ICEmnt} := 0.0$ sf

Total Mount Wind Force =

$F_{mnt} := p \cdot C_d \cdot A_{ICEmnt} = 0$ lbs **BLC 4**

Gravity Loads (without ice)

Weight Each Pipe Mount =

$W_{Tmnt} := W_{mnt} \cdot \frac{L_{mnt}}{12} = 22$ lbs

Weight of All Mounts =

$W_{Tmnt} \cdot N_{mnt} + W_{tb.mnt} = 263$ lbs **BLC 2**

Gravity Load (ice only)

Volume of Each Pipe =

$V_{mnt} := \frac{\pi}{4} \cdot D_{mnt}^2 \cdot L_{mnt} = 319$ cu in

Volume of Ice on Each Pipe =

$V_{ice} := \left[\frac{\pi}{4} \cdot \left[(D_{mnt} + 1)^2 \right] \cdot (L_{mnt} + 1) \right] - V_{mnt} = 334$ cu in

Weight of Ice each mount (incl. hardware) =

$W_{ICEmnt} := \frac{V_{ice}}{1728} \cdot \rho_{ice} = 11$ lbs

Weight of Ice on All Mounts =

$W_{ICEmnt} \cdot N_{mnt} + 5 = 37$ lbs **BLC 3**

Development of Wind & Ice Load on Antennas

Antenna Data:

Antenna Model =	(T-Mobile)	RFSAPX16DWV-16DWVS
Antenna Shape =	Flat	(User Input)
Antenna Height =	$L_{ant} := 55.9$	in (User Input)
Antenna Width =	$W_{ant} := 13$	in (User Input)
Antenna Thickness =	$T_{ant} := 3.15$	in (User Input)
Antenna Weight =	$WT_{ant} := 40.7$	lbs (User Input)
Number of Antennas =	$N_{ant} := 3$	(User Input)

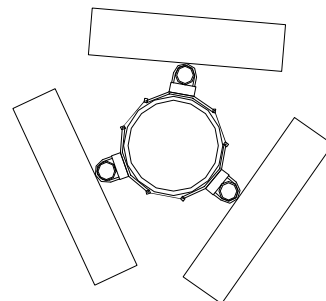

Wind Load (NESC Extreme)

Assumes Maximum Possible Wind Pressure Applied to all Antennas Simultaneously

Surface Area for One Antenna =

$$SA_{ant} := \frac{L_{ant} \cdot W_{ant}}{144} = 5 \quad sf$$

Antenna Projected Surface Area =

$$A_{ant} := SA_{ant} \cdot N_{ant} = 15.1 \quad sf$$

Total Antenna Wind Force =

$$F_{ant} := qz \cdot C_d \cdot A_{ant} = 1053 \quad lbs \quad \text{BLC 5}$$

Wind Load (NESC Heavy)

Assumes Maximum Possible Wind Pressure Applied to all Antennas Simultaneously

Surface Area for One Antenna w/ Ice =

$$SA_{ICEant} := \frac{(L_{ant} + 1) \cdot (W_{ant} + 1)}{144} = 5.5 \quad sf$$

Antenna Projected Surface Area w/ Ice =

$$A_{ICEant} := SA_{ICEant} \cdot N_{ant} = 16.6 \quad sf$$

Total Antenna Wind Force w/ Ice =

$$F_{i_{ant}} := p \cdot C_d \cdot A_{ICEant} = 106 \quad lbs \quad \text{BLC 4}$$

Gravity Load (without ice)

Weight of All Antennas =

$$WT_{ant} \cdot N_{ant} = 122 \quad lbs \quad \text{BLC 2}$$

Gravity Load (ice only)

Volume of Each Antenna =

$$V_{ant} := L_{ant} \cdot W_{ant} \cdot T_{ant} = 2289 \quad cu \text{ in}$$

Volume of Ice on Each Antenna =

$$V_{ice} := (L_{ant} + 1) \cdot (W_{ant} + 1) \cdot (T_{ant} + 1) - V_{ant} = 1017 \quad cu \text{ in}$$

Weight of Ice on Each Antenna =

$$W_{ICEant} := \frac{V_{ice}}{1728} \cdot \rho = 33 \quad lbs$$

Weight of Ice on All Antennas =

$$W_{ICEant} \cdot N_{ant} = 99 \quad lbs \quad \text{BLC 3}$$

Development of Wind & Ice Load on Antennas

Antenna Data:

	(T-Mobile)
Antenna Model =	Commscope ATSBT-TOP-FM-4G Bias Tee
Antenna Shape =	Flat (User Input)
Antenna Height =	$L_{ant} := 5.63$ in (User Input)
Antenna Width =	$W_{ant} := 3.7$ in (User Input)
Antenna Thickness =	$T_{ant} := 2.0$ in (User Input)
Antenna Weight =	$WT_{ant} := 2$ lbs (User Input)
Number of Antennas =	$N_{ant} := 3$ (User Input)

Wind Load (NESC Extreme)

Assumes Maximum Possible Wind Pressure Applied to all Antennas Simultaneously

Surface Area for One Antenna =	$SA_{ant} := \frac{L_{ant} \cdot W_{ant}}{144} = 0.1$	sf
Antenna Projected Surface Area =	$A_{ant} := SA_{ant} \cdot N_{ant} = 0.4$	sf

Total Antenna Wind Force =

$F_{ant} := qz \cdot C_d \cdot A_{ant} = 30$ lbs **BLC 5**

Wind Load (NESC Heavy)

Assumes Maximum Possible Wind Pressure Applied to all Antennas Simultaneously

Surface Area for One Antenna w/ Ice =	$SA_{ICEant} := \frac{(L_{ant} + 1) \cdot (W_{ant} + 1)}{144} = 0.2$	sf
Antenna Projected Surface Area w/ Ice =	$A_{ICEant} := SA_{ICEant} \cdot N_{ant} = 0.6$	sf

Total Antenna Wind Force w/ Ice =

$F_{ant} := p \cdot C_d \cdot A_{ICEant} = 4$ lbs **BLC 4**

Gravity Load (without ice)

Weight of All Antennas =

$WT_{ant} \cdot N_{ant} = 6$ lbs **BLC 2**

Gravity Load (ice only)

Volume of Each Antenna =	$V_{ant} := L_{ant} \cdot W_{ant} \cdot T_{ant} = 42$	cu in
Volume of Ice on Each Antenna =	$V_{ice} := (L_{ant} + 1) \cdot (W_{ant} + 1) \cdot (T_{ant} + 1) - V_{ant} = 52$	cu in
Weight of Ice on Each Antenna =	$W_{ICEant} := \frac{V_{ice}}{1728} \cdot \rho = 2$	lbs
Weight of Ice on All Antennas =	$W_{ICEant} \cdot N_{ant} = 5$	lbs BLC 3

Development of Wind & Ice Load on Antenna Mounts

Mount Data:

Mount Type:	(T-Mobile)	Microfect Universal Tri-Bracket
Mount Shape =	Flat	(User Input)
Pipe Mount Length =	$L_{mnt} := 72$	in (User Input)
2 inch Pipe Mount Linear Weight =	$W_{mnt} := 3.66$	plf (User Input)
Pipe Mount Outside Diameter =	$D_{mnt} := 2.375$	in (User Input)
Number of Mounting Pipes =	$N_{mnt} := 3$	(User Input)
Tri-Bracket Weight =	$W_{tb.mnt} := 197$	lbs (User Input)

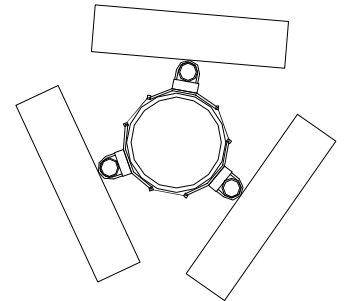

Wind Load (NESC Extreme)

Assumes Mount is Shielded by Antenna

Mount Projected Surface Area = $A_{mnt} := 0.0$ sf

Total Mount Wind Force = $F_{mnt} := qz \cdot C_d \cdot A_{mnt} \cdot m = 0$ lbs **BLC 5**

Wind Load (NESC Heavy)

Assumes Mount is Shielded by Antenna

Mount Projected Surface Area w/ Ice = $A_{ICEmnt} := 0.0$ sf

Total Mount Wind Force = $F_{i_mnt} := p \cdot C_d \cdot A_{ICEmnt} = 0$ lbs **BLC 4**

Gravity Loads (without ice)

Weight Each Pipe Mount = $W_{T_{mnt}} := W_{mnt} \cdot \frac{L_{mnt}}{12} = 22$ lbs

Weight of All Mounts = $W_{T_{mnt}} \cdot N_{mnt} + W_{tb.mnt} = 263$ lbs **BLC 2**

Gravity Load (ice only)

Volume of Each Pipe = $V_{mnt} := \frac{\pi}{4} \cdot D_{mnt}^2 \cdot L_{mnt} = 319$ cu in

Volume of Ice on Each Pipe = $V_{ice} := \left[\frac{\pi}{4} \cdot (D_{mnt} + 1)^2 \cdot (L_{mnt} + 1) \right] - V_{mnt} = 334$ cu in

Weight of Ice each mount (incl. hardware) = $W_{ICEmnt} := \frac{V_{ice}}{1728} \cdot \rho = 11$ lbs

Weight of Ice on All Mounts = $W_{ICEmnt} \cdot N_{mnt} + 5 = 37$ lbs **BLC 3**

Development of Wind & Ice Load on Coax Cables

Coax Cable Data:

Coax Type =	HELIAX 1-1/4"	
Shape =	Round	(User Input)
Coax Outside Diameter =	$D_{\text{coax}} := 1.55$	in (User Input)
Coax Cable Length =	$L_{\text{coax}} := 20$	ft (User Input)
Weight of Coax per foot =	$Wt_{\text{coax}} := 0.66$	plf (User Input)
Total Number of Coax =	$N_{\text{coax}} := 24$	(User Input) (12AT&T & 12 T-Mobile)
No. of Coax Projecting Outside Face of PCS Mast =	$NP_{\text{coax}} := 6$	(User Input)

Wind Load (NESC Extreme)

Coax projected surface area = $A_{\text{coax}} := \frac{(NP_{\text{coax}} \cdot D_{\text{coax}})}{12} = 0.8$ ft

Total Coax Wind Force (Above NU Structure) =

$F_{\text{coax}} := qz \cdot C_{d_{\text{coax}}} \cdot A_{\text{coax}} \cdot m = 54$ plf **BLC 5**

Wind Load (NESC Heavy)

Coax projected surface area w/ Ice = $A_{\text{ICE}_{\text{coax}}} := \frac{(NP_{\text{coax}} \cdot D_{\text{coax}} + 2 \cdot 1r)}{12} = 0.9$ ft

Total Coax Wind Force w/ Ice =

$F_{\text{coax}} := p \cdot C_{d_{\text{coax}}} \cdot A_{\text{ICE}_{\text{coax}}} = 5$ plf **BLC 4**

Gravity Loads (without ice)

Weight of all cables w/o ice

$WT_{\text{coax}} := Wt_{\text{coax}} \cdot N_{\text{coax}} = 16$ plf **BLC 2**

Gravity Load (ice only)

Ice Area per Linear Foot =

$A_{\text{ice}_{\text{coax}}} := \frac{\pi}{4} [(D_{\text{coax}} + 2 \cdot 1r)^2 - D_{\text{coax}}^2] = 3.2$ sq in

Ice Weight All Coax per foot =

$WT_{\text{ice}_{\text{coax}}} := Id \cdot \left(N_{\text{coax}} \cdot \frac{A_{\text{ice}_{\text{coax}}}}{144} \right) = 30$ plf **BLC 3**

Development of Wind & Ice Load on Coax Cables

Coax Cable Data:

Coax Type =	HELIX 1-1/4"	
Shape =	Round	(User Input)
Coax Outside Diameter =	$D_{\text{coax}} := 1.55$	in (User Input)
Coax Cable Length =	$L_{\text{coax}} := 20$	ft (User Input)
Weight of Coax per foot =	$Wt_{\text{coax}} := 0.66$	plf (User Input)
Total Number of Coax =	$N_{\text{coax}} := 12$	(User Input) (12 T-Mobile)
No. of Coax Projecting Outside Face of PCS Mast =	$NP_{\text{coax}} := 3$	(User Input)

Wind Load (NESC Extreme)

Coax projected surface area = $A_{\text{coax}} := \frac{(NP_{\text{coax}} \cdot D_{\text{coax}})}{12} = 0.4$ ft

Total Coax Wind Force (Above NU Structure) =

$F_{\text{coax}} := qz \cdot C_d \cdot A_{\text{coax}} \cdot m = 27$ plf **BLC 5**

Wind Load (NESC Heavy)

Coax projected surface area w/ Ice = $A_{\text{ICE}_{\text{coax}}} := \frac{(NP_{\text{coax}} \cdot D_{\text{coax}} + 2 \cdot 1r)}{12} = 0.5$ ft

Total Coax Wind Force w/ Ice =

$F_{\text{coax}} := p \cdot C_d \cdot A_{\text{ICE}_{\text{coax}}} = 3$ plf **BLC 4**

Gravity Loads (without ice)

Weight of all cables w/o ice

$WT_{\text{coax}} := Wt_{\text{coax}} \cdot N_{\text{coax}} = 8$ plf **BLC 2**

Gravity Load (ice only)

Ice Area per Linear Foot =

$A_{\text{ice}_{\text{coax}}} := \frac{\pi}{4} [(D_{\text{coax}} + 2 \cdot 1r)^2 - D_{\text{coax}}^2] = 3.2$ sq in

Ice Weight All Coax per foot =

$WT_{\text{ice}_{\text{coax}}} := Id \cdot \left(N_{\text{coax}} \cdot \frac{A_{\text{ice}_{\text{coax}}}}{144} \right) = 15$ plf **BLC 3**

Development of Wind & Ice Load on Brace Member

Member Data:

	HSS6x6x1/4	
Shape =	Flat	(User Input)
Width =	$W_{mem} := 6$	in (User Input)
Length =	$L_{mem} := 5$	ft (User Input)
Height =	$H_{mem} := 6$	in (User Input)

Wind Load (NESC Extreme)

Member Projected Surface Area = $A_{mem} := \frac{W_{mem}}{12} = 0.5$

Total Member Wind Force = $qz \cdot C_dF \cdot A_{mem} = 28$ plf **BLC 5,7**

Wind Load (NESE Heavy)

Member Projected Surface Area w/ Ice = $A_{ICE_{mem}} := \frac{(W_{mem} + 2 \cdot lr)}{12} = 0.583$

Total Member Wind Force w/ Ice = $p \cdot C_dF \cdot A_{ICE_{mem}} = 4$ plf **BLC 4,6**

Gravity Loads (without ice)

Weight of the Member = Self Weight (Computed internally by Risa-3D) plf **BLC 1**

Gravity Loads (ice only)

Ice Area per Linear Foot = $A_{i_{mem}} := (W_{mem} + 2 \cdot lr) \cdot (H_{mem} + 2 \cdot lr) - W_{mem} \cdot H_{mem} = 13$ sq in

Weight of Ice on Member = $W_{ICE_{mem}} := Id \cdot \frac{A_{i_{mem}}}{144} = 5$ plf **BLC 3**

(Global) Model Settings

Display Sections for Member Calcs	5
Max Internal Sections for Member Calcs	97
Include Shear Deformation?	Yes
Increase Nailing Capacity for Wind?	Yes
Include Warping?	Yes
Trans Load Btwn Intersecting Wood Wall?	Yes
Area Load Mesh (in^2)	144
Merge Tolerance (in)	.12
P-Delta Analysis Tolerance	0.50%
Include P-Delta for Walls?	Yes
Automatically Iterate Stiffness for Walls?	No
Max Iterations for Wall Stiffness	3
Gravity Acceleration (ft/sec^2)	32.2
Wall Mesh Size (in)	12
Eigensolution Convergence Tol. (1.E-)	4
Vertical Axis	Y
Global Member Orientation Plane	XZ
Static Solver	Sparse Accelerated
Dynamic Solver	Standard Solver

Hot Rolled Steel Code	AISC 9th: ASD
RISAConnection Code	AISC 14th(360-10): ASD
Cold Formed Steel Code	AISI 1999: ASD
Wood Code	AF&PA NDS-91/97: ASD
Wood Temperature	< 100F
Concrete Code	ACI 318-02
Masonry Code	ACI 530-05: ASD
Aluminum Code	AA ADM1-05: ASD - Building
Stainless Steel Code	AISC 14th(360-10): ASD
Adjust Stiffness?	Yes(Iterative)

Number of Shear Regions	4
Region Spacing Increment (in)	4
Biaxial Column Method	PCA Load Contour
Parme Beta Factor (PCA)	.65
Concrete Stress Block	Rectangular
Use Cracked Sections?	Yes
Use Cracked Sections Slab?	Yes
Bad Framing Warnings?	No
Unused Force Warnings?	Yes
Min 1 Bar Diam. Spacing?	No
Concrete Rebar Set	REBAR_SET_ASTMA615
Min % Steel for Column	1
Max % Steel for Column	8

(Global) Model Settings, Continued

Seismic Code	UBC 1997
Seismic Base Elevation (ft)	Not Entered
Add Base Weight?	No
Ct X	.035
Ct Z	.035
T X (sec)	Not Entered
T Z (sec)	Not Entered
R X	8.5
R Z	8.5
Ca	.36
Cv	.54
Nv	1
Occupancy Category	4
Seismic Zone	3
Om Z	1
Om X	1
Rho Z	1
Rho X	1
Footing Overturning Safety Factor	1.5
Optimize for OTM/Sliding	No
Check Concrete Bearing	No
Footing Concrete Weight (k/ft^3)	0
Footing Concrete f'c (ksi)	3
Footing Concrete Ec (ksi)	4000
Lambda	1
Footing Steel fy (ksi)	60
Minimum Steel	0.0018
Maximum Steel	0.0075
Footing Top Bar	#3
Footing Top Bar Cover (in)	3.5
Footing Bottom Bar	#3
Footing Bottom Bar Cover (in)	3.5
Pedestal Bar	#3
Pedestal Bar Cover (in)	1.5
Pedestal Ties	#3

Hot Rolled Steel Properties

	Label	E [ksi]	G [ksi]	Nu	Therm (\1...	Density[k/ft^3]	Yield[ksi]	Ry	Fu[ksi]	Rt
1	A572 Gr.50	29000	11154	.3	.65	.49	50	1.1	65	1.2
2	A992	29000	11154	.3	.65	.49	50	1.1	65	1.2
3	A500 Gr.B (42)	29000	11154	.3	.65	.49	42	1.3	58	1.1
4	A500 Gr. B (46)	29000	11154	.3	.65	.49	46	1.5	58	1.2
5	A500 Gr. C (46)	29000	11154	.3	.65	.49	46	1.5	62	1.2
6	A500 Gr. C (50)	29000	11154	.3	.65	.49	50	1.5	62	1.2
7	A53 Gr. B	29000	11154	.3	.65	.49	35	1.5	60	1.2
8	A36	29000	11154	.3	.65	.49	36	1.5	58	1.2

Hot Rolled Steel Section Sets

	Label	Shape	Type	Design List	Material	Design ... A [in2]	Iyy [in4]	Izz [in4]	J [in4]
1	Mast	PIPE 12.0X	Column	Pipe	A53 Gr. B	Typical	17.5	339	678
2	Brace	HSS6X6X4	Beam	Tube	A500 Gr. B (...)	Typical	5.24	28.6	45.6

Hot Rolled Steel Design Parameters

	Label	Shape	Length...	Lbyy[ft]	Lbzz[ft]	Lcomp to...	Lcomp bo...	Kyy	Kzz	Cm-yy	Cm-zz	Cb	y swayz	sway	Function
1	M1	Mast	33			Lbyy									Lateral
2	M2	Mast	22			Lbyy									Lateral
3	M3	Brace	2.25			Lbyy									Lateral
4	M4	Brace	7			Lbyy									Lateral
5	M5	Brace	2.25			Lbyy									Lateral
6	M6	Brace	2.25			Lbyy									Lateral
7	M7	Brace	7			Lbyy									Lateral
8	M8	Brace	2.25			Lbyy									Lateral

Member Primary Data

	Label	I Joint	J Joint	K Joint	Rotate(d...	Section/Shape	Type	Design List	Material	Design Ru...
1	M1	BOTTO...	FLANGE...			Mast	Column	Pipe	A53 Gr. B	Typical
2	M2	FLANGE...	TOP_M...			Mast	Column	Pipe	A53 Gr. B	Typical
3	M3	N8	N12			Brace	Beam	Tube	A500 Gr...	Typical
4	M4	N12	N11			Brace	Beam	Tube	A500 Gr...	Typical
5	M5	N11	N7			Brace	Beam	Tube	A500 Gr...	Typical
6	M6	N6	N10			Brace	Beam	Tube	A500 Gr...	Typical
7	M7	N10	N9			Brace	Beam	Tube	A500 Gr...	Typical
8	M8	N9	N5			Brace	Beam	Tube	A500 Gr...	Typical

Joint Coordinates and Temperatures

	Label	X [ft]	Y [ft]	Z [ft]	Temp [F]	Detach From Dia...
1	BOTTOM_CONNECTION	0	0	0	0	
2	TOP_CONNECTION	0	21.5	0	0	
3	FLANGE_CONNECTION	0	33	0	0	
4	TOP_MAST	0	55	0	0	
5	N5	-2.25	0	3.5	0	
6	N6	-2.25	0	-3.5	0	
7	N7	-2.25	21.5	3.5	0	
8	N8	-2.25	21.5	-3.5	0	
9	N9	0	0	3.5	0	
10	N10	0	0	-3.5	0	
11	N11	0	21.5	3.5	0	
12	N12	0	21.5	-3.5	0	

Joint Boundary Conditions

	Joint Label	X [k/in]	Y [k/in]	Z [k/in]	X Rot.[k-ft/rad]	Y Rot.[k-ft/rad]	Z Rot.[k-ft/rad]
1	BOTTOM_CONNEC...						
2	TOP_CONNECTION						
3	FLANGE_CONNECTI...						

Joint Boundary Conditions (Continued)

	Joint Label	X [k/in]	Y [k/in]	Z [k/in]	X Rot.[k-ft/rad]	Y Rot.[k-ft/rad]	Z Rot.[k-ft/rad]
4	TOP_MAST						
5	N7	Reaction	Reaction	Reaction			
6	N8	Reaction	Reaction	Reaction			
7	N11						
8	N12						
9	N5	Reaction	Reaction	Reaction			
10	N6	Reaction	Reaction	Reaction			
11	N9						
12	N10						

Member Point Loads (BLC 2 : Weight of PCS Structure)

	Member Label	Direction	Magnitude[k,k-ft]	Location[ft,%]
1	M2	Y	-.109	10
2	M2	Y	-.069	10
3	M2	Y	-.263	10
4	M2	Y	-.459	19
5	M2	Y	-.006	19
6	M2	Y	-.65	19

Member Point Loads (BLC 3 : Weight of Ice Only on PCS Struct)

	Member Label	Direction	Magnitude[k,k-ft]	Location[ft,%]
1	M2	Y	-.096	10
2	M2	Y	-.022	10
3	M2	Y	-.037	10
4	M2	Y	-.338	19
5	M2	Y	-.005	19
6	M2	Y	-.075	19

Member Point Loads (BLC 4 : NESC Heavy Wind)

	Member Label	Direction	Magnitude[k,k-ft]	Location[ft,%]
1	M2	X	.084	10
2	M2	X	.018	10
3	M2	X	.323	19
4	M2	X	.004	19

Member Point Loads (BLC 5 : NESC Extreme Wind)

	Member Label	Direction	Magnitude[k,k-ft]	Location[ft,%]
1	M2	X	.82	10
2	M2	X	.167	10
3	M2	X	3.333	19
4	M2	X	.03	19

Member Distributed Loads (BLC 2 : Weight of PCS Structure)

	Member Label	Direction	Start Magnitude[k/ft,F,ksf]	End Magnitude[k/...Start Location[ft,%]	End Location[ft,%]
1	M1	Y	-.02	-.02	23 33
2	M2	Y	-.02	-.02	0 8
3	M2	Y	-.016	-.016	8 17



Member Distributed Loads (BLC 3 : Weight of Ice Only on PCS Struct)

	Member Label	Direction	Start Magnitude[k/ft,F,ksf]	End Magnitude[k/...	Start Location[ft,%]	End Location[ft,%]
1	M1	Y	-.008	-.008	0	0
2	M2	Y	-.008	-.008	0	0
3	M1	Y	-.038	-.038	23	33
4	M2	Y	-.038	-.038	0	8
5	M2	Y	-.03	-.03	8	17
6	M5	Y	-.005	-.005	0	0
7	M4	Y	-.005	-.005	0	0
8	M3	Y	-.005	-.005	0	0
9	M8	Y	-.005	-.005	0	0
10	M7	Y	-.005	-.005	0	0
11	M6	Y	-.005	-.005	0	0

Member Distributed Loads (BLC 4 : NESC Heavy Wind)

	Member Label	Direction	Start Magnitude[k/ft,F,ksf]	End Magnitude[k/...	Start Location[ft,%]	End Location[ft,%]
1	M1	X	.006	.006	0	23
2	M1	X	.007	.007	23	33
3	M2	X	.007	.007	0	8
4	M2	X	.007	.007	12	17
5	M1	X	.005	.005	23	33
6	M2	X	.005	.005	0	8
7	M2	X	.005	.005	12	17
8	M4	X	.004	.004	0	0
9	M7	X	.004	.004	0	0

Member Distributed Loads (BLC 5 : NESC Extreme Wind)

	Member Label	Direction	Start Magnitude[k/ft,F,ksf]	End Magnitude[k/...	Start Location[ft,%]	End Location[ft,%]
1	M1	X	.048	.048	0	23
2	M1	X	.059	.059	23	33
3	M2	X	.074	.074	0	8
4	M2	X	.074	.074	12	17
5	M1	X	.054	.054	23	33
6	M2	X	.054	.054	0	8
7	M2	X	.054	.054	12	17
8	M4	X	.028	.028	0	0
9	M7	X	.028	.028	0	0

Basic Load Cases

	BLC Description	Category	X Gravity	Y Gravity	Z Gravity	Joint	Point	Distribu...	Area(M... Surface...
1	Self Weight (PCS Mast)	None		-1					
2	Weight of PCS Structure	None					6	3	
3	Weight of Ice Only on PCS Struct	None					6	11	
4	NESC Heavy Wind	None					4	9	
5	NESC Extreme Wind	None					4	9	



Load Combinations

	Description	Solve	PDel...	S...	B...	Fa...	BLC	Fa...	BLC	Fa...	BLC	Fa...	BLC	Fa...	B...	Fa...	BLC	Fa...	B...	Fa...	B...	Fa...	B...	Fa...	B...	Fa...	B...	Fa...	B...	Fa...	B...		
1	NESC Heavy Wind o...	Yes			1	1.5	2	1.5	3	1.5	4	2.5																					
2	NESC Extreme Wind...	Yes			1	1	2	1	5	1																							
3	Self Weight				1	1																											

Envelope Joint Reactions

	Joint		X [k]	LC	Y [k]	LC	Z [k]	LC	MX [k-ft]	LC	MY [k-ft]	LC	MZ [k-ft]	LC
1	N7	max	-2.545	1	2.257	1	5.003	2	0	2	0	2	0	2
2		min	-8.067	2	-1.392	2	1.577	1	0	1	0	1	0	1
3	N8	max	-2.545	1	2.257	1	-1.577	1	0	2	0	2	0	2
4		min	-8.067	2	-1.392	2	-5.003	2	0	1	0	1	0	1
5	N5	max	3.747	2	4.264	2	-.892	1	0	2	0	2	0	2
6		min	1.421	1	3.614	1	-2.354	2	0	1	0	1	0	1
7	N6	max	3.747	2	4.264	2	2.354	2	0	2	0	2	0	2
8		min	1.421	1	3.614	1	.892	1	0	1	0	1	0	1
9	Totals:	max	-2.247	1	11.741	1	0	2						
10		min	-8.64	2	5.745	2	0	1						

Joint Reactions (By Combination)

LC	Joint Label	X [k]	Y [k]	Z [k]	MX [k-ft]	MY [k-ft]	MZ [k-ft]
1	1	N7	-2.545	2.257	1.577	0	0
2	1	N8	-2.545	2.257	-1.577	0	0
3	1	N5	1.421	3.614	-.892	0	0
4	1	N6	1.421	3.614	.892	0	0
5	1	Totals:	-2.247	11.741	0		
6	1	COG (ft):	X: -.03	Y: 33.907	Z: 0		



Company : CENTEK Engineering, Inc.
 Designer : TJJ
 Job Number : 18000.55
 Model Name : South Mast - Tower # 1102

May 21, 2019
 8:37 AM
 Checked By: CAG

Joint Reactions (By Combination)

LC	Joint Label	X [k]	Y [k]	Z [k]	MX [k-ft]	MY [k-ft]	MZ [k-ft]
1	2	N7	-8.067	-1.392	5.003	0	0
2	2	N8	-8.067	-1.392	-5.003	0	0
3	2	N5	3.747	4.264	-2.354	0	0
4	2	N6	3.747	4.264	2.354	0	0
5	2	Totals:	-8.64	5.745	0		
6	2	COG (ft):	X: -.031	Y: 32.982	Z: 0		

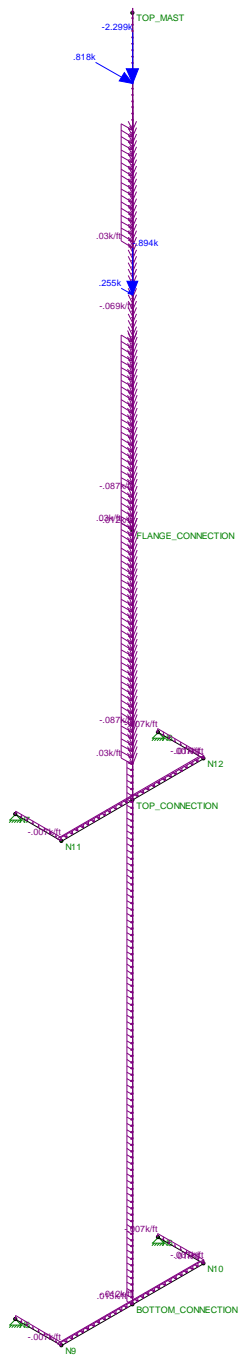

Loads: LC 1, NESC Heavy Wind on PCS Mast

CENTEK Engineering, Inc.
TJL
18000.55

South Mast - Tower # 1102
LC #1 Loads

May 21, 2019 at 8:34 AM
NESC South Mast.r3d

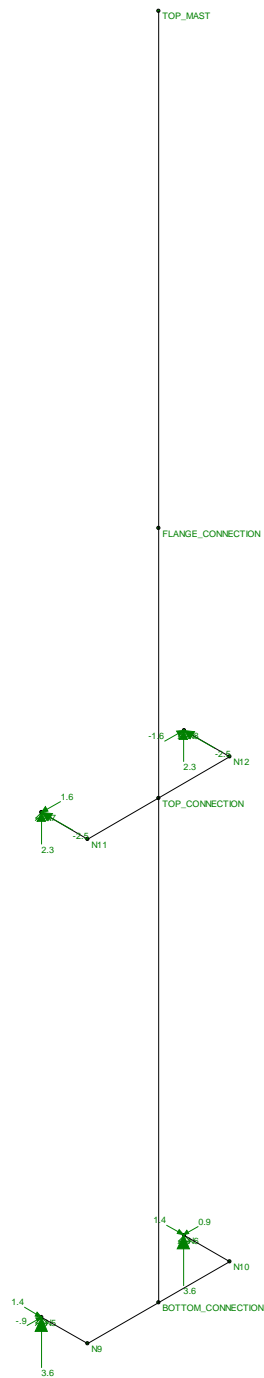

Results for LC 1, NESC Heavy Wind on PCS Mast
Reaction and Moment Units are k and k-ft

CENTEK Engineering, Inc.
TJL
18000.55

South Mast - Tower # 1102
LC #1 Reactions

May 21, 2019 at 8:36 AM
NESC South Mast.r3d

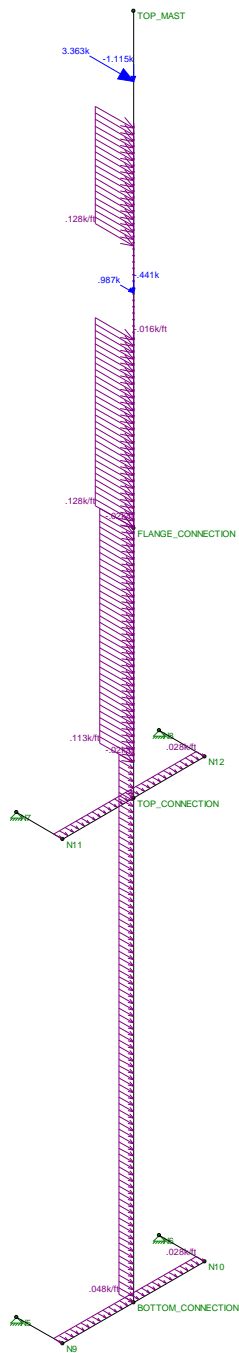

Loads: LC 2, NESC Extreme Wind on PCS Mast

CENTEK Engineering, Inc.
TJL
18000.55

South Mast - Tower # 1102
LC #2 Loads

May 21, 2019 at 8:34 AM
NESC South Mast.r3d

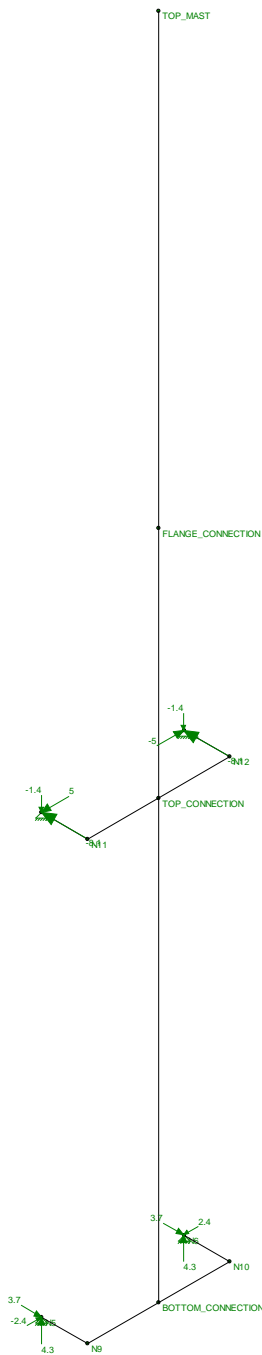

Results for LC 2, NESC Extreme Wind on PCS Mast
Reaction and Moment Units are k and k-ft

CENTEK Engineering, Inc.
TJL
18000.55

South Mast - Tower # 1102
LC #2 Reactions

May 21, 2019 at 8:37 AM
NESC South Mast.r3d

(Global) Model Settings

Display Sections for Member Calcs	5
Max Internal Sections for Member Calcs	97
Include Shear Deformation?	Yes
Increase Nailing Capacity for Wind?	Yes
Include Warping?	Yes
Trans Load Btwn Intersecting Wood Wall?	Yes
Area Load Mesh (in^2)	144
Merge Tolerance (in)	.12
P-Delta Analysis Tolerance	0.50%
Include P-Delta for Walls?	Yes
Automatically Iterate Stiffness for Walls?	No
Max Iterations for Wall Stiffness	3
Gravity Acceleration (ft/sec^2)	32.2
Wall Mesh Size (in)	12
Eigensolution Convergence Tol. (1.E-)	4
Vertical Axis	Y
Global Member Orientation Plane	XZ
Static Solver	Sparse Accelerated
Dynamic Solver	Standard Solver

Hot Rolled Steel Code	AISC 9th: ASD
RISAConnection Code	AISC 14th(360-10): ASD
Cold Formed Steel Code	AISI 1999: ASD
Wood Code	AF&PA NDS-91/97: ASD
Wood Temperature	< 100F
Concrete Code	ACI 318-02
Masonry Code	ACI 530-05: ASD
Aluminum Code	AA ADM1-05: ASD - Building
Stainless Steel Code	AISC 14th(360-10): ASD
Adjust Stiffness?	Yes(Iterative)

Number of Shear Regions	4
Region Spacing Increment (in)	4
Biaxial Column Method	PCA Load Contour
Parme Beta Factor (PCA)	.65
Concrete Stress Block	Rectangular
Use Cracked Sections?	Yes
Use Cracked Sections Slab?	Yes
Bad Framing Warnings?	No
Unused Force Warnings?	Yes
Min 1 Bar Diam. Spacing?	No
Concrete Rebar Set	REBAR_SET_ASTMA615
Min % Steel for Column	1
Max % Steel for Column	8

(Global) Model Settings, Continued

Seismic Code	UBC 1997
Seismic Base Elevation (ft)	Not Entered
Add Base Weight?	No
Ct X	.035
Ct Z	.035
T X (sec)	Not Entered
T Z (sec)	Not Entered
R X	8.5
R Z	8.5
Ca	.36
Cv	.54
Nv	1
Occupancy Category	4
Seismic Zone	3
Om Z	1
Om X	1
Rho Z	1
Rho X	1
Footing Overturning Safety Factor	1.5
Optimize for OTM/Sliding	No
Check Concrete Bearing	No
Footing Concrete Weight (k/ft^3)	0
Footing Concrete f'c (ksi)	3
Footing Concrete Ec (ksi)	4000
Lambda	1
Footing Steel fy (ksi)	60
Minimum Steel	0.0018
Maximum Steel	0.0075
Footing Top Bar	#3
Footing Top Bar Cover (in)	3.5
Footing Bottom Bar	#3
Footing Bottom Bar Cover (in)	3.5
Pedestal Bar	#3
Pedestal Bar Cover (in)	1.5
Pedestal Ties	#3

Hot Rolled Steel Properties

	Label	E [ksi]	G [ksi]	Nu	Therm (\1...	Density[k/ft^3]	Yield[ksi]	Ry	Fu[ksi]	Rt
1	A572 Gr.50	29000	11154	.3	.65	.49	50	1.1	65	1.2
2	A992	29000	11154	.3	.65	.49	50	1.1	65	1.2
3	A500 Gr.B (42)	29000	11154	.3	.65	.49	42	1.3	58	1.1
4	A500 Gr. B (46)	29000	11154	.3	.65	.49	46	1.5	58	1.2
5	A500 Gr. C (46)	29000	11154	.3	.65	.49	46	1.5	62	1.2
6	A500 Gr. C (50)	29000	11154	.3	.65	.49	50	1.5	62	1.2
7	A53 Gr. B	29000	11154	.3	.65	.49	35	1.5	60	1.2
8	A36	29000	11154	.3	.65	.49	36	1.5	58	1.2

Hot Rolled Steel Section Sets

	Label	Shape	Type	Design List	Material	Design ...	A [in ²]	I _{yy} [in ⁴]	I _{zz} [in ⁴]	J [in ⁴]
1	Mast	PIPE 12.0X	Column	Pipe	A53 Gr. B	Typical	17.5	339	339	678
2	Brace	HSS6X6X4	Beam	Tube	A500 Gr. B (...)	Typical	5.24	28.6	28.6	45.6

Hot Rolled Steel Design Parameters

	Label	Shape	Length...	Lbyy[ft]	Lbzz[ft]	Lcomp to...	Lcomp bo...	Kyy	Kzz	Cm-yy	Cm-zz	Cb	y swayz	sway	Function
1	M1	Mast	36			Lbyy									Lateral
2	M2	Mast	20			Lbyy									Lateral
3	M3	Brace	2.25			Lbyy									Lateral
4	M4	Brace	7			Lbyy									Lateral
5	M5	Brace	2.25			Lbyy									Lateral
6	M6	Brace	2.25			Lbyy									Lateral
7	M7	Brace	7			Lbyy									Lateral
8	M8	Brace	2.25			Lbyy									Lateral

Member Primary Data

	Label	I Joint	J Joint	K Joint	Rotate(d...	Section/Shape	Type	Design List	Material	Design Ru...
1	M1	BOTTO...	FLANGE...			Mast	Column	Pipe	A53 Gr. B	Typical
2	M2	FLANGE...	TOP_M...			Mast	Column	Pipe	A53 Gr. B	Typical
3	M3	N8	N12			Brace	Beam	Tube	A500 Gr...	Typical
4	M4	N12	N11			Brace	Beam	Tube	A500 Gr...	Typical
5	M5	N11	N7			Brace	Beam	Tube	A500 Gr...	Typical
6	M6	N6	N10			Brace	Beam	Tube	A500 Gr...	Typical
7	M7	N10	N9			Brace	Beam	Tube	A500 Gr...	Typical
8	M8	N9	N5			Brace	Beam	Tube	A500 Gr...	Typical

Joint Coordinates and Temperatures

	Label	X [ft]	Y [ft]	Z [ft]	Temp [F]	Detach From Dia...
1	BOTTOM_CONNECTION	0	0	0	0	
2	TOP_CONNECTION	0	21.5	0	0	
3	FLANGE_CONNECTION	0	36	0	0	
4	TOP_MAST	0	56	0	0	
5	N5	2.25	0	3.5	0	
6	N6	2.25	0	-3.5	0	
7	N7	2.25	21.5	3.5	0	
8	N8	2.25	21.5	-3.5	0	
9	N9	0	0	3.5	0	
10	N10	0	0	-3.5	0	
11	N11	0	21.5	3.5	0	
12	N12	0	21.5	-3.5	0	

Joint Boundary Conditions

	Joint Label	X [k/in]	Y [k/in]	Z [k/in]	X Rot.[k-ft/rad]	Y Rot.[k-ft/rad]	Z Rot.[k-ft/rad]
1	BOTTOM_CONNEC...						
2	TOP_CONNECTION						
3	FLANGE_CONNECTI...						

Joint Boundary Conditions (Continued)

	Joint Label	X [k/in]	Y [k/in]	Z [k/in]	X Rot.[k-ft/rad]	Y Rot.[k-ft/rad]	Z Rot.[k-ft/rad]
4	TOP_MAST						
5	N7	Reaction	Reaction	Reaction			
6	N8	Reaction	Reaction	Reaction			
7	N11						
8	N12						
9	N5	Reaction	Reaction	Reaction			
10	N6	Reaction	Reaction	Reaction			
11	N9						
12	N10						

Member Point Loads (BLC 2 : Weight of PCS Structure)

	Member Label	Direction	Magnitude[k,k-ft]	Location[ft,%]
1	M2	Y	-.225	6
2	M2	Y	-.132	6
3	M2	Y	-.263	6
4	M2	Y	-.122	16
5	M2	Y	-.006	16
6	M2	Y	-.263	16

Member Point Loads (BLC 3 : Weight of Ice Only on PCS Struct)

	Member Label	Direction	Magnitude[k,k-ft]	Location[ft,%]
1	M2	Y	-.135	6
2	M2	Y	-.041	6
3	M2	Y	-.037	6
4	M2	Y	-.099	16
5	M2	Y	-.005	16
6	M2	Y	-.037	16

Member Point Loads (BLC 4 : NESC Heavy Wind)

	Member Label	Direction	Magnitude[k,k-ft]	Location[ft,%]
1	M2	X	.092	6
2	M2	X	.034	6
3	M2	X	.106	16
4	M2	X	.004	16

Member Point Loads (BLC 5 : NESC Extreme Wind)

	Member Label	Direction	Magnitude[k,k-ft]	Location[ft,%]
1	M2	X	.904	6
2	M2	X	.309	6
3	M2	X	1.053	16
4	M2	X	.03	16

Member Distributed Loads (BLC 2 : Weight of PCS Structure)

	Member Label	Direction	Start Magnitude[k/ft,F,ksf]	End Magnitude[k/... Start Location[ft,%]	End Location[ft,%]
1	M1	Y	-.016	-.016 23	36
2	M2	Y	-.016	-.016 0	4
3	M2	Y	-.008	-.008 4	15

Member Distributed Loads (BLC 3 : Weight of Ice Only on PCS Struct)

	Member Label	Direction	Start Magnitude[k/ft,F,ksf]	End Magnitude[k/...	Start Location[ft,%]	End Location[ft,%]
1	M1	Y	-.008	-.008	0	0
2	M2	Y	-.008	-.008	0	0
3	M1	Y	-.03	-.03	23	36
4	M2	Y	-.03	-.03	0	4
5	M2	Y	-.015	-.015	4	15
6	M5	Y	-.005	-.005	0	0
7	M4	Y	-.005	-.005	0	0
8	M3	Y	-.005	-.005	0	0
9	M8	Y	-.005	-.005	0	0
10	M7	Y	-.005	-.005	0	0
11	M6	Y	-.005	-.005	0	0

Member Distributed Loads (BLC 4 : NESC Heavy Wind)

	Member Label	Direction	Start Magnitude[k/ft,F,ksf]	End Magnitude[k/...	Start Location[ft,%]	End Location[ft,%]
1	M1	X	.006	.006	0	23
2	M1	X	.007	.007	23	36
3	M2	X	.007	.007	0	4
4	M2	X	.007	.007	8	15
5	M1	X	.005	.005	23	36
6	M2	X	.005	.005	0	4
7	M2	X	.003	.003	8	15
8	M4	X	.004	.004	0	0
9	M7	X	.004	.004	0	0

Member Distributed Loads (BLC 5 : NESC Extreme Wind)

	Member Label	Direction	Start Magnitude[k/ft,F,ksf]	End Magnitude[k/...	Start Location[ft,%]	End Location[ft,%]
1	M1	X	.048	.048	0	23
2	M1	X	.059	.059	23	32
3	M1	X	.074	.074	32	36
4	M2	X	.074	.074	0	4
5	M2	X	.074	.074	8	15
6	M1	X	.054	.054	23	36
7	M2	X	.054	.054	0	4
8	M2	X	.027	.027	8	15
9	M4	X	.028	.028	0	0
10	M7	X	.028	.028	0	0

Basic Load Cases

	BLC Description	Category	X Gravity	Y Gravity	Z Gravity	Joint	Point	Distribu...	Area(M...)	Surface...
1	Self Weight (PCS Mast)	None		-1						
2	Weight of PCS Structure	None					6	3		
3	Weight of Ice Only on PCS Struct	None					6	11		
4	NESC Heavy Wind	None					4	9		
5	NESC Extreme Wind	None					4	10		



Load Combinations

	Description	Solve	PDelta	S...	B...	Fa...	B...	Fa...	B...	Fa...	B...	Fa...	B...	Fa...	B...	Fa...	B...	Fa...	B...	Fa...	B...	Fa...	B...	Fa...	
1	NESC Heavy Wind on P...	Yes			1	1.5	2	1.5	3	1.5	4	2.5													
2	NESC Extreme Wind on...	Yes			1	1	2	1	5	1															
3	Self Weight				1	1																			

Envelope Joint Reactions

	Joint		X [k]	LC	Y [k]	LC	Z [k]	LC	MX [k-ft]	LC	MY [k-ft]	LC	MZ [k-ft]	LC
1	N7	max	-0.816	1	2.939	2	-0.501	1	0	2	0	2	0	2
2		min	-4.913	2	2.936	1	-3.039	2	0	1	0	1	0	1
3	N8	max	-0.816	1	2.939	2	3.039	2	0	2	0	2	0	2
4		min	-4.913	2	2.936	1	.501	1	0	1	0	1	0	1
5	N5	max	1.643	2	2.095	1	1.043	2	0	2	0	2	0	2
6		min	-0.064	1	-0.381	2	-0.033	1	0	1	0	1	0	1
7	N6	max	1.643	2	2.095	1	.033	1	0	2	0	2	0	2
8		min	-0.064	1	-0.381	2	-1.043	2	0	1	0	1	0	1
9	Totals:	max	-1.76	1	10.062	1	0	2						
10		min	-6.54	2	5.116	2	0	1						



Company : CENTEK Engineering, Inc.
Designer : TJL
Job Number : 18000.55
Model Name : North Mast - Tower # 1102

Feb 21, 2019
9:55 AM
Checked By: CAG

Joint Reactions

	LC	Joint Label	X [k]	Y [k]	Z [k]	MX [k-ft]	MY [k-ft]	MZ [k-ft]
1	1	N7	-.816	2.936	-.501	0	0	0
2	1	N8	-.816	2.936	.501	0	0	0
3	1	N5	-.064	2.095	-.033	0	0	0
4	1	N6	-.064	2.095	.033	0	0	0
5	1	Totals:	-1.76	10.062	0			
6	1	COG (ft):	X: .034	Y: 31.36	Z: 0			

Joint Reactions

LC	Joint Label	X [k]	Y [k]	Z [k]	MX [k-ft]	MY [k-ft]	MZ [k-ft]
1	2	N7	-4.913	2.939	-3.039	0	0
2	2	N8	-4.913	2.939	3.039	0	0
3	2	N5	1.643	-.381	1.043	0	0
4	2	N6	1.643	-.381	-1.043	0	0
5	2	Totals:	-6.54	5.116	0		
6	2	COG (ft):	X: .035	Y: 30.635	Z: 0		

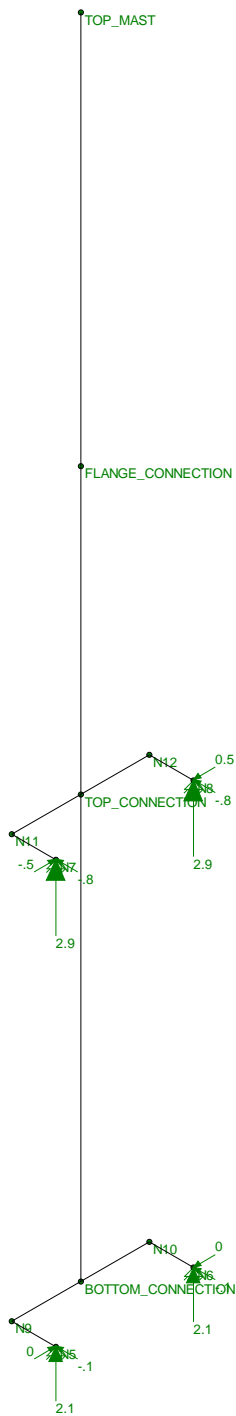

Results for LC 1, NESC Heavy Wind on PCS Mast
 Reaction and Moment Units are k and k-ft

CENTEK Engineering, Inc.	North Mast - Tower # 1102 LC #1 Reactions	
TJL		Feb 21, 2019 at 9:54 AM
18000.55		NESC North Mast.r3d

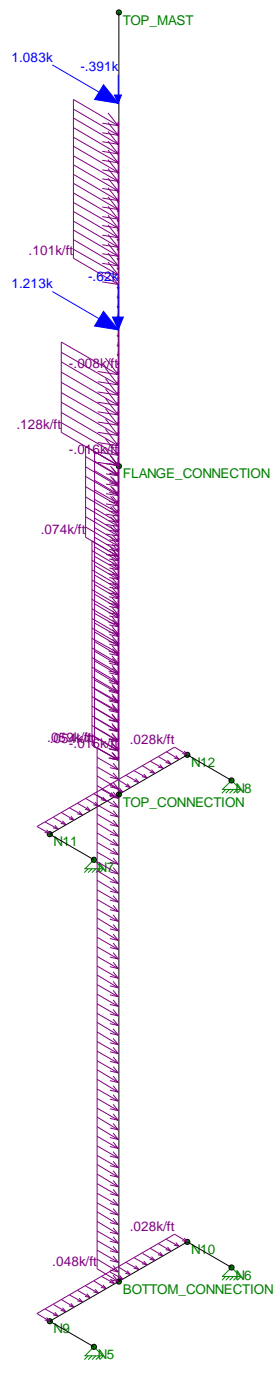

Loads: LC 2, NESC Extreme Wind on PCS Mast

CENTEK Engineering, Inc.	North Mast - Tower # 1102 LC #2 Loads	
TJL		Feb 21, 2019 at 9:54 AM
18000.55		NESC North Mast.r3d

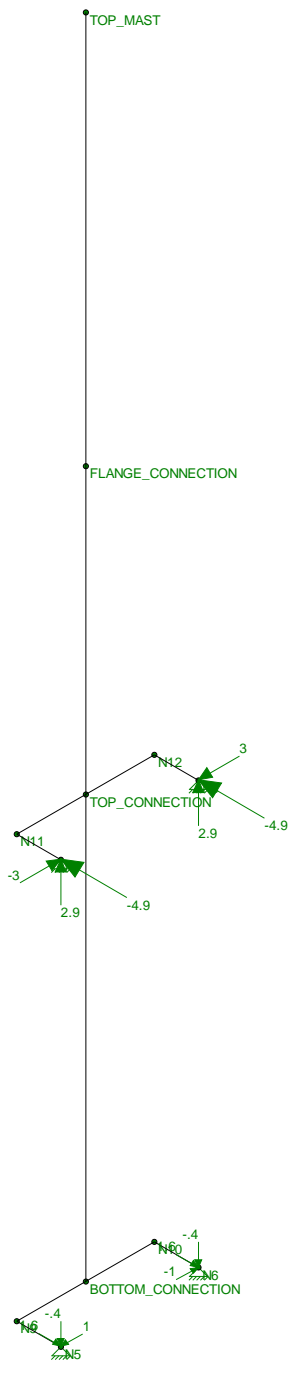

Results for LC 2, NESC Extreme Wind on PCS Mast
Reaction and Moment Units are k and k-ft

CENTEK Engineering, Inc.	North Mast - Tower # 1102 LC #2 Reactions	Feb 21, 2019 at 9:55 AM
TJL		NESC North Mast.r3d
18000.55		

Coax Cable on CL&P Tower

NW Leg - (AT&T)

Distance Between Coax Cable Attach Points =

Coaxial Cable Span =

$$\text{CoaxSpan} := \begin{pmatrix} 10 \\ 10 \\ 10 \\ 10 \\ 13.25 \\ 31.75 \end{pmatrix} \cdot \text{ft} \quad (\text{User Input})$$

Diameter of Coax Cable =

$$D_{\text{coax1}} := 1.55 \cdot \text{in} \quad (\text{User Input})$$

Weight of Coax Cable =

$$W_{\text{coax1}} := 0.66 \cdot \text{plf} \quad (\text{User Input})$$

Number of Coax Cables =

$$N_{\text{coax1}} := 12 \quad (\text{User Input})$$

Number of Projected Coax Cables =

$$NP_{\text{coax1}} := 6 \quad (\text{User Input})$$

Extreme Wind Pressure =

$$q_z := 35 \cdot \text{psf} \quad (\text{User Input})$$

Heavy Wind Pressure =

$$p := 4 \cdot \text{psf} \quad (\text{User Input})$$

Radial Ice Thickness =

$$I_r := 0.5 \cdot \text{in} \quad (\text{User Input})$$

Radial Ice Density =

$$I_d := 56 \cdot \text{pcf} \quad (\text{User Input})$$

Shape Factor =

$$C_{d_{\text{coax}}} := 1.6 \quad (\text{User Input})$$

Overload Factor for NESC Heavy Wind Load =

$$OF_{\text{HW}} := 2.5 \quad (\text{User Input})$$

Overload Factor for NESC Extreme Wind Load =

$$OF_{\text{EW}} := 1.0 \quad (\text{User Input})$$

Overload Factor for NESC Heavy Vertical Load =

$$OF_{\text{HV}} := 1.5 \quad (\text{User Input})$$

Overload Factor for NESC Extreme Vertical Load =

$$OF_{\text{EV}} := 1.0 \quad (\text{User Input})$$

Wind Area with Ice =

$$A_{\text{ice}} := (NP_{\text{coax1}} \cdot D_{\text{coax1}} + 2 \cdot I_r) = 10.3 \cdot \text{in}$$

Wind Area without Ice =

$$A := (NP_{\text{coax1}} \cdot D_{\text{coax1}}) = 9.3 \cdot \text{in}$$

Ice Area per Liner Ft =

$$A_{i_{\text{coax1}}} := \frac{\pi}{4} \cdot \left[(D_{\text{coax1}} + 2 \cdot I_r)^2 - D_{\text{coax1}}^2 \right] = 0.022 \text{ft}^2$$

Weight of Ice on All Coax Cables =

$$W_{\text{ice}} := A_{i_{\text{coax1}}} \cdot I_d \cdot N_{\text{coax1}} = 15 \cdot \text{plf}$$

Heavy Vertical Load =

$$\text{Heavy}_{\text{Vert}} := \overrightarrow{\left[(N_{\text{coax1}} \cdot W_{\text{coax1}} + W_{\text{ice}}) \cdot \text{CoaxSpan} \cdot \text{OF}_{\text{HV}} \right]}$$

Heavy Transverse Load =

$$\text{Heavy}_{\text{Trans}} := \overrightarrow{\left(p \cdot A_{\text{ice}} \cdot C_{d_{\text{coax}}} \cdot \text{CoaxSpan} \cdot \text{OF}_{\text{HW}} \right)}$$

$$\text{Heavy}_{\text{Vert}} = \begin{pmatrix} 344 \\ 344 \\ 344 \\ 344 \\ 456 \\ 1093 \end{pmatrix} \text{ lb}$$

$$\text{Heavy}_{\text{Trans}} = \begin{pmatrix} 137 \\ 137 \\ 137 \\ 137 \\ 182 \\ 436 \end{pmatrix} \text{ lb}$$

Extreme Vertical Load =

$$\text{Extreme}_{\text{Vert}} := \overrightarrow{\left[(N_{\text{coax1}} \cdot W_{\text{coax1}}) \cdot \text{CoaxSpan} \cdot \text{OF}_{\text{EV}} \right]}$$

Extreme Transverse Load =

$$\text{Extreme}_{\text{Trans}} := \overrightarrow{\left[(qz \cdot A \cdot C_{d_{\text{coax}}}) \cdot \text{CoaxSpan} \cdot \text{OF}_{\text{EW}} \right]}$$

$$\text{Extreme}_{\text{Vert}} = \begin{pmatrix} 79 \\ 79 \\ 79 \\ 79 \\ 105 \\ 251 \end{pmatrix} \text{ lb}$$

$$\text{Extreme}_{\text{Trans}} = \begin{pmatrix} 434 \\ 434 \\ 434 \\ 434 \\ 575 \\ 1378 \end{pmatrix} \text{ lb}$$

Coax Cable on CL&P Tower

NE LEG - (T-Mobile)

Distance Between Coax Cable Attach Points =

Coaxial Cable Span =

$$\text{CoaxSpan} := \begin{pmatrix} 10 \\ 10 \\ 10 \\ 10 \\ 13.25 \\ 31.75 \end{pmatrix} \cdot \text{ft} \quad (\text{User Input})$$

Diameter of Coax Cable =

$$D_{\text{coax1}} := 1.55 \cdot \text{in} \quad (\text{User Input})$$

Weight of Coax Cable =

$$W_{\text{coax1}} := 0.66 \cdot \text{plf} \quad (\text{User Input})$$

Number of Coax Cables =

$$N_{\text{coax1}} := 12 \quad (\text{User Input})$$

Number of Projected Coax Cables =

$$NP_{\text{coax1}} := 6 \quad (\text{User Input})$$

Extreme Wind Pressure =

$$q_z := 35 \cdot \text{psf} \quad (\text{User Input})$$

Heavy Wind Pressure =

$$p := 4 \cdot \text{psf} \quad (\text{User Input})$$

Radial Ice Thickness =

$$I_r := 0.5 \cdot \text{in} \quad (\text{User Input})$$

Radial Ice Density =

$$I_d := 56 \cdot \text{pcf} \quad (\text{User Input})$$

Shape Factor =

$$C_{d_{\text{coax}}} := 1.6 \quad (\text{User Input})$$

Overload Factor for NESC Heavy Wind Load =

$$OF_{\text{HW}} := 2.5 \quad (\text{User Input})$$

Overload Factor for NESC Extreme Wind Load =

$$OF_{\text{EW}} := 1.0 \quad (\text{User Input})$$

Overload Factor for NESC Heavy Vertical Load =

$$OF_{\text{HV}} := 1.5 \quad (\text{User Input})$$

Overload Factor for NESC Extreme Vertical Load =

$$OF_{\text{EV}} := 1.0 \quad (\text{User Input})$$

Wind Area with Ice =

$$A_{\text{ice}} := (NP_{\text{coax1}} \cdot D_{\text{coax1}} + 2 \cdot I_r) = 10.3 \cdot \text{in}$$

Wind Area without Ice =

$$A := (NP_{\text{coax1}} \cdot D_{\text{coax1}}) = 9.3 \cdot \text{in}$$

Ice Area per Liner Ft =

$$A_{i_{\text{coax1}}} := \frac{\pi}{4} \cdot \left[(D_{\text{coax1}} + 2 \cdot I_r)^2 - D_{\text{coax1}}^2 \right] = 0.022 \text{ft}^2$$

Weight of Ice on All Coax Cables =

$$W_{\text{ice}} := A_{i_{\text{coax1}}} \cdot I_d \cdot N_{\text{coax1}} = 15 \cdot \text{plf}$$

Heavy Vertical Load =

$$\text{Heavy}_{\text{Vert}} := \overrightarrow{\left[(N_{\text{coax1}} \cdot W_{\text{coax1}} + W_{\text{ice}}) \cdot \text{CoaxSpan} \cdot \text{OF}_{\text{HV}} \right]}$$

Heavy Transverse Load =

$$\text{Heavy}_{\text{Trans}} := \overrightarrow{\left(p \cdot A_{\text{ice}} \cdot C_{d_{\text{coax}}} \cdot \text{CoaxSpan} \cdot \text{OF}_{\text{HW}} \right)}$$

$$\text{Heavy}_{\text{Vert}} = \begin{pmatrix} 344 \\ 344 \\ 344 \\ 344 \\ 456 \\ 1093 \end{pmatrix} \text{ lb}$$

$$\text{Heavy}_{\text{Trans}} = \begin{pmatrix} 137 \\ 137 \\ 137 \\ 137 \\ 182 \\ 436 \end{pmatrix} \text{ lb}$$

Extreme Vertical Load =

$$\text{Extreme}_{\text{Vert}} := \overrightarrow{\left[(N_{\text{coax1}} \cdot W_{\text{coax1}}) \cdot \text{CoaxSpan} \cdot \text{OF}_{\text{EV}} \right]}$$

Extreme Transverse Load =

$$\text{Extreme}_{\text{Trans}} := \overrightarrow{\left[(qz \cdot A \cdot C_{d_{\text{coax}}}) \cdot \text{CoaxSpan} \cdot \text{OF}_{\text{EW}} \right]}$$

$$\text{Extreme}_{\text{Vert}} = \begin{pmatrix} 79 \\ 79 \\ 79 \\ 79 \\ 105 \\ 251 \end{pmatrix} \text{ lb}$$

$$\text{Extreme}_{\text{Trans}} = \begin{pmatrix} 434 \\ 434 \\ 434 \\ 434 \\ 575 \\ 1378 \end{pmatrix} \text{ lb}$$

Coax Cable on CL&P Tower

SE LEG - (AT&T)

Distance Between Coax Cable Attach Points =

Coaxial Cable Span =

$$\text{CoaxSpan} := \begin{pmatrix} 10 \\ 10 \\ 10 \\ 10 \\ 13.25 \\ 31.75 \end{pmatrix} \cdot \text{ft} \quad (\text{User Input})$$

Diameter of Coax Cable =

$$D_{\text{coax1}} := 1.55 \cdot \text{in} \quad (\text{User Input})$$

Weight of Coax Cable =

$$W_{\text{coax1}} := 0.66 \cdot \text{plf} \quad (\text{User Input})$$

Number of Coax Cables =

$$N_{\text{coax1}} := 6 \quad (\text{User Input})$$

Number of Projected Coax Cables =

$$NP_{\text{coax1}} := 3 \quad (\text{User Input})$$

Extreme Wind Pressure =

$$qz := 35 \cdot \text{psf} \quad (\text{User Input})$$

Heavy Wind Pressure =

$$p := 4 \cdot \text{psf} \quad (\text{User Input})$$

Radial Ice Thickness =

$$I_r := 0.5 \cdot \text{in} \quad (\text{User Input})$$

Radial Ice Density =

$$I_d := 56 \cdot \text{pcf} \quad (\text{User Input})$$

Shape Factor =

$$C_{d_{\text{coax}}} := 1.6 \quad (\text{User Input})$$

Overload Factor for NESC Heavy Wind Load =

$$OF_{\text{HW}} := 2.5 \quad (\text{User Input})$$

Overload Factor for NESC Extreme Wind Load =

$$OF_{\text{EW}} := 1.0 \quad (\text{User Input})$$

Overload Factor for NESC Heavy Vertical Load =

$$OF_{\text{HV}} := 1.5 \quad (\text{User Input})$$

Overload Factor for NESC Extreme Vertical Load =

$$OF_{\text{EV}} := 1.0 \quad (\text{User Input})$$

Wind Area with Ice =

$$A_{\text{ice}} := (NP_{\text{coax1}} \cdot D_{\text{coax1}} + 2 \cdot I_r) = 5.65 \cdot \text{in}$$

Wind Area without Ice =

$$A := (NP_{\text{coax1}} \cdot D_{\text{coax1}}) = 4.65 \cdot \text{in}$$

Ice Area per Liner Ft =

$$A_{i_{\text{coax1}}} := \frac{\pi}{4} \cdot \left[(D_{\text{coax1}} + 2 \cdot I_r)^2 - D_{\text{coax1}}^2 \right] = 0.022 \text{ft}^2$$

Weight of Ice on All Coax Cables =

$$W_{\text{ice}} := A_{i_{\text{coax1}}} \cdot I_d \cdot N_{\text{coax1}} = 8 \cdot \text{plf}$$

Heavy Vertical Load =

$$\text{Heavy}_{\text{Vert}} := \overrightarrow{\left[(N_{\text{coax1}} \cdot W_{\text{coax1}} + W_{\text{ice}}) \cdot \text{CoaxSpan} \cdot \text{OF}_{\text{HV}} \right]}$$

Heavy Transverse Load =

$$\text{Heavy}_{\text{Trans}} := \overrightarrow{\left(p \cdot A_{\text{ice}} \cdot C_{d_{\text{coax}}} \cdot \text{CoaxSpan} \cdot \text{OF}_{\text{HW}} \right)}$$

$$\text{Heavy}_{\text{Vert}} = \begin{pmatrix} 172 \\ 172 \\ 172 \\ 172 \\ 228 \\ 546 \end{pmatrix} \text{ lb}$$

$$\text{Heavy}_{\text{Trans}} = \begin{pmatrix} 75 \\ 75 \\ 75 \\ 75 \\ 100 \\ 239 \end{pmatrix} \text{ lb}$$

Extreme Vertical Load =

$$\text{Extreme}_{\text{Vert}} := \overrightarrow{\left[(N_{\text{coax1}} \cdot W_{\text{coax1}}) \cdot \text{CoaxSpan} \cdot \text{OF}_{\text{EV}} \right]}$$

Extreme Transverse Load =

$$\text{Extreme}_{\text{Trans}} := \overrightarrow{\left[(qz \cdot A \cdot C_{d_{\text{coax}}}) \cdot \text{CoaxSpan} \cdot \text{OF}_{\text{EW}} \right]}$$

$$\text{Extreme}_{\text{Vert}} = \begin{pmatrix} 40 \\ 40 \\ 40 \\ 40 \\ 52 \\ 126 \end{pmatrix} \text{ lb}$$

$$\text{Extreme}_{\text{Trans}} = \begin{pmatrix} 217 \\ 217 \\ 217 \\ 217 \\ 288 \\ 689 \end{pmatrix} \text{ lb}$$

Coax Cable on CL&P Tower

SW LEG - (T-Mobile)

Distance Between Coax Cable Attach Points =

Coaxial Cable Span =

$$\text{CoaxSpan} := \begin{pmatrix} 10 \\ 10 \\ 10 \\ 10 \\ 13.25 \\ 31.75 \end{pmatrix} \cdot \text{ft} \quad (\text{User Input})$$

Diameter of Coax Cable =

$$D_{\text{coax1}} := 1.55 \cdot \text{in} \quad (\text{User Input})$$

Weight of Coax Cable =

$$W_{\text{coax1}} := 0.66 \cdot \text{plf} \quad (\text{User Input})$$

Number of Coax Cables =

$$N_{\text{coax1}} := 24 \quad (\text{User Input})$$

Number of Projected Coax Cables =

$$NP_{\text{coax1}} := 6 \quad (\text{User Input})$$

Extreme Wind Pressure =

$$q_z := 35 \cdot \text{psf} \quad (\text{User Input})$$

Heavy Wind Pressure =

$$p := 4 \cdot \text{psf} \quad (\text{User Input})$$

Radial Ice Thickness =

$$I_r := 0.5 \cdot \text{in} \quad (\text{User Input})$$

Radial Ice Density =

$$I_d := 56 \cdot \text{pcf} \quad (\text{User Input})$$

Shape Factor =

$$C_{d_{\text{coax}}} := 1.6 \quad (\text{User Input})$$

Overload Factor for NESC Heavy Wind Load =

$$OF_{\text{HW}} := 2.5 \quad (\text{User Input})$$

Overload Factor for NESC Extreme Wind Load =

$$OF_{\text{EW}} := 1.0 \quad (\text{User Input})$$

Overload Factor for NESC Heavy Vertical Load =

$$OF_{\text{HV}} := 1.5 \quad (\text{User Input})$$

Overload Factor for NESC Extreme Vertical Load =

$$OF_{\text{EV}} := 1.0 \quad (\text{User Input})$$

Wind Area with Ice =

$$A_{\text{ice}} := (NP_{\text{coax1}} \cdot D_{\text{coax1}} + 2 \cdot I_r) = 10.3 \cdot \text{in}$$

Wind Area without Ice =

$$A := (NP_{\text{coax1}} \cdot D_{\text{coax1}}) = 9.3 \cdot \text{in}$$

Ice Area per Liner Ft =

$$A_{i_{\text{coax1}}} := \frac{\pi}{4} \cdot \left[(D_{\text{coax1}} + 2 \cdot I_r)^2 - D_{\text{coax1}}^2 \right] = 0.022 \text{ft}^2$$

Weight of Ice on All Coax Cables =

$$W_{\text{ice}} := A_{i_{\text{coax1}}} \cdot I_d \cdot N_{\text{coax1}} = 30 \cdot \text{plf}$$

Heavy Vertical Load =

$$\text{Heavy}_{\text{Vert}} := \overrightarrow{\left[(N_{\text{coax1}} \cdot W_{\text{coax1}} + W_{\text{ice}}) \cdot \text{CoaxSpan} \cdot \text{OF}_{\text{HV}} \right]}$$

Heavy Transverse Load =

$$\text{Heavy}_{\text{Trans}} := \overrightarrow{\left(p \cdot A_{\text{ice}} \cdot C_{d_{\text{coax}}} \cdot \text{CoaxSpan} \cdot \text{OF}_{\text{HW}} \right)}$$

$$\text{Heavy}_{\text{Vert}} = \begin{pmatrix} 688 \\ 688 \\ 688 \\ 688 \\ 912 \\ 2186 \end{pmatrix} \text{ lb}$$

$$\text{Heavy}_{\text{Trans}} = \begin{pmatrix} 137 \\ 137 \\ 137 \\ 137 \\ 182 \\ 436 \end{pmatrix} \text{ lb}$$

Extreme Vertical Load =

$$\text{Extreme}_{\text{Vert}} := \overrightarrow{\left[(N_{\text{coax1}} \cdot W_{\text{coax1}}) \cdot \text{CoaxSpan} \cdot \text{OF}_{\text{EV}} \right]}$$

Extreme Transverse Load =

$$\text{Extreme}_{\text{Trans}} := \overrightarrow{\left[(qz \cdot A \cdot C_{d_{\text{coax}}}) \cdot \text{CoaxSpan} \cdot \text{OF}_{\text{EW}} \right]}$$

$$\text{Extreme}_{\text{Vert}} = \begin{pmatrix} 158 \\ 158 \\ 158 \\ 158 \\ 210 \\ 503 \end{pmatrix} \text{ lb}$$

$$\text{Extreme}_{\text{Trans}} = \begin{pmatrix} 434 \\ 434 \\ 434 \\ 434 \\ 575 \\ 1378 \end{pmatrix} \text{ lb}$$

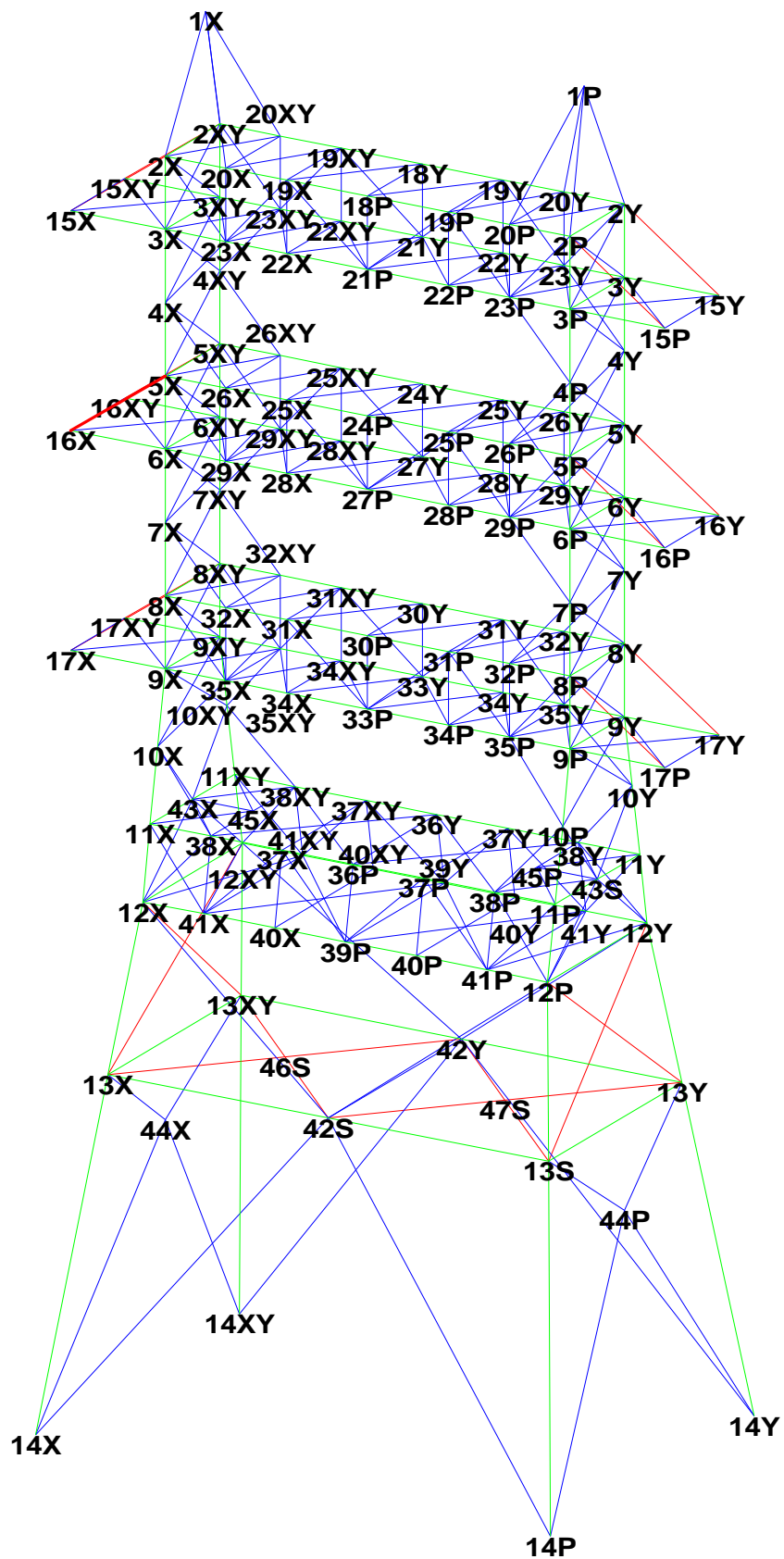

Project Name : 18000.55 - Norwalk, CT
Project Notes: Structure # 1102 / AT&T 5046
Project File : J:\Jobs\1800000.WI\55_CT5046\04_Structural\Calcs\Rev (2)\Pls-Tower\norwalk1102.tow
Date run : 8:40:27 AM Tuesday, May 21, 2019
by : Tower Version 12.50
Licensed to : Centek Engineering Inc

Successfully performed nonlinear analysis

Member "5P" will not be checked for block shear since more than one gage line exists (long edge distance (g) greater than zero); however, end, edge and spacing distances will be checked. ??
Member "5X" will not be checked for block shear since more than one gage line exists (long edge distance (g) greater than zero); however, end, edge and spacing distances will be checked. ??
Member "5XY" will not be checked for block shear since more than one gage line exists (long edge distance (g) greater than zero); however, end, edge and spacing distances will be checked. ??
Member "5Y" will not be checked for block shear since more than one gage line exists (long edge distance (g) greater than zero); however, end, edge and spacing distances will be checked. ??
Member "8P" will not be checked for block shear since more than one gage line exists (long edge distance (g) greater than zero); however, end, edge and spacing distances will be checked. ??
Member "8X" will not be checked for block shear since more than one gage line exists (long edge distance (g) greater than zero); however, end, edge and spacing distances will be checked. ??
Member "8XY" will not be checked for block shear since more than one gage line exists (long edge distance (g) greater than zero); however, end, edge and spacing distances will be checked. ??
Member "8Y" will not be checked for block shear since more than one gage line exists (long edge distance (g) greater than zero); however, end, edge and spacing distances will be checked. ??
Member "10P" will not be checked for block shear since more than one gage line exists (long edge distance (g) greater than zero); however, end, edge and spacing distances will be checked. ??
Member "10X" will not be checked for block shear since more than one gage line exists (long edge distance (g) greater than zero); however, end, edge and spacing distances will be checked. ??
Member "10XY" will not be checked for block shear since more than one gage line exists (long edge distance (g) greater than zero); however, end, edge and spacing distances will be checked. ??
Member "10Y" will not be checked for block shear since more than one gage line exists (long edge distance (g) greater than zero); however, end, edge and spacing distances will be checked. ??
Member "12P" will not be checked for block shear since more than one gage line exists (long edge distance (g) greater than zero); however, end, edge and spacing distances will be checked. ??
Member "12X" will not be checked for block shear since more than one gage line exists (long edge distance (g) greater than zero); however, end, edge and spacing distances will be checked. ??
Member "12XY" will not be checked for block shear since more than one gage line exists (long edge distance (g) greater than zero); however, end, edge and spacing distances will be checked. ??
Member "12Y" will not be checked for block shear since more than one gage line exists (long edge distance (g) greater than zero); however, end, edge and spacing distances will be checked. ??
Member "13P" will not be checked for block shear since more than one gage line exists (long edge distance (g) greater than zero); however, end, edge and spacing distances will be checked. ??
Member "13X" will not be checked for block shear since more than one gage line exists (long edge distance (g) greater than zero); however, end, edge and spacing distances will be checked. ??
Member "13XY" will not be checked for block shear since more than one gage line exists (long edge distance (g) greater than zero); however, end, edge and spacing distances will be checked. ??
Member "13Y" will not be checked for block shear since more than one gage line exists (long edge distance (g) greater than zero); however, end, edge and spacing distances will be checked. ??
KL/R value of 247.53 exceeds maximum of 200.00 for member "26P" ??
KL/R value of 247.53 exceeds maximum of 200.00 for member "26X" ??
KL/R value of 247.53 exceeds maximum of 200.00 for member "26XY" ??
KL/R value of 247.53 exceeds maximum of 200.00 for member "26Y" ??
KL/R value of 244.21 exceeds maximum of 200.00 for member "27P" ??
KL/R value of 244.21 exceeds maximum of 200.00 for member "27X" ??
KL/R value of 244.21 exceeds maximum of 200.00 for member "27XY" ??
KL/R value of 244.21 exceeds maximum of 200.00 for member "27Y" ??
Member "30P" will not be checked for block shear since more than one gage line exists (long edge distance (g) greater than zero); however, end, edge

KL/R value of 213.20 exceeds maximum of 200.00 for member "146X" ??
Member "151P" will not be checked for block shear since more than one gage line exists (long edge distance (g) greater than zero); however, end, edge and spacing distances will be checked. ??
Member "151X" will not be checked for block shear since more than one gage line exists (long edge distance (g) greater than zero); however, end, edge and spacing distances will be checked. ??
Member "151XY" will not be checked for block shear since more than one gage line exists (long edge distance (g) greater than zero); however, end, edge and spacing distances will be checked. ??
Member "151Y" will not be checked for block shear since more than one gage line exists (long edge distance (g) greater than zero); however, end, edge and spacing distances will be checked. ??
Member "153P" will not be checked for block shear since more than one gage line exists (long edge distance (g) greater than zero); however, end, edge and spacing distances will be checked. ??
Member "153X" will not be checked for block shear since more than one gage line exists (long edge distance (g) greater than zero); however, end, edge and spacing distances will be checked. ??
Member "153XY" will not be checked for block shear since more than one gage line exists (long edge distance (g) greater than zero); however, end, edge and spacing distances will be checked. ??
Member "153Y" will not be checked for block shear since more than one gage line exists (long edge distance (g) greater than zero); however, end, edge and spacing distances will be checked. ??
Member "155P" will not be checked for block shear since more than one gage line exists (long edge distance (g) greater than zero); however, end, edge and spacing distances will be checked. ??
Member "155X" will not be checked for block shear since more than one gage line exists (long edge distance (g) greater than zero); however, end, edge and spacing distances will be checked. ??
Member "155XY" will not be checked for block shear since more than one gage line exists (long edge distance (g) greater than zero); however, end, edge and spacing distances will be checked. ??
Member "155Y" will not be checked for block shear since more than one gage line exists (long edge distance (g) greater than zero); however, end, edge and spacing distances will be checked. ??
Member "156P" will not be checked for block shear since more than one gage line exists (long edge distance (g) greater than zero); however, end, edge and spacing distances will be checked. ??
Member "156X" will not be checked for block shear since more than one gage line exists (long edge distance (g) greater than zero); however, end, edge and spacing distances will be checked. ??
Member "156XY" will not be checked for block shear since more than one gage line exists (long edge distance (g) greater than zero); however, end, edge and spacing distances will be checked. ??
Member "156Y" will not be checked for block shear since more than one gage line exists (long edge distance (g) greater than zero); however, end, edge and spacing distances will be checked. ??
KL/R value of 202.97 exceeds maximum of 200.00 for member "158P" ??
KL/R value of 202.97 exceeds maximum of 200.00 for member "158X" ??
KL/R value of 202.97 exceeds maximum of 200.00 for member "158XY" ??
KL/R value of 202.97 exceeds maximum of 200.00 for member "158Y" ??
KL/R value of 222.93 exceeds maximum of 200.00 for member "165P" ??
KL/R value of 250.54 exceeds maximum of 200.00 for member "166P" ??
KL/R value of 250.54 exceeds maximum of 200.00 for member "166X" ??
KL/R value of 250.54 exceeds maximum of 200.00 for member "166XY" ??
KL/R value of 250.54 exceeds maximum of 200.00 for member "166Y" ??
KL/R value of 205.25 exceeds maximum of 200.00 for member "169P" ??
KL/R value of 205.25 exceeds maximum of 200.00 for member "169X" ??
KL/R value of 205.25 exceeds maximum of 200.00 for member "169XY" ??
KL/R value of 205.25 exceeds maximum of 200.00 for member "169Y" ??
The model has 165 warnings. ??

Member check option: ASCE 10
Connection rupture check: ASCE 10
Crossing diagonal check: ASCE 10 [Alternate Unsupported RLOUT = 1]
Included angle check: None
Climbing load check: None
Redundant members checked with: Actual Force

Loads from file: j:\jobs\1800000.wi\55_ct5046\04_structural\calcs\rev (2)\pls-tower\norwalk1102.lca

*** Analysis Results:

Maximum element usage is 98.47% for Angle "80XY" in load case "NESC Heavy Broken Wire"
 Maximum insulator usage is 25.74% for Clamp "C12" in load case "NESC Heavy"

Summary of Joint Support Reactions For All Load Cases:

Load Case	Joint Label	Long. Force (kips)	Tran. Force (kips)	Vert. Force (kips)	Shear Force (kips)	Tran. Moment (ft-k)	Long. Moment (ft-k)	Bending Moment (ft-k)	Vert. Moment (ft-k)	Found. Usage %
NESC Heavy	14P	-24.26	-35.45	-128.21	42.96	-0.00	0.09	0.09	-0.05	0.00
NESC Heavy	14X	11.27	-19.18	50.65	22.25	0.42	0.04	0.42	-0.03	0.00
NESC Heavy	14XY	-15.94	-19.92	70.77	25.51	0.28	-0.17	0.32	-0.02	0.00
NESC Heavy	14Y	22.06	-29.06	-114.56	36.48	-0.08	-0.30	0.31	-0.04	0.00
NESC Extreme	14P	-21.42	-33.26	-116.21	39.56	0.05	0.28	0.28	0.04	0.00
NESC Extreme	14X	16.97	-25.42	79.66	30.57	0.52	0.07	0.53	-0.00	0.00
NESC Extreme	14XY	-19.24	-25.42	88.56	31.88	0.45	-0.16	0.47	-0.01	0.00
NESC Extreme	14Y	20.91	-30.61	-112.43	37.08	-0.04	-0.22	0.22	-0.04	0.00
NESC Heavy Broken Wire	14P	-20.77	-23.40	-101.85	31.29	-0.08	0.19	0.21	0.02	0.00
NESC Heavy Broken Wire	14X	17.47	-21.74	89.01	27.89	0.19	0.06	0.20	0.04	0.00
NESC Heavy Broken Wire	14XY	-7.26	-14.53	20.86	16.24	0.50	-0.19	0.54	0.02	0.00
NESC Heavy Broken Wire	14Y	23.03	-38.09	-127.70	44.51	0.02	-0.20	0.20	0.03	0.00

Summary of Joint Support Reactions For All Load Cases in Direction of Leg:

Load Case	Support Joint	Origin Joint	Leg Member	Force In Leg (kips)	Residual Perpendicular (kips)	Shear To Leg (kips)	Residual Horizontal (kips)	Shear To Leg - Horizontal (kips)	Residual Horizontal (kips)	Shear To Leg - Tran. (kips)	Total Long. Force (kips)	Total Tran. Force (kips)	Total Vert. Force (kips)
NESC Heavy	14P	13S	13P	133.666		20.410	20.537	-0.284		20.535	-24.26	-35.45	-128.21
NESC Heavy	14X	13X	13X	-53.704		13.259	13.381	-1.574		13.288	11.27	-19.18	50.65
NESC Heavy	14XY	13XY	13XY	-74.296		11.792	11.924	2.392		11.682	-15.94	-19.92	70.77
NESC Heavy	14Y	13Y	13Y	119.210		15.620	15.725	-0.130		15.724	22.06	-29.06	-114.56
NESC Extreme	14P	13S	13P	121.175		19.641	19.752	-0.833		19.734	-21.42	-33.26	-116.21
NESC Extreme	14X	13X	13X	-83.795		16.098	16.241	-1.721		16.150	16.97	-25.42	79.66
NESC Extreme	14XY	13XY	13XY	-92.897		15.132	15.283	2.282		15.111	-19.24	-25.42	88.56
NESC Extreme	14Y	13Y	13Y	117.092		17.440	17.541	0.612		17.530	20.91	-30.61	-112.43
NESC Heavy Broken Wire	14P	13S	13P	105.925		11.513	11.617	1.269		11.547	-20.77	-23.40	-101.85
NESC Heavy Broken Wire	14X	13X	13X	-92.586		11.307	11.390	-0.431		11.382	17.47	-21.74	89.01
NESC Heavy Broken Wire	14XY	13XY	13XY	-23.362		12.379	12.537	3.268		12.103	-7.26	-14.53	20.86
NESC Heavy Broken Wire	14Y	13Y	13Y	133.237		23.150	23.271	1.414		23.228	23.03	-38.09	-127.70

Overturning Moment Summary For All Load Cases:

Load Case	Transverse Moment (ft-k)	Longitudinal Moment (ft-k)	Resultant Moment (ft-k)
NESC Heavy	6946.042	441.500	6960.059
NESC Extreme	7569.325	165.696	7571.139
NESC Heavy Broken Wire	6473.682	-1228.756	6589.264

Sections Information:

Section Label	Top Z (ft)	Bottom Z (ft)	Joint Count	Member Count	Tran. Top Width (ft)	Face Tran. Bot Width (ft)	Tran. Face Tran. Gross Area (ft^2)	Long. Top Width (ft)	Face Long. Bot Width (ft)	Long. Face Long. Gross Area (ft^2)

1	94.000	50.000	106	356	0.00	7.00	276.500	28.00	44.00	1416.000
2	50.000	0.000	58	165	7.00	26.15	828.655	30.00	38.15	1642.555

*** Overall summary for all load cases - Usage = Maximum Stress / Allowable Stress
 Printed capacities do not include the strength factor entered for each load case.
 The Group Summary reports on the member and load case that resulted in maximum usage
 which may not necessarily be the same as that which produces maximum force.

Group Summary (Compression Portion):

Group KL/R Length Label Comp. Member Comp. (ft)	Group Curve No. Of Bolts	Angle No. Type	Angle Size	Steel Strength (ksi)	Max Usage Usage Cont- %	Max Use %	Comp. Control Member Comp.	Comp. Force (kips)	Comp. Control Load Case	L/R Capacity (kips)	Comp. Connect. Shear Capacity (kips)	Comp. Connect. Bearing Capacity (kips)	RLX	RLY	RLZ	L/R	
PeakPost	L2.5x2.5x3/16	SAE	2.5X2.5X0.1875	33.0	52.40	Tens	42.29	14XY	-7.057NESC	Hea	16.686	27.200	25.312	0.500	0.500	0.500	124.50
123.47	10.271	5	2														
Leg1	L5x5x3/8	SAE	5X5X0.375	33.0	47.32	Comp	47.32	5XY	-50.404NESC	Hea	106.517	136.000	253.125	1.000	1.000	1.000	60.61
60.61	5.000	1	10														
Leg2	L8x8x1/2	SAE	8X8X0.5	33.0	54.53	Comp	54.53	8XY	-74.166NESC	Hea	245.252	136.000	337.499	1.000	1.000	1.000	37.74
37.74	5.000	1	10														
Leg3	L8x8x1/2	SAE	8X8X0.5	33.0	47.55	Tens	39.63	10Y	-97.036NESC	Hea	244.867	380.800	944.999	1.000	1.000	1.000	38.42
38.42	5.091	1	28														
Leg4	L8x8x1/2	SAE	8X8X0.5	33.0	42.11	Tens	41.19	12Y	-99.512NESC	Hea	241.598	380.800	944.999	0.500	0.500	0.500	43.81
43.81	11.611	1	28														
Leg5	L8x8x1/2	SAE	8X8X0.5	33.0	41.48	Comp	41.48	13P	-99.682NESC	Hea	240.308	380.800	944.999	0.250	0.250	0.250	45.77
45.77	24.257	1	28														
TTTC	L3x3x1/4	SAE	3X3X0.25	33.0	74.67	Tens	56.29	38X	-15.311NESC	Ext	32.243	27.200	33.750	1.000	1.000	1.000	91.22
105.61	4.500	3	2														
TTBC	L3x3x1/4	SAE	3X3X0.25	33.0	42.25	Comp	42.25	39Y	-11.567NESC	Hea	27.374	54.400	67.500	1.000	1.000	1.000	121.62
121.28	6.000	5	4														
ARMTT	L4x4x1/4	SAE	4X4X0.25	33.0	39.57	Comp	39.57	67XY	-10.764NESC	Hea	40.528	27.200	33.750	1.000	1.000	1.000	105.66
112.83	7.000	3	2														
MTTC	L4x4x1/4	SAE	4X4X0.25	33.0	79.62	Tens	69.61	43X	-33.225NESC	Ext	47.728	0.000	0.000	1.000	1.000	1.000	67.92
93.96	4.500	3	0														
MTBC	L4x4x1/4	SAE	4X4X0.25	33.0	46.86	Comp	46.86	46Y	-22.364NESC	Ext	47.728	0.000	0.000	1.000	1.000	1.000	67.92
93.96	4.500	3	0														
ARMMT	L4x4x1/4	SAE	4X4X0.25	33.0	16.10	Comp	16.10	68X	-6.526NESC	Hea	40.528	40.800	50.625	1.000	1.000	1.000	105.66
112.83	7.000	3	3														
BTTC	L4x4x5/16	SAE	4X4X0.3125	33.0	84.82	Tens	71.34	49X	-42.069NESC	Ext	58.971	0.000	0.000	1.000	1.000	1.000	68.27
94.13	4.500	3	0														
BTBC	L4x4x5/16	SAE	4X4X0.3125	33.0	49.91	Comp	49.91	52Y	-29.431NESC	Hea	58.971	0.000	0.000	1.000	1.000	1.000	68.27
94.13	4.500	3	0														
ARMBT	L4x4x1/4	SAE	4X4X0.25	33.0	15.68	Comp	15.68	69X	-6.353NESC	Hea	40.528	40.800	50.625	1.000	1.000	1.000	105.66
112.83	7.000	3	3														
BTC	8x8x1/2	SAE	8X8X0.5	33.0	21.83	Tens	17.11	55XY	-35.714NESC	Hea	208.793	0.000	0.000	1.000	1.000	1.000	39.62
79.81	5.250	3	0														
BBC	6x6x1/2	SAE	6X6X0.5	33.0	33.09	Tens	22.76	59P	-27.856NESC	Ext	152.178	122.400	303.750	1.000	1.000	1.000	45.76
82.88	4.500	3	9														
Diag1	L2x2x3/16	SAE	2X2X0.1875	33.0	26.40	Comp	26.40	15X	-3.245NESC	Hea	12.292	27.200	25.312	0.750	0.500	0.500	131.00
128.42	8.602	5	2														

108.84	Diag2	L2.5x2.5x1/4	SAE	2.5X2.5X0.25	33.0	46.32	Comp	46.32	16X	-11.979NESC	Hea	25.861	27.200	33.750	0.750	0.500	0.500	105.12
95.72	Diag3	L3x3x5/16	SAE	3X3X0.3125	33.0	26.82	Tens	25.72	19X	-10.494NESC	Hea	43.226	40.800	63.281	0.750	0.500	0.500	87.63
152.87	Diag4	L3x3x3/16	SAE	3X3X0.1875	33.0	44.52	Comp	44.52	24Y	-5.944NESC	Hea	13.351	27.200	25.312	1.000	1.000	1.000	163.08
257.78	Diag5	L2.5x2x3/16	SAU	2.5X2X0.1875	33.0	91.75	Comp	91.75	25Y	-3.201NESC	Ext	3.489	27.200	25.312	0.570	0.780	0.570	300.76
247.53	Diag6	L3x2x1/4	SAU	3X2X0.25	33.0	45.41	Comp	45.41	26Y	-2.524NESC	Hea	5.559	40.800	50.625	1.000	1.000	1.000	287.31
106.15	Diag7	L4x4x1/4	SAE	4X4X0.25	33.0	71.87	Comp	71.87	30Y	-31.067NESC	Hea	43.226	54.400	67.500	1.000	1.000	1.000	101.54
107.54	Diag8	L4x4x3/8	SAE	4X4X0.375	33.0	62.07	Comp	62.07	33XY	-39.053NESC	Hea	62.918	68.000	126.562	1.000	1.000	1.000	103.39
133.47	Diag9	L3.5x3x1/4	DAS	3.5X3X0.25	33.0	79.64	Comp	79.64	34XY	-40.052NESC	Hea	50.291	54.400	67.500	0.540	1.000	0.540	137.62
172.72	Diag10	L4x3x7/16	DAS	4X3X0.4375	33.0	79.95	Comp	79.95	35Y	-44.032NESC	Hea	55.072	81.600	177.187	0.250	1.000	0.250	189.13
133.03	Diag11	L3x3x5/16	SAE	3X3X0.3125	33.0	75.13	Comp	75.13	29XY	-21.630NESC	Hea	28.788	40.800	63.281	1.000	1.000	1.000	137.05
244.21	Diag12	L3x3x3/16	SAE	3X3X0.1875	33.0	65.98	Comp	65.98	27P	-3.451NESC	Hea	5.231	40.800	37.969	1.000	0.333	0.333	282.96
153.78	Horz1	L3x3x3/16	SAE	3X3X0.1875	33.0	30.82	Comp	30.82	60XY	-4.066NESC	Ext	13.192	40.800	37.969	0.500	0.500	0.500	164.28
141.14	Horz2	L3.5x3.5x1/4	SAE	3.5X3.5X0.25	33.0	38.01	Comp	38.01	61X	-9.231NESC	Hea	24.283	40.800	50.625	0.500	0.500	0.500	147.69
359.76	Br1	L2x2x3/16	SAE	2X2X0.1875	33.0	45.08	Tens	0.00	65Y	0.000		1.570	13.600	12.656	1.000	1.000	1.000	359.76
171.97	Br2	L3x3x3/16	SAE	3X3X0.1875	33.0	45.95	Comp	45.95	66P	-4.848NESC	Ext	10.549	13.600	12.656	0.750	0.500	0.500	171.97
1911.63	ArmBr1	Bar 2x3/16	BAR	2 x 0.1875	33.0	56.80	Tens	0.00	72Y	0.000		0.029	27.200	25.312	1.000	1.000	1.000	1911.63
151.91	ArmBr2	ArmBr2	SAE	2X2X0.25	33.0	55.81	Comp	55.81	73XY	-6.507NESC	Hea	11.659	13.600	16.875	0.750	0.500	0.500	151.91
154.41	ArmBr3	ArmBr3	SAU	3.5X2.5X0.25	33.0	82.37	Tens	0.00	78X	0.000		17.286	13.600	16.875	1.000	1.000	1.000	154.41
144.64	TTBr1	L2x2x3/16	SAE	2X2X0.1875	33.0	62.45	Comp	62.45	83XY	-6.066NESC	Hea	9.713	27.200	25.312	1.000	1.000	1.000	152.28
142.91	TTBr2	L3x3x3/16	SAE	3X3X0.1875	33.0	98.47	Comp	98.47	80XY	-15.041NESC	Hea	15.275	27.200	25.312	1.000	1.000	1.000	157.25
95.66	TTBr3	L3x3x5/16	SAE	3X3X0.3125	33.0	47.48	Tens	27.64	84P	-11.276NESC	Ext	43.245	40.800	63.281	1.000	0.500	0.500	87.55
144.64	MTBr1	L2x2x3/16	SAE	2X2X0.1875	33.0	13.20	Tens	1.31	85Y	-0.127NESC	Ext	9.713	27.200	25.312	1.000	1.000	1.000	152.28
113.64	MTBr2	L3x2.5x1/4	SAU	3X2.5X0.25	33.0	57.79	Comp	57.79	89XY	-15.684NESC	Hea	27.139	27.200	33.750	1.000	1.000	1.000	113.64
125.90	MTBr3	L4x3.5x1/4	SAU	4X3.5X0.25	33.0	84.82	Comp	84.82	86XY	-27.515NESC	Hea	32.441	40.800	50.625	1.000	1.000	1.000	127.69
117.24	MTBr4	L3.5x3.5x1/4	SAE	3.5X3.5X0.25	33.0	79.13	Comp	79.13	88Y	-26.648NESC	Hea	33.676	40.800	50.625	1.000	1.000	1.000	116.31
106.15	MTBr5	L4x4x1/4	SAE	4X4X0.25	33.0	62.42	Comp	62.42	90P	-26.980NESC	Ext	43.226	54.400	67.500	1.000	1.000	1.000	101.54
144.64	BTBr1	L2x2x3/16	SAE	2X2X0.1875	33.0	13.72	Tens	1.30	91Y	-0.126NESC	Hea	9.713	27.200	25.312	1.000	1.000	1.000	152.28
86.46	BTBr2	L3.5x3.5x1/4	SAE	3.5X3.5X0.25	33.0	47.18	Comp	47.18	95XY	-19.248NESC	Hea	43.754	40.800	50.625	1.000	1.000	1.000	86.46
118.87	BTBr3	L4x4x5/16	SAE	4X4X0.3125	33.0	73.50	Comp	73.50	92XY	-34.506NESC	Hea	46.945	54.400	84.375	1.000	1.000	1.000	118.49
	BTBr4	L4x4x1/4	SAE	4X4X0.25	33.0	75.54	Comp	75.54	94Y	-32.651NESC	Hea	43.226	54.400	67.500	1.000	1.000	1.000	101.54

PeakPost 0.875	L2.5x2.5x3/16	SAE	2.5X2.5X0.1875	33.0	52.40	Tens	52.40	1X	10.113	NESC	Hea	21.917	27.200	25.312	19.301	9.708	2	1.000
Leg1 0.875	L5x5x3/8	SAE	5X5X0.375	33.0	47.32	Comp	37.42	4X	30.965	NESC	Hea	82.747	0.000	0.000	0.000	5.000	0	3.360
Leg2 0.875	L8x8x1/2	SAE	8X8X0.5	33.0	54.53	Comp	44.69	8X	60.779	NESC	Hea	198.000	136.000	337.499	312.500	5.000	10	4.000
Leg3 0.875	L8x8x1/2	SAE	8X8X0.5	33.0	47.55	Tens	47.55	10X	94.140	NESC	Hea	198.000	380.800	944.999	874.999	5.091	28	4.000
Leg4 0.875	L8x8x1/2	SAE	8X8X0.5	33.0	42.11	Tens	42.11	11X	83.382	NESC	Hea	198.000	0.000	0.000	0.000	5.091	0	4.000
Leg5 0.875	L8x8x1/2	SAE	8X8X0.5	33.0	41.48	Comp	38.22	13X	75.682	NESC	Hea	198.000	380.800	944.999	874.999	24.257	28	4.000
TTTC 0.875	L3x3x1/4	SAE	3X3X0.25	33.0	74.67	Tens	74.67	38Y	17.256	NESC	Ext	36.271	27.200	33.750	23.109	4.500	2	1.000
TTBC 0.875	L3x3x1/4	SAE	3X3X0.25	33.0	42.25	Comp	41.74	40XY	12.428	NESC	Ext	29.774	0.000	0.000	0.000	4.500	0	2.000
ARMTT 0.875	L4x4x1/4	SAE	4X4X0.25	33.0	39.57	Comp	16.15	67X	4.392	NESC	Hea	51.121	27.200	33.750	38.750	7.000	2	1.000
MTTC 0.875	L4x4x1/4	SAE	4X4X0.25	33.0	79.62	Tens	79.62	43Y	35.530	NESC	Hea	44.624	0.000	0.000	0.000	4.500	0	2.000
MTBC 0.875	L4x4x1/4	SAE	4X4X0.25	33.0	46.86	Comp	44.89	46XY	20.031	NESC	Ext	44.624	0.000	0.000	0.000	4.500	0	2.000
ARMMT 0.875	L4x4x1/4	SAE	4X4X0.25	33.0	16.10	Comp	3.16	68P	1.290	NESC	Ext	49.952	40.800	50.625	44.118	7.000	3	1.180
BTTC 0.875	L4x4x5/16	SAE	4X4X0.3125	33.0	84.82	Tens	84.82	49Y	46.683	NESC	Hea	55.038	0.000	0.000	0.000	4.500	0	2.000
BTBC 0.875	L4x4x5/16	SAE	4X4X0.3125	33.0	49.91	Comp	46.06	52XY	25.351	NESC	Hea	55.038	0.000	0.000	0.000	4.500	0	2.000
ARMBT 0.875	L4x4x1/4	SAE	4X4X0.25	33.0	15.68	Comp	3.55	69P	1.449	NESC	Ext	49.952	40.800	50.625	44.118	7.000	3	1.180
BTC 0.875	8x8x1/2	SAE	8X8X0.5	33.0	21.83	Tens	21.83	55Y	36.066	NESC	Hea	165.206	0.000	0.000	0.000	5.250	0	5.000
BBC 0.875	6x6x1/2	SAE	6X6X0.5	33.0	33.09	Tens	33.09	59XY	40.497	NESC	Hea	131.794	122.400	303.750	330.882	4.500	9	3.000
Diag1 0.875	L2x2x3/16	SAE	2X2X0.1875	33.0	26.40	Comp	16.27	15XY	2.638	NESC	Hea	16.214	27.200	25.312	18.316	8.602	2	1.000
Diag2 0.875	L2.5x2.5x1/4	SAE	2.5X2.5X0.25	33.0	46.32	Comp	44.38	17XY	12.072	NESC	Hea	28.846	27.200	33.750	29.203	8.602	2	1.000
Diag3 0.875	L3x3x5/16	SAE	3X3X0.3125	33.0	26.82	Tens	26.82	20XY	10.943	NESC	Hea	44.745	40.800	63.281	56.660	8.602	3	1.000
Diag4 0.875	L3x3x3/16	SAE	3X3X0.1875	33.0	44.52	Comp	43.57	23XY	8.562	NESC	Hea	27.500	27.200	25.312	19.652	6.698	2	1.000
Diag5 0.875	L2.5x2x3/16	SAU	2.5X2X0.1875	33.0	91.75	Comp	44.78	25XY	8.590	NESC	Hea	19.184	27.200	25.312	24.609	18.775	2	1.000
Diag6 0.875	L3x2x1/4	SAU	3X2X0.25	33.0	45.41	Comp	26.91	26X	7.762	NESC	Hea	28.846	40.800	50.625	36.328	10.415	3	1.000
Diag7 0.875	L4x4x1/4	SAE	4X4X0.25	33.0	71.87	Comp	60.67	30X	28.451	NESC	Ext	46.898	54.400	67.500	58.823	6.727	4	1.650
Diag8 0.875	L4x4x3/8	SAE	4X4X0.375	33.0	62.07	Comp	57.20	33Y	38.899	NESC	Hea	69.934	68.000	126.562	110.294	6.789	5	1.540
Diag9 0.875	L3.5x3x1/4	DAS	3.5X3X0.25	33.0	79.64	Comp	40.70	34P	19.651	NESC	Ext	72.542	54.400	67.500	48.281	18.923	2	2.000
Diag10 0.875	L4x3x7/16	DAS	4X3X0.4375	33.0	79.95	Comp	36.45	35X	29.744	NESC	Ext	121.751	81.600	177.187	164.062	30.734	3	2.000
Diag11 0.875	L3x3x5/16	SAE	3X3X0.3125	33.0	75.13	Comp	51.62	28XY	21.063	NESC	Hea	44.745	40.800	63.281	46.699	6.727	3	1.000
Diag12 0.875	L3x3x3/16	SAE	3X3X0.1875	33.0	65.98	Comp	25.41	27XY	6.987	NESC	Hea	27.500	40.800	37.969	35.156	22.141	3	1.000

0.875	Horz1	L3x3x3/16	SAE	3X3X0.1875	33.0	30.82	Comp	0.00	60Y	0.000	27.500	40.800	37.969	26.473	16.318	3	1.000	
0.875	Horz2	L3.5x3.5x1/4	SAE	3.5X3.5X0.25	33.0	38.01	Comp	0.00	61X	0.000	43.696	40.800	50.625	36.422	17.082	3	1.000	
0.875	Br1	L2x2x3/16	SAE	2X2X0.1875	33.0	45.08	Tens	45.08	63P	3.693NESC	Ext	16.214	13.600	12.656	8.191	11.812	1	1.000
0.875	Br2	L3x3x3/16	SAE	3X3X0.1875	33.0	45.95	Comp	0.00	66P	0.000	27.500	13.600	12.656	9.949	17.082	1	1.000	
0.875	ArmBr1	Bar 2x3/16	BAR	2 x 0.1875	33.0	56.80	Tens	56.80	72Y	3.558NESC	Hea	6.265	27.200	25.312	17.824	8.602	2	1.000
0.875	ArmBr2	ArmBr2	SAE	2X2X0.25	33.0	55.81	Comp	55.48	73X	7.139NESC	Hea	21.421	13.600	16.875	12.868	9.899	1	1.000
0.875	ArmBr3	ArmBr3	SAU	3.5X2.5X0.25	33.0	82.37	Tens	82.37	78X	11.203NESC	Hea	28.846	13.600	16.875	15.047	7.000	1	1.000
0.875	TTBr1	L2x2x3/16	SAE	2X2X0.1875	33.0	62.45	Comp	24.81	83Y	4.023NESC	Hea	16.214	27.200	25.312	19.160	5.000	2	1.000
0.875	TTBr2	L3x3x3/16	SAE	3X3X0.1875	33.0	98.47	Comp	65.92	80Y	15.451NESC	Hea	27.500	27.200	25.312	23.437	7.810	2	1.000
0.875	TTBr3	L3x3x5/16	SAE	3X3X0.3125	33.0	47.48	Tens	47.48	84XY	19.372NESC	Hea	44.745	40.800	63.281	45.410	6.727	3	1.000
0.875	MTBr1	L2x2x3/16	SAE	2X2X0.1875	33.0	13.20	Tens	13.20	87XY	2.140NESC	Hea	16.214	27.200	25.312	19.301	5.000	2	1.000
0.875	MTBr2	L3x2.5x1/4	SAU	3X2.5X0.25	33.0	57.79	Comp	53.79	89P	14.630NESC	Ext	32.410	27.200	33.750	31.250	5.000	2	1.000
0.875	MTBr3	L4x3.5x1/4	SAU	4X3.5X0.25	33.0	84.82	Comp	68.79	86Y	28.067NESC	Hea	44.531	40.800	50.625	44.118	7.810	3	1.420
0.875	MTBr4	L3.5x3.5x1/4	SAE	3.5X3.5X0.25	33.0	79.13	Comp	53.85	88X	20.786NESC	Ext	40.448	40.800	50.625	38.603	6.727	3	1.500
0.875	MTBr5	L4x4x1/4	SAE	4X4X0.25	33.0	62.42	Comp	57.20	90XY	27.234NESC	Ext	47.613	54.400	67.500	58.823	6.727	4	1.540
0.875	BTBr1	L2x2x3/16	SAE	2X2X0.1875	33.0	13.72	Tens	13.72	93XY	2.224NESC	Hea	16.214	27.200	25.312	19.301	5.000	2	1.000
0.875	BTBr2	L3.5x3.5x1/4	SAE	3.5X3.5X0.25	33.0	47.18	Comp	44.34	95Y	18.090NESC	Hea	43.696	40.800	50.625	42.516	5.000	3	1.000
0.875	BTBr3	L4x4x5/16	SAE	4X4X0.3125	33.0	73.50	Comp	64.67	92Y	35.179NESC	Hea	59.748	54.400	84.375	73.529	7.810	4	1.420
0.875	BTBr4	L4x4x1/4	SAE	4X4X0.25	33.0	75.54	Comp	52.54	94XY	26.075NESC	Hea	49.627	54.400	67.500	58.823	6.727	4	1.230
0.875	BTBr5	L4x4x3/8	SAE	4X4X0.375	33.0	47.74	Comp	47.19	96X	31.989NESC	Hea	67.790	68.000	126.562	110.294	6.727	5	1.760
0.875	TBC1	L2x2x3/16	SAE	2X2X0.1875	33.0	55.68	Tens	55.68	104XY	4.561NESC	Hea	16.214	13.600	12.656	8.191	9.220	1	1.000
0.875	TBC2	L2.5x2.5x1/4	SAE	2.5X2.5X0.25	33.0	46.65	Tens	46.65	111P	12.690NESC	Hea	28.846	27.200	33.750	28.125	7.000	2	1.000
0.875	TBC3	L2x2x1/4	SAE	2X2X0.25	33.0	46.30	Tens	46.30	112X	5.057NESC	Hea	21.421	13.600	16.875	10.922	8.322	1	1.000
0.875	TBC4	L2.5x2.5x3/16	SAE	2.5X2.5X0.1875	33.0	26.70	Comp	5.46	113X	1.153NESC	Ext	21.917	27.200	25.312	21.094	7.000	2	1.000
0.875	TTC1	L2x2x3/16	SAE	2X2X0.1875	33.0	48.87	Tens	48.87	115P	3.591NESC	Hea	16.214	13.600	12.656	7.348	7.000	1	1.000
0.875	TTC2	L2.5x2.5x3/16	SAE	2.5X2.5X0.1875	33.0	91.56	Comp	3.47	122P	0.365NESC	Hea	21.917	13.600	12.656	10.512	8.322	1	1.000
0.875	Horz3	L2.5x2.5x3/16	SAE	2.5X2.5X0.1875	33.0	34.67	Comp	9.70	142X	1.755NESC	Ext	21.917	27.200	25.312	18.105	7.000	2	1.000
0.875	Horz4	L2x2x3/16	SAE	2X2X0.1875	33.0	23.57	Tens	23.57	146P	1.931NESC	Hea	16.214	13.600	12.656	8.191	7.000	1	1.000
0.875	Horz5	L3.5x3.5x5/16	SAE	3.5X3.5X0.3125	33.0	9.46	Comp	2.89	147X	1.177NESC	Ext	53.952	40.800	63.281	47.988	7.000	3	1.000

0.875	Horz6	L3.5x3x1/4	SAU	3.5X3X0.25	33.0	16.25	Comp	16.02	149P	4.356	NESC Ext	39.835	27.200	33.750	28.125	12.744	2	1.000
0.875	BBr1	L2x2x3/16	SAE	2X2X0.1875	33.0	5.11	Comp	2.08	152X	0.329	NESC Ext	16.214	27.200	25.312	15.785	5.091	2	1.000
0.875	BBr2	L4x4x3/8	SAE	4X4X0.375	33.0	43.99	Comp	40.30	151Y	27.404	NESC Hea	70.324	68.000	126.562	110.294	7.313	5	1.500
0.875	BBr3	L4x4x5/16	SAE	4X4X0.3125	33.0	46.91	Tens	46.91	154Y	25.521	NESC Hea	63.159	54.400	84.375	59.355	5.091	4	1.000
0.875	BBr4	L7x4x7/16	SAU	7X4X0.4375	33.0	11.34	Tens	11.34	155X	11.688	NESC Hea	103.105	149.600	324.843	300.781	6.789	11	3.000
0.875	BTC1	L3.5x3.5x1/4	SAE	3.5X3.5X0.25	33.0	10.93	Tens	10.93	157P	2.967	NESC Ext	43.696	27.200	33.750	27.141	10.750	2	1.000
0.875	BTC2	L2x2x3/16	SAE	2X2X0.1875	33.0	46.19	Comp	3.47	158Y	0.563	NESC Hea	16.214	27.200	25.312	19.301	15.027	2	1.000
0.875	BTC3	L3x2.5x1/4	SAU	3X2.5X0.25	33.0	17.20	Tens	17.20	161X	4.937	NESC Ext	28.698	40.800	50.625	32.016	5.375	3	1.000
0.875	BTC4	L2.5x1.5x1/4	SAU	2.5X1.5X0.25	33.0	21.41	Comp	0.00	163Y	0.000		21.421	40.800	50.625	41.016	7.010	3	1.000
0.875	BTC5	L2x2x1/4	SAE	2X2X0.25	33.0	15.17	Tens	15.17	164P	3.193	NESC Ext	21.421	27.200	33.750	21.047	4.500	2	1.000
0.875	BBC1	L3x3x3/16	SAE	3X3X0.1875	33.0	4.88	Comp	0.00	165P	0.000		27.500	27.200	25.312	19.652	12.666	2	1.000
0.875	BBC2	L2x2x3/16	SAE	2X2X0.1875	33.0	37.38	Comp	18.32	166XY	1.500	NESC Hea	16.214	13.600	12.656	8.191	16.452	1	1.000
0.875	BBC3	L3x3x1/4	SAE	3X3X0.25	33.0	2.80	Comp	0.72	168P	0.189	NESC Hea	36.271	27.200	33.750	26.203	12.666	2	1.000

*** Maximum Stress Summary for Each Load Case

Summary of Maximum Usages by Load Case:

Load Case	Maximum Usage %	Element Label	Element Type
NESC Heavy	82.13	78X	Angle
NESC Extreme	91.75	25Y	Angle
NESC Heavy Broken Wire	98.47	80XY	Angle

Summary of Insulator Usages:

Insulator Label	Insulator Type	Maximum Usage %	Load Case	Weight (lbs)
C1	Clamp	8.60	NESC Heavy	0.0
C2	Clamp	17.61	NESC Heavy Broken Wire	0.0
C3	Clamp	22.17	NESC Heavy	0.0
C4	Clamp	23.19	NESC Heavy	0.0
C5	Clamp	20.75	NESC Heavy	0.0
C6	Clamp	21.15	NESC Heavy	0.0
C7	Clamp	22.01	NESC Heavy	0.0
C8	Clamp	25.30	NESC Heavy	0.0
C9	Clamp	22.14	NESC Heavy	0.0
C10	Clamp	22.60	NESC Heavy	0.0
C11	Clamp	22.34	NESC Heavy	0.0

C12	Clamp	25.74	NESC Heavy	0.0
C13	Clamp	22.63	NESC Heavy	0.0
C14	Clamp	24.37	NESC Heavy	0.0
C15	Clamp	23.14	NESC Heavy	0.0
C16	Clamp	21.84	NESC Heavy	0.0
C17	Clamp	21.52	NESC Heavy	0.0
C18	Clamp	23.51	NESC Heavy	0.0
C19	Clamp	24.29	NESC Heavy	0.0
C20	Clamp	24.26	NESC Heavy	0.0
C21	Clamp	22.99	NESC Heavy	0.0
C22	Clamp	23.55	NESC Heavy	0.0
C23	Clamp	24.71	NESC Heavy	0.0
C24	Clamp	24.40	NESC Heavy	0.0
C25	Clamp	23.93	NESC Heavy	0.0
C26	Clamp	23.59	NESC Heavy	0.0
C27	Clamp	1.28	NESC Heavy	0.0
C28	Clamp	1.27	NESC Heavy	0.0
C29	Clamp	5.65	NESC Heavy	0.0
C30	Clamp	1.80	NESC Extreme	0.0
C31	Clamp	1.92	NESC Heavy	0.0
C32	Clamp	4.58	NESC Heavy	0.0
C34	Clamp	0.87	NESC Heavy	0.0
C35	Clamp	0.86	NESC Heavy	0.0
C36	Clamp	12.19	NESC Extreme	0.0
C37	Clamp	1.41	NESC Extreme	0.0
C38	Clamp	1.33	NESC Heavy	0.0
C39	Clamp	3.07	NESC Heavy	0.0
C41	Clamp	1.28	NESC Heavy	0.0
C42	Clamp	1.91	NESC Heavy	0.0
C43	Clamp	5.65	NESC Heavy	0.0
C44	Clamp	12.13	NESC Extreme	0.0
C45	Clamp	13.18	NESC Extreme	0.0
C46	Clamp	13.18	NESC Extreme	0.0
C47	Clamp	19.26	NESC Extreme	0.0
C48	Clamp	19.26	NESC Extreme	0.0
C49	Clamp	1.30	NESC Heavy	0.0
C50	Clamp	1.86	NESC Heavy	0.0
C51	Clamp	1.80	NESC Extreme	0.0
C52	Clamp	2.26	NESC Heavy	0.0
C53	Clamp	1.92	NESC Heavy	0.0
C54	Clamp	2.71	NESC Heavy	0.0
C55	Clamp	4.58	NESC Heavy	0.0
C56	Clamp	6.37	NESC Heavy	0.0

*** Weight of structure (lbs):

Weight of Angles*Section DLF:	30861.1
Total:	30861.1

*** End of Report

*
* TOWER - Analysis and Design - Copyright Power Line Systems, Inc. 1986-2011 *
*

Project Name : 18000.55 - Norwalk, CT
Project Notes: Structure # 1102 / AT&T 5046
Project File : J:\Jobs\1800000.WI\55_CT5046\04_Structural\Calcs\Rev (2)\Pls-Tower\norwalk1102.tow
Date run : 8:40:26 AM Tuesday, May 21, 2019
by : Tower Version 12.50
Licensed to : Centek Engineering Inc

Successfully performed nonlinear analysis

Member "5P" will not be checked for block shear since more than one gage line exists (long edge distance (g) greater than zero); however, end, edge and spacing distances will be checked. ??
Member "5X" will not be checked for block shear since more than one gage line exists (long edge distance (g) greater than zero); however, end, edge and spacing distances will be checked. ??
Member "5XY" will not be checked for block shear since more than one gage line exists (long edge distance (g) greater than zero); however, end, edge and spacing distances will be checked. ??
Member "5Y" will not be checked for block shear since more than one gage line exists (long edge distance (g) greater than zero); however, end, edge and spacing distances will be checked. ??
Member "8P" will not be checked for block shear since more than one gage line exists (long edge distance (g) greater than zero); however, end, edge and spacing distances will be checked. ??
Member "8X" will not be checked for block shear since more than one gage line exists (long edge distance (g) greater than zero); however, end, edge and spacing distances will be checked. ??
Member "8XY" will not be checked for block shear since more than one gage line exists (long edge distance (g) greater than zero); however, end, edge and spacing distances will be checked. ??
Member "8Y" will not be checked for block shear since more than one gage line exists (long edge distance (g) greater than zero); however, end, edge and spacing distances will be checked. ??
Member "10P" will not be checked for block shear since more than one gage line exists (long edge distance (g) greater than zero); however, end, edge and spacing distances will be checked. ??
Member "10X" will not be checked for block shear since more than one gage line exists (long edge distance (g) greater than zero); however, end, edge and spacing distances will be checked. ??
Member "10XY" will not be checked for block shear since more than one gage line exists (long edge distance (g) greater than zero); however, end, edge and spacing distances will be checked. ??
Member "10Y" will not be checked for block shear since more than one gage line exists (long edge distance (g) greater than zero); however, end, edge and spacing distances will be checked. ??
Member "12P" will not be checked for block shear since more than one gage line exists (long edge distance (g) greater than zero); however, end, edge and spacing distances will be checked. ??
Member "12X" will not be checked for block shear since more than one gage line exists (long edge distance (g) greater than zero); however, end, edge and spacing distances will be checked. ??
Member "12XY" will not be checked for block shear since more than one gage line exists (long edge distance (g) greater than zero); however, end, edge and spacing distances will be checked. ??
Member "12Y" will not be checked for block shear since more than one gage line exists (long edge distance (g) greater than zero); however, end, edge and spacing distances will be checked. ??
Member "13P" will not be checked for block shear since more than one gage line exists (long edge distance (g) greater than zero); however, end, edge and spacing distances will be checked. ??
Member "13X" will not be checked for block shear since more than one gage line exists (long edge distance (g) greater than zero); however, end, edge and spacing distances will be checked. ??
Member "13XY" will not be checked for block shear since more than one gage line exists (long edge distance (g) greater than zero); however, end, edge and spacing distances will be checked. ??
Member "13Y" will not be checked for block shear since more than one gage line exists (long edge distance (g) greater than zero); however, end, edge and spacing distances will be checked. ??
KL/R value of 247.53 exceeds maximum of 200.00 for member "26P" ??
KL/R value of 247.53 exceeds maximum of 200.00 for member "26X" ??
KL/R value of 247.53 exceeds maximum of 200.00 for member "26XY" ??

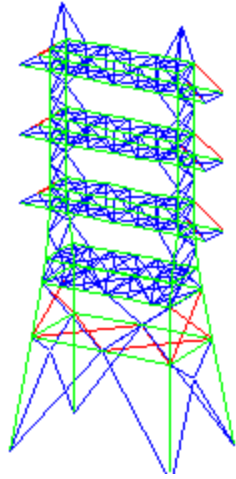

Nonlinear convergence parameters: Use Standard Parameters
 Tension only member maximum compression load as a percent of compression capacity: 100%
 Member check option: ASCE 10
 Connection rupture check: ASCE 10
 Crossing diagonal check: ASCE 10 [Alternate Unsupported RLOUT = 1]
 Included angle check: None
 Climbing load check: None
 Redundant members checked with: Actual Force

Joints Geometry:

Joint Label	Symmetry Code	X Coord. (ft)	Y Coord. (ft)	Z Coord. (ft)	X Disp. Rest.	Y Disp. Rest.	Z Disp. Rest.	X Rot. Rest.	Y Rot. Rest.	Z Rot. Rest.
1P	X-Symmetry	0	14	94	Free	Free	Free	Free	Free	Free
2P	XY-Symmetry	3.5	15	85	Free	Free	Free	Free	Free	Free
3P	XY-Symmetry	3.5	15	80	Free	Free	Free	Free	Free	Free
4P	XY-Symmetry	3.5	15	75	Free	Free	Free	Free	Free	Free
5P	XY-Symmetry	3.5	15	70	Free	Free	Free	Free	Free	Free
6P	XY-Symmetry	3.5	15	65	Free	Free	Free	Free	Free	Free
7P	XY-Symmetry	3.5	15	60	Free	Free	Free	Free	Free	Free
8P	XY-Symmetry	3.5	15	55	Free	Free	Free	Free	Free	Free
9P	XY-Symmetry	3.5	15	50	Free	Free	Free	Free	Free	Free
14P	XY-Symmetry	13.07	19.07	0	Fixed	Fixed	Fixed	Fixed	Fixed	Fixed
15P	XY-Symmetry	3.5	22	80	Free	Free	Free	Free	Free	Free
16P	XY-Symmetry	3.5	22	65	Free	Free	Free	Free	Free	Free
17P	XY-Symmetry	3.5	22	50	Free	Free	Free	Free	Free	Free
18P	Y-Symmetry	3.5	0	85	Free	Free	Free	Free	Free	Free
19P	XY-Symmetry	3.5	6	85	Free	Free	Free	Free	Free	Free
20P	XY-Symmetry	3.5	10.5	85	Free	Free	Free	Free	Free	Free
21P	Y-Symmetry	3.5	0	80	Free	Free	Free	Free	Free	Free
22P	XY-Symmetry	3.5	6	80	Free	Free	Free	Free	Free	Free
23P	XY-Symmetry	3.5	10.5	80	Free	Free	Free	Free	Free	Free
24P	Y-Symmetry	3.5	0	70	Free	Free	Free	Free	Free	Free
25P	XY-Symmetry	3.5	6	70	Free	Free	Free	Free	Free	Free
26P	XY-Symmetry	3.5	10.5	70	Free	Free	Free	Free	Free	Free

27P	Y-Symmetry	3.5	0	65	Free	Free	Free	Free	Free	Free
28P	XY-Symmetry	3.5	6	65	Free	Free	Free	Free	Free	Free
29P	XY-Symmetry	3.5	10.5	65	Free	Free	Free	Free	Free	Free
30P	Y-Symmetry	3.5	0	55	Free	Free	Free	Free	Free	Free
31P	XY-Symmetry	3.5	6	55	Free	Free	Free	Free	Free	Free
32P	XY-Symmetry	3.5	10.5	55	Free	Free	Free	Free	Free	Free
33P	Y-Symmetry	3.5	0	50	Free	Free	Free	Free	Free	Free
34P	XY-Symmetry	3.5	6	50	Free	Free	Free	Free	Free	Free
35P	XY-Symmetry	3.5	10.5	50	Free	Free	Free	Free	Free	Free
36P	Y-Symmetry	5.375	0	40	Free	Free	Free	Free	Free	Free
37P	XY-Symmetry	5.375	5.25	40	Free	Free	Free	Free	Free	Free
38P	XY-Symmetry	5.375	10.5	40	Free	Free	Free	Free	Free	Free
39P	Y-Symmetry	6.333	0	35	Free	Free	Free	Free	Free	Free
40P	XY-Symmetry	6.333	5.25	35	Free	Free	Free	Free	Free	Free
41P	XY-Symmetry	6.333	10.5	35	Free	Free	Free	Free	Free	Free
44P	X-Symmetry	0	17.01	17.75	Free	Free	Free	Free	Free	Free
45P	X-Symmetry	0	10.5	40	Free	Free	Free	Free	Free	Free
10P	XY-Symmetry	4.457	15	45	Free	Free	Free	Free	Free	Free
11P	XY-Symmetry	5.415	15	40	Free	Free	Free	Free	Free	Free
12P	XY-Symmetry	6.372	15	35	Free	Free	Free	Free	Free	Free
1X	X-Gen	0	-14	94	Free	Free	Free	Free	Free	Free
2X	X-GenXY	3.5	-15	85	Free	Free	Free	Free	Free	Free
2XY	XY-GenXY	-3.5	-15	85	Free	Free	Free	Free	Free	Free
2Y	Y-GenXY	-3.5	15	85	Free	Free	Free	Free	Free	Free
3X	X-GenXY	3.5	-15	80	Free	Free	Free	Free	Free	Free
3XY	XY-GenXY	-3.5	-15	80	Free	Free	Free	Free	Free	Free
3Y	Y-GenXY	-3.5	15	80	Free	Free	Free	Free	Free	Free
4X	X-GenXY	3.5	-15	75	Free	Free	Free	Free	Free	Free
4XY	XY-GenXY	-3.5	-15	75	Free	Free	Free	Free	Free	Free
4Y	Y-GenXY	-3.5	15	75	Free	Free	Free	Free	Free	Free
5X	X-GenXY	3.5	-15	70	Free	Free	Free	Free	Free	Free
5XY	XY-GenXY	-3.5	-15	70	Free	Free	Free	Free	Free	Free
5Y	Y-GenXY	-3.5	15	70	Free	Free	Free	Free	Free	Free
6X	X-GenXY	3.5	-15	65	Free	Free	Free	Free	Free	Free
6XY	XY-GenXY	-3.5	-15	65	Free	Free	Free	Free	Free	Free
6Y	Y-GenXY	-3.5	15	65	Free	Free	Free	Free	Free	Free
7X	X-GenXY	3.5	-15	60	Free	Free	Free	Free	Free	Free
7XY	XY-GenXY	-3.5	-15	60	Free	Free	Free	Free	Free	Free
7Y	Y-GenXY	-3.5	15	60	Free	Free	Free	Free	Free	Free
8X	X-GenXY	3.5	-15	55	Free	Free	Free	Free	Free	Free
8XY	XY-GenXY	-3.5	-15	55	Free	Free	Free	Free	Free	Free
8Y	Y-GenXY	-3.5	15	55	Free	Free	Free	Free	Free	Free
9X	X-GenXY	3.5	-15	50	Free	Free	Free	Free	Free	Free
9XY	XY-GenXY	-3.5	-15	50	Free	Free	Free	Free	Free	Free
9Y	Y-GenXY	-3.5	15	50	Free	Free	Free	Free	Free	Free
14X	X-GenXY	13.07	-19.07	0	Fixed	Fixed	Fixed	Fixed	Fixed	Fixed
14XY	XY-GenXY	-13.07	-19.07	0	Fixed	Fixed	Fixed	Fixed	Fixed	Fixed
14Y	Y-GenXY	-13.07	19.07	0	Fixed	Fixed	Fixed	Fixed	Fixed	Fixed
15X	X-GenXY	3.5	-22	80	Free	Free	Free	Free	Free	Free
15XY	XY-GenXY	-3.5	-22	80	Free	Free	Free	Free	Free	Free
15Y	Y-GenXY	-3.5	22	80	Free	Free	Free	Free	Free	Free
16X	X-GenXY	3.5	-22	65	Free	Free	Free	Free	Free	Free
16XY	XY-GenXY	-3.5	-22	65	Free	Free	Free	Free	Free	Free
16Y	Y-GenXY	-3.5	22	65	Free	Free	Free	Free	Free	Free
17X	X-GenXY	3.5	-22	50	Free	Free	Free	Free	Free	Free
17XY	XY-GenXY	-3.5	-22	50	Free	Free	Free	Free	Free	Free
17Y	Y-GenXY	-3.5	22	50	Free	Free	Free	Free	Free	Free
18Y	Y-Gen	-3.5	0	85	Free	Free	Free	Free	Free	Free
19X	X-GenXY	3.5	-6	85	Free	Free	Free	Free	Free	Free

19XY	XY-GenXY	-3.5	-6	85	Free	Free	Free	Free	Free	Free
19Y	Y-GenXY	-3.5	6	85	Free	Free	Free	Free	Free	Free
20X	X-GenXY	3.5	-10.5	85	Free	Free	Free	Free	Free	Free
20XY	XY-GenXY	-3.5	-10.5	85	Free	Free	Free	Free	Free	Free
20Y	Y-GenXY	-3.5	10.5	85	Free	Free	Free	Free	Free	Free
21Y	Y-Gen	-3.5	0	80	Free	Free	Free	Free	Free	Free
22X	X-GenXY	3.5	-6	80	Free	Free	Free	Free	Free	Free
22XY	XY-GenXY	-3.5	-6	80	Free	Free	Free	Free	Free	Free
22Y	Y-GenXY	-3.5	6	80	Free	Free	Free	Free	Free	Free
23X	X-GenXY	3.5	-10.5	80	Free	Free	Free	Free	Free	Free
23XY	XY-GenXY	-3.5	-10.5	80	Free	Free	Free	Free	Free	Free
23Y	Y-GenXY	-3.5	10.5	80	Free	Free	Free	Free	Free	Free
24Y	Y-Gen	-3.5	0	70	Free	Free	Free	Free	Free	Free
25X	X-GenXY	3.5	-6	70	Free	Free	Free	Free	Free	Free
25XY	XY-GenXY	-3.5	-6	70	Free	Free	Free	Free	Free	Free
25Y	Y-GenXY	-3.5	6	70	Free	Free	Free	Free	Free	Free
26X	X-GenXY	3.5	-10.5	70	Free	Free	Free	Free	Free	Free
26XY	XY-GenXY	-3.5	-10.5	70	Free	Free	Free	Free	Free	Free
26Y	Y-GenXY	-3.5	10.5	70	Free	Free	Free	Free	Free	Free
27Y	Y-Gen	-3.5	0	65	Free	Free	Free	Free	Free	Free
28X	X-GenXY	3.5	-6	65	Free	Free	Free	Free	Free	Free
28XY	XY-GenXY	-3.5	-6	65	Free	Free	Free	Free	Free	Free
28Y	Y-GenXY	-3.5	6	65	Free	Free	Free	Free	Free	Free
29X	X-GenXY	3.5	-10.5	65	Free	Free	Free	Free	Free	Free
29XY	XY-GenXY	-3.5	-10.5	65	Free	Free	Free	Free	Free	Free
29Y	Y-GenXY	-3.5	10.5	65	Free	Free	Free	Free	Free	Free
30Y	Y-Gen	-3.5	0	55	Free	Free	Free	Free	Free	Free
31X	X-GenXY	3.5	-6	55	Free	Free	Free	Free	Free	Free
31XY	XY-GenXY	-3.5	-6	55	Free	Free	Free	Free	Free	Free
31Y	Y-GenXY	-3.5	6	55	Free	Free	Free	Free	Free	Free
32X	X-GenXY	3.5	-10.5	55	Free	Free	Free	Free	Free	Free
32XY	XY-GenXY	-3.5	-10.5	55	Free	Free	Free	Free	Free	Free
32Y	Y-GenXY	-3.5	10.5	55	Free	Free	Free	Free	Free	Free
33Y	Y-Gen	-3.5	0	50	Free	Free	Free	Free	Free	Free
34X	X-GenXY	3.5	-6	50	Free	Free	Free	Free	Free	Free
34XY	XY-GenXY	-3.5	-6	50	Free	Free	Free	Free	Free	Free
34Y	Y-GenXY	-3.5	6	50	Free	Free	Free	Free	Free	Free
35X	X-GenXY	3.5	-10.5	50	Free	Free	Free	Free	Free	Free
35XY	XY-GenXY	-3.5	-10.5	50	Free	Free	Free	Free	Free	Free
35Y	Y-GenXY	-3.5	10.5	50	Free	Free	Free	Free	Free	Free
36Y	Y-Gen	-5.375	0	40	Free	Free	Free	Free	Free	Free
37X	X-GenXY	5.375	-5.25	40	Free	Free	Free	Free	Free	Free
37XY	XY-GenXY	-5.375	-5.25	40	Free	Free	Free	Free	Free	Free
37Y	Y-GenXY	-5.375	5.25	40	Free	Free	Free	Free	Free	Free
38X	X-GenXY	5.375	-10.5	40	Free	Free	Free	Free	Free	Free
38XY	XY-GenXY	-5.375	-10.5	40	Free	Free	Free	Free	Free	Free
38Y	Y-GenXY	-5.375	10.5	40	Free	Free	Free	Free	Free	Free
39Y	Y-Gen	-6.333	0	35	Free	Free	Free	Free	Free	Free
40X	X-GenXY	6.333	-5.25	35	Free	Free	Free	Free	Free	Free
40XY	XY-GenXY	-6.333	-5.25	35	Free	Free	Free	Free	Free	Free
40Y	Y-GenXY	-6.333	5.25	35	Free	Free	Free	Free	Free	Free
41X	X-GenXY	6.333	-10.5	35	Free	Free	Free	Free	Free	Free
41XY	XY-GenXY	-6.333	-10.5	35	Free	Free	Free	Free	Free	Free
41Y	Y-GenXY	-6.333	10.5	35	Free	Free	Free	Free	Free	Free
44X	X-Gen	0	-17.01	17.75	Free	Free	Free	Free	Free	Free
45X	X-Gen	0	-10.5	40	Free	Free	Free	Free	Free	Free
10X	X-GenXY	4.457	-15	45	Free	Free	Free	Free	Free	Free
10XY	XY-GenXY	-4.457	-15	45	Free	Free	Free	Free	Free	Free
10Y	Y-GenXY	-4.457	15	45	Free	Free	Free	Free	Free	Free

11X	X-GenXY	5.415	-15	40	Free	Free	Free	Free	Free	Free
11XY	XY-GenXY	-5.415	-15	40	Free	Free	Free	Free	Free	Free
11Y	Y-GenXY	-5.415	15	40	Free	Free	Free	Free	Free	Free
12X	X-GenXY	6.372	-15	35	Free	Free	Free	Free	Free	Free
12XY	XY-GenXY	-6.372	-15	35	Free	Free	Free	Free	Free	Free
12Y	Y-GenXY	-6.372	15	35	Free	Free	Free	Free	Free	Free

Secondary Joints:

Joint Label	Symmetry Code	Origin Joint	End Joint	Fraction	Elevation (ft)	X Disp. Rest.	Y Disp. Rest.	Z Disp. Rest.	X Rot. Rest.	Y Rot. Rest.	Z Rot. Rest.
13S	XY-Symmetry	12P	14P	0	23.67	Free	Free	Free	Free	Free	Free
42S	Y-Symmetry	13X	13S	0.5	0	Free	Free	Free	Free	Free	Free
43S	X-Symmetry	11P	11Y	0.5	0	Free	Free	Free	Free	Free	Free
46S	None	13X	42Y	0.5	0	Free	Free	Free	Free	Free	Free
47S	None	13S	42Y	0.5	0	Free	Free	Free	Free	Free	Free
13X	X-GenXY	12P	14P	0	23.67	Free	Free	Free	Free	Free	Free
13XY	XY-GenXY	12P	14P	0	23.67	Free	Free	Free	Free	Free	Free
13Y	Y-GenXY	12P	14P	0	23.67	Free	Free	Free	Free	Free	Free
42Y	Y-Gen	13X	13S	0.5	0	Free	Free	Free	Free	Free	Free
43X	X-Gen	11P	11Y	0.5	0	Free	Free	Free	Free	Free	Free

The model contains 146 primary and 10 secondary joints for a total of 156 joints.

Steel Material Properties:

Steel Material Label	Modulus of Elasticity (ksi)	Yield Stress Fy (ksi)	Ultimate Stress Fu (ksi)	Member All. Stress Hyp. 1 (ksi)	Member All. Stress Hyp. 2 (ksi)	Member Rupture Hyp. 1 (ksi)	Member Rupture Hyp. 2 (ksi)	Member Bearing Hyp. 1 (ksi)	Member Bearing Hyp. 2 (ksi)
A7	2.9e+004	33	60	0	0	0	0	0	0

Bolt Properties:

Bolt Label	Bolt Diameter (in)	Hole Diameter (in)	Ultimate Shear Capacity (kips)	Default End Distance (in)	Default Bolt Spacing (in)	Shear Capacity Hyp. 1 (kips)	Shear Capacity Hyp. 2 (kips)
3/4 A394	0.75	0.875	13.6	1.35	1.8	0	0

Number Bolts Used By Type:

Bolt Type	Number Bolts
3/4 A394	1561

Angle Properties:

Angle Type	Angle Size (in)	Long Leg (in)	Short Leg (in)	Thick. (in)	Unit Weight (lbs/ft)	Gross Area (in^2)	w/t Ratio	Radius of Gyration Rx (in)	Radius of Gyration Ry (in)	Radius of Gyration Rz (in)	Number of Angles	Wind Width (in)	Short Edge Dist. (in)	Long Edge Dist. (in)	Optimize Factor	Section Modulus (in^3)
------------	-----------------	---------------	----------------	-------------	----------------------	-------------------	-----------	----------------------------	----------------------------	----------------------------	------------------	-----------------	-----------------------	----------------------	-----------------	------------------------

SAE	8X8X0.5	8	8	0.5	26.4	7.75	13.75	2.5	2.5	1.59	1	8	4	0	1.0000	0
SAE	6X6X0.5	6	6	0.5	19.6	5.75	10	1.86	1.86	1.18	1	6	3	0	1.0000	0
SAE	5X5X0.375	5	5	0.375	12.3	3.61	11	1.56	1.56	0.99	1	5	2.5	0	1.0000	0
SAE	4X4X0.375	4	4	0.375	9.8	2.86	8.67	1.23	1.23	0.788	1	4	2	0	1.0000	0
SAE	4X4X0.3125	4	4	0.3125	8.2	2.4	10.6	1.24	1.24	0.791	1	4	2	0	1.0000	0
SAE	4X4X0.25	4	4	0.25	6.6	1.94	13.5	1.25	1.25	0.795	1	4	2	0	1.0000	0
SAE	3.5X3.5X0.3125	3.5	3.5	0.3125	7.2	2.09	9	1.08	1.08	0.69	1	3.5	1.75	0	1.0000	0
SAE	3.5X3.5X0.25	3.5	3.5	0.25	5.8	1.69	11.5	1.09	1.09	0.694	1	3.5	1.75	0	1.0000	0
SAE	3X3X0.3125	3	3	0.3125	6.1	1.78	7.6	0.922	0.922	0.589	1	3	1.5	0	1.0000	0
SAE	3X3X0.25	3	3	0.25	4.9	1.44	9.75	0.93	0.93	0.592	1	3	1.5	0	1.0000	0
SAE	3X3X0.1875	3	3	0.1875	3.71	1.09	13.33	0.939	0.939	0.596	1	3	1.5	0	1.0000	0
SAE	2.5X2.5X0.25	2.5	2.5	0.25	4.1	1.19	7.75	0.769	0.769	0.491	1	2.5	1.25	0	1.0000	0
SAE	2.5X2.5X0.1875	2.5	2.5	0.1875	3.07	0.902	10.67	0.778	0.778	0.495	1	2.5	1.25	0	1.0000	0
SAE	2X2X0.25	2	2	0.25	3.19	0.94	5	0.609	0.609	0.391	1	2	1	0	1.0000	0
SAE	2X2X0.1875	2	2	0.1875	2.44	0.71	8	0.617	0.617	0.394	1	2	1	0	1.0000	0
SAU	7X4X0.4375	7	4	0.4375	15.8	4.62	13.86	2.26	1.12	0.876	1	7	2	0	1.0000	0
SAU	4X3.5X0.25	4	3.5	0.25	6.2	1.81	13.25	1.27	1.07	0.734	1	4	1.75	0	1.0000	0
SAU	3.5X3X0.25	3.5	3	0.25	5.4	1.56	11.25	1.11	0.914	0.631	1	3.5	1.5	0	1.0000	0
SAU	3.5X2.5X0.25	3.5	2.5	0.25	4.9	1.44	11.25	1.12	0.735	0.544	1	3.5	1.25	0	1.0000	0
SAU	3X2.5X0.25	3	2.5	0.25	4.5	1.31	9.5	0.945	0.753	0.528	1	3	1.25	0	1.0000	0
SAU	3X2X0.25	3	2	0.25	4.1	1.19	9.75	0.957	0.574	0.435	1	3	1	0	1.0000	0
SAU	2.5X2X0.1875	2.5	2	0.1875	2.75	0.81	10.67	0.793	0.6	0.427	1	2.5	1	0	1.0000	0
SAU	2.5X1.5X0.25	2.5	1.5	0.25	3.19	0.94	7.75	0.794	0.415	0.324	1	2.5	0.75	0	1.0000	0
DAS	4X3X0.4375	4	3	0.4375	19.6	5.74	7.14	0.871	1.95	0.871	2	4	1.5	0	1.0000	0
DAS	3.5X3X0.25	3.5	3	0.25	10.8	3.13	11.25	0.914	1.65	0.914	2	3.5	1.5	0	1.0000	0
BAR	2 x 0.1875	2	0.1875	0.1875	1.28	0.375	0	0.577	0.054	0.054	1	2	0	0	1.0000	0

Angle Groups:

Group Label	Group Description	Angle Type	Angle Size	Material Type	Element Type	Group Type	Optimize Group	Allow. Angle	Add. Width
									For Optimize (in)
PeakPost	L2.5x2.5x3/16	SAE	2.5X2.5X0.1875	A7	Truss	Other	None		0.000
Leg1	L5x5x3/8	SAE	5X5X0.375	A7	Beam	Leg	None		0.000
Leg2	L8x8x1/2	SAE	8X8X0.5	A7	Beam	Leg	None		0.000
Leg3	L8x8x1/2	SAE	8X8X0.5	A7	Beam	Leg	None		0.000
Leg4	L8x8x1/2	SAE	8X8X0.5	A7	Beam	Leg	None		0.000
Leg5	L8x8x1/2	SAE	8X8X0.5	A7	Beam	Leg	None		0.000
TTTC	L3x3x1/4	SAE	3X3X0.25	A7	Beam	Other	None		0.000
TTBC	L3x3x1/4	SAE	3X3X0.25	A7	Beam	Other	None		0.000
ARMTT	L4x4x1/4	SAE	4X4X0.25	A7	Beam	Other	None		0.000
MTTC	L4x4x1/4	SAE	4X4X0.25	A7	Beam	Other	None		0.000
MTBC	L4x4x1/4	SAE	4X4X0.25	A7	Beam	Other	None		0.000
ARMMT	L4x4x1/4	SAE	4X4X0.25	A7	Beam	Other	None		0.000
BTTC	L4x4x5/16	SAE	4X4X0.3125	A7	Beam	Other	None		0.000
BTBC	L4x4x5/16	SAE	4X4X0.3125	A7	Beam	Other	None		0.000
ARMBT	L4x4x1/4	SAE	4X4X0.25	A7	Beam	Other	None		0.000
BTC	8x8x1/2	SAE	8X8X0.5	A7	Beam	Other	None		0.000
BBC	6x6x1/2	SAE	6X6X0.5	A7	Beam	Other	None		0.000
Diag1	L2x2x3/16	SAE	2X2X0.1875	A7	Truss	Crossing Diagonal	None		0.000
Diag2	L2.5x2.5x1/4	SAE	2.5X2.5X0.25	A7	Truss	Crossing Diagonal	None		0.000
Diag3	L3x3x5/16	SAE	3X3X0.3125	A7	Truss	Crossing Diagonal	None		0.000
Diag4	L3x3x3/16	SAE	3X3X0.1875	A7	Truss	Other	None		0.000
Diag5	L2.5x2x3/16	SAU	2.5X2X0.1875	A7	T-Only	Other	None		0.000
Diag6	L3x2x1/4	SAU	3X2X0.25	A7	Truss	Other	None		0.000
Diag7	L4x4x1/4	SAE	4X4X0.25	A7	Truss	Other	None		0.000
Diag8	L4x4x3/8	SAE	4X4X0.375	A7	Truss	Other	None		0.000

Diag9	L3.5x3x1/4	DAS	3.5X3X0.25	A7	Truss	Other	None	0.000
Diag10	L4x3x7/16	DAS	4X3X0.4375	A7	Truss	Other	None	0.000
Diag11	L3x3x5/16	SAE	3X3X0.3125	A7	Truss	Other	None	0.000
Diag12	L3x3x3/16	SAE	3X3X0.1875	A7	Truss	Other	None	0.000
Horz1	L3x3x3/16	SAE	3X3X0.1875	A7	Beam	Other	None	0.000
Horz2	L3.5x3.5x1/4	SAE	3.5X3.5X0.25	A7	Beam	Other	None	0.000
Br1	L2x2x3/16	SAE	2X2X0.1875	A7	T-Only	Redundant	None	0.000
Br2	L3x3x3/16	SAE	3X3X0.1875	A7	Truss	Other	None	0.000
ArmBr1	Bar 2x3/16	BAR	2 x 0.1875	A7	T-Only	Other	None	0.000
ArmBr2	ArmBr2	SAE	2X2X0.25	A7	Truss	Other	None	0.000
ArmBr3	ArmBr3	SAU	3.5X2.5X0.25	A7	Truss	Other	None	0.000
TTBr1	L2x2x3/16	SAE	2X2X0.1875	A7	Truss	Other	None	0.000
TTBr2	L3x3x3/16	SAE	3X3X0.1875	A7	Truss	Other	None	0.000
TTBr3	L3x3x5/16	SAE	3X3X0.3125	A7	Truss	Other	None	0.000
MTBr1	L2x2x3/16	SAE	2X2X0.1875	A7	Truss	Other	None	0.000
MTBr2	L3x2.5x1/4	SAU	3X2.5X0.25	A7	Truss	Other	None	0.000
MTBr3	L4x3.5x1/4	SAU	4X3.5X0.25	A7	Truss	Other	None	0.000
MTBr4	L3.5x3.5x1/4	SAE	3.5X3.5X0.25	A7	Truss	Other	None	0.000
MTBr5	L4x4x1/4	SAE	4X4X0.25	A7	Truss	Other	None	0.000
BTBr1	L2x2x3/16	SAE	2X2X0.1875	A7	Truss	Other	None	0.000
BTBr2	L3.5x3.5x1/4	SAE	3.5X3.5X0.25	A7	Truss	Other	None	0.000
BTBr3	L4x4x5/16	SAE	4X4X0.3125	A7	Truss	Other	None	0.000
BTBr4	L4x4x1/4	SAE	4X4X0.25	A7	Truss	Other	None	0.000
BTBr5	L4x4x3/8	SAE	4X4X0.375	A7	Truss	Other	None	0.000
TBC1	L2x2x3/16	SAE	2X2X0.1875	A7	Truss	Other	None	0.000
TBC2	L2.5x2.5x1/4	SAE	2.5X2.5X0.25	A7	Truss	Other	None	0.000
TBC3	L2x2x1/4	SAE	2X2X0.25	A7	Truss	Other	None	0.000
TBC4	L2.5x2.5x3/16	SAE	2.5X2.5X0.1875	A7	Truss	Other	None	0.000
TTC1	L2x2x3/16	SAE	2X2X0.1875	A7	Truss	Other	None	0.000
TTC2	L2.5x2.5x3/16	SAE	2.5X2.5X0.1875	A7	Truss	Other	None	0.000
Horz3	L2.5x2.5x3/16	SAE	2.5X2.5X0.1875	A7	Beam	Other	None	0.000
Horz4	L2x2x3/16	SAE	2X2X0.1875	A7	Beam	Other	None	0.000
Horz5	L3.5x3.5x5/16	SAE	3.5X3.5X0.3125	A7	Beam	Other	None	0.000
Horz6	L3.5x3x1/4	SAU	3.5X3X0.25	A7	Beam	Other	None	0.000
BBr1	L2x2x3/16	SAE	2X2X0.1875	A7	Truss	Other	None	0.000
BBr2	L4x4x3/8	SAE	4X4X0.375	A7	Truss	Other	None	0.000
BBr3	L4x4x5/16	SAE	4X4X0.3125	A7	Truss	Other	None	0.000
BBr4	L7x4x7/16	SAU	7X4X0.4375	A7	Truss	Other	None	0.000
BTC1	L3.5x3.5x1/4	SAE	3.5X3.5X0.25	A7	Truss	Other	None	0.000
BTC2	L2x2x3/16	SAE	2X2X0.1875	A7	Truss	Other	None	0.000
BTC3	L3x2.5x1/4	SAU	3X2.5X0.25	A7	Truss	Other	None	0.000
BTC4	L2.5x1.5x1/4	SAU	2.5X1.5X0.25	A7	Truss	Other	None	0.000
BTC5	L2x2x1/4	SAE	2X2X0.25	A7	Truss	Other	None	0.000
BBC1	L3x3x3/16	SAE	3X3X0.1875	A7	Truss	Other	None	0.000
BBC2	L2x2x3/16	SAE	2X2X0.1875	A7	Truss	Other	None	0.000
BBC3	L3x3x1/4	SAE	3X3X0.25	A7	Truss	Other	None	0.000

Aggregate Angle Information:

Note: Estimate of surface area reported for painting purposes, not wind loading.

Angle Type	Angle Material Size	Total Type	Total Length (ft)	Total Surface Area (ft^2)	Total Weight (lbs)
SAE	2.5X2.5X0.1875	A7	319.10	265.91	979.62
SAE	5X5X0.375	A7	80.00	133.33	984.00
SAE	8X8X0.5	A7	324.56	865.50	8568.42

SAE	2X2X0.1875	A7	760.75	507.17	1856.23
SAE	2.5X2.5X0.25	A7	182.82	152.35	749.55
SAE	3X3X0.3125	A7	183.95	183.95	1122.09
SAE	3X3X0.1875	A7	300.93	300.93	1116.44
SAU	2.5X2X0.1875	A7	75.10	56.33	206.53
SAU	3X2X0.25	A7	41.66	34.72	170.81
SAE	4X4X0.25	A7	311.63	415.51	2056.75
SAE	4X4X0.375	A7	139.75	186.33	1369.51
DAS	3.5X3X0.25	A7	75.69	82.00	817.47
DAS	4X3X0.4375	A7	122.94	143.43	2409.55
SAE	3X3X0.25	A7	145.33	145.33	712.13
SAE	4X4X0.3125	A7	171.60	228.81	1407.16
SAE	6X6X0.5	A7	60.00	120.00	1176.01
SAE	3.5X3.5X0.25	A7	91.82	107.13	532.57
BAR	2 x 0.1875	A7	103.23	37.64	132.13
SAE	2X2X0.25	A7	327.51	218.34	1044.77
SAU	3.5X2.5X0.25	A7	42.00	42.00	205.80
SAU	4X3.5X0.25	A7	31.24	39.05	193.69
SAU	3X2.5X0.25	A7	41.50	38.04	186.75
SAE	3.5X3.5X0.3125	A7	14.00	16.33	100.80
SAU	3.5X3X0.25	A7	47.15	51.08	254.60
SAU	7X4X0.4375	A7	54.36	99.66	858.85
SAU	2.5X1.5X0.25	A7	56.20	37.47	179.29

Sections:

The adjustment factors below only apply to dead load and wind areas that are calculated for members in the model. They do not apply to equipment or to manually input dead load and drag areas.

Section Label	Joint Defining Section Bottom	Dead Load Adjust. Factor	Transverse Drag x Area For Face	Longitudinal Drag x Area For Face	Transverse Area Factor (CD From Code)	Longitudinal Area Factor (CD From Code)	Af Factor For EIA Only	Flat Face For EIA Only	Ar Round For EIA Only	Transverse Drag x Area For All	Longitudinal Drag x Area For All	SAPS Drag x Area Factor	Angle Drag x Area Factor	SAPS Round Drag x Area Factor	Force Solid Face
1	9P	1.050	3.200	3.200	1.050	1.000	0.000	0.000	0.000	0.000	0.000	0.000	0.000	0.000	None
2	14P	1.050	3.200	3.200	1.050	1.000	0.000	0.000	0.000	0.000	0.000	0.000	0.000	0.000	None

Angle Member Connectivity:

Member Shear Path	Group Label	Section Label	Symmetry Code	Origin Joint	End Joint	Ecc. Code	Rest. Code	Ratio RLX	Ratio RLY	Ratio RLZ	Bolt Type	# Bolts	# Holes	Shear Planes	Connect Leg	Short Edge	Long Edge	End Dist.	Bolt Spacing		
0	1P	PeakPost	XY-Symmetry	1P	2P	3	5	0.5	0.5	0.5	3/4	A394	2	1	1	Long	only	0.875	0	2.25	2
0	1X	PeakPost	X-GenXY	1X	2X	3	5	0.5	0.5	0.5	3/4	A394	2	1	1	Long	only	0.875	0	2.25	2
0	1XY	PeakPost	XY-GenXY	1X	2XY	3	5	0.5	0.5	0.5	3/4	A394	2	1	1	Long	only	0.875	0	2.25	2
0	1Y	PeakPost	Y-GenXY	1P	2Y	3	5	0.5	0.5	0.5	3/4	A394	2	1	1	Long	only	0.875	0	2.25	2
0	2P	Leg1	XY-Symmetry	2P	3P	1	4	0.5	0.5	0.5	3/4	A394	0	4	0			0	0	0	0
0	2X	Leg1	X-GenXY	2X	3X	1	4	0.5	0.5	0.5	3/4	A394	0	4	0			0	0	0	0

0	0	0																			
0	2XY	0	Leg1	XY-GenXY	2XY	3XY	1	4	0.5	0.5	0.5	3/4	A394	0	4	0	0	0	0		
0	0	0	0																		
0	2Y	0	Leg1	Y-GenXY	2Y	3Y	1	4	0.5	0.5	0.5	3/4	A394	0	4	0	0	0	0		
0	0	0	0																		
0	3P	0	Leg1	XY-Symmetry	3P	4P	1	4	1	1	1	3/4	A394	0	3.36	0	0	0	0		
0	0	0	0																		
0	3X	0	Leg1	X-GenXY	3X	4X	1	4	1	1	1	3/4	A394	0	3.36	0	0	0	0		
0	0	0	0																		
0	3XY	0	Leg1	XY-GenXY	3XY	4XY	1	4	1	1	1	3/4	A394	0	3.36	0	0	0	0		
0	0	0	0																		
0	3Y	0	Leg1	Y-GenXY	3Y	4Y	1	4	1	1	1	3/4	A394	0	3.36	0	0	0	0		
0	0	0	0																		
0	4P	0	Leg1	XY-Symmetry	4P	5P	1	4	1	1	1	3/4	A394	0	3.36	0	0	0	0		
0	0	0	0																		
0	4X	0	Leg1	X-GenXY	4X	5X	1	4	1	1	1	3/4	A394	0	3.36	0	0	0	0		
0	0	0	0																		
0	4XY	0	Leg1	XY-GenXY	4XY	5XY	1	4	1	1	1	3/4	A394	0	3.36	0	0	0	0		
0	0	0	0																		
0	4Y	0	Leg1	Y-GenXY	4Y	5Y	1	4	1	1	1	3/4	A394	0	3.36	0	0	0	0		
0	0	0	0																		
0	5P	0	Leg1	XY-Symmetry	5P	6P	1	4	1	1	1	3/4	A394	10	4	1	Both	1	3	1.25	5.5
0	0	0	0																		
0	5X	0	Leg1	X-GenXY	5X	6X	1	4	1	1	1	3/4	A394	10	4	1	Both	1	3	1.25	5.5
0	0	0	0																		
0	5XY	0	Leg1	XY-GenXY	5XY	6XY	1	4	1	1	1	3/4	A394	10	4	1	Both	1	3	1.25	5.5
0	0	0	0																		
0	5Y	0	Leg1	Y-GenXY	5Y	6Y	1	4	1	1	1	3/4	A394	10	4	1	Both	1	3	1.25	5.5
0	0	0	0																		
0	6P	0	Leg2	XY-Symmetry	6P	7P	1	4	1	1	1	3/4	A394	0	3.14	0	0	0	0	0	
0	0	0	0																		
0	6X	0	Leg2	X-GenXY	6X	7X	1	4	1	1	1	3/4	A394	0	3.14	0	0	0	0	0	
0	0	0	0																		
0	6XY	0	Leg2	XY-GenXY	6XY	7XY	1	4	1	1	1	3/4	A394	0	3.14	0	0	0	0	0	
0	0	0	0																		
0	6Y	0	Leg2	Y-GenXY	6Y	7Y	1	4	1	1	1	3/4	A394	0	3.14	0	0	0	0	0	
0	0	0	0																		
0	7P	0	Leg2	XY-Symmetry	7P	8P	1	4	1	1	1	3/4	A394	0	4	0	0	0	0	0	
0	0	0	0																		
0	7X	0	Leg2	X-GenXY	7X	8X	1	4	1	1	1	3/4	A394	0	4	0	0	0	0	0	
0	0	0	0																		
0	7XY	0	Leg2	XY-GenXY	7XY	8XY	1	4	1	1	1	3/4	A394	0	4	0	0	0	0	0	
0	0	0	0																		
0	7Y	0	Leg2	Y-GenXY	7Y	8Y	1	4	1	1	1	3/4	A394	0	4	0	0	0	0	0	
0	0	0	0																		
0	8P	0	Leg2	XY-Symmetry	8P	9P	1	4	1	1	1	3/4	A394	10	4	1	Both	1.25	5.25	1.25	7.5
0	0	0	0																		
0	8X	0	Leg2	X-GenXY	8X	9X	1	4	1	1	1	3/4	A394	10	4	1	Both	1.25	5.25	1.25	7.5
0	0	0	0																		
0	8XY	0	Leg2	XY-GenXY	8XY	9XY	1	4	1	1	1	3/4	A394	10	4	1	Both	1.25	5.25	1.25	7.5
0	0	0	0																		
0	8Y	0	Leg2	Y-GenXY	8Y	9Y	1	4	1	1	1	3/4	A394	10	4	1	Both	1.25	5.25	1.25	7.5
0	0	0	0																		
0	9P	0	Leg3	XY-Symmetry	9P	10P	1	4	1	1	1	3/4	A394	0	4	0	0	0	0	0	
0	0	0	0																		
0	9X	0	Leg3	X-GenXY	9X	10X	1	4	1	1	1	3/4	A394	0	4	0	0	0	0	0	
0	0	0	0																		
0	9XY	0	Leg3	XY-GenXY	9XY	10XY	1	4	1	1	1	3/4	A394	0	4	0	0	0	0	0	
0	0	0	0																		

0	9Y	Leg3	Y-GenXY	9Y	10Y	1	4	1	1	1 3/4	A394	0	4	0	0	0	0		
0	10P	Leg3	XY-Symmetry	10P	11P	1	4	1	1	1 3/4	A394	28	4	1	Both	1.25	5.25	1.25	3.75
0	10X	Leg3	X-GenXY	10X	11X	1	4	1	1	1 3/4	A394	28	4	1	Both	1.25	5.25	1.25	3.75
0	10XY	Leg3	XY-GenXY	10XY	11XY	1	4	1	1	1 3/4	A394	28	4	1	Both	1.25	5.25	1.25	3.75
0	10Y	Leg3	Y-GenXY	10Y	11Y	1	4	1	1	1 3/4	A394	28	4	1	Both	1.25	5.25	1.25	3.75
0	11P	Leg4	XY-Symmetry	11P	12P	1	4	1	1	1 3/4	A394	0	4	0		0	0	0	0
0	11X	Leg4	X-GenXY	11X	12X	1	4	1	1	1 3/4	A394	0	4	0		0	0	0	0
0	11XY	Leg4	XY-GenXY	11XY	12XY	1	4	1	1	1 3/4	A394	0	4	0		0	0	0	0
0	11Y	Leg4	Y-GenXY	11Y	12Y	1	4	1	1	1 3/4	A394	0	4	0		0	0	0	0
0	12P	Leg4	XY-Symmetry	12P	13S	1	4	0.5	0.5	0.5 3/4	A394	28	4	1	Both	1.25	5.25	1.25	3.75
0	12X	Leg4	X-GenXY	12X	13X	1	4	0.5	0.5	0.5 3/4	A394	28	4	1	Both	1.25	5.25	1.25	3.75
0	12XY	Leg4	XY-GenXY	12XY	13XY	1	4	0.5	0.5	0.5 3/4	A394	28	4	1	Both	1.25	5.25	1.25	3.75
0	12Y	Leg4	Y-GenXY	12Y	13Y	1	4	0.5	0.5	0.5 3/4	A394	28	4	1	Both	1.25	5.25	1.25	3.75
0	13P	Leg5	XY-Symmetry	13S	14P	1	4	0.25	0.25	0.25 3/4	A394	28	4	1	Both	1.25	5.25	1.25	2.25
0	13X	Leg5	X-GenXY	13X	14X	1	4	0.25	0.25	0.25 3/4	A394	28	4	1	Both	1.25	5.25	1.25	2.25
0	13XY	Leg5	XY-GenXY	13XY	14XY	1	4	0.25	0.25	0.25 3/4	A394	28	4	1	Both	1.25	5.25	1.25	2.25
0	13Y	Leg5	Y-GenXY	13Y	14Y	1	4	0.25	0.25	0.25 3/4	A394	28	4	1	Both	1.25	5.25	1.25	2.25
0	14P	PeakPost	XY-Symmetry	1P	20P	3	5	0.5	0.5	0.5 3/4	A394	2	1	1	Long only	0.875	0	2.25	2
0	14X	PeakPost	X-GenXY	1X	20X	3	5	0.5	0.5	0.5 3/4	A394	2	1	1	Long only	0.875	0	2.25	2
0	14XY	PeakPost	XY-GenXY	1X	20XY	3	5	0.5	0.5	0.5 3/4	A394	2	1	1	Long only	0.875	0	2.25	2
0	14Y	PeakPost	Y-GenXY	1P	20Y	3	5	0.5	0.5	0.5 3/4	A394	2	1	1	Long only	0.875	0	2.25	2
0	15P	Diag1	XY-Symmetry	2P	3Y	2	5	0.75	0.5	0.5 3/4	A394	2	1	1	Short only	0.875	0	1.25	2.375
0	15X	Diag1	X-GenXY	2X	3XY	2	5	0.75	0.5	0.5 3/4	A394	2	1	1	Short only	0.875	0	1.25	2.375
0	15XY	Diag1	XY-GenXY	2XY	3X	2	5	0.75	0.5	0.5 3/4	A394	2	1	1	Short only	0.875	0	1.25	2.375
0	15Y	Diag1	Y-GenXY	2Y	3P	2	5	0.75	0.5	0.5 3/4	A394	2	1	1	Short only	0.875	0	1.25	2.375
0	16P	Diag2	XY-Symmetry	3P	4Y	2	5	0.75	0.5	0.5 3/4	A394	2	1	1	Short only	1.25	0	1.3125	2.4375
0	16X	Diag2	X-GenXY	3X	4XY	2	5	0.75	0.5	0.5 3/4	A394	2	1	1	Short only	1.25	0	1.3125	2.4375
0	16XY	Diag2	XY-GenXY	3XY	4X	2	5	0.75	0.5	0.5 3/4	A394	2	1	1	Short only	1.25	0	1.3125	2.4375
0	16Y	Diag2	Y-GenXY	3Y	4P	2	5	0.75	0.5	0.5 3/4	A394	2	1	1	Short only	1.25	0	1.3125	2.4375
0	17P	Diag2	XY-Symmetry	4P	5Y	2	5	0.75	0.5	0.5 3/4	A394	2	1	1	Short only	1.25	0	1.3125	2.5

0	0	0																	
0	17X	Diag2	X-GenXY	4X	5XY	2	5	0.75	0.5	0.5	3/4	A394	2	1	1 Short only	1.25	0	1.3125	2.5
0	0	0																	
0	17XY	Diag2	XY-GenXY	4XY	5X	2	5	0.75	0.5	0.5	3/4	A394	2	1	1 Short only	1.25	0	1.3125	2.5
0	0	0																	
0	17Y	Diag2	Y-GenXY	4Y	5P	2	5	0.75	0.5	0.5	3/4	A394	2	1	1 Short only	1.25	0	1.3125	2.5
0	0	0																	
0	18P	Diag2	XY-Symmetry	5P	6Y	2	5	0.75	0.5	0.5	3/4	A394	2	1	1 Short only	1.25	0	1.3125	2.375
0	0	0																	
0	18X	Diag2	X-GenXY	5X	6XY	2	5	0.75	0.5	0.5	3/4	A394	2	1	1 Short only	1.25	0	1.3125	2.375
0	0	0																	
0	18XY	Diag2	XY-GenXY	5XY	6X	2	5	0.75	0.5	0.5	3/4	A394	2	1	1 Short only	1.25	0	1.3125	2.375
0	0	0																	
0	18Y	Diag2	Y-GenXY	5Y	6P	2	5	0.75	0.5	0.5	3/4	A394	2	1	1 Short only	1.25	0	1.3125	2.375
0	0	0																	
0	19P	Diag3	XY-Symmetry	6P	7Y	2	5	0.75	0.5	0.5	3/4	A394	3	1	1 Short only	1.5	0	1.25	2.5
0	0	0																	
0	19X	Diag3	X-GenXY	6X	7XY	2	5	0.75	0.5	0.5	3/4	A394	3	1	1 Short only	1.5	0	1.25	2.5
0	0	0																	
0	19XY	Diag3	XY-GenXY	6XY	7X	2	5	0.75	0.5	0.5	3/4	A394	3	1	1 Short only	1.5	0	1.25	2.5
0	0	0																	
0	19Y	Diag3	Y-GenXY	6Y	7P	2	5	0.75	0.5	0.5	3/4	A394	3	1	1 Short only	1.5	0	1.25	2.5
0	0	0																	
0	20P	Diag3	XY-Symmetry	7P	8Y	2	5	0.75	0.5	0.5	3/4	A394	3	1	1 Short only	1.5	0	1.25	2.5
0	0	0																	
0	20X	Diag3	X-GenXY	7X	8XY	2	5	0.75	0.5	0.5	3/4	A394	3	1	1 Short only	1.5	0	1.25	2.5
0	0	0																	
0	20XY	Diag3	XY-GenXY	7XY	8X	2	5	0.75	0.5	0.5	3/4	A394	3	1	1 Short only	1.5	0	1.25	2.5
0	0	0																	
0	20Y	Diag3	Y-GenXY	7Y	8P	2	5	0.75	0.5	0.5	3/4	A394	3	1	1 Short only	1.5	0	1.25	2.5
0	0	0																	
0	21P	Diag3	XY-Symmetry	8P	9Y	2	5	0.75	0.5	0.5	3/4	A394	3	1	1 Short only	1.5	0	1.3125	2.375
0	0	0																	
0	21X	Diag3	X-GenXY	8X	9XY	2	5	0.75	0.5	0.5	3/4	A394	3	1	1 Short only	1.5	0	1.3125	2.375
0	0	0																	
0	21XY	Diag3	XY-GenXY	8XY	9X	2	5	0.75	0.5	0.5	3/4	A394	3	1	1 Short only	1.5	0	1.3125	2.375
0	0	0																	
0	21Y	Diag3	Y-GenXY	8Y	9P	2	5	0.75	0.5	0.5	3/4	A394	3	1	1 Short only	1.5	0	1.3125	2.375
0	0	0																	
0	22P	Diag2	XY-Symmetry	9P	10Y	2	5	0.78	0.56	0.56	3/4	A394	2	1	1 Short only	1.375	0	1.3125	2.75
0	0	0																	
0	22X	Diag2	X-GenXY	9X	10XY	2	5	0.78	0.56	0.56	3/4	A394	2	1	1 Short only	1.375	0	1.3125	2.75
0	0	0																	
0	22XY	Diag2	XY-GenXY	9XY	10X	2	5	0.78	0.56	0.56	3/4	A394	2	1	1 Short only	1.375	0	1.3125	2.75
0	0	0																	
0	22Y	Diag2	Y-GenXY	9Y	10P	2	5	0.78	0.56	0.56	3/4	A394	2	1	1 Short only	1.375	0	1.3125	2.75
0	0	0																	
0	23P	Diag4	XY-Symmetry	10Y	43S	2	5	1	1	1	3/4	A394	2	1	1 Short only	1.5	0	1.25	2
0	0	0																	
0	23X	Diag4	X-GenXY	10XY	43X	2	5	1	1	1	3/4	A394	2	1	1 Short only	1.5	0	1.25	2
0	0	0																	
0	23XY	Diag4	XY-GenXY	10X	43X	2	5	1	1	1	3/4	A394	2	1	1 Short only	1.5	0	1.25	2
0	0	0																	
0	23Y	Diag4	Y-GenXY	10P	43S	2	5	1	1	1	3/4	A394	2	1	1 Short only	1.5	0	1.25	2
0	0	0																	
0	24P	Diag4	XY-Symmetry	12Y	43S	2	5	1	1	1	3/4	A394	2	1	1 Short only	1.5	0	1.3125	3
0	0	0																	
0	24X	Diag4	X-GenXY	12XY	43X	2	5	1	1	1	3/4	A394	2	1	1 Short only	1.5	0	1.3125	3
0	0	0																	

0	24XY	Diag4	XY-GenXY	12X	43X	2	5	1	1	1 3/4	A394	2	1	1 Short only	1.5	0	1.3125	3
0	24Y	Diag4	Y-GenXY	12P	43S	2	5	1	1	1 3/4	A394	2	1	1 Short only	1.5	0	1.3125	3
0	25P	Diag5	XY-Symmetry	13S	12Y	2	5	0.57	0.78	0.57 3/4	A394	2	1	1 Long only	1.25	0	1.3125	2.9375
0	25X	Diag5	X-GenXY	13X	12XY	2	5	0.57	0.78	0.57 3/4	A394	2	1	1 Long only	1.25	0	1.3125	2.9375
0	25XY	Diag5	XY-GenXY	13XY	12X	2	5	0.57	0.78	0.57 3/4	A394	2	1	1 Long only	1.25	0	1.3125	2.9375
0	25Y	Diag5	Y-GenXY	13Y	12P	2	5	0.57	0.78	0.57 3/4	A394	2	1	1 Long only	1.25	0	1.3125	2.9375
0	26P	Diag6	XY-Symmetry	13S	44P	2	5	1	1	1 3/4	A394	3	1	1 Long only	1.5	0	1.25	2
0	26X	Diag6	X-GenXY	13X	44X	2	5	1	1	1 3/4	A394	3	1	1 Long only	1.5	0	1.25	2
0	26XY	Diag6	XY-GenXY	13XY	44X	2	5	1	1	1 3/4	A394	3	1	1 Long only	1.5	0	1.25	2
0	26Y	Diag6	Y-GenXY	13Y	44P	2	5	1	1	1 3/4	A394	3	1	1 Long only	1.5	0	1.25	2
0	27P	Diag12	XY-Symmetry	14P	44P	2	5	1	0.333	0.333 3/4	A394	3	1	1 Short only	1.625	0	1.25	3.8125
0	27X	Diag12	X-GenXY	14X	44X	2	5	1	0.333	0.333 3/4	A394	3	1	1 Short only	1.625	0	1.25	3.8125
0	27XY	Diag12	XY-GenXY	14XY	44X	2	5	1	0.333	0.333 3/4	A394	3	1	1 Short only	1.625	0	1.25	3.8125
0	27Y	Diag12	Y-GenXY	14Y	44P	2	5	1	0.333	0.333 3/4	A394	3	1	1 Short only	1.625	0	1.25	3.8125
0	28P	Diag11	XY-Symmetry	23P	4P	2	5	1	1	1 3/4	A394	3	1	1 Short only	1.625	0	1.25	2
0	28X	Diag11	X-GenXY	23X	4X	2	5	1	1	1 3/4	A394	3	1	1 Short only	1.625	0	1.25	2
0	28XY	Diag11	XY-GenXY	23XY	4XY	2	5	1	1	1 3/4	A394	3	1	1 Short only	1.625	0	1.25	2
0	28Y	Diag11	Y-GenXY	23Y	4Y	2	5	1	1	1 3/4	A394	3	1	1 Short only	1.625	0	1.25	2
0	29P	Diag11	XY-Symmetry	4P	26P	2	5	1	1	1 3/4	A394	3	1	1 Long only	1.625	0	1.25	2
0	29X	Diag11	X-GenXY	4X	26X	2	5	1	1	1 3/4	A394	3	1	1 Long only	1.625	0	1.25	2
0	29XY	Diag11	XY-GenXY	4XY	26XY	2	5	1	1	1 3/4	A394	3	1	1 Long only	1.625	0	1.25	2
0	29Y	Diag11	Y-GenXY	4Y	26Y	2	5	1	1	1 3/4	A394	3	1	1 Long only	1.625	0	1.25	2
0	30P	Diag7	XY-Symmetry	29P	7P	2	5	1	1	1 3/4	A394	4	1.65	1 Long only	1	2.5	1.25	2.625
0	30X	Diag7	X-GenXY	29X	7X	2	5	1	1	1 3/4	A394	4	1.65	1 Long only	1	2.5	1.25	2.625
0	30XY	Diag7	XY-GenXY	29XY	7XY	2	5	1	1	1 3/4	A394	4	1.65	1 Long only	1	2.5	1.25	2.625
0	30Y	Diag7	Y-GenXY	29Y	7Y	2	5	1	1	1 3/4	A394	4	1.65	1 Long only	1	2.5	1.25	2.625
0	31P	Diag7	XY-Symmetry	7P	32P	2	5	1	1	1 3/4	A394	4	1.68	1 Long only	1	2.5	1.25	2.5
0	31X	Diag7	X-GenXY	7X	32X	2	5	1	1	1 3/4	A394	4	1.68	1 Long only	1	2.5	1.25	2.5
0	31XY	Diag7	XY-GenXY	7XY	32XY	2	5	1	1	1 3/4	A394	4	1.68	1 Long only	1	2.5	1.25	2.5
0	31Y	Diag7	Y-GenXY	7Y	32Y	2	5	1	1	1 3/4	A394	4	1.68	1 Long only	1	2.5	1.25	2.5

0	0	0																	
0	32P	Diag8	XY-Symmetry	35P	10P	2	5	1	1	1 3/4	A394	5	1.65	1	Long only	1	2.5	1.25	2.625
0	0	0																	
0	32X	Diag8	X-GenXY	35X	10X	2	5	1	1	1 3/4	A394	5	1.65	1	Long only	1	2.5	1.25	2.625
0	0	0																	
0	32XY	Diag8	XY-GenXY	35XY	10XY	2	5	1	1	1 3/4	A394	5	1.65	1	Long only	1	2.5	1.25	2.625
0	0	0																	
0	32Y	Diag8	Y-GenXY	35Y	10Y	2	5	1	1	1 3/4	A394	5	1.65	1	Long only	1	2.5	1.25	2.625
0	0	0																	
0	33P	Diag8	XY-Symmetry	10P	38P	2	5	1	1	1 3/4	A394	5	1.54	1	Long only	1	2.5	1.25	3
0	0	0																	
0	33X	Diag8	X-GenXY	10X	38X	2	5	1	1	1 3/4	A394	5	1.54	1	Long only	1	2.5	1.25	3
0	0	0																	
0	33XY	Diag8	XY-GenXY	10XY	38XY	2	5	1	1	1 3/4	A394	5	1.54	1	Long only	1	2.5	1.25	3
0	0	0																	
0	33Y	Diag8	Y-GenXY	10Y	38Y	2	5	1	1	1 3/4	A394	5	1.54	1	Long only	1	2.5	1.25	3
0	0	0																	
0	34P	Diag9	XY-Symmetry	42S	12P	2	5	0.54	1	0.54 3/4	A394	2	2	2	Short only	1.25	0	1.25	2
0	0	0																	
0	34X	Diag9	X-GenXY	42S	12X	2	5	0.54	1	0.54 3/4	A394	2	2	2	Short only	1.25	0	1.25	2
0	0	0																	
0	34XY	Diag9	XY-GenXY	42Y	12XY	2	5	0.54	1	0.54 3/4	A394	2	2	2	Short only	1.25	0	1.25	2
0	0	0																	
0	34Y	Diag9	Y-GenXY	42Y	12Y	2	5	0.54	1	0.54 3/4	A394	2	2	2	Short only	1.25	0	1.25	2
0	0	0																	
0	35P	Diag10	XY-Symmetry	14P	42S	2	5	0.25	1	0.25 3/4	A394	3	2	2	Short only	1.625	0	1.25	4.375
0	0	0																	
0	35X	Diag10	X-GenXY	14X	42S	2	5	0.25	1	0.25 3/4	A394	3	2	2	Short only	1.625	0	1.25	4.375
0	0	0																	
0	35XY	Diag10	XY-GenXY	14XY	42Y	2	5	0.25	1	0.25 3/4	A394	3	2	2	Short only	1.625	0	1.25	4.375
0	0	0																	
0	35Y	Diag10	Y-GenXY	14Y	42Y	2	5	0.25	1	0.25 3/4	A394	3	2	2	Short only	1.625	0	1.25	4.375
0	0	0																	
0	36P	TTTC	XY-Symmetry	18P	19P	1	5	1	1	1 3/4	A394	4	2	1	Both	1.125	0	1.25	5.5
0	0	0																	
0	36X	TTTC	X-GenXY	18P	19X	1	5	1	1	1 3/4	A394	4	2	1	Both	1.125	0	1.25	5.5
0	0	0																	
0	36XY	TTTC	XY-GenXY	18Y	19XY	1	5	1	1	1 3/4	A394	4	2	1	Both	1.125	0	1.25	5.5
0	0	0																	
0	36Y	TTTC	Y-GenXY	18Y	19Y	1	5	1	1	1 3/4	A394	4	2	1	Both	1.125	0	1.25	5.5
0	0	0																	
0	37P	TTTC	XY-Symmetry	19P	20P	3	4	1	1	1 3/4	A394	0	2	0		0	0	0	0
0	0	0																	
0	37X	TTTC	X-GenXY	19X	20X	3	4	1	1	1 3/4	A394	0	2	0		0	0	0	0
0	0	0																	
0	37XY	TTTC	XY-GenXY	19XY	20XY	3	4	1	1	1 3/4	A394	0	2	0		0	0	0	0
0	0	0																	
0	37Y	TTTC	Y-GenXY	19Y	20Y	3	4	1	1	1 3/4	A394	0	2	0		0	0	0	0
0	0	0																	
0	38P	TTTC	XY-Symmetry	20P	2P	3	4	1	1	1 3/4	A394	2	1	1	Short only	1.125	0	1.25	2
0	0	0																	
0	38X	TTTC	X-GenXY	20X	2X	3	4	1	1	1 3/4	A394	2	1	1	Short only	1.125	0	1.25	2
0	0	0																	
0	38XY	TTTC	XY-GenXY	20XY	2XY	3	4	1	1	1 3/4	A394	2	1	1	Short only	1.125	0	1.25	2
0	0	0																	
0	38Y	TTTC	Y-GenXY	20Y	2Y	3	4	1	1	1 3/4	A394	2	1	1	Short only	1.125	0	1.25	2
0	0	0																	
0	39P	TTBC	XY-Symmetry	21P	22P	1	5	1	1	1 3/4	A394	4	2	1	Both	1.125	0	1.25	5.5
0	0	0																	

0	39X	TTBC	X-GenXY	21P	22X	1	5	1	1	1 3/4	A394	4	2	1	Both	1.125	0	1.25	5.5	
0	0	0																		
0	39XY	TTBC	XY-GenXY	21Y	22XY	1	5	1	1	1 3/4	A394	4	2	1	Both	1.125	0	1.25	5.5	
0	0	0																		
0	39Y	TTBC	Y-GenXY	21Y	22Y	1	5	1	1	1 3/4	A394	4	2	1	Both	1.125	0	1.25	5.5	
0	0	0																		
0	40P	TTBC	XY-Symmetry	22P	23P	3	4	1	1	1 3/4	A394	0	2	0		0	0	0	0	
0	0	0																		
0	40X	TTBC	X-GenXY	22X	23X	3	4	1	1	1 3/4	A394	0	2	0		0	0	0	0	
0	0	0																		
0	40XY	TTBC	XY-GenXY	22XY	23XY	3	4	1	1	1 3/4	A394	0	2	0		0	0	0	0	
0	0	0																		
0	40Y	TTBC	Y-GenXY	22Y	23Y	3	4	1	1	1 3/4	A394	0	2	0		0	0	0	0	
0	0	0																		
0	41P	TTBC	XY-Symmetry	23P	3P	3	4	1	1	1 3/4	A394	4	1	1	Short	only	1.125	0	1.25	2.5
0	0	0																		
0	41X	TTBC	X-GenXY	23X	3X	3	4	1	1	1 3/4	A394	4	1	1	Short	only	1.125	0	1.25	2.5
0	0	0																		
0	41XY	TTBC	XY-GenXY	23XY	3XY	3	4	1	1	1 3/4	A394	4	1	1	Short	only	1.125	0	1.25	2.5
0	0	0																		
0	41Y	TTBC	Y-GenXY	23Y	3Y	3	4	1	1	1 3/4	A394	4	1	1	Short	only	1.125	0	1.25	2.5
0	0	0																		
0	42P	MTTC	XY-Symmetry	24P	25P	1	4	1	1	1 3/4	A394	4	2	1	Both	2.125	0	1.5	9	
0	0	0																		
0	42X	MTTC	X-GenXY	24P	25X	1	4	1	1	1 3/4	A394	4	2	1	Both	2.125	0	1.5	9	
0	0	0																		
0	42XY	MTTC	XY-GenXY	24Y	25XY	1	4	1	1	1 3/4	A394	4	2	1	Both	2.125	0	1.5	9	
0	0	0																		
0	42Y	MTTC	Y-GenXY	24Y	25Y	1	4	1	1	1 3/4	A394	4	2	1	Both	2.125	0	1.5	9	
0	0	0																		
0	43P	MTTC	XY-Symmetry	25P	26P	3	4	1	1	1 3/4	A394	0	2	0		0	0	0	0	
0	0	0																		
0	43X	MTTC	X-GenXY	25X	26X	3	4	1	1	1 3/4	A394	0	2	0		0	0	0	0	
0	0	0																		
0	43XY	MTTC	XY-GenXY	25XY	26XY	3	4	1	1	1 3/4	A394	0	2	0		0	0	0	0	
0	0	0																		
0	43Y	MTTC	Y-GenXY	25Y	26Y	3	4	1	1	1 3/4	A394	0	2	0		0	0	0	0	
0	0	0																		
0	44P	MTTC	XY-Symmetry	26P	5P	3	4	1	1	1 3/4	A394	3	1.81	1	Short	only	2.625	1	1.125	2
0	0	0																		
0	44X	MTTC	X-GenXY	26X	5X	3	4	1	1	1 3/4	A394	3	1.81	1	Short	only	2.625	1	1.125	2
0	0	0																		
0	44XY	MTTC	XY-GenXY	26XY	5XY	3	4	1	1	1 3/4	A394	3	1.81	1	Short	only	2.625	1	1.125	2
0	0	0																		
0	44Y	MTTC	Y-GenXY	26Y	5Y	3	4	1	1	1 3/4	A394	3	1.81	1	Short	only	2.625	1	1.125	2
0	0	0																		
0	45P	MTBC	XY-Symmetry	27P	28P	1	4	1	1	1 3/4	A394	4	2	1	Both	2.125	0	1.5	9	
0	0	0																		
0	45X	MTBC	X-GenXY	27P	28X	1	4	1	1	1 3/4	A394	4	2	1	Both	2.125	0	1.5	9	
0	0	0																		
0	45XY	MTBC	XY-GenXY	27Y	28XY	1	4	1	1	1 3/4	A394	4	2	1	Both	2.125	0	1.5	9	
0	0	0																		
0	45Y	MTBC	Y-GenXY	27Y	28Y	1	4	1	1	1 3/4	A394	4	2	1	Both	2.125	0	1.5	9	
0	0	0																		
0	46P	MTBC	XY-Symmetry	28P	29P	3	4	1	1	1 3/4	A394	0	2	0		0	0	0	0	
0	0	0																		
0	46X	MTBC	X-GenXY	28X	29X	3	4	1	1	1 3/4	A394	0	2	0		0	0	0	0	
0	0	0																		
0	46XY	MTBC	XY-GenXY	28XY	29XY	3	4	1	1	1 3/4	A394	0	2	0		0	0	0	0	

0	0	0																		
0	46Y	0	MTBC	Y-GenXY	28Y	29Y	3	4	1	1	1 3/4	A394	0	2	0	0	0	0		
0	0	0	0																	
0	47P	0	MTBC	XY-Symmetry	29P	6P	3	4	1	1	1 3/4	A394	4	1	1	Short only	1	2.5	1.5	6
0	0	0	0																	
0	47X	0	MTBC	X-GenXY	29X	6X	3	4	1	1	1 3/4	A394	4	1	1	Short only	1	2.5	1.5	6
0	0	0	0																	
0	47XY	0	MTBC	XY-GenXY	29XY	6XY	3	4	1	1	1 3/4	A394	4	1	1	Short only	1	2.5	1.5	6
0	0	0	0																	
0	47Y	0	MTBC	Y-GenXY	29Y	6Y	3	4	1	1	1 3/4	A394	4	1	1	Short only	1	2.5	1.5	6
0	0	0	0																	
0	48P	0	BTTC	XY-Symmetry	30P	31P	1	4	1	1	1 3/4	A394	4	2	1	Both 2.125	0	1.5	9	
0	0	0	0																	
0	48X	0	BTTC	X-GenXY	30P	31X	1	4	1	1	1 3/4	A394	4	2	1	Both 2.125	0	1.5	9	
0	0	0	0																	
0	48XY	0	BTTC	XY-GenXY	30Y	31XY	1	4	1	1	1 3/4	A394	4	2	1	Both 2.125	0	1.5	9	
0	0	0	0																	
0	48Y	0	BTTC	Y-GenXY	30Y	31Y	1	4	1	1	1 3/4	A394	4	2	1	Both 2.125	0	1.5	9	
0	0	0	0																	
0	49P	0	BTTC	XY-Symmetry	31P	32P	3	4	1	1	1 3/4	A394	0	2	0	0	0	0	0	
0	0	0	0																	
0	49X	0	BTTC	X-GenXY	31X	32X	3	4	1	1	1 3/4	A394	0	2	0	0	0	0	0	
0	0	0	0																	
0	49XY	0	BTTC	XY-GenXY	31XY	32XY	3	4	1	1	1 3/4	A394	0	2	0	0	0	0	0	
0	0	0	0																	
0	49Y	0	BTTC	Y-GenXY	31Y	32Y	3	4	1	1	1 3/4	A394	0	2	0	0	0	0	0	
0	0	0	0																	
0	50P	0	BTTC	XY-Symmetry	32P	8P	3	4	1	1	1 3/4	A394	3	1	1	Short only	2	0	1.5	2
0	0	0	0																	
0	50X	0	BTTC	X-GenXY	32X	8X	3	4	1	1	1 3/4	A394	3	1	1	Short only	2	0	1.5	2
0	0	0	0																	
0	50XY	0	BTTC	XY-GenXY	32XY	8XY	3	4	1	1	1 3/4	A394	3	1	1	Short only	2	0	1.5	2
0	0	0	0																	
0	50Y	0	BTTC	Y-GenXY	32Y	8Y	3	4	1	1	1 3/4	A394	3	1	1	Short only	2	0	1.5	2
0	0	0	0																	
0	51P	0	BTBC	XY-Symmetry	33P	34P	1	4	1	1	1 3/4	A394	4	2	1	Both 2.125	0	1.5	9	
0	0	0	0																	
0	51X	0	BTBC	X-GenXY	33P	34X	1	4	1	1	1 3/4	A394	4	2	1	Both 2.125	0	1.5	9	
0	0	0	0																	
0	51XY	0	BTBC	XY-GenXY	33Y	34XY	1	4	1	1	1 3/4	A394	4	2	1	Both 2.125	0	1.5	9	
0	0	0	0																	
0	51Y	0	BTBC	Y-GenXY	33Y	34Y	1	4	1	1	1 3/4	A394	4	2	1	Both 2.125	0	1.5	9	
0	0	0	0																	
0	52P	0	BTBC	XY-Symmetry	34P	35P	3	4	1	1	1 3/4	A394	0	2	0	0	0	0	0	
0	0	0	0																	
0	52X	0	BTBC	X-GenXY	34X	35X	3	4	1	1	1 3/4	A394	0	2	0	0	0	0	0	
0	0	0	0																	
0	52XY	0	BTBC	XY-GenXY	34XY	35XY	3	4	1	1	1 3/4	A394	0	2	0	0	0	0	0	
0	0	0	0																	
0	52Y	0	BTBC	Y-GenXY	34Y	35Y	3	4	1	1	1 3/4	A394	0	2	0	0	0	0	0	
0	0	0	0																	
0	53P	0	BTBC	XY-Symmetry	35P	9P	3	4	1	1	1 3/4	A394	4	1	1	Short only	1	2.5	1.5	6
0	0	0	0																	
0	53X	0	BTBC	X-GenXY	35X	9X	3	4	1	1	1 3/4	A394	4	1	1	Short only	1	2.5	1.5	6
0	0	0	0																	
0	53XY	0	BTBC	XY-GenXY	35XY	9XY	3	4	1	1	1 3/4	A394	4	1	1	Short only	1	2.5	1.5	6
0	0	0	0																	
0	53Y	0	BTBC	Y-GenXY	35Y	9Y	3	4	1	1	1 3/4	A394	4	1	1	Short only	1	2.5	1.5	6
0	0	0	0																	

0	54P	BTC	XY-Symmetry	36P	37P	3	4	1	1	1 3/4	A394	0	4	0	0	0	0		
0	0	0																	
0	54X	BTC	X-GenXY	36P	37X	3	4	1	1	1 3/4	A394	0	4	0	0	0	0		
0	0	0																	
0	54XY	BTC	XY-GenXY	36Y	37XY	3	4	1	1	1 3/4	A394	0	4	0	0	0	0		
0	0	0																	
0	54Y	BTC	Y-GenXY	36Y	37Y	3	4	1	1	1 3/4	A394	0	4	0	0	0	0		
0	0	0																	
0	55P	BTC	XY-Symmetry	37P	38P	3	4	1	1	1 3/4	A394	0	5	0	0	0	0		
0	0	0																	
0	55X	BTC	X-GenXY	37X	38X	3	4	1	1	1 3/4	A394	0	5	0	0	0	0		
0	0	0																	
0	55XY	BTC	XY-GenXY	37XY	38XY	3	4	1	1	1 3/4	A394	0	5	0	0	0	0		
0	0	0																	
0	55Y	BTC	Y-GenXY	37Y	38Y	3	4	1	1	1 3/4	A394	0	5	0	0	0	0		
0	0	0																	
0	56P	BTC	XY-Symmetry	38P	11P	3	4	1	1	1 3/4	A394	8	3	1	Long only	1.25	5.25	1.5	2
0	0	0																	
0	56X	BTC	X-GenXY	38X	11X	3	4	1	1	1 3/4	A394	8	3	1	Long only	1.25	5.25	1.5	2
0	0	0																	
0	56XY	BTC	XY-GenXY	38XY	11XY	3	4	1	1	1 3/4	A394	8	3	1	Long only	1.25	5.25	1.5	2
0	0	0																	
0	56Y	BTC	Y-GenXY	38Y	11Y	3	4	1	1	1 3/4	A394	8	3	1	Long only	1.25	5.25	1.5	2
0	0	0																	
0	57P	BBC	XY-Symmetry	39P	40P	3	4	1	1	1 3/4	A394	0	4	0		0	0	0	0
0	0	0																	
0	57X	BBC	X-GenXY	39P	40X	3	4	1	1	1 3/4	A394	0	4	0		0	0	0	0
0	0	0																	
0	57XY	BBC	XY-GenXY	39Y	40XY	3	4	1	1	1 3/4	A394	0	4	0		0	0	0	0
0	0	0																	
0	57Y	BBC	Y-GenXY	39Y	40Y	3	4	1	1	1 3/4	A394	0	4	0		0	0	0	0
0	0	0																	
0	58P	BBC	XY-Symmetry	40P	41P	3	4	1	1	1 3/4	A394	0	4	0		0	0	0	0
0	0	0																	
0	58X	BBC	X-GenXY	40X	41X	3	4	1	1	1 3/4	A394	0	4	0		0	0	0	0
0	0	0																	
0	58XY	BBC	XY-GenXY	40XY	41XY	3	4	1	1	1 3/4	A394	0	4	0		0	0	0	0
0	0	0																	
0	58Y	BBC	Y-GenXY	40Y	41Y	3	4	1	1	1 3/4	A394	0	4	0		0	0	0	0
0	0	0																	
0	59P	BBC	XY-Symmetry	41P	12P	3	4	1	1	1 3/4	A394	9	3	1	Long only	1.25	5.25	1.5	2
0	0	0																	
0	59X	BBC	X-GenXY	41X	12X	3	4	1	1	1 3/4	A394	9	3	1	Long only	1.25	5.25	1.5	2
0	0	0																	
0	59XY	BBC	XY-GenXY	41XY	12XY	3	4	1	1	1 3/4	A394	9	3	1	Long only	1.25	5.25	1.5	2
0	0	0																	
0	59Y	BBC	Y-GenXY	41Y	12Y	3	4	1	1	1 3/4	A394	9	3	1	Long only	1.25	5.25	1.5	2
0	0	0																	
0	60P	Horz1	XY-Symmetry	42S	13S	3	5	0.5	0.5	0.5 3/4	A394	3	1	1	Short only	1.375	0	1.25	2
0	0	0																	
0	60X	Horz1	X-GenXY	42S	13X	3	5	0.5	0.5	0.5 3/4	A394	3	1	1	Short only	1.375	0	1.25	2
0	0	0																	
0	60XY	Horz1	XY-GenXY	42Y	13XY	3	5	0.5	0.5	0.5 3/4	A394	3	1	1	Short only	1.375	0	1.25	2
0	0	0																	
0	60Y	Horz1	Y-GenXY	42Y	13Y	3	5	0.5	0.5	0.5 3/4	A394	3	1	1	Short only	1.375	0	1.25	2
0	0	0																	
0	61P	Horz2	X-Symmetry	13S	13Y	3	5	0.5	0.5	0.5 3/4	A394	3	1	1	Short only	1.375	0	1.25	2.0625
0	0	0																	
0	61X	Horz2	X-Gen	13X	13XY	3	5	0.5	0.5	0.5 3/4	A394	3	1	1	Short only	1.375	0	1.25	2.0625

0	0	0																
0	62P	Br1	Y-Symmetry	47S	13Y	3	4	1	1	1 3/4	A394	1	1	1 Short only	0.875	0	1.25	0
0	0	0																
0	62Y	Br1	Y-Gen	47S	13S	3	4	1	1	1 3/4	A394	1	1	1 Short only	0.875	0	1.25	0
0	0	0																
0	63P	Br1	Y-Symmetry	42Y	47S	3	4	1	1	1 3/4	A394	1	1	1 Short only	0.875	0	1.25	0
0	0	0																
0	63Y	Br1	Y-Gen	42S	47S	3	4	1	1	1 3/4	A394	1	1	1 Short only	0.875	0	1.25	0
0	0	0																
0	64P	Br1	Y-Symmetry	46S	13X	3	4	1	1	1 3/4	A394	1	1	1 Short only	0.875	0	1.25	0
0	0	0																
0	64Y	Br1	Y-Gen	46S	13XY	3	4	1	1	1 3/4	A394	1	1	1 Short only	0.875	0	1.25	0
0	0	0																
0	65P	Br1	Y-Symmetry	42Y	46S	3	4	1	1	1 3/4	A394	1	1	1 Short only	0.875	0	1.25	0
0	0	0																
0	65Y	Br1	Y-Gen	42S	46S	3	4	1	1	1 3/4	A394	1	1	1 Short only	0.875	0	1.25	0
0	0	0																
0	66P	Br2	None	42S	42Y	3	4	0.75	0.5	0.5 3/4	A394	1	1	1 Long only	1.125	0	1.28125	0
0	0	0																
0	67P	ARMTT	XY-Symmetry	3P	15P	3	5	1	1	1 3/4	A394	2	1	1 Long only	2.125	0	13.5	2
0	0	0																
0	67X	ARMTT	X-GenXY	3X	15X	3	5	1	1	1 3/4	A394	2	1	1 Long only	2.125	0	13.5	2
0	0	0																
0	67XY	ARMTT	XY-GenXY	3XY	15XY	3	5	1	1	1 3/4	A394	2	1	1 Long only	2.125	0	13.5	2
0	0	0																
0	67Y	ARMTT	Y-GenXY	3Y	15Y	3	5	1	1	1 3/4	A394	2	1	1 Long only	2.125	0	13.5	2
0	0	0																
0	68P	ARMMT	XY-Symmetry	6P	16P	3	5	1	1	1 3/4	A394	3	1.18	1 Long only	1	2.5	13.75	4
0	0	0																
0	68X	ARMMT	X-GenXY	6X	16X	3	5	1	1	1 3/4	A394	3	1.18	1 Long only	1	2.5	13.75	4
0	0	0																
0	68XY	ARMMT	XY-GenXY	6XY	16XY	3	5	1	1	1 3/4	A394	3	1.18	1 Long only	1	2.5	13.75	4
0	0	0																
0	68Y	ARMMT	Y-GenXY	6Y	16Y	3	5	1	1	1 3/4	A394	3	1.18	1 Long only	1	2.5	13.75	4
0	0	0																
0	69P	ARMBT	XY-Symmetry	9P	17P	3	5	1	1	1 3/4	A394	3	1.18	1 Long only	1	2.5	13.75	4
0	0	0																
0	69X	ARMBT	X-GenXY	9X	17X	3	5	1	1	1 3/4	A394	3	1.18	1 Long only	1	2.5	13.75	4
0	0	0																
0	69XY	ARMBT	XY-GenXY	9XY	17XY	3	5	1	1	1 3/4	A394	3	1.18	1 Long only	1	2.5	13.75	4
0	0	0																
0	69Y	ARMBT	Y-GenXY	9Y	17Y	3	5	1	1	1 3/4	A394	3	1.18	1 Long only	1	2.5	13.75	4
0	0	0																
0	70P	ArmBr1	XY-Symmetry	2P	15P	3	4	1	1	1 3/4	A394	2	1	1 Long only	1	0	1.25	2.1875
0	0	0																
0	70X	ArmBr1	X-GenXY	2X	15X	3	4	1	1	1 3/4	A394	2	1	1 Long only	1	0	1.25	2.1875
0	0	0																
0	70XY	ArmBr1	XY-GenXY	2XY	15XY	3	4	1	1	1 3/4	A394	2	1	1 Long only	1	0	1.25	2.1875
0	0	0																
0	70Y	ArmBr1	Y-GenXY	2Y	15Y	3	4	1	1	1 3/4	A394	2	1	1 Long only	1	0	1.25	2.1875
0	0	0																
0	71P	ArmBr1	XY-Symmetry	5P	16P	3	4	1	1	1 3/4	A394	2	1	1 Long only	1	0	1.25	2.1875
0	0	0																
0	71X	ArmBr1	X-GenXY	5X	16X	3	4	1	1	1 3/4	A394	2	1	1 Long only	1	0	1.25	2.1875
0	0	0																
0	71XY	ArmBr1	XY-GenXY	5XY	16XY	3	4	1	1	1 3/4	A394	2	1	1 Long only	1	0	1.25	2.1875
0	0	0																
0	71Y	ArmBr1	Y-GenXY	5Y	16Y	3	4	1	1	1 3/4	A394	2	1	1 Long only	1	0	1.25	2.1875
0	0	0																

0	72P	ArmBr1	XY-Symmetry	8P	17P	2	4	1	1	1 3/4	A394	2	1	1	Long only	1	0	1.25	2.1875
0	72X	ArmBr1	X-GenXY	8X	17X	2	4	1	1	1 3/4	A394	2	1	1	Long only	1	0	1.25	2.1875
0	72XY	ArmBr1	XY-GenXY	8XY	17XY	2	4	1	1	1 3/4	A394	2	1	1	Long only	1	0	1.25	2.1875
0	72Y	ArmBr1	Y-GenXY	8Y	17Y	2	4	1	1	1 3/4	A394	2	1	1	Long only	1	0	1.25	2.1875
0	73P	ArmBr2	XY-Symmetry	3P	15Y	3	4	0.75	0.5	0.5 3/4	A394	1	1	1	Short only	0.875	0	1.5	0
0	73X	ArmBr2	X-GenXY	3X	15XY	3	4	0.75	0.5	0.5 3/4	A394	1	1	1	Short only	0.875	0	1.5	0
0	73XY	ArmBr2	XY-GenXY	3XY	15X	3	4	0.75	0.5	0.5 3/4	A394	1	1	1	Short only	0.875	0	1.5	0
0	73Y	ArmBr2	Y-GenXY	3Y	15P	3	4	0.75	0.5	0.5 3/4	A394	1	1	1	Short only	0.875	0	1.5	0
0	74P	ArmBr3	X-Symmetry	15P	15Y	3	4	1	1	1 3/4	A394	1	1	1	Short only	1.375	0	1.25	0
0	74X	ArmBr3	X-Gen	15X	15XY	3	4	1	1	1 3/4	A394	1	1	1	Short only	1.375	0	1.25	0
0	75P	ArmBr2	XY-Symmetry	6P	16Y	3	4	0.75	0.5	0.5 3/4	A394	1	1	1	Short only	0.875	0	1.5	0
0	75X	ArmBr2	X-GenXY	6X	16XY	3	4	0.75	0.5	0.5 3/4	A394	1	1	1	Short only	0.875	0	1.5	0
0	75XY	ArmBr2	XY-GenXY	6XY	16X	3	4	0.75	0.5	0.5 3/4	A394	1	1	1	Short only	0.875	0	1.5	0
0	75Y	ArmBr2	Y-GenXY	6Y	16P	3	4	0.75	0.5	0.5 3/4	A394	1	1	1	Short only	0.875	0	1.5	0
0	76P	ArmBr3	X-Symmetry	16P	16Y	3	4	1	1	1 3/4	A394	1	1	1	Short only	1.375	0	1.25	0
0	76X	ArmBr3	X-Gen	16X	16XY	3	4	1	1	1 3/4	A394	1	1	1	Short only	1.375	0	1.25	0
0	77P	ArmBr2	XY-Symmetry	9P	17Y	3	4	0.75	0.5	0.5 3/4	A394	1	1	1	Short only	0.875	0	1.5	0
0	77X	ArmBr2	X-GenXY	9X	17XY	3	4	0.75	0.5	0.5 3/4	A394	1	1	1	Short only	0.875	0	1.5	0
0	77XY	ArmBr2	XY-GenXY	9XY	17X	3	4	0.75	0.5	0.5 3/4	A394	1	1	1	Short only	0.875	0	1.5	0
0	77Y	ArmBr2	Y-GenXY	9Y	17P	3	4	0.75	0.5	0.5 3/4	A394	1	1	1	Short only	0.875	0	1.5	0
0	78P	ArmBr3	X-Symmetry	17P	17Y	3	4	1	1	1 3/4	A394	1	1	1	Short only	1.375	0	1.25	0
0	78X	ArmBr3	X-Gen	17X	17XY	3	4	1	1	1 3/4	A394	1	1	1	Short only	1.375	0	1.25	0
0	79P	TTBr1	Y-Symmetry	18P	21P	1	5	1	1	1 3/4	A394	2	1	1	Short only	0.875	0	1.25	2.5
0	79Y	TTBr1	Y-Gen	18Y	21Y	1	5	1	1	1 3/4	A394	2	1	1	Short only	0.875	0	1.25	2.5
0	80P	TTBr2	XY-Symmetry	21P	19P	2	6	1	1	1 3/4	A394	2	1	1	Short only	1.375	0	1.25	3.9375
0	80X	TTBr2	X-GenXY	21P	19X	2	6	1	1	1 3/4	A394	2	1	1	Short only	1.375	0	1.25	3.9375
0	80XY	TTBr2	XY-GenXY	21Y	19XY	2	6	1	1	1 3/4	A394	2	1	1	Short only	1.375	0	1.25	3.9375
0	80Y	TTBr2	Y-GenXY	21Y	19Y	2	6	1	1	1 3/4	A394	2	1	1	Short only	1.375	0	1.25	3.9375
0	81P	TTBr1	XY-Symmetry	19P	22P	1	5	1	1	1 3/4	A394	2	1	1	Short only	0.875	0	1.25	2.5
0	81X	TTBr1	X-GenXY	19X	22X	1	5	1	1	1 3/4	A394	2	1	1	Short only	0.875	0	1.25	2.5

0	0	0																	
0	81XY	0	TtBr1	XY-GenXY	19XY	22XY	1	5	1	1	1 3/4	A394	2	1	1 Short only	0.875	0	1.25	2.5
0	0	0	0																
0	81Y	0	TtBr1	Y-GenXY	19Y	22Y	1	5	1	1	1 3/4	A394	2	1	1 Short only	0.875	0	1.25	2.5
0	0	0	0																
0	82P	0	TtBr2	XY-Symmetry	19P	23P	2	5	1	1	1 3/4	A394	2	1	1 Short only	1.375	0	1.25	2
0	0	0	0																
0	82X	0	TtBr2	X-GenXY	19X	23X	2	5	1	1	1 3/4	A394	2	1	1 Short only	1.375	0	1.25	2
0	0	0	0																
0	82XY	0	TtBr2	XY-GenXY	19XY	23XY	2	5	1	1	1 3/4	A394	2	1	1 Short only	1.375	0	1.25	2
0	0	0	0																
0	82Y	0	TtBr2	Y-GenXY	19Y	23Y	2	5	1	1	1 3/4	A394	2	1	1 Short only	1.375	0	1.25	2
0	0	0	0																
0	83P	0	TtBr1	XY-Symmetry	20P	23P	1	5	1	1	1 3/4	A394	2	1	1 Short only	0.875	0	1.25	2.5
0	0	0	0																
0	83X	0	TtBr1	X-GenXY	20X	23X	1	5	1	1	1 3/4	A394	2	1	1 Short only	0.875	0	1.25	2.5
0	0	0	0																
0	83XY	0	TtBr1	XY-GenXY	20XY	23XY	1	5	1	1	1 3/4	A394	2	1	1 Short only	0.875	0	1.25	2.5
0	0	0	0																
0	83Y	0	TtBr1	Y-GenXY	20Y	23Y	1	5	1	1	1 3/4	A394	2	1	1 Short only	0.875	0	1.25	2.5
0	0	0	0																
0	84P	0	TtBr3	XY-Symmetry	23P	2P	2	5	1	0.5	0.5 3/4	A394	3	1	1 Short only	1.5	0	1.25	2
0	0	0	0																
0	84X	0	TtBr3	X-GenXY	23X	2X	2	5	1	0.5	0.5 3/4	A394	3	1	1 Short only	1.5	0	1.25	2
0	0	0	0																
0	84XY	0	TtBr3	XY-GenXY	23XY	2XY	2	5	1	0.5	0.5 3/4	A394	3	1	1 Short only	1.5	0	1.25	2
0	0	0	0																
0	84Y	0	TtBr3	Y-GenXY	23Y	2Y	2	5	1	0.5	0.5 3/4	A394	3	1	1 Short only	1.5	0	1.25	2
0	0	0	0																
0	85P	0	MtBr1	Y-Symmetry	24P	27P	1	5	1	1	1 3/4	A394	2	1	1 Short only	0.875	0	1.25	3.25
0	0	0	0																
0	85Y	0	MtBr1	Y-Gen	24Y	27Y	1	5	1	1	1 3/4	A394	2	1	1 Short only	0.875	0	1.25	3.25
0	0	0	0																
0	86P	0	MtBr3	XY-Symmetry	27P	25P	2	5	1	1	1 3/4	A394	3	1.42	1 Long only	1	2.5	1.5	2.25
0	0	0	0																
0	86X	0	MtBr3	X-GenXY	27P	25X	2	5	1	1	1 3/4	A394	3	1.42	1 Long only	1	2.5	1.5	2.25
0	0	0	0																
0	86XY	0	MtBr3	XY-GenXY	27Y	25XY	2	5	1	1	1 3/4	A394	3	1.42	1 Long only	1	2.5	1.5	2.25
0	0	0	0																
0	86Y	0	MtBr3	Y-GenXY	27Y	25Y	2	5	1	1	1 3/4	A394	3	1.42	1 Long only	1	2.5	1.5	2.25
0	0	0	0																
0	87P	0	MtBr1	XY-Symmetry	25P	28P	1	5	1	1	1 3/4	A394	2	1	1 Short only	0.875	0	1.25	3.25
0	0	0	0																
0	87X	0	MtBr1	X-GenXY	25X	28X	1	5	1	1	1 3/4	A394	2	1	1 Short only	0.875	0	1.25	3.25
0	0	0	0																
0	87XY	0	MtBr1	XY-GenXY	25XY	28XY	1	5	1	1	1 3/4	A394	2	1	1 Short only	0.875	0	1.25	3.25
0	0	0	0																
0	87Y	0	MtBr1	Y-GenXY	25Y	28Y	1	5	1	1	1 3/4	A394	2	1	1 Short only	0.875	0	1.25	3.25
0	0	0	0																
0	88P	0	MtBr4	XY-Symmetry	25P	29P	2	5	1	1	1 3/4	A394	3	1.5	1 Short only	0.875	2.25	1.25	3
0	0	0	0																
0	88X	0	MtBr4	X-GenXY	25X	29X	2	5	1	1	1 3/4	A394	3	1.5	1 Short only	0.875	2.25	1.25	3
0	0	0	0																
0	88XY	0	MtBr4	XY-GenXY	25XY	29XY	2	5	1	1	1 3/4	A394	3	1.5	1 Short only	0.875	2.25	1.25	3
0	0	0	0																
0	88Y	0	MtBr4	Y-GenXY	25Y	29Y	2	5	1	1	1 3/4	A394	3	1.5	1 Short only	0.875	2.25	1.25	3
0	0	0	0																
0	89P	0	MtBr2	XY-Symmetry	26P	29P	1	5	1	1	1 3/4	A394	2	1	1 Long only	1.25	0	1.25	3.25
0	0	0	0																

0	89X	MTBr2	X-GenXY	26X	29X	1	5	1	1	1 3/4	A394	2	1	1	Long only	1.25	0	1.25	3.25
0	89XY	MTBr2	XY-GenXY	26XY	29XY	1	5	1	1	1 3/4	A394	2	1	1	Long only	1.25	0	1.25	3.25
0	89Y	MTBr2	Y-GenXY	26Y	29Y	1	5	1	1	1 3/4	A394	2	1	1	Long only	1.25	0	1.25	3.25
0	90P	MTBr5	XY-Symmetry	29P	5P	2	5	1	1	1 3/4	A394	4	1.54	1	Short only	1	2.5	1.25	3
0	90X	MTBr5	X-GenXY	29X	5X	2	5	1	1	1 3/4	A394	4	1.54	1	Short only	1	2.5	1.25	3
0	90XY	MTBr5	XY-GenXY	29XY	5XY	2	5	1	1	1 3/4	A394	4	1.54	1	Short only	1	2.5	1.25	3
0	90Y	MTBr5	Y-GenXY	29Y	5Y	2	5	1	1	1 3/4	A394	4	1.54	1	Short only	1	2.5	1.25	3
0	91P	BTBr1	Y-Symmetry	30P	33P	1	5	1	1	1 3/4	A394	2	1	1	Short only	0.875	0	1.25	3.5
0	91Y	BTBr1	Y-Gen	30Y	33Y	1	5	1	1	1 3/4	A394	2	1	1	Short only	0.875	0	1.25	3.5
0	92P	BTBr3	XY-Symmetry	33P	31P	2	5	1	1	1 3/4	A394	4	1.42	1	Short only	1	2.5	1.25	2.25
0	92X	BTBr3	X-GenXY	33P	31X	2	5	1	1	1 3/4	A394	4	1.42	1	Short only	1	2.5	1.25	2.25
0	92XY	BTBr3	XY-GenXY	33Y	31XY	2	5	1	1	1 3/4	A394	4	1.42	1	Short only	1	2.5	1.25	2.25
0	92Y	BTBr3	Y-GenXY	33Y	31Y	2	5	1	1	1 3/4	A394	4	1.42	1	Short only	1	2.5	1.25	2.25
0	93P	BTBr1	XY-Symmetry	31P	34P	1	5	1	1	1 3/4	A394	2	1	1	Short only	0.875	0	1.25	3.5
0	93X	BTBr1	X-GenXY	31X	34X	1	5	1	1	1 3/4	A394	2	1	1	Short only	0.875	0	1.25	3.5
0	93XY	BTBr1	XY-GenXY	31XY	34XY	1	5	1	1	1 3/4	A394	2	1	1	Short only	0.875	0	1.25	3.5
0	93Y	BTBr1	Y-GenXY	31Y	34Y	1	5	1	1	1 3/4	A394	2	1	1	Short only	0.875	0	1.25	3.5
0	94P	BTBr4	XY-Symmetry	31P	35P	2	5	1	1	1 3/4	A394	4	1.23	1	Short only	1	2.5	1.25	2.5
0	94X	BTBr4	X-GenXY	31X	35X	2	5	1	1	1 3/4	A394	4	1.23	1	Short only	1	2.5	1.25	2.5
0	94XY	BTBr4	XY-GenXY	31XY	35XY	2	5	1	1	1 3/4	A394	4	1.23	1	Short only	1	2.5	1.25	2.5
0	94Y	BTBr4	Y-GenXY	31Y	35Y	2	5	1	1	1 3/4	A394	4	1.23	1	Short only	1	2.5	1.25	2.5
0	95P	BTBr2	XY-Symmetry	32P	35P	1	5	1	1	1 3/4	A394	3	1	1	Short only	2.25	0	1.25	2
0	95X	BTBr2	X-GenXY	32X	35X	1	5	1	1	1 3/4	A394	3	1	1	Short only	2.25	0	1.25	2
0	95XY	BTBr2	XY-GenXY	32XY	35XY	1	5	1	1	1 3/4	A394	3	1	1	Short only	2.25	0	1.25	2
0	95Y	BTBr2	Y-GenXY	32Y	35Y	1	5	1	1	1 3/4	A394	3	1	1	Short only	2.25	0	1.25	2
0	96P	BTBr5	XY-Symmetry	35P	8P	2	5	1	1	1 3/4	A394	5	1.76	1	Short only	1	2.5	1.25	3.25
0	96X	BTBr5	X-GenXY	35X	8X	2	5	1	1	1 3/4	A394	5	1.76	1	Short only	1	2.5	1.25	3.25
0	96XY	BTBr5	XY-GenXY	35XY	8XY	2	5	1	1	1 3/4	A394	5	1.76	1	Short only	1	2.5	1.25	3.25
0	96Y	BTBr5	Y-GenXY	35Y	8Y	2	5	1	1	1 3/4	A394	5	1.76	1	Short only	1	2.5	1.25	3.25
0	97P	TBC1	None	21P	21Y	3	4	1	1	1 3/4	A394	1	1	1	Short only	0.875	0	1.125	0

0	0	0																		
0	98P	TBC1	XY-Symmetry	21P	22Y	2	4	0.75	0.5	0.5	3/4	A394	1	1	1	Short only	0.875	0	1.25	0
0	0	0																		
0	98X	TBC1	X-GenXY	21P	22XY	2	4	0.75	0.5	0.5	3/4	A394	1	1	1	Short only	0.875	0	1.25	0
0	0	0																		
0	98XY	TBC1	XY-GenXY	21Y	22X	2	4	0.75	0.5	0.5	3/4	A394	1	1	1	Short only	0.875	0	1.25	0
0	0	0																		
0	98Y	TBC1	Y-GenXY	21Y	22P	2	4	0.75	0.5	0.5	3/4	A394	1	1	1	Short only	0.875	0	1.25	0
0	0	0																		
0	99P	TBC2	X-Symmetry	22P	22Y	3	5	1	1	1	3/4	A394	2	1	1	Short only	1.25	0	1.125	3.625
0	0	0																		
0	99X	TBC2	X-Gen	22X	22XY	3	5	1	1	1	3/4	A394	2	1	1	Short only	1.25	0	1.125	3.625
0	0	0																		
0	100P	TBC3	XY-Symmetry	22P	23Y	2	4	0.75	0.5	0.5	3/4	A394	1	1	1	Short only	0.875	0	1.25	0
0	0	0																		
0	100X	TBC3	X-GenXY	22X	23XY	2	4	0.75	0.5	0.5	3/4	A394	1	1	1	Short only	0.875	0	1.25	0
0	0	0																		
0	100XY	TBC3	XY-GenXY	22XY	23X	2	4	0.75	0.5	0.5	3/4	A394	1	1	1	Short only	0.875	0	1.25	0
0	0	0																		
0	100Y	TBC3	Y-GenXY	22Y	23P	2	4	0.75	0.5	0.5	3/4	A394	1	1	1	Short only	0.875	0	1.25	0
0	0	0																		
0	101P	TBC4	X-Symmetry	23P	23Y	3	5	1	1	1	3/4	A394	2	1	1	Short only	1.25	0	1.125	3.625
0	0	0																		
0	101X	TBC4	X-Gen	23X	23XY	3	5	1	1	1	3/4	A394	2	1	1	Short only	1.25	0	1.125	3.625
0	0	0																		
0	102P	TBC3	XY-Symmetry	23P	3Y	2	4	0.75	0.5	0.5	3/4	A394	1	1	1	Short only	0.875	0	1.25	0
0	0	0																		
0	102X	TBC3	X-GenXY	23X	3XY	2	4	0.75	0.5	0.5	3/4	A394	1	1	1	Short only	0.875	0	1.25	0
0	0	0																		
0	102XY	TBC3	XY-GenXY	23XY	3X	2	4	0.75	0.5	0.5	3/4	A394	1	1	1	Short only	0.875	0	1.25	0
0	0	0																		
0	102Y	TBC3	Y-GenXY	23Y	3P	2	4	0.75	0.5	0.5	3/4	A394	1	1	1	Short only	0.875	0	1.25	0
0	0	0																		
0	103P	TBC1	None	27P	27Y	3	4	1	1	1	3/4	A394	1	1	1	Short only	0.875	0	1.125	0
0	0	0																		
0	104P	TBC1	XY-Symmetry	27P	28Y	2	4	0.75	0.5	0.5	3/4	A394	1	1	1	Short only	0.875	0	1.25	0
0	0	0																		
0	104X	TBC1	X-GenXY	27P	28XY	2	4	0.75	0.5	0.5	3/4	A394	1	1	1	Short only	0.875	0	1.25	0
0	0	0																		
0	104XY	TBC1	XY-GenXY	27Y	28X	2	4	0.75	0.5	0.5	3/4	A394	1	1	1	Short only	0.875	0	1.25	0
0	0	0																		
0	104Y	TBC1	Y-GenXY	27Y	28P	2	4	0.75	0.5	0.5	3/4	A394	1	1	1	Short only	0.875	0	1.25	0
0	0	0																		
0	105P	TBC2	X-Symmetry	28P	28Y	3	6	1	1	1	3/4	A394	2	1	1	Short only	1.25	0	1.125	3.625
0	0	0																		
0	105X	TBC2	X-Gen	28X	28XY	3	6	1	1	1	3/4	A394	2	1	1	Short only	1.25	0	1.125	3.625
0	0	0																		
0	106P	TBC3	XY-Symmetry	28P	29Y	2	4	0.75	0.5	0.5	3/4	A394	1	1	1	Short only	0.875	0	1.25	0
0	0	0																		
0	106X	TBC3	X-GenXY	28X	29XY	2	4	0.75	0.5	0.5	3/4	A394	1	1	1	Short only	0.875	0	1.25	0
0	0	0																		
0	106XY	TBC3	XY-GenXY	28XY	29X	2	4	0.75	0.5	0.5	3/4	A394	1	1	1	Short only	0.875	0	1.25	0
0	0	0																		
0	106Y	TBC3	Y-GenXY	28Y	29P	2	4	0.75	0.5	0.5	3/4	A394	1	1	1	Short only	0.875	0	1.25	0
0	0	0																		
0	107P	TBC4	X-Symmetry	29P	29Y	3	6	1	1	1	3/4	A394	2	1	1	Short only	1.25	0	1.125	3.625
0	0	0																		
0	107X	TBC4	X-Gen	29X	29XY	3	6	1	1	1	3/4	A394	2	1	1	Short only	1.25	0	1.125	3.625
0	0	0																		

0	108P	TBC3	XY-Symmetry	29P	6Y	2	4	0.75	0.5	0.5	3/4	A394	1	1	1	Short only	0.875	0	1.25	0
0	0	0																		
0	108X	TBC3	X-GenXY	29X	6XY	2	4	0.75	0.5	0.5	3/4	A394	1	1	1	Short only	0.875	0	1.25	0
0	0	0																		
0	108XY	TBC3	XY-GenXY	29XY	6X	2	4	0.75	0.5	0.5	3/4	A394	1	1	1	Short only	0.875	0	1.25	0
0	0	0																		
0	108Y	TBC3	Y-GenXY	29Y	6P	2	4	0.75	0.5	0.5	3/4	A394	1	1	1	Short only	0.875	0	1.25	0
0	0	0																		
0	109P	TBC1	None	33P	33Y	3	4	1	1	1	3/4	A394	1	1	1	Short only	0.875	0	1.125	0
0	0	0																		
0	110P	TBC1	XY-Symmetry	33P	34Y	2	4	0.75	0.5	0.5	3/4	A394	1	1	1	Short only	0.875	0	1.25	0
0	0	0																		
0	110X	TBC1	X-GenXY	33P	34XY	2	4	0.75	0.5	0.5	3/4	A394	1	1	1	Short only	0.875	0	1.25	0
0	0	0																		
0	110XY	TBC1	XY-GenXY	33Y	34X	2	4	0.75	0.5	0.5	3/4	A394	1	1	1	Short only	0.875	0	1.25	0
0	0	0																		
0	110Y	TBC1	Y-GenXY	33Y	34P	2	4	0.75	0.5	0.5	3/4	A394	1	1	1	Short only	0.875	0	1.25	0
0	0	0																		
0	111P	TBC2	X-Symmetry	34P	34Y	3	6	1	1	1	3/4	A394	2	1	1	Short only	1.25	0	1.125	3.625
0	0	0																		
0	111X	TBC2	X-Gen	34X	34XY	3	6	1	1	1	3/4	A394	2	1	1	Short only	1.25	0	1.125	3.625
0	0	0																		
0	112P	TBC3	XY-Symmetry	34P	35Y	2	4	0.75	0.5	0.5	3/4	A394	1	1	1	Short only	0.875	0	1.25	0
0	0	0																		
0	112X	TBC3	X-GenXY	34X	35XY	2	4	0.75	0.5	0.5	3/4	A394	1	1	1	Short only	0.875	0	1.25	0
0	0	0																		
0	112XY	TBC3	XY-GenXY	34XY	35X	2	4	0.75	0.5	0.5	3/4	A394	1	1	1	Short only	0.875	0	1.25	0
0	0	0																		
0	112Y	TBC3	Y-GenXY	34Y	35P	2	4	0.75	0.5	0.5	3/4	A394	1	1	1	Short only	0.875	0	1.25	0
0	0	0																		
0	113P	TBC4	X-Symmetry	35P	35Y	3	6	1	1	1	3/4	A394	2	1	1	Short only	1.25	0	1.125	3.625
0	0	0																		
0	113X	TBC4	X-Gen	35X	35XY	3	6	1	1	1	3/4	A394	2	1	1	Short only	1.25	0	1.125	3.625
0	0	0																		
0	114P	TBC3	XY-Symmetry	35P	9Y	2	4	0.75	0.5	0.5	3/4	A394	1	1	1	Short only	0.875	0	1.25	0
0	0	0																		
0	114X	TBC3	X-GenXY	35X	9XY	2	4	0.75	0.5	0.5	3/4	A394	1	1	1	Short only	0.875	0	1.25	0
0	0	0																		
0	114XY	TBC3	XY-GenXY	35XY	9X	2	4	0.75	0.5	0.5	3/4	A394	1	1	1	Short only	0.875	0	1.25	0
0	0	0																		
0	114Y	TBC3	Y-GenXY	35Y	9P	2	4	0.75	0.5	0.5	3/4	A394	1	1	1	Short only	0.875	0	1.25	0
0	0	0																		
0	115P	TTC1	None	18P	18Y	3	4	1	1	1	3/4	A394	1	1	1	Short only	0.875	0	1.125	0
0	0	0																		
0	116P	TTC2	None	18P	19Y	3	4	1	1	1	3/4	A394	1	1	1	Short only	1.25	0	1.25	0
0	0	0																		
0	117P	TTC2	None	19X	18Y	3	4	1	1	1	3/4	A394	1	1	1	Short only	1.25	0	1.25	0
0	0	0																		
0	118P	TTC1	X-Symmetry	19P	19Y	3	4	1	1	1	3/4	A394	1	1	1	Short only	0.875	0	1.125	0
0	0	0																		
0	118X	TTC1	X-Gen	19X	19XY	3	4	1	1	1	3/4	A394	1	1	1	Short only	0.875	0	1.125	0
0	0	0																		
0	119P	TTC2	None	19P	20Y	3	4	1	1	1	3/4	A394	1	1	1	Short only	1.25	0	1.25	0
0	0	0																		
0	120P	TTC2	None	20X	19XY	3	4	1	1	1	3/4	A394	1	1	1	Short only	1.25	0	1.25	0
0	0	0																		
0	121P	TTC1	X-Symmetry	20P	20Y	3	4	1	1	1	3/4	A394	1	1	1	Short only	0.875	0	1.125	0
0	0	0																		
0	121X	TTC1	X-Gen	20X	20XY	3	4	1	1	1	3/4	A394	1	1	1	Short only	0.875	0	1.125	0

0	0	0																	
0	122P	0	TTC2	None	20P	2Y	3	4	1	1	1 3/4	A394	1	1	1 Short only	1.25	0	1.25	0
0	0	0																	
0	123P	0	TTC2	None	2X	20XY	3	4	1	1	1 3/4	A394	1	1	1 Short only	1.25	0	1.25	0
0	0	0																	
0	124P	0	TTC1	None	24P	24Y	3	4	1	1	1 3/4	A394	1	1	1 Short only	0.875	0	1.125	0
0	0	0																	
0	125P	0	TTC2	None	24P	25Y	3	4	1	1	1 3/4	A394	1	1	1 Short only	1.25	0	1.25	0
0	0	0																	
0	126P	0	TTC2	None	25X	24Y	3	4	1	1	1 3/4	A394	1	1	1 Short only	1.25	0	1.25	0
0	0	0																	
0	127P	0	TTC1	X-Symmetry	25P	25Y	3	4	1	1	1 3/4	A394	1	1	1 Short only	0.875	0	1.125	0
0	0	0																	
0	127X	0	TTC1	X-Gen	25X	25XY	3	4	1	1	1 3/4	A394	1	1	1 Short only	0.875	0	1.125	0
0	0	0																	
0	128P	0	TTC2	None	25P	26Y	3	4	1	1	1 3/4	A394	1	1	1 Short only	1.25	0	1.25	0
0	0	0																	
0	129P	0	TTC2	None	26X	25XY	3	4	1	1	1 3/4	A394	1	1	1 Short only	1.25	0	1.25	0
0	0	0																	
0	130P	0	TTC1	X-Symmetry	26P	26Y	3	4	1	1	1 3/4	A394	1	1	1 Short only	0.875	0	1.125	0
0	0	0																	
0	130X	0	TTC1	X-Gen	26X	26XY	3	4	1	1	1 3/4	A394	1	1	1 Short only	0.875	0	1.125	0
0	0	0																	
0	131P	0	TTC2	None	26P	5Y	3	4	1	1	1 3/4	A394	1	1	1 Short only	1.25	0	1.25	0
0	0	0																	
0	132P	0	TTC2	None	5X	26XY	3	4	1	1	1 3/4	A394	1	1	1 Short only	1.25	0	1.25	0
0	0	0																	
0	133P	0	TTC1	None	30P	30Y	3	4	1	1	1 3/4	A394	1	1	1 Short only	0.875	0	1.125	0
0	0	0																	
0	134P	0	TTC2	None	30P	31Y	3	4	1	1	1 3/4	A394	1	1	1 Short only	1.25	0	1.25	0
0	0	0																	
0	135P	0	TTC2	None	31X	30Y	3	4	1	1	1 3/4	A394	1	1	1 Short only	1.25	0	1.25	0
0	0	0																	
0	136P	0	TTC1	X-Symmetry	31P	31Y	3	4	1	1	1 3/4	A394	1	1	1 Short only	0.875	0	1.125	0
0	0	0																	
0	136X	0	TTC1	X-Gen	31X	31XY	3	4	1	1	1 3/4	A394	1	1	1 Short only	0.875	0	1.125	0
0	0	0																	
0	137P	0	TTC2	None	31P	32Y	3	4	1	1	1 3/4	A394	1	1	1 Short only	1.25	0	1.25	0
0	0	0																	
0	138P	0	TTC2	None	32X	31XY	3	4	1	1	1 3/4	A394	1	1	1 Short only	1.25	0	1.25	0
0	0	0																	
0	139P	0	TTC1	X-Symmetry	32P	32Y	3	4	1	1	1 3/4	A394	1	1	1 Short only	0.875	0	1.125	0
0	0	0																	
0	139X	0	TTC1	X-Gen	32X	32XY	3	4	1	1	1 3/4	A394	1	1	1 Short only	0.875	0	1.125	0
0	0	0																	
0	140P	0	TTC2	None	32P	8Y	3	4	1	1	1 3/4	A394	1	1	1 Short only	1.25	0	1.25	0
0	0	0																	
0	141P	0	TTC2	None	8X	32XY	3	4	1	1	1 3/4	A394	1	1	1 Short only	1.25	0	1.25	0
0	0	0																	
0	142P	0	Horz3	X-Symmetry	2P	2Y	3	5	1	1	1 3/4	A394	2	1	1 Short only	1.25	0	1.25	2
0	0	0																	
0	142X	0	Horz3	X-Gen	2X	2XY	3	5	1	1	1 3/4	A394	2	1	1 Short only	1.25	0	1.25	2
0	0	0																	
0	143P	0	Horz3	X-Symmetry	3P	3Y	3	5	1	1	1 3/4	A394	2	1	1 Short only	1.25	0	1.25	2
0	0	0																	
0	143X	0	Horz3	X-Gen	3X	3XY	3	5	1	1	1 3/4	A394	2	1	1 Short only	1.25	0	1.25	2
0	0	0																	
0	144P	0	Horz4	X-Symmetry	5P	5Y	3	4	1	1	1 3/4	A394	1	1	1 Short only	0.875	0	1.25	0
0	0	0																	

0	144X	Horz4	X-Gen	5X	5XY	3	4	1	1	1 3/4	A394	1	1	1 Short only	0.875	0	1.25	0
0	145P	Horz3	X-Symmetry	6P	6Y	3	5	1	1	1 3/4	A394	2	1	1 Short only	1.25	0	1.25	2
0	145X	Horz3	X-Gen	6X	6XY	3	5	1	1	1 3/4	A394	2	1	1 Short only	1.25	0	1.25	2
0	146P	Horz4	X-Symmetry	8P	8Y	3	4	1	1	1 3/4	A394	1	1	1 Short only	0.875	0	1.25	0
0	146X	Horz4	X-Gen	8X	8XY	3	4	1	1	1 3/4	A394	1	1	1 Short only	0.875	0	1.25	0
0	147P	Horz5	X-Symmetry	9P	9Y	3	5	1	1	1 3/4	A394	3	1	1 Short only	1.75	0	1.25	2
0	147X	Horz5	X-Gen	9X	9XY	3	5	1	1	1 3/4	A394	3	1	1 Short only	1.75	0	1.25	2
0	148P	Horz6	XY-Symmetry	43S	11P	3	5	1	1	1 3/4	A394	3	1	1 Long only	1.75	0	1.25	2.5
0	148X	Horz6	X-GenXY	43X	11X	3	5	1	1	1 3/4	A394	3	1	1 Long only	1.75	0	1.25	2.5
0	148XY	Horz6	XY-GenXY	43X	11XY	3	5	1	1	1 3/4	A394	3	1	1 Long only	1.75	0	1.25	2.5
0	148Y	Horz6	Y-GenXY	43S	11Y	3	5	1	1	1 3/4	A394	3	1	1 Long only	1.75	0	1.25	2.5
0	149P	Horz6	X-Symmetry	12P	12Y	3	5	0.5	0.5	0.5 3/4	A394	2	1	1 Long only	1.75	0	1.125	2.5
0	149X	Horz6	X-Gen	12X	12XY	3	5	0.5	0.5	0.5 3/4	A394	2	1	1 Long only	1.75	0	1.125	2.5
0	150P	BBr1	Y-Symmetry	36P	39P	1	5	1	1	1 3/4	A394	2	1	1 Short only	0.875	0	1.25	2
0	150Y	BBr1	Y-Gen	36Y	39Y	1	5	1	1	1 3/4	A394	2	1	1 Short only	0.875	0	1.25	2
0	151P	BBr2	XY-Symmetry	39P	37P	2	5	1	1	1 3/4	A394	5	1.5	1 Short only	1 2.625	1.25	3.125	
0	151X	BBr2	X-GenXY	39P	37X	2	5	1	1	1 3/4	A394	5	1.5	1 Short only	1 2.625	1.25	3.125	
0	151XY	BBr2	XY-GenXY	39Y	37XY	2	5	1	1	1 3/4	A394	5	1.5	1 Short only	1 2.625	1.25	3.125	
0	151Y	BBr2	Y-GenXY	39Y	37Y	2	5	1	1	1 3/4	A394	5	1.5	1 Short only	1 2.625	1.25	3.125	
0	152P	BBr1	XY-Symmetry	37P	40P	1	5	1	1	1 3/4	A394	2	1	1 Short only	0.875	0	1.25	2
0	152X	BBr1	X-GenXY	37X	40X	1	5	1	1	1 3/4	A394	2	1	1 Short only	0.875	0	1.25	2
0	152XY	BBr1	XY-GenXY	37XY	40XY	1	5	1	1	1 3/4	A394	2	1	1 Short only	0.875	0	1.25	2
0	152Y	BBr1	Y-GenXY	37Y	40Y	1	5	1	1	1 3/4	A394	2	1	1 Short only	0.875	0	1.25	2
0	153P	BBr2	XY-Symmetry	37P	41P	2	5	1	1	1 3/4	A394	5	1.64	1 Short only	1 2.625	1.25	2.75	
0	153X	BBr2	X-GenXY	37X	41X	2	5	1	1	1 3/4	A394	5	1.64	1 Short only	1 2.625	1.25	2.75	
0	153XY	BBr2	XY-GenXY	37XY	41XY	2	5	1	1	1 3/4	A394	5	1.64	1 Short only	1 2.625	1.25	2.75	
0	153Y	BBr2	Y-GenXY	37Y	41Y	2	5	1	1	1 3/4	A394	5	1.64	1 Short only	1 2.625	1.25	2.75	
0	154P	BBr3	XY-Symmetry	38P	41P	1	5	1	1	1 3/4	A394	4	1	1 Short only	1.625	0	1.25	2
0	154X	BBr3	X-GenXY	38X	41X	1	5	1	1	1 3/4	A394	4	1	1 Short only	1.625	0	1.25	2
0	154XY	BBr3	XY-GenXY	38XY	41XY	1	5	1	1	1 3/4	A394	4	1	1 Short only	1.625	0	1.25	2

0	0	0																		
0	154Y	0	BBr3	Y-GenXY	38Y	41Y	1	5	1	1	1 3/4	A394	4	1	1	Short only	1.625	0	1.25	2
0	0	0	0																	
0	155P	0	BBr4	XY-Symmetry	41P	11P	2	5	0.5	0.75	0.5 3/4	A394	11	3	1	Long only	1.25	3.25	1.25	2.75
0	0	0	0																	
0	155X	0	BBr4	X-GenXY	41X	11X	2	5	0.5	0.75	0.5 3/4	A394	11	3	1	Long only	1.25	3.25	1.25	2.75
0	0	0	0																	
0	155XY	0	BBr4	XY-GenXY	41XY	11XY	2	5	0.5	0.75	0.5 3/4	A394	11	3	1	Long only	1.25	3.25	1.25	2.75
0	0	0	0																	
0	155Y	0	BBr4	Y-GenXY	41Y	11Y	2	5	0.5	0.75	0.5 3/4	A394	11	3	1	Long only	1.25	3.25	1.25	2.75
0	0	0	0																	
0	156P	0	BBr4	XY-Symmetry	38P	12P	2	5	0.5	0.75	0.5 3/4	A394	11	3	1	Long only	1.25	3.25	1.25	2.75
0	0	0	0																	
0	156X	0	BBr4	X-GenXY	38X	12X	2	5	0.5	0.75	0.5 3/4	A394	11	3	1	Long only	1.25	3.25	1.25	2.75
0	0	0	0																	
0	156XY	0	BBr4	XY-GenXY	38XY	12XY	2	5	0.5	0.75	0.5 3/4	A394	11	3	1	Long only	1.25	3.25	1.25	2.75
0	0	0	0																	
0	156Y	0	BBr4	Y-GenXY	38Y	12Y	2	5	0.5	0.75	0.5 3/4	A394	11	3	1	Long only	1.25	3.25	1.25	2.75
0	0	0	0																	
0	157P	0	BTC1	None	36P	36Y	3	5	1	1	1 3/4	A394	2	1	1	Short only	1.75	0	1.25	1.875
0	0	0	0																	
0	158P	0	BTC2	XY-Symmetry	36P	38Y	2	5	0.75	0.5	0.5 3/4	A394	2	1	1	Short only	0.875	0	1.25	2.625
0	0	0	0																	
0	158X	0	BTC2	X-GenXY	36P	38XY	2	5	0.75	0.5	0.5 3/4	A394	2	1	1	Short only	0.875	0	1.25	2.625
0	0	0	0																	
0	158XY	0	BTC2	XY-GenXY	36Y	38X	2	5	0.75	0.5	0.5 3/4	A394	2	1	1	Short only	0.875	0	1.25	2.625
0	0	0	0																	
0	158Y	0	BTC2	Y-GenXY	36Y	38P	2	5	0.75	0.5	0.5 3/4	A394	2	1	1	Short only	0.875	0	1.25	2.625
0	0	0	0																	
0	159P	0	BTC2	X-Symmetry	37P	37Y	3	5	0.75	0.5	0.5 3/4	A394	2	1	1	Short only	0.875	0	1.25	1.875
0	0	0	0																	
0	159X	0	BTC2	X-Gen	37X	37XY	3	5	0.75	0.5	0.5 3/4	A394	2	1	1	Short only	0.875	0	1.25	1.875
0	0	0	0																	
0	160P	0	BTC3	X-Symmetry	38P	45P	3	5	1	1	1 3/4	A394	3	1	1	Short only	1.25	0	1.25	1.875
0	0	0	0																	
0	160X	0	BTC3	X-Gen	38X	45X	3	5	1	1	1 3/4	A394	3	1	1	Short only	1.25	0	1.25	1.875
0	0	0	0																	
0	161P	0	BTC3	X-Symmetry	45P	38Y	3	5	1	1	1 3/4	A394	3	1	1	Short only	1.25	0	1.25	1.875
0	0	0	0																	
0	161X	0	BTC3	X-Gen	45X	38XY	3	5	1	1	1 3/4	A394	3	1	1	Short only	1.25	0	1.25	1.875
0	0	0	0																	
0	162P	0	BTC4	XY-Symmetry	45P	11Y	2	5	0.5	0.75	0.5 3/4	A394	3	1	1	Long only	1.25	0	1.25	2.375
0	0	0	0																	
0	162X	0	BTC4	X-GenXY	45X	11XY	2	5	0.5	0.75	0.5 3/4	A394	3	1	1	Long only	1.25	0	1.25	2.375
0	0	0	0																	
0	162XY	0	BTC4	XY-GenXY	45X	11X	2	5	0.5	0.75	0.5 3/4	A394	3	1	1	Long only	1.25	0	1.25	2.375
0	0	0	0																	
0	162Y	0	BTC4	Y-GenXY	45P	11P	2	5	0.5	0.75	0.5 3/4	A394	3	1	1	Long only	1.25	0	1.25	2.375
0	0	0	0																	
0	163P	0	BTC4	XY-Symmetry	38P	43S	2	5	0.5	0.75	0.5 3/4	A394	3	1	1	Long only	1.25	0	1.25	2.375
0	0	0	0																	
0	163X	0	BTC4	X-GenXY	38X	43X	2	5	0.5	0.75	0.5 3/4	A394	3	1	1	Long only	1.25	0	1.25	2.375
0	0	0	0																	
0	163XY	0	BTC4	XY-GenXY	38XY	43X	2	5	0.5	0.75	0.5 3/4	A394	3	1	1	Long only	1.25	0	1.25	2.375
0	0	0	0																	
0	163Y	0	BTC4	Y-GenXY	38Y	43S	2	5	0.5	0.75	0.5 3/4	A394	3	1	1	Long only	1.25	0	1.25	2.375
0	0	0	0																	
0	164P	0	BTC5	X-Symmetry	45P	43S	3	5	1	1	1 3/4	A394	2	1	1	Long only	0.875	0	1.25	2
0	0	0	0																	

0	164X	BTC5	X-Gen	45X	43X	3	5	1	1	1 3/4	A394	2	1	1	Long only	0.875	0	1.25	2
0	165P	BBC1	None	39P	39Y	3	5	1	1	1 3/4	A394	2	1	1	Short only	1.5	0	1.25	2
0	166P	BBC2	XY-Symmetry	39P	41Y	2	4	0.75	0.5	0.5 3/4	A394	1	1	1	Short only	0.875	0	1.25	0
0	166X	BBC2	X-GenXY	39P	41XY	2	4	0.75	0.5	0.5 3/4	A394	1	1	1	Short only	0.875	0	1.25	0
0	166XY	BBC2	XY-GenXY	39Y	41X	2	4	0.75	0.5	0.5 3/4	A394	1	1	1	Short only	0.875	0	1.25	0
0	166Y	BBC2	Y-GenXY	39Y	41P	2	4	0.75	0.5	0.5 3/4	A394	1	1	1	Short only	0.875	0	1.25	0
0	167P	BBC2	X-Symmetry	40P	40Y	3	4	0.75	0.5	0.5 3/4	A394	1	1	1	Short only	0.875	0	1.25	0
0	167X	BBC2	X-Gen	40X	40XY	3	4	0.75	0.5	0.5 3/4	A394	1	1	1	Short only	0.875	0	1.25	0
0	168P	BBC3	X-Symmetry	41P	41Y	3	5	1	0.5	0.5 3/4	A394	2	1	1	Short only	1.5	0	1.25	2
0	168X	BBC3	X-Gen	41X	41XY	3	5	1	0.5	0.5 3/4	A394	2	1	1	Short only	1.5	0	1.25	2
0	169P	BBC2	XY-Symmetry	41P	12Y	2	4	0.75	0.5	0.5 3/4	A394	1	1	1	Short only	0.875	0	1.25	0
0	169X	BBC2	X-GenXY	41X	12XY	2	4	0.75	0.5	0.5 3/4	A394	1	1	1	Short only	0.875	0	1.25	0
0	169XY	BBC2	XY-GenXY	41XY	12X	2	4	0.75	0.5	0.5 3/4	A394	1	1	1	Short only	0.875	0	1.25	0
0	169Y	BBC2	Y-GenXY	41Y	12P	2	4	0.75	0.5	0.5 3/4	A394	1	1	1	Short only	0.875	0	1.25	0

Member Capacities and Overrides:

Member Override	Group Override	Design Override	Comp. Override	Design Override	Tension	L/r	Length	L/r	Connection	Connection	Net	Rupture	RTE End	RTE Edge	Override
Warnings	Label Comp.	Comp. Tension	Control Tension	Tension Face	Control			Comp.	Shear	Bearing	Section	Tension	Dist.	Dist.	Comp.
Capacity	Control	Capacity	Criterion Control	Capacity Member	Criterion			Capacity	Capacity	Capacity	Tension	Capacity	Tension	Tension	Capacity
Unsup. (kips)	Criterion	(kips)	Criterion	ship (kips)		(ft)	(kips)	(kips)	(kips)	(kips)	(kips)	(kips)	(kips)	(kips)	(kips)
0.000	1P PeakPost	17.649	L/r	19.301	Rupture	118	9.71	17.649	27.200	25.312	21.917	19.301	0.000	0.000	0.000
0.000	1X PeakPost	17.649	L/r	19.301	Rupture	118	9.71	17.649	27.200	25.312	21.917	19.301	0.000	0.000	0.000
0.000	1XY PeakPost	17.649	L/r	19.301	Rupture	118	9.71	17.649	27.200	25.312	21.917	19.301	0.000	0.000	0.000
0.000	1Y PeakPost	17.649	L/r	19.301	Rupture	118	9.71	17.649	27.200	25.312	21.917	19.301	0.000	0.000	0.000
0.000	2P Leg1	115.977	L/r	75.817	Net Sect	30	5.00	115.977	0.000	0.000	75.817	0.000	0.000	0.000	0.000
0.000	2X Leg1	115.977	L/r	75.817	Net Sect	30	5.00	115.977	0.000	0.000	75.817	0.000	0.000	0.000	0.000
0.000	2XY Leg1	115.977	L/r	75.817	Net Sect	30	5.00	115.977	0.000	0.000	75.817	0.000	0.000	0.000	0.000

0.000		0.000	Automatic											
2Y	Leg1	115.977	L/r	75.817	Net Sect	30	5.00	115.977	0.000	0.000	75.817	0.000	0.000	0.000
0.000		0.000	Automatic											
3P	Leg1	106.517	L/r	82.747	Net Sect	61	5.00	106.517	0.000	0.000	82.747	0.000	0.000	0.000
0.000		0.000	Automatic											
3X	Leg1	106.517	L/r	82.747	Net Sect	61	5.00	106.517	0.000	0.000	82.747	0.000	0.000	0.000
0.000		0.000	Automatic											
3XY	Leg1	106.517	L/r	82.747	Net Sect	61	5.00	106.517	0.000	0.000	82.747	0.000	0.000	0.000
0.000		0.000	Automatic											
3Y	Leg1	106.517	L/r	82.747	Net Sect	61	5.00	106.517	0.000	0.000	82.747	0.000	0.000	0.000
0.000		0.000	Automatic											
4P	Leg1	106.517	L/r	82.747	Net Sect	61	5.00	106.517	0.000	0.000	82.747	0.000	0.000	0.000
0.000		0.000	Automatic											
4X	Leg1	106.517	L/r	82.747	Net Sect	61	5.00	106.517	0.000	0.000	82.747	0.000	0.000	0.000
0.000		0.000	Automatic											
4XY	Leg1	106.517	L/r	82.747	Net Sect	61	5.00	106.517	0.000	0.000	82.747	0.000	0.000	0.000
0.000		0.000	Automatic											
4Y	Leg1	106.517	L/r	82.747	Net Sect	61	5.00	106.517	0.000	0.000	82.747	0.000	0.000	0.000
0.000		0.000	Automatic											
5P	Leg1	106.517	L/r	75.817	Net Sect	61	5.00	106.517	136.000	253.125	75.817	220.588	0.000	0.000
0.000		0.000	Automatic											
Member "5P" will not be checked for block shear since more than one gage line exists (long edge distance (g) greater than zero); however, end, edge and spacing distances will be checked. ??														
5X	Leg1	106.517	L/r	75.817	Net Sect	61	5.00	106.517	136.000	253.125	75.817	220.588	0.000	0.000
0.000		0.000	Automatic											
Member "5X" will not be checked for block shear since more than one gage line exists (long edge distance (g) greater than zero); however, end, edge and spacing distances will be checked. ??														
5XY	Leg1	106.517	L/r	75.817	Net Sect	61	5.00	106.517	136.000	253.125	75.817	220.588	0.000	0.000
0.000		0.000	Automatic											
Member "5XY" will not be checked for block shear since more than one gage line exists (long edge distance (g) greater than zero); however, end, edge and spacing distances will be checked. ??														
5Y	Leg1	106.517	L/r	75.817	Net Sect	61	5.00	106.517	136.000	253.125	75.817	220.588	0.000	0.000
0.000		0.000	Automatic											
Member "5Y" will not be checked for block shear since more than one gage line exists (long edge distance (g) greater than zero); however, end, edge and spacing distances will be checked. ??														
6P	Leg2	245.252	L/r	210.416	Net Sect	38	5.00	245.252	0.000	0.000	210.416	0.000	0.000	0.000
0.000		0.000	Automatic											
6X	Leg2	245.252	L/r	210.416	Net Sect	38	5.00	245.252	0.000	0.000	210.416	0.000	0.000	0.000
0.000		0.000	Automatic											
6XY	Leg2	245.252	L/r	210.416	Net Sect	38	5.00	245.252	0.000	0.000	210.416	0.000	0.000	0.000
0.000		0.000	Automatic											
6Y	Leg2	245.252	L/r	210.416	Net Sect	38	5.00	245.252	0.000	0.000	210.416	0.000	0.000	0.000
0.000		0.000	Automatic											
7P	Leg2	245.252	L/r	198.000	Net Sect	38	5.00	245.252	0.000	0.000	198.000	0.000	0.000	0.000
0.000		0.000	Automatic											
7X	Leg2	245.252	L/r	198.000	Net Sect	38	5.00	245.252	0.000	0.000	198.000	0.000	0.000	0.000
0.000		0.000	Automatic											
7XY	Leg2	245.252	L/r	198.000	Net Sect	38	5.00	245.252	0.000	0.000	198.000	0.000	0.000	0.000
0.000		0.000	Automatic											
7Y	Leg2	245.252	L/r	198.000	Net Sect	38	5.00	245.252	0.000	0.000	198.000	0.000	0.000	0.000
0.000		0.000	Automatic											
8P	Leg2	136.000	Shear	136.000	Shear	38	5.00	245.252	136.000	337.499	198.000	312.500	0.000	0.000
0.000		0.000	Automatic											
Member "8P" will not be checked for block shear since more than one gage line exists (long edge distance (g) greater than zero); however, end, edge and spacing distances will be checked. ??														
8X	Leg2	136.000	Shear	136.000	Shear	38	5.00	245.252	136.000	337.499	198.000	312.500	0.000	0.000
0.000		0.000	Automatic											
Member "8X" will not be checked for block shear since more than one gage line exists (long edge distance (g) greater than zero); however, end, edge and spacing distances will be checked. ??														
8XY	Leg2	136.000	Shear	136.000	Shear	38	5.00	245.252	136.000	337.499	198.000	312.500	0.000	0.000
0.000		0.000	Automatic											
Member "8XY" will not be checked for block shear since more than one gage line exists (long edge distance (g) greater than zero); however, end, edge and spacing distances will be checked. ??														
8Y	Leg2	136.000	Shear	136.000	Shear	38	5.00	245.252	136.000	337.499	198.000	312.500	0.000	0.000
0.000		0.000	Automatic											
Member "8Y" will not be checked for block shear since more than one gage line exists (long edge distance (g) greater than zero); however, end, edge and spacing distances will be checked. ??														

9P	Leg3	244.868	L/r	198.000	Net Sect	38	5.09	244.868	0.000	0.000	198.000	0.000	0.000	0.000	0.000
0.000		0.000		Automatic											
9X	Leg3	244.868	L/r	198.000	Net Sect	38	5.09	244.868	0.000	0.000	198.000	0.000	0.000	0.000	0.000
0.000		0.000		Automatic											
9XY	Leg3	244.868	L/r	198.000	Net Sect	38	5.09	244.868	0.000	0.000	198.000	0.000	0.000	0.000	0.000
0.000		0.000		Automatic											
9Y	Leg3	244.868	L/r	198.000	Net Sect	38	5.09	244.868	0.000	0.000	198.000	0.000	0.000	0.000	0.000
0.000		0.000		Automatic											
10P	Leg3	244.867	L/r	198.000	Net Sect	38	5.09	244.867	380.800	944.999	198.000	874.999	0.000	0.000	0.000
0.000		0.000		Automatic											
Member "10P" will not be checked for block shear since more than one gage line exists (long edge distance (g) greater than zero); however, end, edge and spacing distances will be checked. ??															
10X	Leg3	244.867	L/r	198.000	Net Sect	38	5.09	244.867	380.800	944.999	198.000	874.999	0.000	0.000	0.000
0.000		0.000		Automatic											
Member "10X" will not be checked for block shear since more than one gage line exists (long edge distance (g) greater than zero); however, end, edge and spacing distances will be checked. ??															
10XY	Leg3	244.867	L/r	198.000	Net Sect	38	5.09	244.867	380.800	944.999	198.000	874.999	0.000	0.000	0.000
0.000		0.000		Automatic											
Member "10XY" will not be checked for block shear since more than one gage line exists (long edge distance (g) greater than zero); however, end, edge and spacing distances will be checked. ??															
10Y	Leg3	244.867	L/r	198.000	Net Sect	38	5.09	244.867	380.800	944.999	198.000	874.999	0.000	0.000	0.000
0.000		0.000		Automatic											
Member "10Y" will not be checked for block shear since more than one gage line exists (long edge distance (g) greater than zero); however, end, edge and spacing distances will be checked. ??															
11P	Leg4	244.868	L/r	198.000	Net Sect	38	5.09	244.868	0.000	0.000	198.000	0.000	0.000	0.000	0.000
0.000		0.000		Automatic											
11X	Leg4	244.868	L/r	198.000	Net Sect	38	5.09	244.868	0.000	0.000	198.000	0.000	0.000	0.000	0.000
0.000		0.000		Automatic											
11XY	Leg4	244.868	L/r	198.000	Net Sect	38	5.09	244.868	0.000	0.000	198.000	0.000	0.000	0.000	0.000
0.000		0.000		Automatic											
11Y	Leg4	244.868	L/r	198.000	Net Sect	38	5.09	244.868	0.000	0.000	198.000	0.000	0.000	0.000	0.000
0.000		0.000		Automatic											
12P	Leg4	241.598	L/r	198.000	Net Sect	44	11.61	241.598	380.800	944.999	198.000	874.999	0.000	0.000	0.000
0.000		0.000		Automatic											
Member "12P" will not be checked for block shear since more than one gage line exists (long edge distance (g) greater than zero); however, end, edge and spacing distances will be checked. ??															
12X	Leg4	241.598	L/r	198.000	Net Sect	44	11.61	241.598	380.800	944.999	198.000	874.999	0.000	0.000	0.000
0.000		0.000		Automatic											
Member "12X" will not be checked for block shear since more than one gage line exists (long edge distance (g) greater than zero); however, end, edge and spacing distances will be checked. ??															
12XY	Leg4	241.598	L/r	198.000	Net Sect	44	11.61	241.598	380.800	944.999	198.000	874.999	0.000	0.000	0.000
0.000		0.000		Automatic											
Member "12XY" will not be checked for block shear since more than one gage line exists (long edge distance (g) greater than zero); however, end, edge and spacing distances will be checked. ??															
12Y	Leg4	241.598	L/r	198.000	Net Sect	44	11.61	241.598	380.800	944.999	198.000	874.999	0.000	0.000	0.000
0.000		0.000		Automatic											
Member "12Y" will not be checked for block shear since more than one gage line exists (long edge distance (g) greater than zero); however, end, edge and spacing distances will be checked. ??															
13P	Leg5	240.308	L/r	198.000	Net Sect	46	24.26	240.308	380.800	944.999	198.000	874.999	0.000	0.000	0.000
0.000		0.000		Automatic											
Member "13P" will not be checked for block shear since more than one gage line exists (long edge distance (g) greater than zero); however, end, edge and spacing distances will be checked. ??															
13X	Leg5	240.308	L/r	198.000	Net Sect	46	24.26	240.308	380.800	944.999	198.000	874.999	0.000	0.000	0.000
0.000		0.000		Automatic											
Member "13X" will not be checked for block shear since more than one gage line exists (long edge distance (g) greater than zero); however, end, edge and spacing distances will be checked. ??															
13XY	Leg5	240.308	L/r	198.000	Net Sect	46	24.26	240.308	380.800	944.999	198.000	874.999	0.000	0.000	0.000
0.000		0.000		Automatic											
Member "13XY" will not be checked for block shear since more than one gage line exists (long edge distance (g) greater than zero); however, end, edge and spacing distances will be checked. ??															
13Y	Leg5	240.308	L/r	198.000	Net Sect	46	24.26	240.308	380.800	944.999	198.000	874.999	0.000	0.000	0.000
0.000		0.000		Automatic											
Member "13Y" will not be checked for block shear since more than one gage line exists (long edge distance (g) greater than zero); however, end, edge and spacing distances will be checked. ??															
14P	PeakPost	16.686	L/r	19.301	Rupture	125	10.27	16.686	27.200	25.312	21.917	19.301	0.000	0.000	0.000
0.000		0.000		Automatic											
14X	PeakPost	16.686	L/r	19.301	Rupture	125	10.27	16.686	27.200	25.312	21.917	19.301	0.000	0.000	0.000
0.000		0.000		Automatic											
14XY	PeakPost	16.686	L/r	19.301	Rupture	125	10.27	16.686	27.200	25.312	21.917	19.301	0.000	0.000	0.000
0.000		0.000		Automatic											

14Y PeakPost	16.686	L/r	19.301	Rupture	125	10.27	16.686	27.200	25.312	21.917	19.301	0.000	0.000	0.000
0.000	0.000		Automatic											
15P Diag1	12.292	L/r	16.214	Net Sect	131	8.60	12.292	27.200	25.312	16.214	18.316	0.000	0.000	0.000
0.000	0.000		Automatic											
15X Diag1	12.292	L/r	16.214	Net Sect	131	8.60	12.292	27.200	25.312	16.214	18.316	0.000	0.000	0.000
0.000	0.000		Automatic											
15XY Diag1	12.292	L/r	16.214	Net Sect	131	8.60	12.292	27.200	25.312	16.214	18.316	0.000	0.000	0.000
0.000	0.000		Automatic											
15Y Diag1	12.292	L/r	16.214	Net Sect	131	8.60	12.292	27.200	25.312	16.214	18.316	0.000	0.000	0.000
0.000	0.000		Automatic											
16P Diag2	25.861	L/r	27.200	Shear	105	8.60	25.861	27.200	33.750	28.846	28.641	0.000	0.000	0.000
0.000	0.000		Automatic											
16X Diag2	25.861	L/r	27.200	Shear	105	8.60	25.861	27.200	33.750	28.846	28.641	0.000	0.000	0.000
0.000	0.000		Automatic											
16XY Diag2	25.861	L/r	27.200	Shear	105	8.60	25.861	27.200	33.750	28.846	28.641	0.000	0.000	0.000
0.000	0.000		Automatic											
16Y Diag2	25.861	L/r	27.200	Shear	105	8.60	25.861	27.200	33.750	28.846	28.641	0.000	0.000	0.000
0.000	0.000		Automatic											
17P Diag2	25.861	L/r	27.200	Shear	105	8.60	25.861	27.200	33.750	28.846	29.203	0.000	0.000	0.000
0.000	0.000		Automatic											
17X Diag2	25.861	L/r	27.200	Shear	105	8.60	25.861	27.200	33.750	28.846	29.203	0.000	0.000	0.000
0.000	0.000		Automatic											
17XY Diag2	25.861	L/r	27.200	Shear	105	8.60	25.861	27.200	33.750	28.846	29.203	0.000	0.000	0.000
0.000	0.000		Automatic											
17Y Diag2	25.861	L/r	27.200	Shear	105	8.60	25.861	27.200	33.750	28.846	29.203	0.000	0.000	0.000
0.000	0.000		Automatic											
18P Diag2	25.861	L/r	27.200	Shear	105	8.60	25.861	27.200	33.750	28.846	28.078	0.000	0.000	0.000
0.000	0.000		Automatic											
18X Diag2	25.861	L/r	27.200	Shear	105	8.60	25.861	27.200	33.750	28.846	28.078	0.000	0.000	0.000
0.000	0.000		Automatic											
18XY Diag2	25.861	L/r	27.200	Shear	105	8.60	25.861	27.200	33.750	28.846	28.078	0.000	0.000	0.000
0.000	0.000		Automatic											
18Y Diag2	25.861	L/r	27.200	Shear	105	8.60	25.861	27.200	33.750	28.846	28.078	0.000	0.000	0.000
0.000	0.000		Automatic											
19P Diag3	40.800	Shear	40.800	Shear	88	8.60	43.226	40.800	63.281	44.745	56.660	0.000	0.000	0.000
0.000	0.000		Automatic											
19X Diag3	40.800	Shear	40.800	Shear	88	8.60	43.226	40.800	63.281	44.745	56.660	0.000	0.000	0.000
0.000	0.000		Automatic											
19XY Diag3	40.800	Shear	40.800	Shear	88	8.60	43.226	40.800	63.281	44.745	56.660	0.000	0.000	0.000
0.000	0.000		Automatic											
19Y Diag3	40.800	Shear	40.800	Shear	88	8.60	43.226	40.800	63.281	44.745	56.660	0.000	0.000	0.000
0.000	0.000		Automatic											
20P Diag3	40.800	Shear	40.800	Shear	88	8.60	43.226	40.800	63.281	44.745	56.660	0.000	0.000	0.000
0.000	0.000		Automatic											
20X Diag3	40.800	Shear	40.800	Shear	88	8.60	43.226	40.800	63.281	44.745	56.660	0.000	0.000	0.000
0.000	0.000		Automatic											
20XY Diag3	40.800	Shear	40.800	Shear	88	8.60	43.226	40.800	63.281	44.745	56.660	0.000	0.000	0.000
0.000	0.000		Automatic											
20Y Diag3	40.800	Shear	40.800	Shear	88	8.60	43.226	40.800	63.281	44.745	56.660	0.000	0.000	0.000
0.000	0.000		Automatic											
21P Diag3	40.800	Shear	40.800	Shear	88	8.60	43.226	40.800	63.281	44.745	54.551	0.000	0.000	0.000
0.000	0.000		Automatic											
21X Diag3	40.800	Shear	40.800	Shear	88	8.60	43.226	40.800	63.281	44.745	54.551	0.000	0.000	0.000
0.000	0.000		Automatic											
21XY Diag3	40.800	Shear	40.800	Shear	88	8.60	43.226	40.800	63.281	44.745	54.551	0.000	0.000	0.000
0.000	0.000		Automatic											
21Y Diag3	40.800	Shear	40.800	Shear	88	8.60	43.226	40.800	63.281	44.745	54.551	0.000	0.000	0.000
0.000	0.000		Automatic											
22P Diag2	21.126	L/r	27.200	Shear	129	9.40	21.126	27.200	33.750	28.846	32.484	0.000	0.000	0.000

0.000		0.000	Automatic												
22X	Diag2	21.126	L/r	27.200	Shear	129	9.40	21.126	27.200	33.750	28.846	32.484	0.000	0.000	0.000
0.000		0.000	Automatic												
22XY	Diag2	21.126	L/r	27.200	Shear	129	9.40	21.126	27.200	33.750	28.846	32.484	0.000	0.000	0.000
0.000		0.000	Automatic												
22Y	Diag2	21.126	L/r	27.200	Shear	129	9.40	21.126	27.200	33.750	28.846	32.484	0.000	0.000	0.000
0.000		0.000	Automatic												
23P	Diag4	18.078	L/r	19.652	Rupture	135	6.70	18.078	27.200	25.312	27.500	19.652	0.000	0.000	0.000
0.000		0.000	Automatic												
23X	Diag4	18.078	L/r	19.652	Rupture	135	6.70	18.078	27.200	25.312	27.500	19.652	0.000	0.000	0.000
0.000		0.000	Automatic												
23XY	Diag4	18.078	L/r	19.652	Rupture	135	6.70	18.078	27.200	25.312	27.500	19.652	0.000	0.000	0.000
0.000		0.000	Automatic												
23Y	Diag4	18.078	L/r	19.652	Rupture	135	6.70	18.078	27.200	25.312	27.500	19.652	0.000	0.000	0.000
0.000		0.000	Automatic												
24P	Diag4	13.351	L/r	24.609	Rupture	163	8.10	13.351	27.200	25.312	27.500	24.609	0.000	0.000	0.000
0.000		0.000	Automatic												
24X	Diag4	13.351	L/r	24.609	Rupture	163	8.10	13.351	27.200	25.312	27.500	24.609	0.000	0.000	0.000
0.000		0.000	Automatic												
24XY	Diag4	13.351	L/r	24.609	Rupture	163	8.10	13.351	27.200	25.312	27.500	24.609	0.000	0.000	0.000
0.000		0.000	Automatic												
24Y	Diag4	13.351	L/r	24.609	Rupture	163	8.10	13.351	27.200	25.312	27.500	24.609	0.000	0.000	0.000
0.000		0.000	Automatic												
25P	Diag5	3.489	L/r	19.184	Net Sect	301	18.78	3.489	27.200	25.312	19.184	24.609	0.000	0.000	0.000
0.000		0.000	Automatic												
25X	Diag5	3.489	L/r	19.184	Net Sect	301	18.78	3.489	27.200	25.312	19.184	24.609	0.000	0.000	0.000
0.000		0.000	Automatic												
25XY	Diag5	3.489	L/r	19.184	Net Sect	301	18.78	3.489	27.200	25.312	19.184	24.609	0.000	0.000	0.000
0.000		0.000	Automatic												
25Y	Diag5	3.489	L/r	19.184	Net Sect	301	18.78	3.489	27.200	25.312	19.184	24.609	0.000	0.000	0.000
0.000		0.000	Automatic												
26P	Diag6	5.559	L/r	28.846	Net Sect	287	10.42	5.559	40.800	50.625	28.846	36.328	0.000	0.000	0.000
0.000		0.000	Automatic												
KL/R value of 247.53 exceeds maximum of 200.00 for member "26P" ??															
26X	Diag6	5.559	L/r	28.846	Net Sect	287	10.42	5.559	40.800	50.625	28.846	36.328	0.000	0.000	0.000
0.000		0.000	Automatic												
KL/R value of 247.53 exceeds maximum of 200.00 for member "26X" ??															
26XY	Diag6	5.559	L/r	28.846	Net Sect	287	10.42	5.559	40.800	50.625	28.846	36.328	0.000	0.000	0.000
0.000		0.000	Automatic												
KL/R value of 247.53 exceeds maximum of 200.00 for member "26XY" ??															
26Y	Diag6	5.559	L/r	28.846	Net Sect	287	10.42	5.559	40.800	50.625	28.846	36.328	0.000	0.000	0.000
0.000		0.000	Automatic												
KL/R value of 247.53 exceeds maximum of 200.00 for member "26Y" ??															
27P	Diag12	5.231	L/r	27.500	Net Sect	283	22.14	5.231	40.800	37.969	27.500	35.156	0.000	0.000	0.000
0.000		0.000	Automatic												
KL/R value of 244.21 exceeds maximum of 200.00 for member "27P" ??															
27X	Diag12	5.231	L/r	27.500	Net Sect	283	22.14	5.231	40.800	37.969	27.500	35.156	0.000	0.000	0.000
0.000		0.000	Automatic												
KL/R value of 244.21 exceeds maximum of 200.00 for member "27X" ??															
27XY	Diag12	5.231	L/r	27.500	Net Sect	283	22.14	5.231	40.800	37.969	27.500	35.156	0.000	0.000	0.000
0.000		0.000	Automatic												
KL/R value of 244.21 exceeds maximum of 200.00 for member "27XY" ??															
27Y	Diag12	5.231	L/r	27.500	Net Sect	283	22.14	5.231	40.800	37.969	27.500	35.156	0.000	0.000	0.000
0.000		0.000	Automatic												
KL/R value of 244.21 exceeds maximum of 200.00 for member "27Y" ??															
28P	Diag11	28.788	L/r	40.800	Shear	137	6.73	28.788	40.800	63.281	44.745	46.699	0.000	0.000	0.000
0.000		0.000	Automatic												
28X	Diag11	28.788	L/r	40.800	Shear	137	6.73	28.788	40.800	63.281	44.745	46.699	0.000	0.000	0.000
0.000		0.000	Automatic												

0.000	0.000	Automatic	Member "33Y" will not be checked for block shear since more than one gage line exists (long edge distance (g) greater than zero); however, end, edge and spacing distances will be checked. ??												
34P	Diag9	50.291	L/r	48.281	Rupture	138	18.92	50.291	54.400	67.500	72.542	48.281	0.000	0.000	0.000
0.000		0.000		Automatic											
34X	Diag9	50.291	L/r	48.281	Rupture	138	18.92	50.291	54.400	67.500	72.542	48.281	0.000	0.000	0.000
0.000		0.000		Automatic											
34XY	Diag9	50.291	L/r	48.281	Rupture	138	18.92	50.291	54.400	67.500	72.542	48.281	0.000	0.000	0.000
0.000		0.000		Automatic											
34Y	Diag9	50.291	L/r	48.281	Rupture	138	18.92	50.291	54.400	67.500	72.542	48.281	0.000	0.000	0.000
0.000		0.000		Automatic											
35P	Diag10	55.072	L/r	81.600	Shear	189	30.73	55.072	81.600	177.187	121.751	164.062	0.000	0.000	0.000
0.000		0.000		Automatic											
35X	Diag10	55.072	L/r	81.600	Shear	189	30.73	55.072	81.600	177.187	121.751	164.062	0.000	0.000	0.000
0.000		0.000		Automatic											
35XY	Diag10	55.072	L/r	81.600	Shear	189	30.73	55.072	81.600	177.187	121.751	164.062	0.000	0.000	0.000
0.000		0.000		Automatic											
35Y	Diag10	55.072	L/r	81.600	Shear	189	30.73	55.072	81.600	177.187	121.751	164.062	0.000	0.000	0.000
0.000		0.000		Automatic											
36P	TTTC	27.374	L/r	33.082	Net Sect	122	6.00	27.374	54.400	67.500	33.082	62.500	0.000	0.000	0.000
0.000		0.000		Automatic											
36X	TTTC	27.374	L/r	33.082	Net Sect	122	6.00	27.374	54.400	67.500	33.082	62.500	0.000	0.000	0.000
0.000		0.000		Automatic											
36XY	TTTC	27.374	L/r	33.082	Net Sect	122	6.00	27.374	54.400	67.500	33.082	62.500	0.000	0.000	0.000
0.000		0.000		Automatic											
36Y	TTTC	27.374	L/r	33.082	Net Sect	122	6.00	27.374	54.400	67.500	33.082	62.500	0.000	0.000	0.000
0.000		0.000		Automatic											
37P	TTTC	32.243	L/r	29.774	Net Sect	91	4.50	32.243	0.000	0.000	29.774	0.000	0.000	0.000	0.000
0.000		0.000		Automatic											
37X	TTTC	32.243	L/r	29.774	Net Sect	91	4.50	32.243	0.000	0.000	29.774	0.000	0.000	0.000	0.000
0.000		0.000		Automatic											
37XY	TTTC	32.243	L/r	29.774	Net Sect	91	4.50	32.243	0.000	0.000	29.774	0.000	0.000	0.000	0.000
0.000		0.000		Automatic											
37Y	TTTC	32.243	L/r	29.774	Net Sect	91	4.50	32.243	0.000	0.000	29.774	0.000	0.000	0.000	0.000
0.000		0.000		Automatic											
38P	TTTC	27.200	Shear	23.109	Rupture	91	4.50	32.243	27.200	33.750	36.271	23.109	0.000	0.000	0.000
0.000		0.000		Automatic											
38X	TTTC	27.200	Shear	23.109	Rupture	91	4.50	32.243	27.200	33.750	36.271	23.109	0.000	0.000	0.000
0.000		0.000		Automatic											
38XY	TTTC	27.200	Shear	23.109	Rupture	91	4.50	32.243	27.200	33.750	36.271	23.109	0.000	0.000	0.000
0.000		0.000		Automatic											
38Y	TTTC	27.200	Shear	23.109	Rupture	91	4.50	32.243	27.200	33.750	36.271	23.109	0.000	0.000	0.000
0.000		0.000		Automatic											
39P	TTBC	27.374	L/r	33.082	Net Sect	122	6.00	27.374	54.400	67.500	33.082	62.500	0.000	0.000	0.000
0.000		0.000		Automatic											
39X	TTBC	27.374	L/r	33.082	Net Sect	122	6.00	27.374	54.400	67.500	33.082	62.500	0.000	0.000	0.000
0.000		0.000		Automatic											
39XY	TTBC	27.374	L/r	33.082	Net Sect	122	6.00	27.374	54.400	67.500	33.082	62.500	0.000	0.000	0.000
0.000		0.000		Automatic											
39Y	TTBC	27.374	L/r	33.082	Net Sect	122	6.00	27.374	54.400	67.500	33.082	62.500	0.000	0.000	0.000
0.000		0.000		Automatic											
40P	TTBC	32.243	L/r	29.774	Net Sect	91	4.50	32.243	0.000	0.000	29.774	0.000	0.000	0.000	0.000
0.000		0.000		Automatic											
40X	TTBC	32.243	L/r	29.774	Net Sect	91	4.50	32.243	0.000	0.000	29.774	0.000	0.000	0.000	0.000
0.000		0.000		Automatic											
40XY	TTBC	32.243	L/r	29.774	Net Sect	91	4.50	32.243	0.000	0.000	29.774	0.000	0.000	0.000	0.000
0.000		0.000		Automatic											
40Y	TTBC	32.243	L/r	29.774	Net Sect	91	4.50	32.243	0.000	0.000	29.774	0.000	0.000	0.000	0.000
0.000		0.000		Automatic											
41P	TTBC	32.243	L/r	36.271	Net Sect	91	4.50	32.243	54.400	67.500	36.271	56.859	0.000	0.000	0.000

0.000		0.000	Automatic												
41X	TTBC	32.243	L/r	36.271	Net Sect	91	4.50	32.243	54.400	67.500	36.271	56.859	0.000	0.000	0.000
0.000		0.000	Automatic												
41XY	TTBC	32.243	L/r	36.271	Net Sect	91	4.50	32.243	54.400	67.500	36.271	56.859	0.000	0.000	0.000
0.000		0.000	Automatic												
41Y	TTBC	32.243	L/r	36.271	Net Sect	91	4.50	32.243	54.400	67.500	36.271	56.859	0.000	0.000	0.000
0.000		0.000	Automatic												
42P	MTTC	48.884	L/r	49.582	Net Sect	91	6.00	48.884	54.400	67.500	49.582	75.000	0.000	0.000	0.000
0.000		0.000	Automatic												
42X	MTTC	48.884	L/r	49.582	Net Sect	91	6.00	48.884	54.400	67.500	49.582	75.000	0.000	0.000	0.000
0.000		0.000	Automatic												
42XY	MTTC	48.884	L/r	49.582	Net Sect	91	6.00	48.884	54.400	67.500	49.582	75.000	0.000	0.000	0.000
0.000		0.000	Automatic												
42Y	MTTC	48.884	L/r	49.582	Net Sect	91	6.00	48.884	54.400	67.500	49.582	75.000	0.000	0.000	0.000
0.000		0.000	Automatic												
43P	MTTC	47.728	L/r	44.624	Net Sect	68	4.50	47.728	0.000	0.000	44.624	0.000	0.000	0.000	0.000
0.000		0.000	Automatic												
43X	MTTC	47.728	L/r	44.624	Net Sect	68	4.50	47.728	0.000	0.000	44.624	0.000	0.000	0.000	0.000
0.000		0.000	Automatic												
43XY	MTTC	47.728	L/r	44.624	Net Sect	68	4.50	47.728	0.000	0.000	44.624	0.000	0.000	0.000	0.000
0.000		0.000	Automatic												
43Y	MTTC	47.728	L/r	44.624	Net Sect	68	4.50	47.728	0.000	0.000	44.624	0.000	0.000	0.000	0.000
0.000		0.000	Automatic												
44P	MTTC	40.800	Shear	40.800	Shear	68	4.50	47.728	40.800	50.625	45.859	42.187	0.000	0.000	0.000
0.000		0.000	Automatic	Member "44P" will not be checked for block shear since more than one gage line exists (long edge distance (g) greater than zero); however, end, edge and spacing distances will be checked. ??											
44X	MTTC	40.800	Shear	40.800	Shear	68	4.50	47.728	40.800	50.625	45.859	42.187	0.000	0.000	0.000
0.000		0.000	Automatic	Member "44X" will not be checked for block shear since more than one gage line exists (long edge distance (g) greater than zero); however, end, edge and spacing distances will be checked. ??											
44XY	MTTC	40.800	Shear	40.800	Shear	68	4.50	47.728	40.800	50.625	45.859	42.187	0.000	0.000	0.000
0.000		0.000	Automatic	Member "44XY" will not be checked for block shear since more than one gage line exists (long edge distance (g) greater than zero); however, end, edge and spacing distances will be checked. ??											
44Y	MTTC	40.800	Shear	40.800	Shear	68	4.50	47.728	40.800	50.625	45.859	42.187	0.000	0.000	0.000
0.000		0.000	Automatic	Member "44Y" will not be checked for block shear since more than one gage line exists (long edge distance (g) greater than zero); however, end, edge and spacing distances will be checked. ??											
45P	MTBC	48.884	L/r	49.582	Net Sect	91	6.00	48.884	54.400	67.500	49.582	75.000	0.000	0.000	0.000
0.000		0.000	Automatic												
45X	MTBC	48.884	L/r	49.582	Net Sect	91	6.00	48.884	54.400	67.500	49.582	75.000	0.000	0.000	0.000
0.000		0.000	Automatic												
45XY	MTBC	48.884	L/r	49.582	Net Sect	91	6.00	48.884	54.400	67.500	49.582	75.000	0.000	0.000	0.000
0.000		0.000	Automatic												
45Y	MTBC	48.884	L/r	49.582	Net Sect	91	6.00	48.884	54.400	67.500	49.582	75.000	0.000	0.000	0.000
0.000		0.000	Automatic												
46P	MTBC	47.728	L/r	44.624	Net Sect	68	4.50	47.728	0.000	0.000	44.624	0.000	0.000	0.000	0.000
0.000		0.000	Automatic												
46X	MTBC	47.728	L/r	44.624	Net Sect	68	4.50	47.728	0.000	0.000	44.624	0.000	0.000	0.000	0.000
0.000		0.000	Automatic												
46XY	MTBC	47.728	L/r	44.624	Net Sect	68	4.50	47.728	0.000	0.000	44.624	0.000	0.000	0.000	0.000
0.000		0.000	Automatic												
46Y	MTBC	47.728	L/r	44.624	Net Sect	68	4.50	47.728	0.000	0.000	44.624	0.000	0.000	0.000	0.000
0.000		0.000	Automatic												
47P	MTBC	47.728	L/r	51.121	Net Sect	68	4.50	47.728	54.400	67.500	51.121	58.823	0.000	0.000	0.000
0.000		0.000	Automatic	Member "47P" will not be checked for block shear since more than one gage line exists (long edge distance (g) greater than zero); however, end, edge and spacing distances will be checked. ??											
47X	MTBC	47.728	L/r	51.121	Net Sect	68	4.50	47.728	54.400	67.500	51.121	58.823	0.000	0.000	0.000
0.000		0.000	Automatic	Member "47X" will not be checked for block shear since more than one gage line exists (long edge distance (g) greater than zero); however, end, edge and spacing distances will be checked. ??											
47XY	MTBC	47.728	L/r	51.121	Net Sect	68	4.50	47.728	54.400	67.500	51.121	58.823	0.000	0.000	0.000
0.000		0.000	Automatic	Member "47XY" will not be checked for block shear since more than one gage line exists (long edge distance (g) greater than zero); however, end, edge and spacing distances will be checked. ??											

distance (g) greater than zero); however, end, edge and spacing distances will be checked. ??															
47Y	MTBC	47.728	L/r	51.121	Net Sect	68	4.50	47.728	54.400	67.500	51.121	58.823	0.000	0.000	0.000
0.000	0.000	0.000	Automatic	Member "47Y" will not be checked for block shear since more than one gage line exists (long edge distance (g) greater than zero); however, end, edge and spacing distances will be checked. ??											
48P	BTTC	54.400	Shear	54.400	Shear	91	6.00	60.285	54.400	84.375	61.153	93.750	0.000	0.000	0.000
0.000	0.000	0.000	Automatic												
48X	BTTC	54.400	Shear	54.400	Shear	91	6.00	60.285	54.400	84.375	61.153	93.750	0.000	0.000	0.000
0.000	0.000	0.000	Automatic												
48XY	BTTC	54.400	Shear	54.400	Shear	91	6.00	60.285	54.400	84.375	61.153	93.750	0.000	0.000	0.000
0.000	0.000	0.000	Automatic												
48Y	BTTC	54.400	Shear	54.400	Shear	91	6.00	60.285	54.400	84.375	61.153	93.750	0.000	0.000	0.000
0.000	0.000	0.000	Automatic												
49P	BTTC	58.971	L/r	55.038	Net Sect	68	4.50	58.971	0.000	0.000	55.038	0.000	0.000	0.000	0.000
0.000	0.000	0.000	Automatic												
49X	BTTC	58.971	L/r	55.038	Net Sect	68	4.50	58.971	0.000	0.000	55.038	0.000	0.000	0.000	0.000
0.000	0.000	0.000	Automatic												
49XY	BTTC	58.971	L/r	55.038	Net Sect	68	4.50	58.971	0.000	0.000	55.038	0.000	0.000	0.000	0.000
0.000	0.000	0.000	Automatic												
49Y	BTTC	58.971	L/r	55.038	Net Sect	68	4.50	58.971	0.000	0.000	55.038	0.000	0.000	0.000	0.000
0.000	0.000	0.000	Automatic												
50P	BTTC	40.800	Shear	40.800	Shear	68	4.50	58.971	40.800	63.281	63.159	53.379	0.000	0.000	0.000
0.000	0.000	0.000	Automatic												
50X	BTTC	40.800	Shear	40.800	Shear	68	4.50	58.971	40.800	63.281	63.159	53.379	0.000	0.000	0.000
0.000	0.000	0.000	Automatic												
50XY	BTTC	40.800	Shear	40.800	Shear	68	4.50	58.971	40.800	63.281	63.159	53.379	0.000	0.000	0.000
0.000	0.000	0.000	Automatic												
50Y	BTTC	40.800	Shear	40.800	Shear	68	4.50	58.971	40.800	63.281	63.159	53.379	0.000	0.000	0.000
0.000	0.000	0.000	Automatic												
51P	BTBC	54.400	Shear	54.400	Shear	91	6.00	60.285	54.400	84.375	61.153	93.750	0.000	0.000	0.000
0.000	0.000	0.000	Automatic												
51X	BTBC	54.400	Shear	54.400	Shear	91	6.00	60.285	54.400	84.375	61.153	93.750	0.000	0.000	0.000
0.000	0.000	0.000	Automatic												
51XY	BTBC	54.400	Shear	54.400	Shear	91	6.00	60.285	54.400	84.375	61.153	93.750	0.000	0.000	0.000
0.000	0.000	0.000	Automatic												
51Y	BTBC	54.400	Shear	54.400	Shear	91	6.00	60.285	54.400	84.375	61.153	93.750	0.000	0.000	0.000
0.000	0.000	0.000	Automatic												
52P	BTBC	58.971	L/r	55.038	Net Sect	68	4.50	58.971	0.000	0.000	55.038	0.000	0.000	0.000	0.000
0.000	0.000	0.000	Automatic												
52X	BTBC	58.971	L/r	55.038	Net Sect	68	4.50	58.971	0.000	0.000	55.038	0.000	0.000	0.000	0.000
0.000	0.000	0.000	Automatic												
52XY	BTBC	58.971	L/r	55.038	Net Sect	68	4.50	58.971	0.000	0.000	55.038	0.000	0.000	0.000	0.000
0.000	0.000	0.000	Automatic												
52Y	BTBC	58.971	L/r	55.038	Net Sect	68	4.50	58.971	0.000	0.000	55.038	0.000	0.000	0.000	0.000
0.000	0.000	0.000	Automatic												
53P	BTBC	54.400	Shear	54.400	Shear	68	4.50	58.971	54.400	84.375	63.159	73.529	0.000	0.000	0.000
0.000	0.000	0.000	Automatic	Member "53P" will not be checked for block shear since more than one gage line exists (long edge distance (g) greater than zero); however, end, edge and spacing distances will be checked. ??											
53X	BTBC	54.400	Shear	54.400	Shear	68	4.50	58.971	54.400	84.375	63.159	73.529	0.000	0.000	0.000
0.000	0.000	0.000	Automatic	Member "53X" will not be checked for block shear since more than one gage line exists (long edge distance (g) greater than zero); however, end, edge and spacing distances will be checked. ??											
53XY	BTBC	54.400	Shear	54.400	Shear	68	4.50	58.971	54.400	84.375	63.159	73.529	0.000	0.000	0.000
0.000	0.000	0.000	Automatic	Member "53XY" will not be checked for block shear since more than one gage line exists (long edge distance (g) greater than zero); however, end, edge and spacing distances will be checked. ??											
53Y	BTBC	54.400	Shear	54.400	Shear	68	4.50	58.971	54.400	84.375	63.159	73.529	0.000	0.000	0.000
0.000	0.000	0.000	Automatic	Member "53Y" will not be checked for block shear since more than one gage line exists (long edge distance (g) greater than zero); however, end, edge and spacing distances will be checked. ??											
54P	BTC	208.793	L/r	178.200	Net Sect	40	5.25	208.793	0.000	0.000	178.200	0.000	0.000	0.000	0.000
0.000	0.000	0.000	Automatic												
54X	BTC	208.793	L/r	178.200	Net Sect	40	5.25	208.793	0.000	0.000	178.200	0.000	0.000	0.000	0.000

0.000		0.000	Automatic											
54XY	BTC	208.793	L/r 178.200	Net Sect	40	5.25	208.793	0.000	0.000	178.200	0.000	0.000	0.000	0.000
0.000		0.000	Automatic											
54Y	BTC	208.793	L/r 178.200	Net Sect	40	5.25	208.793	0.000	0.000	178.200	0.000	0.000	0.000	0.000
0.000		0.000	Automatic											
55P	BTC	208.793	L/r 165.206	Net Sect	40	5.25	208.793	0.000	0.000	165.206	0.000	0.000	0.000	0.000
0.000		0.000	Automatic											
55X	BTC	208.793	L/r 165.206	Net Sect	40	5.25	208.793	0.000	0.000	165.206	0.000	0.000	0.000	0.000
0.000		0.000	Automatic											
55XY	BTC	208.793	L/r 165.206	Net Sect	40	5.25	208.793	0.000	0.000	165.206	0.000	0.000	0.000	0.000
0.000		0.000	Automatic											
55Y	BTC	208.793	L/r 165.206	Net Sect	40	5.25	208.793	0.000	0.000	165.206	0.000	0.000	0.000	0.000
0.000		0.000	Automatic											
56P	BTC	108.800	Shear 108.800	Shear	34	4.50	212.063	108.800	270.000	191.193	294.117	0.000	0.000	0.000
0.000		0.000	Automatic	Member "56P" will not be checked for block shear since more than one gage line exists (long edge distance (g) greater than zero); however, end, edge and spacing distances will be checked. ??										
56X	BTC	108.800	Shear 108.800	Shear	34	4.50	212.063	108.800	270.000	191.193	294.117	0.000	0.000	0.000
0.000		0.000	Automatic	Member "56X" will not be checked for block shear since more than one gage line exists (long edge distance (g) greater than zero); however, end, edge and spacing distances will be checked. ??										
56XY	BTC	108.800	Shear 108.800	Shear	34	4.50	212.063	108.800	270.000	191.193	294.117	0.000	0.000	0.000
0.000		0.000	Automatic	Member "56XY" will not be checked for block shear since more than one gage line exists (long edge distance (g) greater than zero); however, end, edge and spacing distances will be checked. ??										
56Y	BTC	108.800	Shear 108.800	Shear	34	4.50	212.063	108.800	270.000	191.193	294.117	0.000	0.000	0.000
0.000		0.000	Automatic	Member "56Y" will not be checked for block shear since more than one gage line exists (long edge distance (g) greater than zero); however, end, edge and spacing distances will be checked. ??										
57P	BBC	148.642	L/r 118.800	Net Sect	53	5.25	148.642	0.000	0.000	118.800	0.000	0.000	0.000	0.000
0.000		0.000	Automatic											
57X	BBC	148.642	L/r 118.800	Net Sect	53	5.25	148.642	0.000	0.000	118.800	0.000	0.000	0.000	0.000
0.000		0.000	Automatic											
57XY	BBC	148.642	L/r 118.800	Net Sect	53	5.25	148.642	0.000	0.000	118.800	0.000	0.000	0.000	0.000
0.000		0.000	Automatic											
57Y	BBC	148.642	L/r 118.800	Net Sect	53	5.25	148.642	0.000	0.000	118.800	0.000	0.000	0.000	0.000
0.000		0.000	Automatic											
58P	BBC	148.642	L/r 118.800	Net Sect	53	5.25	148.642	0.000	0.000	118.800	0.000	0.000	0.000	0.000
0.000		0.000	Automatic											
58X	BBC	148.642	L/r 118.800	Net Sect	53	5.25	148.642	0.000	0.000	118.800	0.000	0.000	0.000	0.000
0.000		0.000	Automatic											
58XY	BBC	148.642	L/r 118.800	Net Sect	53	5.25	148.642	0.000	0.000	118.800	0.000	0.000	0.000	0.000
0.000		0.000	Automatic											
58Y	BBC	148.642	L/r 118.800	Net Sect	53	5.25	148.642	0.000	0.000	118.800	0.000	0.000	0.000	0.000
0.000		0.000	Automatic											
59P	BBC	122.400	Shear 122.400	Shear	46	4.50	152.178	122.400	303.750	131.794	330.882	0.000	0.000	0.000
0.000		0.000	Automatic	Member "59P" will not be checked for block shear since more than one gage line exists (long edge distance (g) greater than zero); however, end, edge and spacing distances will be checked. ??										
59X	BBC	122.400	Shear 122.400	Shear	46	4.50	152.178	122.400	303.750	131.794	330.882	0.000	0.000	0.000
0.000		0.000	Automatic	Member "59X" will not be checked for block shear since more than one gage line exists (long edge distance (g) greater than zero); however, end, edge and spacing distances will be checked. ??										
59XY	BBC	122.400	Shear 122.400	Shear	46	4.50	152.178	122.400	303.750	131.794	330.882	0.000	0.000	0.000
0.000		0.000	Automatic	Member "59XY" will not be checked for block shear since more than one gage line exists (long edge distance (g) greater than zero); however, end, edge and spacing distances will be checked. ??										
59Y	BBC	122.400	Shear 122.400	Shear	46	4.50	152.178	122.400	303.750	131.794	330.882	0.000	0.000	0.000
0.000		0.000	Automatic	Member "59Y" will not be checked for block shear since more than one gage line exists (long edge distance (g) greater than zero); however, end, edge and spacing distances will be checked. ??										
60P	Horz1	13.192	L/r 26.473	Rupture	164	16.32	13.192	40.800	37.969	27.500	26.473	0.000	0.000	0.000
0.000		0.000	Automatic											
60X	Horz1	13.192	L/r 26.473	Rupture	164	16.32	13.192	40.800	37.969	27.500	26.473	0.000	0.000	0.000
0.000		0.000	Automatic											
60XY	Horz1	13.192	L/r 26.473	Rupture	164	16.32	13.192	40.800	37.969	27.500	26.473	0.000	0.000	0.000
0.000		0.000	Automatic											

60Y	Horz1	13.192	L/r	26.473	Rupture	164	16.32	13.192	40.800	37.969	27.500	26.473	0.000	0.000	0.000
0.000		0.000		Automatic											
61P	Horz2	24.283	L/r	36.422	Rupture	148	17.08	24.283	40.800	50.625	43.696	36.422	0.000	0.000	0.000
0.000		0.000		Automatic											
61X	Horz2	24.283	L/r	36.422	Rupture	148	17.08	24.283	40.800	50.625	43.696	36.422	0.000	0.000	0.000
0.000		0.000		Automatic											
62P	Br1	1.570	L/r	8.191	Rupture	360	11.81	1.570	13.600	12.656	16.214	8.191	0.000	0.000	0.000
0.000		0.000		Automatic											
62Y	Br1	1.570	L/r	8.191	Rupture	360	11.81	1.570	13.600	12.656	16.214	8.191	0.000	0.000	0.000
0.000		0.000		Automatic											
63P	Br1	1.570	L/r	8.191	Rupture	360	11.81	1.570	13.600	12.656	16.214	8.191	0.000	0.000	0.000
0.000		0.000		Automatic											
63Y	Br1	1.570	L/r	8.191	Rupture	360	11.81	1.570	13.600	12.656	16.214	8.191	0.000	0.000	0.000
0.000		0.000		Automatic											
64P	Br1	1.570	L/r	8.191	Rupture	360	11.81	1.570	13.600	12.656	16.214	8.191	0.000	0.000	0.000
0.000		0.000		Automatic											
64Y	Br1	1.570	L/r	8.191	Rupture	360	11.81	1.570	13.600	12.656	16.214	8.191	0.000	0.000	0.000
0.000		0.000		Automatic											
65P	Br1	1.570	L/r	8.191	Rupture	360	11.81	1.570	13.600	12.656	16.214	8.191	0.000	0.000	0.000
0.000		0.000		Automatic											
65Y	Br1	1.570	L/r	8.191	Rupture	360	11.81	1.570	13.600	12.656	16.214	8.191	0.000	0.000	0.000
0.000		0.000		Automatic											
66P	Br2	10.549	L/r	9.949	Rupture	172	17.08	10.549	13.600	12.656	27.500	9.949	0.000	0.000	0.000
0.000		0.000		Automatic											
67P	ARMTT	27.200	Shear	27.200	Shear	106	7.00	40.528	27.200	33.750	51.121	38.750	0.000	0.000	0.000
0.000		0.000		Automatic											
67X	ARMTT	27.200	Shear	27.200	Shear	106	7.00	40.528	27.200	33.750	51.121	38.750	0.000	0.000	0.000
0.000		0.000		Automatic											
67XY	ARMTT	27.200	Shear	27.200	Shear	106	7.00	40.528	27.200	33.750	51.121	38.750	0.000	0.000	0.000
0.000		0.000		Automatic											
67Y	ARMTT	27.200	Shear	27.200	Shear	106	7.00	40.528	27.200	33.750	51.121	38.750	0.000	0.000	0.000
0.000		0.000		Automatic											
68P	ARMMT	40.528	L/r	40.800	Shear	106	7.00	40.528	40.800	50.625	49.952	44.118	0.000	0.000	0.000
0.000		0.000		Automatic											
68X	ARMMT	40.528	L/r	40.800	Shear	106	7.00	40.528	40.800	50.625	49.952	44.118	0.000	0.000	0.000
0.000		0.000		Automatic											
68XY	ARMMT	40.528	L/r	40.800	Shear	106	7.00	40.528	40.800	50.625	49.952	44.118	0.000	0.000	0.000
0.000		0.000		Automatic											
68Y	ARMMT	40.528	L/r	40.800	Shear	106	7.00	40.528	40.800	50.625	49.952	44.118	0.000	0.000	0.000
0.000		0.000		Automatic											
69P	ARMBT	40.528	L/r	40.800	Shear	106	7.00	40.528	40.800	50.625	49.952	44.118	0.000	0.000	0.000
0.000		0.000		Automatic											
69X	ARMBT	40.528	L/r	40.800	Shear	106	7.00	40.528	40.800	50.625	49.952	44.118	0.000	0.000	0.000
0.000		0.000		Automatic											
69XY	ARMBT	40.528	L/r	40.800	Shear	106	7.00	40.528	40.800	50.625	49.952	44.118	0.000	0.000	0.000
0.000		0.000		Automatic											
69Y	ARMBT	40.528	L/r	40.800	Shear	106	7.00	40.528	40.800	50.625	49.952	44.118	0.000	0.000	0.000
0.000		0.000		Automatic											
70P	ArmBr1	0.029	L/r	6.265	Net Sect	1912	8.60	0.029	27.200	25.312	6.265	17.824	0.000	0.000	0.000
0.000		0.000		Automatic											
70X	ArmBr1	0.029	L/r	6.265	Net Sect	1912	8.60	0.029	27.200	25.312	6.265	17.824	0.000	0.000	0.000

0.000		0.000	Automatic											
70XY	ArmBr1	0.029	L/r 6.265	Net Sect	1912	8.60	0.029	27.200	25.312	6.265	17.824	0.000	0.000	0.000
0.000		0.000	Automatic											
70Y	ArmBr1	0.029	L/r 6.265	Net Sect	1912	8.60	0.029	27.200	25.312	6.265	17.824	0.000	0.000	0.000
0.000		0.000	Automatic											
71P	ArmBr1	0.029	L/r 6.265	Net Sect	1912	8.60	0.029	27.200	25.312	6.265	17.824	0.000	0.000	0.000
0.000		0.000	Automatic											
71X	ArmBr1	0.029	L/r 6.265	Net Sect	1912	8.60	0.029	27.200	25.312	6.265	17.824	0.000	0.000	0.000
0.000		0.000	Automatic											
71XY	ArmBr1	0.029	L/r 6.265	Net Sect	1912	8.60	0.029	27.200	25.312	6.265	17.824	0.000	0.000	0.000
0.000		0.000	Automatic											
71Y	ArmBr1	0.029	L/r 6.265	Net Sect	1912	8.60	0.029	27.200	25.312	6.265	17.824	0.000	0.000	0.000
0.000		0.000	Automatic											
72P	ArmBr1	0.029	L/r 6.265	Net Sect	1912	8.60	0.029	27.200	25.312	6.265	17.824	0.000	0.000	0.000
0.000		0.000	Automatic											
72X	ArmBr1	0.029	L/r 6.265	Net Sect	1912	8.60	0.029	27.200	25.312	6.265	17.824	0.000	0.000	0.000
0.000		0.000	Automatic											
72XY	ArmBr1	0.029	L/r 6.265	Net Sect	1912	8.60	0.029	27.200	25.312	6.265	17.824	0.000	0.000	0.000
0.000		0.000	Automatic											
72Y	ArmBr1	0.029	L/r 6.265	Net Sect	1912	8.60	0.029	27.200	25.312	6.265	17.824	0.000	0.000	0.000
0.000		0.000	Automatic											
73P	ArmBr2	11.659	L/r 12.868	Rupture	152	9.90	11.659	13.600	16.875	21.421	12.868	0.000	0.000	0.000
0.000		0.000	Automatic											
73X	ArmBr2	11.659	L/r 12.868	Rupture	152	9.90	11.659	13.600	16.875	21.421	12.868	0.000	0.000	0.000
0.000		0.000	Automatic											
73XY	ArmBr2	11.659	L/r 12.868	Rupture	152	9.90	11.659	13.600	16.875	21.421	12.868	0.000	0.000	0.000
0.000		0.000	Automatic											
73Y	ArmBr2	11.659	L/r 12.868	Rupture	152	9.90	11.659	13.600	16.875	21.421	12.868	0.000	0.000	0.000
0.000		0.000	Automatic											
74P	ArmBr3	13.600	Shear 13.600	Shear	154	7.00	17.286	13.600	16.875	28.846	15.047	0.000	0.000	0.000
0.000		0.000	Automatic											
74X	ArmBr3	13.600	Shear 13.600	Shear	154	7.00	17.286	13.600	16.875	28.846	15.047	0.000	0.000	0.000
0.000		0.000	Automatic											
75P	ArmBr2	11.659	L/r 12.868	Rupture	152	9.90	11.659	13.600	16.875	21.421	12.868	0.000	0.000	0.000
0.000		0.000	Automatic											
75X	ArmBr2	11.659	L/r 12.868	Rupture	152	9.90	11.659	13.600	16.875	21.421	12.868	0.000	0.000	0.000
0.000		0.000	Automatic											
75XY	ArmBr2	11.659	L/r 12.868	Rupture	152	9.90	11.659	13.600	16.875	21.421	12.868	0.000	0.000	0.000
0.000		0.000	Automatic											
75Y	ArmBr2	11.659	L/r 12.868	Rupture	152	9.90	11.659	13.600	16.875	21.421	12.868	0.000	0.000	0.000
0.000		0.000	Automatic											
76P	ArmBr3	13.600	Shear 13.600	Shear	154	7.00	17.286	13.600	16.875	28.846	15.047	0.000	0.000	0.000
0.000		0.000	Automatic											
76X	ArmBr3	13.600	Shear 13.600	Shear	154	7.00	17.286	13.600	16.875	28.846	15.047	0.000	0.000	0.000
0.000		0.000	Automatic											
77P	ArmBr2	11.659	L/r 12.868	Rupture	152	9.90	11.659	13.600	16.875	21.421	12.868	0.000	0.000	0.000
0.000		0.000	Automatic											
77X	ArmBr2	11.659	L/r 12.868	Rupture	152	9.90	11.659	13.600	16.875	21.421	12.868	0.000	0.000	0.000
0.000		0.000	Automatic											
77XY	ArmBr2	11.659	L/r 12.868	Rupture	152	9.90	11.659	13.600	16.875	21.421	12.868	0.000	0.000	0.000
0.000		0.000	Automatic											
77Y	ArmBr2	11.659	L/r 12.868	Rupture	152	9.90	11.659	13.600	16.875	21.421	12.868	0.000	0.000	0.000
0.000		0.000	Automatic											
78P	ArmBr3	13.600	Shear 13.600	Shear	154	7.00	17.286	13.600	16.875	28.846	15.047	0.000	0.000	0.000
0.000		0.000	Automatic											
78X	ArmBr3	13.600	Shear 13.600	Shear	154	7.00	17.286	13.600	16.875	28.846	15.047	0.000	0.000	0.000
0.000		0.000	Automatic											
79P	TTBr1	9.713	L/r 16.214	Net Sect	152	5.00	9.713	27.200	25.312	16.214	19.160	0.000	0.000	0.000
0.000		0.000	Automatic											

79Y	TTBr1	9.713	L/r	16.214	Net Sect	152	5.00	9.713	27.200	25.312	16.214	19.160	0.000	0.000	0.000
0.000		0.000		Automatic											
80P	TTBr2	15.275	L/r	23.437	Rupture	157	7.81	15.275	27.200	25.312	27.500	23.437	0.000	0.000	0.000
0.000		0.000		Automatic											
80X	TTBr2	15.275	L/r	23.437	Rupture	157	7.81	15.275	27.200	25.312	27.500	23.437	0.000	0.000	0.000
0.000		0.000		Automatic											
80XY	TTBr2	15.275	L/r	23.437	Rupture	157	7.81	15.275	27.200	25.312	27.500	23.437	0.000	0.000	0.000
0.000		0.000		Automatic											
80Y	TTBr2	15.275	L/r	23.437	Rupture	157	7.81	15.275	27.200	25.312	27.500	23.437	0.000	0.000	0.000
0.000		0.000		Automatic											
81P	TTBr1	9.713	L/r	16.214	Net Sect	152	5.00	9.713	27.200	25.312	16.214	19.160	0.000	0.000	0.000
0.000		0.000		Automatic											
81X	TTBr1	9.713	L/r	16.214	Net Sect	152	5.00	9.713	27.200	25.312	16.214	19.160	0.000	0.000	0.000
0.000		0.000		Automatic											
81XY	TTBr1	9.713	L/r	16.214	Net Sect	152	5.00	9.713	27.200	25.312	16.214	19.160	0.000	0.000	0.000
0.000		0.000		Automatic											
81Y	TTBr1	9.713	L/r	16.214	Net Sect	152	5.00	9.713	27.200	25.312	16.214	19.160	0.000	0.000	0.000
0.000		0.000		Automatic											
82P	TTBr2	17.958	L/r	18.879	Rupture	135	6.73	17.958	27.200	25.312	27.500	18.879	0.000	0.000	0.000
0.000		0.000		Automatic											
82X	TTBr2	17.958	L/r	18.879	Rupture	135	6.73	17.958	27.200	25.312	27.500	18.879	0.000	0.000	0.000
0.000		0.000		Automatic											
82XY	TTBr2	17.958	L/r	18.879	Rupture	135	6.73	17.958	27.200	25.312	27.500	18.879	0.000	0.000	0.000
0.000		0.000		Automatic											
82Y	TTBr2	17.958	L/r	18.879	Rupture	135	6.73	17.958	27.200	25.312	27.500	18.879	0.000	0.000	0.000
0.000		0.000		Automatic											
83P	TTBr1	9.713	L/r	16.214	Net Sect	152	5.00	9.713	27.200	25.312	16.214	19.160	0.000	0.000	0.000
0.000		0.000		Automatic											
83X	TTBr1	9.713	L/r	16.214	Net Sect	152	5.00	9.713	27.200	25.312	16.214	19.160	0.000	0.000	0.000
0.000		0.000		Automatic											
83XY	TTBr1	9.713	L/r	16.214	Net Sect	152	5.00	9.713	27.200	25.312	16.214	19.160	0.000	0.000	0.000
0.000		0.000		Automatic											
83Y	TTBr1	9.713	L/r	16.214	Net Sect	152	5.00	9.713	27.200	25.312	16.214	19.160	0.000	0.000	0.000
0.000		0.000		Automatic											
84P	TTBr3	40.800	Shear	40.800	Shear	88	6.73	43.245	40.800	63.281	44.745	45.410	0.000	0.000	0.000
0.000		0.000		Automatic											
84X	TTBr3	40.800	Shear	40.800	Shear	88	6.73	43.245	40.800	63.281	44.745	45.410	0.000	0.000	0.000
0.000		0.000		Automatic											
84XY	TTBr3	40.800	Shear	40.800	Shear	88	6.73	43.245	40.800	63.281	44.745	45.410	0.000	0.000	0.000
0.000		0.000		Automatic											
84Y	TTBr3	40.800	Shear	40.800	Shear	88	6.73	43.245	40.800	63.281	44.745	45.410	0.000	0.000	0.000
0.000		0.000		Automatic											
85P	MTBr1	9.713	L/r	16.214	Net Sect	152	5.00	9.713	27.200	25.312	16.214	19.301	0.000	0.000	0.000
0.000		0.000		Automatic											
85Y	MTBr1	9.713	L/r	16.214	Net Sect	152	5.00	9.713	27.200	25.312	16.214	19.301	0.000	0.000	0.000
0.000		0.000		Automatic											
86P	MTBr3	32.441	L/r	40.800	Shear	128	7.81	32.441	40.800	50.625	44.531	44.118	0.000	0.000	0.000
0.000		0.000		Automatic											
distance (g) greater than zero); however, end, edge and spacing distances will be checked. ??															
86X	MTBr3	32.441	L/r	40.800	Shear	128	7.81	32.441	40.800	50.625	44.531	44.118	0.000	0.000	0.000
0.000		0.000		Automatic											
distance (g) greater than zero); however, end, edge and spacing distances will be checked. ??															
86XY	MTBr3	32.441	L/r	40.800	Shear	128	7.81	32.441	40.800	50.625	44.531	44.118	0.000	0.000	0.000
0.000		0.000		Automatic											
distance (g) greater than zero); however, end, edge and spacing distances will be checked. ??															
86Y	MTBr3	32.441	L/r	40.800	Shear	128	7.81	32.441	40.800	50.625	44.531	44.118	0.000	0.000	0.000
0.000		0.000		Automatic											
distance (g) greater than zero); however, end, edge and spacing distances will be checked. ??															
87P	MTBr1	9.713	L/r	16.214	Net Sect	152	5.00	9.713	27.200	25.312	16.214	19.301	0.000	0.000	0.000

0.000		0.000		Automatic										
87X	MTBr1	9.713	L/r	16.214	Net Sect	152	5.00	9.713	27.200	25.312	16.214	19.301	0.000	0.000
0.000		0.000		Automatic										
87XY	MTBr1	9.713	L/r	16.214	Net Sect	152	5.00	9.713	27.200	25.312	16.214	19.301	0.000	0.000
0.000		0.000		Automatic										
87Y	MTBr1	9.713	L/r	16.214	Net Sect	152	5.00	9.713	27.200	25.312	16.214	19.301	0.000	0.000
0.000		0.000		Automatic										
88P	MTBr4	33.676	L/r	38.603	Rupture	116	6.73	33.676	40.800	50.625	40.448	38.603	0.000	0.000
0.000		0.000		Automatic										
distance (g) greater than zero); however, end, edge and spacing distances will be checked. ??														
88X	MTBr4	33.676	L/r	38.603	Rupture	116	6.73	33.676	40.800	50.625	40.448	38.603	0.000	0.000
0.000		0.000		Automatic										
distance (g) greater than zero); however, end, edge and spacing distances will be checked. ??														
88XY	MTBr4	33.676	L/r	38.603	Rupture	116	6.73	33.676	40.800	50.625	40.448	38.603	0.000	0.000
0.000		0.000		Automatic										
distance (g) greater than zero); however, end, edge and spacing distances will be checked. ??														
88Y	MTBr4	33.676	L/r	38.603	Rupture	116	6.73	33.676	40.800	50.625	40.448	38.603	0.000	0.000
0.000		0.000		Automatic										
distance (g) greater than zero); however, end, edge and spacing distances will be checked. ??														
89P	MTBr2	27.139	L/r	27.200	Shear	114	5.00	27.139	27.200	33.750	32.410	31.250	0.000	0.000
0.000		0.000		Automatic										
89X	MTBr2	27.139	L/r	27.200	Shear	114	5.00	27.139	27.200	33.750	32.410	31.250	0.000	0.000
0.000		0.000		Automatic										
89XY	MTBr2	27.139	L/r	27.200	Shear	114	5.00	27.139	27.200	33.750	32.410	31.250	0.000	0.000
0.000		0.000		Automatic										
89Y	MTBr2	27.139	L/r	27.200	Shear	114	5.00	27.139	27.200	33.750	32.410	31.250	0.000	0.000
0.000		0.000		Automatic										
90P	MTBr5	43.226	L/r	47.613	Net Sect	102	6.73	43.226	54.400	67.500	47.613	58.823	0.000	0.000
0.000		0.000		Automatic										
distance (g) greater than zero); however, end, edge and spacing distances will be checked. ??														
90X	MTBr5	43.226	L/r	47.613	Net Sect	102	6.73	43.226	54.400	67.500	47.613	58.823	0.000	0.000
0.000		0.000		Automatic										
distance (g) greater than zero); however, end, edge and spacing distances will be checked. ??														
90XY	MTBr5	43.226	L/r	47.613	Net Sect	102	6.73	43.226	54.400	67.500	47.613	58.823	0.000	0.000
0.000		0.000		Automatic										
distance (g) greater than zero); however, end, edge and spacing distances will be checked. ??														
90Y	MTBr5	43.226	L/r	47.613	Net Sect	102	6.73	43.226	54.400	67.500	47.613	58.823	0.000	0.000
0.000		0.000		Automatic										
distance (g) greater than zero); however, end, edge and spacing distances will be checked. ??														
91P	BTBr1	9.713	L/r	16.214	Net Sect	152	5.00	9.713	27.200	25.312	16.214	19.301	0.000	0.000
0.000		0.000		Automatic										
91Y	BTBr1	9.713	L/r	16.214	Net Sect	152	5.00	9.713	27.200	25.312	16.214	19.301	0.000	0.000
0.000		0.000		Automatic										
92P	BTBr3	46.945	L/r	54.400	Shear	118	7.81	46.945	54.400	84.375	59.748	73.529	0.000	0.000
0.000		0.000		Automatic										
distance (g) greater than zero); however, end, edge and spacing distances will be checked. ??														
92X	BTBr3	46.945	L/r	54.400	Shear	118	7.81	46.945	54.400	84.375	59.748	73.529	0.000	0.000
0.000		0.000		Automatic										
distance (g) greater than zero); however, end, edge and spacing distances will be checked. ??														
92XY	BTBr3	46.945	L/r	54.400	Shear	118	7.81	46.945	54.400	84.375	59.748	73.529	0.000	0.000
0.000		0.000		Automatic										
distance (g) greater than zero); however, end, edge and spacing distances will be checked. ??														
92Y	BTBr3	46.945	L/r	54.400	Shear	118	7.81	46.945	54.400	84.375	59.748	73.529	0.000	0.000
0.000		0.000		Automatic										
distance (g) greater than zero); however, end, edge and spacing distances will be checked. ??														
93P	BTBr1	9.713	L/r	16.214	Net Sect	152	5.00	9.713	27.200	25.312	16.214	19.301	0.000	0.000
0.000		0.000		Automatic										
93X	BTBr1	9.713	L/r	16.214	Net Sect	152	5.00	9.713	27.200	25.312	16.214	19.301	0.000	0.000

0.000		0.000	Automatic												
93XY	BTBr1	9.713	L/r	16.214	Net Sect	152	5.00	9.713	27.200	25.312	16.214	19.301	0.000	0.000	0.000
0.000		0.000	Automatic												
93Y	BTBr1	9.713	L/r	16.214	Net Sect	152	5.00	9.713	27.200	25.312	16.214	19.301	0.000	0.000	0.000
0.000		0.000	Automatic												
94P	BTBr4	43.226	L/r	49.627	Net Sect	102	6.73	43.226	54.400	67.500	49.627	58.823	0.000	0.000	0.000
0.000		0.000	Automatic		Member "94P" will not be checked for block shear since more than one gage line exists (long edge distance (g) greater than zero); however, end, edge and spacing distances will be checked. ??										
94X	BTBr4	43.226	L/r	49.627	Net Sect	102	6.73	43.226	54.400	67.500	49.627	58.823	0.000	0.000	0.000
0.000		0.000	Automatic		Member "94X" will not be checked for block shear since more than one gage line exists (long edge distance (g) greater than zero); however, end, edge and spacing distances will be checked. ??										
94XY	BTBr4	43.226	L/r	49.627	Net Sect	102	6.73	43.226	54.400	67.500	49.627	58.823	0.000	0.000	0.000
0.000		0.000	Automatic		Member "94XY" will not be checked for block shear since more than one gage line exists (long edge distance (g) greater than zero); however, end, edge and spacing distances will be checked. ??										
94Y	BTBr4	43.226	L/r	49.627	Net Sect	102	6.73	43.226	54.400	67.500	49.627	58.823	0.000	0.000	0.000
0.000		0.000	Automatic		Member "94Y" will not be checked for block shear since more than one gage line exists (long edge distance (g) greater than zero); however, end, edge and spacing distances will be checked. ??										
95P	BTBr2	40.800	Shear	40.800	Shear	86	5.00	43.754	40.800	50.625	43.696	42.516	0.000	0.000	0.000
0.000		0.000	Automatic												
95X	BTBr2	40.800	Shear	40.800	Shear	86	5.00	43.754	40.800	50.625	43.696	42.516	0.000	0.000	0.000
0.000		0.000	Automatic												
95XY	BTBr2	40.800	Shear	40.800	Shear	86	5.00	43.754	40.800	50.625	43.696	42.516	0.000	0.000	0.000
0.000		0.000	Automatic												
95Y	BTBr2	40.800	Shear	40.800	Shear	86	5.00	43.754	40.800	50.625	43.696	42.516	0.000	0.000	0.000
0.000		0.000	Automatic												
96P	BTBr5	63.333	L/r	67.790	Net Sect	102	6.73	63.333	68.000	126.562	67.790	110.294	0.000	0.000	0.000
0.000		0.000	Automatic		Member "96P" will not be checked for block shear since more than one gage line exists (long edge distance (g) greater than zero); however, end, edge and spacing distances will be checked. ??										
96X	BTBr5	63.333	L/r	67.790	Net Sect	102	6.73	63.333	68.000	126.562	67.790	110.294	0.000	0.000	0.000
0.000		0.000	Automatic		Member "96X" will not be checked for block shear since more than one gage line exists (long edge distance (g) greater than zero); however, end, edge and spacing distances will be checked. ??										
96XY	BTBr5	63.333	L/r	67.790	Net Sect	102	6.73	63.333	68.000	126.562	67.790	110.294	0.000	0.000	0.000
0.000		0.000	Automatic		Member "96XY" will not be checked for block shear since more than one gage line exists (long edge distance (g) greater than zero); however, end, edge and spacing distances will be checked. ??										
96Y	BTBr5	63.333	L/r	67.790	Net Sect	102	6.73	63.333	68.000	126.562	67.790	110.294	0.000	0.000	0.000
0.000		0.000	Automatic		Member "96Y" will not be checked for block shear since more than one gage line exists (long edge distance (g) greater than zero); however, end, edge and spacing distances will be checked. ??										
97P	TBC1	4.471	L/r	7.348	Rupture	213	7.00	4.471	13.600	12.656	16.214	7.348	0.000	0.000	0.000
0.000		0.000	Automatic		KL/R value of 213.20 exceeds maximum of 200.00 for member "97P" ??										
98P	TBC1	10.309	L/r	8.191	Rupture	140	9.22	10.309	13.600	12.656	16.214	8.191	0.000	0.000	0.000
0.000		0.000	Automatic												
98X	TBC1	10.309	L/r	8.191	Rupture	140	9.22	10.309	13.600	12.656	16.214	8.191	0.000	0.000	0.000
0.000		0.000	Automatic												
98XY	TBC1	10.309	L/r	8.191	Rupture	140	9.22	10.309	13.600	12.656	16.214	8.191	0.000	0.000	0.000
0.000		0.000	Automatic												
98Y	TBC1	10.309	L/r	8.191	Rupture	140	9.22	10.309	13.600	12.656	16.214	8.191	0.000	0.000	0.000
0.000		0.000	Automatic												
99P	TBC2	13.479	L/r	27.200	Shear	171	7.00	13.479	27.200	33.750	28.846	28.125	0.000	0.000	0.000
0.000		0.000	Automatic												
99X	TBC2	13.479	L/r	27.200	Shear	171	7.00	13.479	27.200	33.750	28.846	28.125	0.000	0.000	0.000
0.000		0.000	Automatic												
100P	TBC3	13.600	Shear	10.922	Rupture	128	8.32	16.440	13.600	16.875	21.421	10.922	0.000	0.000	0.000
0.000		0.000	Automatic												
100X	TBC3	13.600	Shear	10.922	Rupture	128	8.32	16.440	13.600	16.875	21.421	10.922	0.000	0.000	0.000
0.000		0.000	Automatic												
100XY	TBC3	13.600	Shear	10.922	Rupture	128	8.32	16.440	13.600	16.875	21.421	10.922	0.000	0.000	0.000
0.000		0.000	Automatic												

100Y	TBC3	13.600	Shear	10.922	Rupture	128	8.32	16.440	13.600	16.875	21.421	10.922	0.000	0.000	0.000
0.000		0.000	Automatic												
101P	TBC4	10.354	L/r	21.094	Rupture	170	7.00	10.354	27.200	25.312	21.917	21.094	0.000	0.000	0.000
0.000		0.000	Automatic												
101X	TBC4	10.354	L/r	21.094	Rupture	170	7.00	10.354	27.200	25.312	21.917	21.094	0.000	0.000	0.000
0.000		0.000	Automatic												
102P	TBC3	13.600	Shear	10.922	Rupture	128	8.32	16.440	13.600	16.875	21.421	10.922	0.000	0.000	0.000
0.000		0.000	Automatic												
102X	TBC3	13.600	Shear	10.922	Rupture	128	8.32	16.440	13.600	16.875	21.421	10.922	0.000	0.000	0.000
0.000		0.000	Automatic												
102XY	TBC3	13.600	Shear	10.922	Rupture	128	8.32	16.440	13.600	16.875	21.421	10.922	0.000	0.000	0.000
0.000		0.000	Automatic												
102Y	TBC3	13.600	Shear	10.922	Rupture	128	8.32	16.440	13.600	16.875	21.421	10.922	0.000	0.000	0.000
0.000		0.000	Automatic												
103P	TBC1	4.471	L/r	7.348	Rupture	213	7.00	4.471	13.600	12.656	16.214	7.348	0.000	0.000	0.000
0.000		0.000	Automatic												
KL/R value of 213.20 exceeds maximum of 200.00 for member "103P" ??															
104P	TBC1	10.309	L/r	8.191	Rupture	140	9.22	10.309	13.600	12.656	16.214	8.191	0.000	0.000	0.000
0.000		0.000	Automatic												
104X	TBC1	10.309	L/r	8.191	Rupture	140	9.22	10.309	13.600	12.656	16.214	8.191	0.000	0.000	0.000
0.000		0.000	Automatic												
104XY	TBC1	10.309	L/r	8.191	Rupture	140	9.22	10.309	13.600	12.656	16.214	8.191	0.000	0.000	0.000
0.000		0.000	Automatic												
104Y	TBC1	10.309	L/r	8.191	Rupture	140	9.22	10.309	13.600	12.656	16.214	8.191	0.000	0.000	0.000
0.000		0.000	Automatic												
105P	TBC2	14.856	L/r	27.200	Shear	171	7.00	14.856	27.200	33.750	28.846	28.125	0.000	0.000	0.000
0.000		0.000	Automatic												
105X	TBC2	14.856	L/r	27.200	Shear	171	7.00	14.856	27.200	33.750	28.846	28.125	0.000	0.000	0.000
0.000		0.000	Automatic												
106P	TBC3	13.600	Shear	10.922	Rupture	128	8.32	16.440	13.600	16.875	21.421	10.922	0.000	0.000	0.000
0.000		0.000	Automatic												
106X	TBC3	13.600	Shear	10.922	Rupture	128	8.32	16.440	13.600	16.875	21.421	10.922	0.000	0.000	0.000
0.000		0.000	Automatic												
106XY	TBC3	13.600	Shear	10.922	Rupture	128	8.32	16.440	13.600	16.875	21.421	10.922	0.000	0.000	0.000
0.000		0.000	Automatic												
106Y	TBC3	13.600	Shear	10.922	Rupture	128	8.32	16.440	13.600	16.875	21.421	10.922	0.000	0.000	0.000
0.000		0.000	Automatic												
107P	TBC4	11.388	L/r	21.094	Rupture	170	7.00	11.388	27.200	25.312	21.917	21.094	0.000	0.000	0.000
0.000		0.000	Automatic												
107X	TBC4	11.388	L/r	21.094	Rupture	170	7.00	11.388	27.200	25.312	21.917	21.094	0.000	0.000	0.000
0.000		0.000	Automatic												
108P	TBC3	13.600	Shear	10.922	Rupture	128	8.32	16.440	13.600	16.875	21.421	10.922	0.000	0.000	0.000
0.000		0.000	Automatic												
108X	TBC3	13.600	Shear	10.922	Rupture	128	8.32	16.440	13.600	16.875	21.421	10.922	0.000	0.000	0.000
0.000		0.000	Automatic												
108XY	TBC3	13.600	Shear	10.922	Rupture	128	8.32	16.440	13.600	16.875	21.421	10.922	0.000	0.000	0.000
0.000		0.000	Automatic												
108Y	TBC3	13.600	Shear	10.922	Rupture	128	8.32	16.440	13.600	16.875	21.421	10.922	0.000	0.000	0.000
0.000		0.000	Automatic												
109P	TBC1	4.471	L/r	7.348	Rupture	213	7.00	4.471	13.600	12.656	16.214	7.348	0.000	0.000	0.000
0.000		0.000	Automatic												
KL/R value of 213.20 exceeds maximum of 200.00 for member "109P" ??															
110P	TBC1	10.309	L/r	8.191	Rupture	140	9.22	10.309	13.600	12.656	16.214	8.191	0.000	0.000	0.000
0.000		0.000	Automatic												
110X	TBC1	10.309	L/r	8.191	Rupture	140	9.22	10.309	13.600	12.656	16.214	8.191	0.000	0.000	0.000
0.000		0.000	Automatic												
110XY	TBC1	10.309	L/r	8.191	Rupture	140	9.22	10.309	13.600	12.656	16.214	8.191	0.000	0.000	0.000
0.000		0.000	Automatic												
110Y	TBC1	10.309	L/r	8.191	Rupture	140	9.22	10.309	13.600	12.656	16.214	8.191	0.000	0.000	0.000

0.000		0.000		Automatic											
111P	TBC2	14.856	L/r	27.200	Shear	171	7.00	14.856	27.200	33.750	28.846	28.125	0.000	0.000	0.000
0.000		0.000		Automatic											
111X	TBC2	14.856	L/r	27.200	Shear	171	7.00	14.856	27.200	33.750	28.846	28.125	0.000	0.000	0.000
0.000		0.000		Automatic											
112P	TBC3	13.600	Shear	10.922	Rupture	128	8.32	16.440	13.600	16.875	21.421	10.922	0.000	0.000	0.000
0.000		0.000		Automatic											
112X	TBC3	13.600	Shear	10.922	Rupture	128	8.32	16.440	13.600	16.875	21.421	10.922	0.000	0.000	0.000
0.000		0.000		Automatic											
112XY	TBC3	13.600	Shear	10.922	Rupture	128	8.32	16.440	13.600	16.875	21.421	10.922	0.000	0.000	0.000
0.000		0.000		Automatic											
112Y	TBC3	13.600	Shear	10.922	Rupture	128	8.32	16.440	13.600	16.875	21.421	10.922	0.000	0.000	0.000
0.000		0.000		Automatic											
113P	TBC4	11.388	L/r	21.094	Rupture	170	7.00	11.388	27.200	25.312	21.917	21.094	0.000	0.000	0.000
0.000		0.000		Automatic											
113X	TBC4	11.388	L/r	21.094	Rupture	170	7.00	11.388	27.200	25.312	21.917	21.094	0.000	0.000	0.000
0.000		0.000		Automatic											
114P	TBC3	13.600	Shear	10.922	Rupture	128	8.32	16.440	13.600	16.875	21.421	10.922	0.000	0.000	0.000
0.000		0.000		Automatic											
114X	TBC3	13.600	Shear	10.922	Rupture	128	8.32	16.440	13.600	16.875	21.421	10.922	0.000	0.000	0.000
0.000		0.000		Automatic											
114XY	TBC3	13.600	Shear	10.922	Rupture	128	8.32	16.440	13.600	16.875	21.421	10.922	0.000	0.000	0.000
0.000		0.000		Automatic											
114Y	TBC3	13.600	Shear	10.922	Rupture	128	8.32	16.440	13.600	16.875	21.421	10.922	0.000	0.000	0.000
0.000		0.000		Automatic											
115P	TTC1	4.471	L/r	7.348	Rupture	213	7.00	4.471	13.600	12.656	16.214	7.348	0.000	0.000	0.000
0.000		0.000		Automatic											
KL/R value of 213.20 exceeds maximum of 200.00 for member "115P" ??															
116P	TTC2	5.168	L/r	10.512	Rupture	224	9.22	5.168	13.600	12.656	21.917	10.512	0.000	0.000	0.000
0.000		0.000		Automatic											
KL/R value of 223.50 exceeds maximum of 200.00 for member "116P" ??															
117P	TTC2	5.168	L/r	10.512	Rupture	224	9.22	5.168	13.600	12.656	21.917	10.512	0.000	0.000	0.000
0.000		0.000		Automatic											
KL/R value of 223.50 exceeds maximum of 200.00 for member "117P" ??															
118P	TTC1	4.471	L/r	7.348	Rupture	213	7.00	4.471	13.600	12.656	16.214	7.348	0.000	0.000	0.000
0.000		0.000		Automatic											
KL/R value of 213.20 exceeds maximum of 200.00 for member "118P" ??															
118X	TTC1	4.471	L/r	7.348	Rupture	213	7.00	4.471	13.600	12.656	16.214	7.348	0.000	0.000	0.000
0.000		0.000		Automatic											
KL/R value of 213.20 exceeds maximum of 200.00 for member "118X" ??															
119P	TTC2	6.344	L/r	10.512	Rupture	202	8.32	6.344	13.600	12.656	21.917	10.512	0.000	0.000	0.000
0.000		0.000		Automatic											
KL/R value of 201.74 exceeds maximum of 200.00 for member "119P" ??															
120P	TTC2	6.344	L/r	10.512	Rupture	202	8.32	6.344	13.600	12.656	21.917	10.512	0.000	0.000	0.000
0.000		0.000		Automatic											
KL/R value of 201.74 exceeds maximum of 200.00 for member "120P" ??															
121P	TTC1	4.471	L/r	7.348	Rupture	213	7.00	4.471	13.600	12.656	16.214	7.348	0.000	0.000	0.000
0.000		0.000		Automatic											
KL/R value of 213.20 exceeds maximum of 200.00 for member "121P" ??															
121X	TTC1	4.471	L/r	7.348	Rupture	213	7.00	4.471	13.600	12.656	16.214	7.348	0.000	0.000	0.000
0.000		0.000		Automatic											
KL/R value of 213.20 exceeds maximum of 200.00 for member "121X" ??															
122P	TTC2	6.344	L/r	10.512	Rupture	202	8.32	6.344	13.600	12.656	21.917	10.512	0.000	0.000	0.000
0.000		0.000		Automatic											
KL/R value of 201.74 exceeds maximum of 200.00 for member "122P" ??															
123P	TTC2	6.344	L/r	10.512	Rupture	202	8.32	6.344	13.600	12.656	21.917	10.512	0.000	0.000	0.000
0.000		0.000		Automatic											
KL/R value of 201.74 exceeds maximum of 200.00 for member "123P" ??															

124P	TTC1	4.471	L/r	7.348	Rupture	213	7.00	4.471	13.600	12.656	16.214	7.348	0.000	0.000	0.000
0.000		0.000		Automatic											
KL/R value of 213.20 exceeds maximum of 200.00 for member "124P" ??															
125P	TTC2	5.168	L/r	10.512	Rupture	224	9.22	5.168	13.600	12.656	21.917	10.512	0.000	0.000	0.000
0.000		0.000		Automatic											
KL/R value of 223.50 exceeds maximum of 200.00 for member "125P" ??															
126P	TTC2	5.168	L/r	10.512	Rupture	224	9.22	5.168	13.600	12.656	21.917	10.512	0.000	0.000	0.000
0.000		0.000		Automatic											
KL/R value of 223.50 exceeds maximum of 200.00 for member "126P" ??															
127P	TTC1	4.471	L/r	7.348	Rupture	213	7.00	4.471	13.600	12.656	16.214	7.348	0.000	0.000	0.000
0.000		0.000		Automatic											
KL/R value of 213.20 exceeds maximum of 200.00 for member "127P" ??															
127X	TTC1	4.471	L/r	7.348	Rupture	213	7.00	4.471	13.600	12.656	16.214	7.348	0.000	0.000	0.000
0.000		0.000		Automatic											
KL/R value of 213.20 exceeds maximum of 200.00 for member "127X" ??															
128P	TTC2	6.344	L/r	10.512	Rupture	202	8.32	6.344	13.600	12.656	21.917	10.512	0.000	0.000	0.000
0.000		0.000		Automatic											
KL/R value of 201.74 exceeds maximum of 200.00 for member "128P" ??															
129P	TTC2	6.344	L/r	10.512	Rupture	202	8.32	6.344	13.600	12.656	21.917	10.512	0.000	0.000	0.000
0.000		0.000		Automatic											
KL/R value of 201.74 exceeds maximum of 200.00 for member "129P" ??															
130P	TTC1	4.471	L/r	7.348	Rupture	213	7.00	4.471	13.600	12.656	16.214	7.348	0.000	0.000	0.000
0.000		0.000		Automatic											
KL/R value of 213.20 exceeds maximum of 200.00 for member "130P" ??															
130X	TTC1	4.471	L/r	7.348	Rupture	213	7.00	4.471	13.600	12.656	16.214	7.348	0.000	0.000	0.000
0.000		0.000		Automatic											
KL/R value of 213.20 exceeds maximum of 200.00 for member "130X" ??															
131P	TTC2	6.344	L/r	10.512	Rupture	202	8.32	6.344	13.600	12.656	21.917	10.512	0.000	0.000	0.000
0.000		0.000		Automatic											
KL/R value of 201.74 exceeds maximum of 200.00 for member "131P" ??															
132P	TTC2	6.344	L/r	10.512	Rupture	202	8.32	6.344	13.600	12.656	21.917	10.512	0.000	0.000	0.000
0.000		0.000		Automatic											
KL/R value of 201.74 exceeds maximum of 200.00 for member "132P" ??															
133P	TTC1	4.471	L/r	7.348	Rupture	213	7.00	4.471	13.600	12.656	16.214	7.348	0.000	0.000	0.000
0.000		0.000		Automatic											
KL/R value of 213.20 exceeds maximum of 200.00 for member "133P" ??															
134P	TTC2	5.168	L/r	10.512	Rupture	224	9.22	5.168	13.600	12.656	21.917	10.512	0.000	0.000	0.000
0.000		0.000		Automatic											
KL/R value of 223.50 exceeds maximum of 200.00 for member "134P" ??															
135P	TTC2	5.168	L/r	10.512	Rupture	224	9.22	5.168	13.600	12.656	21.917	10.512	0.000	0.000	0.000
0.000		0.000		Automatic											
KL/R value of 223.50 exceeds maximum of 200.00 for member "135P" ??															
136P	TTC1	4.471	L/r	7.348	Rupture	213	7.00	4.471	13.600	12.656	16.214	7.348	0.000	0.000	0.000
0.000		0.000		Automatic											
KL/R value of 213.20 exceeds maximum of 200.00 for member "136P" ??															
136X	TTC1	4.471	L/r	7.348	Rupture	213	7.00	4.471	13.600	12.656	16.214	7.348	0.000	0.000	0.000
0.000		0.000		Automatic											
KL/R value of 213.20 exceeds maximum of 200.00 for member "136X" ??															
137P	TTC2	6.344	L/r	10.512	Rupture	202	8.32	6.344	13.600	12.656	21.917	10.512	0.000	0.000	0.000
0.000		0.000		Automatic											
KL/R value of 201.74 exceeds maximum of 200.00 for member "137P" ??															
138P	TTC2	6.344	L/r	10.512	Rupture	202	8.32	6.344	13.600	12.656	21.917	10.512	0.000	0.000	0.000
0.000		0.000		Automatic											
KL/R value of 201.74 exceeds maximum of 200.00 for member "138P" ??															
139P	TTC1	4.471	L/r	7.348	Rupture	213	7.00	4.471	13.600	12.656	16.214	7.348	0.000	0.000	0.000
0.000		0.000		Automatic											
KL/R value of 213.20 exceeds maximum of 200.00 for member "139P" ??															
139X	TTC1	4.471	L/r	7.348	Rupture	213	7.00	4.471	13.600	12.656	16.214	7.348	0.000	0.000	0.000

```

0.000          0.000          Automatic
KL/R value of 213.20 exceeds maximum of 200.00 for member "139X" ??
 140P      TTC2      6.344      L/r      10.512      Rupture 202      8.32      6.344      13.600      12.656      21.917      10.512      0.000      0.000      0.000
0.000          0.000          Automatic
KL/R value of 201.74 exceeds maximum of 200.00 for member "140P" ??
 141P      TTC2      6.344      L/r      10.512      Rupture 202      8.32      6.344      13.600      12.656      21.917      10.512      0.000      0.000      0.000
0.000          0.000          Automatic
KL/R value of 201.74 exceeds maximum of 200.00 for member "141P" ??
 142P      Horz3     10.354      L/r      18.105      Rupture 170      7.00      10.354      27.200      25.312      21.917      18.105      0.000      0.000      0.000
0.000          0.000          Automatic
 142X      Horz3     10.354      L/r      18.105      Rupture 170      7.00      10.354      27.200      25.312      21.917      18.105      0.000      0.000      0.000
0.000          0.000          Automatic
 143P      Horz3     10.354      L/r      18.105      Rupture 170      7.00      10.354      27.200      25.312      21.917      18.105      0.000      0.000      0.000
0.000          0.000          Automatic
 143X      Horz3     10.354      L/r      18.105      Rupture 170      7.00      10.354      27.200      25.312      21.917      18.105      0.000      0.000      0.000
0.000          0.000          Automatic
 144P      Horz4      4.471      L/r      8.191      Rupture 213      7.00      4.471      13.600      12.656      16.214      8.191      0.000      0.000      0.000
0.000          0.000          Automatic
KL/R value of 213.20 exceeds maximum of 200.00 for member "144P" ??
 144X      Horz4      4.471      L/r      8.191      Rupture 213      7.00      4.471      13.600      12.656      16.214      8.191      0.000      0.000      0.000
0.000          0.000          Automatic
KL/R value of 213.20 exceeds maximum of 200.00 for member "144X" ??
 145P      Horz3     10.354      L/r      18.105      Rupture 170      7.00      10.354      27.200      25.312      21.917      18.105      0.000      0.000      0.000
0.000          0.000          Automatic
 145X      Horz3     10.354      L/r      18.105      Rupture 170      7.00      10.354      27.200      25.312      21.917      18.105      0.000      0.000      0.000
0.000          0.000          Automatic
 146P      Horz4      4.471      L/r      8.191      Rupture 213      7.00      4.471      13.600      12.656      16.214      8.191      0.000      0.000      0.000
0.000          0.000          Automatic
KL/R value of 213.20 exceeds maximum of 200.00 for member "146P" ??
 146X      Horz4      4.471      L/r      8.191      Rupture 213      7.00      4.471      13.600      12.656      16.214      8.191      0.000      0.000      0.000
0.000          0.000          Automatic
KL/R value of 213.20 exceeds maximum of 200.00 for member "146X" ??
 147P      Horz5     39.688      L/r      40.800      Shear 122      7.00      39.688      40.800      63.281      53.952      47.988      0.000      0.000      0.000
0.000          0.000          Automatic
 147X      Horz5     39.688      L/r      40.800      Shear 122      7.00      39.688      40.800      63.281      53.952      47.988      0.000      0.000      0.000
0.000          0.000          Automatic
 148P      Horz6     33.036      L/r      39.835      Net Sect 103      5.42      33.036      40.800      50.625      39.835      46.875      0.000      0.000      0.000
0.000          0.000          Automatic
 148X      Horz6     33.036      L/r      39.835      Net Sect 103      5.42      33.036      40.800      50.625      39.835      46.875      0.000      0.000      0.000
0.000          0.000          Automatic
 148XY     Horz6     33.036      L/r      39.835      Net Sect 103      5.42      33.036      40.800      50.625      39.835      46.875      0.000      0.000      0.000
0.000          0.000          Automatic
 148Y     Horz6     33.036      L/r      39.835      Net Sect 103      5.42      33.036      40.800      50.625      39.835      46.875      0.000      0.000      0.000
0.000          0.000          Automatic
 149P      Horz6     27.200      Shear 27.200      Shear 121      12.74      29.777      27.200      33.750      39.835      28.125      0.000      0.000      0.000
0.000          0.000          Automatic
 149X      Horz6     27.200      Shear 27.200      Shear 121      12.74      29.777      27.200      33.750      39.835      28.125      0.000      0.000      0.000
0.000          0.000          Automatic
 150P      BBr1      9.436      L/r      15.785      Rupture 155      5.09      9.436      27.200      25.312      16.214      15.785      0.000      0.000      0.000
0.000          0.000          Automatic
 150Y     BBr1      9.436      L/r      15.785      Rupture 155      5.09      9.436      27.200      25.312      16.214      15.785      0.000      0.000      0.000
0.000          0.000          Automatic
 151P      BBr2     59.320      L/r     68.000      Shear 111      7.31      59.320      68.000      126.562      70.324      110.294      0.000      0.000      0.000
0.000          0.000          Automatic Member "151P" will not be checked for block shear since more than one gage line exists (long edge
distance (g) greater than zero); however, end, edge and spacing distances will be checked. ??
 151X     BBr2     59.320      L/r     68.000      Shear 111      7.31      59.320      68.000      126.562      70.324      110.294      0.000      0.000      0.000
0.000          0.000          Automatic Member "151X" will not be checked for block shear since more than one gage line exists (long edge
distance (g) greater than zero); however, end, edge and spacing distances will be checked. ??

```

151XY	BBr2	59.320	L/r	68.000	Shear	111	7.31	59.320	68.000	126.562	70.324	110.294	0.000	0.000	0.000
0.000		0.000			Automatic Member "151XY" will not be checked for block shear since more than one gage line exists (long edge distance (g) greater than zero); however, end, edge and spacing distances will be checked. ??										
151Y	BBr2	59.320	L/r	68.000	Shear	111	7.31	59.320	68.000	126.562	70.324	110.294	0.000	0.000	0.000
0.000		0.000			Automatic Member "151Y" will not be checked for block shear since more than one gage line exists (long edge distance (g) greater than zero); however, end, edge and spacing distances will be checked. ??										
152P	BBr1	9.436	L/r	15.785	Rupture	155	5.09	9.436	27.200	25.312	16.214	15.785	0.000	0.000	0.000
0.000		0.000			Automatic										
152X	BBr1	9.436	L/r	15.785	Rupture	155	5.09	9.436	27.200	25.312	16.214	15.785	0.000	0.000	0.000
0.000		0.000			Automatic										
152XY	BBr1	9.436	L/r	15.785	Rupture	155	5.09	9.436	27.200	25.312	16.214	15.785	0.000	0.000	0.000
0.000		0.000			Automatic										
152Y	BBr1	9.436	L/r	15.785	Rupture	155	5.09	9.436	27.200	25.312	16.214	15.785	0.000	0.000	0.000
0.000		0.000			Automatic										
153P	BBr2	59.320	L/r	68.000	Shear	111	7.31	59.320	68.000	126.562	68.960	110.294	0.000	0.000	0.000
0.000		0.000			Automatic Member "153P" will not be checked for block shear since more than one gage line exists (long edge distance (g) greater than zero); however, end, edge and spacing distances will be checked. ??										
153X	BBr2	59.320	L/r	68.000	Shear	111	7.31	59.320	68.000	126.562	68.960	110.294	0.000	0.000	0.000
0.000		0.000			Automatic Member "153X" will not be checked for block shear since more than one gage line exists (long edge distance (g) greater than zero); however, end, edge and spacing distances will be checked. ??										
153XY	BBr2	59.320	L/r	68.000	Shear	111	7.31	59.320	68.000	126.562	68.960	110.294	0.000	0.000	0.000
0.000		0.000			Automatic Member "153XY" will not be checked for block shear since more than one gage line exists (long edge distance (g) greater than zero); however, end, edge and spacing distances will be checked. ??										
153Y	BBr2	59.320	L/r	68.000	Shear	111	7.31	59.320	68.000	126.562	68.960	110.294	0.000	0.000	0.000
0.000		0.000			Automatic Member "153Y" will not be checked for block shear since more than one gage line exists (long edge distance (g) greater than zero); however, end, edge and spacing distances will be checked. ??										
154P	BBr3	54.400	Shear	54.400	Shear	77	5.09	65.583	54.400	84.375	63.159	59.355	0.000	0.000	0.000
0.000		0.000			Automatic										
154X	BBr3	54.400	Shear	54.400	Shear	77	5.09	65.583	54.400	84.375	63.159	59.355	0.000	0.000	0.000
0.000		0.000			Automatic										
154XY	BBr3	54.400	Shear	54.400	Shear	77	5.09	65.583	54.400	84.375	63.159	59.355	0.000	0.000	0.000
0.000		0.000			Automatic										
154Y	BBr3	54.400	Shear	54.400	Shear	77	5.09	65.583	54.400	84.375	63.159	59.355	0.000	0.000	0.000
0.000		0.000			Automatic										
155P	BBr4	130.359	L/r	103.105	Net Sect	55	6.79	130.359	149.600	324.843	103.105	300.781	0.000	0.000	0.000
0.000		0.000			Automatic Member "155P" will not be checked for block shear since more than one gage line exists (long edge distance (g) greater than zero); however, end, edge and spacing distances will be checked. ??										
155X	BBr4	130.359	L/r	103.105	Net Sect	55	6.79	130.359	149.600	324.843	103.105	300.781	0.000	0.000	0.000
0.000		0.000			Automatic Member "155X" will not be checked for block shear since more than one gage line exists (long edge distance (g) greater than zero); however, end, edge and spacing distances will be checked. ??										
155XY	BBr4	130.359	L/r	103.105	Net Sect	55	6.79	130.359	149.600	324.843	103.105	300.781	0.000	0.000	0.000
0.000		0.000			Automatic Member "155XY" will not be checked for block shear since more than one gage line exists (long edge distance (g) greater than zero); however, end, edge and spacing distances will be checked. ??										
155Y	BBr4	130.359	L/r	103.105	Net Sect	55	6.79	130.359	149.600	324.843	103.105	300.781	0.000	0.000	0.000
0.000		0.000			Automatic Member "155Y" will not be checked for block shear since more than one gage line exists (long edge distance (g) greater than zero); however, end, edge and spacing distances will be checked. ??										
156P	BBr4	130.317	L/r	103.105	Net Sect	55	6.80	130.317	149.600	324.843	103.105	300.781	0.000	0.000	0.000
0.000		0.000			Automatic Member "156P" will not be checked for block shear since more than one gage line exists (long edge distance (g) greater than zero); however, end, edge and spacing distances will be checked. ??										
156X	BBr4	130.317	L/r	103.105	Net Sect	55	6.80	130.317	149.600	324.843	103.105	300.781	0.000	0.000	0.000
0.000		0.000			Automatic Member "156X" will not be checked for block shear since more than one gage line exists (long edge distance (g) greater than zero); however, end, edge and spacing distances will be checked. ??										
156XY	BBr4	130.317	L/r	103.105	Net Sect	55	6.80	130.317	149.600	324.843	103.105	300.781	0.000	0.000	0.000
0.000		0.000			Automatic Member "156XY" will not be checked for block shear since more than one gage line exists (long edge distance (g) greater than zero); however, end, edge and spacing distances will be checked. ??										
156Y	BBr4	130.317	L/r	103.105	Net Sect	55	6.80	130.317	149.600	324.843	103.105	300.781	0.000	0.000	0.000
0.000		0.000			Automatic Member "156Y" will not be checked for block shear since more than one gage line exists (long edge distance (g) greater than zero); however, end, edge and spacing distances will be checked. ??										

157P	BTC1	16.690	L/r	27.141	Rupture	186	10.75	16.690	27.200	33.750	43.696	27.141	0.000	0.000	0.000
0.000		0.000		Automatic											
158P	BTC2	4.933	L/r	16.214	Net Sect	229	15.03	4.933	27.200	25.312	16.214	19.301	0.000	0.000	0.000
0.000		0.000		Automatic											
KL/R value of 202.97 exceeds maximum of 200.00 for member "158P" ??															
158X	BTC2	4.933	L/r	16.214	Net Sect	229	15.03	4.933	27.200	25.312	16.214	19.301	0.000	0.000	0.000
0.000		0.000		Automatic											
KL/R value of 202.97 exceeds maximum of 200.00 for member "158X" ??															
158XY	BTC2	4.933	L/r	16.214	Net Sect	229	15.03	4.933	27.200	25.312	16.214	19.301	0.000	0.000	0.000
0.000		0.000		Automatic											
KL/R value of 202.97 exceeds maximum of 200.00 for member "158XY" ??															
158Y	BTC2	4.933	L/r	16.214	Net Sect	229	15.03	4.933	27.200	25.312	16.214	19.301	0.000	0.000	0.000
0.000		0.000		Automatic											
KL/R value of 202.97 exceeds maximum of 200.00 for member "158Y" ??															
159P	BTC2	8.642	L/r	14.941	Rupture	164	10.75	8.642	27.200	25.312	16.214	14.941	0.000	0.000	0.000
0.000		0.000		Automatic											
159X	BTC2	8.642	L/r	14.941	Rupture	164	10.75	8.642	27.200	25.312	16.214	14.941	0.000	0.000	0.000
0.000		0.000		Automatic											
160P	BTC3	24.779	L/r	28.698	Net Sect	122	5.38	24.779	40.800	50.625	28.698	32.016	0.000	0.000	0.000
0.000		0.000		Automatic											
160X	BTC3	24.779	L/r	28.698	Net Sect	122	5.38	24.779	40.800	50.625	28.698	32.016	0.000	0.000	0.000
0.000		0.000		Automatic											
161P	BTC3	24.779	L/r	28.698	Net Sect	122	5.38	24.779	40.800	50.625	28.698	32.016	0.000	0.000	0.000
0.000		0.000		Automatic											
161X	BTC3	24.779	L/r	28.698	Net Sect	122	5.38	24.779	40.800	50.625	28.698	32.016	0.000	0.000	0.000
0.000		0.000		Automatic											
162P	BTC4	12.805	L/r	21.421	Net Sect	153	7.04	12.805	40.800	50.625	21.421	41.016	0.000	0.000	0.000
0.000		0.000		Automatic											
162X	BTC4	12.805	L/r	21.421	Net Sect	153	7.04	12.805	40.800	50.625	21.421	41.016	0.000	0.000	0.000
0.000		0.000		Automatic											
162XY	BTC4	12.805	L/r	21.421	Net Sect	153	7.04	12.805	40.800	50.625	21.421	41.016	0.000	0.000	0.000
0.000		0.000		Automatic											
162Y	BTC4	12.805	L/r	21.421	Net Sect	153	7.04	12.805	40.800	50.625	21.421	41.016	0.000	0.000	0.000
0.000		0.000		Automatic											
163P	BTC4	12.895	L/r	21.421	Net Sect	152	7.01	12.895	40.800	50.625	21.421	41.016	0.000	0.000	0.000
0.000		0.000		Automatic											
163X	BTC4	12.895	L/r	21.421	Net Sect	152	7.01	12.895	40.800	50.625	21.421	41.016	0.000	0.000	0.000
0.000		0.000		Automatic											
163XY	BTC4	12.895	L/r	21.421	Net Sect	152	7.01	12.895	40.800	50.625	21.421	41.016	0.000	0.000	0.000
0.000		0.000		Automatic											
163Y	BTC4	12.895	L/r	21.421	Net Sect	152	7.01	12.895	40.800	50.625	21.421	41.016	0.000	0.000	0.000
0.000		0.000		Automatic											
164P	BTC5	15.020	L/r	21.047	Rupture	138	4.50	15.020	27.200	33.750	21.421	21.047	0.000	0.000	0.000
0.000		0.000		Automatic											
164X	BTC5	15.020	L/r	21.047	Rupture	138	4.50	15.020	27.200	33.750	21.421	21.047	0.000	0.000	0.000
0.000		0.000		Automatic											
165P	BBC1	6.278	L/r	19.652	Rupture	255	12.67	6.278	27.200	25.312	27.500	19.652	0.000	0.000	0.000
0.000		0.000		Automatic											
KL/R value of 222.93 exceeds maximum of 200.00 for member "165P" ??															
166P	BBC2	3.237	L/r	8.191	Rupture	251	16.45	3.237	13.600	12.656	16.214	8.191	0.000	0.000	0.000
0.000		0.000		Automatic											
KL/R value of 250.54 exceeds maximum of 200.00 for member "166P" ??															
166X	BBC2	3.237	L/r	8.191	Rupture	251	16.45	3.237	13.600	12.656	16.214	8.191	0.000	0.000	0.000
0.000		0.000		Automatic											
KL/R value of 250.54 exceeds maximum of 200.00 for member "166X" ??															
166XY	BBC2	3.237	L/r	8.191	Rupture	251	16.45	3.237	13.600	12.656	16.214	8.191	0.000	0.000	0.000
0.000		0.000		Automatic											
KL/R value of 250.54 exceeds maximum of 200.00 for member "166XY" ??															
166Y	BBC2	3.237	L/r	8.191	Rupture	251	16.45	3.237	13.600	12.656	16.214	8.191	0.000	0.000	0.000

```

0.000      0.000      Automatic
KL/R value of 250.54 exceeds maximum of 200.00 for member "166Y" ??
 167P  BBC2  5.462      L/r  8.191  Rupture 193 12.67  5.462      13.600      12.656      16.214      8.191      0.000      0.000      0.000
0.000      0.000      Automatic
 167X  BBC2  5.462      L/r  8.191  Rupture 193 12.67  5.462      13.600      12.656      16.214      8.191      0.000      0.000      0.000
0.000      0.000      Automatic
 168P  BBC3  17.576     L/r  26.203  Rupture 163 12.67  17.576     27.200     33.750     36.271     26.203     0.000     0.000     0.000
0.000      0.000      Automatic
 168X  BBC3  17.576     L/r  26.203  Rupture 163 12.67  17.576     27.200     33.750     36.271     26.203     0.000     0.000     0.000
0.000      0.000      Automatic
 169P  BBC2  4.824      L/r  8.191  Rupture 205 13.48  4.824      13.600      12.656      16.214      8.191      0.000      0.000      0.000
0.000      0.000      Automatic
KL/R value of 205.25 exceeds maximum of 200.00 for member "169P" ??
 169X  BBC2  4.824      L/r  8.191  Rupture 205 13.48  4.824      13.600      12.656      16.214      8.191      0.000      0.000      0.000
0.000      0.000      Automatic
KL/R value of 205.25 exceeds maximum of 200.00 for member "169X" ??
 169XY BBC2  4.824      L/r  8.191  Rupture 205 13.48  4.824      13.600      12.656      16.214      8.191      0.000      0.000      0.000
0.000      0.000      Automatic
KL/R value of 205.25 exceeds maximum of 200.00 for member "169XY" ??
 169Y  BBC2  4.824      L/r  8.191  Rupture 205 13.48  4.824      13.600      12.656      16.214      8.191      0.000      0.000      0.000
0.000      0.000      Automatic
KL/R value of 205.25 exceeds maximum of 200.00 for member "169Y" ??

```

The model contains 521 angle members.

Sum of Unfactored Dead Load and Drag Areas From Equipment, Input and Calculated:

Joint Label	Dead Load (kips)	X-Drag Area (ft^2)	Y-Drag Area (ft^2)
1P	0.0613	3.898	4.024
2P	0.104	4.522	4.535
3P	0.164	5.708	5.592
4P	0.138	4.807	5.125
5P	0.148	5.713	5.709
6P	0.218	6.729	6.576
7P	0.229	6.826	7.151
8P	0.25	7.171	7.317
9P	0.275	7.354	7.605
14P	0.662	15.243	14.806
15P	0.0615	2.467	2.021
16P	0.0615	2.467	2.021
17P	0.0615	2.467	2.021
18P	0.0582	2.542	1.729
19P	0.0801	4.015	2.979
20P	0.0652	3.016	2.735
21P	0.0955	4.869	3.417
22P	0.0707	2.604	2.313
23P	0.119	4.814	4.188
24P	0.0684	3.042	1.729
25P	0.106	4.918	3.292
26P	0.0828	3.435	2.562
27P	0.125	6.020	3.833
28P	0.0796	3.042	2.312
29P	0.142	6.098	4.917
30P	0.078	3.042	1.729
31P	0.125	5.058	3.396
32P	0.0949	3.819	2.875

33P	0.15	6.020	3.833
34P	0.088	3.042	2.312
35P	0.177	6.343	5.140
36P	0.213	5.667	3.784
37P	0.23	6.333	3.017
38P	0.278	8.510	5.324
39P	0.244	7.208	5.815
40P	0.125	3.042	1.480
41P	0.273	7.691	6.887
44P	0.125	5.957	8.109
45P	0.0538	1.313	2.472
10P	0.233	6.721	6.906
11P	0.273	7.264	6.244
12P	0.512	13.485	14.602
1X	0.0613	3.898	4.024
2X	0.117	4.991	5.264
2XY	0.104	4.522	4.535
2Y	0.117	4.991	5.264
3X	0.164	5.708	5.592
3XY	0.164	5.708	5.592
3Y	0.164	5.708	5.592
4X	0.138	4.807	5.125
4XY	0.138	4.807	5.125
4Y	0.138	4.807	5.125
5X	0.161	6.182	6.438
5XY	0.148	5.713	5.709
5Y	0.161	6.182	6.438
6X	0.218	6.729	6.576
6XY	0.218	6.729	6.576
6Y	0.218	6.729	6.576
7X	0.229	6.826	7.151
7XY	0.229	6.826	7.151
7Y	0.229	6.826	7.151
8X	0.263	7.640	8.046
8XY	0.25	7.171	7.317
8Y	0.263	7.640	8.046
9X	0.275	7.354	7.605
9XY	0.275	7.354	7.605
9Y	0.275	7.354	7.605
14X	0.662	15.243	14.806
14XY	0.662	15.243	14.806
14Y	0.662	15.243	14.806
15X	0.0615	2.467	2.021
15XY	0.0615	2.467	2.021
15Y	0.0615	2.467	2.021
16X	0.0615	2.467	2.021
16XY	0.0615	2.467	2.021
16Y	0.0615	2.467	2.021
17X	0.0615	2.467	2.021
17XY	0.0615	2.467	2.021
17Y	0.0615	2.467	2.021
18Y	0.0582	2.542	1.729
19X	0.0815	4.171	2.979
19XY	0.0801	4.015	2.979
19Y	0.0815	4.171	2.979
20X	0.0652	3.016	2.735
20XY	0.0652	3.016	2.735
20Y	0.0652	3.016	2.735
21Y	0.0955	4.869	3.417

22X	0.0707	2.604	2.313
22XY	0.0707	2.604	2.313
22Y	0.0707	2.604	2.313
23X	0.119	4.814	4.188
23XY	0.119	4.814	4.188
23Y	0.119	4.814	4.188
24Y	0.0684	3.042	1.729
25X	0.107	5.074	3.292
25XY	0.106	4.918	3.292
25Y	0.107	5.074	3.292
26X	0.0828	3.435	2.562
26XY	0.0828	3.435	2.562
26Y	0.0828	3.435	2.562
27Y	0.125	6.020	3.833
28X	0.0796	3.042	2.312
28XY	0.0796	3.042	2.312
28Y	0.0796	3.042	2.312
29X	0.142	6.098	4.917
29XY	0.142	6.098	4.917
29Y	0.142	6.098	4.917
30Y	0.078	3.042	1.729
31X	0.126	5.215	3.396
31XY	0.125	5.058	3.396
31Y	0.126	5.215	3.396
32X	0.0949	3.819	2.875
32XY	0.0949	3.819	2.875
32Y	0.0949	3.819	2.875
33Y	0.15	6.020	3.833
34X	0.088	3.042	2.312
34XY	0.088	3.042	2.312
34Y	0.088	3.042	2.312
35X	0.177	6.343	5.140
35XY	0.177	6.343	5.140
35Y	0.177	6.343	5.140
36Y	0.213	5.667	3.784
37X	0.23	6.333	3.017
37XY	0.23	6.333	3.017
37Y	0.23	6.333	3.017
38X	0.278	8.510	5.324
38XY	0.278	8.510	5.324
38Y	0.278	8.510	5.324
39Y	0.244	7.208	5.815
40X	0.125	3.042	1.480
40XY	0.125	3.042	1.480
40Y	0.125	3.042	1.480
41X	0.273	7.691	6.887
41XY	0.273	7.691	6.887
41Y	0.273	7.691	6.887
44X	0.125	5.957	8.109
45X	0.0538	1.313	2.472
10X	0.233	6.721	6.906
10XY	0.233	6.721	6.906
10Y	0.233	6.721	6.906
11X	0.273	7.264	6.244
11XY	0.273	7.264	6.244
11Y	0.273	7.264	6.244
12X	0.512	13.485	14.602
12XY	0.512	13.485	14.602
12Y	0.512	13.485	14.602

13S	0.615	16.398	18.331
42S	0.928	21.055	14.957
43S	0.114	3.812	6.399
46S	0.0576	2.720	2.847
47S	0.0576	2.720	2.847
13X	0.615	16.398	18.331
13XY	0.615	16.398	18.331
13Y	0.615	16.398	18.331
42Y	0.928	21.055	14.957
43X	0.114	3.812	6.399
Total	29.4	922.574	822.888

Unadjusted Dead Load and Drag Areas by Section:

Section Label	Unfactored Dead Load (kips)	X-Drag Area (ft^2)	Y-Drag Area (ft^2)	X-Drag Area Face (ft^2)	Y-Drag Area Face (ft^2)
1	12.638	475.119	409.642	190.768	67.131
2	16.753	447.454	413.246	181.537	133.734
Total	29.392	922.574	822.888	372.305	200.865

Angle Member Weights and Surface Areas by Section:

Section Label	Unfactored Weight (kips)	Factored Weight (kips)	Unfactored Surface Area (ft^2)	Factored Surface Area (ft^2)
1	12.638	13.270	2388.520	2507.946
2	16.753	17.591	2119.786	2225.775
Total	29.392	30.861	4508.306	4733.721

Section Joint Information:

Section Label	Joint Label	Joint Elevation (ft)
1	1P	94.000
1	2P	85.000
1	1X	94.000
1	2X	85.000
1	2XY	85.000
1	2Y	85.000
1	3P	80.000
1	3X	80.000
1	3XY	80.000
1	3Y	80.000
1	4P	75.000
1	4X	75.000
1	4XY	75.000
1	4Y	75.000
1	5P	70.000
1	5X	70.000
1	5XY	70.000
1	5Y	70.000
1	6P	65.000
1	6X	65.000
1	6XY	65.000

1	6Y	65.000
1	7P	60.000
1	7X	60.000
1	7XY	60.000
1	7Y	60.000
1	8P	55.000
1	8X	55.000
1	8XY	55.000
1	8Y	55.000
1	9P	50.000
1	9X	50.000
1	9XY	50.000
1	9Y	50.000
1	20P	85.000
1	20X	85.000
1	20XY	85.000
1	20Y	85.000
1	23P	80.000
1	23X	80.000
1	23XY	80.000
1	23Y	80.000
1	26P	70.000
1	26X	70.000
1	26XY	70.000
1	26Y	70.000
1	29P	65.000
1	29X	65.000
1	29XY	65.000
1	29Y	65.000
1	32P	55.000
1	32X	55.000
1	32XY	55.000
1	32Y	55.000
1	18P	85.000
1	19P	85.000
1	19X	85.000
1	18Y	85.000
1	19XY	85.000
1	19Y	85.000
1	21P	80.000
1	22P	80.000
1	22X	80.000
1	21Y	80.000
1	22XY	80.000
1	22Y	80.000
1	24P	70.000
1	25P	70.000
1	25X	70.000
1	24Y	70.000
1	25XY	70.000
1	25Y	70.000
1	27P	65.000
1	28P	65.000
1	28X	65.000
1	27Y	65.000
1	28XY	65.000
1	28Y	65.000
1	30P	55.000
1	31P	55.000

1	31X	55.000
1	30Y	55.000
1	31XY	55.000
1	31Y	55.000
1	33P	50.000
1	34P	50.000
1	34X	50.000
1	33Y	50.000
1	34XY	50.000
1	34Y	50.000
1	35P	50.000
1	35X	50.000
1	35XY	50.000
1	35Y	50.000
1	15P	80.000
1	15X	80.000
1	15XY	80.000
1	15Y	80.000
1	16P	65.000
1	16X	65.000
1	16XY	65.000
1	16Y	65.000
1	17P	50.000
1	17X	50.000
1	17XY	50.000
1	17Y	50.000
2	9P	50.000
2	10P	45.000
2	9X	50.000
2	10X	45.000
2	9XY	50.000
2	10XY	45.000
2	9Y	50.000
2	10Y	45.000
2	11P	40.000
2	11X	40.000
2	11XY	40.000
2	11Y	40.000
2	12P	35.000
2	12X	35.000
2	12XY	35.000
2	12Y	35.000
2	13S	23.670
2	13X	23.670
2	13XY	23.670
2	13Y	23.670
2	14P	0.000
2	14X	0.000
2	14XY	0.000
2	14Y	0.000
2	43S	40.000
2	43X	40.000
2	44P	17.750
2	44X	17.750
2	35P	50.000
2	35X	50.000
2	35XY	50.000
2	35Y	50.000
2	38P	40.000

2	38X	40.000
2	38XY	40.000
2	38Y	40.000
2	42S	23.670
2	42Y	23.670
2	36P	40.000
2	37P	40.000
2	37X	40.000
2	36Y	40.000
2	37XY	40.000
2	37Y	40.000
2	39P	35.000
2	40P	35.000
2	40X	35.000
2	39Y	35.000
2	40XY	35.000
2	40Y	35.000
2	41P	35.000
2	41X	35.000
2	41XY	35.000
2	41Y	35.000
2	47S	23.670
2	46S	23.670
2	45P	40.000
2	45X	40.000

Sections Information:

Section Label	Top Z (ft)	Bottom Z (ft)	Joint Z Count	Member Count	Tran. Face Top Width (ft)	Tran. Face Bot Width (ft)	Tran. Face Gross Area (ft^2)	Long. Face Top Width (ft)	Long. Face Bot Width (ft)	Long. Face Gross Area (ft^2)
1	94.000	50.000	106	356	0.00	7.00	276.500	28.00	44.00	1416.000
2	50.000	0.000	58	165	7.00	26.15	828.655	30.00	38.15	1642.555

*** Insulator Data

Clamp Properties:

Label	Stock Number	Holding Capacity (lbs)
C-EX1		5e+004

Clamp Insulator Connectivity:

Clamp Label	Structure And Tip Attach	Property Set	Min. Required Vertical Load (uplift) (lbs)
C1	1P	C-EX1	No Limit
C2	1X	C-EX1	No Limit
C3	15P	C-EX1	No Limit
C4	15X	C-EX1	No Limit
C5	15XY	C-EX1	No Limit
C6	15Y	C-EX1	No Limit
C7	16P	C-EX1	No Limit

C8	16X	C-EX1	No Limit
C9	16XY	C-EX1	No Limit
C10	16Y	C-EX1	No Limit
C11	17P	C-EX1	No Limit
C12	17X	C-EX1	No Limit
C13	17XY	C-EX1	No Limit
C14	17Y	C-EX1	No Limit
C15	22P	C-EX1	No Limit
C16	22X	C-EX1	No Limit
C17	22XY	C-EX1	No Limit
C18	22Y	C-EX1	No Limit
C19	28P	C-EX1	No Limit
C20	28X	C-EX1	No Limit
C21	28XY	C-EX1	No Limit
C22	28Y	C-EX1	No Limit
C23	34P	C-EX1	No Limit
C24	34X	C-EX1	No Limit
C25	34XY	C-EX1	No Limit
C26	34Y	C-EX1	No Limit
C27	3XY	C-EX1	No Limit
C28	5XY	C-EX1	No Limit
C29	7XY	C-EX1	No Limit
C30	9XY	C-EX1	No Limit
C31	11XY	C-EX1	No Limit
C32	13XY	C-EX1	No Limit
C34	3Y	C-EX1	No Limit
C35	5Y	C-EX1	No Limit
C36	7Y	C-EX1	No Limit
C37	9Y	C-EX1	No Limit
C38	11Y	C-EX1	No Limit
C39	13Y	C-EX1	No Limit
C41	3X	C-EX1	No Limit
C42	3P	C-EX1	No Limit
C43	7X	C-EX1	No Limit
C44	7P	C-EX1	No Limit
C45	2X	C-EX1	No Limit
C46	2XY	C-EX1	No Limit
C47	2Y	C-EX1	No Limit
C48	2P	C-EX1	No Limit
C49	5X	C-EX1	No Limit
C50	5P	C-EX1	No Limit
C51	9X	C-EX1	No Limit
C52	9P	C-EX1	No Limit
C53	11X	C-EX1	No Limit
C54	11P	C-EX1	No Limit
C55	13X	C-EX1	No Limit
C56	13S	C-EX1	No Limit

*** Loads Data

Loads from file: j:\jobs\1800000.wi\55_ct5046\04_structural\calcs\rev (2)\pls-tower\norwalk1102.lca

Insulator dead and wind loads are already included in the point loads printed below.

Loading Method Parameters:

Structure Height Summary (used for calculating wind/ice adjust with height):

Z of ground for wind height adjust 0.00 (ft) and structure Z coordinate that will be put on the centerline ground profile in PLS-CADD.
 Ground elevation shift 0.00 (ft)
 Z of ground with shift 0.00 (ft)
 Z of structure top (highest joint) 94.00 (ft)
 Structure height 94.00 (ft)
 Structure height above ground 94.00 (ft)
 Tower Shape Rectangular

Load distributed evenly among joints in section for section based load cases

Vector Load Cases:

Load Case Description	Dead Load Factor	Wind Area Factor	SF for Steel Tubular and Towers	SF for Poles Arms and Cables	SF for Guys and	SF for Insuls.	SF For Found.	Point Loads	Wind/Ice Model	Trans. Wind Pressure (psf)	Longit. Wind Pressure (psf)	Ice Thick. (in)	Ice Density (lbs/ft^3)	Temperature (deg F)	Joint Displ.
NESC Heavy	1.5000	2.5000	1.00000	1.0000	1.0000	1.0000	1.0000	58 loads	Wind on Face	4	0	0.000	0.000	0.0	
NESC Extreme	1.0000	1.0000	1.00000	1.0000	1.0000	1.0000	1.0000	58 loads	NESC 2012	31	0	0.000	0.000	0.0	
NESC Heavy Broken Wire	1.5000	2.5000	1.00000	1.0000	1.0000	1.0000	1.0000	58 loads	Wind on Face	4	0	0.000	0.000	0.0	

Point Loads for Load Case "NESC Heavy":

Joint Label	Vertical Load (lbs)	Transverse Load (lbs)	Longitudinal Load (lbs)	Load Comment
1X	1756.8	5097.8	7.7	OPGW-120 Shield Wire
1P	1331.2	4056.2	7.2	0.438 Comp Shield Wire
15P	1145.4	3221.8	10534.3	TERN 795 Conductor Wire (Ahead)
15X	1099.7	3315.4	11032	TERN 795 Conductor Wire (Ahead)
15XY	1944.2	3043.1	-9691.1	TERN 795 Conductor Wire (Back)
15Y	1941.3	3106.4	-9901.4	TERN 795 Conductor Wire (Back)
22P	1138.8	3319.1	11011.9	TERN 795 Conductor Wire (Ahead)
22X	1116.1	3173.8	10377.7	TERN 795 Conductor Wire (Ahead)
22XY	1957.2	3140.1	-10080	TERN 795 Conductor Wire (Back)
22Y	1994.1	3368.5	-11065.8	TERN 795 Conductor Wire (Back)
16P	1155.4	3199.6	10453	TERN 795 Conductor Wire (Ahead)
16X	1063.5	3558.5	12071.7	TERN 795 Conductor Wire (Ahead)
16XY	1968.5	3206.3	-10377.9	TERN 795 Conductor Wire (Back)
16Y	1955.5	3264.4	-10621.4	TERN 795 Conductor Wire (Back)
28P	1131.6	3457.1	11574.2	TERN 795 Conductor Wire (Ahead)
28X	1073.1	3451.9	11568.3	TERN 795 Conductor Wire (Ahead)
28XY	1985.9	3312.7	-10800.6	TERN 795 Conductor Wire (Back)
28Y	1984.9	3375.7	-11080	TERN 795 Conductor Wire (Back)
17P	1141.4	3245.6	10617.2	TERN 795 Conductor Wire (Ahead)

17X	1056.3	3606.6	12288.9	TERN 795 Conductor Wire (Ahead)
17XY	1976.9	3261.3	-10618	TERN 795 Conductor Wire (Back)
17Y	2000.7	3474.2	-11491.3	TERN 795 Conductor Wire (Back)
34P	1108.3	3503.6	11780.8	TERN 795 Conductor Wire (Ahead)
34X	1072.5	3470.6	11631.3	TERN 795 Conductor Wire (Ahead)
34XY	2005.2	3421.6	-11265.1	TERN 795 Conductor Wire (Back)
34Y	1993.3	3384.9	-11094.3	TERN 795 Conductor Wire (Back)
2P	2257	2545	-1577	South Mast Top Connection
2Y	2257	2545	1577	South Mast Top Connection
7P	3614	-1421	892	South Mast Bottom Connection
7Y	3614	-1421	-892	South Mast Bottom Connection
2X	2936	816	501	North Mast Top Connection
2XY	2936	816	-501	North Mast Top Connection
7X	2095	64	33	North Mast Bottom Connection
7XY	2095	64	-33	North Mast Bottom Connection
3X	344	137	0	Coax Cable - NW Leg - AT&T Existing
5X	344	137	0	Coax Cable - NW Leg - AT&T Existing
7X	344	137	0	Coax Cable - NW Leg - AT&T Existing
9X	344	137	0	Coax Cable - NW Leg - AT&T Existing
11X	456	182	0	Coax Cable - NW Leg - AT&T Existing
13X	1093	436	0	Coax Cable - NW Leg - AT&T Existing
3XY	344	137	0	Coax Cable - NE Leg - T-Mobile Existing
5XY	344	137	0	Coax Cable - NE Leg - T-Mobile Existing
7XY	344	137	0	Coax Cable - NE Leg - T-Mobile Existing
9XY	344	137	0	Coax Cable - NE Leg - T-Mobile Existing
11XY	456	182	0	Coax Cable - NE Leg - T-Mobile Existing
13XY	1093	436	0	Coax Cable - NE Leg - T-Mobile Existing
3Y	172	75	0	Coax Cable - SE Leg - AT&T Proposed
5Y	172	75	0	Coax Cable - SE Leg - AT&T Proposed
7Y	172	75	0	Coax Cable - SE Leg - AT&T Proposed
9Y	172	75	0	Coax Cable - SE Leg - AT&T Proposed
11Y	228	100	0	Coax Cable - SE Leg - AT&T Proposed
13Y	546	239	0	Coax Cable - SE Leg - AT&T Proposed
3P	688	137	0	Coax Cable - SW Leg - T-Mobile Existing
5P	688	137	0	Coax Cable - SW Leg - T-Mobile Existing
7P	688	137	0	Coax Cable - SW Leg - T-Mobile Existing
9P	688	137	0	Coax Cable - SW Leg - T-Mobile Existing
11P	912	182	0	Coax Cable - SW Leg - T-Mobile Existing
13S	2186	436	0	Coax Cable - SW Leg - T-Mobile Existing

Section Load Case Information (Standard) for "NESC Heavy":

Section Label	Z of Top (ft)	Z of Bottom (ft)	Ave. Elev. Above Ground (ft)	Res. Adj. Wind (psf)	Tran. Adj. Wind (psf)	Tran. Drag Coef	Tran. Wind Load (lbs)	Long. Wind Adj. (psf)	Long. Drag Coef	Long. Wind Load (lbs)	Ice Weight (lbs)	Total Weight (lbs)
1	94.00	50.00	72.00	10.00	10.00	3.200	2148.2	0.00	3.200	0.0	0	19905
2	50.00	0.00	25.00	10.00	10.00	3.200	4279.5	0.00	3.200	0.0	0	26387

Point Loads for Load Case "NESC Extreme":

Joint Label	Vertical Load (lbs)	Transverse Load (lbs)	Longitudinal Load (lbs)	Load Comment
1X	511.8	3531.4	10.1	OPGW-120 Shield Wire
1P	395.7	2145.9	6.5	0.438 Comp Shield Wire

15P	327.5	2504.1	6115.7	TERN 795 Conductor Wire (Ahead)
15X	292.6	2560.4	6389	TERN 795 Conductor Wire (Ahead)
15XY	906.1	2456.5	-5733.9	TERN 795 Conductor Wire (Back)
15Y	909.7	2484.7	-5841.5	TERN 795 Conductor Wire (Back)
22P	324.5	2549.5	6351.9	TERN 795 Conductor Wire (Ahead)
22X	302.9	2490.2	6059.7	TERN 795 Conductor Wire (Ahead)
22XY	916.6	2505.5	-5936.2	TERN 795 Conductor Wire (Back)
22Y	943.3	2620.1	-6442.6	TERN 795 Conductor Wire (Back)
16P	341.5	2414.4	5907.2	TERN 795 Conductor Wire (Ahead)
16X	277.5	2601.2	6725.9	TERN 795 Conductor Wire (Ahead)
16XY	915.5	2464.9	-5935	TERN 795 Conductor Wire (Back)
16Y	911.1	2485.2	-6049.3	TERN 795 Conductor Wire (Back)
28P	323.8	2545.3	6464.3	TERN 795 Conductor Wire (Ahead)
28X	284	2549.2	6481	TERN 795 Conductor Wire (Ahead)
28XY	927.2	2517.6	-6145.3	TERN 795 Conductor Wire (Back)
28Y	927.3	2545.7	-6282	TERN 795 Conductor Wire (Back)
17P	339.2	2342.2	5782.2	TERN 795 Conductor Wire (Ahead)
17X	286	2520	6600.7	TERN 795 Conductor Wire (Ahead)
17XY	909.5	2401.4	-5862.5	TERN 795 Conductor Wire (Back)
17Y	930.1	2494.5	-6275.2	TERN 795 Conductor Wire (Back)
34P	317	2469.4	6347.7	TERN 795 Conductor Wire (Ahead)
34X	294.5	2460.7	6297.6	TERN 795 Conductor Wire (Ahead)
34XY	929.9	2475.8	-6173.12	TERN 795 Conductor Wire (Back)
34Y	920.7	2462.3	-6096.4	TERN 795 Conductor Wire (Back)
2P	-1392	8067	-5003	South Mast Top Connection
2Y	-1392	8067	5003	South Mast Top Connection
7P	4264	-3747	2354	South Mast Bottom Connection
7Y	4264	-3747	-2354	South Mast Bottom Connection
2X	2939	4913	3039	North Mast Top Connection
2XY	2939	4913	-3039	North Mast Top Connection
7X	-381	-1643	-1043	North Mast Bottom Connection
7XY	-381	-1643	1043	North Mast Bottom Connection
3X	79	434	0	Coax Cable - NW Leg - AT&T Existing
5X	79	434	0	Coax Cable - NW Leg - AT&T Existing
7X	79	434	0	Coax Cable - NW Leg - AT&T Existing
9X	79	434	0	Coax Cable - NW Leg - AT&T Existing
11X	105	575	0	Coax Cable - NW Leg - AT&T Existing
13X	251	1378	0	Coax Cable - NW Leg - AT&T Existing
3XY	79	434	0	Coax Cable - NE Leg - T-Mobile Existing
5XY	79	434	0	Coax Cable - NE Leg - T-Mobile Existing
7XY	79	434	0	Coax Cable - NE Leg - T-Mobile Existing
9XY	79	434	0	Coax Cable - NE Leg - T-Mobile Existing
11XY	105	575	0	Coax Cable - NE Leg - T-Mobile Existing
13XY	251	1378	0	Coax Cable - NE Leg - T-Mobile Existing
3Y	40	217	0	Coax Cable - SE Leg - AT&T Proposed
5Y	40	217	0	Coax Cable - SE Leg - AT&T Proposed
7Y	40	217	0	Coax Cable - SE Leg - AT&T Proposed
9Y	40	217	0	Coax Cable - SE Leg - AT&T Proposed
11Y	52	288	0	Coax Cable - SE Leg - AT&T Proposed
13Y	126	689	0	Coax Cable - SE Leg - AT&T Proposed
3P	158	434	0	Coax Cable - SW Leg - T-Mobile Existing
5P	158	434	0	Coax Cable - SW Leg - T-Mobile Existing
7P	158	434	0	Coax Cable - SW Leg - T-Mobile Existing
9P	158	434	0	Coax Cable - SW Leg - T-Mobile Existing
11P	210	575	0	Coax Cable - SW Leg - T-Mobile Existing
13S	503	1378	0	Coax Cable - SW Leg - T-Mobile Existing

Section Load Case Information (Code) for "NESC Extreme":

Section Label	Z of Top (ft)	Z of Bottom (ft)	Ave. Elev. Above Ground (ft)	Res. Adj. Wind Pres. (psf)	Tran. Adj. Wind Pres. (psf)	Tran. Angle Face Area (ft^2)	Tran. Gross Area (ft^2)	Tran. Soli-dity Ratio	Tran. Angle Drag Coef	Tran. Wind Load (lbs)	Long. Adj. Pres. (psf)	Long. Angle Face Area (ft^2)	Long. Gross Area (ft^2)	Long. Soli-dity Ratio	Long. Angle Drag Coef	Long. Wind Load (lbs)	Ice Weight (lbs)	Total Weight (lbs)
1	94.00	50.00	72.00	31.14	31.14	70.49	276.50	0.255	3.200	7024.8	0.00	190.77	1416.00	0.135	3.200	0.0	0	13270
2	50.00	0.00	25.00	31.14	31.14	140.42	828.65	0.169	3.200	13994.3	0.00	181.54	1642.56	0.111	3.200	0.0	0	17591

Point Loads for Load Case "NESC Heavy Broken Wire":

Joint Label	Vertical Load (lbs)	Transverse Load (lbs)	Longitudinal Load (lbs)	Load Comment
1X	1183	2563.2	-8304.8	OPGW-120 Shield Wire
1P	1331.2	4056.2	7.2	0.438 Comp Shield Wire
15P	1145.4	3221.8	10534.3	TERN 795 Conductor Wire (Ahead)
15X	0	0	0	TERN 795 Conductor Wire (Ahead)
15XY	1944.2	3043.1	-9691.1	TERN 795 Conductor Wire (Back)
15Y	1941.3	3106.4	-9901.4	TERN 795 Conductor Wire (Back)
22P	1138.8	3319.1	11011.9	TERN 795 Conductor Wire (Ahead)
22X	1116.1	3173.8	10377.7	TERN 795 Conductor Wire (Ahead)
22XY	1957.2	3140.1	-10080	TERN 795 Conductor Wire (Back)
22Y	1994.1	3368.5	-11065.8	TERN 795 Conductor Wire (Back)
16P	1155.4	3199.6	10453	TERN 795 Conductor Wire (Ahead)
16X	1063.5	3558.5	12071.7	TERN 795 Conductor Wire (Ahead)
16XY	1968.5	3206.3	-10377.9	TERN 795 Conductor Wire (Back)
16Y	1955.5	3264.4	-10621.4	TERN 795 Conductor Wire (Back)
28P	1131.6	3457.1	11574.2	TERN 795 Conductor Wire (Ahead)
28X	1073.1	3451.9	11568.3	TERN 795 Conductor Wire (Ahead)
28XY	1985.9	3312.7	-10800.6	TERN 795 Conductor Wire (Back)
28Y	1984.9	3375.7	-11080	TERN 795 Conductor Wire (Back)
17P	1141.4	3245.6	10617.2	TERN 795 Conductor Wire (Ahead)
17X	1056.3	3606.6	12288.9	TERN 795 Conductor Wire (Ahead)
17XY	1976.9	3261.3	-10618	TERN 795 Conductor Wire (Back)
17Y	2000.7	3474.2	-11491.3	TERN 795 Conductor Wire (Back)
34P	1108.3	3503.6	11780.8	TERN 795 Conductor Wire (Ahead)
34X	1072.5	3470.6	11631.3	TERN 795 Conductor Wire (Ahead)
34XY	2005.2	3421.6	-11265.1	TERN 795 Conductor Wire (Back)
34Y	1993.3	3384.9	-11094.3	TERN 795 Conductor Wire (Back)
2P	2257	2545	-1577	South Mast Top Connection
2Y	2257	2545	1577	South Mast Top Connection
7P	3614	-1421	892	South Mast Bottom Connection
7Y	3614	-1421	-892	South Mast Bottom Connection
2X	2936	816	501	North Mast Top Connection
2XY	2936	816	-501	North Mast Top Connection
7X	2095	64	33	North Mast Bottom Connection
7XY	2095	64	-33	North Mast Bottom Connection
3X	344	137	0	Coax Cable - NW Leg - AT&T Existing
5X	344	137	0	Coax Cable - NW Leg - AT&T Existing
7X	344	137	0	Coax Cable - NW Leg - AT&T Existing
9X	344	137	0	Coax Cable - NW Leg - AT&T Existing
11X	456	182	0	Coax Cable - NW Leg - AT&T Existing
13X	1093	436	0	Coax Cable - NW Leg - AT&T Existing
3XY	344	137	0	Coax Cable - NE Leg - T-Mobile Existing
5XY	344	137	0	Coax Cable - NE Leg - T-Mobile Existing
7XY	344	137	0	Coax Cable - NE Leg - T-Mobile Existing
9XY	344	137	0	Coax Cable - NE Leg - T-Mobile Existing

11XY	456	182	0	Coax Cable - NE Leg - T-Mobile Existing
13XY	1093	436	0	Coax Cable - NE Leg - T-Mobile Existing
3Y	172	75	0	Coax Cable - SE Leg - AT&T Proposed
5Y	172	75	0	Coax Cable - SE Leg - AT&T Proposed
7Y	172	75	0	Coax Cable - SE Leg - AT&T Proposed
9Y	172	75	0	Coax Cable - SE Leg - AT&T Proposed
11Y	228	100	0	Coax Cable - SE Leg - AT&T Proposed
13Y	546	239	0	Coax Cable - SE Leg - AT&T Proposed
3P	688	137	0	Coax Cable - SW Leg - T-Mobile Existing
5P	688	137	0	Coax Cable - SW Leg - T-Mobile Existing
7P	688	137	0	Coax Cable - SW Leg - T-Mobile Existing
9P	688	137	0	Coax Cable - SW Leg - T-Mobile Existing
11P	912	182	0	Coax Cable - SW Leg - T-Mobile Existing
13S	2186	436	0	Coax Cable - SW Leg - T-Mobile Existing

Section Load Case Information (Standard) for "NESC Heavy Broken Wire":

Section Label	Z of Top	Z of Bottom	Ave. Elev. Above Ground	Res. Adj. Wind	Tran. Adj. Wind Pres.	Tran. Drag Coef	Tran. Wind Load	Long. Adj. Wind Pres.	Long. Drag Coef	Long. Wind Load	Ice Weight	Total Weight
	(ft)	(ft)	(ft)	(psf)	(psf)		(lbs)	(psf)		(lbs)	(lbs)	(lbs)
1	94.00	50.00	72.00	10.00	10.00	3.200	2148.2	0.00	3.200	0.0	0	19905
2	50.00	0.00	25.00	10.00	10.00	3.200	4279.5	0.00	3.200	0.0	0	26387

*** Analysis Results:

Maximum element usage is 98.47% for Angle "80XY" in load case "NESC Heavy Broken Wire"
 Maximum insulator usage is 25.74% for Clamp "C12" in load case "NESC Heavy"

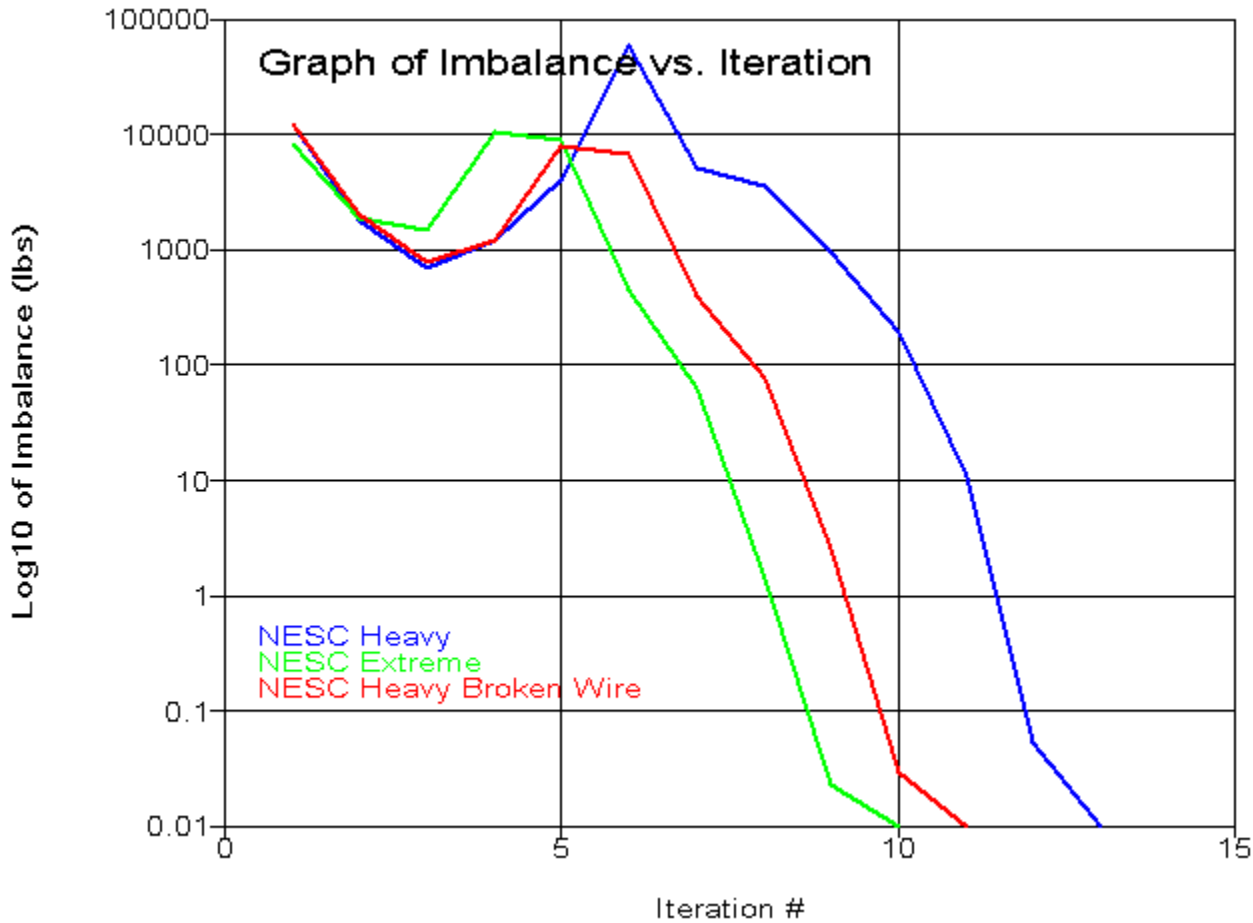

Angle Forces For All Load Cases:

Positive for tension - negative for compression

Group Label	Angle Label	Max. Usage For All LC %	Max. Tens. For All LC (kips)	Max. Comp. For All LC (kips)	LC 1 (kips)	LC 2 (kips)	LC 3 (kips)
PeakPost	1P	27.08	0.000	-4.779	-4.779	-2.448	-4.471
PeakPost	1X	52.40	10.113	0.000	4.980	3.795	10.113
PeakPost	1XY	31.35	4.633	-5.533	4.633	3.449	-5.533
PeakPost	1Y	31.02	0.000	-5.475	-5.168	-2.757	-5.475

Leg1	2P	9.78	7.414	-0.226	0.015	7.414	-0.226
Leg1	2X	9.86	3.634	-11.437	-11.437	-11.369	3.634
Leg1	2XY	22.62	0.000	-26.237	-12.637	-12.388	-26.237
Leg1	2Y	8.51	6.451	-3.723	-1.259	6.451	-3.723
Leg1	3P	7.26	6.010	-1.719	-1.719	6.010	-0.293
Leg1	3X	13.93	11.529	-12.559	-12.559	-11.267	11.529
Leg1	3XY	32.60	0.000	-34.722	-12.684	-11.811	-34.722
Leg1	3Y	6.54	5.408	-5.288	-1.929	5.408	-5.288
Leg1	4P	24.64	0.000	-26.244	-26.244	-24.309	-11.692
Leg1	4X	37.42	30.965	0.000	8.062	17.014	30.965
Leg1	4XY	19.95	16.506	-17.186	8.438	16.506	-17.186
Leg1	4Y	32.17	0.000	-34.266	-25.285	-24.233	-34.266
Leg1	5P	10.92	0.000	-11.629	-11.629	-5.231	-1.058
Leg1	5X	35.50	26.912	-12.348	-12.348	-3.726	26.912
Leg1	5XY	47.32	0.000	-50.404	-10.626	-3.906	-50.404
Leg1	5Y	18.85	0.000	-20.079	-10.781	-5.702	-20.079
Leg2	6P	5.49	0.000	-13.471	-13.471	-6.764	-2.025
Leg2	6X	17.97	37.807	-15.083	-15.083	-4.432	37.807
Leg2	6XY	25.23	0.000	-61.867	-9.091	-2.653	-61.867
Leg2	6Y	8.63	0.000	-21.157	-11.693	-6.959	-21.157
Leg2	7P	22.74	0.000	-55.762	-55.762	-50.799	-33.936
Leg2	7X	36.87	73.002	0.000	14.974	33.197	73.002
Leg2	7XY	18.55	36.732	-38.721	25.687	36.732	-38.721
Leg2	7Y	26.89	0.000	-65.946	-51.703	-50.137	-65.946
Leg2	8P	24.93	0.000	-33.909	-33.909	-27.180	-16.770
Leg2	8X	44.69	60.779	-13.014	-13.014	7.207	60.779
Leg2	8XY	54.53	13.151	-74.166	3.184	13.151	-74.166
Leg2	8Y	32.89	0.000	-44.737	-31.656	-28.091	-44.737
Leg3	9P	15.12	0.000	-37.012	-37.012	-29.351	-21.383
Leg3	9X	31.30	61.970	-16.723	-16.723	6.078	61.970
Leg3	9XY	31.58	14.709	-77.321	5.016	14.709	-77.321
Leg3	9Y	18.55	0.000	-45.424	-34.339	-30.323	-45.424
Leg3	10P	37.20	0.000	-91.088	-91.088	-82.607	-69.424
Leg3	10X	47.55	94.140	0.000	31.454	54.171	94.140
Leg3	10XY	31.95	63.261	-16.713	54.682	63.261	-16.713
Leg3	10Y	39.63	0.000	-97.036	-86.651	-82.295	-97.036
Leg4	11P	34.40	0.000	-84.232	-84.232	-75.582	-64.010
Leg4	11X	42.11	83.382	0.000	24.754	46.564	83.382
Leg4	11XY	27.81	55.063	-20.006	46.468	55.063	-20.006
Leg4	11Y	36.51	0.000	-89.408	-79.259	-75.063	-89.408
Leg4	12P	39.97	0.000	-96.569	-96.569	-87.041	-78.587
Leg4	12X	41.60	82.367	0.000	37.405	59.809	82.367
Leg4	12XY	34.51	68.321	-1.836	57.416	68.321	-1.836
Leg4	12Y	41.19	0.000	-99.512	-90.373	-86.135	-99.512
Leg5	13P	41.48	0.000	-99.682	-99.682	-91.112	-82.955
Leg5	13X	38.22	75.682	0.000	31.440	55.387	75.682
Leg5	13XY	32.84	65.019	-0.440	52.947	65.019	-0.440
Leg5	13Y	40.52	0.000	-97.378	-91.985	-90.091	-97.378
PeakPost	14P	21.94	4.235	0.000	4.235	2.287	3.939
PeakPost	14X	37.95	0.810	-6.333	-6.333	-4.389	0.810
PeakPost	14XY	42.29	0.000	-7.057	-5.931	-3.989	-7.057
PeakPost	14Y	25.74	4.968	0.000	4.673	2.634	4.968
Diag1	15P	17.22	0.000	-2.116	-0.134	-0.643	-2.116
Diag1	15X	26.40	0.000	-3.245	-0.678	-0.067	-3.245
Diag1	15XY	16.27	2.638	-0.525	-0.525	0.049	2.638
Diag1	15Y	13.93	2.259	-0.802	-0.345	-0.802	2.259
Diag2	16P	4.68	1.274	0.000	1.111	1.274	0.818
Diag2	16X	46.32	0.200	-11.979	0.200	-0.653	-11.979
Diag2	16XY	37.04	10.075	-1.805	-1.805	-1.588	10.075

Diag2	16Y	3.69	1.003	-0.072	0.368	1.003	-0.072
Diag2	17P	4.87	0.062	-0.999	-0.425	-0.999	0.062
Diag2	17X	39.01	1.836	-10.088	1.836	1.594	-10.088
Diag2	17XY	44.38	12.072	-0.192	-0.192	0.641	12.072
Diag2	17Y	6.17	0.000	-1.265	-1.173	-1.265	-0.867
Diag2	18P	6.05	0.000	-1.564	-0.425	-0.310	-1.564
Diag2	18X	37.69	0.161	-9.748	0.161	0.137	-9.748
Diag2	18XY	33.05	8.989	-1.710	-1.710	-0.693	8.989
Diag2	18Y	6.57	0.600	-1.348	-1.348	-0.703	0.600
Diag3	19P	5.01	2.044	0.000	1.491	2.044	1.839
Diag3	19X	25.72	2.088	-10.494	2.088	-0.040	-10.494
Diag3	19XY	21.90	8.936	-3.375	-3.375	-2.576	8.936
Diag3	19Y	4.78	1.950	-0.021	0.803	1.950	-0.021
Diag3	20P	2.30	0.938	0.000	0.124	0.464	0.938
Diag3	20X	21.74	3.598	-8.871	3.598	1.603	-8.871
Diag3	20XY	26.82	10.943	-1.925	-1.925	-0.956	10.943
Diag3	20Y	1.87	0.378	-0.761	-0.575	0.378	-0.761
Diag3	21P	5.39	0.000	-1.938	-1.931	-1.938	-1.874
Diag3	21X	19.98	2.054	-8.151	2.054	1.796	-8.151
Diag3	21XY	17.76	7.246	-3.344	-3.344	-0.710	7.246
Diag3	21Y	7.30	0.000	-2.625	-2.625	-2.055	-1.810
Diag2	22P	16.25	4.420	0.000	0.390	0.461	4.420
Diag2	22X	20.47	5.567	-0.077	0.689	-0.077	5.567
Diag2	22XY	34.75	0.000	-7.342	-3.040	-2.058	-7.342
Diag2	22Y	12.08	1.354	-2.552	1.354	0.855	-2.552
Diag4	23P	35.40	0.000	-6.400	-2.389	-2.108	-6.400
Diag4	23X	35.23	1.185	-6.369	-0.042	1.185	-6.369
Diag4	23XY	43.57	8.562	0.000	3.219	2.966	8.562
Diag4	23Y	18.47	0.669	-3.339	-3.339	-2.490	0.669
Diag4	24P	29.48	0.000	-3.936	-3.936	-3.155	-1.322
Diag4	24X	31.37	7.720	0.000	2.861	2.822	7.720
Diag4	24XY	40.53	1.527	-5.411	0.634	1.527	-5.411
Diag4	24Y	44.52	0.000	-5.944	-3.325	-3.082	-5.944
Diag5	25P	88.50	0.000	-3.088	-0.352	-3.088	0.000
Diag5	25X	2.08	0.398	-0.056	-0.056	0.398	0.000
Diag5	25XY	44.78	8.590	0.000	1.128	1.365	8.590
Diag5	25Y	91.75	3.662	-3.201	0.000	-3.201	3.662
Diag6	26P	11.12	2.217	-0.618	-0.618	2.217	2.011
Diag6	26X	26.91	7.762	0.000	6.520	6.909	7.762
Diag6	26XY	20.80	6.000	0.000	5.187	6.000	3.093
Diag6	26Y	45.41	2.576	-2.524	0.123	2.576	-2.524
Diagl2	27P	65.98	1.743	-3.451	0.219	1.743	-3.451
Diagl2	27X	13.74	3.777	0.000	3.123	3.777	0.510
Diagl2	27XY	25.41	6.987	0.000	4.974	5.040	6.987
Diagl2	27Y	15.51	2.847	-0.811	-0.811	1.244	2.847
Diagl1	28P	74.32	0.000	-21.395	-17.029	-21.395	-7.650
Diagl1	28X	50.20	20.483	0.000	15.411	20.483	5.729
Diagl1	28XY	51.62	21.063	0.000	14.158	19.755	21.063
Diagl1	28Y	73.49	0.000	-21.155	-16.824	-21.155	-20.440
Diagl1	29P	51.02	20.816	0.000	16.312	20.816	7.295
Diagl1	29X	70.19	0.000	-20.206	-15.463	-20.206	-4.942
Diagl1	29XY	75.13	0.000	-21.630	-14.237	-19.507	-21.630
Diagl1	29Y	50.40	20.565	0.000	16.111	20.565	19.597
Diag7	30P	69.94	0.000	-30.232	-27.910	-30.232	-19.781
Diag7	30X	60.67	28.451	0.000	25.386	28.451	20.366
Diag7	30XY	58.95	27.646	0.000	24.382	27.646	25.208
Diag7	30Y	71.87	0.000	-31.067	-27.168	-29.901	-31.067
Diag7	31P	51.49	24.046	0.000	23.260	24.046	16.131
Diag7	31X	58.30	0.000	-25.203	-24.260	-25.203	-16.801

Diag7	31XY	61.25	0.000	-26.478	-23.022	-24.385	-26.478
Diag7	31Y	54.96	25.668	0.000	22.707	23.520	25.668
Diag8	32P	59.72	0.000	-37.555	-37.555	-36.072	-30.023
Diag8	32X	48.53	32.997	0.000	32.997	32.920	28.599
Diag8	32XY	47.31	32.168	0.000	31.561	31.841	32.168
Diag8	32Y	61.60	0.000	-38.734	-35.588	-34.992	-38.734
Diag8	33P	56.02	38.094	0.000	38.094	37.420	30.764
Diag8	33X	59.16	0.000	-37.220	-37.220	-35.994	-28.458
Diag8	33XY	62.07	0.000	-39.053	-34.591	-34.431	-39.053
Diag8	33Y	57.20	38.899	0.000	36.057	36.118	38.899
Diag9	34P	40.70	19.651	0.000	15.912	19.651	13.809
Diag9	34X	64.90	0.000	-32.639	-32.639	-27.998	-13.405
Diag9	34XY	79.64	0.000	-40.052	-23.014	-24.167	-40.052
Diag9	34Y	38.53	18.603	0.000	14.000	18.603	13.931
Diag10	35P	70.88	0.000	-39.033	-39.033	-36.853	-22.169
Diag10	35X	36.45	29.744	0.000	24.044	29.744	20.511
Diag10	35XY	34.04	27.777	0.000	20.997	27.777	21.747
Diag10	35Y	79.95	0.000	-44.032	-29.982	-32.720	-44.032
TTTC	36P	12.33	4.078	-1.302	-1.302	-0.443	4.078
TTTC	36X	4.30	0.998	-1.176	-1.176	-0.287	0.998
TTTC	36XY	5.76	1.906	-1.022	-1.022	-0.222	1.906
TTTC	36Y	4.27	0.000	-1.168	-0.886	-0.180	-1.168
TTTC	37P	59.63	17.755	0.000	13.679	17.755	9.821
TTTC	37X	52.53	0.000	-16.937	-13.173	-16.937	-2.531
TTTC	37XY	49.25	0.000	-15.879	-11.656	-15.879	-13.983
TTTC	37Y	61.72	18.378	0.000	14.259	18.132	18.378
TTTC	38P	72.51	16.757	0.000	12.032	16.757	10.503
TTTC	38X	56.29	0.000	-15.311	-10.928	-15.311	-5.108
TTTC	38XY	53.13	0.000	-14.451	-9.657	-14.451	-10.990
TTTC	38Y	74.67	17.256	0.000	12.766	17.256	14.384
TTBC	39P	32.28	2.022	-8.837	-7.435	-8.837	2.022
TTBC	39X	28.53	9.439	0.000	6.699	9.439	6.417
TTBC	39XY	29.28	9.686	0.000	7.441	9.686	7.407
TTBC	39Y	42.25	0.000	-11.567	-5.978	-8.042	-11.567
TTBC	40P	36.58	0.000	-11.794	-11.070	-11.794	-4.566
TTBC	40X	40.81	12.152	0.000	9.404	11.938	12.152
TTBC	40XY	41.74	12.428	0.000	10.535	12.428	7.456
TTBC	40Y	38.52	0.000	-12.421	-9.924	-11.275	-12.421
TTBC	41P	6.46	2.343	0.000	1.014	1.883	2.343
TTBC	41X	22.40	8.125	-5.460	-5.460	-3.521	8.125
TTBC	41XY	41.36	0.000	-13.334	-3.998	-3.098	-13.334
TTBC	41Y	4.25	1.541	-0.113	1.157	1.541	-0.113
MTTC	42P	3.87	1.920	-0.336	-0.336	-0.020	1.920
MTTC	42X	0.76	0.092	-0.371	-0.243	0.092	-0.371
MTTC	42XY	1.40	0.692	-0.056	-0.056	0.040	0.692
MTTC	42Y	3.17	0.094	-1.550	0.094	0.090	-1.550
MTTC	43P	77.92	34.772	0.000	29.384	34.772	16.972
MTTC	43X	69.61	0.000	-33.225	-26.830	-33.225	-12.836
MTTC	43XY	67.66	0.000	-32.294	-24.438	-31.718	-32.294
MTTC	43Y	79.62	35.530	0.000	29.200	34.439	35.530
MTTC	44P	50.65	20.664	0.000	18.339	20.664	13.711
MTTC	44X	48.12	0.000	-19.632	-16.431	-19.632	-11.258
MTTC	44XY	45.86	0.000	-18.711	-15.036	-18.711	-16.156
MTTC	44Y	50.82	20.735	0.000	18.527	20.689	20.735
MTBC	45P	39.12	0.000	-19.124	-15.991	-19.124	-7.187
MTBC	45X	34.78	17.242	0.000	13.822	17.242	6.951
MTBC	45XY	35.86	17.782	0.000	13.322	16.777	17.782
MTBC	45Y	41.45	0.000	-20.263	-15.550	-18.791	-20.263
MTBC	46P	46.85	0.000	-22.360	-19.964	-22.360	-13.763

MTBC	46X	44.50	19.857	0.000	16.597	19.857	12.331
MTBC	46XY	44.89	20.031	0.000	17.264	20.031	18.990
MTBC	46Y	46.86	0.000	-22.364	-19.933	-22.364	-21.911
MTBC	47P	4.52	2.313	0.000	0.949	0.566	2.313
MTBC	47X	15.33	0.000	-7.318	-4.751	-2.064	-7.318
MTBC	47XY	6.88	0.000	-3.284	-3.284	-1.673	-0.897
MTBC	47Y	2.76	0.000	-1.316	-0.350	-0.296	-1.316
BTTC	48P	2.30	0.000	-1.253	-1.188	-1.253	-0.701
BTTC	48X	4.60	0.000	-2.505	-1.169	-1.198	-2.505
BTTC	48XY	2.77	1.369	-1.505	-1.505	-1.419	1.369
BTTC	48Y	2.60	0.000	-1.414	-1.406	-1.414	-0.361
BTTC	49P	76.01	41.832	0.000	41.832	41.080	30.647
BTTC	49X	71.34	0.000	-42.069	-40.924	-42.069	-31.010
BTTC	49XY	69.96	0.000	-41.253	-38.492	-40.401	-41.253
BTTC	49Y	84.82	46.683	0.000	40.473	40.133	46.683
BTTC	50P	64.10	26.152	0.000	26.152	24.835	21.065
BTTC	50X	61.71	0.000	-25.176	-24.702	-25.176	-21.145
BTTC	50XY	59.04	0.000	-24.090	-23.177	-24.090	-22.259
BTTC	50Y	69.14	28.209	0.000	25.344	24.373	28.209
BTBC	51P	42.67	0.000	-23.212	-23.212	-23.017	-15.199
BTBC	51X	40.77	22.179	0.000	21.421	22.179	16.120
BTBC	51XY	42.55	23.148	0.000	20.777	21.554	23.148
BTBC	51Y	49.31	0.000	-26.827	-22.442	-22.483	-26.827
BTBC	52P	45.59	0.000	-26.884	-26.884	-25.683	-20.192
BTBC	52X	44.19	24.323	0.000	23.944	24.323	19.943
BTBC	52XY	46.06	25.351	0.000	24.339	24.193	25.351
BTBC	52Y	49.91	0.000	-29.431	-26.407	-25.381	-29.431
BTBC	53P	2.62	1.426	-0.258	-0.258	-0.086	1.426
BTBC	53X	8.59	0.000	-4.671	-1.504	-0.014	-4.671
BTBC	53XY	3.89	2.116	-0.517	-0.517	0.071	2.116
BTBC	53Y	7.01	0.000	-3.815	-2.579	-1.545	-3.815
BTC	54P	0.85	0.000	-1.768	-1.768	-0.659	-1.028
BTC	54X	0.83	0.320	-1.734	-0.561	0.320	-1.734
BTC	54XY	0.53	0.047	-1.116	-1.116	0.047	-0.173
BTC	54Y	0.99	0.000	-2.058	-1.166	-0.486	-2.058
BTC	55P	21.48	35.481	0.000	34.827	35.481	26.856
BTC	55X	16.54	0.000	-34.536	-34.536	-33.171	-26.950
BTC	55XY	17.11	0.000	-35.714	-31.918	-31.674	-35.714
BTC	55Y	21.83	36.066	0.000	32.273	33.888	36.066
BTC	56P	8.82	9.597	0.000	8.850	9.597	6.892
BTC	56X	8.36	0.000	-9.094	-4.248	-5.524	-9.094
BTC	56XY	5.65	0.000	-6.151	-5.855	-6.151	-0.264
BTC	56Y	8.58	9.332	0.000	8.282	9.332	9.145
BBC	57P	9.79	0.000	-14.554	-13.218	-14.554	-11.833
BBC	57X	19.25	22.867	0.000	22.867	21.165	15.760
BBC	57XY	20.61	24.487	0.000	19.307	19.641	24.487
BBC	57Y	9.65	0.000	-14.339	-12.994	-14.339	-12.190
BBC	58P	9.95	0.000	-14.796	-13.218	-14.796	-11.833
BBC	58X	19.25	22.867	0.000	22.867	21.407	15.760
BBC	58XY	20.61	24.487	0.000	19.307	19.883	24.487
BBC	58Y	9.81	0.000	-14.581	-12.994	-14.581	-12.190
BBC	59P	22.76	0.000	-27.856	-25.527	-27.856	-21.296
BBC	59X	29.13	35.650	0.000	35.650	32.809	21.023
BBC	59XY	33.09	40.497	0.000	28.769	29.924	40.497
BBC	59Y	21.87	0.000	-26.766	-23.534	-26.766	-24.316
Horz1	60P	8.47	0.000	-1.118	-1.118	-0.775	-0.020
Horz1	60X	29.49	0.000	-3.890	-2.036	-3.890	-3.127
Horz1	60XY	30.82	0.000	-4.066	-2.442	-4.066	-1.275
Horz1	60Y	13.30	0.000	-1.755	-0.705	-1.221	-1.755

Horz2	61P	10.64	0.000	-2.584	-1.138	-2.584	-2.476
Horz2	61X	38.01	0.000	-9.231	-7.095	-8.968	-9.231
Br1	62P	39.79	3.260	0.000	1.211	3.260	2.678
Br1	62Y	42.95	3.518	0.000	1.815	3.518	0.283
Br1	63P	45.08	3.693	0.000	1.815	3.693	0.283
Br1	63Y	41.92	3.434	0.000	1.211	3.434	2.678
Br1	64P	37.41	3.065	0.000	1.003	3.065	2.441
Br1	64Y	40.46	3.314	0.000	1.585	3.314	0.064
Br1	65P	35.28	2.890	0.000	1.003	2.890	2.441
Br1	65Y	38.33	3.139	0.000	1.585	3.139	0.064
Br2	66P	45.95	0.000	-4.848	-2.323	-4.848	-2.269
ARMTT	67P	4.33	1.178	0.000	0.279	1.178	0.310
ARMTT	67X	22.25	4.392	-6.051	-6.051	-3.733	4.392
ARMTT	67XY	39.57	0.000	-10.764	-5.627	-3.827	-10.764
ARMTT	67Y	2.36	0.642	-0.324	-0.285	0.642	-0.324
ARMMT	68P	3.16	1.290	0.000	0.542	1.290	0.582
ARMMT	68X	16.10	0.000	-6.526	-6.397	-3.798	-6.526
ARMMT	68XY	13.90	0.000	-5.631	-5.631	-3.760	-5.476
ARMMT	68Y	1.58	0.451	-0.641	-0.636	0.451	-0.641
ARMBT	69P	3.55	1.449	0.000	1.057	1.449	1.047
ARMBT	69X	15.68	0.000	-6.353	-6.282	-3.651	-6.353
ARMBT	69XY	13.74	0.000	-5.569	-5.569	-3.665	-5.447
ARMBT	69Y	1.83	0.311	-0.744	-0.744	0.311	-0.731
ArmBr1	70P	34.34	2.152	0.000	2.124	0.800	2.152
ArmBr1	70X	31.43	1.969	0.000	1.969	0.650	0.201
ArmBr1	70XY	54.54	3.417	0.000	3.417	1.693	3.282
ArmBr1	70Y	55.47	3.475	0.000	3.475	1.783	3.441
ArmBr1	71P	35.22	2.206	0.000	2.182	0.876	2.206
ArmBr1	71X	32.01	2.005	0.000	1.850	0.572	2.005
ArmBr1	71XY	54.35	3.405	0.000	3.405	1.659	3.276
ArmBr1	71Y	56.40	3.533	0.000	3.533	1.835	3.496
ArmBr1	72P	34.13	2.138	0.000	2.108	0.801	2.138
ArmBr1	72X	31.98	2.003	0.000	1.894	0.653	2.003
ArmBr1	72XY	55.50	3.477	0.000	3.477	1.717	3.380
ArmBr1	72Y	56.80	3.558	0.000	3.558	1.796	3.527
ArmBr2	73P	6.61	0.851	0.000	0.810	0.653	0.851
ArmBr2	73X	55.48	7.139	-0.354	-0.354	-0.109	7.139
ArmBr2	73XY	55.81	1.545	-6.507	1.545	0.819	-6.507
ArmBr2	73Y	13.31	1.713	0.000	1.713	1.047	1.694
ArmBr3	74P	68.56	9.324	0.000	9.324	5.376	9.316
ArmBr3	74X	73.08	9.939	0.000	9.939	5.811	4.635
ArmBr2	75P	11.50	1.480	0.000	1.464	0.865	1.480
ArmBr2	75X	5.16	0.000	-0.602	-0.564	-0.176	-0.602
ArmBr2	75XY	14.19	1.826	0.000	1.826	0.942	1.792
ArmBr2	75Y	9.67	1.244	0.000	1.244	0.676	1.192
ArmBr3	76P	70.56	9.596	0.000	9.583	5.439	9.596
ArmBr3	76X	79.40	10.799	0.000	10.773	6.056	10.799
ArmBr2	77P	14.67	1.888	0.000	1.884	1.120	1.888
ArmBr2	77X	7.36	0.000	-0.858	-0.812	-0.288	-0.858
ArmBr2	77XY	11.99	1.543	0.000	1.543	0.754	1.501
ArmBr2	77Y	5.18	0.667	0.000	0.667	0.435	0.660
ArmBr3	78P	74.78	10.170	0.000	10.170	5.504	10.170
ArmBr3	78X	82.37	11.203	0.000	11.170	6.049	11.203
TTBr1	79P	1.30	0.000	-0.126	-0.087	-0.121	-0.126
TTBr1	79Y	1.30	0.000	-0.127	-0.096	-0.127	-0.092
TTBr2	80P	56.95	13.348	0.000	10.381	13.348	1.715
TTBr2	80X	84.76	0.000	-12.947	-9.990	-12.947	-1.238
TTBr2	80XY	98.47	0.000	-15.041	-9.345	-12.471	-15.041
TTBr2	80Y	65.92	15.451	0.000	9.771	12.894	15.451

TTBr1	81P	7.47	1.212	0.000	1.200	0.398	1.212
TTBr1	81X	7.66	1.242	0.000	1.242	0.456	1.231
TTBr1	81XY	12.76	2.069	0.000	2.069	1.057	2.045
TTBr1	81Y	12.61	2.045	0.000	2.045	1.008	2.019
TTBr2	82P	67.49	0.000	-12.120	-10.638	-12.120	-3.187
TTBr2	82X	54.42	10.274	-0.741	6.660	10.274	-0.741
TTBr2	82XY	52.49	9.910	0.000	5.012	9.067	9.910
TTBr2	82Y	89.59	0.000	-16.089	-11.235	-12.538	-16.089
TTBr1	83P	21.10	3.421	0.000	3.421	1.681	3.206
TTBr1	83X	56.43	0.597	-5.482	-5.482	-3.814	0.597
TTBr1	83XY	62.45	0.000	-6.066	-5.146	-3.473	-6.066
TTBr1	83Y	24.81	4.023	0.000	3.790	1.976	4.023
TTBr3	84P	27.64	0.000	-11.276	-10.647	-11.276	-8.429
TTBr3	84X	39.76	16.223	0.000	16.223	15.304	5.903
TTBr3	84XY	47.48	19.372	0.000	16.190	15.343	19.372
TTBr3	84Y	26.97	0.000	-11.004	-10.327	-11.004	-9.407
MTBr1	85P	1.27	0.000	-0.123	-0.107	-0.122	-0.123
MTBr1	85Y	1.31	0.000	-0.127	-0.117	-0.127	-0.107
MTBr3	86P	63.50	25.907	0.000	21.495	25.907	9.163
MTBr3	86X	78.57	0.000	-25.489	-20.971	-25.489	-8.608
MTBr3	86XY	84.82	0.000	-27.515	-19.738	-24.617	-27.515
MTBr3	86Y	68.79	28.067	0.000	20.313	25.066	28.067
MTBr1	87P	7.21	1.169	0.000	1.123	0.312	1.169
MTBr1	87X	7.74	1.256	0.000	1.256	0.499	1.237
MTBr1	87XY	13.20	2.140	0.000	2.140	1.121	2.138
MTBr1	87Y	12.09	1.961	0.000	1.961	0.903	1.931
MTBr4	88P	66.94	0.000	-22.544	-19.951	-22.544	-9.511
MTBr4	88X	53.85	20.786	0.000	15.872	20.786	5.393
MTBr4	88XY	52.49	20.263	0.000	13.653	19.215	20.263
MTBr4	88Y	79.13	0.000	-26.648	-20.057	-22.613	-26.648
MTBr2	89P	53.79	14.630	0.000	11.416	14.630	4.950
MTBr2	89X	54.08	0.000	-14.676	-11.196	-14.676	-3.584
MTBr2	89XY	57.79	0.000	-15.684	-10.314	-14.170	-15.684
MTBr2	89Y	53.13	14.451	0.000	11.274	14.451	13.765
MTBr5	90P	62.42	0.000	-26.980	-22.787	-26.980	-16.457
MTBr5	90X	56.95	27.116	0.000	24.522	27.116	19.949
MTBr5	90XY	57.20	27.234	0.000	24.599	27.234	25.898
MTBr5	90Y	60.91	0.000	-26.328	-21.729	-26.328	-22.371
BTBr1	91P	1.28	0.000	-0.125	-0.117	-0.116	-0.125
BTBr1	91Y	1.30	0.000	-0.126	-0.125	-0.120	-0.126
BTBr3	92P	58.00	31.552	0.000	31.458	31.552	21.678
BTBr3	92X	66.34	0.000	-31.141	-30.841	-31.141	-21.048
BTBr3	92XY	73.50	0.000	-34.506	-29.267	-30.076	-34.506
BTBr3	92Y	64.67	35.179	0.000	29.935	30.518	35.179
BTBr1	93P	6.71	1.089	0.000	1.041	0.259	1.089
BTBr1	93X	8.18	1.327	0.000	1.327	0.559	1.296
BTBr1	93XY	13.72	2.224	0.000	2.218	1.166	2.224
BTBr1	93Y	11.80	1.913	0.000	1.913	0.852	1.884
BTBr4	94P	65.59	0.000	-28.351	-28.351	-27.287	-20.096
BTBr4	94X	51.41	25.515	0.000	24.134	25.515	15.842
BTBr4	94XY	52.54	26.075	0.000	21.614	23.799	26.075
BTBr4	94Y	75.54	0.000	-32.651	-28.220	-27.200	-32.651
BTBr2	95P	41.58	16.966	0.000	16.362	16.966	11.275
BTBr2	95X	44.96	0.000	-18.342	-17.659	-18.342	-12.273
BTBr2	95XY	47.18	0.000	-19.248	-16.779	-17.755	-19.248
BTBr2	95Y	44.34	18.090	0.000	15.981	16.598	18.090
BTBr5	96P	47.74	0.000	-30.232	-30.002	-30.232	-24.023
BTBr5	96X	47.19	31.989	0.000	31.989	31.627	28.915
BTBr5	96XY	47.18	31.984	0.000	31.984	31.537	31.318

BTBr5	96Y	46.05	0.000	-29.168	-27.667	-28.751	-29.168
TBC1	97P	37.66	0.000	-1.684	-1.515	-0.969	-1.684
TBC1	98P	33.75	2.765	-0.879	-0.145	-0.879	2.765
TBC1	98X	26.64	2.182	-0.503	2.182	2.179	-0.503
TBC1	98XY	55.45	4.542	0.000	1.992	2.053	4.542
TBC1	98Y	22.28	0.047	-2.297	0.047	-0.751	-2.297
TBC2	99P	38.24	10.400	0.000	10.400	7.133	10.007
TBC2	99X	22.79	6.200	0.000	6.091	2.315	6.200
TBC3	100P	29.39	3.209	-0.271	0.650	-0.271	3.209
TBC3	100X	29.81	3.256	0.000	3.256	2.574	0.803
TBC3	100XY	46.17	5.043	0.000	2.725	2.311	5.043
TBC3	100Y	9.22	0.881	-1.254	0.881	-0.051	-1.254
TBC4	101P	5.14	0.128	-0.532	-0.374	0.128	-0.532
TBC4	101X	17.77	0.000	-1.839	-1.666	-1.438	-1.839
TBC3	102P	17.52	1.913	-0.414	-0.414	-0.086	1.913
TBC3	102X	20.71	0.000	-2.816	-0.706	-0.580	-2.816
TBC3	102XY	13.14	1.435	-1.229	-1.229	-0.832	1.435
TBC3	102Y	18.92	0.133	-2.573	-0.180	0.133	-2.573
TBC1	103P	31.98	0.000	-1.430	-1.373	-0.726	-1.430
TBC1	104P	18.81	1.373	-1.939	-1.201	-1.939	1.373
TBC1	104X	38.06	3.118	0.000	3.118	2.952	0.626
TBC1	104XY	55.68	4.561	0.000	2.413	2.556	4.561
TBC1	104Y	25.13	0.000	-2.590	-0.499	-1.541	-2.590
TBC2	105P	42.55	11.572	0.000	11.572	8.185	11.248
TBC2	105X	23.36	6.353	0.000	6.149	1.899	6.353
TBC3	106P	23.88	2.608	-0.697	0.363	-0.697	2.608
TBC3	106X	37.97	4.147	0.000	4.147	3.076	1.968
TBC3	106XY	42.20	4.609	0.000	2.601	2.319	4.609
TBC3	106Y	11.08	0.404	-1.507	0.404	-0.560	-1.507
TBC4	107P	3.24	0.684	-0.174	-0.068	0.684	-0.174
TBC4	107X	17.70	0.000	-2.015	-2.015	-1.789	-1.911
TBC3	108P	16.50	1.802	-0.294	-0.294	-0.268	1.802
TBC3	108X	16.66	0.000	-2.266	-0.082	-0.121	-2.266
TBC3	108XY	11.83	0.500	-1.608	-1.608	-0.850	0.500
TBC3	108Y	17.76	0.000	-2.415	-0.231	-0.118	-2.415
TBC1	109P	32.63	0.000	-1.459	-1.441	-0.794	-1.459
TBC1	110P	17.20	0.000	-1.773	-1.464	-1.773	-0.125
TBC1	110X	42.62	3.491	0.000	3.491	2.885	2.183
TBC1	110XY	45.83	3.754	0.000	2.750	2.537	3.754
TBC1	110Y	16.63	0.000	-1.714	-0.722	-1.423	-1.714
TBC2	111P	46.65	12.690	0.000	12.690	8.612	12.413
TBC2	111X	19.90	5.412	0.000	5.188	1.165	5.412
TBC3	112P	10.81	0.676	-1.469	-0.554	-1.469	0.676
TBC3	112X	46.30	5.057	0.000	5.057	3.761	3.884
TBC3	112XY	44.58	4.869	0.000	3.953	3.297	4.869
TBC3	112Y	11.64	0.000	-1.584	-0.699	-1.455	-1.584
TBC4	113P	26.70	0.000	-3.041	-3.041	-2.563	-2.931
TBC4	113X	5.46	1.153	0.000	0.787	1.153	0.735
TBC3	114P	14.51	0.021	-1.974	-1.974	-1.610	0.021
TBC3	114X	8.45	0.923	-0.832	0.805	0.923	-0.832
TBC3	114XY	7.92	0.865	-0.519	-0.519	0.308	0.865
TBC3	114Y	26.84	0.000	-3.651	-1.787	-1.412	-3.651
TTC1	115P	48.87	3.591	-0.154	-0.154	-0.117	3.591
TTC2	116P	91.56	0.194	-4.732	0.194	0.138	-4.732
TTC2	117P	91.37	0.209	-4.722	0.209	0.167	-4.722
TTC1	118P	48.58	3.570	-0.162	-0.162	-0.123	3.570
TTC1	118X	48.78	3.585	-0.147	-0.147	-0.116	3.585
TTC2	119P	66.85	0.197	-4.241	0.197	0.168	-4.241
TTC2	120P	67.10	0.182	-4.257	0.182	0.132	-4.257

TTC1	121P	39.00	1.846	-1.744	-1.744	-1.031	1.846
TTC1	121X	45.04	3.309	0.000	1.989	1.374	3.309
TTC2	122P	59.15	0.365	-3.752	0.365	0.277	-3.752
TTC2	123P	17.41	0.022	-1.105	0.022	-0.017	-1.105
TTC1	124P	35.97	2.643	-0.142	-0.142	-0.095	2.643
TTC2	125P	68.13	0.142	-3.521	0.142	0.070	-3.521
TTC2	126P	66.64	0.232	-3.444	0.232	0.179	-3.444
TTC1	127P	35.61	2.616	-0.156	-0.156	-0.115	2.616
TTC1	127X	36.10	2.652	-0.148	-0.148	-0.102	2.652
TTC2	128P	48.11	0.239	-3.052	0.239	0.204	-3.052
TTC2	129P	50.26	0.142	-3.188	0.142	0.083	-3.188
TTC1	130P	34.39	2.527	-0.185	-0.185	-0.147	2.527
TTC1	130X	36.03	2.647	-0.138	-0.138	-0.095	2.647
TTC2	131P	47.38	0.199	-3.005	0.199	0.145	-3.005
TTC2	132P	49.54	0.191	-3.142	0.191	0.141	-3.142
TTC1	133P	28.03	2.059	-0.068	-0.068	-0.036	2.059
TTC2	134P	53.63	0.028	-2.772	0.028	-0.017	-2.772
TTC2	135P	51.42	0.153	-2.657	0.153	0.109	-2.657
TTC1	136P	27.77	2.040	-0.076	-0.076	-0.039	2.040
TTC1	136X	27.99	2.057	-0.092	-0.092	-0.053	2.057
TTC2	137P	36.66	0.178	-2.326	0.178	0.143	-2.326
TTC2	138P	39.36	0.054	-2.497	0.054	0.013	-2.497
TTC1	139P	25.31	1.859	-0.192	-0.192	-0.172	1.859
TTC1	139X	28.77	2.114	-0.005	-0.005	0.011	2.114
TTC2	140P	35.80	0.150	-2.271	0.150	0.100	-2.271
TTC2	141P	38.41	0.097	-2.436	0.097	0.054	-2.436
Horz3	142P	34.67	1.719	-3.590	0.233	-3.590	1.719
Horz3	142X	9.70	1.755	-0.729	-0.729	1.755	0.403
Horz3	143P	9.60	0.000	-0.994	-0.994	-0.950	-0.940
Horz3	143X	8.23	1.490	0.000	1.490	1.238	1.318
Horz4	144P	23.45	1.921	0.000	1.249	1.175	1.921
Horz4	144X	15.04	0.808	-0.672	-0.087	-0.672	0.808
Horz3	145P	12.16	0.000	-1.259	-0.759	-1.259	-0.848
Horz3	145X	7.00	1.267	0.000	1.267	1.191	1.104
Horz4	146P	23.57	1.931	0.000	1.594	1.186	1.931
Horz4	146X	15.59	0.312	-0.697	-0.251	-0.697	0.312
Horz5	147P	9.46	0.000	-3.753	-3.750	-2.968	-3.753
Horz5	147X	2.89	1.177	-0.674	-0.196	1.177	-0.674
Horz6	148P	5.25	2.092	0.000	1.289	2.092	1.191
Horz6	148X	1.45	0.000	-0.479	-0.309	-0.078	-0.479
Horz6	148XY	0.74	0.000	-0.244	-0.244	-0.052	-0.151
Horz6	148Y	5.12	2.041	0.000	1.471	2.041	1.359
Horz6	149P	16.02	4.356	0.000	2.198	4.356	0.678
Horz6	149X	16.25	0.000	-4.420	-1.928	-2.197	-4.420
BBr1	150P	4.29	0.000	-0.405	-0.405	-0.299	-0.269
BBr1	150Y	5.11	0.000	-0.483	-0.350	-0.279	-0.483
BBr2	151P	38.64	26.276	0.000	26.276	25.991	19.912
BBr2	151X	42.26	0.000	-25.071	-25.071	-25.019	-18.897
BBr2	151XY	43.99	0.000	-26.096	-22.858	-23.770	-26.096
BBr2	151Y	40.30	27.404	0.000	23.979	24.709	27.404
BBr1	152P	1.22	0.192	0.000	0.110	0.192	0.118
BBr1	152X	2.08	0.329	0.000	0.272	0.329	0.166
BBr1	152XY	2.08	0.328	0.000	0.244	0.314	0.328
BBr1	152Y	1.27	0.201	0.000	0.115	0.201	0.105
BBr2	153P	41.64	0.000	-24.703	-24.703	-24.689	-18.932
BBr2	153X	32.72	22.248	0.000	22.248	21.963	16.225
BBr2	153XY	34.42	23.405	0.000	20.044	20.746	23.405
BBr2	153Y	43.33	0.000	-25.704	-22.604	-23.512	-25.704
BBr3	154P	45.52	24.765	0.000	24.765	24.042	19.529

BBr3	154X	38.98	0.000	-21.207	-20.090	-21.207	-19.768
BBr3	154XY	38.48	0.000	-20.934	-20.010	-20.934	-17.672
BBr3	154Y	46.91	25.521	0.000	23.184	23.305	25.521
BBr4	155P	7.07	0.000	-9.212	-9.212	-8.369	-7.581
BBr4	155X	11.34	11.688	0.000	6.127	7.850	11.688
BBr4	155XY	8.42	8.678	0.000	8.195	8.678	1.649
BBr4	155Y	7.14	0.000	-9.304	-9.049	-8.501	-9.304
BBr4	156P	1.66	1.715	0.000	1.074	1.715	1.536
BBr4	156X	6.20	0.000	-8.085	-8.085	-5.067	-0.111
BBr4	156XY	10.14	0.000	-13.220	-5.648	-3.936	-13.220
BBr4	156Y	1.49	1.539	0.000	1.422	1.539	0.754
BTC1	157P	10.93	2.967	0.000	1.298	2.967	1.286
BTC2	158P	26.58	0.064	-1.311	0.064	-1.223	-1.311
BTC2	158X	46.19	0.000	-2.278	-1.663	-2.278	-0.300
BTC2	158XY	43.28	0.000	-2.135	-0.841	-1.961	-2.135
BTC2	158Y	31.30	0.563	-1.544	-0.769	-1.544	0.563
BTC2	159P	13.38	0.000	-1.156	-0.466	-1.156	-0.468
BTC2	159X	13.74	0.000	-1.188	-0.605	-1.188	-0.596
BTC3	160P	16.06	4.609	0.000	1.941	4.609	1.533
BTC3	160X	16.78	4.817	0.000	2.091	4.817	2.650
BTC3	161P	15.73	4.515	0.000	1.660	4.515	2.100
BTC3	161X	17.20	4.937	0.000	2.392	4.937	1.829
BTC4	162P	20.46	0.000	-2.619	-0.920	-2.619	-1.465
BTC4	162X	16.31	0.000	-2.088	-1.045	-2.088	-0.322
BTC4	162XY	15.09	0.000	-1.933	-0.654	-1.933	-1.389
BTC4	162Y	21.41	0.000	-2.742	-1.284	-2.742	-0.727
BTC4	163P	17.04	0.000	-2.197	-0.876	-2.197	-1.676
BTC4	163X	19.26	0.000	-2.484	-1.217	-2.484	-0.524
BTC4	163XY	17.83	0.000	-2.300	-0.757	-2.300	-1.467
BTC4	163Y	18.51	0.000	-2.387	-1.311	-2.387	-0.501
BTC5	164P	15.17	3.193	0.000	1.410	3.193	1.402
BTC5	164X	13.39	2.818	0.000	1.087	2.818	1.095
BBC1	165P	4.88	0.000	-0.306	-0.251	-0.162	-0.306
BBC2	166P	25.64	0.000	-0.830	-0.488	-0.830	-0.062
BBC2	166X	11.71	0.959	0.000	0.728	0.959	0.358
BBC2	166XY	18.32	1.500	0.000	1.156	0.899	1.500
BBC2	166Y	37.38	0.000	-1.210	-0.916	-0.768	-1.210
BBC2	167P	1.36	0.000	-0.074	-0.046	-0.074	-0.019
BBC2	167X	0.59	0.015	-0.032	-0.032	-0.017	0.015
BBC3	168P	1.36	0.189	-0.239	0.039	-0.239	0.189
BBC3	168X	2.80	0.000	-0.492	-0.476	-0.492	-0.160
BBC2	169P	5.17	0.423	0.000	0.258	0.423	0.356
BBC2	169X	20.64	0.000	-0.996	-0.195	-0.087	-0.996
BBC2	169XY	3.17	0.093	-0.153	0.093	-0.153	-0.015
BBC2	169Y	13.01	0.482	-0.627	-0.027	0.482	-0.627

Equilibrium Joint Positions and Rotations for Load Case "NESC Heavy":

Joint Label	X-Displ (ft)	Y-Displ (ft)	Z-Displ (ft)	X-Rot (deg)	Y-Rot (deg)	Z-Rot (deg)	X-Pos (ft)	Y-Pos (ft)	Z-Pos (ft)
1P	0.009909	0.1879	-0.02112	0.0000	0.0000	0.0000	0.009909	14.19	93.98
2P	0.007716	0.1616	-0.02295	-0.0954	0.0173	0.0193	3.508	15.16	84.98
3P	0.006397	0.1532	-0.02294	-0.1182	0.0105	0.0190	3.506	15.15	79.98
4P	0.005716	0.1392	-0.02284	-0.2116	0.0105	0.0149	3.506	15.14	74.98
5P	0.004285	0.1204	-0.02155	-0.1608	0.0214	0.0106	3.504	15.12	69.98
6P	0.002749	0.1105	-0.02098	-0.1759	0.0060	0.0068	3.503	15.11	64.98
7P	0.002269	0.09233	-0.02065	-0.2409	0.0089	-0.0012	3.502	15.09	59.98
8P	0.0009315	0.07222	-0.01937	-0.1724	0.0220	-0.0093	3.501	15.07	54.98
9P	-0.0005806	0.06143	-0.0186	-0.1425	0.0007	-0.0217	3.499	15.06	49.98
14P	0	0	0	0.0000	0.0000	0.0000	13.07	19.07	0
15P	0.004111	0.1532	-0.03761	-0.1210	0.0105	0.0185	3.504	22.15	79.96
16P	0.0003074	0.1105	-0.03827	-0.1244	0.0061	0.0265	3.5	22.11	64.96
17P	-0.002339	0.06153	-0.03715	-0.1565	0.0008	0.0323	3.498	22.06	49.96
18P	0.01451	0.1591	-0.011	-0.0124	0.0166	0.0310	3.515	0.1591	84.99
19P	0.01114	0.1589	-0.01121	0.0127	0.0169	0.0297	3.511	6.159	84.99
20P	0.009166	0.1603	-0.01254	-0.0913	0.0171	0.0205	3.509	10.66	84.99
21P	0.01367	0.1553	-0.01098	-0.0042	0.0171	0.0272	3.514	0.1553	79.99
22P	0.01192	0.1543	-0.0115	-0.0001	0.0145	0.0293	3.512	6.154	79.99
23P	0.008627	0.1531	-0.01337	-0.0797	0.0125	0.0406	3.509	10.65	79.99
24P	0.008229	0.1166	-0.008622	0.0047	0.0218	0.0264	3.508	0.1166	69.99
25P	0.005507	0.1166	-0.007034	0.0349	0.0217	0.0160	3.506	6.117	69.99
26P	0.004925	0.1189	-0.007399	-0.1069	0.0215	0.0050	3.505	10.62	69.99
27P	0.009112	0.1137	-0.008596	0.0161	0.0184	0.0204	3.509	0.1137	64.99
28P	0.00804	0.112	-0.007304	0.0125	0.0136	0.0247	3.508	6.112	64.99
29P	0.004865	0.1104	-0.008894	-0.0898	0.0098	0.0425	3.505	10.61	64.99
30P	0.002833	0.06795	-0.007565	0.0088	0.0229	0.0203	3.503	0.06795	54.99
31P	0.0007854	0.06785	-0.005199	0.0470	0.0226	0.0073	3.501	6.068	54.99
32P	0.0008932	0.07055	-0.004723	-0.1037	0.0224	-0.0009	3.501	10.57	55
33P	0.004098	0.0652	-0.007536	0.0204	0.0126	0.0100	3.504	0.0652	49.99
34P	0.003867	0.0632	-0.005449	0.0254	0.0080	0.0218	3.504	6.063	49.99
35P	0.0006911	0.06146	-0.006384	-0.0962	0.0044	0.0423	3.501	10.56	49.99
36P	0.001796	0.02804	-0.006507	-0.0196	0.0153	0.0123	5.377	0.02804	39.99
37P	0.0002716	0.028	-0.007567	0.0041	0.0151	0.0257	5.375	5.278	39.99
38P	-0.00207	0.02881	-0.008119	-0.0517	0.0149	0.0108	5.373	10.53	39.99
39P	0.0007762	0.02394	-0.006599	-0.0109	0.0059	0.0120	6.334	0.02394	34.99
40P	-0.0003042	0.02353	-0.007703	-0.0141	0.0016	0.0123	6.333	5.274	34.99
41P	-0.001445	0.02311	-0.00984	-0.0393	-0.0027	0.0116	6.332	10.52	34.99
44P	-0.0006109	0.3095	0.03304	0.0000	0.0000	0.0000	-0.0006109	17.32	17.78
45P	-0.0008741	0.03011	-0.1339	0.0000	0.0000	0.0000	-0.0008741	10.53	39.87
10P	8.301e-005	0.04445	-0.01759	-0.2048	0.0009	-0.0312	4.457	15.04	44.98
11P	-0.001651	0.02898	-0.0158	-0.1198	0.0137	-0.0125	5.413	15.03	39.98
12P	-0.00211	0.02242	-0.01394	-0.0587	-0.0067	0.0036	6.37	15.02	34.99
1X	0.02663	0.1922	0.003294	0.0000	0.0000	0.0000	0.02663	-13.81	94
2X	0.02385	0.1618	0.003644	-0.0851	0.0157	0.0339	3.524	-14.84	85
2XY	0.02405	0.1579	0.006322	-0.0879	0.0258	0.0367	-3.476	-14.84	85.01
2Y	0.007654	0.1582	-0.02143	-0.0949	0.0086	0.0307	-3.492	15.16	84.98
3X	0.02226	0.154	0.004196	-0.1276	0.0236	0.0383	3.522	-14.85	80
3XY	0.02186	0.1498	0.006932	-0.1258	0.0240	0.0315	-3.478	-14.85	80.01
3Y	0.006664	0.1498	-0.02136	-0.1187	0.0173	0.0310	-3.493	15.15	79.98
4X	0.01979	0.1375	0.004824	-0.2245	0.0294	0.0352	3.52	-14.86	75

4XY	0.01982	0.1337	0.007565	-0.2189	0.0241	0.0323	-3.48	-14.87	75.01
4Y	0.004873	0.136	-0.02125	-0.2080	0.0182	0.0279	-3.495	15.14	74.98
5X	0.01754	0.1201	0.004469	-0.1353	0.0220	0.0319	3.518	-14.88	70
5XY	0.01757	0.1168	0.007191	-0.1334	0.0278	0.0330	-3.482	-14.88	70.01
5Y	0.003861	0.1174	-0.02001	-0.1613	0.0070	0.0249	-3.496	15.12	69.98
6X	0.01552	0.1113	0.005067	-0.1889	0.0305	0.0218	3.516	-14.89	65.01
6XY	0.01519	0.1081	0.007706	-0.1804	0.0241	0.0292	-3.485	-14.89	65.01
6Y	0.002953	0.1073	-0.01948	-0.1763	0.0205	0.0340	-3.497	15.11	64.98
7X	0.01286	0.09181	0.005442	-0.2472	0.0286	0.0130	3.513	-14.91	60.01
7XY	0.01308	0.08927	0.007944	-0.2418	0.0256	0.0345	-3.487	-14.91	60.01
7Y	0.001197	0.08934	-0.01919	-0.2346	0.0163	0.0365	-3.499	15.09	59.98
8X	0.01066	0.07232	0.005147	-0.1590	0.0233	0.0041	3.511	-14.93	55.01
8XY	0.01075	0.06987	0.007411	-0.1611	0.0264	0.0398	-3.489	-14.93	55.01
8Y	0.0003901	0.06984	-0.018	-0.1692	0.0028	0.0391	-3.5	15.07	54.98
9X	0.008657	0.06193	0.005448	-0.1581	0.0240	-0.0146	3.509	-14.94	50.01
9XY	0.00868	0.05954	0.007351	-0.1479	0.0195	0.0487	-3.491	-14.94	50.01
9Y	-0.000147	0.05903	-0.01729	-0.1412	0.0197	0.0524	-3.5	15.06	49.98
14X	0	0	0	0.0000	0.0000	0.0000	13.07	-19.07	0
14XY	0	0	0	0.0000	0.0000	0.0000	-13.07	-19.07	0
14Y	0	0	0	0.0000	0.0000	0.0000	-13.07	19.07	0
15X	0.02753	0.1547	0.01093	-0.0191	0.0237	0.0456	3.528	-21.85	80.01
15XY	0.02587	0.1505	0.01196	0.0010	0.0241	0.0335	-3.474	-21.85	80.01
15Y	0.002549	0.1497	-0.03798	-0.1446	0.0173	0.0350	-3.497	22.15	79.96
16X	0.0202	0.1121	0.01317	-0.0054	0.0307	0.0464	3.52	-21.89	65.01
16XY	0.01839	0.1088	0.01378	0.0153	0.0241	0.0248	-3.482	-21.89	65.01
16Y	-0.001298	0.1072	-0.03908	-0.1525	0.0205	0.0351	-3.501	22.11	64.96
17X	0.01264	0.06272	0.01604	-0.0512	0.0241	0.0560	3.513	-21.94	50.02
17XY	0.01077	0.06024	0.01618	-0.0346	0.0194	0.0013	-3.489	-21.94	50.02
17Y	-0.004043	0.0589	-0.0381	-0.1849	0.0196	0.0216	-3.504	22.06	49.96
18Y	0.01457	0.1554	-0.009445	-0.0162	0.0172	0.0351	-3.485	0.1554	84.99
19X	0.01792	0.1592	-0.01018	0.0073	0.0163	0.0403	3.518	-5.841	84.99
19XY	0.01797	0.1556	-0.008263	-0.0020	0.0207	0.0306	-3.482	-5.844	84.99
19Y	0.0112	0.1553	-0.01009	0.0144	0.0138	0.0230	-3.489	6.155	84.99
20X	0.0213	0.1606	-0.008143	-0.1124	0.0159	0.0380	3.521	-10.34	84.99
20XY	0.02063	0.1568	-0.005391	-0.1167	0.0232	0.0411	-3.479	-10.34	84.99
20Y	0.00976	0.1568	-0.01102	-0.0881	0.0112	0.0204	-3.49	10.66	84.99
21Y	0.01419	0.1516	-0.00942	-0.0081	0.0207	0.0330	-3.486	0.1516	79.99
22X	0.01774	0.1544	-0.01048	-0.0123	0.0197	0.0289	3.518	-5.846	79.99
22XY	0.01651	0.1505	-0.008762	-0.0205	0.0221	0.0327	-3.483	-5.849	79.99
22Y	0.009812	0.1507	-0.01058	0.0007	0.0193	0.0272	-3.49	6.151	79.99
23X	0.01932	0.1534	-0.006806	-0.1051	0.0217	0.0262	3.519	-10.35	79.99
23XY	0.01977	0.1494	-0.004136	-0.1132	0.0230	0.0350	-3.48	-10.35	80
23Y	0.008728	0.1497	-0.01193	-0.0734	0.0183	0.0155	-3.491	10.65	79.99
24Y	0.008278	0.1136	-0.006616	0.0013	0.0174	0.0265	-3.492	0.1136	69.99
25X	0.01102	0.1167	-0.009961	0.0305	0.0220	0.0363	3.511	-5.883	69.99
25XY	0.01107	0.1136	-0.007556	0.0226	0.0217	0.0364	-3.489	-5.886	69.99
25Y	0.005561	0.1136	-0.005489	0.0315	0.0133	0.0155	-3.494	6.114	69.99
26X	0.01447	0.1188	-0.009217	-0.1114	0.0220	0.0451	3.514	-10.38	69.99
26XY	0.01452	0.1155	-0.006202	-0.1130	0.0247	0.0446	-3.485	-10.38	69.99
26Y	0.004989	0.1159	-0.005951	-0.1060	0.0101	0.0062	-3.495	10.62	69.99
27Y	0.00958	0.1106	-0.006587	0.0123	0.0223	0.0271	-3.49	0.1106	64.99
28X	0.01245	0.1123	-0.01026	0.0079	0.0233	0.0199	3.512	-5.888	64.99
28XY	0.0112	0.1092	-0.008074	0.0012	0.0230	0.0258	-3.489	-5.891	64.99
28Y	0.005694	0.1089	-0.005963	0.0099	0.0215	0.0235	-3.494	6.109	64.99
29X	0.01329	0.1109	-0.007737	-0.1011	0.0269	0.0189	3.513	-10.39	64.99
29XY	0.01383	0.1078	-0.004839	-0.1058	0.0235	0.0242	-3.486	-10.39	65
29Y	0.004884	0.1073	-0.007427	-0.0875	0.0210	0.0118	-3.495	10.61	64.99
30Y	0.002857	0.06573	-0.006156	0.0056	0.0145	0.0193	-3.497	0.06573	54.99
31X	0.004919	0.06805	-0.00952	0.0420	0.0232	0.0298	3.505	-5.932	54.99

31XY	0.004951	0.06586	-0.00765	0.0336	0.0194	0.0322	-3.495	-5.934	54.99
31Y	0.0008116	0.06561	-0.004181	0.0437	0.0097	0.0091	-3.499	6.066	55
32X	0.008081	0.0707	-0.009587	-0.1107	0.0233	0.0462	3.508	-10.43	54.99
32XY	0.008084	0.06835	-0.007112	-0.1118	0.0228	0.0373	-3.492	-10.43	54.99
32Y	0.0009591	0.06822	-0.003771	-0.1004	0.0062	-0.0079	-3.499	10.57	55
33Y	0.004589	0.06286	-0.006125	0.0169	0.0194	0.0234	-3.495	0.06286	49.99
34X	0.006639	0.06336	-0.00984	0.0187	0.0172	0.0176	3.507	-5.937	49.99
34XY	0.005587	0.06106	-0.008187	0.0108	0.0194	0.0158	-3.494	-5.939	49.99
34Y	0.001293	0.06092	-0.004643	0.0230	0.0194	0.0137	-3.499	6.061	50
35X	0.007499	0.06181	-0.007778	-0.1110	0.0207	0.0184	3.507	-10.44	49.99
35XY	0.00729	0.05949	-0.005393	-0.1139	0.0193	0.0134	-3.493	-10.44	49.99
35Y	0.001505	0.05921	-0.005393	-0.0911	0.0195	-0.0027	-3.498	10.56	49.99
36Y	0.001511	0.02595	-0.004433	-0.0220	0.0101	0.0155	-5.373	0.02595	40
37X	0.002769	0.02805	-0.005136	-0.0044	0.0154	0.0072	5.378	-5.222	39.99
37XY	0.003085	0.02598	-0.00285	-0.0060	0.0124	0.0203	-5.372	-5.224	40
37Y	0.0005154	0.02592	-0.00575	0.0001	0.0079	0.0017	-5.374	5.276	39.99
38X	0.003496	0.02886	-0.003536	-0.0618	0.0156	0.0150	5.378	-10.47	40
38XY	0.004781	0.02672	-0.001231	-0.0606	0.0146	0.0101	-5.37	-10.47	40
38Y	0.0003978	0.02668	-0.006634	-0.0522	0.0057	0.0150	-5.375	10.53	39.99
39Y	0.0008773	0.02146	-0.004222	-0.0143	0.0066	0.0122	-6.332	0.02146	35
40X	0.001921	0.02322	-0.005365	-0.0189	0.0102	0.0127	6.335	-5.227	34.99
40XY	0.001941	0.02085	-0.002689	-0.0220	0.0061	0.0113	-6.331	-5.229	35
40Y	-0.0002757	0.02105	-0.005625	-0.0172	0.0070	0.0125	-6.333	5.271	34.99
41X	0.002945	0.0225	-0.002141	-0.0597	0.0145	0.0080	6.336	-10.48	35
41XY	0.00309	0.02024	0.0005879	-0.0557	0.0056	0.0150	-6.33	-10.48	35
41Y	-0.001456	0.02064	-0.008001	-0.0410	0.0075	0.0144	-6.334	10.52	34.99
44X	0.001098	0.1939	-0.0201	0.0000	0.0000	0.0000	0.001098	-16.81	17.73
45X	0.004138	0.02627	-0.1039	0.0000	0.0000	0.0000	0.004138	-10.47	39.9
10X	0.006494	0.04287	0.005456	-0.2112	0.0210	-0.0120	4.463	-14.96	45.01
10XY	0.007132	0.04128	0.007566	-0.2031	0.0198	0.0411	-4.45	-14.96	45.01
10Y	-0.002281	0.04211	-0.01606	-0.1964	0.0143	0.0577	-4.459	15.04	44.98
11X	0.005075	0.02897	0.004479	-0.1177	0.0167	0.0186	5.42	-14.97	40
11XY	0.005142	0.02684	0.006707	-0.1177	0.0155	0.0066	-5.41	-14.97	40.01
11Y	-0.00198	0.02681	-0.01409	-0.1160	0.0047	0.0369	-5.417	15.03	39.99
12X	0.003618	0.02155	0.003635	-0.0730	0.0188	0.0136	6.376	-14.98	35
12XY	0.004162	0.01946	0.005828	-0.0658	0.0048	0.0077	-6.368	-14.98	35.01
12Y	-0.002729	0.01999	-0.01212	-0.0571	0.0082	0.0178	-6.375	15.02	34.99
13S	-0.0005747	0.008803	-0.01011	-0.0557	-0.0129	-0.0015	8.541	16.33	23.66
42S	0.0001304	0.009383	-0.001773	-0.0077	0.0003	0.0015	8.541	0.009383	23.67
43S	-0.001805	0.02877	-0.01494	-0.1179	0.0089	0.0111	-0.001805	15.03	39.99
46S	0.001381	0.009318	-0.2062	0.0000	0.0000	0.0000	0.001381	-8.15	23.46
47S	0.0001336	0.008383	-0.1828	0.0000	0.0000	0.0000	0.0001336	8.168	23.49
13X	0.0006952	0.01043	0.002394	-0.0453	0.0135	0.0089	8.542	-16.31	23.67
13XY	0.003168	0.008845	0.004219	-0.0387	0.0039	0.0042	-8.538	-16.31	23.67
13Y	-0.0001779	0.007217	-0.009301	-0.0472	-0.0109	0.0111	-8.541	16.33	23.66
42Y	0.001386	0.007583	-0.001343	-0.0141	-0.0035	0.0050	-8.54	0.007583	23.67
43X	0.005113	0.02743	0.005798	-0.1177	0.0096	0.0106	0.005113	-14.97	40.01

Joint Support Reactions for Load Case "NESC Heavy":

Joint Label	X Force (kips)	X Usage %	Y Force (kips)	Y Usage %	Y H-Shear Usage %	Z Comp. Force (kips)	Z Usage %	Uplift Usage %	Result. Force (kips)	Result. Usage %	X X-M. Moment (ft-k)	X Usage %	Y Y-M. Moment (ft-k)	Y Usage %	H-Bend-M Usage (ft-k)	Z Z-M. Moment (ft-k)	Z Usage %	Max. Usage %
14P	-24.26	0.0	-35.45	0.0	0.0	-128.21	0.0	0.0	135.22	0.0	-0.00	0.0	0.1	0.0	0.0	-0.05	0.0	0.0
14X	11.27	0.0	-19.18	0.0	0.0	50.65	0.0	0.0	55.32	0.0	0.42	0.0	0.0	0.0	0.0	-0.03	0.0	0.0
14XY	-15.94	0.0	-19.92	0.0	0.0	70.77	0.0	0.0	75.23	0.0	0.28	0.0	-0.2	0.0	0.0	-0.02	0.0	0.0
14Y	22.06	0.0	-29.06	0.0	0.0	-114.56	0.0	0.0	120.23	0.0	-0.08	0.0	-0.3	0.0	0.0	-0.04	0.0	0.0

Joint Displacements, Loads and Member Forces on Joints for Load Case "NESC Heavy":

Joint Label	X External Load (kips)	Y External Load (kips)	Z External Load (kips)	X Member Force (kips)	Y Member Force (kips)	Z Member Force (kips)	X Disp. (ft)	Y Disp. (ft)	Z Disp. (ft)
1P	0.0072	4.0562	-1.4278	-0.0072	-4.0562	1.4278	0.0099	0.1879	-0.0211
2P	-1.5770	2.5450	-2.4207	1.5770	-2.5450	2.4207	0.0077	0.1616	-0.0229
3P	0.0000	0.1370	-0.9456	-0.0000	-0.1370	0.9456	0.0064	0.1532	-0.0229
4P	0.0000	0.0000	-0.2170	0.0000	-0.0000	0.2170	0.0057	0.1392	-0.0228
5P	0.0000	0.1370	-0.9209	-0.0000	-0.1370	0.9209	0.0043	0.1204	-0.0215
6P	0.0000	0.0000	-0.3439	-0.0000	-0.0000	0.3439	0.0027	0.1105	-0.0210
7P	0.8920	-1.2840	-4.6625	-0.8920	1.2840	4.6625	0.0023	0.0923	-0.0207
8P	0.0000	0.0000	-0.3936	-0.0000	-0.0000	0.3936	0.0009	0.0722	-0.0194
9P	0.0000	0.1370	-1.1204	0.0000	-0.1370	1.1204	-0.0006	0.0614	-0.0186
14P	0.0000	0.0000	-1.0434	24.2621	35.4550	-127.1657	0.0000	0.0000	0.0000
15P	10.5343	3.2218	-1.2423	-10.5343	-3.2218	1.2423	0.0041	0.1532	-0.0376
16P	10.4530	3.1996	-1.2523	-10.4530	-3.1996	1.2523	0.0003	0.1105	-0.0383
17P	10.6172	3.2456	-1.2383	-10.6172	-3.2456	1.2383	-0.0023	0.0615	-0.0372
18P	0.0000	0.0000	-0.0917	-0.0000	-0.0000	0.0917	0.0145	0.1591	-0.0110
19P	0.0000	0.0000	-0.1262	-0.0000	-0.0000	0.1262	0.0111	0.1589	-0.0112
20P	0.0000	0.0000	-0.1027	-0.0000	-0.0000	0.1027	0.0092	0.1603	-0.0125
21P	0.0000	0.0000	-0.1504	-0.0000	-0.0000	0.1504	0.0137	0.1553	-0.0110
22P	11.0119	3.3191	-1.2501	-11.0119	-3.3191	1.2501	0.0119	0.1543	-0.0115
23P	0.0000	0.0000	-0.1874	0.0000	-0.0000	0.1874	0.0086	0.1531	-0.0134
24P	0.0000	0.0000	-0.1077	-0.0000	-0.0000	0.1077	0.0082	0.1166	-0.0086
25P	0.0000	0.0000	-0.1666	-0.0000	-0.0000	0.1666	0.0055	0.1166	-0.0070
26P	0.0000	0.0000	-0.1304	0.0000	-0.0000	0.1304	0.0049	0.1189	-0.0074
27P	0.0000	0.0000	-0.1971	0.0000	-0.0000	0.1971	0.0091	0.1137	-0.0086
28P	11.5742	3.4571	-1.2570	-11.5742	-3.4571	1.2570	0.0080	0.1120	-0.0073
29P	0.0000	0.0000	-0.2239	0.0000	-0.0000	0.2239	0.0049	0.1104	-0.0089
30P	0.0000	0.0000	-0.1228	0.0000	-0.0000	0.1228	0.0028	0.0680	-0.0076
31P	0.0000	0.0000	-0.1964	0.0000	-0.0000	0.1964	0.0008	0.0678	-0.0052
32P	0.0000	0.0000	-0.1495	0.0000	-0.0000	0.1495	0.0009	0.0706	-0.0047
33P	0.0000	0.0000	-0.2368	0.0000	-0.0000	0.2368	0.0041	0.0652	-0.0075
34P	11.7808	3.5036	-1.2469	-11.7808	-3.5036	1.2469	0.0039	0.0632	-0.0054
35P	0.0000	0.0000	-0.2790	0.0000	-0.0000	0.2790	0.0007	0.0615	-0.0064
36P	0.0000	0.0000	-0.3349	0.0000	-0.0000	0.3349	0.0018	0.0280	-0.0065
37P	0.0000	0.0000	-0.3616	0.0000	-0.0000	0.3616	0.0003	0.0280	-0.0076
38P	0.0000	0.0000	-0.4381	0.0000	0.0000	0.4381	-0.0021	0.0288	-0.0081
39P	0.0000	0.0000	-0.3850	0.0000	-0.0000	0.3850	0.0008	0.0239	-0.0066
40P	0.0000	0.0000	-0.1962	0.0000	-0.0000	0.1962	-0.0003	0.0235	-0.0077
41P	0.0000	0.0000	-0.4307	0.0000	-0.0000	0.4307	-0.0014	0.0231	-0.0098
44P	0.0000	0.0000	-0.1966	-0.0000	-0.0000	0.1966	-0.0006	0.3095	0.0330
45P	0.0000	0.0000	-0.0848	0.0000	-0.0000	0.0848	-0.0009	0.0301	-0.1339
10P	0.0000	0.0000	-0.3664	0.0000	-0.0000	0.3664	0.0001	0.0444	-0.0176
11P	0.0000	0.1820	-1.3424	-0.0000	-0.1820	1.3424	-0.0017	0.0290	-0.0158
12P	0.0000	0.0000	-0.8067	0.0000	0.0000	0.8067	-0.0021	0.0224	-0.0139
1X	0.0077	5.1622	-1.8534	-0.0077	-5.1622	1.8534	0.0266	0.1922	0.0033
2X	0.5010	0.9078	-3.1198	-0.5010	-0.9078	3.1198	0.0238	0.1618	0.0036
2XY	-0.5010	0.9078	-3.0997	0.5010	-0.9078	3.0997	0.0240	0.1579	0.0063
2Y	1.5770	2.5450	-2.4408	-1.5770	-2.5450	2.4408	0.0077	0.1582	-0.0214
3X	0.0000	0.2219	-0.6016	-0.0000	-0.2219	0.6016	0.0223	0.1540	0.0042
3XY	0.0000	0.2219	-0.6016	-0.0000	-0.2219	0.6016	0.0219	0.1498	0.0069
3Y	0.0000	0.0750	-0.4296	-0.0000	-0.0750	0.4296	0.0067	0.1498	-0.0214
4X	0.0000	0.1240	-0.2170	0.0000	-0.1240	0.2170	0.0198	0.1375	0.0048
4XY	0.0000	0.1240	-0.2170	0.0000	-0.1240	0.2170	0.0198	0.1337	0.0076
4Y	0.0000	0.0000	-0.2170	0.0000	-0.0000	0.2170	0.0049	0.1360	-0.0213

5X	0.0000	0.2597	-0.5970	-0.0000	-0.2597	0.5970	0.0175	0.1201	0.0045
5XY	0.0000	0.2597	-0.5769	-0.0000	-0.2597	0.5769	0.0176	0.1168	0.0072
5Y	0.0000	0.0750	-0.4250	-0.0000	-0.0750	0.4250	0.0039	0.1174	-0.0200
6X	0.0000	0.1164	-0.3439	-0.0000	-0.1164	0.3439	0.0155	0.1113	0.0051
6XY	0.0000	0.1164	-0.3439	-0.0000	-0.1164	0.3439	0.0152	0.1081	0.0077
6Y	0.0000	0.0000	-0.3439	-0.0000	-0.0000	0.3439	0.0030	0.1073	-0.0195
7X	0.0330	0.3765	-2.7995	-0.0330	-0.3765	2.7995	0.0129	0.0918	0.0054
7XY	-0.0330	0.3765	-2.7995	0.0330	-0.3765	2.7995	0.0131	0.0893	0.0079
7Y	-0.8920	-1.3460	-4.1465	0.8920	1.3460	4.1465	0.0012	0.0893	-0.0192
8X	0.0000	0.1542	-0.4138	-0.0000	-0.1542	0.4138	0.0107	0.0723	0.0051
8XY	0.0000	0.1542	-0.3936	-0.0000	-0.1542	0.3936	0.0107	0.0699	0.0074
8Y	0.0000	0.0000	-0.4138	-0.0000	-0.0000	0.4138	0.0004	0.0698	-0.0180
9X	0.0000	0.2570	-0.7764	0.0000	-0.2570	0.7764	0.0087	0.0619	0.0054
9XY	0.0000	0.2570	-0.7764	0.0000	-0.2570	0.7764	0.0087	0.0595	0.0074
9Y	0.0000	0.0750	-0.6044	-0.0000	-0.0750	0.6044	-0.0001	0.0590	-0.0173
14X	0.0000	0.3452	-1.0434	-11.2703	18.8366	51.6888	0.0000	0.0000	0.0000
14XY	0.0000	0.3452	-1.0434	15.9412	19.5720	71.8112	0.0000	0.0000	0.0000
14Y	0.0000	0.0000	-1.0434	-22.0636	29.0554	-113.5162	0.0000	0.0000	0.0000
15X	11.0320	3.3614	-1.1966	-11.0320	-3.3614	1.1966	0.0275	0.1547	0.0109
15XY	-9.6911	3.0891	-2.0411	9.6911	-3.0891	2.0411	0.0259	0.1505	0.0120
15Y	-9.9014	3.1064	-2.0382	9.9014	-3.1064	2.0382	0.0025	0.1497	-0.0380
16X	12.0717	3.6045	-1.1604	-12.0717	-3.6045	1.1604	0.0202	0.1121	0.0132
16XY	-10.3779	3.2523	-2.0654	10.3779	-3.2523	2.0654	0.0184	0.1088	0.0138
16Y	-10.6214	3.2644	-2.0524	10.6214	-3.2644	2.0524	-0.0013	0.1072	-0.0391
17X	12.2889	3.6526	-1.1532	-12.2889	-3.6526	1.1532	0.0126	0.0627	0.0160
17XY	-10.6180	3.3073	-2.0738	10.6180	-3.3073	2.0738	0.0108	0.0602	0.0162
17Y	-11.4913	3.4742	-2.0976	11.4913	-3.4742	2.0976	-0.0040	0.0589	-0.0381
18Y	0.0000	0.0000	-0.0917	-0.0000	-0.0000	0.0917	0.0146	0.1554	-0.0094
19X	0.0000	0.0000	-0.1283	-0.0000	-0.0000	0.1283	0.0179	0.1592	-0.0102
19XY	0.0000	0.0000	-0.1262	-0.0000	-0.0000	0.1262	0.0180	0.1556	-0.0083
19Y	0.0000	0.0000	-0.1283	-0.0000	-0.0000	0.1283	0.0112	0.1553	-0.0101
20X	0.0000	0.0000	-0.1027	-0.0000	-0.0000	0.1027	0.0213	0.1606	-0.0081
20XY	0.0000	0.0000	-0.1027	-0.0000	-0.0000	0.1027	0.0206	0.1568	-0.0054
20Y	0.0000	0.0000	-0.1027	-0.0000	-0.0000	0.1027	0.0098	0.1568	-0.0110
21Y	0.0000	0.0000	-0.1504	-0.0000	-0.0000	0.1504	0.0142	0.1516	-0.0094
22X	10.3777	3.1738	-1.2274	-10.3777	-3.1738	1.2274	0.0177	0.1544	-0.0105
22XY	-10.0800	3.1401	-2.0685	10.0800	-3.1401	2.0685	0.0165	0.1505	-0.0088
22Y	-11.0658	3.3685	-2.1054	11.0658	-3.3685	2.1054	0.0098	0.1507	-0.0106
23X	0.0000	0.0000	-0.1874	-0.0000	-0.0000	0.1874	0.0193	0.1534	-0.0068
23XY	0.0000	0.0000	-0.1874	-0.0000	-0.0000	0.1874	0.0198	0.1494	-0.0041
23Y	0.0000	0.0000	-0.1874	0.0000	-0.0000	0.1874	0.0087	0.1497	-0.0119
24Y	0.0000	0.0000	-0.1077	-0.0000	-0.0000	0.1077	0.0083	0.1136	-0.0066
25X	0.0000	0.0000	-0.1688	0.0000	-0.0000	0.1688	0.0110	0.1167	-0.0100
25XY	0.0000	0.0000	-0.1666	0.0000	-0.0000	0.1666	0.0111	0.1136	-0.0076
25Y	0.0000	0.0000	-0.1688	-0.0000	-0.0000	0.1688	0.0056	0.1136	-0.0055
26X	0.0000	0.0000	-0.1304	-0.0000	-0.0000	0.1304	0.0145	0.1188	-0.0092
26XY	0.0000	0.0000	-0.1304	-0.0000	-0.0000	0.1304	0.0145	0.1155	-0.0062
26Y	0.0000	0.0000	-0.1304	0.0000	-0.0000	0.1304	0.0050	0.1159	-0.0060
27Y	0.0000	0.0000	-0.1971	0.0000	-0.0000	0.1971	0.0096	0.1106	-0.0066
28X	11.5683	3.4519	-1.1985	-11.5683	-3.4519	1.1985	0.0124	0.1123	-0.0103
28XY	-10.8006	3.3127	-2.1113	10.8006	-3.3127	2.1113	0.0112	0.1092	-0.0081
28Y	-11.0800	3.3757	-2.1103	11.0800	-3.3757	2.1103	0.0057	0.1089	-0.0060
29X	0.0000	0.0000	-0.2239	-0.0000	-0.0000	0.2239	0.0133	0.1109	-0.0077
29XY	0.0000	0.0000	-0.2239	-0.0000	-0.0000	0.2239	0.0138	0.1078	-0.0048
29Y	0.0000	0.0000	-0.2239	0.0000	-0.0000	0.2239	0.0049	0.1073	-0.0074
30Y	0.0000	0.0000	-0.1228	0.0000	-0.0000	0.1228	0.0029	0.0657	-0.0062
31X	0.0000	0.0000	-0.1985	0.0000	-0.0000	0.1985	0.0049	0.0681	-0.0095
31XY	0.0000	0.0000	-0.1964	0.0000	-0.0000	0.1964	0.0050	0.0659	-0.0077
31Y	0.0000	0.0000	-0.1985	0.0000	-0.0000	0.1985	0.0008	0.0656	-0.0042

32X	0.0000	0.0000	-0.1495	-0.0000	-0.0000	0.1495	0.0081	0.0707	-0.0096
32XY	0.0000	0.0000	-0.1495	0.0000	-0.0000	0.1495	0.0081	0.0683	-0.0071
32Y	0.0000	0.0000	-0.1495	0.0000	-0.0000	0.1495	0.0010	0.0682	-0.0038
33Y	0.0000	0.0000	-0.2368	0.0000	-0.0000	0.2368	0.0046	0.0629	-0.0061
34X	11.6313	3.4706	-1.2111	-11.6313	-3.4706	1.2111	0.0066	0.0634	-0.0098
34XY	-11.2651	3.4216	-2.1438	11.2651	-3.4216	2.1438	0.0056	0.0611	-0.0082
34Y	-11.0943	3.3849	-2.1319	11.0943	-3.3849	2.1319	0.0013	0.0609	-0.0046
35X	0.0000	0.0000	-0.2790	-0.0000	-0.0000	0.2790	0.0075	0.0618	-0.0078
35XY	0.0000	0.0000	-0.2790	-0.0000	-0.0000	0.2790	0.0073	0.0595	-0.0054
35Y	0.0000	0.0000	-0.2790	0.0000	-0.0000	0.2790	0.0015	0.0592	-0.0054
36Y	0.0000	0.0000	-0.3349	0.0000	-0.0000	0.3349	0.0015	0.0259	-0.0044
37X	0.0000	0.0000	-0.3616	0.0000	0.0000	0.3616	0.0028	0.0281	-0.0051
37XY	0.0000	0.0000	-0.3616	0.0000	0.0000	0.3616	0.0031	0.0260	-0.0029
37Y	0.0000	0.0000	-0.3616	0.0000	-0.0000	0.3616	0.0005	0.0259	-0.0057
38X	0.0000	0.1018	-0.4381	0.0000	-0.1018	0.4381	0.0035	0.0289	-0.0035
38XY	0.0000	0.1018	-0.4381	-0.0000	-0.1018	0.4381	0.0048	0.0267	-0.0012
38Y	0.0000	0.0000	-0.4381	-0.0000	0.0000	0.4381	0.0004	0.0267	-0.0066
39Y	0.0000	0.0000	-0.3850	0.0000	-0.0000	0.3850	0.0009	0.0215	-0.0042
40X	0.0000	0.0000	-0.1962	0.0000	-0.0000	0.1962	0.0019	0.0232	-0.0054
40XY	0.0000	0.0000	-0.1962	0.0000	-0.0000	0.1962	0.0019	0.0208	-0.0027
40Y	0.0000	0.0000	-0.1962	0.0000	-0.0000	0.1962	-0.0003	0.0210	-0.0056
41X	0.0000	0.0746	-0.4307	0.0000	-0.0746	0.4307	0.0029	0.0225	-0.0021
41XY	0.0000	0.0746	-0.4307	0.0000	-0.0746	0.4307	0.0031	0.0202	0.0006
41Y	0.0000	0.0000	-0.4307	0.0000	-0.0000	0.4307	-0.0015	0.0206	-0.0080
44X	0.0000	0.2595	-0.1966	0.0000	-0.2595	0.1966	0.0011	0.1939	-0.0201
45X	0.0000	0.0000	-0.0848	0.0000	-0.0000	0.0848	0.0041	0.0263	-0.1039
10X	0.0000	0.1938	-0.3664	0.0000	-0.1938	0.3664	0.0065	0.0429	0.0055
10XY	0.0000	0.1938	-0.3664	0.0000	-0.1938	0.3664	0.0071	0.0413	0.0076
10Y	0.0000	0.0000	-0.3664	0.0000	0.0000	0.3664	-0.0023	0.0421	-0.0161
11X	0.0000	0.3633	-0.8864	-0.0000	-0.3633	0.8864	0.0051	0.0290	0.0045
11XY	0.0000	0.3633	-0.8864	-0.0000	-0.3633	0.8864	0.0051	0.0268	0.0067
11Y	0.0000	0.1000	-0.6584	0.0000	-0.1000	0.6584	-0.0020	0.0268	-0.0141
12X	0.0000	0.3792	-0.8067	-0.0000	-0.3792	0.8067	0.0036	0.0216	0.0036
12XY	0.0000	0.3792	-0.8067	0.0000	-0.3792	0.8067	0.0042	0.0195	0.0058
12Y	0.0000	0.0000	-0.8067	-0.0000	0.0000	0.8067	-0.0027	0.0200	-0.0121
13S	0.0000	0.4360	-3.1544	-0.0000	-0.4360	3.1544	-0.0006	0.0088	-0.0101
42S	0.0000	0.0000	-1.4613	-0.0000	0.0000	1.4613	0.0001	0.0094	-0.0018
43S	0.0000	0.0000	-0.1790	0.0000	-0.0000	0.1790	-0.0018	0.0288	-0.0149
46S	0.0000	0.0000	-0.0908	0.0000	0.0000	0.0908	0.0014	0.0093	-0.2062
47S	0.0000	0.0000	-0.0908	0.0000	0.0000	0.0908	0.0001	0.0084	-0.1828
13X	0.0000	0.9998	-2.0614	-0.0000	-0.9998	2.0614	0.0007	0.0104	0.0024
13XY	0.0000	0.9998	-2.0614	-0.0000	-0.9998	2.0614	0.0032	0.0088	0.0042
13Y	0.0000	0.2390	-1.5144	0.0000	-0.2390	1.5144	-0.0002	0.0072	-0.0093
42Y	0.0000	0.0000	-1.4613	0.0000	0.0000	1.4613	0.0014	0.0076	-0.0013
43X	0.0000	0.1689	-0.1790	0.0000	-0.1689	0.1790	0.0051	0.0274	0.0058

Crossing Diagonal Check for Load Case "NESC Heavy" (RLOUT controls):

Comp. Member Label	Tens. Member Label	Connect Leg for Comp. Member	Force In Comp. Member (kips)	Force In Tens. Member (kips)	-----Original-----						-----Alternate-----							
					-----Supported-----						-----Unsupported-----							
					L/R	RLX	RLY	RLZ	L/R	KL/R	Curve	No.	L/R	RLOUT	L/R	KL/R	Curve	No.
					Cap.						Cap.							
					(kips)						(kips)							
15P	15Y	Short only	-0.13	-0.35	12.29	0.750	0.500	0.500	131.00	128.42	5	9.14	1.000	167.31	149.09	6		
15X	15XY	Short only	-0.68	-0.53	12.29	0.750	0.500	0.500	131.00	128.42	5	9.14	1.000	167.31	149.09	6		
15XY	15X	Short only	-0.53	-0.68	12.29	0.750	0.500	0.500	131.00	128.42	5	9.14	1.000	167.31	149.09	6		
15Y	15P	Short only	-0.35	-0.13	12.29	0.750	0.500	0.500	131.00	128.42	5	9.14	1.000	167.31	149.09	6		
16XY	16X	Short only	-1.81	0.20	25.86	0.750	0.500	0.500	105.12	108.84	2	20.50	1.000	134.24	128.76	6		

17P	17Y Short only	-0.42	-1.17	25.86	0.750	0.500	0.500	105.12	108.84	2	20.50	1.000	134.24	128.76	6
17Y	17P Short only	-1.17	-0.42	25.86	0.750	0.500	0.500	105.12	108.84	2	20.50	1.000	134.24	128.76	6
18P	18Y Short only	-0.42	-1.35	25.86	0.750	0.500	0.500	105.12	108.84	2	20.50	1.000	134.24	128.76	6
18XY	18X Short only	-1.71	0.16	25.86	0.750	0.500	0.500	105.12	108.84	2	20.50	1.000	134.24	128.76	6
18Y	18P Short only	-1.35	-0.42	25.86	0.750	0.500	0.500	105.12	108.84	2	20.50	1.000	134.24	128.76	6
21P	21Y Short only	-1.93	-2.62	43.23	0.750	0.500	0.500	87.63	95.72	2	35.96	1.000	111.96	115.98	3
21Y	21P Short only	-2.62	-1.93	43.23	0.750	0.500	0.500	87.63	95.72	2	35.96	1.000	111.96	115.98	3

Summary of Clamp Capacities and Usages for Load Case "NESC Heavy":

Clamp Label	Force (kips)	Input Holding Capacity (kips)	Factored Holding Capacity (kips)	Usage %
C1	4.300	50.00	50.00	8.60
C2	5.485	50.00	50.00	10.97
C3	11.086	50.00	50.00	22.17
C4	11.595	50.00	50.00	23.19
C5	10.374	50.00	50.00	20.75
C6	10.576	50.00	50.00	21.15
C7	11.003	50.00	50.00	22.01
C8	12.652	50.00	50.00	25.30
C9	11.070	50.00	50.00	22.14
C10	11.300	50.00	50.00	22.60
C11	11.171	50.00	50.00	22.34
C12	12.872	50.00	50.00	25.74
C13	11.313	50.00	50.00	22.63
C14	12.187	50.00	50.00	24.37
C15	11.569	50.00	50.00	23.14
C16	10.921	50.00	50.00	21.84
C17	10.759	50.00	50.00	21.52
C18	11.757	50.00	50.00	23.51
C19	12.145	50.00	50.00	24.29
C20	12.132	50.00	50.00	24.26
C21	11.493	50.00	50.00	22.99
C22	11.773	50.00	50.00	23.55
C23	12.354	50.00	50.00	24.71
C24	12.198	50.00	50.00	24.40
C25	11.967	50.00	50.00	23.93
C26	11.793	50.00	50.00	23.59
C27	0.641	50.00	50.00	1.28
C28	0.633	50.00	50.00	1.27
C29	2.825	50.00	50.00	5.65
C30	0.818	50.00	50.00	1.64
C31	0.958	50.00	50.00	1.92
C32	2.291	50.00	50.00	4.58
C34	0.436	50.00	50.00	0.87
C35	0.432	50.00	50.00	0.86
C36	4.450	50.00	50.00	8.90
C37	0.609	50.00	50.00	1.22
C38	0.666	50.00	50.00	1.33
C39	1.533	50.00	50.00	3.07
C41	0.641	50.00	50.00	1.28
C42	0.955	50.00	50.00	1.91
C43	2.825	50.00	50.00	5.65
C44	4.918	50.00	50.00	9.84

C45	3.288	50.00	50.00	6.58
C46	3.269	50.00	50.00	6.54
C47	3.863	50.00	50.00	7.73
C48	3.850	50.00	50.00	7.70
C49	0.651	50.00	50.00	1.30
C50	0.931	50.00	50.00	1.86
C51	0.818	50.00	50.00	1.64
C52	1.129	50.00	50.00	2.26
C53	0.958	50.00	50.00	1.92
C54	1.355	50.00	50.00	2.71
C55	2.291	50.00	50.00	4.58
C56	3.184	50.00	50.00	6.37

Equilibrium Joint Positions and Rotations for Load Case "NESC Extreme":

Joint Label	X-Displ (ft)	Y-Displ (ft)	Z-Displ (ft)	X-Rot (deg)	Y-Rot (deg)	Z-Rot (deg)	X-Pos (ft)	Y-Pos (ft)	Z-Pos (ft)
1P	0.0004622	0.2033	-0.01725	0.0000	0.0000	0.0000	0.0004622	14.2	93.98
2P	-0.0001089	0.178	-0.01927	-0.1118	-0.0031	0.0140	3.5	15.18	84.98
3P	0.0001964	0.1678	-0.01961	-0.1473	-0.0038	0.0111	3.5	15.17	79.98
4P	0.0005318	0.1501	-0.01987	-0.2591	-0.0023	0.0054	3.501	15.15	74.98
5P	0.0003704	0.128	-0.01866	-0.1842	0.0085	-0.0003	3.5	15.13	69.98
6P	-0.0001067	0.1165	-0.01839	-0.2134	-0.0095	-0.0038	3.5	15.12	64.98
7P	0.000683	0.0952	-0.0182	-0.2623	-0.0022	-0.0129	3.501	15.1	59.98
8P	0.0001373	0.07469	-0.01703	-0.1716	0.0109	-0.0220	3.5	15.07	54.98
9P	-0.0003033	0.0637	-0.01641	-0.1467	-0.0078	-0.0372	3.5	15.06	49.98
14P	0	0	0	0.0000	0.0000	0.0000	13.07	19.07	0
15P	-0.00111	0.1679	-0.03446	-0.1087	-0.0038	0.0105	3.499	22.17	79.97
16P	-0.001298	0.1167	-0.03563	-0.1051	-0.0094	0.0165	3.499	22.12	64.96
17P	-0.001077	0.06386	-0.03324	-0.1333	-0.0076	0.0280	3.499	22.06	49.97
18P	0.003289	0.1744	-0.005509	-0.0042	0.0015	0.0176	3.503	0.1744	84.99
19P	0.001435	0.1743	-0.00533	0.0089	-0.0004	0.0098	3.501	6.174	84.99
20P	0.001006	0.1762	-0.007494	-0.1072	-0.0017	0.0088	3.501	10.68	84.99
21P	0.004272	0.1702	-0.005478	0.0013	0.0030	0.0133	3.504	0.1702	79.99
22P	0.003459	0.1689	-0.005423	0.0012	0.0003	0.0161	3.503	6.169	79.99
23P	0.001544	0.1676	-0.007895	-0.0989	-0.0017	0.0244	3.502	10.67	79.99
24P	0.0008001	0.1236	-0.003951	0.0083	0.0063	0.0138	3.501	0.1236	70
25P	-0.0006297	0.1236	-0.001778	0.0441	0.0072	0.0018	3.499	6.124	70
26P	-3.477e-006	0.1263	-0.002049	-0.1259	0.0078	-0.0099	3.5	10.63	70
27P	0.003331	0.1203	-0.00392	0.0228	0.0036	0.0087	3.503	0.1203	65
28P	0.002977	0.1183	-0.00185	0.0154	-0.0015	0.0118	3.503	6.118	65
29P	0.001206	0.1165	-0.003965	-0.1085	-0.0054	0.0274	3.501	10.62	65
30P	-0.0004515	0.07056	-0.004023	0.0036	0.0076	0.0101	3.5	0.07056	55
31P	-0.001433	0.07045	-0.002164	0.0420	0.0089	-0.0034	3.499	6.07	55
32P	-0.0005397	0.07311	-0.002106	-0.1093	0.0100	-0.0087	3.499	10.57	55
33P	0.001946	0.06737	-0.003993	0.0159	0.0034	0.0014	3.502	0.06737	50
34P	0.002109	0.06538	-0.002224	0.0192	-0.0009	0.0111	3.502	6.065	50
35P	0.0002041	0.06372	-0.003828	-0.1034	-0.0042	0.0294	3.5	10.56	50
36P	0.001593	0.02961	-0.003378	-0.0226	0.0025	0.0038	5.377	0.02961	40
37P	0.0004614	0.0296	-0.004845	-0.0028	0.0021	0.0301	5.375	5.28	40
38P	-0.002247	0.03042	-0.00604	-0.0553	0.0016	0.0001	5.373	10.53	39.99
39P	0.000992	0.02514	-0.003416	-0.0140	0.0045	0.0043	6.334	0.02514	35
40P	0.0005821	0.02468	-0.004868	-0.0178	0.0007	0.0053	6.334	5.275	35
41P	0.0001508	0.02422	-0.007366	-0.0444	-0.0030	0.0022	6.333	10.52	34.99
44P	-0.0002959	0.3482	0.03837	0.0000	0.0000	0.0000	-0.0002959	17.36	17.79
45P	0.0002596	0.03499	-0.1902	0.0000	0.0000	0.0000	0.0002596	10.53	39.81
10P	0.0008207	0.04613	-0.01549	-0.2038	-0.0060	-0.0525	4.458	15.05	44.98
11P	0.0001204	0.03059	-0.01369	-0.1178	0.0004	-0.0404	5.415	15.03	39.99
12P	0.000456	0.02346	-0.01188	-0.0624	-0.0066	-0.0125	6.372	15.02	34.99
1X	0.009979	0.208	0.008204	0.0000	0.0000	0.0000	0.009979	-13.79	94.01
2X	0.009693	0.1779	0.009968	-0.1082	0.0059	0.0216	3.51	-14.82	85.01
2XY	0.009224	0.1757	0.01077	-0.1083	0.0059	0.0196	-3.491	-14.82	85.01
2Y	0.000852	0.1761	-0.01928	-0.1128	0.0040	0.0134	-3.499	15.18	84.98
3X	0.009069	0.1679	0.01052	-0.1534	0.0097	0.0222	3.509	-14.83	80.01
3XY	0.008738	0.1657	0.01137	-0.1516	0.0053	0.0171	-3.491	-14.83	80.01
3Y	0.000451	0.1658	-0.01957	-0.1479	0.0054	0.0162	-3.5	15.17	79.98
4X	0.008036	0.149	0.0111	-0.2632	0.0122	0.0209	3.508	-14.85	75.01

4XY	0.008267	0.1469	0.01197	-0.2604	0.0061	0.0198	-3.492	-14.85	75.01
4Y	-3.042e-005	0.1483	-0.0198	-0.2559	0.0044	0.0142	-3.5	15.15	74.98
5X	0.007265	0.1278	0.01033	-0.1703	0.0041	0.0196	3.507	-14.87	70.01
5XY	0.007494	0.126	0.01122	-0.1682	0.0131	0.0226	-3.493	-14.87	70.01
5Y	-2.908e-005	0.1264	-0.0186	-0.1844	-0.0060	0.0122	-3.5	15.13	69.98
6X	0.006771	0.1171	0.01052	-0.2105	0.0164	0.0108	3.507	-14.88	65.01
6XY	0.006452	0.1154	0.01142	-0.2067	0.0037	0.0177	-3.494	-14.88	65.01
6Y	0.0002305	0.1148	-0.01831	-0.2125	0.0113	0.0222	-3.5	15.11	64.98
7X	0.005354	0.09579	0.01066	-0.2648	0.0124	0.0048	3.505	-14.9	60.01
7XY	0.006096	0.09444	0.01152	-0.2616	0.0079	0.0222	-3.494	-14.91	60.01
7Y	-0.0006898	0.09373	-0.01811	-0.2578	0.0037	0.0272	-3.501	15.09	59.98
8X	0.004759	0.07504	0.009966	-0.1717	0.0039	-0.0012	3.505	-14.92	55.01
8XY	0.004997	0.07386	0.01075	-0.1712	0.0147	0.0266	-3.495	-14.93	55.01
8Y	-0.0002659	0.07357	-0.01696	-0.1702	-0.0092	0.0323	-3.5	15.07	54.98
9X	0.004178	0.06391	0.009818	-0.1579	0.0140	-0.0150	3.504	-14.94	50.01
9XY	0.004042	0.06283	0.01047	-0.1528	0.0030	0.0327	-3.496	-14.94	50.01
9Y	3.957e-005	0.06254	-0.01632	-0.1453	0.0087	0.0492	-3.5	15.06	49.98
14X	0	0	0	0.0000	0.0000	0.0000	13.07	-19.07	0
14XY	0	0	0	0.0000	0.0000	0.0000	-13.07	-19.07	0
14Y	0	0	0	0.0000	0.0000	0.0000	-13.07	19.07	0
15X	0.01184	0.1684	0.02246	-0.0701	0.0098	0.0229	3.512	-21.83	80.02
15XY	0.01087	0.1662	0.02181	-0.0525	0.0053	0.0176	-3.489	-21.83	80.02
15Y	-0.002011	0.1659	-0.036	-0.1277	0.0055	0.0221	-3.502	22.17	79.96
16X	0.009087	0.1176	0.02391	-0.0594	0.0165	0.0229	3.509	-21.88	65.02
16XY	0.008072	0.1159	0.02318	-0.0413	0.0037	0.0110	-3.492	-21.88	65.02
16Y	-0.002209	0.1148	-0.03717	-0.1255	0.0113	0.0188	-3.502	22.11	64.96
17X	0.00596	0.06437	0.02404	-0.0958	0.0141	0.0293	3.506	-21.94	50.02
17XY	0.004946	0.0633	0.02323	-0.0804	0.0029	-0.0052	-3.495	-21.94	50.02
17Y	-0.001999	0.06256	-0.03477	-0.1540	0.0085	0.0005	-3.502	22.06	49.97
18Y	0.003329	0.1724	-0.005406	-0.0069	0.0049	0.0191	-3.497	0.1724	84.99
19X	0.005168	0.1744	-0.005347	0.0087	0.0033	0.0269	3.505	-5.826	84.99
19XY	0.005208	0.1724	-0.004984	0.0022	0.0054	0.0219	-3.495	-5.828	85
19Y	0.001477	0.1723	-0.005532	0.0097	0.0045	0.0084	-3.499	6.172	84.99
20X	0.007731	0.1763	-0.002993	-0.1213	0.0046	0.0311	3.508	-10.32	85
20XY	0.007264	0.1741	-0.002066	-0.1238	0.0056	0.0280	-3.493	-10.33	85
20Y	0.001356	0.1743	-0.00745	-0.1053	0.0042	0.0005	-3.499	10.67	84.99
21Y	0.004602	0.1681	-0.005373	-0.0015	0.0054	0.0200	-3.495	0.1681	79.99
22X	0.006437	0.1688	-0.005454	-0.0054	0.0057	0.0159	3.506	-5.831	79.99
22XY	0.005968	0.1667	-0.005238	-0.0108	0.0054	0.0183	-3.494	-5.833	79.99
22Y	0.002013	0.1669	-0.005773	0.0014	0.0054	0.0151	-3.498	6.167	79.99
23X	0.007343	0.1675	-0.002059	-0.1128	0.0077	0.0156	3.507	-10.33	80
23XY	0.007729	0.1653	-0.001215	-0.1179	0.0053	0.0176	-3.492	-10.33	80
23Y	0.00151	0.1657	-0.007922	-0.0951	0.0054	0.0071	-3.498	10.67	79.99
24Y	0.0008324	0.122	-0.003605	0.0058	0.0035	0.0140	-3.499	0.122	70
25X	0.002274	0.1235	-0.005974	0.0432	0.0055	0.0263	3.502	-5.876	69.99
25XY	0.002309	0.122	-0.005314	0.0377	0.0074	0.0259	-3.498	-5.878	69.99
25Y	-0.0005906	0.122	-0.001744	0.0417	-0.0004	0.0013	-3.501	6.122	70
26X	0.005069	0.1262	-0.005761	-0.1237	0.0048	0.0362	3.505	-10.37	69.99
26XY	0.005101	0.1245	-0.004693	-0.1251	0.0102	0.0373	-3.495	-10.38	70
26Y	4.656e-005	0.1247	-0.002083	-0.1250	-0.0032	-0.0087	-3.5	10.62	70
27Y	0.003578	0.1186	-0.003572	0.0200	0.0075	0.0164	-3.496	0.1186	65
28X	0.00495	0.1185	-0.006092	0.0147	0.0088	0.0099	3.505	-5.882	64.99
28XY	0.004565	0.1169	-0.005583	0.0100	0.0060	0.0144	-3.495	-5.883	64.99
28Y	0.001317	0.1166	-0.00196	0.0137	0.0090	0.0131	-3.499	6.117	65
29X	0.005435	0.1169	-0.003821	-0.1096	0.0126	0.0121	3.505	-10.38	65
29XY	0.005914	0.1153	-0.00282	-0.1131	0.0048	0.0100	-3.494	-10.38	65
29Y	0.001023	0.1148	-0.003975	-0.1064	0.0101	0.0016	-3.499	10.61	65
30Y	-0.0004391	0.06954	-0.00382	0.0011	0.0027	0.0091	-3.5	0.06954	55
31X	0.0005715	0.07066	-0.005497	0.0392	0.0062	0.0204	3.501	-5.929	54.99

31XY	0.0005896	0.06967	-0.004946	0.0335	0.0076	0.0219	-3.499	-5.93	55
31Y	-0.001419	0.06942	-0.002262	0.0393	-0.0022	-0.0008	-3.501	6.069	55
32X	0.002984	0.07339	-0.005375	-0.1144	0.0051	0.0351	3.503	-10.43	54.99
32XY	0.00298	0.07228	-0.004424	-0.1153	0.0111	0.0299	-3.497	-10.43	55
32Y	-0.0004811	0.07202	-0.002286	-0.1074	-0.0058	-0.0187	-3.5	10.57	55
33Y	0.002216	0.06624	-0.003789	0.0130	0.0056	0.0146	-3.498	0.06624	50
34X	0.003043	0.06546	-0.005629	0.0149	0.0077	0.0100	3.503	-5.935	49.99
34XY	0.002807	0.06438	-0.005226	0.0097	0.0045	0.0061	-3.497	-5.936	49.99
34Y	0.0003618	0.0643	-0.002466	0.0172	0.0067	0.0055	-3.5	6.064	50
35X	0.003686	0.06389	-0.003494	-0.1116	0.0109	0.0120	3.504	-10.44	50
35XY	0.003377	0.06282	-0.002604	-0.1139	0.0037	0.0022	-3.497	-10.44	50
35Y	0.00089	0.06266	-0.00397	-0.1001	0.0076	-0.0105	-3.499	10.56	50
36Y	0.0009423	0.02877	-0.002884	-0.0247	0.0045	0.0073	-5.374	0.02877	40
37X	0.001466	0.0296	-0.001867	-0.0034	0.0029	-0.0120	5.376	-5.22	40
37XY	0.002086	0.02877	-0.001178	-0.0054	0.0063	0.0230	-5.373	-5.221	40
37Y	0.001065	0.02876	-0.004559	-0.0056	0.0027	-0.0191	-5.374	5.279	40
38X	0.0005121	0.03038	-0.0003692	-0.0641	0.0034	0.0099	5.376	-10.47	40
38XY	0.004016	0.02951	0.0004424	-0.0644	0.0080	0.0002	-5.371	-10.47	40
38Y	0.002782	0.02955	-0.005987	-0.0562	0.0009	0.0103	-5.372	10.53	39.99
39Y	0.001057	0.02408	-0.002833	-0.0166	0.0012	0.0048	-6.332	0.02408	35
40X	0.001432	0.02447	-0.001953	-0.0219	0.0083	0.0055	6.334	-5.226	35
40XY	0.001443	0.02347	-0.001131	-0.0245	-0.0008	0.0034	-6.332	-5.227	35
40Y	0.000628	0.02363	-0.004523	-0.0205	0.0033	0.0039	-6.332	5.274	35
41X	0.001754	0.0238	0.001453	-0.0582	0.0121	-0.0013	6.335	-10.48	35
41XY	0.001903	0.02284	0.002411	-0.0576	-0.0029	0.0093	-6.331	-10.48	35
41Y	0.0002234	0.02317	-0.007228	-0.0457	0.0054	0.0068	-6.333	10.52	34.99
44X	0.0007491	0.1748	-0.01736	0.0000	0.0000	0.0000	0.0007491	-16.83	17.73
45X	0.002261	0.02605	-0.1619	0.0000	0.0000	0.0000	0.002261	-10.47	39.84
10X	0.002708	0.0453	0.009431	-0.2138	0.0105	-0.0072	4.46	-14.95	45.01
10XY	0.004005	0.04461	0.01017	-0.2093	0.0064	0.0209	-4.453	-14.96	45.01
10Y	-0.00108	0.04519	-0.01537	-0.1991	0.0056	0.0628	-4.458	15.05	44.98
11X	0.002649	0.03052	0.008192	-0.1276	0.0047	0.0278	5.418	-14.97	40.01
11XY	0.002665	0.02965	0.008991	-0.1276	0.0085	-0.0175	-5.412	-14.97	40.01
11Y	-0.0003736	0.0297	-0.01359	-0.1167	0.0002	0.0502	-5.415	15.03	39.99
12X	0.001824	0.02292	0.006966	-0.0711	0.0157	0.0120	6.374	-14.98	35.01
12XY	0.002443	0.02203	0.007769	-0.0689	-0.0050	-0.0040	-6.37	-14.98	35.01
12Y	-0.0007711	0.02244	-0.01178	-0.0625	0.0074	0.0213	-6.373	15.02	34.99
13S	-0.0007155	0.009505	-0.00911	-0.0549	0.0025	-0.0091	8.54	16.33	23.66
42S	-0.0008037	0.009907	-0.001007	-0.0111	0.0068	0.0011	8.54	0.009907	23.67
43S	-0.0001298	0.03206	-0.01391	-0.1173	0.0006	0.0046	-0.0001298	15.03	39.99
46S	0.0008396	0.01058	-0.2867	0.0000	0.0000	0.0000	0.0008396	-8.149	23.38
47S	0.0001743	0.009589	-0.2626	0.0000	0.0000	0.0000	0.0001743	8.169	23.41
13X	-0.0004201	0.01192	0.004656	-0.0459	0.0112	0.0076	8.541	-16.31	23.67
13XY	0.002706	0.0111	0.005379	-0.0435	-0.0019	-0.0028	-8.539	-16.31	23.68
13Y	0.000185	0.008367	-0.009027	-0.0526	-0.0033	0.0147	-8.541	16.33	23.66
42Y	0.001816	0.008999	-0.0009413	-0.0139	-0.0026	0.0036	-8.539	0.008999	23.67
43X	0.002659	0.02882	0.008661	-0.1276	0.0030	0.0043	0.002659	-14.97	40.01

Joint Support Reactions for Load Case "NESC Extreme":

Joint Label	X Force (kips)	X Usage %	Y Force (kips)	Y Usage %	Y H-Shear Usage %	Z Comp. Force (kips)	Z Usage %	Uplift Usage %	Result. Force (kips)	Result. Usage %	X Moment (ft-k)	X-M. Usage %	Y Moment (ft-k)	Y-M. Usage %	H-Bend-M Usage %	Z Moment (ft-k)	Z-M. Usage %	Max. Usage %
14P	-21.42	0.0	-33.26	0.0	0.0	-116.21	0.0	0.0	122.76	0.0	0.05	0.0	0.3	0.0	0.0	0.04	0.0	0.0
14X	16.97	0.0	-25.42	0.0	0.0	79.66	0.0	0.0	85.33	0.0	0.52	0.0	0.1	0.0	0.0	-0.00	0.0	0.0
14XY	-19.24	0.0	-25.42	0.0	0.0	88.56	0.0	0.0	94.12	0.0	0.45	0.0	-0.2	0.0	0.0	-0.01	0.0	0.0
14Y	20.91	0.0	-30.61	0.0	0.0	-112.43	0.0	0.0	118.38	0.0	-0.04	0.0	-0.2	0.0	0.0	-0.04	0.0	0.0

Joint Displacements, Loads and Member Forces on Joints for Load Case "NESC Extreme":

Joint Label	X External Load (kips)	Y External Load (kips)	Z External Load (kips)	X Member Force (kips)	Y Member Force (kips)	Z Member Force (kips)	X Disp. (ft)	Y Disp. (ft)	Z Disp. (ft)
1P	0.0065	2.2122	-0.5209	-0.0065	-2.2122	0.5209	0.0005	0.2033	-0.0173
2P	-5.0030	8.1333	1.2668	5.0030	-8.1333	-1.2668	-0.0001	0.1780	-0.0193
3P	0.0000	0.5003	-0.2832	0.0000	-0.5003	0.2832	0.0002	0.1678	-0.0196
4P	0.0000	0.0663	-0.1252	0.0000	-0.0663	0.1252	0.0005	0.1501	-0.0199
5P	0.0000	0.5003	-0.2832	0.0000	-0.5003	0.2832	0.0004	0.1280	-0.0187
6P	0.0000	0.0663	-0.1252	0.0000	-0.0663	0.1252	-0.0001	0.1165	-0.0184
7P	2.3540	-3.2467	-4.5472	-2.3540	3.2467	4.5472	0.0007	0.0952	-0.0182
8P	0.0000	0.0663	-0.1252	0.0000	-0.0663	0.1252	0.0001	0.0747	-0.0170
9P	0.0000	0.7416	-0.5865	-0.0000	-0.7416	0.5865	-0.0003	0.0637	-0.0164
14P	0.0000	0.2413	-0.3033	21.4158	33.0163	-115.9052	0.0000	0.0000	0.0000
15P	6.1157	2.5704	-0.4527	-6.1157	-2.5704	0.4527	-0.0011	0.1679	-0.0345
16P	5.9072	2.4807	-0.4667	-5.9072	-2.4807	0.4667	-0.0013	0.1167	-0.0356
17P	5.7822	2.4085	-0.4644	-5.7822	-2.4085	0.4644	-0.0011	0.0639	-0.0332
18P	0.0000	0.0663	-0.1252	-0.0000	-0.0663	0.1252	0.0033	0.1744	-0.0055
19P	0.0000	0.0663	-0.1252	-0.0000	-0.0663	0.1252	0.0014	0.1743	-0.0053
20P	0.0000	0.0663	-0.1252	-0.0000	-0.0663	0.1252	0.0010	0.1762	-0.0075
21P	0.0000	0.0663	-0.1252	-0.0000	-0.0663	0.1252	0.0043	0.1702	-0.0055
22P	6.3519	2.6158	-0.4497	-6.3519	-2.6158	0.4497	0.0035	0.1689	-0.0054
23P	0.0000	0.0663	-0.1252	-0.0000	-0.0663	0.1252	0.0015	0.1676	-0.0079
24P	0.0000	0.0663	-0.1252	0.0000	-0.0663	0.1252	0.0008	0.1236	-0.0040
25P	0.0000	0.0663	-0.1252	0.0000	-0.0663	0.1252	-0.0006	0.1236	-0.0018
26P	0.0000	0.0663	-0.1252	-0.0000	-0.0663	0.1252	-0.0000	0.1263	-0.0020
27P	0.0000	0.0663	-0.1252	0.0000	-0.0663	0.1252	0.0033	0.1203	-0.0039
28P	6.4643	2.6116	-0.4490	-6.4643	-2.6116	0.4490	0.0030	0.1183	-0.0018
29P	0.0000	0.0663	-0.1252	-0.0000	-0.0663	0.1252	0.0012	0.1165	-0.0040
30P	0.0000	0.0663	-0.1252	0.0000	-0.0663	0.1252	-0.0005	0.0706	-0.0040
31P	0.0000	0.0663	-0.1252	0.0000	-0.0663	0.1252	-0.0014	0.0705	-0.0022
32P	0.0000	0.0663	-0.1252	-0.0000	-0.0663	0.1252	-0.0005	0.0731	-0.0021
33P	0.0000	0.0663	-0.1252	0.0000	-0.0663	0.1252	0.0019	0.0674	-0.0040
34P	6.3477	2.5357	-0.4422	-6.3477	-2.5357	0.4422	0.0021	0.0654	-0.0022
35P	0.0000	0.3076	-0.4285	-0.0000	-0.3076	0.4285	0.0002	0.0637	-0.0038
36P	0.0000	0.2413	-0.3033	0.0000	-0.2413	0.3033	0.0016	0.0296	-0.0034
37P	0.0000	0.2413	-0.3033	0.0000	-0.2413	0.3033	0.0005	0.0296	-0.0048
38P	0.0000	0.2413	-0.3033	0.0000	-0.2413	0.3033	-0.0022	0.0304	-0.0060
39P	0.0000	0.2413	-0.3033	0.0000	-0.2413	0.3033	0.0010	0.0251	-0.0034
40P	0.0000	0.2413	-0.3033	0.0000	-0.2413	0.3033	0.0006	0.0247	-0.0049
41P	0.0000	0.2413	-0.3033	-0.0000	-0.2413	0.3033	0.0002	0.0242	-0.0074
44P	0.0000	0.2413	-0.3033	-0.0000	-0.2413	0.3033	-0.0003	0.3482	0.0384
45P	0.0000	0.2413	-0.3033	0.0000	-0.2413	0.3033	0.0003	0.0350	-0.1902
10P	0.0000	0.2413	-0.3033	0.0000	-0.2413	0.3033	0.0008	0.0461	-0.0155
11P	0.0000	0.8163	-0.5133	0.0000	-0.8163	0.5133	0.0001	0.0306	-0.0137
12P	0.0000	0.2413	-0.3033	-0.0000	-0.2413	0.3033	0.0005	0.0235	-0.0119
1X	0.0101	3.5977	-0.6370	-0.0101	-3.5977	0.6370	0.0100	0.2080	0.0082
2X	3.0390	4.9793	-3.0642	-3.0390	-4.9793	3.0642	0.0097	0.1779	0.0100
2XY	-3.0390	4.9793	-3.0642	3.0390	-4.9793	3.0642	0.0092	0.1757	0.0108
2Y	5.0030	8.1333	1.2668	-5.0030	-8.1333	-1.2668	0.0009	0.1761	-0.0193
3X	0.0000	0.5003	-0.2042	-0.0000	-0.5003	0.2042	0.0091	0.1679	0.0105
3XY	0.0000	0.5003	-0.2042	-0.0000	-0.5003	0.2042	0.0087	0.1657	0.0114
3Y	0.0000	0.2833	-0.1652	0.0000	-0.2833	0.1652	0.0005	0.1658	-0.0196
4X	0.0000	0.0663	-0.1252	-0.0000	-0.0663	0.1252	0.0080	0.1490	0.0111
4XY	0.0000	0.0663	-0.1252	0.0000	-0.0663	0.1252	0.0083	0.1469	0.0120
4Y	0.0000	0.0663	-0.1252	0.0000	-0.0663	0.1252	-0.0000	0.1483	-0.0198

5X	0.0000	0.5003	-0.2042	0.0000	-0.5003	0.2042	0.0073	0.1278	0.0103
5XY	0.0000	0.5003	-0.2042	-0.0000	-0.5003	0.2042	0.0075	0.1260	0.0112
5Y	0.0000	0.2833	-0.1652	0.0000	-0.2833	0.1652	-0.0000	0.1264	-0.0186
6X	0.0000	0.0663	-0.1252	0.0000	-0.0663	0.1252	0.0068	0.1171	0.0105
6XY	0.0000	0.0663	-0.1252	-0.0000	-0.0663	0.1252	0.0065	0.1154	0.0114
6Y	0.0000	0.0663	-0.1252	0.0000	-0.0663	0.1252	0.0002	0.1148	-0.0183
7X	-1.0430	-1.1427	0.1768	1.0430	-1.1427	-0.1768	0.0054	0.0958	0.0107
7XY	1.0430	-1.1427	0.1768	-1.0430	1.1427	-0.1768	0.0061	0.0944	0.0115
7Y	-2.3540	-3.4637	-4.4292	2.3540	3.4637	4.4292	-0.0007	0.0937	-0.0181
8X	0.0000	0.0663	-0.1252	0.0000	-0.0663	0.1252	0.0048	0.0750	0.0100
8XY	0.0000	0.0663	-0.1252	-0.0000	-0.0663	0.1252	0.0050	0.0739	0.0107
8Y	0.0000	0.0663	-0.1252	-0.0000	-0.0663	0.1252	-0.0003	0.0736	-0.0170
9X	0.0000	0.7416	-0.5075	0.0000	-0.7416	0.5075	0.0042	0.0639	0.0098
9XY	0.0000	0.7416	-0.5075	-0.0000	-0.7416	0.5075	0.0040	0.0628	0.0105
9Y	0.0000	0.5246	-0.4685	0.0000	-0.5246	0.4685	0.0000	0.0625	-0.0163
14X	0.0000	0.2413	-0.3033	-16.9736	25.1794	79.9677	0.0000	0.0000	0.0000
14XY	0.0000	0.2413	-0.3033	19.2373	25.1759	88.8625	0.0000	0.0000	0.0000
14Y	0.0000	0.2413	-0.3033	-20.9130	30.3725	-112.1254	0.0000	0.0000	0.0000
15X	6.3890	2.6267	-0.4178	-6.3890	-2.6267	0.4178	0.0118	0.1684	0.0225
15XY	-5.7339	2.5228	-1.0313	5.7339	-2.5228	1.0313	0.0109	0.1662	0.0218
15Y	-5.8415	2.5510	-1.0349	5.8415	-2.5510	1.0349	-0.0020	0.1659	-0.0360
16X	6.7259	2.6675	-0.4027	-6.7259	-2.6675	0.4027	0.0091	0.1176	0.0239
16XY	-5.9350	2.5312	-1.0407	5.9350	-2.5312	1.0407	0.0081	0.1159	0.0232
16Y	-6.0493	2.5515	-1.0363	6.0493	-2.5515	1.0363	-0.0022	0.1148	-0.0372
17X	6.6007	2.5863	-0.4112	-6.6007	-2.5863	0.4112	0.0060	0.0644	0.0240
17XY	-5.8625	2.4677	-1.0347	5.8625	-2.4677	1.0347	0.0049	0.0633	0.0232
17Y	-6.2752	2.5608	-1.0553	6.2752	-2.5608	1.0553	-0.0020	0.0626	-0.0348
18Y	0.0000	0.0663	-0.1252	-0.0000	-0.0663	0.1252	0.0033	0.1724	-0.0054
19X	0.0000	0.0663	-0.1252	-0.0000	-0.0663	0.1252	0.0052	0.1744	-0.0053
19XY	0.0000	0.0663	-0.1252	-0.0000	-0.0663	0.1252	0.0052	0.1724	-0.0050
19Y	0.0000	0.0663	-0.1252	-0.0000	-0.0663	0.1252	0.0015	0.1723	-0.0055
20X	0.0000	0.0663	-0.1252	0.0000	-0.0663	0.1252	0.0077	0.1763	-0.0030
20XY	0.0000	0.0663	-0.1252	0.0000	-0.0663	0.1252	0.0073	0.1741	-0.0021
20Y	0.0000	0.0663	-0.1252	-0.0000	-0.0663	0.1252	0.0014	0.1743	-0.0074
21Y	0.0000	0.0663	-0.1252	-0.0000	-0.0663	0.1252	0.0046	0.1681	-0.0054
22X	6.0597	2.5565	-0.4281	-6.0597	-2.5565	0.4281	0.0064	0.1688	-0.0055
22XY	-5.9362	2.5718	-1.0418	5.9362	-2.5718	1.0418	0.0060	0.1667	-0.0052
22Y	-6.4426	2.6864	-1.0685	6.4426	-2.6864	1.0685	0.0020	0.1669	-0.0058
23X	0.0000	0.0663	-0.1252	0.0000	-0.0663	0.1252	0.0073	0.1675	-0.0021
23XY	0.0000	0.0663	-0.1252	0.0000	-0.0663	0.1252	0.0077	0.1653	-0.0012
23Y	0.0000	0.0663	-0.1252	-0.0000	-0.0663	0.1252	0.0015	0.1657	-0.0079
24Y	0.0000	0.0663	-0.1252	0.0000	-0.0663	0.1252	0.0008	0.1220	-0.0036
25X	0.0000	0.0663	-0.1252	-0.0000	-0.0663	0.1252	0.0023	0.1235	-0.0060
25XY	0.0000	0.0663	-0.1252	-0.0000	-0.0663	0.1252	0.0023	0.1220	-0.0053
25Y	0.0000	0.0663	-0.1252	0.0000	-0.0663	0.1252	-0.0006	0.1220	-0.0017
26X	0.0000	0.0663	-0.1252	0.0000	-0.0663	0.1252	0.0051	0.1262	-0.0058
26XY	0.0000	0.0663	-0.1252	0.0000	-0.0663	0.1252	0.0051	0.1245	-0.0047
26Y	0.0000	0.0663	-0.1252	-0.0000	-0.0663	0.1252	0.0000	0.1247	-0.0021
27Y	0.0000	0.0663	-0.1252	0.0000	-0.0663	0.1252	0.0036	0.1186	-0.0036
28X	6.4810	2.6155	-0.4092	-6.4810	-2.6155	0.4092	0.0050	0.1185	-0.0061
28XY	-6.1453	2.5839	-1.0524	6.1453	-2.5839	1.0524	0.0046	0.1169	-0.0056
28Y	-6.2820	2.6120	-1.0525	6.2820	-2.6120	1.0525	0.0013	0.1166	-0.0020
29X	0.0000	0.0663	-0.1252	0.0000	-0.0663	0.1252	0.0054	0.1169	-0.0038
29XY	0.0000	0.0663	-0.1252	0.0000	-0.0663	0.1252	0.0059	0.1153	-0.0028
29Y	0.0000	0.0663	-0.1252	-0.0000	-0.0663	0.1252	0.0010	0.1148	-0.0040
30Y	0.0000	0.0663	-0.1252	0.0000	-0.0663	0.1252	-0.0004	0.0695	-0.0038
31X	0.0000	0.0663	-0.1252	-0.0000	-0.0663	0.1252	0.0006	0.0707	-0.0055
31XY	0.0000	0.0663	-0.1252	-0.0000	-0.0663	0.1252	0.0006	0.0697	-0.0049
31Y	0.0000	0.0663	-0.1252	0.0000	-0.0663	0.1252	-0.0014	0.0694	-0.0023

32X	0.0000	0.0663	-0.1252	0.0000	-0.0663	0.1252	0.0030	0.0734	-0.0054
32XY	0.0000	0.0663	-0.1252	0.0000	-0.0663	0.1252	0.0030	0.0723	-0.0044
32Y	0.0000	0.0663	-0.1252	-0.0000	-0.0663	0.1252	-0.0005	0.0720	-0.0023
33Y	0.0000	0.0663	-0.1252	-0.0000	-0.0663	0.1252	0.0022	0.0662	-0.0038
34X	6.2976	2.5270	-0.4197	-6.2976	-2.5270	0.4197	0.0030	0.0655	-0.0056
34XY	-6.1731	2.5421	-1.0551	6.1731	-2.5421	1.0551	0.0028	0.0644	-0.0052
34Y	-6.0964	2.5286	-1.0459	6.0964	-2.5286	1.0459	0.0004	0.0643	-0.0025
35X	0.0000	0.3076	-0.4285	0.0000	-0.3076	0.4285	0.0037	0.0639	-0.0035
35XY	0.0000	0.3076	-0.4285	0.0000	-0.3076	0.4285	0.0034	0.0628	-0.0026
35Y	0.0000	0.3076	-0.4285	-0.0000	-0.3076	0.4285	0.0009	0.0627	-0.0040
36Y	0.0000	0.2413	-0.3033	-0.0000	-0.2413	0.3033	0.0009	0.0288	-0.0029
37X	0.0000	0.2413	-0.3033	-0.0000	-0.2413	0.3033	0.0015	0.0296	-0.0019
37XY	0.0000	0.2413	-0.3033	0.0000	-0.2413	0.3033	0.0021	0.0288	-0.0012
37Y	0.0000	0.2413	-0.3033	0.0000	-0.2413	0.3033	0.0011	0.0288	-0.0046
38X	0.0000	0.2413	-0.3033	0.0000	-0.2413	0.3033	0.0005	0.0304	-0.0004
38XY	0.0000	0.2413	-0.3033	-0.0000	-0.2413	0.3033	0.0040	0.0295	0.0004
38Y	0.0000	0.2413	-0.3033	-0.0000	-0.2413	0.3033	0.0028	0.0296	-0.0060
39Y	0.0000	0.2413	-0.3033	0.0000	-0.2413	0.3033	0.0011	0.0241	-0.0028
40X	0.0000	0.2413	-0.3033	-0.0000	-0.2413	0.3033	0.0014	0.0245	-0.0020
40XY	0.0000	0.2413	-0.3033	0.0000	-0.2413	0.3033	0.0014	0.0235	-0.0011
40Y	0.0000	0.2413	-0.3033	-0.0000	-0.2413	0.3033	0.0006	0.0236	-0.0045
41X	0.0000	0.2413	-0.3033	-0.0000	-0.2413	0.3033	0.0018	0.0238	0.0015
41XY	0.0000	0.2413	-0.3033	0.0000	-0.2413	0.3033	0.0019	0.0228	0.0024
41Y	0.0000	0.2413	-0.3033	0.0000	-0.2413	0.3033	0.0002	0.0232	-0.0072
44X	0.0000	0.2413	-0.3033	-0.0000	-0.2413	0.3033	0.0007	0.1748	-0.0174
45X	0.0000	0.2413	-0.3033	0.0000	-0.2413	0.3033	0.0023	0.0261	-0.1619
10X	0.0000	0.2413	-0.3033	-0.0000	-0.2413	0.3033	0.0027	0.0453	0.0094
10XY	0.0000	0.2413	-0.3033	0.0000	-0.2413	0.3033	0.0040	0.0446	0.0102
10Y	0.0000	0.2413	-0.3033	-0.0000	-0.2413	0.3033	-0.0011	0.0452	-0.0154
11X	0.0000	0.8163	-0.4083	-0.0000	-0.8163	0.4083	0.0026	0.0305	0.0082
11XY	0.0000	0.8163	-0.4083	0.0000	-0.8163	0.4083	0.0027	0.0297	0.0090
11Y	0.0000	0.5293	-0.3553	-0.0000	-0.5293	0.3553	-0.0004	0.0297	-0.0136
12X	0.0000	0.2413	-0.3033	0.0000	-0.2413	0.3033	0.0018	0.0229	0.0070
12XY	0.0000	0.2413	-0.3033	-0.0000	-0.2413	0.3033	0.0024	0.0220	0.0078
12Y	0.0000	0.2413	-0.3033	-0.0000	-0.2413	0.3033	-0.0008	0.0224	-0.0118
13S	0.0000	1.6193	-0.8063	-0.0000	-1.6193	0.8063	-0.0007	0.0095	-0.0091
42S	0.0000	0.2413	-0.3033	0.0000	-0.2413	0.3033	-0.0008	0.0099	-0.0010
43S	0.0000	0.2413	-0.3033	0.0000	-0.2413	0.3033	-0.0001	0.0321	-0.0139
46S	0.0000	0.2413	-0.3033	-0.0000	-0.2413	0.3033	0.0008	0.0106	-0.2867
47S	0.0000	0.2413	-0.3033	-0.0000	-0.2413	0.3033	0.0002	0.0096	-0.2626
13X	0.0000	1.6193	-0.5543	-0.0000	-1.6193	0.5543	-0.0004	0.0119	0.0047
13XY	0.0000	1.6193	-0.5543	0.0000	-1.6193	0.5543	0.0027	0.0111	0.0054
13Y	0.0000	0.9303	-0.4293	0.0000	-0.9303	0.4293	0.0002	0.0084	-0.0090
42Y	0.0000	0.2413	-0.3033	-0.0000	-0.2413	0.3033	0.0018	0.0090	-0.0009
43X	0.0000	0.2413	-0.3033	-0.0000	-0.2413	0.3033	0.0027	0.0288	0.0087

Crossing Diagonal Check for Load Case "NESC Extreme" (RLOUT controls):

Comp. Member Label	Tens. Member Label	Connect Leg for Comp. Member	Force In Comp. Member (kips)	Force In Tens. Member (kips)	-----Original-----						-----Alternate-----					
					-----Supported-----						-----Unsupported-----					
					L/R Cap. (kips)	RLX	RLY	RLZ	L/R	KL/R Curve No.	L/R Cap. (kips)	RLOUT	L/R	KL/R Curve No.		
15P	15Y Short only		-0.64	-0.80	12.29	0.750	0.500	0.500	131.00	128.42	5	9.14	1.000	167.31	149.09	6
15Y	15P Short only		-0.80	-0.64	12.29	0.750	0.500	0.500	131.00	128.42	5	9.14	1.000	167.31	149.09	6
16X	16XY Short only		-0.65	-1.59	25.86	0.750	0.500	0.500	105.12	108.84	2	20.50	1.000	134.24	128.76	6
16XY	16X Short only		-1.59	-0.65	25.86	0.750	0.500	0.500	105.12	108.84	2	20.50	1.000	134.24	128.76	6
17P	17Y Short only		-1.00	-1.27	25.86	0.750	0.500	0.500	105.12	108.84	2	20.50	1.000	134.24	128.76	6

17Y	17P Short only	-1.27	-1.00	25.86	0.750	0.500	0.500	105.12	108.84	2	20.50	1.000	134.24	128.76	6
18P	18Y Short only	-0.31	-0.70	25.86	0.750	0.500	0.500	105.12	108.84	2	20.50	1.000	134.24	128.76	6
18XY	18X Short only	-0.69	0.14	25.86	0.750	0.500	0.500	105.12	108.84	2	20.50	1.000	134.24	128.76	6
18Y	18P Short only	-0.70	-0.31	25.86	0.750	0.500	0.500	105.12	108.84	2	20.50	1.000	134.24	128.76	6
19X	19XY Short only	-0.04	-2.58	43.23	0.750	0.500	0.500	87.63	95.72	2	35.96	1.000	111.96	115.98	3
19XY	19X Short only	-2.58	-0.04	43.23	0.750	0.500	0.500	87.63	95.72	2	35.96	1.000	111.96	115.98	3
21P	21Y Short only	-1.94	-2.05	43.23	0.750	0.500	0.500	87.63	95.72	2	35.96	1.000	111.96	115.98	3
21Y	21P Short only	-2.05	-1.94	43.23	0.750	0.500	0.500	87.63	95.72	2	35.96	1.000	111.96	115.98	3
22X	22XY Short only	-0.08	-2.06	21.13	0.780	0.560	0.560	128.62	126.61	5	18.31	1.000	146.65	136.39	6
22XY	22X Short only	-2.06	-0.08	21.13	0.780	0.560	0.560	128.62	126.61	5	18.31	1.000	146.65	136.39	6

Summary of Clamp Capacities and Usages for Load Case "NESC Extreme":

Clamp Label	Force (kips)	Input Holding Capacity (kips)	Factored Holding Capacity (kips)	Usage %
C1	2.273	50.00	50.00	4.55
C2	3.654	50.00	50.00	7.31
C3	6.649	50.00	50.00	13.30
C4	6.920	50.00	50.00	13.84
C5	6.349	50.00	50.00	12.70
C6	6.458	50.00	50.00	12.92
C7	6.424	50.00	50.00	12.85
C8	7.247	50.00	50.00	14.49
C9	6.536	50.00	50.00	13.07
C10	6.647	50.00	50.00	13.29
C11	6.281	50.00	50.00	12.56
C12	7.101	50.00	50.00	14.20
C13	6.444	50.00	50.00	12.89
C14	6.859	50.00	50.00	13.72
C15	6.884	50.00	50.00	13.77
C16	6.591	50.00	50.00	13.18
C17	6.553	50.00	50.00	13.11
C18	7.062	50.00	50.00	14.12
C19	6.986	50.00	50.00	13.97
C20	7.001	50.00	50.00	14.00
C21	6.749	50.00	50.00	13.50
C22	6.884	50.00	50.00	13.77
C23	6.850	50.00	50.00	13.70
C24	6.799	50.00	50.00	13.60
C25	6.759	50.00	50.00	13.52
C26	6.682	50.00	50.00	13.36
C27	0.540	50.00	50.00	1.08
C28	0.540	50.00	50.00	1.08
C29	1.557	50.00	50.00	3.11
C30	0.899	50.00	50.00	1.80
C31	0.913	50.00	50.00	1.83
C32	1.712	50.00	50.00	3.42
C34	0.328	50.00	50.00	0.66
C35	0.328	50.00	50.00	0.66
C36	6.096	50.00	50.00	12.19
C37	0.703	50.00	50.00	1.41
C38	0.637	50.00	50.00	1.27
C39	1.025	50.00	50.00	2.05
C41	0.540	50.00	50.00	1.08

C42	0.575	50.00	50.00	1.15
C43	1.557	50.00	50.00	3.11
C44	6.063	50.00	50.00	12.13
C45	6.589	50.00	50.00	13.18
C46	6.589	50.00	50.00	13.18
C47	9.632	50.00	50.00	19.26
C48	9.632	50.00	50.00	19.26
C49	0.540	50.00	50.00	1.08
C50	0.575	50.00	50.00	1.15
C51	0.899	50.00	50.00	1.80
C52	0.945	50.00	50.00	1.89
C53	0.913	50.00	50.00	1.83
C54	0.964	50.00	50.00	1.93
C55	1.712	50.00	50.00	3.42
C56	1.809	50.00	50.00	3.62

Equilibrium Joint Positions and Rotations for Load Case "NESC Heavy Broken Wire":

Joint Label	X-Displ (ft)	Y-Displ (ft)	Z-Displ (ft)	X-Rot (deg)	Y-Rot (deg)	Z-Rot (deg)	X-Pos (ft)	Y-Pos (ft)	Z-Pos (ft)
1P	-0.051	0.1732	-0.02016	0.0000	0.0000	0.0000	-0.051	14.17	93.98
2P	-0.03491	0.1343	-0.01633	-0.0828	-0.0852	-0.2090	3.465	15.13	84.98
3P	-0.02761	0.127	-0.01631	-0.1000	-0.0824	-0.1908	3.472	15.13	79.98
4P	-0.02091	0.1161	-0.01627	-0.1515	-0.0723	-0.1632	3.479	15.12	74.98
5P	-0.01517	0.103	-0.0157	-0.1167	-0.0622	-0.1354	3.485	15.1	69.98
6P	-0.01009	0.09471	-0.01564	-0.1493	-0.0612	-0.0966	3.49	15.09	64.98
7P	-0.004982	0.07967	-0.01557	-0.1932	-0.0535	-0.0867	3.495	15.08	59.98
8P	-0.001018	0.06376	-0.01478	-0.1388	-0.0389	-0.0767	3.499	15.06	54.99
9P	0.002264	0.0545	-0.0144	-0.1261	-0.0433	-0.0691	3.502	15.05	49.99
14P	0	0	0	0.0000	0.0000	0.0000	13.07	19.07	0
15P	-0.002981	0.127	-0.0294	-0.1111	-0.0824	-0.2067	3.497	22.13	79.97
16P	0.003128	0.09475	-0.0302	-0.1044	-0.0614	-0.1138	3.503	22.09	64.97
17P	0.006555	0.05461	-0.03047	-0.1343	-0.0431	-0.0181	3.507	22.05	49.97
18P	-0.09638	0.1317	0.001314	-0.0520	-0.1831	-0.2310	3.404	0.1317	85
19P	-0.07223	0.1322	-0.004166	-0.0330	-0.1441	-0.2321	3.428	6.132	85
20P	-0.05355	0.1333	-0.007287	-0.0883	-0.1146	-0.2459	3.446	10.63	84.99
21P	-0.07742	0.1271	0.001383	-0.0496	-0.1834	-0.2020	3.423	0.1271	80
22P	-0.05564	0.1273	-0.00443	-0.0435	-0.1431	-0.1903	3.444	6.127	80
23P	-0.04196	0.1268	-0.008048	-0.0785	-0.1127	-0.1723	3.458	10.63	79.99
24P	-0.05094	0.1004	0.001067	-0.0317	-0.1611	-0.1213	3.449	0.1004	70
25P	-0.03808	0.1006	-0.001759	-0.0158	-0.1217	-0.1348	3.462	6.101	70
26P	-0.02661	0.1019	-0.004771	-0.1004	-0.0919	-0.1509	3.473	10.6	70
27P	-0.03611	0.09643	0.00112	-0.0260	-0.1349	-0.1091	3.464	0.09643	65
28P	-0.02382	0.09565	-0.002021	-0.0266	-0.1055	-0.0993	3.476	6.096	65
29P	-0.01734	0.09454	-0.005408	-0.0864	-0.0834	-0.0821	3.483	10.59	64.99
30P	-0.01784	0.06051	-0.001311	-0.0134	-0.1092	-0.0467	3.482	0.06051	55
31P	-0.01268	0.06044	-0.00156	0.0169	-0.0812	-0.0640	3.487	6.06	55
32P	-0.006803	0.06242	-0.002592	-0.0958	-0.0600	-0.0761	3.493	10.56	55
33P	-0.005779	0.05704	-0.001265	-0.0048	-0.0804	-0.0450	3.494	0.05704	50
34P	-0.0003891	0.05572	-0.001807	0.0019	-0.0654	-0.0308	3.5	6.056	50
35P	0.0003002	0.05442	-0.003731	-0.0891	-0.0542	-0.0005	3.5	10.55	50
36P	0.002681	0.02439	-0.0003972	-0.0299	-0.0331	-0.0177	5.378	0.02439	40
37P	0.003869	0.02436	-0.002511	-0.0111	-0.0266	-0.0040	5.379	5.274	40
38P	0.004189	0.02499	-0.004315	-0.0553	-0.0202	-0.0161	5.379	10.52	40
39P	0.004602	0.01962	4.132e-005	-0.0232	-0.0083	-0.0124	6.338	0.01962	35
40P	0.005788	0.01925	-0.00217	-0.0257	-0.0078	-0.0132	6.339	5.269	35
41P	0.006938	0.01888	-0.005239	-0.0472	-0.0074	-0.0113	6.34	10.52	34.99
44P	0.003736	0.3056	0.03264	0.0000	0.0000	0.0000	0.003736	17.31	17.78
45P	0.0055	0.02833	-0.1324	0.0000	0.0000	0.0000	0.0055	10.53	39.87
10P	0.005771	0.03897	-0.01321	-0.1759	-0.0262	-0.0645	4.463	15.04	44.99
11P	0.006589	0.0251	-0.01143	-0.1079	-0.0154	-0.0373	5.422	15.03	39.99
12P	0.007862	0.01829	-0.009709	-0.0596	-0.0072	-0.0144	6.38	15.02	34.99
1X	-0.2032	0.1685	0.001825	0.0000	0.0000	0.0000	-0.2032	-13.83	94
2X	-0.1566	0.1325	0.02011	-0.1005	-0.2804	-0.2209	3.343	-14.87	85.02
2XY	-0.1566	0.1586	-0.01285	-0.0457	-0.2744	-0.2164	-3.657	-14.84	84.99
2Y	-0.03532	0.1593	-0.02559	-0.0990	-0.0984	-0.2042	-3.535	15.16	84.97
3X	-0.132	0.1241	0.02	-0.0851	-0.2842	-0.2226	3.368	-14.88	80.02
3XY	-0.1322	0.1533	-0.01153	-0.1250	-0.2874	-0.2263	-3.632	-14.85	79.99
3Y	-0.02731	0.1506	-0.0254	-0.1201	-0.0802	-0.1819	-3.527	15.15	79.97
4X	-0.1071	0.1159	0.01952	-0.1320	-0.2829	-0.1774	3.393	-14.88	75.02

4XY	-0.1069	0.1341	-0.009774	-0.2511	-0.2847	-0.1759	-3.607	-14.87	74.99
4Y	-0.02155	0.1365	-0.02512	-0.2166	-0.0619	-0.1553	-3.522	15.14	74.97
5X	-0.08347	0.1024	0.01812	-0.1195	-0.2597	-0.1319	3.417	-14.9	70.02
5XY	-0.08368	0.1165	-0.008868	-0.1233	-0.2541	-0.1244	-3.584	-14.88	69.99
5Y	-0.01581	0.1169	-0.02344	-0.1673	-0.0755	-0.1285	-3.516	15.12	69.98
6X	-0.06265	0.09532	0.01688	-0.1155	-0.2081	-0.0839	3.437	-14.9	65.02
6XY	-0.06289	0.1079	-0.00641	-0.2212	-0.2161	-0.0751	-3.563	-14.89	64.99
6Y	-0.009849	0.1071	-0.02247	-0.1668	-0.0494	-0.0731	-3.51	15.11	64.98
7X	-0.0451	0.08221	0.01609	-0.1980	-0.1948	-0.0719	3.455	-14.92	60.02
7XY	-0.04484	0.08585	-0.004953	-0.2509	-0.1953	-0.0491	-3.545	-14.91	60
7Y	-0.00594	0.08964	-0.02197	-0.2404	-0.0446	-0.0537	-3.506	15.09	59.98
8X	-0.02877	0.06412	0.01452	-0.1595	-0.1795	-0.0597	3.471	-14.94	55.01
8XY	-0.02885	0.06827	-0.004035	-0.1318	-0.1776	-0.0226	-3.529	-14.93	55
8Y	-0.001671	0.06903	-0.02046	-0.1784	-0.0572	-0.0341	-3.502	15.07	54.98
9X	-0.0151	0.05468	0.0132	-0.1155	-0.1178	-0.0527	3.485	-14.95	50.01
9XY	-0.015	0.05887	-0.002357	-0.1663	-0.1212	0.0087	-3.515	-14.94	50
9Y	0.0027	0.05813	-0.01945	-0.1391	-0.0259	-0.0009	-3.497	15.06	49.98
14X	0	0	0	0.0000	0.0000	0.0000	13.07	-19.07	0
14XY	0	0	0	0.0000	0.0000	0.0000	-13.07	-19.07	0
14Y	0	0	0	0.0000	0.0000	0.0000	-13.07	19.07	0
15X	-0.1655	0.1236	0.03232	-0.1107	-0.2842	-0.2999	3.334	-21.88	80.03
15XY	-0.1661	0.1548	-0.01194	0.0650	-0.2883	-0.3032	-3.666	-21.85	79.99
15Y	-0.004492	0.1505	-0.04248	-0.1501	-0.0801	-0.1890	-3.504	22.15	79.96
16X	-0.07382	0.09615	0.0242	-0.0328	-0.2083	-0.0950	3.426	-21.9	65.02
16XY	-0.07557	0.1086	-0.002263	0.0586	-0.2166	-0.1179	-3.576	-21.89	65
16Y	0.001541	0.107	-0.04195	-0.1559	-0.0495	-0.1030	-3.498	22.11	64.96
17X	-0.01768	0.05548	0.02393	-0.0741	-0.1177	-0.0051	3.482	-21.94	50.02
17XY	-0.01952	0.05955	0.003587	0.0098	-0.1213	-0.0596	-3.52	-21.94	50
17Y	0.004859	0.05801	-0.04062	-0.1903	-0.0260	-0.0259	-3.495	22.06	49.96
18Y	-0.09752	0.1561	-0.01952	0.0220	-0.1870	-0.2295	-3.598	0.1561	84.98
19X	-0.1208	0.1316	0.006163	-0.0631	-0.2221	-0.2340	3.379	-5.868	85.01
19XY	-0.1219	0.1558	-0.02286	0.0502	-0.2222	-0.2363	-3.622	-5.844	84.98
19Y	-0.0734	0.1558	-0.01611	0.0473	-0.1520	-0.2370	-3.573	6.156	84.98
20X	-0.139	0.1319	0.0125	-0.0951	-0.2512	-0.2277	3.361	-10.37	85.01
20XY	-0.14	0.1574	-0.02366	-0.0992	-0.2479	-0.2179	-3.64	-10.34	84.98
20Y	-0.05413	0.1578	-0.01515	-0.0787	-0.1251	-0.2531	-3.554	10.66	84.98
21Y	-0.07676	0.1537	-0.01946	0.0314	-0.1843	-0.1972	-3.577	0.1537	79.98
22X	-0.09776	0.1262	0.00592	-0.0617	-0.2237	-0.2075	3.402	-5.874	80.01
22XY	-0.09891	0.1526	-0.02331	0.0275	-0.2257	-0.2034	-3.599	-5.847	79.98
22Y	-0.05761	0.152	-0.01657	0.0327	-0.1429	-0.1925	-3.558	6.152	79.98
23X	-0.1151	0.1249	0.01242	-0.1003	-0.2538	-0.2184	3.385	-10.38	80.01
23XY	-0.1144	0.1519	-0.02212	-0.0906	-0.2564	-0.2102	-3.614	-10.35	79.98
23Y	-0.04178	0.1506	-0.01611	-0.0634	-0.1114	-0.1959	-3.542	10.65	79.98
24Y	-0.05181	0.1126	-0.01653	0.0350	-0.1653	-0.1214	-3.552	0.1126	69.98
25X	-0.06389	0.1005	0.003883	-0.0231	-0.2006	-0.1189	3.436	-5.9	70
25XY	-0.06473	0.1126	-0.02131	0.0672	-0.2010	-0.1202	-3.565	-5.887	69.98
25Y	-0.03895	0.1125	-0.01146	0.0712	-0.1298	-0.1342	-3.539	6.112	69.99
26X	-0.07313	0.1015	0.007561	-0.1017	-0.2301	-0.1237	3.427	-10.4	70.01
26XY	-0.07395	0.1152	-0.02285	-0.1059	-0.2274	-0.1195	-3.574	-10.38	69.98
26Y	-0.02746	0.1153	-0.009357	-0.0909	-0.1026	-0.1551	-3.527	10.62	69.99
27Y	-0.03558	0.1112	-0.01648	0.0491	-0.1333	-0.1032	-3.536	0.1112	64.98
28X	-0.04624	0.0957	0.003616	-0.0334	-0.1643	-0.1060	3.454	-5.904	65
28XY	-0.04747	0.1093	-0.0218	0.0388	-0.1667	-0.1004	-3.547	-5.891	64.98
28Y	-0.02608	0.109	-0.01191	0.0452	-0.1000	-0.1007	-3.526	6.109	64.99
29X	-0.05527	0.09472	0.008069	-0.0903	-0.1862	-0.1087	3.445	-10.41	65.01
29XY	-0.05468	0.1078	-0.02075	-0.1022	-0.1915	-0.1029	-3.555	-10.39	64.98
29Y	-0.01727	0.1073	-0.01115	-0.0708	-0.0747	-0.1115	-3.517	10.61	64.99
30Y	-0.01853	0.06425	-0.012	0.0279	-0.1178	-0.0477	-3.519	0.06425	54.99
31X	-0.0228	0.06072	-0.0005586	0.0070	-0.1373	-0.0391	3.477	-5.939	55

31XY	-0.02348	0.06414	-0.01621	0.0642	-0.1418	-0.0381	-3.523	-5.936	54.98
31Y	-0.01337	0.06422	-0.007715	0.0668	-0.0939	-0.0613	-3.513	6.064	54.99
32X	-0.02535	0.06273	0.00136	-0.1062	-0.1583	-0.0319	3.475	-10.44	55
32XY	-0.02604	0.0668	-0.01774	-0.0994	-0.1597	-0.0358	-3.526	-10.43	54.98
32Y	-0.007433	0.06723	-0.005847	-0.0937	-0.0756	-0.0876	-3.507	10.57	54.99
33Y	-0.005273	0.06261	-0.01195	0.0405	-0.0739	-0.0325	-3.505	0.06261	49.99
34X	-0.009044	0.05565	-0.0008519	-0.0106	-0.0954	-0.0370	3.491	-5.944	50
34XY	-0.01012	0.06062	-0.01673	0.0397	-0.0929	-0.0387	-3.51	-5.939	49.98
34Y	-0.002902	0.0603	-0.00816	0.0434	-0.0549	-0.0387	-3.503	6.06	49.99
35X	-0.01241	0.05436	0.002636	-0.1027	-0.1065	-0.0352	3.488	-10.45	50
35XY	-0.01258	0.05898	-0.01576	-0.1056	-0.1072	-0.0388	-3.513	-10.44	49.98
35Y	0.001087	0.0584	-0.007678	-0.0837	-0.0404	-0.0435	-3.499	10.56	49.99
36Y	0.002404	0.02623	-0.01059	-0.0076	-0.0436	-0.0147	-5.373	0.02623	39.99
37X	0.0008894	0.02443	0.001936	-0.0139	-0.0396	-0.0224	5.376	-5.226	40
37XY	0.001208	0.02624	-0.01026	0.0051	-0.0488	-0.0092	-5.374	-5.224	39.99
37Y	0.004116	0.02618	-0.01054	0.0171	-0.0384	-0.0276	-5.371	5.276	39.99
38X	-0.0009294	0.02506	0.004109	-0.0636	-0.0460	-0.0104	5.374	-10.47	40
38XY	0.000371	0.02707	-0.009484	-0.0506	-0.0540	-0.0155	-5.375	-10.47	39.99
38Y	0.0066	0.02703	-0.009891	-0.0399	-0.0332	-0.0118	-5.368	10.53	39.99
39Y	0.00473	0.02306	-0.01091	0.0010	-0.0125	-0.0120	-6.328	0.02306	34.99
40X	0.003579	0.01913	0.002413	-0.0318	-0.0088	-0.0097	6.337	-5.231	35
40XY	0.003577	0.02229	-0.0108	-0.0059	-0.0180	-0.0135	-6.329	-5.228	34.99
40Y	0.005803	0.02267	-0.01089	-0.0014	-0.0071	-0.0116	-6.327	5.273	34.99
41X	0.002607	0.01863	0.006264	-0.0535	-0.0093	-0.0144	6.336	-10.48	35.01
41XY	0.002664	0.02152	-0.008604	-0.0536	-0.0234	-0.0014	-6.33	-10.48	34.99
41Y	0.006883	0.02229	-0.01184	-0.0264	-0.0017	-0.0122	-6.326	10.52	34.99
44X	0.003842	0.2077	-0.02213	0.0000	0.0000	0.0000	0.003842	-16.8	17.73
45X	-0.000209	0.02455	-0.1044	0.0000	0.0000	0.0000	-0.000209	-10.48	39.9
10X	-0.007611	0.04011	0.01323	-0.1810	-0.0708	-0.0429	4.449	-14.96	45.01
10XY	-0.007305	0.03867	-0.002001	-0.2055	-0.0697	0.0082	-4.464	-14.96	45
10Y	0.003438	0.04202	-0.01851	-0.1985	-0.0125	0.0183	-4.454	15.04	44.98
11X	-0.001351	0.02525	0.01228	-0.1238	-0.0508	-0.0095	5.414	-14.97	40.01
11XY	-0.001265	0.0271	-0.002755	-0.0961	-0.0594	-0.0202	-5.416	-14.97	40
11Y	0.006285	0.0272	-0.0168	-0.1111	-0.0277	0.0096	-5.409	15.03	39.98
12X	0.001414	0.01806	0.0109	-0.0585	-0.0094	-0.0111	6.373	-14.98	35.01
12XY	0.002667	0.02043	-0.003041	-0.0700	-0.0287	-0.0085	-6.369	-14.98	35
12Y	0.007673	0.02164	-0.015	-0.0481	0.0032	-0.0051	-6.364	15.02	34.99
13S	0.003081	0.006337	-0.007848	-0.0428	0.0250	-0.0068	8.544	16.32	23.66
42S	0.001936	0.006349	0.0001713	-0.0207	0.0193	-0.0042	8.543	0.006349	23.67
43S	0.006447	0.02701	-0.01399	-0.1095	-0.0317	-0.0098	0.006447	15.03	39.99
46S	0.001894	0.0091	-0.212	0.0000	0.0000	0.0000	0.001894	-8.15	23.46
47S	0.003277	0.007847	-0.1863	0.0000	0.0000	0.0000	0.003277	8.167	23.48
13X	-7.346e-005	0.007965	0.007429	-0.0352	0.0137	-0.0096	8.541	-16.31	23.68
13XY	0.003147	0.01044	-0.001869	-0.0420	0.0083	-0.0097	-8.538	-16.31	23.67
13Y	0.003945	0.008877	-0.01049	-0.0547	0.0286	0.0031	-8.537	16.33	23.66
42Y	0.003163	0.009784	-0.003278	0.0014	0.0184	-0.0005	-8.538	0.009784	23.67
43X	-0.001289	0.0257	0.005195	-0.1099	-0.0918	-0.0075	-0.001289	-14.97	40.01

Joint Support Reactions for Load Case "NESC Heavy Broken Wire":

Joint Label	X Force (kips)	X Usage %	Y Force (kips)	Y Usage %	Y H-Shear Usage %	Z Comp. Force (kips)	Z Usage %	Uplift Usage %	Result. Force (kips)	Result. Usage %	X X-M. Usage Moment (ft-k)	X X-M. Usage %	Y Y-M. Usage Moment (ft-k)	Y Y-M. Usage %	H-Bend-M Usage Moment (ft-k)	Z Z-M. Usage Moment (ft-k)	Z Z-M. Usage %	Max. Usage %
14P	-20.77	0.0	-23.40	0.0	0.0	-101.85	0.0	0.0	106.55	0.0	-0.08	0.0	0.2	0.0	0.0	0.02	0.0	0.0
14X	17.47	0.0	-21.74	0.0	0.0	89.01	0.0	0.0	93.27	0.0	0.19	0.0	0.1	0.0	0.0	0.04	0.0	0.0
14XY	-7.26	0.0	-14.53	0.0	0.0	20.86	0.0	0.0	26.44	0.0	0.50	0.0	-0.2	0.0	0.0	0.02	0.0	0.0
14Y	23.03	0.0	-38.09	0.0	0.0	-127.70	0.0	0.0	135.23	0.0	0.02	0.0	-0.2	0.0	0.0	0.03	0.0	0.0

Joint Displacements, Loads and Member Forces on Joints for Load Case "NESC Heavy Broken Wire":

Joint Label	X External Load (kips)	Y External Load (kips)	Z External Load (kips)	X Member Force (kips)	Y Member Force (kips)	Z Member Force (kips)	X Disp. (ft)	Y Disp. (ft)	Z Disp. (ft)
1P	0.0072	4.0562	-1.4278	-0.0072	-4.0562	1.4278	-0.0510	0.1732	-0.0202
2P	-1.5770	2.5450	-2.4207	1.5770	-2.5450	2.4207	-0.0349	0.1343	-0.0163
3P	0.0000	0.1370	-0.9456	-0.0000	-0.1370	0.9456	-0.0276	0.1270	-0.0163
4P	0.0000	0.0000	-0.2170	-0.0000	-0.0000	0.2170	-0.0209	0.1161	-0.0163
5P	0.0000	0.1370	-0.9209	-0.0000	-0.1370	0.9209	-0.0152	0.1030	-0.0157
6P	0.0000	0.0000	-0.3439	-0.0000	-0.0000	0.3439	-0.0101	0.0947	-0.0156
7P	0.8920	-1.2840	-4.6625	-0.8920	1.2840	4.6625	-0.0050	0.0797	-0.0156
8P	0.0000	0.0000	-0.3936	0.0000	-0.0000	0.3936	-0.0010	0.0638	-0.0148
9P	0.0000	0.1370	-1.1204	0.0000	-0.1370	1.1204	0.0023	0.0545	-0.0144
14P	0.0000	0.0000	-1.0434	20.7693	23.4000	-100.8085	0.0000	0.0000	0.0000
15P	10.5343	3.2218	-1.2423	-10.5343	-3.2218	1.2423	-0.0030	0.1270	-0.0294
16P	10.4530	3.1996	-1.2523	-10.4530	-3.1996	1.2523	0.0031	0.0948	-0.0302
17P	10.6172	3.2456	-1.2383	-10.6172	-3.2456	1.2383	0.0066	0.0546	-0.0305
18P	0.0000	0.0000	-0.0917	-0.0000	-0.0000	0.0917	-0.0964	0.1317	0.0013
19P	0.0000	0.0000	-0.1262	0.0000	-0.0000	0.1262	-0.0722	0.1322	-0.0042
20P	0.0000	0.0000	-0.1027	0.0000	-0.0000	0.1027	-0.0536	0.1333	-0.0073
21P	0.0000	0.0000	-0.1504	-0.0000	-0.0000	0.1504	-0.0774	0.1271	0.0014
22P	11.0119	3.3191	-1.2501	-11.0119	-3.3191	1.2501	-0.0556	0.1273	-0.0044
23P	0.0000	0.0000	-0.1874	0.0000	-0.0000	0.1874	-0.0420	0.1268	-0.0080
24P	0.0000	0.0000	-0.1077	-0.0000	-0.0000	0.1077	-0.0509	0.1004	0.0011
25P	0.0000	0.0000	-0.1666	0.0000	-0.0000	0.1666	-0.0381	0.1006	-0.0018
26P	0.0000	0.0000	-0.1304	0.0000	-0.0000	0.1304	-0.0266	0.1019	-0.0048
27P	0.0000	0.0000	-0.1971	-0.0000	-0.0000	0.1971	-0.0361	0.0964	0.0011
28P	11.5742	3.4571	-1.2570	-11.5742	-3.4571	1.2570	-0.0238	0.0956	-0.0020
29P	0.0000	0.0000	-0.2239	-0.0000	-0.0000	0.2239	-0.0173	0.0945	-0.0054
30P	0.0000	0.0000	-0.1228	-0.0000	-0.0000	0.1228	-0.0178	0.0605	-0.0013
31P	0.0000	0.0000	-0.1964	-0.0000	-0.0000	0.1964	-0.0127	0.0604	-0.0016
32P	0.0000	0.0000	-0.1495	-0.0000	-0.0000	0.1495	-0.0068	0.0624	-0.0026
33P	0.0000	0.0000	-0.2368	-0.0000	-0.0000	0.2368	-0.0058	0.0570	-0.0013
34P	11.7808	3.5036	-1.2469	-11.7808	-3.5036	1.2469	-0.0004	0.0557	-0.0018
35P	0.0000	0.0000	-0.2790	-0.0000	-0.0000	0.2790	0.0003	0.0544	-0.0037
36P	0.0000	0.0000	-0.3349	-0.0000	-0.0000	0.3349	0.0027	0.0244	-0.0004
37P	0.0000	0.0000	-0.3616	-0.0000	-0.0000	0.3616	0.0039	0.0244	-0.0025
38P	0.0000	0.0000	-0.4381	-0.0000	0.0000	0.4381	0.0042	0.0250	-0.0043
39P	0.0000	0.0000	-0.3850	-0.0000	-0.0000	0.3850	0.0046	0.0196	0.0000
40P	0.0000	0.0000	-0.1962	-0.0000	-0.0000	0.1962	0.0058	0.0193	-0.0022
41P	0.0000	0.0000	-0.4307	-0.0000	-0.0000	0.4307	0.0069	0.0189	-0.0052
44P	0.0000	0.0000	-0.1966	0.0000	-0.0000	0.1966	0.0037	0.3056	0.0326
45P	0.0000	0.0000	-0.0848	-0.0000	-0.0000	0.0848	0.0055	0.0283	-0.1324
10P	0.0000	0.0000	-0.3664	-0.0000	0.0000	0.3664	0.0058	0.0390	-0.0132
11P	0.0000	0.1820	-1.3424	-0.0000	-0.1820	1.3424	0.0066	0.0251	-0.0114
12P	0.0000	0.0000	-0.8067	0.0000	-0.0000	0.8067	0.0079	0.0183	-0.0097
1X	-8.3048	2.6276	-1.2796	8.3048	-2.6276	1.2796	-0.2032	0.1685	0.0018
2X	0.5010	0.9078	-3.1198	-0.5010	-0.9078	3.1198	-0.1566	0.1325	0.0201
2XY	-0.5010	0.9078	-3.0997	0.5010	-0.9078	3.0997	-0.1566	0.1586	-0.0128
2Y	1.5770	2.5450	-2.4408	-1.5770	-2.5450	2.4408	-0.0353	0.1593	-0.0256
3X	0.0000	0.2219	-0.6016	0.0000	-0.2219	0.6016	-0.1320	0.1241	0.0200
3XY	0.0000	0.2219	-0.6016	-0.0000	-0.2219	0.6016	-0.1322	0.1533	-0.0115
3Y	0.0000	0.0750	-0.4296	-0.0000	-0.0750	0.4296	-0.0273	0.1506	-0.0254
4X	0.0000	0.1240	-0.2170	-0.0000	-0.1240	0.2170	-0.1071	0.1159	0.0195
4XY	0.0000	0.1240	-0.2170	0.0000	-0.1240	0.2170	-0.1069	0.1341	-0.0098
4Y	0.0000	0.0000	-0.2170	-0.0000	-0.0000	0.2170	-0.0215	0.1365	-0.0251

5X	0.0000	0.2597	-0.5970	-0.0000	-0.2597	0.5970	-0.0835	0.1024	0.0181
5XY	0.0000	0.2597	-0.5769	0.0000	-0.2597	0.5769	-0.0837	0.1165	-0.0089
5Y	0.0000	0.0750	-0.4250	-0.0000	-0.0750	0.4250	-0.0158	0.1169	-0.0234
6X	0.0000	0.1164	-0.3439	0.0000	-0.1164	0.3439	-0.0626	0.0953	0.0169
6XY	0.0000	0.1164	-0.3439	0.0000	-0.1164	0.3439	-0.0629	0.1079	-0.0064
6Y	0.0000	0.0000	-0.3439	0.0000	-0.0000	0.3439	-0.0098	0.1071	-0.0225
7X	0.0330	0.3765	-2.7995	-0.0330	-0.3765	2.7995	-0.0451	0.0822	0.0161
7XY	-0.0330	0.3765	-2.7995	0.0330	-0.3765	2.7995	-0.0448	0.0858	-0.0050
7Y	-0.8920	-1.3460	-4.1465	0.8920	1.3460	4.1465	-0.0059	0.0896	-0.0220
8X	0.0000	0.1542	-0.4138	0.0000	-0.1542	0.4138	-0.0288	0.0641	0.0145
8XY	0.0000	0.1542	-0.3936	0.0000	-0.1542	0.3936	-0.0288	0.0683	-0.0040
8Y	0.0000	0.0000	-0.4138	0.0000	-0.0000	0.4138	-0.0017	0.0690	-0.0205
9X	0.0000	0.2570	-0.7764	0.0000	-0.2570	0.7764	-0.0151	0.0547	0.0132
9XY	0.0000	0.2570	-0.7764	-0.0000	-0.2570	0.7764	-0.0150	0.0589	-0.0024
9Y	0.0000	0.0750	-0.6044	0.0000	-0.0750	0.6044	0.0027	0.0581	-0.0194
14X	0.0000	0.3452	-1.0434	-17.4715	21.3947	90.0502	0.0000	0.0000	0.0000
14XY	0.0000	0.3452	-1.0434	7.2615	14.1857	21.9036	0.0000	0.0000	0.0000
14Y	0.0000	0.0000	-1.0434	-23.0345	38.0886	-126.6538	0.0000	0.0000	0.0000
15X	0.0000	0.0460	-0.0969	0.0000	-0.0460	0.0969	-0.1655	0.1236	0.0323
15XY	-9.6911	3.0891	-2.0411	9.6911	-3.0891	2.0411	-0.1661	0.1548	-0.0119
15Y	-9.9014	3.1064	-2.0382	9.9014	-3.1064	2.0382	-0.0045	0.1505	-0.0425
16X	12.0717	3.6045	-1.1604	-12.0717	-3.6045	1.1604	-0.0738	0.0961	0.0242
16XY	-10.3779	3.2523	-2.0654	10.3779	-3.2523	2.0654	-0.0756	0.1086	-0.0023
16Y	-10.6214	3.2644	-2.0524	10.6214	-3.2644	2.0524	0.0015	0.1070	-0.0419
17X	12.2889	3.6526	-1.1532	-12.2889	-3.6526	1.1532	-0.0177	0.0555	0.0239
17XY	-10.6180	3.3073	-2.0738	10.6180	-3.3073	2.0738	-0.0195	0.0596	0.0036
17Y	-11.4913	3.4742	-2.0976	11.4913	-3.4742	2.0976	0.0049	0.0580	-0.0406
18Y	0.0000	0.0000	-0.0917	0.0000	-0.0000	0.0917	-0.0975	0.1561	-0.0195
19X	0.0000	0.0000	-0.1283	-0.0000	-0.0000	0.1283	-0.1208	0.1316	0.0062
19XY	0.0000	0.0000	-0.1262	0.0000	-0.0000	0.1262	-0.1219	0.1558	-0.0229
19Y	0.0000	0.0000	-0.1283	0.0000	-0.0000	0.1283	-0.0734	0.1558	-0.0161
20X	0.0000	0.0000	-0.1027	-0.0000	-0.0000	0.1027	-0.1390	0.1319	0.0125
20XY	0.0000	0.0000	-0.1027	-0.0000	-0.0000	0.1027	-0.1400	0.1574	-0.0237
20Y	0.0000	0.0000	-0.1027	0.0000	-0.0000	0.1027	-0.0541	0.1578	-0.0152
21Y	0.0000	0.0000	-0.1504	0.0000	-0.0000	0.1504	-0.0768	0.1537	-0.0195
22X	10.3777	3.1738	-1.2274	-10.3777	-3.1738	1.2274	-0.0978	0.1262	0.0059
22XY	-10.0800	3.1401	-2.0685	10.0800	-3.1401	2.0685	-0.0989	0.1526	-0.0233
22Y	-11.0658	3.3685	-2.1054	11.0658	-3.3685	2.1054	-0.0576	0.1520	-0.0166
23X	0.0000	0.0000	-0.1874	-0.0000	-0.0000	0.1874	-0.1151	0.1249	0.0124
23XY	0.0000	0.0000	-0.1874	-0.0000	-0.0000	0.1874	-0.1144	0.1519	-0.0221
23Y	0.0000	0.0000	-0.1874	0.0000	-0.0000	0.1874	-0.0418	0.1506	-0.0161
24Y	0.0000	0.0000	-0.1077	0.0000	-0.0000	0.1077	-0.0518	0.1126	-0.0165
25X	0.0000	0.0000	-0.1688	-0.0000	-0.0000	0.1688	-0.0639	0.1005	0.0039
25XY	0.0000	0.0000	-0.1666	0.0000	-0.0000	0.1666	-0.0647	0.1126	-0.0213
25Y	0.0000	0.0000	-0.1688	0.0000	-0.0000	0.1688	-0.0389	0.1125	-0.0115
26X	0.0000	0.0000	-0.1304	-0.0000	-0.0000	0.1304	-0.0731	0.1015	0.0076
26XY	0.0000	0.0000	-0.1304	-0.0000	-0.0000	0.1304	-0.0740	0.1152	-0.0229
26Y	0.0000	0.0000	-0.1304	0.0000	-0.0000	0.1304	-0.0275	0.1153	-0.0094
27Y	0.0000	0.0000	-0.1971	-0.0000	-0.0000	0.1971	-0.0356	0.1112	-0.0165
28X	11.5683	3.4519	-1.1985	-11.5683	-3.4519	1.1985	-0.0462	0.0957	0.0036
28XY	-10.8006	3.3127	-2.1113	10.8006	-3.3127	2.1113	-0.0475	0.1093	-0.0218
28Y	-11.0800	3.3757	-2.1103	11.0800	-3.3757	2.1103	-0.0261	0.1090	-0.0119
29X	0.0000	0.0000	-0.2239	-0.0000	-0.0000	0.2239	-0.0553	0.0947	0.0081
29XY	0.0000	0.0000	-0.2239	-0.0000	-0.0000	0.2239	-0.0547	0.1078	-0.0207
29Y	0.0000	0.0000	-0.2239	-0.0000	-0.0000	0.2239	-0.0173	0.1073	-0.0112
30Y	0.0000	0.0000	-0.1228	-0.0000	-0.0000	0.1228	-0.0185	0.0643	-0.0120
31X	0.0000	0.0000	-0.1985	-0.0000	-0.0000	0.1985	-0.0228	0.0607	-0.0006
31XY	0.0000	0.0000	-0.1964	-0.0000	-0.0000	0.1964	-0.0235	0.0641	-0.0162
31Y	0.0000	0.0000	-0.1985	-0.0000	-0.0000	0.1985	-0.0134	0.0642	-0.0077

32X	0.0000	0.0000	-0.1495	-0.0000	-0.0000	0.1495	-0.0254	0.0627	0.0014
32XY	0.0000	0.0000	-0.1495	-0.0000	-0.0000	0.1495	-0.0260	0.0668	-0.0177
32Y	0.0000	0.0000	-0.1495	-0.0000	-0.0000	0.1495	-0.0074	0.0672	-0.0058
33Y	0.0000	0.0000	-0.2368	-0.0000	-0.0000	0.2368	-0.0053	0.0626	-0.0120
34X	11.6313	3.4706	-1.2111	-11.6313	-3.4706	1.2111	-0.0090	0.0556	-0.0009
34XY	-11.2651	3.4216	-2.1438	11.2651	-3.4216	2.1438	-0.0101	0.0606	-0.0167
34Y	-11.0943	3.3849	-2.1319	11.0943	-3.3849	2.1319	-0.0029	0.0603	-0.0082
35X	0.0000	0.0000	-0.2790	-0.0000	-0.0000	0.2790	-0.0124	0.0544	0.0026
35XY	0.0000	0.0000	-0.2790	-0.0000	-0.0000	0.2790	-0.0126	0.0590	-0.0158
35Y	0.0000	0.0000	-0.2790	-0.0000	-0.0000	0.2790	0.0011	0.0584	-0.0077
36Y	0.0000	0.0000	-0.3349	-0.0000	-0.0000	0.3349	0.0024	0.0262	-0.0106
37X	0.0000	0.0000	-0.3616	-0.0000	-0.0000	0.3616	0.0009	0.0244	0.0019
37XY	0.0000	0.0000	-0.3616	-0.0000	0.0000	0.3616	0.0012	0.0262	-0.0103
37Y	0.0000	0.0000	-0.3616	-0.0000	-0.0000	0.3616	0.0041	0.0262	-0.0105
38X	0.0000	0.1018	-0.4381	-0.0000	-0.1018	0.4381	-0.0009	0.0251	0.0041
38XY	0.0000	0.1018	-0.4381	-0.0000	-0.1018	0.4381	0.0004	0.0271	-0.0095
38Y	0.0000	0.0000	-0.4381	-0.0000	-0.0000	0.4381	0.0066	0.0270	-0.0099
39Y	0.0000	0.0000	-0.3850	-0.0000	-0.0000	0.3850	0.0047	0.0231	-0.0109
40X	0.0000	0.0000	-0.1962	-0.0000	-0.0000	0.1962	0.0036	0.0191	0.0024
40XY	0.0000	0.0000	-0.1962	-0.0000	-0.0000	0.1962	0.0036	0.0223	-0.0108
40Y	0.0000	0.0000	-0.1962	-0.0000	-0.0000	0.1962	0.0058	0.0227	-0.0109
41X	0.0000	0.0746	-0.4307	-0.0000	-0.0746	0.4307	0.0026	0.0186	0.0063
41XY	0.0000	0.0746	-0.4307	-0.0000	-0.0746	0.4307	0.0027	0.0215	-0.0086
41Y	0.0000	0.0000	-0.4307	-0.0000	-0.0000	0.4307	0.0069	0.0223	-0.0118
44X	0.0000	0.2595	-0.1966	-0.0000	-0.2595	0.1966	0.0038	0.2077	-0.0221
45X	0.0000	0.0000	-0.0848	-0.0000	-0.0000	0.0848	-0.0002	0.0245	-0.1044
10X	0.0000	0.1938	-0.3664	-0.0000	-0.1938	0.3664	-0.0076	0.0401	0.0132
10XY	0.0000	0.1938	-0.3664	0.0000	-0.1938	0.3664	-0.0073	0.0387	-0.0020
10Y	0.0000	0.0000	-0.3664	-0.0000	0.0000	0.3664	0.0034	0.0420	-0.0185
11X	0.0000	0.3633	-0.8864	-0.0000	-0.3633	0.8864	-0.0014	0.0252	0.0123
11XY	0.0000	0.3633	-0.8864	0.0000	-0.3633	0.8864	-0.0013	0.0271	-0.0028
11Y	0.0000	0.1000	-0.6584	-0.0000	-0.1000	0.6584	0.0063	0.0272	-0.0168
12X	0.0000	0.3792	-0.8067	0.0000	-0.3792	0.8067	0.0014	0.0181	0.0109
12XY	0.0000	0.3792	-0.8067	-0.0000	-0.3792	0.8067	0.0027	0.0204	-0.0030
12Y	0.0000	0.0000	-0.8067	-0.0000	0.0000	0.8067	0.0077	0.0216	-0.0150
13S	0.0000	0.4360	-3.1544	-0.0000	-0.4360	3.1544	0.0031	0.0063	-0.0078
42S	0.0000	0.0000	-1.4613	-0.0000	0.0000	1.4613	0.0019	0.0063	0.0002
43S	0.0000	0.0000	-0.1790	-0.0000	-0.0000	0.1790	0.0064	0.0270	-0.0140
46S	0.0000	0.0000	-0.0908	-0.0000	0.0000	0.0908	0.0019	0.0091	-0.2120
47S	0.0000	0.0000	-0.0908	-0.0000	0.0000	0.0908	0.0033	0.0078	-0.1863
13X	0.0000	0.9998	-2.0614	0.0000	-0.9998	2.0614	-0.0001	0.0080	0.0074
13XY	0.0000	0.9998	-2.0614	0.0000	-0.9998	2.0614	0.0031	0.0104	-0.0019
13Y	0.0000	0.2390	-1.5144	0.0000	-0.2390	1.5144	0.0039	0.0089	-0.0105
42Y	0.0000	0.0000	-1.4613	0.0000	0.0000	1.4613	0.0032	0.0098	-0.0033
43X	0.0000	0.1689	-0.1790	-0.0000	-0.1689	0.1790	-0.0013	0.0257	0.0052

Crossing Diagonal Check for Load Case "NESC Heavy Broken Wire" (RLOUT controls):

Comp. Member Label	Tens. Member Label	Connect Leg for Comp. Member	Force In Comp. Member (kips)	Force In Tens. Member (kips)	-----Original-----							-----Alternate-----						
					-----Supported-----				-----Unsupported-----									
					L/R	RLX	RLY	RLZ	L/R	KL/R	Curve	No.	L/R	RLOUT	L/R	KL/R	Curve	No.
17Y	17P	Short only	-0.87	0.06	25.86	0.750	0.500	0.500	105.12	108.84		2	20.50	1.000	134.24	128.76		6
21P	21Y	Short only	-1.87	-1.81	43.23	0.750	0.500	0.500	87.63	95.72		2	35.96	1.000	111.96	115.98		3
21Y	21P	Short only	-1.81	-1.87	43.23	0.750	0.500	0.500	87.63	95.72		2	35.96	1.000	111.96	115.98		3

Summary of Clamp Capacities and Usages for Load Case "NESC Heavy Broken Wire":

Clamp Label	Force (kips)	Input Holding Capacity (kips)	Factored Holding Capacity (kips)	Usage %
C1	4.300	50.00	50.00	8.60
C2	8.804	50.00	50.00	17.61
C3	11.086	50.00	50.00	22.17
C4	0.107	50.00	50.00	0.21
C5	10.374	50.00	50.00	20.75
C6	10.576	50.00	50.00	21.15
C7	11.003	50.00	50.00	22.01
C8	12.652	50.00	50.00	25.30
C9	11.070	50.00	50.00	22.14
C10	11.300	50.00	50.00	22.60
C11	11.171	50.00	50.00	22.34
C12	12.872	50.00	50.00	25.74
C13	11.313	50.00	50.00	22.63
C14	12.187	50.00	50.00	24.37
C15	11.569	50.00	50.00	23.14
C16	10.921	50.00	50.00	21.84
C17	10.759	50.00	50.00	21.52
C18	11.757	50.00	50.00	23.51
C19	12.145	50.00	50.00	24.29
C20	12.132	50.00	50.00	24.26
C21	11.493	50.00	50.00	22.99
C22	11.773	50.00	50.00	23.55
C23	12.354	50.00	50.00	24.71
C24	12.198	50.00	50.00	24.40
C25	11.967	50.00	50.00	23.93
C26	11.793	50.00	50.00	23.59
C27	0.641	50.00	50.00	1.28
C28	0.633	50.00	50.00	1.27
C29	2.825	50.00	50.00	5.65
C30	0.818	50.00	50.00	1.64
C31	0.958	50.00	50.00	1.92
C32	2.291	50.00	50.00	4.58
C34	0.436	50.00	50.00	0.87
C35	0.432	50.00	50.00	0.86
C36	4.450	50.00	50.00	8.90
C37	0.609	50.00	50.00	1.22
C38	0.666	50.00	50.00	1.33
C39	1.533	50.00	50.00	3.07
C41	0.641	50.00	50.00	1.28
C42	0.955	50.00	50.00	1.91
C43	2.825	50.00	50.00	5.65
C44	4.918	50.00	50.00	9.84
C45	3.288	50.00	50.00	6.58
C46	3.269	50.00	50.00	6.54
C47	3.863	50.00	50.00	7.73
C48	3.850	50.00	50.00	7.70
C49	0.651	50.00	50.00	1.30
C50	0.931	50.00	50.00	1.86
C51	0.818	50.00	50.00	1.64
C52	1.129	50.00	50.00	2.26
C53	0.958	50.00	50.00	1.92

C54	1.355	50.00	50.00	2.71
C55	2.291	50.00	50.00	4.58
C56	3.184	50.00	50.00	6.37

*** Overall summary for all load cases - Usage = Maximum Stress / Allowable Stress
 Printed capacities do not include the strength factor entered for each load case.
 The Group Summary reports on the member and load case that resulted in maximum usage
 which may not necessarily be the same as that which produces maximum force.

Group Summary (Compression Portion):

Group KL/R Length Label Comp. No.	Group Angle Curve No. Desc. Type Of Bolts	Angle Size	Steel Strength (ksi)	Max Usage Usage Cont- %	Max Use %	Comp. Control Member Comp.	Comp. Force (kips)	Comp. Control Load Case	L/R Capacity (kips)	Comp. Connect. Shear Capacity (kips)	Comp. Connect. Bearing Capacity (kips)	RLX	RLY	RLZ	L/R	
PeakPost	L2.5x2.5x3/16	SAE 2.5X2.5X0.1875	33.0	52.40	Tens	42.29	14XY	-7.057NESC	Hea	16.686	27.200	25.312	0.500	0.500	0.500	124.50
123.47	10.271	5	2													
Leg1	L5x5x3/8	SAE 5X5X0.375	33.0	47.32	Comp	47.32	5XY	-50.404NESC	Hea	106.517	136.000	253.125	1.000	1.000	1.000	60.61
60.61	5.000	1	10													
Leg2	L8x8x1/2	SAE 8X8X0.5	33.0	54.53	Comp	54.53	8XY	-74.166NESC	Hea	245.252	136.000	337.499	1.000	1.000	1.000	37.74
37.74	5.000	1	10													
Leg3	L8x8x1/2	SAE 8X8X0.5	33.0	47.55	Tens	39.63	10Y	-97.036NESC	Hea	244.867	380.800	944.999	1.000	1.000	1.000	38.42
38.42	5.091	1	28													
Leg4	L8x8x1/2	SAE 8X8X0.5	33.0	42.11	Tens	41.19	12Y	-99.512NESC	Hea	241.598	380.800	944.999	0.500	0.500	0.500	43.81
43.81	11.611	1	28													
Leg5	L8x8x1/2	SAE 8X8X0.5	33.0	41.48	Comp	41.48	13P	-99.682NESC	Hea	240.308	380.800	944.999	0.250	0.250	0.250	45.77
45.77	24.257	1	28													
TTTC	L3x3x1/4	SAE 3X3X0.25	33.0	74.67	Tens	56.29	38X	-15.311NESC	Ext	32.243	27.200	33.750	1.000	1.000	1.000	91.22
105.61	4.500	3	2													
TTBC	L3x3x1/4	SAE 3X3X0.25	33.0	42.25	Comp	42.25	39Y	-11.567NESC	Hea	27.374	54.400	67.500	1.000	1.000	1.000	121.62
121.28	6.000	5	4													
ARMTT	L4x4x1/4	SAE 4X4X0.25	33.0	39.57	Comp	39.57	67XY	-10.764NESC	Hea	40.528	27.200	33.750	1.000	1.000	1.000	105.66
112.83	7.000	3	2													
MTTC	L4x4x1/4	SAE 4X4X0.25	33.0	79.62	Tens	69.61	43X	-33.225NESC	Ext	47.728	0.000	0.000	1.000	1.000	1.000	67.92
93.96	4.500	3	0													
MTBC	L4x4x1/4	SAE 4X4X0.25	33.0	46.86	Comp	46.86	46Y	-22.364NESC	Ext	47.728	0.000	0.000	1.000	1.000	1.000	67.92
93.96	4.500	3	0													
ARMMT	L4x4x1/4	SAE 4X4X0.25	33.0	16.10	Comp	16.10	68X	-6.526NESC	Hea	40.528	40.800	50.625	1.000	1.000	1.000	105.66
112.83	7.000	3	3													
BTTC	L4x4x5/16	SAE 4X4X0.3125	33.0	84.82	Tens	71.34	49X	-42.069NESC	Ext	58.971	0.000	0.000	1.000	1.000	1.000	68.27
94.13	4.500	3	0													
BTBC	L4x4x5/16	SAE 4X4X0.3125	33.0	49.91	Comp	49.91	52Y	-29.431NESC	Hea	58.971	0.000	0.000	1.000	1.000	1.000	68.27
94.13	4.500	3	0													
ARMBT	L4x4x1/4	SAE 4X4X0.25	33.0	15.68	Comp	15.68	69X	-6.353NESC	Hea	40.528	40.800	50.625	1.000	1.000	1.000	105.66
112.83	7.000	3	3													
BTC	8x8x1/2	SAE 8X8X0.5	33.0	21.83	Tens	17.11	55XY	-35.714NESC	Hea	208.793	0.000	0.000	1.000	1.000	1.000	39.62
79.81	5.250	3	0													
BBC	6x6x1/2	SAE 6X6X0.5	33.0	33.09	Tens	22.76	59P	-27.856NESC	Ext	152.178	122.400	303.750	1.000	1.000	1.000	45.76
82.88	4.500	3	9													
Diag1	L2x2x3/16	SAE 2X2X0.1875	33.0	26.40	Comp	26.40	15X	-3.245NESC	Hea	12.292	27.200	25.312	0.750	0.500	0.500	131.00
128.42	8.602	5	2													
Diag2	L2.5x2.5x1/4	SAE 2.5X2.5X0.25	33.0	46.32	Comp	46.32	16X	-11.979NESC	Hea	25.861	27.200	33.750	0.750	0.500	0.500	105.12

BTBr5	L4x4x3/8	SAE	4X4X0.375	33.0	47.74	Comp	47.74	96P	-30.232	NESC	Ext	63.333	68.000	126.562	1.000	1.000	1.000	102.44
106.83	6.727	2	5															
TBC1	L2x2x3/16	SAE	2X2X0.1875	33.0	55.68	Tens	37.66	97P	-1.684	NESC	Hea	4.471	13.600	12.656	1.000	1.000	1.000	213.20
213.20	7.000	4	1															
TBC2	L2.5x2.5x1/4	SAE	2.5X2.5X0.25	33.0	46.65	Tens	0.00	111X	0.000			14.856	27.200	33.750	1.000	1.000	1.000	171.08
151.41	7.000	6	2															
TBC3	L2x2x1/4	SAE	2X2X0.25	33.0	46.30	Tens	26.84	114Y	-3.651	NESC	Hea	16.440	13.600	16.875	0.750	0.500	0.500	127.70
127.70	8.322	4	1															
TBC4	L2.5x2.5x3/16	SAE	2.5X2.5X0.1875	33.0	26.70	Comp	26.70	113P	-3.041	NESC	Hea	11.388	27.200	25.312	1.000	1.000	1.000	169.70
150.56	7.000	6	2															
TTC1	L2x2x3/16	SAE	2X2X0.1875	33.0	48.87	Tens	39.00	121P	-1.744	NESC	Hea	4.471	13.600	12.656	1.000	1.000	1.000	213.20
213.20	7.000	4	1															
TTC2	L2.5x2.5x3/16	SAE	2.5X2.5X0.1875	33.0	91.56	Comp	91.56	116P	-4.732	NESC	Hea	5.168	13.600	12.656	1.000	1.000	1.000	223.50
223.50	9.220	4	1															
Horz3	L2.5x2.5x3/16	SAE	2.5X2.5X0.1875	33.0	34.67	Comp	34.67	142P	-3.590	NESC	Ext	10.354	27.200	25.312	1.000	1.000	1.000	169.70
157.91	7.000	5	2															
Horz4	L2x2x3/16	SAE	2X2X0.1875	33.0	23.57	Tens	15.59	146X	-0.697	NESC	Ext	4.471	13.600	12.656	1.000	1.000	1.000	213.20
213.20	7.000	4	1															
Horz5	L3.5x3.5x5/16	SAE	3.5X3.5X0.3125	33.0	9.46	Comp	9.46	147P	-3.753	NESC	Hea	39.688	40.800	63.281	1.000	1.000	1.000	121.74
121.37	7.000	5	3															
Horz6	L3.5x3x1/4	SAU	3.5X3X0.25	33.0	16.25	Comp	16.25	149X	-4.420	NESC	Hea	29.777	27.200	33.750	0.500	0.500	0.500	121.18
120.94	12.744	5	2															
BBr1	L2x2x3/16	SAE	2X2X0.1875	33.0	5.11	Comp	5.11	150Y	-0.483	NESC	Hea	9.436	27.200	25.312	1.000	1.000	1.000	155.05
146.75	5.091	5	2															
BBr2	L4x4x3/8	SAE	4X4X0.375	33.0	43.99	Comp	43.99	151XY	-26.096	NESC	Hea	59.320	68.000	126.562	1.000	1.000	1.000	111.37
113.52	7.313	2	5															
BBr3	L4x4x5/16	SAE	4X4X0.3125	33.0	46.91	Tens	38.98	154X	-21.207	NESC	Ext	65.583	54.400	84.375	1.000	1.000	1.000	77.23
77.23	5.091	1	4															
BBr4	L7x4x7/16	SAU	7X4X0.4375	33.0	11.34	Tens	10.14	156XY	-13.220	NESC	Hea	130.317	149.600	324.843	0.500	0.750	0.500	54.65
70.98	6.800	2	11															
BTC1	L3.5x3.5x1/4	SAE	3.5X3.5X0.25	33.0	10.93	Tens	0.00	157P	0.000			16.690	27.200	33.750	1.000	1.000	1.000	185.88
170.24	10.750	5	2															
BTC2	L2x2x3/16	SAE	2X2X0.1875	33.0	46.19	Comp	46.19	158X	-2.278	NESC	Ext	4.933	27.200	25.312	0.750	0.500	0.500	228.84
202.97	15.027	5	2															
BTC3	L3x2.5x1/4	SAU	3X2.5X0.25	33.0	17.20	Tens	0.00	161X	0.000			24.779	40.800	50.625	1.000	1.000	1.000	122.16
121.69	5.375	5	3															
BTC4	L2.5x1.5x1/4	SAU	2.5X1.5X0.25	33.0	21.41	Comp	21.41	162Y	-2.742	NESC	Ext	12.805	40.800	50.625	0.500	0.750	0.500	152.69
144.95	7.041	5	3															
BTC5	L2x2x1/4	SAE	2X2X0.25	33.0	15.17	Tens	0.00	164X	0.000			15.020	27.200	33.750	1.000	1.000	1.000	138.11
133.84	4.500	5	2															
BBC1	L3x3x3/16	SAE	3X3X0.1875	33.0	4.88	Comp	4.88	165P	-0.306	NESC	Hea	6.278	27.200	25.312	1.000	1.000	1.000	255.02
222.93	12.666	5	2															
BBC2	L2x2x3/16	SAE	2X2X0.1875	33.0	37.38	Comp	37.38	166Y	-1.210	NESC	Hea	3.237	13.600	12.656	0.750	0.500	0.500	250.54
250.54	16.452	4	1															
BBC3	L3x3x1/4	SAE	3X3X0.25	33.0	2.80	Comp	2.80	168X	-0.492	NESC	Ext	17.576	27.200	33.750	1.000	0.500	0.500	163.43
153.14	12.666	5	2															

Group Summary (Tension Portion):

Group Hole Diameter	Group Label	Angle Desc.	Angle Type	Steel Size	Max Usage Cont-	Max Tension Use	Tension Control	Tension Force Control	Net Section	Tension Connect.	Tension Connect.	Tension Connect.	Tension Connect.	Length Tens.	No. Of	No. Of
(in)				(ksi)	%	Tens. %	Member	(kips)	Capacity Case	Shear Capacity	Bearing Capacity	Rupture Capacity	Member	Bolts	Holes	

----- PeakPost 0.875	L2.5x2.5x3/16	SAE	2.5X2.5X0.1875	33.0	52.40	Tens	52.40	1X	10.113	NESC	Hea	21.917	27.200	25.312	19.301	9.708	2	1.000
Leg1 0.875	L5x5x3/8	SAE	5X5X0.375	33.0	47.32	Comp	37.42	4X	30.965	NESC	Hea	82.747	0.000	0.000	0.000	5.000	0	3.360
Leg2 0.875	L8x8x1/2	SAE	8X8X0.5	33.0	54.53	Comp	44.69	8X	60.779	NESC	Hea	198.000	136.000	337.499	312.500	5.000	10	4.000
Leg3 0.875	L8x8x1/2	SAE	8X8X0.5	33.0	47.55	Tens	47.55	10X	94.140	NESC	Hea	198.000	380.800	944.999	874.999	5.091	28	4.000
Leg4 0.875	L8x8x1/2	SAE	8X8X0.5	33.0	42.11	Tens	42.11	11X	83.382	NESC	Hea	198.000	0.000	0.000	0.000	5.091	0	4.000
Leg5 0.875	L8x8x1/2	SAE	8X8X0.5	33.0	41.48	Comp	38.22	13X	75.682	NESC	Hea	198.000	380.800	944.999	874.999	24.257	28	4.000
TTTC 0.875	L3x3x1/4	SAE	3X3X0.25	33.0	74.67	Tens	74.67	38Y	17.256	NESC	Ext	36.271	27.200	33.750	23.109	4.500	2	1.000
TTBC 0.875	L3x3x1/4	SAE	3X3X0.25	33.0	42.25	Comp	41.74	40XY	12.428	NESC	Ext	29.774	0.000	0.000	0.000	4.500	0	2.000
ARMTT 0.875	L4x4x1/4	SAE	4X4X0.25	33.0	39.57	Comp	16.15	67X	4.392	NESC	Hea	51.121	27.200	33.750	38.750	7.000	2	1.000
MTTC 0.875	L4x4x1/4	SAE	4X4X0.25	33.0	79.62	Tens	79.62	43Y	35.530	NESC	Hea	44.624	0.000	0.000	0.000	4.500	0	2.000
MTBC 0.875	L4x4x1/4	SAE	4X4X0.25	33.0	46.86	Comp	44.89	46XY	20.031	NESC	Ext	44.624	0.000	0.000	0.000	4.500	0	2.000
ARMMT 0.875	L4x4x1/4	SAE	4X4X0.25	33.0	16.10	Comp	3.16	68P	1.290	NESC	Ext	49.952	40.800	50.625	44.118	7.000	3	1.180
BTTC 0.875	L4x4x5/16	SAE	4X4X0.3125	33.0	84.82	Tens	84.82	49Y	46.683	NESC	Hea	55.038	0.000	0.000	0.000	4.500	0	2.000
BTBC 0.875	L4x4x5/16	SAE	4X4X0.3125	33.0	49.91	Comp	46.06	52XY	25.351	NESC	Hea	55.038	0.000	0.000	0.000	4.500	0	2.000
ARMBT 0.875	L4x4x1/4	SAE	4X4X0.25	33.0	15.68	Comp	3.55	69P	1.449	NESC	Ext	49.952	40.800	50.625	44.118	7.000	3	1.180
BTC 0.875	8x8x1/2	SAE	8X8X0.5	33.0	21.83	Tens	21.83	55Y	36.066	NESC	Hea	165.206	0.000	0.000	0.000	5.250	0	5.000
BBC 0.875	6x6x1/2	SAE	6X6X0.5	33.0	33.09	Tens	33.09	59XY	40.497	NESC	Hea	131.794	122.400	303.750	330.882	4.500	9	3.000
Diag1 0.875	L2x2x3/16	SAE	2X2X0.1875	33.0	26.40	Comp	16.27	15XY	2.638	NESC	Hea	16.214	27.200	25.312	18.316	8.602	2	1.000
Diag2 0.875	L2.5x2.5x1/4	SAE	2.5X2.5X0.25	33.0	46.32	Comp	44.38	17XY	12.072	NESC	Hea	28.846	27.200	33.750	29.203	8.602	2	1.000
Diag3 0.875	L3x3x5/16	SAE	3X3X0.3125	33.0	26.82	Tens	26.82	20XY	10.943	NESC	Hea	44.745	40.800	63.281	56.660	8.602	3	1.000
Diag4 0.875	L3x3x3/16	SAE	3X3X0.1875	33.0	44.52	Comp	43.57	23XY	8.562	NESC	Hea	27.500	27.200	25.312	19.652	6.698	2	1.000
Diag5 0.875	L2.5x2x3/16	SAU	2.5X2X0.1875	33.0	91.75	Comp	44.78	25XY	8.590	NESC	Hea	19.184	27.200	25.312	24.609	18.775	2	1.000
Diag6 0.875	L3x2x1/4	SAU	3X2X0.25	33.0	45.41	Comp	26.91	26X	7.762	NESC	Hea	28.846	40.800	50.625	36.328	10.415	3	1.000
Diag7 0.875	L4x4x1/4	SAE	4X4X0.25	33.0	71.87	Comp	60.67	30X	28.451	NESC	Ext	46.898	54.400	67.500	58.823	6.727	4	1.650
Diag8 0.875	L4x4x3/8	SAE	4X4X0.375	33.0	62.07	Comp	57.20	33Y	38.899	NESC	Hea	69.934	68.000	126.562	110.294	6.789	5	1.540
Diag9 0.875	L3.5x3x1/4	DAS	3.5X3X0.25	33.0	79.64	Comp	40.70	34P	19.651	NESC	Ext	72.542	54.400	67.500	48.281	18.923	2	2.000
Diag10 0.875	L4x3x7/16	DAS	4X3X0.4375	33.0	79.95	Comp	36.45	35X	29.744	NESC	Ext	121.751	81.600	177.187	164.062	30.734	3	2.000
Diag11 0.875	L3x3x5/16	SAE	3X3X0.3125	33.0	75.13	Comp	51.62	28XY	21.063	NESC	Hea	44.745	40.800	63.281	46.699	6.727	3	1.000
Diag12 0.875	L3x3x3/16	SAE	3X3X0.1875	33.0	65.98	Comp	25.41	27XY	6.987	NESC	Hea	27.500	40.800	37.969	35.156	22.141	3	1.000

0.875	Horz1	L3x3x3/16	SAE	3X3X0.1875	33.0	30.82	Comp	0.00	60Y	0.000	27.500	40.800	37.969	26.473	16.318	3	1.000
0.875	Horz2	L3.5x3.5x1/4	SAE	3.5X3.5X0.25	33.0	38.01	Comp	0.00	61X	0.000	43.696	40.800	50.625	36.422	17.082	3	1.000
0.875	Br1	L2x2x3/16	SAE	2X2X0.1875	33.0	45.08	Tens	45.08	63P	3.693NESC Ext	16.214	13.600	12.656	8.191	11.812	1	1.000
0.875	Br2	L3x3x3/16	SAE	3X3X0.1875	33.0	45.95	Comp	0.00	66P	0.000	27.500	13.600	12.656	9.949	17.082	1	1.000
0.875	ArmBr1	Bar 2x3/16	BAR	2 x 0.1875	33.0	56.80	Tens	56.80	72Y	3.558NESC Hea	6.265	27.200	25.312	17.824	8.602	2	1.000
0.875	ArmBr2	ArmBr2	SAE	2X2X0.25	33.0	55.81	Comp	55.48	73X	7.139NESC Hea	21.421	13.600	16.875	12.868	9.899	1	1.000
0.875	ArmBr3	ArmBr3	SAU	3.5X2.5X0.25	33.0	82.37	Tens	82.37	78X	11.203NESC Hea	28.846	13.600	16.875	15.047	7.000	1	1.000
0.875	TTBr1	L2x2x3/16	SAE	2X2X0.1875	33.0	62.45	Comp	24.81	83Y	4.023NESC Hea	16.214	27.200	25.312	19.160	5.000	2	1.000
0.875	TTBr2	L3x3x3/16	SAE	3X3X0.1875	33.0	98.47	Comp	65.92	80Y	15.451NESC Hea	27.500	27.200	25.312	23.437	7.810	2	1.000
0.875	TTBr3	L3x3x5/16	SAE	3X3X0.3125	33.0	47.48	Tens	47.48	84XY	19.372NESC Hea	44.745	40.800	63.281	45.410	6.727	3	1.000
0.875	MTBr1	L2x2x3/16	SAE	2X2X0.1875	33.0	13.20	Tens	13.20	87XY	2.140NESC Hea	16.214	27.200	25.312	19.301	5.000	2	1.000
0.875	MTBr2	L3x2.5x1/4	SAU	3X2.5X0.25	33.0	57.79	Comp	53.79	89P	14.630NESC Ext	32.410	27.200	33.750	31.250	5.000	2	1.000
0.875	MTBr3	L4x3.5x1/4	SAU	4X3.5X0.25	33.0	84.82	Comp	68.79	86Y	28.067NESC Hea	44.531	40.800	50.625	44.118	7.810	3	1.420
0.875	MTBr4	L3.5x3.5x1/4	SAE	3.5X3.5X0.25	33.0	79.13	Comp	53.85	88X	20.786NESC Ext	40.448	40.800	50.625	38.603	6.727	3	1.500
0.875	MTBr5	L4x4x1/4	SAE	4X4X0.25	33.0	62.42	Comp	57.20	90XY	27.234NESC Ext	47.613	54.400	67.500	58.823	6.727	4	1.540
0.875	BTBr1	L2x2x3/16	SAE	2X2X0.1875	33.0	13.72	Tens	13.72	93XY	2.224NESC Hea	16.214	27.200	25.312	19.301	5.000	2	1.000
0.875	BTBr2	L3.5x3.5x1/4	SAE	3.5X3.5X0.25	33.0	47.18	Comp	44.34	95Y	18.090NESC Hea	43.696	40.800	50.625	42.516	5.000	3	1.000
0.875	BTBr3	L4x4x5/16	SAE	4X4X0.3125	33.0	73.50	Comp	64.67	92Y	35.179NESC Hea	59.748	54.400	84.375	73.529	7.810	4	1.420
0.875	BTBr4	L4x4x1/4	SAE	4X4X0.25	33.0	75.54	Comp	52.54	94XY	26.075NESC Hea	49.627	54.400	67.500	58.823	6.727	4	1.230
0.875	BTBr5	L4x4x3/8	SAE	4X4X0.375	33.0	47.74	Comp	47.19	96X	31.989NESC Hea	67.790	68.000	126.562	110.294	6.727	5	1.760
0.875	TBC1	L2x2x3/16	SAE	2X2X0.1875	33.0	55.68	Tens	55.68	104XY	4.561NESC Hea	16.214	13.600	12.656	8.191	9.220	1	1.000
0.875	TBC2	L2.5x2.5x1/4	SAE	2.5X2.5X0.25	33.0	46.65	Tens	46.65	111P	12.690NESC Hea	28.846	27.200	33.750	28.125	7.000	2	1.000
0.875	TBC3	L2x2x1/4	SAE	2X2X0.25	33.0	46.30	Tens	46.30	112X	5.057NESC Hea	21.421	13.600	16.875	10.922	8.322	1	1.000
0.875	TBC4	L2.5x2.5x3/16	SAE	2.5X2.5X0.1875	33.0	26.70	Comp	5.46	113X	1.153NESC Ext	21.917	27.200	25.312	21.094	7.000	2	1.000
0.875	TTC1	L2x2x3/16	SAE	2X2X0.1875	33.0	48.87	Tens	48.87	115P	3.591NESC Hea	16.214	13.600	12.656	7.348	7.000	1	1.000
0.875	TTC2	L2.5x2.5x3/16	SAE	2.5X2.5X0.1875	33.0	91.56	Comp	3.47	122P	0.365NESC Hea	21.917	13.600	12.656	10.512	8.322	1	1.000
0.875	Horz3	L2.5x2.5x3/16	SAE	2.5X2.5X0.1875	33.0	34.67	Comp	9.70	142X	1.755NESC Ext	21.917	27.200	25.312	18.105	7.000	2	1.000
0.875	Horz4	L2x2x3/16	SAE	2X2X0.1875	33.0	23.57	Tens	23.57	146P	1.931NESC Hea	16.214	13.600	12.656	8.191	7.000	1	1.000
0.875	Horz5	L3.5x3.5x5/16	SAE	3.5X3.5X0.3125	33.0	9.46	Comp	2.89	147X	1.177NESC Ext	53.952	40.800	63.281	47.988	7.000	3	1.000
0.875	Horz6	L3.5x3x1/4	SAU	3.5X3X0.25	33.0	16.25	Comp	16.02	149P	4.356NESC Ext	39.835	27.200	33.750	28.125	12.744	2	1.000

0.875	BBr1	L2x2x3/16	SAE	2X2X0.1875	33.0	5.11	Comp	2.08	152X	0.329	NESC Ext	16.214	27.200	25.312	15.785	5.091	2	1.000
0.875	BBr2	L4x4x3/8	SAE	4X4X0.375	33.0	43.99	Comp	40.30	151Y	27.404	NESC Hea	70.324	68.000	126.562	110.294	7.313	5	1.500
0.875	BBr3	L4x4x5/16	SAE	4X4X0.3125	33.0	46.91	Tens	46.91	154Y	25.521	NESC Hea	63.159	54.400	84.375	59.355	5.091	4	1.000
0.875	BBr4	L7x4x7/16	SAU	7X4X0.4375	33.0	11.34	Tens	11.34	155X	11.688	NESC Hea	103.105	149.600	324.843	300.781	6.789	11	3.000
0.875	BTC1	L3.5x3.5x1/4	SAE	3.5X3.5X0.25	33.0	10.93	Tens	10.93	157P	2.967	NESC Ext	43.696	27.200	33.750	27.141	10.750	2	1.000
0.875	BTC2	L2x2x3/16	SAE	2X2X0.1875	33.0	46.19	Comp	3.47	158Y	0.563	NESC Hea	16.214	27.200	25.312	19.301	15.027	2	1.000
0.875	BTC3	L3x2.5x1/4	SAU	3X2.5X0.25	33.0	17.20	Tens	17.20	161X	4.937	NESC Ext	28.698	40.800	50.625	32.016	5.375	3	1.000
0.875	BTC4	L2.5x1.5x1/4	SAU	2.5X1.5X0.25	33.0	21.41	Comp	0.00	163Y	0.000		21.421	40.800	50.625	41.016	7.010	3	1.000
0.875	BTC5	L2x2x1/4	SAE	2X2X0.25	33.0	15.17	Tens	15.17	164P	3.193	NESC Ext	21.421	27.200	33.750	21.047	4.500	2	1.000
0.875	BBC1	L3x3x3/16	SAE	3X3X0.1875	33.0	4.88	Comp	0.00	165P	0.000		27.500	27.200	25.312	19.652	12.666	2	1.000
0.875	BBC2	L2x2x3/16	SAE	2X2X0.1875	33.0	37.38	Comp	18.32	166XY	1.500	NESC Hea	16.214	13.600	12.656	8.191	16.452	1	1.000
0.875	BBC3	L3x3x1/4	SAE	3X3X0.25	33.0	2.80	Comp	0.72	168P	0.189	NESC Hea	36.271	27.200	33.750	26.203	12.666	2	1.000

*** Maximum Stress Summary for Each Load Case

Summary of Maximum Usages by Load Case:

Load Case	Maximum Usage %	Element Label	Element Type
NESC Heavy	82.13	78X	Angle
NESC Extreme	91.75	25Y	Angle
NESC Heavy Broken Wire	98.47	80XY	Angle

Summary of Insulator Usages:

Insulator Label	Insulator Type	Maximum Usage %	Load Case	Weight (lbs)
C1	Clamp	8.60	NESC Heavy	0.0
C2	Clamp	17.61	NESC Heavy Broken Wire	0.0
C3	Clamp	22.17	NESC Heavy	0.0
C4	Clamp	23.19	NESC Heavy	0.0
C5	Clamp	20.75	NESC Heavy	0.0
C6	Clamp	21.15	NESC Heavy	0.0
C7	Clamp	22.01	NESC Heavy	0.0
C8	Clamp	25.30	NESC Heavy	0.0
C9	Clamp	22.14	NESC Heavy	0.0
C10	Clamp	22.60	NESC Heavy	0.0
C11	Clamp	22.34	NESC Heavy	0.0
C12	Clamp	25.74	NESC Heavy	0.0

C13	Clamp	22.63	NESC Heavy	0.0
C14	Clamp	24.37	NESC Heavy	0.0
C15	Clamp	23.14	NESC Heavy	0.0
C16	Clamp	21.84	NESC Heavy	0.0
C17	Clamp	21.52	NESC Heavy	0.0
C18	Clamp	23.51	NESC Heavy	0.0
C19	Clamp	24.29	NESC Heavy	0.0
C20	Clamp	24.26	NESC Heavy	0.0
C21	Clamp	22.99	NESC Heavy	0.0
C22	Clamp	23.55	NESC Heavy	0.0
C23	Clamp	24.71	NESC Heavy	0.0
C24	Clamp	24.40	NESC Heavy	0.0
C25	Clamp	23.93	NESC Heavy	0.0
C26	Clamp	23.59	NESC Heavy	0.0
C27	Clamp	1.28	NESC Heavy	0.0
C28	Clamp	1.27	NESC Heavy	0.0
C29	Clamp	5.65	NESC Heavy	0.0
C30	Clamp	1.80	NESC Extreme	0.0
C31	Clamp	1.92	NESC Heavy	0.0
C32	Clamp	4.58	NESC Heavy	0.0
C34	Clamp	0.87	NESC Heavy	0.0
C35	Clamp	0.86	NESC Heavy	0.0
C36	Clamp	12.19	NESC Extreme	0.0
C37	Clamp	1.41	NESC Extreme	0.0
C38	Clamp	1.33	NESC Heavy	0.0
C39	Clamp	3.07	NESC Heavy	0.0
C41	Clamp	1.28	NESC Heavy	0.0
C42	Clamp	1.91	NESC Heavy	0.0
C43	Clamp	5.65	NESC Heavy	0.0
C44	Clamp	12.13	NESC Extreme	0.0
C45	Clamp	13.18	NESC Extreme	0.0
C46	Clamp	13.18	NESC Extreme	0.0
C47	Clamp	19.26	NESC Extreme	0.0
C48	Clamp	19.26	NESC Extreme	0.0
C49	Clamp	1.30	NESC Heavy	0.0
C50	Clamp	1.86	NESC Heavy	0.0
C51	Clamp	1.80	NESC Extreme	0.0
C52	Clamp	2.26	NESC Heavy	0.0
C53	Clamp	1.92	NESC Heavy	0.0
C54	Clamp	2.71	NESC Heavy	0.0
C55	Clamp	4.58	NESC Heavy	0.0
C56	Clamp	6.37	NESC Heavy	0.0

Loads At Insulator Attachments For All Load Cases:

Load Case	Insulator Label	Insulator Type	Structure Attach Label	Structure Attach Load X (kips)	Structure Attach Load Y (kips)	Structure Attach Load Z (kips)	Structure Attach Load Res. (kips)
NESC Heavy	C1	Clamp	1P	0.007	4.056	1.428	4.300
NESC Heavy	C2	Clamp	1X	0.008	5.162	1.853	5.485
NESC Heavy	C3	Clamp	15P	10.534	3.222	1.242	11.086
NESC Heavy	C4	Clamp	15X	11.032	3.361	1.197	11.595
NESC Heavy	C5	Clamp	15XY	-9.691	3.089	2.041	10.374
NESC Heavy	C6	Clamp	15Y	-9.901	3.106	2.038	10.576
NESC Heavy	C7	Clamp	16P	10.453	3.200	1.252	11.003
NESC Heavy	C8	Clamp	16X	12.072	3.604	1.160	12.652
NESC Heavy	C9	Clamp	16XY	-10.378	3.252	2.065	11.070

NESC Heavy	C10	Clamp	16Y	-10.621	3.264	2.052	11.300
NESC Heavy	C11	Clamp	17P	10.617	3.246	1.238	11.171
NESC Heavy	C12	Clamp	17X	12.289	3.653	1.153	12.872
NESC Heavy	C13	Clamp	17XY	-10.618	3.307	2.074	11.313
NESC Heavy	C14	Clamp	17Y	-11.491	3.474	2.098	12.187
NESC Heavy	C15	Clamp	22P	11.012	3.319	1.250	11.569
NESC Heavy	C16	Clamp	22X	10.378	3.174	1.227	10.921
NESC Heavy	C17	Clamp	22XY	-10.080	3.140	2.069	10.759
NESC Heavy	C18	Clamp	22Y	-11.066	3.369	2.105	11.757
NESC Heavy	C19	Clamp	28P	11.574	3.457	1.257	12.145
NESC Heavy	C20	Clamp	28X	11.568	3.452	1.199	12.132
NESC Heavy	C21	Clamp	28XY	-10.801	3.313	2.111	11.493
NESC Heavy	C22	Clamp	28Y	-11.080	3.376	2.110	11.773
NESC Heavy	C23	Clamp	34P	11.781	3.504	1.247	12.354
NESC Heavy	C24	Clamp	34X	11.631	3.471	1.211	12.198
NESC Heavy	C25	Clamp	34XY	-11.265	3.422	2.144	11.967
NESC Heavy	C26	Clamp	34Y	-11.094	3.385	2.132	11.793
NESC Heavy	C27	Clamp	3XY	0.000	0.222	0.602	0.641
NESC Heavy	C28	Clamp	5XY	0.000	0.260	0.577	0.633
NESC Heavy	C29	Clamp	7XY	-0.033	0.376	2.799	2.825
NESC Heavy	C30	Clamp	9XY	0.000	0.257	0.776	0.818
NESC Heavy	C31	Clamp	11XY	0.000	0.363	0.886	0.958
NESC Heavy	C32	Clamp	13XY	0.000	1.000	2.061	2.291
NESC Heavy	C34	Clamp	3Y	0.000	0.075	0.430	0.436
NESC Heavy	C35	Clamp	5Y	0.000	0.075	0.425	0.432
NESC Heavy	C36	Clamp	7Y	-0.892	-1.346	4.146	4.450
NESC Heavy	C37	Clamp	9Y	0.000	0.075	0.604	0.609
NESC Heavy	C38	Clamp	11Y	0.000	0.100	0.658	0.666
NESC Heavy	C39	Clamp	13Y	0.000	0.239	1.514	1.533
NESC Heavy	C41	Clamp	3X	0.000	0.222	0.602	0.641
NESC Heavy	C42	Clamp	3P	0.000	0.137	0.946	0.955
NESC Heavy	C43	Clamp	7X	0.033	0.376	2.799	2.825
NESC Heavy	C44	Clamp	7P	0.892	-1.284	4.662	4.918
NESC Heavy	C45	Clamp	2X	0.501	0.908	3.120	3.288
NESC Heavy	C46	Clamp	2XY	-0.501	0.908	3.100	3.269
NESC Heavy	C47	Clamp	2Y	1.577	2.545	2.441	3.863
NESC Heavy	C48	Clamp	2P	-1.577	2.545	2.421	3.850
NESC Heavy	C49	Clamp	5X	0.000	0.260	0.597	0.651
NESC Heavy	C50	Clamp	5P	0.000	0.137	0.921	0.931
NESC Heavy	C51	Clamp	9X	0.000	0.257	0.776	0.818
NESC Heavy	C52	Clamp	9P	0.000	0.137	1.120	1.129
NESC Heavy	C53	Clamp	11X	0.000	0.363	0.886	0.958
NESC Heavy	C54	Clamp	11P	0.000	0.182	1.342	1.355
NESC Heavy	C55	Clamp	13X	0.000	1.000	2.061	2.291
NESC Heavy	C56	Clamp	13S	0.000	0.436	3.154	3.184
NESC Extreme	C1	Clamp	1P	0.007	2.212	0.521	2.273
NESC Extreme	C2	Clamp	1X	0.010	3.598	0.637	3.654
NESC Extreme	C3	Clamp	15P	6.116	2.570	0.453	6.649
NESC Extreme	C4	Clamp	15X	6.389	2.627	0.418	6.920
NESC Extreme	C5	Clamp	15XY	-5.734	2.523	1.031	6.349
NESC Extreme	C6	Clamp	15Y	-5.842	2.551	1.035	6.458
NESC Extreme	C7	Clamp	16P	5.907	2.481	0.467	6.424
NESC Extreme	C8	Clamp	16X	6.726	2.667	0.403	7.247
NESC Extreme	C9	Clamp	16XY	-5.935	2.531	1.041	6.536
NESC Extreme	C10	Clamp	16Y	-6.049	2.551	1.036	6.647
NESC Extreme	C11	Clamp	17P	5.782	2.408	0.464	6.281
NESC Extreme	C12	Clamp	17X	6.601	2.586	0.411	7.101
NESC Extreme	C13	Clamp	17XY	-5.862	2.468	1.035	6.444
NESC Extreme	C14	Clamp	17Y	-6.275	2.561	1.055	6.859

NESC Extreme	C15	Clamp	22P	6.352	2.616	0.450	6.884
NESC Extreme	C16	Clamp	22X	6.060	2.556	0.428	6.591
NESC Extreme	C17	Clamp	22XY	-5.936	2.572	1.042	6.553
NESC Extreme	C18	Clamp	22Y	-6.443	2.686	1.068	7.062
NESC Extreme	C19	Clamp	28P	6.464	2.612	0.449	6.986
NESC Extreme	C20	Clamp	28X	6.481	2.615	0.409	7.001
NESC Extreme	C21	Clamp	28XY	-6.145	2.584	1.052	6.749
NESC Extreme	C22	Clamp	28Y	-6.282	2.612	1.052	6.884
NESC Extreme	C23	Clamp	34P	6.348	2.536	0.442	6.850
NESC Extreme	C24	Clamp	34X	6.298	2.527	0.420	6.799
NESC Extreme	C25	Clamp	34XY	-6.173	2.542	1.055	6.759
NESC Extreme	C26	Clamp	34Y	-6.096	2.529	1.046	6.682
NESC Extreme	C27	Clamp	3XY	0.000	0.500	0.204	0.540
NESC Extreme	C28	Clamp	5XY	0.000	0.500	0.204	0.540
NESC Extreme	C29	Clamp	7XY	1.043	-1.143	-0.177	1.557
NESC Extreme	C30	Clamp	9XY	0.000	0.742	0.507	0.899
NESC Extreme	C31	Clamp	11XY	0.000	0.816	0.408	0.913
NESC Extreme	C32	Clamp	13XY	0.000	1.619	0.554	1.712
NESC Extreme	C34	Clamp	3Y	0.000	0.283	0.165	0.328
NESC Extreme	C35	Clamp	5Y	0.000	0.283	0.165	0.328
NESC Extreme	C36	Clamp	7Y	-2.354	-3.464	4.429	6.096
NESC Extreme	C37	Clamp	9Y	0.000	0.525	0.468	0.703
NESC Extreme	C38	Clamp	11Y	0.000	0.529	0.355	0.637
NESC Extreme	C39	Clamp	13Y	0.000	0.930	0.429	1.025
NESC Extreme	C41	Clamp	3X	0.000	0.500	0.204	0.540
NESC Extreme	C42	Clamp	3P	0.000	0.500	0.283	0.575
NESC Extreme	C43	Clamp	7X	-1.043	-1.143	-0.177	1.557
NESC Extreme	C44	Clamp	7P	2.354	-3.247	4.547	6.063
NESC Extreme	C45	Clamp	2X	3.039	4.979	3.064	6.589
NESC Extreme	C46	Clamp	2XY	-3.039	4.979	3.064	6.589
NESC Extreme	C47	Clamp	2Y	5.003	8.133	-1.267	9.632
NESC Extreme	C48	Clamp	2P	-5.003	8.133	-1.267	9.632
NESC Extreme	C49	Clamp	5X	0.000	0.500	0.204	0.540
NESC Extreme	C50	Clamp	5P	0.000	0.500	0.283	0.575
NESC Extreme	C51	Clamp	9X	0.000	0.742	0.507	0.899
NESC Extreme	C52	Clamp	9P	0.000	0.742	0.586	0.945
NESC Extreme	C53	Clamp	11X	0.000	0.816	0.408	0.913
NESC Extreme	C54	Clamp	11P	0.000	0.816	0.513	0.964
NESC Extreme	C55	Clamp	13X	0.000	1.619	0.554	1.712
NESC Extreme	C56	Clamp	13S	0.000	1.619	0.806	1.809
NESC Heavy Broken Wire	C1	Clamp	1P	0.007	4.056	1.428	4.300
NESC Heavy Broken Wire	C2	Clamp	1X	-8.305	2.628	1.280	8.804
NESC Heavy Broken Wire	C3	Clamp	15P	10.534	3.222	1.242	11.086
NESC Heavy Broken Wire	C4	Clamp	15X	0.000	0.046	0.097	0.107
NESC Heavy Broken Wire	C5	Clamp	15XY	-9.691	3.089	2.041	10.374
NESC Heavy Broken Wire	C6	Clamp	15Y	-9.901	3.106	2.038	10.576
NESC Heavy Broken Wire	C7	Clamp	16P	10.453	3.200	1.252	11.003
NESC Heavy Broken Wire	C8	Clamp	16X	12.072	3.604	1.160	12.652
NESC Heavy Broken Wire	C9	Clamp	16XY	-10.378	3.252	2.065	11.070
NESC Heavy Broken Wire	C10	Clamp	16Y	-10.621	3.264	2.052	11.300
NESC Heavy Broken Wire	C11	Clamp	17P	10.617	3.246	1.238	11.171
NESC Heavy Broken Wire	C12	Clamp	17X	12.289	3.653	1.153	12.872
NESC Heavy Broken Wire	C13	Clamp	17XY	-10.618	3.307	2.074	11.313
NESC Heavy Broken Wire	C14	Clamp	17Y	-11.491	3.474	2.098	12.187
NESC Heavy Broken Wire	C15	Clamp	22P	11.012	3.319	1.250	11.569
NESC Heavy Broken Wire	C16	Clamp	22X	10.378	3.174	1.227	10.921
NESC Heavy Broken Wire	C17	Clamp	22XY	-10.080	3.140	2.069	10.759
NESC Heavy Broken Wire	C18	Clamp	22Y	-11.066	3.369	2.105	11.757
NESC Heavy Broken Wire	C19	Clamp	28P	11.574	3.457	1.257	12.145

NESC Heavy Broken Wire	C20	Clamp	28X	11.568	3.452	1.199	12.132
NESC Heavy Broken Wire	C21	Clamp	28XY	-10.801	3.313	2.111	11.493
NESC Heavy Broken Wire	C22	Clamp	28Y	-11.080	3.376	2.110	11.773
NESC Heavy Broken Wire	C23	Clamp	34P	11.781	3.504	1.247	12.354
NESC Heavy Broken Wire	C24	Clamp	34X	11.631	3.471	1.211	12.198
NESC Heavy Broken Wire	C25	Clamp	34XY	-11.265	3.422	2.144	11.967
NESC Heavy Broken Wire	C26	Clamp	34Y	-11.094	3.385	2.132	11.793
NESC Heavy Broken Wire	C27	Clamp	3XY	0.000	0.222	0.602	0.641
NESC Heavy Broken Wire	C28	Clamp	5XY	0.000	0.260	0.577	0.633
NESC Heavy Broken Wire	C29	Clamp	7XY	-0.033	0.376	2.799	2.825
NESC Heavy Broken Wire	C30	Clamp	9XY	0.000	0.257	0.776	0.818
NESC Heavy Broken Wire	C31	Clamp	11XY	0.000	0.363	0.886	0.958
NESC Heavy Broken Wire	C32	Clamp	13XY	0.000	1.000	2.061	2.291
NESC Heavy Broken Wire	C34	Clamp	3Y	0.000	0.075	0.430	0.436
NESC Heavy Broken Wire	C35	Clamp	5Y	0.000	0.075	0.425	0.432
NESC Heavy Broken Wire	C36	Clamp	7Y	-0.892	-1.346	4.146	4.450
NESC Heavy Broken Wire	C37	Clamp	9Y	0.000	0.075	0.604	0.609
NESC Heavy Broken Wire	C38	Clamp	11Y	0.000	0.100	0.658	0.666
NESC Heavy Broken Wire	C39	Clamp	13Y	0.000	0.239	1.514	1.533
NESC Heavy Broken Wire	C41	Clamp	3X	0.000	0.222	0.602	0.641
NESC Heavy Broken Wire	C42	Clamp	3P	0.000	0.137	0.946	0.955
NESC Heavy Broken Wire	C43	Clamp	7X	0.033	0.376	2.799	2.825
NESC Heavy Broken Wire	C44	Clamp	7P	0.892	-1.284	4.662	4.918
NESC Heavy Broken Wire	C45	Clamp	2X	0.501	0.908	3.120	3.288
NESC Heavy Broken Wire	C46	Clamp	2XY	-0.501	0.908	3.100	3.269
NESC Heavy Broken Wire	C47	Clamp	2Y	1.577	2.545	2.441	3.863
NESC Heavy Broken Wire	C48	Clamp	2P	-1.577	2.545	2.421	3.850
NESC Heavy Broken Wire	C49	Clamp	5X	0.000	0.260	0.597	0.651
NESC Heavy Broken Wire	C50	Clamp	5P	0.000	0.137	0.921	0.931
NESC Heavy Broken Wire	C51	Clamp	9X	0.000	0.257	0.776	0.818
NESC Heavy Broken Wire	C52	Clamp	9P	0.000	0.137	1.120	1.129
NESC Heavy Broken Wire	C53	Clamp	11X	0.000	0.363	0.886	0.958
NESC Heavy Broken Wire	C54	Clamp	11P	0.000	0.182	1.342	1.355
NESC Heavy Broken Wire	C55	Clamp	13X	0.000	1.000	2.061	2.291
NESC Heavy Broken Wire	C56	Clamp	13S	0.000	0.436	3.154	3.184

Overturning Moments For User Input Concentrated Loads:

Moments are static equivalents based on central axis of 0,0 (i.e. a single pole).

Load Case	Total Tran. Load (kips)	Total Long. Load (kips)	Total Vert. Load (kips)	Transverse Overturning Moment (ft-k)	Longitudinal Overturning Moment (ft-k)	Torsional Moment (ft-k)
NESC Heavy	97.182	6.869	75.064	6672.813	440.974	121.440
NESC Extreme	93.690	2.766	29.552	6603.547	165.471	68.288
NESC Heavy Broken Wire	91.332	-12.475	73.390	6201.555	-1226.810	-249.243

*** Weight of structure (lbs):

Weight of Angles*Section DLF: 30861.1
Total: 30861.1

*** End of Report

Foundation Analysis

Input Data:

Max. Reactions at Tower Leg:

Shear = Shear := 44.5 · 1.1 · kips = 49 · kips (User Input)

Compression = Comp := 128.2 · 1.1 · kips = 141 · kips (User Input)

Uplift = Uplift := 89.0 · 1.1 · kips = 97.9 · kips (User Input)

Tower Properties:

Tower Height = $H_t := 94 \text{ ft}$ (User Input)

Foundation Properties:

Pier Height = $P_H := 9.5 \text{ ft}$ (User Input)

Pier Width Top = $P_{W1} := 3 \text{ ft}$ (User Input)

Pier Width Bottom = $P_{W2} := 6 \text{ ft}$ (User Input)

Pier Projection Above Grade = $P_P := 0.5 \text{ ft}$ (User Input)

Pad Width = $Pd_W := 11 \text{ ft}$ (User Input)

Pad Thickness = $Pd_t := 3 \text{ ft}$ (User Input)

Subgrade Properties:

Concrete Unit Weight = $\gamma_c := 150 \text{ pcf}$ (User Input)

Water Unit Weight = $\gamma_w := 62.4 \text{ pcf}$ (User Input)

Soil Unit Weight = $\gamma_s := 100 \text{ pcf}$ (User Input)

Uplift Angle = $\psi := 30.0 \text{ deg}$ (User Input)

Soil Bearing Capacity = $BC_{\text{Soil}} := 3500 \text{ psf}$ (User Input)

Calculated Data:

Volume of the Concrete Pad = $V_{pad} := Pd_w^2 \cdot Pd_t = 363 \cdot ft^3$

Volume of the Concrete Pier = $V_{pier} := \frac{(P_H)}{3} \cdot (P_{w1}^2 + P_{w2}^2 + \sqrt{P_{w1}^2 \cdot P_{w2}^2}) = 199.5 \cdot ft^3$

Resisting Pyramid Base 1 = $B_1 := P_{w2}^2 = 36 \cdot ft^2$

Resisting Pyramid Base 2 = $B_2 := [2 \cdot \tan(\psi) \cdot (P_H - P_P) + Pd_w]^2 = 458 \cdot ft^2$

Volume of Soil = $V_{soil} := \left[\frac{(P_H - P_P)}{3} \cdot (B_1 + B_2 + \sqrt{B_1 \cdot B_2}) \right] - V_{pier} = 1.67 \times 10^3 \cdot ft^3$

Total Volume of Concrete = $V_{Conc} := V_{pad} + V_{pier} = 563 \cdot ft^3$

Mass of Concrete = $Mass_{Conc} := V_{Conc} \cdot \gamma_C = 84.4 \cdot kips$

Mass of Soil = $Mass_{Soil} := V_{soil} \cdot \gamma_S = 167 \cdot kips$

Total Mass = $Mass_{tot} := Mass_{Conc} + Mass_{Soil} = 251 \cdot kips$

Check Uplift:

Required Factor of Safety = $F_S := 1.0$

Actual FS = $ActualFS := \frac{Mass_{tot}}{Uplift} = 2.56$

Uplift Check = $Uplift_Check := \text{if} \left(\frac{Mass_{tot}}{Uplift} \geq F_S, "OK", "Overstressed" \right)$

Uplift_Check = "OK"

Cross Sectional Area of Pad = $A_{pad} := Pd_w^2 = 121 \cdot ft^2$

Section Modulus of Pad = $S_{pad} := \frac{(Pd_w)^3}{6} = 222 \cdot ft^3$

Check Bearing:

Bearing = $Bearing := \frac{Comp + Mass_{Conc}}{A_{pad}} = 1.86 \cdot ksf$

Bearing Check = $Bearing_Check := \text{if} (Bearing \leq BC_{soil}, "OK", "No Good")$

Bearing_Check = "OK"

Antenna Mast Top Connection:**Maximum Design Reactions at Brace:**

Compression Force =	Compression := 26.1-kips	(User Input from PLS-Tower)
Tension Force =	Tension := 3.9-kips	(User Input from PLS-Tower)
Moment =	$M_x := 2.55\text{-ft-kips}$	(User Input)
Moment =	$M_y := 0.6\text{-ft-kips}$	(User Input)

Member Properties:

Member Type =	L5x5x3/8	
Member Width =	$w := 5\text{-in}$	(User Input)
Member Thickness =	$t := 0.375\text{-in}$	(User Input)
Member Area =	$A := 3.65\text{-in}^2$	(User Input)
Moment of Inertia =	$I_x := 7.44\text{-in}^4$	(User Input)
Moment of Inertia =	$I_y := 7.44\text{-in}^4$	(User Input)
Section Modulus x-dir =	$S_x := 2.04\text{-in}^3$	(User Input)
Section Modulus y-dir =	$S_y := 2.04\text{-in}^3$	(User Input)
Unbraced Length =	$L := 2.5\text{-ft}$	(User Input)
Effective Length Coefficient =	$K := 1$	(User Input)
Radius of Gyration =	$r_x := 1.56\text{-in}$	(User Input)
Radius of Gyration =	$r_y := 1.56\text{-in}$	(User Input)
Yield Stress =	$F_y := 33\text{-ksi}$	(User Input)
Modulus of Elasticity =	$E := 29000\text{-ksi}$	(User Input)
	$k_{des} := 0.875\text{-in}$	

Calculate Design Compression Stress:

(Per ASCE 10-97 Section 3.6 and 3.7)

Width Thickness Ratio =

$$w_t := \frac{w - k_{des}}{t} = 11$$

Yield Stress =

$$F_y := \begin{cases} F_y & \text{if } w_t < \frac{80}{\sqrt{f_y}} \\ \left[1.677 - 0.677 \cdot \left(\frac{w_t}{\frac{80}{\sqrt{f_y}}} \right) \right] \cdot F_y & \text{if } \frac{80}{\sqrt{f_y}} \leq w_t \leq \frac{144}{\sqrt{f_y}} \\ \frac{0.0332 \cdot \pi^2 \cdot E}{(w_t)^2} & \text{if } w_t > \frac{144}{\sqrt{f_y}} \end{cases} = 33\text{-ksi} \quad (3.7-1)$$

$$\left[1.677 - 0.677 \cdot \left(\frac{w_t}{\frac{80}{\sqrt{f_y}}} \right) \right] \cdot F_y \quad \text{if } \frac{80}{\sqrt{f_y}} \leq w_t \leq \frac{144}{\sqrt{f_y}} \quad (3.7-2)$$

$$\frac{0.0332 \cdot \pi^2 \cdot E}{(w_t)^2} \quad \text{if } w_t > \frac{144}{\sqrt{f_y}} \quad (3.7-3)$$

Column Slenderness Ratio =

$$C_c := \pi \cdot \sqrt{\frac{2 \cdot E}{F_y}} = 131.706 \quad (3.6-3)$$

Design Axial Compressive Stress =

$$F_a := \begin{cases} \left[1 - 0.5 \cdot \left(\frac{\frac{K \cdot L}{r_x}}{C_c} \right)^2 \right] \cdot F_y & \text{if } \frac{K \cdot L}{r_x} \leq C_c \\ \frac{\pi^2 \cdot E}{\left(\frac{K \cdot L}{r_x} \right)^2} & \text{if } \frac{K \cdot L}{r_x} > C_c \end{cases} = 32.6\text{-ksi} \quad (3.6-1)$$

$$\frac{\pi^2 \cdot E}{\left(\frac{K \cdot L}{r_x} \right)^2} \quad \text{if } \frac{K \cdot L}{r_x} > C_c \quad (3.6-2)$$

Calculate Allowable Bending Moment:

(Per ASCE 10-97 Section 3.14.8)

$$b := w - \frac{t}{2} = 4.813\text{-in}$$

Elastic Critical Moment =

$$M_e := \frac{(0.66 \cdot E \cdot b^4 \cdot t)}{(K \cdot L)^2} \cdot \left[\sqrt{1 + \frac{0.81 \cdot (K \cdot L)^2 \cdot t^2}{b^4}} + 1 \right] = 8946.4\text{-kips-in} \quad (3.14-7)$$

Moment Causing Compressive Yield =

$$M_{xc} := F_y \cdot S_x = 67.32\text{-in-kips} \quad (3.14-9)$$

Moment Causing Compressive Yield =

$$M_{yc} := F_y \cdot S_y = 67.32\text{-kips-in} \quad (3.14-9)$$

Lateral Bukiing Moment =

$$M_b := \begin{cases} M_e & \text{if } M_e \leq 0.5 \cdot M_{yc} \\ M_{yc} \cdot \left(1 - \frac{M_{yc}}{4 \cdot M_e} \right) & \text{if } M_e > 0.5 \cdot M_{yc} \end{cases} = 67.2\text{-kips-in} \quad (3.14-5)$$

Allowable Moment =

$$M_a := \begin{pmatrix} M_{yc} & \text{if } M_{yc} \leq M_b \\ M_b \end{pmatrix} = 67.2\text{-kips-in} \quad (3.14-6)$$

Check Combined Axial Compression and Bending:

(Per ASCE 10-97 Section 3.12)

Bending Coefficient = $C_m := 1$ (for restrained ends)

Applied Axial Compression = $P := \text{Compression} = 26.1 \text{ kips}$

Design Axial Compression = $P_a := F_a \cdot A = 119.2 \text{ kips}$

Axial Compression at Yield = $P_y := F_y \cdot A = 120.45 \text{ kips}$

Euler Bukiing Load = $P_{ex} := \frac{\pi^2 \cdot E \cdot I_x}{(K \cdot L)^2} = 2366.1 \text{ kips}$

Euler Bukiing Load = $P_{ey} := \frac{\pi^2 \cdot E \cdot I_y}{(K \cdot L)^2} = 2366.1 \text{ kips}$

$$\text{Condition1} := \text{if} \left[\frac{P}{P_a} + \frac{C_m \cdot M_x}{M_{xc}} \cdot \left[\frac{1}{\left(1 - \frac{P}{P_{ex}}\right)} \right] + \frac{C_m \cdot M_y}{M_{yc}} \cdot \left[\frac{1}{\left(1 - \frac{P}{P_{ey}}\right)} \right] \leq 1.00, \text{"OK"}, \text{"Overstressed"} \right] \quad (3.12-1)$$

$$\frac{P}{P_a} + \frac{C_m \cdot M_x}{M_{xc}} \cdot \left[\frac{1}{\left(1 - \frac{P}{P_{ex}}\right)} \right] + \frac{C_m \cdot M_y}{M_{yc}} \cdot \left[\frac{1}{\left(1 - \frac{P}{P_{ey}}\right)} \right] = 0.787 \quad \text{Condition1} = \text{"OK"} \quad (3.12-2)$$

$$\text{Condition2} := \text{if} \left(\frac{P}{P_y} + \frac{M_x}{M_{xc}} + \frac{M_y}{M_{yc}} \leq 1.00, \text{"OK"}, \text{"Overstressed"} \right)$$

$$\frac{P}{P_y} + \frac{M_x}{M_{xc}} + \frac{M_y}{M_{yc}} = 0.778 \quad \text{Condition2} = \text{"OK"}$$

Antenna Mast Bottom Connection:

Maximum Design Reactions at Brace:

Compression Force =	Compression := 62.2-kips	(User Input from PLS-Tower)
Tension Force =	Tension := 37.5-kips	(User Input from PLS-Tower)
Moment =	$M_x := 2.374\text{-ft-kips}$	(User Input - Max Mment)
Moment =	$M_y := 0.53\text{-ft-kips}$	(User Input - Max Mment)

Member Properties:

Member Type =	L8x8x1/2	
Member Width =	w := 8-in	(User Input)
Member Thickness =	t := 0.5-in	(User Input)
Member Area =	A := 7.84-in ²	(User Input)
Moment of Inertia =	$I_x := 48.8\text{-in}^4$	(User Input)
Moment of Inertia =	$I_y := 48.8\text{-in}^4$	(User Input)
Section Modulus x-dir =	$S_x := 8.36\text{-in}^3$	(User Input)
Section Modulus y-dir =	$S_y := 8.36\text{-in}^3$	(User Input)
Unbraced Length =	L := 5-ft	(User Input)
Effective Length Coefficient =	K := 1	(User Input)
Radius of Gyration =	$r_x := 2.49\text{-in}$	(User Input)
Radius of Gyration =	$r_y := 2.49\text{-in}$	(User Input)
Yield Stress =	$F_y := 33\text{-ksi}$	(User Input)
Modulus of Elasticity =	E := 29000-ksi	(User Input)
	$k_{des} := 1.125\text{-in}$	

Calculate Design Compression Stress:

(Per ASCE 10-97 Section 3.6 and 3.7)

Width Thickness Ratio =

$$w_t := \frac{w - k_{des}}{t} = 13.75$$

Yield Stress =

$$F_y := \begin{cases} F_y & \text{if } w_t < \frac{80}{\sqrt{f_y}} \\ \left[1.677 - 0.677 \cdot \frac{w_t}{\left(\frac{80}{\sqrt{f_y}}\right)} \right] \cdot F_y & \text{if } \frac{80}{\sqrt{f_y}} \leq w_t \leq \frac{144}{\sqrt{f_y}} \\ \frac{0.0332 \cdot \pi^2 \cdot E}{(w_t)^2} & \text{if } w_t > \frac{144}{\sqrt{f_y}} \end{cases} = 33 \text{ ksi} \quad (3.7-1)$$

$$\left[1.677 - 0.677 \cdot \frac{w_t}{\left(\frac{80}{\sqrt{f_y}}\right)} \right] \cdot F_y \quad \text{if } \frac{80}{\sqrt{f_y}} \leq w_t \leq \frac{144}{\sqrt{f_y}} \quad (3.7-2)$$

$$\frac{0.0332 \cdot \pi^2 \cdot E}{(w_t)^2} \quad \text{if } w_t > \frac{144}{\sqrt{f_y}} \quad (3.7-3)$$

Column Slenderness Ratio =

$$C_c := \pi \cdot \sqrt{\frac{2 \cdot E}{F_y}} = 131.706 \quad (3.6-3)$$

Design Axial Compressive Stress =

$$F_a := \begin{cases} \left[1 - 0.5 \left(\frac{K \cdot L}{r_x} \right)^2 \right] \cdot F_y & \text{if } \frac{K \cdot L}{r_x} \leq C_c \\ \frac{\pi^2 \cdot E}{\left(\frac{K \cdot L}{r_x} \right)^2} & \text{if } \frac{K \cdot L}{r_x} > C_c \end{cases} = 32.4 \text{ ksi} \quad (3.6-1)$$

$$\frac{\pi^2 \cdot E}{\left(\frac{K \cdot L}{r_x} \right)^2} \quad \text{if } \frac{K \cdot L}{r_x} > C_c \quad (3.6-2)$$

Calculate Allowable Bending Moment:

(Per ASCE 10-97 Section 3.14.8)

$$b := w - \frac{t}{2} = 7.75 \text{ in}$$

Elastic Critical Moment =

$$M_e := \frac{(0.66 \cdot E \cdot b^4 \cdot t)}{(K \cdot L)^2} \cdot \left[\sqrt{1 + \frac{0.81 \cdot (K \cdot L)^2 \cdot t^2}{b^4}} + 1 \right] = 20104.3 \text{ kips-in} \quad (3.14-7)$$

Moment Causing Compressive Yield =

$$M_{xc} := F_y \cdot S_x = 275.88 \text{ in-kips} \quad (3.14-9)$$

Moment Causing Compressive Yield =

$$M_{yc} := F_y \cdot S_y = 275.88 \text{ kips-in} \quad (3.14-9)$$

Lateral Bukiing Moment =

$$M_b := \begin{cases} M_e & \text{if } M_e \leq 0.5 \cdot M_{yc} \\ M_{yc} \cdot \left(1 - \frac{M_{yc}}{4 \cdot M_e} \right) & \text{if } M_e > 0.5 \cdot M_{yc} \end{cases} = 274.9 \text{ kips-in} \quad (3.14-5)$$

Allowable Moment =

$$M_a := \begin{cases} M_{yc} & \text{if } M_{yc} \leq M_b \\ M_b & \end{cases} = 274.9 \text{ kips-in} \quad (3.14-6)$$

Check Combined Axial Compression and Bending:

(Per ASCE 10-97 Section 3.12)

- Bending Coefficient = $C_m := 1$ (for restrained ends)
- Applied Axial Compression = $P :=$ Compression = 62.2 kips
- Design Axial Compression = $P_a := F_a \cdot A = 254.4$ kips
- Axial Compression at Yield = $P_y := F_y \cdot A = 258.72$ kips
- Euler Buckling Load = $P_{ex} := \frac{\pi^2 \cdot E \cdot I_x}{(K \cdot L)^2} = 3879.9$ kips
- Euler Buckling Load = $P_{ey} := \frac{\pi^2 \cdot E \cdot I_y}{(K \cdot L)^2} = 3879.9$ kips

$$\text{Condition1} := \text{if} \left[\frac{P}{P_a} + \frac{C_m \cdot M_x}{M_{xc}} \cdot \left[\frac{1}{\left(1 - \frac{P}{P_{ex}}\right)} \right] + \frac{C_m \cdot M_y}{M_{yc}} \cdot \left[\frac{1}{\left(1 - \frac{P}{P_{ey}}\right)} \right] \leq 1.00, \text{"OK"}, \text{"Overstressed"} \right] \quad (3.12-1)$$

$$\frac{P}{P_a} + \frac{C_m \cdot M_x}{M_{xc}} \cdot \left[\frac{1}{\left(1 - \frac{P}{P_{ex}}\right)} \right] + \frac{C_m \cdot M_y}{M_{yc}} \cdot \left[\frac{1}{\left(1 - \frac{P}{P_{ey}}\right)} \right] = 0.373 \quad \text{Condition1} = \text{"OK"} \quad (3.12-2)$$

$$\text{Condition2} := \text{if} \left(\frac{P}{P_y} + \frac{M_x}{M_{xc}} + \frac{M_y}{M_{yc}} \leq 1.00, \text{"OK"}, \text{"Overstressed"} \right)$$

$$\frac{P}{P_y} + \frac{M_x}{M_{xc}} + \frac{M_y}{M_{yc}} = 0.367 \quad \text{Condition2} = \text{"OK"}$$

Section 1 - RFDS GENERAL INFORMATION

RFDS NAME:	CTL05046	DATE:	03/15/2018	RF DESIGN ENG:	Md Mateen	RF PERF ENG:		RFDS PROGRAM TYPE:	2018 LTE Next Carrier				
ISSUE:	Bronze Standard	Approved? (Y/N):	Yes	RF DESIGN PHONE:	8602586382	RF PERF PHONE:		RFDS TECHNOLOGY:	LTE				
REVISION:	Final	RF MANAGER:	Benedetto, John	RF DESIGN EMAIL:	MM093Q@ATT.COM	RF PERF EMAIL:		STATE/STATUS:	As Built/In Progress				
INITIATIVE /PROJECT:	LTE 3C WCS, LTE 4C AWS,J, LTE 5C 850 B(U), This is Utility pole, Ground, 2 ant soln.				RFDS VERSION:	1.00	RFDS ID:	2284440					
					GSM FREQUENCY:		Created By:	mm093q	Updated By:	mm093q			
					UMTS FREQUENCY:	850	Date Created:	3/15/2018 12:12:23 PM	Date Updated:	8/30/2018 3:08:13 PM			
					LTE FREQUENCY:	700, 850, 1900, AWS, WCS							
					5G FREQUENCY:	850							
					I-PLAN JOB # 1:	NER-RCTB-17-07903		IPLAN PRD GRP SUB GRP #1:	LTE Next Carrier LTE 3C				
					I-PLAN JOB # 2:	NER-RCTB-18-02342		IPLAN PRD GRP SUB GRP #2:	LTE Next Carrier LTE 4C				
					I-PLAN JOB # 3:	NER-RCTB-18-02381		IPLAN PRD GRP SUB GRP #3:	LTE Next Carrier LTE 5C				
					I-PLAN JOB # 4:			IPLAN PRD GRP SUB GRP #4:					
					I-PLAN JOB # 5:			IPLAN PRD GRP SUB GRP #5:					
I-PLAN JOB # 6:			IPLAN PRD GRP SUB GRP #6:										
I-PLAN JOB # 7:			IPLAN PRD GRP SUB GRP #7:										
I-PLAN JOB # 8:			IPLAN PRD GRP SUB GRP #8:										

Section 2 - LOCATION INFORMATION

USID:	4535	FA LOCATION CODE:	10071181	LOCATION NAME:	NORWALK CENTER	ORACLE PTN # 1:	2051A0GJ85	PACE JOB # 1:	MRCTB031041
REGION:	NORTHEAST	MARKET CLUSTER:	NEW ENGLAND	MARKET:	CONNECTICUT	ORACLE PTN # 2:	2051A0GH88	PACE JOB # 2:	MRCTB031949
ADDRESS:	1 WILL RUSS COURT	CITY:	NORWALK	STATE:	CT	ORACLE PTN # 3:	2051A0GH6R	PACE JOB # 3:	MRCTB031707
ZIP CODE:	06850	COUNTY:	FAIRFIELD	LONG (DEC. DEG.):	-73.4327989	ORACLE PTN # 4:		PACE JOB # 4:	
LATITUDE (D-M-S):	41d 7m36.09084s	LONGITUDE (D-M-S):	-73d -25m-58.07604s	LAT (DEC. DEG.):	41.1266919	ORACLE PTN # 5:		PACE JOB # 5:	
DIRECTIONS, ACCESS AND EQUIPMENT LOCATION:	CT-046 NORWALK NORTH NORWALK TAKE ROUTE 80 EAST ACROSS G.W. BRIDGE, FOLLOW CROSS BRONX EXPRESSWAY TO I-95 NORTH INTO CT. YOU WILL GET OFF AT EXIT 15 FOR RT 7 NORTH, TAKE 7 NORTH TO EXIT 2(RT. 123). AT THE END OF EXIT MAKE RIGHT ONTO NEW CANAAN AVE. GO STR				ORACLE PTN # 6:		PACE JOB # 6:		
					ORACLE PTN # 7:		PACE JOB # 7:		
					ORACLE PTN # 8:		PACE JOB # 8:		
					BORDER CELL WITH CONTOUR COORD:		SEARCH RING NAME:		
					AM STUDY REQ'D (Y/N):	No	SEARCH RING ID:		
					FREQ COORD:		BTA:		MSA / RSA:
					OPS DISTRICT:	CT-South	LAC(GSM):		
					OPS ZONE:	NE_CT_S_FRFD_W_CS	LAC(UMTS):	05989	
					RF DISTRICT:	NPO Triage	BSC(GSM):		
					RF ZONE:	Hotseat	RNC(UMTS):	BRPCT04CRBR06	
PARENT NAME(GSM):		MME POOL ID(LTE):	FF01						
PARENT NAME(UMTS):	BRIDGEPORT RNC06 ERICSSON 3820								

Section 3 - LICENSE COVERAGE/FILING INFORMATION

CGSA - NO FILING TRIGGERED (Yes/No):	No	CGSA LOSS:		PCS REDUCED - UPS ZIP:		CGSA CALL SIGNS:
CGSA - MINOR FILING NEEDED (Yes/No):	No	CGSA EXT AGMT NEEDED:		PCS POPS REDUCED:		
CGSA - MAJOR FILING NEEDED (Yes/No):	Yes	CGSA SCORECARD UPDATED:				

Section 4 - TOWER/REGULATORY INFORMATION

STRUCTURE AT&T OWNED?:	No	GROUND ELEVATION (ft):	0	STRUCTURE TYPE:	UTILITY	MARKET LOCATION 700 MHz Band:	
ADDITIONAL REGULATORY?:	No	HEIGHT OVERALL (ft):	0.00	FCC ASR NUMBER:	NR	MARKET LOCATION 850 MHz Band:	
SUB-LEASE RIGHTS?:	No	STRUCTURE HEIGHT (ft):	0.00			MARKET LOCATION 1900 MHz Band:	
LIGHTING TYPE:	NOT REQUIRED					MARKET LOCATION AWS Band:	
						MARKET LOCATION WCS Band:	
						MARKET LOCATION Future Band:	

Section 6 - RBS GENERAL INFORMATION - existing

	UMTS 1ST RBS	UMTS 2ND RBS	LTE 1ST RBS	5G 1ST RBS							
RBS ID:	172416	222843	360150								
CTS COMMON ID:	CTU5046	CTV5046	CTL05046								
CELL ID / BCF:	CTU5046	CTU5046	CTL05046								
BTA/TID:	321V	321U	321L								
4-9 DIGIT SITE ID:	5046	9046	5046								
COW OR TOY?:	No	No	No								
CELL SITE TYPE:	SECTORIZED	SECTORIZED	SECTORIZED								
SITE TYPE:	MACRO-CONVENTIONAL	MACRO-CONVENTIONAL	MACRO-CONVENTIONAL								
BTS LOCATION ID:	INTERNAL	GROUND	INTERNAL								
BASE STATION TYPE:	BASE	OVERLAY	BASE								
EQUIPMENT NAME:	NORWALK CENTER	NORWALK CENTER	NORWALK CENTER								
DISASTER PRIORITY:	1	1	3								

Section 6 - RBS GENERAL INFORMATION - final

	UMTS 1ST RBS	UMTS 2ND RBS	LTE 1ST RBS	5G 1ST RBS							
RBS ID:	172416	222843	360150	RFDS_36270436							
CTS COMMON ID:	CTU5046	CTV5046	CTL05046	CTN0005046							
CELL ID / BCF:	CTU5046	CTU5046	CTL05046	CTN0005046							
BTA/TID:	321V	321U	321L	321L							
4-9 DIGIT SITE ID:	5046	9046	5046	005046							
COW OR TOY?:	No	No	No	No							
CELL SITE TYPE:	SECTORIZED	SECTORIZED	SECTORIZED	SECTORIZED							
SITE TYPE:	MACRO-CONVENTIONAL	MACRO-CONVENTIONAL	MACRO-CONVENTIONAL	MACRO-CONVENTIONAL							
BTS LOCATION ID:	INTERNAL	GROUND	INTERNAL	INTERNAL							
BASE STATION TYPE:	BASE	OVERLAY	BASE	BASE							
EQUIPMENT NAME:	NORWALK CENTER	NORWALK CENTER	NORWALK CENTER	NORWALK CENTER							
DISASTER PRIORITY:	1	1	3	3							

Section 15A - CURRENT TOWER CONFIGURATION - SECTOR A (OR OMNI)

ANTENNA POSITION is LEFT to RIGHT from BACK OF ANTENNA (unless otherwise specified)	ANTENNA POSITION 1	ANTENNA POSITION 2	ANTENNA POSITION 3	ANTENNA POSITION 4	ANTENNA POSITION 5	ANTENNA POSITION 6	ANTENNA POSITION 7
ANTENNA MAKE - MODEL	7770		AM-X-CD-14-65-00T-RET				
ANTENNA VENDOR	Powerwave		KMW				
ANTENNA SIZE (H x W x D)	55X11X5		48X11.8X5.9				
ANTENNA WEIGHT	35		36.4				
AZIMUTH	0		30				
MAGNETIC DECLINATION							
RADIATION CENTER (feet)	105		105				
ANTENNA TIP HEIGHT							
MECHANICAL DOWNTILT	0		0				
FEEDER AMOUNT	2		2				
VERTICAL SEPARATION from ANTENNA ABOVE (TIP to TIP)							
VERTICAL SEPARATION from ANTENNA BELOW (TIP to TIP)							
HORIZONTAL SEPARATION from CLOSEST ANTENNA to LEFT (CENTERLINE to CENTERLINE)							
HORIZONTAL SEPARATION from CLOSEST ANTENNA to RIGHT (CENTERLINE to CENTERLINE)							
HORIZONTAL SEPARATION from ANOTHER ANTENNA (which antenna # / # of inches)							
Antenna RET Motor (QTY/MODEL)	2	Powerwave 7020		Built in			
SURGE ARRESTOR (QTY/MODEL)			4	Andrew APTDC-BDFDM-DB			
DIPLEXER (QTY/MODEL)	2	Powerwave / LGP 21901	2	Powerwave / CM1007-DBPXC-003			
DUPLEXER (QTY/MODEL)							
Antenna RET CONTROL UNIT (QTY/MODEL)	1	Kathrein / 860-10006					
DC BLOCK (QTY/MODEL)							
TMA/LNA (QTY/MODEL)	1	Pwav TT19-08BP111-001 Twin 1900 w/ 850BP	1	Kaelus TMA2093FxxVx-1 Twin TMA 850 BP			
CURRENT INJECTORS FOR TMA (QTY/MODEL)	2	Polyphaser 1000860					
PDU FOR TMA (QTY/MODEL)	1	LGP 12104 (1900 AND 850 Bypass TMA)					
FILTER (QTY/MODEL)							
SQUID (QTY/MODEL)							
FIBER TRUNK (QTY/MODEL)							
DC TRUNK (QTY/MODEL)							
REPEATER (QTY/MODEL)							
RRH - 700 band (QTY/MODEL)			1	RRUS-11 (REUSE ONLY)			
RRH - 850 band (QTY/MODEL)							
RRH - 1900 band (QTY/MODEL)			1	RRUS-12			
RRH - AWS band (QTY/MODEL)							
RRH - WCS band (QTY/MODEL)							
Additional RRH #1 - any band (QTY/MODEL)							
Additional RRH #2 - any band (QTY/MODEL)							
Additional Component 1 (QTY/MODEL)							
Additional Component 2 (QTY/MODEL)							
Additional Component 3 (QTY/MODEL)							
Local Market Note 1							
Local Market Note 2							
Local Market Note 3							

PORT SPECIFIC FIELDS	PORT NUMBER	USEID (CSSng)	USEID (Atoll)	ATOLL TXID	ATOLL CELL ID	TX/RX ?	TECHNOLOGY/FREQUENCY	ANTENNA ATOLL	ANTENNA GAIN	ELECTRICAL AZIMUTH	ELECTRICAL TILT	RRH LOCATION (Top/Bottom/Integrated/None)	FEEDERS TYPE	FEEDER LENGTH (feet)	RX/AIT KIT MODULE?	TRIPLEXER or LLC (QTY)	TRIPLEXER or LLC (MODEL)	SCPA/MCPA MODULE?	HATCHPLATE POWER (Watts)	ERP (Watts)	Antenna RET Name	CABLE NUMBER	CABLE ID (CSSNG)
ANTENNA POSITION 1	PORT 1		4535.A.850.3G.1	CTV50461	CTV50461		UMTS 850	7770.00.850.05	13.5		5	None	Andrew 1-1/4 (850)	145.04					272.27			1	
	PORT 2		4535.A.850.3G.2	CTV50461	CTV5046A		UMTS 850	7770.00.850.05	13.5		5	Bottom	Andrew 1-1/4 (850)	145.04					272.27			1	
	PORT 3		4535.A.1900.3G.1	CTU50467	CTU50467		UMTS 1900	7770.00.1900.02	15.5		2	None	Andrew 1-1/4 (850)	145.04	CCI RxAIT 1900	1	CCI LLC 1900		583.45			1	
	PORT 4		4535.A.1900.3G.2	CTU50464	CTU50464		UMTS 1900	7770.00.1900.02	15.5		2	Bottom	Andrew 1-1/4 (850)	145.04	CCI RxAIT 1900	1	CCI LLC 1900		583.45			1	

	PORT 7		4535.A.1900.25G.1	321P50461	321P50461		GSM 1900	7770.00.1900.02	16.79		2	None	Andrew 1-1/4 (850)	145.04	CCI RxAIT 1900	1	CCI LLC 1900		7.07	167.1		1	
ANTENNA POSITION 3	PORT 1		4535.A.700.4G.1	CTL05046_7A_1	CTL05046_7A_1		LTE 700	AM-X-CD-14-65-00T- RET_725MHz_02DT	14.1		2	Bottom	1 1/4" ANDREW LDF6-50A_700 MHz	145.04						1475.7065		5	
	PORT 3		4535.A.1900.4G.1	CTL05046_9A_1	CTL05046_9A_1		LTE 1900	AM-X-CD-14-65-00T- RET_1930MHz_05DT	17.1		5	Bottom	1 1/4" ANDREW LDF6-50A_700 MHz	145.04						2421.029		5	
	PORT 4			CTL05046_9A_2	CTL05046_9A_2		LTE 1900	AM-X-CD-14-65-00T- RET_1930MHz_05DT	17.1		5	Bottom	1 1/4" ANDREW LDF6-50A_700 MHz	145.04						2421.029		5	

Section 15B - CURRENT TOWER CONFIGURATION - SECTOR B

ANTENNA POSITION is LEFT to RIGHT from BACK OF ANTENNA (unless otherwise specified)	ANTENNA POSITION 1	ANTENNA POSITION 2	ANTENNA POSITION 3	ANTENNA POSITION 4	ANTENNA POSITION 5	ANTENNA POSITION 6	ANTENNA POSITION 7
ANTENNA MAKE - MODEL	7770		AM-X-CD-14-65-00T-RET				
ANTENNA VENDOR	Powerwave		KMW				
ANTENNA SIZE (H x W x D)	55X11X5		48X11.8X5.9				
ANTENNA WEIGHT	35		36.4				
AZIMUTH	120		150				
MAGNETIC DECLINATION							
RADIATION CENTER (feet)	105		105				
ANTENNA TIP HEIGHT							
MECHANICAL DOWNTILT	0		0				
FEEDER AMOUNT	2		2				
VERTICAL SEPARATION from ANTENNA ABOVE (TIP to TIP)							
VERTICAL SEPARATION from ANTENNA BELOW (TIP to TIP)							
HORIZONTAL SEPARATION from CLOSEST ANTENNA to LEFT (CENTERLINE to CENTERLINE)							
HORIZONTAL SEPARATION from CLOSEST ANTENNA to RIGHT (CENTERLINE to CENTERLINE)							
HORIZONTAL SEPARATION from ANOTHER ANTENNA (which antenna # / # of inches)							
Antenna RET Motor (QTY/MODEL)	2	Powerwave 7020	Built in				
SURGE ARRESTOR (QTY/MODEL)			4	Andrew APTDC-BDFDM-DB			
DIPLEXER (QTY/MODEL)	2	Powerwave / LGP 21901	2	Powerwave / CM1007-DBPXC-003			
DUPLEXER (QTY/MODEL)							
Antenna RET CONTROL UNIT (QTY/MODEL)							
DC BLOCK (QTY/MODEL)							
TMA/LNA (QTY/MODEL)	1	Pwav TT19-08BP111-001 Twin 1900 w/ 850BP	1	Kaelus TMA2093FxxVx-1 Twin TMA 850 BP			
CURRENT INJECTORS FOR TMA (QTY/MODEL)	2	Polyphaser 1000860					
PDU FOR TMAS (QTY/MODEL)							
FILTER (QTY/MODEL)							
SQUID (QTY/MODEL)							
FIBER TRUNK (QTY/MODEL)							
DC TRUNK (QTY/MODEL)							
REPEATER (QTY/MODEL)							
RRH - 700 band (QTY/MODEL)			1	RRUS-11 (REUSE ONLY)			
RRH - 850 band (QTY/MODEL)							
RRH - 1900 band (QTY/MODEL)			1	RRUS-12			
RRH - AWS band (QTY/MODEL)							
RRH - WCS band (QTY/MODEL)							
Additional RRH #1 - any band (QTY/MODEL)							
Additional RRH #2 - any band (QTY/MODEL)							
Additional Component 1 (QTY/MODEL)							
Additional Component 2 (QTY/MODEL)							
Additional Component 3 (QTY/MODEL)							
Local Market Note 1							
Local Market Note 2							
Local Market Note 3							

PORT SPECIFIC FIELDS	PORT NUMBER	USEID (CSSng)	USEID (Atoll)	ATOLL TXID	ATOLL CELL ID	TX/RX ?	TECHNOLOGY/FREQUENCY	ANTENNA ATOLL	ANTENNA GAIN	ELECTRICAL AZIMUTH	ELECTRICAL TILT	RRH LOCATION (Top/Bottom/Integrated/None)	FEEDERS TYPE	FEEDER LENGTH (feet)	RXAIT KIT MODULE?	TRIPLEXER or LLC (QTY)	TRIPLEXER or LLC (MODEL)	SCPA/MCPA MODULE?	HATCHPLATE POWER (Watts)	ERP (Watts)	Antenna RET Name	CABLE NUMBER	CABLE ID (CSSNG)
ANTENNA POSITION 1	PORT 1		4535.B.850.3G.1	CTV50462	CTV50462		UMTS 850	7770.00.850.10	13.5		10	None	Andrew 1-1/4 (850)	145.04					272.27			9	
	PORT 2		4535.B.850.3G.2	CTV50462	CTV5046B		UMTS 850	7770.00.850.10	13.5		10	Bottom	Andrew 1-1/4 (850)	145.04					272.27			9	
	PORT 3		4535.B.1900.3G.1	CTU50468	CTU50468		UMTS 1900	7770.00.1900.05	15.5		5	None	Andrew 1-1/4 (850)	145.04	CCI RxAIT 1900	1	CCI LLC 1900		583.45			9	
	PORT 4		4535.B.1900.3G.2	CTU50465	CTU50465		UMTS 1900	7770.00.1900.05	15.5		5	Bottom	Andrew 1-1/4 (850)	145.04	CCI RxAIT 1900	1	CCI LLC 1900		583.45			9	
	PORT 7		4535.B.1900.25G.1	321P50462	321P50462		GSM 1900	7770.00.1900.05	16.79		5	None	Andrew 1-1/4 (850)	145.04	CCI RxAIT	1	CCI LLC 1900		7.07	167.1		9	

														1900									
ANTENNA POSITION 3	PORT 1	4535.B.700.4G.1	CTL05046_7B_1	CTL05046_7B_1	LTE 700	AM-X-CD-14-65-00T-RET_725MHz_02DT	14.1		2	Bottom	1 1/4" ANDREW LDF6-50A_700 MHz	145.04							1475.7065		13		
	PORT 3	4535.B.1900.4G.1	CTL05046_9B_1	CTL05046_9B_1	LTE 1900	AM-X-CD-14-65-00T-RET_1930MHz_05DT	17.1		5	Bottom	1 1/4" ANDREW LDF6-50A_700 MHz	145.04							2421.029		13		
	PORT 4		CTL05046_9B_2	CTL05046_9B_2	LTE 1900	AM-X-CD-14-65-00T-RET_1930MHz_05DT	17.1		5	Bottom	1 1/4" ANDREW LDF6-50A_700 MHz	145.04							2421.029		13		

Section 15C - CURRENT TOWER CONFIGURATION - SECTOR C

ANTENNA POSITION is LEFT to RIGHT from BACK OF ANTENNA (unless otherwise specified)	ANTENNA POSITION 1	ANTENNA POSITION 2	ANTENNA POSITION 3	ANTENNA POSITION 4	ANTENNA POSITION 5	ANTENNA POSITION 6	ANTENNA POSITION 7
ANTENNA MAKE - MODEL	7770		AM-X-CD-14-65-00T-RET				
ANTENNA VENDOR	Powerwave		KMW				
ANTENNA SIZE (H x W x D)	55X11X5		48X11.8X5.9				
ANTENNA WEIGHT	35		36.4				
AZIMUTH	240		270				
MAGNETIC DECLINATION							
RADIATION CENTER (feet)	105		105				
ANTENNA TIP HEIGHT							
MECHANICAL DOWNTILT	0		0				
FEEDER AMOUNT	2		2				
VERTICAL SEPARATION from ANTENNA ABOVE (TIP to TIP)							
VERTICAL SEPARATION from ANTENNA BELOW (TIP to TIP)							
HORIZONTAL SEPARATION from CLOSEST ANTENNA to LEFT (CENTERLINE to CENTERLINE)							
HORIZONTAL SEPARATION from CLOSEST ANTENNA to RIGHT (CENTERLINE to CENTERLINE)							
HORIZONTAL SEPARATION from ANOTHER ANTENNA (which antenna # / # of inches)							
Antenna RET Motor (QTY/MODEL)	2	Powerwave 7020		Built in			
SURGE ARRESTOR (QTY/MODEL)			4	Andrew APTDC-BDFDM-DB			
DIPLEXER (QTY/MODEL)	2	Powerwave / LGP 21901	2	Powerwave / CM1007-DBPXC-003			
DUPLEXER (QTY/MODEL)							
Antenna RET CONTROL UNIT (QTY/MODEL)							
DC BLOCK (QTY/MODEL)							
TMA/LNA (QTY/MODEL)	1	Pwav TT19-08BP111-001 Twin 1900 w/ 850BP	1	Kaelus TMA2093FxxVx-1 Twin TMA 850 BP			
CURRENT INJECTORS FOR TMA (QTY/MODEL)	2	Polyphaser 1000860					
PDU FOR TMA (QTY/MODEL)							
FILTER (QTY/MODEL)							
SQUID (QTY/MODEL)							
FIBER TRUNK (QTY/MODEL)							
DC TRUNK (QTY/MODEL)							
REPEATER (QTY/MODEL)							
RRH - 700 band (QTY/MODEL)			1	RRUS-11 (REUSE ONLY)			
RRH - 850 band (QTY/MODEL)							
RRH - 1900 band (QTY/MODEL)			1	RRUS-12			
RRH - AWS band (QTY/MODEL)							
RRH - WCS band (QTY/MODEL)							
Additional RRH #1 - any band (QTY/MODEL)							
Additional RRH #2 - any band (QTY/MODEL)							
Additional Component 1 (QTY/MODEL)							
Additional Component 2 (QTY/MODEL)							
Additional Component 3 (QTY/MODEL)							
Local Market Note 1							
Local Market Note 2							
Local Market Note 3							

PORT SPECIFIC FIELDS	PORT NUMBER	USEID (CSSng)	USEID (Atoll)	ATOLL TXID	ATOLL CELL ID	TX/RX ?	TECHNOLOGY/FREQUENCY	ANTENNA ATOLL	ANTENNA GAIN	ELECTRICAL AZIMUTH	ELECTRICAL TILT	RRH LOCATION (Top/Bottom/Integrated/None)	FEEDERS TYPE	FEEDER LENGTH (feet)	RXAIT KIT MODULE?	TRIPLEXER or LLC (QTY)	TRIPLEXER or LLC (MODEL)	SCPA/MCPA MODULE?	HATCHPLATE POWER (Watts)	ERP (Watts)	Antenna RET Name	CABLE NUMBER	CABLE ID (CSSNG)
ANTENNA POSITION 1	PORT 1		4535.C.850.3G.1	CTV50463	CTV50463		UMTS 850	7770.00.850.00	13.5		0	None	Andrew 1-1/4 (850)	145.04						272.27		17	
	PORT 2		4535.C.850.3G.2	CTV50463	CTV5046C		UMTS 850	7770.00.850.00	13.5		0	Bottom	Andrew 1-1/4 (850)	145.04						272.27		17	
	PORT 3		4535.C.1900.3G.1	CTU50469	CTU50469		UMTS 1900	7770.00.1900.02	15.5		2	None	Andrew 1-1/4 (850)	145.04	CCI RxAIT 1900	1	CCI LLC 1900			583.45		17	
	PORT 4		4535.C.1900.3G.2	CTU50466	CTU50466		UMTS 1900	7770.00.1900.02	15.5		2	Bottom	Andrew 1-1/4 (850)	145.04	CCI RxAIT 1900	1	CCI LLC 1900			583.45		17	
	PORT 7		4535.C.1900.25G.1	321P50463	321P50463		GSM 1900	7770.00.1900.02	16.79		2	None	Andrew 1-1/4 (850)	145.04	CCI RxAIT	1	CCI LLC 1900		14.12	333.42		17	

														1900								
ANTENNA POSITION 3	PORT 1	4535.C.700.4G.1	CTL05046_7C_1	CTL05046_7C_1	LTE 700	AM-X-CD-14-65-00T-RET_725MHz_02DT	14.1		2	Bottom	1 1/4" ANDREW LDF6-50A_700 MHz	145.04							1475.7065		21	
	PORT 3	4535.C.1900.4G.1	CTL05046_9C_1	CTL05046_9C_1	LTE 1900	AM-X-CD-14-65-00T-RET_1930MHz_02DT	16.79		2	Bottom	1 1/4" ANDREW LDF6-50A_700 MHz	145.04							2421.029		21	
	PORT 4		CTL05046_9C_2	CTL05046_9C_2	LTE 1900	AM-X-CD-14-65-00T-RET_1930MHz_02DT	16.79		2	Bottom	1 1/4" ANDREW LDF6-50A_700 MHz	145.04							2421.029		21	

Section 16A - PLANNED/PROPOSED TOWER CONFIGURATION - SECTOR A (OR OMNI)

ANTENNA POSITION is LEFT to RIGHT from BACK OF ANTENNA (unless otherwise specified)		ANTENNA POSITION 1	ANTENNA POSITION 2	ANTENNA POSITION 3	ANTENNA POSITION 4	ANTENNA POSITION 5	ANTENNA POSITION 6	ANTENNA POSITION 7															
Existing Antenna?				Yes																			
ANTENNA MAKE - MODEL		QS46512-2																					
ANTENNA VENDOR		Quintel																					
ANTENNA SIZE (H x W x D)		52X12X10.8																					
ANTENNA WEIGHT		75																					
AZIMUTH		30																					
MAGNETIC DECLINATION																							
RADIATION CENTER (feet)		105																					
ANTENNA TIP HEIGHT																							
MECHANICAL DOWNTILT																							
FEEDER AMOUNT		2																					
VERTICAL SEPARATION from ANTENNA ABOVE (TIP to TIP)																							
VERTICAL SEPARATION from ANTENNA BELOW (TIP to TIP)																							
HORIZONTAL SEPARATION from CLOSEST ANTENNA to LEFT (CENTERLINE to CENTERLINE)																							
HORIZONTAL SEPARATION from CLOSEST ANTENNA to RIGHT (CENTERLINE to CENTERLINE)																							
HORIZONTAL SEPARATION from ANOTHER ANTENNA (which antenna # / # of inches)																							
Antenna RET Motor (QTY/MODEL)		Built in																					
SURGE ARRESTOR (QTY/MODEL)		8	TSXDC-4310FM	4	TSXDC-4310FM(4)																		
DIPLEXER (QTY/MODEL)		4	QBC0007F1V51-1	2	CCI Triplexer -TPX-070821																		
DIPLEXER (QTY/MODEL)																							
Antenna RET CONTROL UNIT (QTY/MODEL)																							
DC BLOCK (QTY/MODEL)																							
TMA/LNA (QTY/MODEL)		1	TMAT21X23B68-31-43 (Twin AWS-WCS w/700/850 BP)																				
CURRENT INJECTORS FOR TMA (QTY/MODEL)			Aisg Quadplexer																				
PDU FOR TMA (QTY/MODEL)																							
FILTER (QTY/MODEL)																							
SQUID (QTY/MODEL)																							
FIBER TRUNK (QTY/MODEL)																							
DC TRUNK (QTY/MODEL)																							
REPEATER (QTY/MODEL)																							
RRH - 700 band (QTY/MODEL)																							
RRH - 850 band (QTY/MODEL)				1	4478 B5																		
RRH - 1900 band (QTY/MODEL)																							
RRH - AWS band (QTY/MODEL)		1	4426 B66																				
RRH - WCS band (QTY/MODEL)		1	RRUS-32																				
Additional RRH #1 - any band (QTY/MODEL)																							
Additional RRH #2 - any band (QTY/MODEL)																							
Additional Component 1 (QTY/MODEL)				2	K SBT 782-11055																		
Additional Component 2 (QTY/MODEL)																							
Additional Component 3 (QTY/MODEL)																							
Local Market Note 1		LTE 3C WCS, LTE 4C AWSJ, LTE 5C 850 B(U). This is Utility pole, 2 ant soln, Shelter mount. SOW: Replace the existing UMTS Antenna with a 12 port Antenna, Add 2 coax per sector, Add LTE AWS 4426 B66, with SA's. Add LTE WCS RADIO RRUS-32 B30, Replace Diplexers with Quadplexers, Replace TMA with TWin TMA, Replace Diplexers on existing LTE Antenna on pos4 with Triplexers, Add LTE 850 4478 B5 with SA's Swap DUS with 5216, Add 2nd XMU. Add LTE RBS 6630.																					
Local Market Note 2																							
Local Market Note 3																							
PORT SPECIFIC FIELDS	PORT NUMBER	USEID (CSSng)	USEID (Atoll)	ATOLL TXID	ATOLL CELL ID	TX/RX ?	TECHNOLOGY/FREQUENCY	ANTENNA ATOLL	ANTENNA GAIN	ELECTRICAL AZIMUTH	ELECTRICAL TILT	RRH LOCATION (Top/Bottom/Integrated/None)	FEEDERS TYPE	FEEDER LENGTH (feet)	RXAIT KIT MODULE?	TRIPLEXER or LLC (QTY)	TRIPLEXER or LLC (MODEL)	SCPA/MCPA MODULE?	HATCHPLATE POWER (Watts)	ERP (Watts)	Antenna RET Name	CABLE NUMBER	CABLE ID (CSSNG)
ANTENNA POSITION 1	PORT 3		4535.A.AWS.4G.4	CTL05046_2A_2	CTL05046_2A_2		LTE AWS	QS46512-	16.2	30	5	Bottom	Andrew 1-1/4 (850)	145.04						5070.2572		2	

Section 16B - PLANNED/PROPOSED TOWER CONFIGURATION - SECTOR B

ANTENNA POSITION is LEFT to RIGHT from BACK OF ANTENNA (unless otherwise specified)		ANTENNA POSITION 1	ANTENNA POSITION 2	ANTENNA POSITION 3	ANTENNA POSITION 4	ANTENNA POSITION 5	ANTENNA POSITION 6	ANTENNA POSITION 7															
Existing Antenna?				Yes																			
ANTENNA MAKE - MODEL		QS46512-2																					
ANTENNA VENDOR		Quintel																					
ANTENNA SIZE (H x W x D)		52X12X10.8																					
ANTENNA WEIGHT		75																					
AZIMUTH		150																					
MAGNETIC DECLINATION																							
RADIATION CENTER (feet)		105																					
ANTENNA TIP HEIGHT																							
MECHANICAL DOWNTILT																							
FEEDER AMOUNT		2																					
VERTICAL SEPARATION from ANTENNA ABOVE (TIP to TIP)																							
VERTICAL SEPARATION from ANTENNA BELOW (TIP to TIP)																							
HORIZONTAL SEPARATION from CLOSEST ANTENNA to LEFT (CENTERLINE to CENTERLINE)																							
HORIZONTAL SEPARATION from CLOSEST ANTENNA to RIGHT (CENTERLINE to CENTERLINE)																							
HORIZONTAL SEPARATION from ANOTHER ANTENNA (which antenna # / # of inches)																							
Antenna RET Motor (QTY/MODEL)		Built in																					
SURGE ARRESTOR (QTY/MODEL)		8	TSXDC-4310FM	4	TSXDC-4310FM(4)																		
DIPLEXER (QTY/MODEL)		4	QBC0007F1V51-1	2	CCI Triplexer -TPX-070821																		
DIPLEXER (QTY/MODEL)																							
Antenna RET CONTROL UNIT (QTY/MODEL)																							
DC BLOCK (QTY/MODEL)																							
TMA/LNA (QTY/MODEL)		1	TMAT21X23B68-31-43 (Twin AWS-WCS w/700/850 BP)																				
CURRENT INJECTORS FOR TMA (QTY/MODEL)			Aisg Quadplexer																				
PDU FOR TMA (QTY/MODEL)																							
FILTER (QTY/MODEL)																							
SQUID (QTY/MODEL)																							
FIBER TRUNK (QTY/MODEL)																							
DC TRUNK (QTY/MODEL)																							
REPEATER (QTY/MODEL)																							
RRH - 700 band (QTY/MODEL)																							
RRH - 850 band (QTY/MODEL)				1	4478 B5																		
RRH - 1900 band (QTY/MODEL)																							
RRH - AWS band (QTY/MODEL)		1	4426 B66																				
RRH - WCS band (QTY/MODEL)		1	RRUS-32																				
Additional RRH #1 - any band (QTY/MODEL)																							
Additional RRH #2 - any band (QTY/MODEL)																							
Additional Component 1 (QTY/MODEL)				2	K SBT 782-11055																		
Additional Component 2 (QTY/MODEL)																							
Additional Component 3 (QTY/MODEL)																							
Local Market Note 1		LTE 3C WCS, LTE 4C AWSJ, LTE 5C 850 B(U). This is Utility pole, 2 ant soln, Shelter mount. SOW: Replace the existing UMTS Antenna with a 12 port Antenna, Add 2 coax per sector, Add LTE AWS 4426 B66, with SA's. Add LTE WCS RADIO RRUS-32 B30, Replace Diplexers with Quadplexers, Replace TMA with TWin TMA, Replace Diplexers on existing LTE Antenna on pos4 with Triplexers, Add LTE 850 4478 B5 with SA's Swap DUS with 5216, Add 2nd XMU. Add LTE RBS 6630.																					
Local Market Note 2																							
Local Market Note 3																							
PORT SPECIFIC FIELDS	PORT NUMBER	USEID (CSSng)	USEID (Atoll)	ATOLL TXID	ATOLL CELL ID	TX/RX ?	TECHNOLOGY/FREQUENCY	ANTENNA ATOLL	ANTENNA GAIN	ELECTRICAL AZIMUTH	ELECTRICAL TILT	RRH LOCATION (Top/Bottom/Integrated/None)	FEEDERS TYPE	FEEDER LENGTH (feet)	RXAIT KIT MODULE?	TRIPLEXER or LLC (QTY)	TRIPLEXER or LLC (MODEL)	SCPA/MCPA MODULE?	HATCHPLATE POWER (Watts)	ERP (Watts)	Antenna RET Name	CABLE NUMBER	CABLE ID (CSSNG)
ANTENNA POSITION 1	PORT 3		4535.B.AWS.4G.4	CTL05046_2B_2	CTL05046_2B_2		LTE AWS	QS46512-	16.2	150	5	Bottom	Andrew 1-1/4 (850)	145.04						5070.2572		10	

							2_2170MHz_05DT																	
	PORT 4		4535.B.WCS.4G.1	CTL05046_3B_1	CTL05046_3B_1		LTE WCS	QS46512-2_2355MHz_03DT	16.7	150	3	Bottom	Andrew 1-1/4 (850)	145.04							1285.2866	10		
ANTENNA POSITION 3	PORT 5		4535.B.850.4G.1	CTL05046_8B_1	CTL05046_8B_1		LTE 850	AM-X-CD-14-65-00T-RET_850MHz_02DT	14.8	150	2	Bottom	1 1/4 ANDREW LDF6-50A_700 MHz	145.04							1000		13	
	PORT 6		4535.B.850.4G.1	CTN0005046_8B_1	CTN0005046_8B_1		LTE 850	AM-X-CD-14-65-00T-RET_850MHz_02DT	14.8	150	2	Bottom	1 1/4 ANDREW LDF6-50A_700 MHz	145.04							1000		13	

Section 16C - PLANNED/PROPOSED TOWER CONFIGURATION - SECTOR C

ANTENNA POSITION is LEFT to RIGHT from BACK OF ANTENNA (unless otherwise specified)		ANTENNA POSITION 1	ANTENNA POSITION 2	ANTENNA POSITION 3	ANTENNA POSITION 4	ANTENNA POSITION 5	ANTENNA POSITION 6	ANTENNA POSITION 7															
Existing Antenna?				Yes																			
ANTENNA MAKE - MODEL		QS46512-2																					
ANTENNA VENDOR		Quintel																					
ANTENNA SIZE (H x W x D)		52X12X10.8																					
ANTENNA WEIGHT		75																					
AZIMUTH		270																					
MAGNETIC DECLINATION																							
RADIATION CENTER (feet)		105																					
ANTENNA TIP HEIGHT																							
MECHANICAL DOWNTILT																							
FEEDER AMOUNT		2																					
VERTICAL SEPARATION from ANTENNA ABOVE (TIP to TIP)																							
VERTICAL SEPARATION from ANTENNA BELOW (TIP to TIP)																							
HORIZONTAL SEPARATION from CLOSEST ANTENNA to LEFT (CENTERLINE to CENTERLINE)																							
HORIZONTAL SEPARATION from CLOSEST ANTENNA to RIGHT (CENTERLINE to CENTERLINE)																							
HORIZONTAL SEPARATION from ANOTHER ANTENNA (which antenna # / # of inches)																							
Antenna RET Motor (QTY/MODEL)		Built in																					
SURGE ARRESTOR (QTY/MODEL)		8	TSXDC-4310FM	4	TSXDC-4310FM(4)																		
DIPLEXER (QTY/MODEL)		4	QBC0007F1V51-1	2	CCI Triplexer -TPX-070821																		
DIPLEXER (QTY/MODEL)																							
Antenna RET CONTROL UNIT (QTY/MODEL)																							
DC BLOCK (QTY/MODEL)																							
TMA/LNA (QTY/MODEL)		1	TMAT21X23B68-31-43 (Twin AWS-WCS w/700/850 BP)																				
CURRENT INJECTORS FOR TMA (QTY/MODEL)			Aisg Quadplexer																				
PDU FOR TMA (QTY/MODEL)																							
FILTER (QTY/MODEL)																							
SQUID (QTY/MODEL)																							
FIBER TRUNK (QTY/MODEL)																							
DC TRUNK (QTY/MODEL)																							
REPEATER (QTY/MODEL)																							
RRH - 700 band (QTY/MODEL)																							
RRH - 850 band (QTY/MODEL)				1	4478 B5																		
RRH - 1900 band (QTY/MODEL)																							
RRH - AWS band (QTY/MODEL)		1	4426 B66																				
RRH - WCS band (QTY/MODEL)		1	RRUS-32																				
Additional RRH #1 - any band (QTY/MODEL)																							
Additional RRH #2 - any band (QTY/MODEL)																							
Additional Component 1 (QTY/MODEL)				2	K SBT 782-11055																		
Additional Component 2 (QTY/MODEL)																							
Additional Component 3 (QTY/MODEL)																							
Local Market Note 1		LTE 3C WCS, LTE 4C AWSJ, LTE 5C 850 B(U). This is Utility pole, 2 ant soln, Shelter mount. SOW: Replace the existing UMTS Antenna with a 12 port Antenna, Add 2 coax per sector, Add LTE AWS 4426 B66, with SA's. Add LTE WCS RADIO RRUS-32 B30, Replace Diplexers with Quadplexers, Replace TMA with TWin TMA, Replace Diplexers on existing LTE Antenna on pos4 with Triplexers, Add LTE 850 4478 B5 with SA's Swap DUS with 5216, Add 2nd XMU. Add LTE RBS 6630.																					
Local Market Note 2																							
Local Market Note 3																							
PORT SPECIFIC FIELDS	PORT NUMBER	USEID (CSSng)	USEID (Atoll)	ATOLL TXID	ATOLL CELL ID	TX/RX ?	TECHNOLOGY/FREQUENCY	ANTENNA ATOLL	ANTENNA GAIN	ELECTRICAL AZIMUTH	ELECTRICAL TILT	RRH LOCATION (Top/Bottom/Integrated/None)	FEEDERS TYPE	FEEDER LENGTH (feet)	RXAIT KIT MODULE?	TRIPLEXER or LLC (QTY)	TRIPLEXER or LLC (MODEL)	SCPA/MCPA MODULE?	HATCHPLATE POWER (Watts)	ERP (Watts)	Antenna RET Name	CABLE NUMBER	CABLE ID (CSSNG)
ANTENNA POSITION 1	PORT 3		4535.C.AWS.4G.4	CTL05046_2C_2	CTL05046_2C_2		LTE AWS	QS46512-	15.9	270	2	Bottom	Andrew 1-1/4 (850)	145.04						5070.2572		18	

							2_2170MHz_02DT																	
	PORT 4		4535.C.WCS.4G.1	CTL05046_3C_1	CTL05046_3C_1		LTE WCS	QS46512-2_2355MHz_03DT	16.7	270	3	Bottom	Andrew 1-1/4 (850)	145.04							1285.2866		18	
ANTENNA POSITION 3	PORT 5		4535.C.850.4G.1	CTL05046_8C_1	CTL05046_8C_1		LTE 850	AM-X-CD-14-65-00T-RET_850MHz_02DT	14.8	270	2	Bottom	1 1/4 ANDREW LDF6-50A_700 MHz	145.04								1000		21
	PORT 6		4535.C.850.4G.1	CTN0005046_8C_1	CTN0005046_8C_1		LTE 850	AM-X-CD-14-65-00T-RET_850MHz_02DT	14.8	270	2	Bottom	1 1/4 ANDREW LDF6-50A_700 MHz	145.04								1000		21

Section 17A - FINAL TOWER CONFIGURATION - SECTOR A (OR OMNI)

ANTENNA POSITION is LEFT to RIGHT from BACK OF ANTENNA (unless otherwise specified)	ANTENNA POSITION 1	ANTENNA POSITION 2	ANTENNA POSITION 3	ANTENNA POSITION 4	ANTENNA POSITION 5	ANTENNA POSITION 6	ANTENNA POSITION 7
ANTENNA MAKE - MODEL	QS46512-2		AM-X-CD-14-65-00T-RET				
ANTENNA VENDOR	Quintel		KMW				
ANTENNA SIZE (H x W x D)	52X12X10.8		48X11.8X5.9				
ANTENNA WEIGHT	75		36.4				
AZIMUTH	30		30				
MAGNETIC DECLINATION							
RADIATION CENTER (feet)	105		105				
ANTENNA TIP HEIGHT							
MECHANICAL DOWNTILT	0		0				
FEEDER AMOUNT	4		2				
VERTICAL SEPARATION from ANTENNA ABOVE (TIP to TIP)							
VERTICAL SEPARATION from ANTENNA BELOW (TIP to TIP)							
HORIZONTAL SEPARATION from CLOSEST ANTENNA to LEFT (CENTERLINE to CENTERLINE)							
HORIZONTAL SEPARATION from CLOSEST ANTENNA to RIGHT (CENTERLINE to CENTERLINE)							
HORIZONTAL SEPARATION from ANOTHER ANTENNA (which antenna # / # of inches)							
Antenna RET Motor (QTY/MODEL)	Built in		Built in				
SURGE ARRESTOR (QTY/MODEL)	8 TSXDC-4310FM		8 Andrew APTDC-BDFDM-DB(4)+TSXDC-4310FM(4)				
DIPLEXER (QTY/MODEL)	4 QBC0007F1V51-1		2 CCI Triplexer -TPX-070821				
DUPLEXER (QTY/MODEL)							
Antenna RET CONTROL UNIT (QTY/MODEL)	1 Kathrein / 860-10006						
DC BLOCK (QTY/MODEL)							
TMA/LNA (QTY/MODEL)	1 TMAT21X23B68-31-43 (Twin AWS-WCS w/700/850 BP)		1 Kaelus TMA2093FxxVx-1 Twin TMA 850 BP				
CURRENT INJECTORS FOR TMA (QTY/MODEL)	Aisg Quadplexer						
PDU FOR TMA (QTY/MODEL)							
FILTER (QTY/MODEL)							
SQUID (QTY/MODEL)							
FIBER TRUNK (QTY/MODEL)							
DC TRUNK (QTY/MODEL)							
REPEATER (QTY/MODEL)							
RRH - 700 band (QTY/MODEL)			1 RRUS-11 (REUSE ONLY)				
RRH - 850 band (QTY/MODEL)			1 4478 B5				
RRH - 1900 band (QTY/MODEL)			1 RRUS-12				
RRH - AWS band (QTY/MODEL)	1 4426 B66						
RRH - WCS band (QTY/MODEL)	1 RRUS-32						
Additional RRH #1 - any band (QTY/MODEL)							
Additional RRH #2 - any band (QTY/MODEL)							
Additional Component 1 (QTY/MODEL)			2 K SBT 782-11055				
Additional Component 2 (QTY/MODEL)							
Additional Component 3 (QTY/MODEL)							

Local Market Note 1
 LTE 3C WCS, LTE 4C AWSJ, LTE 5C 850 B(U).
 This is Utility pole, 2 ant soln, Shelter mount.
 SOW: Replace the existing UMTS Antenna with a 12 port Antenna, Add 2 coax per sector,
 Add LTE AWS 4426 B66, with SA's.
 Add LTE WCS RADIO RRUS-32 B30,
 Replace Diplexers with Quadplexers, Replace TMA with TWin TMA,
 Replace Diplexers on existing LTE Antenna on pos4 with Triplexers,
 Add LTE 850 4478 B5 with SA's
 Swap DUS with 5216, Add 2nd XMU.
 Add LTE RBS 6630.

Local Market Note 2

Local Market Note 3

PORT SPECIFIC FIELDS	PORT NUMBER	USEID (CSSng)	USEID (Atoll)	ATOLL TXID	ATOLL CELL ID	TX/RX ?	TECHNOLOGY/FREQ UENCY	ANTENNA ATOLL	ANTENNA GAIN	ELECTRICAL AZIMUTH	ELECTRICAL TILT	RRH LOCATION (Top/Bottom/Integrated/None)	FEEDERS TYPE	FEEDER LENGTH (feet)	RXAIT KIT MODULE?	TRIPLEXER or LLC (QTY)	TRIPLEXER or LLC (MODEL)	SCPA/MCPA MODULE?	HATCHPLATE POWER (Watts)	ERP (Watts)	Antenna RET Name	CABLE NUMBER	CABLE ID (CSSNG)
ANTENNA POSITION 1	PORT 1	4535.A.850.3G.1		CTV50461	CTV50461		UMTS 850	QS46512-	12.3	30	5	None	Andrew 1-1/4 (850)	145.04						272.27		1	

Section 17B - FINAL TOWER CONFIGURATION - SECTOR B

ANTENNA POSITION is LEFT to RIGHT from BACK OF ANTENNA (unless otherwise specified)	ANTENNA POSITION 1	ANTENNA POSITION 2	ANTENNA POSITION 3	ANTENNA POSITION 4	ANTENNA POSITION 5	ANTENNA POSITION 6	ANTENNA POSITION 7
ANTENNA MAKE - MODEL	QS46512-2		AM-X-CD-14-65-00T-RET				
ANTENNA VENDOR	Quintel		KMW				
ANTENNA SIZE (H x W x D)	52X12X10.8		48X11.8X5.9				
ANTENNA WEIGHT	75		36.4				
AZIMUTH	150		150				
MAGNETIC DECLINATION							
RADIATION CENTER (feet)	105		105				
ANTENNA TIP HEIGHT							
MECHANICAL DOWNTILT	0		0				
FEEDER AMOUNT	4		2				
VERTICAL SEPARATION from ANTENNA ABOVE (TIP to TIP)							
VERTICAL SEPARATION from ANTENNA BELOW (TIP to TIP)							
HORIZONTAL SEPARATION from CLOSEST ANTENNA to LEFT (CENTERLINE to CENTERLINE)							
HORIZONTAL SEPARATION from CLOSEST ANTENNA to RIGHT (CENTERLINE to CENTERLINE)							
HORIZONTAL SEPARATION from ANOTHER ANTENNA (which antenna # / # of inches)							
Antenna RET Motor (QTY/MODEL)	Built in		Built in				
SURGE ARRESTOR (QTY/MODEL)	8 TSXDC-4310FM		8 Andrew APTDC-BDFDM-DB(4)+TSXDC-4310FM(4)				
DIPLEXER (QTY/MODEL)	4 QBC0007F1V51-1		2 CCI Triplexer -TPX-070821				
DUPLEXER (QTY/MODEL)							
Antenna RET CONTROL UNIT (QTY/MODEL)							
DC BLOCK (QTY/MODEL)							
TMA/LNA (QTY/MODEL)	1 TMAT21X23B68-31-43 (Twin AWS-WCS w/700/850 BP)		1 Kaelus TMA2093FxxVx-1 Twin TMA 850 BP				
CURRENT INJECTORS FOR TMA (QTY/MODEL)	Aisg Quadplexer						
PDU FOR TMA (QTY/MODEL)							
FILTER (QTY/MODEL)							
SQUID (QTY/MODEL)							
FIBER TRUNK (QTY/MODEL)							
DC TRUNK (QTY/MODEL)							
REPEATER (QTY/MODEL)							
RRH - 700 band (QTY/MODEL)			1 RRUS-11 (REUSE ONLY)				
RRH - 850 band (QTY/MODEL)			1 4478 B5				
RRH - 1900 band (QTY/MODEL)			1 RRUS-12				
RRH - AWS band (QTY/MODEL)	1 4426 B66						
RRH - WCS band (QTY/MODEL)	1 RRUS-32						
Additional RRH #1 - any band (QTY/MODEL)							
Additional RRH #2 - any band (QTY/MODEL)							
Additional Component 1 (QTY/MODEL)			2 K SBT 782-11055				
Additional Component 2 (QTY/MODEL)							
Additional Component 3 (QTY/MODEL)							

Local Market Note 1
 LTE 3C WCS, LTE 4C AWSJ, LTE 5C 850 B(U).
 This is Utility pole, 2 ant soln, Shelter mount.
 SOW: Replace the existing UMTS Antenna with a 12 port Antenna, Add 2 coax per sector,
 Add LTE AWS 4426 B66, with SA's.
 Add LTE WCS RADIO RRUS-32 B30,
 Replace Diplexers with Quadplexers, Replace TMA with TWin TMA,
 Replace Diplexers on existing LTE Antenna on pos4 with Triplexers,
 Add LTE 850 4478 B5 with SA's
 Swap DUS with 5216, Add 2nd XMU.
 Add LTE RBS 6630.

Local Market Note 2

Local Market Note 3

PORT SPECIFIC FIELDS	PORT NUMBER	USEID (CSSng)	USEID (Atoll)	ATOLL TXID	ATOLL CELL ID	TX/RX ?	TECHNOLOGY/FREQUENCY	ANTENNA ATOLL	ANTENNA GAIN	ELECTRICAL AZIMUTH	ELECTRICAL TILT	RRH LOCATION (Top/Bottom/Integrated/None)	FEEDERS TYPE	FEEDER LENGTH (feet)	RXAIT KIT MODULE?	TRIPLEXER or LLC (QTY)	TRIPLEXER or LLC (MODEL)	SCPA/MCPA MODULE?	HATCHPLATE POWER (Watts)	ERP (Watts)	Antenna RET Name	CABLE NUMBER	CABLE ID (CSSNG)
ANTENNA POSITION 1	PORT 1	4535.B.850.3G.1		CTV50462	CTV50462		UMTS 850	QS46512-	12	150	10	None	Andrew 1-1/4 (850)	145.04						272.27		9	

Section 17C - FINAL TOWER CONFIGURATION - SECTOR C

ANTENNA POSITION is LEFT to RIGHT from BACK OF ANTENNA (unless otherwise specified)		ANTENNA POSITION 1	ANTENNA POSITION 2	ANTENNA POSITION 3	ANTENNA POSITION 4	ANTENNA POSITION 5	ANTENNA POSITION 6	ANTENNA POSITION 7
ANTENNA MAKE - MODEL	QS46512-2			AM-X-CD-14-65-00T-RET				
ANTENNA VENDOR	Quintel			KMW				
ANTENNA SIZE (H x W x D)	52X12X10.8			48X11.8X5.9				
ANTENNA WEIGHT	75			36.4				
AZIMUTH	270			270				
MAGNETIC DECLINATION								
RADIATION CENTER (feet)	105			105				
ANTENNA TIP HEIGHT								
MECHANICAL DOWNTILT	0			0				
FEEDER AMOUNT	4			2				
VERTICAL SEPARATION from ANTENNA ABOVE (TIP to TIP)								
VERTICAL SEPARATION from ANTENNA BELOW (TIP to TIP)								
HORIZONTAL SEPARATION from CLOSEST ANTENNA to LEFT (CENTERLINE to CENTERLINE)								
HORIZONTAL SEPARATION from CLOSEST ANTENNA to RIGHT (CENTERLINE to CENTERLINE)								
HORIZONTAL SEPARATION from ANOTHER ANTENNA (which antenna # / # of inches)								
Antenna RET Motor (QTY/MODEL)		Built in		Built in				
SURGE ARRESTOR (QTY/MODEL)	8	TSXDC-4310FM		8	Andrew APTDC-BDFDM-DB(4)+TSXDC-4310FM(4)			
DIPLEXER (QTY/MODEL)	4	QBC0007F1V51-1		2	CCI Triplexer -TPX-070821			
DUPLEXER (QTY/MODEL)								
Antenna RET CONTROL UNIT (QTY/MODEL)								
DC BLOCK (QTY/MODEL)								
TMA/LNA (QTY/MODEL)	1	TMAT21X23B68-31-43 (Twin AWS-WCS w/700/850 BP)		1	Kaelus TMA2093FxxVx-1 Twin TMA 850 BP			
CURRENT INJECTORS FOR TMA (QTY/MODEL)		Aisg Quadplexer						
PDU FOR TMA (QTY/MODEL)								
FILTER (QTY/MODEL)								
SQUID (QTY/MODEL)								
FIBER TRUNK (QTY/MODEL)								
DC TRUNK (QTY/MODEL)								
REPEATER (QTY/MODEL)								
RRH - 700 band (QTY/MODEL)				1	RRUS-11 (REUSE ONLY)			
RRH - 850 band (QTY/MODEL)				1	4478 B5			
RRH - 1900 band (QTY/MODEL)				1	RRUS-12			
RRH - AWS band (QTY/MODEL)	1	4426 B66						
RRH - WCS band (QTY/MODEL)	1	RRUS-32						
Additional RRH #1 - any band (QTY/MODEL)								
Additional RRH #2 - any band (QTY/MODEL)								
Additional Component 1 (QTY/MODEL)				2	K SBT 782-11055			
Additional Component 2 (QTY/MODEL)								
Additional Component 3 (QTY/MODEL)								
Local Market Note 1	LTE 3C WCS, LTE 4C AWSJ, LTE 5C 850 B(U). This is Utility pole, 2 ant soln, Shelter mount. SOW: Replace the existing UMTS Antenna with a 12 port Antenna, Add 2 coax per sector, Add LTE AWS 4426 B66, with SA's. Add LTE WCS RADIO RRUS-32 B30, Replace Diplexers with Quadplexers, Replace TMA with TWin TMA, Replace Diplexers on existing LTE Antenna on pos4 with Triplexers, Add LTE 850 4478 B5 with SA's Swap DUS with 5216, Add 2nd XMU. Add LTE RBS 6630.							
Local Market Note 2								
Local Market Note 3								

PORT SPECIFIC FIELDS	PORT NUMBER	USEID (CSSng)	USEID (Atoll)	ATOLL TXID	ATOLL CELL ID	TX/RX ?	TECHNOLOGY/FREQUENCY	ANTENNA ATOLL	ANTENNA GAIN	ELECTRICAL AZIMUTH	ELECTRICAL TILT	RRH LOCATION (Top/Bottom/Integrated/None)	FEEDERS TYPE	FEEDER LENGTH (feet)	RXAIT KIT MODULE?	TRIPLEXER or LLC (QTY)	TRIPLEXER or LLC (MODEL)	SCPA/MCPA MODULE?	HATCHPLATE POWER (Watts)	ERP (Watts)	Antenna RET Name	CABLE NUMBER	CABLE ID (CSSNG)
ANTENNA POSITION 1	PORT 1	4535.C.850.3G.1		CTV50463	CTV50463		UMTS 850	QS46512-	12.2	270	2	None	Andrew 1-1/4 (850)	145.04						272.27		17	

Antenna 1
 UMTS 850 / LTE AWS / WCS
65° BW Antenna

Antenna 3
 LTE 850/ 700 BC / PCS

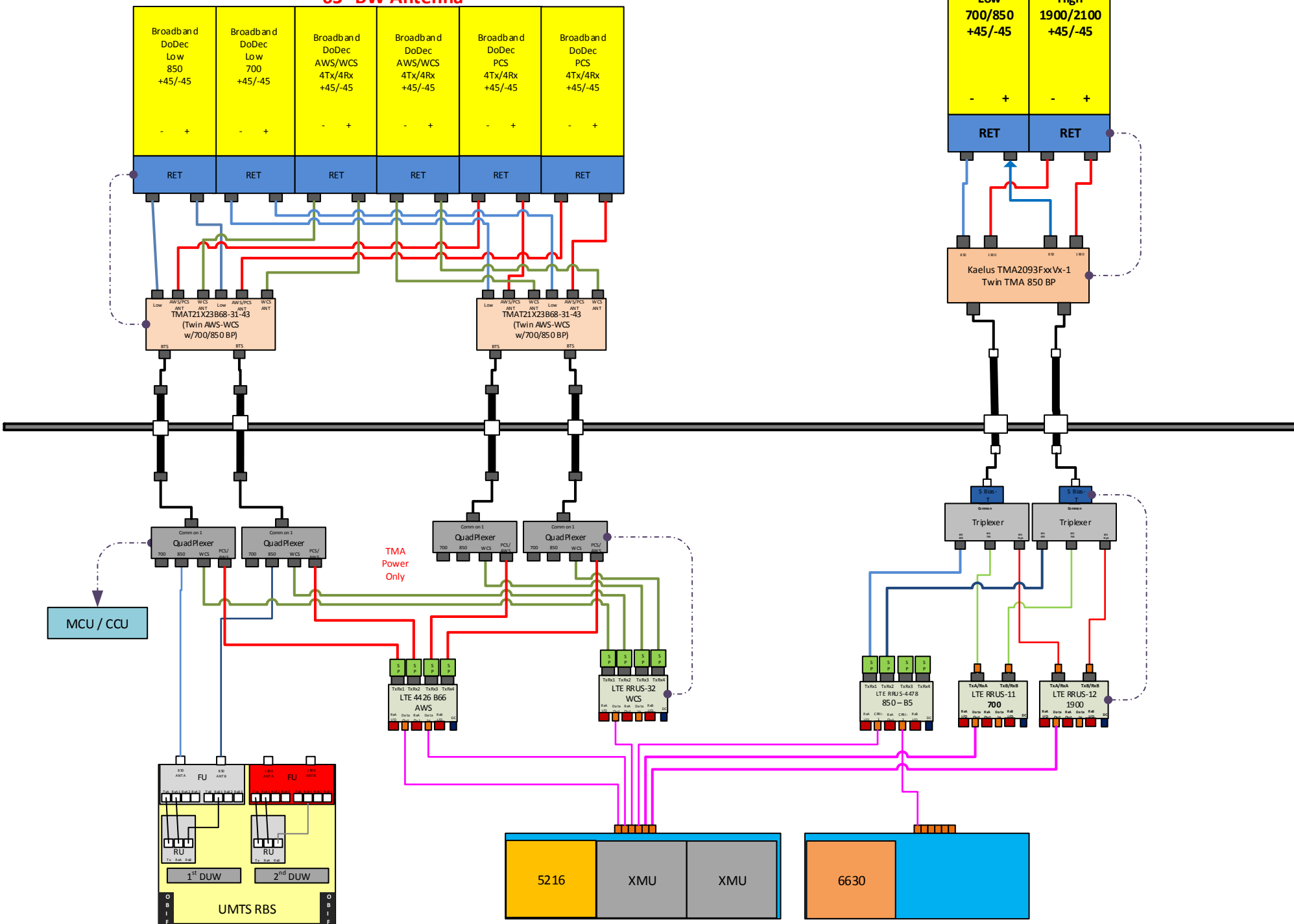

Antenna 1
 UMTS 850 / LTE AWS / WCS
65° BW Antenna

Antenna 3
 LTE 850/ 700 BC / PCS

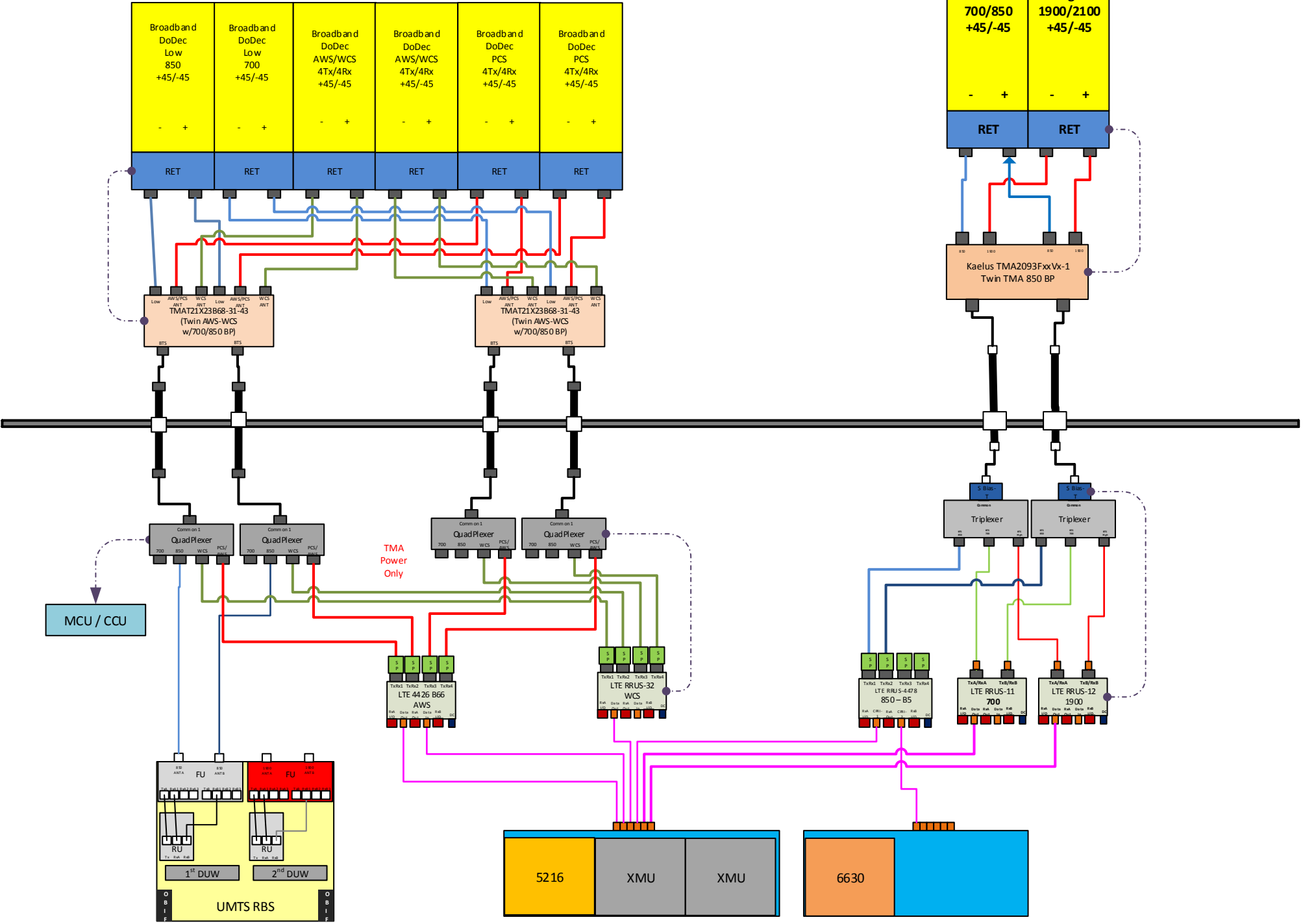

Antenna 1
 UMTS 850 / LTE AWS / WCS
65° BW Antenna

Antenna 3
 LTE 850/ 700 BC / PCS

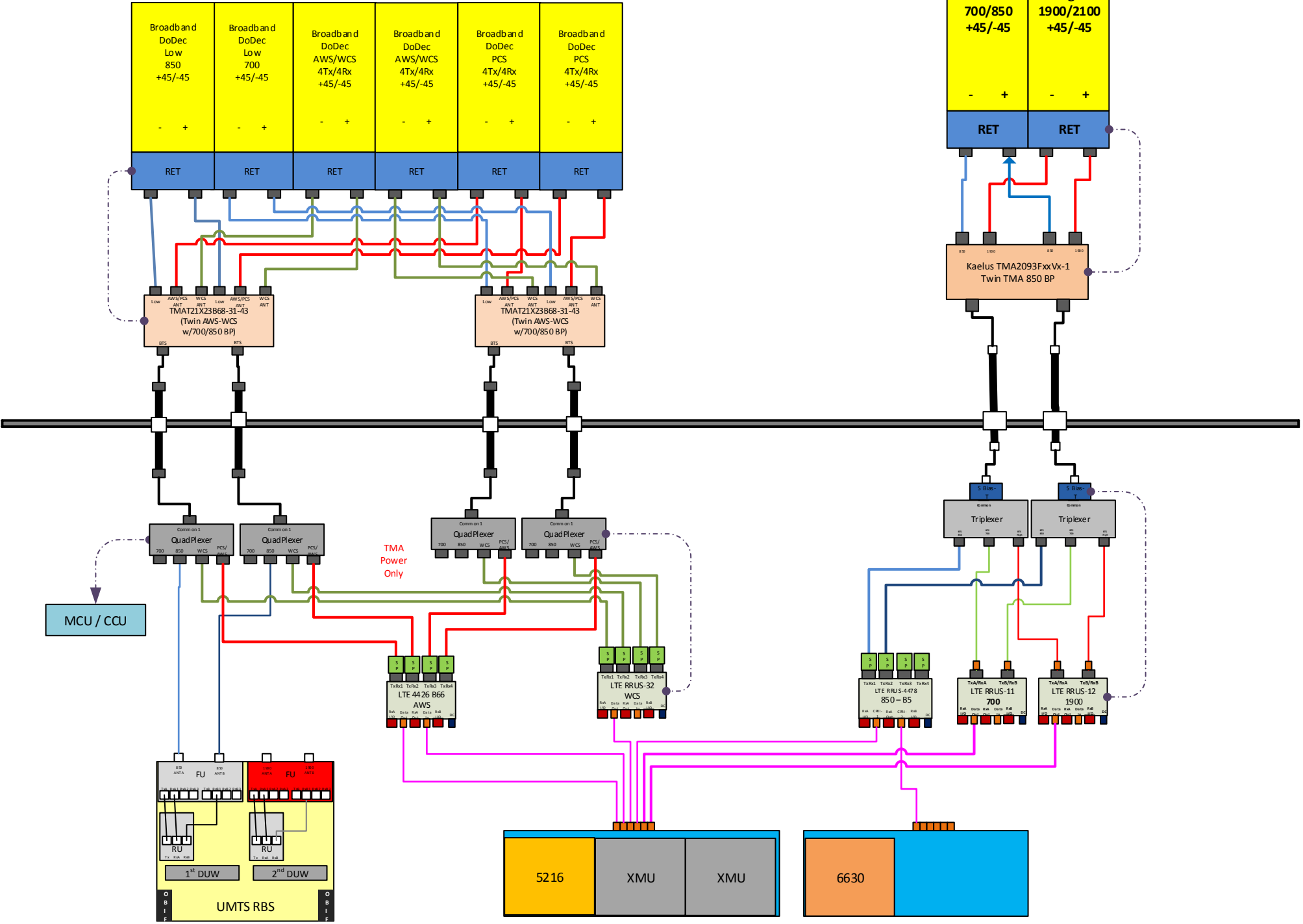

WORKFLOW SUMMARY

Date	FROM State / Status	FROM ATTUID	TO State / Status	TO ATTUID	Operation	Comments	PACE Status
05/09/2018	Preliminary In Progress	mm093q	Preliminary Submitted for Approval	RC475S	Promote	Preliminary RFDS	NER-RCTB-17-07903 MRCTB031041 SUCCESS 05/09/2018 2:50:05 AM NER-RCTB-18-02342 MRCTB031949 SUCCESS 05/09/2018 2:50:05 AM NER-RCTB-18-02381 MRCTB031707 SUCCESS 05/09/2018 2:50:05 AM
05/14/2018	Preliminary Submitted for Approval	RC475S	Preliminary Approved	JK0520	Promote		
06/27/2018	Preliminary Approved	JK0520	Preliminary In Progress	mm093q	Pull Back	Pull back to update PD.	
06/27/2018	Preliminary In Progress	mm093q	Preliminary Submitted for Approval	RC475S	Promote	Updated PD.	NER-RCTB-17-07903 FAILURE 06/27/2018 12:32:02 PM NER-RCTB-18-02342 FAILURE 06/27/2018 12:32:02 PM NER-RCTB-18-02381 FAILURE 06/27/2018 12:32:02 PM
06/28/2018	Preliminary Submitted for Approval	RC475S	Preliminary Approved	DC5778	Promote		
08/17/2018	Preliminary Approved	DC5778	Final RF Approval	mm093q	Promote		
08/31/2018	Final Approved	DC5778	As Built In Progress	dc5778	Promote		NER-RCTB-17-07903 MRCTB031041 SUCCESS 08/31/2018 10:35:51 AM NER-RCTB-18-02342 MRCTB031949 SUCCESS 08/31/2018 10:35:51 AM NER-RCTB-18-02381 MRCTB031707 SUCCESS 08/31/2018 10:35:51 AM

AM-X-CD-14-65-00T-RET (4' 65° Dual Broadband Antenna)

Dual Band Electrical DownTilt Antenna

698 ~ 894MHz, X-pol., H65° / V17.0°

1710 ~ 2170MHz, X-pol., H65° / V8.5°

Electrical Specification

Frequency Range	698~894MHz	1710~2170MHz
Impedance	50Ω	
Polarization	Dual, Slant ±45°	
Gain	14.0dBi / 11.85dBd @ 698-806MHz 14.8dBi / 12.65dBd @ 824-894MHz	16.1dBi / 13.95dBd @1710-1755MHz 16.3dBi / 14.15dBd @1850-1900MHz 16.0dBi / 13.85dBd @2110-2155MHz
Beamwidth	Horizontal	60° @ 1710-1755MHz 61° @ 1850-1900MHz 64° @ 2110-2155MHz
	Vertical	8.8° @ 1710-1755MHz 8.5° @ 1850-1900MHz 8.0° @ 2110-2155MHz
VSWR	≤1.5:1	
Front-to-Back Ratio	≥28 dB	
Electrical Downtilt Range	2° ~ 16°	0° ~ 10°
Isolation Between Ports	≥30 dB	
Isolation Between Ports of Different Frequency Elements	≥35 dB	
Cross Pole Discrimination	10.0 dB @ ±60° 15.0 dBi @ 0°	
First Upper Side Lobe Suppression	16dB	
Side Lobe Suppression	> 16 dB @ 0-6° Tilt > 18 dB @ 7-12° Tilt (Up to 15° from Boresight)	> 16 dB @ 0-6° Tilt > 18 dB @ 7-10° Tilt (Up to 15° from Boresight)
Passive Intermodulation	≤ -150 dBc @ 2x20w	
Input Maximum CW Power	500 W	300 W
Environmental Compliance	IP65 for Radome IP67 for Connectors	
RET Motor Configuration	Field Replaceable RET Electronic Control Module / RET Motor is internal to antenna & not field replaceable	
Compliant with AISG 1.1 and 2.0	AISG 1.1 and 2.0	

Mechanical Specification

Dimension (W×D×H)	11.8×5.9×48 inches (300×150×1219mm)
Weight (Without clamp)	36.4 lbs (16.5 kg)
Connector	4 x 7/16 DIN(F), Long Neck
Max Wind Speed	150 mph
Wind Load (@150 mph)	1260 N



- Provides 12 antenna Ports in a slim-line form factor
- Optimized Azimuth patterns for Min Inter-Sector Interference
- Industry leading Minimal Wind-Load design

- 700, 850, PCS, AWS & WCS bands in one antenna
- AISG & 3GPP compliant internal remote electrical tilt (RET)
- AWS & PCS Cross band PIM >159dBc

The Quintel MultiServ™ Multiband 12 Port Antenna with patented QTilt™ technology uniquely delivers four independent services in a single slim-line antenna. This enables existing antenna network sites to be upgraded constraint free to add new services such as LTE for 700, 850, PCS, AWS and WCS bands with the replacement of one antenna. The QS46512-2 also provides 4x1695-1780+2110-2400MHz & 4x1850-1990MHz ports as two side-by-side (CLA-2X) arrays, each set of 4x ports having independent tilt, for connection to 2T4R/4T4R services.

Electrical Characteristics	2x Ports 1&2	2x Ports 3&4	4x Ports 5-8			4x Ports 9-12
Operating Frequency (MHz)	698-806	824-894	1695-1780 and 2110-2400			1850-1990
	698-806	824-894	1695-1780	2110-2180	2300-2400	1850-1990
Azimuth beamwidth ¹	65°	61°	72°	65°	60°	68°
Elevation beamwidth ¹	15.5°	14°	7.7°	6.2°	5.7°	7.3°
Gain ¹ (dBi)	12.7	12.5	15.5	16.0	16.2	15.3
Polarization	±45°	±45°	±45°			±45°
Electrical down-tilt range	2°-10°	2°-10°	2° - 10°			2° - 10°
Upper SLL (20° > mainbeam) ¹	-16dB	-19dB	-17.5dB	-16dB	-17dB	-19dB
Front to Back Ratio(180°±10°) ¹	≥25dB	≥24dB	≥34dB	≥28dB	≥30dB	≥28dB
Port to Port isolation ¹	≥26dB	≥29dB	≥30dB	≥30dB	≥30dB	≥30dB
Return loss (VSWR)	14dB(1.5)	14dB(1.5)	14dB(1.5)	14dB(1.5)	14dB(1.5)	14dB(1.5)
X Polar Discrimination (at 0°)	>16dB	>17.5dB	>21dB	>20dB	>21dB	>18dB
Max Power handling (per any port)	500 watts	500 watts	250 watts			250 watts
Total Composite Power (all ports)	1750 watts					
PIM (3 rd Order) (2x43dBm)	>153dBc	>153dBc	>153dBc			>153dBc
XBand PIM (3 rd Order) (2x43dBm)	>159dBc					

¹Typical Performance across frequency and Downtilt.



Mechanical Characteristics	
Dimensions	L 52"(1320mm) x W 12"(304mm) x D 10.8"(275mm)
Weight (excl mounting brackets)	75lbs (34kg)
No. of Connectors	12x 4.3-10.0 DIN Female Long Neck
Max Wind Speed	150mph (67m/s)
Equivalent Flat Plate Area	2.02ft ² (0.19m ²)
Wind Load @ 160km/h (45m/s)	Front: 445N (100 lbs), Side: 267N (60 lbs)
Operating Temperature	-40°C to +65°C

Fully Integrated RET Characteristics	
AISG Standards	V1.1, V 2.0 and 3GPP
Factory Default	AISG 2.0
Surge immunity	IEC 61000-4-5:2005 4KV(AISG PIN)
Device Type	SRET Type 1
AISG Data rate	9.6 kbps
No of connectors	RET1 1in/1out.
Connector type	IEC 60130-9 (Ed 3.0)
MTBF	36,000 Operational moves



All specifications are subject to change without notice. Please contact your Quintel representative for complete information.

TMA2093F00V1-1

AWS / 1900, Dual Band, Twin TMA with Lo Band bypass and AISG2.0

Designed to be deployed in co-located AWS, 1900 and low band (698-960) systems with wideband antennas the Kaelus TMA2093 provides internal duplexing in all three bands with gain in the high bands, thereby saving capital expenditure and tower leasing fees.



PRODUCT FEATURES

- Improved base station sensitivity through gain in the AWS and 1900 uplink bands
- AISG2.0 compatible, hardware & software configuration using AISG “personality” upload
- Excellent noise figure performance
- Internal duplexing of AWS and 1900MHz bands
- Internal duplexing of 698-960MHz signals to be passed to additional ANT ports

TECHNICAL SPECIFICATIONS

Downlink Path, Band 1	1900
Passband	1930 - 1990
Insertion Loss	0.7dB typ
Return Loss	18dB min
Max Average input power (W)	160
Max PEP Input Power (W)	2000
Intermodulation, 2 x 43dBm TX carriers (dBc)	-153dBc, (3rd order)
Uplink Path, Band 1	
Passband	1850 - 1910
Gain (dB)	12
Gain window	+/- 1dB max
Return Loss (Operating)	18dB min
Return Loss (Bypass)	12dB min
Noise Figure	1.4dB typ

AISG MODE OF OPERATION (AUTO SELECTED ON VALID AISG 2.0 FRAMES)

AISG Version	2
AISG Supply Current	300mA @ 7.5V, 85mA @ 30V typ
AISG Connector	IEC60130-9, 8-pin female
AISG Connector Current rating	< 4A peak, 2A continuous, pin 6
Field firmware upgradable	Yes

ENVIRONMENTAL

Temperature range	-40°C to +65°C -40° to +149°F
Environmental sealing	IP67
Lightning protection	RF port: +/- 5kA max (8/20us), AISG port: +/- 2kA max (8/20us) IEC61312-1
MTBF	>1,000,000 hours
Compliance	EMC:EN301 489, Ingress ETSI EN 300 019 class 4.1, RoHS

MECHANICAL

Connectors	DIN 7-16 (F) x 6 long neck, AISG (F) x 1
Dimensions, H x D x W	300 x 95 x 250mm 11.8 x 3.7 x 9.8 in
Finish	Painted, light grey (RAL7035)
Weight	10.5kg 23.1lbs
Mounting	Pole/wall bracket supplied with two metal clamps 45-178mm diameter poles

ELECTRICAL BLOCK DIAGRAM

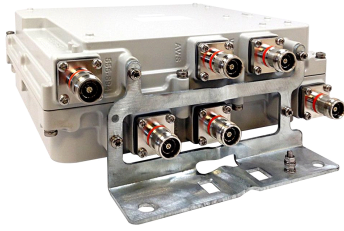

Twin TMA AWS/WCS with 555-894 Bypass, 4.3-10 connectors

Electrical Specifications

Sub-module	1 2	1 2	1 2
Branch	1	2	3
Port Designation	ANT 555-894	ANT AWS	ANT WCS
AISG 2.0 Device Subunit		E25A01P12 1/3	E25A01P12 2/4
License Band	CEL 850, Band Pass USA 700, Band Pass USA 750, Band Pass	AWS 1700, LNA	WCS 2300, LNA

Electrical Specifications Rx (Uplink)

Frequency Range	1695–1780 MHz	2305–2315 MHz
Gain, nominal	13.0 dB	13.0 dB
Noise Figure, typical	1.4 dB	1.8 dB
Total Group Delay, maximum	80 ns	150 ns
Return Loss, typical	20 dB	21 dB
Insertion Loss - Bypass Mode, typical	2.2 dB	3.0 dB
Return Loss - Bypass Mode, typical	18 dB	18 dB

Electrical Specifications Tx (Downlink)

Frequency Range	2110–2200 MHz	2350–2360 MHz
Insertion Loss, typical	0.25 dB	0.50 dB
Total Group Delay, maximum	15 ns	50 ns
Return Loss, typical	22 dB	22 dB
Input Power, RMS, maximum	200 W	200 W
Input Power, PEP, maximum	2 kW	2 kW
Higher Order PIM, maximum	-153 dBc	-153 dBc
Higher Order PIM Test Method	2 x 20 W CW tones	2 x 20 W CW tones

Electrical Specifications, Band Pass

Frequency Range	555–894 MHz
Insertion Loss, maximum	0.20 dB
Return Loss, minimum	20 dB
Isolation, minimum	60 dB
Input Power, RMS, maximum	200 W
Input Power, PEP, maximum	2 kW

Block Diagram

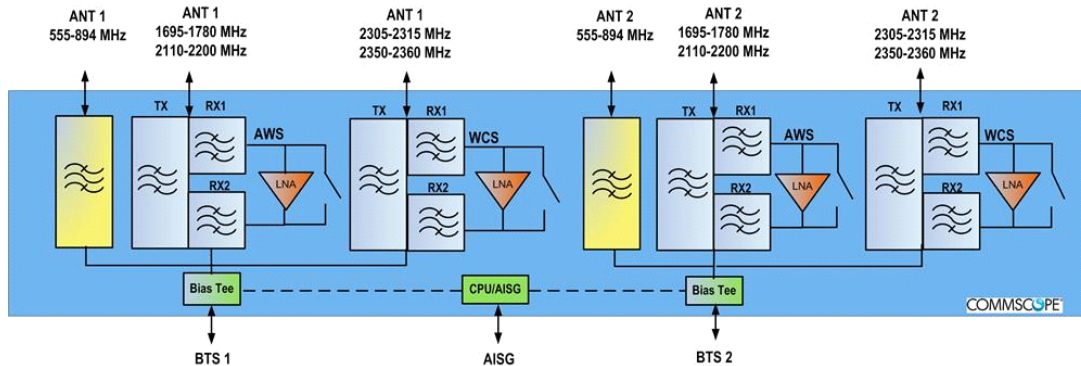

Mechanical Specifications

RF Connector Interface	4.3-10 Female
RF Connector Interface Body Style	Long neck
Ground Screw Diameter	5.00 mm

Dimensions

Height	247.0 mm 9.7 in
Width	280.0 mm 11.0 in
Depth	99.0 mm 3.9 in
Weight, without mounting hardware	9.6 kg 21.2 lb
Mounting Hardware Weight	0.7 kg 1.5 lb

Environmental Specifications

Operating Temperature	-40 °C to +65 °C (-40 °F to +149 °F)
Relative Humidity	Up to 100%
Ingress Protection Test Method	IEC 60529:2001, IP67



Optimizer® Side-by-Side Dual Polarized Antenna, 1710-2200, 65deg, 18.4dBi, 1.4m, VET, 0-10deg RET

Product Description

A combination of two X-Polarized antennas in a single radome, this pair of variable tilt antennas provides exceptional suppression of all upper sidelobes at all downtilt angles. It also features a wide downtilt range. This antenna is optimized for performance across the entire frequency band (1710-2200 MHz). The antenna comes pre-connected with two antenna control units (ACU).

Features/Benefits

- Variable electrical downtilt - provides enhanced precision in controlling intercell interference. The tilt is infield adjustable 0-10 deg.
- High Suppression of all Upper Sidelobes (Typically <-20dB).
- Gain tracking – difference between AWS UL (1710-1755 MHz) and DL (2110-2155 MHz) <1dB.
- Two X-Polarised panels in a single radome.
- Azimuth horizontal beamwidth difference <4deg between AWS UL (1710-1755 MHz) and DL (2110-2155 MHz).
- Low profile for low visual impact.
- Dual polarization; Broadband design.
- Includes (2) AISG 2.0 Compatible ACU-A20-N antenna control units.



Technical Specifications

Electrical Specifications

Frequency Range, MHz	1710-2200
Horizontal Beamwidth, deg	65
Vertical Beamwidth, deg	5.9 to 7.7
Electrical Downtilt, deg	0-10
Gain, dBi (dBd)	18.4 (16.3)
1st Upper Sidelobe Suppression, dB	> 18 (typically > 20)
Upper Sidelobe Suppression, dB	> 18 all (typically > 20)
Front-To-Back Ratio, dB	>26 (typically 28)
Polarization	Dual pol +/-45°
VSWR	< 1.5:1
Isolation between Ports, dB	> 30
3rd Order IMP @ 2 x 43 dBm, dBc	> 150 (155 Typical)
Impedance, Ohms	50
Maximum Power Input, W	300
Lightning Protection	Direct Ground
Connector Type	(4) 7-16 Long Neck Female

Mechanical Specifications

Dimensions - HxWxD, mm (in)	1420 x 331 x 80 (55.9 x 13 x 3.15)
Weight w/o Mtg Hardware, kg (lb)	18.5 (40.7)
Survival Wind Speed, km/h (mph)	200 (125)
Rated Wind Speed, km/h (mph)	160 (100)
Max Wind Loading Area, m ² (ft ²)	0.47 (5.03)
Front Thrust @ Rated Wind, N (lbf)	756 (170)
Maximum Thrust @ Rated Wind, N (lbf)	756 (170)
Wind Load - Side @ Rated Wind, N (lbf)	231 (52)
Wind Load - Rear @ Rated Wind, N (lbf)	408 (92)
Radome Material	Fiberglass
Radome Color	Light Grey RAL7035
Mounting Hardware Material	Diecasted Aluminum
Shipping Weight, kg (lb)	24.5 (53.9)
Packing Dimensions, HxWxD, mm (in)	1520 x 408 x 198 (59.8 x 16 x 7.8)

Ordering Information

Mounting Hardware APM40-2 + APM40-E2

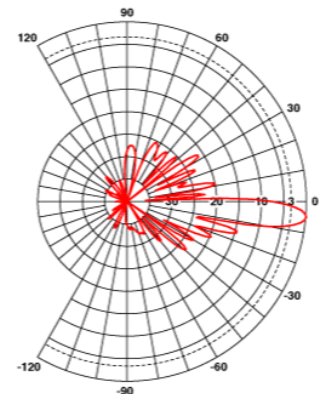

Vertical Pattern

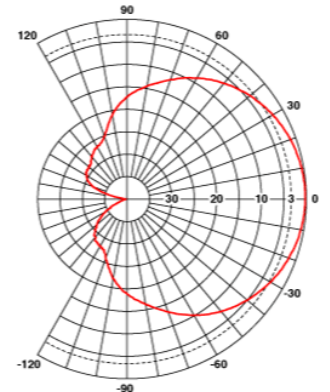

Horizontal Pattern

All information contained in the present datasheet is subject to confirmation at time of ordering

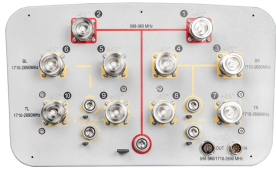

RV4PX306R

Multiband Antenna, 698–960 and 4x 1710–2690 MHz, 65° horizontal beamwidth, internal electrical tilt with manual override.

Electrical Specifications

Frequency Band, MHz	698–790	790–890	890–960	1710–1920	1920–2180	2300–2690
Gain, dBi	14.2	14.4	14.9	14.7	15.2	16.1
Beamwidth, Horizontal, degrees	68	69	63	63	63	62
Beamwidth, Vertical, degrees	16.4	14.9	13.6	13.7	12.2	9.7
Beam Tilt, degrees	0–10	0–10	0–10	0–10	0–10	0–10
USLS (First Lobe), dB	18	18	18	18	18	18
Null Fill, dB	-22	-22	-22	-22	-22	-22
Front-to-Back Ratio at 180°, dB	23	23	23	27	28	28
CPR at Boresight, dB	16	12	12	17	15	14
CPR at Sector, dB	8	8	6	5	3	2
Isolation, dB	25	25	25	25	25	25
Isolation, Intersystem, dB	30	30	30	30	30	30
VSWR Return Loss, dB	1.43 15.0	1.43 15.0	1.43 15.0	1.5 14.0	1.5 14.0	1.5 14.0
PIM, 3rd Order, 2 x 20 W, dBc	-150	-150	-150	-150	-150	-150
Input Power per Port, maximum, watts	300	300	300	250	250	250
Polarization	±45°	±45°	±45°	±45°	±45°	±45°
Impedance	50 ohm	50 ohm	50 ohm	50 ohm	50 ohm	50 ohm

Electrical Specifications, BASTA*

Frequency Band, MHz	698–790	790–890	890–960	1710–1920	1920–2180	2300–2690
Gain by all Beam Tilts, average, dBi	14.0	14.2	14.6	14.6	15.0	15.8
Gain by all Beam Tilts Tolerance, dB	±0.2	±0.2	±0.3	±0.5	±0.4	±0.5
Gain by Beam Tilt, average, dBi	0° 14.0	0° 14.2	0° 14.6	0° 14.6	0° 15.0	0° 16.0
	5° 14.0	5° 14.2	5° 14.6	5° 14.6	5° 15.0	5° 15.8
	10° 14.0	10° 14.1	10° 14.6	10° 14.6	10° 15.1	10° 15.6
Beamwidth, Horizontal Tolerance, degrees	±1.4	±1.2	±1.6	±2.5	±3.5	±6.4
Beamwidth, Vertical Tolerance, degrees	±0.8	±0.8	±0.5	±0.9	±1	±0.9
USLS, beampeak to 20° above beampeak, dB	18	18	18	18	18	18
Front-to-Back Total Power at 180° ± 30°, dB	25	23	23	23	25	25
CPR at Boresight, dB	17	13	13	20	17	18
CPR at Sector, dB	10	10	8	7	5	4

* CommScope® supports NGMN recommendations on Base Station Antenna Standards (BASTA). To learn more about the benefits of BASTA, [download the whitepaper Time to Raise the Bar on BSAs.](#)

General Specifications

Antenna Type	Sector with internal RET
Band	Multiband
Brand	DualPol®
Operating Frequency Band	1710 – 2690 MHz 698 – 960 MHz
Performance Note	Outdoor usage

RV4PX306R

Mechanical Specifications

Lightning Protection	dc Ground inner/outer conductor
Radome Material	ASA, UV stabilized
Reflector Material	Aluminum
RF Connector Interface	7-16 DIN Female
RF Connector Location	Bottom
RF Connector Quantity, total	10
Wind Loading, maximum	681.0 N @ 150 km/h 153.1 lbf @ 150 km/h
Wind Speed, maximum	250 km/h 155 mph

Dimensions

Depth	209.0 mm 8.2 in
Length	1599.0 mm 63.0 in
Width	353.0 mm 13.9 in
Net Weight, without mounting kit	24.0 kg 52.9 lb

Remote Electrical Tilt (RET) Information

Input Voltage	10–30 Vdc
Internal RET	High band (4) Low band (1)
Power Consumption, idle state, maximum	2.0 W
Power Consumption, normal conditions, maximum	13.0 W
Protocol	3GPP/AISG 2.0 (Single RET)
RET Interface	8-pin DIN Female 8-pin DIN Male
RET Interface, quantity	1 female 1 male

Packed Dimensions

Depth	325.0 mm 12.8 in
Length	1787.0 mm 70.4 in
Width	427.0 mm 16.8 in
Shipping Weight	39.0 kg 86.0 lb

Regulatory Compliance/Certifications

Agency

RoHS 2011/65/EU
China RoHS SJ/T 11364-2006
ISO 9001:2008

Classification

Included Products

T-041-GL-E — Argus® Adjustable Tilt Pipe Mounting Kit for 2.0"-4.5" (50-115mm) OD round members for panel antennas. Includes 2 clamp sets.

* Footnotes

Performance Note Severe environmental conditions may degrade optimum performance



ATSBT-TOP-FM-4G

Teletilt® Top Smart Bias Tee

- Injects AISG power and control signals onto a coaxial cable line
- Reduces cable and site lease costs by eliminating the need for AISG home run cables
- AISG 1.1 and 2.0 compliant
- Operates at 10-30 Vdc
- Weatherproof AISG connectors
- Intuitive schematics simplify and ensure proper installation
- Enhanced lightning protection plus grounding stud for additional surge protection
- 7-16 DIN female connector (BTS)
- 7-16 DIN male connector (ANT)

General Specifications

Smart Bias Tee Type	10–30 V Top
Brand	Teletilt®
Operating Frequency Band	694 – 2690 MHz

Electrical Specifications

EU Certification	CE
Protocol	AISG 1.1 AISG 2.0
Antenna Interface Signal	dc Blocked RF
BTS Interface Signal	AISG data dc RF
Interface Protocol Signal	Data dc
Voltage Range	10–30 Vdc
VSWR Return Loss	1.17:1 22 dB, typical
Power Consumption, maximum	0.6 W
RF Power, maximum	250 W @ 1850 MHz 500 W @ 850 MHz
Impedance	50 ohm
Insertion Loss, typical	0.1 dB
3rd Order IMD	-158.0 dBc (relative to carrier)
3rd Order IMD Test Method	Two +43 dBm carriers
Electromagnetic Compatibility (EMC)	CFR 47 Part 15, Subpart B, Class B EN 55022, Class B ICES-003 Issue 4 CAN/CSA-CEI/IEC CISPR 22:02

Mechanical Specifications

Antenna Interface	7-16 DIN Male
BTS Interface	7-16 DIN Female
AISG Input Connector	8-pin DIN Female
Color	Silver
Grounding Lug Thread Size	M8
Material Type	Aluminum
Lightning Surge Capability	5 times @ -3 kA 5 times @ 3 kA

ATSBT-TOP-FM-4G

POWERED BY



Lightning Surge Capability Test Method IEC 61000-4-5, Level X

Lightning Surge Capability Waveform 1.2/50 voltage and 8/20 current combination waveform

Environmental Specifications

Ingress Protection Test Method IEC 60529:2001, IP66

Operating Temperature -40 °C to +70 °C (-40 °F to +158 °F)

Interface Port Drawing



Dimensions

Width	94.0 mm 3.7 in
Depth	50.0 mm 2.0 in
Height	143.00 mm 5.63 in
Net Weight	0.8 kg 1.8 lb

Regulatory Compliance/Certifications

Agency
RoHS 2011/65/EU

Classification
Compliant by Exemption

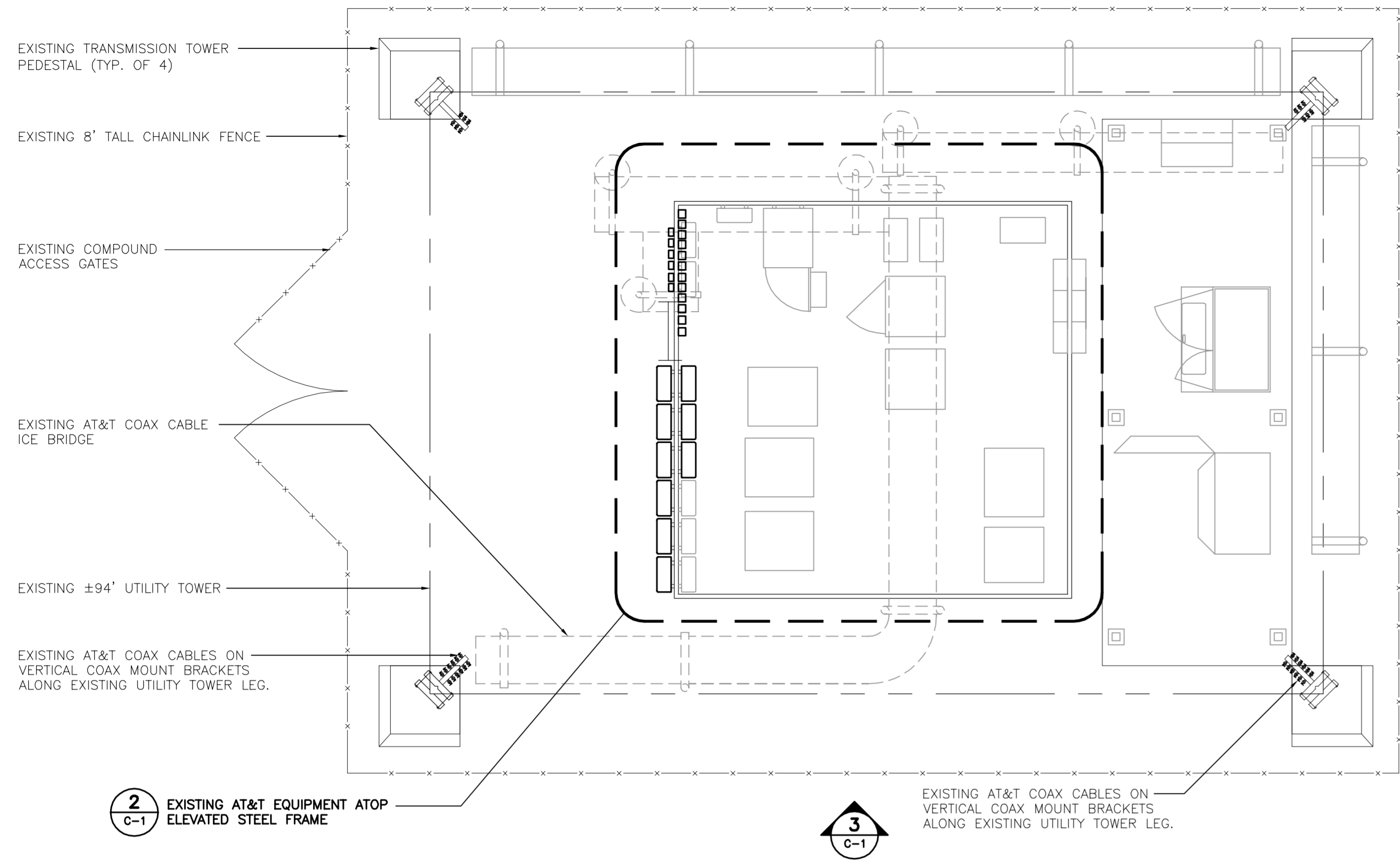

1
C-1 **COMPOUND PLAN**
SCALE: 1/4" = 1'
APPROXIMATE NORTH

GRAPHIC SCALE
(IN FEET)
1/4 inch = 1 ft.

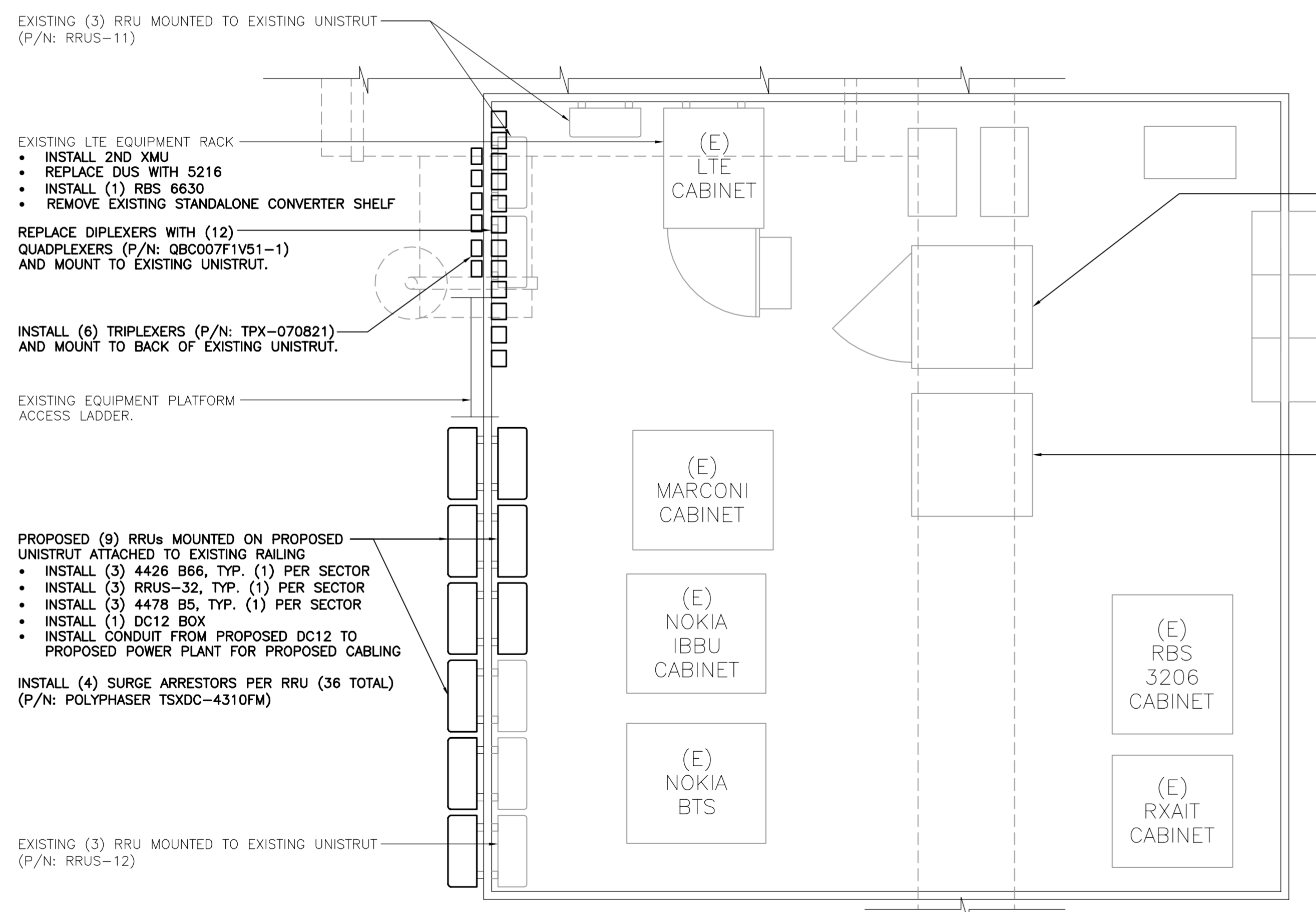

2
C-1 **EQUIPMENT LAYOUT PLAN**
SCALE: 1/2" = 1'
APPROXIMATE NORTH

GRAPHIC SCALE
(IN FEET)
1/2 inch = 1 ft.

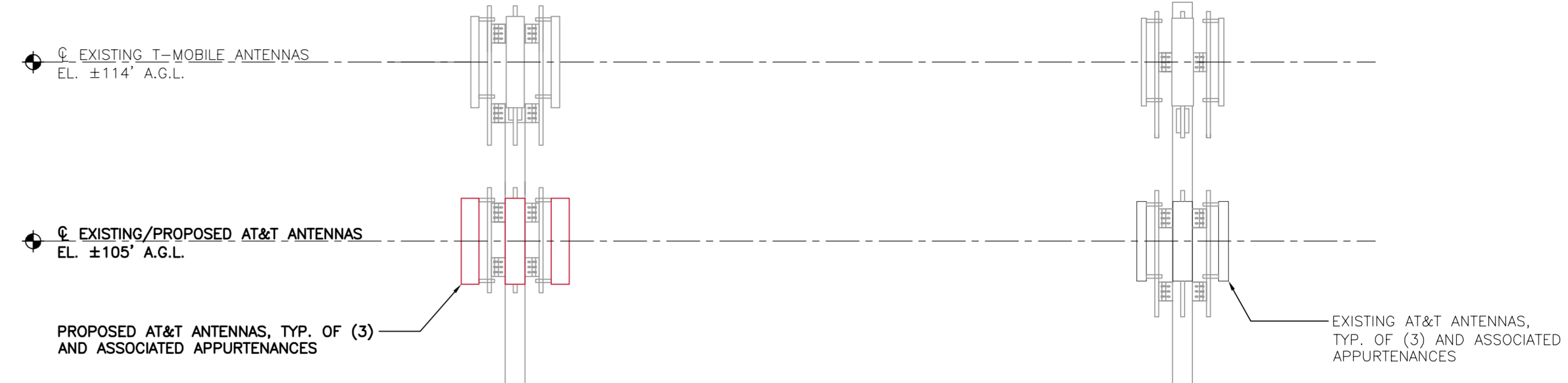

TOWER STRUCTURAL NOTES:

- REFER TO STRUCTURAL ANALYSIS REPORT PREPARED BY CENTEK ENGINEERING, INC., PROJ. NO. 18000.55, DATED MAY 21, 2019 FOR ADDITIONAL INFORMATION AND REQUIREMENTS.
- ALL ANTENNAS AND COAX TO BE INSTALLED IN ACCORDANCE WITH STRUCTURAL ANALYSIS PROVIDED BY CENTEK ENGINEERING, INC. AND FINAL AT&T RF DATA SHEET.

NOTES:

- A.G.L. = ABOVE GRADE LEVEL

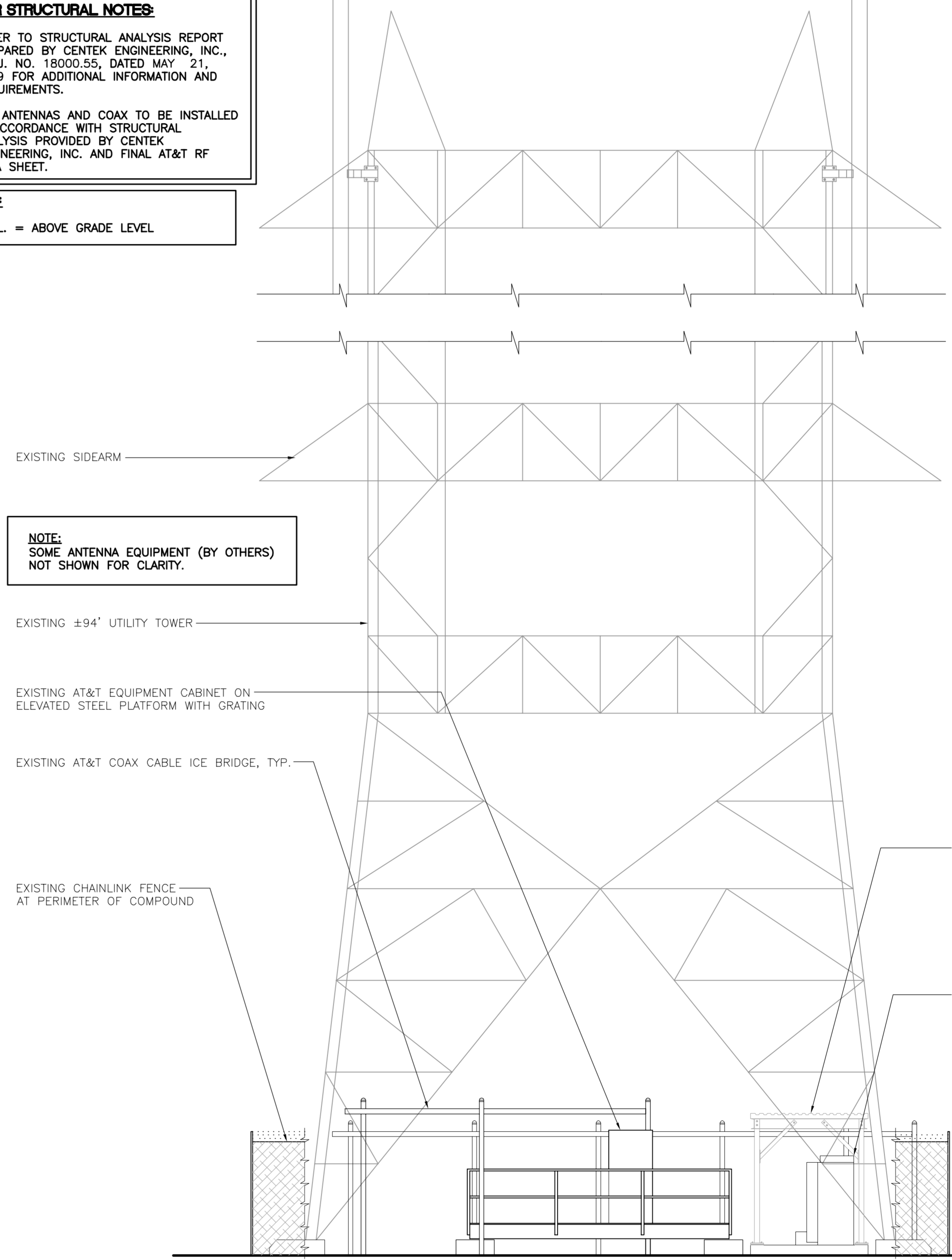

3
C-1 **PARTIAL SOUTHWEST ELEVATION - PROPOSED**
SCALE: 3/16" = 1'-0"

PROFESSIONAL ENGINEER SEAL

STATE OF CONNECTICUT
REGISTERED PROFESSIONAL ENGINEER

at&t
EMPIRE telecom

CENTEK engineering
Centered on Solutions
(203) 488-0360
(203) 488-8387 Fax
63-2 North Branford Road
Branford, CT 06405
www.CentekEng.com

AT&T MOBILITY
WIRELESS COMMUNICATIONS FACILITY
NORWALK CENTER
CT5046 - LTE 3C/4C/5C
1 WILL RUSS COURT
NORWALK, CT 06850

REV.	DATE	BY	CHK'D BY	DESCRIPTION
2	05/21/19	TJL		CONSTRUCTION DRAWINGS - ISSUED FOR CONSTRUCTION
1	05/02/19	KAWUR		CONSTRUCTION DRAWINGS - ISSUED FOR CONSTRUCTION
0	04/26/19	TJL		CONSTRUCTION DRAWINGS - ISSUED FOR CONSTRUCTION

DATE: 09/26/18
SCALE: AS NOTED
JOB NO. 18000.55

PLANS AND ELEVATION

C-1

Sheet No. 3 of 10

1A
C-2

0'
UMTS 850/1900
ALPHA SECTOR
POSITION 3

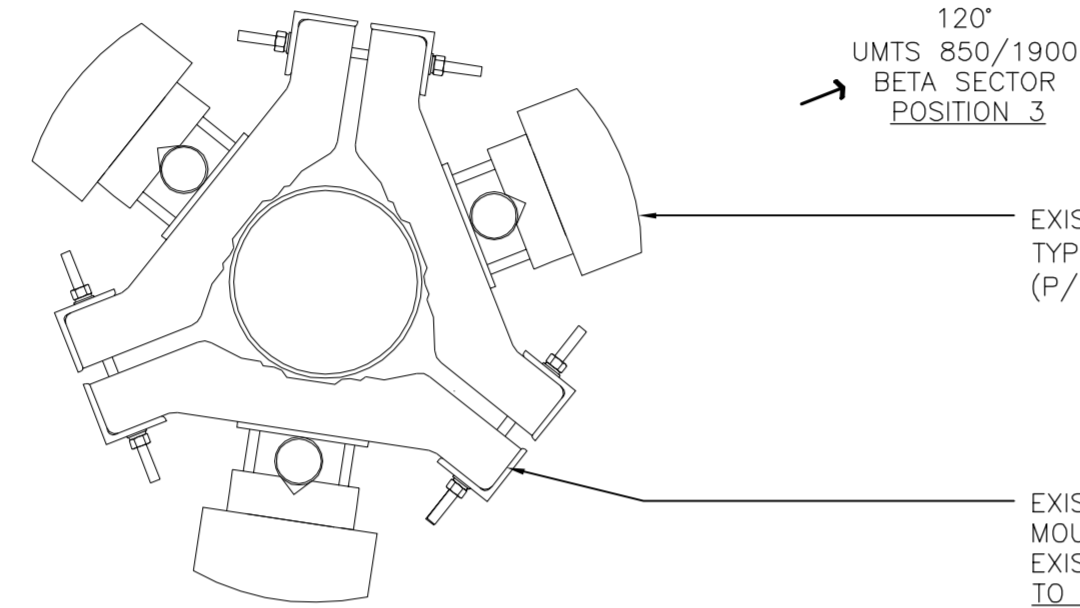

EXISTING AT&T PANEL ANTENNA POS.3,
TYP. (1) PER SECTOR, TOTAL (3)
(P/N: POWERWAVE 7770) **TO BE REMOVED**

EXISTING UNIVERSAL TRI-BRACKET
MOUNT ASSEMBLY ATTACHED TO
EXISTING ANTENNA SUPPORT MAST
TO REMAIN.

240'
UMTS 850/1900
GAMMA SECTOR
POSITION 3

1
C-2 **EXISTING ANTENNA PLAN**
SCALE: 1" = 1'-0"



2A
C-2

30'
LTE AWS/WCS
ALPHA SECTOR
POSITION 1

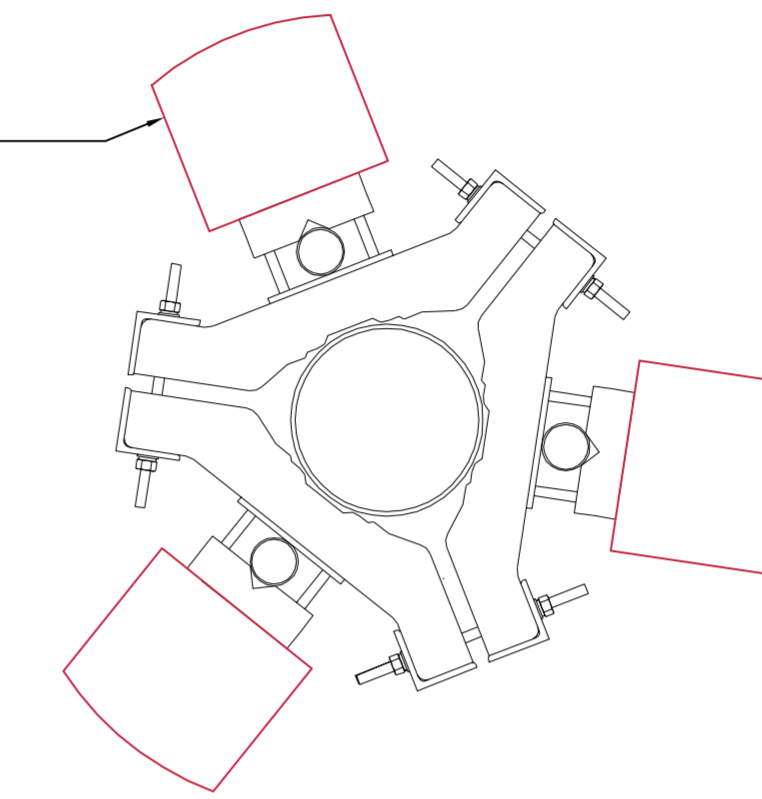

PROPOSED AT&T PANEL ANTENNA POS.1,
TYP. (1) PER SECTOR, TOTAL (3)
(P/N: QUNTEL QS46512-2) WITH (6)
TWIN TMA MOUNTED BELOW ANTENNAS.
(P/N: POWERWAVE TMA21X23B68-31-43)

150'
LTE AWS/WCS
BETA SECTOR
POSITION 1

270'
LTE AWS/WCS
GAMMA SECTOR
POSITION 1

2
C-2 **PROPOSED ANTENNA PLAN**
SCALE: 2" = 1'-0"

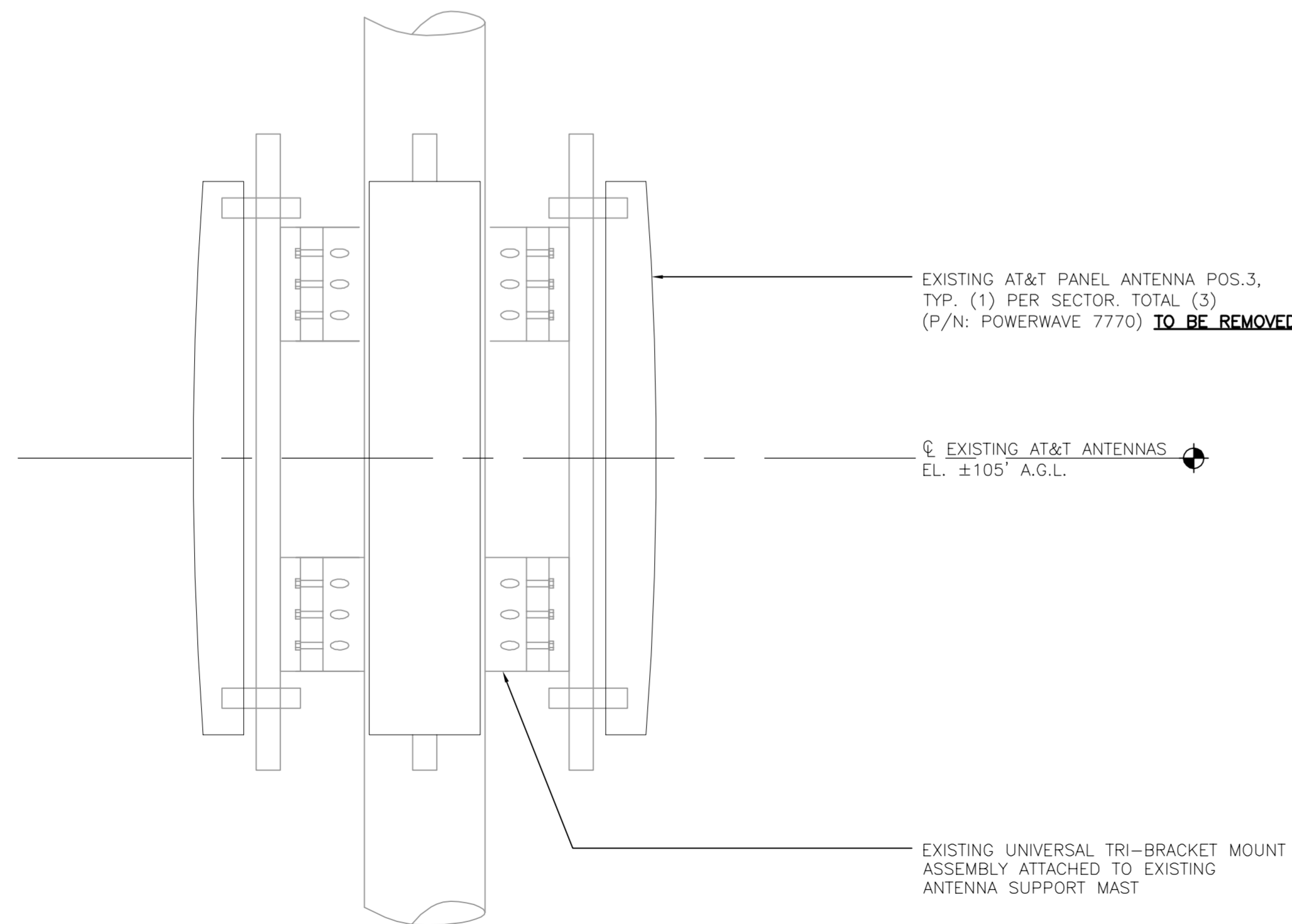

EXISTING AT&T PANEL ANTENNA POS.3,
TYP. (1) PER SECTOR, TOTAL (3)
(P/N: POWERWAVE 7770) **TO BE REMOVED**

EXISTING AT&T ANTENNAS
EL. ±105' A.G.L.

EXISTING UNIVERSAL TRI-BRACKET MOUNT
ASSEMBLY ATTACHED TO EXISTING
ANTENNA SUPPORT MAST

1A
C-2 **EXISTING ANTENNA ELEVATION**
SCALE: 1" = 1'-0"

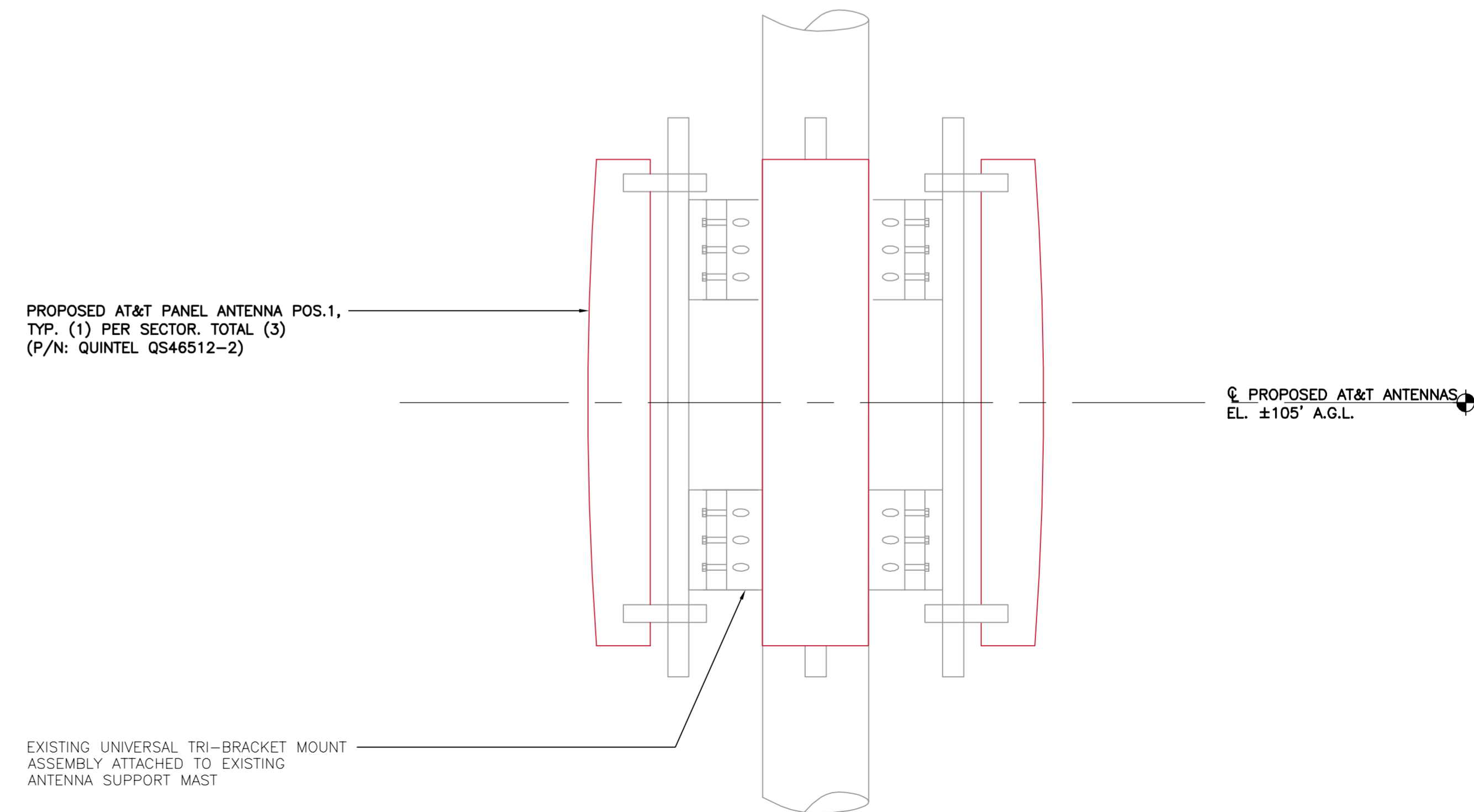

PROPOSED AT&T PANEL ANTENNA POS.1,
TYP. (1) PER SECTOR, TOTAL (3)
(P/N: QUNTEL QS46512-2)

PROPOSED AT&T ANTENNAS
EL. ±105' A.G.L.

EXISTING UNIVERSAL TRI-BRACKET MOUNT
ASSEMBLY ATTACHED TO EXISTING
ANTENNA SUPPORT MAST

2A
C-2 **PROPOSED ANTENNA ELEVATION**
SCALE: 1" = 1'-0"

REV.	DATE	BY	CHK'D	DESCRIPTION
2	05/21/19	TJL		CONSTRUCTION DRAWINGS - ISSUED FOR CONSTRUCTION
1	05/02/19	KAWUR		CONSTRUCTION DRAWINGS - ISSUED FOR CONSTRUCTION
0	04/26/19	TJL		CONSTRUCTION DRAWINGS - ISSUED FOR CONSTRUCTION

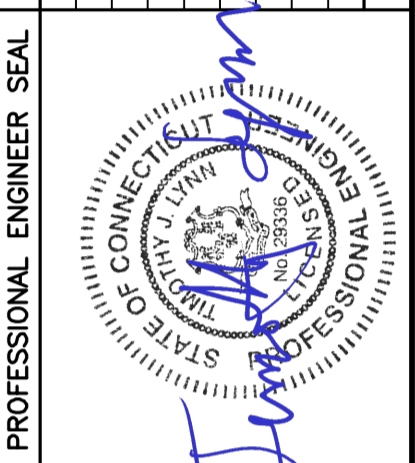

CENITEK engineering
Centered on Solutions™
(203) 488-0380
(203) 488-8387 Fax
63-2 North Branford Road
Branford, CT 06405
www.CenitekEng.com

AT&T MOBILITY
WIRELESS COMMUNICATIONS FACILITY
NORWALK CENTER
CT5046 - LTE 3C/4C/5C
1 WILL RUSS COURT
NORWALK, CT 06850

DATE: 09/26/18
SCALE: AS NOTED
JOB NO. 18000.55

ANTENNA
CONFIGURATION
DETAILS

C-2
Sheet No. 4 of 10

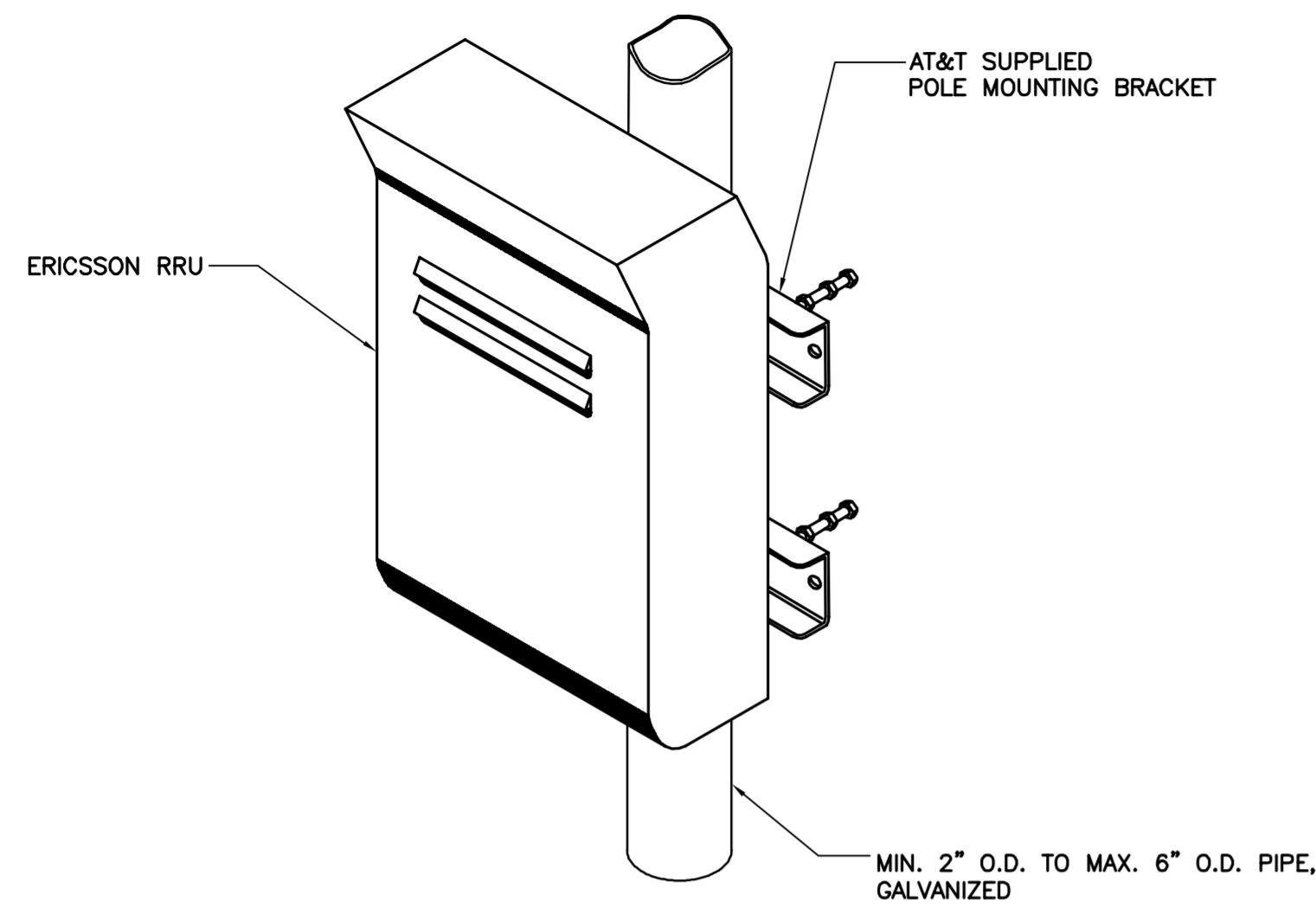

ISOMETRIC VIEW

NOTES:

- AT&T SHALL SUPPLY RRU, AND RRU POLE-MOUNTING BRACKET. CONTRACTOR SHALL SUPPLY POLE/PIPE AND INSTALL ALL MOUNTING HARDWARE INCLUDING ERICSSON RRU POLE-MOUNTING BRACKET. CONTRACTOR SHALL INSTALLS RRU AND MAKES CABLE TERMINATIONS.
- NO PAINTING OF THE RRU OR SOLAR SHIELD IS ALLOWED.

1 TYPICAL RRUS MOUNTING DETAILS
C-3 NOT TO SCALE

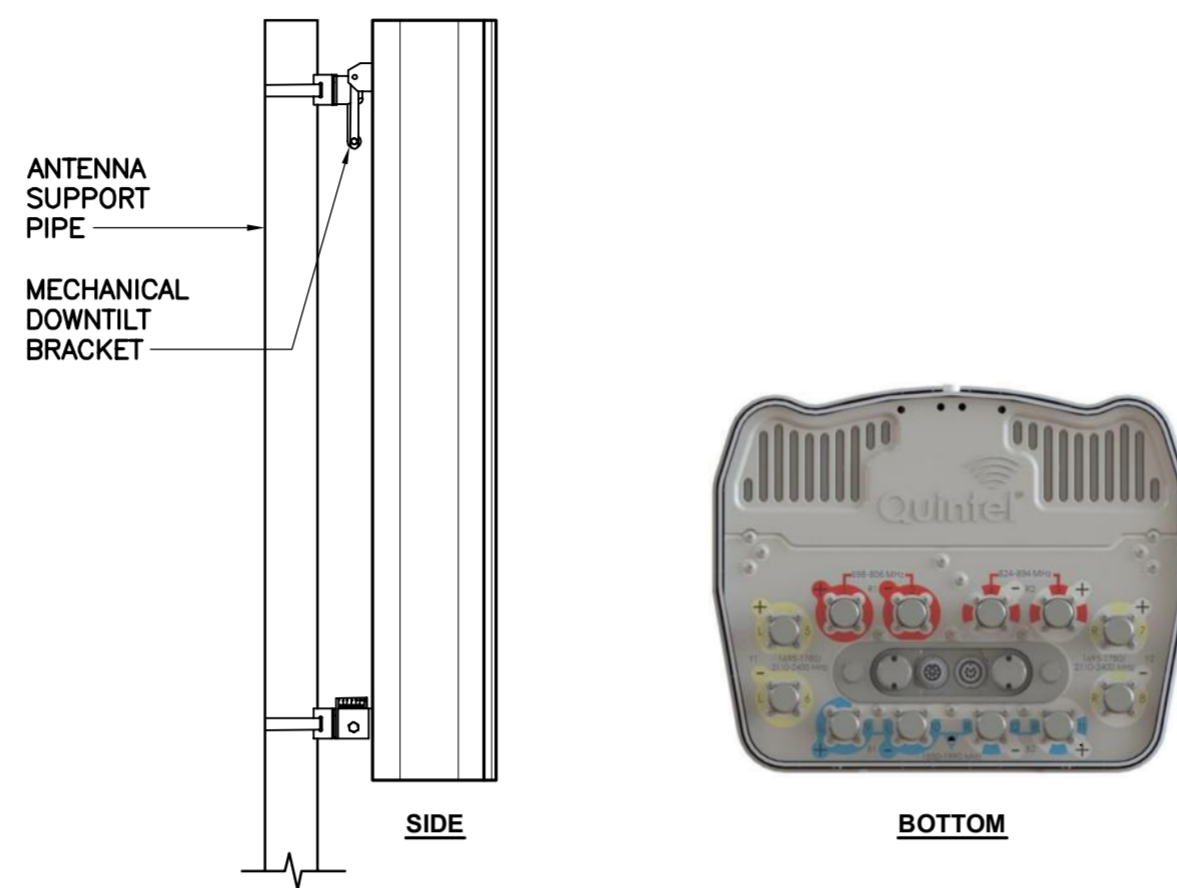

ALPHA/BETA/GAMMA ANTENNA

EQUIPMENT	DIMENSIONS	WEIGHT
MAKE: QUINTEL MODEL: QS46512-2	52"L x 12"W x 10.8"D	75 LBS.

2 PROPOSED ANTENNA DETAIL
C-3 NOT TO SCALE



SURGE ARESSTOR		
EQUIPMENT	DIMENSIONS	WEIGHT
MAKE: POLYPHASER MODEL: TSXDC-4310FM	3.07"H x 1.49"W x 1.65"D	1.32 LBS.

NOTES:
1. CONTRACTOR TO COORDINATE FINAL EQUIPMENT MODEL SELECTION WITH AT&T CONSTRUCTION MANAGER PRIOR TO ORDERING.

3 POLYPHASER - TSXDC-4310FM DETAIL
C-3 NOT TO SCALE

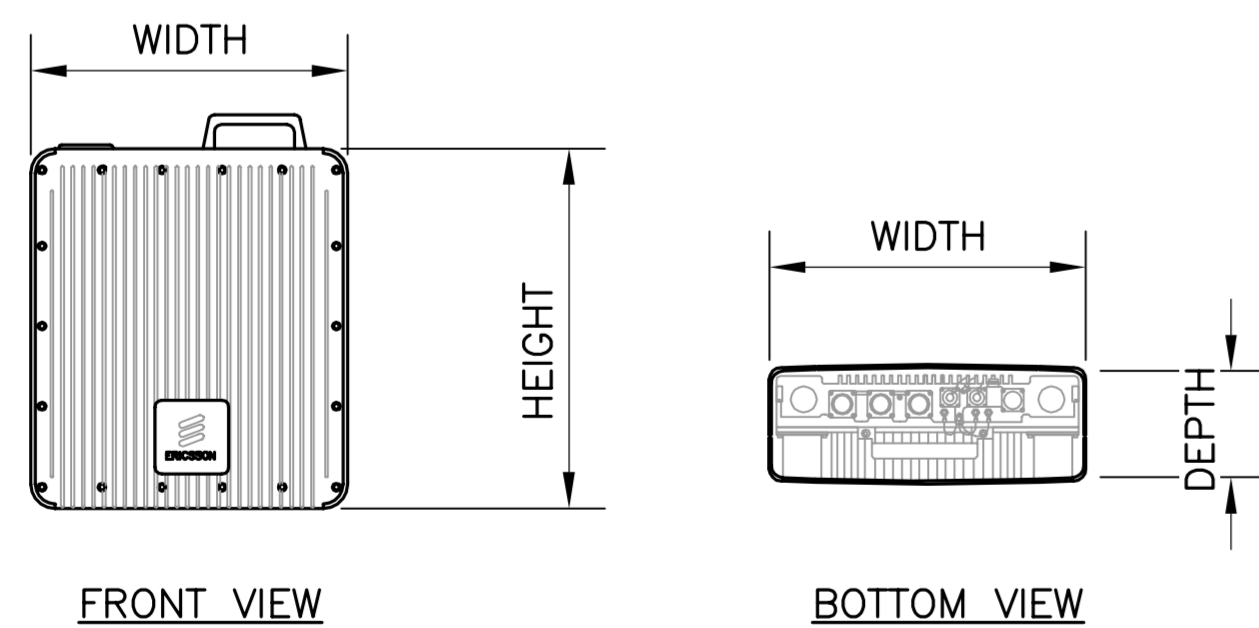

FRONT VIEW

BOTTOM VIEW

RRU (REMOTE RADIO UNIT)			
EQUIPMENT	DIMENSIONS	WEIGHT	CLEARANCES
MAKE: ERICSSON MODEL: 4426 B66	15.0"L x 13.2"W x 5.8"D	48.5 LBS.	ABOVE: 16" MIN. BELOW: 12" MIN. FRONT: 36" MIN.

NOTES:
1. CONTRACTOR TO COORDINATE FINAL EQUIPMENT MODEL SELECTION WITH AT&T CONSTRUCTION MANAGER PRIOR TO ORDERING.

4 ERICSSON 4426 B66 DETAIL
C-3 NOT TO SCALE



EQUIPMENT	DIMENSIONS	WEIGHT	CLEARANCES
MAKE: ERICSSON MODEL: 4478 B5	16.5"L x 13.4"W x 7.7"D	59.9 LBS.	ABOVE: 16" MIN. BELOW: 12" MIN. FRONT: 36" MIN.

NOTES:
1. CONTRACTOR TO COORDINATE FINAL EQUIPMENT MODEL SELECTION WITH AT&T CONSTRUCTION MANAGER PRIOR TO ORDERING.

5 ERICSSON 4478 B5 DETAIL
C-3 NOT TO SCALE

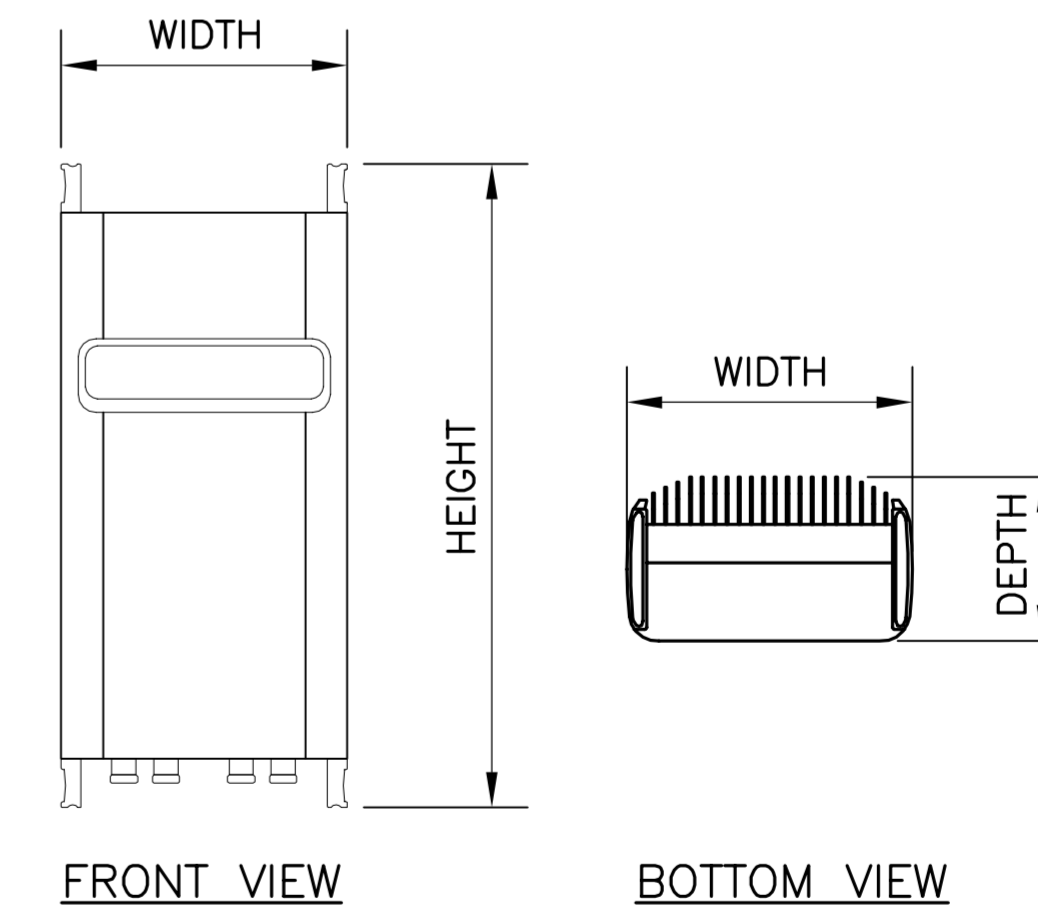

FRONT VIEW

BOTTOM VIEW

RRU (REMOTE RADIO UNIT)			
EQUIPMENT	DIMENSIONS	WEIGHT	CLEARANCES
MAKE: ERICSSON MODEL: RRUS-32	27.17"L x 12.05"W x 7.01"D	52.91 LBS.	ABOVE: 16" MIN. BELOW: 12" MIN. FRONT: 36" MIN.

NOTES:
1. CONTRACTOR TO COORDINATE FINAL EQUIPMENT MODEL SELECTION WITH AT&T CONSTRUCTION MANAGER PRIOR TO ORDERING.

6 ERICSSON RRUS-32 DETAIL
C-3 NOT TO SCALE

REV.	DATE	BY	CHK'D	DESCRIPTION
2	05/21/19	TJL		DND CONSTRUCTION DRAWINGS - ISSUED FOR CONSTRUCTION
1	05/02/19	KAWUR		DND CONSTRUCTION DRAWINGS - ISSUED FOR CONSTRUCTION
0	04/26/19	TJL		DND CONSTRUCTION DRAWINGS - ISSUED FOR CONSTRUCTION

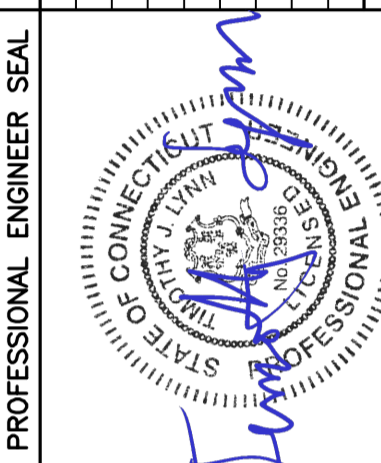

CEN TEK engineering
Centered on Solutions™
(203) 488-0380
(203) 488-8387 Fax
63.2 North Branford Road
Branford, CT 06405
www.CentekEng.com

AT&T MOBILITY
WIRELESS COMMUNICATIONS FACILITY
NORWALK CENTER
CT5046 - LTE 3C/4C/5C
1 WILL RUSSELL COURT
NORWALK, CT 06850

DATE: 09/26/18
SCALE: AS NOTED
JOB NO. 18000.55

DETAILS



QUADRUPLER 700/850/1900 - AWS/WCS		
EQUIPMENT	DIMENSIONS	WEIGHT
MAKE: KAELUS MODEL: QBC0007F1V51-1	9.73"H x 8.78"W x 8.06"D	16.7 LBS.
NOTES: 1. CONTRACTOR TO COORDINATE FINAL EQUIPMENT MODEL SELECTION WITH AT&T CONSTRUCTION MANAGER PRIOR TO ORDERING.		

1 KAELUS - QBC0007F1V51-1 DETAIL
C-4 NOT TO SCALE

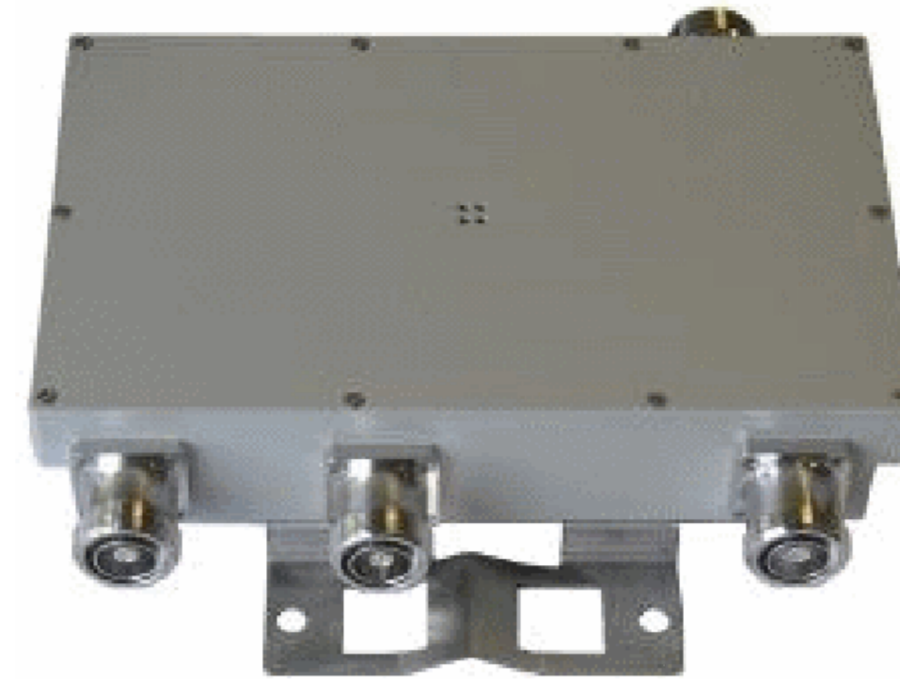

TRIPLEXER		
EQUIPMENT	DIMENSIONS	WEIGHT
MAKE: CCI MODEL: TPX-070821	5.83"H x 9.65"W x 2.05"D	7.5 LBS.
NOTES: 1. CONTRACTOR TO COORDINATE FINAL EQUIPMENT MODEL SELECTION WITH AT&T CONSTRUCTION MANAGER PRIOR TO ORDERING.		

2 CCI - TPX-070821 DETAIL
C-4 NOT TO SCALE



TWIN TMA		
EQUIPMENT	DIMENSIONS	WEIGHT
MAKE: POWERWAVE MODEL: TMAT21X23B68-31-43	9.7"H x 11.0"W x 3.9"D	22 LBS.
NOTES: 1. CONTRACTOR TO COORDINATE FINAL EQUIPMENT MODEL SELECTION WITH AT&T CONSTRUCTION MANAGER PRIOR TO ORDERING.		

3 POWERWAVE - TMAT21X23B68-31-43 DETAIL
C-4 NOT TO SCALE



SMART BIAS TEE		
EQUIPMENT	DIMENSIONS	WEIGHT
MAKE: KATHREIN MODEL: 782-11055	3.18"H x 3.18"W x 1.81"D	1.76 LBS.
NOTES: 1. CONTRACTOR TO COORDINATE FINAL EQUIPMENT MODEL SELECTION WITH AT&T CONSTRUCTION MANAGER PRIOR TO ORDERING.		

4 KATHREIN - K SBT 782-11055 DETAIL
C-4 NOT TO SCALE

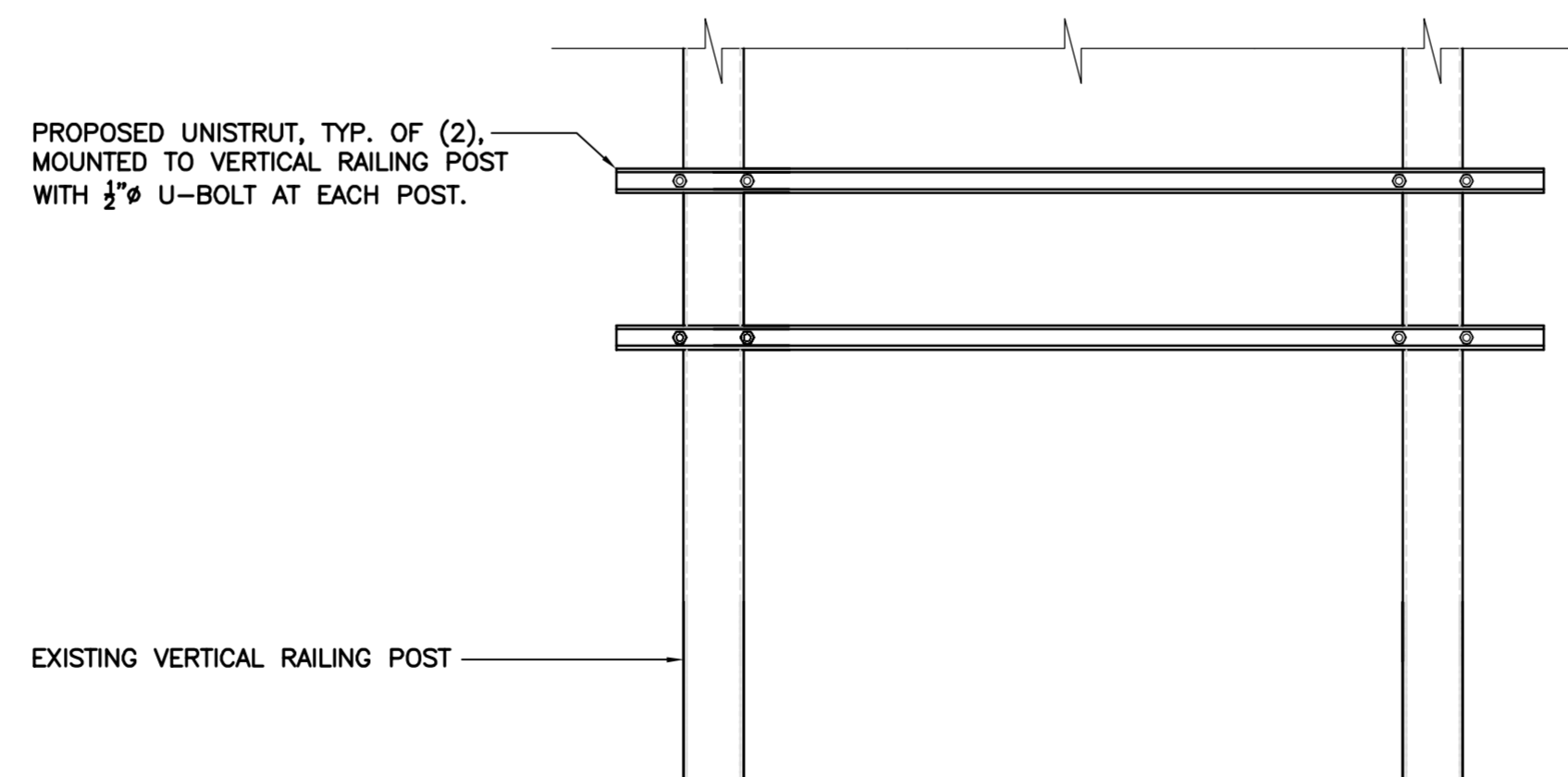

5 TYPICAL APPURTENANCE FRAME DETAIL
C-4 NOT TO SCALE

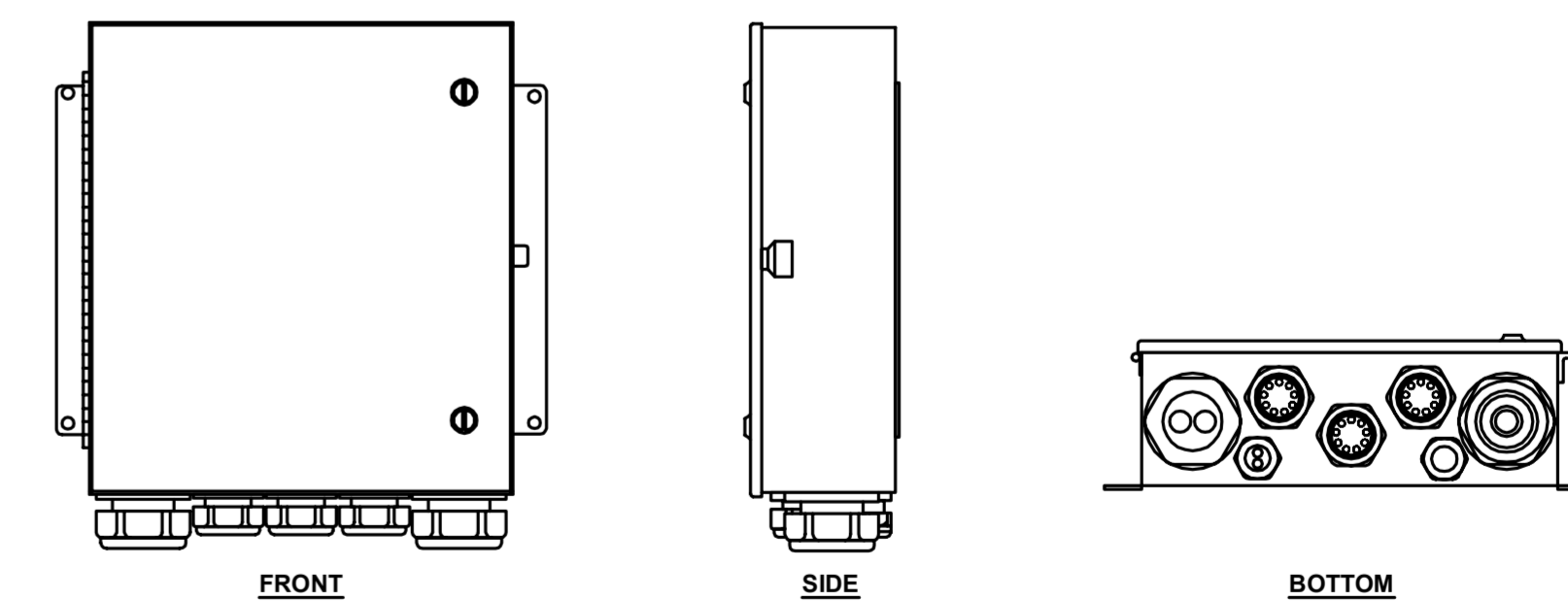

SURGE ARRESTOR			
ARRESTOR MAKE/MODEL	QTY REQUIRED	ARRESTOR LOCATION	WEIGHT
MAKE: RAYCAP MODEL: DC12-48-60-0-25E	ONE (1)	AT&T LEASE AREA	56.3 LBS.
NOTES: 1. CONTRACTOR TO COORDINATE FINAL SURGE ARRESTOR MODEL SELECTION(S) WITH AT&T CONSTRUCTION MANAGER PRIOR TO ORDERING. 2. CONTRACTOR TO INSTALL ARRESTOR IN CONFORMANCE WITH MANUFACTURERS RECOMMENDATIONS.			

6 SURGE ARRESTOR DETAIL
C-4 NOT TO SCALE

REV.	DATE	BY	CHK'D	DESCRIPTION
2	05/21/19	TJL		DND CONSTRUCTION DRAWINGS - ISSUED FOR CONSTRUCTION
1	05/02/19	KAWJR		DND CONSTRUCTION DRAWINGS - ISSUED FOR CONSTRUCTION
0	04/26/19	TJL		DND CONSTRUCTION DRAWINGS - ISSUED FOR CONSTRUCTION



CENITEK
 engineering
 Centered on Solutions™
 (203) 488-0360
 (203) 488-8387 Fax
 63-2 North Branford Road
 Branford, CT 06405
 www.CenitekEng.com

AT&T MOBILITY
 WIRELESS COMMUNICATIONS FACILITY
NORWALK CENTER
 CT5046 - LTE 3C/4C/5C
 1 WILL RUSS COURT
 NORWALK, CT 06850

DATE: 09/26/18
 SCALE: AS NOTED
 JOB NO. 18000.55

DETAILS

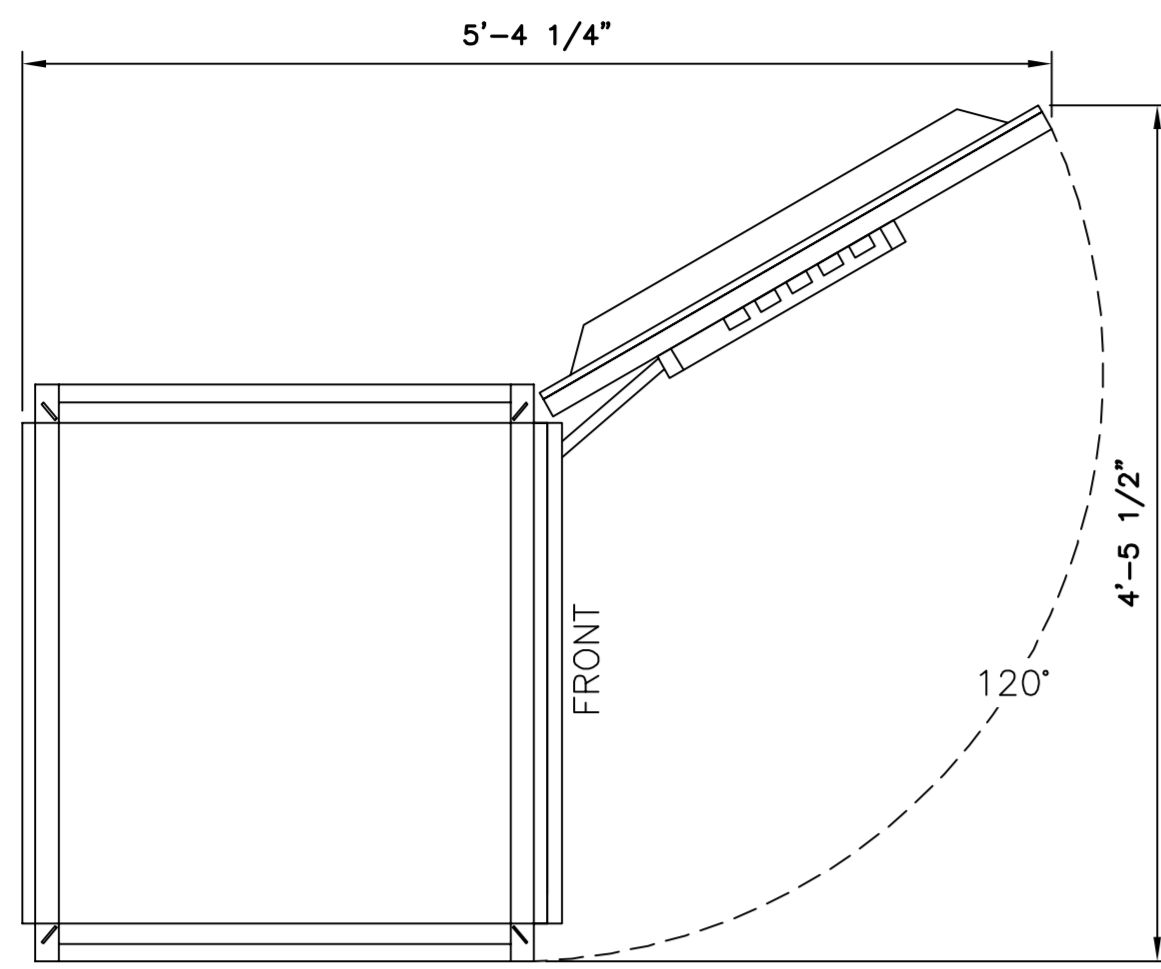

AT&T No. NEQ. 15918 -48V DC BATTERY CABINET
 NEQ. 15919 24V DC BATTERY CABINET

TECHNICAL SPECIFICATIONS

EQUIPMENT
 BATTERY SHELVES (5) SHELVES (+24V - 12 STRING MAX/-48V - 6 STRING MAX)
 THERMAL SOLUTION FREE AIR VENTED
 GROUND BAR 10 POSITIONS
 TERMINAL BLOCK 12-PAIR PHOENIX BLOCK

ENVIRONMENTAL
 NEMA ENCLOSURE 3R

WEIGHT
 NetXtend™ FLEX BATTERY CABINET 980lbs (W/O BATTERIES)
 4010lbs (W/BATTERIES)
 PLINTH TBD

CLEARANCES
 FRONT 36"
 LEFT AND RIGHT 0"
 REAR 12"

TOP VIEW

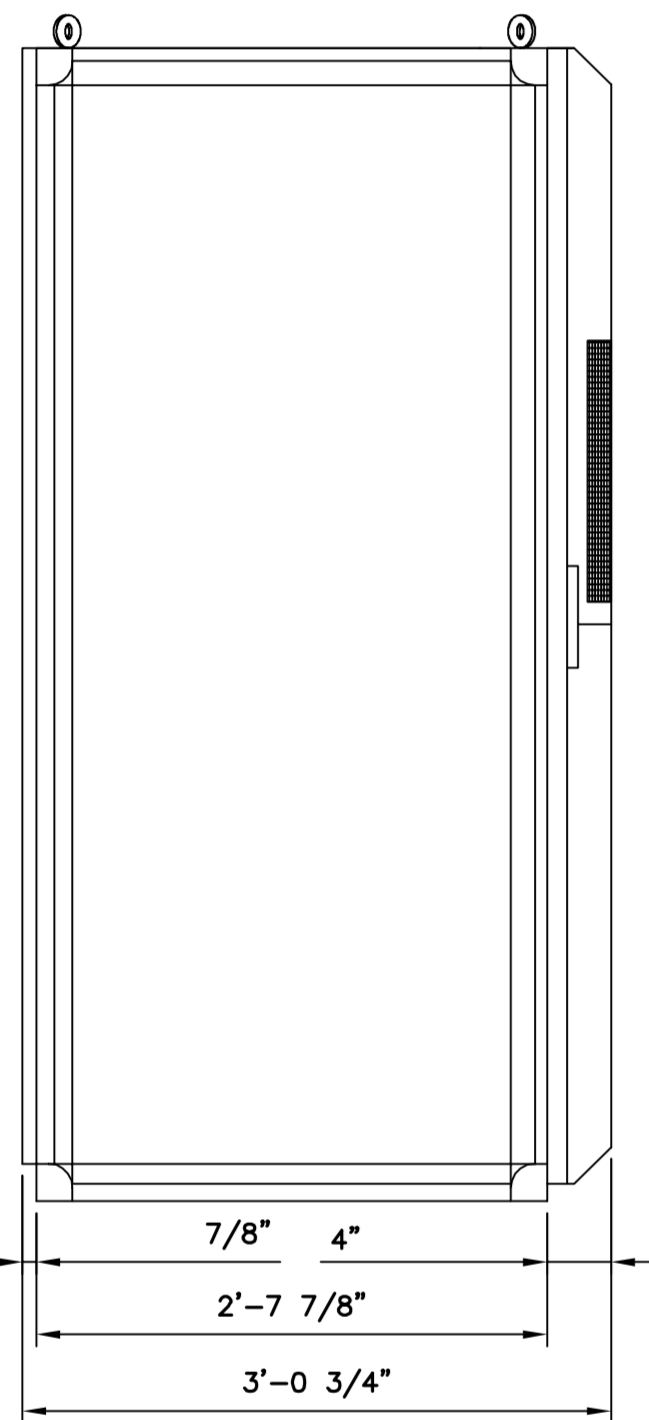

LEFT SIDE VIEW

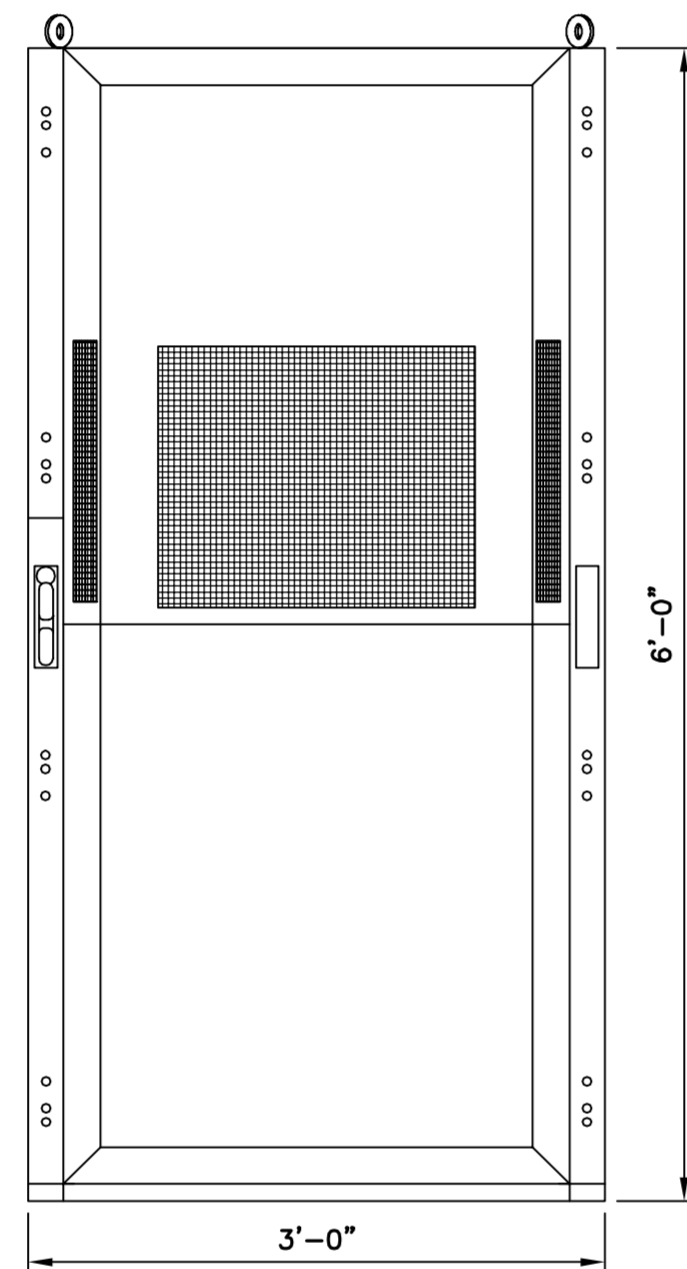

FRONT VIEW

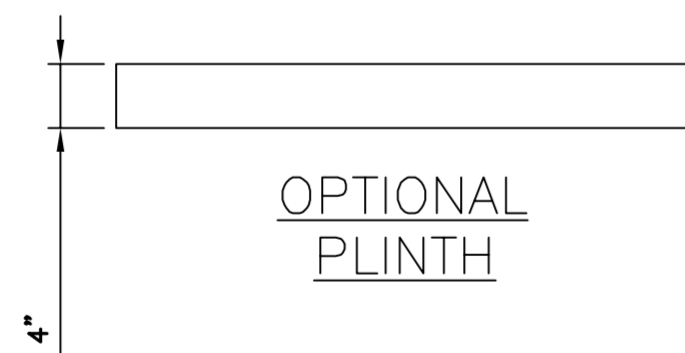

OPTIONAL PLINTH

TEMPLATE NOTES:

- A. (4) 1" DIAMETER HOLE POSITIONS "A" USED FOR MOUNTING CABINETS ON PLINTHS.
- B. (6) 3/4" DIAMETER HOLE POSITIONS "B" USED FOR MOUNTING CABINETS ON PAD WITH OR WITHOUT METAL MOUNTING TEMPLATES.

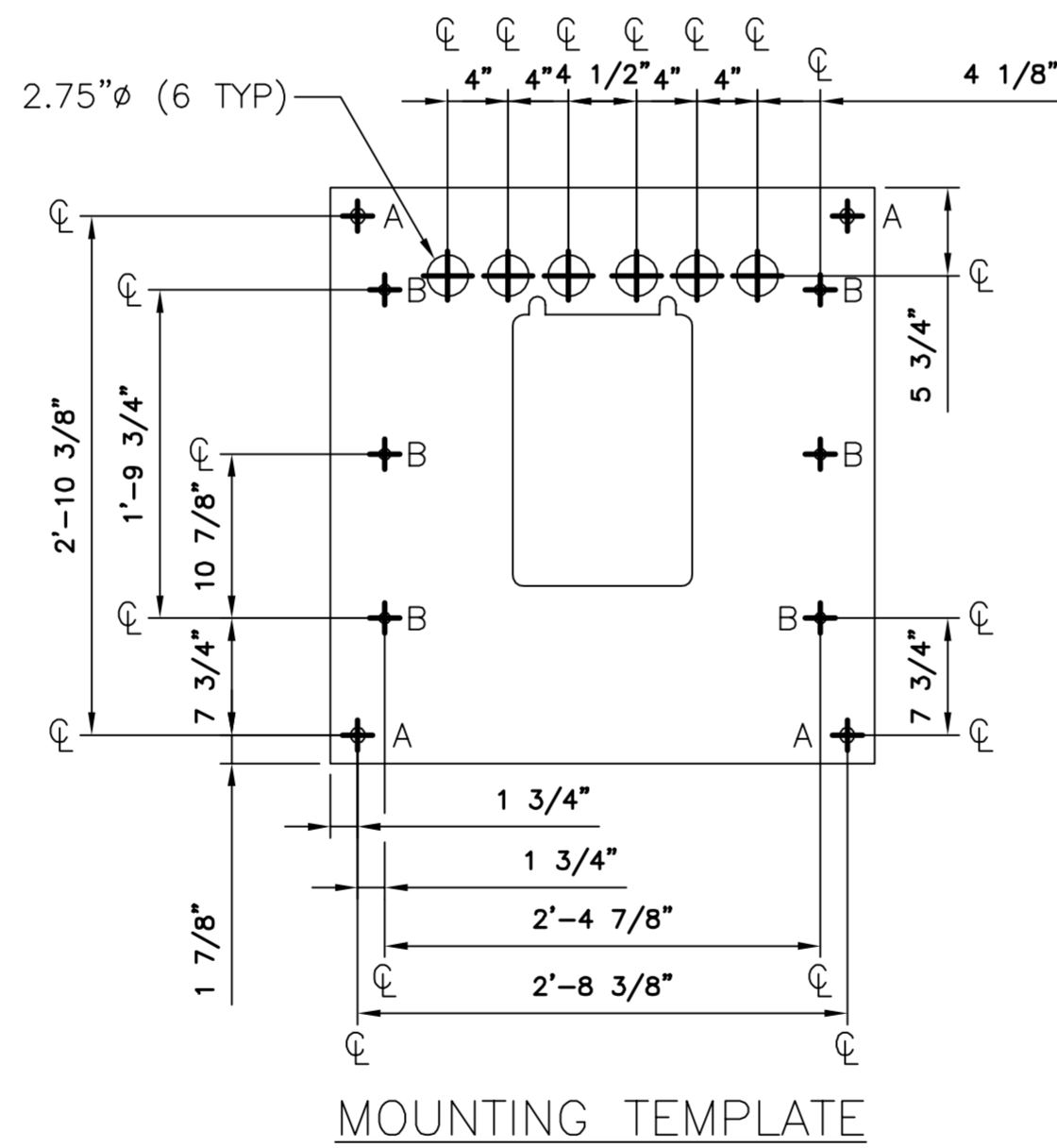

MOUNTING TEMPLATE

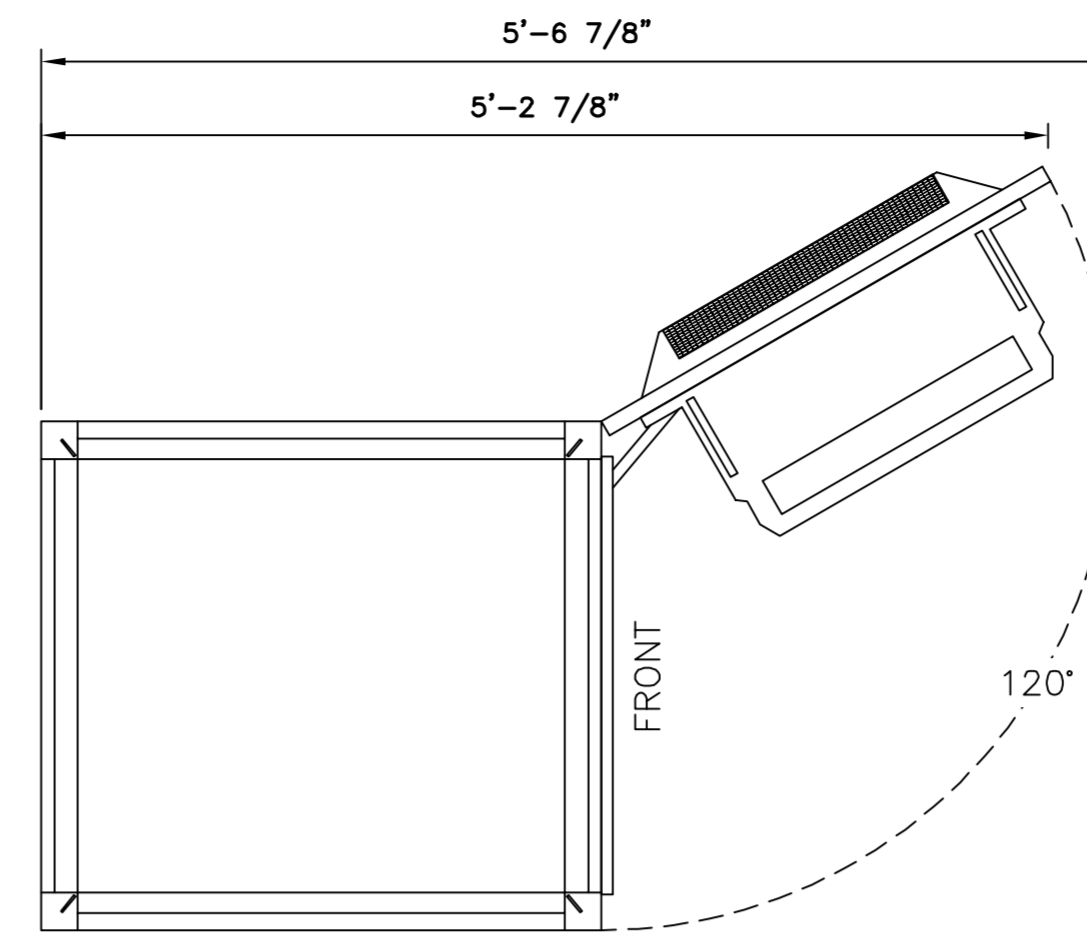

TOP VIEW

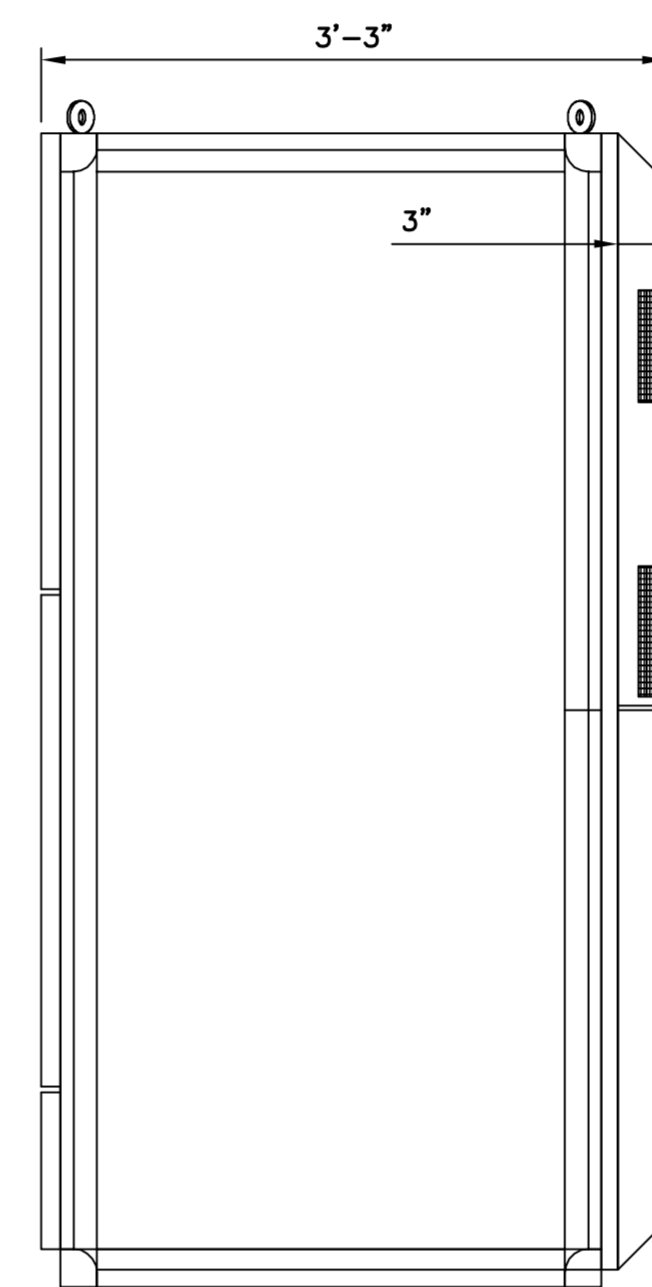

LEFT SIDE VIEW

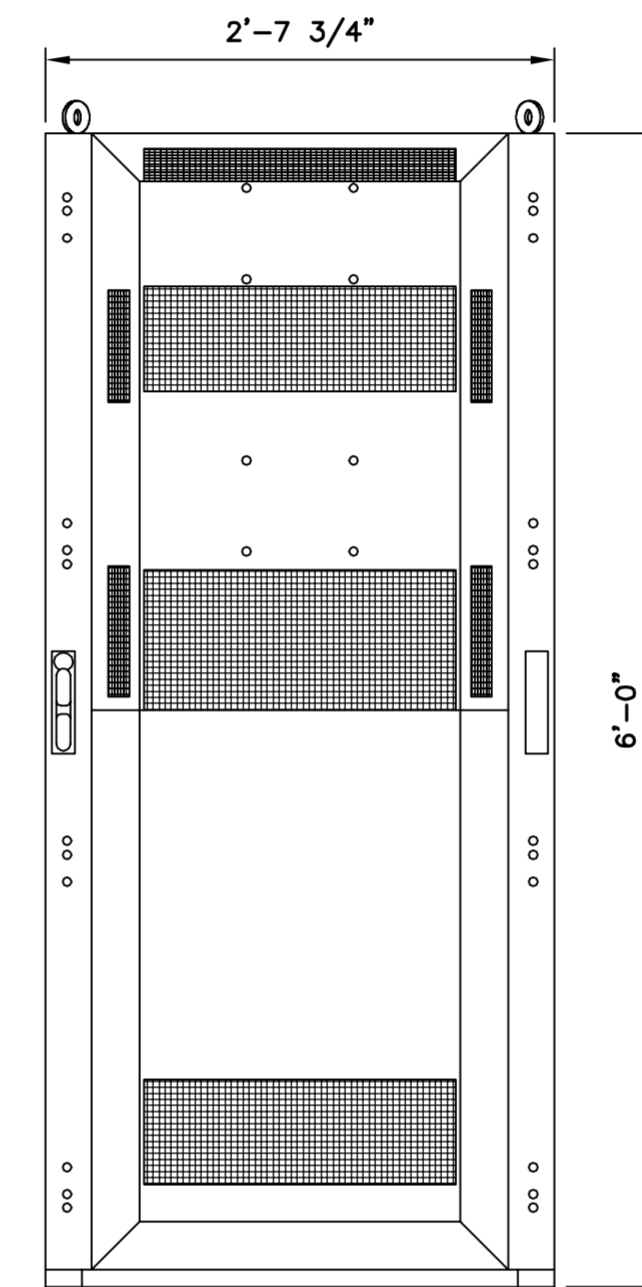

FRONT VIEW



OPTIONAL PLINTH

AT&T No. NEQ.15917
TECHNICAL SPECIFICATIONS

DC POWER SYSTEM FEATURES
 NOMINAL SYSTEM VOLTAGE -48VDC OR +24VDC
 CONTROL MICROPROCESSOR (ACU+)

RATED OUTPUT CAPACITY - MAXIMUM CONFIGURATION
 SYSTEM 550 AMPS AT -48VDC PLUS REDUNDANCY
 400 AMPS AT +24VDC PLUS REDUNDANCY
 RECTIFIER 2000 WATTS (41.7A)
 CONVERTER 1200 WATTS (50A), -48VDC TO +24VDC
 DISTRIBUTION PANEL (TOP) WIRED FOR (16) +24V AND (13) -48V BULLET POSITIONS
 (BOTTOM) (30) -48V BULLET POSITIONS

ENVIRONMENTAL
 OPERATING TEMPERATURE -40°F TO 115°F (-40°C TO 46°C) CONTINUOUS OPERATION
 HUMIDITY 0% TO 95% RELATIVE HUMIDITY, NON-CONDENSING

NEMA ENCLOSURE 3R

THERMAL SOLUTIONS
 POWER CHAMBER 2500 WATT DOOR-MOUNTED HEAT EXCHANGER, 2RU AVAILABLE SPACE FOR SURGE PROTECTION FAN COOLED, FRESH AIR VENTILATION, HOLDS UP TO (3) BATTERY STRINGS

BATTERY CHAMBER

EQUIPMENT
 GROUND BAR 10 POSITIONS
 TERMINAL BLOCK 12-POSITION PHOENIX ALARM BLOCK, 32-POSITION PHOENIX ALARM BUNCHING BLOCK

SAFETY
 DC POWER SYSTEM UL 1801 LISTED (US & CANADA), NEBS LEVEL 3
 ENCLOSURE GR-487, UL 60950, AND SEISMIC ZONE 4 COMPLIANT

WEIGHT
 OUTDOOR NetSure™ 512 816lbs (W/O BATTERIES)
 2300lbs (W/GNB BATTERIES)
 PLINTH TBD

CLEARANCES
 FRONT 36"
 LEFT AND RIGHT 0"
 REAR 12"

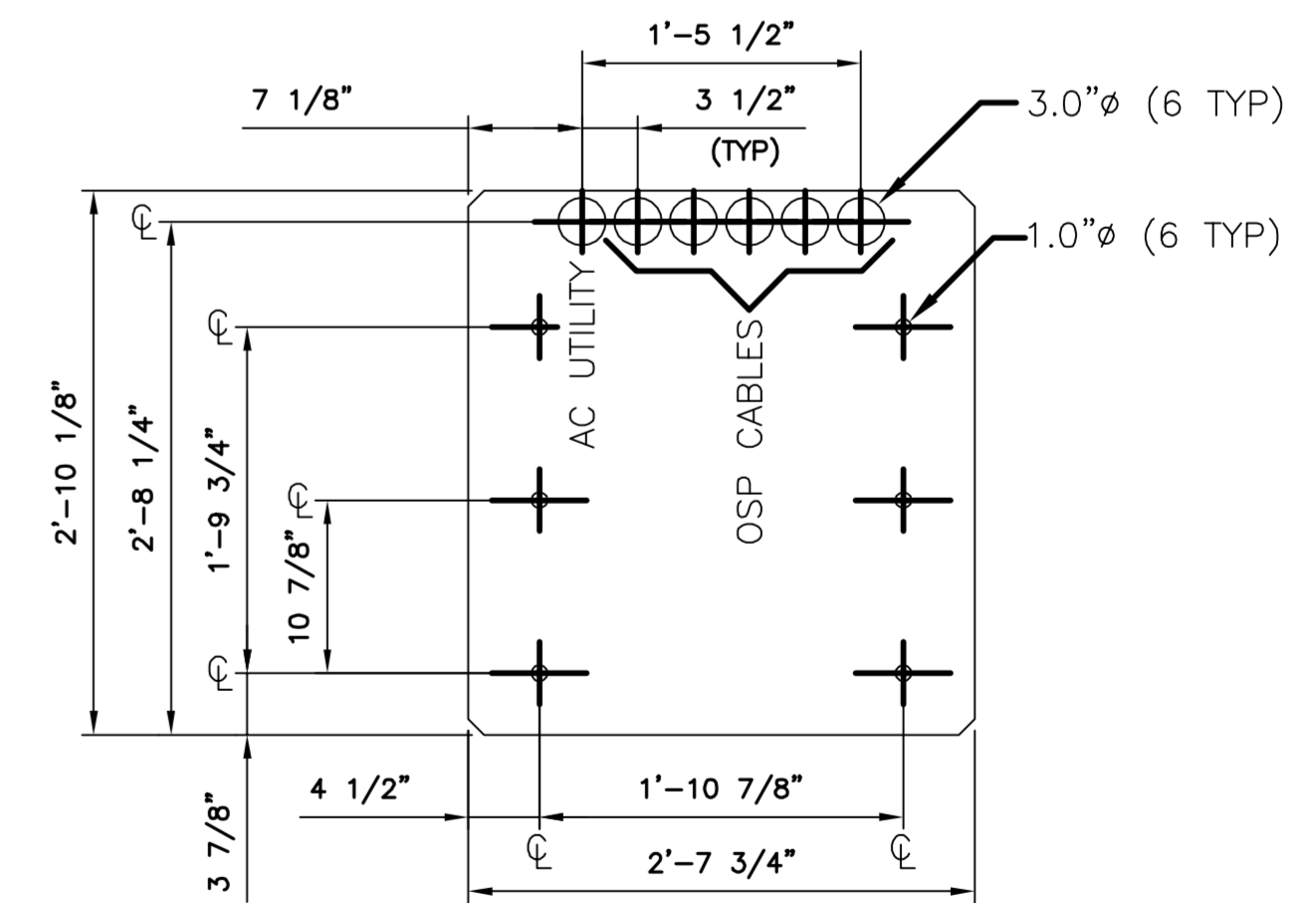

MOUNTING TEMPLATE

1 EMERSON NETSURE 721 -48V DC BATTERY RACK
 C-5 SCALE: 1" = 1'-0"

2 EMERSON NETSURE 7100 -48V DC POWER SYSTEM
 C-5 SCALE: 1" = 1'-0"

REV.	DATE	BY	CHK'D	DESCRIPTION
2	05/21/19	TJL		CONSTRUCTION DRAWINGS - ISSUED FOR CONSTRUCTION
1	05/02/19	KAWUR		CONSTRUCTION DRAWINGS - ISSUED FOR CONSTRUCTION
0	04/26/19	TJL		CONSTRUCTION DRAWINGS - ISSUED FOR CONSTRUCTION

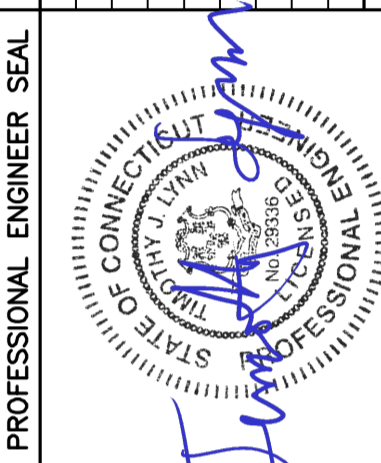

CENTEK engineering
 Centered on Solutions™
 (203) 488-0360
 (203) 488-8387 Fax
 632 North Branford Road
 Branford, CT 06405
 www.CentekEng.com

AT&T MOBILITY
 WIRELESS COMMUNICATIONS FACILITY
NORWALK CENTER
 CT5046 - LTE 3C/4C/5C
 1 WILL RUSS COURT
 NORWALK, CT 06850

DATE: 09/26/18
 SCALE: AS NOTED
 JOB NO. 18000.55

BATTERY RACK
 AND DC POWER
 SYSTEM DETAILS

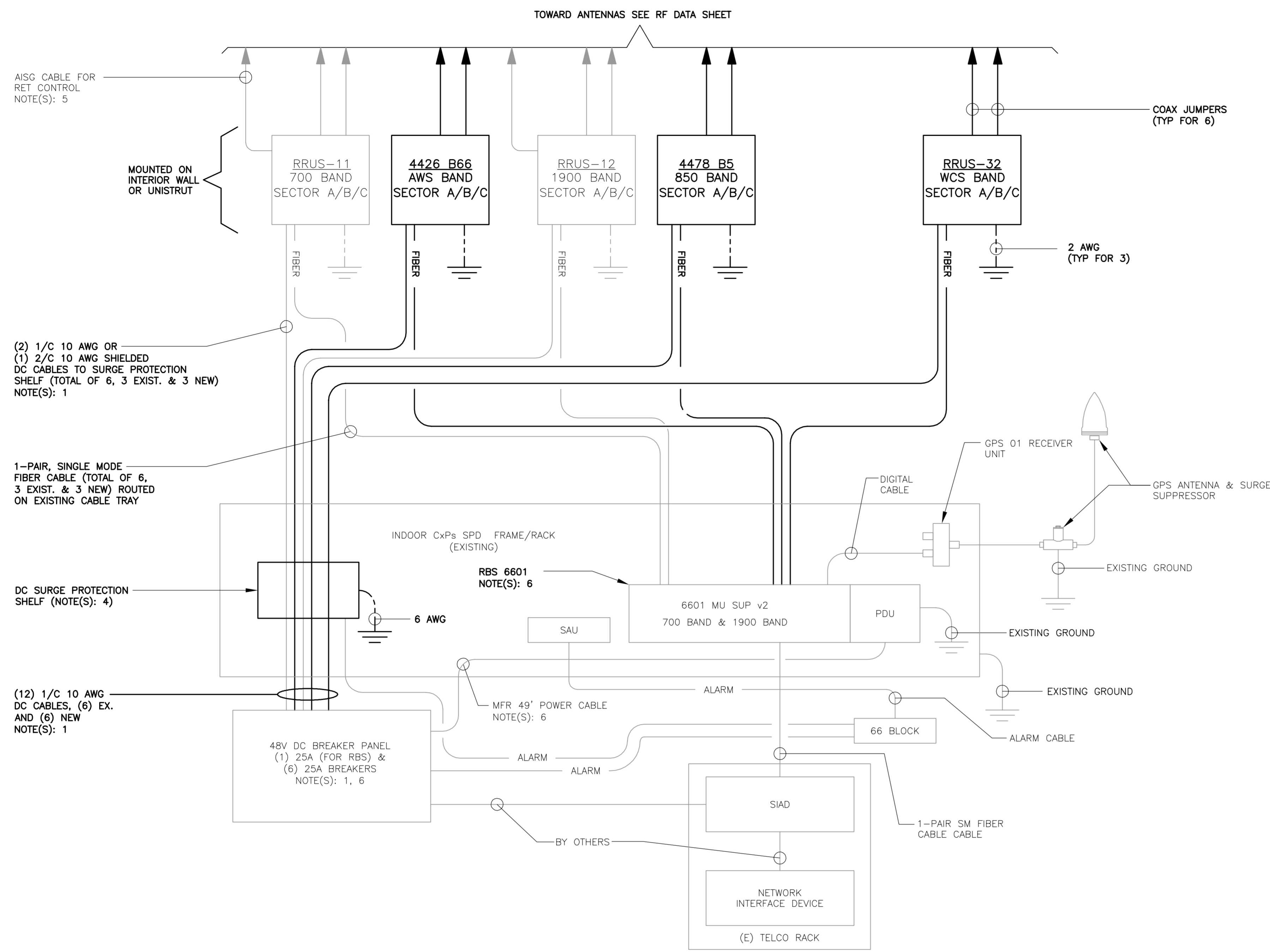

SCHEMATIC DIAGRAM NOTES:

- BREAKERS TO BE TAGGED AND LOCKED OUT. A 20A (MIN.) OR 30A (MAX.) BREAKER FOR RRUS MAY BE SUBSTITUTED FOR THE RECOMMENDED 25A BREAKER. SIZE 12 CONDUCTORS MAY BE USED ONLY WITH 20A BREAKERS.
- LEAVE COILED AND PROTECTED UNTIL TERMINATED.
- DC AND FIBER CABLE SHALL BE ROUTED WITH THE EXISTING COAX CABLE.
- DC SURGE PROTECTION SHELF SHALL BE RAYCAP DCx-48-60-RM.
- FIBER & DC DISTRIBUTION BOX W/DC SURGE PROTECTION SHALL BE RAYCAP DC6-48-60-18-8F.
- SUPPORT FIBER & DC POWER CABLES WITH SNAP-IN HANGERS SPACED NO GREATER THAN 3 FEET APART ON TOWER. SUPPORT FIBER AND DC POWER CABLES INSIDE MONOPOLE WITH CABLE HOISTING GRIPS AT 250 FT MAXIMUM INTERVALS. DRESS CABLES TO PREVENT CONTACT WITH ENTRANCE AND EXIT OPENINGS.
- CONDUIT TO BE USED ON A TOWER IF THE RRU IS MORE THAN 10' FROM THE DISTRIBUTION UNITS. MAX CABLE LENGTH IS 16 FEET.
- SINGLE-CONDUCTOR DC POWER CABLES SHALL BE TELCOFLEX® OR KS24194", COPPER, UL LISTED RHH NON-HALOGEN, LOW SMOKE WITH BRAIDED COVER, TYPE TC (1/0 AND LARGER). UNLESS OTHERWISE NOTED, STRANDING SHALL BE CLASS B (TYPE III) FOR CABLES SIZES 14, 12 & 10 AWG AND CLASS I (TYPE IV) FOR SIZES 8 AWG AND LARGER. CABLES SHALL BE COLOR CODED RED FOR +24V, BLUE FOR -48V AND GRAY FOR 24V AND 48V RETURN CONDUCTORS. MULTI-CONDUCTOR DC POWER CABLES SHALL BE COPPER, CLASS B STRANDING WITH FLAME RETARDANT PVC JACKET, TYPE TC, UL LISTED FOR 90°C DRY/75°C WET INSTALLATION.
- GROUNDING WIRES SHALL BE COPPER. GREEN THHN/THWN UL LISTED FOR 90°C DRY/75°C WET INSTALLATION. MINIMUM SIZE IS 6 AWG UNLESS NOTED OTHERWISE.
- FIBER OPTIC CABLES SHALL BE INSTALLED IN FLEXIBLE CONDUIT AS SCOPED BY MARKET.
- RET CONTROL FROM THE RRU IS AN OPTIONAL METHOD OF CONNECTION. REFER TO RF DATA SHEET FOR APPLICABILITY.
- RBS 6601 VARIANT 2 REQUIRES A 25A BREAKER AND 10 AWG (MIN.) CONDUCTORS. REPLACE EXISTING 15A OR 20A BREAKERS AND 12 AWG CONDUCTORS WHEN UPGRADING AN EXISTING RBS 6601 VARIANT 1.

1 SCHEMATIC DIAGRAM
E-1 NOT TO SCALE

ELECTRICAL NOTES

- PRIOR TO START OF CONSTRUCTION CONTRACTOR SHALL COORDINATE WITH OWNER FOR ALL CONSTRUCTION STANDARDS AND SPECIFICATIONS, AND ALL MANUFACTURER DOCUMENTATION FOR ALL EQUIPMENT TO BE INSTALLED.
- INSTALL ALL EQUIPMENT IN ACCORDANCE WITH LOCAL BUILDING CODE, NATIONAL ELECTRIC CODE, OWNER AND MANUFACTURER'S SPECIFICATIONS.
- CONNECT ALL NEW EQUIPMENT TO EXISTING TELCO AS REQUIRED BY MANUFACTURER.
- MAINTAIN ALL CLEARANCES REQUIRED BY NEC AND EQUIPMENT MANUFACTURER.
- PRIOR TO INSTALLATION CONTRACTOR SHALL MEASURE EXISTING ELECTRICAL LOAD AND VERIFY EXISTING AVAILABLE CAPACITY FOR PROPOSED INSTALLATION. IF INADEQUATE CAPACITY IS AVAILABLE, CONTRACTOR SHALL COORDINATE WITH LOCAL ELECTRIC UTILITY COMPANY TO UPGRADE EXISTING ELECTRIC SERVICE.
- CONTRACTOR SHALL INSPECT EXISTING GROUNDING AND LIGHTNING PROTECTION SYSTEM AND ENSURE THAT IT IS IN COMPLIANCE WITH NEC, AND SITE OWNER'S SPECIFICATIONS. THE RESULTS OF THIS INSPECTION SHALL BE PRESENTED TO OWNERS REPRESENTATIVE, AND ANY DEFICIENCIES SHALL BE CORRECTED.
- ALL TRANSMISSION TOWER SITES CONTAIN AN EXTENSIVE BURIED GROUNDING SYSTEM. ALL GROUNDING WORK MUST BE COORDINATED WITH, AND APPROVED BY, THE TOWER OWNER'S SITE REPRESENTATIVE. ALL OF THE TOWER OWNER'S SPECIFICATIONS MUST BE STRICTLY FOLLOWED.
- PROVIDE AND INSTALL GROUND KITS FOR ALL NEW COAXIAL CABLES AND BOND TO EXISTING OWNERS GROUNDING SYSTEM PER OWNERS SPECIFICATIONS AND NEC.
- ALL CONDUCTORS SHALL BE TYPE THWN (INT. APPLICATION) AND XHHW (EXT. APPLICATION), 75 DEGREE C, 600 VOLT INSULATION, SOFT ANNEALED STRANDED COPPER. #10 AWG AND SMALLER SHALL BE SPLICED USING ACCEPTABLE SOLDERLESS PRESSURE CONNECTORS. #8 AWG AND LARGER SHALL BE SPLICED USING COMPRESSION SPLIT-BOLT TYPE CONNECTORS, #12 AWG SHALL BE THE MINIMUM SIZE CONDUCTOR FOR LINE VOLTAGE BRANCH CIRCUITS. REFER TO PANEL SCHEDULE FOR BRANCH CIRCUIT CONDUCTOR SIZE(S). CONDUCTORS SHALL BE COLOR CODED FOR CONSISTENT PHASE IDENTIFICATION.
- MINIMUM BENDING RADIUS FOR CONDUCTORS SHALL BE 12 TIMES THE LARGEST DIAMETER OF BRANCH CIRCUIT CONDUCTOR.
- THE ENTIRE ELECTRICAL INSTALLATION SHALL BE MADE IN STRICT ACCORDANCE WITH ALL LOCAL, STATE AND NATIONAL CODES AND REGULATIONS WHICH MAY APPLY AND NOTHING IN THE DRAWINGS OR SPECIFICATIONS SHALL BE INTERPRETED AS AN INFRINGEMENT OF SUCH CODES OR REGULATIONS.
- THE ELECTRICAL CONTRACTOR IS TO BE RESPONSIBLE FOR THE COMPLETE INSTALLATION AND COORDINATION OF THE ENTIRE ELECTRICAL SERVICE. ALL ACTIVITIES TO BE COORDINATED THROUGH OWNER'S REPRESENTATIVE, DESIGN ENGINEER AND OTHER AUTHORITIES HAVING JURISDICTION OF TRADES.
- THE CONTRACTOR SHALL BE RESPONSIBLE FOR OBTAINING ALL PERMITS AND PAY ALL FEES AS MAY BE REQUIRED FOR THE ELECTRICAL WORK AND FOR SCHEDULING OF ALL INSPECTIONS AS MAY BE REQUIRED BY THE LOCAL AUTHORITY.
- THE CONTRACTOR SHALL BE RESPONSIBLE FOR COORDINATION WITH THE SITE AND/OR BUILDING OWNER FOR NEW AND/OR DEMOLITION WORK INVOLVED.
- THE CONTRACTOR SHALL GUARANTEE ALL NEW WORK FOR A PERIOD OF ONE YEAR FROM THE ACCEPTANCE DATE BY THE OWNER. THE CONTRACTOR SHALL BE RESPONSIBLE FOR OBTAINING WARRANTIES FROM ALL EQUIPMENT MANUFACTURERS FOR SUBMISSION TO THE OWNER.
- DRAWINGS INDICATE GENERAL ARRANGEMENT OF WORK INCLUDED IN CONTRACT. CONTRACTOR SHALL WITHOUT EXTRA CHARGE, MAKE MODIFICATIONS TO THE LAYOUT OF THE WORK TO PREVENT CONFLICT WITH WORK OF OTHER TRADES AND FOR THE PROPER INSTALLATION OF WORK. CHECK ALL DRAWINGS AND VISIT JOB SITE TO VERIFY SPACE AND TYPE OF EXISTING CONDITIONS IN WHICH WORK WILL BE DONE, PRIOR TO SUBMITTAL OF BID.
- ALL NON-CURRENT CARRYING PARTS OF THE ELECTRICAL AND TELEPHONE CONDUIT SYSTEMS SHALL BE MECHANICALLY AND ELECTRICALLY CONNECTED TO PROVIDE AN INDEPENDENT RETURN PATH TO THE EQUIPMENT GROUNDING SOURCES.
- GROUNDING SYSTEM WILL BE IN ACCORDANCE WITH THE LATEST ACCEPTABLE EDITION OF THE NATIONAL ELECTRICAL CODE AND REQUIREMENTS PER LOCAL INSPECTOR HAVING JURISDICTION.
- EACH EQUIPMENT GROUND CONDUCTOR SHALL BE SIZED IN ACCORDANCE WITH THE N.E.C. ARTICLE 250-122. (MIN. #12 AWG).
- CONTRACTOR SHALL PROVIDE A CELLULAR GROUNDING SYSTEM WITH THE MAXIMUM AC RESISTANCE TO GROUND OF 5 OHM BETWEEN ANY POINT ON THE GROUNDING SYSTEM AS MEASURED BY 3-POINT GROUNDING TEST. (REFER TO SECTION 16960).

TESTS BY INDEPENDENT ELECTRICAL TESTING FIRM

- CONTRACTOR SHALL RETAIN THE SERVICES OF A LOCAL INDEPENDENT ELECTRICAL TESTING FIRM (WITH MINIMUM 5 YEARS COMMERCIAL EXPERIENCE IN THE ELECTRICAL TESTING INDUSTRY) AS SPECIFIED BY OWNER TO PERFORM:
 - TEST 1: RESISTANCE TO GROUND TEST ON THE CELLULAR GROUNDING SYSTEM. THE TESTING FIRM SHALL INCLUDE THE FOLLOWING INFORMATION WITH THE REPORT:
 - TESTING PROCEDURE INCLUDING THE MAKE AND MODEL OF TEST EQUIPMENT.
 - CERTIFICATION OF TESTING EQUIPMENT CALIBRATION WITHIN SIX (6) MONTHS OF DATE OF TESTING. INCLUDE CERTIFICATION LAB ADDRESS AND TELEPHONE NUMBER.
 - GRAPHICAL DESCRIPTION OF TESTING METHOD ACTUALLY IMPLEMENTED.
- TESTING SHALL BE PERFORMED IN THE PRESENCE AND TO THE SATISFACTION OF OWNERS CONSTRUCTION REPRESENTATIVE. TESTING DATA SHALL BE INITIALED AND DATED BY THE CONSTRUCTION AND INCLUDED WITH THE WRITTEN REPORT/ANALYSIS.
- THE CONTRACTOR SHALL FORWARD SIX (6) COPIES OF THE INDEPENDENT ELECTRICAL TESTING FIRM REPORT/ANALYSIS TO ENGINEER A MINIMUM OF TEN (10) WORKING DAYS PRIOR TO THE JOB TURNOVER.
- CONTRACTOR TO PROVIDE A MINIMUM OF ONE (1) WEEK NOTICE TO OWNER AND ENGINEER FOR ALL TESTS REQUIRING WITNESSING.

REV.	DATE	BY	CHK'D	DESCRIPTION
2	05/21/19	TJL		CONSTRUCTION DRAWINGS - ISSUED FOR CONSTRUCTION
1	05/02/19	KAWUR		CONSTRUCTION DRAWINGS - ISSUED FOR CONSTRUCTION
0	04/26/19	TJL		ISSUED FOR CONSTRUCTION

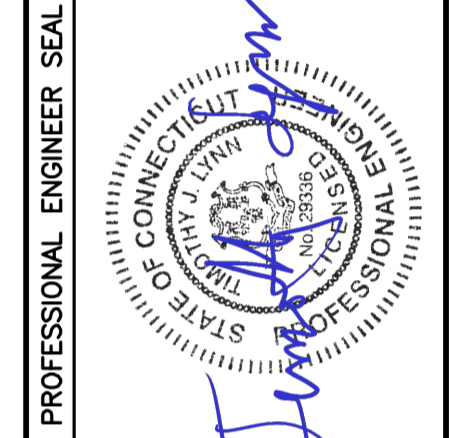

CENTEX engineering
 Centered on Solutions™
 (203) 488-0360
 (203) 488-8387 Fax
 63-2 North Branford Road
 Branford, CT 06405
 www.CentexEng.com

AT&T MOBILITY
 WIRELESS COMMUNICATIONS FACILITY
NORWALK CENTER
 CT5046 - LTE 3C/4C/5C
 1 WILL RUSS COURT
 NORWALK, CT 06850

DATE: 09/26/18
 SCALE: AS NOTED
 JOB NO. 18000.55

SCHEMATIC
 DIAGRAM
 AND NOTES

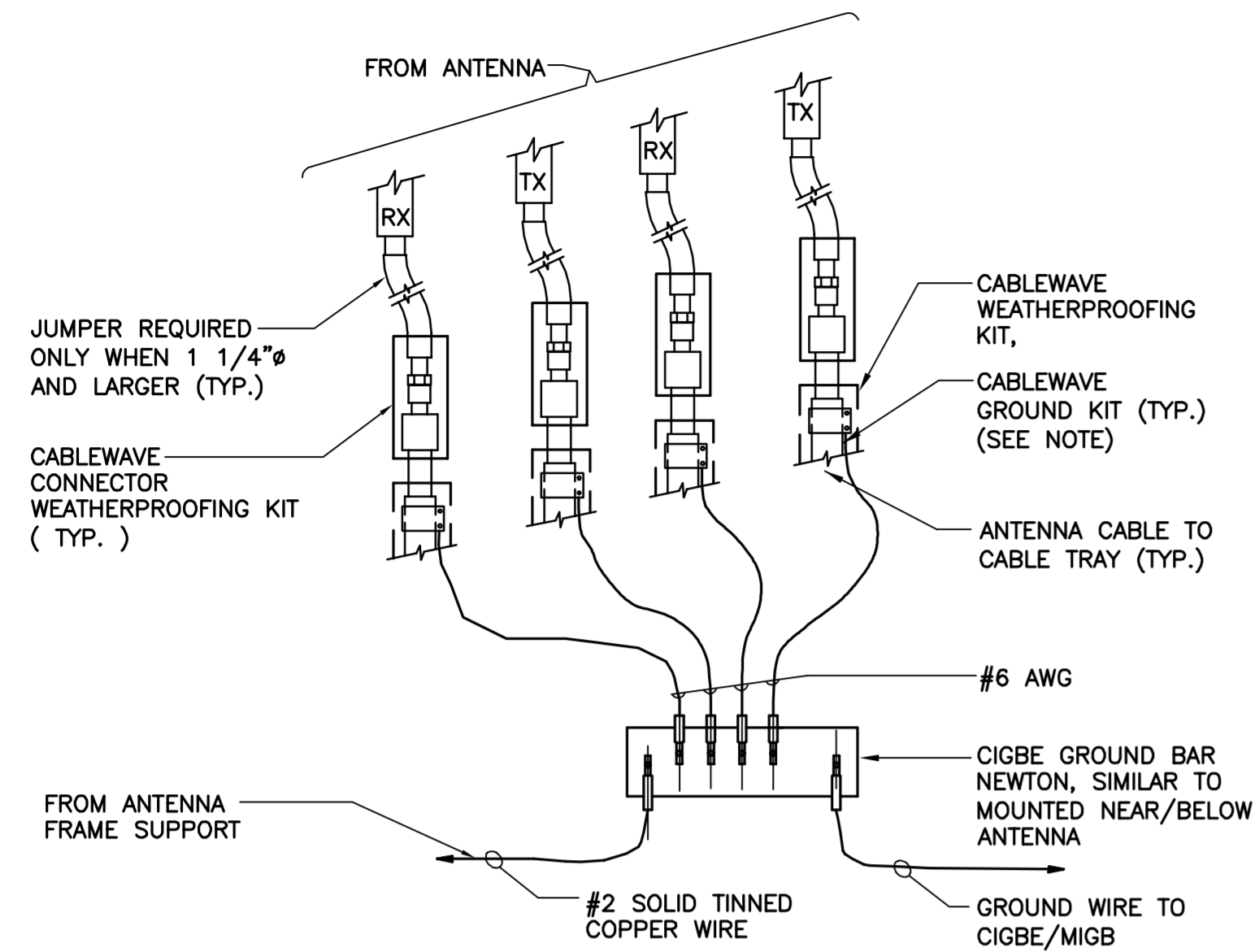

NOTE:

- DO NOT INSTALL CABLE GROUND KIT AT A BEND AND ALWAYS DIRECT GROUND WIRE DOWN TO CIGBE

1 CONNECTION OF GROUND WIRES TO GROUND BAR
E-3 NOT TO SCALE

EACH RRH CABINET SHALL BE GROUNDED IN THE FOLLOWING MANNER:
1. AT TOP OF THE CABINET
2. AT RIGHT SIDE OF THE CABINET.

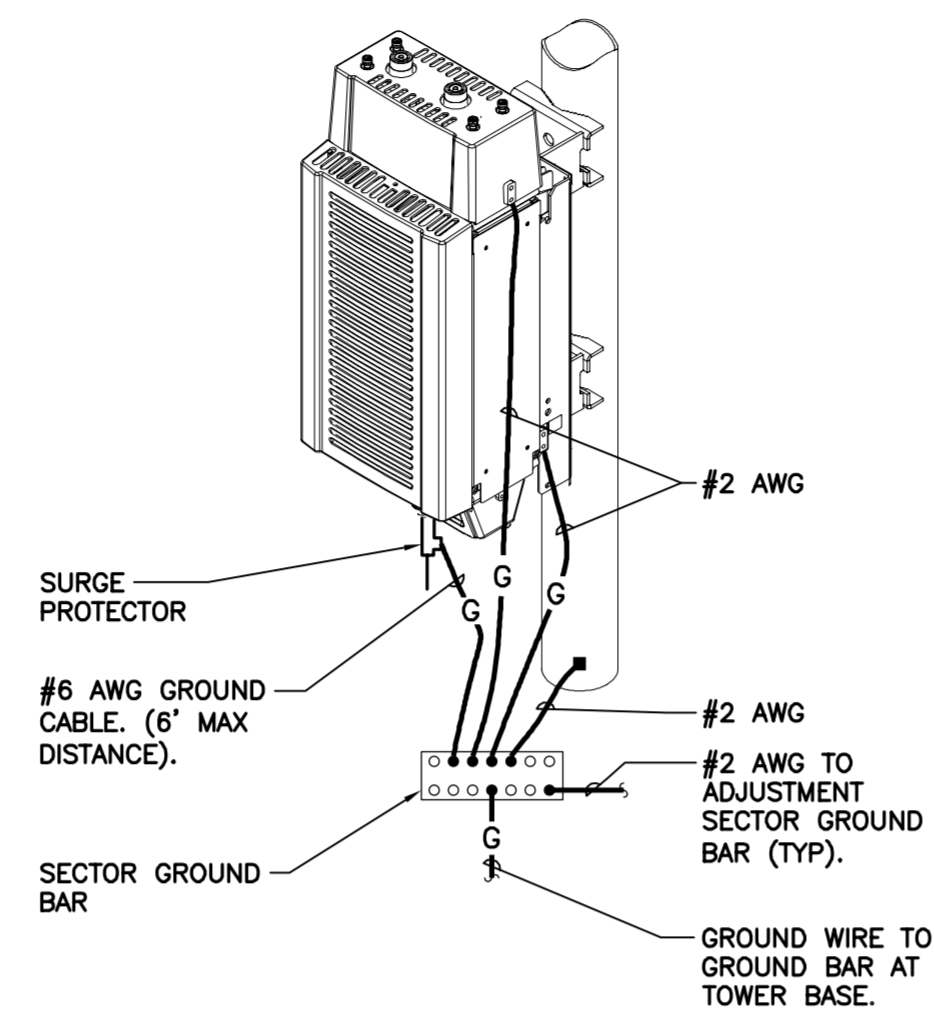

2 RRU POLE MOUNT GROUNING
E-3 NOT TO SCALE

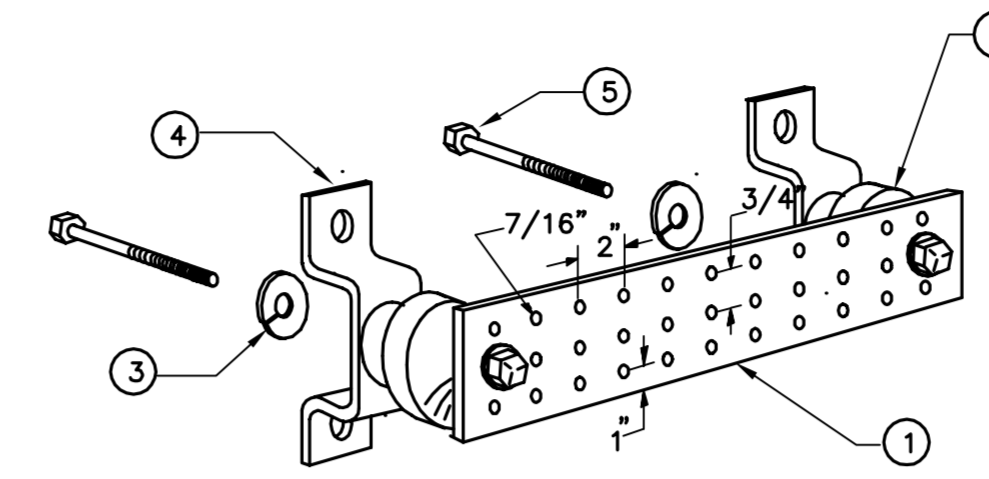

LEGEND

- TINNED COPPER GROUND BAR, 1/4" x 4" x 20", NEWTON INSTRUMENT CO. HOLE CENTERS TO MATCH NEMA DOUBLE LUG.
- INSULATORS, NEWTON INSTRUMENT CAT. NO. 2. 3061-4.
3. 5/8" LOCK WASHERS, NEWTON INSTRUMENT CO. CAT. NO. 3015-8.
- WALL MOUNTING BRACKET, NEWTON INSTRUMENT CO. CAT. NO. A-6056.
- STAINLESS STEEL SECURITY SCREWS.

3 GROUND BAR DETAIL
E-3 NOT TO SCALE

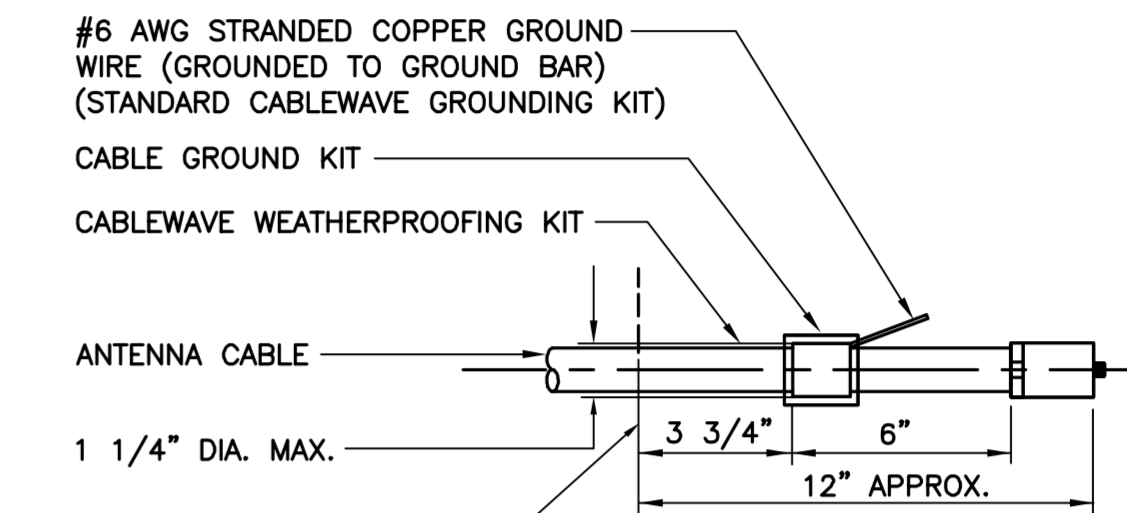

NOTE:

- DO NOT INSTALL CABLE GROUND KIT AT A BEND AND ALWAYS DIRECT GROUND WIRE DOWN TO GROUND BAR.

4 ANTENNA CABLE GROUNING DETAIL
E-3 NOT TO SCALE

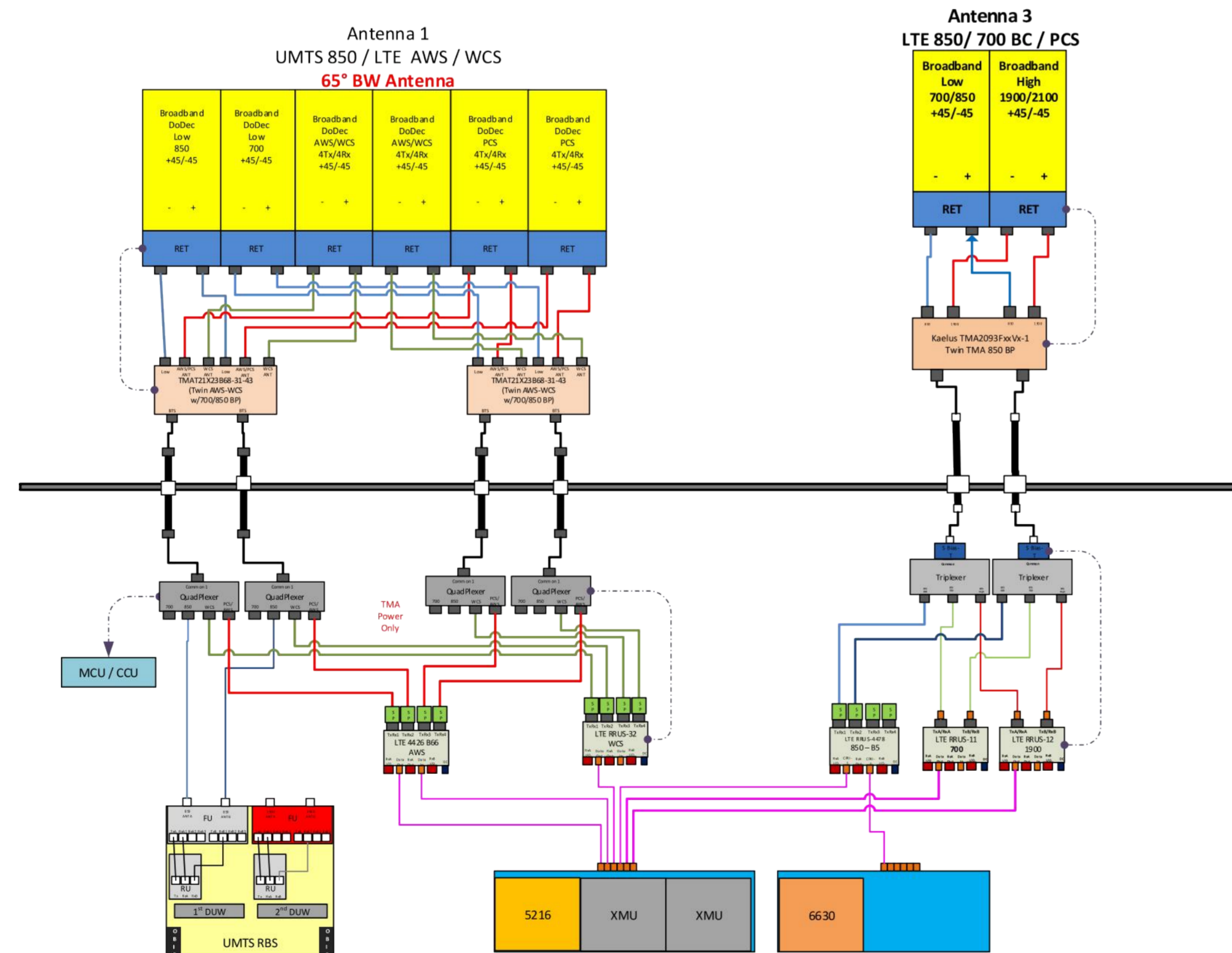

5 RF PLUMBING DIAGRAM
E-3 NOT TO SCALE

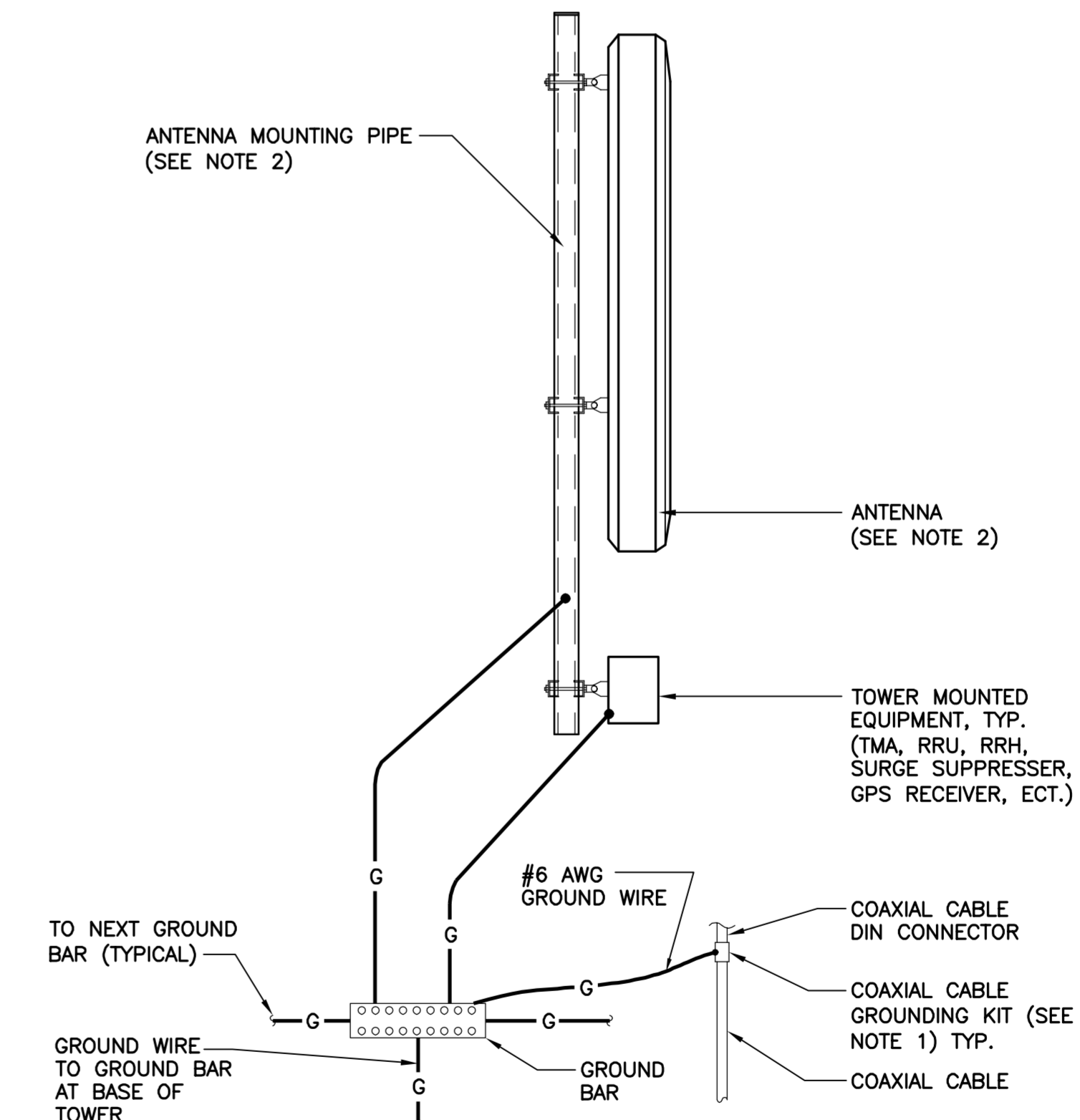

NOTES:

- BOND COAXIAL CABLE GROUND KITS TO EACH OWNER'S GROUND BAR ALONG ENTIRE COAX RUN FROM ANTENNA TO SHELTER.
- BOND ALL EQUIPMENT TO GROUND PER NEC AND MANUFACTURERS SPECIFICATIONS.
- DETAIL IS TYPICAL FOR ALL ANTENNA SECTORS, INCLUDING GPS ANTENNA.

6 TYPICAL ANTENNA GROUNING DETAIL
E-3 NOT TO SCALE

CONSTRUCTION DRAWINGS - ISSUED FOR CONSTRUCTION	DND	TJL	05/21/19
CONSTRUCTION DRAWINGS - ISSUED FOR CONSTRUCTION	DND	KAWUR	05/02/19
CONSTRUCTION DRAWINGS - ISSUED FOR CONSTRUCTION	DND	TJL	04/26/19
DATE	DRAWN BY/CHK'D BY/DESCRIPTION		

PROFESSIONAL ENGINEER SEAL

at&t

EMPIRE telecom

CENTEK engineering
Centered on Solutions™
(203) 488-0360
(203) 488-8387 Fax
63.2 North Branford Road
Branford, CT 06405
www.CentekEng.com

AT&T MOBILITY
WIRELESS COMMUNICATIONS FACILITY
NORWALK CENTER
CT5046 - LTE 3C/4C/5C
1 WILL RUSS COURT
NORWALK, CT 06850

DATE: 09/26/18
SCALE: AS NOTED
JOB NO. 18000.55

TYPICAL ELECTRICAL DETAILS

E-3
Sheet No. 10 of 10