

**U.S. Postal Service™  
CERTIFIED MAIL® RECEIPT** CT1015  
Domestic Mail Only

For delivery information, visit our website at [www.usps.com](http://www.usps.com)®.  
MERIDEN, CT 06450

7016 2140 0000 9458 6313

Certified Mail Fee \$3.45  
Extra Services & Fees (check box, add fee as appropriate)  
 Return Receipt (hardcopy) \$0.00  
 Return Receipt (electronic) \$0.00  
 Certified Mail Restricted Delivery \$0.00  
 Adult Signature Required \$0.00  
 Adult Signature Restricted Delivery \$0.00  
 Postage \$1.63  
**Total Postage and Fees \$7.83**

Postmark Here  
MAR 02 2018  
BILERICA POST OFFICE  
BILERICA MA 01821

Sent To  
Kevin Scarpati  
Mayor, City of Meriden  
Meriden City Hall  
142 East Main Street  
Meriden, CT 06450

PS Form 3800, April 2015 PSN 7530-02-000-9047 See Reverse for Instructions

**U.S. Postal Service™  
CERTIFIED MAIL® RECEIPT** CT1015  
Domestic Mail Only

For delivery information, visit our website at [www.usps.com](http://www.usps.com)®.  
MERIDEN, CT 06450

7016 2140 0000 9458 6313

Certified Mail Fee \$3.45  
Extra Services & Fees (check box, add fee as appropriate)  
 Return Receipt (hardcopy) \$0.00  
 Return Receipt (electronic) \$0.00  
 Certified Mail Restricted Delivery \$0.00  
 Adult Signature Required \$0.00  
 Adult Signature Restricted Delivery \$0.00  
 Postage \$1.63  
**Total Postage and Fees \$7.83**

Postmark Here  
MAR 02 2018  
BILERICA POST OFFICE  
BILERICA MA 01821

Sent To  
Ken Morgan  
Interim City Manager  
Meriden City Hall  
142 East Main Street  
Meriden, CT 06450

PS Form 3800, April 2015 PSN 7530-02-000-9047 See Reverse for Instructions

**U.S. Postal Service™  
CERTIFIED MAIL® RECEIPT** CT1015  
Domestic Mail Only

For delivery information, visit our website at [www.usps.com](http://www.usps.com)®.  
MERIDEN, CT 06450

7016 2140 0000 9458 6320

Certified Mail Fee \$3.45  
Extra Services & Fees (check box, add fee as appropriate)  
 Return Receipt (hardcopy) \$0.00  
 Return Receipt (electronic) \$0.00  
 Certified Mail Restricted Delivery \$0.00  
 Adult Signature Required \$0.00  
 Adult Signature Restricted Delivery \$0.00  
 Postage \$1.63  
**Total Postage and Fees \$7.83**

Postmark Here  
MAR 02 2018  
BILERICA POST OFFICE  
BILERICA MA 01821

Sent To  
Bob Seale  
Director, Development and Enforcement  
Meriden City Hall  
142 East Main Street  
Meriden, CT 06450

PS Form 3800, April 2015 PSN 7530-02-000-9047 See Reverse for Instructions

**U.S. Postal Service™  
CERTIFIED MAIL® RECEIPT** CT1015  
Domestic Mail Only

For delivery information, visit our website at [www.usps.com](http://www.usps.com)®.  
MERIDEN, CT 06450

7016 2140 0000 9458 6344

Certified Mail Fee \$3.45  
Extra Services & Fees (check box, add fee as appropriate)  
 Return Receipt (hardcopy) \$0.00  
 Return Receipt (electronic) \$0.00  
 Certified Mail Restricted Delivery \$0.00  
 Adult Signature Required \$0.00  
 Adult Signature Restricted Delivery \$0.00  
 Postage \$1.63  
**Total Postage and Fees \$7.83**

Postmark Here  
MAR 02 2018  
BILERICA POST OFFICE  
BILERICA MA 01821

Sent To  
119 Empire Ave LLC  
1150 Old Colony Road  
Meriden, CT 06451-6301

PS Form 3800, April 2015 PSN 7530-02-000-9047 See Reverse for Instructions

**U.S. Postal Service™  
CERTIFIED MAIL® RECEIPT** CT1015  
Domestic Mail Only

For delivery information, visit our website at [www.usps.com](http://www.usps.com)®.  
CANONSBURG, PA 15317

7016 2140 0000 9458 6337

Certified Mail Fee \$3.45  
Extra Services & Fees (check box, add fee as appropriate)  
 Return Receipt (hardcopy) \$0.00  
 Return Receipt (electronic) \$0.00  
 Certified Mail Restricted Delivery \$0.00  
 Adult Signature Required \$0.00  
 Adult Signature Restricted Delivery \$0.00  
 Postage \$1.63  
**Total Postage and Fees \$7.83**

Postmark Here  
MAR 02 2018  
BILERICA POST OFFICE  
BILERICA MA 01821

Sent To  
Natalie Thompson  
Real Estate Specialist Land Management  
Crown Castle  
2000 Corporate Drive  
Canonsburg, PA 15317

PS Form 3800, April 2015 PSN 7530-02-000-9047 See Reverse for Instructions



**SENDER: COMPLETE THIS SECTION**

- Complete items 1, 2, and 3.
- Print your name and address on the reverse so that we can return the card to you.
- Attach this card to the back of the mailpiece, or on the front if space permits.

1. Article Addressed to:

Kevin Scarpati  
 Mayor, City of Meriden  
 Meriden City Hall  
 142 East Main Street  
 Meriden, CT 06450



9590 9402 1864 6104 9648 23

2. Article Number (Transfer from service label)

7016 2140 0000 9458 6306

PS Form 3811, July 2015 PSN 7530-02-000-9053

**COMPLETE THIS SECTION ON DELIVERY**

A. Signature

*Melanie L. Rivera*  Agent  
 Addressee

B. Received by (Printed Name)

Melanie L. Rivera

C. Date of Delivery

3-5

D. Is delivery address different from item 1?  Yes  
 If YES, enter delivery address below:  No

3. Service Type

- Adult Signature
- Adult Signature Restricted Delivery
- Certified Mail®
- Certified Mail Restricted Delivery
- Collect on Delivery
- Collect on Delivery Restricted Delivery
- Priority Mail Express®
- Registered Mail™
- Registered Mail Restrict Delivery
- Return Receipt for Merchandise
- Signature Confirmation™
- Signature Confirmation Restricted Delivery

**SENDER: COMPLETE THIS SECTION**

- Complete items 1, 2, and 3.
- Print your name and address on the reverse so that we can return the card to you.
- Attach this card to the back of the mailpiece, or on the front if space permits.

1. Article Addressed to:

Ken Morgan  
 Interim City Manager  
 Meriden City Hall  
 142 East Main Street  
 Meriden, CT 06450



9590 9402 1864 6104 9648 16

2. Article Number (Transfer from service label)

7016 2140 0000 9458 6313

PS Form 3811, July 2015 PSN 7530-02-000-9053

**COMPLETE THIS SECTION ON DELIVERY**

A. Signature

*Melanie L. Rivera*  Agent  
 Addressee

B. Received by (Printed Name)

Melanie L. Rivera

C. Date of Delivery

3-5

D. Is delivery address different from item 1?  Yes  
 If YES, enter delivery address below:  No

3. Service Type

- Adult Signature
- Adult Signature Restricted Delivery
- Certified Mail®
- Certified Mail Restricted Delivery
- Collect on Delivery
- Collect on Delivery Restricted Delivery
- Priority Mail Express®
- Registered Mail™
- Registered Mail Restrict Delivery
- Return Receipt for Merchandise
- Signature Confirmation™
- Signature Confirmation Restricted Delivery

**SENDER: COMPLETE THIS SECTION**

- Complete items 1, 2, and 3.
- Print your name and address on the reverse so that we can return the card to you.
- Attach this card to the back of the mailpiece, or on the front if space permits.

1. Article Addressed to:

Bob Seale  
 Director, Development and Enforcement  
 Meriden City Hall  
 142 East Main Street  
 Meriden, CT 06450



9590 9402 1864 6104 9648 09

2. Article Number (Transfer from service label)

7016 2140 0000 9458 6320

PS Form 3811, July 2015 PSN 7530-02-000-9053

**COMPLETE THIS SECTION ON DELIVERY**

A. Signature

*Melanie L. Rivera*  Agent  
 Addressee

B. Received by (Printed Name)

Melanie L. Rivera

C. Date of Delivery

3-5

D. Is delivery address different from item 1?  Yes  
 If YES, enter delivery address below:  No

3. Service Type

- Adult Signature
- Adult Signature Restricted Delivery
- Certified Mail®
- Certified Mail Restricted Delivery
- Collect on Delivery
- Collect on Delivery Restricted Delivery
- Priority Mail Express®
- Registered Mail™
- Registered Mail Restrict Delivery
- Return Receipt for Merchandise
- Signature Confirmation™
- Signature Confirmation Restricted Delivery



SENDER: COMPLETE THIS SECTION	COMPLETE THIS SECTION ON DELIVERY	
<ul style="list-style-type: none"> <li>Complete items 1, 2, and 3.</li> <li>Print your name and address on the reverse so that we can return the card to you.</li> <li>Attach this card to the back of the mailpiece, or on the front if space permits.</li> </ul>	<p>A. Signature <input checked="" type="checkbox"/> <i>Thomas Todd</i> <input type="checkbox"/> Agent <input type="checkbox"/> Addressee</p> <p>B. Received by (Printed Name) _____ C. Date of Delivery _____</p>	
<p>1. Article Addressed to:</p> <p>Natalie Thompson Real Estate Specialist – Land Management Crown Castle 2000 Corporate Drive Canonsburg, PA 15317</p>	<p>D. Is delivery address different from item 1? <input type="checkbox"/> Yes If YES, enter delivery address below: <input type="checkbox"/> No</p>	
 9590 9402 1864 6104 9647 93	<p>3. Service Type</p> <ul style="list-style-type: none"> <li><input type="checkbox"/> Adult Signature</li> <li><input type="checkbox"/> Adult Signature Restricted Delivery</li> <li><input type="checkbox"/> Certified Mail®</li> <li><input type="checkbox"/> Certified Mail Restricted Delivery</li> <li><input type="checkbox"/> Collect on Delivery</li> <li><input type="checkbox"/> Collect on Delivery Restricted Delivery</li> <li><input type="checkbox"/> Priority Mail Express®</li> <li><input type="checkbox"/> Registered Mail™</li> <li><input type="checkbox"/> Registered Mail Restricted Delivery</li> <li><input type="checkbox"/> Return Receipt for Merchandise</li> <li><input type="checkbox"/> Signature Confirmation™</li> <li><input type="checkbox"/> Signature Confirmation Restricted Delivery</li> </ul>	
<p>2. Article Number (Transfer from service label)</p> <p>7016 2140 0000 9458 6337</p>	<p>Restricted Delivery</p>	
PS Form 3811, July 2015 PSN 7530-02-000-9053		Domestic Return Receipt

SENDER: COMPLETE THIS SECTION	COMPLETE THIS SECTION ON DELIVERY	
<ul style="list-style-type: none"> <li>Complete items 1, 2, and 3.</li> <li>Print your name and address on the reverse so that we can return the card to you.</li> <li>Attach this card to the back of the mailpiece, or on the front if space permits.</li> </ul>	<p>A. Signature <input checked="" type="checkbox"/> <i>Paul Masse</i> <input type="checkbox"/> Agent <input type="checkbox"/> Addressee</p> <p>B. Received by (Printed Name) _____ C. Date of Delivery _____</p>	
<p>1. Article Addressed to:</p> <p>119 Empire Ave LLC <del>1150 Old Colony Road</del> Meriden, CT 06451-6301</p>	<p>D. Is delivery address different from item 1? <input checked="" type="checkbox"/> Yes If YES, enter delivery address below: <input type="checkbox"/> No</p> <p><i>119 Empire Ave Meriden ct 06450</i></p>	
 9590 9402 1864 6104 9647 86	<p>3. Service Type</p> <ul style="list-style-type: none"> <li><input type="checkbox"/> Adult Signature</li> <li><input type="checkbox"/> Adult Signature Restricted Delivery</li> <li><input type="checkbox"/> Certified Mail®</li> <li><input type="checkbox"/> Certified Mail Restricted Delivery</li> <li><input type="checkbox"/> Collect on Delivery</li> <li><input type="checkbox"/> Collect on Delivery Restricted Delivery</li> <li><input type="checkbox"/> Priority Mail Express®</li> <li><input type="checkbox"/> Registered Mail™</li> <li><input type="checkbox"/> Registered Mail Restricted Delivery</li> <li><input type="checkbox"/> Return Receipt for Merchandise</li> <li><input type="checkbox"/> Signature Confirmation™</li> <li><input type="checkbox"/> Signature Confirmation Restricted Delivery</li> </ul>	
<p>2. Article Number (Transfer from service label)</p> <p>7016 2140 0000 9458 6344</p>	<p>Restricted Delivery</p>	
PS Form 3811, July 2015 PSN 7530-02-000-9053		Domestic Return Receipt



March 2, 2018

Melanie A. Bachman  
Executive Director  
Connecticut Siting Council  
10 Franklin Street  
New Britain, CT 06051

Regarding: Notice of Exempt Modification – RRH Installation  
Property Address: 119 Empire Avenue, Meriden, CT 06450  
AT&T Site: CT1015/FA 10035234

Dear Ms. Bachman:

AT&T currently maintains a wireless telecommunications facility on an existing water tank at the above-referenced address, latitude 41.5730200, longitude -72.7791931. Said water tank is owned by 119 Empire Avenue, LLC.

AT&T desires to modify its existing telecommunications facility by adding (3) three remote-radio heads (“RRHs”). The centerline height of the existing antennas will remain the same.

Please accept this application as notification pursuant to R.C.S.A. §16-50j-73, for construction that constitutes an exempt modification pursuant to R.C.S.A. §16-50j-72 (b)(2). In accordance with R.C.S.A. §16-50j-73, a copy of this letter is being sent to a copy of this letter is being sent to Kevin Scarpati, Mayor of the City of Meriden, Ken Morgan, Interim City Manager, City of Meriden and Robert Seale, Director of Development and Enforcement, City of Meriden. A copy of this letter is also being sent to the property owner, 119 Empire Avenue, LLC and tower operator, Crown Castle.

The planned modifications to AT&T’s facility fall squarely within those activities explicitly provided for in R.C.S.A. §16-50j-72 (b)(2). Specifically:

1. The planned modification will not result in an increase in the height of the existing structure. The remote-radio heads to be swapped will be installed at the existing height of approximately 95-feet on the 108-foot water tank.
2. The proposed modifications will not involve any changes to ground-mounted equipment, and therefore will not require an extension of the site boundary.
3. The proposed modification will not increase the noise level at the facility by six decibels or more, or to levels that exceed state and local criteria.

4. The operation of the modified facility will not increase radio frequency (RF) emissions at the facility to a level at or above Federal Communications Commission (FCC) safety standard. An RF emissions calculation (enclosed) for AT&T's modified facility is herein provided.
5. The proposed modifications will not cause a change or alteration in the physical or environmental characteristics of the site.
6. The existing structure and its foundation can support AT&T's proposed modifications (please see enclosed mount analysis completed by Trylon dated October 31, 2016).

For the foregoing reasons, AT&T respectfully requests that the proposed remote-radio head installation be allowed within the exempt modifications under R.C.S.A. §16-50j-72 (b)(2).

Sincerely,

*Jennifer Iliades*

Jennifer Iliades  
Site Acquisition Specialist

Enclosures: Exhibit 1 – Property Card and GIS Map  
Exhibit 2 – Construction Drawings  
Exhibit 3 – Mount Analysis  
Exhibit 4 – RF Emissions Analysis Report Evaluation

cc: Kevin Scarpati, Mayor, City of Meriden  
Ken Morgan, Interim City Manager, City of Meriden  
Robert Seale, Director of Development and Enforcement, City of Meriden  
119 Empire Avenue, LLC  
Crown Castle

# Exhibit 1



# CITY OF MERIDEN

## GIS Services

**Property Information:** Address: 119 EMPIRE AVE Map/Lot: 0417-0154-0007-0000

**Owner Information:** 119 EMPIRE AVENUE LLC Owner Address: 1150 OLD COLONY RD  
MERIDEN, CT 06451

**Building Information:**

Card	Units	Rooms	Bed rooms	Year Built	Full Bath	Half Bath	Other Fixtures	Fire Places	Heat Type	Heat Fuel	Roof Mat	Grade	Type	Ext Wall	Finished Area
1	1			1976					Steam w/Boil	Oil		C	Ind Mfg (L)		160,720

**Sub Area Summary:**

SubArea	Description	SketchedArea	Perimeter	AdjArea	Rate	AreaValue
CPY	CANOPY	10,266	734	10,266	4.57000	\$46,947.00
FFL	1st FLOOR	38,400	880	38,400	44.45000	\$1,707,006.00
FFL	1st FLOOR	12,000	520	12,000	44.45000	\$533,439.38
FFL	1st FLOOR	63,200	1,120	63,200	44.45000	\$2,809,447.25
FFL	1st FLOOR	40,560	972	40,560	44.45000	\$1,803,025.00
FFL	1st FLOOR	1,120	136	1,120	44.45000	\$49,787.68
FFL	1st FLOOR	400	80	400	44.45000	\$17,781.31
FFL	1st FLOOR	480	88	480	44.45000	\$21,337.57
FFL	1st FLOOR	4,560	272	4,560	44.45000	\$202,706.95
LDK	LOAD DOCK	10,266	734	10,266	22.57000	\$231,735.00

**Special Features:**

Description	Condition	Year	Assessed Value
FENCE-10 CHAIN	AV	1976	\$40,000
PAVING ASPHALT	AV	1976	\$87,500
SHED	AV	1976	\$2,300

**Appraisal Information:** Tax District: 1 District Name: OUTER DISTRICT District Mill Rate: 39.92

Current Values by Card Number					
Card	Building Value	Yard Items	Land Value	Total	Assessed
1	\$1,856,400	\$129,800	\$713,800	\$2,700,000	\$1,890,000
<b>TOTAL PARCEL:</b>					
	<b>\$1,856,400</b>	<b>\$129,800</b>	<b>\$713,800</b>	<b>\$2,700,000</b>	<b>\$1,890,000</b>

**Previous Year Totals**

Year	Building Value	Yard Items	Land Value
------	----------------	------------	------------

2016	\$2,083,500	\$129,800	\$713,800
------	-------------	-----------	-----------

Special Land Value: \$0

Land Information:	Type	Lot Size	Lot Unit	Zoning*
	Commercial Building	541,015.00	SF	M-2

Total Acreage:12.42

\*Confirm zoning with Planning Office. Zoning map is the official document.

Sales Information:	Book	Page	Grantor	Sale Date	Sale Price	Deed Type
	4985	258	ATLAS CONTAINER LLC,	4/2/2015	\$1,200,000	Warranty Deed
	2756	182	WEYERHAEUSER COMPANY	10/19/2001	\$2,450,000	
	2142	136		12/2/1995	\$0	

Assessor's Permit History:	Date	Permit Number	Notes	Type
	12/21/2016	B-16-1235	REPLACING ANTENNAE PANELS/ADDING REMOTE RADIO HEADS TO CELL TOWER.	
	1/20/2016	P-16-16	GAS PIPING TO CONNECT OWNER SUPPLIED RADIANT HEAT PANELS.Approved by Bldg Dept.	
	11/23/2015	B-15-965	NEW ANTENNAE ON NEW PIPE MOUNTS.Approved by Bldg Dept.	
	7/23/2015	E-15-322	FIT-OUT LOGAN STEEL.INSTALL NEW LIGHTING AT WAREHOUSE AND OFFICE/WIRE NEW MACHINE TO EXISTING BUSDUCT.	
	3/24/2015	B-15-71	NEW ANTENNA W/NEW MASTS/RELOCATE EXISTING TMA.Est complete.	
	1/26/2015	E-14-154	CELL TOWER/RUN DC CIRCUITS TO INVERTERS/RADIO HEADS ON CABINETS.Est complete.	
	7/26/2013	2377	CELL TOWER.Est complete.	
	3/8/2013	611	SPRINT - MODIF. OF TELECOMM. INST. ON WATER TANK, REPL. 3 ANTS. & CABLES AND ADD RRH'S AND NOTCH FILTERS BEHIND ANTS. ON WATER TANK, ADD CIENA EQUIP. ENCL. & FIBER JUNC. BOX & EITHER RETROFIT OR REPL. BTS CABINET WITHIN SPRINT'S EXISTING EQUIP. SHELTER	
	6/12/2012	1847	AT&T REMOVE AND REPLACE 9 EXISTING ANTENNAS INSTALL 6 REMOTE RED HEADS AND INSTALL 1 3" CONDUIT TO HOUSE FIBER AND DC POWER ALL TO CODE	C
	3/3/2010	503	VERIZON REMOVAL OF EXISTING ANTENNAE ON MONOPOLE& REPLACE WITH 6 LTE ANTENNAE PER PLAN (WILL BE PAINTED TO MATCH EXISTING )	R
	3/3/2010	504	SPRINT- MODIFICATIONS TO EXISTING TELECOMMUNICATIONS SITE PER PLANS AND TO CODE(REQUIRES SEPARATE ELECTRICAL PERMIT)	
	9/23/2009	2822	REROOF BLDG W/ RUBBER ROOF	
	5/29/2009	1586	SWAP EXISTING ANTENNAS ON EXISTING TOWER, ADD ONE TELE CABINET	
	7/18/2006	2672	GAS PIPE FOR GENERATOR	CA
	3/9/2006	734	NEW AMP SERV ,1PH WIRE	CA
	3/9/2006	734	1VERIZON, 1TMOBILE SERV	CA
	3/9/2006	734	1VERIZON,1T MOBILE SERV	CA
	3/9/2006	734	REVAMP EX SERV	CA



3/9/2006	741	400 AMPS 1PH 3WIRE SERV	CA
11/30/2005	4507	INSTALL VERIZON 12X30 PRE	CA
11/30/2005	4507	T-MOBILE MOUNTED EQUIP	CA
11/30/2005	4507	128' MONOPOLE FOR WIRELES	CA
5/24/2005	1786	INSTALL POWER & GROUNDING	CA
5/24/2005	1786	PREWIRED NEXTEL COMM SHEL	CA
5/13/2005	1626	INSTALL PRE FAB SHELTER,A	CA
5/13/2005	1626	ANTENNAS ON EX WATER TANK	CA
9/9/2003	3154	WIRE CELLULAR EQUIP	CA
7/25/2003	2591	AT&T COMMUN TOWER	CA
4/16/2003	1140	INSTALL 400 AMP SERV	CA
4/16/2003	1140	ALSO INSTALL 200 AMP SERV	CA
11/15/2002	3802	INSTALL PC ANTENNAS ON WA	CA
11/15/2002	3802	SPRINT RADIO EQUIP ON GRO	CA
11/28/2001	3843	3000 AMP SERV UPGRADE	CA
11/28/2001	3843	2000AMP SERV BACKFEED	CA

**Property Images**



FBLA = 0

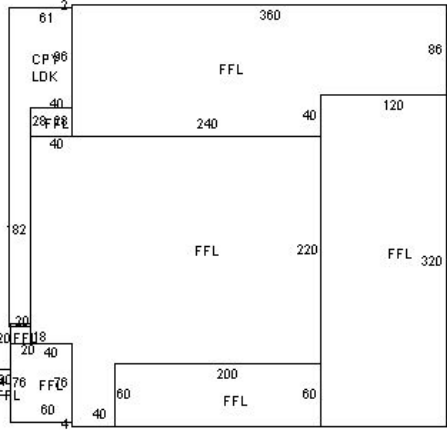

74310417-0154-0007-00001

## Exhibit 2

**PROJECT TEAM**

CLIENT REPRESENTATIVE:  
 EMPIRE TELECOM  
 16 ESQUIRE ROAD  
 BILLERICA, MA 01821  
 DAVID COOPER  
 617-639-4908  
 dcooper@empiretelecomm.com

SITE ACQUISITION & ZONING:  
 EMPIRE TELECOM  
 16 ESQUIRE ROAD  
 BILLERICA, MA 01821  
 DAVID COOPER  
 617-639-4908  
 dcooper@empiretelecomm.com

ENGINEERING:  
 TRYLON TSF  
 24 QUEEN ST E  
 BRAMPTON, ON L6V 1A2  
 KATYA SERAVALLE  
 PHONE: 519-465-4125

RF ENGINEER:  
 AT&T MOBILITY - NEW ENGLAND  
 550 COCHITUATE ROAD  
 SUITE 550 T3 & 14  
 FRAMINGHAM, MA 01701  
 CAMERON SYME  
 508-596-7146  
 cs6970@att.com

CONSTRUCTION MANAGEMENT:  
 EMPIRE TELECOM  
 16 ESQUIRE ROAD  
 BILLERICA, MA 01821  
 GRZEGORZ "GREG" DORMAN  
 484-683-1750  
 gdorman@empiretelecomm.com

TOWER OWNER:  
 N/A



**LTE EXTENDED CARRIER RRH ADD  
 CT1015  
 MERIDEN NORTH  
 119 EMPIRE AVENUE  
 MERIDEN, CT 06450  
 FA CODE: 10035234**

**APPROVALS**

AT&T (RF): \_\_\_\_\_ DATE: \_\_\_\_\_  
 AT&T (CONST.): \_\_\_\_\_ DATE: \_\_\_\_\_  
 AT&T (OPS): \_\_\_\_\_ DATE: \_\_\_\_\_  
 TOWER OWNER: \_\_\_\_\_ DATE: \_\_\_\_\_

**JURISDICTIONAL APPROVAL**

BASED ON INFORMATION PROVIDED BY AT&T REGULATORY COMPLIANCE PROFESSIONALS AND LEGAL COUNSEL, THIS TELECOMMUNICATIONS EQUIPMENT DEPLOYMENT IS CONSIDERED AN ELIGIBLE FACILITY UNDER THE MIDDLE CLASS TAX RELIEF AND JOB CREATION ACT OF 2012, 47 USC 1455(A), SECTION 6409(A), AND IS SUBJECT TO AN ELIGIBLE FACILITY REQUEST, EXPEDITED REVIEW AND LIMITED/PARTIAL ZONING PRE-EMPTION FOR LOCAL DISCRETIONARY PERMITS (VARIANCE, SPECIAL PERMIT, SITE PLAN REVIEW OR ADMINISTRATIVE REVIEW).

**PROJECT DESCRIPTION**

THIS PROJECT WILL BE COMPRISED OF:  
**CHANGES ON THE EXISTING WATER TANK:**

- REUSE (9) EXISTING ANTENNA (3) PER SECTOR FOR (3) SECTORS.
- REMOVE (3) EXISTING RRUS-11 (1) PER SECTOR FOR (3) SECTORS.
- INSTALL (3) NEW RRUS-12, (1) PER SECTOR FOR (3) SECTORS.
- REUSE (1) EXISTING FIBER TRUNK.
- REUSE (2) EXISTING DC TRUNK.
- REUSE (1) EXISTING RET CABLE.
- REUSE (1) EXISTING DC/FIBER SQUID.
- REUSE (12) EXISTING RF CABLES.

**CHANGES IN THE EXISTING AT&T EQUIPMENT ENCLOSURE AREA:**

- INSTALL (1) NEW XMU.
- REPLACE DUL TO DUS41.



NO.	DATE	DESCRIPTION	BY
A	09/17/16	FOR REVIEW	NPS
0	10/05/16	ISSUE FOR CONSTRUCTION	NPS
1	02/09/18	UPDATE AS PER REMARKS	NPS

**SITE INFORMATION:**

**CT1015  
 MERIDEN NORTH  
 FA CODE: 10035234**

119 EMPIRE AVENUE  
 MERIDEN, CT 06450

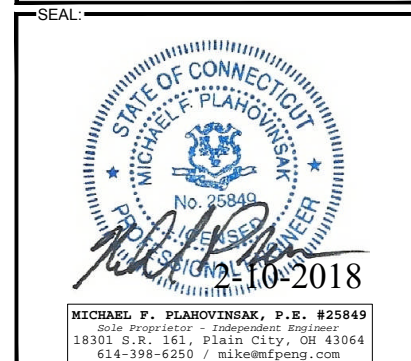

**SHEET TITLE:**

**TITLE SHEET**

**SHEET NUMBER:**

**T-1**

**GENERAL NOTES**

**DO NOT SCALE DRAWINGS**  
 CONTRACTOR SHALL VERIFY ALL PLANS AND EXISTING DIMENSIONS AND CONDITIONS ON THE JOB SITE AND SHALL IMMEDIATELY NOTIFY THE ARCHITECT/ENGINEER IN WRITING OF ANY DISCREPANCIES BEFORE PROCEEDING WITH THE WORK OR BE RESPONSIBLE FOR SAME.

THE FACILITY IS UNMANNED AND NOT FOR HUMAN HABITATION. A TECHNICIAN WILL VISIT THE SITE AS REQUIRED FOR ROUTINE MAINTENANCE. THE PROJECT WILL NOT RESULT IN ANY SIGNIFICANT DISTURBANCE OR EFFECT ON DRAINAGE; NO SANITARY SEWER SERVICE, POTABLE WATER, OR TRASH DISPOSAL IS REQUIRED AND NO COMMERCIAL SIGNAGE IS PROPOSED.

**VICINITY MAP**

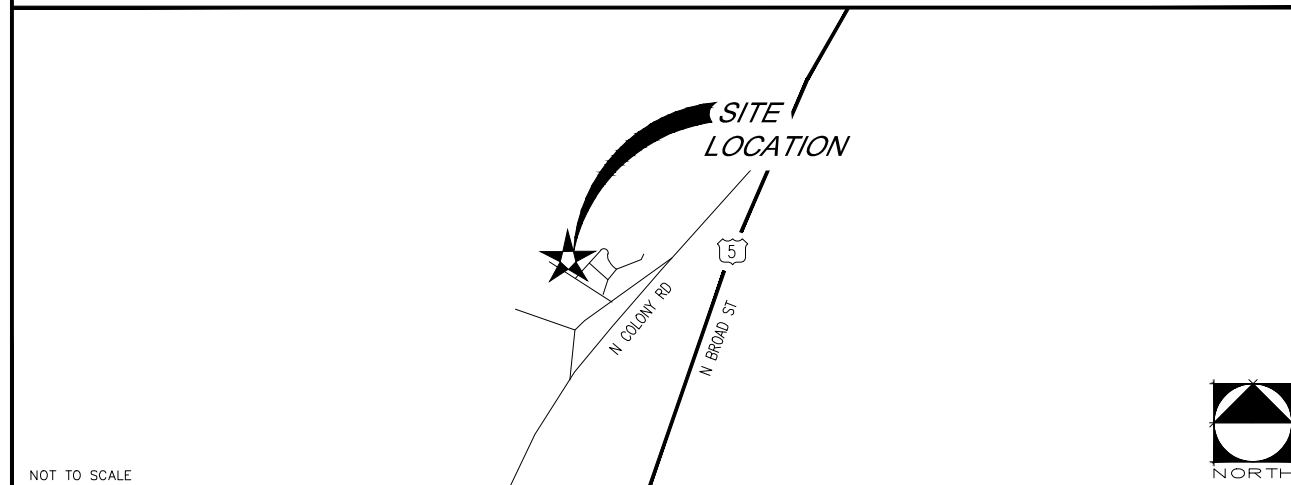

**SITE INFORMATION**

LATITUDE: 41° 34' 23.20" N  
 LONGITUDE: 72° 46' 45.01" W  
 LAT./LONG. TYPE: NAD 83  
 GROUND ELEVATION: N/A  
 APN/UPC: N/A  
 AREA OF CONSTRUCTION: EXISTING  
 ZONING/JURISDICTION: CITY OF MERIDEN  
 CURRENT ZONING: UNKNOWN  
 EXISTING USE: TELECOMMUNICATIONS FACILITY  
 COUNTY: NEW HAVEN COUNTY  
 HANDICAP REQUIREMENTS: FACILITY IS UNMANNED AND NOT FOR HUMAN HABITATION. HANDICAPPED ACCESS NOT REQUIRED.

**DRIVING DIRECTIONS**

LEGACY ORANGE1015 WEYERHAUSER GATE COMBO 5913691 EAT TO EXIT 7 GO THRU STOP SIGN TO LIGHT TURN LEFT AND FOLLOW FOR APPROXIMATELY 2 MILES AT FORK IN ROAD BARE LEFT SIGN FOR WEYERHAUSER TURN LEFT ON EMPIRE AVE GATE COMBO 2551 691 WEST TO EXIT 7 BARE RIGHT AT STOP SIGN TURN LEFT AND FOLLOW TO END TURN RIGHT AND FOLLOW TO FORK IN ROAD SIGN FOR WEYERHAUSER BEAR LEFT AND FOLLOW TO EMPIRE AVENUE: (800) 448-1008 AND (203) 420-3131 (24-HR REPAIR)

**CODE COMPLIANCE**

BUILDING CODE: 2012 CONNECTICUT COMMERCIAL BUILDING CODE  
 ELECTRICAL CODE: 2014 CONNECTICUT ELECTRICAL CODE  
 LIGHTNING PROTECTION CODE: NFPA 780 - 2000, LIGHTNING PROTECTION CODE

SUBCONTRACTOR'S WORK SHALL COMPLY WITH ALL APPLICABLE NATIONAL, STATE, AND LOCAL CODES AS ADOPTED BY THE LOCAL AUTHORITY HAVING JURISDICTION (AHJ) FOR THE LOCATION. THE EDITION OF THE AHJ ADOPTED CODES AND STANDARDS IN EFFECT ON THE DATE OF CONTRACT AWARD SHALL GOVERN THE DESIGN.

FOR ANY CONFLICTS BETWEEN SECTIONS OF LISTED CODES AND STANDARDS REGARDING MATERIAL, METHODS OF CONSTRUCTION, OR OTHER REQUIREMENTS, THE MOST RESTRICTIVE REQUIREMENT SHALL GOVERN. WHERE THERE IS CONFLICT BETWEEN A GENERAL REQUIREMENT AND A SPECIFIC REQUIREMENT, THE SPECIFIC REQUIREMENT SHALL GOVERN.

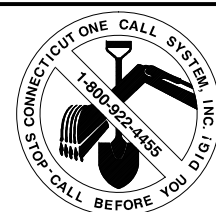

CONNECTICUT LAW REQUIRES TWO WORKING DAYS NOTICE PRIOR TO ANY EARTH MOVING ACTIVITIES BY CALLING 800-922-4455 OR DIAL 811

**SHEET**

**DESCRIPTION**

T-1	TITLE SHEET
GN-1	GROUNDING & GENERAL NOTES
A-1	SITE PLAN
A-2	EQUIPMENT LAYOUTS
A-3	ANTENNA LAYOUTS
A-4	TOWER ELEVATION
A-5	DETAILS
G-1	GROUNDING, ONE-LINE DIAGRAM & DETAILS



GENERAL NOTES:

1. FOR THE PURPOSE OF CONSTRUCTION DRAWING, THE FOLLOWING DEFINITIONS SHALL APPLY:
  - CONTRACTOR - EMPIRE TELECOM
  - SUBCONTRACTOR - GENERAL CONTRACTOR (CONSTRUCTION)
  - OWNER - AT&T MOBILITY
  - DEM - ORIGINAL EQUIPMENT MANUFACTURER
2. PRIOR TO THE SUBMISSION OF BIDS, THE BIDDING SUBCONTRACTOR SHALL VISIT THE CELL SITE TO FAMILIARIZE WITH THE EXISTING CONDITIONS AND TO CONFIRM THAT THE WORK CAN BE ACCOMPLISHED AS SHOWN ON THE CONSTRUCTION DRAWINGS. ANY DISCREPANCY FOUND SHALL BE BROUGHT TO THE ATTENTION OF CONTRACTOR.
3. ALL MATERIALS FURNISHED AND INSTALLED SHALL BE IN STRICT ACCORDANCE WITH ALL APPLICABLE CODES, REGULATIONS, AND ORDINANCES. SUBCONTRACTOR SHALL ISSUE ALL APPROPRIATE NOTICES AND COMPLY WITH ALL LAWS, ORDINANCES, RULES, REGULATIONS, AND LAWFUL ORDERS OF ANY PUBLIC AUTHORITY REGARDING THE PERFORMANCE OF THE WORK. ALL WORK CARRIED OUT SHALL COMPLY WITH ALL APPLICABLE MUNICIPAL AND UTILITY COMPANY SPECIFICATIONS AND LOCAL JURISDICTIONAL CODES, ORDINANCES AND APPLICABLE REGULATIONS.
4. DRAWINGS PROVIDED HERE ARE NOT TO BE SCALED AND ARE INTENDED TO SHOW OUTLINE ONLY.
5. UNLESS NOTED OTHERWISE, THE WORK SHALL INCLUDE FURNISHING MATERIALS, EQUIPMENT, APPURTENANCES, AND LABOR NECESSARY TO COMPLETE ALL INSTALLATIONS AS INDICATED ON THE DRAWINGS.
6. THE SUBCONTRACTOR SHALL INSTALL ALL EQUIPMENT AND MATERIALS IN ACCORDANCE WITH MANUFACTURER'S RECOMMENDATIONS UNLESS SPECIFICALLY STATED OTHERWISE.
7. IF THE SPECIFIED EQUIPMENT CANNOT BE INSTALLED AS SHOWN ON THESE DRAWINGS, THE SUBCONTRACTOR SHALL PROPOSE AN ALTERNATIVE INSTALLATION SPACE FOR APPROVAL BY THE CONTRACTOR.
8. SUBCONTRACTOR SHALL DETERMINE ACTUAL ROUTING OF CONDUIT, POWER AND T1 CABLES, GROUNDING CABLES AS SHOWN ON THE POWER, GROUNDING AND TELCO PLAN DRAWING. SUBCONTRACTOR SHALL UTILIZE EXISTING TRAYS AND/OR SHALL ADD NEW TRAYS AS NECESSARY. SUBCONTRACTOR SHALL CONFIRM THE ACTUAL ROUTING WITH THE CONTRACTOR. ROUTING OF TRENCHING SHALL BE APPROVED BY CONTRACTOR
9. THE SUBCONTRACTOR SHALL PROTECT EXISTING IMPROVEMENTS, PAVEMENTS, CURBS, LANDSCAPING AND STRUCTURES. ANY DAMAGED PART SHALL BE REPAIRED AT SUBCONTRACTOR'S EXPENSE TO THE SATISFACTION OF OWNER.
10. SUBCONTRACTOR SHALL LEGALLY AND PROPERLY DISPOSE OFF ALL SCR1 'AP MATERIALS SUCH AS COAXIAL CABLES AND OTHER ITEMS REMOVED FROM THE EXISTING FACILITY. ANTENNAS REMOVED SHALL BE RETURNED TO THE OWNER'S DESIGNATED LOCATION.
11. SUBCONTRACTOR SHALL LEAVE PREMISES IN CLEAN CONDITION.
12. ALL CONCRETE REPAIR WORK SHALL BE DONE IN ACCORDANCE WITH AMERICAN CONCRETE INSTITUTE (ACI) 301.
13. ANY NEW CONCRETE NEEDED FOR THE CONSTRUCTION SHALL HAVE 4000 PSI STRENGTH AT 28 DAYS UNLESS OTHERWISE SPECIFIED. ALL CONCRETING WORK SHALL BE DONE IN ACCORDANCE WITH ACI 318 CODE REQUIREMENTS.
14. ALL STRUCTURAL STEEL WORK SHALL BE DETAILED, FABRICATED AND ERECTED IN ACCORDANCE WITH AISC SPECIFICATIONS. ALL STRUCTURAL STEEL SHALL BE ASTM A36 (Fy=36 ksi). ALL STEEL EXPOSED TO WEATHER SHALL BE HOT DIPPED GALVANIZED. TOUCH UP ALL SCRATCHES AND OTHER MARKS IN THE FIELD AFTER STEEL IS ERECTED USING A COMPATIBLE ZINC RICH PAINT.
15. CONSTRUCTION SHALL COMPLY WITH SPECIFICATION 25741-000-3APS-A00Z-00002, "GENERAL CONSTRUCTION SERVICES FOR CONSTRUCTION OF AT&T MOBILITY SITES."
16. SUBCONTRACTOR SHALL VERIFY ALL EXISTING DIMENSIONS AND CONDITIONS PRIOR TO COMMENCING ANY WORK. ALL DIMENSIONS OF EXISTING CONSTRUCTION SHOWN ON THE DRAWINGS MUST BE VERIFIED. SUBCONTRACTOR SHALL NOTIFY THE CONTRACTOR OF ANY DISCREPANCIES PRIOR TO ORDERING MATERIAL OR PROCEEDING WITH CONSTRUCTION.
17. THE EXISTING CELL SITE IS IN FULL COMMERCIAL OPERATION. ANY CONSTRUCTION WORK BY SUBCONTRACTOR SHALL NOT DISRUPT THE EXISTING NORMAL OPERATION. ANY WORK ON EXISTING EQUIPMENT MUST BE COORDINATED WITH CONTRACTOR. ALSO, WORK MAY NEED TO BE SCHEDULED FOR AN APPROPRIATE MAINTENANCE WINDOW USUALLY IN LOW TRAFFIC PERIODS AFTER MIDNIGHT.
18. SINCE THE CELL SITE MAY BE ACTIVE, ALL SAFETY PRECAUTIONS MUST BE TAKEN WHEN WORKING AROUND HIGH LEVELS OF ELECTROMAGNETIC RADIATION. EQUIPMENT SHOULD BE SHUTDOWN PRIOR TO PERFORMING ANY WORK THAT COULD EXPOSE THE WORKERS TO DANGER. PERSONAL RF EXPOSURE MONITORS ARE REQUIRED TO BE WORN TO ALERT OF ANY DANGEROUS EXPOSURE LEVELS.
19. SUBCONTRACTOR'S WORK SHALL COMPLY WITH ALL APPLICABLE NATIONAL, STATE, AND LOCAL CODES AS ADOPTED BY THE LOCAL AUTHORITY HAVING JURISDICTION (AHJ) FOR THE LOCATION. THE EDITION OF THE AHJ ADOPTED CODES AND STANDARDS IN EFFECT ON THE DATE OF CONTRACT AWARD SHALL GOVERN THE DESIGN.
  - INTERNATIONAL BUILDING CODE: IBC 2009 WITH LOCAL & COUNTY AMENDMENTS
  - NATIONAL ELECTRICAL CODE: NEC 2011 WITH LOCAL & COUNTY AMENDMENTS
  - FIRE/LIFE SAFETY CODE: NFPA-101 2009 WITH LOCAL & COUNTY AMENDMENTS
20. SUBCONTRACTOR'S WORK SHALL COMPLY WITH THE LATEST EDITION OF THE FOLLOWING STANDARDS:
  - AMERICAN CONCRETE INSTITUTE (ACI) 318, BUILDING CODE REQUIREMENTS FOR STRUCTURAL CONCRETE
  - AMERICAN INSTITUTE OF STEEL CONSTRUCTION (AISC), MANUAL OF STEEL CONSTRUCTION, THIRTEENTH EDITION
  - AMERICAN SOCIETY OF TESTING OF MATERIALS, ASTM
  - TELECOMMUNICATIONS INDUSTRY ASSOCIATION (ANSI/TIA-222-G-1), STRUCTURAL STANDARDS FOR STEEL ANTENNA TOWER AND ANTENNA SUPPORTING STRUCTURES:
  - TIA 607, COMMERCIAL BUILDING GROUNDING AND BONDING REQUIREMENTS FOR TELECOMMUNICATIONS
  - OCCUPATIONAL SAFETY AND HEALTH ADMINISTRATION, OSHA
  - INSTITUTE FOR ELECTRICAL AND ELECTRONICS ENGINEERS (IEEE) 81, GUIDE FOR MEASURING EARTH RESISTIVELY, GROUND IMPEDANCE, AND EARTH SURFACE POTENTIALS OF A GROUND SYSTEM IEEE 1100 (1999) RECOMMENDED PRACTICE FOR POWERING AND GROUNDING OF ELECTRONIC EQUIPMENT
  - TELCORDIA GR-1503, COAXIAL CABLE CONNECTIONS
21. FOR ANY CONFLICTS BETWEEN SECTIONS OF LISTED CODES AND STANDARDS REGARDING MATERIAL, METHODS OF CONSTRUCTION, OR OTHER REQUIREMENTS, THE MOST RESTRICTIVE REQUIREMENT SHALL GOVERN. WHERE THERE IS CONFLICT BETWEEN A GENERAL REQUIREMENT AND A SPECIFIC REQUIREMENT, THE SPECIFIC REQUIREMENT SHALL GOVERN.

GROUNDING NOTES:

1. THE SUBCONTRACTOR SHALL REVIEW AND INSPECT THE EXISTING FACILITY GROUNDING SYSTEM AND LIGHTNING PROTECTION SYSTEM (AS DESIGNED AND INSTALLED) FOR STRICT COMPLIANCE WITH THE NEC (AS ADOPTED BY THE AHJ), THE SITE-SPECIFIC (UL, LPI, OR NFPA) LIGHTNING PROTECTION CODE, AND GENERAL COMPLIANCE WITH TELCORDIA AND TIA GROUNDING STANDARDS. THE SUBCONTRACTOR SHALL REPORT ANY VIOLATIONS OR ADVERSE FINDINGS TO THE CONTRACTOR FOR RESOLUTION.
2. ALL GROUND ELECTRODE SYSTEMS (INCLUDING TELECOMMUNICATION, RADIO, LIGHTNING PROTECTION, AND AC POWER GES'S) SHALL BE BONDED TOGETHER, AT OR BELOW GRADE, BY TWO OR MORE COPPER BONDING CONDUCTORS IN ACCORDANCE WITH THE NEC.
3. THE SUBCONTRACTOR SHALL PERFORM IEEE FALL-OF-POTENTIAL RESISTANCE TO EARTH TESTING (PER IEEE 1100 AND 81) FOR NEW GROUND ELECTRODE SYSTEMS. THE SUBCONTRACTOR SHALL FURNISH AND INSTALL SUPPLEMENTAL GROUND ELECTRODES AS NEEDED TO ACHIEVE A TEST RESULT OF 5 OHMS OR LESS. TESTS SHALL BE PERFORMED IN ACCORDANCE WITH 25471-000-3PS-EG00-0001, DESIGN & TESTING OF FACILITY GROUNDING FOR CELL SITES.
4. METAL RACEWAY SHALL NOT BE USED AS THE NEC REQUIRED EQUIPMENT GROUND CONDUCTOR. STRANDED COPPER CONDUCTORS WITH GREEN INSULATION, SIZED IN ACCORDANCE WITH THE NEC, SHALL BE FURNISHED AND INSTALLED WITH THE POWER CIRCUITS TO BTS EQUIPMENT.
5. EACH BTS CABINET FRAME SHALL BE DIRECTLY CONNECTED TO THE MASTER GROUND BAR WITH GREEN INSULATED SUPPLEMENTAL EQUIPMENT GROUND WIRES, 6 AWG STRANDED COPPER OR LARGER FOR INDOOR BTS; 2 AWG STRANDED COPPER FOR OUTDOOR BTS.
6. EXOTHERMIC WELDS SHALL BE USED FOR ALL GROUNDING CONNECTIONS BELOW GRADE.
7. APPROVED ANTIOXIDANT COATINGS (I.E., CONDUCTIVE GEL OR PASTE) SHALL BE USED ON ALL COMPRESSION AND BOLTED GROUND CONNECTIONS.
8. ICE BRIDGE BONDING CONDUCTORS SHALL BE EXOTHERMICALLY BONDED OR BOLTED WITH STAINLESS STEEL HARDWARE TO THE BRIDGE AND THE TOWER GROUND BAR.
9. ALUMINUM CONDUCTOR OR COPPER CLAD STEEL CONDUCTOR SHALL NOT BE USED FOR GROUNDING CONNECTIONS.
10. MISCELLANEOUS ELECTRICAL AND NON-ELECTRICAL METAL BOXES, FRAMES AND SUPPORTS SHALL BE BONDED TO THE GROUND RING, IN ACCORDANCE WITH THE NEC.
11. METAL CONDUIT AND TRAY SHALL BE GROUNDED AND MADE ELECTRICALLY CONTINUOUS WITH LISTED BONDING FITTINGS OR BY BONDING ACROSS THE DISCONTINUITY WITH 6 AWG COPPER WIRE UL APPROVED GROUNDING TYPE CONDUIT CLAMPS.
12. GROUND CONDUCTORS USED IN THE FACILITY GROUND AND LIGHTNING PROTECTION SYSTEMS SHALL NOT BE ROUTED THROUGH METALLIC OBJECTS THAT FORM A RING AROUND THE CONDUCTOR, SUCH AS METALLIC CONDUITS, METAL SUPPORT CLIPS OR SLEEVES THROUGH WALLS OR FLOORS. WHEN IT IS REQUIRED TO BE HOUSED IN CONDUIT TO MEET CODE REQUIREMENTS OR LOCAL CONDITIONS, NON-METALLIC MATERIAL SUCH AS PVC PLASTIC CONDUIT SHALL BE USED. WHERE USE OF METAL CONDUIT IS UNAVOIDABLE (E.G., NON-METALLIC CONDUIT PROHIBITED BY LOCAL CODE) THE GROUND CONDUCTOR SHALL BE BONDED TO EACH END OF THE METAL CONDUIT.
13. ALL TOWER GROUNDING SYSTEMS SHALL COMPLY WITH THE REQUIREMENTS OF ANSI/TIA 222. FOR TOWERS BEING BUILT TO REV-G OF THE STANDARD, THE WIRE SIZE OF THE BURIED GROUND RING AND CONNECTIONS BETWEEN THE TOWER AND THE BURIED GROUND RING SHALL BE CHANGED FROM 2 AWG TO 2/0 AWG. IN ADDITION, THE MINIMUM LENGTH OF THE GROUND RODS SHALL BE INCREASED FROM EIGHT FEET (8') TO TEN FEET (10').
14. ALL NEW STRUCTURES WITH A FOUNDATION AND/OR FOOTING HAVING 20 FT. OR MORE 1/2" OR GREATER ELECTRICALLY CONDUCTIVE REINFORCING STEEL MUST HAVE IT BONDED TO THE GROUND RING USING AN EXOTHERMIC WELD CONNECTION USING #2 AWG SOLID TINNED COPPER GROUND WIRE, PER NEC 250.50.



1355 WEST UNIVERSITY DRIVE  
MESA, AZ 85201-5419



16 ESQUIRE ROAD  
BILLERICA, MA 01821

PLANS PREPARED BY:



24 QUEEN ST E  
BRAMPTON, ON  
1 (519) 572-9995

NO.	DATE	DESCRIPTION	BY
A	09/17/16	FOR REVIEW	NPS
0	10/05/16	ISSUE FOR CONSTRUCTION	NPS
1	02/09/18	UPDATE AS PER REMARKS	NPS

SITE INFORMATION:

CT1015  
MERIDEN NORTH  
FA CODE: 10035234  
  
119 EMPIRE AVENUE  
MERIDEN, CT 06450

SEAL:



SHEET TITLE:

- ENERAL NOTES
- ROUNDIN NOTES

SHEET NUMBER:

N-1



1355 WEST UNIVERSITY DRIVE  
MESA, AZ 85201-5419



16 ESQUIRE ROAD  
BILLERICA, MA 01821

PLANS PREPARED BY:



24 QUEEN ST E  
BRAMPTON, ON  
1 (519) 572-9995

NO.	DATE	DESCRIPTION	BY
A	09/17/16	FOR REVIEW	NPS
0	10/05/16	ISSUE FOR CONSTRUCTION	NPS
1	02/09/18	UPDATE AS PER REMARKS	NPS

SITE INFORMATION:

CT1015  
MERIDEN NORTH  
FA CODE: 10035234

119 EMPIRE AVENUE  
MERIDEN, CT 06450

SEAL:



MICHAEL F. PLAHOVINSAK, P.E. #25849  
Sole Proprietor - Independent Engineer  
18301 S.R. 161, Plain City, OH 43064  
614-398-6250 / mike@fpeng.com

SHEET TITLE:

SITE PLAN

SHEET NUMBER:

A-1

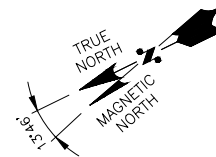
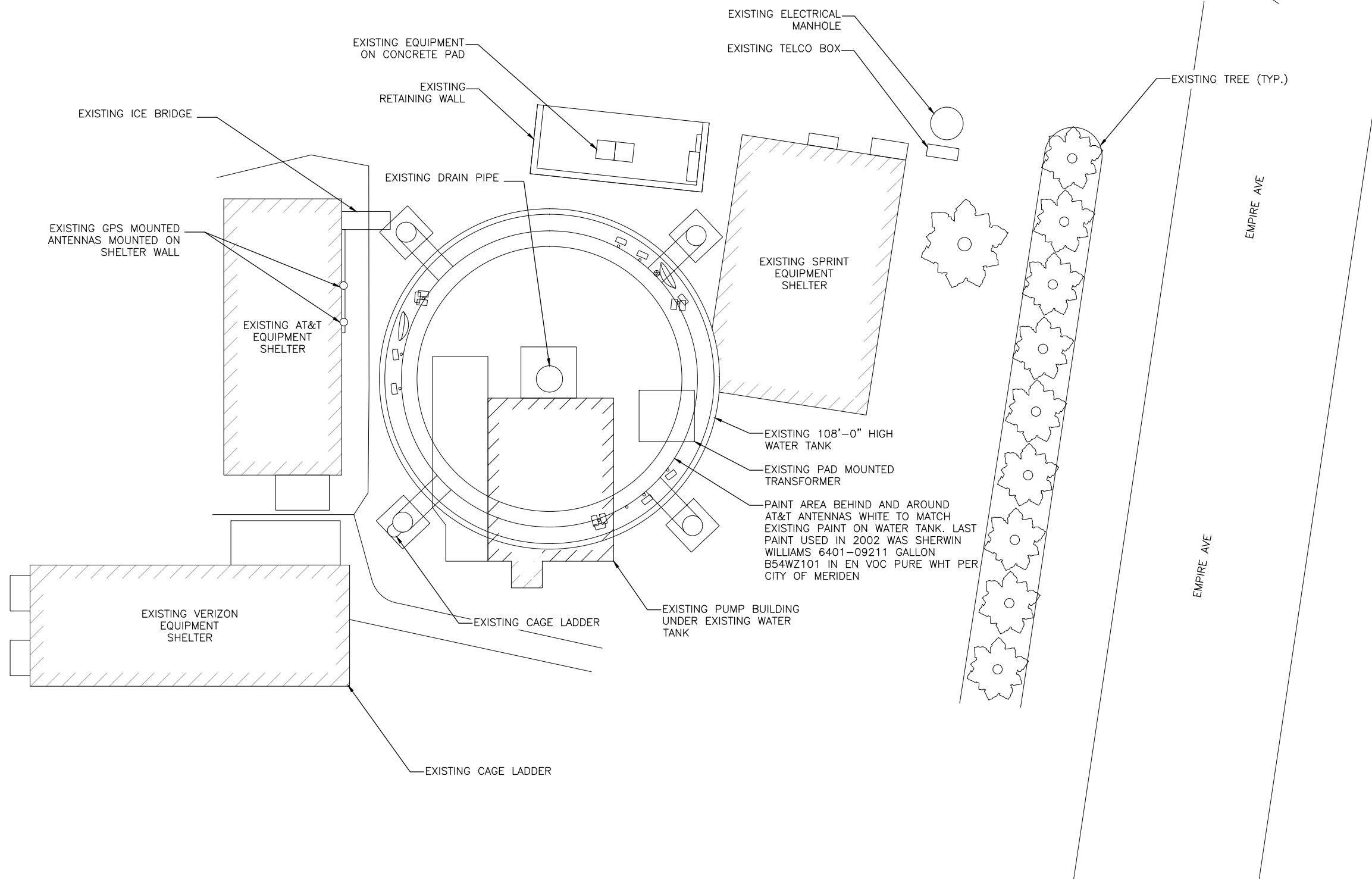

EMPIRE AVE

EMPIRE AVE

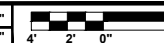



1355 WEST UNIVERSITY DRIVE  
MESA, AZ 85201-5419



PLANS PREPARED BY:



24 QUEEN ST E  
BRAMPTON, ON  
1 (519) 572-9995

NO.	DATE	DESCRIPTION	BY
A	09/17/16	FOR REVIEW	NPS
0	10/05/16	ISSUE FOR CONSTRUCTION	NPS
1	02/09/18	UPDATE AS PER REMARKS	NPS

SITE INFORMATION:

CT1015  
MERIDEN NORTH  
FA CODE: 10035234

119 EMPIRE AVENUE  
MERIDEN, CT 06450

SEAL:



MICHAEL F. PLAHOVINSAK, P.E. #25849  
Sole Proprietor - Independent Engineer  
18301 S.R. 161, Plain City, OH 43064  
614-398-6250 / mike@mfpeng.com

SHEET TITLE:

EQUIPMENT LAYOUTS

SHEET NUMBER:

A-2

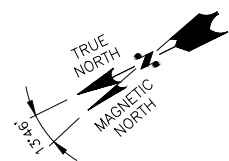
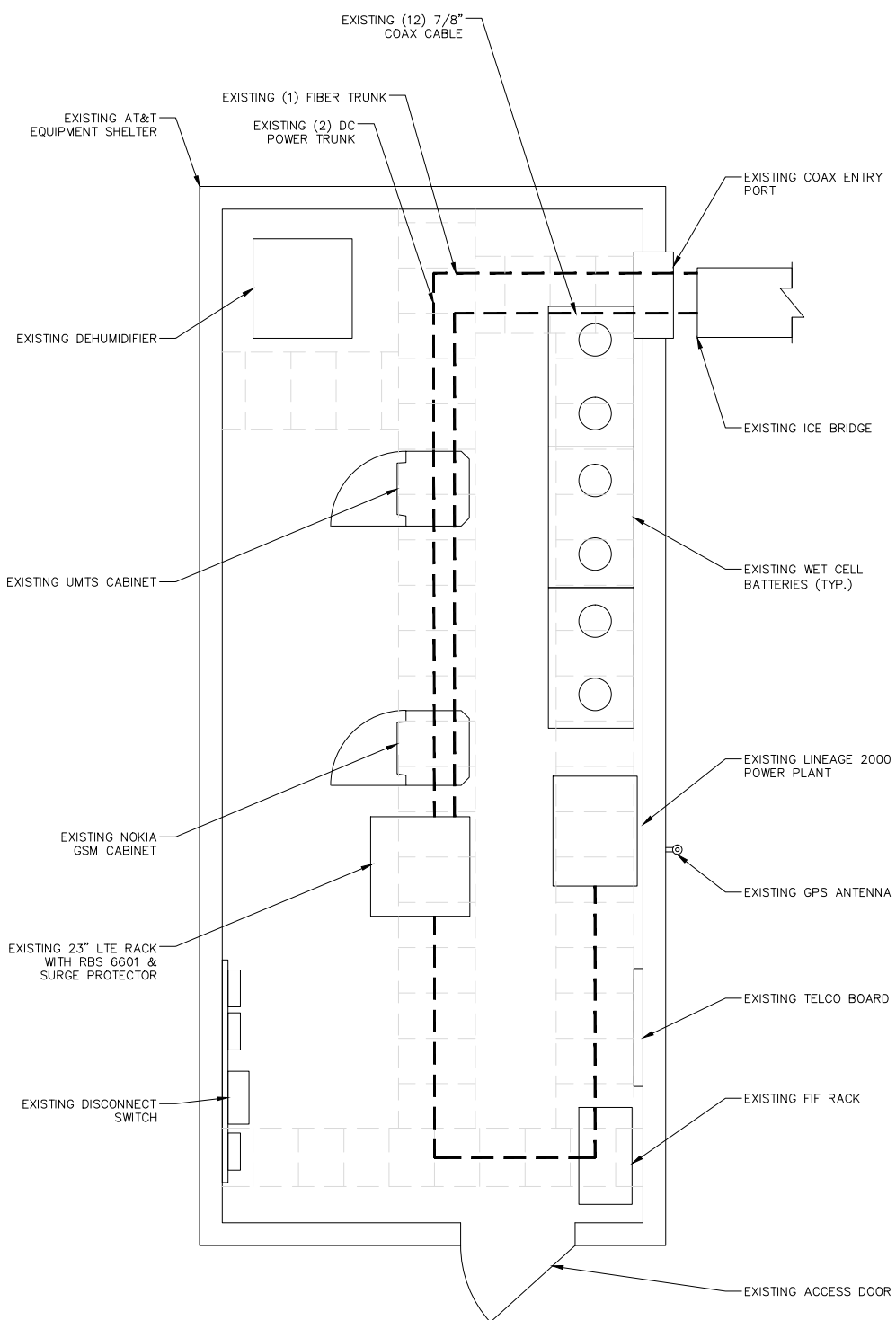

EXISTING EQUIPMENT LAYOUT

22"x34" SCALE: 1/4" = 1'-0"  
11"x17" SCALE: 1/8" = 1'-0"  
4' 3' 2' 1' 0" 4'

1

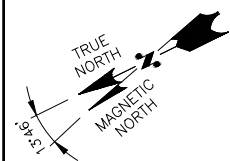
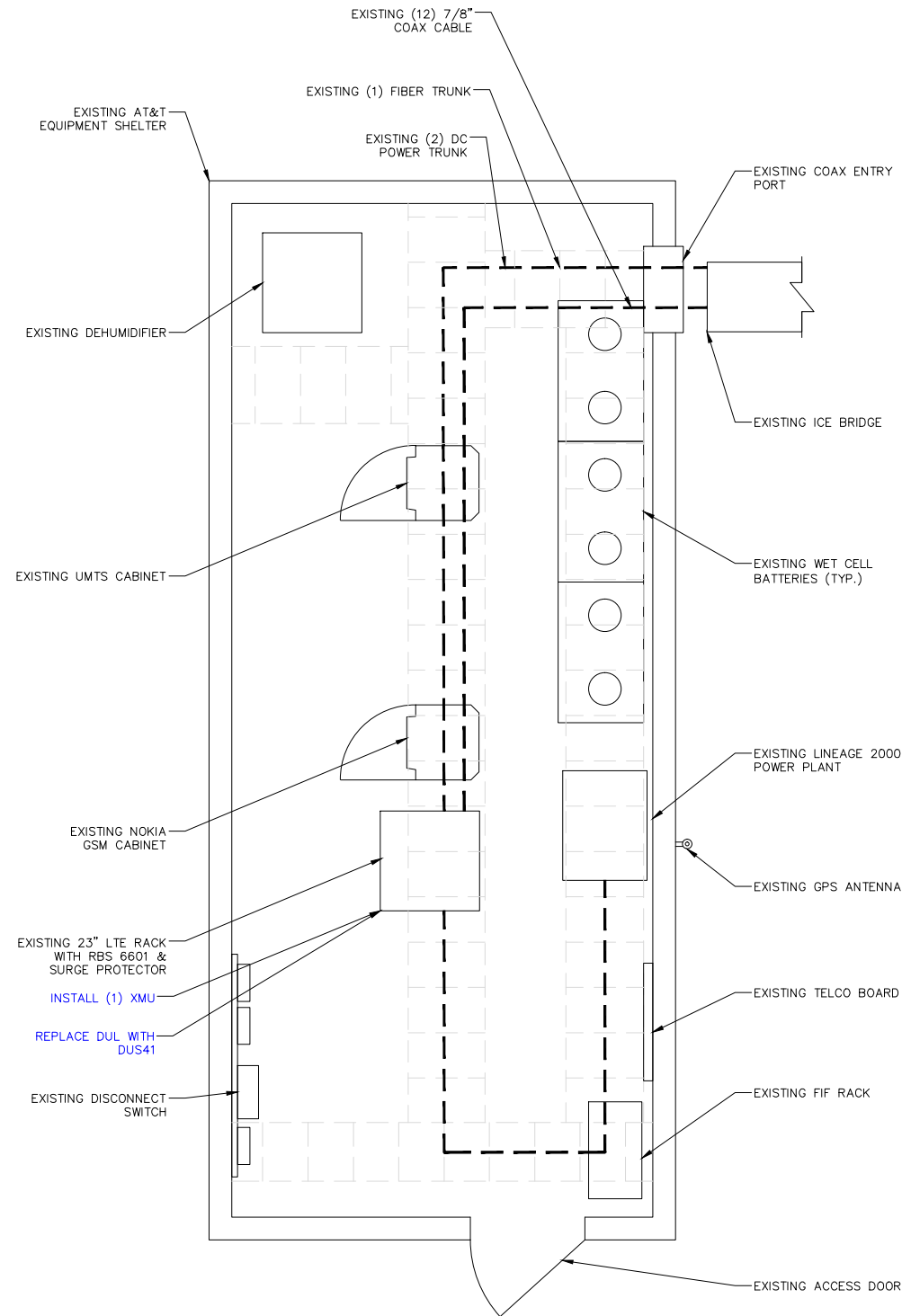

PROPOSED EQUIPMENT LAYOUT

22"x34" SCALE: 1/4" = 1'-0"  
11"x17" SCALE: 1/8" = 1'-0"  
4' 3' 2' 1' 0" 4'

2



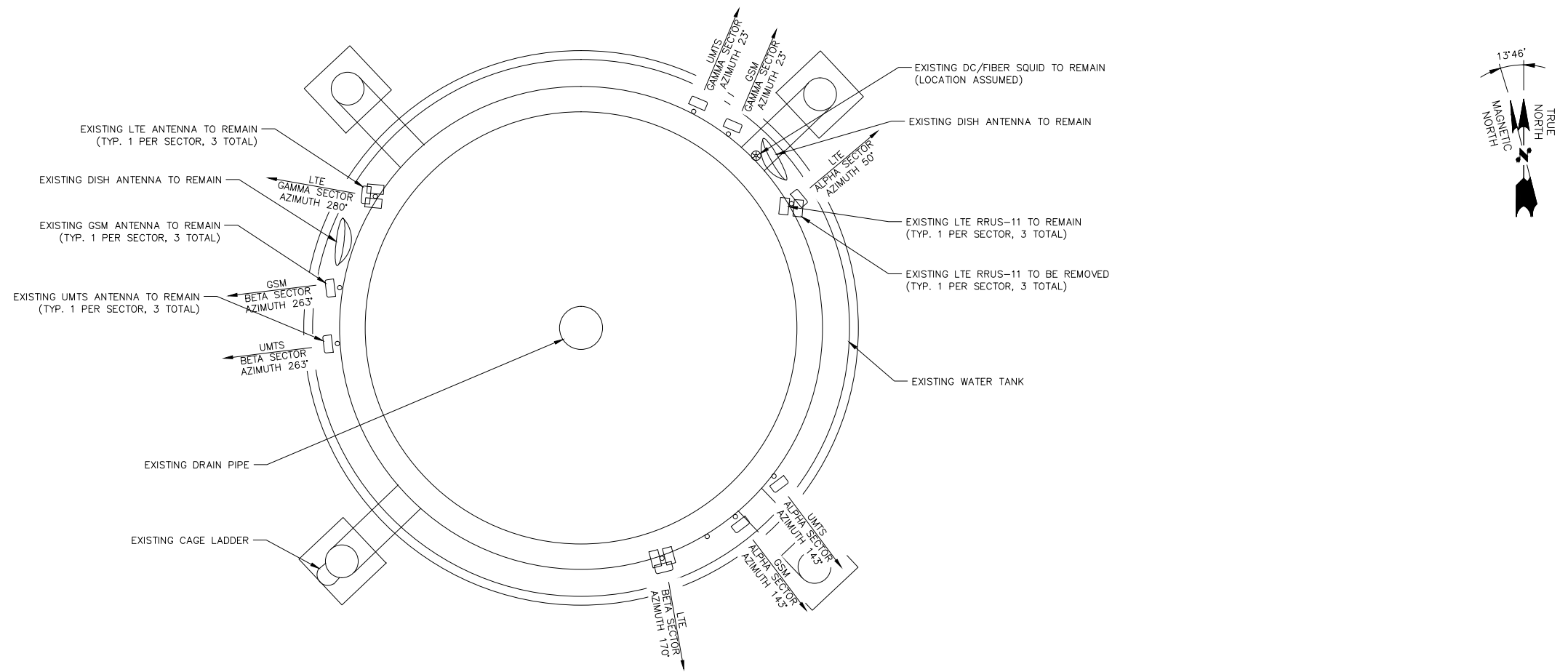

EXISTING ANTENNA LAYOUT

22"x34" SCALE: 1/4" = 1'-0"  
 11"x17" SCALE: 1/8" = 1'-0"  
 4' 3' 2' 1' 0" 4'

1

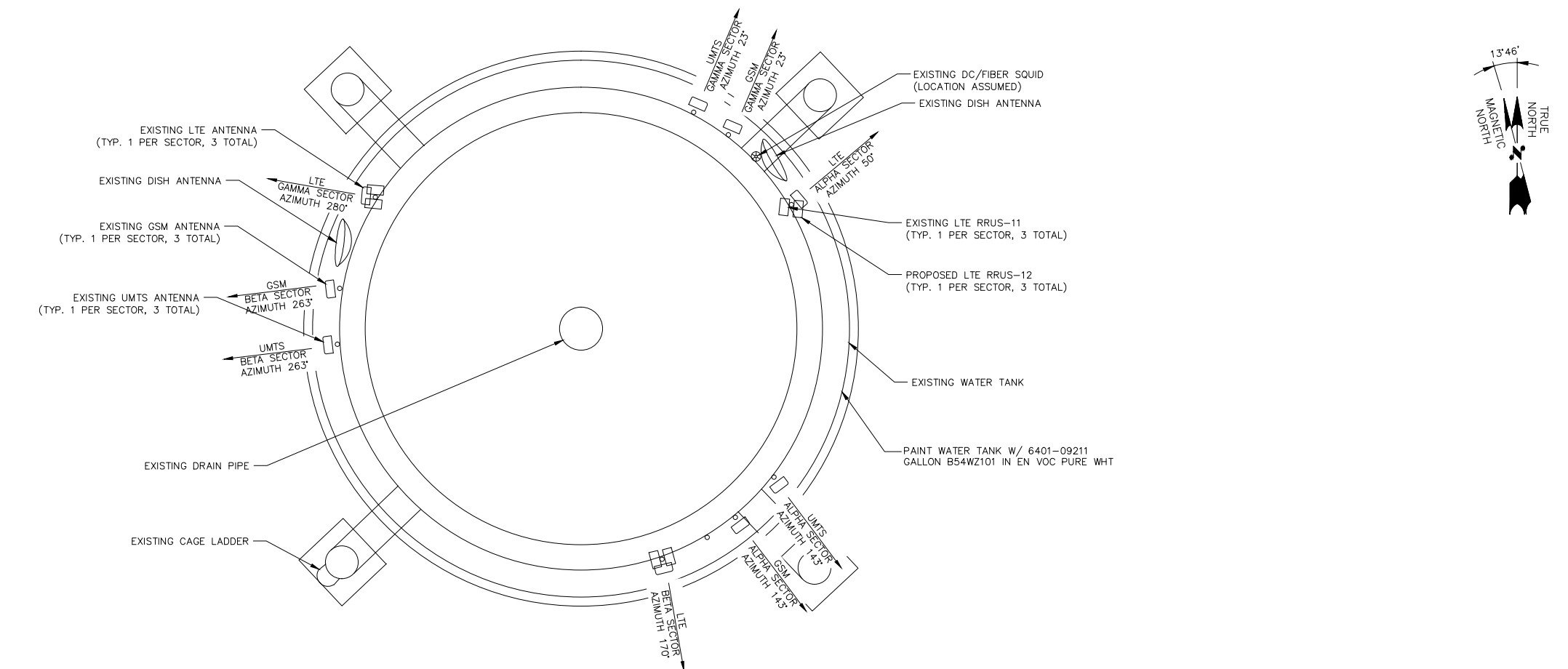

PROPOSED ANTENNA LAYOUT

22"x34" SCALE: 1/4" = 1'-0"  
 11"x17" SCALE: 1/8" = 1'-0"  
 4' 3' 2' 1' 0" 4'

2



1355 WEST UNIVERSITY DRIVE  
 MESA, AZ 85201-5419



16 ESQUIRE ROAD  
 BILLERICA, MA 01821

PLANS PREPARED BY:



24 QUEEN ST E  
 BRAMPTON, ON  
 1 (519) 572-9995

NO.	DATE	DESCRIPTION	BY
A	09/17/16	FOR REVIEW	NPS
0	10/05/16	ISSUE FOR CONSTRUCTION	NPS
1	02/09/18	UPDATE AS PER REMARKS	NPS

SITE INFORMATION:

CT1015  
 MERIDEN NORTH  
 FA CODE: 10035234  
 119 EMPIRE AVENUE  
 MERIDEN, CT 06450

SEAL:

MICHAEL F. PLAHOVINSAK, P.E. #25849  
 Sole Proprietor - Independent Engineer  
 18301 S.R. 161, Plain City, OH 43064  
 614-398-6250 / mikeempeng.com

SHEET TITLE:

ANTENNA LAYOUTS

SHEET NUMBER:

A-3



1355 WEST UNIVERSITY DRIVE  
MESA, AZ 85201-5419



16 ESQUIRE ROAD  
BILLERICA, MA 01821

PLANS PREPARED BY:



24 QUEEN ST E  
BRAMPTON, ON  
1 (519) 572-9995

NO.	DATE	DESCRIPTION	BY
A	09/17/16	FOR REVIEW	NPS
0	10/05/16	ISSUE FOR CONSTRUCTION	NPS
1	02/09/18	UPDATE AS PER REMARKS	NPS

SITE INFORMATION:

CT1015  
MERIDEN NORTH  
FA CODE: 10035234  
  
119 EMPIRE AVENUE  
MERIDEN, CT 06450

SEAL:

MICHAEL F. PLAHOVINSAK, P.E. #25849  
Sole Proprietor - Independent Engineer  
18301 S.R. 161, Plain City, OH 43064  
614-398-6250 / mikeempeng.com

SHEET TITLE:  
**TOWER ELEVATION**

SHEET NUMBER:  
**A-4**

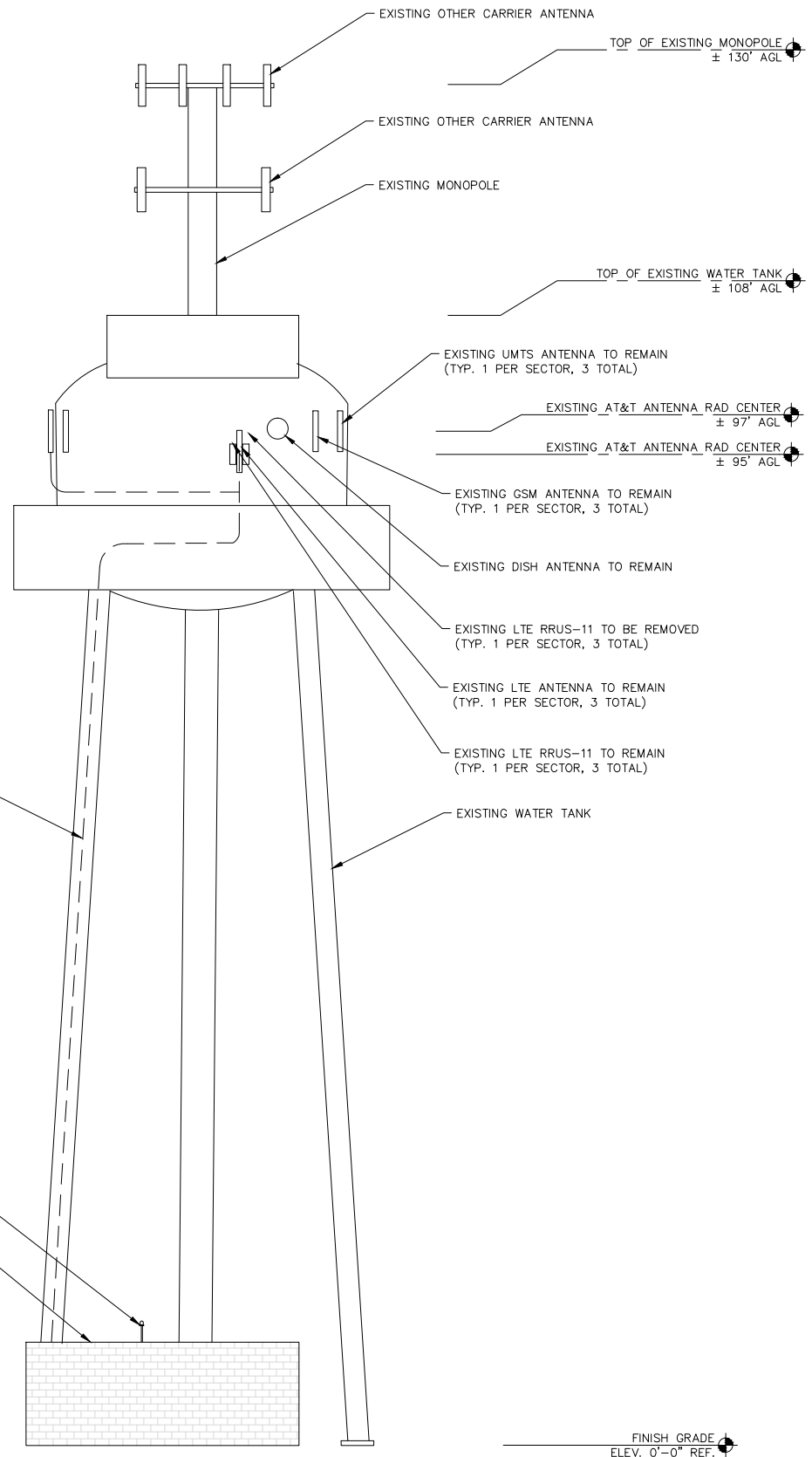

EXISTING (12) 7/8" COAX CABLE  
EXISTING (2) DC POWER TRUNK  
EXISTING (1) FIBER TRUNK

EXISTING ELEVATION

22"x34" SCALE: 1/8" = 1'-0"  
11"x17" SCALE: 1/16" = 1'-0"  
8' 6' 4' 2' 0' 8'

1 PROPOSED ELEVATION

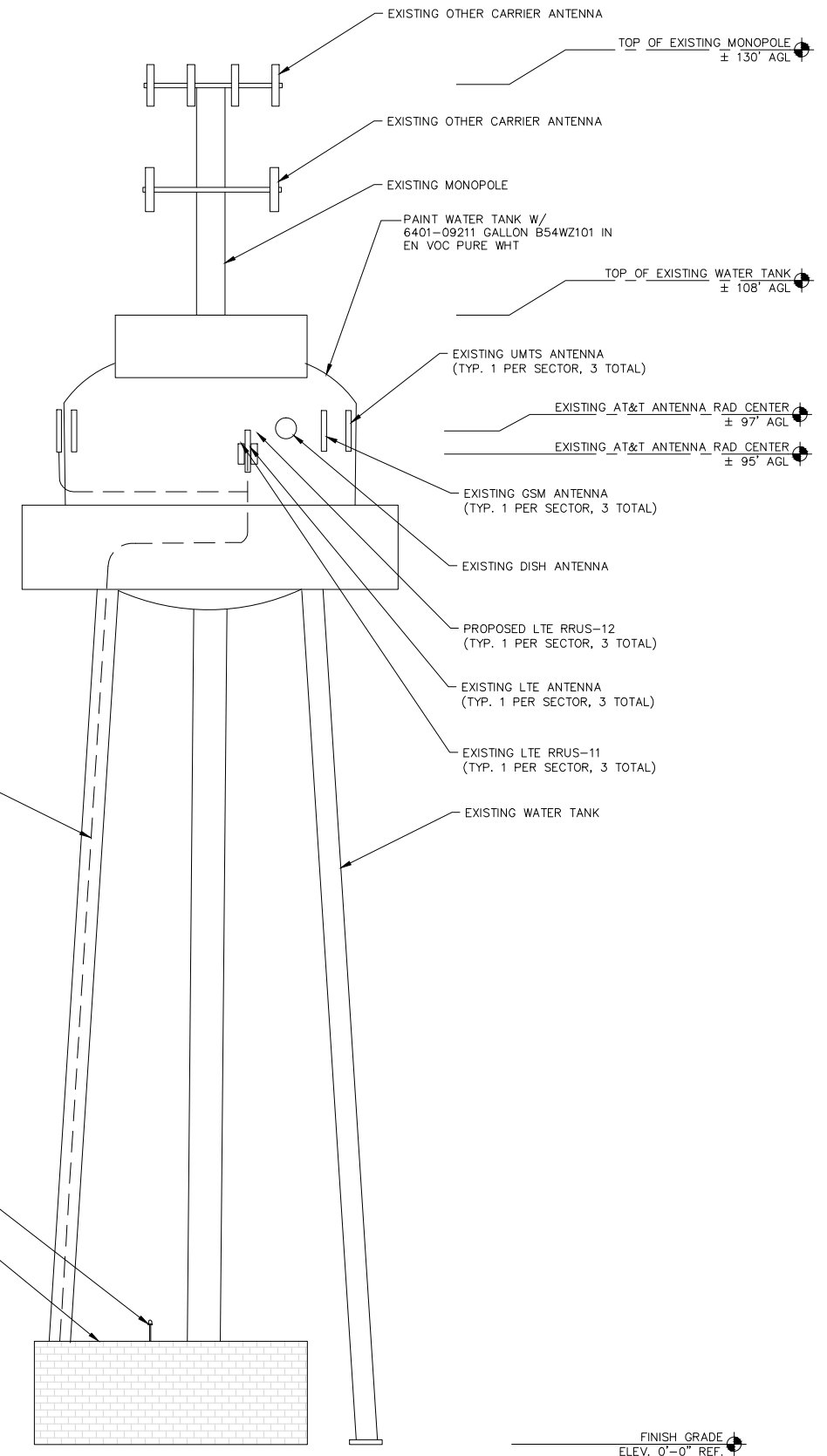

EXISTING (12) 7/8" COAX CABLE  
EXISTING (2) DC POWER TRUNK  
EXISTING (1) FIBER TRUNK

22"x34" SCALE: 1/8" = 1'-0"  
11"x17" SCALE: 1/16" = 1'-0"  
8' 6' 4' 2' 0' 8'

2

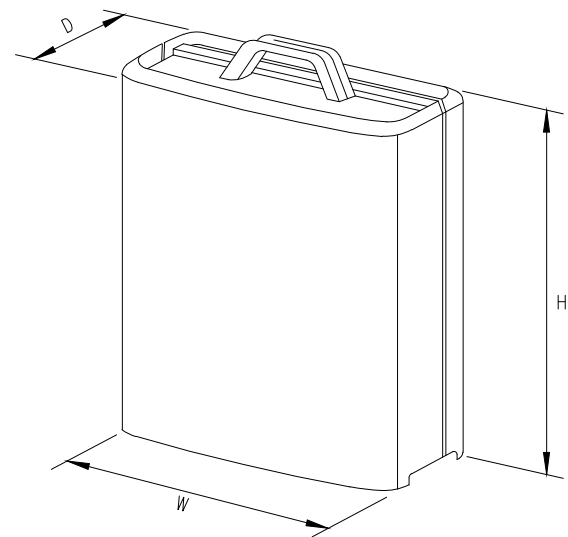

MODEL	L x W x H	WEIGHT
RRUS-11	19.69' x 16.97' x 7.17'	50.7 LBS
RRUS-12	20.4' x 18.5' x 7.5'	58 LBS
RRUS-32	29.9' x 13.3' x 9.5'	77 LBS
RRUS-32 B2	20.9' x 9.5' x 3.3'	77 LBS
RRUS-E2	20.4' x 18.5' x 7.5'	58 LBS
A2 MODULE	16.4' x 15.2' x 3.4'	22 LBS



1355 WEST UNIVERSITY DRIVE  
MESA, AZ 85201-5419



16 ESQUIRE ROAD  
BILLERICA, MA 01821

PLANS PREPARED BY:



24 QUEEN ST E  
BRAMPTON, ON  
1 (519) 572-9995

NO.	DATE	DESCRIPTION	BY
A	09/17/16	FOR REVIEW	NPS
0	10/05/16	ISSUE FOR CONSTRUCTION	NPS
1	02/09/18	UPDATE AS PER REMARKS	NPS

RRUS DETAILS

N.T.S 1

NOT USED

N.T.S 2

SITE INFORMATION:

CT1015  
MERIDEN NORTH  
FA CODE: 10035234  
  
119 EMPIRE AVENUE  
MERIDEN, CT 06450

SEAL:

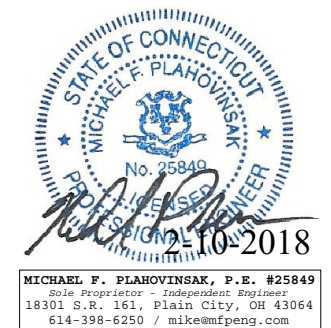

SHEET TITLE:

DETAILS

SHEET NUMBER:

A-5

NOT USED

N.T.S 3



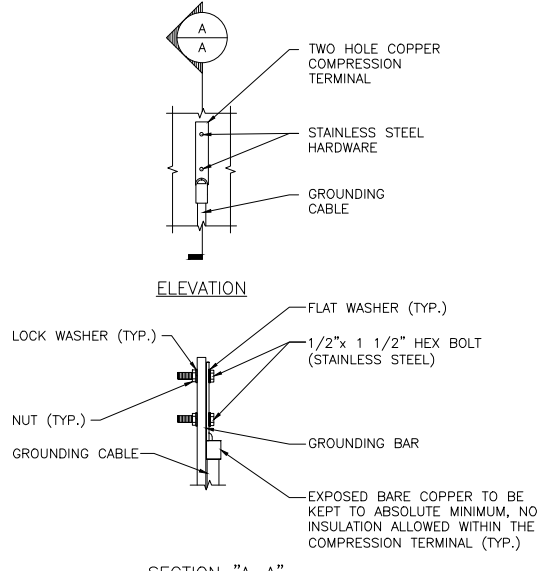
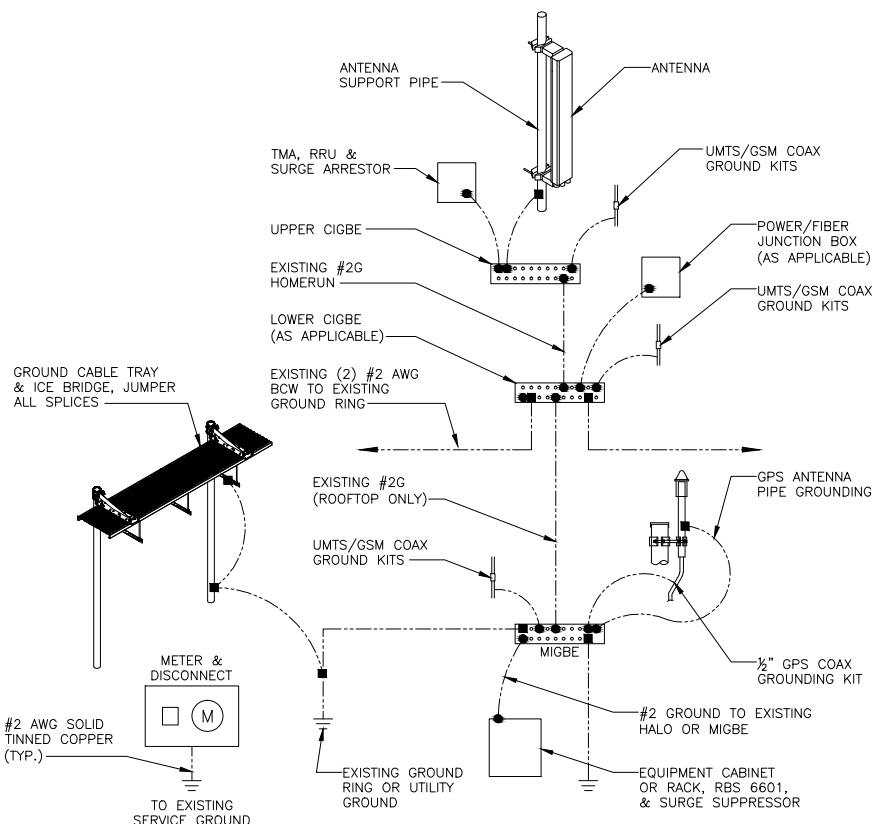
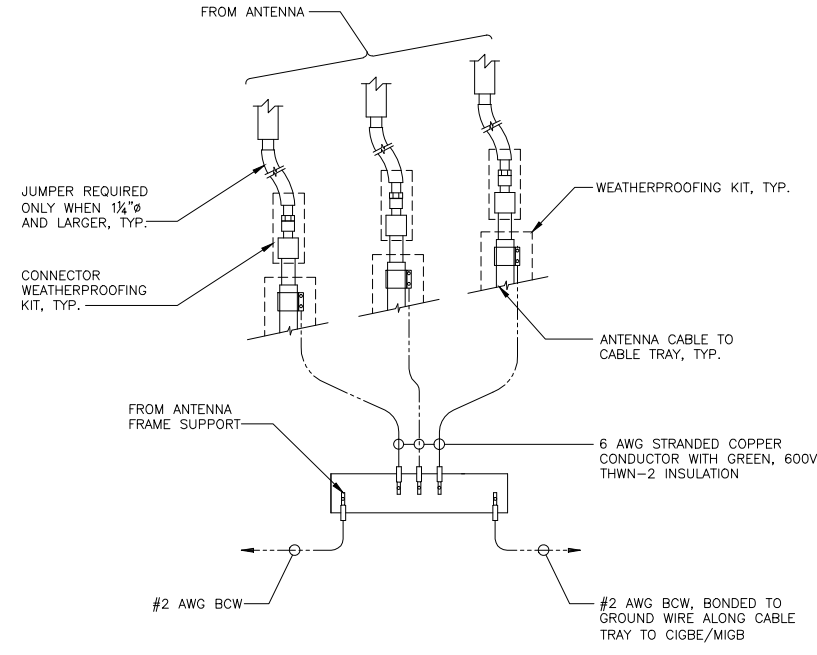

NOTE:  
 1. "DOUBLING UP" OR "STACKING" OF CONNECTIONS IS NOT PERMITTED.  
 2. OXIDE INHIBITING COMPOUND TO BE USED AT ALL LOCATIONS.  
 3. CADWELD DOWNLEADS FROM UPPER EGB, LOWER EGB, AND MGB.

ROUND WIRE TO ROUND BAR CONNECTION DETAILS

N.T.S 1

ROUND RISER DIA RAM

N.T.S 2

TYPICAL ROUND BAR CONNECTION DETAILS N.T.S 3

NO.	DATE	DESCRIPTION	BY
A	09/17/16	FOR REVIEW	NPS
0	10/05/16	ISSUE FOR CONSTRUCTION	NPS
1	02/09/18	UPDATE AS PER REMARKS	NPS

SITE INFORMATION:  
 CT1015  
 MERIDEN NORTH  
 FA CODE: 10035234  
 119 EMPIRE AVENUE  
 MERIDEN, CT 06450

SEAL:

MICHAEL F. PLAHOVINSAK, P.E. #25849  
 18301 S.W. 361, Plain City, OH 43064  
 614-398-6250 / mike@mpeng.com

SHEET TITLE:  
 ROUNDING, ONE-LINE DIA RAM DETAILS

SHEET NUMBER:  
 -1

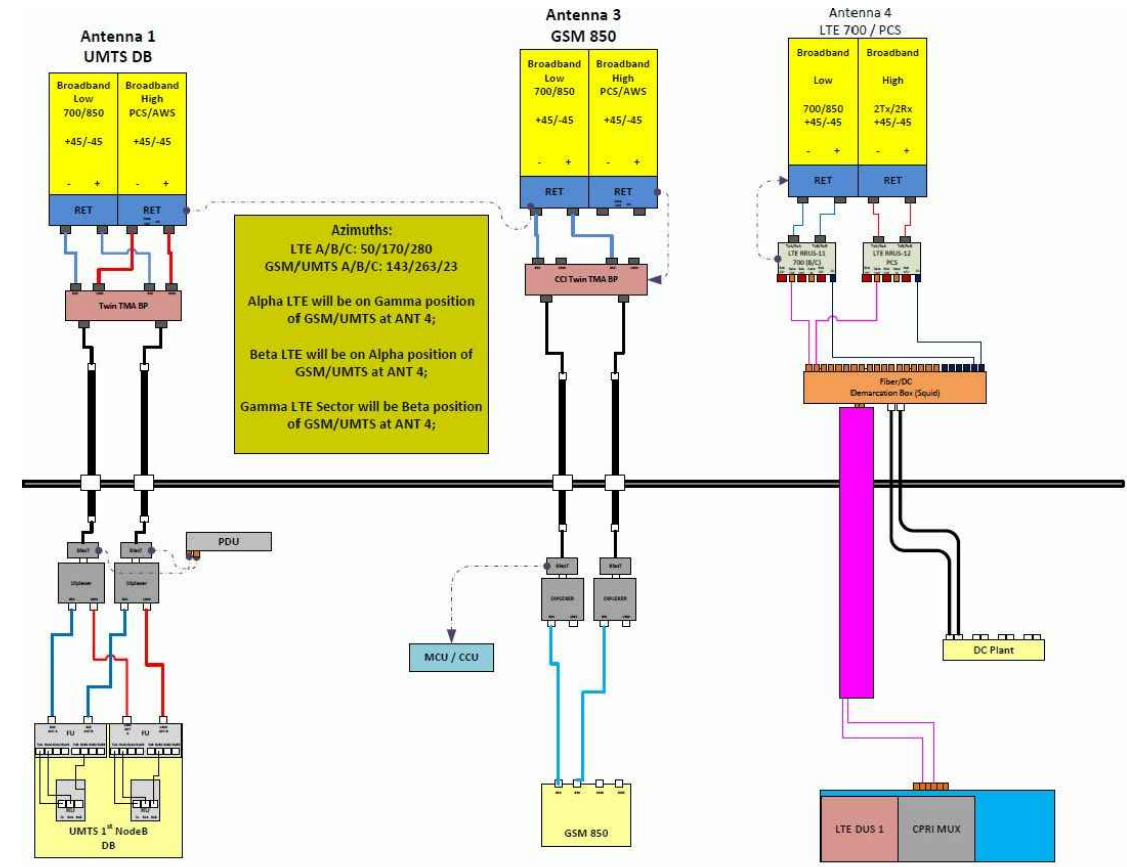

PLUMBING DIA RAM

N.T.S 4

ROUND BAR DETAILS

N.T.S 5

## Exhibit 3



# Trylon

Prepared For



## Mount Analysis



**Michael F. Plahovinsak, P.E.**

*Sole Proprietor - Independent Engineer*  
18301 SR 161, Plain City, Ohio  
614-398-6250 / mike@mfpeng.com

**MFP Project #23216-046**

Meriden North

FA10035234

10/31/2016

PASS



## MOUNT ANALYSIS REPORT

### EMPIRE TELECOM

16 Esquire Road  
Billerica, MA 01862

**Attention:** Mr. Dave Cooper

**Reference:** Analysis of the existing mounts installed at 97-ft elevation. (Trylon job No. **119643**)  
Site name: Meriden North  
FA Code: 10035234  
Site Number: CTV1015  
Site Address: 119 Empire Avenue, New Haven County, CT 06450  
Tower Profile: 106-ft Water Tank

**Dear Sir:**

We have been provided with RF information, CD's, photos and sketches of the structure for above-referenced site. AT&T is proposing to change the equipment configuration on the existing mounting hardware.

A revised antenna, coax and miscellaneous equipment schematic have been provided to us. We have been asked to evaluate this information to determine whether or not the existing structures and mounting apparatus are adequate to safely support the proposed loading change. The structural evaluation refers to the mounts installed at 97-ft elevation on the existing 106-ft water tank located at 119 Empire Avenue, New Haven County, CT 06450.

The proposed changes were provided to us in a RFDS package (dated 05/12/2016). The antennas are located at 97-ft elevation on all sectors.

The structural member sizes and lengths of the mount were considered as per previous mount analysis by Dewberry Engineers Inc., dated 5/25/2012 and drawing package dated 04/27/2012.

The existing antenna configuration consists of:

- (1) Kathrein 800 10121 antenna (54.5"x10.3"x5.9" – 50.7lbs) in position #1 on each sector,
- (1) KMW AM-X-CD-16-65-00T-RET antenna (72"x11.8"x7.4" – 48.5lbs) in position #3 on each sector,
- (1) KMW AM-X-CD-16-65-00T-RET antenna (72"x11.8"x7.4" – 48.5lbs) in position #4 on each sector,
- Additional equipment: (1) TT19-08BP111-001 Twin TMA, DTMABP7819VG12A TMA, (2) RRUS-11 and (1) DC/Fiber Squids for each sector.





The final antenna configuration considered in our analysis is:

- (1) Kathrein 800 10121 antenna (54.5”x10.3”x5.9” – 50.7lbs) in position #1 on each sector,
- (1) KMW AM-X-CD-16-65-00T-RET antenna (72”x11.8”x7.4” – 48.5lbs) in position #3 on each sector,
- (1) KMW AM-X-CD-16-65-00T-RET antenna (72”x11.8”x7.4” – 48.5lbs) in position #4 on each sector,
- Additional equipment: (1) TT19-08BP111-001 Twin TMA, DTMABP7819VG12A TMA, (1) RRUS-11, (1) RRUS-12 and (1) DC/Fiber Squids for each sector.

The existing equipment mounts we have reviewed are three individual 9’ height pipe mounts (11’ on sector alpha) fixed to the existing water tank through (3) L3x3x1/4” single angle stand-offs. For a conservative approach, we have analyzed the most loaded mount.

The previous analysis and the drawings provided contain the cross section only of bottom single angle stand-off member. We have assumed that all three stand-off members are made of L3x3x1/4”-3’ Lg.. This assumption should be verified on site before any changes will be made. If the middle and the top stand-off members have a smaller cross section than what we have assumed, we recommend to re-run the analysis.

We assume steel grade to be A36 for all members of the mounting hardware.

## **CONCLUSIONS AND RECOMMENDATIONS**

Based on information provided, our calculations conclude that the existing AT&T mounts located at 97-ft elevation on the existing water tank at the specified address, are **ADEQUATE** to safely support the proposed equipment, subject to the attached Standard Conditions on page 3.

Should you have any questions, comments or require additional information, please do not hesitate to call.

Sincerely,

Analysis performed by:

Adrian Vintilescu  
Trylon Engineer

Reviewed by:

  
Michael Plahovinsak, P.E.



### **Standard Conditions for Providing Structural Consulting Services on Existing Structures**

1. Mounting hardware is analyzed to the best of our ability using all information that is provided or can be obtained during fieldwork (if authorized by client). If the existing conditions are not as we have represented in this analysis, we should be contacted to evaluate the significance of the deviation and revise the assessment accordingly.
2. The structural analysis has been performed assuming that hardware is in "like new" condition. No allowance was made for excessive corrosion, damaged or missing structural members, loose bolts, misaligned parts, or any reduction in strength due to the age or fatigue of the product.
3. The structural analysis provided is an assessment of the primary load carrying capacity of the hardware. We provide a limited scope of service. In some cases we cannot verify the capacity of every weld, plate, connection detail, etc. In some cases, structural fabrication details are unknown at the time of our analysis, and the detailed field measurement of some of the required details may not be possible. In instances where we cannot perform connection capacity calculations, it is assumed that the existing manufactured connections develop the full capacity of the primary members being connected.
4. We cannot be held responsible for mounting hardware that is installed improperly or hardware that is loose or has a tendency of working loose over the lifetime of the mounting hardware. Our analysis has been performed assuming fully tightened connections, and proper installation and symmetry of the mounting hardware per manufacturer's instructions.
5. The structural analysis has been performed using information currently provided by the client and potentially field verified. We have been provided with a mounting arrangement for all telecommunications equipment, including antennas RRH's, TMA's, RRU's, diplexers, surge protection devices, etc. Our analysis has been based upon a particular mounting arrangement. We are not responsible for deviations in the mounting arrangement that may occur over time. If deviations in equipment type or mounting arrangements are proposed, then we should be contacted to revise the recommendations of this structural report.
6. We cannot be held responsible for temporary and unbalanced loads on mounting hardware. Our analysis is based on a particular mounting arrangement or as-built field condition. We are not responsible for the methods and means of how the mounting arrangement is accomplished by the contractor. These methods and means may include rigging of equipment or hardware to lift and locate, temporary hanging of equipment in locations other than the final arrangement, movement and tie off of tower riggers, personnel, and their equipment, etc.
7. Steel grade and strength is unknown and cannot be field tested. We cannot be held responsible for equipment manufactured from inferior steel or bolts. Our analysis assumes that standard structural grade steel has been used by the equipment manufacturer for all assembled parts of the mounting apparatus. Acceptable steels and connection components are specified by the American Institute of Steel Construction. It is assumed all welded connections are performed in the shop under the latest American Welding Society Code. No field welds are permitted or assumed for the existing pre-manufactured equipment.

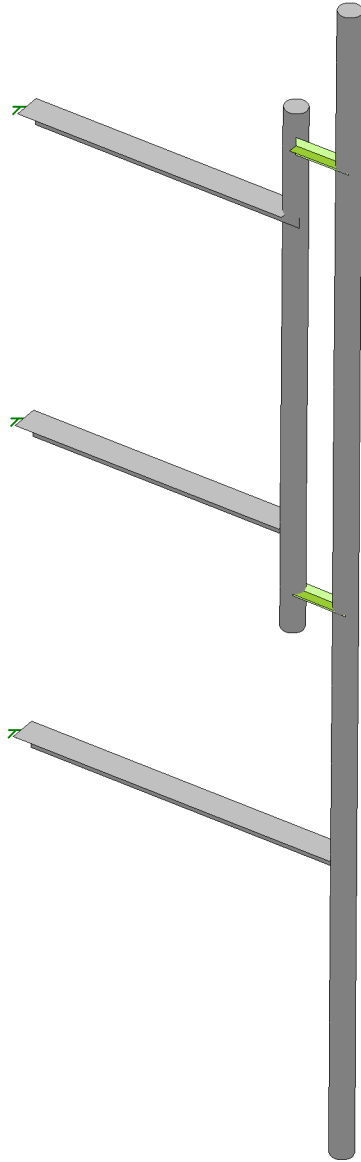
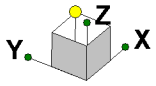

Trylon

AV

119643

CTV1015 - Meriden North

SK - 1

Oct 31, 2016 at 3:19 PM

119643.R3D

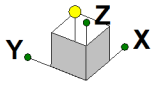

Section Sets

- L3x3x1/4
- Pipe 2.375" O.D.
- RIGID

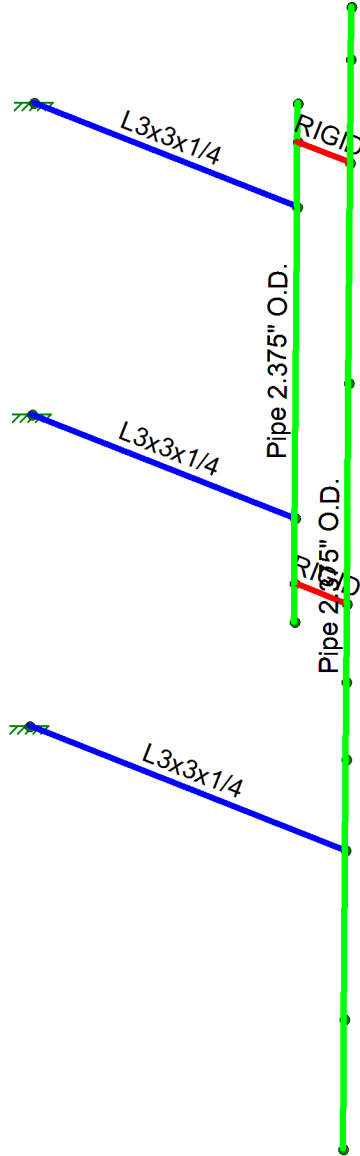

Trylon

AV

119643

CTV1015 - Meriden North

SK - 2

Oct 31, 2016 at 3:19 PM

119643.R3D



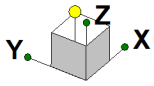

Material Sets

- RIGID
- A36 Gr.36

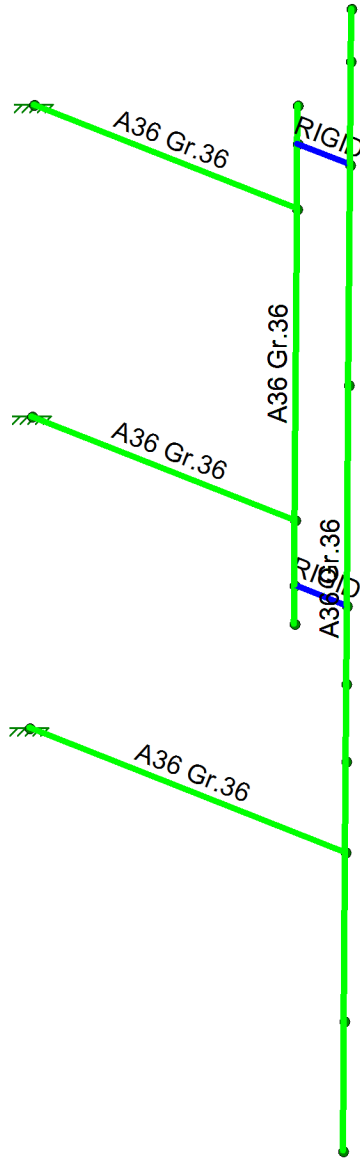

Trylon

AV

119643

CTV1015 - Meriden North

SK - 3

Oct 31, 2016 at 3:20 PM

119643.R3D

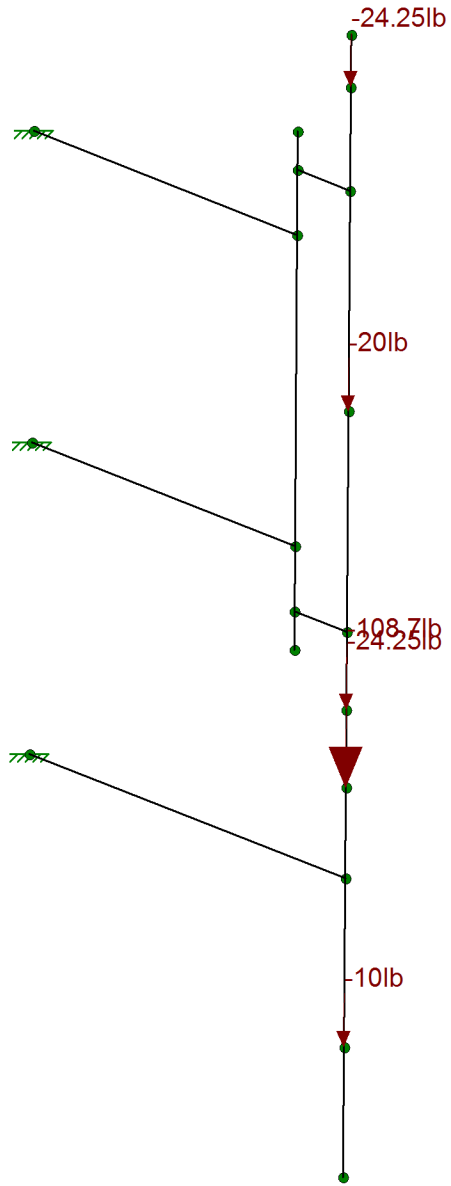
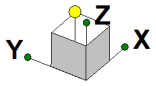

Loads: BLC 2, Weight

Trylon

AV

119643

CTV1015 - Meriden North

SK - 5

Oct 31, 2016 at 3:22 PM

119643.R3D

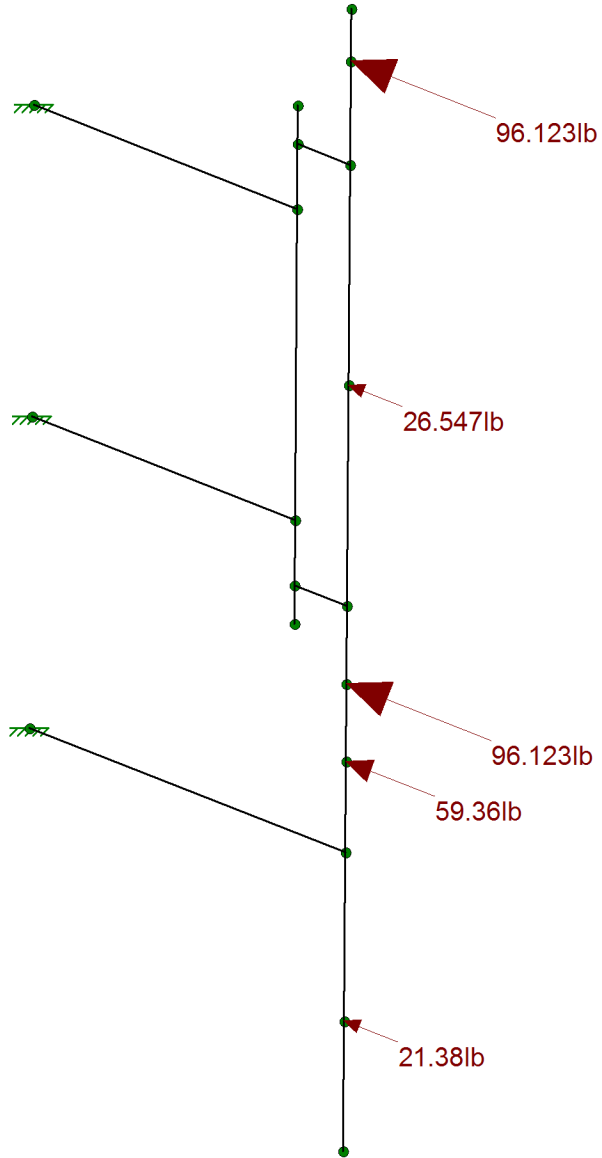
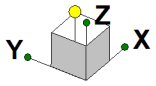

Loads: BLC 3, Frontal Wind

Trylon	CTV1015 - Meriden North	SK - 6
AV		Oct 31, 2016 at 3:22 PM
119643		119643.R3D

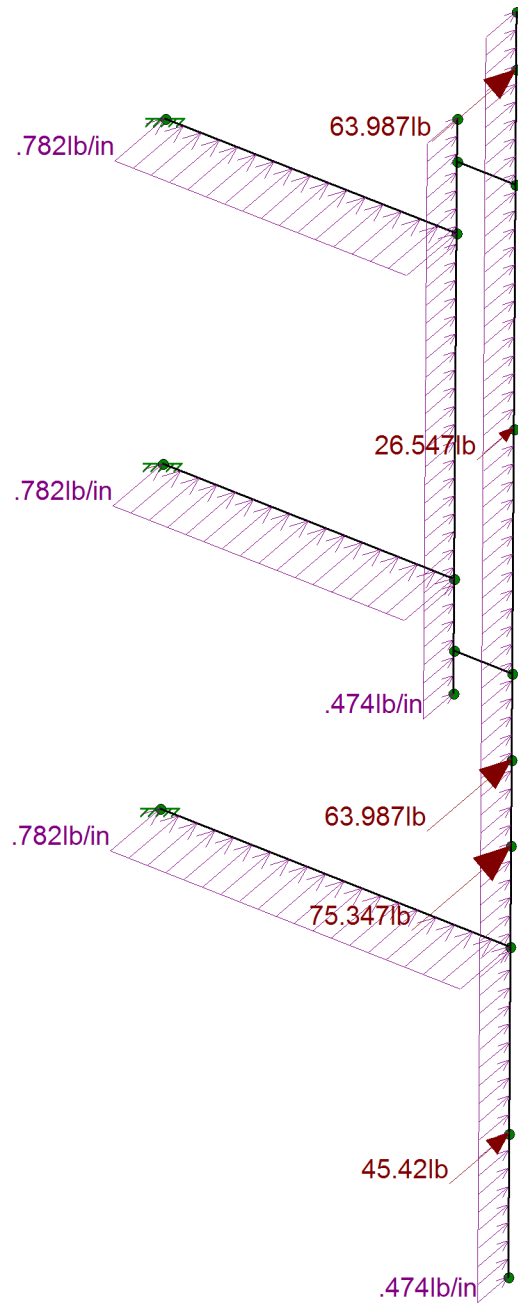
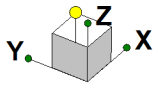

Loads: BLC 4, Lateral Wind

Trylon	CTV1015 - Meriden North	SK - 1
AV		Oct 31, 2016 at 3:29 PM
119643		119643.R3D



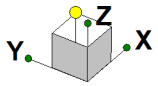

Code Check  
( Env )

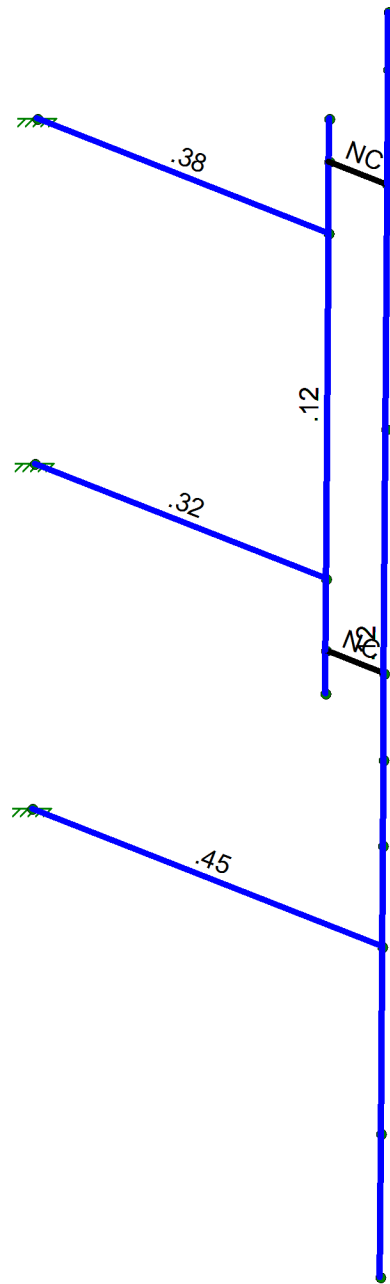
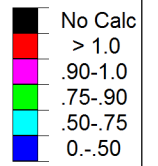

Member Code Checks Displayed (Enveloped)  
Results for LC 1, We+FW

Trylon	CTV1015 - Meriden North	SK - 2
AV		Oct 31, 2016 at 3:30 PM
119643		119643.R3D



TRYLON JOB NO. : 120643  
 SITE NAME : I 20/Gordon JCT  
 FA CODE : 10042487  
 Design by :

State : Connecticut  
 County : New Haven

V = 96 mph  
 V<sub>i</sub> = 50 mph  
 t<sub>i</sub> = 0.75 in  
 z = 97 ft

STRUCTURE CLASS:	I for W <sub>o</sub>	I for W <sub>i</sub>	I for t <sub>iz</sub>
	1	1	1
EXPOSURE CATEGORY:	z <sub>g</sub> (ft)	α	K <sub>zmin</sub>
	900	9.5	0.85
	C		1.258
TOPOGRAPHIC CATEGORY:	K <sub>t</sub>	f	K <sub>h</sub>
	1	1	-
			1.000
Height of crest :	H =	0 ft --> only for cat. 2,3,4	
Wind direction prob. factor :	K <sub>d</sub> =	0.95	
Wind pressure without ice :	q <sub>z</sub> =	28.185 lb/ft <sup>2</sup>	0.196 lb/in <sup>2</sup>
Wind pressure with ice :	q <sub>z</sub> =	7.646 lb/ft <sup>2</sup>	0.053 lb/in <sup>2</sup>
Gust factor :	G <sub>h</sub> =	0.85	
Ice thickness :	t <sub>iz</sub> =	1.671 in	

**WIND FORCES FRONTAL DIRECTION - NO ICE**

ELEMENT TYPE	DESCRIPTION	Flat or Round	Length of Normal Face [in]	Width of Normal Face [in]	Length of Transversal Face [in]	Width of Transversal Face [in]	θ (wind direction from normal face) [°]	A <sub>N</sub> [in <sup>2</sup> ]	A <sub>T</sub> [in <sup>2</sup> ]	K <sub>a</sub>	Aspect Ratio Normal	Aspect Ratio Transversal	C <sub>aN</sub>	C <sub>aT</sub>	Wind Force Frontal [lbs]	Wind Force Frontal distributed [lbs/in]	Weight [lbs]
Antenna/RRU/TMA	Kathrein 800 10121	F	54.5	10.3	54.5	5.9	0	561.35	321.55	1	5.291	9.237	1.324	1.475	123.658	-	50.70
Antenna/RRU/TMA	KMW AM-X-CD-16-65-00T-RET	F	72	11.8	72	7.1	0	849.60	511.20	1	6.102	10.141	1.360	1.505	192.246	-	48.50
Antenna/RRU/TMA	RRUS-11	F	19.7	17	19.7	7.2	90	334.90	141.84	1	1.159	2.736	1.200	1.210	28.565	-	50.70
Antenna/RRU/TMA	RRUS-12	F	20.4	18.5	20.4	7.5	90	377.40	153.00	1	1.103	2.720	1.200	1.210	30.795	-	58.00
Antenna/RRU/TMA	DC/Fiber Squid	R	23.5	9.7	23.5	9.7	0	227.95	227.95	1	2.423	2.423	0.700	0.700	26.547	-	20.00
Antenna/RRU/TMA	Fiber Power Conector	F	16.25	14	16.25	6.59	90	227.50	107.09	1	1.161	2.466	1.200	1.200	21.380	-	10.00
Pipe	Pipe 2.375"x0.154"	R	132	2.375	132	2.375	0	313.50	313.50	1	55.579	55.579	1.200	1.200	62.589	0.474	
Equal Angle	L3x3x1/4	F	36	3	36	3	0	108.00	108.00	1	12.000	12.000	1.567	1.567	28.150	0.782	

**WIND FORCES LATERAL DIRECTION - NO ICE**

ELEMENT TYPE	DESCRIPTION	Flat or Round	Length of Normal Face [in]	Width of Normal Face [in]	Length of Transversal Face [in]	Width of Transversal Face [in]	θ (wind direction from normal face) [°]	A <sub>N</sub> [in <sup>2</sup> ]	A <sub>T</sub> [in <sup>2</sup> ]	K <sub>a</sub>	Aspect Ratio Normal	Aspect Ratio Transversal	C <sub>aN</sub>	C <sub>aT</sub>	Wind Force Lateral [lbs]	Wind Force Lateral distributed [lbs/in]	Weight [lbs]
Antenna/RRU/TMA	Kathrein 800 10121	F	54.5	10.3	54.5	5.9	90	561.35	321.55	1	5.291	9.237	1.324	1.475	78.885	-	50.70
Antenna/RRU/TMA	KMW AM-X-CD-16-65-00T-RET	F	72	11.8	72	7.1	90	849.60	511.20	1	6.102	10.141	1.360	1.505	127.973	-	48.50
Antenna/RRU/TMA	RRUS-11	F	19.7	17	19.7	7.2	0	334.90	141.84	1	1.159	2.736	1.200	1.210	66.862	-	50.70
Antenna/RRU/TMA	RRUS-12	F	20.4	18.5	20.4	7.5	0	377.40	153.00	1	1.103	2.720	1.200	1.210	75.347	-	58.00
Antenna/RRU/TMA	DC/Fiber Squid	R	23.5	9.7	23.5	9.7	90	227.95	227.95	1	2.423	2.423	0.700	0.700	26.547	-	20.00
Antenna/RRU/TMA	Fiber Power Conector	F	16.25	14	16.25	6.59	0	227.50	107.09	1	1.161	2.466	1.200	1.200	45.420	-	10.00
Pipe	Pipe 2.375"x0.154"	R	132	2.375	132	2.375	90	313.50	313.50	1	55.579	55.579	1.200	1.200	62.589	0.474	
Pipe	L3x3x1/4	F	36	3	36	3	90	108.00	108.00	1	12.000	12.000	1.567	1.567	28.150	0.782	

[ASCE 7 Windspeed](#)
[ASCE 7 Ground Snow Load](#)
[Related Resources](#)
[Sponsors](#)
[About ATC](#)
[Contact](#)

## Search Results

**Query Date:** Mon Oct 31 2016

**Latitude:** 41.5730

**Longitude:** -72.7792

**ASCE 7-10 Windspeeds  
(3-sec peak gust in mph\*):**

**Risk Category I:** 113

**Risk Category II:** 124

**Risk Category III-IV:** 133

**MRI\*\* 10-Year:** 77

**MRI\*\* 25-Year:** 87

**MRI\*\* 50-Year:** 93

**MRI\*\* 100-Year:** 100

**ASCE 7-05 Windspeed:**

103 (3-sec peak gust in mph)

**ASCE 7-93 Windspeed:**

81 (fastest mile in mph)

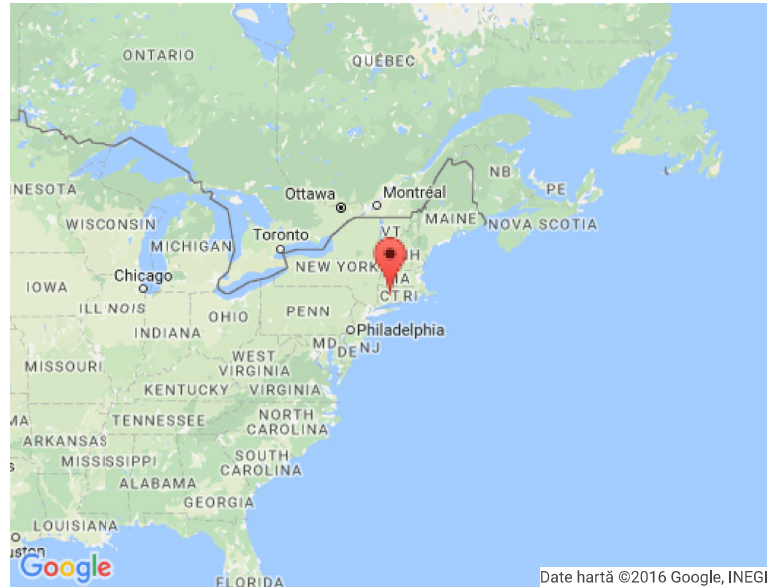

\*Miles per hour

\*\*Mean Recurrence Interval

Users should consult with local building officials to determine if there are community-specific wind speed requirements that govern.



[Print your results](#)

### WINDSPEED WEBSITE DISCLAIMER

While the information presented on this website is believed to be correct, ATC and its sponsors and contributors assume no responsibility or liability for its accuracy. The material presented in the windspeed report should not be used or relied upon for any specific application without competent examination and verification of its accuracy, suitability and applicability by engineers or other licensed professionals. ATC does not intend that the use of this information replace the sound judgment of such competent professionals, having experience and knowledge in the field of practice, nor to substitute for the standard of care required of such professionals in interpreting and applying the results of the windspeed report provided by this website. Users of the information from this website assume all liability arising from such use. Use of the output of this website does not imply approval by the governing building code bodies responsible for building code approval and interpretation for the building site described by latitude/longitude location in the windspeed load report.

## Exhibit 4



## RADIO FREQUENCY EMISSIONS ANALYSIS REPORT EVALUATION OF HUMAN EXPOSURE POTENTIAL TO NON-IONIZING EMISSIONS

AT&T Existing Facility

Site ID: CT1015

Meriden North  
119 Empire Avenue  
Meriden, CT 06450

**November 17, 2016**

**EBI Project Number: 6216005194**

Site Compliance Summary	
Compliance Status:	<b>COMPLIANT</b>
Site total MPE% of FCC general public allowable limit:	<b>12.95 %</b>





November 17, 2016

AT&T Mobility – New England  
Attn: Cameron Syme, RF Manager  
550 Cochituate Road  
Suite 550 – 13&14  
Framingham, MA 06040

## Emissions Analysis for Site: **CT1015 – Meriden North**

EBI Consulting was directed to analyze the proposed AT&T facility located at **119 Empire Avenue, Meriden, CT**, for the purpose of determining whether the emissions from the Proposed AT&T Antenna Installation located on this property are within specified federal limits.

All information used in this report was analyzed as a percentage of current Maximum Permissible Exposure (% MPE) as listed in the FCC OET Bulletin 65 Edition 97-01 and ANSI/IEEE Std C95.1. The FCC regulates Maximum Permissible Exposure in units of microwatts per square centimeter ( $\mu\text{W}/\text{cm}^2$ ). The number of  $\mu\text{W}/\text{cm}^2$  calculated at each sample point is called the power density. The exposure limit for power density varies depending upon the frequencies being utilized. Wireless Carriers and Paging Services use different frequency bands each with different exposure limits, therefore it is necessary to report results and limits in terms of percent MPE rather than power density.

All results were compared to the FCC (Federal Communications Commission) radio frequency exposure rules, 47 CFR 1.1307(b)(1) – (b)(3), to determine compliance with the Maximum Permissible Exposure (MPE) limits for General Population/Uncontrolled environments as defined below.

General population/uncontrolled exposure limits apply to situations in which the general public may be exposed or in which persons who are exposed as a consequence of their employment may not be made fully aware of the potential for exposure or cannot exercise control over their exposure. Therefore, members of the general public would always be considered under this category when exposure is not employment related, for example, in the case of a telecommunications tower that exposes persons in a nearby residential area.

Public exposure to radio frequencies is regulated and enforced in units of microwatts per square centimeter ( $\mu\text{W}/\text{cm}^2$ ). The general population exposure limits for the 700 and 850 MHz Bands are approximately  $467 \mu\text{W}/\text{cm}^2$  and  $567 \mu\text{W}/\text{cm}^2$  respectively. The general population exposure limit for the 1900 MHz (PCS), 2100 MHz (AWS) and 2300 MHz (WCS) bands is  $1000 \mu\text{W}/\text{cm}^2$ . Because each carrier will be using different frequency bands, and each frequency band has different exposure limits, it is necessary to report percent of MPE rather than power density.



Occupational/controlled exposure limits apply to situations in which persons are exposed as a consequence of their employment and in which those persons who are exposed have been made fully aware of the potential for exposure and can exercise control over their exposure. Occupational/controlled exposure limits also apply where exposure is of a transient nature as a result of incidental passage through a location where exposure levels may be above general population/uncontrolled limits (see below), as long as the exposed person has been made fully aware of the potential for exposure and can exercise control over his or her exposure by leaving the area or by some other appropriate means.

Additional details can be found in FCC OET 65.

## CALCULATIONS

Calculations were done for the proposed AT&T Wireless antenna facility located at **119 Empire Avenue, Meriden, CT**, using the equipment information listed below. All calculations were performed per the specifications under FCC OET 65. Since AT&T is proposing highly focused directional panel antennas, which project most of the emitted energy out toward the horizon, all calculations were performed assuming a lobe representing the maximum gain of the antenna per the antenna manufactures supplied specifications, minus 10 dB, was focused at the base of the tower. For this report the sample point is the top of a 6-foot person standing at the base of the tower.

For all calculations, all equipment was calculated using the following assumptions:

- 1) 2 UMTS channels (850 MHz) were considered for each sector of the proposed installation. These Channels have a transmit power of 30 Watts per Channel.
- 2) 2 UMTS channels (1900 MHz (PCS)) were considered for each sector of the proposed installation. These Channels have a transmit power of 30 Watts per Channel.
- 3) 2 GSM channels (850 MHz) were considered for each sector of the proposed installation. These Channels have a transmit power of 30 Watts per Channel.
- 4) 2 LTE channels (700 MHz) were considered for each sector of the proposed installation. These Channels have a transmit power of 60 Watts per Channel.
- 5) All radios at the proposed installation were considered to be running at full power and were uncombined in their RF transmissions paths per carrier prescribed configuration. Per FCC OET Bulletin No. 65 - Edition 97-01 recommendations to achieve the maximum anticipated value at each sample point, all power levels emitting from the proposed antenna installation are increased by a factor of 2.56 to account for possible in-phase reflections from the surrounding environment. This is rarely the case, and if so, is never continuous.



- 6) For the following calculations the sample point was the top of a 6-foot person standing at the base of the tower. The maximum gain of the antenna per the antenna manufactures supplied specifications minus 10 dB was used in this direction. This value is a very conservative estimate as gain reductions for these particular antennas are typically much higher in this direction.
- 7) The antennas used in this modeling are the **Kathrein 800-10121** and the **KMW AM-X-CD-16-65-00T-RET** for transmission in the 700 MHz, 850 MHz and 1900 MHz (PCS) frequency bands. This is based on feedback from the carrier with regards to anticipated antenna selection. Maximum gain values for all antennas are listed in the Inventory and Power Data table below. The maximum gain of the antenna per the antenna manufactures supplied specifications, minus 10 dB, was used for all calculations. This value is a very conservative estimate as gain reductions for these particular antennas are typically much higher in this direction.
- 8) The antenna mounting height centerlines of the proposed antennas are **97 feet** above ground level (AGL) for **Sector A**, **97 feet** above ground level (AGL) for **Sector B** and **97 feet** above ground level (AGL) for Sector C.
- 9) Emissions values for additional carriers were taken from the Connecticut Siting Council active database. Values in this database are provided by the individual carriers themselves.

All calculations were done with respect to uncontrolled / general public threshold limits.



## AT&T Site Inventory and Power Data by Antenna

Sector:	A	Sector:	B	Sector:	C
Antenna #:	1	Antenna #:	1	Antenna #:	1
Make / Model:	Kathrein 800-10121	Make / Model:	Kathrein 800-10121	Make / Model:	Kathrein 800-10121
Gain:	11.45 / 14.35 dBd	Gain:	11.45 / 14.35 dBd	Gain:	11.45 / 14.35 dBd
Height (AGL):	97 feet	Height (AGL):	97 feet	Height (AGL):	97 feet
Frequency Bands	850 MHz / 1900 MHz (PCS)	Frequency Bands	850 MHz / 1900 MHz (PCS)	Frequency Bands	850 MHz / 1900 MHz (PCS)
Channel Count	4	Channel Count	4	Channel Count	4
Total TX Power(W):	120 Watts	Total TX Power(W):	120 Watts	Total TX Power(W):	120 Watts
ERP (W):	2,471.44	ERP (W):	2,471.44	ERP (W):	2,471.44
Antenna A1 MPE%	1.35 %	Antenna B1 MPE%	1.35 %	Antenna C1 MPE%	1.35 %
Antenna #:	2	Antenna #:	2	Antenna #:	2
Make / Model:	KMW AM-X-CD-16-65-00T-RET	Make / Model:	KMW AM-X-CD-16-65-00T-RET	Make / Model:	KMW AM-X-CD-16-65-00T-RET
Gain:	13.85 dBd	Gain:	13.85 dBd	Gain:	13.85 dBd
Height (AGL):	97 feet	Height (AGL):	97 feet	Height (AGL):	97 feet
Frequency Bands	850 MHz	Frequency Bands	850 MHz	Frequency Bands	850 MHz
Channel Count	2	Channel Count	2	Channel Count	2
Total TX Power(W):	60 Watts	Total TX Power(W):	60 Watts	Total TX Power(W):	60 Watts
ERP (W):	1,455.97	ERP (W):	1,455.97	ERP (W):	1,455.97
Antenna A2 MPE%	1.11 %	Antenna B2 MPE%	1.11 %	Antenna C2 MPE%	1.11 %
Antenna #:	3	Antenna #:	3	Antenna #:	3
Make / Model:	KMW AM-X-CD-16-65-00T-RET	Make / Model:	KMW AM-X-CD-16-65-00T-RET	Make / Model:	KMW AM-X-CD-16-65-00T-RET
Gain:	13.35 / 15.25 dBd	Gain:	13.35 / 15.25 dBd	Gain:	13.35 / 15.25 dBd
Height (AGL):	97 feet	Height (AGL):	97 feet	Height (AGL):	97 feet
Frequency Bands	700 MHz / 1900 MHz (PCS)	Frequency Bands	700 MHz / 1900 MHz (PCS)	Frequency Bands	700 MHz / 1900 MHz (PCS)
Channel Count	4	Channel Count	4	Channel Count	4
Total TX Power(W):	240 Watts	Total TX Power(W):	240 Watts	Total TX Power(W):	240 Watts
ERP (W):	6,614.85	ERP (W):	6,614.85	ERP (W):	6,614.85
Antenna A3 MPE%	4.16 %	Antenna B3 MPE%	4.16 %	Antenna C3 MPE%	4.16 %

Site Composite MPE%	
Carrier	MPE%
AT&T – Max per sector	6.62 %
Cingular	1.47 %
Nextel	1.09 %
Sprint	0.76 %
Verizon	2.83 %
Clearwire	0.18 %
<b>Site Total MPE %:</b>	<b>12.95 %</b>

AT&T Sector A Total:	6.62 %
AT&T Sector B Total:	6.62 %
AT&T Sector C Total:	6.62 %
<b>Site Total:</b>	<b>12.95 %</b>

AT&T _ Frequency Band / Technology Per Sector	# Channels	Watts ERP (Per Channel)	Height (feet)	Total Power Density ( $\mu\text{W}/\text{cm}^2$ )	Frequency (MHz)	Allowable MPE ( $\mu\text{W}/\text{cm}^2$ )	Calculated % MPE
AT&T 850 MHz UMTS	2	418.91	97	3.64	850 MHz	567	0.64%
AT&T 1900 MHz (PCS) UMTS	2	816.81	97	7.09	1900 MHz (PCS)	1000	0.71%
AT&T 850 MHz GSM	2	727.98	97	6.32	850 MHz	567	1.11%
AT&T 700 MHz LTE	2	1,297.63	97	11.27	700 MHz	467	2.41%
AT&T 1900 MHz (PCS) LTE	2	2,009.79	97	17.45	1900 MHz (PCS)	1000	1.75%
						Total:	6.62%



## Summary

All calculations performed for this analysis yielded results that were **within** the allowable limits for general public exposure to RF Emissions.

The anticipated maximum composite contributions from the AT&T facility as well as the site composite emissions value with regards to compliance with FCC's allowable limits for general public exposure to RF Emissions are shown here:

AT&T Sector	Power Density Value (%)
Sector A:	6.62 %
Sector B:	6.62 %
Sector C:	6.62 %
AT&T Maximum Total (per sector):	6.62 %
Site Total:	12.95 %
Site Compliance Status:	<b>COMPLIANT</b>

The anticipated composite MPE value for this site assuming all carriers present is **12.95 %** of the allowable FCC established general public limit sampled at the ground level. This is based upon values listed in the Connecticut Siting Council database for existing carrier emissions.

FCC guidelines state that if a site is found to be out of compliance (over allowable thresholds), that carriers over a 5% contribution to the composite value will require measures to bring the site into compliance. For this facility, the composite values calculated were well within the allowable 100% threshold standard per the federal government.