



**QC Development**

PO Box 916

Storrs, CT 06268

860-670-9068

Mark.Roberts@QCDevelopment.net

September 9, 2016

Melanie A. Bachman  
Acting Executive Director  
Connecticut Siting Council  
10 Franklin Square  
New Britain, CT 06051

**Notice of Exempt Modification – New Cingular Wireless PCS, LLC (AT&T)**  
**17 Cottage Road, Madison, CT 06443 – AT&T SITE # CT2517**  
**N 41-16-33.64**  
**W 72-33-41.50**

Dear Ms. Bachman:

AT&T currently maintains nine (9) antennas at the 127-foot level of the existing 130-foot Monopole at 17 Cottage Road, Madison, CT. The tower is owned by SBA and the property is owned by Paul Stonehart. AT&T now intends to remove three (3) Powerwave antennas and install three (3) Andrew antennas. AT&T also intends to remove and replace three (3) existing Ericsson RRUS-11 radio heads and install three (3) Ericsson RRUS-12 B2 radio heads, also at the 127-foot level.

This facility was approved by the Siting Council, Docket 333 on September 25, 2007. There were no conditions that could feasibly be violated by this modification, including total facility height or mounting restrictions. This modification therefore complies with the aforementioned approval.

Please accept this letter as notification pursuant to Regulations of Connecticut State Agencies § 16-50j-73, for construction that constitutes an exempt modification pursuant to R.C.S.A. § 16-50j-72(b)(2). In accordance with R.C.S.A. § 16-50j-73, a copy of this letter is being sent to Tom Banisch, First Selectman of the Town of Madison, as well as the property and tower owner.

The planned modifications to the facility fall squarely within those activities explicitly provided for in R.C.S.A. § 16-50j-72(b)(2).

1. The proposed modifications will not result in an increase in the height of the existing structure.
2. The proposed modifications will not require the extension of the site boundary.
3. The proposed modifications will not increase noise levels at the facility by six decibels or more, or to levels that exceed state and local criteria.
4. The operation of the replacement antennas will not increase radio frequency emissions at the facility to a level at or above the Federal Communications Commission safety standard.
5. The proposed modifications will not cause a change or alteration in the physical or environmental characteristics of the site.
6. The existing structure and its foundation can support the proposed loading.

For the foregoing reasons, AT&T respectfully submits that the proposed modifications to the above-referenced telecommunications facility constitute an exempt modification under R.C.S.A. § 16-50j-72(b)(2).

Please feel free to call me at (860) 670-9068 with any questions regarding this matter. Thank you for your consideration.

Sincerely,

A handwritten signature in black ink, appearing to read 'MR', with a large, stylized flourish extending from the end of the signature.

Mark Roberts  
QC Development  
Consultant for AT&T

Attachments

cc: Mr. Tom Banisch - as elected official (via e-mail)  
SBA - as tower owner (via e-mail)  
Paul Stonehart – as property owner

## Power Density

### Existing Loading on Tower

Carrier	# of Channels	ERP/Ch (W)	Antenna Centerline Height (ft)	Power Density (mW/cm <sup>2</sup> )	Freq. Band (MHz <sup>**</sup> )	Limit S (mW/cm <sup>2</sup> )	%MPE
Other Carriers*							4.58%
AT&T GSM	2	443	127	0.0218	880	0.5867	0.37%
AT&T UMTS	1	428	127	0.0105	1900	1.0000	0.11%
AT&T UMTS	1	500	127	0.0123	880	0.5867	0.21%
AT&T LTE	1	500	127	0.0123	700	0.4667	0.12%
AT&T LTE	1	500	127	0.0123	1900	1.0000	0.26%
Site Total							5.65%

\*Per CSC Records (available upon request, includes calculation formulas)

\*\* If a range of frequencies are used, such as 880-894, enter the lowest value, i.e. 880

### Proposed Loading on Tower

Carrier	# of Channels	ERP/Ch (W)	Antenna Centerline Height (ft)	Power Density (mW/cm <sup>2</sup> )	Freq. Band (MHz <sup>**</sup> )	Limit S (mW/cm <sup>2</sup> )	%MPE
Other Carriers*							4.58%
AT&T GSM	1	150	127	0.0037	880	0.5867	0.06%
AT&T UMTS	2	331	127	0.0163	880	0.5867	0.16%
AT&T UMTS	1	437	127	0.0107	1900	1.0000	0.11%
AT&T LTE	1	1476	127	0.0363	700	0.4667	0.78%
AT&T LTE	1	2421	127	0.0595	1900	1.0000	1.27%
Site Total							6.96%

\*Per CSC Records (available upon request, includes calculation formulas)

\*\* If a range of frequencies are used, such as 880-894, enter the lowest value, i.e. 880

Note: Proposed Loading may also include corrections to certain Existing Loading values



**PROJECT INFORMATION**

SCOPE OF WORK: TELECOMMUNICATIONS FACILITY UPGRADE (BWE 2017 UPGRADE):

SITE ADDRESS: 17 COTTAGE ROAD  
MADISON, CT 06443

LATITUDE: 41.275858 N 41° 16' 33.08" N

LONGITUDE: 72.561382° W 72° 33' 40.97" W

TYPE OF SITE: MONOPOLE / OUTDOOR EQUIPMENT

TOWER HEIGHT: 130'±

RAD CENTER: 127'±

JURISDICTION: NATIONAL, STATE & LOCAL CODES OR ORDINANCES

CURRENT USE: TELECOMMUNICATIONS FACILITY

PROPOSED USE: TELECOMMUNICATIONS FACILITY



**SITE NUMBER: CT2517**

**SITE NAME: MADISON COTTAGE ROAD**

**PROJECT: BWE 2017 UPGRADE**

**DRAWING INDEX**

SHEET NO.	DESCRIPTION	REV.
T-1	TITLE SHEET	1
GN-1	GENERAL NOTES	1
A-1	COMPOUND & EQUIPMENT PLANS	1
A-2	ANTENNA LAYOUTS & ELEVATION	1
A-3	DETAILS	1
RF-1	RF-PLUMBING DIAGRAM	1
G-1	GROUNDING DETAILS	1

**VICINITY MAP**

**DIRECTIONS TO SITE:**

TURN LEFT ONTO CAPITAL BLVD. THEN 0.27 MILES TURN LEFT ONTO WEST ST. THEN 0.30 MILES MERGE ONTO I-91 S VIA THE RAMP ON THE LEFT TOWARD NEW HAVEN. THEN 1.41 MILES MERGE ONTO CT-9 S VIA EXIT 22S ON THE LEFT TOWARD MIDDLETOWN/OLD SAYBROOK. THEN 13.89 MILES TAKE THE CT-81 EXIT, EXIT 9, TOWARD KILLINGWORTH/CLINTON. THEN 0.24 MILES TURN RIGHT ONTO KILLINGWORTH RD/CT-81. CONTINUE TO FOLLOW CT-81. PASS THROUGH 1 ROUNDABOUT THEN 13.84 MILES TURN LEFT ONTO HULL ST/CT-81. HULL ST IS 0.2 MILES PAST SILVERBROOK LN THEN 0.09 MILES TAKE THE 1ST RIGHT ONTO W MAIN ST/US-1 S. CONTINUE TO FOLLOW US-1 S. MALONE'S SANDWICH AND COFFEE HOUSE IS ON THE CORNER THEN 1.70 MILES TURN RIGHT ONTO MILL RD. MILL RD IS 0.2 MILES PAST DUDLEY LN THEN 0.09 MILES TAKE THE 1ST LEFT ONTO COTTAGE RD. 17 COTTAGE RD IS ON THE RIGHT.

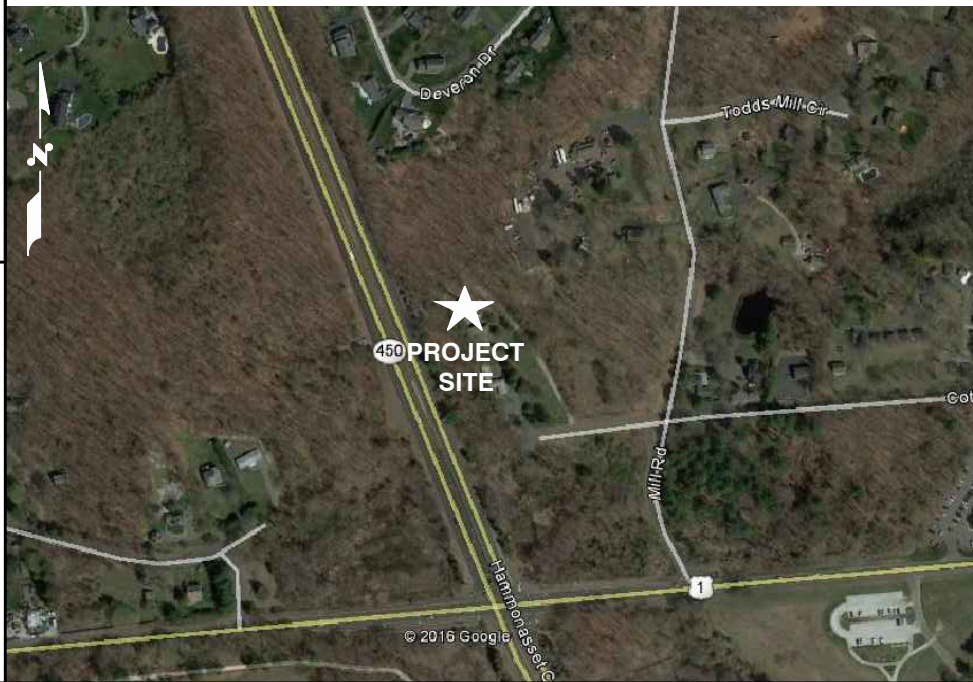

**GENERAL NOTES**

1. THIS DOCUMENT IS THE CREATION, DESIGN, PROPERTY AND COPYRIGHTED WORK OF AT&T. ANY DUPLICATION OR USE WITHOUT EXPRESS WRITTEN CONSENT IS STRICTLY PROHIBITED. DUPLICATION AND USE BY GOVERNMENT AGENCIES FOR THE PURPOSES OF CONDUCTING THEIR LAWFULLY AUTHORIZED REGULATORY AND ADMINISTRATIVE FUNCTIONS IS SPECIFICALLY ALLOWED.
2. THE FACILITY IS AN UNMANNED PRIVATE AND SECURED EQUIPMENT INSTALLATION. IT IS ONLY ACCESSED BY TRAINED TECHNICIANS FOR PERIODIC ROUTINE MAINTENANCE AND THEREFORE DOES NOT REQUIRE ANY WATER OR SANITARY SEWER SERVICE. THE FACILITY IS NOT GOVERNED BY REGULATIONS REQUIRING PUBLIC ACCESS PER ADA REQUIREMENTS.
3. CONTRACTOR SHALL VERIFY ALL PLANS AND EXISTING DIMENSIONS AND CONDITIONS ON THE JOB SITE AND SHALL IMMEDIATELY NOTIFY THE AT&T MOBILITY REPRESENTATIVE IN WRITING OF DISCREPANCIES BEFORE PROCEEDING WITH THE WORK OR BE RESPONSIBLE FOR SAME.

**72 HOURS**



CALL BEFORE YOU DIG



CALL TOLL FREE 1-800-922-4455

OR CALL 811

**UNDERGROUND SERVICE ALERT**



**SITE NUMBER: CT2517**  
**SITE NAME: MADISON COTTAGE ROAD**

17 COTTAGE ROAD  
MADISON, CT 06443  
NEWHAVEN COUNTY



NO.	DATE	REVISIONS	BY	CHK	APP'D
1	09/08/16	ISSUED FOR CONSTRUCTION	SG	AT	DPH
A	07/19/16	ISSUED FOR REVIEW	RB	AT	DPH

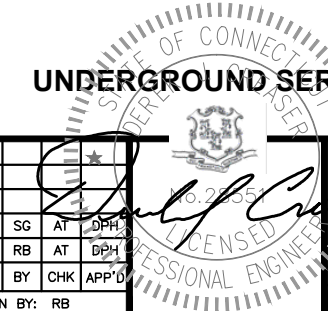

AT&T

TITLE SHEET  
BWE

SITE NUMBER	DRAWING NUMBER	REV
2517.00	T-1	1

1600 OSGOOD STREET  
BUILDING 20 NORTH, SUITE 3090  
N. ANDOVER, MA 01845  
TEL: (978) 557-5553  
FAX: (978) 336-5586

27 NORTHWESTERN DR.  
SALEM, NH 03079

500 ENTERPRISE DRIVE, SUITE 3A  
ROCKY HILL, CT 06067

SCALE: AS SHOWN DESIGNED BY: AT DRAWN BY: RB

**GROUNDING NOTES**

1. THE SUBCONTRACTOR SHALL REVIEW AND INSPECT THE EXISTING FACILITY GROUNDING SYSTEM AND LIGHTNING PROTECTION SYSTEM (AS DESIGNED AND INSTALLED) FOR STRICT COMPLIANCE WITH THE NEC (AS ADOPTED BY THE AHJ), THE SITE-SPECIFIC (UL, LPI, OR NFPA) LIGHTING PROTECTION CODE, AND GENERAL COMPLIANCE WITH TELCORDIA AND TIA GROUNDING STANDARDS. THE SUBCONTRACTOR SHALL REPORT ANY VIOLATIONS OR ADVERSE FINDINGS TO THE CONTRACTOR FOR RESOLUTION.
2. ALL GROUND ELECTRODE SYSTEMS (INCLUDING TELECOMMUNICATION, RADIO, LIGHTNING PROTECTION, AND AC POWER GES'S) SHALL BE BONDED TOGETHER, AT OR BELOW GRADE, BY TWO OR MORE COPPER BONDING CONDUCTORS IN ACCORDANCE WITH THE NEC.
3. THE SUBCONTRACTOR SHALL PERFORM IEEE FALL-OF-POTENTIAL RESISTANCE TO EARTH TESTING (PER IEEE 1100 AND 81) FOR NEW GROUND ELECTRODE SYSTEMS. THE SUBCONTRACTOR SHALL FURNISH AND INSTALL SUPPLEMENTAL GROUND ELECTRODES AS NEEDED TO ACHIEVE A TEST RESULT OF 5 OHMS OR LESS.
4. METAL RACEWAY SHALL NOT BE USED AS THE NEC REQUIRED EQUIPMENT GROUND CONDUCTOR. STRANDED COPPER CONDUCTORS WITH GREEN INSULATION, SIZED IN ACCORDANCE WITH THE NEC, SHALL BE FURNISHED AND INSTALLED WITH THE POWER CIRCUITS TO BTS EQUIPMENT.
5. EACH BTS CABINET FRAME SHALL BE DIRECTLY CONNECTED TO THE MASTER GROUND BAR WITH GREEN INSULATED SUPPLEMENTAL EQUIPMENT GROUND WIRES, 6 AWG STRANDED COPPER OR LARGER FOR INDOOR BTS 2 AWG STRANDED COPPER FOR OUTDOOR BTS.
6. EXOTHERMIC WELDS SHALL BE USED FOR ALL GROUNDING CONNECTIONS BELOW GRADE.
7. APPROVED ANTIOXIDANT COATINGS (I.E., CONDUCTIVE GEL OR PASTE) SHALL BE USED ON ALL COMPRESSION AND BOLTED GROUND CONNECTIONS.
8. ICE BRIDGE BONDING CONDUCTORS SHALL BE EXOTHERMICALLY BONDED OR BOLTED TO GROUND BAR.
9. ALUMINUM CONDUCTOR OR COPPER CLAD STEEL CONDUCTOR SHALL NOT BE USED FOR GROUNDING CONNECTIONS.
10. MISCELLANEOUS ELECTRICAL AND NON-ELECTRICAL METAL BOXES, FRAMES AND SUPPORTS SHALL BE BONDED TO THE GROUND RING, IN ACCORDANCE WITH THE NEC.
11. METAL CONDUIT SHALL BE MADE ELECTRICALLY CONTINUOUS WITH LISTED BONDING FITTINGS OR BY BONDING ACROSS THE DISCONTINUITY WITH 6 AWG COPPER WIRE UL APPROVED GROUNDING TYPE CONDUIT CLAMPS.
12. ALL NEW STRUCTURES WITH A FOUNDATION AND/OR FOOTING HAVING 20 FT. OR MORE OF 1/2 IN. OR GREATER ELECTRICALLY CONDUCTIVE REINFORCING STEEL MUST HAVE IT BONDED TO THE GROUND RING USING AN EXOTHERMIC WELD CONNECTION USING #2 AWG SOLID BARE TINNED COPPER GROUND WIRE, PER NEC 250.50

**GENERAL NOTES**

1. FOR THE PURPOSE OF CONSTRUCTION DRAWING, THE FOLLOWING DEFINITIONS SHALL APPLY:  
 CONTRACTOR – SAI  
 SUBCONTRACTOR – GENERAL CONTRACTOR (CONSTRUCTION)  
 OWNER – AT&T MOBILITY
2. PRIOR TO THE SUBMISSION OF BIDS, THE BIDDING SUBCONTRACTOR SHALL VISIT THE CELL SITE TO FAMILIARIZE WITH THE EXISTING CONDITIONS AND TO CONFIRM THAT THE WORK CAN BE ACCOMPLISHED AS SHOWN ON THE CONSTRUCTION DRAWINGS. ANY DISCREPANCY FOUND SHALL BE BROUGHT TO THE ATTENTION OF CONTRACTOR.
3. ALL MATERIALS FURNISHED AND INSTALLED SHALL BE IN STRICT ACCORDANCE WITH ALL APPLICABLE CODES, REGULATIONS, AND ORDINANCES. SUBCONTRACTOR SHALL ISSUE ALL APPROPRIATE NOTICES AND COMPLY WITH ALL LAWS, ORDINANCES, RULES, REGULATIONS, AND LAWFUL ORDERS OF ANY PUBLIC AUTHORITY REGARDING THE PERFORMANCE OF THE WORK. ALL WORK CARRIED OUT SHALL COMPLY WITH ALL APPLICABLE MUNICIPAL AND UTILITY COMPANY SPECIFICATIONS AND LOCAL JURISDICTIONAL CODES, ORDINANCES AND APPLICABLE REGULATIONS.
4. DRAWINGS PROVIDED HERE ARE NOT TO BE SCALED AND ARE INTENDED TO SHOW OUTLINE ONLY.
5. UNLESS NOTED OTHERWISE, THE WORK SHALL INCLUDE FURNISHING MATERIALS, EQUIPMENT, APPURTENANCES, AND LABOR NECESSARY TO COMPLETE ALL INSTALLATIONS AS INDICATED ON THE DRAWINGS.
6. "KITTING LIST" SUPPLIED WITH THE BID PACKAGE IDENTIFIES ITEMS THAT WILL BE SUPPLIED BY CONTRACTOR. ITEMS NOT INCLUDED IN THE BILL OF MATERIALS AND KITTING LIST SHALL BE SUPPLIED BY THE SUBCONTRACTOR.
7. THE SUBCONTRACTOR SHALL INSTALL ALL EQUIPMENT AND MATERIALS IN ACCORDANCE WITH MANUFACTURER'S RECOMMENDATIONS UNLESS SPECIFICALLY STATED OTHERWISE.
8. IF THE SPECIFIED EQUIPMENT CANNOT BE INSTALLED AS SHOWN ON THESE DRAWINGS, THE SUBCONTRACTOR SHALL PROPOSE AN ALTERNATIVE INSTALLATION SPACE FOR APPROVAL BY THE CONTRACTOR.
9. SUBCONTRACTOR SHALL DETERMINE ACTUAL ROUTING OF CONDUIT, POWER AND T1 CABLES, GROUNDING CABLES AS SHOWN ON THE POWER, GROUNDING AND TELCO PLAN DRAWING. SUBCONTRACTOR SHALL UTILIZE EXISTING TRAYS AND/OR SHALL ADD NEW TRAYS AS NECESSARY. SUBCONTRACTOR SHALL CONFIRM THE ACTUAL ROUTING WITH THE CONTRACTOR.
10. THE SUBCONTRACTOR SHALL PROTECT EXISTING IMPROVEMENTS, PAVEMENTS, CURBS, LANDSCAPING AND STRUCTURES. ANY DAMAGED PART SHALL BE REPAIRED AT SUBCONTRACTOR'S EXPENSE TO THE SATISFACTION OF OWNER.
11. SUBCONTRACTOR SHALL LEGALLY AND PROPERLY DISPOSE OF ALL SCRAP MATERIALS SUCH AS COAXIAL CABLES AND OTHER ITEMS REMOVED FROM THE EXISTING FACILITY. ANTENNAS REMOVED SHALL BE RETURNED TO THE OWNER'S DESIGNATED LOCATION.
12. SUBCONTRACTOR SHALL LEAVE PREMISES IN CLEAN CONDITION.
13. ALL CONCRETE REPAIR WORK SHALL BE DONE IN ACCORDANCE WITH AMERICAN CONCRETE INSTITUTE (ACI) 301.

14. ANY NEW CONCRETE NEEDED FOR THE CONSTRUCTION SHALL BE AIR-ENTRAINED AND SHALL HAVE 4000 PSI STRENGTH AT 28 DAYS. ALL CONCRETE WORK SHALL BE DONE IN ACCORDANCE WITH ACI 318 CODE REQUIREMENTS.
15. ALL STRUCTURAL STEEL WORK SHALL BE DETAILED, FABRICATED AND ERECTED IN ACCORDANCE WITH AISC SPECIFICATIONS. ALL STRUCTURAL STEEL SHALL BE ASTM A36 (Fy = 36 ksi) UNLESS OTHERWISE NOTED. PIPES SHALL BE ASTM A53 TYPE E (Fy = 36 ksi). ALL STEEL EXPOSED TO WEATHER SHALL BE HOT DIPPED GALVANIZED. TOUCHUP ALL SCRATCHES AND OTHER MARKS IN THE FIELD AFTER STEEL IS ERECTED USING A COMPATIBLE ZINC RICH PAINT.
16. CONSTRUCTION SHALL COMPLY WITH SPECIFICATIONS AND "GENERAL CONSTRUCTION SERVICES FOR CONSTRUCTION OF AT&T SITES."
17. SUBCONTRACTOR SHALL VERIFY ALL EXISTING DIMENSIONS AND CONDITIONS PRIOR TO COMMENCING ANY WORK. ALL DIMENSIONS OF EXISTING CONSTRUCTION SHOWN ON THE DRAWINGS MUST BE VERIFIED. SUBCONTRACTOR SHALL NOTIFY THE CONTRACTOR OF ANY DISCREPANCIES PRIOR TO ORDERING MATERIAL OR PROCEEDING WITH CONSTRUCTION.
18. THE EXISTING CELL SITE IS IN FULL COMMERCIAL OPERATION. ANY CONSTRUCTION WORK BY SUBCONTRACTOR SHALL NOT DISRUPT THE EXISTING NORMAL OPERATION. ANY WORK ON EXISTING EQUIPMENT MUST BE COORDINATED WITH CONTRACTOR. ALSO, WORK SHOULD BE SCHEDULED FOR AN APPROPRIATE MAINTENANCE WINDOW USUALLY IN LOW TRAFFIC PERIODS AFTER MIDNIGHT.
19. SINCE THE CELL SITE IS ACTIVE, ALL SAFETY PRECAUTIONS MUST BE TAKEN WHEN WORKING AROUND HIGH LEVELS OF ELECTROMAGNETIC RADIATION. EQUIPMENT SHOULD BE SHUTDOWN PRIOR TO PERFORMING ANY WORK THAT COULD EXPOSE THE WORKERS TO DANGER. PERSONAL RF EXPOSURE MONITORS ARE ADVISED TO BE WORN TO ALERT OF ANY DANGEROUS EXPOSURE LEVELS.
20. APPLICABLE BUILDING CODES:  
 SUBCONTRACTOR'S WORK SHALL COMPLY WITH ALL APPLICABLE NATIONAL, STATE, AND LOCAL CODES AS ADOPTED BY THE LOCAL AUTHORITY HAVING JURISDICTION (AHJ) FOR THE LOCATION. THE EDITION OF THE AHJ ADOPTED CODES AND STANDARDS IN EFFECT ON THE DATE OF CONTRACT AWARD SHALL GOVERN THE DESIGN.  
 BUILDING CODE: 2003 IBC WITH 2005 CT SUPPLEMENT, + 2009 & 2013 CT AMENDMENTS  
 ELECTRICAL CODE: REFER TO ELECTRICAL DRAWINGS  
 LIGHTENING CODE: REFER TO ELECTRICAL DRAWINGS

SUBCONTRACTOR'S WORK SHALL COMPLY WITH THE LATEST EDITION OF THE FOLLOWING STANDARDS:

- AMERICAN CONCRETE INSTITUTE (ACI) 318; BUILDING CODE REQUIREMENTS FOR STRUCTURAL CONCRETE;
- AMERICAN INSTITUTE OF STEEL CONSTRUCTION (AISC) MANUAL OF STEEL CONSTRUCTION, ASD, FOURTEENTH EDITION;
- TELECOMMUNICATIONS INDUSTRY ASSOCIATION (TIA) 222-F, STRUCTURAL STANDARDS FOR STEEL
- EQUIPMENT AND ANTENNA SUPPORTING STRUCTURES; REFER TO ELECTRICAL DRAWINGS FOR SPECIFIC ELECTRICAL STANDARDS.

FOR ANY CONFLICTS BETWEEN SECTIONS OF LISTED CODES AND STANDARDS REGARDING MATERIAL, METHODS OF CONSTRUCTION, OR OTHER REQUIREMENTS, THE MOST RESTRICTIVE REQUIREMENT SHALL GOVERN. WHERE THERE IS CONFLICT BETWEEN A GENERAL REQUIREMENT AND A SPECIFIC REQUIREMENT, THE SPECIFIC REQUIREMENT SHALL GOVERN.

ABBREVIATIONS					
AGL	ABOVE GRADE LEVEL	EQ	EQUAL	REQ	REQUIRED
AWG	AMERICAN WIRE GAUGE	GC	GENERAL CONTRACTOR	RF	RADIO FREQUENCY
BBU	BATTERY BACKUP UNIT	GRC	GALVANIZED RIGID CONDUIT	TBD	TO BE DETERMINED
BTCW	BARE TINNED SOLID COPPER WIRE	MGB	MASTER GROUND BAR	TBR	TO BE REMOVED
BGR	BURIED GROUND RING	MIN	MINIMUM	TBRR	TO BE REMOVED AND REPLACED
BTS	BASE TRANSCEIVER STATION	P	PROPOSED	TYP	TYPICAL
E	EXISTING	NTS	NOT TO SCALE	UG	UNDER GROUND
EGB	EQUIPMENT GROUND BAR	RAD	RADIATION CENTER LINE (ANTENNA)	VIF	VERIFY IN FIELD
EGR	EQUIPMENT GROUND RING	REF	REFERENCE		

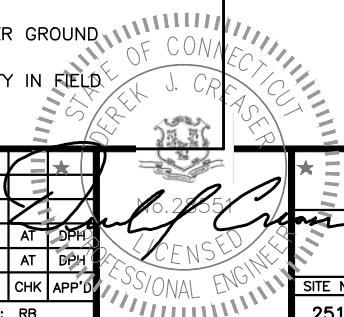

**Hudson Design Group**  
 1600 OSGOOD STREET  
 BUILDING 20 NORTH, SUITE 3090  
 N. ANDOVER, MA 01845  
 TEL: (978) 557-5553  
 FAX: (978) 336-5586

**SAI**  
 27 NORTHWESTERN DR.  
 SALEM, NH 03079

**SITE NUMBER: CT2517**  
**SITE NAME: MADISON COTTAGE ROAD**  
 17 COTTAGE ROAD  
 MADISON, CT 06443  
 NEWHAVEN COUNTY

**at&t**  
 500 ENTERPRISE DRIVE, SUITE 3A  
 ROCKY HILL, CT 06067

NO.	DATE	REVISIONS	BY	CHK	APP'D
1	09/08/16	ISSUED FOR CONSTRUCTION	SG	AT	DPH
A	07/19/16	ISSUED FOR REVIEW	RB	AT	DPH
SCALE: AS SHOWN    DESIGNED BY: AT    DRAWN BY: RB					

**AT&T**  
**GENERAL NOTES**  
**BWE**  
 SITE NUMBER: 2517.00    DRAWING NUMBER: GN-1    REV: 1

**NOTE:**  
 AN ASSESSMENT FOR THE CAPACITY OF THE EXISTING ANTENNA MOUNT TO SUPPORT THE PROPOSED LOADING HAS BEEN COMPLETED BY: HUDSON DESIGN GROUP, LLC. DATED: AUGUST 05, 2016

**NOTE:**  
 AN ANALYSIS FOR THE CAPACITY OF THE EXISTING STRUCTURES TO SUPPORT THE PROPOSED EQUIPMENT SHALL BE DETERMINED PRIOR TO CONSTRUCTION.

**NOTE:**  
 REFER TO THE FINAL RF DATA SHEET FOR FINAL ANTENNA CONFIGURATION.

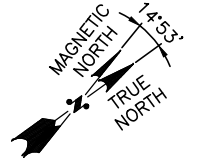
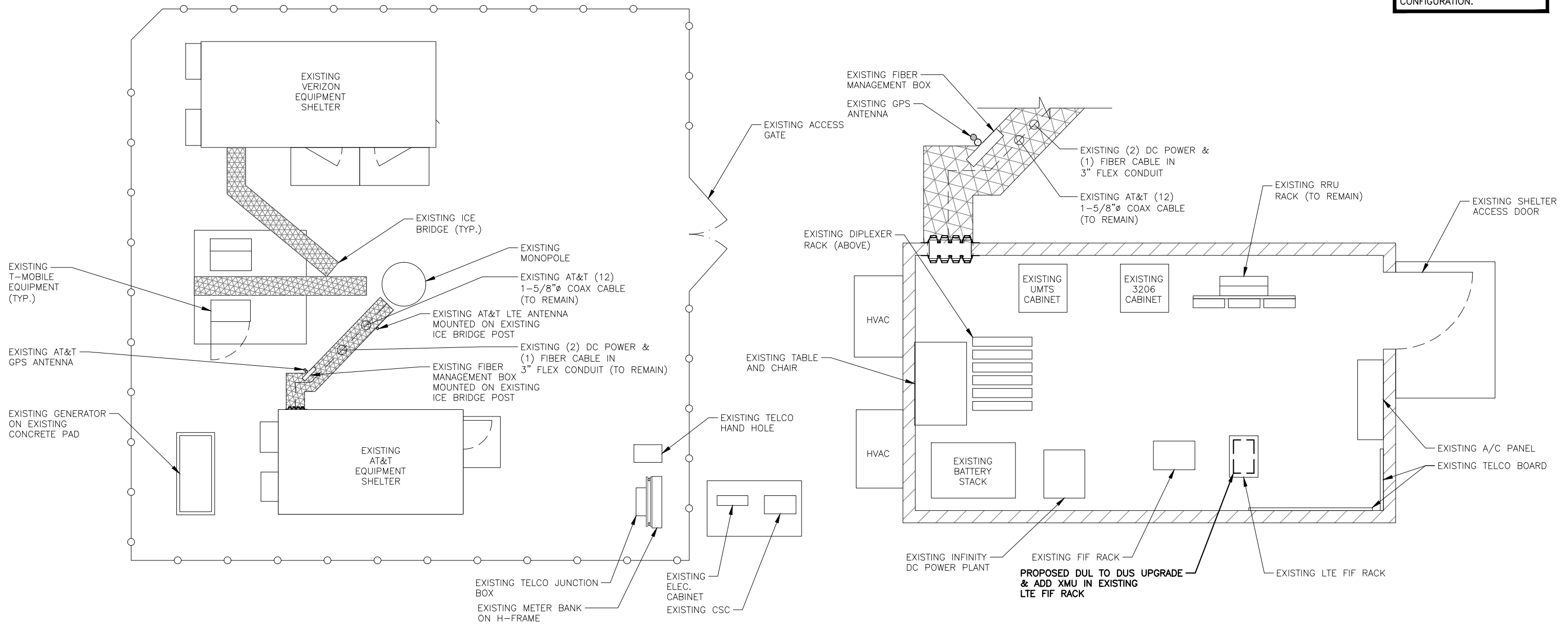

**COMPOUND PLAN**  
 22x34 SCALE: 3/16"=1'-0"  
 11x17 SCALE: 3/32"=1'-0"

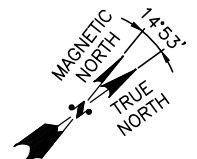
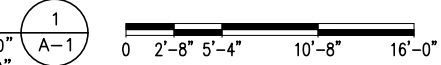

**EQUIPMENT PLAN**  
 22x34 SCALE: 1/2"=1'-0"  
 11x17 SCALE: 1/4"=1'-0"

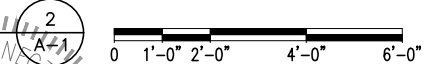

**Hudson Design Group**  
 1600 OSGOOD STREET  
 BUILDING 20 NORTH, SUITE 309D  
 N. ANDOVER, MA 01845  
 TEL: (978) 557-5553  
 FAX: (978) 336-5586

**SAI**  
 27 NORTHWESTERN DR.  
 SALEM, NH 03079

**SITE NUMBER: CT2517**  
**SITE NAME: MADISON COTTAGE ROAD**  
 17 COTTAGE ROAD  
 MADISON, CT 06443  
 NEWHAVEN COUNTY

**at&t**  
 500 ENTERPRISE DRIVE, SUITE 3A  
 ROCKY HILL, CT 06067

NO.	DATE	REVISIONS	BY	CHK	APP'D
1	09/08/16	ISSUED FOR CONSTRUCTION	SG	AT	DPH
A	07/19/16	ISSUED FOR REVIEW	RB	AT	DPH

SCALE: AS SHOWN    DESIGNED BY: AT    DRAWN BY: RB



**AT&T**  
**COMPOUND & EQUIPMENT PLANS**  
**BWE**  
 SITE NUMBER: 2517.00  
 DRAWING NUMBER: A-1  
 REV: 1



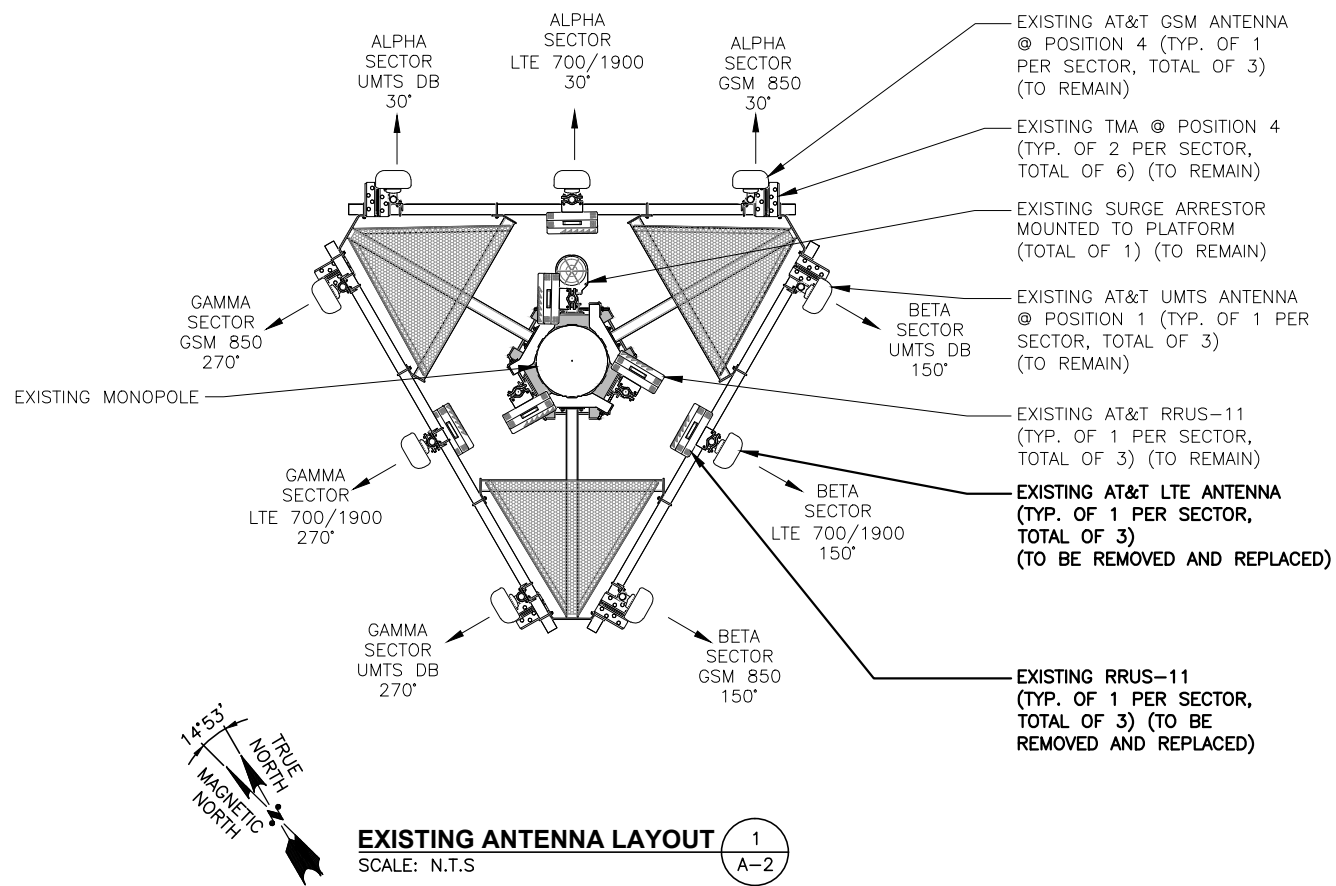

**EXISTING ANTENNA LAYOUT** 1  
SCALE: N.T.S. A-2

**NOTE:**  
AN ANALYSIS FOR THE CAPACITY OF THE EXISTING STRUCTURES TO SUPPORT THE PROPOSED EQUIPMENT SHALL BE DETERMINED PRIOR TO CONSTRUCTION.

**NOTE:**  
REFER TO THE FINAL RF DATA SHEET FOR FINAL ANTENNA CONFIGURATION.

**NOTE:**  
AN ASSESSMENT FOR THE CAPACITY OF THE EXISTING ANTENNA MOUNT TO SUPPORT THE PROPOSED LOADING HAS BEEN COMPLETED BY: HUDSON DESIGN GROUP, LLC. DATED: AUGUST 05, 2016

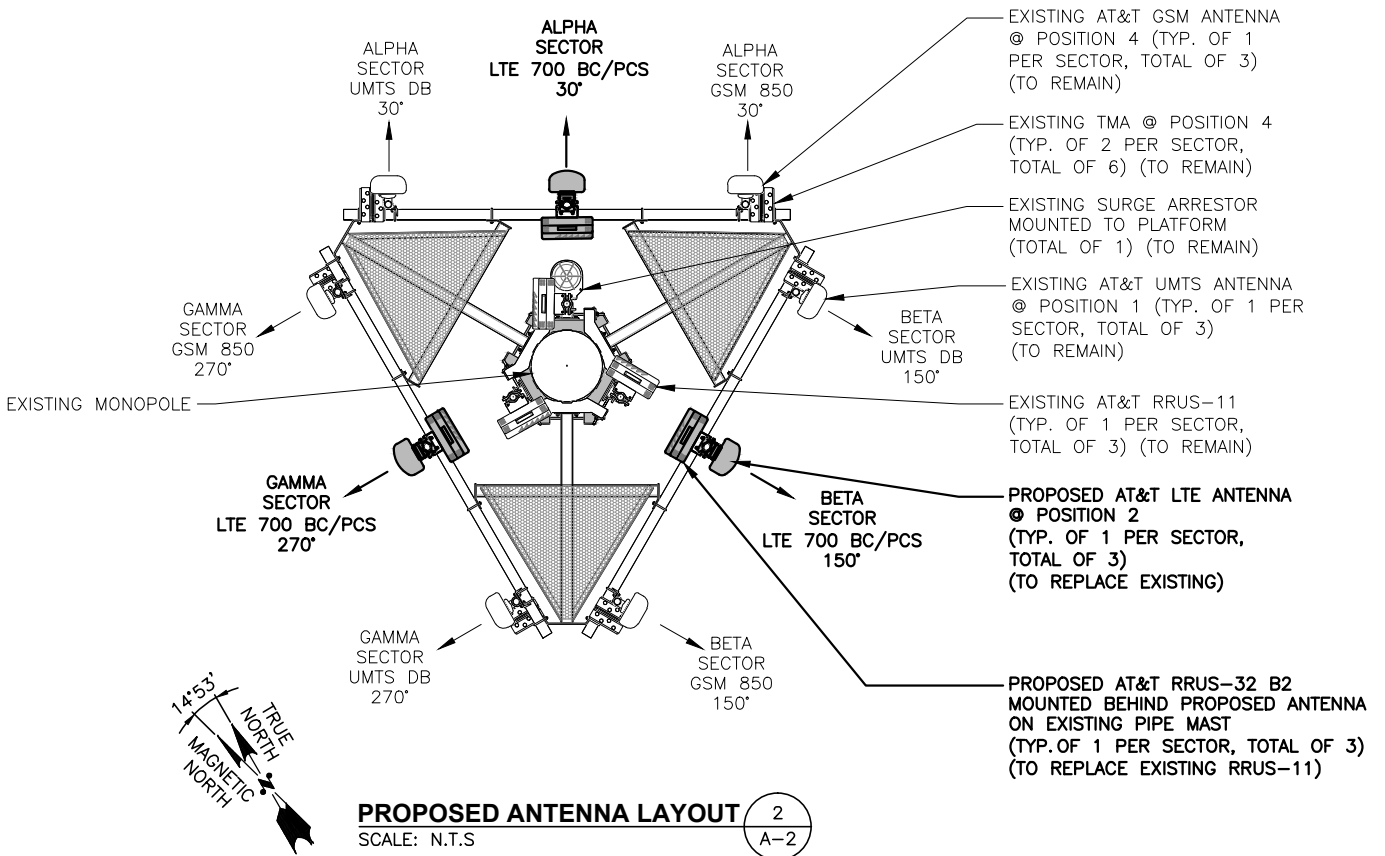

**PROPOSED ANTENNA LAYOUT** 2  
SCALE: N.T.S. A-2

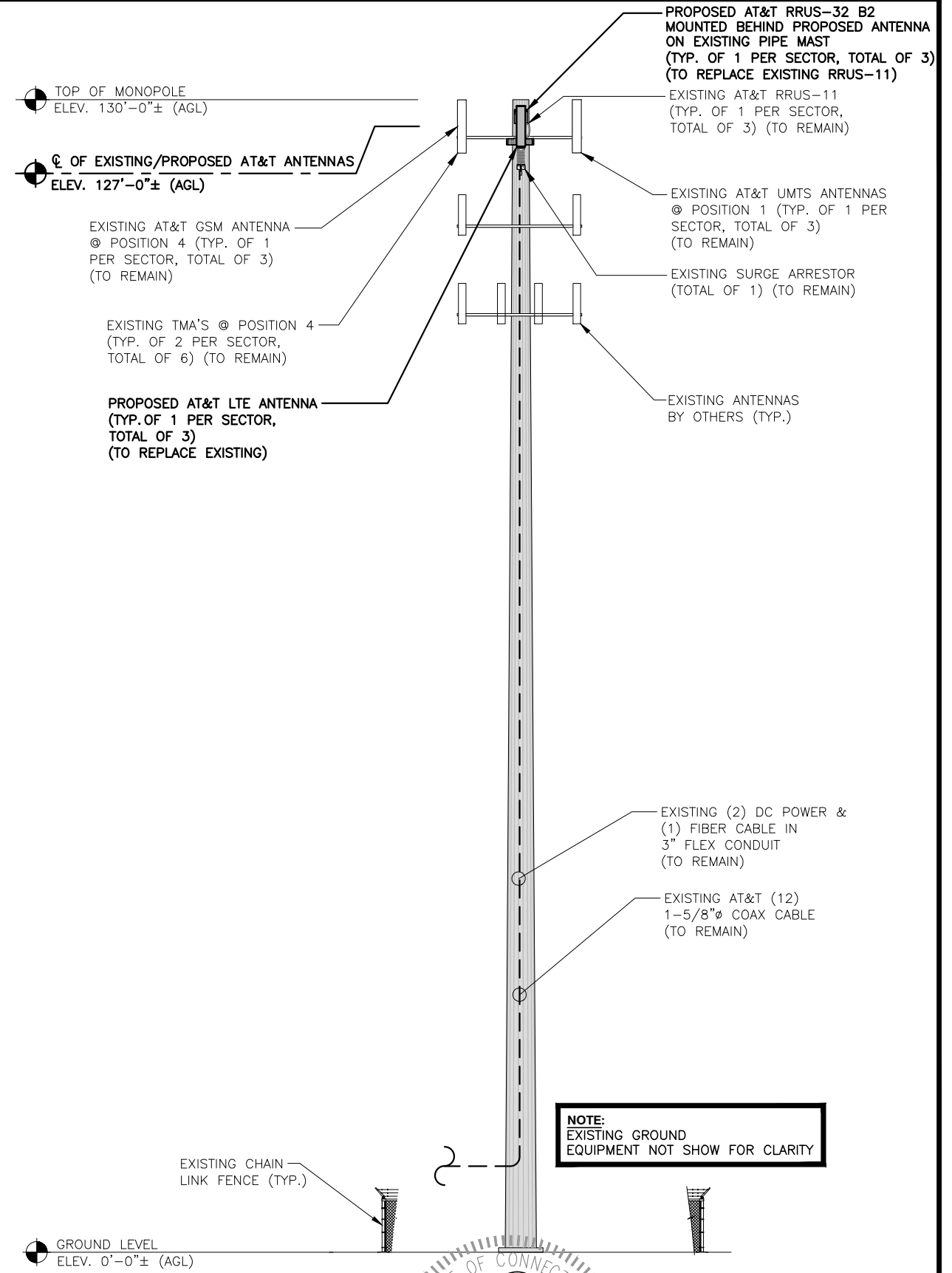

**ELEVATION**  
22x34 SCALE: 1/8" = 4'-0"  
11x17 SCALE: 1/16" = 1'-0"

**Hudson Design Group**  
1600 OSGOOD STREET  
BUILDING 20 NORTH, SUITE 309D  
N. ANDOVER, MA 01845  
TEL: (978) 557-5553  
FAX: (978) 336-5586

**SAI**  
27 NORTHWESTERN DR.  
SALEM, NH 03079

**SITE NUMBER: CT2517**  
**SITE NAME: MADISON COTTAGE ROAD**  
  
17 COTTAGE ROAD  
MADISON, CT 06443  
NEWHAVEN COUNTY

**at&t**  
500 ENTERPRISE DRIVE, SUITE 3A  
ROCKY HILL, CT 06067

NO.	DATE	REVISIONS	BY	CHK	APP'D
1	09/08/16	ISSUED FOR CONSTRUCTION	SG	AT	DPH
A	07/19/16	ISSUED FOR REVIEW	RB	AT	DPH

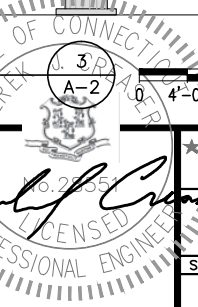

AT&T	
ANTENNA LAYOUTS & ELEVATION	
BWE	
SITE NUMBER	DRAWING NUMBER
2517.00	A-2
	1

EXISTING ANTENNA SCHEDULE			
SECTOR	MAKE	MODEL#	SIZE (INCHES)
ALPHA:	POWERWAVE	P90-15-XLH-RR	72X12X7.3
	POWERWAVE	P65-16-XLH-RR	51X12X6
	POWERWAVE	P90-15-XLH-RR	72X12X7.3
BETA:	POWERWAVE	P90-15-XLH-RR	72X12X7.3
	POWERWAVE	P65-16-XLH-RR	51X12X6
	POWERWAVE	P90-15-XLH-RR	72X12X7.3
GAMMA:	POWERWAVE	P90-15-XLH-RR	72X12X7.3
	POWERWAVE	P65-16-XLH-RR	51X12X6
	POWERWAVE	P90-15-XLH-RR	72X12X7.3

PROPOSED ANTENNA SCHEDULE			
SECTOR	MAKE	MODEL#	SIZE (INCHES)
ALPHA:	POWERWAVE	P90-15-XLH-RR	72X12X7.3
	ANDREW	SBNHH-1D65A	55X11.9X7.1
	POWERWAVE	P90-15-XLH-RR	72X12X7.3
BETA:	POWERWAVE	P90-15-XLH-RR	72X12X7.3
	ANDREW	SBNHH-1D65A	55X11.9X7.1
	POWERWAVE	P90-15-XLH-RR	72X12X7.3
GAMMA:	POWERWAVE	P90-15-XLH-RR	72X12X7.3
	ANDREW	SBNHH-1D65A	55X11.9X7.1
	POWERWAVE	P90-15-XLH-RR	72X12X7.3

**NOTE:**  
AN ASSESSMENT FOR THE CAPACITY OF THE EXISTING **ANTENNA MOUNT** TO SUPPORT THE PROPOSED LOADING HAS BEEN COMPLETED BY: HUDSON DESIGN GROUP, LLC. DATED: AUGUST 05, 2016

**NOTE:**  
AN ANALYSIS FOR THE CAPACITY OF THE EXISTING STRUCTURES TO SUPPORT THE PROPOSED EQUIPMENT SHALL BE DETERMINED PRIOR TO CONSTRUCTION.

**NOTE:**  
REFER TO THE FINAL RF DATA SHEET FOR FINAL ANTENNA CONFIGURATION.

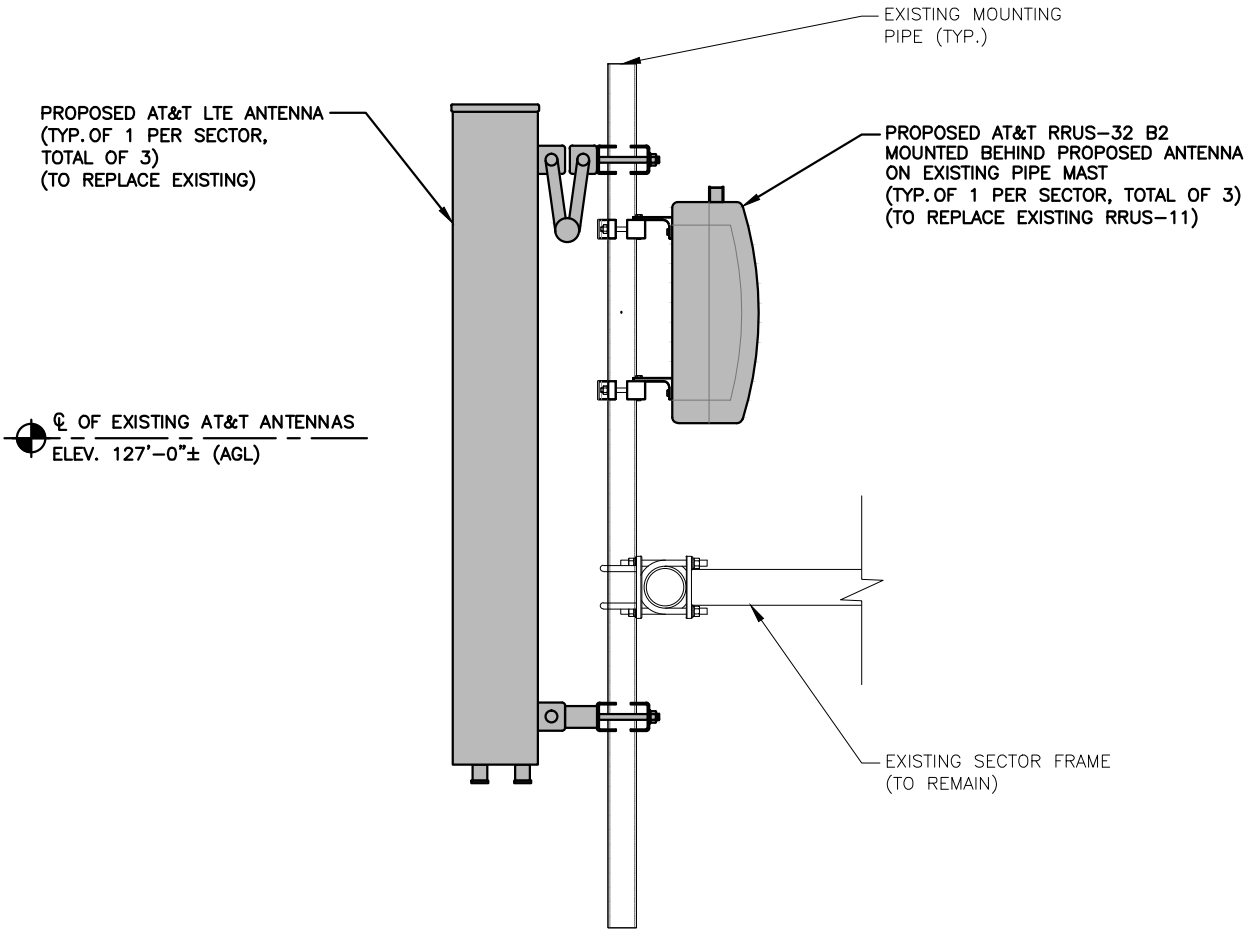

RRU CHART				
QUANTITY	MODEL	L	W	D
3(E)	RRUS-11	19.7"	17.0"	7.2"
-	RRUS-12	20.4"	18.5"	7.5"
3(P)	RRUS-32	26.7"	12.1"	6.7"
-	RRUS-E2	20.4"	18.5"	7.5"
-	LTE-A2	16.4"	15.2"	3.4"

**NOTE:**  
MOUNT PER MANUFACTURER'S SPECIFICATIONS

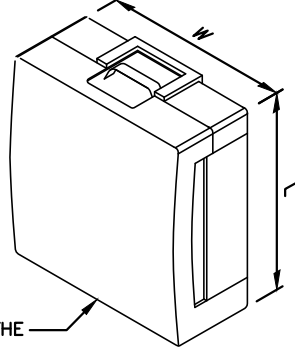

PROPOSED RRU REFER TO THE FINAL RFDS AND CHART FOR QUANTITY, MODEL AND DIMENSIONS

**PROPOSED LTE ANTENNA & RRH MOUNTING DETAIL**  
22x34 SCALE: 1-1/2"=1'-0"  
11x17 SCALE: 3/4"=1'-0"

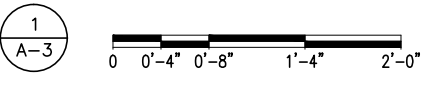

**RRU DETAIL**  
SCALE: N.T.S.

**Hudson Design Group**  
1600 OSGOOD STREET  
BUILDING 20 NORTH, SUITE 309D  
N. ANDOVER, MA 01845  
TEL: (978) 557-5553  
FAX: (978) 336-5586

**SAI**  
27 NORTHWESTERN DR.  
SALEM, NH 03079

**SITE NUMBER: CT2517**  
**SITE NAME: MADISON COTTAGE ROAD**  
  
17 COTTAGE ROAD  
MADISON, CT 06443  
NEWHAVEN COUNTY

**at&t**  
500 ENTERPRISE DRIVE, SUITE 3A  
ROCKY HILL, CT 06067

1	09/08/16	ISSUED FOR CONSTRUCTION	SG	AT	DPH
A	07/19/16	ISSUED FOR REVIEW	RB	AT	DPH
NO.	DATE	REVISIONS	BY	CHK	APP'D
SCALE: AS SHOWN		DESIGNED BY: AT	DRAWN BY: RB		

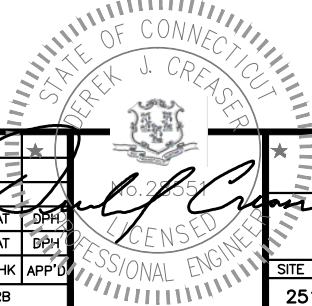

<b>AT&amp;T</b>		
DETAILS		
BWE		
SITE NUMBER	DRAWING NUMBER	REV
2517.00	A-3	1



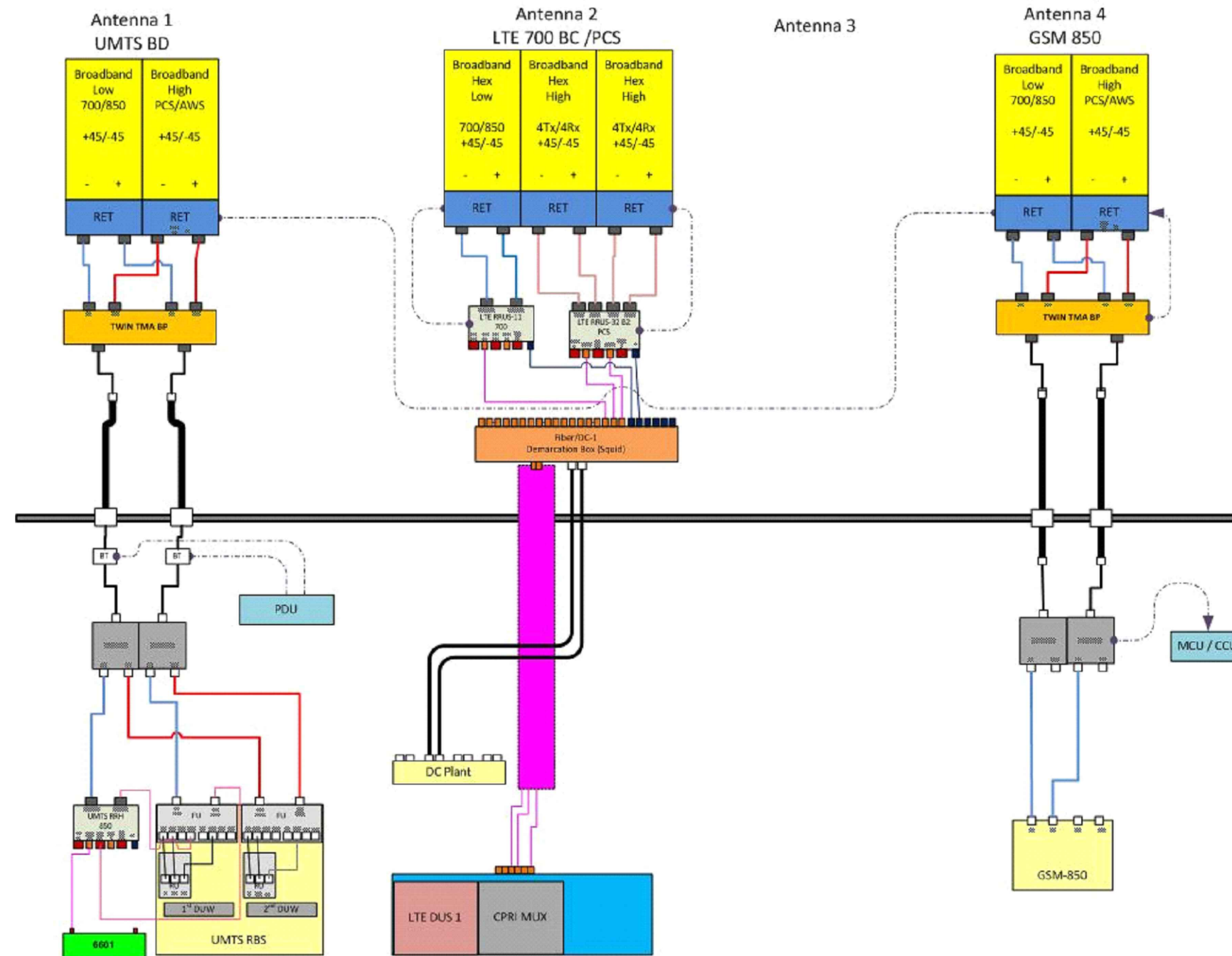

**RF PLUMBING DIAGRAM**  
SCALE: N.T.S.

1  
RF-1

**NOTE:**  
1. CONTRACTOR TO CONFIRM ALL PARTS.  
2. INSTALL ALL EQUIPMENT TO MANUFACTURER'S RECOMMENDATIONS

**NOTE:**  
REFER TO THE FINAL RF DATA SHEET FOR FINAL ANTENNA SETTINGS.

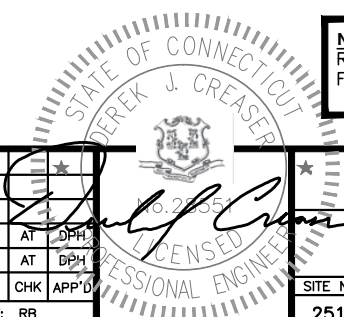

**Hudson Design Group**  
1600 OSGOOD STREET  
BUILDING 20 NORTH, SUITE 309D  
N. ANDOVER, MA 01845  
TEL: (978) 557-5553  
FAX: (978) 336-5586

**SAI**  
27 NORTHWESTERN DR.  
SALEM, NH 03079

**SITE NUMBER: CT2517**  
**SITE NAME: MADISON COTTAGE ROAD**  
  
17 COTTAGE ROAD  
MADISON, CT 06443  
NEWHAVEN COUNTY

**at&t**  
500 ENTERPRISE DRIVE, SUITE 3A  
ROCKY HILL, CT 06067

NO.	DATE	REVISIONS	BY	CHK	APP'D
1	09/08/16	ISSUED FOR CONSTRUCTION	SG	AT	DPH
A	07/19/16	ISSUED FOR REVIEW	RB	AT	DPH

SCALE: AS SHOWN    DESIGNED BY: AT    DRAWN BY: RB

**AT&T**

**RF PLUMBING DIAGRAM**  
BWE

SITE NUMBER	DRAWING NUMBER	REV
2517.00	RF-1	1

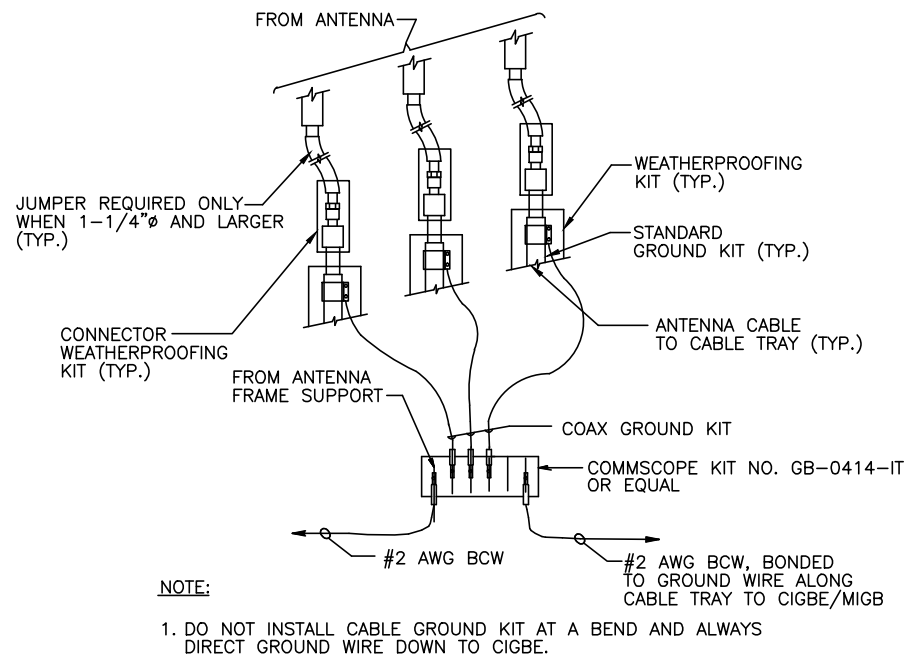

**GROUND WIRE TO GROUND BAR CONNECTION DETAIL**

SCALE: N.T.S.

1  
G-1

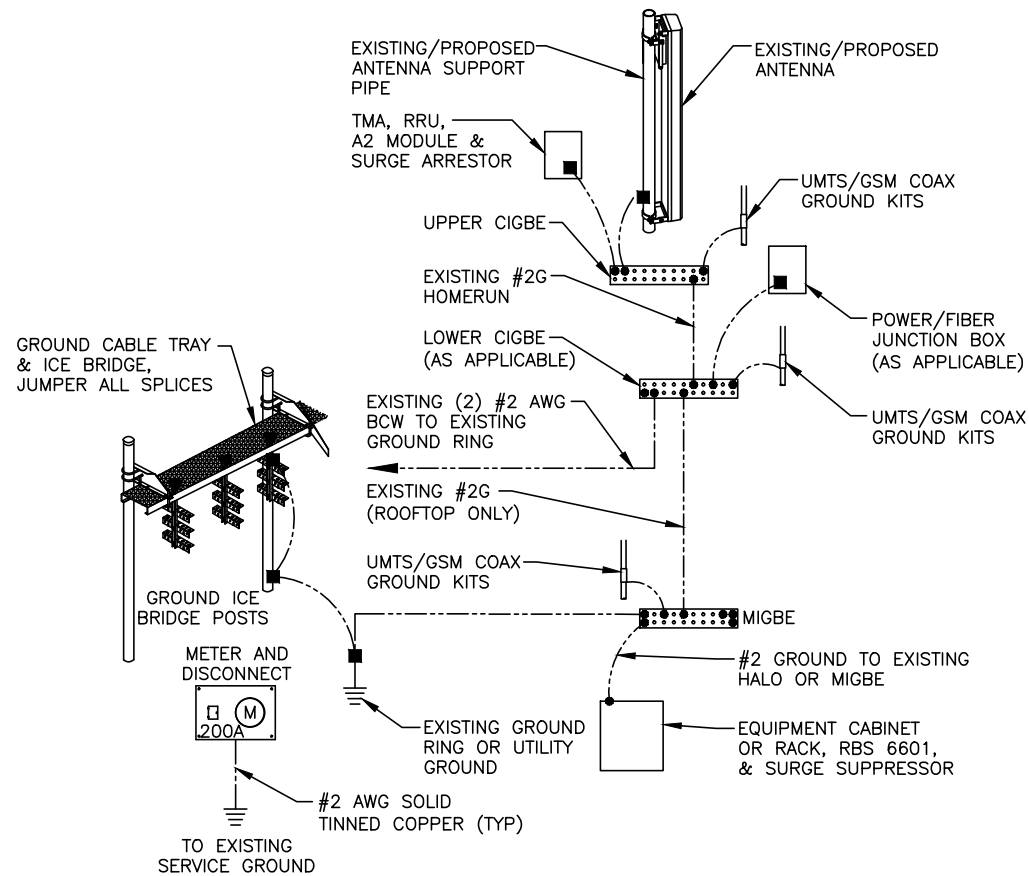

**GROUNDING RISER DIAGRAM**

SCALE: N.T.S.

2  
G-1

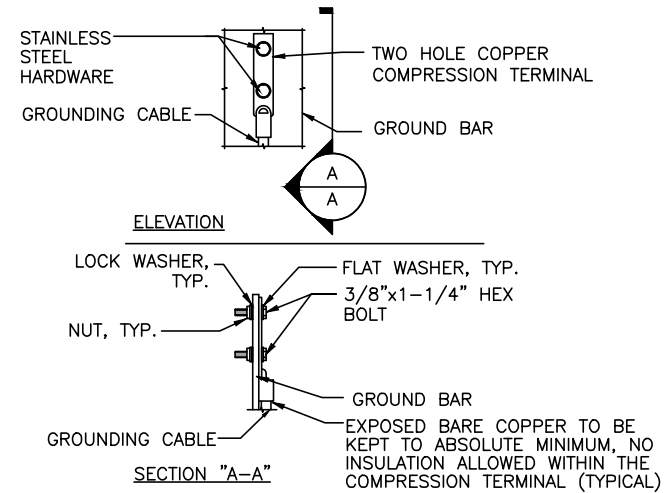

NOTE:

- "DOUBLING UP" OR "STACKING" OF CONNECTION IS NOT PERMITTED.
- OXIDE INHIBITING COMPOUND TO BE USED AT ALL LOCATION.
- CADWELDED DOWNLEADS FROM UPPER EGB, LOWER EGB, AND MGB

**TYPICAL GROUND BAR CONNECTION DETAIL**

SCALE: N.T.S.

3  
G-1

EACH GROUND CONDUCTOR TERMINATING ON ANY GROUND BAR SHALL HAVE AN IDENTIFICATION TAG ATTACHED AT EACH END THAT WILL IDENTIFY ITS ORIGIN AND DESTINATION.

**SECTION "P" - SURGE PRODUCERS**

- CABLE ENTRY PORTS (HATCH PLATES) (#2)
- GENERATOR FRAMEWORK (IF AVAILABLE) (#2)
- TELCO GROUND BAR
- COMMERCIAL POWER COMMON NEUTRAL/GROUND BOND (#2)
- +24V POWER SUPPLY RETURN BAR (#2)
- 48V POWER SUPPLY RETURN BAR (#2)
- RECTIFIER FRAMES.

**SECTION "A" - SURGE ABSORBERS**

- INTERIOR GROUND RING (#2)
- EXTERNAL EARTH GROUND FIELD (BURIED GROUND RING) (#2)
- METALLIC COLD WATER PIPE (IF AVAILABLE) (#2)
- BUILDING STEEL (IF AVAILABLE) (#2)

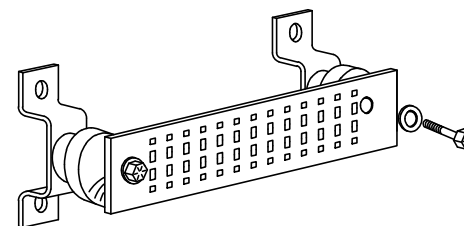

**GROUND BAR - DETAIL**

SCALE: N.T.S.

4  
G-1



1600 OSGOOD STREET  
BUILDING 20 NORTH, SUITE 309D  
N. ANDOVER, MA 01845  
TEL: (978) 557-5553  
FAX: (978) 336-5586



27 NORTHWESTERN DR.  
SALEM, NH 03079

SITE NUMBER: CT2517  
SITE NAME: MADISON COTTAGE ROAD

17 COTTAGE ROAD  
MADISON, CT 06443  
NEWHAVEN COUNTY



500 ENTERPRISE DRIVE, SUITE 3A  
ROCKY HILL, CT 06067

NO.	DATE	REVISIONS	BY	CHK	APP'D
1	09/08/16	ISSUED FOR CONSTRUCTION	SG	AT	DPH
A	07/19/16	ISSUED FOR REVIEW	RB	AT	DPH

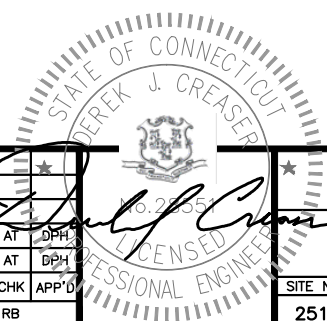

AT&T

GROUNDING DETAILS  
BWE

SITE NUMBER	DRAWING NUMBER	REV
2517.00	G-1	1



**Tower Engineering Solutions**

Phone (972) 483-0607, Fax (972) 975-9615  
8445 Freeport Parkway, Suite 375, Irving, Texas 75063

---

## Structural Analysis Report

**Existing 130 ft Rohn Monopole**  
**Customer Name: SBA Communications Corp**  
**Customer Site Number: CT13615-A**  
**Customer Site Name: Madison 7, CT**  
**Carrier Name: AT&T**  
**Carrier Site ID / Name: CT2517**  
**Site Location: 17 Cottage Road**  
**Madison, Connecticut**  
**New Haven County**  
**Latitude: 41.275916**  
**Longitude: -72.561444**

**Analysis Result:**

**Max Structural Usage: 74.1% [Pass]**  
**Max Foundation Usage: 66.0% [Pass]**  
**Report Prepared by: Tawfeeq Alajaj**







**Tower Engineering Solutions**

Phone (972) 483-0607, Fax (972) 975-9615  
8445 Freeport Parkway, Suite 375, Irving, Texas 75063

---

## **Structural Analysis Report**

**Existing 130 ft Rohn Monopole**

**Customer Name: SBA Communications Corp**

**Customer Site Number: CT13615-A**

**Customer Site Name: Madison 7, CT**

**Carrier Name: AT&T**

**Carrier Site ID / Name: CT2517**

**Site Location: 17 Cottage Road**

**Madison, Connecticut**

**New Haven County**

**Latitude: 41.275916**

**Longitude: -72.561444**

### **Analysis Result:**

**Max Structural Usage: 74.1% [Pass]**

**Max Foundation Usage: 66.0% [Pass]**

**Report Prepared by: Tawfeeq Alajaj**

## Introduction

The purpose of this report is to summarize the analysis results on the 130 ft Monopole to support the proposed antennas and transmission lines in addition to those currently installed. Any modification listed under Sources of Information was assumed completed and was included in this analysis.

## Sources of Information

<b>Tower Drawings</b>	Radian Communication Services, Drawing No. A070592 1-3 dated 10/1/2007.
<b>Foundation Drawing</b>	Radian Communication Services, Drawing No. A070593 1-3 dated 10/1/2007.
<b>Geotechnical Report</b>	JGI, Project No. J2075395 dated 9/10/2007.
<b>Modification Drawings</b>	N/A

## Analysis Criteria

The analysis was performed in accordance with the requirements and stipulations of the ANSI/TIA/EIA 222-F. In accordance with this standard, the structure was analyzed using **TESPoles**, a proprietary analysis software. The program considers the structure as an elastic 3-D model with second-order effects and temperature effects incorporated in the analysis. The analysis was performed using multiple wind directions.

<b>Basic Wind Speed Used in the Analysis:</b>	85.0 mph (fastest mile)
<b>Basic Wind Speed with Ice:</b>	74 mph (fastest mile) with 1/2" radial ice concurrent
<b>Operational Wind Speed:</b>	50 mph + 0" Radial ice
<b>Standard/Codes:</b>	ANSI/TIA/EIA 222-F / 2005 Connecticut State Building Code

## Existing Antennas, Mounts and Transmission Lines

The table below summarizes the antennas, mounts and transmission lines that were considered in the analysis as existing on the tower.

Items	Elevation (ft)	Qty.	Antenna Descriptions	Mount Type & Qty.	Transmission Lines	Owner
-	127.0	6	Powerwave - P90-15-XLH-RR - Panel	Low Profile Platform (1) Ring Mount	(12) 1-5/8" (1) 1/2" Fiber (2) 3/4" DC (1) 3" Flex Conduit	AT&T
-		3	KMW - AM-X-CD-14-65-00T- Panel			
-		6	Powerwave TT19-08BP111-001 TMA			
-		6	Ericsson RRUS-11 RRH			
-		6	Powerwave CM1007-DBPXBC-003 Diplexer			
-		1	Raycap DC6-48-60-18-8F Surge			
8	117	3	Ericsson Air 21 B2A B4P	(1) 12.5' Low Profile Platform	(12) 1-5/8" (1) 1-5/8" Fiber	T-Mobile
9		3	Ericsson Air 21 B4A B2P			
10		3	Ericsson KRY 112 144 TMAs			
11	107	3	Commscope SBNHH-1D65B Panel	(1) Low Profile Platform	(10) 1-5/8" Coax (2) 1-5/8" Fiber	Verizon
12		3	Antel BXA-70063-6CF-2 Panel			
13		6	Commscope SBNHH-1D65B Panel			
14		3	Alcatel Lucent RRH2x60-700 RRU			
15		3	Alcatel Lucent RRH2X60-PCS RRU			
16		3	Alcatel Lucent RRH4x45AWS RRU			
17		2	Rfs Celwave DB-T1-6Z-8AB-0Z ODU			

## Proposed Carrier's Final Configuration of Antennas, Mounts and Transmission Lines

Information pertaining to the proposed carrier's final configuration of antennas and transmission lines was provided by SBA Communications Corp. The proposed antennas and lines are listed below.

Items	Elevation (ft)	Qty.	Antenna Descriptions	Mount Type & Qty.	Transmission Lines	Owner
1	127.0	6	Powerwave - P90-15-XLH-RR - Panel	Platform w/ Hand Rail Handrail kit Site Pro HRK-14-U (1) Collar Mount	(12) 1-5/8" (1) 1/2" Fiber (2) 3/4" DC (1) 3" Flex Conduit	AT&T
2		3	Andrew - SBNHH-1D65A - Panel			
3		6	Powerwave TT19-08BP111-001 TMA			
4		3	Ericsson RRUS-11 RRH			
5		3	Ericsson RRUS-32 RRH			
6		6	Powerwave CM1007-DBPXBC-003 Diplexer			
7		1	Raycap DC6-48-60-18-8F Surge			

All transmission lines are considered running inside of the pole shafts.



## **Analysis Results**

The results of the structural analysis, performed for the wind and ice loading and antenna equipment as defined above, are summarized as the following:

	Pole shafts	Anchor Bolts	Base Plate
Max. Usage:	<b>49.2%</b>	<b>60.1%</b>	<b>74.1%</b>
Pass/Fail	<b>Pass</b>	<b>Pass</b>	<b>Pass</b>

## **Foundations**

	Moment (Kip-Ft)	Shear (Kips)
Original Design Reactions	5098.4	46.4
Analysis Reactions	2375.3	25.0
% of Design Reactions	46.6%	53.9%

The foundation has been investigated using the supplied documents and soils report and was found adequate. Therefore, no modification to the foundation will be required.

## **Operational Condition (Rigidity):**

Operational characteristics of the tower are found to be within the limits prescribed by ANSI/TIA/EIA 222-F for the installed antennas. The maximum twist/sway at the elevation of the proposed equipment is 0.7436 degrees under the operational wind speed as specified in the Analysis Criteria.

## **Conclusions**

Based on the analysis results, the existing structure and its foundation were found to be adequate to safely support the existing and proposed equipment and meet the minimum requirements per the ANSI/TIA/EIA 222-F Standard under the design basic wind speed as specified in the Analysis Criteria.

## **Note:**

The structure capacity usage percentage (74%) on the cover sheet reflects the antennas plus the new mount. The capacity usage considering the exiting mount plus the proposed antennas is (72%). The new mount causes an additional 2% of overstress.

## Standard Conditions

1. This analysis was performed based on the information supplied to **(TES) Tower Engineering Solutions, LLC**. Verification of the information provided was not included in the Scope of Work for **TES**. The accuracy of the analysis is dependent on the accuracy of the information provided.
2. The analysis is based on the presumption that the tower members and components along with any existing reinforcement items have been correctly and properly designed, manufactured, installed and maintained.
3. All the existing structural members were assumed to be in good condition with no physical damage or deterioration associated with corrosion.
4. An initial tension of 10% of the break strength on all the existing guy wires was assumed in all the structural analyses of guyed towers unless different values were provided by the client. **TES** cannot take responsibility for the deviations in the analysis results because of differences in the initial tension forces of the existing guy wires.
5. Secondary component or connection secondary components, welds and bolts are assumed to be able to carry their intended original design loads. **TES** cannot take responsibility for verification of the adequacy on the connections, bolts and welds present in the structure.
6. The analyses will be performed based on the codes as specified by the client or based on the best knowledge of the engineering staff of **TES**. In the absence of information to the contrary, all work will be performed in accordance with the latest relevant revision of ANSI/TIA-222. If wind speed or/and ice loads are different from the minimum values recommended by the EIA/TIA-222 standard or other codes, **TES** should be notified in writing and the applicable minimum values provided by the client.
7. The configuration of the existing mounts, antennas, coax and other appurtenances were supplied by the customer for the current structural analysis. **TES** has not visited the tower site to verify the adequacy of the information provided. If there is any discrepancy found in the report regarding the existing conditions, **TES** should be notified immediately to evaluate the effect of the discrepancy on the analysis results.
8. The client will assume responsibility for rework associated with the differences in initially provided information, including tower and foundation information, existing and/or proposed equipment and transmission lines.
9. If a feasibility analysis was performed, final acceptance of changed conditions shall be based upon a rigorous structural analysis.

# Usage Diagram - Max Stress 49.2% at 0.0ft

**Structure:** CT13615-A-SBA  
**Site Name:** Madison 7, CT  
**Height:** 130.00 (ft)  
**Base Elev:** 0.000 (ft)

**Code:** EIA/TIA-222-F  
**Exposure:** C  
**Gh:** 1.69

8/26/2016



Page: 1

Dead Load Factor: 1.00  
 Wind Load Factor: 1.00

Iterations: 19

**Load Case : 85 mph Wind with 0 in Ice**

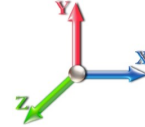

**52** Allowable Stress  
**26** Resulting Stress

*Copyright © 2016 by Tower Engineering Solutions, LLC. All rights reserved.*

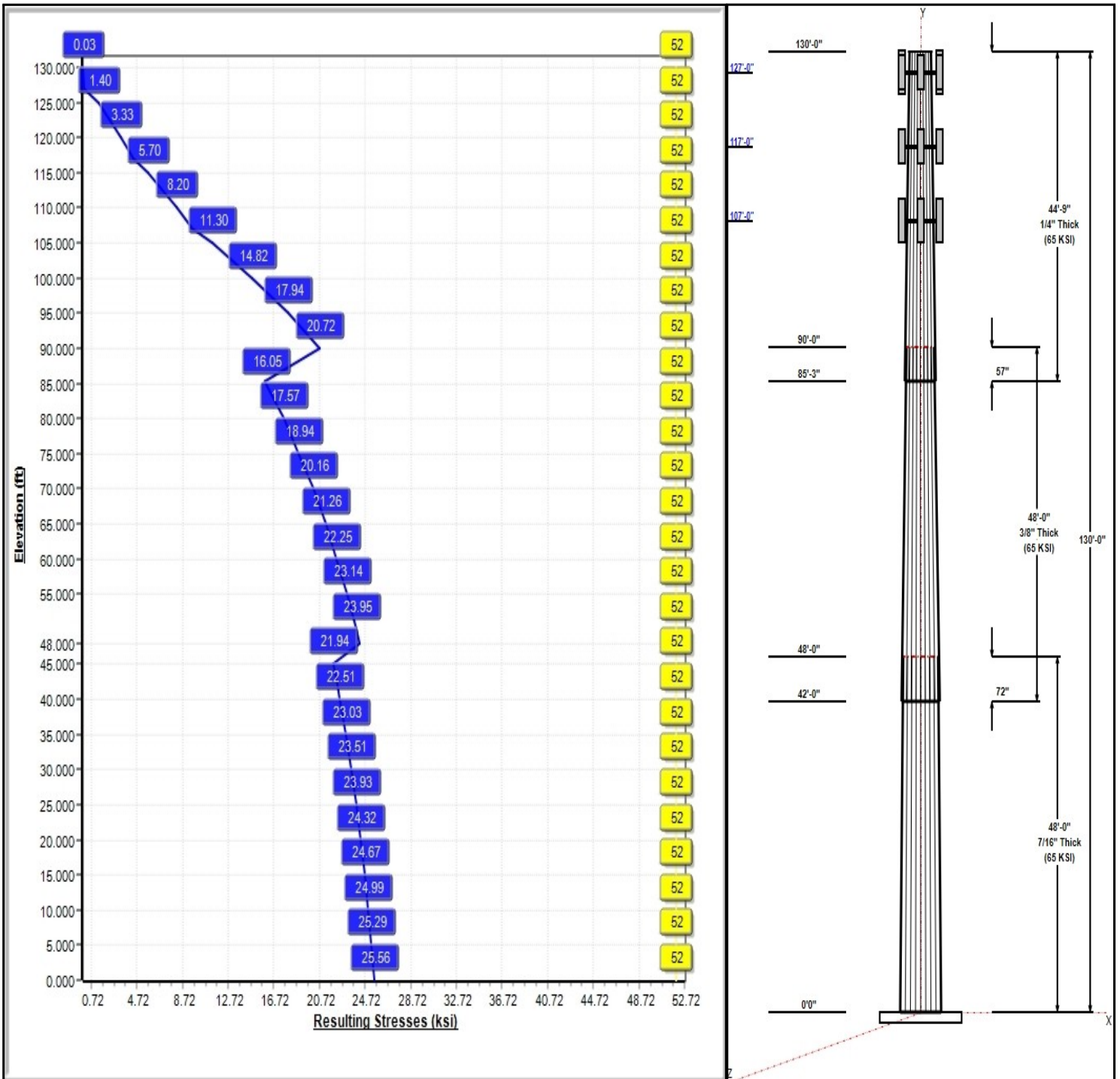



## Structure: CT13615-A-SBA

**Type:** Tapered  
**Site Name:** Madison 7, CT  
**Height:** 130.00 (ft)  
**Base Elev:** 0.00 (ft)

**Base Shape:** 18 Sided  
**Taper:** 0.24800

8/26/2016

Page: 2



### Shaft Properties

Seq	Length (ft)	Top (in)	Bottom (in)	Thick (in)	Joint Type	Taper	Grade (ksi)
1	48.00	46.10	58.00	0.438		0.24800	65
2	48.00	36.43	48.33	0.375	Slip	0.24800	65
3	44.75	27.01	38.11	0.250	Slip	0.24800	65

### Discrete Appurtenances

Attach Elev (ft)	Force Elev (ft)	Qty	Description	Carrier
127.00	127.00	3	Ericsson RRUS-11 RRH	AT&T
127.00	127.00	6	P90-15-XLH-RR	AT&T
127.00	127.00	6	Powerwave	AT&T
127.00	127.00	1	Raycap DC6-48-60-18-8F	AT&T
127.00	127.00	3	SBNHH-1D65A	AT&T
127.00	127.00	6	Powerwave	AT&T
127.00	127.00	1	Platform w/ Hand Rail	AT&T
127.00	127.00	3	Ericsson RRUS-32 RRH	AT&T
117.00	117.00	3	Air 21 B2A B4P	T-Mobile
117.00	117.00	3	Air 21 B4A B2P	T-Mobile
117.00	117.00	3	KRY 112 144	T-Mobile
117.00	117.00	1	12.5' Low Profile Platform	T-Mobile
107.00	107.00	1	Low Profile Platform	Verizon
107.00	107.00	3	SBNHH-1D65B	Verizon
107.00	107.00	3	BXA-70063-6CF-2	Verizon
107.00	107.00	6	SBNHH-1D65B	Verizon
107.00	107.00	3	RRH2x60-700	Verizon
107.00	107.00	3	RRH2X60-PCS	Verizon
107.00	107.00	3	RRH4x45AWS	Verizon
107.00	107.00	2	DB-T1-6Z-8AB-0Z	Verizon

### Linear Appurtenances

Elev From (ft)	Elev To (ft)	Placement	Description	Carrier
0.00	128.00	Inside	1 5/8"	AT&T
0.00	128.00	Inside	1/2" Fiber	AT&T
0.00	128.00	Inside	3" Flex Conduit	AT&T
0.00	128.00	Inside	3/4" DC	AT&T
0.00	117.00	Inside	1 5/8"	T-Mobile
0.00	117.00	Inside	1 5/8" Fiber	T-Mobile
0.00	107.00	Inside	1 5/8" Coax	Verizon
0.00	107.00	Inside	1 5/8" Fiber	Verizon

### Anchor Bolts

Qty	Specifications	Grade (ksi)	Arrangement
26	1.5" F1554 105	105.0	Radial

### Base Plate

Thickness (in)	Specifications (in)	Grade (ksi)	Geometry
1.7500	67.0	50.0	Round

### Reactions

Load Case	Moment	Shear	Axial
85 mph Wind with 0" Ice	2375.3	25.0	36.0

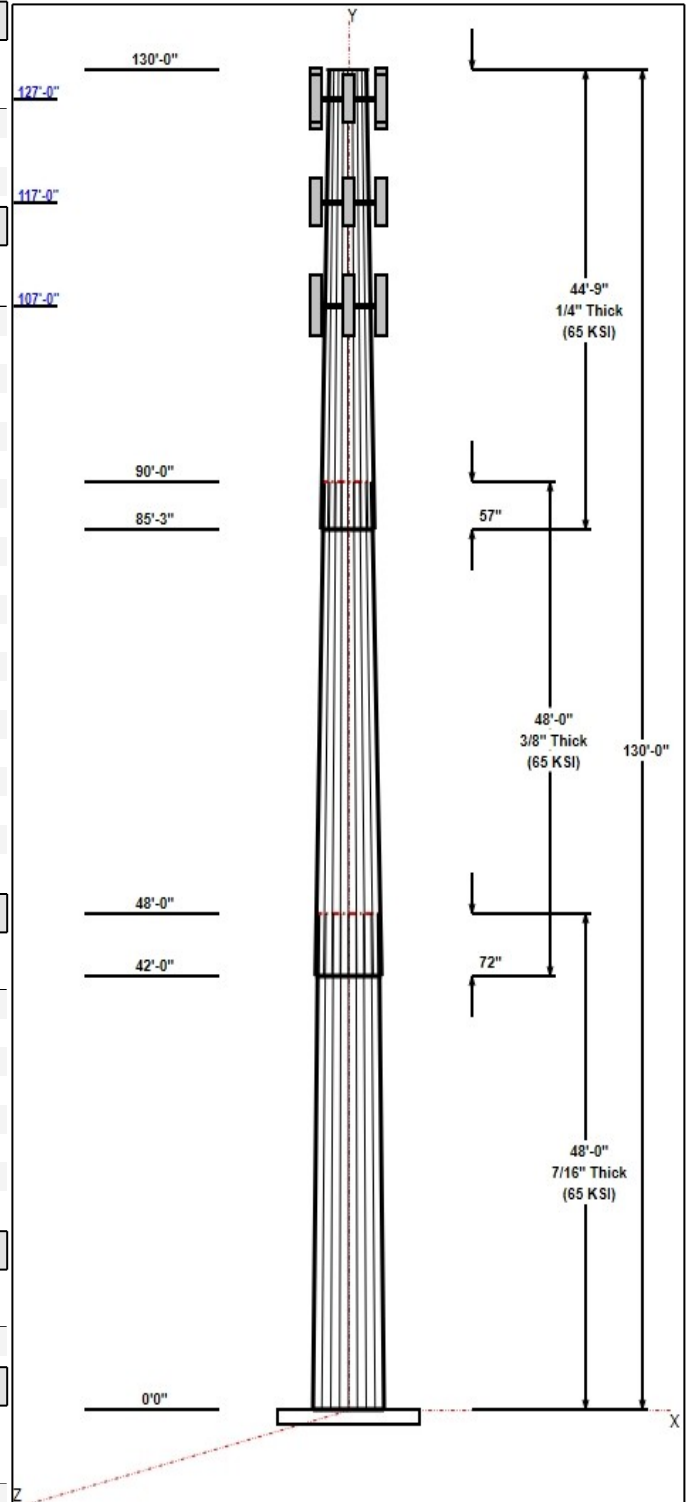

## Structure: CT13615-A-SBA

**Type:** Tapered  
**Site Name:** Madison 7, CT  
**Height:** 130.00 (ft)  
**Base Elev:** 0.00 (ft)

**Base Shape:** 18 Sided  
**Taper:** 0.24800

8/26/2016

Page: 3



73.61 mph Wind with 0.5" Ice	1951.8	20.2	42.5
50 mph Wind with 0" Ice	822.1	8.7	36.0

# Structure: CT13615-A-SBA - Coax Line Placement

**Type:** Monopole  
**Site Name:** Madison 7, CT  
**Height:** 130.00 (ft)

8/26/2016

Page: 4

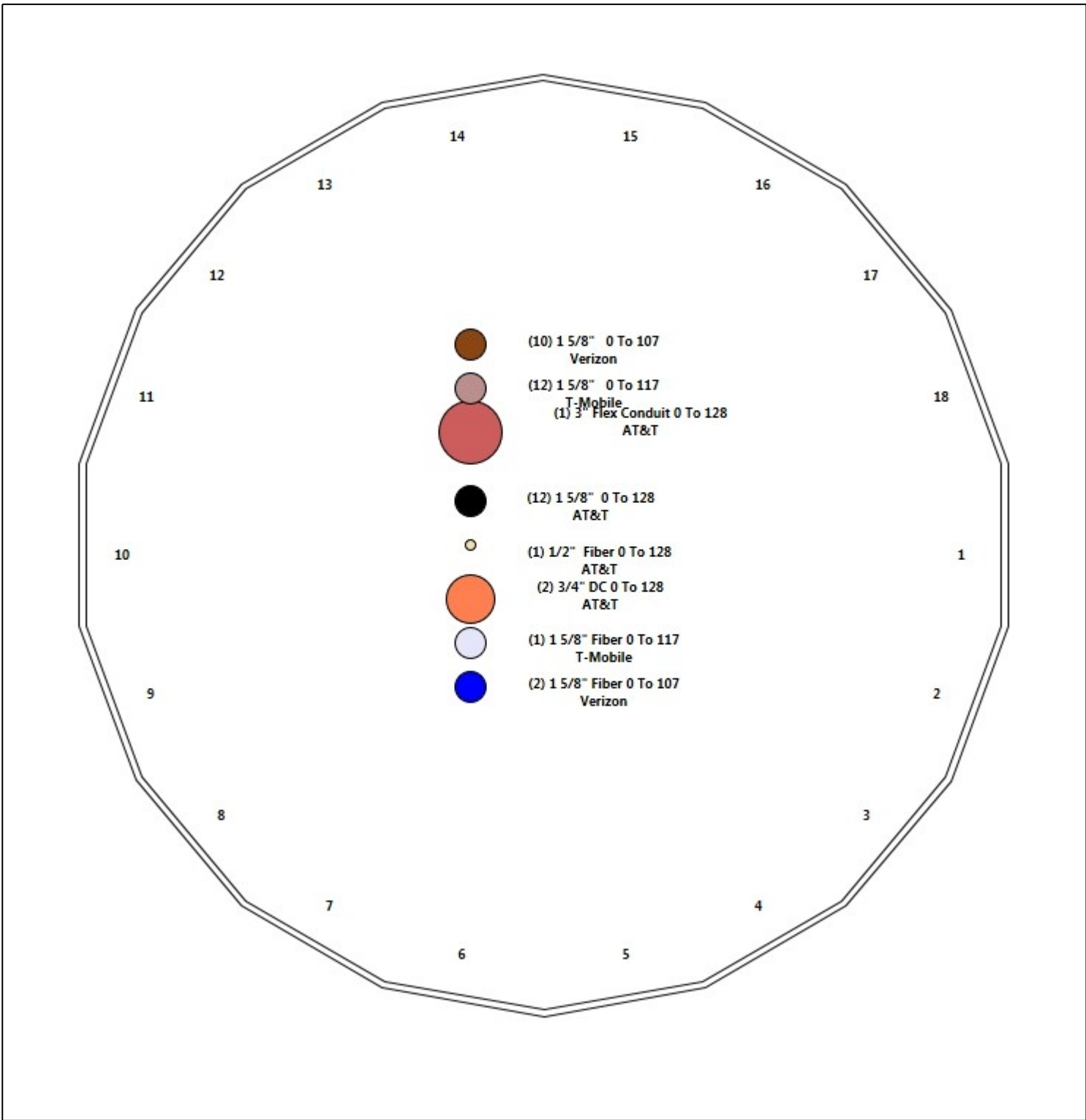



## Shaft Properties

**Structure:** CT13615-A-SBA  
**Site Name:** Madison 7, CT  
**Height:** 130.00 (ft)  
**Base Elev:** 0.000 (ft)

**Code:** EIA/TIA-222-F  
**Exposure:** C  
**Gh:** 1.69  
**Struct Class:** II

8/26/2016

Page: 5



Sec. No.	Shape	Length (ft)	Thick (in)	Fy (ksi)	Joint Type	Overlap (in)	Weight (lb)
1	18	48.000	0.4375	65		0.00	11,705
2	18	48.000	0.3750	65	Slip	72.00	8,166
3	18	44.750	0.2500	65	Slip	57.00	3,904
<b>Total Shaft Weight:</b>							<b>23,775</b>

### Bottom

### Top

Sec. No.	Dia (in)	Elev (ft)	Area (sqin)	Ix (in^4)	W/t Ratio	D/t Ratio	Dia (in)	Elev (ft)	Area (sqin)	Ix (in^4)	W/t Ratio	D/t Ratio	Taper
1	58.00	0.00	79.93	33461.19	21.97	132.57	46.10	48.00	63.40	16698.8	17.17	105.36	0.248000
2	48.33	42.00	57.08	16587.69	21.32	128.89	36.43	90.00	42.91	7048.10	15.72	97.15	0.248000
3	38.11	85.25	30.04	5439.48	25.47	152.43	27.01	130.0	21.23	1921.07	17.64	108.04	0.248000

## Loading Summary

**Structure:** CT13615-A-SBA  
**Site Name:** Madison 7, CT  
**Height:** 130.00 (ft)  
**Base Elev:** 0.000 (ft)

**Code:** EIA/TIA-222-F  
**Exposure:** C  
**Gh:** 1.69  
**Struct Class:** II

8/26/2016  
 Page: 6



### Discrete Appurtenances

No.	Elev (ft)	Description	Qty	No Ice			Ice			Hor. Ecc. (ft)	Vert Ecc (ft)
				Weight (lb)	CaAa (sf)	CaAa Factor	Weight (lb)	CaAa (sf)	CaAa Factor		
1	127.00	Ericsson RRUS-11 RRH	3	55.00	4.42	0.68	80.70	4.850	0.70	0.00	0.00
2	127.00	P90-15-XLH-RR	6	53.00	8.40	0.75	100.20	9.230	0.77	0.00	0.00
3	127.00	Powerwave TT19-08BP111-001 TMA	6	16.00	0.64	0.90	21.80	0.820	0.92	0.00	0.00
4	127.00	Raycap DC6-48-60-18-8F Surge	1	32.80	1.47	1.00	50.50	1.670	1.00	0.00	0.00
5	127.00	SBNHH-1D65A	3	33.50	6.36	0.83	68.80	6.740	0.83	0.00	0.00
6	127.00	Powerwave CM1007-DBPXBC-003 Di	6	6.50	0.43	0.83	9.90	0.570	0.83	0.00	0.00
7	127.00	Platform w/ Hand Rail	1	1600.00	35.00	1.00	2200.00	40.000	1.00	0.00	0.00
8	127.00	Ericsson RRUS-32 RRH	3	77.00	3.87	0.87	103.50	4.300	0.87	0.00	0.00
9	117.00	Air 21 B2A B4P	3	91.50	6.58	0.86	129.20	6.970	0.88	0.00	0.00
10	117.00	Air 21 B4A B2P	3	90.40	6.58	0.86	128.10	6.970	0.88	0.00	0.00
11	117.00	KRY 112 144	3	11.00	0.41	0.70	14.10	0.550	0.72	0.00	0.00
12	117.00	12.5' Low Profile Platform	1	1600.00	25.55	1.00	2100.00	27.320	1.00	0.00	0.00
13	107.00	Low Profile Platform	1	1200.00	25.00	1.00	1500.00	31.000	1.00	0.00	0.00
14	107.00	SBNHH-1D65B	3	40.60	8.33	0.83	87.00	8.800	0.85	0.00	0.00
15	107.00	BXA-70063-6CF-2	3	17.00	7.73	0.73	59.50	8.540	0.75	0.00	0.00
16	107.00	SBNHH-1D65B	6	40.60	8.33	0.83	87.00	8.800	0.85	0.00	0.00
17	107.00	RRH2x60-700	3	60.00	3.96	0.76	80.10	4.230	0.78	0.00	0.00
18	107.00	RRH2X60-PCS	3	55.00	2.57	0.89	70.90	2.760	0.91	0.00	0.00
19	107.00	RRH4x45AWS	3	60.00	2.71	0.98	83.10	3.070	1.00	0.00	0.00
20	107.00	DB-T1-6Z-8AB-OZ	2	18.90	5.60	0.71	46.00	5.870	0.73	0.00	0.00
<b>Totals:</b>			<b>63</b>	<b>6,940.20</b>			<b>9,970.90</b>				

### Linear Appurtenances

Bottom Elev. (ft)	Top Elev. (ft)	Description	No Ice		Ice		Exposed
			Weight (lb/ft)	CaAa (sf/ft)	Weight (lb/ft)	CaAa (sf/ft)	
0.00	128.00	(12) 1 5/8"	12.48	0.00	12.48	0.00	Inside
0.00	128.00	(1) 1/2" Fiber	0.16	0.00	0.16	0.00	Inside
0.00	128.00	(1) 3" Flex Conduit	2.50	0.00	2.50	0.00	Inside
0.00	128.00	(2) 3/4" DC	3.56	0.00	3.56	0.00	Inside
0.00	117.00	(12) 1 5/8"	12.48	0.00	12.48	0.00	Inside
0.00	117.00	(1) 1 5/8" Fiber	1.10	0.00	1.10	0.00	Inside
0.00	107.00	(10) 1 5/8" Coax	10.40	0.00	10.40	0.00	Inside
0.00	107.00	(2) 1 5/8" Fiber	2.20	0.00	2.20	0.00	Inside
<b>Totals:</b>			<b>5,330.66</b>		<b>5,330.66</b>		

## Shaft Section Properties

**Structure:** CT13615-A-SBA  
**Site Name:** Madison 7, CT  
**Height:** 130.00 (ft)  
**Base Elev:** 0.000 (ft)

**Code:** EIA/TIA-222-F  
**Exposure:** C  
**Gh:** 1.69  
**Struct Class:** II

8/26/2016

Page: 7



**Increment Length:** 5 (ft)

Elev (ft)	Description	Thick (in)	Dia (in)	Area (in^2)	Ix (in^4)	W/t Ratio	D/t Ratio	Fy (ksi)	Fb (ksi)	Weight (lb)
0.00		0.4375	58.000	79.930	33461.2	21.97	132.57	65	52	0.0
5.00		0.4375	56.760	78.208	31345.0	21.47	129.74	65	52	1345.3
10.00		0.4375	55.520	76.486	29320.0	20.97	126.90	65	52	1316.0
15.00		0.4375	54.280	74.764	27384.1	20.47	124.07	65	52	1286.7
20.00		0.4375	53.040	73.043	25535.3	19.97	121.23	65	52	1257.4
25.00		0.4375	51.800	71.321	23771.7	19.47	118.40	65	52	1228.1
30.00		0.4375	50.560	69.599	22091.3	18.97	115.57	65	52	1198.8
35.00		0.4375	49.320	67.877	20491.9	18.47	112.73	65	52	1169.5
40.00		0.4375	48.080	66.155	18971.7	17.97	109.90	65	52	1140.2
42.00	Bot - Section 2	0.4375	47.584	65.466	18385.3	17.77	108.76	65	52	447.9
45.00		0.4375	46.840	64.433	17528.6	17.47	107.06	65	52	1241.2
48.00	Top - Section 1	0.3750	46.846	55.310	15091.1	20.62	124.92	65	52	1221.6
50.00		0.3750	46.350	54.720	14613.0	20.38	123.60	65	52	374.4
55.00		0.3750	45.110	53.244	13462.3	19.80	120.29	65	52	918.4
60.00		0.3750	43.870	51.768	12373.5	19.22	116.99	65	52	893.3
65.00		0.3750	42.630	50.292	11345.1	18.63	113.68	65	52	868.2
70.00		0.3750	41.390	48.816	10375.4	18.05	110.37	65	52	843.1
75.00		0.3750	40.150	47.340	9462.5	17.47	107.07	65	52	818.0
80.00		0.3750	38.910	45.865	8604.8	16.89	103.76	65	52	792.9
85.00		0.3750	37.670	44.389	7800.6	16.30	100.45	65	52	767.8
85.25	Bot - Section 3	0.3750	37.608	44.315	7761.8	16.27	100.29	65	52	37.7
90.00	Top - Section 2	0.2500	36.930	29.105	4947.3	24.64	147.72	65	52	1182.9
95.00		0.2500	35.690	28.121	4462.4	23.76	142.76	65	52	486.8
100.00		0.2500	34.450	27.137	4010.2	22.89	137.80	65	52	470.1
105.00		0.2500	33.210	26.153	3589.6	22.01	132.84	65	52	453.3
107.00		0.2500	32.714	25.759	3430.0	21.66	130.86	65	52	176.6
110.00		0.2500	31.970	25.169	3199.5	21.14	127.88	65	52	259.9
115.00		0.2500	30.730	24.185	2838.8	20.26	122.92	65	52	419.9
117.00		0.2500	30.234	23.791	2702.4	19.91	120.94	65	52	163.3
120.00		0.2500	29.490	23.201	2506.2	19.39	117.96	65	52	239.9
125.00		0.2500	28.250	22.217	2200.7	18.51	113.00	65	52	386.4
127.00		0.2500	27.754	21.824	2085.8	18.16	111.02	65	52	149.9
130.00		0.2500	27.010	21.233	1921.1	17.64	108.04	65	52	219.8

**23775.2**

## Wind Loading - Shaft

**Structure:** CT13615-A-SBA  
**Site Name:** Madison 7, CT  
**Height:** 130.00 (ft)  
**Base Elev:** 0.000 (ft)

**Code:** EIA/TIA-222-F  
**Exposure:** C  
**Gh:** 1.69  
**Struct Class:** II

8/26/2016  
 Page: 8



**Load Case:** 85 mph Wind with 0" Ice

**Dead Load Factor** 1.00  
**Wind Load Factor** 1.00

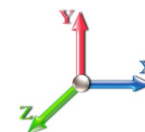

**Iterations:** 19

Elev (ft)	Description	Kzt	Kz	qz (psf)	qzGh (psf)	C (mph-ft)	Cf	Ice Thick (in)	Tributary (ft)	Aa (sf)	CfAa (sf)	Wind Force X (lb)	Dead Load Ice (lb)	Tot Dead Load (lb)
0.00		0.00	1.00	18.496	31.26	410.83	0.650	0.000	0.00	0.000	0.00	0.0	0.0	0.0
5.00		0.00	1.00	18.496	31.26	402.05	0.650	0.000	5.00	23.908	15.54	485.8	0.0	1345.3
10.00		0.00	1.00	18.496	31.26	393.27	0.650	0.000	5.00	23.392	15.20	475.3	0.0	1316.0
15.00		0.00	1.00	18.496	31.26	384.48	0.650	0.000	5.00	22.875	14.87	464.8	0.0	1286.7
20.00		0.00	1.00	18.496	31.26	375.70	0.650	0.000	5.00	22.358	14.53	454.3	0.0	1257.4
25.00		0.00	1.00	18.496	31.26	366.92	0.650	0.000	5.00	21.842	14.20	443.8	0.0	1228.1
30.00		0.00	1.00	18.496	31.26	358.13	0.650	0.000	5.00	21.325	13.86	433.3	0.0	1198.8
35.00		0.00	1.02	18.810	31.79	352.30	0.650	0.000	5.00	20.808	13.53	429.9	0.0	1169.5
40.00		0.00	1.06	19.541	33.02	350.06	0.650	0.000	5.00	20.292	13.19	435.6	0.0	1140.2
42.00	Bot - Section 2	0.00	1.07	19.815	33.49	348.87	0.650	0.000	2.00	7.972	5.18	173.5	0.0	447.9
45.00		0.00	1.09	20.210	34.15	346.81	0.650	0.000	3.00	11.991	7.79	266.2	0.0	1241.2
48.00	Top - Section 1	0.00	1.11	20.586	34.79	344.47	0.650	0.000	3.00	11.805	7.67	266.9	0.0	1221.6
50.00		0.00	1.13	20.827	35.20	348.39	0.650	0.000	2.00	7.766	5.05	177.7	0.0	374.4
55.00		0.00	1.16	21.402	36.17	343.72	0.650	0.000	5.00	19.054	12.39	448.0	0.0	918.4
60.00		0.00	1.19	21.941	37.08	338.45	0.650	0.000	5.00	18.538	12.05	446.8	0.0	893.3
65.00		0.00	1.21	22.449	37.94	332.67	0.650	0.000	5.00	18.021	11.71	444.4	0.0	868.2
70.00		0.00	1.24	22.929	38.75	326.43	0.650	0.000	5.00	17.504	11.38	440.9	0.0	843.1
75.00		0.00	1.26	23.386	39.52	319.79	0.650	0.000	5.00	16.988	11.04	436.4	0.0	818.0
80.00		0.00	1.29	23.821	40.26	312.78	0.650	0.000	5.00	16.471	10.71	431.0	0.0	792.9
85.00		0.00	1.31	24.237	40.96	305.45	0.650	0.000	5.00	15.954	10.37	424.8	0.0	767.8
85.25	Bot - Section 3	0.00	1.31	24.257	40.99	305.07	0.650	0.000	0.25	0.784	0.51	20.9	0.0	37.7
90.00	Top - Section 2	0.00	1.33	24.636	41.63	297.81	0.650	0.000	4.75	14.851	9.65	401.9	0.0	1182.9
95.00		0.00	1.35	25.020	42.28	294.03	0.650	0.000	5.00	15.129	9.83	415.8	0.0	486.8
100.00		0.00	1.37	25.389	42.91	285.90	0.650	0.000	5.00	14.613	9.50	407.5	0.0	470.1
105.00		0.00	1.39	25.745	43.51	277.53	0.650	0.000	5.00	14.096	9.16	398.6	0.0	453.3
107.00	Appurtenance(s)	0.00	1.40	25.885	43.74	274.13	0.650	0.000	2.00	5.494	3.57	156.2	0.0	176.6
110.00		0.00	1.41	26.090	44.09	268.95	0.650	0.000	3.00	8.085	5.26	231.7	0.0	259.9
115.00		0.00	1.43	26.423	44.66	260.17	0.650	0.000	5.00	13.063	8.49	379.2	0.0	419.9
117.00	Appurtenance(s)	0.00	1.44	26.554	44.88	256.60	0.650	0.000	2.00	5.080	3.30	148.2	0.0	163.3
120.00		0.00	1.45	26.747	45.20	251.19	0.650	0.000	3.00	7.465	4.85	219.3	0.0	239.9
125.00		0.00	1.46	27.060	45.73	242.04	0.650	0.000	5.00	12.029	7.82	357.6	0.0	386.4
127.00	Appurtenance(s)	0.00	1.47	27.183	45.94	238.33	0.650	0.000	2.00	4.667	3.03	139.4	0.0	149.9
130.00		0.00	1.48	27.365	46.25	232.71	0.650	0.000	3.00	6.845	4.45	205.8	0.0	219.8
<b>Totals:</b>									<b>130.00</b>			<b>11,061.4</b>		<b>23,775.2</b>



## Discrete Appurtenance Forces

**Structure:** CT13615-A-SB  
**Site Name:** Madison 7, CT  
**Height:** 130.00 (ft)  
**Base Elev:** 0.000 (ft)

**Code:** EIA/TIA-222-F  
**Exposure:** C  
**Gh:** 1.69  
**Struct Class:** II

8/26/2016

Page: 9



**Load Case:** 85 mph Wind with 0" Ice

**Dead Load Factor** 1.00  
**Wind Load Factor** 1.00

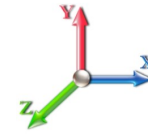

**Iterations:** 19

No.	Elev (ft)	Description	Qty	qz (psf)	qzGh (psf)	CaAa Factor	Total CaAa (sf)	Dead Load (lb)	Horiz Ecc (ft)	Vert Ecc (ft)	Wind FX (lb)	Mom Y (lb-ft)	Mom Z (lb-ft)
1	127.00	Powerwave	6	27.183	45.940	0.90	3.46	96.00	0.000	0.000	158.77	0.00	0.00
2	127.00	P90-15-XLH-RR	6	27.183	45.940	0.75	37.80	318.00	0.000	0.000	1736.53	0.00	0.00
3	127.00	Ericsson RRUS-11 RRH	3	27.183	45.940	0.68	9.02	165.00	0.000	0.000	414.23	0.00	0.00
4	127.00	Ericsson RRUS-32 RRH	3	27.183	45.940	0.87	10.10	231.00	0.000	0.000	464.03	0.00	0.00
5	127.00	Platform w/ Hand Rail	1	27.183	45.940	1.00	35.00	1600.00	0.000	0.000	1607.90	0.00	0.00
6	127.00	Powerwave	6	27.183	45.940	0.83	2.14	39.00	0.000	0.000	98.38	0.00	0.00
7	127.00	SBNHH-1D65A	3	27.183	45.940	0.83	15.84	100.50	0.000	0.000	727.52	0.00	0.00
8	127.00	Raycap DC6-48-60-18-8F	1	27.183	45.940	1.00	1.47	32.80	0.000	0.000	67.53	0.00	0.00
9	117.00	KRY 112 144	3	26.554	44.876	0.70	0.86	33.00	0.000	0.000	38.64	0.00	0.00
10	117.00	12.5' Low Profile Platform	1	26.554	44.876	1.00	25.55	1600.00	0.000	0.000	1146.58	0.00	0.00
11	117.00	Air 21 B4A B2P	3	26.554	44.876	0.86	16.98	271.20	0.000	0.000	761.83	0.00	0.00
12	117.00	Air 21 B2A B4P	3	26.554	44.876	0.86	16.98	274.50	0.000	0.000	761.83	0.00	0.00
13	107.00	DB-T1-6Z-8AB-0Z	2	25.885	43.745	0.71	7.95	37.80	0.000	0.000	347.86	0.00	0.00
14	107.00	RRH4x45AWS	3	25.885	43.745	0.98	7.97	180.00	0.000	0.000	348.53	0.00	0.00
15	107.00	RRH2X60-PCS	3	25.885	43.745	0.89	6.86	165.00	0.000	0.000	300.17	0.00	0.00
16	107.00	RRH2x60-700	3	25.885	43.745	0.76	9.03	180.00	0.000	0.000	394.96	0.00	0.00
17	107.00	SBNHH-1D65B	6	25.885	43.745	0.83	41.48	243.60	0.000	0.000	1814.69	0.00	0.00
18	107.00	BXA-70063-6CF-2	3	25.885	43.745	0.73	16.93	51.00	0.000	0.000	740.54	0.00	0.00
19	107.00	SBNHH-1D65B	3	25.885	43.745	0.83	20.74	121.80	0.000	0.000	907.34	0.00	0.00
20	107.00	Low Profile Platform	1	25.885	43.745	1.00	25.00	1200.00	0.000	0.000	1093.62	0.00	0.00
<b>Totals:</b>								<b>6,940.20</b>			<b>13,931.49</b>		

## Total Applied Force Summary

**Structure:** CT13615-A-SB  
**Site Name:** Madison 7, CT  
**Height:** 130.00 (ft)  
**Base Elev:** 0.000 (ft)

**Code:** EIA/TIA-222-F  
**Exposure:** C  
**Gh:** 1.69  
**Struct Class:** II

8/26/2016

Page: 10



**Load Case:** 85 mph Wind with 0" Ice

**Dead Load Factor** 1.00  
**Wind Load Factor** 1.00

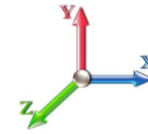

**Iterations:** 19

Elev (ft)	Description	Lateral FX (-) (lb)	Axial FY (-) (lb)	Torsion MY (lb-ft)	Moment MZ (lb-ft)
0.00		0.00	0.00	0.00	0.00
5.00		485.77	1569.67	0.00	0.00
10.00		475.27	1540.37	0.00	0.00
15.00		464.77	1511.08	0.00	0.00
20.00		454.27	1481.78	0.00	0.00
25.00		443.78	1452.49	0.00	0.00
30.00		433.28	1423.19	0.00	0.00
35.00		429.95	1393.90	0.00	0.00
40.00		435.58	1364.60	0.00	0.00
42.00		173.53	537.64	0.00	0.00
45.00		266.20	1375.85	0.00	0.00
48.00		266.94	1356.27	0.00	0.00
50.00		177.69	464.17	0.00	0.00
55.00		447.97	1142.84	0.00	0.00
60.00		446.80	1117.73	0.00	0.00
65.00		444.39	1092.62	0.00	0.00
70.00		440.89	1067.51	0.00	0.00
75.00		436.39	1042.40	0.00	0.00
80.00		431.00	1017.29	0.00	0.00
85.00		424.77	992.18	0.00	0.00
85.25		20.89	48.95	0.00	0.00
90.00		401.92	1396.10	0.00	0.00
95.00		415.81	711.21	0.00	0.00
100.00		407.54	694.47	0.00	0.00
105.00		398.65	677.73	0.00	0.00
107.00	(24) appurtenances	6103.93	2445.61	0.00	0.00
110.00		231.73	356.79	0.00	0.00
115.00		379.15	581.25	0.00	0.00
117.00	(10) appurtenances	2857.07	2406.51	0.00	0.00
120.00		219.34	295.96	0.00	0.00
125.00		357.58	479.87	0.00	0.00
127.00	(29) appurtenances	5414.24	2769.56	0.00	0.00
130.00		205.78	238.47	0.00	0.00
<b>Totals:</b>		<b>24,992.87</b>	<b>36,046.08</b>	<b>0.00</b>	<b>0.00</b>

## Resulting Forces and Deflections

**Structure:** CT13615-A-SB  
**Site Name:** Madison 7, CT  
**Height:** 130.00 (ft)  
**Base Elev:** 0.000 (ft)

**Code:** EIA/TIA-222-F  
**Exposure:** C  
**Gh:** 1.69  
**Struct Class:** II

8/26/2016  
 Page: 11



**Load Case:** 85 mph Wind with 0" Ice

**Dead Load Factor** 1.00  
**Wind Load Factor** 1.00

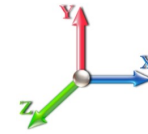

**Iterations:** 19

Elev (ft)	Lateral FX (-) (kips)	Axial FY (-) (kips)	Lateral FZ (kips)	Moment MX (ft-kips)	Torsion MY (ft-kips)	Moment MZ (ft-kips)	Deflect X (in)	Deflect Z (in)	Deflect Resultant (in)	Rotation Sway (deg)	Rotation Twist (deg)
0.00	-25.024	-36.024	0.000	0.000	0.000	-2375.297	0.000	0.000	0.000	0.000	0.000
5.00	-24.596	-34.412	0.000	0.000	0.000	-2250.180	-0.053	0.000	0.053	-0.098	0.000
10.00	-24.174	-32.831	0.000	0.000	0.000	-2127.201	-0.210	0.000	0.210	-0.198	0.000
15.00	-23.758	-31.280	0.000	0.000	0.000	-2006.333	-0.471	0.000	0.471	-0.298	0.000
20.00	-23.347	-29.760	0.000	0.000	0.000	-1887.546	-0.838	0.000	0.838	-0.399	0.000
25.00	-22.942	-28.270	0.000	0.000	0.000	-1770.812	-1.311	0.000	1.311	-0.501	0.000
30.00	-22.544	-26.811	0.000	0.000	0.000	-1656.101	-1.891	0.000	1.891	-0.603	0.000
35.00	-22.143	-25.382	0.000	0.000	0.000	-1543.385	-2.579	0.000	2.579	-0.707	0.000
40.00	-21.720	-23.996	0.000	0.000	0.000	-1432.669	-3.375	0.000	3.375	-0.810	0.000
42.00	-21.560	-23.441	0.000	0.000	0.000	-1389.229	-3.724	0.000	3.724	-0.852	0.000
45.00	-21.297	-22.046	0.000	0.000	0.000	-1324.549	-4.280	0.000	4.280	-0.915	0.000
48.00	-21.027	-20.675	0.000	0.000	0.000	-1260.658	-4.876	0.000	4.876	-0.978	0.000
50.00	-20.869	-20.186	0.000	0.000	0.000	-1218.605	-5.295	0.000	5.295	-1.020	0.000
55.00	-20.437	-19.011	0.000	0.000	0.000	-1114.262	-6.425	0.000	6.425	-1.134	0.000
60.00	-20.002	-17.864	0.000	0.000	0.000	-1012.078	-7.674	0.000	7.674	-1.246	0.000
65.00	-19.565	-16.744	0.000	0.000	0.000	-912.070	-9.039	0.000	9.039	-1.357	0.000
70.00	-19.127	-15.652	0.000	0.000	0.000	-814.247	-10.519	0.000	10.519	-1.465	0.000
75.00	-18.689	-14.588	0.000	0.000	0.000	-718.614	-12.111	0.000	12.111	-1.570	0.000
80.00	-18.253	-13.552	0.000	0.000	0.000	-625.168	-13.810	0.000	13.810	-1.671	0.000
85.00	-17.809	-12.558	0.000	0.000	0.000	-533.904	-15.613	0.000	15.613	-1.767	0.000
85.25	-17.797	-12.496	0.000	0.000	0.000	-529.451	-15.706	0.000	15.706	-1.772	0.000
90.00	-17.367	-11.088	0.000	0.000	0.000	-444.916	-17.513	0.000	17.513	-1.857	0.000
95.00	-16.945	-10.363	0.000	0.000	0.000	-358.080	-19.503	0.000	19.503	-1.938	0.000
100.00	-16.529	-9.657	0.000	0.000	0.000	-273.356	-21.589	0.000	21.589	-2.038	0.000
105.00	-16.114	-8.979	0.000	0.000	0.000	-190.712	-23.771	0.000	23.771	-2.121	0.000
107.00	-9.927	-6.758	0.000	0.000	0.000	-158.484	-24.666	0.000	24.666	-2.148	0.000
110.00	-9.687	-6.403	0.000	0.000	0.000	-128.703	-26.028	0.000	26.028	-2.184	0.000
115.00	-9.289	-5.832	0.000	0.000	0.000	-80.268	-28.342	0.000	28.342	-2.230	0.000
117.00	-6.341	-3.537	0.000	0.000	0.000	-61.691	-29.280	0.000	29.280	-2.245	0.000
120.00	-6.111	-3.248	0.000	0.000	0.000	-42.669	-30.696	0.000	30.696	-2.261	0.000
125.00	-5.735	-2.782	0.000	0.000	0.000	-12.115	-33.074	0.000	33.074	-2.277	0.000
127.00	-0.215	-0.230	0.000	0.000	0.000	-0.645	-34.028	0.000	34.028	-2.278	0.000
130.00	-0.206	0.000	0.000	0.000	0.000	0.000	0.000	0.000	35.460	-2.278	0.000

## Resulting Stresses

**Structure:** CT13615-A-SBA  
**Site Name:** Madison 7, CT  
**Height:** 130.00 (ft)  
**Base Elev:** 0.000 (ft)

**Code:** EIA/TIA-222-F  
**Exposure:** C  
**Gh:** 1.69  
**Struct Class:** II

8/26/2016  
 Page: 12



**Load Case:** 85 mph Wind with 0" Ice

**Dead Load Factor** 1.00  
**Wind Load Factor** 1.00

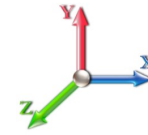

**Iterations:** 19

### Applied Stresses

Elev (ft)	fa Axial (Y) (ksi)	fvx Shear (X) (ksi)	fvz Shear (Z) (ksi)	fvT Torsion (ksi)	fbx Bending (X) (ksi)	fbz Bending (Z) (ksi)	fb Combined (ksi)	Fb Allow Stress (ksi)	f/Fb Stress Ratio
0.00	0.45	0.63	0.00	0.00	0.00	25.08	25.56	52.0	0.492
5.00	0.44	0.63	0.00	0.00	0.00	24.83	25.29	52.0	0.487
10.00	0.43	0.64	0.00	0.00	0.00	24.54	24.99	52.0	0.481
15.00	0.42	0.64	0.00	0.00	0.00	24.23	24.67	52.0	0.475
20.00	0.41	0.64	0.00	0.00	0.00	23.89	24.32	52.0	0.468
25.00	0.40	0.65	0.00	0.00	0.00	23.51	23.93	52.0	0.460
30.00	0.39	0.65	0.00	0.00	0.00	23.09	23.51	52.0	0.452
35.00	0.37	0.66	0.00	0.00	0.00	22.63	23.03	52.0	0.443
40.00	0.36	0.66	0.00	0.00	0.00	22.12	22.51	52.0	0.433
42.00	0.36	0.66	0.00	0.00	0.00	21.91	22.29	52.0	0.429
45.00	0.34	0.67	0.00	0.00	0.00	21.56	21.94	52.0	0.422
48.00	0.37	0.77	0.00	0.00	0.00	23.84	24.25	52.0	0.467
50.00	0.37	0.77	0.00	0.00	0.00	23.55	23.95	52.0	0.461
55.00	0.36	0.77	0.00	0.00	0.00	22.75	23.14	52.0	0.445
60.00	0.35	0.78	0.00	0.00	0.00	21.86	22.25	52.0	0.428
65.00	0.33	0.78	0.00	0.00	0.00	20.88	21.26	52.0	0.409
70.00	0.32	0.79	0.00	0.00	0.00	19.79	20.16	52.0	0.388
75.00	0.31	0.80	0.00	0.00	0.00	18.58	18.94	52.0	0.364
80.00	0.30	0.80	0.00	0.00	0.00	17.22	17.57	52.0	0.338
85.00	0.28	0.81	0.00	0.00	0.00	15.71	16.05	52.0	0.309
85.25	0.28	0.81	0.00	0.00	0.00	15.63	15.97	52.0	0.307
90.00	0.38	1.20	0.00	0.00	0.00	20.23	20.72	52.0	0.399
95.00	0.37	1.21	0.00	0.00	0.00	17.45	17.94	52.0	0.345
100.00	0.36	1.23	0.00	0.00	0.00	14.31	14.82	52.0	0.285
105.00	0.34	1.24	0.00	0.00	0.00	10.75	11.30	52.0	0.217
107.00	0.26	0.78	0.00	0.00	0.00	9.21	9.57	52.0	0.184
110.00	0.25	0.78	0.00	0.00	0.00	7.84	8.20	52.0	0.158
115.00	0.24	0.77	0.00	0.00	0.00	5.29	5.70	52.0	0.110
117.00	0.15	0.54	0.00	0.00	0.00	4.21	4.45	52.0	0.086
120.00	0.14	0.53	0.00	0.00	0.00	3.06	3.33	52.0	0.064
125.00	0.13	0.52	0.00	0.00	0.00	0.95	1.40	52.0	0.027
127.00	0.01	0.02	0.00	0.00	0.00	0.05	0.07	52.0	0.001
130.00	0.00	0.02	0.00	0.00	0.00	0.00	0.03	52.0	0.001



## Wind Loading - Shaft

**Structure:** CT13615-A-SBA  
**Site Name:** Madison 7, CT  
**Height:** 130.00 (ft)  
**Base Elev:** 0.000 (ft)

**Code:** EIA/TIA-222-F  
**Exposure:** C  
**Gh:** 1.69  
**Struct Class:** II

8/26/2016  
 Page: 13



**Load Case:** 73.61 mph Wind with 0.5" Ice

**Dead Load Factor** 1.00  
**Wind Load Factor** 1.00

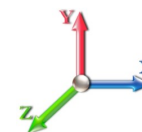

**Iterations:** 19

Elev (ft)	Description	Kzt	Kz	qz (psf)	qzGh (psf)	C (mph-ft)	Cf	Ice Thick (in)	Tributary (ft)	Aa (sf)	CfAa (sf)	Wind Force X (lb)	Dead Load Ice (lb)	Tot Dead Load (lb)
0.00		0.00	1.00	13.871	23.44	355.78	0.650	0.500	0.00	0.000	0.00	0.0	0.0	0.0
5.00		0.00	1.00	13.871	23.44	348.18	0.650	0.500	5.00	24.325	15.81	370.7	176.7	1522.0
10.00		0.00	1.00	13.871	23.44	340.57	0.650	0.500	5.00	23.808	15.48	362.8	172.9	1488.8
15.00		0.00	1.00	13.871	23.44	332.96	0.650	0.500	5.00	23.292	15.14	354.9	169.0	1455.7
20.00		0.00	1.00	13.871	23.44	325.36	0.650	0.500	5.00	22.775	14.80	347.0	165.2	1422.6
25.00		0.00	1.00	13.871	23.44	317.75	0.650	0.500	5.00	22.258	14.47	339.2	161.4	1389.5
30.00		0.00	1.00	13.871	23.44	310.14	0.650	0.500	5.00	21.742	14.13	331.3	157.6	1356.4
35.00		0.00	1.02	14.106	23.84	305.09	0.650	0.500	5.00	21.225	13.80	328.9	153.7	1323.2
40.00		0.00	1.06	14.655	24.77	303.15	0.650	0.500	5.00	20.708	13.46	333.4	149.9	1290.1
42.00	Bot - Section 2	0.00	1.07	14.861	25.11	302.12	0.650	0.500	2.00	8.139	5.29	132.9	59.3	507.2
45.00		0.00	1.09	15.156	25.61	300.34	0.650	0.500	3.00	12.241	7.96	203.8	89.0	1330.2
48.00	Top - Section 1	0.00	1.11	15.439	26.09	298.31	0.650	0.500	3.00	12.055	7.84	204.4	87.7	1309.3
50.00		0.00	1.13	15.620	26.40	301.71	0.650	0.500	2.00	7.933	5.16	136.1	57.8	432.2
55.00		0.00	1.16	16.051	27.13	297.66	0.650	0.500	5.00	19.471	12.66	343.3	140.7	1059.2
60.00		0.00	1.19	16.455	27.81	293.10	0.650	0.500	5.00	18.954	12.32	342.6	136.9	1030.2
65.00		0.00	1.21	16.836	28.45	288.09	0.650	0.500	5.00	18.438	11.98	341.0	133.1	1001.3
70.00		0.00	1.24	17.196	29.06	282.69	0.650	0.500	5.00	17.921	11.65	338.5	129.3	972.4
75.00		0.00	1.26	17.538	29.64	276.93	0.650	0.500	5.00	17.404	11.31	335.3	125.4	943.4
80.00		0.00	1.29	17.865	30.19	270.87	0.650	0.500	5.00	16.887	10.98	331.4	121.6	914.5
85.00		0.00	1.31	18.177	30.72	264.52	0.650	0.500	5.00	16.371	10.64	326.9	117.8	885.6
85.25	Bot - Section 3	0.00	1.31	18.192	30.74	264.19	0.650	0.500	0.25	0.805	0.52	16.1	5.9	43.6
90.00	Top - Section 2	0.00	1.33	18.476	31.22	257.91	0.650	0.500	4.75	15.247	9.91	309.5	109.7	1292.6
95.00		0.00	1.35	18.764	31.71	254.63	0.650	0.500	5.00	15.546	10.10	320.4	111.7	598.5
100.00		0.00	1.37	19.041	32.18	247.59	0.650	0.500	5.00	15.029	9.77	314.4	107.8	577.9
105.00		0.00	1.39	19.308	32.63	240.35	0.650	0.500	5.00	14.512	9.43	307.8	104.0	557.4
107.00	Appurtenance(s)	0.00	1.40	19.412	32.81	237.39	0.650	0.500	2.00	5.660	3.68	120.7	41.0	217.6
110.00		0.00	1.41	19.566	33.07	232.91	0.650	0.500	3.00	8.335	5.42	179.2	60.1	320.1
115.00		0.00	1.43	19.816	33.49	225.31	0.650	0.500	5.00	13.479	8.76	293.4	96.4	516.2
117.00	Appurtenance(s)	0.00	1.44	19.914	33.65	222.22	0.650	0.500	2.00	5.247	3.41	114.8	37.9	201.2
120.00		0.00	1.45	20.059	33.90	217.53	0.650	0.500	3.00	7.715	5.02	170.0	55.5	295.4
125.00		0.00	1.46	20.294	34.30	209.61	0.650	0.500	5.00	12.446	8.09	277.5	88.7	475.1
127.00	Appurtenance(s)	0.00	1.47	20.386	34.45	206.39	0.650	0.500	2.00	4.834	3.14	108.2	34.9	184.7
130.00		0.00	1.48	20.523	34.68	201.53	0.650	0.500	3.00	7.095	4.61	160.0	50.9	270.7
<b>Totals:</b>									<b>130.00</b>			<b>8,496.2</b>		<b>27,184.9</b>

## Discrete Appurtenance Forces

**Structure:** CT13615-A-SB  
**Site Name:** Madison 7, CT  
**Height:** 130.00 (ft)  
**Base Elev:** 0.000 (ft)

**Code:** EIA/TIA-222-F  
**Exposure:** C  
**Gh:** 1.69  
**Struct Class:** II

8/26/2016

Page: 14



**Load Case:** 73.61 mph Wind with 0.5" Ice

**Dead Load Factor** 1.00  
**Wind Load Factor** 1.00

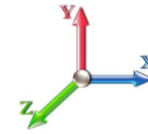

**Iterations:** 19

No.	Elev (ft)	Description	Qty	qz (psf)	qzGh (psf)	CaAa Factor	Total CaAa (sf)	Dead Load (lb)	Horiz Ecc (ft)	Vert Ecc (ft)	Wind FX (lb)	Mom Y (lb-ft)	Mom Z (lb-ft)
1	127.00	Powerwave	6	20.386	34.453	0.92	4.53	130.80	0.000	0.000	155.95	0.00	0.00
2	127.00	P90-15-XLH-RR	6	20.386	34.453	0.77	42.64	601.20	0.000	0.000	1469.16	0.00	0.00
3	127.00	Ericsson RRUS-11 RRH	3	20.386	34.453	0.70	10.18	242.10	0.000	0.000	350.90	0.00	0.00
4	127.00	Ericsson RRUS-32 RRH	3	20.386	34.453	0.87	11.22	310.50	0.000	0.000	386.67	0.00	0.00
5	127.00	Platform w/ Hand Rail	1	20.386	34.453	1.00	40.00	2200.00	0.000	0.000	1378.12	0.00	0.00
6	127.00	Powerwave	6	20.386	34.453	0.83	2.84	59.40	0.000	0.000	97.80	0.00	0.00
7	127.00	SBNHH-1D65A	3	20.386	34.453	0.83	16.78	206.40	0.000	0.000	578.21	0.00	0.00
8	127.00	Raycap DC6-48-60-18-8F	1	20.386	34.453	1.00	1.67	50.50	0.000	0.000	57.54	0.00	0.00
9	117.00	KRY 112 144	3	19.914	33.655	0.72	1.19	42.30	0.000	0.000	39.98	0.00	0.00
10	117.00	12.5' Low Profile Platform	1	19.914	33.655	1.00	27.32	2100.00	0.000	0.000	919.45	0.00	0.00
11	117.00	Air 21 B4A B2P	3	19.914	33.655	0.88	18.40	384.30	0.000	0.000	619.28	0.00	0.00
12	117.00	Air 21 B2A B4P	3	19.914	33.655	0.88	18.40	387.60	0.000	0.000	619.28	0.00	0.00
13	107.00	DB-T1-6Z-8AB-0Z	2	19.412	32.807	0.73	8.57	92.00	0.000	0.000	281.16	0.00	0.00
14	107.00	RRH4x45AWS	3	19.412	32.807	1.00	9.21	249.30	0.000	0.000	302.15	0.00	0.00
15	107.00	RRH2X60-PCS	3	19.412	32.807	0.91	7.53	212.70	0.000	0.000	247.19	0.00	0.00
16	107.00	RRH2x60-700	3	19.412	32.807	0.78	9.90	240.30	0.000	0.000	324.73	0.00	0.00
17	107.00	SBNHH-1D65B	6	19.412	32.807	0.85	44.88	522.00	0.000	0.000	1472.37	0.00	0.00
18	107.00	BXA-70063-6CF-2	3	19.412	32.807	0.75	19.21	178.50	0.000	0.000	630.38	0.00	0.00
19	107.00	SBNHH-1D65B	3	19.412	32.807	0.85	22.44	261.00	0.000	0.000	736.18	0.00	0.00
20	107.00	Low Profile Platform	1	19.412	32.807	1.00	31.00	1500.00	0.000	0.000	1017.01	0.00	0.00
<b>Totals:</b>								<b>9,970.90</b>			<b>11,683.50</b>		

## Total Applied Force Summary

**Structure:** CT13615-A-SB  
**Site Name:** Madison 7, CT  
**Height:** 130.00 (ft)  
**Base Elev:** 0.000 (ft)

**Code:** EIA/TIA-222-F  
**Exposure:** C  
**Gh:** 1.69  
**Struct Class:** II

8/26/2016

Page: 15



**Load Case:** 73.61 mph Wind with 0.5" Ice

**Dead Load Factor** 1.00  
**Wind Load Factor** 1.00

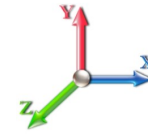

**Iterations:** 19

Elev (ft)	Description	Lateral FX (-) (lb)	Axial FY (-) (lb)	Torsion MY (lb-ft)	Moment MZ (lb-ft)
0.00		0.00	0.00	0.00	0.00
5.00		370.65	1746.36	0.00	0.00
10.00		362.78	1713.24	0.00	0.00
15.00		354.91	1680.12	0.00	0.00
20.00		347.03	1646.99	0.00	0.00
25.00		339.16	1613.87	0.00	0.00
30.00		331.29	1580.75	0.00	0.00
35.00		328.90	1547.63	0.00	0.00
40.00		333.37	1514.51	0.00	0.00
42.00		132.86	596.99	0.00	0.00
45.00		203.80	1464.89	0.00	0.00
48.00		204.44	1443.93	0.00	0.00
50.00		136.12	521.99	0.00	0.00
55.00		343.31	1283.58	0.00	0.00
60.00		342.61	1254.64	0.00	0.00
65.00		340.98	1225.71	0.00	0.00
70.00		338.52	1196.77	0.00	0.00
75.00		335.30	1167.84	0.00	0.00
80.00		331.40	1138.90	0.00	0.00
85.00		326.88	1109.96	0.00	0.00
85.25		16.09	54.83	0.00	0.00
90.00		309.45	1505.82	0.00	0.00
95.00		320.43	822.88	0.00	0.00
100.00		314.35	802.32	0.00	0.00
105.00		307.81	781.75	0.00	0.00
107.00	(24) appurtenances	5131.87	3563.20	0.00	0.00
110.00		179.16	416.90	0.00	0.00
115.00		293.42	677.62	0.00	0.00
117.00	(10) appurtenances	2312.78	3179.95	0.00	0.00
120.00		170.01	351.48	0.00	0.00
125.00		277.46	568.59	0.00	0.00
127.00	(29) appurtenances	4582.58	4023.03	0.00	0.00
130.00		159.96	289.40	0.00	0.00
<b>Totals:</b>		<b>20,179.67</b>	<b>42,486.44</b>	<b>0.00</b>	<b>0.00</b>

## Resulting Forces and Deflections

**Structure:** CT13615-A-SB  
**Site Name:** Madison 7, CT  
**Height:** 130.00 (ft)  
**Base Elev:** 0.000 (ft)

**Code:** EIA/TIA-222-F  
**Exposure:** C  
**Gh:** 1.69  
**Struct Class:** II

8/26/2016  
 Page: 16



**Load Case:** 73.61 mph Wind with 0.5" Ice

**Dead Load Factor** 1.00  
**Wind Load Factor** 1.00

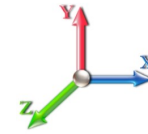

**Iterations:** 19

Elev (ft)	Lateral FX (-) (kips)	Axial FY (-) (kips)	Lateral FZ (kips)	Moment MX (ft-kips)	Torsion MY (ft-kips)	Moment MZ (ft-kips)	Deflect X (in)	Deflect Z (in)	Deflect Resultant (in)	Rotation Sway (deg)	Rotation Twist (deg)
0.00	-20.210	-42.472	0.000	0.000	0.000	-1951.847	0.000	0.000	0.000	0.000	0.000
5.00	-19.896	-40.697	0.000	0.000	0.000	-1850.800	-0.044	0.000	0.044	-0.081	0.000
10.00	-19.585	-38.957	0.000	0.000	0.000	-1751.324	-0.173	0.000	0.173	-0.163	0.000
15.00	-19.278	-37.250	0.000	0.000	0.000	-1653.400	-0.388	0.000	0.388	-0.245	0.000
20.00	-18.975	-35.577	0.000	0.000	0.000	-1557.011	-0.689	0.000	0.689	-0.329	0.000
25.00	-18.675	-33.938	0.000	0.000	0.000	-1462.138	-1.079	0.000	1.079	-0.413	0.000
30.00	-18.379	-32.333	0.000	0.000	0.000	-1368.763	-1.557	0.000	1.557	-0.497	0.000
35.00	-18.082	-30.762	0.000	0.000	0.000	-1276.868	-2.124	0.000	2.124	-0.583	0.000
40.00	-17.762	-29.232	0.000	0.000	0.000	-1186.460	-2.781	0.000	2.781	-0.668	0.000
42.00	-17.644	-28.623	0.000	0.000	0.000	-1150.936	-3.068	0.000	3.068	-0.703	0.000
45.00	-17.447	-27.145	0.000	0.000	0.000	-1098.004	-3.527	0.000	3.527	-0.755	0.000
48.00	-17.242	-25.691	0.000	0.000	0.000	-1045.665	-4.019	0.000	4.019	-0.807	0.000
50.00	-17.127	-25.152	0.000	0.000	0.000	-1011.182	-4.365	0.000	4.365	-0.843	0.000
55.00	-16.803	-23.846	0.000	0.000	0.000	-925.548	-5.298	0.000	5.298	-0.937	0.000
60.00	-16.475	-22.571	0.000	0.000	0.000	-841.535	-6.330	0.000	6.330	-1.030	0.000
65.00	-16.145	-21.326	0.000	0.000	0.000	-759.160	-7.459	0.000	7.459	-1.122	0.000
70.00	-15.814	-20.112	0.000	0.000	0.000	-678.435	-8.684	0.000	8.684	-1.212	0.000
75.00	-15.481	-18.929	0.000	0.000	0.000	-599.367	-10.001	0.000	10.001	-1.300	0.000
80.00	-15.149	-17.776	0.000	0.000	0.000	-521.962	-11.409	0.000	11.409	-1.384	0.000
85.00	-14.806	-16.664	0.000	0.000	0.000	-446.219	-12.903	0.000	12.903	-1.464	0.000
85.25	-14.800	-16.600	0.000	0.000	0.000	-442.518	-12.979	0.000	12.979	-1.468	0.000
90.00	-14.470	-15.085	0.000	0.000	0.000	-372.218	-14.477	0.000	14.477	-1.539	0.000
95.00	-14.146	-14.252	0.000	0.000	0.000	-299.872	-16.127	0.000	16.127	-1.607	0.000
100.00	-13.827	-13.441	0.000	0.000	0.000	-229.144	-17.858	0.000	17.858	-1.691	0.000
105.00	-13.505	-12.658	0.000	0.000	0.000	-160.012	-19.669	0.000	19.669	-1.760	0.000
107.00	-8.270	-9.252	0.000	0.000	0.000	-133.002	-20.412	0.000	20.412	-1.784	0.000
110.00	-8.083	-8.836	0.000	0.000	0.000	-108.193	-21.543	0.000	21.543	-1.814	0.000
115.00	-7.772	-8.164	0.000	0.000	0.000	-67.779	-23.465	0.000	23.465	-1.853	0.000
117.00	-5.358	-5.060	0.000	0.000	0.000	-52.236	-24.245	0.000	24.245	-1.865	0.000
120.00	-5.178	-4.713	0.000	0.000	0.000	-36.162	-25.421	0.000	25.421	-1.879	0.000
125.00	-4.882	-4.153	0.000	0.000	0.000	-10.273	-27.397	0.000	27.397	-1.892	0.000
127.00	-0.169	-0.284	0.000	0.000	0.000	-0.508	-28.190	0.000	28.190	-1.893	0.000
130.00	-0.160	0.000	0.000	0.000	0.000	0.000	0.000	0.000	29.380	-1.893	0.000

## Resulting Stresses

**Structure:** CT13615-A-SBA  
**Site Name:** Madison 7, CT  
**Height:** 130.00 (ft)  
**Base Elev:** 0.000 (ft)

**Code:** EIA/TIA-222-F  
**Exposure:** C  
**Gh:** 1.69  
**Struct Class:** II

8/26/2016

Page: 17



**Load Case:** 73.61 mph Wind with 0.5" Ice

**Dead Load Factor** 1.00  
**Wind Load Factor** 1.00

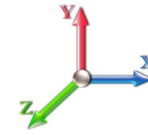

**Iterations:** 19

### Applied Stresses

Elev (ft)	fa Axial (Y) (ksi)	fvx Shear (X) (ksi)	fvz Shear (Z) (ksi)	fvT Torsion (ksi)	fbx Bending (X) (ksi)	fbz Bending (Z) (ksi)	fb Combined (ksi)	Fb Allow Stress (ksi)	f/Fb Stress Ratio
0.00	0.53	0.51	0.00	0.00	0.00	20.61	21.16	52.0	0.407
5.00	0.52	0.51	0.00	0.00	0.00	20.42	20.96	52.0	0.403
10.00	0.51	0.52	0.00	0.00	0.00	20.20	20.73	52.0	0.399
15.00	0.50	0.52	0.00	0.00	0.00	19.97	20.49	52.0	0.394
20.00	0.49	0.52	0.00	0.00	0.00	19.70	20.21	52.0	0.389
25.00	0.48	0.53	0.00	0.00	0.00	19.41	19.91	52.0	0.383
30.00	0.46	0.53	0.00	0.00	0.00	19.09	19.57	52.0	0.377
35.00	0.45	0.54	0.00	0.00	0.00	18.72	19.20	52.0	0.369
40.00	0.44	0.54	0.00	0.00	0.00	18.32	18.78	52.0	0.361
42.00	0.44	0.54	0.00	0.00	0.00	18.15	18.61	52.0	0.358
45.00	0.42	0.55	0.00	0.00	0.00	17.88	18.32	52.0	0.352
48.00	0.46	0.63	0.00	0.00	0.00	19.78	20.27	52.0	0.390
50.00	0.46	0.63	0.00	0.00	0.00	19.54	20.03	52.0	0.385
55.00	0.45	0.64	0.00	0.00	0.00	18.90	19.37	52.0	0.373
60.00	0.44	0.64	0.00	0.00	0.00	18.18	18.65	52.0	0.359
65.00	0.42	0.65	0.00	0.00	0.00	17.38	17.84	52.0	0.343
70.00	0.41	0.65	0.00	0.00	0.00	16.49	16.94	52.0	0.326
75.00	0.40	0.66	0.00	0.00	0.00	15.49	15.94	52.0	0.307
80.00	0.39	0.67	0.00	0.00	0.00	14.38	14.81	52.0	0.285
85.00	0.38	0.67	0.00	0.00	0.00	13.13	13.55	52.0	0.261
85.25	0.37	0.67	0.00	0.00	0.00	13.06	13.49	52.0	0.259
90.00	0.52	1.00	0.00	0.00	0.00	16.93	17.53	52.0	0.337
95.00	0.51	1.01	0.00	0.00	0.00	14.61	15.22	52.0	0.293
100.00	0.50	1.03	0.00	0.00	0.00	11.99	12.61	52.0	0.243
105.00	0.48	1.04	0.00	0.00	0.00	9.02	9.67	52.0	0.186
107.00	0.36	0.65	0.00	0.00	0.00	7.73	8.17	52.0	0.157
110.00	0.35	0.65	0.00	0.00	0.00	6.59	7.03	52.0	0.135
115.00	0.34	0.65	0.00	0.00	0.00	4.47	4.94	52.0	0.095
117.00	0.21	0.45	0.00	0.00	0.00	3.56	3.85	52.0	0.074
120.00	0.20	0.45	0.00	0.00	0.00	2.59	2.90	52.0	0.056
125.00	0.19	0.44	0.00	0.00	0.00	0.80	1.25	52.0	0.024
127.00	0.01	0.02	0.00	0.00	0.00	0.04	0.06	52.0	0.001
130.00	0.00	0.02	0.00	0.00	0.00	0.00	0.03	52.0	0.001



## Wind Loading - Shaft

**Structure:** CT13615-A-SBA  
**Site Name:** Madison 7, CT  
**Height:** 130.00 (ft)  
**Base Elev:** 0.000 (ft)

**Code:** EIA/TIA-222-F  
**Exposure:** C  
**Gh:** 1.69  
**Struct Class:** II

8/26/2016  
 Page: 18



**Load Case:** 50 mph Wind with 0" Ice

**Dead Load Factor** 1.00  
**Wind Load Factor** 1.00

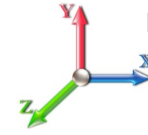

**Iterations:** 19

Elev (ft)	Description	Kzt	Kz	qz (psf)	qzGh (psf)	C (mph-ft)	Cf	Ice Thick (in)	Tributary (ft)	Aa (sf)	CfAa (sf)	Wind Force X (lb)	Dead Load Ice (lb)	Tot Dead Load (lb)
0.00		0.00	1.00	6.400	10.82	241.67	0.650	0.000	0.00	0.000	0.00	0.0	0.0	0.0
5.00		0.00	1.00	6.400	10.82	236.50	0.650	0.000	5.00	23.908	15.54	168.1	0.0	1345.3
10.00		0.00	1.00	6.400	10.82	231.33	0.650	0.000	5.00	23.392	15.20	164.5	0.0	1316.0
15.00		0.00	1.00	6.400	10.82	226.17	0.650	0.000	5.00	22.875	14.87	160.8	0.0	1286.7
20.00		0.00	1.00	6.400	10.82	221.00	0.650	0.000	5.00	22.358	14.53	157.2	0.0	1257.4
25.00		0.00	1.00	6.400	10.82	215.83	0.650	0.000	5.00	21.842	14.20	153.6	0.0	1228.1
30.00		0.00	1.00	6.400	10.82	210.67	0.650	0.000	5.00	21.325	13.86	149.9	0.0	1198.8
35.00		0.00	1.02	6.509	11.00	207.23	0.650	0.000	5.00	20.808	13.53	148.8	0.0	1169.5
40.00		0.00	1.06	6.762	11.43	205.92	0.650	0.000	5.00	20.292	13.19	150.7	0.0	1140.2
42.00	Bot - Section 2	0.00	1.07	6.857	11.59	205.22	0.650	0.000	2.00	7.972	5.18	60.0	0.0	447.9
45.00		0.00	1.09	6.993	11.82	204.01	0.650	0.000	3.00	11.991	7.79	92.1	0.0	1241.2
48.00	Top - Section 1	0.00	1.11	7.123	12.04	202.63	0.650	0.000	3.00	11.805	7.67	92.4	0.0	1221.6
50.00		0.00	1.13	7.207	12.18	204.94	0.650	0.000	2.00	7.766	5.05	61.5	0.0	374.4
55.00		0.00	1.16	7.406	12.52	202.19	0.650	0.000	5.00	19.054	12.39	155.0	0.0	918.4
60.00		0.00	1.19	7.592	12.83	199.09	0.650	0.000	5.00	18.538	12.05	154.6	0.0	893.3
65.00		0.00	1.21	7.768	13.13	195.69	0.650	0.000	5.00	18.021	11.71	153.8	0.0	868.2
70.00		0.00	1.24	7.934	13.41	192.02	0.650	0.000	5.00	17.504	11.38	152.6	0.0	843.1
75.00		0.00	1.26	8.092	13.68	188.11	0.650	0.000	5.00	16.988	11.04	151.0	0.0	818.0
80.00		0.00	1.29	8.242	13.93	183.99	0.650	0.000	5.00	16.471	10.71	149.1	0.0	792.9
85.00		0.00	1.31	8.387	14.17	179.67	0.650	0.000	5.00	15.954	10.37	147.0	0.0	767.8
85.25	Bot - Section 3	0.00	1.31	8.394	14.19	179.45	0.650	0.000	0.25	0.784	0.51	7.2	0.0	37.7
90.00	Top - Section 2	0.00	1.33	8.525	14.41	175.18	0.650	0.000	4.75	14.851	9.65	139.1	0.0	1182.9
95.00		0.00	1.35	8.657	14.63	172.96	0.650	0.000	5.00	15.129	9.83	143.9	0.0	486.8
100.00		0.00	1.37	8.785	14.85	168.18	0.650	0.000	5.00	14.613	9.50	141.0	0.0	470.1
105.00		0.00	1.39	8.908	15.06	163.26	0.650	0.000	5.00	14.096	9.16	137.9	0.0	453.3
107.00	Appurtenance(s)	0.00	1.40	8.957	15.14	161.25	0.650	0.000	2.00	5.494	3.57	54.1	0.0	176.6
110.00		0.00	1.41	9.028	15.26	158.21	0.650	0.000	3.00	8.085	5.26	80.2	0.0	259.9
115.00		0.00	1.43	9.143	15.45	153.04	0.650	0.000	5.00	13.063	8.49	131.2	0.0	419.9
117.00	Appurtenance(s)	0.00	1.44	9.188	15.53	150.94	0.650	0.000	2.00	5.080	3.30	51.3	0.0	163.3
120.00		0.00	1.45	9.255	15.64	147.76	0.650	0.000	3.00	7.465	4.85	75.9	0.0	239.9
125.00		0.00	1.46	9.363	15.82	142.38	0.650	0.000	5.00	12.029	7.82	123.7	0.0	386.4
127.00	Appurtenance(s)	0.00	1.47	9.406	15.90	140.19	0.650	0.000	2.00	4.667	3.03	48.2	0.0	149.9
130.00		0.00	1.48	9.469	16.00	136.89	0.650	0.000	3.00	6.845	4.45	71.2	0.0	219.8
<b>Totals:</b>									<b>130.00</b>			<b>3,827.5</b>		<b>23,775.2</b>

## Discrete Appurtenance Forces

**Structure:** CT13615-A-SB  
**Site Name:** Madison 7, CT  
**Height:** 130.00 (ft)  
**Base Elev:** 0.000 (ft)

**Code:** EIA/TIA-222-F  
**Exposure:** C  
**Gh:** 1.69  
**Struct Class:** II

8/26/2016

Page: 19



**Load Case:** 50 mph Wind with 0" Ice

**Dead Load Factor** 1.00  
**Wind Load Factor** 1.00

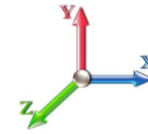

**Iterations:** 19

No.	Elev (ft)	Description	Qty	qz (psf)	qzGh (psf)	CaAa Factor	Total CaAa (sf)	Dead Load (lb)	Horiz Ecc (ft)	Vert Ecc (ft)	Wind FX (lb)	Mom Y (lb-ft)	Mom Z (lb-ft)
1	127.00	Powerwave	6	9.406	15.896	0.90	3.46	96.00	0.000	0.000	54.94	0.00	0.00
2	127.00	P90-15-XLH-RR	6	9.406	15.896	0.75	37.80	318.00	0.000	0.000	600.87	0.00	0.00
3	127.00	Ericsson RRUS-11 RRH	3	9.406	15.896	0.68	9.02	165.00	0.000	0.000	143.33	0.00	0.00
4	127.00	Ericsson RRUS-32 RRH	3	9.406	15.896	0.87	10.10	231.00	0.000	0.000	160.56	0.00	0.00
5	127.00	Platform w/ Hand Rail	1	9.406	15.896	1.00	35.00	1600.00	0.000	0.000	556.37	0.00	0.00
6	127.00	Powerwave	6	9.406	15.896	0.83	2.14	39.00	0.000	0.000	34.04	0.00	0.00
7	127.00	SBNHH-1D65A	3	9.406	15.896	0.83	15.84	100.50	0.000	0.000	251.74	0.00	0.00
8	127.00	Raycap DC6-48-60-18-8F	1	9.406	15.896	1.00	1.47	32.80	0.000	0.000	23.37	0.00	0.00
9	117.00	KRY 112 144	3	9.188	15.528	0.70	0.86	33.00	0.000	0.000	13.37	0.00	0.00
10	117.00	12.5' Low Profile Platform	1	9.188	15.528	1.00	25.55	1600.00	0.000	0.000	396.74	0.00	0.00
11	117.00	Air 21 B4A B2P	3	9.188	15.528	0.86	16.98	271.20	0.000	0.000	263.61	0.00	0.00
12	117.00	Air 21 B2A B4P	3	9.188	15.528	0.86	16.98	274.50	0.000	0.000	263.61	0.00	0.00
13	107.00	DB-T1-6Z-8AB-0Z	2	8.957	15.137	0.71	7.95	37.80	0.000	0.000	120.37	0.00	0.00
14	107.00	RRH4x45AWS	3	8.957	15.137	0.98	7.97	180.00	0.000	0.000	120.60	0.00	0.00
15	107.00	RRH2X60-PCS	3	8.957	15.137	0.89	6.86	165.00	0.000	0.000	103.87	0.00	0.00
16	107.00	RRH2x60-700	3	8.957	15.137	0.76	9.03	180.00	0.000	0.000	136.67	0.00	0.00
17	107.00	SBNHH-1D65B	6	8.957	15.137	0.83	41.48	243.60	0.000	0.000	627.92	0.00	0.00
18	107.00	BXA-70063-6CF-2	3	8.957	15.137	0.73	16.93	51.00	0.000	0.000	256.24	0.00	0.00
19	107.00	SBNHH-1D65B	3	8.957	15.137	0.83	20.74	121.80	0.000	0.000	313.96	0.00	0.00
20	107.00	Low Profile Platform	1	8.957	15.137	1.00	25.00	1200.00	0.000	0.000	378.42	0.00	0.00
<b>Totals:</b>								<b>6,940.20</b>			<b>4,820.58</b>		

## Total Applied Force Summary

**Structure:** CT13615-A-SB  
**Site Name:** Madison 7, CT  
**Height:** 130.00 (ft)  
**Base Elev:** 0.000 (ft)

**Code:** EIA/TIA-222-F  
**Exposure:** C  
**Gh:** 1.69  
**Struct Class:** II

8/26/2016

Page: 20



**Load Case:** 50 mph Wind with 0" Ice

**Dead Load Factor** 1.00  
**Wind Load Factor** 1.00

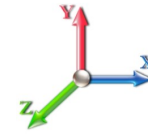

**Iterations:** 19

Elev (ft)	Description	Lateral FX (-) (lb)	Axial FY (-) (lb)	Torsion MY (lb-ft)	Moment MZ (lb-ft)
0.00		0.00	0.00	0.00	0.00
5.00		168.09	1569.67	0.00	0.00
10.00		164.45	1540.37	0.00	0.00
15.00		160.82	1511.08	0.00	0.00
20.00		157.19	1481.78	0.00	0.00
25.00		153.56	1452.49	0.00	0.00
30.00		149.92	1423.19	0.00	0.00
35.00		148.77	1393.90	0.00	0.00
40.00		150.72	1364.60	0.00	0.00
42.00		60.04	537.64	0.00	0.00
45.00		92.11	1375.85	0.00	0.00
48.00		92.37	1356.27	0.00	0.00
50.00		61.48	464.17	0.00	0.00
55.00		155.01	1142.84	0.00	0.00
60.00		154.60	1117.73	0.00	0.00
65.00		153.77	1092.62	0.00	0.00
70.00		152.56	1067.51	0.00	0.00
75.00		151.00	1042.40	0.00	0.00
80.00		149.13	1017.29	0.00	0.00
85.00		146.98	992.18	0.00	0.00
85.25		7.23	48.95	0.00	0.00
90.00		139.07	1396.10	0.00	0.00
95.00		143.88	711.21	0.00	0.00
100.00		141.02	694.47	0.00	0.00
105.00		137.94	677.73	0.00	0.00
107.00	(24) appurtenances	2112.09	2445.61	0.00	0.00
110.00		80.18	356.79	0.00	0.00
115.00		131.19	581.25	0.00	0.00
117.00	(10) appurtenances	988.61	2406.51	0.00	0.00
120.00		75.90	295.96	0.00	0.00
125.00		123.73	479.87	0.00	0.00
127.00	(29) appurtenances	1873.44	2769.56	0.00	0.00
130.00		71.20	238.47	0.00	0.00
<b>Totals:</b>		<b>8,648.05</b>	<b>36,046.08</b>	<b>0.00</b>	<b>0.00</b>

## Resulting Forces and Deflections

**Structure:** CT13615-A-SB  
**Site Name:** Madison 7, CT  
**Height:** 130.00 (ft)  
**Base Elev:** 0.000 (ft)

**Code:** EIA/TIA-222-F  
**Exposure:** C  
**Gh:** 1.69  
**Struct Class:** II

8/26/2016  
 Page: 21



**Load Case:** 50 mph Wind with 0" Ice

**Dead Load Factor** 1.00  
**Wind Load Factor** 1.00

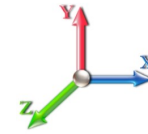

**Iterations:** 19

Elev (ft)	Lateral FX (-) (kips)	Axial FY (-) (kips)	Lateral FZ (kips)	Moment MX (ft-kips)	Torsion MY (ft-kips)	Moment MZ (ft-kips)	Deflect X (in)	Deflect Z (in)	Deflect Resultant (in)	Rotation Sway (deg)	Rotation Twist (deg)
0.00	-8.659	-36.043	0.000	0.000	0.000	-822.089	0.000	0.000	0.000	0.000	0.000
5.00	-8.511	-34.469	0.000	0.000	0.000	-778.796	-0.018	0.000	0.018	-0.034	0.000
10.00	-8.365	-32.923	0.000	0.000	0.000	-736.243	-0.073	0.000	0.073	-0.068	0.000
15.00	-8.221	-31.408	0.000	0.000	0.000	-694.419	-0.163	0.000	0.163	-0.103	0.000
20.00	-8.079	-29.921	0.000	0.000	0.000	-653.316	-0.290	0.000	0.290	-0.138	0.000
25.00	-7.939	-28.464	0.000	0.000	0.000	-612.922	-0.454	0.000	0.454	-0.173	0.000
30.00	-7.801	-27.037	0.000	0.000	0.000	-573.228	-0.655	0.000	0.655	-0.209	0.000
35.00	-7.663	-25.639	0.000	0.000	0.000	-534.223	-0.893	0.000	0.893	-0.245	0.000
40.00	-7.516	-24.271	0.000	0.000	0.000	-495.910	-1.168	0.000	1.168	-0.280	0.000
42.00	-7.461	-23.732	0.000	0.000	0.000	-480.878	-1.289	0.000	1.289	-0.295	0.000
45.00	-7.370	-22.354	0.000	0.000	0.000	-458.495	-1.481	0.000	1.481	-0.317	0.000
48.00	-7.277	-20.996	0.000	0.000	0.000	-436.384	-1.688	0.000	1.688	-0.339	0.000
50.00	-7.222	-20.528	0.000	0.000	0.000	-421.831	-1.833	0.000	1.833	-0.353	0.000
55.00	-7.073	-19.382	0.000	0.000	0.000	-385.720	-2.224	0.000	2.224	-0.392	0.000
60.00	-6.923	-18.261	0.000	0.000	0.000	-350.356	-2.656	0.000	2.656	-0.431	0.000
65.00	-6.772	-17.165	0.000	0.000	0.000	-315.743	-3.129	0.000	3.129	-0.470	0.000
70.00	-6.620	-16.094	0.000	0.000	0.000	-281.885	-3.641	0.000	3.641	-0.507	0.000
75.00	-6.469	-15.049	0.000	0.000	0.000	-248.783	-4.192	0.000	4.192	-0.543	0.000
80.00	-6.318	-14.030	0.000	0.000	0.000	-216.438	-4.781	0.000	4.781	-0.578	0.000
85.00	-6.165	-13.037	0.000	0.000	0.000	-184.846	-5.405	0.000	5.405	-0.612	0.000
85.25	-6.161	-12.987	0.000	0.000	0.000	-183.304	-5.437	0.000	5.437	-0.613	0.000
90.00	-6.012	-11.589	0.000	0.000	0.000	-154.040	-6.062	0.000	6.062	-0.643	0.000
95.00	-5.866	-10.876	0.000	0.000	0.000	-123.979	-6.751	0.000	6.751	-0.671	0.000
100.00	-5.723	-10.180	0.000	0.000	0.000	-94.647	-7.473	0.000	7.473	-0.706	0.000
105.00	-5.579	-9.503	0.000	0.000	0.000	-66.034	-8.229	0.000	8.229	-0.734	0.000
107.00	-3.437	-7.084	0.000	0.000	0.000	-54.875	-8.539	0.000	8.539	-0.744	0.000
110.00	-3.354	-6.727	0.000	0.000	0.000	-44.564	-9.010	0.000	9.010	-0.756	0.000
115.00	-3.216	-6.147	0.000	0.000	0.000	-27.794	-9.812	0.000	9.812	-0.772	0.000
117.00	-2.196	-3.754	0.000	0.000	0.000	-21.361	-10.136	0.000	10.136	-0.777	0.000
120.00	-2.116	-3.459	0.000	0.000	0.000	-14.775	-10.627	0.000	10.627	-0.783	0.000
125.00	-1.986	-2.981	0.000	0.000	0.000	-4.195	-11.450	0.000	11.450	-0.788	0.000
127.00	-0.074	-0.237	0.000	0.000	0.000	-0.223	-11.781	0.000	11.781	-0.789	0.000
130.00	-0.071	0.000	0.000	0.000	0.000	0.000	0.000	0.000	12.276	-0.789	0.000

## Resulting Stresses

**Structure:** CT13615-A-SBA  
**Site Name:** Madison 7, CT  
**Height:** 130.00 (ft)  
**Base Elev:** 0.000 (ft)

**Code:** EIA/TIA-222-F  
**Exposure:** C  
**Gh:** 1.69  
**Struct Class:** II

8/26/2016  
 Page: 22



**Load Case:** 50 mph Wind with 0" Ice

**Dead Load Factor** 1.00  
**Wind Load Factor** 1.00

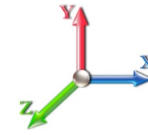

**Iterations:** 19

### Applied Stresses

Elev (ft)	fa Axial (Y) (ksi)	fvx Shear (X) (ksi)	fvz Shear (Z) (ksi)	fvT Torsion (ksi)	fbx Bending (X) (ksi)	fbz Bending (Z) (ksi)	fb Combined (ksi)	Fb Allow Stress (ksi)	f/Fb Stress Ratio
0.00	0.45	0.22	0.00	0.00	0.00	8.68	9.14	52.0	0.176
5.00	0.44	0.22	0.00	0.00	0.00	8.59	9.04	52.0	0.174
10.00	0.43	0.22	0.00	0.00	0.00	8.49	8.93	52.0	0.172
15.00	0.42	0.22	0.00	0.00	0.00	8.39	8.81	52.0	0.170
20.00	0.41	0.22	0.00	0.00	0.00	8.27	8.69	52.0	0.167
25.00	0.40	0.22	0.00	0.00	0.00	8.14	8.55	52.0	0.164
30.00	0.39	0.23	0.00	0.00	0.00	7.99	8.39	52.0	0.161
35.00	0.38	0.23	0.00	0.00	0.00	7.83	8.22	52.0	0.158
40.00	0.37	0.23	0.00	0.00	0.00	7.66	8.03	52.0	0.155
42.00	0.36	0.23	0.00	0.00	0.00	7.58	7.96	52.0	0.153
45.00	0.35	0.23	0.00	0.00	0.00	7.46	7.82	52.0	0.150
48.00	0.38	0.27	0.00	0.00	0.00	8.25	8.64	52.0	0.166
50.00	0.38	0.27	0.00	0.00	0.00	8.15	8.54	52.0	0.164
55.00	0.36	0.27	0.00	0.00	0.00	7.87	8.25	52.0	0.159
60.00	0.35	0.27	0.00	0.00	0.00	7.57	7.93	52.0	0.153
65.00	0.34	0.27	0.00	0.00	0.00	7.23	7.58	52.0	0.146
70.00	0.33	0.27	0.00	0.00	0.00	6.85	7.20	52.0	0.138
75.00	0.32	0.28	0.00	0.00	0.00	6.43	6.77	52.0	0.130
80.00	0.31	0.28	0.00	0.00	0.00	5.96	6.29	52.0	0.121
85.00	0.29	0.28	0.00	0.00	0.00	5.44	5.75	52.0	0.111
85.25	0.29	0.28	0.00	0.00	0.00	5.41	5.72	52.0	0.110
90.00	0.40	0.42	0.00	0.00	0.00	7.01	7.44	52.0	0.143
95.00	0.39	0.42	0.00	0.00	0.00	6.04	6.47	52.0	0.124
100.00	0.38	0.43	0.00	0.00	0.00	4.95	5.38	52.0	0.103
105.00	0.36	0.43	0.00	0.00	0.00	3.72	4.15	52.0	0.080
107.00	0.28	0.27	0.00	0.00	0.00	3.19	3.49	52.0	0.067
110.00	0.27	0.27	0.00	0.00	0.00	2.71	3.02	52.0	0.058
115.00	0.25	0.27	0.00	0.00	0.00	1.83	2.14	52.0	0.041
117.00	0.16	0.19	0.00	0.00	0.00	1.46	1.65	52.0	0.032
120.00	0.15	0.18	0.00	0.00	0.00	1.06	1.25	52.0	0.024
125.00	0.13	0.18	0.00	0.00	0.00	0.33	0.56	52.0	0.011
127.00	0.01	0.01	0.00	0.00	0.00	0.02	0.03	52.0	0.001
130.00	0.00	0.01	0.00	0.00	0.00	0.00	0.01	52.0	0.000



## Final Analysis Summary

**Structure:** CT13615-A-SBA  
**Site Name:** Madison 7, CT  
**Height:** 130.00 (ft)  
**Base Elev:** 0.000 (ft)

**Code:** EIA/TIA-222-F  
**Exposure:** C  
**Gh:** 1.69  
**Struct Class:** II

8/26/2016  
 Page: 23



### Reactions

Load Case	Shear FX (kips)	Shear FZ (kips)	Axial FY (kips)	Moment MX (ft-kips)	Moment MY (ft-kips)	Moment MZ (ft-kips)
85 mph Wind with 0" Ice	25.0	0.00	36.02	0.00	0.00	2375.30
73.61 mph Wind with 0.5" Ice	20.2	0.00	42.47	0.00	0.00	1951.85
50 mph Wind with 0" Ice	8.7	0.00	36.04	0.00	0.00	822.09

### Max Stresses

Load Case	fa Axial (Y) (ksi)	fvx Shear (X) (ksi)	fvz Shear (Z) (ksi)	fvT Torsion (ksi)	fbx Bending (X) (ksi)	fbz Bending (Z) (ksi)	Combined Stress (ksi)	Allowable Stress (ksi)	Elev (ft)	Stress Ratio
85 mph Wind with 0" Ice	0.45	0.63	0.00	0.00	0.00	25.08	25.56	52.0	0.00	0.492
73.61 mph Wind with 0.5" Ice	0.53	0.51	0.00	0.00	0.00	20.61	21.16	52.0	0.00	0.407
50 mph Wind with 0" Ice	0.45	0.22	0.00	0.00	0.00	8.68	9.14	52.0	0.00	0.176



# Monopole Mat Foundation Design

Date

12/3/2015

<b>Customer Name:</b>	Verizon	<b>EIA/TIA Standard:</b>	EIA-222-F
<b>Site Name:</b>		<b>Structure Height (Ft.):</b>	130
<b>Site Number:</b>	CT13615-A-SBA	<b>Engineer Name:</b>	F. Yazdani
<b>Engr. Number:</b>	18882	<b>Engineer Login ID:</b>	

**Foundation Info Obtained from:**

Drawings/Calculations

**Structure Type:**

Monopole

**Analysis or Design?**

Analysis

**Base Reactions (Unfactored)**

Axial Load (Kips):	36.0	Shear Force (Kips):	25.0
Uplift Force (Kips):	0.0	Moment (Kips-ft):	2375.3

Allowable overstress %: 5.0%

**Foundation Geometries:**

		Mods required -Yes/No ?:	No
Diameter of Pier (ft.):	7.5	Depth of Base BG (ft.):	4.0
Pier Height A. G. (ft.):	2.50	Thickness of Pad (ft):	3.50
Length of Pad (ft.):	26	Width of Pad (ft.):	26
Final Length of pad (ft)	26.0	Final width of pad (ft):	26.0
Control Value for Cell D18:	0	Control Value for Cell F18:	0

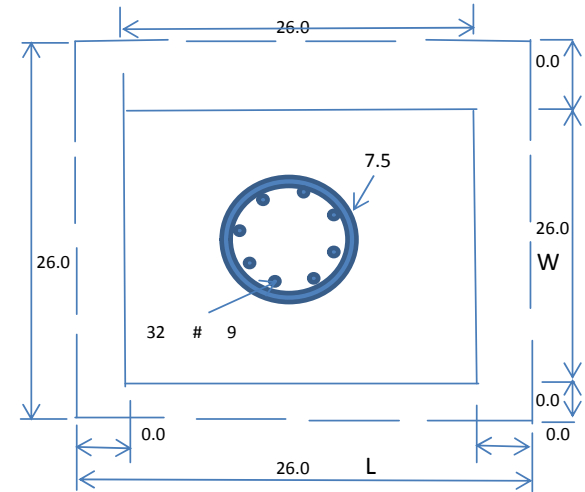
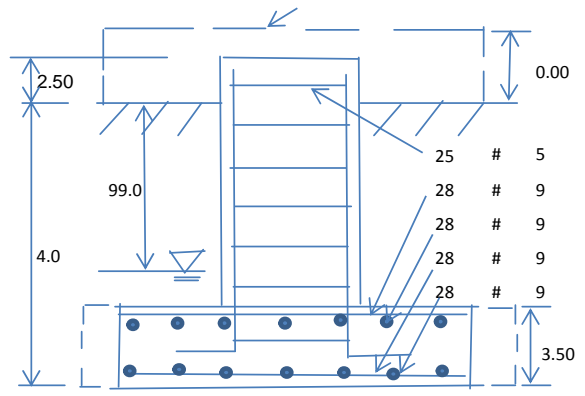

**Material Properties and Rebar Info:**

Concrete Strength (psi):	4000	Steel Elastic Modulus:	29000	ksi
Vertical bar yield (ksi)	60	Tie steel yield (ksi):	60	
Vertical Rebar Size #:	9	Tie / Stirrup Size #:	5	
Qty. of Vertical Rebars:	32	Tie Spacing (in):	3.0	
Pad Rebar Yield (Ksi):	60	Pad Steel Rebar Size (#):	9	
Concrete Cover (in.):	3	Unit Weight of Concrete:	150.0	pcf
Rebar at the bottom of the concrete pad:				
Qty. of Rebar in Pad (L):	28	Qty. of Rebar in Pad (W):	28	
Rebar at the top of the concrete pad:				
Qty. of Rebar in Pad (L):	28	Qty. of Rebar in Pad (W):	28	

Apply 1.35 factor for e/w Per G: 1.35

**Soil Design Parameters:**

Soil Unit Weight (pcf):	110.0	Soil Buoyant Weight:	50.0	Pcf
Water Table B.G.S. (ft):	99.0	Unit Weight of Water:	62.4	pcf
Allowable Net Soil Bearing (psf):	15000	Allowable Skin Friction:	0	Psf
Consider Friction for O.T.M. (Y/N):	No	Consider Friction for bearing (Y/N):	No	
Consider soil hori. force for O.T.M.:	No	Reduction factor on the maximum soil bearing pressure:	1.00	
		Angle from Top of Pad:	30	
		Angle from Bottm of Pad:	25	
		Angle from Bottm of Pad:	25	

**Foundation Analysis and Design:**

Total Dry Soil Volume (cu. Ft.):	315.91	Total Dry Soil Weight (Kips):	34.75
Total Buoyant Soil Volume (cu. Ft.):	0.00	Total Buoyant Soil Weight (Kips):	0.00
Total Effective Soil Weight (Kips):	34.75	Weight from the Concrete Block at Top (K):	0.00
Total Dry Concrete Volume (cu. Ft.):	2498.54	Total Dry Concrete Weight (Kips):	374.78
Total Buoyant Concrete Volume (cu. Ft.):	0.00	Total Buoyant Concrete Weight (Kips):	0.00
Total Effective Concrete Weight (Kips):	374.78	Total Vertical Load on Base (Kips):	445.55

**Check Soil Capacities:**

Calculated Maxium Net Soil Pressure under the base (psf):	1518	<	Allowable Soil Bearing (psf):	15000	0.10	OK!
Allowable Foundation Overturning Resistance (SF=1.5, kips-ft.):	3861.4	>	Applied Momnt (kips-ft):	2538	0.66	OK!
Factor of Safety Against Overturning (O. R. Moment/Design Moment):	2.28					OK!

Load/  
Capacity  
Ratio

**Check the capacities of Reinforcing Concrete:**

Strength reduction factor (Flexure and axial tension):	0.90	Strength reduction factor (Shear):	0.75
Strength reduction factor (Axial compression):	0.65	Wind Load Factor on Concrete Design:	1.30

Load/  
Capacity  
Ratio

**(1) Concrete Pier:**

Vertical Steel Rebar Area (sq. in./each):	1.00	Tie / Stirrup Area (sq. in./each):	0.31		
Calculated Moment Capacity (Mn,Kips-Ft):	5835.6	> Design Factored Moment (Mu, Kips-Ft)	2450.3	0.42	OK!
Calculated Shear Capacity (Kips):	1496.3	> Design Factored Shear (Kips):	32.5	0.02	OK!
Calculated Tension Capacity (Tn, Kips):	1728.0	> Design Factored Tension (Tu Kips):	0.0	0.00	OK!
Calculated Compression Capacity (Pn, Kips):	11191.0	> Design Factored Axial Load (Pu Kips):	46.8	0.00	OK!
Moment & Axial Strength Combination:	0.42	OK! Check Tie Spacing (Design/Required):		0.25	OK!
Pier Reinforcement Ratio:	0.005	Reinforcement Ratio is satisfied per ACI			

**(2).Concrete Pad:**

One-Way Design Shear Capacity (L-Direction, Kips):	1137.7	> One-Way Factored Shear (L-D. Kips):	182.7	0.16	OK!
One-Way Design Shear Capacity (W-Direction, Kips):	1137.7	> One-Way Factored Shear (W-D., Kips)	182.7	0.16	OK!
One-Way Design Shear Capacity (Corner-Corner. Kips):	1280.8	> One-Way Factored Shear (C-C, Kips):	307.7	0.24	OK!
Lower Steel Pad Reinforcement Ratio (L-Direct. ):	0.0023	OK! Lower Steel Pad Reinf. Ratio (W-Direc	0.0023		
Lower Steel Pad Moment Capacity (L-Direction. Kips-ft):	4743.4	> Moment at Bottom ( L-Direct. K-Ft):	424.9	0.09	OK!
Lower Steel Pad Moment Capacity (W-Direction. Kips-ft):	4743.4	> Moment at Bottom ( W-Direct. K-Ft):	424.9	0.09	OK!
Lower Steel Pad Moment Capacity (Corner-Corner,K-ft):	6672.0	> Moment at Bottom ( C-C Dir. K-Ft):	601.0	0.09	OK!
Upper Steel Pad Reinforcement Ratio (L-Direct. ):	0.0023	OK! Upper Steel Reinf. Ratio (W-Direct. ):	0.0023		
Upper Steel Pad Moment Capacity (L-Direction. Kips-ft):	4743.4	> Moment at the top (L-Dir Kips-Ft):	84.8	0.02	OK!
Upper Steel Pad Moment Capacity (W-Direction. Kips-ft):	4743.4	> Moment at the top (W-Dir Kips-Ft):	84.8	0.02	OK!
Upper Steel Pad Moment Capacity (Corner-Corner. K-ft):	6672.0	> Moment at the top (C-C Direc. K-Ft):	517.7	0.08	OK!



# 17 COTTAGE RD

**Location** 17 COTTAGE RD

**Mblu** 30/ 34/ / /

**Acct#** 00167700

**Owner** STONEHART PAUL

**Assessment** \$380,600

**Appraisal** \$543,500

**PID** 1691

**Building Count** 2

## Current Value

Appraisal			
Valuation Year	Improvements	Land	Total
2015	\$234,000	\$309,500	\$543,500

Assessment			
Valuation Year	Improvements	Land	Total
2015	\$163,900	\$216,700	\$380,600

## Owner of Record

**Owner** STONEHART PAUL

**Sale Price** \$0

**Co-Owner**

**Certificate**

**Book & Page** 239/ 105

**Sale Date**

## Ownership History

Ownership History				
Owner	Sale Price	Certificate	Book & Page	Sale Date
STONEHART PAUL	\$0		239/ 105	

## Building Information

### Building 1 : Section 1

**Year Built:** 1984

**Living Area:** 2,221

### Building Photo

Building Attributes	
Field	Description
STYLE	Office Bldg
MODEL	Commercial
Stories:	1
Roof Structure	Gable/Hip
Heating Fuel	Oil
Heating Type	Forced Air-Duc



AC Type	Central
Bldg Use	Office Building
Total Rooms	
Total Bedrms	00
Total Baths	0
Fireplace	
Xtra Fireplaces	



(<http://images.vgsi.com/photos/MadisonCTPhotos//\01\00\90\70.jpg>)

### Building Layout

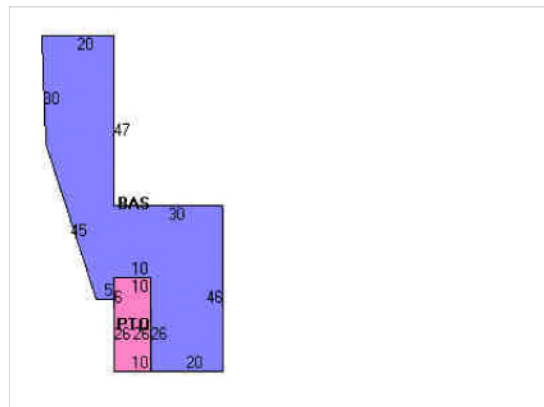

Building Sub-Areas (sq ft)			Legend
Code	Description	Gross Area	Living Area
BAS	First Floor	2,221	2,221
PTO	Patio	260	0
		2,481	2,221

### Building 2 : Section 1

**Year Built:** 1979  
**Living Area:** 1,038

Building Attributes : Bldg 2 of 2	
Field	Description
STYLE	Office Bldg
MODEL	Commercial
Stories:	1
Roof Structure	Shed
Heating Fuel	Oil
Heating Type	Forced Air-Duc
AC Type	None
Bldg Use	Office Building
Total Rooms	

### Building Photo



(<http://images.vgsi.com/photos/MadisonCTPhotos//\01\00\90\71.jpg>)







**DIV. SITE ACQUISITION, LLC**  
 27 NORTHWESTERN DRIVE  
 SALEM, NH 03079

BANK OF AMERICA

54-49  
114

54936

Pay: \*\*\*\*\*Six hundred five dollars and 40 cents

DATE: September 2, 2016  
 CHECK NO.: 54936  
 AMOUNT: \$\*\*\*\*\*605.40

**PAY**  
TO THE  
ORDER  
OF

City of Stamford CT  
 888 Washington Blvd.  
 Stamford, CT 06901

*Ann Z. Mill*

⑈054936⑈ ⑆011400495⑆ 000089877441⑈

CITY24 City of Stamford CT		SAI DIV. SITE ACQUISITION, LLC		54936	
DATE	INVOICE NO.	DESCRIPTION	INVOICE AMOUNT	DEDUCTION	BALANCE
9-02-16	CR090216	CT2647-LTE-3C-BP Fee	605.40		605.40
<b>CHECK DATE</b>	9-02-16	<b>CHECK NUMBER</b>	54936	<b>TOTALS</b>	605.40
			605.40		605.40





**DIV. SITE ACQUISITION, LLC**  
 27 NORTHWESTERN DRIVE  
 SALEM, NH 03079

BANK OF AMERICA

54-49  
114

54947

Pay: \*\*\*\*\*One thousand two hundred dollars and no cents

DATE: September 2, 2016  
 CHECK NO.: 54947  
 AMOUNT: \$\*\*\*\*\*1,200.00

**PAY**  
TO THE  
ORDER  
OF

City of Stamford CT  
 888 Washington Blvd.  
 Stamford, CT 06901

*Chris J. Miller*

⑈054947⑈ ⑆011400495⑆ 000089877441⑈

CITY34 City of Stamford CT		SAI DIV. SITE ACQUISITION, LLC		54947	
DATE	INVOICE NO.	DESCRIPTION	INVOICE AMOUNT	DEDUCTION	BALANCE
9-02-16	CR090216A	CT2647-LTE-3C-Zoning	1200.00		1200.00
<b>CHECK DATE</b>	9-02-16	<b>CHECK NUMBER</b>	54947	<b>TOTALS</b>	1200.00
			1200.00		1200.00





**DIV. SITE ACQUISITION, LLC**  
 27 NORTHWESTERN DRIVE  
 SALEM, NH 03079

BANK OF AMERICA

54-49  
114

54935

Pay: \*\*\*\*\*Three hundred seventy-eight dollars and 90 cents

DATE: September 2, 2016  
 CHECK NO.: 54935  
 AMOUNT: \$\*\*\*\*\*378.90

**PAY**  
 TO THE  
 ORDER  
 OF  
 City of Hartford  
 550 Main Street  
 Hartford, CT 06103

*Ann Z. Miller*

⑈054935⑈ ⑆011400495⑆ 000089877441⑈

CITY11 City of Hartford		SAI DIV. SITE ACQUISITION, LLC		54935	
DATE	INVOICE NO.	DESCRIPTION	INVOICE AMOUNT	DEDUCTION	BALANCE
9-02-16	CR090216	CT5152-LTE-BWE-BP Fe	378.90		378.90
<b>CHECK DATE</b>	9-02-16	<b>CHECK NUMBER</b>	54935	<b>TOTALS</b>	378.90
			378.90		378.90



**DIV. SITE ACQUISITION, LLC**  
 27 NORTHWESTERN DRIVE  
 SALEM, NH 03079

BANK OF AMERICA

54-49  
114

54941

Pay: \*\*\*\*\*Six hundred twenty-five dollars and no cents

DATE: September 2, 2016  
 CHECK NO.: 54941  
 AMOUNT: \$\*\*\*\*\*625.00

**PAY**  
TO THE  
ORDER  
OF

Connecticut Siting Council  
 10 Franklin Sq  
 New Britain, CT 06051

*Ann Z. Miller*

⑈05494⑈ ⑆011400495⑆ 00008987744⑈

CONN03 Connecticut Siting Council		SAI DIV. SITE ACQUISITION, LLC		54941	
DATE	INVOICE NO.	DESCRIPTION	INVOICE AMOUNT	DEDUCTION	BALANCE
9-02-16	CR090216	CT2517-LTE-BWE-CSC A	625.00		625.00
<b>CHECK DATE</b>	9-02-16	<b>CHECK NUMBER</b>	54941	<b>TOTALS</b>	625.00





**DIV. SITE ACQUISITION, LLC**  
 27 NORTHWESTERN DRIVE  
 SALEM, NH 03079

BANK OF AMERICA

54-49  
114

54934

Pay: \*\*\*\*\*Three hundred ninety-eight dollars and no cents

DATE: September 2, 2016  
 CHECK NO.: 54934  
 AMOUNT: \$\*\*\*\*\*398.00

**PAY TO THE ORDER OF**  
 City of Leominster  
 25 West Street  
 Leominster, MA 01453

*Carly Miller*



⑈054934⑈ ⑆011400495⑆ 000089877441⑈

City of Leominster SAI DIV. SITE ACQUISITION, LLC 54934

DATE	INVOICE NO.	DESCRIPTION	INVOICE AMOUNT	DEDUCTION	BALANCE	
9-02-16	CR090216	MA3255-LTE-2C-BP Fee	398.00		398.00	
<b>CHECK DATE</b>	9-02-16	<b>CHECK NUMBER</b>	54934	<b>TOTALS</b>	398.00	398.00



**DIV. SITE ACQUISITION, LLC**  
 27 NORTHWESTERN DRIVE  
 SALEM, NH 03079

BANK OF AMERICA

54-49  
114

54933

Pay: \*\*\*\*\*Eight hundred four dollars and no cents

DATE: September 2, 2016  
 CHECK NO.: 54933  
 AMOUNT: \$\*\*\*\*\*804.00

**PAY**  
 TO THE  
 ORDER  
 OF  
 City of Cranston  
 869 Park Avenue  
 Cranston, RI 02910

*Con J. Mills*

⑈054933⑈ ⑆011400495⑆ 000089877441⑈

CIT109 City of Cranston		SAI DIV. SITE ACQUISITION, LLC		54933	
DATE	INVOICE NO.	DESCRIPTION	INVOICE AMOUNT	DEDUCTION	BALANCE
9-02-16	CR090216	RI4004-LTE-2C-BP Fee	804.00		804.00
<b>CHECK DATE</b>	9-02-16	<b>CHECK NUMBER</b>	54933	<b>TOTALS</b>	804.00





**DIV. SITE ACQUISITION, LLC**  
 27 NORTHWESTERN DRIVE  
 SALEM, NH 03079

BANK OF AMERICA

54-49  
 114

54943

Pay: \*\*\*\*\*Four hundred dollars and no cents

DATE: September 2, 2016  
 CHECK NO.: 54943  
 AMOUNT: \$\*\*\*\*\*400.00

**PAY**  
 TO THE  
 ORDER  
 OF  
 Town of Burlington MA  
 29 Center Street  
 Burlington, MA 01803

*Am J. Mills*

⑈054943⑈ ⑆011400495⑆ 000089877441⑈

TOW283 Town of Burlington MA SAI DIV. SITE ACQUISITION, LLC 54943

DATE	INVOICE NO.	DESCRIPTION	INVOICE AMOUNT	DEDUCTION	BALANCE	
9-02-16	CR090216	MA3134-LTE-BWE-BP Fe	400.00		400.00	
<b>CHECK DATE</b>	9-02-16	<b>CHECK NUMBER</b>	54943	<b>TOTALS</b>	400.00	400.00