

CONNECT DDE GUIDE



CONNECTICUT DEPARTMENT OF TRANSPORTATION

DIGITAL DESIGN

ENVIRONMENT GUIDE

CONNECT EDITION

Volume 3.4 – OpenRoads Designer Civil Cells

Published Date: March 12, 2025

Table of Contents

Table of Contents	1
Course Overview	3
<i>Exercise 1 – Driveway (No Provision for Sidewalks)</i>	6
1.1 Civil Cell Placement.....	7
1.1.1 Place Reference Lines	7
1.1.2 Select the Civil Cell	9
1.1.3 Place the Civil Cell	10
1.2 Adjust the Civil Cell Placement.....	12
1.2.1 Add Template Drops at Civil Cell Locations	12
1.2.2 Adjustment of the Reference Element	16
1.2.3 Edit Horizontal Geometry	17
1.2.4 Edit Vertical Geometry.....	20
1.3 Swap Out.....	22
1.3.1 Swap Out or Edit the Linear Template.....	22
1.3.2 Swap Out or Edit the Surface Template	26
1.4 Curb Editing.....	32
<i>Exercise 2 – Driveway (Sidewalk with Buffer Area)</i>	42
2.1 Civil Cell Placement	43
2.1.1 Place Reference Lines	43
2.1.2 Select the Civil Cell	45
2.1.3 Place the Civil Cell	46
2.2 Adjust the Cell Placement	48
2.2.1 Civil Cell Clipping.....	48
2.2.2 Adjustment of Reference Element.....	51
2.2.3 Edit the Horizontal Geometry.....	52
2.2.4 Edit Vertical Geometry of Sidewalk in Civil Cell.....	57
2.2.5 Edit Vertical Geometry of Driveway Centerline in Civil Cell.....	61
2.3 Swap Out.....	63
2.3.1 Swap out or Edit the Liner Template	63
2.3.2 Swap out or Edit the Surface Template	67
2.4 Curb Editing.....	72

Volume 3.3 - OpenRoads Designer Civil Cells

Exercise 3 – Driveway (Sidewalk No Buffer Area)	79
3.1 Civil Cell Placement	80
3.1.1 Place Reference Lines	80
3.1.2 Select the Civil Cell	82
3.1.3 Place the Civil Cell	83
3.2 Adjust the Civil Cell Placement	85
3.2.1 Civil Cell Clipping	85
3.2.2 Adjustment of the Reference Element	88
3.2.3 Edit Horizontal Geometry	88
3.2.4 Edit Vertical Geometry of Sidewalk in Civil Cell	93

Course Overview

These exercises will instruct users on how to place and edit Civil Cells in a design file for a project.

A civil cell is a collection of civil elements - geometry, templates, and terrain models - which can be placed repeatedly in a design. The collection of civil elements will have been created relative to one or more reference elements. When you place the civil cell, you choose the new reference elements, and a new collection of civil elements is then created relative to them. A civil cell can therefore be thought of as a copy of the original collection of civil elements, relative to the geometry of the new reference elements. Civil cells can be 2D or 3D. They can consist of 2D (plan) elements only, or 3D elements (2D elements with profiles), and can include terrains, linear templates, area templates, and simple corridors.

When the new civil elements are created, all the rules associated to them are also created. This means that the new civil elements retain their relationships, both with each other and with the reference elements, and therefore know how to react when these relationships change. In addition, the Civil and MicroStation toolsets can still be used on the new civil elements, to adjust and further refine the design as required, because there is no difference between a civil element created by a civil tool, and one created by placing a civil cell.

Civil cells can save a lot of time and effort, because they replicate the complete series of steps needed to create the civil elements. They also help to ensure compliance with design standards, by making a civil cell available to the design team.

Before placing civil cells, users are encouraged to complete the ***Using Civil Cells in OpenRoads Designer*** training course under ***01 - OpenRoads Designer - Roadway Design & Modeling - Intermediate » (CONNECT Edition - English - Fundamental) on the Bentley LearnServer.***

<https://learn.bentley.com/app/Public/BrowseLearningPaths>

This guide will not document each tool that is available in the OpenRoads Modeling interface. See the Bentley Online Help for commands not detailed in this document.

Skills Taught

Place a Civil Cell

Edit Horizontal Geometry or Vertical Geometry of Civil Cell

Swap Out or Edit the Linear Template or Surface Template of Civil Cell

Introduction

Model Detailing Tab

Activate the **OpenRoads Modeling** workflow from the pick list next to Quick access toolbar in the upper left corner if it is not already active. The ribbon menu will reflect the OpenRoads Modeling tools. Select the Model Detailing tab, notice the Civil Cells area.

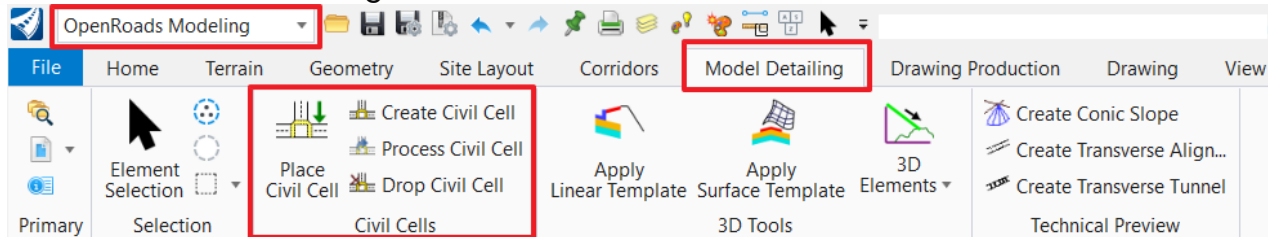

Figure 1

Place Civil Cell – This will activate the browser to select the civil cell to be placed. Civil cells can be selected from the active drawing's graphics, or from the browser that provides a schematic preview of available civil cells from all design models in the current drawing, or via the currently defined configuration.

Create Civil Cell – This will activate the command to create civil cell. It prompts you to name the new civil cell and select reference elements. The dependent elements are identified and highlighted for verification.

Process Civil Cell – This will reprocess all linear templates and templates for the selected civil cell. This may be necessary where the active terrain has been changed or where reference file interaction needs to be refreshed.

Drop Civil Cell – This will activate the drop command and targets civil cells. The standard MicroStation Drop command works on civil cells, but selection is dependent on element priority in the model and may require element cycling to select the civil cell.

Placing Driveway Civil Cells

This exercise will instruct users on how to place and edit Driveway Civil Cell in a design file for a project. Commercial Driveway and Residential Driveway Civil Cells are provided. Both Driveway Civil Cells are similar in Civil Cell Reference requirement and placement. The workflow described will be same for both Civil Cells.

Quick Steps:

- Step 1. Place a Driveway Civil Cell
- Step 2. Add Template Drops at Civil Cell Locations
- Step 3. Edit Horizontal Geometry
- Step 4. Edit Vertical Geometry
- Step 5. Swap Out or Edit the Linear Template

Volume 3.3 - OpenRoads Designer Civil Cells

Step 6. Swap Out or Edit the Surface Template

Step 7. Additional Driveway Civil Cells

Notes:

- Civil Cells for Driveways have been created to comply with the **CT DOT Highway Manual 11-8.0 Driveways.**
- The number of reference elements can vary for each civil cell.
- Both Commercial Driveway and Residential Driveway Civil Cells are similar in Civil Cell Reference requirement and placement. The workflow described will be same for both Civil Cells.

CIVIL CELL REFERENCE REQUIREMENTS:

1. **Edge of Road** (EOR) of main road. EOR should have its own profile.
2. **Driveway Centerline** drawn perpendicular to Baseline of main road.
3. **Driveway Matchline** at the back of driveway

NOTE: *Driveway Civil cells provided by CTDOT are only for simple repetitive geometry and are not intended for complex geometry.*

Exercise 1 – Driveway (No Provision for Sidewalks)

For use with Civil Cells:

- Commercial Driveway (No Provision for Sidewalks) without curb
- Residential Driveway (No Provision for Sidewalks) without curb

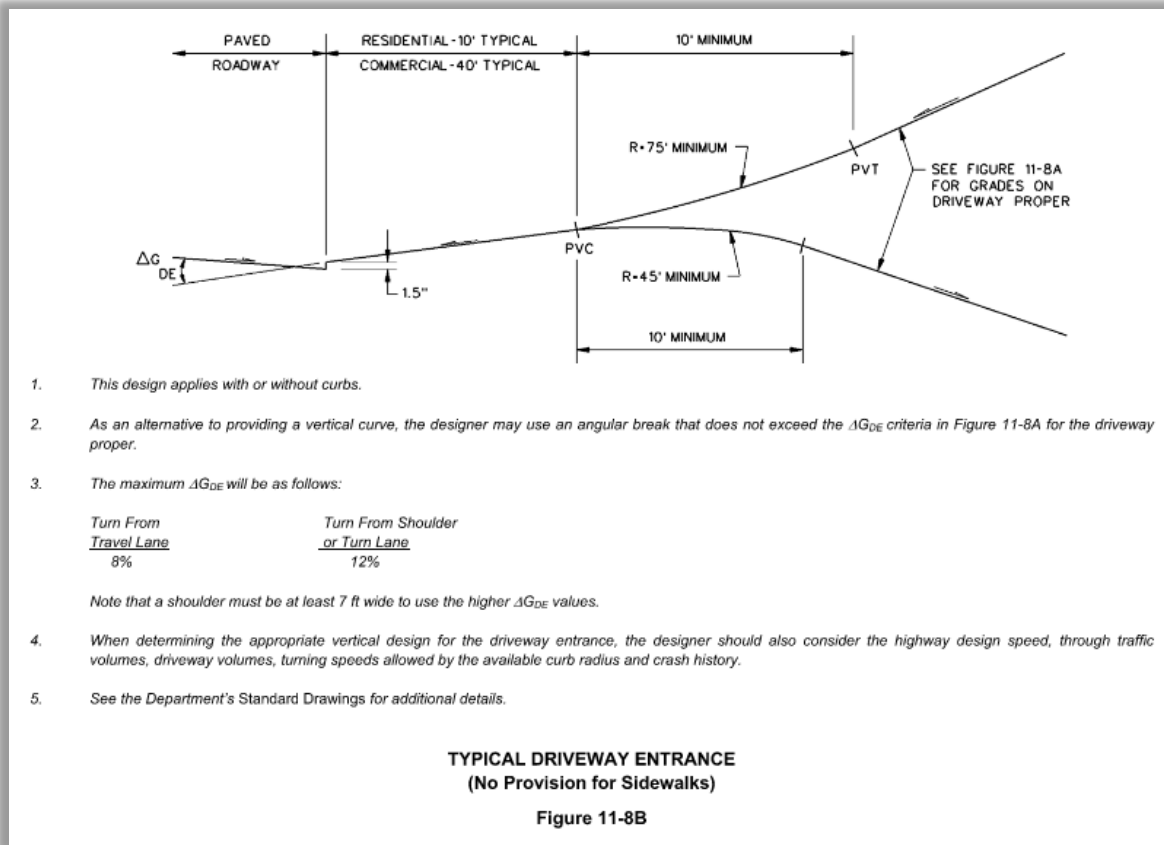

Figure 2 CTDOT Highway Manual 11-8B

1.1 Civil Cell Placement

The design file should have Baseline Alignment, Baseline Profile and a roadway corridor in order to place civil cell. Profiled Edge of Road will come from template of Corridor.

1.1.1 Place Reference Lines

1. Activate the **OpenRoads Modeling** workflow, from the ribbon, select the **Geometry** tab, **Horizontal** group. Select to tool **Lines > Line Between Points**. In the dialog box select the Feature Definition:

Alignment > Center > Driveway

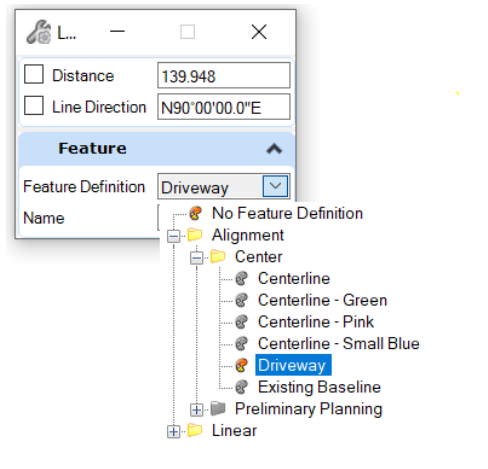

Figure 3

2. Using the perpendicular snap draw a **Line** perpendicular to Baseline of Main Road towards the Proposed Driveway. This is Driveway Centerline. The default Name **DCL** can be modified as required.

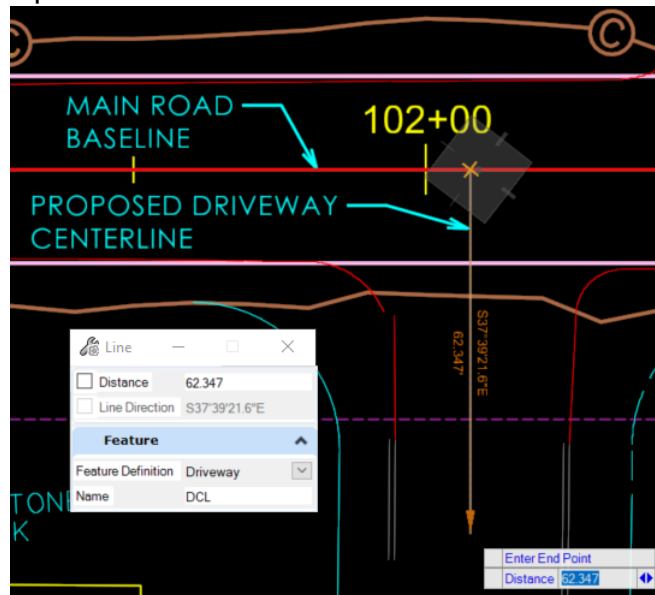

Figure 4

- From the **Horizontal** group select **Lines > Line Between Points**. Select *the* Feature Definition: **Linear > Roadway Geometry > Driveway Match Line**

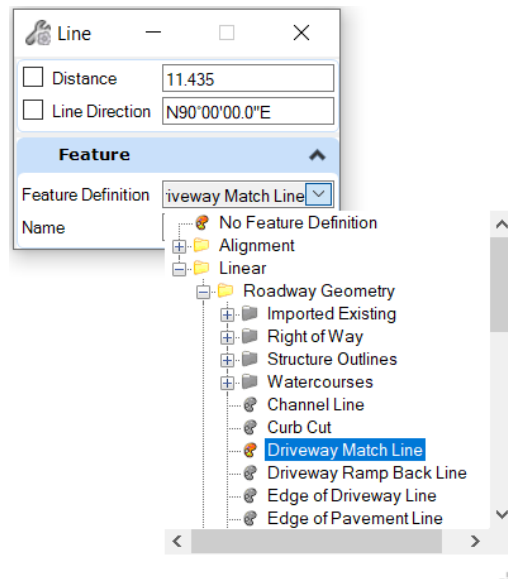

Figure 5

- Draw a **line** crossing the Driveway Center line. This line is the limit of the driveway where it matches the existing driveway or ground. The default name **DrivewayMatch_Line** can be modified as required.

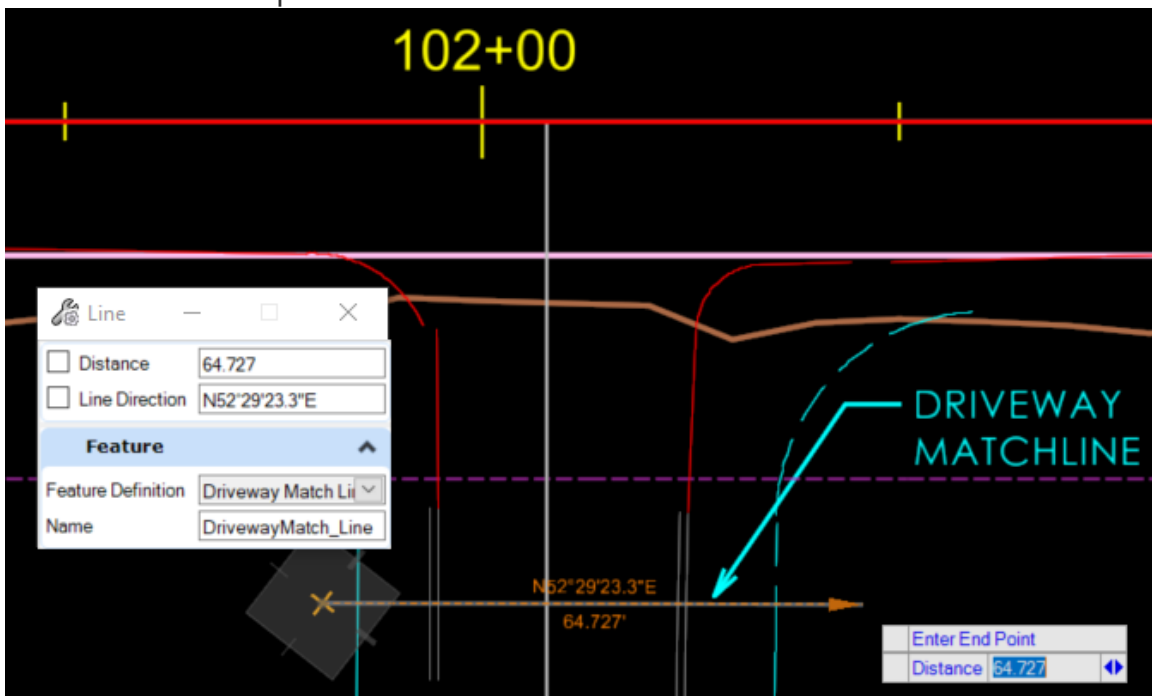

Figure 6

Now we have all three references required for placing the Driveway Civil Cell. We can place the civil cell.

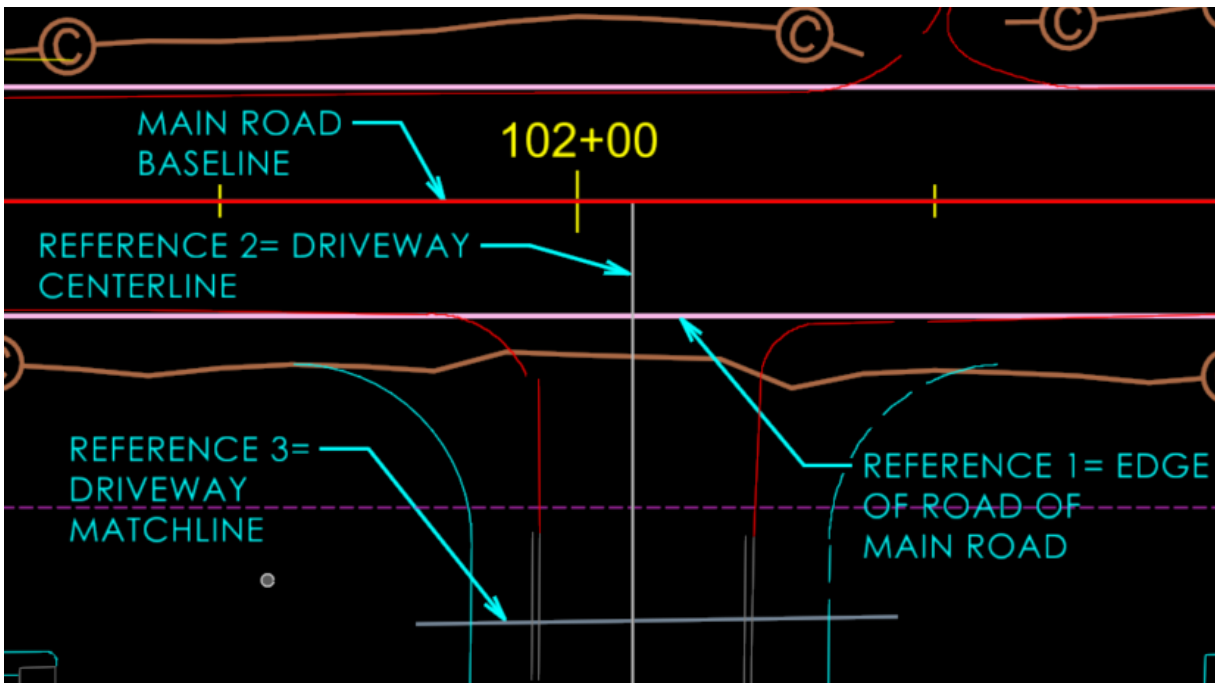

Figure 7

1.1.2 Select the Civil Cell

1. From the ribbon, select **Model Detailing** tab, **Civil Cells** group, **Place Civil Cell**.

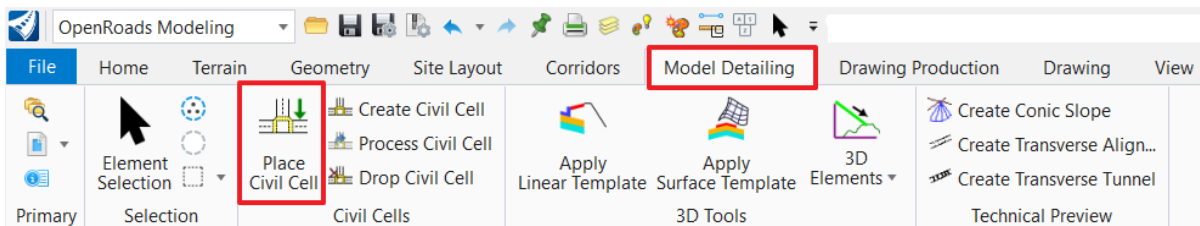

Figure 8

2. In Civil Cell Name dialog box, click the **browse** button to open Civil Cell Library.

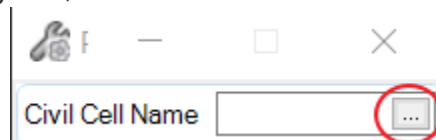

Figure 9

Two options can be chosen from as per requirement.

- a. For Commercial Driveway, expand the **CV_Commercial_Driveway_CivilCells.dgnlib** and select **Commercial Driveway (No Provision for Sidewalks) without curb**.

Volume 3.3 – OpenRoads Designer Civil Cells

b. For Residential Driveway, expand

the **CV_Residential_Driveway_CivilCells.dgnlib** and select **Residential Driveway (No Provision for Sidewalks) without curb**.

- The dialog displays the planimetric layout of the selected civil cell with **black lines**
- The dialog also shows the reference lines on which the civil cell is based. These are the **red lines** and represent the references that must be present within the design file to place the civil cell.

3. Click **OK**.

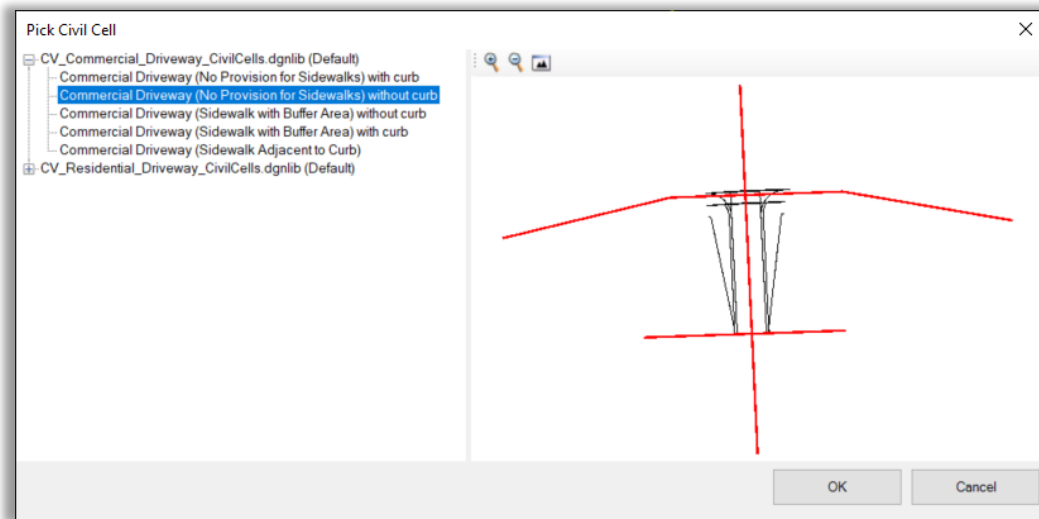

Figure 10

1.1.3 Place the Civil Cell

Follow the heads-up prompts:

1. **Locate Reference Element: EOR (Profiled) (1/3)**, select the **Main Road Edge of Road** element.
2. **Locate Reference Element: DRV CL (Perpendicular to Baseline) (2/3)**, select the **Driveway Centerline** element.
3. **Locate Reference Element: DRV ML (3/3)**, select the **Driveway Matchline** element.
4. **Select Elements to View Alternatives (Reset to Skip)**, there are couple of options according to the direction of the driveway cell
 - If the direction of driveway cell is correct, then **right-click** to reset.
 - If the direction of driveway cell is incorrect, see figure below, **hover** over the Edge of Road, the arrow should appear over the EOR, **left-click** on the arrow. This should cause the curb return to flip to the correct side. Note the arrow's change of direction.

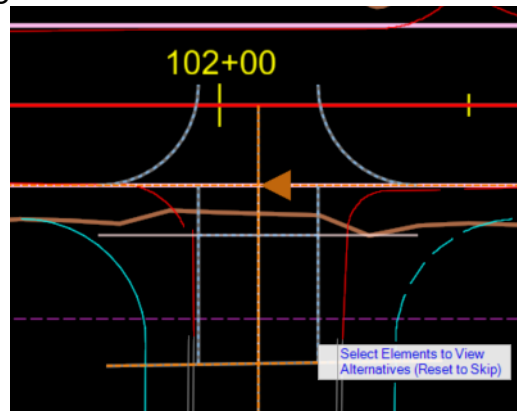

Figure 11

Hover over the EOR until the arrow appears over EOR then **left-click** on arrow.

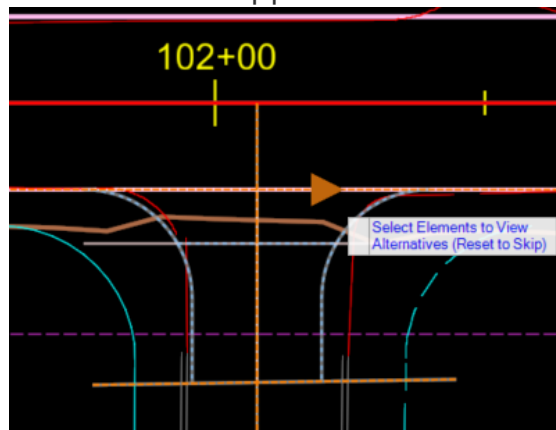

Figure 12

The curb return will flip to the correct side.

5. **Select Corridors To Be Clipped (Reset To Complete)**, **right-click** to reset.
6. **Accept Civil Cell Placement**, **left-click** to accept. The Civil Cell is placed.

1.2 Adjust the Civil Cell Placement

Series of edits can be done to the Civil Cells which demonstrate the flexibility and the ability to edit their component.

If the capabilities of Civil Cells seem confining, user can use the **Drop Civil Cell** tool to drop the placed Civil Cell into the components that make it up.

1.2.1 Add Template Drops at Civil Cell Locations

It is preferred to add template drops over clipping the corridor when blending the civil cell to the corridor.

Note: *Issue with Civil Cell Clipping, Driveway Civil Cells can be used to clip the corridor where it is placed. But this method does not work every time. Civil Cell clipping does not clip out 2D graphics of the corridor but only in 3D view. Template edit of the main road corridor is recommended. Dropping elements outside of the curb from the corridor template at driveway limits is recommended for this civil cell.*

There is various method to edit the template drop. One method is shown below.

1. From the ribbon, select **Corridors** Tab. From the **Create** group select **Copy Template Drop**.

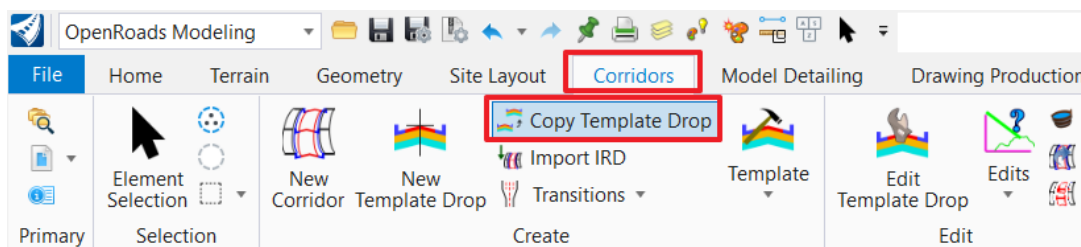

Figure 13

2. Follow the heads-up prompts. At **Locate Template Drop**, Select the **Main road Corridor Template Drop**.

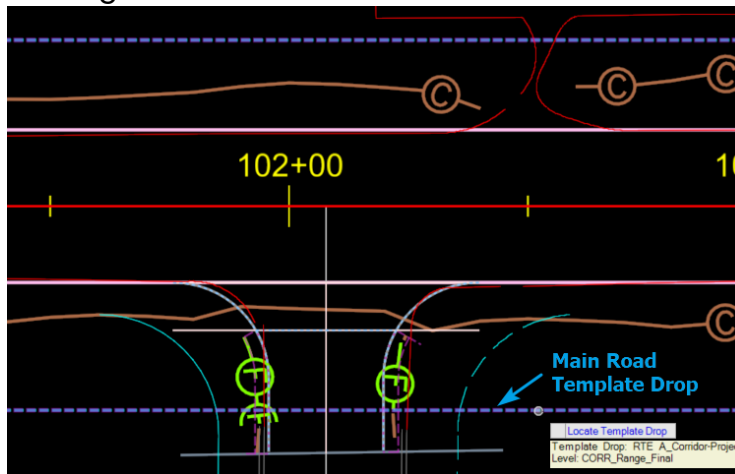

Figure 14

3. For **Start Station, keypoint snap** at start of right-side radius of driveway. For **end station, keypoint snap** at end of left-side radius of driveway. This will create copy of existing template drop at the driveway portion.

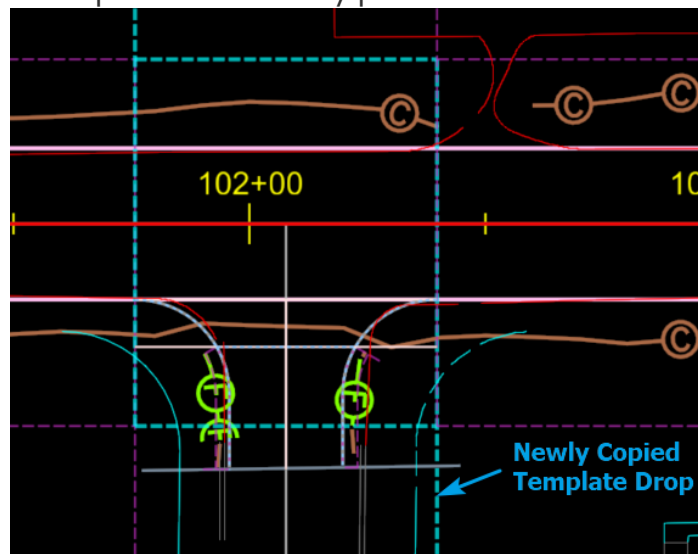

Figure 15

4. This newly copied template drop needs to be edited. From the **Edit** group select **Edit Template Drop**.

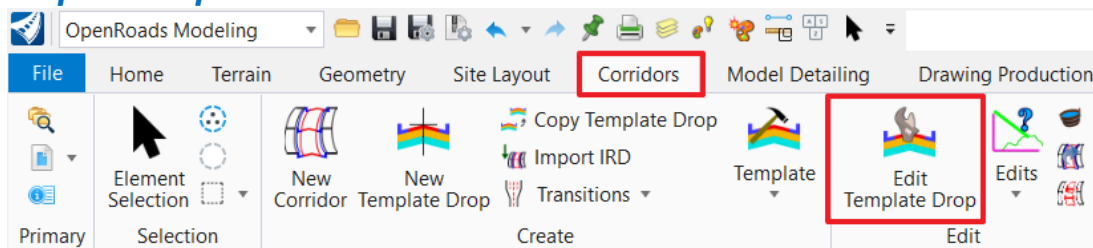

Figure 16

5. For **Locate Template Drop**, select the **Newly Copied Template Drop**.

Volume 3.3 - OpenRoads Designer Civil Cells

- Click **OK** to close the **Editing Roadway Designer Template Drop** dialog.
- Review the driveway location. Notice the side slopes have been removed along the right side of the main road or across the newly placed driveway civil cell. The designer needs to add and transition the side slope at the curb return.

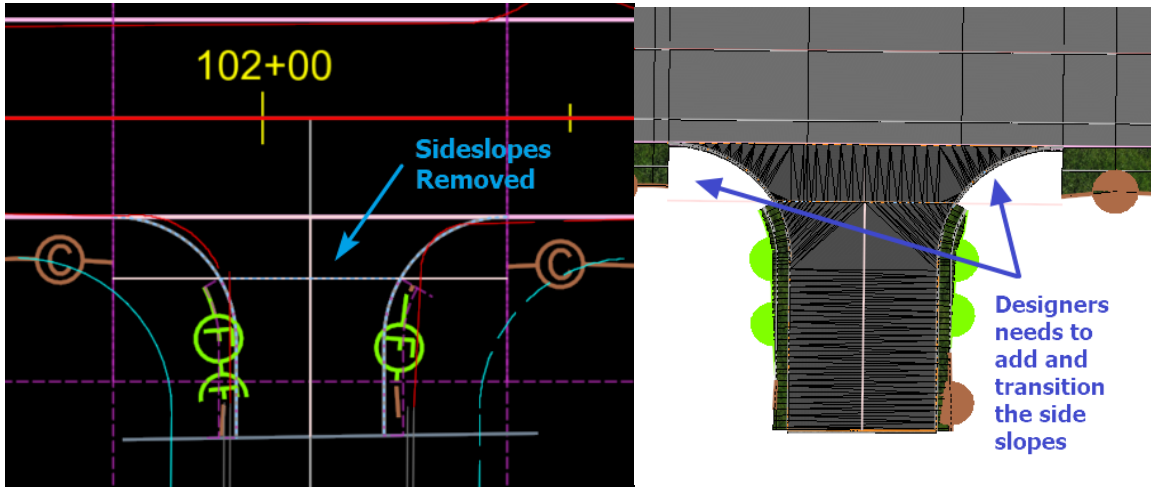

Figure 20

1.2.2 Adjustment of the Reference Element

The placement of Civil Cells can be edited by editing the reference elements from which it was placed.

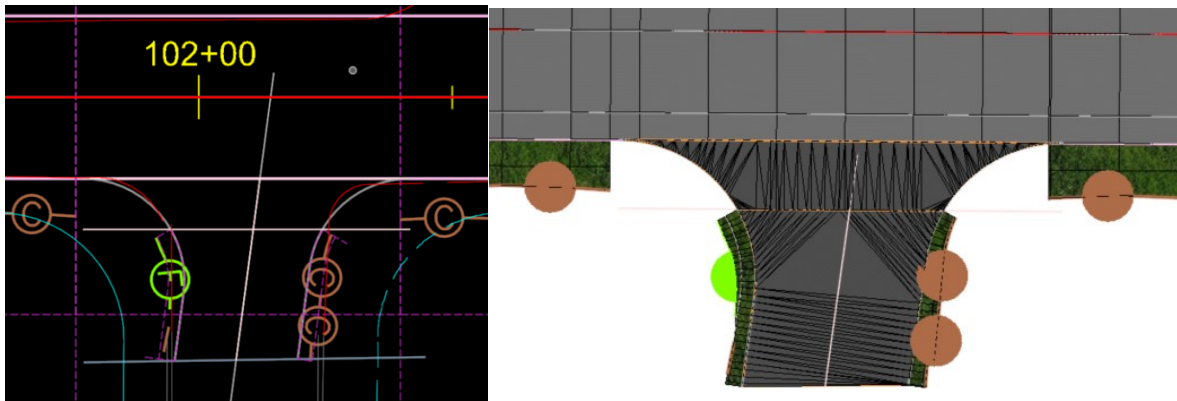

Figure 21

Users are advised to draw the **Driveway Centerline** perpendicular to Baseline of main road. But Driveway Civil Cell can be placed at a situation when there is slight angle between Driveway Centerline and Main Road Baseline.

1. Using the **Element Selection** tool, select the **Driveway Centerline**
2. **Move** the end point of the Driveway Centerline by using the **element handlers**, (the circles and arrows on the selected element).
3. **Click** on the circle at the end point of the Driveway Centerline element and modify the angle of the intersection. The civil cell will update.

1.2.3 Edit Horizontal Geometry

1. **Turn off** the display of the Referenced 3D model, if it is not already turned off.

One “challenge” in editing Civil Cells is that sometimes it is hard to select what user want to select, especially with full 3D Civil Cells. User may have multiple overlapping 2D features overlapped with multiple overlapping 3D Features in the reference 3D Model. User may have to **right-click** a couple times to select the intended element.

2. Depending on user needs, user can **turn off** the **Level** of the 3D Model Reference or **turn off** its Display entirely. User can also **turn off** levels with graphics user find “unnecessary” right now. Construction Class element display can be **turned on** and off via **View Attributes**.

Change the Width of Driveway Shelf or Ramped Section and Sidewalk width of Civil Cell.

- a. Make sure **Constructions** option is turned on in **View Attributes** window.

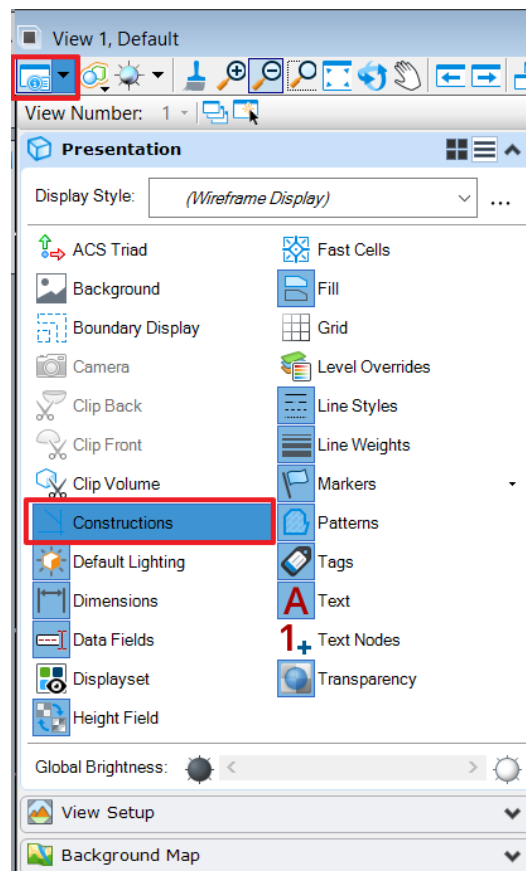

Figure 22

- b. From the ribbon, select **Home** Tab.
- c. From the **Primary** Group, Select **Level Display**.
- d. **Turn on** the display for Level **CIVILCELL_Const** if it’s not on already.

Volume 3.3 - OpenRoads Designer Civil Cells

- Widen the Lane of Driveway Civil Cell. Use the **Element Selection tool** and **Click** on the **right Edge of Driveway** of the Civil Cell.

Tip: It may be easier to select it by **hovering** over its "gap". Element at gap is not visible until user **hover** over it. The Edges of Pavement are full-length offsets from the centerline. The curb returns create "gaps" where the edges are trimmed back, but trimmed features are still able to be selected in its "gaps".

- Once the edge is selected, click on the **midpoint Offset text manipulator**.
- Type desired value say **14'** and hit **Return**. The pavement is widened, and all dependent geometry and modeling is updated.

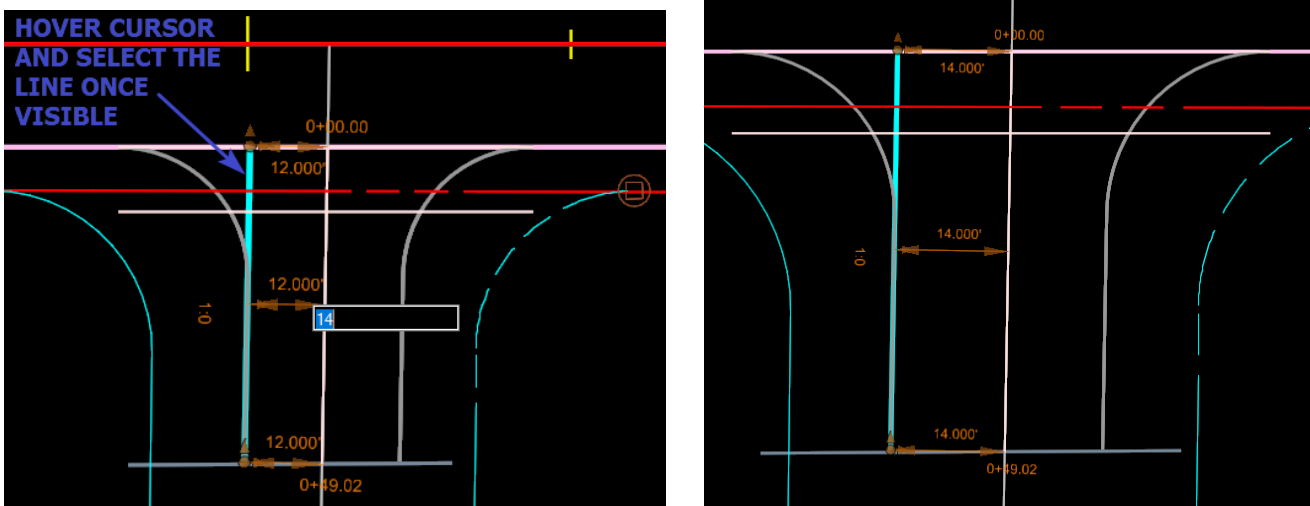

Figure 23

To widen the Left Lane of Driveway Civil Cell, the steps to follow are same as widening right Lane.

Volume 3.3 - OpenRoads Designer Civil Cells

4. Change the Curb Return Radius of Civil Cell.
 - a. Click on the **right Edge of Driveway curb return**. This might require multiple **right-clicks** until the Radius value is visible.
 - b. Click on the **Radius text manipulator**.
 - c. Type desired value say **25'** and hit **Return**. The Curb Return Radius and all dependent geometry and modeling is updated.

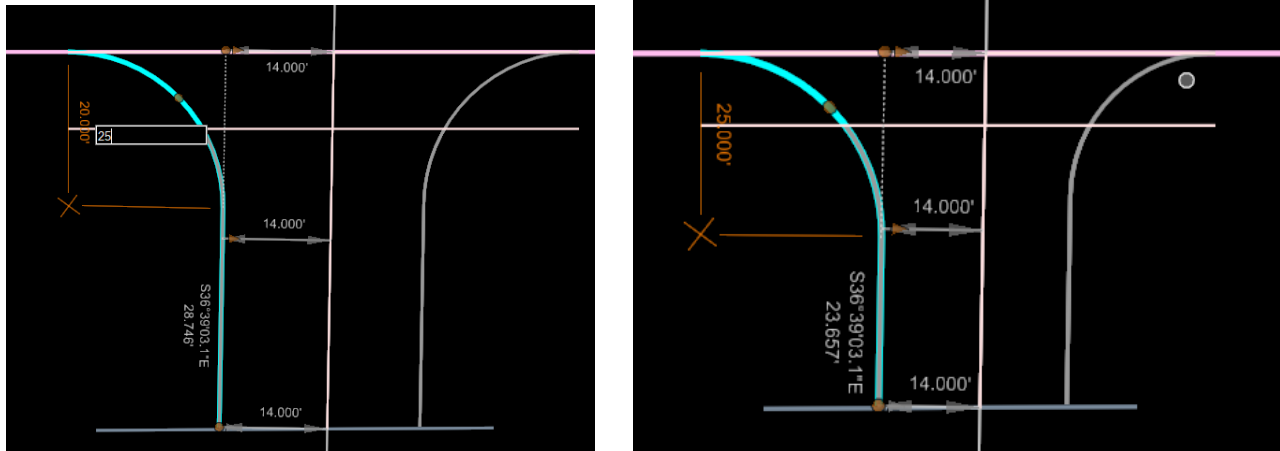

Figure 24

5. Change the Width of Driveway Shelf or Ramped Section of Civil Cell.
 - a. Use the **Element Selection tool** and Click on the **DRV Shelf Line**.
 - b. Once the line is selected, click on the **midpoint Offset text manipulator**.
 - c. Type desired value say **15'** and hit **Return**. The ramp section is widened, and all dependent geometry and modeling is updated.

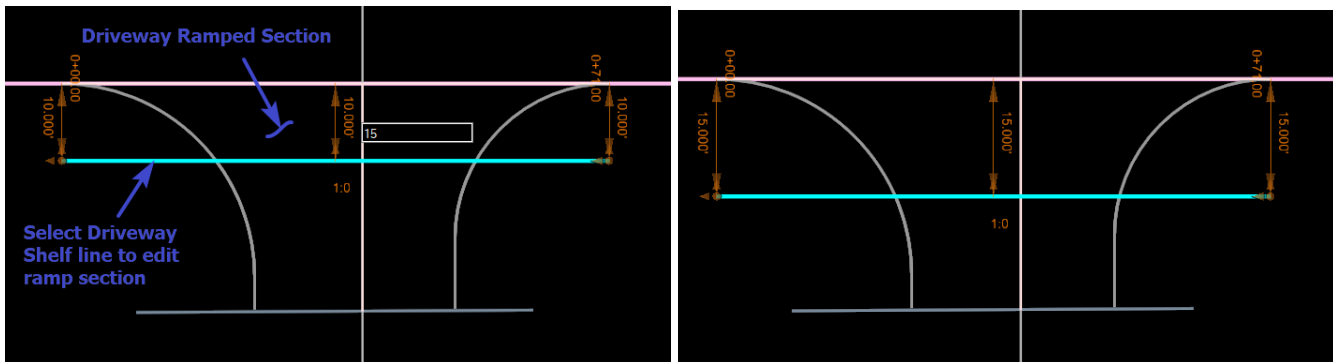

Figure 25

1.2.4 Edit Vertical Geometry

As per CTDOT standards, the driveway is provided with 1½" lip at the Edge of Road and Driveway Shelf line is placed 4" vertical offset from the edge of roadway. Driveway match line takes the elevation from the existing terrain.

1. Select the **Driveway Centerline (1-CC_Pr DRV CL)**. **Hover** over the selected element until the **Context Tool Bar** pops up. Click open **profile model**.

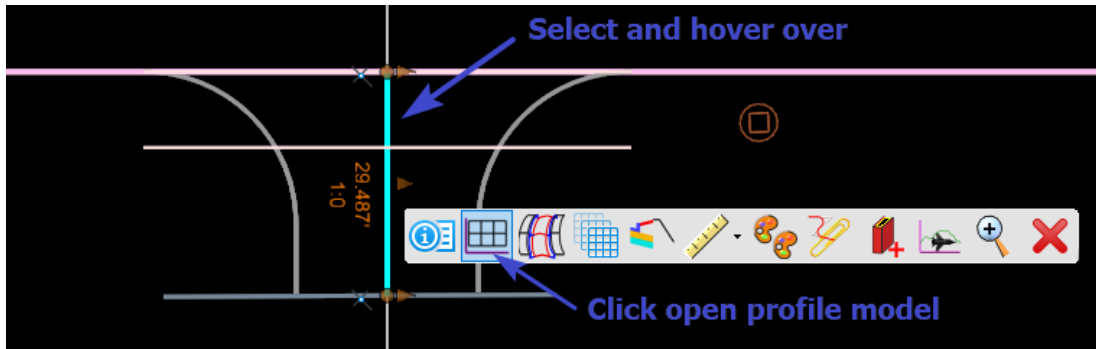

Figure 26

2. On **Select or Open View** model prompt, select one of the views and **left-click** on that view window.

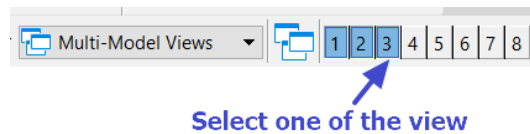

Figure 27

3. The profile view of the Driveway Centerline will show up.

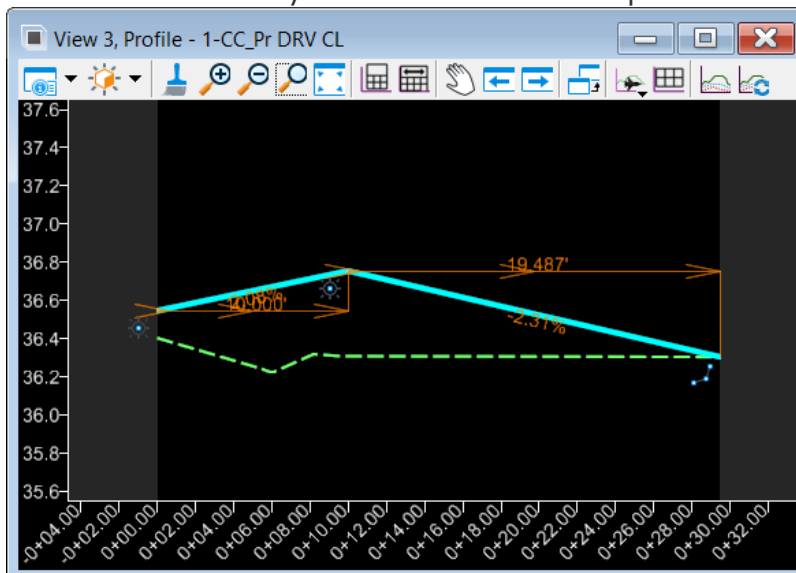

Figure 28

4. Similarly, both Edges of driveway's profile can be viewed.

Volume 3.3 - OpenRoads Designer Civil Cells

5. The profile of Driveway CL and Edge of driveway is generated from Edge of road elevation, Driveway Shelf line elevation and the existing ground elevation at match line.
6. The Driveway Shelf line's elevation is 4" vertical offset from the edge of roadway.
 - a. If the designer wants to change the elevation, select the **DRV Shelf Line**.
 - b. Open the **Properties** dialog and expand *Profile By Projecting LinEnt3d Slope Rule* group, Change **Vertical Offset** to desired elevation.

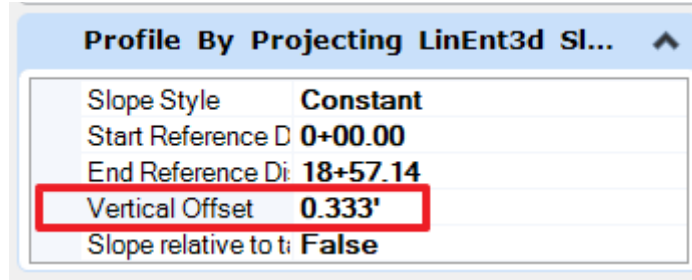

Figure 29

7. The profile will update automatically.

1.3 Swap Out

1.3.1 Swap Out or Edit the Linear Template

The side slope at the Edges of Driveway has 2' of snow shelf. The designer can edit the 2' snow shelf from **edit template drop** or simply switch to a different template.

1. Turn on all the levels associated to Driveway Civil cells from the **level display** window. Make sure **Constructions** option is turned on in **View Attributes** window.

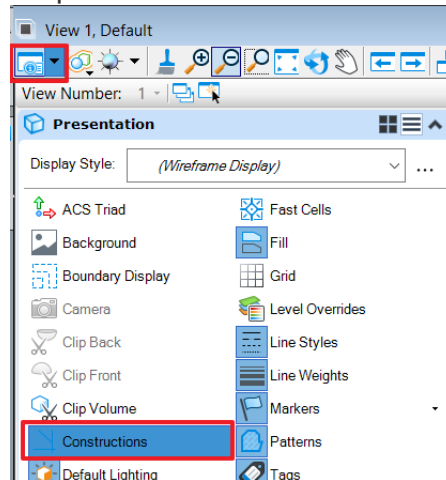

Figure 30

2. Click on a **Linear Template** in View 1, the 2D View. The Linear Template is a 2D shape shown as a dashed line.

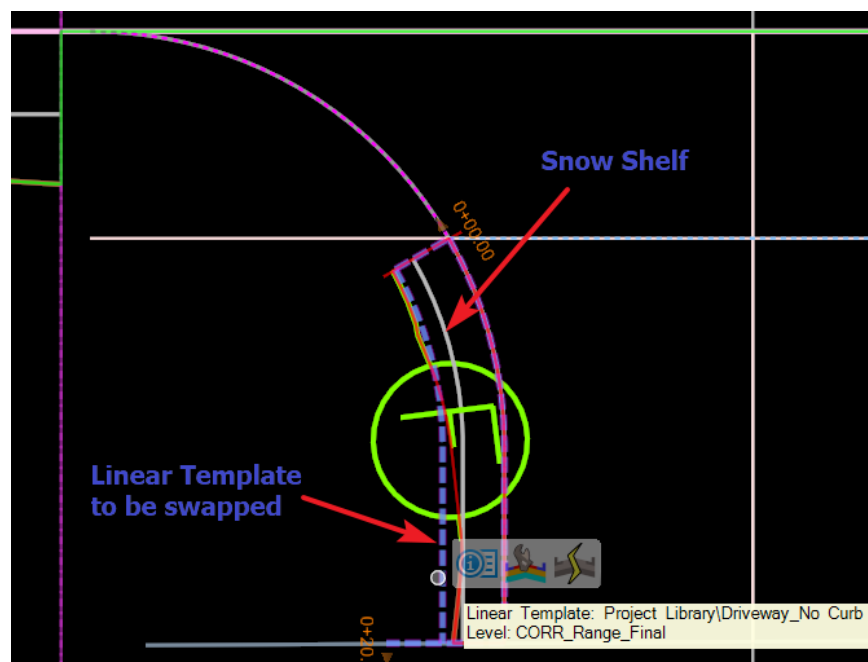

Figure 31

3. Open the **Properties** dialog, and expand the **Template Drop** group. The current template is **Project Library>Driveway_No Curb**

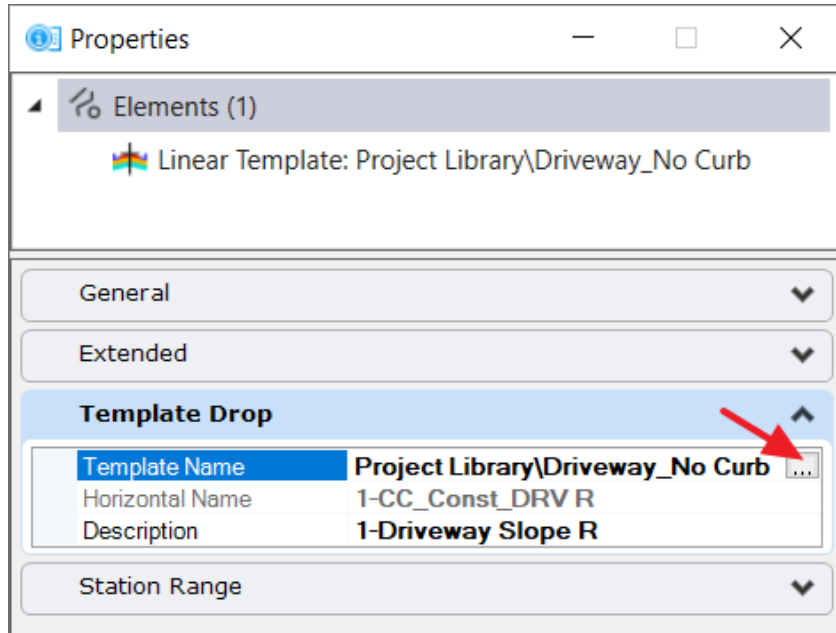

Figure 32

4. Click the **Browse** button in the right side of the **Template Name** label. This opens the Pick Template dialog. Select the desired template prepared for the project and review. For this example, choose **HWY End Conditions > Fill**. This template has no snow shelf

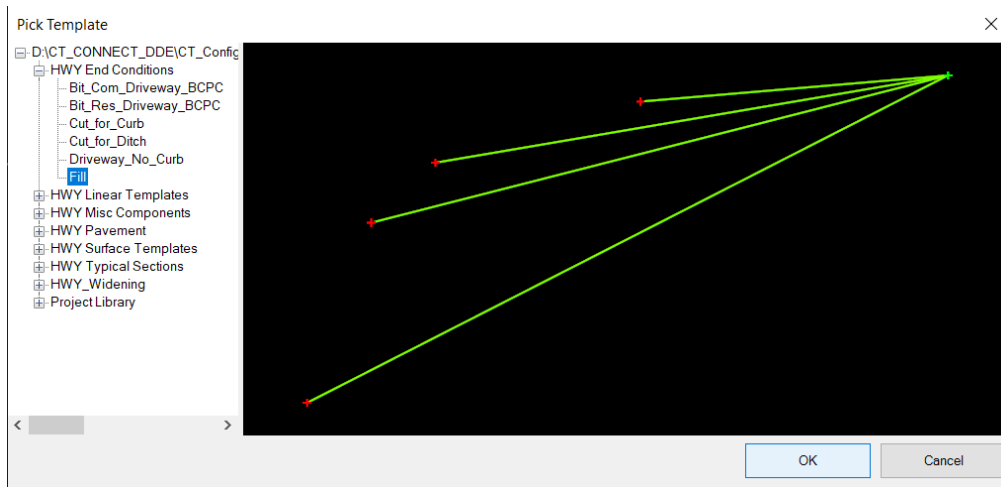

Figure 33

Volume 3.3 - OpenRoads Designer Civil Cells

5. Click **OK**. The linear template processes with the new Template. Notice the change, there is no snow shelf.

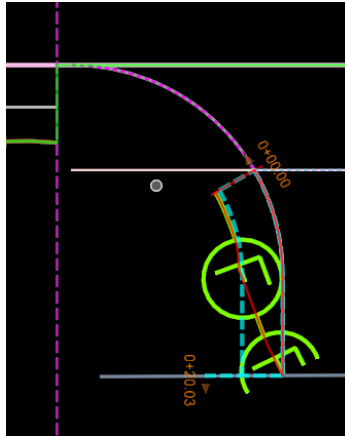

Figure 34

6. Edit Linear Template. From the **Corridors** tab, then from **Edit** Group Select **Edit Template Drop**.

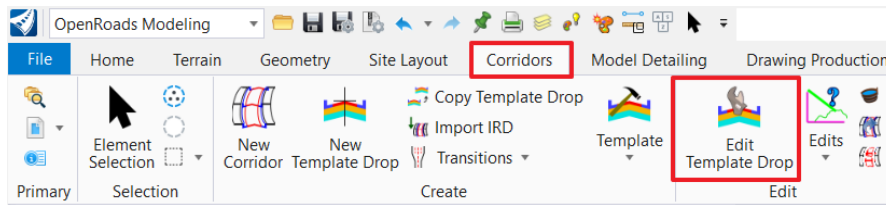

Figure 35

7. In the **Locate Template Drop** prompt, Select the **Linear Template at Edge of Driveway**.

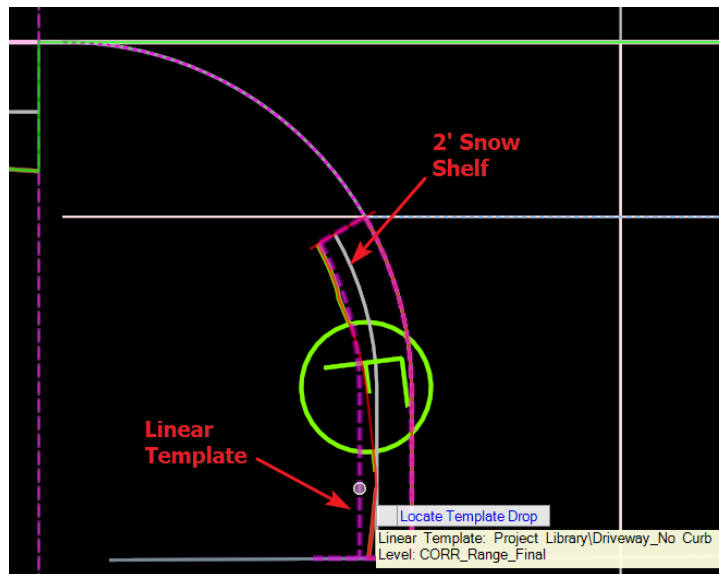

Figure 36

9. **Editing Roadway Designer Template Drop** window appears along with the existing template used at the template window i.e. **Project Library>Driveway_No Curb**

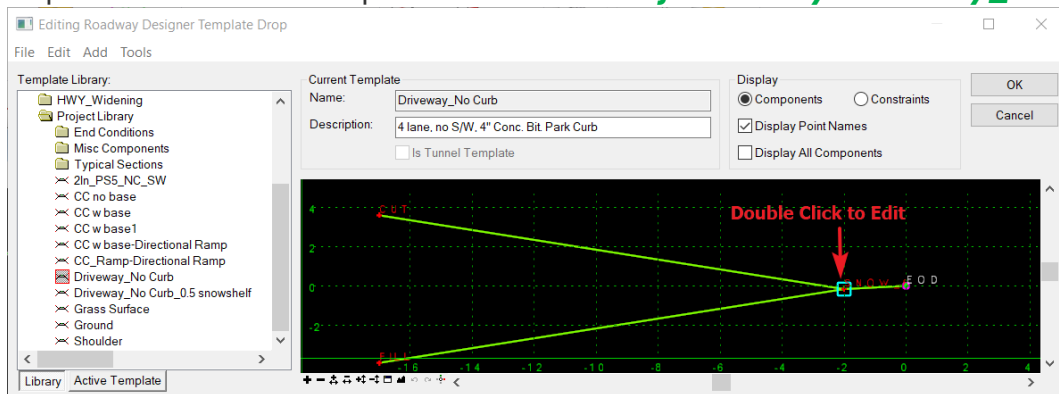

Figure 37

10. Template can be edited in various ways and reviewed. For this example, Snow shelf will be changed from 2' to 0.5'.
11. Double click on **SNOW_f** point.
12. In the Point Properties dialog, change Horizontal Value from **-2 to -0.5** under **Constraint 2** and click **Apply**, then click **Close**.

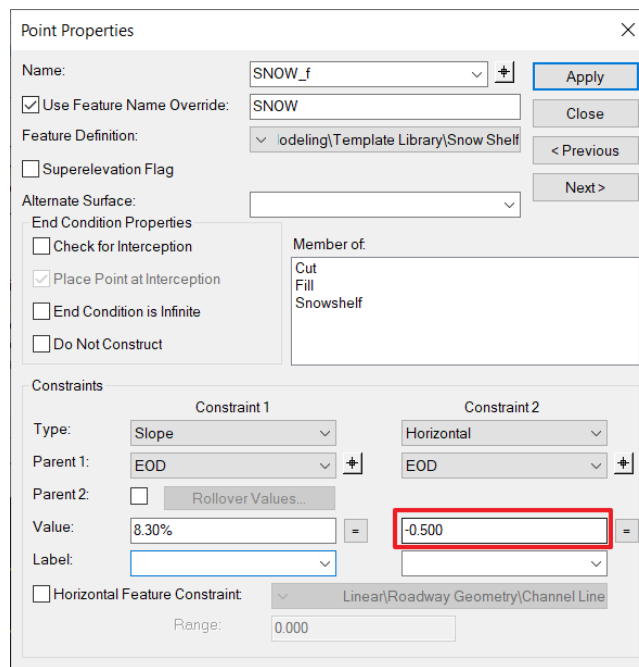

Figure 38

13. Click **OK** to close the **Editing Roadway Designer Template Drop** dialog.

14. The linear template processes with the new Template. Notice the change in width of snow shelf.

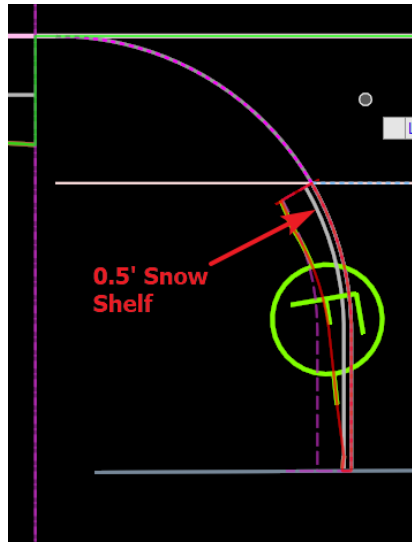

Figure 39

1.3.2 Swap Out or Edit the Surface Template

Driveway Civil Cell can have various surface templates. The Surface Templates can be swapped or edited as per the project requirement.

1. Configure your screen views so that the Default view of civil cell is visible in **View 1**, and the 3D pavement section is visible in **View 2**.
2. In an open view, **right-click** and **hold**, and then select **View Control > 2 Views Plan/3D**.

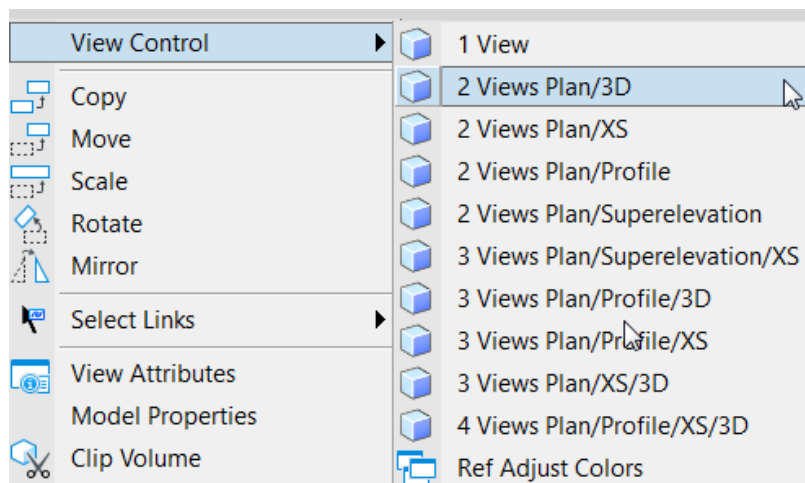

Figure 40

3. In **View 1**, window area so that Driveway Civil Cell is visible.
4. In **View 2**, use the View Rotation tool to rotate the view to the end of the pavement section.

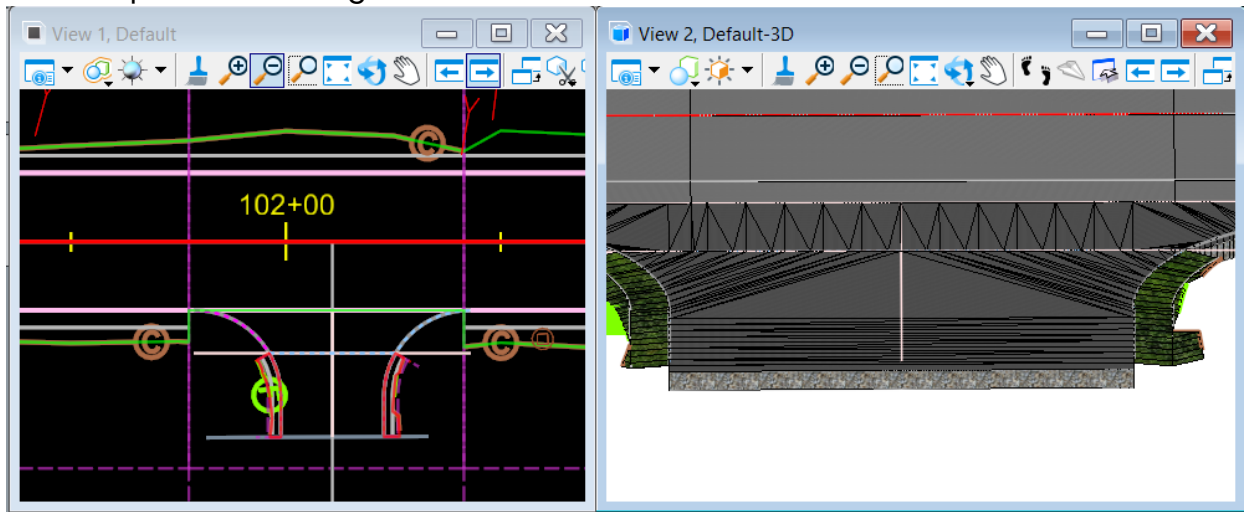

Figure 41

5. Click on a **Driveway Main Surface Template (1-P_DRV Main Surface Template)** in the 3D View.

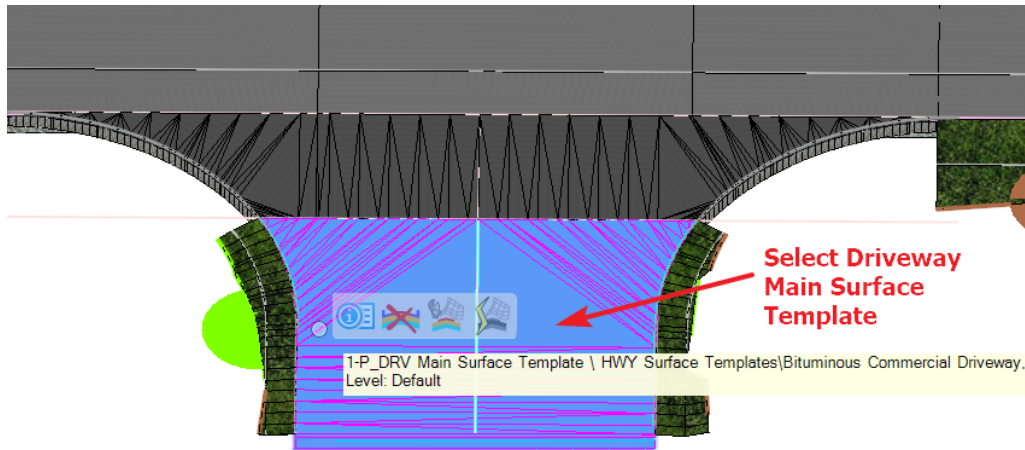

Figure 42

6. Open the **Properties** dialog and expand the **Mesh Template** group.
7. The current template is **HWY Surface Templates > Bituminous Commercial Driveway**

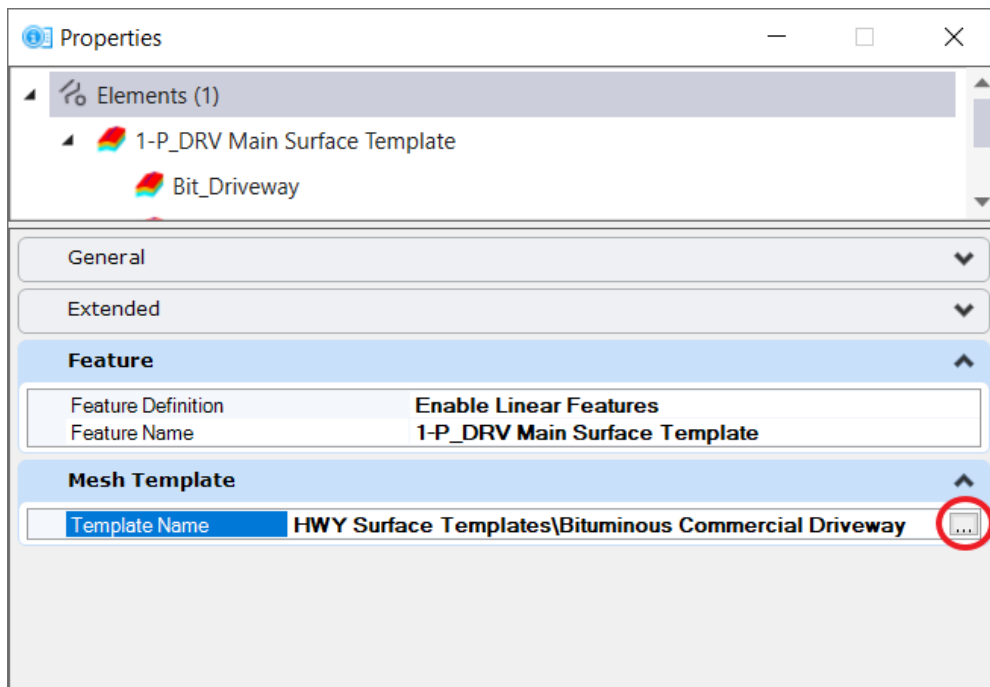

Figure 43

Volume 3.3 - OpenRoads Designer Civil Cells

- Click the **Browse** button in the right side of the **Template Name** label. This opens the **Pick Template** dialog.

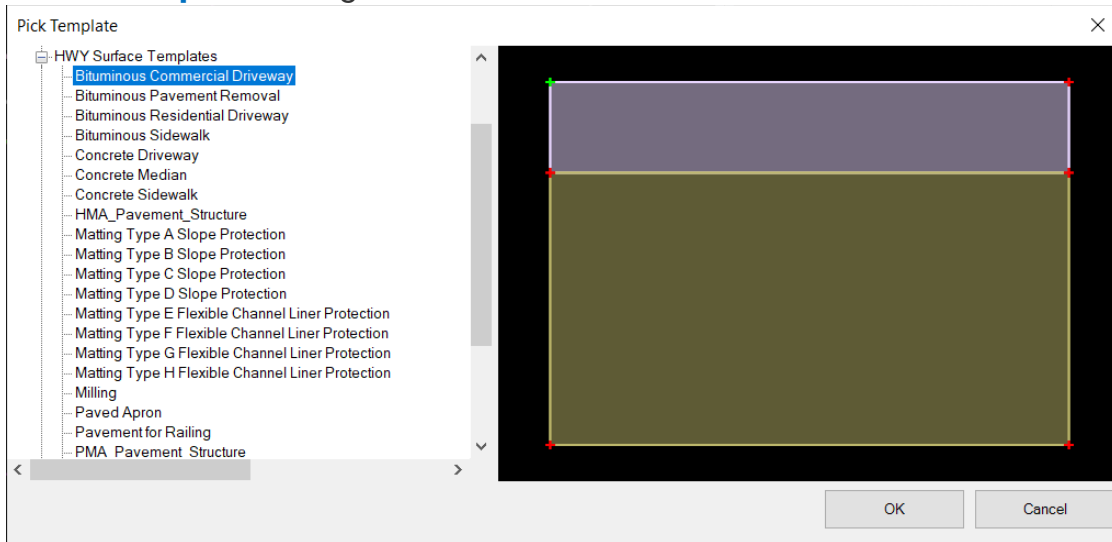

Figure 44

- Select the desired template prepared for the project and review. For this example, choose **HWY Surface Templates > HMA_Pavement_Structure**

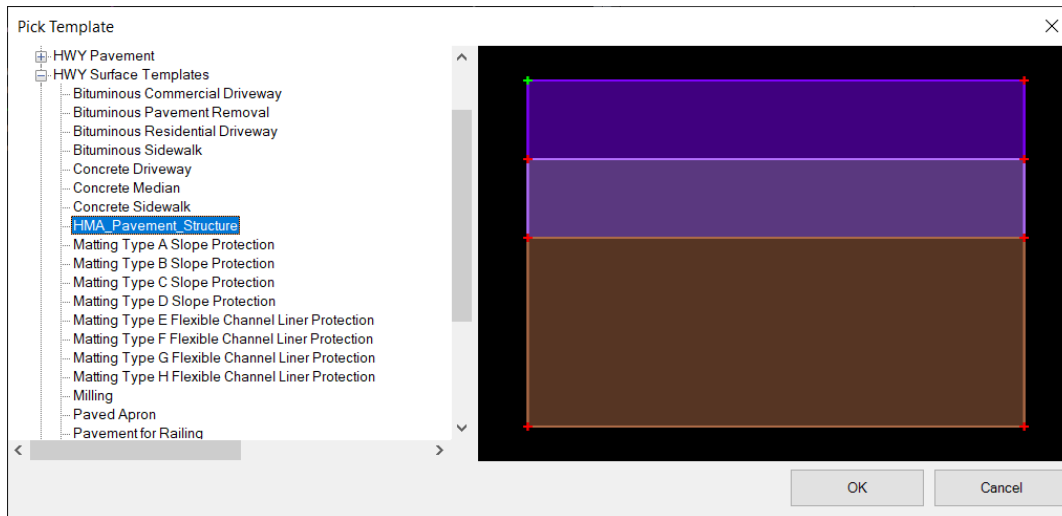

Figure 45

Volume 3.3 - OpenRoads Designer Civil Cells

10. Click **OK**. The surface template processes with the new Template. Notice the change in 3D view. The surface updated from 2 layer to 3 layers of pavement.

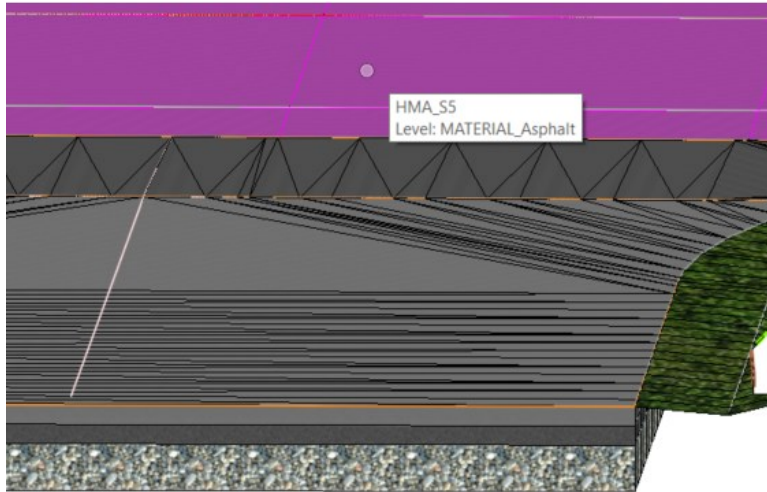

Figure 46

11. User can edit the pavement thickness, **Click** and **hover** over the **Driveway Main Surface Template (1-P_DRV Main Surface Template)** in the 3D View.
12. From the **Context Tool Bar**, select **Edit An Applied Surface Template**.

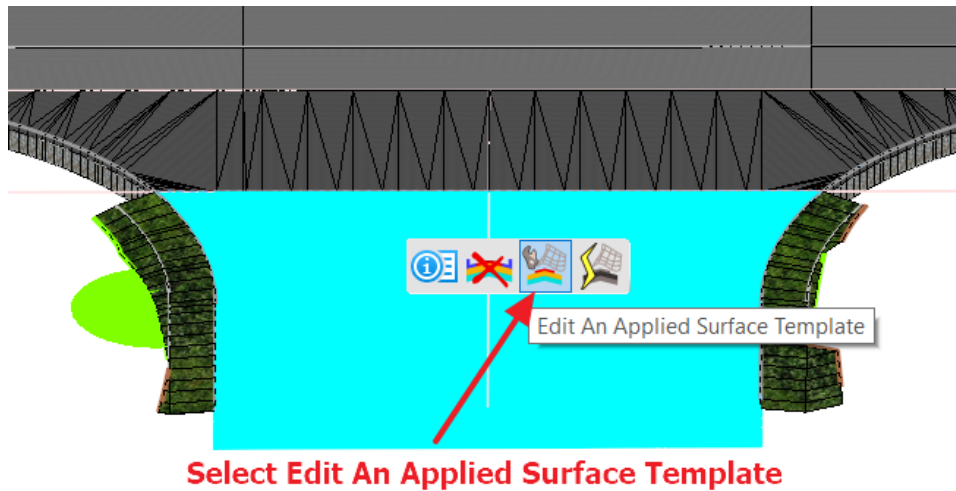

Figure 47

13. In the **Editing Roadway Designer Template Drop** dialog, the pavement thickness can be edited.

- For this example, **EOR_sg_lt** and **EOR_sg_rt** points depth will be changed from **1'** to **1.33'**.

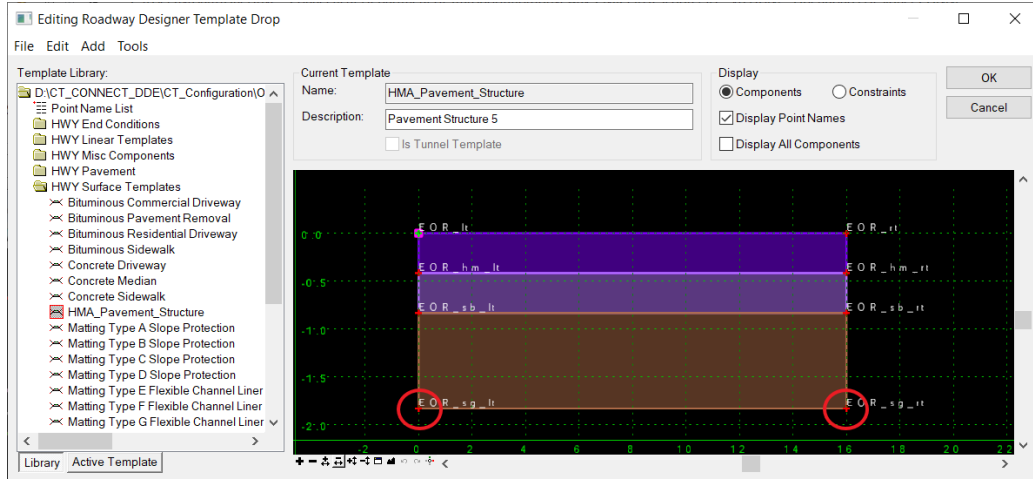

Figure 48

- Double click on **EOR_sg_lt** point. In the **Point Properties** dialog, change Vertical Value from **-1** to **-1.333** under **Constraint 2** and click **Apply** then click **Close**.

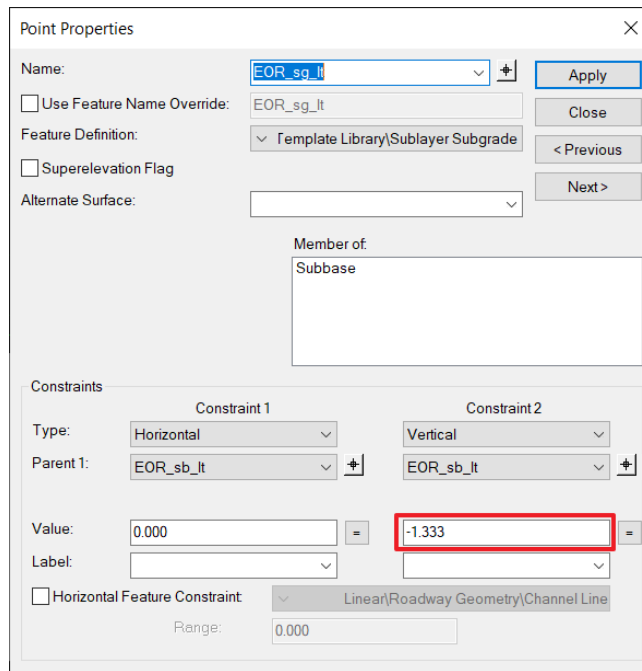

Figure 49

- Double click on **EOR_sg_rt** point. In the **Point Properties** dialog, change Vertical Value from **-1** to **-1.333** under **Constraint 2** and click **Apply** then click **Close**.
- Click **OK** to close the **Editing Roadway Designer Template Drop** dialog.
- The Depth of the bottom layer of the surface template is updated to the new value. You can see the change in the 3D view.

1.4 Curb Editing

For use with Civil Cells:

- Commercial Driveway (No Provision for Sidewalks) with curb
- Residential Driveway (No Provision for Sidewalks) with curb

This civil cell is same as Driveway (No Provision for Sidewalks) without curb. Only addition is there is a concrete curb provided at both sides of curb return.

Follow Sections above for Civil Cell Placement and Edits.

- For this example, Residential Driveway (No Provision for Sidewalks) with curb is placed.
 - For this Civil Cell, only edits for the curb is shown.
1. Concrete curb is provided at both sides of curb return from Edge of road up to Driveway Shelf.
 2. Height of concrete curb is transitioned from existing curb height to zero from Edge of road to Driveway Shelf respectively as shown below.

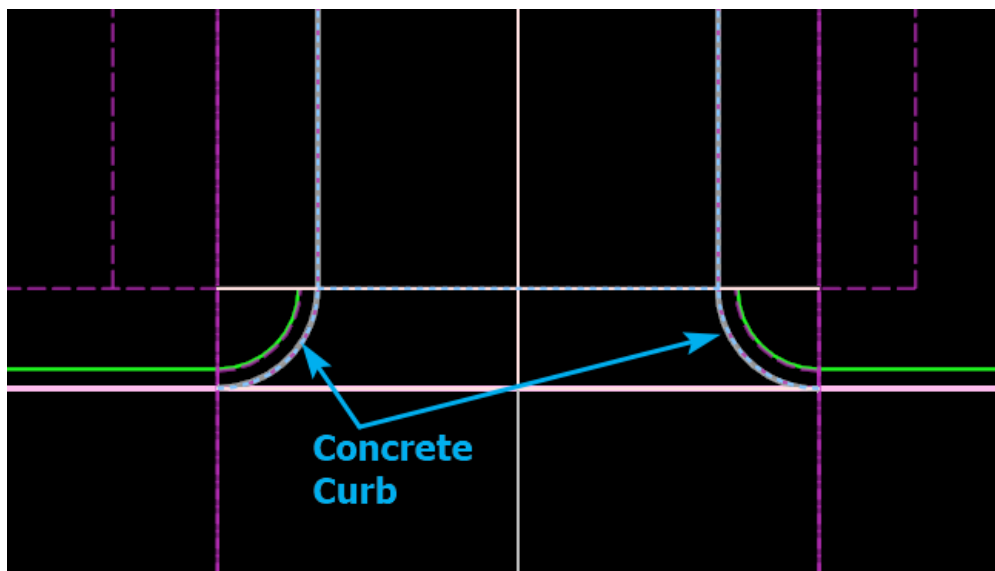

Figure 50

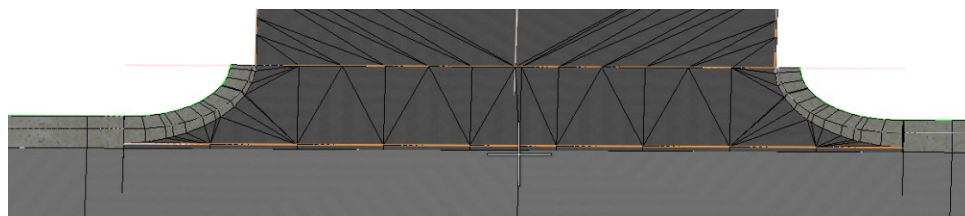

Figure 51

Volume 3.3 - OpenRoads Designer Civil Cells

3. Length of curb and transition height of curb can be edited as required. This can be done via point controls.
4. Based on the requirements of the design, civil cell may need to be dropped.
5. Select **Linear Template of Concrete Curb**, Change the **End station** to **0+03.00** or as desired. The Length of the curb will update.

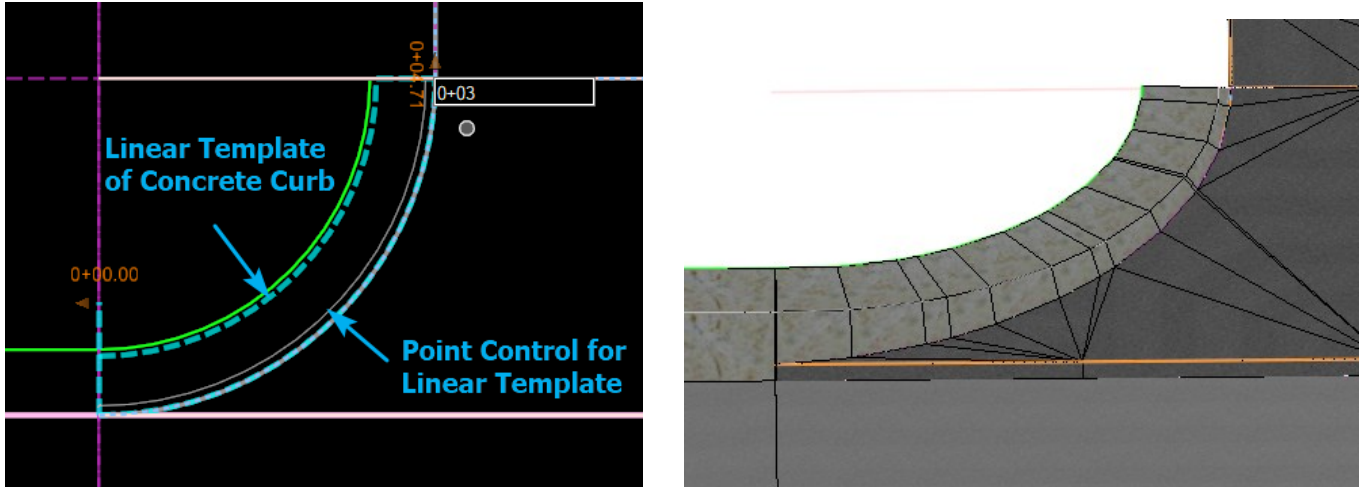

Figure 52

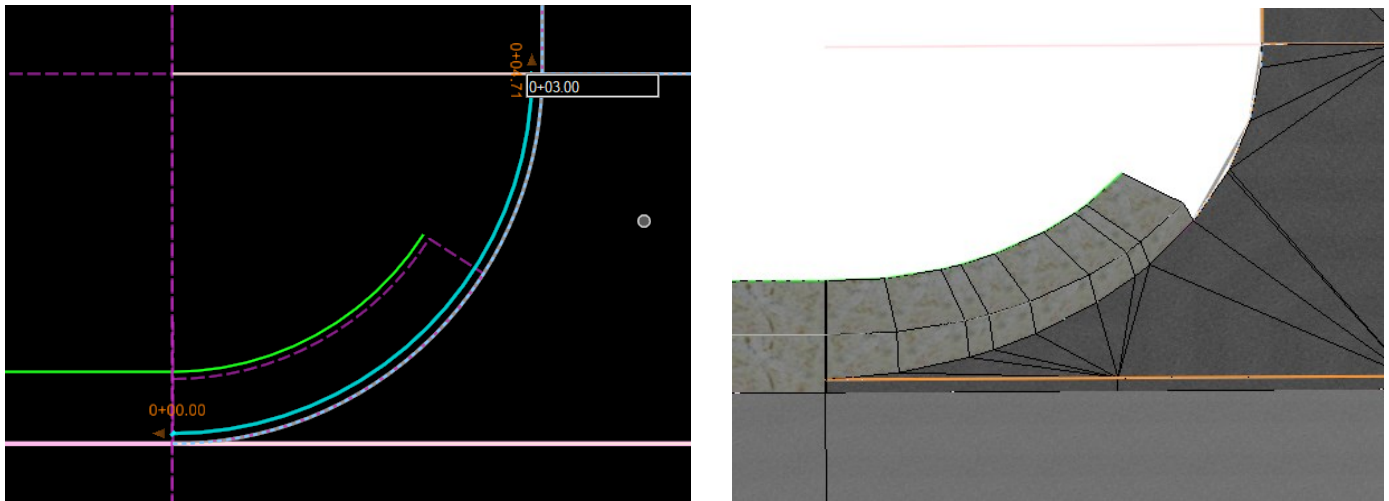

Figure 53

Volume 3.3 - OpenRoads Designer Civil Cells

6. Select **Point Control** for the Linear Template, Change the **End Station** to **0+03.00** or match the Linear Template Station. This Point control will define the curb transition from existing curb height to zero. Curb will update.

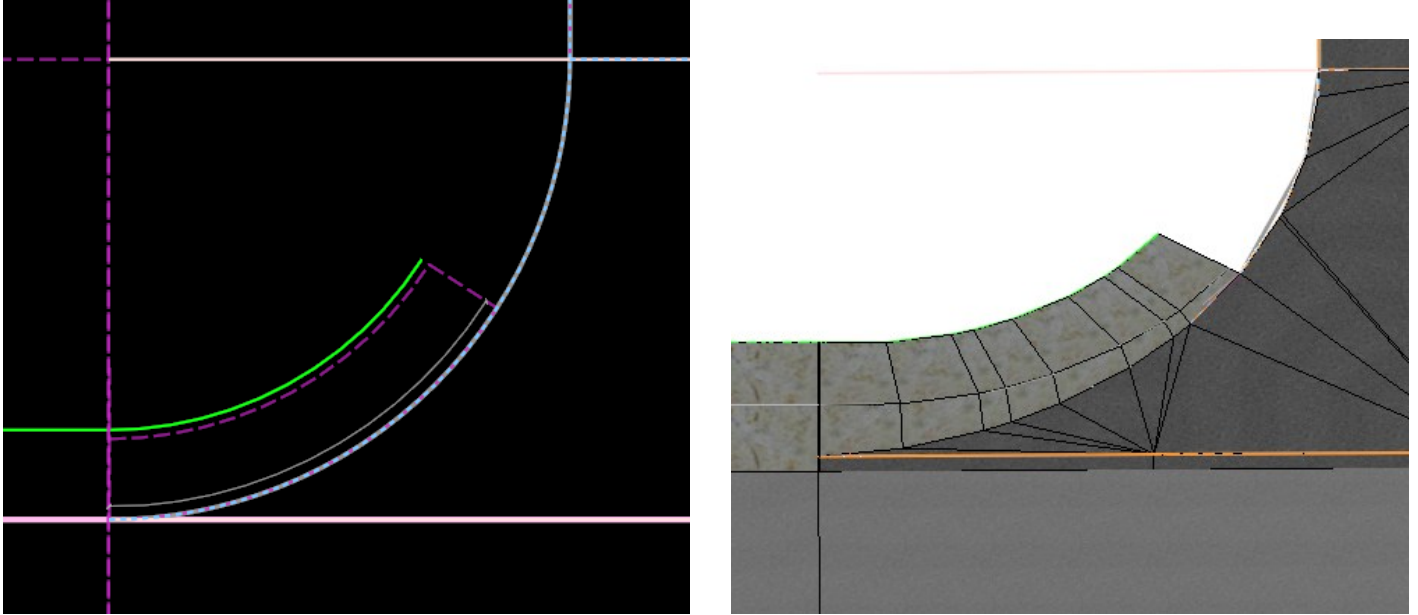

Figure 54

7. To edit or check the point control of the linear template of curb, From the **Corridors** tab, then from **Edit** Group Select **Corridor Objects**.

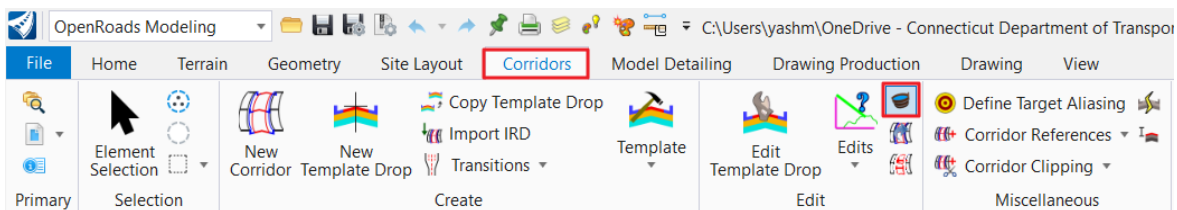

Figure 55

- At **Locate Corridor** prompt select the **Linear Template for of Concrete Curb**. Select **Point Control Tab** in the **Corridor Objects Window**. From this window the height of curb and Length of curb can be defined.

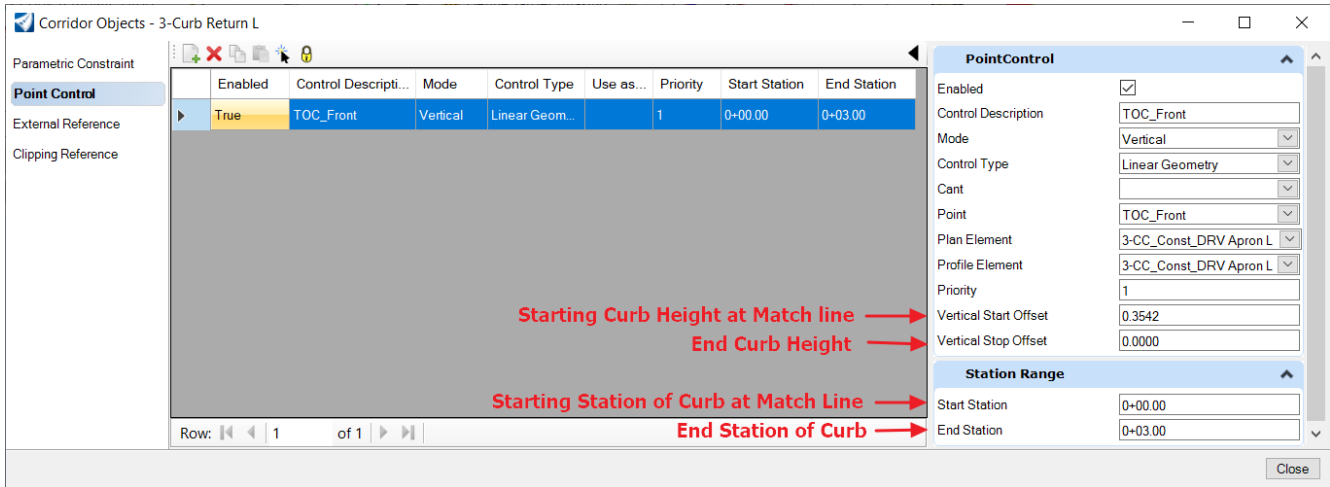

Figure 56

- For example, lets change the value of the **Vertical Stop Offset** (Curb Height) at **End Station** from **0.00** to **0.3542**. Civil Cell will update, Note the change in the curb height.

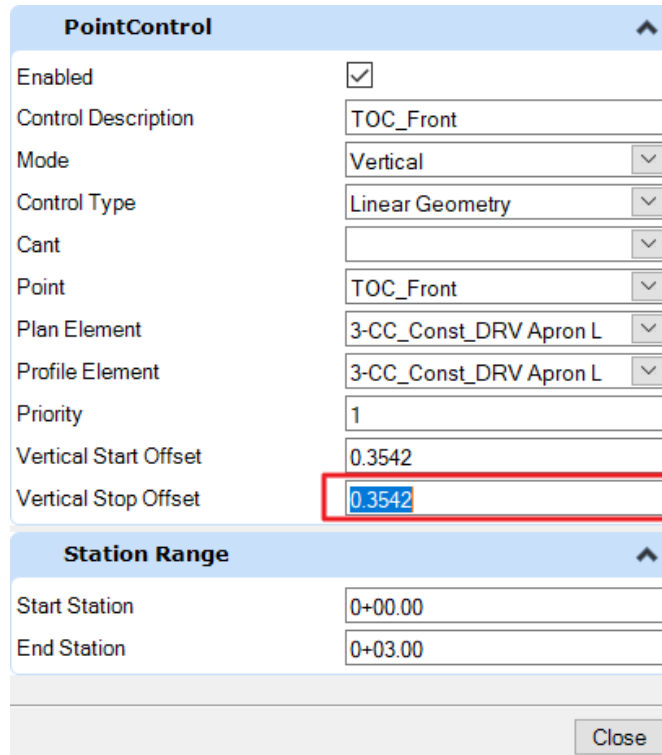

Figure 57

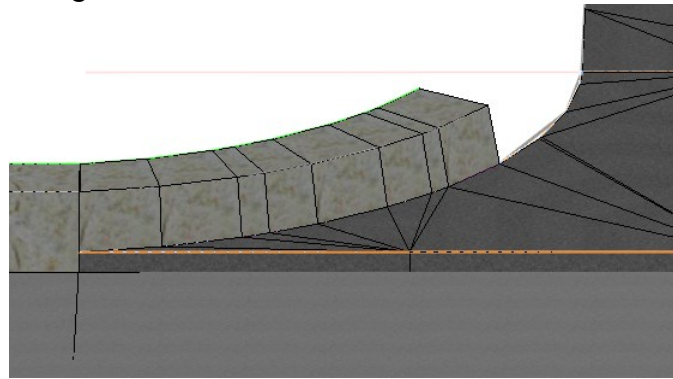

Figure 58

10. Swap out Linear Template from **Concrete Curb** to **Bituminous Concrete Lip Curb (BCLC)**.
 - a. Click on a **Linear Template of Concrete Curb** in **View 1**, the 2D View.

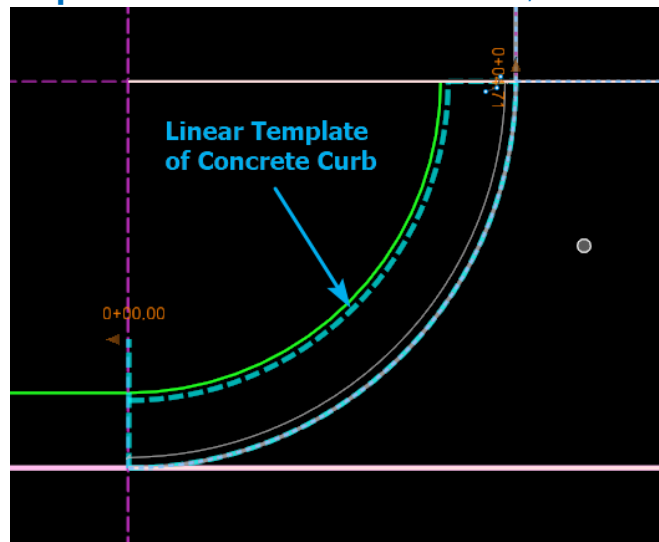

Figure 59

- b. Open the **Properties** dialog, and expand the **Template Drop** group. The current template is **Project Library>CC w base**

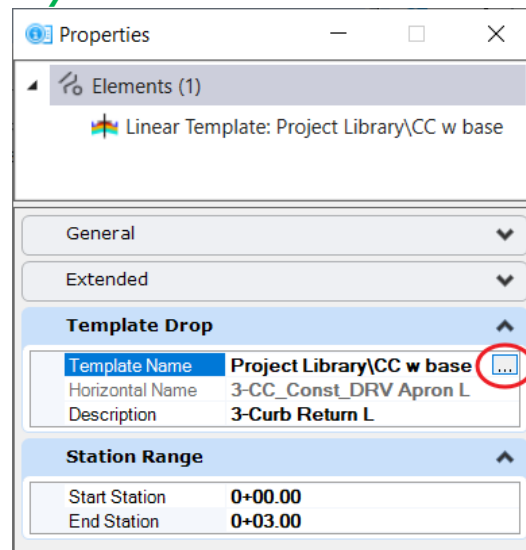

Figure 60

Volume 3.3 – OpenRoads Designer Civil Cells

- c. Click the **Browse** button in the right side of the **Template Name** label. This opens the **Pick Template** dialog.
- d. Select the desired template prepared for the project and review. For this example, choose **Project Library>BCLC w base**.

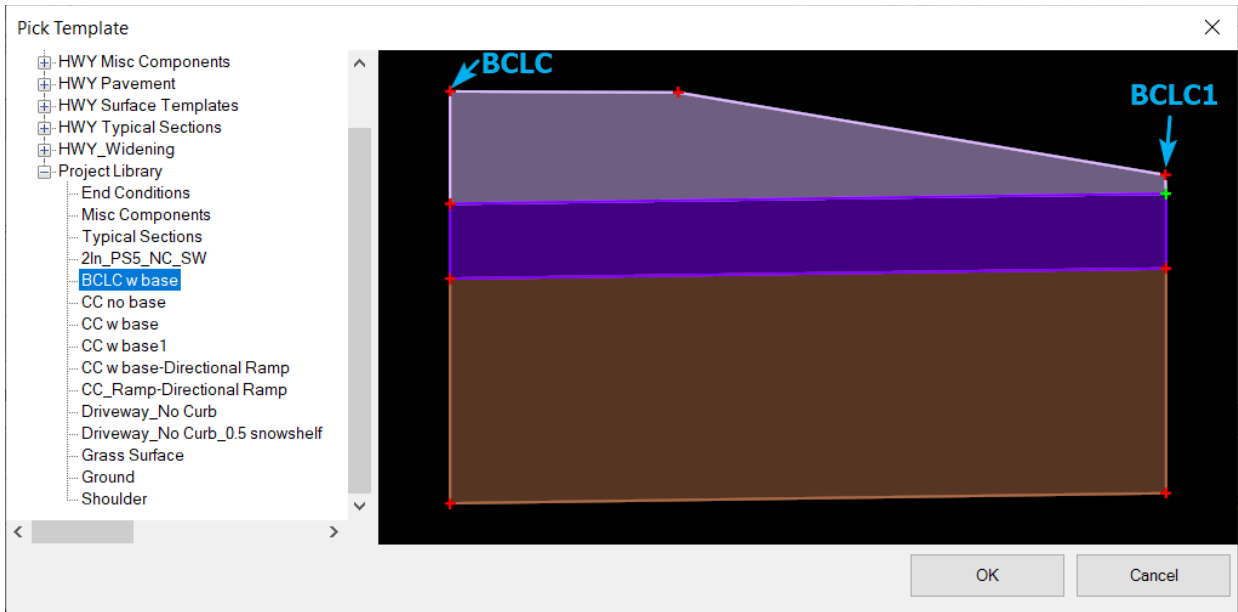

Figure 61

- e. Click **OK**.
- f. The linear template processes with the new Template of **BCLC w base**. Notice the change in curb.

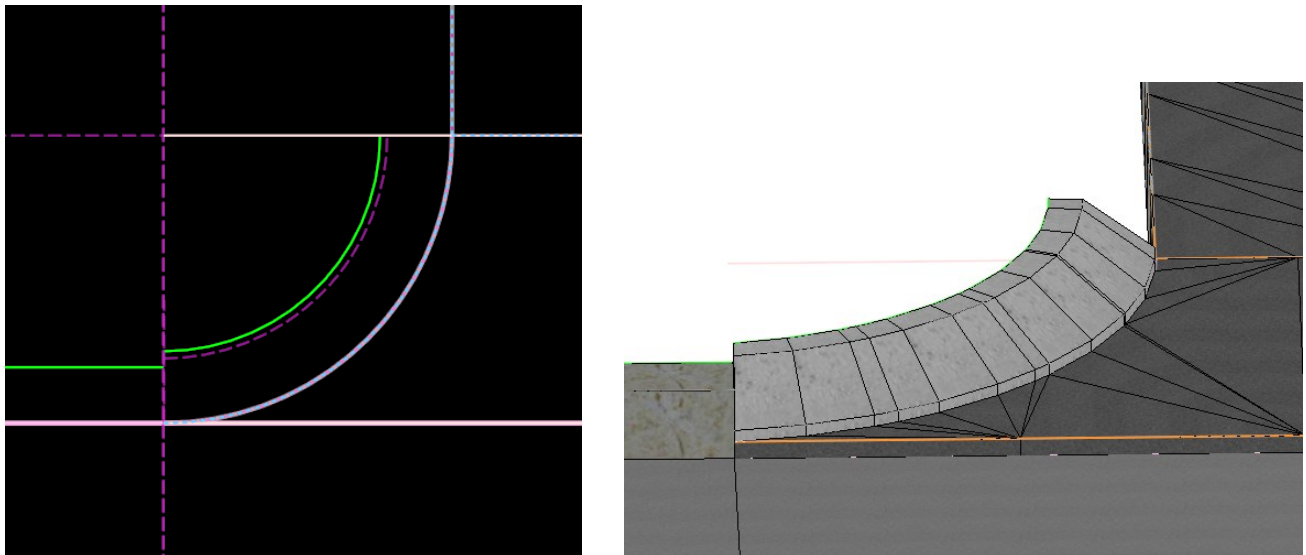

Figure 62

Volume 3.3 – OpenRoads Designer Civil Cells

- g. New point control should be defined to the new Bituminous curb. Old point control for the concrete curb should be deleted. (User can edit Old point control to reflect BCLC, so that new point control is not required. For this example old point control is deleted and new point control is added.)
- h. To delete old point control and add new point control for the linear template of curb, From the **Corridors** tab, then from **Edit** Group Select **Corridor Objects**.
- i. At **Locate Corridor** prompt select the **Linear Template for of Concrete Curb**. Select **Point Control** Tab in the Corridor Objects Window. Select the desired **Point Control** and hit **Delete** button to delete the selected Point Control.

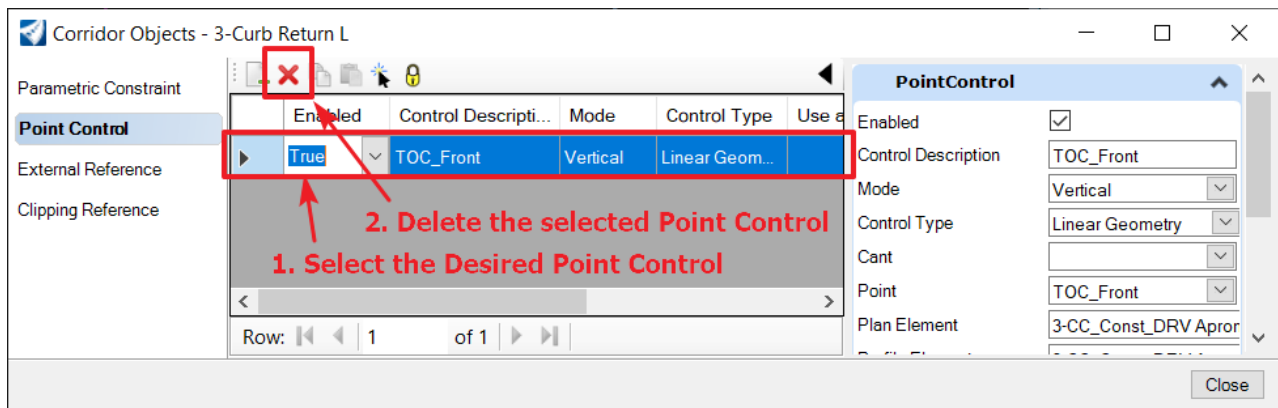

Figure 63

- j. Click **Add New** button to add **new Point Control** for the selected corridor.

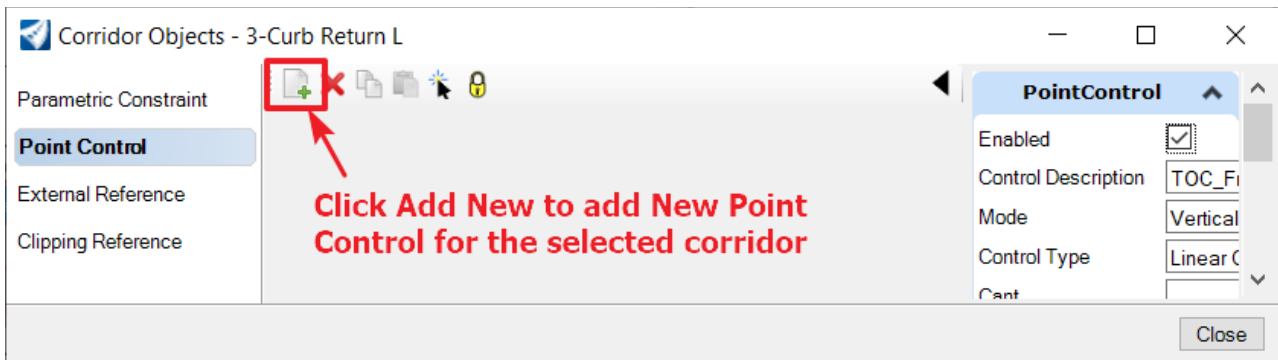

Figure 64

NOTE: Another method to **Create Point Control**.

- k. From the ribbon, select **Corridors** Tab, then from **Edit** Group Select **Edits > Create Point Control**. Locate desired corridor i.e. **Linear Template of BCLC w base, Create Point Control Window** will appear then follow the prompts.

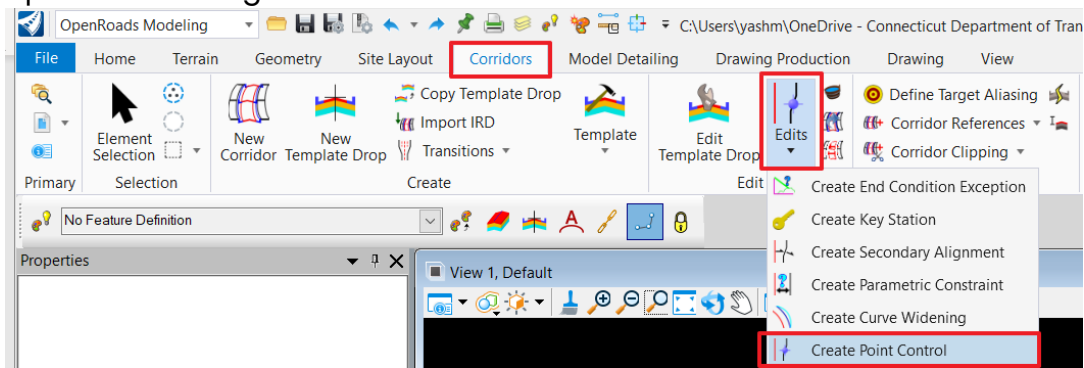

Figure 65

- I. **Create Point Control Window** appears. Fill the box according to your **point control** criteria. For this example, **point control at Back of BCLC** is shown. Follow prompts

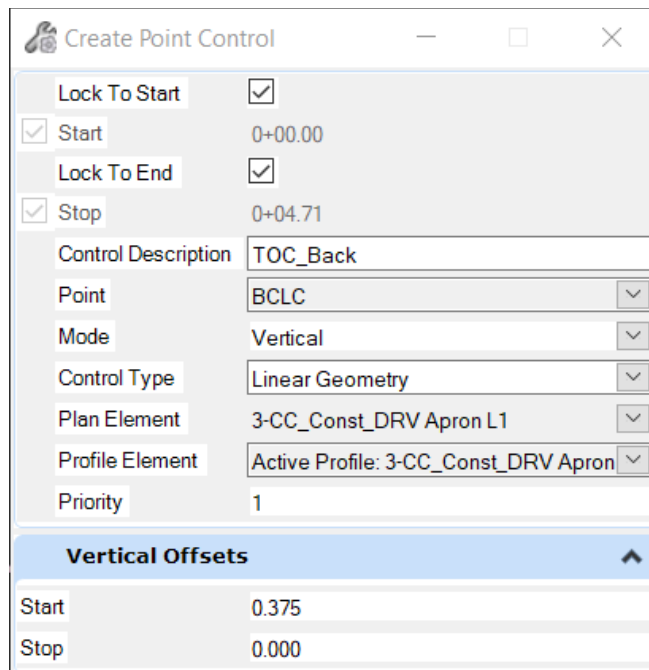

Figure 66

- Start Station: **Lock to Start**
- End Station: **Lock to End**
- Control Description: **TOC_Back**
- Locate Point: **BCLC** (This point can be selected either from dropdown menu or selecting Back of curb element named BCLC directly from the drawing)
- Mode: **Vertical**
- Control Type: **Linear Geometry**
- Locate Plan Or Profile Element: **3-CC_Const_DRV Apron L**

NOTE: During element selection if the element cannot be selected and there notification as **Invalid Plan Element-Child of Civil Cell**.

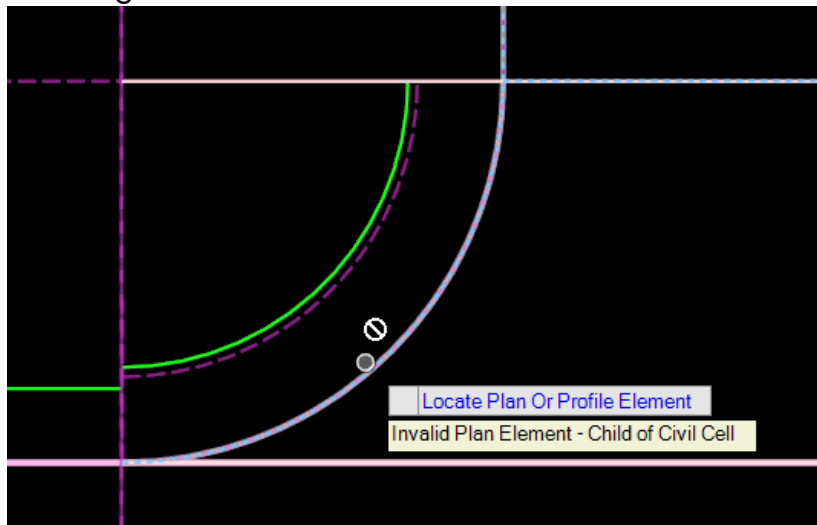

Figure 67

Exit out of the command. From the ribbon, select **Model Detailing** Tab, then from **Civil Cells** Group Select **Drop Civil Cell**. After dropping the civil cell redo the whole point control step.

Accept **Active Profile: 3-CC_Const_DRV Apron L** : **Left Click** to accept

- Priority: **1**
- Vertical Offset Start: **0.375**
- Vertical Offset Stop: **0.000**

The Curb will update.

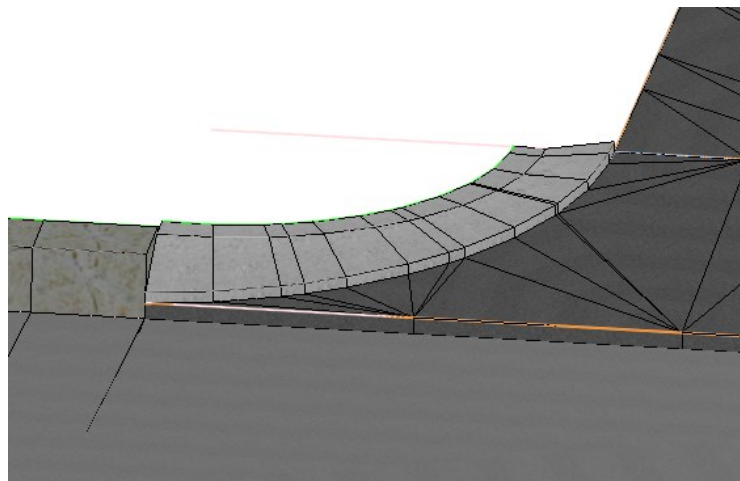

Figure 68

m. Add **point control** for **Front of BCLC**. Follow the previous step for **Create Point Control**

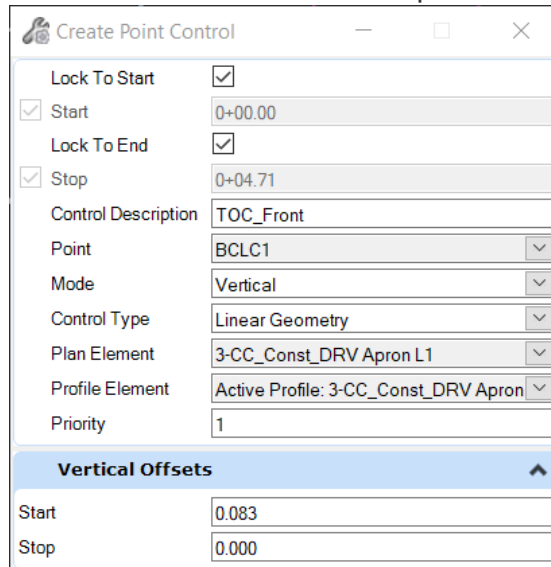

Figure 69

- Start Station: **Lock to Start**
- End Station: **Lock to End**
- Control Description: **TOC_Front**
- *Locate Point:* **BCLC1** (This point can be selected either from dropdown menu or selecting Front of curb element named BCLC1 directly from the drawing)
- *Mode:* **Vertical**
- Control Type: **Linear Geometry**
- Locate Plan Or Profile Element: 3-CC_Const_DRV Apron L
- Accept "**Active Profile: 3-CC_Const_DRV Apron L**" : **Left Click** to accept
- Priority: **1**
- Vertical Offset Start: **0.083**
- Vertical Offset Stop: **0.000**

The Curb will update.

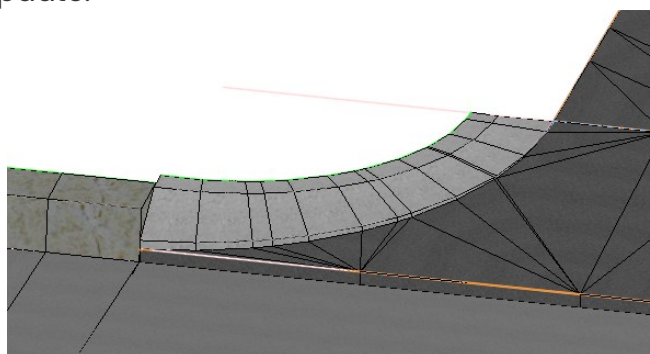

Figure 70

n. Repeat the same process to edit the curb type and height for the right side of the driveway.

Exercise 2 – Driveway (Sidewalk with Buffer Area)

For use with Civil Cells:

- Commercial Driveway (Sidewalk with Buffer Area) without curb
- Residential Driveway (Sidewalk with Buffer Area) without curb

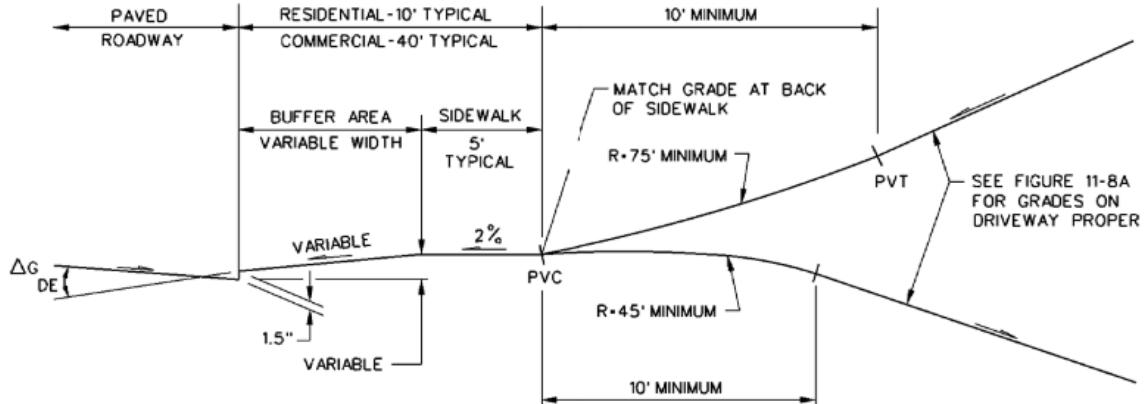

1. This design applies with or without curbs.
2. As an alternative to providing a vertical curve, the designer may use an angular break which does not exceed the ΔG criteria in Figure 11-8A for the driveway proper.
3. The maximum ΔG_{DE} will be as follows:

Turn From <u>Travel Lane</u>	Turn From <u>Shoulder or Turn Lane</u>
8%	12%

Note that a shoulder must be at least 7 ft wide to use the higher ΔG_{DE} values.
4. The grade for the driveway portion through the border area should not exceed the grades on the driveway proper in Figure 11-8A.
5. When compromises are necessary, the criteria for the max ΔG_{DE} should receive more weight than the 2% sidewalk cross slope (i.e., the sidewalk should be warped as necessary to allow the smallest practical ΔG_{DE}). This, in effect, gives preference to the safety of the vehicular traffic. If the turn will be made from a travel lane, it will usually be necessary to alter the sidewalk cross slope if curbs are present. However, if the sidewalk is on an accessible route, the designer must also consider ADA criteria for disabled individuals, see Section 15-1.0.
6. When determining the appropriate vertical design for the driveway entrance, the designer should also consider the highway design speed, through traffic volumes, driveway volumes, turning speeds allowed by the available curb radius and crash history.
7. See the Department's Standard Drawings for additional details.

**TYPICAL DRIVEWAY ENTRANCE
(Sidewalk With Buffer Area)**

Figure 11-8C

Figure 71 CTDOT Highway Manual 11-8C

2.1 Civil Cell Placement

The design file should have Baseline Alignment, Baseline Profile and roadway corridor in order to place civil cell. Profiled Edge of Road will come from template of Corridor.

2.1.1 Place Reference Lines

1. Activate the **OpenRoads Modeling** workflow, from the ribbon, select the **Geometry** tab, **Horizontal** group. Select to tool **Lines > Line Between Points**. In the dialog box select the Feature Definition:

Alignment > Center > Driveway

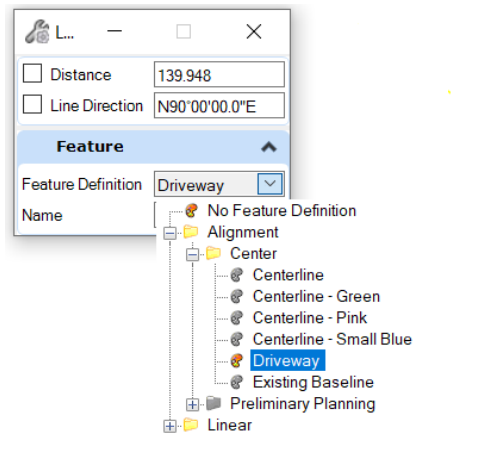

Figure 72

2. Using the perpendicular snap draw a **Line** perpendicular to Baseline of Main Road towards the Proposed Driveway. This is Driveway Centerline. Default name is **DCL**. Which can be modified as required.

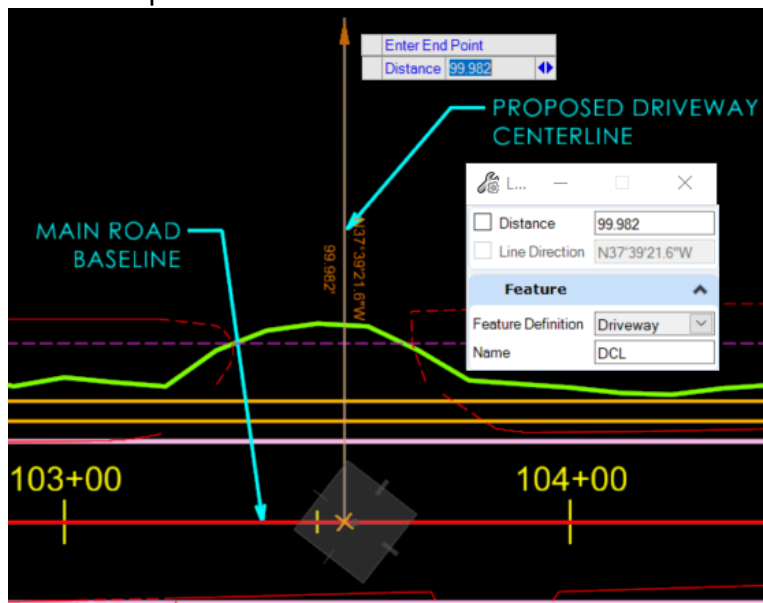

Figure 73

- From the **Horizontal** group select **Lines > Line Between Points**. Select the Feature Definition: **Linear > Roadway Geometry > Driveway Match Line**

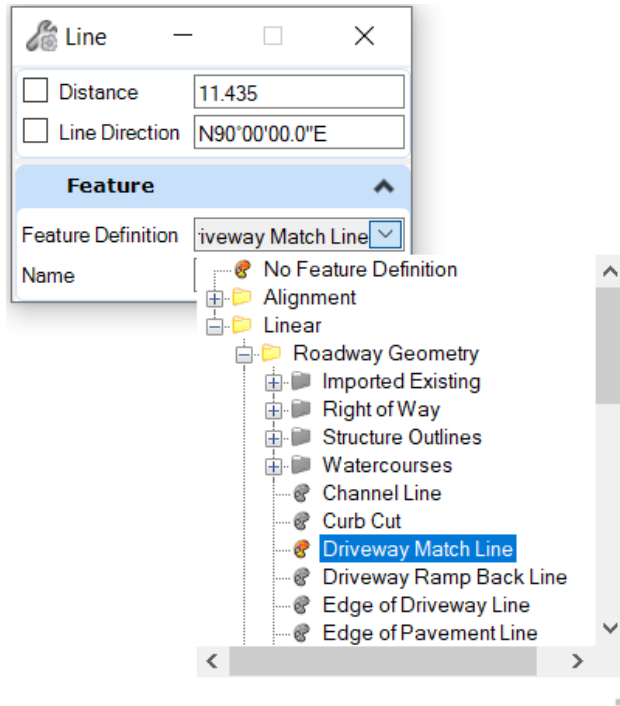

Figure 74

- Draw a **line** crossing the Driveway Center line. This line is the limit of the driveway where it matches the existing driveway or ground. The default name **DrivewayMatch_Line** can be modified as required.

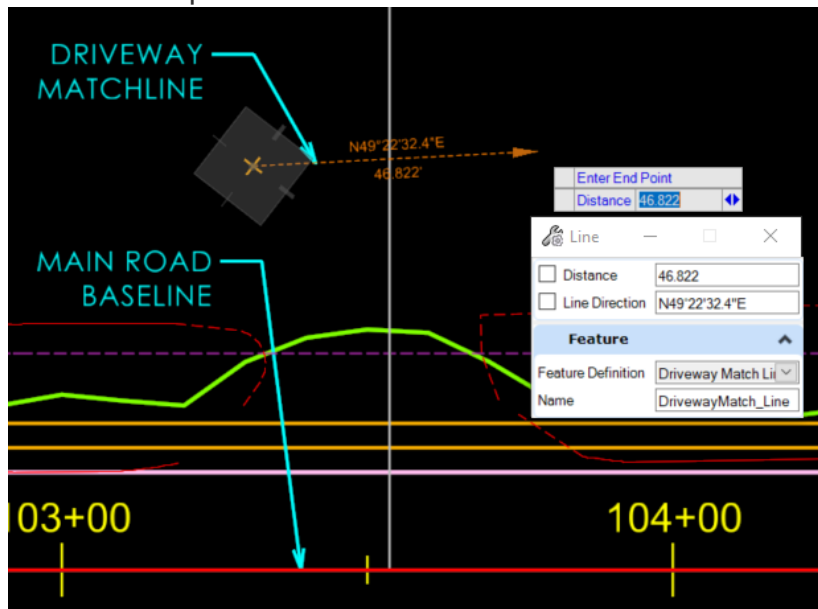

Figure 75

Volume 3.3 - OpenRoads Designer Civil Cells

Now we have all three references required for placing the Driveway Civil Cell. We can place the civil cell.

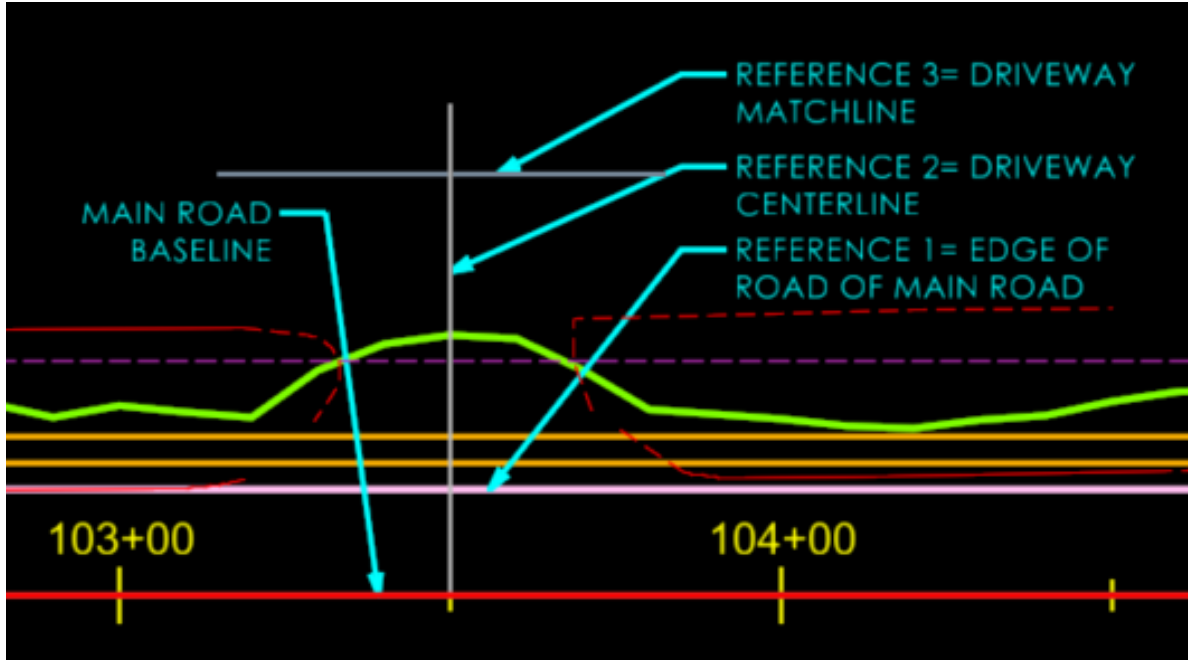

Figure 76

2.1.2 Select the Civil Cell

1. From the ribbon, select **Model Detailing** tab, **Civil Cells** group, **Place Civil Cell**.

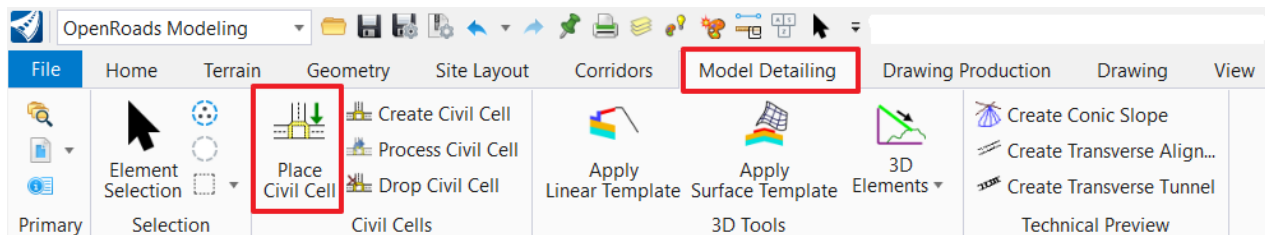

Figure 77

2. In Civil Cell Name dialog box, click the **browse** button to open civil cell library.

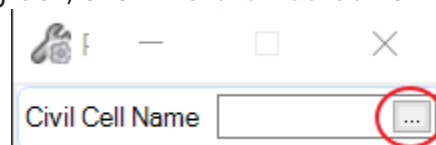

Figure 78

3. Two options to can be chosen from as per requirement.
 - a. For Commercial Driveway, expand the **CV_Commercial_Driveway_CivilCells.dgnlib** and select **Commercial Driveway (Sidewalk with Buffer Area) without curb**.

Volume 3.3 – OpenRoads Designer Civil Cells

- b. For Residential Driveway, expand the **CV_Residential_Driveway_CivilCells.dgnlib** and select **Residential Driveway (Sidewalk with Buffer Area) without curb**.
- The dialog displays the planimetric layout of the selected civil cell with **black lines**
- The dialog also shows the reference lines on which the civil cell is based. These are the **red lines** and represent the baselines that must be present within the design file to place the civil cell

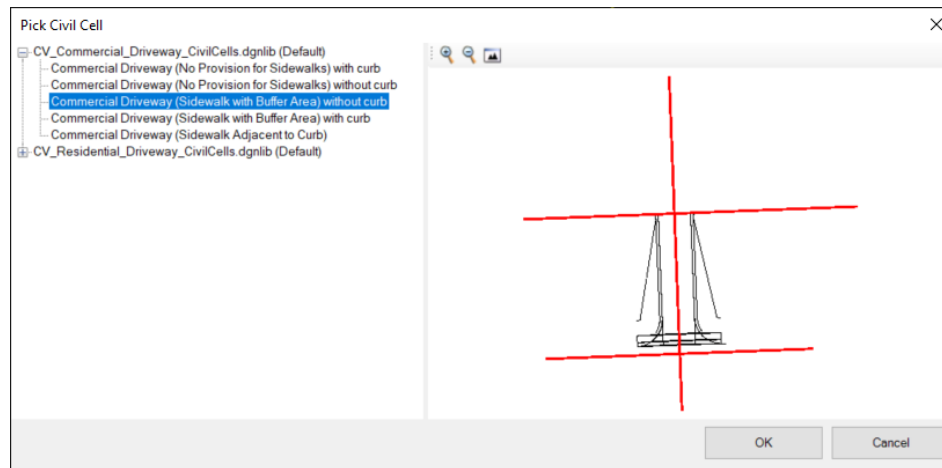

Figure 79

4. Click **OK**.

2.1.3 Place the Civil Cell

Follow the heads-up prompts:

1. **Locate Reference Element: EOR (Profiled)(1/3)**, select the **Main Road Edge of Road** element.
2. **Locate Reference Element: DRV CL (Perpendicular to Baseline) (2/3)**, select the **Driveway Centerline** element.
3. **Locate Reference Element: DRV ML (3/3)**, select the **Driveway Matchline** element.
4. **Select Elements to View Alternatives (Reset to Skip)**, there are couple of options according to the direction of the driveway cell
 - If the direction of driveway is correct, then **right-click** to reset.
 - If the direction of driveway is incorrect, see below, then **hover** over the Edge of Road, the arrow should appear over the EOR, **left-click** on the arrow. This should cause the curb return to flip to the correct side. Note the arrow's change of direction.

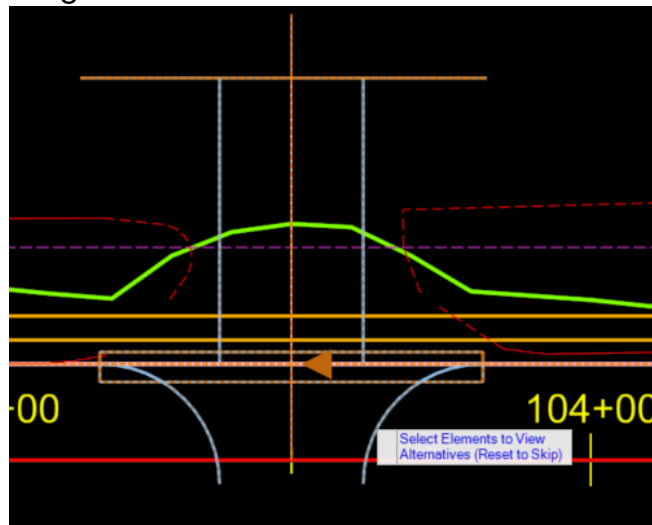

Figure 80

Hover over the EOR until the arrow appears over EOR then **left-click** on arrow.

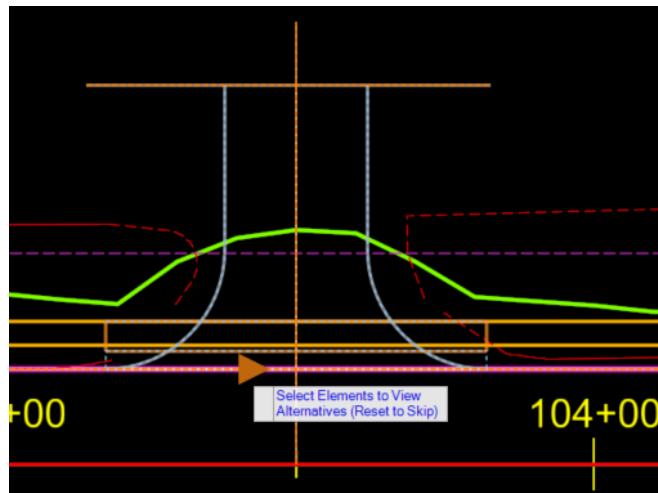

Figure 81

The curb return will flip to the correct side.

5. **Select Corridors To Be Clipped (Reset To Complete)**, **right-click** to reset.
6. **Accept Civil Cell Placement**, **left-click** to accept. The Civil Cell is placed.

2.2 Adjust the Cell Placement

Series of edits can be done to the Civil Cells which demonstrate the flexibility and the ability to edit their component.

If the capabilities of Civil Cells seem confining, user can use the **Drop Civil Cell** tool to drop the placed Civil Cell into the components that make it up.

2.2.1 Civil Cell Clipping

Driveway Civil Cells can be used to clip the corridor where it is placed. Civil Cell clipping does not clip out 2D graphics of the corridor but only in 3D view. Template edit of the main road corridor is recommended. Dropping elements outside of the curb from the corridor template at driveway limits is recommended for this civil cell.

There is various method to edit the template. One method is shown below.

1. From the ribbon, select **Corridors** Tab.. From the **Create** Group Select **Copy Template Drop**.

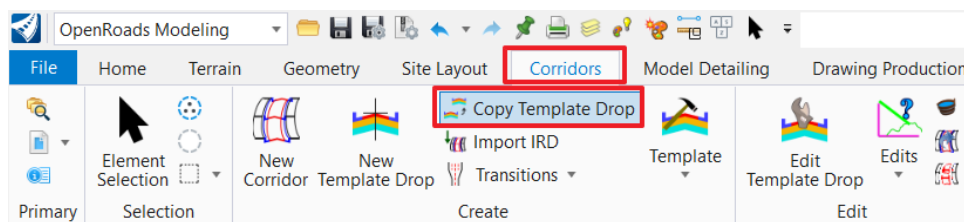

Figure 82

2. Follow the heads-up prompts.
3. At Locate Template Drop, Select the **Main road Corridor Template Drop**.

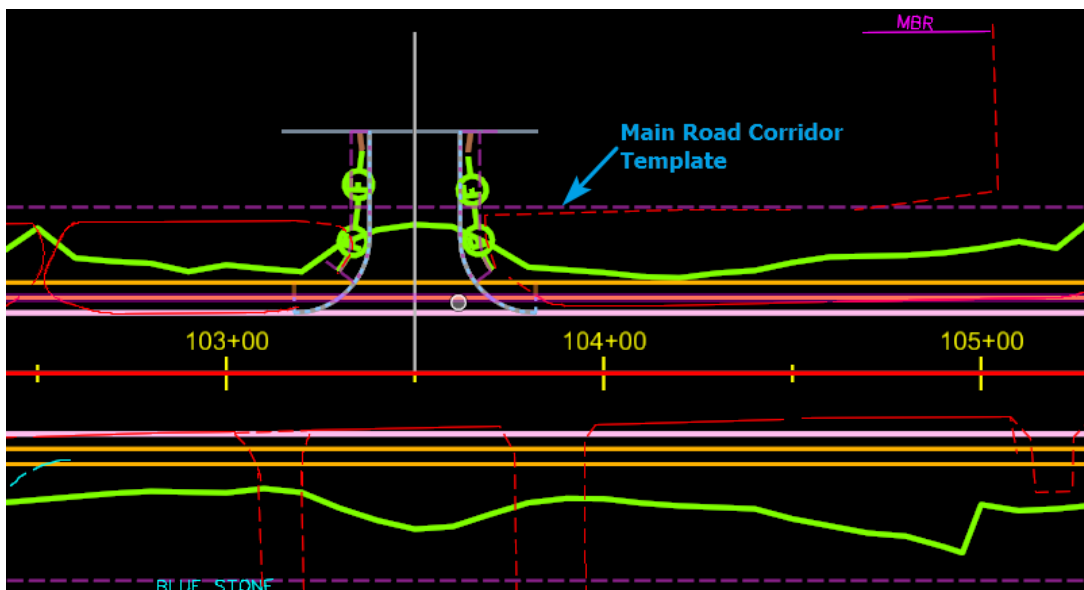

Figure 83

- For **Start Station, keypoint snap** at start of left-side radius of driveway. For **end station, keypoint snap** at end of right-side radius of driveway. This will create copy of existing template drop at the driveway portion.

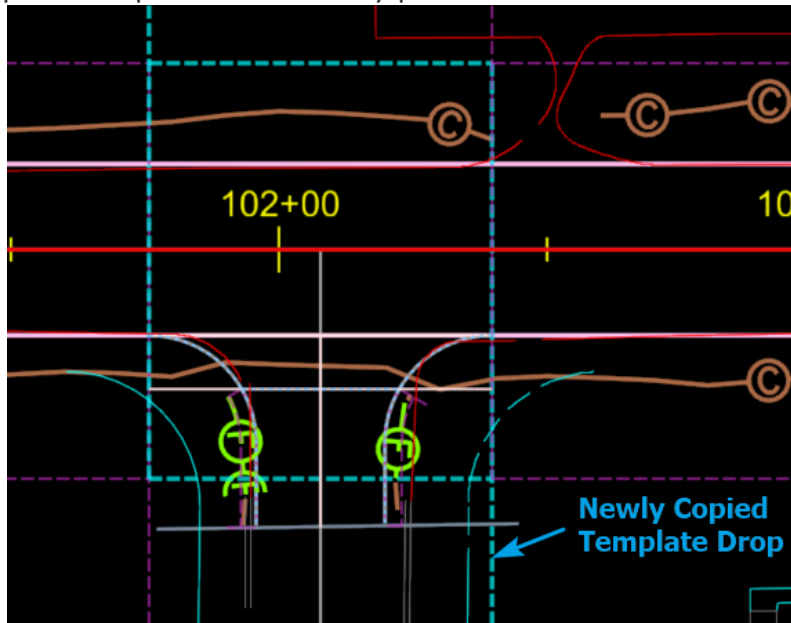

Figure 84

- This newly copied template drop needs to be edited. From the **Edit** Group Select **Edit Template Drop**.

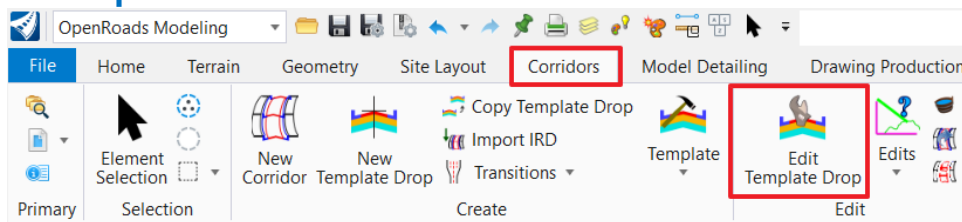

Figure 85

- For **Locate Template Drop**, Select the **Newly Copied Template Drop**
- Editing Roadway Designer Template Drop** Window appears along with the existing templated used at the template window.
- Delete the end conditions component from the template outside of the Edge of Road element. For this **right-click** in the template window and select **Delete Components** from the drop-down menu.

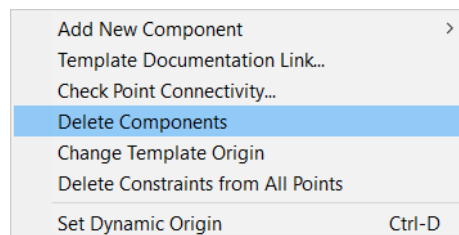

Figure 86

10. Draw a **line** across each of the elements you wish to delete.

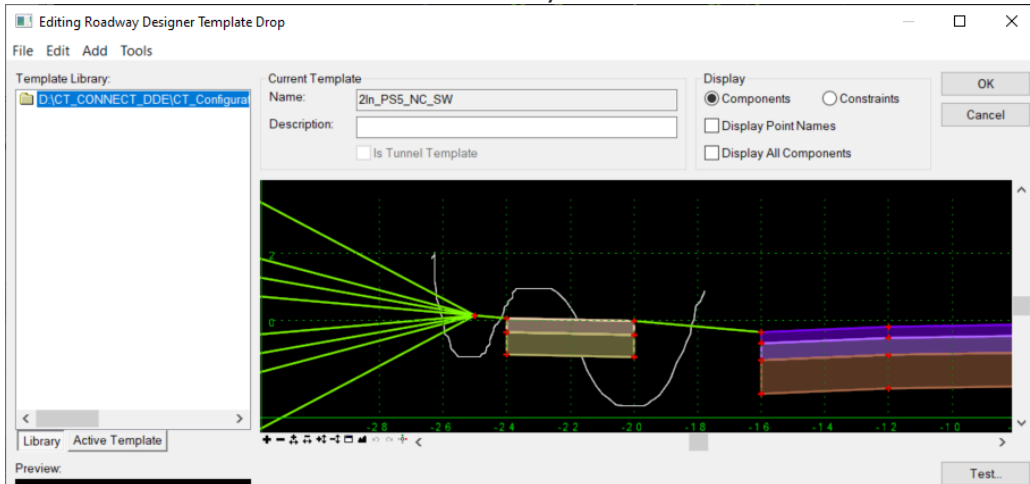

Figure 87

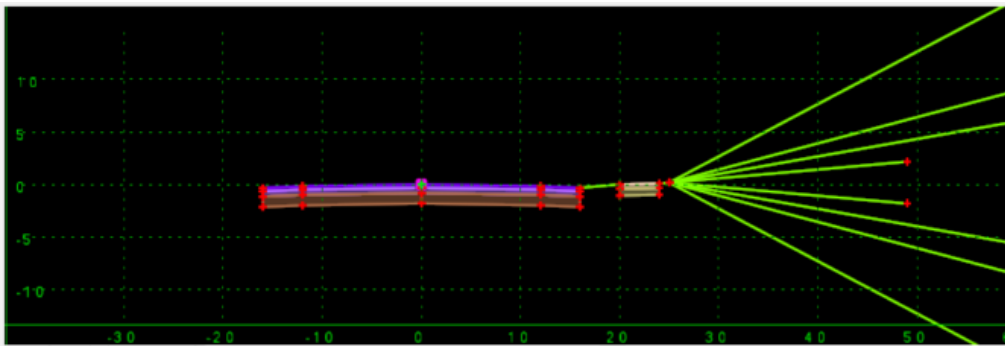

Figure 88

11. Click **OK** to close the **Editing Roadway Designer Template Drop** dialog.
12. Review the driveway location. Notice the side slopes have been removed along the left side of the main road or across the newly placed driveway civil cell. The designer needs to add and transition the side slope at the curb return.

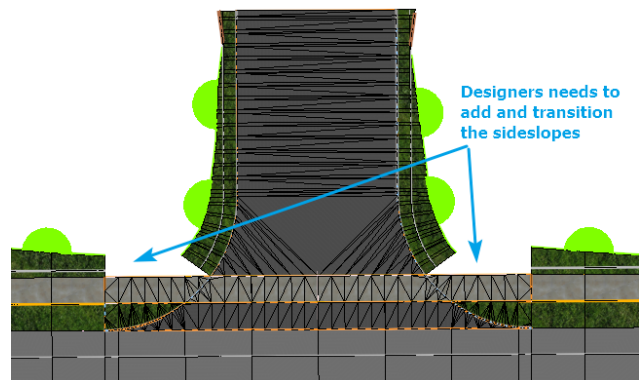
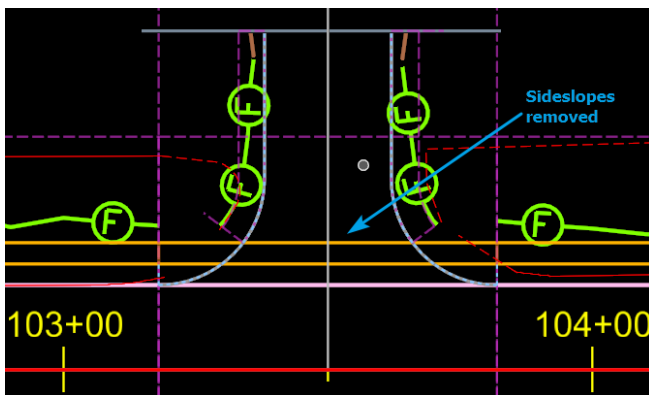

Figure 89

2.2.2 Adjustment of Reference Element

The placement of Civil Cells can be edited by editing the reference elements from which it was placed.

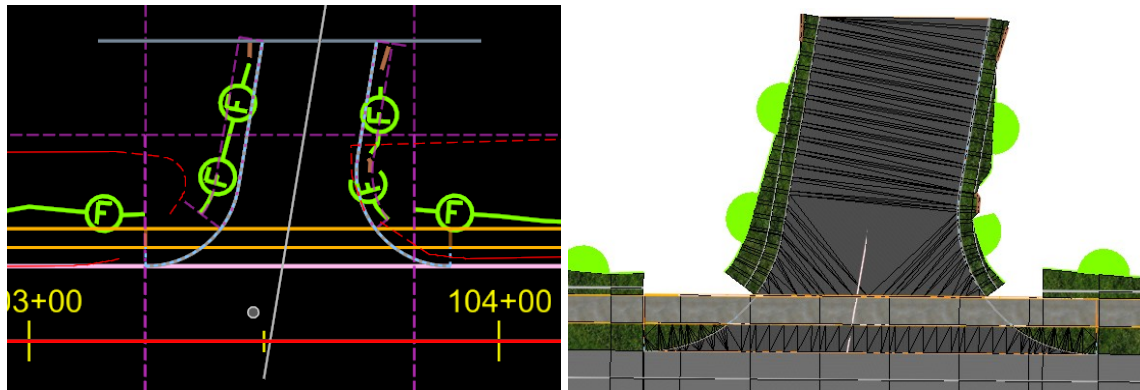

Figure 90

Users are advised to draw the **Driveway Centerline** perpendicular to Baseline of main road. But Driveway Civil Cell can be placed at a situation when there is slight angle between Driveway Centerline and Main Road Baseline.

1. Using the **Element Selection tool**, select the **Driveway Centerline**.
2. **Move** the end point of the Driveway Centerline by using the **element handlers**, (the circles and arrows on the selected element).
3. **Click** on the circle at the end point of the Driveway Centerline element and modify the angle of the intersection.
4. The civil cell will update.

2.2.3 Edit the Horizontal Geometry

1. **Turn off** the display of the Referenced 3D model, if it is not already turned off.

One “challenge” in editing Civil Cells is that sometimes it is hard to select what user want to select, especially with full 3D Civil Cells. User may have multiple overlapping 2D features overlapped with multiple overlapping 3D Features in the reference 3D Model. User may have to **right-click** a couple times to select the intended element.

2. Depending on user needs, user can **turn off** the **Level** of the 3D Model Reference or **turn off** its Display entirely. User can also **turn off** levels with graphics user find “unnecessary” right now. Construction Class element display can be **turned on** and off via **View Attributes**.

Change the Width of Driveway Shelf or Ramped Section and Sidewalk width of Civil Cell.

- a. Make sure **Constructions** option is turned on in **View Attributes** window.

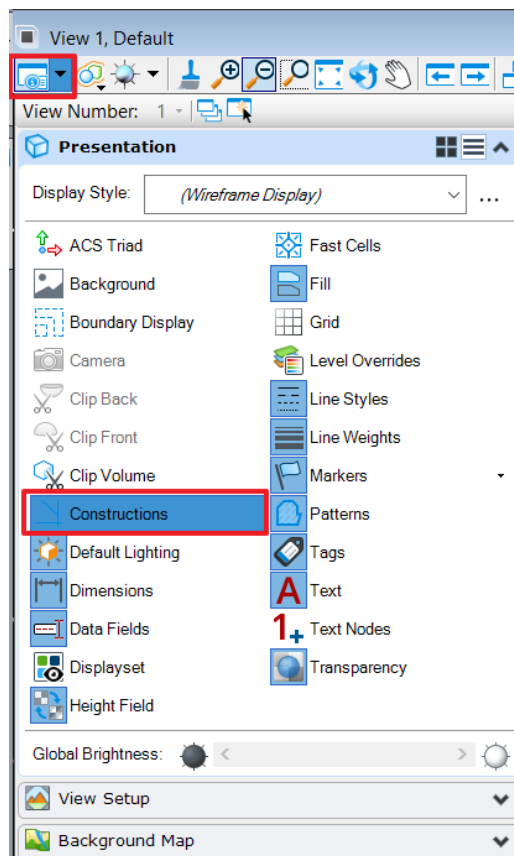

Figure 91

- b. From the ribbon, select **Home** Tab.
- c. From the **Primary** Group, Select **Level Display**.
- d. **Turn on** the display for Level **CIVILCELL_Const** if it’s not on already.

Volume 3.3 - OpenRoads Designer Civil Cells

3. Use the **Element Selection tool** and Click on the **Sidewalk Front Line** whose feature name is **2-CC_Const_SW Ft.**
 - a. Once the line is selected, click on the **midpoint Offset text manipulator**.
 - b. Type desired value say **-4'** and hit **Return** to coincide with the existing Sidewalk front. The driveway shelf section is widened, and all dependent geometry and modeling is updated.

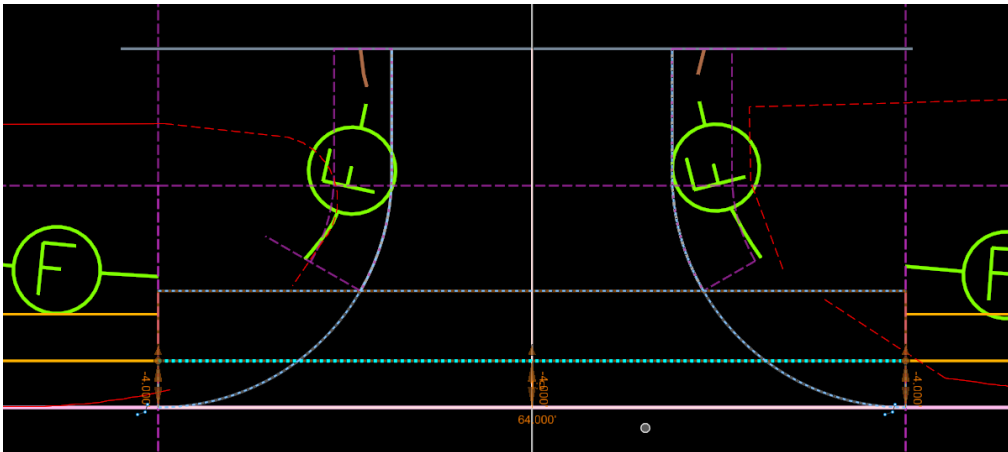
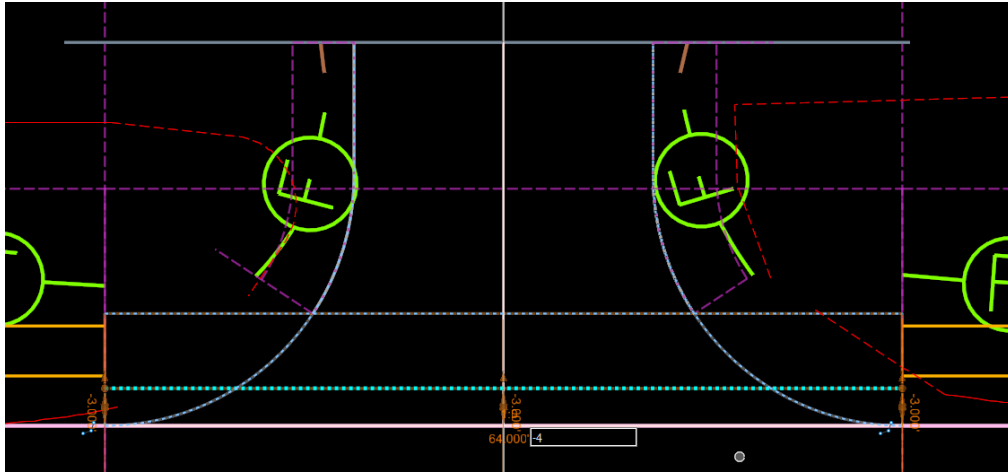

Figure 92

- c. Use the **Element Selection tool** and Click on the **Sidewalk Back Line** whose feature name is **2-CC_Const_SW Bk.**
- d. Once the line is selected, click on the **midpoint Offset text manipulator**.

Volume 3.3 - OpenRoads Designer Civil Cells

- e. Type desired value say **-4'** and hit **Return** to coincide with the existing Sidewalk back. The sidewalk is widened, and all dependent geometry and modeling is updated.



Figure 93

4. Widen the Lane of Driveway Civil Cell.

- a. Use the **Element Selection tool** and **Click** on the **right Edge of Driveway** of the Civil Cell.

Tip: It may be easier to select it by **hovering** over its “gap”. Element at gap is not visible until user **hover** over it.

The Edges of Pavement are full-length offsets from the centerline. The curb returns create “gaps” where the edges are trimmed back, but trimmed features are still able to be selected in its “gaps”.

- b. Once the edge is selected, click on the **midpoint Offset text manipulator**.



Figure 94

- c. Type desired value say **14'** and hit **Return**. The pavement is widened, and all dependent geometry and modeling is updated.
- d. **Sidewalk Matchline** also moves as driveway width is changed. Designer needs to adjust the limits of Template drop.

To widen the Left Lane of Driveway Civil Cell, the steps to follow are same as widening right Lane.

5. Change the Curb Return Radius of Civil Cell.
 - a. Click on the **right Edge of Driveway curb return**. This might require multiple **right-clicks** until the Radius value is visible.
 - b. Click on the **Radius text manipulator**.
 - c. Type desired value say **25'** and hit **Return**. The Curb Return Radius and all dependent geometry and modeling is updated.
 - d. **Sidewalk Matchline** also moves as radius is changed. Designer needs to adjust the limits of Template drop.

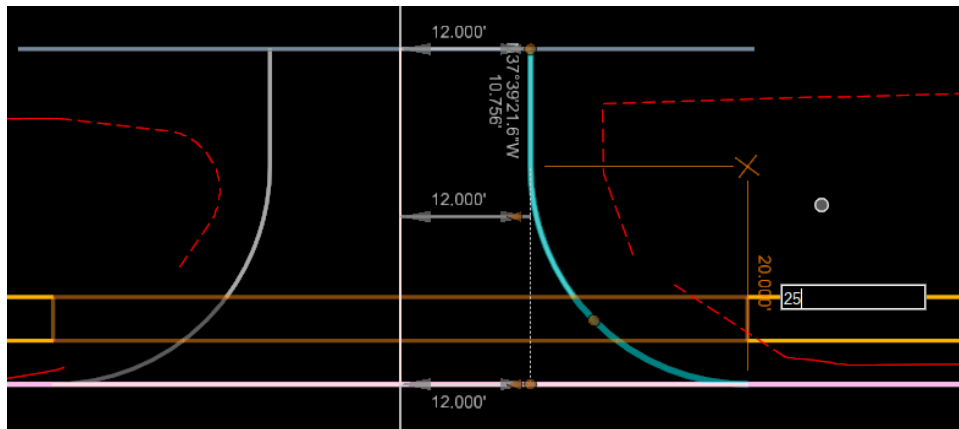

Figure 95

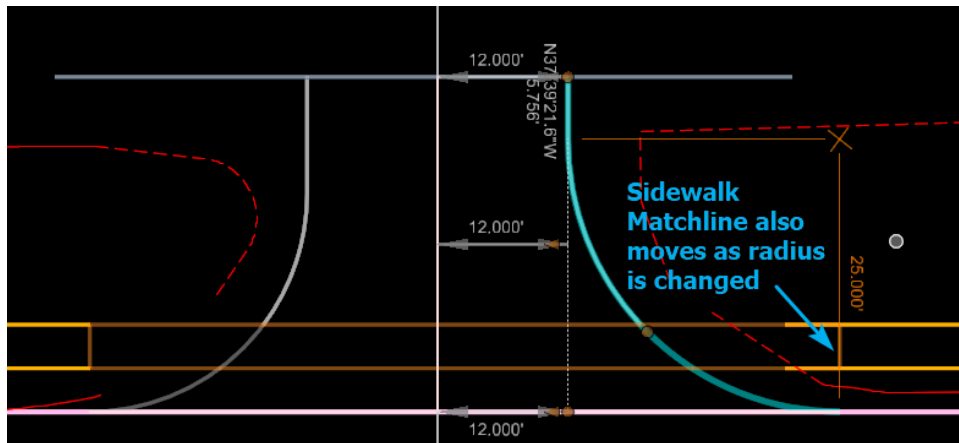

Figure 96

2.2.4 Edit Vertical Geometry of Sidewalk in Civil Cell

1. Elements to be familiar with, in order to edit the vertical geometry of Sidewalk in this Civil Cell.

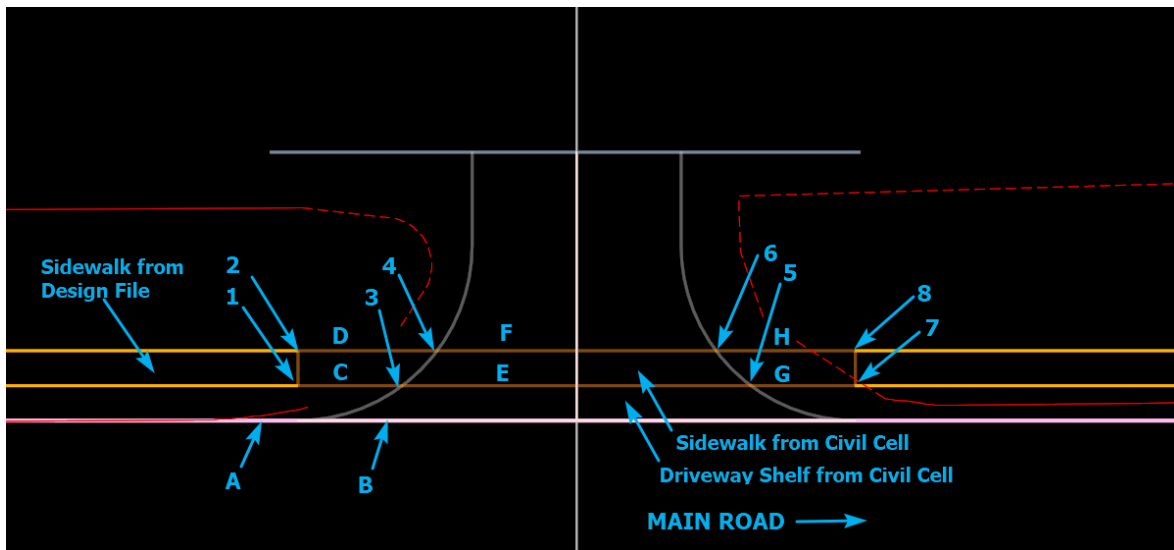

Figure 97

- A = Edge of Road Element (From Design File)
- B = Driveway Lip Element (1½" above (A))
- C = Front of Sidewalk Element outside of Left Side of Driveway Edge (Default is 4" above (A))
- D = Back of Sidewalk Element outside of Left Side of Driveway Edge (Default is 4.9" above (A))
- E = Front of Sidewalk Element inside of Driveway Edges (Default is 4" above (A))
- F = Back of Sidewalk Element inside of Driveway Edge (Default is at +1.5% slope from (E))
- G = Front of Sidewalk Element outside of Right Side of Driveway Edge (Default is 4" above (A))
- H = Back of Sidewalk Element outside of Right Side of Driveway Edge (Default is 4.9" above (A))
- 1 = Start point of Vertical Offset of elements C
- 2 = Start point of Vertical Offset of elements D
- 3 = End point of Vertical Offset of elements C
- 4 = End point of Vertical Offset of elements D
- 5 = Start point of Vertical Offset of elements G
- 6 = Start point of Vertical Offset of elements H
- 7 = End point of Vertical Offset of elements G
- 8 = End point of Vertical Offset of elements H

Points 1, 2, 7 and 8 are Vertical Offsets referenced from Edge of Road (A). Its value can be changed as needed to match Existing or Designed Sidewalk elevation

Points 3, 4, 5 and 6 are Vertical Offsets referenced from Edge of Road (A). Its value can be changed as needed. But its value should match elevation of elements (E) & (F)

The Driveway Civil cell is provided with 1½" lip at the Edge of Road as per CTDOT standards. The Sidewalk front is placed 4" vertical offset from the edge of roadway, Sidewalk back inside the Driveway edge is +1.5% from Sidewalk front as per CTDOT Standards Drawing and Sidewalk back

Volume 3.3 - OpenRoads Designer Civil Cells

outside of Driveway edges are 4.9" vertical offset from edge of roadway, Driveway match line takes the elevation from the existing terrain. The elevation values can be changed for the sidewalk front and back.

As an example, Looking at the 3D view Civil Cell Match line does not exactly coincides with the existing sidewalk. **Point 1** is 0.147' below the existing Front of sidewalk and **Point 2** is 0.152' below the Existing Back of Sidewalk. Let's edit the elevation or offset values of **points 1 and 2**, in order to coincide the existing sidewalk.

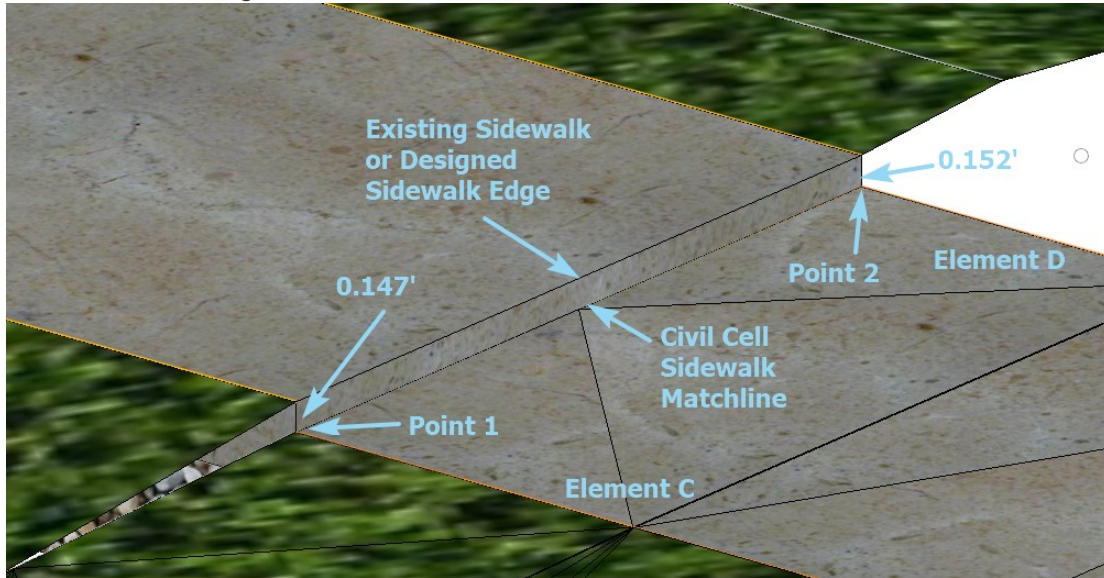

Figure 98

2. **Constructions** option can be turned off in **View Attributes** window so that it is easy to select and edit the sidewalk elements.
3. Select **element (C)**, Front of Sidewalk Element outside of Left Side of Driveway Edge (**2-SW Ft L**).

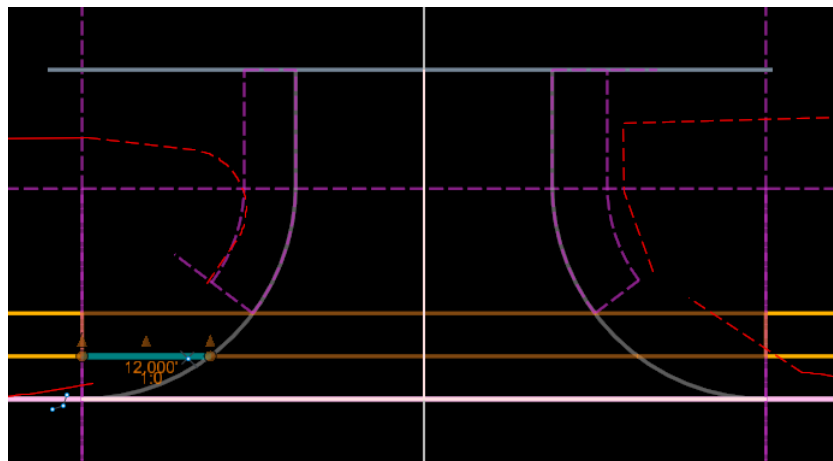

Figure 99

4. Open the **Properties** dialog and expand the **Profile By Projecting LinEnt3d Slope Rule** group.

- The current value of Start Vertical Offset is 0.333'. This is **Point (1)** and it is 0.333' vertical offset from **Edge of Road (A)**.

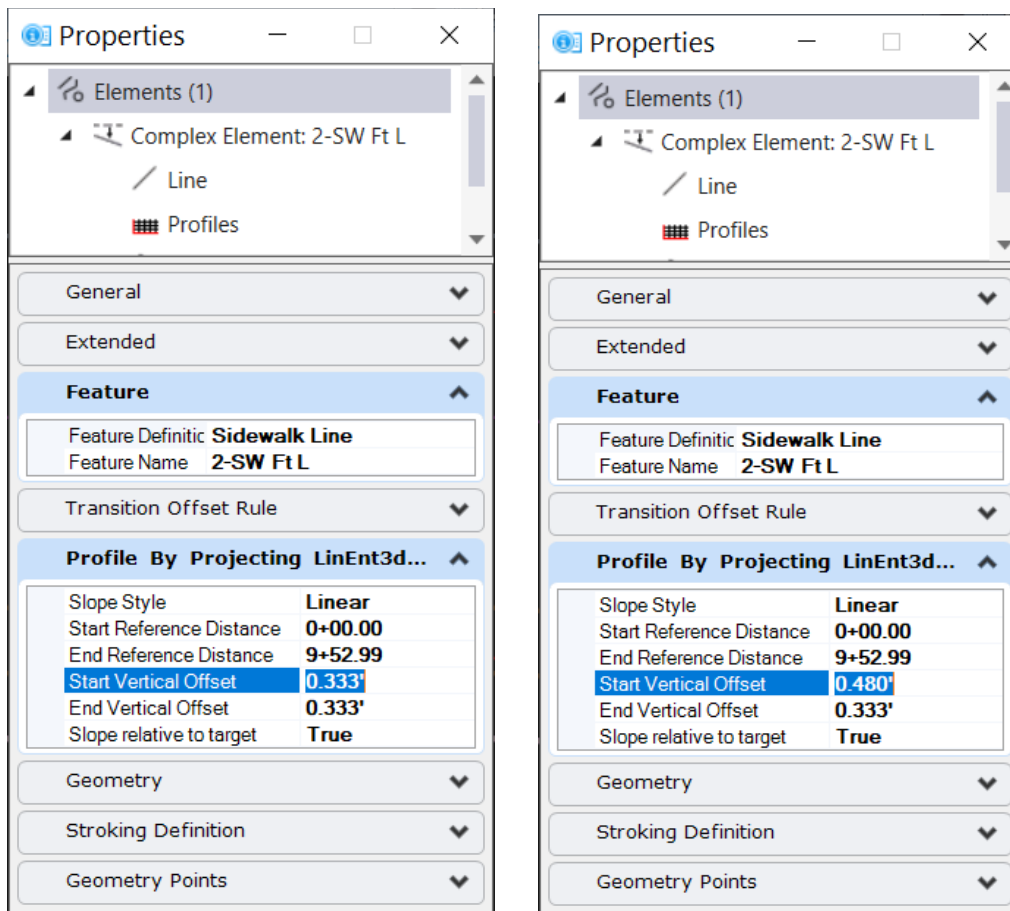

Figure 100

- There is difference of 0.147' between existing and civil cell sidewalk front end. We need to add 0.147' value to the current value of **Start Vertical Offset** of 0.333'. Change the value to **0.48'** and note the change.

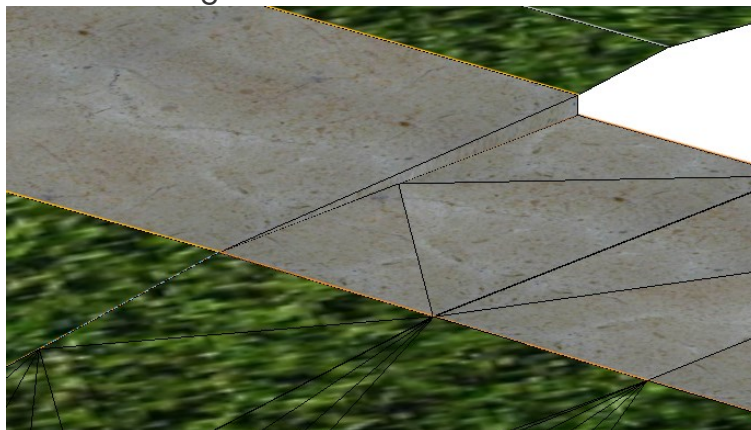

Figure 101

7. Select **element (D)**, Back of Sidewalk Element outside of Left Side of Driveway Edge (**2-SW Ft L**).

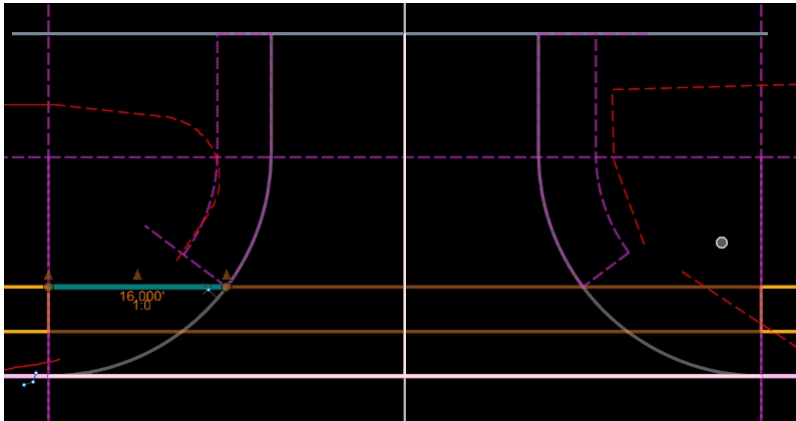

Figure 102

8. Open the **Properties** dialog and expand the **Profile By Projecting LinEnt3d Slope Rule** group.
9. The current value of Start Vertical Offset is 0.408'. This is **Point (2)** and it is 0.408' vertical offset from **Edge of Road (A)**.

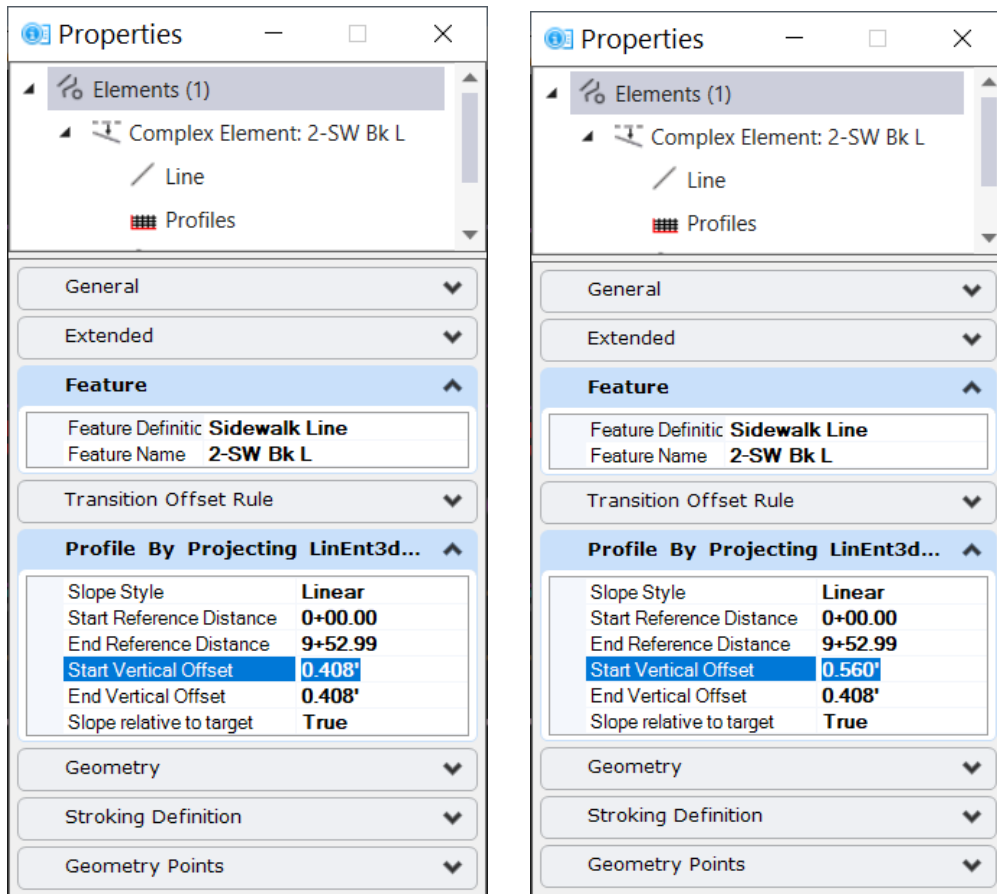

Figure 103

10. There is difference of 0.152' between existing and civil cell sidewalk back. We need to add 0.152' value to the current value of **Start Vertical Offset** of 0.408'. Change the value to **0.56'** and note the change.

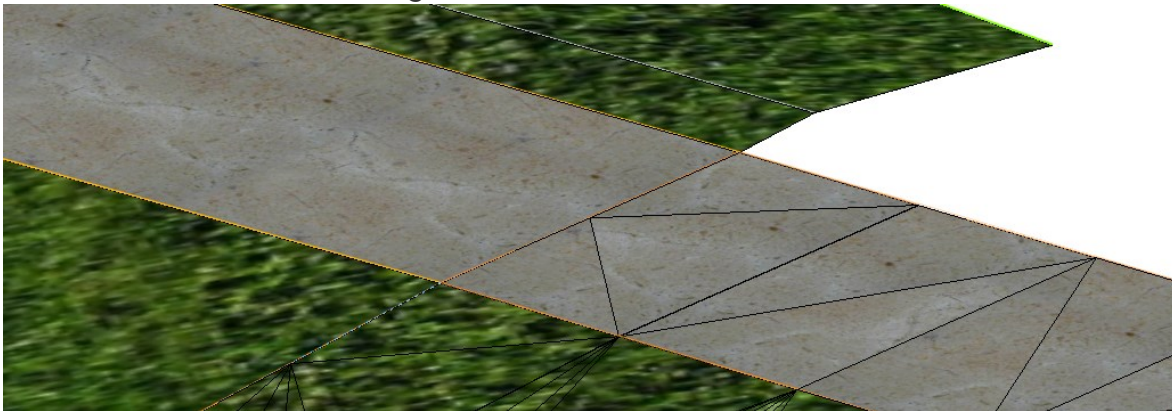

Figure 104

Similarly **Point (7) and (8)** can be edited.

NOTE: For editing **Point (7) and (8)**, **End Vertical Offset** value from the **Properties** menu should be changed.

2.2.5 Edit Vertical Geometry of Driveway Centerline in Civil Cell

1. Select the **Driveway Centerline (2-CC_Pr DRV CL)**.
2. **Hover** over the selected element over it until the **Context Tool Bar** pops up.
3. Click open **profile model**.

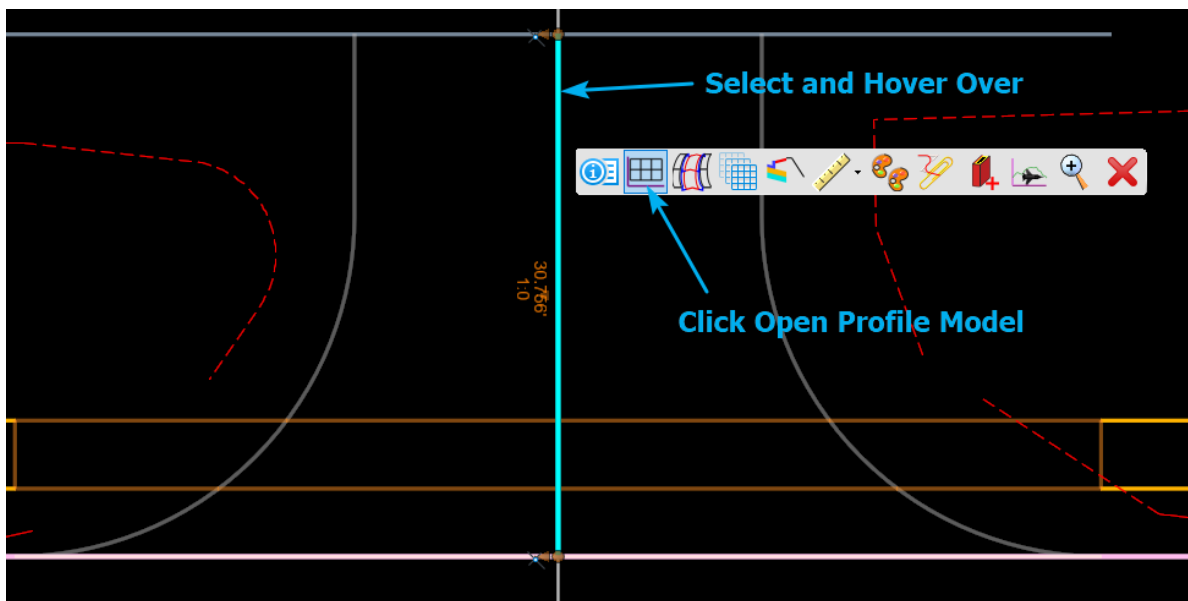

Figure 105

Volume 3.3 - OpenRoads Designer Civil Cells

- On **Select or Open View** model prompt, select one of the views and **left-click** on that view window.



Select one of the view

Figure 106

- The profile view of the Driveway Centerline will show up.

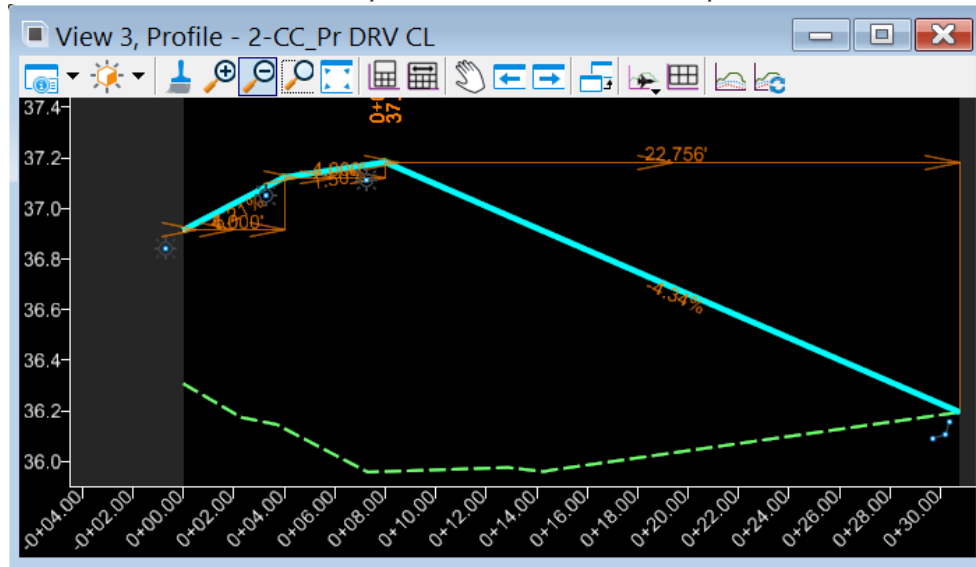

Figure 107

- Similarly, both Edges of driveway's profile can be viewed.
- The profile of Driveway CL and Edge of driveway is generated from Edge of road elevation, Sidewalk front- and back-line elevation and the existing ground elevation at match line.
- If the designer wants to change the elevation, select *the Sidewalk front line or sidewalk back line element*. (Select **element (E) or (F)**)
- Open the **Properties** dialog and expand **Profile By Projecting LinEnt3d Slope Rule** group, Change **Vertical Offset** to desired elevation.

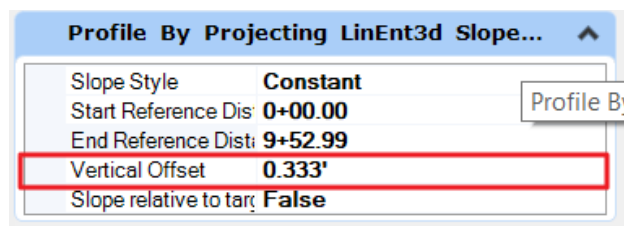

Figure 108

The profile will update automatically.

2.3 Swap Out

2.3.1 Swap out or Edit the Liner Template

The side slope at the Edges of Driveway has 2' of snow shelf. The designer can edit the 2' snow shelf from **edit template drop** or simply switch to a different template.

Turn on all the levels associated to Driveway Civil cells from the **level display** window. Make sure **Constructions** option is turned on in **View Attributes** window.

1. Swap out Linear Template
 - a. Click on a **Linear Template** in View 1, the 2D View. The Linear Template is a 2D shape shown as a dashed line.

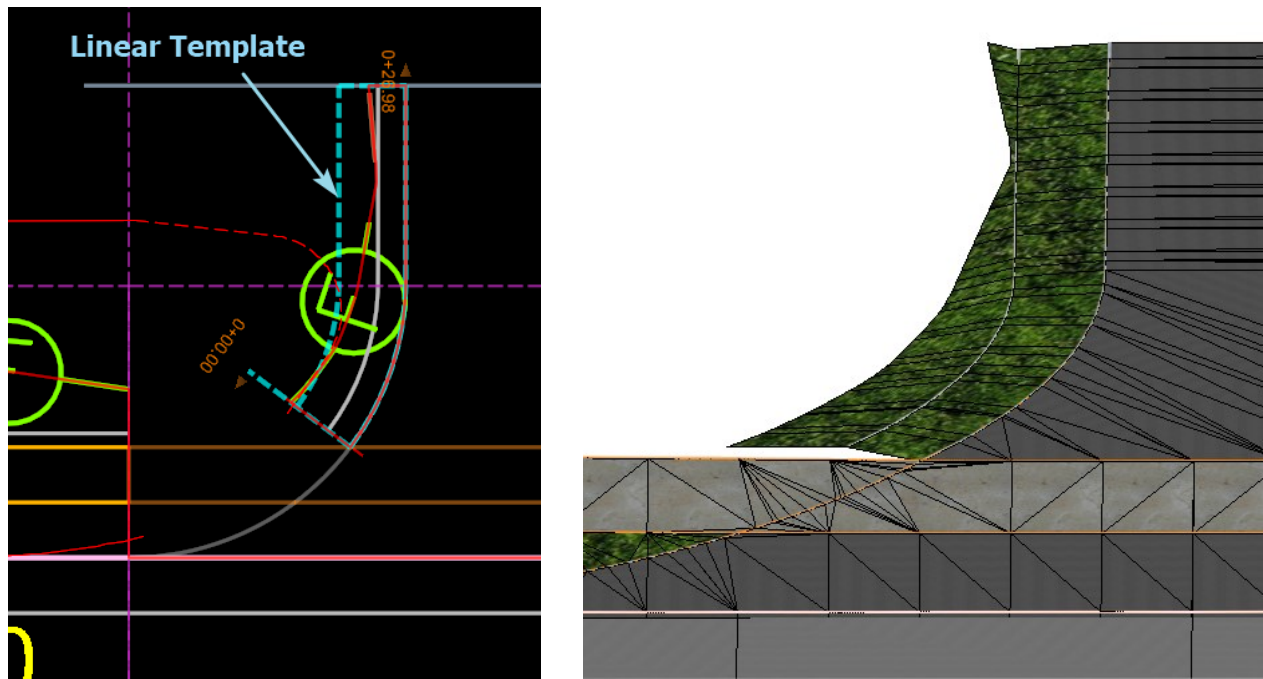

Figure 109

- b. Open the **Properties** dialog, and expand the **Template Drop** group. The current template is **Project Library>Driveway_No Curb**

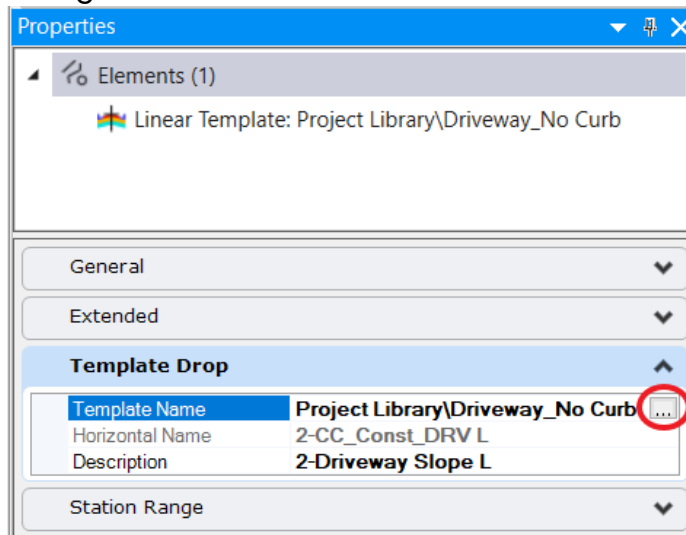

Figure 110

- c. Click the **Browse** button in the right side of the **Template Name** label. This opens the **Pick Template** dialog.
- d. Select the desired template prepared for the project and review. For this example, choose **HWY End Conditions > Bit_Com_Driveway_BCPC**. This template has curb.

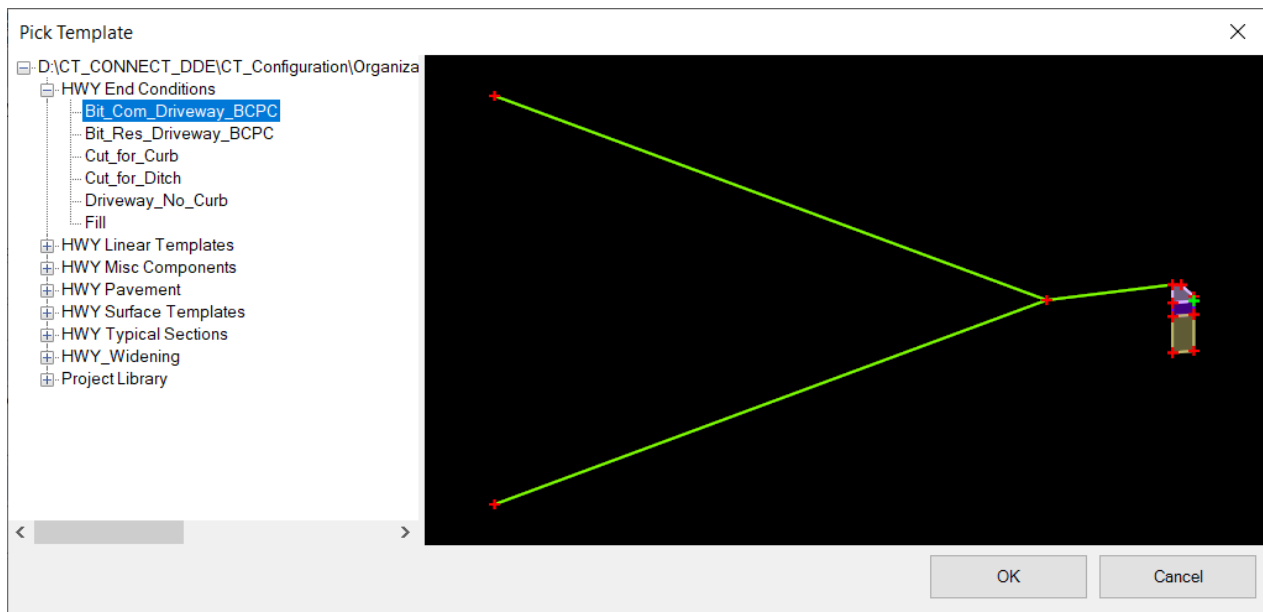

Figure 111

- e. Click **OK**.

- f. The linear template processes with the new Template. Notice the change, there is curb at edge of driveway.

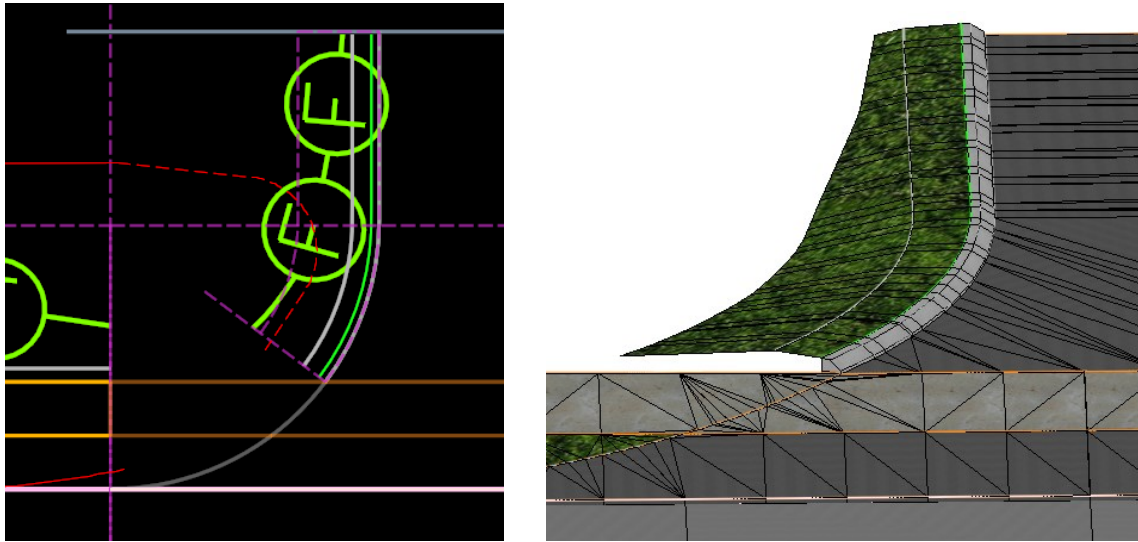

Figure 112

2. Edit Linear Template

- a. From the **Corridors** tab, then from **Edit** Group Select **Edit Template Drop**.

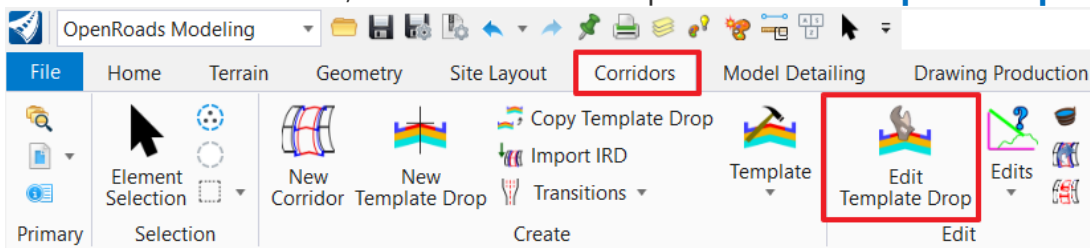

Figure 113

- b. In the **Locate Template Drop** prompt, Select the **Linear Template** at Edge of Driveway.

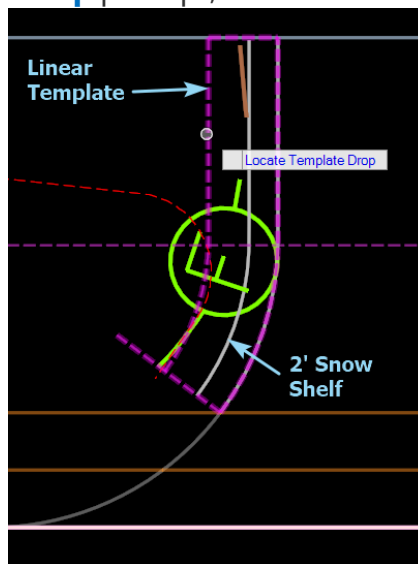

Figure 114

Volume 3.3 – OpenRoads Designer Civil Cells

- c. **Editing Roadway Designer Template Drop** Window appears along with the existing templated used at the template window i.e. Project Library>Driveway_No Curb

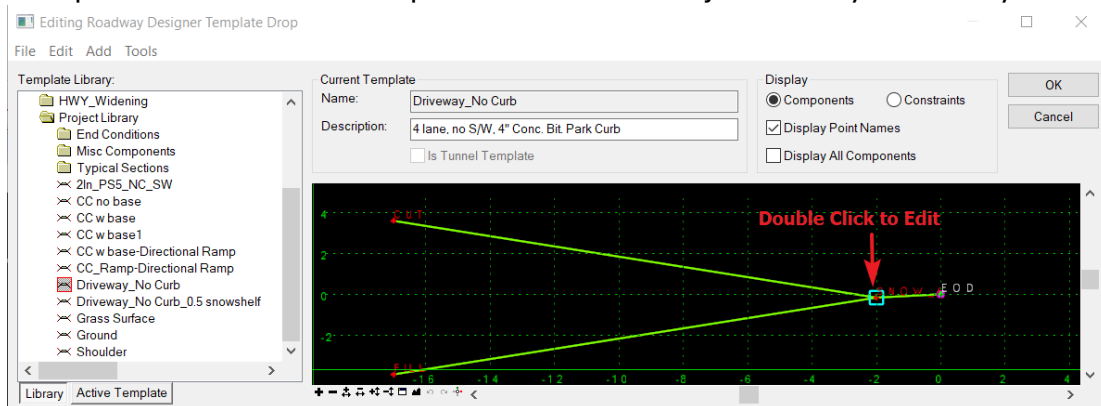

Figure 115

- d. Template can be edited in various ways and reviewed. For this example, Snow shelf will be changed from 2' to 0.5'.
- e. Double click **SNOW_f** point.
- f. In the **Point Properties** dialog, change Horizontal Value from -2 to -0.5 under **Constraint 2** and click **Apply**, then click **Close**.

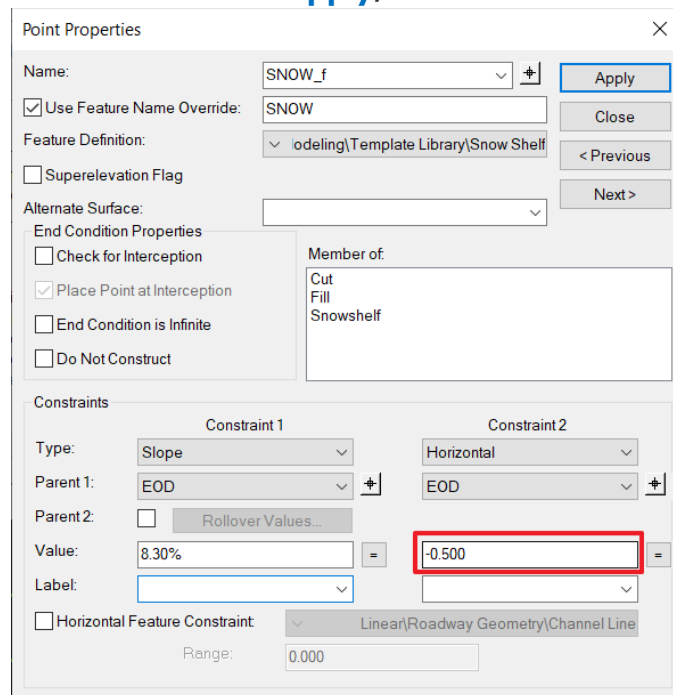

Figure 116

- g. Click **OK** to close the **Editing Roadway Designer Template Drop** dialog.

Volume 3.3 - OpenRoads Designer Civil Cells

- h. The linear template processes with the new Template. Notice the change in width of snow shelf.

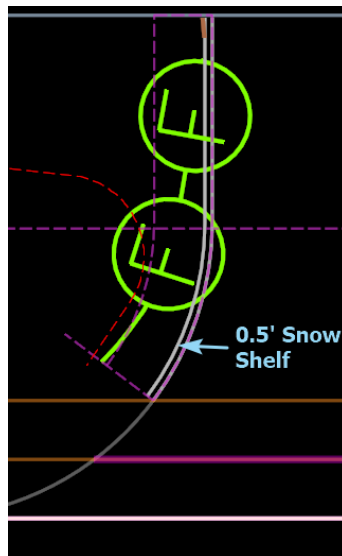

Figure 117

2.3.2 Swap out or Edit the Surface Template

Driveway Civil Cell can have various surface templates. The Surface Templates can be swapped or edited as per the project requirement.

1. Configure your screen views so that the Default view of civil cell is visible in **View 1**, and the 3D pavement section is visible in **View 2**.
 - a. In an open view, **right-click** and **hold**, and then select **View Control > 2 Views Plan/3D**.

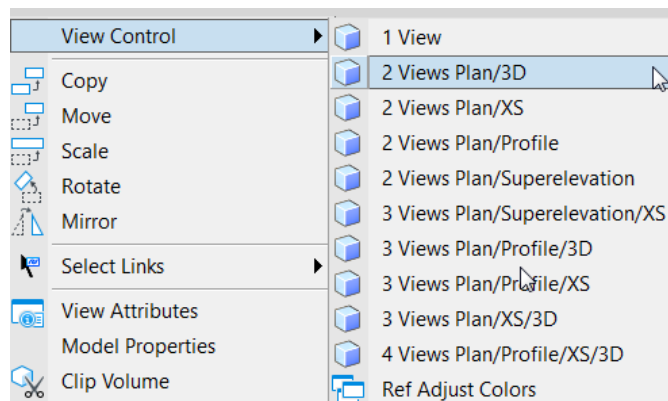

Figure 118

- b. In **View 1**, window area so that Driveway Civil Cell is visible.
- c. In **View 2**, use the View Rotation tool to rotate the view to the end of the pavement section.

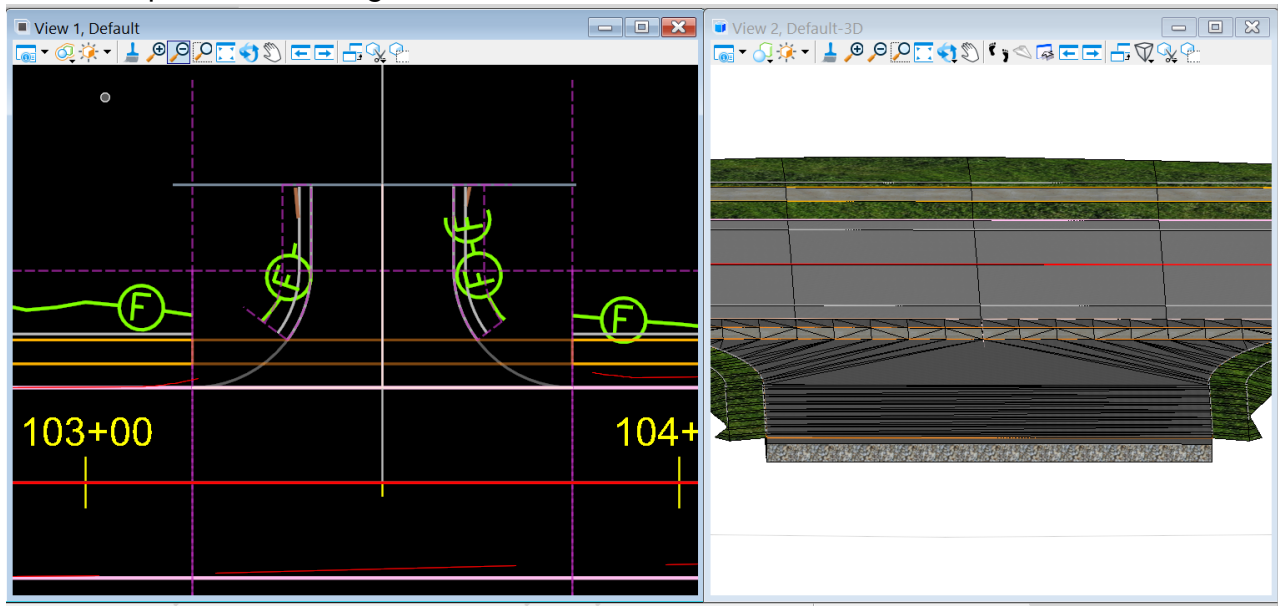

Figure 119

- d. Click on a **Driveway Main Surface Template (2-P_DRV Main Surface Template)** in the 3D View.

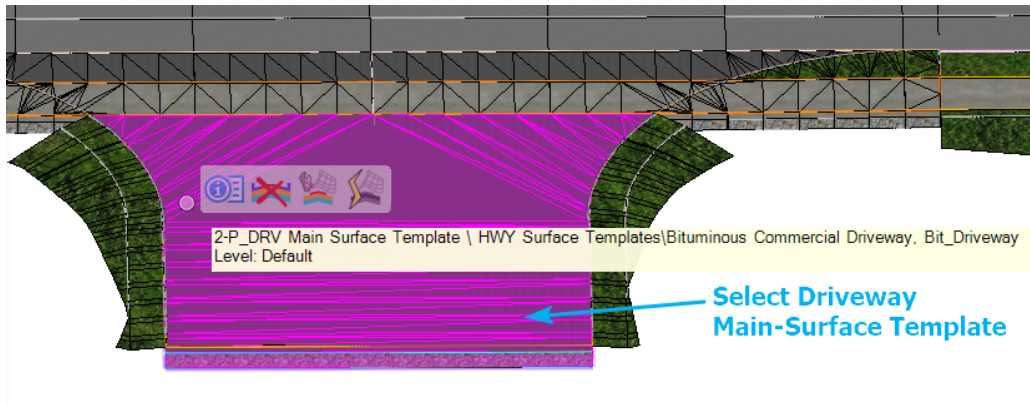

Figure 120

- e. Open the **Properties** dialog and expand the **Mesh Template** group.
- f. The current template is **HWY Surface Templates > Bituminous Commercial Driveway**

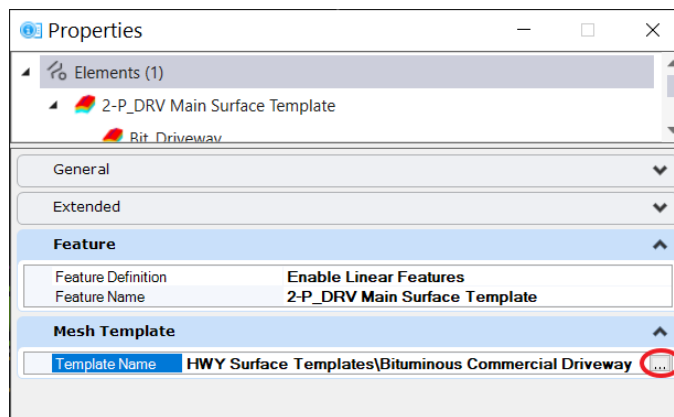

Figure 121

Volume 3.3 – OpenRoads Designer Civil Cells

- g. Click the **Browse** button in the right side of the **Template Name** label. This opens the **Pick Template** dialog.

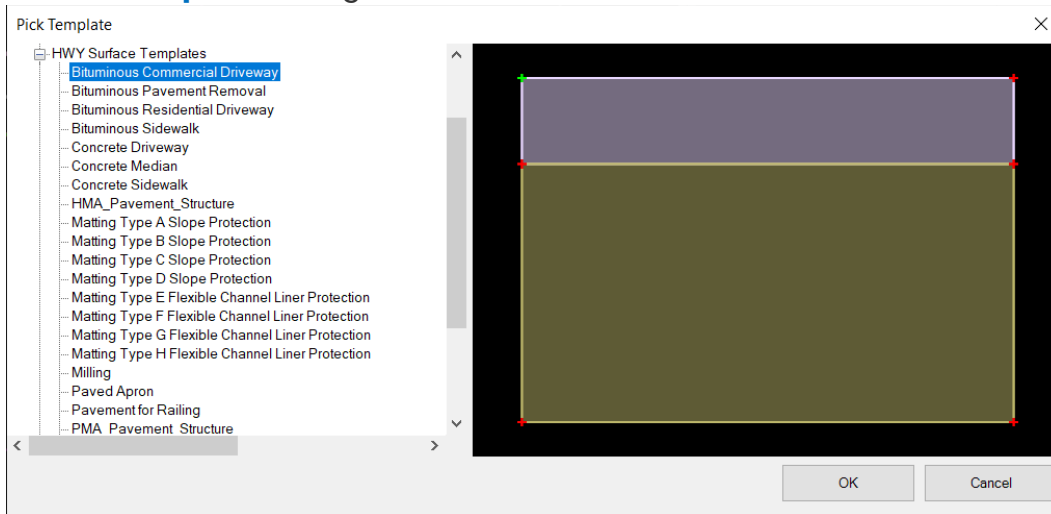

Figure 122

- h. Select the desired template prepared for the project and review. For this example, choose **HWY Surface Templates > HMA_Pavement_Structure**

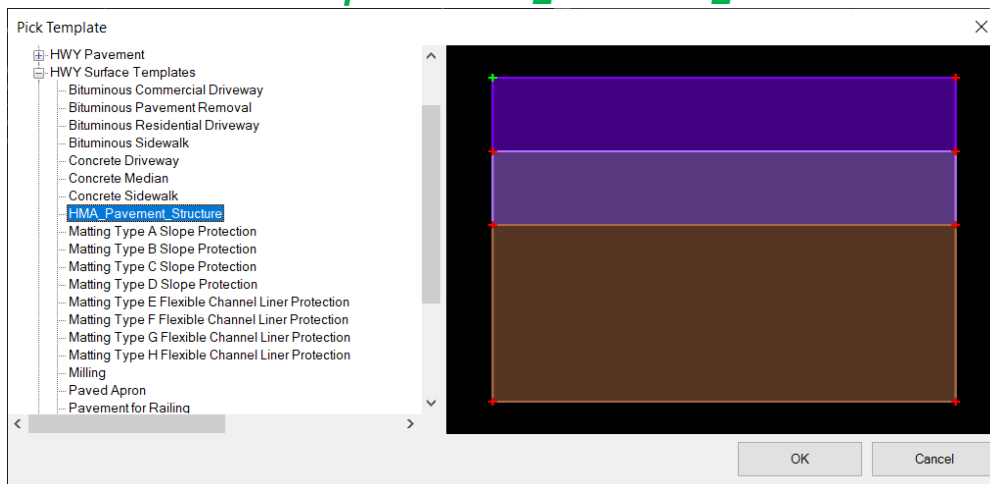

Figure 123

- i. Click **OK**.
- j. The surface template processes with the new Template. Notice the change in 3D view. The surface updated from 2 layer to 3 layers of pavement.

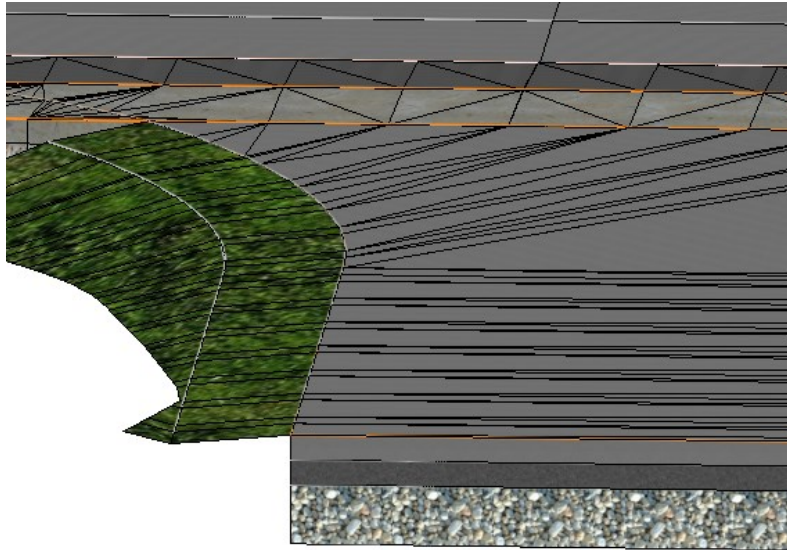
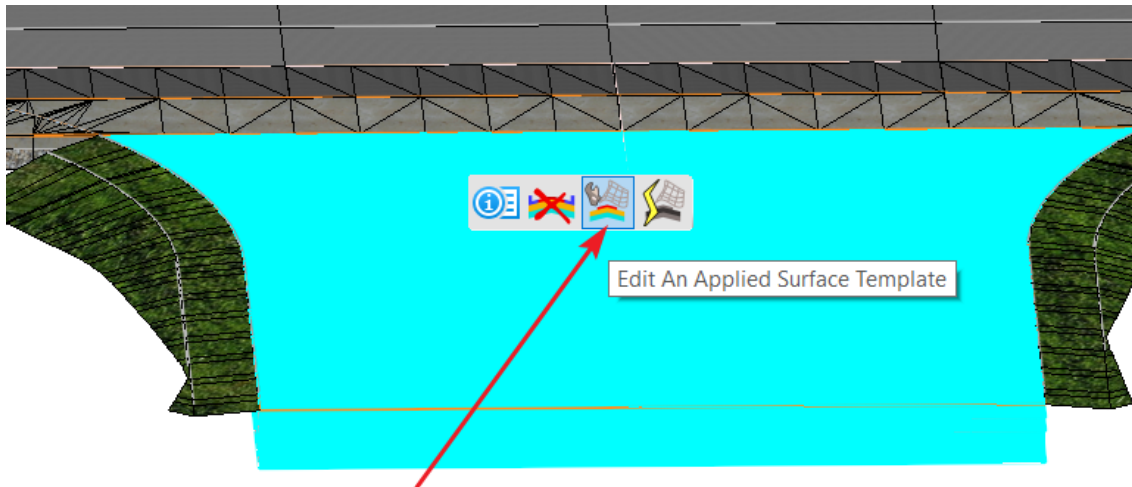

Figure 124

2. User can edit the pavement thickness
 - a. Click and **hover** over the **Driveway Main Surface Template (2-P_DRV Main Surface Template)** in the 3D View.
 - b. From the **Context Tool Bar**, select **Edit An Applied Surface Template**.



Select "Edit An Applied Surface Template"

Figure 125

- c. In the **Editing Roadway Designer Template Drop** dialog, the pavement thickness can be edited.
- d. For this example, **EOR_sg_lt** and **EOR_sg_rt** points depth will be changed from **1'** to **1.33'**.

Volume 3.3 – OpenRoads Designer Civil Cells

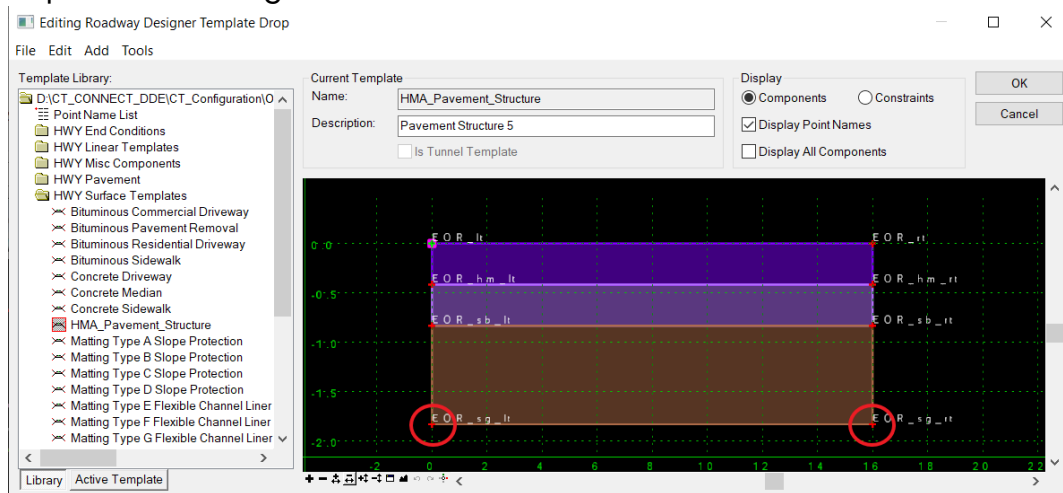

Figure 126

- e. Double click **EOR_sg_lt** point.
- f. In the **Point Properties** dialog, change Vertical Value from **-1 to -1.333** under **Constraint 2** and click **Apply** then click **Close**.

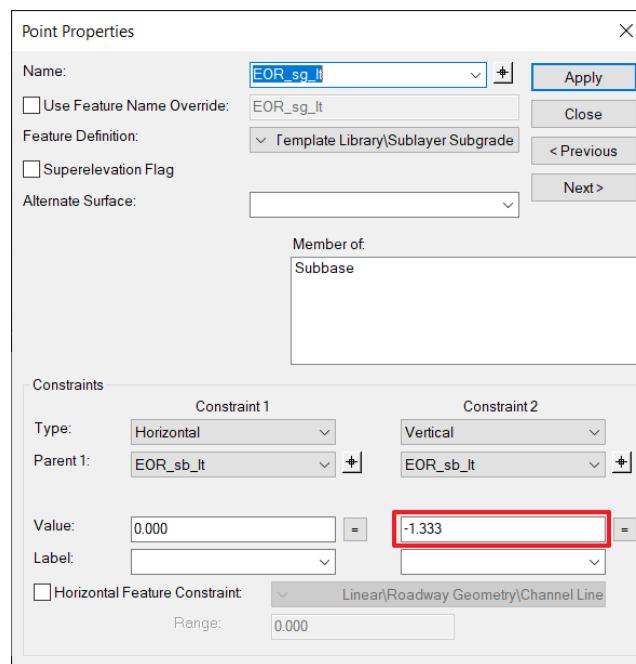

Figure 127

- g. Double click **EOR_sg_rt** point.
- h. In the **Point Properties** dialog, change Vertical Value from **-1 to -1.333** under **Constraint 2** and click **Apply** then Click **Close**.
- i. Click **OK** to close the **Editing Roadway Designer Template Drop** dialog.
- j. The Depth of the bottom layer of the surface template is updated to the new value. You can see the change in the 3D view.

2.4 Curb Editing

For use with Civil Cells:

- Commercial Driveway (Sidewalk with Buffer Area) with curb
- Residential Driveway (Sidewalk with Buffer Area) with curb

This civil cell is same as Driveway (Sidewalk with Buffer Area) without curb. Only addition is there is a concrete curb provided at both sides of curb return.

Follow Section 3.3 above for Civil Cell Placement and Edits.

For this example, Residential Driveway (Sidewalk with Buffer Area) with curb is placed. For this Civil Cell Only edits for the curb is shown.

1. Concrete curb is provided at both sides of curb return. The curb starts from Edge of road and ends just before the sidewalk
2. Height of concrete curb is transitioned from existing curb height to zero from Edge of road to curb end respectively as shown below.

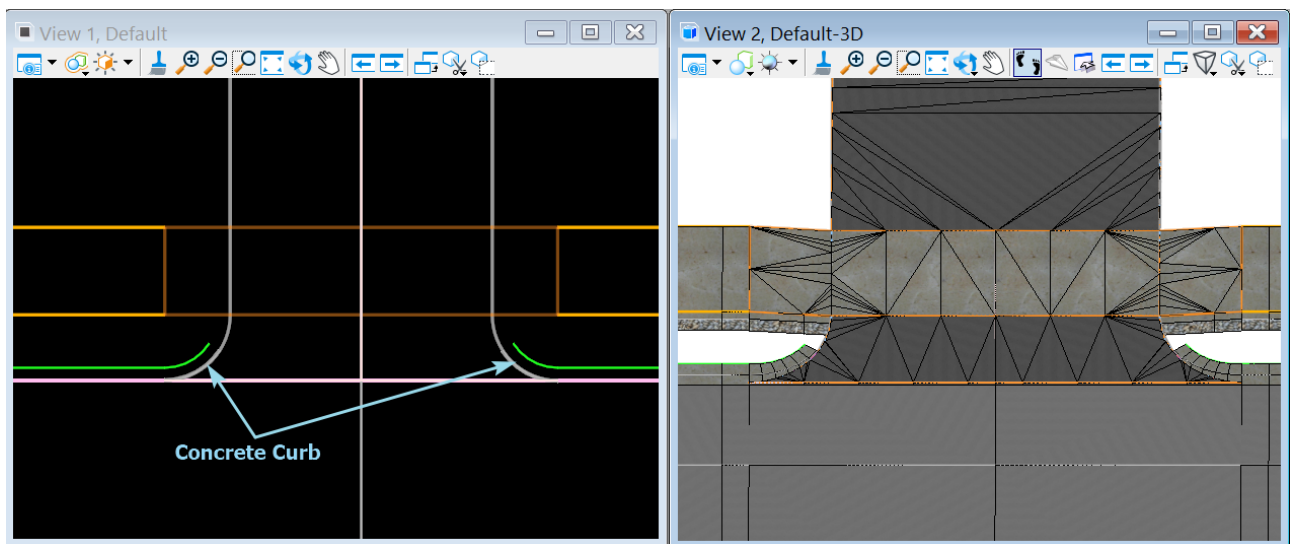

Figure 128

3. Length of curb and transition height of curb can be edited as required. This can be done via point controls.
4. Based on the requirements of the design, civil cell may need to be dropped.
5. The curb edits in this civil cell is similar to Exercise 1. Only difference is, there is as extra element **4-Curb Line L and 4-Curb Line R** is added at curb return into the cell. We can select those line and slide up and down to change the length of the curb. The Linear Template of Concrete curb and point control associated with it will update automatically.

6. Select **4-Curb Line L**. User may have to **right-click** a couple times to select the intended element as there are multiple overlapping elements. Change the **End station** to **0+04.00** or as desired. The Length and height transition of the curb will update.

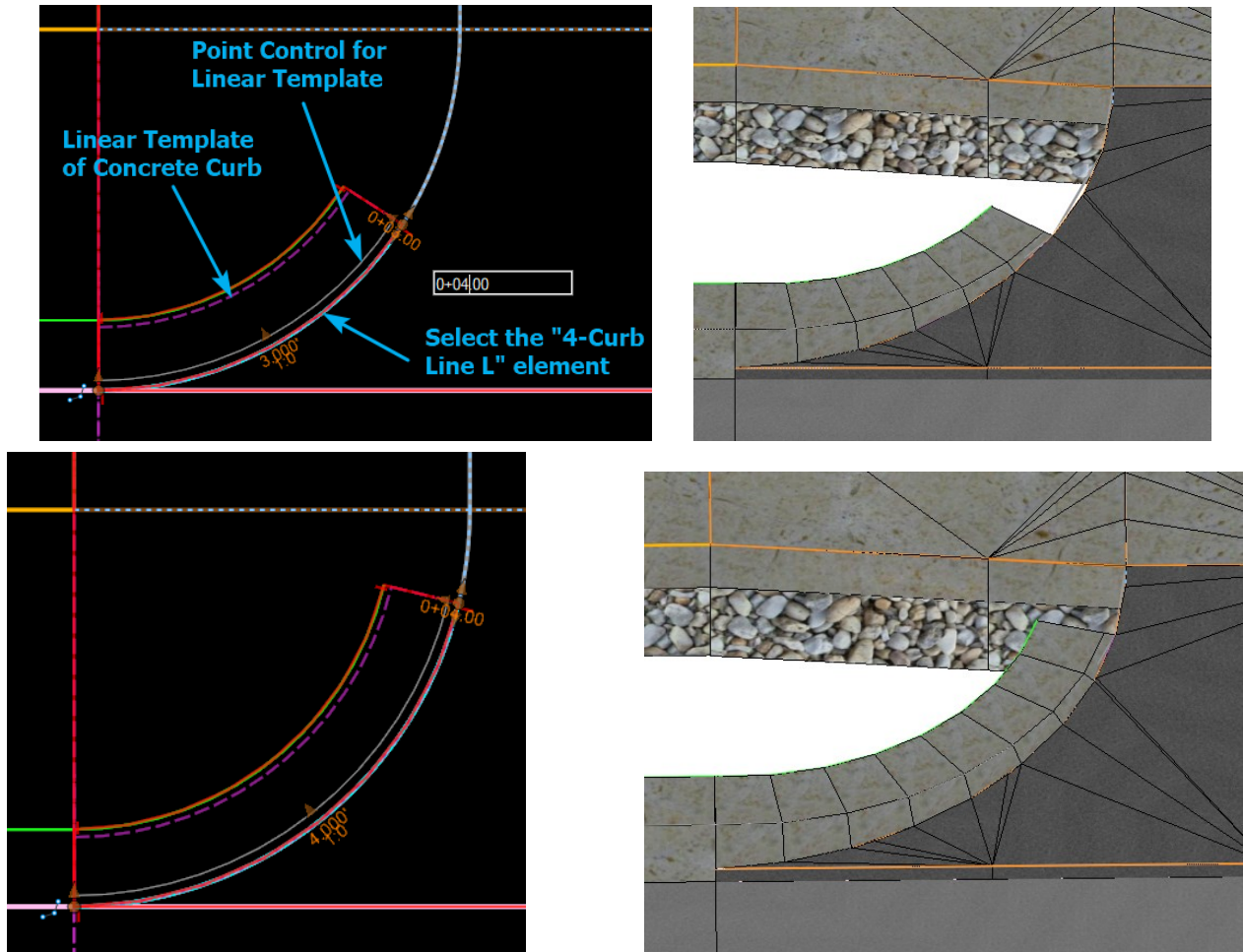

Figure 129

7. To edit or check the point control of the linear template of curb, From the **Corridors** tab, then from **Edit Group** Select **Corridor Objects**.

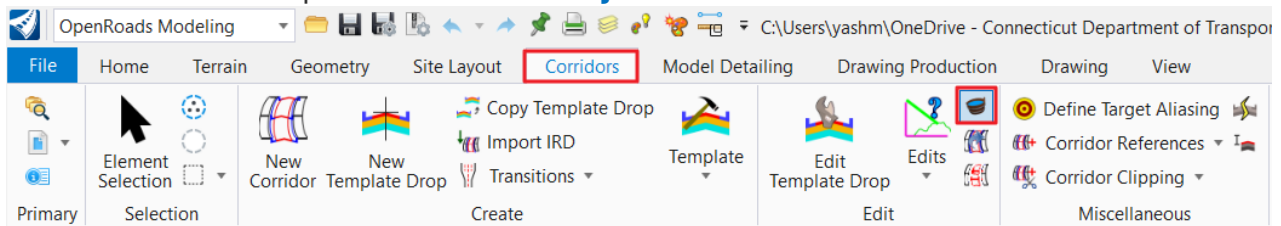

Figure 130

- At **Locate Corridor** prompt select the **Linear Template for of Concrete Curb**. Select Point **Control Tab** in the **Corridor Objects** Window. From this window the height of curb and Length of curb can be defined.

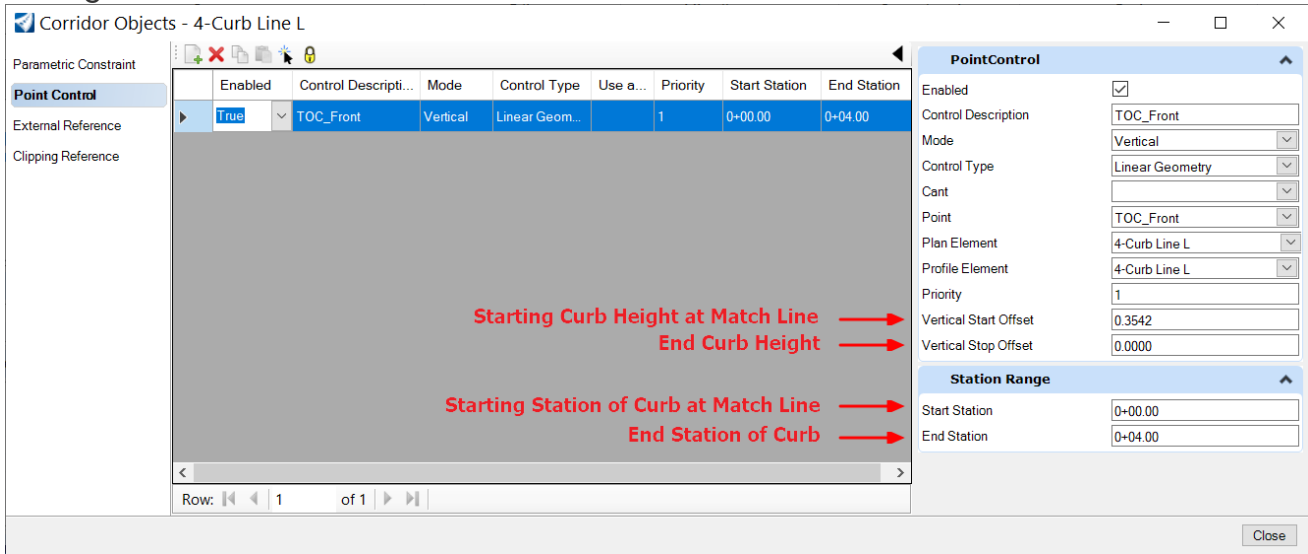

Figure 131

- For example, lets change the value of the Curb Height at **End Station** from **0.00 to 0.3542**. Civil Cell will update, Note the change in the curb height.

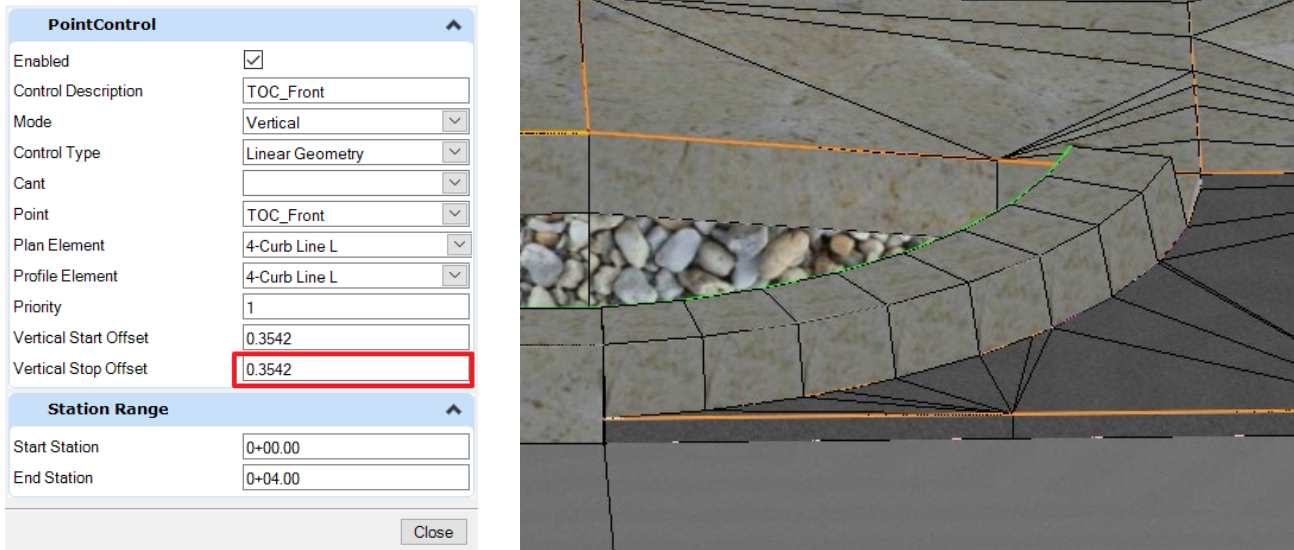

Figure 132

- Swap out **Linear Template** from **Concrete Curb to Bituminous Concrete Lip Curb (BCLC)**.
Click on a **Linear Template of Concrete Curb in View 1**, the 2D View.
- Open the **Properties** dialog, and expand the **Template Drop** group. The current template is **Project Library>CC w base**

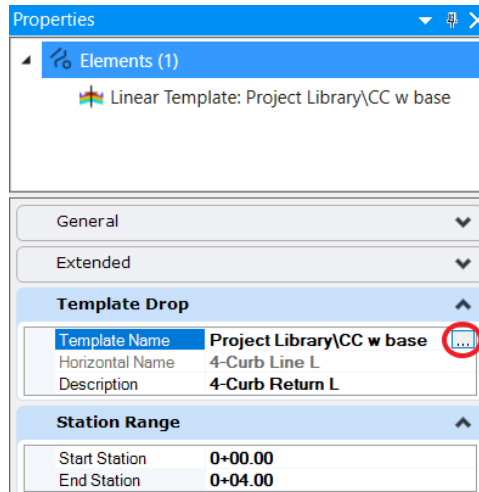

Figure 133

- Click the **Browse** button in the right side of the **Template Name** label. This opens the **Pick Template** dialog.
- Select the desired template prepared for the project and review. For this example, choose **Project Library>BCLC w base**.

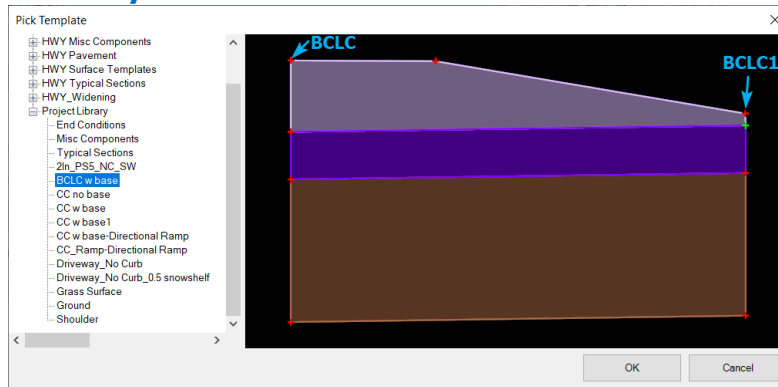

Figure 134

- Click **OK**. The linear template processes with the new Template of BCLC w base. Notice the change in curb.

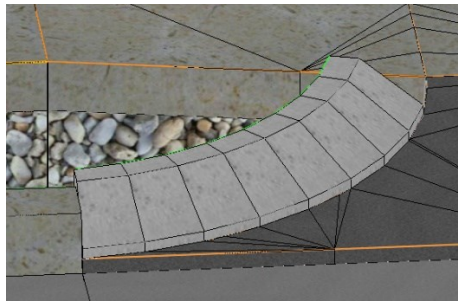

Figure 135

15. New point control should be defined to the new Bituminous curb or Old point control for the concrete curb should be edited to match the Bituminous curb.
16. For this example old point control will be edited for the linear template of curb, From the **Corridors** tab, then from **Edit** Group Select **Corridor Objects**.
17. At **Locate Corridor** prompt select the **Linear Template for of Concrete Curb**. Select **Point Control** Tab in the **Corridor Objects Window**. Select the desired **Point Control** to edit.

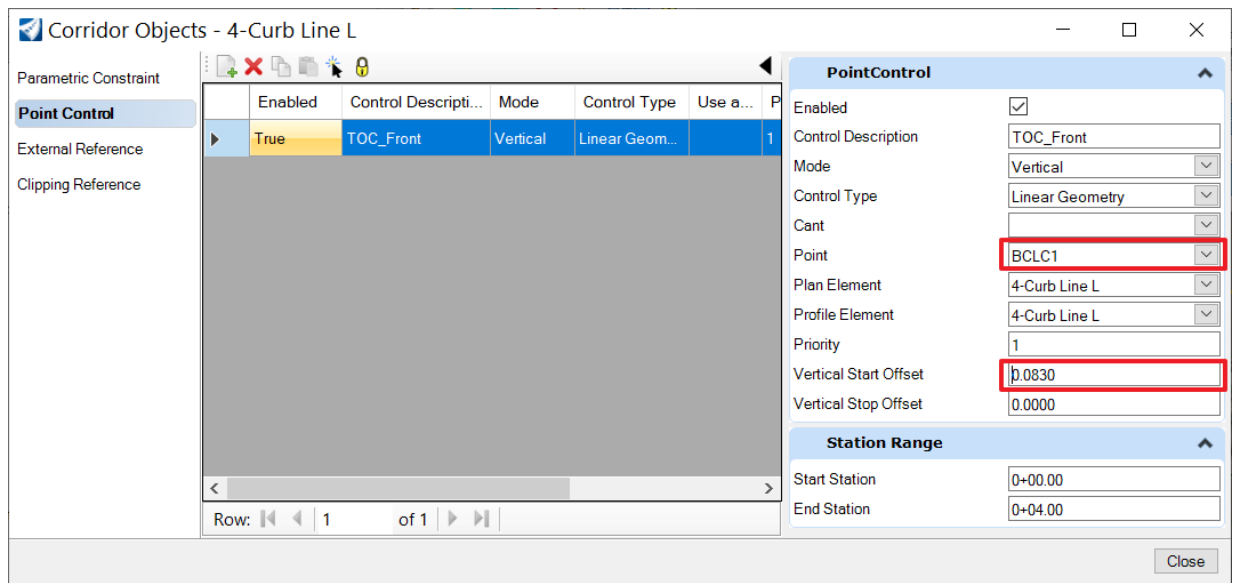

Figure 136

Change the following:

Point: BCLC1 (This point is the name of the front point of the bituminous curb and it can be selected from dropdown menu)

- **Vertical Offset Start: 0.083**

The Curb will update.

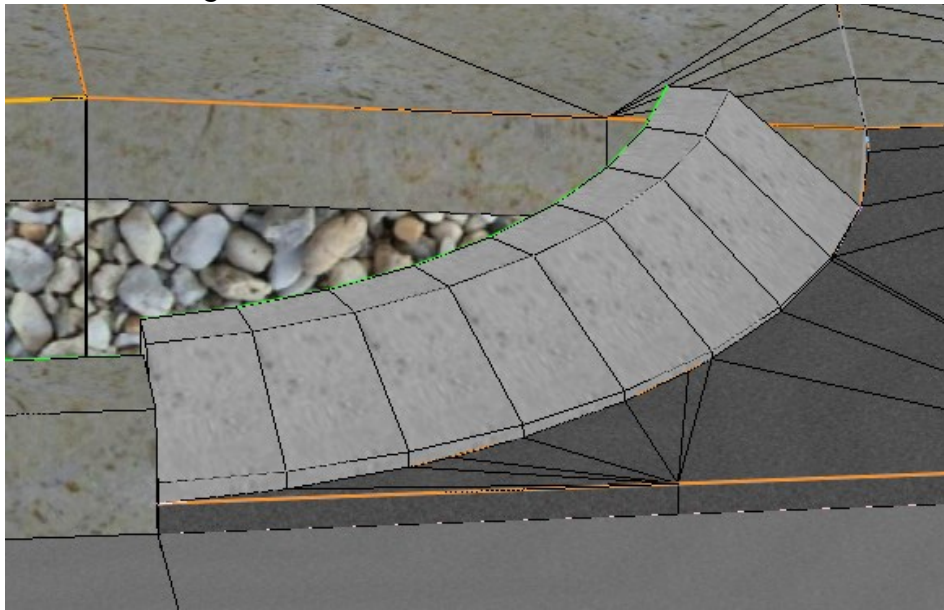

Figure 137

- Highlight the desired point control, click **Copy** button then click **Paste** button to add new Point Control for the selected corridor.

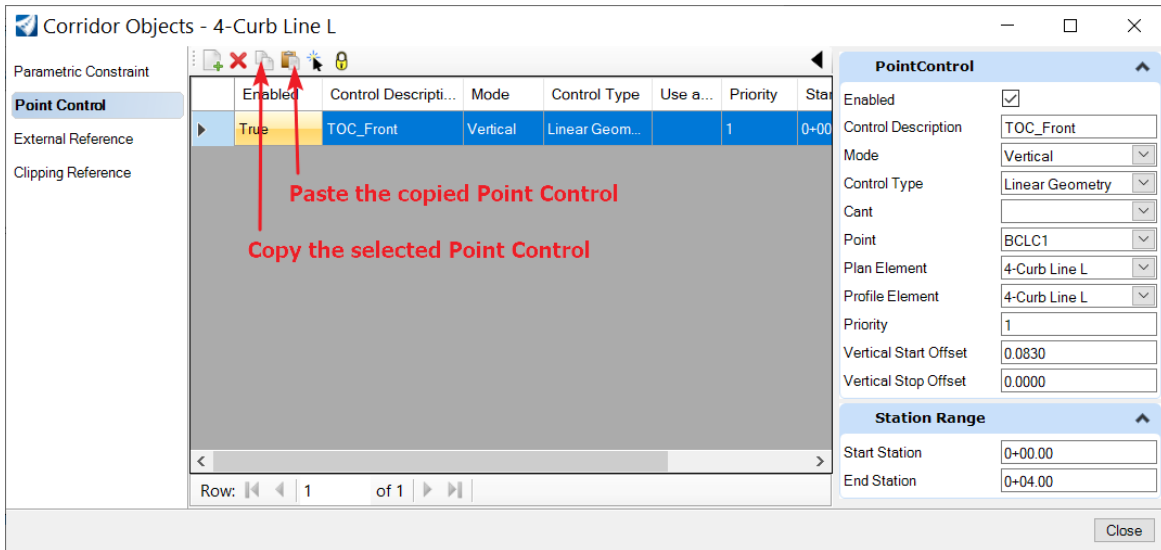

Figure 138

19. Select the copied Point Control to edit.

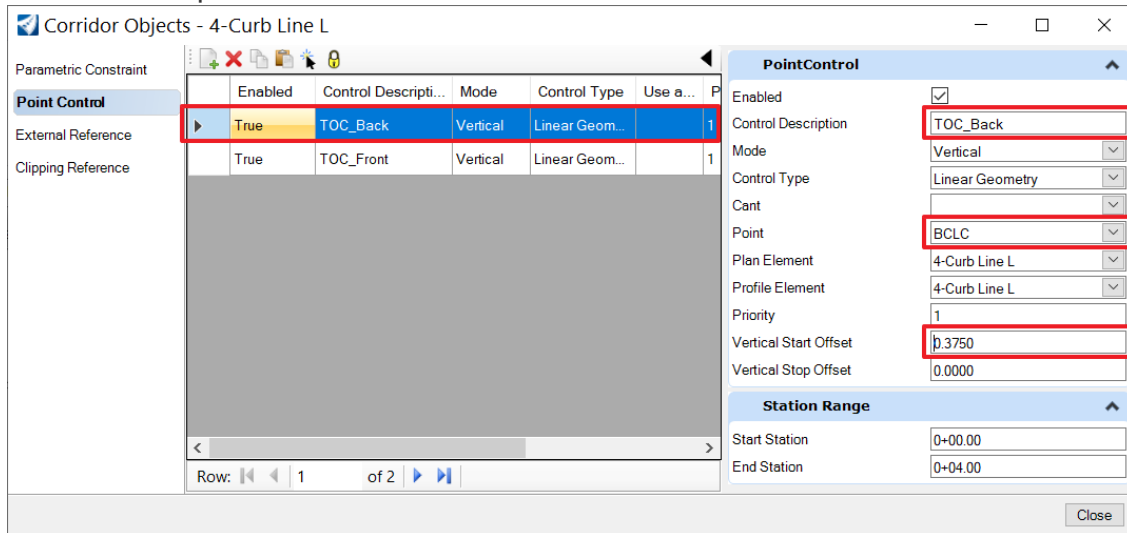

Figure 139

Change the following:

- Control Description: **TOC_Back**
- Point: **BCLC** (This point is the name of the back point of the bituminous curb, it can be selected from dropdown menu)
- Vertical Offset Start: **0.375**

The Curb will update.

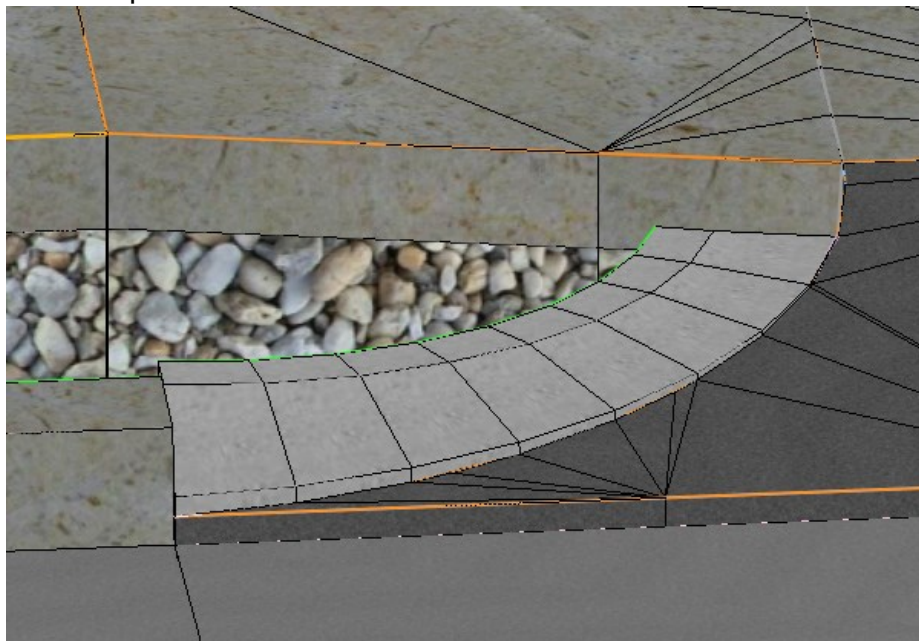

Figure 140

20. Repeat the same process to edit the curb type and height for the right side of the driveway.

Exercise 3 – Driveway (Sidewalk No Buffer Area)

For use with Civil Cells:

- Commercial Driveway (Sidewalk Adjacent to Curb)
- Residential Driveway (Sidewalk Adjacent to Curb)

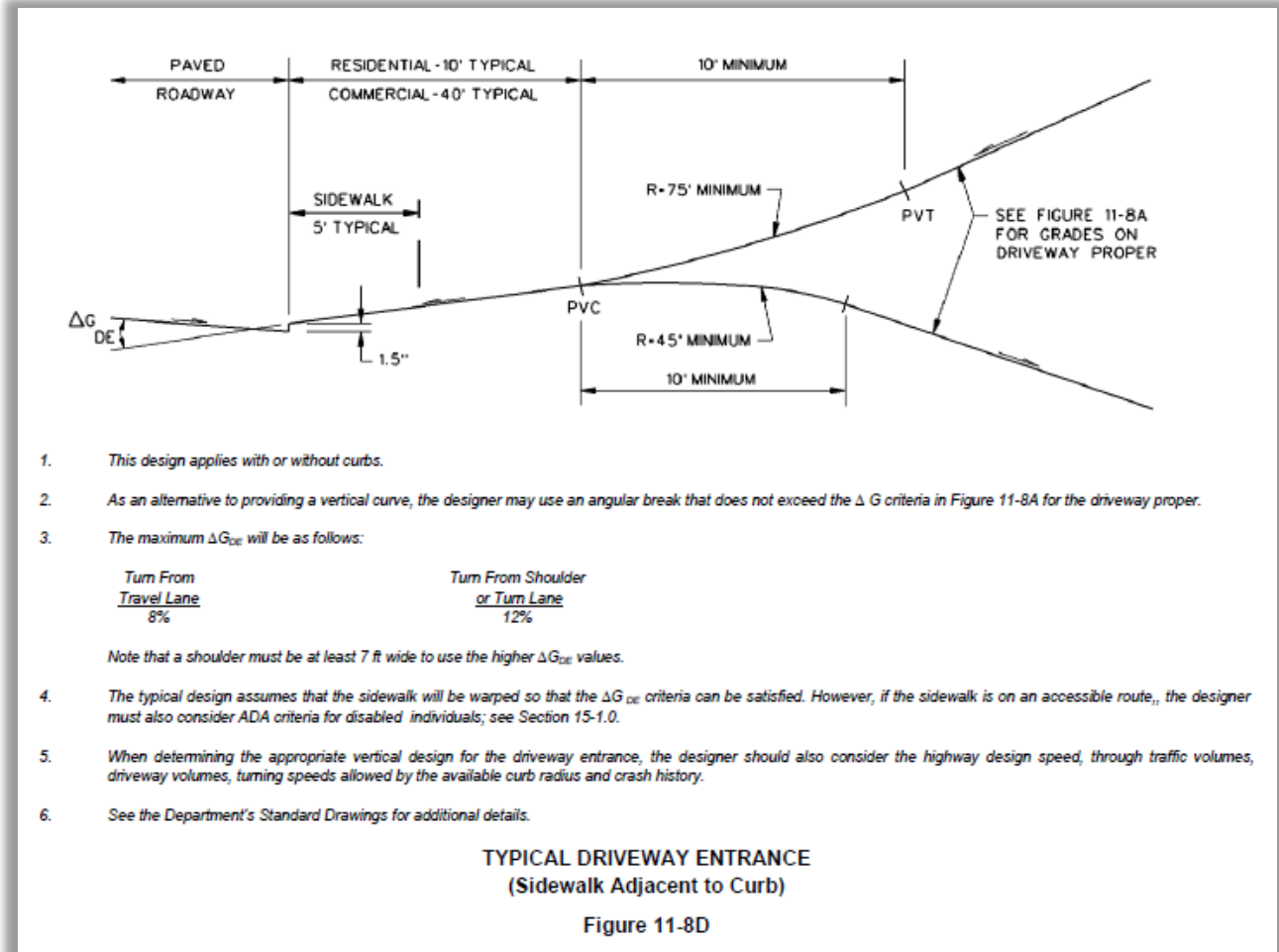

Figure 141 CTDOT Highway Manual 11-8D

3.1 Civil Cell Placement

The design file should have Baseline Alignment, Baseline Profile and roadway corridor in order to place civil cell. Profiled Edge of Road will come from template of Corridor.

3.1.1 Place Reference Lines

1. Activate the **OpenRoads Modeling** workflow, from the ribbon, select the **Geometry** tab, **Horizontal** group. Select to tool **Lines > Line Between Points**. In the dialog box select the Feature Definition:

Alignment > Center > Driveway

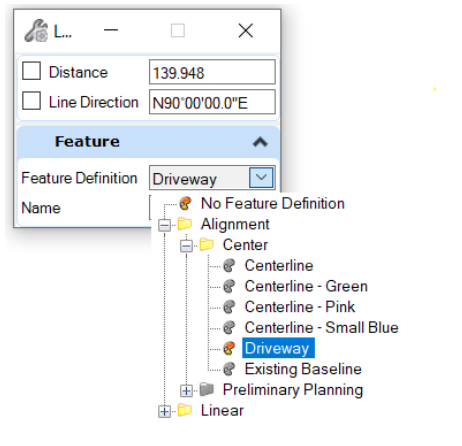

Figure 142

2. Using the perpendicular snap draw a **Line** perpendicular to Baseline of Main Road towards the Proposed Driveway. This is Driveway Centerline. Default name is **DCL**. Which can be modified as required.

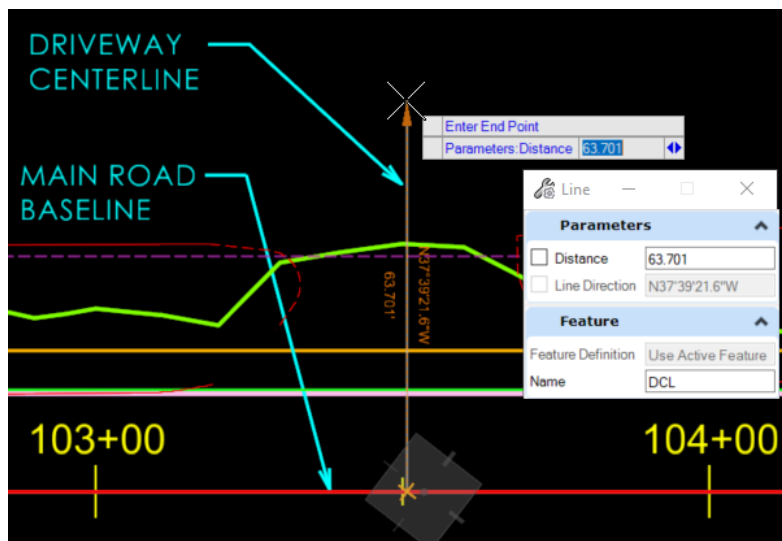

Figure 143

Volume 3.3 - OpenRoads Designer Civil Cells

3. Draw a **line** crossing the Driveway Center line. This line is the limit of the driveway where it matches the existing driveway or ground. The default name **DrivewayMatch_Line** can be modified as required.

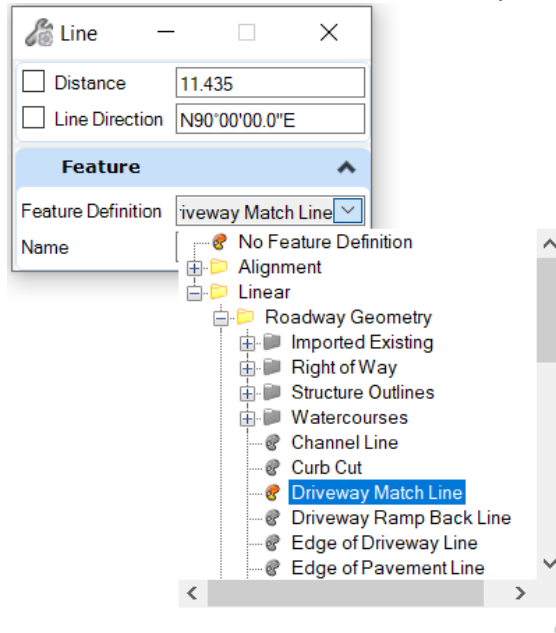

Figure 144

4. Draw a **line** crossing the Driveway Center line. This line is the limit of the driveway where it matches the existing driveway or ground. The default name **DrivewayMatch_Line** can be modified as required.

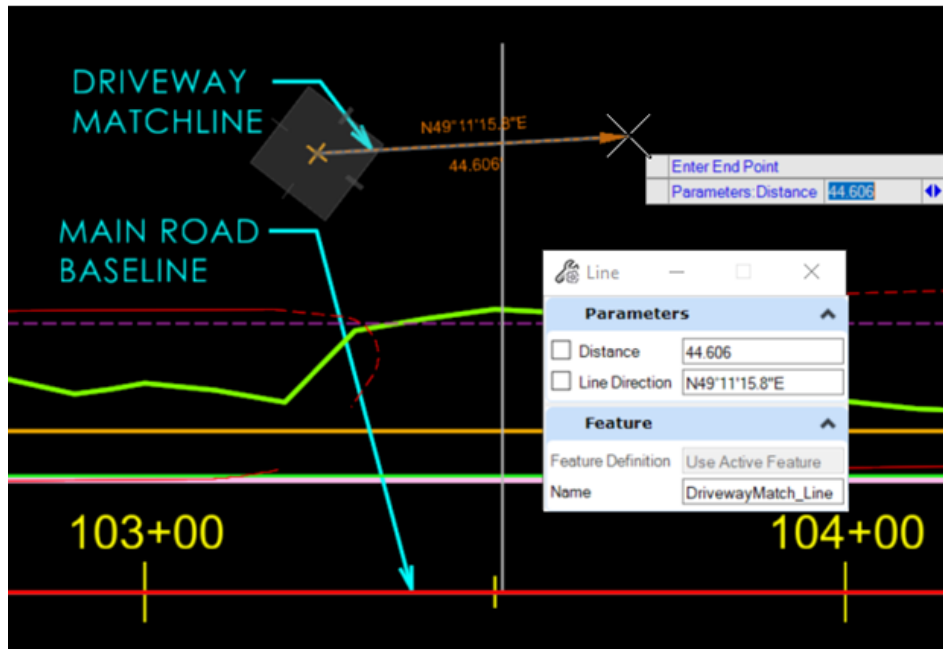

Figure 145

Volume 3.3 – OpenRoads Designer Civil Cells

Now we have all three references required for placing the Driveway Civil Cell. We can place the civil cell.

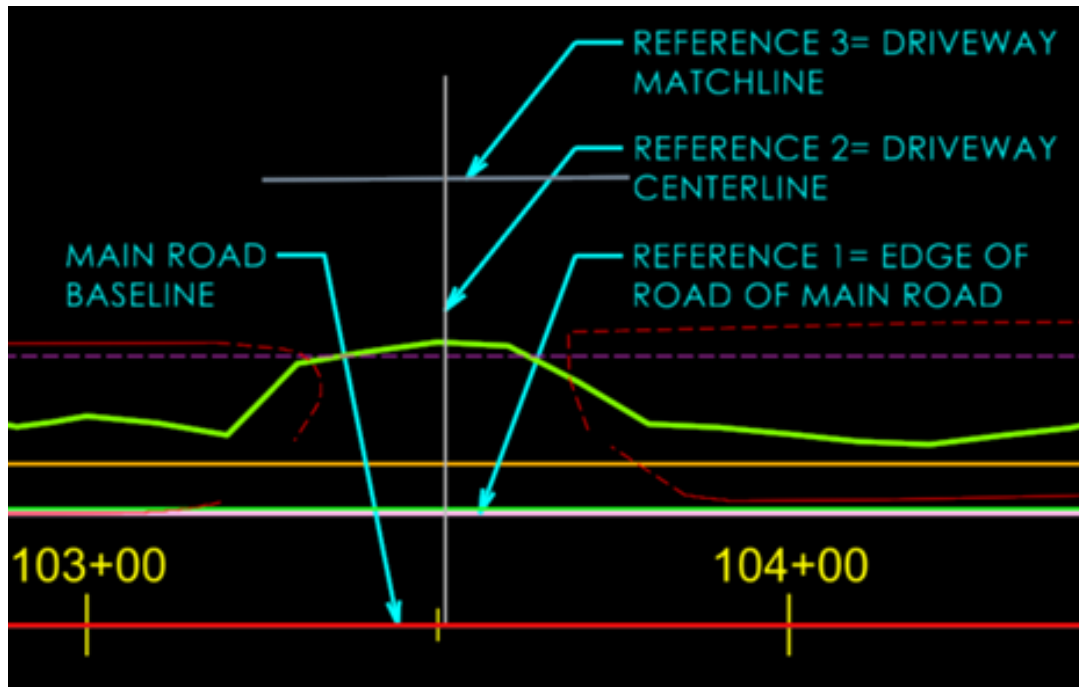

Figure 146

3.1.2 Select the Civil Cell

1. From the ribbon, select **Model Detailing** tab. From **Civil Cells** group select **Place Civil Cell**.

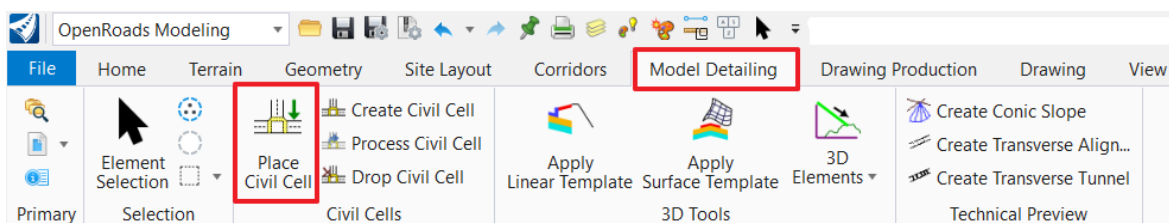

Figure 147

2. In **Civil Cell Name** dialog box, click the **browse** button to open civil cell library.

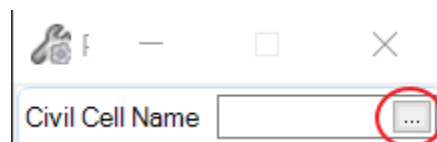

Figure 148

3. Two options to can be chosen from, Commercial Driveway or Residential Driveway as per requirement.

Volume 3.3 - OpenRoads Designer Civil Cells

- 1) For Commercial Driveway, expand the **CV_Commercial_Driveway_CivilCells.dgnlib** and Select **Commercial Driveway (Sidewalk Adjacent to Curb)** civil cell.
 - 2) For Residential Driveway, expand the **CV_Residential_Driveway_CivilCells.dgnlib** and Select **Residential Driveway (Sidewalk Adjacent to Curb)** civil cell.
- The dialog displays the planimetric layout of the selected civil cell with black lines.
 - The dialog also shows the reference lines on which the civil cell is based. These are the red lines and represent the baselines that must be present within the design file to place the civil cell.
4. Click **OK**

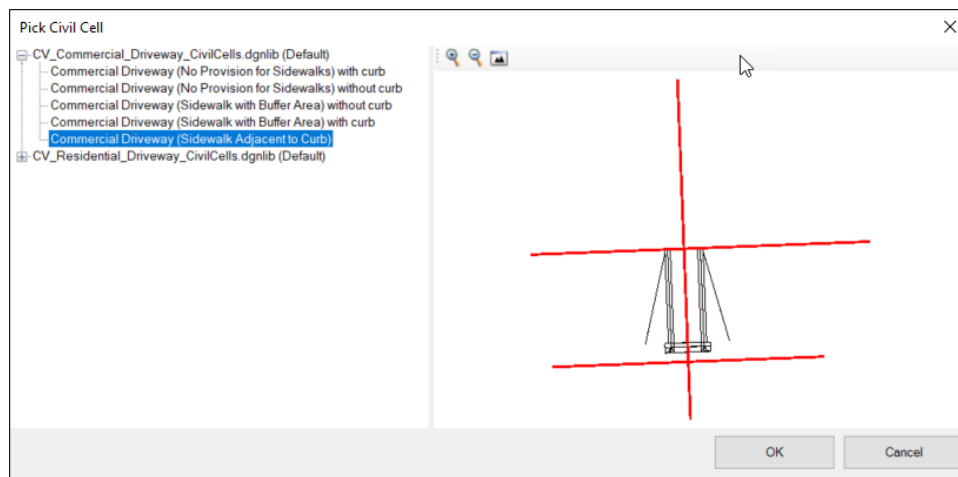

Figure 149

3.1.3 Place the Civil Cell

1. Follow the heads-up prompts. **Locate Reference Element: EOR (Profiled)(1/3)**, select the **Main Road Edge of Road** element.
2. **Locate Reference Element: DRV CL (Perpendicular to Baseline) (2/3)**, select the **Driveway Centerline** element.
3. **Locate Reference Element: DRV ML (3/3)**, select the **Driveway Matchline** element.
4. **Select Elements to View Alternatives (Reset to Skip)**, there are couple of options according to the direction of the driveway cell.

If the direction of driveway is correct, then **right-click** to reset.

If the direction of driveway is incorrect, see below, then **hover** over the Edge of Road, the arrow should appear over the EOR, **left-click** on the arrow. This should cause the curb return to flip to the correct side. Note the arrow's change of direction.

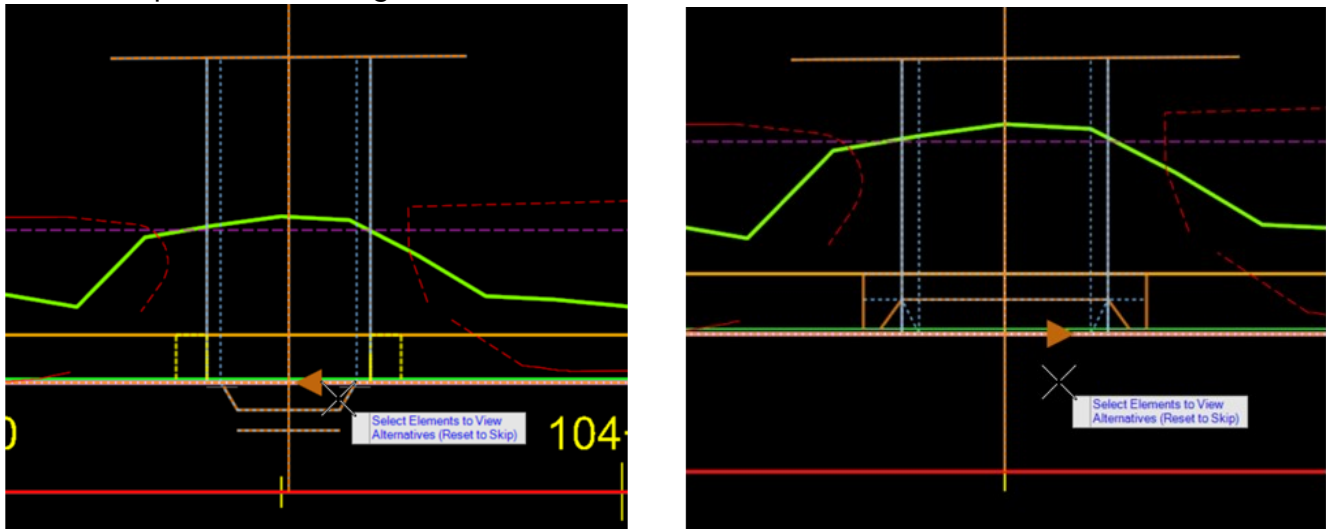

Figure 150

Hover over the EOR until the arrow appears over EOR then **left-click** on arrow. The curb return will flip to the correct side.

5. **Select Corridors To Be Clipped (Reset To Complete)**, **right-click** to reset.
6. **Accept Civil Cell Placement**, **left-click** to accept. The Civil Cell is placed.

3.2 Adjust the Civil Cell Placement

Series of edits can be done to the Civil Cells which demonstrate the flexibility and the ability to edit their component.

If the capabilities of Civil Cells seem confining, user can use the **Drop Civil Cell** tool to drop the placed Civil Cell into the components that make it up.

3.2.1 Civil Cell Clipping

Driveway Civil Cells can be used to clip the corridor where it is placed. Civil Cell clipping does not clip out 2D graphics of the corridor but only in 3D view. Template edit of the main road corridor is recommended. Dropping elements outside of the curb from the corridor template at driveway limits is recommended for this civil cell.

There is various method to edit the template. One method is shown below.

1. From the ribbon, select **Corridors** Tab.
2. From the **Create** Group Select **Copy Template Drop**.

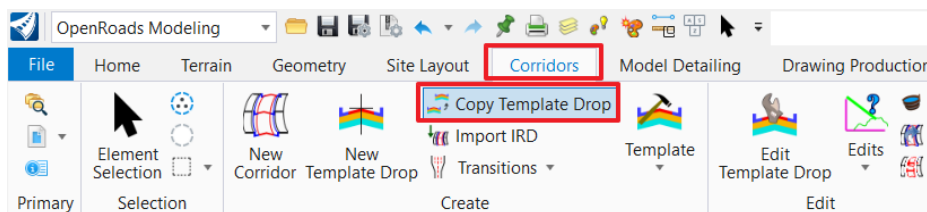

Figure 151

3. Follow the heads-up prompts.
4. At **Locate Template Drop**, Select the **Main road Corridor Template Drop**.

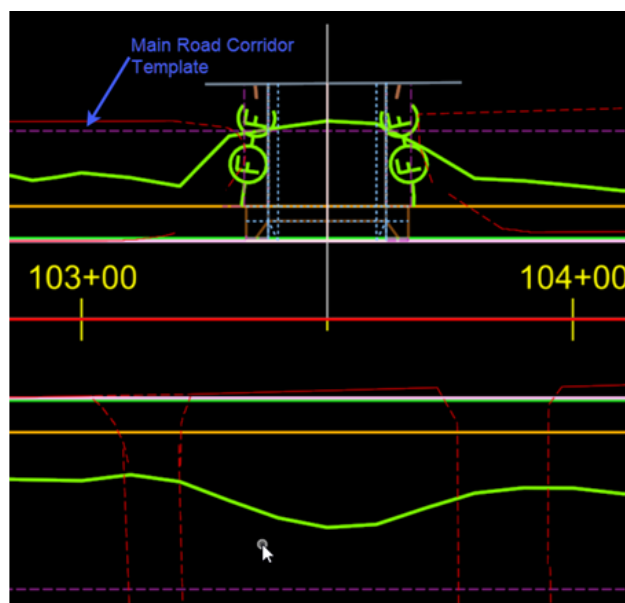

Figure 152

- For **Start Station, keypoint snap** at start of left-side radius of driveway. For **end station, keypoint snap** at end of right-side radius of driveway. This will create copy of existing template drop at the driveway portion.

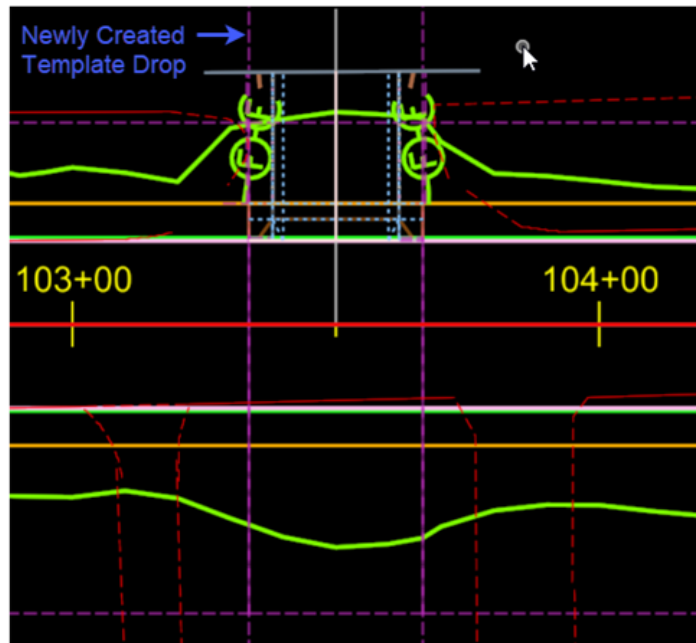

Figure 153

- This newly copied template drop needs to be edited. From the **Edit** Group Select **Edit Template Drop**.

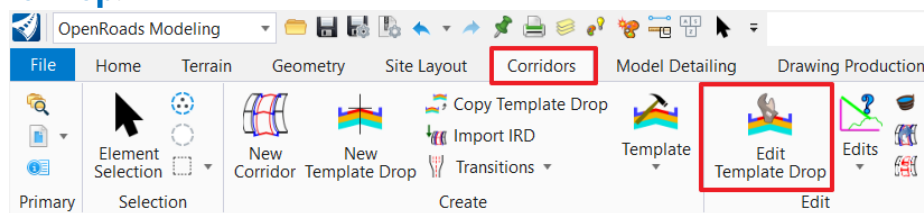

Figure 154

- For **Locate Template Drop**, Select the **Newly Copied Template Drop**.
- Editing Roadway Designer Template Drop** Window appears along with the existing template used at the template window.
- Delete the end conditions component from the template outside of the Edge of Road element. For this **right-click** in the template window and select **Delete Components** from the drop-down menu.

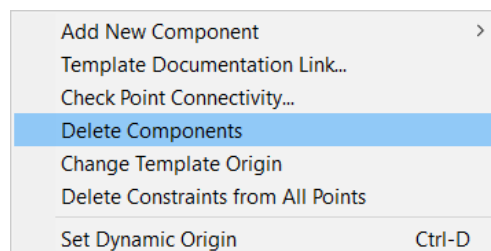

Figure 155

10. Draw a **line** across each of the elements you wish to delete.

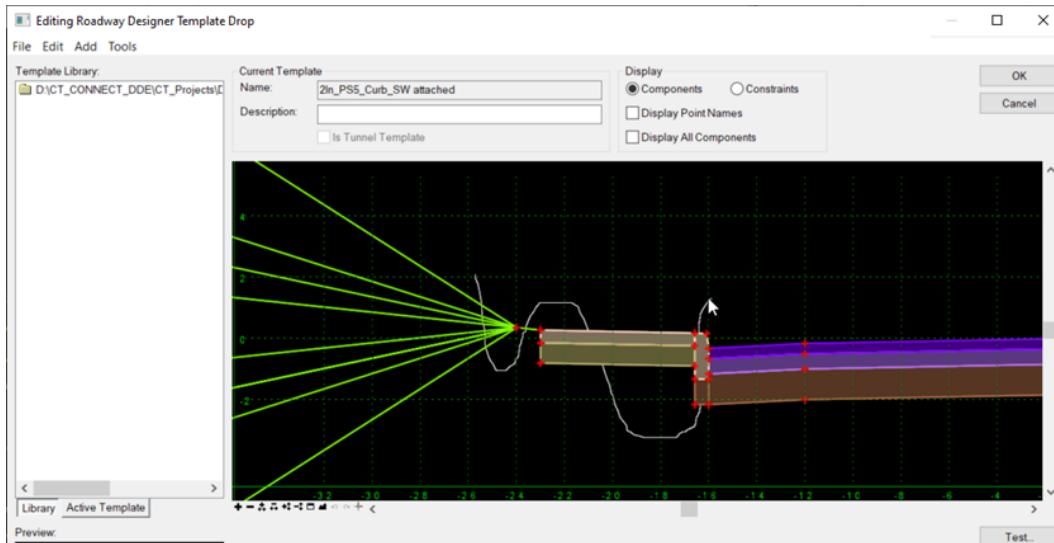

Figure 156

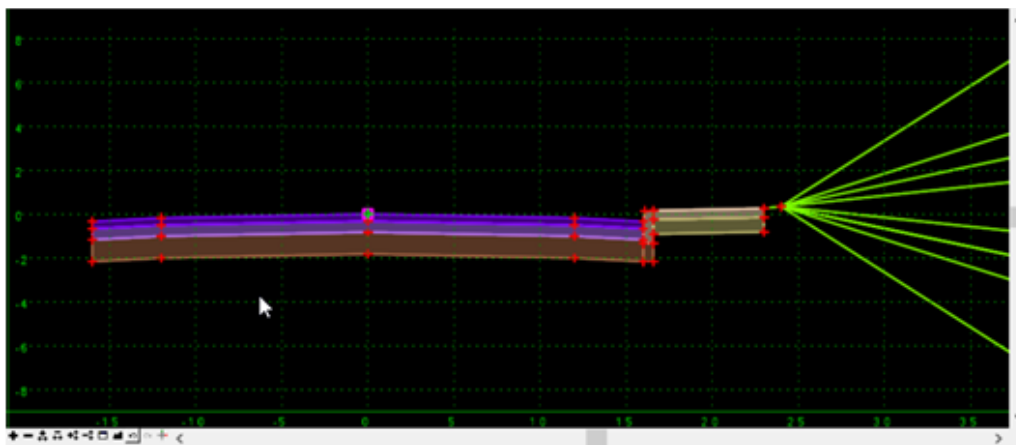

Figure 157

11. Click **OK** to close the **Editing Roadway Designer Template Drop** dialog.
12. Review the driveway location. Notice the side slopes have been removed along the left side of the main road or across the newly placed driveway civil cell. The designer needs to add and transition the side slope at the curb return.

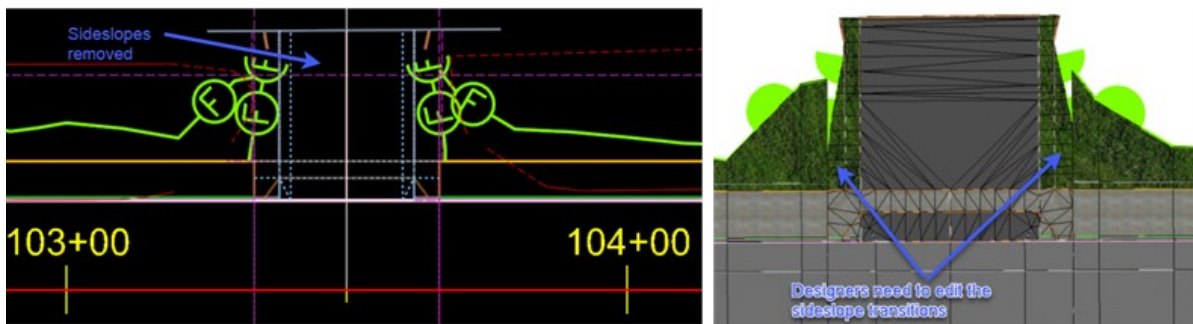

Figure 158

3.2.2 Adjustment of the Reference Element

For this section, please refer to previous civil cell as the process is identical.

Designers may need to adjust the curb transitions manually after the adjustment of the Reference Element.

3.2.3 Edit Horizontal Geometry

1. **Turn off** the display of the Referenced 3D model, if it is not already turned off.

One “challenge” in editing Civil Cells is that sometimes it is hard to select what user want to select, especially with full 3D Civil Cells. User may have multiple overlapping 2D features overlapped with multiple overlapping 3D Features in the reference 3D Model. User may have to **right-click** a couple times to select the intended element.

2. Depending on user needs, user can **turn off** the **Level** of the 3D Model Reference or **turn off** its Display entirely. User can also **turn off** levels with graphics user find “unnecessary” right now. Construction Class element display can be **turned on** and off via **View Attributes**.

Change the Width of Driveway Shelf or Ramped Section and Sidewalk width of Civil Cell.

- a. Make sure **Constructions** option is turned on in **View Attributes** window.

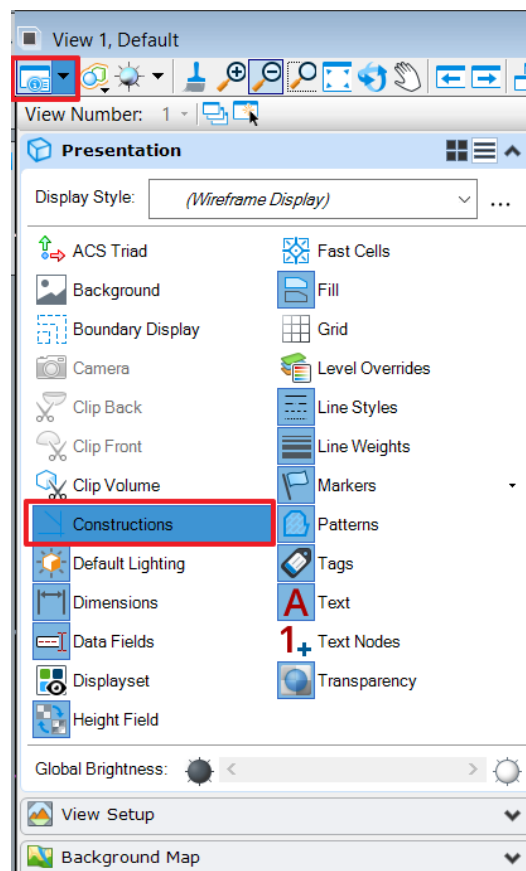

Figure 159

Volume 3.3 - OpenRoads Designer Civil Cells

- b. From the ribbon, select **Home** Tab.
 - c. From the **Primary** Group, Select **Level Display**.
 - d. **Turn on** the display for Level **CIVILCELL_Const** if it's not on already.
2. Use the **Element Selection tool** and Click on the **Sidewalk Front Line** whose feature name is **5-CC_Const_SW Ft.**
- a. Once the line is selected, click on the **midpoint Offset text manipulator**.
 - b. Type desired value say **-4'** and hit **Return**. The driveway shelf section is widened, and all dependent geometry and modeling is updated.

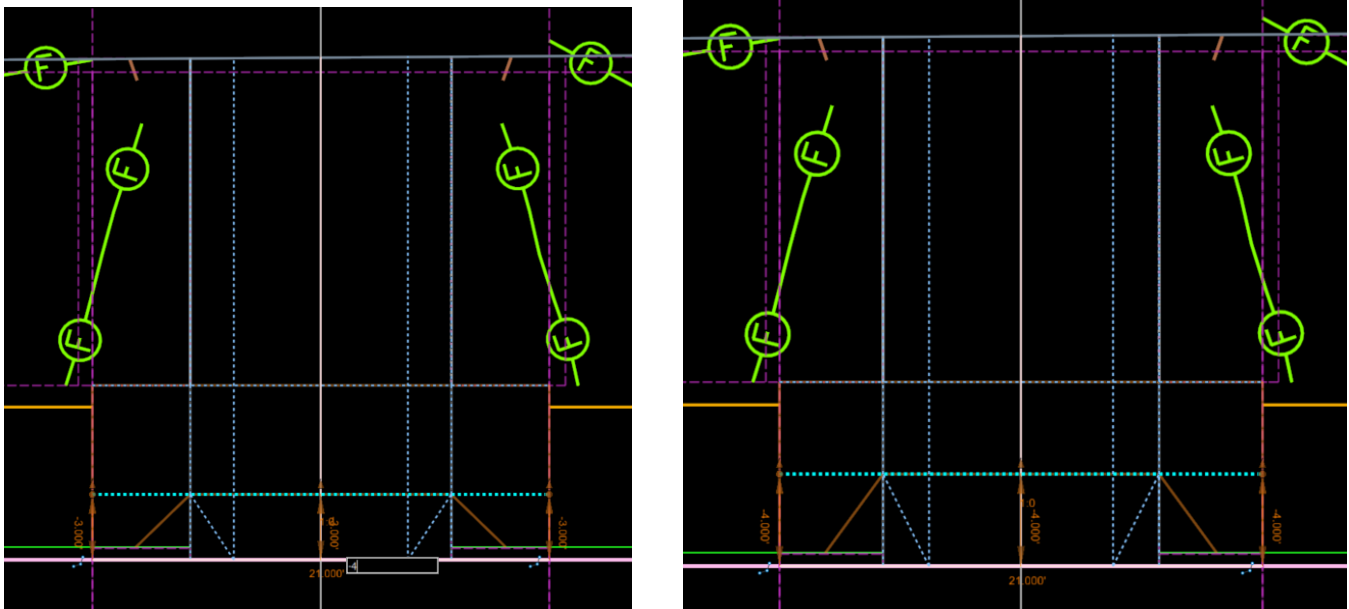

Figure 160

- c. Use the **Element Selection tool** and Click on the **Sidewalk Back Line** whose feature name is **5-CC_Const_SW Bk.**
- d. Once the line is selected, click on the **midpoint Offset text manipulator**.
- e. Type desired value say **-8'** and hit **Return**. The sidewalk is widened, and all dependent geometry and modeling is updated. Adjust **Sidewalk Back Line** so that it's back coincides with the existing Sidewalk back.

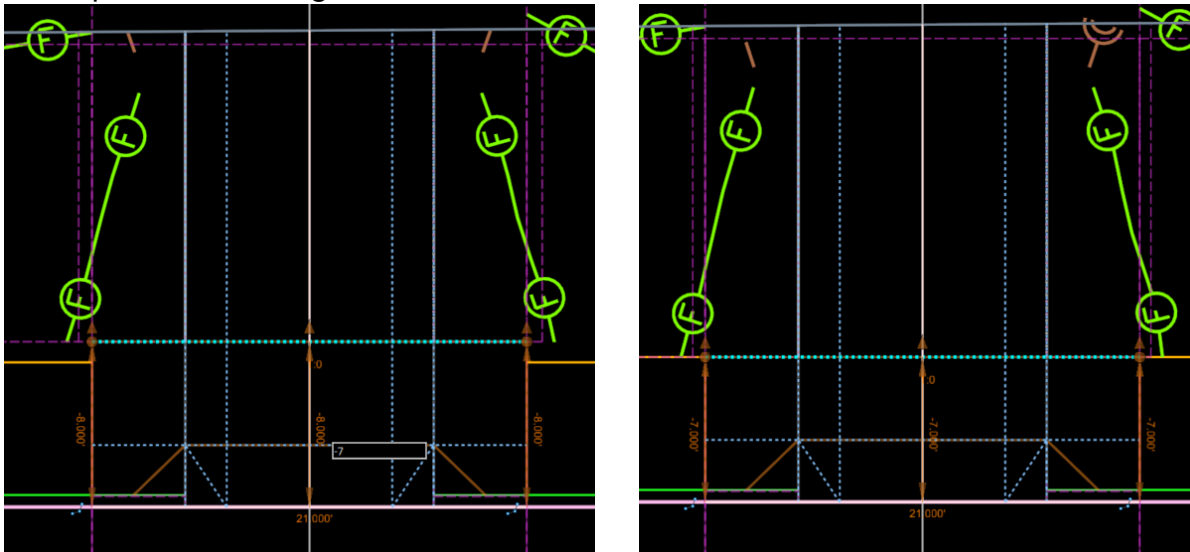

Figure 161

3. Edit the Lane of Driveway Civil Cell. Use the **Element Selection tool** and Click on the **right Edge of Driveway** of the Civil Cell. User may have to **right-click** a couple times to select the intended element.

- a. Once the edge is selected, click on the **midpoint Offset text manipulator**.

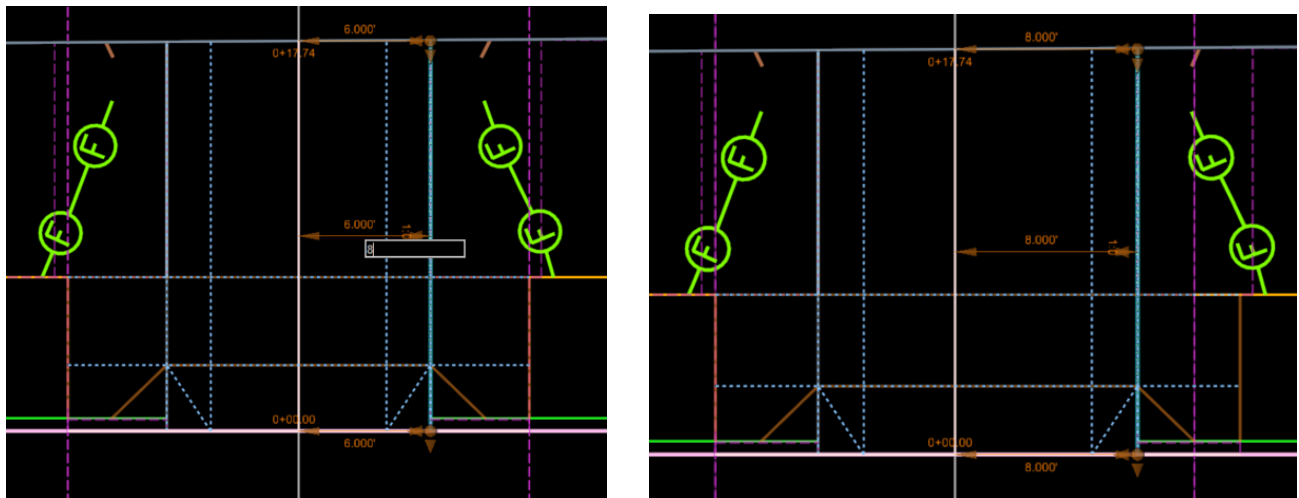

Figure 162

- b. Type desired value say **8'** and hit **Return**. The Lane width is widened, and all dependent geometry and modeling is updated.
- c. Follow the same steps to edit the Left Lane width. Edit the Width of Warped Section .
- d. Use the **Element Selection tool** and Click on the **5-CC_Const_SW Ramp R1** of the Civil Cell. Once the edge is selected, click on the **midpoint Offset text manipulator**.

Volume 3.3 - OpenRoads Designer Civil Cells

- e. Type desired value say **-3'** and hit **Return**. The **warped section** is widened, and all dependent geometry and modeling is updated.

5. Follow the same steps to edit the Left Lane width.

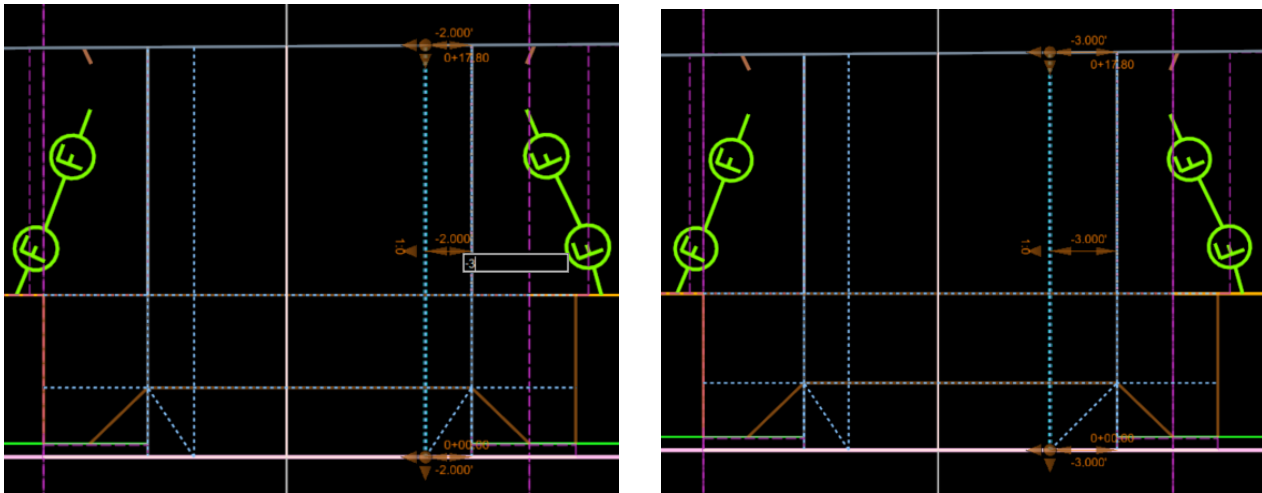

Figure 163

- a. Edit length of Sidewalk Transition and length of Sidewalk of Civil Cell along with Concrete Curb. Sidewalk Transition length and Normal Sidewalk length are related to the curb length. User needs to change Length of Curb Transition in order to change Sidewalk Transition length. Similarly, Length of Curb changes the length of the Sidewalk.
- b. Click on the **Curb Front of Sidewalk at the right side of Driveway**. This might require multiple **right-clicks** until the **text manipulator** is visible. The Elements of Curb and Curb Transition are combined in the Civil Cell. Both Length are editable.
- c. Edit Length of Curb Transition from default **2.5'** to **3'** and hit **Return**. Sidewalk transition along with concrete curb and all dependent geometry and modeling is updated. User can edit Length of curb as needed; default is **2'**.
- d. **Sidewalk Matchline** also moves as length of Curb is changed. Designer needs to adjust the limits of Template drop.

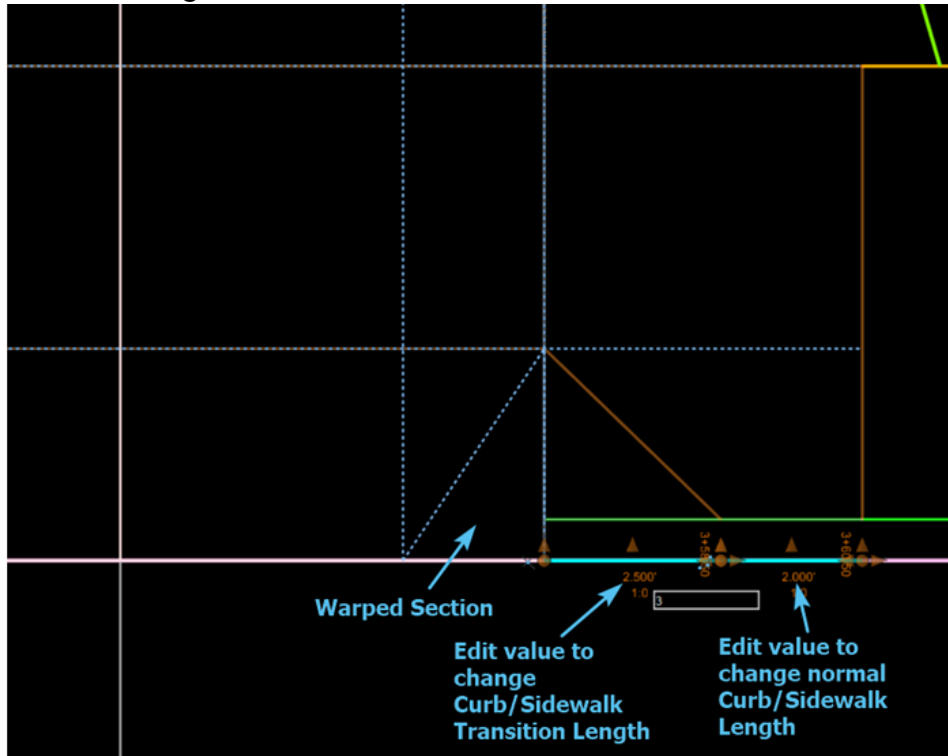

Figure 164

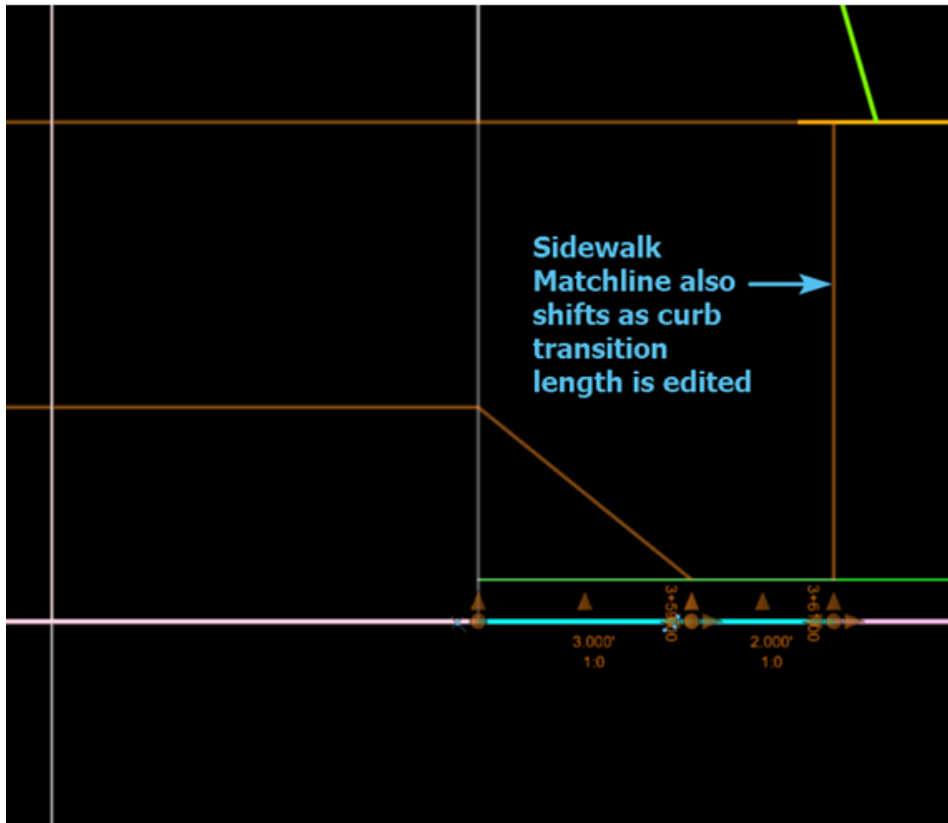

Figure 165

3.2.4 Edit Vertical Geometry of Sidewalk in Civil Cell

1. Elements to be familiar with, in order to edit the vertical geometry of Sidewalk in this Civil Cell.

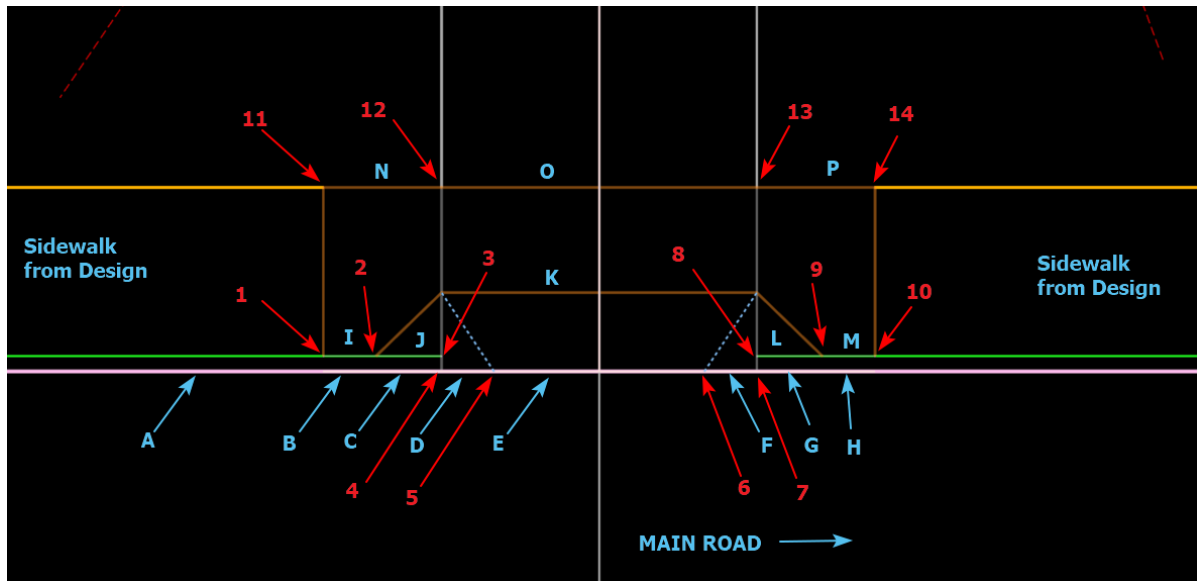

Figure 166

- A = Edge of Road Element (From Design File)
- B = Curb Front at Left Side of Driveway (Same elevation as (A))
- C = Curb Front Transition at Left Side of Driveway (Same elevation as (A))
- D = Warped Section at Left Side of Driveway (1½" at (E) and Maintain 1:12 Slope towards (C))
- E = Driveway Lip Element (1½" above (A))
- F = Warped Section at Right Side of Driveway (1½" at (E) and Maintain 1:12 Slope towards (G))
- G = Curb Front Transition at Right Side of Driveway (Same elevation as (A))
- H = Curb Front at Right Side of Driveway (Same elevation as (A))
- I = Curb Back at Left Side of Driveway (Curb Height, Default is 6" above (A))
- J = Curb Back Transition at Left Side of Driveway (Line between (I) and (D), Maintain 1:12 Slope)
- K = Front of Sidewalk Element inside of Driveway Edges (Default is 4" above (A))
- L = Curb Back Transition at Right Side of Driveway (Line between (F) and (M), Maintain 1:12 Slope)
- M = Curb Back at Right Side of Driveway (Curb Height, Default is 6" above (A))
- N = Back of Sidewalk Element outside of Left Side of Driveway Edge (Default is 4.7" above (A))
- O = Back of Sidewalk Element inside of Driveway Edge (Default is at +1.5% slope from (K))
- P = Back of Sidewalk Element outside of Right Side of Driveway Edge (Default is 4.7" above (A))
- 1 = Start point of Vertical Offset of elements B
- 2 = End point of Vertical Offset of elements B
- 3 = Point (4) Projected from Start point of elements D
- 4 = Start point of Vertical Offset of elements D
- 5 = End point of Vertical Offset of elements D
- 6 = Start point of Vertical Offset of elements F
- 7 = End point of Vertical Offset of elements F
- 8 = Point (7) Projected from End point of elements F

Volume 3.3 - OpenRoads Designer Civil Cells

9 = Start point of Vertical Offset of elements H

10 = End point of Vertical Offset of elements H

11 = Start point of Vertical Offset of element N

12 = End point of Vertical Offset of element N

13 = Start point of Vertical Offset of element P

14 = End point of Vertical Offset of element P

Points 1, 10, 11 and 14 are Vertical Offsets referenced from Edge of Road (A). Its value can be changed as needed to match Existing or Designed Sidewalk elevation.

Points 12 and 13 are Vertical Offsets referenced from Edge of Road (A). Its value can be changed as needed. But its value should match elevation of element (O).

Points 4, 5, 6 and 7 are Vertical Offsets referenced from Edge of Road (A). Its value can be changed as needed to match Sidewalk warped section requirement.

Point 3 is projected from element (D) and should match point 4. Point 8 is projected from element (F) and should match point 7.

The Driveway Civil cell is provided with 1½" lip at the Edge of Road as per CTDOT standards. The Sidewalk front is placed 4" vertical offset from the edge of roadway, Sidewalk back inside the Driveway edge is +1.5% from Sidewalk front as per CTDOT Standards Drawing and Sidewalk back outside of Driveway edges are 4.9" vertical offset from edge of roadway, Driveway match line takes the elevation from the existing terrain. The elevation values can be changed for the sidewalk front and back.

As an example, Looking at the 3D view Civil Cell Match line does not exactly coincides with the existing sidewalk. Point 14 is 0.218' below the Existing Back of sidewalk. Let's edit the elevation or offset values of points 14, in order to coincide the existing sidewalk.

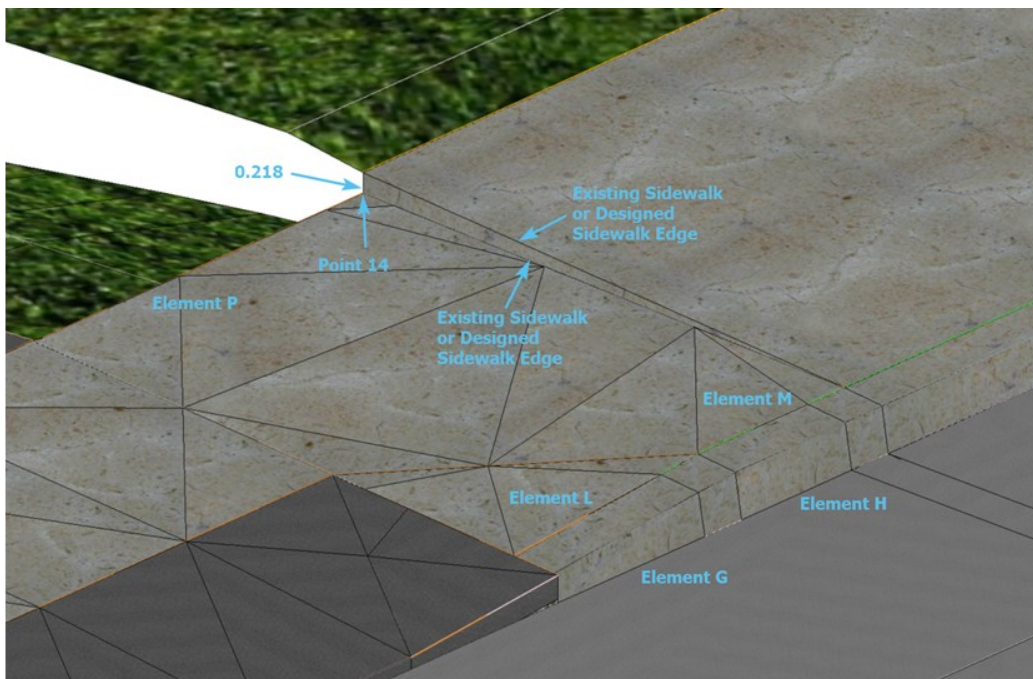

Figure 167

Volume 3.3 - OpenRoads Designer Civil Cells

3. **Constructions** option can be turned off in **View Attributes** window so that it is easy to select and edit the sidewalk elements.
4. Select **element (P)**, Back of Sidewalk Element outside of Right Side of Driveway Edge (**5-SW Bk R**).

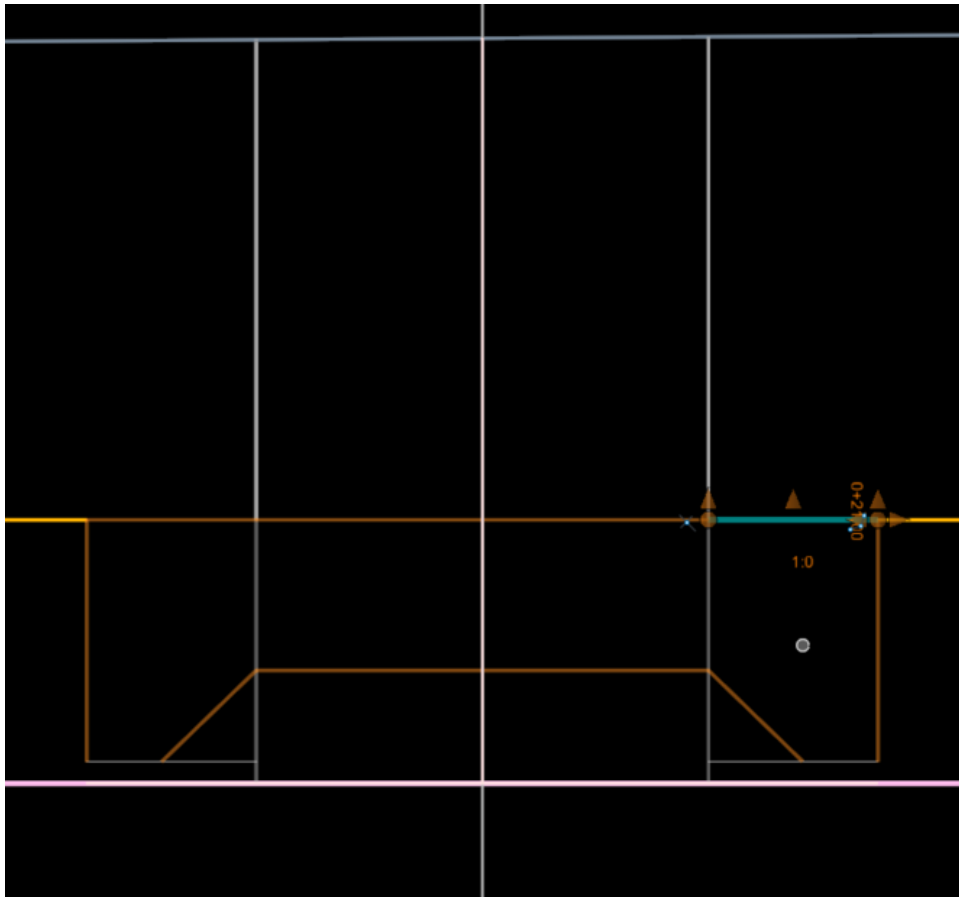

Figure 168

5. Open the **Properties** dialog and expand the **Profile By Projecting LinEnt3d Slope Rule** group.
6. The current value of **End Vertical Offset** is 0.378'. This is **Point (14)** and it is 0.378' vertical offset from **Edge of Road (A)**.

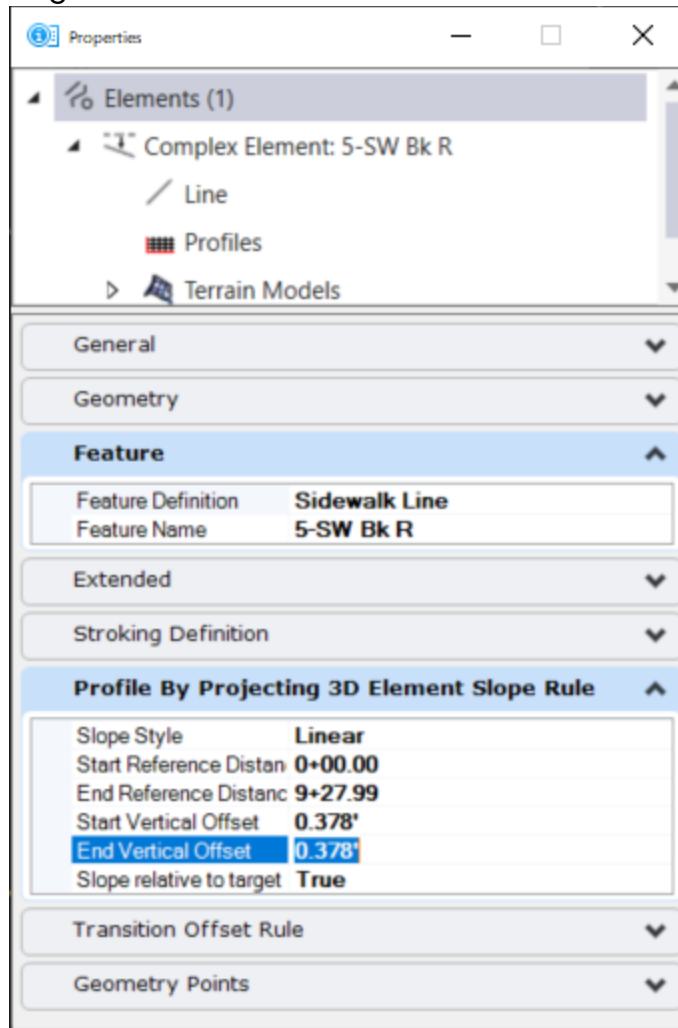

Figure 169

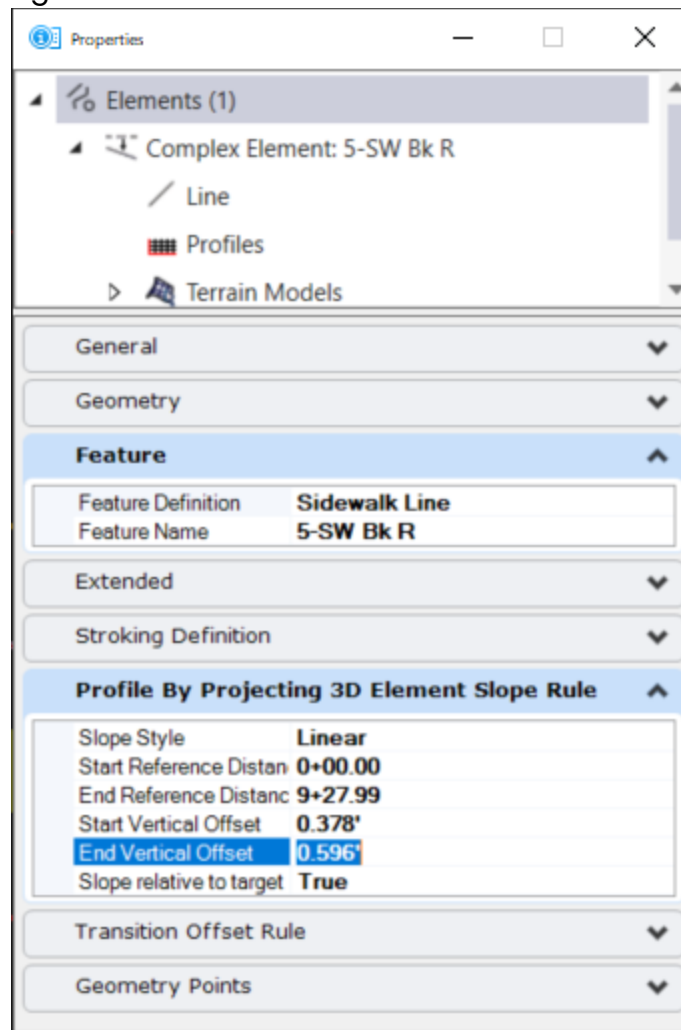

Figure 170



Figure 171

Volume 3.3 - OpenRoads Designer Civil Cells

7. Similarly **Point (11)** can be edited.

NOTE: For editing **Point (11)**, **Start Vertical Offset** value from the **Properties** menu should be changed.

8. Edit Vertical Geometry of Driveway Centerline in Civil Cell. Select the **Driveway Centerline (5-CC_Pr DRV CL)**.
9. **Hover** over the selected element over it until the **Context Tool Bar** pops up.
10. Click open **profile model**.

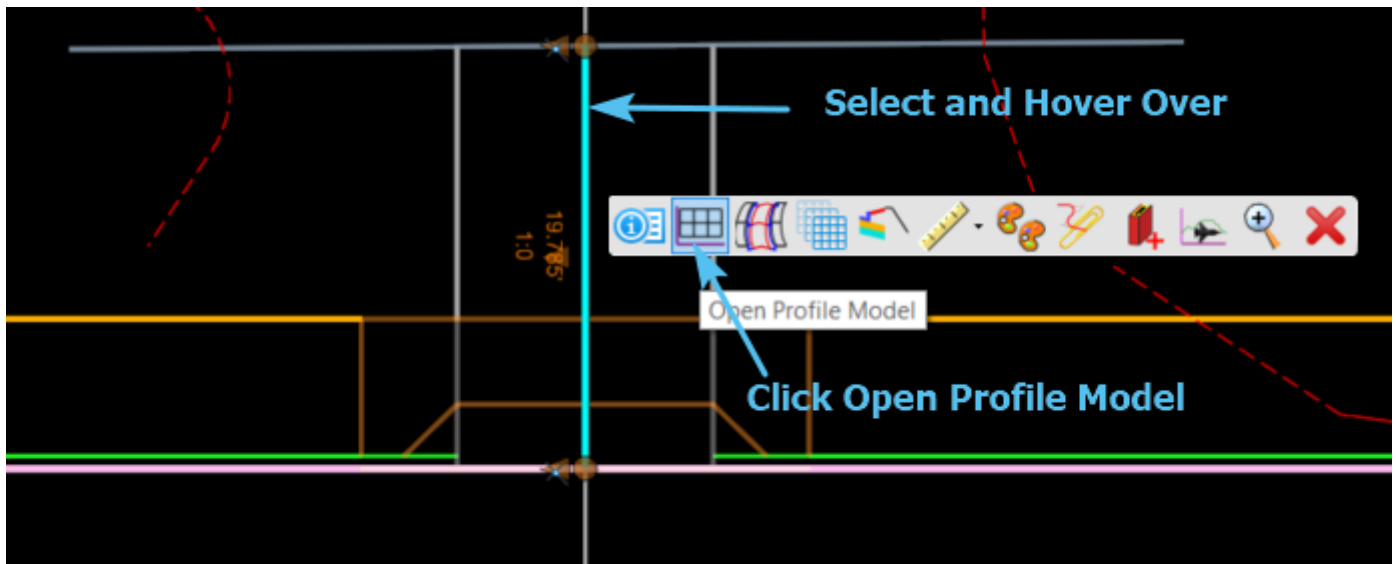

Figure 172

11. **On Select or Open View** model prompt, select one of the views and **left-click** on that view window.

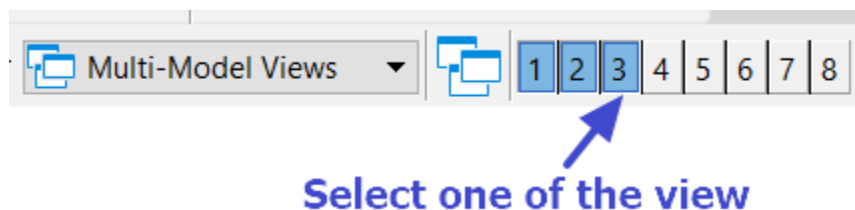

Figure 173

12. The profile view of the Driveway Centerline will show up.

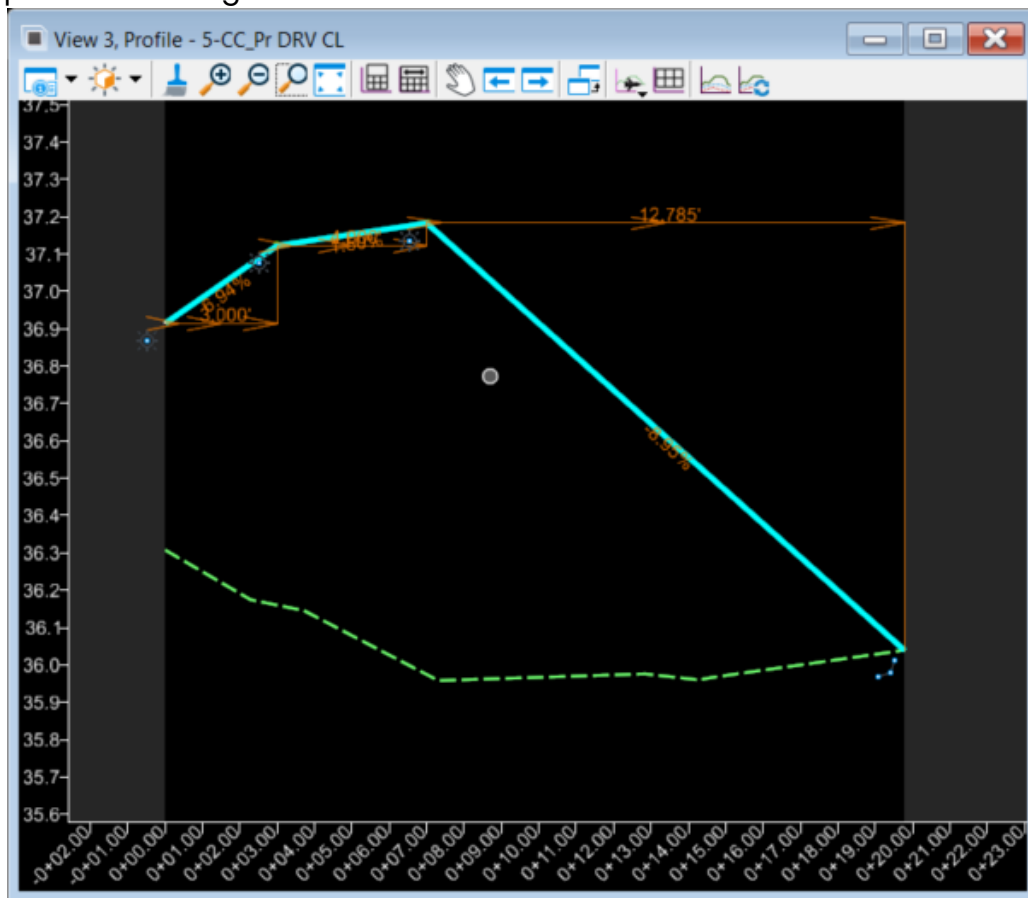

Figure 174

13. Similarly, both Edges of driveway's profile can be viewed.
14. The profile of Driveway CL and Edge of driveway is generated from Edge of road elevation, Sidewalk front- and back-line elevation and the existing ground elevation at match line.
15. If the designer wants to change the elevation, select the **Sidewalk front line or sidewalk back line element**. (Select **element (K) or (O)**)
16. Select **Sidewalk front line**, Open the **Properties** dialog and expand **Profile By Projecting LinEnt3d Slope Rule** group, Change **Vertical Offset** to desired elevation.

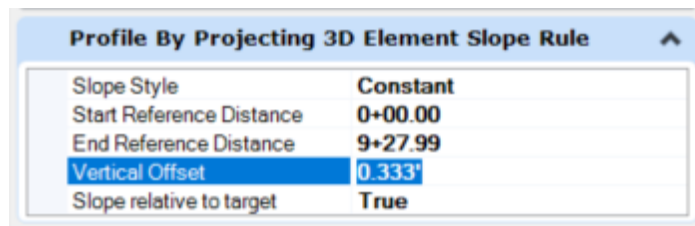

Figure 175

17. The profile will update automatically.