

CONNECT DDE GUIDE



CONNECTICUT DEPARTMENT OF TRANSPORTATION

DIGITAL DESIGN

ENVIRONMENT GUIDE

CONNECT EDITION

Volume 3.2 – OpenRoads Designer Roadway Templates

Published Date: February 20, 2026

Table of Contents

- Table of Contents 1
- Course Overview 3
- Exercise 1 – Getting Started 4
 - 1.1 Introduction 4
 - 1.1.1 CTDOT Point Names 6
 - 1.1.2 CTDOT Component Names and Features 7
 - 1.2 Opening the Application 9
 - 1.3 Setting up the Project Roadway Templates 12
 - 1.4 Copy Typical Sections Templates into Project Library 14
 - 1.5 Point Names and Features 16
 - 1.6 Change the Widths and Slopes of a Pavement Section 19
- Exercise 2 - Assemble a Template from Components 24
 - 2.1 Copy over Template Components 25
 - 2.2 Setup Template Options 26
 - 2.3 Create and Assemble a New Template 27
 - 2.3.1 Assemble the Backbone 27
 - 2.3.2 Merge the Backbone 31
 - 2.3.3 Add Parametric Constraints 32
 - 2.3.4 Add End Condition to the Template 33
- Exercise 3 - Edit a Template 36
 - 3.1 Assemble the Backbone 36
 - 3.2 Make Adjustment to the Backbone 39
 - 3.3 Add End Conditions 43
- Appendix 44
 - 3.4 Create Template Menu Commands 44
 - 3.4.1 Options... Dialog 45
 - 3.4.2 Dynamic Settings Dialog 47
 - 3.5 Template Library 48
 - 3.5.1 Folders and Template list 48
 - 3.5.2 Active Template 49

Volume 3.2 - OpenRoads Designer Roadway Modeling

- 3.5.3 Creating New Folders and Templates 49
- 3.5.4 Current Library 50
- 3.6 Template Points 53
 - 3.6.1 The Point Properties Dialog..... 53
 - 3.6.2 Point Constraints 55
- 3.7 Point Constraint Types 57
 - 3.7.1 Editing Points with the Left Active Template Window 59
 - 3.7.2 Null Points 60
 - 3.7.3 Testing Point Controls 60
- 3.8 Template Components..... 61
 - 3.8.1 Creating Template Components 64
 - 3.8.2 Drag and Drop Component Operations 68
 - 3.8.3 Affixes..... 70
 - 3.8.4 Merge Components..... 71
 - 3.8.1 Component Editing 72
 - 3.8.2 End Conditions 74

Course Overview

This course teaches how to efficiently modify and use existing templates, such as those delivered in the Workspace, for your project situations. You will learn how to manage template libraries and edit templates to satisfy project specifications.

Skills Taught

Learn how to:

- use the Template Library Organizer to copy templates from the standards template library to the project template library
- assemble a template from pavement, curbing, and end condition components
- edit roadway templates

DGN File uses:

Exercise 1 – Highway\Base_Models\HW_CB_0047_0122_Corridor_Route140.dgn

Exercise 2 – Highway\Base_Models\HW_CB_0047_0122_Corridor_Route140.dgn

Exercise 3 – Highway\Base_Models\HW_CB_0047_0122_Corridor_Route140.dgn

Exercise 1 – Getting Started

1.1 Introduction

Templates are made up of components which in turn are defined by points. One or more components combine to create a template. Components can be closed shapes such as an asphalt layer, or they can be open shapes such as cut and fill slopes. Examples of components include curbing, sidewalks, asphalt layers, aggregate layers, median barriers, or the side slopes to be used when in cut and fill areas.

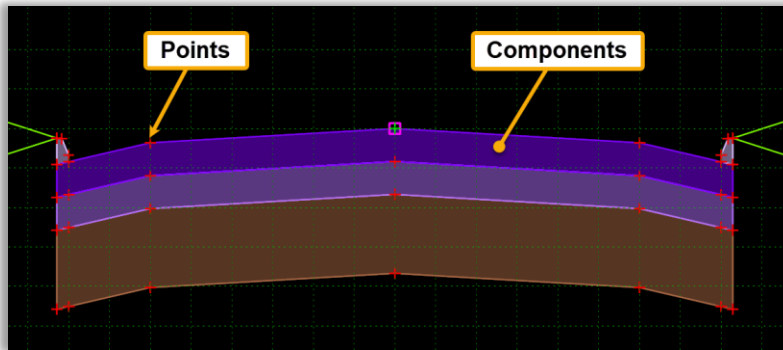

Figure 1 – Points and Components

Templates represent cross sectional geometry. A 3D model is created by extruding the template along a 3D geometric path. As the template is extruded the template points connect longitudinally to create 3D surfaces and meshes. Templates can be used along a road or rail centerline and profile grade line using Corridor tools to model a roadway but they can also be applied along any 3D geometry using the Apply Linear Template tool. For example, a curb template can be applied around a traffic island. Templates are stored in a Template Library File, which has the file extension .itl.

The Create Template command generates the transverse geometry that is the central to roadway design. A template is comprised of a series of points and components that represent breakline features that are later processed using the Roadway Designer command. Roadway features that have been processed are saved to the design surface. Templates are stored in a template library (*.itl). In simple terms, the template is a “smart” typical section that you “push” along an alignment to create the proposed 3D model. Template tools can be accessed by selecting **Corridors > Template > Create Template**.

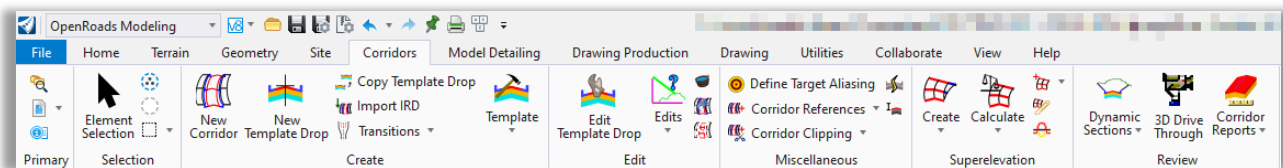

Figure 2 – Corridor Tools

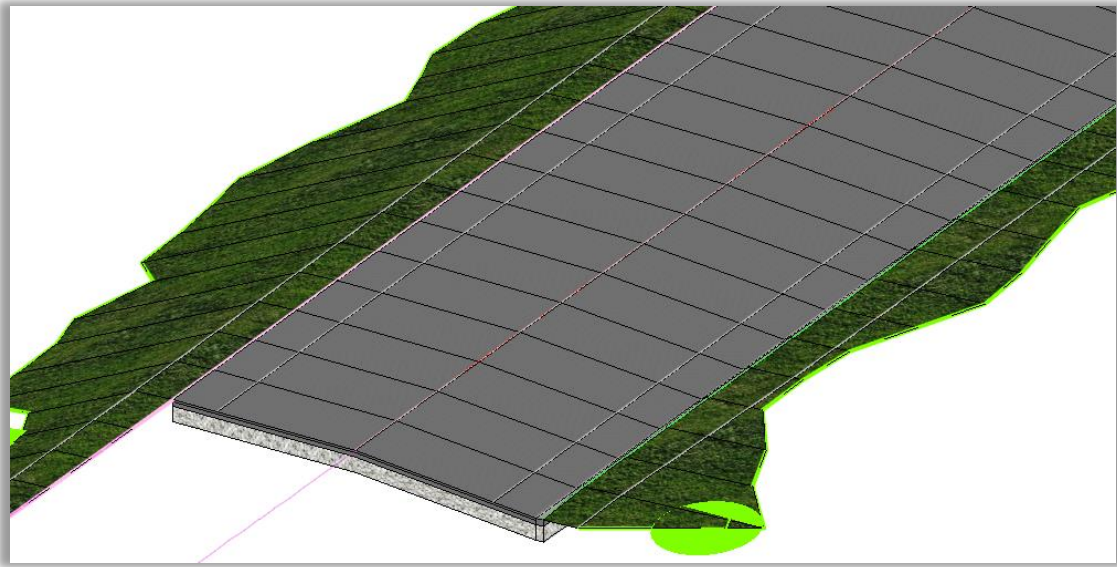

Figure 3 - 3D View

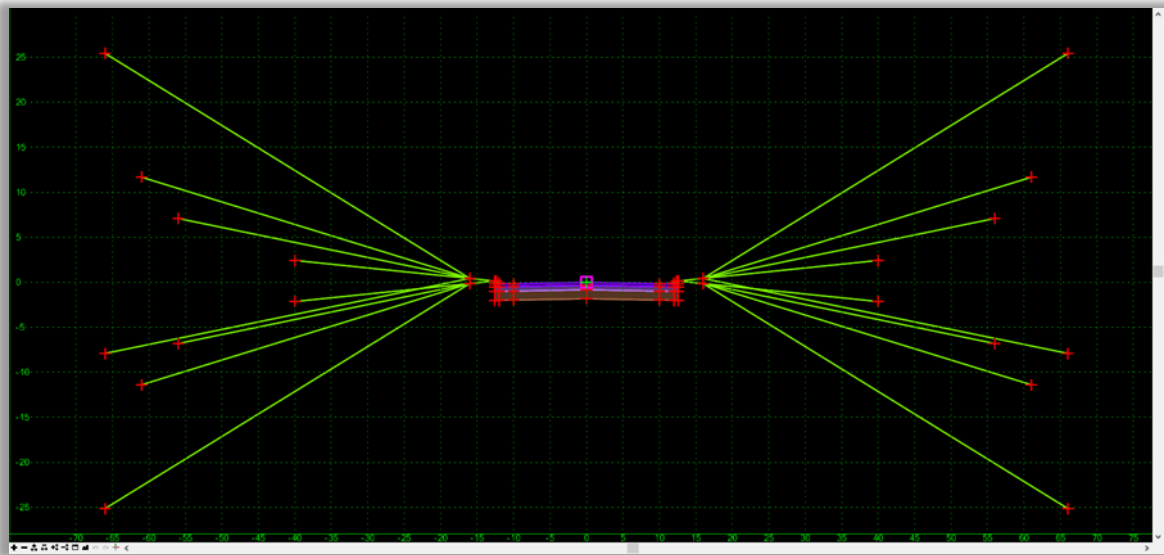

Figure 4 - Example of a template for a 2-Lane undivided highway

1.1.1 CTDOT Point Names

An example of the standard point names with suffixes are listed below:

Point Name	Description
EOR	Edge of Road on Top Surface
EOR_b	Edge of Road on Pavement Base Course
EOR_sb	Edge of Road on Subbase
EOR_sg	Edge of Road at Subgrade
EOR_pa	Edge of Road on Processed Aggregate

List of Point Name (prefixes):

Prefix Point Name	Description
BCLC	Bituminous Concrete Lip Curbing
BCPC	Bituminous Concrete Park Curbing
BOC	Back of Curb
CC	Concrete Curb
CL	Centerline
CPC	Concrete Park Curb
CUT	Cut Slope Limit
DNC	Do Not Include
EOR	Edge of Road
FILL	Fill Slope Limit
GC	Granite Curb
GSC	Granite Slope Curb
SHDR	Shoulder
SNOW	Snow Shelf
TRWY	Travelway

1.1.2 CTDOT Component Names and Features

When creating new Components in the Template Library the Mesh Feature Definitions defined in **CV_Highway_Features_Levels_ElemTemp.dgnlib** should be used.

The component feature definitions can be reviewed by browsing to the following folder in the Civil Standards tab: **Libraries > Feature Definitions > Mesh**

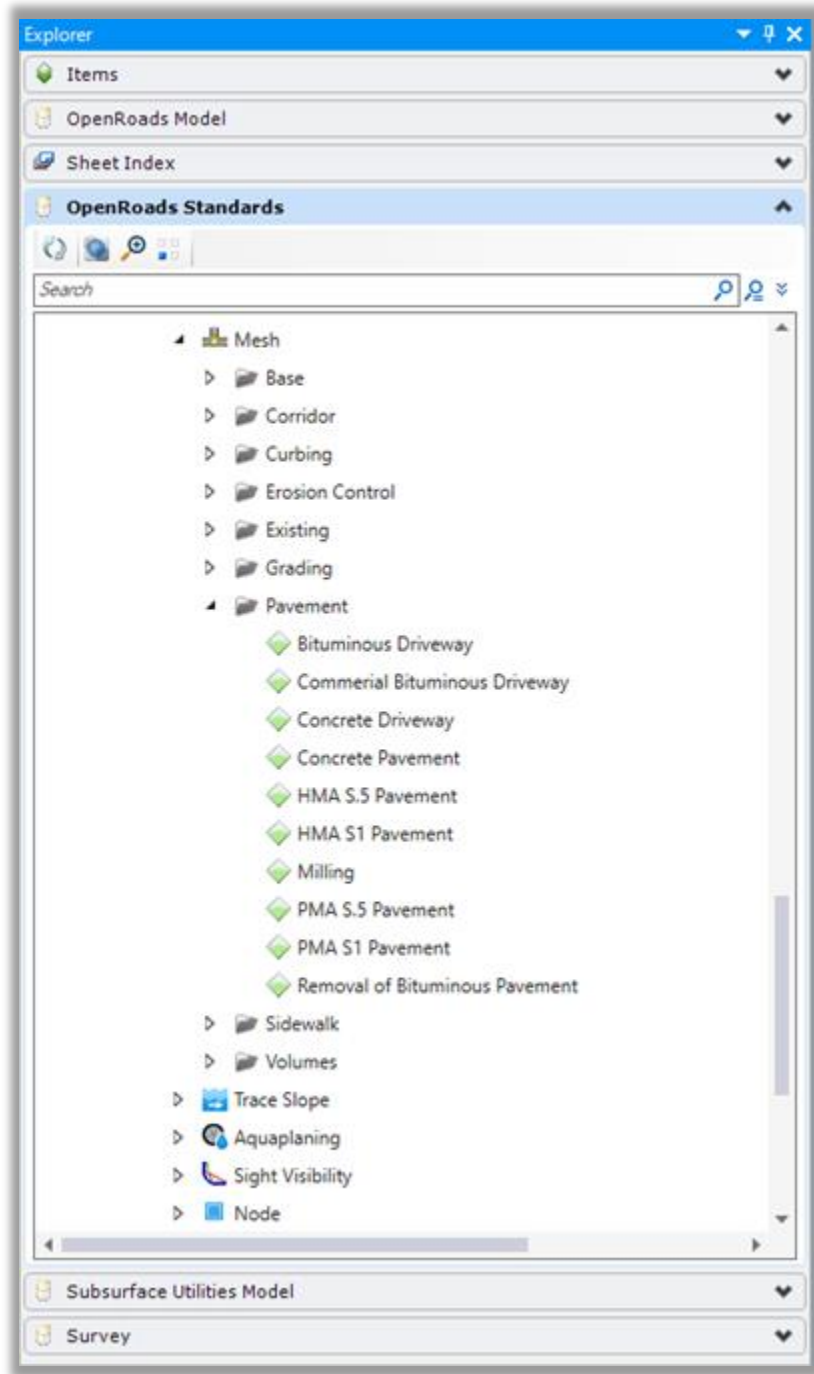

Figure 5 - Component Names

Volume 3.2 - OpenRoads Designer Roadway Modeling

Component Names and Features can be reviewed and edited by double-clicking on a component to open the Component Properties dialog.

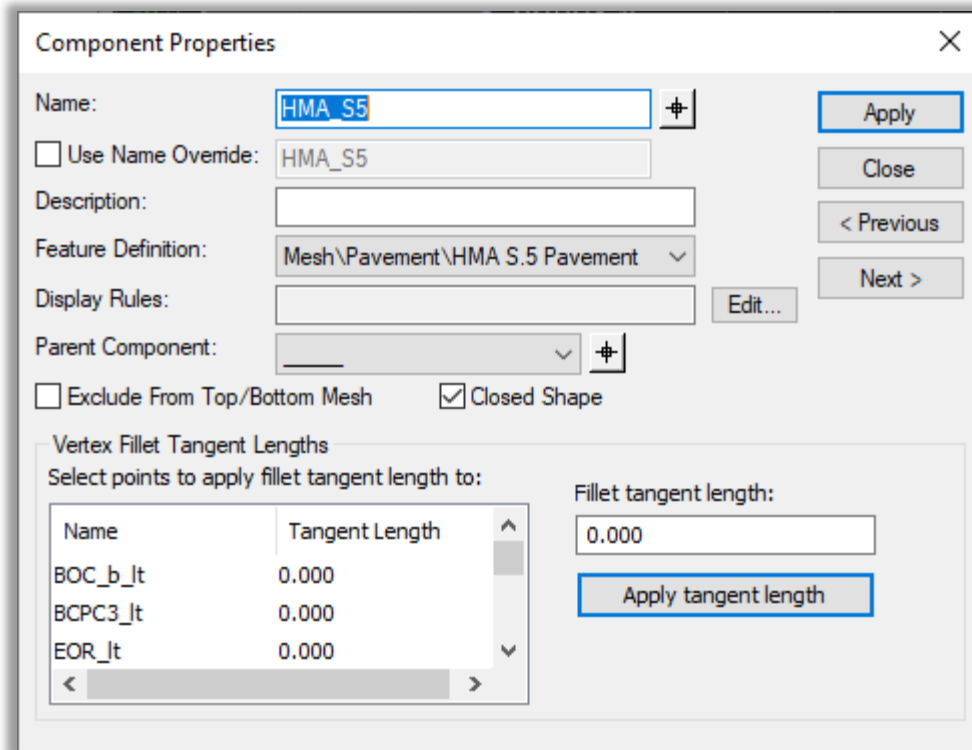

Figure 6 - Component Properties

1.2 Opening the Application

Before starting this exercise:

1. The CTDOT CONNECT DDE synced through SharePoint
2. The COMPASS **Training** Project Synced (i.e. 9999-0001 - Design)

Notes for working on actual projects:

1. CTDOT users should have the CTDOT CONNECT DDE synced through SharePoint with the COMPASS Project Synced along with the CAD Configuration.
2. Consultants should have CTDOT DDE properly installed or be syncing to the CTDOT DDE SharePoint/COMPASS system.
3. Make note of the **Coordinate System** you will be working in. If you have existing survey data, you will need to find out what system is being used (**NAD 83/NAVD 88 or NAD 27/NAVD 29**).
4. Log on to the CONNECTION Client. *Bentley Connect licensing requires users to log into their Bentley account to secure a software license. CTDOT users should log in using your CTDOT email address and Bentley password. If you do not see the dialog box, select the ^ icon on the bottom Windows Screen. Click on the Connection Client Icon and select **Open**.*

3. Launch the Application. On your desktop double click on the **Accounting Icon**.

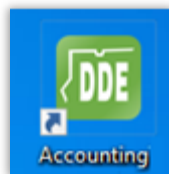

Figure 7 - CTDOT CAD Accounting Icon

4. On the CTDOT Accounting Menu there will be several applications to pick. In the **Run Program** field select the needed program:
 - **Compass OpenRoads CE**
 - for the Available Account select **OVERHEAD** for training proposes.
 - Click on the **Start** button to load the program.

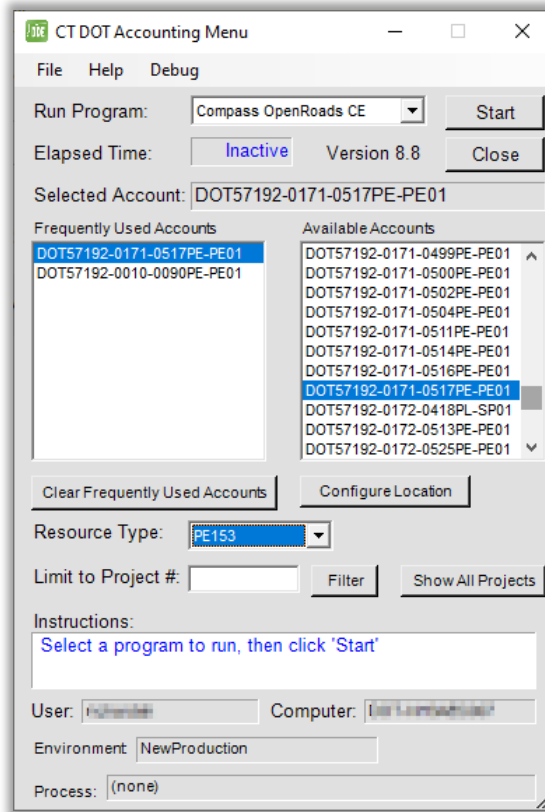

Figure 8 - CT DOT CAD Account Dialog Box

5. After launching the program, a Welcome Screen for **OpenRoads Designer** will appear.
6. Ensure you are using the **Custom Configuration** and **CT_WorkSpace**, then select the relevant **WorkSet** (Training WorkSets start with 9999_0001, select the # that you were assigned) and **Role**.
7. Browse to: **Highway|Base_Models|HW_CB_0047_0122_Corridor_Route140.dgn**

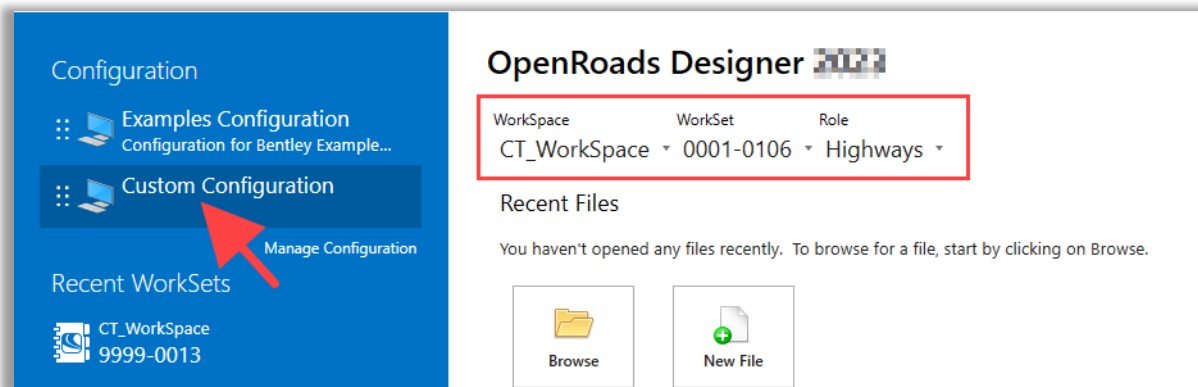

Figure 9 - OpenRoads Start up Screen

Volume 3.2 - OpenRoads Designer Roadway Modeling

8. In the upper left select the **OpenRoads Modeling** Workflow, and click on the **Corridors** tab. The commands are separated into five main categories:

- Create
- Edit
- Miscellaneous
- Superelevation
- Review

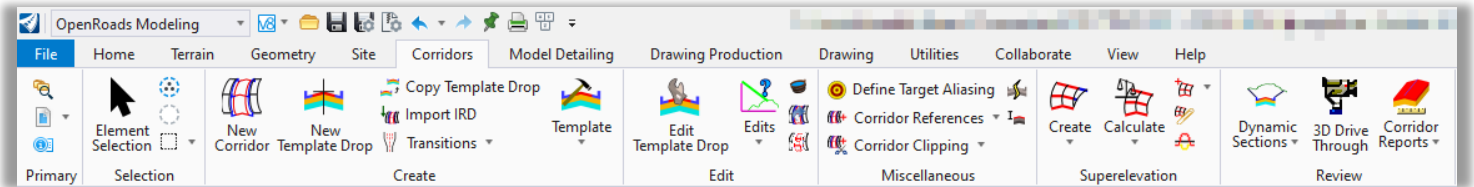

Figure 10 - Corridor Tools

1.3 Setting up the Project Roadway Templates

Templates are used to define the typical section for each alignment. Multiple templates can be used to define different typical section designs, or the template geometry can be modified using a variety of corridor editing tools.

CTDOT provides a sample template library in the following folder:

...CT_Configuration\Organization-BIM_CT_Civil Standards\Template Library\CV_ORDTypicals.itl

A blank ITL file can be found by default in the highway design folder

...Highways/Eng_Data/Project_Typicals.itl.

Required individual templates will be copied over from

CV_ORDTypicals.itl to **Project_Typicals.itl** using the **Template Library Organizer**.

Please note: Any other disciplines modeling a corridor can **copy** a blank ITL from **...CT_Configuration\Organization-BIM_CT_Civil Standards\Template Library\Project_Typicals.itl** and paste the file into the discipline-specific folder for engineering data:

Discipline project location of ITL:

- Bridge/Eng_Data/
- Envir/Eng_Data/
- F_Civil/Eng_Data/
- Geotech/Eng_Data/
- Hwy_Man/Eng_Data/
- Hwy_Ops/Eng_Data/
- Hydro/Eng_Data/
- Illumination/Eng_Data/
- Landscape/Eng_Data/
- Public_Trans/Eng_Data/
- R_Catenary/Eng_Data/
- R_Signals/Eng_Data/
- R_Track/Eng_Data/
- Traffic/Eng_Data/
- SVY_District/_Eng_Data/
- PMaps/
- SVY_Central/
- SVY_Consultant/

Warning:

Do not change the name or path of the Project_Typical.itl file.

If this file name gets modified after Templates are placed in a Corridor the **Synchronize with Library** tool will not be able to update itl edited templates.

This path is also set as a variable used across all projects so your file will always be read in.

1. Select **OpenRoads Modeling > Corridors > Template > Create Template**

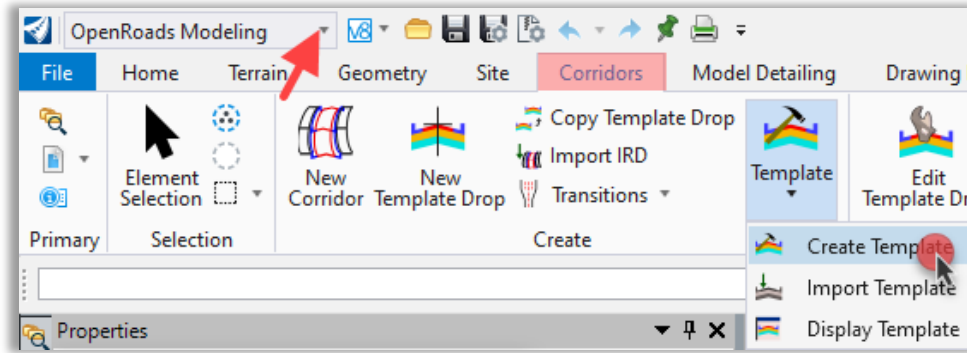

Figure 11 Create Template Tool

2. The Template Library will open to **...Highways/Eng_Data/Project_Typicals.itl**.

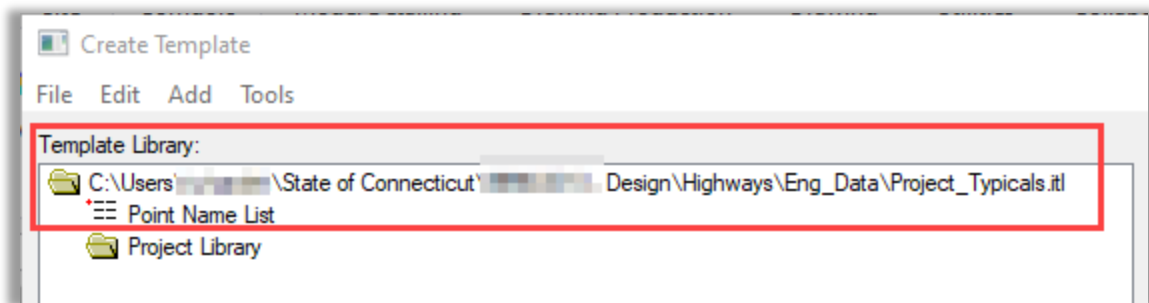

Figure 12 Project Typicals File

If the template library is pointing to a random place or file please do the following.

- a. Go to file explorer and copy **...DOT CTDOT_DDE - Connect|CT_Configuration|Organization-BIM|_CT_Civil Standards|Template Library|Project_Typicals.itl**
- b. Paste the file into **...Highways/Eng_Data/**
- c. Any other disciplines modeling a corridor can **copy** a blank ITL from **...CT_Configuration|Organization-BIM|_CT_Civil Standards|Template Library|Project_Typicals.itl** and paste the file into the discipline-specific folder for engineering data:
- d. Now back in the Create Template select **File > Open** and open the **.itl** file you just copied to your project.

1.4 Copy Typical Sections Templates into Project Library

Sometimes you will need to copy templates from one template library to another. A common use of this is to copy templates from your CTDOT standards template library (which is read only) to your project template library where you can edit the templates as necessary.

In this section, we will use the Template Library Organizer to copy existing templates from the CTDOT template library into the project template library so we can then include the curbs on our template.

1. In the Create Template dialog box select **Tools > Template Library Organizer...**

This dialog allows dragging and dropping of templates and folders between the active template library and another template source. The active template library (our standards library that loaded automatically when we restarted the software) is displayed on the left.

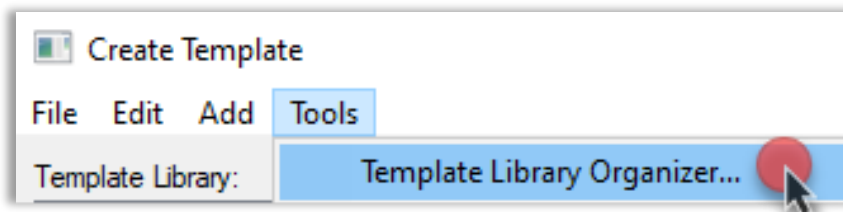

Figure 13 - Template Library Organizer Pull Down Tool

2. Select **Browse...**

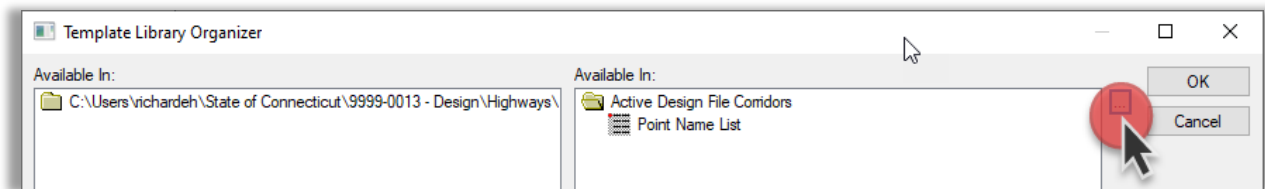

Figure 14 - Template Library Organizer Browse Button

3. Browse to **...CT_Configuration|Organization-BIM|_CT_Civil Standards|Template Library| CV_ORDTypicals.itl** and click **Open**.

The template library you opened is shown on the right side of the window. The active template library is shown on the left side of the window.

4. Expand the right hand **Available in** folders and to view **HWY Typical Sections**
5. Drag **2In_HMA_BCPC** and **2In_HMA_NC** from the right to the **Project Library** folder on the left.

You have now copied over two roadway templates. You can also copy an entire folder and all of its contents from one template library to another by dragging a folder over.

6. When complete click **OK**.

Volume 3.2 - OpenRoads Designer Roadway Modeling

- The templates and components are organized in the template library using a folder structure much like files are stored on your computer. The template folder tree appears on the left side of the dialog.
- To navigate the folder structure, double-click the folders you want to open or close. The organization of the folder structure is user-definable. The folder structure also supports common Windows functions, such as drag and drop, cut and paste, etc. Most commonly-used commands can be accessed by right-clicking on the folder and template names.
- Double-clicking a template name sets it as the active template. The Active Template is signified by a red box around the template icon. The Active Template is also displayed in the center of the dialog box.

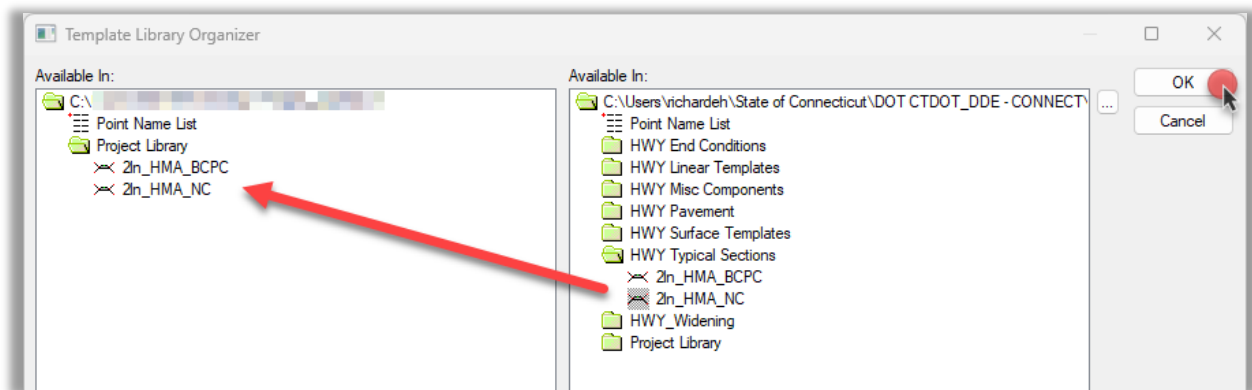

Figure 15 - Template Library Organizer Dialog Box

7. **Save** the template library.

1.5 Point Names and Features

CTDOT's template library is supplied with many template components defined that can be used as the starting point for creating and editing templates for a project. The folders in this library contain various Components and End Conditions that can be used to create completed templates. These components use CTDOT Standard Point Names, Component Names and Feature Definitions. If a user decides to create templates from scratch, it's important to remember that each point and component in the template is assigned a **Name** and a **Feature Definition**. It is imperative to ensure that the points and components are named and assigned features consistent with CTDOT standards.

Feature definitions for template points and components are defined in **CV_Highway_Features_Levels_ElemTemp.dgnlib**, which is attached by a configuration variable. As the template is applied to the corridor, 3D line strings are drawn in the design file by connecting the points from template drop to template drop by their **Name**. The symbology of these line strings is controlled by the **Feature Definition** that is assigned to each point. The CTDOT CONNECT DDE includes a multitude **Feature Definitions** that can be used for template points.

The point feature definitions can be reviewed by browsing to the following folder in the Civil Standards tab: **Libraries > Feature Definitions > Linear > Roadway Modeling > Template Library**

The component feature definitions can be reviewed by browsing to the following folder in the Civil Standards tab: **Libraries > Feature Definitions > Mesh > ...**

Templates are defined by inserting Points, Components.

1. To view a standard Roadway Template double-click **Project Library** to expand the folder.
2. Double-click on the **2In_HMA_NC** template to make it active and editable. The template is now displayed. This template is made up of pavement and base components for the pavement and shoulders. The side slopes are made up of end condition components which are used to tie down to an existing terrain model.

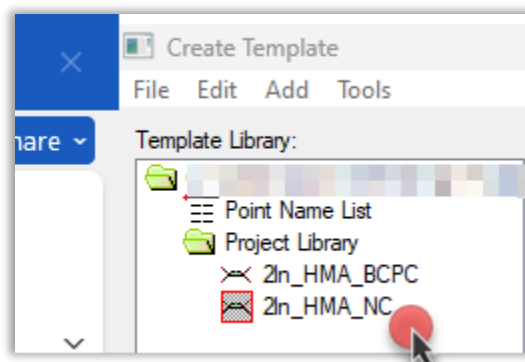

Figure 16 - Open Roadway Template

3. In the Template Display Window click on the Point **EOR_It**. In the Point Properties notice the Feature Definition. Review the other settings and Close the box.

Template Points - The points of a template represent breakline features that will be created when the template is processed using the Roadway Designer command. Points have a name and feature style; there is no limit to the number of points in a template. Once processed in Roadway Designer as features, they are saved to the design surface.

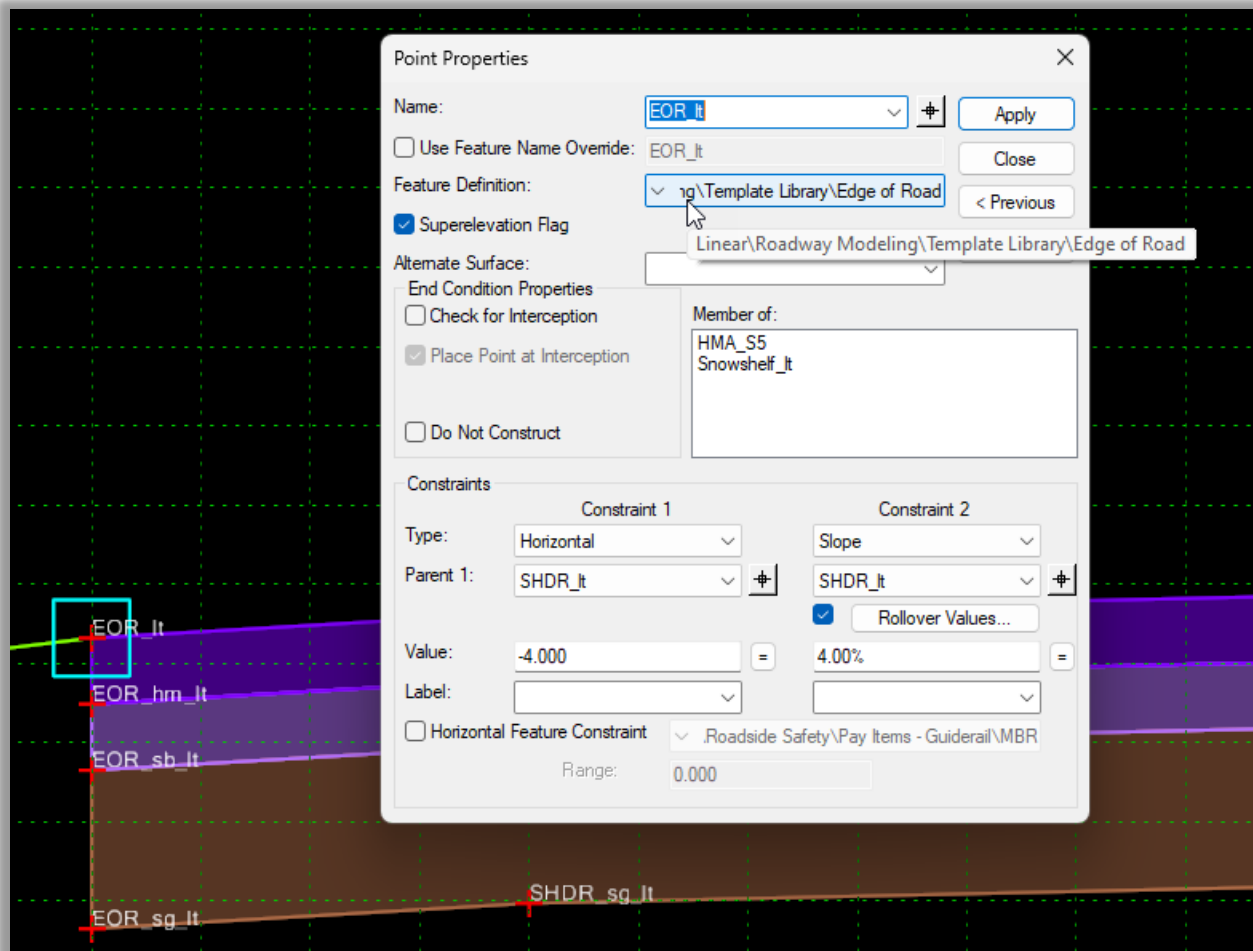

Figure 17 - Point Properties

4. In the Template Display Window click on the Top Component **HMA_S5**. In the Component Properties notice the Feature Definition. Review the other settings and Close the box.

Template Components - A component is a set of points that define an open or closed shape. Each component, whether open or closed, can represent a different material or area of interest. Components are named and have an assigned feature style. There are 6 types of components created in InRoads: *Simple, Constrained, Unconstrained, Null Point, End Condition, and Overlay/Stripping*.

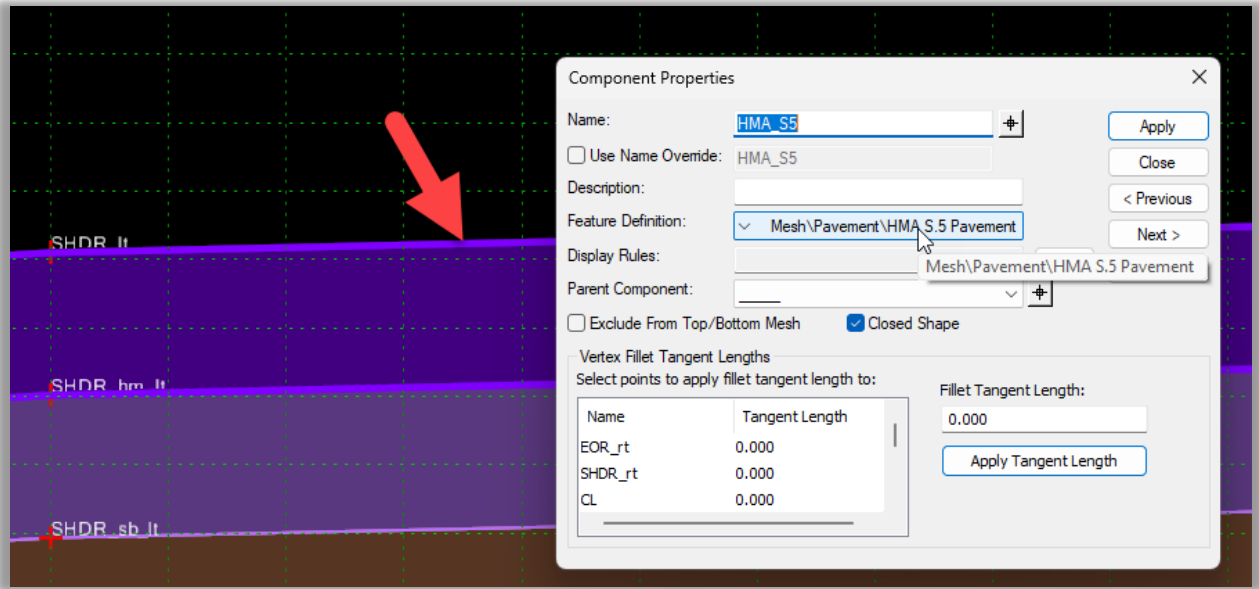

Figure 18 - Component Properties

1.6 Change the Widths and Slopes of a Pavement Section

In this section, we will review the widths and slopes of a pavement section in an existing template. We also will change the width and slope of the Edge of Pavement (SHDR_rt) using two methods. The first is to directly edit the point. The second method we will edit the Parametric Constraint so all points update at once.

1. Double-click **Project Library** to expand the folder.
2. Double-click on the **2In_HMA_NC** template to make it active and editable.

The template is now displayed. This template is made up of pavement and base components. The side slopes are made up of end condition components which are used to tie down to an existing terrain model.

Templates utilize constraints to define the relationship between template points such as the distance or slope between two points. Each point can have up to two constraints which is considered a fully constrained point. A fully constrained points position is fixed relative to its parent point(s). A point with one or zero constraints is free to move in one or more directions.

In the image below, the **CL** point is unconstrained (green) and the **SHDR_rt** point is fully constrained (red). The SHDR_rt point is located **12 feet** from the CL (parent) and at a slope of **-1.5%** from the CL (parent). In this example, the parent is the same for both constraints but that is not a requirement.

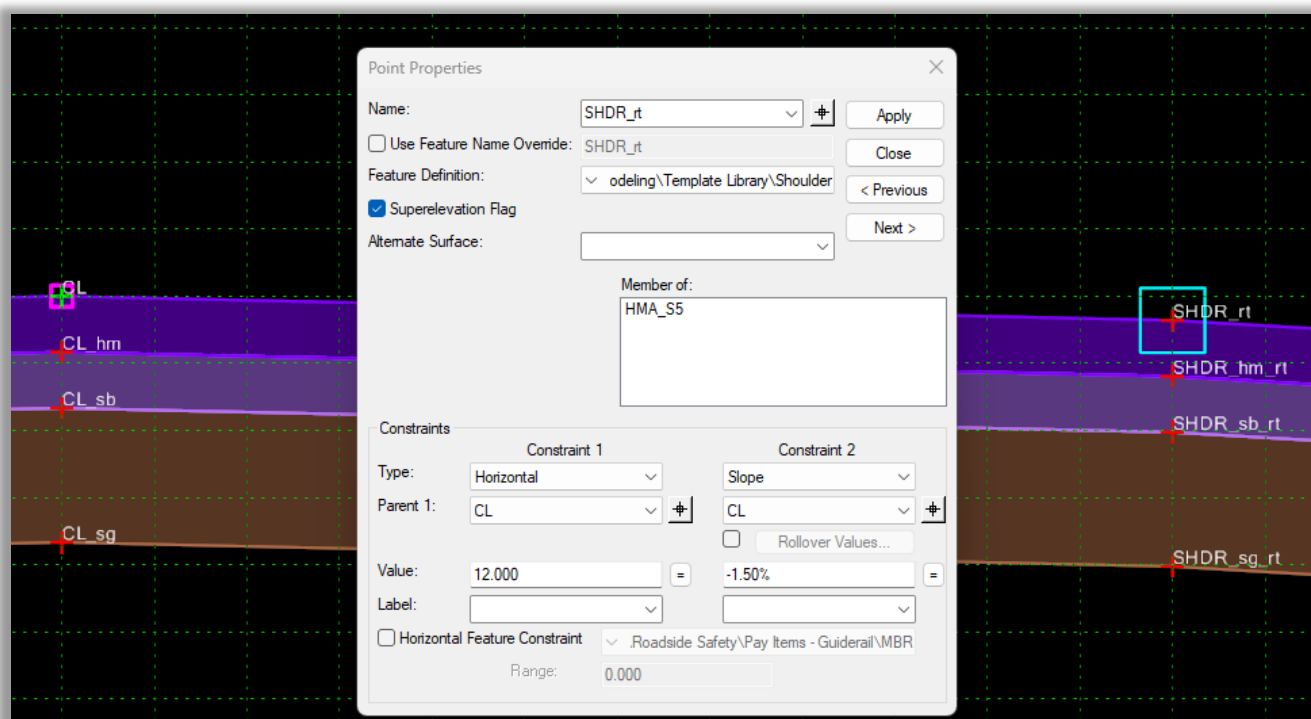





Figure 19 – Point Constraints

Volume 3.2 - OpenRoads Designer Roadway Modeling

The number of constraints a point has is easily identifiable in the interface by the color of the plus sign that represents the point.

-  Red = Fully constrained point with two constraints
-  Yellow = Partially constrained point with one constraint
-  Green = Unconstrained point with zero constraint

The sign of constraint values is also important.

- The distance is positive if the parent has a lower X or Y value than the child.
- The distance is negative if the parent has a higher X or Y value than the child.
- The sign of the component slope is based on the mathematical slope.

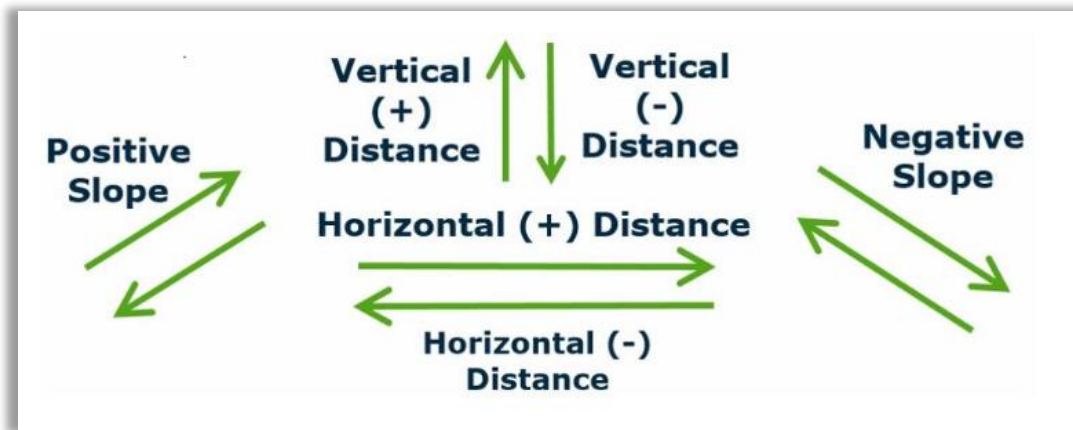

Figure 20

3. Review the SHDR_rt template point properties.
 - a. Using the wheel mouse button Zoom in so the **SHDR_rt** point is easily visible. You can also use the zoom buttons at the bottom of the template display window.
 - b. Double-click on the **SHDR_rt** point.
 - c. The Point Properties dialog appears. At the bottom of the dialog are the constraints that define how the **SHDR_rt** point is geometrically constrained to the **CL** point.

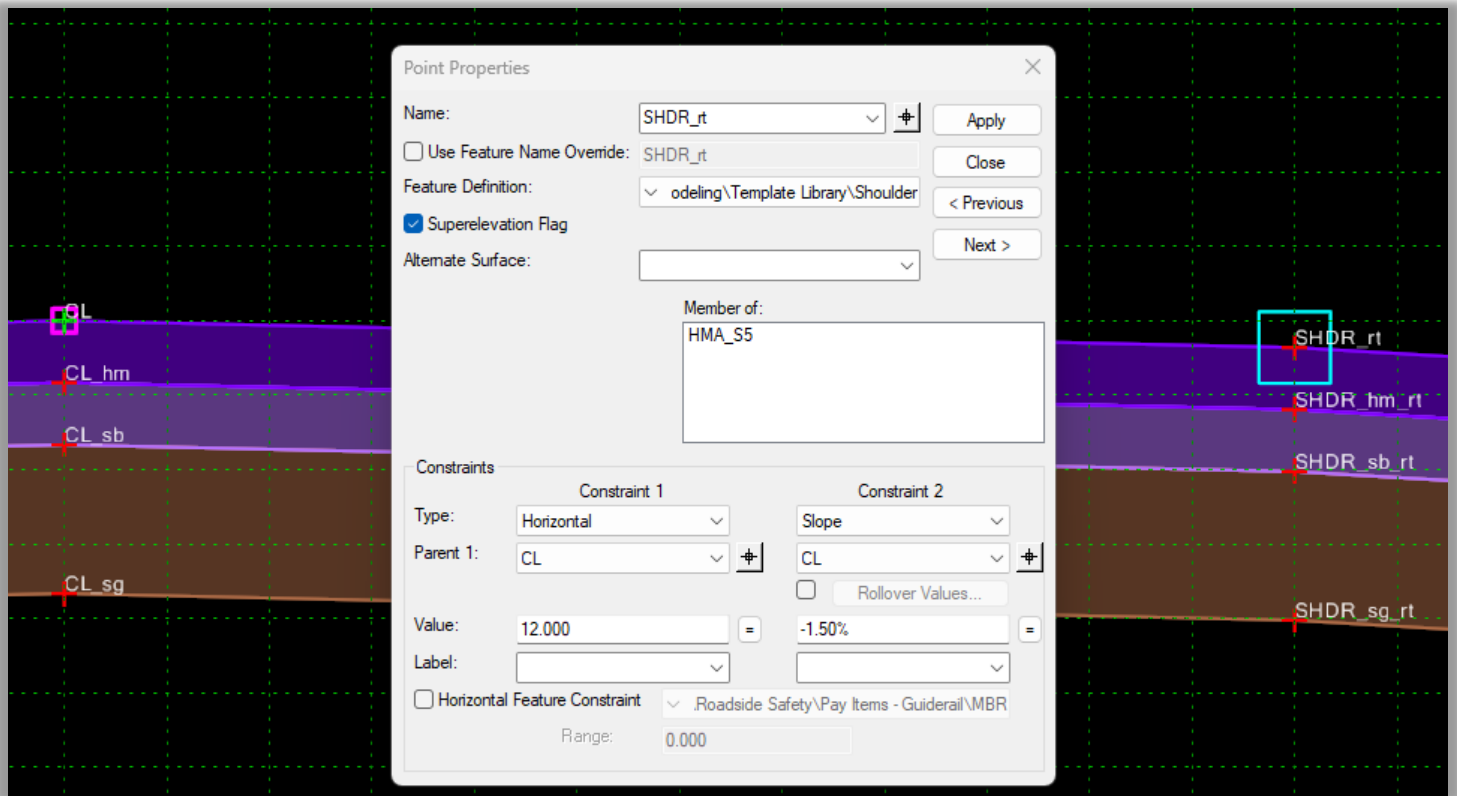

Figure 21 – Point Properties

4. Change the point using the direct method.
 - a. If the Point Properties dialog is closed, Double Click on the **SHDR_rt** point.
 - b. Change the Horizontal constraint value (representing pavement width) to **11 feet**
 - c. Select, **Apply**.
 - d. The **SHDR_rt** point is moved to be 11 feet from the CL point. The points below **SHDR_rt** also adjusted because they are constrained to be at a 0 horizontal offset from the **SHDR_rt** point.
 - e. Use the zoom tools at the bottom of the template window to adjust the display if necessary.
 - f. Type **-2.0%** for the Slope constraint value.
 - g. Select, **Apply**.
 The points below **SHDR_rt** also adjusted because they are constrained to be at a 0 horizontal offset and fixed vertical offset from the **SHDR_rt** point.
 - h. **Close** the Point Properties dialog.

5. Change another point using the direct method.
 - a. Double Click on the **CL_sg** point.
 - b. Change the Vertical constraint value (representing pavement depth) to **-1.5**
 - c. Click **Apply**.
 - d. **Close** the Point Properties dialog.
 - e. Zoom out to view the full pavement width.

The subbase depth updated but only for this single point. We could edit the other points at the bottom of the pavement layer but that would be time consuming and there is a more efficient method using Parametric Constraints. This vertical constraint uses the Label named Subbase Depth. All of the subgrade points use this same label. The label is defined in the Point Properties window.

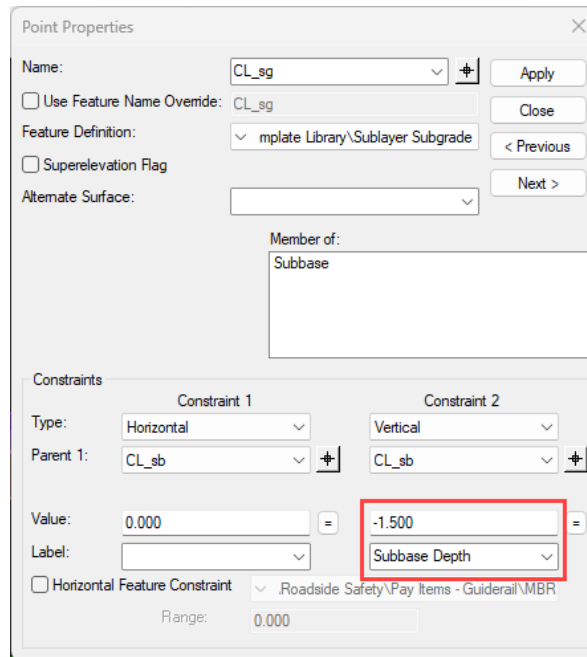

Figure 22 – Depth Constraint

6. Undo the previous change to the pavement depth.

Select the **Undo** icon at the bottom of the Create Template window (not the MicroStation/CAD tools Undo) to undo changing the pavement depth.

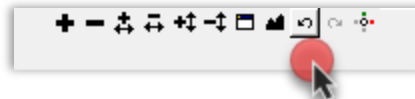

Figure 23 – Undo icon

7. Change the concrete subbase depth by adjusting the Subbase Depth Parametric Constraint.

The values in the Label fields are Parametric Labels or Parametric Constraints. These labels allow the same values to easily be defined across multiple points. In addition, these values can be changed as the template is being extruded resulting in variable thicknesses, slopes, offset distances, etc.

- a. Select the **Active Template** tab on the bottom left side of the Create Template dialog. The Active Template view replaces the tree view of the template library with a list of the elements and values in the active template.
- b. Expand the **Parametric Constraints** list. The Parametric Constraints group lists the predefined constraint value "Labels". These values can be set here as a constant for all templates in this template library. Parametric Constraints can also be changed at runtime as the template is dropped along a corridor. Every corridor has the ability to set any of the templates values station-by-station using the Corridor's Parametric Constraints functionality (visit the learn.bentley.com for additional training on using templates to model a corridor).
- c. Double-click on the **Subbase Depth** parametric constraint. Notice the default value. The Edit Default Parametric Value dialog opens, and the point(s) constrained by the value are highlighted. There should be **5** points highlighted.
- d. Change the Subbase Depth default value to **-1.5**.
- e. Select **OK** and observe the changed depth across the entire template.
- f. **Save** the template library.

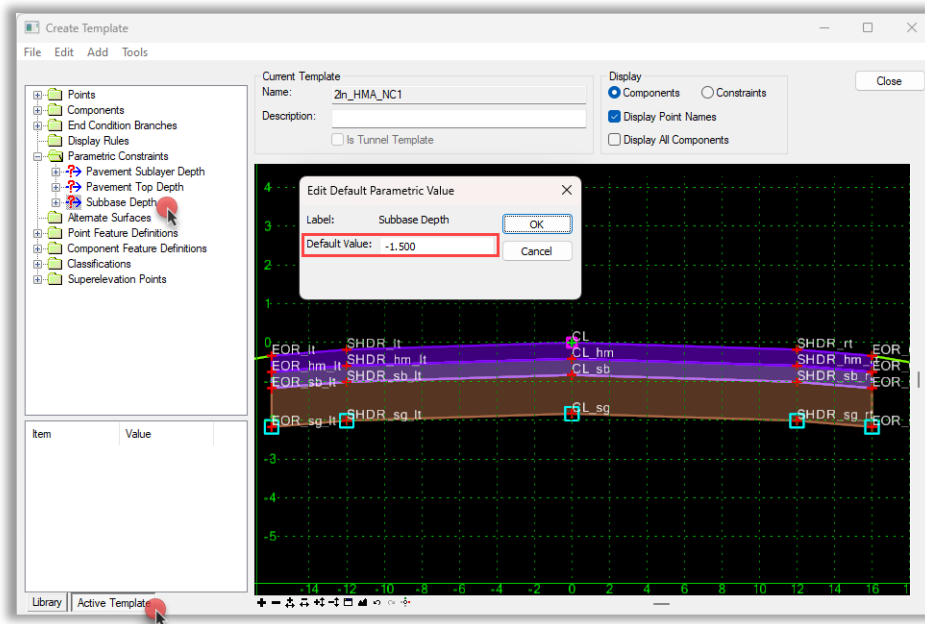

Figure 24 - Parametric Constraints

Exercise 2 – Assemble a Template from Components

In this section, we will create a new template by assembling existing components already in the template library.

Basic Steps

While the process to create templates will have many variables, the general procedure to create templates is summarized below:

1. Copy the needed CTDOT Standard Roadway Templates to the Project's Master Library. Templates can be copied from one library to another by selecting **Tools > Template Library Organizer** from the *Create Templates* dialog.
2. Create a new template or copy a template.
3. Drag and drop template backbones or individual components into the active template.
4. Create/edit the components as necessary.
5. Merge components as desired.
6. Add Parametric Constraints Labels
7. Review the point names and point name overrides. Assure Left and Right are properly set.
8. Review the component names and component name overrides.
9. Test the template behavior.
10. Save the template library.

2.1 Copy over Template Components

In this section, we will set up the template options to be able to efficiently assemble components.

1. Select **OpenRoads Modeling > Corridors > Template > Create Template**
2. Open the **Template Library Organizer**.
3. Create a folder names **Exercises**.
4. Browse to open the CTDOT standard library and copy over to the following to the new Exercise 2 folder:

HWY End Conditions | Cut_for_Curb

HWY End Conditions | Cut_for_Ditch

HWY End Conditions | Fill

HWY Mics Components | HMA | 1Ln

HWY Mics Components | HMA | 1Ln_BCPC

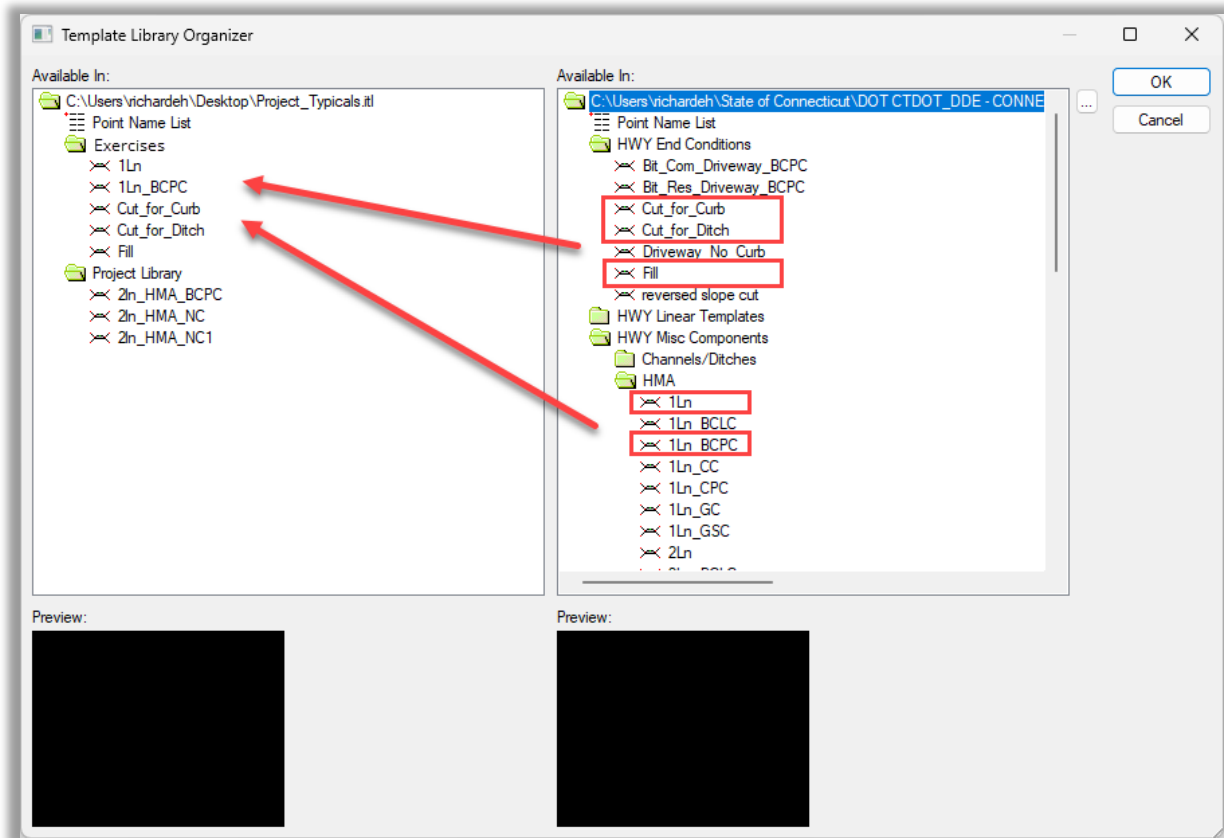

Figure 25 – Template Library Organizer

5. Click **OK**, the Template Library Organizer will close.
6. **Save** the template library.

2.2 Setup Template Options

1. Open the Dynamic Settings by clicking the icon at the bottom of the template window or selecting **Tools > Dynamic Settings**.
 - The Dynamic Settings dialog has many inputs and controls you will use when creating and editing templates.
 - The current cursor position is shown at the top left corner.
2. Define the Step Options

The step options setup a snap grid in the templates window making it easier to drag and drop components and points accurately. These values can be adjusted at anytime.

 - a. Set the Step Options X value to **1.0**.
 - b. Set the Step Options Y value to **1.0**.
3. **Apply Affixes** checkbox should be enabled.

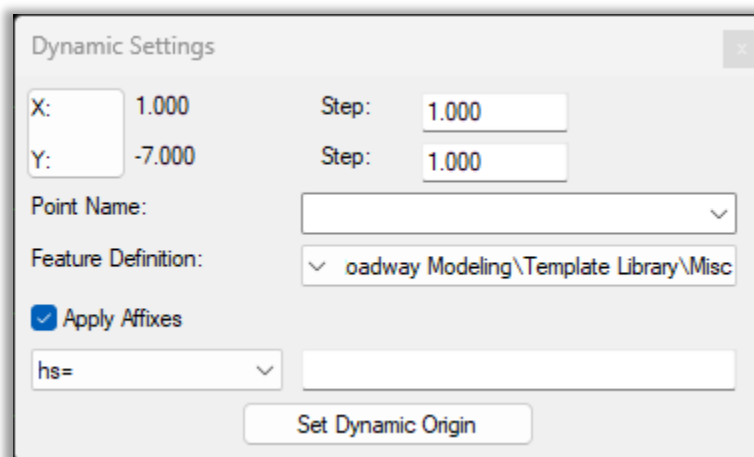

Figure 26 – Dynamic Settings

2.3 Create and Assemble a New Template

2.3.1 Assemble the Backbone

In this section, you will create a new template by dragging and dropping existing components onto the new template to define concrete pavement and aggregate base layers for one lane of concrete pavement and a shoulder which will function as a bike lane.

1. Select the **Library tab** on the left side of the Create Template dialog.

The Library view replaces the active template view.

2. Right-click on the **Project Library** and select **New > Template**.

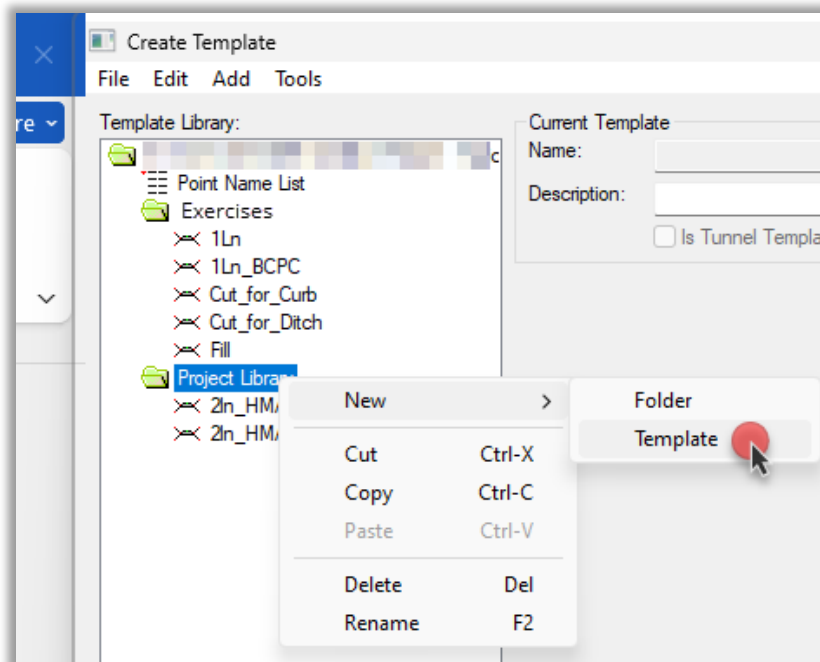

Figure 27 – New Template

3. Type the name **Route 123**.

The new template is made active and editable in the template window. If it is not, Double Click on Route 123.

4. Add the right side of the road.
 - a. Single click on the **1Ln** template the Exercise 2 folder.

Important: Do not right-click or double-click; we want the **Route 123** template to remain Active.

Volume 3.2 – OpenRoads Designer Roadway Modeling

The Preview window in the lower left shows the 1Ln template and its attachment point (blue box). If a different attachment point is desired, click on the new point in the Preview window.

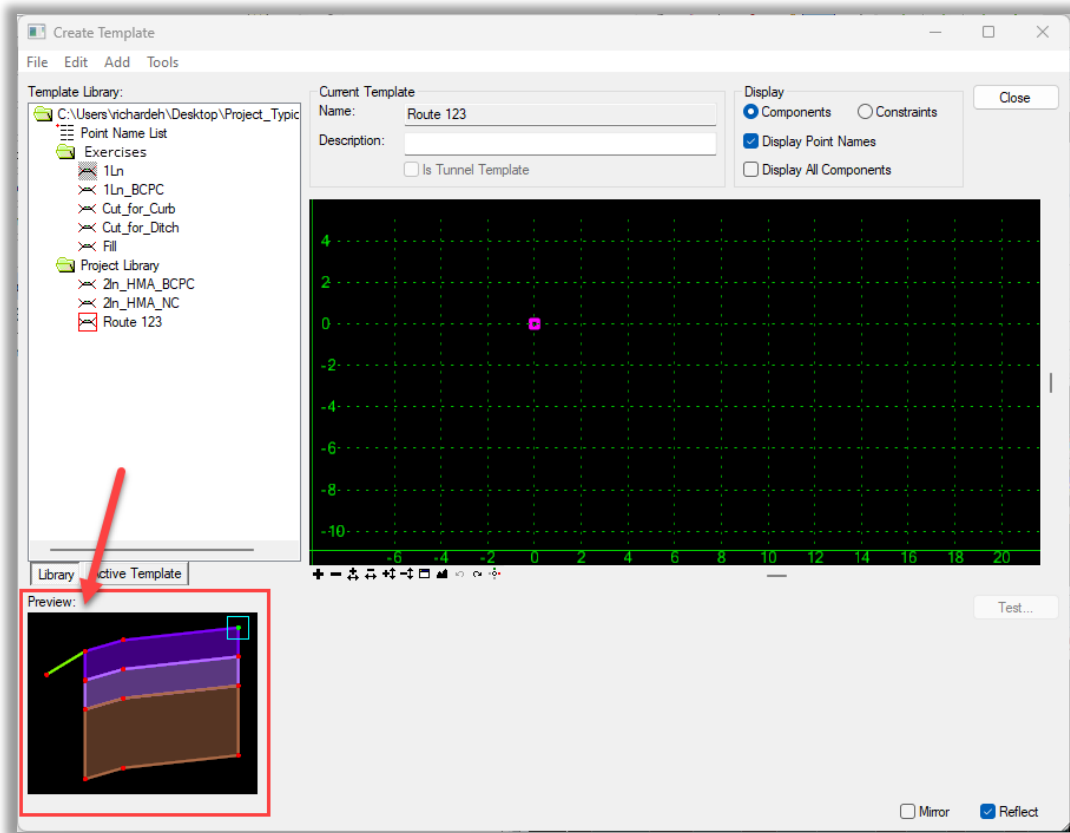

Figure 28 – Template Preview

Volume 3.2 – OpenRoads Designer Roadway Modeling

- b. Select and drag the **1Ln** template into the template window. Before dropping Right-Click and select **reflect**. This will swap to template to drop on the right.
- c. Drag the template to the **0,0 point (the origin)**. Use the Dynamic Settings dialog to see precisely when you are located at (0,0).

Position can be verified by holding the cursor over the point. If you “missed” you can

- Move the point to the origin
- Move the template origin to the point via the Change Template Origin tool which can be reached by right-clicking in the Edit Template window.

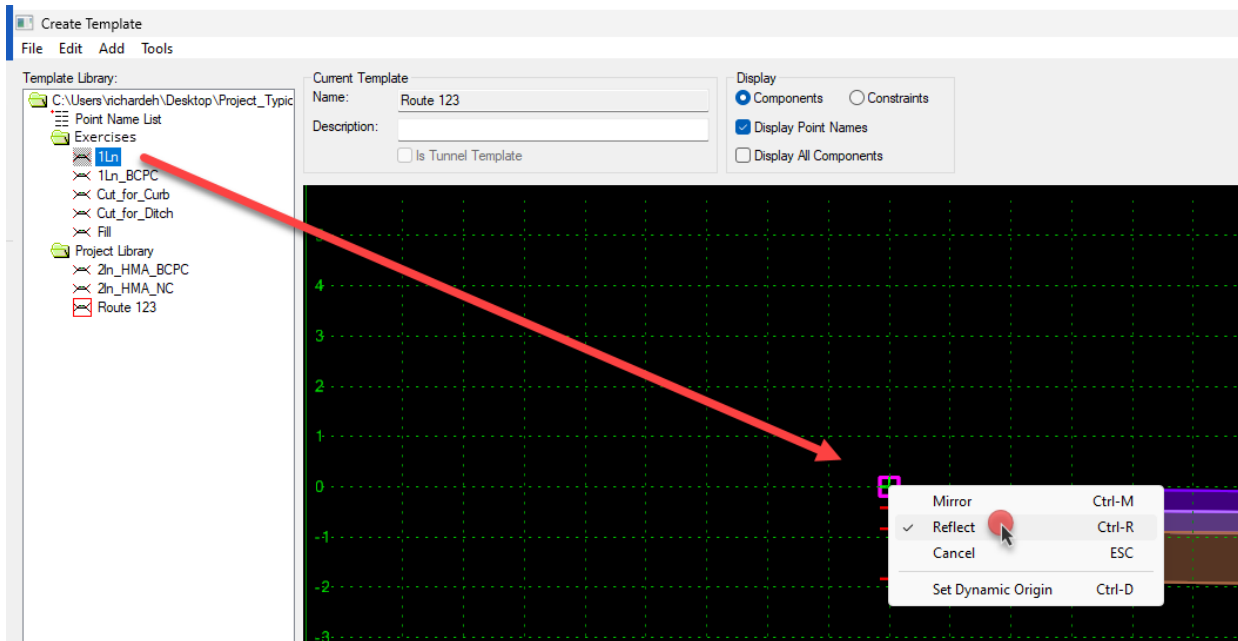

Figure 29 – Drag in Template

Volume 3.2 – OpenRoads Designer Roadway Modeling

- Adjust the window limits as necessary to see the component. (fit view.)
- Add left side of the road, this time dragging in **1Ln_BCPC** and turning **off reflect**.

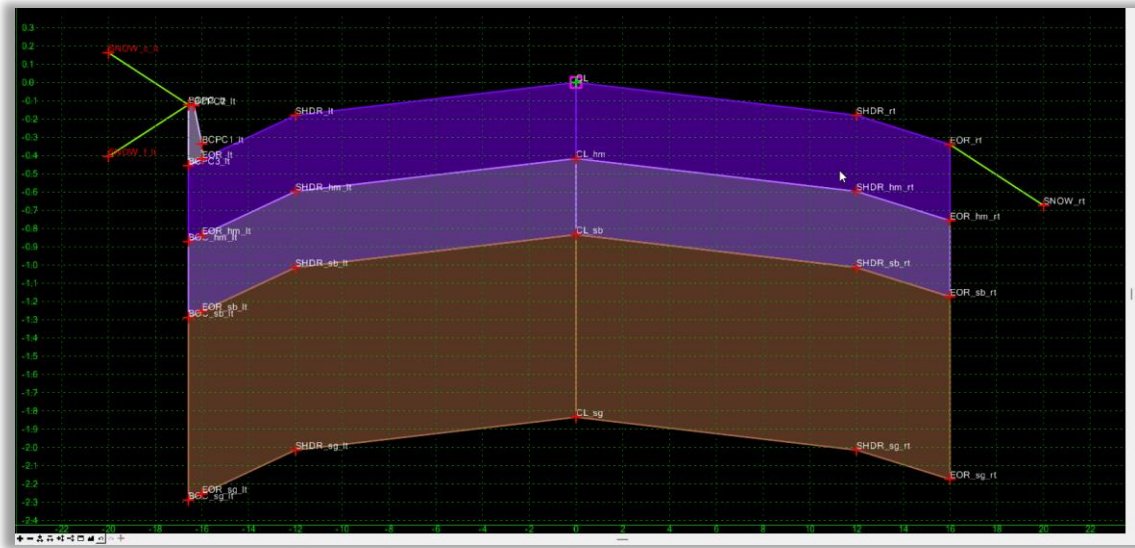

Figure 30 – Pre-Merged Template

- Click on **Subbase** layer in the Component Properties dialog remove **_rt** from the Component name. Click **Apply** and **Close**.
- Repeat for **HMA_S1** and **HMA_S5**.

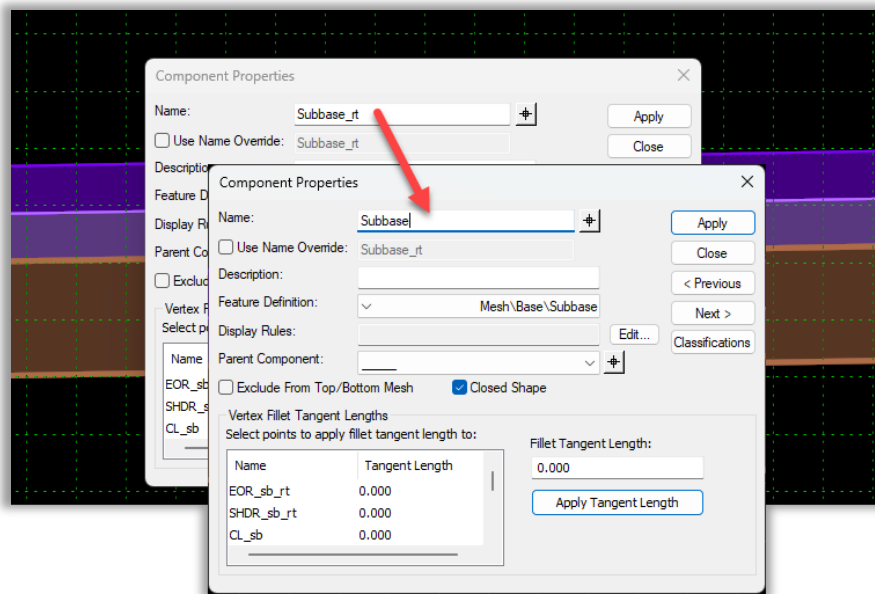

Figure 31 – Update Component Name

- Select **File > Save** to save the template library.

2.3.2 Merge the Backbone

1. Merge common pavement components into a single pavement component.

At the centerline where the two mirrored templates come together there are two components that define the pavement layer. Sometimes it is desirable to merge these into a single component.

- a. Zoom to see the CL where the surface components come together.
- b. Right-click on the shared boundary between the left and right top pavement layer, click Merge Components.

The components now become one.

- c. Repeat the Merge process for the sublayer components.

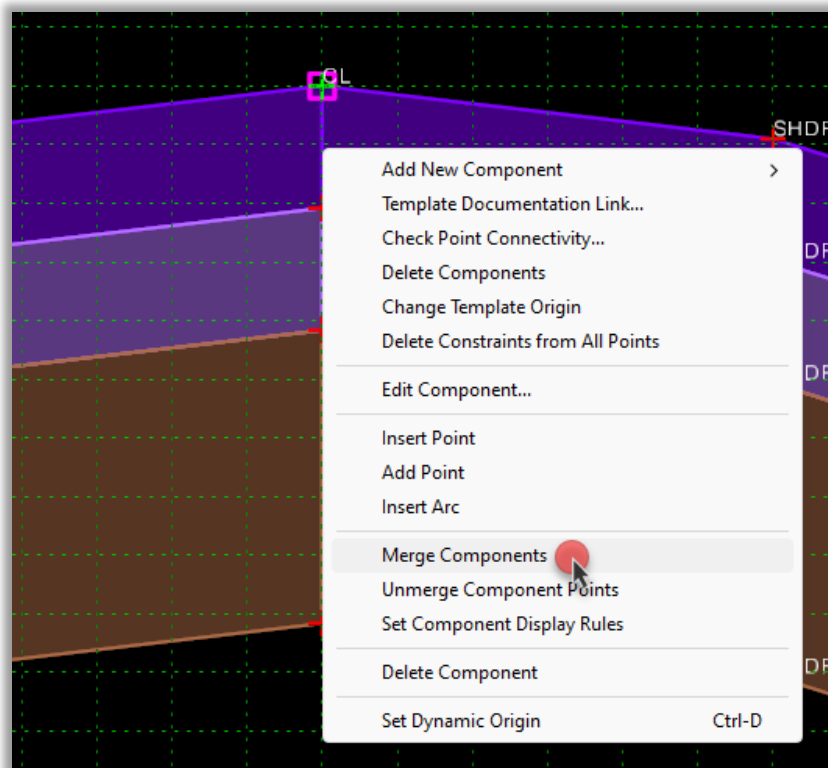

Figure 32 – Merge Template

2. Select **File > Save** to save the template library.

2.3.3 Add Parametric Constraints

1. Add the **Parametric Constraints** to each sublayer on the backbone.

Click on each **CL** sublayer point, in the Point Properties enter:

- CL_sg** = Label: **Subbase Depth**
- CL_sb** = Label: **Pavement Sublayer Depth**
- CL_hm** = Label: **Pavement Top Depth**

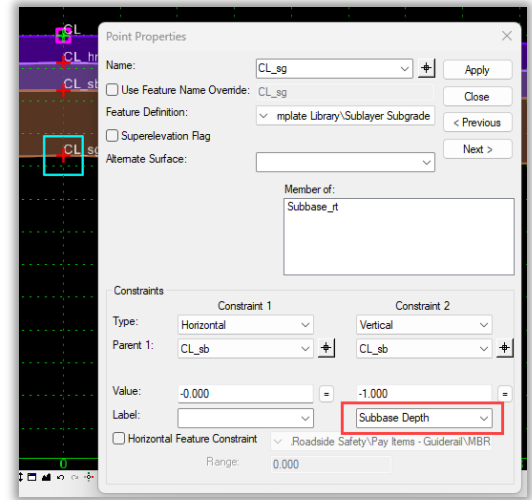

Figure 33 - Point Properties fill in Label

2. These Labels are now a pick lists, click on the other sublayer points and update the label. Click **Apply** and **Next** to update save each Point update.

Subbase Depth	SHDR_sg_rt SHDR_sg_lt	EOR_sg_rt EOR_sg_lt	BOC_sg_lt
Pavement Sublayer Depth	SHDR_sb_rt SHDR_sb_lt	EOR_sb_rt EOR_sb_lt	BOC_sb_lt
Pavement Top Depth	SHDR_hm_rt SHDR_hm_lt	EOR_hm_rt EOR_hm_lt	BOC_hm_lt

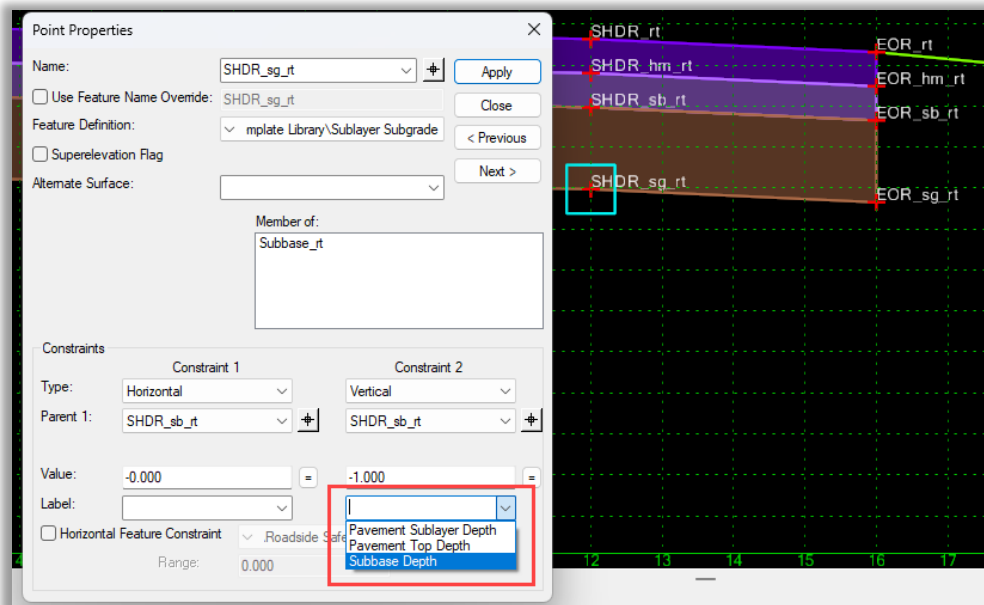

Figure 34 - Point Properties Label Pick List

3. Click **Close** on the Point Properties dialog.
4. Select **File > Save** to save the template library.

2.3.4 Add End Condition to the Template

End conditions are open components that seek and target existing and proposed terrains and corridor features. In this section, you will add an end condition to seek intersection with the existing ground at different slopes depending on the depth of cut or fill.

1. The **Route 123** Template should be active.

2. Expand the **Exercises** folder.

3. Drag and drop:
Cut_for_Curb to **Snow_c_It**

Fill to **Snow_f_It**

4. With reflect on Drag and drop
Cut_for_Ditch to **Snow_f_rt**

Fill to **Snow_f_rt**

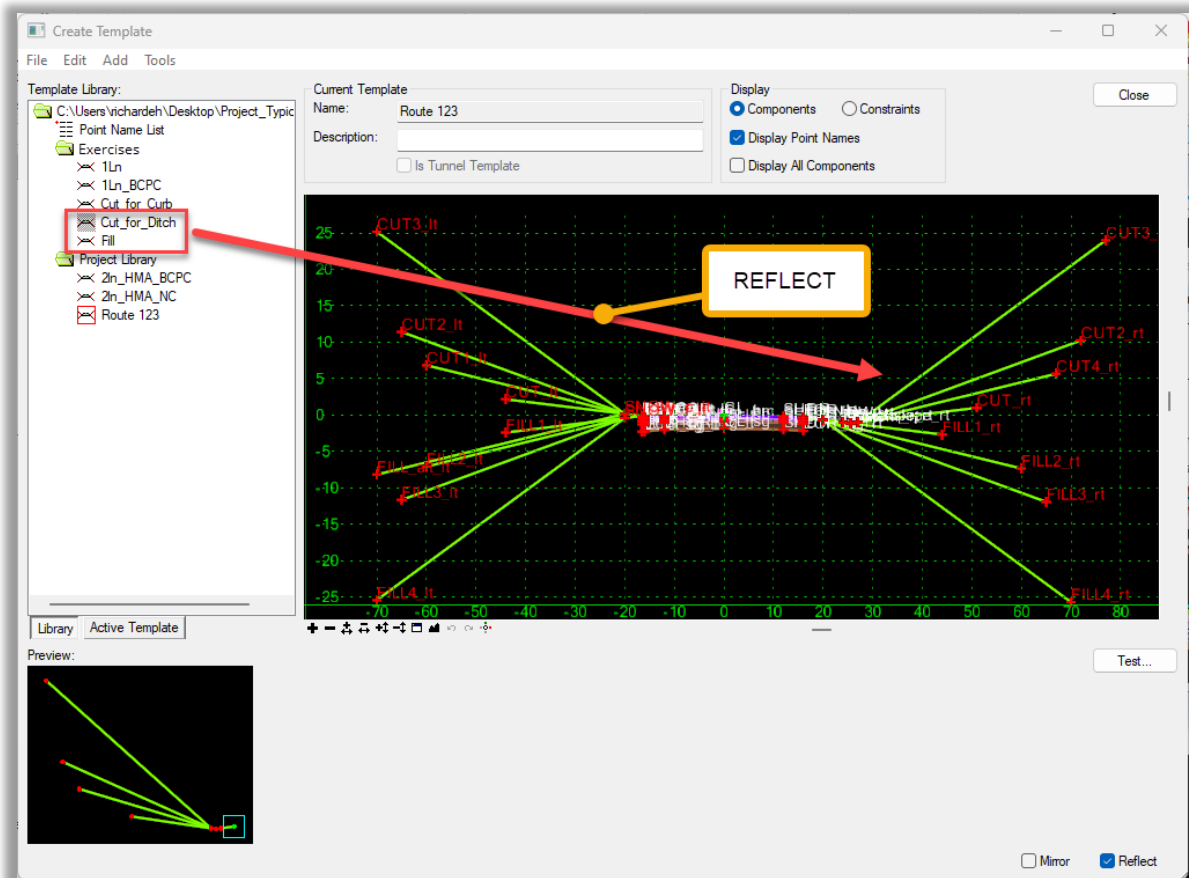

Figure 35 - Drag in End Conditions

5. Test the End Conditions.

- a. Select the **Test** button to open the Test End Conditions dialog.
- b. Select **OK** when the Warning appears telling you there are conflicts. It turns out that two (or more) components share the same Priority Value and the software does not know what the designer's priorities are. We will fix this.

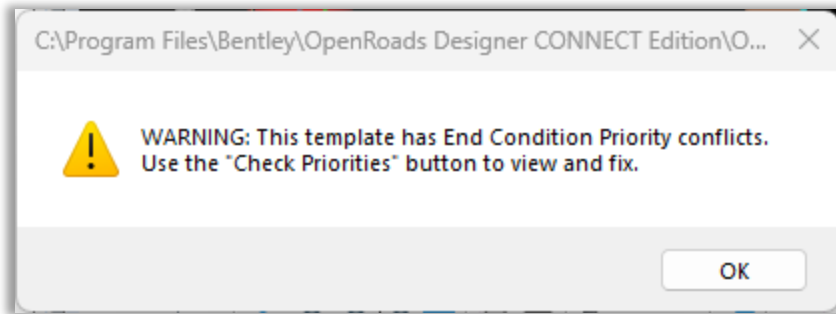

Figure 36 - End Condition Priority Warning

- c. In the Test End Conditions dialog, Select **Check Priorities**. The End Condition Priorities dialog shows that there is a conflict at the SNOW_rt. Select **SNOW_rt** and click **Edit**.

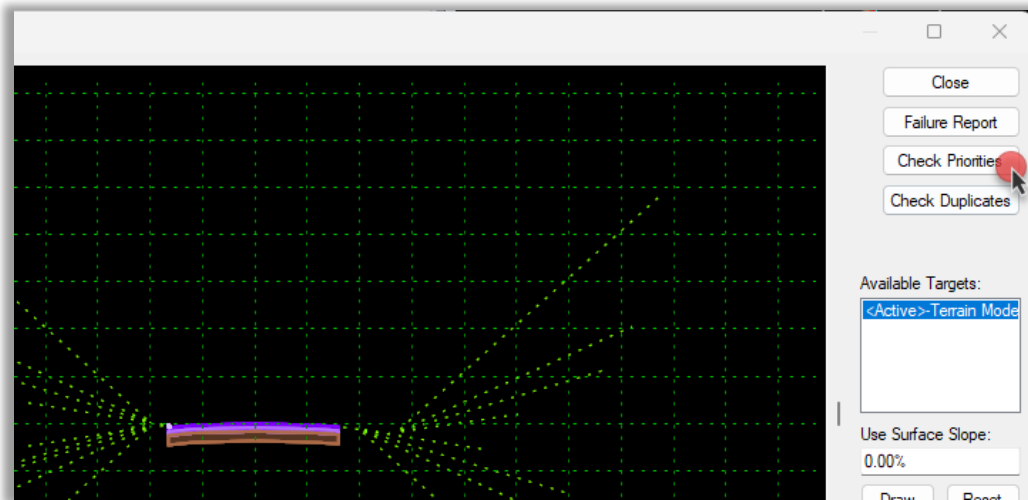

Figure 37 - Check Priority

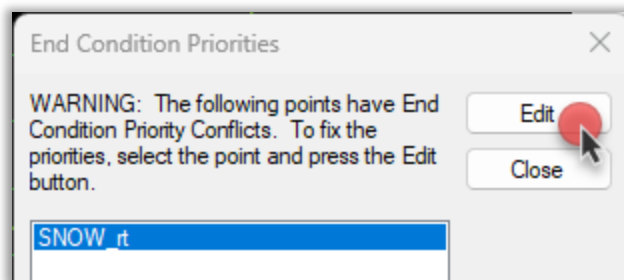

Figure 38 - End Condition Priorities

- d. Change the Priority values to match the image below.

Change **Ditch_rt** to Priority **5**

- e. Click **OK**.



Figure 39 – Fix Priorities

- f. The End Condition Priorities dialog now shows no conflicts. **Close** it.
 - g. Select the **Draw** button. Drag the cursor up and down. Observe which end condition component finds the Active Terrain Model surface (the horizontal line represents the simulated terrain model as you move your cursor).
 - h. Verify that the solution sequence is correct. Slopes will solve in order from flattest to steepest.
 - i. **Close** the Test dialog.
6. Click on **CUT3_It**, notice the Use Feature Name Override is on and set to **CUT_It** and **Close**.

Click on **CUT3_rt**, notice the Use Feature Name Override is on and set to **CUT_rt** and **Close**.

It is important that each end condition point override is set correctly, or you will get flip flopping linear feature after running your corridor.

7. Notice **Red** text indicates “Use Feature Name Override” is set to Active and white Text does not use the override.

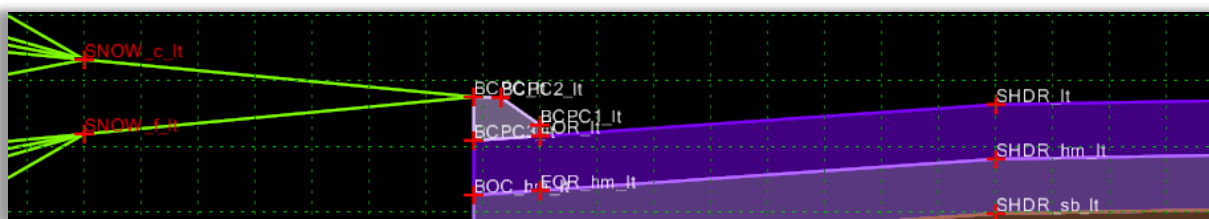

Figure 40 – Red text vs White Text

8. **Save** the template library.

Exercise 3 – Edit a Template

3.1 Assemble the Backbone

1. Copy over the Granite Curbing Component from the workspace.
 - a. In the Template Library Organizer browse to ... | **CT_Configuration** | **Organization-BIM** | **_CT_Civil Standards** | **Template Library** | **CV_ORDTypicals.itl**. copy over **HWY Misc Components/HMA/GC** from the workspace library
 - b. Paste it in the **Exercises** folder.
2. Copy the needed template.
 - a. In the Project Library right-click the **2In_HMA_NC** and click **Copy**.
 - b. Right-click the Project Library folder and click **Paste**.
 - c. Right-click the new **2In_HMA_NC1** template
 - d. Select **Rename** and enter **2In_HMA_GC_NC**.
 - e. Double-click **2In_HMA_GC_NC** to active and make it editable.
3. Delete the existing left end conditions.
 - a. Right-click in a clear area of the edit view in the Create Template dialog and select **Delete Components**.
 - b. Hold down the left mouse button and drag the cursor over the all the **Left End Condition components**. Release the mouse button when you are through.
 - The lower left corner of the Create Template dialog prompts you to drag the cursor over any components you want to delete.
 - This method can also be used to delete closed components.

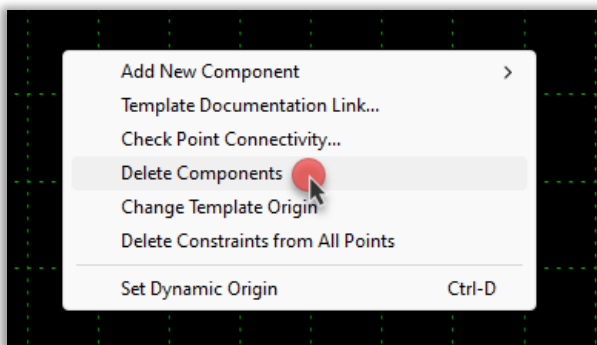

Figure 41 - Delete Components Tool

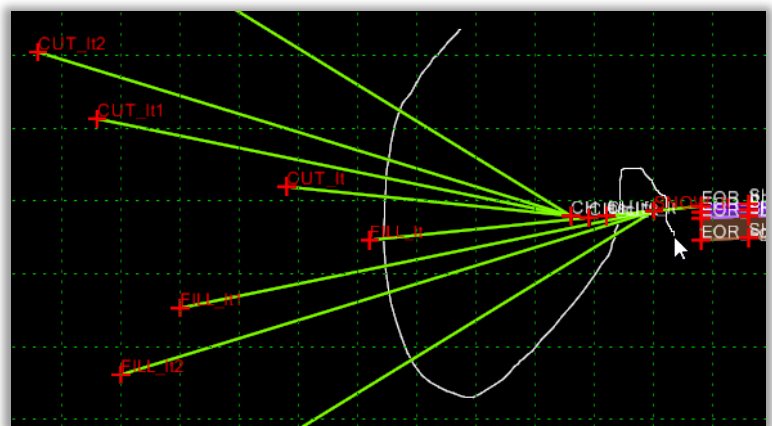

Figure 42 - Delete Components

4. Add the Granite Curbing Component.
 - a. Drag **Exercises/GC** into **2In_HMA_GC_NC**
 - b. Drop it on the point **EOR_It**

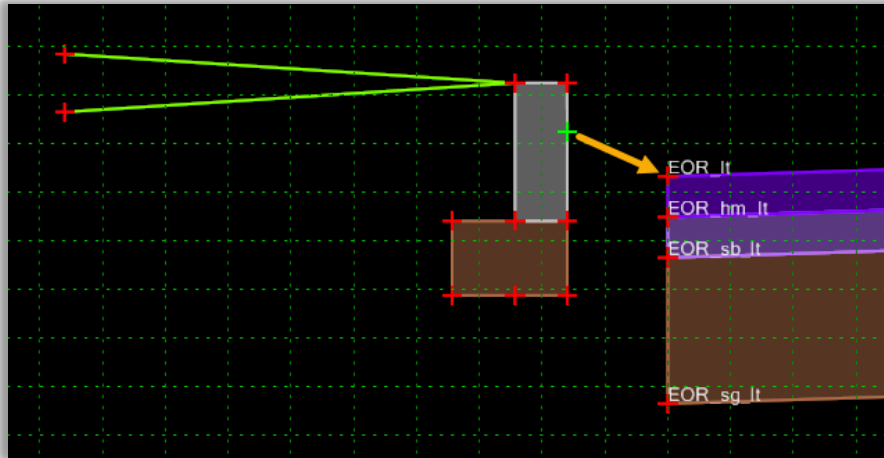

Figure 43 - Drag in Curbing Component

5. Adjust the subbase depth and parent points so they line up.
 - a. Click on **EOR_sg1_It** and right click, select **Delete Both Constraints**. The point symbol will turn from Red to Green, allowing you now to move it as required.

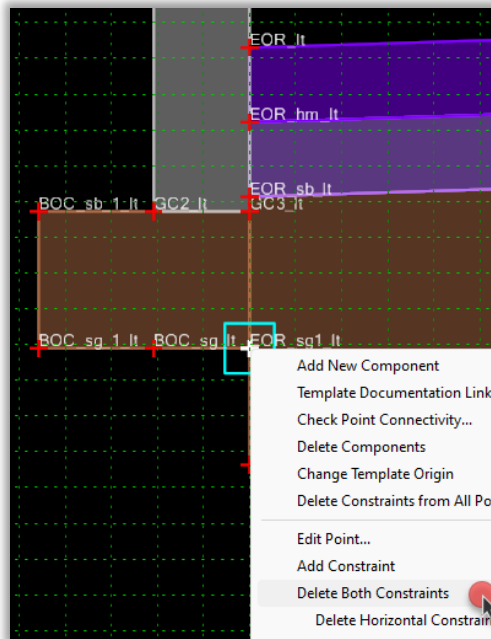

Figure 44 - Delete Point Constraints

Volume 3.2 - OpenRoads Designer Roadway Modeling

- b. Right click on **EOR_sg1_It** and select **Move Point**, move it to snap on **EOR_sg_It**, note the other points that move with it.



Figure 45

- c. Double click on **BOC_sg_It** and change Constraint 2 Vertical Parent to **EOR_sg_It**.

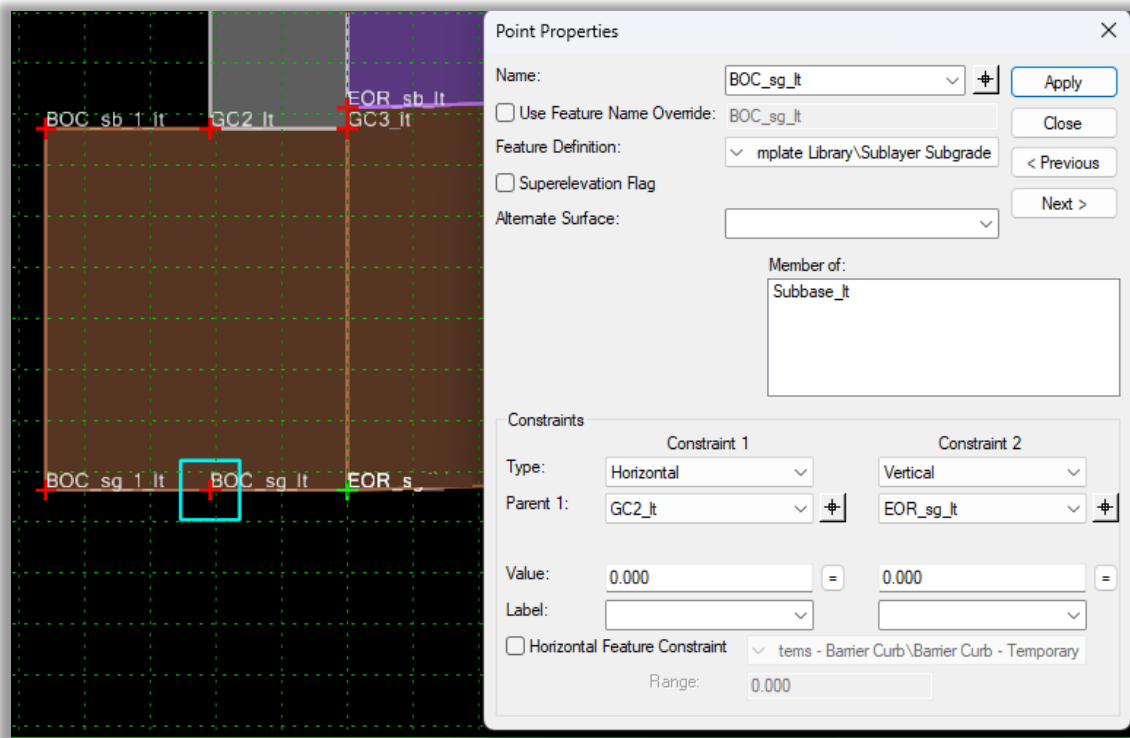

Figure 46 - Move Point and update date parent constraint

3.2 Make Adjustment to the Backbone

1. Check and fix Point Connectivity.
 - a. Right click in the template window and select **Check Point Connectivity**

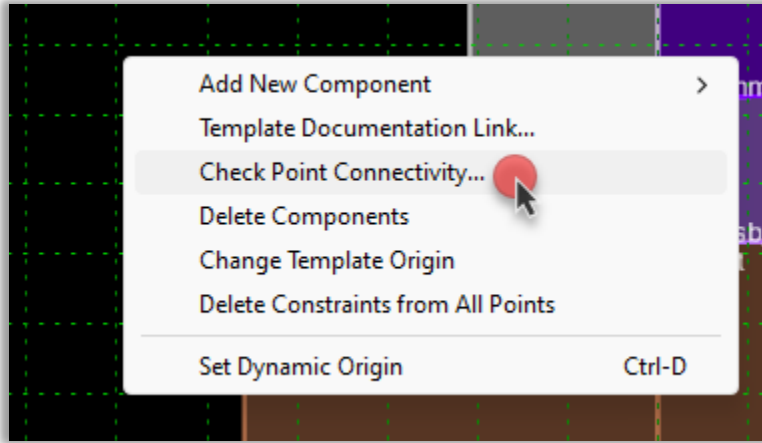

Figure 47 - Check Point Connectivity

- b. Click **OK** to **.005**. This will check and prompt you to delete a point within a .005 tolerance of another.

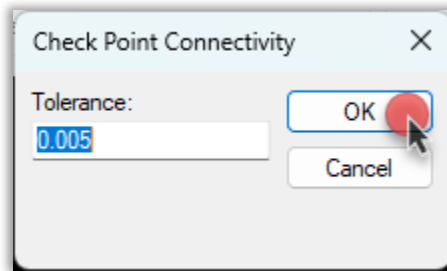

Figure 48 - Check Point Connectivity Tolerance

- c. Delete point **EOR_sg1_lt**

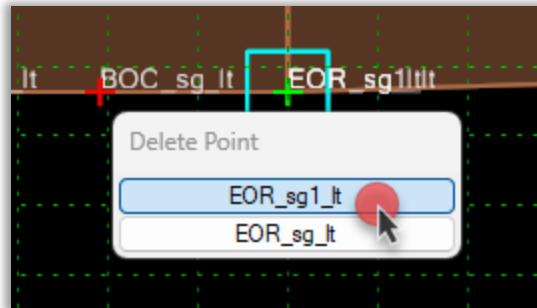

Figure 49 - Delete Duplicate Point

Volume 3.2 - OpenRoads Designer Roadway Modeling

2. Merge the two Subbase components.

To merge these two components, we will need to add another common point to the Subbase Components.

- a. Right click near the vertical line between the two subbase components and select **Insert Point**.

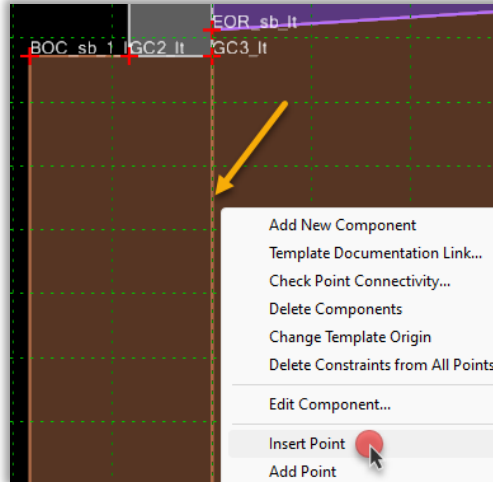

Figure 50 - Insert Point

- b. Select **Subbase**.

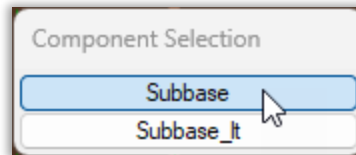

Figure 51 - Select Component

- c. Add the new point and place it on top of **GCS3_It**.

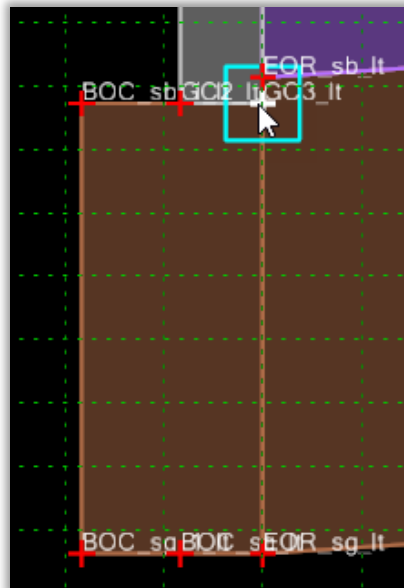

Figure 52 - Add new point

- e. Right-click and select **Finish** to disable adding any more points.

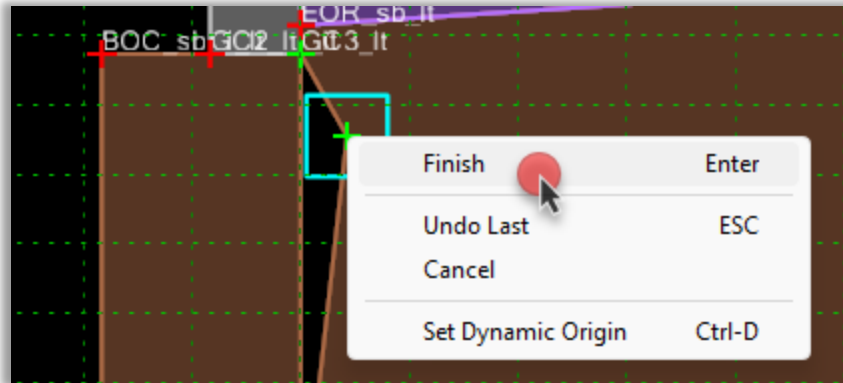

Figure 53 - Finish adding points

- 3. Repeat the **Check Point Connectivity** process and delete **_It**, this will make it so **GC3_It** is part of both **Subbase components**. This is needed to allow the merging of the Subbase components.
- 4. Now you can merge the components. Select near the vertical line separating the two subbase components and select **Merge Components**.

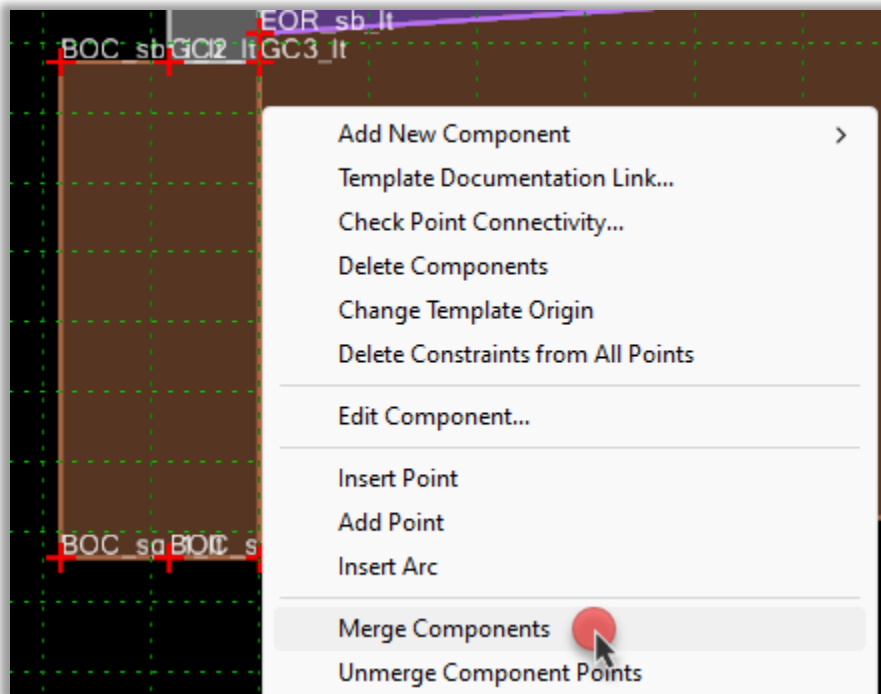

Figure 54 - Merge Components

5. Double click on the newly formed component and check the name, it should be **Subbase**, update if needed, click **Apply** and **Close**.

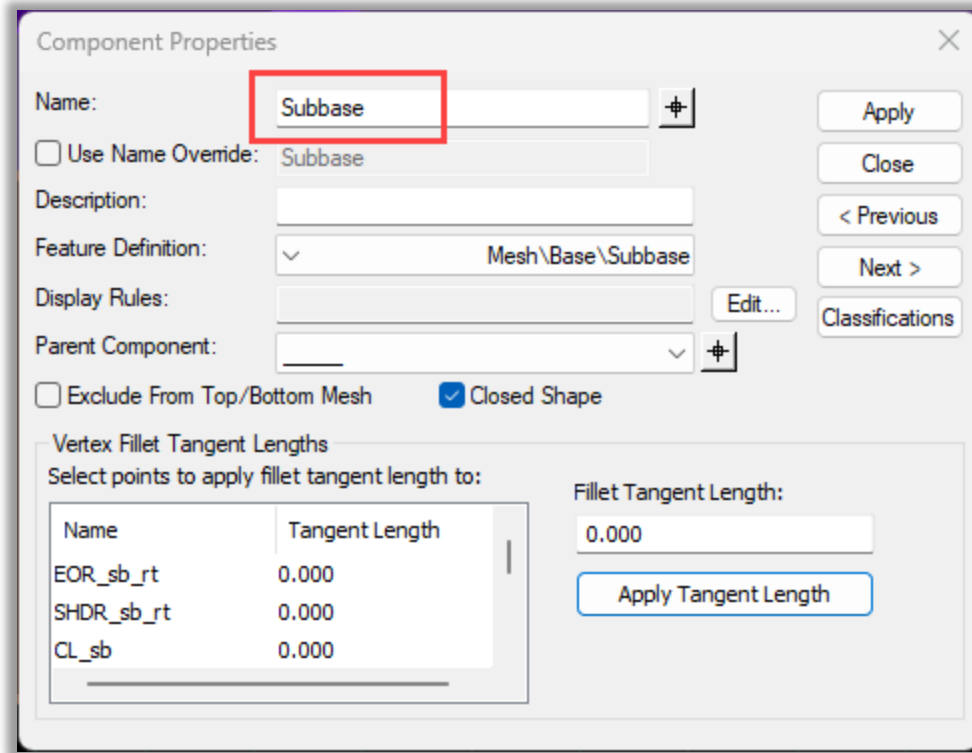

Figure 55 – Check Component name

3.3 Add End Conditions

1. Expand the **Exercises** folder.

Drag and drop:

Cut_for_Curb to **Snow_c_It**

Fill to **Snow_f_It**

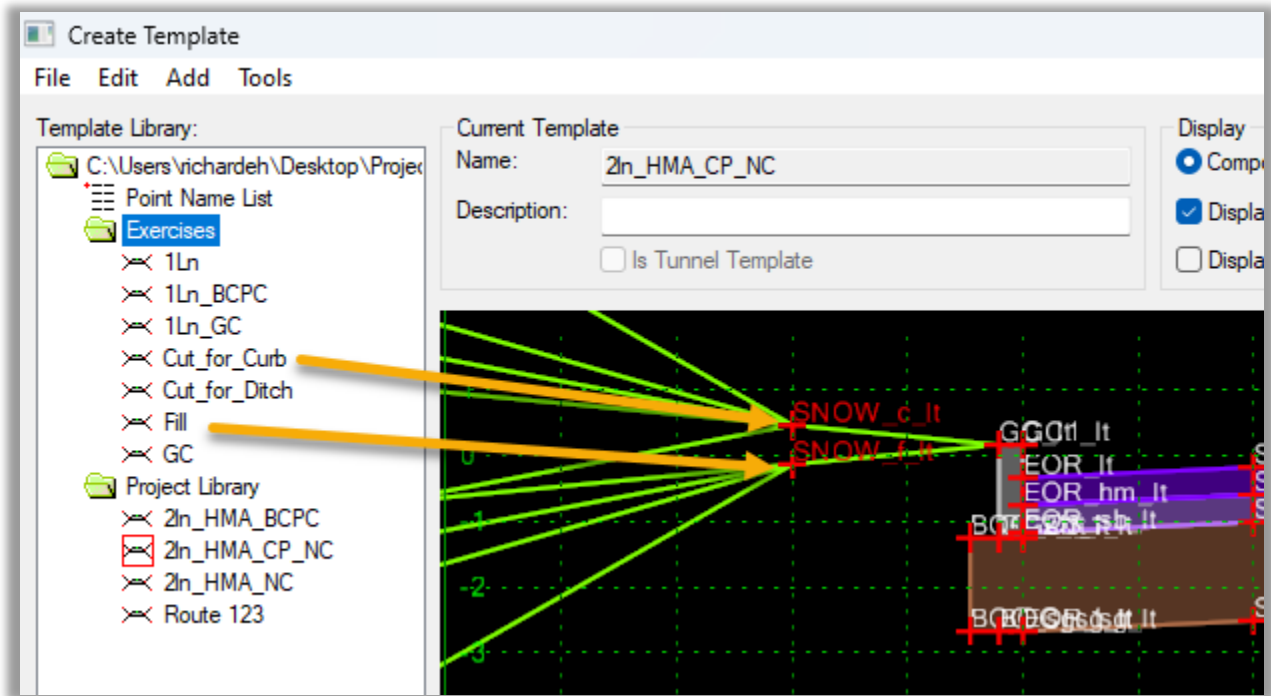

Figure 56 – Drag in End Conditions

3. Test for End Conditions Priorities and fix as required.
4. **Save** the template library.

Appendix

3.4 Create Template Menu Commands

The dialog is split into several areas. Each area is briefly described below.

- **File** - The File menu contains familiar commands for creating new Templates and new folders within the template library, as well as commands to save and open template libraries.
- **Edit** - The Edit menu contains commands used when editing templates such as Undo, Redo, Cut, Copy, Paste, etc...
- **Add** - The Add menu contains commands to add points and components to the active template.
- **Tools** - The Tools menu contains various tools for template creation. The Options and Dynamic Settings menu items are described on the following page.

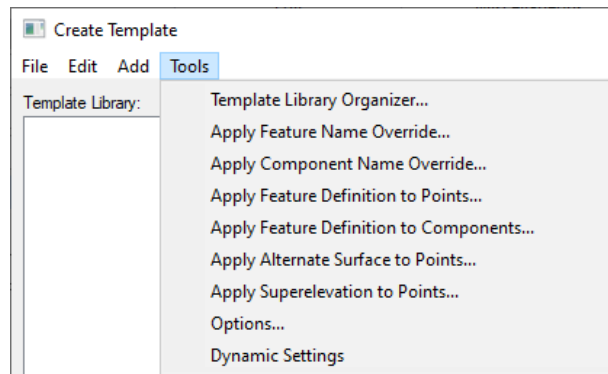

Figure 57 - Create Template tools list

3.4.1 Options... Dialog

Tools > Options... displays the Template Options dialog which allows you to specify naming and step options for the current template. Use the Dynamic Settings dialog, detailed on the following page, to toggle these settings on/off as you design the template.

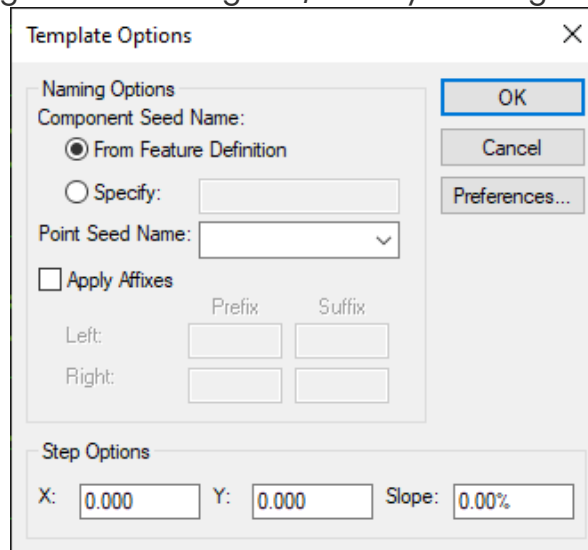

Figure 58 – Template Options

Naming Options

Component Seed Name

- From Feature Definition indicates, when selected, the component name is derived from the style specified when the component is created.
- Specify indicates, when selected, the component name is specified in the field.
- Point Seed Name allows you to specify the seed name for point in the current template. Since point names must be unique, the seed name is appended with a different number each time a point is created.

Apply Affixes

Indicates, when on, that affixes are applied.

- Left Prefix/Suffix specifies which prefix/suffix should be added to a point or component when the value is on the left of 0.0 (absolute).
- Right Prefix/Suffix specifies which prefix/suffix should be added to a point or component when the value is on the right of 0.0 (absolute).

Step Options

These options are used to specify precision step input for components and points. These values can also be accessed from the Dynamic Settings dialog.

Volume 3.2 - OpenRoads Designer Roadway Modeling

- **X Step** specifies the step increment for the X distance from the dynamic origin. If this value is non-zero, then the cursor moves to the horizontal increments of the specified value as measured from the dynamic origin.
- **Y Step** specifies the step increment for the Y distance from the dynamic origin. If this value is non-zero, then the cursor moves in vertical increments of the specified value as measured from the dynamic origin.
- **Slope -** specifies the step increment for slope from the dynamic origin. If this value is not 0, then the cursor moves in slope increments of the dynamic origin. Slope is applicable only when the dynamic settings are in horizontal/slope mode.

3.4.2 Dynamic Settings Dialog

Tools > Dynamic Settings... displays the Dynamic Settings dialog, which is used for precision input of template components and to assign point names and styles when defining components.

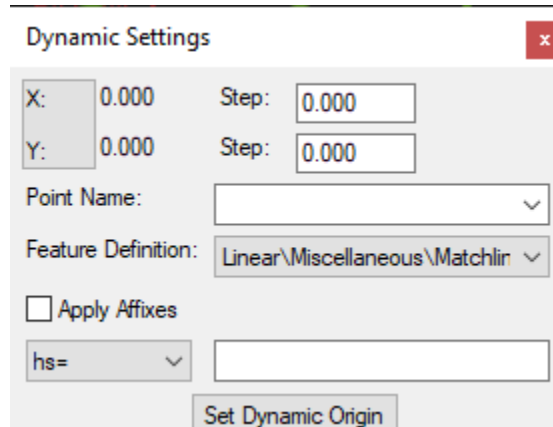

Figure 59- Dynamic Settings

X:Y/X:Slope toggles between X,Y step lock and X/Slope step lock.

X Value displays the current X distance from the dynamic origin.

X Step specifies the step increment. If this value is non-zero, then the cursor moves in horizontal increments of the specified value as measured from the dynamic origin.

Y value displays the current Y distance from the dynamic origin.

Y Step specifies the step increment. If this value is non-zero, then the cursor moves in vertical increments of the specified value as measured from the dynamic origin.

Point Name specifies the name of the point to be placed.

Apply Affixes specifies, when selected, that point name affixes (prefix or suffix) are to be applied to the point name when placing points. The Affixes are defined on the Template Options dialog. The **Key-in** pull down is used to specify the type of key in to be performed.

- XY = key in absolute coordinates.
- DL = key in delta coordinates from last point placed (defaults to the dynamic origin if it is the first point of a component).
- HS = key in horizontal delta distance and slope from last point placed.
- VS = key in vertical delta distance and slope from last point placed.
- OL = key in delta coordinates from dynamic origin.
- OS = key in horizontal delta distance and slope from dynamic origin.

Set Dynamic Origin sets the location of the dynamic origin.

3.5 Template Library

On the left side of the *Create Template* dialog is the **Template Library** area which contains a Windows-like folder structure. This area is used to manage the content of the current template library. Two tabs are supported for the **Template Library** area as described below.

3.5.1 Folders and Template list

When the **Library** tab is selected, the **Template Library** displays the contents of the current template library in a familiar Windows folder structure as shown at right. The **Template Library** area also supports common Windows functions like drag, drop, cut, paste, etc..

- When a template is selected from the list, the Preview window is used to display a preview of the template.
- Double-click the template name to set it as the active template.

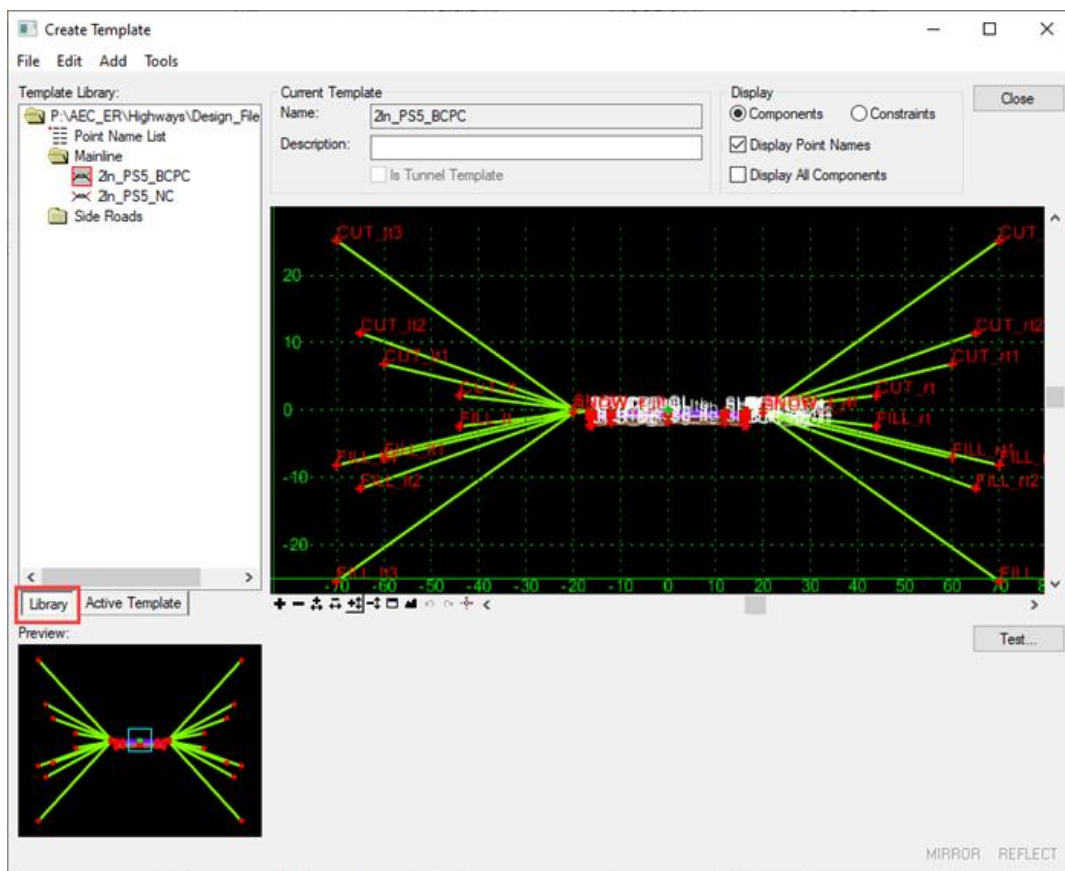

Figure 60 - Roadway Template

3.5.2 Active Template

When this tab is selected, the Template Library area displays the contents of the active template as shown at right. The Active Template option is used to review and edit template points, components, and parameters in a table format.

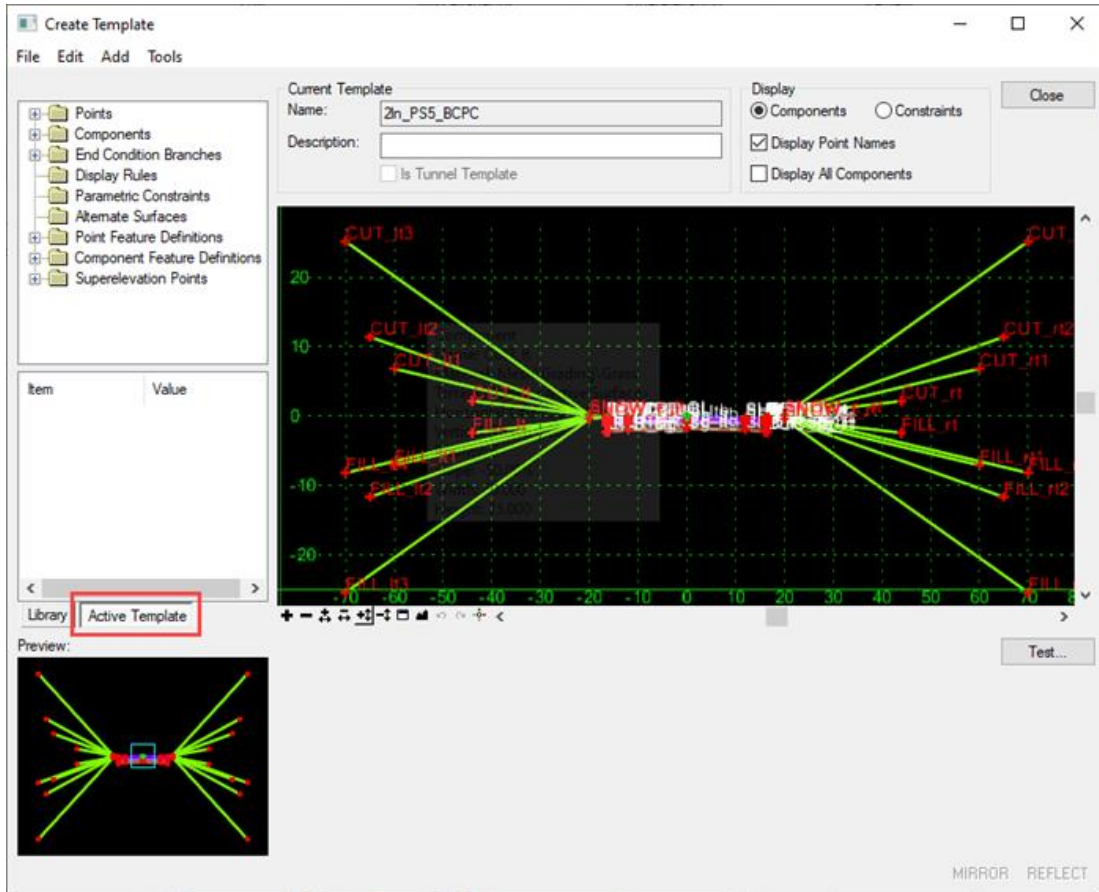

Figure 61 – Active Template

3.5.3 Creating New Folders and Templates

Templates can be organized into folders in the Project Library. The Project Templates folder is intended to be used to create new folders and templates for a specific project.

- To create a new folder, right click on the Project Templates folder and choose the **New > Folder option**.
- To create a new template, right click on the folder and choose the **New > Template option**.
- You can also cut, copy and paste templates from the HWY folders to the desired Project Library folder.

3.5.4 Current Library

The right side of the Create Template dialog is used to display and edit the current template.

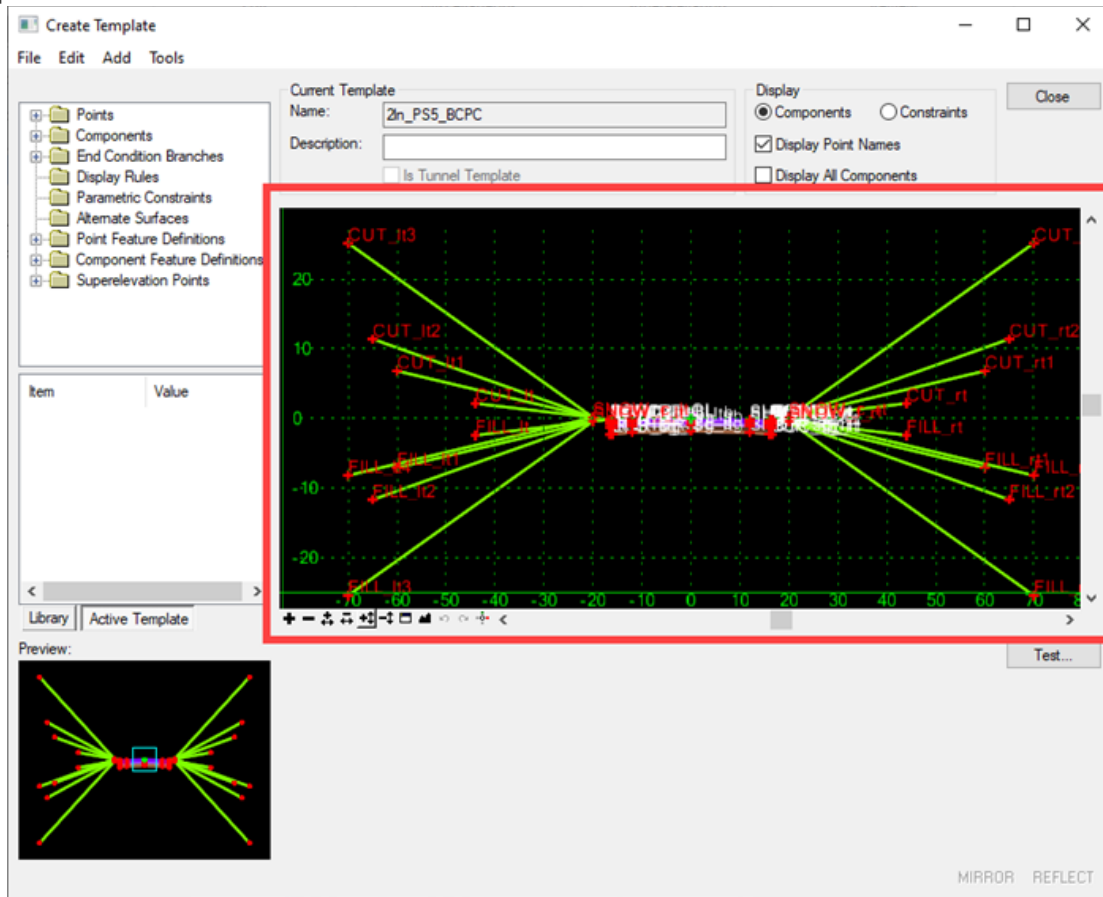

Figure 62 – Figure Current Library

Name – Shows the name of the current template.

Description – Allows you to review/edit the current template description.

Display –

Components/Constraints – This option is used to set the display mode of the template. If Components is selected, then the template components are displayed. If Constraints is selected, then the point constraints for the template are displayed. Template points are always displayed.

Display Point Names – Toggle this option on to display the template point names.

Display All Components – When this option is checked on, any components that are “hidden” are displayed with dashed lines.

Current Template Window – The Current Template Window is used to display and edit the current template. The window uses its own graphics engine and is not a MicroStation view.

A magenta-colored box is used to designate the origin of the template.

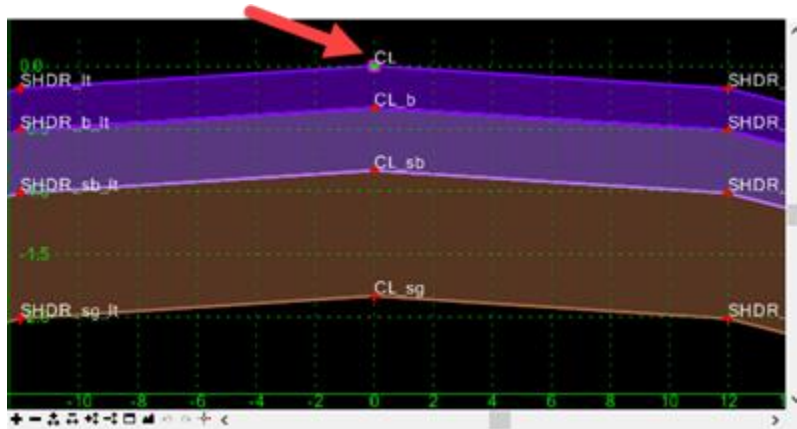

Figure 63 – Origin of the template

At the bottom of the Current Template Window are view commands similar to the MicroStation view commands. The two buttons that look like MicroStation View Previous and View Next commands are undo and redo commands used on template operations. The CTRL-Z keyboard shortcut can also be used to undo the last template operation.

Within the **Current Template Window**, you can right-click to access commonly used template functions. You can also double click template components for editing purposes.

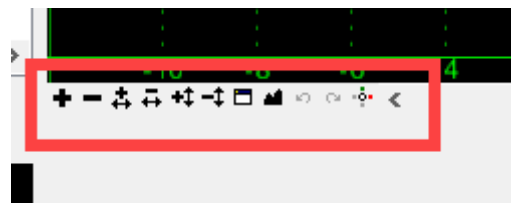

Figure 64 – Current Template Window

Mouse Wheel Functions – The mouse wheel has the following functions when creating templates:

- Scroll the wheel to zoom in or out in the template window.
- Hold down the **Shift** key while scrolling the mouse wheel to zoom in or out in the vertical direction only.
- Hold down the **Ctrl** key while scrolling the mouse wheel to zoom in or out in the horizontal direction only.

Point Properties - Features can be reviewed and assigned in a variety of ways.

- The Name and Feature Definition can easily be edited the Point Properties dialog which is accessed by double-clicking the point in the Current Template window.

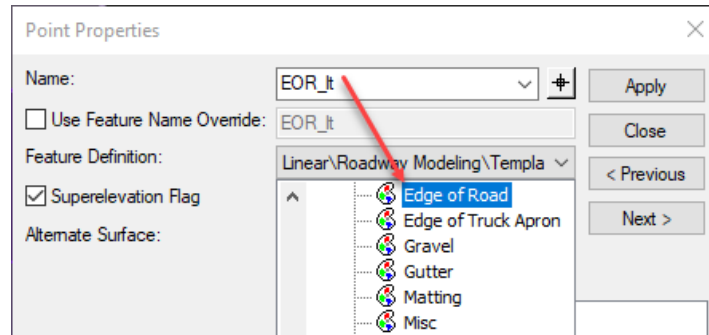

Figure 65 - Point Properties

- The Dynamic Settings dialog can be used to define the Point Name that will be assigned to points as they are created. The Point Name field can be used to key-in a name for the point or to select a name from a predefined list as shown at right. It is recommended that you use the point names from this list when designing your templates. When a point name is selected from the list, the Point Style, which is the Feature Definition, is automatically set to the appropriate value. The Point Style list contains a list of all the Feature Definitions available in the CTDOT DDE.

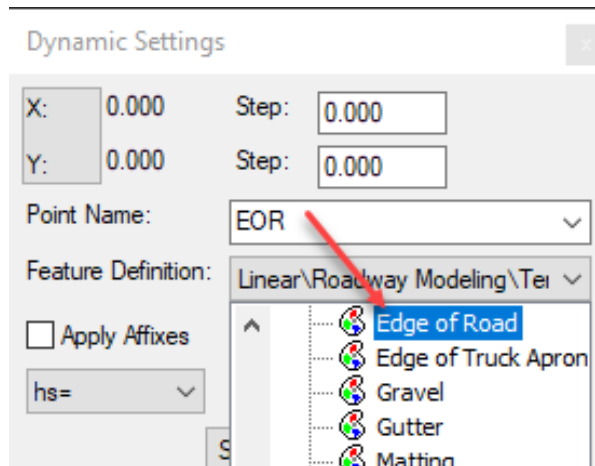

Figure 66- Point Name

3.6 Template Points

When the template is processed using the corridor modeling command, the points of a template are connected to form breakline features. Each point will be connected longitudinally to the next template drop location to form 3D longitudinal breakline surface features. The breaklines are drawn using the symbology defined with the **Feature Definition** that is assigned to each point.

Since the template points are connected to generate the completed surface, establishing a standard name for template features that are used on each template is very important to the quality of the proposed design surface. For example, if a Shoulder point is named SHDR_It on the first template, and it is named Shoulder_Left on the next, the software will not automatically connect these points to generate the breakline feature. **Following a point naming convention is important to obtain the best results with Corridor Modeling.**

It is equally important to ensure that the feature definition assigned to points is consistent from template to template.

Each template point name must be unique to the template. The software automatically appends a number to the point name if the same name is used during template creation.

There is no limit to the number of points in a template.

3.6.1 The Point Properties Dialog

The **Point Properties** dialog is used to review and edit various properties associated with the template points, including the definition of the point constraints. To access the **Point Properties** dialog, in the *Create Template* dialog double-click on the point in the **Current Template** window. The **Point Properties** dialog, shown below, is opened.

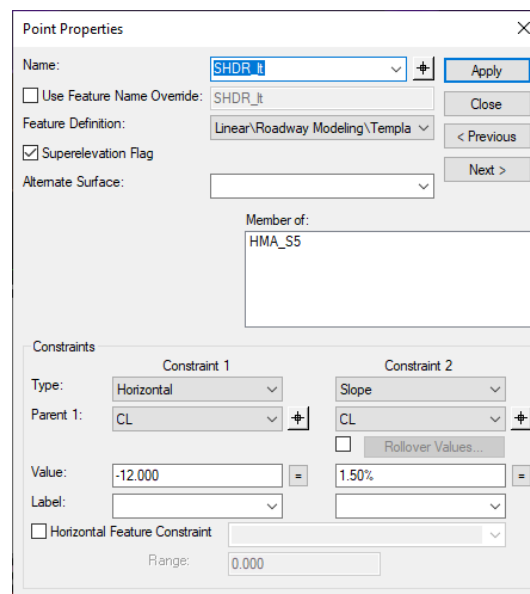

Figure 67 – Point Properties

Volume 3.2 - OpenRoads Designer Roadway Modeling

The dialog contains the following options:

Name displays the point name. The point name can be keyed-in or selected from the drop-down list. If the point name is selected from the list, the corresponding Feature Definition is automatically assigned. Point names must be unique to the template.

Use Feature Name Override displays the name of the feature that will be created in the surface to correspond to the point. This field is optional. If it is blank, then the point name will be used as the feature name.

- The option is intended primarily for end condition components to create connectivity from one station to the next when the template end conditions change. For example, if you want all surface tie-in points to belong to one feature, then set the feature name of all the ending end condition points on each side of the template to the same name (i.e. all Cut and Fill end points on the right would be given the feature name R-Tie and all the ones on the left would be given the feature name L-Tie).
- If the point has a Feature Name Override defined, the point name is displayed in red in the Template window.

Feature Definition is used to define the feature definition of the point. If no style is specified, then it comes from the first component of which the point is a member.

Superelevation Flag is used to identify the point as a candidate to be used for assigning superelevation control lines. This option should only be toggled on for pavement points on the surface of the pavement.

Alternate Surface allows you to specify the name of an alternate surface for a point. You may choose multiple alternate surface names. Select from the list of available surfaces in the active template.

Member Of indicates in which components the point is included.

Constraints - The Constraints portion of the Point Properties dialog allows you to review/edit the constraints on a point.

- Type specifies the constraint type: None, Horizontal, Vertical, Slope, Vector-Offset, Project to Surface, Project to Design, Horizontal Maximum, Horizontal Minimum, Vertical Maximum, Vertical Minimum, Angle Distance. The constraints are described in more detail below.
- Setting up the appropriate constraint types is critical to achieve the desired results when pavement layers, superelevation, and transitioning are introduced to the design.
- Label displays the optional label for the constraint. Constraints that are labeled can have their value changed during design processing. The same label name can be assigned to more than one constraint and more than one point. See Section 10.4 for details.

- Horizontal Feature Constraint is used to allow a point to target elements in the design file that are defined with the specified Feature Definition within a specific Range. Use of this option is not recommended.

3.6.2 Point Constraints

Point constraints are used to manage the behavior of points in a template. They are used so that if a point is moved in a template, either by the user editing the template or by the application of a horizontal or vertical control during design processing, all the points related to the point being moved behave in a rational and predictable manner.

For example, when a **Simple** component is inserted into the active template, it is comprised of four points which are connected to define the component as shown in the example below.

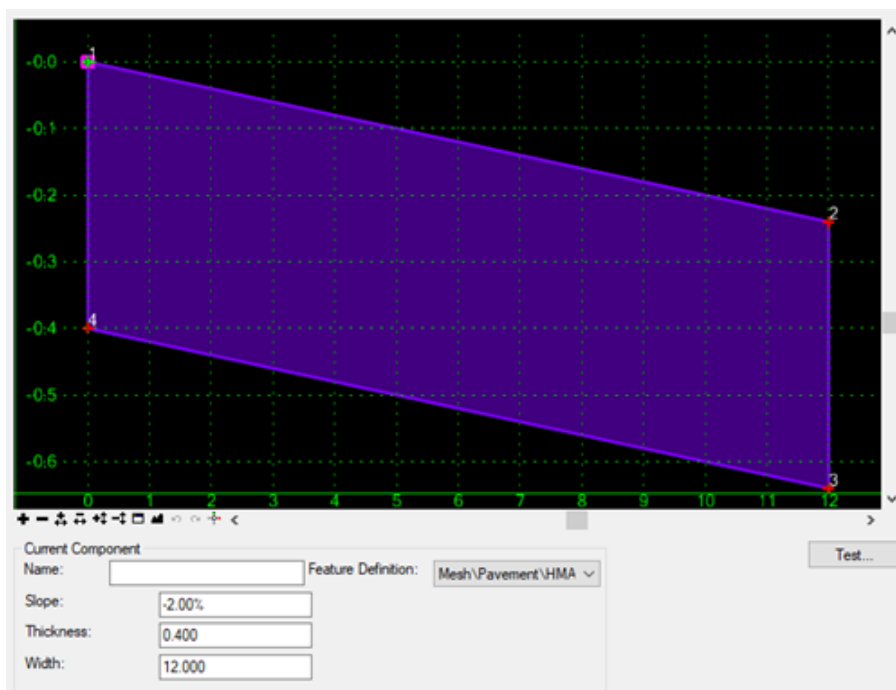

Figure 68 - Point Constraints

The constraints for all the points in a template can be displayed by choosing the Display Constraints option on the Create Template dialog.

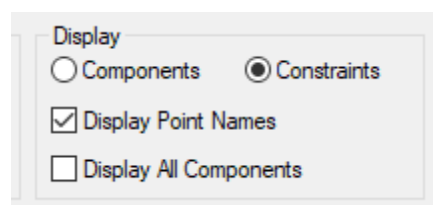

Figure 69 - Display Constraints option

Three of the four points are constrained with relation to the insertion point. If the original insertion point is moved, the other three points move in relation to the first point.

Volume 3.2 – OpenRoads Designer Roadway Modeling

- A point can have at most two constraints. If two constraints are defined, the point is said to be “fully constrained”. A point that is fully constrained is represented by a red plus sign. In the example above, points **2**, **3**, and **4** are fully constrained.
- A point that is partially constrained, meaning that it has only one constraint on it, is shown as a yellow plus sign.
- An unconstrained point is shown as a green plus sign.

Point constraints are two-dimensional and one-way. Two-dimensional means that the constraints can only affect the points offset and elevation (x and y coordinates in the cross-section view). One-way means there is a child-parent relationship between points. In other words, if point 2 is constrained by point 1, point 1 is said to be the parent of point 2 and moving point 1 will affect point 2, but you cannot move point 2 to affect point 1. The example below shows a sample of this where the blue arrow indicates a parent/child relationship from point 1 to point 2:

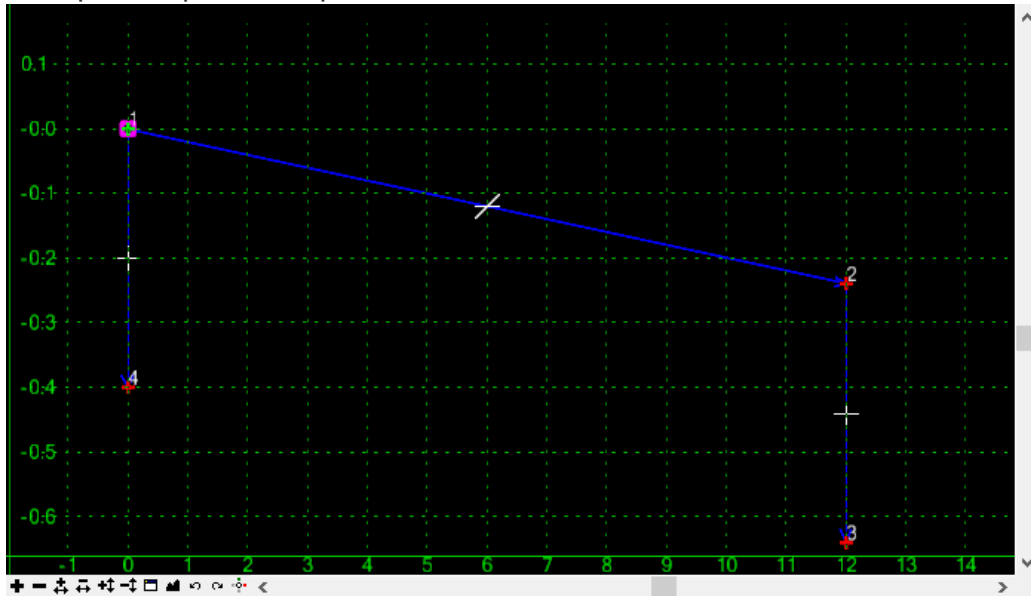

Figure 70 – Point Constraints

Constraints are displayed as blue lines between the parent and the child point. At the midpoint of the constraint line, there is a short white line designating the constraint type as follows:

- Horizontal line = Horizontal Constraint
- Vertical line = Vertical Constraint
- Sloped line = Slope Constraint

Multiple lines will be shown for points with two constraints.

Floating the cursor over a point will temporarily display an arrow designating the direction of the constraint (the arrow points to the child point) and a pop-up menu displaying information about the point.

3.7 Point Constraint Types

Horizontal - The child point remains at the given horizontal distance from the parent point.

- In the example above, point B has been constrained to point A with one constraint as shown below.
- If point A is moved horizontally, point B will maintain its relative distance from point A.
- If point A is moved vertically, point B is unaffected.

Vertical - The child point remains at the given vertical distance from the parent point.

- In the example above, point B has been constrained to point A with one constraint as shown below.
- If point A is moved horizontally, point B is unaffected.
- If point A is moved vertically, point B will maintain its vertical relationship to point A.

Slope - The child point will maintain the given slope from the parent point.

- In the example above, point C has been defined with a Horizontal and a Slope constraint as shown below:
- Slope constraints are absolute. Slopes going from lower-left to upper-right are positive regardless of whether the child point is to the left or right of the parent.
- Slope constraints can also have Rollover Values assigned to them. Rollover values are used to set the slope constraint based on variety of high side and low side slope parameters. A Reference Point is specified which defines the controlling slope to the parent point.
- The example above documents the Rollover Values can as defined in CTDOT's example templates for the shoulder break point behavior. See the online help for more information on the available parameters.

Horizontal Maximum - The child point has two parent points and remains at the given horizontal distance from the parent point that is farthest to the right (has the maximum horizontal or X value).

Horizontal Minimum - The child point has two parent points and remains at the given horizontal distance from the parent point that is farthest to the left (has the minimum horizontal or X value).

Vertical Maximum - The child point has two parent points and remains at the given vertical distance from the parent point that is highest (has the maximum vertical or Y value).

Vertical Minimum - The child point has two parent points and remains at the given vertical distance from the parent point that is lowest (has the minimum vertical or Y value).

Volume 3.2 - OpenRoads Designer Roadway Modeling

Vector Offset - The child point has two parent points and will be projected onto the vector defined by the two parents. If the offset is not zero, then the child point will maintain a perpendicular offset from the parent vector at the specified offset value. Negative values indicate an offset to the left of the vector defined by the parent points. Positive values indicate an offset to the right.

Project to Surface - This constraint must be used in conjunction with one of the previously define constraints. The other constraint will define the projection direction. The child point will then be projected to the surface with the name or parametric label given when the design is processed. If the surface does not exist, or no solution is found, then the point will remain where it is placed in the template.

Project to Design - This constraint is like the Project to Surface, except that the point is projected to the design surface of the template. A projection value is given to indicate whether the projection is to be to the left or to the right. The point must also be constrained by one of the previous constraints, excluding the Project to Surface, so that a direction for the projection may be determined. A negative value limits the projection to the left of 0; a positive value limits the projection to the right. A value of 0 will seek to the left and to the right of 0 to project the point. If no solution is found, then the point will remain where it is placed in the template.

Angle Distance - This constraint takes two parent points, a distance, and an angle. The selected point is then fully constrained to the location defined by the first parent, and the angle from the first parent relative to the vector defined by the two parent points. This constraint creates a rigid-body rotation. When selected, no other constraint types are available.

3.7.1 Editing Points with the Left Active Template Window

In addition to the Point Properties dialog, points can be edited from a pop-up menu that is accessed by right-clicking on a point in the **Active Template** window. The menu is shown below.

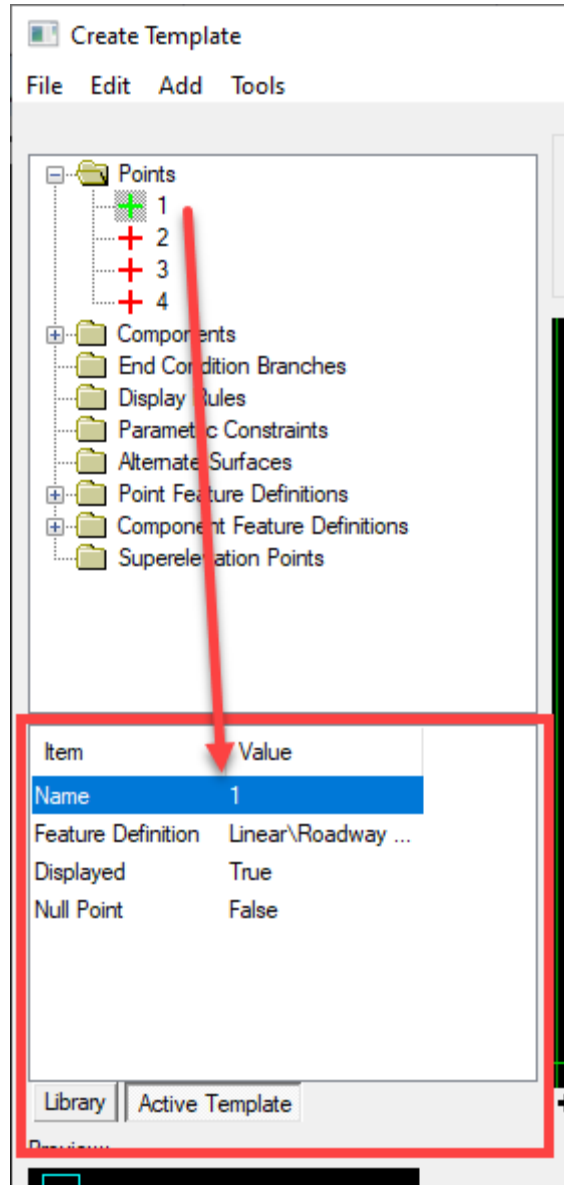

Figure 71 - Editing Points with the Left Active Template Window

3.7.2 Null Points

A null point is a template point that is purposely not related to any particular component. It's most often used as a reference for controlling other points. To create a null point, right-click in the current template window and select **Add New Component > Null Point**, or select **Add > Null Point** from the pull-down menu of the *Create Template* dialog to initiate the command.

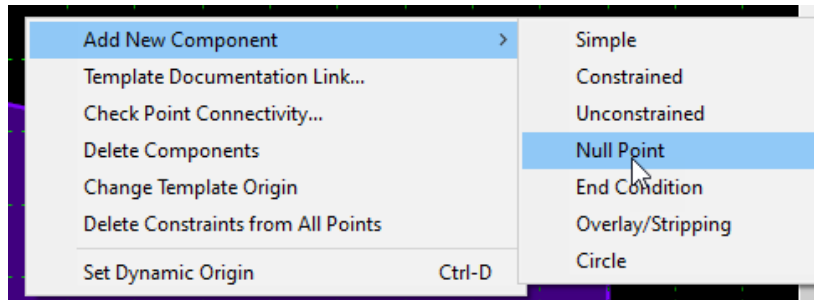

Figure 72 - Null Points

3.7.3 Testing Point Controls

The behavior of fully constrained points can be tested by right-clicking on the point and selecting **Test Point Controls** as shown below. Select the desired option to test the behavior of a template as the point is moved either horizontally, vertically, or both at the same time.

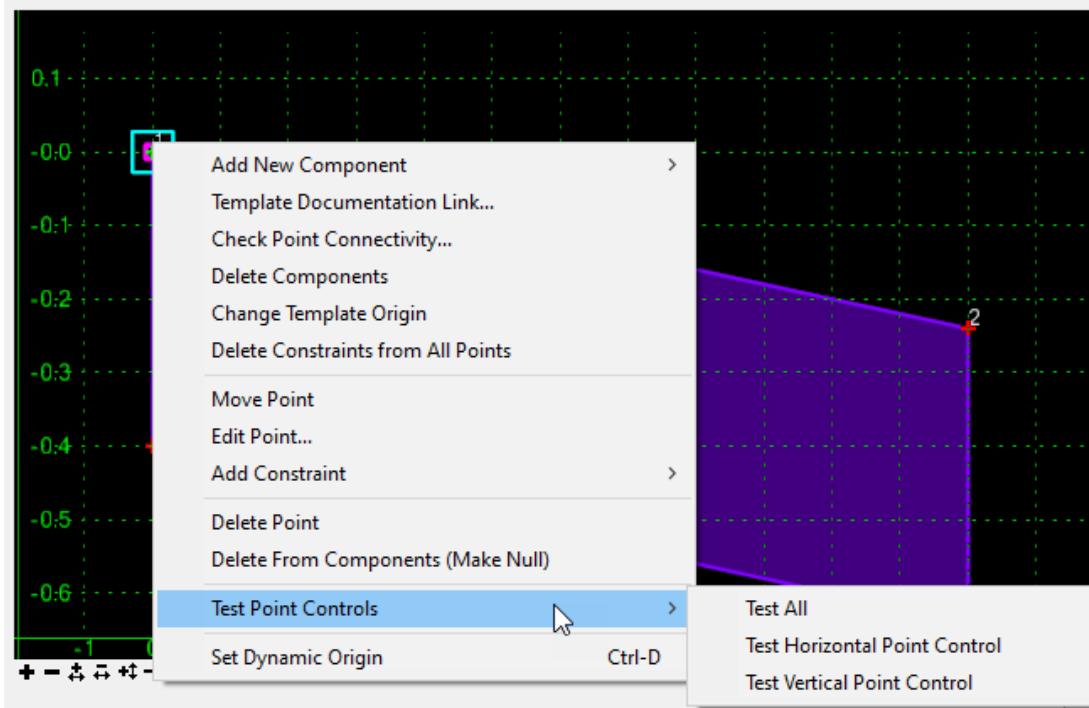

Figure 73 - Testing Point Controls

3.8 Template Components

A component is a set of points that define an open or closed shape. Each component, whether open or closed, can represent a different material or area of interest. Components are named and have an assigned feature style. Component types are described below:

Simple Components - A simple component typically represents a section of pavement. It's a closed parallelogram (4 constrained points) that is defined by the slope and thickness.

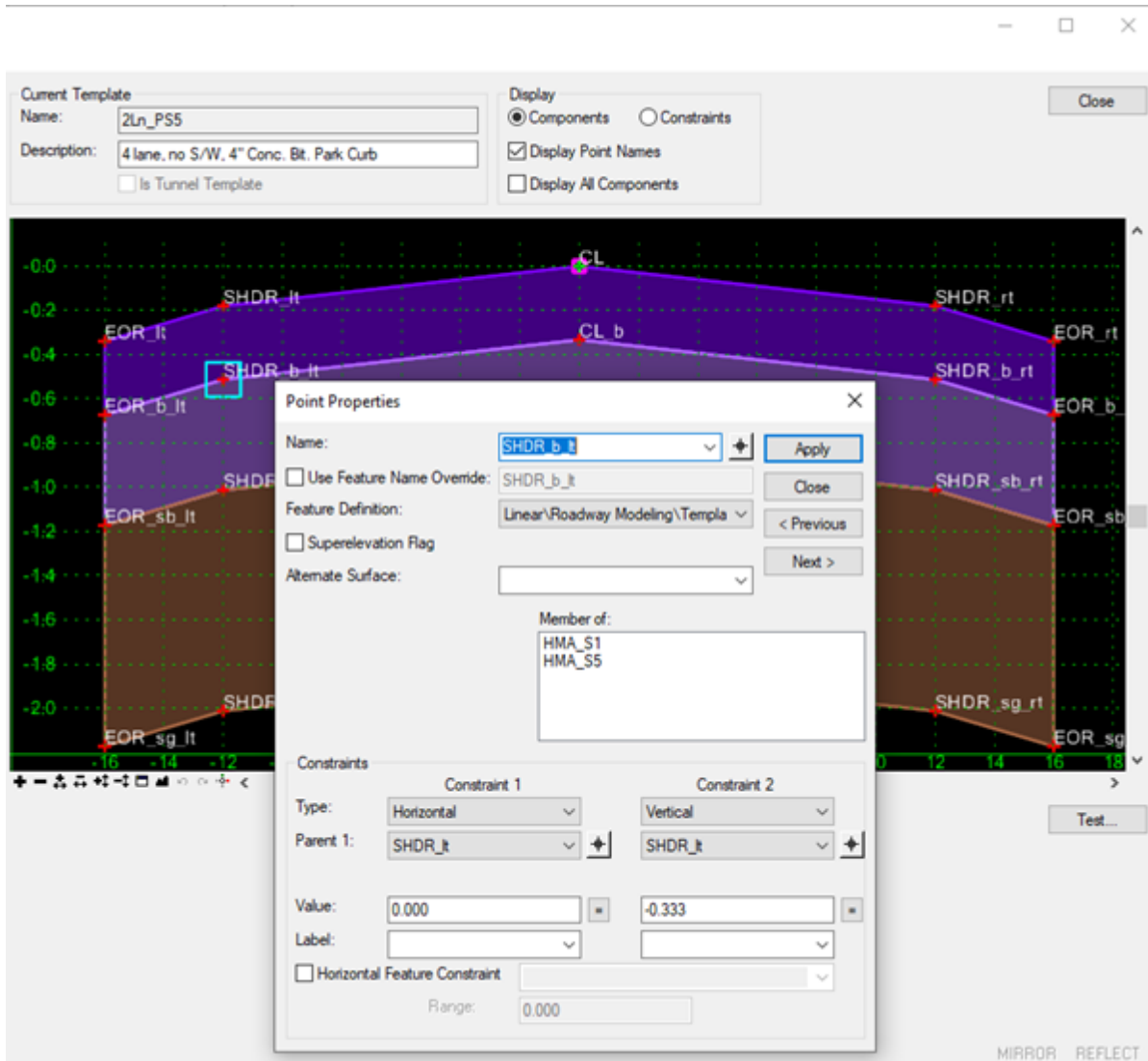

Figure 74 - Template Components

Constrained Components - A constrained component consists of points that are all restricted to the movement of the first point. A constrained point is typically used to manage the behavior of other points in the template. When a point (parent) is moved, any constrained point (child) also moves. This restriction only affects the offset and elevation (x,y) of the restrained point and the relationship is unidirectional (movement of child point does not move the parent point). Fully constrained points are displayed with a red + symbol.

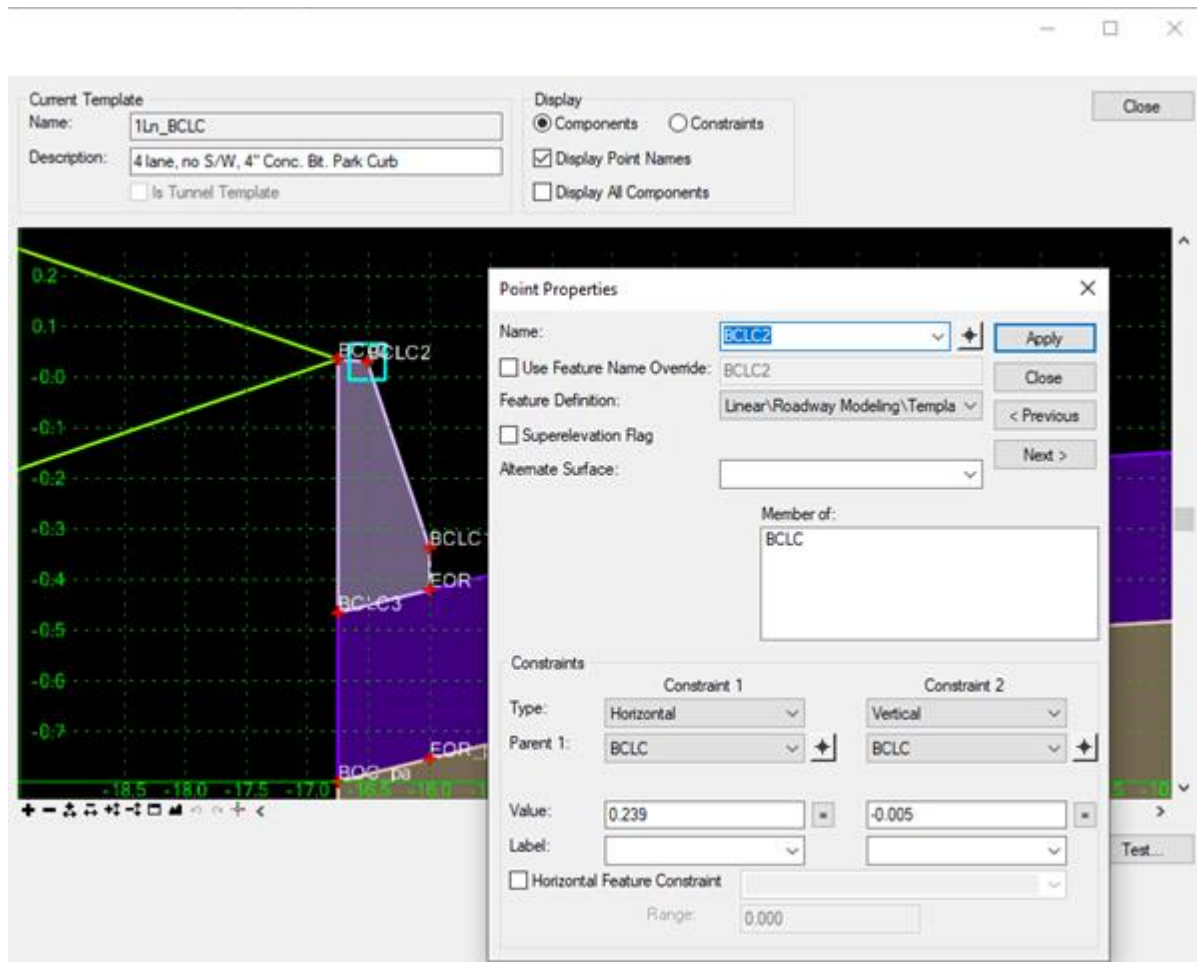

Figure 75 - Constrained Components

Unconstrained Components - An unconstrained component is open or closed-shaped with no movement restrictions. Moving one point has no impact on the other points that make up the component.

Null Point - A null point is a template point that is purposely not related to a specific component. It's most often used as a reference for controlling other points.

End Condition - An end condition is a special open-shaped component that targets a surface, an elevation, or an alignment. End conditions are typically used to define cut and fill slope solutions.

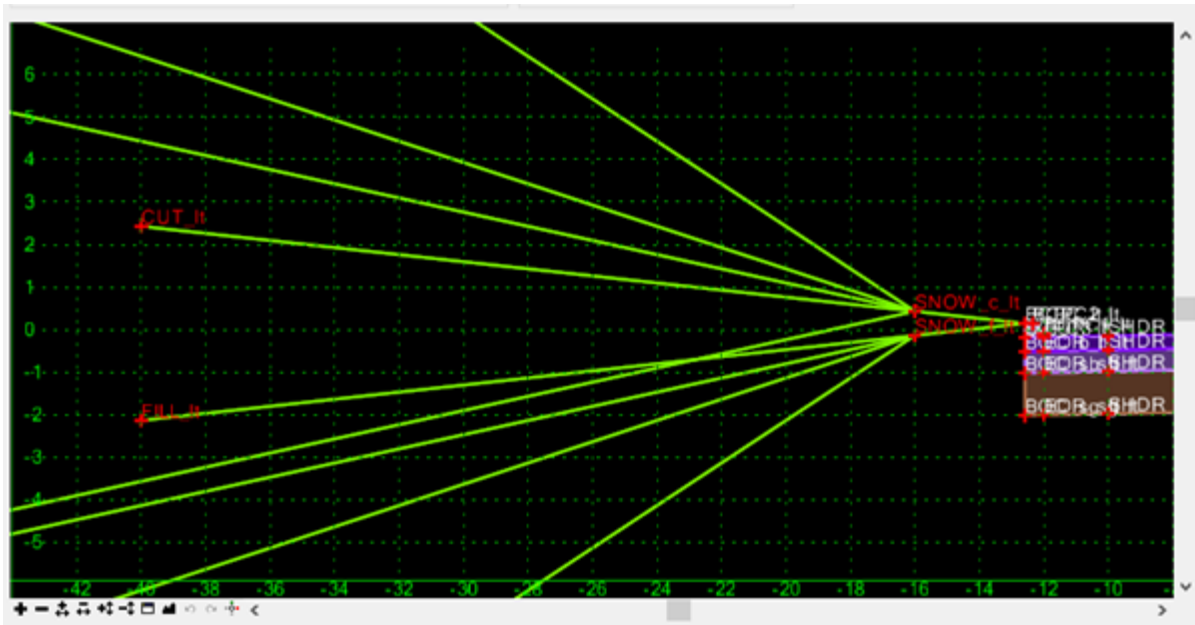

Figure 76 - End Condition

Overlay/Stripping Components - A specialized component type that is used for defining pavement planning and overlay materials.

3.8.1 Creating Template Components

CTDOT provides an example template library that contains several commonly used components. These components can be used to build templates. It may also be necessary to make specialized components to meet specific project requirements.

To create a simple component, right-click in the active template window and select **Add New Component > Simple**, or **select Add > Simple** from the pull-down menu of the Create Template dialog to initiate the command.

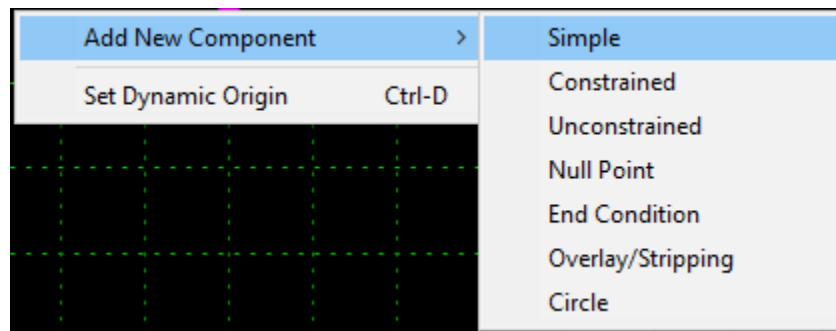

Figure 77 - Creating Template Components

As new components are created, the Current Component portion of the Create Templates dialog is used to define the Name, Style, and any other relevant parameters for the component type being created. A simple component consists of four points defined by **Slope, Thickness, and Width**. The top points are constrained by **Horizontal** and **Slope** constraints. The lower points are constrained to the points directly above them by a **Horizontal** and **Vertical** constraint.

Define the **Name, Slope, Thickness, Width, and Feature** of the component before placing the component in the template.

The **Feature** is used to set the symbology for the graphics drawn to represent the component in the 3D model.

The *Dynamic Settings* dialog is used to facilitate component placement. The point names are derived from the **Point Name** selected in the *Dynamic Settings* dialog. Each point is appended with a number that is incremented. The points are assigned the **Point Style** feature that is active in the *Dynamic Settings* dialog.

Point names and the feature that is assigned to each point should be reviewed and edited after the component is placed.

Volume 3.2 - OpenRoads Designer Roadway Modeling

In the example below, a simple component is created representing a single lane of pavement.

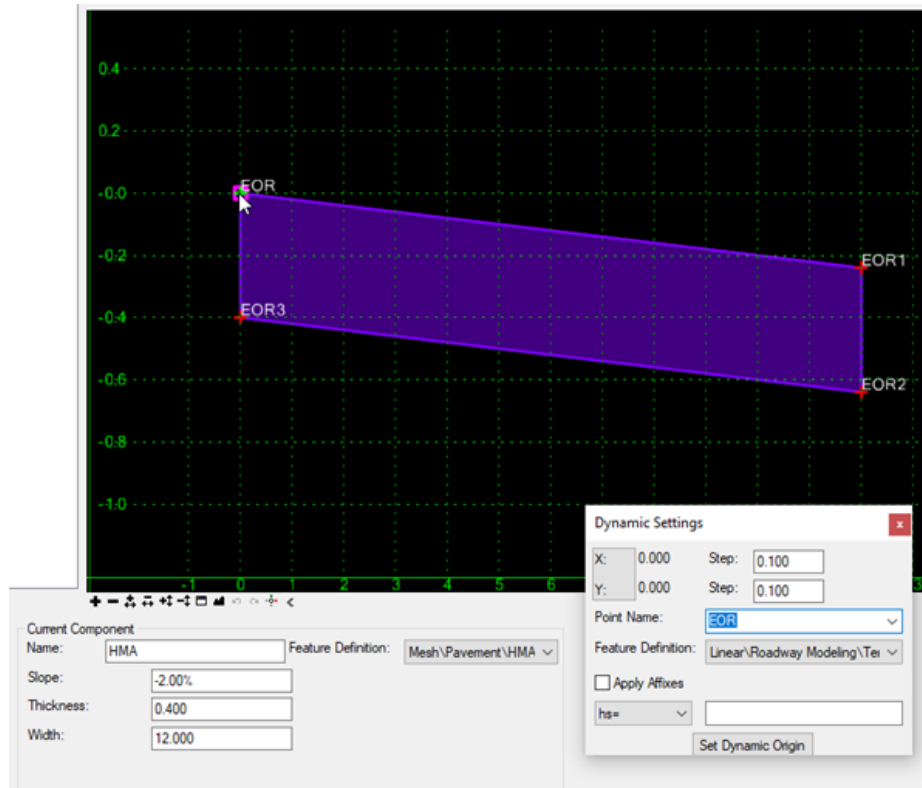

Figure 78 - Dynamic Settings

Before placing the component in the template, various options are available to control how the template is placed by right-clicking in the template window to reveal the menu shown below.

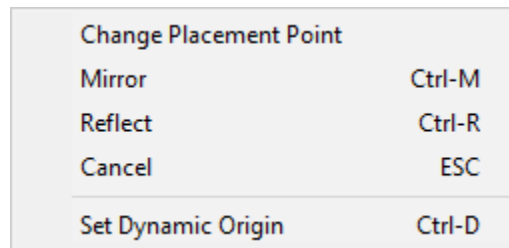

Figure 79 - template placed by right-clicking

- **Change placement Point** can be used to change which component point is used as the point placed at the point you specify. Each time this command is selected, the placement point will move in a clockwise direction to the next point in the component.
- **Mirror** will create the original component as well as a mirrored component reflected horizontally about the template origin.
- **Reflect** will create a single component reflected about the template origin.

- The **Mirror** and **Reflect** options are toggles that are turned on or off and remain active. The on/off status of the **Mirror** and **Reflect** options is displayed at the bottom right corner of the Create Templates dialog.
- Select **Set Dynamic Origin** to set the location of the dynamic origin. The dynamic origin is indicated by the purple box in the template display window.

Creating Constrained and Unconstrained Components

Constrained or **Unconstrained** components can be used to create any open or closed shapes in the template such as curbing, median barriers, retaining walls, or complex pavement situations such as the shoulder break on the high side of superelevation.

Constrained Components

To create a constrained component, right-click in the current template window and select **Add New Component > Constrained, or select Add > Constrained** from the pull-down menu of the Create Template dialog to initiate the command. When constrained components are created, both horizontal and vertical constraints are applied to each point.

Unconstrained Components

To create an unconstrained component, right-click in the current template window and select **Add New Component > Unconstrained, or select Add > Unconstrained** from the pull-down menu of the Create Template dialog to initiate the command. When unconstrained components are created, no constraints are applied. This option is useful when you wish to define constraints other than Horizontal and Vertical constraints.

Dynamic Settings

The *Dynamic Settings* dialog can be for precision input when creating the component. In the example below, point **EOR** will be created at a defined horizontal distance and slope from point **CL** using a horizontal distance of 12 and a slope of -1.5% by using the **hs=12** option with a value of **12, -1.5%**. Use the **Enter** key to execute the command.

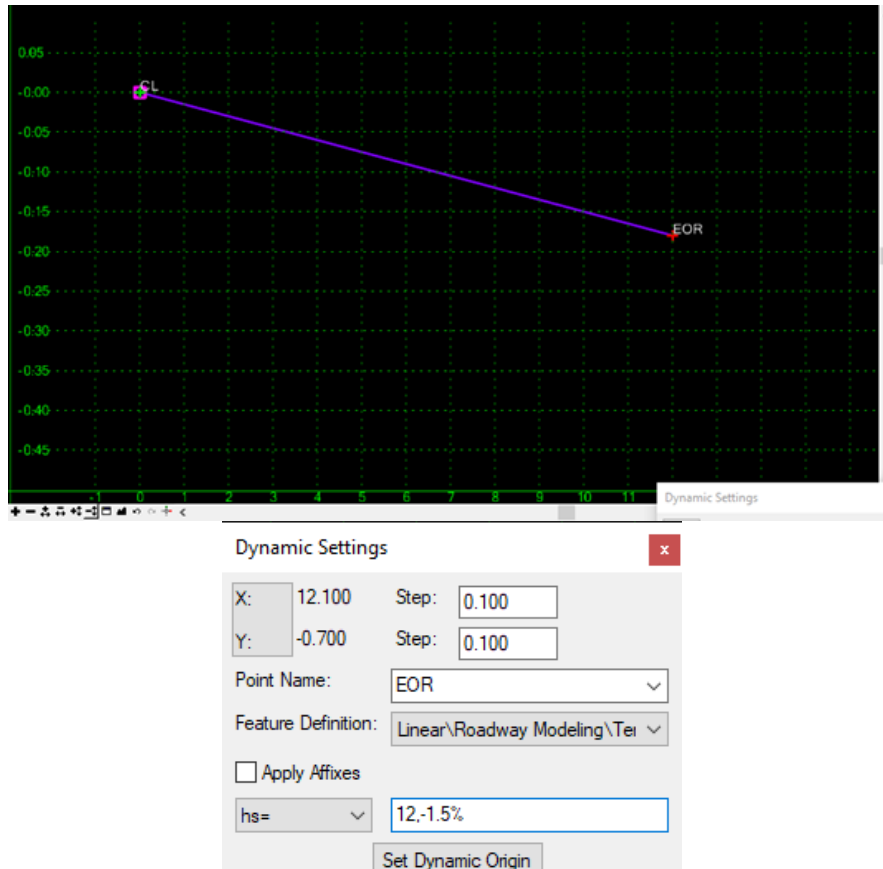

Figure 80 - Dynamic Settings

Right-click in the current template window at any time during the component creation process to access the menu shown below:

Finish	Enter
Closed Shape	Ctrl-L
Mirror	Ctrl-M
Undo Last	ESC
Cancel	
Set Dynamic Origin	Ctrl-D

Figure 81 - Right-click Menu

- Select Finish when you have completed creation of the component.
- Components can be created as open or closed shapes. To toggle on/off the option to placed closed shapes, select **Closed Shape**.

Volume 3.2 – OpenRoads Designer Roadway Modeling

- Select **Mirror** to create two components at the same time. The second component is a mirror image of the one you are defining. The component is mirrored about a vertical line passing through the **Dynamic Origin** location.
- Select **Undo Last** to undo the last point that was added to the component.
- Select **Cancel** to terminate the component creation process.
- Select **Set Dynamic Origin** to specify the location of the dynamic origin.

3.8.2 Drag and Drop Component Operations

A previously created template component can be included in the active template by use of drag and drop operations. Select a previously drawn component from the active template library and drag the component into the **Current Template** window. The component dynamically floats on the cursor. Release the mouse button to drop the component at the desired location.

While dragging the component in the **Current Template** window, right-click anywhere in the **Current Template** window to access the placement options discussed previously (**Mirror, Reflect, etc...**)

When connecting two components by dragging a component into the active template, the connecting point will change to a white colored plus sign prior to placing the component to indicate that the points are coincident. The point name from the previously placed component will be retained. Point names can be edited at any time during the template creation process.

1. In the example below, a new blank template is created **New Template1**, this will be built with a left template having one lane and a right template having 2 lanes.
2. The Left side of the road is placed by dragging in the **1Ln_BCPC** component. It is dropped with **Apply Affixes** at the origin in the active template.
3. The right side of the road is then placed with the **Mirror** option is turned on, with **Apply Affixes** also toggled on, **2Ln_BCPC** component is also dropped at the origin.

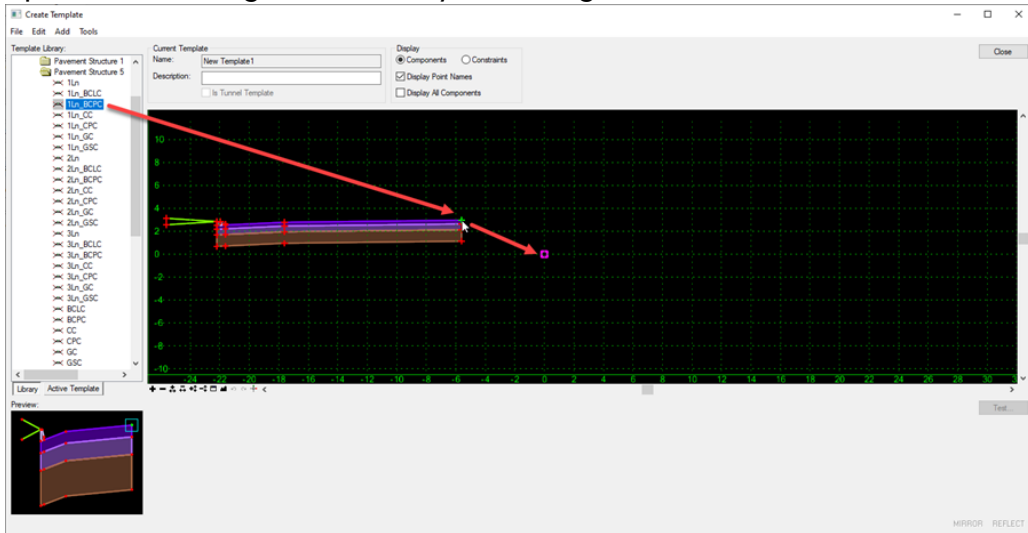

Figure 82 - Create Template Drag Over

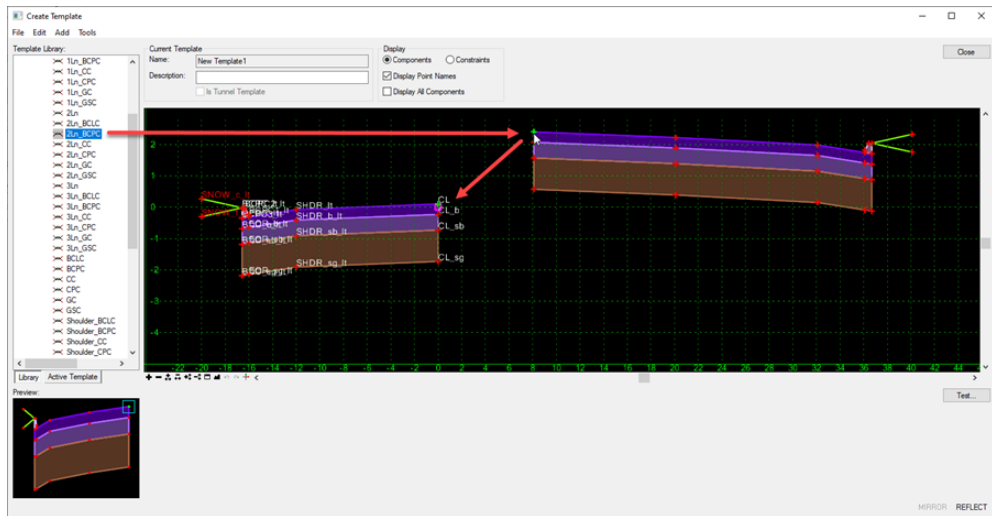

Figure 83 - Create Template Drag In

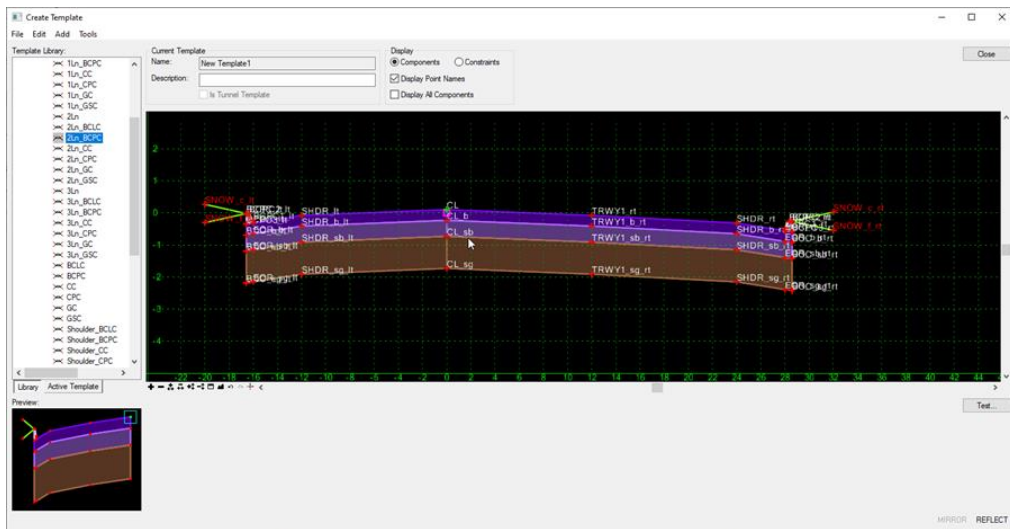

Figure 84 - Create Template Drop

3.8.3 Affixes

The **Apply Affixes** option is used to add a user defined prefix or suffix to the point name. In the example below a simple component was added with the **Mirror** option toggled on (as the component is being placed, right-click to reveal a menu to choose the **Mirror** option). The prefix of "lt-" is applied to the points on the left side of the template. The prefix of "rt-" is applied to the points on the right side of the template.



Figure 85 - Apply Affixes

The affixes are defined in the Template Options dialog.

Tip: As a rule, affixes should not be applied to templates that contain individual components that will be used as "building blocks" for complete roadway templates. This is because the component maybe used on either the left or right side of the template. Affixes should always be applied when creating completed templates for use with Roadway Designer.

Note that all the points of the component are named using the currently defined **Point Name**. After the component is placed, it is necessary to rename the points and assigned feature definitions to ensure that the points and 3D line strings are drawn using the appropriate standards. This can be done by double-clicking on each point to access the *Point Properties* dialog shown below.

The **Name** can be typed in or selected from the drop-down list. If the **Name** is selected from the list, the associated **Feature Definition** is automatically defined. The Point Properties dialog is covered later in this document.

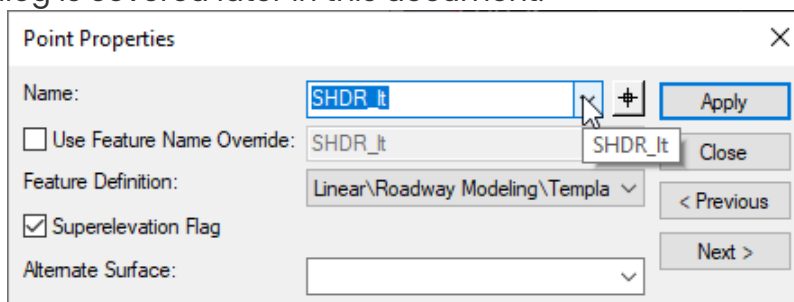

Figure 86 - Point Properties

3.8.4 Merge Components

Deletes all the shared point line segments of two overlapping components and merge them into the selected component. The second component is deleted. Access this command with a right-click over a location that is above line segments from two overlapping components. The dialog appears only when 2 or more components share a common line.

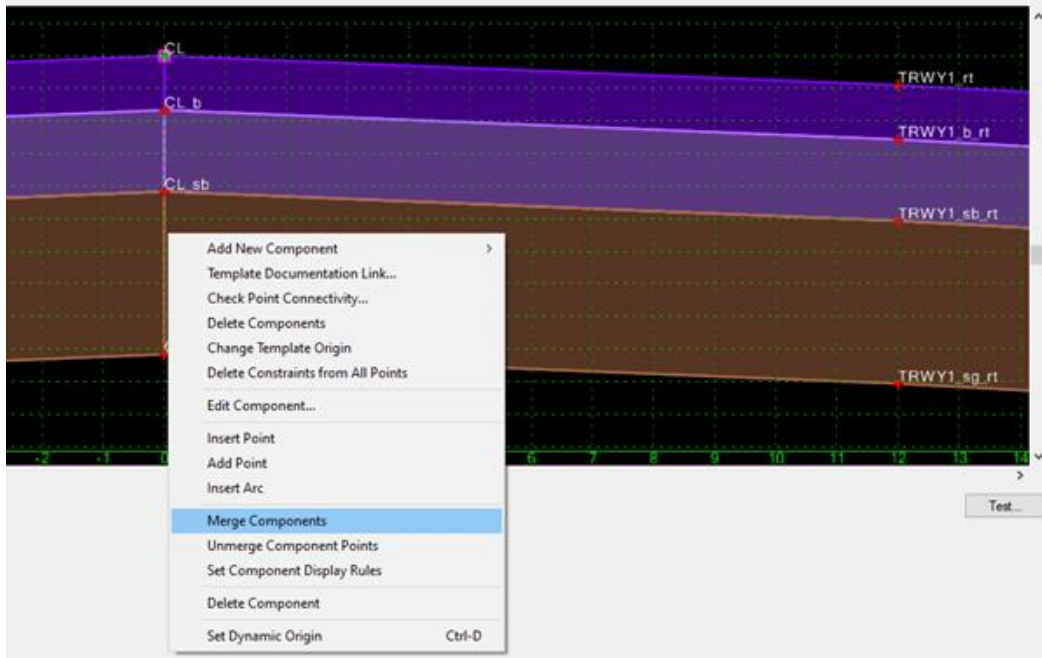

Figure 87 - Merge Components

3.8.1 Component Editing

The properties of the component can be edited by double-clicking on the component. The Component Properties dialog is opened.

Figure 88 – Component Editing

Name – Specifies the name of the current component. Select a different component using the locate button.

Use Name Override – The name override is used to specify the name used by the software to connect components from one template drop location to the next.

The option is intended to create connectivity from one station to the next when the template components change. For example, a template may contain more than one solution for a fill condition as shown below.

Two end conditions are defined for the fill slopes named R-FILL2 and R-FILL3. When the templates are processed, the software will evaluate each template drop location to determine whether the R-FILL2 or the R-FILL3 component is used. 3D Mesh elements are created by connect all the components by the name of the component. All the components named R-FILL2 will be connected to create 3D Mesh element, and all of the components named R-FILL3 will be connected to create another mesh element. This leaves a gap in components at the locations where the fill slope transitions from 3:1 to 2:1 since the components named R-FILL3 will not be connected to the components named R-FILL2. The solution is to assign the same **Override Name** for each component.

Description – Specifies an optional description of the component.

Feature Definition - Specifies the feature style of the component. This option is used for display and also to define the component’s material. CTDOT has defined a specific group of styles to be used for components prefixed with the word “Component”. When the components are plotted in MicroStation, either as a 3D model, or as cross sections, the symbology defined by the selected Style is used. Care should be taken to select the appropriate style for each template component.

Parent Component - Specifies the parent component. If a component has a parent component, then it is only displayed if the parent component is displayed. The parent component can be either a non-end condition component, or an end condition component. Specify the component or identify it using the locate button.

The **Active Template** listing can also be used to display and edit the parent child relationship between points and components. In the example at right, the Components category is open to show the parent/child relationship between the **components** in the tree. Drag and drop operations can be used to move one component under another.

Note: The component names are listed alphabetically, not from top to bottom as drawn in the template.

Exclude from Top/Bottom Mesh - Specifies that the component will be excluded from the top and bottom mesh elements that are created in the corridor modeling process.

Close Shape - This option is only available for non-End Condition components. Only closed shapes can be used to compute component quantities.

In this example the components were merged so the **Name** needs to be edited to remove the **_lt** suffix.

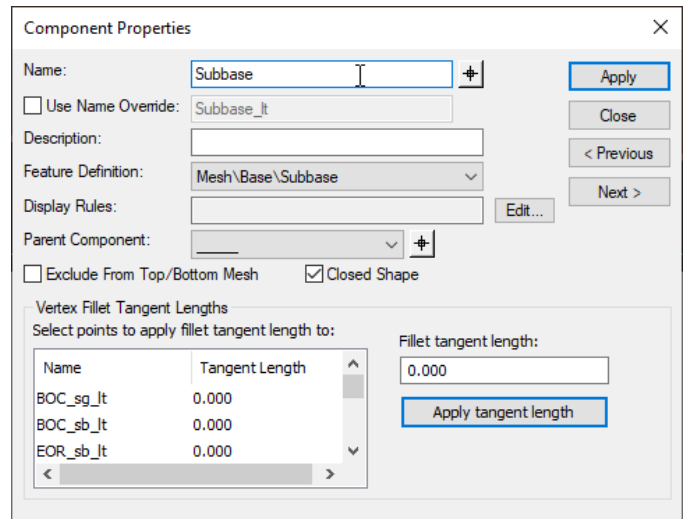
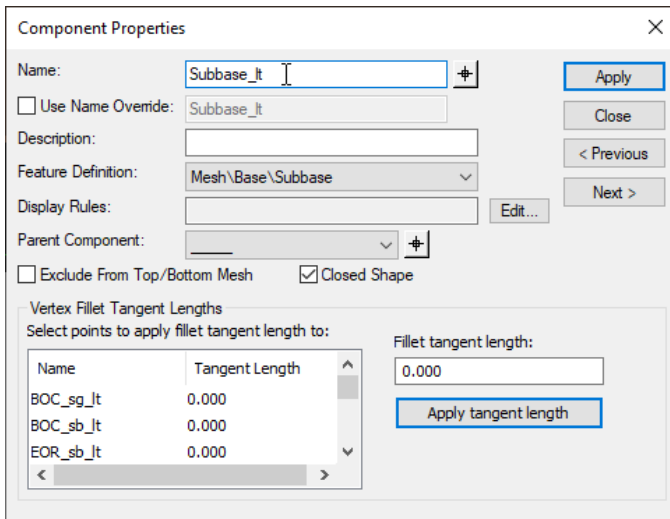

Figure 89 - Close Shape

3.8.2 End Conditions

An end condition is a special open-shaped component that targets a surface, a feature of a surface, an elevation, or an alignment. End Conditions are commonly used for cut and fill definitions. End Conditions are added to the end of simple, constrained, or unconstrained components.

To create an end condition, right-click in the template window and select **Add New Component > End Condition**, or select **Add > End Condition** from the *Create Template* dialog’s pull-down menu.

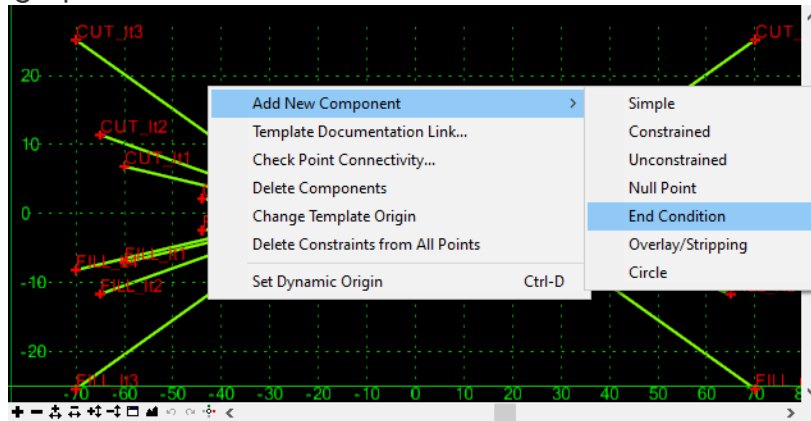

Figure 90 – End Conditions

When adding an end condition to the current template, the **Current Component** portion of the Create Template dialog displays the following options:

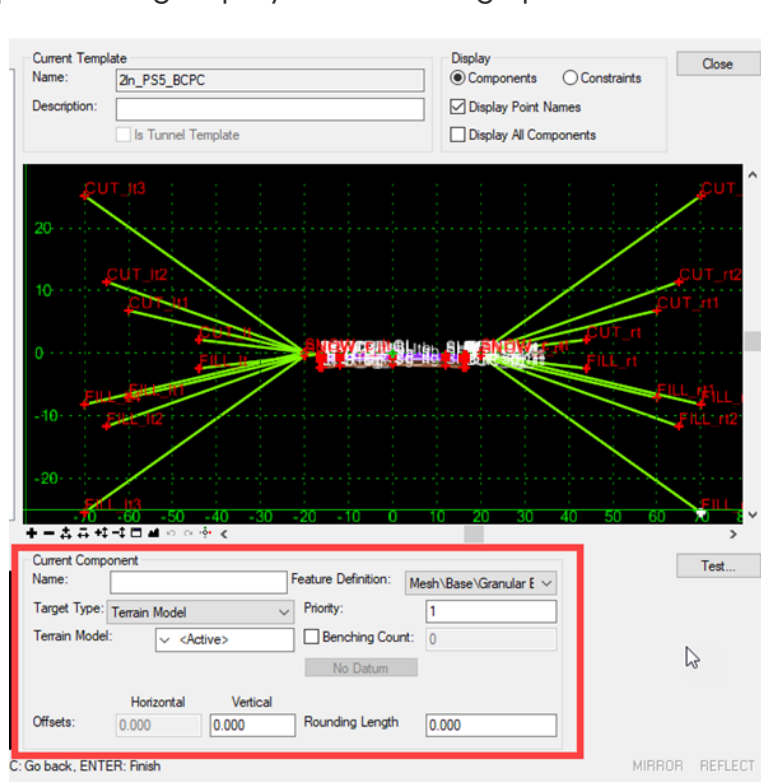

Figure 91 – Current Component

Volume 3.2 – OpenRoads Designer Roadway Modeling

The **Name** field is used to specify the user defined name for the component.

The **Feature Definition** is used to set the feature definition for the component.

Target Type specifies the type of target the End Condition is seeking. Targets include:

- Terrain Model – Seeks an OpenRoads Terrain Model.
- Elevation – Seeks a particular elevation.
- Linear Horizontal/Vertical/Both – Seeks the intersection with a particular linear element selected from a list.
- Feature Definition Horizontal/Vertical/Both – Seeks the intersection with a particular feature type.

Horizontal Offset specifies a horizontal offset from the target. This option only applies if the target is a horizontal target or has a horizontal aspect.

Vertical Offset specifies a vertical offset from the target. Applies only if the target is a vertical target or has a vertical aspect. For an elevation target, specify the elevation here.

Priority specifies the order in which end conditions are attempted in seeking a solution. Where more than one End Condition starts at the same point, this value determines the order in which End Conditions are attempted to find a solution. Lower numbers, which have a higher priority, are attempted first.

Benching Checkbox indicates, when on, the set of segments of the End Condition are repeated until a solution is found.

Benching Count indicates the maximum number of times that benching should occur. If this value is 0, then the repeat count is unlimited, and the benching End Condition must find its target for it to be valid. If any other number is entered, then if the benching is repeated for the specified count and if the target is not reached, the benching End Condition will still be considered successful if an End Condition attached to the end of the benching End Condition is successful.

From Datum indicates, when on, the benching will use a datum elevation and step elevation to set the benching rather than using the End Condition segments as they are defined.

Datum Elevation specifies the elevation that represents the basis for the step elevation. Datum + Current bench elevation = n * Step Elevation.

Step Elevation specifies the increment for benching when a datum is being used. Each bench elevation is always located at the end of the first segment (or the second point) of the benching End Condition.

Rounding Length specifies the length used to round the end condition. When this value is something other than 0.0, 4 additional points are added to the end of the end condition using a parabolic formula to smooth out the transition of the intersection of the end

condition with the surface. This rounding effect is only applied when the target is a terrain model or an elevation. Any other end conditions attached to the end of this one is attached to the end of the rounded section.

End Condition Priority

The end condition priority value is used when more than one end condition is defined starting at the same point. A simple end condition consisting of two fill lines is shown in the example below.

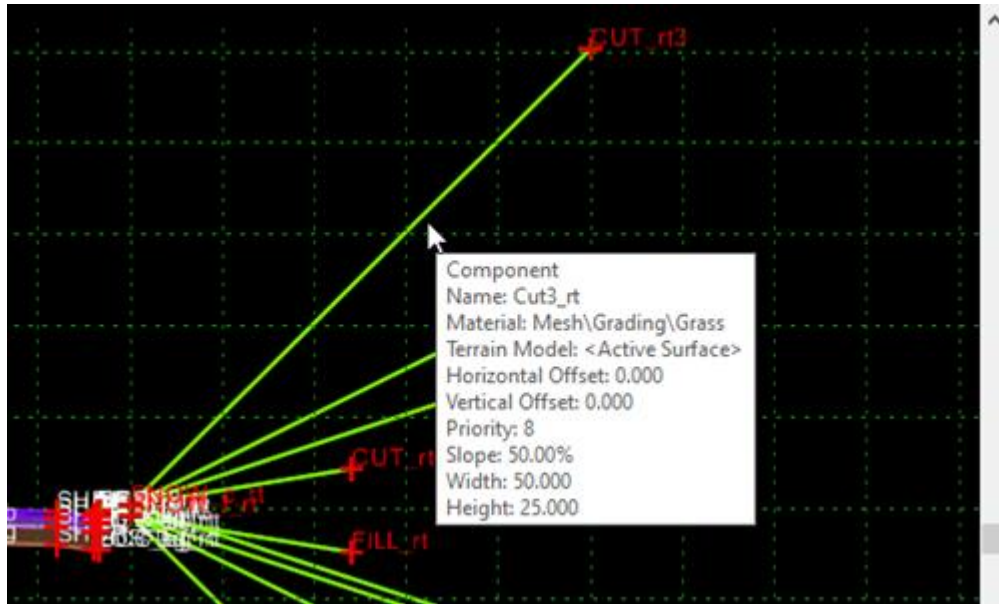

Figure 92 - End Condition Priority

When the end condition is processed in corridor modeling, each end condition will be tested in the order specified by the user. The order is determined by the **Priority** value entered by the user during the end condition creation. The most desirable solution, and the first condition to be tested, is given a priority value of 1.

Volume 3.2 - OpenRoads Designer Roadway Modeling

Double-clicking on a component will open the Component Properties dialog shown below. If the component is an end condition, the **End Condition Properties** are displayed. The **Priority** is set as shown below.

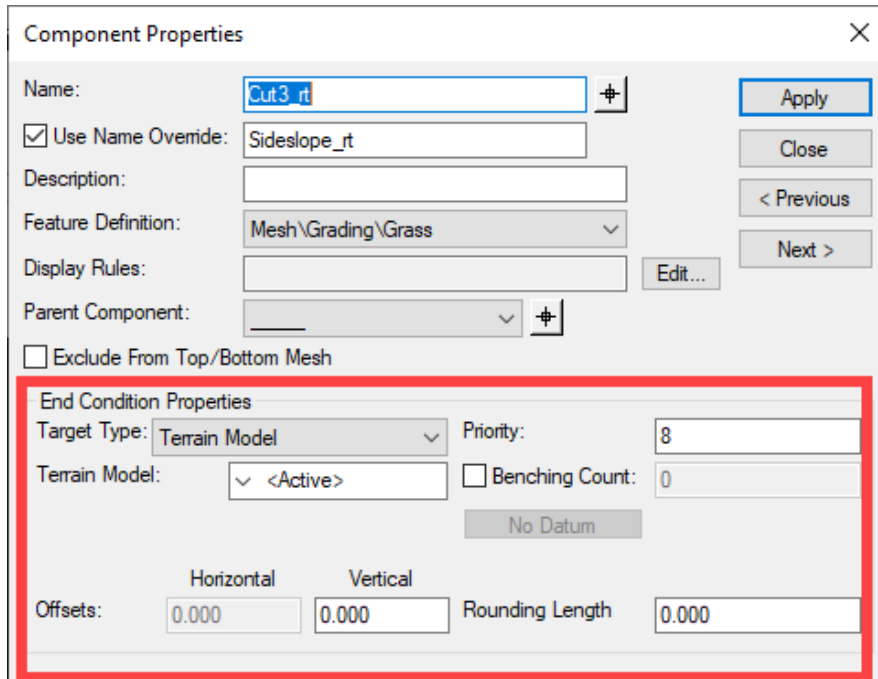

Figure 93 - End Condition Properties

The properties for point CUT_rt2 were defined as shown Below. **Check for Interception** is toggled on, and **End Condition is Infinite** is toggled off. The point is defined with a 25% Slope for a horizontal distance of 45.0' from the snow shelf.

Volume 3.2 - OpenRoads Designer Roadway Modeling

The properties for the point CUT_rt3 were defined to specify a 2:1 slope with the **End Condition is Infinite** option toggled on. The priority for the end condition component Cut3_rt is set to a value of 8.

With these settings, the end condition CUT_rt2 (Priority=7) will be tested before CUT_rt3 (Priority=8) for an interception with the surface within the horizontal distance of 45.0'. If an interception is found within the vertical distance, the end condition is used for the cross section and a point will be placed at the interception.

If no interception is found within 45.0' horizontally from the snow shelf, the condition fails and the software will test the next end condition, CUT_rt3, which has a Priority value of 8.

Volume 3.2 - OpenRoads Designer Roadway Modeling

Since **End Condition is Infinite** is toggled on for point CUT_rt3, the solution will solve for an interception with the surface regardless of the vertical constraint definition.

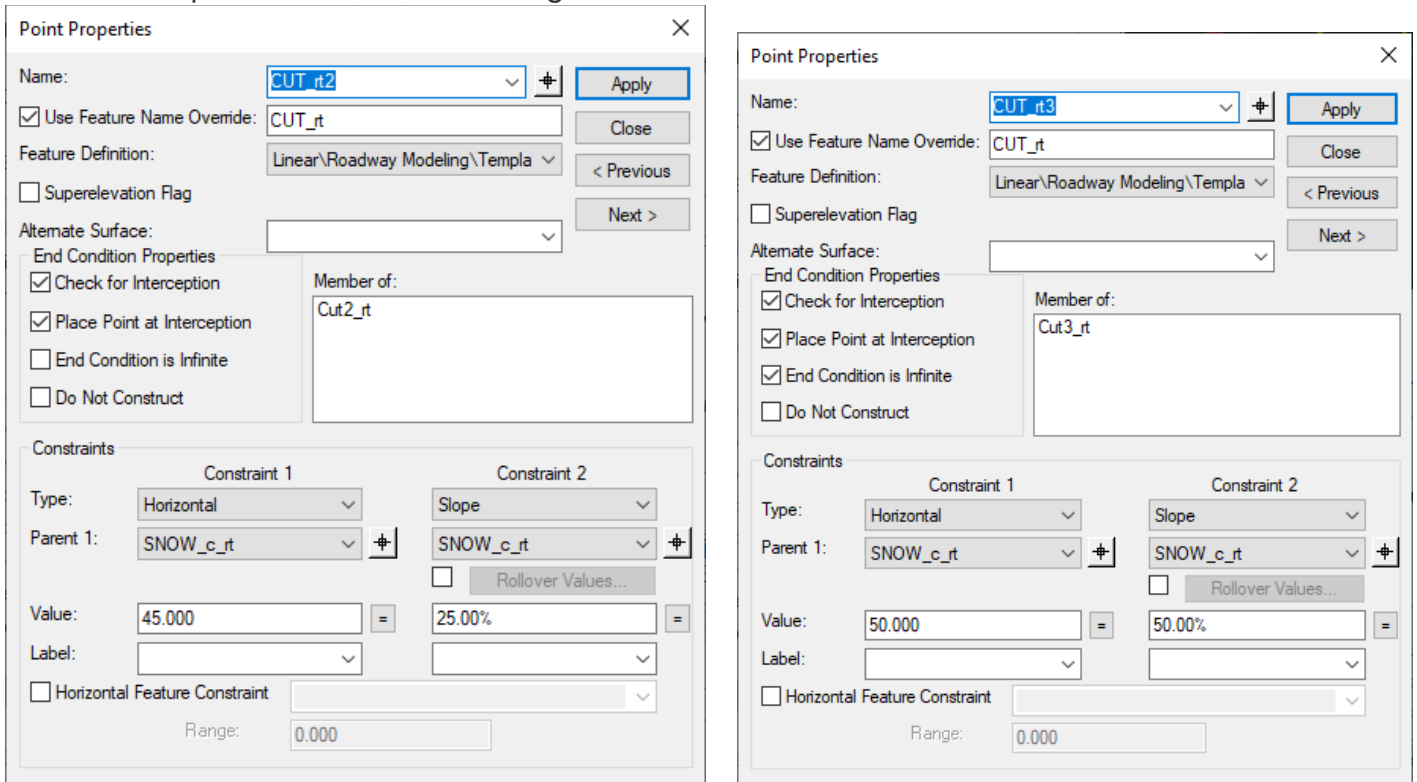

Figure 94 - Point Property End Condition is Infinite

Testing End Conditions

End conditions can be tested in the Create Template dialog before processing the template with corridor modeling. Testing simulates how the end condition will behave when the corridor is processed.

This is extremely useful for complex end condition definitions with multiple solutions. To test the end condition, select the **Test** command, located below the **Current Template** window. The Test End Conditions dialog is opened.

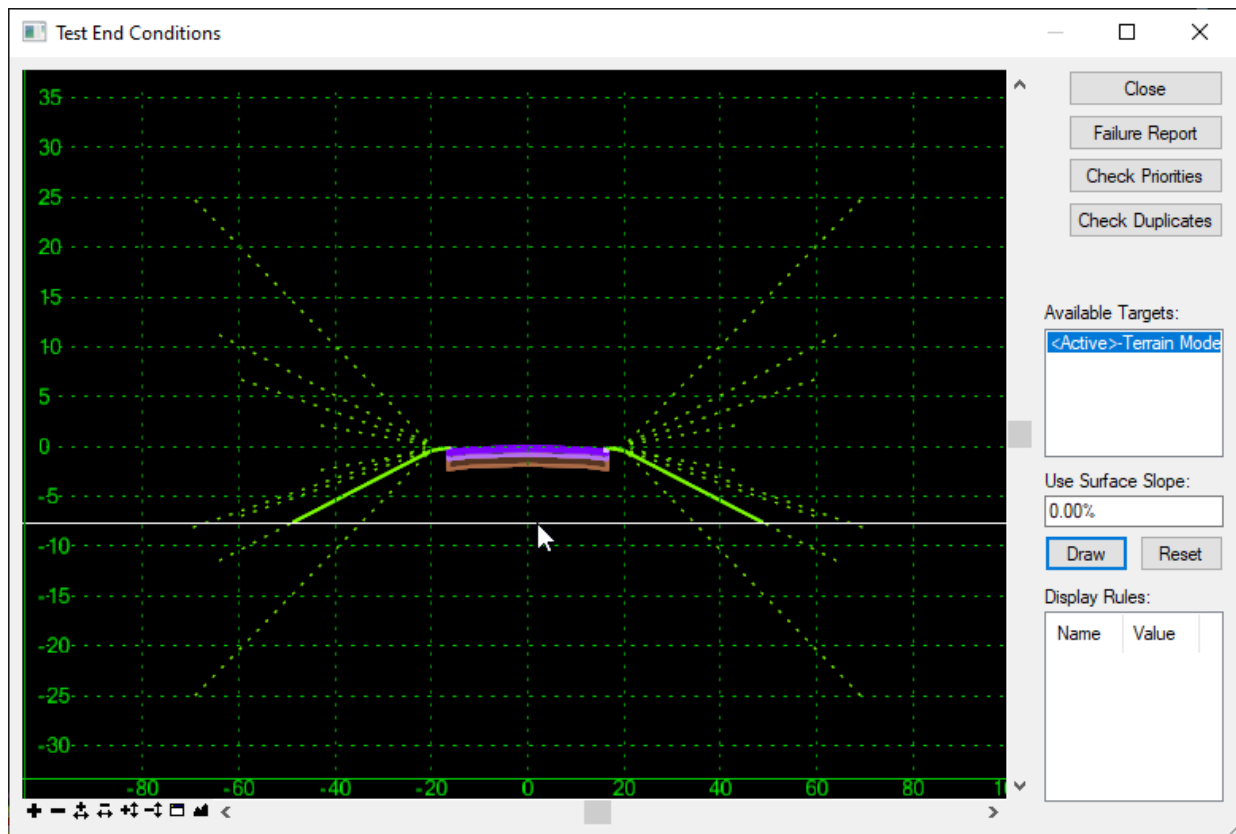

Figure 95 - Testing End Conditions

The software will check for conflicts in the priorities defined in the template before opening the Test End Condition dialog. If conflicts exist, a warning is issued.

The dialog displays the current template. Non-solved end conditions, and their child components, are displayed in dashed lines. Normal components and solved end conditions are displayed as solid lines.

To test the end condition, select one of the available targets and then select the Draw button. Move your cursor over to the testing window. The end conditions will change from a dotted line to a solid line indicating the solution for the target interception.

Failure Report activates the Results dialog. When you fail to get a solution on one or both sides, the results show which components failed and which end condition start points were not solved.

Check Priorities tests the template for priority conflicts. When conflicts exist, a message is displayed indicating there are end conditions that start from the same point and have the same priorities. The End Condition Priority Conflicts dialog is displayed. If no conflicts exist, a message box indicating no conflicts is displayed.

Available Targets lists all of the targets applicable to the current template. You can select the desired target and draw it in the display.

Use Surface Slope specifies the slope of the surface that is being placed. This is useful in certain instances where an end condition intersects a surface more than once, such as a ditch profile.

Draw draws the selected target. Surfaces and elevations are drawn as horizontal lines. Features and alignments are drawn as a “+” mark. As you draw a target, the display dynamically updates to show the solution(s).

Reset clears all the drawn targets.

Display Rules list the display rules for the current template. Left-click the **Value** to toggle between **True** and **False**. Press the Reset button to restore the original **Display Rules** values.

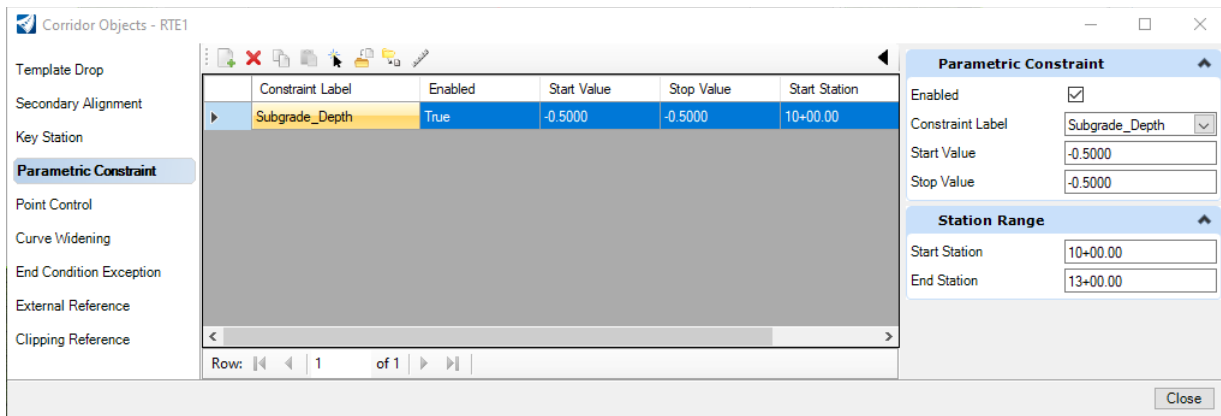

Figure 96 - Display Rules

If at any time user need to modify the values user can do it here.