

Gale Associates, Inc.
Engineers and Planners

Air and Moisture Control in Building Enclosures

2014 Design & Trade Conference

Marc A. Loranger, P.E., LEED AP
May 29, 2014



Gale's Expertise

- Building Enclosure Technology
- Structural Engineering
- Civil Engineering
- Athletic Facilities Planning and Design
- Airport Engineering and Planning



Building Enclosure Commissioning Services Newton, MA



Building Enclosure Commissioning Services
Boston, MA



Building Enclosure Commissioning Services
New Haven, CT



Building Enclosure Function

- Commercial and Residential buildings use 40% of the nations primary energy usage.
- Heating, Ventilating, and Air Conditioning accounts for 17%.
- NIST 2005 Study indicated Northeast can save 42% of heat cost and 26% of cooling cost with air barriers and continuous insulation
- Heating and Cooling a typical home consist of 54% of utility bills (DOE)



Building Enclosure Function

- Control water penetration
- Control air flow
- Control water vapor flow
- Control heat flow
- Control noise transmission
- Control solar radiation
- Fire separation



Presentation Outline

- Part I – Air and Vapor Barriers 101
- Part II – The Good, the Bad, the Ugly
- Part III – Energy Retrofit Case Study
- Part IV – Insulation Retrofit



Part 1 – Air and Vapor Barriers 101



Learning Objectives

Air /vapor barriers (AVB'S), when correctly installed, help buildings achieve high levels of energy efficiency. But, when AVB's are incorrectly installed, they can cause problems, including deterioration of sheathing, structural members, and the formation of mold.

- Improving thermal/moisture performance and interior air quality of buildings
- Unique solutions to improve overall building performances and aesthetics through a continuous air barrier
- Attendees will learn methods to include when specifying or detailing an AVB
- Review substrate preparation requirements that are critical to a good AVB installation but are the responsibility of another trade



Topics & Definitions

- Basic Principals & Characteristics of AVB's
- Why Consider AVB's
- Types of AVB's
- Design Concepts
- Site Observations



Basic Principles of Vapor Barriers

What is a Vapor Barrier?

- A material used to slow or stop the diffusion of moisture vapor through exterior building enclosures
- Does NOT need to be continuous
- Connecticut is Zone 5A (moist)
- 2003 IBC/2005 CSBC..... “approved vapor retarder”
- 2012 IBC/IECC
 - Class 1 = Sheet polyethylene, non perforated aluminum foil
 - Class 2 = Kraft-faced fiberglass batt or paint with a perm rating > 0.1 and < or = 1 Perm
 - Class 3 = Latex or enamel paint (vented cladding or insulated sheathing)



Basic Principles of Air Barriers

Code References:

- 2003 IBC/2009 IECC
 - ANSI/ASHRAE 90.1 (2010 envelope sealing)
 - Chapter 5 – Commercial
- 2012 IBC/IECC
 - ANSI/ASHRAE 90.1 (2013 requires AB)
 - Chapter 4 - Commercial



Basic Principles of Air Barriers

What is an Air Barrier?

- A group of assemblies made of materials and accessories designated to prevent or retard the flow of air through a building envelope assembly and its transitions.

AIR BARRIER STANDARDS			
Air Infiltration Requirements (cfm/ft ² @ 0.3 in w.g., 75Pa)	Materials (ASTM E2178)	Assemblies (ASTM E2357 or E1677)	Whole Building (ASTM E779)
ASHRAE 90.1 (2010)	0.004	0.04	-
USACE (2008) NAVFAC (2011)	0.004	-	0.25
GSA (2010) USAF (2011)	0.004	0.04	0.4
ASHRAE 189.1 (2009) IECC (2012)	0.004	0.04	0.4



Basic Principles of Air Barriers

Characteristics:

- Clearly identified or noted on Contract Documents
- Continuous over all surfaces from lowest floor to, and including roof
- Resist positive/negative wind, fan, stack effect pressures
- Joint, transitions and penetrations shall accommodate movement in the structure



Why Use an Air Barrier System?

- Several states now include air barrier requirements in their building codes.
- Up to 40% of energy used to heat/cool a building is from uncontrolled air leakage
- US Government Agencies require them on federally funded building projects
- Reduced building enclosure moisture problems
- Improved indoor air quality



Why Stop the Flow of Air through the Building Enclosure?

- Can transport 30 to 200 times more moisture into the building than vapor diffusion
- Can cause concentrated areas of condensation, mold, corrosion and premature failure
- Causes the HVAC system to use more energy
- Reduces the effectiveness of thermal insulation, increasing heating and cooling costs
- Disrupts mechanical system pressurization



Why Stop the Flow of Air through the Building Enclosure?

- Air leakage: moisture travels in the air as it freely passes through wall cracks and penetrations
- Vapor diffusion: moisture is driven through a material by vapor pressure

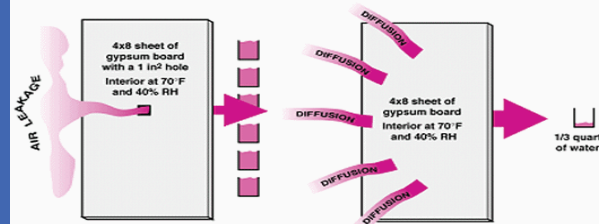

Impacts of Air Leakage



Impacts of Air Leakage



Impacts of Air Leakage



Types of Air Barriers

- Plywood – minimum 3/8”
- OSB – minimum 3/8”
- Exterior Gypsum Sheathing – min 1/2”
- Fully Adhered Roofing Membranes
- Extruded Polystyrene Board – min 1/2”
- Stucco – min 1/2”
- Cast in Place and Precast Concrete
- Sheet Metal
- Closed Cell Polyurethane Foam 2lb/cf
- Membranes (vapor permeable)



Types of Vapor Barriers

- Liquid Applied Membranes
 - Spray or Roll Applied
- Sheet Applied Membranes
 - Self-Adhering
- Spray Polyurethane Foam (SPF)
- Extruded Polystyrene
- Sheet Metal
- Polyethylene Sheet



Design Considerations for AVB Systems

Connections should be made between:

- Foundations and walls
- Walls and windows/doors
- Different wall systems
- Wall and roof over conditioned space
- Walls, floor and roof across construction, control and expansion joints
- At Penetrations



Detailing

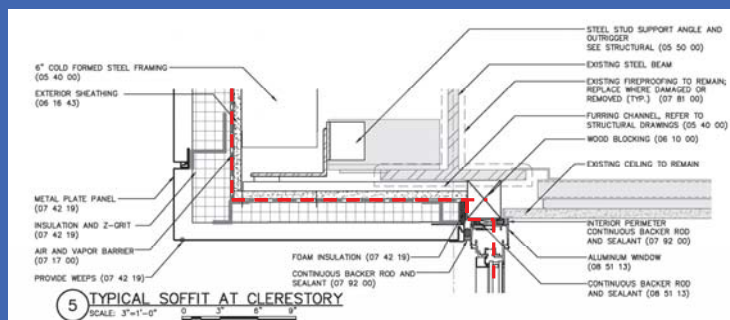

Detailing

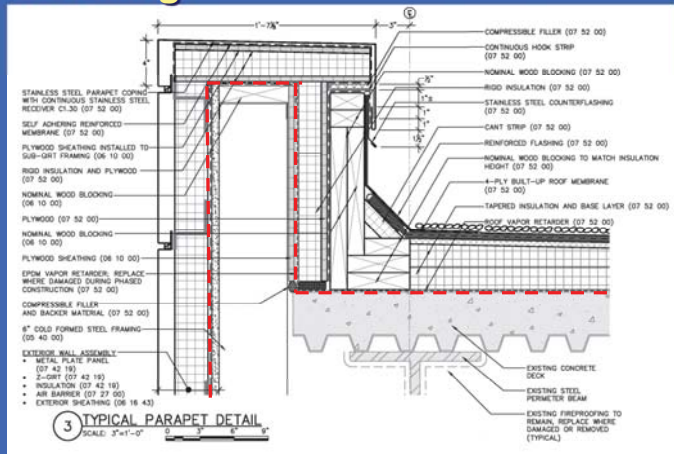

Detailing

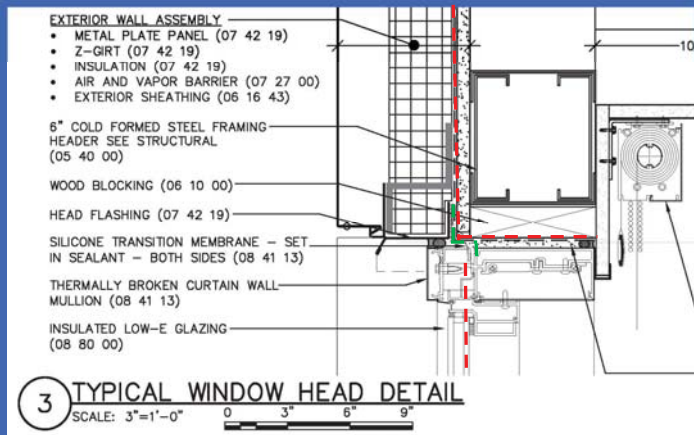

Detailing

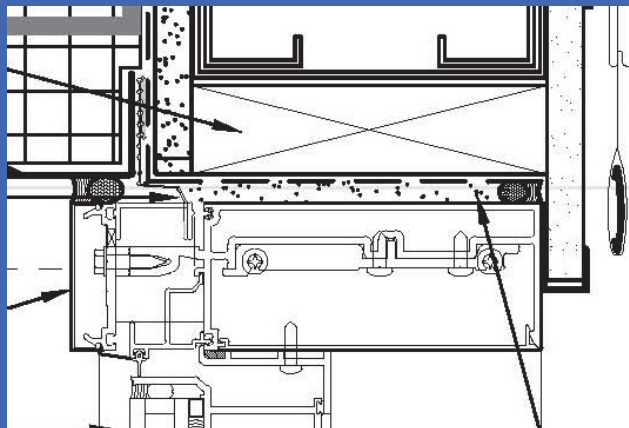

Detailing

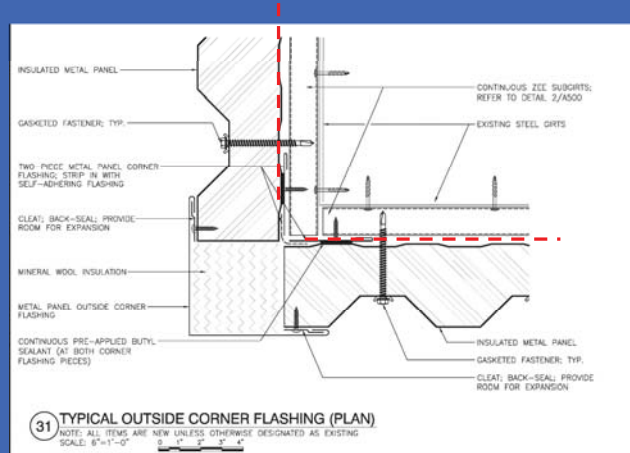

General Observations



GALE

General Observations

Substrates – Preparation and Application



GALE

General Observations

Substrates – Preparation and Application



General Observations

Substrates – Preparation and Application



General Observations

Substrates – Preparation and Application

- Projections
- Stone anchors



General Observations

Substrates

- Gypsum Sheathing

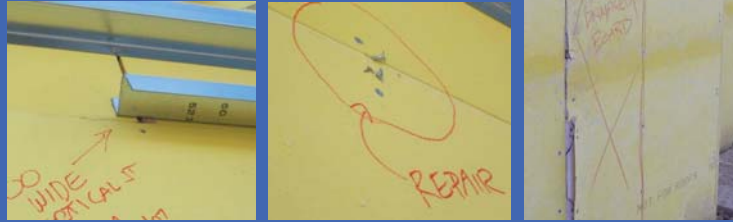

General Observations

Substrates

- Steel Beams/Columns
 - Debris/overspray/fireproofing
 - Rust/scale



General Observations

Substrates

- Penetrations
 - Pipes/conduits
 - Structural tails/fins/relieving angles



General Observations

Damages by other trades:

- Window Sub-contractors
 - Transition membranes
- Masonry Sub-contractors
 - Damages to membrane
 - Insulation installation
 - Veneer & cladding installation



General Observations

Damages by other trades:

- Mechanical/Electrical/Plumbing
 - *They come in after the fact and cut openings in the wall!*

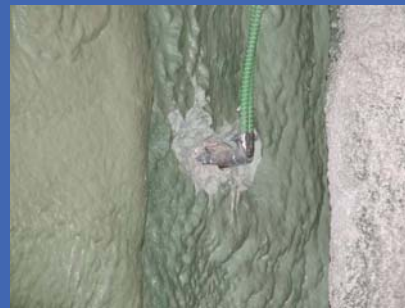

General Observations

Membranes

- SPF
 - Uniform appearance
 - Penetrations
 - Shrinkage cracking



General Observations



General Observations

Membranes

- Material Storage



GALE

Key Causes of AVB Failures

- Lack of coordinated details between construction trades
- Workmanship
- Lack of technical understanding of moisture/air intrusion mechanisms
- No defined expectation of building's performance with regard to selecting materials and details
- Lack of modeling / review / testing

GALE

Part II

THE GOOD THE BAD & THE UGLY

GALE

Learning Objectives

- Addressing envelope issues in the early stages of building construction projects saves money and time, and reduces liability for the design and construction team.
- Avoid common issues in building construction, including water intrusion, indoor air quality issues, mold growth, air infiltration, and energy loss.
- HVAC and BET go hand in hand as the HVAC systems will never operate as designed unless the building envelope performs.
- The earlier the commissioning process begins, the easier it is to incorporate the comments into the construction documents.

GALE

Most Common Issue – Leakage/Business Interruption



20th Century Building Envelopes

- Simple building materials
- Limited layers
- Trained workforce



GALE

Today's Building Envelopes

- Complex, new building materials
- Multiple layers / configurations
- Limited designer/contractor experience



GALE

Wall System Peer Review (BOD)



Wall System Peer Review (BOD)

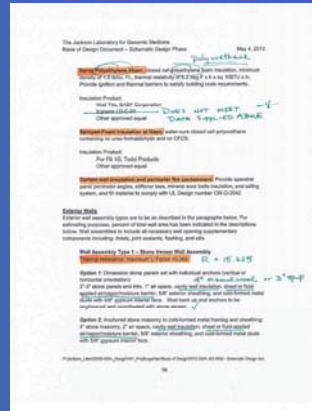
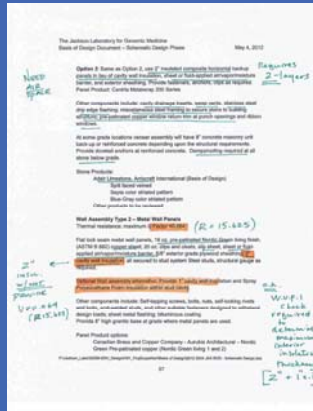

Names of these projects are withheld to protect the guilty...



The Good



Detailing Membrane



Patching



Roof Tie-in



Roof Steps



What about the Sill?



End Dams? Who needs End Dams?



Through-wall flashing?



The Forgotten Column



Bad or Ugly?



Bad or Ugly?



How do you install behind conduits



The Runs



Wet Substrates



Got Water?



What Water?





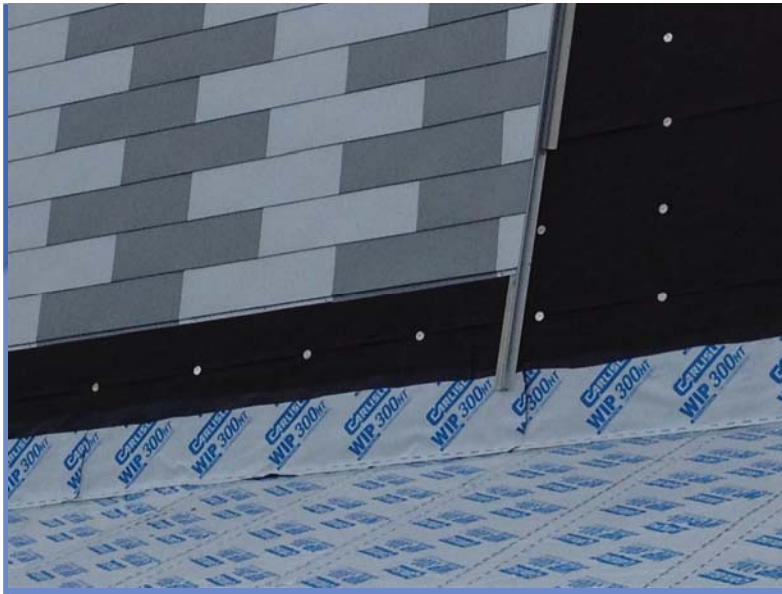

Mock-Up Testing

- To be built by on-site trades
- Full-scale laboratory testing
- To include as many typical details as possible
- To be tested for compliance with established standards
- Access for modifications to address potential problems
- Troubleshoot potential problems
- Establishes standard of care for trades



On-Site Mock-Up



On-Building Mock-Up



ASTM E 2813 – Standard Practice for Building Enclosure Commissioning

E2813 – 12

TABLE A2.1 Continued

Property	Standard Designation	Title	Lab System Testing	Enhanced		Fundamental	
				Field Mockup Testing ^a	In Situ Field Testing	Field Mockup Testing	In Situ Field Testing
Water Penetration							
Water penetration	ASTM E301	Test Method for Water Penetration of Exterior Windows, Skylights, Doors, and Curtain Walls by Uniform Static Air Pressure Difference	(M)	---	---	---	---
	ASTM E514	Test Method for Water Penetration and Leakage Through Masonry	OL	(OF)	(OF)	(OF)	(OF)
	ASTM C1601	Test Method for Field Determination of Water Penetration of Masonry Wall Surfaces	---	(OF)	(OF)	(OF)	(OF)
	ASTM D5957 ^b	Guide for Flood Testing Horizontal Waterproofing Installations	---	(OF)	(All horizontal surfaces)	(OF)	(All horizontal surfaces)
Static water penetration	ASTM E1105	Test Method for Field Determination of Water Penetration of Installed Exterior Windows, Skylights, Doors, and Curtain Walls by Uniform or Cyclic Static Air Pressure Difference	---	(TX)	(TX)	(TX)	(TX)
Dynamic water penetration	AAMA 501.1	Standard Test Method for Water Penetration of Windows, Curtain Walls, and Doors Using Dynamic Pressure	OL (M)	(OF)	(TX)	(OF)	(OF)
	ASTM E2208 ^c	Standard Test Method for Water Penetration of Exterior Windows, Skylights, and Doors by Rapid Pulsed Air Pressure Difference	OL	(OF)	(OF)	(OF)	(OF)
	AAMA 501.2	Quality Assurance and Diagnostic Water Leakage Field Check of Installed Storefronts, Curtain Walls and Slated Glazing Systems	---	(TX)	(TX)	(TX)	(TX)

ASTM E 783 Standard Test Method for Field Measurement of Air Leakage through Installed Exterior Windows and Doors



ASTM E-1105 and AAMA 501.2 Testing



Electric Field Vector Monitoring and ASTM D-5957 Flood Testing



ASTM E 1186 Standard Practice for Air Leakage Detection in Building Enclosures and Air Barrier Systems

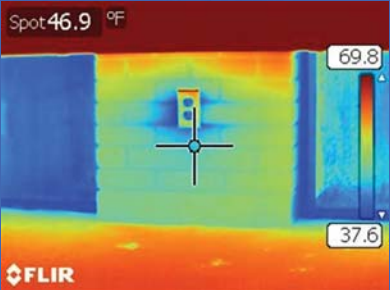

ASTM E 1186, Standard Practice for Air Leakage Detection in Building Envelopes and Air Barrier Systems



ASTM E 779, Standard Test Method for Determining Air Leakage Rate by Fan Pressurization



ASTM D 4541 Standard Test Method for Pull-Off Strength of Coatings – Portable Adhesion Testing



ASTM C 1153, Standard Practice for Location of Wet Insulation in Roofing Using Infrared Imaging

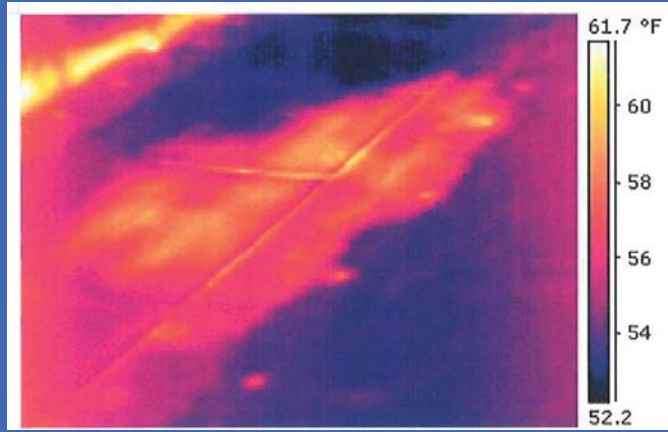

AAMA 501.1 Water Penetration Test Using Dynamic Pressure



AAMA 501.1 Water Penetration Test Using Dynamic Pressure







Part III

Renovations to Existing Building Enclosures to Improve Energy Performance



Learning Objectives

- Improving thermal, moisture and air infiltration management performance, and occupant comfort with resultant improvement of indoor air quality
- Unique solutions to improve overall building performance
- Coordinating construction at occupied facilities, and complying with campus funding levels
- Attendees can gain an understanding of various options available to improve their buildings' performance



Background - History



- Typical three story dorm building – east / courtyard elevation.
- Typical two story dorm buildings, photo shows the south elevation of the north wing.

Background - History

- The EIFS panels are cracked at the vertical joints and are bowing
- Staining of EIFS under the window.
- Open joints were observed at the horizontal sealant line.
- The EIFS is not adhered to the wall at the foundation which is wet, note water running down behind the EIFS.



Background - History

- South wing roof which blew off in the wind storm of April 15th and 16th, 2007.
- Prior to the storm, the EIFS wall was previously secured with fasteners by University staff.
- The EIFS is in direct contact with the shingles. Step flashing was observed behind the EIFS. The step flashing was not flashed or secured tightly to the substrate.



Background - History

- Typical staining at the window sill corners.
- The sealant at the corners is failed and has vegetation staining.
- The sealant surface is crazed, split at the sill exposing the backer rod.
- The sealant and backer rod is wet and is experiencing algae growth at the window sill corner.

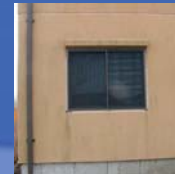

GALE

Background - History



Background - History



Background - History

- Area highlighted by IR Scan
- Test cut performed to confirm condition.
- The OSB was observed to be wet and deteriorated
- The sealant, backer rod, wood blocking were wet
- Standing water was observed on the OSB sheet below the sealant



GALE

Background - History

- The canopy's mechanical duct penetration exhibited severe deterioration.
- Staining and algae growth noted
- Panels are loose and not adhered to the wall.
- The EIFS was removed to expose fully deteriorated and delaminated OSB.
- At the canopy, the OSB was removed to expose wet and deteriorating sill plate and wet insulation

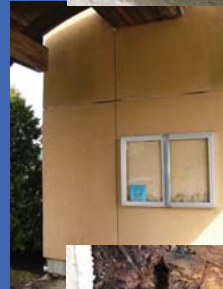

GALE

Proposed Design

- New plywood sheathing
- Continuous air barrier from foundation to roof eave
- Exterior continuous insulation
- Cementitious wood siding and trim
- With goal to provide a "New England" aesthetic to existing modern style dormitory complex

GALE

Proposed Design

- Proposed design included the installation an air barrier and continuous rigid insulation on top of roof deck with a vented nail board
- Would have provided continuous air barrier and insulation at full building enclosure
- Roof Air Barrier engineered out of the project due to budget concerns



Proposed Design

- Budget limitations eliminated scope of air sealing at ceiling and roof
- Air barrier tie-in at eave line was limited due to access
- Limited interior work performed so air leakage between units not addressed
- Due to existing recessed entries exterior insulation was limited to 1"



Proposed Design

- Project performed under IBC 2009 (with state modifications)
- Plywood installed as sheer wall to comply with current code requirements



Proposed Design

- Don't forget the thermal impact of the cladding support elements passing through the exterior insulation.

ASHRAE Research Project
1365 "Thermal Performance of
Building Envelope Details for
Mid- and High-Rise Buildings"¹

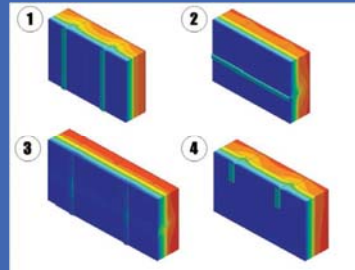

Morrison Hershfield – Solutions MH Vol 2011, Issue 02
Figure 2: Thermal Gradients and heat flow paths for the selected
cladding attachments 1) Vertical, 2) Horizontal, 3)
Vertical/Horizontal

Proposed Design

- New Cellulose insulation R-21 equivalent to R16.3 ci when framing taken into account
- Exterior insulation installed R-value of 6.5 but wood furring with R-1.875 reduces total exterior R-value to approximately R-5.49
- System R-value is 24.07 or U-value of 0.0415

GALE

Proposed Design

WUFI - Hygrothermal Analyses

- Assess wall system behavior with respect to static vapor drive, condensation potential, and capability for drying out accumulated moisture over time.
- Utilizes integral building physics calculations, employs historic weather patterns for specific project locations.
- One-dimensional analyses by transient modeling.

WUFI® PRO

Proposed Design

WUFI - Hygrothermal Analyses

Limitations:

- Dependent of specific material properties
- Standard WUFI material database may not reflect exact in-place conditions

Boundary Conditions:

- Orientation (Exposure / Rain Load)
- Climate (Exterior / Interior)
- Surface Transfer Coefficients
- Initial Conditions
- Calculation Period



Proposed Design

WUFI - Hygrothermal Analyses

FAILURE CRITERIA:

1. Inner Masonry Wythes – 100% RH & Temps. > 32oF
2. Metal Components – RH > 80%
3. Interior Finishes – RH > 70%
4. Increase in Component Moisture Content
5. Mold Growth Potentials:
 - RH > 80% For 30 Days
 - RH > 98% For 7 Days
 - RH > 100% For 24 Hours
6. Liquid Moisture Formation (100% RH)



Proposed Design

Proposed Design:

- Siding attached through furring and into existing wood studs
- Insulation continuous behind furring members

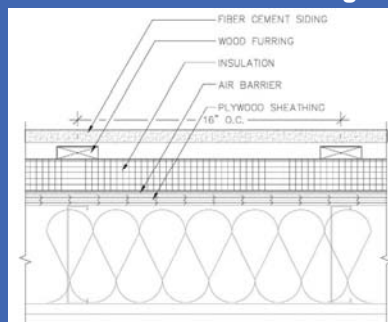

Proposed Design

Design Requirements:

- Recent research indicates that installation of claddings of ≤ 5 psf through up to 8" thickness of insulation does not create short or long-term deflection or creep issues.
- Wood, metal, vinyl and fiber cement siding ≤ 5 psf typically
- Insulation between furring and exterior wall sheathing provides increased capacity for:
 - Rotational resistance
 - Vertical movement resistance



Construction



Construction



Construction



Construction



Construction



Construction



Testing

- After Year 1 – Phase 1
- Complex 1 renovations complete
- Complex 2 undergoing renovations
- Complex 3 awaiting renovations



Testing

- ASTM 779-10
- HVAC balancing dampers/registers left open
- Operable dampers (bathroom vents, fireplaces, etc.) that do not pass air to pressurize the building are sealed off



Testing

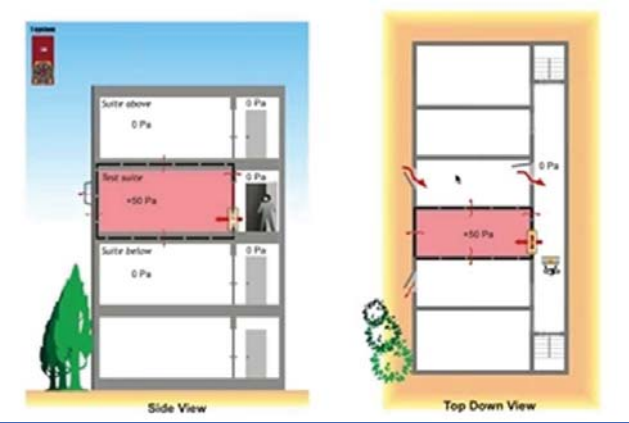
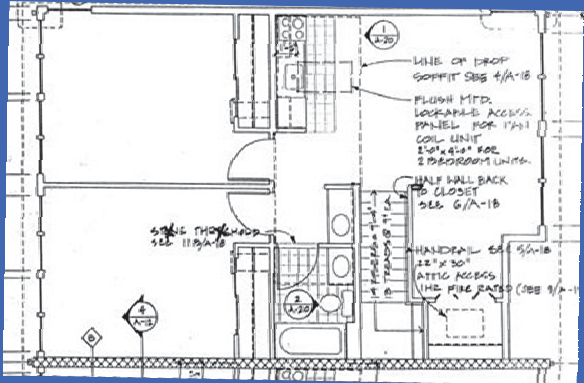

Photo Credit: Retrotec

Testing

- Unit plan 2nd floor



Testing

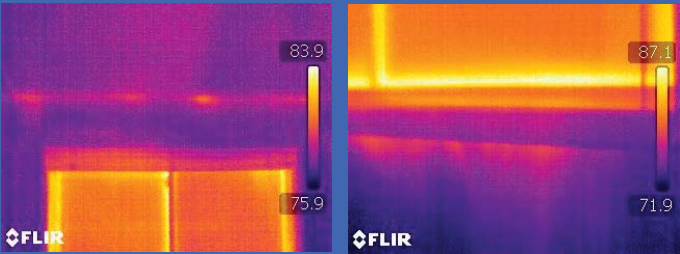

- Air infiltration at penetrations
- At existing building

Testing

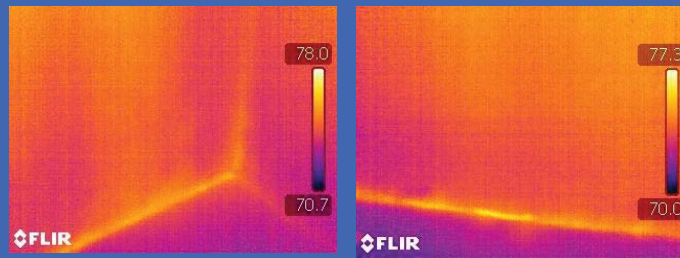

- Air infiltration at floor
- At existing building

Testing

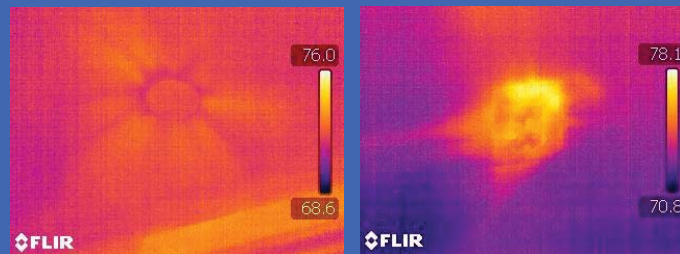

- Air infiltration at penetrations
- At existing building

Testing



- Smoke entry under wall sill plate

Testing



- Smoke entry at window

Testing

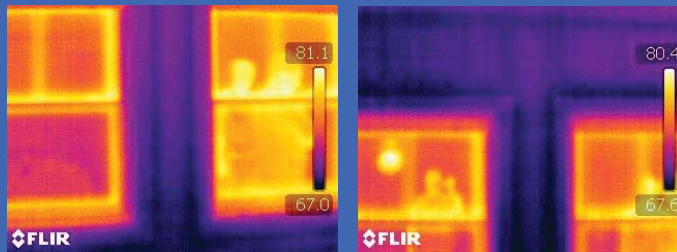

- ASTM 779-10 Blower Door Test
- Renovated Dorm

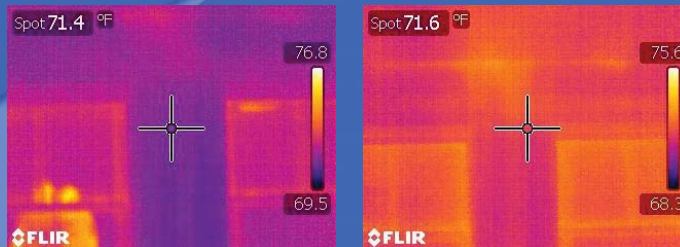

- ASTM 779-10 Blower Door Test
- Renovated Dorm

Testing

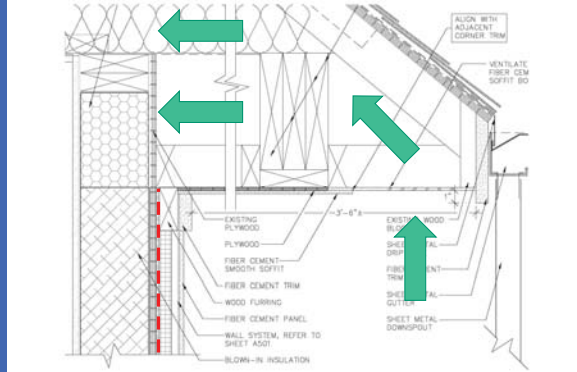

Potential Air Infiltration

Testing

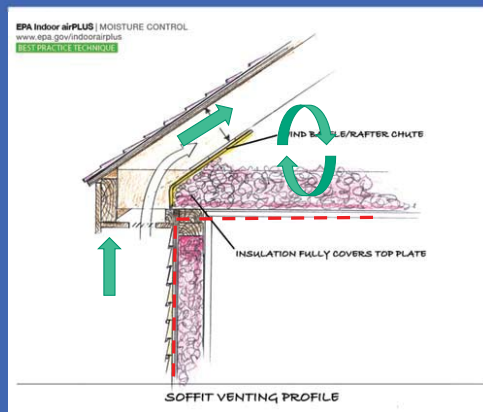

Preferred Design Detail

Energy Comparison

- Test results: What do you get and how?
- 50 vs 75 Pascal Test Pressure

Air Flow Measurement

- Cubic Feet per Minute (CFM) vs Air Exchanges per Hour ACH

$$\text{ACH} = \frac{\text{CFM} \times 60}{\text{Building Volume}}$$

Energy Comparison



Energy Comparison

How to calculate energy loss

- Conduction – Contact
- Convection – Fluid Movement
- Radiation – Less Impact on Energy Loss/Gain

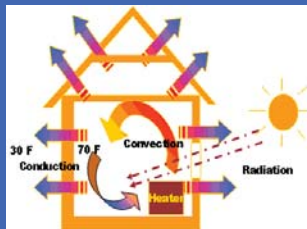

Energy Comparison

Heat Loss via Air Movement (Q_A)

- Measured in BTU/HR

Air Movement = Convection

$$Q_A = CFM \times D_{AIR} \times C_p \times (T_i - T_o) \times 60$$

CFM – Ventilation of air in cubic feet/min

D_{AIR} – Density of air

C_p – Specific heat capacity of air @ constant pressure

T_i – Indoor air temperature

T_o – Outdoor air temperature

Energy Comparison

Example:

$$Q_A = \text{CFM} \times D_{\text{AIR}} \times C_p \times (T_i - T_o) \times 60$$

CFM = 1.73 – Measured difference between new and existing building

$D_{\text{AIR}} = 0.0749$ – Density of air (lb/ft³)

$C_p = 0.24$ – Specific heat capacity of air @ constant pressure (BTU/lb * °F)

T_i – Indoor air temperature (°F)

T_o – Outdoor air temperature (°F)

Result: 44640 BTU/Month

Energy Comparison

Heat Loss via Conduction

Thermal Resistance (R)

$$U = 1/R$$

Coefficient of Heat Transmittance (U)

$$Q_C = U \times A \times \Delta T$$

Q_C – Heat loss through substrate/building enclosure

U – Coefficient of heat transmittance

A – Wall area

ΔT – Temperature difference between exterior and interior environments

Energy Comparison

Calculate Individual Conduction through:

- Walls
- Roof/Ceiling
- Windows/Doors/Other Fenestrations

Combine heat transfer modes to anticipate total energy loss

$$Q_A + Q_C = Q_{\text{Total}}$$

Energy Comparison

- Determining Heating Degree Days (HDD)
- And Cooling Degree Days (CDD)
- Specifics for regions/cities
- HDD = 65°F - avg daily Temp ≤ 65°F
- CDD = avg daily Temp ≥ 65°F - 65°F

Month	Base Year (2013)		
	HDD	CDD	TDD
January	1094	0	1094
February	992	0	992
March	889	0	889
April	488	0	488
May	198	34	232
June	40	137	177
July	5	343	348
August	6	161	167
September	120	66	186
October	337	5	342
November	755	0	755



Energy Comparison

Daily Heat Loss Calculation

$$\frac{Q_{\text{Total}} \times 24\text{hrs/day} \times TDD_D}{(65 - T_{\text{AVG}})} = \text{Daily Energy Loss (BTU/Day)}$$

Q_{Total} – Daily Heat Loss (Calculated as

TDD_D – Total Degree Days (Daily)

T_{AVG} – Average Daily Temperature

Can be used to determine monthly and annual heat loss as well

Energy Comparison

Calculating Energy Usage and Cost

Information Required

- Heating/cooling system efficiencies
- Fuel cost
- Fuel energy constant

Heating Equipment	Fuel	Fuel Cost (Note #1)	Fuel energy content (in millions Btu per unit)	Heating System Efficiency (Note #2)	Heat Cost in \$ per million Btu (Note #3)
Baseboard		kWh			
Heat Pump	Electric	\$0.086 per kWh	0.003412	2	= \$12.60
Medium Efficiency Furnace	Natural Gas	\$9.96 per thousand cubic feet	1.03	0.90	= \$10.74
Medium Efficiency Furnace	Fuel Oil	\$1.25 per gallon	0.14	0.85	= \$10.5
Medium Efficiency Furnace	Propane	\$1.09 per gallon	0.0913	0.85	= \$14.65



Energy Comparison

Example:

- Energy Loss for January via Air Movement Only

Example:

Monthly Energy Loss (January): 246,053 BTU/Month

Heat Cost \$/MBTU: X

$$\frac{X}{1,000,000 \text{ BTU}} \times \frac{246,053 \text{ BTU}}{1 \text{ Year}} = \$X/\text{Month/Unit}$$

Energy Comparison

Calculating Energy Usage and Cost

Annual Energy Cost = Total Annual Energy Loss x
Energy Cost per BTU

Example:

Monthly Energy Loss: 100,000,000 BTU/Year

Heat Cost \$/MBTU: \$14.05

$$\frac{\$14.05}{1,000,000 \text{ BTU}} \times \frac{100,000,000 \text{ BTU}}{1 \text{ Year}} = \$1,450/\text{Year}$$

Energy Comparison



Energy Comparison

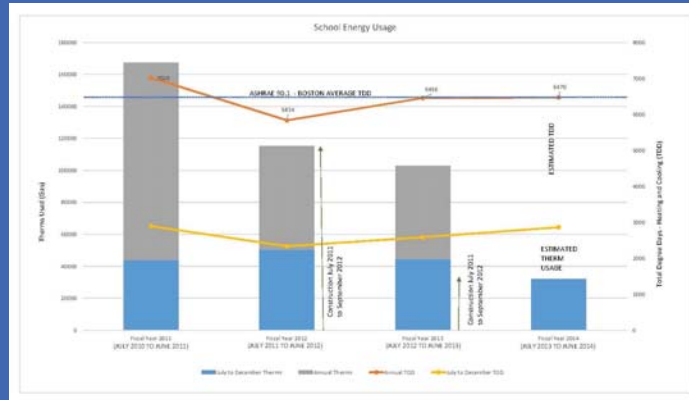

Part V

Comparative Analysis of Insulation Methods for Transitional Masonry Structures



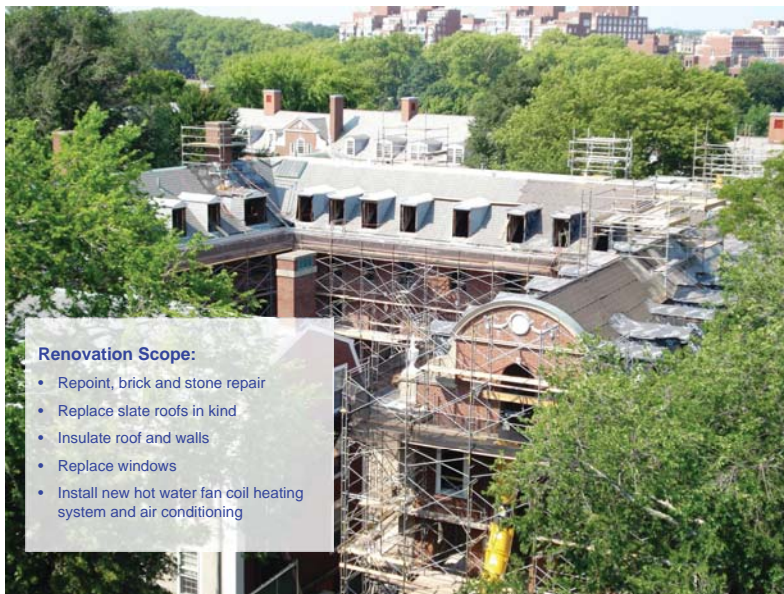

Renovation Scope:

- Repoint, brick and stone repair
- Replace slate roofs in kind
- Insulate roof and walls
- Replace windows
- Install new hot water fan coil heating system and air conditioning

Wall Assemblies

	Unrenovated	Renovated SPF	Renovated FG Batt
Red Brick Exterior Wythe	✓	✓	✓
Terra Cotta Block	✓	✓	✓
Plaster	✓	Removed	Removed
Insulation	-	1" closed cell polyurethane spray foam	3" fiberglass batt
Vapor Retarder	-	-	Polyethylene
Gypsum Sheathing	-	✓	✓
Paint	Acrylic latex	Acrylic latex	Acrylic latex

Original Building Construction

Exterior Brick Masonry
Terra Cotta Back Up Wall
Interior Plaster Finish

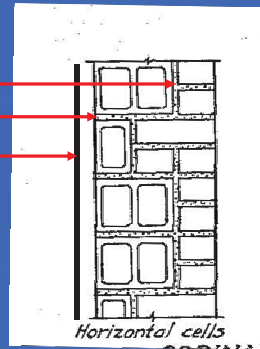

GALE

Renovated Building – SPF

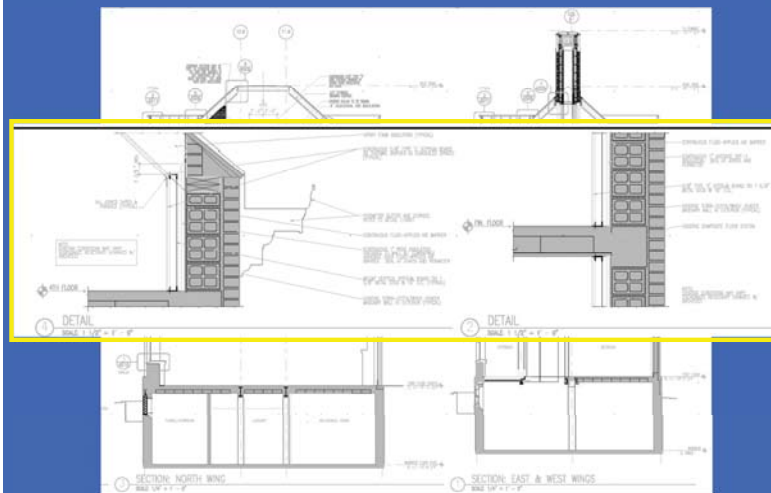



Renovated Building – FG Batt

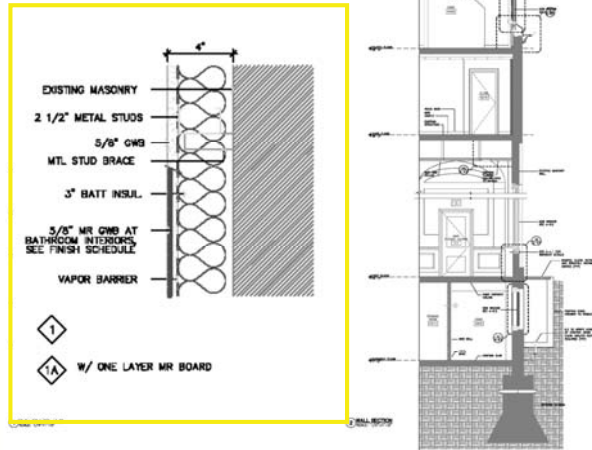

Static Dewpoint Analysis

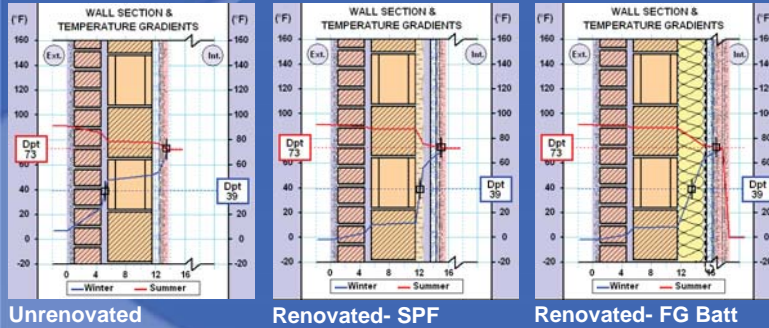

GALE

WUFI (Wärme und Feuchte instationär - Transient Heat and Moisture)

- Software program for hygrothermal (thermal and moisture) analysis for building envelope construction
- Provides a model of how the assembly will perform in a real climate

GALE

ASHRAE STANDARD 160: Criteria for Moisture Control Design Analysis in Buildings

- Provides guidelines for...
 - Initial moisture content of building materials
 - Interior design temperature and humidity
 - Interior RH values based on exterior temp., and building HVAC systems
 - Rain penetration



Modeling a Historic Structure

- Run a model of the original building system for the term of its current life
- Utilize resulting material moisture contents for the building system to be renovated
- Run models for renovated system, long term (10 years) and seasonal models to see worst conditions



User Input

- Component/assembly information



Comparison of Assemblies

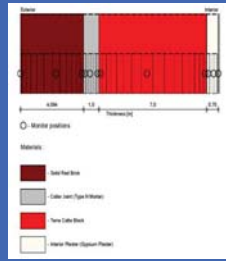

Unrenovated

Wall thickness: 12.84 in

R: 4.01 h ft² °F/Btu

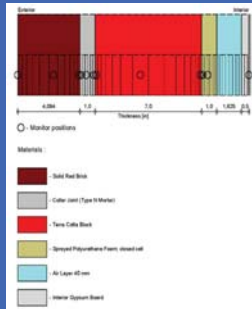

Renovated – SPF

Wall thickness: 15.22 in

R: 10.9 h ft² °F/Btu

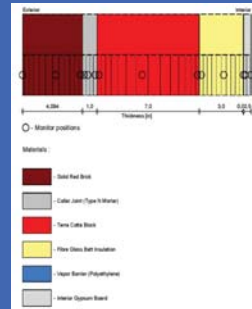

Renovated – FG Batt

Wall thickness: 15.63 in

R: 16.43 h ft² °F/Btu

Additional Exterior Factors

Moisture source
to account for
penetration due to
driving rain

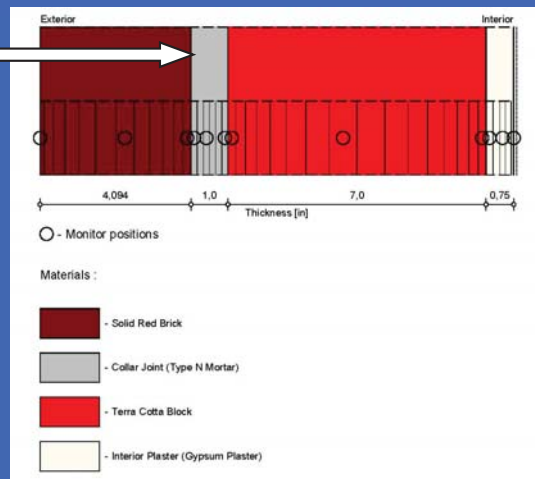

User Input

- Component/assembly information
- Building height and orientation
- Surface transfer coefficients

Surface Transfer Coefficients

Red brick:
Absorption .68
Emissivity .9

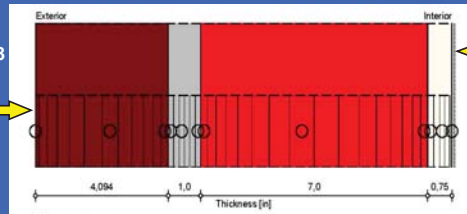

Paint on interior surface, 7 perm.

○ - Monitor positions

Materials :

- Solid Red Brick
- Collar Joint (Type N Mortar)
- Terra Cotta Block
- Interior Plaster (Gypsum Plaster)

User Input

- Calculation period
- Exterior and interior climate conditions

GALE

Boston, Massachusetts

Mean Temperature [F]: 49.4
Max Temperature [F]: 81.0
Min Temperature [F]: -4.0

Analyze

Mean Relative Humidity [%]: 65
Max Relative Humidity [%]: 100
Min Relative Humidity [%]: 6

Normal Rain Sum [in/a]: 44

Sun Radiation Sum [10⁶ Btu/ft²a]

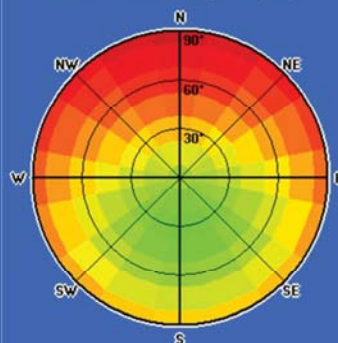

Driving Rain Sum [in/a]

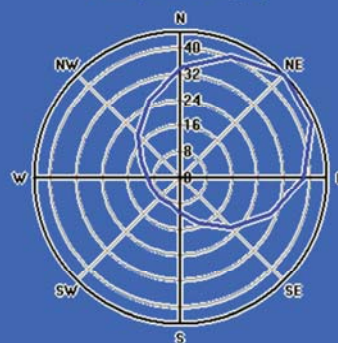

Boston, Massachusetts

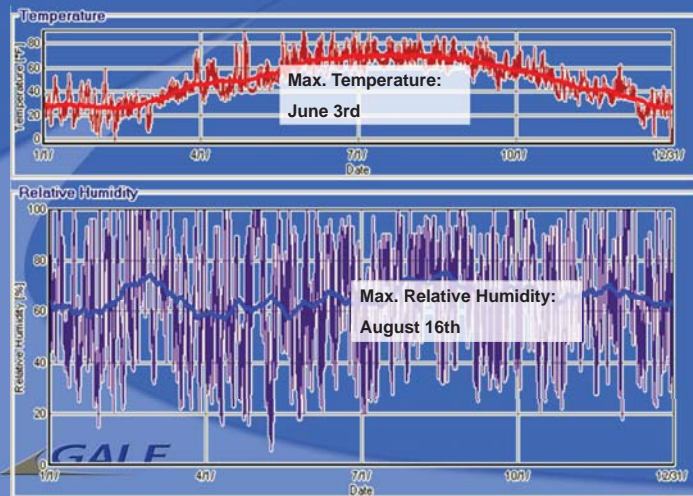

Interior Conditions: Post Renovation Values

- Temperature:
– 70 °F +/- 2 °F
- Relative Humidity
– measured at 25% +/-2

GALE

Program Output

- Water content analysis

GALE

Comparison: Terra Cotta

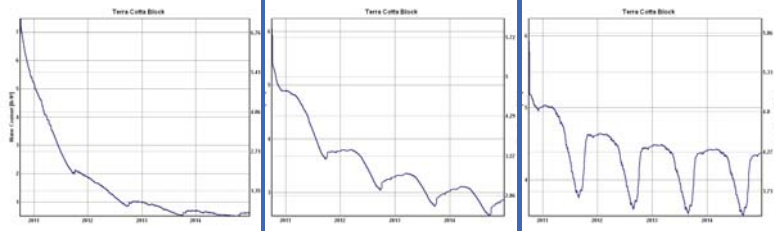

Unrenovated

Renovated-SPF

Renovated-FG Batt



Comparison: Insulation

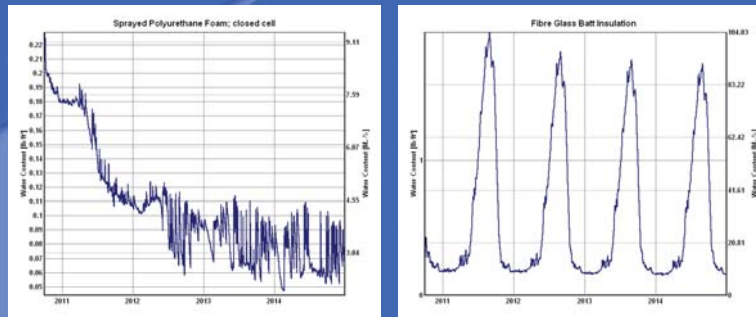

Renovated-SPF

Renovated-FG Batt



Interior Surface

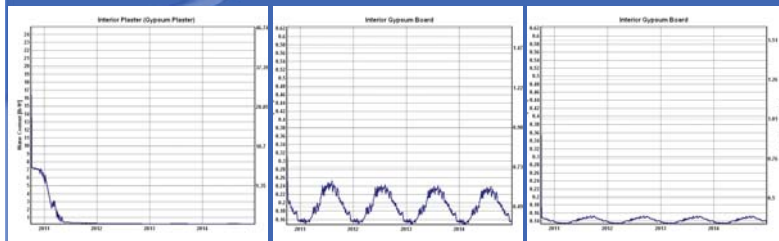

Unrenovated

Renovated-SPF

Renovated-FG Batt



Water Content of Wall Assembly

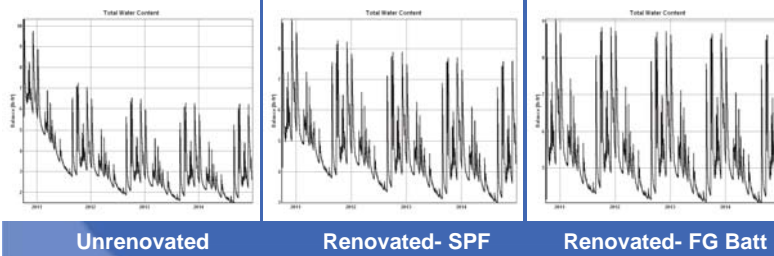

GALE

Potential Effects of Accumulated Moisture

- Corrosion of embedded structural and light gauge steel
- Reduction of the thermal performance of insulation
- Mold
- Accelerated freeze/thaw deterioration in masonry

GALE

Corrosion of steel

- Potential to occur if 30 day running average of surface RH > 80%

(Reference ASHRAE 160-2009)

GALE

Mold

- Potential to occur if average surface temperature is between 41°F and 104°F and...
 - 30 day average surface RH>80%
 - 7 day average surface RH>98%
 - 24 hour average surface RH>100%

(Reference ASHRAE 160-2009)



Variables

- Moisture sources
- Material properties
- Air exchange/ventilation sources
- Continuity of installed air, vapor barrier and insulation systems

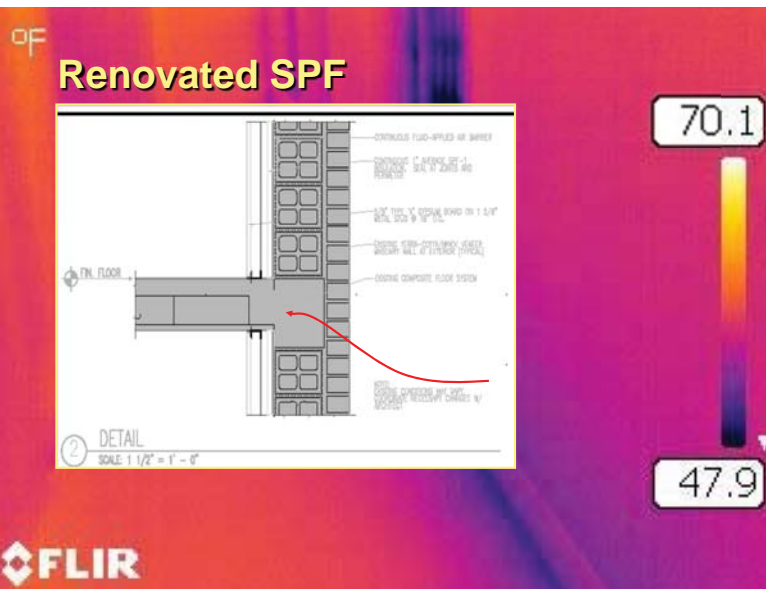

Unrenovated vs. Renovated SPF

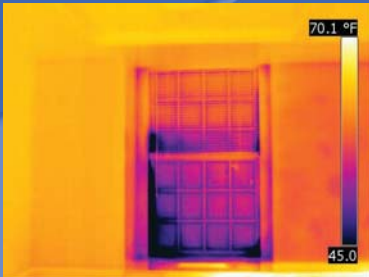

Room Temp: 69 °F
Wall Temp: 58.6 °F

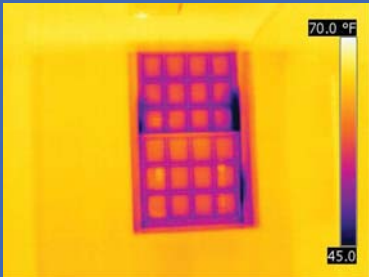

Room Temp: 65.4 °F
Wall Temp: 64.5 °F

