

The State of Connecticut

M. Jodi Rell, Governor

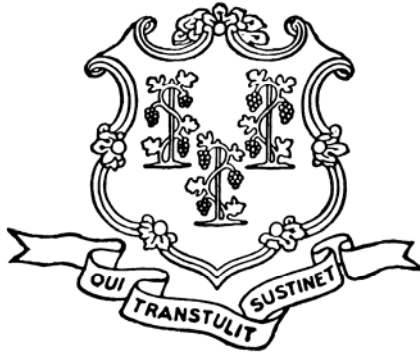

VIOLENCE IN THE WORKPLACE

Policy and Procedures Manual
for Human Resource Professionals

September 2010

Permission to copy and distribute this document is hereby granted provided that the information (text and graphics) is not used for any commercial purpose. The information in this document must not be altered and this notice must be retained on the cover page of all copies. Abstracting with credit is permitted. To reproduce or copy otherwise, to republish, to post on servers, or to redistribute to lists requires prior specific permission. To request permission, please contact:

**Department of Public Works
165 Capitol Avenue
Hartford, CT 06106-1606
Attention: Statewide Security Unit**

VIOLENCE IN THE WORKPLACE Policy and Procedures Manual

Acknowledgements

This manual was prepared by the Department of Public Works, Statewide Security Unit, with the assistance of the Departments of Public Safety, Administrative Services, Mental Health and Addiction Services, the Office of Policy and Management, and the Office of the Attorney General. Special appreciation goes to the individuals from these agencies who offered their time, expertise, and commitment. Dr. James T. Reese, B.C.E.T.S., B.C.S.C.R., B.C.E.C.R., Fellow, American Academy of Experts in Traumatic Stress, provided professional consultation and advice. Much of the content is based upon existing Federal publications: *Violence in the Workplace Risk Factors and Prevention Strategies* (National Institute for Occupational Safety and Health), and *Guidelines for Preventing Workplace Violence for Health Care and Social Service Workers* (Occupational Safety and Health Administration).

Table of Contents

- 1. Overview 1
- 2. Policy 2
 - Executive Order No.16 - Workplace Violence Prevention2
 - Policy4
- 3. Response Procedures 7
 - Response Procedures Flow Charts8
 - Non-Emergency (threatening) Response Procedure - In Detail9
 - Emergency Response Procedure- In Detail.....11
 - Follow-up Emergency Response Procedures - Flow Chart.....13
 - Follow-up Emergency Response Procedures - In Detail.....14
- 4. Roles and Responsibilities 16
 - The Human Resource Office.....16
 - The Threat Assessment Team19
 - The Statewide Security Management Council21
- 5. Prevention..... 22
 - Definitions and Types of Violence22
 - The Phenomenon and Dynamics of Violence23
 - Early Warning Signs of Potential Violence23
 - Common Issues Triggering Workplace Violence24
 - Caution.....25
 - Conducting Risk And Threat Assessments25
 - Pre-employment Screening and Additional Prevention Actions.....27
- 6. Organizational Recovery 28
- 7. Media Interaction and Internal Communication..... 31
- 8. Support 32
 - Workplace Security.....32
 - Training and Employee Assistance Program (EAP)37
 - Behavioral Health Services (DMHAS).....38
 - Public Safety (DPS).....39
- 9. Legal Considerations.....41
- Appendices.....42
 - A. State of Connecticut Violence in the Workplace Prevention Policy (Blank).....43
 - B. Map of Connecticut State Police Troop.....45
 - C. Contact Tree for 165 Capitol Avenue (Sample).....46
 - D. Contact Card (Sample).....47
 - E. Security Related Expenditures Repor (Sample)49
 - F. Human Resource professionals50
 - G. How to Conduct an Investigation.....52
 - H. Tips for Interviewing a Potentially Violent Employee.....54
 - I. Lockdown Procedures (Sample).....56
 - J. Connecticut General Statutes.....58

OVERVIEW

VIOLENCE IN THE WORKPLACE POLICY AND PROCEDURES MANUAL

Purpose

The purpose of this *Violence in the Workplace Policy and Procedures Manual* is to provide direction to Human Resource (HR) personnel in preventing and/or responding to incidents of workplace violence or a perceived threat of violence in the workplace. Every agency in the executive branch and all elective state offices are expected to comply with these procedures.

The goal of the policy and manual is twofold:

1. To reduce the probability that employees will engage in verbal threats or physical actions that create a security hazard for others in the workplace, and
2. To ensure that any complaint of violence or the threat of violence is taken seriously and is thoroughly and promptly investigated.

This manual outlines the major components of this effort: policy, procedures, workplace security assessment, control and prevention, training and other support services. It is being issued statewide to ensure that matters are handled in a consistent fashion across agencies. HR Personnel shall review this document, including the items in the appendices and implement this manual as is or modify your current policies and procedures so that they are in compliance with this manual. In those agencies where there may be a potential conflict with the contents of this document, interpretations will be assessed on a case-by-case basis. Questions regarding employment issues should be addressed to the Office of Labor Relations (OLR) at the Office of Policy and Management (OPM).

Scope

The violence in the Workplace Policy and Procedures Manual is available in Portable Document (PDF) and can be downloaded from the Department of Public Works website and the Office of Policy and Management website. This format will allow updates and new sections to be easily inserted. **This document will be the basis of any training offered to HR professionals by DAS.** The intent is for the training to address each of the areas in this manual in more detail, with emphasis on understanding the source of workplace violence, prevention, and determining the appropriate intervention.

STATE OF CONNECTICUT BY HIS EXCELLENCY

JOHN G. ROWLAND

EXECUTIVE ORDER NO. 16

WHEREAS, the State of Connecticut recognizes that workplace violence is a growing problem that must be addressed; and

WHEREAS, the State is committed to providing its employees a reasonably safe and healthy working environment, free from intimidation, harassment, threats, and /or violent acts; and

WHEREAS, violence or the threat of violence by or against any employee of the State of Connecticut or member of the public in the workplace is unacceptable and will subject the perpetrator to serious disciplinary action up to and including discharge and criminal penalties.

NOW, THEREFORE, I, John G. Rowland, Governor of the State of Connecticut, acting by virtue of the authority vested in me by the Constitution and by the statutes of this state, do hereby ORDER and DIRECT:

1. That all state agency personnel, contractors, subcontractors, and vendors comply with the following **Violence in the Workplace Prevention Policy**:

The State of Connecticut adopts a statewide zero tolerance policy for workplace violence.

Therefore, except as may be required as a condition of employment –

- o No employee shall bring into any state worksite any weapon or dangerous instrument as defined herein.
- o No employee shall use, attempt to use, or threaten to use any such weapon or dangerous instrument in a state worksite.
- o No employee shall cause or threaten to cause death or physical injury to any individual in a state worksite.

Weapon means any firearm, including a BB gun, whether loaded or unloaded, any knife (excluding a small pen or pocket knife), including a switchblade or other knife having an automatic spring release device, a stiletto, any police baton or nightstick or any martial arts weapon or electronic defense weapon.

Dangerous instrument means any instrument, article, or substance that, under the circumstances, is capable of causing death or serious physical injury.

Violation of the above reasonable work rules shall subject the employee to disciplinary action up to and including discharge.

2. That each agency must prominently post this policy and that all managers and supervisors must clearly communicate this policy to all state employees.

EXECUTIVE ORDER NO. 16

3. That all managers and supervisors are expected to enforce this policy fairly and uniformly.
4. That any employee who feels subjected to or witnesses violent, threatening, harassing, or intimidating behavior in the workplace immediately report the incident or statement to their supervisor, manager, or human resources office.
5. That any employee who believes that there is a serious threat to their safety or the safety of others that requires immediate attention notify proper law enforcement authorities and his or her manager or supervisor.
6. That any manager or supervisor receiving such a report shall immediately contact their human resources office to evaluate, investigate and take appropriate action.
7. That all parties must cooperate fully when questioned regarding violations of this policy.
8. That all parties be advised that any weapon or dangerous instrument at the worksite will be confiscated and that there is no reasonable expectation of privacy with respect to such items in the workplace.
9. That this order applies to all state employees in the executive branch.
10. That each agency will monitor the effective implementation of this policy.
11. That this order shall take effect immediately.

Dated in Hartford, Connecticut this 4th day of August 1999.



John G. Rowland, Governor

Filed this 4th day of August 1999



Susan Bysiewicz, Secretary of the State

POLICY

Zero tolerance

The State adopted a statewide zero tolerance policy for workplace violence. This means the State will not tolerate violence in the workplace and will make every reasonable effort to prevent violence or threats of violence from occurring. Agencies are hereby directed to review and refine their workplace violence prevention programs using the guidelines herein. However, it is important to note that an organization can follow all the prescribed guidelines and still experience violence. Each agency has a unique set of conditions and a context for such acts. The intent of this manual and a zero tolerance policy, therefore, is to help agencies take positive steps to be prepared and diminish the likelihood of violence.

Examples of workplace violence behaviors

The Executive Order specifically identifies three types of workplace violence.

- Bringing any weapon or dangerous instrument into any state worksite
- Using, attempting to use, or threatening to use any weapon or dangerous instrument in a state worksite
- Causing or threatening to cause death or physical injury to any individual in a state worksite

The spectrum of impermissible behavior is, however, broader than these three examples. According to the National Institute for Occupational Safety and Health (NIOSH), "workplace violence" is defined as:

“ any physical assault, threatening behavior or verbal abuse occurring in the work setting. It includes but is not limited to beatings, stabbings, suicides, shootings, rapes, near suicides, psychological traumas such as threats, obscene phone calls, an intimidating presence, and harassment of any nature such as being followed, sworn at, or shouted at.”

The term “violence” refers to a range of inappropriate behaviors that include but are not limited to the following:

- intimidating or threatening behaviors
- physical or verbal abuse
- vandalism
- arson
- sabotage
- carrying or possessing weapons of any kind on property owned/leased or otherwise controlled or occupied by the state, unless properly authorized
- using such weapons

- any other act(s) which a reasonable person would consider as inappropriate and/or posing a danger or threat of danger/violence in the workplace
- such behavior includes, but is not limited to oral, written or e-mail statements, gestures, or expressions that communicate a direct or indirect threat of physical harm
- offensive comments regarding violent events and/or behaviors

Moreover, by state regulation, offensive or abusive conduct toward the public, co-workers, or inmates, patients or clients of State institutions or facilities, is also forbidden and may be just cause for disciplinary action, up to and including termination. (C.G.S. Chapter 67 §5-240 Appendix J)

Worksite

The worksite is any location, either permanent or temporary, where an employee performs any work-related duty. This includes but is not limited to the buildings and the surrounding perimeters, including the parking lots. It includes all state-owned and leased space, including vehicles, and any location where state business is conducted.

Who is covered?

All state employees, contractors, subcontractors, and vendors are responsible for complying with this policy and maintaining a reasonably safe and healthy working environment.

Reporting incidents

Employee Reports: Employees who feel subjected to any kind of inappropriate behaviors listed above must immediately report the incident to their supervisor. Employees may also contact the HR office directly.

Supervisors' and Managers' Reporting Responsibilities: Any supervisor or manager who receives a complaint about potential workplace violence or who has witnessed or become aware of potential workplace violence is mandated to report it to Human Resources. Ignoring such conduct is not acceptable and may subject the supervisor or manager to disciplinary action.

Emergencies: A situation is an "emergency" if an injury has occurred or there is an immediate threat of physical harm or injury. **Employees should immediately notify proper law enforcement authorities and/or security in the case of an emergency.**

In the case of an emergency, agency HR professionals must immediately inform the Agency Head. Additionally, the Agency Head (or his/her backup) must immediately inform the following three offices:

- The Governor's office (860)566-4840
- The Commissioner of the Department of Public Safety (860) 685-8000 and
- The Commissioner of the Department of Public Works (860) 713-5800

Investigations

All agencies must act to stop inappropriate behaviors as listed above. All reports of incidents must be taken seriously and shall be dealt with appropriately. All reports must be immediately evaluated and investigated and prompt, remedial action must be taken, as appropriate and based upon the results of the investigation.

Anyone questioned regarding violations of this policy must cooperate fully and honestly. Providing false information, including knowingly providing a false report, or failing to cooperate fully when questioned, may lead to disciplinary action.(C.G.S. Chapter 67 §5-240 Appendix J)

Employees should be advised there is no reasonable expectation of privacy with respect to such matters in the workplace.

Violations

Individuals who commit such acts of workplace violence may be removed from the premises. Any weapon or dangerous instrument at the worksite must be confiscated and turned over to appropriate law enforcement authorities.

Any violations of this policy can lead to disciplinary action up to dismissal from employment. Violations may also result in criminal penalties.

The Office of Labor Relations can assist the HR office in determining the appropriate level of disciplinary action.

Distribution

Each agency must customize this policy by adding agency-specific information, such as the phone number of its building security office or safety officer and the HR office, and must print the policy on agency letterhead paper. (See Appendix A for a generic form.)

The policy, with the information on who to call, shall be distributed to all employees. Distribution can be accomplished by e-mail, hard copy, or any method or combination of methods designed to ensure that all state employees are aware of the policy. Agencies should also make its policy part of the agency's orientation package for new employees. In addition, it should be posted in prominent places such as bulletin boards, offices, and newsletter articles throughout the agency.

All contractors, subcontractors, and vendors doing business with the agency must be advised that they must comply with this policy. Agencies shall include provisions in all its contracts, including but not limited to all its Personal Services Agreements and Purchase of Service contracts, requiring vendors to adhere to Executive Order 16. notify the agency business office to work with the Attorney General's office to add standard language to contracts regarding adherence to Executive Order 16.

Response Procedures

Purpose

The following procedures are recommended to be followed whenever an employee files a complaint alleging that a violation of the Violence in the Workplace Prevention Policy has occurred or when a violent incident occurs.

Emergency and non-emergency (threatening) situations

Emergency situations: A situation is an “emergency” if: an injury has occurred or there is an immediate threat of physical harm or injury. **Individuals should always consider their personal safety first in all emergency situations.** If possible, the “Emergency Response Procedure” should be followed whenever an emergency occurs.

Non -emergency (threatening) situations: A “threat” is a communicated intent to inflict physical or other harm on another person. A threat can be communicated either verbally or by gesture, or a combination of the two. If sufficiently egregious, a threat can constitute a criminal act. (C.G.S. Chapter 952 § 53a-62, Appendix J).

A “threatening situation” is a situation where one person, through intimidating words or gestures has induced fear and apprehension of physical or other harm in another person but there is no immediate danger of such harm being inflicted. The steps listed under the “Non-Emergency (threatening) Response Procedure” are recommended to be followed whenever a threatening situation occurs.

Response Procedures - Flowcharts

| Non-Emergency (threatening)Response Procedure | Emergency Response Procedure |
|--|--|
| <p style="text-align: center;"><i>A threatening situation is defined as a situation where:</i></p> <p>one person, through intimidating words or gestures has induced fear and apprehension of physical or other harm in another person but there is no immediate danger of such harm being inflicted</p> | <p style="text-align: center;"><i>A situation is an emergency if:</i></p> <p>1) an injury has occurred OR 2) there is an immediate threat of physical harm or injury</p> <p style="text-align: center;"><i>You should consider your personal safety first in all emergency situations. If possible, you should use the following response procedure</i></p> |
| <p style="text-align: center;">Step 1</p> <p style="text-align: center;">Notify HR or on-site manager</p> | <p style="text-align: center;">Step 1</p> <p style="text-align: center;">First person on the scene quickly assesses the situation and risk</p> |
| <p style="text-align: center;">Step 2</p> <p style="text-align: center;">HR begins an investigation</p> | <p style="text-align: center;">Step 2</p> <p style="text-align: center;">First person on the scene calls 911 for assistance and then HR and/or management</p> |
| <p style="text-align: center;">Step 3</p> <p style="text-align: center;">HR meets with threat assessment team (TAT) to assess options and develop an action plan</p> | <p style="text-align: center;">Step 3</p> <p style="text-align: center;">HR notifies appropriate personnel</p> |
| <p style="text-align: center;">Step 4</p> <p style="text-align: center;">HR implements action plan and HR and TAT monitor outcome</p> | <p style="text-align: center;">Step 4</p> <p style="text-align: center;">First person on the scene ensures that the needs of the injured are met</p> |
| <p style="text-align: center;">Step 5</p> <p style="text-align: center;">If necessary, implement disciplinary action</p> | <p style="text-align: center;">Step 5</p> <p style="text-align: center;">As appropriate, HR separates the parties involved until they can be interviewed</p> |
| <p style="text-align: center;">Step 6</p> <p style="text-align: center;">If an emergency situation develops, follow steps for emergency response procedure</p> | <p style="text-align: center;">Step 6</p> <p style="text-align: center;">HR coordinates securing the affected areas and assessing damage</p> |
| <p style="text-align: center;">Step 7</p> <p style="text-align: center;">HR and TAT regularly conduct a review of incidents</p> | <p style="text-align: center;">Step 7</p> <p style="text-align: center;">HR seeks immediate intervention assistance from EAP provider</p> |

Non-Emergency (Threatening) Response Procedure - In Detail

A threatening situation is defined as a situation where:

One person, through intimidating words or gestures has induced fear and apprehension of physical or other harm in another person but there is no immediate danger of such harm being inflicted.

Step 1: Notify HR or on-site manager

- | |
|--|
| <ol style="list-style-type: none">1. Notification should occur on the same day as the incident or situation.2. If the incident/situation occurs on a Friday, notification should occur on Friday when possible, or on Monday (within 48 hours).3. If HR personnel are unavailable, notify on-site manager.4. If an on-site manager is notified, he/she must notify HR as soon as possible.5. HR staff should notify the agency head. |
|--|

Step 2: HR begins an investigation

| | |
|---|---|
| <ol style="list-style-type: none">1. Meet with any or all of the following to determine the facts and seek resolution, if possible:<ul style="list-style-type: none">▪ the target or victim of the threat▪ the subject of the complaint▪ the supervisor of the subject of the complaint and victim's supervisor▪ the appropriate union(s)▪ any witnesses2. If deemed appropriate, consult with the TAT.3. If appropriate, conduct a threat assessment (see page 15).4. If all parties agree, attempt to resolve the conflict.5. Maintain appropriate documentation. | <ul style="list-style-type: none">▪ What is the behavior?▪ What is causing the behavior?▪ Are the causes work-related or non-work related (personal)? |
|---|---|

¹ A reference section on "How to Conduct and Investigation" is included in Appendix G. This appendix contains suggestions for preparing for interviews, possible questions to guide a structured interview process, and some cautions. These suggestions can apply to both emergency and non-emergency situations. DAS sponsored training for HR professionals will review the response procedures as well as provide additional information on how to conduct and investigation.

Step 3: HR meets with the TAT to assess options and develop an action plan

1. Possible options for non-work related causes impacting behavior include:
 - EAP referral/counseling services
2. Possible options for work-related causes impacting behavior include:
 - EAP referral/counseling services
 - Time off
 - Training
 - Revise policies or procedures
3. Consult OLR, EAP provider, etc. for advice
4. Keep agency head informed

Step 4: HR implements action plan and HR and TAT monitor outcome

1. Ensure that the appropriate actions have been taken by the proper individuals

Step 5: If necessary, implement disciplinary action

1. Determine if disciplinary action is necessary
2. Consult OLR for advice
3. Implement the most appropriate step in the progressive discipline process (i.e., verbal warning, written warning/reprimand, suspension, termination)
4. Ensure the rights of employees are not violated

Step 6: If an emergency situation develops, follow steps for emergency response procedure

1. A situation is an emergency if: 1) an injury has occurred OR 2) there is an immediate threat of physical harm or injury
2. If the situation escalates to an emergency or possible emergency, follow the steps outlined in the Emergency Response Procedure

Step 7: HR and TAT regularly conduct a review of incidents

1. Perform an internal review of incidents at least twice a year to identify patterns and take appropriate actions to prevent recurrences
2. Work with resource agencies/contacts such as EAP and OLR to identify and modify work practices to reduce risk

Emergency Response Procedure - In Detail

A situation is an emergency if:

- 1) An injury has occurred OR
- 2) There is an immediate threat of physical harm or injury

You should consider your personal safety first in all emergency situations. If possible, you should use the following response procedure.

Step 1: First person on the scene quickly assesses the situation and any risk

| | |
|---|--|
| <ol style="list-style-type: none"> 1. What's happening? 2. Who's involved? How many? 3. How dangerous is the situation? 4. Are weapons involved? What kind? | <ul style="list-style-type: none"> ▪ Keep yourself safe ▪ Remain calm ▪ Think rationally ▪ Don't overreact |
|---|--|

Step 2: First person on the scene calls for assistance

| | |
|--|--|
| <ol style="list-style-type: none"> 1. Dial 911 (from cell will reach State Police from hard line will reach local police): <ul style="list-style-type: none"> ▪ <i>Identify yourself</i> ▪ <i>State the nature of the emergency</i> ▪ <i>Provide details about persons injured and the perpetrator</i> <p>If you <i>are not</i> in danger and time permits:</p> <ol style="list-style-type: none"> 2. Notify internal security 3. Notify HR office or an On-Site supervisor/manager | <ul style="list-style-type: none"> ▪ If you're in doubt about whether to call, <u>CALL</u> ▪ If necessary, ask a bystander to assist you in getting help ▪ Become familiar with how you can quickly access the appropriate phone numbers ▪ Do not attempt to physically remove the perpetrator(s) - Let the police do it |
|--|--|

Step 3: HR office notifies appropriate personnel.

| |
|--|
| <ol style="list-style-type: none"> 1. Agency head is notified immediately 2. Agency head must notify the Governor's Office, Public Safety Commissioner, Commissioner of the Department of Public Works and the DPW Director of Statewide Security. 3. HR ensures that law enforcement has been notified by double checking that 911 and internal security have been called 4. HR notifies other intended target(s), if known, to ensure their safety 5. HR also notifies appropriate supervisors/managers |
|--|

Step 4: First person on the scene ensures that the needs of the injured are met

1. Utilize internal agency resources such as first aid kits, employees who are certified to administer first aid, qualified paramedics, emergency medical technicians (EMT's), agency police and security personnel.
2. If required, ambulance services can be summoned by contacting 911

Step 5: As appropriate, HR separates the parties involved until they can be interviewed

- | | |
|--|---|
| <ol style="list-style-type: none">1. Do not send employees/witnesses home2. Put each individual in a separate room; ask someone to stay with them so that they will not have to be alone – Help the individual to remain calm and do not ask the individual any questions | <ul style="list-style-type: none">▪ Remain non-judgmental about who is right and who is wrong▪ Do not physically try to remove an individual; this is a <u>police responsibility</u>▪ If an assault has occurred, this is a <u>law enforcement</u> matter |
|--|---|

Step 6: HR coordinates securing the affected areas and assessing damage

1. Close a door, station someone near the area, or use a sign to prohibit entrance to affected areas
2. Make sure that nothing in the affected area is touched
3. If possible, provide coverage for affected work areas

Step 7: HR seeks immediate intervention assistance from EAP provider

1. Consult with EAP to plan an effective response
2. Assist in any efforts to defuse the situation
3. Reassess the situation to make sure it does not rekindle
4. Assist in making referrals as determined by appropriate professionals
5. Document all actions and statements

Note: If A Weapon Is Involved, Use Your Best Judgment

1. Stay calm and signal for help
2. Maintain eye contact
3. Try to negotiate to get as many “Yes” responses as possible to your requests - Stall for time – Keep the person talking
4. Do not argue - Do what you are told
5. Do not try to be a hero by grabbing the weapon
6. If you have an opportunity to escape, do so if you can do it quickly, quietly, and safely

Follow-up Emergency Response Procedures - Flow Chart

As needed, contact

Office of Labor Relations for assistance with labor relation issues.....(860) 418-6447

Department of Public Works for assistance with building security issues.....(860) 713-5811

Department of Public Safety for assistance with criminal investigations.....Insert Local Troop #

Agency Police.....Insert Agency Police #

Step 1
HR conducts investigation by taking appropriate statements and conducting interviews

Step 2
HR convenes Threat Assessment Team (TAT) to develop an action plan

Step 3
HR implements approved course of action

Step 4
HR and the TAT monitor the outcome

Step 5
HR and the TAT regularly conduct a review of Incidents

Follow-Up Emergency Response Procedure - In Detail

As needed, contact:

1. Office of Labor Relations for assistance with labor relations issues (860) 418-6447
2. Department of Public Works for assistance with building security issues (860) 713-5811
3. Department of Public Safety for assistance with criminal investigations.....Local Troop #
4. Agency Police.....Insert Number

Step 1: HR conducts investigation by taking appropriate statements and conducting interviews

| | |
|---|--|
| <ol style="list-style-type: none"> 1. If applicable, contact state police or agency police and coordinate activities 2. Request appropriate staff, including the alleged subject of the complaint, to complete agency’s incident report 3. As with any other investigation, conduct interviews with victims and witnesses and maintain documentation; interview the subject of the complaint with appropriate union representation present 4. Document all interviews 5. Check background of the subject of the complaint (history of violence, stress level, warning signs) 6. Review pertinent records, such as medical, work performance, and grievance records 7. Identify causes that may have contributed to the situation | <ul style="list-style-type: none"> ▪ Remain objective and professional ▪ This step should be taken as soon as possible following an incident or report/complaint ▪ Collect facts on who, what, when, where, why, and how ▪ Ensure protection from discrimination <p>The alleged subject of the complaint may be placed on paid administrative leave during the process of investigation if the incident is sufficiently serious to invoke Connecticut General Statute, Title 5, Chapter 67 Section 5-240 (a) State Personnel Regulation, (Appendix J).</p> |
|---|--|

Step 2: HR convenes TAT to develop an action plan

| | |
|---|--|
| <ol style="list-style-type: none"> 1. Convene the TAT or other appropriate personnel to review findings from investigation and develop an action plan 2. Keep the agency head informed 3. Draft recommendations for: <ul style="list-style-type: none"> ▪ Corrective action(s) ▪ Changes in controls, procedures, and policies to prevent a recurrence ▪ Organizational recovery actions | <ul style="list-style-type: none"> ▪ The TAT should consider how to handle internal communications as well as the press and media ▪ OLR is available to provide advice and counsel and should be contacted for assistance ▪ The EAP should be offered as an option to employees and the agency, as appropriate ▪ If discipline is contemplated, the pre-disciplinary requirements of the Regulations, contract, and/or <u>Loudermill</u> decision must be complied with, as appropriate ▪ DPW Statewide Security unit has experience in workplace violence and is available for assistance and consultation as needed |
|---|--|

Step 3: HR implements approved course of action

| | |
|--|---|
| <ol style="list-style-type: none">1. Anticipate the potential behavior of the subject of the complaint following the investigation and/or subsequent disciplinary action and plan a response2. If appropriate, continue to attempt to ensure the physical safety of the victim(s) and witness(es)3. Handle appeals of disciplinary actions4. Make arrangements to respond to ongoing medical and psychological needs of employees5. Publish and distribute policy/procedure changes to all employees6. Train managers and supervisors concerning specific changes | <ul style="list-style-type: none">▪ Administrative options include administrative leave, work restrictions, conditional medical leave, disability retirement▪ Appropriate disciplinary actions include verbal warning, written warning/reprimand, suspension, termination▪ Obtain advice from OLR, internal counsel, DPW Statewide Security Unit, CT State Police, Agency Police, Office of the Attorney General, when necessary▪ Coordinate with EAP for support services |
|--|---|

Step 4: HR and the TAT monitor the outcome

| |
|---|
| <ol style="list-style-type: none">1. Complete investigation and documentation2. Conduct on-site reviews of the workplace regularly3. Follow-up with victim(s) and witness(es)4. Provide support to employees |
|---|

Step 5: HR and the TAT regularly conduct a review of incidents

| |
|--|
| <ol style="list-style-type: none">1. Perform an internal review of incidents at least twice a year to identify patterns and take appropriate actions to prevent recurrences2. Work with resource agencies/contacts such as EAP and OLR to identify and modify work practices to reduce risk |
|--|

ROLES AND RESPONSIBILITIES

The Human Resource (HR) Office or Professional

The HR office is responsible for helping all employees deal with violent, threatening, harassing, intimidating or other disruptive behavior in the workplace. The HR office shall be responsible for the following:

Prepare and Disseminate the Agency's Workplace Violence Prevention Policy.

- Customize the statewide Violence in the Workplace Policy (Appendix A) with agency-specific information, including the phone numbers of your agency's HR office, agency police and building security. Print Policy on agency letterhead.
- Post and distribute Policy to all employees. Policies should be posted in prominent places such as bulletin boards, offices, and newsletter articles through the agency.
- Include policy in agency's employee orientation packet.

Investigate Complaints and Take Prompt, Remedial Action.

- Respond to and investigate all complaints in a timely manner. Appendix G includes guidance on how to conduct an investigation and Appendix H includes suggestions about interviewing a potentially violent employee.
- Take any necessary action to protect employees from harm during the course of any investigation.
- Take prompt, remedial action after each investigation, as appropriate, and based upon the results of the investigation.
- Advise employees, as necessary, that there is no reasonable expectation of privacy with respect to such matters in the workplace as they are expected to fully and honestly participate in any investigation under this policy.

Implement the Appropriate Response Procedures As Necessary.

- Non-Emergency (threatening) Response Procedure
- Emergency Response Procedure
- Follow-up Emergency Response Procedure

Prepare Contact Cards.

- Prepare and distribute a "contact card" (wallet-sized, laminated card of names and phone numbers) to assist managers in accessing appropriate numbers quickly in an emergency.
- Contact information must include: 911 (police, fire, ambulance), DPW Statewide Security, building security, state police, agency head and deputies, HR office, EAP provider.

- Optional information may include: Public Information Officer (PIO), other personnel appropriate to your agency's organizational structure.
- An accompanying transmittal letter to appropriate staff will help to put the contact card in context.
- Contact cards for Agency Heads and Agency HR staff's should also include the phone numbers of the Governor's office (860) 566-4840; the Commissioner of the Department of Public Safety (860) 685-8000; and the Commissioner of the Department of Public Works (860) 713-5800, to use as required in the case of an emergency.

Establish Agency's Threat Assessment Team.

- Establish a Threat Assessment Team (TAT) to handle workplace violence complaints.
- Team members may include: HR professional, EAP provider, representative from OLR, ad hoc manager of the person reporting the incident, union official, internal security
- Three major functions of the team include: identifying the potential for violence in your organization, determining ways to prevent potentially violent incidents, and responding to individual acts of violence.

Assess Training and Education.

- Assess training needs of agency employees, including HR staff, and notify appropriate DAS staff of agency training needs.

Implement Ongoing Workplace Assessments and Prevention Strategies.

- Continually review internal workplace assessment of agency management style, human resource practices (including disciplinary meetings/hearings), and facility security measures.
- Regularly conduct review of emergency and non-emergency (threatening) incidents. Monitor whether the policy and response procedures are being implemented effectively and take appropriate actions.
- Look for ways to increase security and safety.
- Establish ongoing relationships with state police, agency police and local police, EAP provider, and OLR.

Assist with Contract Compliance.

- To assist the agency in complying with the requirements that all agency contracts, including but not limited to Personal Service Agreements and Purchase of Service contracts, include provisions requiring vendors to adhere to Executive Order 16, HR should notify its business office of this requirement and encourage them to work with the Office of the Attorney General on drafting appropriate contract language.

Establish a Relationship with State Police, Agency Police and Local Police.

- Know where 911 calls are received and who is likely to respond.
- A protocol for handling 911 contact is provided in Section 8, page 38 "Public Safety Support Services".
- Note that calls from a cell phone to 911 are received at the nearest state police troop or local police department.
- A map of the troops and service areas is included in Appendix B.
- A list of the state police troops with phone numbers is provided in Section 8, page 39 "Public Safety Support Services".

Document and maintain the proper records.

- The goal of record keeping is to have all information pertaining to a particular incident readily available when needed.
- Maintain information about the incident and investigation (for example, a summary of the incident findings, corrective actions, agency's response, final disposition).
- Maintain medical records, worker's compensation information and other customary reports and records as appropriate.
- Maintain training records (for example, dates of training, type of training, number and level of employees).
- Keep notes from meetings, assessments, inspections, etc. as appropriate.
- An additional report for DPW to track security-related expenditures is required. An example of the type of information required is provided in Appendix E.

The Threat Assessment Team

The Threat Assessment Team (TAT) is responsible for handling workplace violence complaints regarding behaviors and activities that violate this policy, assessing the agency's vulnerability to workplace violence, and reaching agreement on preventative actions.

Membership

TAT members may include:

- HR professional
- EAP provider
- Internal security, Agency police
- DPW Statewide Security
- Risk management personnel
- Legal counsel
- Affirmative action officer
- Representative from the statewide Office of Labor Relations (available for consultation as needed)
- Ad Hoc manager (the manager of the person reporting the incident or a designee)
- If dealing with a member of a union, it may be helpful to have a high ranking union official involved

When choosing team members, select decision-makers that have the necessary skills to complement the team.

All employees should be provided with an opportunity to personally meet the members of this team to show management's commitment to deal with incidents and to raise the comfort level of employees in seeking assistance from team members.

Role of threat assessment team

This team will be addressing threats as well as incidents of actual violence. One goal of this team approach is to ensure that people are prepared to work together to deal with these situations. Although violence cannot always be prevented, planning ahead and being prepared to act swiftly to deal with threats, intimidation and other disruptive behavior at an early stage can reduce the risk. In assisting the HR office, the team has three major functions:

1. ***Identifying the potential for violence***—identify and analyze any apparent trend in incidents relating to particular units, jobs, activities, time of day and so forth.
2. ***Prevention***—adopt procedures agency wide to prevent the occurrence of violence, recommend/implement employee training programs on workplace violence, communicate internally with employees, inspect the workplace, evaluate the work tasks of employees to determine risk levels, conduct follow-up audits, conduct employee surveys, advise on improvements in physical measures, equipment, and work practices, etc.

3. ***Responding to individual acts of violence***—Incidents will be reported to and evaluated by the Threat Assessment Team. The team will guide the investigation and intervention process as it deems appropriate. This may entail planning a response and mitigating further damage, coordinating responses with law enforcement and the community, managing the media, and inspecting the workplace periodically to discover and correct hazards.

Availability

All employees should be able to obtain help or assistance from any member of the Threat Assessment Team and from the HR office. Agencies shall make a provision for workers who work second or third shift or on weekends to obtain this assistance. There are three ways to do this. One way is to select team members who can provide this type of coverage. A second way is to provide an off-hours phone (landline or cell) number to access a team member. Third, alternate or backup team members who are available should be identified.

Small agencies

Smaller agencies that are unable to convene a full Threat Assessment Team should establish a relationship with an agency that can assist in providing support resources to them. A list of agencies and their HR personnel is included in Appendix F.

The Statewide Security Management Council

Membership

Chapter 60a of the Connecticut General Statutes (Appendix J) established a comprehensive approach to workplace security in state government agencies. It established the Department of Public Works as the primary agency responsible for the administrative functions associated with creating and maintaining security measures in state buildings. It also created a State-Wide Security Management Council to help coordinate security activities in state agencies. The council consists of the Commissioner of Public Safety (DPS), the Commissioner of Administrative Services (DAS), the Commissioner of Mental Health and Addiction Services (DMHAS), the Commissioner of Public Works (DPW), the Commissioner of Emergency Management and Homeland Security (DEMHS), the Secretary of the Office of Police and Management (OPM) the Chief Court Administrator, an attorney appointed by the Commissioner of Public Works, the executive director of the Joint Committee on Legislative Management, a representative of the Governor, a representative of the State Employees Bargaining Agent Coalition and the president of the Connecticut State Police Union or the president's designee. The Commissioner of Public Works serves as the chairperson of the council.

Role

Each council member provides technical assistance in the member's area of expertise. The specific support services performed for state agencies reporting to the State-Wide Security Management Council by DAS, OPM, DPS, DMHAS, DPW, and DEMHS are delineated throughout this manual.

Prevention

Introduction

Prevention is the responsibility of every employee. This section focuses on some measures to reduce the risk of violent behavior. Human Resource professionals, supervisors, and managers should be familiar with and knowledgeable of the issues below *before* violence occurs.

Workplace violence is a common phenomenon that is a cause for grave concern in the workplace today. When the subject of workplace violence is brought up, most people think of horrific events such as the killings of coworkers by U.S. Postal Service employees at several sites in the past, the murder of city employees by a disgruntled former employee in a Los Angeles building, the killings at an Atlanta, Georgia day-trading firm, the shootings at the Connecticut Lottery Headquarters and most recently the killings at the Hartford Distributors in Manchester. Deaths such as these, as horrible as they may be, form only a small percentage of the total picture of workplace violence as it exists today.

Incidents of homicides in the workplace are extensively covered by the media and well documented by law enforcement. However, data on incidents of assaults, harassment, intimidation, or threats to employees in the workplace are much more difficult to collect as many incidents go unreported. Reasonable estimates suggest that there may be a million or more incidents of this type of violence each year affecting one in four employees over the course of their work life.

Definitions and types of violence

As noted in the policy explanation on page 4 of this manual, workplace violence is defined to include not only homicide, but also assault, harassment, intimidation, threats, and coercion.

In reviewing homicides in the workplace, the stereotype of the disgruntled employee does not entirely reflect the reality of the situation. On the average, between 600 and 800 employees are murdered on the job each year. In looking at the cause of these deaths, the breakdown is as follows: 60 percent of the homicides are the result of stranger violence, most commonly robberies committed in retail establishments such as convenience stores, jewelry stores, motels, and taxicabs. Criminals who do not know the victim typically commit these homicides. Another 30 percent of homicides fall into the category of client violence. These acts are committed by customers, clients, or patients who become enraged at some real or imagined grievance with the agency or an employee and lash out.

Victims of this type of violence typically include customer service representatives, nurses, social workers, etc. The final category, employee violence, accounts for about 10 percent of workplace violence. This includes both violence directed by employees such as those referenced above and incidents of domestic violence directed at employees by spouses, ex-lovers, etc. These each account for approximately 5 percent of the incidents.

It is clear that workplace violence is a major concern in the modern workplace, and one that requires a multifaceted approach by the employer, employees, and employee assistance programs or other agencies providing support to victims of violence.

The phenomenon and dynamics of violence

Less than thirty years ago, workplace violence was virtually unheard of. What are the social forces that have led up to the current problem which some describe as an epidemic? As with many complex social phenomena, it is difficult to find a simple explanation. Most experts agree that the following contribute in a significant way to the situation:

- inappropriate stress levels in the workplace, which can be caused by downsizing, reorganization, and higher workloads on individual employees
- the increasing prevalence of substance abuse in the workplace
- the general pervasiveness of violence in our society, including the easy availability of weapons, excessive violence in the media, and the general acceptance among many in the population that violence is an acceptable way to resolve differences
- mistrust and animosity among different ethnic, social, and racial groups in the workplace, accompanied by difficulties in communication
- bullying by co-workers or supervisors.

Other research suggests that violence is more likely to occur in workplaces where morale is low, where employees believe that they are not treated with dignity or respect.

Workplaces where employees believe that they are treated “fairly,” where there is a sense of “employment security,” lateral or upward movement is possible, and workers have some perceived control over their jobs are less likely to be interrupted by violence (J. Baring, Ph.D. 1998).

Early warning signs of potential violence

The main concern of many people is how to identify potentially violent individuals. While generally past behavior is the best predictor of future behavior, it must be remembered, **there is no specific “profile” of a potentially dangerous individual.** For example, people who do not fit a specific profile may engage in acts of violence. In addition, many people who fit a “profile” do not engage in acts of violence and should not be automatically viewed with suspicion. It should also be noted that other acts of violence may occur in the workplace related to such issues as **domestic violence** which are more likely to be directed at the spouse/loved one. Sometimes, in retrospect, victims and witnesses indicate that violent acts occurred without warning and seemingly “out of the blue.” However, more careful histories and analysis indicate that there are patterns of behavior and events that frequently precede episodes of violence.

Below is a list of indicators of increased risk of violent behavior. This list is based on research conducted by the Federal Bureau of Investigation’s National Center for the Analysis of Violent Crime (NCAVC) and other experts. While human behavior cannot be accurately predicted, the behaviors below should be viewed with concern.

- direct or veiled threats of harm
- intimidation, belligerent, bullying or other inappropriate behavior directed at others
- numerous conflicts with supervisors and employees; verbal comments indicating expression of hostility directed at coworkers, supervisors, or others
- bringing a weapon to work, brandishing a weapon in the workplace, making inappropriate reference to guns or fascination with weapons

- fascination with incidents of workplace violence, statements indicating approval of the use of violence to resolve a problem, or statements indicating identification with perpetrators of workplace homicides
- statements indicating an increased tone of desperation from the person, feeling that normal interventions to solve the problem will not work, feeling hopeless about a situation at work, with family, financial, and other personal problems
- signs of abuse of drugs/alcohol on or off the job
- extreme or uncharacteristic changes in behavior or displays of emotion

Such behaviors should be reported to the HR office. The TAT and the HR office must be prepared to assist supervisors and managers in dealing with such behavior. Some behaviors require immediate police or security intervention, others require disciplinary action, and others indicate an immediate need for an EAP referral.

Sometimes, small behavior problems, which can precede the above behaviors, are dismissed or ignored, allowing problems to fester. In the employee's mind, the situation can become more intense. Early involvement by the HR office is the appropriate intervention. It is important to remember the employee must be treated with dignity, mutual respect and fairness in this process. Some of these types of behavior are listed below.

- withdrawal from friends, coworkers, and/or one's social circle
- reduced productivity
- unexplained absence from work area or marked increase in tardiness and/or absenteeism
- noticeable deterioration of personal hygiene and appearance

Common issues triggering workplace violence

There are multiple issues that may trigger workplace violence. These tend to fall into two categories: employee issues and workplace issues. In terms of **employee issues**, the following events are potential "triggers."

- negative performance review
- unwelcome change in role due to performance or reorganization issue
- criticism of performance
- conflict with coworker or supervisor
- personal stress outside the workplace
- increased workload or pressure (*e.g.* deadlines, projects, etc.)

In addition, certain **workplace characteristics** may contribute to an atmosphere which makes the occurrence of workplace violence more likely. These include:

- no clearly defined rules of conduct
- lack of training
- inadequate hiring practices/screening of potential employees
- insufficient supervision
- Lack of discipline or inconsistent discipline in workplace

- No or inadequate employee support systems
- Failure to address incidents as they occur
- Overly authoritarian management style

Experts agree that three key elements that may prevent a potentially violent situation from occurring are:

1. recognizing the early warning signs (often there is a change in a persons behavior preceding an episode of violence)
2. recognizing issues or events that may trigger violence and
3. intervening early to prevent a violent incident from occurring

Have a crisis plan and anticipate problems before they occur. A workplace policy and plan is helpful in addressing issues and problems as they occur in the workplace.

Caution

A caution is necessary here. It is important to be careful when drawing assumptions or relying on any of the above behaviors as indicators of violence. Many people experience stress, loss, or illness at some point. Many experience the workplace and organizational conditions cited above. All but a very few people handle these disruptions and conditions without resorting to violence. The intervention should focus on supporting the employee through these disruptions and managers should be trained to deal with these difficulties.

Conducting risk and threat assessments

Definition

Whenever a situation in the workplace arises, it is important that an assessment occurs to determine the degree of risk. All threats must be treated in a serious manner. The purpose of a threat assessment is to **identify** the potential perpetrator, **assess** the risks of violence by that potential perpetrator, and **manage** the subject and the situation risks in a way that protects employees.

Who

Ordinarily, a threat assessment will be conducted by the HR office in conjunction with one or more of the threat assessment team members. In some situations, agencies have sought expertise directly from law enforcement officials knowledgeable in all relevant State and Federal laws and regulations (including privacy issues, ordering exams, etc.). This assistance has also been particularly helpful in developing options to deal with the situation.

Gather Information

It is clear that the agency will not always have the information that would be useful in order to make the best assessment, but will have to use information at hand. The following items are necessary for violence to occur:

- the opportunity that permits the behavior to occur
- the individual must have access to the intended victim
- the individual has the will to commit the act
- there are normally precipitating factors that generate the act of violence

It is important to know, if at all possible, who the intended victim(s) is/are. The individual may display animosity toward a particular person (referred to as victim of choice) or the person may simply lash out randomly at anyone who is present (victim of opportunity).

In addition, it is important to assess how the individual verbalizes any apparent statement/threat about violence in the context of the person's known history.

For example, the person may:

- Make a direct threat, *e.g.* "I am going to kill you."
- Conditional threat, *e.g.* "If you don't stop giving me warnings, I will get even with you."
- Veiled or hidden threat, *e.g.* "Something bad might happen to your family," not direct or contingent.

Keep in mind that some persons who make threats actually carry them out; some persons who make threats do not carry them out; and some persons who commit an act of violence never made a threat

Threats are best understood in the context of the history of the person making the threats, *e.g.* do they have a history of aggressive behavior at work, are they showing signs of deteriorating performance, etc. Direct or conditional threats clearly need to be addressed immediately, either via law enforcement or the HR progressive discipline process. Veiled threats require more judgment on the part of the evaluator. Other variables that may be assessed include the individual characteristics and status of the current situation in the workplace (*e.g.* is there downsizing going on, is the person undergoing progressive discipline?) to determine if precipitating factors are present. If in doubt, an investigation by HR is critical and should take place immediately.

If the HR office is confronted with, in their judgement, a high risk situation, follow the response procedures outlined on pages 7–15 of this manual. These include notifying the person identified as a victim if a clear victim is identified, creating a physical separation between the intended victim and the individual making the threat to reduce the likelihood of confrontation, and notification to the proper law enforcement authorities.

The area of threat assessment is an evolving field for security and law enforcement professionals. Reference material on threat assessment from the Department of Justice is available. The document, "Protective Intelligence and Threat Assessment Investigations: A Guide for State and Local Law Enforcement Officials," by Robert A. Fein and Bryan Vossekuil, can be downloaded at <http://www.ncjrs.org>. [Click on law enforcement, click on documents, select the document from an alphabetical listing.](#) A hard copy is available at no

cost by contacting the National Criminal Justice Reference Service, Division of Department of Justice Clearinghouse, Document # NCJ170612, at 1-800-851-3420.

Pre-employment screening

The violence prevention literature suggests that pre-employment screening is a critical component of a prevention program. Questions must be consistent with State and Federal laws and regulations and appropriate for the position being considered. HR should be prepared to advise managers and supervisors on appropriate interview questions, interviewing techniques, conducting reference checks, and determining the need for a background check.

Additional prevention actions

The following is a list of other possible prevention activities:

- weapons prohibition
- clear workplace violence prevention policy that is fairly enforced and specifies unacceptable behaviors
- clear reporting procedures
- means to conduct threat assessments and determine appropriate interventions
- work site risk analysis of both the organizational climate and the workplace environment
- hazard prevention and control plan
- education and training on warning signs and management style, stress management, conflict resolution, communication skills, proper disciplinary practices, and self esteem
- record keeping
- evaluation and improvement

Organizational Recovery

Introduction

An incident of workplace violence can occur at any time. This may include, dependent upon the workplace, an armed robbery, an intruder threatening staff, a domestic situation that spills over into the workplace, assaulting a coworker, a disgruntled former employee brandishing a weapon. The painful or tragic results of such incidents often have consequences well beyond those workers directly affected by the incident. For example:

- workers who witnessed the incident may suffer from emotional upset
- workers may become distracted and unable to concentrate on work
- workers may feel angry, guilty, or fearful
- some may feel responsible for the incident, feeling they could have done something to prevent it
- some may feel guilty for not trying to intervene or stop the incident

In order to facilitate organizational recovery from an incident of workplace violence, two things need to occur: employees need to be cared for and the workplace response to the incident needs to be assessed and reviewed.

Critical incident stress

It is important to note that critical incident stress is a *normal* reaction to an *abnormal* situation. Employees who experience a severely traumatic event may feel shaky, upset, etc. In addition, they frequently have lingering effects, which often include:

- feeling jumpy, anxious, irritable
- poor concentration, inability to make decisions, think clearly
- having difficulty returning to the scene
- fear in different places of another traumatic event
- locking doors and windows in their home
- nightmares about the event
- intrusive vivid recollections of the event which cannot be “turned off”

After effects from these incidents can be serious and can linger, disrupting the employee’s work and personal life, causing poor sleep, depression, and poor work performance. Employees may become disillusioned about the workplace and their safety in it, and may seek other employment.

How to manage critical incidents

It is extremely important that employers respond quickly to these situations by providing support to employees. Plans for these are best developed in advance and not during an emergency. The best response is a 4-step one, as follows:

1. defusing
2. debriefing
3. critiquing session
4. TAT review

Defusing session

A defusing session should be held immediately, or as soon as possible, after the incident. It should be led by someone certified in Critical Incident Stress Management (CISM) for example, the DMHAS or EAP providers. The leader will assist employees in understanding what they have been through, what the process will be like, what they are likely to feel, think, and experience. The leader will also provide information on how employees should care for their emotional and physical health. They may provide the number of the local crisis or helpline. This educational process will prepare employees for the after effects of trauma, which may otherwise be experienced as “going crazy” or pathological.

Debriefing session

A debriefing is generally held 24-48 hours after the incident, once the shock has worn off. A debriefing is a structured, educational group meeting which is designed to provide support, alleviate trauma, and speed up the recovery process. It is not therapy. Participants are encouraged to discuss their feelings about the incident as a tool for resolving the traumatic event. Debriefing sessions generally run about two hours. Like defusing sessions, debriefings should only be held by certified professionals.

Critiquing session

A critiquing session should be held about two weeks after the incident, where the managers, supervisors, and employees get together and review how the situation was managed. The goal of these sessions is to identify how the incident might have been handled better, and how to improve future management if such an event recurs. Typical critiquing sessions include:

- How was the incident handled? Who responded? How quickly, etc.?
- How could it have gone better?
- How could it have been prevented? (review of security procedures and the HR intervention)
- How effective were the defusing and debriefing sessions?
- Is there a need for new policies for better management of these incidents?
- Do security procedures and workflow procedures exist? Were they followed? Did they work?

TAT review

Special attention should be given to evaluating incidents on a regular basis.

The following issues should be addressed:

- review of agency responses to incidents
- review of emergency procedures and their effectiveness
- review of outside responders, *e.g.* paramedics, law enforcement, etc.
- prevention strategies—need for new policies or protocols to reduce likelihood of any further incidents especially in areas of HR, and EAP
- supervisory issues, management style
- review of organizational culture and extent to which that may have contributed

The TAT review has the purpose of taking a hard look at the organization to review/ensure that everything possible is done to prevent and manage workplace violence. Needed changes should be accompanied by action plans to make progress over time in addressing issues. Executive level buy-in is needed to ensure that any needed change occurs. It is also important to note that not all incidents can be anticipated nor does the organization always contribute to these incidents, only that self-analysis is important in order to facilitate continuous improvement.

Management actions

There are several actions agency managers can take that can facilitate recovery. They are:

- Managers and supervisors need to spend a great deal of time with their employees for support and to answer questions.
- A clear, simple information strategy to keep employees informed and to answer their questions is necessary.
- The site of the incident may be an area of grieving and needs to be handled carefully.
- Engage union representatives to help reassure employees and to answer questions.
- Employees' return to the site can be traumatic. Returning soon after the event, even briefly and ideally with support of family and close work associates, can make this easier.

Media Interaction and Internal Communication

During a crisis at a state facility, it is important to get timely, accurate information out to your employees and, through the media, to the public. This must be done in a quick, efficient manner to control rumor mill and distorted information. In a multiple agency response, a gate keeper of all information, both internal and external, must be in place for each involved agency to effectively manage the flow of accurate details of the incident.

In any multiple agency response, the distribution of information to the press should normally come from one sole source, from a single voice. The message during this type of response to any state facility requires that the message to the press be delivered with coordination. One must also consider that a criminal case may result from a specific incident so release of facts must be kept orderly and controlled. All media information will come from and be coordinated by the Connecticut State Police Spokesperson (CSP Spokesperson). The CSP Spokesperson will confer with the Governor's PIO staff and all responding agencies to ensure that all accurate information is provided and properly released.

The agency media plan should include the following:

DESIGNATE A LIAISON: To both gather needed facts from your agency and provide those facts to the CSP Spokesperson.

The liaison from the state agency and all responding departments **will prepare an oral or written message** and **provide that information to the CSP Spokesperson** on the scene who will be responsible to present the information to the press and prepare a written release containing all details. This will result in a coordinated message being released relative to the incident.

The **release(s) or press conference(s) prepared by the Connecticut State Police may include specialists from other agencies** as deemed appropriate to fully inform the public.

LIAISONS:

1. Keep the message from your agency short and concise. Ensure that information provided to assist the CSP Spokesperson regarding your employees and their safety or any detail at all regarding the incident is as complete as possible
2. Submit your message to the State Police PIO on scene ASAP for the coordinated release. Be sure to include your name and cell number to enable the PIO easy access to you and your expertise or specialty should it be needed by the press.
3. Stay in constant contact with your agency via cell or in person, if possible. This will keep you fully informed and enable you to update the CSP PIO if your agency's status at the incident changes.

Support

Workplace Security

Introduction

An integral part of a workplace violence prevention program is the completion of a comprehensive physical security site survey at state owned or leased facilities. This process includes a thorough review of any existing building security features that may be in place. Access control, alarms, barriers, bollards, fencing, lighting, locks, video surveillance, and other physical security components are assessed and evaluated for their current level of effectiveness. Existing security policies and procedures are also reviewed as are any contract security personnel that may be currently assigned to the facility. Each physical security site survey also includes any recommendations to enhance the overall safety and security of the employees and visitors as well as other assets of the State of Connecticut.

Through the physical security audit process, the DPW Statewide Security Unit compiles information on an on-going basis relevant to the current level of security features that are in place at the various non-exempt state agency locations. Alarms, access controls, video surveillance, keys, security policies and procedures and contract security personnel, their post orders and deployment details are just some of the factors taken into account when reviewing the current level of security being provided at a given site. Based on the information gathered during these security audits, the Statewide Security Unit ranks each facility as either a high, medium or low risk. Then, with some additional evaluation of all the related information, as well as the pricing out of any improvements that may be recommended, the Statewide Security Unit creates a prioritized list of the proposed project improvements and seeks the funding to implement these changes. The Statewide Security Unit then administers many of the projects that are approved from the installation phase right up through and including the on-going, day to day operations of these systems.

Department of Public Works (DPW)

The DPW Statewide Security Unit:

- Assists agencies in conducting threat assessments related to threats or incidents of workplace violence.
- Provides agencies with photographs, when available, of suspected perpetrators for use by security personnel in screening visitors to the worksite.
- Upon request, provides agencies with specific threat mitigation strategies in response to incidents they may encounter
- Serves as a liaison between the agencies and law enforcement authorities in matters of workplace violence and other issues wherein law enforcement may need to become involved.
- Conducts or monitors comprehensive building security audits of non-exempt facilities. This initiative includes work site analysis, identifying security exposures, determining building risk classifications, hazard prevention and control, and recommendations for risk management processes.

- The security audit reports are used as part of the planning and prioritization process for future building security improvement projects that are also administered by the Statewide Security Unit.
- Has developed and maintains a comprehensive set of building security standards to ensure that the appropriate level of security is applied to all non-exempt buildings based on the level of risk. These standards have also been provided to agencies for use in planning their own security improvement projects.
- Has initiated and administers both a statewide card access control system and a statewide employee identification system. As of August 2010, the card access control system has been installed and is operational in 72 state agency sites, has more than 17,500 card users and handles an average of 850,000 transactions per month. The Statewide Security Unit has also enrolled more than 25,000 employees at 58 different state agencies into the picture identification badging system

Physical security in state-owned or leased space *

According to C.G.S. Chapter 60a § 4b-136 (Appendix J), there will be five vehicles for agencies to ensure building security. They are as follows:

1. **New construction**—Designs for non-exempt agencies for capital projects shall comply with the state security standards. In the event sufficient funds to meet these standards are not available in the existing construction budget for a particular project, the DPW Statewide Security Unit may be able to assist with funding through the DPW Infrastructure Program.
2. **Renovations**—All renovation designs shall comply with state security standards where applicable. When possible, renovations should build in security considerations *e.g.* floor plans laid out to provide access control points, and any necessary funding for these should be incorporated in the original design. As with new construction, the DPW Statewide Security Unit may be able to assist with funding through the DPW Infrastructure Program for security systems and/or equipment such as card access systems and video surveillance cameras.
3. **Leased space**—As of October 1, 1999, new leases must be in compliance with established security standards. Current leases can be renegotiated to bring those premises into compliance with statewide security standards.
4. **DPW buildings**—DPW has already initiated changes in the physical and administrative security measures in 74 DPW-managed buildings totaling \$9,330,456.00 since September 2001. Changes were made predominantly to building perimeters—card access systems, panic buttons, alarms, lighting, cameras, and security guard services—as well as policies and procedures. Additional improvements are routinely being planned for these and other state owned and leased facilities.

Detailed comprehensive security assessments for non-exempt buildings are continuously being conducted to determine whether more extensive improvements are needed. It is expected that this type of audit will continue to be done periodically for all of the non-exempt buildings on a prioritized basis as a matter of routine or in the event new circumstances arise at a particular site or sites. As part of the process, the DPW Statewide Security Unit will contact agencies in these buildings to get a thorough understanding of the mission of each particular agency as well as to get their input relative to the possible security features that will best meet the needs of that agency.

5. **All other buildings**—Where no projects are planned or in progress, an audit must be conducted and could result in the need for capital improvements that may qualify for funding via the DPW Infrastructure Program. Requests can be directed to the Director of the DPW Statewide Security Unit at (860)713-5811 for assistance in seeking funding for security improvement projects. Funding for security improvements may be provided based on the established risk classification, availability and other security project priorities as determined by the DPW Commissioner.

**Note:* The following are exempt from the above: DOT mass transit, marine and aviation facilities, the State Capitol, Legislative Office Building and related facilities, facilities under the care and control of UCONN or constituent units of the state system of higher education, Judicial Department facilities, DPS facilities, Military Department facilities, DOC facilities, client occupied facilities, and facilities occupied by the Governor, Lieutenant Governor, Attorney General, Comptroller, Secretary of the State and State Treasurer. For the purposes of this section, the term “Judicial Department” does not include the courts of probate, the Division of Criminal Justice and the Public Defender Services Commission, except where they share facilities in state-maintained courts.

Administrative improvements

During the audit process, DPW will be reviewing each agency's procedures and practices. Some relatively inexpensive examples of actions to improve security in an office and/or building include the following:

- Ensure that responsibility for building security is clear.
- Post a security guard at the public entrances or at the entrances to specific office areas.
- Issue photo identification cards and direct employees to wear them at all times.
- Assign temporary passes to visitors.
- Implement a sign in and out process.
- Have your reception desk call to confirm appointments for the offices of the agency head, deputies and HR, at a minimum.
- Where possible, provide an escort for visitors, to and from their destination.
- Install silent, concealed alarms at reception desks as a minimum precaution.
- Take entry and re-entry precautions. Many agencies have a standard practice of collecting ID badges and building passes or keys when employees leave their job. Internal security should also be notified when a termination occurs.
- Have a list of emergency phone numbers for your building available. Include internal building security, fire, ambulance, and police. Many agencies distribute this information to their employees on an index card, which is kept close to each phone for easy reference. Some agencies access building security or the state police by speed dialing.
- Most buildings have an emergency evacuation plan in place. Review this and ensure that people have a clear understanding of where to exit and how to regain entry.

Use existing safety committees as a resource when you assess your current situation. Obtain feedback from employees by using a survey and/or meeting with them to obtain their input. If there are multiple tenants in your facility or facilities, you are encouraged to coordinate your activities with them.

Capital improvements

More extensive actions can be taken if needed. DPW has found that items below may require some building modifications and/or interagency cooperation and coordination. Some improvements that have already been implemented in state facilities are as follows:

- Ensuring that guards have a clear view of employee entrances at all times.
- Securing entry areas with appropriate security devices, including but not limited to controlled card access, lighting, closed circuit monitoring devices.

- Separating employees from visitors where possible. Rearranging office furniture to ensure that front-line staff that come in daily contact with members of the public, clients, or customers, are surrounded by “natural” barriers such as desks or countertops.
- Providing a means for employees to contact internal security quickly from within a building where possible.
- Providing a means for guards to contact local law enforcement quickly. There should be a crisis communication procedure among key personnel and security providers, involving intercoms, telephones, duress alarms, and other concealed means of communications.
- DPW is in the process of implementing a statewide card access system. In the meantime, agencies may wish to consider upgrades that include an access control combination lock on access doors.
- Periodically inventory, reissue, and reassign control badges and access passes.
- Mount closed circuit television cameras and adequate lighting to monitor entrances and exits and customer service areas.
- Consider security needs for parking lots, waiting areas and other specific office areas.

Agencies in buildings that require a level of intervention with significant capital improvements should have an audit first.

Other support services

The Department of Public Safety is pursuing legislation to regulate security guard services. This would result in the upgrading of these services, mandated training requirements contingent upon risk and need, etc. Currently, the payment for such services is the responsibility of individual agencies; it is expected that this practice will continue.

There are several items in the appendices being piloted in DPW buildings. These are examples of tools to assist an agency or building in dealing with workplace violence situations:

- Draft building lockdown procedures Guidelines(Appendix I) for full and partial lockdowns will be addressed in briefings with agency heads, building superintendents, property managers, and on site security personnel.
- It is critical to have a coordinated response to any situation involving a threat. A contact tree for each state owned building should contain, at a minimum, names and numbers of key tenants, the local state police troop, the property manager, on-site superintendent, and on-site security (Appendix C).
- Additional items relevant to workplace security, such as computer security and the need to safeguard systems from tampering or sabotage, will be addressed at a later time.

Support

Training and Employee Assistance Program (EAP)

Training as a resource for preventing workplace violence

Training is one of the most effective ways to help employees learn how to react to and report incidents of violence as well as intimidating, threatening and other disruptive behavior. In addition, training is an essential tool to help employees identify whom within their agency they can turn for help in resolving potentially violent situations. Employees seek assistance much earlier when they know who can help them. Most importantly, training provides an opportunity for employees to understand how “workplace wellness” is the most effective tool in preventing workplace violence.

In addition to general employee training, supervisory training is extremely important in the development of sound approaches to creating a healthy, productive workplace to prevent potentially violent situations. Understanding effective interventions may be the difference between a difficult situation and a violent situation.

EAP as a resource for preventing workplace violence

The Employee Assistance Program (EAP) plays an integral part in the planning and implementation of workplace violence prevention programs. It provides an essential link to workplace health and safety. The EAP can and should be involved in prevention efforts and should participate as a member of the Threat Assessment Team for prevention, incident response and organizational recovery.

The scope of EAP services has expanded since their early beginnings of assessment, referral, and follow-up services particularly as related to occupational alcoholism. Employee Assistance Programs now include services focusing on personal or work related problems of employees. As such, it is reasonable and desirable to have EAP involvement in related organizational needs, particularly workplace violence prevention programs.

Specifically, Employee Assistance Programs play a key role in three significant areas.

1. ***Prevention***—through promotion of the EAP by senior management; for information dissemination; involvement in organizational change; for training on a variety of topics related to anger management and conflict resolution, etc.; and the availability of EAP staff for referral and consultation.
2. ***Response/intervention***—in critical incidents for victims and/or perpetrators providing critical incident stress debriefing functions.
3. ***Organizational recovery***—providing guidance to management following a workplace violence incident.

Support

Department of Mental Health and Addiction Services **Behavioral Health Services**

Support services before and after traumatic events

Any successful effort to manage workplace violence will have as one of its components behavioral health training and services for employees as well as support services for staff who have been victims of violence or who have witnessed traumatic events in the workplace.

DMHAS is able to offer support to this effort in several different dimensions:

- DMHAS has a well-developed regional and sub-regional service system capacity for critical incident stress management response. This process, described more fully in the organizational recovery section, provides support and education to victims of trauma. This service has been provided statewide to DMHAS employees for several years in many of its facilities after assaults by clients or other traumatic events. In addition, DMHAS has coordinated the responses to other organizations after workplace violence incidents. This service is available to any state employee experiencing an act of workplace violence that results in victim or bystander trauma.
- Expertise in mental health issues is also important in order to recognize the potential for violence in the workplace, especially for staff in Human Resources. Training may assist staff in recognizing mental illness, recognizing and managing violent situations, employee selection, and other aspects of workplace violence prevention.
- Expertise in substance abuse prevention and management is also available. As noted in the prevention section, a history of substance abuse problems is frequently noted in persons who engage in violent behavior in the workplace. Substance abuse prevention programs can be helpful in assisting HR and other staff in recognizing when employees have addiction problems, how to help, and how to encourage employees to get help.

In general, direct behavioral health services to employees are best managed in the context of the Employee Assistance Program. The EAP provider can offer such services in confidence, can assist employees in getting access to community services, and can assist staff in getting ongoing behavioral health services through their employee health insurance plans.

Support

Department of Public Safety

DPS is committed to working with other agencies to help provide a safe work environment. Several initiatives are underway:

- DPS and DMHAS are working together to prevent individuals who possess a pistol permit and are committed by the Probate Court from obtaining a firearm.
- DPS is pursuing legislation to regulate the security guard industry. The regulations are to mandate training of security guards prior to deployment and to mandate site-specific in-service training. The goal is to upgrade the standards and the quality of these services before an agency signs a contract for such services.
- DPS provides on-site trooper coverage on an as-needed basis. Many agencies have already availed themselves of this service.

Emergency situations

DPS provides support services in emergency situations. All troops are staffed 24 hours per day. When 911 is dialed from a hard line, the local police authority will respond. Then a follow up call must be made to the nearest State Police Troop. When dialing from a cell phone, 911 will connect you directly to the nearest State Police Troop. Below is a suggested protocol to help the HR office obtain assistance from the police.

- State the nature of your emergency (*e.g.* violent incident, medical, fire, etc.)
- Identify yourself to the responding officers.
- Provide as much detail as possible (*e.g.* persons injured, identity of the person causing the emergency if known, their location in the building, description of clothing, etc.)
- The police will notify other emergency services as necessary, such as ambulance and fire services, major crimes unit, and any other appropriate personnel.

Non-emergency (threatening) situations

Often, DPS receives calls from agency representatives who are concerned a situation may escalate into violence. These may include situations where employees have observed or heard threatening or intimidating comments or behavior, disciplinary and/or grievance hearing, and workers compensation hearings. In those situations, follow the procedures outlined in this manual. (See page 11) DPS support can be provided as indicated below.

- Anyone with a concern should contact the agency's HR office. The HR office should ensure they file an agency incident report to begin the tracking history of the complaint.
- In the course of following the response procedures in this manual, the HR office may wish to obtain advice directly from DPS. The HR office may direct situational questions to a supervisor at their local troop for a suggested course of action.

State Police Troops 24-hour toll free numbers

| | | |
|----|-----------------|----------------|
| A | Southbury | (800) 376-1554 |
| B | Canaan | (800) 497-0403 |
| C | Tolland | (800) 318-7633 |
| D | Danielson | (800) 954-8828 |
| E | Montville | (800) 953-7747 |
| F | Westbrook | (800) 256-5761 |
| G | Bridgeport | (800) 575-6330 |
| H | Hartford | (800) 968-0664 |
| I | Bethany | (800) 956-8818 |
| K | Colchester | (800) 546-5005 |
| L | Litchfield | (800) 953-9949 |
| W. | Bradley Airport | (888) 495-8213 |

*Note: A map of the State Police troops is included as **Appendix B**.*

- A trooper or a member of the criminal investigation unit from the local troop will respond to complaints or requests for assistance from the HR person. Their primary role is to conduct possible criminal complaint investigations.
- Pre-employment background checks may be conducted by DPS. These will require a memorandum of understanding (MOU) between the agencies. The MOU will establish the nature and depth of the background investigation (*i.e.* prior employment, claimed education, personal history, criminal history, military service, credit, print verification, etc.).

Some agencies have an arrangement with DPS for trooper coverage at their facilities. The HR office can recommend this to the agency head if deemed necessary. This also requires a MOU between the agencies.

Legal Considerations

As agencies work to enforce the statewide zero tolerance policy against workplace violence, and strive to construct preventative measures to promote the safety of its worksites, legal questions may arise. In many ways, the law puts conflicting pressures on employers and others concerned with preventing or mitigating workplace violence. On the one hand, employers are required to provide a safe workplace for employees, and may face liability under a number of federal and state laws if workplace violence incidents occur. On the other hand, the law requires employers to protect the due process and other rights of employees; therefore, employers may be subject to liability if they respond to incidents or complaints, or attempt to take preventative actions, for example, infringe on employee rights to due process, privacy, or other individual rights.

Because each situation is factually different, it is important that legal questions faced by agencies are addressed on a case-by-case basis.

If agencies have any legal questions concerning the rights and responsibilities under the procedures set forth in this manual, including questions about the Americans with Disabilities Act; reasonable security precautions; liability for independent contractors; harassment issues; guidelines concerning hiring, supervision and retention decisions; defamation; and other matters, the agency should contact its representative within the Office of the Attorney General. Should the legal question involve a possible criminal issue, the agency should contact the Office of the Chief State's Attorney.

Appendices

- A. State of Connecticut Violence in the Workplace Prevention Policy (blank form)
- B. Map of State Police Troops
- C. SAMPLE Contact Tree
- D. SAMPLE Contact Card
- E. SAMPLE Security-Related Expenditures Report
- F. List of State Agencies and Human Resource Professionals
- G. How to Conduct an Investigation
- H. Tips for Interviewing a Potentially Violent Employee
- I. SAMPLE of Building Lockdown Procedures
- J. Connecticut General Statutes referenced in Manual

Note: the samples (Appendices C, D, E and I) were created based on the DPW location at the State Office Building , 165 Capitol Avenue, Hartford and should be adapted for each agency's specific building location.

(to be printed on agency letterhead)

STATE OF CONNECTICUT

VIOLENCE IN THE WORKPLACE PREVENTION POLICY

The State of Connecticut has adopted a statewide zero tolerance policy for workplace violence. The insert Agency name fully supports this policy and recognizes the right of its employees to work in a safe and secure environment that is characterized by respect and professionalism.

Prohibited Conduct

Except as may be required as a condition of employment:

- No employee shall bring into any state worksite any weapon or dangerous instrument as defined herein.
- No employee shall use, attempt to use, or threaten to use any such weapon or dangerous instrument in a state worksite.
- No employee shall cause or threaten to cause death or physical injury to any individual in a state worksite.

In addition, the insert Agency name prohibits all conduct, either verbal or physical, that is abusive, threatening, intimidating or demeaning.

Definitions

"Weapon" means any firearm, including a BB gun, whether loaded or unloaded, any knife (excluding a small pen or pocket knife), including a switchblade or other knife having an automatic spring release device, a stiletto, any police baton or nightstick or any martial arts weapon or electronic defense weapon.

"Dangerous instrument" means any instrument, article, or substance that, under the circumstances, is capable of causing death or serious physical injury.

Confiscation of Weapons and Dangerous Instruments

Any weapon or dangerous instrument at the worksite will be confiscated and there is no reasonable expectation of privacy with respect to such items in the workplace.

Reporting Procedures

- **Emergency Situations:** Any employee who believes that there is a serious threat to his/her safety or the safety of others that requires immediate attention should contact **911**. The employee must also contact his/her **immediate supervisor** or the **Human Resources Office** at insert Agency HR phone number.

Please note that when 911 is dialed from a hard line, the local police authority will respond. When dialing from a cell phone, 911 will connect you directly to the nearest State Police Troop

- **Non-Emergency Situations:** any employee who feels subjected to or witnesses violent, threatening, harassing, or intimidating behavior in the workplace should immediately report the incident or statement to his/her supervisor or manager, the Human Resources Office, or the insert Agency
- **Supervisors/Managers Responsibilities:** Any manager or supervisor who receives a report of violent, threatening, harassing, or intimidating behavior shall immediately contact the Human Resources Office so that office may evaluate, investigate, and take appropriate action.

Investigation and Corrective Action

- Insert Agency will promptly investigate all reports or alleged incidents of violent, threatening, harassing or intimidating behavior.
- All employees are expected to cooperate fully in all such investigations.
- Any employee suspected of violating this policy may be placed immediately on administrative leave pending the results of the investigation.
- If the claims of violent, threatening, harassing or intimidating conduct are substantiated, or if it is found that the employee has otherwise violated this policy, the employee will be dealt with through the appropriate disciplinary process, and may be subject to discipline up to and including dismissal from state service.
- Where the situation warrants, Insert Agency will request that the appropriate law enforcement agencies become involved in the investigation of the matter, and insert Agency may seek prosecution of conduct that violates the law.

Enforcement of the Policy

This policy will be prominently posted for all agency employees.

Agency Head

Date

Connecticut State Police Troops

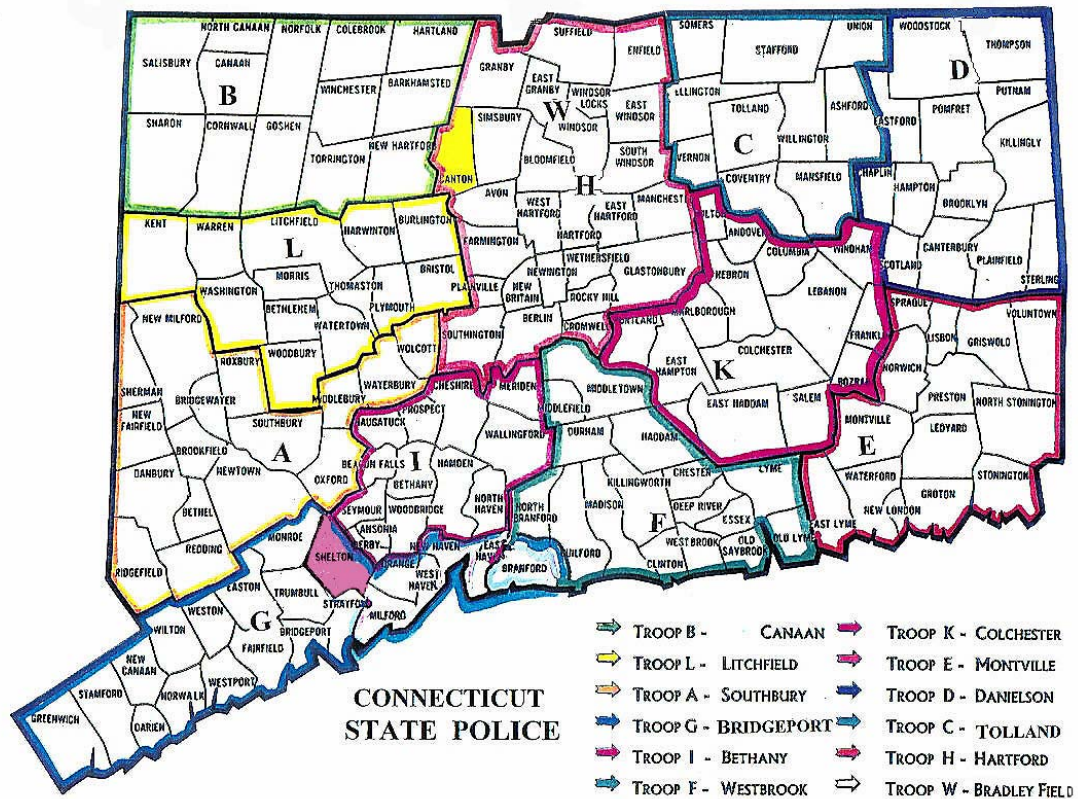

State Police Troops 24-hour toll free numbers

- A. Southbury.....(800) 376-1554
- B. Canaan.....(800) 497-0403
- C. Tolland.....(800) 318-7633
- D. Danielson.....(800) 954-8828
- E. Montville.....(800) 953-7747
- F. Westbrook.....(800) 256-5761
- G. Bridgeport.....(800) 575-6330
- H. Hartford.....(800) 968-0664
- I. Bethany.....(800) 956-8818
- K. Colchester(800) 546-5005
- L. Litchfield(800) 953-9949
- W. Bradley Airport(888) 495-8213

165 Capitol Avenue Contact Tree

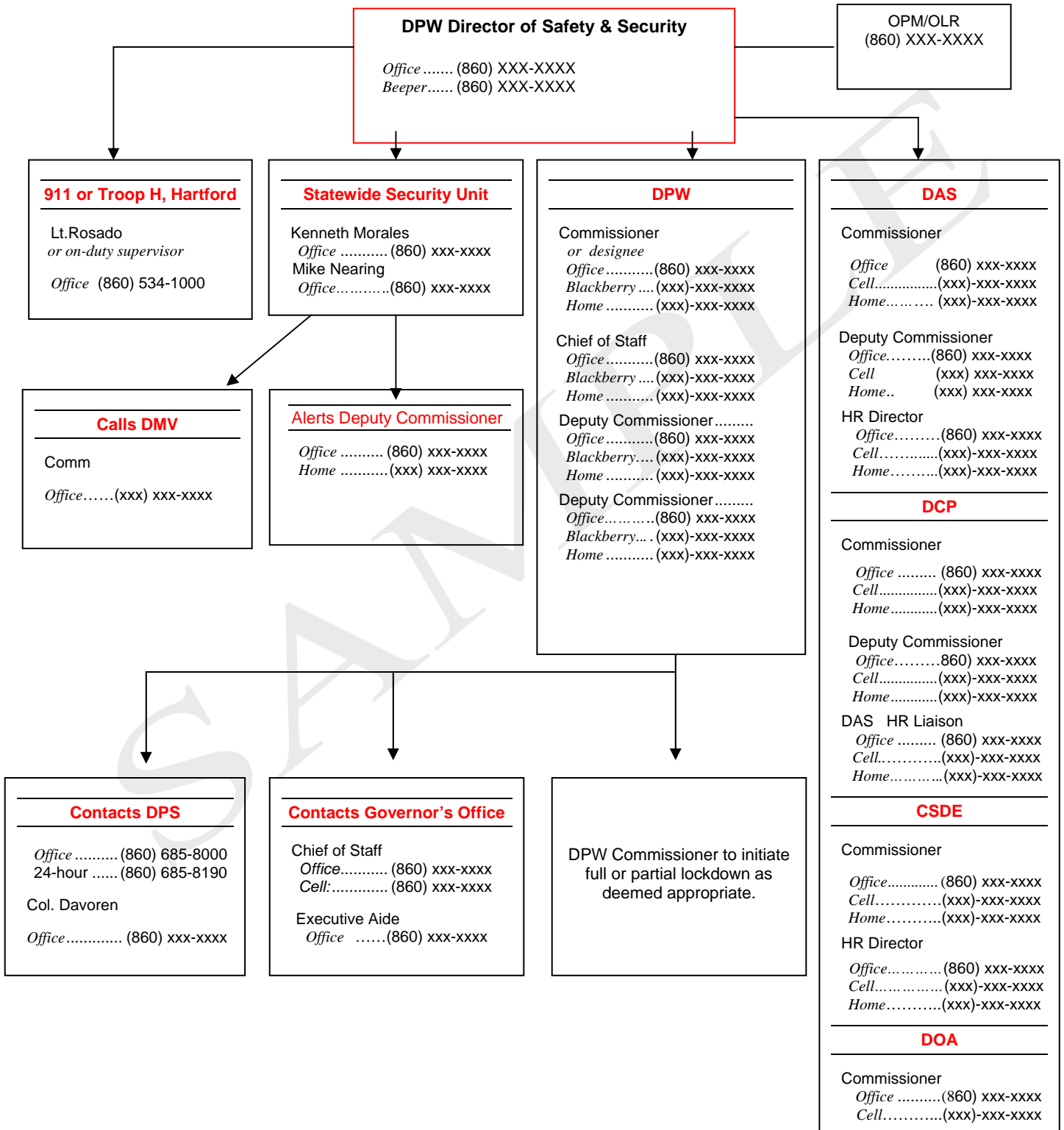

Workplace Violence Emergency Contact List

| DPW WORKPLACE VIOLENCE EMERGENCY CONTACT LIST | |
|---|----------------|
| Commissioner | |
| Office..... | (xxx) xxx-xxxx |
| Beeper | (xxx) xxx-xxxx |
| Car | (xxx) xxx-xxxx |
| Home | (xxx) xxx-xxxx |
| Chief of Staff | |
| Office | (xxx) xxx-xxxx |
| Beeper..... | (xxx) xxx-xxxx |
| Cell..... | (xxx) xxx-xxxx |
| Home | (xxx) xxx-xxxx |
| Deputy Commissioner | |
| Office | (xxx) xxx-xxxx |
| Beeper..... | (xxx) xxx-xxxx |
| Cell..... | (xxx) xxx-xxxx |
| Home | (xxx) xxx-xxxx |

| Department of Public Works WORKPLACE VIOLENCE EMERGENCY CONTACT LIST | |
|---|-----------------------------------|
| Hartford Police, Fire, Ambulance | 911 |
| Building Security | (xxx) xxx-xxxx |
| State Police, Troop H..... | 1-800-968-0664 |
| HR Liaison | <i>Office</i>(xxx) xxx-xxxx |
| | <i>Home</i>(xxx) xxx-xxxx |
| DPW Director of Safety & Security | <i>Office</i>(860)xxx-xxxx |
| EAP Provider | <i>Home</i>(xxx) xxx-xxxx |
| |(xxx) xxx-xxxx |

Appendix E Security-Related Expenditures Report March xxxx – January xxxx

| A | B | C | D | E | F | G | H | I | J | K | L | M | N | O | P | Q | R | S | T |
|---|------------------------|---------------|-----------|--------|---------|--------|--------|--------|---------|--------|---------|--------|----------|--------|------------------------|--------|--------|-------------|---------|
| ADDRESS | | TOWN | Security | DATE | Cameras | DATE | Locks/ | DATE | Card | DATE | Panic | DATE | Exterior | DATE | RECONFIGURE PROCEDURES | | | | |
| | | | Personnel | | | | Alarms | | Access | | Buttons | | Lighting | | Sign-In | Badges | | Revised | TOTAL |
| | | | | | | | | | | | | | | | | | | Post Orders | |
| 1 | BRIDGEPORT PKG GAR. | BRIDGEPORT | | | | | | | | | | | | | | | | | 0 |
| 2 | CAPITOL AVE 410-474 | HARTFORD | | | 350 | May-98 | | | 600 | Jun-98 | | | | | X | X | Jun-98 | Apr-98 | 950 |
| 3 | CAPITOL AVENUE 165 | HARTFORD | 16,640 | Oct-98 | 5,983 | Dec-98 | | | | | | | | | | | | Apr-98 | 22,623 |
| 4 | CAPITOL AVENUE 340 | HARTFORD | | | | | | | | | | | | | | | | | 0 |
| 5 | CLINTON STREET 10 | HARTFORD | | | | | | | | | | | | | | | | | 0 |
| 6 | COUNTRY CLUB ROAD 1111 | MIDDLETOWN | | | | | | | | | | | | | | | | | 0 |
| 7 | EAST ST 880 (TROOP G) | COLCHESTER | | | | | | | | | | | | | | | | | 0 |
| 8 | ELM STREET 79 | HARTFORD | | | | | | | 4,095 | Jul-98 | | | | | | 3,495 | Jul-98 | | 7,590 |
| 9 | FAIRFIELD HILLS | NEWTOWN | | | | | | | | | | | | | | | | | 0 |
| 10 | FARMINGTON AVENUE 92 | HARTFORD | | | | | | | | | | | 505.36 | Aug-98 | | | | | 505 |
| 11 | FOLLYBROOK BLVD 200 | WETHERSFIELD | | | | | | | | | | | | | | | | | 0 |
| 12 | FRANKLIN SQ 10 | NEW BRITAIN | | | | | | | | | | | | | | | | | 0 |
| 13 | GRAND STREET 21 | HARTFORD | | | 2,401 | | | | | | 1,093 | Jul-98 | | | Jul-98 | | | | 3,494 |
| 14 | HUDSON ST 505 | HARTFORD | 48,800 | Mar-98 | | | | | | | | | | | Jun-98 | X | Oct-98 | May-98 | 48,800 |
| 15 | NORWICH HOSPITAL | NORWICH | | | | | | | | | | | | | | | | | 0 |
| 16 | OLD HARTFORD ROAD 15 | COLCHESTER | | | | | | | | | | | | | | | | | 0 |
| 17 | ORAL SCHOOL RD 240 | MYSTIC | | | | | 900 | Jun-98 | | | | | | | | | | | 900 |
| 18 | PROSPECT AVE 990 | HARTFORD | | | | | | | | | | | | | | | | | 0 |
| 19 | RIDGE ROAD 170 | WETHERSFIELD | | | | | | | | | | | | | | | | | 0 |
| 20 | SHERMAN STREET 110 | HARTFORD | | | | | 988 | May-98 | | | | | | | | | | | 988 |
| 21 | SHORE ROAD (SEASIDE) | WATERFORD | | | | | | | | | | | | | | | | | 0 |
| 22 | SHUTTLE RD 11 | FARMINGTON | | | | | | | 120,000 | Nov-98 | | | | | | | | | 120,000 |
| 23 | SIGOURNEY ST 25 | HARTFORD | 21,000 | Mar-98 | | | | | | | | | | | | | | | 21,000 |
| 24 | TRINITY STREET 30 | HARTFORD | 21,000 | Apr-98 | | | | | | | | | | | | | | | 21,000 |
| 25 | TRINITY STREET 18-20 | HARTFORD | | | | | 2,700 | Apr-98 | | | | | | | | | | | 2,700 |
| 26 | UNDERCLIFF ROAD 1 | MERIDEN | | | | | | Nov-98 | | | | | | | | | | | 0 |
| 27 | WASHINGTON ST 60 | HARTFORD | | | | | 50 | Jun-98 | | | | | | | | | | Apr-98 | 50 |
| 28 | WASHINGTON ST 80 | HARTFORD | | | | | | | | | | | | | | | | May-98 | 0 |
| 29 | WEST MAIN STREET 41 | WATERBURY | | | | | | | | | | | | | | | | | 0 |
| 30 | WEST MAIN STREET 395 | WATERBURY | 2,400 | Jun-98 | | | 600 | Dec-98 | | | | | | | | | | | 3,000 |
| 31 | WEST THAMES 401 | UNCAS | | | | | | | | | | | | | | | | | 0 |
| 32 | WINDSOR AVENUE 9 | HARTFORD | | | | | | | | | | | | | | | | | 0 |
| 33 | WOLCOTT HILL 24 | WETHERSFIELD | | | | | | | | | | | | | | | | | 0 |
| 34 | WOLCOTT HILL 38 | WETHERSFIELD | | | | | 1,200 | Sep-98 | | | | | | | | | | | 1,200 |
| 35 | WOODLAND STREET 39 | HARTFORD | | | | | | | | | 1,000 | Apr-98 | | | | X | Dec-98 | | 1,000 |
| | | TOTALS | 109,840 | | 8,734 | | 5,238 | | 124,695 | | 1,093 | | 505.36 | | | 3,495 | | | 255,800 |
| Other Miscellaneous: Escort upon request of parking garages; improve seating for security personnel so visitors don't see just tops of heads; security person stands in front of console to direct visitors; some locations inverted cameras to see people entering instead of exiting; redirected cameras; all locations held monthly services meetings that reviewed and implemented changes with agency participation; UNICCO requested to hold "Violence in the Workplace" training for UNICCO staff. | | | | | | | | | | | | | | | | | | | |

Human Resource Professionals

| DEPARTMENT/HR CONTACT | PHONE | DEPARTMENT/HR CONTACT | PHONE | DEPARTMENT/HR CONTACT | PHONE |
|---|-------|---|-------|---|-------|
| Dept. of Administrative Services-HRBC David Lynn (860) 713-5107 | | Department of Environmental Protection Joanne Driver..... (860)424-3162 | | Psychiatric Security Review Board Skip Wallace.....(860) 262-6746 | |
| Department of Agriculture Diana McKenney..... (860) 713-5306 | | Ethics, Office of State Kathleen Howe (860) 263-2401 | | Department of Public Health Michael Carey.....(860) 509-7178 | |
| Connecticut Agriculture Experiment Station Michael Last (203) 974-8442 | | Commission on Fire Prevention & Control Diana McKenney (860) 713-5306 | | Department of Public Safety Diane Bennedetto(860) 685-8257 | |
| Asnuntuck Community Technical College Joseph Bleicherr.....(860) 253-3050 | | Freedom of Information Commission Colleen Murphy (860) 566-5682 | | Department of Public Safety/Firearms Permit Susan Turko (DAS).....(860) 713-5163 | |
| Office of the Attorney General Richard Campbell..... (860) 808-5317 | | Gateway Community Technical College Lucy Brown (203) 285-2528 | | Department of Public Utilities Control Debby Hearl.....(860) 713-5314 | |
| Department of Banking Claudia Helfgott..... (860) 240-8162 | | Office of the Governor & Lt. Governor Carolyn Kozak..... (860)713-5058 | | Department of Public Works Tim Geary.....(860) 713-5307 | |
| Capitol Community Technical College Lester Primus (860) 906-5050 | | Department of Higher Education Toby Bates (860) 947-1842 | | Quinebaug Valley Comm.- Tech. College Jerry Blazek..... (860) 412-7351 | |
| Charter Oak College/Acad Awards Cliff Williams..... (860) 832-3898 | | Housatonic Community Technical College Brenda Alexander..... (203) 332-5160 | | Department of Revenue Services Sandy Millholen(860) 297-5731 | |
| Chief Medical Examiner Joseph Oleander (860) 679-3982 | | Comm. on Human Rights and Opportunities Robert Brothers (860) 541-3431 | | Office of the Secretary of State Gloria Sparverl.....(860) 509-6171 | |
| Department of Children and Families Wanda Estrella..... (860) 550-6489 | | Insurance Department Patty Tiberio (860) 297-3632/3932 | | Department of Social Services Jeanne Anderson.....(860) 424-5084 | |
| Connecticut Siting Council Diana McKenney (860) 713-5306 | | Judicial Department Robert Coffey (860) 706-5280 | | Soldiers', Sailors' and Marine Fund Charles Berry.....(860) 296-0719 | |
| Board of Trustees Comm. Technical Colleges Corrine Sumple (860) 244-7630 | | Judicial Selection Diana McKenney..... (860) 713-5306 | | Special Revenue, Division of Elizabeth Janak (860) 594-0514 | |
| Office of the Comptroller Doris Vieira..... (860) 702-3320 | | Department of Labor Thomas Donlon..... (860) 263-6686 | | Statewide Police Officer Standards Training Council Thomas Flaherty.....(203) 238-6505 | |
| Connecticut Innovations Bonnie Greenwell (860) 257-2344 | | Connecticut Lottery Corporation Sandra Cady (860) 713-2669 | | State Insurance Purchasing Board Daria Cirish.....(860) 702-3432 | |
| Consumer Counsel Debby Hearl (860) 713-5314 | | Manchester Community Technical College Deborah Wilson..... (860) 512-3613 | | State Library Louise Carey.....(860) 424-3668 | |
| Department of Consumer Protection Carolyn Kozak..... (860) 713-5058 | | Dept. of Mental Health and Addiction Svcs. Fred Ferris..... (860) 418-6880 | | State Properties Review Board David Lynn.....(860) 713-5107 | |
| Department of Correction Daniel Callahan..... (860) 692-6801 | | Middlesex Community Technical College Josephine Agnello-Veley (860) 343-5751 | | Connecticut State University System David Trainor (860) 493-0032 | |
| Criminal Justice Division Susan M. Claus..... (860) 258-5862 | | Military Department Anthony Lewis (860) 548-3248 | | Teachers' Retirement Board Darlene Perez.....(860) 241-8402 | |
| Commission on Deaf and Hearing Impaired Deborah Craig..... (860) 713-5313 | | Department of Motor Vehicles Steven Shonta..... (860) 263-5268 | | Three Rivers Community Technical College Louisa Summa.....(860) 892-5734 | |
| Department of Developmental Disabilities Caren Clark (860) 418-6868 | | Naugatuck Community Technical College A.J. DuBois..... (203) 575-8056 | | Department of Transportation Vicki Arpin.....(860) 594-3100/3119 | |
| Dept. of Economic and Community Dev. Antoinette Alphonse (860) 270-8022 | | Northwestern Connecticut Community College Fran Almida Pistilli (860) 738-6325 | | Office of the Treasurer Theodore Janiszewski (860) 702-3144 | |
| Board of Ed and Services for the Blind Deborah Craig..... (860) 713-5313 | | Norwalk Community Technical College Ginny DellaMura..... (203) 857-7311 | | Tunxis Community Technical College Pamela Kowar (860) 255-3603 | |
| Department of Education Karen Shaw..... (860) 713-6693 | | Board of Parole Linda Ferreira (860) 692-7628 | | UCONN Jay Hickey (860) 486-0258 | |
| Election Enforcement Commission David Barry (860) 250-2956 | | Office of Policy and Management Laila Maidelis..... (860) 418-6324 | | UCONN Health Center Brian Eaton.....(860) 679-1000 | |
| Office of Emergency Management Irena Baj-Wright (860) 713-5391 | | Connecticut Protection and Advocacy for Persons with Disabilities Deborah Craig..... (860) 713-5313 | | Office of Veterans' Affairs Noreen Sinclair(860) 721-5938 | |
| Department of Environmental Protection Joanne Driver..... (860) 424-3162 | | | | Workers' Comp Commission Sandy Cunningham(860) 493-1518 | |

Police Officer Standards & Training
Diana McKenney..... (860) 713-5306
Child Advocate
Debby Hearl..... (860) 713-5314
Workforce Competiveness
Tim Geary (860)713-5307
Victims Advocate
Eileen Morin.....(860) 713-5313
Fire Prevention Control
Diana McKenney.....(860)713-5306
State Marshall Commission
Steve Dygus.....(860) 713-5372
Dept. of Emerg. Mgmt & Homeland Security
Irena Baj-Wright.....(860) 713-5391
Dept. of Culture & Tourism
Debby Hearl..... (860) 713-5314

How to Conduct an Investigation

Because violations of this workplace violence policy must be treated seriously and may result in disciplinary action, investigative procedures must be done fairly, consistently and recorded accurately on a case-by-case basis. The following guidelines are intended to aid the HR office in conducting a sound investigation. Upon notification by an employee of a threat of danger, violence, actual violence, etc., the following **P.R.O.C.E.D.U.R.E.S.** will apply.

- P—Provide immediate notification** of the threat to the intended harmed person (if they are not knowledgeable of the threat) that the threat has been made, the exact nature of the threat, and the identity or the person who made the threat. Thereafter, notify supervisors, security, and or law enforcement as appropriate.
- R—Resolve complaints** and disputes in a timely manner. Separate subjects and victims as appropriate for their safety.
- O—Obtain complete details** of the complaint from the victim and witnesses.
- C—Conduct a preliminary investigation** to determine the immediacy and/or the severity of the violence and/or threat of violence and make a determination concerning the type of continuing investigation to be conducted, *i.e.*, informal discussions or full-scale investigation.
- E—Evidence** preservation is critical.
- D—Document** every aspect of the investigation. Signed statements should be obtained from victim(s), witness(es), and the perpetrator, if possible.
- U—Understand the facts** completely, the nature of the complaint, the violation of policy, and all of the information gathered prior to concluding the investigation.
- R—Report** to the Threat Assessment Team and agency head on the status of the investigation.
- E—Evaluate facts** gathered; ensure that the analysis is perceived as being fair and impartial overall.
- S—Secure opinion from the Office of the State’s Attorney** if criminal charges are being considered. If disciplinary action is contemplated, contact OLR for advice. Any action must be defensible in the event the decision is subsequently challenged.

The following questions can aid the HR office in gaining the needed information to properly conduct the investigation. Begin the interview process with the complainant, usually the victim. First consider whether the complainant is in immediate danger or, if not, who is in immediate danger and what action should be taken, or avoided, to ensure safety.

A complaint may be filed by someone other than the victim; it could be a witness or someone else. The questions below can be asked of **all parties**.

- What happened, or what was said, or what gesture was made, etc.?
- Where did it happen?
- When did it happen?
- Who did it happen to?
- Why did it happen?
- Who caused it to happen?
- Was anyone else present? (Get names.)
- Is there corroborative evidence?
- Document all comments.
- Get a signed statement.

Some specific questions you should ask the complainant if he/she is **the victim** are as follows:

- Was your supervisor notified?
- Was your union representative notified?
- Were you alone when the incident occurred?
- Were you singled out or was the violence directed at more than one person?
- Do you have any idea why this happened?
- Was the assailant involved in previous incidents? If so, describe.
- Has this type or similar incident(s) ever happened to you or your co-workers previously? If yes, please describe.
- If injured, were you treated at the scene? If yes, by whom? Were you transported to a hospital? If so, what medical facility and by what means of transportation?
- Were the police notified? If so, what police department? Did they respond to the scene at the time of the incident? If yes, provide approximate time of arrival.
- Was a police report filed? If so, provide a report number and if available attach a copy of the report.

You may wish to interview the victim at regular intervals following the incident as well:

- Are you still under doctor's care?
- Have you lost any workdays? If yes, how many?
- Have you received counseling or similar support? If yes, describe.
- Do you believe anything can be done to prevent future incidents from occurring?
- Are you aware of any new measure(s) that have or will be put in place to prevent similar incidents? If so, describe.

Tips for Interviewing a Potentially Violent Employee

While conducting investigations, HR may need to interview a potentially violent employee. Below are some suggestions to assist HR staff in managing this difficult task.

In implementing these suggestions, the most useful skills for HR professionals and others to employ are the classic active listening skills—*listening, probing, empathizing, paraphrasing, clarifying, and summarizing*. Frequently, the goal is to defuse the tension or resolve the conflict. Often, HR professionals mediate such discussions. However, due to the potentially high risk of some situations, these skills must be sensitively and judiciously applied. Development and refinement of these skills can best be addressed in the DAS state-sponsored training sessions.

Interviewing a potentially violent employee

There may be incidents where you need to gather information from a potentially violent employee. This person may have made a direct, conditional or hidden threat. The interview can occur before an incident, during an incident, during your investigation or afterwards. The ground rules are the same.

- Never interview them alone. Always interview in pairs.
- Consider holding the interview in a neutral conference area, away from office space.
- Keep yourself between the person and the door so that you have a means to escape if the discussion escalates to violence. Please bear in mind that suspicious people may have difficulty with this as they may be accustomed to keeping themselves in this position.
- Give the person sufficient space so they do not feel trapped, crowded or threatened.
- Establish “model” behavior. Act calm, stable, and in control (even if you do not feel calm). Be courteous and patient.
- Use active listening skills, acknowledgement of feelings, repeating back so as to communicate that you want to understand.
- Avoid statements that are judgmental or accusatory.
- Allow the subject to save face.
- Adjust your style to meet the need of the subject.
- Offer support to the person via the EAP or other services.
- Maintain eye contact.

There is an art to this form of interviewing. The goal is to develop enough of a relationship with the subject so that she or he will talk about the incident. Tone and approach are important. Keep in mind the individual may not want to talk with you and/or may complain of intimidation. If you are conducting an interview as part of an investigation, it is possible they may leave during the interview. (If this occurs, remember to document what was said, mannerisms, gestures, and tone of voice.)

What to do if a person is shouting, swearing, or threatening

- Attend to the person's need to be heard.
- Signal a colleague to call security or police.
- Do not call security while talking to the person.
- Acknowledge the person's feeling of anger, hurt, etc.
- What to do if the person is threatening with a weapon.
- Alert authorities, if possible.
- Stay calm, and signal for help if possible.
- Maintain eye contact.
- Stall for time, engage the person, and try to keep them talking.
- Do not argue with the person. Do what they tell you.
- Do not try to be a hero by grabbing the weapon, etc.
- If you have the opportunity to escape, do so if you can do it quickly, quietly, and safely.

Lockdown procedure for XXXXXXXXXXXXXXX

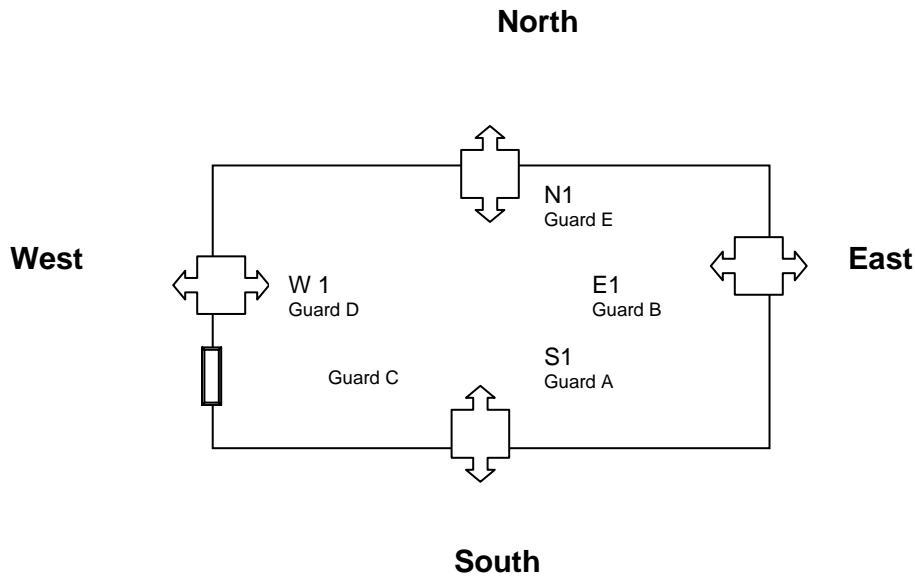

1. Only the Commissioner of the Department of Public Works (or his/her designee) can issue a full lockdown order at *(insert address)*. A situation warranting this meets several criteria for high risk:
 - o Imminent danger to the people in the building
 - o Perpetrator with history and capability to be violent
 - o Presence of specific or nonspecific targets in the building
2. During a full lockdown, all entrances are closed to incoming and outgoing traffic. See above diagram.

3. Guards will be stationed at all building entrances:
 - Loading DockGuard A
 - East 1 (E1)Guard B
 - South 1 (S1).....Guard C
 - West (W1)Guard D
 - North (N1)Guard E

The purpose of deploying guards to these locations is to monitor the location to ensure no one leaves the building, determine whether someone is seeking entry, and maintain communication with the main security station.

4. Guards may be equipped with a two-way radio or cell phones for internal communication.
5. The agency heads in the building may also have two way radios or cell phones to enable them to speak directly with building security and each other.
6. It is recommended that each agency prepare an internal contact tree to ensure that there is a vehicle to communicate agency-wide in case it is needed.
7. To expedite this, software enabling a global page to all or selected staff may be available. This will enable the agency head to notify managers individually or all of his/her managers simultaneously.
8. Buildings with a public address system typically have a taped recording in place for fire emergencies, providing instructions for people in the building. Three modifications may be made to use this system effectively in a lockdown situation:
 - o determine a signal for “lockdown”
 - o a taped recording may be deployed with instructions and procedures for people in the building to follow; and
 - o several remote locations in the building with restricted access to enable building security to activate the building’s PA system will be beneficial.
9. Arrangements may be made to acquire pictures of suspected perpetrators (contact Ray Philbrick, Director of Safety & Security)
10. Communications must be coordinated in a lockdown situation. Only the police will be providing direction via the PA system, phone, and pagers.
11. During a lockdown, managers will usher anyone in the hallways and/or public areas to the nearest room and then managers will lock the doors and, as much as possible, move themselves and all personnel away from doors and windows.
12. Managers will check restrooms nearest their rooms if they are safely accessible and have anyone in them join the manager in his/her room.
13. Managers will take attendance.
14. All staff will be instructed to get on the floor at all times.
15. No television, radios, private cell phones, or Internet should be used by anyone.
16. There will be no restroom breaks.
17. Everyone needs to be prepared to stay in “lockdown” for an extensive period of time. No one is to be released until directed. Follow the directions provided over the PA system or pagers indicating that the “emergency is over.” These will be from the police.
18. If directed to exit the building, no one will be allowed to go and obtain belongings.
20. A set of procedures will be issued to all staff and briefings will be provided to managers by building security to each agency. The procedures will also be included in the *Tenant Safety Manual*.
21. “Lockdown” drills should be conducted on a regular basis

DPW may be able to provide assistance in developing a site specific lockdown procedure. Contact DPW Director of Statewide Security at 860-713-5811 for additional information

Connecticut General Statutes

Title 4b - Chapter 60a - Security for State Buildings

Sec. 4b-136. State-Wide Security Management Council. Duties. Reports. (a) There is established a State-Wide Security Management Council. The council shall consist of the Commissioner of Public Safety, the Commissioner of Administrative Services, the Commissioner of Mental Health and Addiction Services, the Commissioner of Public Works, the Commissioner of Emergency Management and Homeland Security, the Secretary of the Office of Policy and Management, the Chief Court Administrator, an attorney appointed by the Commissioner of Public Works, the executive director of the Joint Committee on Legislative Management, a representative of the Governor, a representative of the State Employees Bargaining Agent Coalition and the president of the Connecticut State Police Union or the president's designee. The Commissioner of Public Works shall serve as chairperson of the council. Each council member shall provide technical assistance in the member's area of expertise, as required by the council.

(b) The council shall coordinate the activities of state agencies, as defined in section 4b-130, that relate to state-wide state facility security.

(c) Each state agency and each department, board, commission, institution or other agency of the state listed in the exceptions to the term "state agency" in section 4b-130 shall report quarterly to the council on the frequency, character and resolution of workplace violence incidents and all security-related expenditures.

Title 53a - Chapter 952 - Penal Code

Sec. 53a-62. Threatening in the second degree: Class A misdemeanor. (a) A person is guilty of threatening in the second degree when: (1) By physical threat, such person intentionally places or attempts to place another person in fear of imminent serious physical injury, (2) such person threatens to commit any crime of violence with the intent to terrorize another person, or (3) such person threatens to commit such crime of violence in reckless disregard of the risk of causing such terror.

(b) Threatening in the second degree is a class A misdemeanor.

Title 5 - Chapter 67 - State Personnel Act

Sec. 5-240. Reprimand, suspension, demotion, dismissal. Layoffs. Notice period pay. (a) An appointing authority, subject to any regulations issued by the Secretary of the Office of Policy and Management, may reprimand or warn an employee in the classified service under the appointing authority's jurisdiction or suspend such an employee without pay or with reduced pay for an aggregate period not exceeding sixty calendar days in any calendar year. For any employee not included in any collective bargaining unit of state employees, any written reprimand or warning shall be included in the employee's personnel file and, if not merged in the next service rating, shall be expunged after twelve months from the date of reprimand or warning. Any such written reprimand or warning may be reviewed in accordance with the procedures established in subsections (h) and (i) of section 5-202.

(b) An appointing authority, subject to any regulations issued by the Secretary of the Office of Policy and Management, may demote an employee in the classified service under the appointing authority's jurisdiction from a position in any given class or grade to a position in a lower class or grade. The appointing authority shall give the Secretary of the Office of Policy and Management or the secretary's designated representative written notice of the authority's intention to effect any such demotion not less than two weeks before the date it is intended to become effective. The Secretary of the Office of Policy and Management may transfer such an employee whose record is otherwise satisfactory to a position under the jurisdiction of another appointing authority, with the approval of such other appointing authority.

(c) An appointing authority may dismiss any employee in the classified service when the authority considers the good of the service will be served thereby. A permanent employee shall be given written notice of such dismissal at least two weeks in advance of the employee's dismissal, except as hereinafter provided, and a copy of the same shall be filed with the Secretary of the Office of Policy and Management or the secretary's designated representative. Such notice shall set forth the reasons for dismissal in sufficient detail to indicate whether the employee was discharged for misconduct, incompetence or other reasons relating to the effective performance of the employee's duties and shall be prepared in such form and given in such manner as the Secretary of the Office of Policy and Management prescribes. The Secretary of the Office of Policy and Management may provide by regulation for the waiving of advance notice in cases of serious misconduct by an employee affecting the public, the welfare, health or safety of patients, inmates or state employees or the protection of state property. Such regulation shall provide for written notice to a permanent employee who has attained permanent status and shall not preclude whatever rights any employee may have to appeal. The name of any such employee dismissed for incompetence or other reasons relating to the effective performance of the employee's duties shall be immediately removed from the eligible list in the office of the Commissioner of Administrative Services. No appointing authority shall pay any dismissed employee notice period pay or any other separation pay at a rate that exceeds the dismissed employee's rate of compensation, at the time of dismissal, for two weeks, or the amount of notice period provided for in an applicable collective bargaining agreement.