

Chapter 12 – Stormwater Management Plan

Introduction

A Stormwater Management Plan documents how the proposed stormwater management measures meet the stormwater management standards, performance criteria, and design guidelines contained in this Manual, as well as other local, state, and federal stormwater management requirements.

A Stormwater Management Plan is required as described in [Chapter 4 - Stormwater](#)

[Management Standards and Performance Criteria](#), a Stormwater Management Plan is required (Standard 5 – Stormwater Management Plan) for all new development, redevelopment, retrofits, and other land disturbance activities that require a local, state, or federal permit or approval. A Stormwater Management Plan is not required for retrofit projects that do not require review and approval, although designers are encouraged to document the design basis for all stormwater retrofits following good engineering/design practice. A Stormwater Management Plan should be prepared by the project proponent and designing qualified professional, as defined in the General Permit for the Discharge of Stormwater and Dewatering Wastewaters from Construction Activities and submitted for review by the local or state reviewing authority.

The chapter presents the recommended minimum content for a Stormwater Management Plan. Many municipalities and state agencies have stormwater management submission requirements as specified by municipal land use regulations and state permit programs. The recommended Stormwater Management Plan presented in this chapter is provided as guidance only and does not replace other local and state submission requirements. Municipalities or state agencies may adopt this or similar Stormwater Management Plan requirements into future updates of municipal land use regulations and state permit programs.

Plan Content

A Stormwater Management Plan should include the following major elements:

- Stormwater Management Report (narrative)
- Design Calculations
- Design Drawings (plans)
- Soil Erosion and Sediment Control Plan
- Operation and Maintenance Plan
- Other Supporting Documents

What's New in this Chapter?

- ❖ Updated Stormwater Management Plan content consistent with revised stormwater management standards and performance criteria
- ❖ Updated Stormwater Management Plan Checklist ([Appendix E](#))

[Appendix E](#) contains a checklist that can be used in preparing or reviewing a Stormwater Management Plan.

Stormwater Management Report

The stormwater management report provides a written narrative of the project, including existing and proposed conditions, proposed stormwater management measures, and how the project meets the stormwater management standards and performance criteria contained in this Manual. The stormwater management report should include, but is not limited to, the following sections and information.

General Information

- Applicant's name, address, contact information (email & phone)
- Licensed professional engineer's name, address, contact information (email & phone)
- Street address of project site
- Site locus map
- Current use and zoning of property
- Proposed use of property

Project Summary

- Project description and purpose
- Project schedule and project phasing (if any)
- Applicable local, state, and federal regulatory permits, approvals, and associated regulatory requirements related to post-construction stormwater management
- Applicable regulatory authority(ies)

Existing (Pre-Development) Conditions Description (As Applicable)

- Site area, ground cover, vegetation, existing development features (roads, buildings, utilities, septic systems, etc.)
- Site topography (2-foot contours based on aerial or field survey), slopes, drainage patterns, drainage systems, drainage areas, and stormwater discharge locations
- Existing impervious area and existing Directly Connected Impervious Area (DCIA)
- On-site and adjacent waterbody information⁷⁴
 - Water quality classifications
 - Water quality impairments and Total Maximum Daily Loads (TMDLs)
- Site soils as identified by USDA NRCS mapping or soil scientist
 - Soil types
 - Hydrologic Soil Groups
- Soil evaluation results
 - Initial screening information

⁷⁴ The applicable waterbody information can be found at: [MS4 Map | CT NEMO Program \(uconn.edu\)](#)

- Test pits and soil borings results
- USDA soil textural class
- Depth to bedrock
- Depth to seasonal high groundwater
- Significant subsurface or geologic features
- Field infiltration testing results (if required)
- Other site constraints
 - Site contamination
- On-site and off-site critical resources
 - Inland wetlands and watercourses, tidal wetlands, and associated regulatory setbacks
 - Streams
 - Lakes/ponds
 - Vernal pools
 - Coastal waters including Connecticut Coastal Jurisdiction Line
 - Coldwater streams
 - Drinking water supply areas (wells, Aquifer Protection Areas, public drinking water supplies)
 - Tree canopy
 - Steep slopes (25% and greater)
 - Conservation easement areas
- Locations of 100-year floodplain, floodway, and flood elevations from current FEMA mapping
- Land uses and development adjacent to the site

Proposed (Post-Development) Conditions Description (As Applicable)

- Type of project or activity (new development, redevelopment, linear project, retrofit)
- Proposed ground cover, vegetation, development features (roads, buildings, utilities, septic systems, etc.)
- Proposed drainage area boundaries and design points
- Proposed activities classified as Land Uses with Higher Potential Pollutant Loads (LUHPPLs)
- Proposed impervious area and DCIA
- Proposed area of land disturbance
- Coastal Jurisdiction Line (CJL) for properties fronting coastal, tidal, or navigable waters

Applicable Stormwater Management Standards and Performance Criteria

- Standard 1 – Runoff Volume and Pollutant Reduction
 - LID Site Planning and Design
 - Stormwater Retention and Treatment
- Standard 2 – Stormwater Runoff Quantity Control
 - Design Storm Rainfall Depth and Distribution
 - Peak Runoff Attenuation
 - Conveyance Protection

- Emergency Outlet Sizing

Proposed LID Site Planning and Design Strategies Description

- Avoid Impacts
 - Minimizing Soil Compaction
 - Minimizing Site Disturbance
 - Protecting Sensitive Natural Areas
 - Preserving Vegetated Buffers
 - Avoiding Disturbance of Steep Slopes
 - Siting on Permeable and Erodible Soils
 - Protecting Natural Flow Pathways
 - Conservation and Compact Development
- Reduce Impacts
 - Reducing Impervious Surfaces (Roads, Cul-de-sacs, Sidewalks, Driveways, Buildings, Parking Lots)
 - Preserving Pre-development Time of Concentration
 - Use of Low Maintenance Landscaping
- Manage Impacts at the Source
 - Disconnecting Impervious Surfaces - Impervious Area (Simple) Disconnection
 - Conversion of Impervious Areas to Pervious Areas
 - Source Controls

Proposed Structural Stormwater BMPs

- Description of proposed structural stormwater BMPs and why they were selected
 - Location, size, types by drainage area/design point
 - Design criteria

Summary of Compliance with Stormwater Management Standards and Criteria

Standard 1 – Runoff Volume and Pollutant Reduction (for each design point for Site Development and Redevelopment Projects)⁷⁵

- LID Site Planning and Design
 - LID Site Planning and Design Opportunities and Constraints Plan
 - Completed LID Site Planning and Design Checklist
 - Total LID Site Planning and Design credits and DCIA reduction

⁷⁵ Per the CTDOT MS4 Permit, linear projects have alternative standards and may take an alternative approach to address constraints that are different than those that affect traditional parcel development projects. These alternative linear project standards can be found in the CTDOT drainage manual, the CTDOT MS4 General Permit, the General Construction Permit and in the supporting materials that CTDOT has developed.

- Stormwater Retention and Treatment
 - Impervious area and Directly Connected Impervious Area (DCIA)
 - Retention and Treatment Required
 - Water Quality Volume and Water Quality Flow
 - Required Retention Volume
 - Retention and Treatment Provided including Maximum Extent Achievable Documentation, as applicable
 - Explanation of site limitations
 - Description of the stormwater retention practices implemented
 - Explanation of why this constitutes the Maximum Extent Achievable
 - Alternate retention volume
 - Description of measures used to provide additional stormwater treatment without retention
 - Use of EPA stormwater BMP performance curves to demonstrate compliance with required average annual pollutant load reductions

Standard 2 – Stormwater Runoff Quantity Control for Site Development and Redevelopment Projects (for each design point)⁷⁶

- Design Storm Rainfall Depth and Distribution
- Comparison of pre- and post-development
 - Runoff volume and peak flow rate
 - 2-year, 10-year, and potentially the 25-year and 100-year, 24-hour storms
- Downstream analysis
 - Comparison of pre- and post-development peak flows, velocities, and hydraulic effects at critical downstream locations (stream confluences, culverts, other channel constrictions, and flood-prone areas) to the confluence point where the 10 percent rule applies
- Conveyance Protection
- Emergency Outlet Sizing

Design Calculations

The Stormwater Management Plan should include the following design calculations to demonstrate that the proposed stormwater management measures meet the standards and performance criteria described in [Chapter 4 - Stormwater Management Standards and](#)

⁷⁶ Per the CTDOT MS4 Permit, linear projects have alternative standards and may take an alternative approach to address constraints that are different than those that affect traditional parcel development projects. These alternative linear project standards can be found in the CTDOT drainage manual, the CTDOT MS4 General Permit, the General Construction Permit and in the supporting materials that CTDOT has developed.

[Performance Criteria](#) and are designed in accordance with the guidance contained in this Manual.

- Standard 1 – Runoff Volume and Pollutant Reduction (for each design point)
 - LID Site Planning and Design Credit Calculations
 - Impervious area and Directly Connected Impervious Area (DCIA)
 - Water Quality Volume, Water Quality Flow, and Required Retention Volume
 - Structural Stormwater BMP Sizing Calculations
 - Static and dynamic sizing methods (infiltration systems)
 - Drain time and groundwater mounding analysis (infiltration systems)
 - Required versus provided design volumes
 - Pollutant specific load reductions (BMP performance curves) where Standard 1 cannot be met by retention alone

- Standard 2 – Stormwater Runoff Quantity Control (for each design point)
 - Stormwater Runoff Calculations for Pre-Development and Post-Development (with and without stormwater BMPs) Conditions
 - Design storm depth and duration, recurrence interval, and rainfall distribution
 - Runoff volume and peak flow rate (2-year, 10-year, and potentially the 25-year, 100-year, 24-hour storms)
 - Runoff Curve Number
 - Time of Concentration (and associated flow paths)
 - Routing analysis for proposed stormwater BMPs including drainage routing diagram
 - Conveyance protection (including flow velocity calculations and outlet protection sizing) and emergency outlet sizing calculations
 - Downstream analysis hydrograph routing calculations
 - Storm drain system conveyance calculations

Design Drawings

Design drawings should be prepared by designing qualified professional, as defined in the General Permit for the Discharge of Stormwater and Dewatering Wastewaters from Construction Activities. Design drawings should be signed and sealed by the appropriate design professionals (landscape architects and/or professional engineers) responsible for the project design and consistent with their areas of expertise, including LID site planning and design elements and structural stormwater BMPs. The following design drawings should be included with a Stormwater Management Plan.

- Existing (Pre-Development) Conditions Plan
 - Location of existing man-made features on or adjacent to the site, such as roads, buildings, driveways, parking areas, other impervious surfaces, drainage systems, utilities, easements, septic systems, etc.
 - Surveyed locations of property boundaries and easements

- Drainage systems and sanitary sewers should include rim and invert elevations of all structures and sizes and connectivity of all pipes
 - Vegetative communities on the site, including locations of tree canopy
 - Site topography (2-foot contours based on aerial or field survey), slopes, drainage patterns, conveyances systems (swales, storm drains, etc.), drainage area boundaries, flow paths, times of concentration
 - Locations of existing stormwater discharges
 - Areas of steep (25% or greater) slopes
 - Perennial and intermittent streams
 - Inland wetlands and watercourses (and associated regulatory setbacks) as defined by a soil scientist in the field and flags located by a licensed land surveyor
 - Locations of vernal pools
 - Locations of 100-year floodplain, floodway, and flood elevations from current FEMA mapping
 - Locations of soil types as identified by USDA NRCS mapping or soil scientist, test pit and soil boring locations, and field infiltration testing locations
 - Areas of site contamination
 - Location, size, type of existing structural stormwater BMPs and conveyance systems
 - Limits of developable area based on site development constraints
 - Coastal Jurisdiction Line (CJL) for properties fronting coastal, tidal, or navigable waters
- Proposed (Post-Development) Conditions Plan
- Location of proposed man-made features on or adjacent to the site such as roads, buildings, driveways, parking areas, other impervious surfaces, drainage systems, utilities, easements, septic systems, etc.
 - Surveyed locations of property boundaries and easements
 - Drainage systems and sanitary sewers should include rim and invert elevations of all structures and sizes and connectivity of all pipes
 - Vegetative communities on the site, including proposed limits of clearing and disturbance
 - Site topography (2-foot contours based on aerial or field survey), slopes, drainage patterns, conveyances systems (swales, storm drains, etc.), drainage area boundaries, flow paths, times of concentration
 - Locations of proposed stormwater discharges/design points
 - Perennial and intermittent streams
 - Inland wetlands and watercourses (and associated regulatory setbacks) as defined by a soil scientist in the field and flags located by a licensed land surveyor
 - Locations of vernal pools
 - Locations of 100-year floodplain, floodway, and flood elevations from current FEMA mapping

- Locations and results of on-site soil evaluation (test pits/soil borings and field infiltration testing)
 - Areas of site contamination
 - Development envelope and areas of site preserved in natural condition
 - Location, size, type of proposed structural stormwater BMPs and conveyance systems. Structural BMPs should have rim, invert, and contour elevations and pipe sizes and construction material.
 - Locations of soil erosion and sedimentation controls
 - Locations of non-structural source controls
- LID Site Planning and Design Opportunities and Constraints Plan
 - Structural Stormwater BMP Design Details and Notes
 - Coastal Jurisdiction Line (CJL) for properties fronting coastal, tidal, or navigable waters

Soil Erosion and Sediment Control Plan

Consistent with Standard 3 of this Manual, project proponents must develop and implement a Soil Erosion and Sediment Control (SESC) Plan in accordance with local and/or state regulatory requirements, the [Connecticut Guidelines for Soil Erosion and Sediment Control Guidelines](#), as amended (Guidelines), and the requirements of the CTDEEP General Permit for the Discharge of Stormwater and Dewatering Wastewaters from Construction Activities. The SESC Plan should, at a minimum, demonstrate the methods and designs to be utilized during construction and stabilization of the site following completion of construction activity. Erosion and sediment control measures should be included on the plans with sufficient detail to facilitate review of the design by the reviewing authority and proper construction of the measures.

Operation and Maintenance Plan

As required by Standard 4, project proponents must develop and implement a long-term Operation and Maintenance (O&M) Plan, which identifies required inspection and maintenance activities for structural stormwater BMPs. [Chapter 13 - Structural Stormwater BMP Design Guidance](#) of this Manual contains operation and maintenance guidelines and recommendations for each type of stormwater BMP. [Appendix B](#) contains maintenance inspection checklists.

Recommended elements of an O&M Plan include but are not limited to:

- Detailed inspection and maintenance requirements/tasks
- Inspection and maintenance schedules
- Parties legally responsible for maintenance (name, address, and telephone number)
- Provisions for financing of operation and maintenance activities
- As-built plans of completed structures
- Letter of compliance from the designer
- Post-construction documentation to demonstrate compliance with maintenance activities

Operational source control and pollution prevention measures for the site (see [Chapter 6 - Source Control Practices and Pollution Prevention](#)) should also be described in the O&M Plan.

Other Supporting Documents

Other information relevant to the design of the stormwater management measures for a project should be included (or referenced, if appropriate) in the Stormwater Management Plan.

Pertinent information may include but is not limited to:

- Completed Stormwater Management Plan Checklist
- LID Site Planning and Design Checklist (Chapter 5 – Low Impact Development Site Planning and Design Strategies)
- NRCS Soils Mapping
- Soil Evaluation Documentation (Test Pits/Soil Borings and Field Infiltration Testing Results)
- DCIA Tracking Worksheet required by the reviewing authority to satisfy MS4 Permit requirements
- Groundwater impacts for proposed infiltration structures
- Reports on wetlands and other surface waters (including available information such as Maximum Contaminant Levels [MCLs], Total Maximum Daily Loads [TMDLs], 303(d) or 305(b) impaired waters listings, etc.)
- Water quality impacts to receiving waters
- Impacts on biological populations/ecological communities including fish, wildlife (vertebrates and invertebrates), and vegetation, including the [Natural Diversity Database](#) evaluation.
- Flood study/calculations
- Other permits and approvals issued for the project.

Chapter 13 – Structural Stormwater BMP Design Guidance

Introduction

This chapter provides detailed guidance on the design, construction, and maintenance of the structural stormwater Best Management Practices (BMPs) contained in this Manual. [Table 13- 1](#) lists each of the stormwater BMPs for which detailed guidance is provided. It is important to note this is not intended to be an exhaustive list, but rather a method to provide the soundest science available and develop guiding principles to BMP design. Hyperlinks are provided corresponding to sections of this chapter where information on specific BMPs can be found. Guidance for multiple types of BMPs is provided in a single combined section for several categories of BMPs (Pretreatment BMPs, Stormwater Pond and Wetland BMPs).

Table 13- 1 Structural Stormwater BMPs Addressed in Chapter 13

BMP Category	BMP Type
Pretreatment BMPs	Pretreatment BMPs Sediment Forebay Pretreatment Vegetated Filter Strip Pretreatment Swale Deep Sump Hooded Catch Basin Oil Grit Separator Proprietary Pretreatment Device
Infiltration BMPs	Infiltration Trench Underground Infiltration System Infiltration Basin Dry Well & Infiltrating Catch Basin Permeable Pavement
Filtering BMPs	Bioretention Tree Filter Sand Filter
Stormwater Pond and Wetland BMPs	Stormwater Pond Wet Pond Micropool Extended Detention Pond Wet Extended Detention Pond Multiple Pond System Stormwater Wetland Subsurface Gravel Wetland Shallow Wetland Extended Detention Shallow Wetland Pond/Wetland System
Water Quality Conveyance BMPs	Dry Water Quality Swale Wet Water Quality Swale
Stormwater Reuse BMPs	Rain Barrel and Cistern Rain Barrel Cistern
Other BMPs and BMP Accessories	Green Roof Dry Extended Detention Basin Underground Detention (no infiltration) Inlet and Outlet Controls

The following BMP-specific design guidance is provided in each section:

- **Description.** A brief description of the stormwater BMP and common design variations. The stormwater management benefits of the BMP (runoff volume and pollutant reduction, stormwater runoff quantity control, etc.) and effectiveness for removal of specific categories of pollutants are summarized at the beginning of each section for quick reference and screening.
- **Advantages.** The major beneficial factors or considerations (e.g., environmental, economic, safety) for selecting a specific stormwater BMP.
- **Limitations.** The major limitations or drawbacks of a stormwater BMP that may preclude its use for a given site.
- **Siting Considerations.** The site conditions required for implementation of a stormwater BMP such as subsurface conditions and minimum setbacks.
- **Soil Evaluation.** Where necessary, evaluation of the soil characteristics and subsurface conditions at the location of the proposed system including soil type, depth to the seasonal high groundwater table, depth to bedrock, and soil infiltration rate (for infiltration systems).
- **Design Requirements.** Specific technical requirements for designing the major elements of a stormwater BMP such as pretreatment, system sizing and dimensions for retention and treatment, drain time, conveyance, materials, vegetation, etc.⁷⁷
- **Construction Requirements.** Recommended construction procedures and methods, as well as recommended stages of construction to be inspected by a qualified inspector as defined in the General Permit for the Discharge of Stormwater and Dewatering Wastewaters from Construction Activities, to ensure that stormwater BMPs are constructed as designed.
- **Maintenance Requirements.** Routine and non-routine operation and maintenance, including inspection frequencies, required for the stormwater treatment practice to function properly over time.

⁷⁷ Per the CTDOT MS4 Permit, linear projects have alternative standards and may take an alternative approach to address constraints that are different than those that affect traditional parcel development projects. These alternative linear project standards can be found in the CTDOT drainage manual, the CTDOT MS4 General Permit, the General Construction Permit and in the supporting materials that CTDOT has developed.

Pretreatment BMPs

General

Pretreatment BMPs remove coarse sediment and debris (e.g., trash, leaves, floatables) upstream of other structural stormwater BMPs, while consolidating maintenance to a specific location. Properly designed Pretreatment BMPs help preserve the pollutant removal efficiency, extend the service life, and reduce maintenance costs of the main stormwater BMP.

Pretreatment BMPs can be designed as an integral component of another BMP, such as a sediment forebay within another practice, or as a separate structure preceding the main stormwater BMP, such as an upstream proprietary device. Pretreatment BMPs can also be configured as on-line or off-line. On-line systems are designed to provide pretreatment for the entire design volume or flow rate and safely convey larger flows. Off-line systems are typically designed to receive a specified volume or flow rate, such as the design Water Quality Volume (WQV) or Water Quality Flow (WQF), and bypass larger flows. A flow diversion structure (flow splitter) is used to divert the design volume or flow rate to the off-line stormwater BMP. The [Inlet and Outlet Controls](#) section addresses the design of flow diversion structures.

Pretreatment BMPs are only suitable as pretreatment for other stormwater BMPs and cannot be used alone to meet the retention or treatment performance criteria, with the exception of proprietary devices. When designed to achieve the minimum pollutant load reductions described in [Chapter 4 - Stormwater Management Standards and Performance Criteria](#), proprietary devices can be used for stormwater treatment.

Access Considerations

The performance of pretreatment practices is dependent on regular maintenance. Pretreatment practices should be designed for easy maintenance. Maintenance access must be carefully considered and incorporated into the design. Refer to the general maintenance considerations provided in [Chapter 7 - Overview of Structural Stormwater Best Management Practices](#), which also apply to Pretreatment BMPs.

Selection

Pretreatment BMPs should be selected based on the following factors:

- The downstream stormwater BMP
- Site-specific constraints (e.g., available space, topography, accessibility)
- Flow type (e.g., sheet flow or concentrated flow)

Pretreatment BMPs Included in this Section

- ❖ Sediment Forebay
- ❖ Pretreatment Vegetated Filter Strip
- ❖ Pretreatment Swale
- ❖ Flow-through Devices
 - Deep Sump Hooded Catch Basin
 - Oil Grit Separator
 - Proprietary Pretreatment Device

- Required pretreatment capacity.

[Table 13- 2](#) and [Table 13- 3](#) provide a general summary of the applicability of different types of Pretreatments BMPs and can assist in selecting an appropriate pretreatment practice. Multiple pretreatment BMPs may be used, as necessary, to enhance pretreatment effectiveness.

Table 13- 2 Pretreatment BMP Selection Factors

Pretreatment BMP	Pollutant Removal Processes	Inlet Flow Type	Sizing Criteria (Capacity)	Maintenance Frequency	Maintenance Effort	Required Space	Capital Cost
Sediment Forebay	Settling	Concentrated	10% to 25% of the WQV (Small to large)	Moderate	Moderate	Moderate to High	Low to Moderate
Pretreatment Vegetated Filter Strip	Filtration, Some Infiltration, Vegetative Uptake	Diffuse	Length / Drainage Area Dependent (small)	Low	Low to Moderate	High	Low
Pretreatment Swale	Filtration, Some Infiltration, Vegetative Uptake	Diffuse/ Concentrated	WQF & 10-minute Residence Time (Small to medium)	Low	Low to Moderate	Moderate	Low
Deep Sump Hooded Catch Basin	Settling & Floatables Removal	Concentrated	WQF (small)	Moderate to High	Moderate	Low	Low
Oil Grit Separator	Settling & Floatables	Concentrated	WQF (small)	High	Moderate	Low to Moderate	Moderate
Proprietary Pretreatment Device	Settling & Floatables Removal	Concentrated	WQF (small/medium)	High	Moderate	Low	Moderate to High

WQV = Water Quality Volume WQF = Water Quality Flow

- Inlet flow type is either diffuse flow such as sheet flow or concentrated flow such as pipe flow or channelized flow.
- Pretreatment BMPs are sized on a volume or flow rate basis. Sediment forebays are sized as a percentage of the WQV, typically 10% to 25% of the WQV. The storage volume of the sediment forebay can be included in the overall design storage volume of the main stormwater BMP provided that the sediment forebay drains to the BMP. Most other Pretreatment BMPs are sized to treat the WQF, which is the peak flow rate associated with the WQV.
- Maintenance frequency reflects how often maintenance will typically be required for these practices, while maintenance effort reflects the anticipated time, skill of labor, and equipment necessary to complete maintenance. These vary depending on pretreatment device placement (ease of access), size, and the pollutants/soil types in the drainage area. These ratings are relative to the other pretreatment practices.
- Required space is the anticipated footprint used by the specific pretreatment practice after installation. This provides a relative comparison of the footprint required for the various pretreatment practices. If the practice is large but located below ground, it is considered to have a small footprint and is classified as low.
- Capital cost is the anticipated cost required for purchasing the practice and/or the installation costs that are required to implement the pretreatment practice.

Table 13- 3 Suitability of Pretreatment BMPs Based on Type of Primary Stormwater BMP

BMP Category	BMP Type	Sediment Forebay	Pretreatment Vegetated Filter Strip	Pretreatment Swale	Deep Sump Hooded Catch Basin (1)	Oil Grit Separator (2)	Proprietary Pretreatment Device (3)	
Infiltration BMPs	Infiltration Trench	☐	☐	☐	☐	☐	☐	
	Underground Infiltration System	☐	☐	☐	☐	☐	☐	
	Infiltration Basin	☐	☐	☐	☐	☐	☐	
	Dry Well	Pretreatment Not Required						
	Infiltrating Catch Basin (4)	☐	☐	☐	☐	☐	☐	
	Permeable Pavement	Pretreatment Not Required						
Filtering BMPs	Bioretention	☐	☐	☐	☐	☐	☐	
	Surface Sand Filter	☐	☐	☐	☐	☐	☐	
	Tree Filter	☐	☐	☐	☐	☐	☐	
Stormwater Pond BMPs	Wet Pond	☐	☐	☐	☐	☐	☐	
	Micro pool Extended Detention Pond	☐	☐	☐	☐	☐	☐	
	Wet Extended Detention Pond	☐	☐	☐	☐	☐	☐	
	Multiple Pond System	☐	☐	☐	☐	☐	☐	
Stormwater Wetland BMPs	Subsurface Gravel Wetland	☐	☐	☐	☐	☐	☐	
	Shallow Wetland	☐	☐	☐	☐	☐	☐	
	Extended Detention Shallow Wetland	☐	☐	☐	☐	☐	☐	
	Pond/Wetland System	☐	☐	☐	☐	☐	☐	

BMP Category	BMP Type	Sediment Forebay	Pretreatment Vegetated Filter Strip	Pretreatment Swale	Deep Sump Hooded Catch Basin (1)	Oil Grit Separator (2)	Proprietary Pretreatment Device (3)
Water Quality Conveyance BMPs	Dry Water Quality Swale	☐	☐	☐	☐	☐	☐
	Wet Water Quality Swale	☐	☐	☐	☐	☐	☐
Stormwater Reuse BMPs	Rain Barrel	Pretreatment Not Required					
	Cistern	☐	☐	☐	☐	☐	☐
Proprietary BMPs	Manufactured Treatment Systems (5)	Pretreatment Not Required					
Other BMPs and BMP Accessories	Green Roof	Pretreatment Not Required					
	Dry Extended Detention Basin	☐	☐	☐	☐	☐	☐
	Underground Detention (no infiltration)	☐	☐	☐	☐	☐	☐
Notes:							
<p>(1) Recommended for use with other Pretreatment BMPs or for space constrained sites where no other Pretreatment BMPs are feasible. Deep sump hooded catch basins can be impractical for use with surface stormwater BMPs (unless adequate grade difference exists between the drainage system and BMP) due to the depth of the catch basin outlet pipe.</p> <p>(2) Oil grit separators are useful pretreatment practices for runoff from Land Uses with Higher Potential Pollutant Loads (LUHPPLs) that are expected to have high pollutant loads of oil and grease (refer to Chapter 4 - Stormwater Management Standards and Performance Criteria for list of LUHPPLS).</p> <p>(3) Proprietary pretreatment devices are useful pretreatment practices for runoff from LUHPPLs that are expected to have high pollutant loads of oil and grease, metals, and other targeted pollutants.</p> <p>(4) Requires pretreatment BMP separate from the infiltrating catch basin itself.</p> <p>(5) See Chapter 11 - Proprietary Stormwater BMPs for use of proprietary stormwater BMPs as stand-alone treatment.</p>							
Legend	☐	Suitable for use with primary stormwater BMP					
	☐	Generally not suitable					

Sediment Forebay



Source: MassDEP,
<https://megamanual.geosyntec.com/npsmanual/sedimentforebays.aspx>

Description

A sediment forebay is a separate cell within or immediately upstream of a structural stormwater BMP designed to capture, temporarily store, and settle coarse sediment and debris from runoff in an accessible area. A sediment forebay is formed by a barrier such as an earthen berm, concrete weir, granite curbing, or stone gabion baskets. Sediment forebays are highly flexible and can be adapted to meet site-specific constraints. The forebay has a non-erosive outlet into the primary stormwater BMP and can be configured as a riser and pipe, overflow weir, or culvert. The elevation of the outlet should be set such that the forebay is sized to temporarily store 10% to 25% of the Water Quality Volume (WQV). [Figure 13-1](#) shows a schematic elevation view of a sediment forebay designed within a stormwater BMP.

<i>Stormwater BMP Type</i>	
Pretreatment BMP	■
Infiltration BMP	□
Filtering BMP	□
Stormwater Pond BMP	□
Stormwater Wetland BMP	□
Water Quality Conveyance BMP	□
Stormwater Reuse BMP	□
Proprietary BMP	□
Other BMPs and Accessories	□

<i>Stormwater Management Suitability</i>	
Retention	□
Treatment	□
Pretreatment	■
Peak Runoff Attenuation	□

<i>Pollutant Removal</i>	
Sediment*	High
Phosphorus	Low
Nitrogen	Low
Bacteria	Low

*Includes sediment-bound pollutants

<i>Implementation</i>	
Capital Cost	Low to Moderate
Maintenance Burden	Moderate
Land Requirement	Moderate to High

Figure 13-1. Sediment Forebay Schematic

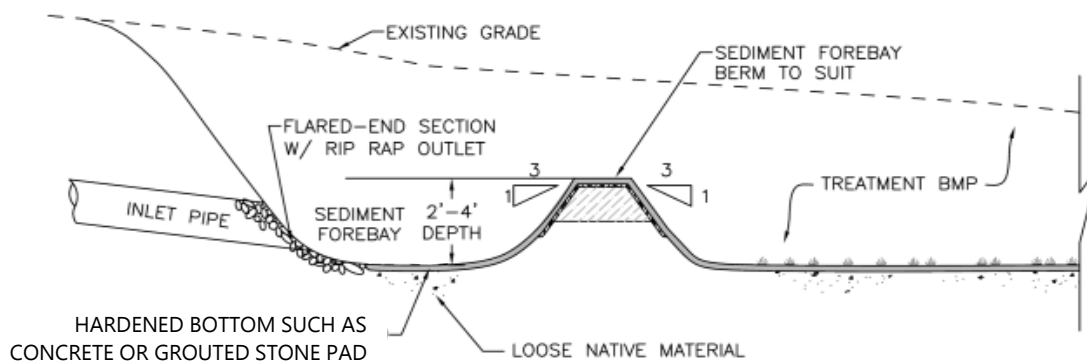

Source: Adapted from Rhode Island Stormwater Design and Installation Standards Manual (2015)

Siting Considerations

Sediment forebays should be located at each inflow point into the primary stormwater BMP. There may be multiple inflow points into a single forebay.

Design Recommendations

Sizing and Dimensions

- Inflow Velocity
 - In accordance with [Inlet and Outlet Controls](#) section of Chapter 13
- Length/Width
 - Minimum: 1:1 ratio (2:1 or greater preferred)
- Freeboard
 - Minimum: 0.5-foot for off-line BMPs; 1-foot for on-line BMPs
- Bottom Surface Area
 - Use the following equation (Camp-Hazen equation) for sizing the surface area of the bottom of the forebay:

$$A = -\frac{Q}{W} \ln(1 - E) = 0.066 * \%WQV$$

where:

A = minimum required surface area of sediment forebay (square feet)

Q = discharge from drainage area (cubic feet per second)

= $\%WQV / 86,400$ seconds

$\%WQV$ = percent of the water quality volume required for sediment forebay design (cubic feet)

W = 0.0004 feet per second particle settling velocity for silt

E = sediment removal efficiency (assume 0.9 or 90%)

- Volume
 - Size the sediment forebay to store 10% to 25% of the WQV below the outlet invert unless specified otherwise in the respective BMP design sections of this Manual. The storage volume of the sediment forebay can be included in the overall design storage volume of the main stormwater BMP provided that the sediment forebay drains to the BMP.
 - Do not account for infiltration in the forebay sizing analysis.
 - Ensure adequate depth to prevent resuspension of collected sediments during the design storm with flowthrough velocities not exceeding 2 feet/second for all design storms.

- Side Slope
 - Maximum: 3(H):1(V)

Features

- Forebay Berm
 - Use gabion baskets, concrete or granite curbing, precast or cast-in-place concrete weirs, or earthen berm. Earthen berms should be armored to prevent erosion of the embankment.
- Bottom of Forebay
 - Use a hardened bottom (line with a concrete or grouted stone pad) to make sediment removal easier. UngROUTED stone riprap should not be used within the forebay since it makes removal of accumulated sediment more difficult and costly.
 - If using concrete or a grouted stone pad, provide at least two weep holes (2.5 inches in diameter) for every 25 square feet of surface area in the bottom of the forebay to facilitate low level drainage.
- Stage Indicator/Gage
 - Install a stage indicator/gage to monitor sediment levels.
 - The gage should indicate the level at which the forebay is considered full.

Materials

- Curbing
 - If used, granite or concrete curbing should conform to State of Connecticut Department of Transportation Standard Specifications, Section M.12.06 (Stone Curbing) and Section 8.11 (Concrete Curbing).
- Gabion Basket
 - If used, should conform to ASTM A-974-97 and US Federal Specification QQ-W-461H and coated in accordance with ASTM A641, Finish 5, Class 3.
- Grouted Riprap
 - If used, stone riprap should conform to State of Connecticut Department of Transportation Standard Specifications, Section M.12.02 (Riprap).
 - Grout should be a non-shrink grout having a 4,000 psi 28-day compressive strength and a 2,400 psi 7-day compressive strength in accordance with State of Connecticut Department of Transportation Standard Specifications, Section M.03.05.
- Outlet or Riser Pipe
 - Refer to [Inlet and Outlet Controls](#) section of Chapter 13.

- Poured-in-Place Concrete
 - If used, should be an appropriate class of concrete based on the application and conform to State of Connecticut Department of Transportation Standard Specifications, Section 6.01 (Concrete for Structures).
- Precast Concrete
 - If used, should be an appropriate class of concrete based on the application and conform to State of Connecticut Department of Transportation Standard Specifications, Section M.08.02-4 (Precast Concrete).

Maintenance Needs

- Inspect the sediment forebay and measure the depth of accumulated sediment twice a year.
- Remove sediment from the sediment forebay or other pretreatment area when it accumulates to a depth of more than 12 inches or 50% of the design depth. Clean outlet of sediment forebay or other pretreatment measures when drawdown time exceeds 36 hours after the end of a storm event.

Pretreatment Vegetated Filter Strip



Description

A pretreatment vegetated filter strip is a uniformly graded, vegetated area (i.e., grass or close-growing native vegetation) that is used to treat sheet flow from adjacent pervious and impervious areas prior to entering a structural stormwater BMP.

Pretreatment vegetated filter strips reduce runoff velocity and utilize vegetation to filter coarse sediment and debris. Pretreatment vegetated filter strips should span the entire width of the contributing area to ensure treatment of runoff from the entire area and are most effective if they receive uniformly distributed sheet flow. A level spreader is required if the filter strip receives concentrated flow or flow that could become concentrated because concentrated flows reduce the effectiveness of the practice. [Figure 13-2](#) shows a schematic of a vegetated filter strip used for pretreatment of runoff from pervious and impervious areas prior to discharge to a structural stormwater BMP.

Unlike the vegetated pervious areas that are suitable for providing stormwater retention and treatment credit as described in [Chapter 5 - Low Impact Development Site Planning and Design Strategies](#), pretreatment vegetated filter strips are not stand-alone treatment practices due to their relatively small size and should only be used immediately upgradient of another structural stormwater BMP. Pretreatment vegetated filter strips provide relatively limited runoff volume reduction, infiltration, and peak flow reduction.

Stormwater BMP Type

Pretreatment BMP	■
Infiltration BMP	□
Filtering BMP	□
Stormwater Pond BMP	□
Stormwater Wetland BMP	□
Water Quality Conveyance BMP	□
Stormwater Reuse BMP	□
Proprietary BMP	□
Other BMPs and Accessories	□

Stormwater Management Suitability

Retention	□
Treatment	□
Pretreatment	■
Peak Runoff Attenuation	□

Pollutant Removal

Sediment*	High
Phosphorus	Variable
Nitrogen	Variable
Bacteria	Low

*Includes sediment-bound pollutants

Implementation

Capital Cost	Low
Maintenance Burden	Low to Moderate
Land Requirement	High

Figure 13-2. Pretreatment Vegetated Filter Strip Schematic

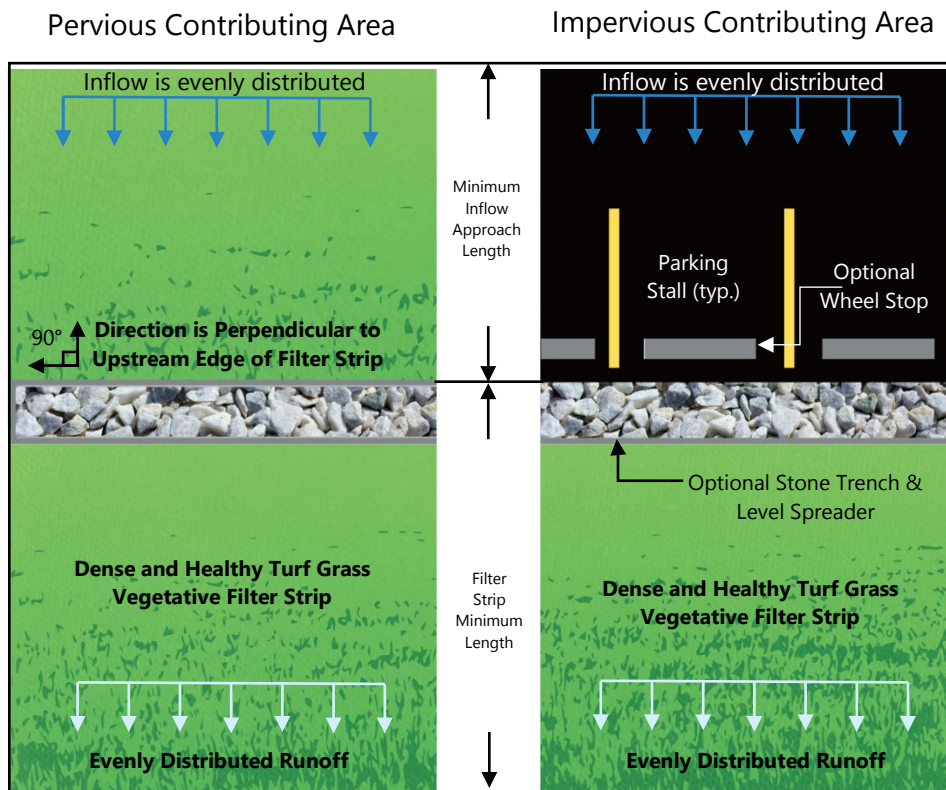

Source: Adapted from New Jersey Stormwater Best Management Practices Manual (2021)

Siting Considerations

- Applicable to small drainage areas and when trying to manage sheet flow.
- Best located in wide, uniformly sloped areas with ample space and mild slopes between the pollutant source and the downstream stormwater BMP.
- Locate where:
 - Area is not subject to excessive fertilizer application or excessive irrigation.
 - Site conditions promote a dense vegetative growth.
 - Site use and aesthetic considerations allow for infrequent mowing (2-4 times a year).
 - Filter strip slopes between the pollutant source and downstream BMPs are between 2% and 4%.
 - Sheet flow should be maintained across the length and width of the filter strip.
 - There is at least 18 inches of separation to seasonal high groundwater.
 - Contributing watersheds have low sediment and floatable loads.

Design Recommendations

Inlet

- The pretreatment vegetated filter strip should receive evenly distributed sheet flow.
- If runoff directed to a pretreatment vegetated filter strip is concentrated or could become concentrated, design the filter strip to include a level spreader in accordance with the [Inlet and Outlet Controls](#) section of Chapter 13.
- The velocity of the sheet flow should be non-erosive (less than 3 feet per second).
- Contributing upstream area should not have a slope in the direction perpendicular to flow that exceeds 2%, and a slope in the direction parallel to flow that exceeds 5%.
- The top of the filter strip (or the level spreader if using a stone-filled trench) should be set 2 inches below the adjacent pavement so that sediment and debris accumulated at the edge of the strip does not prevent runoff from exiting the pavement surface.

Sizing and Dimensions

- Length (direction of flow). Refer to [Table 13-4](#).

Table 13-1. Pretreatment Vegetated Filter Strip Sizing Guidelines

Parameter	Impervious Contributing Area				Pervious Contributing Area			
	35		75		75		150	
Maximum Inflow Approach Length (feet)	35		75		75		150	
Filter Strip Slope (%)	<2	2-4	<2	2-4	<2	2-4	<2	2-4
Filter Strip Minimum Length (feet)	10	15	20	25	10	12	15	18

- Width (perpendicular to direction of flow)
 - Set width equal to or greater than the width of the upgradient contributing area.
- Slope
 - Minimum Slope: 2%; slopes less than 2% may result in ponding and other nuisances
 - Maximum Slope: 4%; slopes greater than 4% may result in concentrated flow and erosion
 - Maximum velocity for water quality storm: 1 foot per second
 - Maximum velocity for 10-year, 24-hour design storm: 3 feet per second

- If velocities are greater than the maximum velocities listed above, provide turf reinforcement matting (TRM).
- Slopes may be between 4% and 6% if TRM is provided.
- Vegetation
 - Vegetation should consist of 100% ground cover and be selected with guidance of [Appendix F](#) of this Manual based on site-specific conditions.
 - Use non-erosive vegetation that can withstand relatively high velocity flows, and both wet and dry conditions.
 - Some woody vegetation is acceptable. However, to maximize pretreatment effectiveness, most of the area should be grassed. Woody vegetation is more susceptible to re-concentration of flow than turf and other herbaceous species.
 - Manage vegetation to be thick and vigorous. Clumping vegetation should be avoided.

Maintenance Needs

- Regular maintenance is critical for the effectiveness of vegetated filter strips, especially to ensure that concentrated flow does not short-circuit the system. Early detection and maintenance of erosion and/or head cuts is key to long-term performance.
- Inspect the vegetated filter strip and any level spreaders twice a year. Measure the depth of accumulated sediment and inspect the vegetation for erosion, bare spots, and overall health.
- Remove sediment and debris from the filter strip and level spreader, and re-seed bare spots as necessary.
- Regular, frequent mowing of the grass to a height of 3 to 4 inches is recommended.

Pretreatment Swale



Description

A pretreatment swale is a gradually sloped channel that increases travel time, reduces runoff velocity, and utilizes vegetation to filter coarse sediment and debris from runoff. Pretreatment swales provide both conveyance and pretreatment for downstream stormwater BMPs. Check dams may be utilized to increase pretreatment capacity by temporarily storing runoff, further reducing the runoff velocity in the swale. Pretreatment swales can be incorporated into highway and road drainage systems but can also be used in place of traditional curb and gutter drainage systems. [Figure 13-3](#) shows a schematic of a pretreatment swale used for pretreatment of runoff from an adjacent road surface prior to discharge to a structural stormwater BMP.

Unlike the Water Quality Conveyance BMPs ([Wet Water Quality Swale](#) and [Dry Water Quality Swale](#)), which are suitable for providing stormwater retention and treatment credit, pretreatment swales are not stand-alone treatment practices due to their limited pollutant removal, runoff volume reduction, and groundwater recharge. Pretreatment swales should only be used upgradient of another structural stormwater BMP.

<i>Stormwater BMP Type</i>	
Pretreatment BMP	■
Infiltration BMP	□
Filtering BMP	□
Stormwater Pond BMP	□
Stormwater Wetland BMP	□
Water Quality Conveyance BMP	□
Stormwater Reuse BMP	□
Proprietary BMP	□
Other BMPs and Accessories	□
<i>Stormwater Management Suitability</i>	
Retention	□
Treatment	□
Pretreatment	■
Peak Runoff Attenuation	□
<i>Pollutant Removal</i>	
Sediment*	High
Phosphorus	Variable
Nitrogen	Variable
Bacteria	Low
*Includes sediment-bound pollutants	
<i>Implementation</i>	
Capital Cost	Low
Maintenance Burden	Low to Moderate
Land Requirement	Moderate

Figure 13-3. Pretreatment Swale Schematic

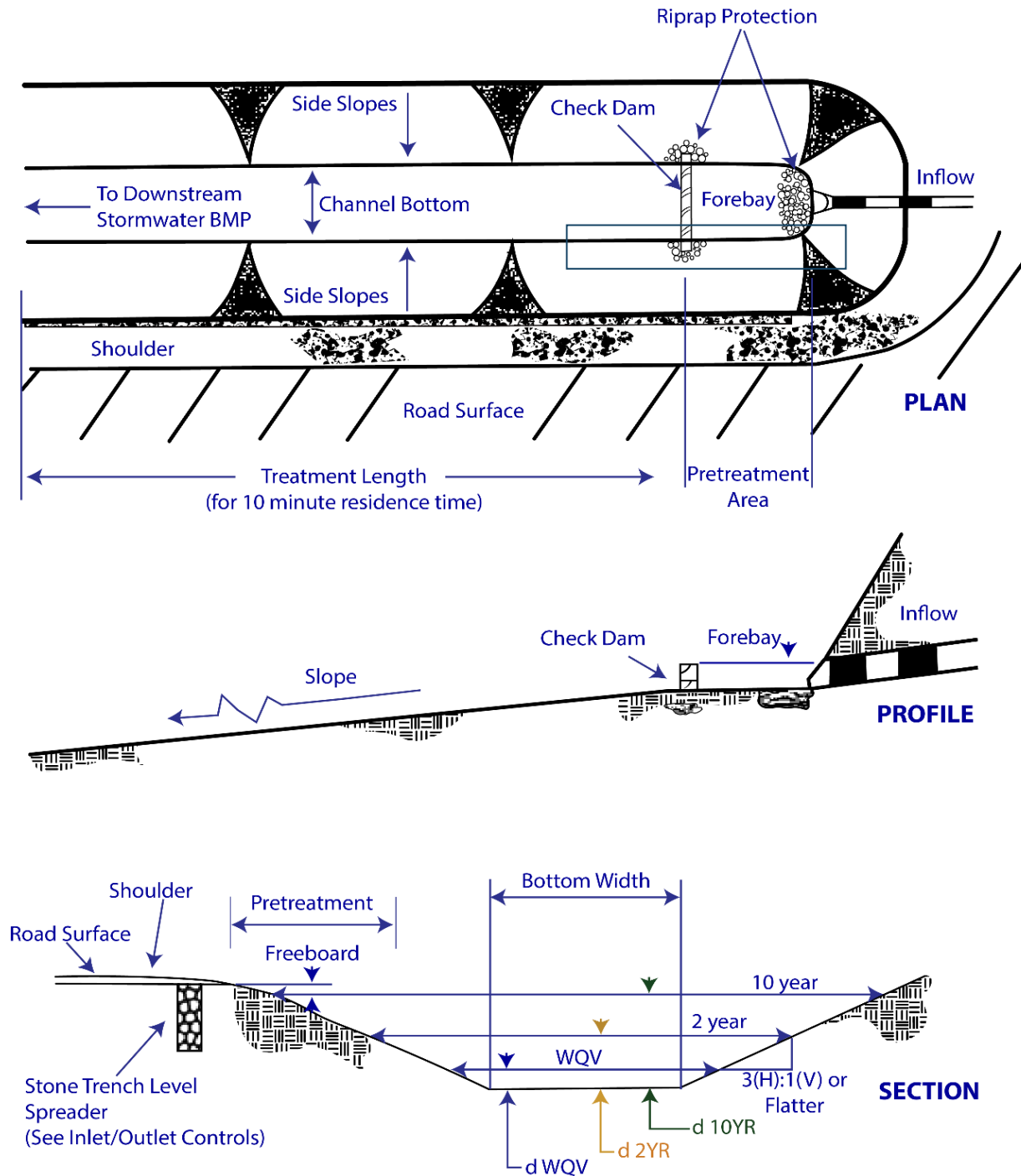

Note: Per the CTDOT MS4 Permit, linear projects have alternative standards and may take an alternative approach to address constraints that are different than those that affect traditional parcel development projects. These alternative linear project standards can be found in the CTDOT drainage manual, the CTDOT MS4 General Permit, the General Construction Permit and in the supporting materials that CTDOT has developed.

Siting Considerations

- Pretreatment swales can be used as an alternative conveyance mechanism to traditional curb and gutter systems.
- Adequate length to ensure sufficient filtering of runoff.
- Do not use in areas with:
 - Steep grades
 - In watersheds with high sediment loads
 - Unstable upgradient areas
- Should not be used for runoff from Land Uses with Higher Potential Pollutant Loads (LUHPPLs) unless the swales are lined to prevent infiltration.

Design Recommendations

Inlet

- A sediment forebay should be used at the upstream end of the channel to trap incoming coarse sediments and debris. A stone-filled trench level spreader and vegetated filter strip can also be used to pretreat sheet flow runoff that enters the sides of the channel.
- Design the inlet(s) in accordance with the [Inlet and Outlet Controls](#) section of Chapter 13.

Sizing and Dimensions

- Cross Section Channel Shape
 - Minimum Bottom Width: 2 feet
 - Shape: Trapezoidal or parabolic; maximize wetted perimeter to the extent possible to increase vegetation contact and reduce velocities
- Side Slope
 - Maximum: 3(H):1(V)
 - For enhanced pollutant removal, design the swale side slopes to serve as vegetated filter strips by accepting sheet flow runoff.
- Length
 - Provide minimum residence time of 10 minutes from inlet to outlet for the water quality storm. Where sheet flow enters the swale, residence time is measured from the mid-point between the upgradient-most part of the swale to the outlet.
- Longitudinal Slope
 - Optimal Range: 1% to 2%
 - Utilize check dams if necessary to ensure adequate residence time for steeper slopes.

- Velocity
 - Maximum velocity for water quality storm: 1 foot per second
 - Maximum velocity for 10-year, 24-hour design storm: 3 feet per second
 - If velocities are greater than the maximum velocities listed above, provide turf reinforcement matting (TRM).

Features

- Topsoil
 - Minimum Depth: 4 inches
- Check Dams
 - Can be installed to increase hydraulic residence time and promote additional infiltration.
 - Can be created using gabion baskets, concrete or granite curbing, or precast or cast-in-place concrete.
 - Maximum Height: 1/2 the height of swale bank
 - Spacing and height of check dams will depend on both the longitudinal slope of the swale and the runoff travel time.
 - Anchor check dams into swale side slopes to prevent washout. Each side of the dam must extend 2-3 feet into the swale side slopes and bottom.
 - Protect downstream side of check dam from scour with stabilized surface measure.
 - When check dams are used near the inlet to control the inlet flow velocity, protect the swale from scour with stabilized surface measure if inlet velocities are greater than 3 feet per second.
- Culverts can be used to maintain swale connectivity where a driveway, walkway, or roadway crosses the swale. The culvert should be sized to pass the 10-year, 24-hour design storm (at a minimum) without causing overtopping.

Materials

- Vegetation
 - Select vegetation with guidance provided in [Appendix F](#) of this Manual based on site-specific conditions.
 - Use non-erosive vegetation that can withstand relatively high velocity flows, and both wet and dry conditions.
- Turf Reinforcement Matting
 - If used, shall be a woven material included on the CTDOT Qualified Products List or equivalent that exceeds the design velocity of the design storm and allows for the growth of the proposed vegetative species.

- Curbing
 - If used, granite or concrete curbing shall conform to State of Connecticut Department of Transportation Standard Specifications, Section M.12.06 (Stone Curbing) and Section 8.11 (Concrete Curbing).
- Gabion Basket
 - If used, should conform to ASTM A-974-97 and US Federal Specification QQ-W-461H and coated in accordance with ASTM A641, Finish 5, Class 3.
- Poured-in-Place Concrete
 - If used, should be an appropriate class of concrete based on the application and conform to State of Connecticut Department of Transportation Standard Specifications, Section 6.01 (Concrete for Structures).
- Precast Concrete
 - If used, should be an appropriate class of concrete based on the application and conform to State of Connecticut Department of Transportation Standard Specifications, Section M.08.02-4 (Precast Concrete).
- Check Dams
 - If used, construct of gabions, granite or concrete curbing, or poured-in-place or precast concrete.

Maintenance Needs

- Inspect the pretreatment swale and any sediment forebay, check dams, and level spreaders twice a year. Measure the depth of accumulated sediment in the forebay and swale and inspect the vegetation for erosion, bare spots, and overall health.
- Remove sediment from the sediment forebay when it accumulates to a depth of more than 12 inches or 50% of the design depth. Clean outlet of sediment forebay when drawdown time exceeds 36 hours after the end of a storm event.
- Remove sediment from the swale and check dams when it accumulates to a depth of more than 50% of the design depth and reconfigure the channel to its original dimensions.
- Remove sediment from any level spreaders, as necessary.
- Mow the vegetation in the swale at least 2 times during the growing season to a height of 4 to 6 inches.
- If the surface of the grass channel becomes clogged to the point that standing water is observed on the surface 48 hours after the end of a storm event, the bottom of the swale should be roto-tilled or cultivated to break up any hard-packed sediment, and then re-seeded.

Oil Grit Separator

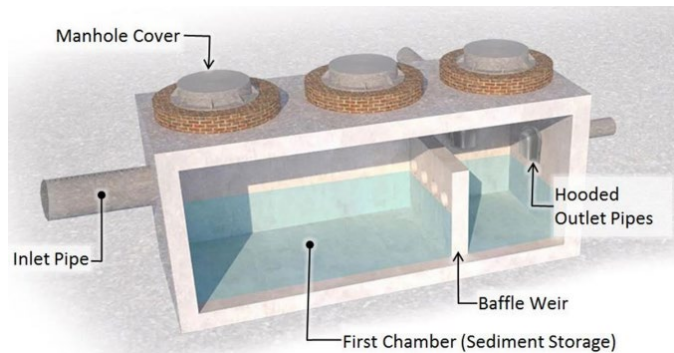

Source: University of Illinois at Urbana-Champaign and UNH Stormwater Center (2017), <https://railtec.illinois.edu/wp/wp-content/uploads/pdf-archive/14.3.pdf>

Description

Oil grit separators are underground, multi-chambered systems designed to remove coarse sediment, debris, and floatables including trash and oil. Oil grit separators are typically designed as off-line systems for pretreatment of runoff from small impervious areas and bypass of larger flows. Due to their limited storage capacity and volume, these systems have only limited water quality treatment and peak flow attenuation capabilities.

Oil grit separators typically consist of multiple baffled chambers (Figure 13-4) and rely on gravity and the physical characteristics of oil and sediments to achieve pollutant removal. In a typical three-

chamber system, the first chamber is a sedimentation chamber where floatable debris is trapped and gravity settling of sediments occurs, the second chamber is designed primarily for oil separation, and the third chamber provides additional settling prior to discharging to the storm drain system or downstream treatment practice. Many design modifications exist to enhance system performance including the addition of orifices, inverted elbow pipes, and diffusion structures. A two chambered system, as shown in Figure 13-5, can be used to maximize sediment storage when the outlet pipes, in the second chamber, are fitted with hoods.

Single-chamber wastewater oil/water separators should not be used for stormwater applications because the single-chamber design does not provide sufficient protection against re-suspension of sediment during runoff events.

Proprietary separators and similar devices can be used as pretreatment. These are addressed in the [Proprietary Pretreatment Device](#) section of this Manual, as well as in [Chapter 11 - Proprietary Stormwater BMPs](#).

Stormwater BMP Type

Pretreatment BMP	■
Infiltration BMP	□
Filtering BMP	□
Stormwater Pond BMP	□
Stormwater Wetland BMP	□
Water Quality Conveyance BMP	□
Stormwater Reuse BMP	□
Proprietary BMP	□
Other BMPs and Accessories	□

Stormwater Management Suitability

Retention	□
Treatment	□
Pretreatment	■
Peak Runoff Attenuation	□

Pollutant Removal

Sediment*	High
Phosphorus	Low
Nitrogen	Low
Bacteria	Low

*Includes sediment-bound pollutants and floatables

Implementation

Capital Cost	Moderate
Maintenance Burden	Moderate to High
Land Requirement	Low to Moderate

Figure 13-4. Typical Three-Chamber Oil Grit Separator

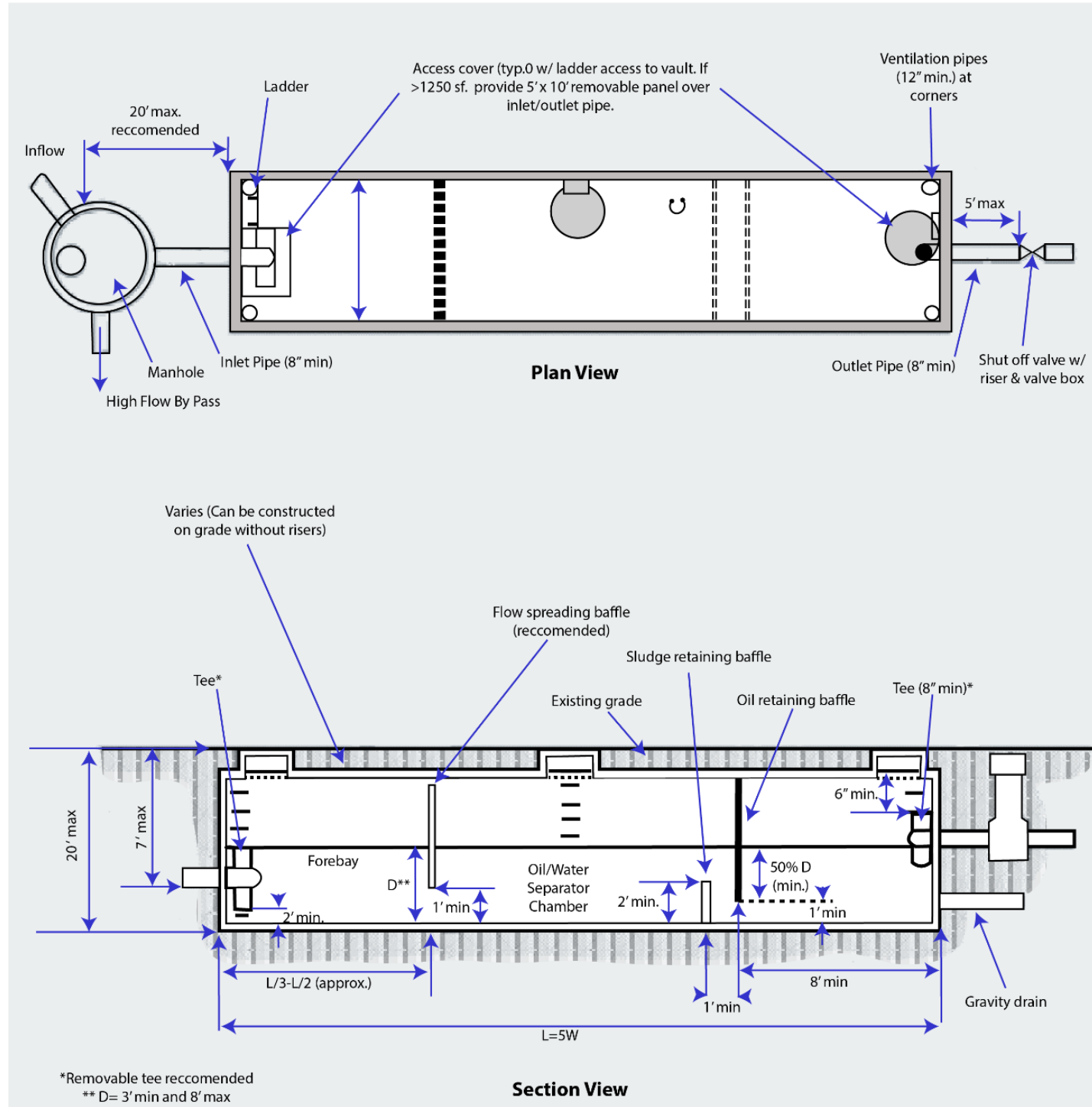
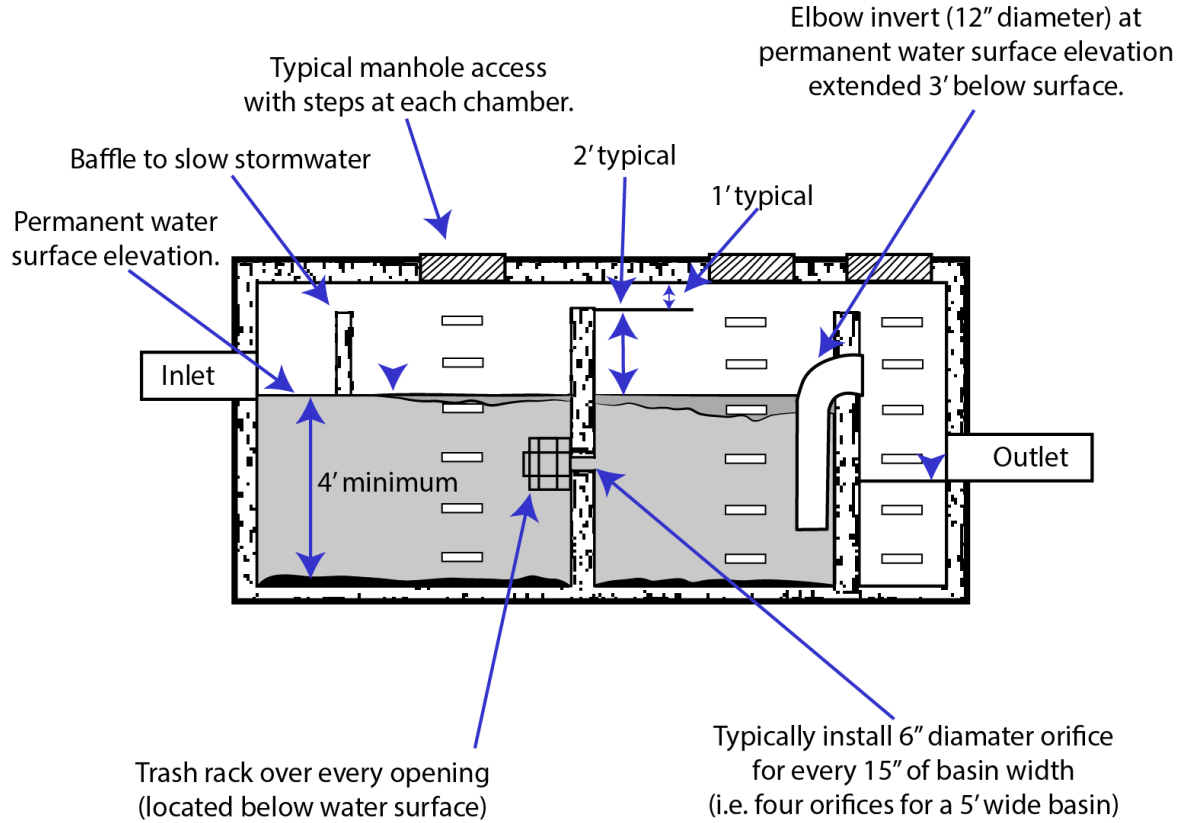

Figure 13-5. Typical Two-Chamber Oil Grit Separator



Siting Considerations

- Contributing drainage area to an oil grit separator generally should not exceed 1 acre of impervious cover.
- Locate where:
 - Land use requirements prohibit use of other pretreatment approaches.
 - Underground features are necessary due to site conditions.
 - Can accept runoff from watersheds with high trash, debris, oil and grease and other floatable loads.
- In areas with high groundwater, buoyancy and anchoring requirements must be considered.
- Siting limitations include:
 - Depth of bedrock
 - Presence of utilities
 - Unstable subsurface conditions that limit depth of excavation.

Design Recommendations

- Separators should only be used in an off-line configuration to treat the Water Quality Flow (peak flow associated with the Water Quality Volume). Design the device to bypass storms greater than the WQF.
- Upstream diversion structures can be used to divert higher flows around the separator. On-line units receive higher flows that cause increased turbulence and resuspension of settled material.
- Oil grit separator tanks can also be designed as flow diversion structures (see [Inlet and Outlet Controls](#) section of Chapter 13).
- Make the permanent pool at least 4 feet deep relative to the outlet invert.
- The separator should be fitted with frame and cover to facilitate maintenance access to each chamber.
- The separator should be designed with enough internal vault space to allow access for a vacuum truck suction nozzle without damaging hoods or access ladder steps.

Maintenance Needs

- Oil grit separators should be accessible for maintenance and/or emergency removal of oil or chemical spills.

- Inspect oil grit separators a minimum of 2 times per year – in late Spring after snowmelt and in late Fall after leaf fall and before the first snowfall. Establish a cleaning frequency such that the oil grit separator storage capacity is reduced by no more than 50%.
- Typical maintenance includes removal of accumulated oil and grease, floatables, and sediment using a vacuum truck or other catch basin cleaning equipment.
- The Operation and Maintenance (O&M) Plan should indicate the maximum allowable level of oil, sediment, and debris accumulation. These levels should be monitored during inspections to ensure that removal of these materials is performed when necessary.
- Dispose of material removed from the device, in accordance with CT DEEP guidelines (see [Chapter 6 - Source Control Practices and Pollution Prevention](#)) and other state and federal requirements, by a properly licensed contractor.

Proprietary Pretreatment Device

Description

Proprietary stormwater BMPs are manufactured systems that use proprietary settling, filtration, absorption/adsorption, vortex principles, vegetation, and other processes to remove pollutants from stormwater runoff.

Proprietary BMPs are commonly used as pretreatment for other BMPs, as described in this section (Proprietary Pretreatment Device), or as treatment systems in retrofit applications where physical site constraints limit the use of other retention and/or treatment BMPs (refer to Chapter 11 - Proprietary Stormwater BMPs for use of Proprietary BMPs for stand-alone treatment).

Common types of proprietary BMPs include hydrodynamic separators, media filtration devices, and catch basin inserts. This category of stormwater BMPs also includes new and emerging technologies that are continually coming onto the market.

[Chapter 11 - Proprietary Stormwater BMPs](#) of

this Manual further describes the appropriate uses and limitations of proprietary stormwater BMPs, third-party BMP performance verification requirements for proprietary BMPs, and general design criteria and maintenance requirements.

Siting Considerations

- Proprietary pretreatment devices are generally designed to pretreat runoff from relatively small impervious drainage areas. The maximum contributing drainage area to a proprietary pretreatment device varies depending on the type of device and manufacturer's recommendations.

Stormwater BMP Type

Pretreatment BMP	■
Infiltration BMP	□
Filtering BMP	□
Stormwater Pond BMP	□
Stormwater Wetland BMP	□
Water Quality Conveyance BMP	□
Stormwater Reuse BMP	□
Proprietary BMP	□
Other BMPs and Accessories	□

Stormwater Management Suitability

Retention	□
Treatment	□
Pretreatment	■
Peak Runoff Attenuation	□

Pollutant Removal

Sediment*	High
Phosphorus	Low
Nitrogen	Low
Bacteria	Low
Includes sediment-bound pollutants and floatables	

Implementation

Capital Cost	Moderate to High
Maintenance Burden	Moderate to High
Land Requirement	Low

- Locate where:
 - Land use requirements prohibit use of other pretreatment approaches.
 - Underground features are necessary due to site conditions.
 - Can accept runoff from watersheds with high trash, debris, oil and grease, floatables, and other pollutant loads.
 - In areas with high groundwater, buoyancy and anchoring requirements must be considered.

- Siting limitations include:
 - Depth of bedrock
 - Presence of utilities
 - Unstable subsurface conditions that limit depth of excavation.

Design Recommendations⁷⁸

Proprietary devices should meet all the following criteria to qualify as acceptable for pretreatment applications:

- Remove a minimum of 50% TSS, based on pollutant concentrations or loads, as verified by a recommended independent third-party stormwater BMP performance verification program (refer to [Chapter 11 - Proprietary Stormwater BMPs](#) for recommended programs)
- Be designed per the manufacturer's recommendations
- Be designed as off-line systems or have an internal bypass to avoid large flows and resuspension of pollutants.
 - If designed in an on-line configuration, proprietary pretreatment devices should be designed in accordance with the manufacturer's recommendations and any applicable use limitations upon which the third-party performance certification is based.

The following are general design criteria for proprietary pretreatment devices, in addition to the design criteria specified by the device manufacturer and any design criteria and/or use limitations upon which the third-party performance certification is based.

- The proprietary device should be designed and installed with the same configuration utilized during the performance verification testing.

⁷⁸ Per the CTDOT MS4 Permit, linear projects have alternative standards and may take an alternative approach to address constraints that are different than those that affect traditional parcel development projects. These alternative linear project standards can be found in the CTDOT drainage manual, the CTDOT MS4 General Permit, the General Construction Permit and in the supporting materials that CTDOT has developed.

- Locate proprietary devices to be accessible for maintenance and/or emergency removal of oil or chemical spills.
- Designs for hydrodynamic separators may not include grate inlets directly into the unit unless they were specifically tested with this type of inlet.
- Proprietary devices subject to vehicular loading should be designed for at least HS-20 traffic loading at the surface.
- All joints and connections should be watertight.
- The manhole cover, or other approved permanent marker, should clearly indicate that the BMP is a pollutant-trapping device.
- Proprietary devices should be designed to safely convey overflows to downgradient drainage systems, including overflow structures designed to provide safe, stable discharge of stormwater runoff in the event of an overflow.
- Any connection to downgradient stormwater management facilities should include access points such as inspections ports and manholes for visual inspection and maintenance, as appropriate, to prevent blockage of flow and ensure operation as intended.
- Tailwater effects should be considered based upon the manufacturer's recommendations.

Maintenance Needs

- Maintain proprietary devices in accordance with the manufacturer's guidelines.
- Perform inspections of proprietary devices a minimum of once per year. However, 2 times per year – in late Spring after snowmelt and in late Fall after leaf fall and before the first snowfall is recommended to prevent BMP failure.
- During inspections, examine the device for standing water. If standing water is present in the device, and standing water is not a component of the design, take corrective action and revise the maintenance plan to prevent similar failures in the future.
- Clean proprietary devices when pollutant removal capacity is reduced by 50% or more, or when the pollutant storage capacity is reduced by 50% or more.
- Typical maintenance includes removal of accumulated oil and grease, floatables, and sediment using a vacuum truck or other catch basin cleaning equipment.
- The Operation and Maintenance (O&M) Plan should indicate the maximum allowable level of oil, sediment, and debris accumulation. These levels should be monitored during inspections to ensure that removal of these materials is performed when necessary.
- Dispose of material removed from the device, in accordance with CT DEEP guidelines (see Chapter 6 - Source Control Practices and Pollution Prevention) and other state and federal requirements, by a properly licensed contractor.

Deep Sump Hooded Catch Basin



Source: University of Illinois at Urbana-Champaign and UNH Stormwater Center (2017), <https://railtec.illinois.edu/wp/wp-content/uploads/pdf-archive/14.3.pdf>

Description

Deep sumps catch basins are storm drain inlets that have a sump below the outlet pipe to capture trash, debris, and coarse sediment. Deep sump catch basins are unique pretreatment BMPs, in that they function very differently and therefore have very different design and maintenance needs than other pretreatment BMPs.

Stormwater runoff enters the catch basin via a grated or curb inlet at the top of the catch basin. The catch basin outlet pipe is located below the inlet and is equipped with a hood (e.g., an inverted pipe). Floatables such as trash and oil and grease are trapped on the permanent pool of water, while coarse sediment settles to the bottom of the catch basin sump. [Figure 13-6](#) shows a schematic of a typical deep sump hooded catch basin.

Deep sump hooded catch basins may be used in conjunction with other Pretreatment BMPs or for space constrained sites where no other Pretreatment BMPs are feasible. Deep sump hooded catch basins and can be impractical for use with surface stormwater BMPs due to the depth of the catch basin outlet pipe.

Stormwater BMP Type

Pretreatment BMP	<input checked="" type="checkbox"/>
Infiltration BMP	<input type="checkbox"/>
Filtering BMP	<input type="checkbox"/>
Stormwater Pond BMP	<input type="checkbox"/>
Stormwater Wetland BMP	<input type="checkbox"/>
Water Quality Conveyance BMP	<input type="checkbox"/>
Stormwater Reuse BMP	<input type="checkbox"/>
Proprietary BMP	<input type="checkbox"/>
Other BMPs and Accessories	<input type="checkbox"/>

Stormwater Management Suitability

Retention	<input type="checkbox"/>
Treatment	<input type="checkbox"/>
Pretreatment	<input checked="" type="checkbox"/>
Peak Runoff Attenuation	<input type="checkbox"/>

Pollutant Removal

Sediment*	High
Phosphorus	Low
Nitrogen	Low
Bacteria	Low

*Includes sediment-bound pollutants and floatables

Implementation

Capital Cost	Low
Maintenance Burden	Moderate to High
Land Requirement	Low

Figure 13-6. Typical Deep Sump Hooded Catch Basin

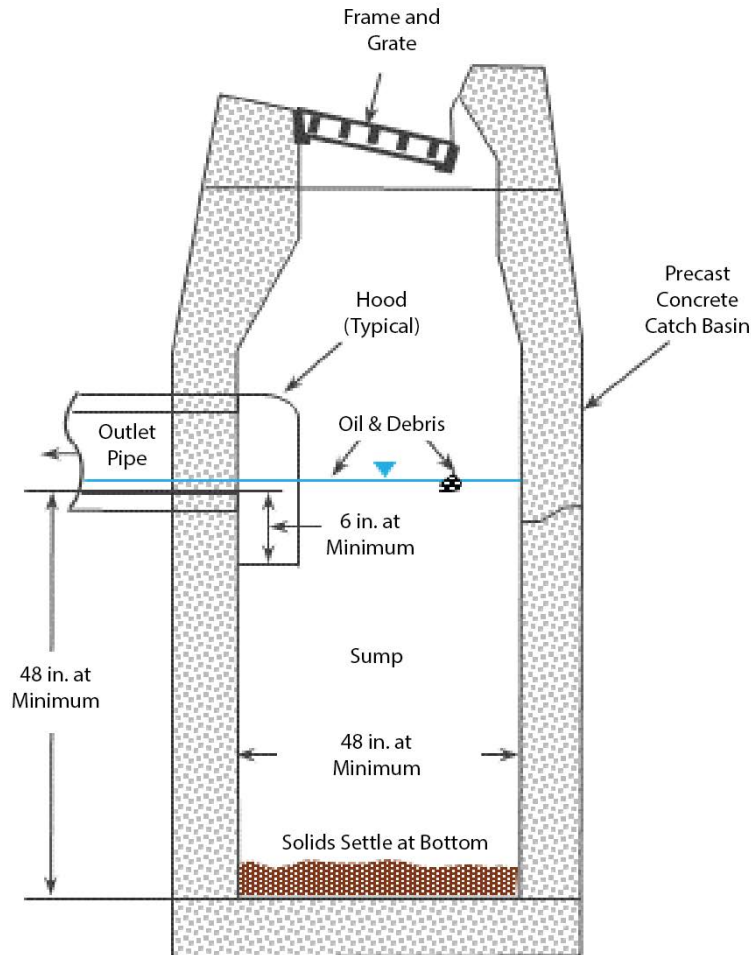

Source: Fuss & O'Niell

Siting Considerations

- To be used as pretreatment for other stormwater BMPs or in conjunction with other Pretreatment BMPs. Recommended for space constrained sites where no other Pretreatment BMPs are feasible. Can be impractical for use with surface stormwater BMPs due to the depth of the catch basin outlet pipe.

- Only use deep sump hooded catch basins in an off-line configuration (i.e., catch basin-to-manhole, NOT catch basin-to-catch basin) to minimize re-suspension of sediment. On-line configurations (catch basin-to-catch basin) cannot be counted as pretreatment.
- Contributing drainage area to a single deep sump catch basin should not exceed 0.25 acres.
- Locate where:
 - Land use requirements prohibit use of other pretreatment approaches.
 - Underground features are necessary due to site conditions.
 - Can accept runoff from watersheds with high trash, debris, oil and grease and other floatable loads.
 - In areas with high groundwater, buoyancy and anchoring requirements must be considered.
- Siting limitations include:
 - Depth of bedrock
 - Presence of utilities
 - Unstable subsurface conditions that limit depth of excavation.

Design Recommendations

Sizing and Dimensions

- Inlet grate should be sized based on the contributing drainage area to ensure that the flow rate does not exceed the capacity of the grate. The grate should not allow flow rates greater than 3 cubic feet per second for the 10-year, 24-hour storm event.
- The sump depth (distance from the bottom of the lowest outlet pipe to the floor of the sump) should be a minimum of 48 inches.
- All outlet pipes in the catch basin that discharge to a stormwater BMP should be equipped with hoods (e.g., inverted elbow pipe, pre-manufactured PVC hood). The bottom of the hood opening should extend a minimum of 6 inches below the invert of the outlet pipe. Hooded outlets may be impractical for outlet pipes larger than 24 inches in diameter.
- Use catch basin hoods that reduce or eliminate siphoning.
- Catch basins should be watertight to maintain a permanent pool of water and provide higher floatable capture efficiency.

Maintenance Needs

- Inspect catch basins twice per year – in late Spring after snowmelt and in late Fall after leaf fall and before the first snowfall. Establish a catch basin cleaning frequency such that the catch basin is no more than 50% full.

- Clean more frequently catch basins with known heavier sediment and debris loads, sensitive waterbodies, drainage problems, flat grades, etc.
- Cleaning should include:
 - Removal of sediment from catch basin sump
 - Removal of floatables and hydrocarbons from the water surface inside the catch basin
 - Removal of trash and debris from catch basin grate.
- The Operation and Maintenance (O&M) Plan should indicate the maximum allowable level of oil, sediment, and debris accumulation. These levels should be monitored during inspections to ensure that removal of these materials is performed when necessary.
- Dispose of material removed from the device, in accordance with CT DEEP guidelines (see [Chapter 6 - Source Control Practices and Pollution Prevention](#)) and other state and federal requirements, by a properly licensed contractor.

Infiltration Trench



Description

Infiltration trenches are shallow, excavated, stone-filled trenches in which stormwater is collected and infiltrated into the ground. Infiltration trenches can be constructed at a ground surface depression to intercept overland flow. This BMP can also receive piped runoff discharged directly into the trench such that the trench is designed to distribute the flow from a point discharge in a manner that does not result in erosion. Runoff gradually percolates through the bottom and sides of the trench, removing pollutants through sorption, trapping, straining, and bacterial degradation, or transformation. Infiltration trenches may also be used to provide stormwater quantity control when designed as on-line facilities.

Infiltration trenches are a cost-effective approach to managing stormwater where there is adequate space for a narrow stormwater feature and where plantings are not needed, and the surface of the trench can be left open. They require less space than infiltration basins as they utilize the void spaces of the stone in the trench to temporarily store water.

Advantages

- Cost-effective approach to recharge stormwater.
- Requires less surface area than infiltration basins.
- Ideal for linear applications such as along sidewalks, medians, roadways, and bicycle paths.

Stormwater BMP Type

Pretreatment BMP	<input type="checkbox"/>
Infiltration BMP	<input checked="" type="checkbox"/>
Filtering BMP	<input type="checkbox"/>
Stormwater Pond BMP	<input type="checkbox"/>
Stormwater Wetland BMP	<input type="checkbox"/>
Water Quality Conveyance BMP	<input type="checkbox"/>
Stormwater Reuse BMP	<input type="checkbox"/>
Proprietary BMP	<input type="checkbox"/>
Other BMPs and Accessories	<input type="checkbox"/>

Stormwater Management Suitability

Retention	<input checked="" type="checkbox"/>
Treatment	<input checked="" type="checkbox"/>
Pretreatment	<input type="checkbox"/>
Peak Runoff Attenuation*	<input checked="" type="checkbox"/>

*On-line systems only

Pollutant Removal

Sediment*	High
Phosphorus	High
Nitrogen	Low
Bacteria	High

*Includes sediment-bound pollutants and floatables (with pretreatment)

Implementation

Capital Cost	Low
Maintenance Burden	Low
Land Requirement	Medium

- High solids, phosphorus, and bacteria removal efficiency. While not high removal efficiency Nitrogen reduction can be enhanced with careful design, typical removal efficiencies range between 10-55%.⁷⁹
- Can provide stormwater retention, runoff volume reduction, groundwater recharge, and some peak runoff attenuation when designed as an on-line system.
- Surface of trench can be vegetated (with grass or plants) to provide landscaped features.

Limitations

- Pretreatment options are limited and should not be used in locations with the potential for high sediment loads.
- System clogging would require replacement of the trench.
- Low removal of dissolved pollutants especially in coarse soils.
- Should not be used with underdrain systems.

Siting Considerations

- **Potential Locations:** Best located parallel to linear features such as roads, sidewalks, and bicycle paths where runoff from a limited impervious surface can sheet flow onto the surface of the trench after being pretreated by a vegetative filter strip between the trench and impervious surface. Can be designed to receive point-source discharges to prevent erosion in the trench and distribute stormwater across the trench.
- **Drainage Area:** The maximum contributing drainage area for infiltration trenches is 5 acres.
- **General:** Meet the soils, water table, bedrock, and horizontal setback requirements specified in [Chapter 10 - General Design Guidance for Stormwater Infiltration Systems](#)([General Design Guidance for Stormwater Infiltration Systems](#)). Infiltration trenches can be designed as on-line or off-line practices.

Soil Evaluation

- Conduct an evaluation of the soil characteristics and subsurface conditions at the location of the proposed system including soil type, depth to the seasonal high groundwater table, depth to bedrock, and soil infiltration rate. Refer to [Chapter 10 - General Design Guidance for Stormwater Infiltration Systems](#) for soil evaluation guidance.

⁷⁹ <https://www.des.nh.gov/sites/g/files/ehbemt341/files/documents/2020-01/vol2-appB.pdf>

Design Recommendations

Pretreatment

- Incorporate pretreatment measures at locations where runoff enters the infiltration trench in accordance with the Pretreatment BMPs section of this Manual.
- Acceptable pretreatment measures include vegetative filter strips, sediment forebays, pretreatment swales, deep sump hooded catch basins,⁸⁰ oil grit separators, and proprietary pretreatment devices.
- Sediment forebays should have a minimum storage volume of 25% of the Water Quality Volume (WQV), while flow-through Pretreatment BMPs should treat at least the equivalent Water Quality Flow (WQF). A minimum sediment forebay storage volume of 10% of the WQV may be used in urban settings, space constrained sites, and as retrofits, with the approval of the review authority.

Sizing and Dimensions

- Trench should be designed by either the Static or Dynamic Methods as described in [Chapter 10 - General Design Guidance for Stormwater Infiltration Systems](#).
- Trench should completely drain in 48 hours or less after the end of the design storm as described in [Chapter 10 - General Design Guidance for Stormwater Infiltration Systems](#).
- Trench depth may be limited by the requirement to maintain adequate separation to groundwater and bedrock as specified in [Chapter 10 - General Design Guidance for Stormwater Infiltration Systems](#).
- Ponding Depth
 - Maximum for required water quality storm: 12 inches
 - Maximum for overflow events: 36 inches
- Bottom and Top Slope
 - Slope of the bottom of the trench should be level. Slope of the top of the trench should not exceed 0.5%.
- Side Slopes
 - Side slopes above the trench should be 3(H):1(V) or flatter especially on grassed slopes where mowing is required.
 - In ultra-urban locations or space constrained areas; side slopes of 2(H):1(V) may be utilized if properly designed to account for erosion and slope stability.

⁸⁰ Only recommended for space constrained sites where no other Pretreatment BMPs are feasible.

- Stabilize the slope with turf reinforcement matting or equivalent if the slope could potentially erode.
 - If site topography does not allow for 3(H):1(V) slopes or adequately stabilized 2(H):1(V) slopes, vertical concrete walls with a maximum height of 30 inches can be used. Drop curbs or similar precast structures can also be used to create stable, vertical side walls.
 - The excavated side walls of the trench ideally should be vertical to maximize storage and infiltration capacity.
- Ensure adequate vehicle access to the entire length of the trench and pretreatment practices in order to allow trench media to be replaced if needed.

Inlet

- Design the inlet in accordance with the Inlet and Outlet Controls section of this Manual.
- Runoff can be introduced through overland flow, curb cuts, inlet structures, swales/channels, and/or pipes.
- Design in an off-line configuration to the extent feasible if runoff is delivered by a storm drainpipe or is along the main storm conveyance system.

Outlet & Overflow

- Design the outlet in accordance with the Inlet and Outlet Controls section of this Manual.
- Outlets are typically a stabilized spillway, gabion berm, concrete weir, curb cut opening, precast concrete structure, or polyethylene/polyvinyl chloride riser structure.
- On-line systems should have a primary outlet sized to convey the 10-year, 24-hour storm event, at a minimum, to the storm drainage system or stabilized channel. An emergency spillway is required to convey the 100-year storm event (assuming the primary outlet is not designed to pass the 100-year storm event).
- Off-line systems should be designed with a bypass or overflow for flows in excess of the water quality storm.

Materials

- Crushed Stone Storage Media
 - The trench should be filled with clean (washed and free from dirt and debris), crushed, angular aggregate with a diameter of 1.5" to 3" (porosity of 40 percent).
 - The sides and top of the trench should be lined with a non-woven geotextile (filter fabric).

- Observation Well
 - An observation well should be installed along the trench centerline to monitor the water drainage in the system. The well should consist of a well-anchored, vertical perforated 4- to 6-inch diameter PVC pipe with a lockable aboveground cap. Install one observation well per 50 feet of length.
- Surface Cover
 - Should consist of a minimum 3-inch-thick layer of pea gravel to suppress weed growth and improve sediment filtering in the top of the trench.
 - Pea gravel should consist of 3/8" AASHTO No. 8 stone. Pea gravel should be clean (washed and free from dirt and debris) and rounded in shape.
 - 4 to 6 inches of loam/topsoil and grass can also be used as an alternative surface cover for the surface of the trench. Select vegetation in accordance with [Appendix F](#) of this Manual.
- Filter Fabric
 - Use non-woven filter fabric that complies with State of Connecticut Department of Transportation Standard Specifications, Section M.08.01.19 (Drainage – Geotextiles).

Winter Operations

- Infiltration trenches should not be used as dedicated snow storage areas. To the extent feasible, locate and design the system to avoid snow storage areas and potential damage from snow plowing activities. Refer to [Chapter 7 - Overview of Structural Stormwater Best Management Practices](#) for general design considerations related to winter operations.

Construction Recommendations

- The designing qualified professional should develop a detailed, site-specific construction sequence.
- The designing qualified professional should inspect the installation during the following stages of construction, at a minimum:
 - After excavation of the infiltration trench and scarification of bottom and sidewalls of excavation
 - After installation of observation well
 - After placement and leveling of stone storage media
 - After installation of bypass, outlet/overflow, and inlet controls
 - After pea gravel or loam/topsoil and grass surface cover have been installed
- The designing qualified professional should provide an as-built plan of the completed infiltration trench along with a certification that the system was designed in accordance with the guidance contained in this Manual and other local or state requirements and that the system was installed in accordance with the approved plans.

- The entire contributing drainage area should be completely stabilized prior to directing any flow to the system. Adequate vegetative cover must be established over any pervious area adjacent or contributing to the system before runoff can be accepted.
- Erosion and sediment controls should be in place during construction in accordance with the [Connecticut Guidelines for Soil Erosion and Sediment Control](#) and the Soil Erosion and Sediment Control (SESC) Plan developed for the project.
- Infiltration trenches should not be used as temporary sediment traps for construction erosion and sediment control.
- During clearing and grading of the site, measures should be taken to avoid soil compaction at the location of the proposed system.
- The system should be fenced off during the construction period to prevent disturbance of the soils.
- The infiltration trench should be excavated to the dimensions, side slopes, and elevations shown on the plans. The method of excavation should avoid compaction of the bottom of the system. A hydraulic excavator or backhoe loader, operating outside the limits of the infiltration trench, should be used to excavate the system. Excavation equipment should not be allowed within the limits of the system.
- The stone storage media and pea gravel layer should be placed in the excavation by a hydraulic excavator or backhoe loader located outside the limits of the infiltration trench and then hand-raked to the desired elevation.
- Install vegetation (e.g., drought tolerant grass) on the side slopes and surface of the infiltration trench (if grass is used instead of pea gravel) in accordance with the planting plan and plant schedule on the plans. Water vegetation thoroughly immediately after planting and as necessary until fully established.

Maintenance Needs

- Infiltration trenches should be designed with easy access to all components of the system for maintenance purposes. Refer to [Chapter 7 - Overview of Structural Stormwater Best Management Practices](#) for general design considerations to reduce and facilitate system maintenance.
- Detailed inspection and maintenance requirements, inspection and maintenance schedules, and those parties responsible for maintenance should be identified on the plans and in the Stormwater Management Plan.
- Maintenance should be detailed in a legally binding maintenance agreement.

- Maintenance activities such as sediment removal, mowing, and repairs should be performed with rakes and light-weight equipment rather than heavy construction equipment to avoid compaction of the filter media and underlying soils. Heavy equipment may be used for sediment removal and other maintenance activities if the equipment is positioned outside the limits of the system. Heavy construction equipment should not be allowed within the limits of the system for maintenance purposes.

Recommended Maintenance Activities

- Inspect after major storms (1 inch or more of precipitation) in the first few months following construction.
- Inspect the sediment forebay or other pretreatment area twice a year.
- Inspect the remainder of the infiltration trench annually.
- Refer to [Appendix B](#) for maintenance inspection checklists, including items to focus on during inspections.
- Remove trash and organic debris (leaves) in the Spring and Fall.
- Remove sediment from the sediment forebay or other pretreatment area when it accumulates to a depth of more than 12 inches or 50% of the design depth. Clean outlet of sediment forebay or other pretreatment measures when drawdown time exceeds 36 hours after the end of a storm event.
- Remove sediment from the infiltration trench surface when the sediment accumulation exceeds 2 inches or when drawdown time exceeds 48 hours after the end of a storm event, indicating that the system is clogged.
- Weed as necessary. Mow grass within infiltration trench to a height of 4 to 6 inches. Maintain a healthy, vigorous stand of grass cover; re-seed as necessary.
- Maintain vegetated filter strips or grassed side slopes of infiltration trench in accordance with maintenance recommendations in the Pretreatment BMPs section of this Manual.
- Periodically remove grass clippings to prevent clogging of the surface of the infiltration trench.
- Mowing should not be performed when the ground is soft to avoid the creation of ruts and compaction, which can reduce infiltration.

Figure 13-7. Infiltration Trench Schematic 1

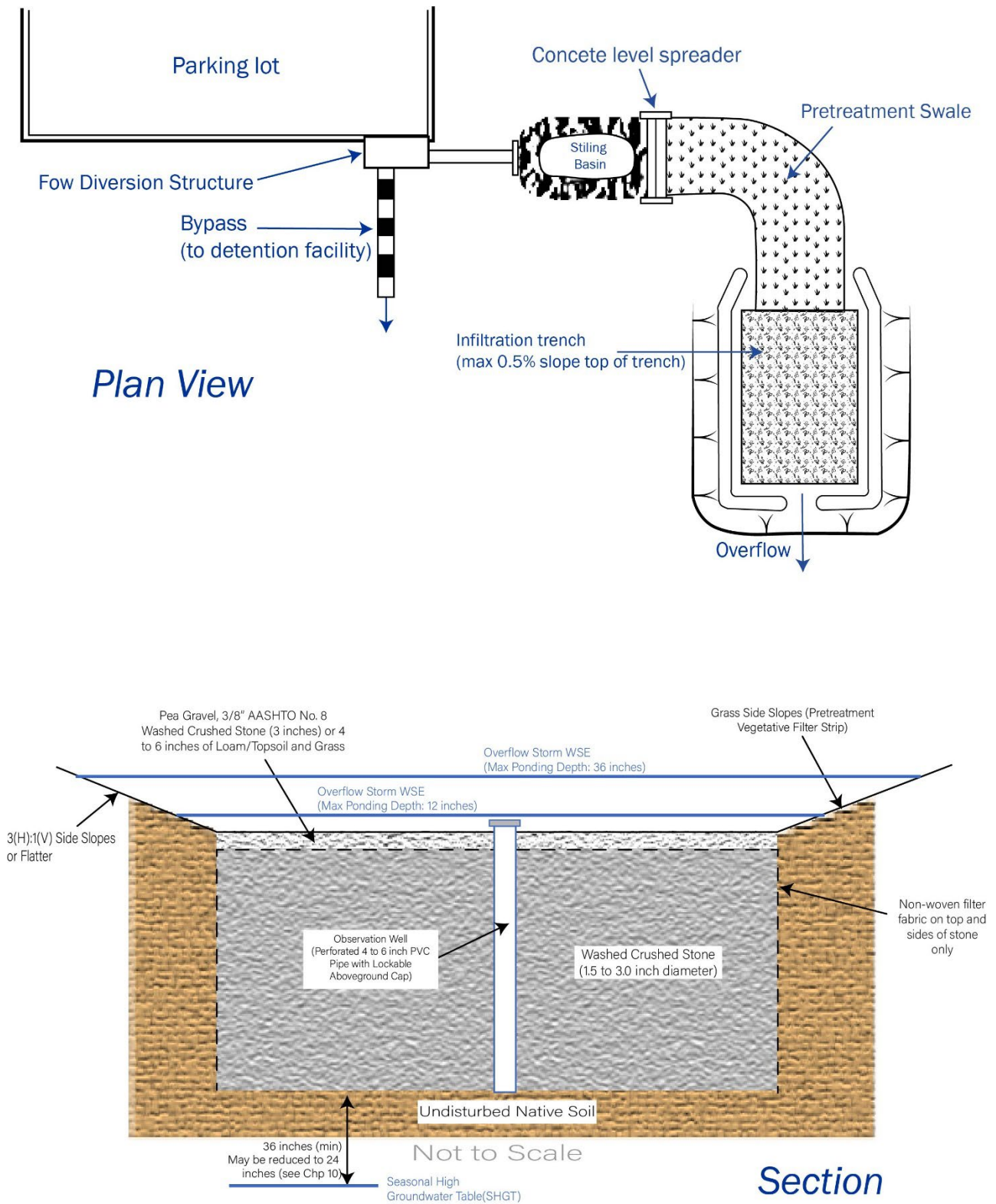
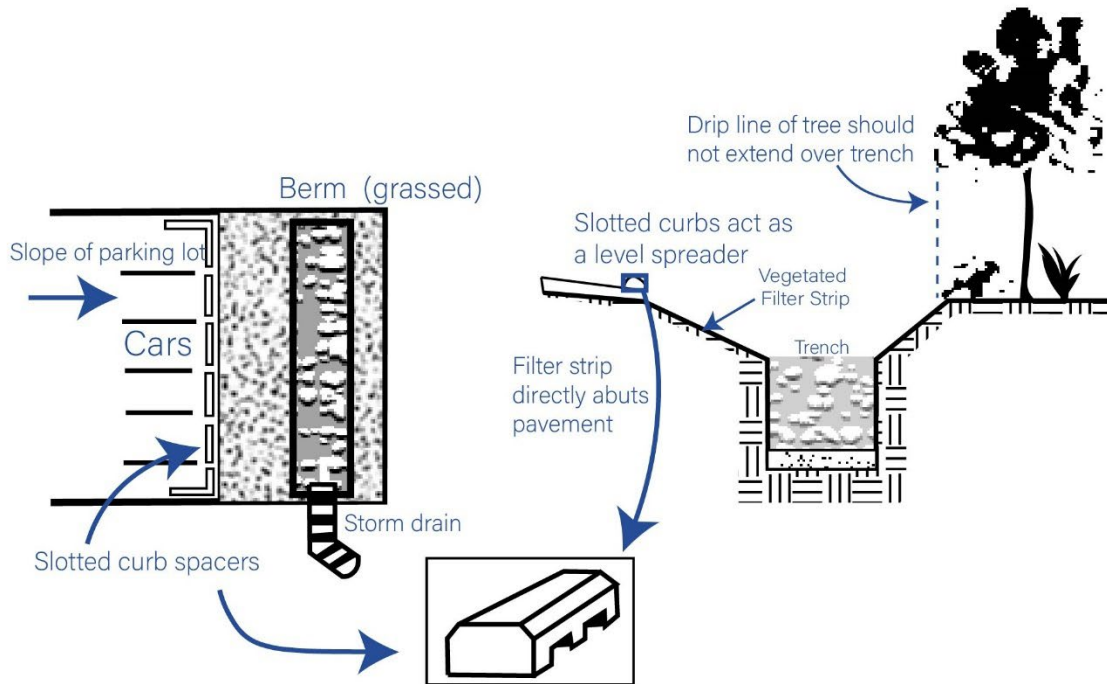

Figure 13-8. Infiltration Trench Schematic 2

Top View

Side View



Top View

Side View

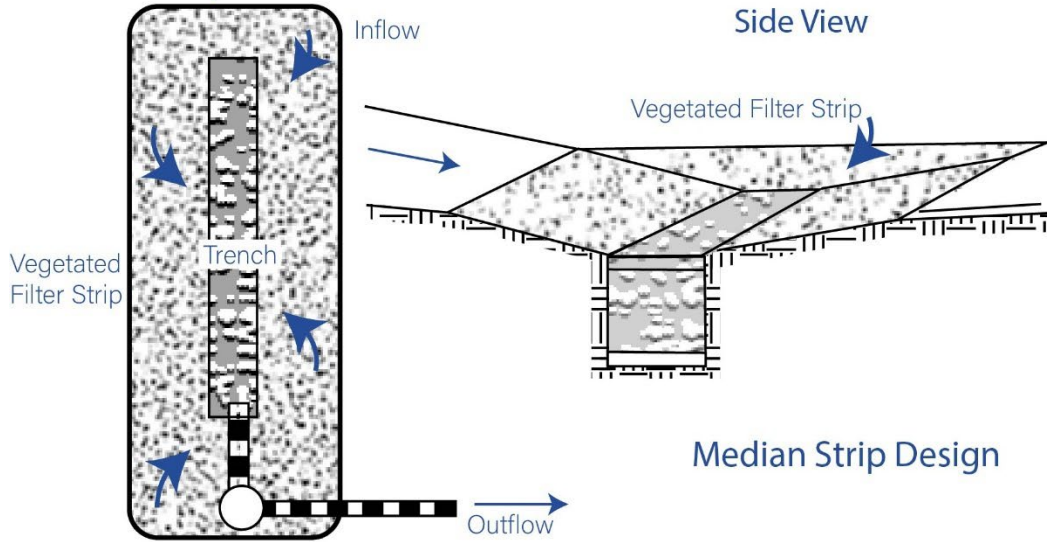
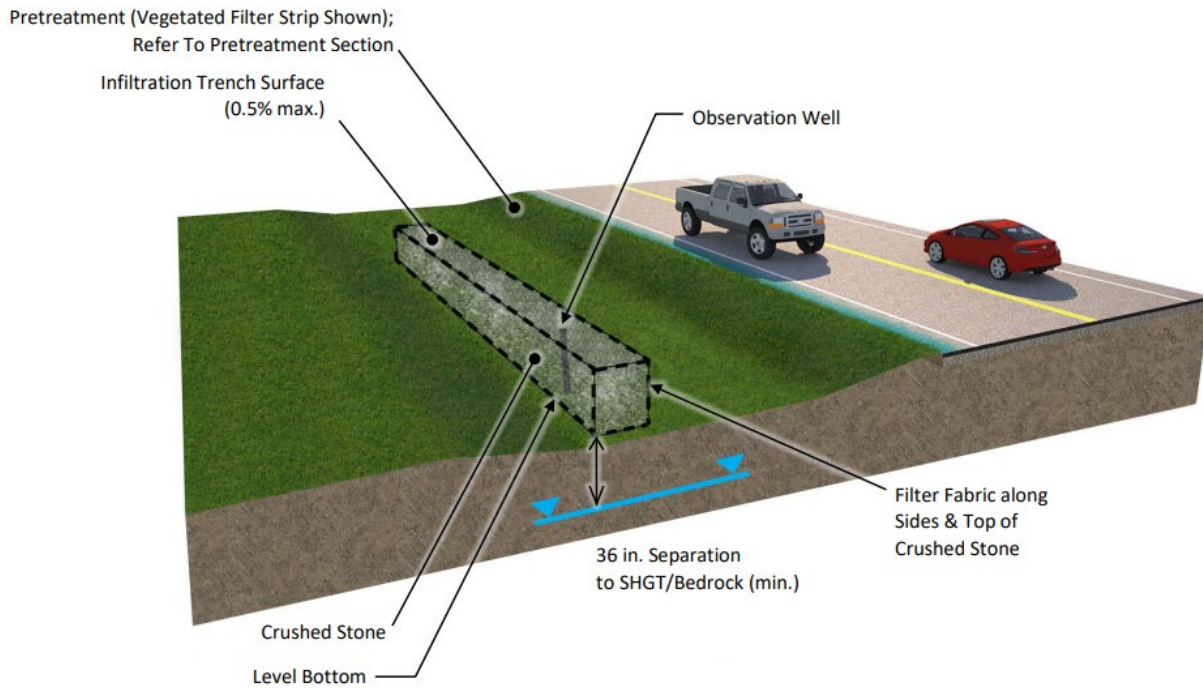

Figure 13-9. Infiltration Trench Schematic - Near Road



Source: [Rhode Island Department of Transportation Linear Stormwater Manual, RIDOT \(2019\)](#)

Underground Infiltration System



Description

An underground infiltration system consists of open-bottomed storage chambers in a crushed stone reservoir. The chamber and crushed stone reservoir provide temporary storage for stormwater before it infiltrates into the underlying soil. A number of underground infiltration chamber products, including pipes, vaults, and modular structures, have been developed as alternatives to infiltration trenches and basins for space-limited sites and stormwater retrofit applications. Similar to traditional infiltration trenches and basins, these systems are designed to capture, temporarily store, and infiltrate stormwater runoff. Underground infiltration systems are typically designed as off-line systems for retention/runoff reduction, treatment, and groundwater recharge. These systems can provide stormwater quantity control for larger storms when used in soils with high infiltration rates or when designed with additional below-ground storage. The design and layout of these systems varies by manufacturer and system design.

While underground infiltration systems are more costly than other Infiltration BMPs that are located at the surface, they can be an effective approach to manage stormwater where there is little or no space on the surface.

Advantages

- Allows stormwater to be recharged on sites where there is little space available at the ground surface. Can be located under pavement.

Stormwater BMP Type

Pretreatment BMP	<input type="checkbox"/>
Infiltration BMP	<input checked="" type="checkbox"/>
Filtering BMP	<input type="checkbox"/>
Stormwater Pond BMP	<input type="checkbox"/>
Stormwater Wetland BMP	<input type="checkbox"/>
Water Quality Conveyance BMP	<input type="checkbox"/>
Stormwater Reuse BMP	<input type="checkbox"/>
Proprietary BMP	<input type="checkbox"/>
Other BMPs and Accessories	<input type="checkbox"/>

Stormwater Management Suitability

Retention	<input checked="" type="checkbox"/>
Treatment	<input checked="" type="checkbox"/>
Pretreatment	<input type="checkbox"/>
Peak Runoff Attenuation*	<input checked="" type="checkbox"/>

*Soils with high infiltration rates or when designed with additional storage

Pollutant Removal

Sediment*	High
Phosphorus	High
Nitrogen	Low
Bacteria	High

*Includes sediment-bound pollutants and floatables (with pretreatment)

Implementation

Capital Cost	High
Maintenance Burden	Medium
Land Requirement	Medium

- Suitable in both urban and rural settings.
- Suitable for piped drainage systems.
- Can be used to enhance storage and recharge capability of other BMPs.
- High solids, phosphorus, and bacteria removal efficiency.
- Can provide stormwater retention, runoff volume reduction, and groundwater recharge.
- Can also provide stormwater quantity control for larger storms when used in soils with high infiltration rates or when designed with additional below-ground storage.

Limitations

- Infiltration surfaces are buried, often under paved surfaces. Failed systems require excavating and replacing the system as well as repairing at-grade improvements built over the system. As a result, pretreatment is more critical for underground systems.
- Routine maintenance can be overlooked because the practice is not readily visible.
- Buried utilities can also be a substantial conflict to constructing these systems. While these systems can be constructed in a road right-of-way, utility conflicts can be a challenge in those spaces.
- Typically requires a piped drainage system to divert runoff into the buried chambers.
- Lower removal of dissolved pollutants especially in coarse soils.
- Should not be used with underdrain systems.

Siting Considerations

- **Potential Locations:** Best located where there is inadequate surface area for more cost-effective approaches to infiltrate stormwater. Suitable under parking lots, roads, sidewalks, and other at-grade, built features. Can also be placed under landscaped areas. Surfaces above the system may need to be excavated in the future in the case of a failed system, and thereby need to be replaceable. Therefore, infiltration chambers should not be used under structures.⁸¹
- **Drainage Area:** The maximum contributing drainage area for underground infiltration systems is 5 acres.

⁸¹ Note: Infiltration systems below CT DOT roads are not permitted. Infiltration systems adjacent to CTDOT roads shall be directed exfiltration away from pavements base, subbase and subgrade. An impermeable barrier may be required.

- **Maintenance Considerations:** Ensure adequate vehicle access to pretreatment elements for the system as well as to inspection ports and manholes. Any at-grade improvements constructed above the systems should be replaceable in case of the need to replace the system if it fails.
- **General:** Meet the soils, water table, bedrock, and horizontal setback requirements specified in [Chapter 10 - General Design Guidance for Stormwater Infiltration Systems](#). Infiltration chambers can be designed as on-line or off-line practices.

Soil Evaluation

- Conduct an evaluation of the soil characteristics and subsurface conditions at the location of the proposed system including soil type, depth to the seasonal high groundwater table, depth to bedrock, and soil infiltration rate. Refer to [Chapter 10](#) for soil evaluation guidance.

Design Recommendations

Pretreatment

- Incorporate pretreatment measures at locations where runoff enters the infiltration system in accordance with the [Pretreatment BMPs](#) section of this Manual.
- Acceptable pretreatment measures are those that are suitable for piped drainage systems and include deep sump hooded catch basins,⁸² oil grit separators, and proprietary pretreatment devices.
- Pretreatment measure(s) should treat at least the Water Quality Flow (WQF).

Sizing and Dimensions

- Infiltration systems should be designed by either the Static or Dynamic Methods as described in [Chapter 10](#), including design guidance of the product manufacturer.
- Water Surface
 - Water surface elevations in the system should be designed to avoid flooding the subbase of the overlying paved surfaces.
- Bottom Slope
 - Bottom slope of the system should be level.

Inlet

- Design the inlet in accordance with the [Inlet and Outlet Controls](#) section of this Manual.

⁸² Only recommended for space constrained sites where no other Pretreatment BMPs are feasible.

- Runoff is typically introduced into the system through a piped drainage system.
- Design in an off-line configuration, to the extent feasible, to bypass flows in excess of the water quality storm or larger storms if designed to provide stormwater quantity control.

Outlet & Overflow

- Design the outlet in accordance with the [Inlet and Outlet Controls](#) section of this Manual.
- Off-line systems should be designed with a bypass or overflow for flows in excess of the water quality storm and typically do not require an outlet. Once the system has reached its capacity (i.e., once the system is full), additional flow will bypass the system via a flow diversion structure.
- Underground infiltration systems designed in an on-line configuration should have a primary outlet sized to convey the 10-year, 24-hour storm event, at a minimum, to the storm drainage system.
- Outlets are typically a closed conduit/pipe that discharges to a storm drainage system.

Materials

- Underground Infiltration Chambers
 - As available from the manufacturer. Appurtenant structures (e.g., end caps, cross connectors, observation wells, etc.) should be from or approved for use by the chamber manufacturer.
 - Designer should comply with manufacturer's written specifications, details, installation instructions, and other guidance documents.
- Crushed Stone
 - The chambers should be underlain and backfilled with clean (washed and free from dirt and debris), crushed, angular aggregate with a diameter of 1.5" to 3" (porosity of 40 percent), or as specified by the manufacturer.
 - The top and sides of the stone reservoir surrounding the chambers should be lined with a non-woven geotextile (filter fabric). The non-woven geotextile should be compatible with the soil textures and application.
- Inspection Ports or Manholes
 - Inspection ports or inspection manholes should be provided along the infiltration chambers to monitor the water drainage in the system and to allow for sediment removal. The number and locations of observation ports or manholes should be in accordance with the manufacturer's recommendations.
- Filter Fabric

- Wrap around the exterior sides and top of the crushed stone only. Do not provide filter fabric on the bottom of the crushed stone unless recommended by the manufacturer of the underground infiltration system.
- Install fabric (including overlap) as specified by the manufacturer.
- Use non-woven filter fabric that complies with State of Connecticut Department of Transportation Standard Specifications, Section M.08.01.19 (Drainage – Geotextiles).

Construction Recommendations

- The designing qualified professional should develop a detailed, site-specific construction sequence.
- The designing qualified professional should inspect the installation during the following stages of construction, at a minimum:
 - After excavation and scarification of bottom and sidewalls of excavation
 - After placement and leveling of stone below the chambers, placement of the chambers and inspection ports/manholes, and placement of stone above the chambers
 - After installation of bypass, outlet/overflow, and inlet controls
 - After infiltration system has been backfilled
- The designing qualified professional should provide an as-built plan of the completed infiltration system along with a certification that the system was designed in accordance with the guidance contained in this Manual and other local or state requirements and that the system was installed in accordance with the approved plans and manufacturer's guidelines.
- The entire contributing drainage area should be completely stabilized prior to directing any flow to the system. Adequate vegetative cover must be established over any pervious area adjacent or contributing to the system before runoff can be accepted.
- Erosion and sediment controls should be in place during construction in accordance with the [Connecticut Guidelines for Soil Erosion and Sediment Control](#) and the Soil Erosion and Sediment Control (SESC) Plan developed for the project.
- During clearing and grading of the site, measures should be taken to avoid soil compaction at the location of the proposed system.
- The system should be fenced off during the construction period to prevent disturbance of the soils.
- The infiltration system should be excavated to the dimensions, side slopes, and elevations shown on the plans. The method of excavation should avoid compaction of the bottom of the system. A hydraulic excavator or backhoe loader, operating outside the limits of the

infiltration system, should be used to excavate the system. Excavation equipment should not be allowed within the limits of the system.

- The stone storage media should be placed in the excavation by a hydraulic excavator or backhoe loader located outside the limits of the infiltration system and then hand-raked to the desired elevation.

Maintenance Needs

- Underground infiltration systems should be designed with easy access to all components of the system for maintenance purposes. Refer to [Chapter 7](#) for general design considerations to reduce and facilitate system maintenance.
- Detailed inspection and maintenance requirements, inspection and maintenance schedules, and those parties responsible for maintenance should be identified on the plans and in the Stormwater Management Plan.
- Maintenance should be detailed in a legally binding maintenance agreement.
- Maintain infiltration chambers in accordance with the manufacturer's guidelines.
- Typical maintenance includes removal of accumulated oil and grease, floatables, and sediment from the pretreatment structure using a vacuum truck and removal of accumulated sediment from the infiltration chambers using a high-pressure water nozzle (i.e., JetVac process) and vacuum truck.

Recommended Maintenance Activities

- Inspect after major storms (1 inch or more of precipitation) in the first few months following construction.
- Inspect the pretreatment structure and isolator row (if one is used) twice a year.
- Inspect the remainder of the infiltration system annually.
- Refer to [Appendix B](#) for maintenance inspection checklists, including items to focus on during inspections.
- Remove sediment from the pretreatment structure when it accumulates to more than 50% of the design depth.
- Remove sediment from the infiltration chambers when the sediment accumulation exceeds 2 inches throughout the length of the chamber or when drawdown time exceeds 48 hours after the end of a storm event, indicating that the system is clogged.

Infiltration Basin



Description

Infiltration basins are open stormwater impoundments designed to capture and infiltrate the stormwater over several days but do not retain a permanent pool of water. The bottom of an infiltration basin typically contains vegetation to increase the infiltration capacity of the basin, allow for vegetative uptake, and reduce soil erosion and scouring of the basin. This BMP can receive both sheet flow and piped runoff discharged directly into the basin. Runoff gradually infiltrates into the underlying soil through the bottom of the basin, removing pollutants through sorption, trapping, straining, and bacterial degradation, or transformation. Infiltration basins may also be used to provide stormwater quantity control when designed as on-line facilities.

Infiltration basins are a cost-effective approach to managing stormwater where there is adequate space. Water is stored above the bottom of the basin rather than in subsurface storage media, which is more cost-effective than other infiltration approaches.

Advantages

- Cost-effective approach to recharge stormwater as it does not require subsurface storage media and stormwater can be temporarily stored aboveground.
- Naturally can take advantage of topographic low areas.
- High solids, phosphorus, and bacteria removal efficiency.
- Can provide stormwater retention, runoff volume reduction, groundwater recharge, and some peak runoff attenuation when designed as an on-line system

Stormwater BMP Type

Pretreatment BMP	<input type="checkbox"/>
Infiltration BMP	<input checked="" type="checkbox"/>
Filtering BMP	<input type="checkbox"/>
Stormwater Pond BMP	<input type="checkbox"/>
Stormwater Wetland BMP	<input type="checkbox"/>
Water Quality Conveyance BMP	<input type="checkbox"/>
Stormwater Reuse BMP	<input type="checkbox"/>
Proprietary BMP	<input type="checkbox"/>
Other BMPs and Accessories	<input type="checkbox"/>

Stormwater Management Suitability

Retention	<input checked="" type="checkbox"/>
Treatment	<input checked="" type="checkbox"/>
Pretreatment	<input type="checkbox"/>
Peak Runoff Attenuation*	<input checked="" type="checkbox"/>

*On-line systems only

Pollutant Removal

Sediment*	High
Phosphorus	High
Nitrogen	Low
Bacteria	High

*Includes sediment-bound pollutants and floatables (with pretreatment)

Implementation

Capital Cost	Low
Maintenance Burden	Low
Land Requirement	Medium

Limitations

- Require adequate space to store stormwater aboveground. Difficult to site in urban and fully developed locations.
- System clogging would require replacement of basin surface.
- Lower removal of dissolved pollutants especially in coarse soils.
- Should not be used with underdrain systems.

Siting Considerations

- **Potential Locations:** Best located where there is adequate surface area to temporarily store stormwater. Infiltration basins are suitable in urban and rural settings, but require adequate space, which makes their use limited in urban areas. Locate where:
 - The topography allows the design of the infiltration basin bottom to be level
 - Snow storage will not occur atop the basin
 - There is a low likelihood that pedestrian traffic will cut across the basin.
- **Drainage Area:** The maximum contributing drainage area for infiltration basins is 10 acres.
- **General:** Meet the soils, water table, bedrock, and horizontal setback requirements specified in [Chapter 10 - General Design Guidance for Stormwater Infiltration Systems](#). Infiltration basins can be designed as on-line or off-line practices.

Soil Evaluation

- Conduct an evaluation of the soil characteristics and subsurface conditions at the location of the proposed system including soil type, depth to the seasonal high groundwater table, depth to bedrock, and soil infiltration rate. Refer to [Chapter 10 - General Design Guidance for Stormwater Infiltration Systems](#) for soil evaluation guidance.

Design Recommendations

Pretreatment

- Incorporate pretreatment measures at locations where runoff enters the infiltration basin in accordance with the [Pretreatment BMPs](#) section of this Manual.
- Acceptable pretreatment measures include vegetative filter strips, sediment forebays, pretreatment swales, deep sump hooded catch basins,⁸³ oil grit separators, and proprietary pretreatment devices.
- Sediment forebays should have a minimum storage volume of 25% of the Water Quality Volume (WQV), while flow-through Pretreatment BMPs should treat at least the equivalent Water Quality Flow (WQF). A minimum sediment forebay storage volume of 10% of the

⁸³ Only recommended for space constrained sites where no other Pretreatment BMPs are feasible.

WQV may be used in urban settings, space constrained sites, and as retrofits, with the approval of the review authority.

Sizing and Dimensions

- Basin Surface Area
 - Basin should be designed by either the Static or Dynamic Methods as described in [Chapter 10 - General Design Guidance for Stormwater Infiltration Systems](#).
 - Basin should completely drain in 48 hours or less after the end of the design storm as described in [Chapter 10 - General Design Guidance for Stormwater Infiltration Systems](#).
- Ponding Depth
 - Maximum depth of water above the basin bottom: 36 inches
- Bottom Slope
 - Bottom slope of the basin should be level.
- Side Slopes
 - Side slopes should be 3(H):1(V) or flatter especially on grassed slopes where mowing is required.
 - In ultra-urban locations or space constrained areas; side slopes of 2(H):1(V) may be utilized if properly designed to account for erosion and slope stability. Stabilize the slope with turf reinforcement matting or equivalent if the slope could potentially erode.
 - If site topography does not allow for 3(H):1(V) slopes or adequately stabilized 2(H):1(V) slopes, vertical concrete walls with a maximum height of 30 inches can be used. Drop curbs or similar precast structures can also be used to create stable, vertical side walls.

Inlet

- Design the inlet in accordance with the [Inlet and Outlet Controls](#) section of this Manual.
- Runoff can be introduced through overland flow, curb cuts, inlet structures, swales/channels, and/or pipes.
- Design in an off-line configuration to the extent feasible if runoff is delivered by a storm drainpipe or is along the main storm conveyance system.

Outlet & Overflow

- Design the outlet in accordance with the [Inlet and Outlet Controls](#) section of this Manual.
- Outlets are typically a stabilized spillway, gabion berm, concrete weir, curb cut opening, precast concrete structure, or polyethylene/polyvinyl chloride riser structure.

- On-line systems should have a primary outlet sized to convey the 10-year, 24-hour storm event, at a minimum, to the storm drainage system or stabilized channel. An emergency spillway is required to convey the 100-year storm event (assuming the primary outlet is not designed to pass the 100-year storm event).
- Off-line systems should be designed with a bypass or overflow for flows in excess of the water quality storm.

Materials

- Surface Cover
 - Should use 4 to 6 inches of loam/topsoil and seed to establish stabilized permanent vegetative cover as desired for the site and application. Select vegetation with the guidance provided in [Appendix F](#) of this Manual.
 - Alternatively, the bottom of the basin can be landscaped utilizing plant materials suitable for the site and application. Select plants with the guidance provided in [Appendix F](#) of this Manual.
 - Mulch can be 2 to 4 inches of shredded hardwood bark mulch, aged for 6 months or 3 inches of 3/8" to 3/4" size pea gravel conforming to AASHTO No. 8 or No. 5 stone. Pea gravel should be clean (washed and free from dirt and debris) and rounded in shape. Mulch may be used directly around the plants, but mulch should NOT be used to cover the entire bottom of the infiltration basin.
 - Do not plant any woody vegetation (e.g., shrubs and trees) on embankments that are used to retain water in the basin. Those embankments should be stabilized with a grass cover.

Winter Operations

- Infiltration basins should not be used for storage of plowed snow. To the extent feasible, locate and design the system to avoid snow storage areas and potential damage from snow plowing activities. Refer to [Chapter 7 - Overview of Structural Stormwater Best Management Practices](#) for general design considerations related to winter operations.

Construction Recommendations

- The designing qualified professional should develop a detailed, site-specific construction sequence.
- The designing qualified professional should inspect the installation during the following stages of construction, at a minimum:
 - After excavation of the infiltration basin and scarification of bottom and side slopes of excavation
 - After installation of bypass, outlet/overflow, and inlet controls
 - After pea gravel or loam/topsoil and grass surface cover have been installed

- The designing qualified professional should provide an as-built plan of the completed infiltration basin along with a certification that the system was designed in accordance with the guidance contained in this Manual and other local or state requirements and that the system was installed in accordance with the approved plans.
- The entire contributing drainage area should be completely stabilized prior to directing any flow to the system. Adequate vegetative cover must be established over any pervious area adjacent or contributing to the system before runoff can be accepted.
- Erosion and sediment controls should be in place during construction in accordance with the [Connecticut Guidelines for Soil Erosion and Sediment Control](#) and the Soil Erosion and Sediment Control (SESC) Plan developed for the project.
- Infiltration basins should not be used as temporary sediment traps for construction erosion and sediment control.
- During clearing and grading of the site, measures should be taken to avoid soil compaction at the location of the proposed system.
- The system should be fenced off during the construction period to prevent disturbance of the soils.
- The infiltration basin should be excavated to the dimensions, side slopes, and elevations shown on the plans. The method of excavation should avoid compaction of the bottom of the system. A hydraulic excavator or backhoe loader, operating outside the limits of the infiltration basin, should be used to excavate the system. Excavation equipment should not be allowed within the limits of the system.
- The pea gravel layer (if used) should be placed in the excavation by a hydraulic excavator or backhoe loader located outside the limits of the infiltration basin and then hand-raked to the desired elevation.
- Install vegetation (e.g., drought tolerant grass) on the side slopes and surface of the infiltration basin (if grass is used instead of pea gravel) in accordance with the planting plan and plant schedule on the plans. Water vegetation thoroughly immediately after planting and as necessary until fully established.

Maintenance Needs

- Infiltration basins should be designed with easy access to all components of the system for maintenance purposes. Refer to [Chapter 7 - Overview of Structural Stormwater Best Management Practices](#) for general design considerations to reduce and facilitate system maintenance.

- Detailed inspection and maintenance requirements, inspection and maintenance schedules, and those parties responsible for maintenance should be identified on the plans and in the Site Stormwater Management Plan.
- Maintenance should be detailed in a legally binding maintenance agreement.
- Maintenance activities such as sediment removal, mowing, and repairs should be performed with rakes and light-weight equipment rather than heavy construction equipment to avoid compaction of the filter media and underlying soils. Heavy equipment may be used for sediment removal and other maintenance activities if the equipment is positioned outside the limits of the system. Heavy construction equipment should not be allowed within the limits of the system for maintenance purposes.

Recommended Maintenance Activities

- Inspect after major storms (1 inch or more of precipitation) in the first few months following construction.
- Inspect the sediment forebay or other pretreatment area twice a year.
- Inspect the remainder of the infiltration basin annually.
- Refer to [Appendix B](#) for maintenance inspection checklists, including items to focus on during inspections.
- Remove trash and organic debris (leaves) in the Spring and Fall.
- Remove sediment from the sediment forebay or other pretreatment area when it accumulates to a depth of more than 12 inches or 50% of the design depth. Clean outlet of sediment forebay or other pretreatment measures when drawdown time exceeds 36 hours after the end of a storm event.
- Remove sediment from the infiltration basin surface when the sediment accumulation exceeds 2 inches or when drawdown time exceeds 48 hours after the end of a storm event, indicating that the system is clogged.
- Weed as necessary. Mow grass within infiltration basin to a height of 3 to 6 inches. Maintain a healthy, vigorous stand of grass cover; re-seed as necessary.
- Maintain vegetated filter strips or grassed side slopes of infiltration basin in accordance with maintenance recommendations in the [Pretreatment BMPs](#) section of this Manual.
- Periodically remove grass clippings to prevent clogging of the surface of the infiltration basin.

Mowing should not be performed when the ground is soft to avoid the creation of ruts and compaction, which can reduce infiltration.

Figure 13-10. Infiltration Basin Schematic

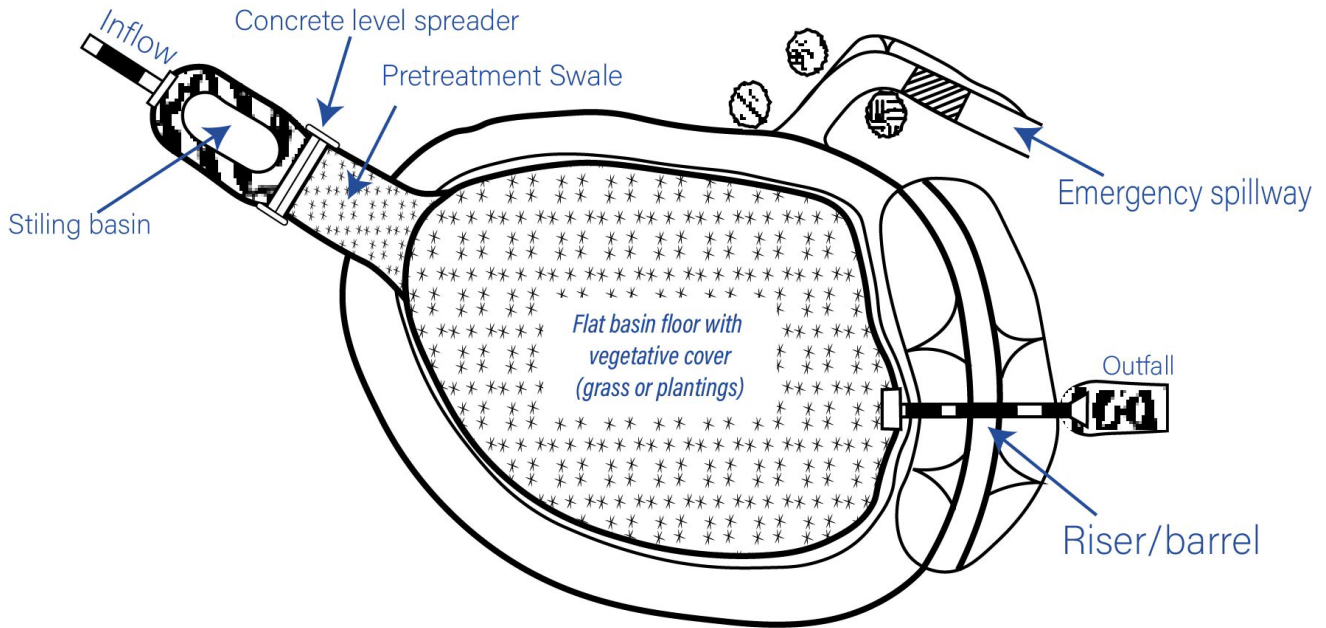

Plan View

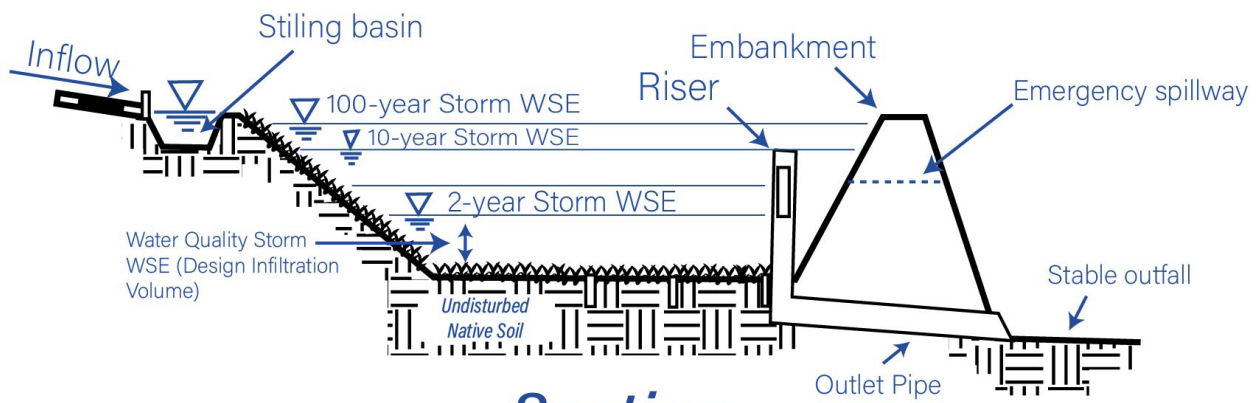

Section

Dry Well & Infiltrating Catch Basin



Source: Eastern CT Conservation District, nianticriverwatershed.org

Description

Dry wells and infiltrating catch basins are open-bottom subsurface storage structures and/or stone reservoirs designed to infiltrate stormwater in a small footprint. While the general design is consistent between the two applications, a dry well is used to manage clean, roof runoff and thereby does not require pretreatment. An infiltrating catch basin is used to manage stormwater from other sources such as roads and parking lots and thereby requires pretreatment.

Dry wells and infiltrating catch basins can both be designed as perforated precast concrete structures surrounded by crushed stone. The perforated structure that makes up the system temporarily stores stormwater before it infiltrates into the surrounding soils. Dry wells can also consist of an excavated stone-filled pit. Filter fabric is used along the sidewalls of both dry wells and infiltrating catch basins. Both types of systems should be designed as off-line practices for retention/runoff reduction, treatment, and groundwater recharge of stormwater runoff from the water quality storm.

These systems are typically more costly than other infiltration BMPs that are located at the surface. Infiltrating catch basins require a separate pretreatment structure such as a proprietary BMP or separate deep sump hooded catch basins. Their advantage is that they are buried, and their footprint is small compared to infiltration chambers. As a result, these practices are ideal when space is limited and only small, discrete controls can fit into a site.

Stormwater BMP Type

Pretreatment BMP	<input type="checkbox"/>
Infiltration BMP	<input checked="" type="checkbox"/>
Filtering BMP	<input type="checkbox"/>
Stormwater Pond BMP	<input type="checkbox"/>
Stormwater Wetland BMP	<input type="checkbox"/>
Water Quality Conveyance BMP	<input type="checkbox"/>
Stormwater Reuse BMP	<input type="checkbox"/>
Proprietary BMP	<input type="checkbox"/>
Other BMPs and Accessories	<input type="checkbox"/>

Stormwater Management Suitability

Retention	<input checked="" type="checkbox"/>
Treatment	<input checked="" type="checkbox"/>
Pretreatment	<input type="checkbox"/>
Peak Runoff Attenuation	<input type="checkbox"/>

Pollutant Removal

Sediment*	High
Phosphorus	High
Nitrogen	Low
Bacteria	High

*Includes sediment-bound pollutants and floatables (with pretreatment)

Implementation

Capital Cost	Medium
Maintenance Burden	Medium
Land Requirement	Low

and [Figure 13-12](#) are schematics of two typical dry well designs, one using a stone-filled pit and the other a perforated precast concrete structure. [Figure 13-13](#) and [Figure 13-14](#) show schematics of two different infiltrating catch basin designs, including a perforated precast concrete structure and a vertical corrugated perforated pipe.

Advantages

- Allows stormwater to be recharged on sites where there is little space available at the ground surface and below grade because of utility conflicts. Can be located under pavement. As a result, useful in stormwater retrofit applications where space is limited and where additional runoff control is required.
- Suitable in both urban and rural settings.
- Suitable for piped drainage systems.
- Can be used to enhance storage and recharge capability of other BMPs.
- High solids, phosphorus, and bacteria removal efficiency.
- Can provide stormwater retention, runoff volume reduction, and groundwater recharge.

Limitations

- Infiltration surfaces are buried, often under paved surfaces. Failed systems require excavating and replacing the system as well as repairing at-grade improvements built over the system. As a result, pretreatment is more critical for underground systems.
- Routine maintenance can be overlooked because the practice is not readily visible.
- Buried utilities can be a substantial conflict to constructing these systems, but less potential conflict compared to infiltration chambers.
- Typically requires a piped drainage system to divert runoff into the structure.
- Lower removal of dissolved pollutants especially in coarse soils.
- Should not be used with underdrain systems.
- Cannot provide significant stormwater quantity control unless used in areas with very high infiltration rates, or if a dry well is used in conjunction with a cistern and rainwater harvesting system.

Siting Considerations

- **Potential Locations:** Best located where there is inadequate surface area for more cost-effective approaches to infiltrate stormwater. Suitable under parking lots, roads, sidewalks and other at-grade, built features. Dry wells can also be placed under lawn areas to

infiltrate roof runoff. Surfaces above the system may need to be excavated in the future in the case of a failed system, and thereby need to be replaceable. As a result, these systems should not be used under structures. Suitable in urban and rural settings.⁸⁴

- **Siting In / Adjacent to Roadways:** The top elevation of the perforated chamber is recommended to be kept at least 2' below the bottom of the roadway base material.⁸⁴
- **Drainage Area:** The maximum contributing drainage area should not exceed 1 acre; however, a series of connected dry wells or infiltrating catch basins can be used to manage a larger area to a maximum of 5 acres.
- **Maintenance Considerations:** Ensure adequate vehicle maintenance access to pretreatment elements for infiltrating catch basins. Any at-grade improvements constructed above the systems should be replaceable in case of the need to replace the system if it fails.
- **General:** Meet the soils, water table, bedrock, and horizontal setback requirements specified in [Chapter 10 - General Design Guidance for Stormwater Infiltration Systems](#) (General Design Guidance for Stormwater Infiltration Systems). Should be designed as off-line practices.

Soil Evaluation

- Conduct an evaluation of the soil characteristics and subsurface conditions at the location of the proposed system including soil type, depth to the seasonal high groundwater table, depth to bedrock, and soil infiltration rate. Refer to Chapter 10 for soil evaluation guidance.

Design Recommendations

Pretreatment

- Pretreatment is not required for dry wells that only receive clean roof runoff.
- For infiltrating catch basins that manage runoff from other sources, incorporate pretreatment measures at locations where runoff enters the system in accordance with the Pretreatment BMPs section of this Manual.
- Acceptable pretreatment measures are those that are suitable for piped drainage systems and include deep sump hooded catch basins and proprietary pretreatment devices.

⁸⁴ Note: Infiltration systems below CT DOT roads are not permitted. Infiltration systems adjacent to CTDOT roads shall be directed exfiltration away from pavements base, subbase and subgrade. An impermeable barrier may be required.

- Pretreatment measure(s) should have a minimum storage volume of 25% of the Water Quality Volume (WQV) or treat at least the equivalent Water Quality Flow (WQF) if using a proprietary treatment device.

Sizing and Dimensions

- Size the precast concrete structure and crushed stone reservoir to hold and infiltrate the design volume below the elevation of any outlet and fully dewater within 48 hours after the end of a storm event.
- Multiple connected structures can be used to achieve the required design volume.
- These systems should be designed by either the Static or Dynamic Methods as described in [Chapter 10 - General Design Guidance for Stormwater Infiltration Systems](#).
- Water Surface
 - Water surfaces elevations in the system should be designed to avoid flooding the subbase of paved surfaces.
- Bottom Slope
 - Bottom slope should be level.
- Surface Cover
 - Dry wells and infiltrating catch basins should be covered by a minimum of 12 inches of soil or subbase material.

Inlet

- Design the inlet in accordance with the Inlet and Outlet Controls section of this Manual.
- Runoff is typically introduced through inlet structures and pipes.
- Design infiltrating catch basins in an off-line configuration to the extent feasible if runoff is delivered by a storm drainpipe or is along the main storm conveyance system.

Outlet & Overflow

- Design the outlet in accordance with the Inlet and Outlet Controls section of this Manual.
- Outlets are typically a pipe that discharges to a storm drainage system. The outlet should be designed in a manner that allows the desired storage volume to be maintained in the system.
- Dry wells that receive runoff from a roof downspout are typically designed to bypass flows in excess of the water quality storm via a surface overflow to a splash pad and vegetated area.

Materials

- Precast Concrete Structures
 - Open-bottom perforated precast concrete vault as available from the manufacturer.
- Crushed Stone
 - Perforated precast concrete dry wells and infiltrating catch basin structures should be underlain and backfilled with clean (washed and free from dirt and debris), crushed, angular stone with a diameter of 1.5 to 3 inches (porosity of 40 percent).
 - A minimum of 6 inches of crushed stone should be placed below the bottom of the precast concrete structure and a minimum of 12 inches of crushed stone surrounding the structure. Additional stone may be used on the bottom and sides of the structure to increase the available storage volume.
 - Dry wells constructed as stone-filled excavated pits should be backfill with clean (washed and free from dirt and debris), crushed, angular stone with a diameter of 1.5 to 3 inches (porosity of 40 percent).
- Observation Well
 - For dry wells constructed as stone-filled excavated pits, an observation well should be installed within the dry well to monitor the water drainage in the system. The well should consist of a well-anchored, vertical perforated 4- to 6-inch diameter PVC pipe with a lockable aboveground cap ([Figure 13-14](#)).
- Observation wells are not required in precast concrete dry wells or infiltrating catch basins because water levels in these systems can be visually inspected via a manhole.
- Filter Fabric
 - Wrap around the exterior sides and top of the crushed stone only. Do not provide filter fabric on the bottom of the crushed stone.
 - Use non-woven filter fabric that complies with State of Connecticut Department of Transportation Standard Specifications, Section M.08.01.19 (Drainage – Geotextiles).

Construction Recommendations

- The designing qualified professional should develop a detailed, site-specific construction sequence.
- The designing qualified professional should inspect the installation during the following stages of construction, at a minimum:
 - After excavation and scarification of bottom and sidewalls of excavation
 - After placement and leveling of stone

- After placement of precast concrete structure
 - After installation of bypass, outlet/overflow, and inlet controls
 - After infiltration system has been backfilled
- The designing qualified professional should provide an as-built plan of the completed infiltration system along with a certification that the system was designed in accordance with the guidance contained in this Manual and other local or state requirements and that the system was installed in accordance with the approved plans and manufacturer's guidelines.
 - The entire contributing drainage area should be completely stabilized prior to directing any flow to the system. Adequate vegetative cover must be established over any pervious area adjacent or contributing to the system before runoff can be accepted.
 - Erosion and sediment controls should be in place during construction in accordance with the Connecticut Guidelines for Soil Erosion and Sediment Control and the Soil Erosion and Sediment Control (SESC) Plan developed for the project.
 - During clearing and grading of the site, measures should be taken to avoid soil compaction at the location of the proposed system.
 - The system should be fenced off during the construction period to prevent disturbance of the soils.
 - The infiltration system should be excavated to the dimensions, side slopes, and elevations shown on the plans. The method of excavation should avoid compaction of the bottom of the system. Excavation equipment should not be allowed within the limits of the system.
 - The stone storage media should be placed in the excavation by a hydraulic excavator or backhoe loader located outside the limits of the infiltration system and then hand-raked to the desired elevation.

Maintenance Needs

- Dry wells and infiltrating catch basins should be designed with easy access to all components of the system for maintenance purposes. Refer to [Chapter 7 - Overview of Structural Stormwater Best Management Practices](#) for general design considerations to reduce and facilitate system maintenance.
- Detailed inspection and maintenance requirements, inspection and maintenance schedules, and those parties responsible for maintenance should be identified on the plans and in the Stormwater Management Plan.
- Maintenance should be detailed in a legally binding maintenance agreement.

- Typical maintenance includes removal of accumulated oil and grease, floatables, and sediment from the precast concrete structure and any pretreatment structures using a vacuum truck.

Recommended Maintenance Activities

- Inspect after major storms (1 inch or more of precipitation) in the first few months following construction.
- Inspect precast concrete infiltration structure and any pretreatment structures twice a year.
- Refer to [Appendix B](#) for maintenance inspection checklists, including items to focus on during inspections.
- Remove sediment from the pretreatment structure when it accumulates to more than 50% of the design depth.
- Remove sediment from the precast concrete infiltration structure when the sediment accumulation exceeds 2 inches throughout the bottom of the structure or when drawdown time exceeds 48 hours after the end of a storm event (for any style dry well or infiltrating catch basin), indicating that the system is clogged.

Figure 13-11. Schematic of Typical Drywell

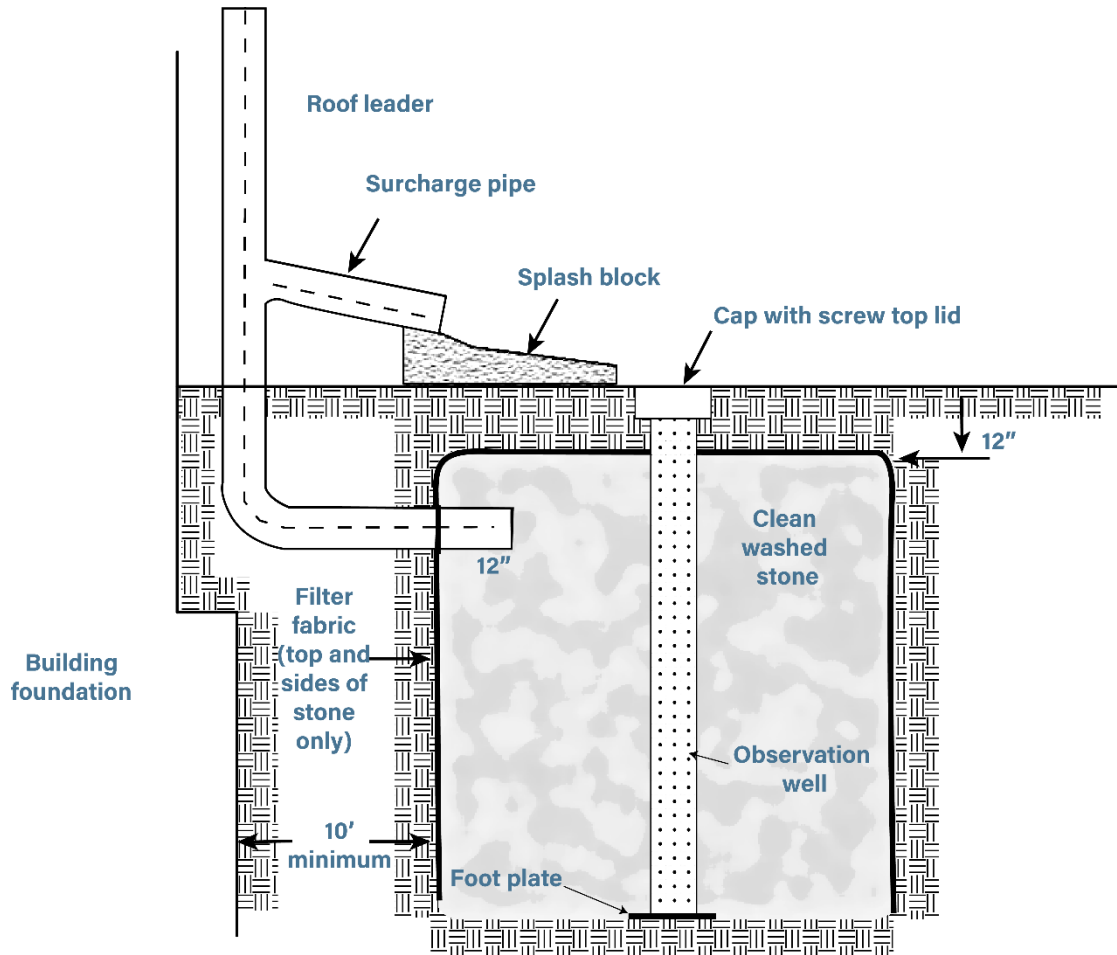

Source: Adapted from Center for Watershed Protection, 2000.

Figure 13-12. Schematic of Typical Perforated Precast Concrete Drywell

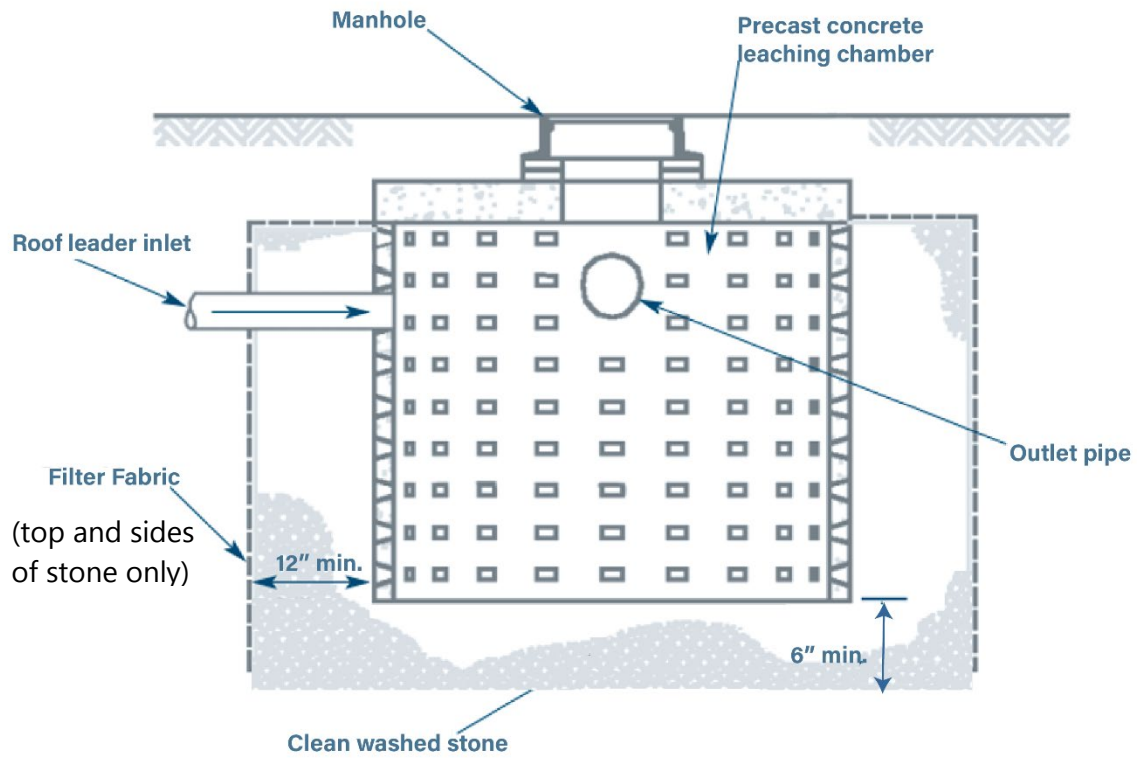

Source: Fuss & O'Neill, Inc.

Figure 13-13. Schematic of Typical Perforated Precast Concrete Infiltrating Catch Basin

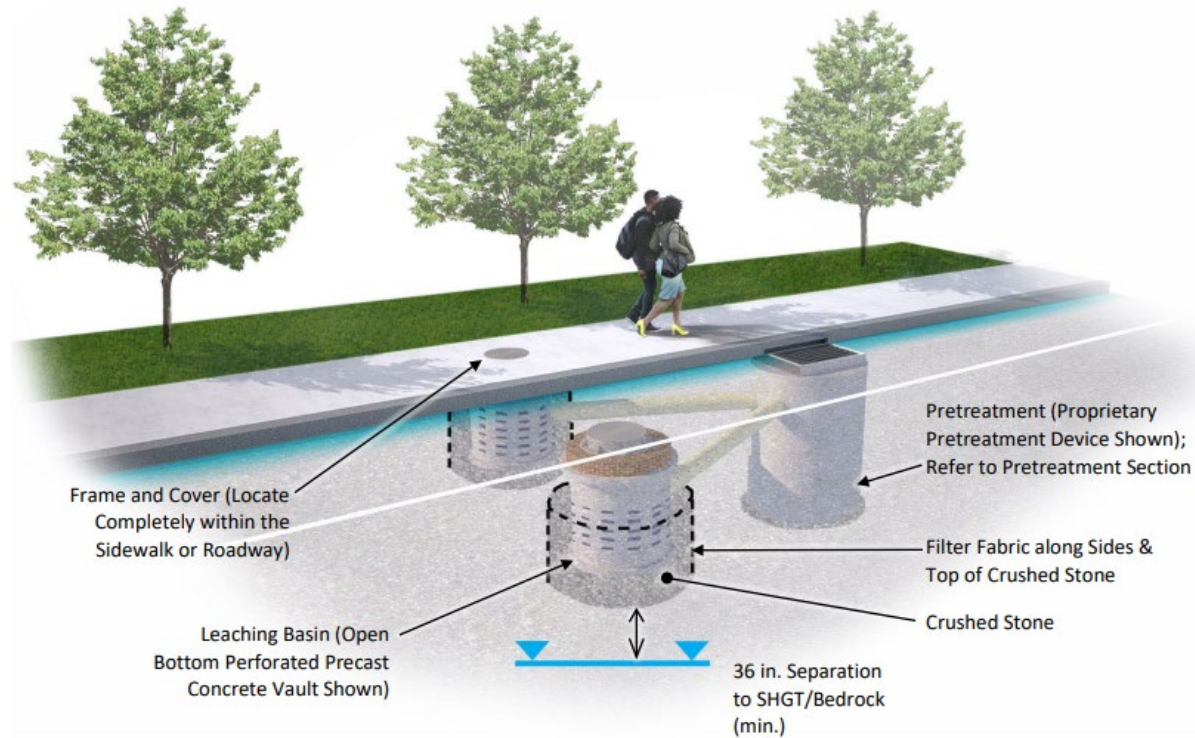

Source: RIDOT, 2019.

Note: Infiltration systems below CT DOT roads are not permitted. Infiltration systems adjacent to CTDOT roads shall be directed exfiltration away from pavements base, subbase and subgrade. An impermeable barrier may be required.

Figure 13-14. Schematic of Typical Vertical Corrugated Perforated Pipe Infiltrating Catch Basin

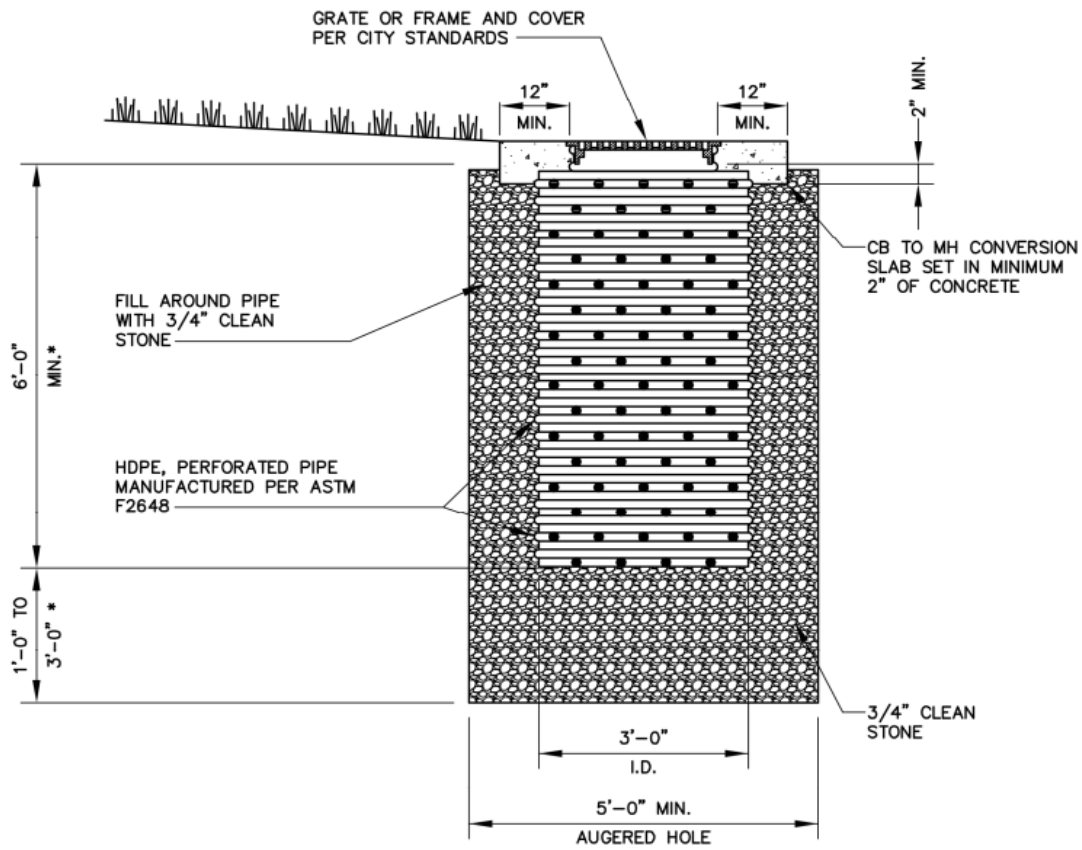

Source: Adapted from City of New Haven Engineering Department.

Permeable Pavement



Description

Permeable pavement is an alternative paved surface and stormwater management facility designed to capture stormwater runoff and snowmelt and allow it to move through void spaces in the surface course or through the joints in paver units. The captured stormwater is filtered as it moves vertically through the surface course, a transition and filter course, and a storage bed of open-graded aggregate where it is temporarily stored. The stormwater is discharged from the system through infiltration into the underlying soil or using an optional underdrain. Permeable pavement can be used to manage stormwater that falls on the pavement surface, but it may also accept some runoff from adjacent impervious areas.

When design for infiltration, permeable pavement can provide retention of stormwater, reducing runoff volumes and recharging groundwater. Filtration of stormwater is the primary pollutant removal mechanism in permeable pavement systems, although hydrocarbons and other pollutants can biodegrade in the system. Permeable pavement can be designed to store larger volumes of water and provide peak runoff attenuation for larger storms. Similar to other Infiltration BMPs, permeable pavement systems should be lined for certain applications.

There are many types of permeable pavement systems, but the most common are porous asphalt, pervious concrete, and permeable interlocking concrete pavers (PICP). The following photographs show common types of permeable pavement installations in Connecticut.

<i>Stormwater BMP Type</i>	
Pretreatment BMP	<input type="checkbox"/>
Infiltration BMP	<input checked="" type="checkbox"/>
Filtering BMP	<input type="checkbox"/>
Stormwater Pond BMP	<input type="checkbox"/>
Stormwater Wetland BMP	<input type="checkbox"/>
Water Quality Conveyance BMP	<input type="checkbox"/>
Stormwater Reuse BMP	<input type="checkbox"/>
Proprietary BMP	<input type="checkbox"/>
Other BMPs and Accessories	<input type="checkbox"/>
<i>Stormwater Management</i>	
<i>Suitability</i>	
Retention*	<input checked="" type="checkbox"/>
Treatment	<input checked="" type="checkbox"/>
Pretreatment	<input type="checkbox"/>
Peak Runoff Attenuation	<input checked="" type="checkbox"/>
*Exfiltration systems only	
<i>Pollutant Removal</i>	
Sediment*	High
Phosphorus	Moderate
Nitrogen	Moderate
Bacteria	High
*Includes sediment-bound pollutants	
<i>Implementation</i>	
Capital Cost	High
Maintenance Burden	High
Land Requirement	Low



Porous Asphalt (Storrs Hall, UConn, Storrs, CT)



Grass and Grid Pavers (Hole in the Wall Parking Lot, East Lyme, CT)



Pervious Concrete (Residential Subdivision, East Haddam, CT)

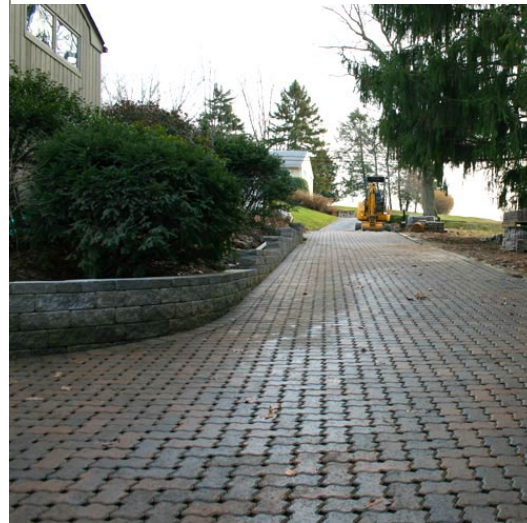

Concrete Pavers (residential driveway, Middletown, CT)

Photos Source: UConn NEMO Program

Advantages

- Well-suited to locations where space for other stormwater BMPs is limited.
- Provide dual functions, and therefore co-benefits including retention (volume reduction), groundwater recharge, treatment, and some stormwater quantity control.

- Other benefits include improved traction while wet, reduced surface ponding, reduced freeze-thaw, and reduced need for de-icing due to well drained base.

Limitations

- Susceptible to clogging by sediment.
- Not recommended in areas with high traffic volumes. Should only be used in low speed and low traffic areas or outside main travel lanes.
- Avoid areas of excessive sediment loading.
- Do not apply sand in winter months, as sand increases need for vacuum sweeping.
- Some permeable pavement surfaces (i.e., pavers) may be damaged by snow removal without modified equipment such as special plow blades.
- Quality control for material production and installation are essential for success.
- Accidental seal-coating or similar surface treatment will result in failure of porous asphalt installations.
- Successful long-term functioning of permeable pavement systems is highly dependent on regular and appropriate maintenance (routine vacuum sweeping).
- Higher material cost than conventional pavement (although may be offset by reduced stormwater infrastructure costs).

Siting Considerations

- **Potential Locations:** Low traffic areas such as within the roadway outside of the travel way (roadside rights-of-way and emergency access lanes), parking stalls and other low traffic areas of parking lots, driveways for residential and light commercial use, walkways, plazas, bike paths, and patios, where sanding will not occur within the contributing drainage area. Useful in stormwater retrofit applications where space is limited and where additional runoff control is required.
- **Drainage Area:** Contributing drainage area to the permeable pavement should not exceed three times the surface area of the permeable pavement. Runoff from upgradient permeable surfaces should be minimal. Porous asphalt installations of 0.5 acre or less are generally not cost effective.
- **Slopes:** Locate where pavement slopes do not exceed 5%.
- **General:** Meet the soils, water table, bedrock, and horizontal setback requirements specified in [Chapter 10 - General Design Guidance for Stormwater Infiltration Systems](#) (General Design Guidance for Stormwater Infiltration Systems).

Soil Evaluation

- Conduct an evaluation of the soil characteristics and subsurface conditions at the location of the proposed system including soil type, depth to the seasonal high groundwater table, depth to bedrock, and soil infiltration rate. Refer to [Chapter 10 - General Design Guidance for Stormwater Infiltration Systems](#) for soil evaluation guidance.

Design Recommendations

General Considerations

This section addresses design considerations for the most common types of permeable pavement systems.

- **Porous Asphalt:** Porous asphalt consists of a contiguous permeable asphalt surface course installed over a filter course and a base course that serves as a storage reservoir. Stormwater runoff moves vertically through the interconnected void spaces (10-25%) of the surface course and the filter course and temporarily accumulates in the underlying storage reservoir until it is discharged from the system or infiltrated into the underlying soil. The high infiltration rate through the surface course is achieved by eliminating the finer aggregates that are typically used in conventional asphalt. The remaining aggregates are bound together with an asphalt or Portland cement binder.
- **Pervious Concrete:** Like porous asphalt, pervious concrete consists of a contiguous permeable concrete surface course installed over a filter course and a base course that serves as a storage reservoir. Pervious concrete is like conventional concrete except the fine particles are absent from the mix, creating the interconnected void space and high infiltration capacity.
- **Permeable Interlocking Concrete Pavers (PICP):** This system uses concrete pavers that come in a variety of shapes, sizes, and many possible interlocking arrangements. Stormwater infiltrates vertically through the permeable joints between the paver units, or through voids in the permeable concrete units (similar to pervious concrete), then through the bedding layer, choker course, and an underlying storage reservoir.

[Figure 13-15](#) is a typical section of porous asphalt and pervious concrete, and a typical section of permeable interlocking concrete pavers designed for vehicle and non-vehicle loads. Other open course paver systems are available that can be filled with pea gravel or topsoil and seeded with grass, ranging from plastic turf reinforcing grids to concrete grid pavers.

All types of permeable pavement systems can be used with an impermeable liner and underdrain. A liner and underdrain system are required for use with Land Uses with Higher Potential Pollutant Loads (LUHPPLs) (see [Chapter 10 - General Design Guidance for Stormwater Infiltration Systems](#)), in locations where contaminated soils exist, where the required vertical separation to SHGT cannot be met, or in locations with unacceptable horizontal

setbacks for infiltration. Such systems are suitable for providing treatment and peak runoff attenuation but do not provide retention credit.

Pretreatment

- Pretreatment is not required for permeable pavement but may be appropriate if system receives stormwater runoff from pervious surfaces.

Inlet

- An inlet structure is not required if porous pavement receives evenly distributed sheet flow. Provide a level spreader or other feature to convert concentrated flow to sheet flow in accordance with the [Inlet and Outlet Controls](#) section of this Manual.
- Conveyance to porous pavement is typically overland and must be sheet flow; avoid concentrating flows due to features such as raised islands. Porous pavement receiving concentrated flow is more likely to clog and require additional maintenance.

Sizing and Dimensions

Surface Area and Volume

- Permeable pavement should be designed by either the Static or Dynamic Methods as described in [Chapter 10 - General Design Guidance for Stormwater Infiltration Systems](#).
- Size the filter and reservoir course to retain the Required Retention Volume (100% or 50% of the Water Quality Volume or WQV) and fully drain within 48 hours after the end of the design storm as described in [Chapter 10 - General Design Guidance for Stormwater Infiltration Systems](#).
- Assume a porosity of 40% when computing the amount of available storage within the aggregate courses.
- Size the permeable pavement surface area such that the contributing drainage area to the permeable pavement does not exceed three times the surface area of the permeable pavement.

Porous Asphalt and Pervious Concrete

- Surface Course
 - Porous Asphalt:
 - Thickness: 4 to 6 inches
 - Pervious Concrete
 - Thickness: 4 inches (minimum)
 - Design the surface course to support anticipated traffic and other design loads, including additional stresses that may be anticipated at the edges of the installation.

- Choker Course
 - Thickness: 4 to 8 inches
- Filter Course
 - Thickness: 8 to 12 inches; increase to 18 inches if an underdrain is used or there is inadequate separation from SHGT/bedrock.
- Filter Blanket
 - Thickness: 3 inches
- Reservoir Course
 - Thickness (without underdrain): 4 inches minimum
 - Thickness (with underdrain system): 8 inches minimum
 - Thicker reservoir course may be needed to retain the Required Retention Volume (100% or 50% of the WQV) or larger storms for stormwater quantity control
 - Ensure the reservoir course depth is sufficient to prevent winter freeze-thaw and heaving.
 - Combined pavement system and subbase thickness should exceed 0.65 times the design frost depth for the area.

Permeable Interlocking Concrete Pavers

- Surface Course
 - Pavers
 - Thickness: Per manufacturer
 - Gap Width: Per manufacturer
 - Design the surface course to support anticipated traffic and other design loads, including additional stresses that may be anticipated at the edges of the installation.
- Bedding Course
 - Thickness: 2 inches
- Base Reservoir Course
 - Thickness: 6 inches
- Subbase Reservoir Course
 - Thickness (without underdrain): 6 inches (non-vehicle loads), 8 inches (vehicle loads)
 - Thickness (with underdrain system): 8 inches minimum

Underdrain System

- Install an underdrain system when a proposed permeable pavement installation meets one or more of the following conditions:

- Is in native soil that has an infiltration rate less than 0.3 inch per hour (HSG C and D soils)
 - Does not meet vertical separation distance to SHGT or bedrock ([Chapter 10 - General Design Guidance for Stormwater Infiltration Systems](#)) and should be lined
 - Does not meet minimum horizontal setback distances ([Chapter 10 - General Design Guidance for Stormwater Infiltration Systems](#)) and should be lined
 - Is within a Land Use with Higher Potential Pollutant Loads (LUHPPL) ([Chapter 10 - General Design Guidance for Stormwater Infiltration Systems](#)) or area of contaminated soils and should be lined.
- Minimum underdrain pipe diameter: 4 inches
 - Minimum underdrain pipe slope: 0.5%
 - Install perforated underdrains within a minimum 8-inch-thick reservoir course with a minimum of 2 inches of crushed stone above and below the underdrain.
 - For unlined systems, install the perforated underdrain pipe 2 inches below the top of the reservoir course to promote infiltration. For systems that are lined with an impermeable liner to prevent infiltration, install the underdrain pipe 2 inches above the bottom of the reservoir course so the system can drain between storm events.
 - Lay underdrain such that perforations are on the bottom of the pipe.
 - Use solid (non-perforated) pipe sections and watertight joints wherever the underdrain system passes below berms, extends down steep slopes, connects to a drainage structure, and/or daylights.
 - Other considerations when designing/installing underdrains:
 - Provide a marking stake and an animal guard for underdrains that daylight at grade.
 - If designed with laterals, space collection laterals every 25 feet or less.
 - Include a minimum of two observation wells/cleanouts for each underdrain, one at the upstream end and one at the downstream end.
 - Cleanouts should be at least 4 inches in diameter, be nonperforated, and extend to the surface (flush with the surface). Cap cleanouts with a watertight removable cap. The cleanout should be highly visible.
 - Provide one cleanout for every 1,000 square feet of surface area (at a minimum) or for every 250 linear feet of total pipe length in larger systems.

Materials

Porous Asphalt and Pervious Concrete

- Porous Asphalt
 - Should conform to the latest version of the [University of New Hampshire Stormwater Center Design Specifications for Porous Asphalt Pavement and Infiltration Beds](#).
- Pervious Concrete
 - Should conform to the latest version of the [American Concrete Institute Specification for Pervious Concrete Pavement \(ACI SPEC-522.1-13\)](#).
- Choker Course
 - Should consist of AASHTO No. 57 clean, washed stone.
- Filter Course
 - Should consist of washed concrete sand (ASTM C33 or AASHTO M-6) or coarse washed sand with a hydraulic conductivity of 10 to 60 feet per day at 95% Standard Proctor.
- Filter Blanket
 - Should consist of 3/8" AASHTO No. 8 stone. Pea gravel should be clean (washed and free from dirt and debris) and rounded in shape.
- Reservoir Course
 - Should consist of 3/4" AASHTO No. 5 stone. Gravel should be clean (washed and free from dirt and debris), crushed, and angular.

Permeable Interlocking Concrete Pavers

- Pavers
 - PCIP: Concrete pavers should conform to ASTM C936 and have a minimum thickness of 3.125 inches when subject to vehicular traffic.
 - Other open course paver systems should conform to manufacturer guidelines.
- Bedding Course
 - Non-vehicle Loads: washed concrete sand (ASTM C33 or AASHTO M-6)
 - Vehicle Loads: pea gravel, 3/8" AASHTO No. 8 washed crushed stone
- Base Reservoir Course
 - Non-vehicle Loads: pea gravel, 3/8" AASHTO No. 8 washed crushed stone
 - Vehicle Loads: AASHTO No. 57 washed crushed stone
- Subbase Reservoir Course
 - Non-vehicle Loads: 3/4" AASHTO No. 5 washed crushed stone

- Vehicle Loads: 1.5" AASHTO No. 4 washed crushed stone

General

- Filter Fabric
 - Use along sides of excavation; filter fabrics should not be used between aggregate courses or beneath the bottom course.
 - Where reservoir courses extend beneath conventional pavement, use filter fabric at the top of the reservoir course.
 - Use non-woven filter fabric that complies with State of Connecticut Department of Transportation Standard Specifications, Section M.08.01.19 (Drainage – Geotextiles).
- Underdrain (perforated and non-perforated pipe sections)
 - Polyethylene or polyvinyl pipe.
- Liner
 - If used, should consist of a 30 mil (minimum) HDPE or PVC liner, or one of the alternative liner systems described in [Chapter 10 - General Design Guidance for Stormwater Infiltration Systems](#) with the approval of the review authority.

Stormwater Quantity Control Design – Adjusted Runoff Curve Number

- Permeable pavement systems reduce the volume of runoff from the paved surface and therefore result in a reduced NRCS Runoff Curve Number (CN), which should be used for stormwater hydrologic and hydraulic routing calculations that are required for stormwater quantity control design.
- Determine adjusted CN values for the permeable pavement surface by the following method:
 1. Calculate the volume of stormwater retained by the permeable pavement system as described above.
 2. Calculate the stormwater runoff volume for the water quality storm and the 2-, 10-, and 100-year, 24-hour storms as described in [Chapter 4 - Stormwater Management Standards and Performance Criteria](#) of this Manual.
 3. Subtract the volume of stormwater retained by the permeable pavement system from the stormwater runoff volume for the various storm events. The result is the runoff volume that will be discharged from the permeable pavement during each storm event.
 4. Convert the volume of stormwater discharged from the permeable pavement system to an equivalent discharge depth (in inches) by dividing the volume discharged by the area of the permeable pavement surface.
 5. Using the calculated discharge depth described above and the precipitation for each design storm event, calculate the adjusted CN values using the equation or graphical

solution (Figure 2-1 from TR-55) presented in [Appendix D](#) of this Manual (i.e., Graphical Peak Discharge Method).

- Once the adjusted CN values are determined, also calculate the time of concentration and either follow the remaining steps in the Graphical Peak Discharge Method in [Appendix D](#) or use a stormwater hydrologic/hydraulic routing model based on the NRCS Curve Number method (e.g., Hydro CAD or similar software) to calculate peak discharge rates for each design storm event.

Outlet & Overflow

- Permeable pavement should be graded to convey runoff to a properly designed conveyance system for storms greater than the design storm event.
- In addition to underdrains, common overflow outlets include curb cuts, catch basins, or a perimeter stone trench.
- Design the outlet in accordance with the [Inlet and Outlet Controls](#) section of this Manual.

Other Considerations

- The existing native subgrade material under permeable pavement should not be compacted or subject to excessive construction equipment traffic.
- The entire contributing drainage area should be completely stabilized prior to directing any flow to permeable pavement.
 - Adequate vegetative cover should be established over any pervious area adjacent or contributing to the installation before runoff can be accepted.
- Provide terraces and impermeable baffles or graded impermeable berms to maximize storage and prevent lateral reservoir course flow when subgrade slope exceeds 2%.
- In systems where pervious pavement is installed adjacent to conventional pavement, a full-depth barrier (impermeable liner) should be used between the two types of pavements to ensure that structural integrity is maintained and to prevent inadvertent saturation of the adjacent impervious pavement surface course.

Construction Recommendations

- The designing qualified professional should develop a detailed, site-specific construction sequence.
- The designing qualified professional should inspect the installation during the following stages of construction, at a minimum:
 - After excavation of the system and scarification of bottom and sidewalls of excavation
 - After placement of each gravel layer and drainpipes (if any)

- After installation of bypass, outlet/overflow, and inlet controls
 - Before and during placement of the pavement material (porous asphalt, pervious concrete, or pavers)
 - After pavement and pavers have been installed
- The designing qualified professional should provide an as-built plan of the completed permeable pavement system along with a certification that the system was designed in accordance with the guidance contained in this Manual and other local or state requirements and that the system was installed in accordance with the approved plans.
 - Materials testing requirements per the applicable specifications for each type of permeable pavement system.
 - The entire contributing drainage area should be completely stabilized prior to directing any flow to the system. Adequate vegetative cover must be established over any pervious area adjacent or contributing to the system before runoff can be accepted.
 - Erosion and sediment controls should be in place during construction in accordance with the [Connecticut Guidelines for Soil Erosion and Sediment Control](#) and the Soil Erosion and Sediment Control (SESC) Plan developed for the project.
 - During clearing and grading of the site, measures should be taken to avoid soil compaction at the location of the proposed permeable pavement system.
 - The system should be fenced off during the construction period to prevent disturbance of the soils.
 - The system should be excavated to the dimensions, side slopes, and elevations shown on the plans. The method of excavation should avoid compaction of the bottom of the system. A hydraulic excavator or backhoe loader, operating outside the limits of the system, should be used to excavate the system. Excavation equipment should not be allowed within the limits of the system.
 - The various gravel layers should be placed in the excavation by a hydraulic excavator or backhoe loader located outside the limits of the system and compacted.
 - The pavement material should be placed in accordance with the applicable installation requirements, as specified below:

- **Porous Asphalt:** The latest version of the University of New Hampshire Stormwater Center Design Specifications for Porous Asphalt Pavement and Infiltration Beds.⁸⁵
 - **Pervious Concrete:** The latest version of the American Concrete Institute Specification for Pervious Concrete Pavement (ACI SPEC-522.1-13)
 - **Permeable Interlocking Concrete Pavers:** Manufacturer guidelines.
- For open course paver systems with vegetation, install grass according to the manufacturer's guidelines and in accordance with these general recommendations:
- At least 1/8" to 1/4" of the paver must remain above the soil to bear the traffic load.
 - Sod or seeding method may be used.
 - If sod is used, the depth of backfill required will depend on the depth of the sod. Sod is laid over the pavers, watered thoroughly, and then compressed into the cells of the pavers.
 - If grass is planted from seed, the appropriate soil should be placed in the cells, tamped into the cells, and then watered thoroughly so that the appropriate amount of paver is exposed. The soil is then ready for planting with a durable grass seed.
 - Traffic should be excluded from the area for at least a month to allow for establishment of grass.

Maintenance Needs

- Permeable pavement systems should be designed with easy access to all components of the system for maintenance purposes. Refer to [Chapter 7 - Overview of Structural Stormwater Best Management Practices](#) for general design considerations to reduce and facilitate system maintenance.
- Detailed inspection and maintenance requirements, inspection and maintenance schedules, and those parties responsible for maintenance should be identified on the plans and in the Stormwater Management Plan.
- Maintenance must be performed by properly trained personnel trained in the use of the special equipment necessary in accordance with industry or manufacturer's requirements such as vacuum sweeping, specialized snow plowing accessories, etc.
- Maintenance should be detailed in a legally binding maintenance agreement.

⁸⁵ https://www.unh.edu/unhsc/sites/unh.edu.unhsc/files/pubs_specs_info/unhsc_pa_spec_10_09.pdf

- Maintenance activities such as sediment removal, mowing, and repairs should be performed with rakes and light-weight equipment rather than heavy construction equipment to avoid compaction of the bioretention soil media and underlying soils. Heavy equipment may be used for sediment removal and other maintenance activities if the equipment is positioned outside the limits of the bioretention system. Heavy construction equipment should not be allowed within the limits of the bioretention system for maintenance purposes.

Recommended Maintenance Activities

- Inspect surface course after major storms (1 inch or more of precipitation) in the first year following construction.
- Inspect surface course annually.
- Refer to [Appendix B](#) for maintenance inspection checklists, including items to focus on during the inspections.
- Vacuum sweep and air blow (using a leaf blower or equipment recommended by the manufacturer) the permeable pavement surface quarterly.
- Regularly remove tracked mud or sediment and leaves. Power washing can be effective for cleaning clogged areas.
- Do not apply sand during winter operations.
- Minimize use of deicing chemicals. Only use as necessary based on site-specific drainage and icing conditions.
- Do not use deicing chemicals on pervious concrete less than one year old. Never use deicers containing magnesium chloride, calcium magnesium acetate or potassium acetate on pervious concrete.
 - Use caution when removing snow from the surface course. Some permeable paving surface courses such as pavers may be damaged by snowplows or loader buckets not equipped with a rubber blade guard to avoid catching on the paver units.
 - Under no circumstances may any sealants or coatings be applied to permeable paving systems, except for those approved by the manufacturer to improve surface course resistance to deicing chemicals or refresh traffic striping.
 - Take corrective action if the system fails to drain the design storm volume within 48 hours after the end of a storm.

Figure 13-15.. Permeable Pavement – Typical Sections

Porous Asphalt or Pervious Concrete

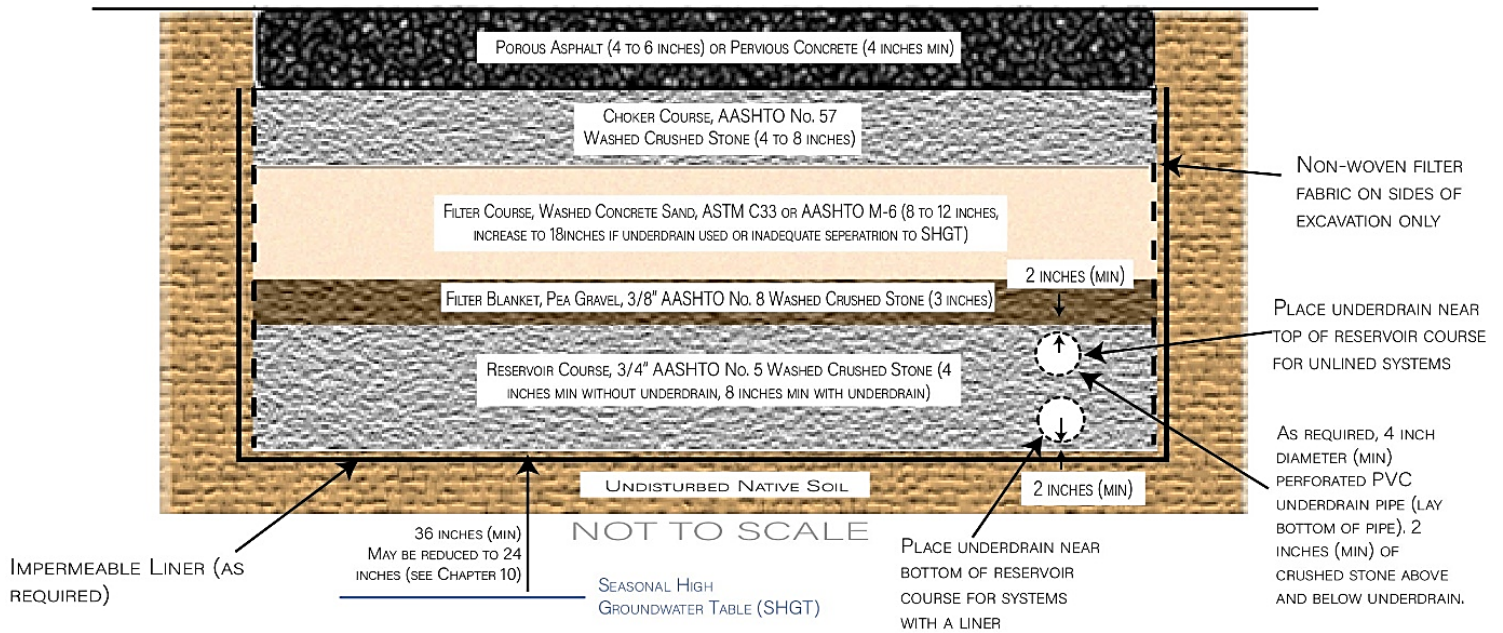

Permeable Interlocking Concrete Pavers

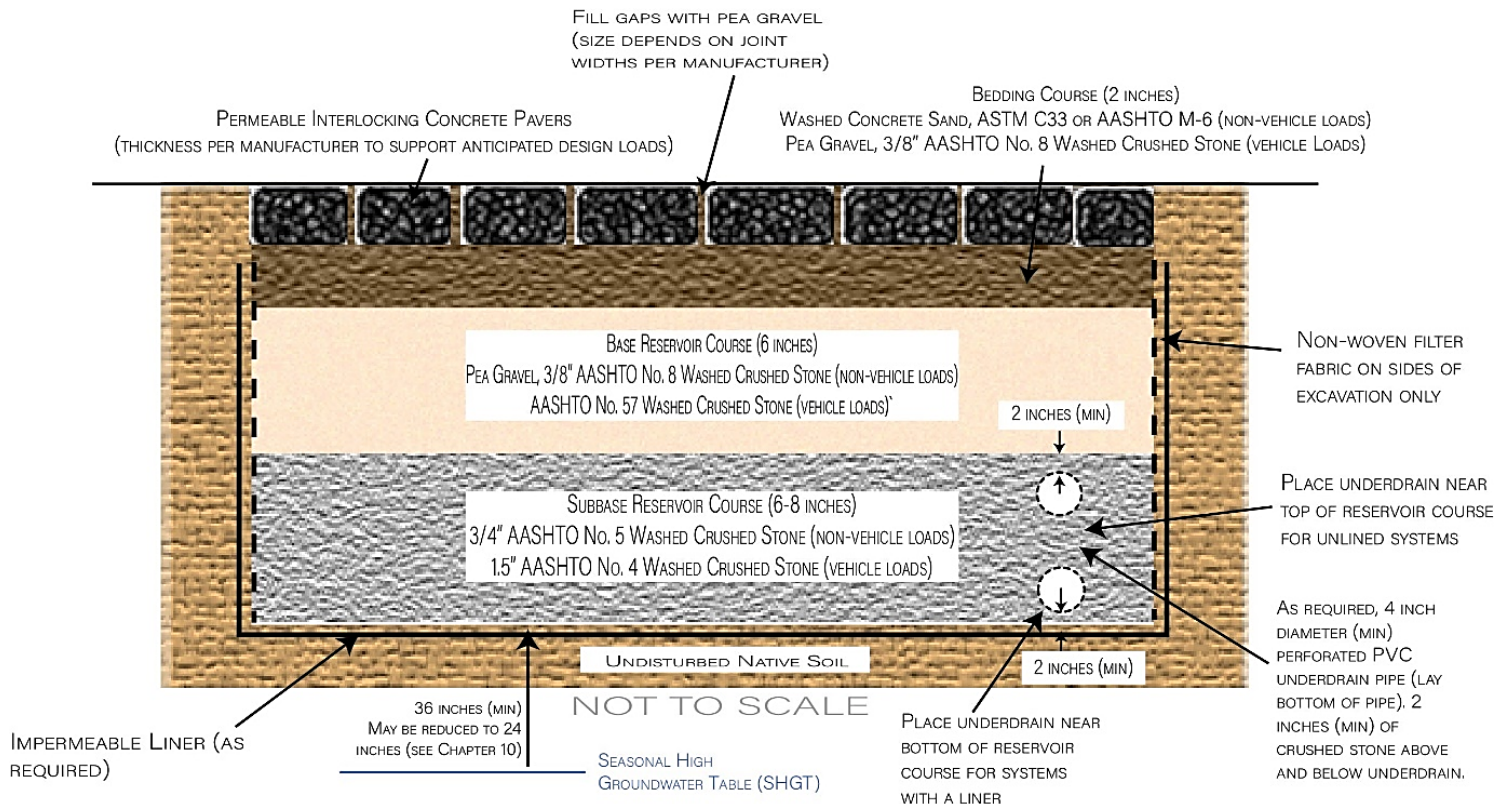

Bioretention



Description

Bioretention systems are shallow, vegetated depressions that capture, temporarily store, and filter stormwater runoff. Bioretention systems have an engineered soil⁸⁶ media below the surface of the system that facilitates stormwater filtration and vegetative growth. Bioretention systems are frequently designed to infiltrate, commonly referred to as “infiltration” or “exfiltration” bioretention systems but can be designed with an underdrain to capture filtered water and assist with drainage from the system, typically referred to as “flow-through” bioretention systems. In certain situations, bioretention systems can also be designed with impermeable liners to prevent infiltration into the underlying soil.

Bioretention systems remove pollutants through a variety of physical, chemical, and biological processes including filtration, pollutant uptake, and adsorption. Vegetation in the soil bed provides uptake of pollutants and runoff, and the root system helps maintain the infiltration rate in the soil bed. If not designed with an impermeable liner, bioretention systems can provide retention of stormwater and reduce runoff volumes through infiltration and groundwater recharge. Bioretention systems may also be used to provide stormwater quantity control when designed as on-line facilities.

Bioretention systems can be implemented on most sites as part of the urban, suburban, or rural landscape. Given their versatility, many design variants of bioretention systems exist, including bioretention basins, stormwater planters, bioswales, tree filters (see [Tree Filter](#) section), and

Stormwater BMP Type

Pretreatment BMP	<input type="checkbox"/>
Infiltration BMP	<input type="checkbox"/>
Filtering BMP	<input checked="" type="checkbox"/>
Stormwater Pond BMP	<input type="checkbox"/>
Stormwater Wetland BMP	<input type="checkbox"/>
Water Quality Conveyance BMP	<input type="checkbox"/>
Stormwater Reuse BMP	<input type="checkbox"/>
Proprietary BMP	<input type="checkbox"/>
Other BMPs and Accessories	<input type="checkbox"/>

Stormwater Management Suitability

Retention	<input checked="" type="checkbox"/>
Treatment	<input checked="" type="checkbox"/>
Pretreatment	<input type="checkbox"/>
Peak Runoff Attenuation	<input checked="" type="checkbox"/>

Pollutant Removal

Sediment*	High
Phosphorus	Moderate
Nitrogen	Low
Bacteria	High

*Includes sediment-bound pollutants and floatables (with pretreatment)

Implementation

Capital Cost	Medium
Maintenance Burden	Medium
Land Requirement	Varies

⁸⁶ Engineered soil is a manufactured soil consisting of specified ratios of sand, silt, clay, and organic amendments such as compost and designed for a specific application.

other systems that vary based on shape, location, and configuration. The following photographs are examples of common types of bioretention systems.



Bioretention basin at the edge of a parking lot.



Rain garden on a residential lot.



Roadside bioswale in urban residential setting.



Bioretention planter in urban downtown setting.

Advantages

- Applicable to small drainage areas.
- Can be applied to most sites due to relatively few constraints and many design variations (i.e., highly versatile).
- Ideal for stormwater retrofits and highly developed sites.
- High pollutant removal efficiency and water quality benefits.
- Can provide stormwater retention, runoff volume reduction, and groundwater recharge if designed for infiltration.
- Vegetation can also provide aesthetic, ecological, and other green infrastructure benefits, like cooling the urban heat island effect.

Limitations

- Limited to smaller drainage areas.
- Frequent maintenance required.
- Infiltration bioretention systems generally have higher relative construction costs than other stormwater infiltration systems due to cost of bioretention soil media.

Siting Considerations

- **Potential Locations:** Within parking lot islands, along borders of parking lots, roundabouts, planted islands, medians, streetscapes (e.g., between the curb and sidewalk), wide roadway shoulders, and along shared-use paths. Bioretention systems such as small-scale rain gardens are also well-suited to residential areas because of the co-benefits they provide
- **Drainage Area:** Small-scale bioretention systems should have a contributing drainage area of 1 acre or less. The recommended maximum contributing drainage area for bioretention systems is 5 acres. For larger sites, multiple bioretention systems should be distributed throughout the site or off-line designs should be used to bypass larger flows. For curb inlet planters, the recommended maximum ratio of contributing impervious drainage area to planter bed area is 10:1.
- **Soils:** Bioretention systems that return filtered runoff to the conveyance system and do not infiltrate into the ground can be used in almost any soil type. Bioretention designs that rely on infiltration should be used only when the soil infiltration characteristics are appropriate (see [Chapter 10 - General Design Guidance for Stormwater Infiltration Systems](#) for design guidance for stormwater infiltration systems).
- **Land Use:** Bioretention systems can be used in most land use settings where space is available.
- **Water Table and Bedrock:** For bioretention systems designed for infiltration (unlined systems), meet the minimum required vertical separation distances from the top and bottom of the filtering system to the seasonal high groundwater table (SHGT) and bedrock, as described in [Chapter 10 - General Design Guidance for Stormwater Infiltration Systems](#).
- **Horizontal Setbacks:** For bioretention systems designed for infiltration (unlined systems), meet the minimum horizontal setback distances in [Chapter 10 - General Design Guidance for Stormwater Infiltration Systems](#).

Soil Evaluation

- Conduct an evaluation of the soil characteristics and subsurface conditions at the location of the proposed system including soil type, depth to the seasonal high groundwater table, depth to bedrock, and soil infiltration rate. Refer to Chapter 10 –

General Design Guidance for Stormwater Infiltration Systems, for soil evaluation guidance.

Design Recommendations

General Considerations

This section addresses three types of bioretention system designs ([Table 13-5](#)):

- **Bioretention System with Underdrain (Partial Infiltration Bioretention System):** Most bioretention systems should be designed with an underdrain to account for potential infiltration failure due to clogging, groundwater mounding, or periods of excessive rainfall. Underdrained bioretention systems can be used with any soil type or soil infiltration rate, although bioretention systems in HSG C or D soils an underdrain is necessary. The underdrain should be raised above the bottom of the system to maximize infiltration and enhance nitrogen removal. Underdrained bioretention systems (without a liner) are suitable for providing stormwater retention, although only the infiltrated volume (not the volume discharged via the underdrain) can be credited toward the Standard 1 retention requirement.
- **Bioretention System with Underdrain and Liner (Flow-Through Bioretention System):** An underdrain and impermeable liner are required for use with Land Uses with Higher Potential Pollutant Loads (LUHPPLs) (see [Chapter 10 - General Design Guidance for Stormwater Infiltration Systems](#)), in locations where contaminated soils exist, where the required vertical separation to SHGT cannot be met, or in locations with unacceptable horizontal setbacks for infiltration. Such systems are suitable for providing treatment but do not provide retention credit.
- **Bioretention System with No Underdrain (Infiltration Bioretention System):** Bioretention systems can be designed to fully infiltrate into the native soil without an underdrain. Such systems are best suited for use with Hydrologic Soil Group (HSG) A and B soils. Bioretention systems have higher relative construction costs than other surface infiltration systems presented in this Manual (infiltration basins and trenches) due to the cost of the engineered bioretention soil, plantings, etc. Therefore, infiltration bioretention systems tend to be less cost-effective than other surface infiltration practices.

[Figure 13-16.](#) and [Figure 13-17.](#) are schematics of these bioretention system designs.

Table 13-2. Bioretention System Design Types

Type of System	Underdrain Type	Infiltration or Filtration Design?	Suitable for Retention?	Suitable for Treatment?	General Conditions for Use
Bioretention System with Underdrain Partial Infiltration Bioretention System	Raised Underdrain	Infiltration and Filtration (partial infiltration)	Yes (infiltration volume only)	Yes	All HSG Soil types Underdrain required for HSG C and D Soils
Bioretention System with Underdrain and Liner Flow-Through Bioretention System	Underdrain and Impermeable Liner	Filtration Only	No	Yes	Land Uses with Higher Potential Pollutant Loads Contaminated sites Where required vertical separation to SHGT cannot be met Sites with unacceptable setback distances for infiltration
Bioretention System Without Underdrain Infiltration Bioretention System	No Underdrain	Infiltration and Filtration (Full infiltration)	Yes	Yes	HSG A and B Soils

Pretreatment

- Incorporate pretreatment measures at locations where runoff enters the bioretention system in accordance with the [Pretreatment BMPs](#) section of this Manual.
- Acceptable pretreatment measures include vegetative filter strips, sediment forebays, pretreatment swales, deep sump hooded catch basins,⁸⁷ oil grit separators, and proprietary pretreatment devices.
- Sediment forebays should have a minimum storage volume of 25% of the Water Quality Volume (WQV), while flow-through Pretreatment BMPs should treat at least the equivalent Water Quality Flow (WQF). A minimum sediment forebay storage volume of 10% of the WQV may be used in urban settings, space constrained sites, and as retrofits, with the approval of the review authority.

Sizing and Dimensions

- Bioretention Filter Bed (Bottom) Area
 - Bioretention system should be designed by either the Static or Dynamic Methods as described in [Chapter 10 - General Design Guidance for Stormwater Infiltration Systems](#).
 - Bioretention system should completely drain in 48 hours or less after the end of the design storm as described in [Chapter 10 - General Design Guidance for Stormwater Infiltration Systems](#).
 - For unlined systems, the design infiltration rate used for system sizing and drain time analysis should be equal to 50% of the slowest observed field infiltration rate of the underlying soils or 0.5 inches per hour (1.0 feet per day) for the bioretention soil media, whichever value is lower.
 - For lined systems, use the coefficient of permeability of the bioretention soil media (0.5 inches per hour or 1.0 feet per day or) in the drain time analysis.
- Bioretention Soil Depth
 - Engineered bioretention soil media should have a depth of 24 to 48 inches as necessary to accommodate the required sizing, vegetation species and root establishment, and subsurface conditions.
 - Bioretention systems with trees should have a minimum soil depth of 30 inches.
 - Soil depth may be limited by the requirement to maintain adequate separation to groundwater and bedrock as specified in [Chapter 10 - General Design Guidance for Stormwater Infiltration Systems](#).
- Ponding Depth
 - Maximum for water quality storm: 12 inches

⁸⁷ Only recommended for space constrained sites where no other Pretreatment BMPs are feasible.

- Maximum for overflow events: 36 inches
- Freeboard Depth
 - Minimum freeboard depth: 3 to 6 inches
 - As measured from the elevation of the maximum ponding depth to the facility's overflow elevation or to the invert of the inlet to the facility, whichever is lower.
- Bottom Width
 - Minimum: 4 feet (ideal). For bioretention planters, narrower widths may be allowed, with a minimum width of 2.5 feet. The design should consider plant health, water quality performance, and implementation costs.
- Bottom Slope
 - Design bottom of infiltration bioretention systems to be level or have a maximum slope of 0.5% to promote infiltration and even distribution.
 - Flow-through bioretention systems with bottom slopes greater than 0.5% should be designed with impermeable check dams (e.g., constructed from granite or concrete curbing) or as a terraced system with relatively flat bottoms in each cell to promote infiltration throughout the bottom of the entire system.
- Side Slopes
 - 3(H):1(V) slopes or flatter are preferred especially on grassed slopes where mowing is required.
 - In ultra-urban locations or space constrained areas; side slopes of 2(H):1(V) may be utilized if properly designed to account for erosion and slope stability. Stabilize the slope with turf reinforcement matting or equivalent if the slope could potentially erode.
 - If site topography does not allow for 3(H):1(V) slopes or adequately stabilized 2(H):1(V) slopes, vertical concrete walls with a maximum height of 30 inches can be used. Drop curbs or similar precast structures can also be used to create stable, vertical bioretention side walls.

Inlet

- Design the inlet in accordance with the [Inlet and Outlet Controls](#) section of this Manual.
- Runoff can be introduced to the bioretention system through overland flow, curb cuts, inlet structures, swales/channels, and/or pipes.
- Design the bioretention system in an off-line configuration to the extent feasible if runoff is delivered by a storm drain pipe or is along the main storm conveyance system.

Outlet & Overflow

- Design the outlet in accordance with the [Inlet and Outlet Controls](#) section of this Manual.

- Outlets are typically a stabilized spillway, gabion berm, concrete weir, curb cut opening, precast concrete structure, or polyethylene/polyvinyl chloride riser structure.
- On-line systems should have a primary outlet sized to convey the 10-year, 24-hour storm event, at a minimum, to the storm drainage system or stabilized channel. An emergency spillway is required to convey the 100-year storm event (assuming the primary outlet is not designed to pass the 100-year storm event).
- Off-line systems should be designed with a bypass or overflow for flows in excess of the water quality storm.

Underdrain System

- Install an underdrain system when a proposed bioretention system meets one or more of the following conditions:
 - Is in native soil that has an infiltration rate less than 0.3 inch per hour (HSG C and D soils)
 - Does not meet vertical separation distance to SHGT or bedrock ([Chapter 10 - General Design Guidance for Stormwater Infiltration Systems](#)) and should be lined
 - Is within a Land Use with Higher Potential Pollutant Loads (LUHPPL) ([Chapter 10 - General Design Guidance for Stormwater Infiltration Systems](#)) or area of contaminated soils and should be lined.
- An underdrain is also recommended, but not required, for other bioretention systems to account for potential infiltration failure due to clogging, groundwater mounding, or periods of excessive rainfall.
- Minimum underdrain pipe diameter: 4 inches
- Minimum underdrain pipe slope: 0.5%
- Use two layers of gravel with the underdrain system. Both layers of gravel should be located below and extend across the entire bottom of the bioretention system. The upper gravel layer should consist of 3 inches of pea gravel, and the lower layer should consist of a 12-inch thick gravel sump.
- For unlined bioretention systems, install the perforated underdrain pipe 2 inches below the top of the gravel sump to promote infiltration. For systems that are lined with an impermeable liner to prevent infiltration, install the underdrain pipe 2 inches above the bottom of the gravel sump so the system can drain between storm events.
- For enhanced removal of nitrogen, use an upturned underdrain in combination with a low permeability native soil (HSG C or D soils) or liner to create a thicker saturated zone (also called an Internal Water Storage zone or Internal Storage Reservoir) that extends up to a maximum of 6 inches into the bottom of the bioretention soil media. This type of

underdrain configuration is recommended for bioretention systems that discharge to coastal, estuarine, and nitrogen impaired waters where enhanced nitrogen removal is desired.

- If the bioretention system is designed without an underdrain, pea gravel and gravel sump are optional.
- Lay underdrain such that perforations are on the bottom of the pipe.
- Use solid (non-perforated) pipe sections and watertight joints wherever the underdrain system passes below berms, extends down steep slopes, connects to a drainage structure, and/or daylights.
- Place filter fabric along sidewalls of excavation and above the pea gravel (below the bioretention soil layer) for a distance of 1 to 2 feet on both sides of the underdrain. Filter fabric shall not be placed across the entire width of the bioretention system.
- Other considerations when designing/installing underdrains:
 - Provide a marking stake and an animal guard for underdrains that daylight at grade.
 - If designed with laterals, space collection laterals every 25 feet or less.
- Include a minimum of two observation wells/cleanouts for each underdrain, one at the upstream end and one at the downstream end.
 - Cleanouts should be at least 4 inches in diameter, be nonperforated, and extend to the surface. Cap cleanouts with a watertight removable cap. The cleanout should be highly visible.
 - Provide one cleanout for every 1,000 square feet of surface area (at a minimum) or for every 250 linear feet of total pipe length in larger systems.

Materials

- Surface Cover
 - Grass or river stone are the preferred surface cover types for bioretention systems to minimize required maintenance. Mulch may be used directly around the plants, but mulch should NOT be used to cover the entire bottom of the bioretention system.
 - If mulch is used, use 2 to 4 inches of shredded hardwood bark mulch, aged for 6 months minimum.
 - Alternative surface covers such as pea gravel may be used if allowed by the review authority.
- Vegetation
 - Select bioretention plantings/vegetation and develop a planting plan with guidance provided in [Appendix F](#) of this Manual.

- A native grass/wildflower seed mix can be used as an alternative to groundcover plantings.
- Establish a dense vegetative cover or adequately stabilized surface throughout the bioretention system and any upgradient areas disturbed by construction before runoff can be accepted into the facility.
- Plant layout should be random and natural.
- Trees should be planted primarily along the perimeter of the facility and with 15 feet of separation from underdrain piping.
- Trees should not be planted in lined bioretention systems.
- Do not plant trees, shrubs, or grasses with a mature vegetation height exceeding 24 inches above the surrounding sidewalk or pavement surface in bioretention systems within medians, near intersections, or near pedestrian crossings to avoid obstruction of sight lines.

➤ Engineered Bioretention Soil Media

- The engineered soil media in bioretention systems is designed to filter/treat runoff and to provide sufficient organic material to support plant establishment and growth.
- The engineered bioretention soil media should be a homogeneous soil mix of (by volume):
 - 60–85% Sand
 - 15–25% Topsoil
 - 3–8% Organic Matter
- **Sand** should be washed concrete sand (ASTM C33 or AASHTO M-6) or coarse washed sand that meets the gradation schedule as shown in State of Connecticut Department of Transportation Standard Specifications, Section M.01 (Aggregates), Table M.01.04-1 for Fine Aggregate Gradations.
- **Topsoil** should contain 5–20% organic material, have a pH range of 5.5 to 7.0, and be a sandy loam, loamy sand, or loam per USDA soil texture with less than 5% clay content. Topsoil that meets the State of Connecticut Department of Transportation Standard Specifications, Section M.13.01 (Roadside Development) for Topsoil may also be used, except it should contain less than 5% clay content.
- **Organic matter** should consist of one of the following materials
 - Sphagnum Peat: Partially decomposed sphagnum peat moss, finely divided or of granular texture with 100 percent passing through a 1/2-inch (13-mm) sieve, a pH of 3.4 to 4.8.
 - Wood Derivatives: Shredded wood, wood chips, ground bark, or wood waste; of uniform texture and free of stones, sticks, soil, or toxic materials.

- Compost shall NOT be used as organic matter since the use of compost in bioretention soil media can result in nutrient export from the system.
- **Other soil amendments** such as zerovalent iron and/or processed drinking water treatment residuals (alum) may be used to further enhance phosphorus sorption as specified by the designer. Processed drinking water treatment residuals should have a minimum of 30% solids. Drinking water treatment residuals are typically processed and dried using a belt filter press.
- Bioretention soil media should meet the following particle size distribution according to ASTM D422 (Standard Test Method for Particle-Size Analysis of Soils) as specified in [Table 13-6](#).

Table 13-3. Acceptable Particle Size Distribution of Bioretention Soil Media

Media Type	Sieve #	Size (inches)	Size (mm)	% Passing
Coarse Sand	4	0.187	4.76	100
Medium Sand	10	0.079	2.00	95
Fine Sand	40	0.017	0.42	10-20
Silt/Clay	200	0.003	0.075	0-5

- Bioretention soil media should also meet the following specifications:
 - pH (soil reaction): 5.5 to 7.5
 - Cation Exchange Capacity (CEC): minimum of 10 milliequivalents per 100 grams of soil (meq/100 g) at pH of 7.0
 - Organic Matter (percentage by volume): 3% to 10%
 - Total Phosphorus: <100 mg/kg
- Bioretention soil media should NOT contain any of the following materials: stones, clods, roots, clay lumps, and pockets of coarse sand exceeding 0.187 inches (4.76 mm) in any dimension; plants, sod, concrete slurry, concrete layers or chunks, cement, plaster, building debris, asphalt, bricks, oils, gasoline, diesel fuel, paint thinner, turpentine, tar, roofing compound, acid, solid waste, and any other extraneous materials that are harmful to plant growth.
- Pea Gravel
 - Should consist of 3/8" AASHTO No. 8 stone. Pea gravel should be clean (washed and free from dirt and debris) and rounded in shape.
- Gravel Sump
 - Should consist of 3/4" AASHTO No. 5 stone. Gravel should be clean (washed and free from dirt and debris), crushed, and angular.

- Filter Fabric
 - Use non-woven filter fabric that complies with State of Connecticut Department of Transportation Standard Specifications, Section M.08.01.19 (Drainage – Geotextiles).
- Poured-in-place Concrete
 - If used, should be an appropriate class of concrete based on the application and conform to State of Connecticut Department of Transportation Standard Specifications, Section 6.01 (Concrete for Structures).
 - Underdrain (perforated and non-perforated pipe sections)
 - Polyethylene or polyvinyl pipe.
- Liner
 - If used, should consist of a 30 mil (minimum) HDPE or PVC liner, or one of the alternative liner systems described in [Chapter 10 - General Design Guidance for Stormwater Infiltration Systems](#) with the approval of the review authority.
- Curbing (for Overflow Weirs or Check Dams)
 - If used for check dams, granite or concrete curbing shall conform to State of Connecticut Department of Transportation Standard Specifications, Section M.12.06 (Stone Curbing) and Section 8.11 (Concrete Curbing).
- Turf Reinforcement Matting (TRM)
 - Stabilize the side slopes of the bioretention system with TRM to limit erosion in locations where flow velocities exceed 3 to 5 feet per second (depending on soil and vegetation types) for the 1-year, 24-hour storm event.
 - If used, shall be a woven material included on the CTDOT Qualified Products List that exceeds the design velocity of the design storm and allows for the growth of the proposed vegetative species.

Other Considerations

- If designing a lined system in a location where SHGT is located at or above the bottom of the liner or closed bottom of the system, complete a buoyancy analysis to ensure buoyancy of the system will not be an issue.
- For lined bioretention systems within LUHPPLs, a shutoff valve can be installed on the underdrain outlet to capture and contain accidental spills or releases that reach the bioretention system.
- Roadway stability can be a design issue when installing bioretention systems along roadways. It may be necessary to provide a vertical impermeable barrier to keep water from saturating the road's sub-base. The barrier should be capable of supporting H-20 loads.

- Non-woven filter fabric should be placed along the sidewalls of the bioretention system to help direct the water flow downward, reduce lateral flows, and to reduce lateral soil migration. Non-woven filter fabric should also be placed above the pea gravel layer (below the bioretention soil layer) for a distance of 1 to 2 feet on both sides of the underdrain pipe. Filter fabric should NOT be placed across the entire width of the bioretention system because filter fabric installed in this manner can result in clogging and system failure.

Winter Operations

- Bioretention systems should not be used as dedicated snow storage areas. To the extent feasible, locate and design the system to avoid snow storage areas and potential damage from snow plowing activities. Refer to [Chapter 7 - Overview of Structural Stormwater Best Management Practices](#) for general design considerations related to winter operations.

Construction Requirements

- The designing qualified professional should develop a detailed, site-specific construction sequence.
- The designing qualified professional should inspect the installation during the following stages of construction, at a minimum:
 - After excavation of the bioretention system and scarification of bottom and sidewalls of excavation
 - After placement of gravel layer
 - After placement of underdrain before covering by the pea gravel layer
 - After placement of bioretention soil media
 - After installation of bypass, outlet/overflow, and inlet controls
 - After plants have been installed
- The designing qualified professional should provide an as-built plan of the completed bioretention system along with a certification that the system was designed in accordance with the guidance contained in this Manual and other local or state requirements and that the system was installed in accordance with the approved plans.
- The bioretention soil mix should be tested prior to placement according to the specifications in this section (at least one test per bioretention system). The designing qualified professional should certify that the bioretention soil mix meets the specifications in the previous section based on soil testing results.
- The entire contributing drainage area should be completely stabilized prior to directing any flow to the bioretention system. Adequate vegetative cover must be established over any pervious area adjacent or contributing to the system before runoff can be accepted.

- Erosion and sediment controls should be in place during construction in accordance with the [Connecticut Guidelines for Soil Erosion and Sediment Control](#) and the Soil Erosion and Sediment Control (SESC) Plan developed for the project.
- During clearing and grading of the site, measures should be taken to avoid soil compaction at the location of the proposed bioretention system.
- The bioretention system should be fenced off during the construction period to prevent disturbance of the soils.
- The bioretention system should be excavated to the dimensions, side slopes, and elevations shown on the plans. The method of excavation should avoid compaction of the bottom of the bioretention system. A hydraulic excavator or backhoe loader, operating outside the limits of the bioretention system, should be used to excavate the system. Excavation equipment should not be allowed within the limits of the bioretention system.
- The gravel, pea gravel, and bioretention soil media should be placed in the excavation by a hydraulic excavator or backhoe loader located outside the limits of the bioretention system and then hand-raked to the desired elevation.
- Place the bioretention soil in 6 to 12-inch lifts. The bioretention soil needs to settle before planting. Lightly tamp or spray the surface of the bioretention soil with water until saturated. The elevation of the bioretention soil can be a couple of inches higher at installation than the design elevation in anticipation of settling. Bring bioretention soil levels back to the design elevation if necessary.
 - Install vegetation (plants, grass, etc.) in the bioretention system in accordance with the planting plan and plant schedule on the plans. Water vegetation thoroughly immediately after planting and as necessary until fully established. The bioretention soil mix provides enough organic material to adequately supply nutrients from natural cycling.

Maintenance Needs

- Bioretention systems should be designed with easy access to all components of the system for maintenance purposes. Refer to [Chapter 7 - Overview of Structural Stormwater Best Management Practices](#) for general design considerations to reduce and facilitate system maintenance.
- Detailed inspection and maintenance requirements, inspection and maintenance schedules, and those parties responsible for maintenance should be identified on the plans and in the Stormwater Management Plan.
- Maintenance should be detailed in a legally binding maintenance agreement.

- Maintenance activities such as sediment removal, mowing, and repairs should be performed with rakes and light-weight equipment rather than heavy construction equipment to avoid compaction of the bioretention soil media and underlying soils. Heavy equipment may be used for sediment removal and other maintenance activities if the equipment is positioned outside the limits of the bioretention system. Heavy construction equipment should not be allowed within the limits of the bioretention system for maintenance purposes.

Recommended Maintenance Activities

- Inspect after major storms (1 inch or more of precipitation) in the first few months following construction.
- Inspect bioretention system annually.
- Refer to [Appendix B](#) for maintenance inspection checklists, including items to focus on during the inspections.
- Remove trash and organic debris (leaves) in the Spring and Fall.
- Remove sediment from the sediment forebay or other pretreatment area when it accumulates to a depth of more than 12 inches or 50% of the design depth. Clean outlet of sediment forebay or other pretreatment measures when drawdown time exceeds 36 hours after the end of a storm event.
- Remove accumulated sediment from the bioretention system when the sediment accumulation exceeds 1 inch or when drawdown time exceeds 48 hours after the end of a storm event, indicating that the soil media is clogged. Replace with fresh bioretention soil media that conforms to the specifications in this section.
- Maintain vegetated filter strips or grassed side slopes of bioretention system in accordance with maintenance recommendations in [Pretreatment BMPs](#) section of this Manual.
- Periodically remove grass clippings to prevent clogging of the surface of the bioretention system.
- Mowing should not be performed when the ground is soft to avoid the creation of ruts and compaction, which can reduce infiltration.
- Bioretention systems require other seasonal landscape maintenance, including:
 - Watering plants as necessary during first growing season
 - Watering as necessary during dry periods
 - Replacing dead or dying plants, or pruning plants, as necessary
 - Inspection of soil and repairing eroded areas
 - Removal of litter and debris

Figure 13-16. Bioretention System Schematic (Plan View and Elevation)

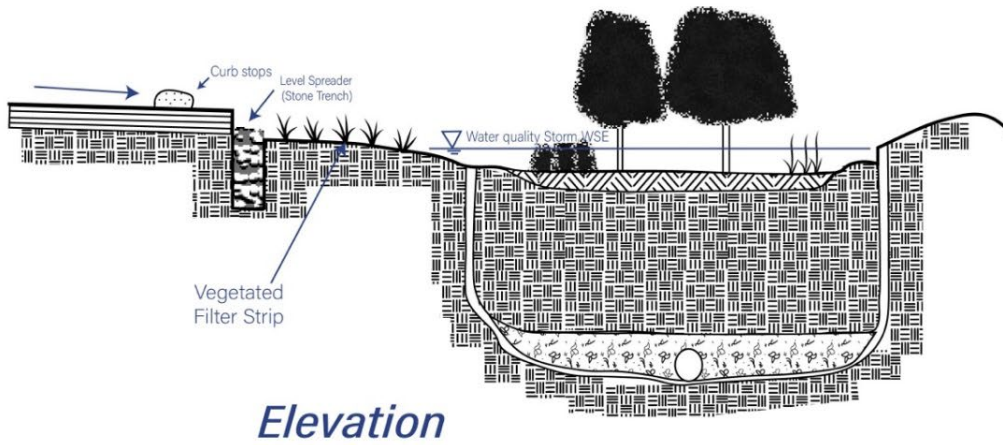
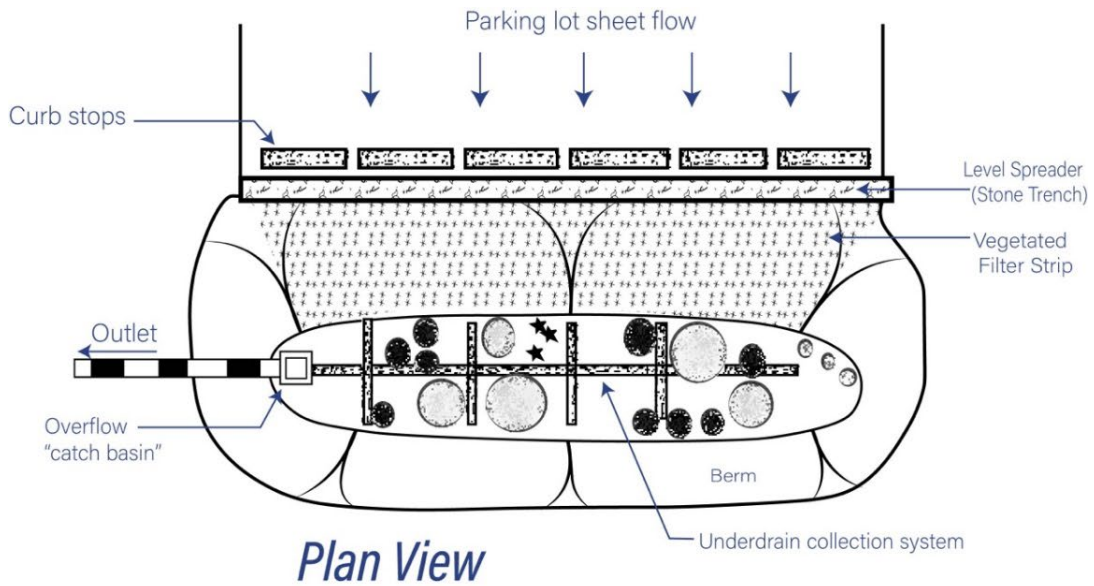
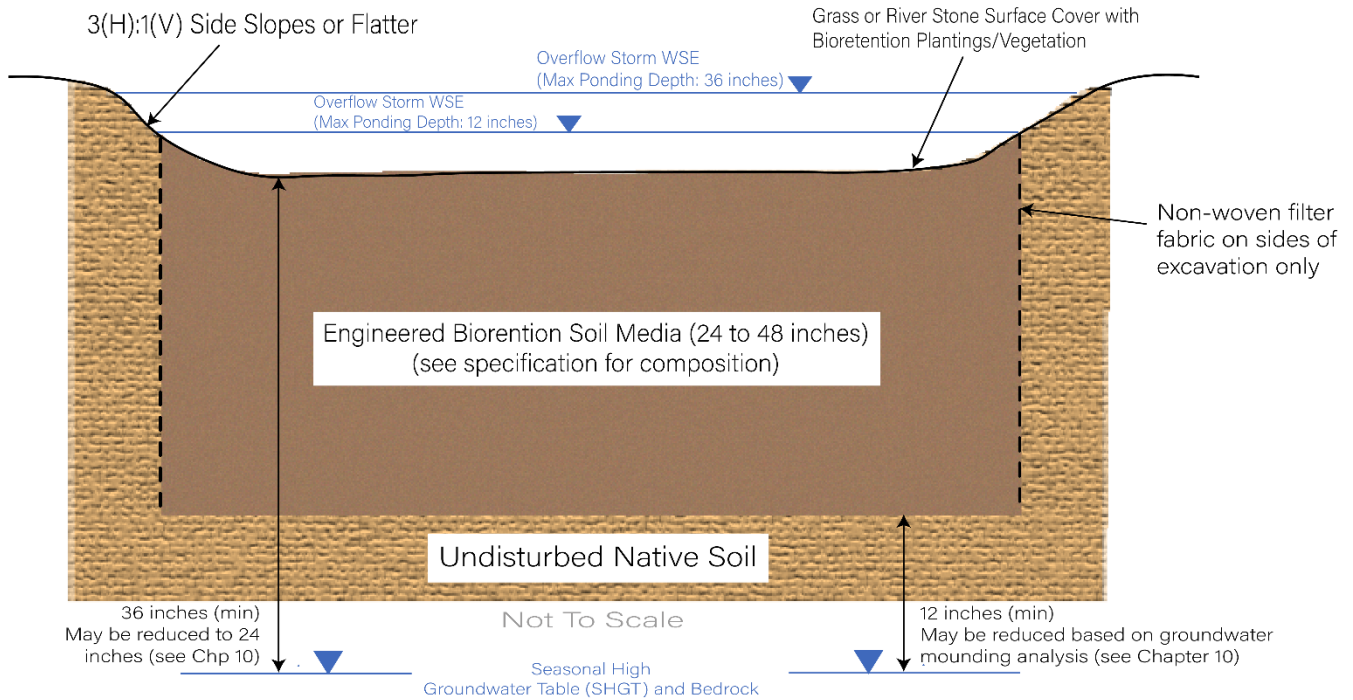

Figure 13-17. Bioretention System without and with Underdrain Schematic

Without Underdrain



With Underdrain

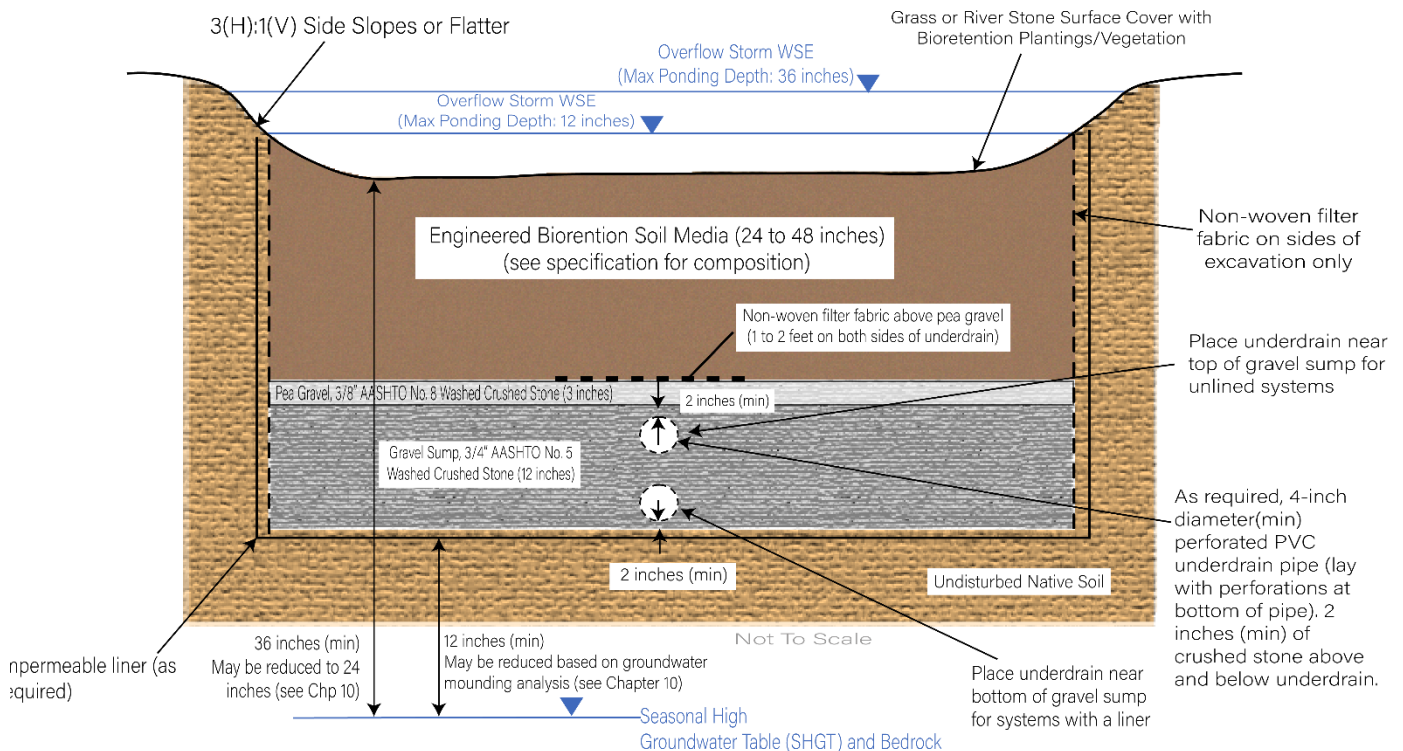
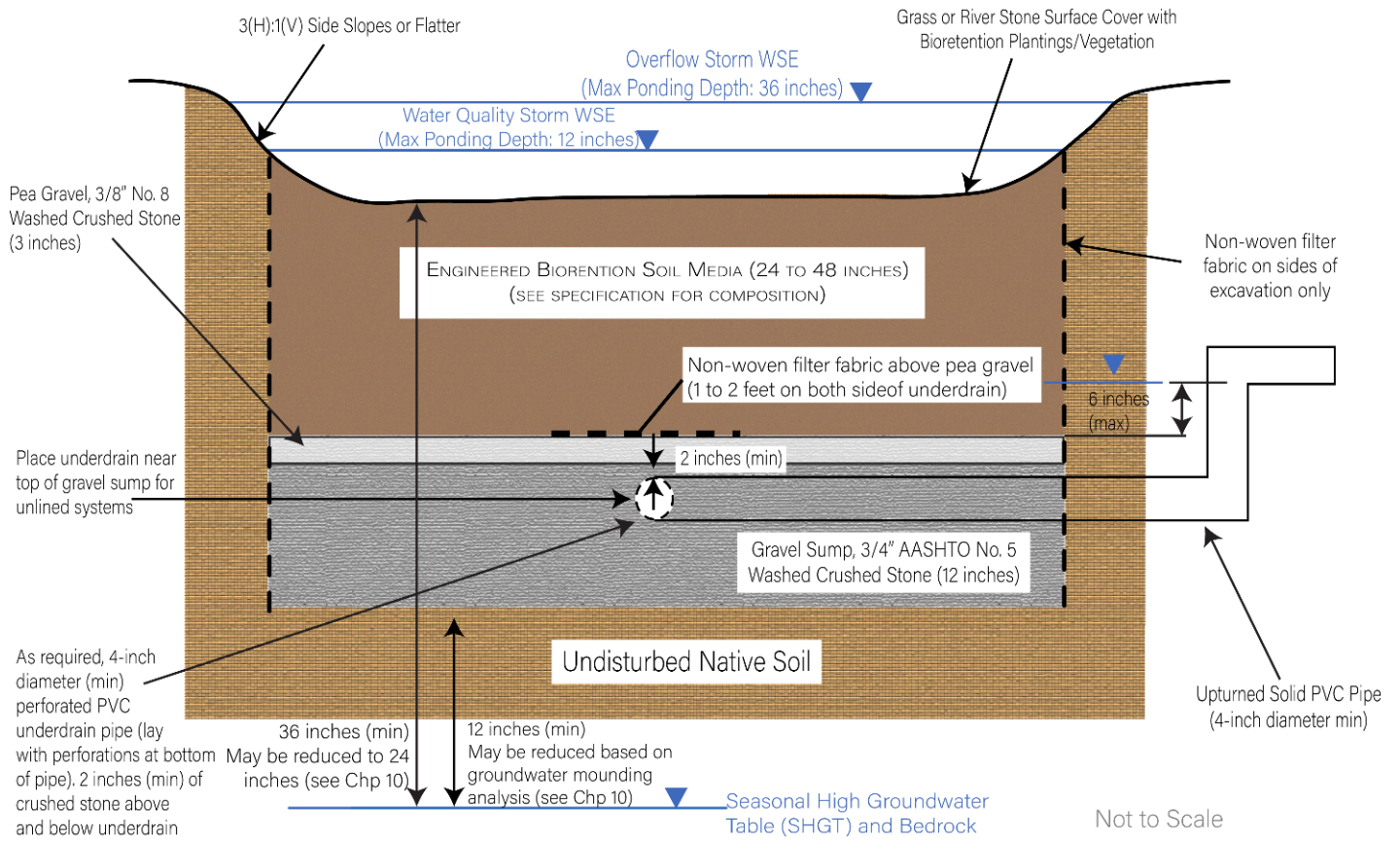

Figure 13-18. Bioretention System with Underdrain and Internal Water Storage Zone



Tree Filter



Description

Tree filters are compact bioretention systems consisting of an open-bottomed chamber with one or more trees and filled with engineered soil media. Tree filters collect, temporarily store, and filter stormwater runoff through the engineered soil media, and the tree provides pollutant uptake. Tree filters are particularly well suited to urban or built-out areas where they can easily fit into small footprints and/or work as retrofits. Tree filters often work in tandem with existing stormwater networks allowing less frequent, high-intensity storm events to bypass the system.

Tree filters consist of three main parts: the tree, soil media, and chamber. The chamber is typically filled with engineered soil media that is designed for rapid infiltration. The system is planted with non-invasive trees or shrubs. The top of the chamber typically has a tree grate to protect the base of the tree, soil, and root system, as well as for pedestrian safety. The grate also serves to keep trash and debris from entering the top of the chamber. Most of the stormwater enters the system through a curb cut under the grate. Within the chamber there is typically storage for ponded stormwater runoff above the soil media. The engineered soil media filters the stormwater runoff as it flows downward through the system. The filtered runoff is collected in an underdrain and returned to the storm drainage system or infiltrates into the underlying soil. Tree filters provide pollutant removal via filtration, infiltration, pollutant uptake, and adsorption.

Advantages

- Applicable to small drainage areas and narrow right-of-way areas where space is limited.

Stormwater BMP Type

Pretreatment BMP	<input type="checkbox"/>
Infiltration BMP	<input type="checkbox"/>
Filtering BMP	<input checked="" type="checkbox"/>
Stormwater Pond BMP	<input type="checkbox"/>
Stormwater Wetland BMP	<input type="checkbox"/>
Water Quality Conveyance BMP	<input type="checkbox"/>
Stormwater Reuse BMP	<input type="checkbox"/>
Proprietary BMP	<input type="checkbox"/>
Other BMPs and Accessories	<input type="checkbox"/>

Stormwater Management Suitability

Retention*	<input checked="" type="checkbox"/>
Treatment	<input checked="" type="checkbox"/>
Pretreatment	<input type="checkbox"/>
Peak Runoff Attenuation	<input type="checkbox"/>

*Exfiltration systems only

Pollutant Removal

Sediment*	High
Phosphorus	Moderate
Nitrogen	Moderate
Bacteria	Moderate

*Includes sediment-bound pollutants and floatables (with pretreatment)

Implementation

Capital Cost	High
Maintenance Burden	Medium
Land Requirement	Low

- Ideal for stormwater retrofits and highly developed sites.
- Requires less space than other forms of bioretention.
- Can provide stormwater retention, runoff volume reduction, and groundwater recharge if designed for infiltration.
- Can provide aesthetic benefits by enhancing the streetscape like standard street trees.
- Provides other non-stormwater benefits of trees including cleaner air, reduction of heat island effect, carbon sequestration, reduced noise pollution, reduced pavement maintenance needs, and cooler cars in shaded parking lots.
- Available with pre-cast concrete or proprietary (i.e., manufactured) designs or non-proprietary designs for reduced cost.

Limitations

- Limited to smaller drainage areas.
- Frequent maintenance required.
- Should not be used in areas of heavy sediment loads (i.e., unstabilized construction sites).
- Generally, less cost-effective than other stormwater infiltration systems in terms of cost per cubic foot of runoff treated due to cost of bioretention soil media and subsurface structural components.

Siting Considerations

- **Drainage Area:** The maximum contributing drainage area for one individual tree filter is between 0.25 and 0.5 acre. Larger drainage areas can be managed with the use of multiple tree filters; however, there may be more cost-effective solutions for larger drainage areas.
- **Soils:** Tree filters that return filtered runoff to the conveyance system and do not infiltrate into the ground can be used in almost any soil type. Tree filters that rely on infiltration should be used only when the soil infiltration characteristics are appropriate (see [Chapter 10](#) for design guidance for stormwater infiltration systems).
- **Land Use:** Tree filters are suitable in ultra-urban settings where space is limited as well as residential and suburban areas. Potential locations include medians, streetscapes (e.g., between the curb and sidewalk), roadway shoulders, and along shared-use paths. Locate where the structural integrity of the roadbed material will not be compromised and where snow storage will not occur atop the tree filter.
- **Water Table and Bedrock:** For tree filters designed for infiltration (unlined systems), meet the minimum required vertical separation distances from the top and bottom of the filtering system to the seasonal high groundwater table (SHGT) and bedrock, as described in [Chapter 10](#).
- **Horizontal Setbacks:** For bioretention systems designed for infiltration (unlined systems), meet the minimum horizontal setback distances in [Chapter 10](#).

Soil Evaluation

- Conduct an evaluation of the soil characteristics and subsurface conditions at the location of the proposed system including soil type, depth to the seasonal high groundwater table, depth to bedrock, and soil infiltration rate. Refer to [Chapter 10](#) for soil evaluation guidance.

Design Recommendations

General Considerations

This section addresses three types of tree filter designs ([Table 13-7](#). Tree Filter Design Types

Type of System	Underdrain Type	Infiltration or Filtration Design?	Suitable for Retention?	Suitable for Treatment?	General Conditions for Use
Tree Filter with Underdrain Partial Infiltration System	Raised Underdrain	Infiltration and Filtration (partial infiltration)	Yes (infiltration volume only)	Yes	All HSG Soil types Underdrain required for HSG C and D Soils
Tree Filter with Underdrain and Liner Flow-Through System	Underdrain and Impermeable Liner	Filtration Only	No	Yes	Land Uses with Higher Potential Pollutant Loads Contaminated sites Where required vertical separation to SHGT cannot be met Sites with unacceptable setback distances for infiltration
Tree Filter Without Underdrain Infiltration System	No Underdrain	Infiltration and Filtration (Full infiltration)	Yes	Yes	HSG A and B Soils

- **Tree Filter with Underdrain (Partial Infiltration System):** Tree filters are commonly designed with an underdrain to account for potential infiltration failure due to clogging, groundwater mounding, or periods of excessive rainfall. Underdrained systems can be used with any soil type or soil infiltration rate. The underdrain should be raised above the bottom of the system to maximize infiltration and enhance nitrogen removal. Underdrained systems (without a liner) are suitable for providing stormwater retention, although only the infiltrated volume (not the volume discharged via the underdrain) can be credited toward the Standard 1 retention requirement.
- **Tree Filter with Underdrain and Liner (Flow-Through System):** An underdrain and impermeable liner are required for use with Land Uses with Higher Potential Pollutant Loads (LUHPPLs) (see [Chapter 10](#)), in locations where contaminated soils exist, where the required vertical separation to SHGT cannot be met, or in locations with unacceptable horizontal setbacks for infiltration. Such systems are suitable for providing treatment but do not provide retention credit.
- **Tree Filter with No Underdrain (Infiltration System):** Tree filters can be designed to fully infiltrate into the native soil without an underdrain. Such systems, also called “treewells,” are best suited for use with Hydrologic Soil Group (HSG) A and B soils. Tree filters can have higher relative construction costs than other surface infiltration systems presented in this Manual (infiltration basins and trenches) due to the cost of the engineered bioretention soil, plantings, subsurface structural components, etc. Infiltration tree filters (tree wells) can be designed without pre-cast or proprietary concrete chambers at reduced construction cost.

Table 13-4. Tree Filter Design Types

Type of System	Underdrain Type	Infiltration or Filtration Design?	Suitable for Retention?	Suitable for Treatment?	General Conditions for Use
Tree Filter with Underdrain Partial Infiltration System	Raised Underdrain	Infiltration and Filtration (partial infiltration)	Yes (infiltration volume only)	Yes	All HSG Soil types Underdrain required for HSG C and D Soils
Tree Filter with Underdrain and Liner Flow-Through System	Underdrain and Impermeable Liner	Filtration Only	No	Yes	Land Uses with Higher Potential Pollutant Loads Contaminated sites Where required vertical separation to SHGT cannot be met Sites with unacceptable setback distances for infiltration
Tree Filter Without Underdrain Infiltration System	No Underdrain	Infiltration and Filtration (Full infiltration)	Yes	Yes	HSG A and B Soils

Pretreatment

- Commonly incorporate pretreatment measures at locations where runoff enters the tree filter in accordance with the [Pretreatment BMPs](#) section of this Manual.
- Acceptable pretreatment measures include interior concrete sediment collection chambers and exterior deep sump hooded catch basins.
- Interior Concrete Sediment Collection Chambers
 - Should be designed to overflow directly into the tree filter via a level overflow weir wall.
 - Elevation of overflow weir wall should be sufficiently lower than gutter line to at least pass the applicable Water Quality Volume (WQV) or Water Quality Flow (WQF) below the elevation of the gutter line.
 - Should be equipped with a cover or with an overall tree filter grate.
 - Minimum depth: 4 feet from top of overflow weir wall.
 - Minimum bottom surface area: 6 square feet with no individual dimension (length or width) less than 2 feet.
 - Provide two 2-inch diameter seep holes (the lowest being 2 feet above interior bottom of collection chamber) along the weir wall.
- Deep Sump Hooded Catch Basin
 - Typically requires the tree filter surface to be at least 24 inches below the top of curb/sidewalk due to the depth of the catch basin outlet pipe.
 - If constructing a new catch basin, use a square catch basin structure, which should directly abut the tree filter. The width of the outlet should extend the full inside width of the catch basin structure. Outlet opening height should be sufficient to convey the applicable WQV or WQF but should not be less than 4 inches.
 - Minimum sump depth: 4 feet
 - If utilizing an existing round deep sump hooded catch basin structure, runoff can be conveyed to the tree filter via a pipe (see deep sump hooded catch basin design in the [Pretreatment BMPs](#) section of this Manual).

Sizing and Dimensions

- Tree Filter Bed (Bottom) Area
 - Tree filters should be designed by either the Static or Dynamic Methods as described in [Chapter 10](#).
 - Tree filters should completely drain in 48 hours or less after the end of the design storm as described in [Chapter 10](#).
 - For unlined systems, the design infiltration rate used for system sizing and drain time analysis should be equal to 50% of the slowest observed field infiltration rate of the underlying soils or 0.5 inches per hour (1.0 feet per day) for the bioretention soil media, whichever value is lower.

- For lined systems, use the coefficient of permeability of the bioretention soil media (0.5 inches per hour or 1.0 feet per day or) in the drain time analysis.
- Multiple tree filters can be combined to meet water quality goals.
- Bioretention Soil Depth
 - Engineered bioretention soil media should have a depth of 24 to 48 inches ,or as necessary to accommodate the required sizing, vegetation species and root establishment/growth, and subsurface conditions. The volume should be adequate to ensure root systems and thereby the tree will be viable and able to grow.
 - Bioretention systems with trees should have a minimum soil depth of 30 inches.
 - Soil depth may be limited by the requirement to maintain adequate separation to groundwater and bedrock as specified in [Chapter 10](#).
- Ponding Depth
 - Maximum for water quality storm: 6 inches
 - Maximum for overflow events: 9 inches (preferred) to 12 inches (absolute maximum)
- Freeboard Depth
 - Minimum freeboard depth: 3 to 6 inches
 - As measured from the elevation of the maximum ponding depth to the facility's overflow elevation or to the invert of the inlet to the facility, whichever is lower.
- Bottom Width
 - Minimum: 5 feet
- Bottom Slope
 - Design bottom of tree filter to be level.
- Concrete Tree Filter Chamber
 - Should be a minimum of 18 inches deep below top of curb/sidewalk and should be designed to support adjacent structures.

Inlet

- Design the inlet in accordance with the [Inlet and Outlet Controls](#) section of this Manual.
- Runoff can be introduced via a curb cut or drop inlet. Runoff can be introduced via a pipe from an upstream structure such as a catch basin, although this option is limited as it requires either a shallow upstream structure and/or deeper tree filter .
- Design the bioretention system in an off-line configuration to the extent feasible if runoff is delivered by a storm drain pipe or is along the main storm conveyance system.

- Depth between inlet and top of engineered soil media should be 2 inches or less and should be designed to minimize erosion within the tree filter.

Outlet & Overflow

- Tree filters designed off-line are typically sized to handle only the Water Quality Volume.
 - If the tree filter is designed to infiltrate and meets the infiltration criteria, an outlet is not required. Once the system has reached its capacity (i.e., once the system is full), additional flow will bypass the tree filter. The designer should confirm that the bypassed flow is managed downstream and does not worsen flooding.
- Tree filters designed in an on-line configuration must have an outlet sized to convey the 10-year, 24-hour storm event, at a minimum.
 - Design the outlet in accordance with the [Inlet and Outlet Controls](#) section of this Manual.
 - Outlets are typically an overflow riser that discharges to a storm drainage system.
 - Outlets must be designed such that stormwater does not overflow from the tree filter onto adjacent roadway surfaces.
- If used, underdrains can connect to a downstream drainage system or daylight at an approved discharge point.

Underdrain System

- Use an underdrain system when a proposed tree filter meets one or more of the following conditions:
 - Is in native soil that has an infiltration rate less than 0.3 inch per hour (HSG C and D soils)
 - Does not meet vertical separation distance to SHGT or bedrock ([Chapter 10](#)) and should be lined
 - Does not meet minimum horizontal setback distances ([Chapter 10](#)) and should be lined
 - Is within a Land Use with Higher Potential Pollutant Loads (LUHPPL) ([Chapter 10](#)) or area of contaminated soils and should be lined.
- An underdrain is also recommended, but not required, for other tree filter installations to account for potential infiltration failure due to clogging, groundwater mounding, or periods of excessive rainfall.
- Minimum underdrain pipe diameter: 4 inches
- Minimum underdrain pipe slope: 0.5%

- Use two layers of gravel with the underdrain system. Both layers of gravel should be located below and extend across the entire bottom of the tree filter chamber. The upper gravel layer should consist of 3 inches of pea gravel, and the lower layer should consist of a 12-inch thick gravel sump.
- For unlined systems, install the perforated underdrain pipe at the top of the 12-inch gravel sump. For systems that are lined with an impermeable liner to prevent infiltration, install the underdrain pipe at the bottom of the 12-inch gravel sump so the system can drain completely between storm events.
- If the tree filter is designed without an underdrain, pea gravel and gravel sump are optional.
- Lay underdrain such that perforations are on the bottom of the pipe.
- Use solid (non-perforated) pipe sections and watertight joints outside the BMP.
- If an underdrain is used, place non-woven filter fabric above the pea gravel (below the bioretention soil layer) for a distance of 1 to 2 feet on both sides of the underdrain. Filter fabric should not be placed across the entire width of the chamber. If gravel storage/underdrain layers extend below the concrete chamber, place filter fabric along sidewalls of excavation below the chamber.
- Other considerations when designing/installing underdrains:
 - Provide a marking stake and an animal guard for underdrains that daylight at grade.
- Include a minimum of one observation well/cleanout for each underdrain.
 - Cleanouts should be at least 4 inches in diameter, be nonperforated, and extend to the surface. Cap cleanouts with a watertight removable cap. The cleanout should be highly visible at the ground surface or below the grate when the grate is removed.

Materials

- Surface Cover
 - If a tree filter grate is used, no surface cover is required over the bioretention soil media.
 - If a tree filter grate is not used, a minimum 3-inch thick layer of river stone may be used on top of the bioretention soil media.
 - Mulch may be used directly around the base of the tree, but mulch should NOT be used to cover the entire surface of the tree filter.
 - If mulch is used, use 2 to 4 inches of shredded hardwood bark mulch, aged for 6 months minimum.

- Vegetation
 - Select tree/shrub species with guidance provided in [Appendix F](#) of this Manual. Use of native species is recommended.
 - Location of tree filter and species should be selected to avoid obstruction of sight lines.

- Engineered Bioretention Soil Media
 - The engineered bioretention soil media in tree filters systems is designed to filter/treat runoff and to provide sufficient organic material to support plant establishment and growth.
 - The engineered bioretention soil media should be a homogeneous soil mix of (by volume):
 - 60–85% Sand
 - 15–25% Topsoil
 - 3–8% Organic Matter
 - **Sand** should be washed concrete sand (ASTM C33 or AASHTO M-6) or coarse washed sand that meets the gradation schedule as shown in State of Connecticut Department of Transportation Standard Specifications, Section M.01 (Aggregates), Table M.01.04-1 for Fine Aggregate Gradations.
 - **Topsoil** should contain 5–20% organic material, have a pH range of 5.5 to 7.0, and be a sandy loam, loamy sand, or loam per USDA soil texture with less than 5% clay content. Topsoil that meets the State of Connecticut Department of Transportation Standard Specifications, Section M.13.01 (Roadside Development) for Topsoil may also be used, except it should contain less than 5% clay.
 - **Organic matter** should consist of one of the following materials
 - Sphagnum Peat: Partially decomposed sphagnum peat moss, finely divided or of granular texture with 100 percent passing through a 1/2-inch (13-mm) sieve, a pH of 3.4 to 4.8.
 - Wood Derivatives: Shredded wood, wood chips, ground bark, or wood waste; of uniform texture and free of stones, sticks, soil, or toxic materials.
 - Compost shall NOT be used as organic matter since the use of compost in bioretention soil media can result in nutrient export from the system.
 - Soil amendments such as zerovalent iron and/or drinking water treatment residuals (alum) may be used to further enhance phosphorus sorption.
 - Bioretention soil mix should have a pH of 5.2 to 7.0 and meet the particle size distribution defined in [Table 13-8](#).

Table 13-5. Acceptable Particle Size Distribution of Final Bioretention Soil Mix

Media Type	Sieve #	Size (inches)	Size (mm)	% Passing
Coarse Sand	4	0.187	4.76	100
Medium Sand	10	0.079	2.00	95
Fine Sand	40	0.017	0.42	40-15
Silt	200	0.003	0.075	10-20
Clay	<200	Pan	Pan	0-5

- Bioretention soil mix should NOT contain any of the following materials: stones, clods, roots, clay lumps, and pockets of coarse sand exceeding 0.187 inches (4.76 mm) in any dimension; plants, sod, concrete slurry, concrete layers or chunks, cement, plaster, building debris, asphalt, bricks, oils, gasoline, diesel fuel, paint thinner, turpentine, tar, roofing compound, acid, solid waste, and any other extraneous materials that are harmful to plant growth.
- Pea Gravel
 - Should consist of 3/8" AASHTO No. 8 stone. Pea gravel should be clean (washed and free from dirt and debris) and rounded in shape.
- Gravel Sump
 - Should consist of 3/4" AASHTO No. 5 stone. Gravel should be clean (washed and free from dirt and debris), crushed, and angular.
- Filter Fabric
 - Use non-woven filter fabric that complies with State of Connecticut Department of Transportation Standard Specifications, Section M.08.01.19 (Drainage – Geotextiles).
- Poured-in-place Concrete
 - If used, should be an appropriate class of concrete based on the application and conform to State of Connecticut Department of Transportation Standard Specifications, Section 6.01 (Concrete for Structures).
- Underdrain (perforated and non-perforated pipe sections)
 - Polyethylene or polyvinyl pipe.
- Liner
 - If used, should consist of a 30 mil (minimum) HDPE or PVC liner, or one of the alternative liner systems described in [Chapter 10](#) with the approval of the review authority.

Other Considerations

- If tree filter is located adjacent to a sidewalk or in an area subject to high pedestrian traffic, consider the use of curb around the perimeter of the tree filter, or the use of a grate over the tree filter to reduce trip hazard and prevent pet waste and trampling.
 - If height from top of tree filter media to sidewalk elevation is greater than 12 inches, use a grate.
- Where existing sidewalks are modified to incorporate tree filters, the sidewalk should comply with meet accessibility requirements.
 - Grates can be used over tree filters to meet sidewalk width accessibility requirements.
- If designing a lined system in a location where SHGT is located at or above the bottom of the liner or closed bottom of the system, complete a buoyancy analysis to ensure buoyancy of the system will not be an issue.
- For lined systems within LUHPPLs, a shutoff valve can be installed on the underdrain outlet to capture and contain accidental spills or releases that reach the bioretention system.
- Roadway stability can be a design issue when installing tree filters along roadways. It may be necessary to provide a vertical impermeable barrier to keep water from saturating the road's sub-base. The barrier should be capable of supporting H-20 loads.

Winter Operations

- Tree filters should not be used as dedicated snow storage areas. To the extent feasible, locate and design the system to avoid snow storage areas and potential damage from snow plowing activities. If unavoidable, use grates and tree protection barriers to minimize potential damage to the system. Refer to [Chapter 7](#) for general design considerations related to winter operations.

Construction Recommendations

- The designing qualified professional should develop a detailed, site-specific construction sequence.
- The designing qualified professional should inspect the installation during the following stages of construction, at a minimum:
 - After excavation of the system and installation of the concrete chamber
 - After placement of gravel layer
 - After placement of underdrain before covering by the pea gravel layer
 - After placement of bioretention soil media
 - After installation of bypass, outlet/overflow, and inlet controls
 - After tree has been installed

- The designing qualified professional should provide an as-built plan of the completed system along with a certification that the system was designed in accordance with the guidance contained in this Manual and other local or state requirements and that the system was installed in accordance with the approved plans.
- The bioretention soil mix should be tested prior to placement according to the specifications in this section (at least one test per bioretention system). The designing qualified professional should certify that the bioretention soil mix meets the specifications in the previous section based on soil testing results.
- The entire contributing drainage area should be completely stabilized prior to directing any flow to the bioretention system. Adequate vegetative cover must be established over any pervious area adjacent or contributing to the system before runoff can be accepted.
- Erosion and sediment controls should be in place during construction in accordance with the [Connecticut Guidelines for Soil Erosion and Sediment Control](#) and the Soil Erosion and Sediment Control (SESC) Plan developed for the project.
- During clearing and grading of the site, measures should be taken to avoid soil compaction at the location of the proposed tree filter.
- The system should be fenced off during the construction period to prevent disturbance of the soils.
- The system should be excavated to the dimensions and elevations shown on the plans. The method of excavation should avoid compaction of the bottom of the system. Excavation equipment should not be allowed within the limits of the system.
- The gravel, pea gravel, and bioretention soil media should be placed in the excavation by a hydraulic excavator located outside the limits of the system and then hand-raked to the desired elevation.
- Place the bioretention soil in 6 to 12-inch lifts. The bioretention soil needs to settle before planting. Lightly tamp or spray the surface of the bioretention soil with water until saturated. The elevation of the bioretention soil can be a couple of inches higher at installation than the design elevation in anticipation of settling. Bring bioretention soil levels back to the design elevation if necessary.
- Install tree or shrub(s) in the tree filter. Water tree/shrubs thoroughly immediately after planting and as necessary until fully established. The bioretention soil mix provides enough organic material to adequately supply nutrients from natural cycling.

Maintenance Needs

- Tree filters should be designed with easy access to all components of the system for maintenance purposes. Refer to [Chapter 7](#) for general design considerations to reduce and facilitate system maintenance.
- Detailed inspection and maintenance requirements, inspection and maintenance schedules, and those parties responsible for maintenance should be identified on the plans and in the Stormwater Management Plan.
- Maintenance should be detailed in a legally binding maintenance agreement.
- Maintenance activities such as sediment removal and repairs should be performed with rakes and light-weight equipment rather than heavy construction equipment to avoid compaction of the bioretention soil media and underlying soils. Heavy equipment may be used for sediment removal and other maintenance activities if the equipment is positioned outside the limits of the system. Heavy construction equipment should not be allowed within the limits of the system for maintenance purposes.

Recommended Maintenance Activities

- Inspect after major storms (1 inch or more of precipitation) in the first few months following construction.
- Inspect tree filter annually.
- Refer to [Appendix B](#) for maintenance inspection checklists, including items to focus on during the inspections.
- Remove trash and organic debris (leaves) in the Spring and Fall.
- Remove sediment from the sediment chamber or other pretreatment area when it accumulates to a depth of more than 12 inches or 50% of the design depth. Clean outlet of sediment forebay or other pretreatment measures when drawdown time exceeds 36 hours after the end of a storm event.
- Remove accumulated sediment from the tree filter when the sediment accumulation exceeds 1 inch or when drawdown time exceeds 48 hours after the end of a storm event, indicating that the soil media is clogged. Replace with fresh bioretention soil media that conforms to the specifications in this section.
- Tree filters require seasonal landscape maintenance, including:
 - Watering trees and shrubs as necessary during first growing season
 - Watering as necessary during dry periods
 - Treating diseased trees and shrubs as necessary
 - Inspection of soil and repairing eroded areas around the tree filter

- Removal of litter and debris from the tree filter surface and/or grate

Figure 13-19. Tree Filter with Underdrain Schematic

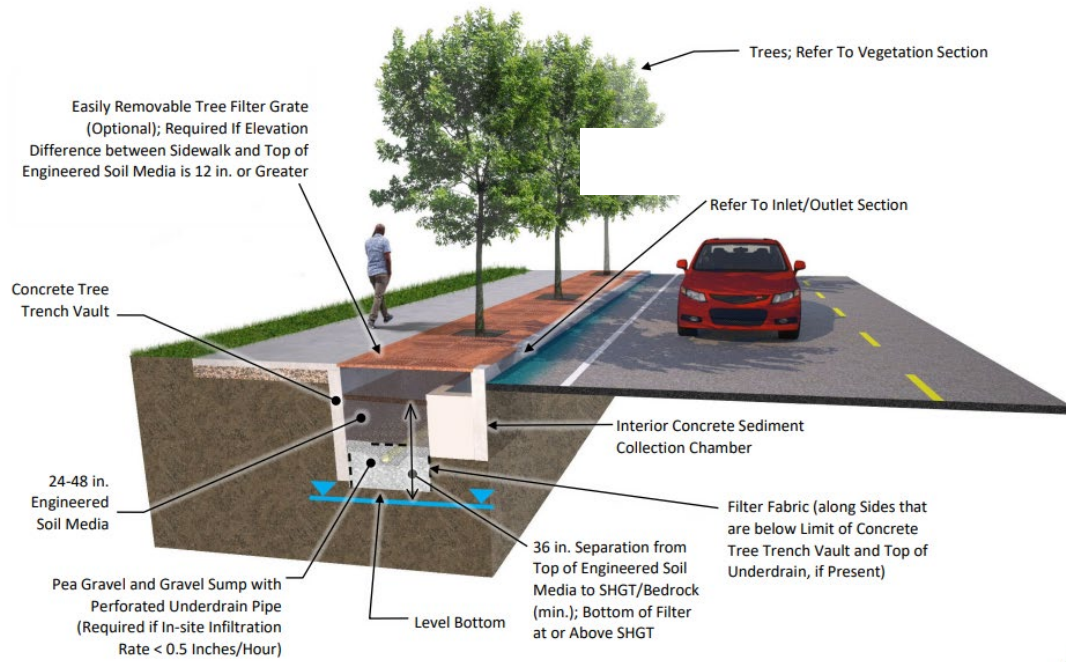

RIDOT Linear Stormwater Manual

2-115



Figure 13-20. Tree Filter without Underdrain (Treewell) Schematic

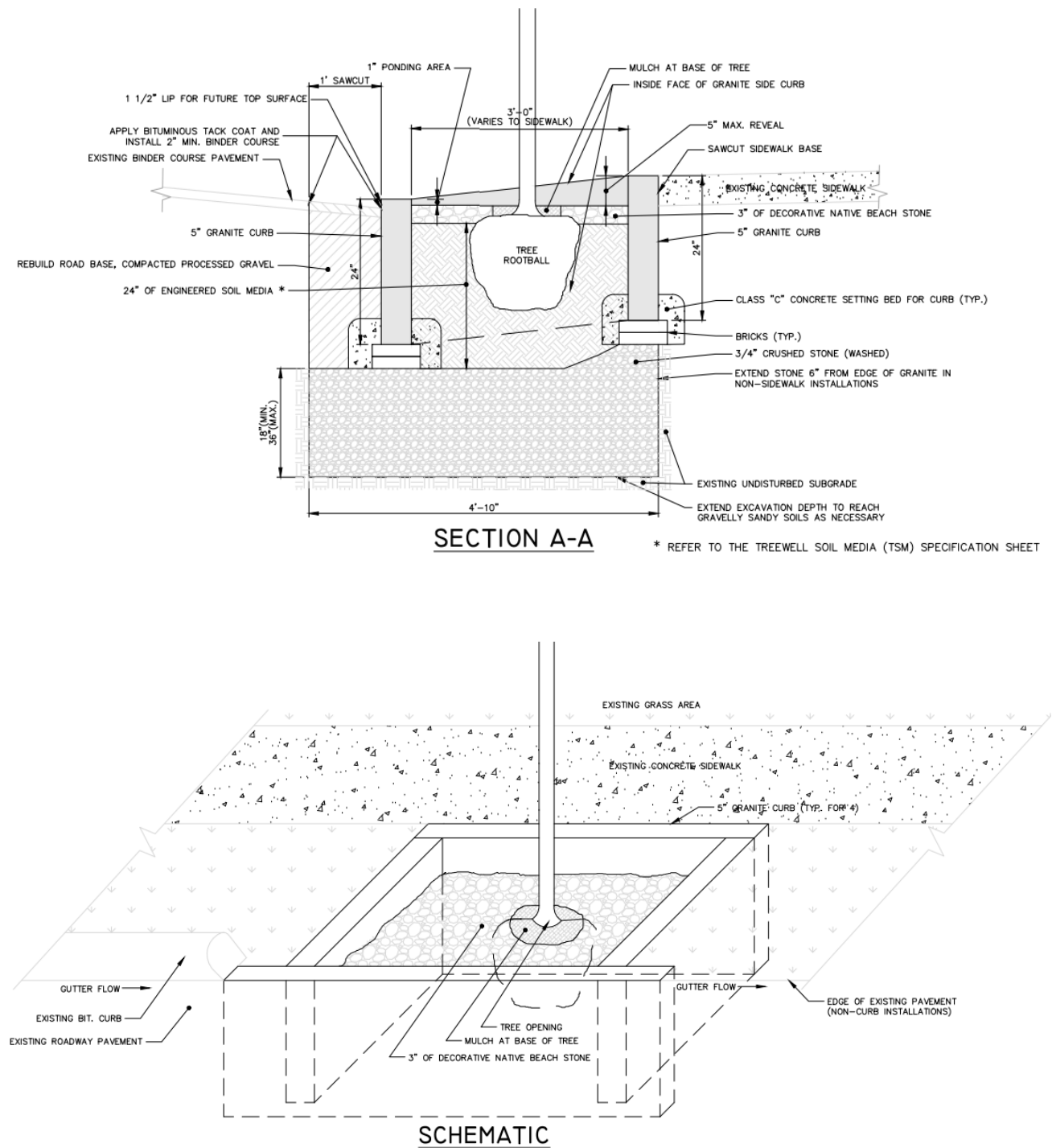

Source: Niantic Treewell Design, Town of East Lyme Engineering Department.

Sand Filter



Description

Sand filters are sand-filled basins or trenches that capture, temporarily store, and filter stormwater runoff. Sand filters can be designed as surface filters or underground filters. The design guidelines in this section focus on surface sand filters. Sand filters require less space than other filtering practices but must be in locations with adequate elevation to provide the necessary hydraulic head. Sand filters have higher longevity than other filtering practices and generally have a lower land requirement than bioretention basins.

Sand filters are frequently designed to infiltrate but are always equipped with an underdrain to capture filtered water and assist with drainage from the system. Following pretreatment, stormwater is temporarily stored above the surface of the sand filter and flows downward through a layer of sand that filters the runoff before discharging from the system through an underdrain or into the underlying soil via infiltration. Pollutants in runoff are treated in sand filters through the processes of settling, filtration, and adsorption. Surface sand filters may also be used to provide stormwater quantity control when designed as on-line facilities.

Sand filters are better suited for impervious drainage areas. They are not recommended for use in pervious drainage areas where high sediment loads, and organic material can clog the sand bed.

Advantages

- Applicable to small drainage areas.
- May require less space than other BMPs.

Stormwater BMP Type	
Pretreatment BMP	<input type="checkbox"/>
Infiltration BMP	<input type="checkbox"/>
Filtering BMP	<input checked="" type="checkbox"/>
Stormwater Pond BMP	<input type="checkbox"/>
Stormwater Wetland BMP	<input type="checkbox"/>
Water Quality Conveyance BMP	<input type="checkbox"/>
Stormwater Reuse BMP	<input type="checkbox"/>
Proprietary BMP	<input type="checkbox"/>
Other BMPs and Accessories	<input type="checkbox"/>
Stormwater Management Suitability	
Retention	<input checked="" type="checkbox"/>
Treatment	<input checked="" type="checkbox"/>
Pretreatment	<input type="checkbox"/>
Peak Runoff Attenuation	<input checked="" type="checkbox"/>
Pollutant Removal	
Sediment*	High
Phosphorus	Moderate
Nitrogen	Moderate
Bacteria	High
*Includes sediment-bound pollutants and floatables (with pretreatment)	
Implementation	
Capital Cost	Medium
Maintenance Burden	High
Land Requirement	Medium

- Ideal for stormwater retrofits and highly developed sites.
- High solids, metals, and bacteria removal efficiency.
- High longevity.

Limitations

- Limited to smaller drainage areas.
- Frequent maintenance required.
- Typically require a minimum head difference of approximately 5 feet between the allowable pool elevation above the filter and outlet of the filter.
- Not feasible in areas of high-water tables.
- Should not be used in areas of heavy sediment loads (i.e., unstabilized construction sites).
- Can be unattractive without grass or vegetative cover. Bioretention may be a more aesthetically pleasing alternative due to incorporation of more diverse selection of plants.

Siting Considerations

- **Drainage Area and Head:** The maximum contributing drainage area for surface sand filters is 5 acres. Sand filters are best located where there is adequate surface area to temporarily store stormwater and enough elevation difference (2 to 6 feet) between the design pool elevation and the outlet of the sand filter (underdrain or underlying soil).
- **Slopes:** Sand filters can be used on sites with slopes of approximately 6 percent or less. Locate sand filters where the topography allows the design of the sand filter bottom to be level.
- **Soils:** Sand filters that return filtered runoff to the conveyance system and do not infiltrate into the ground can be used in almost any soil type. Sand filters that rely on infiltration should be used only when the soil infiltration characteristics are appropriate (see [Chapter 10 - General Design Guidance for Stormwater Infiltration Systems](#) for design guidance for stormwater infiltration systems).
- **Land Use:** Sand filters are suitable in urban and rural settings. Sand filter systems are generally applicable to highly impervious sites. Potential locations include along shared-use paths, along borders of parking lots, and within available open space/pervious areas. Sand filters should be sited in locations that will not be used as dedicated snow storage areas and which have low likelihood for pedestrian traffic.
- **Water Table and Bedrock:** For sand filters designed for infiltration (unlined systems), at least 3 feet of separation is recommended between the bottom of the sand and the seasonal high groundwater table (SHGT) and bedrock to maintain adequate drainage, prevent structural damage to the filter, and minimize the potential for interaction with groundwater. The vertical separation distance to the SHGT or bedrock may be reduced to 2 feet as described in [Chapter 10 - General Design Guidance for Stormwater Infiltration Systems](#).

Soil Evaluation

- Conduct an evaluation of the soil characteristics and subsurface conditions at the location of the proposed system including soil type, depth to the seasonal high groundwater table, depth to bedrock, and soil infiltration rate. Refer to [Chapter 10 - General Design Guidance for Stormwater Infiltration Systems](#) for soil evaluation guidance.

Design Recommendations

General Considerations

This section addresses two types of surface sand filter designs. [Figure 13-21](#) is a schematic of a surface sand filter design. (See [Table 13-9](#)):

- **Surface Sand Filter with Underdrain - Unlined (Partial Infiltration System):** All surface sand filters should be designed with an underdrain to account for potential infiltration failure due to clogging, groundwater mounding, or periods of excessive rainfall. Underdrained systems can be used with any soil type or soil infiltration rate. The underdrain should be raised above the bottom of the system to maximize infiltration. Underdrained sand filter systems (without a liner) are suitable for providing stormwater retention, although only the infiltrated volume (not the volume discharged via the underdrain) can be credited toward the Standard 1 retention requirement.
- **Surface Sand Filter with Underdrain and Liner (Flow-Through System):** An underdrain and liner are required for use with Land Uses with Higher Potential Pollutant Loads (LUHPPLs) (see [Chapter 10 - General Design Guidance for Stormwater Infiltration Systems](#)), in locations where contaminated soils exist, where the required vertical separation to SHGT cannot be met, or in locations with unacceptable horizontal setbacks for infiltration. Such systems are suitable for providing treatment but do not provide retention credit.

[Figure 13-21](#) is a schematic of a surface sand filter design.

Table 13-6. Surface Sand Filter Design Types

Type of System	Underdrain Type	Infiltration or Filtration Design?	Suitable for Retention?	Suitable for Treatment?	General Conditions for Use
Surface Sand Filter with Underdrain – Unlined Partial Infiltration System	Raised Underdrain	Infiltration and Filtration	Yes (infiltration volume only)	Yes	All HSG Soil types
Surface Sand Filter with Underdrain and Liner Flow-Through System	Underdrain and Impermeable Liner	Filtration Only	No	Yes	Land Uses with Higher Potential Pollutant Loads Contaminated sites Where required vertical separation to SHGT cannot be met Sites with unacceptable setback distances for infiltration

Pretreatment

- Incorporate pretreatment measures at locations where runoff enters the sand filter in accordance with the [Pretreatment BMPs](#) section of this Manual.
- Acceptable pretreatment measures include vegetative filter strips, sediment forebays, pretreatment swales, deep sump hooded catch basins, and proprietary pretreatment devices.
- Sediment forebays should have a minimum storage volume of 25% of the Water Quality Volume (WQV) and release it to the filter media over a 24-hour period, while flow-through Pretreatment BMPs should treat at least the equivalent Water Quality Flow (WQF).

Sizing and Dimensions

- Surface Sand Filter Bed (Bottom) Area
 - Sand filter should be designed by either the Static or Dynamic Methods as described in [Chapter 10 - General Design Guidance for Stormwater Infiltration Systems](#).
 - Sand filter should completely drain in 48 hours or less after the end of the design storm as described in [Chapter 10](#).
 - For the drain time analysis, use the coefficient of permeability of the filter media (3.5 feet per day or 1.75 inches per hour for sand). If the sand filter is designed

with a loam surface, use a coefficient of permeability value of 1.0 feet per day or 0.52 inches per hour.

- Sand Filter Bed Thickness
 - 18 inches (minimum)
 - Filter bed thickness may be limited by the requirement to maintain adequate separation to groundwater and bedrock as specified in [Chapter 10](#).
- Ponding Depth
 - Maximum for water quality storm: 24 inches
 - Maximum for overflow events: 36 inches
- Bottom Width
 - Minimum: 4 feet
- Bottom Slope
 - Design the top and bottom of sand filter bed to be level.
- Side Slopes
 - Maximum: 3(H):1(V) slopes. If site topography does not allow for 3(H):1(V) slopes, vertical concrete walls with a maximum height of 30 inches can be used.

Inlet

- Design the inlet in accordance with the [Inlet and Outlet Controls](#) section of this Manual.
- Runoff can be introduced to the sand filter through overland flow, curb cuts, inlet structures, swales/channels, and/or pipes.
- Design the sand filter in an off-line configuration to the extent feasible if runoff is delivered by a storm drain pipe or is along the main storm conveyance system.

Outlet & Overflow

- Design the outlet in accordance with the [Inlet and Outlet Controls](#) section of this Manual.
- Outlets are typically a stabilized spillway, gabion berm, concrete weir, precast concrete structure, or polyethylene/polyvinyl chloride riser structure.
- On-line systems should be designed to avoid erosion of the sand filter bed and have a primary outlet sized to convey the 10-year, 24-hour storm event, at a minimum, to the storm drainage system or stabilized channel. An emergency spillway is required to convey the 100-year storm event (assuming the primary outlet is not designed to pass the 100-year storm event).
- Off-line systems should be designed with a bypass or overflow for flows in excess of the water quality storm

Underdrain System

- Minimum underdrain pipe diameter: 4 inches
- Minimum underdrain pipe slope: 0.5%
- Use two layers of gravel with the underdrain system. Both layers of gravel should be located below and extend across the entire bottom of the sand filter. The upper gravel layer should consist of 3 inches of pea gravel, and the lower layer should consist of a 12-inch thick gravel sump.
- For unlined systems, install the perforated underdrain pipe 2 inches below the top of the gravel sump to promote infiltration. For systems that are lined with an impermeable liner to prevent infiltration, install the underdrain pipe 2 inches above the bottom of the gravel sump so the system can drain between storm events.
- Lay underdrain such that perforations are on the bottom of the pipe.
- Use solid (non-perforated) pipe sections and watertight joints wherever the underdrain system passes below berms, extends down steep slopes, connects to a drainage structure and/or daylights.
- Place filter fabric along sidewalls of excavation and above the pea gravel (below the sand layer) for a distance of 1 to 2 feet on both sides of the underdrain. Filter fabric shall not be placed across the entire width of the sand filter.
- Other considerations when designing/installing underdrains:
 - Provide a marking stake and an animal guard for underdrains that daylight at grade.
 - If designed with laterals, space collection laterals every 25 feet or less.
- Include a minimum of two observation wells/cleanouts for each underdrain; one at the upstream end and one at the downstream end.
- Cleanouts shall be at least 4 inches in diameter, be non-perforated and extend to the surface. Cap cleanouts with a watertight removable cap. The cleanout should be easily visible.
- Provide one cleanout for every 1,000 square feet of surface area (at a minimum) or for every 250 linear feet of total pipe length in larger systems.

Materials

- Surface Cover
 - The side slopes and surface of the sand filter bed should consist of 3 to 6 inches of loam/topsoil and grass. If a loam/topsoil and grass surface layer is selected for

- the surface of the sand filter bed, use a hydraulic conductivity value of 1.04 feet per day (0.52 inches per hour) for system sizing.
- To minimize maintenance, no additional cover material is required over the surface of the sand filter bed. Pea gravel or river stone may also be placed on top of the sand layer as an alternative to the exposed sand layer.
- Filter fabric should not be used between the surface cover layer (if any) and the sand layer.
- Vegetation
 - Specify vegetation (e.g., drought tolerant grass) for the sand filter side slopes and on top of the sand filter bed (vegetation on the filter bed is optional) with the guidance provided in [Appendix F](#) of this Manual.
- Sand
 - Should be washed concrete sand (ASTM C33 or AASHTO M-6) or coarse washed sand that meets the gradation schedule as shown in State of Connecticut Department of Transportation Standard Specifications, Section M.01 (Aggregates), Table M.01.04-1 for Fine Aggregate Gradations.
- Pea Gravel
 - Should consist of 3/8" AASHTO No. 8 stone. Pea gravel should be clean (washed and free from dirt and debris) and rounded in shape.
- Gravel Sump
 - Should consist of 3/4" AASHTO No. 5 stone. Gravel should be clean (washed and free from dirt and debris), crushed, and angular.
- Filter Fabric
 - Use non-woven filter fabric that complies with State of Connecticut Department of Transportation Standard Specifications, Section M.08.01.19 (Drainage – Geotextiles).
- Underdrain (perforated and non-perforated pipe sections)
 - Polyethylene or polyvinyl pipe.
- Liner
 - If used, should consist of a 30 mil (minimum) HDPE or PVC liner, or one of the alternative liner systems described in [Chapter 10 - General Design Guidance for Stormwater Infiltration Systems](#) with the approval of the review authority.
- Turf Reinforcement Matting (TRM)
 - Stabilize the side slopes of the sand filter with TRM to limit erosion in locations where flow velocities exceed 3 to 5 feet per second (depending on soil and vegetation types) for the 1-year, 24-hour storm event.

- If used, shall be a woven material included on the CTDOT Qualified Products List that exceeds the design velocity of the design storm and allows for the growth of the proposed vegetative species.

Other Considerations

- If designing a lined system in a location where SHGT is located at or above the bottom of the liner or closed bottom of the system, complete a buoyancy analysis to ensure buoyancy of the system will not be an issue.
- For lined sand filters within LUHPPLs, a shutoff valve can be installed on the underdrain outlet to capture and contain accidental spills or releases that reach the bioretention system.
- Non-woven filter fabric should be placed along the sidewalls of the excavation to help direct the water flow downward, reduce lateral flows, and to reduce lateral soil migration. Place filter fabric along sidewalls of excavation and above the pea gravel (below the sand layer) for a distance of 1 to 2 feet on both sides of the underdrain. Filter fabric shall not be placed across the entire width of the sand filter.

Winter Operations

- Surface sand filters should not be used as dedicated snow storage areas. To the extent feasible, locate and design the system to avoid snow storage areas and potential damage from snow plowing activities. Refer to [Chapter 7 - Overview of Structural Stormwater Best Management Practices](#) for general design considerations related to winter operations.

Construction Recommendations

- The designing qualified professional should develop a detailed, site-specific construction sequence.
- The designing qualified professional should inspect the installation during the following stages of construction, at a minimum:
 - After excavation of the sand filter and scarification of bottom and sidewalls of excavation
 - After placement of gravel layer
 - After placement of underdrain before covering by the pea gravel layer
 - Inspection of sand material prior to placement
 - After placement and leveling of sand layer
 - After installation of bypass, outlet/overflow, and inlet controls
 - After grass and/or pea gravel surface cover have been installed
- The designing qualified professional should provide an as-built plan of the completed sand filter along with a certification that the system was designed in accordance with the

guidance contained in this Manual and other local or state requirements and that the system was installed in accordance with the approved plans.

- The entire contributing drainage area should be completely stabilized prior to directing any flow to the system. Adequate vegetative cover must be established over any pervious area adjacent or contributing to the system before runoff can be accepted.
- Erosion and sediment controls should be in place during construction in accordance with the [Connecticut Guidelines for Soil Erosion and Sediment Control](#) and the Soil Erosion and Sediment Control (SESC) Plan developed for the project.
- Sand filters should not be used as temporary sediment traps for construction erosion and sediment control.
- During clearing and grading of the site, measures should be taken to avoid soil compaction at the location of the proposed system.
- The sand filter should be fenced off during the construction period to prevent disturbance of the soils.
- The sand filter should be excavated to the dimensions, side slopes, and elevations shown on the plans. The method of excavation should avoid compaction of the bottom of the system. A hydraulic excavator or backhoe loader, operating outside the limits of the sand filter, should be used to excavate the system. Excavation equipment should not be allowed within the limits of the sand filter.
- The gravel, pea gravel, and sand layers should be placed in the excavation by a hydraulic excavator or backhoe loader located outside the limits of the sand filter and then hand-raked to the desired elevation.
- Place the sand in 6 to 12-inch lifts. Lightly tamp or spray the surface of the sand with water. The sand can be expected to settle, especially after becoming saturated. For this reason, the elevation of the sand layer can be a couple of inches higher at installation than the design elevation in anticipation of settling. Sand should be carefully placed to avoid formation of voids and short-circuiting.
- Install vegetation (e.g., drought tolerant grass) on the side slopes and surface of the sand filter in accordance with the planting plan and plant schedule on the plans. Water vegetation thoroughly immediately after planting and as necessary until fully established.

Maintenance Needs

- Surface sand filters should be designed with easy access to all components of the system for maintenance purposes. Refer to [Chapter 7 - Overview of Structural Stormwater Best Management Practices](#) for general design considerations to reduce and facilitate system maintenance.

- Detailed inspection and maintenance requirements, inspection and maintenance schedules, and those parties responsible for maintenance should be identified on the plans and in the Stormwater Management Plan.
- Maintenance should be detailed in a legally binding maintenance agreement.
- Maintenance activities such as sediment removal, mowing, and repairs should be performed with rakes and light-weight equipment rather than heavy construction equipment to avoid compaction of the filter media and underlying soils. Heavy equipment may be used for sediment removal and other maintenance activities if the equipment is positioned outside the limits of the system. Heavy construction equipment should not be allowed within the limits of the system for maintenance purposes.

Recommended Maintenance Activities

- Inspect after major storms (1 inch or more of precipitation) in the first few months following construction.
- Inspect the sediment forebay or other pretreatment area twice a year.
- Inspect the remainder of the sand filter annually.
- Refer to [Appendix B](#) for maintenance inspection checklists, including items to focus on during inspections.
- Remove trash and organic debris (leaves) in the Spring and Fall.
- Remove sediment from the sediment forebay or other pretreatment area when it accumulates to a depth of more than 12 inches or 50% of the design depth. Clean outlet of sediment forebay or other pretreatment measures when drawdown time exceeds 36 hours after the end of a storm event.
- Remove sediment from the sand filter when the sediment accumulation exceeds 2 inches or when drawdown time exceeds 48 hours after the end of a storm event, indicating that the filter is clogged. Replace with fresh washed concrete sand that conforms to the specifications in this section.
- Weed as necessary. Mow grass within sand filter to a height of 6 inches or more. Maintain a healthy, vigorous stand of grass cover; re-seed as necessary.
- Periodically remove grass clippings to prevent clogging of the surface of the sand filter.
- Mowing should not be performed when the ground is soft to avoid the creation of ruts and compaction, which can reduce infiltration.

Figure 13-21. Surface Sand Filter Schematic

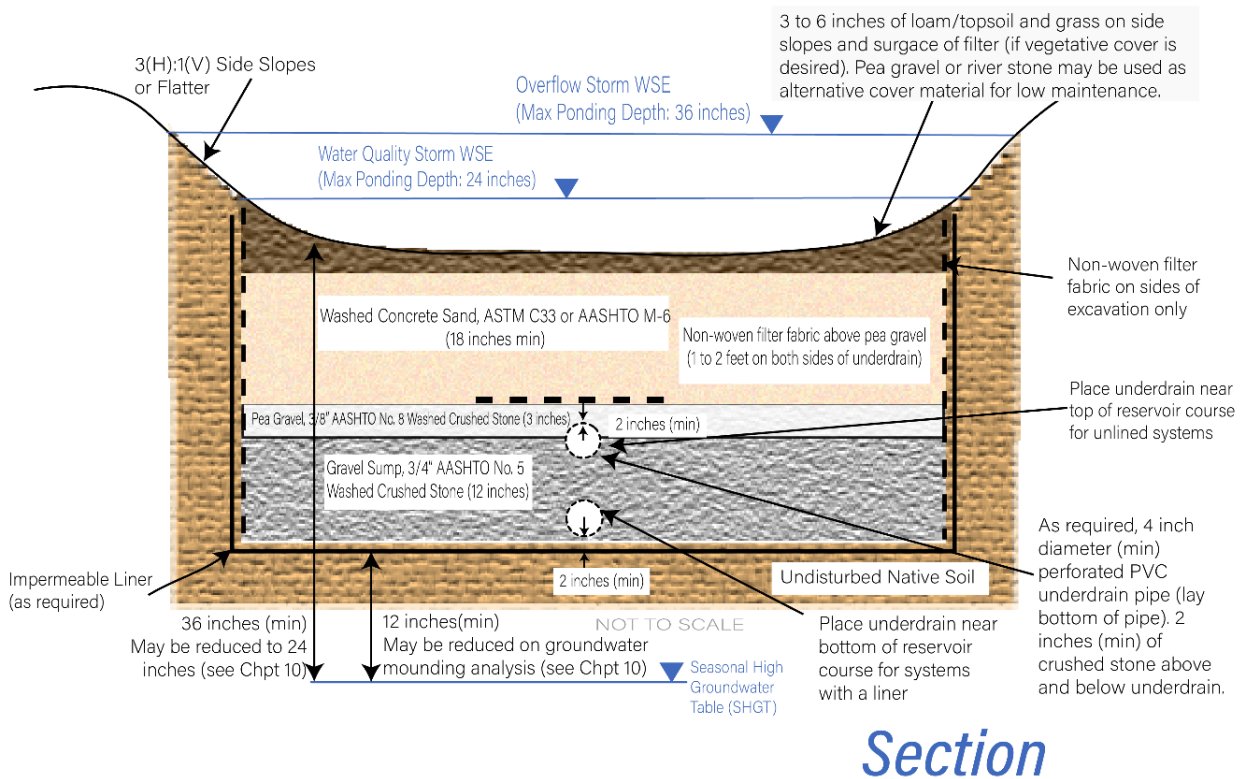
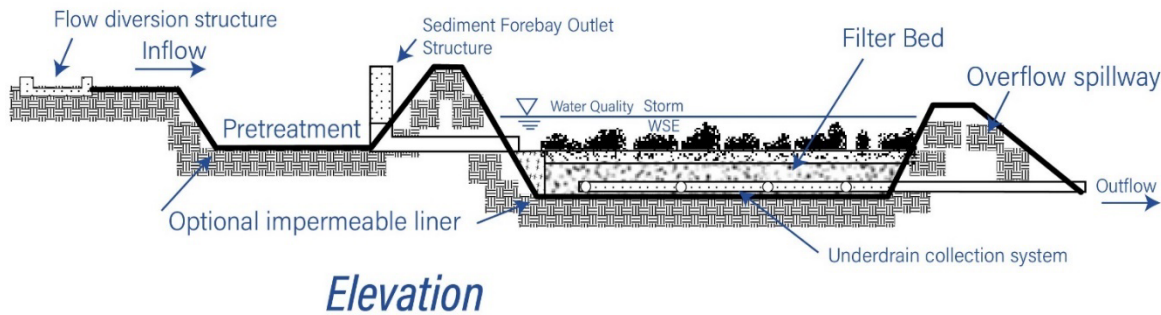
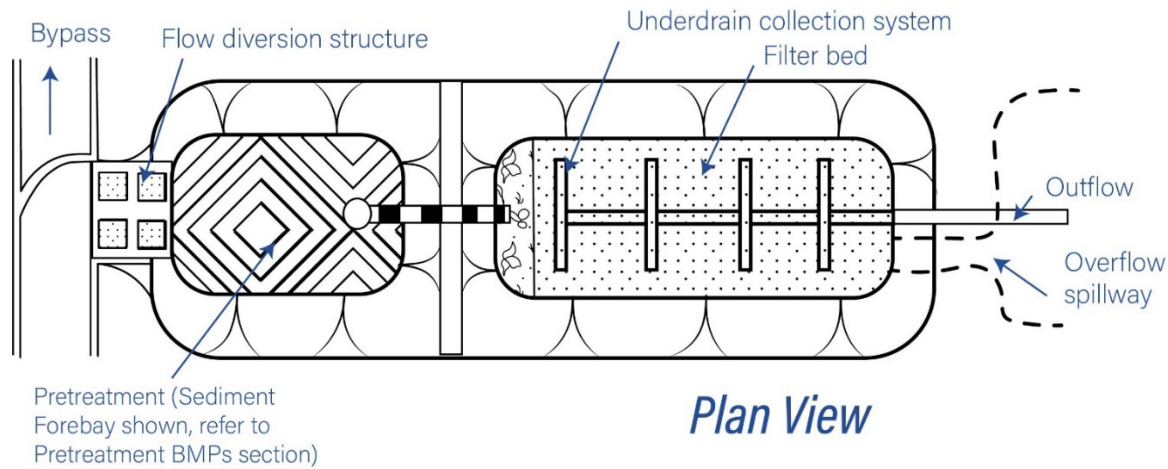

Stormwater Pond



Description

Stormwater ponds are designed to retain a permanent pool of water that provides treatment for the water quality storm event and peak runoff attenuation for larger storms. This section addresses four types of stormwater ponds:

- Wet Pond
- Micro pool Extended Detention Pond
- Wet Extended Detention Pond
- Multiple Pond System

Stormwater is treated primarily through sedimentation, as suspended particles and attached pollutants settle to the bottom of the pond.

Stormwater ponds can also reduce soluble pollutants in stormwater discharges by adsorption to sediment, bacterial decomposition, and the biological processes of aquatic and fringe wetland vegetation.

The key to maximizing the pollutant removal effectiveness of stormwater ponds is maintaining a permanent pool of water. To achieve this, the bottom of stormwater ponds should be located below the seasonal high groundwater table or should have a sufficiently large contributing drainage area and an impermeable liner if located in permeable soils. The pool typically operates on the instantaneously mixed reservoir principle where incoming water mixes with the existing pool and undergoes treatment through sedimentation and other processes. When the existing pool is at or near the pond outlet or when the primary flow path through the pond is highly linear, the pond may act as a plug flow system in which incoming water displaces the permanent pool, which is then discharged from the pond. In this process, a portion of the “new” polluted runoff enters the pond as the “old” treated water is discharged from the pond, thereby allowing treatment of the Water Quality Volume (WQV). When designed in an on-line

Stormwater BMP Type

Pretreatment BMP	<input type="checkbox"/>
Infiltration BMP	<input type="checkbox"/>
Filtering BMP	<input type="checkbox"/>
Stormwater Pond BMP	<input checked="" type="checkbox"/>
Stormwater Wetland BMP	<input type="checkbox"/>
Water Quality Conveyance BMP	<input type="checkbox"/>
Stormwater Reuse BMP	<input type="checkbox"/>
Proprietary BMP	<input type="checkbox"/>
Other BMPs and Accessories	<input type="checkbox"/>

Stormwater Management Suitability

Retention	<input type="checkbox"/>
Treatment	<input checked="" type="checkbox"/>
Pretreatment	<input type="checkbox"/>
Peak Runoff Attenuation	<input checked="" type="checkbox"/>

Pollutant Removal

Sediment*	High
Phosphorus	Moderate
Nitrogen	Moderate
Bacteria	Moderate

*Includes sediment-bound pollutants and floatables (with pretreatment)

Implementation

Capital Cost	Medium
Maintenance Burden	Medium
Land Requirement	High

configuration, stormwater ponds can also be sized to treat and provide peak runoff attenuation for storms larger than the water quality storm event.

The permanent pool of a stormwater pond reduces the velocity of incoming water to prevent resuspension of particles and promote settling of newly introduced suspended solids. The energy dissipating and treatment properties of the permanent pool are enhanced by aquatic vegetation, which is an essential part of the stormwater pond design. In contrast, a dry extended detention basin, which has no permanent pool, is not suitable for stormwater treatment due to the potential for resuspension of accumulated sediment by incoming storm flows during the early portion of a storm event when the basin is empty.

Stormwater ponds do not provide sufficient retention or runoff volume reduction through infiltration or other processes and therefore cannot be used to meet the Standard 1 retention performance criterion of this Manual.

Advantages

- Effective for removal of particulate and soluble pollutants.
- Can provide an aesthetic benefit if open water is desired as part of an overall landscaping plan.
- Can provide wildlife habitat with appropriate design elements.
- Can provide peak runoff attenuation.

Limitations

- Do not provide infiltration or sufficient runoff volume reduction, and therefore cannot be used to meet the Standard 1 retention performance criterion.
- Unlined ponds that intercept groundwater have potential to impact groundwater quality if dissolved pollutants are present in the runoff.
- Lined ponds typically require a minimum drainage area in order to maintain a permanent pool, which may become difficult during extended dry periods.
- Require a relatively large land area.
- May cause thermal impacts to receiving waters and therefore should not discharge directly to Coldwater streams or other receiving water environments that are sensitive to thermal loads.
- Ponds with steep side slopes and/or deep wet pools may present a safety risk in residential areas and areas with public access.
- Stormwater ponds can serve as decoy wetlands, intercepting breeding amphibians moving toward vernal pools. If amphibians deposit their eggs in these artificial ponds, they rarely survive due to the sediment and pollutant loads, as well as fluctuations in water quality, quantity, and temperature.

Siting Considerations

- **Drainage Area:** Stormwater ponds that utilize a liner system should have a contributing drainage area that is adequate to maintain minimum water levels. Typically, the minimum contributing drainage area for lined ponds is 10 acres. Smaller drainage areas may be suitable if intercepting groundwater or with sufficient surface runoff to support a permanent pool. A water budget analysis should be performed to demonstrate that sufficient groundwater flow and/or surface runoff is available to maintain the permanent pool depth.
- **Groundwater:** Stormwater ponds should intercept groundwater or have an impermeable liner to maintain a permanent pool if located in permeable soils. The elevations of unlined ponds should be established such that the groundwater elevation is equal to the desired permanent pool elevation. Seasonal variations of groundwater elevations should be considered.
- **Land Uses:** Land uses will dictate potential pollutants-of-concern and potential safety risks. A liner is required for stormwater ponds that receive runoff from Land Uses with Higher Potential Pollutant Loads (LUHPPLs) (see [Chapter 10 - General Design Guidance for Stormwater Infiltration Systems](#)) or on contaminated sites. The pond's permanent pool may pose a safety risk in residential areas and areas with public access, sometimes requiring fencing to limit access to the pond.
- **Baseflow:** A small amount of baseflow is desirable to maintain circulation and reduce the potential for low dissolved oxygen levels during late summer. This baseflow can be provided by groundwater discharge to the pond or the drainage system that feeds the pond.
- **Site Slopes:** Site slopes greater than 6% may result in the need for an embankment greater than 4 feet above existing grade to provide the desired storage volume, which would be subject to CT DEEP dam safety regulatory requirements. Steep slopes may also present design and construction challenges, and significantly increase the cost of earthwork.
- **Receiving Waters:** Stormwater ponds should not be used for sites that discharge within 200 feet of coldwater streams, 200 feet from a public water supply reservoir, or 100 feet from streams tributary to a public water supply reservoir.
- **Natural Wetlands/Vernal Pools:** Natural wetlands and vernal pool depressions should not be used, either temporarily or permanently, as a stormwater pond. Stormwater ponds should be located at least 750 feet from a vernal pool. They should not be sited between vernal pools, or in areas that are known primary amphibian overland migration routes.

Soil Evaluation and Water Budget Analysis

- Conduct an evaluation of the soil characteristics and subsurface conditions at the location of the proposed system including soil type, depth to the seasonal high groundwater table, and depth to bedrock. Perform test pits or soil borings in accordance with the soil evaluation guidance in [Chapter 10 - General Design Guidance for Stormwater Infiltration Systems](#).
- A water budget analysis should be performed for stormwater pond designs. The water budget consists of calculations, on a daily basis, of the inflows to and outflows from the pond to show that the required depth of water in the pond is maintained throughout the year. The analysis should be performed for a wet year, a dry year, and an average year. The analysis should demonstrate that the permanent pool of the stormwater pond meets the minimum requirements of this section for all of the days in each of the three analyses. All of the inputs to and outputs from the pond should be considered, including direct precipitation, runoff, flooding, groundwater inflow, evapotranspiration, groundwater outflow, and any reuse of the pond water such as irrigation.

Design Recommendations

General Considerations

This section addresses the following types of stormwater pond designs:

- **Wet Pond:** A wet pond typically consists of two major components - a forebay and a permanent wet pool. The forebay provides pretreatment by capturing coarse sediment particles to minimize the need to remove the sediments from the primary wet pool. The wet pool serves as the primary treatment mechanism and where much of the storage capacity exists. Wet ponds can be sized for a wide range of watershed sizes, if adequate space exists. For example, a variation on the conventional wet pond, sometimes referred to as a "pocket pond", is intended to serve relatively small drainage areas (between one and five acres). Because of these smaller drainage areas and the resulting lower hydraulic loads of pocket ponds, outlet structures can be simplified and often do not have safety features such as emergency spillways and low-level drains. Figure 13-22 depicts a typical schematic design of a conventional wet stormwater pond, while Figure 13-23 shows a typical schematic design of a modified wet pond or "pocket pond."

Several adaptations of this basic design have been developed to achieve the specific treatment goals of various watershed or site conditions. These wet pond design variations are described below.

- **Micropool Extended Detention Pond:** Micropool extended detention ponds are primarily used for peak runoff control and utilize a smaller permanent pool than conventional wet ponds. While micropool extended detention ponds are not as efficient as wet ponds for the removal of pollutants, they should be considered when a large open pool might be undesirable or unacceptable. Undesirable conditions could include thermal

impacts to receiving streams from a large open pool, safety concerns in residential areas, or where maintaining a large open pool of water would be difficult due to a limited drainage area or deep groundwater.

Micropool extended detention ponds are also efficient as a stormwater retrofit to improve the treatment performance of existing dry detention basins. Figure 13-24 depicts a typical schematic design of a micropool extended detention pond.

- **Wet Extended Detention Pond:** These ponds are very similar to wet ponds with the exception that their design is more focused on attenuating peak rates of runoff. As a result, more storage volume is committed to managing peak flows as opposed to maximizing the wet pool depth. The configuration of the outfall structure may also differ from typical wet pond designs to provide additional storage volume above the level of the permanent pool. Figure 13-25 depicts a typical schematic design of a wet extended detention pond.
- **Multiple Pond System:** Multiple Pond systems consist of several wet pools that are constructed in a series following a forebay. The advantage of these systems is that they can improve treatment efficiency by better simulating plug flow conditions as compared to a single large wet pool. Also, these systems can reduce overall maintenance needs since more frequent maintenance would be performed within the first pool cells as opposed to the large, primary pool. The disadvantage of these systems is that they typically require more land area to treat the WQV. Figure 13-26 depicts a typical schematic design of a multiple pond system.

Pretreatment – Sediment Forebay

- A sediment forebay is recommended for all wet pond systems, although other forms of pretreatment may be used at locations where runoff enters the stormwater pond.
- The sediment forebay and other pretreatment measures should be designed in accordance with the Pretreatment BMPs section of this Manual.
- The sediment forebay should be sized to contain at least 10% of the WQV. The forebay storage volume may be used to fulfill the WQV requirement of the overall stormwater pond. The forebay should also include additional sediment storage volume that may not be used for WQV calculations.

Sizing and Dimensions

- The pond volume, including the volume of the sediment forebay, permanent pool, and extended detention area, should be equal to or exceed the WQV. A larger volume should be used to achieve greater pollutant removal when it is necessary to meet specific water quality standards. The recommended division of storage between the forebay, permanent pool, and extended detention is outlined in [Table 13-10](#).

Table 13-7. Water Quality Volume Distribution in Stormwater Pond Designs

Design Variant	Percent of Water Quality Volume (WQV)		
	Sediment Forebay	Permanent Pool	Extended Detention
Wet Pond	10%	90%	0%
Micropool Extended Detention Pond	10%	10%	80%
Wet Extended Detention Pond	10%	40%	50%
Multiple Pond System	10%	40%	50%
Pocket Pond	10%	40%	50%

Source: NYDEC, 2001.

- Water quality storage can be provided in multiple cells. Performance is enhanced when multiple treatment pathways are provided by using multiple cells, longer flow paths, high surface area to volume ratios, complex microtopography, and/or redundant treatment methods (combinations of pool, extended detention, and marsh).
- The extended detention storage volume (storage volume above the permanent pool provided for additional water quality and stormwater quantity control) should drain out of the pond over a minimum of 24 hours, after which the water surface elevation in the pond will return to the permanent pool elevation.
- Underwater or marsh berms may be incorporated in the design to lengthen the flow path through the pond.
- Thermal impacts of stormwater ponds may be mitigated by implementing one or more of the following design measures:
 - Use of a smaller permanent pool with more extended detention storage and an extended detention time of 24 hours or less
 - Planting of shade trees around the perimeter of the pond (but at least 25 feet away from inlet/outlet structures and the pond embankment) to reduce solar warming of the pool
 - Designing the pond with a series of pools, as opposed to a single pool, to allow cooling prior to discharge
 - Use of an outlet structure designed to draw water from near the bottom of the pond where water temperatures may be cooler
 - Use of an underdrained gravel trench outlet.
- The pond should have a curvilinear shape and a minimum length: width ratio of 3:1 from the pond inlet to outlet.

- Upper stages of the pond should provide temporary storage of larger storms (2-year, 10-year, and 100-year, 24-hour events) to control peak discharge rates.
- Provide variable pond depths of 4 to 6 feet but not exceeding depths of 8 feet. Maintaining pond water depths in excess of 4 feet precludes invasive emergent vegetation such as cattails. Emergent vegetation provides mosquito larvae with refuge from predators and increases nutrient availability.
- Maintain pond water quality sufficient to support mosquito-feeding fish. Stormwater ponds often develop mini ecosystems where birds, frogs, and other insects feed, many of which are natural predators of mosquitoes and nuisance insects. Ponds can also be stocked with predatory fish native to Connecticut that feed on mosquito larvae such as banded sunfish, flathead minnows, Eastern mud minnows, and several species of killifish. The CT DEEP Fisheries Division should be consulted regarding species selection. Other natural predators of mosquitoes such as dragonfly nymphs can also be used.
- Pumping of groundwater to maintain the permanent pool should not be allowed.
- The volume below the surface elevation of the permanent pool should not be included in storage calculations for peak flow management.

Side Slopes

- 3(H):1(V) slopes or flatter are preferred.
- The perimeter of permanent pool areas four feet or greater in depth should provide two benches:
 - Provide a flat safety bench that extends 10 feet outward from the normal water edge to the toe of the pond side slope.
 - Provide a flat aquatic bench that extends 10 feet inward from the normal water edge at a depth of 12-18 inches below the normal pool water surface elevation.

Inlet

- Design the inlet in accordance with the [Inlet and Outlet Controls](#) section of this Manual.
- The number of inlets should be minimized, and one inlet is preferable. The inlet should be located at the most hydraulically remote point from the outlet to minimize the potential for short-circuiting and should be located in a manner that meets or exceeds desired length to width ratios.
- The ideal inlet configuration is above the permanent pool to prevent potential hydraulic constrictions due to freezing.

Outlet & Overflow

- Design the outlet and any overflows in accordance with the Inlet and Outlet Controls section of this Manual.
- Stormwater ponds should have an outlet structure sized to convey up to the 10-year, 24-hour storm event, at a minimum, to the storm drainage system or stabilized channel. An emergency spillway is required to convey the 100-year storm event if the outlet structure is not designed to pass the 100-year storm event. Off-line systems should be designed with a bypass or overflow for flows in excess of the water quality storm.

Conveyance

- Stormwater should be conveyed to and from all stormwater management practices safely and to minimize erosion potential.
- Stabilize any portion of the stormwater pond with Turf Reinforcement Matting (TRM) to limit erosion in locations where flow velocities exceed 3 to 5 feet per second (depending on soil and vegetation types) for the 1-year, 24-hour storm event.
- TRM should be a woven material included on the CTDOT Qualified Products List that exceeds the design velocity of the design storm and allows for the growth of the proposed vegetative species.

Liner

- When a stormwater pond is located such that the bottom of the pond does not intercept groundwater and the pond is located in permeable soils, an impermeable liner is needed to maintain a permanent pool of water. Pond liners are also necessary to avoid impacts to groundwater quality for stormwater ponds that receive runoff from Land Uses with Higher Potential Pollutant Loads (LUHPPLs) or on contaminated sites.
- If used, should consist of a 30 mil (minimum) HDPE or PVC liner, or one of the alternative liner systems described in [Chapter 10 - General Design Guidance for Stormwater Infiltration Systems](#) with the approval of the review authority.

Non-clogging Low-Flow Orifice

- A low-flow orifice should be provided, with the size of the orifice sufficient to avoid clogging (recommended minimum orifice diameter of 6 inches, although orifice diameters as small as 3 inches are allowed if required to provide the necessary hydraulic control). The low flow orifice should be protected from clogging using an external trash rack.
- A submerged reverse-slope pipe may also be used that extends downward from the riser to an inflow point one foot below the normal pool elevation.

- Alternative methods are to employ a broad crested rectangular, V-notch, or proportional weir, protected by a half-round pipe that extends at least 12 inches below the normal pool level.

Riser in Embankment

- The riser should be located within the embankment for maintenance access and safety.
- Lockable manhole covers and manhole steps within easy reach of valves and other controls should provide access to the riser.

Drain

- For stormwater ponds that do not intercept groundwater, the design may include a drainpipe that can completely or partially drain the pond. The drainpipe should have an elbow or protected intake within the pond to prevent sediment deposition in the pipe, and a diameter capable of draining the pond within 24 hours.
- Care should be exercised during draining to prevent rapid drawdown and minimize downstream discharge of sediments or anoxic water. The review/approving authority should be notified before draining the system.

Adjustable Gate Valve

- Both the WQV extended detention pipe and the drain may be equipped with an adjustable gate valve, typically a handwheel activated knife gate valve.
- Valves should be located inside of the riser at a point where they will not normally be inundated and can be operated in a safe manner.
- Both the WQV extended detention pipe and the drain should be sized one pipe size greater than the calculated design diameter.
- To prevent vandalism, the handwheel should be chained to a ringbolt, manhole step, or other fixed object.

Vegetation

- Aquatic plantings around the edge of the pond can provide pollutant uptake, stabilize the soil at the edge of the pond, and improve habitat. Maintaining high vegetation along the edge of the pond (not mowing to the edge) can also deter waterfowl access and filter pollutants.
- Select vegetation and develop a planting plan with the guidance provided in [Appendix F](#) of this Manual.

- Wetland plantings should be included in a pond design, either along the aquatic bench (fringe wetlands), the safety bench and side slopes, or within shallow areas of the pool.
- The best depth for establishing wetland plants, either through transplantation or volunteer colonization, is within approximately six inches of the normal pool elevation.
- Soils should be modified (e.g., scarified or tilled) to mitigate compaction that occurs during construction around the proposed planting sites.
- Avoid species that require full shade, are susceptible to winterkill, or are prone to wind damage.
- Woody vegetation may not be planted or allowed to grow within 25 feet of the toe of the embankment and 25 feet from the principal spillway structure.
- Existing trees should be preserved in the buffer area during construction. It is desirable to locate forest conservation areas adjacent to ponds. To help discourage resident geese populations, the buffer can be planted with trees, shrubs, and native ground covers.
- Annual mowing of the pond buffer is only required along maintenance rights-of-way and the embankment. The remaining buffer can be managed as a meadow (mowing every other year) or forest.
- Plant the pond with salt-tolerant vegetation if the stormwater pond receives road runoff.

Safety Features

- The principal spillway opening must not permit access by small children, and end walls above pipe outfalls greater than 48 inches in diameter should be fenced to prevent a hazard.
- Both the safety bench and the aquatic bench may be landscaped to prevent access to the pool.
- Fencing around the perimeter of the pond is generally not encouraged but may be required by some municipalities. The preferred method is to grade the pond to eliminate drop-offs or other safety hazards.

Maintenance Reduction Features

- Ponds should be designed with non-clogging outlets, such as a weir, or by incorporating trash racks for culverts and orifice openings.
- To prevent clogging from ice or floatables, a reverse slope outlet pipe can be used to draw water from below the permanent pool up to the outlet structure. The invert of the pipe drawing from the pool should be at least 18 inches from the bottom to prevent sediment discharge.

- Orifices should be less than 6 inches in diameter with a trash rack to prevent clogging. Smaller orifice diameters (3 inches or larger) are allowed if required to provide the necessary hydraulic control.
- Ponds should have a manually operated drain to draw down the pond for infrequent maintenance or dredging of the main cell of the pond.
- Metal components of outlet structures should be corrosion resistant, but not galvanized due to the contribution of zinc to water.
- Outlet structures should be resistant to frost heave and ice action in the pond.

Cold Climate Design Considerations

The following design elements should be considered to minimize potential performance impacts caused by cold weather:

- Inlet pipes should not be submerged since this can result in freezing and upstream damage or flooding.
- Bury pipes below the frost line to prevent frost heave and pipe freezing. Bury pipes at the point furthest from the pond deeper than the frost line to minimize the length of pipe exposed.
- Increase the slope of inlet pipes to a minimum of 1 percent, if site conditions allow, to prevent standing water in the pipe and reduce the potential for ice formation.
- If perforated riser pipes are used, the minimum orifice diameter should be 0.5 inches. In addition, the pipe should have a diameter of at least 6 inches.
- When a standard weir is used, the minimum slot width should be 3 inches, especially when the slot is tall.
- Baffle weirs can prevent ice formation near the outlet by preventing surface ice from blocking the inlet, encouraging the movement of base flow through the system.
- Riser hoods and reverse slope pipes should draw from at least 6 inches below the typical ice layer. This design encourages circulation in the pond, preventing stratification and formation of ice at the outlet. Reverse slope pipes should not be used for off-line ponds.
- Trash racks should be installed at a shallow angle to prevent ice formation.
- Additional storage should be provided to account for storage lost to ice buildup. Ice thickness may be estimated by consulting with local authorities (e.g., the fire department) with knowledge of the typical ice thickness in the area.

Winter Operations

- Stormwater ponds should not be used as dedicated snow storage areas. To the extent feasible, locate and design the system to avoid snow storage areas and potential damage from snow plowing activities. Refer to [Chapter 7 - Overview of Structural Stormwater Best Management Practices](#) for general design considerations related to winter operations.

Construction Recommendations

- The designing qualified professional should develop a detailed, site-specific construction sequence.
- The designing qualified professional should inspect the installation during the following stages of construction, at a minimum:
 - After excavation of the pond
 - After internal grading of microtopography, berms, safety benches, etc.
 - After installation of bypass, outlet/overflow, and inlet controls
 - After vegetation and wetland plants/seed mix has been installed
- The designing qualified professional should provide an as-built plan of the completed system along with a certification that the system was designed in accordance with the guidance contained in this Manual and other local or state requirements and that the system was installed in accordance with the approved plans.
- The entire contributing drainage area should be completely stabilized prior to directing any flow to the system. Adequate vegetative cover must be established over any pervious area adjacent or contributing to the system before runoff can be accepted.
- Erosion and sediment controls should be in place during construction in accordance with the [Connecticut Guidelines for Soil Erosion and Sediment Control](#) and the Soil Erosion and Sediment Control (SESC) Plan developed for the project.
- Temporary dewatering may be required if excavation extends below the water table. Appropriate sedimentation controls will be required for any dewatering discharges.
- During clearing and grading of the site, measures should be taken to avoid soil compaction at the location of the proposed system to promote growth of vegetation.
- The system should be fenced off during the construction period to prevent disturbance of the soils.
- The system should be excavated to the dimensions, side slopes, and elevations shown on the plans. The method of excavation should avoid compaction of the bottom of the pond. A hydraulic excavator or backhoe loader, operating outside the limits of the system, should

be used to excavate the system. Excavation equipment should not be allowed within the limits of the system.

- Install vegetation in accordance with the planting plan and plant schedule on the plans. Water vegetation thoroughly immediately after planting and as necessary until fully established.
- Stormwater ponds classified as dams under the CT DEEP dam safety program (generally those with embankments greater than 4 feet above existing grade) should be constructed, inspected, and maintained in accordance with applicable CT DEEP dam safety regulations and guidance.

Maintenance Needs

- Detailed inspection and maintenance requirements, inspection and maintenance schedules, and those parties responsible for maintenance should be identified on the plans and in the Stormwater Management Plan.
- Maintenance should be detailed in a legally binding maintenance agreement.
- Maintenance activities such as sediment removal, mowing, and repairs should be performed with rakes and light-weight equipment rather than heavy construction equipment to avoid soil compaction and damage to vegetation. Heavy equipment may be used for sediment removal and other maintenance activities if the equipment is positioned outside the limits of the system. Heavy construction equipment should not be allowed within the limits of the system for maintenance purposes.

Maintenance Access

- Stormwater ponds should be designed with easy access to all components of the system for maintenance purposes. In addition to the maintenance reduction design factors described in this section, also refer to [Chapter 7 - Overview of Structural Stormwater Best Management Practices](#) for general design considerations to reduce and facilitate system maintenance.
- A maintenance right-of-way or easement should extend to the pond from a public road.
- Maintenance access should be at least 12 feet wide, have a maximum slope of no more than 15 percent, and be appropriately stabilized to withstand maintenance equipment and vehicles.
- The maintenance access should extend to the forebay, safety bench, riser, and outlet and be designed to allow vehicles to turn around.
- The principal spillway should be equipped with a removable trash rack, and generally accessible from dry land.

Recommended Maintenance Activities

- Inspect after major storms (1 inch or more of precipitation) in the first few months following construction.
- Inspect sediment forebay twice per year and the rest of the system annually, including inlet and outlet control structures and the pond embankment.
- Refer to [Appendix B](#) for maintenance inspection checklists, including items to focus on during the inspections.
- Remove trash and organic debris (leaves) in the Spring and Fall.
- Remove sediment from the sediment forebay or other pretreatment area when it accumulates to a depth of more than 24 inches or 50% of the design depth.
- Remove sediment from the permanent pool when the pool volume has become reduced significantly, or when significant algal growth is observed.
- The vegetative cover should be maintained at 85%. If vegetation has damage, the area should be reestablished in accordance with the original specifications.
- Periodically mow the pond side slopes during the growing season. Maintain side slope vegetation at 6 inches or higher. High grass along the pond edge will discourage waterfowl from taking up residence and serve to filter pollutants.
- Inspect and remove invasive vegetation as necessary.
- Inspect wetland plants and manage/harvest dead or dying plants as necessary.
- Remove trees and woody vegetation within 25 feet of all risers, pipe outlet structures, spillways, and downstream embankments that hold back water.
- Prune other woody vegetation where dead or dying branches are observed. Plant reinforcement plantings as necessary.

Other References

New York State Department of Environmental Conservation (NYDEC). 2001. *New York State Stormwater Management Design Manual*. Prepared by Center for Watershed Protection. Albany, New York.

Figure 13-22. Wet Pond Schematic

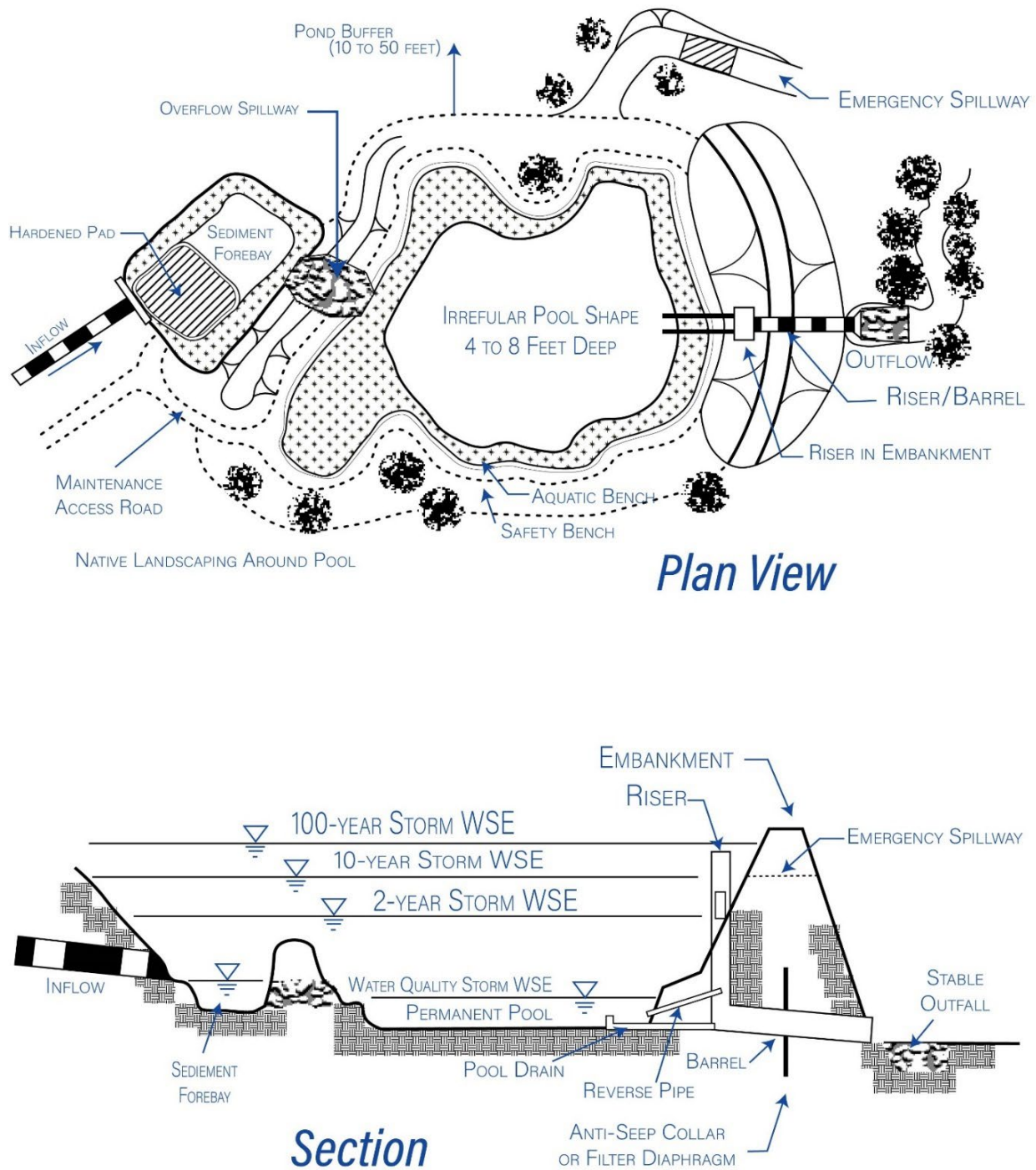

Source: Adapted from NYDEC, 2001.

Figure 13-23. Pocket Pond Schematic

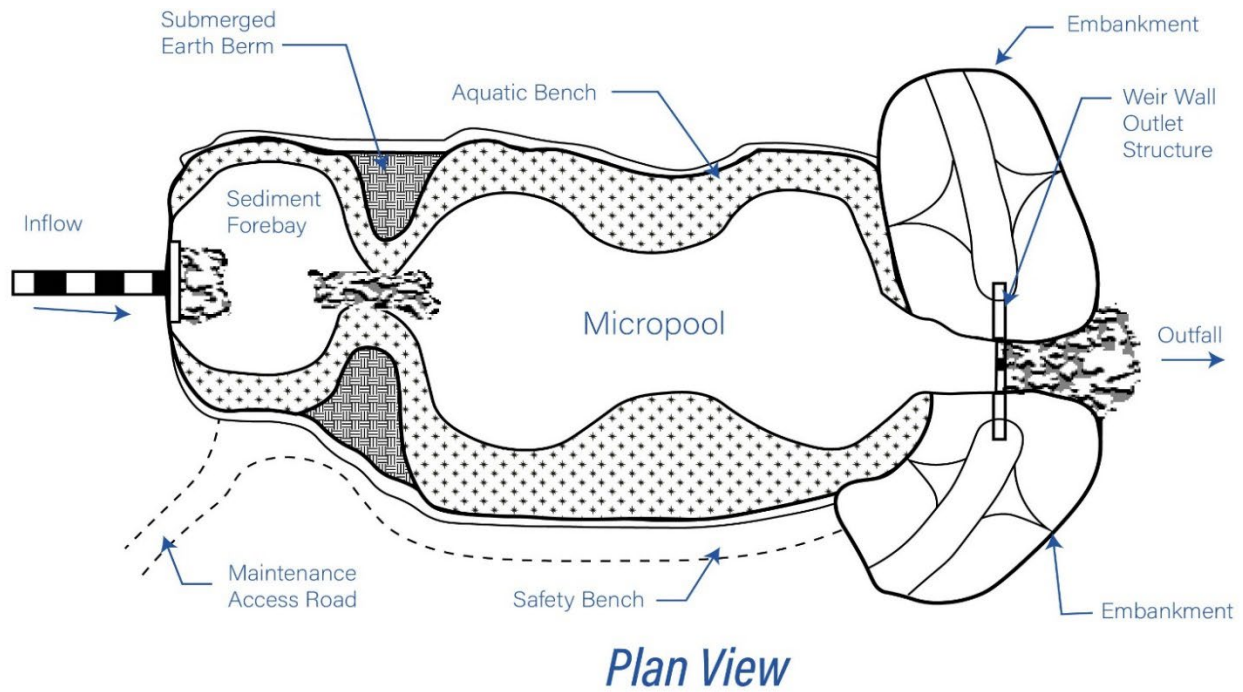

Plan View

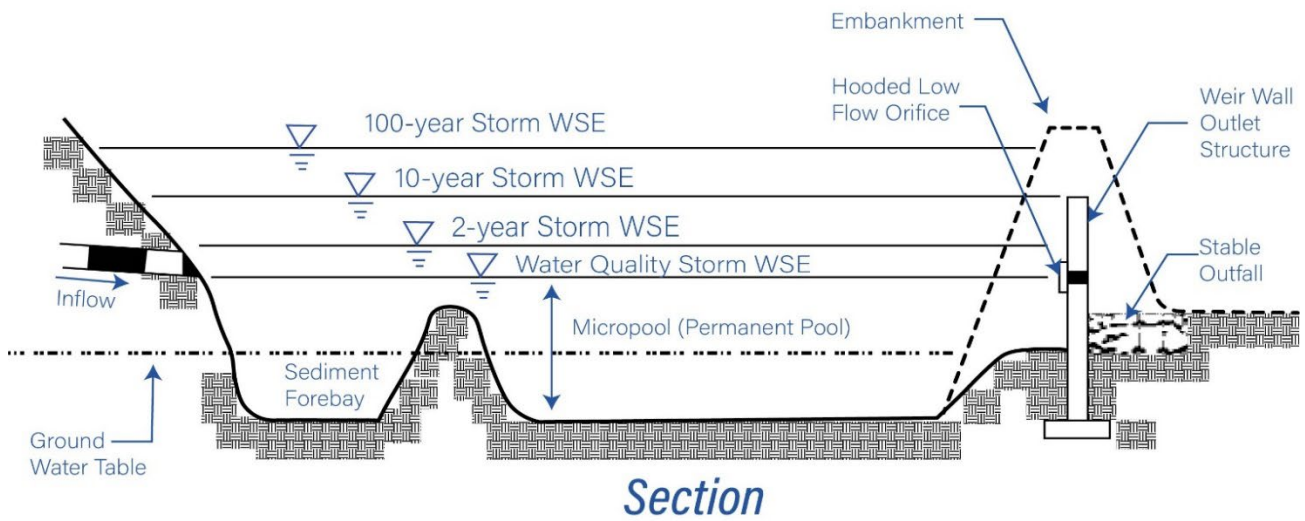

Section

Source: Adapted from NYDEC, 2001.

Figure 13-24. Micropool Extended Detention Pond Schematic

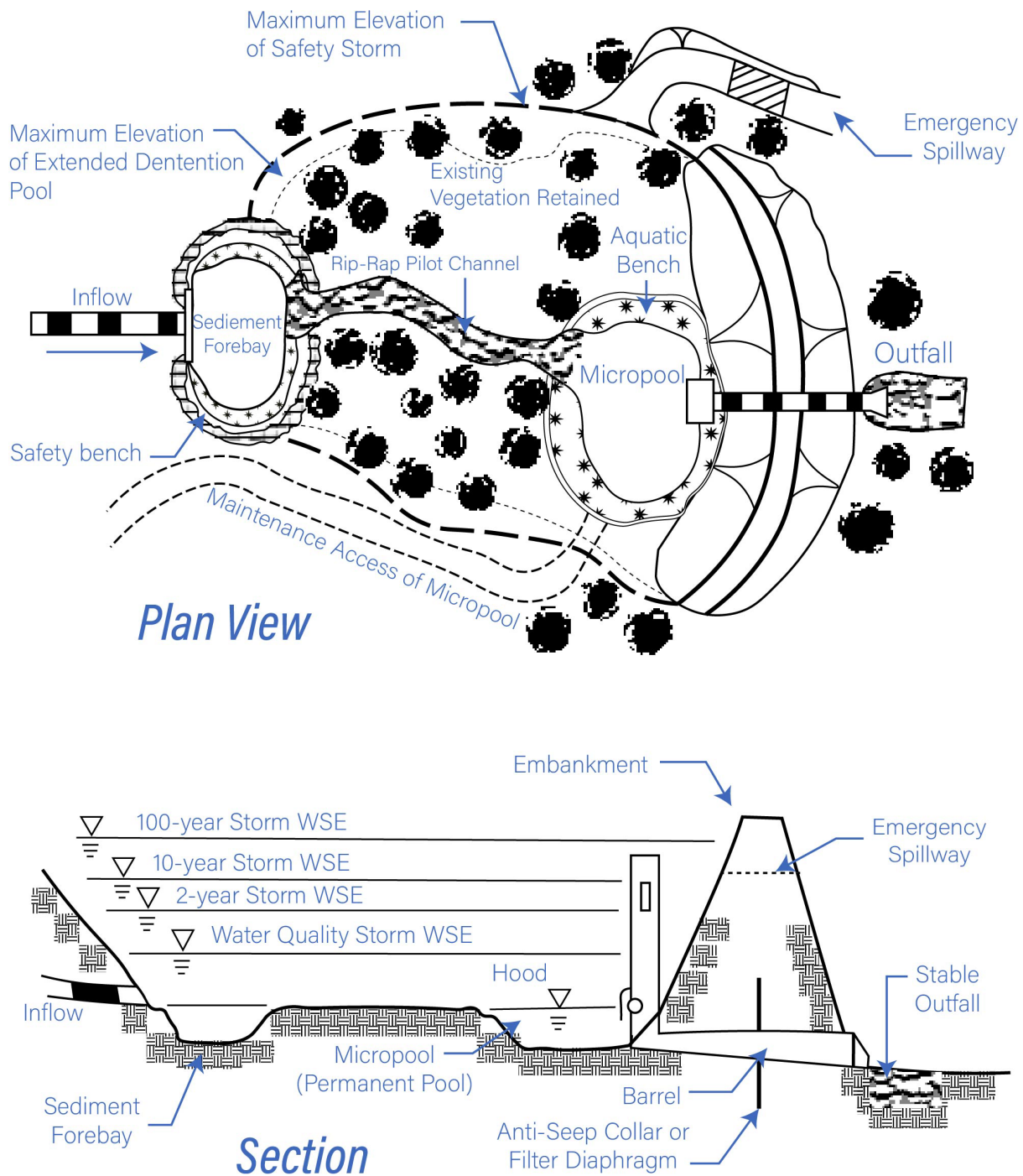

Source: Adapted from NYDEC, 2001.

Figure 13-25. Wet Extended Detention Pond Schematic

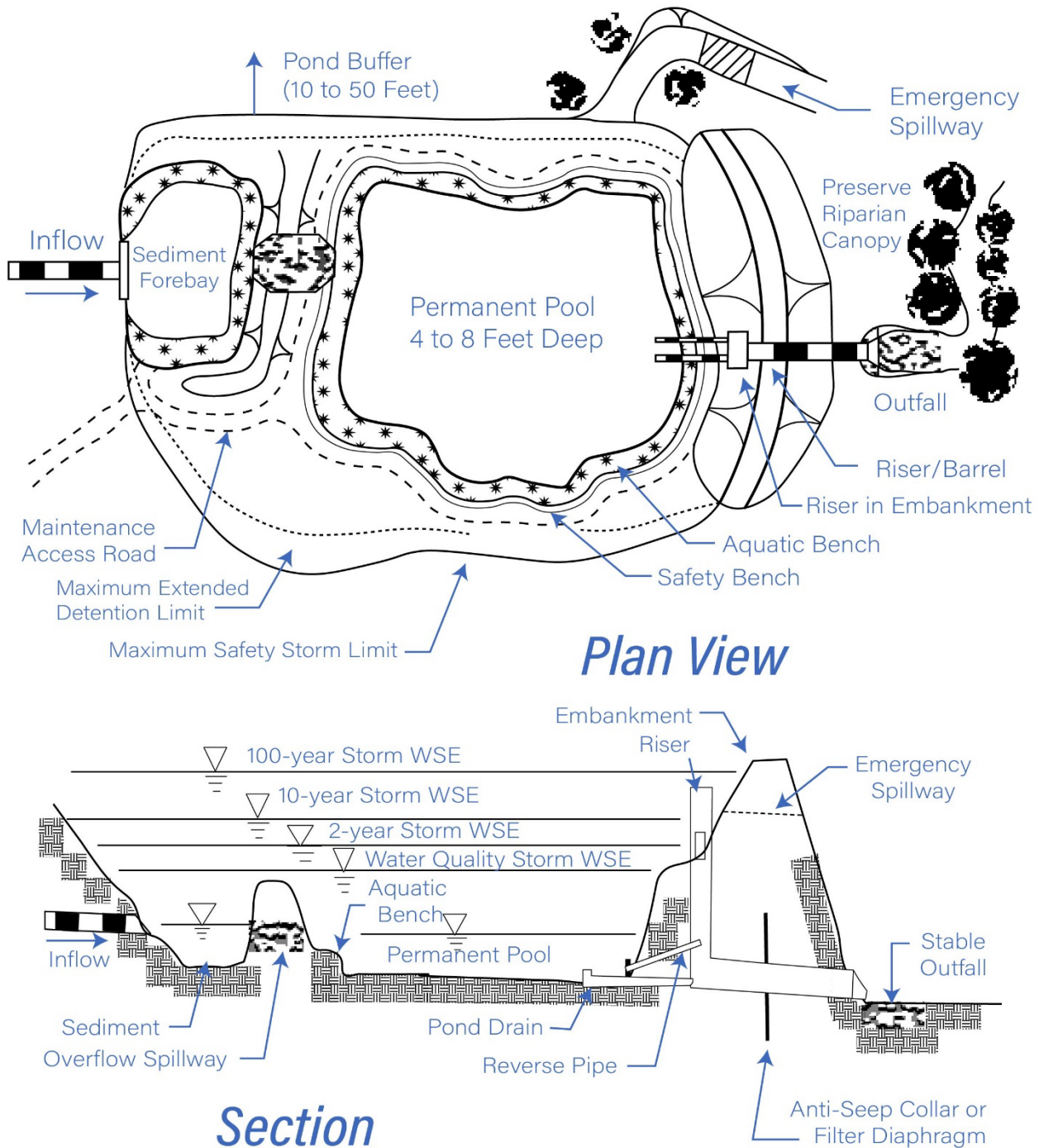

Source: Adapted from NYDEC, 2001.

Figure 13-26. Multiple Pond System Schematic

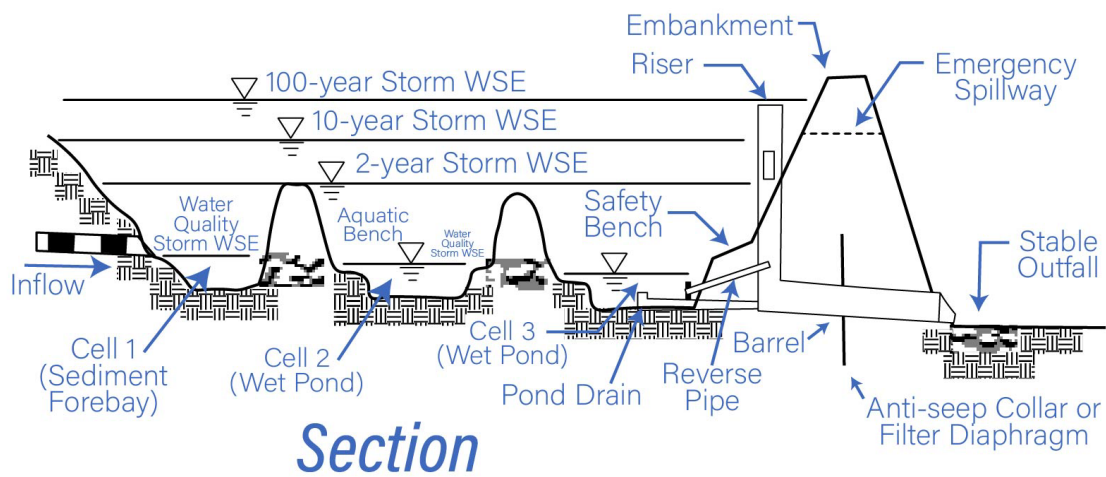
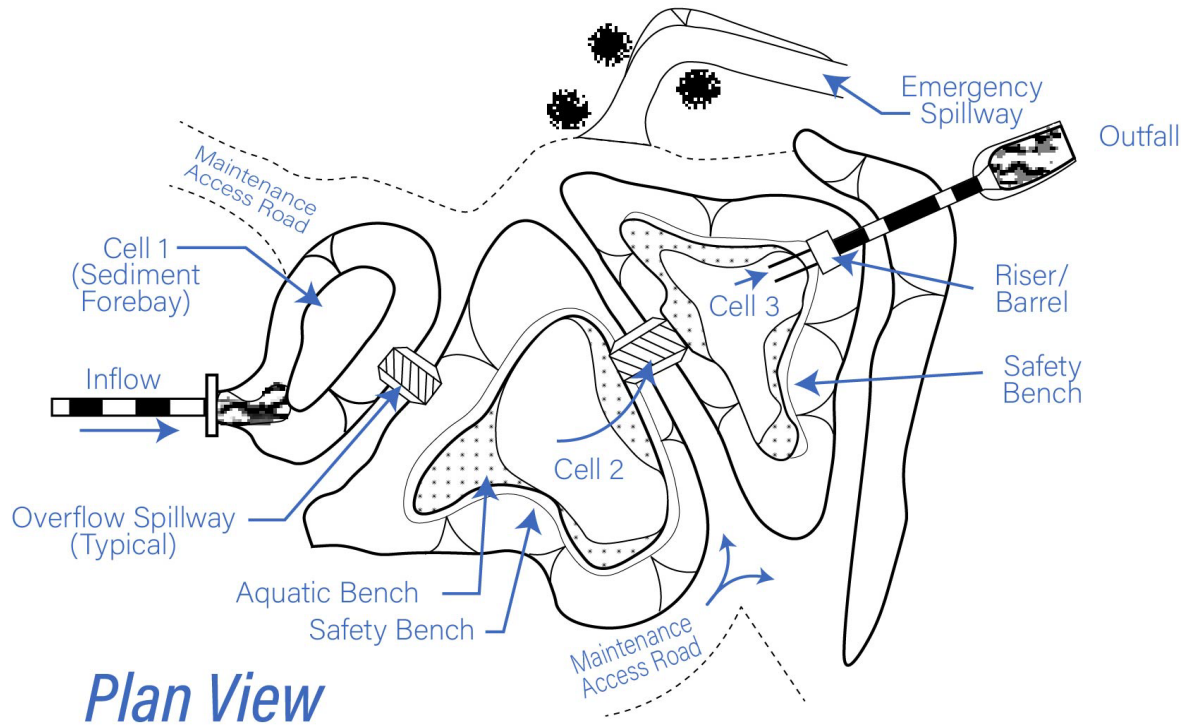

Source: Adapted from NYDEC, 2001.

Stormwater Wetland



Description

Stormwater wetlands are man-made wetland systems that incorporate marsh areas and permanent pools to provide treatment and attenuation of stormwater flows. Stormwater wetlands differ from stormwater ponds in that wetland vegetation is a major element of the overall treatment mechanism as opposed to a supplementary component. This section addresses four types of stormwater wetlands:

- Subsurface Gravel Wetland
- Shallow Wetland
- Extended Detention Shallow Wetland
- Pond/Wetland System

While stormwater wetlands can provide some of the ecological benefits associated with natural wetlands, these benefits are secondary to the function of the system to treat stormwater. Particulate and soluble pollutants are removed as stormwater runoff flows through the open marsh system. The primary pollutant removal mechanisms include sedimentation and filtration/uptake by wetland vegetation.

Subsurface gravel wetlands are a more recent stormwater wetland design variant that combines a surface marsh and subsurface gravel bed. Pollutants are removed through settling and filtration/uptake by wetland vegetation and by the process of denitrification in the subsurface gravel bed. Subsurface gravel wetlands are particularly effective for nitrogen removal.

The key to maximizing pollutant removal effectiveness in stormwater wetlands is maintaining wet conditions adequate to support wetland vegetation and saturated conditions in the

<i>Stormwater BMP Type</i>	
Pretreatment BMP	<input type="checkbox"/>
Infiltration BMP	<input type="checkbox"/>
Filtering BMP	<input type="checkbox"/>
Stormwater Pond BMP	<input type="checkbox"/>
Stormwater Wetland BMP	<input checked="" type="checkbox"/>
Water Quality Conveyance BMP	<input type="checkbox"/>
Stormwater Reuse BMP	<input type="checkbox"/>
Proprietary BMP	<input type="checkbox"/>
Other BMPs and Accessories	<input type="checkbox"/>
<i>Stormwater Management Suitability</i>	
Retention	<input type="checkbox"/>
Treatment	<input checked="" type="checkbox"/>
Pretreatment	<input type="checkbox"/>
Peak Runoff Attenuation*	<input checked="" type="checkbox"/>
*On-line systems only	
<i>Pollutant Removal</i>	
Sediment**	High
Phosphorus	Moderate
Nitrogen	Moderate
Bacteria	Moderate
**Includes sediment-bound pollutants and floatables (with pretreatment)	
<i>Implementation</i>	
Capital Cost	Medium
Maintenance Burden	Medium
Land Requirement	High

subsurface gravel bed of subsurface gravel wetlands. Stormwater wetlands should either intercept the groundwater table or should be lined with an impermeable liner if located in permeable soils and should have a watershed large enough to supply storm flows that will maintain wetness even during dry periods.

Stormwater wetland systems are designed to operate on the plug flow principle where the “new” polluted incoming runoff displaces the “old” treated water held in the system from the previous storm event. This is accomplished by maximizing length versus width ratios and/or by creating distinct cells along the treatment path. Stormwater wetlands are designed to treat the Water Quality Volume (WQV). When designed in an on-line configuration, stormwater wetlands can also be sized to treat and provide peak runoff attenuation for storms larger than the water quality storm event.

Stormwater wetlands do not provide sufficient retention or runoff volume reduction through infiltration or other processes and therefore cannot be used to meet the Standard 1 retention performance criterion of this Manual.

Advantages

- Effective for removal of particulate and soluble pollutants. Subsurface gravel wetlands are particularly effective at removing nitrogen.
- Can provide aesthetic benefits.
- Can provide wildlife habitat with appropriate design elements.
- Can provide peak runoff attenuation.
- Subsurface gravel wetlands are well-suited for retrofitting existing stormwater detention and retention ponds to enhance pollutant removal.

Limitations

- Do not provide infiltration or sufficient runoff volume reduction, and therefore cannot be used to meet the Standard 1 retention performance criterion.
- Require a relatively large land area.
- Very sensitive to the ability to maintain wet conditions especially during extended dry weather when there may be significant evaporative losses.
- May cause thermal impacts to receiving waters and therefore should not discharge directly to coldwater streams or other receiving water environments that are sensitive to thermal loads.
- Stormwater wetlands with steep side slopes and/or deep wet pools may present a safety risk in residential areas and areas with public access.
- Stormwater wetlands can serve as decoy wetlands, intercepting breeding amphibians moving toward vernal pools. If amphibians deposit their eggs in these artificial wetlands,

they rarely survive due to the sediment and pollutant loads, as well as fluctuations in water quality, quantity, and temperature.

Siting Considerations

- **Drainage Area:** Stormwater wetlands that utilize a liner system should have a contributing drainage area that is adequate to maintain minimum water levels. Typically, the minimum contributing drainage area for lined wetlands is 10 acres (5 acres for subsurface gravel wetlands). Smaller drainage areas may be suitable if intercepting groundwater or with sufficient surface runoff to support wetlands and a submerged gravel bed for subsurface gravel wetlands. A water budget analysis should be performed to demonstrate that sufficient groundwater flow and/or surface runoff is available to maintain the required water elevations in the various zones of the stormwater wetland.
- **Groundwater:** Stormwater wetlands should intercept groundwater or have an impermeable liner to maintain a permanent pool if located in permeable soils. The elevations of unlined wetlands should be established such that the groundwater elevation is equal to the desired permanent pool elevation. Seasonal variations of groundwater elevations should be considered.
- **Land Uses:** Land uses will dictate potential pollutants-of-concern and potential safety risks. A liner is required for stormwater wetlands that receive runoff from Land Uses with Higher Potential Pollutant Loads (LUHPPLs) (see [Chapter 10](#)) or on contaminated sites. The wetland's standing water may pose a safety risk in residential areas and areas with public access, sometimes requiring fencing to limit access to the wetland.
- **Baseflow:** A small amount of baseflow is desirable to maintain circulation and reduce the potential for low dissolved oxygen levels during late summer. This baseflow can be provided by groundwater discharge to the wetland or the drainage system that feeds the wetland.
- **Site Slopes:** Site slopes greater than 6% may result in the need for an embankment greater than 4 feet above existing grade to provide the desired storage volume, which would be subject to CT DEEP dam safety regulatory requirements. Steep slopes may also present design and construction challenges, and significantly increase the cost of earthwork.
- **Receiving Waters:** Stormwater wetlands should not be used for sites that discharge within 200 feet of coldwater streams, 200 feet from a public water supply reservoir, or 100 feet from streams tributary to a public water supply reservoir.
- **Natural Wetlands/Vernal Pools:** Natural wetlands and vernal pool depressions should not be used, either temporarily or permanently, as a stormwater wetland. Stormwater wetlands should be located at least 750 feet from a vernal pool. They should not be sited between vernal pools, or in areas that are known primary amphibian overland migration routes.

Soil Evaluation and Water Budget Analysis

- Conduct an evaluation of the soil characteristics and subsurface conditions at the location of the proposed system including soil type, depth to the seasonal high groundwater table, and depth to bedrock. Perform test pits or soil borings in accordance with the soil evaluation guidance in [Chapter 10](#).
- A water budget analysis should be performed for stormwater wetland designs. The water budget consists of calculations, on a daily basis, of the inflows to and outflows from the wetland to show that the required depth of water in the wetland is maintained throughout the year. The analysis should be performed for a wet year, a dry year, and an average year. The analysis should demonstrate that the depths of water in the various zones of the stormwater wetland meet the minimum requirements of this section for all of the days in each of the three analyses. All of the inputs to and outputs from the wetland should be considered, including direct precipitation, runoff, flooding, groundwater inflow, evapotranspiration, groundwater outflow.

Design Recommendations – Subsurface Gravel Wetland

Subsurface gravel wetlands combine a surface marsh and a subsurface gravel bed. In the surface marsh, pollutants are treated through filtration and biological uptake by the marsh vegetation and through sedimentation. Stormwater runoff flows vertically from the surface marsh through perforated pipe into the saturated gravel bed, located directly below the surface marsh. Runoff then flows horizontally through the gravel where additional treatment occurs via denitrification, which is a microbially-facilitated process whereby nitrogen compounds in stormwater runoff are transformed to nitrogen gas. The nitrogen gas is then permanently removed from the system via the soil into the atmosphere. The subsurface gravel bed must always be completely filled with stormwater runoff in order to provide the anoxic environment necessary for denitrification to occur.

A subsurface gravel wetland consists of the following basic components:

- Pretreatment
- Two surface wetland treatment cells connected by a cross drain
- Transition layer located below each surface wetland cell
- Two subsurface gravel cells connected by a subsurface cross drain
- Two perforated riser pipes connecting each of the wetland treatment cells to the gravel cells below them
- Outlet structure.

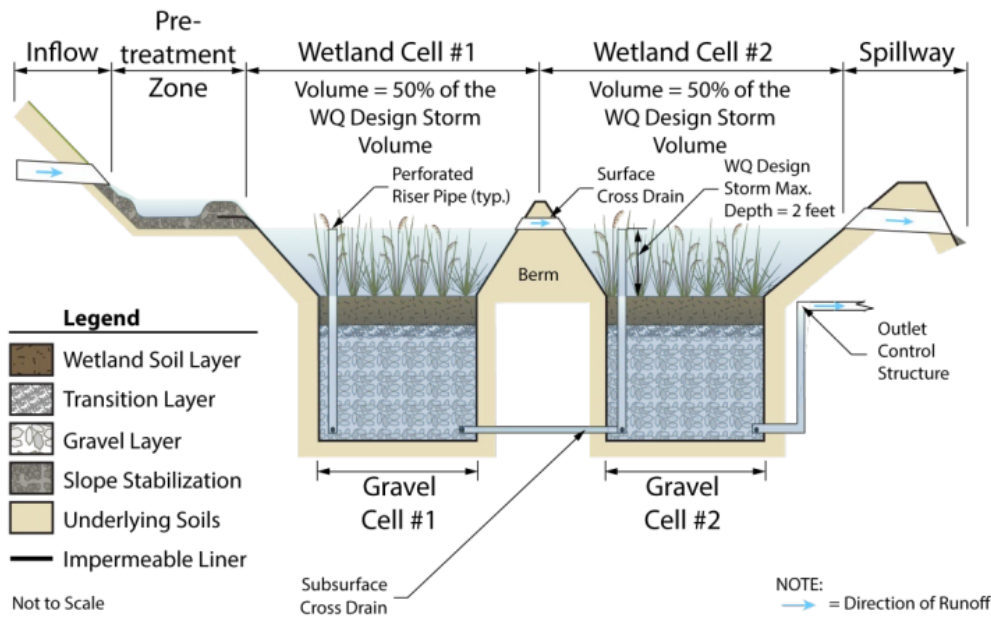

Source: Adapted from NJDEP, 2021.

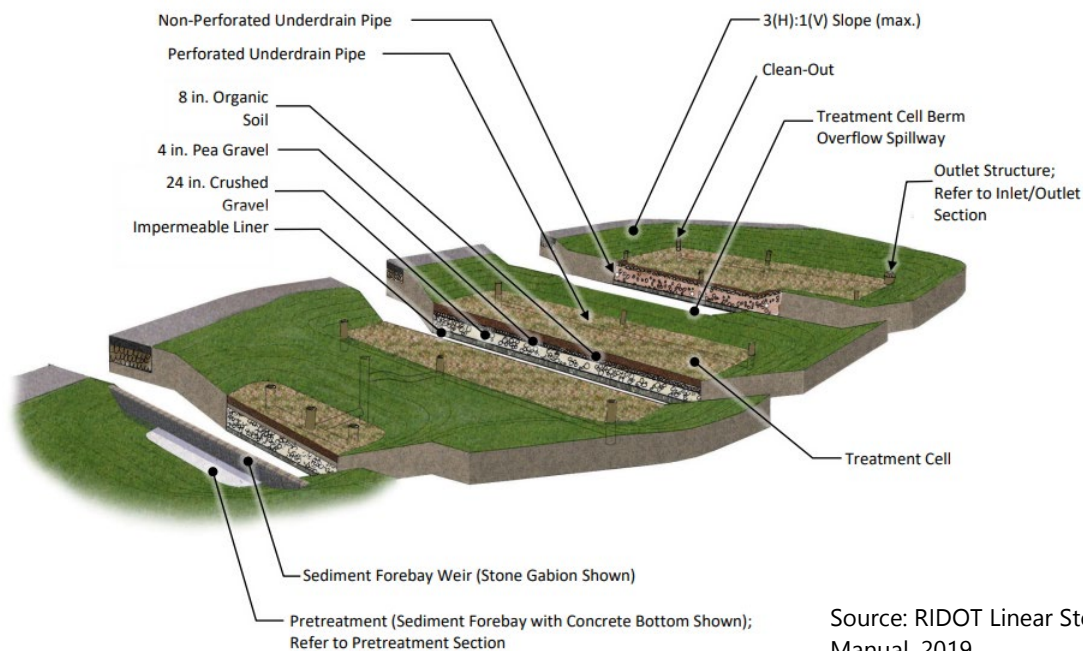

Source: RIDOT Linear Stormwater Manual, 2019.

Pretreatment – Sediment Forebay

- A sediment forebay is recommended for subsurface gravel wetlands, although other forms of pretreatment may be used at locations where runoff enters the system.
- The sediment forebay and other pretreatment measures should be designed in accordance with the [Pretreatment BMPs](#) section of this Manual.

- The sediment forebay should be a minimum of 3 feet deep and sized to contain at least 10% of the WQV. The forebay storage volume may be used to fulfill the WQV requirement of the overall stormwater wetland. The forebay should also include additional sediment storage volume that may not be used for WQV calculations.

Sizing and Dimensions

- Volume
 - Size the entire facility (including pretreatment, surface ponding in wetland treatment cells, and volume of voids in subsurface gravel beds) to hold 100% of the WQV and to drain the WQV over a 24 to 30 hour period after the end of a storm event.
 - Assume 40% void space when computing the amount of available storage within the gravel substrate.
 - WQV treatment should be equally distributed in each wetland treatment cell.
 - When used as an on-line treatment practice, the subsurface gravel wetland can be designed for extended detention for peak runoff control. In this case, the extended detention volume shall drain over a 24 to 48 hour period.
- Treatment Cell Ponding Depth and Freeboard
 - The maximum ponding depth in the surface wetland cells is 2 feet.
 - Provide at least 1 foot of freeboard above the WQV elevation (if designed to handle the WQV only).
 - Provide a maximum freeboard of 4 feet above the WQV elevation or 6 inches of freeboard above the 100-year storm elevation, whichever is less (if extended detention is provided).
- Treatment Cell Length, Width, and Slope
 - Minimum length: 15 feet (in the direction of flow) to provide sufficient travel time in the anoxic environment for denitrification to occur.
 - Maximum length: None; the length of the flow path in the gravel cell should be maximized to maximize treatment.
 - Minimum width: 1:1 length to width ratio
 - Bottom slope: the top and bottom of the treatment cell should be level.
 - Maximum side slope: 3(H):1(V) slopes or flatter

Berms

- The top of the berms separating treatment cells shall be set at or above the height of the WQV elevation.
- Construct berms of low permeability soils (hydraulic conductivity less than 0.03 feet per day), to prevent water seepage between cells and to maintain the structural integrity of the berm.

- Use solid (non-perforated) pipe sections and watertight joints to connect pipes through the base of the berm to promote flow of the WQV between treatment cells.
- Extended detention (optional) when designed as an on-line system:
 - If provided, extended detention occurs above the treatment cells. An overflow spillway or bypass pipe should be provided in the berm at the height of the WQV elevation.
 - The surface of the berm should be designed with materials to resist erosive velocities.
 - Provide stable and non-erosive energy dissipating devices between berms where overflow velocities are considered erosive.

Conveyance

- Stormwater should be conveyed to and from all stormwater management practices safely and to minimize erosion potential.

Inlet

- Design the inlet in accordance with the [Inlet and Outlet Controls](#) section of this Manual.
- The number of inlets should be minimized, and one inlet is preferable. The inlet should be located at the most hydraulically remote point from the outlet to minimize the potential for short-circuiting and should be located in a manner that meets or exceeds desired length to width ratios.

Outlet & Overflow

- Design the outlet and any overflows in accordance with the [Inlet and Outlet Controls](#) section of this Manual.
- The primary outlet control structure should be a riser with an orifice/outlet pipe for low flow. The WQV is conveyed into the outlet control structure through the underdrain.
- The WQV orifice/outlet should be located 4-8 inches below the elevation of the organic soil surface.
- The top of the structure should remain open with a grate for overflow. This configuration reduces the potential for creating siphoning.
- Extended detention (optional) when designed as an on-line system:
 - A weir should be provided in the center of the structure with a WQV orifice located in the weir. The elevation of the top of the weir should be set to provide control of lower frequency storm events, such as the 2-year or 10-year, 24-hour storm event.

- If the outlet controls multiple storm events, additional orifices may be added to the structure.
- The top of the structure should be set to allow the bypass of the 100-year event.

Underdrain and Risers

- Underdrains and risers are critical in subsurface gravel wetlands as they convey and distribute stormwater through the treatment cells as driven by the hydraulic head.
- Risers
 - Minimum central riser pipe diameter: 12 inches
 - Minimum end riser pipe diameter: 6 inches
 - Space perforated riser pipes across the width of the treatment cell with a maximum spacing of 15 feet.
 - Place inlet grates atop risers for an overflow when water levels exceed the WQV.
- Underdrains
 - Minimum diameter: 6 inches
 - Use solid (non-perforated) pipe sections and watertight joints wherever the underdrain system passes below berms, connects to a drainage structure and/or daylights.
 - Place the subsurface perforated distribution line at the upstream end of each treatment cell and the subsurface perforated collection drain at the downstream end. At a minimum, there should be 15 feet between both.
 - Provide a marking stake and an animal guard for underdrains that daylight at grade.
- Include an observation well/cleanout at each end of the underdrains. The cleanout should be highly visible.
 - Cleanouts should be at least 6 inches in diameter, should be perforated only within the gravel layer and solid within the organic soil and storage area.
 - Cap cleanouts with a watertight removable cap.

Liner

- Proper functioning of the system requires stormwater runoff to enter the subsurface gravel cells only from the surface wetland cells and only through the perforated riser pipes. It is also essential that discharges from the gravel cells occur only through the outlet structure and not into the underlying soil.
- An impermeable liner is required to prevent groundwater exchange with runoff in the subsurface gravel bed unless the underlying soils are sufficiently impermeable (soils with a field-verified infiltration rate of 0.05 in/hr or less), in which case the liner may be omitted provided that the system is above the seasonal high groundwater table (SHGT).

- A liner is also necessary to avoid impacts to groundwater quality for systems that receive runoff from Land Uses with Higher Potential Pollutant Loads (LUHPPLs) or on contaminated sites.
- Where SHGT is located at or above the bottom of the liner, complete a buoyancy analysis to verify buoyancy will not be an issue.

Materials

- Vegetation
 - Select vegetation and develop a planting plan in with guidance provided in [Appendix F](#) of this Manual.
 - Establish a dense vegetative cover or adequately stabilized landscaped surface across any upgradient areas disturbed by construction before runoff can be accepted into the facility.
 - The bottom of the subsurface gravel wetland should be planted to achieve a rigorous root mat with grasses, forbs, and shrubs with obligate and facultative wetland species, such as New England Wetland Plants Wet Mix.
- Gravel Substrate
 - Do not use geotextiles between subsurface layers as they will clog and prevent root growth.
 - Organic Soil
 - Similar to a low permeability wetland soil made up of compost, sand and fine soils blended to have an organic matter content > 15%. Avoid using clay contents in excess of 15%, as the fines could migrate into the subsurface crushed stone (gravel) layer.
 - Pea Gravel
 - Provide a 4-inch layer of pea gravel to provide separation between the organic soil layer and the crushed gravel layer.
 - Should consist of 3/8" AASHTO No. 8 stone. Pea gravel should be clean (washed and free from dirt and debris) and rounded in shape.
 - Crushed Gravel
 - Minimum Thickness: 24 inches
 - Should consist of 3/4" AASHTO No. 5 stone. Gravel should be clean (washed and free from dirt and debris), crushed, and angular.
- Underdrain/Riser (perforated and non-perforated sections)
 - Polyethylene or polyvinyl pipe.
- Liner
 - should consist of a 30 mil (minimum) HDPE or PVC liner, or one of the alternative liner systems described in Chapter 10 with the approval of the review authority.

- Turf Reinforcement Matting (TRM)
 - Stabilize the side slopes with a TRM to limit erosion in locations where flow velocities exceed 3 to 5 feet per second (depending on soil and vegetation types) for the 1-year, 24-hour storm event.
 - If used, shall be a woven material included on the CTDOT Qualified Products List that exceeds the design velocity of the design storm and allows for the growth of the proposed vegetative species.

Winter Operations

- Subsurface gravel wetlands should not be used as dedicated snow storage areas. To the extent feasible, locate and design the system to avoid snow storage areas and potential damage from snow plowing activities. Refer to [Chapter 7](#) for general design considerations related to winter operations.

Design Recommendations – Conventional Stormwater Wetlands

The following conventional stormwater wetland design variants are characterized by the volume of the wetland in the deep pool, high marsh, and low marsh zones, and whether the design allows for detention of larger storms above the permanent pool (extended detention).

- **Shallow Wetland:** Shallow wetland systems, also referred to as shallow marsh wetlands, consist of aquatic vegetation with a permanent pool ranging from 6 to 18 inches during normal conditions. Shallow wetlands are designed such that flow through the wetlands is conveyed uniformly across the treatment area. While pathways, channels, or other varied water depths could enhance the aesthetic or ecosystem value of the wetland, they could also cause short-circuiting through the wetland thereby reducing the overall treatment effectiveness. A uniformly sloped system is recommended to maximize treatment performance. Individual wetland cells can be separated by weirs to enhance plug flow conditions across the wetland. Figure 13-27 is a typical schematic design of a shallow wetland.

Shallow wetlands are typically designed as off-line systems to provide treatment of the Water Quality Volume (WQV) but not to provide stormwater quantity control for larger storms.

Figure 13-27. Shallow Wetland Schematic

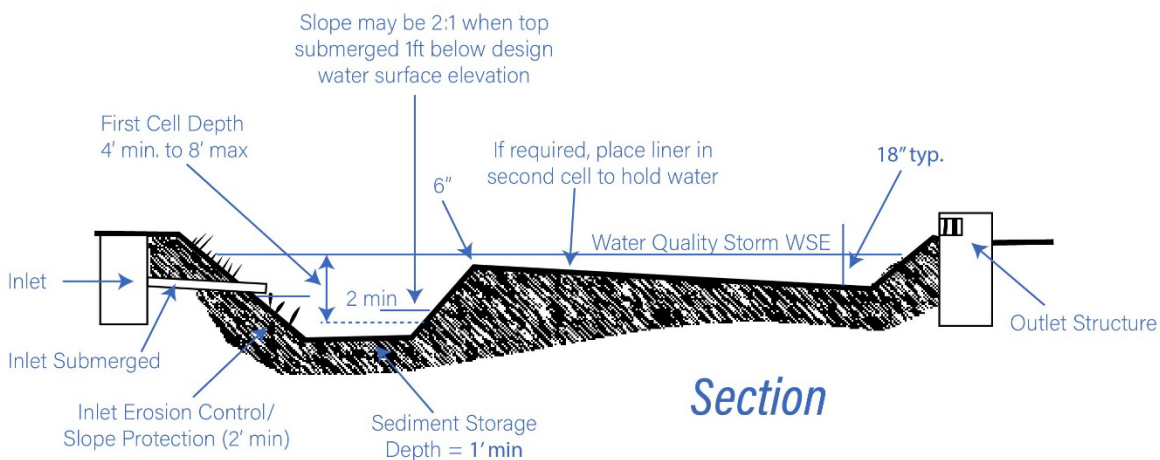
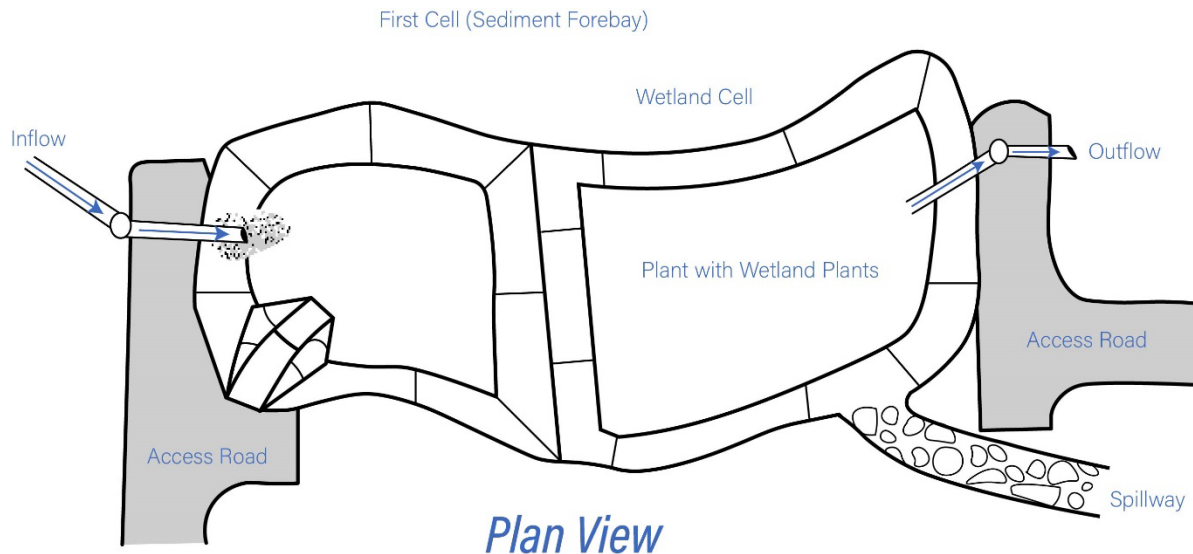

- **Extended Detention Shallow Wetland:** Extended detention shallow wetlands provide a greater degree of stormwater quantity control as they are designed with more vertical storage capacity. The additional vertical storage volume also provides extra runoff detention above the normal pool elevation. Water levels in the extended detention shallow wetland may increase by as much as 3 feet after a storm event and return gradually to pre-storm elevations within 24 hours of the storm event. The extended detention zone is the inundation area above the normal pool elevation up to the water quality storm elevation. Wetland plants that tolerate intermittent flooding and dry periods should be selected for the extended detention area above normal pool elevation. [Figure 13-28](#) is a typical schematic design of an extended detention shallow wetland.

Figure 13-28. Extended Detention Shallow Wetland Schematic

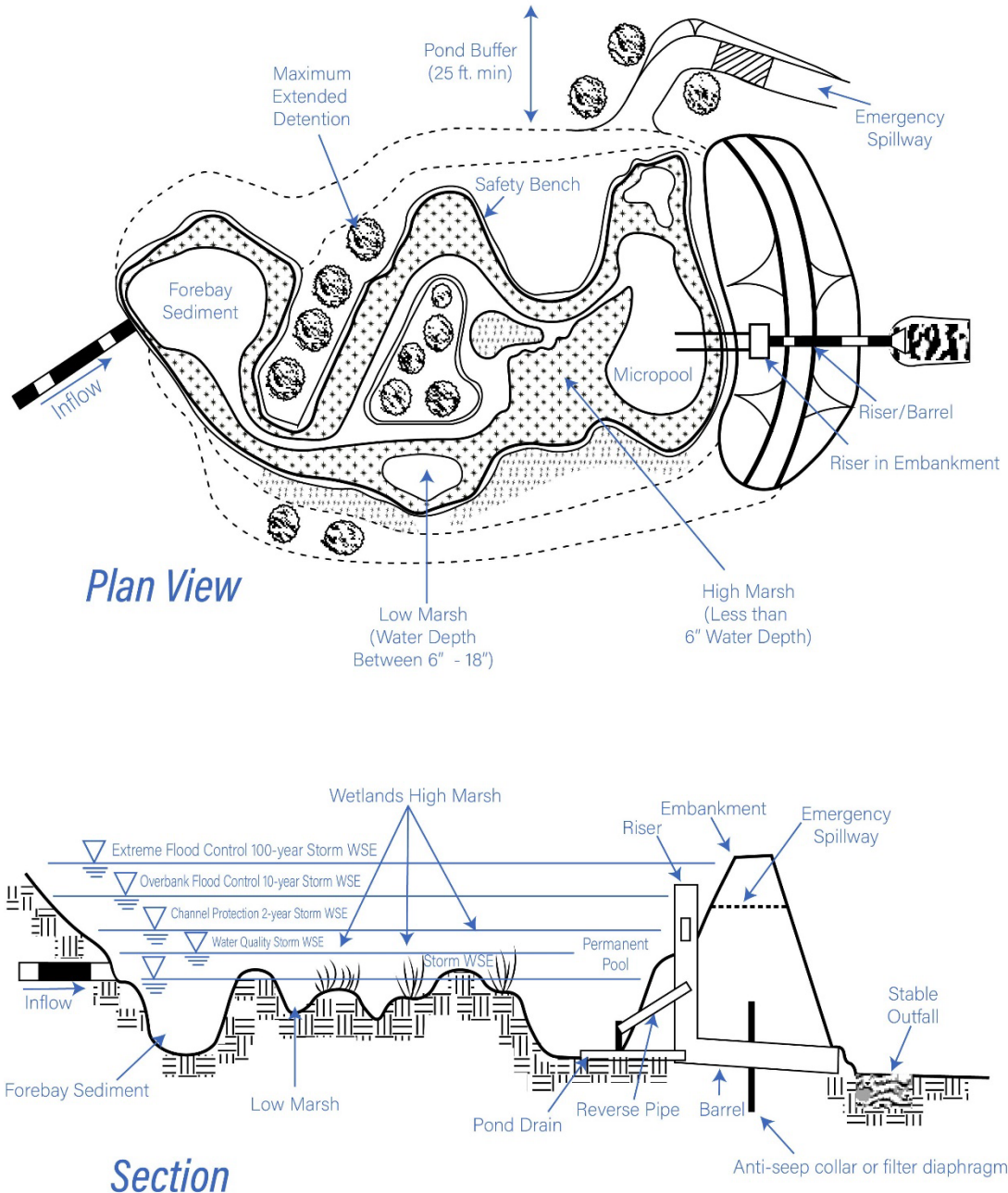

- **Pond/Wetland System:** Multiple cell systems, such as pond/wetland systems, utilize at least one pond component in conjunction with a shallow marsh component. The first cell is typically a wet pond, which provides pretreatment of the runoff by removing particulate pollutants and reduce the velocity of the runoff entering the system. The shallow marsh

then polishes the runoff, particularly for soluble pollutants, prior to discharge. These systems require less space than the shallow marsh systems since more of the water volume is stored in the deep pool which can be designed to reduce peak flows. Because of this system's ability to significantly reduce the velocity and volume of incoming peak flows (i.e., flow equalization or dampening), it can often achieve higher pollutant removal rates than other similarly sized stormwater wetland systems. [Figure 13-29](#) is a typical schematic design of a pond/wetland system.

Figure 13-29. Pond/Wetland System Schematic

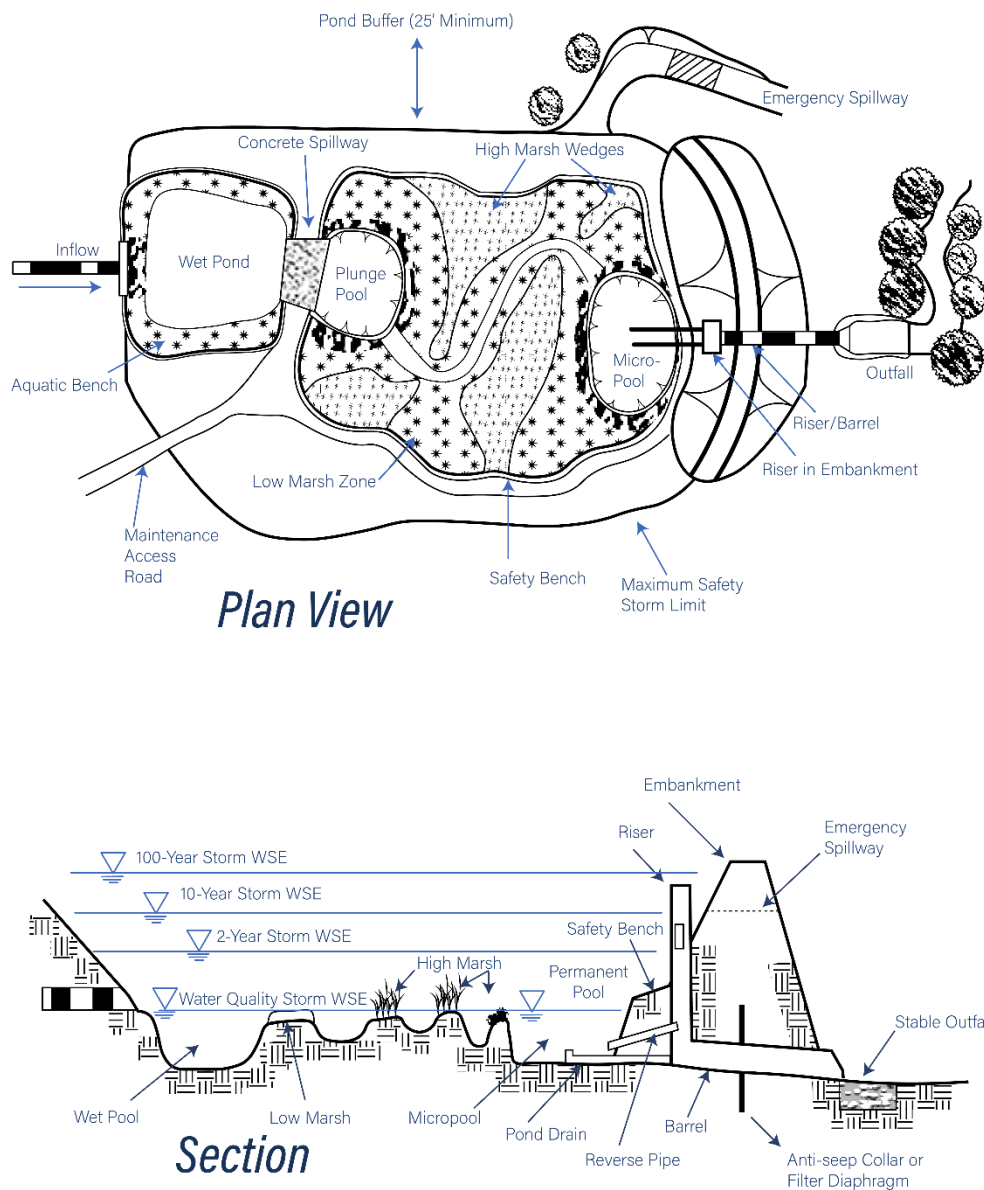

Source: Adapted from NYDEC, 2001.

Pretreatment – Sediment Forebay

- A sediment forebay is recommended for conventional stormwater wetlands, although other forms of pretreatment may be used at locations where runoff enters the system.
- The sediment forebay and other pretreatment measures should be designed in accordance with the [Pretreatment BMPs](#) section of this Manual.
- The sediment forebay should be a minimum of 3 feet deep and sized to contain at least 10% of the WQV. The forebay storage volume may be used to fulfill the WQV requirement of the overall stormwater wetland. The forebay should also include additional sediment storage volume that may not be used for WQV calculations.

Sizing and Dimensions

- The wetland volume, including the volume of the sediment forebay, the permanent pool volume (high marsh zone, low marsh zone, and pool zone), and the volume of the extended detention area (if any), should be equal to or exceed the WQV. [Table 13-11](#) provides the recommended division of storage between these zones for each stormwater wetland design variant.

Table 13-8. Water Quality Volume Distribution in Stormwater Wetland Designs

Design Variant	Percent of Water Quality Volume (WQV)				
	Sediment Forebay	High Marsh Zone	Low Marsh Zone	Pool Zone	Extended Detention Zone
Water Depth	3 feet min (below permanent pool)	6 inches max (below permanent pool)	6-18 inches (below permanent pool)	4-6 feet (below permanent pool)	Varies (above permanent pool)
Shallow Wetland	10%	0%	90%	0%	0%
Extended Detention Shallow Wetland	10%	10%	20%	10%	50%
Pond/Wetland System	10%	10%	20%	60%	0%

Adapted from NYDEC, 2001 and NJDEP, 2021.

- Water quality storage can be provided in multiple cells. Performance is enhanced when multiple treatment pathways are provided by using multiple cells, longer flow paths, high surface area to volume ratios, complex microtopography, and/or redundant treatment methods (combinations of pool, extended detention, and marsh).
- For extended detention shallow wetlands, the extended detention storage volume (storage volume above the permanent pool provided for additional water quality and stormwater

quantity control) should drain out of the wetland over a minimum of 24 hours, after which the water surface elevation in the wetland will return to the permanent pool elevation.

- Thermal impacts of stormwater wetlands may be mitigated by implementing one or more of the following design measures:
 - Use of a smaller permanent pool with more extended detention storage and an extended detention time of 24 hours or less
 - Planting of shade trees around the perimeter of the wetland (but at least 25 feet away from inlet/outlet structures and the wetland embankment) to reduce solar warming of the pool
 - Designing the wetland with a series of pools, as opposed to a single pool, to allow cooling prior to discharge
 - Use of an outlet structure designed to draw water from near the bottom of the outlet pool where water temperatures may be cooler
 - Use of an underdrained gravel trench outlet.
- The wetland should have a curvilinear shape and a minimum length:width ratio of 3:1 from the wetland inlet to outlet.
- For extended detention shallow wetland and pond/wetland systems, the upper stages of the wetland should provide temporary storage of larger storms (2-year, 10-year, and 100-year, 24-hour events) to control peak discharge rates.
- Wetland Water Depths:
 - High Marsh Zone: 6 inches maximum (below permanent pool)
 - Low Marsh Zone: 6-18 inches (below permanent pool)
 - Pool Zone: 4-6 feet (below permanent pool), includes deeper pool at outlet structure (i.e., micropool)
 - Extended Detention Zone: varies (above permanent pool)
- Pumping of groundwater to maintain the permanent pool should not be allowed.
- The volume below the surface elevation of the permanent pool should not be included in storage calculations for peak flow management.

Side Slopes

- 3(H):1(V) slopes or flatter are preferred.
- The perimeter of permanent pool areas (sediment forebay and outlet pool) four feet or greater in depth should provide two benches:
 - Provide a flat safety bench that extends 10 feet outward from the normal water edge to the toe of the wetland side slope.
 - Provide a flat aquatic bench that extends 10 feet inward from the normal water edge at a depth of 12-18 inches below the normal pool water surface elevation.

Inlet

- Design the inlet in accordance with the [Inlet and Outlet Controls](#) section of this Manual.
- The number of inlets should be minimized, and one inlet is preferable. The inlet should be located at the most hydraulically remote point from the outlet to minimize the potential for short-circuiting and should be located in a manner that meets or exceeds desired length to width ratios.
- The ideal inlet configuration is above the permanent pool to prevent potential hydraulic constrictions due to freezing.

Outlet & Overflow

- Design the outlet and any overflows in accordance with the [Inlet and Outlet Controls](#) section of this Manual.
- Shallow wetlands should be designed as off-line systems and have an outlet structure sized to convey the water quality storm to the storm drainage system or stabilized channel. An emergency spillway is required to convey flows up to the 100-year, 24-hour storm event in the event that the primary outlet structure gets clogged.
- Extended detention shallow wetlands and pond/wetland systems should have an outlet structure sized to convey flows up to the 10-year, 24-hour storm event, at a minimum, to the storm drainage system or stabilized channel. An emergency spillway is required to convey the 100-year storm event if the outlet structure is not designed to pass the 100-year storm event.

Conveyance

- Stormwater should be conveyed to and from all stormwater management practices safely and to minimize erosion potential.
- Stabilize any portion of the stormwater wetland with Turf Reinforcement Matting (TRM) to limit erosion in locations where flow velocities exceed 3 to 5 feet per second (depending on soil and vegetation types) for the 1-year, 24-hour storm event.
- TRM should be a woven material included on the CTDOT Qualified Products List that exceeds the design velocity of the design storm and allows for the growth of the proposed vegetative species.

Liner

- When a stormwater wetland is located such that the bottom of the wetland does not intercept groundwater and the wetland is located in permeable soils, an impermeable liner is needed to maintain a permanent pool of water. A liner is also necessary to avoid impacts

to groundwater quality for stormwater wetlands that receive runoff from Land Uses with Higher Potential Pollutant Loads (LUHPPLs) or on contaminated sites.

- If used, should consist of a 30 mil (minimum) HDPE or PVC liner, or one of the alternative liner systems described in [Chapter 10](#) with the approval of the review authority.

Non-clogging Low-Flow Orifice

- A low-flow orifice should be provided, with the size of the orifice sufficient to avoid clogging (recommended minimum orifice diameter of 6 inches, although orifice diameters as small as 3 inches are allowed if required to provide the necessary hydraulic control). The low flow orifice should be protected from clogging using an external trash rack.
- A submerged reverse-slope pipe may also be used that extends downward from the riser to an inflow point one foot below the normal pool elevation.
- Alternative methods are to employ a broad crested rectangular, V-notch, or proportional weir, protected by a half-round pipe that extends at least 12 inches below the normal pool level.

Riser in Embankment

- The riser should be located within the embankment for maintenance access and safety.
- Lockable manhole covers and manhole steps within easy reach of valves and other controls should provide access to the riser.

Drain

- For stormwater wetlands that do not intercept groundwater, the design may include a drain pipe that can completely or partially drain the permanent pool. The drain pipe should have an elbow or protected intake within the outlet pool to prevent sediment deposition in the pipe, and a diameter capable of draining the pool within 24 hours.
- Care should be exercised during draining to prevent rapid drawdown and minimize downstream discharge of sediments or anoxic water. The review/approving authority should be notified before draining the system.

Adjustable Gate Valve

- Both the WQV extended detention pipe and the drain may be equipped with an adjustable gate valve, typically a handwheel activated knife gate valve.
- Valves should be located inside of the riser at a point where they will not normally be inundated and can be operated in a safe manner.

- Both the WQV extended detention pipe and the drain should be sized one pipe size greater than the calculated design diameter.
- To prevent vandalism, the handwheel should be chained to a ringbolt, manhole step, or other fixed object.

Vegetation

- Establishing and maintaining wetland vegetation is critical to the success of stormwater wetlands. Use plants that have high colonization and growth rates, can establish large surface areas that continue through the winter dormant season, have high potential for treating pollutants, and are very robust in flooded environments. Selected species must be able to adapt to a broad range of conditions, including large variations in water depth and inundation. Select vegetation and develop a planting plan in with guidance provided in [Appendix F](#) of this Manual.
 - The best depth for establishing emergent wetland plants, either through transplantation or volunteer colonization, is within approximately six inches of the normal pool elevation.
 - Soils should be modified (e.g., scarified or tilled) to mitigate compaction that occurs during construction around the proposed planting sites.
 - Avoid species that require full shade, are susceptible to winterkill, or are prone to wind damage.
 - Woody vegetation may not be planted or allowed to grow within 25 feet of the toe of the embankment and 25 feet from the principal spillway structure.
 - Existing trees should be preserved in the buffer area during construction. It is desirable to locate forest conservation areas adjacent to wetlands. To help discourage resident geese populations, the buffer can be planted with trees, shrubs, and native ground covers.
 - Annual mowing of the wetland buffer is only required along maintenance rights-of-way and the embankment. The remaining buffer can be managed as a meadow (mowing every other year) or forest.
 - Plant the wetland with salt-tolerant vegetation if the stormwater wetland receives road runoff.

Safety Features

- The principal spillway opening must not permit access by small children, and endwalls above pipe outfalls greater than 48 inches in diameter should be fenced to prevent a hazard.
- Both the safety bench and the aquatic bench may be landscaped to prevent access to the pool.

- Fencing around the perimeter of the wetland is generally not encouraged but may be required by some municipalities. The preferred method is to grade the wetland to eliminate dropoffs or other safety hazards.

Maintenance Reduction Features

- Wetlands should be designed with non-clogging outlets, such as a weir, or by incorporating trash racks for culverts and orifice openings.
- To prevent clogging from ice or floatables, a reverse slope outlet pipe can be used to draw water from below the permanent pool up to the outlet structure. The invert of the pipe drawing from the pool should be at least 18 inches from the bottom to prevent sediment discharge.
- Orifices should be less than 6 inches in diameter with a trash rack to prevent clogging. Smaller orifice diameters (3 inches or larger) are allowed if required to provide the necessary hydraulic control.
- Metal components of outlet structures should be corrosion resistant, but not galvanized due to the contribution of zinc to water.
- Outlet structures should be resistant to frost heave and ice action in the wetland.

Cold Climate Design Considerations

The following design elements should be considered to minimize potential performance impacts caused by cold weather:

- Inlet pipes should not be submerged since this can result in freezing and upstream damage or flooding.
- Bury pipes below the frost line to prevent frost heave and pipe freezing. Bury pipes at the point furthest from the pond deeper than the frost line to minimize the length of pipe exposed.
- Increase the slope of inlet pipes to a minimum of 1 percent, if site conditions allow, to prevent standing water in the pipe and reduce the potential for ice formation.
- If perforated riser pipes are used, the minimum orifice diameter should be 0.5 inches. In addition, the pipe should have a diameter of at least 6 inches.
- When a standard weir is used, the minimum slot width should be 3 inches, especially when the slot is tall.
- Baffle weirs can prevent ice formation near the outlet by preventing surface ice from blocking the inlet, encouraging the movement of base flow through the system.

- Riser hoods and reverse slope pipes should draw from at least 6 inches below the typical ice layer. This design encourages circulation in the pond, preventing stratification and formation of ice at the outlet. Reverse slope pipes should not be used for off-line systems.
- Trash racks should be installed at a shallow angle to prevent ice formation.
- Additional storage should be provided to account for storage lost to ice buildup. Ice thickness may be estimated by consulting with local authorities (e.g., the fire department) with knowledge of the typical ice thickness in the area.

Winter Operations

- Stormwater wetlands should not be used as dedicated snow storage areas. To the extent feasible, locate and design the system to avoid snow storage areas and potential damage from snow plowing activities. Refer to [Chapter 7](#) for general design considerations related to winter operations.

Construction Recommendations

- The design engineer should develop a detailed, site-specific construction sequence.
- The design engineer should inspect the installation during the following stages of construction, at a minimum:
 - After excavation of the wetland
 - After internal grading of microtopography, berms, safety benches, etc.
 - After installation of bypass, outlet/overflow, and inlet controls
 - After vegetation and wetland plants/seed mix has been installed
- The design engineer should provide an as-built plan of the completed system along with a certification that the system was designed in accordance with the guidance contained in this Manual and other local or state requirements and that the system was installed in accordance with the approved plans.
- The entire contributing drainage area should be completely stabilized prior to directing any flow to the system. Adequate vegetative cover must be established over any pervious area adjacent or contributing to the system before runoff can be accepted.
- Erosion and sediment controls should be in place during construction in accordance with the [Connecticut Guidelines for Soil Erosion and Sediment Control](#) and the Soil Erosion and Sediment Control (SESC) Plan developed for the project.
- Temporary dewatering may be required if excavation extends below the water table. Appropriate sedimentation controls will be required for any dewatering discharges.
- During clearing and grading of the site, measures should be taken to avoid soil compaction at the location of the proposed system to promote growth of vegetation.

- The system should be fenced off during the construction period to prevent disturbance of the soils.
- The system should be excavated to the dimensions, side slopes, and elevations shown on the plans. The method of excavation should avoid compaction of the bottom of the wetland. A hydraulic excavator or backhoe loader, operating outside the limits of the system, should be used to excavate the system. Excavation equipment should not be allowed within the limits of the system.
- Install vegetation in accordance with the planting plan and plant schedule on the plans. Water vegetation thoroughly immediately after planting and as necessary until fully established.
- Stormwater wetlands classified as dams under the CT DEEP dam safety program (generally those with embankments greater than 4 feet above existing grade) should be constructed, inspected, and maintained in accordance with applicable CT DEEP dam safety regulations and guidance.

Maintenance Needs

- Detailed inspection and maintenance requirements, inspection and maintenance schedules, and those parties responsible for maintenance should be identified on the plans and in the Stormwater Management Plan.
- Maintenance should be detailed in a legally binding maintenance agreement.
- Maintenance activities such as sediment removal, mowing, and repairs should be performed with rakes and light-weight equipment rather than heavy construction equipment to avoid soil compaction and damage to vegetation. Heavy equipment may be used for sediment removal and other maintenance activities if the equipment is positioned outside the limits of the system. Heavy construction equipment should not be allowed within the limits of the system for maintenance purposes.

Maintenance Access

- Stormwater wetlands should be designed with easy access to all components of the system for maintenance purposes. In addition to the maintenance reduction design factors described in this section, also refer to [Chapter 7](#) for general design considerations to reduce and facilitate system maintenance.
- A maintenance right-of-way or easement should extend to the wetland from a public road.
- Maintenance access should be at least 12 feet wide, have a maximum slope of no more than 15 percent, and be appropriately stabilized to withstand maintenance equipment and vehicles.

- The maintenance access should extend to the forebay, safety bench, outlet pool, riser, and outlet and be designed to allow vehicles to turn around.
- The principal spillway should be equipped with a removable trash rack, and generally accessible from dry land.

Recommended Maintenance Activities

- Inspect after major storms (1 inch or more of precipitation) in the first few months following construction.
- Inspect sediment forebay twice per year and the rest of the system annually, including inlet and outlet control structures and the pond embankment.
- Refer to [Appendix B](#) for maintenance inspection checklists, including items to focus on during the inspections.
- Remove trash and organic debris (leaves) in the Spring and Fall.
- Remove sediment from the sediment forebay or other pretreatment area when it accumulates to a depth of more than 24 inches or 50% of the design depth.
- Remove sediment from the permanent pool when the pool volume has become reduced significantly, or when significant algal growth is observed.
- The vegetative cover should be maintained at 85%. If vegetation has damage, the area should be reestablished in accordance with the original specifications.
- Prune wetland vegetation on a regular schedule. Inspect wetland plants and manage/harvest dead or dying plants as necessary. Plant reinforcement plantings as necessary.
- Periodically mow perimeter grass during the growing season. Maintain perimeter grass at 6 inches or higher. High grass along the wetland edge will discourage waterfowl from taking up residence and serve to filter pollutants.
- Inspect and remove invasive vegetation as necessary.
- Remove trees and woody vegetation within 25 feet of all risers, pipe outlet structures, spillways, and downstream embankments that hold back water.
- Prune other woody vegetation where dead or dying branches are observed.

Other References

King County Department of Natural Resources. 1998. *King County Surface Water Design Manual*. Seattle, WA. <https://kingcounty.gov/services/environment/water-and-land/stormwater/documents/surface-water-design-manual.aspx>

New York State Department of Environmental Conservation (NYDEC). 2001. *New York State Stormwater Management Design Manual*. Prepared by Center for Watershed Protection. Albany, New York. <https://www.dec.ny.gov/chemical/29072.html>

New Jersey Department of Environmental Protection (NJDEP). 2021. *New Jersey Stormwater Best Management Practices Manual*. https://nj.gov/dep/stormwater/bmp_manual2.htm

Rhode Island Department of Environmental Management (RIDEM) and Coastal Resources Management Council (CRMC). 2015. *Rhode Island Stormwater Design and Installation Standards Manual*. Amended March 2015. <https://dem.ri.gov/sites/g/files/xkgbur861/files/pubs/regs/regs/water/swmanual15.pdf>

Rhode Island Department of Transportation (RIDOT). 2019. Rhode Island Department of Transportation Linear Stormwater Manual. http://www.dot.ri.gov/documents/about/protecting/stormwater/RIDOT_Linear_SW_Manual.pdf

Dry Water Quality Swale



Description

Water quality swales are shallow vegetated open channels designed to treat and convey stormwater runoff. Water quality swales provide higher pollutant removal than traditional grass drainage channels, which are designed strictly for conveyance.

Dry water quality swales (also referred to as “dry swales”) have a bioretention soil media below the surface of the swale that facilitates stormwater filtration and vegetative growth. Dry swales are frequently designed to infiltrate but can be designed with an underdrain to capture filtered water and assist with drainage from the system. In certain situations, bioretention swales can also be designed with impermeable liners to prevent infiltration into the underlying soil. Dry swales are planted with dense, native grasses or plants that function to slow the flow of runoff and encourage filtration. The use of check dams is recommended to enhance water quality performance by promoting ponding, filtration, and infiltration of stormwater into the underlying soil. Pollutants are removed through sedimentation, filtration, adsorption, pollutant uptake, and infiltration.

If not designed with an impermeable liner, dry water quality swales can provide retention of stormwater and reduce runoff volumes through infiltration and groundwater recharge. Dry swales may also be used to provide stormwater quantity control when designed as on-line facilities.

<i>Stormwater BMP Type</i>	
Pretreatment BMP	<input type="checkbox"/>
Infiltration BMP	<input type="checkbox"/>
Filtering BMP	<input type="checkbox"/>
Stormwater Pond BMP	<input type="checkbox"/>
Stormwater Wetland BMP	<input type="checkbox"/>
Water Quality Conveyance BMP	<input checked="" type="checkbox"/>
Stormwater Reuse BMP	<input type="checkbox"/>
Proprietary BMP	<input type="checkbox"/>
Other BMPs and Accessories	<input type="checkbox"/>
<i>Stormwater Management Suitability</i>	
Retention	<input checked="" type="checkbox"/>
Treatment	<input checked="" type="checkbox"/>
Pretreatment	<input type="checkbox"/>
Peak Runoff Attenuation	<input checked="" type="checkbox"/>
<i>Pollutant Removal</i>	
Sediment*	High
Phosphorus	Moderate
Nitrogen	Moderate
Bacteria	Moderate
*Includes sediment-bound pollutants and floatables (with pretreatment)	
<i>Implementation</i>	
Capital Cost	Medium
Maintenance Burden	Medium
Land Requirement	Medium

Dry water quality swales are valuable systems for linear projects as well. However, linear projects have alternative standards and may take an alternative approach to address constraints that are different than those that affect traditional parcel development projects. These alternative linear project standards can be found in the CTDOT drainage manual, the CTDOT MS4 General Permit and in the supporting materials that CTDOT has developed.

Advantages

- Dry water quality swales are an alternative to bioretention systems where the site requires a sloped base or must convey runoff between points.
- Can provide stormwater retention, runoff volume reduction, and groundwater recharge if designed for infiltration.
- Provide runoff conveyance and can provide some peak runoff attenuation by reducing runoff velocity and providing temporary storage.
- High pollutant removal efficiency and water quality benefits, like bioretention.

Limitations

- Individual dry swales treat a relatively small area.
- May be impractical in areas with steep topography or poorly drained soils.
- Large area requirements for highly impervious sites.
- May not be practical in areas with many driveway culverts or extensive sidewalk systems.
- Higher relative construction costs than other stormwater infiltration systems due to cost of bioretention soil media.

Siting Considerations

- **Potential Locations:** Linear nature makes swales ideal for use within roadway right-of-way areas, along shared-use paths, and within or around parking lots. Dry swales are suitable in urban and rural settings.
- **Drainage Area:** The maximum contributing drainage area is 5 acres to any single inlet, unless the flow enters the dry swale via sheet flow along a linear feature such as a road.
- **Soils:** Dry swales that return filtered runoff to the conveyance system and do not infiltrate into the ground can be used in almost any soil type. Dry swale designs that rely on infiltration should be used only when the soil infiltration characteristics are appropriate (see [Chapter 10 - General Design Guidance for Stormwater Infiltration Systems for design guidance for stormwater infiltration systems](#)).
- **Land Use:** Dry swales can be used in most land use settings where space is available.

- **Water Table and Bedrock:** For dry swales designed for infiltration (unlined systems), at least 3 feet of separation is recommended between the bottom of the system and the seasonal high groundwater table (SHGT) and bedrock. The vertical separation distance to the SHGT or bedrock may be reduced to 2 feet as described in [Chapter 10 - General Design Guidance for Stormwater Infiltration Systems](#).
- Horizontal Setbacks: For dry swales designed for infiltration (unlined systems), meet the minimum horizontal setback distances in [Chapter 10 - General Design Guidance for Stormwater Infiltration Systems](#).

Soil Evaluation

- Conduct an evaluation of the soil characteristics and subsurface conditions at the location of the proposed system including soil type, depth to the seasonal high groundwater table, depth to bedrock, and soil infiltration rate. Refer to [Chapter 10 - General Design Guidance for Stormwater Infiltration Systems](#) for soil evaluation guidance.

Design Recommendations

Pretreatment

- Incorporate pretreatment measures at locations where runoff enters the swale in accordance with the Pretreatment BMPs section of this Manual.
- Acceptable pretreatment measures include vegetative filter strips, sediment forebays, pretreatment swales, deep sump catch basins, oil grit separators, and proprietary pretreatment devices.
- Sediment forebays should have a minimum storage volume of 10% of the Water Quality Volume (WQV), while flow-through Pretreatment BMPs should treat at least the equivalent Water Quality Flow (WQF).

Sizing and Dimensions

- Dry Swale Filter Bed (Bottom) Area
 - Dry swale should be designed by either the Static or Dynamic Methods as described in [Chapter 10 - General Design Guidance for Stormwater Infiltration Systems](#)
 - System should completely drain in 48 hours or less after the end of the design storm as described in [Chapter 10](#).
 - For underdrained systems, use the coefficient of permeability of the bioretention soil media (1.0 feet per day or 0.52 inches per hour) in the drain time analysis. If the system is designed with a loam surface, also use a coefficient of permeability value of 1.0 feet per day or 0.52 inches per hour.
 - Install check dams to retain the applicable Water Quality Volume and to accommodate slopes greater than 2%. The volume of water retained behind check dams should be included in the system storage volume calculation.

➤ Bioretention Soil Depth

- Engineered bioretention soil media should have a depth of 24 to 48 inches as necessary to accommodate the required sizing, vegetation species and root establishment, and subsurface conditions.
- Soil depth may be limited by the requirement to maintain adequate separation to groundwater and bedrock as specified in [Chapter 10 - General Design Guidance for Stormwater Infiltration Systems](#).

- Ponding Depth
 - Maximum ponding depth for water quality storm: 12 inches at longitudinal mid-point of swale; 18 inches at downstream end of swale
 - Maximum ponding depth for overflow events: 36 inches
 - Minimum freeboard for overflow events: 6 inches above the 10-year, 24-hour storm water surface elevation to top of swale
- Bottom Width
 - Minimum: 2 feet
 - Maximum: 8 feet
- Bottom Slope
 - Dry swales should have a maximum longitudinal slope of 2%, provided flow velocities are non-erosive (e.g., flow velocities should not exceed 3 feet per second for grassed surfaces).
 - Dry swales can have slightly steeper slopes (up to 6%) if designed with check dams.
 - Check dams should be designed to reduce the effective slope of the bottom of the dry swale to 2.0% or less for optimum water quality performance. Consider designing as a terraced system with check dams and relatively flat bottoms in each cell.
- Side Slopes
 - 3(H):1(V) slopes or flatter are preferred especially on grassed slopes where mowing is required.
 - In ultra-urban locations or space constrained areas, side slopes of 2(H):1(V) may be utilized if properly designed to account for erosion and slope stability. Stabilize the slope with turf reinforcement matting or equivalent if the slope could potentially erode.
- Water Velocity
 - For water quality storm: 1.5 feet per second (maximum)
 - Peak flow design storm: 5.0 feet per second (maximum)

Check Dams

- Check dams should be evenly spaced and designed with a maximum height of 18 inches. Check dams should be designed to pass the design flow over the top of the check dam without exceeding maximum ponding depths.
- Spacing of check dams should be a function of both the longitudinal slope of the swale and the design volume that must be retained behind the dams. Space such that the upstream limit of ponding from one check dam is just below the downstream edge of the adjacent check dam.

- Check dams that are designed to infiltrate (with no underdrain system) should not be constructed of permeable materials like gabions, as water must sufficiently pond behind each check dam and be forced to infiltrate.
- Utilize weirs constructed from concrete or granite curbing.
- Anchor check dams into swale side slopes to prevent washout. Each side of the dam should extend 2-3 feet into the swale side slopes.
- Protect downstream side of check dams from scour with stabilized surface protection measures.

Inlet

- Design the inlet in accordance with the Inlet and Outlet Controls section of this Manual.
- Runoff can be introduced to the dry swale through overland flow, curb cuts, inlet structures, swales/channels, and/or pipes.
- Design the system in an off-line configuration to the extent feasible if runoff is delivered by a storm drainpipe or is along the main storm conveyance system.

Outlet & Overflow

- Design the outlet in accordance with the Inlet and Outlet Controls section of this Manual.
- Outlets are typically a stabilized spillway, gabion berm, concrete weir, curb cut opening, precast concrete structure, or polyethylene/polyvinyl chloride riser structure.
- Dry water quality swales should have an outlet sized to convey the 10-year, 24-hour storm event, at a minimum. Off-line systems should be designed with a bypass or overflow for flows in excess of the water quality storm.

Underdrain System

- Install an underdrain system when a proposed dry swale meets one or more of the following conditions:
 - Is in native soil that has an infiltration rate less than 0.3 inch per hour (HSG C and D soils)
 - Does not meet vertical separation distance to SHGT or bedrock ([Chapter 10 - General Design Guidance for Stormwater Infiltration Systems](#)) and should be lined
 - Does not meet minimum horizontal setback distances ([Chapter 10](#)) and should be lined
 - Is within a Land Use with Higher Potential Pollutant Loads (LUHPPL) ([Chapter 10](#)) or area of contaminated soils and should be lined.

- An underdrain is also recommended, but not required, for all other dry swales to account for potential infiltration failure due to clogging, groundwater mounding, or periods of excessive rainfall.
- Minimum underdrain pipe diameter: 4 inches
- Minimum underdrain pipe slope: 0.5%
- Use two layers of gravel with the underdrain system. Both layers of gravel should be located below and extend across the entire bottom of the system. The upper gravel layer should consist of 3 inches of pea gravel, and the lower layer should consist of a 12-inch-thick gravel sump.
- For unlined systems, install the perforated underdrain pipe 2 inches below the top of the gravel sump to promote infiltration. For systems that are lined with an impermeable liner to prevent infiltration, install the underdrain pipe 2 inches above the bottom of the gravel sump so the system can drain between storm events.
- If the system is designed without an underdrain, pea gravel and gravel sump are optional.
- Lay underdrain such that perforations are on the bottom of the pipe.
- Use solid (non-perforated) pipe sections and watertight joints wherever the underdrain system passes below berms, extends down steep slopes, connects to a drainage structure, and/or daylights.
- Place filter fabric along sidewalls of excavation and above the pea gravel (below the bioretention soil layer) for 1 to 2 feet on both sides of the underdrain. Filter fabric shall not be placed across the entire width of the swale.
- Other considerations when designing/installing underdrains:
 - Provide a marking stake and an animal guard for underdrains that daylight at grade.
 - If designed with laterals, space collection laterals every 25 feet or less.
- Include a minimum of two observation wells/cleanouts for each underdrain, one at the upstream end and one at the downstream end.
 - Cleanouts should be at least 4 inches in diameter, be nonperforated, and extend to the surface. Cap cleanouts with a watertight removable cap. The cleanout should be highly visible.
 - Provide one cleanout for every 1,000 square feet of surface area (at a minimum) or for every 250 linear feet of total pipe length in larger systems.

Liner

- An impermeable liner is required for use of dry swales when receiving runoff from Land Uses with Higher Potential Pollutant Loads (LUHPPLs) ([Chapter 10 - General Design Guidance for Stormwater Infiltration Systems](#)), in locations with subsurface contamination, where the required vertical separation to SHGT cannot be met, and in locations with unacceptable horizontal setbacks for infiltration.
- If designing a lined system in a location where SHGT is located at or above the bottom of the liner or closed bottom of the system, complete a buoyancy analysis to ensure buoyancy of the system will not be an issue.
- For lined swales within LUHPPLs, a shutoff valve can be installed on the underdrain outlet to capture and contain accidental spills or releases that reach the swale.

Materials

- Surface Cover
 - Native grasses or plants is the preferred surface cover type for dry water quality swales. 3 to 4 inches of washed river stone or smooth crushed stone sized to resist the 10-year, 24-hour storm may also be used as an alternative surface cover type. Mulch should NOT be used on the bottom of the swale.
- Vegetation
 - Vegetation should be designed for regular mowing, like a typical lawn, or less frequently.
 - Select vegetation and provide a planting plan with the guidance provided in [Appendix F](#) of this Manual.
 - Native grasses are preferred for enhanced biodiversity, wildlife habitat, and drought tolerance.
 - Grass species should be sod-forming to resist scouring; have a high stem density to help slow water and facilitate sedimentation; be tolerant to frequent inundation; and be able to survive and continue to grow after the inundation period.
 - If to be used near a road that is subject to winter salt operations, the vegetation must also be salt tolerant.
 - Establish a dense vegetative cover or adequately stabilized landscaped surface throughout swale and any upgradient areas disturbed by construction before runoff can be accepted into the facility.
 - Trees should only be planted along the perimeter of the facility and with 15 feet of separation from underdrain piping.
 - Trees should not be planted in dry swales.
 - Do not use vegetation with a mature vegetation height exceeding 24 inches above the surrounding sidewalk or pavement surface in dry swales within

medians, near intersections, or near pedestrian crossings to avoid obstruction of sight lines.

➤ Engineered Bioretention Soil Media

- The engineered soil media in bioretention systems is designed to filter/treat runoff and to provide sufficient organic material to support plant establishment and growth.
- The engineered bioretention soil media should be a homogeneous soil mix of (by volume):
 - 60–85% Sand
 - 15–25% Topsoil
 - 3–8% Organic Matter
- **Sand** should be washed concrete sand (ASTM C33 or AASHTO M-6) or coarse washed sand that meets the gradation schedule as shown in State of Connecticut Department of Transportation Standard Specifications, Section M.01 (Aggregates), Table M.01.04-1 for Fine Aggregate Gradations.
- **Topsoil** should contain 5–20% organic material, have a pH range of 5.5 to 7.0, and be a sandy loam, loamy sand, or loam per USDA soil texture with less than 5% clay content. Topsoil that meets the State of Connecticut Department of Transportation Standard Specifications, Section M.13.01 (Roadside Development) for Topsoil may also be used, except it should contain less than 5% clay.
- **Organic matter** should consist of one of the following materials
 - Sphagnum Peat: Partially decomposed sphagnum peat moss, finely divided or of granular texture with 100 percent passing through a 1/2-inch (13-mm) sieve, a pH of 3.4 to 4.8.
 - Wood Derivatives: Shredded wood, wood chips, ground bark, or wood waste; of uniform texture and free of stones, sticks, soil, or toxic materials.
- Compost shall NOT be used as organic matter since the use of compost in bioretention soil media can result in nutrient export from the system.
- Soil amendments such as zerovalent iron and/or drinking water treatment residuals (alum) may be used to further enhance phosphorus sorption.
- Bioretention soil mix should have a pH of 5.2 to 7.0 and meet the particle size distribution in [Table 13-12](#).

Table 13-9. Acceptable Particle Size Distribution of Final Bioretention Soil Mix

Media Type	Sieve #	Size (inches)	Size (mm)	% Passing
Coarse Sand	4	0.187	4.76	100
Medium Sand	10	0.079	2.00	95
Fine Sand	40	0.017	0.42	40-15
Silt	200	0.003	0.075	10-20
Clay	<200	Pan	Pan	0-5

- Bioretention soil mix should NOT contain any of the following materials: stones, clods, roots, clay lumps, and pockets of coarse sand exceeding 0.187 inches (4.76 mm) in any dimension; plants, sod, concrete slurry, concrete layers or chunks, cement, plaster, building debris, asphalt, bricks, oils, gasoline, diesel fuel, paint thinner, turpentine, tar, roofing compound, acid, solid waste, and any other extraneous materials that are harmful to plant growth.
- Pea Gravel
 - Should consist of 3/8" AASHTO No. 8 stone. Pea gravel should be clean (washed and free from dirt and debris) and rounded in shape.
- Gravel Sump
 - Should consist of 3/4" AASHTO No. 5 stone. Gravel should be clean (washed and free from dirt and debris), crushed, and angular.
- Filter Fabric
 - Use non-woven filter fabric that complies with State of Connecticut Department of Transportation Standard Specifications, Section M.08.01.19 (Drainage – Geotextiles).
- Underdrain (perforated and non-perforated pipe sections)
 - Polyethylene or polyvinyl pipe
- Liner
 - If used, should consist of a 30 mil (minimum) HDPE or PVC liner, or one of the alternative liner systems described in [Chapter 10 - General Design Guidance for Stormwater Infiltration Systems](#) with the approval of the review authority.
- Check Dams
 - Construct of gabions, granite or concrete curbing, or precast/poured-in-place concrete. If constructed of granite or concrete curbing, curbing should conform

to State of Connecticut Department of Transportation Standard Specifications, Section M.12.06 (Stone Curbing) and Section 8.11 (Concrete Curbing).

- Poured-in-place Concrete
 - If used, should be an appropriate class of concrete based on the application and conform to State of Connecticut Department of Transportation Standard Specifications, Section 6.01 (Concrete for Structures).
- Turf Reinforcement Matting (TRM)
 - Stabilize the side slopes of the swale with TRM to limit erosion in locations where flow velocities exceed 3 to 5 feet per second (depending on soil and vegetation types) for the 1-year, 24-hour storm event.
 - If used, shall be a woven material included on the CTDOT Qualified Products List that exceeds the design velocity of the design storm and allows for the growth of the proposed vegetative species.

Other Considerations

- Roadway stability can be a design issue when installing swales along roadways. It may be necessary to provide a vertical impermeable barrier to keep water from saturating the road's sub-base. The barrier should be capable of supporting H-20 loads.
- Non-woven filter fabric should be placed along the sidewalls of the system to help direct the water flow downward, reduce lateral flows, and to reduce lateral soil migration. This is critical when installing swales in a median strip or adjacent to a roadway or parking lot.
- Non-woven filter fabric should also be placed above the pea gravel layer (below the bioretention soil layer) for 1 to 2 feet on both sides of the underdrain pipe. Filter fabric should NOT be placed across the entire width of the bioretention system because filter fabric installed in this manner can result in clogging and system failure.

Winter Operations

- Swales should not be used as dedicated snow storage areas. To the extent feasible, locate and design the system to avoid snow storage areas and potential damage from snow plowing activities. Refer to [Chapter 7 - Overview of Structural Stormwater Best Management Practices](#) for general design considerations related to winter operations.

Construction Recommendations

- The designing qualified professional should develop a detailed, site-specific construction sequence.
- The designing qualified professional should inspect the installation during the following stages of construction, at a minimum:
 - After excavation of the swale and scarification of bottom and sidewalls of excavation

- After placement of gravel layer
 - After placement of underdrain before covering by the pea gravel layer
 - After placement of bioretention soil media
 - After installation of bypass, outlet/overflow, and inlet controls
 - After grass or other vegetation has been installed
- The designing qualified professional should provide an as-built plan of the completed system along with a certification that the system was designed in accordance with the guidance contained in this Manual and other local or state requirements and that the system was installed in accordance with the approved plans.
 - The bioretention soil mix should be tested prior to placement according to the specifications in this section (at least one test per bioretention system). The designing qualified professional should certify that the bioretention soil mix meets the specifications in the previous section based on soil testing results.
 - The entire contributing drainage area should be completely stabilized prior to directing any flow to the system. Adequate vegetative cover must be established over any pervious area adjacent or contributing to the system before runoff can be accepted.
 - Erosion and sediment controls should be in place during construction in accordance with the Connecticut Guidelines for Soil Erosion and Sediment Control and the Soil Erosion and Sediment Control (SESC) Plan developed for the project.
 - During clearing and grading of the site, measures should be taken to avoid soil compaction at the location of the proposed system.
 - The system should be fenced off during the construction period to prevent disturbance of the soils.
 - The system should be excavated to the dimensions, side slopes, and elevations shown on the plans. The method of excavation should avoid compaction of the bottom of the bioretention system. A hydraulic excavator or backhoe loader, operating outside the limits of the system, should be used to excavate the system. Excavation equipment should not be allowed within the limits of the system.
 - The gravel, pea gravel, and bioretention soil media should be placed in the excavation by a hydraulic excavator or backhoe loader located outside the limits of the system and then hand-raked to the desired elevation.
 - Place the bioretention soil in 6 to 12-inch lifts. The bioretention soil needs to settle before planting. Lightly tamp or spray the surface of the bioretention soil with water until saturated. The elevation of the bioretention soil can be a couple of inches higher at installation than the design elevation in anticipation of settling. Bring bioretention soil levels back to the design elevation if necessary.

- Install vegetation in the swale in accordance with the planting plan and plant schedule on the plans. Water vegetation thoroughly immediately after planting and as necessary until fully established. The bioretention soil mix provides enough organic material to adequately supply nutrients from natural cycling.

Maintenance Needs

- Swales should be designed with easy access to all components of the system for maintenance purposes. Refer to [Chapter 7 - Overview of Structural Stormwater Best Management Practices](#) for general design considerations to reduce and facilitate system maintenance.
- Detailed inspection and maintenance requirements, inspection and maintenance schedules, and those parties responsible for maintenance should be identified on the plans and in the Stormwater Management Plan.
- Maintenance should be detailed in a legally binding maintenance agreement.
- Maintenance activities such as sediment removal, mowing, and repairs should be performed with rakes and light-weight equipment rather than heavy construction equipment to avoid compaction of the bioretention soil media and underlying soils. Heavy equipment may be used for sediment removal and other maintenance activities if the equipment is positioned outside the limits of the system. Heavy construction equipment should not be allowed within the limits of the system for maintenance purposes.

Recommended Maintenance Activities

- Inspect after major storms (1 inch or more of precipitation) in the first few months following construction.
- Inspect swale annually.
- Refer to [Appendix B](#) for maintenance inspection checklists, including items to focus on during the inspections.
- Remove trash and organic debris (leaves) in the Spring and Fall.
- Remove sediment from the sediment forebay or other pretreatment area when it accumulates to a depth of more than 12 inches or 50% of the design depth. Clean outlet of sediment forebay or other pretreatment measures when drawdown time exceeds 36 hours after the end of a storm event.
- Remove sediment from the swale surface when the sediment accumulation exceeds 2 inches or when drawdown time exceeds 48 hours after the end of a storm event, indicating that the system is clogged.

- Weed as necessary. Mow grass within swale to a height of 4 to 6 inches. Maintain a healthy, vigorous stand of grass cover, re-seed as necessary.
- Maintain vegetated filter strips or grassed side slopes of swale in accordance with maintenance recommendations in the Pretreatment BMPs section of this Manual.
- Periodically remove grass clippings to prevent clogging of the surface of the swale.
- Mowing should not be performed when the ground is soft to avoid the creation of ruts and compaction, which can reduce infiltration.

Figure 13-30. Dry Water Quality Swale with and without Underdrain Schematics

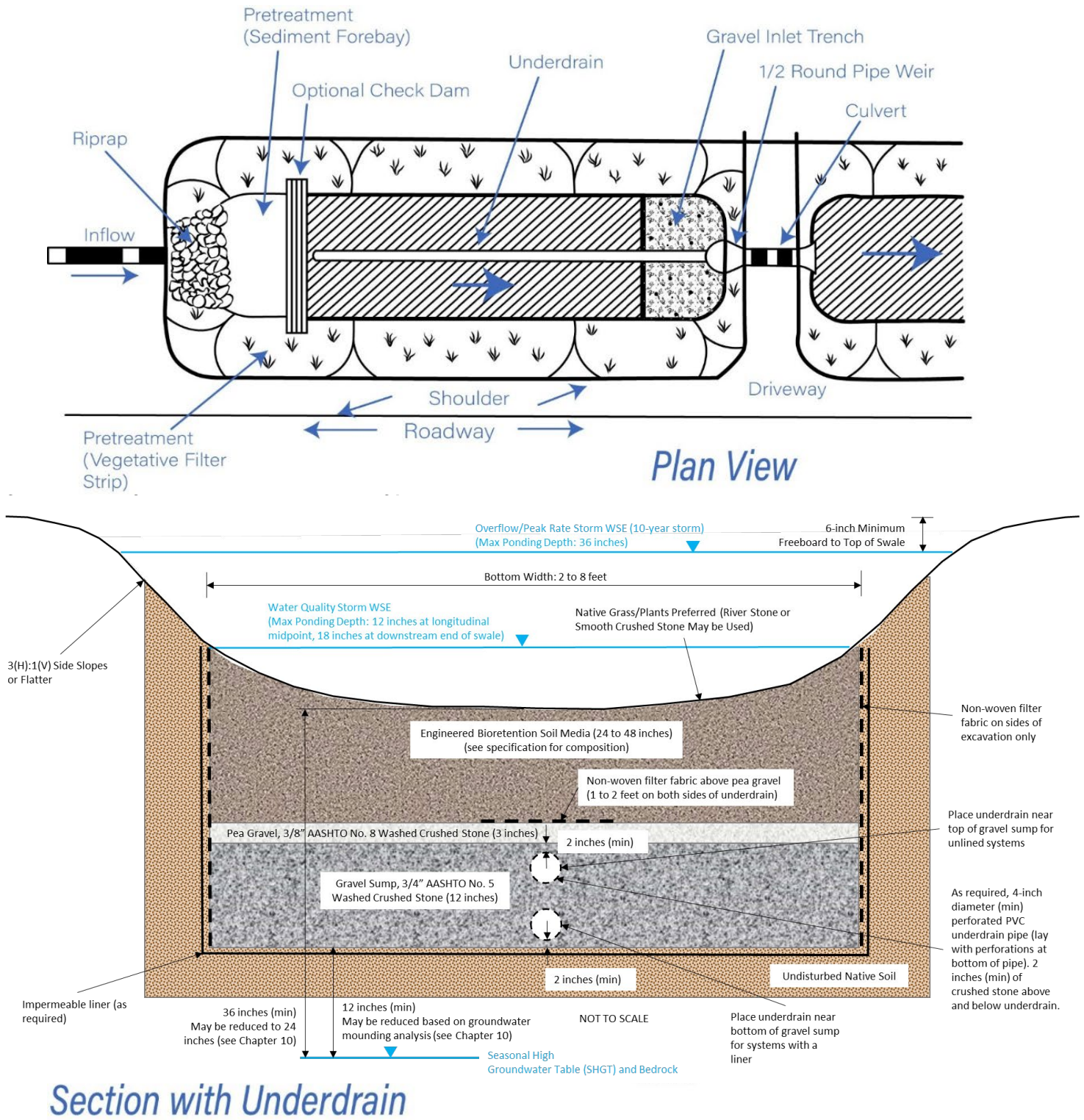

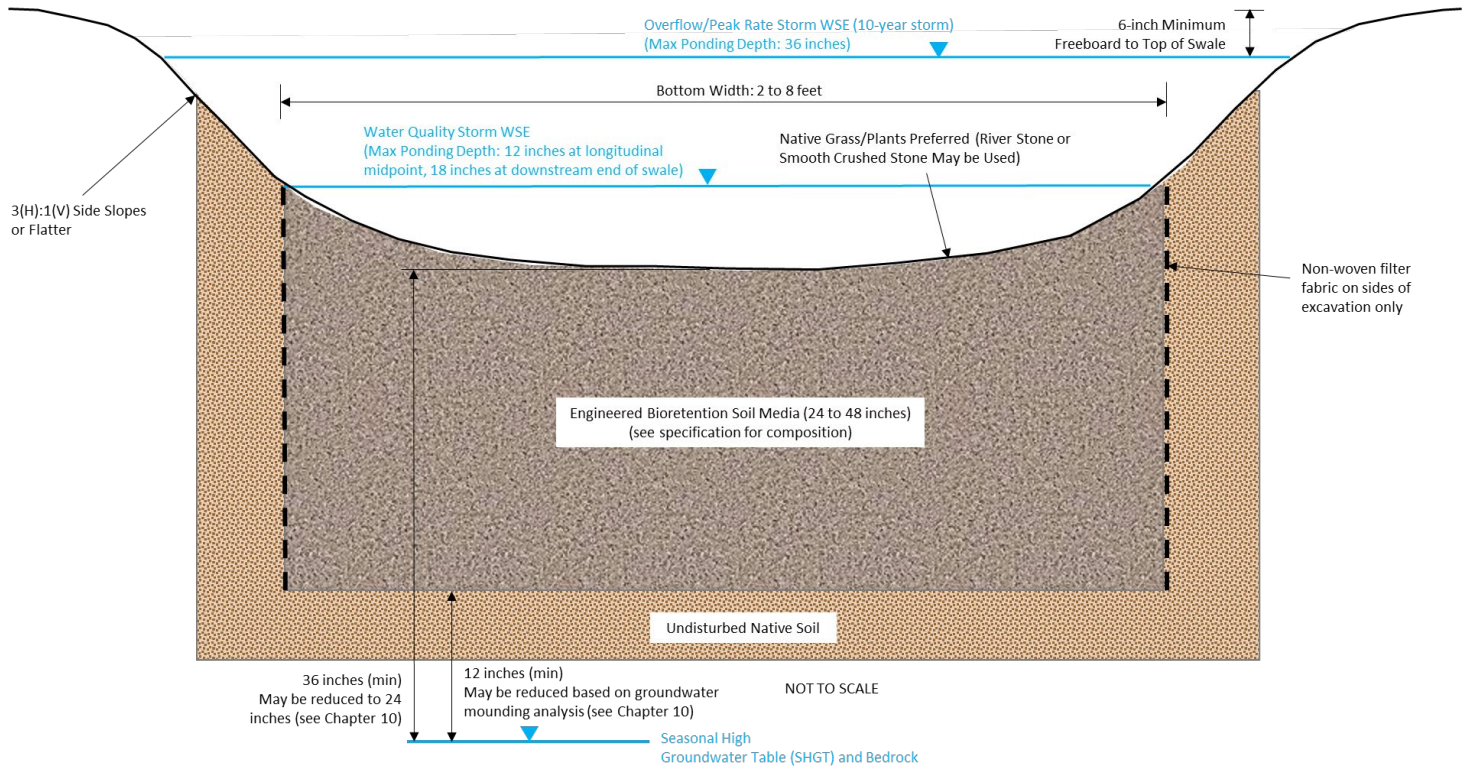

Section without Underdrain

Wet Water Quality Swale



Description

Water quality swales are shallow vegetated open channels designed to treat and convey stormwater runoff. Water quality swales provide higher pollutant removal than traditional grass drainage channels, which are designed strictly for conveyance.

Wet water quality swales (also referred to as “wet swales”) temporarily store and treat stormwater runoff from the water quality storm. However, unlike [Dry Water Quality Swales](#), wet swales are constructed directly within existing soils and are not underlain by a bioretention soil media or underdrain system. Wet swales store stormwater runoff within a series of cells within the channel, which may be formed by berms or check dams. Wet swales are designed to remain saturated, maintaining wetland plants and conditions. The pollutant removal mechanisms in wet swales are similar to those of [Stormwater Wetland BMPs](#), which rely on sedimentation, adsorption, and microbial breakdown.

Wet water quality swales are primarily used for treatment and conveyance of stormwater runoff. They do not provide stormwater retention, runoff volume reduction, or groundwater recharge because they are constructed in groundwater and are not designed for infiltration. Wet swales may also be used to provide stormwater quantity control when designed as on-line facilities.

<i>Stormwater BMP Type</i>	
Pretreatment BMP	<input type="checkbox"/>
Infiltration BMP	<input type="checkbox"/>
Filtering BMP	<input type="checkbox"/>
Stormwater Pond BMP	<input type="checkbox"/>
Stormwater Wetland BMP	<input type="checkbox"/>
Water Quality Conveyance BMP	<input checked="" type="checkbox"/>
Stormwater Reuse BMP	<input type="checkbox"/>
Proprietary BMP	<input type="checkbox"/>
Other BMPs and Accessories	<input type="checkbox"/>

Stormwater Management Suitability

Retention	<input type="checkbox"/>
Treatment	<input checked="" type="checkbox"/>
Pretreatment	<input type="checkbox"/>
Peak Runoff Attenuation*	<input checked="" type="checkbox"/>

*On-line systems only

Pollutant Removal

Sediment*	High
Phosphorus	Moderate
Nitrogen	Moderate
Bacteria	Low

*Includes sediment-bound pollutants and floatables (with pretreatment)

Implementation

Capital Cost	Medium
Maintenance Burden	Medium
Land Requirement	Medium

Advantages

- Wet water quality swales are an alternative to stormwater pond and wetlands where the site requires a sloped base or must convey runoff between points.
- Provide runoff conveyance and can provide some peak runoff attenuation by reducing runoff velocity and providing temporary storage.
- Can be used on sites with high groundwater or poorly drained soils.

Limitations

- Do not provide stormwater retention, runoff volume reduction, or groundwater recharge.
- May be impractical in areas with steep topography.
- Large area requirements for highly impervious sites unless used with another stormwater BMP solely to provide additional treatment along with stormwater conveyance.
- May not be practical in areas with many driveway culverts or extensive sidewalk systems.

Siting Considerations

- **Potential Locations:** Linear nature makes swales ideal for use within roadway right-of-way areas, along shared-use paths, and around the perimeter of parking lots.
- **Drainage Area:** The maximum contributing drainage area is 5 acres to any single inlet, unless the flow enters the wet swale via sheet flow along a linear feature such as a road.
- **Soils:** Wet swales are best suited to sites with poorly drained soils (HSG C and D soils). Although feasible if constructed with an impermeable liner similar to those used with stormwater ponds and wetlands, wet swales are generally impractical for use in HSG A and B soils.
- **Land Use:** Wet swales can be used in most land use settings where stormwater can be conveyed in surface channels. Wet swales are not recommended in residential areas or within commercial parking lots with significant foot traffic because of the potential for stagnant water and other nuisance ponding.
- **Water Table and Bedrock:** Wet swales should only be used where the water table is at or near the soil surface. The bottom of a wet swale should be constructed at or below the seasonal high groundwater table (SHGT). At least 1 foot of separation is recommended between the bottom of the swale and bedrock. Test pits or soil borings are required at the location of the proposed system to verify soil types, depth to SHGT, and depth to bedrock in accordance with the soil evaluation guidance provided in [Chapter 10](#).
- **Horizontal Setbacks:** Wet swales should be located at least 50 feet downgradient of on-site subsurface sewage disposal systems for single family residential use, and at least 75 feet downgradient from on-site subsurface sewage disposal systems for all other uses.

Soil Evaluation

- Conduct an evaluation of the soil characteristics and subsurface conditions at the location of the proposed system including soil type, depth to the seasonal high groundwater table, and depth to bedrock. Perform test pits or soil borings in accordance with the soil evaluation guidance in [Chapter 10](#).

Design Recommendations

Pretreatment

- Incorporate pretreatment measures at locations where runoff enters the swale in accordance with the [Pretreatment BMPs](#) section of this Manual.
- Acceptable pretreatment measures include vegetative filter strips, sediment forebays, pretreatment swales, oil grit separators, and proprietary pretreatment devices.
- Sediment forebays should have a minimum storage volume of 10% of the Water Quality Volume (WQV), while flow-through Pretreatment BMPs should treat at least the equivalent Water Quality Flow (WQF).

Sizing and Dimensions

- Wet Swale Dimensions
 - Wet swale length, width, depth, and slope should be designed to temporarily store the Water Quality Volume through surface ponding. The permanent pool may be included in the static storage volume calculation and system sizing.
 - Install check dams as necessary to store the Water Quality Volume and to accommodate slopes greater than 2%. The volume of water retained behind check dams should be included in the design storage volume calculation.
 - The soil bed below wet swales should consist of undisturbed soils. The underlying soil should be inundated as the bottom of the swale should be at or below the SHGT.
 - Wet swales should not be constructed in highly permeable soils that cannot easily support dense vegetation.
- Ponding Depth
 - Maximum ponding depth for water quality storm: 12 inches at longitudinal mid-point of swale; 18 inches at downstream end of swale
 - Maximum ponding depth for overflow events: 36 inches
 - Minimum freeboard for overflow events: 6 inches above the 10-year, 24-hour storm water surface elevation to top of swale
- Bottom Width
 - Minimum: 2 feet
 - Maximum: 8 feet

- Bottom Slope
 - Wet swales should have a maximum longitudinal slope of 2% without check dams, provided flow velocities are non-erosive (e.g., flow velocities should not exceed 3 feet per second for grassed surfaces).
 - Wet swales can have slightly steeper slopes (up to 6%) if designed with check dams.
 - Check dams should be designed to reduce the effective slope of the bottom of the wet swale to 2.0% or less for optimum water quality performance. Consider designing as a terraced system with check dams and relatively flat bottoms in each cell.
- Side Slopes
 - 3(H):1(V) slopes or flatter are preferred especially on vegetated slopes where mowing is required.
 - In ultra-urban locations or space constrained areas, side slopes of 2(H):1(V) may be utilized if properly designed to account for erosion and slope stability. Stabilize the slope with turf reinforcement matting or equivalent if the slope could potentially erode.
- Water Velocity
 - For water quality storm: 1.5 feet per second (maximum)
 - Peak flow design storm: 5.0 feet per second (maximum)

Check Dams

- Check dams should be evenly spaced and designed with a maximum height of 18 inches. Check dams should be designed to pass the design flow over the top of the check dam without exceeding maximum ponding depths.
- Spacing of check dams should be a function of both the longitudinal slope of the swale and the design volume that must be retained behind the dams. Space such that the upstream limit of ponding from one check dam is just below the downstream edge of the adjacent check dam.
- Check dams should be constructed of washed crushed stone, gabions, granite or concrete curbing, or precast/poured-in-place concrete.
- Anchor check dams into swale side slopes to prevent washout. Each side of the dam should extend 2-3 feet into the swale side slopes.
- Protect downstream side of check dams from scour with stabilized surface protection measures.

Inlet

- Design the inlet in accordance with the [Inlet and Outlet Controls](#) section of this Manual.

- Runoff can be introduced to the wet swale through overland flow, curb cuts, inlet structures, swales/channels, and/or pipes.
- Design the system in an off-line configuration to the extent feasible if runoff is delivered by a storm drain pipe or is along the main storm conveyance system.

Outlet & Overflow

- Design the outlet in accordance with the [Inlet and Outlet Controls](#) section of this Manual.
- Outlets are typically a stabilized spillway, gabion berm, concrete weir, curb cut opening, precast concrete structure, or polyethylene/polyvinyl chloride riser structure.
- Wet water quality swales should have an outlet sized to convey the 10-year, 24-hour storm event, at a minimum. Off-line systems should be designed with a bypass or overflow for flows in excess of the water quality storm.

Materials

- Vegetation
 - Emergent wetland plants are the preferred type of vegetation for wet water quality swales.
 - Select vegetation and provide a planting plan with the guidance provided in [Appendix F](#) of this Manual.
 - Native vegetation is preferred for enhanced biodiversity and wildlife habitat.
 - Vegetation should be suitable for sustained inundation and/or a high water table.
 - If to be used near a road that is subject to winter salt operations, the vegetation must also be salt tolerant.
 - Establish a dense vegetative cover throughout swale and any upgradient areas disturbed by construction before runoff can be accepted into the facility.
 - Trees should be planted only along the perimeter of the facility.
 - Trees should not be planted in wet swales.
- Check Dams
 - Construct of washed crushed stone, gabions, granite or concrete curbing, or precast/poured-in-place concrete. If constructed of granite or concrete curbing, curbing shall conform to State of Connecticut Department of Transportation Standard Specifications, Section M.12.06 (Stone Curbing) and Section 8.11 (Concrete Curbing).
- Poured-in-place Concrete
 - If used, should be an appropriate class of concrete based on the application and conform to State of Connecticut Department of Transportation Standard Specifications, Section 6.01 (Concrete for Structures).

- Turf Reinforcement Matting (TRM)
 - Stabilize the side slopes of the swale with TRM to limit erosion in locations where flow velocities exceed 3 to 5 feet per second (depending on soil and vegetation types) for the 1-year, 24-hour storm event.
 - If used, shall be a woven material included on the CTDOT Qualified Products List that exceeds the design velocity of the design storm and allows for the growth of the proposed vegetative species.

Other Considerations

- Roadway stability can be a design issue when installing swales along roadways. It may be necessary to provide a vertical impermeable barrier to keep water from saturating the road's sub-base. The barrier should be capable of supporting H-20 loads.

Winter Operations

- Swales should not be used as dedicated snow storage areas. To the extent feasible, locate and design the system to avoid snow storage areas and potential damage from snow plowing activities. Refer to [Chapter 7](#) for general design considerations related to winter operations.

Construction Recommendations

- The designing qualified professional should develop a detailed, site-specific construction sequence.
- The designing qualified professional should inspect the installation during the following stages of construction, at a minimum:
 - After excavation of the swale and scarification of bottom and sidewalls of excavation
 - After installation of bypass, outlet/overflow, and inlet controls
 - After vegetation and wetland plants/seed mix has been installed
- The designing qualified professional should provide an as-built plan of the completed system along with a certification that the system was designed in accordance with the guidance contained in this Manual and other local or state requirements and that the system was installed in accordance with the approved plans.
- The entire contributing drainage area should be completely stabilized prior to directing any flow to the system. Adequate vegetative cover must be established over any pervious area adjacent or contributing to the system before runoff can be accepted.
- Erosion and sediment controls should be in place during construction in accordance with the [Connecticut Guidelines for Soil Erosion and Sediment Control](#) and the Soil Erosion and Sediment Control (SESC) Plan developed for the project.

- Temporary dewatering may be required if excavation extends below the water table. Appropriate sedimentation controls will be required for any dewatering discharges.
- During clearing and grading of the site, measures should be taken to avoid soil compaction at the location of the proposed system.
- The system should be fenced off during the construction period to prevent disturbance of the soils.
- The system should be excavated to the dimensions, side slopes, and elevations shown on the plans. The method of excavation should avoid compaction of the bottom of the swale. A hydraulic excavator or backhoe loader, operating outside the limits of the system, should be used to excavate the system. Excavation equipment should not be allowed within the limits of the system.
- Install vegetation in the swale in accordance with the planting plan and plant schedule on the plans. Water vegetation thoroughly immediately after planting and as necessary until fully established.

Maintenance Needs

- Swales should be designed with easy access to all components of the system for maintenance purposes. Refer to [Chapter 7](#) for general design considerations to reduce and facilitate system maintenance.
- Detailed inspection and maintenance requirements, inspection and maintenance schedules, and those parties responsible for maintenance should be identified on the plans and in the Stormwater Management Plan.
- Maintenance should be detailed in a legally binding maintenance agreement.
- Maintenance activities such as sediment removal, mowing, and repairs should be performed with rakes and light-weight equipment rather than heavy construction equipment to avoid soil compaction and damage to vegetation. Heavy equipment may be used for sediment removal and other maintenance activities if the equipment is positioned outside the limits of the system. Heavy construction equipment should not be allowed within the limits of the system for maintenance purposes.

Recommended Maintenance Activities

- Inspect after major storms (1 inch or more of precipitation) in the first few months following construction.
- Inspect swale annually.
- Refer to [Appendix B](#) for maintenance inspection checklists, including items to focus on during the inspections.

- Remove trash and organic debris (leaves) in the Spring and Fall.
- Remove sediment from the sediment forebay or other pretreatment area when it accumulates to a depth of more than 12 inches or 50% of the design depth. Clean outlet of sediment forebay or other pretreatment measures when drawdown time exceeds 36 hours after the end of a storm event.
- Remove sediment from the swale surface when the sediment accumulation exceeds 2 inches or when drawdown time exceeds 48 hours after the end of a storm event, indicating that the system is clogged.
- Periodically mow vegetation within swale. Maintain a healthy, vigorous stand of vegetation; re-seed as necessary.
- Prune woody vegetation in wet swales where dead or dying branches are observed. Plant reinforcement plantings as necessary.
- Maintain vegetated filter strips or grassed side slopes of swale in accordance with maintenance recommendations in the [Pretreatment BMPs](#) section of this Manual.
- Periodically remove grass clippings to prevent clogging of the surface of the swale.
- Mowing should not be performed when the ground is soft to avoid the creation of ruts, soil compaction, and damage to vegetation.

Figure 13-31. Wet Water Quality Swale Schematic

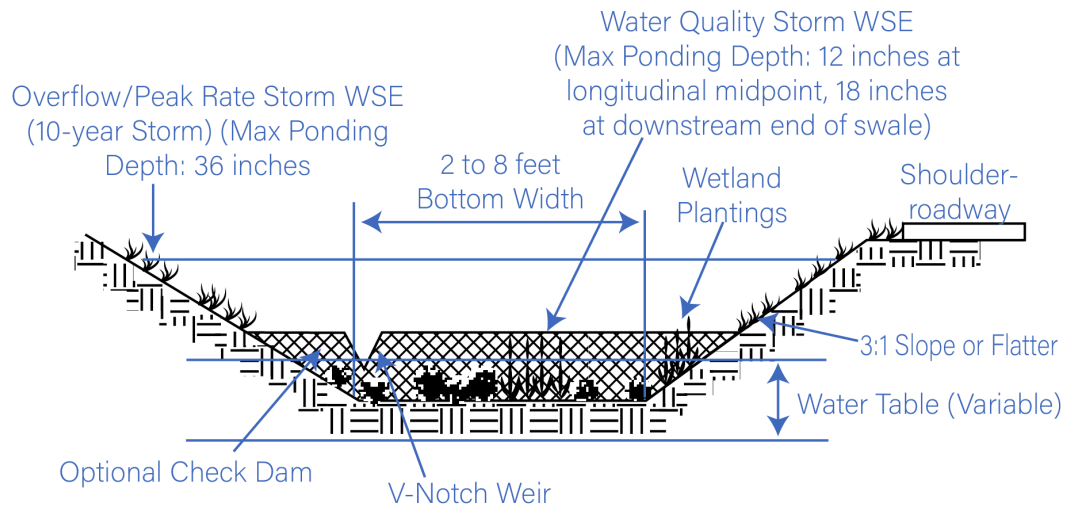
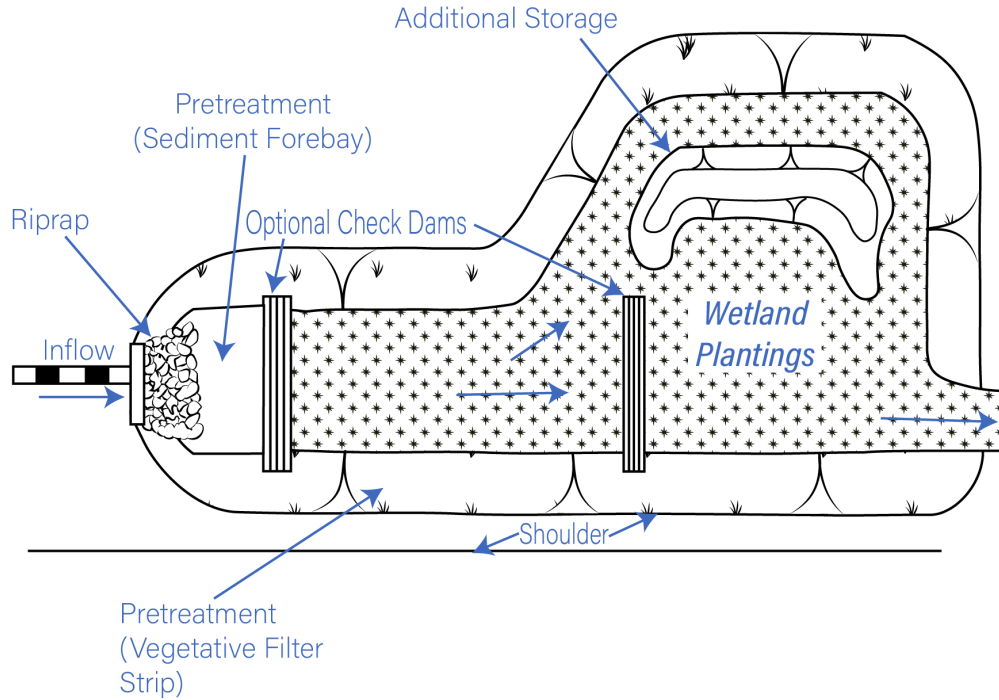

Rain Barrel and Cistern



Description

Rainwater harvesting involves the collection of rainwater from rooftops and other impervious surfaces and storage of the rainwater in a rain barrel or cistern for non-potable use. Rainwater harvesting practices are extremely versatile and scalable from small-scale residential applications to large-scale commercial or industrial sites. Collection systems can be located outside, inside, above or below the ground and can be designed in a variety of shapes and sizes to fit the site conditions.

Rainwater harvesting systems generally consist of five main components: catchment, conveyance, pretreatment, storage, and distribution. Catchment areas include clean roofs (rain barrels and cisterns) and other impervious surfaces (cisterns only). Pretreatment is required for larger harvesting systems (cisterns) to remove stormwater pollutants from paved surfaces and to remove leaves, debris, and other coarse solids from roof runoff. Storage can be in a prefabricated or custom-built above or below ground system, and either detached or structurally integrated with a building. Finally, distribution systems can range from garden hoses on a rain barrel, to plumbing or underground irrigation systems associated with a cistern.

Stormwater BMP Type

Pretreatment BMP	<input type="checkbox"/>
Infiltration BMP	<input type="checkbox"/>
Filtering BMP	<input type="checkbox"/>
Stormwater Pond BMP	<input type="checkbox"/>
Stormwater Wetland BMP	<input type="checkbox"/>
Water Quality Conveyance BMP	<input type="checkbox"/>
Stormwater Reuse BMP	<input checked="" type="checkbox"/>
Proprietary BMP	<input type="checkbox"/>
Other BMPs and Accessories	<input type="checkbox"/>

Stormwater Management Suitability

Retention	<input checked="" type="checkbox"/>
Treatment	<input type="checkbox"/>
Pretreatment	<input type="checkbox"/>
Peak Runoff Attenuation	<input checked="" type="checkbox"/>

Pollutant Removal

Sediment*	Low
Phosphorus	Low
Nitrogen	Low
Bacteria	Low
*Includes sediment-bound pollutants and floatables (with pretreatment)	

Implementation

Capital Cost	Varies
Maintenance Burden	Low
Land Requirement	Low

Rain barrels are storage containers that are connected to a downspout and capture runoff from a roof. Rain barrels are typically sized to retain 50-100 gallons of irrigation water for gardening and landscaping. Many different types of rain barrels are commercially available. Although they primarily function as storage for stormwater reuse, rain barrels can help to control localized drainage issues and reduce the effects of small-scale point discharge, such as scour at the outlet of a roof drain system.

Cisterns have a greater storage capacity than rain barrels and may be located above or below ground. Cisterns typically collect runoff from areas larger than residential rooftops such as roof areas of larger buildings or parking lots. Stored water is fed by gravity or pumped via a distribution system to the point of use. Unlike rain barrels, cisterns can provide some peak runoff attenuation depending on the size of the system and the volume of water in the cistern at the start of a storm event.

Table 13-10. Summary Comparison of Rain Barrels and Cisterns

Feature	Rain Barrel	Cistern
Uses (non-potable)	Outdoor uses: gardening, landscape irrigation, rinsing.	Indoor and outdoor uses: landscape and turf irrigation, washing, flushing, cooling.
Size	Small; usually serve an individual roof. Typically, sufficient for 100-200 square feet of roof area.	Large; usually collect runoff from a larger area and often multiple sources.
Location	Above ground	Above ground tanks or underground storage system.
Cost	Inexpensive (Sometimes barrels can be obtained at little or no charge)	More expensive (Cost depends on materials, size, and construction method)
Requires Pretreatment or Treatment?	No	Yes
Suitable for Treatment?	No	No
Suitable for Retention?	Yes	Yes
Suitable for Peak Runoff Attenuation?	Too small to attenuate peak runoff; can have localized drainage benefits. Multiple barrels can be installed on a site to increase their effectiveness.	Can be large enough to attenuate peak flows depending on the size of the system and the amount of water stored when the storm event occurs.

Rain barrels and cisterns can provide retention credit for the volume of water captured and reused. However, they are limited in their capacity to achieve other goals such as pretreatment and infiltration. For example, neither system recharges groundwater. As stand-alone strategies, they do not provide stormwater treatment but are nonetheless ideal for capturing, collecting, and reusing stormwater for non-potable uses such as irrigation, vehicle washing, or toilet flushing. Providing an alternate source of water for those activities can lower demand on public and private water supplies, which is especially beneficial during dry spells in summer months.

Additionally, rain barrels and cisterns can be an important component of a more complex stormwater management system. For example, the overflow from rain barrels and cisterns can be directed to a dry well or other infiltration BMP to provide groundwater recharge and additional retention. Including a cistern in a stormwater treatment train can also increase the overall capacity of the system.

Advantages

- Conserve potable water for essential uses.
- Provide alternative to potable water during time of peak demand.
- Reduce or limit withdrawals from ground or surface water supply.
- Effective method for capturing runoff for a variety of uses, especially in areas where public water supply is limited.
- Efficient use of space in urban areas and for retrofits.
- Cisterns can be sized to fit small to large scale needs.
- Quick installation using prefabricated modular systems.
- Systems are durable with a long life with effective pretreatment and routine maintenance.
- Suitable for use as part of a stormwater treatment train, particularly in combination with off-line retention and treatment stormwater BMPs.
- Rainwater is typically soft compared to other sources of water and contains low levels of dissolved salts and minerals which makes it preferable for irrigation, gardening, and landscaping uses. Soft water can also be less taxing on plumbing if the water is harvested to supply flushing, car washing, or other non-potable uses.

Limitations

- Strictly for stormwater reuse and limited quantity control. Not suitable for treatment.
- Rain barrels and smaller cisterns have minimal impact on runoff volume and peak flows.
- Capture and reuse of stormwater from paved surfaces and some roof surfaces requires appropriate pretreatment, as well as additional post-storage treatment for certain uses, which can add cost and complexity to the system.
- Deteriorated and/or clogged gutters and downspouts can cause a system to fail.
- Underground cisterns can require extensive, costly excavation.

Siting Considerations

- **Drainage Area:** A single 55-gallon rain barrel can generally serve a roof area of 100 to 200 square feet depending on how frequently the stored water is used for irrigation. Cisterns

can be used to store runoff from larger drainage areas, including rooftops and other impervious surfaces, generally up to 1 acre or more depending on the water demand.

- **Groundwater and Bedrock:** No restrictions. Anti-buoyancy measures may be needed for underground cisterns at or below the water table.
- **Land Uses:** Rain barrels are applicable to a wide range of land uses (i.e., residential, commercial, industrial, municipal, institutional) where reuse for gardening or landscape irrigation is desired. Cisterns are typically used in land use settings with larger water demand such as commercial, institutional, and industrial facilities.
- **General:** Both rain barrels and cisterns should be located as close as possible to the source and/or point of use. This minimizes the infrastructure required to convey the water to the system and distribute it where it is needed. To function effectively, rain barrels and cisterns should be sized according to the on-site water needs. An over-sized system will not be drained sufficiently to accommodate input during rain events and an under-sized system will not meet the water needs for the site.

Soil Evaluation

- A soil evaluation is not required for rain barrels.
- A soil evaluation is required for all subsurface rainwater harvesting storage systems and may be required for large aboveground storage tanks to evaluate the need for a foundation (i.e., crushed stone and/or concrete or concrete block) to support the weight of the tank when full and to prevent the cistern from settling, overturning, or incurring other damage.
- Conduct an evaluation of the soil characteristics and subsurface conditions at the location of the proposed cistern including soil type, depth to the seasonal high groundwater table, depth to bedrock, and other geotechnical testing as necessary. Perform test pits or soil borings in accordance with the soil evaluation guidance in [Chapter 10 - General Design Guidance for Stormwater Infiltration Systems](#).

Design Recommendations – Rain Barrel

- Rain barrels are typically located at the downspout of a roof gutter system.
- Place the rain barrel on a sturdy, level surface 1-3 feet above the ground. The surface or platform should be capable of supporting the barrel when it is full, which for a standard 55-gallon rain barrel can be between 400 and 500 pounds. Elevating the barrel increases the water pressure and facilitates drainage.
- Install an overflow pipe from the top of the barrel to an Infiltration BMP, Filtering BMP designed for infiltration, or onto a vegetated surface consistent with the requirements for

simple disconnection as described in [Chapter 5 - Low Impact Development Site Planning and Design Strategies](#) of this Manual.

- A single 55-gallon rain barrel can typically serve 100 to 200 square feet of roof area depending on the water needs for gardening or landscape irrigation. Use multiple rain barrels if larger volumes are desired. Calculate the volume of stormwater runoff generated for a given storm and roof area using the following equation:

$$V = \frac{A * P * 0.9 * 7.5}{12}$$

where:

- V = required volume of rain barrel (gallons)
- A = surface area of roof (square feet)
- P = rainfall (inches)
- 0.9 = losses to system (no units)
- 12 = conversion factor (inches per foot)
- 7.5 = conversion factor (gallons per cubic foot)

Example: One 60-gallon rain barrel would provide sufficient storage from a rooftop area of approximately 100 square feet for a 1.0-inch storm, assuming that the rain barrel is empty prior to the storm.

$$V = \frac{100 \text{ ft}^2 * 1.0 \text{ in} * 0.9 * 7.5 \text{ gal/ft}^3}{12 \text{ in/ft}} = 56.25 \text{ gallons}$$

- Pretreatment of stored rainwater is typically not required for gardening or landscape uses.
- If there is a downspout from the roof and it extends to the ground, use a downspout diverter to divert water to the top of a “closed-top” rain barrel.
- If the downspout is cut a few feet above the ground use a plastic, flexible gutter extension or elbow to connect to top of an “open-top” rain barrel.
- If there isn’t a downspout, a rain chain can be used to connect the roof to the top of an “open-top” rain barrel.
- A filter system, such as a screen, can be installed as a part of the connection to prevent sediment and debris from entering the barrel.
- Cover the top of the barrel with a tight-fitting, light-blocking, locking lid that will keep the lid from blowing off in a storm, keep children and animals out of the water, limit the development of algae, and limit access to the standing water for mosquitos.

- Cover all openings into the barrel with window screening that is tightly affixed, or even caulked, at all edges. A screen can be added under the lid as an extra precaution.
- Provide a spigot, with garden hose threading, a few inches (minimum) above the bottom of the rain barrel to create a sump for sediment and debris on the bottom of the barrel. A regular garden hose can be connected to the spigot. Use a garden hose that is at least 8-10 feet long to discourage mosquitos from flying up the hose. The end of the hose can be fitted with screen to further prevent intrusions.
- Disconnect and drain rain barrels in the winter to prevent freezing and deformation of the rainwater harvesting system.

Design Recommendations - Cistern

The selection and design of stormwater cisterns and larger rainwater harvesting systems depends on many factors including the size and characteristics of the contributing drainage area; the volume, timing and location of water use on the site; physical and operational site constraints; system costs versus anticipated water savings; operation and maintenance considerations; and other factors. Cisterns come in many configurations and sizes, and the design of stormwater cisterns is highly site-specific. [Table 13-14](#) provides a summary comparison of various types of cisterns. System design should be consistent with design guidance of the product manufacturer as well as local and state building and public health codes regarding beneficial reuse of rainwater or stormwater.

Table 13-11. Comparison of Types of Rainwater Harvesting Storage Systems (Cisterns)

Type/Material	Advantages	Disadvantages
Fiberglass and Fiber Reinforced Polymer	<ul style="list-style-type: none"> ➤ Economical storage solution for larger volumes of water ➤ Protection from UV sunlight degradation ➤ Available in a variety of sizes and capacities ➤ Provides strength and durability for reliable performance ➤ Material is inert to soil compounds which can degrade tanks manufactured with other materials ➤ Accessible for maintenance, minimal maintenance 	<ul style="list-style-type: none"> ➤ Expensive in smaller sizes ➤ Excavation for cistern can be difficult ➤ Can be expensive to ship
Polyethylene, Polypropylene, & HDPE Pipe	<ul style="list-style-type: none"> ➤ Commercially available ➤ Alterable and movable ➤ Affordable ➤ Available in a variety of sizes ➤ Easy to install & Accessible for maintenance, minimal maintenance 	<ul style="list-style-type: none"> ➤ Can be degraded by UV sunlight if aboveground ➤ Can detract visually if not well-sited
Plastic (Aboveground) Cistern	<ul style="list-style-type: none"> ➤ Commercially available ➤ Alterable and movable ➤ Available in a variety of sizes, shaped, configurations, colors ➤ Easy to access for maintenance 	<ul style="list-style-type: none"> ➤ Possible UV deterioration ➤ Aboveground use only ➤ Must be insulated & heat traced for year-round use ➤ Can detract visually if not well-sited ➤ Can be expensive to ship
Galvanized Metal	<ul style="list-style-type: none"> ➤ Commercially available ➤ Alterable and movable ➤ Available in a variety of sizes, shapes, configurations ➤ Easy to access for maintenance 	<ul style="list-style-type: none"> ➤ Possible corrosion and rust ➤ Aboveground use only ➤ Must be insulated and heat traced for year-round use ➤ Can detract visually if not well-sited ➤ Can be expensive to ship
Concrete	<ul style="list-style-type: none"> ➤ Can be economical storage solution for larger volumes of water ➤ Long life ➤ Load bearing capabilities for use under parking lots and driveways ➤ Can be configured in custom shape and layout ➤ Can neutralize slightly acidic rainwater ➤ Can be made accessible for maintenance 	<ul style="list-style-type: none"> ➤ Expensive in smaller sizes ➤ Excavation for cistern can be difficult ➤ Precast concrete cisterns are not readily available & may involve expensive shipping costs ➤ Susceptible to cracks & leaks over time (install liner inside tank)
Modular (Plastic Lattice) Storage Systems	<ul style="list-style-type: none"> ➤ Can be economical storage solution for larger volumes of water ➤ Low shipping cost compared to other system types ➤ Flexible in shape, layout, and depth ➤ Available in a variety of sizes and capacities ➤ Units can be specified for traffic loading for use under parking lots & driveways ➤ Provides strength and durability for reliable performance 	<ul style="list-style-type: none"> ➤ Requires specific excavation and burial preparation to ensure longevity of system ➤ Internal cleaning is not possible; pretreatment system is extremely important for system longevity

Water Budget Analysis

- Perform a water budget analysis to determine if the desired capture volumes can be achieved and to properly size the system. A water balance consists of estimating the amount of water that can be captured and the amount of water that is used. Key considerations include balancing the amount of storage unit overflow with the size of the storage unit and limiting or eliminating the need for a secondary water supply.
- Estimate the water budget using a daily time step, mass balance approach. Daily changes in storage volume are equal to watershed runoff inputs minus evaporation, overflow, and indoor/outdoor use outputs.
- Water budget calculations can be performed using a water balance calculator specifically designed for rainwater harvesting systems, other models, or a spreadsheet.
- Water demand for irrigation is determined based on irrigation rates and water needs of the landscaped or turf area

Siting

- Located the cistern as close as possible to the water collection and/or point of use.
- Locate the cistern upslope from the point of use, if possible, to maximize gravity flow to the point of use.
- Locate the cistern below ground, if possible, to avoid freezing in the winter.
- Co-locate the cistern with building foundations, where possible.
- Grade away from the cistern; avoid low points where a cistern can become flooded.
- Direct cistern overflow away from an adjacent structure's foundation.
- Locate the cistern upslope from any sewage disposal facilities, septic tanks, or other source of potential contamination.
- Where possible, do not locate cisterns under areas with high vehicle loading. If unavoidable, design the structure to support the vehicle load.

Pretreatment

- Pretreatment is required to extend the functional life of a cistern. Incorporate pretreatment measures at locations where runoff enters the cistern in accordance with the Pretreatment BMPs section of this Manual.
- Pretreatment measure(s) should treat at least the Water Quality Flow (WQF).

- Acceptable pretreatment measures depend on the characteristics of the drainage area.
 - **Runoff from Paved Areas:** Pretreatment of runoff from paved areas includes pretreatment measures that are suitable for piped drainage systems – deep sump hooded catch basins,⁸⁸ oil grit separators, and proprietary pretreatment devices.
 - **Roof Runoff:** For runoff from roofs with low potential for accumulation of leaves or other solids, pretreatment may be waived by the reviewing authority. For roofs with moderate or high potential to collect leaves or other solids (e.g., roofs that are lower than the surrounding trees), pretreatment is required to remove coarse solids from the runoff prior to entering the cistern. Pretreatment options for roof runoff include leaf screens, first flush diverters, or roof washers.
- Additional treatment of the stored water may be necessary prior to use depending on the water quality requirements of the proposed use.

General Design Considerations

- The cistern should have sufficient storage volume to contain the Water Quality Volume (WQV) without overflow.
- The demand for stormwater reuse on site should be sufficient to empty the cistern within 72 hours after a rain event in order to allow for sufficient storage for the next rain event. Additionally, storage in excess of 72 hours may result in anaerobic conditions, odor, and both water quality and mosquito breeding issues.
- If the lowest 3-day water demand is insufficient to empty a cistern sized for the water quality storm, but the demand is greater on other days, a secondary storage tank should be used, sized with sufficient capacity to hold water from each storm event until it is reused.
- Cisterns can be constructed as off-line or on-line systems. In an off-line configuration, runoff from storms larger than the water quality storm bypasses the cistern through an upgradient diversion. On-line systems receive runoff from all storm events, which can be used or pumped to a secondary storage tank for later use. Runoff from larger storm events is conveyed through an overflow. On-line systems can also provide some stormwater runoff quantity control.
- Aboveground cisterns should be insulated to prevent the contents from freezing in the winter, or the cistern and rainwater harvesting system should be drained in the winter and only used seasonally. Aboveground cisterns should be covered to avoid becoming a breeding ground for insects.

⁸⁸ Only recommended for space constrained sites where no other Pretreatment BMPs are feasible.

- Underground cisterns should be located 3 feet below grade (or below the frost line) to prevent the harvested rainwater from freezing. For underground installations, the cistern should be at or above the seasonal high groundwater table (SHGT) and bedrock. Anti-buoyancy measures may be needed if cisterns are designed at or below the water table.
- When installing a cistern on a rooftop, consider the weight of the cistern at full capacity to be certain the roof structure is designed to accommodate the full load.
- To find the minimum required elevation of a cistern, calculate the hydraulic head required to distribute the water to the point of use. If the cistern cannot be located at that elevation, then pumps are required to distribute the water.
- All cisterns should include a vent pipe. The vent is necessary to allow fresh air to circulate in the cistern and it should be installed so that the opening faces the prevailing wind. Provide a water-tight seal where the vent pipe penetrates the cistern.
- All cisterns should include an overflow pipe. The diameter of the overflow pipe should be at least as large as the diameter of the inflow pipe. Install a fine-mesh screen on the end of the vent and overflow pipes to prevent the incursion of animals and insects. The overflow should discharge to an Infiltration BMP, Filtering BMP designed for infiltration, or onto a vegetated surface consistent with the requirements for simple disconnection as described in [Chapter 5 - Low Impact Development Site Planning and Design Strategies](#) of this Manual. The cistern may be designed to continuously discharge water at a very slow rate so that there is capacity in the cistern to retain stormwater in subsequent rain events.
- The water line from the cistern to the point of use should be buried below the frost line, be located at least one foot above the floor of the cistern and be positioned on the opposite side of the cistern from the input pipe to allow for sediment to settle.
- A separate input pipe can be included if water needs to be added to the cistern from a source other than captured stormwater.
- Provide a backflow prevention system to prevent contamination of public water supplies when public water is used as a backup source of water.
- Include sufficient freeboard above the outlet to allow for large storm events to pass through the cistern without backing up in upstream pipes or spilling out onto nearby surfaces.
- For cistern systems where controls to automate or regulate flow are required to move water from the cistern into the distribution system, include methods for detecting flows, identifying system failure (i.e., high level alarm) as well as an emergency shut-off and emergency backup power.
- All cisterns should include a cleanout drain for system cleaning. Slope the floor of the cistern towards the cleanout drain to facilitate cleaning. The drain cover can be controlled

by a valve that is either controlled from ground level or directly. The drain line and valve to control the drain cover will both need to be buried below the frost line to avoid freezing. The drain line should be sized adequately to move sediment that builds up in the cistern. A 4-inch diameter pipe is typically sufficient.

- Provide access manholes for system maintenance. Manholes should be placed, at a minimum, near the inlet and outlet of the system and in intermediate locations. The number of manholes depends on maintenance methods and design guidance of the product manufacturer.
- Custom concrete cisterns should be a minimum of 6 inches thick and reinforced with steel rods.
- When using prefabricated units follow the product manufacturer guidelines for installation requirements, minimum cover, and bedding/foundation design below the structure to support the design load associated with the structure, water storage, and adjacent backfill weight.
- If a liner is used for underground modular storage systems, the liner should consist of a 30 mil (minimum) HDPE or PVC liner, or one of the alternative liner systems described in [Chapter 10 - General Design Guidance for Stormwater Infiltration Systems](#) with the approval of the review authority.

Construction Recommendations

Rain Barrel

- Commercially available rain barrels can be installed quickly by placing the rain barrel on a sturdy, level, elevated platform and connecting it to a downspout.
- Use a food-grade container for the barrel, if possible, to prevent harmful chemicals from leaching into the stored rainwater.
- When drilling holes into the rain barrel, make the orifice fit the attachments as close as possible. Ragged edges can create openings for mosquitos and other insects to enter the rain barrel.
- Teflon tape can be used to fill spaces between the threads of any fittings and the barrel to create a water-tight seal. Wrap the tap clockwise to prevent it from coming undone when the adapter is screwed into place.
- Use washers on the inside and outside of each fitting attachment to ensure a snug fit.
- Caulk or plumbing adhesive can be used to seal the fittings.

Cistern

- The designing qualified professional should develop a detailed, site-specific construction sequence.
- The designing qualified professional should inspect the installation during the following stages of construction, at a minimum:
 - After excavation of the system (underground systems)
 - After placement and leveling of any necessary bedding or foundation below the cistern
 - After placement of the cistern(s) and any pretreatment devices and secondary storage tanks
 - After the installation of bypass, outlet/overflow, and inlet controls
 - After connection of the cistern and harvesting system to secondary water sources
 - After the system has been backfilled (underground systems)
- The designing qualified professional should provide an as-built plan of the completed system along with a certification that the system was designed in accordance with the guidance contained in this Manual and other local or state requirements and that the system was installed in accordance with the approved plans.
- The entire contributing drainage area should be completely stabilized prior to directing any flow to the system. Adequate vegetative cover must be established over any pervious area adjacent or contributing to the system before runoff can be accepted.
- Erosion and sediment controls should be in place during construction in accordance with the [Connecticut Guidelines for Soil Erosion and Sediment Control](#) and the Soil Erosion and Sediment Control (SESC) Plan developed for the project.
- The system should be fenced off during the construction period.
- The system should be excavated to the dimensions, side slopes, and elevations shown on the plans.

Maintenance Needs

Rain Barrel

- Detailed inspection and maintenance requirements, inspection and maintenance schedules, and those parties responsible for maintenance should be identified on the plans and in the Stormwater Management Plan.
- Maintenance should be detailed in a legally binding maintenance agreement.
- Sediment and debris should be cleaned out on a regular basis.

- Use a screw-on lid, whether it is a solid or screened lid to facilitate easy access for maintenance.
- Gutters on the roof should be kept clear of debris to limit the amount of stormwater that reaches the rain barrel or could contribute to a build-up of debris in the rain barrel that limits its performance.
- Winterization is required to limit damage to the barrel from freeze-thaw cycles. Drain the barrel and store it upside down for the winter.
- Before reconnecting it to the downspout in the spring, clean the barrel with a nontoxic cleaning solution, check all of the connections, and make any necessary repairs.
- Inspect the roof catchment area for leaves or particulate matter that may be entering the gutter and downspout to the rain barrel.
- Inspect the gutters, downspouts, and entrance to the rain barrel for leaks or obstructions.
- Inspect the rain barrel for potential leaks, including barrel top and seal.
- Inspect the overflow pipe for erosion at the outlet.
- Inspect the spigot to ensure that it is functioning correctly.
- Drain and disconnect the system before winter to prevent freezing and cracking.
- Mosquito larvae can form in rain barrels when water is retained over 72 hours. The larvae need to be at the surface to breathe so controlling the growth of mosquitos at this stage is manageable. Adding a tablespoon of non-toxic liquid dish soap after a storm or even on a weekly basis will add a film on the top of the water that will break the surface tension of the water and make it impossible for adults to lay eggs. Another strategy is to add ¼ cup of vegetable oil can be added weekly or after storm events. The oil forms a film on top of the water that prevents the larvae from breathing.
- Cleaning with a diluted bleach solution periodically can help remove any available food for the mosquito larvae and it makes the barrel less attractive to adults looking to lay eggs.

Cistern

- Detailed inspection and maintenance requirements, inspection and maintenance schedules, and those parties responsible for maintenance should be identified on the plans and in the Stormwater Management Plan.
- Maintenance should be detailed in a legally binding maintenance agreement.
- Maintain underground structures in accordance with the manufacturer's guidelines.

- Typical maintenance includes removal of accumulated oil and grease, floatables, and sediment from the pretreatment structure using a vacuum truck and removal of accumulated sediment from the cistern using a high-pressure water nozzle (i.e., JetVac process) and vacuum truck.
- Confined space safety procedures as required by OSHA regulations must be followed by workers entering an underground cistern.
- Inspect the pretreatment structure and cistern twice a year.
- Inspect the remainder of the system annually including an inspection for material failure (such as cracking, spalling, deterioration, subsidence, etc.).
- Pumps, valves, alarms, and other controls should be kept in good working order in compliance with the manufacturer's guidelines.
- Refer to [Appendix B](#) for maintenance inspection checklists, including items to focus on during inspections.
- Remove sediment from the pretreatment structure when it accumulates to more than 50% of the design depth.
- Remove sediment from the cistern when the sediment accumulation exceeds 2 inches throughout the length of the structure.
- Because rainwater is acidic and therefore corrosive, measures should be taken to neutralize rainwater in cisterns. Using plastic pipe can reduce corrosion or a neutralizing agent, such as limestone, quick lime, hydrated lime, soda ash, or caustic soda, can be added directly to the cistern.
- During winter months, downspouts, pretreatment mechanisms, and outflows should be periodically checked for ice buildup and all ice removed to keep the system functioning. It is sometimes economical to add heat trace to the piping in larger stormwater harvesting installations.

Other References

Connecticut Department of Energy and Environmental Protection. 2009. *Rainfall as a Resource: A Resident's Guide to Rain Barrels in Connecticut*. June 2009.

https://portal.ct.gov/-/media/DEEP/water/watershed_management/wm_plans/LID/whatisarainbarrelpdf.pdf?la=en

Edward S. Young, Jr., and William E. Sharpe. 2016. *Rainwater Cisterns: Design, Construction, and Treatment*. PennState Extension. June 2016.

Massachusetts Department of Environmental Protection. *Rain Barrels & Cisterns. Massachusetts Clean Water Toolkit*.

<https://megamanual.geosyntec.com/npsmanual/rainbarrelsandcisterns.aspx>

New Jersey Department of Environmental Protection (NJDEP). 2021. *New Jersey Stormwater Best Management Practices Manual*.

https://www.njstormwater.org/bmp_manual/NJ_SWBMP_9.1-cisterns.pdf

South Burlington Stormwater Utility. 2009. *Low Impact Development Guidance Manual*.

http://www.sburlstormwater.com/wp-content/uploads/downloads/manuals/SB_Low_Impact_Development_Manual.pdf

Green Roof



Description

Green roofs, also known as eco-roofs or vegetated roofs, consist of layers of soil and vegetation installed on building rooftops. Green roofs are typically multilayered systems that consist of a waterproof membrane, a synthetic drainage layer, a root barrier topped with a lightweight soil media, and a selection of plants suited to harsh rooftop conditions. Green roofs reduce runoff volumes and peak discharge rates by retaining runoff and creating longer flow paths. Rainwater is either intercepted by vegetation and evaporated to the atmosphere or retained in the substrate before being returned to the atmosphere through evapotranspiration.

The ability of a green roof to absorb and/or retain stormwater depends primarily on the type of plant material and soil medium but also depends on the drainage layer, the roof slope, the size of the roof and the season and climate. Green roofs may be used on newly constructed buildings or as retrofits of existing buildings. The structural integrity of the building is an important consideration for evaluating the feasibility of a green roof for a given application.

A green roof's ability to influence the water quality of runoff depends on the chemical composition of the rain falling on it, the materials used to promote plant growth such as fertilizer, and the type of plants. While the soil media and vegetation of green roofs can reduce pollutants in stormwater, green roofs are generally not used for stormwater treatment because

Stormwater BMP Type

Pretreatment BMP	<input type="checkbox"/>
Infiltration BMP	<input type="checkbox"/>
Filtering BMP	<input type="checkbox"/>
Stormwater Pond BMP	<input type="checkbox"/>
Stormwater Wetland BMP	<input type="checkbox"/>
Water Quality Conveyance BMP	<input type="checkbox"/>
Stormwater Reuse BMP	<input type="checkbox"/>
Proprietary BMP	<input type="checkbox"/>
Other BMPs and Accessories	<input checked="" type="checkbox"/>

Stormwater Management

Suitability

Retention	<input checked="" type="checkbox"/>
Treatment	<input type="checkbox"/>
Pretreatment	<input type="checkbox"/>
Peak Runoff Attenuation	<input checked="" type="checkbox"/>

Pollutant Removal

Sediment*	High
Phosphorus	Moderate
Nitrogen	Moderate
Bacteria	Moderate

*Includes sediment-bound pollutants and floatables (with pretreatment)

Implementation

Capital Cost	Medium
Maintenance Burden	Medium
Land Requirement	Varies

they capture rainwater, which is typically relatively clean. Green roofs primarily slow the flow of stormwater or intercept rainwater and supply it for non-potable uses like flushing toilets and irrigation. In addition to reducing the amount of stormwater runoff leaving a site, green roofs can mitigate heat island effects, reduce local air pollution, and lower building energy costs by providing additional insulation, among other benefits.

Advantages

- Can reduce the peak rate of runoff by 50-90% as well as delay the peak rate by up to three hours as compared to runoff from a conventional impermeable roof.
- Can reduce stormwater runoff volumes by retaining a portion if not all the rainfall in a storm event by releasing it back into the atmosphere via evaporation and evapotranspiration. (Unplanted “Blue Roofs” are designed specifically to retain water and slowly release it back via managed release of runoff and/or evaporation.)
- Can moderate the temperature of runoff.
- Can be used in densely developed areas where the use of other stormwater management practices is limited due to space constraints.
- Can improve runoff water quality if planted with material that naturally takes up contaminants from the soil.
- Can buffer the effects of acid rain by filtering it through a growth medium with a basic pH.
- Can contribute to air quality improvements by reducing carbon dioxides levels, binding airborne particulates and sequestering greenhouse gases.
- Can provide habitat for birds and pollinators and thus promote biodiversity.
- Can reduce the “urban heat island” effect by helping to regulate air temperature.
- Can extend the life of the conventional roof below.
- Can contribute to building’s energy efficiency by providing additional insulation and reducing heat loss in the winter and cooling the roof in the hot summer months.
- Can provide sites for recreational amenities or even urban agriculture.
- Can increase the property’s marketability or that of surrounding properties by improving views from neighbors into the site.

Limitations

- Can be expensive to design and construct.
- Construction can be challenging and require gardening and roofing experts to work together.
- Roof system must be designed to support the green roof under fully saturated conditions.
- Inadequate or improperly maintained drainage can cause the system to underperform or in extreme cases exceed the capacity of the load-bearing structure supporting it.
- Sloped-roof applications require additional erosion control measures.
- Historic buildings and building codes/standards can increase regulatory requirements and cost.
- More frequent maintenance required than for a conventional roof.
- Can contribute nutrient pollutant loads if fertilizer is used.
- Leaks can damage the building it is sited on.

- Damage to materials under the plantings such as the root barrier or waterproofing materials can be difficult to repair or replace.
- Plants can be difficult to establish and even once they are established, they can expire from the harsh conditions and need replacement.
- Soils can erode if soil levels are not maintained as organic matter deteriorates or if soils are washed out by a rain event.

Siting Considerations

- **Potential Locations:** Green roofs are appropriate for all types of structures and uses from commercial, institutional to residential. Wide, relatively flat roof areas are preferred but not necessary as green roofs can be installed in narrow areas and on slopes. Green roof technology makes it possible to install a green roof in a wide variety of locations where stormwater flow reduction is desired. Green roofs can be incorporated into new construction and can often be added to existing structures.
- **Drainage Area:** A green roof has no maximum contributing drainage area limitation because it only manages the precipitation that falls on the vegetated roof surface. Runoff from other surfaces and structures should not be directed onto the green roof.
- **Roof Slope:** Roof slope can affect the overall cost and performance. The flatter the roof the easier it is to retain water and stabilize planted areas. When roofs are sloped it is necessary to consider the different requirements for upslope and downslope conditions, which will tend to collect more water and will require plant, depth of soil media, and structural considerations to accommodate those conditions. Green roofs are difficult to install on structures with a pitch in excess of 45 degrees and it is recommended that green wall technology be implemented in those situations. Sloped roofs do not necessarily result in increased peak flows in comparison to flat roofs as long as the green roof system is designed to accommodate the flow of water down the slope of the conventional roof. Gravel ballast, wrapped in filter fabric, can be used along the perimeter of the roof to promote drainage and prevent soil medium migration.⁸⁹
- **Roof Size:** Roof size is a factor that contributes to the overall performance. Larger green roof installations tend to have a higher capacity to reduce runoff volumes, peak flow rates, and time of runoff concentration than smaller roof areas.
- **Seasons and Climate:** Season and climate should be considered in Connecticut where conditions differ dramatically throughout the year. Green roofs tend to retain more stormwater during the growing months and less when plants are dormant. Additionally, evaporation rates are higher during the warmer months. Green roofs also typically work more effectively during low-impact short-term rain events in comparison to high-intensity

⁸⁹ Landscape Development and Landscaping Research Society e.V., Forschungsgesellschaft Landschaftsentwicklung Landschaftsbau (FLL). 2018 Edition. Guidelines for the Planning, Construction and Maintenance of Green Roofs.

events or storms that have a long duration. Micro-climatic conditions such as seasonal shade, seasonal wind shifts, etc. can affect the performance of a green roof. Height of the rooftop and orientation can create stronger winds requiring tree staking and special mulching

- **Use with Other BMPs:** Green roofs can be sited so that runoff from them feeds into other BMPs, which can provide additional retention, treatment, peak runoff attenuation, or stormwater reuse. Pairing a green roof with cisterns and other structural stormwater BMPs can improve the overall system's ability to achieve stormwater quality and quantity objectives for the range of storm conditions that can be expected in Connecticut.

Types of Green Roofs

A variety of green roof designs exist, which fall into two major categories based on the type of construction, the program, and related specifically to the depth of the growing medium ([Table 13-15](#)):

- **Extensive:** Typically less complex and less expensive than an intensive system, these installations usually include a planted area sometimes accessible only to maintenance personnel and do not typically require irrigation after the initial establishment of plant material. Extensive green roofs can be used on flat or sloped roofs.
- **Intensive:** or, roof gardens, are typically designed to provide amenity spaces and accommodate varied planting designs, and thus deeper planting media is typically necessary to accommodate larger plant material, like trees. Intensive green roofs can be designed to provide more environmental services than extensive roofs, but tend to cost more than extensive green roofs. Intensive green roofs are typically used on flat roofs. In addition to garden spaces, intensive green roofs can be used for urban agriculture or even turf sports fields.

The following photographs are examples of extensive and intensive green roofs in Connecticut. Figure 13-32 provides schematics of common types of extensive and intensive green roofs showing the differences in the various layers that comprise each type.



**Extensive Green Roof, Laurel Hall,
Storrs, CT**



**Simple Intensive Green Roof, Storrs
Hall, Storrs, CT**



**Modular Green Roof, Gant Plaza, Storrs,
CT**



**Intensive Green Roof, Stamford
Government Center, Stamford, CT**

Source: [UConn NEMO Program](#)

Figure 13-32. Typical Green Roof Types

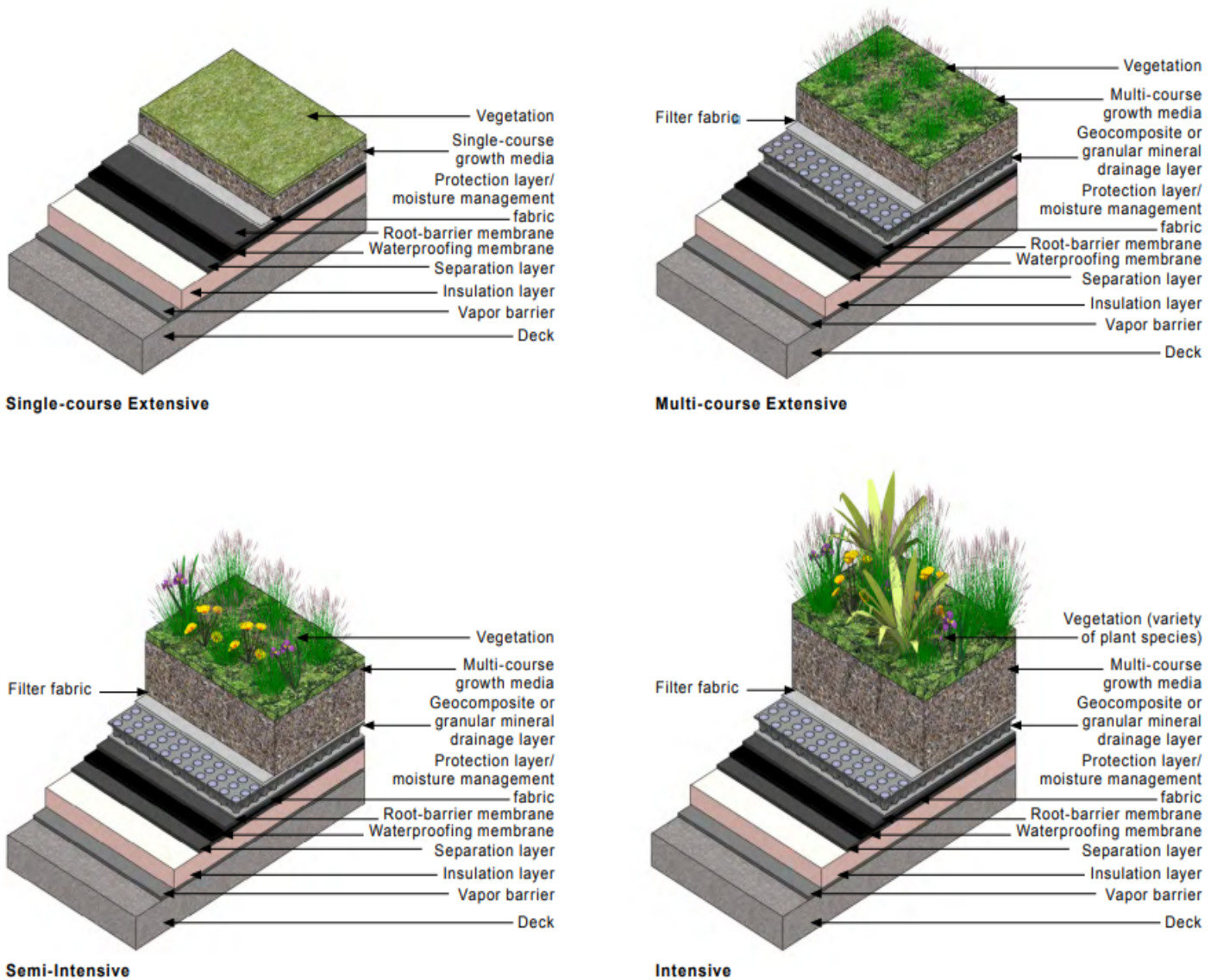



Source: GSA, 2011⁹⁰

⁹⁰ U.S. General Services Administration (GSA). 2011. The Benefits and Challenges of Green Roofs on Public and Commercial Buildings: A Report of the United States General Services Administration. May 2011, p.18. https://www.gsa.gov/cdnstatic/The_Benefits_and_Challenges_of_Green_Roofs_on_Public_and_Commercial_Buildings.pdf

Table 13-12. Comparison of Extensive and Intensive Green Roof Systems

Typical Feature	Extensive		Intensive	
	Single Course	Multi Course	Simple	Full
Relative Cost	\$ Least Expensive		Most Expensive \$\$\$	
Thickness	3-4"	4-6"	6-12"	>12"
Establishment	As short as one growing season	1-3 growing seasons	Depends on plant selection	Intensive care throughout
 Vegetation	Self-sustaining, adapted to extreme site conditions with a high regeneration rate such as succulents, sedums, moss, or a native meadow seed mix appropriate to the site's USDA hardiness zone and local biotope.	Self-sustaining, adapted to extreme site conditions with a high regeneration rate such as succulents, sedums, moss, or native herbaceous material; other plants as possible, such as grasses, depending on the USDA hardiness zone and the availability of supplemental irrigation when required.	A variety of species can be supported with the right blend of soil medium and moisture. Species include herbaceous and smaller woody meadow perennials, turf grasses, and other ornamentals. Plants that can withstand extreme site conditions should be given preference.	Depending on the roof garden's micro-climate, plantings can be implemented similar to ground-level installations. Due to micro-climates on rooftops, plants that can withstand heat, wind and fluctuations in moisture are more likely to thrive and will require less maintenance.
 Growth media	Light-weight coarse growing media integrated with a drainage media	Light-weight, typically finer-grained media over a discrete drainage layer	Multi-course growth media overlaid on a discrete drainage layer	Growth media must be compiled at sufficient depths and composition to support the plant's needs. Higher levels of organics might be necessary and their effects on the water storage and density of the media must be considered when designing the structural support system. For trees a minimum planting depth 30 inches is required. The use of structural soil or soil cell system will be required for larger trees integrated with pavement areas

Typical Feature	Extensive		Intensive	
	Single Course	Multi Course	Simple	Full
Relative Cost	\$ Least Expensive 		Most Expensive \$\$	
Thickness	3-4"	4-6"	6-12"	>12"
Establishment	As short as one growing season	1-3 growing seasons	Depends on plant selection	Intensive care throughout
 <p>Drainage & Other Layers</p>	Least complex layer structure. Drainage is integrated into soil media.	Potential for a less-complex layer structure. Typically a geocomposite is used but specific selection is related to the composition of the soil media, the types of plants selected, and regional climate and micro-climate conditions	Complex layer structure. Discrete drainage layer: either geocomposite or drainage media such as sand or gravel wrapped in a filter fabric or underlain with drainage board	Most complex layer structure. Discrete drainage layer is essential: either geocomposite or drainage media such as sand or gravel wrapped in a filter fabric or underlain with drainage board
 <p>Irrigation</p>	None	Usually provided to establish vegetation; used to supplement as needed afterwards	Usually provided to establish vegetation; used to supplement as needed afterwards; required to maintain a turf grass installation	Typically required to supplement rainfall. Must be regulated to maintain the roof's ability to attenuate stormwater during a rain events

	Extensive		Intensive	
Typical Feature	Single Course	Multi Course	Simple	Full
Relative Cost	\$ Least Expensive		Most Expensive \$\$	
Thickness	3-4"	4-6"	6-12"	>12"
Establishment	As short as one growing season	1-3 growing seasons	Depends on plant selection	Intensive care throughout
Maintenance	Minimal: regular weeding, plant replacement as necessary, regular material inspection to insure functionality. If the material is planted in a certain pattern or design additional maintenance to retain the desired pattern will be required.	Minimal: regular weeding, plant replacement as necessary, seasonal removal of spent plant material (such as cutting back meadow grasses); regular material inspection of hardscape layers to insure functionality	Intensive: regular weeding, plant care, mulching, pruning and typical garden maintenance; irrigation as necessary; regular material inspections, care, and maintenance	Intensive: regular weeding, plant care, mulching, pruning and typical garden maintenance; irrigation as necessary; regular material inspections, care, and maintenance

Created with Canva.com

- **Modular Green Roofs:** Modular green roof systems are either extensive or semi-intensive and can be used with new installations and building retrofits. These prefabricated systems consist of interlocking modules (trays or units) containing plants and soil medium. The modules typically have established vegetation prior to installation and can be easily installed and removed/replaced, thereby facilitating roof maintenance and repair. These systems can be more expensive than the built-in-place systems, and aspects of modular construction can interfere with the optimal performance of the green roof to achieve stormwater benefits. Figure 13-33 is a schematic cross-section of a modular green roof.

Figure 13-33. Typical Modular Green Roof Assembly

Example of Modular Tray Unit that includes:

- Vegetation layer
- Soil Media
- Filter
- Tray



Full Roof with Modular Tray Installation



Photos courtesy of the UConn Center for Land Use Education and Research (CLEAR)

Design Recommendations

Pretreatment

No pretreatment is required for direct rainfall onto the green roof surface.

Sizing and Dimensions

- Green roofs should be designed to retain without bypass or overflow the Required Retention Volume (100% or 50% of the roof's Water Quality Volume or WQV).
- Maximum roof slope: 20%

Green Roof Elements

The elements of a green roof are all interdependent and must be carefully selected and detailed to work together to achieve the desired goal of the green roof installation. For example, a green roof designed to maximize the interception of stormwater might rely on large-leafed plants to maximize evapotranspiration. Those types of plants will require a deeper growth medium than plants with lower evapotranspiration rates, which will present a larger load that the structure will need to support. Alternatively, a roof garden that uses a water-retention system such as hydrogel will require a structure that will bear the load of the material when it is fully saturated.

Vegetation

Plant choices must be appropriate to the USDA growing zone as well as the rooftop microclimate, balanced with the roof's capacity to support their needs for growth medium and moisture as well as with the project's overall budget for installation and ongoing maintenance. Evaluating the rooftop for site-specific conditions such as reflections, thermal loading and/ or shade from adjacent structures, specific air quality resultant from co-located utilities, as well as wind tunnel effects due to adjacent structures, is critical when identifying species that will succeed.

Plants that succeed are typically:

- Hardy in a harsh rooftop microclimate:
 - Able to survive intense temperature fluctuation
 - Able to endure freeze-thaw cycles
 - Capable of withstanding the impact and desiccation from high winds
 - Tolerant of droughts as well as deluges
 - Adapted to urban air quality
- Self-sustaining with a high rate of regeneration
- Low growing for extensive, but can be all different sizes in an intensive application
- Fire-resistant
- Low maintenance

Plants that take up water through roots more readily can help maximize the performance of the green roof, but those species are often not low-maintenance or suited for rooftop conditions and thus require more care. Sedums and other succulents, like *Delosperma* (ice plant) or *Sempervivums*, as well as creeping thyme, *Allium*, *Annenaria*, *Ameria* and *Abretia* along with urban-tolerant meadow grasses, such as *Ammophila brevigulata* are typically selected for rooftop installations because they are highly tolerant of droughts and desiccating winds and have a high capacity for absorbing stormwater.

Evapotranspiration rates for all plants vary depending on the species, climate, and localized environmental conditions. Plants with higher evapotranspiration rates increase the stormwater absorption rates but they tend to require deeper growth medium and potentially could require a supplemental irrigation system. Adding an irrigation system requires monitoring so that the roof is not already saturated, and thus unable to retain and reduce runoff when a rain event occurs.

Vegetation should be kept back from roof edges so that drainage is not inadvertently conveyed over the edge of a building.

Growth Medium

- Particle sizes, type of material and depth of medium must be balanced as together they affect the overall performance of a green roof. The soil medium must support the vegetation and retain stormwater without overburdening the structural system. The shallower the growth medium, the more diminished the water retention capacity and the less nutrients necessary to support plants.
- Smaller particles, with more surface area, have a higher capacity for retaining stormwater, but smaller particles can retain too much water or get washed out during heavy storm events and end up clogging the drainage system. It is recommended that no grain diameter be smaller than 0.063 mm as smaller material will clog typical filter fabrics.
- The organic content must be balanced to promote plant growth without causing negative effects. As organic material decomposes it can contribute phosphorus and nitrogen to the runoff and it can also lose volume which would need to be replaced to sustain root masses. Deeper soil medium can retain more water, but the bearing capacity of the roof must be designed to accommodate a higher load, which can greatly increase project costs. A typical planting medium for a green roof will consist of 80-90% lightweight aggregate and 10-20% stable organic matter.
- For extensive green roofs, use 2 to 6 inches of lightweight growth substrate consisting of inorganic absorbent material such as perlite, clay shale, pumice, or crushed terracotta, with no more than 5% organic content.
- The pH of the planting medium should be between 6 and 8.5.

- Tested permeability (hydraulic conductivity) of the growing medium to be at least 1 inch per hour. The permeability can be determined by following the test method outlined in ASTM E2399.
- The following growth media design criteria apply to extensive green roofs: (NJDEP, 2021)
 - The tested maximum media water retention, when using the ASTM E2399 method, or the maximum water capacity, when using the *FLL* method, should be at least 35% by volume but not greater than 65% by volume.
 - The organic content should be less than 4.06 pounds per cubic foot or 65 grams per liter.
- The following growth media design criteria apply to intensive green roofs: (NJDEP, 2021)
 - The tested maximum media water retention, when using the ASTM E2399 method, or the maximum water capacity, when using the *FLL* method, should be at least 45% by volume but not greater than 65% by volume.
 - The organic content should be less than 5.62 pounds per cubic foot or 90 grams per liter.
- Consider adding biochar to the soil medium to (NJDEP, 2021):
 - Increase water absorption
 - Manage the weight of the soil medium
 - Decrease the pollution discharge including decreasing the suspended solids in runoff

Drainage Layer

- Overall, the drainage layer should be dimensioned and implemented with consideration of the roof pitch, unevenness on the roof surface, and to tie into roof drains.
- The hydraulic conductivity of the drainage layer should exceed the planting medium's hydraulic conductivity to promote positive conveyance of runoff.
- Factors to consider include:
 - Structure and layer stability/ compatibility with other materials
 - Compressive performance (i.e., will it still perform under compression)
 - Water permeability
 - Water storage capacity
 - Plant compatibility (phytotoxicity safety)
 - Root penetrability
 - Particle distribution/ mesh width
 - Resistance to freeze-thaw cycles
 - pH value (should match the growing medium or, at a minimum avoid a deleterious effect on it)

- Salt content
 - Weatherability/ vulnerability to erosion
 - Chemical stability (tendency to leach)
 - Resistance to micro-organisms/ rot potential
- Multi-course systems should consist of either a coarse aggregate material like sand or gravel wrapped in a filter fabric or a synthetic geocomposite made from plastic or filaments. Aggregate materials tend to resist the horizontal flow of stormwater and so they delay peak runoff effectively. However, even though they tend to promote root development, they tend to be heavier and store less water than geocomposites. Fabricated from synthetic polymers, geocomposites are typically designed to achieve a specific goal such as stormwater storage, promotion of drainage, or the reduction of hydrostatic pressure on the waterproofing layer.
- Drainage can be addressed with multiple layers. It can be useful to install a geocomposite directly above the waterproofing membrane in addition to a multi-course drainage layer directly under the growth medium.
- Vegetated and non-vegetated areas should be drained and often require different drainage design and separate overflow mechanisms. At least one drain and one emergency overflow are recommended for each drainage field.
- Ideally, the system should be designed so that the pressure of the rainwater flow through the system will self-clean the mechanisms so that maintenance and inspections can be minimized.
- Calcareous materials, such as recycled concrete aggregate, should not be used in drainage layers as they can lead to efflorescence in the drainage system which can damage the system in the long term.
- Drainage such as gravel strips should be installed at the edge of green roofs to convey water at the edges to the designed system and to avoid allowing runoff to flow over the edge of the building.
- While roots can grow in the drainage layer, drainage infrastructure, such as scuppers, drains, and other conveyances for stormwater should be kept clear of vegetation and protected from clogging with debris with a filter screen or mesh coordinated with the particle sizes of the growth medium and/or gravel used in the drainage layer.
- Drainage must be considered at all thresholds to the green roof installation and can require special detailing that includes:
- A heated channel drain at the threshold
 - Splash protection/ protection from snow accumulation

- Doors with special sealing functions
- Additional waterproofing and drainage in the interior of the threshold

Moisture Management Layer

- Separation fabric can directly affect drainage and should be selected and installed so that it achieves the desired design goal.

Root Barrier/ Protective Layer

- Can consist of:
 - A layer of perforated plastic sheets
 - A thin layer of gravel that prevents root growth from advancing but does not interfere with the drainage or the roots' ability to access water
 - A full surface coating or liquid sealant on the roof material below
- Can be combined with the waterproofing layer
- The required strength of the barrier is directly related to the type of root growth of the specified plant species. For example, bamboos with aggressive rhizome growth may require extra-strength protection.
- Special root protection treatment may be required at transition points, roof penetrations and joints in the roofing material.
- Thinner growth medium can cause an increase in competition among plants which respond with more aggressive root growth and can require additional protection.
- Should arrest the advancement of root growth to prevent damage to the waterproof membrane, the leak detection system below it, and the roof itself.
- Root barriers containing chemical root-growth-blockers and/or herbicide should be avoided as they will contaminate the runoff from the green roof.
- Some installations, such as waterproof concrete roofs, or roofs constructed from welded metal sections, do not require a root barrier because the material is already resistant to root penetration.
- Special care should be taken when installing the root barrier layer as many are UV-sensitive and can deteriorate if left exposed during construction. Also, protection for the material may be necessary when installing it over a rough surface below.
- Root protection layers can be manipulated to establish pockets of water in areas of the garden where they are needed to support plant material but should be installed carefully to prevent unwanted ponding from occurring.

- On sloped roofs, root protection should be installed and pinned as necessary to prevent it from sliding relative to a waterproof membrane below it.

Waterproof Membrane

- Typically made of materials such as bitumen, synthetic rubber (such as EPDM), hypolan (CPSE), or reinforced PVC. Adhesives used to bind panels of the membrane together should be impermeable.
- An impermeable root barrier sometimes doubles as a waterproofing membrane.
- The waterproofing must be extended at all transitions, particularly at the edge of the roof where it should wrap around and overlap with the wall waterproofing.
- The waterproof membrane should be reviewed by both the roof expert and the garden expert to be certain that it meets the physical requirements for the structure below and the green roof installation above.

Leak Detection System

- Many options for electronic leak detection and moisture monitoring systems exist in the market. A leak detection system should be used under the waterproof membrane and above the roof so that leaks can be detected quickly before damage to the underlying roof structure occurs.

Roof Materials

- Transition points
 - Special care is needed to secure root barriers and waterproofing where roof materials or slopes transition. Snow accumulation at these points should also be considered.
- Separation Layer(s)
 - Can be installed as needed between the green roof layers or under the green roof materials and above the traditional roof materials.
 - Should be compatible with other materials in the installation.
 - Should be resistant to mechanical, thermal, and chemical stresses of the green roof installation
 - Should be resistant to rotting from exposure to biological factors present in a living green roof system.
 - Should not off-gas or leach pollutants into the stormwater released from the green roof.
- Insulation Layer
 - Needed if there is an occupied space directly under the green roof.

- Vapor Barrier
- Roof Deck or Membrane
 - If not separated from the stormwater conveyance system:
 - Concrete roofing can leach carbonates
 - Asphalt roofing can leach polycyclic aromatic hydrocarbons (PAHs) and hydrocarbons

Safety Considerations

- All green roofs will require access whether just for maintenance personnel or for recreational users. Safety measures, such as proper tie-off points for fall protection, will need to be installed to enable maintenance of all green spaces.
- All synthetic materials layered in the green roof installation should be chosen to be chemically compatible with one another so as to avoid leaching or off-gassing of pollutants. Additionally, materials should be evaluated to be certain that they are not toxic to the plant species.

Stormwater Quantity Control Design – Adjusted Runoff Curve Number

- Green roofs reduce the volume of runoff from building roofs and therefore result in a reduced NRCS Runoff Curve Number (CN), which should be used for hydrologic and hydraulic routing calculations that are required for stormwater quantity control design.
- Determine adjusted CN values for the green roof by the following method:
 1. Calculate the volume of stormwater retained by the green roof based on the available water capacity of the planting/growing media using the methodology presented in the [New Jersey Stormwater Best Management Practices Manual](#).
 2. Calculate the stormwater runoff volume produced by the water quality storm and the 2-, 10-, and 100-year, 24-hour design storms as described in [Chapter 4 of this Manual](#).
 3. Subtract the volume of stormwater retained by the green roof from the stormwater runoff volume for the various design storm events. The result is the runoff volume that will be discharged from the green roof during each design storm event.
 4. Convert the volume of stormwater retained by the green roof to an equivalent retention depth (in inches) by dividing the volume retained by the area of the green roof.
 5. Convert the volume of stormwater discharged from the green roof to an equivalent discharge depth (in inches) by dividing the volume discharged by the area of the green roof.

6. Determine the adjusted CN values for each design storm using one of the following two approaches:
 - Intensive green roofs should use the runoff CNs for Woods, Brush, or Grass, depending on the specific plant communities used. Extensive green roofs should use the adjusted CN values listed in [Table 13-16](#) based on the calculated retention depth in inches.
 - Using the calculated discharge depth described above and the precipitation for each design storm event, calculate the adjusted CN values using the equation or graphical solution (Figure 2-1 from TR-55) presented in [Appendix D](#) of this Manual (i.e., Graphical Peak Discharge Method).

Table 13-13. Adjusted Curve Numbers for Extensive Green Roofs

Retention Depth (inches)	Adjusted Curve Number (CN)
0.6	94
1.0	92
1.2	90
1.4	88
1.6	86
1.8	85
2.0	82
2.2	81
2.4	77

Adapted from Maryland Department of the Environment, Stormwater Design Guidance – Green Roofs, March 2018.

- Once the adjusted CN values are determined, also calculate the time of concentration and either follow the remaining steps in the Graphical Peak Discharge Method in [Appendix D](#) or use a stormwater hydrologic/hydraulic routing model based on the NRCS Curve Number method (e.g., HydroCAD or similar software) to calculate peak discharge for each design storm event.

Green Roof Retrofit Assessment

- Where a green roof is proposed as a retrofit, perform a site assessment of the existing building and roof integrity necessary to support the proposed green roof.

- Structural Analysis
 - For the roof to be considered viable for green roof installation, the structural analysis must indicate that the roof structure is capable of supporting the additional load from the proposed green roof(s) when saturated in addition to any other live loads expected as part of the project.
 - Connections to building systems, such as plumbing (for irrigation), drainage, electrical, etc. should be carefully considered so as to not compromise those systems or to create issues.
- Roof Membrane Assessment
 - Evaluate the condition of the existing roof membrane and confirm the remaining years on its warranty, if any.
 - If there are remaining year(s) on the warranty, contact the roof membrane manufacturer and confirm the necessary steps required to protect the membrane before installing the proposed green roof.
 - Confirm if the manufacturer cannot continue to honor the warranty if a green roof is installed.
 - Note major or numerous roof penetrations by pipes, ducts, equipment, or other features.
- Historic Structure Considerations
 - Evaluate historic structure code requirements and any limitations of prohibitions relative to the use of green roofs. Can the historic character of the building be maintained? For example, green roofs on federal buildings cannot be visible from public thoroughfares.

Outlet & Overflow

- Runoff exceeding the retention capacity of the green roof system should be safely conveyed to the drainage system or another structural stormwater BMP. Design the outlet/overflow in accordance with the [Inlet and Outlet Controls](#) section of this Manual.
- The green roof system should safely convey runoff from the 100-year, 24-hour storm to a downgradient drainage system to avoid erosion or flooding.
- Roof drains and scuppers should be protected to prevent clogging through the use of a stone/gravel apron surrounding the drain or similar measures.

Other Considerations

- The following ASTM standards should be used for design of a green roof system:
 - ASTM E2396 – Standard Testing Method for Saturated Water Permeability of Granular Drainage Media (Falling-Head Method) for Green Roof Systems
 - ASTM E2397 – Standard Practice for Determination of Dead Loads and Live Loads Associated with Green Roof Systems

- ASTM E2398 – Standard Test Method for Water Capture and Media Retention of Geocomposite Drain Layers for Green Roof Systems
- ASTM E2399 – Standard Test Method for Maximum Media Density for Dead Load Analysis
- ASTM E2400 – Standard Guide for Selection, Installation, and Maintenance of Plants for Green Roof Systems
- ANSI/SPRI VF-1 – External Fire Design Standard for Vegetative Roofs
- ANSI/ SPRI Standard for Wind Design- method for designing wind uplift resistance of green roofs
- ANSI/ SPRI Fire Design Standard- method for designing external fire resistance for green roofs
- ANSI/ SPRI Standard for Preventing Root Penetration- in development

Construction Recommendations

- The designing qualified professional should develop a detailed, site-specific construction sequence.
- The designing qualified professional should inspect the installation after placement of each roof layer, plantings, modular units, and outlet/overflow structures.
- The designing qualified professional should provide an as-built plan of the completed system along with a certification that the system was designed in accordance with the guidance contained in this Manual and other local or state requirements and that the system was installed in accordance with the approved plans.
- The green roof planting media should be tested prior to placement according to the specifications in this section. The designing qualified professional should certify that the planting media meets the specifications based on soil testing results and soil weight requirements.
- Erosion and sediment controls should be in place during construction in accordance with the [Connecticut Guidelines for Soil Erosion and Sediment Control](#) and the Soil Erosion and Sediment Control (SESC) Plan developed for the project.
- Temporary erosion protection, such as mats or mesh, should be provided until plant cover is well established.
- Vegetation can be installed as vegetation mats, plugs, sprigs, seeds or as potted plants. Mats tend to be the fastest to establish, but the material is expensive even though it requires lower labor costs to install. In comparison, potted plants can establish coverage quickly but are expensive to purchase and install. Sprigs can be cost effective but often require irrigation, weeding and can be difficult to establish and often require replacement.

Maintenance Needs

- Green roof systems should be designed with easy access to the building roof and all components of the system for maintenance purposes. Refer to [Chapter 7](#) for general design considerations to reduce and facilitate system maintenance.
- Detailed inspection and maintenance requirements, inspection and maintenance schedules, and those parties responsible for maintenance should be identified on the plans and in the Stormwater Management Plan.
- A method for detecting leaks should be included in the green roof's maintenance plan.
- Maintenance should be detailed in a legally binding maintenance agreement.

Recommended Maintenance Activities

- Plan for extra maintenance, often labor-intensive work like hand-watering and weeding, while plants establish.
- Perform inspections at least four times annually and after every storm event exceeding 1 inch of rainfall. Check for and clear debris, sediment, dead vegetation, and check whether the planting medium has eroded or been transported to the drainage gutter or outlets.
- Remove organic litter, cutting herbaceous material back and pruning woody material two to three times annually.
- Provide extra maintenance to retain the desired aesthetic of a detailed planting.
- Perform periodic weeding, sometimes every other week during the growing season.
- Replace plants as needed. Maintain a minimum 85% vegetative cover at all times.
- Replace organic matter as it deteriorates.
- Fertilize to maintain plant health only as needed. Avoid use of fertilizer or over-fertilization to minimize nutrient export from the roof.
- Provide seasonal irrigation when necessary.
- Periodically maintain outflows (unclogging if debris enters) and inspect them two times a year at a minimum.
- Inspect roof materials for any problems, particularly the underlying membrane for deterioration.

- Relatively low-cost electronic grids can be installed under the membrane to help pinpoint leaks if they occur.

Other References

Massachusetts Low Impact Development Toolkit. *Fact Sheet #9 Green Roofs*. Metropolitan Area Planning Council.

https://www.mapc.org/wp-content/uploads/2017/11/LID_toolkit_factsheets_7-9.pdf

New Jersey Department of Environmental Protection (NJDEP). 2021. *New Jersey Stormwater Best Management Practices Manual*. https://nj.gov/dep/stormwater/bmp_manual2.htm

Save the Sound. Reduce Runoff.org. <https://www.reducerunoff.org/green-blue-roofs>

U.S. Environmental Protection Agency (EPA). 2018. *Estimating the environmental effects of green roofs: A case study in Kansas City, Missouri*. EPA 430-S-18-001. www.epa.gov/heat-islands/using-greenroofs-reduce-heat-islands

U.S. General Services Administration (GSA). 2011. *The Benefits and Challenges of Green Roofs on Public and Commercial Buildings: A Report of the United States General Services Administration*. May 2011, p.18.

https://www.gsa.gov/cdnstatic/The_Benefits_and_Challenges_of_Green_Roofs_on_Public_and_Commercial_Buildings.pdf

Dry Extended Detention Basin



Description

Dry extended detention basins, also called “dry ponds” or “detention basins”, are stormwater basins designed to capture, temporarily hold, and gradually release a volume of stormwater runoff to attenuate and delay stormwater runoff peaks. Dry extended detention basins are typically designed as on-line systems and provide stormwater quantity control but only limited water quality benefit. The primary outlet structure of a dry extended detention basin is located at the bottom of the basin and sized to limit the maximum flow rate from the basin for the water quality storm. The higher stages of the basin attenuate the peak rates of runoff from larger storm events. Dry basins are designed to completely empty between storms, typically in 24 to 48 hours, resulting in limited settling of particulate matter and the potential for re-suspension of sediment by subsequent runoff events.

Dry extended detention basins differ from wet extended detention ponds, which provide a permanent pool and greater pollutant removal (see Stormwater Ponds section of this chapter). Dry extended detention basins are not suitable as infiltration or groundwater recharge measures, and therefore do not reduce runoff volumes and cannot be used to meet the Standard 1 retention or treatment performance criterion of this Manual. Figure 13-34 shows a schematic of a typical dry extended detention basin.

Advantages

- Low-density residential, industrial, and commercial developments with adequate space and low visibility.

Stormwater BMP Type

Pretreatment BMP	<input type="checkbox"/>
Infiltration BMP	<input type="checkbox"/>
Filtering BMP	<input type="checkbox"/>
Stormwater Pond BMP	<input type="checkbox"/>
Stormwater Wetland BMP	<input type="checkbox"/>
Water Quality Conveyance BMP	<input type="checkbox"/>
Stormwater Reuse BMP	<input type="checkbox"/>
Proprietary BMP	<input type="checkbox"/>
Other BMPs and Accessories	<input checked="" type="checkbox"/>

Stormwater Management Suitability

Retention	<input type="checkbox"/>
Treatment	<input type="checkbox"/>
Pretreatment	<input type="checkbox"/>
Peak Runoff Attenuation	<input checked="" type="checkbox"/>

Pollutant Removal

Sediment*	Moderate
Phosphorus	Low
Nitrogen	Low
Bacteria	Low

*Includes sediment-bound pollutants and floatables (with pretreatment)

Implementation

Capital Cost	Medium
Maintenance Burden	Medium
Land Requirement	High

- Suitable for use as part of a stormwater treatment train, particularly in combination with off-line retention and treatment stormwater BMPs. The size of dry detention basins can be reduced substantially by placing them at the end of the treatment train to take advantage of reduced runoff volume resulting from upstream practices that employ infiltration.
- Less frequently used portions of larger or regional dry detention basins can offer recreational, aesthetic, and open space opportunities (e.g., athletic fields, jogging and walking trails, picnic areas).

Limitations

- Strictly for water quantity control to attenuate peak flows, limit downstream flooding, and provide some degree of channel protection.
- Not suitable for treatment. Most dry extended detention basins have detention times of less than 24 hours and lack a permanent pool, providing insufficient settling of particles, and minimal stormwater treatment.
- Not suitable for stormwater retention or runoff reduction since dry detention basins drain completely between storms and do not provide significant infiltration.
- Susceptible to re-suspension of settled material by subsequent storms.

Siting Considerations

- **Drainage Area:** Dry extended detention basins generally require a drainage area of 10 acres or greater to avoid an excessively small outlet structure susceptible to clogging. Dry extended detention basins are impractical and less cost-effective for drainage areas smaller than 1 acre.
- **Groundwater and Bedrock:** The lowest point in the bottom of the basin should be at least 1 foot above the seasonal high groundwater table (SHGT) and bedrock. Intercepting groundwater or shallow bedrock may result in the loss of runoff storage volume. An impermeable liner is recommended when the lowest point in the bottom of the basin is less than 1 foot above SHGT.
- **Land Uses:** Land uses will dictate potential pollutants-of-concern and potential safety risks. A liner is required for dry detention basins that receive runoff from Land Uses with Higher Potential Pollutant Loads (LUHPPLs) (see [Chapter 10 - General Design Guidance for Stormwater Infiltration Systems](#)) or on contaminated sites. The basin's temporary pool may pose a safety risk in residential areas and areas with public access, sometimes requiring fencing to limit access to the basin.
- **Soils:** Well-drained soils are preferred (HSG A and B soils). A liner is recommended for use in HSG C and D soils to prevent groundwater inflow and loss of storage volume.

- **Site Slopes:** Site slopes greater than 6% may result in the need for a large embankment to be constructed to provide the desired storage volume, which could be subject to CT DEEP dam safety regulatory requirements. Steep slopes may also present design and construction challenges, and significantly increase the cost of earthwork.
- **Receiving Waters:** Stormwater ponds should not be used for sites that discharge within 200 feet of cold-water streams, 200 feet from a public water supply reservoir, or 100 feet from streams tributary to a public water supply reservoir.

Soil Evaluation

- Conduct an evaluation of the soil characteristics and subsurface conditions at the location of the proposed system including soil type, depth to the seasonal high groundwater table, and depth to bedrock. Perform test pits or soil borings in accordance with the soil evaluation guidance in [Chapter 10 - General Design Guidance for Stormwater Infiltration Systems](#).

Design Recommendations

Pretreatment – Sediment Forebay

- A sediment forebay is recommended for dry extended detention basins, although other forms of pretreatment may be used at locations where runoff enters the basin.
- The sediment forebay and other pretreatment measures should be designed in accordance with the Pretreatment BMPs section of this Manual.
- The sediment forebay should be sized to contain at least 10% of the Water Quality Volume (WQV).

Extended Detention Storage

- Extended detention requires sufficient storage capacity to hold stormwater for at least 24 hours to allow solids to settle out.
- The primary outlet structure of a dry extended detention basin is located at the bottom of the basin and sized to limit the maximum flow rate from the basin for the water quality storm. The higher stages of the basin attenuate the peak rates of runoff from larger storms (2-year, 10-year, 25-year and 100-year, 24-hour events).
- The detention basin should completely drain within 48 hours after the end of a storm.
- Thermal impacts of dry extended detention basins may be mitigated by:
 - Planting of shade trees around the perimeter of the basin (but at least 25 feet away from inlet/outlet structures and the basin embankment) to reduce solar warming of the temporary pool
 - Use of an underdrained gravel trench outlet.

- A minimum length-to-width ratio of 2:1 is recommended, although a 3:1 ratio is preferred for longer flow path lengths and enhanced sedimentation.
- Irregularly shaped basins are desirable due to their more natural and less engineered appearance.
- To enhance safety by minimizing standing water depths, the depth of the temporary pool associated with the water quality design storm should be no greater than 3 feet.
- Maximum ponding depths of 4 feet are recommended to avoid CT DEEP dam safety regulatory requirements, unless the basin is excavated below existing grade and does not require an embankment that may be subject to CT DEEP dam safety provisions.

Conveyance

- Stormwater should be conveyed to and from all stormwater management practices safely and to minimize erosion potential.

Inlet

- Design the inlet in accordance with the Inlet and Outlet Controls section of this Manual.
- The number of inlets should be minimized, and one inlet is preferable. The inlet should be located at the most hydraulically remote point from the outlet to minimize the potential for short-circuiting and should be in a manner that meets or exceeds desired length to width ratios.

Outlet & Overflow

- Design the outlet and any overflows in accordance with the [Inlet and Outlet Controls](#) section of this Manual.
- A low flow orifice or weir should be located at the lowest point in the bottom of the detention basin with the size of the orifice sufficient to avoid clogging (recommended minimum orifice diameter of 6 inches, although orifice diameters as small as 3 inches are allowed if required to provide the necessary hydraulic control). The low flow orifice should be protected from clogging using an external trash rack.
- Multiple orifices or weirs in the outlet structure provide stormwater quantity control of larger storm events.
- The outlet structure should be sized to convey up to the 10-year, 24-hour storm event, at a minimum, to the storm drainage system or stabilized channel. An emergency spillway is required to convey the 100-year storm event if the outlet structure is not designed to pass the 100-year storm event.

Low Flow Channel

- A stone-lined low flow channel should be installed in the bottom of the basin to convey low flows from the basin inlet(s) to the outlet structure.

Bottom and Side Slopes

- Bottom of the basin should be sloped from the inlet to the outlet with a minimum slope of 1%.
- 3(H):1(V) slopes or flatter are preferred.

Riser in Embankment

- The riser should be located within the embankment for maintenance access and safety.
- Lockable manhole covers and manhole steps within easy reach of valves and other controls should provide access to the riser.

Liner

- A liner is required for dry detention basins that receive runoff from LUHPPLs or on contaminated sites. A liner is recommended when the lowest point in the bottom of the basin is less than 1 foot above SHGT or for use in HSG C and D soils to prevent groundwater inflow and loss of storage volume.
- If used, should consist of a 30 mil (minimum) HDPE or PVC liner, or one of the alternative liner systems described in [Chapter 10 - General Design Guidance for Stormwater Infiltration Systems](#) with the approval of the review authority.

Safety Features

- The principal spillway opening must not permit access by small children, and endwalls above pipe outfalls greater than 48 inches in diameter should be fenced to prevent a hazard.
- Fencing around the perimeter of the basin is generally not encouraged but may be required by some municipalities. The preferred method is to grade the basin to eliminate dropoffs or other safety hazards.

Maintenance Reduction Features

- Dry detention basins should be designed with non-clogging outlets, such as a weir, or by incorporating trash racks for orifice openings.
- Orifices should be less than 6 inches in diameter with a trash rack to prevent clogging. Smaller orifice diameters (3 inches or larger) are allowed if required to provide the necessary hydraulic control.

- Metal components of outlet structures should be corrosion resistant, but not galvanized due to the contribution of zinc to water.
- Outlet structures should be resistant to frost heave and ice action in the basin.

Vegetation

- Select vegetation and develop a planting plan with the guidance provided in [Appendix F](#) of this Manual.
- Vegetation in a dry extended detention basin typically consists of grasses that can tolerate temporary inundation by up to 4 feet of water for 24 to 48 hours in duration.
- Woody vegetation may not be planted or allowed to grow within 25 feet of the toe of the embankment and 25 feet from the principal spillway structure.
- Use salt-tolerant vegetation if the basin receives road runoff.

Winter Operations

- Detention basins should not be used as dedicated snow storage areas. To the extent feasible, locate and design the system to avoid snow storage areas and potential damage from snow plowing activities. Refer to Chapter 7 - Overview of Structural Stormwater Best Management Practices for general design considerations related to winter operations.

Construction Recommendations

- The designing qualified professional should develop a detailed, site-specific construction sequence.
- The designing qualified professional should inspect the installation during the following stages of construction, at a minimum:
 - After excavation of the basin
 - After internal grading of basin bottom, low-flow channel, microtopography, berms, etc.
 - After installation of outlet/overflow and inlet controls
 - After seeding and final stabilization of the basin
- The designing qualified professional should provide an as-built plan of the completed system along with a certification that the system was designed in accordance with the guidance contained in this Manual and other local or state requirements and that the system was installed in accordance with the approved plans.
- The entire contributing drainage area should be completely stabilized prior to directing any flow to the system. Adequate vegetative cover must be established over any pervious area adjacent or contributing to the system before runoff can be accepted.

- Erosion and sediment controls should be in place during construction in accordance with the [Connecticut Guidelines for Soil Erosion and Sediment Control](#) and the Soil Erosion and Sediment Control (SESC) Plan developed for the project.
- During clearing and grading of the site, measures should be taken to avoid soil compaction at the location of the proposed system to promote growth of vegetation.
- The system should be fenced off during the construction period to prevent disturbance of the soils.
- The system should be excavated to the dimensions, side slopes, and elevations shown on the plans.
- Install vegetation in accordance with the planting plan and plant schedule on the plans. Water vegetation thoroughly immediately after planting and as necessary until fully established.
- Dry extended detention basins classified as dams under the CT DEEP dam safety program should be constructed, inspected, and maintained in accordance with applicable CT DEEP dam safety regulations and guidance.

Maintenance Needs

- Detailed inspection and maintenance requirements, inspection and maintenance schedules, and those parties responsible for maintenance should be identified on the plans and in the Stormwater Management Plan.
- Maintenance should be detailed in a legally binding maintenance agreement.
- Maintenance activities such as sediment removal, mowing, and repairs should be performed with rakes and light-weight equipment rather than heavy construction equipment to avoid soil compaction and damage to vegetation. Heavy equipment may be used for sediment removal and other maintenance activities if the equipment is positioned outside the limits of the system. Heavy construction equipment should not be allowed within the limits of the system for maintenance purposes.

Maintenance Access

- Dry detention basins should be designed with easy access to all components of the system for maintenance purposes. In addition to the maintenance reduction design factors described in this section, also refer to [Chapter 7 - Overview of Structural Stormwater Best Management Practices](#) for general design considerations to reduce and facilitate system maintenance.
- A maintenance right-of-way or easement should extend to the basin from a public road.

- Maintenance access should be at least 12 feet wide, have a maximum slope of no more than 15 percent, and be appropriately stabilized to withstand maintenance equipment and vehicles.
- The maintenance access should extend to the forebay and outlet structure/spillway and be designed to allow vehicles to turn around.

Recommended Maintenance Activities

- Inspect after major storms (1 inch or more of precipitation) in the first few months following construction.
- Inspect sediment forebay twice per year and the rest of the system annually, including inlet and outlet control structures and the pond embankment.
- Refer to [Appendix B](#) for maintenance inspection checklists, including items to focus on during the inspections.
- Remove trash and organic debris (leaves) in the Spring and Fall.
- Remove sediment from the sediment forebay or other pretreatment area when it accumulates to a depth of more than 24 inches or 50% of the design depth.
- Remove sediment from the main portion of the basin when the basin volume has become reduced significantly.
- The vegetative cover should be maintained at 85%. If vegetation has damage, the area should be reestablished in accordance with the original specifications.
- Periodically mow the basin during the growing season. Maintain vegetation at 6 inches or higher.
- Inspect and remove invasive vegetation as necessary.
- Remove trees and woody vegetation within the basin and within 25 feet of all risers, pipe outlet structures, spillways, and downstream embankments that hold back water.

Other References

New Jersey Department of Environmental Protection (NJDEP). 2021. *New Jersey Stormwater Best Management Practices Manual*. New Jersey Department of Environmental Protection (NJDEP). 2021. *New Jersey Stormwater Best Management Practices Manual*. https://nj.gov/dep/stormwater/bmp_manual2.htm

Figure 13-34. Dry Extended Detention Basin Schematic

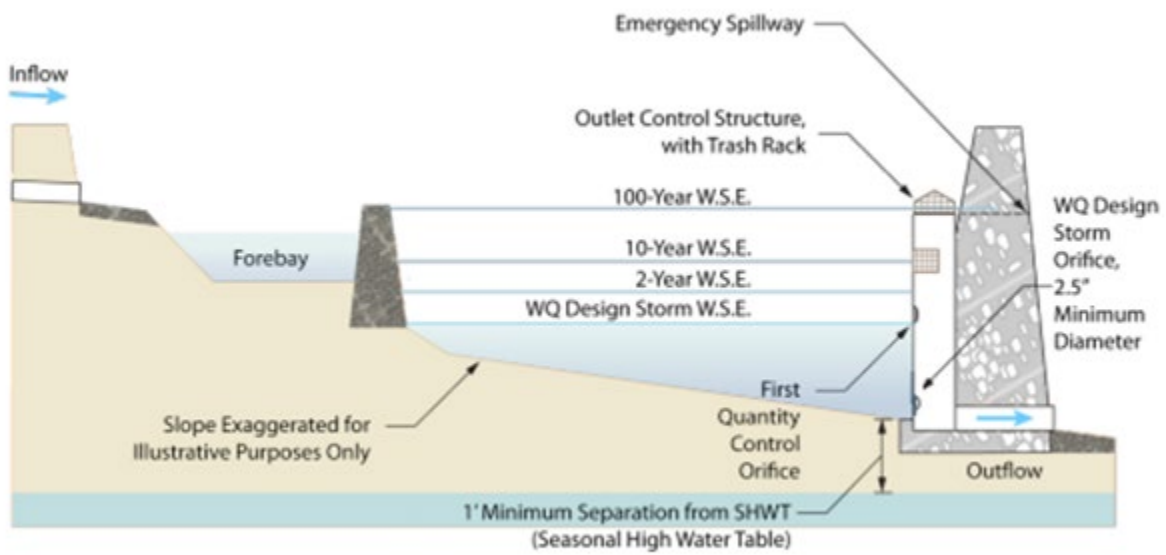
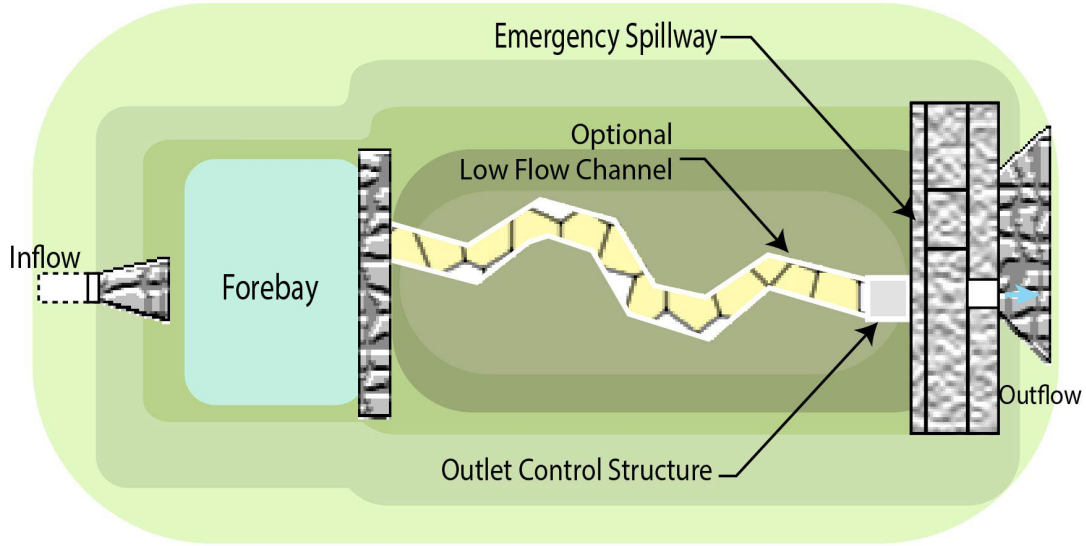

NOTE:
 = Direction of Runoff

Not to Scale

Source: Adapted from New Jersey Stormwater Best Management Practices Manual, 2021.

Underground Detention

Description

Underground detention facilities are subsurface storage structures designed to temporarily store stormwater runoff and release it slowly at pre-development peak flow rates. Like aboveground dry detention basins, underground detention facilities are designed to drain completely between storm events, thereby providing storage capacity for subsequent events. Underground detention facilities are typically designed as on-line systems to attenuate peak flow rates. They provide little, if any, pollutant removal (i.e., settling of coarse sediment) and are susceptible to re-suspension of sediment during subsequent storms. They are not designed to provide infiltration and therefore cannot be used to meet the Standard 1 retention performance criterion of this Manual.

Underground detention systems are typically used at sites where land availability or land costs preclude the use of surface stormwater detention system. They are often used below parking lots, roads, and other paved areas. Underground detention structures are typically made of concrete (vaults or tanks), large diameter solid pipes, enclosed arches made of plastic, steel, or metal (aluminized steel, aluminum, and others), or other modular systems. Figure 13-35 is a schematic of an underground detention pipe system.

<i>Stormwater BMP Type</i>	
Pretreatment BMP	<input type="checkbox"/>
Infiltration BMP	<input type="checkbox"/>
Filtering BMP	<input type="checkbox"/>
Stormwater Pond BMP	<input type="checkbox"/>
Stormwater Wetland BMP	<input type="checkbox"/>
Water Quality Conveyance BMP	<input type="checkbox"/>
Stormwater Reuse BMP	<input type="checkbox"/>
Proprietary BMP	<input type="checkbox"/>
Other BMPs and Accessories	<input checked="" type="checkbox"/>

<i>Stormwater Management Suitability</i>	
Retention	<input type="checkbox"/>
Treatment	<input type="checkbox"/>
Pretreatment	<input type="checkbox"/>
Peak Runoff Attenuation	<input checked="" type="checkbox"/>

<i>Pollutant Removal</i>	
Sediment*	Low
Phosphorus	Low
Nitrogen	Low
Bacteria	Low
*Includes sediment-bound pollutants and floatables (with pretreatment)	

<i>Implementation</i>	
Capital Cost	High
Maintenance Burden	High
Land Requirement	Low

Figure 13-35. Underground Detention Pipe System Schematic

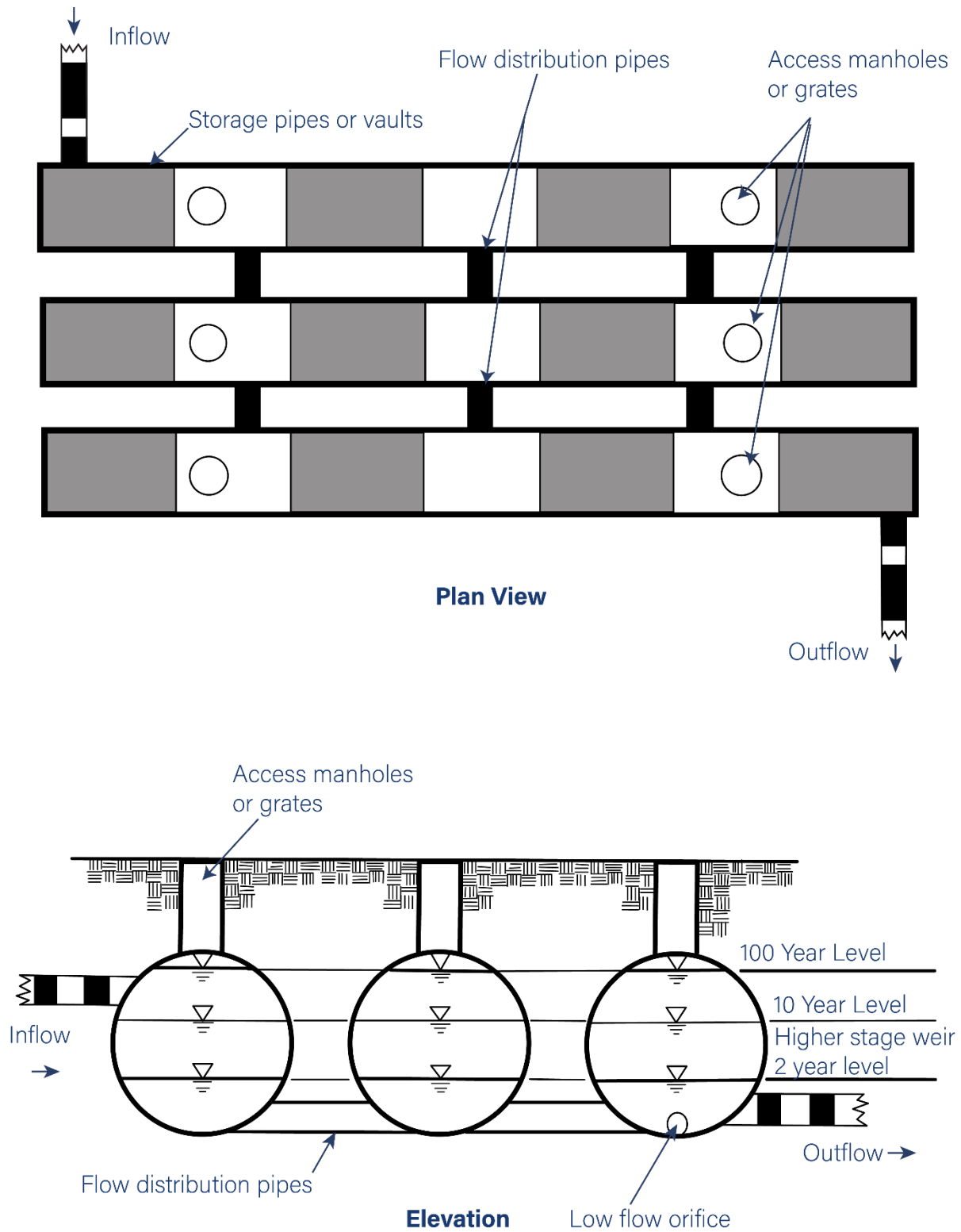

The underground structures described in the [Underground Infiltration System](#) section of this chapter can also be used as detention facilities if they are fully enclosed or used with a liner to prevent infiltration or interaction with groundwater. Open-bottom underground structures or perforated pipe should be designed as underground infiltration systems in accordance with the guidance provided in [Chapter 10](#) and the [Underground Infiltration System](#) section of this chapter.

Advantages

- Efficient use of space in urban areas and for retrofits.
- Quick installation using prefabricated modular systems.
- Systems are durable with a long life with effective pretreatment and routine maintenance.
- Greater public safety as compared to deep surface storage ponds or basins.
- Ground provides insulation from freezing and some cooling of runoff from paved surfaces.
- Suitable for use as part of a stormwater treatment train, particularly in combination with off-line retention and treatment stormwater BMPs.
- Useful in stormwater retrofit applications to provide additional temporary storage volume and attenuate peak flows (not for retention or treatment).

Limitations

- Require extensive, costly excavation.
- Material and maintenance costs are high compared to surface detention systems.
- Routine maintenance can be overlooked because the practice is not readily visible.
- Strictly for water quantity control to attenuate peak flows, limit downstream flooding, and provide some degree of channel protection.
- Not suitable for treatment. Most underground detention systems have detention times of less than 24 hours, providing insufficient settling of particles, and minimal stormwater treatment. These systems are also susceptible to re-suspension of settled material by subsequent storms.
- Not suitable for stormwater retention or runoff reduction since underground detention systems drain completely between storms and do not provide infiltration.

Siting Considerations

- **Drainage Area:** Underground detention systems can be used on sites with a wide range of drainage areas. The maximum recommended drainage area to a single underground detention system is 25 acres.
- **Groundwater and Bedrock:** The system should be at or above the seasonal high groundwater table (SHGT) and bedrock. Anti-buoyancy measures may be needed if systems are designed at or below the water table.

- **Land Uses:** Underground detention systems are typically used at sites where land availability or land costs preclude the use of surface stormwater detention system. They are often used below parking lots, roads, and other paved areas. They should be installed in locations that are easily accessible for maintenance and should not be in areas or below structures that cannot be excavated in the event the system needs to be replaced.
- **Receiving Waters:** Underground detention systems are preferred over surface stormwater detention basins for sites that discharge to coldwater streams due to cooling of runoff in subsurface storage as opposed to a surface pool of water, which is more susceptible to warming and thermal impacts. Discharges from underground detention systems should not be located within 200 feet from a public water supply reservoir or 100 feet from streams tributary to a public water supply reservoir.

Soil Evaluation

- Conduct an evaluation of the soil characteristics and subsurface conditions at the location of the proposed system including soil type, depth to the seasonal high groundwater table, and depth to bedrock. Perform test pits or soil borings in accordance with the soil evaluation guidance in [Chapter 10](#).

Design Recommendations

Pretreatment

- Incorporate pretreatment measures at locations where runoff enters the underground detention system in accordance with the [Pretreatment BMPs](#) section of this Manual.
- Acceptable pretreatment measures are those that are suitable for piped drainage systems and include deep sump hooded catch basins,⁹¹ oil grit separators, and proprietary pretreatment devices.
- Pretreatment measure(s) should treat at least the Water Quality Flow (WQF).

Storage

- Storage capacity and discharge rate from the system will depend on the peak runoff attenuation requirement (2-year, 10-year, 25-year and 100-year, 24-hour events) and design guidance of the product manufacturer.
- Deeper and larger excavated areas require more fill for maintaining the integrity of plastic or metal pipe. Pipes require more fill than concrete structures, thus using more excavated area. Pipes also store less water than concrete vaults per unit of land surface. For

⁹¹ Only recommended for space constrained sites where no other Pretreatment BMPs are feasible.

underground pipe storage systems, use the largest pipe diameter possible, which can cost-effectively increase storage capacity.

- Access manholes should be provided for system maintenance. Manholes should be placed, at a minimum, near the inlet and outlet of the system and in intermediate locations. The number of manholes depends on maintenance methods and design guidance of the product manufacturer.
- A high water table can cause structures to displace due to uplift forces. In areas with high groundwater, buoyancy and anchoring requirements should be considered and addressed in the design.
- The detention system should completely drain within 48 hours after the end of a storm.
- Pipes and floors of vaults should be designed with a maximum of 2% slope.
- Follow manufacturer recommendations for minimum cover above the underground storage system to accommodate required loading conditions.
- Use appropriate bedding/foundation below the structure to support the design load associated with the structure, water storage, and adjacent backfill weight and to maintain its integrity during construction. Follow manufacturer recommendations related to bedding/foundation design.

Conveyance

- Stormwater should be conveyed to and from all stormwater management practices safely and to minimize erosion potential.

Inlet

- Design the inlet in accordance with the [Inlet and Outlet Controls](#) section of this Manual and in accordance with design guidance of the product manufacturer.

Outlet & Overflow

- Design the outlet and any overflows in accordance with the [Inlet and Outlet Controls](#) section of this Manual and in accordance with design guidance of the product manufacturer.
- A low flow orifice or weir should be used within the storage system or inside a separate outlet control structure, with the size of the orifice sufficient to avoid clogging (recommended minimum orifice diameter of 6 inches, although orifice diameters as small as 3 inches are allowed if required to provide the necessary hydraulic control). The low flow orifice should be protected from clogging using a trash rack.

- The system and outlet control structure should be sized to convey up to the 100-year, 24-hour storm event, at a minimum, to the storm drainage system or stabilized channel.
- Emergency surface overflows should be designed to convey or bypass flows in excess of the 100-year event in case the outlet becomes clogged.

Liner

- A liner may be needed to prevent infiltration or interaction with groundwater if open-bottom storage structures or perforated pipe are used.
- If used, should consist of a 30 mil (minimum) HDPE or PVC liner, or one of the alternative liner systems described in [Chapter 10](#) with the approval of the review authority.

Construction Recommendations

- The designing qualified professional should develop a detailed, site-specific construction sequence.
- The designing qualified professional should inspect the installation during the following stages of construction, at a minimum:
 - After excavation of the system
 - After placement and leveling of aggregate below the storage structure, placement of the structure(s) and inspection ports/manholes, and placement of backfill above the structure(s)
 - After installation of bypass, outlet/overflow, and inlet controls
 - After the system has been backfilled
- The designing qualified professional should provide an as-built plan of the completed system along with a certification that the system was designed in accordance with the guidance contained in this Manual and other local or state requirements and that the system was installed in accordance with the approved plans.
- The entire contributing drainage area should be completely stabilized prior to directing any flow to the system. Adequate vegetative cover must be established over any pervious area adjacent or contributing to the system before runoff can be accepted.
- Erosion and sediment controls should be in place during construction in accordance with the [Connecticut Guidelines for Soil Erosion and Sediment Control](#) and the Soil Erosion and Sediment Control (SESC) Plan developed for the project.
- The system should be fenced off during the construction period.
- The system should be excavated to the dimensions, side slopes, and elevations shown on the plans.

Maintenance Needs

- Underground infiltration systems should be designed with easy access to all components of the system for maintenance purposes. Refer to [Chapter 7](#) for general design considerations to reduce and facilitate system maintenance.
- Detailed inspection and maintenance requirements, inspection and maintenance schedules, and those parties responsible for maintenance should be identified on the plans and in the Stormwater Management Plan.
- Maintenance should be detailed in a legally binding maintenance agreement.
- Maintain underground structures in accordance with the manufacturer's guidelines.
- Typical maintenance includes removal of accumulated oil and grease, floatables, and sediment from the pretreatment structure using a vacuum truck and removal of accumulated sediment from the underground detention system using a high-pressure water nozzle (i.e., JetVac process) and vacuum truck.
- Confined space safety procedures as required by OSHA regulations must be followed by workers entering an underground stormwater storage facility.

Recommended Maintenance Activities

- Inspect after major storms (1 inch or more of precipitation) in the first few months following construction.
- Inspect the pretreatment structure twice a year.
- Inspect the remainder of the system annually.
- Refer to [Appendix B](#) for maintenance inspection checklists, including items to focus on during inspections.
- Remove sediment from the pretreatment structure when it accumulates to more than 50% of the design depth.
- Remove sediment from the storage structures when the sediment accumulation exceeds 2 inches throughout the length of the structures or when drawdown time exceeds 48 hours after the end of a storm event, indicating that the outlet may be clogged.

Inlet and Outlet Controls

Inlet and outlet control measures manage runoff into and out of structural stormwater Best Management Practices (BMPs), respectively. This section presents inlet and outlet controls that can be used with the BMPs in this Manual. Refer to the specific BMP design sections in [Chapter 13 - Structural Stormwater BMP Design Guidance](#) for further information relative to inlet and outlet controls that are best suited for a given type of BMP and site-specific application.

Inlet Controls

General Design Guidance

In addition to the design guidance outlined below for the respective inlet control types, the following general criteria should be considered when designing inlet controls for stormwater BMPs:

- Flow velocities should not exceed 3 feet per second for grassed surfaces and 1 foot per second for mulched surfaces.
- Inlet areas should be stabilized to ensure that non-erosive conditions exist for at least the 1-year, 24-hour design storm event.
- If designing the BMP as an on-line system, inlet controls should be designed to accommodate flows in excess of the Water Quality Flow (WQF).⁹² At a minimum, inlet controls for on-line BMPs should be designed to accommodate flows generated by the 10-year, 24-hour design storm event.
- If designing the BMP as an off-line system, the flow diversion structure should be designed to convey the WQF to the BMP and allow larger flows to bypass the system.

Inlet and Outlet Controls Included in this Section

- ❖ Inlet Control Types
 - Level Spreader
 - Inlet Curb Cut Opening
 - Inlet Structure
 - Piped Flow Entrance
 - Flow Diversion Structure
- ❖ Outlet Control Types
 - Outlet Curb Cut Openings
 - Raised Overflow Structures or Risers
 - Outflow Weirs
 - Outlet Pipes/Culverts
- ❖ Inlet and Outlet Protection
 - Stone Rip Rap Apron
 - Stone Rip Rap Stilling Basin or Plunge Pool

⁹² Use of the term Water Quality Flow (WQF) in this section refers to the peak flow associated with the Required Retention Volume, which is either 100% or 50% of the site's Water Quality Volume (WQV) depending on the applicable retention/treatment requirement as described in Chapter 4 - Stormwater Management Standards and Performance Criteria.

- Design the inlet to resist incursion by vehicles and bicycles for BMPs located along roads, parking lots, and other areas with vehicle and bicycle traffic.
- Design the inlet to resist blockage from trash, debris, and sediment in addition to ice and snow.
- Design inlet structures and diversion structures to withstand the effects of freezing, frost in foundations, erosion, and flotation due to high water conditions.

Level Spreader

Level spreaders collect stormwater from an upgradient impervious surface and distribute it uniformly over the ground surface, typically over a pretreatment vegetated filter strip, as sheet flow prior to entering a downgradient stormwater BMP. Level spreaders promote uniform sheet flow to maximize pollutant removal and infiltration. Level spreaders also reduce the energy and velocity of runoff, which reduces the potential for erosion.

Many level spreader design variations exist, including level stone-filled trenches, curbing, concrete weirs, etc. All level spreader designs operate on the same basic principles:

- Stormwater enters the spreader through overland flow, a pipe, ditch, or swale
- The flow is distributed throughout a long linear shallow trench or behind a low berm
- Stormwater flows over the berm/ditch uniformly along the entire length of the spreader.

Inflow level spreaders (i.e., level spreaders that are part of an inlet control measure) are typically used with pretreatment vegetated filter strips to promote filtering and infiltration and with other stormwater BMPs where concentrated flow presents design constraints, such as with some Filtering BMPs.

Figure 13-36 through Figure 13-38 show several examples of common level spreader designs. Figure 13-36 and Figure 13-37 are concrete level spreader designs, while Figure 13-38 is a stone-filled trench level spreader design.

Key design considerations for level spreaders include:

- Concentrated flow may enter the level spreader at a single or multiple points, with appropriate energy dissipation, and leave as uniformly distributed sheet flow.
- The maximum contributing drainage area for a level spreader should be 2.5 acres for maximum efficiency.
- Flow should be uniformly distributed and crest over the downgradient edge of the spreader along its entire length. The downgradient edge over which flow is distributed

must be level. Small variations in height (of more than 0.25 inch) will result in concentrated flow and erosion.

- Stormwater flowing over the lip of a level spreader should have a maximum velocity of 1 foot per second for the water quality storm and 3 feet per second for the 10-year, 24-hour design storm to maintain non-erosive velocities over the downgradient vegetated surface.
- Calculate the required length of the level spreader so that the flow velocity over the level spreader is equal to or less than the maximum allowable velocity in the downgradient area.
 - For a thick vegetated surface immediately downgradient of the level spreader such as a vegetated filter strip or pretreatment swale (see [Pretreatment BMPs](#)), the length of the level spreader should be selected to convey 0.25 cfs per linear foot of spreader during the design storm event. This equates to 4 feet of length for every 1 cfs of flow. This design specification is based on maximum flow velocities and a water depth of approximately 1 inch flowing over the lip of the level spreader. For example, a level spreader designed for a peak flow rate of 5 cfs would need to be 20 feet long.
- The minimum length for a level spreader shall be 6 feet.
- Level spreaders should not be constructed in newly deposited fill as these areas are most susceptible to erosion. Undisturbed earth is more resistant to erosion than fill.
- Level spreaders consisting of stone-filled trenches (Design Example 3) should be placed immediately upgradient of a vegetated filter strip and be 12 inches wide and 18 to 24 inches deep, filled with 1.5-inch diameter AASHTO No. 4 stone. The stone should be clean (washed and free from dirt and debris), crushed, and angular. Non-woven filter fabric should be placed on the sides and bottom of the trench.

Figure 13-36. Level Spreader Design Example 1

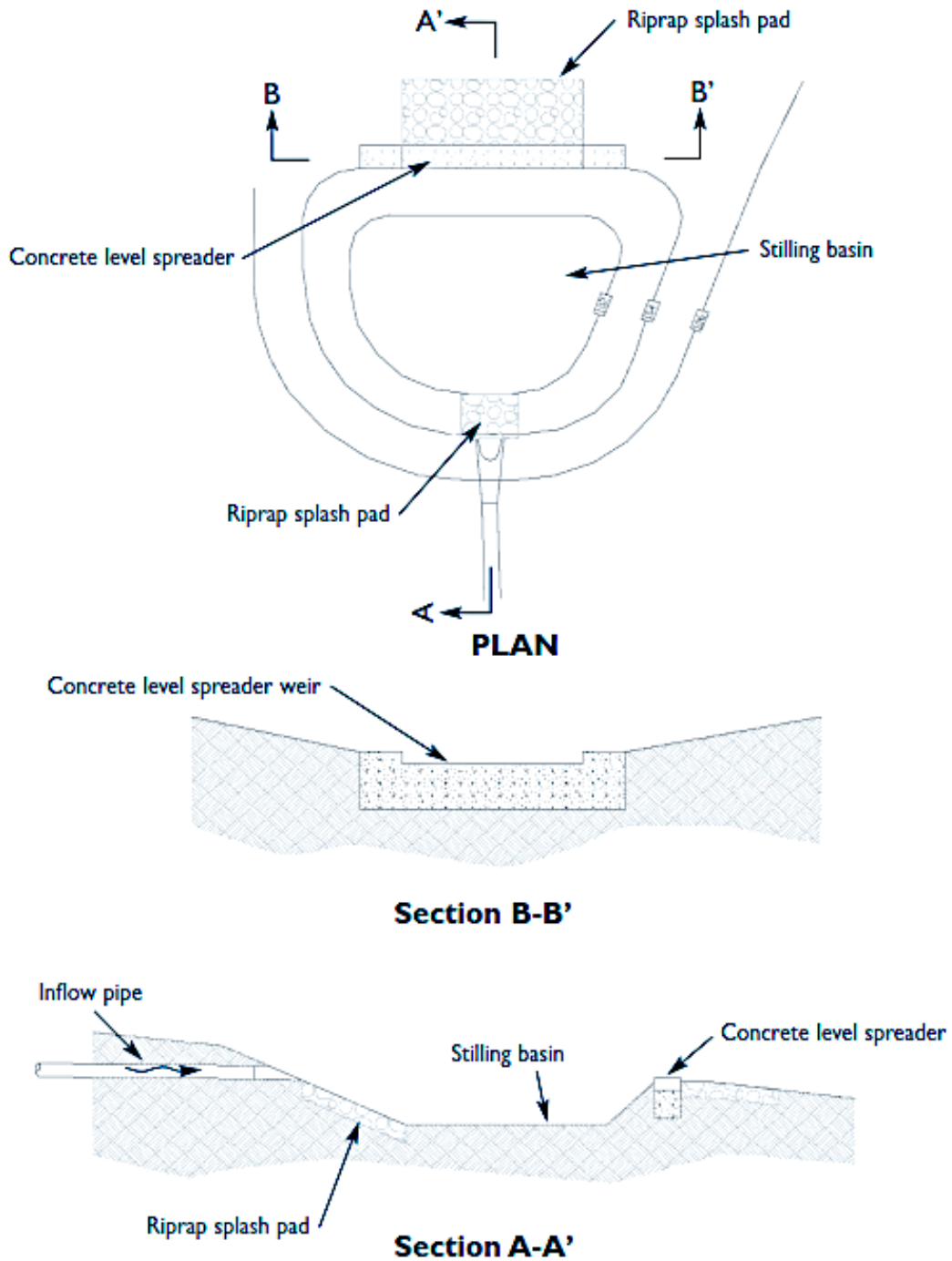

Figure 13-37. Level Spreader Design Example 2

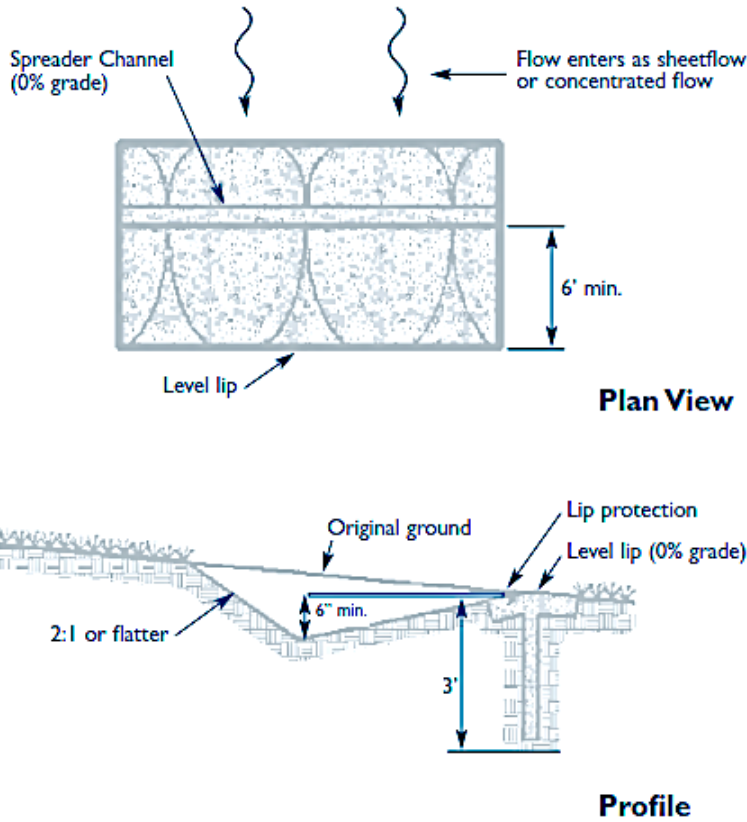
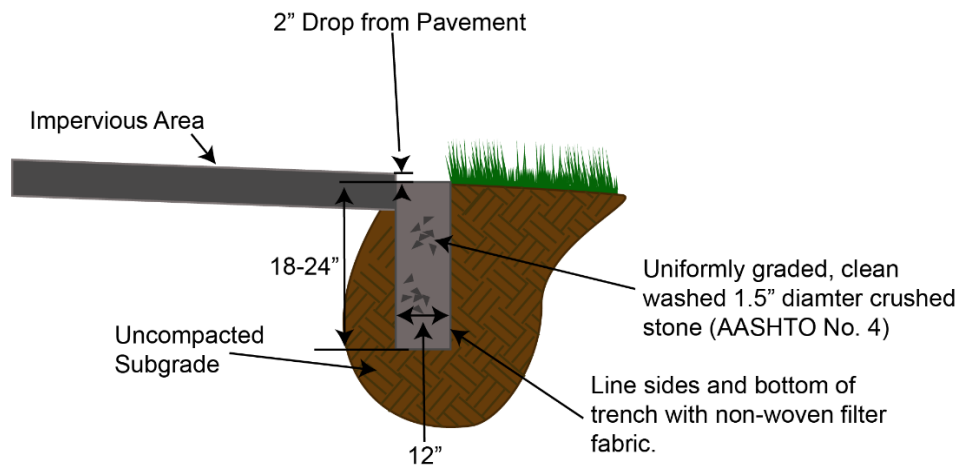

Figure 13-38. Level Spreader Design Example 3



Source: Adapted from Pennsylvania Stormwater Best Management Practices Manual.

Inlet Curb Cut Opening

Inlet curb cut openings are used in locations where stormwater BMPs are installed along curbed streets, parking lots, or landscaped islands. In certain situations, stormwater overflow discharges out of the BMP via the same curb cut opening through which it entered. Once stormwater fills the BMP, stormwater overflow will be directed back out through the curb opening to an existing drain structure that will then function as an overflow structure. Figure 13-39 show several examples of common inlet curb cut openings.

Key design considerations for inlet curb cut openings include:

- Curb cuts should be transition-style and have a width not less than 18 inches to prevent clogging.
- If designing the BMP as an on-line structure, design the opening width to prevent flow from bypassing the opening. Slope the bottom of the curb cut to drain toward the BMP and create a low point in the pavement in front of the opening by creating a small rectangular area with a lower elevation than the surrounding pavement (i.e., depressed curb inlet).
- Provide a minimum 2-inch drop in grade between the curb cut entry point and the downgradient finished surface/grade.
- Woody plants should not be placed directly in the entrance flow path. Woody plants can restrict and concentrate flows and be damaged by erosion around the root ball.
- Stabilize the area downstream of the curb cut opening to prevent erosion. Concrete (e.g., a splash pad), paver blocks, or grouted stone should be used to armor the flow path to the base of the BMP.

Inlet Structure

Inlet structures may be used to capture runoff, slow runoff velocities, settle solids and convey runoff to a downstream stormwater BMP. A deep sump catch basin (see design guidance for deep sump hooded catch basins in the Pretreatment BMPs section of [Chapter 7](#)) is an example of an inlet structure (Figure 13-40).

Key design considerations for inlet structures include:

- The recommended minimum sump depth for deep-sump structures is 48 inches.
- Utilize hoods to minimize floatable pollutants discharged to the BMP.

Figure 13-39. Typical Inlet Curb Cut Openings



Curb cut openings at inlets to bioretention basins designed to capture runoff from adjacent parking areas.

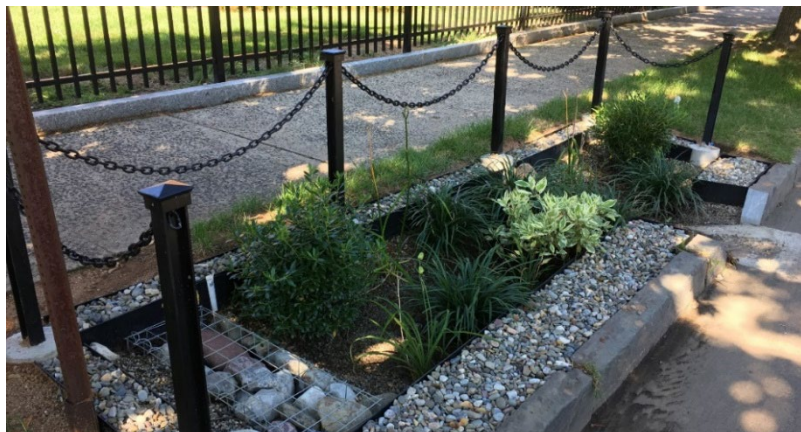

Curb cut opening at inlet to roadside bioswale. The single opening serves as the inlet and overflow.



Installation of depressed concrete pad in front of inlet curb opening to create a low point that helps convey gutter flow into the bioswale (left photo). Curb cut opening to direct road runoff beneath the adjacent sidewalk into a stormwater BMP (right photo).

Figure 13-40. Deep Sump Catch Basin Inlet Structure



Piped Flow Entrance

Runoff may discharge to a stormwater BMP via a pipe or culvert. The following should be considered when designing piped flow entrances:

- Include energy dissipation measures to dissipate energy and distribute runoff. The energy dissipation measure should extend the entire width of the piped flow entrance and extend into the bottom of the BMP. Acceptable energy dissipation measures include grouted stone riprap aprons, concrete splash pads, and forebays/stilling areas created using concrete/granite curbing or gabion weir/baffles. When using concrete/granite curbing or gabion weir/baffles, consider potential tailwater impacts.
- Woody plants should not be placed directly in the entrance flow path. Woody plants can restrict or concentrate flows and be damaged by erosion around the root ball.

Flow Diversion Structure

Stormwater BMPs can be designed to receive all the flow from a given area (on-line) or to receive only a portion of the flow (off-line). Flow diversion structures, also called flow splitters, are designed to divert flows up to the peak flow rate associated with the water quality storm (i.e., the Water Quality Flow or WQF) from a conveyance system to an off-line BMP. Flows in excess of the WQF bypass the BMP and continue through the conveyance system downgradient of the BMP. Refer to [Appendix D](#) of this Manual for the recommended procedure for calculating the WQF.

Flow diversion structures are typically manholes or vaults equipped with weirs, orifices, or pipes to bypass flows in excess of the design flow. Several design options exist. Figure 13-41 through Figure 13-43. Flow Diversion Structure Design Example 3 show common examples of flow diversion structures for use upstream of off-line stormwater BMPs. Other equivalent designs that achieve the result of diverting flows in excess of the WQF around the BMP, including bypasses or overflows located inside the BMP, are also acceptable. Refer to the Guidelines for the Use Hydrodynamic Separators on CTDOT Projects (4/2021) for additional diversion examples.

Key design considerations for flow diversion structures include:

- Size the low flow outlet to convey flows up to the WQF to the stormwater BMP.
- Set the top elevation of the diversion weir or the overflow outlet at the maximum water surface elevation associated with the WQF, or the water surface elevation in the downstream stormwater BMP when the entire WQV is being held in the BMP, whichever elevation is higher. Consider tailwater conditions when modeling bypass flows.
- Determine the diversion structure dimensions required to divert flows in excess of the WQF using standard equations for a rectangular sharp-crested weir, uniform flow in pipes or channels, or orifice depending on the type of diversion structure.
- Provide sufficient freeboard in the diversion structure to accommodate the maximum water surface elevation in the diversion structure and in the BMP. Avoid surcharging the BMP under higher flow conditions.
- Design diversion structures to minimize clogging potential and to allow for ease of inspection and maintenance. Maintenance access should be provided to both sides of diversion weir for cleaning by a vacuum truck.

Figure 13-41. Flow Diversion Structure Design Example 1

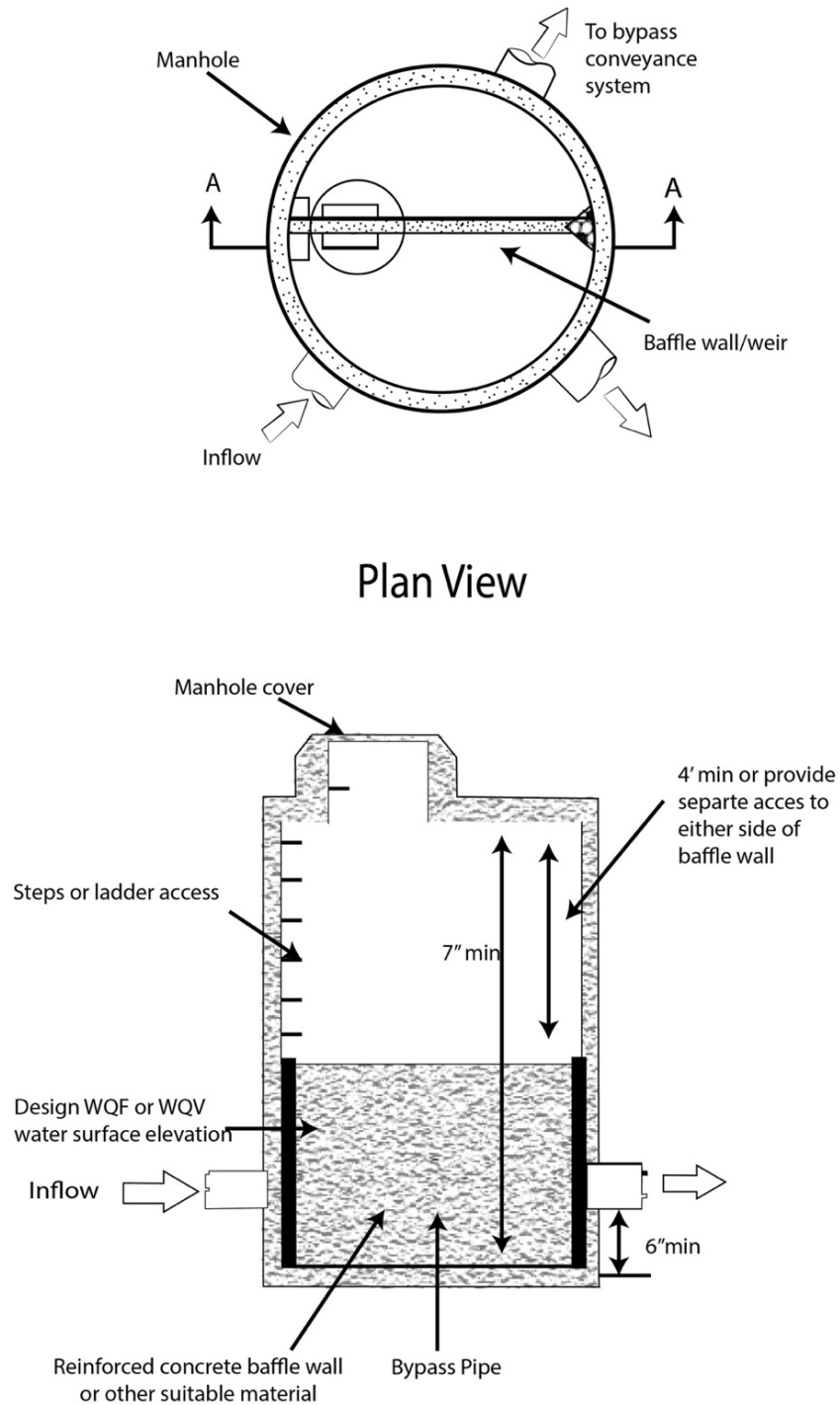

Figure 13-43. Flow Diversion Structure Design Example 2

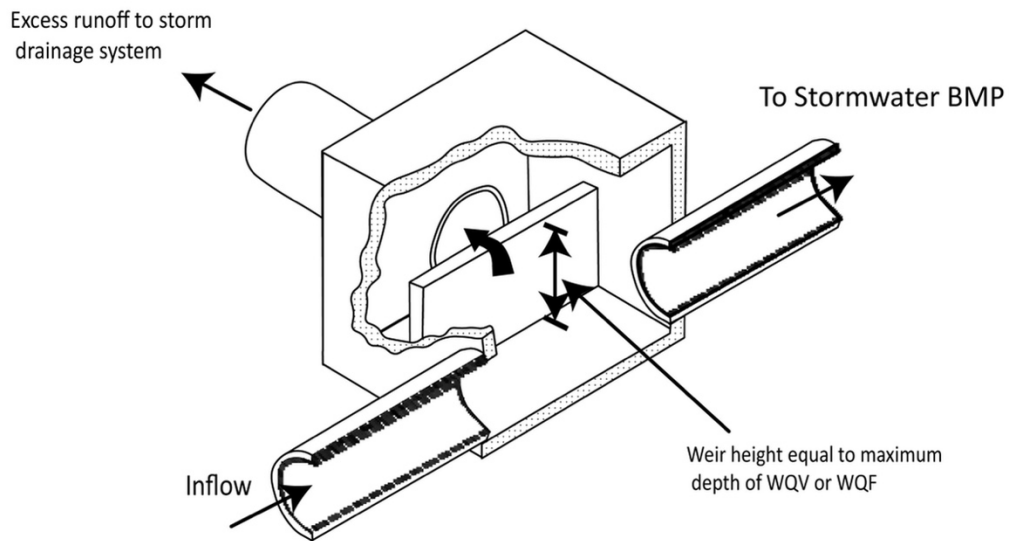
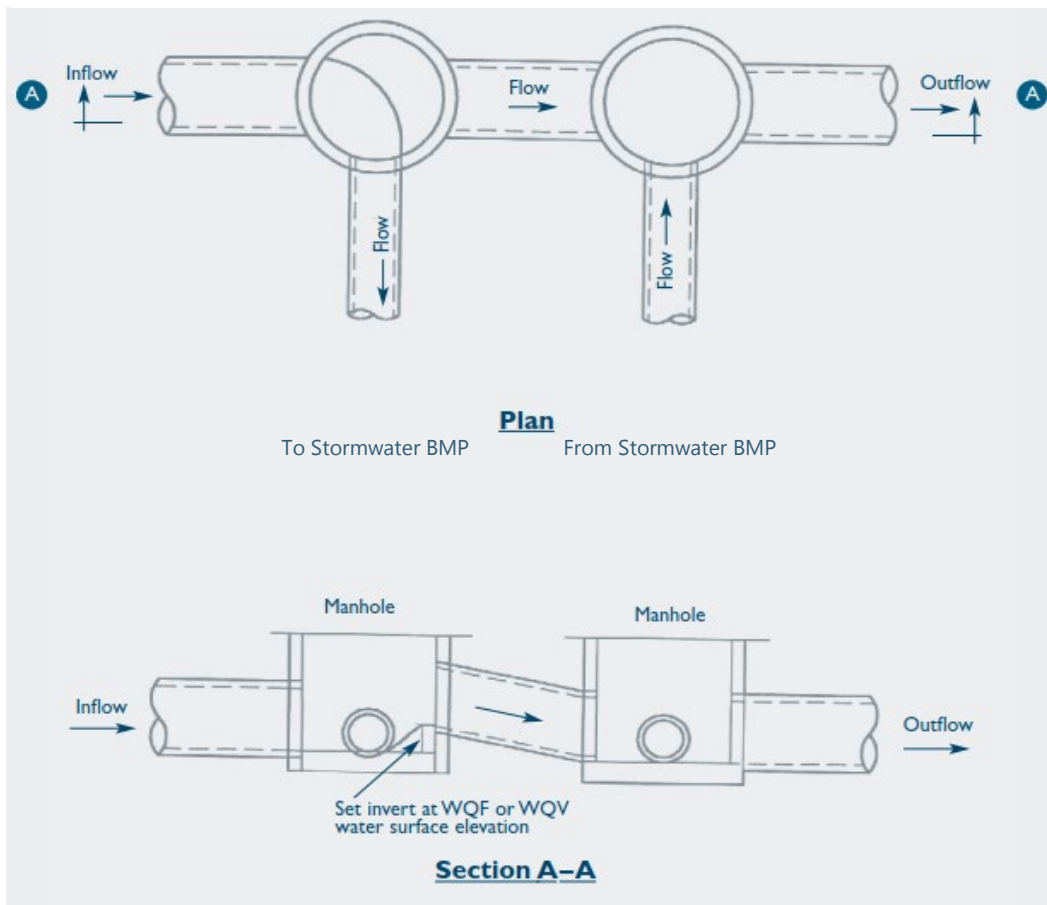

Figure 13-42. Flow Diversion Structure Design Example 3



Outlet Controls

General Design Guidance

In addition to the design criteria outlined below for the respective outlet control types, the following general criteria should be considered when designing outlet controls for BMPs:

All on-line stormwater BMPs must have a provision for outlet/overflow, as follows:

- An outlet control structure should be provided for runoff in excess of the WQF or WQV. The outlet control structure should be designed with openings to safely pass the 10-year, 24-hour design storm, at a minimum, with adequate freeboard.
 - For BMPs without a perimeter constructed earthen berm (e.g., bioretention swale), design the outlet/overflow structure of an on-line BMP to safely convey flows from the 10-year storm event (at minimum) with 6 inches of freeboard (unless noted otherwise in individual BMP design sections).
 - For BMPs with a perimeter constructed earthen berm, design the outlet/overflow structure of an on-line BMP to safely convey flows from the 100-year storm event with 3 inches of freeboard (unless noted otherwise in individual BMP design sections).
- For on-line BMPs, the outlet control structure should be designed as a multi-stage outlet structure positioned to meet each control requirement independently (e.g., retention/treatment of stormwater, conveyance of larger storms, peak runoff attenuation, emergency overflow, etc.).
 - For water quality purposes, the elevation of the lowest outlet should be set at, or slightly above, the design storage elevation, which is the elevation of ponded water associated with the Required Retention Volume (100% or 50% of the site's WQV).
- Overflow spillways should be a minimum of 8 feet wide, 1 foot deep, and have side slopes no steeper than 3(H):1(V).
- Discharge from an outlet should be conveyed to either a stormwater structure (e.g., manhole), drainage system, or stabilized discharge point.
 - Confirm that the conveyance system/storm drain network has adequate capacity to receive the proposed flow and that the system meets the stormwater quantity control requirements described in [Chapter 4 - Stormwater Management Standards and Performance Criteria](#).

Protection from Clogging

Protection from clogging is required for any orifice size utilized as part of the outlet control structure. Small orifices, typically less than six inches in diameter, used for slow-release applications can be susceptible to clogging. The following design measures should be taken to minimize the potential for clogging.

- The low-flow orifice should be adequately protected from clogging by a trash rack. The orifice diameter should always be greater than the thickness of the trash rack openings. The trash rack area should be at least ten times the area of the outlet opening being protected from clogging.
 - The minimum recommended orifice size is 3 inches.
 - Orifice diameters smaller than 3 inches should only be allowed on a case-by-case basis as demonstrated by the designer and/or upon approval from the review authority.

Outlet Curb Cut Openings

Outlet curb cut openings (Figure 13-44) can be used as a type of outlet control for BMPs located along streets with a gradual but consistent slope. Excess volume above the designed ponding depth flows out of the outlet curb cut opening installed at the downstream end of the facility. The following should be considered when designing outlet curb cut openings:

- Set the crest of the outlet curb opening at or above the elevation of the shallow ponding depth; and at least 3 inches below the inlet elevation to prevent overtopping of the BMP during the design storm.

Raised Overflow Structures or Risers

Raised overflow structures or risers can be designed as single-stage or multi-stage vertical structures consisting of orifices and/or weir openings set at different elevations to meet stormwater management requirements. The following should be considered when designing raised overflow structures and risers:

- Single-stage structures should consist of a vertical (riser) overflow structure or riser pipe with an open top that is covered by a "beehive" grate (Figure 13-45), domed riser grate, or trash rack. The crest of the overflow structure is set at or slightly above the design storage elevation associated with the WQV.

Figure 13-44. Roadside Bioswale with Inlet and Outlet Curb Cut Openings



Figure 13-45. Typical Dome Grate Overflow/Outlet Structure



Outflow Weirs

Outflow weirs typically consist of stabilized overflow spillways or structural weirs constructed from gabions, concrete, or curbing. Outflow weirs promote sedimentation by slowing flow velocities as water ponds behind the weir. They also provide a means of uniformly distributing runoff as it is discharged, helping to decrease concentrated flow and reduce velocities as the water travels downstream. In certain situations, these types of weirs may be designed with notches to limit or restrict overflow to desired locations or match pre-development peak flow rates. The following should be considered when designing outflow weirs:

- Account for structural stability during extreme conditions in addition to flow velocities and upstream hydrostatic pressure from ponded water.
- Select materials that withstand design flow velocities and exposure to the elements.

Outlet Pipes/Culverts

An outlet pipe/culvert from a BMP should be designed to convey controlled flow in excess of the Water Quality Flow to either a stormwater structure, drainage system, or approved discharge point. Confirm that the conveyance system/storm drain network has adequate capacity to receive the proposed flow and that the system meets the stormwater quantity control requirements described in [Chapter 4 - Stormwater Management Standards and Performance Criteria](#).

Inlet and Outlet Protection

Inlet and outlet protection should be installed to dissipate energy and limit erosion. Typical inlet and outlet protection measures include level spreaders, stone/riprap aprons, stone riprap stilling basins or plunge pools, concrete pads or splash blocks, and non-degradable turf reinforcement matting designed to reduce the velocity, energy, and turbulence of the flow. Other options may be considered if allowed by the review authority. These measures can be used when highly erosive velocities are encountered at inlet and outlet locations, at the bottom of steep slopes, or where the discharge of sheet flow or non-erosive flow to down-gradient locations is required.

Provide stable and non-erosive energy dissipating devices at inflow and outlet locations where concentrated flow velocities are considered erosive. Flow velocities should not exceed 3 feet per second for grassed surfaces and 1 foot per second for mulched surfaces.

Stone Riprap Apron

Stone riprap aprons are commonly used for energy dissipation due to their relatively low cost and ease of installation. A flat stone riprap apron can be used to prevent erosion at the transition from a pipe, culvert, or spillway outlet to a natural channel. Riprap aprons will provide adequate protection if there is sufficient length and flare to dissipate energy by expanding the flow. To facilitate removal of sediment and minimize vandalism potential, stone riprap aprons may be grouted.

- The aprons should be designed for the water quality storm for off-line stormwater BMPs and for the 10-year, 24-hour storm event at a minimum for on-line BMPs.
- If the apron is installed at an inlet location within the BMP that will be part of a sediment forebay, the stone riprap should be grouted to facilitate maintenance.
 - If grouted, provide at least two weep holes (2.5 inches in diameter) for every 25 square feet of surface area in the bottom of the forebay to facilitate low level drainage.
 - If grouted riprap is used, stone riprap should conform to State of Connecticut Department of Transportation Standard Specifications, Section M.12.02 (Riprap). Grout should be a non-shrink grout having a 4,000 psi 28-day compressive strength and a 2,400 psi 7-day compressive strength in accordance with State of

Connecticut Department of Transportation Standard Specifications, Section M.03.05.

Stone Riprap Stilling Basin or Plunge Pool

A riprap stilling basin or plunge pool is a pre-shaped scour hole lined with riprap that functions as an energy dissipator. Like a riprap apron, a riprap stilling basin can be used to prevent erosion at the transition from a pipe or box culvert outlet to an earthen channel.

- The appropriate inlet and outlet protection type should be based on site characteristics such as slope, available area, and aesthetics.
- A key design issue is the interface between the end of the inlet/outlet protection structure and the adjacent downstream area, which is typically vegetated. Vegetation should be well established at this interface. Turf reinforcement matting may be used at this interface to provide additional structure for vegetation.
- Vegetation/plantings can be used to obscure views of inlet/outlet protection structures if aesthetics is a concern.