

---

---

---

---

---

---

---

---

---

---

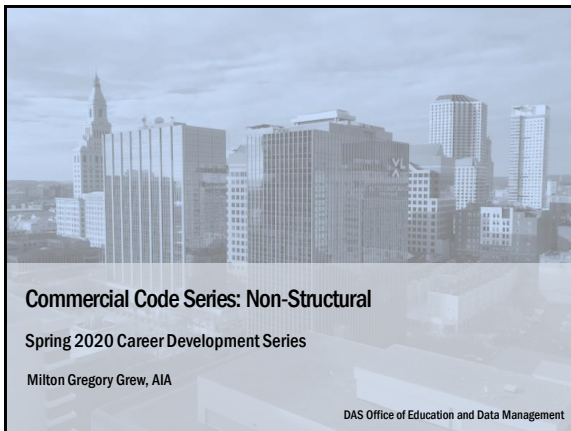

---

---

---

---

---

---

---

---

---

---

**Course Objectives: Plan Review**

At the conclusion of this plan review section, participants should be able to:

- Identify the applicable standards of 2015 IBC regarding nonstructural plan reviews.
- Perform a building plan review to identify compliance with the State Building Code.
- Perform a code compliance review of fire-resistance-rated construction and interior finishes.
- Perform a code compliance review of the fire protection systems.
- Perform a code compliance review of the means of egress including identification of exit access, exit and exit discharge.
- Identify the requirements for accessible design of buildings, structures and the site.

3

---

---

---

---

---

---

---

---

---

---



**Course Objectives: Inspections**

At the conclusion of this inspection section, participants should be able to:

- Prepare an inspection checklist for means of egress, fire resistance materials and fire protection systems.
- Explain the role of building materials with in a structure and identify locate of this information in the IBC.
- Identify the fire safety aspects of a commercial building inspection.
- Explain the means of egress requirements as they relate to commercial building inspections.
- Communicate scoping requirements for accessible design for buildings, structures and the site on which they are located.

4

---



---



---



---



---



---



---



---

**Non-Structural Plan Review – 2015 IBC**

- Chapter 3: Use & Occupancy Classification
- Chapter 4: Special Detailed Requirements Based on Use & Occupancy
- Chapter 5: General Building Heights & Areas
- Chapter 6: Types of Construction
- Chapter 7: Fire & Smoke Protection Features
- Chapter 8: Interior Finishes

5

---



---



---



---



---



---



---



---

**Non-Structural Plan Review – 2015 IBC**

- Chapter 9: Fire Protection Systems
- Chapter 10: Means of Egress
- Chapter 11: Accessibility
- Chapter 12: Interior Environment
- Chapter 14: Exterior Walls
- Chapter 15: Roof Assemblies & Rooftop Structures

6

---



---



---



---



---



---



---



---



**Sample Project**  
81 Arch Street, Hartford



7

---

---

---

---

---

---

---

---

**Sample Project**  
81 Arch Street, Hartford



8

---

---

---

---

---

---

---

---

**Description of the Building**

- Total of 5 stories
- Total of 53 apartments on floors 2 - 5
- Ground floor can be developed as retail
- Elevator
- Total area of 67,810 SF

9

---

---

---

---

---

---

---

---

### 107.2 – Construction Documents

- Show in detail that project will conform to code
- Means of egress shown in sufficient detail all portions of MOE, occupant load
- Describe exterior wall envelope with details of flashing, intersections, comers, joints, roof, drainage, water-resistive membrane, openings and manufacturer's installation instructions

10

---

---

---

---

---

---

---

---

### 107.2 – Construction Documents

- Show in detail that project will conform to code
- Means of egress shown in sufficient detail all portions of MOE, occupant load
- Describe exterior wall envelope with details of flashing, intersections, comers, joints, roof, drainage, water-resistive membrane, openings and manufacturer's installation instructions

11

---

---

---

---

---

---

---

---

### Occupancy Classification (Ch. 3)

- Code sheet indicates M for 1st floor.
- Apartments: R-2 on floors 2 - 5

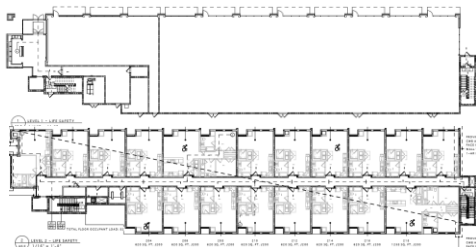

---

---

---

---

---

---

---

---



### 420 – Group R-2

- Separation walls: Fire partitions per 708.
- Horizontal separation: Floor assemblies separating DU's from each other or other occupancies per 711.
- Automatic sprinkler system per 903.
- Fire alarm systems & smoke alarms per 907.
- *We will save these thoughts for later....*

13

---

---

---

---

---

---

---

---

### 504 – Building Height

**504.1 General.** The height, in feet, and the number of stories of a building shall be determined based on the type of construction, occupancy classification and whether there is an *automatic sprinkler system* installed throughout the building.

**504.1.2 Special provisions.** The special provisions of Section 510 permit the use of special conditions that are exempt from, or modify, the specific requirements of this chapter regarding the allowable heights of buildings based on the occupancy classification and type of construction, provided the special condition complies with the provisions specified in Section 510.

14

---

---

---

---

---

---

---

---

### 504 – Building Height in Feet

- Bldg hgt in ft measured from grade plane to highest roof.

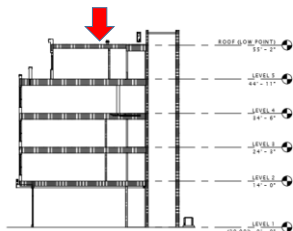

6 BUILDING SECTION - FIRE SAFETY  
 ASD 1/16" = 1'-0"

15

---

---

---

---

---

---

---

---





### 506 - Building Area

- Building area determined by type of construction, occupancy classification, sprinklers, & frontage.

19

---

---

---

---

---

---

---

---

### 506 - Building Area

TABLE 506.2<sup>a</sup>  
ALLOWABLE AREA FACTOR (A1 = NS, S1, S13R, or SM, as applicable) IN SQUARE FEET

OCCUPANCY CLASSIFICATION	SEE FOOTNOTES	TYPE OF CONSTRUCTION									
		TYPE I		TYPE II		TYPE III		TYPE IV HT	TYPE V		
		A	B	A	B	A	B		A	B	
M	NS	UL	UL	21,500	12,500	18,500	12,500	20,500	14,000	9,000	
	S1	UL	UL	86,000	50,000	74,000	50,000	82,000	56,000	36,000	
	SM	UL	UL	64,500	37,500	55,500	37,500	61,500	42,000	27,000	
R-2	NS <sup>1</sup>	UL	UL	24,000	16,000	24,000	16,000	20,500	12,000	7,000	
	S13R	UL	UL	96,000	64,000	96,000	64,000	82,000	48,000	28,000	
	S1	UL	UL	96,000	64,000	96,000	64,000	82,000	48,000	28,000	
	SM	UL	UL	72,000	48,000	72,000	48,000	61,500	36,000	21,000	

20

---

---

---

---

---

---

---

---

### 508 - Mixed Use & Occupancy

- **Accessory occupancies:** Ancillary & no more than 10% of each story; no separation required.
  - Exception for R-2 DU's to be separated from other DU's & accessory occupancies per 420.

21

---

---

---

---

---

---

---

---



### 508 - Mixed Use & Occupancy

- Accessory occupancies

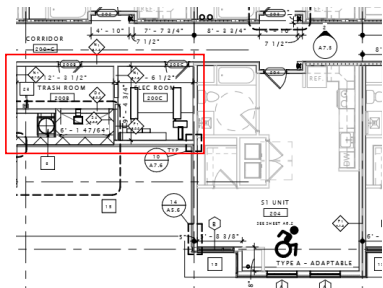

22

---

---

---

---

---

---

---

---

### 508 - Mixed Use & Occupancy

- 508.3 Nonseparated occupancies
  - Most restrictive occupancy governs for the building.
  - Generally no separations required, with some exceptions like dwelling units

23

---

---

---

---

---

---

---

---

### 508 - Mixed Use & Occupancy

- 508.4 Separated occupancies

TABLE 508.4  
REQUIRED SEPARATION OF OCCUPANCIES (HOURS)

OCCUPANCY	A, E		I-1, I-3, I-4		I-2	R <sup>a</sup>	F-2, S-2, U		B <sup>1</sup> , F-1, M, S <sup>1</sup>		H-1	H-2	H-3, H-4		H-5					
	S	NS	S	NS			S	NS	S	NS			S	NS		S	NS	S	NS	
A, E	N	N	1	2	2	NP	1	2	N	1	1	2	NP	NP	3	4	2	3	2	NP
I-1, I-3, I-4	---	---	N	N	2	NP	1	NP	1	2	1	2	NP	NP	3	NP	2	NP	2	NP
I-2	---	---	---	---	N	N	2	NP	2	NP	2	NP	NP	NP	3	NP	2	NP	2	NP
R <sup>a</sup>	---	---	---	---	---	N	N	1 <sup>a</sup>	2 <sup>a</sup>	1	2	NP	NP	NP	3	NP	2	NP	2	NP
F-2, S-2, U	---	---	---	---	---	---	N	N	1	2	NP	NP	NP	NP	3	4	2	3	2	NP
B <sup>1</sup> , F-1, M, S-1	---	---	---	---	---	---	---	N	N	NP	NP	NP	NP	NP	2	3	1	2	1	NP
H-1	---	---	---	---	---	---	---	---	N	NP	NP	NP	NP	NP	NP	NP	NP	NP	NP	NP
H-2	---	---	---	---	---	---	---	---	---	N	NP	NP	NP	NP	NP	NP	NP	NP	NP	NP
H-3, H-4	---	---	---	---	---	---	---	---	---	---	---	---	---	---	1 <sup>a</sup>	NP	NP	NP	NP	NP
H-5	---	---	---	---	---	---	---	---	---	---	---	---	---	---	---	---	---	---	N	NP

S = Buildings equipped throughout with an automatic sprinkler system installed in accordance with Section 903.3.1.1.  
 NS = Buildings not equipped throughout with an automatic sprinkler system installed in accordance with Section 903.3.1.1.  
 NP = Not permitted.  
 a. See Section 403.

24

---

---

---

---

---

---

---

---





### 510 – Special Provisions

**510.2 Horizontal building separation allowance.** A building shall be considered as separate and distinct buildings for the purpose of determining area limitations, continuity of *fire walls*, limitation of number of *stories* and type of construction where all of the following conditions are met:

1. The buildings are separated with a *horizontal assembly* having a *fire-resistance rating* of not less than 3 hours.
2. The building below the *horizontal assembly* is of Type IA construction.
3. *Shaft, stairway, ramp* and escalator enclosures through the *horizontal assembly* shall have not less than a 2-hour *fire-resistance rating* with opening protectives in accordance with Section 716.5.

25

---

---

---

---

---

---

---

---

---

---

### 510 – Special Provisions

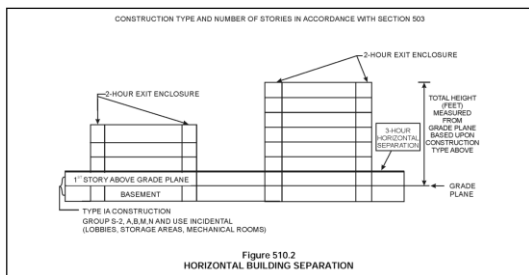

Figure 510.2  
HORIZONTAL BUILDING SEPARATION

From 2015 IBC Commentary

26

---

---

---

---

---

---

---

---

---

---

### 510 – Special Provisions

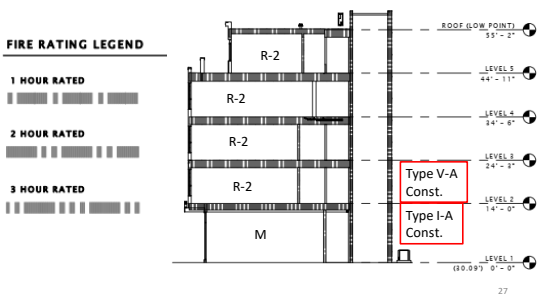

27

---

---

---

---

---

---

---

---

---

---



## 602 – Construction Classification

- Type I: Noncombustible materials with exceptions in 603
- Type V: Any materials permitted by code, generally wood frame.

28

## 602 – Construction Classification

TABLE 601  
FIRE-RESISTANCE RATING REQUIREMENTS FOR BUILDING ELEMENTS (HOURS)

BUILDING ELEMENT	TYPE I		TYPE II		TYPE III		TYPE IV	TYPE V	
	A	B	A	B	A	B	HT	A	B
Primary structural frame <sup>a</sup> (see Section 202)	3 <sup>a</sup>	2 <sup>a</sup>	1	0	1	0	HT	1	0
Bearing walls									
Exterior <sup>c</sup>	3	2	1	0	2	2	2	1	0
Interior	3 <sup>a</sup>	2 <sup>a</sup>	1	0	1	0	1/HT	1	0
Nonbearing walls and partitions	See Table 602								
Exterior									
Nonbearing walls and partitions							See Section 602.4.6		
Interior <sup>d</sup>	0	0	0	0	0	0	HT	0	0
Floor construction and associated secondary members (see Section 202)	2	2	1	0	1	0	HT	1	0
Roof construction and associated secondary members (see Section 202)	1 1/2 <sup>b</sup>	1 <sup>b,c</sup>	1 <sup>b,c</sup>	0 <sup>e</sup>	1 <sup>b,c</sup>	0	HT	1 <sup>b,c</sup>	0

For SI: 1 foot = 304.8 mm.  
a. Roof supports: Fire-resistance ratings of primary structural frame and bearing walls are permitted to be reduced by 1 hour where supporting a roof only.  
b. Except in Group F-1, H, M and S-1 occupancies, fire protection of structural members shall not be required, including protection of roof framing and decking where every part of the roof construction is 20 feet or more above any floor immediately below. Fire-retardant-treated wood members shall be allowed to be used for such unprotected members.  
c. In all occupancies, heavy timber shall be allowed where a 1-hour or less fire-resistance rating is required.  
d. Not less than the fire-resistance rating required by other sections of this code.  
e. Not less than the fire-resistance rating based on fire separation distance (see Table 602).  
f. Not less than the fire-resistance rating as referenced in Section 704.10.

29

## 602 – Construction Classification

### FIRE RESISTANCE RATINGS:

GROUND LEVEL (1) TYPE IA	STRUCTURAL FRAME (COLUMNS, GIRDERS, TRUSSES)	1 HR
	BEARING WALLS (INTERIOR)	2 HR
	BEARING WALLS (EXTERIOR)	2 HR
	NONBEARING WALLS AND PARTITIONS	0 HR
	FLOOR CONSTRUCTION (BEAMS, JOISTS)	2 HR
	ROOF CONSTRUCTION (BEAMS, JOISTS)	1 1/2 HR
NOTE: A (3) HOUR HORIZONTAL SEPARATION ASSEMBLY IS REQUIRED BETWEEN THE GROUND LEVEL AND UPPER LEVELS 2-5		
LEVELS (2-5) TYPE VA	STRUCTURAL FRAME (COLUMNS, GIRDERS, TRUSSES)	1 HR
	BEARING WALLS (INTERIOR)	1 HR
	BEARING WALLS (EXTERIOR)	1 HR
	NONBEARING WALLS AND PARTITIONS	0 HR
	FLOOR CONSTRUCTION (BEAMS, JOISTS)	1 HR
	ROOF CONSTRUCTION (BEAMS, JOISTS)	1 HR
	FIRE PARTITION RATING BETWEEN RESIDENTIAL UNITS (PER 708.3)	1 HR REQUIRED - 1 HR PROVIDED
	FIRE PARTITION RATING OF CORRIDORS (PER 1016.1)	1/2 HR REQUIRED - 1 HR PROVIDED
	HORIZONTAL ASSEMBLY BETWEEN RESIDENTIAL UNIT (PER 711.3)	1 HR REQUIRED - 1 HR PROVIDED

From sheet A0.0

Later we will look at some of the details to verify compliance with required fire resistance.

30



### 703 – Fire-Resistance Ratings

- ASTM E119 or UL 263 test criteria
- Fire-resistance designs documented from approved sources (UL, FM, GA, etc)
- Alternate means:
  - Prescriptive designs per 721
  - Calculated per 722
  - Engineering analysis

31

---

---

---

---

---

---

---

---

---

---

### 705 - Fire-Resistance of Exterior Walls

TABLE 602  
FIRE-RESISTANCE RATING REQUIREMENTS FOR EXTERIOR WALLS BASED ON FIRE SEPARATION DISTANCE<sup>a, b</sup>

FIRE SEPARATION DISTANCE <sup>a</sup> X (feet)	TYPE OF CONSTRUCTION	OCCUPANCY GROUP <sup>b</sup>	OCCUPANCY GROUP F-1, M, S, U <sup>c</sup>	OCCUPANCY GROUP A, B, E, F-2, I, R, S-2, U <sup>c</sup>
X < 5 <sup>d</sup>	All	3	2	1
5 ≤ X < 10	IA Others	3 2	2 1	1 1 <sup>e</sup>
10 ≤ X < 30	IA, IB IIB, VB Others	2 1 1	1 0 1	1 <sup>e</sup> 0 1 <sup>e</sup>
X ≥ 30	All	0	0	0

Fire Separation Distance is distance to property line, imaginary FSD line between buildings, or centerline of public way.

Need site plan to review for this.

32

---

---

---

---

---

---

---

---

---

---

### 705 - Fire-Resistance of Exterior Walls

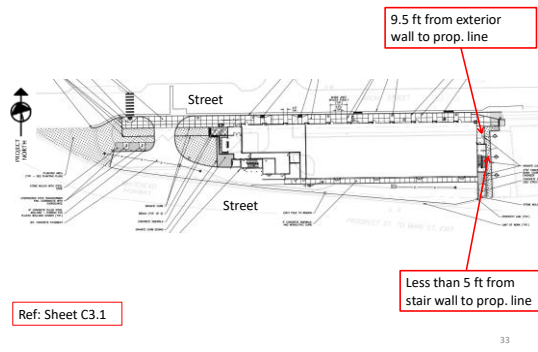

---

---

---

---

---

---

---

---

---

---



### 705 - Fire-Resistance of Exterior Walls

**FIRE RATING LEGEND**

- 1 HOUR RATED
- 2 HOUR RATED
- 3 HOUR RATED

Ref: Sheet A0.0

34

---

---

---

---

---

---

---

---

### 705 – Fire-Resistance of Exterior Walls

WALL TAG LEGEND

WALL CONSTRUCTION TYPE — RATING IN HOURS

SIZE OF STRUCTURAL MEMBER — SEE REMARKS LEGEND FOR FURTHER INFORMATION

BATT INSULATION (1=YES, 0=NO)

WALL CONSTRUCTION TYPE LEGEND	
A	METAL STUD WALL
B	METAL STUD FURRING WALL
D	METAL STUD SHAFT WALL
N	WOOD STUD WALL
F	WOOD STUD FURRING WALL
S	CMU WALL

Sheet: A0.1

35

---

---

---

---

---

---

---

---

### 705 – Fire-Resistance of Exterior Walls

Sheet: A5.5

36

---

---

---

---

---

---

---

---



### 705 – Fire-Resistance of Exterior Walls

S2  
1205

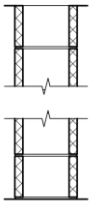

U.L.E. U90S  
THICKNESS: 11 5/8"  
FIRERATING: 2-HOUR  
STC:

**DESCRIPTION**  
-12"x8"x16" CONCRETE MASONRY UNITS LAID IN A FULL BED OF MORTAR, NOMINALLY 3/8" THICK. MORTAR TO BE NOT LESS THAN 2 1/4" AND NOT MORE THAN 3 1/2" PARTS CLEAN SHARP SAND TO 1 PART PORTLAND CEMENT (PROPORTIONED BY VOLUME) AND NOT MORE THAN 50% HYDRATED LIME BY CEMENT VOLUME.

PARTITION RUNS TO UNDERSIDE OF STRUCTURE

Sheet:  
A0.1

37

---

---

---

---

---

---

---

---

---

---

### 705 – Fire-Resistance of Exterior Walls

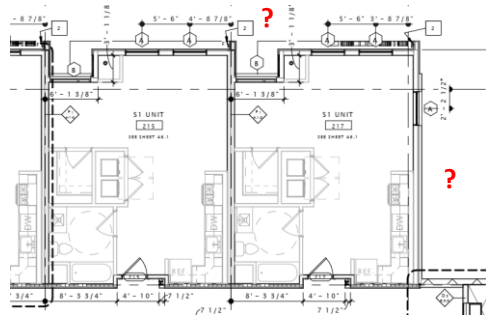

Sheet: A1.2

38

---

---

---

---

---

---

---

---

---

---

### 705 – Fire-Resistance of Exterior Walls

ONE HOUR RATED---HUBER "ZIP SYSTEM" SHEATHING AND TAPE SYSTEM--- PROVIDE TYPE X GYP. BD. AT INTERIOR FACE OF ALL EXTERIOR BEARING WALLS

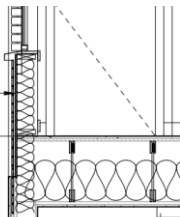

3 WALL SECTION  
A5.2 1 1/2" = 1'-0"

39

---

---

---

---

---

---

---

---

---

---



## 705.8 - Exterior Wall Openings

**TABLE 705.8  
MAXIMUM AREA OF EXTERIOR WALL OPENINGS BASED ON  
FIRE SEPARATION DISTANCE AND DEGREE OF OPENING PROTECTION**

FIRE SEPARATION DISTANCE (ft)(m)	DEGREE OF OPENING PROTECTION	ALLOWABLE AREA*
0 to less than 3 <sup>0-1</sup>	Unprotected, Non-sprinklered (U.P. NS)	Not Permitted <sup>b</sup>
	Unprotected, Sprinklered (U.P. S)	Not Permitted <sup>b</sup>
	Protected (P)	Not Permitted <sup>b</sup>
3 to less than 5 <sup>0-1</sup>	Unprotected, Non-sprinklered (U.P. NS)	Not Permitted
	Unprotected, Sprinklered (U.P. S)	15%
	Protected (P)	15%
5 to less than 10 <sup>0-1</sup>	Unprotected, Non-sprinklered (U.P. NS)	10% <sup>b</sup>
	Unprotected, Sprinklered (U.P. S)	25%
	Protected (P)	25%
10 to less than 15 <sup>0-1,2</sup>	Unprotected, Non-sprinklered (U.P. NS)	15% <sup>b</sup>
	Unprotected, Sprinklered (U.P. S)	45%
	Protected (P)	45%
15 to less than 20 <sup>0-1,2</sup>	Unprotected, Non-sprinklered (U.P. NS)	25%
	Unprotected, Sprinklered (U.P. S)	75%
	Protected (P)	75%
20 to less than 25 <sup>0-1,2</sup>	Unprotected, Non-sprinklered (U.P. NS)	45%
	Unprotected, Sprinklered (U.P. S)	No Limit
	Protected (P)	No Limit
25 to less than 30 <sup>0-1,2</sup>	Unprotected, Non-sprinklered (U.P. NS)	70%
	Unprotected, Sprinklered (U.P. S)	No Limit
	Protected (P)	No Limit
30 or greater	Unprotected, Non-sprinklered (U.P. NS)	No Limit
	Unprotected, Sprinklered (U.P. S)	No Limit
	Protected (P)	No Limit

For SI: 1 foot = 304.8 mm.  
 U.P. NS = Unprotected openings in buildings not equipped throughout with an automatic sprinkler system in accordance with Section 903.3.1.1.  
 U.P. S = Unprotected openings in buildings equipped throughout with an automatic sprinkler system in accordance with Section 903.3.1.1.  
 P = Openings protected with an opening protective assembly in accordance with Section 705.8.2.

40



## 705.8 - Exterior Wall Openings

**PER TABLE 705.8 MAXIMUM AREA OF EXTERIOR WALL  
OPENINGS BASED ON FIRE SEPARATION DISTANCE AND  
DEGREE OF OPENING PROTECTION**

NORTH FACE OF BUILDING TO CENTERLINE OF ARCH STREET	22.2' -> 20' TO LESS THAN 25' = NO LIMIT TO AREA FOR UNPROTECTED, SPRINKLERED OPENINGS
EAST FACADE SET BACK (NOT STAIR) TO PROPERTY LINE	9.5' -> 5' TO LESS THAN 10' = 25% LIMIT TO AREA FOR UNPROTECTED, SPRINKLERED OPENINGS
EAST STAIR TOWER FACADE LIES DIRECTLY ON PROPERTY LINE	0' -> 0' TO LESS THAN 0' = NO OPENINGS ARE PERMITTED
SOUTH FACE OF BUILDING TO CENTERLINE OF WHITE HEAD HIGHWAY	31.4' -> 30' OR GREATER = NO LIMIT TO AREA FOR UNPROTECTED, SPRINKLERED OPENINGS
WEST FACE OF BUILDING TO CENTERLINE OF PROSPECT STREET	-> 25.7' -> 30' OR GREATER = NO LIMIT TO AREA FOR UNPROTECTED, SPRINKLERED OPENINGS

Ref: Sheet A0.0

41



## 705.8 - Exterior Wall Openings

DISTANCE FROM FACE TO PROPERTY LINE: 9.5'

PER TABLE 705.8: 25% ALLOWABLE UNPROTECTED, SPRINKLERED OPENING

BUILDING FACE SQ. FT.: 1890 SQ. FT.

ALLOWABLE UNPROTECTED, SPRINKLERED OPENING SQUARE ACTUAL UNPROTECTED, SPRINKLERED OPENING SQUARE FOOTAGE: 210 SQ. FT. ACTUAL OPENING



Ref: Sheet A0.0

42



### 707 – Fire Barriers

- Shaft enclosures: 2 hr per 713
- Interior exit stairways: 2 hr
- Continuity: from top of foundation or floor/ceiling assembly below to the underside of the floor or roof sheathing above; continuous through concealed spaces.

43

---

---

---

---

---

---

---

---

### 707 – Fire Barriers

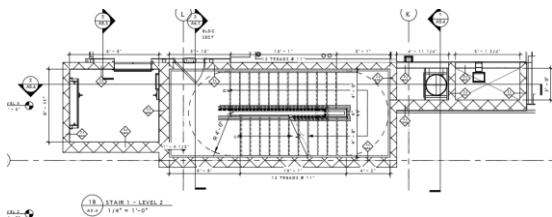

44

---

---

---

---

---

---

---

---

### 707 – Fire Barriers

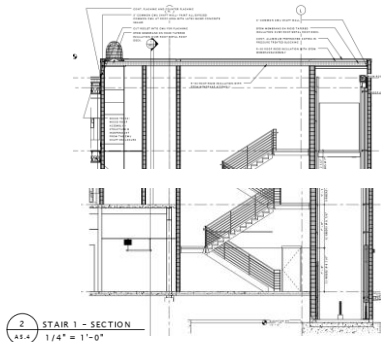

45

---

---

---

---

---

---

---

---



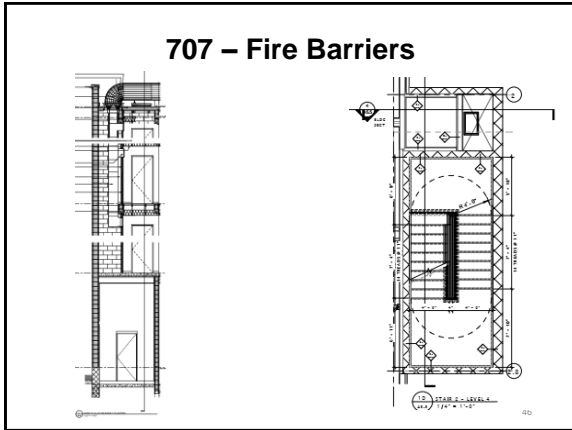

---

---

---

---

---

---

---

---

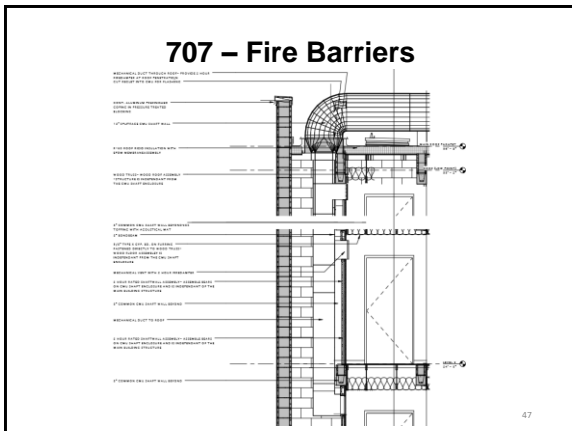

---

---

---

---

---

---

---

---

**708 – Fire Partitions**

- Separation walls for dwelling units
  - 1 hour
- Corridor walls
  - ½ hour (1020.1)
- Continuity: from top of foundation or floor/ceiling assembly below to the underside of the floor or roof sheathing above; or to the fire-resistance-rated F/C or R/C assembly <sup>48</sup>

---

---

---

---

---

---

---

---



### 708 – Fire Partitions

- More than 4-stories: Attic fireblocking or draftstopping required at the partition line
- Not required if sprinklers are installed in combustible F/C and R/C spaces.

49

---

---

---

---

---

---

---

---

### 708 – Fire Partitions

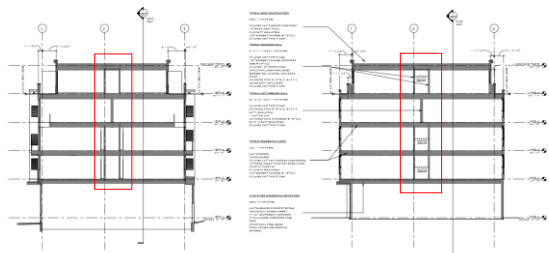

50

---

---

---

---

---

---

---

---

### 708 – Fire Partitions

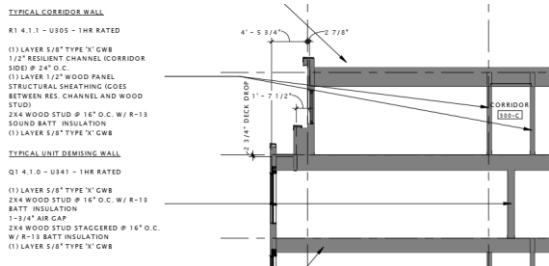

51

---

---

---

---

---

---

---

---





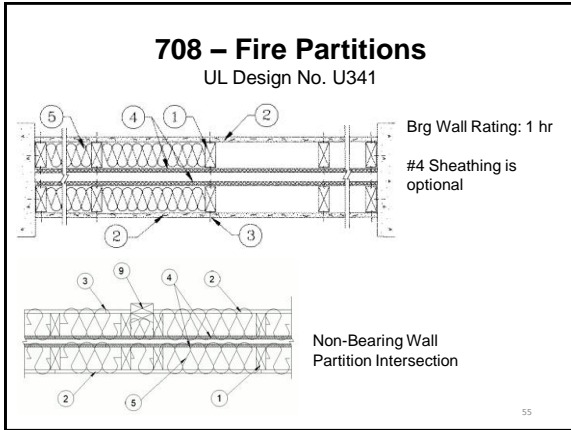

---

---

---

---

---

---

---

---

---

---

---

---

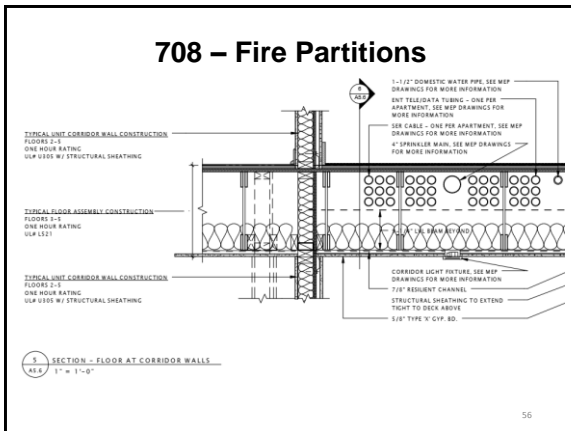

---

---

---

---

---

---

---

---

---

---

---

---

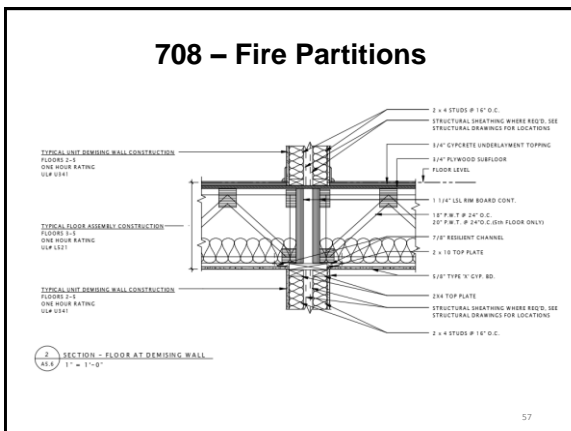

---

---

---

---

---

---

---

---

---

---

---

---



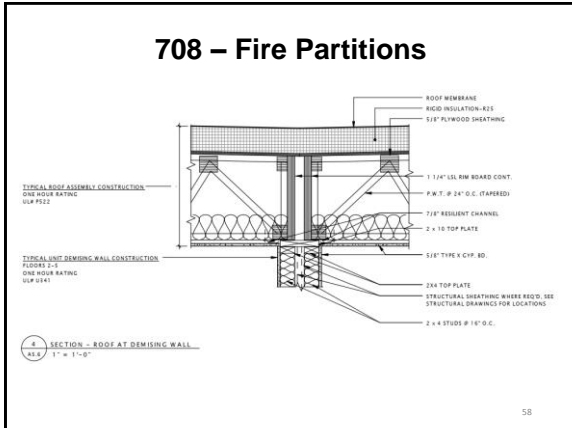

---

---

---

---

---

---

---

---

---

---

- ### 711 – Floor & Roof Assemblies
- Continuous w/o openings; exceptions in 712:
    - Shafts
    - Inside dwelling units
    - Protected penetrations
  - Supporting construction to have same rating
  - Between buildings: 3 hours
  - Upper floors: 1 hour (Type V-A & D.U.'s)
  - Roof: 1 hour (Type V-A)
- 59

---

---

---

---

---

---

---

---

---

---

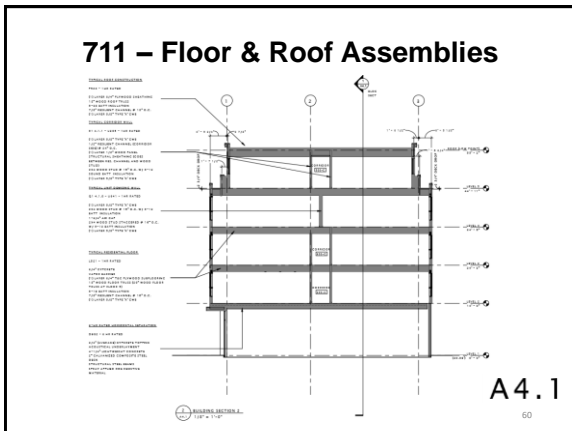

---

---

---

---

---

---

---

---

---

---



### 711 – Floor & Roof Assemblies

**TYPICAL RESIDENTIAL FLOOR**  
 LS21 - 1 HR RATED

3/4" C/PCRETE  
 VAPOR BARRIER  
 (1) LAYER 3/4" T&G PLYWOOD SUBFLOORING  
 1 1/2" WOOD FLOOR TRUSS (20" WOOD FLOOR TRUSS AT FLOOR 5)  
 R-19 BATT INSULATION  
 7/8" RESILIENT CHANNEL @ 16" O.C.  
 (1) LAYER 5/8" TYPE 'X' CWB

**3-HR RATED HORIZONTAL SEPARATION**  
 D902 - 3 HR RATED

3/4" (AVERAGE) C/PCRETE TOPPING  
 ACOUSTICAL UNDERLAYMENT  
 4- 1/4" LIGHTWEIGHT CONCRETE  
 2" GALVANIZED COMPOSITE STEEL DECK  
 STRUCTURAL STEEL BEAMS  
 SPRAY APPLIED FIRE RESISTIVE MATERIAL

**A 4.1**  
61

---

---

---

---

---

---

---

---

---

---

### 711 – Floor & Roof Assemblies

#### Horizontal Separation – UL Design No. D902

**Restrained Assembly Ratings — 0, 1, 1-1/2, 2 and 3 Hr.**  
**Unrestrained Assembly Ratings — 0, 1, 1-1/2, 2 or 3 Hr. (See Items 4 & 6)**  
**Unrestrained Beam Ratings — 1, 1-1/2, 2 and 3 Hr.**

5 1/4" th. Min. normal weight conc., Fc 3,500 PSI  
 REINF.  
 Steel decking, Many options  
 Spray-Applied Fire Resistive Materials  
 W8x28 min. size beam; W/D ratio 0.8

**SECTION A-A**  
62

---

---

---

---

---

---

---

---

---

---

### 711 – Floor & Roof Assemblies

#### Horizontal Separation – UL Design No. D902

Restrained Assembly Rating Hr	Unrestrained Beam Rating Hr	Concrete Type	Min Thkns Spray Applied Resistive Mtl. In			
			W8x28 When Deck Is All Fluted	W8x28 When Deck Is Blend or All Cellular	Joist Item 1A When Deck Is Fluted Cellular or Blend	Joist Item 1B When Deck Is Fluted Cellular or Blend
4	3	FWV	1'-3/16	1'-3/16	—	3'-1/4
3	1-1/2	NW	1/2	1/2	—	3-1/4
3	2	NW	3/4	13/16	—	3-1/4
3	3	NW	1-3/16	1-5/16	—	3-1/4
1	1	FWV	2'-0" C/PCRETE	2'-11 1/2" C/PCRETE	1'-1-1/2"	—

63

---

---

---

---

---

---

---

---

---

---



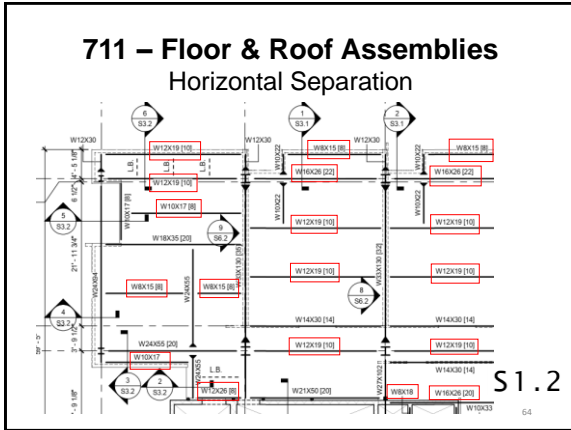

---

---

---

---

---

---

---

---

---

---

### 711 – Floor & Roof Assemblies

Spec Section 078100 – Applied Fireproofing

- Section includes sprayed fire resistive materials (SFRM).
- Shop drawings: Framing plans or schedules to show extent, minimum thicknesses needed.
- Installer qualifications.
- Fire-resistance design tested per UL 263.
- Steel members are to be considered unrestrained U.O.N.
- Application procedure.
- Special inspections required.
- Repair.

65

---

---

---

---

---

---

---

---

---

---

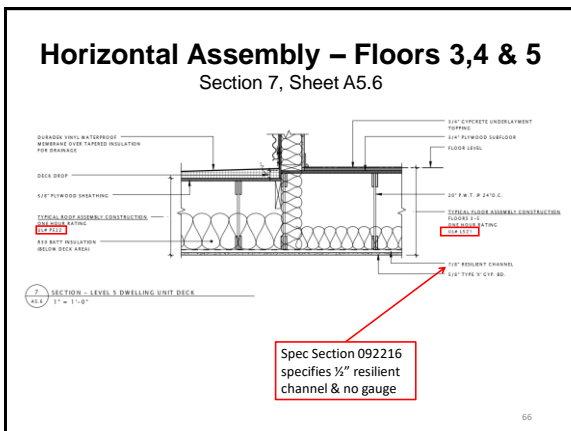

---

---

---

---

---

---

---

---

---

---





## UL Design No. L521 – 1 Hr

### From USG's *Fire & Sound In Multifamily Floors Design Considerations*:

The most common problem for both fire and sound in a floor/ceiling assembly is the use of the wrong length screw when attaching the wallboard to the RC-1 channel.

All UL Designs require a 1-1/4 in. (32 mm) minimum length screw to attach the RC-1 channel to the truss or joist. A 1 in. (25 mm) maximum screw is required to attach the first layer of 5/8 in. (16 mm) wallboard to the RC-1 channel. However, the wallboard is typically fastened with a screw that exceeds the 1 in. (25 mm) maximum length. If the longer screw penetrates the RC-1 and anchors into the truss or joist, you have effectively caused the floor/ceiling assembly to fall well short of the designed STC and IIC numbers. More importantly, if the screw anchors into the truss or joist on the first layer of wallboard, you have no UL fire rating.

70

---

---

---

---

---

---

---

---

---

---

## UL Design No. P522 – 1 Hr R/C

Section 7, Sheet A5.6

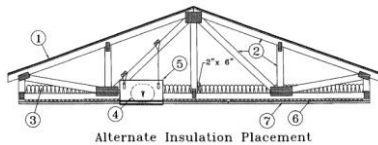

- 6. **Furring Channels** — Resilient channels formed of 25 MSG thick galv steel. Installed perpendicular to the trusses (Item 2), spaced ... a max of 12 in. OC when insulation (Item 3 or 3A) is fitted in the concealed space, draped over the resilient channel/gypsum board ceiling membrane...
- 7. **Gypsum Board\*** — One layer of nom 5/8 in. thick by 48 in. wide boards, installed with long dimension parallel to trusses. Attached to the resilient channels using 1 in. long Type S bugle-head screws. Screws spaced ... a max of 8 in. OC along butted end-joints and in the field when insulation (Item 3 or 3A) is fitted in the concealed space, draped over the resilient channel/gypsum board ceiling membrane.

71

---

---

---

---

---

---

---

---

---

---

## Roof/Ceiling Construction

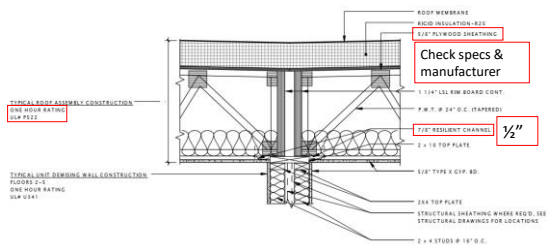

72

---

---

---

---

---

---

---

---

---

---





### Roof/Ceiling Construction

Spec Section 061600 – Sheathing (HEW Zip System)

The roof sheathing specified by the Architect is Huber Engineered Woods LLC, ZIP System Roof and Wall Sheathing



73

---

---

---

---

---

---

---

---

### Roof/Ceiling Construction

ICC-ES Evaluation Report ESR-1473  
Huber Engineered Woods, LLC  
ZIP System Roof Sheathing

#### 5.0 CONDITIONS OF USE

5.6 Installation is limited to roofs having a **slope of 2:12** (16.67% slope) **or greater**

74

---

---

---

---

---

---

---

---

### Roof/Ceiling Construction



#### ZIP SYSTEM® SHEATHING // NOTES & LIMITATIONS

 Do not use on roofs with slopes less than 2/12.

INSTALLATION MANUAL

ZIPSYSTEM.COM

75

---

---

---

---

---

---

---

---



### Roof/Ceiling Construction

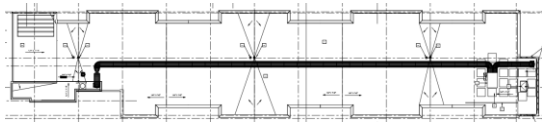

Typical roof slope is 1/4" per foot

A1.6  
76

---

---

---

---

---

---

---

---

### 712 – Vertical Openings

- Shaft enclosures: Per 713
- Penetrations: Per 714
- Joints: Per 715
- Ducts & air transfer openings: Per 717

77

---

---

---

---

---

---

---

---

### 712 – Vertical Openings

- Individual dwelling unit: Permitted to connect up to 4 stories, unconcealed.

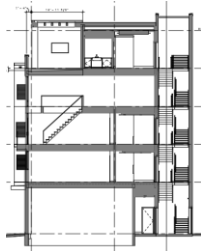

A4.1  
78

---

---

---

---

---

---

---

---



### 713 – Shaft Enclosures

- Constructed as fire barriers 707
  - Or horizontal assemblies per 711 (or both)
- Fire resistance
  - 2 hrs connecting 4 or more stories
  - 1 hr connecting less
- Sides that are exterior walls need not be rated, just comply with 705.
- No unnecessary penetrations

79

---

---

---

---

---

---

---

---

### 713 – Shaft Enclosures

**TYPICAL SHAFT WALL**  
 02 R.R.D. - 0900 - 2HR RATED  
 02 J.S.D. - 0900 - 2HR RATED  
 RATED, WHERE INDICATED!  
 REBAR FOR LEAST 60"  
 CONCRETE REINFORCING BARS  
 LAYED IN FULL DEPTH OF MORTAR

**TYPICAL SHAFT WALL AT FACE OF TRASH  
 CHUTE & DUCT SHAFT (BEHIND)**  
 02 R.R.D. - 0415 - 2HR RATED  
 02 LAYERS 5/8" THICK G-1  
 1" METAL L-CHANNEL @ 24" O.C.  
 02 LAYERS 1/2" GYPSUM LINER PANELS

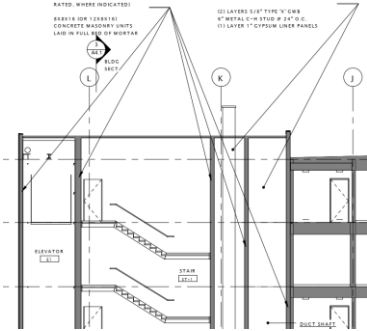

A4.1

80

---

---

---

---

---

---

---

---

### 713 – Shaft Enclosures

713.11 Enclosures at the Bottom

1. Enclosed at the lowest level with the same fire resistance rating as the lowest floor through which the shaft passes, but not less than the rating required for the shaft enclosure.

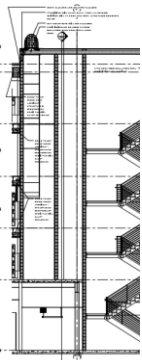

A5.4

81

---

---

---

---

---

---

---

---



### 713 – Shaft Enclosures

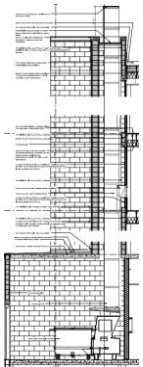

#### 713.11 Enclosures at the Bottom

2. Terminate in a room having a use related to the shaft. The room separated from the building by fire barriers or horiz. assemblies.

#### 713.13.1 Waste Chutes

- No other purpose for shaft
- Protected openings (not in corridors)
- Self-closing doors

A5.4  
82

---

---

---

---

---

---

---

---

---

---

### 714 – Penetrations

Protection of through penetrations and membrane penetrations of horizontal assemblies and fire-resistance-rated wall assemblies.

No details provided on the architectural drawings, however, 16 systems provided with details in specs.

#### Spec section 078413 – Penetration Firestopping

- Submission of product data
- Installer qualifications: Approved by FM Global
- Products for every type of penetration with the proper F-, T-, or W- rating
- Installation instructions
- Labeling of each penetration firestop

83

---

---

---

---

---

---

---

---

---

---

### 714 – Penetrations



84

---

---

---

---

---

---

---

---

---

---

### 714.3.2 – Membrane Penetrations

Required fire-resistance of a wall or partition cannot be reduced by a building element that penetrates only one side of an assembly.

Exceptions for steel electrical boxes, listed electrical boxes of other materials.

Approved membrane protection firestop systems

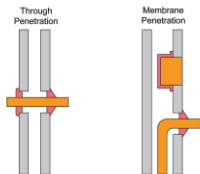

85

---

---

---

---

---

---

---

---

### 714.3.2 – Membrane Penetrations

**Firestop Pully Pad (SPF-101, CP-101, and CP-102)**

**Product Description:**  
 • Firestop Pully Pad (SPF-101, CP-101, and CP-102) is a firestop system designed to protect openings in fire-resistance-rated walls and partitions.

**Technical Data:**

Product Name	SPF-101	CP-101	CP-102
Material	FRP	FRP	FRP
Color	Red	Red	Red
Weight	1.5 lbs	1.5 lbs	1.5 lbs
Dimensions	12" x 12" x 1/2"	12" x 12" x 1/2"	12" x 12" x 1/2"
Fire Rating	1-1/2 hr	1-1/2 hr	1-1/2 hr
Installation	See technical manual	See technical manual	See technical manual

**Installation Instructions for CP-101:**

1. Prepare the opening in the fire-resistance-rated wall or partition.
2. Clean the opening of any debris or loose material.
3. Apply a fireproofing material to the opening.
4. Install the Firestop Pully Pad (CP-101) over the opening.
5. Tighten the bolts to secure the pad.
6. Inspect the installation for proper fit and finish.

This page added to end of spec section 078413 – Penetration Firestopping

86

---

---

---

---

---

---

---

---

### 714.4 – Horizontal Assemblies

Through-penetrations of fire-resistance-rated horizontal assemblies shall:

- Be installed as tested in an approved fire-resistance-rated assembly; or
- Protected by an approved penetration firestop system (ASTM E814 or UL 1479)

Unless protected by a shaft enclosure.

There are exceptions....

87

---

---

---

---

---

---

---

---



### 714.4 – Horizontal Assemblies

#### Section 714.4.1 – Exception 1

- Through-penetration firestop systems are not required for through penetrations of a single fire-resistance-rated floor assembly for steel, ferrous or copper conduits, pipes, tubes or vents where:
  - Annular space protected with materials that prevent the passage of flame and hot gases in accordance with ASTM E 119 or UL 263.

88

---

---

---

---

---

---

---

---

### 714.4 – Horizontal Assemblies

#### Section 714.4.1 – Exception 2

- Through-penetration firestop systems are not required for through penetrations of a single fire resistance-rated concrete floor assembly for steel, ferrous or copper conduits, pipes, tubes or vents where:
  - Maximum size of penetrating item is 6 inches in diameter.
  - Annular space is protected with concrete, grout or mortar for the full thickness of the floor or the thickness required to maintain the fire-resistance rating.

89

---

---

---

---

---

---

---

---

### 714.4 – Horizontal Assemblies

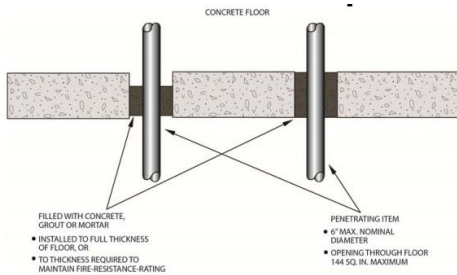

90

---

---

---

---

---

---

---

---



## 714.4 – Horizontal Assemblies

### Section 714.4.1.2 – Through-penetration firestop system

As a general requirement, through penetrations of a floor assembly will require the firestop system to have both an “F” and a “T” rating. Three exceptions can eliminate the T rating at the floor:

- Penetrations contained and located within the cavity of a wall (above or below)
- Penetrations by floor drains, tub drains or shower drains protected by the ceiling of a floor/ceiling assembly (“contained and located within”)
- Penetration into metal-enclosed electrical switchgear (4 inch maximum diameter)

91

---

---

---

---

---

---

---

---

---

---

## 714.4 – Horizontal Assemblies

### Section 714.4.1.2 Exception 1

- T rating exempted for penetrations contained and located within the cavity of a wall (above or below)

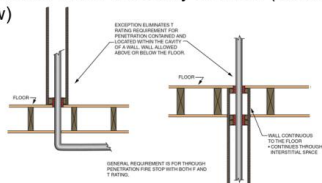

92

---

---

---

---

---

---

---

---

---

---

## 714.4 – Horizontal Assemblies

### Section 714.4.1.2 Exception 2

- T rating exempted for floor drains, tub drains or shower drains protected by the ceiling of a floor/ceiling assembly

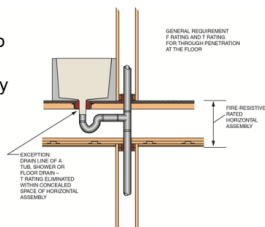

93

---

---

---

---

---

---

---

---

---

---

### 714.4 – Horizontal Assemblies

#### Section 714.4.1.2 Exception 3

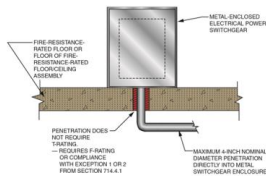

- T rating exempt if penetration directly enters a metal-enclosed electrical power switchgear.

94

---

---

---

---

---

---

---

---

### 714.4 – Horizontal Assemblies

#### Section 714.4.2 – Membrane Penetrations

Penetrations of membranes that are a part of a fire-resistance-rated horizontal assembly shall comply with the requirements for through penetrations.

The following are exceptions....

95

---

---

---

---

---

---

---

---

### 714.4 – Horizontal Assemblies

#### Section 714.4.2 – Exception 1

- Annular space protection of membrane penetrations permitted in lieu of listed firestop system where:
  - Penetrating items are steel, ferrous or copper pipes, tubes or conduits.
  - Annular space is protected to prevent the free passage of flame and products of combustion.
  - Aggregate area of openings through membrane is limited to 100 square inches in any 100 square feet.

96

---

---

---

---

---

---

---

---





### 714.4 – Horizontal Assemblies

#### Section 714.4.2 – Exception 2

- Ceiling membrane penetrations of steel electrical boxes may be made subject to the following conditions:
  - Horizontal assembly to be maximum 2 hours.
  - Boxes to be a maximum of 16 square inches.
  - Aggregate area of boxes is not to exceed 100 square inches per 100 square feet of wall area.
  - Annular space between box and ceiling membrane is not to exceed 1/8 inch.

97

---

---

---

---

---

---

---

---

### 714.4 – Horizontal Assemblies

#### Section 714.4.2 – Exception 2

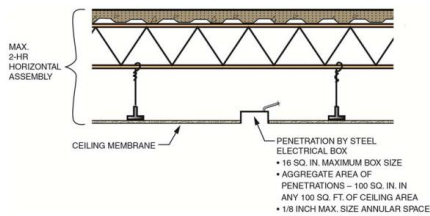

98

---

---

---

---

---

---

---

---

### 714.4 – Horizontal Assemblies

#### Section 714.4.2 – Exception 3 and 4

- Ceiling membrane penetrations of listed electrical boxes of any material may be made subject to the following conditions:
  - Boxes have been tested for use in a fire-resistance-rated assembly.
  - Boxes are installed in accordance with their listing.
  - Annular space between the box and ceiling membrane is not to exceed 1/8 inch.

99

---

---

---

---

---

---

---

---



### 714.4 – Horizontal Assemblies

#### Section 714.4.1.2 – Exception 5

- Ceiling membrane penetrations created by the penetration of a fire sprinkler need not be protected by an approved firestop system provided the annular space is covered by a metal escutcheon plate.
  - Applicable only where a sprinkler is installed at the point of the ceiling membrane penetration.

100

---

---

---

---

---

---

---

---

### 714.4 – Horizontal Assemblies

#### Section 714.4.2 – Exception 5

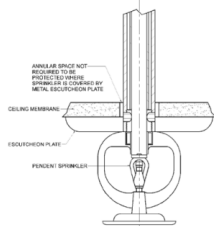

- Penetration of a sprinkler protected by a metal escutcheon plate

101

---

---

---

---

---

---

---

---

### 714.4 – Horizontal Assemblies

#### Section 714.4.1.2 – Exception 6

- Penetrations of noncombustible items are permitted where cast into concrete building elements provided the items do not penetrate both the top and bottom surfaces of the element.

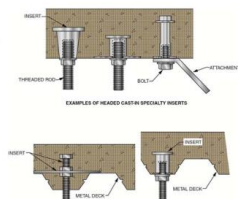

102

---

---

---

---

---

---

---

---



## 714.4 – Horizontal Assemblies

### Section 714.4.2 – Exception 7

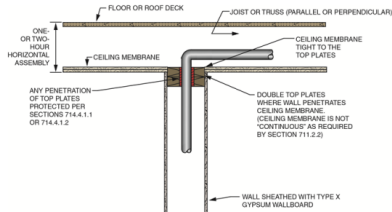

103

---

---

---

---

---

---

---

---

## 715 – Fire-Resistant Joint Systems

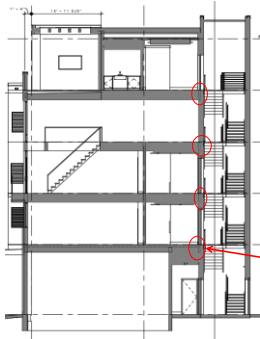

Joints installed in or between fire-resistance-rated walls & floor/ceiling assemblies.

Approved system designed to resist passage of fire for same rating.

No details on drawings for these locations.

104

---

---

---

---

---

---

---

---

## 715 – Fire-Resistant Joint Systems

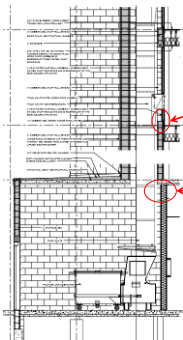

Joint between concrete block & shaftwall transition within a shaftwall.

Head of wall between steel floor deck and framed wall which is part of 2-hour trash chute/room enclosure.

No details on drawings.

A 5.4

105

---

---

---

---

---

---

---

---

## 715 – Fire-Resistant Joint Systems

### Spec. Section 078446 – Fire-Resistive Joint Systems

- Product data submittals required.
- Installer Qualifications: FM Global
- Use fire tested joint systems (UL Directory)

Other than a general description of where they are required that corresponds with 715, they don't graphically show where or what joints must be protected.

106

---

---

---

---

---

---

---

---

## 715 – Fire-Resistant Joint Systems

### PART 2 - PRODUCTS

#### 2.1 FIRE-RESISTIVE JOINT SYSTEMS

- A. Where required, provide fire-resistive joint systems that are produced and installed to resist spread of fire according to requirements indicated, resist passage of smoke and other gases, and maintain original fire-resistance rating of assemblies in or between which fire-resistive joint systems are installed. Fire-resistive joint systems shall accommodate building movements without impairing their ability to resist the passage of fire and hot gases.
- B. Joints in or between Fire-Resistance-Rated Construction: Provide fire-resistive joint systems with ratings determined per ASTM E 1966 or UL 2079.
  - 1. Joints include those installed in or between fire-resistance-rated walls, floor or floor/ceiling assemblies, and roofs or roof/ceiling assemblies.
  - 2. Fire-Resistance Rating: Equal to or exceeding the fire-resistance rating of construction they joint.
- C. Joints in Smoke Barriers: Provide fire-resistive joint systems with ratings determined per UL 2079.
  - 1. L-Rating: Not exceeding 5.0 cfm/ft of joint at 0.30 inch wg at both ambient and elevated temperatures.
- D. Exposed Fire-Resistive Joint Systems: Provide products with flame-spread and smoke-developed indexes of less than 25 and 450, respectively, as determined per ASTM E 84.
- E. Accessories: Provide components of fire-resistive joint systems, including primers and forming materials, that are needed to install fill materials and to maintain ratings required. Use only components specified by fire-resistive joint system manufacturer and approved by the qualified testing agency for systems indicated.

107

---

---

---

---

---

---

---

---

## 715 – Fire-Resistant Joint Systems



108

---

---

---

---

---

---

---

---



### 716 – Opening Protectives

Protection of openings required in:

- Fire barriers
- Fire partitions

In this project:

- Exit doors into stairways
- Doors in corridors
- Trash chute doors
- Elevator doors

109

---

---

---

---

---

---

---

---

### 716 – Opening Protectives

Protection of openings required in:

- Fire barriers
- Fire partitions

In this project:

- Exit doors into stairways
- Doors in corridors
- Trash chute doors
- Elevator doors

110

---

---

---

---

---

---

---

---

### 716 – Opening Protectives

TABLE 716.5  
OPENING FIRE PROTECTION ASSEMBLIES, RATINGS AND MARKINGS

TYPE OF ASSEMBLY	REQUIRED WALL AND FIRE DOOR SHUTTER ASSEMBLY RATING (hours)	MINIMUM FIRE DOOR AND FIRE SHUTTER ASSEMBLY RATING (hours)	DOOR VISION PANEL SIZE	FIRE RATED GLAZING MARKING DOOR VISION PANEL*	MINIMUM SIDELIGHT/TRANSOM ASSEMBLY RATING (hours)		FIRE RATED GLAZING MARKING SIDELIGHT/TRANSOM PANEL	
					Fire protection	Fire resistance	Fire protection	Fire resistance
Enclosures for shafts, interior exit stairways and interior exit ramps.	2	1 1/2	100 sq. in.	≤100 sq. in. = D-H-90 > 100 sq. in. = D-H-T-W-90	Not Permitted	2	Not Permitted	W-120
Fire partitions:	1	1/2	Maximum size tested	D-20	1/2			D-H-OH-45
Corridor walls	0.5	1/2	Maximum size tested	D-20	1/2			D-H-OH-20
Other fire partitions	1	1/2	Maximum size tested	D-H-45	1/2			D-H-45
	0.5	1/2	Maximum size tested	D-H-20	1/2			D-H-20

111

---

---

---

---

---

---

---

---



### 716 – Opening Protectives

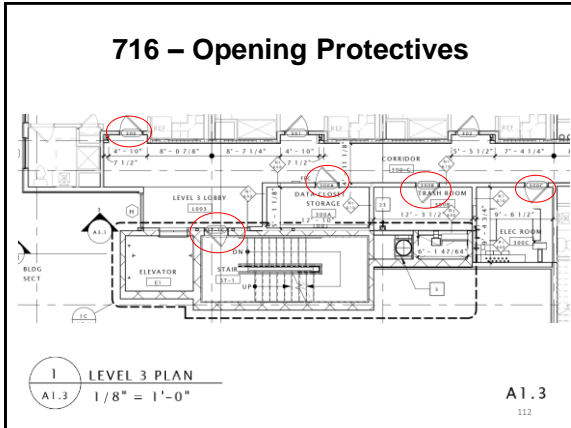

---

---

---

---

---

---

---

---

### 716 – Opening Protectives

DOOR SCHEDULE													
MARK	TYPE	ROOM NAME	ROOM NUMBER	MATERIAL	HEIGHT	WIDTH	THICKNESS	TYPE	MATERIAL	HARDWARE	FRAME MATERIAL	REMARKS	TYPE COMMENTS
LEVEL 3													
1000	IC	BL DOOR	1000	HW	7'-0"	3'-0"	1 1/2"	HW	14	14	14		
1004A	A	DATA CLOSET / STORAGE	1004A	HW	7'-0"	3'-0"	1 1/2"	HW	13	13	13		
1004B	A	SERVER ROOM	1004B	HW	7'-0"	3'-0"	1 1/2"	HW	14	14	14		
1005C	A	BLDG ROOM	1005C	HW	7'-0"	3'-0"	1 1/2"	HW	13	13	13		
1007	IC	BL DOOR	1007	HW	7'-0"	3'-0"	1 1/2"	HW	14	14	14		
LEVEL 4													
1000	IC	BL DOOR	1000	HW	7'-0"	3'-0"	1 1/2"	HW	14	14	14		
1011C	IC	STAIR	1011C	HW	7'-0"	3'-0"	1 1/2"	HW	13	13	13		
1011D	IC	STAIR	1011D	HW	7'-0"	3'-0"	1 1/2"	HW	13	13	13		

DOOR TYPES LEGEND			
TYPE A	TYPE C UNIT ENTRY DOOR	TYPE D	

---

---

---

---

---

---

---

---

### 717 – Ducts & Air Transfer Openings

This will be covered in the Mechanical Seminar.

---

---

---

---

---

---

---

---



### 718 – Concealed Spaces

To cut off smoke and gases spreading within combustible construction, concealed spaces are protected by two means:

- Fireblocking
- Draftstopping

This applies to floors 2 – 5, Type V-A

115

---

---

---

---

---

---

---

---

### 718 – Concealed Spaces

**718.2.1 Fireblocking materials.** *Fireblocking* shall consist of the following materials:

1. Two-inch (51 mm) nominal lumber.
2. Two thicknesses of 1-inch (25 mm) nominal lumber with broken lap joints.
3. One thickness of 0.719-inch (18.3 mm) wood structural panels with joints backed by 0.719-inch (18.3 mm) wood structural panels.
4. One thickness of 0.75-inch (19.1 mm) particleboard with joints backed by 0.75-inch (19 mm) particleboard.
5. One-half-inch (12.7 mm) gypsum board.
6. One-fourth-inch (6.4 mm) cement-based millboard.
7. Batts or blankets of *mineral wool*, *mineral fiber* or other *approved* materials installed in such a manner as to be securely retained in place.
8. Cellulose insulation installed as tested for the specific application.

116

---

---

---

---

---

---

---

---

### 718 – Concealed Spaces

#### 718.2.3 Connections Between Horizontal and Vertical Spaces

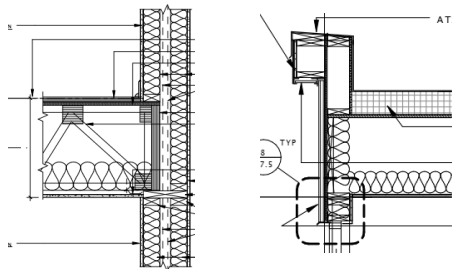

117

---

---

---

---

---

---

---

---



**718 – Concealed Spaces**

718.3 Draftstopping in Floors

Materials:

- 1/2" min. gypsum board
- 3/8" min. wood structural panel
- 3/8" min. particleboard
- 1" min. nominal lumber
- Cement fiberboard (no thickness specified)
- Mineral wool or glass fiber, batts or blankets
- Other approved materials

118

---

---

---

---

---

---

---

---

**718 – Concealed Spaces**

718.3 Draftstopping in Floors

- Group R-2, sprinklered per NFPA 13:
- Not required

119

---

---

---

---

---

---

---

---

**718 – Concealed Spaces**

718.4 Draftstopping in Attics

- Group R-2 w/ NFPA 13 sprinkler system:
- Not required.

120

---

---

---

---

---

---

---

---





### NFPA 13-2013

#### 8.15.1.2 Concealed Spaces Not Requiring Sprinkler Protection

The base requirement is that concealed spaces in wood-framed floors and roofs will have sprinklers.

Several conditions are provided where sprinklers would not be required in concealed spaces.

121

---

---

---

---

---

---

---

---

### NFPA 13-2013

#### 8.15.1.2 Concealed Spaces Not Requiring Sprinkler Protection

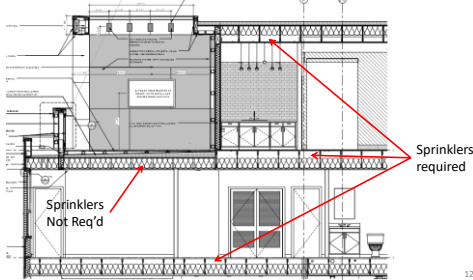

122

---

---

---

---

---

---

---

---

### 803 – Wall & Ceiling Finishes

TABLE 803.11  
INTERIOR WALL AND CEILING FINISH REQUIREMENTS BY OCCUPANCY\*

GROUP	SPRINKLERED			NONSPRINKLERED		
	Interior exit stairways and ramps and exit passageways**	Corridors and enclosures for exit access stairways and ramps	Rooms and enclosed spaces†	Interior exit stairways and ramps and exit passageways**	Corridors and enclosures for exit access stairways and ramps	Rooms and enclosed spaces†
A-1 & A-2	B	B	C	A	A <sup>1</sup>	B <sup>1</sup>
A-3 <sup>1</sup> , A-4, A-5	B	B	C	A	A <sup>1</sup>	C
B, E, M, R-1	B	C	C	A	B	C
R-4	B	C	C	A	B	B
F	C	C	C	A	C	C
H	B	B	C <sup>2</sup>	A	A	B
I-1	B	C	C	A	B	B
I-2	B	B	B <sup>1-1</sup>	A	A	B
I-3	A	A <sup>1</sup>	C	A	A	B
I-4	B	B	B <sup>1-1</sup>	A	A	B
R-2	C	C	C	B	B	C
R-3	C	C	C	C	C	C
S	C	C	C	B	B	C
U	No restrictions			No restrictions		

123

---

---

---

---

---

---

---

---



### 804 – Floor Finishes

804.4.2 Floor coverings minimum critical radiant flux not less than Class II for Groups M and R-2.

With sprinklers, materials complying with DOC FF-1 “pill test” or with ASTM D2859 are permitted.

124

---

---

---

---

---

---

---

---

---

---

### Interior Finishes

ROOM FINISH SCHEDULE					
Number	Name	Floor Finish	Base Finish	Wall Finish	Ceiling Finish
001	TRASH CHUTE	EF-1	EF-1		
101	LOBBY	PFT-1	PTB-1	VWC-1, VWC-5, VWC-6, VWC-8 FCP-1	PNT-4
101A	VESTIBULE	PFT-1, CPT-2	PTB-1	FCP-1	PNT-4
102	MAIL ROOM	PFT-1	PTB-1	VWC-1, VWC-7	PNT-4
103	TRASH ROOM	EF-1	EF-1		
104	ELEC ROOM	SEALED CONCRETE	VB-1	PNT-1	
105	METER ROOM	SEALED CONCRETE	VB-1	PNT-1	
107	RETAIL 1	N/A	N/A	N/A	N/A
108	RETAIL 2	N/A	N/A	N/A	N/A
109	RETAIL 3	N/A	N/A	N/A	N/A
110	RETAIL 4	N/A	N/A	N/A	N/A
111	RETAIL 5	N/A	N/A	N/A	N/A
200-C	CORRIDOR	CPT-2	PNT-3	PNT-1	PNT-4
200A	DATA CLOSET/STORAGE	VCT-1	VB-1	PNT-1	
300B	TRASH ROOM	VCT-1	EF-1		PNT-6
300C	ELEC ROOM	VCT-1	VB-1	PNT-1	
300-C	CORRIDOR	CPT-3	PNT-3	PNT-1	PNT-4
300A	DATA CLOSET / STORAGE	VCT-1	VB-1	PNT-1	
300B	TRASH ROOM	VCT-1	EF-1		PNT-6
300C	ELEC ROOM	VCT-1	VB-1	PNT-1	
400A	TRASH ROOM	VCT-1	EF-1		
400B	ELEC ROOM	VCT-1	VB-1	PNT-1	
500	ROOF DECK	WD-1	FCP-1		

A 8.2

---

---

---

---

---

---

---

---

---

---

### 903 – Automatic Sprinkler Systems

**903.2.8 Group R.** An automatic sprinkler system installed in accordance with Section 903.3 shall be provided throughout all newly constructed *buildings* with a Group R fire area or in existing *buildings* that have a Group R fire area newly introduced by *change of occupancy*, occupancy group designation or by an *addition*.

**[F] 903.2.11.3 Buildings 55 feet or more in height.** An *automatic sprinkler system* shall be installed throughout buildings that have one or more stories with an occupant load of 30 or more located 55 feet (16 764 mm) or more above the lowest level of fire department vehicle access, measured to the finished floor.

126

---

---

---

---

---

---

---

---

---

---



### 905 – Standpipe Systems

[F] **905.3 Required installations.** Standpipe systems shall be installed where required by Sections 905.3.1 through 905.3.8. Standpipe systems are allowed to be combined with *automatic sprinkler systems*.

[F] **905.3.1 Height.** Class III standpipe systems shall be installed throughout buildings where the floor level of the highest *story* is located more than 30 feet (9144 mm) above the lowest level of fire department vehicle access, or where the floor level of the lowest *story* is located more than 30 feet (9144 mm) below the highest level of fire department vehicle access.

**Exceptions:**

- 1. Class I standpipes are allowed in buildings equipped throughout with an *automatic sprinkler system* in accordance with Section 903.3.1.1 or 903.3.1.2.

127

---

---

---

---

---

---

---

---

---

---

### 906 - Portable Fire Extinguishers

- Refers to 2018 CSFPC (NFPA 1-2015 amended)
- Table 13.6.1.2 (amended)
  - Not required for R-2 apartment occupancies
  - Required in M which are ground floor occupancies. No tenant fit up plans yet.

128

---

---

---

---

---

---

---

---

---

---

### 907 - Fire Alarm & Detection Systems

**907.2.9 Group R-2.** Fire alarm systems and smoke alarms shall be installed in Group R-2 occupancies as required in Sections 907.2.9.1 through 907.2.9.3.

**907.2.9.1 Manual fire alarm system.** A manual fire alarm system that activates the occupant notification system in accordance with Section 907.5 shall be installed in Group R-2 occupancies where:

- 1. Any *dwelling unit* or *sleeping unit* is located three or more stories above the lowest *level of exit discharge*;
- 3. The *building* contains more than 11 *dwelling units* or *sleeping units*.

**Exceptions:**

- 2. *Manual fire alarm boxes* are not required where the *building* is equipped throughout with an automatic sprinkler system in accordance with Section 903.3.1.1 or 903.3.1.2 and the occupant notification appliances will automatically activate throughout the notification zones upon a sprinkler water flow.

129

---

---

---

---

---

---

---

---

---

---



### 1004 – Occupant Load

TABLE 1004.1.2  
MAXIMUM FLOOR AREA ALLOWANCES PER OCCUPANT

FUNCTION OF SPACE	OCCUPANT LOAD FACTOR*
Accessory storage areas, mechanical equipment room	300 gross
Assembly without fixed seats	
Concentrated (chairs only—not fixed)	7 net
Standing space	5 net
Unconcentrated (tables and chairs)	15 net
Mercantile	60 gross
Storage, stock, shipping areas	300 gross
Residential	200 gross

130

---

---

---

---

---

---

---

---

---

---

### 1004 – Occupant Load

2015 IBC Code Commentary:

“The gross floor area technique applied to a building only allows the deduction of the plan area of the exterior walls, vent shafts and interior courts from the plan area of the building.”

Gross floor area includes corridors, stairways, mechanical rooms and closets.

131

---

---

---

---

---

---

---

---

---

---

### 1004 – Occupant Load

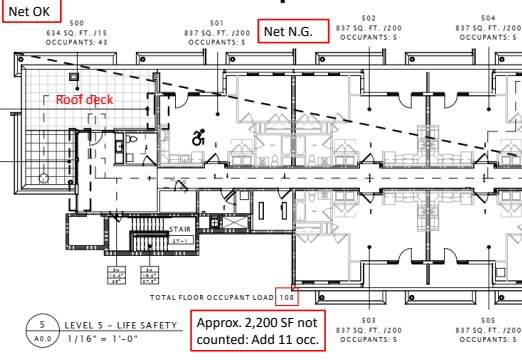

---

---

---

---

---

---

---

---

---

---



### 1005 – Means of Egress Sizing

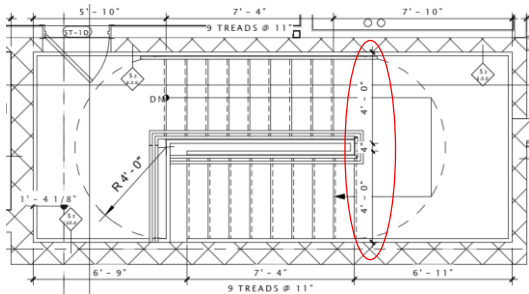

119 occupants (5<sup>th</sup> floor) x 0.3' = 35.7' required width of each stairway

133

---

---

---

---

---

---

---

---

---

---

### Means of Egress

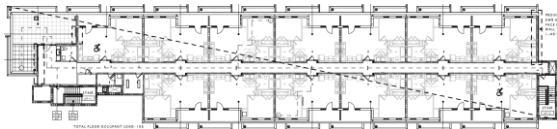

**1006.2.1:** 2 MOE required from each story; 1 MOE from each dwelling unit.

**Table 1006.2.1** allows 1 MOE from roof deck, less than 49 occupants & max. common path of egress travel less than 75'

**1007.1.1** Exits separated by at least 1/3 diagonal of story.

**1017:** Max. exit access travel distance, 250'.

134

---

---

---

---

---

---

---

---

---

---

### 1008 – Means of Egress Illumination

- MOE including discharge illuminated at all times building space served by MOE is occupied.
  - Not req'd within dwelling units
- Emergency power required for MOE illumination in corridors and exit stairways.

135

---

---

---

---

---

---

---

---

---

---



### 1009 – Accessible Means of Egress

- Not less than 1 accessible MOE required.
  - Accessible routes
  - Interior exit stairways
  - Elevators (accessible floor 4+ stories above LED)
    - Emergency operation & signaling per ASME 17.1
    - Standby power provided.

**ACCESSIBLE MEAN OF EGRESS SECTION 1007**

**A0.0**

PER 1007.1 TWO ACCESSIBLE MEANS OF EGRESS ARE REQUIRED PER FLOOR.  
EACH STAIRWAY WITHIN AN EXIT ENCLOSURE COMPLIES WITH SECTION 1007.3 AND 1019.1

PER 1007.2 AT LEAST ONE REQUIRED ACCESSIBLE MEANS OF EGRESS SHALL BE AN ELEVATOR COMPLYING WITH SECTION 1007.4

136

---

---

---

---

---

---

---

---

---

---

### Egress Stair Dimensions Typical Stair Detail, Sheet A5.5

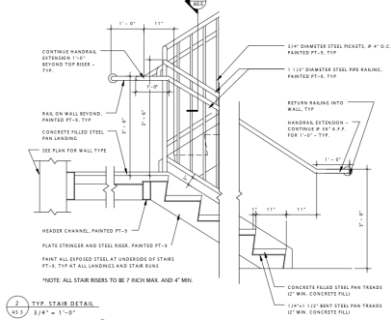

137

---

---

---

---

---

---

---

---

---

---

### Handrail Extensions Stair 2, Level 1, Sheet A5.5

1014.6

- Depth of 1 tread beyond bottom.

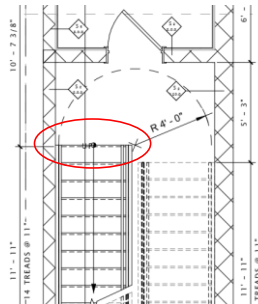

138

---

---

---

---

---

---

---

---

---

---



### Handrail Extensions

Stair 2, Level 5, Sheet A5.5

1014.6

- 12" beyond top
- In the same direction of the flight of stairs
- No turns before 12"

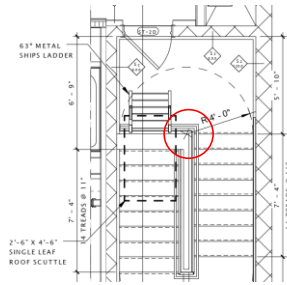

139

---

---

---

---

---

---

---

---

---

---

### 1107 - Accessibility for Dwelling Units

1107.6.2.2 Apartment houses

- Type A units: at least 10% containing more than 20 DU's
- Type B units: all others

**UNIT COUNT:**

FLOOR LEVEL	COUNT	TYPE A UNITS
LEVEL 2	19 UNITS	4 TYPE A UNITS (STUDIO UNITS #204, #213) (TWO BEDROOM UNIT #205, #218)
LEVEL 3	21 UNITS	
LEVEL 4	9 UNITS	
LEVEL 5	13 UNITS	2 TYPE A UNITS (ONE BEDROOM UNITS #501, 513)
<b>TOTAL</b>	<b>62 UNITS</b>	<b>6TYPE A UNITS (AS PER 1107.6.2.2.1)</b>

NOTE: ALL UNITS ARE TYPE B UNLESS OTHERWISE NOTED

A0.0

140

---

---

---

---

---

---

---

---

---

---

### Compare Type A & B Dwelling Units A117.1, Sections 1003 & 1004

Element	Type A	Type B
Accessible entrance	Yes	Yes
Accessible route within unit	Yes	Yes
Turning space in each room	Yes Exceptions for add'l bathrooms; closets & pantries <48" deep	No
Level walking surfaces	Yes	Yes
Doors clear width	32" min.	32" entrance 31 1/4" others
Door maneuvering clearance	1003.5 has exceptions	No
Operable parts	Comply w/ 309. Clear floor space per 305. Reach range per 308. 1003.9 has exceptions	Comply w/ 309.2 & 309.3. Clear floor space per 305. Reach range per 308. 1003.9 has exceptions

---

---

---

---

---

---

---

---

---

---



### Compare Type A & B Dwelling Units A117.1, Sections 1003 & 1004

Element	Type A	Type B
Laundry equipment	Comply w/ 611. Clear space per 305. Controls per 309.	Comply w/ 1004.10 Clear space per 305.3
Toilet & bathing facilities		
•Primary bathroom	1003.11.2	1004.11
•Other bathrooms	1003.11.1	1004.11 exceptions
Primary bathroom		
•Door swing not overlap fixture clear space	Yes	Yes
•Fixture clear spaces	Yes	Yes
•Grab bars	No – blocking Removable	No – blocking Removable
•Vanity cabinet	40" max. height	40" max. height
•Mirror	Adjacent to wall	Option A or B
•Water closet		

142

---

---

---

---

---

---

---

---

---

---

### Compare Type A & B Dwelling Units A117.1, Sections 1003 & 1004

Element- KITCHENS	Type A	Type B
Clearance between opposing cabinets	40" galley 60" U-shape	40" galley 60" U-shape
Work surface 30" wide – may be removable base cabinet	Yes	No
Sink	30"x48" clear space for forward approach. Knee clearance under 1 bowl. May have removable cab.	30"x48" clear space for parallel approach. Forward approach is an exception.
Appliances	30"x48" clear space for parallel or forward approach.	30"x48" clear space for parallel or forward approach.
Refrigerator/freezer	Reach range for 50% of freezer shelf. Parallel approach.	Parallel approach.

---

---

---

---

---

---

---

---

---

---

### Type A Unit

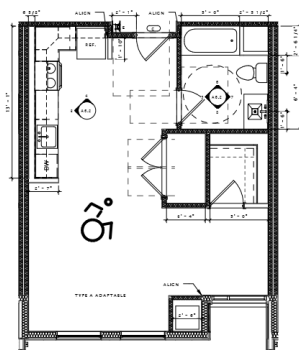

144

---

---

---

---

---

---

---

---

---

---





### Type A Unit

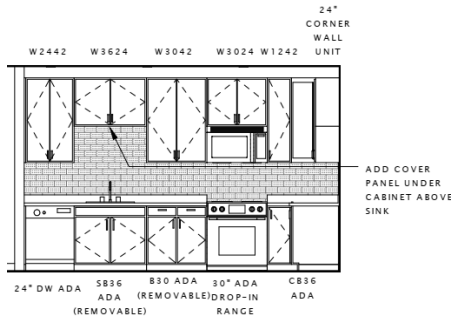

---

---

---

---

---

---

---

---

### Type A Unit

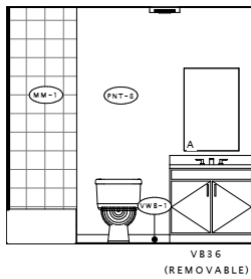

7 BATHROOM ELEV.  
A6.2 1/4" = 1'-0"

146

---

---

---

---

---

---

---

---

### Type B Unit

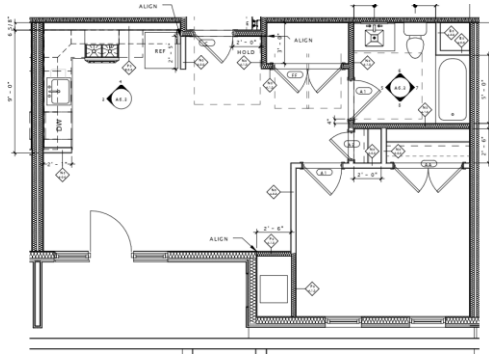

---

---

---

---

---

---

---

---



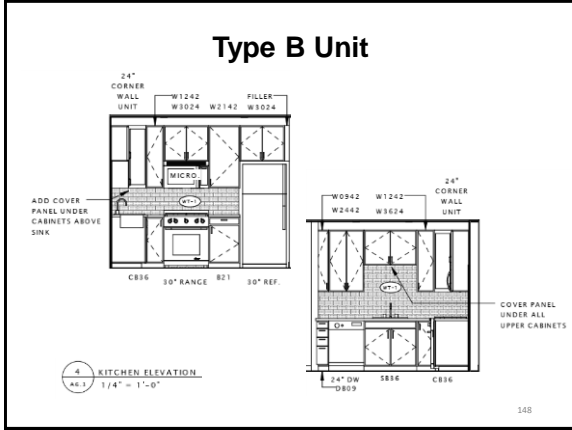

---

---

---

---

---

---

---

---

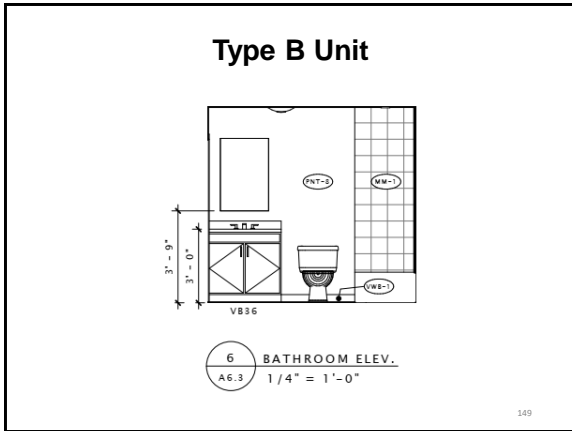

---

---

---

---

---

---

---

---

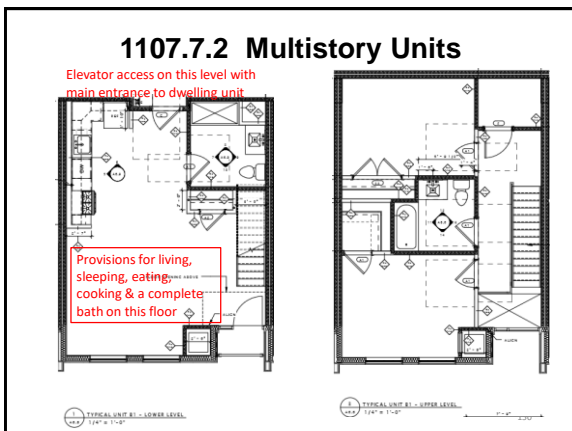

---

---

---

---

---

---

---

---



### 1108.2.7 – Assistive Listening Systems

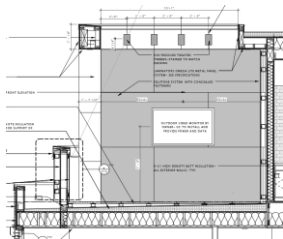

Space used for assembly purpose with audible communications

A/V monitor on roof deck

TABLE 1108.2.7.1  
RECEIVERS FOR ASSISTIVE LISTENING SYSTEMS

CAPACITY OF SEATING IN ASSEMBLY AREAS	MINIMUM REQUIRED NUMBER OF RECEIVERS	MINIMUM NUMBER OF RECEIVERS TO BE HEARING-AID COMPATIBLE
50 or less	2	2
51 to 500	9 plus 1 per 95 seats over 50 seats*	9

---

---

---

---

---

---

---

---

---

---



### Use of OEDM Training Materials

Use of Office of Education and Data Management (OEDM) training materials must be approved in writing by the State of Connecticut, Department of Administrative Services' Office of Communications. In approving of such use, the State of Connecticut assumes no liability associated with such use, including, but not limited to, the user's dissemination of any inaccurate information or interpretation in connection with its use of these training materials. Use of the training materials is at the sole risk of the user, and the State's approval of the use does not constitute an endorsement of the user or its intended use.

152

---

---

---

---

---

---

---

---

---

---

**MILTON GREGORY GREW, AIA**  
"GREG"

*Licensed Architect - Licensed Building Official - Codes Consultant*  
(203) 217-1074  
mgregrew@grewdesign.com  
www.CTbuildingcodes.com  
www.linkedin.com/in/mgregrew

Director of Inspections & Permits  
Town of East Hartford  
(860) 291-7345  
mgregrew@easthartfordct.gov

153

---

---

---

---

---

---

---

---

---

---

