



Office of Education and Data Management
Fall 2018 Career Development Seminar

September 2018

NFPA 13, 14 and 20 - From 2002 to 2016 - What's New

*Presented by
Ignatius Kapalczynski, Principal, American Fire Services Solutions*

Purpose

- Three new editions since adoption of long term 12/31/2005 Codes
- Many technological advances
- Long time since last fire suppression systems in-service
- Nearly 500 newly certified fire marshals and as many building officials
- Credits, coffee & doughnuts, networking

2



Fire Suppression Systems Installation Standards

- NFPA 13 Automatic Sprinkler Systems
- NFPA 14 Standpipe Systems
- NFPA 20 Fire Pumps

3

Scope & Objective

- New information and changes in the codes
- Forthcoming 2016 Installation Codes
- Designers may use latest edition of code long before State adopts it
- Refresher on organization and use of the installation standards

4



Sprinklers



Sprinklers

- Not much new since the invention of water
- Presently adopted 2010 edition
- Expected adoption 2013 edition
 - Based on 2015 edition model codes for 2018 CSFSC
- Available edition 2016
 - Newer editions refine and clarify earlier editions

6



NFPA 13 Sprinkler Systems Summary of Changes 2007

- Storage definition? One area
- Private water supply terms
- Ordinary Hazard 1, Ordinary Hazard 2 clarified
- Requirements for trapeze hangers
- Seismic
- Separation of storage chapters

7

NFPA 13 Sprinkler Systems Summary of Changes 2010

- Large drop and CMSA sprinklers
- Smoke vents Chapter 12
- Sway bracing zones of influence Chapter 9
- Expansion chambers (note MDC issues)
- Ceiling pocket rules
- Large anti-freeze systems

8



NFPA 13 Sprinkler Systems Summary of Changes 2010

- Reduce storage design areas to 3000 ft.²
- Shelf areas
- Back to back shelf storage
- Carton records storage
- Compact shelving
- High bay records

9

NFPA 13 Sprinkler Systems Summary of Changes 2013

- Separation of NFPA 750 mist systems
- Anti-freeze prohibited but.....
- Heat tracing
- Dry drop lengths
- Alternative freeze protection
- Elevator omissions
- Shared support
- Sway bracing
- Performance based storage protection

10



NFPA 13 Sprinkler Systems Summary of Changes 2016

- Metric conversion
 - Exact to approximate
 - Enforce in English but tolerate in SI
- Single vent for wet system to remove air
- Alternative protection scheme, and NFPA 30
- Cloud ceilings
- Chapter 10 equals NFPA 24

11

NFPA 13 Sprinkler Systems Chapter 1 Administration

- 1.1.2 Standard does not include Water Mist Systems
 - Not considered fire sprinkler systems
 - Separate standard NFPA 750
 - Connecticut history
 - Codes and Standards interpretation
 - Requirement for hardship
 - New technology.

12



NFPA 13 Sprinkler Systems Chapter 1 Administration

- 1.1.3 Standard assumptions
 - Single fire originating within building
 - One point of origin
 - Natural or accidental cause. Not arson

13

NFPA 13 Sprinkler Systems Chapter 1 Administration

- 1.3.2 Application
 - Combined service mains
 - Fire protection mains
- 1.4 Retroactivity
 - Acceptable requirements at time when issued

14



NFPA 13 Sprinkler Systems Chapter 1 Administration

- 1.5 Equivalency
 - Nothing prevents use of equivalents or superior
 - Systems
 - Methods
 - Devices
 - Strength
 - Fire resistance
 - Effectiveness
 - Durability
 - Safety
 - (NFPA 750?)

15

NFPA 13 Sprinkler Systems Chapter 1 Administration

- 1.7 New technology
 - Nothing prevents or restricts
 - New technologies
 - Alternate arrangements
 - Level of safety not lowered

16



NFPA 13 Sprinkler Systems Chapter 1 Administration 2016

- 1.6.3 Metric Conversion Guidance
 - Exact dimensions
 - Nominal dimensions (e.g. pipe sizes)
 - Metric equivalent might not be exact conversion
 - Nominal metric equivalent is reasonable equivalent
 - Exact or nominal conversion acceptable
 - Be reasonable but be consistent.

17

NFPA 13 Sprinkler Systems Chapter 2 Reference Publications

- 2.4 References for extract in mandatory sections
 - Good supporting references.

18



NFPA 13 Sprinkler Systems Chapter 3 Definitions

- New definitions
- Newly explicit definitions for existing terms
- Concepts that were causing arguments or misinterpretations
 - Ceiling pocket
 - Vaulted, architectural
 - Control valve
 - Floor control valves
 - Draft curtain
 - Construction, protection, location
 - Fuel fired heating unit

19

NFPA 13 Sprinkler Systems Chapter 3 Definitions

- New definitions
- Newly explicit definitions for existing terms
- Concepts that were causing arguments or misinterpretations
 - High volume low speed fans (HVLS)
 - Large, slow, Casablanca type
 - Obstruction
 - Not what it is but what it does
 - Raw water source
 - Contamination, chemical, biological
 - Premixed anti-freeze solution
 - Not flammable

20



NFPA 13 Sprinkler Systems Chapter 3 Definitions

- New definitions
- Newly explicit definitions for existing terms
- Concepts that were causing arguments or misinterpretations
 - Multi cycle system
 - On-Off, back to the 1970's
 - Air receiver
 - Chamber, diaphragm for dry/preaction systems
 - Dampens surges
 - Air reservoir
 - Chamber, same pressure for wet systems
 - Dampens water hammer
 - Armover
 - New explicit definition, ancient concept.

21

NFPA 13 Sprinkler Systems Chapter 4 General Requirements

- 4.4 Additives
- Not permitted
 - Stop leak additives or chemicals
 - Sodium silicate
 - Derivatives of sodium silicate
 - Brine
 - Similar acting chemicals

22



NFPA 13 Sprinkler Systems Chapter 4 General Requirements

- 4.5 Air, nitrogen, or other approved gas
- Permitted
 - Charging
 - Maintaining
 - Supervising

23

NFPA 13 Sprinkler Systems Chapter 4 General Requirements

- Nitrogen
 - MIC control
 - Dehumidification
 - Atmospheric nitrogen is 79% anyway.
 - Did anyone here put nitrogen in their tires?
 - What does the extra 20% nitrogen do?
 - What did they tell you it does?

24



NFPA 13 Sprinkler Systems Chapter 5 Classification of Occupancy and Commodities

- 5.6.2 Classifying commodities stored on pallets
 - Commodity classes may increase by one or two
 - Affects design densities

25

NFPA 13 Sprinkler Systems Chapter 6 System Components and Hardware

- 6.2.1.1 Removed Sprinkler shall not be reinstalled.
- 2016 6.2.1.1.1 Removed dry sprinklers may be reinstalled
 - Per manufacturers installation/maintenance instructions.
 - Annex – Undamaged sprinklers attached to original fitting
 - Flexible hose connections are considered a fitting.
- 6.6.1.2 (2016 6.7.1.2) Valve closure time
 - Not less than 5 seconds
 - Operating at maximum possible speed
 - From fully open position
 - All sprinkler listed valves should comply
- 6.6 Hangers
 - In accordance with Section 9.1
 - This is a handy cross reference.

26





27

NFPA 13 Sprinkler Systems Chapter 6 System Components and Hardware

- 6.2.6.2 Painting
- 6.2.6.2.1 Sprinklers only painted by sprinkler manufacturer.
- 6.2.6.2.2 When sprinklers painted by others:
 - REPLACE with new!
- 6.2.6.2.3 When cover plates and concealed sprinklers painted by others:
 - REPLACE with new!
- 6.2.6.4.3 Sprinklers that have been painted or coated:
 - REPLACE with new!

28



NFPA 13 Sprinkler Systems Chapter 6 System Components and Hardware

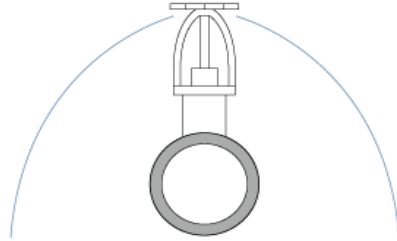

29

NFPA 13 Sprinkler Systems Chapter 6 System Components and Hardware

- 6.2.7.1 Plates, escutcheons or other devices
 - Metallic
 - Listed for application
- 6.2.7.4 Caulking or glue to seal fix recessed escutcheon
 - Not permitted
- 6.3.7 NEW Detailed requirements for nonmetallic pipe.

30



NFPA 13 Sprinkler Systems Chapter 6 System Components and Hardware

- 2016 NEW 6.4.5 Fitting pressure limits (300 psi)
- 6.8.1.2 Threadless couplings permitted
 - Per authority having jurisdiction
 - Per listing for such use.
- NOTE - Sprinkler systems only
 - Not standpipes
 - Not combined sprinkler standpipe
 - Option will likely vanish with the higher pressure requirements, beware of fittings no longer being listed.
- 6.9, 6.10 Signs. Section reserved but time is coming
 - Proper signage is vital for people new to the system
 - Usually outlives most careers.

31

NFPA 13 Sprinkler Systems Chapter 6 System Components and Hardware

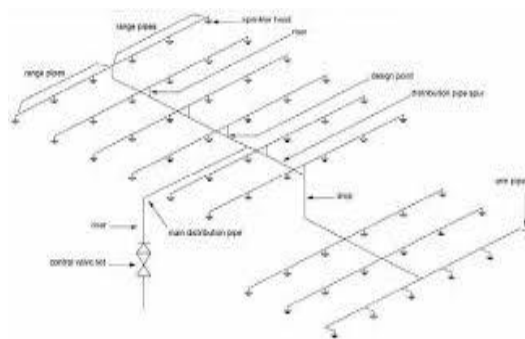

32

NFPA 13 Sprinkler Systems Chapter 7 System Requirements

- 7.1.2.2 Where auxiliary air reservoirs installed to absorb pressure increases, a relief valve shall not be required
 - Maybe for sprinkler, but fire pump still needs
- 7.1.4 Heat tracing shall not be used in lieu of heated valve enclosures for freeze protection
 - Valves
 - Supply pipe

33

NFPA 13 Sprinkler Systems Chapter 7 System Requirements

- 7.2.3 Size of dry pipe systems.
 - HISTORY - Size determines:
 - Volume
 - Water delivery time
 - Size limitations attempted to limit water delivery time
 - Water delivery times have decreased
 - Calculation models for evaluating water delivery time acceptable
 - Exhausters not permitted
 - Case study, many challenges

34



NFPA 13 Sprinkler Systems Chapter 7 System Requirements

- 7.2.3.6 Dry pipe system water delivery times
 - Per chart by occupancy hazard
 - Note that 7.2.3.1.1.1 and 7.2.3.6.3 dwelling units is 15 seconds
 - Calculations necessary
- 7.2.4 Quick Opening Device detailed requirements
- 7.2.5.4 High water level protection for externally resetting dry pipe valves.
- 7.2.6.8 Nitrogen
 - As previously discussed cross reference

35

NFPA 13 Sprinkler Systems Chapter 7 System Requirements

- 7.5 Multi-cycle systems
 - On-Off
 - Abandoned – more fire damage
 - They're baaaaack!
- 7.6 Anti-freeze systems
 - More details
 - Requirements for anti-freeze solutions
 - No size limitation
 - History – flammable antifreeze situations

36



NFPA 13 Sprinkler Systems Chapter 7 System Requirements 2016

- 2016 7.1.5 Air venting
 - Single air vent for metallic wet pipe system
 - MIC issue???
- 2016 7.7 Outside sprinklers (exposure protection sprinkler systems)
 - More detailed requirements.

37

NFPA 13 Sprinkler Systems Chapter 7 System Requirements

- 7.9 Refrigerated spaces
 - Refrigerated warehouses
- 7.9.2.8 Detectors for pre-action systems

38



NFPA 13 Sprinkler Systems Chapter 7 System Requirements

- 7.11 Additives and coatings
 - Control of microbiological or other corrosion
 - Listed for use - internally and externally
 - No prescription necessary
- Case study do they actually work, is there much experience with it?

39

NFPA 13 Sprinkler Systems Chapter 8 Installation Requirements

- 8.1 Basic requirements
 - 96% of the requirements
 - 96% of the installation and enforcement issues.

40



NFPA 13 Sprinkler Systems Chapter 8 Installation Requirements

Basic principles:

- 1 - Sprinklers installed throughout premises
- 2 - Sprinkler located within maximum protection area
- 3 - Sprinkler positioned:
 - Satisfactory activation time
 - Satisfactory distribution
- 4 - Sprinkler omitted only where specifically allowed
- In Connecticut by amendments to the Building and Fire Safety Codes.

41

NFPA 13 Sprinkler Systems Chapter 8 Installation Requirements

Basic principles:

- 5 – Per listing and testing
- 6 – Per manufacturers specifications
- 7 – Not inside furniture, such as portable wardrobe units, cabinets, trophy cases, unless occupied
- 8 – Not electrical equipment, mechanical equipment, or handling units unless occupied
- Connecticut – Not where people live and sleep in new town houses and 1 & 2 family dwellings.
 - Legislature agrees with sprinkler opponents that fire fatalities in what would have been sprinkled buildings are just statistical anomalies.

42



Sprinkler obstruction

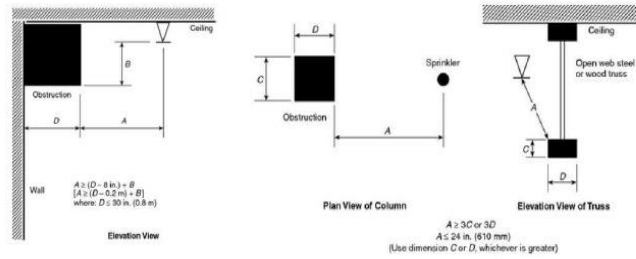

43

Inspection

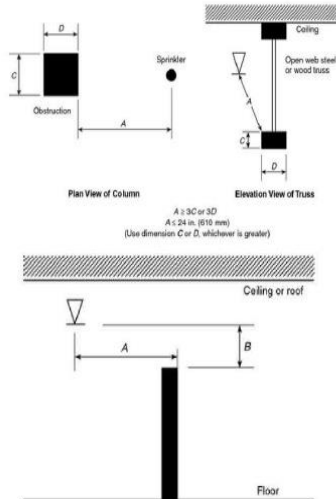

Sprinkler obstructions

- Pattern development
- Water distribution

44

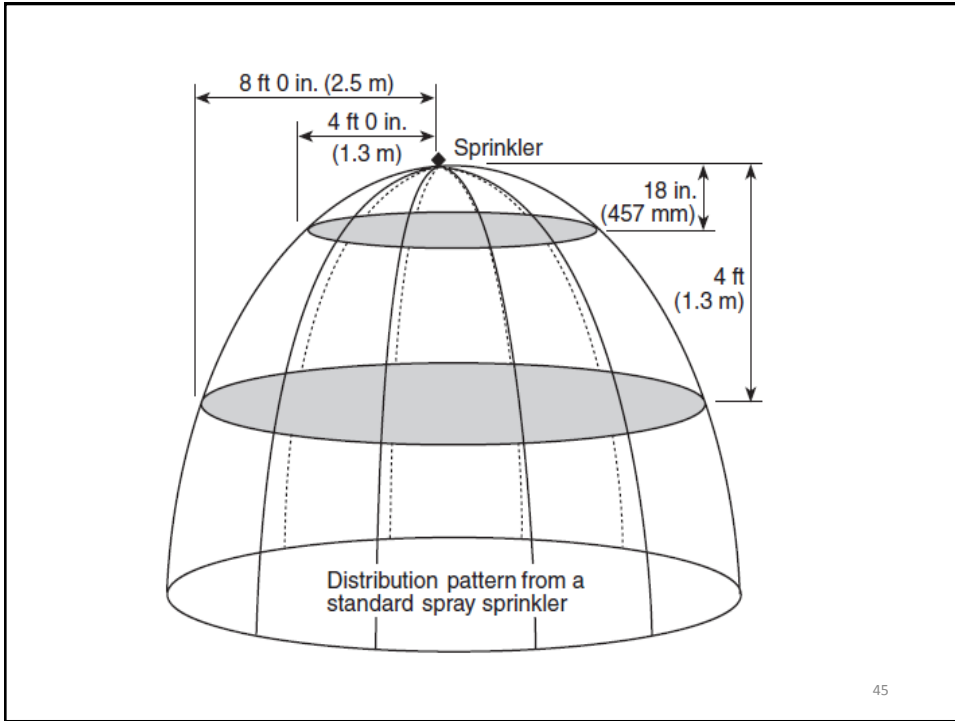

NFPA 13 Sprinkler Systems Chapter 8 Installation Requirements

- 8.2.4 Single riser for multiple buildings attached by canopies, covered breezeways, common roofs, or a common wall
 - Maximum size per 8.2.1.
- 8.2.5 Detached buildings need separate fire sprinkler systems.
 - Unless acceptable to Authority Having Jurisdiction
 - And Mechanical Code

47

NFPA 13 Sprinkler Systems Chapter 8 Installation Requirements

- 8.3.1.5 Protective caps and straps removed per manufacturers installation instructions.
 - Protective caps and straps shall be removed from all sprinklers prior to sprinkler system placed in service
- 8.4.9.1 Dry barrel sprinkler requirements

48



Dry Drop

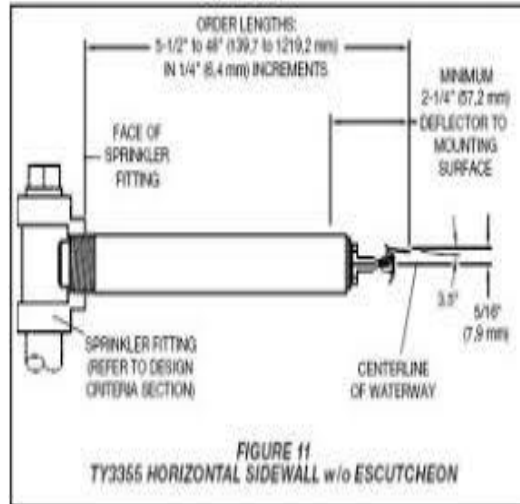

49

NFPA 13 Sprinkler Systems Chapter 8 Installation Requirements

- 8.16.1.5 and 2016 8.2.4 Floor Control Valve Assemblies
 - Multi story buildings exceeding two stories in height
 - Floor control valve
 - Check valve
 - Main drain valve
 - Flow switch for isolation, control, annunciation of water flow
 - For each individual floor level.
 - Top floors of birdcage design
 - Area of all floors is less than system size limit

50

NFPA 13 Sprinkler Systems Chapter 8 Installation Requirements

- 8.16.2.4.7 Floor control valve drains
- 8.16.2.4.8 Riser drains
- Floor control valve, check valve, main drain valve, and flow switch required by 8.2.4.1 shall not be required with the total area of all floors combine does not exceed the system protection area limitations of 8.2.1.
- Requirements of 8.2.4 shall not apply to dry systems in parking garages

51

NFPA 13 Sprinkler Systems Chapter 8 Installation Requirements

- 8.5.3.2.4 Bay window coverage rule
- 8.5.4.1.2 Corrugated roof, measuring from the bottom of the flute, from the top of the flute, or to the insulation.
- 8.5.4.1.4 Heat collectors not permitted. Attention design professionals.
 - Sometimes you have to wonder why these things have to be put in writing.
 - And all of you will catch them.
- 8.5.5.4 Closets
 - Note – Measurement is cubic volume, not square area
 - Used to be known as the small room rule.

52



NFPA 13 Sprinkler Systems Chapter 8 Installation Requirements

- 8.9.5.2.1.7 Sprinkles and fans
 - Less than 60 inches diameter
 - Plan view of fan at least 50% open
- 8.11 Control Mode Special Application (CMSA) sprinklers
 - Previously known as ESFR and large drop sprinklers
- 8.14 Pilot line detectors
 - Follow detector requirements, not sprinkler spacing
- 8.15.5.7 Combustible suspension in elevators

53

NFPA 13 Sprinkler Systems Chapter 8 Installation Requirements 2016

- 2016 8.15.24 Cloud ceiling requirements
- 2016 8.15.1.2.1.3 Space above Clouds Ceilings
 - Openings limited 20% of the ceiling
 - Construction feature
 - Plane of boundaries
 - Note – No reference to angle of installation
- 2016 8.18 Sprinkler system not used for electrical bonding and grounding
 - May be grounded itself for lightning protection

54



NFPA 13 Sprinkler Systems Chapter 8 Installation Requirements

- 8.15.1.2.7.1 Concealed spaces filled with non-combustible insulation
 - Not require sprinkler protection
 - Maximum 2 inch gap at the top permitted
 - Spaces difficult to fill
 - Insulation settles
- 8.15.1.2.15-18 Exterior columns, soffits, eaves, overhangs and decorative frame elements
 - NOTE 2016 No openings or direct penetrations into building
- 8.15.1.3 Concealed space design requirements
 - Cross reference to chapter 11 requirements for unsprinklered concealed spaces

55

NFPA 13 Sprinkler Systems Chapter 8 Installation Requirements

- 8.15.4 Vertical openings draft stops and closely spaced sprinklers
 - Versus Connecticut amended 903.3.1.1.2
 - History
- 8.15.5.7 Combustible suspension elevators
 - As mentioned before in summary
- 8.15.6.2 Sprinklers under ground floors
 - Misinterpretation with basement concealed spaces

56



NFPA 13 Sprinkler Systems Chapter 8 Installation Requirements

- 8.15.9 Hospital clothes closets
 - Comment added when sprinklers in wardrobes were being required by health inspectors
- 2016 8.15.8.1 Sprinklers and bathrooms of healthcare facilities
- 2016 8.15.25 Sprinkler is not required in revolving door enclosures
 - Not rocket science, took years to put in code
- 8.15.26 Sprinkler protected glazing as an alternative to fire resistance rated construction
 - Although Specified in the sprinkler code, not permitted in Building Code (Section 703.4)
 - Cross reference 11.3.5

57

NFPA 13 Sprinkler Systems Chapter 8 Installation Requirements

- 2016 8.16.2.4.6 Main drain connections
 - Discharge outside
 - Floor drain capable of handling flow of main drain
 - Common mistake - floor drain 4 inches or less versus 2 inch main drain under pressure. 4 inch inadequate
- 2016 8.16.6 Air Venting
 - Air bleed from systems
 - Wet systems only, think about it
- 8.16.1.1.2.5 Listed backflow prevention assembly shall be permitted to be control valve
 - Provided both control valves listed for fire protection system use

58



NFPA 13 Sprinkler Systems Chapter 8 Installation Requirements

- 8.16.3 Ordinary Hazard systems arranged for flushing
 - Periodic flushing is not required by NFPA 25
- 8.16.4.1.4 Heat tracing systems
 - Listing required
 - Specific to supply mains, cross mains, branch lines
 - Electrically supervised
- 2016 8.17.2.5.2.3.7 Sign showing location of all low point drains at main valve
- 2016 8.17.4.3.5 & 8.17.4.4.7 Trip test manifolds for water delivery time testing for dry pipe and preaction systems

59

NFPA 13 Sprinkler Systems Chapter 9 Hanging, Bracing, and Restraint of System Piping

- 9.1.1.3 Support structures may be shared
 - Certified by registered professional engineer
 - Support five times weight of water filled sprinkler pipe +250 pounds plus all the other stuff
 - But nothing can be supported from the sprinkler piping as before

60



NFPA 13 Sprinkler Systems Chapter 9 Hanging, Bracing, and Restraint of System Piping

- 9.1.2.3 Where branch line pitch 6 in 12 or greater
 - Reduction in lateral loading by:
 - 1 - Second hanger in addition to required hangers,
 - 2 - Lateral sway bracing assemblies on the mains
 - 3 – Branch line hangers utilizing articulating structural attachment
 - 4 - Equivalent means
 - Provide drawings

61

NFPA 13 Sprinkler Systems Chapter 9 Hanging, Bracing, and Restraint of System Piping

- 9.1.2.6 Threaded sections of rods shall not be formed or bent
 - NOTE – Most rods are all threaded
- 9.1.5.5 Nails not acceptable for fastening hangers

62



NFPA 13 Sprinkler Systems Chapter 9 Hanging, Bracing, and Restraint of System Piping

- 9.2.1.3.3.3 Flexible sprinkler hose fittings exceeding 6 feet in length
 - Additional hanger
- 9.2.3.7 Sprigs greater than 4 feet
 - Restrained against lateral movement.
 - Note that this would also apply to dry drops
- 9.2.5.3 Riser clamps anchored to walls using hanger rods in the horizontal position not permitted to vertically support risers
- 9.2.6 Requirements for pipe stands

63

NFPA 13 Sprinkler Systems Chapter 9 Hanging, Bracing, and Restraint of System Piping

- 9.3.2 Flexible couplings to accommodate differential building movement
- 9.3.5.2 Sway bracing
 - Required to be listed
 - Except when not required to be listed
 - That's what it says (must follow Table specifications)
- 2016 9.3.4 Clearance is required for pipes
 - New sections provide exceptions
- 2016 9.3.5 More sway bracing requirements
- 9.3.5.12.8.2 Prying factor for concrete fasteners - new

64



NFPA 13 Sprinkler Systems Chapter 10 Underground Piping 2016

- 2016 10.1.1.2.2 Where listing limitations or installation instructions differ from the requirements of the standard, the listing limitations and installation instructions shall apply
 - This is in the underground pipe section

65

NFPA 13 Sprinkler Systems Chapter 10 Underground Piping 2016

- 10.1.3 FDC – coated, wrapped, internally galvanized
- 10.2 Fittings
- 10.3 Connections
- 10.4 Private mains
 - 10.4.3 Not under buildings (always there – now explicit)
- 10.5 Grounding, Bonding
- 10.7 Steep grades

66



NFPA 13 Sprinkler Systems Chapter 10 Underground Piping

- 10.10.2.2 Hydrostatic testing
- 10.10.2.4 Operating test
- 10.10.2.5 Forward flow test of backflow prevention assemblies

67

NFPA 13 Sprinkler Systems Chapter 11 Design Approaches

- Coordinate with Chapter 23
- 11.1.4.2 Minimum sprinkler system water demand requirements
 - Hose stream allowance plus
 - Water demand for sprinklers.
 - Exception for stored supplies deleted in 2013
- 11.1.5.1 Duration
 - Occupancy hazard
 - Per Chapter 11
- 11.1.5.2 Tanks sized to supply equipment served
 - NOTE - Differs from break tank requirements
 - Reviewed further in fire pump section

68



NFPA 13 Sprinkler Systems Chapter 11 Design Approaches

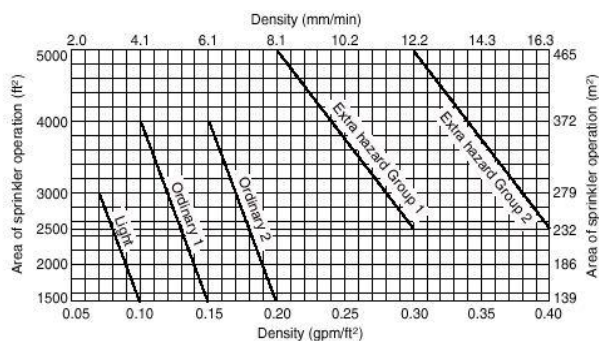

FIGURE 11.2.3.1.5 Density/Area Curves.

69

NFPA 13 Sprinkler Systems Chapter 11 Design Approaches

- 11.1.7 High Volume Low Speed Fans
 - 1 - Maximum fan diameter 24 feet
 - 2 - Fan centered approximately between 4 adjacent sprinklers
 - 3 - Vertical clearance fan to sprinkler deflector minimum 3 feet
 - Fans interlock to shut down immediately upon receiving fire signal from alarm system

70

NFPA 13 Sprinkler Systems Chapter 11 Design Approaches

- Time of Water Delivery
 - By Occupancy
 - Calculation program
 - Submitted for review
 - Verified by acceptance test

71

NFPA 13 Sprinkler Systems Chapter 11 Design Approaches

- 11.2.3.3.3 To utilize Room Design Method
 - All rooms enclosed with walls having a fire resistance rating equal to the water supply
 - In a strange twist, the walls have to have a fire resistant rated construction but do not have to be constructed as fire resistance rated walls, that is extending to and from another assembly of equal rating

72



NFPA 13 Sprinkler Systems Chapter 11 Design Approaches

- 11.2.3.1.4 (3,4) Design area adjustment for buildings having unsprinklered combustible concealed spaces
 - Allows designs that require 50% more water to substitute for providing sprinklers in combustible concealed spaces
 - Usually not a cost-effective option due to the amount of water and larger pipes necessary but an option nonetheless

73

NFPA 13 Sprinkler Systems Chapter 11 Design Approaches

- 11.3.1.4.1 Replacing residential sprinklers manufactured prior to 2003 that are no longer available from the manufacturer and that are installed using a design density of less than 0.05 GPM per square foot
 - Code outlasted the product

74



NFPA 13 Sprinkler Systems Chapter 11 Design Approaches

- 11.3.5 Sprinkler protected glazing, water supply duration requirement.
 - Note- as mentioned earlier concept not permitted by Building Code section 703.4

75

NFPA 13 Sprinkler Systems Chapter 11 Design Approaches

- 2016 11.3.4.2 Sprinkler spacing exceeds 8 feet measured perpendicular to the slope
 - Minimum sprinkler discharge pressure 20 PSI
 - Note - this one is easy to miss on drawings
- 11.3.1 Sprinkler design area increases to 8 sprinklers from 4 in residential occupancy is with unprotected combustible concealed spaces

76



NFPA 13 Sprinkler Systems Chapter 12 General Requirements for Storage

- 12.1.1.1 Vents, draft curtains, and ESFR sprinklers
- 12.1.4.1 High Volume Low Speed (HVLS) fans
 - Just repeating earlier requirements

77

NFPA 13 Sprinkler Systems Chapter 13 Miscellaneous Storage

78



NFPA 13 Sprinkler Systems Chapter 14 through Chapter 21 Specialized Storage

- Chapter 14 is now chapter 23
- Chapter 15 is now chapter 24
- Chapter 16 is now chapter 25
- Chapter 17 is now chapter 26
- Chapter 18 is now chapter 27

79

NFPA 13 Sprinkler Systems Chapter 14 through Chapter 21 Specialized Storage

- Chapter 14 – Class I through Class IV Commodities
Palletized, Solid Piled, Bin Box, Shelf, or Back-to-Back Shelf
Storage



80

NFPA 13 Sprinkler Systems Chapter 14 through Chapter 21 Specialized Storage

- Chapter 15 – Plastic and Rubber Commodities Palletized, Solid Piled, Bin Box, Shelf, or Back-to-Back Shelf Storage



81

NFPA 13 Sprinkler Systems Chapter 14 through Chapter 21 Specialized Storage

- Chapter 16 – Class I through Class IV Commodities in Racks



82

NFPA 13 Sprinkler Systems Chapter 14 through Chapter 21 Specialized Storage

- Chapter 17 – Plastic and Rubber Commodities in Racks



83

NFPA 13 Sprinkler Systems Chapter 14 through Chapter 21 Specialized Storage

- Chapter 18 – Rubber Tire Storage



84

NFPA 13 Sprinkler Systems Chapter 14 through Chapter 21 Specialized Storage

- Chapter 19 – Roll Paper



85

NFPA 13 Sprinkler Systems Chapter 14 through Chapter 21 Specialized Storage

- Chapter 20 Special Designs
 - Plastic Motor Vehicle Components
 - Plastics
 - Baled Cotton
 - Carton Records Storage in Racks
 - Compact Storage Units
 - High Bay Records Storage

86

Compact Storage System



87

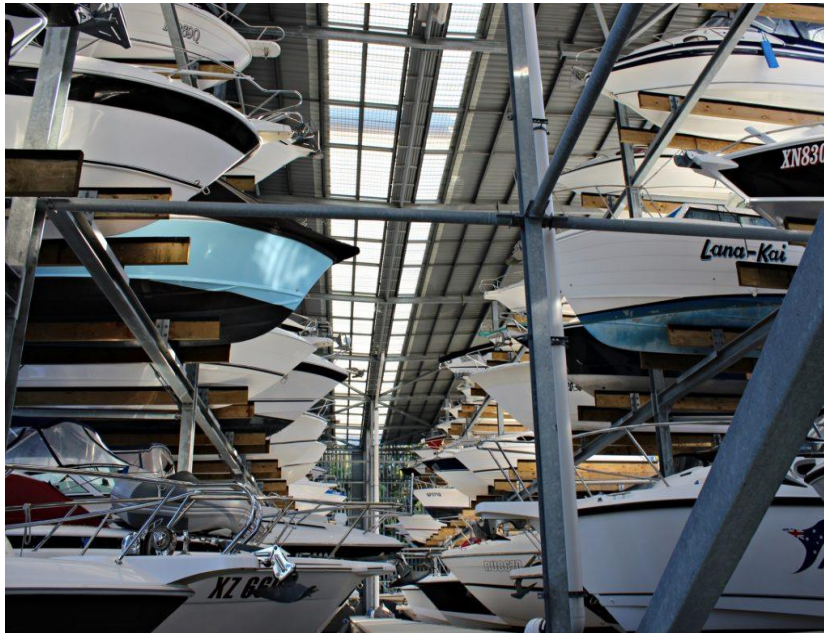

88

NFPA 13 Sprinkler Systems Chapter 14 through Chapter 21 Specialized Storage

- Chapter 21 – Alternative Sprinkler Designs for Chapter 12 through 20

89

NFPA 13 Sprinkler Systems Chapter 22 Special Occupancy Requirements

- 1 – General
- 2 – Flammable & Combustible Liquids (NFPA 30)
- 3 – Aerosol Products (NFPA 30B)
- 4 – Spray Application Using Flammable or Combustible Materials (Spray Booths) (NFPA 33)
- 5 – Solvent Extraction Plants (NFPA 36)
- 6 – Stationary Combustion Engines and Gas Turbines (NFPA 37)
- 7 – Nitrate Film (NFPA 40)

90



NFPA 13 Sprinkler Systems Chapter 22 Special Occupancy Requirements

- 8 – Laboratories Using Chemicals (NFPA 45)
- 9 – Oxygen Fuel Gas Systems for Welding, Cutting, and Allied Processes (NFPA 51)
- 10 – Acetylene Cylinder Charging Plants (NFPA 51A)
- 11 – Compressed Gases and Cryogenic Fluids (NFPA 55)
- 12 – Utility LP-Gas Plants (NFPA 59)
- 13 – Production, Storage, and Handling of LNG (NFPA 59A)

91

NFPA 13 Sprinkler Systems Chapter 22 Special Occupancy Requirements

- 14 – Information Technology Equipment (NFPA 75)
- 15 – Incinerators and Waste and Linen Handling Systems and Equipment (NFPA 82)
- 16 – Ovens and Furnaces (NFPA 86)
- 17 – Health Care Facilities Hyperbaric Chambers (NFPA 99)
- 18 – Fixed Guideway Transit and Passenger Rail Systems (NFPA 130)
- 19 – Motion Picture and Television Production Studio Soundstages (NFPA 140)

92



NFPA 13 Sprinkler Systems Chapter 22 Special Occupancy Requirements

- 20 – Animal Housing Facilities (NFPA 150)
- 21 – Water Cooling Towers (NFPA 214)
- 22 – Marine Terminals, Piers, and Wharves (NFPA 307)
- 23 – Semiconductor Fabrication Facilities (NFPA 318)
- 24 – Aircraft Hangars (NFPA 409)
- 25 – Aircraft Terminal Buildings, Fueling Ramp Drainage, and Loading Walkways (NFPA 415)

93

NFPA 13 Sprinkler Systems Chapter 22 Special Occupancy Requirements

- 26 – Aircraft Engine Test Facilities (NFPA 423)
- 27 – Advanced Light Water Reactor Electric Generating Plants
- 28 – Light Water Nuclear Power Plants (NFPA 804)
- 29 – Hydroelectric Generating Plants (NFPA 851)
- 30 - Cultural Resource Properties – Museums, Libraries and Places of Worship (NFPA 909)
- 31 – National Electrical Code (NFPA 70)

94



NFPA 13 Sprinkler Systems Chapter 22 Special Occupancy Requirements

- 32 – Telecommunication Facilities (NFPA 76)
- 33 – Exhaust Systems for Air Conveying of Vapors, Gases, Mists, and Noncombustible Particulate Solids (NFPA 91)
- 34 – Hypobaric Facilities (NFPA 99B)
- 35 – Coal Mines (NFPA 120 & 123)
- 36 – Metal/Non Metal Mining and Metal Mineral Processing Facilities (NFPA 122)
- 37 – Hazardous Materials (NFPA 400)

95

NFPA 13 Sprinkler Systems Chapter 23 Plans and Calculations

- Coordinate with Chapter 11
- 23.2.1.1 Water flow test for system design
 - No more than 12 months prior
 - Water purveyor approval may be required
 - Approved by authority having jurisdiction
- 23.4.4.1.1.5 When total design discharge from operating sprinklers less than minimum required discharge rate determined by multiplying the required design density time
 - Additional flow to be added at point of connection of branch line to cross main furthest from source

96



NFPA 13 Sprinkler Systems Chapter 23 Plans and Calculations 2016

- 2016 23.3.5.2 Summary sheet
 - Additional information required
- 2016 23.5 Note added for deluge sprinklers
 - Do them like everything else
- 23.8 In rack sprinkler demands
- 23.9 Hose allowance demands

97

NFPA 13 Sprinkler Systems Chapter 24 Water Supplies

- 24.1.5 Water supply treatment
 - Water supplies and environmental conditions shall be evaluated
 - Existence of microbes
 - Conditions that contribute to microbiologically influenced corrosion
 - Unusual corrosive properties

98



NFPA 13 Sprinkler Systems Chapter 24 Water Supplies

- Owners shall notify the sprinkler system installer and a plan shall be developed to treat the system using one of the following methods:
 - 1 - Install piping not affected by microbes,
 - 2 - Treat all water in system with approved biocide or corrosion inhibitors,
 - 3 - Implement approved plan for monitoring interior conditions of pipe at established time intervals and locations,
 - 4 - Install corrosion monitoring station and monitor at established intervals

99

Fire Department Connection - Sprinkler



100

NFPA 13 Sprinkler Systems Chapter 25 Systems Acceptance

- 2016 25.2.2.1.1 Additional test for leakage
 - Four hours with compressor off
- 25.2.4 Acceptance testing for pressure reducing valves
- 25.2.5 Acceptance testing for backflow prevention assemblies
- 25.6 General information sign
 - 2016 even more info
 - Important data for people new to the system

101

NFPA 13 Sprinkler Systems Chapter 26 Marine Systems

- Not referenced by SBC, CSFSC, CSFPC

102



NFPA 13 Sprinkler Systems Chapter 27 System Inspection, Testing, and Maintenance

- 27.2.1 Inactive sprinkler systems abandoned in place
 - When all or part of an inactive sprinkler system is up and in place, components including sprinklers, hose valves and hoses, and alarm devices shall be removed.
 - Correlate with Connecticut abandoned building requirements in Building Code

103

NFPA 13 Sprinkler Systems Annexes Annex A – Explanatory Material

Handbook stuff

104



NFPA 13 Sprinkler Systems Annexes Annex B – Miscellaneous Topics

Performance Criteria

Selection of Density and Area of Application

Geometry of Area of Application (Remote Area)

Ability to Predict Expected Performance from Calculated Performance

Future Upgrading of System Performance

Effect of Clearance to Ceiling on Sprinkler Performance

These are the rationales needed to resolve uninformed arguments by designers who didn't know about them

105

NFPA 13 Sprinkler Systems Annexes Annex C – Explanation of Test Data and Procedures for Rack Storage

106



NFPA 13 Sprinkler Systems
Annexes
Annex D – Sprinkler System Information from
the 2012 Edition of the Life Safety Code

Handy information where NFPA 101 requirements match CT
Part III IBC requirements

107

NFPA 13 Sprinkler Systems
Annexes
Annex E – Development of the Design Approach to
Conform with SEI/ASCE 7

Useful for Seismic Bracing
Annex E design approach to seismic

Scam – Fancy numbers and calculations cut and pasted
from an entirely different project

108



NFPA 13 Sprinkler Systems Annexes Annex F – Informational References

Related Standards from everywhere

109

Standpipes



110

NFPA 14 – Standpipes What's new

- Pressure reducing valve
- Horizontal standpipe requirements
- Heat tracing
- Valve and drain requirements
- Welding requirements

111

NFPA 14 – Standpipes What's new

- 4.4.2.4 Welding requirements
- 4.8.2 Each fire department connection shall have:
 - At least two 2 1/2 inch internal threaded swivel fittings
 - Having NHS threads per NFPA 1963
- 5.2 Dry pipe systems
 - More requirements
- 5.5 Pressure regulating devices

112



NFPA 14 – Standpipes What's new

- 6.1.2 Heat tracing requirements if used
- 8.1.2 Plans and calculations, information required
- 8.2.1 Standpipe system piping
 - Shall be sized by hydraulic calculations
 - No more pipe schedule
- 12.8.1 Timing of water supply installation
 - When construction reaches a height at which public waterworks system pressure can no longer provide the required flow and pressure
 - Temporary or permanent fire pumps shall be installed
 - To provide protection to the uppermost level
 - Or to the height required by the AHJ.

113

NFPA 14 – Standpipes What's new

- What about abandoned buildings?
- What about buildings under demolition?
- Hartford, Deutsche Bank, etc.

114



Fire Pump



115

Fire Pump

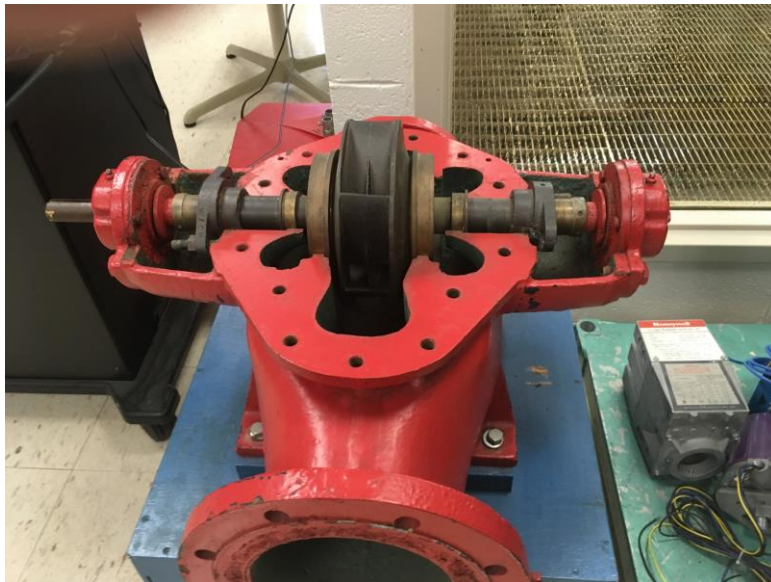

116

NFPA 20 – Fire Pumps What's new

- Variable speed drives
- Break tanks
- Component replacement
- High-rise buildings
- Fire pumps in series
- Positive displacement fire pumps for water mist systems
- Re-organization of Chapter 5 and Chapter 11

117

Fire Pump and Driver

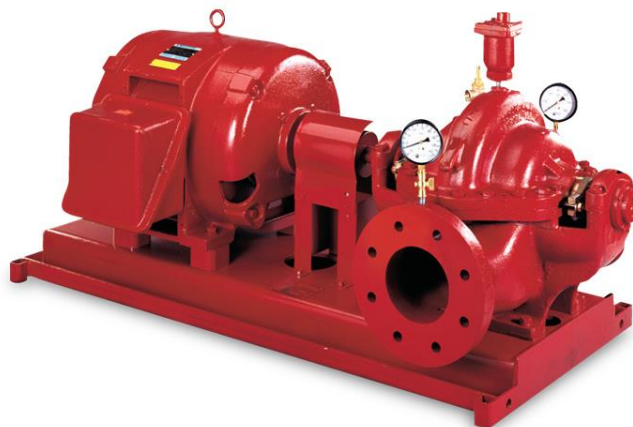

118

NFPA 20 – Fire Pumps What's new

- 4.4.1 Fire pump unit performance
 - Fire pump unit, consisting of a pump, driver, and control
 - Perform as an entire unit
 - When installed
 - When components replaced
- 4.6.1 Adequacy and dependability of the water source
 - Fully determined
 - Allowance for future reliability
 - Water flow test not more than 12 months prior
 - Otherwise as accepted by Authority Having Jurisdiction

119

NFPA 20 – Fire Pumps What's new

- Some water companies
 - No longer guarantee fire flows
 - Require issuing approval for any fire protection connections
 - Limit amount and type of demand that can be taken
- 4.6.2.2 Where water supply from public service main inadequate in quality, quantity, or pressure
 - Alternative water source shall be provided
 - Some water companies are making full usage of requirement

120



NFPA 20 – Fire Pumps What's new

- 4.6.2.3 Adequacy of the water supply
 - Shall be determined
 - Evaluated prior to specification and installation of fire pump
 - Some water companies placing limits on amount of fire protection water that can be used
 - Impact on the fire service is yet to be evaluated.

121

NFPA 20 – Fire Pumps What's new

- 4.7.7.1 Net pump shut off churn pressure
 - Maximum static suction pressure
 - Adjusted for elevation
 - Shall not exceed pressure rating of system components
- 4.7.7.3 Variable speed pressure limiting control drivers
 - Shall be acceptable to limit system pressure.

122



NFPA 20 – Fire Pumps What's new

- 4.12 Equipment protection
- Fire pump, driver, controller, water supply, and power supply shall be protected against possible interruption of service through damage
 - Explosion
 - Fire
 - Flood
 - Earthquake
 - Rodents
 - Insects
 - Winter storm
 - Freezing
 - Vandalism
 - Other adverse conditions

123

NFPA 20 – Fire Pumps What's new

- 4.18 Relief valves for centrifugal pumps
- 4.18.5.1 Relief valve shall discharge into an open pipe or cone or funnel secured to the outlet of valve
- 4.18.6.3 Relief valve discharge piping returning water back to the supply source, such as an aboveground storage tank.
- 4.18.7 Discharge to source of supply is still permitted
 - Provided there is a circulation relief valve on the loop
 - High cooling water temperature signal to stop the engine
 - If no active emergency requirements for pump to run.

124



NFPA 20 – Fire Pumps What's new

- 4.19 Fire pumps arranged in series
- 4.20.2.10 Where flow measuring device installed in loop arrangement for fire pump testing
 - Alternate means of measuring flow shall be located downstream of and in series with flow meter
 - This is a major change

125



126

NFPA 20 – Fire Pumps What's new

- 4.31 Break tanks
 - Where break tank provides pump suction water supply
 - Installation shall comply with section 4.31.
- 4.31.1 Application

Break tanks may be used for one or more of the following reasons:

 - 1 - Backflow prevention device between the water supply and the fire pump suction pipe
 - 2 - Eliminate fluctuations in water supply pressure
 - 3 - Provide quantity of stored water on site
 - Where normal water supply inadequate
 - Where water company does not allow for proper water supply to be drawn

127

NFPA 20 – Fire Pumps What's new

- 4.31.2 Break tank size
 - Break tank sized for minimum duration of 15 minutes with the fire pump operating at 150% of rated capacity
 - That's nice, then what?

128



NFPA 20 – Fire Pumps What's new

- 4.31.2.1 When break tank capacity less than maximum system demand for 30 minutes,
 - Refill mechanism shall meet requirements of 4.301.3.1.1 through 4.3 1.3.1.5
 - Refill mechanism shall be listed and arranged for automatic operation
 - 1 - Dual automatic refill lines
 - Each capable of refilling the tank at a minimum rate of 150% of the fire pump capacity shall be installed
 - Two 150% capacity lines? Not going to happen
 - Twice the demand of the fire pump, let's be serious.
 - 2 - Or at least two lines that meet or exceed 110% of the maximum for protection system design flow
 - Really???

129

NFPA 20 – Fire Pumps What's new

- Some designers try to use the break tank as a parallel storage tank however the municipal flow rate if inadequate cannot be supplemented with a partial duration storage tank. It doesn't work.

130



NFPA 20 – Fire Pumps What's new

Chapter 5 Fire pumps for high rise buildings.

- Very tall buildings require back up systems to the fire pump
- Either by storage or by backup pumps
- Two water supplies are required, storage permitted
- Two water supplies are required in earthquake zones
- Modified in Connecticut.

- Buildings under construction, abandon high-rise buildings, and buildings under demolition

131

NFPA 20 – Fire Pumps What's new

- 10.10 Controllers with variable speed pressure limit in control or variable speed suction limiting control
- Many detailed requirements
- 14.2.6.3.1 Pumps with variable speed pressure control
 - Tested at no flow, 25%, 50%, 75%, 100%, 125%, and 150% of rated load in the variable speed mode
 - Also tested at minimum, rated, and peak loads at rated speed.
- Variable fire pumps already present in Connecticut

132



NFPA 20 – Fire Pumps What's new

- Fire pump room shall be physically separated by fire rated construction
- Fire pump room shall be free from storage, equipment, and penetrations not essential to the operation of the pump and related components
- Access, heating, emergency lighting, ventilation, drainage, guards,
- These requirements are not found in the fire safety codes and consequently may be missed by design professionals. Design errors have been liberally modified by the state
- Modifications encroach on contractual agreements and arbitration and cost recovery

133

SBC and CSFSC Chapter 4

- 402 Mall buildings (AS & SP)
- 403 High Rise Buildings (AS & SP)
- 404 Atriums (CT exception) (AS)
- 405 Underground Buildings (AS & SP)
- 406 Open Parking Garage (SP)
- 407 I-2 Occupancies (AS)

134



SBC and CSFSC Chapter 4

- 408 I-3 Occupancies (AS)
- 410 Stages (AS & SP)
- 411 Special Amusement (AS)
- 412 Hangars per NFPA 409 (AS & SP)
- 414 Hazardous Materials (AS)
- 415 H Occupancies (AS)

135

SBC and CSFSC Chapter 4

- 416 Spray Booths (AS)
- 417 Drying Rooms (AS)
- 419 Live/Work Units (AS)
- 420 R Occupancies (AS)
- 422 Ambulatory Care Facilities (AS)

136



SBC and CSFSC Chapter 7

- 713.13 Refuse and Laundry Chutes
- 712 Escalators and CBC/CFSC 903.3.1.1.2

137

SBC and CSFSC Chapter 9

- 901.4.6 Fire pump and riser rooms (13 & 20)
- 903.2 Sprinklers where required
- 903.3.1.2 Balconies & decks
- 903.3.2 QR sprinklers
- 903.3 Obstructions, kiosks, etc

138



SBC and CSFSC Chapter 9

- 903.3.5.1.1 Limited area sprinklers
- 903.3.5.1.3 Water authority approval
- 903.3.5.2 Secondary water supply and earthquake zones
- 903.3.6 Hose threads per AHJ for sprinklers only

139

SBC and CSFSC Chapter 9

- 903.4.1 Monitoring requirements
- 903.4.2 Alarms
- 903.4.3 Floor control valves
- 903.6 Deleted (Existing Buildings)

140



SBC and CSFSC Chapter 9

- 905.2.1 Standpipe piping design
- 905 Standpipe Locations
- 912 Fire Department Connections
- 913 Fire Pumps
- 914 Correlation with Chapter 4

141

Master Index

142



Use of OEDM Training Materials

Use of Office of Education and Data Management (OEDM) training materials must be approved in writing by the State of Connecticut, Department of Administrative Services' Office of Communications. In approving of such use, the State of Connecticut assumes no liability associated with such use, including, but not limited to, the user's dissemination of any inaccurate information or interpretation in connection with its use of these training materials. Use of the training materials is at the sole risk of the user, and the State's approval of the use does not constitute an endorsement of the user or its intended use.

143

American Fire Services

1982

Fire Protection Solutions

Analyses, Alternatives, Innovations

Ignatius Kapalczyński
Principal

139 Selden Hill Drive Office: (860) 521-7056
West Hartford, CT Cell: (860) 817-3771
06107-3128 AmericanFireServicesSolutions@gmail.com

144

