



**Northeast
Utilities System**

*The Middletown, Connecticut
Reliability Project*

Transient Stability Analysis

Dennis J. Carberry, P.E.
Northeast Utilities
Transmission Planning

The Middletown, Connecticut Reliability Project

(The Haddam Autotransformer)

NEPOOL Section 18.4
Transient Stability Analysis

Prepared for the ISO-NE
Stability Task Force

Prepared By:
Dennis J. Carberry
Northeast Utilities
Transmission Planning

June 23, 2003

Executive Summary

This report presents transient stability analysis results for the addition of 345/115-kV, 450 MVA, autotransformer to be installed at Northeast Utilities' (NU) 115-kV Haddam Substation (11C) located in Haddam, Connecticut. The autotransformer would connect to the 345-kV, Millstone to Southington, 348-line. In addition to the autotransformer, the 115-kV, Middletown to Bokum, 1620 line would loop into the Haddam Substation. The studied in service date for the "Project" is June 2005.

This transient stability analysis study began with the required transmission system upgrades listed in the "Middletown, Connecticut Reliability Project" steady-state report. In the steady-state report, the 348 line was split into two sections, Millstone to Haddam 348E and Haddam to Southington 348W. However, the sectionalizing of the 348 line produced an un-satisfactory stability result because of the Millstone units losing synchronism. The Millstone Units are protected by the Severe Line Outage Detection (SLOD) Special Protection System (SPS). The Millstone SLOD Type I SPS, which would trip Millstone 3 (MP3), was installed to preserve system stability in the event that three of the four critical transmission paths around Millstone become unavailable while the total Millstone generation is above 1200 MW. Stability results showed that with a 348W line-out condition, taking a double-circuit-tower (DCT) contingency at Millstone would cause system instability unless MP3 was tripped. However, to arm the SLOD scheme for the 348W line-out condition would require remote monitoring of the transmission line. The New England Power Pool's (NEPOOL) SPS guideline prohibits remote monitoring for a Type 1 SPS. Therefore, the recommended alternative is to tap the 348 line, thereby keeping the local monitoring of the Millstone to Southington 348-line intact. The stability analysis of the alternative 348 line tap configuration showed satisfactory results.

Bulk power system testing showed that the Haddam Substation (11C) will be classified as part of the Bulk Power System.

The Project would not have a significant adverse impact on the reliability of the bulk power system as specified in Section 18.4 of the Restated NEPOOL Agreement.

Table of Contents

1	Introduction.....	1
2	Conclusions.....	2
3	Methodology.....	3
3.1	System Representation.....	3
3.2	Initial Conditions	3
3.3	Sensitivity Cases.....	4
3.4	Transient Stability Analysis.....	4
3.5	Stability Contingencies.....	4
3.6	Stability Performance Criteria	5
3.7	Bulk Power System (BPS) Analysis.....	5
4	Transient Stability Results.....	5
4.1	Peak Load Case PkA Results.....	6
4.2	Peak Load Case Pk1A Results.....	6
4.3	Light Load Case LtA Results.....	6
4.4	Sensitivity Case Results.....	7
4.5	Bulk Power System Testing Results.....	7

List of Tables

Table 1	– Connecticut Dispatch Summary	8
Table 2	– Fault Simulation Summary	9
Table 3	– Fault Simulation Summary.....	10
Table 4	– Case Summary Pk.....	14
Table 5	– Case Summary Pk1.....	15
Table 6	– Case Summary PkA.....	16
Table 7	– Case Summary Pk1A.....	17
Table 8	– Case Summary Lt.....	18
Table 9	– Case Summary LtA.....	19
Table 10	– Sensitivity Case Summary LtA-S.....	20
Table 11	– Sensitivity Case Summary PkA-S.....	21
Table 12	– Contingency List.....	38
Table 13	– Contingency List.....	39
Table 14	– Contingency List.....	40
Table 15	– Contingency List.....	41
Table 16	– Contingency List.....	42

List of Figures

Figure 1	– Geographical Map Middletown, Connecticut Area.....	11
Figure 2	– Transmission One-line Diagram Middletown, Connecticut.....	12
Figure 3	– Existing Haddam 11C Substation One-Line	13
Figure 4	– Initial Haddam 11C Substation Design One-Line.....	13
Figure 5	– Proposed Haddam 11C Substation Design One-Line	13
Figure 6	– Plot Pk Middletown Area All-Lines-In	22
Figure 7	– Plot Pk New England All-Lines-In.....	23
Figure 8	– Plot Pk1 Middletown Area All-Lines-In.....	24
Figure 9	– Plot Pk1 New England All-Lines-In	25
Figure 10	– Plot PkA Middletown Area All-Lines-In.....	26
Figure 11	– Plot PkA New England All-Lines-In.....	27
Figure 12	– Plot Pk1A Middletown Area All-Lines-In.....	28
Figure 13	– Plot Pk1A New England All-Lines-In	29

Figure 14 – Plot Lt Middletown Area All-Lines-In.....	30
Figure 15 – Plot Lt New England All-Lines-In.....	31
Figure 16 – Plot LtA Middletown Area All-Lines-In.....	32
Figure 17 – Plot LtA New England All-Lines-In.....	33
Figure 18 – Plot LtA-S Middletown Area All-Lines In.....	34
Figure 19 – Plot LtA-S New England All-Lines -In.....	35
Figure 20 – Plot PkA-S Middletown Area All-Lines-In.....	36
Figure 21 – Plot PkA-S New England All-Lines-In.....	37

Appendix A – PkA Plots	
Appendix B – MD-Plots	
Appendix C – PkA A-Plots	
Appendix D – PkA BPS HD-Plots	
Appendix E – PkA BPS MD-Plots	
Appendix F – Pk1A Plots	
Appendix G – Pk1A A-Plots	
Appendix H – LtA Plots	
Appendix I – Lt MD&SO-Plots	
Appendix J – Lt HD204-Plots	
Appendix K – LtA A-Plots	
Appendix L – LtA BPS HD-Plots	
Appendix M – LtA BPS MD-Plots	
Appendix N – LtA-S Sensitivity Plots	
Appendix O – PkA-S Sensitivity Plots	
Appendix P – LtA_LtA-S Compare Plots	
Appendix Q – PkA_PkA-S Compare Plots	

1 Introduction

This report presents the Middletown, Connecticut, Reliability Project transient stability analysis results. The Middletown area consists of sections east and west of the Connecticut River. The easterly section runs along the Connecticut River in a band that is 5 to 10 miles wide from Glastonbury to Old Lyme. The westerly sections consist of a triangular area that runs from Middletown to Old Saybrook to Guilford and then back to Middletown, which includes the eastern part of Meriden. A geographical map of the area appears on page 10, [Figure 1](#).

The Middletown area's 460 MW load is served by two local generators, Middletown Station Unit 2 (117 MW) and Middletown Station Unit 3 (233 MW), connected to the 115-kV system. A third generator located at Middletown, Unit 4 (400 MW), interconnects to the 345-kV Scovill Rock Substation. The Middletown Unit 4 power output does not serve the local area load because the Scovill Rock Substation does not have 345/115-kV transformation.

In addition to the Middletown generation, four 115-kV transmission lines serve the local area, these lines are as follows:

1. Line 1355 Southington to Hanover to Colony
2. Line 1765 Berlin to West Side
3. Line 1767 Manchester to Hopewell
4. Line 1508 Branford to Green Hill

The Middletown area was first evaluated using steady-state analyses to determine its capability to serve peak load should the local 115-kV generation, at Middletown, not be available. The steady-state analysis report titled, "The Middletown, Connecticut Reliability Project" dated January 7, 2003, lists the following transmission system upgrades that are assumed in-service at the start of this stability analysis:

1. Expand and reconfigure the existing 115-kV Haddam 11C Substation by building a breaker and a half scheme that includes replacing the three existing 115-kV circuit breakers and adding nine new 115-kV circuit breakers.
2. Split the existing 345-kV Millstone to Southington 348 line, terminating the ends to the Haddam 11C Substation, which creates a new Haddam to Millstone 348E line and a new Haddam to Southington 348W line.
3. Add a new 345/115-kV tap-changing autotransformer at the Haddam 11C Substation with a 450/560/595 MVA summer thermal rating and $(0.00053 + 0.029)$ per unit impedance.
4. Split the existing 115-kV, Middletown to Bokum, 1620 line, terminating the ends at the Haddam 11C Substation, which creates a new Middletown to Haddam 1620N line and a new Haddam to Bokum 1620S line.
5. Add a new 115-kV, 37.8 Mvar shunt capacitor bank at the Haddam 11C Substation.
6. Add a new 115-kV, 37.8 Mvar shunt capacitor bank at the Branford 11J Substation.
7. Upgrade the existing 115-kV, Manchester to Hopewell, 1767 line to a minimum 228 MVA summer long-time-emergency (LTE) rating.

8. Upgrade the existing 115-kV, East Meriden to North Wallingford, 1466 line to a minimum 165 MVA summer LTE rating.

A transmission network one-line diagram appears on Page 11, [Figure 2](#). An existing Haddam 11C Substation one-line diagram appears on Page 12, [Figure 3](#). An initial Haddam Substation design one-line diagram, used for the start of this stability study, appears on Page 12, [Figure 4](#). The proposed Haddam Substation design one-line diagram appears on Page 12, [Figure 5](#). This proposed Haddam Substation design is the preferred design based on fault performance associated with SLOD, and the NEPOOL SPS Guideline.

The studied in service date for the Project is June 2005.

2 Conclusions

Sectionalizing the 345-kV 348 line caused an unsatisfactory transient stability result in the light load case, and an un-damped system response in the peak load case. The 348W, Haddam to Southington, line-out condition coupled with a 371+383 double-circuit-tower (DCT) contingency, the SLOD5 contingency, caused Millstone 2 and Millstone 3 to lose synchronism. To mitigate the SLOD5 contingency, the Millstone Severe Line Outage Detection (SLOD) Special Protection System (SPS) would need to be armed for the 348W line-out condition. Arming SLOD for the 348W line-out condition would require remote monitoring of the transmission line. However, SLOD is a Type 1 SPS, and according to the New England Power Pool (NEPOOL) Planning Procedure PP-5, “Special Protection Systems Application Guideline”, a Type 1 SPS location of monitoring must be local. Therefore, remote monitoring of the 348W line is not acceptable. A practical alternative to sectionalizing the 348 line is to tap the 348 line with a 345-kV circuit breaker at the high-side of the Haddam 11C autotransformer.

Tapping the 348 line is a viable alternative that eliminates the remote sensing concern of the 348W line-out condition for the SLOD SPS. Tapping the 348 line keeps the SLOD scheme intact, as it is today, with local monitoring of the 348 line. The 348 line tap transient stability analysis results showed no significant adverse impact in both the peak and light load cases.

Transient stability results showed generator instability for extreme contingency faults MD201-204 at Middletown. The Middletown Units 2 and 3 went unstable for a total source loss of 350 MW in both the pre-and post-project peak and light load cases.

Light load transient stability results showed generator instability for two extreme contingency faults, HD201 and HD204, at Haddam 11C. The Middletown Units 2 and 3 lose synchronism for a total source loss of 350 MW. Extreme contingency HD204 caused instability in both the pre- and post-project cases. Extreme contingency HD201 was only applicable in the post-project case.

Extreme contingency SO201, at Southington, causes entry into the Keswick SPS GCX relay characteristic in both the pre- and post-project light load cases. The post-project response was not any worse than the pre-project response.

Bulk Power System (BPS) testing showed that a fault on the 115-kV Haddam (11C) bus would cause a source loss of 2100 MW. Therefore, Haddam will be classified as part of the Bulk Power System.

Based on the proposed 348 line tap transient stability results, the Haddam Autotransformer Project would not have a significant adverse impact on the reliability of the bulk power system as specified in Section 18.4 of the Restated NEPOOL Agreement.

3 Methodology

3.1 System Representation

A peak load power flow case, Pk, and a light load case, Lt, were developed from ISO-NE's 2000 library. In the peak load case, the NEPOOL load is representative of approximately 25,480 MW, and in the light load case 11,520 MW. Both the peak and light load cases include the required upgrades listed in the "Introduction" part of this report. The Haddam autotransformer is modeled to hold a 1.026 per unit voltage at the 115-kV Haddam 11C Substation bus.

A second peak load case, Pk1, was developed with the Middletown 115-kV generation, Middletown Unit 2 (117 MW) and Middletown Unit 3 (233 MW), out-of-service. A table showing the Connecticut generation dispatch, at peak and light loads, appears on Page 8, [Table 1](#).

3.2 Initial Conditions

The peak load cases, Pk and Pk1, were developed with the New Brunswick (NB) to New England (NE) transfer maintained at 700 MW. Power flow on the Long Island Cable was maintained at 0 MW. The Cross Sound Cable (CSC) flow was maintained at 346 MW from Connecticut to New York. The New England to New York (NY) transfer was maintained at approximately 0 MW, not including CSC. The Phase II HVdc dispatch was maintained at 2000 MW. In the Pk case the Connecticut export was maintained at approximately -205 MW, and in the Pk1 case the Connecticut export was maintained at approximately -2230 MW with both Middletown Units 2 and 3 off. The peak load case summaries, Pk and Pk1, appear in [Table 4](#) and [Table 5](#) on Pages 15 and 16, respectively. Load flow cases with the Haddam Autotransformer Project in service are PkA and Pk1A. The PkA and Pk1A case summaries appear in [Table 6](#) and [Table 7](#) on Pages 17 and 18, respectively.

The light load case, Lt, was developed with the NB-NE transfer maintained at 700 MW. Power flow on the Long Island Cable was maintained at approximately 100 MW. The Cross Sound Cable flow was maintained at 346 MW from Connecticut to New York. The NY-NE transfer was maintained at approximately 20 MW. The Phase II HVdc dispatch was maintained at 0 MW. The Connecticut export was maintained at approximately 2590 MW. The LtA load flow case has the Haddam Autotransformer Project in service. The Lt and LtA case summaries appear in [Table 8](#) and [Table 9](#) on Pages 19 and 20, respectively.

3.3 Sensitivity Cases

Initial transient stability results revealed that a line shunt had been incorrectly modeled at the Cross Sound Cable (CSC) bus in both the peak and light load cases. Therefore, sensitivity cases LtA-S and PkA-S were created to determine the impact of the line-shunt. The expectation is that the line shunt would have a negligible impact on the transient stability results. Summaries for the LtA-S and PkA-S cases appear in [Table 10](#) and [Table 11](#) on Pages 21 and 22, respectively.

3.4 Transient Stability Analysis

The transient stability analysis was performed using Power System Simulator for Engineering (PSSE) software, version 26.2, from Power Technologies Incorporated (PTI).

A first set of contingencies were simulated against cases with the Project in-service. Simulation results were then reviewed to determine if the Project had caused an unacceptable power system response. If an unacceptable system response was observed, then the pre-project load flow case was tested and the results reviewed to determine if the adverse impact was an existing system condition.

3.5 Stability Contingencies

The majority of contingencies simulated are located in and around the Middletown, Connecticut area. Included in the contingency list are contingencies for testing the Millstone Severe Line Outage Detection Special Protection System. The Millstone SLOD Type 1 SPS was installed to preserve system stability in the event that three of the four critical transmission paths around Millstone become unavailable while the total Millstone generation is above 1200 MW. Testing also included a new contingency, SLOD5, created by sectionalizing the 345-kV, Millstone to Southington, 348-line.

Because transient stability results showed a significant adverse impact with the proposed 345-kV 348 line configuration, an alternative configuration is proposed and contingencies for that proposal have the letter “A” appended onto the end of the contingency ID.

All normal design criteria contingency faults will be cleared by the slower of the two protection groups. A set of limiting normal and extreme contingencies will be simulated. The normal contingency (NC) assessment will consist of the following:

1. A permanent three-phase fault on any generator, transmission circuit, transformer or bus section with normal fault clearing (the fastest of two protection schemes out-of-service).
2. A permanent phase to ground fault on any transmission circuit, transformer or bus section with delayed fault clearing. (Delayed fault clearing consistent with correct operation of a breaker failure protection group and its associated breakers or of a backup protection group with an intentional time delay.)
3. Simultaneous permanent phase to ground faults on different phases of each of two adjacent transmission circuits on a multiple circuit tower, with normal fault clearing (the fastest of the two protection schemes out-of-service).

All extreme criteria (EC) contingencies will be simulated in accordance with NPCC criterion, which assumes that all protection groups operate correctly. The extreme contingency assessment will consist of the following:

1. A permanent three-phase fault on any generator, transmission circuit, transformer, or bus section, with delayed fault clearing.

All EC contingencies will be critiqued using NC criteria. If these EC simulations do not meet the NC criteria, then the simulations will be re-done using single line to ground fault impedance.

Contingencies

The contingency lists appear on Pages 39-43, Tables [12](#), [13](#), [14](#), [15](#), [16](#).

3.6 Stability Performance Criteria

The following criteria define stable transmission system performance for normal contingencies.

- All units transiently stable except for units tripped for fault clearing
- A 50% reduction in the magnitude of system oscillations must be observed over the last four periods of the 30 second oscillation plot
- Loss of source not greater than 1200 MW
- Having no Keswick GCX Relay entry

The following criteria define stable transmission system performance for an extreme contingency.

- Units transiently stable with positive damping
- A loss of source greater than 1400 MW is not immediately acceptable
- A loss of source between 1400 MW and 2200 MW may be acceptable depending upon the likelihood of occurrence and other factors
- A loss of source above 2200 MW is not acceptable
- A 50% reduction in the magnitude of system oscillations must be observed over the last four periods of the 30 second oscillation plot

3.7 Bulk Power System (BPS) Analysis

The Middletown and Haddam Substations were analyzed using BPS criteria. For this test, the analysis assumes that a single bus protection system group exists, and the protection group fails to operate. A three phase bus fault was applied for 5 seconds, the fault was then cleared, and all transmission lines emanating from the station opened.

4 Transient Stability Results

The transient stability analysis results are summarized and appear in [Table 2](#) and [Table 3](#) on Pages 9 and 10, respectively. Upon reviewing results, an error in the modeling of the Cross Sound Cable was noticed. A 200 MVA line shunt was placed at the CSC bus by inserting a PSS/E model from a software version higher than that being used for the study. To determine the impact of this line shunt, two sensitivity cases were created and each case tested against seven contingencies. The seven contingencies are as follows: HD101, HD202, HD205, MP106, MP203, SLOD4A, and SO201.

4.1 Peak Load Case PkA Results

Four EC contingencies, MD201-204, resulted in both Middletown Units 2 and 3 going unstable for each fault. These same four contingencies were tested against the pre-project case, Pk, and the results were the same as in the post-project case. With the fault applied at the Middletown bus, the delayed fault clearing, due to a breaker failure at Middletown, causes the instability for a total source loss of 350 MW.

The SLOD5 contingency, Haddam to Southington 348W line-out and the 371+383 DCT, caused an un-damped system response.

Contingency NC106 (Keswick fault), which is one of the NEPOOL Stability Task Force's (STF) Standard Seven Simulations, resulted in a trip of the New England – New Brunswick tie.

4.2 Peak Load Case Pk1A Results

Contingency, NC106, (Keswick fault) resulted in a trip of the New England – New Brunswick tie.

4.3 Light Load Case LtA Results

As in the peak load case, the four EC contingencies at Middletown, EC201-204, cause both Middletown Units 2 and 3 to go unstable for a total source loss of 350 MW. These same four contingencies were tested against the pre-project case, Lt, and the results were the same as in the post-project case. With the fault applied at the Middletown bus, the delayed fault clearing, due to a breaker failure at Middletown, causes the instability.

Two EC contingencies at Haddam 11C, HD201 and HD204, resulted in both Middletown Units 2 and 3 going unstable for a total source loss of 350 MW. Contingency HD201 applies to the post-project cases only, since the fault is applied to the 115-kV 1620N line; therefore this contingency was not tested against the pre-project case. The HD204 contingency was modified for and tested against the pre-project case resulting in the Middletown Units 2 and 3 going unstable.

Extreme contingency SO201, at Southington, caused entry into the Keswick SPS GCX relay characteristic. This contingency was tested against the pre-project case and resulted with entry into the GCX relay characteristic that was not any less severe than the post-project case.

Extreme contingency EC301, fault at Northfield Mountain, showed system instability due to the Northfield Units going unstable. The simulation was rerun with the Northfield Units being tripped on under-frequency, 59.65 for 0.1 seconds, and results showed a damped system response.

Extreme contingency EC303, fault at Vermont Yankee, showed system instability due to the Vermont Yankee nuclear unit going unstable. The contingency was rerun with Vermont Yankee being tripped at 0.69 seconds or approximately 250 degrees, resulting in a trip of the New England – New Brunswick tie.

Contingency, NC106, fault at Keswick, resulted in a trip of the New England – New Brunswick tie.

The SLOD5 contingency, Haddam to Southington 348W line-out and the 371+383 DCT, resulted in Millstone Units 2 and 3 going unstable for a 2115 MW source loss.

4.4 Sensitivity Case Results

As expected, the sensitivity case results showed very little to no change in system response for the contingencies tested. Therefore, the impact of modeling at line shunt at the Cross Sound Cable bus is negligible. The LtA-S and PkA-S sensitivity case plots appear in Appendix N and O, respectively. The LtA and LtA-S case comparison plots, which shows the Middletown 2, Middletown 3, and Millstone 3 megawatt outputs in the two cases, appears in Appendix P. The PkA and PkA-S case comparison plots appear in Appendix Q.

4.5 Bulk Power System Testing Results

At Middletown Substation, an un-cleared 115-kV bus fault resulted in Middletown Units 2 and 3 going unstable for a total source loss of 350 MW. The Middletown Units were the only units to lose synchronism. Therefore, the Middletown Substation would be considered a non-BPS substation. The LtA and PkA BPS case plots appear in Appendix M and E, respectively.

At Haddam 11C Substation, an un-cleared 115-kV fault resulted in a total source loss of 2108 MW. Both the Middletown 115-kV units (350 MW) and Millstone Unit 3 (1208 MW) lose synchronism. The New Brunswick tie trips (550 MW) due to entry into the Keswick GCX relay characteristic. Therefore, Haddam 11C would be classified as part of the Bulk Power System. The LtA and PkA BPS case plots appear in Appendix L and D, respectively.

Table 1 – Connecticut Dispatch Summary

Generator	Unit (MW)	Pk (MW)	Pk1 (MW)	PkA (MW)	Pk1A (MW)	Lt (MW)	LtA (MW)
Millstone 2	907	907	0	907	0	907	907
Millstone 3	1208	1208	1208	1208	1208	1208	1208
Montville 5	81	81	0	81	0	0	0
Montville 6	402	402	402	402	402	402	402
Middletown 2	117	117	0	117	0	117	117
Middletown 3	233	233	0	233	0	223	233
Middletown 4	400	400	400	400	400	400	400
Meriden GT1	172	172	172	172	172	172	172
Meriden GT2	172	172	172	172	172	172	172
Meriden ST	195	195	195	195	195	195	195
Norwalk Harbor 1	161	161	0	161	0	0	0
Norwalk Harbor 2	168	168	168	168	168	168	168
Bridgeport Energy 10	180	180	180	180	180	180	180
Bridgeport Energy 11	170	170	170	170	170	170	170
Bridgeport Energy 12	170	170	170	170	170	170	170
Bridgeport Harbor 2	170	170	170	170	170	0	0
Bridgeport Harbor 3	375	375	375	375	375	375	375
Bridgeport Harbor 4	22	0	0	0	0	0	0
Bridgeport RESCO	57	57	57	57	57	57	57
Milford 1	305	305	305	305	305	305	305
Milford 2	305	305	0	305	0	0	0
Devon 7	106	106	0	106	0	0	0
Devon 8	106	106	0	106	0	0	0
New Haven Harbor	447	447	447	447	447	447	447
AES Thames	180	180	180	180	180	180	180
Wallingford 1	102	102	102	102	102	0	0
Wallingford 2	102	102	102	102	102	102	102
Wallingford 3	51	51	51	51	51	0	0
NY-NE		-3	-2	-2	-1	20	20
LI Cable 1385-Ckt CT-NY		-2	1	0	0	100	100
Cross Sound Cable CT-NY		346	346	346	346	346	346
Connecticut Export		-205	-2230	-207	-2235	2594	2593
SW CT Import		757	1427	763	1431	-230	-229

- Pk Peak load, No Haddam Autotransformer, Middletown Units 2 & 3 In-Service
- PkA Peak load, Haddam Autotransformer In-Service, Middletown Units 2 & 3 In-Service
- Pk1 Peak load, No Haddam Autotransformer, Middletown Units 2 & 3 Out-of-Service
- Pk1A Peak load, Haddam Autotransformer In-Service, Middletown Units 2 & 3 Out-of-Service
- Lt Light load, No Haddam Autotransformer, Middletown Units 2 & 3 In-Service
- LtA Light load, Haddam Autotransformer In-Service, Middletown Units 2 & 3 In-Service

Table 2– Fault Simulation Summary

Fault	Pk	PkA	Pk1A	Lt	LtA
MD101	N/A	D	D	N/A	D
MD102	N/A	D	D	N/A	D
MD103	N/A	D	D	N/A	D
MD104	N/A	D	D	N/A	D
HD101	N/A	D	D	N/A	D
HD102	N/A	D	D	N/A	D
HD103	N/A	D	D	N/A	D
HD104	N/A	D	D	N/A	D
HD105	N/A	D	D	N/A	D
HD106	N/A	D	D	N/A	D
HD107	N/A	D	D	N/A	D
HD108	N/A	D	D	N/A	D
SO101	N/A	D	D	N/A	D
SO101A	N/A	D	D	N/A	D
SO102	N/A	D	D	N/A	D
SO103	N/A	D	D	N/A	D
MP101	N/A	D	D	N/A	D
MP102	N/A	D	D	N/A	D
MP103	N/A	D	D	N/A	D
MP103A	N/A	D	D	N/A	D
MP104	N/A	D	D	N/A	D
MP105	N/A	D	D	N/A	D
MP105A	N/A	D	D	N/A	D
MP106	N/A	D	D	N/A	D
MD201	Mdltwn 2&3 unstable	Mdltwn 2&3 unstable	D	Mdltwn 2&3 unstable	Mdltwn 2&3 unstable
MD202	Mdltwn 2&3 unstable	Mdltwn 2&3 unstable	D	Mdltwn 2&3 unstable	Mdltwn 2&3 unstable
MD203	Mdltwn 2&3 unstable	Mdltwn 2&3 unstable	D	Mdltwn 2&3 unstable	Mdltwn 2&3 unstable
MD204	Mdltwn 2&3 unstable	Mdltwn 2&3 unstable	D	Mdltwn 2&3 unstable	Mdltwn 2&3 unstable
HD201	N/A	D	D	N/A	Mdltwn 2&3 unstable
HD202	N/A	D	D	N/A	D
HD203	N/A	D	D	N/A	D
HD204	N/A	D	D	Mdltwn 2&3 unstable	Mdltwn 2&3 unstable
HD205	N/A	D	D	N/A	D
HD206	N/A	D	D	N/A	D
HD207	N/A	D	D	N/A	D
HD208	N/A	D	D	N/A	D
HD208A	N/A	D	D	N/A	D
HD209	N/A	D	D	N/A	D
MP201	N/A	D	D	N/A	D
MP202	N/A	D	D	N/A	D
MP203	N/A	D	D	N/A	D
MP204	N/A	D	D	N/A	D
MP204A	N/A	D	D	N/A	D

Table 3 - Fault Simulation Summary

Fault	Pk	PkA	Pk1A	Lt	LtA
SO201	N/A	D	D	GCX	GCX
SO202	N/A	D	D	N/A	D
SO202A	N/A	D	D	N/A	D
SLOD1	N/A	D	D	N/A	D
SLOD1A	N/A	D	D	N/A	D
SLOD2	N/A	D	D	N/A	D
SLOD2A	N/A	D	D	N/A	D
SLOD3	N/A	D	D	N/A	D
SLOD4	N/A	D	D	N/A	D
SLOD4A	N/A	D	D	N/A	D
SLOD5	N/A	UD	D	N/A	MP 2 & 3 unstable GCX
EC102	N/A	D	D	N/A	D
EC103	N/A	D	D	N/A	D
EC212	N/A	D	D	N/A	D
EC301	N/A	D	D	N/A	Nrthfld 3&4 unstable
EC402	N/A	D	D	N/A	D
NC106	N/A	C.Cove & Dalhousie unstable GCX	C.Cove & Dalhousie unstable GCX	N/A	C.Cove & LePreau unstable GCX
EC303	N/A	D	D	N/A	VY, Coleson Cove and LePreau unstable GCX

D = Damped, UD = Un-damped, N/A = Not Applicable
GCX= Keswick GCX Relay Characteristic Entry

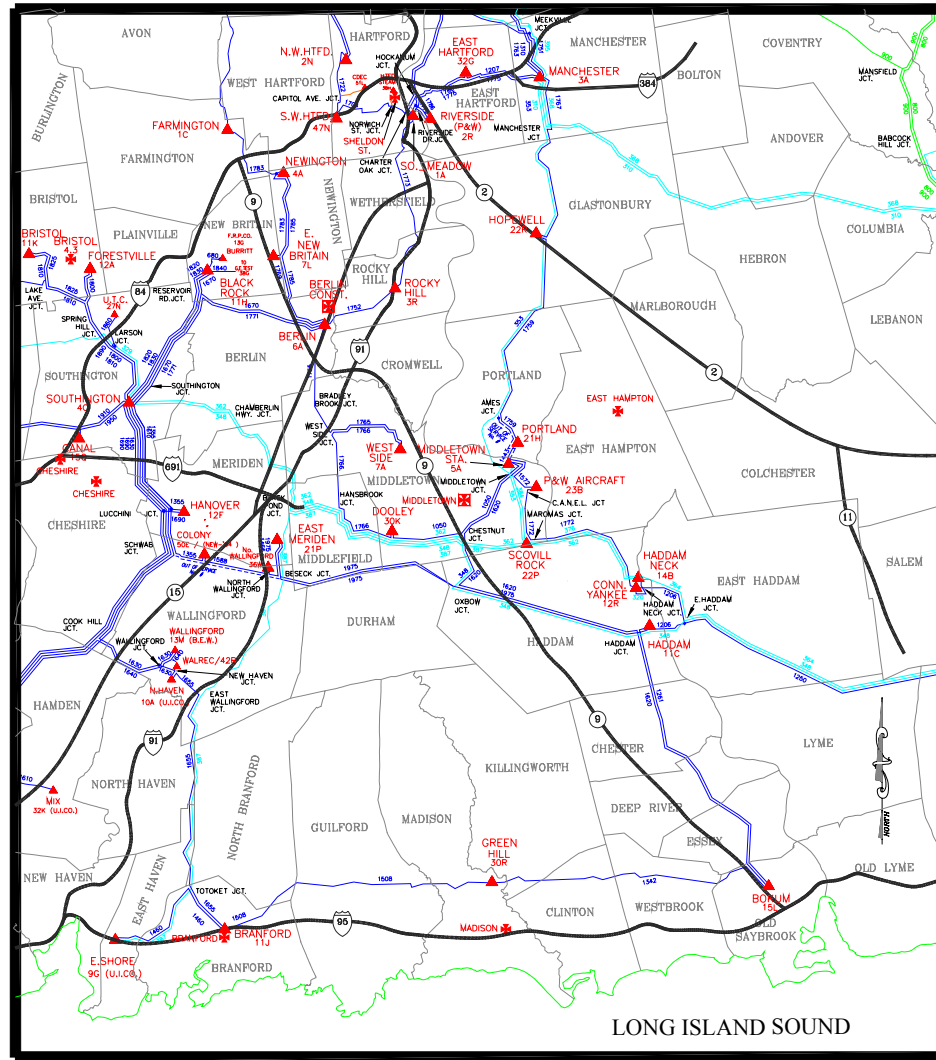

Figure 1 – Geographical Map Middletown, Connecticut Area

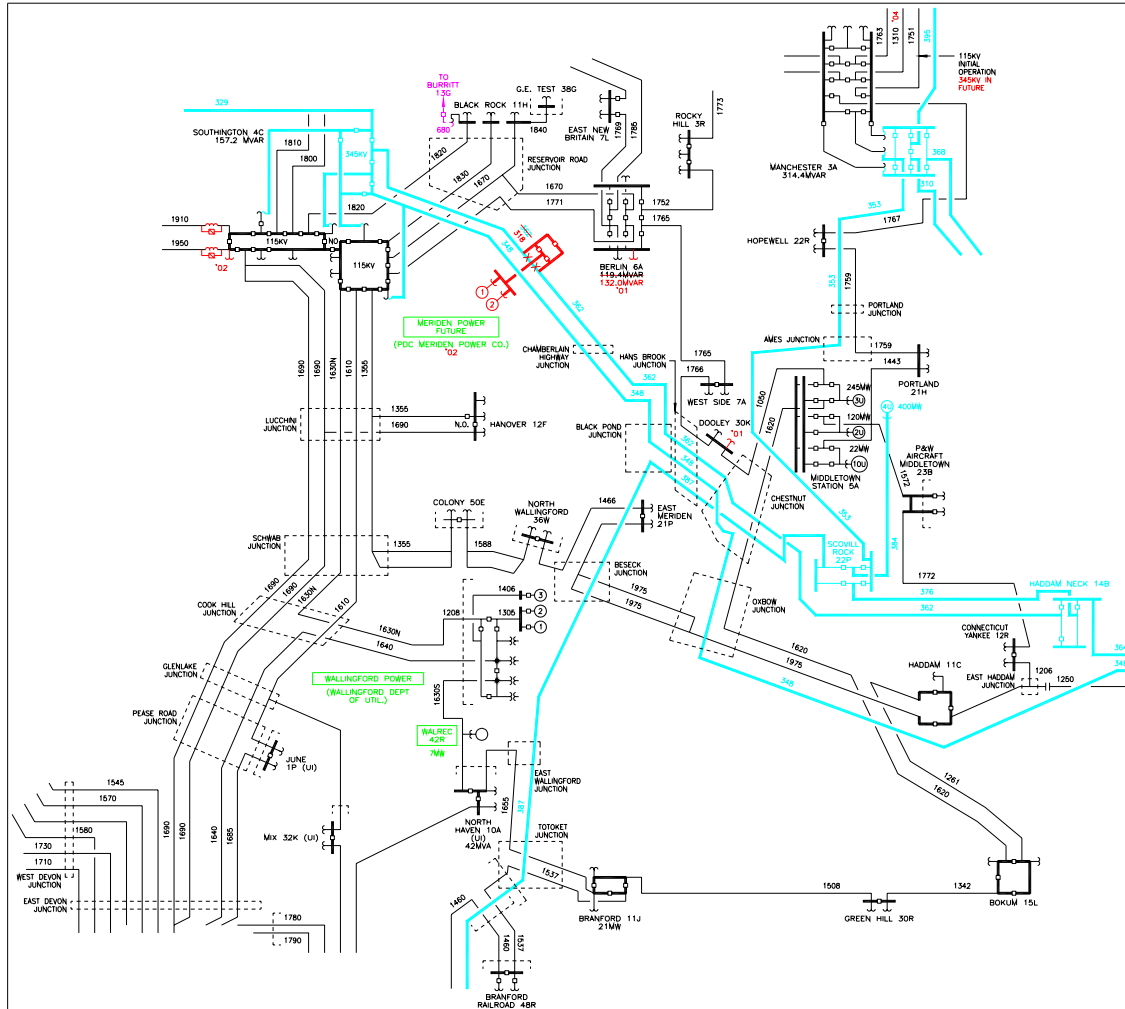

Figure 2 – Transmission One-line Diagram Middletown, Connecticut

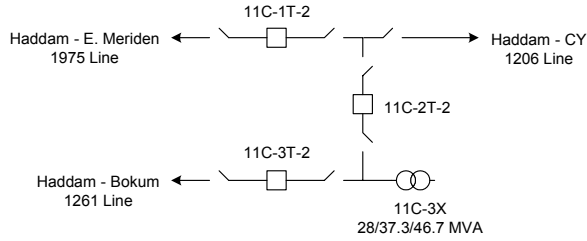

Figure 3 – Existing Haddam 11C Substation One-Line

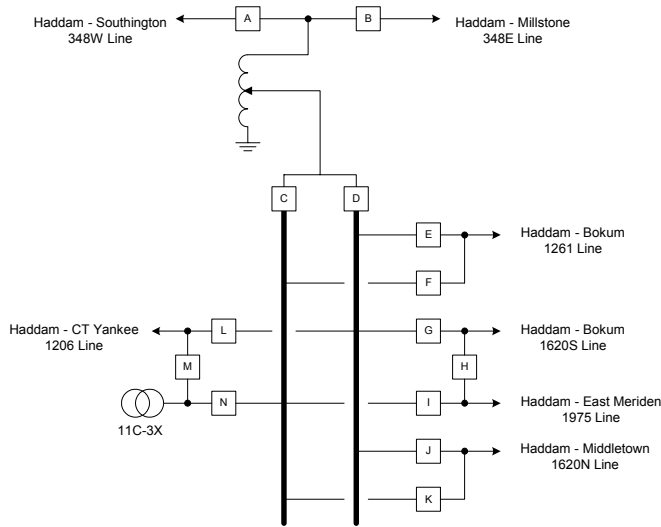

Figure 4 – Initial Haddam 11C Substation Design One-Line

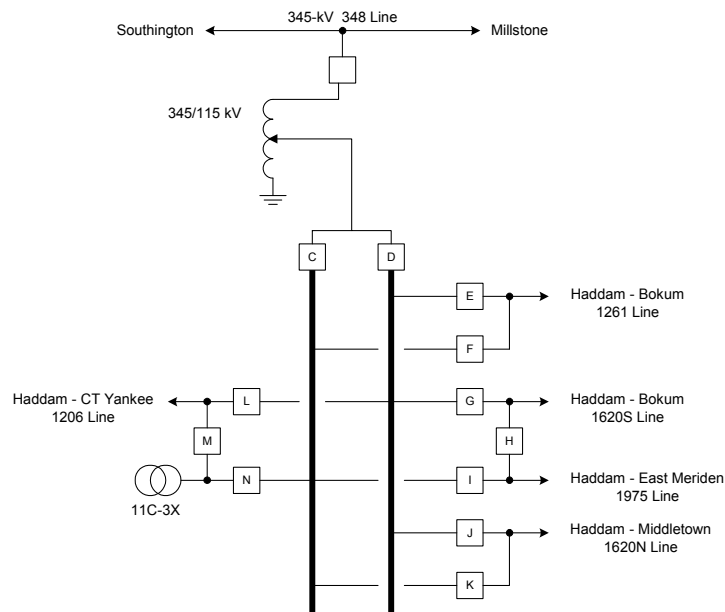

Figure 5 – Proposed Haddam 11C Substation Design One-Line

Table 4 – Case Summary Pk

PK.SAV MIDDLETOWN RELIABILITY STUDY, NO AUTOTRANSFORMER, MIDDLETOWN 2 & 3 ON GENERATION											
#	V	MW	MX	#	V	MW	MX	#	V	MW	MX
73538 AESTH PF	0.996	180	27	73549 SMD1112J	0.000	0	0	73550 SMD1314J	0.000	0	0
73551 NORHAR#1	0.994	161	22	73552 NORHAR#2	0.994	168	22	73553 DEVON#7	0.980	106	7
73554 DEVON#8	0.980	106	7	73570 DEVGAS11	0.000	0	0	73571 DEVGAS12	0.000	0	0
73572 DEVGAS13	0.000	0	0	73555 MIDDTN#2	1.027	117	54	73556 MIDDTN#3	0.994	233	54
73557 MIDDTN#4	0.984	400	9	73558 MONTV#5	0.984	81	12	73559 MONTV#6	0.992	402	60
73562 MILL#2	0.985	907	57	73563 MILL#3	0.983	1208	57	73565 LAKERD#1	1.001	305	48
73566 LAKERD#2	1.001	305	48	73567 LAKERD#3	1.001	305	48	73574 MILFD#1	1.028	305	39
73575 MILFD#2	1.028	305	39	73588 MERIDEN1	1.038	172	55	73589 MERIDEN2	1.038	172	55
73590 MERIDEN3	1.062	195	55	73594 WALL LV1	1.025	102	19	73595 WALL LV2	1.025	102	19
73596 WALL LV3	1.025	51	15	73646 BPTHBR#1	0.000	0	0	73647 BPTHBR#2	0.985	170	72
73648 BPTHBR#3	0.980	375	72	73649 BPTHBR#4	0.000	0	0	73651 NH HARBR	0.988	447	123
73652 BE 11	0.990	170	24	73653 BE 12	0.989	170	24	73654 BE 10 ST	0.988	180	24
70705 VTYAK G	0.978	563	73	72243 MILLENCT	0.000	0	0	72244 MILLENST	0.000	0	0
73080 WSPFLD 3	1.001	107	6	73085 MT.TOM	0.000	0	0	72512 BRSWP G1	0.992	294	67
72513 BRSWP G2	0.992	294	67	72986 BERKFPWR	1.017	305	14	73083 NRTHFD12	1.011	270	80*
73084 NRTHFD34	0.000	0	0	73072 ALT12 PF	1.026	65	15*	73073 ALT34 PF	1.025	80	15
73069 MAPR1 PF	1.047	56	47*	73070 MAPR2 PF	0.000	0	0	73071 MAPR3 PF	0.000	0	0
72930 STNYBK1A	1.043	65	8	72931 STNYBK1B	1.043	65	8	72932 STNYBK1C	1.043	65	8
70060 MIS GT1	0.000	0	0	70061 MIS GT2	0.000	0	0	70062 MIS ST	0.000	0	0
70389 BUCKS G4	1.040	191	92	70381 RPA CG1	0.000	0	0	70382 RPA SG2	0.000	0	0
70386 WBK G1	1.040	184	31	70387 WBK G2	1.040	184	31	70388 WBK G3	1.040	195	33
70365 WF WY #1	1.010	57	6	70366 WF WY #2	1.010	57	6	70367 WF WY #3	1.010	125	12
70368 WF WY #4	1.038	540	105	70426 CHAMP G2	0.961	15	6*	70424 CHAMP G3	0.000	0	0
70377 AEC G1	1.040	52	7	70378 AEC G2	1.040	52	7	70379 AEC G3	1.040	52	7
72866 MERMK G1	1.033	113	23	72867 MERMK G2	1.034	320	67	72868 NWNMT G1	0.994	422	55
72870 SCHILLER	0.992	48	1	72871 SCHILLER	0.992	50	1	72872 SCHILLER	0.992	48	1
70010 NEW_G1	0.000	0	0	70011 NEW_G2	0.000	0	0	70012 NEW_G3	0.000	0	0
72869 SBKR G1	1.010	1150	304	71857 COMRF G1	1.001	37	-5	71858 COMRF G2	1.001	37	-5
71859 COMRF G3	1.002	29	-5	71860 COMRF G4	1.002	29	-5	71861 MOORE G1	1.003	40	-3
71862 MOORE G2	1.006	33	-3	71863 MOORE G3	1.022	33	10	71864 MOORE G4	1.039	33	10
71123 KENDALL	1.025	63	2	71124 KND JETS	1.025	36	0	71060 MYST G4	0.000	0	0
71061 MYST 5G	0.000	0	0	71062 MYST G6	0.000	0	0	71063 MYST G7	1.044	565	335*
71064 MYST J1	0.000	0	0	71073 N.BOST 1	0.000	0	0	71074 N.BOST 2	1.021	380	230*
71946 SALEM G1	1.028	79	32*	71947 SALEM G2	1.026	78	29*	71948 SALEM G3	1.022	143	50*
71949 SALEM G4	0.000	0	0	71251 CANAL G1	1.034	566	239*	71252 CANAL G2	1.011	576	120*
71094 PLGRM G1	1.030	702	161	71095 ANPBCK1	0.000	0	0	71096 ANPBCK2	1.088	290	150*
72377 BELL #1	0.000	0	0	72378 BELL #2	0.000	0	0	72372 BP #1 GN	1.027	238	120*
72375 BP #2 GN	0.000	0	0	72370 BP #3 GN	1.042	605	218	72371 BP #4 GN	0.000	0	0
71084 NEA GTPF	1.040	85	40*	71085 NEA GTPF	1.040	85	40*	71086 NEA STPF	1.055	80	55*
71531 OSP1 PF	1.024	77	17	71532 OSP2 PF	1.024	77	17	71533 OSP3 PF	1.024	108	23
71534 OSP4 PF	1.024	77	17	71535 OSP5 PF	0.000	0	0	71536 OSP6 PF	0.000	0	0
72669 TIVER G1	1.030	189	27	72670 TIVER G2	1.030	92	14	71394 EMI_GEN	0.989	185	24
72661 MANCH09A	1.002	119	35*	72662 MANCH10A	1.002	119	35*	72663 MANCH11A	1.002	119	35*
72666 FRSQ SC1	0.991	43	2	72667 FRSQ SC2	0.991	43	1	72668 FRSQ SC3	0.991	42	3
72671 HOPE G1	0.000	0	0	72672 HOPE G2	0.000	0	0	72673 HOPE G3	0.000	0	0
MILLSTONE	2115	114		MIDDLETOWN	750	117		MONTVILLE	483	72	
NORWALK	329	43		BRIDGEPORT	1065	216		NHHARBOUR	447	123	
DEVON	212	14		MERIDEN	539	166		BRAYTONPT	1448	557	
MANCHSTRST	485	111		SOMERSET	70	0		OSP	339	74	
NEA	249	135		PAWTKTPWR	64	-6		ENRON	124	80	
CANAL	1142	359		PILGRIM	702	161		MYSTIC	565	335	
NEWBOSTON	380	230		SALEMHR	300	111		SEABROOK	1150	304	
NEWINGTON	422	55		SCHILLER	145	4		MERRIMACK	433	90	
STONYBROOK	0	0		WYMAN	779	129		VTYANKEE	563	73	
BEARSWAMP	588	134		NORTHFIELD	270	80		MASSPWR	56	47	
INTERFACE FLOWS											
NB-NE	700	-38		MEYANKEE-SOUTH	265	-158		MAINE-NH	968	-69	
NNE-SCOBIE+394	2003	128		SEABROOK-SOUTH	1285	131		NORTH-SOUTH	1899	135	
CMFD/MOORE-SO	189	-28		SNYPOND-SOUTH	2278	31		CONN EXPORT	-205	140	
CONN-MASS	-202	77		CONN-RI	730	30		SW CONN IMPORT	757	245	
NORWLK-STAMFORD	938	-17		BOSTON IMPORT	3661	245		NEMA/BOS IMPORT	4228	160	
SEMA/RI EXPORT	623	257		CONVEX-REMEVEC	819	64		EAST-WEST	-608	2	
NY-NE	-3	-235		PV20	110	-11		CT-LI-1385	-2	-44	
HVDC TRANSFERS FROM H-Q											
CHAT-1 =	0			CHAT-2 =	0			HIGHGATE =	225		
MADAWASK =	-151			PHII-P1 =	1000			PHII-P2 =	1000		
EEL =	75										
BUS VOLTAGES											
70001 CHESTER	345	340.		70002 ORRINGTN	345	345.		70003 MAXCYS	345	349.	
70086 ME YANK	345	355.		70090 BUXTON	345	358.		72692 NWTN345	345	357.	
72694 SEBRK345	345	357.		71789 TEWKS	345	355.		70759 MYSTIC	345	359.	
71797 MILLBURY	345	352.		72925 LUDLOW	345	353.		72926 NRTHFLD	345	359.	
73106 SOUTHGTN	345	356.		73108 CARD	345	357.		73109 MONTVILLE	345	357.	
73110 MILLSTNE	345	357.		73112 MANCHSTR	345	358.		73116 MIDLTLWN	345	357.	
71801 BRAYTN P	345	358.		71811 KENT CO.	345	351.		71326 BRIDGWTR	345	352.	
71336 SHERMAN	345	355.		71337 WFARNUM	345	354.		70772 W MEDWAY	345	351.	
70780 WWALP345	345	350.		70783 PILGRIM	345	355.		71193 CANAL	345	356.	
71133 CARVER	345	353.		70795 FRMNGHAM	230	228.		70793 MDFRM230	230	234.	
70794 MDWLT230	230	236.		70818 MYSTC MA	115	117.		71891 SALEM HR	115	118.	
73195 DEVON	115	117.		73259 HOPEWELL	115	116.		73264 PORTLAND	115	118.	
73241 MIDLTLWN	115	118.		73230 HADDAM	115	115.		73231 BOKUM	115	115.	
73265 GREEN HL	115	115.		73153 BRANFORD	115	117.		73227 E.MERIDN	115	114.	
73633 NO.WALLF	115	114.		73634 COLONY	115	114.		73198 SOUTHGTN	115	116.	
AREA/ZONE TOTALS											
NEPOOL_GEN	22815			NEPOOL_LOAD	24977			NEPOOL_LOSS	591		
NEPOOL_INT	-2984										

Table 5 – Case Summary Pk1

PK1.SAV MIDDLETOWN RELIABILITY STUDY, NO AUTOTRANSFORMER, MIDDLETOWN 2 & 3 OFF, CT IMPORT

GENERATION														
#	V	MW	MX	#	V	MW	MX	#	V	MW	MX			
73538	AESTH PF	0.996	180	27	73549	SMD1112J	0.000	0	0	73550	SMD1314J	0.000	0	0
73551	NORHAR#1	0.000	0	0	73552	NORHAR#2	1.013	168	57	73553	DEVON#7	0.000	0	0
73554	DEVON#8	0.000	0	0	73570	DEVGAS11	0.000	0	0	73571	DEVGAS12	0.000	0	0
73572	DEVGAS13	0.000	0	0	73555	MIDDTN#2	0.000	0	0	73556	MIDDTN#3	0.000	0	0
73557	MIDDTN#4	1.020	400	164	73558	MONTV#5	0.000	0	0	73559	MONTV#6	0.991	402	61
73562	MILL#2	0.000	0	0	73563	MILL#3	0.995	1208	192	73565	LAKERD#1	1.019	305	88
73566	LAKERD#2	1.019	305	88	73567	LAKERD#3	1.019	305	88	73574	MILFD#1	1.040	305	66
73575	MILFD#2	0.000	0	0	73588	MERIDEN1	1.048	172	73	73589	MERIDEN2	1.048	172	73
73590	MERIDEN3	1.072	195	73	73594	WALL LV1	1.025	102	20	73595	WALL LV2	1.025	102	20
73596	WALL LV3	1.025	51	17	73646	BPTHBR#1	0.000	0	0	73647	BPTHBR#2	0.991	170	83
73648	BPTHBR#3	0.983	375	83	73649	BPTHBR#4	0.000	0	0	73651	NH HARB	0.997	447	175*
73652	BE 11	0.993	170	27	73653	BE 12	0.993	170	27	73654	BE 10 ST	0.991	180	27
70705	VTYAK G	0.989	563	150*	72243	MILLENCT	0.000	0	0	72244	MILLENST	0.000	0	0
73080	WSPFLD 3	1.003	107	9	73085	MT.TOM	0.000	0	0	72512	BRSWP G1	0.989	294	60
72513	BRSWP G2	0.989	294	60	72986	BERKPWR	1.036	305	48	73083	NRTHFD12	1.002	270	80*
73084	NRTHFD34	0.000	0	0	73072	ALT12 PF	1.036	65	24*	73073	ALT34 PF	1.035	80	24*
73069	MAPR1 PF	1.045	56	47*	73070	MAPR2 PF	0.000	0	0	73071	MAPR3 PF	0.000	0	0
72930	STNYBK1A	1.043	65	13	72931	STNYBK1B	1.043	65	13	72932	STNYBK1C	1.043	65	13
70060	MIS GT1	1.067	179	62	70061	MIS GT2	1.067	179	62	70062	MIS ST	1.066	191	62
70389	BUCKS G4	1.040	191	75	70381	RPA CG1	0.000	0	0	70382	RPA SG2	0.000	0	0
70386	WBK G1	1.040	184	29	70387	WBK G2	1.040	184	29	70388	WBK G3	1.040	195	31
70365	WF WY #1	1.018	57	10	70366	WF WY #2	1.018	57	10	70367	WF WY #3	0.000	0	0
70368	WF WY #4	1.050	631	178	70426	CHAMP G2	0.975	15	6*	70424	CHAMP G3	0.000	0	0
70377	AEC G1	1.040	52	9	70378	AEC G2	1.040	52	9	70379	AEC G3	0.000	0	0
72866	MERMK G1	1.034	113	24	72867	MERMK G2	1.034	320	68	72868	NWNGT G1	0.988	422	36
72870	SCHILLER	0.988	48	-1	72871	SCHILLER	0.988	50	-1	72872	SCHILLER	0.988	48	-1
70010	NEW_G1	1.000	169	36	70011	NEW_G2	1.000	169	36	70012	NEW_G3	0.997	195	36
72869	SBRK G1	1.021	1150	444	71857	COMRF G1	1.002	37	-4	71858	COMRF G2	1.002	37	-4
71859	COMRF G2	1.003	29	-4	71860	COMRF G3	1.003	29	-4	71861	MOORE G1	1.003	40	-3
71862	MOORE G3	1.006	33	-3	71863	MOORE G4	1.023	33	11	71864	MOORE G4	1.040	33	11
71123	KENDALL	1.028	63	0	71124	KND JETS	1.027	36	0	71060	MYST G4	0.000	0	0
71061	MYST 5G	0.000	0	0	71062	MYST G6	0.000	0	0	71063	MYST G7	1.045	565	335*
71064	MYST J1	0.000	0	0	71073	N.BOST 1	0.000	0	0	71074	N.BOST 2	1.021	380	219
71946	SALEM G1	1.023	79	16	71947	SALEM G2	1.023	78	16	71948	SALEM G3	1.024	143	32
71949	SALEM G4	1.026	400	95	71251	CANAL G1	1.035	566	239*	71252	CANAL G2	1.012	576	120*
71094	PLGRM G1	1.028	702	140	71095	ANPBLC1	1.093	290	150*	71096	ANPBLC2	1.093	290	150*
72377	BELL #1	0.000	0	0	72378	BELL #2	0.000	0	0	72372	BP #1 GN	1.025	238	120*
72375	BP #2 GN	0.000	0	0	72370	BP #3 GN	1.030	605	135	72371	BP #4 GN	1.035	421	101
71084	NEA GTFP	1.043	85	40*	71085	NEA GTFP	1.043	85	40*	71086	NEA STFP	1.058	80	55*
71531	OSP1 PF	1.005	77	4	71532	OSP2 PF	1.005	77	4	71533	OSP3 PF	1.004	108	5
71534	OSP4 PF	1.005	77	4	71535	OSP5 PF	0.000	0	0	71536	OSP6 PF	0.000	0	0
72669	TIVER G1	1.030	189	27	72670	TIVER G2	1.030	92	14	71394	EMI_GEN	0.987	185	21
72661	MANCH09A	1.001	119	35*	72662	MANCH10A	1.001	119	35*	72663	MANCH11A	1.001	119	35*
72666	FRSQ SC1	0.991	43	4	72667	FRSQ SC2	0.991	43	2	72668	FRSQ SC3	0.991	42	4
72671	HOPE G1	0.000	0	0	72672	HOPE G2	0.000	0	0	72673	HOPE G3	0.000	0	0
MILLSTONE		1208	192		MIDDLETOWN		400	164		MONTVILLE		402	61	
NORWALK		168	57		BRIDGEPORT		1065	248		NHHARBOUR		447	175	
DEVON		0	0		MERIDEN		539	219		BRAYTONPT		1869	490	
MANCHSTRST		485	115		SOMERSET		70	0		OSP		339	15	
NEA		249	135		PAWTKTPWR		64	-6		ENRON		124	80	
CANAL		1142	359		PILGRIM		702	140		MYSTIC		565	335	
NEWBOSTON		380	219		SALEMHBR		700	158		SEABROOK		1150	444	
NEWINGTON		955	144		SCHILLER		145	-3		MERRIMACK		433	92	
STONYBROOK		0	0		WYMAN		745	198		VTYANKEE		563	150	
BEARSWAMP		588	120		NORTHFIELD		270	80		MASSPWR		56	47	
INTERFACE FLOWS														
NB-NE		700	-44		MEYANKEE-SOUTH		660	-162		MAINE-NH		1410	-35	
NNE-SCOBIE+394		2898	252		SEABROOK-SOUTH		1644	228		NORTH-SOUTH		2798	147	
CMFD/MOORE-SO		186	-26		SNDYPOND-SOUTH		2552	-83		CONN EXPORT		-2230	388	
CONN-MASS		-1000	200		CONN-RI		-147	95		SW CONN IMPORT		1427	167	
NORWLK-STAMFORD		1104	-23		BOSTON IMPORT		3262	188		NEMA/BOS IMPORT		3824	85	
SEMA/RI EXPORT		1328	234		CONVEX-REMVEC		-1095	162		EAST-WEST		1414	-120	
NY-NE		-2	-192		PV20		109	-11		CT-LI-1385		1	-44	
HVDC TRANSFERS FROM H-Q														
CHAT-1	=	0			CHAT-2	=	0			HIGHGATE	=	225		
MADAWASK	=	-151			PHII-P1	=	1000			PHII-P2	=	1000		
EEL	=	74												
BUS VOLTAGES														
70001	CHESTER	345	342.		70002	ORRINGTN	345	351.		70003	MAXCYS	345	351.	
70086	ME YANK	345	355.		70090	BUXTON	345	356.		72692	NWGTN345	345	357.	
72694	SEBRK345	345	357.		71789	TEWKS	345	355.		70759	MYSTIC	345	359.	
71797	MILLBURY	345	351.		72925	LUDDLOW	345	349.		72926	NRTHFLD	345	355.	
73106	SOUTHGTN	345	356.		73108	CARD	345	354.		73109	MONTVILLE	345	357.	
73110	MILLSTNE	345	357.		73112	MANCHSTR	345	354.		73116	MIDDLTWN	345	358.	
71801	BRAYTN P	345	358.		71811	KENT CO.	345	351.		71326	BRIDGWTR	345	353.	
71336	SHERMAN	345	355.		71337	WFARNUM	345	354.		70772	W MEDWAY	345	352.	
70780	WWALP345	345	351.		70783	PILGRIM	345	355.		71193	CANAL	345	356.	
71133	CARVER	345	353.		70795	FRMNGHAM	230	230.		70793	MDFRM230	230	235.	
70794	MDWLT230	230	237.		70818	MYSTC MA	115	117.		71891	SALEM HR	115	119.	
73195	DEVON	115	117.		73259	HOPEWELL	115	113.		73264	PORTLAND	115	111.	
73241	MIDDLTWN	115	111.		73230	HADDAM	115	110.		73231	BOKUM	115	110.	
73265	GREEN HL	115	112.		73153	BRANFORD	115	116.		73227	E.MERIDN	115	111.	
73633	NO.WALLF	115	111.		73634	COLONY	115	112.		73198	SOUTHGTN	115	116.	
AREA/ZONE TOTALS														
NEPOOL_GEN		22911			NEPOOL_LOAD		24977			NEPOOL_LOSS		689		
NEPOOL_INT		-2983												

Table 6 – Case Summary PkA

PKA.SAV MIDDLETOWN RELIABILITY STUDY, HADDAM AUTOTRANSFORMER, MIDDLETOWN 2 & 3 ON GENERATION												
#	V	MW	MX	#	V	MW	MX	#	V	MW	MX	
73538 AESTH PF	0.996	180	26	73549 SMD1112J	0.000	0	0	73550 SMD1314J	0.000	0	0	
73551 NORHAR#1	0.994	161	22	73552 NORHAR#2	0.994	168	22	73553 DEVON#7	0.979	106	7	
73554 DEVON#8	0.979	106	7	73570 DEVGAS1	0.000	0	0	73571 DEVGAS12	0.000	0	0	
73572 DEVGAS13	0.000	0	0	73555 MIDDTN#2	1.003	117	26	73556 MIDDTN#3	0.983	233	26	
73557 MIDDTN#4	0.982	400	3	73558 MONTV#5	0.983	81	11	73559 MONTV#6	0.992	402	58	
73562 MILL#2	0.986	907	63	73563 MILL#3	0.984	1208	63	73565 LAKERD#1	1.001	305	48	
73566 LAKERD#2	1.001	305	48	73567 LAKERD#3	1.001	305	48	73574 MILFD#1	1.028	305	39	
73575 MILFD#2	1.028	305	39	73588 MERIDEN1	1.037	172	53	73589 MERIDEN2	1.037	172	53	
73590 MERIDEN3	1.061	195	53	73594 WALL LV1	1.025	102	16	73595 WALL LV2	1.025	102	16	
73596 WALL LV3	1.025	51	13	73646 BPTHBR#1	0.000	0	0	73647 BPTHBR#2	0.985	170	73	
73648 BPTHBR#3	0.980	375	73	73649 BPTHBR#4	0.000	0	0	73651 NH HARBR	0.981	447	81	
73652 BE 11	0.990	170	24	73653 BE 12	0.990	170	24	73654 BE 10 ST	0.988	180	24	
70705 VTYAK G	0.978	563	73	72243 MILLENCT	0.000	0	0	72244 MILLENST	0.000	0	0	
73080 WSPFLD 3	1.001	107	6	73085 MT.TOM	0.000	0	0	72512 BRSWP G1	0.992	294	67	
72513 BRSWP G2	0.992	294	67	72986 BERKFPWR	1.016	305	13	73083 NRTHFD12	1.011	270	80*	
73084 NRTHFD34	0.000	0	0	73072 ALT12 PF	1.026	65	15*	73073 ALT34 PF	1.025	80	15	
73069 MAPR1 PF	1.047	56	47*	73070 MAPR2 PF	0.000	0	0	73071 MAPR3 PF	0.000	0	0	
72930 STNYBK1A	1.043	65	8	72931 STNYBK1B	1.043	65	8	72932 STNYBK1C	1.043	65	8	
70060 MIS GT1	0.000	0	0	70061 MIS GT2	0.000	0	0	70062 MIS ST	0.000	0	0	
70389 BUCKS G4	1.040	191	92	70381 RPA CG1	0.000	0	0	70382 RPA SG2	0.000	0	0	
70386 WBK G1	1.040	184	31	70387 WBK G2	1.040	184	31	70388 WBK G3	1.040	195	33	
70365 WF WY #1	1.010	57	6	70366 WF WY #2	1.010	57	6	70367 WF WY #3	1.010	125	12	
70368 WF WY #4	1.038	537	104	70426 CHAMP G2	0.961	15	6*	70424 CHAMP G3	0.000	0	0	
70377 AEC G1	1.040	52	8	70378 AEC G2	1.040	52	7	70379 AEC G3	1.040	52	7	
72866 MERMK G1	1.033	113	23	72867 MERMK G2	1.033	320	67	72868 NWNMT G1	0.994	422	54	
72870 SCHILLER	0.992	48	1	72871 SCHILLER	0.992	50	1	72872 SCHILLER	0.992	48	1	
70010 NEW_G1	0.000	0	0	70011 NEW_G2	0.000	0	0	70012 NEW_G3	0.000	0	0	
72869 SBKR G1	1.010	1150	303	71857 COMRF G1	1.001	37	-5	71858 COMRF G2	1.001	37	-5	
71859 COMRF G3	1.002	29	-5	71860 COMRF G4	1.002	29	-5	71861 MOORE G1	1.003	40	-3	
71862 MOORE G2	1.006	33	-3	71863 MOORE G3	1.022	33	10	71864 MOORE G4	1.039	33	10	
71123 KENDALL	1.025	63	2	71124 KND JETS	1.025	36	0	71060 MYST G4	0.000	0	0	
71061 MYST 5G	0.000	0	0	71062 MYST G6	0.000	0	0	71063 MYST G7	1.044	565	335*	
71064 MYST J1	0.000	0	0	71073 N.BOST 1	0.000	0	0	71074 N.BOST 2	1.021	380	230*	
71946 SALEM G1	1.028	79	32*	71947 SALEM G2	1.026	78	29*	71948 SALEM G3	1.022	143	50*	
71949 SALEM G4	0.000	0	0	71251 CANAL G1	1.034	566	239*	71252 CANAL G2	1.011	576	120*	
71094 PLGRM G1	1.030	702	160	71095 ANPBCK1	0.000	0	0	71096 ANPBCK2	1.088	290	150*	
72377 BELL #1	0.000	0	0	72378 BELL #2	0.000	0	0	72372 BP #1 GN	1.027	238	120*	
72375 BP #2 GN	0.000	0	0	72370 BP #3 GN	1.042	605	218	72371 BP #4 GN	0.000	0	0	
71084 NEA GTPF	1.040	85	40*	71085 NEA GTPF	1.040	85	40*	71086 NEA STPF	1.055	80	55*	
71531 OSP1 PF	1.024	77	17	71532 OSP2 PF	1.024	77	17	71533 OSP3 PF	1.024	108	23	
71534 OSP4 PF	1.024	77	17	71535 OSP5 PF	0.000	0	0	71536 OSP6 PF	0.000	0	0	
72669 TIVER G1	1.030	189	27	72670 TIVER G2	1.030	92	14	71394 EMI_GEN	0.989	185	24	
72661 MANCH09A	1.002	119	35*	72662 MANCH10A	1.002	119	35*	72663 MANCH11A	1.002	119	35*	
72666 FRSQ SC1	0.991	43	2	72667 FRSQ SC2	0.991	43	1	72668 FRSQ SC3	0.991	42	3	
72671 HOPE G1	0.000	0	0	72672 HOPE G2	0.000	0	0	72673 HOPE G3	0.000	0	0	
MILLSTONE	2115	126		MIDDLETOWN	750	55		MONTVILLE	483	69		
NORWALK	329	44		BRIDGEPORT	1065	216		NHHARBOUR	447	81		
DEVON	212	13		MERIDEN	539	159		BRAYTONPT	1448	557		
MANCHSTRST	485	111		SOMERSET	70	0		OSP	339	74		
NEA	249	135		PAWTKTPWR	64	-6		ENRON	124	80		
CANAL	1142	359		PILGRIM	702	160		MYSTIC	565	335		
NEWBOSTON	380	230		SALEMHR	300	111		SEABROOK	1150	303		
NEWINGTON	422	54		SCHILLER	145	4		MERRIMACK	433	90		
STONYBROOK	0	0		WYMAN	776	128		VTYANKEE	563	73		
BEARSWAMP	588	134		NORTHFIELD	270	80		MASSPWR	56	47		
INTERFACE FLOWS												
NB-NE	700	-39		MEYANKEE-SOUTH	266	-152		MAINE-NH	966	-68		
NNE-SCOBIE+394	2001	129		SEABROOK-SOUTH	1285	130		NORTH-SOUTH	1897	135		
CMFD/MOORE-SO	189	-28		SNDYPOND-SOUTH	2278	31		CONN EXPORT	-207	143		
CONN-MASS	-196	77		CONN-RI	725	30		SW CONN IMPORT	763	206		
NORWLK-STAMFORD	940	-17		BOSTON IMPORT	3661	246		NEMA/BOS IMPORT	4228	161		
SEMA/RI EXPORT	623	257		CONVEX-REMEVEC	820	65		EAST-WEST	-610	2		
NY-NE	-2	-236		PV20	110	-11		CT-LI-1385	0	-44		
HVDC TRANSFERS FROM H-Q												
CHAT-1 =	0			CHAT-2 =	0			HIGHGATE =	225			
MADAWASK =	-151			PHII-P1 =	1000			PHII-P2 =	1000			
EEL =	74											
BUS VOLTAGES												
70001 CHESTER	345	340.		70002 ORRINGTN	345	345.		70003 MAXCYS	345	349.		
70086 ME YANK	345	355.		70090 BUXTON	345	358.		72692 NWTN345	345	357.		
72694 SEBRK345	345	357.		71789 TEWKS	345	355.		70759 MYSTIC	345	359.		
71797 MILLBURY	345	352.		72925 LUDLOW	345	353.		72926 NRTHFLD	345	359.		
73106 SOUTHGTN	345	356.		73108 CARD	345	357.		73109 MONTVILLE	345	357.		
73110 MILLSTNE	345	357.		73112 MANCHSTR	345	358.		73116 MIDLTLWN	345	357.		
71801 BRAYTN P	345	358.		71811 KENT CO.	345	351.		71326 BRIDGWTR	345	352.		
71336 SHERMAN	345	355.		71337 WFARNUM	345	354.		70772 W MEDWAY	345	351.		
70780 WWALP345	345	350.		70783 PILGRIM	345	355.		71193 CANAL	345	356.		
71133 CARVER	345	353.		70795 FRMNGHAM	230	228.		70793 MDFRM230	230	234.		
70794 MDWLT230	230	236.		70818 MYSTC MA	115	117.		71891 SALEM HR	115	118.		
73195 DEVON	115	117.		73259 HOPEWELL	115	116.		73264 PORTLAND	115	118.		
73241 MIDLTLWN	115	118.		73230 HADDAM	115	118.		73231 BOKUM	115	117.		
73265 GREEN HL	115	117.		73153 BRANFORD	115	119.		73227 E.MERIDN	115	116.		
73633 NO.WALLF	115	115.		73634 COLONY	115	115.		73198 SOUTHGTN	115	116.		
AREA/ZONE TOTALS												
NEPOOL_GEN	22812			NEPOOL_LOAD	24977			NEPOOL_LOSS	590			
NEPOOL_INT	-2985											

Table 7 – Case Summary Pk1A

PK1A.SAV MIDDLETOWN RELIABILITY STUDY, HADDAM AUTOTRANSFORMER, MIDDLETOWN 2 & 3 OFF, CT IMPORT GENERATION														
#	V	MW	MX	#	V	MW	MX	#	V	MW	MX			
73538	AESTH PF	0.995	180	26	73549	SMD1112J	0.000	0	0	73550	SMD1314J	0.000	0	0
73551	NORHAR#1	0.000	0	0	73552	NORHAR#2	1.013	168	57	73553	DEVON#7	0.000	0	0
73554	DEVON#8	0.000	0	0	73570	DEVGAS11	0.000	0	0	73571	DEVGAS12	0.000	0	0
73572	DEVGAS13	0.000	0	0	73555	MIDDTN#2	0.000	0	0	73556	MIDDTN#3	0.000	0	0
73557	MIDDTN#4	1.005	400	98	73558	MONTV#5	0.000	0	0	73559	MONTV#6	0.991	402	59
73562	MILL#2	0.000	0	0	73563	MILL#3	0.997	1208	213	73565	LAKERD#1	1.017	305	85
73566	LAKERD#2	1.017	305	85	73567	LAKERD#3	1.017	305	85	73574	MILFD#1	1.039	305	64
73575	MILFD#2	0.000	0	0	73588	MERIDEN1	1.042	172	63	73589	MERIDEN2	1.042	172	63
73590	MERIDEN3	1.066	195	63	73594	WALL LV1	1.025	102	16	73595	WALL LV2	1.025	102	16
73596	WALL LV3	1.025	51	13	73646	BPTHBR#1	0.000	0	0	73647	BPTHBR#2	0.991	170	83
73648	BPTHBR#3	0.983	375	83	73649	BPTHBR#4	0.000	0	0	73651	NH HARB	0.983	447	108
73652	BE 11	0.993	170	27	73653	BE 12	0.993	170	27	73654	BE 10 ST	0.991	180	27
70705	VTYAK G	0.991	563	150*	72243	MILLENCT	0.000	0	0	72244	MILLENST	0.000	0	0
73080	WSPFLD 3	1.006	107	12	73085	MT.TOM	0.000	0	0	72512	BRSWP G1	0.989	294	59
72513	BRSWP G2	0.989	294	59	72986	BERKPWR	1.032	305	41	73083	NRTHFD12	1.004	270	80*
73084	NRTHFD34	0.000	0	0	73072	ALT12 PF	1.034	65	22*	73073	ALT34 PF	1.033	80	22*
73069	MAPR1 PF	1.044	56	47*	73070	MAPR2 PF	0.000	0	0	73071	MAPR3 PF	0.000	0	0
72930	STNYBK1A	1.043	65	12	72931	STNYBK1B	1.043	65	12	72932	STNYBK1C	1.043	65	12
70060	MIS GT1	1.067	179	62	70061	MIS GT2	1.067	179	62	70062	MIS ST	1.066	191	62
70389	BUCKS G4	1.040	191	74	70381	RPA CG1	0.000	0	0	70382	RPA SG2	0.000	0	0
70386	WBK G1	1.040	184	31	70387	WBK G2	1.040	184	31	70388	WBK G3	1.040	195	33
70365	WF WY #1	1.020	57	12	70366	WF WY #2	1.020	57	12	70367	WF WY #3	0.000	0	0
70368	WF WY #4	1.048	635	167	70426	CHAMP G2	0.975	15	6*	70424	CHAMP G3	0.000	0	0
70377	AEC G1	1.040	52	9	70378	AEC G2	1.040	52	9	70379	AEC G3	0.000	0	0
72866	MERMK G1	1.035	113	27	72867	MERMK G2	1.036	320	76	72868	NWNGT G1	0.988	422	33
72870	SCHILLER	0.995	48	3	72871	SCHILLER	0.995	50	3	72872	SCHILLER	0.995	48	3
70010	NEW_G1	0.998	169	33	70011	NEW_G2	0.998	169	33	70012	NEW_G3	0.996	195	33
72869	SBRK G1	1.019	1150	418	71857	COMRF G1	1.001	37	-5	71858	COMRF G2	1.001	37	-5
71859	COMRF G2	1.002	29	-5	71860	COMRF G3	1.002	29	-5	71861	MOORE G1	1.003	40	-3
71862	MOORE G3	1.006	33	-3	71863	MOORE G4	1.023	33	11	71864	MOORE G4	1.040	33	11
71123	KENDALL	1.028	63	0	71124	KND JETS	1.028	36	0	71060	MYST G4	0.000	0	0
71061	MYST 5G	0.000	0	0	71062	MYST G6	0.000	0	0	71063	MYST G7	1.046	565	335*
71064	MYST J1	0.000	0	0	71073	N.BOST 1	0.000	0	0	71074	N.BOST 2	1.018	380	204
71946	SALEM G1	1.023	79	15	71947	SALEM G2	1.023	78	15	71948	SALEM G3	1.024	143	31
71949	SALEM G4	1.026	400	93	71251	CANAL G1	1.035	566	239*	71252	CANAL G2	1.012	576	120*
71094	PLGRM G1	1.026	702	131	71095	ANPBLC1	1.094	290	150*	71096	ANPBLC2	1.094	290	150*
72377	BELL #1	0.000	0	0	72378	BELL #2	0.000	0	0	72372	BP #1 GN	1.025	238	120*
72375	BP #2 GN	0.000	0	0	72370	BP #3 GN	1.029	605	131	72371	BP #4 GN	1.034	421	98
71084	NEA GTFP	1.043	85	40*	71085	NEA GTFP	1.043	85	40*	71086	NEA STFP	1.058	80	55*
71531	OSP1 PF	1.002	77	2	71532	OSP2 PF	1.002	77	2	71533	OSP3 PF	1.001	108	2
71534	OSP4 PF	1.002	77	2	71535	OSP5 PF	0.000	0	0	71536	OSP6 PF	0.000	0	0
72669	TIVER G1	1.030	189	26	72670	TIVER G2	1.030	92	14	71394	EMI_GEN	0.986	185	20
72661	MANCH09A	1.001	119	35*	72662	MANCH10A	1.001	119	35*	72663	MANCH11A	1.001	119	35*
72666	FRSQ SC1	0.991	43	4	72667	FRSQ SC2	0.991	43	2	72668	FRSQ SC3	0.991	42	4
72671	HOPE G1	0.000	0	0	72672	HOPE G2	0.000	0	0	72673	HOPE G3	0.000	0	0
MILLSTONE	1208	213	MIDDLETOWN	400	98	MONTVILLE	402	59						
NORWALK	168	57	BRIDGEPORT	1065	248	NHHARBOUR	447	108						
DEVON	0	0	MERIDEN	539	189	BRAYTONPT	1869	480						
MANCHSTRST	485	115	SOMERSET	70	0	OSP	339	7						
NEA	249	135	PAWTKTPWR	64	-6	ENRON	124	80						
CANAL	1142	359	PILGRIM	702	131	MYSTIC	565	335						
NEWBOSTON	380	204	SALEMHBR	700	154	SEABROOK	1150	418						
NEWINGTON	955	131	SCHILLER	145	9	MERRIMACK	433	102						
STONYBROOK	0	0	WYMAN	749	190	VTYANKEE	563	150						
BEARSWAMP	588	118	NORTHFIELD	270	80	MASSPWR	56	47						
INTERFACE FLOWS														
NB-NE	700	-44	MEYANKEE-SOUTH	660	-163	MAINE-NH	1414	-40						
NNE-SCOBIE+394	2902	218	SEABROOK-SOUTH	1645	204	NORTH-SOUTH	2801	125						
CMFD/MOORE-SO	186	-26	SNDYPOND-SOUTH	2557	-39	CONN EXPORT	-2235	418						
CONN-MASS	-991	215	CONN-RI	-158	96	SW CONN IMPORT	1431	125						
NORWLK-STAMFORD	1103	-22	BOSTON IMPORT	3262	200	NEMA/BOS IMPORT	3824	97						
SEMA/RI EXPORT	1328	210	CONVEX-REMVEC	-1099	167	EAST-WEST	1418	-125						
NY-NE	-1	-200	PV20	109	-11	CT-LI-1385	0	-44						
HVDC TRANSFERS FROM H-Q														
CHAT-1	=	0	CHAT-2	=	0	HIGHGATE	=	225						
MADAWASK	=	-151	PHII-P1	=	1000	PHII-P2	=	1000						
EEL	=	74												
BUS VOLTAGES														
70001	CHESTER	345	342.	70002	ORRINGTN	345	351.	70003	MAXCYS	345	352.			
70086	ME YANK	345	355.	70090	BUXTON	345	356.	72692	NWGTN345	345	357.			
72694	SEBRK345	345	357.	71789	TEWKS	345	355.	70759	MYSTIC	345	359.			
71797	MILLBURY	345	352.	72925	LULOW	345	350.	72926	NRTHFLD	345	356.			
73106	SOUTHGTN	345	356.	73108	CARD	345	354.	73109	MONTVILLE	345	357.			
73110	MILLSTNE	345	357.	73112	MANCHSTR	345	355.	73116	MIDDLTWN	345	358.			
71801	BRAYTN P	345	358.	71811	KENT CO.	345	351.	71326	BRIDGWTR	345	353.			
71336	SHERMAN	345	355.	71337	WFARNUM	345	354.	70772	W MEDWAY	345	352.			
70780	WWALP345	345	351.	70783	PILGRIM	345	355.	71193	CANAL	345	356.			
71133	CARVER	345	353.	70795	FRMNGHAM	230	230.	70793	MDFRM230	230	235.			
70794	MDWLT230	230	237.	70818	MYSTC MA	115	117.	71891	SALEM HR	115	119.			
73195	DEVON	115	117.	73259	HOPEWELL	115	116.	73264	PORTLAND	115	116.			
73241	MIDDLTWN	115	116.	73230	HADDAM	115	118.	73231	BOKUM	115	117.			
73265	GREEN HL	115	117.	73153	BRANFORD	115	118.	73227	E.MERIDN	115	116.			
73633	NO.WALLF	115	116.	73634	COLONY	115	115.	73198	SOUTHGTN	115	116.			
AREA/ZONE TOTALS														
NEPOOL_GEN	22900	NEPOOL_LOAD	24977	NEPOOL_LOSS	677									
NEPOOL_INT	-2985													

Table 8 – Case Summary Lt

LT.SAV MIDDLETOWN RELIABILITY STUDY, NO AUTOTRANSFORMER, MIDDLETOWN 2 & 3 ON

GENERATION

#	V	MW	MX	#	V	MW	MX	#	V	MW	MX
73538 AESTH PF	0.992	180	11	73549 SMD1112J	0.000	0	0	73550 SMD1314J	0.000	0	0
73551 NORHAR#1	0.000	0	0	73552 NORHAR#2	0.985	168	6	73553 DEVON#7	0.000	0	0
73554 DEVON#8	0.000	0	0	73570 DEVGAS11	0.000	0	0	73571 DEVGAS12	0.000	0	0
73572 DEVGAS13	0.000	0	0	73555 MIDDTN#2	0.968	117	5	73556 MIDDTN#3	0.958	233	5
73557 MIDDTN#4	0.983	400	7	73558 MONTV#5	0.000	0	0	73559 MONTV#6	0.989	402	24
73562 MILL#2	0.989	907	90	73563 MILL#3	0.986	1208	90	73565 LAKERD#1	0.000	0	0
73566 LAKERD#2	0.000	0	0	73567 LAKERD#3	0.000	0	0	73574 MILFD#1	1.040	305	25
73575 MILFD#2	0.000	0	0	73588 MERIDEN1	1.014	172	14	73589 MERIDEN2	1.014	172	14
73590 MERIDEN3	1.038	195	14	73594 WALL LV1	0.000	0	0	73595 WALL LV2	1.025	102	26*
73596 WALL LV3	0.000	0	0	73646 BPTHBR#1	0.000	0	0	73647 BPTHBR#2	0.000	0	0
73648 BPTHBR#3	0.965	375	9	73649 BPTHBR#4	0.000	0	0	73651 NH HARB	0.974	447	46
73652 BE 11	0.968	170	1	73653 BE 12	0.968	170	1	73654 BE 10 ST	0.963	180	1
70705 VTYAK G	0.957	563	51	72243 MILLENCT	0.000	0	0	72244 MILLENST	0.000	0	0
73080 WSPFLD 3	0.000	0	0	73085 MT.TOM	0.000	0	0	72512 BRSWP G1	0.977	-280	81
72513 BRSWP G2	0.977	-280	81	72986 BERKPWR	0.000	0	0	73083 NRTHFD12	0.964	-500	36
73084 NRTHFD34	0.965	-500	36	73072 ALT12 PF	1.015	65	6	73073 ALT34 PF	1.014	80	6
73069 MAPR1 PF	0.000	0	0	73070 MAPR2 PF	0.000	0	0	73071 MAPR3 PF	0.000	0	0
72930 STNYBK1A	0.000	0	0	72931 STNYBK1B	0.000	0	0	72932 STNYBK1C	0.000	0	0
70060 MIS GT1	0.000	0	0	70061 MIS GT2	0.000	0	0	70062 MIS ST	0.000	0	0
70389 BUCKS G4	0.000	0	0	70381 RPA CG1	0.000	0	0	70382 RPA SG2	0.000	0	0
70386 WBK G1	0.000	0	0	70387 WBK G2	0.000	0	0	70388 WBK G3	0.000	0	0
70365 WF WY #1	0.997	57	2	70366 WF WY #2	0.998	32	2	70367 WF WY #3	0.998	125	4
70368 WF WY #4	1.007	605	63	70426 CHAMP G2	0.000	0	0	70424 CHAMP G3	0.000	0	0
70377 AEC G1	0.000	0	0	70378 AEC G2	0.000	0	0	70379 AEC G3	0.000	0	0
72866 MERMK G1	0.000	0	0	72867 MERMK G2	1.019	320	12	72868 NWNGT G1	0.000	0	0
72870 SCHILLER	0.000	0	0	72871 SCHILLER	0.000	0	0	72872 SCHILLER	0.000	0	0
70010 NEW_G1	0.000	0	0	70011 NEW_G2	0.000	0	0	70012 NEW_G3	0.000	0	0
72869 SBK G1	0.995	1150	106	71857 COMRF G1	0.000	0	0	71858 COMRF G2	0.000	0	0
71859 COMRF G2	0.000	0	0	71860 COMRF G3	0.000	0	0	71861 MOORE G1	0.000	0	0
71862 MOORE G3	0.000	0	0	71863 MOORE G4	0.000	0	0	71864 MOORE G4	0.000	0	0
71123 KENDALL	0.000	0	0	71124 KND JETS	0.000	0	0	71060 MYST G4	0.000	0	0
71061 MYST 5G	0.000	0	0	71062 MYST G6	0.000	0	0	71063 MYST G7	0.990	565	-150
71064 MYST J1	0.000	0	0	71073 N.BOST 1	0.000	0	0	71074 N.BOST 2	0.000	0	0
71946 SALEM G1	0.000	0	0	71947 SALEM G2	0.000	0	0	71948 SALEM G3	0.983	143	-37
71949 SALEM G4	0.000	0	0	71251 CANAL G1	0.000	0	0	71252 CANAL G2	0.000	0	0
71094 PLGRM G1	1.022	702	97	71095 ANPBLC1	0.000	0	0	71096 ANPBLC2	0.000	0	0
72377 BELL #1	0.000	0	0	72378 BELL #2	0.000	0	0	72372 BP #1 GN	0.000	0	0
72375 BP #2 GN	0.000	0	0	72370 BP #3 GN	0.994	605	6	72371 BP #4 GN	0.000	0	0
71084 NEA GTFP	0.000	0	0	71085 NEA GTFP	0.000	0	0	71086 NEA STFP	0.000	0	0
71531 OSP1 PF	0.000	0	0	71532 OSP2 PF	0.000	0	0	71533 OSP3 PF	0.000	0	0
71534 OSP4 PF	0.000	0	0	71535 OSP5 PF	0.000	0	0	71536 OSP6 PF	0.000	0	0
72669 TIVER G1	0.000	0	0	72670 TIVER G2	0.000	0	0	71394 EMI_GEN	0.965	185	7
72661 MANCH09A	0.000	0	0	72662 MANCH10A	0.000	0	0	72663 MANCH11A	0.000	0	0
72666 FRSQ SC1	0.000	0	0	72667 FRSQ SC2	0.000	0	0	72668 FRSQ SC3	0.000	0	0
72671 HOPE G1	0.000	0	0	72672 HOPE G2	0.000	0	0	72673 HOPE G3	0.000	0	0
MILLSTONE	2115	180		MIDDLETOWN	750	16		MONTVILLE	402	24	
NORWALK	168	6		BRIDGEPORT	895	12		NHHARBOUR	447	46	
DEVON	0	0		MERIDEN	539	42		BRAYTONPT	1210	12	
MANCHSTRST	0	0		SOMERSET	105	0		OSP	0	0	
NEA	0	0		PAWTKTPWR	7	-7		ENRON	0	0	
CANAL	0	0		PILGRIM	702	97		MYSTIC	565	-150	
NEWBOSTON	0	0		SALEMHRB	143	-37		SEABROOK	1150	106	
NEWINGTON	0	0		SCHILLER	0	0		MERRIMACK	320	12	
STONYBROOK	0	0		WYMAN	818	72		VTYANKEE	563	51	
BEARSWAMP	-560	161		NORTHFIELD	-1000	71		MASSPWR	0	0	
INTERFACE FLOWS											
NB-NE	702	-42		MEYANKEE-SOUTH	248	-18		MAINE-NH	728	-109	
NNE-SCOBIE+394	1637	-104		SEABROOK-SOUTH	1046	-11		NORTH-SOUTH	2269	-72	
CMFD/MOORE-SO	5	-10		SNDYPOND-SOUTH	546	85		CONN EXPORT	2594	-7	
CONN-MASS	876	17		CONN-RI	897	-51		SW CONN IMPORT	-230	121	
NORWLK-STAMFORD	427	-48		BOSTON IMPORT	1332	25		NEMA/BOS IMPORT	1604	6	
SEMA/RI EXPORT	-670	61		CONVEX-REMVEC	776	-126		EAST-WEST	-1033	187	
NY-NE	20	74		PV20	110	-2		CT-LI-1385	100	-56	
HVDC TRANSFERS FROM H-Q											
CHAT-1	=	0		CHAT-2	=	0		HIGHGATE	=	150	
MADAWASK	=	0		PHII-P1	=	0		PHII-P2	=	0	
BUS VOLTAGES											
70001 CHESTER	345	342.		70002 ORRINGTN	345	349.		70003 MAXCYS	345	354.	
70086 ME YANK	345	354.		70090 BUXTON	345	354.		72692 NWTN345	345	357.	
72694 SEBRK345	345	357.		71789 TEWKS	345	359.		70759 MYSTIC	345	359.	
71797 MILLBURY	345	354.		72925 LUDLOW	345	352.		72926 NRTHFLD	345	351.	
73106 SOUTHTN	345	357.		73108 CARD	345	354.		73109 MONTVILLE	345	357.	
73110 MILLSTNE	345	357.		73112 MANCHSTR	345	357.		73116 MIDLTLWN	345	357.	
71801 BRAYTN P	345	352.		71811 KENT CO.	345	350.		71326 BRIDGWTR	345	353.	
71336 SHERMAN	345	351.		71337 WFARNUM	345	351.		70772 W MEDWAY	345	352.	
70780 WWALP345	345	352.		70783 PILGRIM	345	355.		71193 CANAL	345	355.	
71133 CARVER	345	354.		70795 FRMNGHAM	230	236.		70793 MDFRM230	230	238.	
70794 MDWLT230	230	239.		70818 MYSTC MA	115	118.		71891 SALEM HR	115	118.	
73195 DEVON	115	118.		73259 HOPEWELL	115	116.		73264 PORTLAND	115	116.	
73241 MIDLTLWN	115	116.		73230 HADDAM	115	116.		73231 BOKUM	115	116.	
73265 GREEN HL	115	117.		73153 BRANFORD	115	118.		73227 E.MERIDN	115	116.	
73633 NO.WALLF	115	116.		73634 COLONY	115	116.		73198 SOUTHTN	115	116.	
AREA/ZONE TOTALS											
NEPOOL_GEN	10941			NEPOOL_LOAD	11284			NEPOOL_LOSS	292		
NEPOOL_INT	-864										

Table 9 – Case Summary LtA

LTA.SAV MIDDLETOWN RELIABILITY STUDY, HADDAM AUTOTRANSFORMER, MIDDLETOWN 2 & 3 ON GENERATION												
#	V	MW	MX	#	V	MW	MX	#	V	MW	MX	
73538 AESTH PF	0.992	180	11	73549 SMD1112J	0.000	0	0	73550 SMD1314J	0.000	0	0	
73551 NORHAR#1	0.000	0	0	73552 NORHAR#2	0.985	168	6	73553 DEVON#7	0.000	0	0	
73554 DEVON#8	0.000	0	0	73570 DEVGAS11	0.000	0	0	73571 DEVGAS12	0.000	0	0	
73572 DEVGAS13	0.000	0	0	73555 MIDDTN#2	0.951	117	-13	73556 MIDDTN#3	0.951	233	-13	
73557 MIDDTN#4	0.983	400	7	73558 MONTV#5	0.000	0	0	73559 MONTV#6	0.989	402	24	
73562 MILL#2	0.989	907	90	73563 MILL#3	0.986	1208	90	73565 LAKERD#1	0.000	0	0	
73566 LAKERD#2	0.000	0	0	73567 LAKERD#3	0.000	0	0	73574 MILFD#1	1.039	305	23	
73575 MILFD#2	0.000	0	0	73588 MERIDEN1	1.013	172	12	73589 MERIDEN2	1.013	172	12	
73590 MERIDEN3	1.037	195	12	73594 WALL LV1	0.000	0	0	73595 WALL LV2	1.025	102	23	
73596 WALL LV3	0.000	0	0	73646 BPTHBR#1	0.000	0	0	73647 BPTHBR#2	0.000	0	0	
73648 BPTHBR#3	0.964	375	7	73649 BPTHBR#4	0.000	0	0	73651 NH HARBR	0.969	447	20	
73652 BE 11	0.968	170	1	73653 BE 12	0.968	170	1	73654 BE 10 ST	0.963	180	1	
70705 VTYAK G	0.957	563	51	72243 MILLENCT	0.000	0	0	72244 MILLENST	0.000	0	0	
73080 WSPFLD 3	0.000	0	0	73085 MT.TOM	0.000	0	0	72512 BRSWP G1	0.977	-280	81	
72513 BRSWP G2	0.977	-280	81	72986 BERKPWR	0.000	0	0	73083 NRTHFD12	0.964	-500	36	
73084 NRTHFD34	0.965	-500	36	73072 ALT12 PF	1.015	65	6	73073 ALT34 PF	1.014	80	6	
73069 MAPR1 PF	0.000	0	0	73070 MAPR2 PF	0.000	0	0	73071 MAPR3 PF	0.000	0	0	
72930 STNYBK1A	0.000	0	0	72931 STNYBK1B	0.000	0	0	72932 STNYBK1C	0.000	0	0	
70060 MIS GT1	0.000	0	0	70061 MIS GT2	0.000	0	0	70062 MIS ST	0.000	0	0	
70389 BUCKS G4	0.000	0	0	70381 RPA CG1	0.000	0	0	70382 RPA SG2	0.000	0	0	
70386 WBK G1	0.000	0	0	70387 WBK G2	0.000	0	0	70388 WBK G3	0.000	0	0	
70365 WF WY #1	0.997	57	2	70366 WF WY #2	0.998	32	2	70367 WF WY #3	0.998	125	4	
70368 WF WY #4	1.007	605	63	70426 CHAMP G2	0.000	0	0	70424 CHAMP G3	0.000	0	0	
70377 AEC G1	0.000	0	0	70378 AEC G2	0.000	0	0	70379 AEC G3	0.000	0	0	
72866 MERMK G1	0.000	0	0	72867 MERMK G2	1.019	320	13	72868 NWNGT G1	0.000	0	0	
72870 SCHILLER	0.000	0	0	72871 SCHILLER	0.000	0	0	72872 SCHILLER	0.000	0	0	
70010 NEW_G1	0.000	0	0	70011 NEW_G2	0.000	0	0	70012 NEW_G3	0.000	0	0	
72869 SBRC G1	0.995	1150	106	71857 COMRF G1	0.000	0	0	71858 COMRF G2	0.000	0	0	
71859 COMRF G3	0.000	0	0	71860 COMRF G4	0.000	0	0	71861 MOORE G1	0.000	0	0	
71862 MOORE G2	0.000	0	0	71863 MOORE G3	0.000	0	0	71864 MOORE G4	0.000	0	0	
71123 KENDALL	0.000	0	0	71124 KND JETS	0.000	0	0	71060 MYST G4	0.000	0	0	
71061 MYST 5G	0.000	0	0	71062 MYST G6	0.000	0	0	71063 MYST G7	0.990	565	-150	
71064 MYST J1	0.000	0	0	71073 N.BOST 1	0.000	0	0	71074 N.BOST 2	0.000	0	0	
71946 SALEM G1	0.000	0	0	71947 SALEM G2	0.000	0	0	71948 SALEM G3	0.983	143	-37	
71949 SALEM G4	0.000	0	0	71251 CANAL G1	0.000	0	0	71252 CANAL G2	0.000	0	0	
71094 PLGRM G1	1.022	702	96	71095 ANPBLC1	0.000	0	0	71096 ANPBLC2	0.000	0	0	
72377 BELL #1	0.000	0	0	72378 BELL #2	0.000	0	0	72372 BP #1 GN	0.000	0	0	
72375 BP #2 GN	0.000	0	0	72370 BP #3 GN	0.994	605	5	72371 BP #4 GN	0.000	0	0	
71084 NEA GTPF	0.000	0	0	71085 NEA GTPF	0.000	0	0	71086 NEA STPF	0.000	0	0	
71531 OSP1 PF	0.000	0	0	71532 OSP2 PF	0.000	0	0	71533 OSP3 PF	0.000	0	0	
71534 OSP4 PF	0.000	0	0	71535 OSP5 PF	0.000	0	0	71536 OSP6 PF	0.000	0	0	
72669 TIVER G1	0.000	0	0	72670 TIVER G2	0.000	0	0	71394 EMI_GEN	0.965	185	7	
72661 MANCH09A	0.000	0	0	72662 MANCH10A	0.000	0	0	72663 MANCH11A	0.000	0	0	
72666 FRSQ SC1	0.000	0	0	72667 FRSQ SC2	0.000	0	0	72668 FRSQ SC3	0.000	0	0	
72671 HOPE G1	0.000	0	0	72672 HOPE G2	0.000	0	0	72673 HOPE G3	0.000	0	0	
MILLSTONE	2115	180		MIDDLETOWN	750	-19		MONTVILLE	402	24		
NORWALK	168	6		BRIDGEPORT	895	10		NHHARBOUR	447	20		
DEVON	0	0		MERIDEN	539	36		BRAYTONPT	1210	11		
MANCHSTRST	0	0		SOMERSET	105	0		OSP	0	0		
NEA	0	0		PAWTKTPWR	7	-7		ENRON	0	0		
CANAL	0	0		PILGRIM	702	96		MYSTIC	565	-150		
NEWBOSTON	0	0		SALEMHR	143	-37		SEABROOK	1150	106		
NEWINGTON	0	0		SCHILLER	0	0		MERRIMACK	320	13		
STONYBROOK	0	0		WYMAN	819	72		VTYANKEE	563	51		
BEARSWAMP	-560	161		NORTHFIELD	-1000	71		MASSPWR	0	0		
INTERFACE FLOWS												
NB-NE	702	-42		MEYANKEE-SOUTH	248	-18		MAINE-NH	728	-109		
NNE-SCOBIE+394	1638	-104		SEABROOK-SOUTH	1046	-11		NORTH-SOUTH	2269	-72		
CMFD/MOORE-SO	5	-10		SNYPOND-SOUTH	546	85		CONN EXPORT	2593	-7		
CONN-MASS	876	17		CONN-RI	896	-51		SW CONN IMPORT	-229	86		
NORWLK-STAMFORD	427	-47		BOSTON IMPORT	1332	24		NEMA/BOS IMPORT	1604	6		
SEMA/RI EXPORT	-670	60		CONVEX-REMVEC	776	-126		EAST-WEST	-1033	187		
NY-NE	20	73		PV20	110	-2		CT-LI-1385	100	-56		
HVDC TRANSFERS FROM H-Q												
CHAT-1 =	0			CHAT-2 =	0			HIGHGATE =	150			
MADAWASK =	0			PHII-P1 =	0			PHII-P2 =	0			
BUS VOLTAGES												
70001 CHESTER	345	342.		70002 ORRINGTN	345	349.		70003 MAXCYS	345	354.		
70086 ME YANK	345	354.		70090 BUXTON	345	354.		72692 NWGTN345	345	357.		
72694 SEBRK345	345	357.		71789 TEWKS	345	359.		70759 MYSTIC	345	359.		
71797 MILLBURY	345	354.		72925 LUDLOW	345	352.		72926 NRTHFLD	345	351.		
73106 SOUTHGTN	345	357.		73108 CARD	345	354.		73109 MONTVILLE	345	357.		
73110 MILLSTNE	345	357.		73112 MANCHSTR	345	357.		73116 MDDLTLWN	345	357.		
71801 BRAYTN P	345	352.		71811 KENT CO.	345	350.		71326 BRIDGWTR	345	353.		
71336 SHERMAN	345	351.		71337 WFARNUM	345	351.		70772 W MEDWAY	345	352.		
70780 WWALP345	345	352.		70783 PILGRIM	345	355.		71193 CANAL	345	355.		
71133 CARVER	345	354.		70795 FRMNGHAM	230	236.		70793 MDFRM230	230	238.		
70794 MDWLT230	230	239.		70818 MYSTC MA	115	118.		71891 SALEM HR	115	118.		
73195 DEVON	115	118.		73259 HOPEWELL	115	116.		73264 PORTLAND	115	116.		
73241 MDDLTLWN	115	116.		73230 HADDAM	115	117.		73231 BOKUM	115	117.		
73265 GREEN HL	115	118.		73153 BRANFORD	115	119.		73227 E.MERIDN	115	116.		
73633 NO.WALLF	115	116.		73634 COLONY	115	116.		73198 SOUTHGTN	115	116.		
AREA/ZONE TOTALS												
NEPOOL_GEN	10942			NEPOOL_LOAD	11284			NEPOOL_LOSS	292			
NEPOOL_INT	-864											

Table 10 – Sensitivity Case Summary LtA-S

LTA.SAV MIDDLETOWN RELIABILITY STUDY, HADDAM AUTOTRANSFORMER, MIDDLETOWN 2 & 3 ON GENERATION											
~~~~~											
#	V	MW	MX	#	V	MW	MX	#	V	MW	MX
73538 AESTH PF	0.992	180	11	73549 SMD1112J	0.000	0	0	73550 SMD1314J	0.000	0	0
73551 NORHAR#1	0.000	0	0	73552 NORHAR#2	0.986	168	8	73553 DEVON#7	0.000	0	0
73554 DEVON#8	0.000	0	0	73570 DEVGAS11	0.000	0	0	73571 DEVGAS12	0.000	0	0
73572 DEVGAS13	0.000	0	0	73555 MIDDTN#2	0.952	117	-12	73556 MIDDTN#3	0.951	233	-12
73557 MIDDTN#4	0.985	400	17	73558 MONTV#5	0.000	0	0	73559 MONTV#6	0.989	402	25
73562 MILL#2	0.990	907	101	73563 MILL#3	0.987	1208	101	73565 LAKERD#1	0.000	0	0
73566 LAKERD#2	0.000	0	0	73567 LAKERD#3	0.000	0	0	73574 MILFD#1	1.040	305	25
73575 MILFD#2	0.000	0	0	73588 MERIDEN1	1.015	172	16	73589 MERIDEN2	1.015	172	16
73590 MERIDEN3	1.039	195	16	73594 WALL LV1	0.000	0	0	73595 WALL LV2	1.025	102	23
73596 WALL LV3	0.000	0	0	73646 BPTHBR#1	0.000	0	0	73647 BPTHBR#2	0.000	0	0
73648 BPTHBR#3	0.965	375	8	73649 BPTHBR#4	0.000	0	0	73651 NH HARB	0.966	447	6
73652 BE 11	0.968	170	1	73653 BE 12	0.968	170	1	73654 BE 10 ST	0.963	180	1
70705 VTYAK G	0.955	563	43	72243 MILLENCT	0.000	0	0	72244 MILLENST	0.000	0	0
73080 WSPFLD 3	0.000	0	0	73085 MT.TOM	0.000	0	0	72512 BRSWP G1	0.978	-280	82
72513 BRSWP G2	0.978	-280	82	72986 BERKPWR	0.000	0	0	73083 NRTHFD12	0.966	-500	40
73084 NRTHFD34	0.966	-500	40	73072 ALT12 PF	1.016	65	7	73073 ALT34 PF	1.015	80	7
73069 MAPR1 PF	0.000	0	0	73070 MAPR2 PF	0.000	0	0	73071 MAPR3 PF	0.000	0	0
72930 STNYBK1A	0.000	0	0	72931 STNYBK1B	0.000	0	0	72932 STNYBK1C	0.000	0	0
70060 MIS GT1	0.000	0	0	70061 MIS GT2	0.000	0	0	70062 MIS ST	0.000	0	0
70389 BUCKS G4	0.000	0	0	70381 RPA CG1	0.000	0	0	70382 RPA SG2	0.000	0	0
70386 WBK G1	0.000	0	0	70387 WBK G2	0.000	0	0	70388 WBK G3	0.000	0	0
70365 WF WY #1	0.996	57	1	70366 WF WY #2	0.997	32	1	70367 WF WY #3	0.997	125	3
70368 WF WY #4	1.000	392	9	70426 CHAMP G2	0.000	0	0	70424 CHAMP G3	0.000	0	0
70377 AEC G1	0.000	0	0	70378 AEC G2	0.000	0	0	70379 AEC G3	0.000	0	0
72866 MERMK G1	0.000	0	0	72867 MERMK G2	1.018	320	8	72868 NWNGT G1	0.000	0	0
72870 SCHILLER	0.000	0	0	72871 SCHILLER	0.000	0	0	72872 SCHILLER	0.000	0	0
70010 NEW_G1	0.000	0	0	70011 NEW_G2	0.000	0	0	70012 NEW_G3	0.000	0	0
72869 SBK G1	0.993	1150	75	71857 COMRF G1	0.000	0	0	71858 COMRF G2	0.000	0	0
71859 COMRF G2	0.000	0	0	71860 COMRF G3	0.000	0	0	71861 MOORE G1	0.000	0	0
71862 MOORE G3	0.000	0	0	71863 MOORE G4	0.000	0	0	71864 MOORE G4	0.000	0	0
71123 KENDALL	0.000	0	0	71124 KND JETS	0.000	0	0	71060 MYST G4	0.000	0	0
71061 MYST 5G	0.000	0	0	71062 MYST G6	0.000	0	0	71063 MYST G7	0.991	565	-150
71064 MYST J1	0.000	0	0	71073 N.BOST 1	0.000	0	0	71074 N.BOST 2	0.000	0	0
71946 SALEM G1	0.000	0	0	71947 SALEM G2	0.000	0	0	71948 SALEM G3	0.984	143	-37
71949 SALEM G4	0.000	0	0	71251 CANAL G1	0.000	0	0	71252 CANAL G2	0.000	0	0
71094 PLGRM G4	1.022	702	101	71095 ANPBLC1	0.000	0	0	71096 ANPBLC2	0.000	0	0
72377 BELL #1	0.000	0	0	72378 BELL #2	0.000	0	0	72372 BP #1 GN	0.000	0	0
72375 BP #2 GN	0.000	0	0	72370 BP #3 GN	0.996	605	17	72371 BP #4 GN	0.000	0	0
71084 NEA GTFP	0.000	0	0	71085 NEA GTFP	0.000	0	0	71086 NEA STFP	0.000	0	0
71531 OSP1 PF	0.000	0	0	71532 OSP2 PF	0.000	0	0	71533 OSP3 PF	0.000	0	0
71534 OSP4 PF	0.000	0	0	71535 OSP5 PF	0.000	0	0	71536 OSP6 PF	0.000	0	0
72669 TIVER G1	0.000	0	0	72670 TIVER G2	0.000	0	0	71394 EMI_GEN	0.966	185	8
72661 MANCH09A	0.000	0	0	72662 MANCH10A	0.000	0	0	72663 MANCH11A	0.000	0	0
72666 FRSQ SC1	0.000	0	0	72667 FRSQ SC2	0.000	0	0	72668 FRSQ SC3	0.000	0	0
72671 HOPE G1	0.000	0	0	72672 HOPE G2	0.000	0	0	72673 HOPE G3	0.000	0	0
MILLSTONE	2115	MX	202	MIDDLETOWN	750	MX	-7	MONTVILLE	402	MX	25
NORWALK	168		8	BRIDGEPORT	895		12	NHHARBOR	447		6
DEVON	0		0	MERIDEN	539		47	BRAYTONPT	1210		34
MANCHSTRST	0		0	SOMERSET	105		0	OSP	0		0
NEA	0		0	PAWKTPWR	7		-7	ENRON	0		0
CANAL	0		0	PILGRIM	702		101	MYSTIC	565		-150
NEWBOSTON	0		0	SALEMHR	143		-37	SEABROOK	1150		75
NEWINGTON	0		0	SCHILLER	0		0	MERRIMACK	320		8
STONYBROOK	0		0	WYMAN	606		15	VTYANKEE	563		43
BEARSWAMP	-560		164	NORTHFIELD	-1000		81	MASSPWR	0		0
INTERFACE FLOWS											
~~~~~											
NB-NE	702		-42	MEYANKEE-SOUTH	248		-21	MAINE-NH	518		-99
NNE-SCOBIE+394	1450		-116	SEABROOK-SOUTH	1010		-31	NORTH-SOUTH	2068		-73
CMFD/MOORE-SO	6		-10	SNDYPOND-SOUTH	469		102	CONN EXPORT	2803		0
CONN-MASS	970		21	CONN-RI	970		-61	SW CONN IMPORT	-230		88
NORWLK-STAMFORD	428		-47	BOSTON IMPORT	1332		13	NEMA/BOS IMPORT	1603		-7
SEMA/RI EXPORT	-671		68	CONVEX-REMEVEC	968		-152	EAST-WEST	-1235		233
NY-NE	21		86	PV20	110		-2	CT-LI-1385	100		-56
HVDC TRANSFERS FROM H-Q											
~~~~~											
CHAT-1 =	0			CHAT-2 =	0			HIGHGATE =	150		
MADAWASK =	0			PHII-P1 =	0			PHII-P2 =	0		
BUS VOLTAGES											
~~~~~											
70001 CHESTER	345	V	342.	70002 ORRINGTN	345	V	349.	70003 MAXCYS	345	V	354.
70086 ME YANK	345	LMT	355.	70090 BUXTON	345	LMT	355.	72692 NWTN345	345	LMT	357.
72694 SEBRK345	345		357.	71789 TEWKS	345		359.	70759 MYSTIC	345		360.
71797 MILLBURY	345		354.	72925 LUDLOW	345		351.	72926 NRTHFLD	345		351.
73106 SOUTHGTN	345		357.	73108 CARD	345		353.	73109 MONTVILLE	345		357.
73110 MILLSTNE	345		357.	73112 MANCHSTR	345		356.	73116 MIDDLTWN	345		357.
71801 BRAYTN P	345		352.	71811 KENT CO.	345		350.	71326 BRIDGWTR	345		353.
71336 SHERMAN	345		351.	71337 WFARNUM	345		350.	70772 W MEDWAY	345		352.
70780 WWALP345	345		352.	70783 PILGRIM	345		355.	71193 CANAL	345		355.
71133 CARVER	345		354.	70795 FRMNGHAM	230		236.	70793 MDFRM230	230		238.
70794 MDWLT230	230		239.	70818 MYSTC MA	115		118.	71891 SALEM HR	115		118.
73195 DEVON	115		118.	73259 HOPEWELL	115		116.	73264 PORTLAND	115		116.
73241 MIDDLTWN	115		116.	73230 HADDAM	115		117.	73231 BOKUM	115		117.
73265 GREEN HL	115		118.	73153 BRANFORD	115		119.	73227 E.MERIDN	115		116.
73633 NO.WALLF	115		116.	73634 COLONY	115		116.	73198 SOUTHGTN	115		116.
AREA/ZONE TOTALS											
~~~~~											
NEPOOL_GEN	10728			NEPOOL_LOAD	11284			NEPOOL_LOSS	293		
NEPOOL_INT	-864										

Table 11 – Sensitivity Case Summary PkA-S

PKA.SAV MIDDLETOWN RELIABILITY STUDY, HADDAM AUTOTRANSFORMER, MIDDLETOWN 2 & 3 ON GENERATION											
~~~~~											
#	V	MW	MX	#	V	MW	MX	#	V	MW	MX
73538 AESTH PF	0.995	180	25	73549 SMD1112J	0.000	0	0	73550 SMD1314J	0.000	0	0
73551 NORHAR#1	0.994	161	22	73552 NORHAR#2	0.994	168	22	73553 DEVON#7	0.984	106	11
73554 DEVON#8	0.984	106	11	73570 DEVGAS11	0.000	0	0	73571 DEVGAS12	0.000	0	0
73572 DEVGAS13	0.000	0	0	73555 MIDDTN#2	1.003	117	26	73556 MIDDTN#3	0.983	233	26
73557 MIDDTN#4	0.979	400	-11	73558 MONTV#5	0.982	81	11	73559 MONTV#6	0.991	402	57
73562 MILL#2	0.986	907	62	73563 MILL#3	0.984	1208	62	73565 LAKERD#1	1.001	305	48
73566 LAKERD#2	1.001	305	48	73567 LAKERD#3	1.001	305	48	73574 MILFD#1	1.028	305	39
73575 MILFD#2	1.028	305	39	73588 MERIDEN1	1.038	172	55	73589 MERIDEN2	1.038	172	55
73590 MERIDEN3	1.062	195	55	73594 WALL LV1	1.025	102	17	73595 WALL LV2	1.025	102	17
73596 WALL LV3	1.025	51	14	73646 BPTHBR#1	0.000	0	0	73647 BPTHBR#2	0.985	170	73
73648 BPTHBR#3	0.981	375	73	73649 BPTHBR#4	0.000	0	0	73651 NH HARB	0.971	447	40
73652 BE 11	0.990	170	24	73653 BE 12	0.990	170	24	73654 BE 10 ST	0.988	180	24
70705 VTYAK G	0.977	563	68	72243 MILLENCT	0.000	0	0	72244 MILLENST	0.000	0	0
73080 WSPFLD 3	1.002	107	7	73085 MT.TOM	0.000	0	0	72512 BRSWP G1	0.993	294	69
72513 BRSWP G2	0.993	294	69	72986 BERKPWR	1.015	305	11	73083 NRTHFD12	1.011	270	80*
73084 NRTHFD34	0.000	0	0	73072 ALT12 PF	1.025	65	15*	73073 ALT34 PF	1.024	80	15
73069 MAPR1 PF	1.047	56	47*	73070 MAPR2 PF	0.000	0	0	73071 MAPR3 PF	0.000	0	0
72930 STNYBK1A	1.043	65	8	72931 STNYBK1B	1.043	65	8	72932 STNYBK1C	1.043	65	8
70060 MIS GT1	0.000	0	0	70061 MIS GT2	0.000	0	0	70062 MIS ST	0.000	0	0
70389 BUCKS G4	1.040	191	90	70381 RPA CG1	0.000	0	0	70382 RPA SG2	0.000	0	0
70386 WBK G1	1.040	184	29	70387 WBK G2	1.040	184	29	70388 WBK G3	1.040	195	31
70365 WF WY #1	1.009	57	5	70366 WF WY #2	1.009	57	5	70367 WF WY #3	1.009	125	11
70368 WF WY #4	1.031	318	56	70426 CHAMP G2	0.963	15	6*	70424 CHAMP G3	0.000	0	0
70377 AEC G1	1.040	52	7	70378 AEC G2	1.040	52	7	70379 AEC G3	1.040	52	7
72866 MERMK G1	1.032	113	22	72867 MERMK G2	1.032	320	62	72868 NWNGT G1	0.990	422	40
72870 SCHILLER	0.990	48	0	72871 SCHILLER	0.989	50	0	72872 SCHILLER	0.989	48	0
70010 NEW_G1	0.000	0	0	70011 NEW_G2	0.000	0	0	70012 NEW_G3	0.000	0	0
72869 SBK G1	1.009	1150	279	71857 COMRF G1	1.001	37	-5	71858 COMRF G2	1.000	37	-5
71859 COMRF G3	1.001	29	-5	71860 COMRF G4	1.001	29	-5	71861 MOORE G1	1.003	40	-3
71862 MOORE G2	1.006	33	-3	71863 MOORE G3	1.022	33	10	71864 MOORE G4	1.039	33	10
71123 KENDALL	1.025	63	2	71124 KND JETS	1.025	36	0	71060 MYST G4	0.000	0	0
71061 MYST 5G	0.000	0	0	71062 MYST G6	0.000	0	0	71063 MYST G7	1.045	565	335*
71064 MYST J1	0.000	0	0	71073 N.BOST 1	0.000	0	0	71074 N.BOST 2	1.021	380	230*
71946 SALEM G1	1.028	79	32*	71947 SALEM G2	1.026	78	29*	71948 SALEM G3	1.023	143	50*
71949 SALEM G4	0.000	0	0	71251 CANAL G1	1.034	566	239*	71252 CANAL G2	1.011	576	120*
71094 PLGRM G4	1.031	702	165	71095 ANPBLCK1	0.000	0	0	71096 ANPBLCK2	1.088	290	150*
72377 BELL #1	0.000	0	0	72378 BELL #2	0.000	0	0	72372 BP #1 GN	1.027	238	120*
72375 BP #2 GN	0.000	0	0	72370 BP #3 GN	1.045	605	238	72371 BP #4 GN	0.000	0	0
71084 NEA GTPF	1.039	85	40*	71085 NEA GTPF	1.039	85	40*	71086 NEA STPF	1.054	80	55*
71531 OSP1 PF	1.026	77	18	71532 OSP2 PF	1.026	77	18	71533 OSP3 PF	1.026	108	24
71534 OSP4 PF	1.026	77	18	71535 OSP5 PF	0.000	0	0	71536 OSP6 PF	0.000	0	0
72669 TIVER G1	1.031	189	28	72670 TIVER G2	1.031	92	14	71394 EMI_GEN	0.990	185	25
72661 MANCH09A	1.001	119	35*	72662 MANCH10A	1.001	119	35*	72663 MANCH11A	1.001	119	35*
72666 FRSQ SC1	0.991	43	3	72667 FRSQ SC2	0.991	43	2	72668 FRSQ SC3	0.991	42	3
72671 HOPE G1	0.000	0	0	72672 HOPE G2	0.000	0	0	72673 HOPE G3	0.000	0	0
MILLSTONE	2115	124		MIDDLETOWN	750	42		MONTVILLE	483	68	
NORWALK	329	45		BRIDGEPORT	1065	218		NHHARBOUR	447	40	
DEVON	212	22		MERIDEN	539	165		BRAYTONPT	1448	596	
MANCHSTRST	485	114		SOMERSET	70	0		OSP	339	79	
NEA	249	135		PAWTKTPWR	64	-6		ENRON	124	80	
CANAL	1142	359		PILGRIM	702	165		MYSTIC	565	335	
NEWBOSTON	380	230		SALEMHR	300	111		SEABROOK	1150	279	
NEWINGTON	422	40		SCHILLER	145	-1		MERRIMACK	433	84	
STONYBROOK	0	0		WYMAN	557	78		VTYANKEE	563	68	
BEARSWAMP	588	138		NORTHFIELD	270	80		MASSPWR	56	47	
INTERFACE FLOWS											
~~~~~											
NB-NE	700	-41		MEYANKEE-SOUTH	266	-154		MAINE-NH	750	-58	
NNE-SCOBIE+394	1808	115		SEABROOK-SOUTH	1249	110		NORTH-SOUTH	1692	141	
CMFD/MOORE-SO	190	-29		SNDYPOND-SOUTH	2198	46		CONN EXPORT	7	121	
CONN-MASS	-95	66		CONN-RI	795	28		SW CONN IMPORT	761	201	
NORWLK-STAMFORD	941	-16		BOSTON IMPORT	3662	245		NEMA/BOS IMPORT	4228	159	
SEMA/RI EXPORT	621	261		CONVEX-REMEVC	1019	56		EAST-WEST	-818	31	
NY-NE	-2	-235		PV20	110	-11		CT-LI-1385	0	-45	
HVDC TRANSFERS FROM H-Q											
~~~~~											
CHAT-1 =	0			CHAT-2 =	0			HIGHGATE =	225		
MADAWASK =	-151			PHII-P1 =	1000			PHII-P2 =	1000		
BUS VOLTAGES											
~~~~~											
70001 CHESTER	345	341.		70002 ORRINGTN	345	346.		70003 MAXCYS	345	350.	
70086 ME YANK	345	356.		70090 BUXTON	345	359.		72692 NWTN345	345	357.	
72694 SEBRK345	345	357.		71789 TEWKS	345	355.		70759 MYSTIC	345	359.	
71797 MILLBURY	345	352.		72925 LUDLOW	345	353.		72926 NRTHFLD	345	359.	
73106 SOUTHGTN	345	356.		73108 CARD	345	357.		73109 MONTVILLE	345	357.	
73110 MILLSTNE	345	357.		73112 MANCHSTR	345	358.		73116 MIDDLTWN	345	357.	
71801 BRAYTN P	345	358.		71811 KENT CO.	345	350.		71326 BRIDGWTR	345	352.	
71336 SHERMAN	345	355.		71337 WFARNUM	345	353.		70772 W MEDWAY	345	351.	
70780 WWALP345	345	350.		70783 PILGRIM	345	355.		71193 CANAL	345	356.	
71133 CARVER	345	353.		70795 FRMNGHAM	230	228.		70793 MDFRM230	230	234.	
70794 MDWLT230	230	236.		70818 MYSTC MA	115	117.		71891 SALEM HR	115	118.	
73195 DEVON	115	117.		73259 HOPEWELL	115	116.		73264 PORTLAND	115	118.	
73241 MIDDLTWN	115	118.		73230 HADDAM	115	118.		73231 BOKUM	115	117.	
73265 GREEN HL	115	117.		73153 BRANFORD	115	118.		73227 E.MERIDN	115	116.	
73633 NO.WALLF	115	115.		73634 COLONY	115	115.		73198 SOUTHGTN	115	116.	
AREA/ZONE TOTALS											
~~~~~											
NEPOOL_GEN	22593			NEPOOL_LOAD	24977			NEPOOL_LOSS	584		
NEPOOL_INT	-2985										

Figure 6 – Plot Pk Middletown Area All-Lines-In

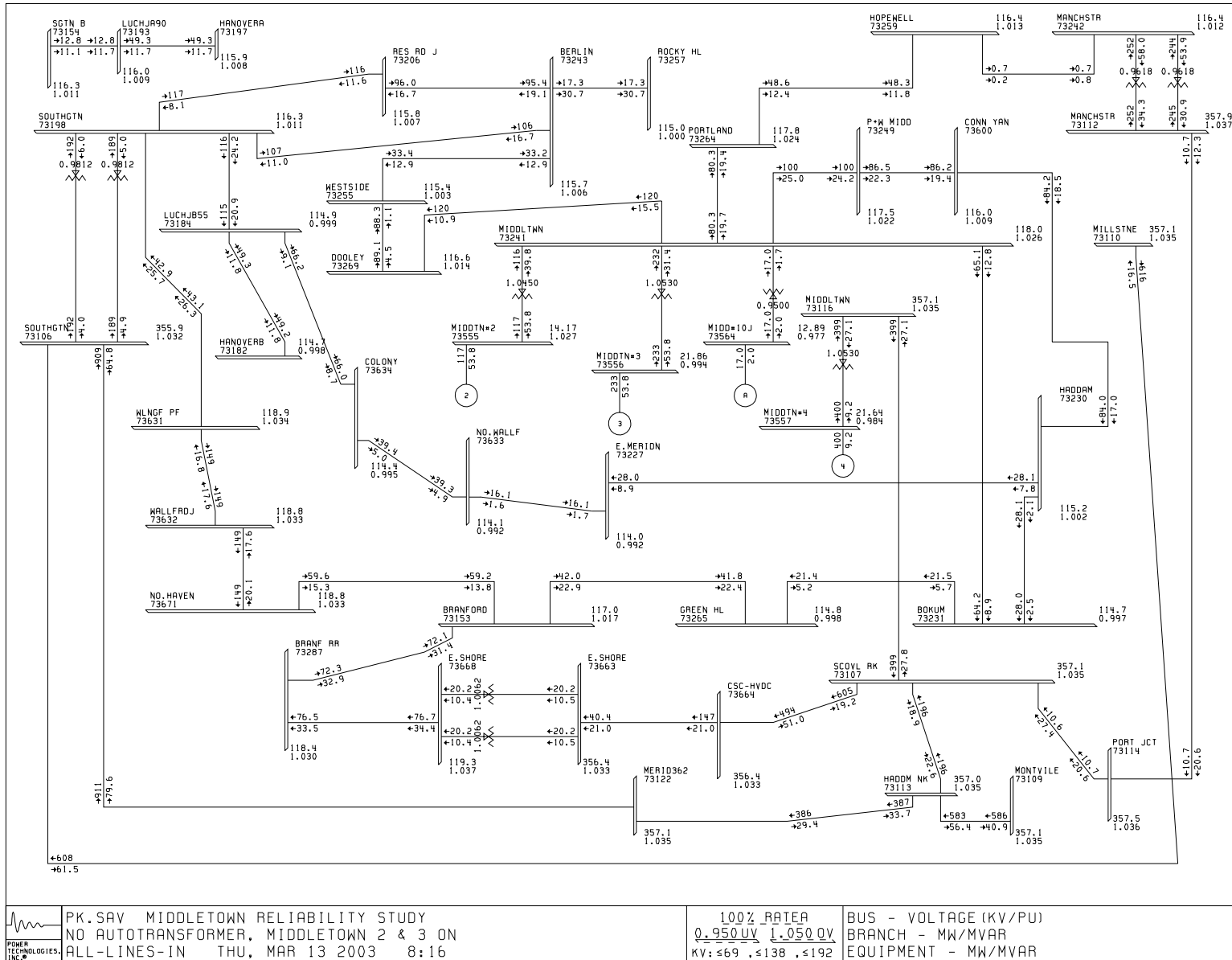

Figure 7 - Plot Pk New England All-Lines-In

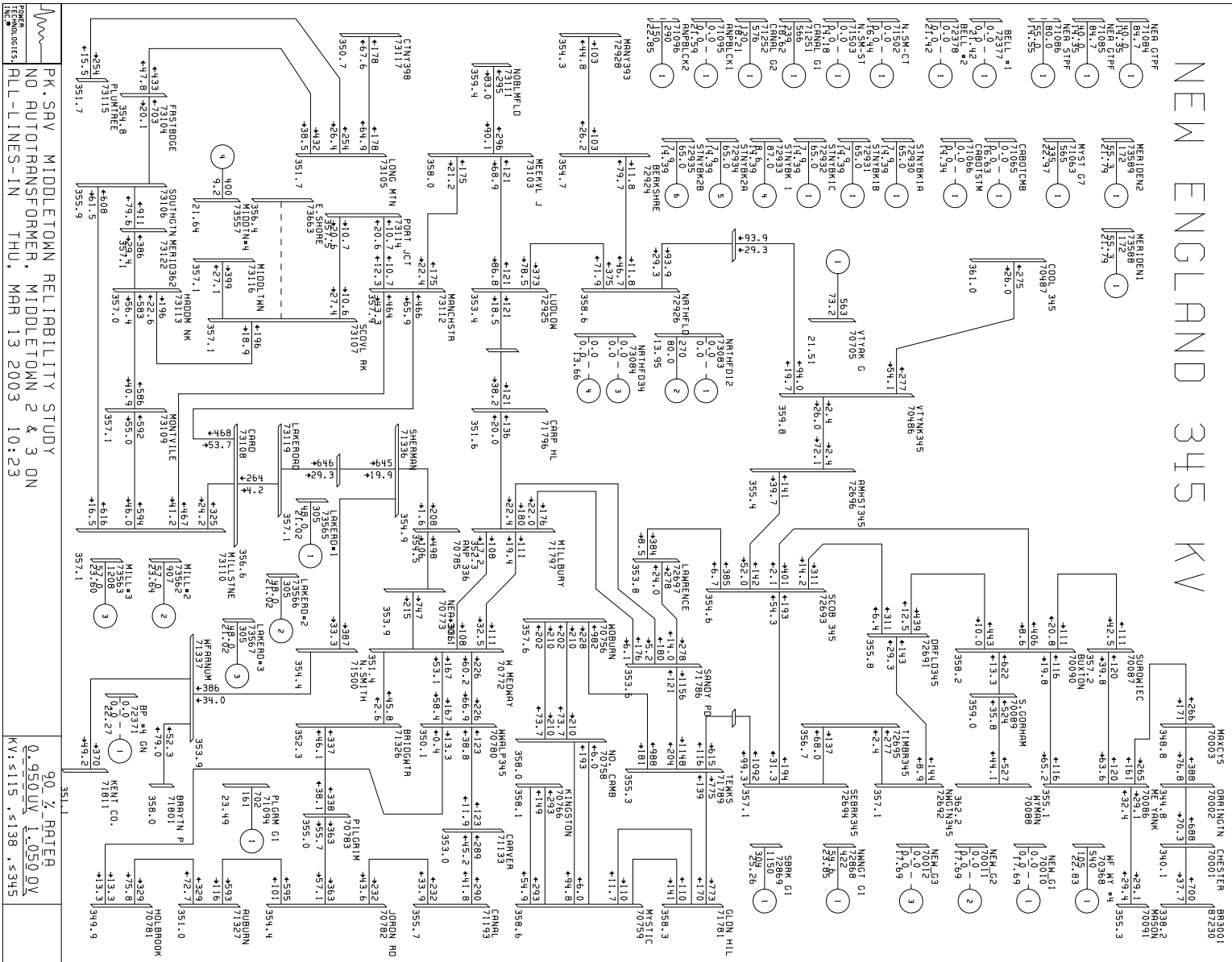

Figure 8 – Plot Pk1 Middletown Area All-Lines-In

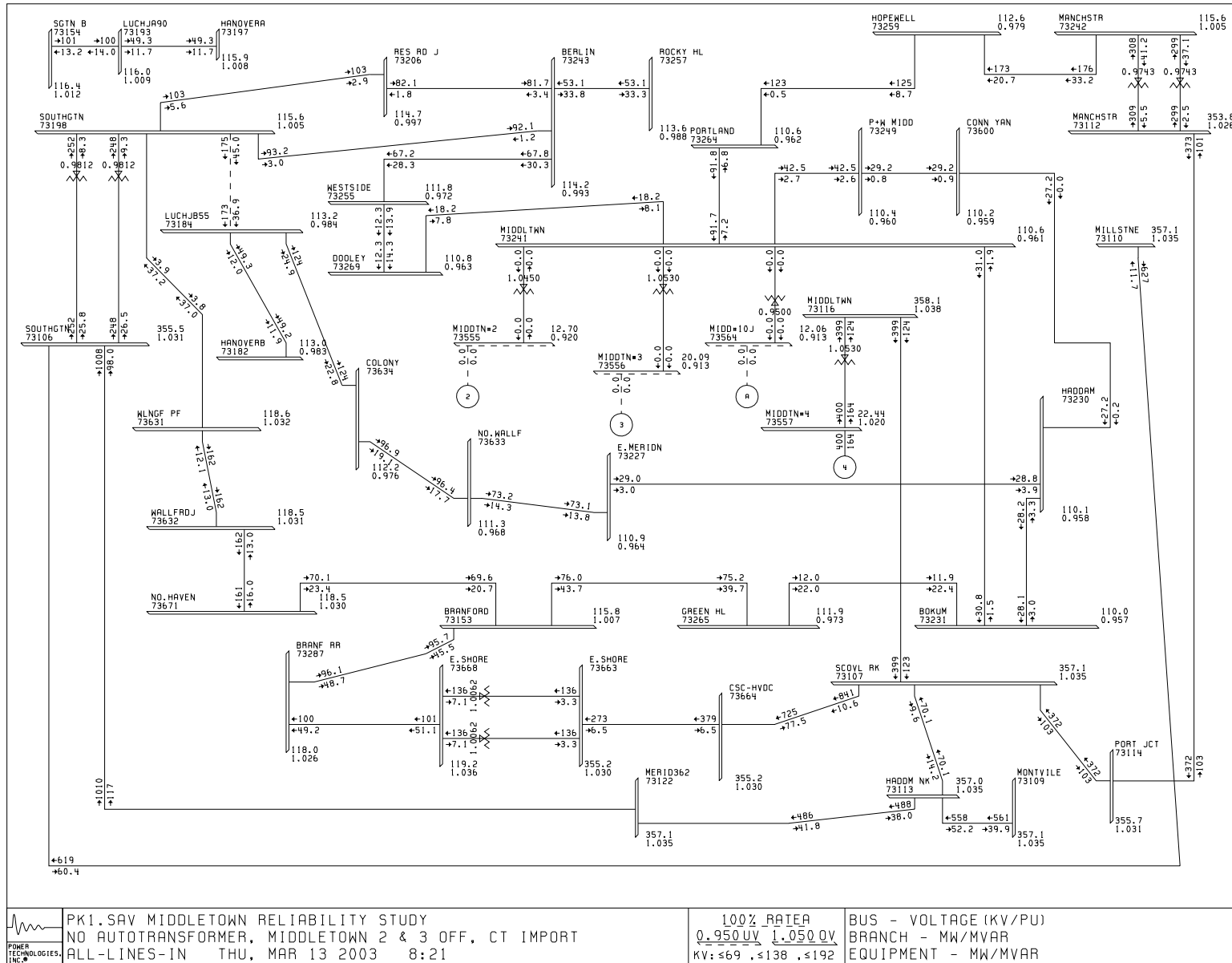

Figure 9 - Plot Pk1 New England All-Lines-In

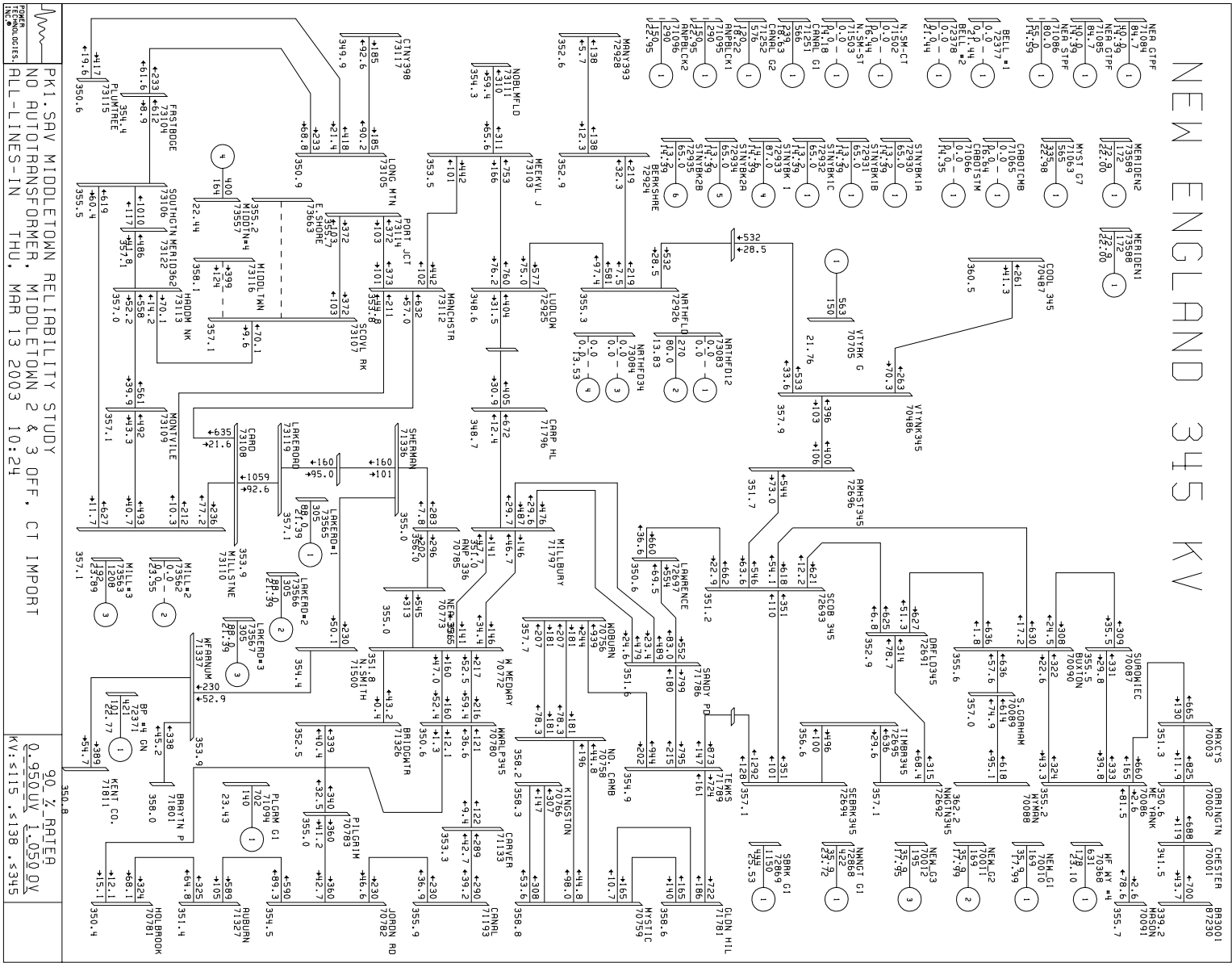

Figure 10 – Plot PkA Middletown Area All-Lines-In

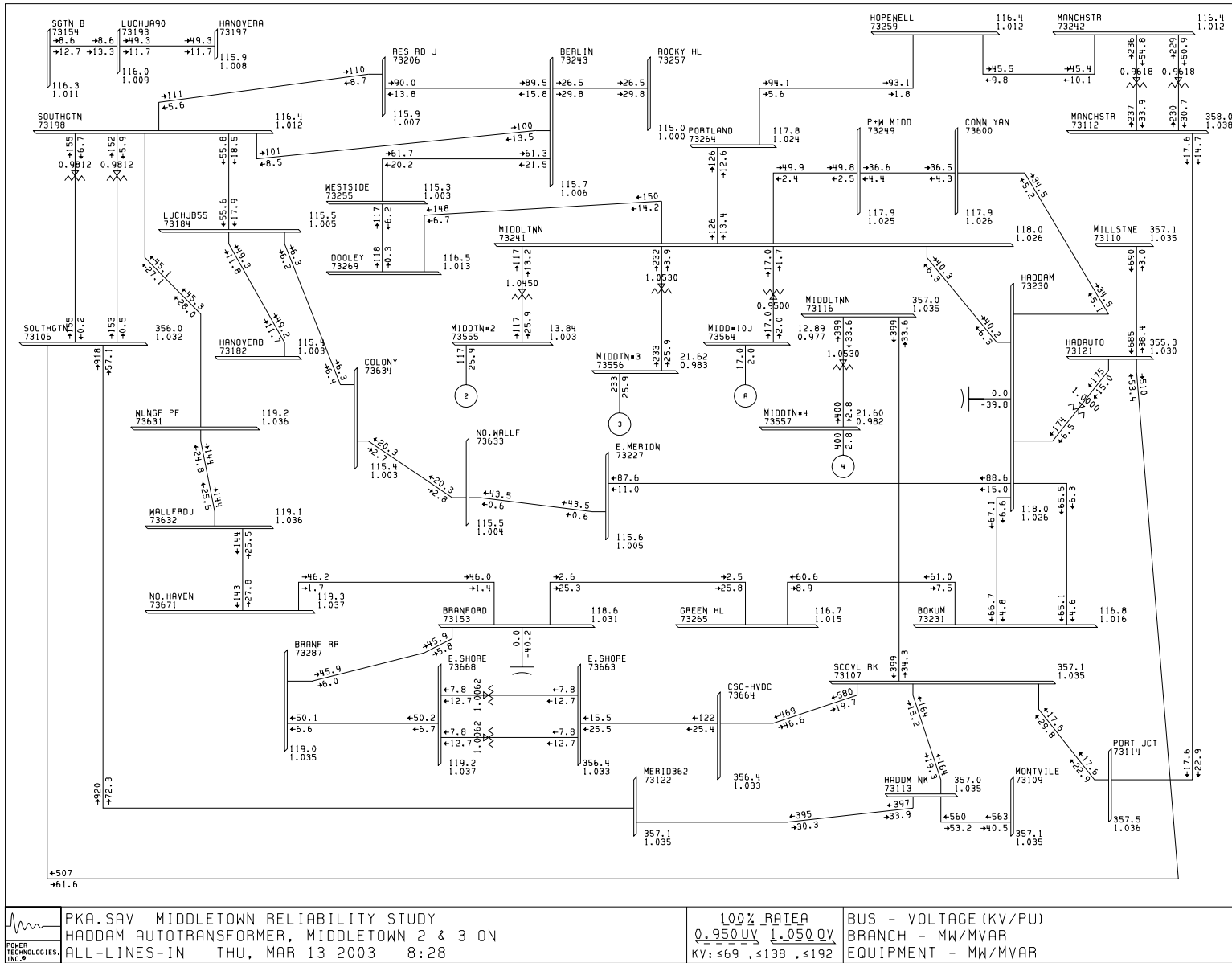

Figure 11 - Plot PkA New England All-Lines-In

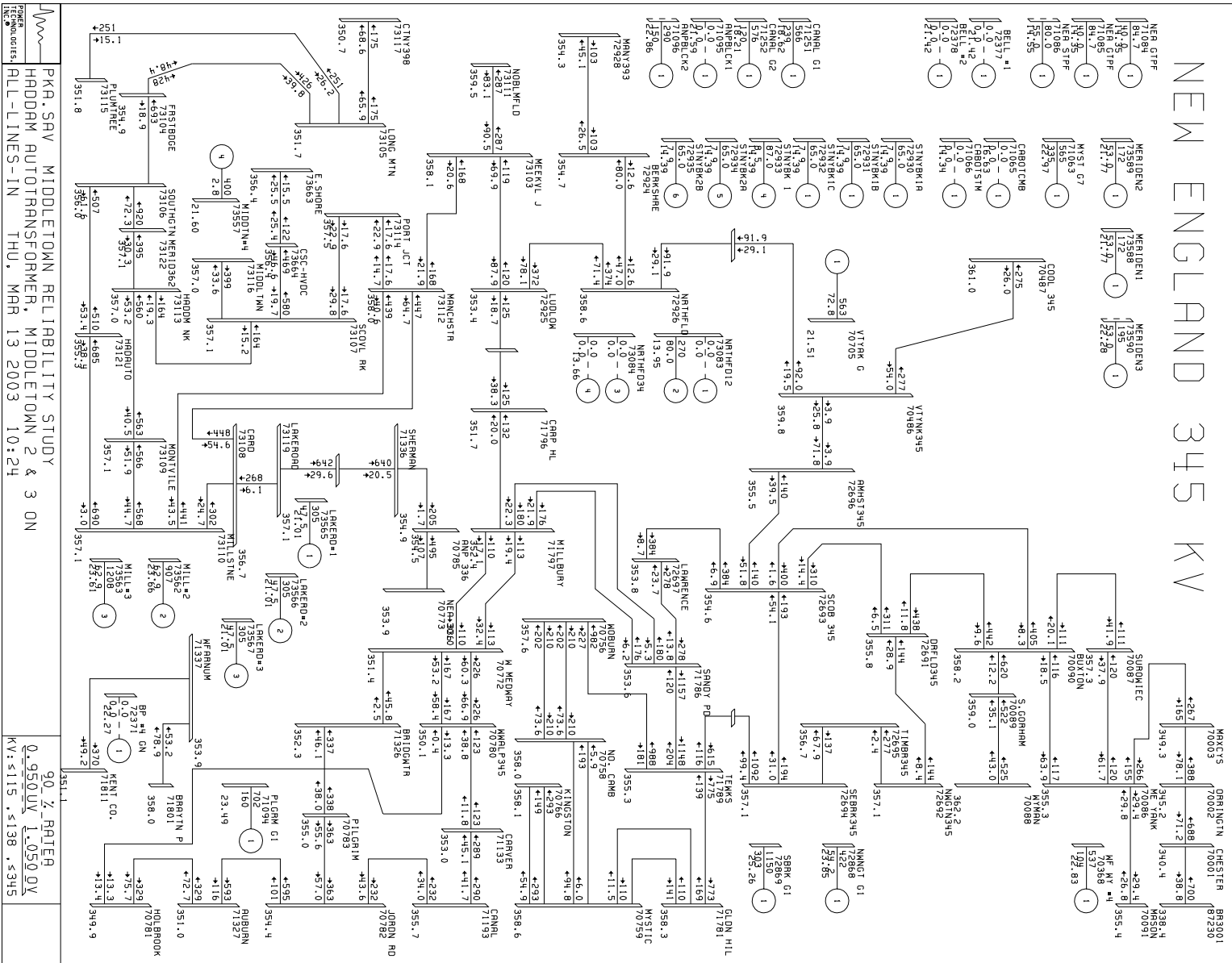

Figure 12 – Plot Pk1A Middletown Area All-Lines-In

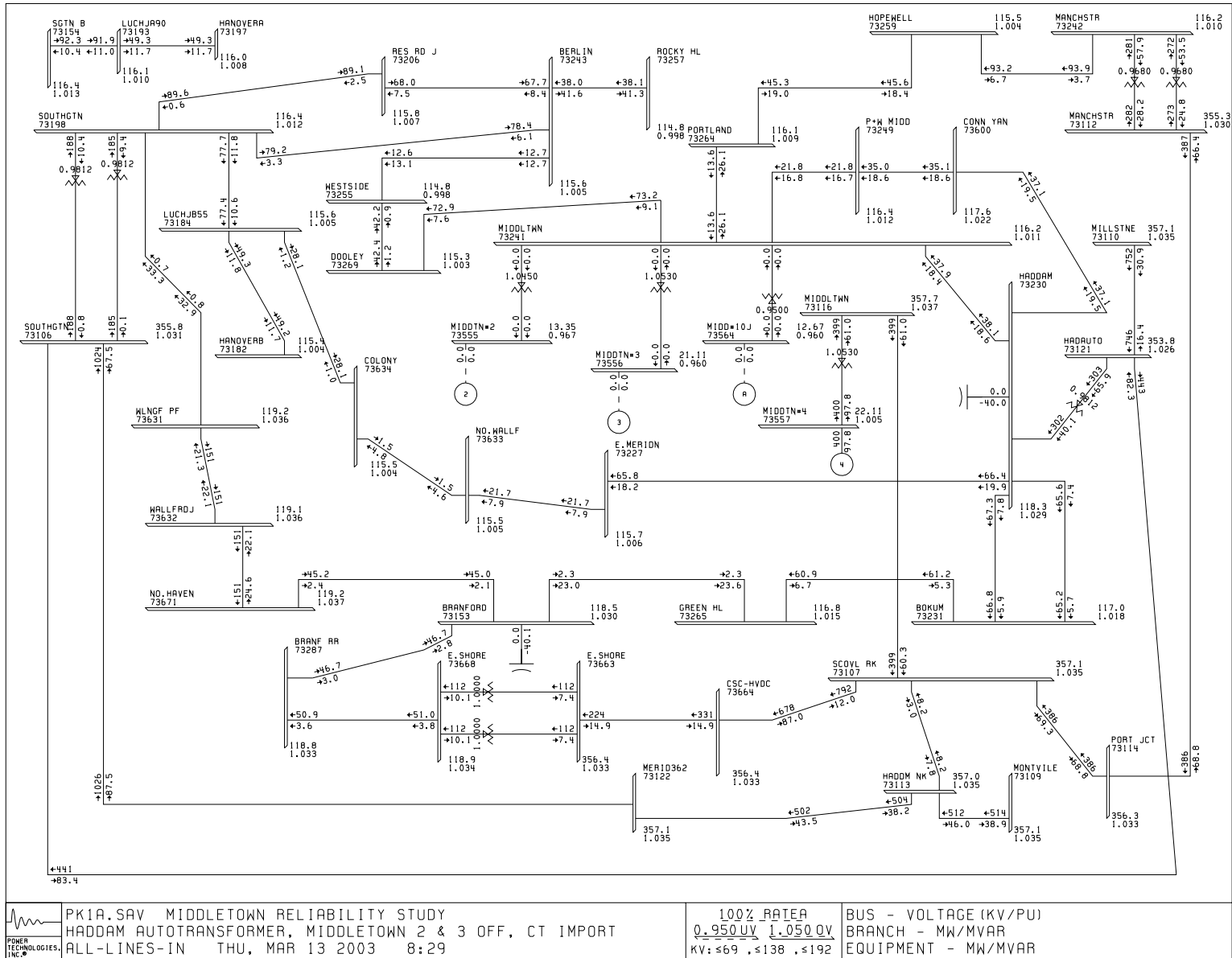

Figure 13 – Plot Pk1A New England All-Lines-In

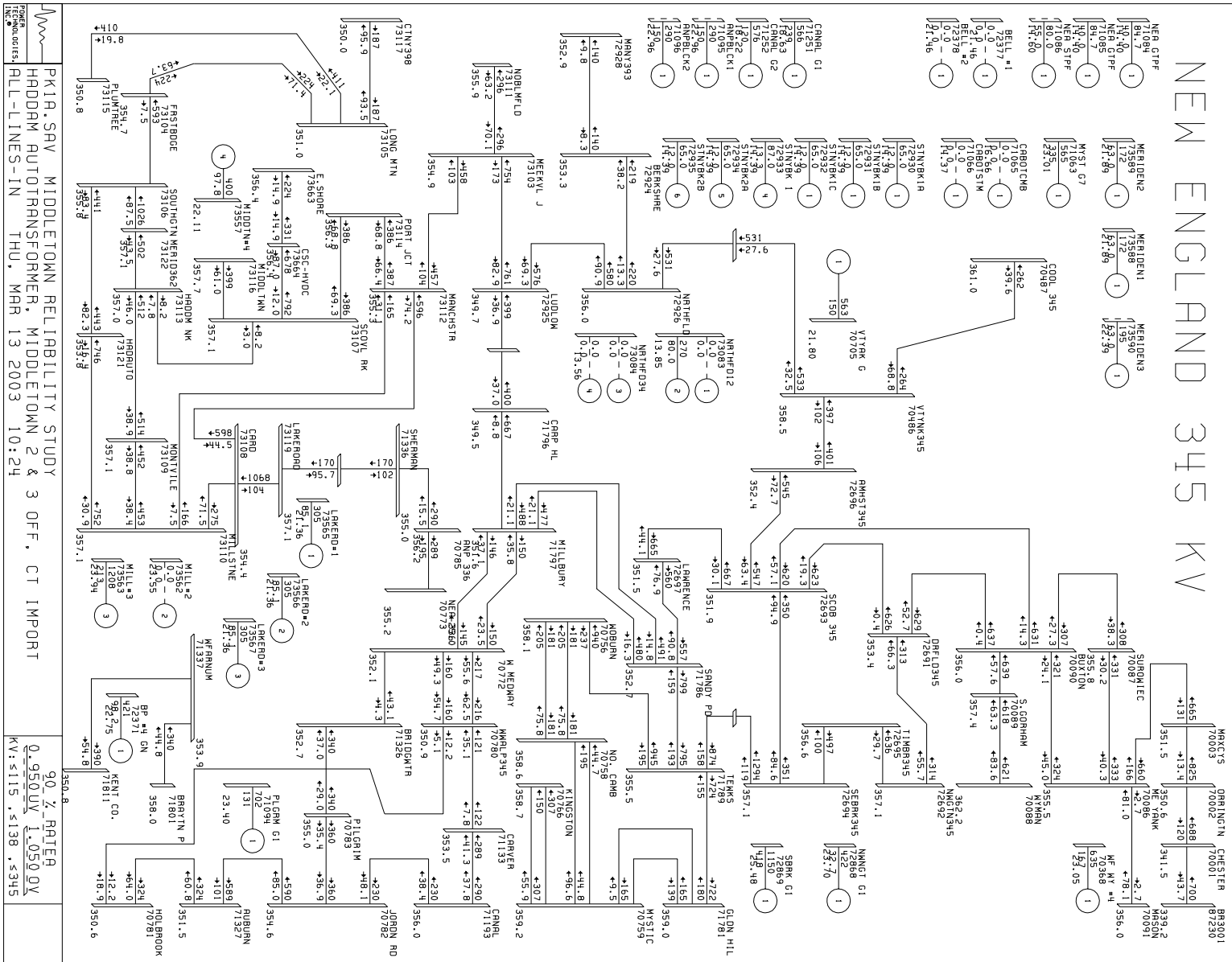

Figure 14 – Plot Lt Middletown Area All-Lines-In

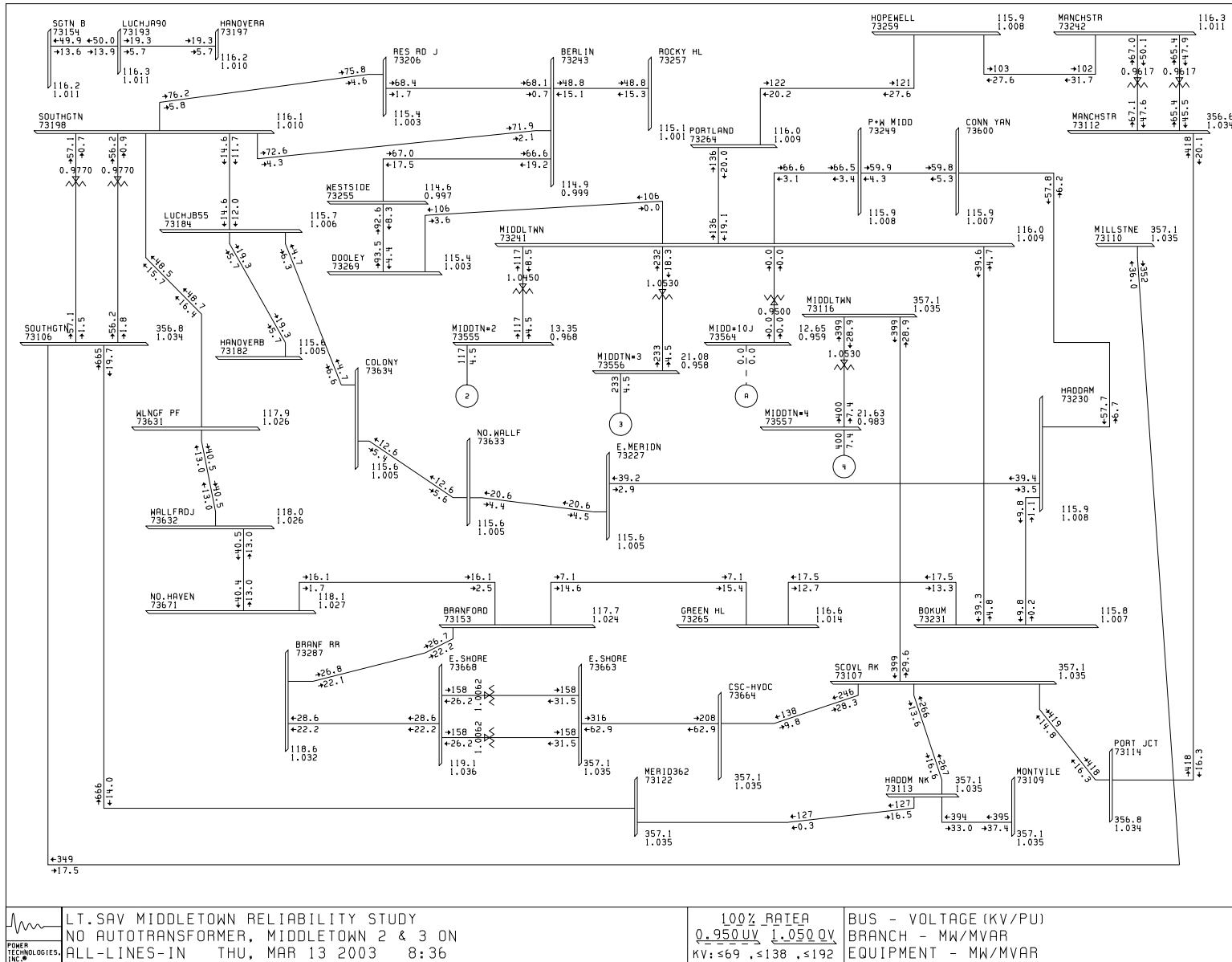

Figure 15 – Plot Lt New England All-Lines-In

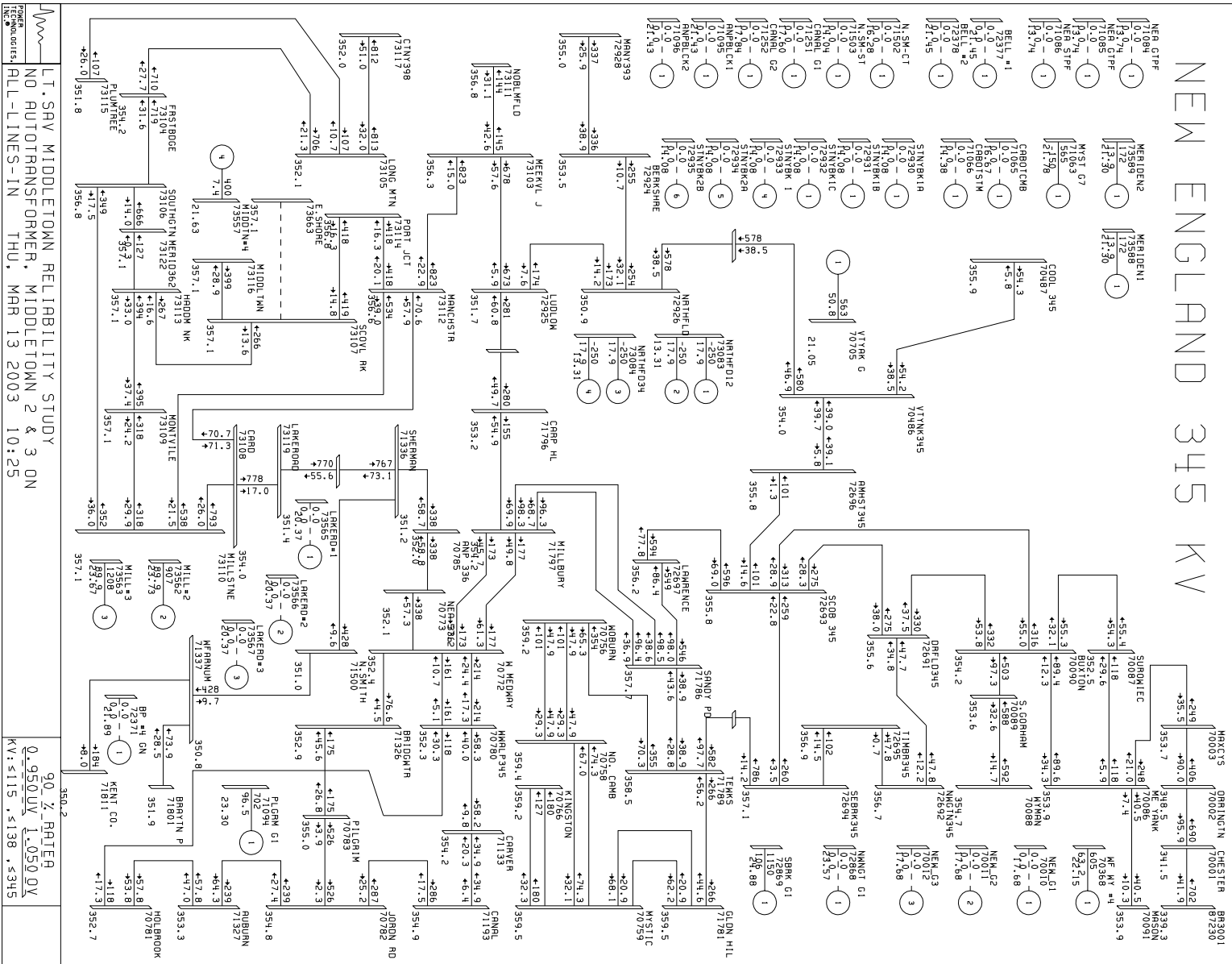

Figure 16 – Plot LtA Middletown Area All-Lines-In

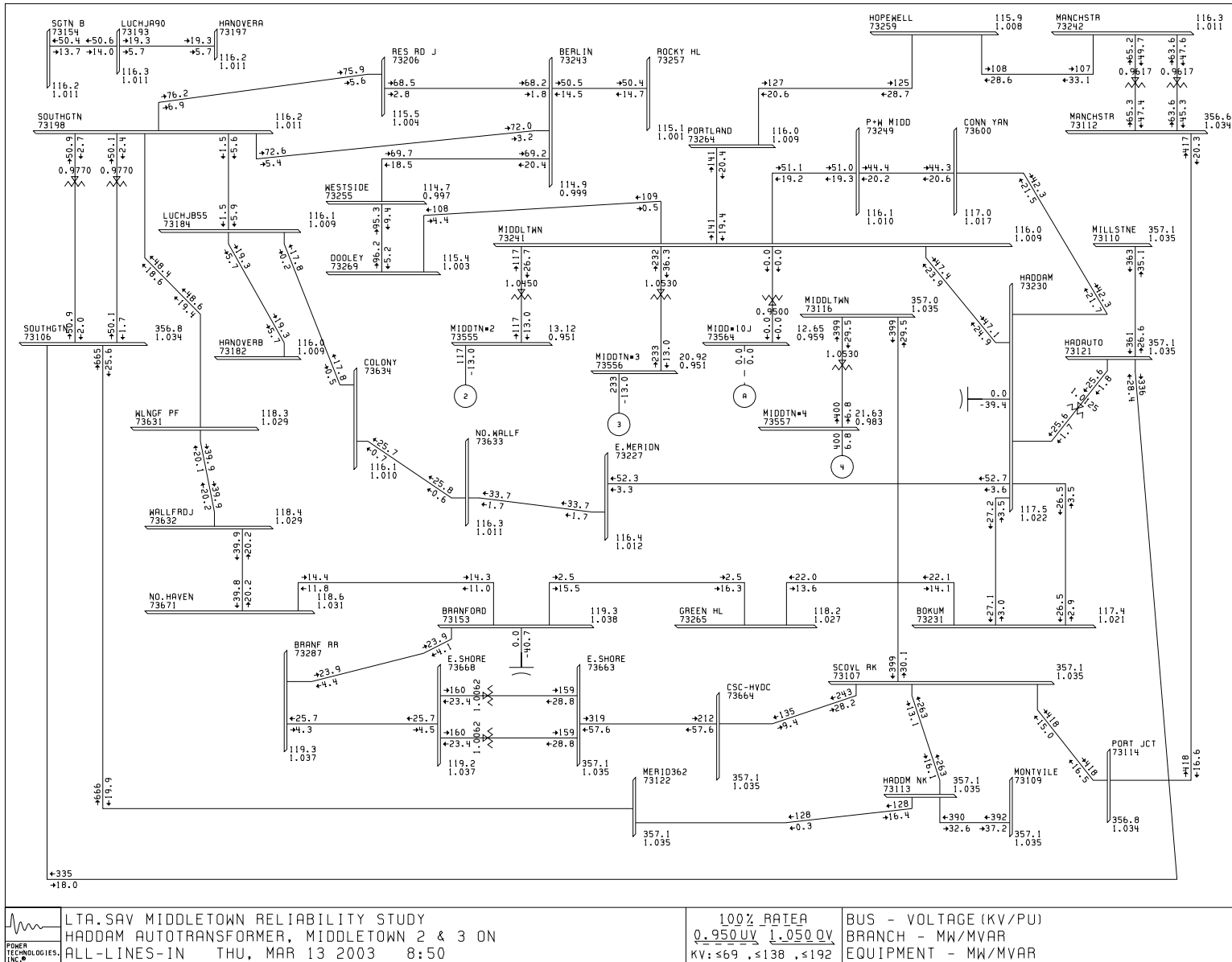

Figure 17 - Plot LtA New England All-Lines-In

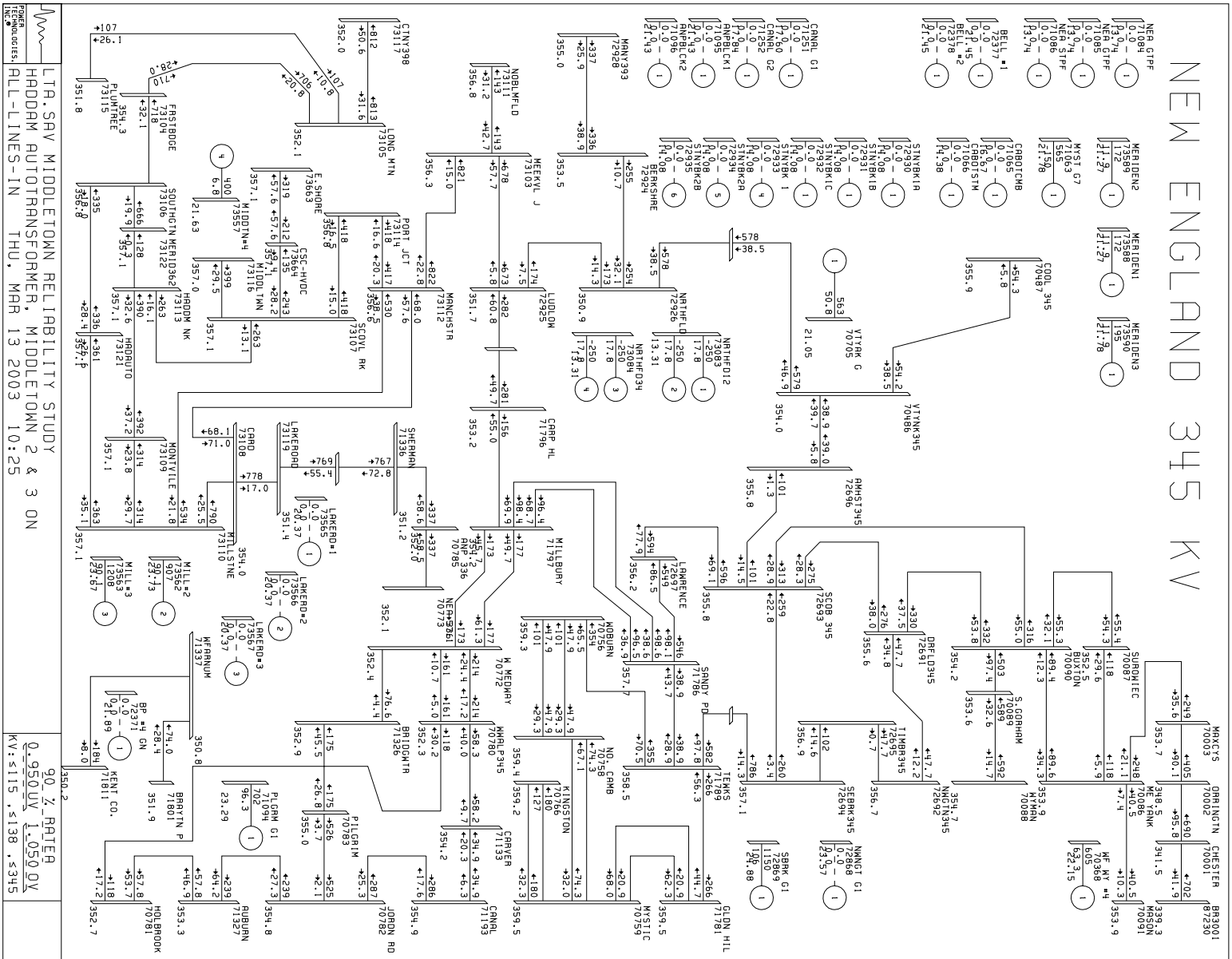

Figure 18 – Plot LtA-S Middletown Area All-Lines In

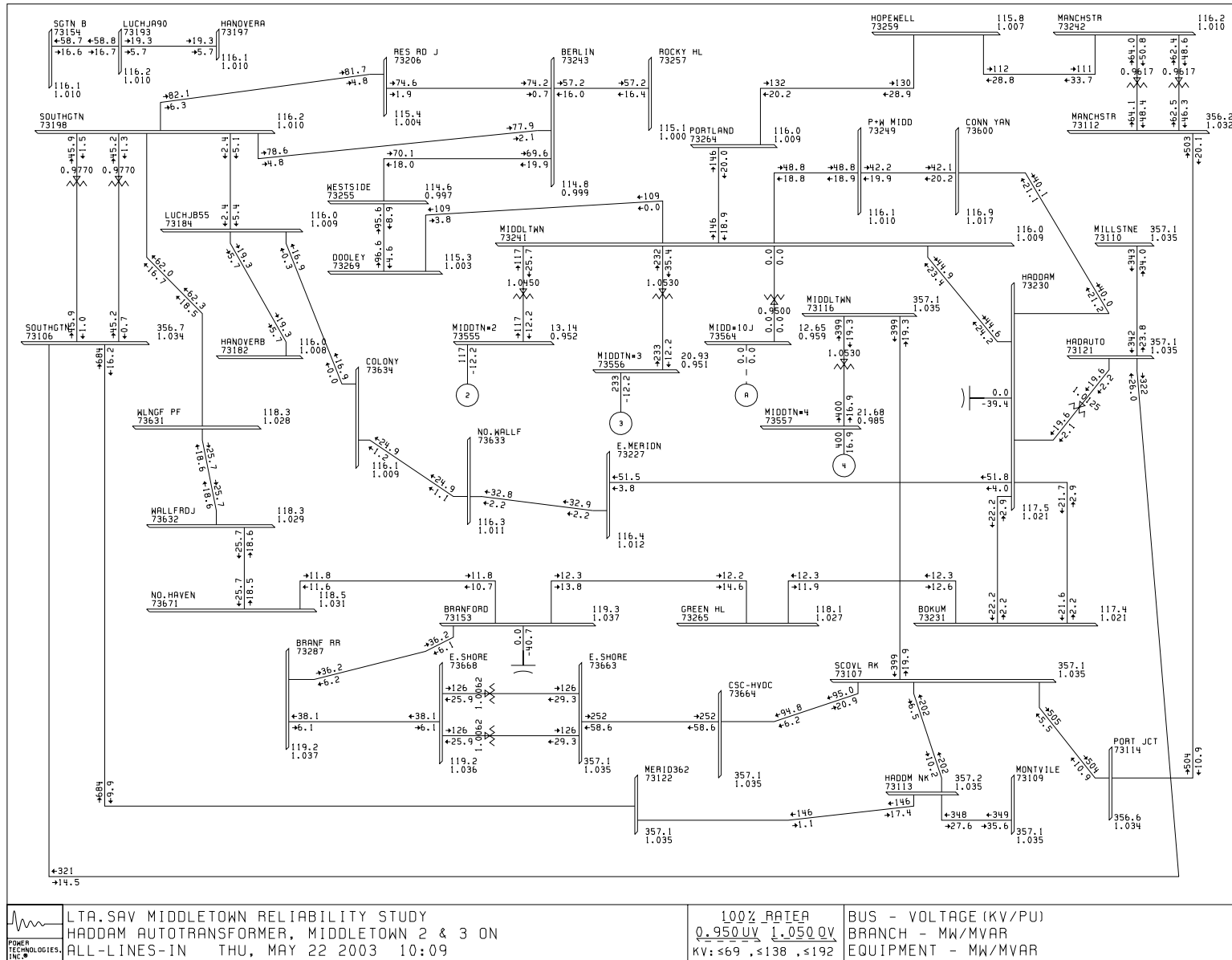

Figure 19 – Plot LtA-S New England All-Lines -In

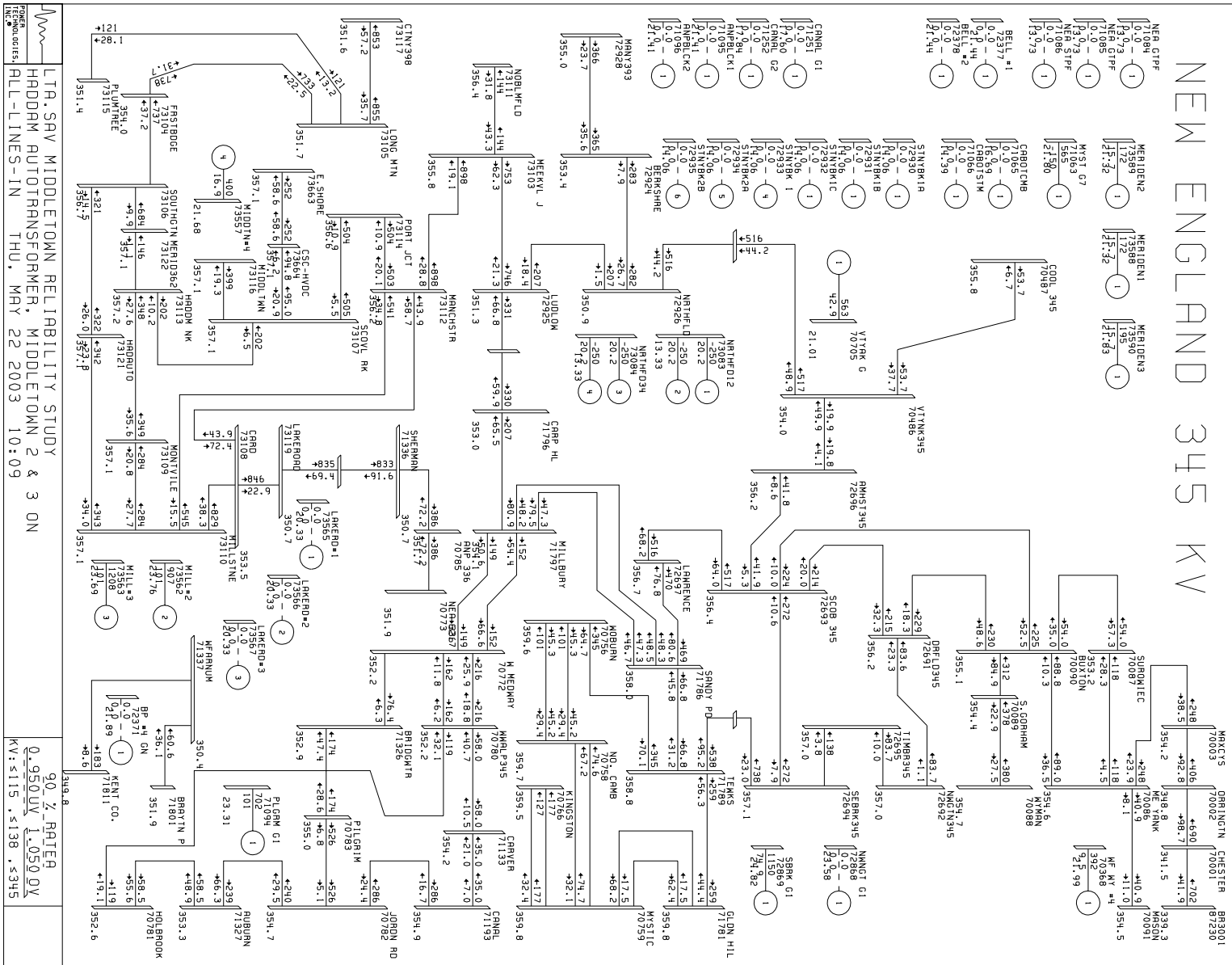

Table 12 – Contingency List

ID	Type	Fault	Fault Location & Description	Fault Clearing Time in Cycles Location and Breaker(s)
115-kV 3-Phase Line to Ground Fault				
MD101	NC	3-Phase	Middletown 1050/1766 Line	5 cy at Middletown (11T & 12T) 28.5 cy at West Side (1T)
MD102	NC	3-Phase	Middletown 1620N Line	5 cy at Middletown (9T & 10T) 34.5 cy Haddam (J & K)
MD103	NC	3-Phase	Middletown 1443/1759 Line	5 cy at Middletown (3T & 4T) 34.5 cy at Hopewell (1T)
MD104	NC	3-Phase	Middletown 1572/1772/1206 Line	5 cy at Middletown (7T & 8T) 34.5 cy at Haddam (L & M)
HD101	NC	3-Phase	Haddam 1620N Line	5 cy at Haddam (J & K) 34.5cy at Middletown (9T & 10T)
HD102	NC	3-Phase	Haddam 1620S Line	5 cy at Haddam (G & H) 34.5 cy at Bokum (1T & 2T)
HD103	NC	3-Phase	Haddam 1975 Line	5 cy at Haddam (I & H) 34.5 cy at East Meriden (1T)
HD104	NC	3-Phase	Haddam 1206/1772/1572 Line	5 cy at Haddam (L & M) 34.5 cy at Middletown (7T & 8T)
HD105	NC	3-Phase	Haddam 1261 Line	5 cy at Haddam (E & F) 34.5 cy at Bokum (1T & 3T)
HD106	NC	3-Phase	Haddam Auto-Xfmr High Side	4 cy at Haddam (A & B) 5 cy at Haddam (C & D)
115-kV 3-Phase Line to Ground Fault with Breaker Failure				
MD201	EC	3-Ø & BF	Middletown 1050/1766 Line & 12T-BF	5 cy at Middletown (11T) 16.5 cy at Middletown (4T) 16.5 cy at Middletown (8T) 28.5 cy at West Side (1T)
MD202	EC	3-Ø & BF	Middletown 1620N Line & 9T-BF	5 cy at Middletown (10T) 16.5 cy at Middletown (1T) 16.5 cy at Middletown (5T) 34.5 cy at Haddam (J & K)
MD203	EC	3-Ø & BF	Middletown 1443/1759 Line & 4T-BF	5 cy at Middletown (3T) 16.5 cy at Middletown (8T) 16.5 cy at Middletown (12T) 34.5 cy at Hopewell (1T)
MD204	EC	3-Ø & BF	Middletown 1572/1772/1206 Line & 8T-BF	5 cy at Middletown (7T) 16.5 cy at Middletown (4T) 16.5 cy at Middletown (12T) 34.5 cy at Haddam (L & M)
HD201	EC	3-Ø & BF	Haddam 1620N Line & J-BF	5 cy at Haddam (K) 16.5 cy at Haddam (D) 16.5 cy at Haddam (E) 16.5 cy at Haddam (G) 16.5 cy at Haddam (L) 34.5 cy at Middletown (9T & 10T)
HD202	EC	3-Ø & BF	Haddam 1620S Line & G-BF	5 cy at Haddam (H) 16.5 cy at Haddam (D) 16.5 cy at Haddam (E) 16.5 cy at Haddam (J) 16.5 cy at Haddam (L) 34.5 cy at Bokum (1T & 2T)

Table 13 – Contingency List

ID	Type	Fault	Fault Location & Description	Fault Clearing Time in Cycles Location and Breaker(s)
115-kV 3-Phase Line to Ground Fault with Breaker Failure				
HD203	EC	3-Ø & BF	Haddam 1975 Line & I-BF	5 cy at Haddam (H) 16.5 cy at Haddam (C) 16.5 cy at Haddam (F) 16.5 cy at Haddam (K) 16.5 cy at Haddam (N) 34.5 cy at East Meriden (1T)
HD204	EC	3-Ø & BF	Haddam 1206/1772/1572 Line & L-BF	5 cy at Haddam (M) 16.5 cy at Haddam (D) 16.5 cy at Haddam (E) 16.5 cy at Haddam (G) 16.5 cy at Haddam (J) 34.5 cy at Middletown (7T & 8T)
HD205	EC	3-Ø & BF	Haddam 1261 Line & E-BF	5 cy at Haddam (F) 16.5cy at Haddam (D) 16.5 cy at Haddam (G) 16.5 cy at Haddam (J) 16.5 cy at Haddam (L) 34.5 cy at Bokum (1T & 3T)
345-kV 3-Phase Line to Ground Fault				
HD107	NC	3-Phase	Haddam 348E Line	4 cy at Haddam (B) 4 cy at Millstone (14T & 15T)
HD108	NC	3-Phase	Haddam 348W Line	4 cy at Haddam (A) 4 cy at Southington (1T & 7T) 5 cy at Southington (14T & 20T)
SO101	NC	3-Phase	Southington 348W Line	4 cy at Southington (1T & 7T) 5 cy at Southington (14T & 20T) 4 cy at Haddam (A)
SO101A	NC	3-Phase	Southington 348 Line	4 cy at Southington (1T & 7T) 5 cy at Southington (14T & 20T) 4 cy at Millstone (14T & 15T) 9 cy Haddam
SO102	NC	3-Phase	Southington 318 Line	4 cy at Southington (3T & 4T) 4 cy at Meriden
SO103	NC	3-Phase	Southington 329 Line	4 cy at Southington (4T & 5T) 4 cy at Frost Bridge (1T)
MP101	NC	3-Phase	Millstone 310 Line	4 cy at Millstone (7T & 8T) 4 cy at Manchester (21T & 22T)
MP102	NC	3-Phase	Millstone 371 Line	4 cy at Millstone (4T & 5T) 4 cy at Montville (1T) 5 cy at Montville (19X3)
MP103	NC	3-Phase	Millstone 348E Line	4 cy at Millstone (14T & 15T) 4 cy at Haddam (B)
MP103A	NC	3-Phase	Millstone 348 Line	4 cy at Millstone (14T & 15T) 4 cy at Southington (1T & 7T) 5 cy at Southington (14T & 20T) 9 cy Haddam
MP104	NC	3-Phase	Millstone 383 Line	4 cy at Millstone (1T & 2T) 4 cy at Card (2T & 3T)

Table 14 – Contingency List

ID	Type	Fault	Fault Location & Description	Fault Clearing Time in Cycles Location and Breaker(s)
Millstone 345-kV Double-Circuit-Tower (DCT)				
MP105	NC	DLG	Millstone 310 + 348E DCT Zdlg = (0.02902 – j0.36952) Ω (345 kV Base)	4 cy at Millstone (7T & 8T) 4 cy at Millstone (14T & 15T) 4 cy at Manchester (21T & 22T) 4 cy at Haddam (B)
MP105A	NC	DLG	Millstone 310 + 348 DCT Zdlg = (0.02902 – j0.36952) Ω (345 kV Base)	4 cy at Millstone (7T & 8T) 4 cy at Millstone (14T & 15T) 4 cy at Manchester (21T & 22T) 4 cy at Southington (1T & 7T) 5 cy at Southington (14T & 20T) 9 cy at Haddam
MP106	NC	DLG	Millstone 371 + 383 DCT Zdlg = (0.02902 – j0.36952) Ω (345 kV Base)	4 cy at Millstone (4T & 5T) 4 cy at Millstone (1T & 2T) 4 cy at Montville (1T) 5 cy at Montville (19X3) 4 cy at Card (2T & 3T)
345-kV 3-Phase Line to Ground Fault Degrading to a Single Line to Ground Fault with Breaker Failure				
SO201	EC	3PLBF	Southington 329 & 4T-BF Zslg = (2.08403 + j14.92749) Ω (345 kV Base)	4 cy at Southington (5T) 4 cy at Frost Bridge (1T) 11.9 cy at Southington (3T) 14.15 cy at Meriden
SO202	EC	3PLBF	Southington 2X xfmr High Side & 1T-BF Zslg = (2.08403 + j14.92749) Ω (345 kV Base)	4 cy at Southington (3T) 5 cy at Southington (21T & 22T) 11.9 cy at Southington (7T) 12.9 cy at Southington (14T & 20T) 14.15 cy at Haddam (A)
SO202A	EC	3PLBF	Southington 2X xfmr High Side & 1T-BF Zslg = (2.08403 + j14.92749) Ω (345 kV Base)	4 cy at Southington (3T) 5 cy at Southington (21T & 22T) 11.9 cy at Southington (7T) 12.9 cy at Southington (14T & 20T) 14.15 cy at Haddam (A) 14.15 cy at Millstone (14T & 15T)
MP201	EC	3PLBF	Millstone 310 Line & 7T-BF Zslg = (0.80129 + j11.19864) Ω (345 kV Base)	4 cy at Millstone (8T) 8.15 cy at Millstone (1T & 4T & 13T) 4 cy at Manchester (21T & 22T)
MP202	EC	3PLBF	Millstone 371 Line & 4T-BF Zslg = (0.80129 + j11.19864) Ω (345 kV Base)	4 cy at Millstone (5T) 8.15 cy at Millstone (1T & 7T & 13T) 4 cy at Montville (1T) 5 cy at Montville (19X3)
MP203	EC	3PLBF	Millstone 383 Line & 1T-BF Zslg = (0.80129 + j11.19864) Ω (345 kV Base)	4 cy at Millstone (2T) 8.15 cy at Millstone (4T & 7T & 13T) 4 cy at Card (2T & 3T)
MP204	EC	3PLBF	Millstone 348E Line & 15T-BF Zslg = (0.80129 + j11.19864) Ω (345 kV Base)	4 cy at Millstone (14T) 7.82 cy at Millstone (3T & 6T & 9T) 4 cy at Haddam (B)
MP204A	EC	3PLBF	Millstone 348 Line & 15T-BF Zslg = (0.80129 + j11.19864) Ω (345 kV Base)	4 cy at Millstone (14T) 7.82 cy at Millstone (3T & 6T & 9T) 4 cy at Southington 11.82 at Haddam

Table 15 – Contingency List

ID	Type	Fault	Fault Location & Description	Fault Clearing Time in Cycles Location and Breaker(s)
345-kV 3-Phase Line to Ground Fault Degrading to a Single Line to Ground Fault with Breaker Failure				
HD206	EC	3PLBF	Haddam 348W Line & A-BF Zslg = (7.89153 + j 31.86330) Ω _(345 kV Base)	4 cy at Southington (1T & 7T) 5 cy at Southington (14T & 20T) 14 cy at Haddam (B) 15 cy at Haddam (C & D)
HD207	EC	3PLBF	Haddam 348E Line & B-BF Zslg = (7.89153 + j 31.86330) Ω _(345 kV Base)	4 cy at Millstone (14T) 14 cy at Haddam (A) 15 cy at Haddam (C & D)
HD208	EC	3PLBF	Haddam Autoxfmr High Side & A-BF Zslg = (7.89153 + j 31.86330) Ω _(345 kV Base)	4 cy at Haddam (B) 5 cy at Haddam (C & D) 16.25 cy at Southington (1T & 7T) 17.25 cy at Southington (14T & 20T)
HD208A	EC	3PLBF	Haddam Autoxfmr High Side & BF Zslg = (7.89153 + j 31.86330) Ω _(345 kV Base)	5 cy at Haddam (C & D) 11.25 cy at Millstone (14T & 15T) 11.25 cy at Southington (1T & 7T) 12.25 cy at Southington (14T & 20T)
HD209	EC	3PLBF	Haddam Autoxfmr High Side & B-BF Zslg = (7.89153 + j 31.86330) Ω _(345 kV Base)	4 cy at Haddam (A) 5 cy at Haddam (C & D) 16.25 cy at Millstone (14T & 15T)
Millstone SPS (SLOD)				
SLOD1	NC	DLG	371 Line-out + [310+348E] DCT Zdlg = (0.02153 – j0.32889) Ω _(345 kV Base)	4 cy at Millstone (7T & 8T) 4 cy at Manchester (21T & 22T) 4 cy at Millstone (14T & 15T) 4 cy at Haddam (B) 12 cy at Millstone (13T) U3-Trip
SLOD1A	NC	DLG	371 Line-out + [310+348] DCT Zdlg = (0.02153 – j0.32889) Ω _(345 kV Base)	4 cy at Millstone (7T & 8T) 4 cy at Manchester (21T & 22T) 4 cy at Millstone (14T & 15T) 4 cy at Southington (1T & 7T) 5 cy at Southington (14T & 20T) 8 cy at Haddam 12 cy at Millstone (13T) U3 Trip
SLOD2	NC	DLG	383 Line-out + [310+348E] DCT Zdlg = (0.02477 – j0.34910) Ω _(345 kV Base)	4 cy at Millstone (7T & 8T) 4 cy at Manchester (21T & 22T) 4 cy at Millstone (14T & 15T) 4 cy at Haddam (B) 12 cy at Millstone (13T) U3 Trip
SLOD2A	NC	DLG	383 Line-out + [310+348] DCT Zdlg = (0.02477 – j0.34910) Ω _(345 kV Base)	4 cy at Millstone (7T & 8T) 4 cy at Manchester (21T & 22T) 4 cy at Millstone (14T & 15T) 4 cy at Southington (1T & 7T) 5 cy at Southington (14T & 20T) 8 cy at Haddam 12 cy at Millstone (13T) U3 Trip
SLOD3	NC	DLG	310 Line-out + [371+383] DCT Zdlg = (0.02655 – j0.35578) Ω _(345 kV Base)	4 cy at Millstone (4T & 5T) 4 cy at Montville (1T) 5 cy at Montville (19X3) 4 cy at Millstone (1T & 2T) 4 cy at Card (2T & 3T) 12 cy at Millstone (13T & 14T) U3 Trip

Table 16 – Contingency List

ID	Type	Fault	Fault Location & Description	Fault Clearing Time in Cycles Location and Breaker(s)
Millstone SPS (SLOD)				
SLOD4	NC	DLG	348E Line-out + [371+383] DCT Zdlg = (0.02389 – j0.34640) Ω (345 kV Base)	4 cy at Millstone (4T & 5T) 4 cy at Montville (1T) 5 cy at Montville (19X3) 4 cy at Millstone (1T & 2T) 4 cy at Card (2T & 3T) 12 cy at Millstone (13T & 14T) U3 Trip
SLOD4A	NC	DLG	348 Line-out + [371+383] DCT Zdlg = (0.02389 – j0.34640) Ω (345 kV Base)	4 cy at Millstone (4T & 5T) 4 cy at Montville (1T) 5 cy at Montville (19X3) 4 cy at Millstone (1T & 2T) 4 cy at Card (2T & 3T) 12 cy at Millstone (13T & 14T) U3 Trip
SLOD5	NC	DLG	348W Line-out + [371+383] DCT Zdlg = (0.02600 – j0.35628) Ω (345 kV Base)	4 cy at Millstone (4T & 5T) 4 cy at Montville (1T) 5 cy at Montville (19X3) 4 cy at Millstone (1T & 2T) 4 cy at Card (2T & 3T)
The STF Standard 7 Simulations				
EC102	EC	3PLBF	Scobie 345-kV + 9126-B.F Zslg = (0.0055 + j0.0256) Ω (10 kV Base)	4 cy at Scobie (262) 6 cy at Lawrence Rd. 4 cy at Sandy Pond (326 + 2643) 8 cy at Scobie (911) 9 cy at Buxton (K391-1) 9 cy at Buxton (K391/386)
EC103	EC	3PLBF	Seabrook 345-kV + 294-BF Zslg = (0.00081 + j0.01351) Ω (10 kV Base)	4 cy at Seabrook (941) 4 cy at Tewksbury (339 + 38-94) 4 cy at Ward Hill (Auto) 8 cy at Seabrook (22)
EC212	EC	3PLBF	Card 345-kV + 2T-BF Zslg = (0.00438 + j0.02106) Ω (10 kV Base)	4 cy at Card (1T) 4 cy at Manchester (23T + 25T) 10.5 cy at Card (3T) 12.75 cy at Millstone (1T & 2T)
EC301	EC	3PLBF	Northfield 345-kV + 3T-BF Zslg = (0.00002 + j0.0256) Ω (10 kV Base)	4 cy at Northfield 4 cy at Alps 5 cy at Berkshire (Auto) 8.7 cy at Northfield (2T) 11.5 cy at VT Yankee (81-1T + 381)
EC402	EC	3-Ø & BF	Sherman Road 345-kV + 143-BF	4 cy at Sherman Rd (142) 4 cy at West Farnum (176 + 172) 9.5 cy at Sherman Rd (141) 10.5 cy at Ocean State Power Gen
NC106	NC	3-Phase	Orrington 345-kV	4 cy at Orrington (K396-1 + K396/388) 4 cy at Keswick (K3-6 + K3-5) 4 cy at Chester (SVC)
EC303	EC	3-Ø & BF	Vermont Yankee 345-kV + 379-BF	4 cy at VT Yankee (381) 5.5 cy at VT Yankee (Transformer) 10.3 cy at VT Yankee (79-40) 11.3 cy at Amherst (Transfmr) + Scobie (792 + 793)