

LOCATION MAP
N.T.S.



PLANS FOR THE CONSTRUCTION
OF THE
MIDDLETOWN-NORWALK
345-kV TRANSMISSION LINE PROJECT

SEGMENT 3
TOWN OF STRATFORD / CITY OF MILFORD, CONNECTICUT

CONNECTICUT SITING COUNCIL
DOCKET NO. 272

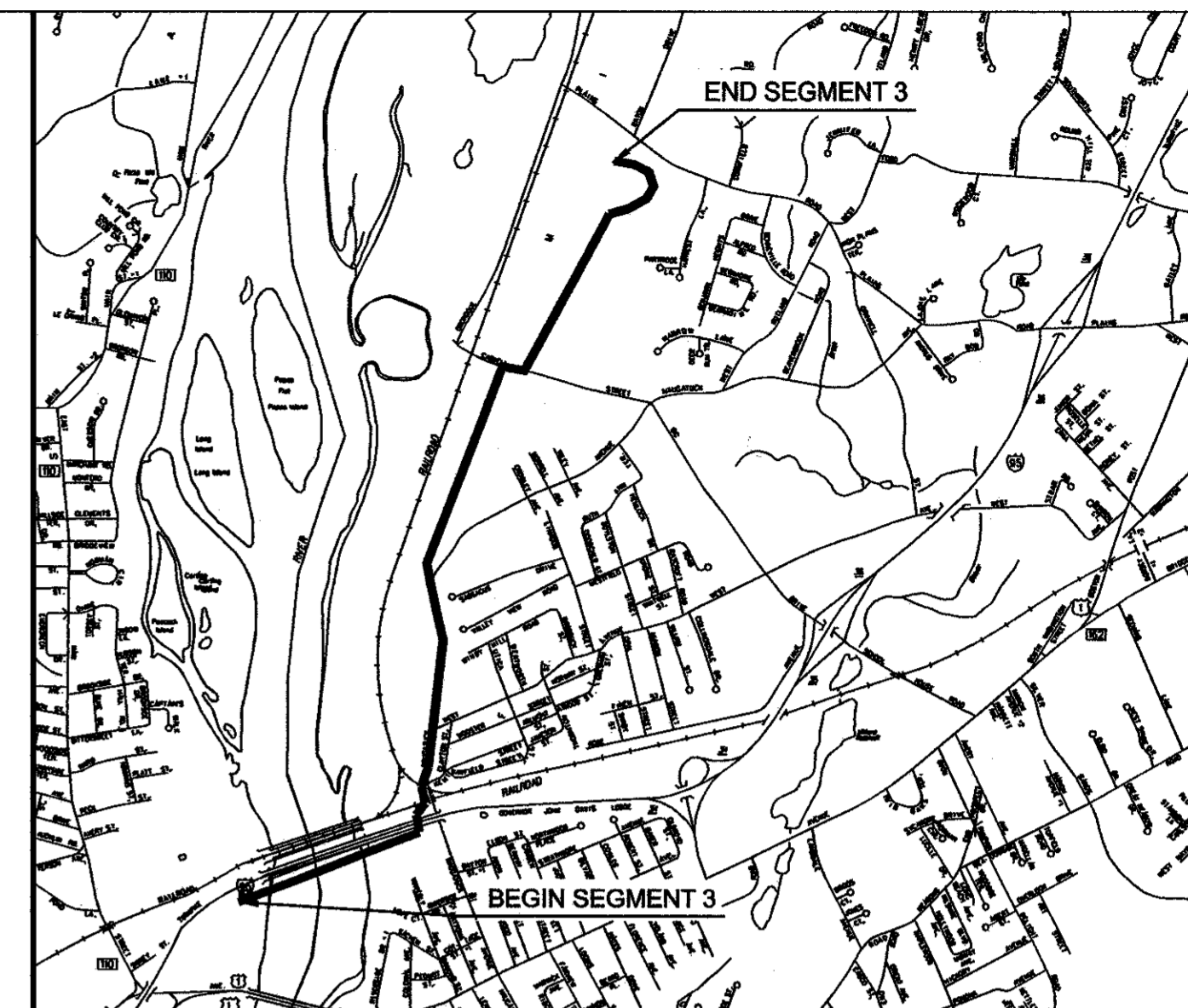

VICINITY MAP
N.T.S.

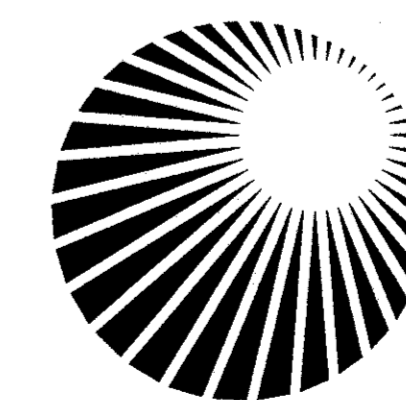
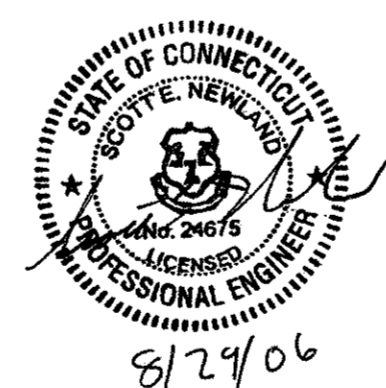

Connecticut
Light & Power
The Northeast Utilities System

DRAWING INDEX

DRAWING INDEX:

DWG NO	TITLE/DESCRIPTION
01223-00000 PG 001	CONSTRUCTION SET
01223-00001 PG 001	HOUSATONIC RIVER TO EAST DEVON SS PAGE INDEX
01223-00001 PG 002	HOUSATONIC RIVER TO EAST DEVON SS GENERAL NOTES AND LEGEND
01223-10002 PG 001	CITY OF MILFORD INDEX KEY MAP
01223-10002 PG 002	CITY OF MILFORD ROUTE DATA TABLES
01223-10001 PG 003	CITY OF MILFORD P & P Sta 1010+00 TO 1017+25
01223-10001 PG 004	CITY OF MILFORD P & P Sta 1017+25 TO 1023+50
01223-10001 PG 005	CITY OF MILFORD P & P Sta 1021+50 TO 1030+00
01223-10001 PG 006	CITY OF MILFORD P & P Sta 1028+50 TO 1037+50
01223-10001 PG 007	CITY OF MILFORD P & P Sta 1035+50 TO 1044+00
01223-10001 PG 008	CITY OF MILFORD P & P Sta 1043+00 TO 1051+00
01223-10001 PG 009	CITY OF MILFORD P & P Sta 1049+00 TO 1058+00
01223-10001 PG 010	CITY OF MILFORD P & P Sta 1056+00 TO 1065+00
01223-10001 PG 011	CITY OF MILFORD P & P Sta 1063+50 TO 1072+50
01223-10001 PG 012	CITY OF MILFORD P & P Sta 1071+00 TO 1080+00
01223-10001 PG 013	CITY OF MILFORD P & P Sta 1078+50 TO 1086+50
01223-10001 PG 014	CITY OF MILFORD P & P Sta 1085+50 TO 1094+50
01223-10001 PG 015	CITY OF MILFORD P & P Sta 1092+50 TO 1101+50
01223-10001 PG 016	CITY OF MILFORD P & P Sta 1100+00 TO 1108+50
01223-10001 PG 017	CITY OF MILFORD P & P Sta 1107+50 TO 1115+50
01223-10001 PG 018	CITY OF MILFORD P & P Sta 1113+00 TO EAST DEVON SS
01223-45003 PG 001	VAULT, GROUNDING AND HANDHOLE DETAILS
01223-45003 PG 002	VAULT AND GROUNDING DETAILS
01223-45003 PG 003	UTILITY BRIDGE SPLICE VAULT DETAILS
01223-45003 PG 004	HORIZONTAL DIRECTIONAL DRILL SPLICE VAULT DETAILS
01223-45003 PG 005	CROSSING SPLICE VAULT DETAILS
01223-45003 PG 006	CONDUIT TRANSITIONS
01223-46003 PG 001	TYPICAL DUCT BANK DETAILS
01223-46003 PG 002	UTILITY BRIDGE DUCT BANK DETAILS AND UTILITY CROSSING DETAIL
01223-46003 PG 003	UTILITY BRIDGE DUCT BANK DETAILS
01223-46003 PG 004	JACK AND BORE AND HORIZONTAL DIRECTIONAL DRILL DUCT BANK DETAILS
01223-46003 PG 005	CABLE AND TEMPERATURE MONITORING DETAILS
01223-46003 PG 006	HORIZONTAL DIRECTIONAL DRILL AND JACK AND BORE SECTIONS
01223-15003 PG 001	EROSION CONTROL DETAILS
01223-15003 PG 002	EROSION CONTROL DETAILS
LL-01	LANDSCAPE PLAN
SB-01	LOT LINE ADJUSTMENT PLAN
UTL-01	UTILITY PLAN

COPYRIGHT © 2008 BURNS & McDONNELL ENGINEERING COMPANY, INC.

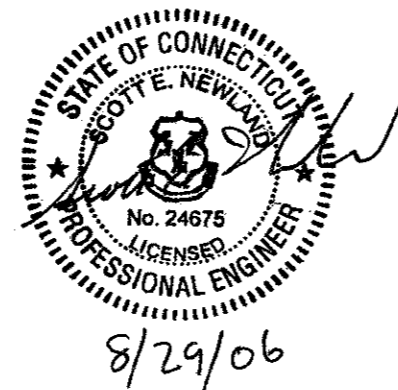

ISSUED FOR CONSTRUCTION

DOCKET No. 272

												
date		10/11/05		detailed		L. ROWSE						
designed		C. COURTRIGHT		checked		S. NEWLAND						
no.	date	revisions	by	chk	MF	NO.	DATE	REVISIONS	BY	CHK	APP	APP
1	8/29/06	ISSUED FOR CONSTRUCTION	CTC									
NORTHEAST UTILITIES SERVICE CO.												
FOR THE CONNECTICUT LIGHT & POWER COMPANY												
TITLE MIDDLETOWN-NORWALK 345KV TRANSMISSION PROJECT												
HOUSATONIC RIVER TO EAST DEVON SS PAGE INDEX												
BY SEN-BMCD		CHKD		APP		APP						
DATE 10/11/05		DATE		DATE		DATE						
SCALE AS NOTED												
D												
										DWG. NO. 01223-00001 PG 001		

ABBREVIATIONS		UTILITY - GAS		PIPE MATERIALS		STRUCTURES	
BUILDINGS		GG	GAS GATE	CI	CAST IRON	*C* CB	CURBED CATCH BASIN
GAR.	GARAGE	ST.	STEEL	DI	DUCTILE IRON	*C-L* CB	CURBLESS CATCH BASIN
GUIDE RAILS				HP.	HIGH PRESSURE	MH	MANHOLE
MBR	METAL BEAM RAIL	LP.	LOW PRESSURE	STM.	STORM	SAN.	SANITARY
CGRM	CABLE GUIDE RAIL METAL POSTS	PLA	PLASTIC	TF	TOP OF FRAME	STM.	STORM
CGRW	CABLE GUIDE RAIL WOOD POSTS	PVC	POLYVINYL CHLORIDE	INV.	INVERT	TF	TOP OF FRAME
TGR	TIMBER GUIDE RAIL	RCP	REINFORCED CONCRETE PIPE	BTM	BOTTOM	INV.	INVERT
FENCES/WALLS		CMP	CORRUGATED METAL PIPE	N/A	NOT AVAILABLE	BTM	BOTTOM
CLF	CHAIN LINK FENCE	WRP	WRAPPED PIPE	MISC.		N/A	NOT AVAILABLE
PICK.FENCE	PICKET FENCE	600*	600 PSI	(ABAN.)	ABANDONED	MISC.	
RAIL FENCE	WOOD RAIL FENCE	CWD	CREOSOTE WOOD DUCT	(MAP)	COMPILED FROM EXISTING MAPPING	(ABAN.)	ABANDONED
STOCK.FENCE	STOCKADE FENCE	MTD	MULTI TILED DUCTS	UG	UNDERGROUND	(MAP)	COMPILED FROM EXISTING MAPPING
WIRE FENCE	WIRE FENCE	STD	SINGLE TILED DUCTS	F.O.	FIBER OPTIC	UG	UNDERGROUND
RET.WALL	RETAINING WALL	F	FIBERGLASS			F.O.	FIBER OPTIC
MONUMENTATION		P	PLASTIC				
CHD	CONN.HIGHWAY DEPT.MON.	I	IRON				
DH	DRILL HOLE	W	WOOD				
I.PIN	IRON PIN	HWF					
I.PIPE	IRON PIPE	TH	TEST HOLE				
MAG.NAIL	MAGNETIC NAIL						
MON.	MONUMENT						
PK NAIL	*PK* NAIL						
SPIKE	SPIKE						
SURFACE/WALL/CURB MATERIALS							
BIT.	BITUMINOUS						
BOL.	BOLLARD						
CONC.	CONCRETE						
GRAN.	GRANITE						
GRAV.	GRAVEL						
B.C.L.C.	BITUMINOUS CONCRETE LIP CURB						
UTILITY - WATER							
WG	WATER GATE (OR CURB BOX)						
WM	WATER METER						
TRAFFIC							
LOOP DET.	LOOP DETECTOR						
UTILITY - COMMUNICATIONS AND ELECTRIC							
ELEC.MH	ELECTRIC MANHOLE						
TEL.MH	TELEPHONE/COMMUNICATIONS MANHOLE						
TRANS.							
UI	UNITED ILLUMINATING						
SNET	SOUTHERN NEW ENGLAND TELEPHONE						
CL&P	CONNECTICUT LIGHT AND POWER						

LEGEND	
Edge Of Road	Easement Line
Concrete Pavement	Edge of Water
Dirt Road	Stone Wall
B.C.L.C.	Transmission Tower
Curb (Type As Labeled)	Riprap
Guide Rail	Hedge Row
Concrete Median Barrier	Tree Line
Railroad Tracks	Shrub
Fence	All Trees
Storm	Hand Hole
Sanitary	Pedestrian Signal
Gas Main	Span Pole
Water Main	Most Arm
Underground Electric	Traffic Controller
Telephone Duct Bank	Traffic Signal
Underground Tele. Conduit	Sign
Overhead Wires	2-Post Sign
Retaining Wall	Double-Faced Sign
Highway Line	Billboard
Street Line	Utility Pole
Property Line	Utility Pole With Light
Lot Line Of Common Ownership	General Purpose Lamp
Town Line	Light Standard
DUCT BANK	Guy Wire
Water/RR Crossing	Guy Pole
Demolition	Water Meter
Approx. Limits of Thermally Approved Unbound Aggregate Backfill	Hydrant
	Type "C-L" Catch Basin
	Type "C" Catch Basin
	Manhole
	Benchmark
	Control Point
	Monuments
	Pin, Pipe, Drillhole
	Marsh
	Wetlands Boundary
	Fiber Optic Handhole
	Splice Vault
	Test Hole
	Temperature Monitor Station

- GENERAL NOTES**
1. THE UTILITIES AND NATURAL FEATURES SHOWN HEREON ARE BASED ON FIELD SURVEYS, AERIAL PHOTOGRAPHY AND RECORD DOCUMENTS. OTHER FACILITIES MAY EXIST NOT DISCOVERED THROUGH THE RECORD CHECK. THE CONTRACTOR SHALL VERIFY THE EXACT LOCATION, BOTH HORIZONTAL AND VERTICAL, OF ALL UTILITIES THROUGH THE APPROPRIATE UTILITY COMPANIES. CALL BEFORE YOU DIG.
 2. ALL VERTICAL RADII ARE 400' UNLESS OTHERWISE NOTED.
 3. DUCT BANK SHALL MAINTAIN MINIMUM COVER DEPTH OF 2'-6" UNLESS OTHERWISE SHOWN ON DRAWINGS. MAINTAIN 2'-0" VERTICAL CLEARANCE OVER OR UNDER EXISTING UTILITIES UNLESS OTHERWISE SHOWN ON DRAWINGS.
 4. ALL AREAS DISTURBED BY CONSTRUCTION SHALL BE RETURNED TO THE ORIGINAL CONDITIONS AS DETERMINED BY NORTHEAST UTILITIES.
 5. COORDINATES AND STATIONING INDICATED ARE AT CENTERLINE OF DUCT BANK.
 6. SEE INDEX KEY MAPS FOR THE DESIGNATION BETWEEN MUNICIPAL ROADS AND STATE ROADS.
 7. TREES AND SHRUBS SHALL BE REMOVED AND REPLACED WITH SIMILAR TYPES AND SIZES TYPICAL OF GENERAL CONSUMER NURSERY STOCK, PROVIDED THAT NO REPLACEMENT TREE SHALL EXCEED TWELVE (12) FEET IN HEIGHT, NOR SHALL ANY REPLACEMENT SHRUB EXCEED A THREE (3) GALLON POT AND PROVIDED THAT NOTHING SHALL BE PLANTED WITHIN FIFTEEN (15) FEET OF AN INSTALLED VAULT OR WITHIN TEN (10) FEET OF AN INSTALLED CABLE DUCT BANK.
 8. COORDINATES ARE BASED ON THE CONNECTICUT STATE PLANE COORDINATE SYSTEM. (NAD 83)
 9. VERTICAL DATUM IS BASED ON NAVD 88.
 10. SILT FENCE SHALL BE USED ALONG THE DOWN SLOPE SIDE OF THE CONSTRUCTION AREA WHERE THERE IS THE POTENTIAL FOR STORM WATER RUNOFF. THIS INCLUDES ANY PERVIOUS AREAS ALONG THE ROUTE. INLET PROTECTION SHALL BE USED IN ROADWAYS WHERE STORM DRAINS ARE PRESENT AND POTENTIAL FOR STORM WATER RUNOFF EXISTS.
 11. TEMPORARY AND PERMANENT EASEMENTS SHALL BE ACQUIRED FOR INSTALLATION OF THE DUCT BANK AND VAULTS ALONG PRIVATE PROPERTY. A TYPICAL VAULT LOCATION INSTALLED ALONG PRIVATE PROPERTY REQUIRES A PERMANENT EASEMENT OF APPROXIMATELY 10,000 SF AND A TEMPORARY EASEMENT OF APPROXIMATELY 6,500 SF.
 12. VAULT AND DUCT BANK LOCATIONS ARE SUBJECT TO ADJUSTMENT DUE TO UNFORESEEN CONDITIONS.
 13. NORTHING AND EASTING DESIGNATIONS FOR SPLICE VAULT LOCATIONS ARE REFERENCED TO CENTER OF SPLICE VAULT.

COPYRIGHT © 2008 BURNS & MCDONNELL ENGINEERING COMPANY, INC.



ONE CALL SYSTEMS
1-800-922-4455
CALL BEFORE YOU DIG.....IT'S THE LAW!
48 HOUR NOTICE REQUIRED

DOCKET No. 272

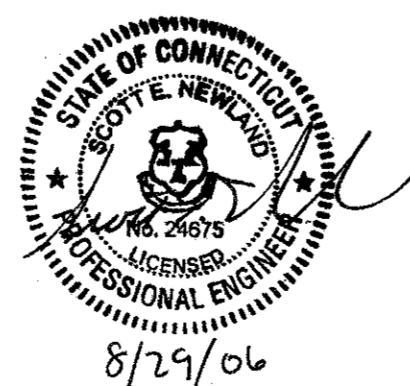

ISSUED FOR CONSTRUCTION

no.	date	revisions	by	chk
1	8/29/06	ISSUED FOR CONSTRUCTION	CTC	

Burns & McDonnell SINCE 1898	
date	10/11/05
detailed	L. ROWSE
designed	C. COURTRIGHT
checked	S. NEWLAND

MF	NO.	DATE	REVISIONS	BY	CHK	APP	APP

NORTHEAST UTILITIES SERVICE CO.			
FOR THE CONNECTICUT LIGHT & POWER COMPANY			
TITLE MIDDLETOWN-NORWALK 345KV TRANSMISSION PROJECT			
HOUSATONIC RIVER TO EAST DEVON SS GENERAL NOTES AND LEGEND			
BY SEN-BMCD	CHKD	APP	APP
DATE 10/11/05	DATE	DATE	DATE
SCALE AS NOTED		DWG. NO.	01223-00001 PG 002
	D		

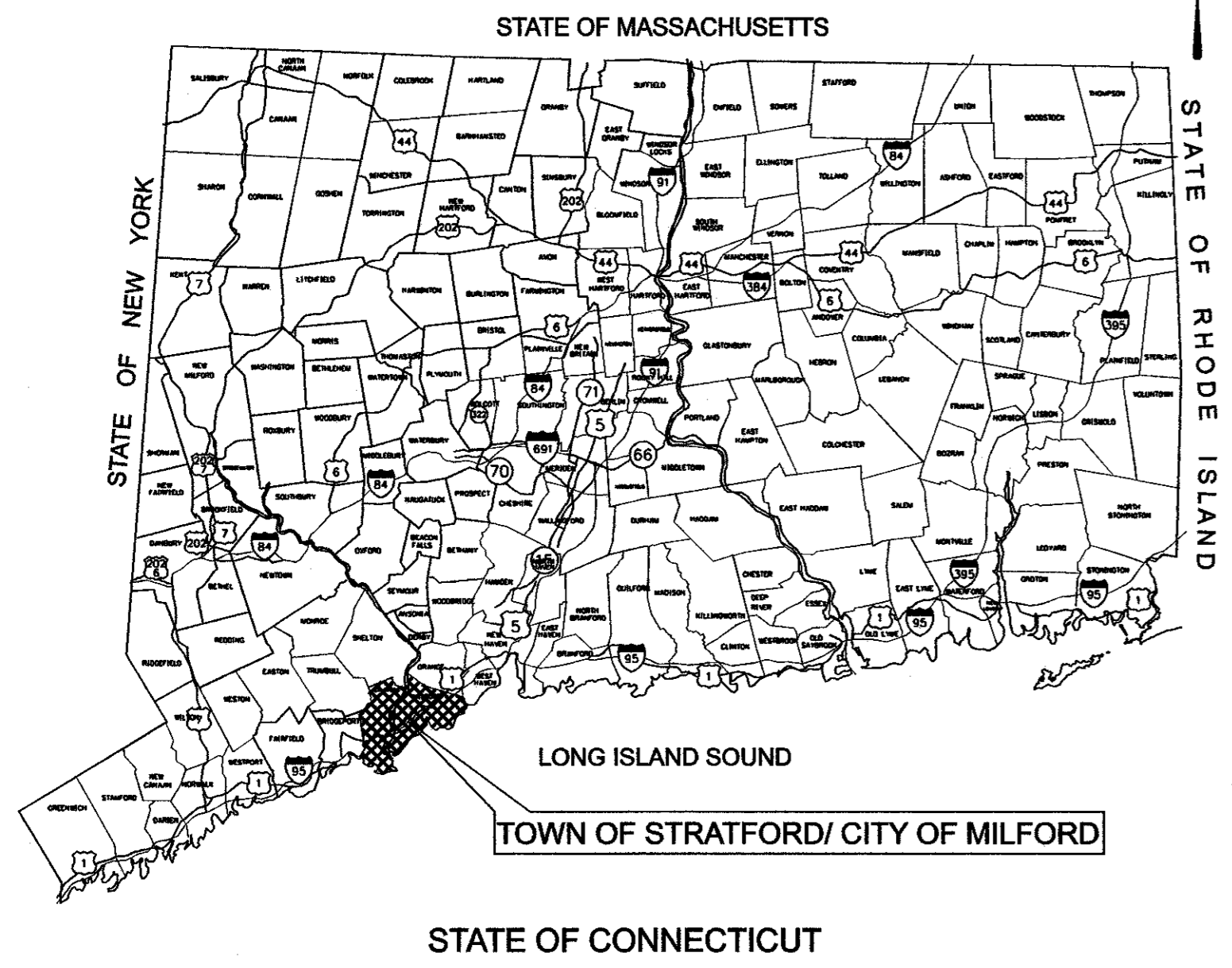

LOCATION MAP
N.T.S.

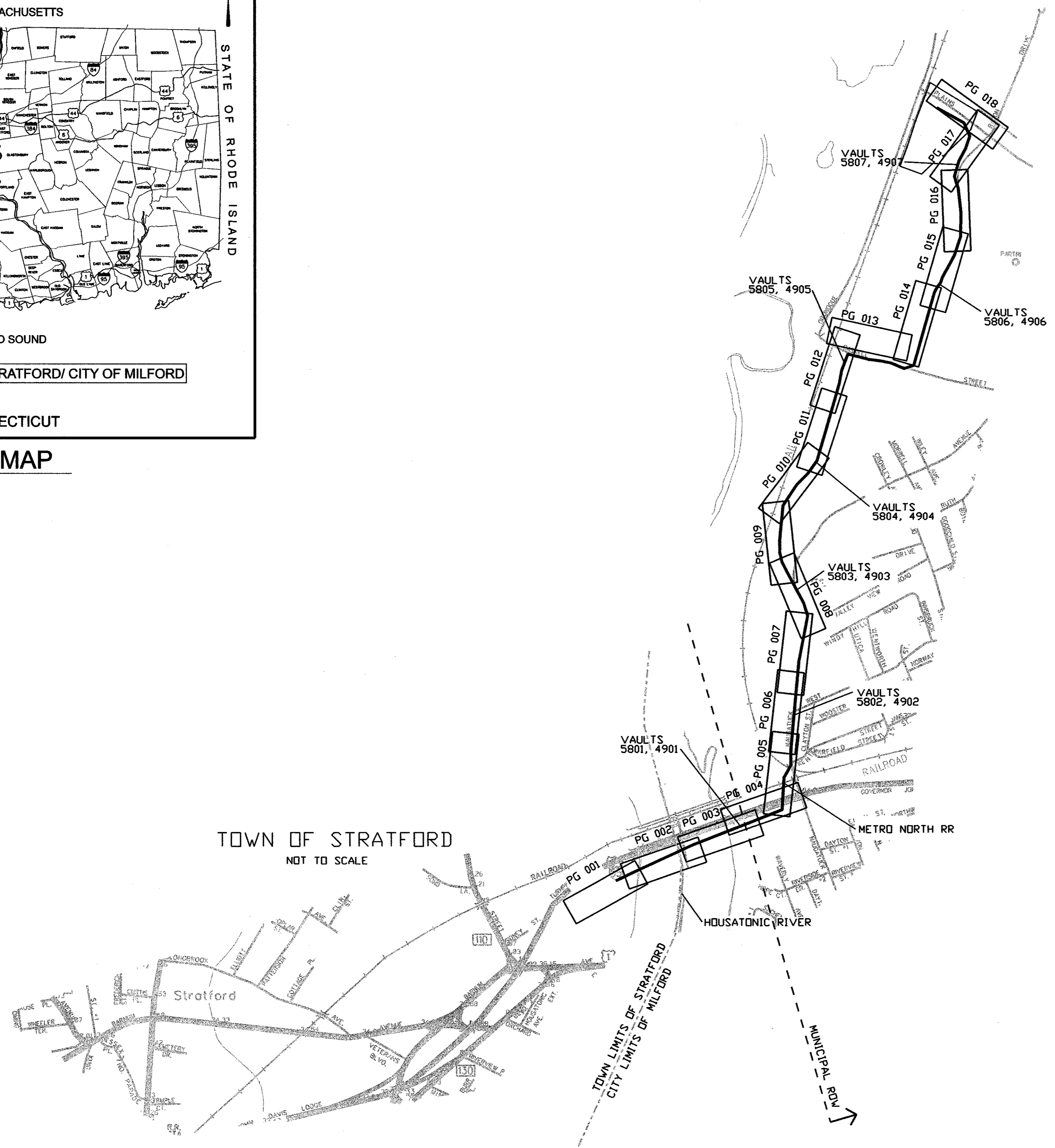

TOWN OF STRATFORD
NOT TO SCALE

CITY OF MILFORD
NOT TO SCALE

COPYRIGHT © 2006 BURNS & MCDONNELL ENGINEERING COMPANY, INC.

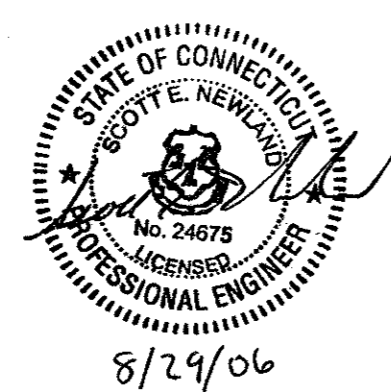

DOCKET No. 272



ISSUED FOR CONSTRUCTION

no.	date	revisions	by	chk
1	8/29/06	ISSUED FOR CONSTRUCTION	CTC	



date 10/11/05
designed C. COURTRIGHT
detailed L. ROWSE
checked S. NEWLAND

MF	NO.	DATE	REVISIONS	BY	CHK	APP	APP

NORTHEAST UTILITIES SERVICE CO.			
FOR THE CONNECTICUT LIGHT & POWER COMPANY			
TITLE MIDDLETOWN-NORWALK 345KV TRANSMISSION PROJECT			
CITY OF MILFORD INDEX KEY MAP			
BY SEN-BMCD	CHKD	APP	APP
DATE 10/11/05	DATE	DATE	DATE
SCALE AS NOTED	D	DWG. NO. 01223-10002 PG 001	

CURVE DATA TABLE								
CURVE NO.	RADIUS	CURVE LENGTH	TANGENT LENGTH	DEFLECTION ANGLE	POINT OF INTERSECTION	POINT OF CURVATURE	POINT OF TANGENCY	SHEET REFERENCE
PI-M-01	200'	71.75'	36.27'	20°33'18.22"	N 635,677.4090 E 901,708.9843	N 635,664.5835 E 901,675.0628	N 635,701.3281 E 901,736.2430	10001 PG 003
PI-M-02	200'	80.81'	40.96'	23°08'58.23"	N 635,728.3452 E 901,767.0324	N 635,701.3281 E 901,736.2430	N 635,741.0827 E 901,805.9639	10001 PG 003
PI-M-03	52'	79.98'	50.33'	88°07'47.64"	N 635,908.4232 E 902,317.4329	N 635,892.7728 E 902,303.3519	N 635,956.7432 E 902,303.3519	10001 PG 004
PI-M-04	400'	76.65'	38.44'	10°58'47.65"	N 636,001.0301 E 902,290.4462	N 635,964.1206 E 902,301.2020	N 636,039.3126 E 902,286.9171	10001 PG 004
PI-M-05	200'	121.17'	62.51'	34°42'49.35"	N 636,294.1257 E 902,263.4274	N 636,231.8788 E 902,269.1656	N 636,348.5609 E 902,294.1588	10001 PG 005
PI-M-06	200'	71.27'	36.02'	20°25'00.67"	N 636,382.6343 E 902,313.3949	N 646,351.2711 E 902,295.6888	N 636,418.2040 E 902,319.0477	10001 PG 005
PI-M-07	100'	38.52'	19.50'	22°04'19.74"	N 636,548.1850 E 902,339.7044	N 636,528.9234 E 902,336.6433	N 636,567.1853 E 902,335.3031	10001 PG 005
PI-M-08	200'	99.91'	51.02'	28°37'21.25"	N 636,651.7386 E 902,315.7169	N 636,602.0334 E 902,327.2308	N 636,700.8851 E 902,329.4207	10001 PG 005
PI-M-09	200'	44.11'	22.14'	12°38'11.64"	N 636,722.2162 E 902,335.3686	N 636,700.8851 E 902,329.4207	N 636,744.3317 E 902,336.5059	10001 PG 006
PI-M-10	200'	15.24'	7.62'	4°21'54.89"	N 636,751.9442 E 902,366.8974	N 636,744.3317 E 902,336.5059	N 636,759.5047 E 902,337.8671	10001 PG 006
PI-M-11	200'	46.62'	23.42'	13°21'23.20"	N 636,902.0677 E 902,356.1528	N 636,878.8404 E 902,353.1736	N 636,923.9784 E 902,364.4172	10001 PG 006
PI-M-12	200'	44.56'	22.37'	12°45'59.07"	N 636,944.9130 E 902,372.3133	N 636,923.9784 E 902,364.4172	N 636,967.0750 E 902,375.3882	10001 PG 006
PI-M-13	200'	41.99'	21.07'	12°01'44.25"	N 637,042.7258 E 902,385.8844	N 637,021.8538 E 902,382.9885	N 637,063.7430 E 902,384.3669	10001 PG 006
PI-M-14	202'	45.43'	22.81'	12°53'04.58"	N 637,086.4928 E 902,382.7243	N 637,063.7430 E 902,384.3669	N 637,109.0360 E 902,386.1959	10001 PG 006
PI-M-15	500'	3.21'	1.60'	0°22'03.21"	N 637,121.8317 E 902,388.1665	N 637,120.2466 E 902,387.9224	N 637,123.4152 E 902,388.4207	10001 PG 006
PI-M-16	500'	19.81'	9.91'	2°16'13.22"	N 637,275.2411 E 902,412.8000	N 637,265.4588 E 902,411.2292	N 637,285.0778 E 902,413.9820	10001 PG 006
PI-M-17	200'	39.31'	19.72'	11°15'42.51"	N 637,482.6067 E 902,437.7177	N 637,463.0284 E 902,435.3651	N 637,501.3485 E 902,443.8485	10001 PG 007
PI-M-18	200'	42.56'	21.36'	12°11'32.42"	N 637,521.6502 E 902,450.4895	N 637,501.3485 E 902,443.8485	N 637,542.8966 E 902,452.6932	10001 PG 007
PI-M-19	1,000'	178.45'	89.46'	10°13'27.63"	N 637,713.5127 E 902,469.5507	N 637,624.4463 E 902,461.1514	N 637,799.6738 E 902,493.6262	10001 PG 007
PI-M-20	350'	240.98'	125.49'	39°26'57.87"	N 638,212.0951 E 902,604.9939	N 638,090.9462 E 902,572.2796	N 638,326.4311 E 902,553.2779	10001 PG 008
PI-M-21	400'	12.48'	6.24'	1°47'17.92"	N 638,412.2013 E 902,514.4826	N 638,406.5132 E 902,517.0554	N 638,417.9669 E 902,512.0885	10001 PG 008
PI-M-22	202'	45.15'	22.67'	12°48'23.20"	N 638,456.3535 E 902,496.1492	N 638,435.4172 E 902,504.8426	N 638,478.6960 E 902,492.3128	10001 PG 008
PI-M-23	200'	44.70'	22.45'	12°48'23.20"	N 638,500.8172 E 902,488.5144	N 638,478.6960 E 902,492.3128	N 638,521.5462 E 902,479.9071	10001 PG 008
PI-M-24	500'	99.32'	49.83'	11°22'54.32"	N 638,721.6334 E 902,396.8248	N 638,675.6165 E 902,415.9324	N 638,762.9745 E 902,369.0117	10001 PG 009
PI-M-25	500'	280.90'	144.26'	32°11'17.58"	N 638,882.6695 E 902,288.4846	N 638,762.9745 E 902,369.0117	N 639,026.8647 E 902,284.0961	10001 PG 009
PI-M-26	500'	65.50'	32.80'	7°30'21.17"	N 639,075.2774 E 902,282.6226	N 639,042.4952 E 902,283.6203	N 639,107.9091 E 902,285.9157	10001 PG 009
PI-M-27	300'	135.77'	69.07'	25°55'50.19"	N 639,523.9008 E 902,327.8965	N 639,455.1809 E 902,320.9615	N 639,582.6698 E 902,364.1834	10001 PG 010
PI-M-28	700'	113.80'	57.03'	9°18'53.87"	N 639,744.6902 E 902,464.2229	N 639,696.1670 E 902,434.2623	N 639,787.7241 E 902,501.6425	10001 PG 010
PI-M-29	200'	49.36'	24.80'	14°08'23.20"	N 639,843.0998 E 902,549.7938	N 639,824.3819 E 902,533.5178	N 639,857.2746 E 902,570.1492	10001 PG 010
PI-M-30	200'	49.28'	24.77'	14°07'07.82"	N 639,871.4282 E 902,590.4741	N 639,857.2746 E 902,570.1492	N 639,890.1121 E 902,606.7325	10001 PG 010
PI-M-31	200'	49.47'	24.86'	14°10'18.78"	N 639,948.2071 E 902,657.2856	N 639,929.4522 E 902,640.9655	N 639,970.3869 E 902,668.5173	10001 PG 010
PI-M-31A	200'	49.40'	24.82'	14°09'03.41"	N 639,992.5336 E 902,679.7322	N 639,970.3869 E 902,668.5173	N 640,011.2664 E 902,696.0211	10001 PG 010
PI-M-31B	200'	78.80'	39.92'	22°34'24.88"	N 640,075.8883 E 902,752.2123	N 640,045.7671 E 902,726.0207	N 640,113.7560 E 902,764.8346	10001 PG 011
PI-M-32	2,000'	96.37'	48.19'	2°45'38.48"	N 640,299.2723 E 902,826.6722	N 640,253.5529 E 902,811.4327	N 640,344.2047 E 902,844.0961	10001 PG 011
PI-M-33	400'	147.97'	74.84'	21°11'43.14"	N 640,879.6828 E 903,051.7440	N 640,809.9045 E 903,024.6854	N 640,954.5238 E 903,051.7440	10001 PG 012
PI-M-34	1,000'	195.54'	98.08'	11°12'12.27"	N 640,094.7860 E 903,051.7440	N 640,996.7051 E 903,051.7440	N 641,190.9978 E 903,070.8004	10001 PG 012
PI-M-35	200'	44.78'	22.48'	12°49'43.04"	N 641,298.6303 E 903,092.1189	N 641,276.5746 E 903,087.7504	N 641,321.1054 E 903,091.4812	10001 PG 012

CURVE DATA TABLE								
CURVE NO.	RADIUS	CURVE LENGTH	TANGENT LENGTH	DEFLECTION ANGLE	POINT OF INTERSECTION	POINT OF CURVATURE	POINT OF TANGENCY	SHEET REFERENCE
PI-M-36	200'	44.78'	22.48'	12°49'43.04"	N 641,343.5806 E 903,090.8435	N 641,321.1054 E 903,091.4812	N 641,365.6363 E 903,095.2120	10001 PG 012
PI-M-37	100'	172.32'	116.53'	98°43'54.79"	N 641,542.1464 E 903,130.1729	N 641,542.1464 E 903,130.1729	N 641,542.1439 E 903,107.5316	10001 PG 013
PI-M-38	500'	74.62'	37.38'	8°33'01.97"	N 641,452.2105 E 903,378.1408	N 641,464.9549 E 903,343.0024	N 641,444.8321 E 903,414.7835	10001 PG 013
PI-M-39	125'	186.58'	115.59'	85°31'17.97"	N 641,344.5559 E 903,912.7824	N 641,367.3735 E 903,799.4642	N 641,455.7465 E 903,944.3784	10001 PG 014
PI-M-40	202'	81.97'	41.56'	23°14'59.93"	N 642,027.2258 E 904,106.7706	N 641,987.2519 E 904,095.4116	N 642,059.4695 E 904,132.9866	10001 PG 015
PI-M-41	200'	35.25'	17.67'	10°05'52.50"	N 642,073.1797 E 904,144.1338	N 642,059.4695 E 904,132.9866	N 642,088.6319 E 904,152.7044	10001 PG 015
PI-M-42	100'	25.81'	12.98'	14°47'08.22"	N 642,145.1202 E 904,184.0359	N 642,133.7737 E 904,177.7426	N 642,157.6971 E 904,187.2253	10001 PG 015
PI-M-43	202'	52.13'	26.21'	14°47'08.22"	N 642,183.1024 E 904,193.6678	N 642,157.6971 E 904,187.2253	N 642,206.0223 E 904,206.3804	10001 PG 015
PI-M-44	200'	41.62'	20.88'	11°55'20.57"	N 642,444.3913 E 904,338.5929	N 642,426.1286 E 904,328.4634	N 642,464.3528 E 904,344.7311	10001 PG 015
PI-M-45	200'	61.02'	30.75'	17°28'49.83"	N 642,667.7748 E 904,407.2838	N 642,638.3848 E 904,398.2463	N 642,698.5222 E 904,407.0757	10001 PG 016
PI-M-46	200'	20.41'	10.22'	5°50'52.23"	N 642,934.4273 E 904,405.4792	N 642,924.2122 E 904,405.5484	N 642,944.5821 E 904,404.3697	10001 PG 016
PI-M-47	400'	122.20'	61.58'	17°30'14.69"	N 643,257.7330 E 904,370.1538	N 643,196.5169 E 904,376.8425	N 643,314.1028 E 904,345.3627	10001 PG 016
PI-M-48	150'	105.87'	55.25'	40°26'19.11"	N 643,364.6748 E 904,323.1214	N 643,314.1028 E 904,345.3627	N 643,417.5916 E 904,338.9962	10001 PG 017
PI-M-49	100'	13.76'	6.89'	7°53'04.11"	N 643,451.6946 E 904,349.2269	N 643,445.0938 E 904,347.2467	N 643,457.9613 E 904,352.0938	10001 PG 017
PI-M-50	102'	14.04'	7.03'	7°53'04.11"	N 643,464.3533 E 904,355.0181	N 643,457.9613 E 904,352.0938	N 643,471.0861 E 904,357.0379	10001 PG 017
PI-M-51	75'	37.84'	19.33'	28°54'33.67"	N 643,538.1015 E 904,377.1422	N 643,519.5838 E 904,371.5870	N 643,551.6261 E 904,390.9547	10001 PG 017
PI-M-52	225'	451.43'	352.88'	114°57'23.35"	N 643,930.0862 E 904,777.5403	N 643,683.2233 E 904,525.3788	N 644,054.5442 E 904,447.3329	10001 PG 018

VAULT CURVE DATA TABLE								
CURVE NO.	RADIUS	CURVE LENGTH	TANGENT LENGTH	DEFLECTION ANGLE	POINT OF INTERSECTION	POINT OF CURVATURE	POINT OF TANGENCY	SHEET REFERENCE
PI-M4901-1	200'	85.86'	43.60'	24° 35' 54.51"	N 635,656.8363 E 901,707.7124	N 635,640.2930 E 901,667.3683	N 635,688.6718 E 901,737.5090	10001 PG 003
PI-M4901-2	150'	75.34'	38.48'	28° 46' 40.41"	N 635,716.7679 E 901,763.8057	N 635,688.6718 E 901,737.5090	N 635,728.7343 E 901,800.3805	10001 PG 003
PI-M4901-3	200'	44.82'	22.50'	12° 50' 18.80"	N 635,752.2751 E 901,872.3319	N 635,745.2781 E 901,850.9457	N 635,763.8494 E 901,891.6287	10001 PG 003
PI-M4901-4	200'	44.82'	22.50'	12° 50' 18.80"	N 635,775.4236 E 901,910.9255	N 635,763.8494 E 901,891.6287	N 635,782.4207 E 901,932.3116	10001 PG 003
PI-M5802-1	400'	32.74'	16.38'	4° 41' 24.34"	N 637,047.8475 E 902,376.4993	N 637,031.6223 E 902,374.2481	N 637,063.8344 E 902,380.0696	10001 PG 006
PI-M5802-2	202'	29.59'	14.82'	8° 23' 29.60"	N 637,078.2971 E 902,383.2995	N 637,063.8344 E 902,380.0696	N 637,093.0763 E 902,384.3843	10001 PG 006
PI-M5803-1	200'	44.70'	22.44'	12° 48' 20.75"	N 638,558.8738 E 902,453.5797	N 638,538.1459 E 902,462.1866	N 638,580.9938 E 902,449.7812	10001 PG 008
PI-M5803-2	202'	45.16'	22.67'	12° 48' 33.09"	N 638,603.3411 E 902,445.9437	N 638,580.9938 E 902,449.7812	N 638,624.2814 E 902,437.2472	10001 PG 008
PI-M4905-1	100'	172.32'	116.53'	98° 43' 54.79"	N 641,538.7022 E 903,139.6692	N 641,542.1464 E 903,130.1729	N 641,498.9696 E 903,249.2182	10001 PG 013

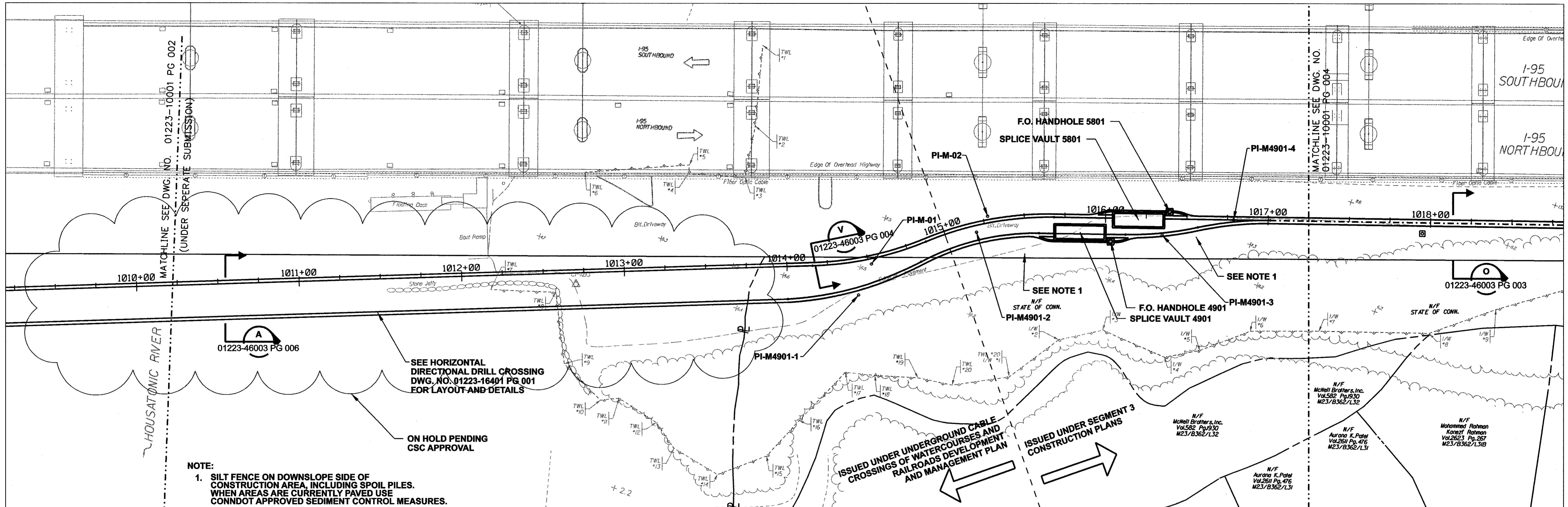

NOTE:
 1. SILT FENCE ON DOWNSLOPE SIDE OF CONSTRUCTION AREA, INCLUDING SPOIL PILES. WHEN AREAS ARE CURRENTLY PAVED USE CONNDOT APPROVED SEDIMENT CONTROL MEASURES.

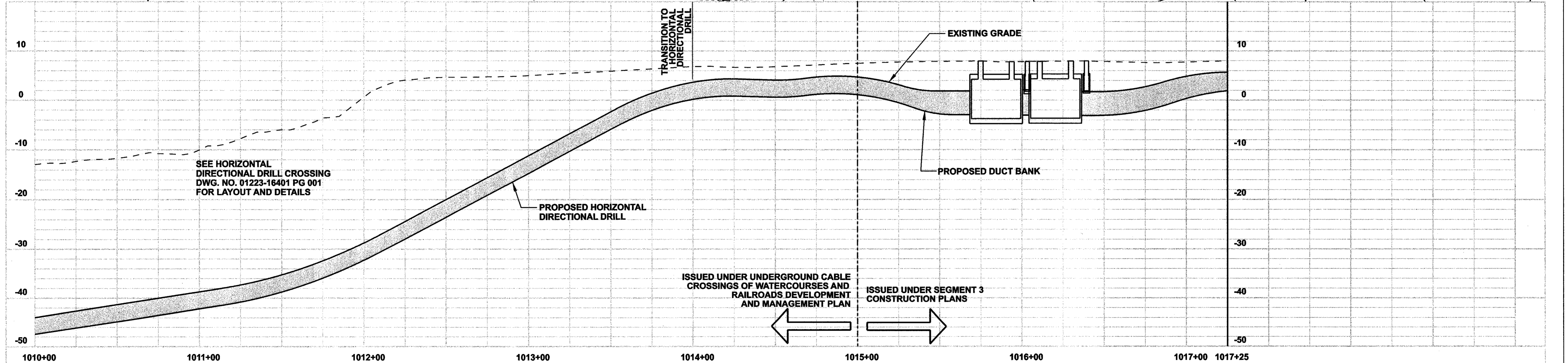

COPYRIGHT © 2006 BURNS & MCDONNELL ENGINEERING COMPANY, INC.

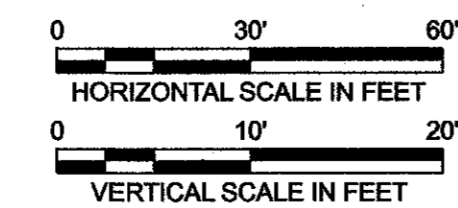
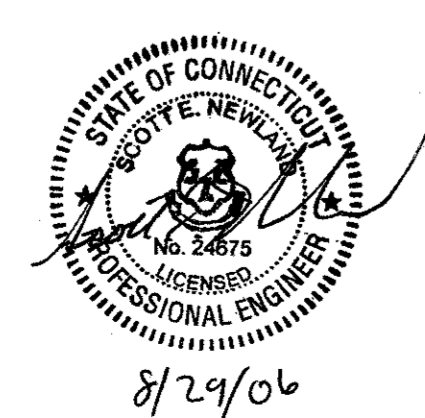
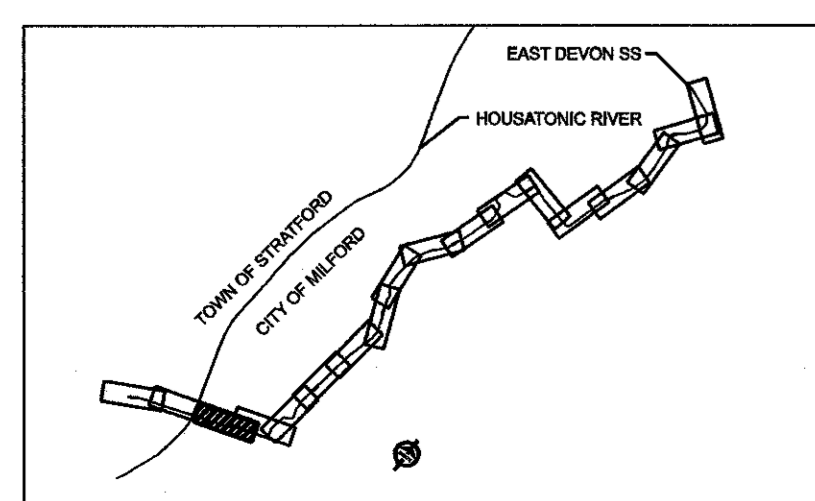

ISSUED FOR CONSTRUCTION

DOCKET No. 272

no.	date	revisions	by	chk
1	8/29/06	ISSUED FOR CONSTRUCTION	CTC	

Burns & McDonnell
SINCE 1898

date 10/11/05
 designed C. COURTRIGHT
 detailed L. ROWSE
 checked S. NEWLAND

MF	NO.	DATE	REVISIONS	BY	CHK	APP	APP

NORTHEAST UTILITIES SERVICE CO.

FOR THE CONNECTICUT LIGHT & POWER COMPANY

TITLE MIDDLETOWN-NORWALK 345KV TRANSMISSION PROJECT

CITY OF MILFORD
 PLAN AND PROFILE Sta. 1010+00 to 1017+25

BY SEN-BMCD	CHKD	APP	APP
DATE 10-11-05	DATE	DATE	DATE
SCALE AS NOTED		DWC. NO.	
	D	01223-10001 PG 003	

NOTE:

1. SILT FENCE ON DOWNSLOPE SIDE OF CONSTRUCTION AREA, INCLUDING SPOIL PILES. WHEN AREAS ARE CURRENTLY PAVED USE CONNDOT APPROVED SEDIMENT CONTROL MEASURES.

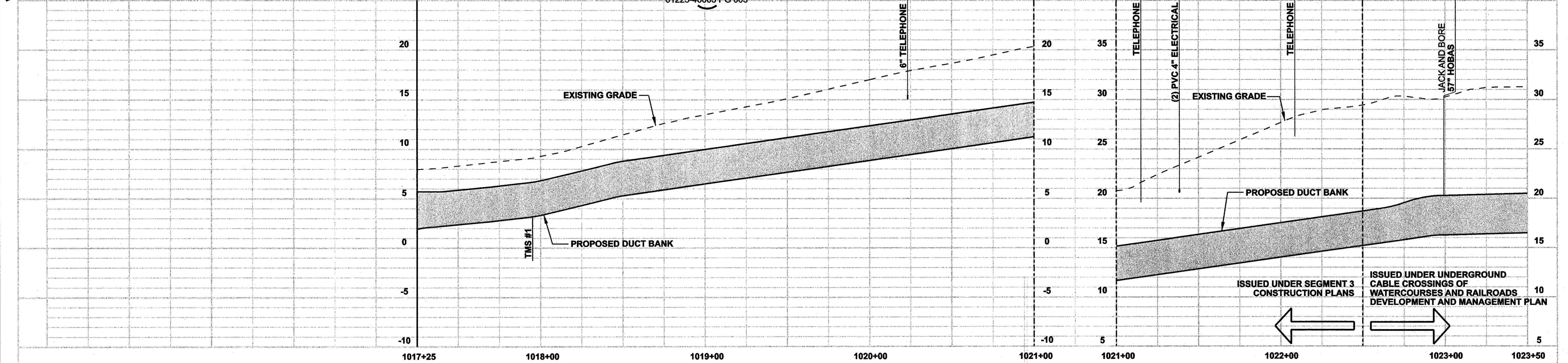
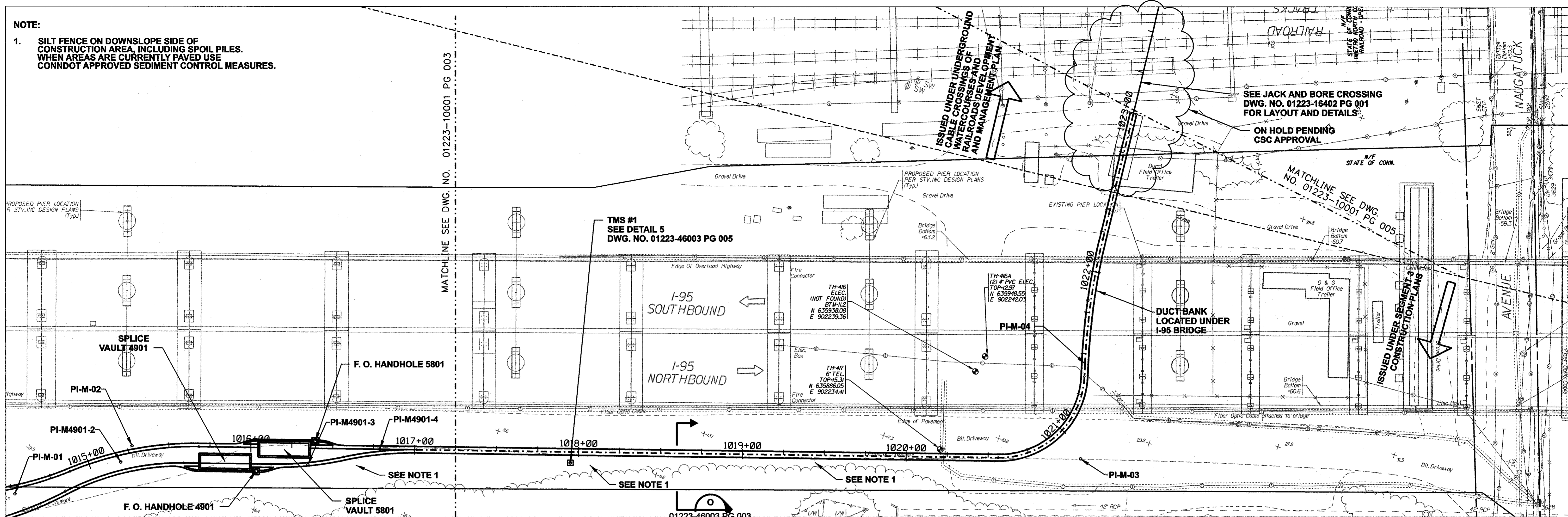

COPYRIGHT © 2008 BURNS & MCDONNELL ENGINEERING COMPANY, INC.

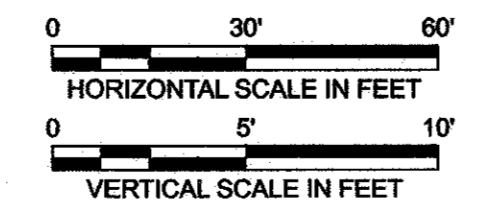
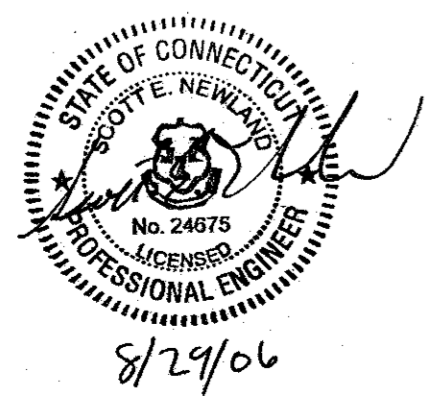
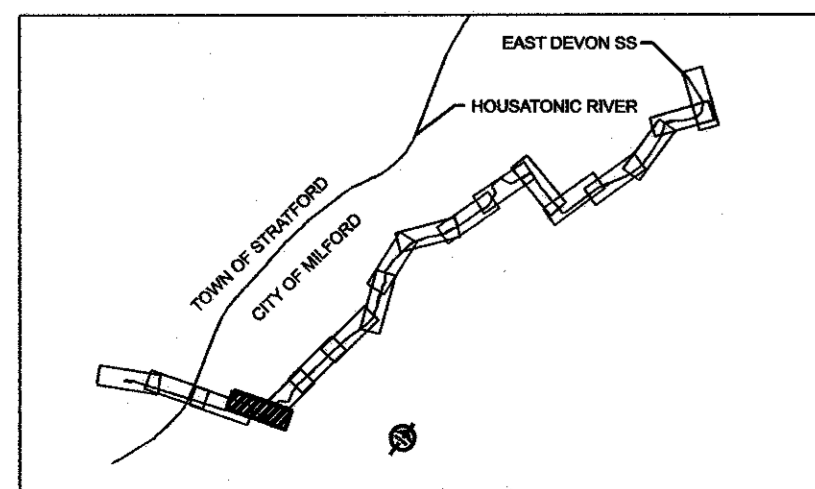

ISSUED FOR CONSTRUCTION

DOCKET No. 272

no.	date	revisions	by	chk
1	8/29/06	ISSUED FOR CONSTRUCTION	CTC	

Burns & McDonnell
SINCE 1898

date: 10/11/05
designed: C. COURTRIGHT
detailed: L. ROWSE
checked: S. NEWLAND

MF NO.	DATE	REVISIONS	BY	CHK	APP	APP

NORTHEAST UTILITIES SERVICE CO.

FOR THE CONNECTICUT LIGHT & POWER COMPANY

TITLE: MIDDLETOWN-NORWALK 345KV TRANSMISSION PROJECT

CITY OF MILFORD
PLAN AND PROFILE Sta. 1017+25 to 1023+50

BY SEN-BMCD	CHKD	APP	APP
DATE 10-11-05	DATE	DATE	DATE
SCALE AS NOTED		DWG. NO.	01223-10001 PG 004

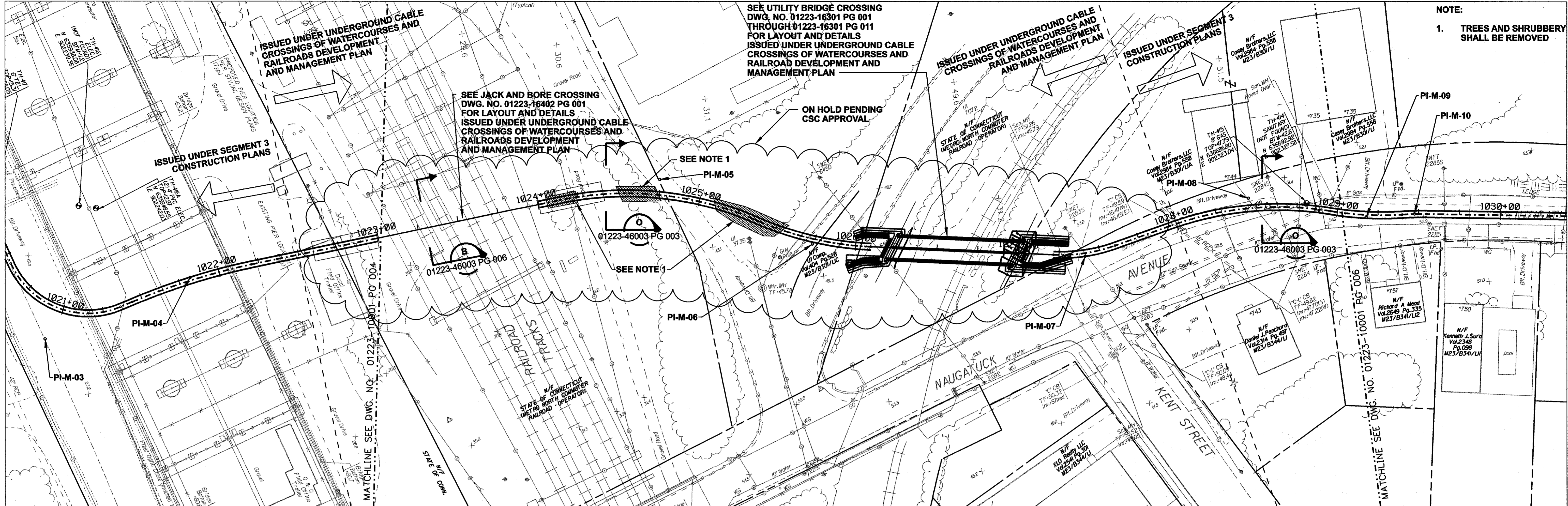

NOTE:
1. TREES AND SHRUBBERY SHALL BE REMOVED

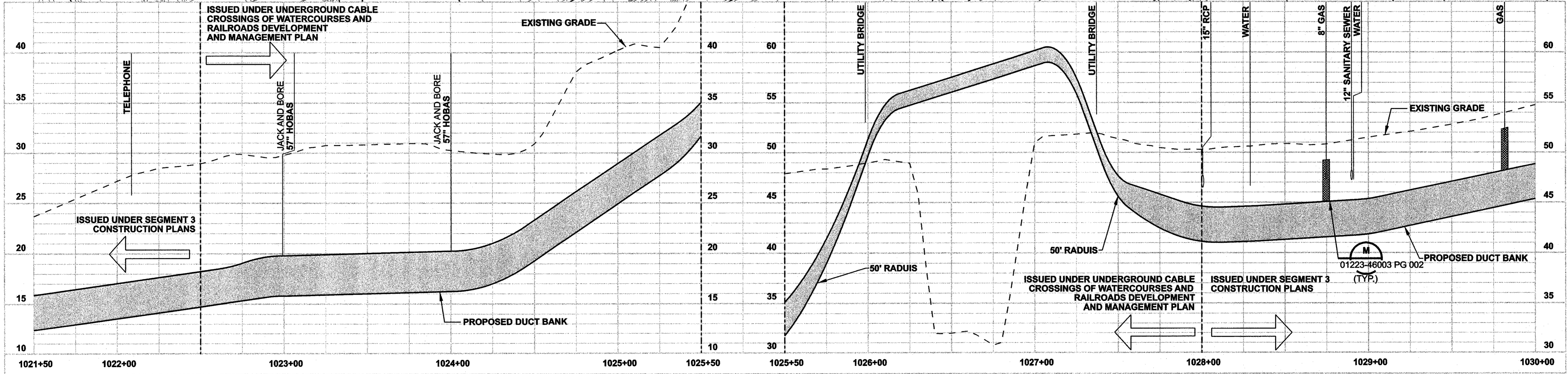

COPYRIGHT © 2008 BURNS & MCDONNELL ENGINEERING COMPANY, INC.

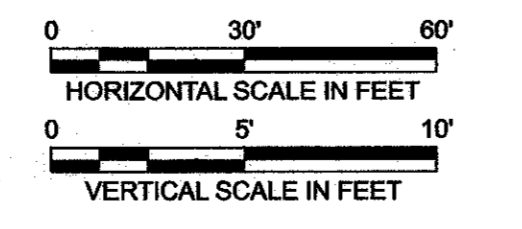
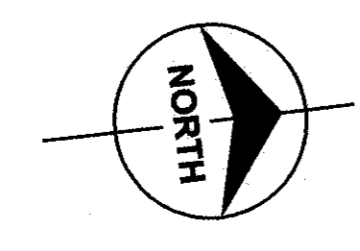
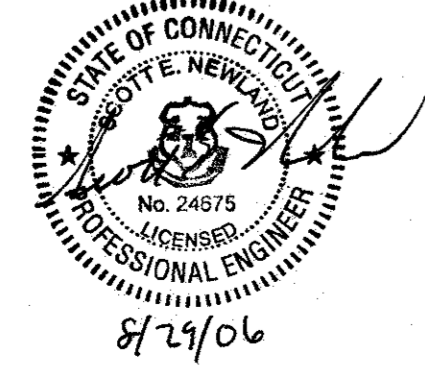
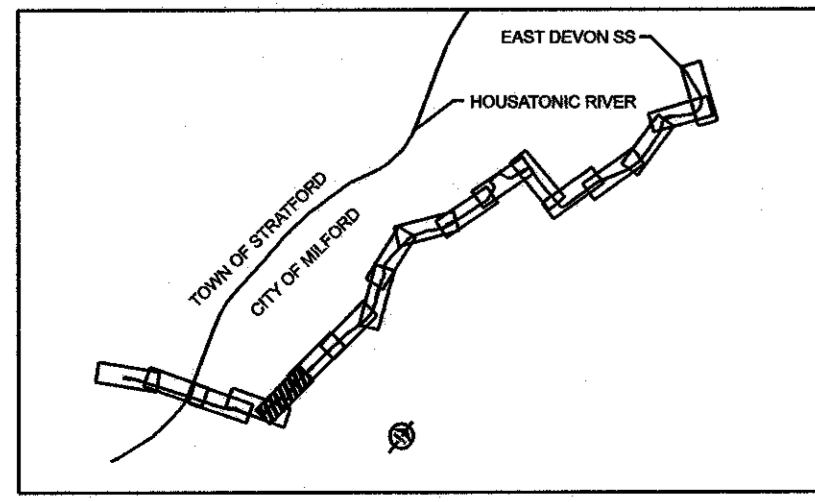

ISSUED FOR CONSTRUCTION

DOCKET No. 272

1	8/29/06	ISSUED FOR CONSTRUCTION	CTC
no.	date	revisions	by

Burns & McDonnell
SINCE 1898

date 10/11/05
designed C. COURTRIGHT
detailed L. ROWSE
checked S. NEWLAND

MF NO.	DATE	REVISIONS	BY	CHK	APP	APP

NORTHEAST UTILITIES SERVICE CO.

FOR THE CONNECTICUT LIGHT & POWER COMPANY

TITLE MIDDLETOWN-NORWALK 345KV TRANSMISSION PROJECT

CITY OF MILFORD
PLAN AND PROFILE Sta. 1021+50 to 1030+00

BY SEN-BMCD	CHKD	APP	APP
DATE 10-11-05	DATE	DATE	DATE
SCALE AS NOTED	D	DWG. NO.	01223-10001 PG 005

COPYRIGHT © 2006 BURNS & MCDONNELL ENGINEERING COMPANY, INC.

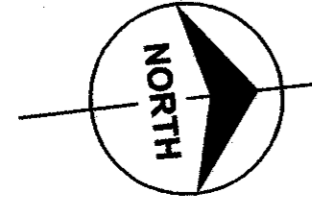
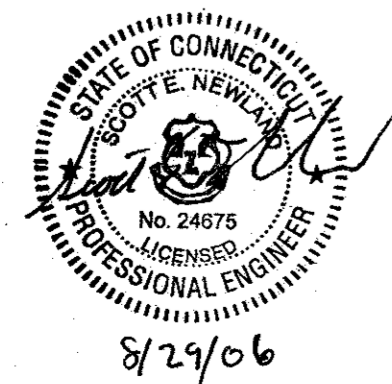
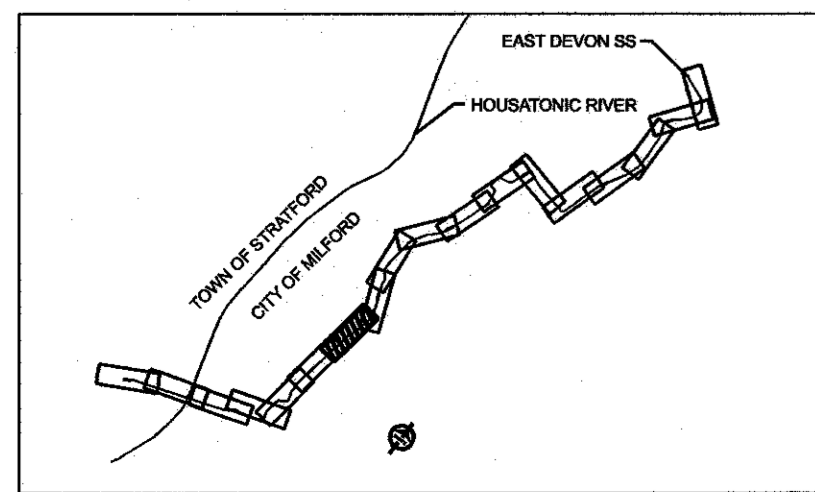
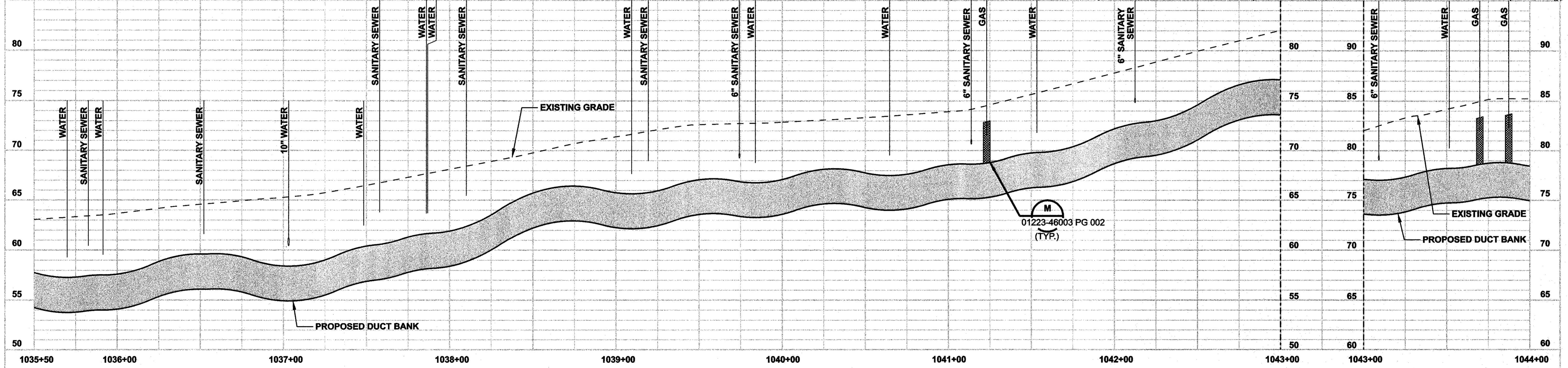
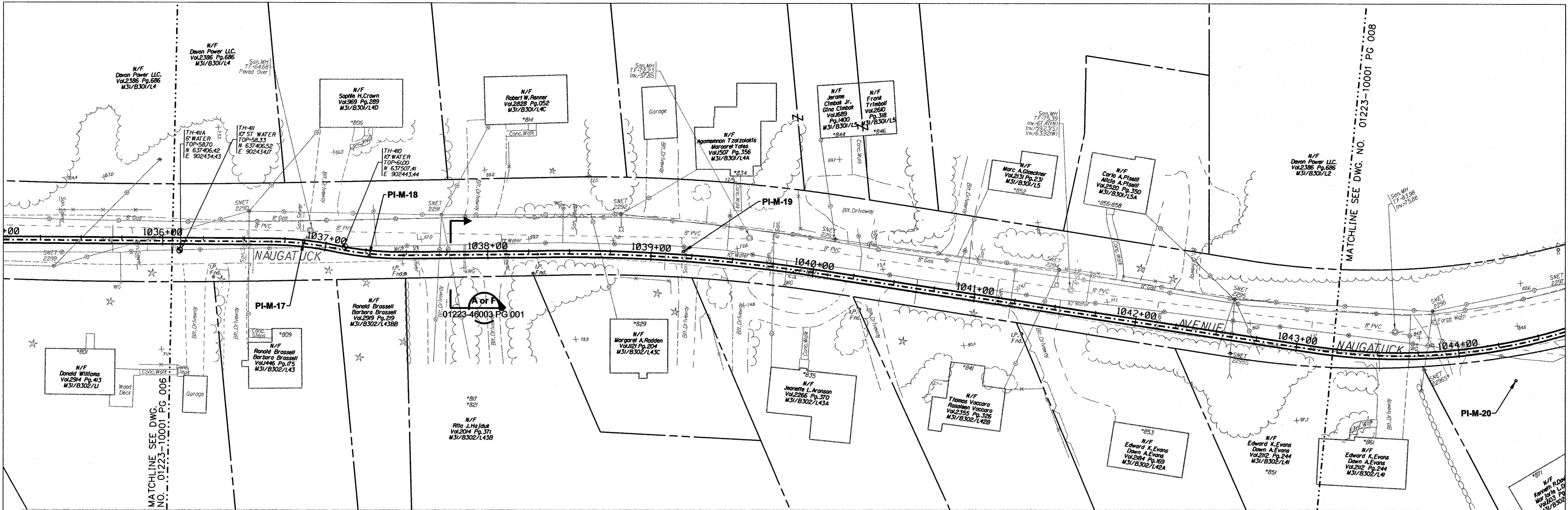

DOCKET No. 272

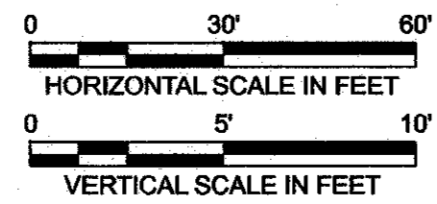

**ISSUED FOR
CONSTRUCTION**

no.	date	revisions	by	chk
1	8/29/06	ISSUED FOR CONSTRUCTION	CTC	

date 10/11/05
designed C. COURTRIGHT

detailed L. ROWSE
checked S. NEWLAND

MF	NO.	DATE	REVISIONS	BY	CHK	APP	APP

NORTHEAST UTILITIES SERVICE CO.

FOR THE CONNECTICUT LIGHT & POWER COMPANY

TITLE MIDDLETOWN-NORWALK 345KV TRANSMISSION PROJECT

CITY OF MILFORD
PLAN AND PROFILE Sta. 1035+50 to 1044+00

BY SEN-EMCD	CHKD	APP	APP
DATE 10-11-05	DATE	DATE	DATE
SCALE AS NOTED		DWG. NO.	01223-10001 PG 007

NOTE:
 1. SILT FENCE ON DOWNSLOPE SIDE OF CONSTRUCTION AREA, INCLUDING SPOIL PILES. WHEN AREAS ARE CURRENTLY PAVED USE CONDOT APPROVED SEDIMENT CONTROL MEASURES.
 2. TREES AND SHRUBBERY SHALL BE REMOVED

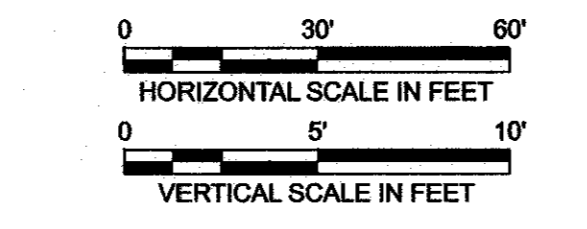
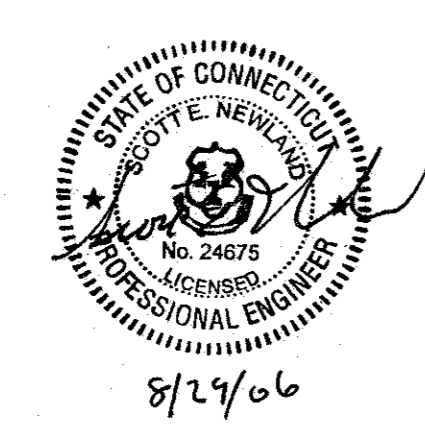
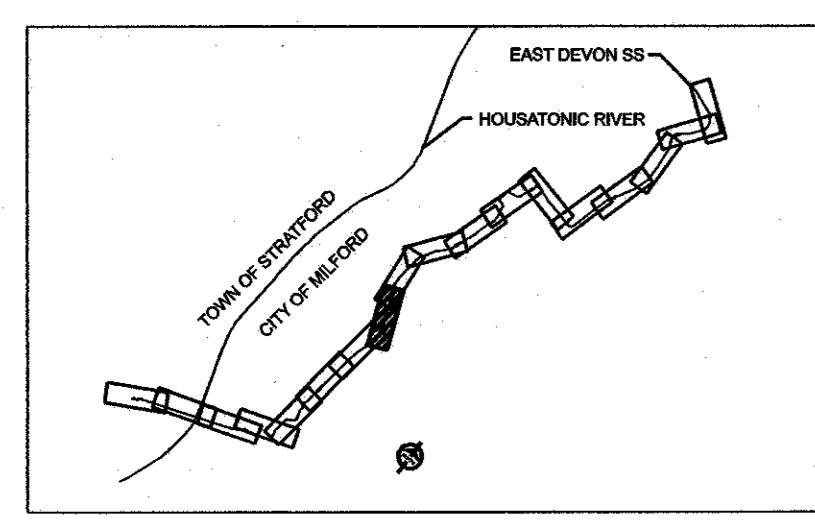
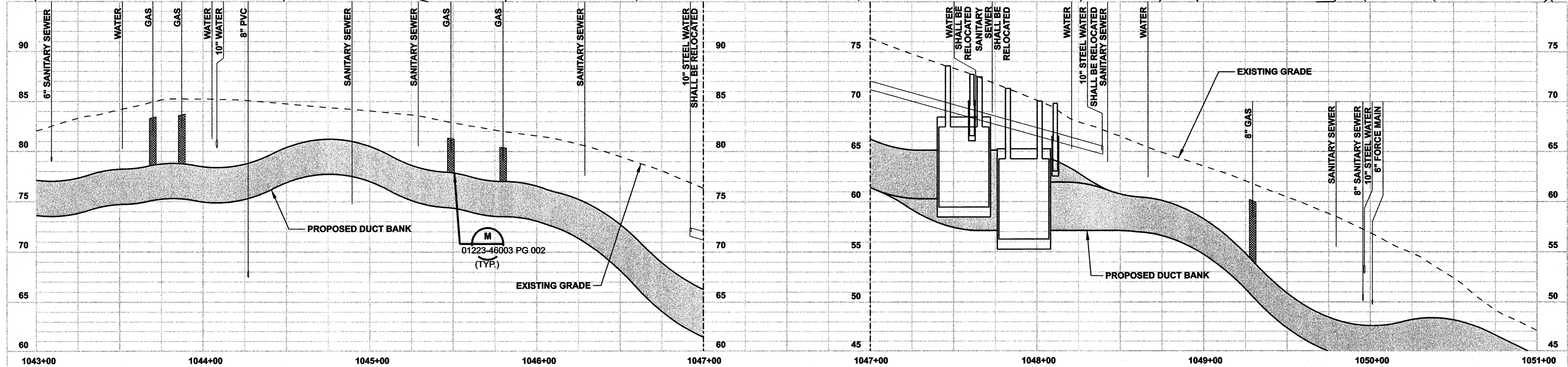
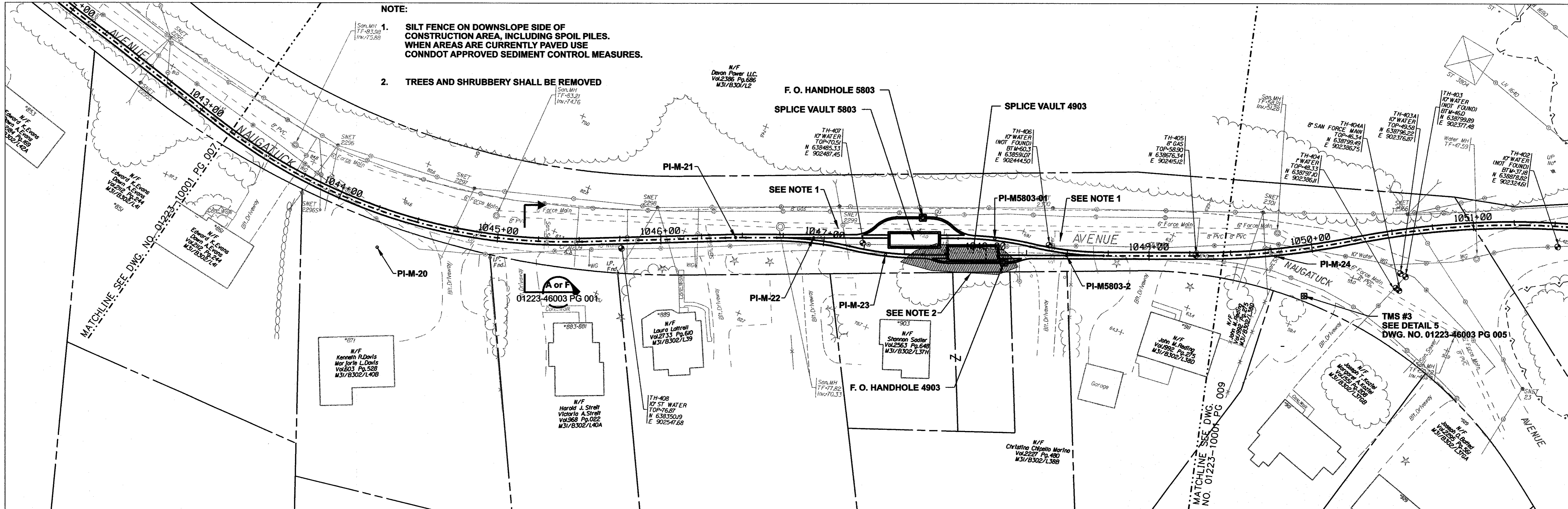

ISSUED FOR CONSTRUCTION



date 10/11/05
 designed C. COURTRIGHT
 detailed L. ROWSE
 checked S. NEWLAND

no.	date	revisions	by	chk
1	8/29/06	ISSUED FOR CONSTRUCTION	CTC	

MF	NO.	DATE	REVISIONS	BY	CHK	APP	APP

NORTHEAST UTILITIES SERVICE CO.
 FOR THE CONNECTICUT LIGHT & POWER COMPANY
 TITLE MIDDLETOWN-NORWALK 345KV TRANSMISSION PROJECT
 CITY OF MILFORD
 PLAN AND PROFILE Sta. 1043+00 to 1051+00

BY SEN-BMCD	CHKD	APP	APP
DATE 10-11-05	DATE	DATE	DATE
SCALE AS NOTED	D	DWG. NO.	01223-10001 PG 008

COPYRIGHT © 2006 BURNS & MCDONNELL ENGINEERING COMPANY, INC.

NOTE:
1. TREES AND SHRUBBERY SHALL BE REMOVED

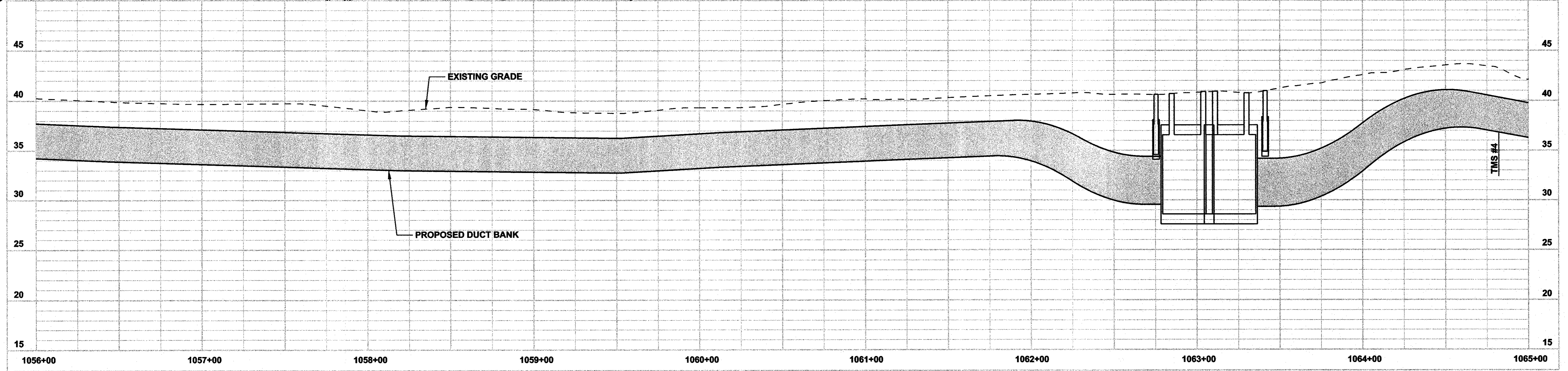
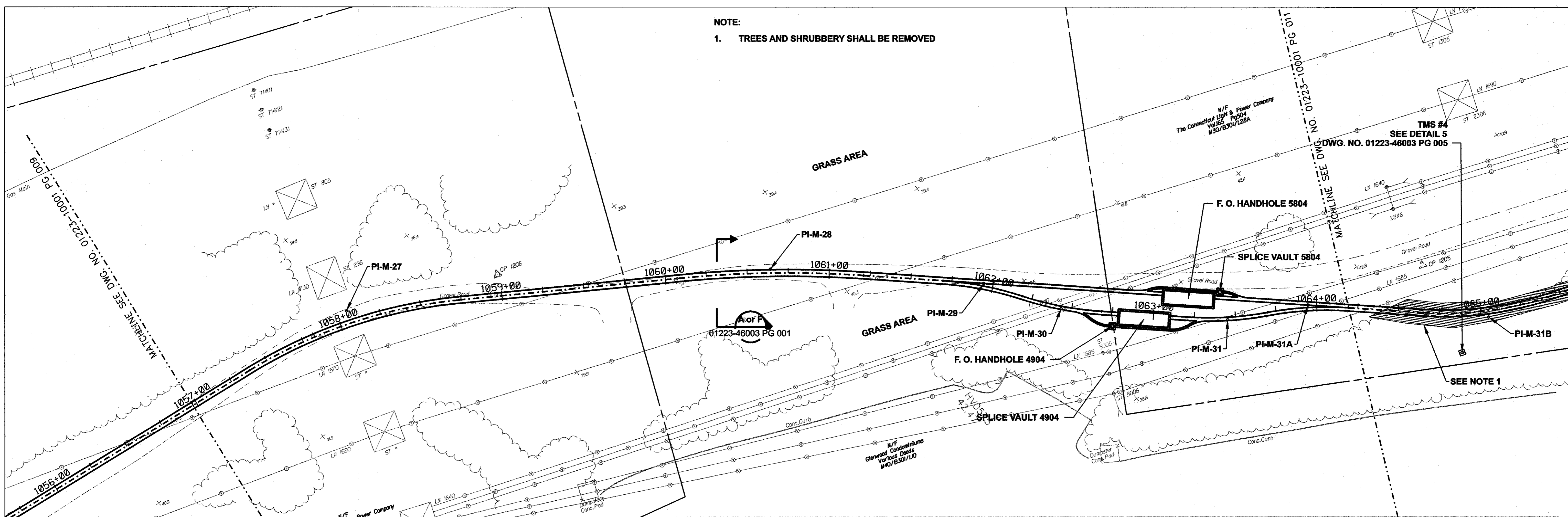

COPYRIGHT © 2006 BURNS & MCDONNELL ENGINEERING COMPANY, INC.

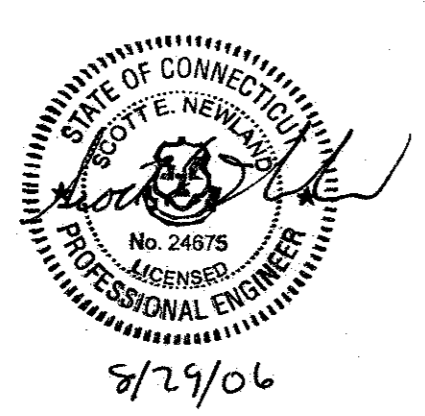
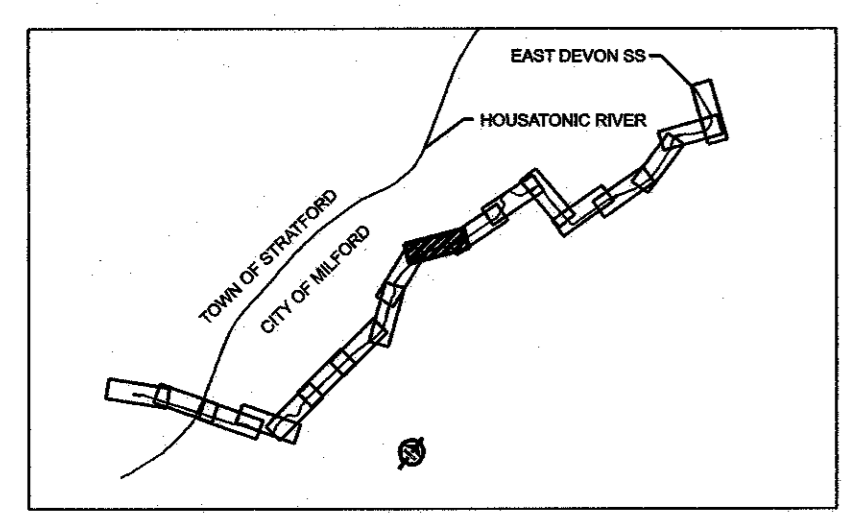

DOCKET No. 272

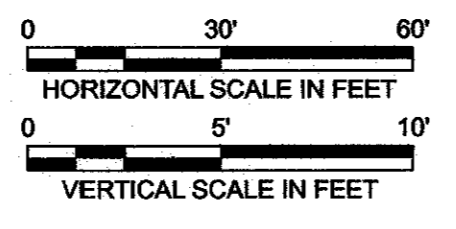

ISSUED FOR CONSTRUCTION

no.	date	revisions	by	chk
1	8/29/06	ISSUED FOR CONSTRUCTION	CTC	

		date	10/11/05	detailed	L. ROWSE
		designed	C. COURTRIGHT	checked	S. NEWLAND

MF	NO.	DATE	REVISIONS	BY	CHK	APP	APP

NORTHEAST UTILITIES SERVICE CO.			
FOR THE CONNECTICUT LIGHT & POWER COMPANY			
TITLE MIDDLETOWN-NORWALK 345KV TRANSMISSION PROJECT			
CITY OF MILFORD PLAN AND PROFILE Sta. 1056+00 to 1065+00			
BY SEN-BMCD	CHKD	APP	APP
DATE 10-11-05	DATE	DATE	DATE
SCALE AS NOTED	D		DWG. NO. 01223-10001 PG 010

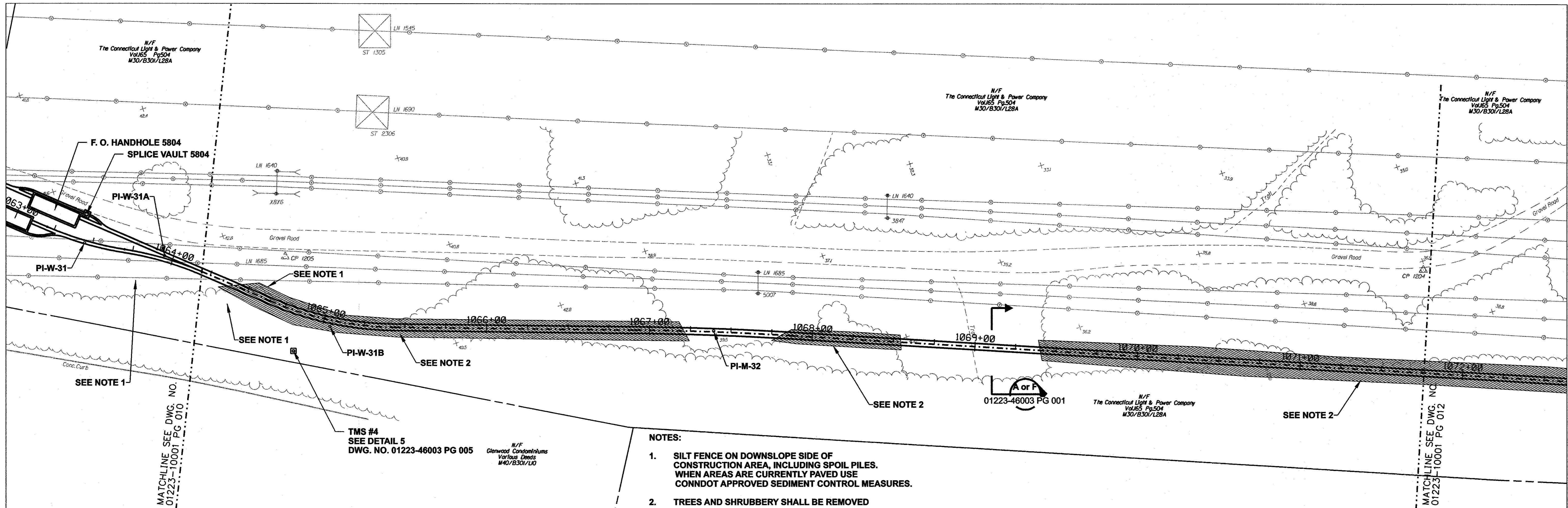

- NOTES:**
1. SILT FENCE ON DOWNSLOPE SIDE OF CONSTRUCTION AREA, INCLUDING SPOIL PILES. WHEN AREAS ARE CURRENTLY PAVED USE CONNDOT APPROVED SEDIMENT CONTROL MEASURES.
 2. TREES AND SHRUBBERY SHALL BE REMOVED

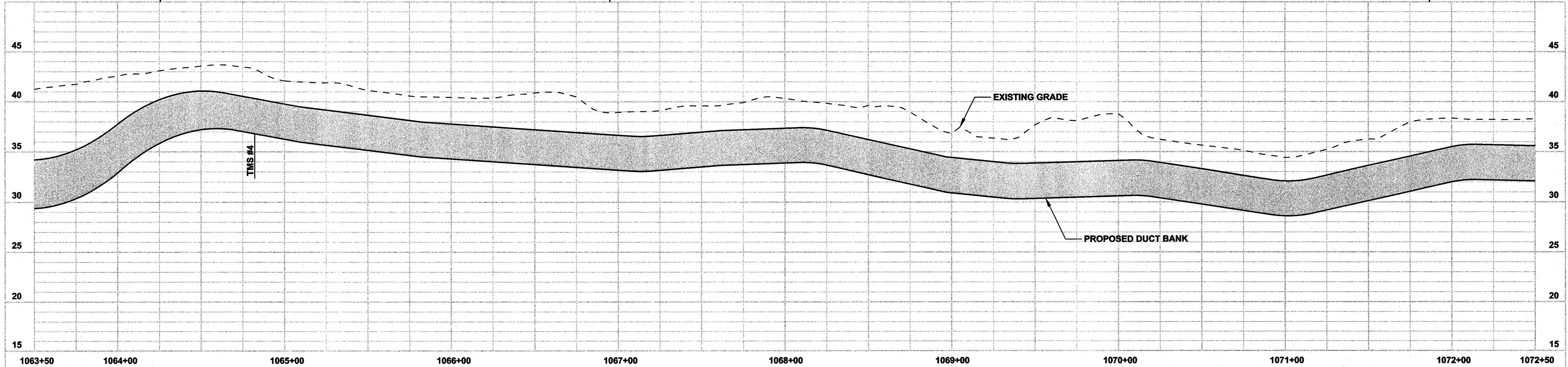

COPYRIGHT © 2006 BURNS & MCDONNELL ENGINEERING COMPANY, INC.

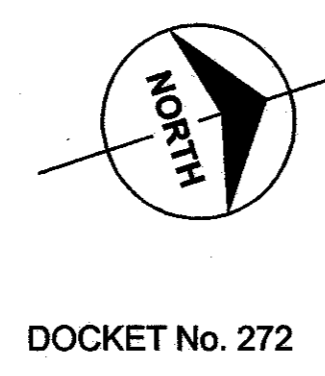
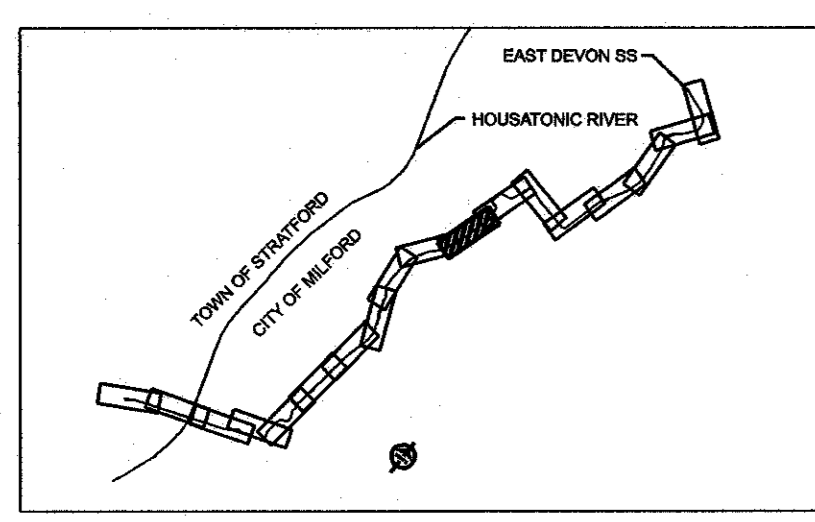

0 30' 60'
HORIZONTAL SCALE IN FEET
0 5' 10'
VERTICAL SCALE IN FEET

ISSUED FOR CONSTRUCTION

no.	date	revisions	by	chk
1	8/29/06	ISSUED FOR CONSTRUCTION	CTC	

Burns & McDonnell
SINCE 1898

date 10/11/05
designed C. COURTRIGHT
detailed L. ROWSE
checked S. NEWLAND

MF NO.	DATE	REVISIONS	BY	CHK	APP	APP

NORTHEAST UTILITIES SERVICE CO.

FOR THE CONNECTICUT LIGHT & POWER COMPANY

TITLE MIDDLETOWN-NORWALK 345KV TRANSMISSION PROJECT

CITY OF MILFORD
PLAN AND PROFILE Sta. 1063+50 to 1072+50

BY SEN-BMCD	CHKD	APP	APP
DATE 10-11-05	DATE	DATE	DATE
SCALE AS NOTED	D	DWG. NO. 01223-10001 PG 011	

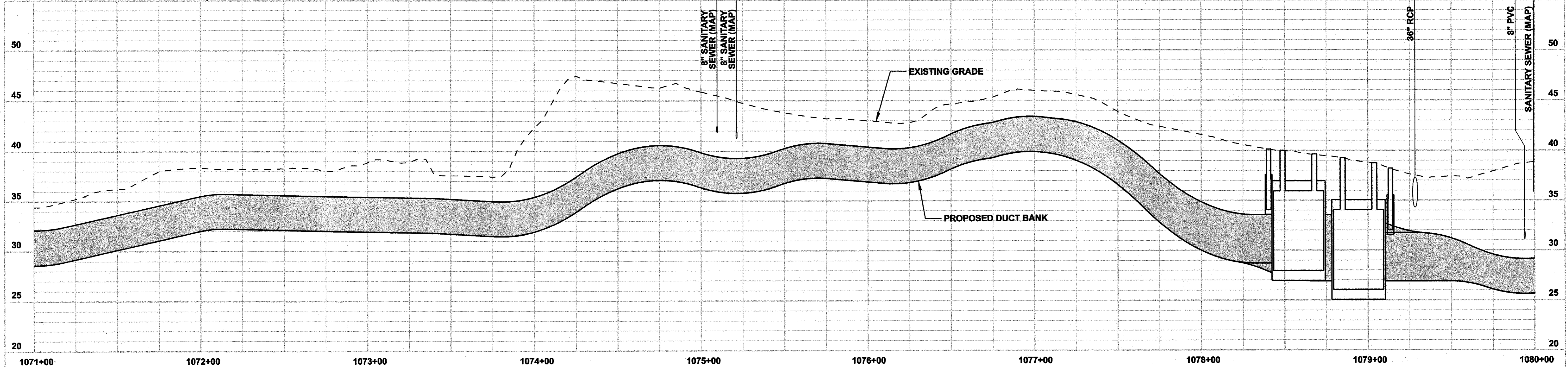
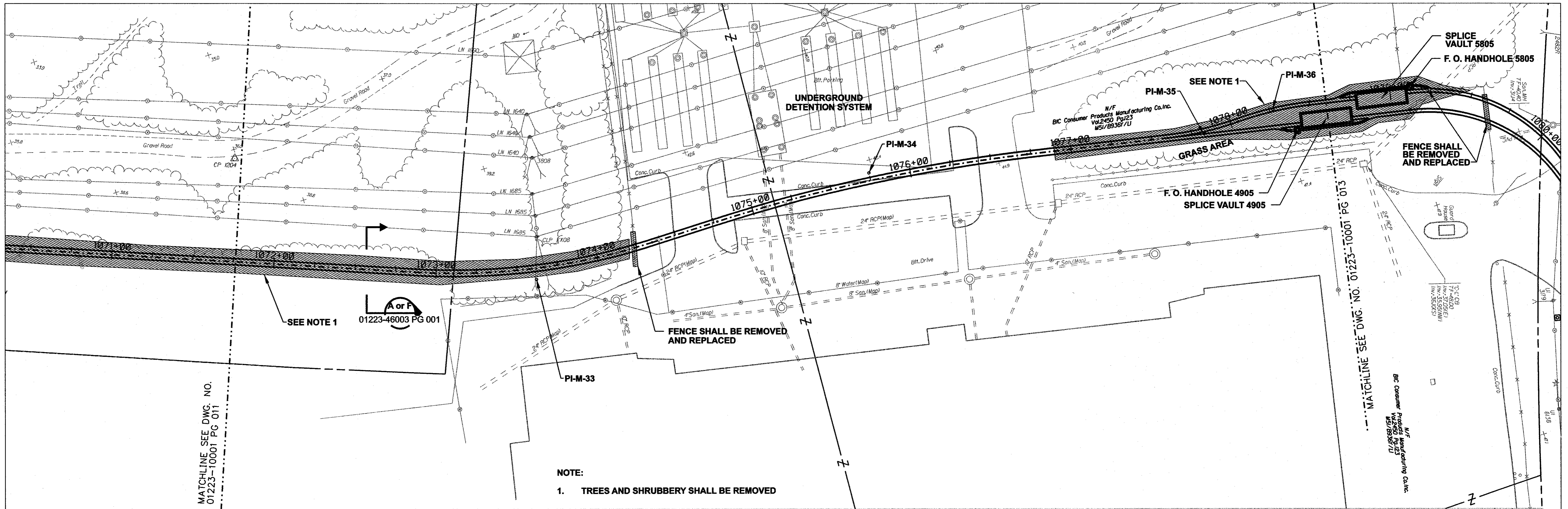

COPYRIGHT © 2006 BURNS & MCDONNELL ENGINEERING COMPANY, INC.

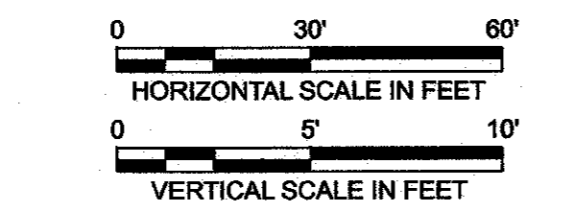
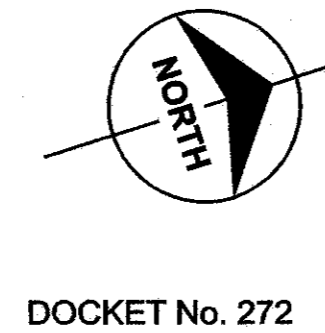
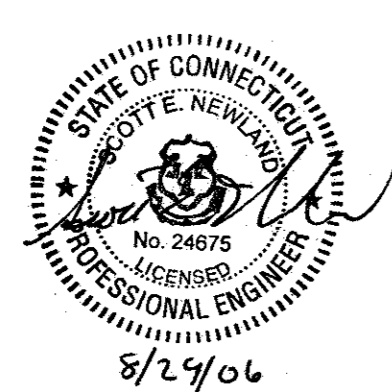
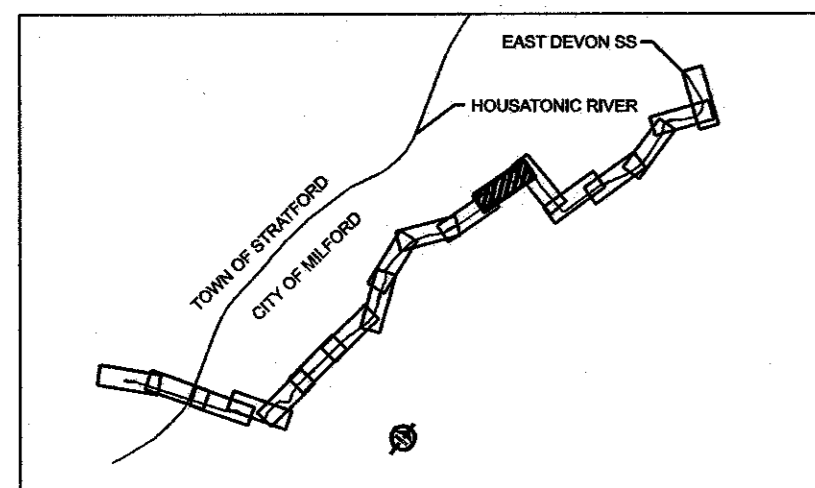

ISSUED FOR CONSTRUCTION

no.	date	revisions	by	chk
1	8/29/06	ISSUED FOR CONSTRUCTION	CTC	

Burns & McDonnell
SINCE 1898

date: 10/11/05
designed: C. COURTRIGHT
detailed: L. ROWSE
checked: S. NEWLAND

MF NO.	DATE	REVISIONS	BY	CHK	APP	APP

NORTHEAST UTILITIES SERVICE CO.

FOR: THE CONNECTICUT LIGHT & POWER COMPANY

TITLE: MIDDLETOWN-NORWALK 345KV TRANSMISSION PROJECT

CITY OF MILFORD
PLAN AND PROFILE Sta. 1071+00 to 1080+00

DATE 10-11-05	DATE	DATE	DATE
SCALE AS NOTED	D	DWG. NO. 01223-10001 PG 012	

- NOTES:**
1. SILT FENCE ON DOWNSLOPE SIDE OF CONSTRUCTION AREA, INCLUDING SPOIL PILES. WHEN AREAS ARE CURRENTLY PAVED USE CONDOT APPROVED SEDIMENT CONTROL MEASURES.
 2. TREES AND SHRUBBERY SHALL BE REMOVED

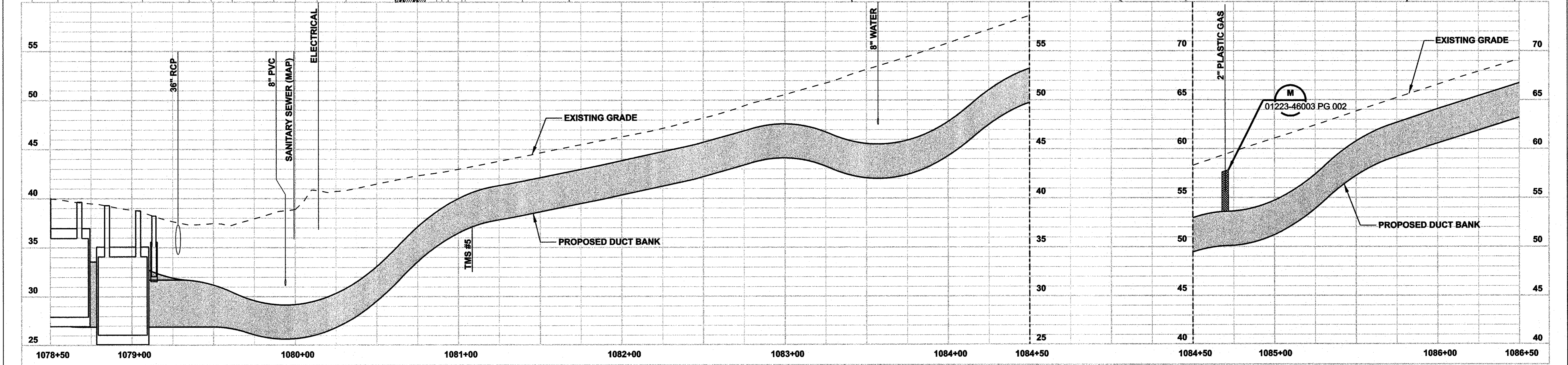
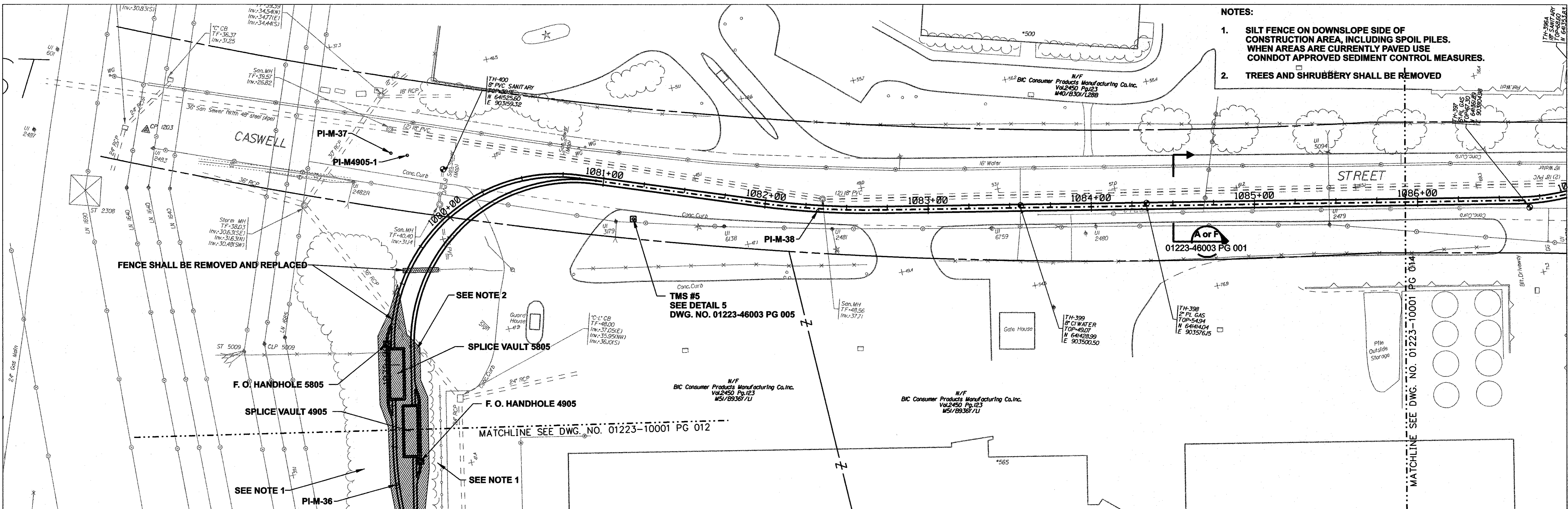

COPYRIGHT © 2006 BURNS & MCDONNELL ENGINEERING COMPANY, INC.

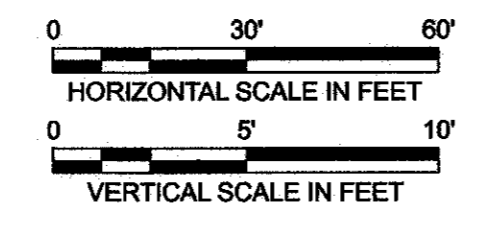
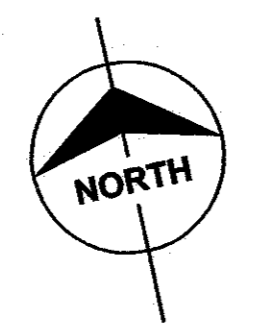
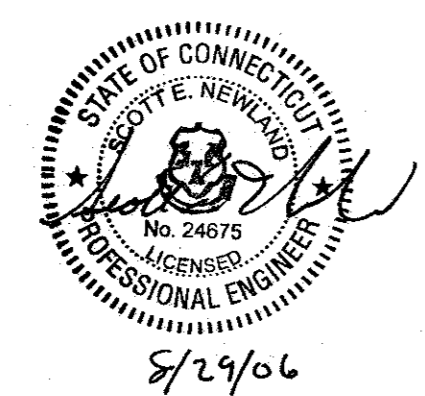
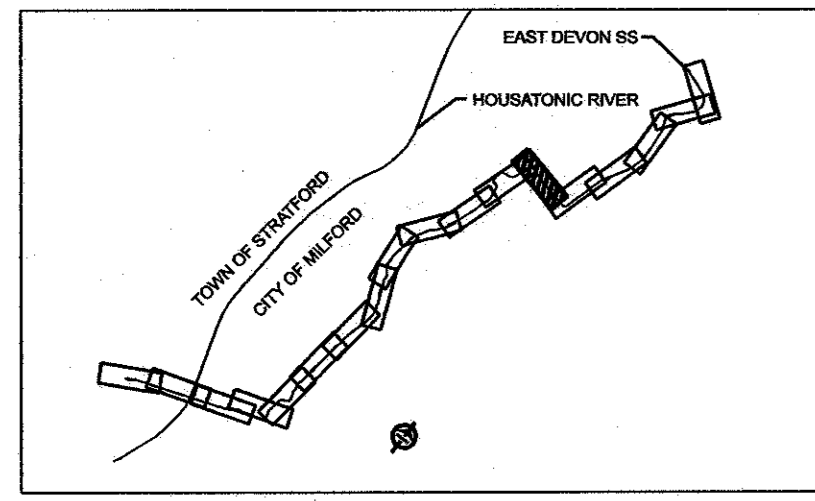

ISSUED FOR CONSTRUCTION

DOCKET No. 272

1	8/29/06	ISSUED FOR CONSTRUCTION	CTC	
no.	date	revisions	by	chk

Burns & McDonnell
SINCE 1898

date: 10/11/05
designed: C. COURTRIGHT
detailed: L. ROWSE
checked: S. NEWLAND

MF NO.	DATE	REVISIONS	BY	CHK	APP	APP

NORTHEAST UTILITIES SERVICE CO.

FOR THE CONNECTICUT LIGHT & POWER COMPANY

TITLE: MIDDLETOWN-NORWALK 345KV TRANSMISSION PROJECT

CITY OF MILFORD
PLAN AND PROFILE Sta. 1078+50 to 1086+50

BY SEN-BMCD	CHKD	APP	APP
DATE 10-11-05	DATE	DATE	DATE
SCALE AS NOTED		DWG. NO.	
	D	01223-10001 PG 013	

NOTE:
1. TREES AND SHRUBBERY SHALL BE REMOVED

MATCHLINE SEE DWG. NO. 01223-10001 PG 013

MATCHLINE SEE DWG. NO. 01223-10001 PG 015

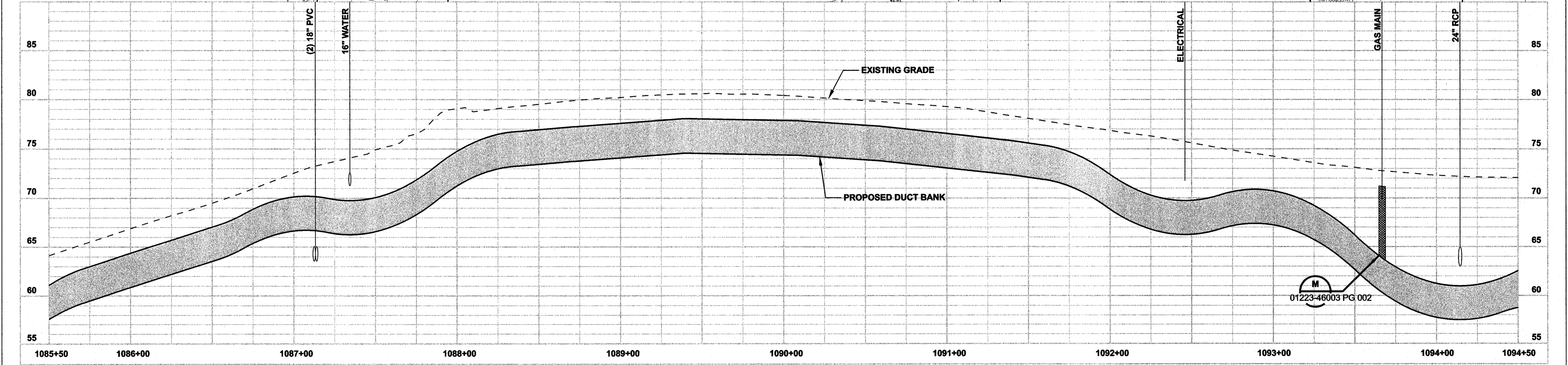
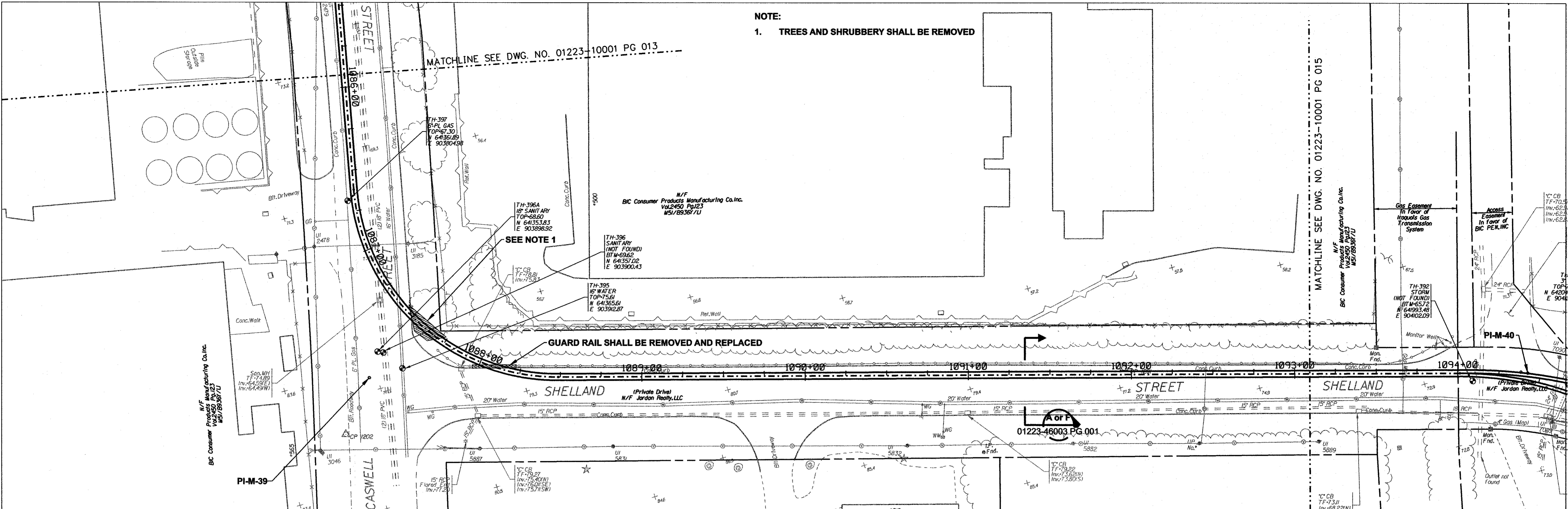

COPYRIGHT © 2008 BURNS & MCDONNELL ENGINEERING COMPANY, INC.

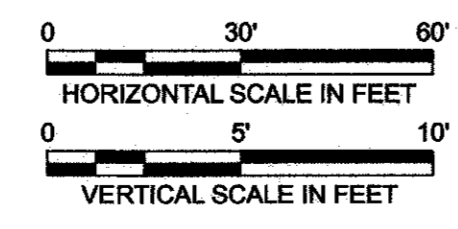
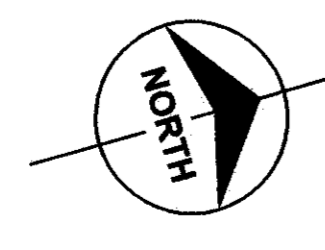
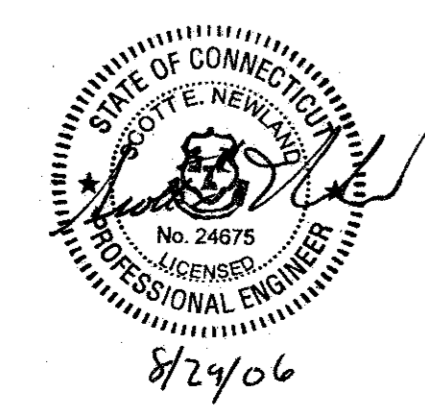
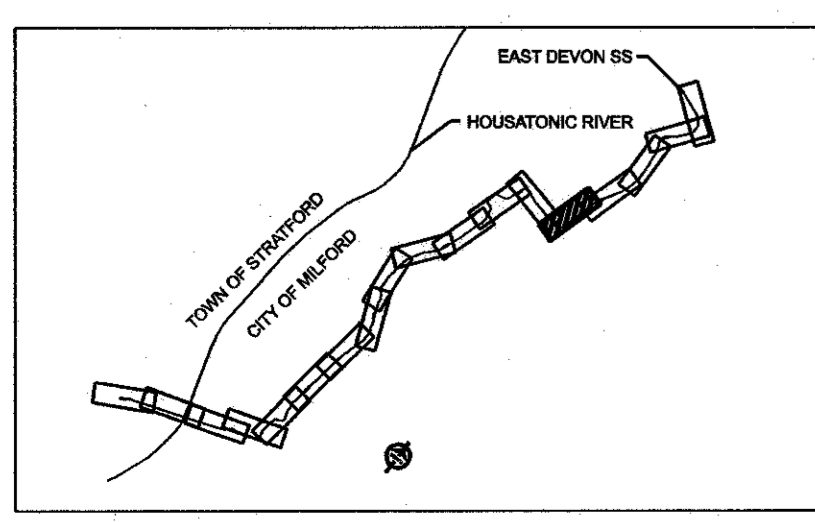

ISSUED FOR CONSTRUCTION

DOCKET No. 272

no.	date	revisions	by	chk
1	8/29/06	ISSUED FOR CONSTRUCTION	CTC	

Burns & McDonnell
SINCE 1898

date: 10/11/05
designed: C. COURTRIGHT
detailed: L. ROWSE
checked: S. NEWLAND

MF NO.	DATE	REVISIONS	BY	CHK	APP	APP

NORTHEAST UTILITIES SERVICE CO.

FOR THE CONNECTICUT LIGHT & POWER COMPANY

TITLE: MIDDLETOWN-NORWALK 345KV TRANSMISSION PROJECT

CITY OF MILFORD
PLAN AND PROFILE Sta. 1085+50 to 1094+50

BY SEN-BMCD	CHKD	APP	APP
DATE 10-11-05	DATE	DATE	DATE
SCALE AS NOTED		DWG. NO.	
	D	01223-10001 PG 014	

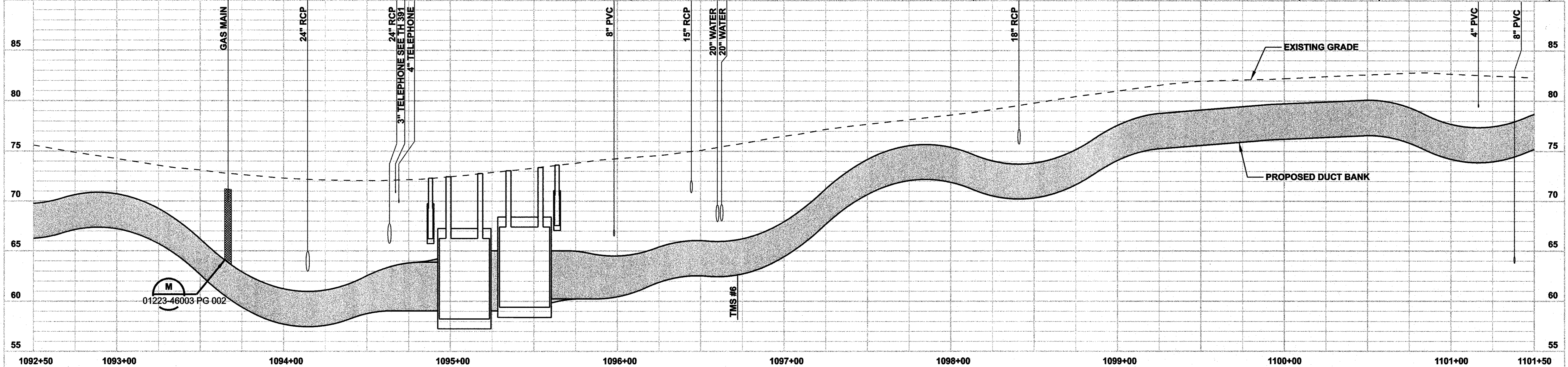
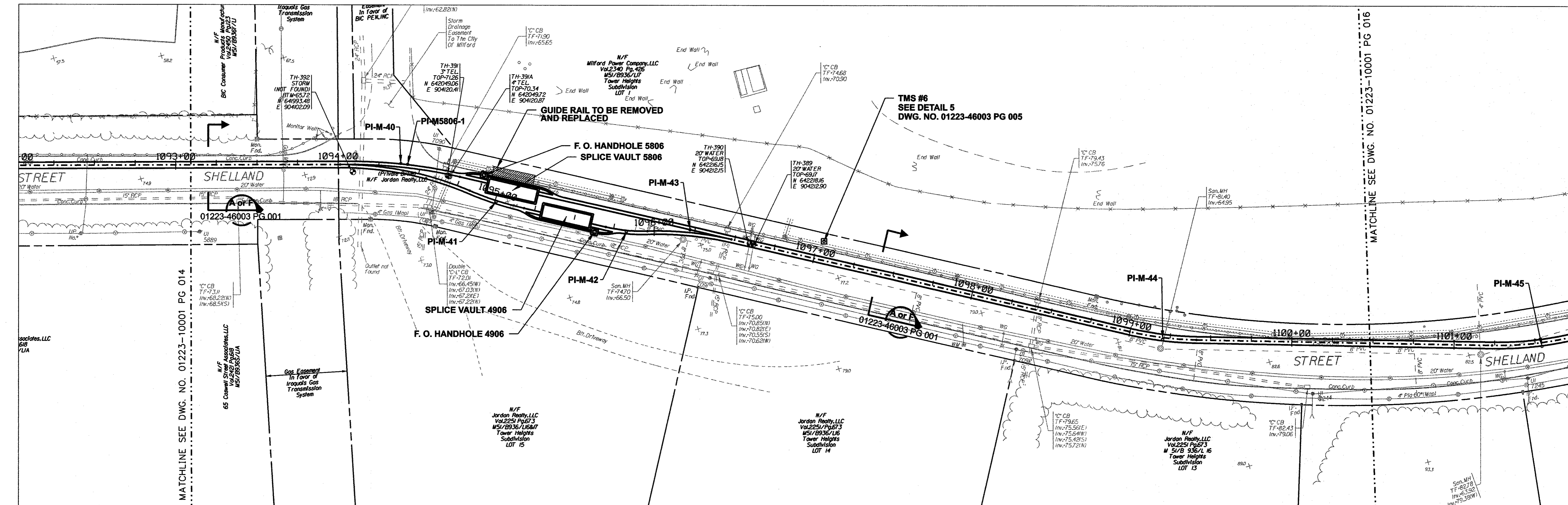

COPYRIGHT © 2006 BURNS & MCDONNELL ENGINEERING COMPANY, INC.

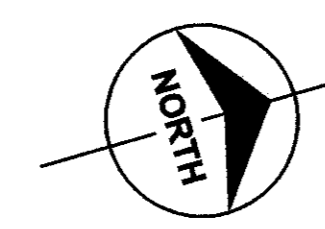
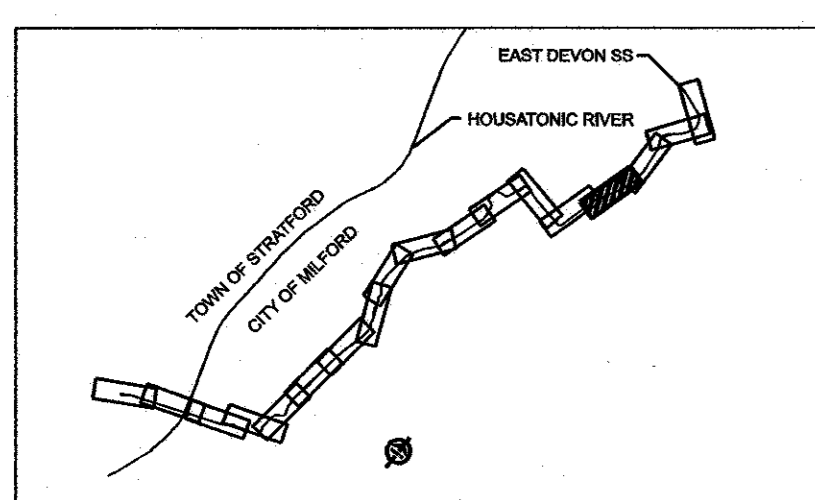

DOCKET No. 272

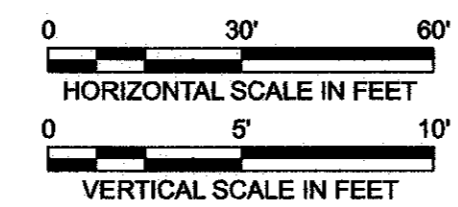

ISSUED FOR CONSTRUCTION

no.	date	revisions	by	chk
1	8/29/06	ISSUED FOR CONSTRUCTION	CTC	



Burns & McDonnell
SINCE 1998

date	10/11/05	detailed	L. ROWSE
designed	C. COURTRIGHT	checked	S. NEWLAND

MF NO.	DATE	REVISIONS	BY	CHK	APP	APP

NORTHEAST UTILITIES SERVICE CO.

FOR THE CONNECTICUT LIGHT & POWER COMPANY

TITLE MIDDLETOWN-NORWALK 345KV TRANSMISSION PROJECT

CITY OF MILFORD
PLAN AND PROFILE Sta. 1092+50 to 1101+50

BY SEN-BMCD	CHKD	APP	APP
DATE 10-11-05	DATE	DATE	DATE
SCALE AS NOTED		DWG. NO.	01223-10001 PG 015

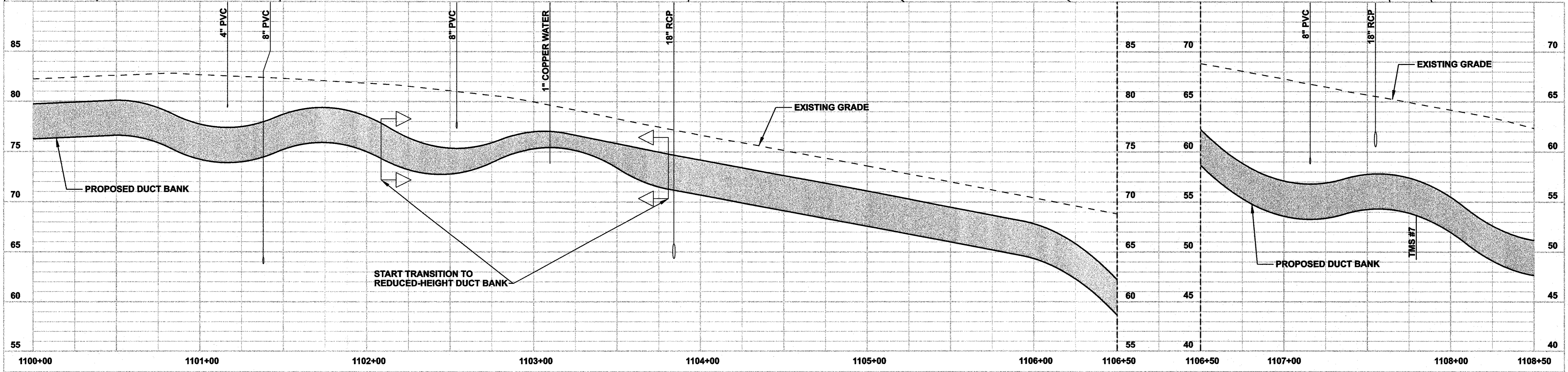
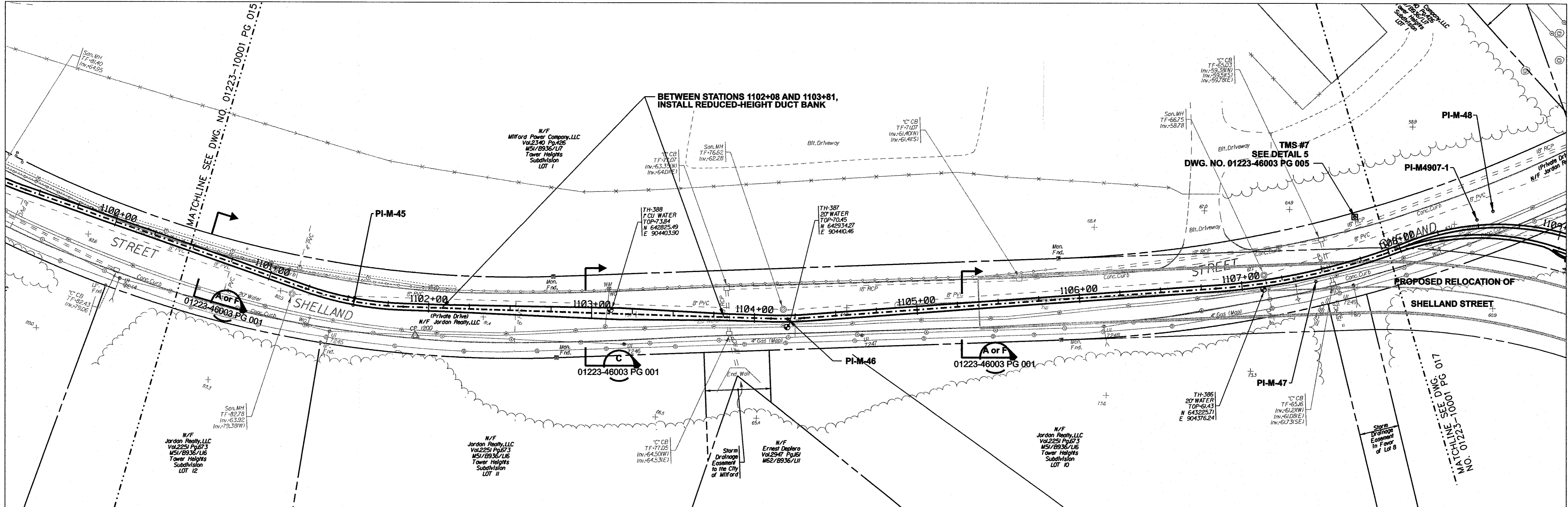

COPYRIGHT © 2006 BURNS & MCDONNELL ENGINEERING COMPANY, INC.

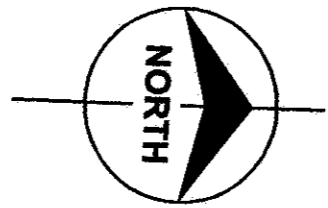
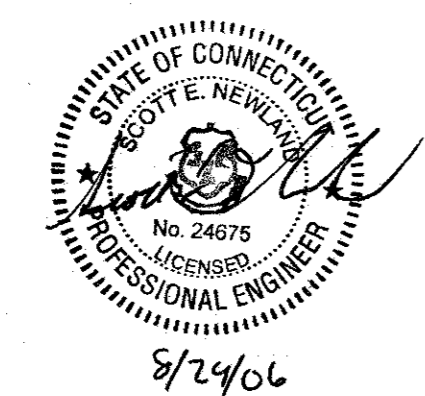
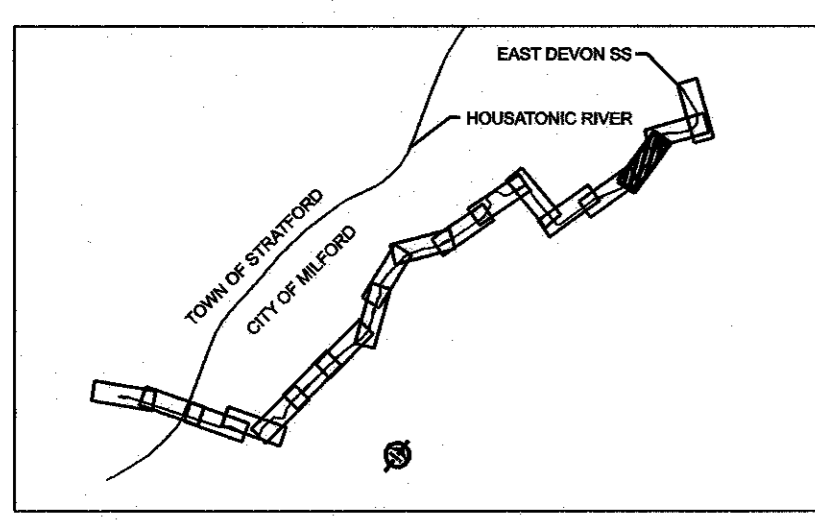

DOCKET No. 272

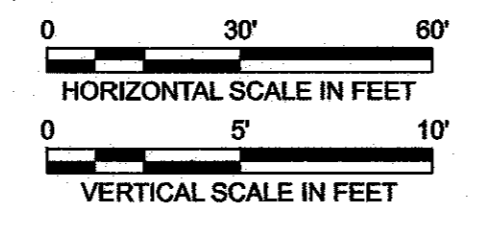

**ISSUED FOR
CONSTRUCTION**

no.	date	revisions	by	chk
1	8/29/06	ISSUED FOR CONSTRUCTION	CTC	



date
10/11/05
designed
C. COURTRIGHT

detailed
L. ROWSE
checked
S. NEWLAND

MF NO.	DATE	REVISIONS	BY	CHK	APP	APP

NORTHEAST UTILITIES SERVICE CO.			
FOR	THE CONNECTICUT LIGHT & POWER COMPANY		
TITLE	MIDDLETOWN-NORWALK 345KV TRANSMISSION PROJECT		
CITY OF MILFORD			
PLAN AND PROFILE Sta. 1100+00 to 1108+50			
BY SEN-BMCD	CHKD	APP	APP
DATE 10-11-05	DATE	DATE	DATE
SCALE AS NOTED		DWG. NO.	01223-10001 PG 016

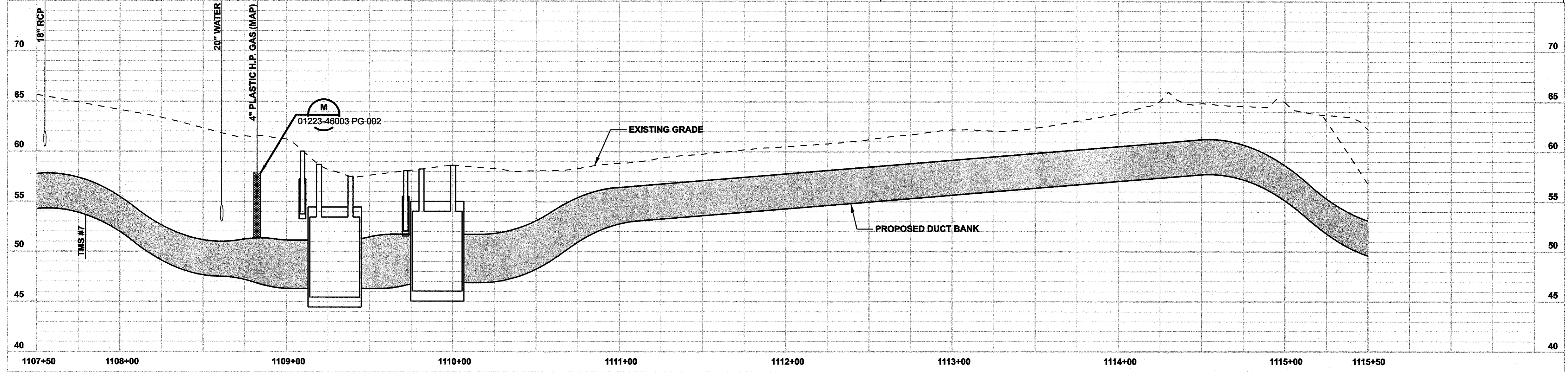
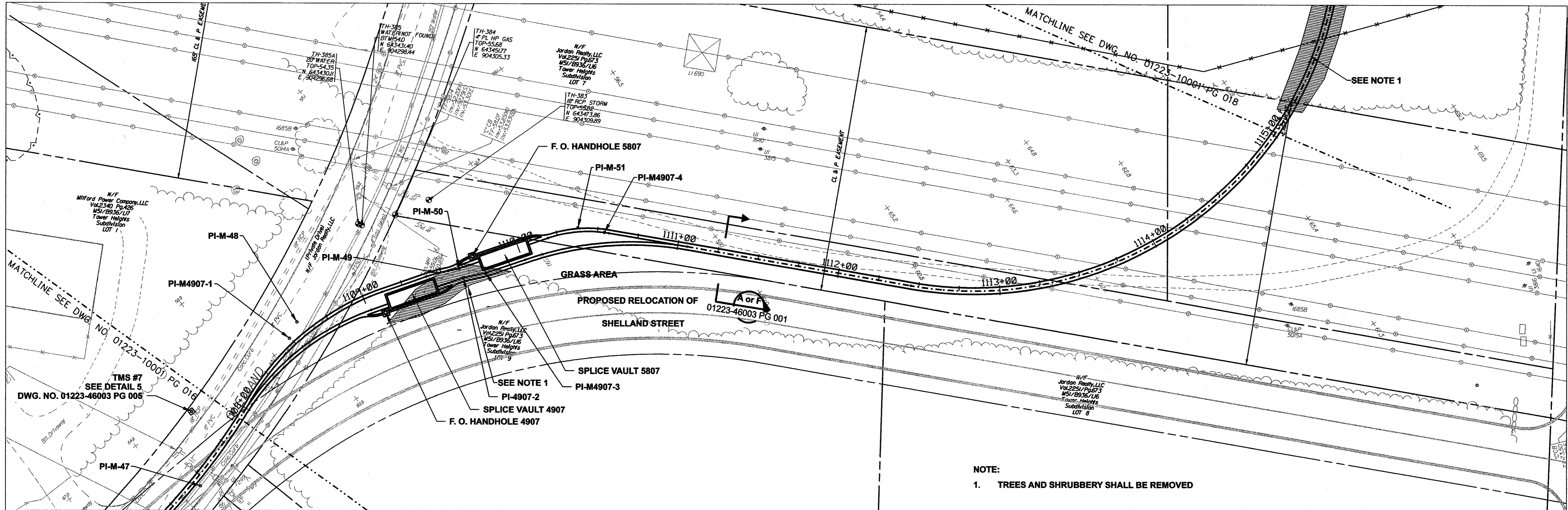

COPYRIGHT © 2008 BURNS & MCDONNELL ENGINEERING COMPANY, INC.

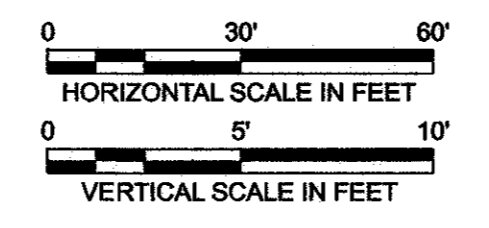
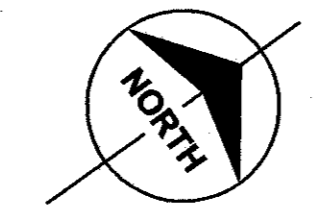
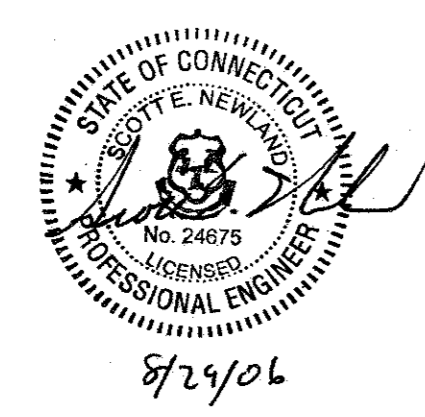
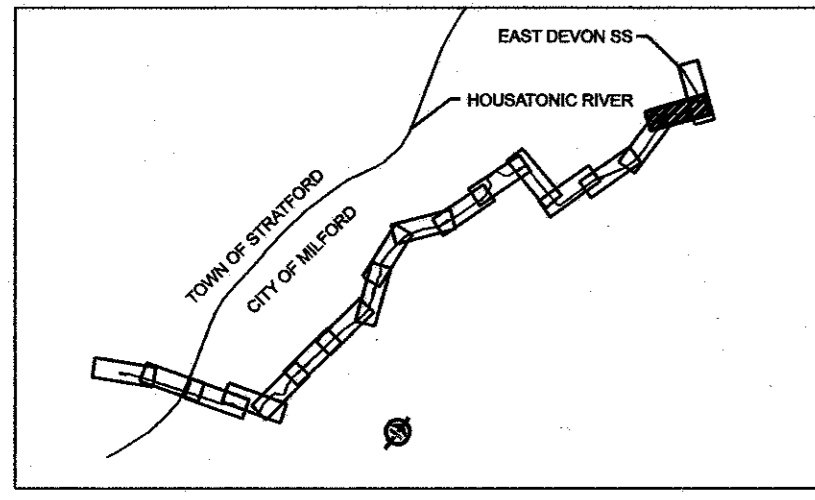

ISSUED FOR CONSTRUCTION

DOCKET No. 272

no.	date	revisions	by	chk
1	8/29/06	ISSUED FOR CONSTRUCTION	CTC	

Burns & McDonnell
SINCE 1898

date: 10/11/05
 detailed: L. ROWSE
 designed: C. COURTRIGHT
 checked: S. NEWLAND

MF NO.	DATE	REVISIONS	BY	CHK	APP	APP

NORTHEAST UTILITIES SERVICE CO.

FOR THE CONNECTICUT LIGHT & POWER COMPANY

TITLE: MIDDLETOWN-NORWALK 345KV TRANSMISSION PROJECT

CITY OF MILFORD
 PLAN AND PROFILE Sta. 1107+50 to 1115+50

BY SEN-BMCD	CHKD	APP	APP
DATE 10-11-05	DATE	DATE	DATE
SCALE AS NOTED		DWG. NO.	01223-10001 PG 017

NOTES:

1. SILT FENCE ON DOWNSLOPE SIDE OF CONSTRUCTION AREA, INCLUDING SPOIL PILES. WHEN AREAS ARE CURRENTLY PAVED USE CONDOT APPROVED SEDIMENT CONTROL MEASURES.
2. TREES AND SHRUBBERY SHALL BE REMOVED

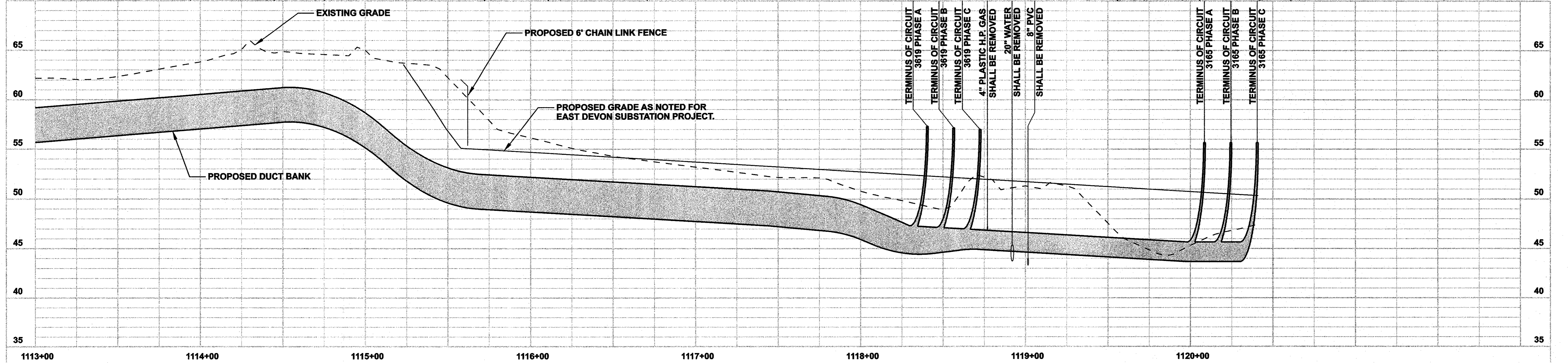
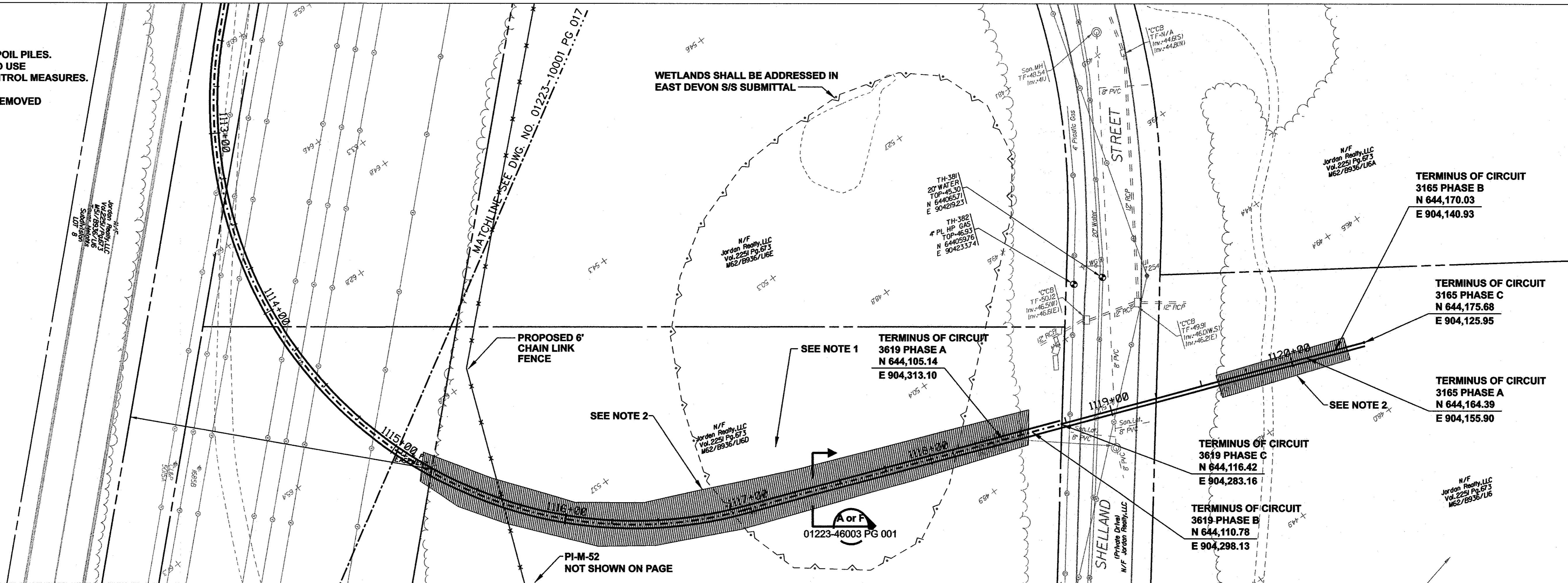

COPYRIGHT © 2006 BURNS & MCDONNELL ENGINEERING COMPANY, INC.

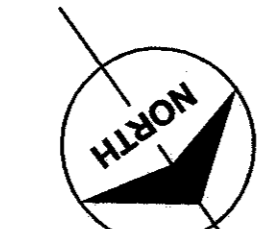
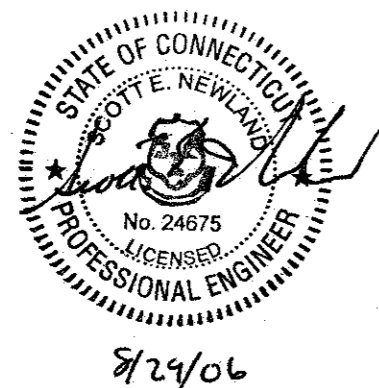
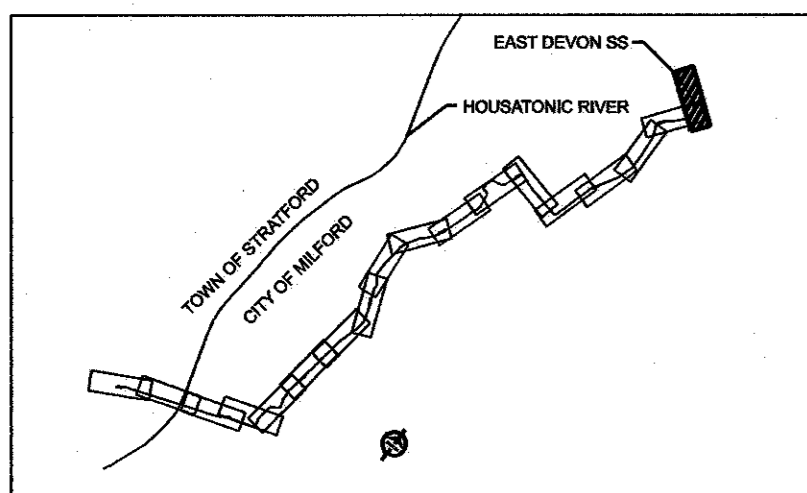

DOCKET No. 272

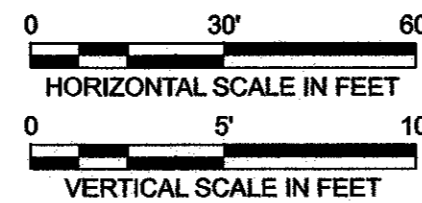

ISSUED FOR CONSTRUCTION

no.	date	revisions	by	chk
1	8/29/06	ISSUED FOR CONSTRUCTION	CTC	

		date	10/11/05	detailed	L. ROWSE
		designed	C. COURTRIGHT	checked	S. NEWLAND

MF	NO.	DATE	REVISIONS	BY	CHK	APP	APP

NORTHEAST UTILITIES SERVICE CO.			
FOR THE CONNECTICUT LIGHT & POWER COMPANY			
TITLE MIDDLETOWN-NORWALK 345KV TRANSMISSION PROJECT			
CITY OF MILFORD			
PLAN AND PROFILE Sta. 1113+00 to EAST DEVON S/S			
BY SEN-BMCD	CHKD	APP	APP
DATE 10-11-05	DATE	DATE	DATE
SCALE AS NOTED	D	DWG. NO.	01223-10001 PG 018

COPYRIGHT © 2006 BURNS & MCDONNELL ENGINEERING COMPANY, INC.

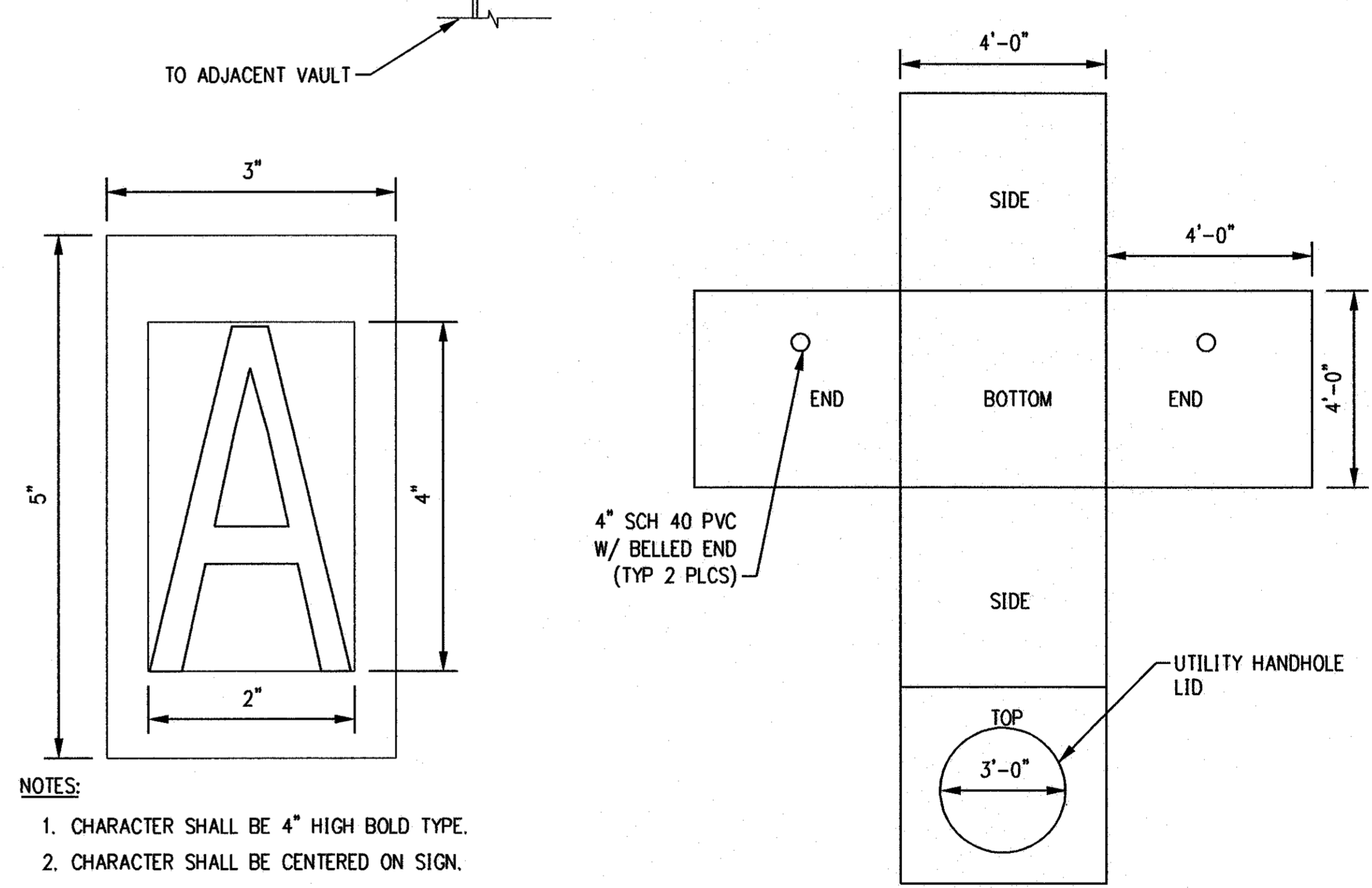
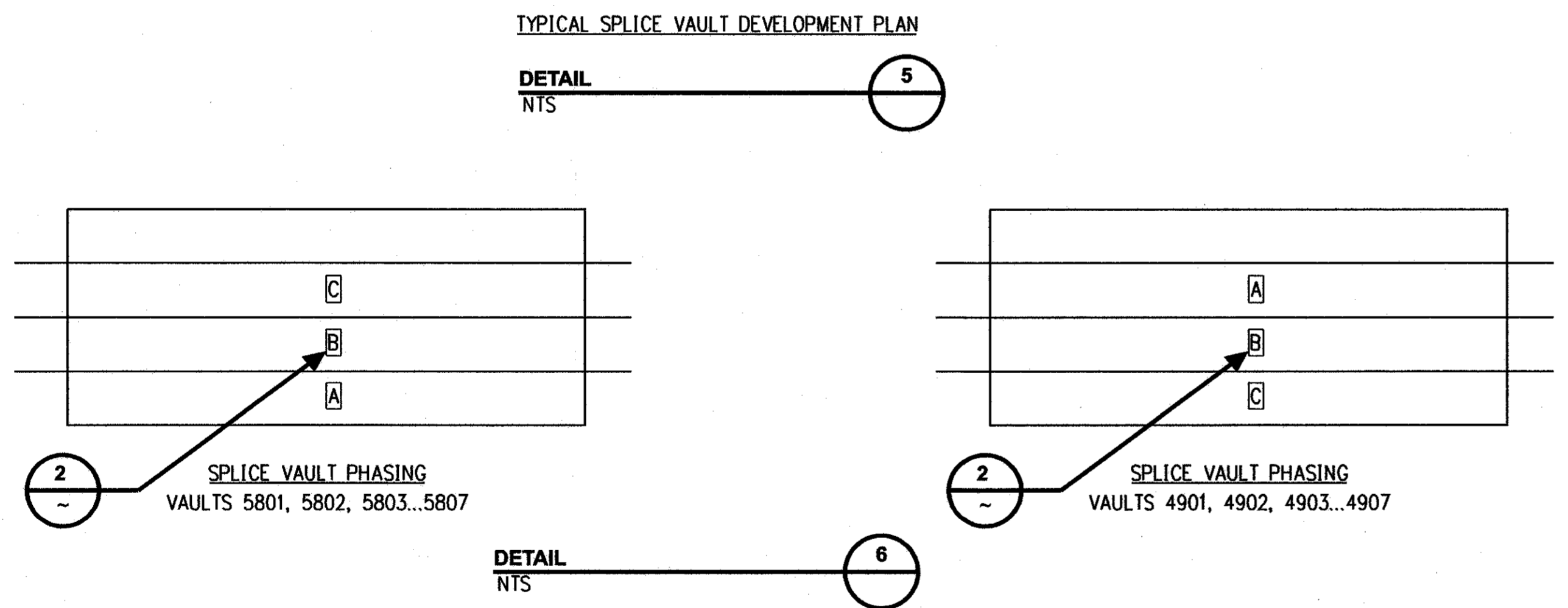
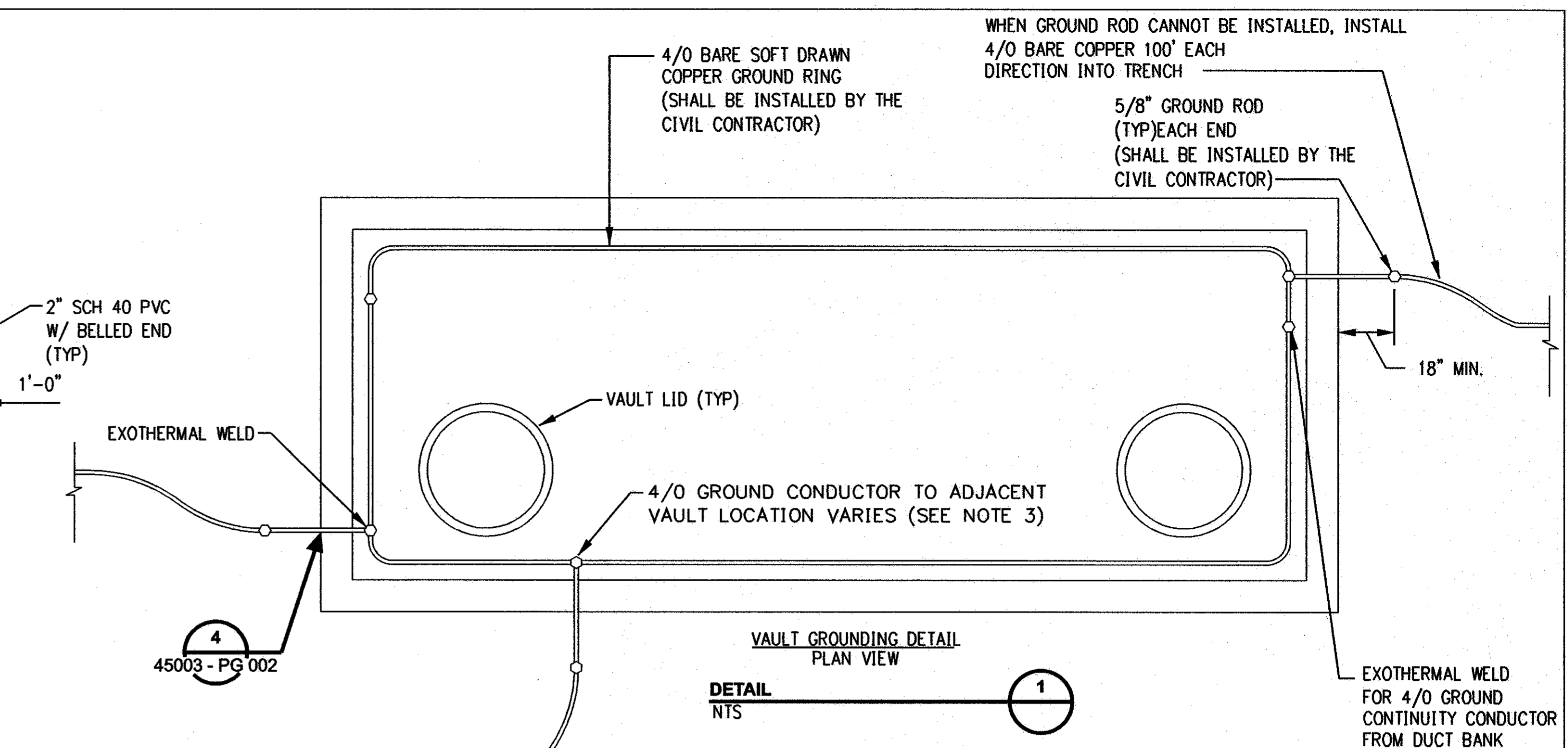
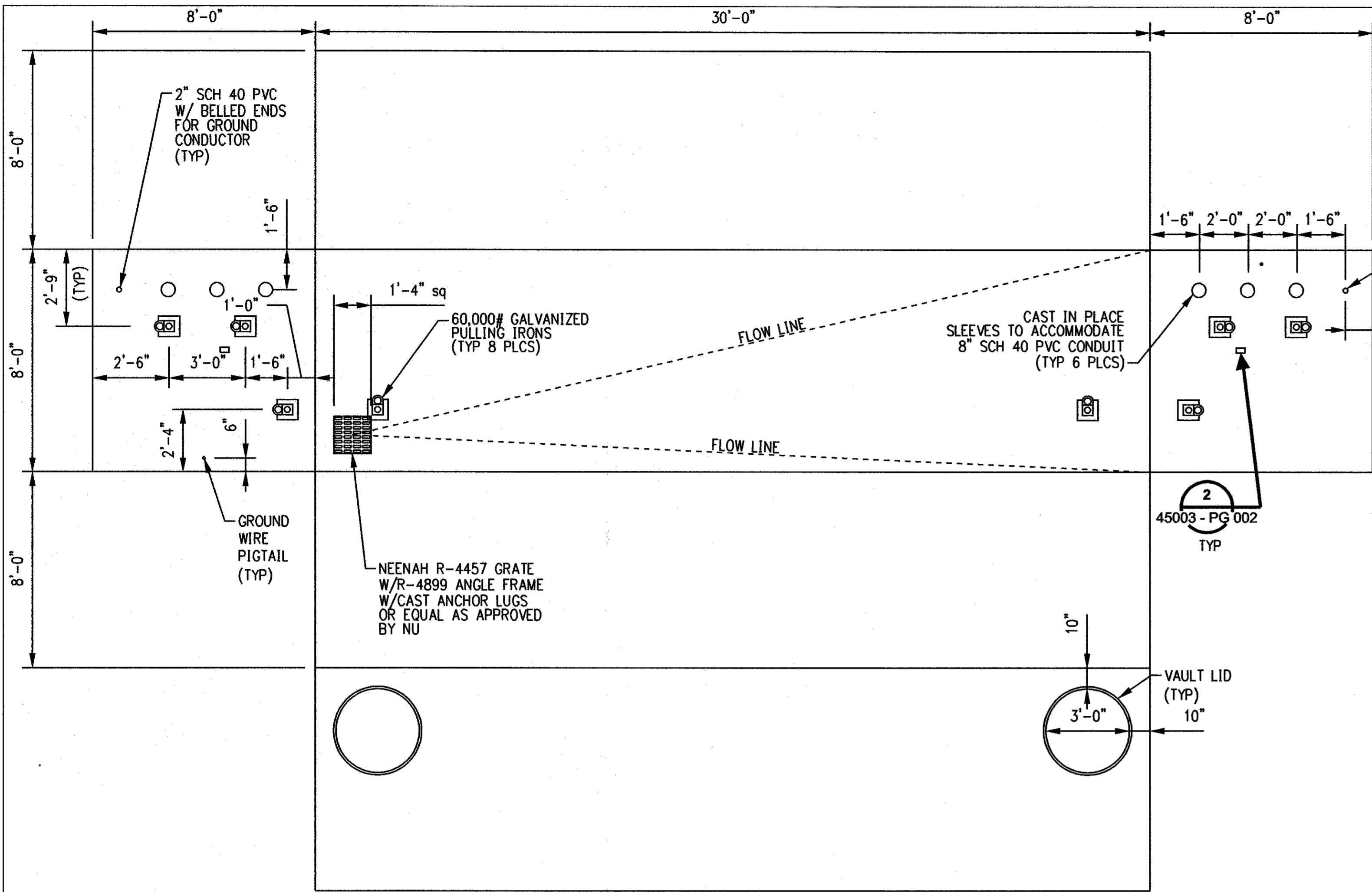

- NOTES:**
- GROUND PIGTAILS TO EXTEND A MINIMUM OF 18 INCHES FROM BOTH SIDES OF VAULT WALL PENETRATION.
 - ALL EXTERNAL AREAS OF VAULT SHALL BE SEALED USING SONNEDORN HYDROCID 700 OR APPROVED NU EQUIVALENT.
 - EACH VAULT SHALL HAVE AN ADDITIONAL 2" SCHEDULE 40 PVC WITH BELLED ENDS CAST IN PLACE TO CONNECT INTERNAL VAULT GROUNDING AND COMPLETE CONNECTION WITH EXOTHERMAL WELD.

- NOTES:**
- CHARACTER SHALL BE 4" HIGH BOLD TYPE.
 - CHARACTER SHALL BE CENTERED ON SIGN.
 - BACKGROUND: WHITE
LETTERING: BLACK
CHARACTERS: A, B & C AS SHOWN
 - ELECTRICAL CONTRACTOR SHALL ATTACH TAG TO SPLICE.

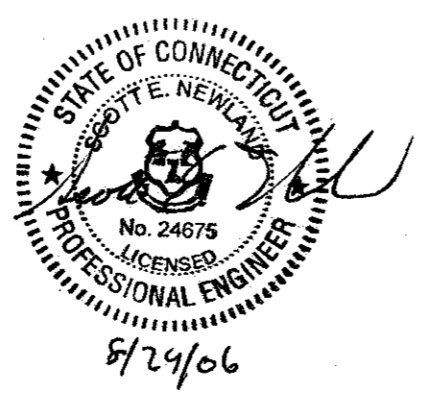

ISSUED FOR CONSTRUCTION

DOCKET No. 272

				NORTHEAST UTILITIES SERVICE CO. FOR THE CONNECTICUT LIGHT & POWER COMPANY TITLE MIDDLETOWN-NORWALK 345KV TRANSMISSION PROJECT VAULT, GROUNDING AND HANDHOLE DETAILS			
date	8/15/05	detailed	L. ROWSE	BY SEN-BMCD	CHKD	APP	APP
designed	C. COURTRIGHT	checked	S. NEWLAND	DATE 8-15-05	DATE	DATE	DATE
no.	8/29/06	ISSUED FOR CONSTRUCTION	CTC	SCALE AS NOTED	D	DWG. NO.	01223-45003 PG 001
revisions							

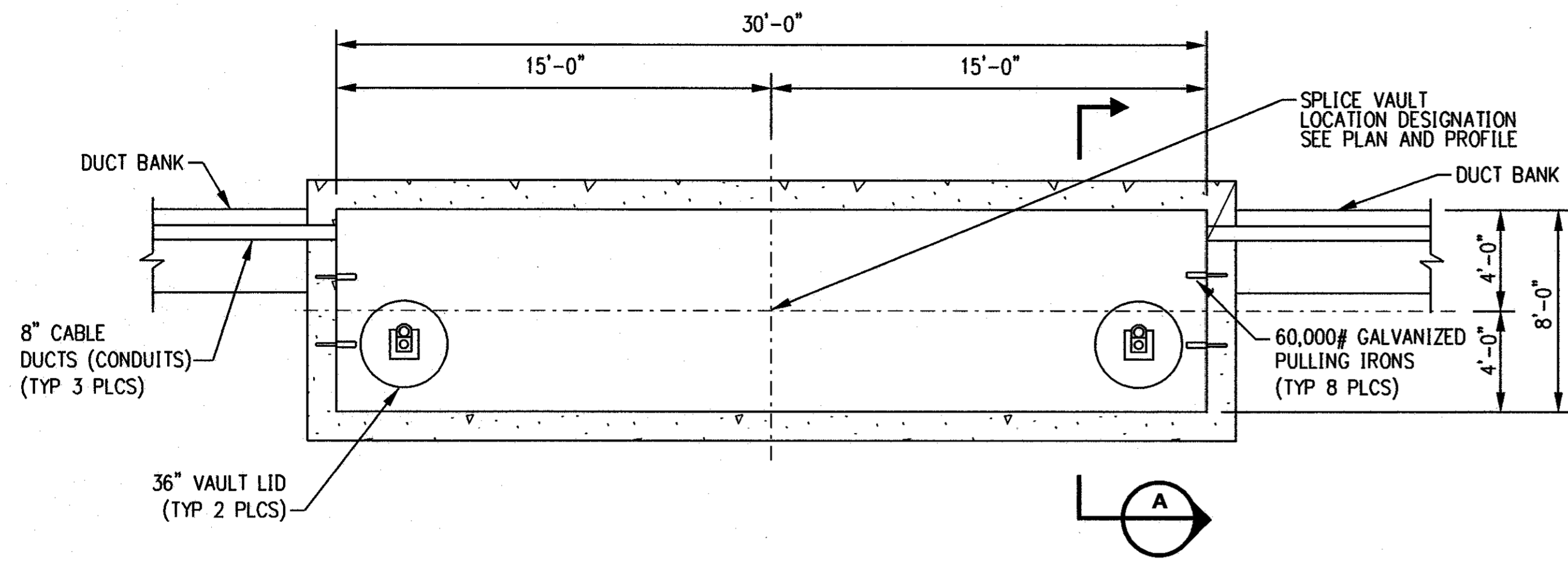

INTERIOR PLAN ELECTRICAL SPLICE VAULT

DETAIL 1
NTS

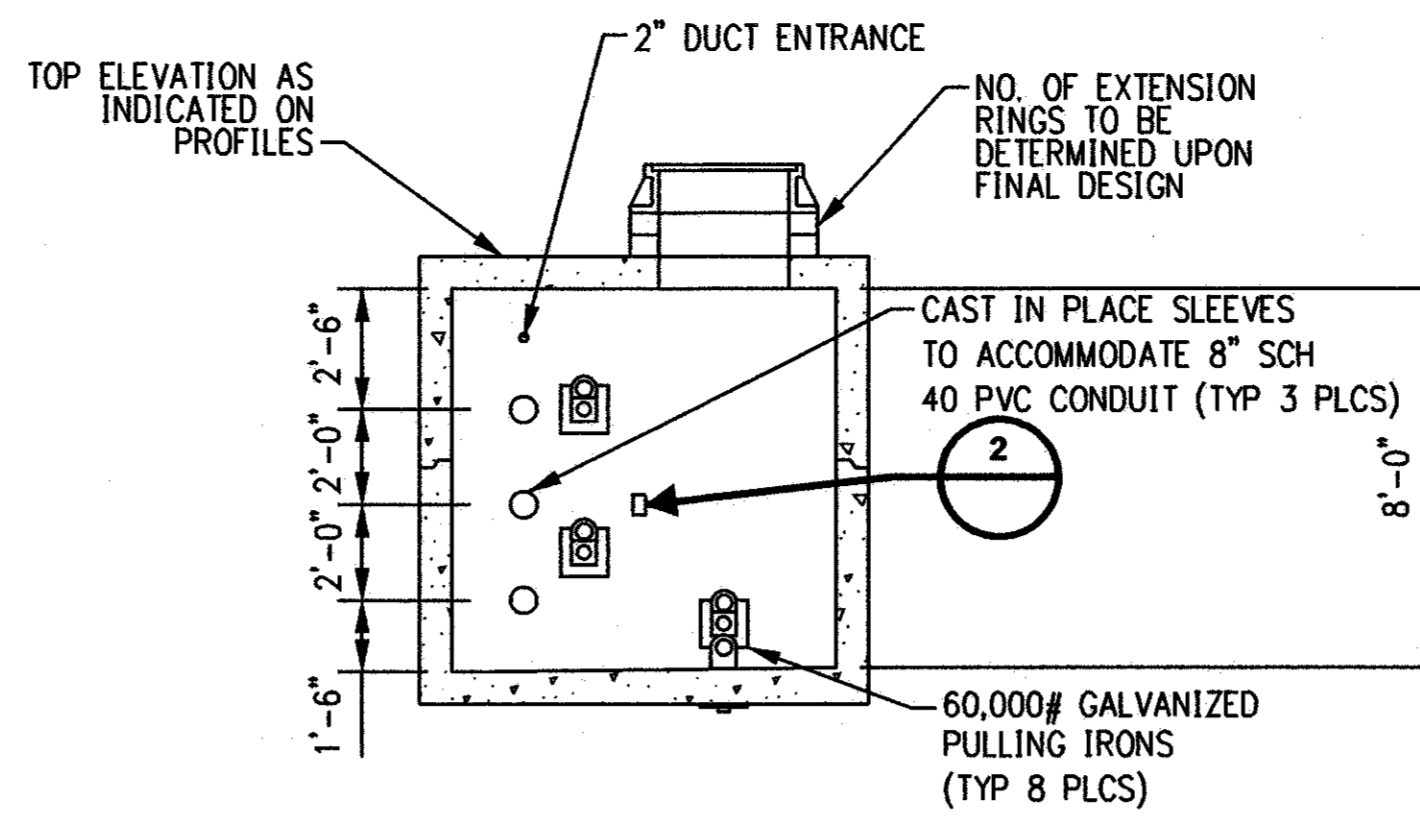

SPLICE VAULT SECTION A
NTS

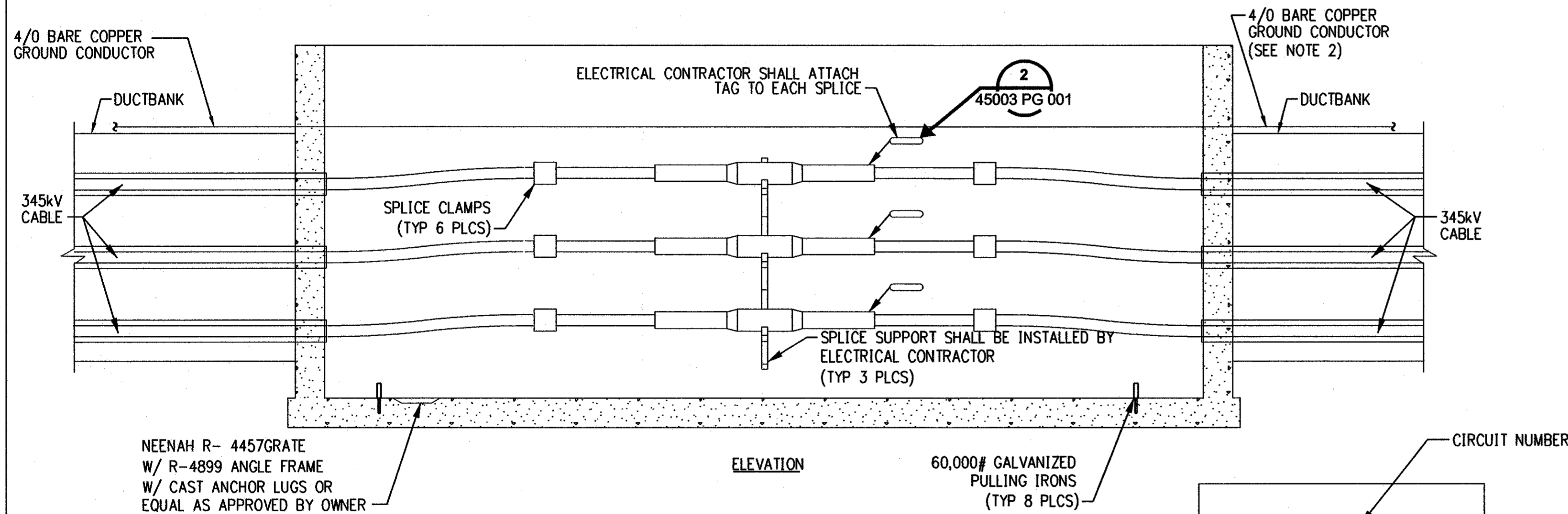

ELEVATION

SPLICE VAULT DETAIL 3
NTS

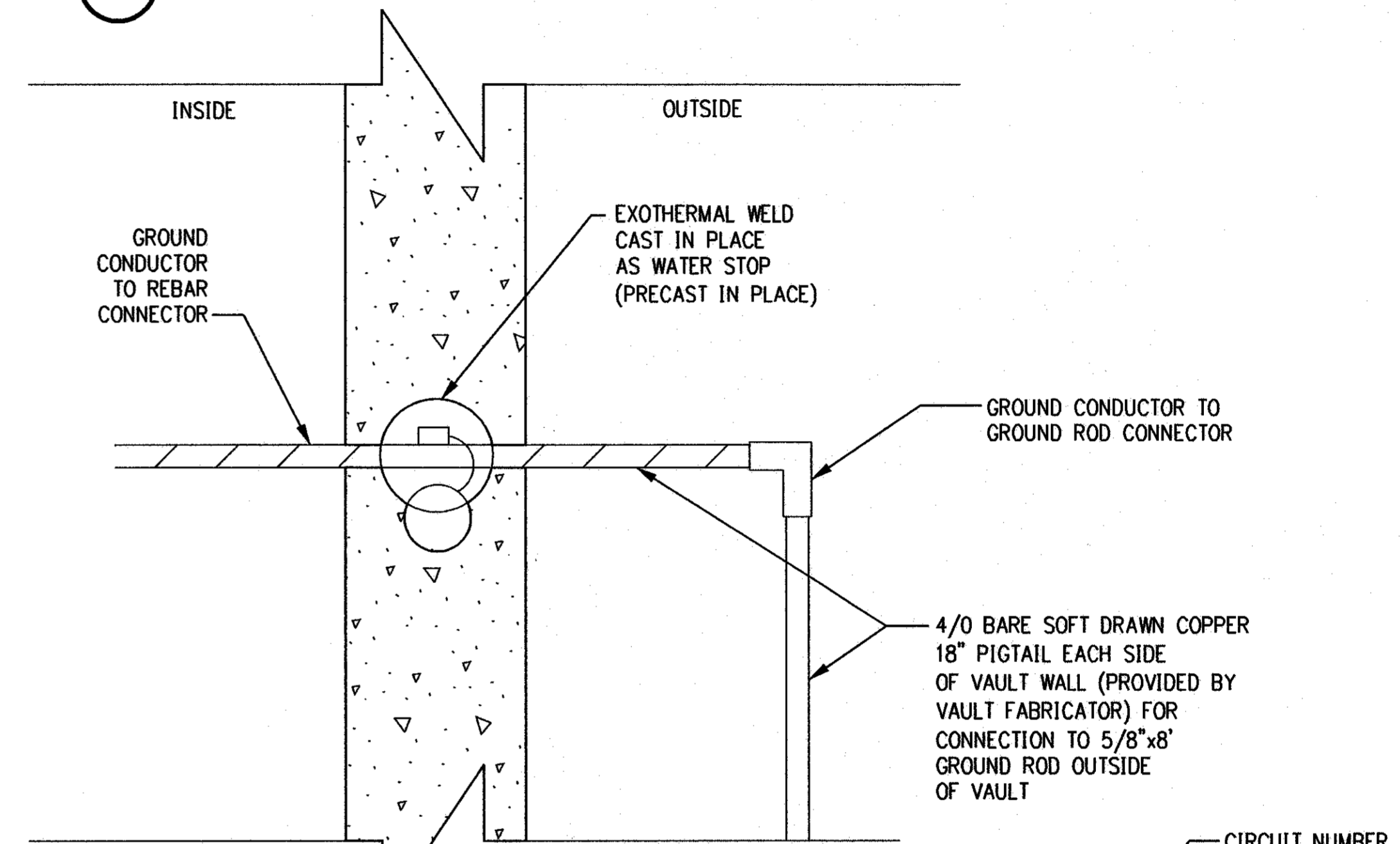

GROUND WIRE DETAIL PROFILE VIEW

DETAIL 4
NTS

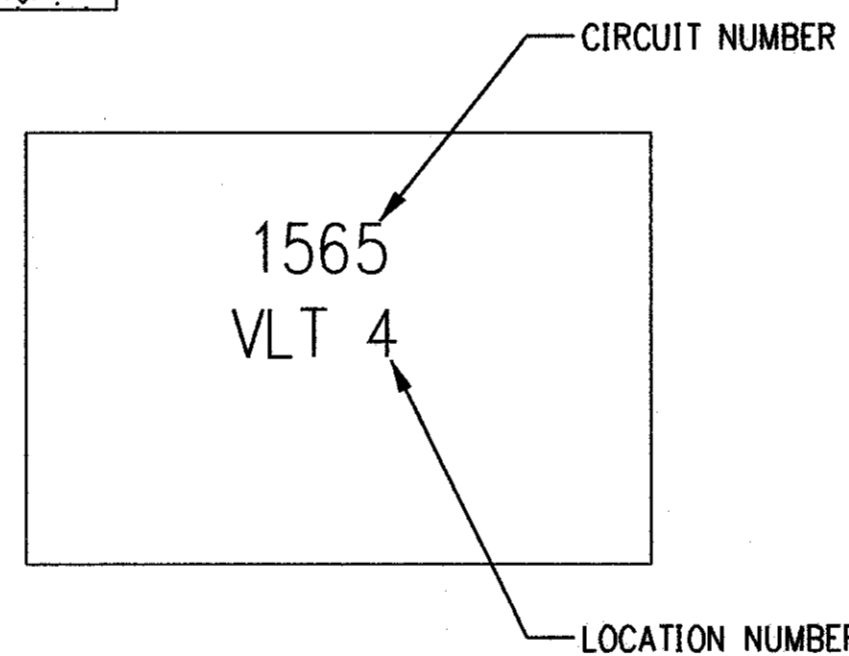

PROFILE VIEW

DETAIL 5
NTS

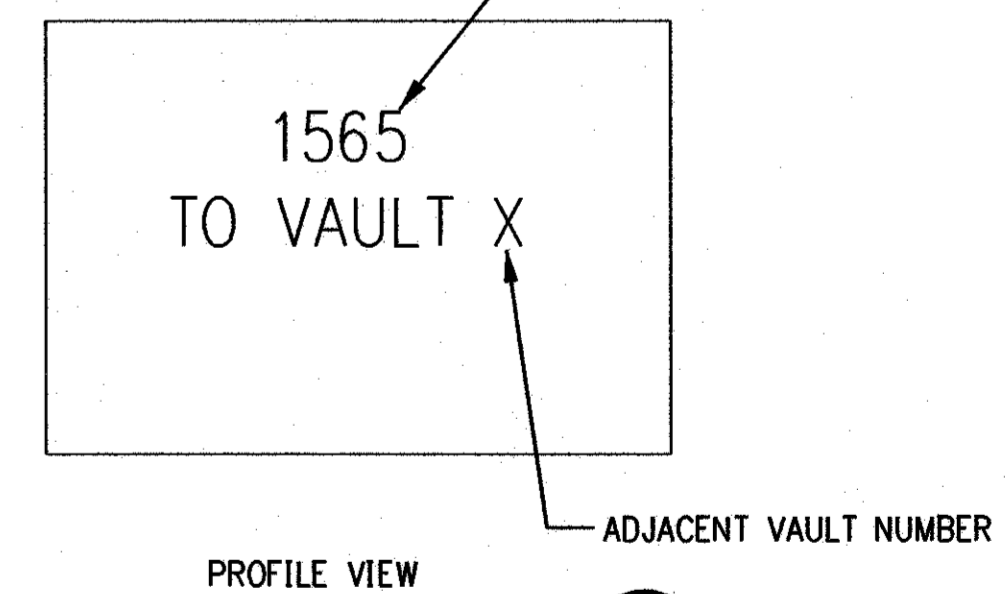

PROFILE VIEW

DETAIL 2
NTS

NOTES:

- PASS GROUND CONDUCTOR THROUGH VAULT WALL AND SUPPORT ALONG VAULT WALL.
- BOND GROUNDS FROM EARTHING TO VAULT/ DUCTBANK GROUND.

CIVIL CONTRACTOR SHALL ATTACH TAG 1'-6" BELOW FINISHED GRADE ON THE INSIDE OF THE EXTENSION RINGS AND ON THE VAULT WALL OPPOSITE THE RACKING

CIVIL CONTRACTOR SHALL ATTACH TAG TO EACH ENDWALL DESIGNATING NEXT ADJACENT VAULT IN CIRCUIT



ISSUED FOR CONSTRUCTION

DOCKET No. 272

				NORTEAST UTILITIES SERVICE CO. FOR THE CONNECTICUT LIGHT & POWER COMPANY TITLE MIDDLETOWN-NORWALK 345KV TRANSMISSION PROJECT VAULT AND GROUNDING DETAILS			
				BY SEN-BMCD DATE 8-15-05 SCALE AS NOTED	CHKD DATE D	APP DATE DWG. NO. 01223-45003 PG 002	APP DATE
date 8/15/05 designed C. COURTRIGHT	detailed L. ROWSE checked S. NEWLAND	MF NO. DATE REVISIONS	BY CHK APP APP	1 8/29/06 ISSUED FOR CONSTRUCTION CTC no. date revisions by chk	1 8/29/06 ISSUED FOR CONSTRUCTION CTC no. date revisions by chk	1 8/29/06 ISSUED FOR CONSTRUCTION CTC no. date revisions by chk	1 8/29/06 ISSUED FOR CONSTRUCTION CTC no. date revisions by chk

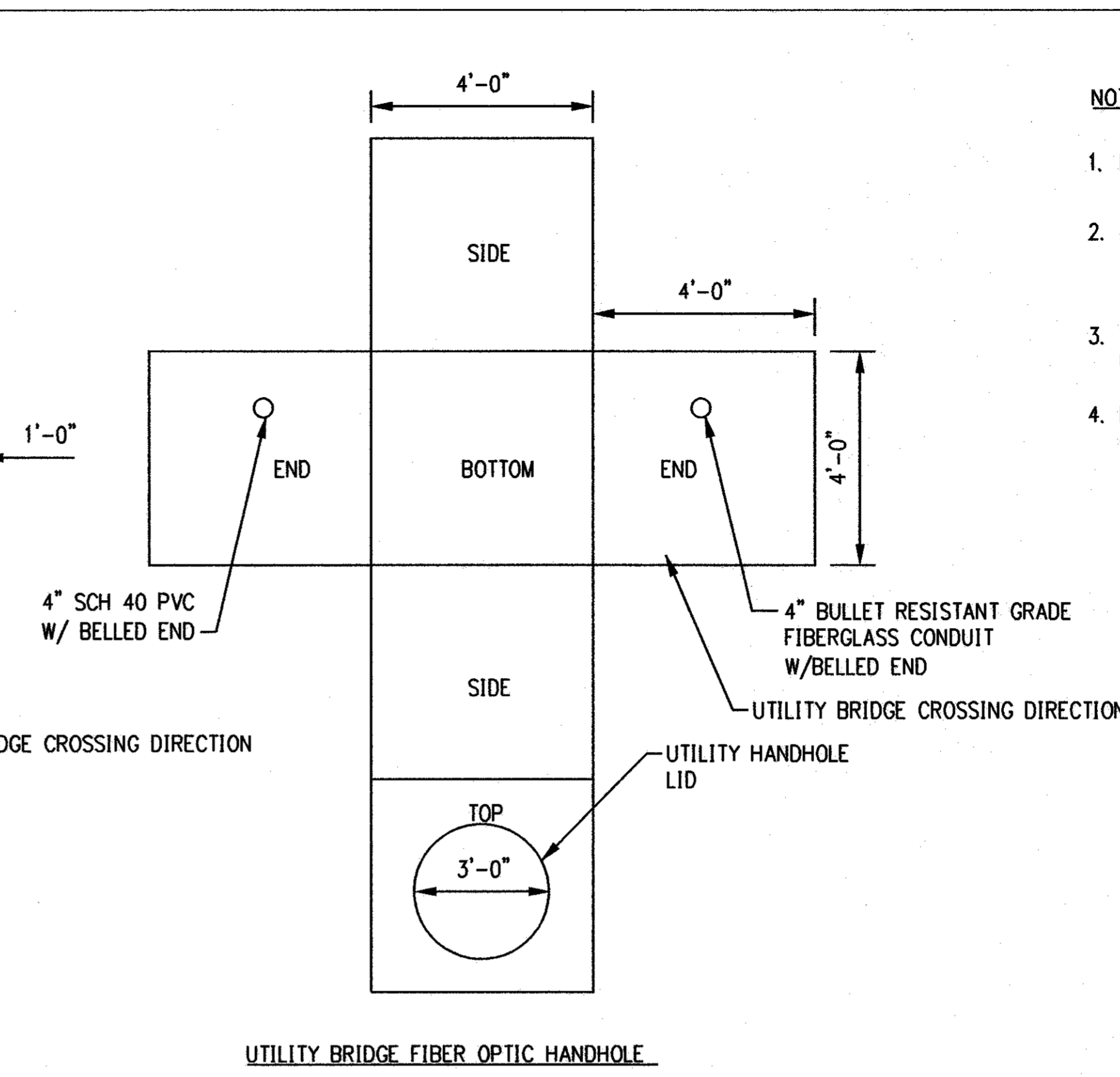
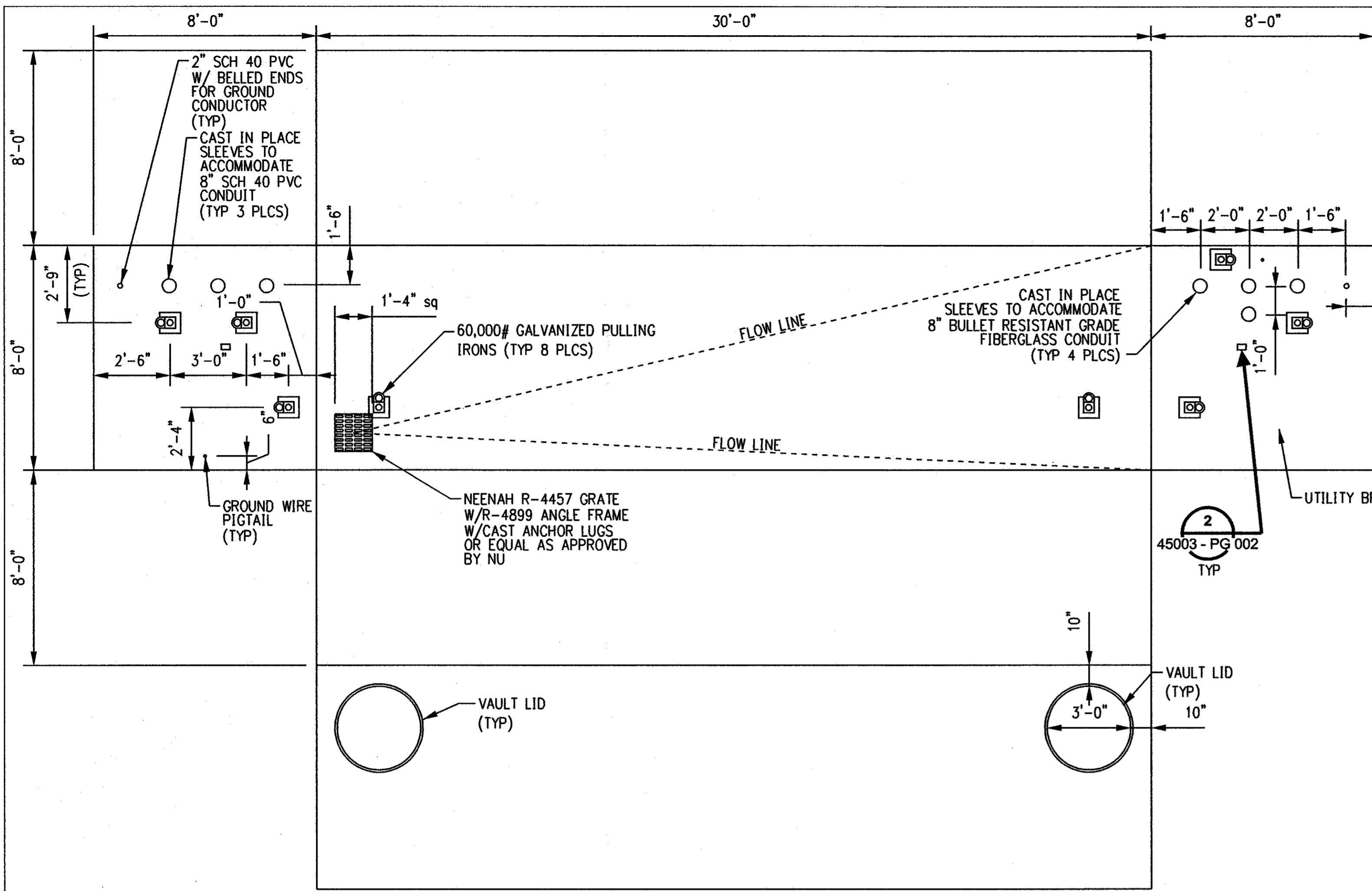

- NOTES:
1. REBAR WITHIN SPLICE CHAMBER WALLS SHALL NOT FORM A LOOP AROUND ANY 8" CONDUIT OPENING.
 2. ALL UNUSED CONDUITS SHALL BE PLUGGED AND SEALED USING WATERTIGHT DUCT PLUGS AS MANUFACTURED BY JACKMOON USA, INC. OR ACCEPTABLE EQUAL.
 3. VAULT ENDS HAVING FIBERGLASS SPARE DUCTS ARE ORIENTED TOWARD UTILITY BRIDGES.
 4. FIBER OPTIC HANDHOLES HAVING FIBERGLASS BELLED ENDS SHALL BE ORIENTED TOWARD THE UTILITY BRIDGE.

SPLICE VAULT DEVELOPMENT PLAN FOR VAULTS ADJACENT TO UTILITY BRIDGE CROSSINGS

DETAIL 2
NTS

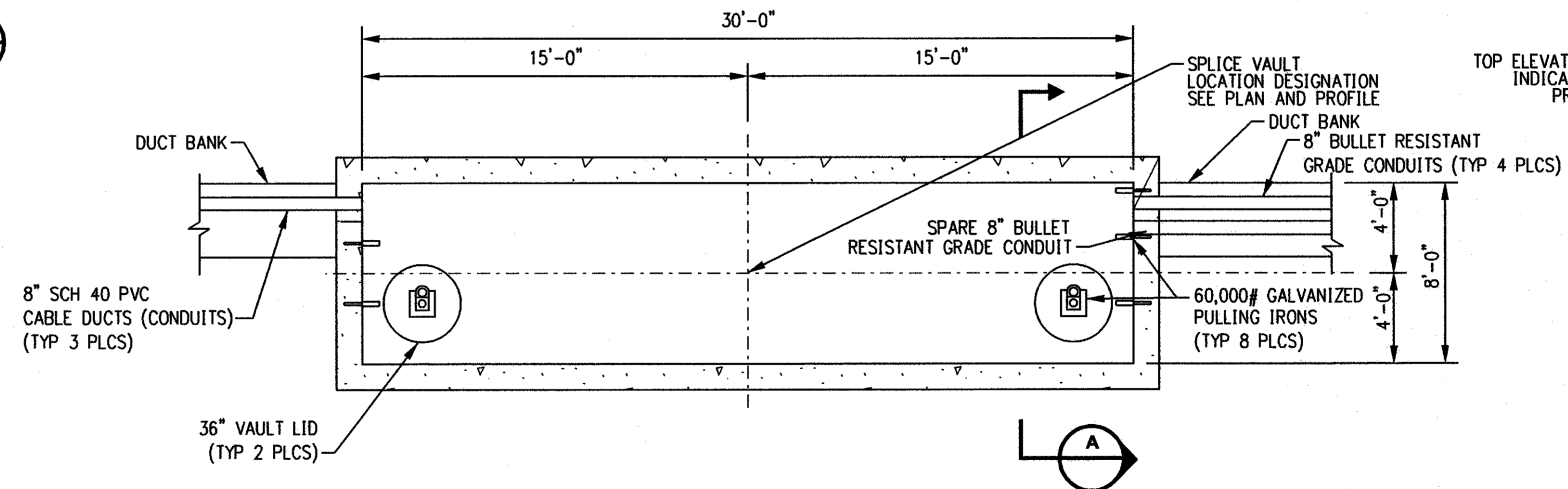

INTERIOR PLAN OF ELECTRICAL SPLICE VAULTS ADJACENT TO UTILITY BRIDGE CROSSINGS

DETAIL 1
NTS

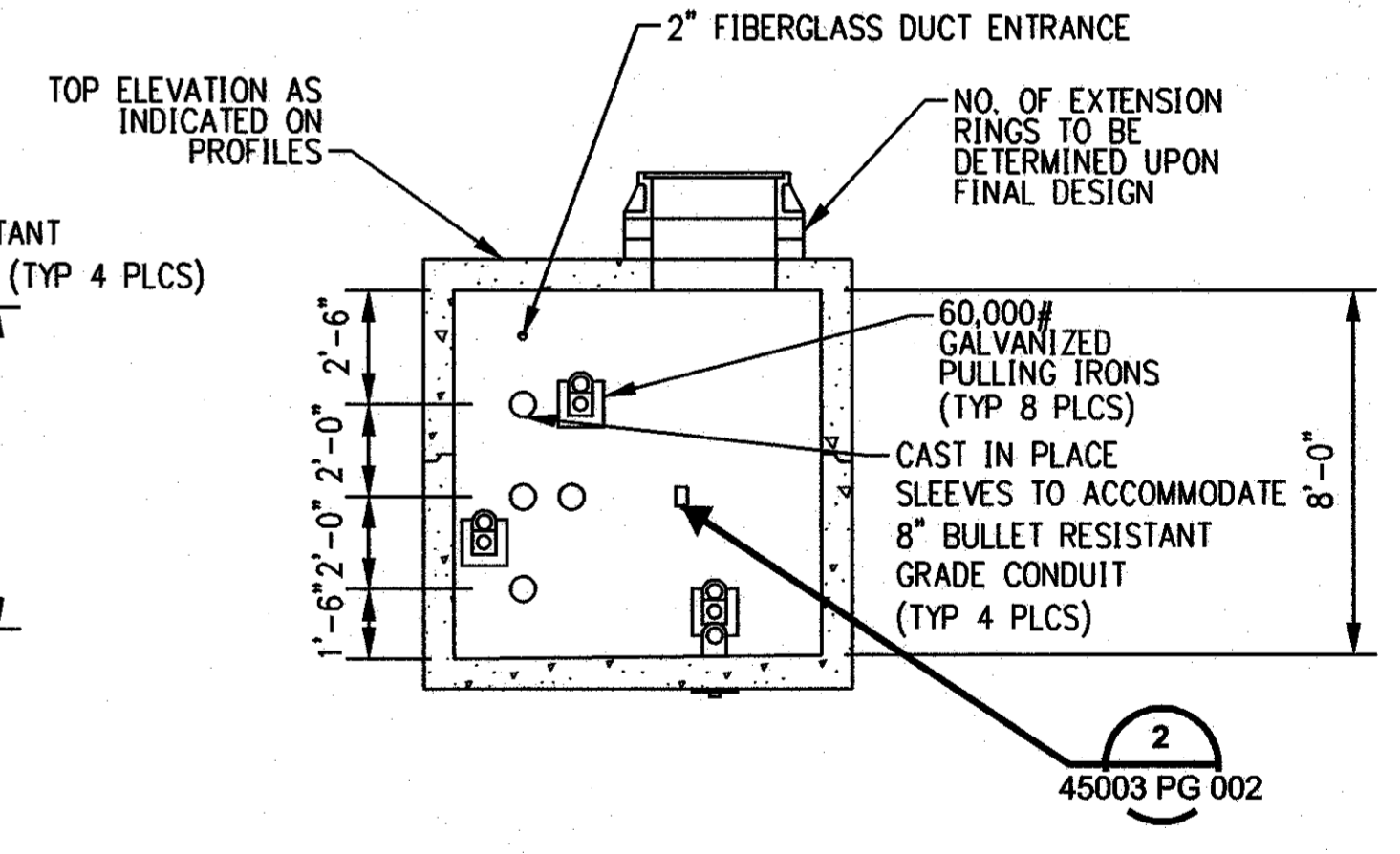

UTILITY BRIDGE SPLICE VAULT SECTION A
NTS

COPYRIGHT © 2006 BURNS & MCDONNELL ENGINEERING COMPANY, INC.



ISSUED FOR CONSTRUCTION

DOCKET No. 272

no.	date	revisions	by	chk
1	8/29/06	ISSUED FOR CONSTRUCTION	CTC	

Burns & McDonnell
SINCE 1898

date 05/05/06 detailed L. ROWSE
designed C. COURTRIGHT checked S. NEWLAND

MF	NO.	DATE	REVISIONS	BY	CHK	APP	APP

NORTHEAST UTILITIES SERVICE CO.

FOR THE CONNECTICUT LIGHT & POWER COMPANY

TITLE MIDDLETOWN-NORWALK 345KV TRANSMISSION PROJECT
UTILITY BRIDGE SPLICE VAULT DETAILS

BY SEN-BMCD	CHKD	APP	APP
DATE 5-05-06	DATE	DATE	DATE
SCALE AS NOTED		DWG. NO.	01223-45003 PG 003

COPYRIGHT © 2008 BURNS & MCDONNELL ENGINEERING COMPANY, INC.

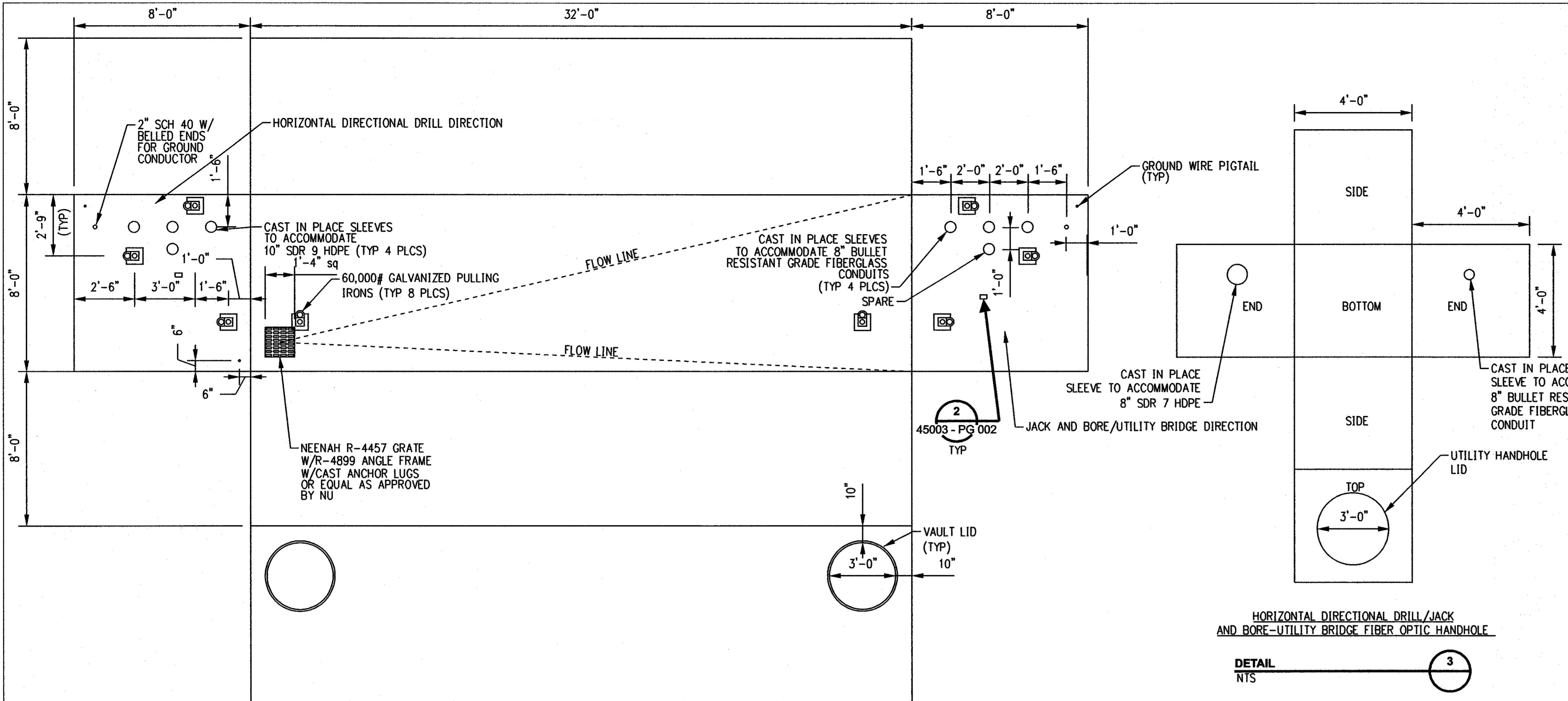

SPlice VAULT DEVELOPMENT PLAN FOR VAULTS ADJACENT TO HORIZONTAL DIRECTIONAL DRILL/JACK AND BORE-UTILITY BRIDGE CROSSINGS

- NOTES:**
- REBAR WITHIN SPLICE CHAMBER WALLS SHALL NOT FORM A LOOP AROUND ANY 8" AND 10" CONDUIT OPENING.
 - ALL UNUSED CONDUITS SHALL BE PLUGGED AND SEALED USING WATERTIGHT DUCT PLUGS AS MANUFACTURED BY JACKMOON USA, INC. OR ACCEPTABLE EQUAL.
 - VAULT ENDS HAVING SPARE DUCTS ARE ORIENTED TOWARD TRENCHLESS CROSSINGS. (JACK AND BORES, UTILITY BRIDGES, OR HORIZONTAL DIRECTIONAL DRILLS)

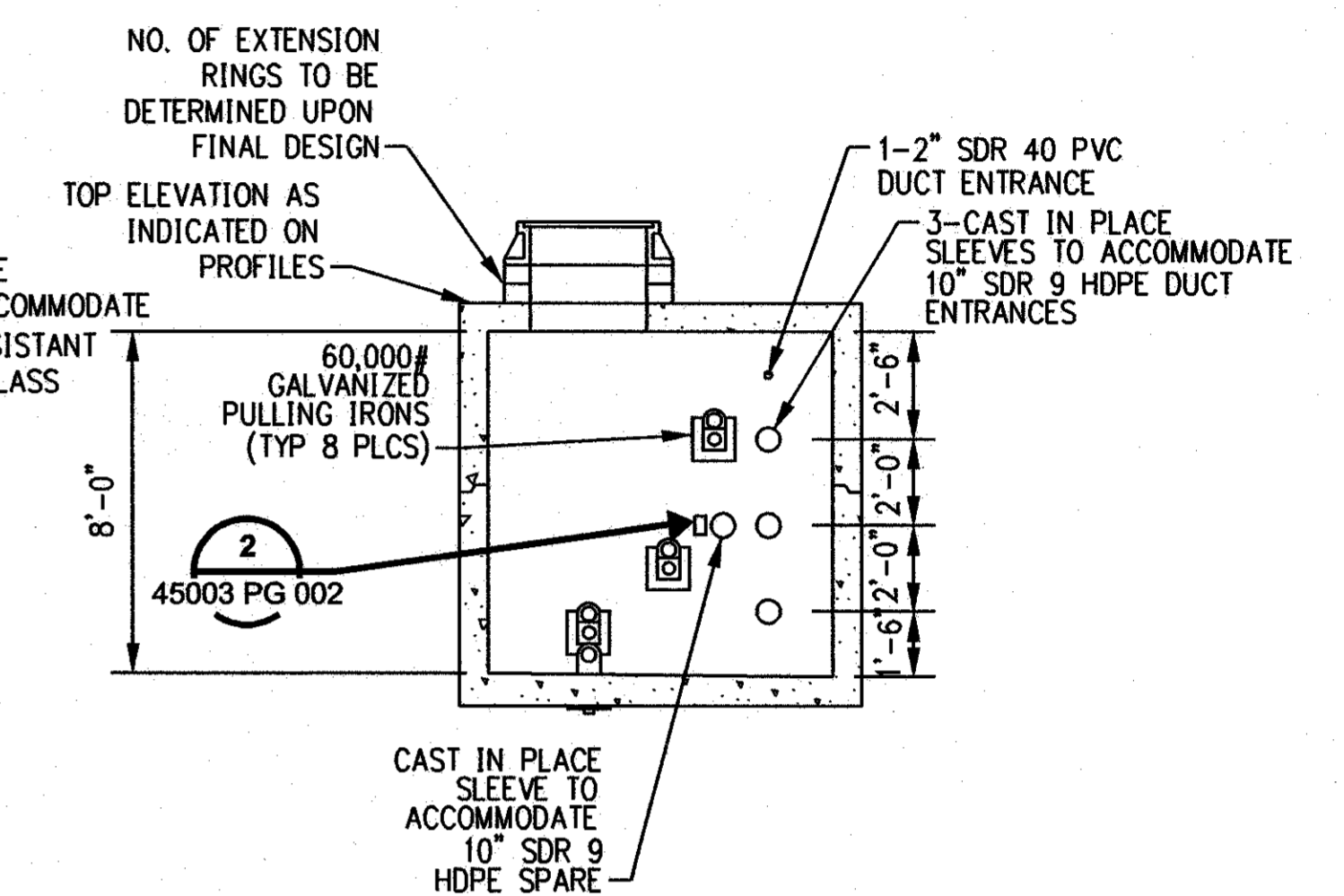

HORIZONTAL DIRECTIONAL DRILL/JACK AND BORE-UTILITY BRIDGE SPLICE VAULT

DETAIL 2 NTS

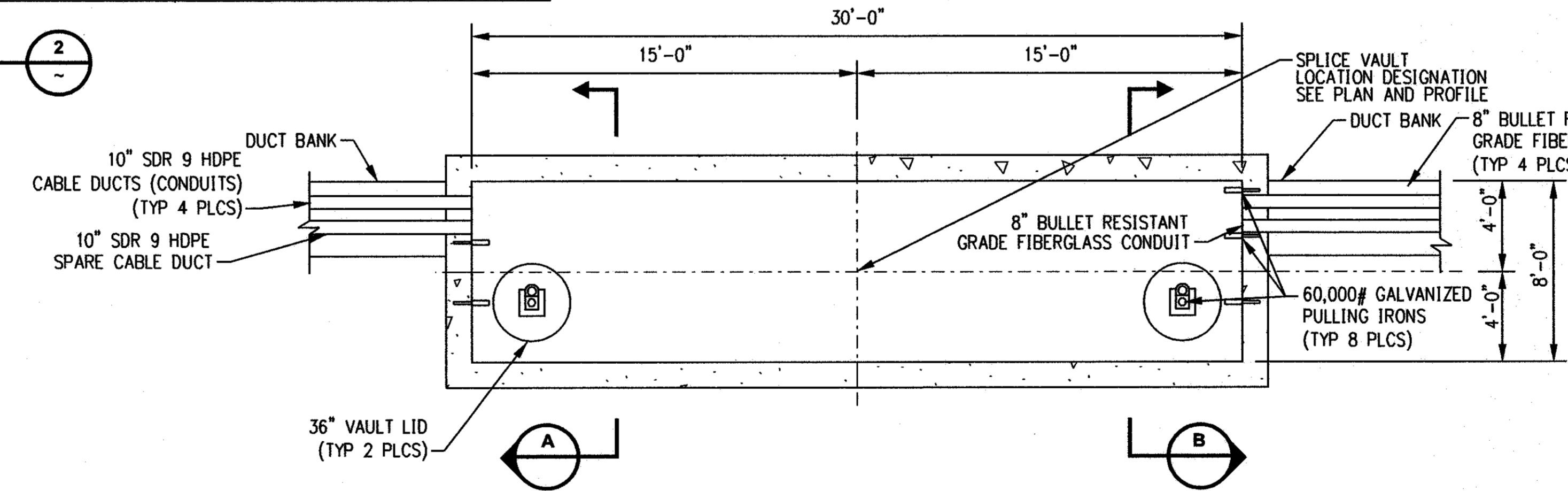

INTERIOR PLAN FOR ELECTRICAL SPLICE VAULTS ADJACENT TO HORIZONTAL DIRECTIONAL DRILL/JACK AND BORE-UTILITY BRIDGE CROSSINGS

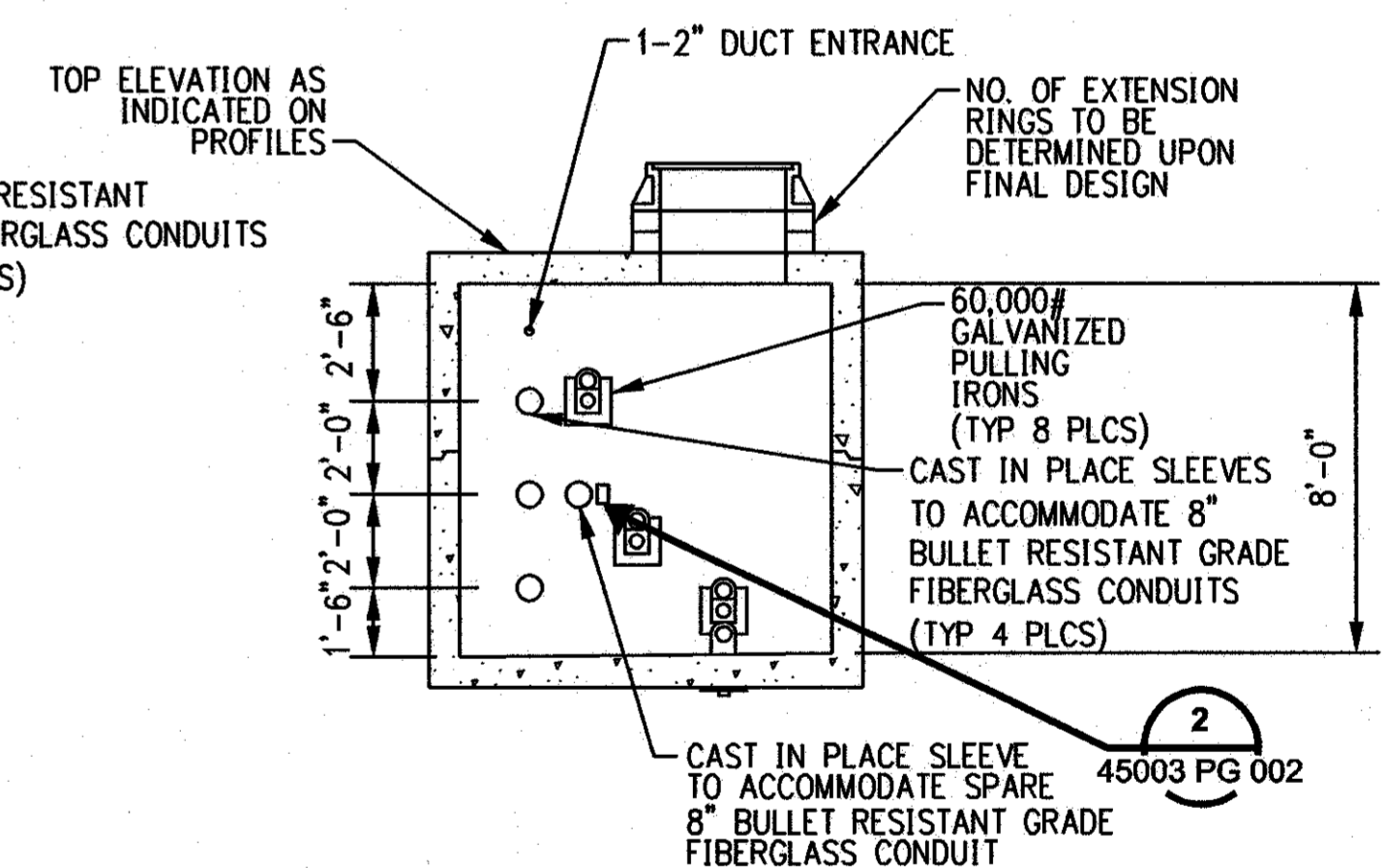

HORIZONTAL DIRECTIONAL DRILL/JACK AND BORE-UTILITY BRIDGE SPLICE VAULT

DETAIL 1 NTS



ISSUED FOR CONSTRUCTION

DOCKET No. 272



				Burns & McDonnell SINCE 1898								NORTHEAST UTILITIES SERVICE CO.			
				date 05/05/06								FOR THE CONNECTICUT LIGHT & POWER COMPANY			
				designed C. COURTRIGHT								TITLE MIDDLETOWN-NORWALK 345KV TRANSMISSION PROJECT			
				detailed L. ROWSE								HORIZONTAL DIRECTIONAL DRILL SPLICE VAULT DETAILS			
				checked S. NEWLAND								BY SEN-BMCD CHKD APP APP			
				no. date revisions by chk								DATE 5-05-06 DATE DATE DATE			
				1 8/29/06 ISSUED FOR CONSTRUCTION CTC								SCALE AS NOTED D DWG. NO. 01223-45003 PG 004			
				MF NO. DATE REVISIONS BY CHK APP APP											

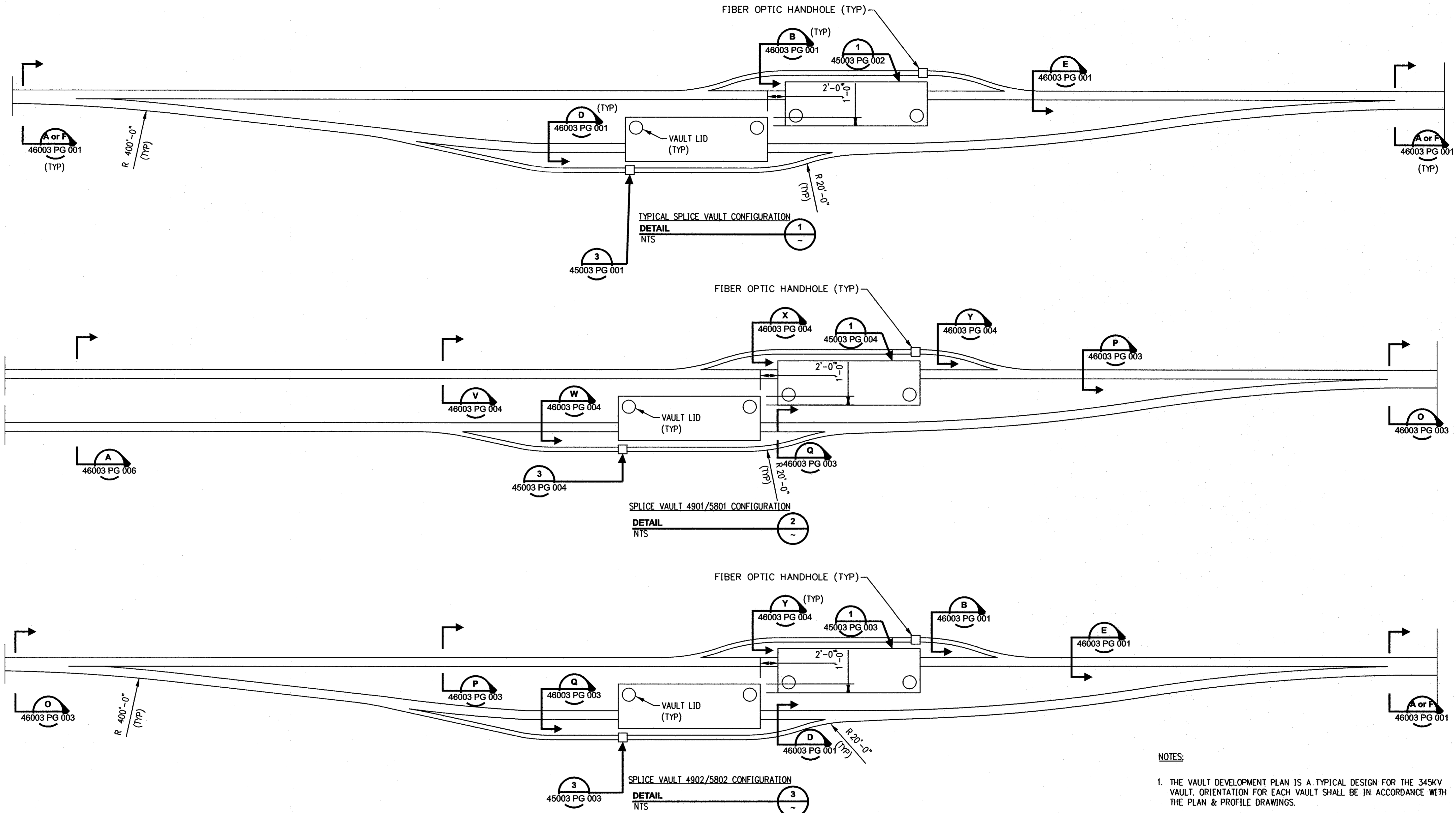

NOTES:
 1. THE VAULT DEVELOPMENT PLAN IS A TYPICAL DESIGN FOR THE 345KV VAULT. ORIENTATION FOR EACH VAULT SHALL BE IN ACCORDANCE WITH THE PLAN & PROFILE DRAWINGS.

COPYRIGHT © 2006 BURNS & MCDONNELL ENGINEERING COMPANY, INC.

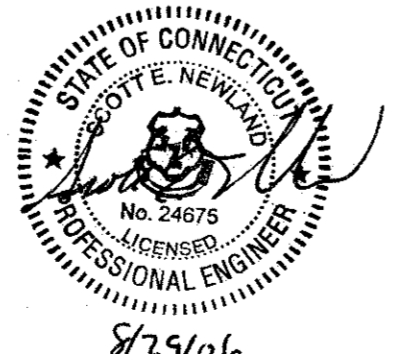

ISSUED FOR CONSTRUCTION

DOCKET No. 272

no.	date	revisions	by	chk
1	8/29/06	ISSUED FOR CONSTRUCTION	CTC	

Burns & McDonnell SINCE 1898	
date 06/15/06	detailed L. ROWSE
designed C. COURTRIGHT	checked S. NEWLAND

MF	NO.	DATE	REVISIONS	BY	CHK	APP	APP

NORTHEAST UTILITIES SERVICE CO.			
FOR THE CONNECTICUT LIGHT & POWER COMPANY			
TITLE MIDDLETOWN-NORWALK 345KV TRANSMISSION PROJECT			
CROSSING SPLICE VAULT DETAILS			
BY SEN-BMCD	CHKD	APP	APP
DATE 6-15-06	DATE	DATE	DATE
SCALE AS NOTED	D		DWG. NO. 01223-45003 PG 005

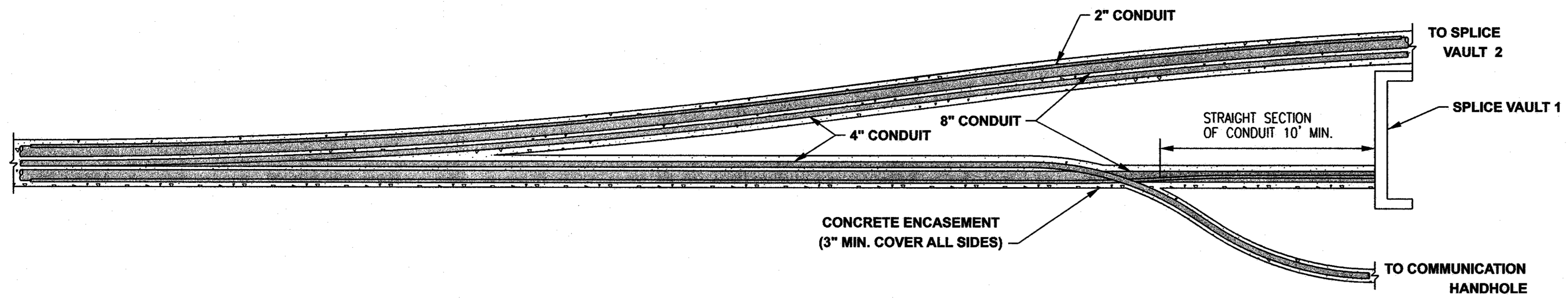

PLAN

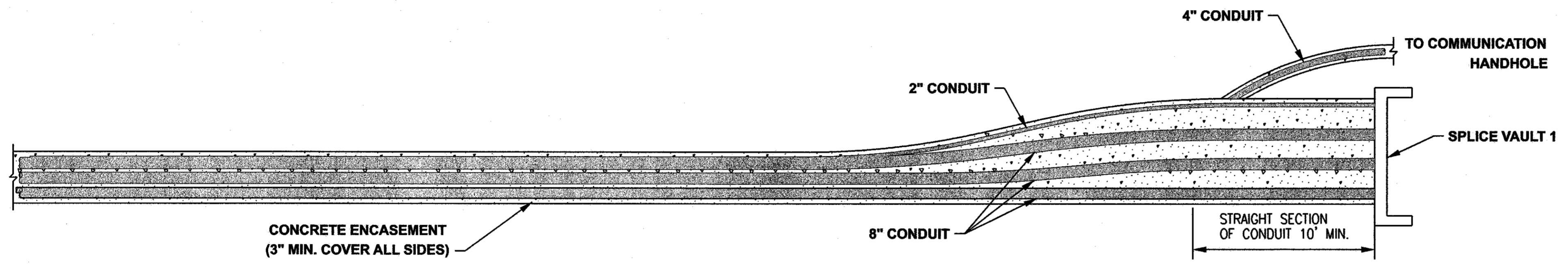

PROFILE

DUCT BANK CONDUIT TRANSITION
 DETAIL 1

COPYRIGHT © 2006 BURNS & McDONNELL ENGINEERING COMPANY, INC.

DOCKET No. 272

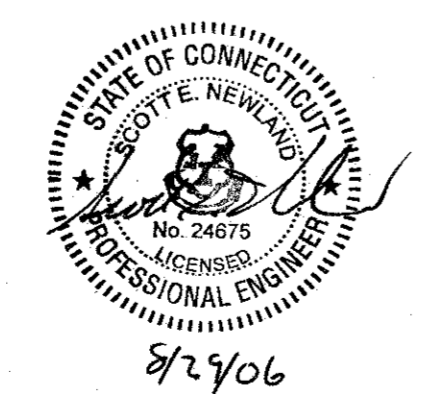

ISSUED FOR CONSTRUCTION

no.	date	revisions	by	chk
1	8/29/06	ISSUED FOR CONSTRUCTION	CTC	

Burns & McDonnell
SINCE 1898

date 07/05/06
designed C. COURTRIGHT

detailed L. ROWSE
checked S. NEWLAND

MF	NO.	DATE	REVISIONS	BY	CHK	APP	APP

NORTHEAST UTILITIES SERVICE CO.

FOR THE CONNECTICUT LIGHT & POWER COMPANY

TITLE MIDDLETOWN-NORWALK 345KV TRANSMISSION PROJECT
 CONDUIT TRANSITIONS

BY SEN-BMCD	CHKD	APP	APP
DATE 7-05-06	DATE	DATE	DATE
SCALE AS NOTED	D	DWG. NO. 01223-45003	PG 006

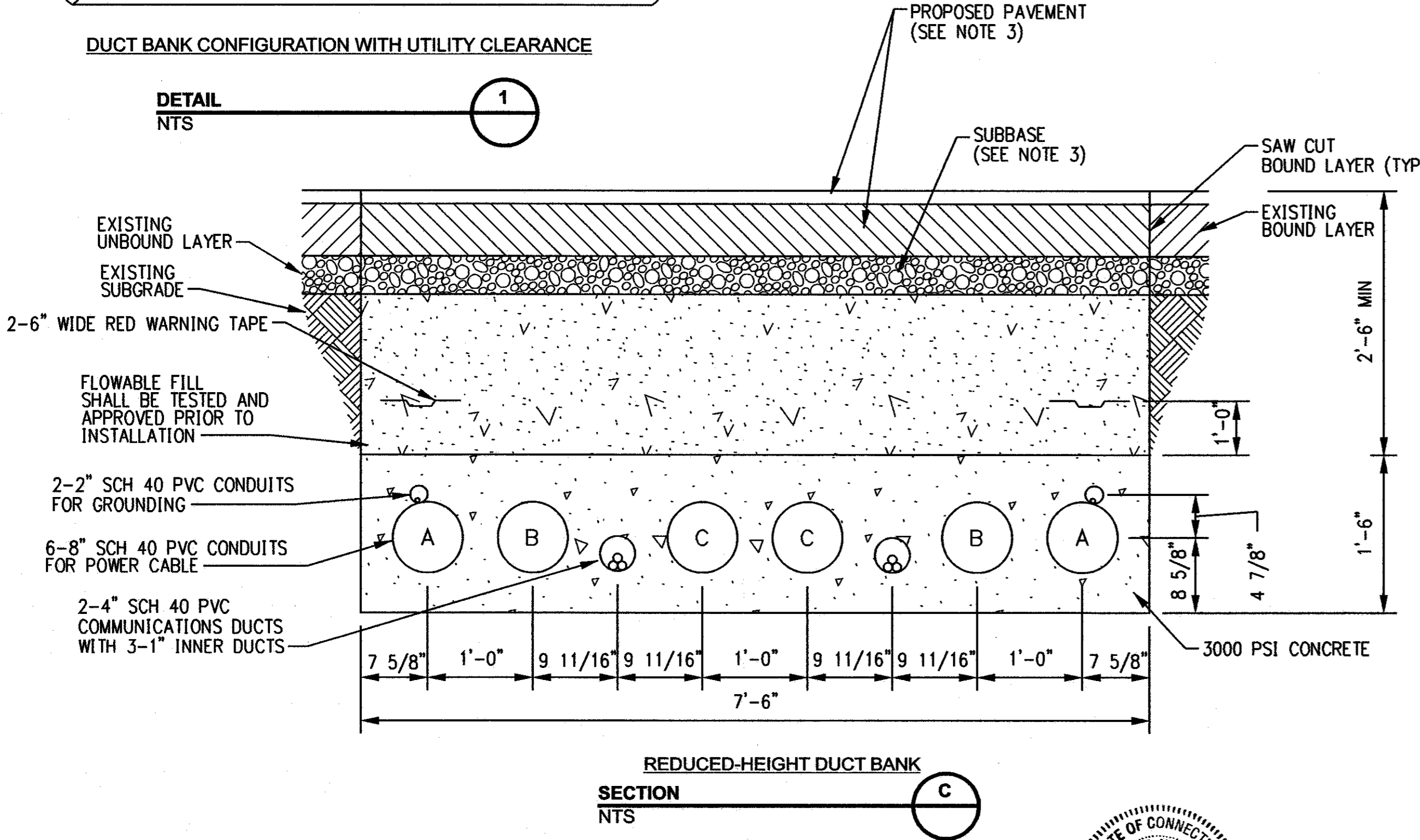
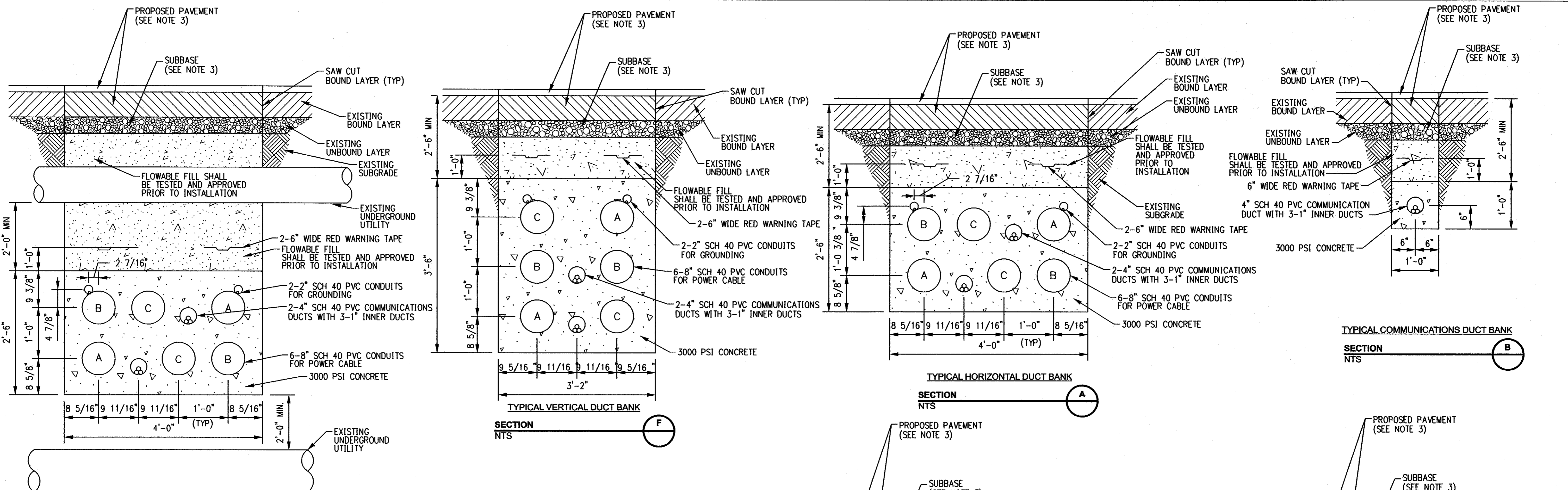

- GENERAL NOTES:**
- STANDARD TRENCH WITH PERMANENT PAVEMENT RESTORATION IN STATE HIGHWAY SHOWN. PAVEMENT RESTORATION REQUIREMENTS SHALL VARY DEPENDENT ON SPECIFIC EXISTING PAVEMENT CROSS SECTIONS AND MATERIALS.
 - OMITTED
 - REFERENCE RESTORATION DRAWINGS FOR PROPOSED PAVEMENT SECTIONS.

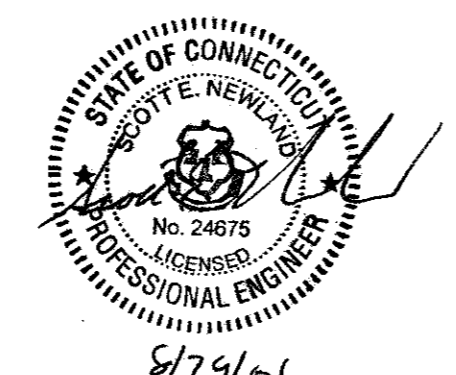

ISSUED FOR CONSTRUCTION

DOCKET No. 272

				NORTHEAST UTILITIES SERVICE CO. FOR THE CONNECTICUT LIGHT & POWER COMPANY TITLE MIDDLETOWN-NORWALK 345KV TRANSMISSION PROJECT TYPICAL DUCT BANK DETAILS			
				date 10/11/05 designed BL COMPANIES	detailed L. ROWSE checked S. NEWLAND	BY SEN-BMCD DATE 10-11-05	CHKD DATE
1 8/29/06 ISSUED FOR CONSTRUCTION CTC	no. date revisions by chk	MF NO. DATE REVISIONS BY CHK APP APP	SCALE AS NOTED	D	DWG. NO. 01223-46003 PG 001		

COPYRIGHT © 2008 BURNS & MCDONNELL ENGINEERING COMPANY, INC.

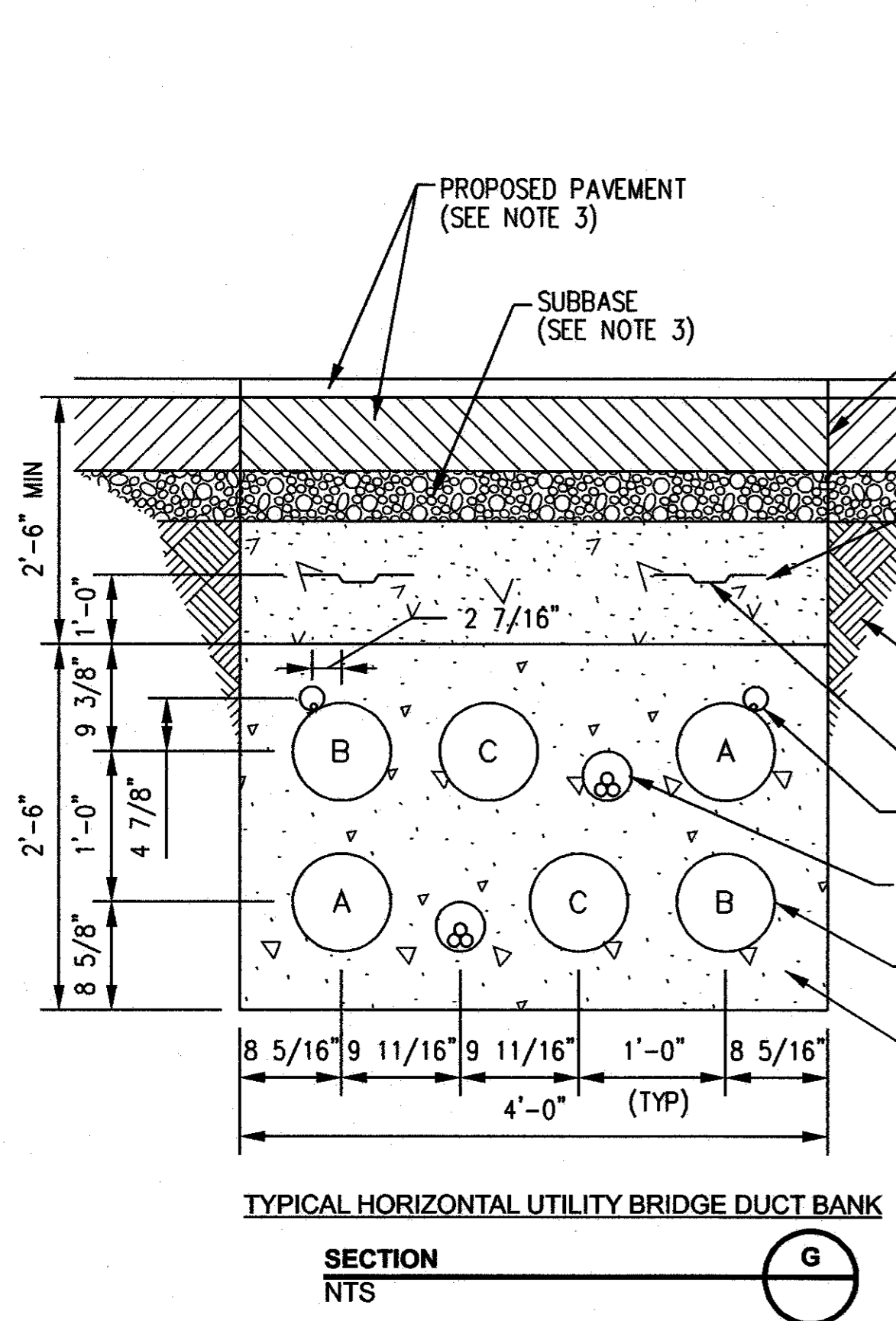

TYPICAL HORIZONTAL UTILITY BRIDGE DUCT BANK
SECTION NTS G

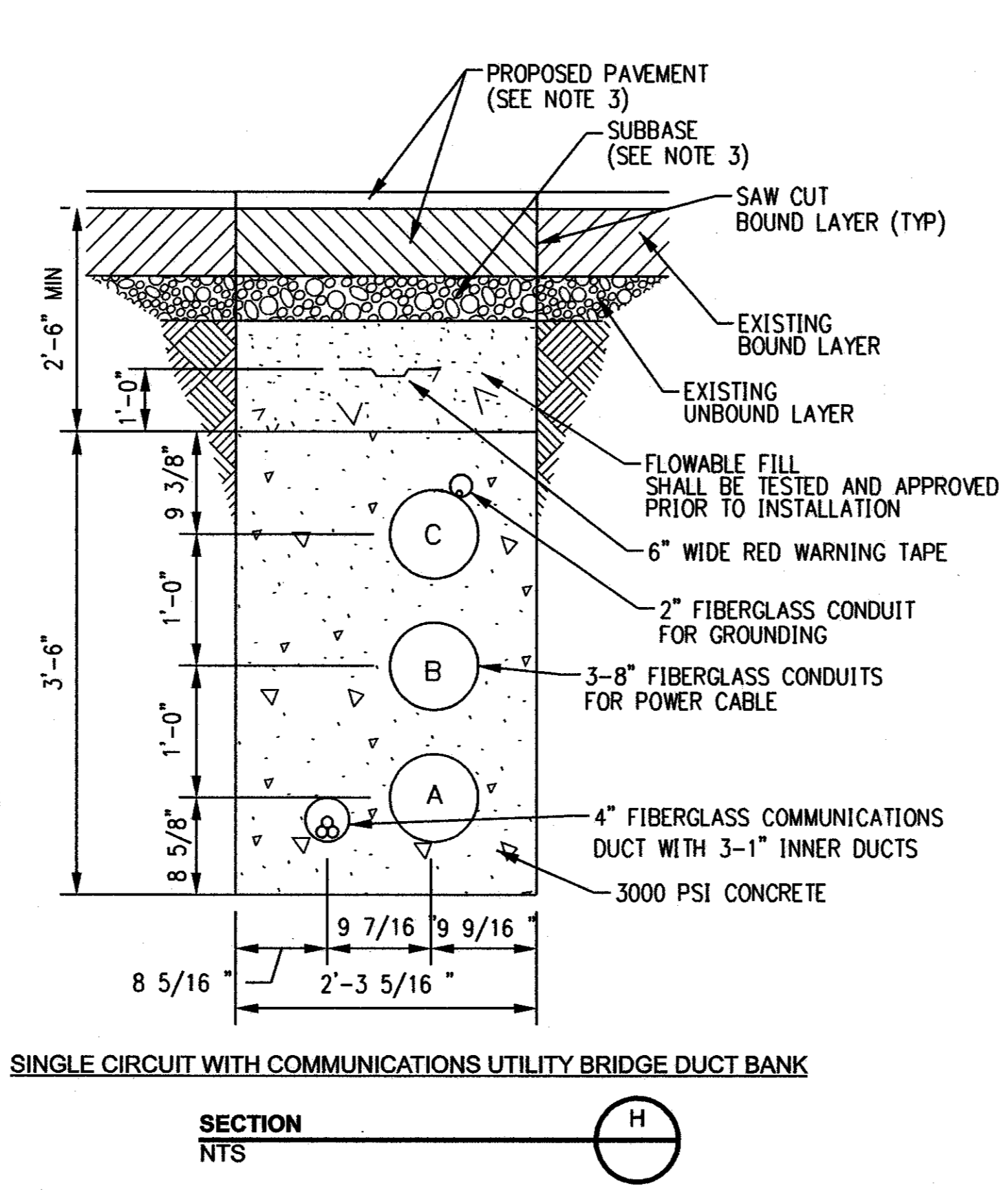

SINGLE CIRCUIT WITH COMMUNICATIONS UTILITY BRIDGE DUCT BANK
SECTION NTS H

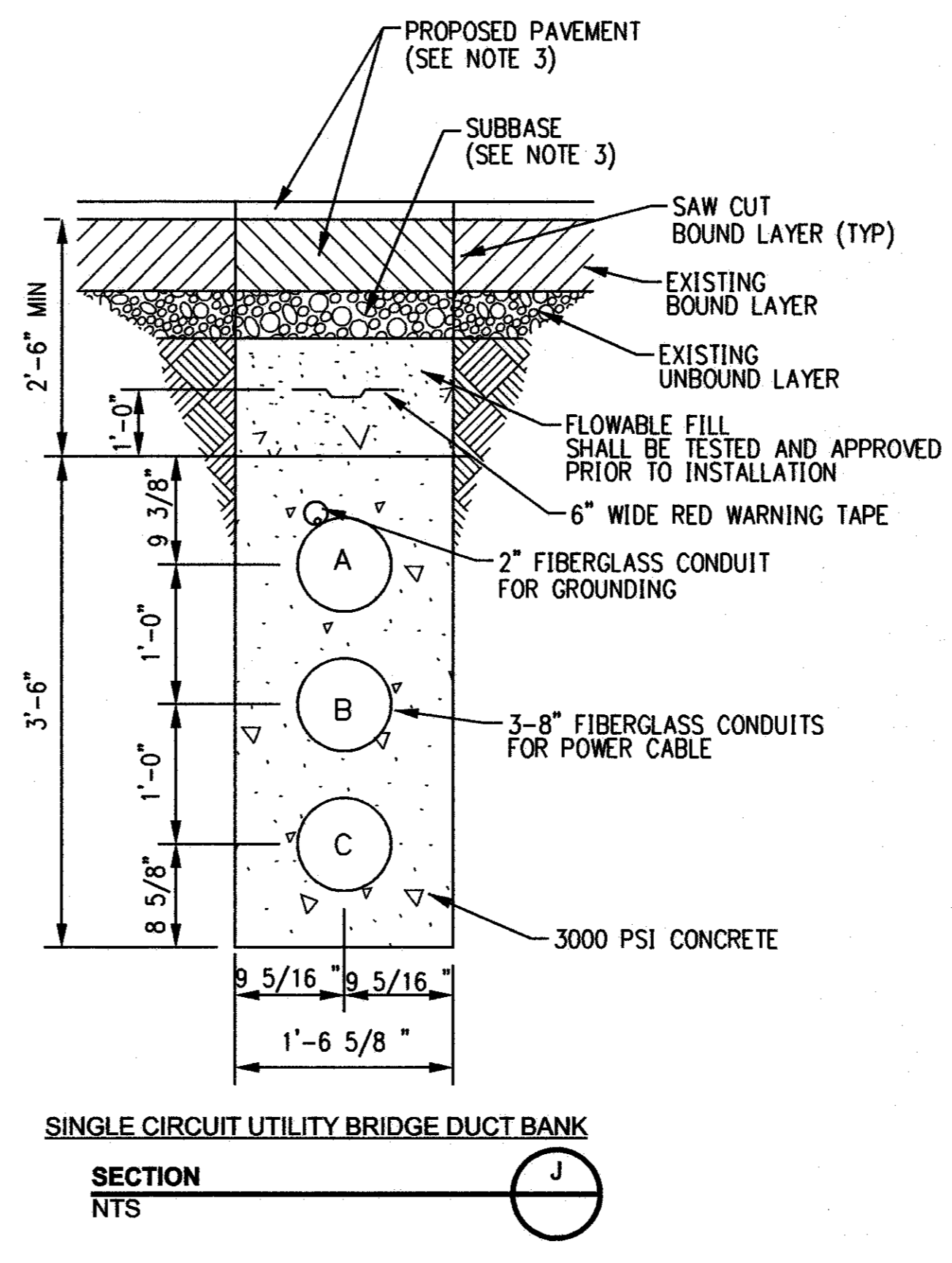

SINGLE CIRCUIT UTILITY BRIDGE DUCT BANK
SECTION NTS J

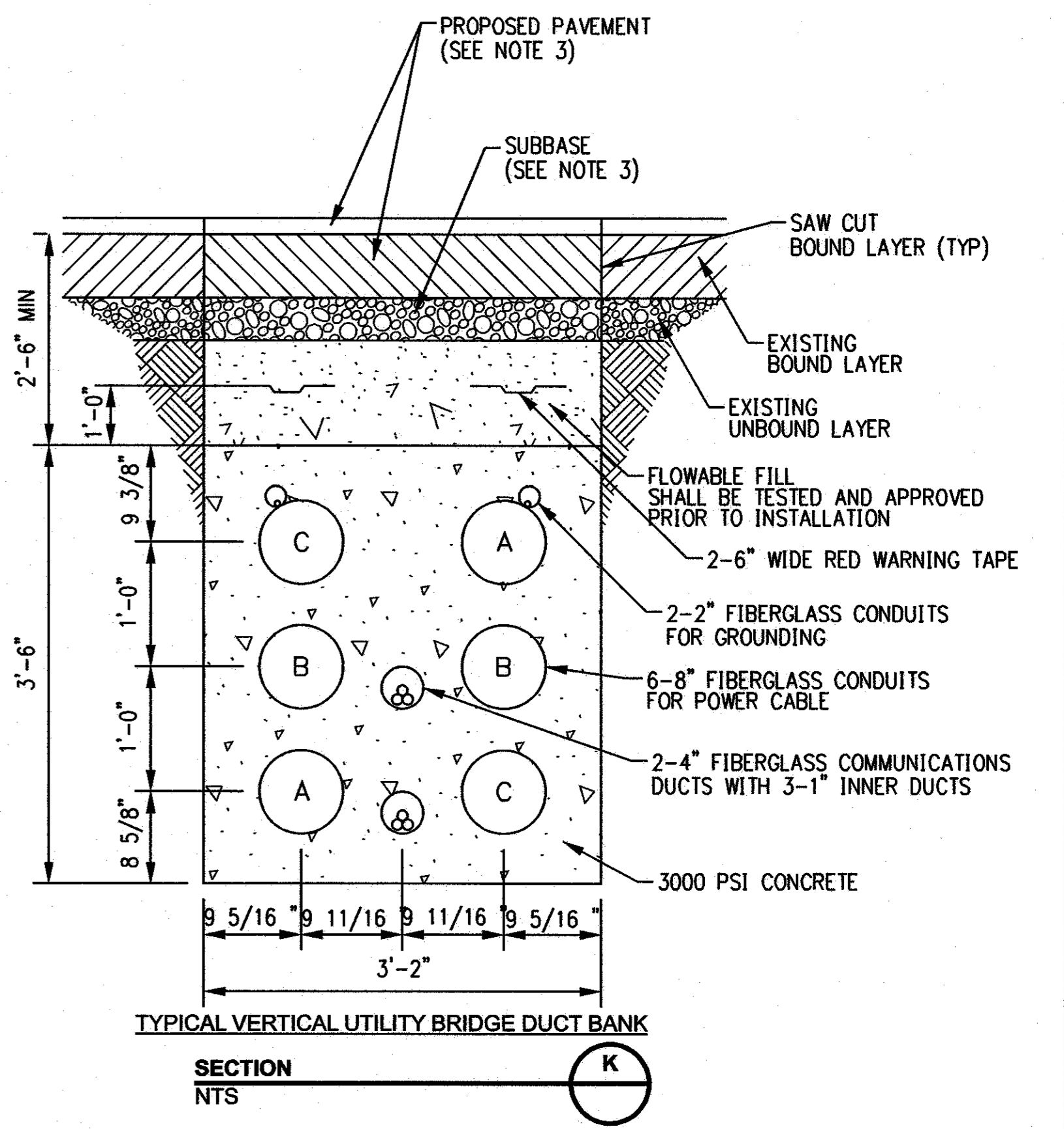

TYPICAL VERTICAL UTILITY BRIDGE DUCT BANK
SECTION NTS K

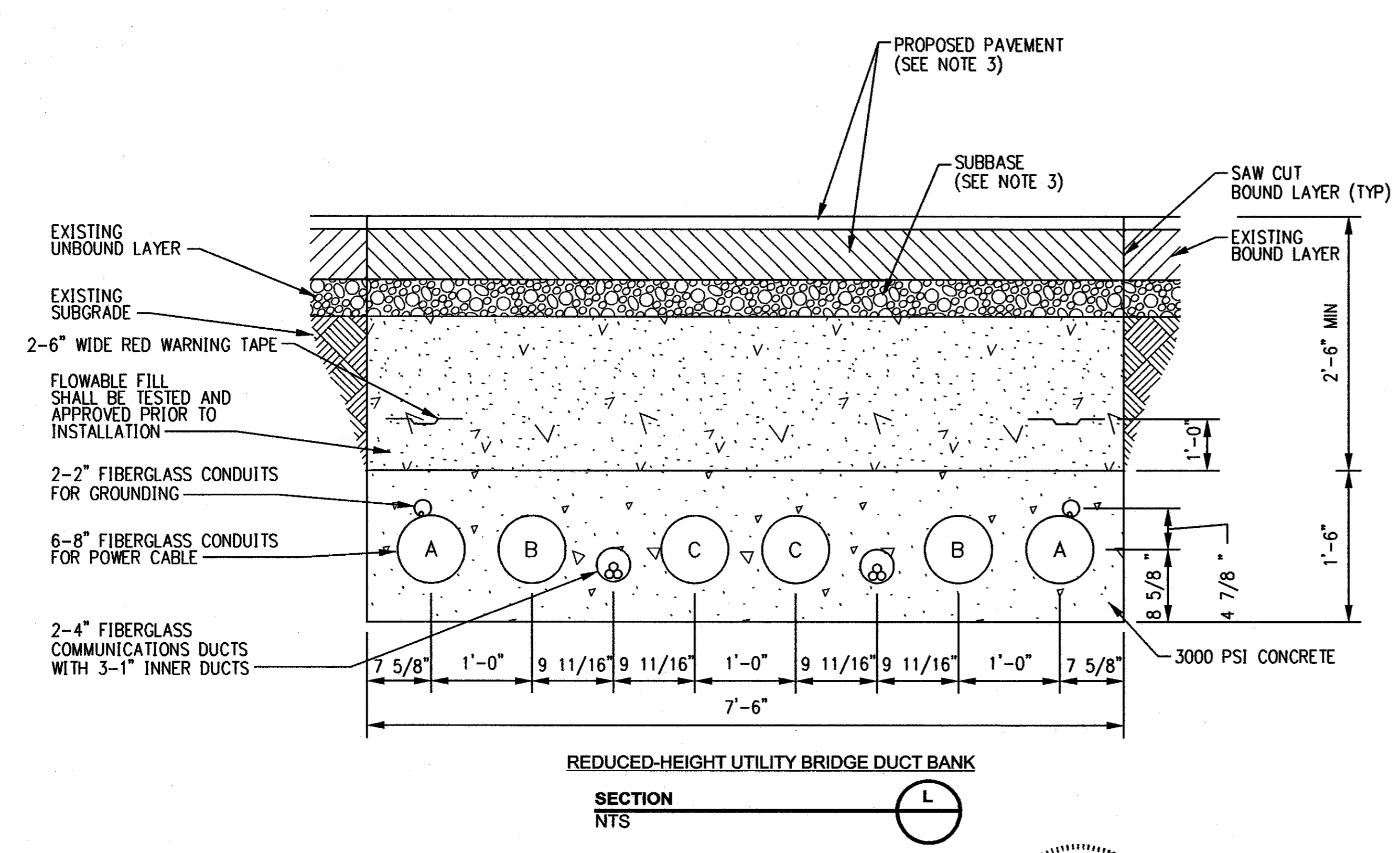

REDUCED-HEIGHT UTILITY BRIDGE DUCT BANK
SECTION NTS L

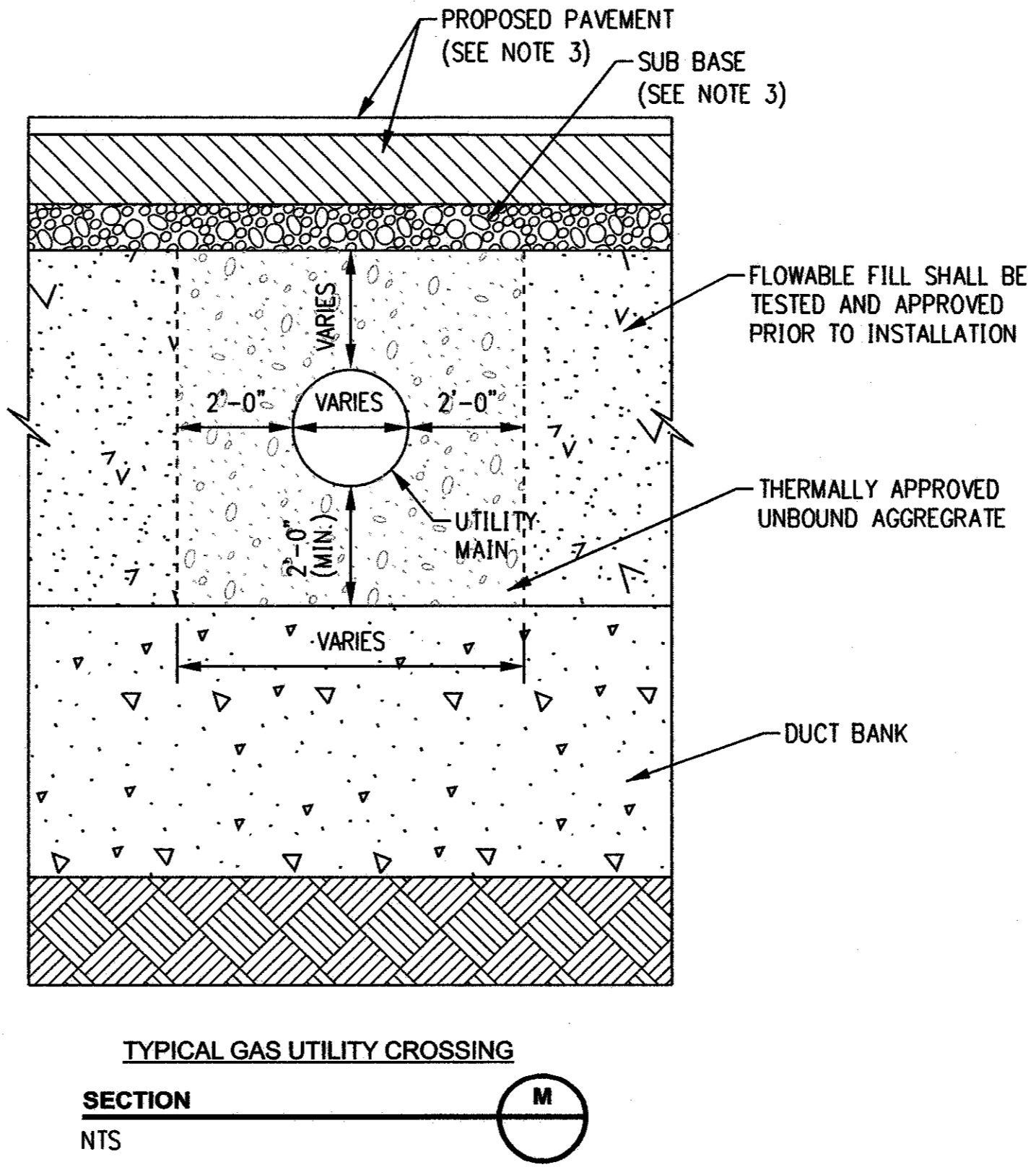

TYPICAL GAS UTILITY CROSSING
SECTION NTS M

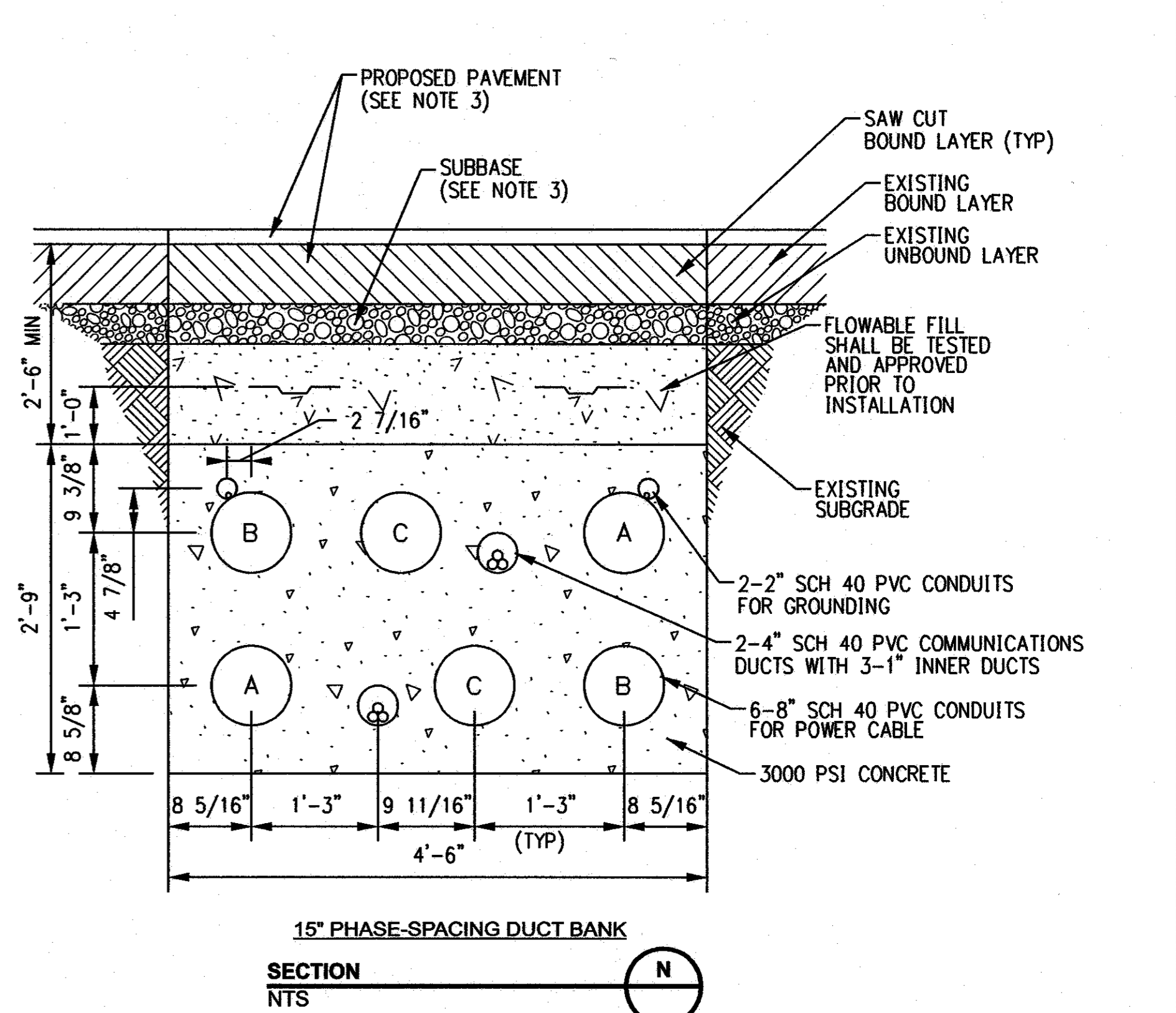

15" PHASE-SPACING DUCT BANK
SECTION NTS N

- GENERAL NOTES:
- STANDARD TRENCH WITH PERMANENT PAVEMENT RESTORATION IN STATE HIGHWAY SHOWN. PAVEMENT RESTORATION REQUIREMENTS SHALL VARY DEPENDENT ON SPECIFIC EXISTING PAVEMENT CROSS SECTIONS AND MATERIALS.
 - ALL FIBERGLASS CONDUITS SHALL BE OF BULLET-RESISTANT GRADE OR APPROVED OTHER.
 - REFERENCE RESTORATION DRAWINGS FOR PROPOSED PAVEMENT SECTIONS.

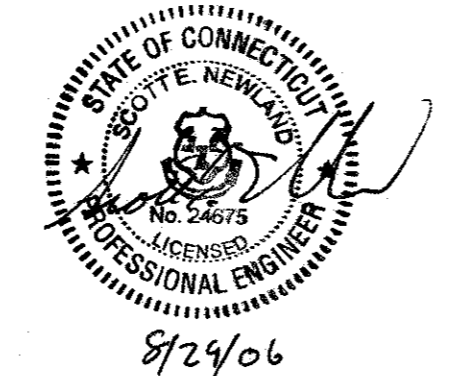

ISSUED FOR CONSTRUCTION

DOCKET No. 272



date 4/15/06 detailed L. ROWSE
designed C. COURTRIGHT checked S. NEWLAND

no.	date	revisions	by	chk
1	8/29/06	ISSUED FOR CONSTRUCTION	CTC	

MF	NO.	DATE	REVISIONS	BY	CHK	APP	APP

NORTHEAST UTILITIES SERVICE CO.			
FOR THE CONNECTICUT LIGHT & POWER COMPANY			
TITLE MIDDLETOWN-NORWALK 345KV TRANSMISSION PROJECT			
UTILITY BRIDGE DUCT BANK DETAILS AND UTILITY CROSSING DETAIL			
BY SEN-BMCD	CHKD	APP	APP
DATE 4-15-06	DATE	DATE	DATE
SCALE AS NOTED	D	DWG. NO. 01223-46003	PG 002

COPYRIGHT © 2006 BURNS & MCDONNELL ENGINEERING COMPANY, INC.

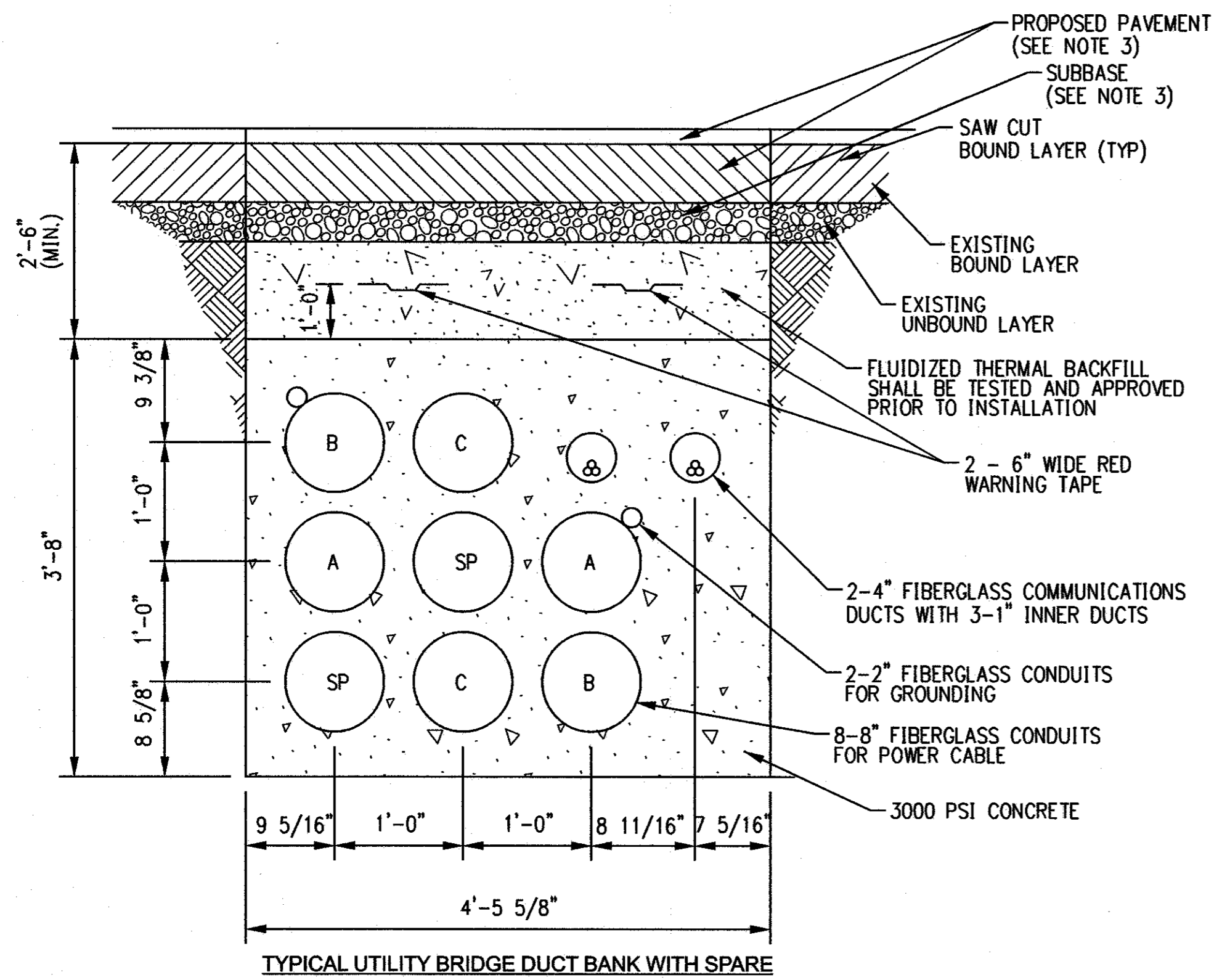

TYPICAL UTILITY BRIDGE DUCT BANK WITH SPARE

SECTION O
NTS

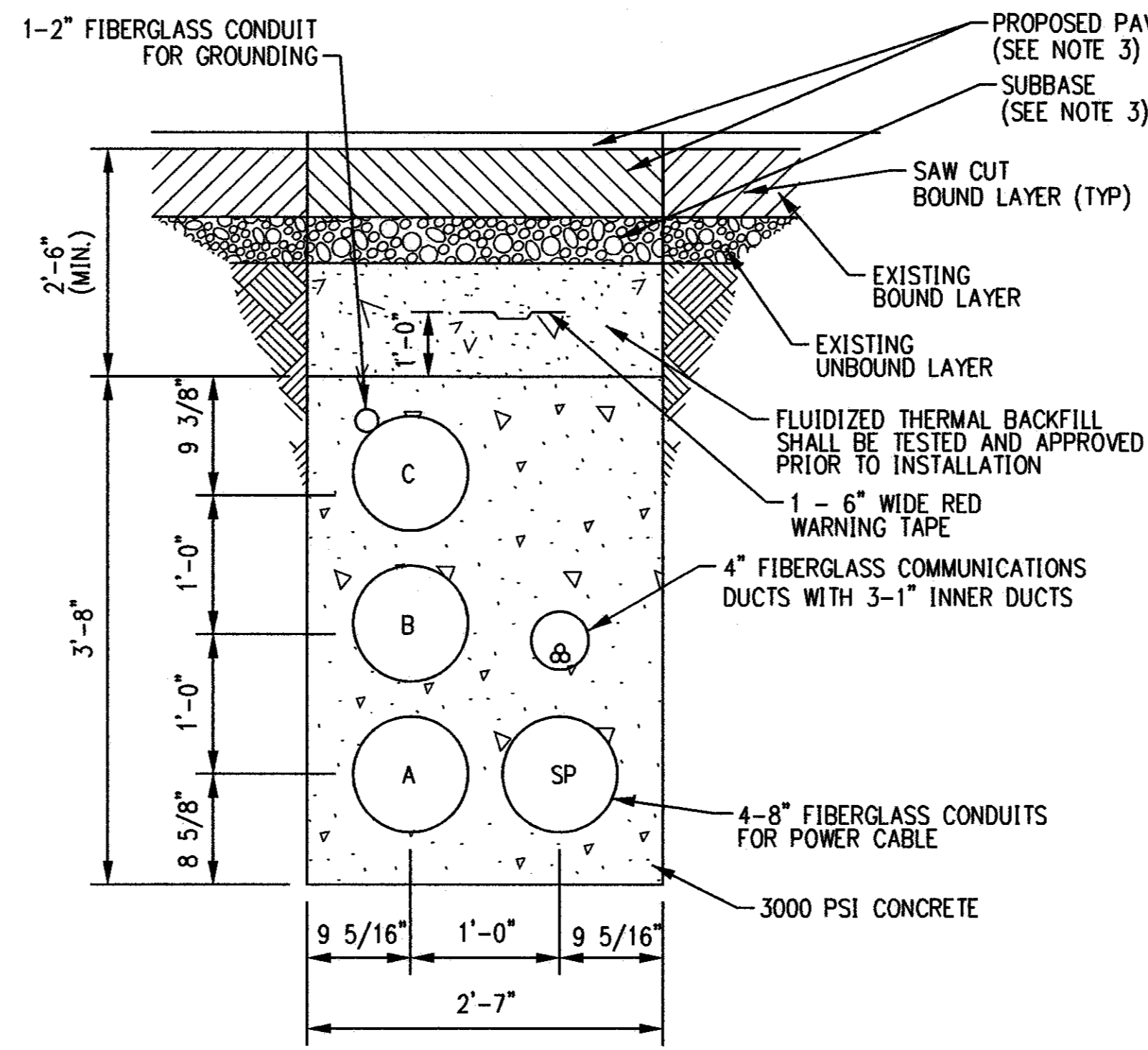

UTILITY BRIDGE SINGLE CIRCUIT WITH COMMUNICATIONS DUCT BANK AND SPARE

SECTION P
NTS

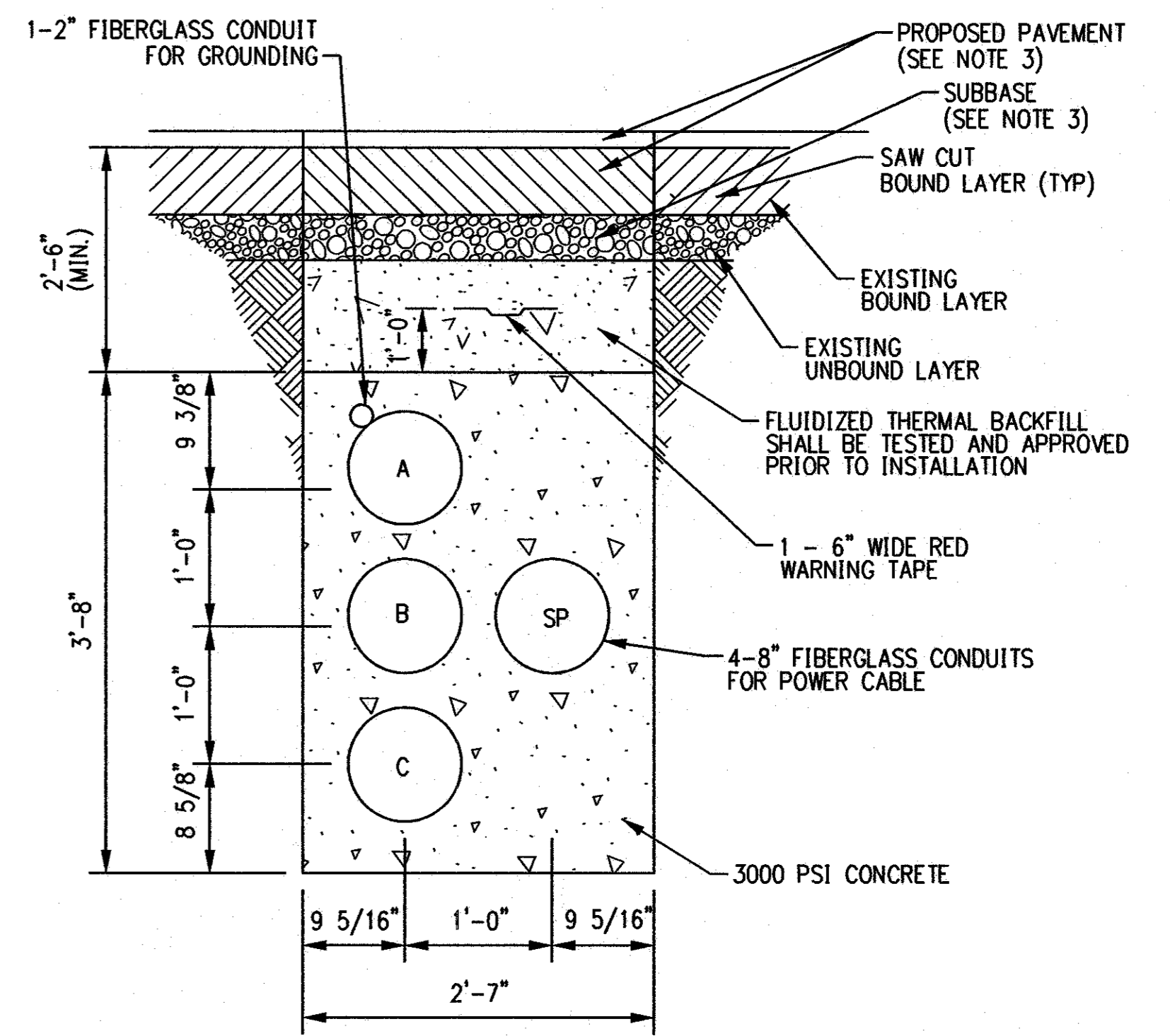

UTILITY BRIDGE SINGLE CIRCUIT DUCT BANK WITH SPARE

SECTION Q
NTS

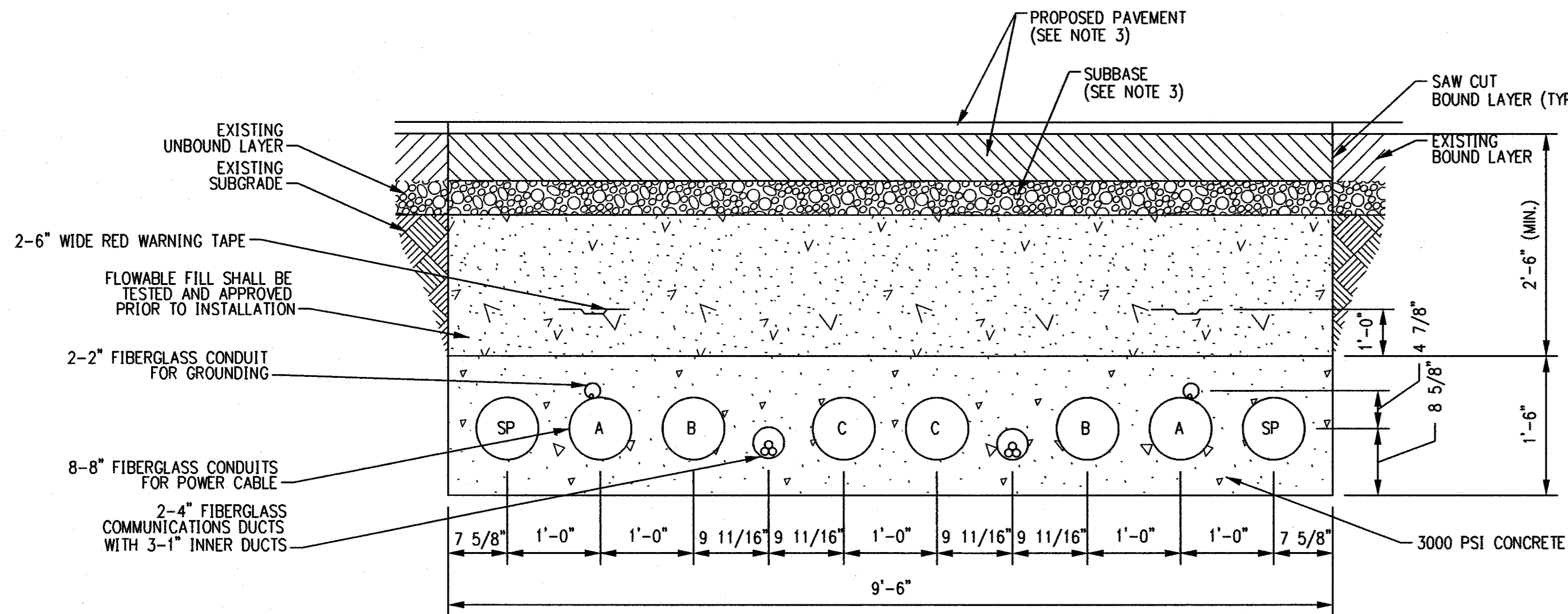

UTILITY BRIDGE REDUCED-HEIGHT DUCT BANK WITH SPARE

SECTION R
NTS

GENERAL NOTES:

- STANDARD TRENCH WITH PERMANENT PAVEMENT RESTORATION IN STATE HIGHWAY SHOWN. PAVEMENT RESTORATION REQUIREMENTS SHALL VARY DEPENDENT ON SPECIFIC EXISTING PAVEMENT CROSS SECTIONS AND MATERIALS.
- ALL FIBERGLASS CONDUITS SHALL BE OF BULLET-RESISTANT GRADE OR APPROVED OTHER.
- REFERENCE RESTORATION DRAWINGS FOR PROPOSED PAVEMENT SECTIONS.

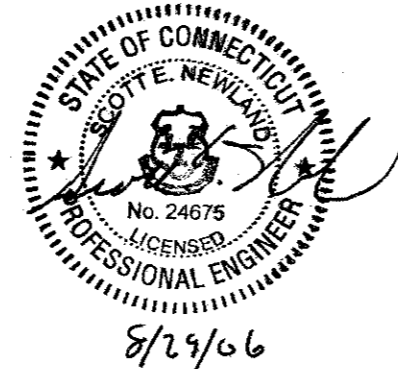

ISSUED FOR CONSTRUCTION

DOCKET No. 272

no.	date	revisions	by	chk
1	8/29/06	ISSUED FOR CONSTRUCTION	CTC	

date	4/15/06	detailed	L. ROWSE
designed	C. COURTRIGHT	checked	S. NEWLAND



NORTHEAST UTILITIES SERVICE CO.

FOR THE CONNECTICUT LIGHT & POWER COMPANY
TITLE MIDDLETOWN-NORWALK 345KV TRANSMISSION PROJECT
UTILITY BRIDGE DUCT BANK DETAILS

BY SEN-BMCD	CHKD	APP	APP
DATE 4-15-06	DATE	DATE	DATE
SCALE AS NOTED		DWG. NO.	01223-46003 PG 003

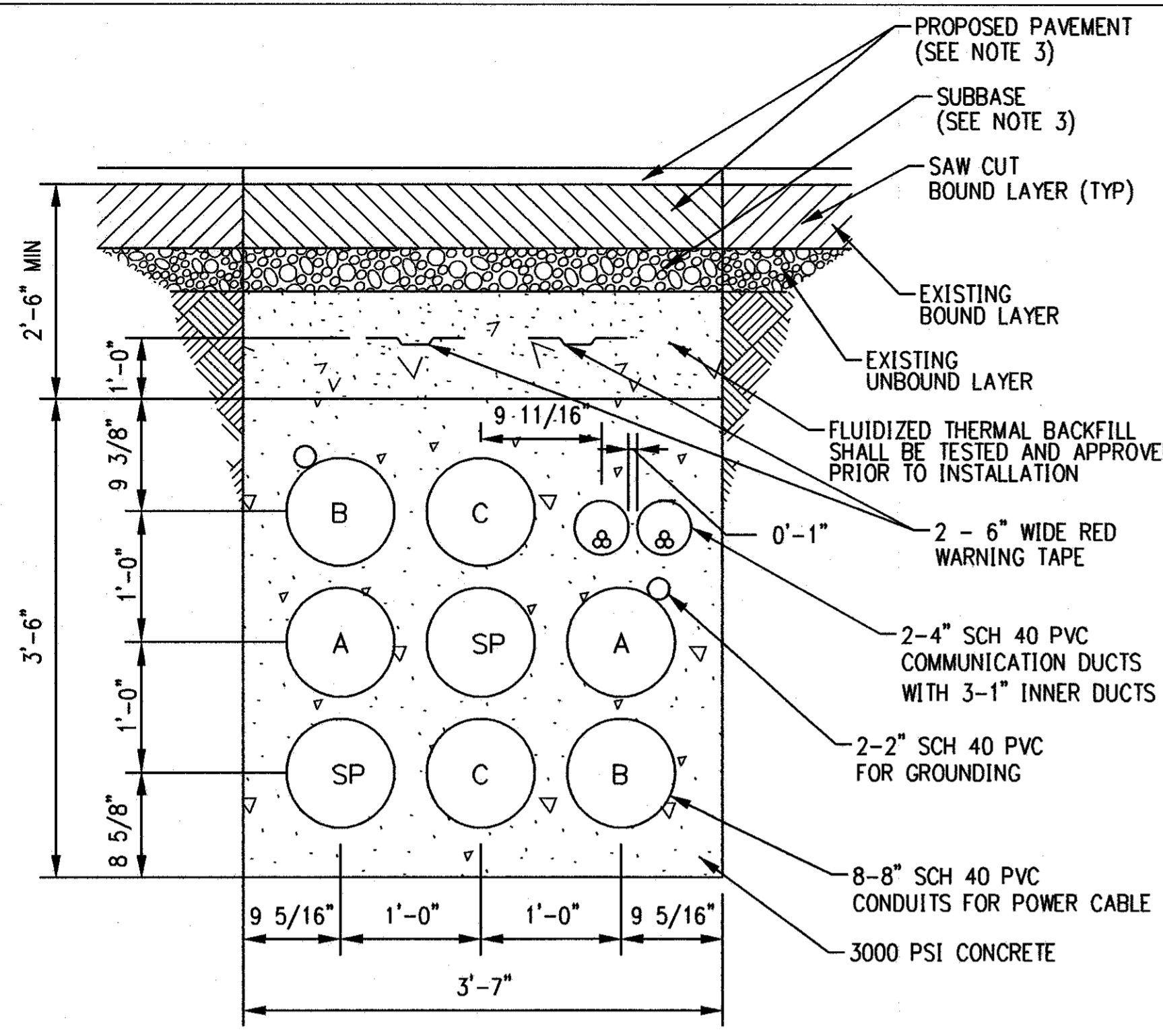

TYPICAL JACK AND BORE DUCT BANK

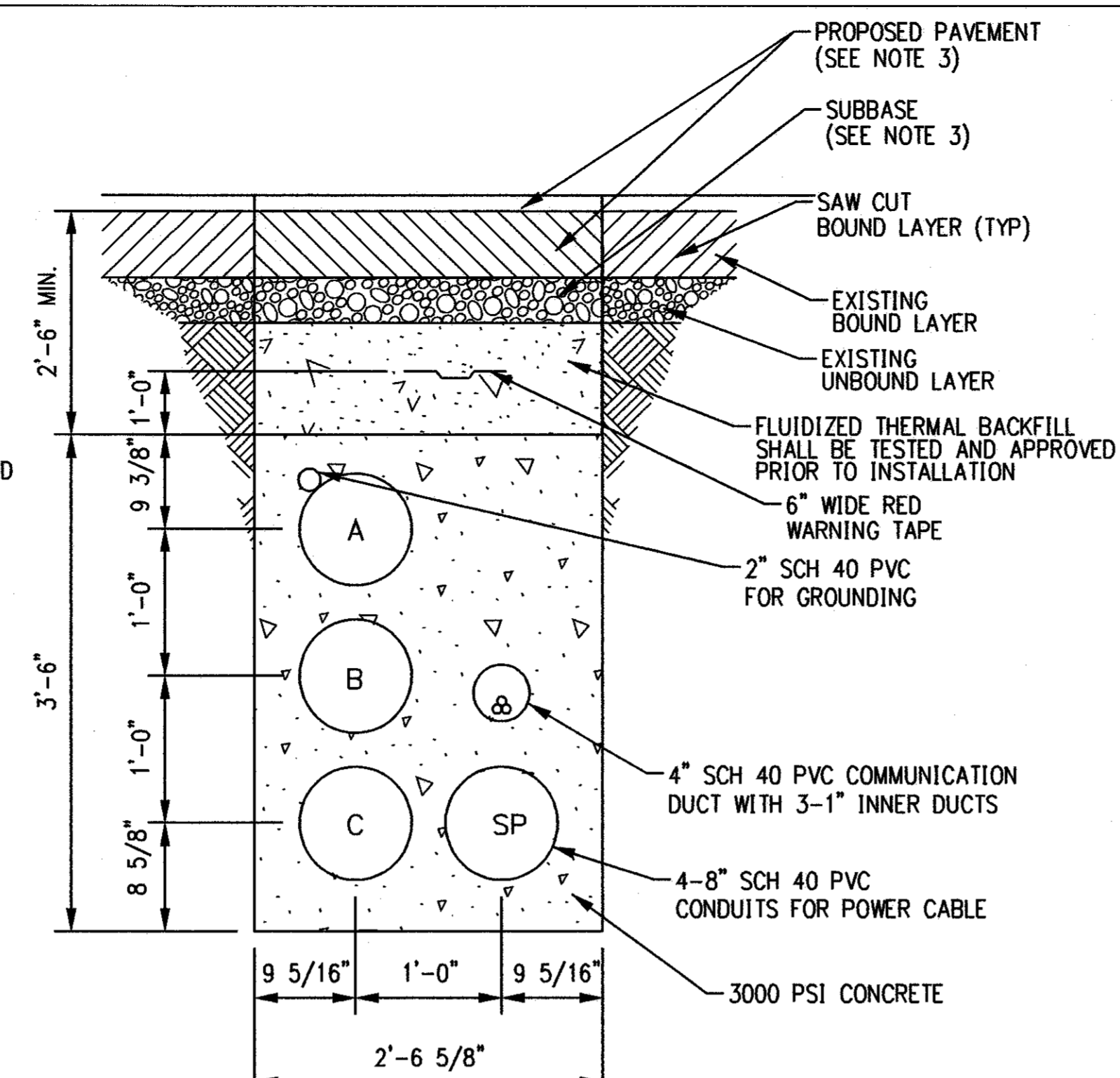

JACK AND BORE SINGLE CIRCUIT WITH COMMUNICATIONS DUCT BANK

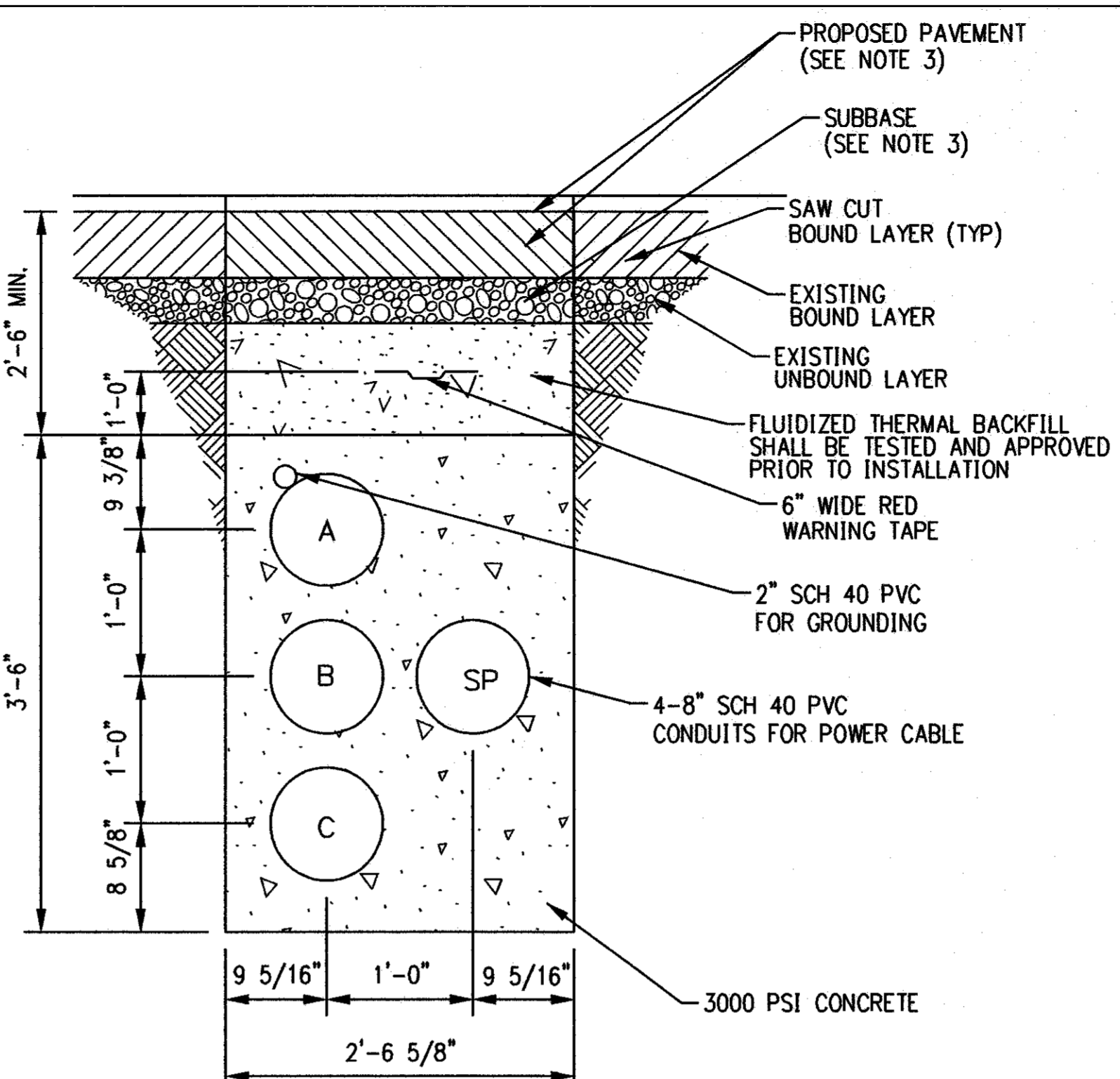

JACK AND BORE SINGLE CIRCUIT DUCT BANK

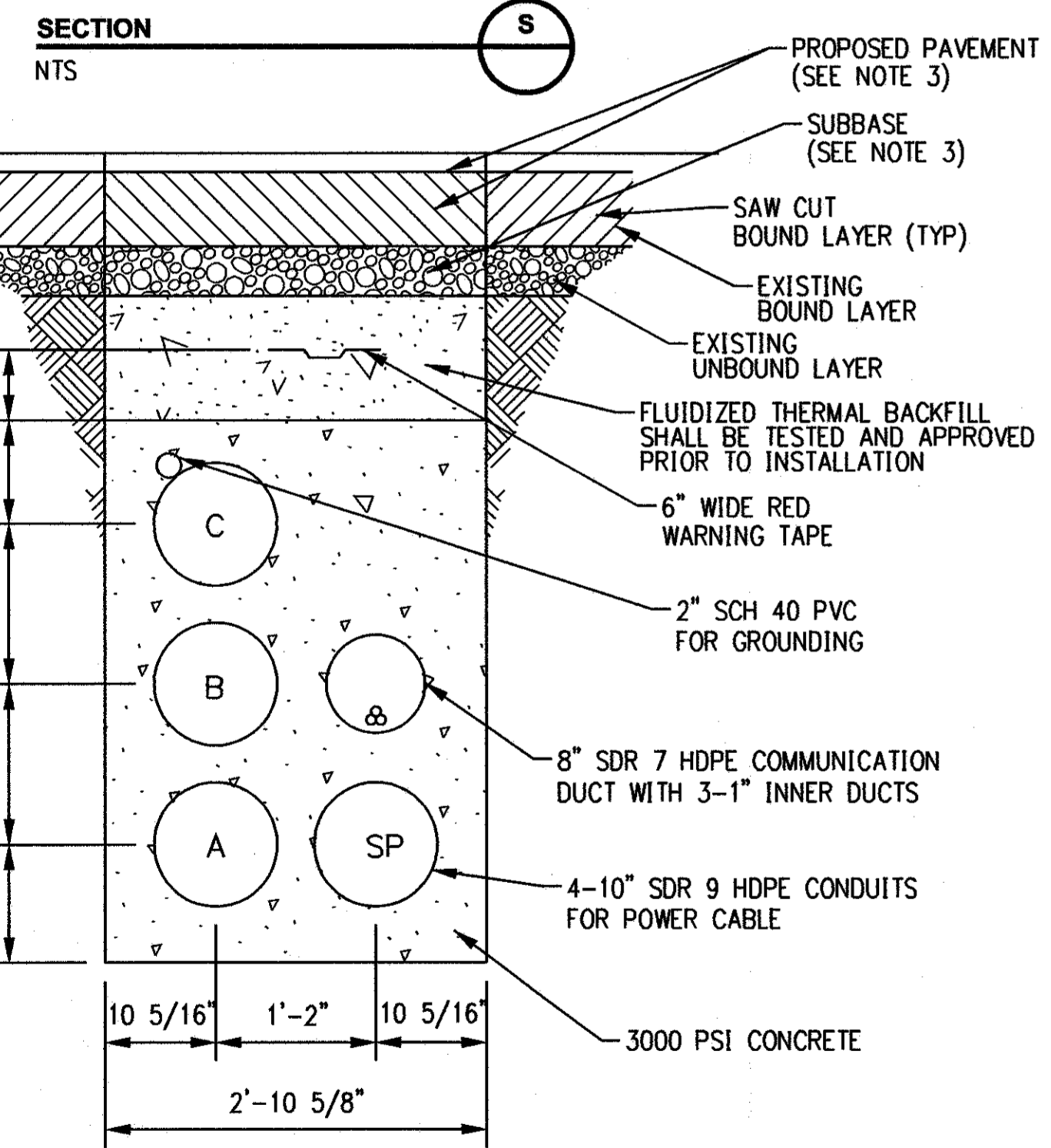

HORIZONTAL DIRECTIONAL DRILL SINGLE CIRCUIT WITH COMMUNICATIONS DUCT BANK

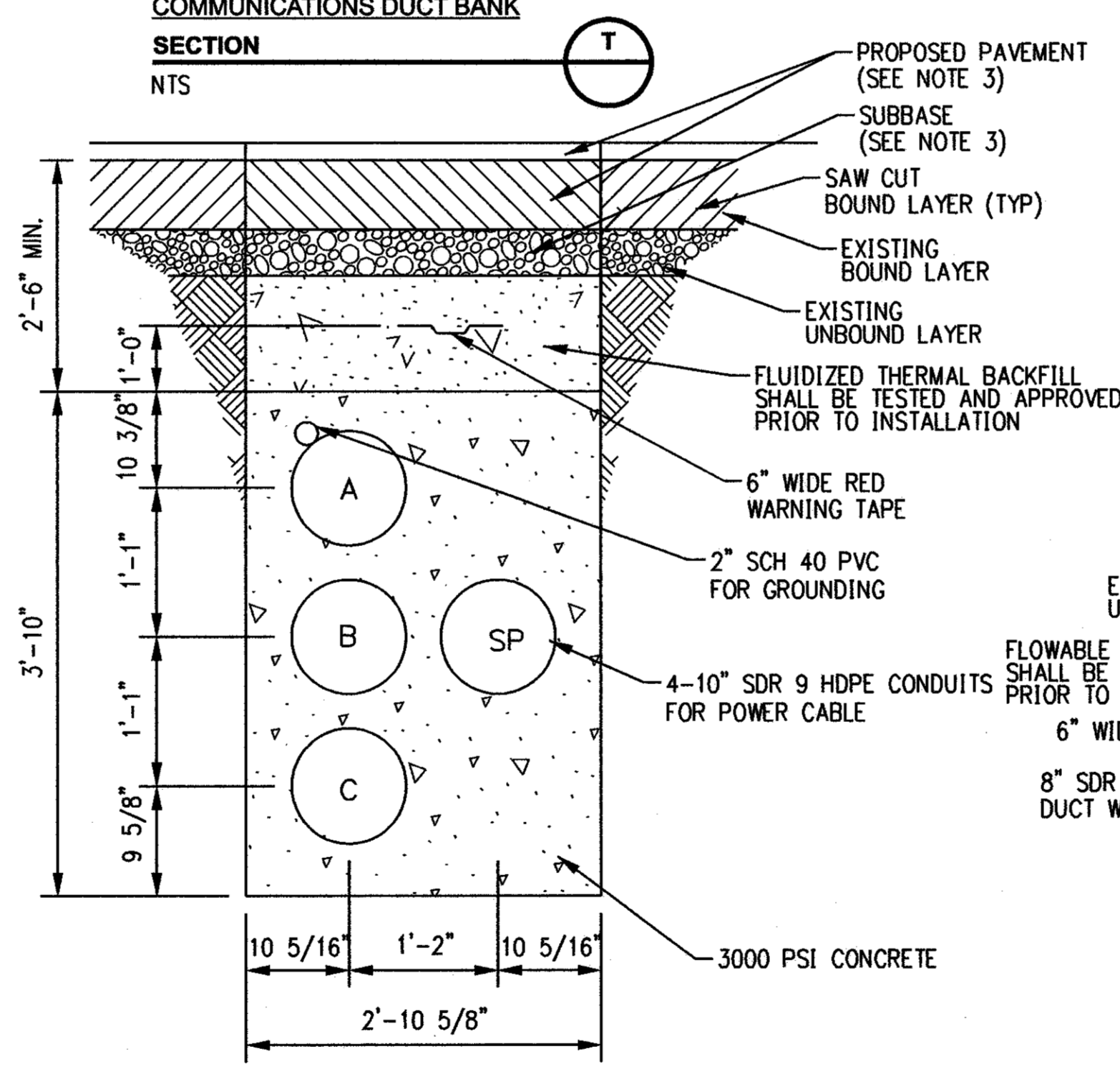

HORIZONTAL DIRECTIONAL DRILL SINGLE CIRCUIT DUCT BANK

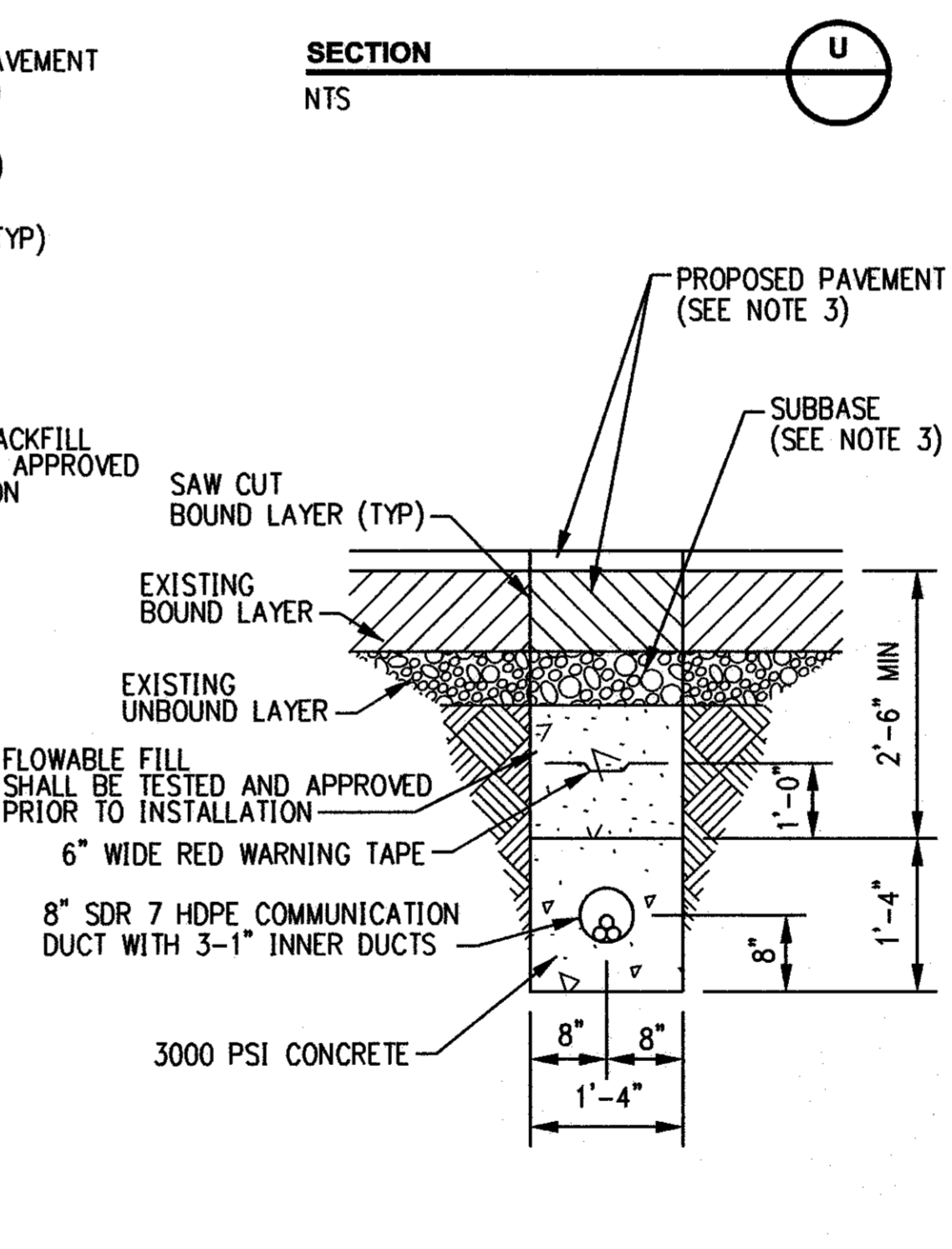

HORIZONTAL DIRECTIONAL DRILL COMMUNICATIONS DUCT BANK

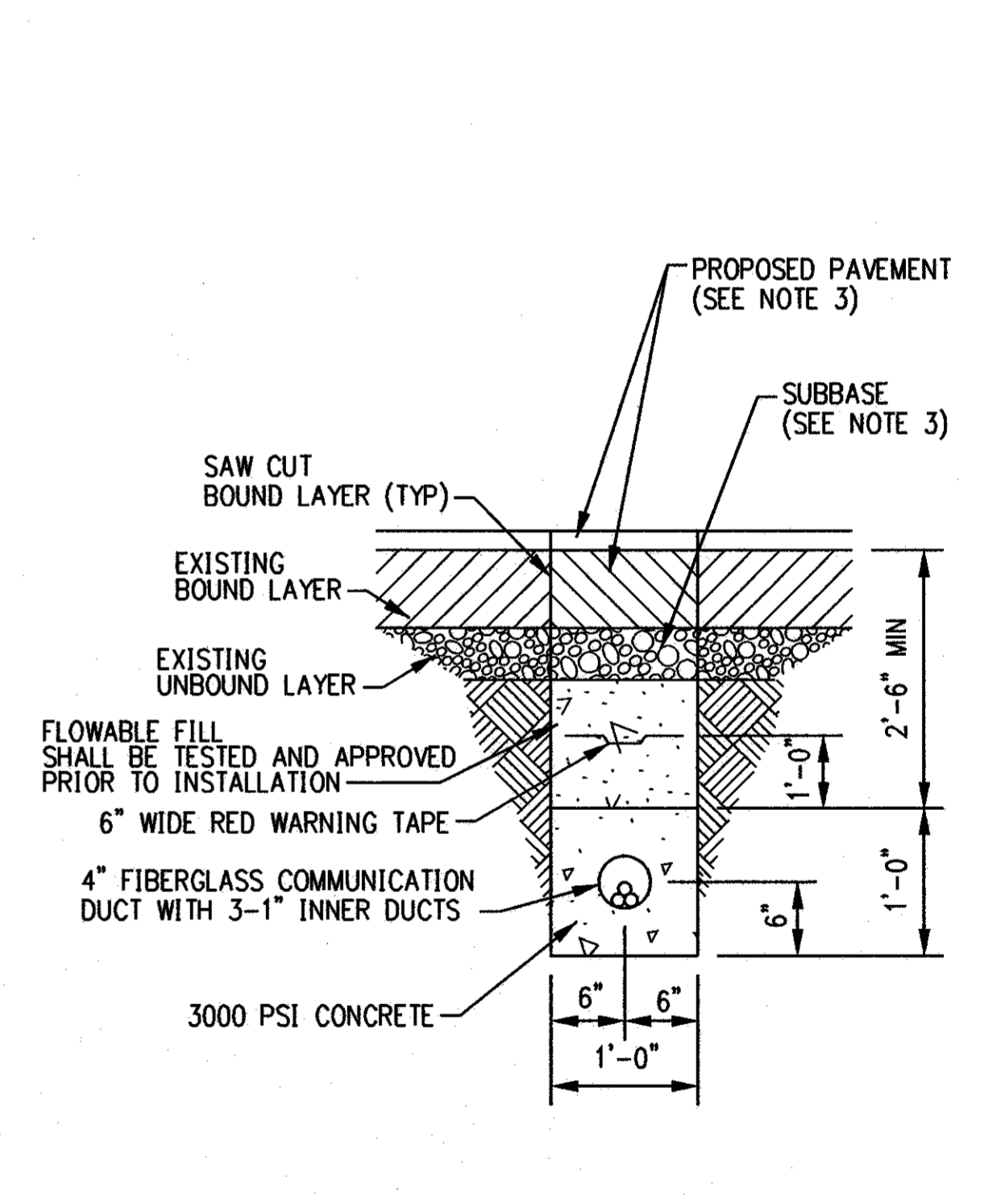

UTILITY BRIDGE COMMUNICATIONS DUCT BANK

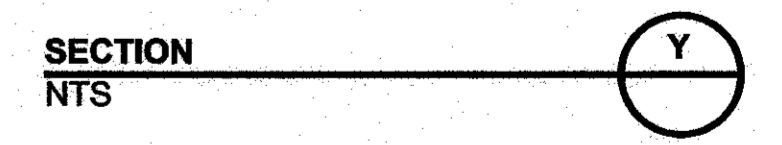
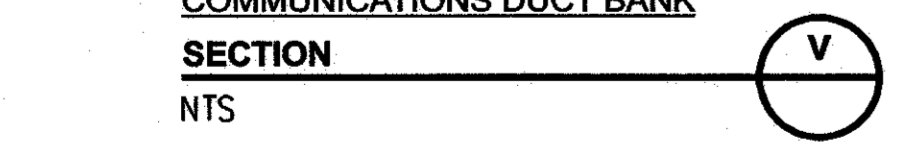

- GENERAL NOTES:
- STANDARD TRENCH WITH PERMANENT PAVEMENT RESTORATION IN STATE HIGHWAY SHOWN. PAVEMENT RESTORATION REQUIREMENTS SHALL VARY DEPENDENT ON SPECIFIC EXISTING PAVEMENT CROSS SECTIONS AND MATERIALS.
 - ALL FIBERGLASS CONDUITS SHALL BE OF BULLET-RESISTANT GRADE OR APPROVED OTHER.
 - REFERENCE RESTORATION DRAWINGS FOR PROPOSED PAVEMENT SECTIONS.

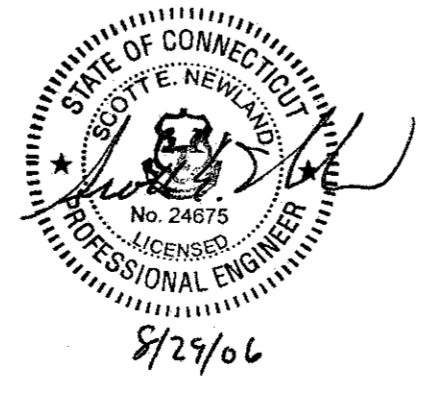

ISSUED FOR CONSTRUCTION



date 4/15/06 detailed L. ROWSE
 designed C. COURTRIGHT checked S. NEWLAND

no.	date	revisions	by	chk
1	8/29/06	ISSUED FOR CONSTRUCTION	CTC	

WF	NO.	DATE	REVISIONS	BY	CHK	APP	APP

NORTHEAST UTILITIES SERVICE CO.			
FOR THE CONNECTICUT LIGHT & POWER COMPANY			
TITLE MIDDLETOWN-NORWALK 345KV TRANSMISSION PROJECT JACK AND BORE AND HORIZONTAL DIRECTIONAL DRILL DUCT BANK DETAILS			
BY SEN-BMCD	CHKD	APP	APP
DATE 4-15-06	DATE	DATE	DATE
SCALE AS NOTED	D	DWG. NO. 01223-46003	PG 004

DOCKET No. 272

COPYRIGHT © 2006 BURNS & MCDONNELL ENGINEERING COMPANY, INC.

Cable Pulling Direction and Tension			
Middletown-Norwalk 345-kV Transmission Line Project Segment 3 Milford, Connecticut			
Cable Pulling Direction	Calculated Tension (lb.)	Calculated Maximum Side Wall Pressure (lb/ft.)	
From Vault	To Vault		
SC18 (UI Portion)	1	14,900	70
2	1	19,600	280
2	3	13,200	70
4	3	11,900	30
5	4	12,600	120
6	5	15,900	160
7	6	11,400	110
7	East Devon S/S	8,574	25

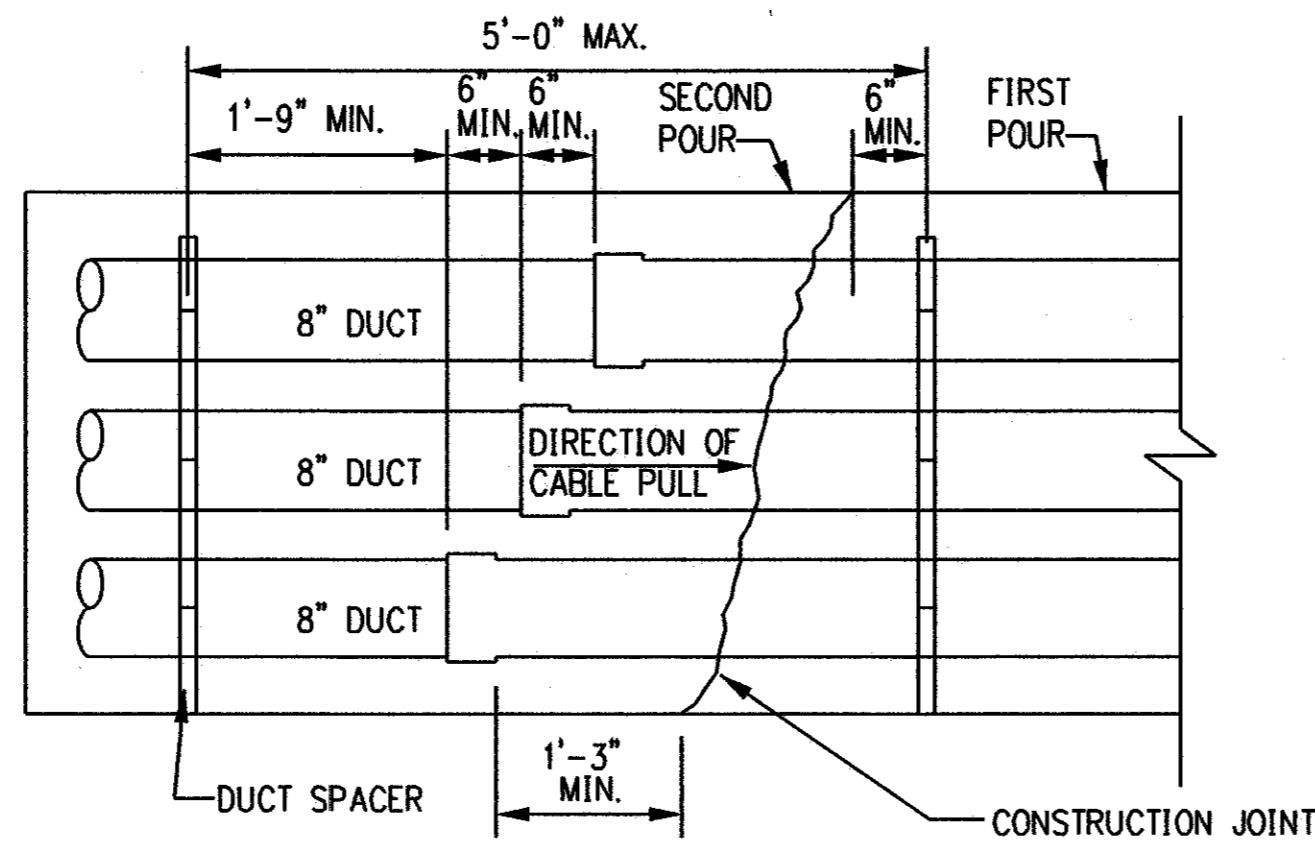

CONSTRUCTION JOINT DETAIL

DETAIL 1
NTS

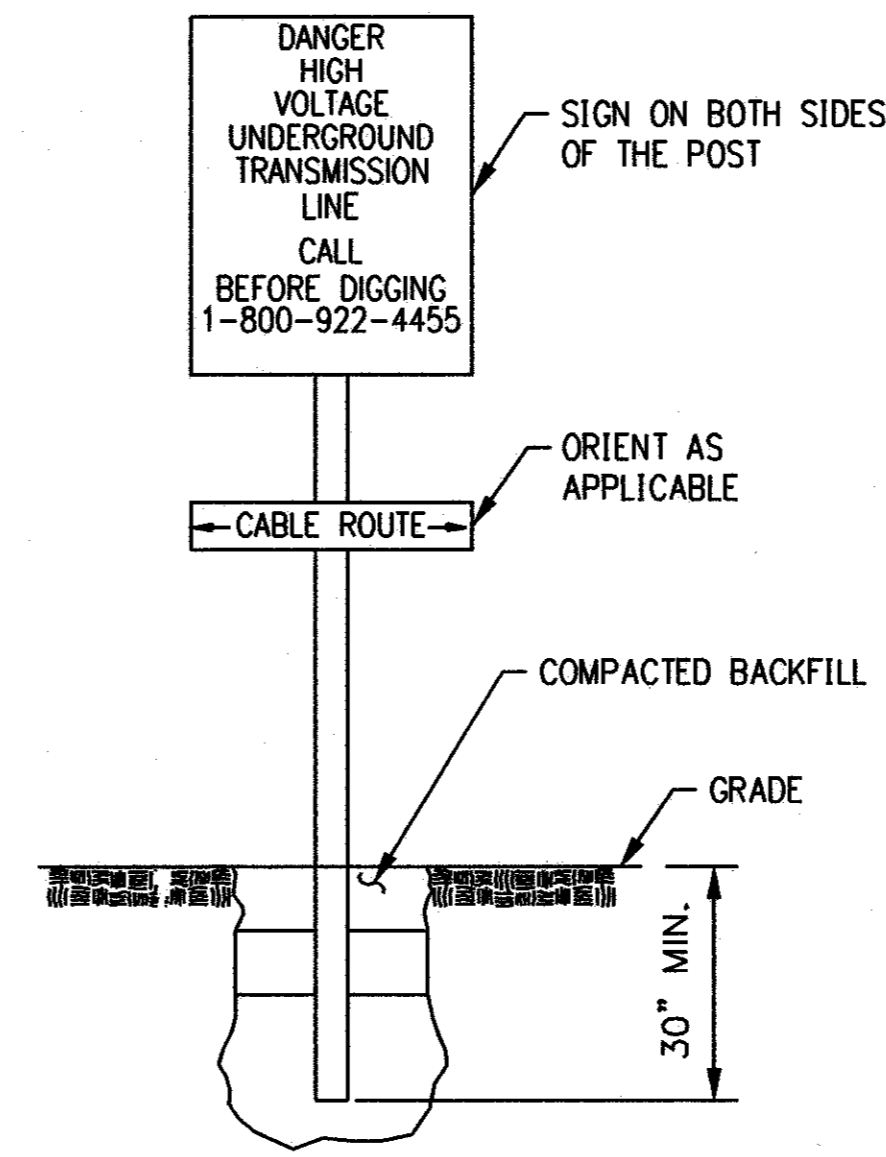

TYPICAL WARNING SIGN

DETAIL 2
NTS

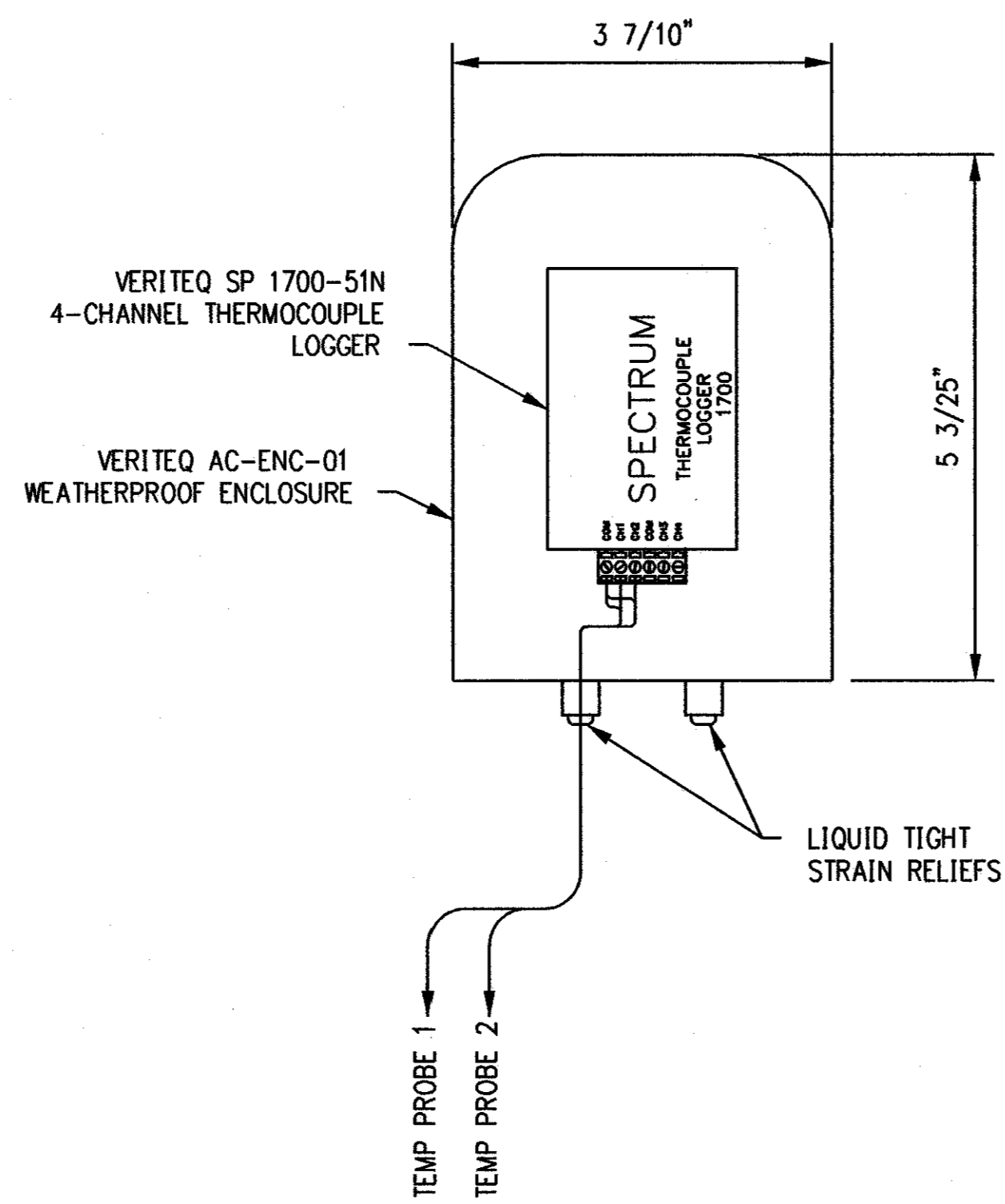

THERMOCOUPLE TEMPERATURE DATA LOGGER

DETAIL 4
NTS

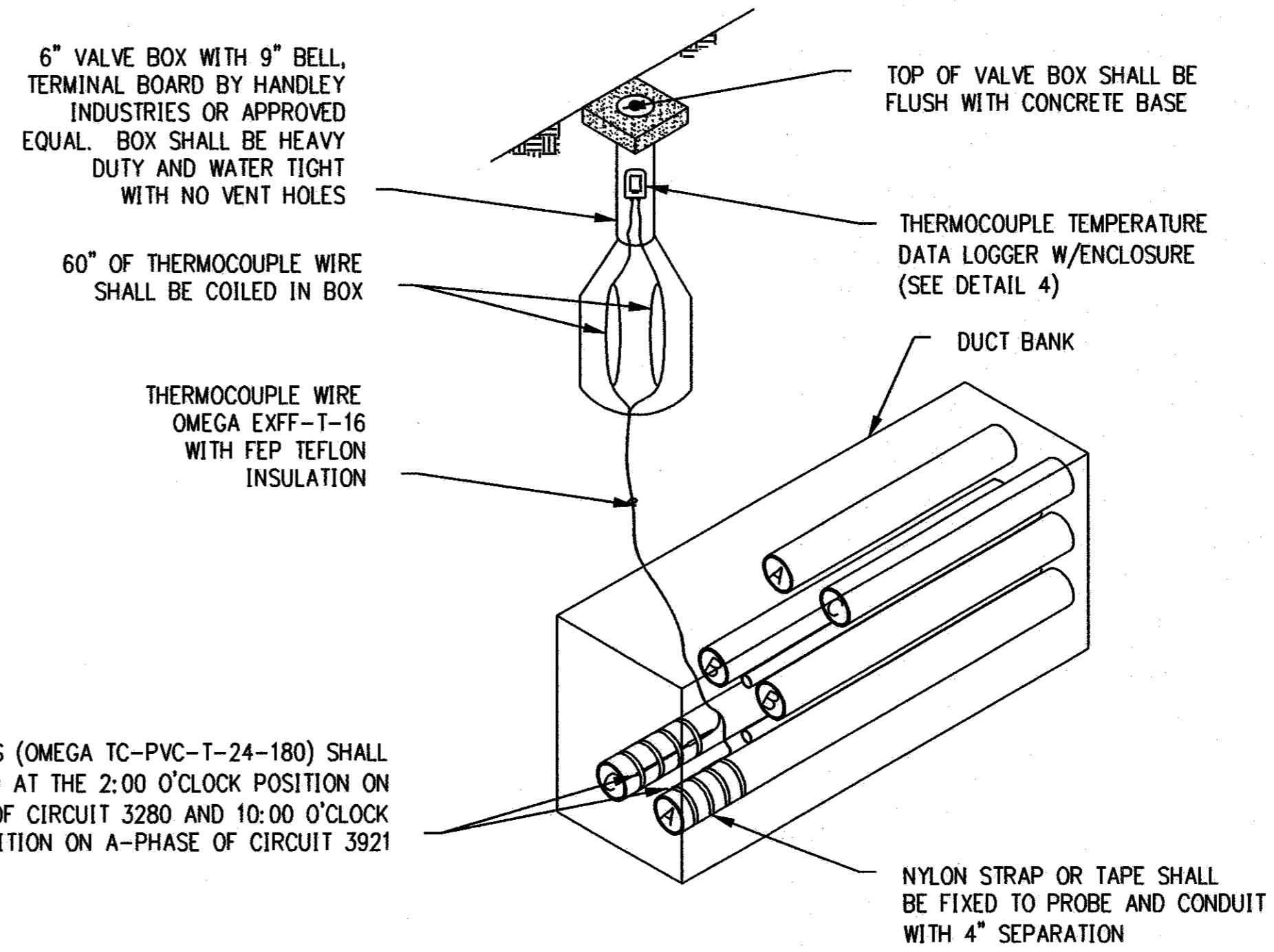

TEMPERATURE MONITORING STATION INSTALLATION

DETAIL 5
NTS

TEMPERATURE MONITORING STATION TABLE	
TMS #S	CENTER OF TMS
TMS #1	N 635,805.2937 E 902,023.4409
TMS #2	N 637,115.6960 E 902,405.3252
TMS #3	N 638,747.1784 E 902,412.4686
TMS #4	N 640,049.9964 E 902,759.6060
TMS #5	N 641,471.2471 E 903,266.6231
TMS #6	N 642,260.5161 E 904,223.2260
TMS #7	N 643,280.0469 E 904,329.8339

COPYRIGHT © 2006 BURNS & MCDONNELL ENGINEERING COMPANY, INC.

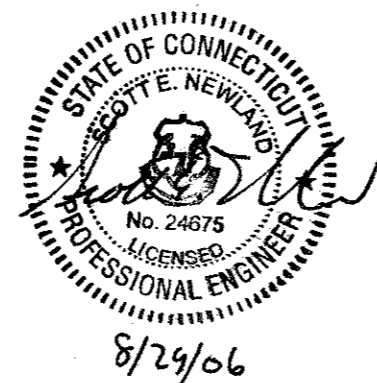

ISSUED FOR CONSTRUCTION

DOCKET No. 272



date 11/09/05 detailed L. ROWSE
designed C. COURTRIGHT checked S. NEWLAND

no.	date	revisions	by	chk
1	8/29/06	ISSUED FOR CONSTRUCTION	CTC	

MF	NO.	DATE	REVISIONS	BY	CHK	APP	APP

NORTHEAST UTILITIES SERVICE CO.

FOR THE CONNECTICUT LIGHT & POWER COMPANY
TITLE MIDDLETOWN-NORWALK 345KV TRANSMISSION PROJECT
CABLE AND TEMPERATURE MONITORING DETAILS

BY	CHKD	APP	APP
SEN-BMCD			
DATE 11-09-05	DATE	DATE	DATE
SCALE AS NOTED		DWG. NO.	
	D	01223-46003	PG 005

CONDUIT SIZE	MIN. DISTANCE
2 & 3	3.000
4 & 4	2.500
4 & 8	3.000
8 & 8	3.000

CONDUIT SIZE	MIN. DISTANCE
2 & 3	4.817
4 & 4	7.152
4 & 8	9.834
8 & 8	12.000

- NOTES:**
- USE ONE BORE SPACER FOR EVERY 5 FEET OF DUCT BANK.
 - THE CASING ID MUST BE SMOOTH AND FREE FROM RIDGES, PROJECTIONS AND SEAMS THAT MIGHT IMPIDE THE ROLLING OF WHEELS.
 - A TROUGH OR FEEDER BRIDGE SHOULD BE CONSTRUCTED AT THE LEADING END OF THE CASING TO SUPPORT SECTIONS OF DUCT BANK AS THEY ARE ASSEMBLED AND PULLED INTO THE CASING.
 - THIS BORE SPACER IS DESIGNED FOR A CASING THAT IS STRAIGHT AND TRUE.
 - IT IS POSSIBLE THAT THE DUCT BANK WILL ROTATE (CORNERS) AS IT IS PULLED THRU THE CASING UNLESS AN "OFF CENTER WEIGHT TECHNIQUE", "STABILIZATION CABLES" OR "L" ANGLE & SLOT TECHNIQUE IS USED.
 - THIS BORE SPACER WILL ACCOMMODATE THE "SINGLE-END", FLUSH COUPLED EXTRACTABLE INJECTION PIPE* OR STATIONARY SACRIFICIAL INJECTION PIPE* METHODS OF GROUT FILLING. REASON AS THE GROUT IS PUMPED INTO THE CASING, THE COMPARTMENTS BETWEEN THE BORE SPACERS ARE MORE OR LESS FILLED SEQUENTIALLY, PLACING A TEMPORARY THRUST LOAD ON EACH BORE SPACER.
 - IT IS ESSENTIAL THAT THE BORE SPACERS ARE HELD IN PLACE RELATIVE TO THE CONDUIT.
 - WHEN FILLING THE AREA BETWEEN THE CONDUITS AND CASING WITH GROUT, TAKE CARE NOT TO EXCEED THE HYDRAULIC COLLAPSE PRESSURE OF THE CONDUITS.
 - THE DUCT BANK MUST BE HELD IN POSITION AT BOTH ENDS TO ACCOMMODATE POSSIBLE UNEVEN THRUST LOADS THAT MAY BE GENERATED DURING THE GROUTING OPERATION.
 - WHEN FILLING THE AREA BETWEEN THE CONDUITS AND CASING WITH GROUT, TAKE CARE NOT TO EXCEED THE HYDRAULIC COLLAPSE PRESSURE OF THE CONDUITS.
 - DEPENDING ON THE GROUT SPECIFIC GRAVITY AND GROUT FLOW, IT IS POSSIBLE THAT THE DUCT BANK WILL FLOAT TO THE TOP OF THE CASING.
 - ACTUAL QUANTITY OF GROUT USED SHOULD BE MEASURED AND RECORDED.

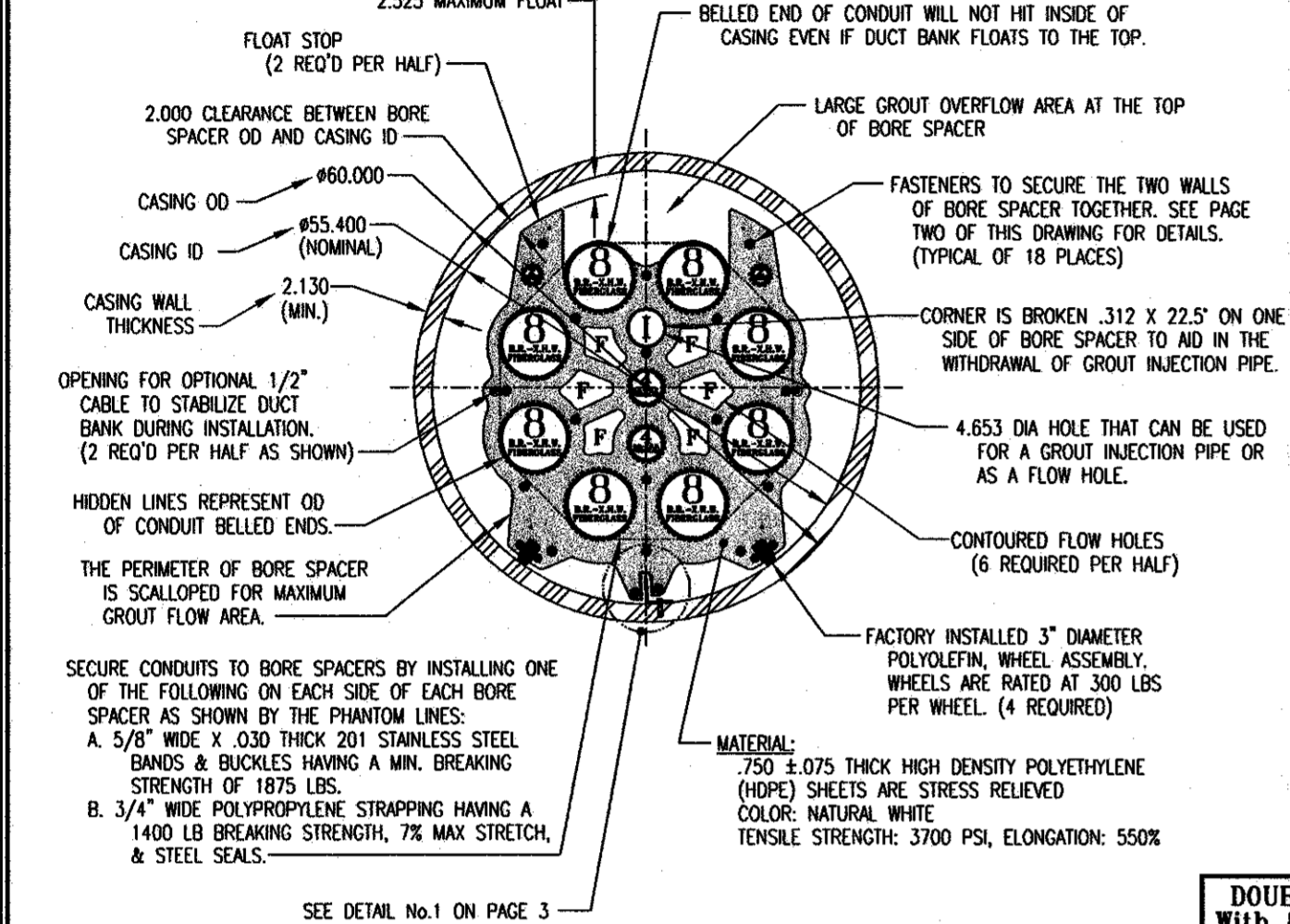

DOUBLE WALL, FULL COMPLEMENT BORE SPACER
With 8 Ea. 8", 2 Ea. 4" & 2 Ea. 2" RTRC-XHW (Bullet-Resistant, Extra Heavy Wall Fiberglass) Conduits Per NEMA TC-2002 in a 60,000 OD X 2,130 Min. Wall HOBAS (Centrifugally Cast Fiberglass Reinforced Polymer Mortar) Casing.
See At Left: [Don Armstrong](#) [Don Muehlenbeck](#) [Don McCoy](#)
7-7-06
1st Designed For BURNS & MCDONNELL
Kansas City, MO - CHRIS COURTRIGHT - Phone: 816-333-9400
UNDERGROUND DEVICES, INC. 90-4150
NORTHBROOK, ILLINOIS 60062 - PHONE: (847) 205-9000 PAGE 1 OF 3

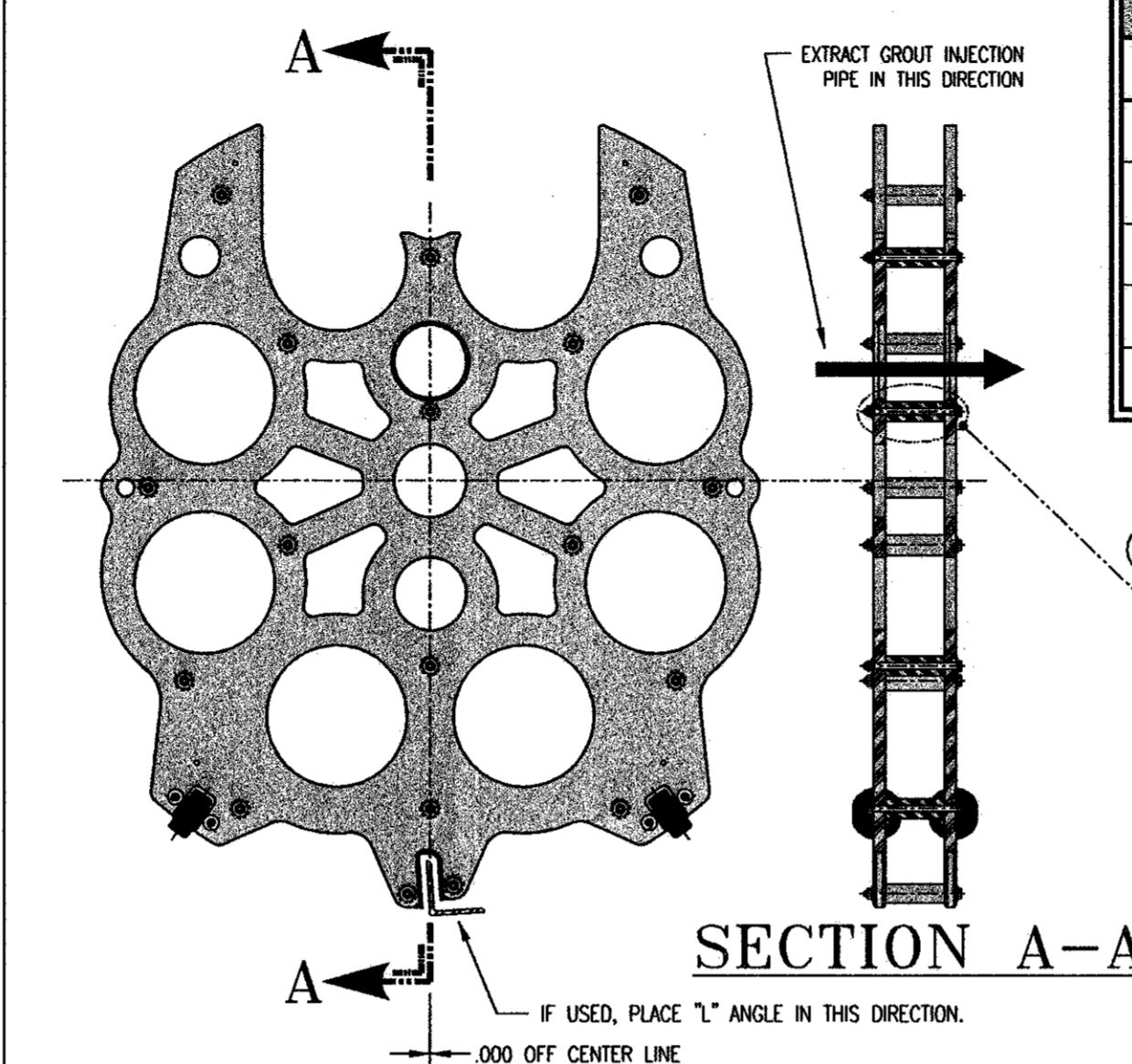

DOUBLE WALL, FULL COMPLEMENT BORE SPACER
With 8 Ea. 8", 2 Ea. 4" & 2 Ea. 2" RTRC-XHW (Bullet-Resistant, Extra Heavy Wall Fiberglass) Conduits Per NEMA TC-2002 in a 60,000 OD X 2,130 Min. Wall HOBAS (Centrifugally Cast Fiberglass Reinforced Polymer Mortar) Casing.
See At Left: [Don Armstrong](#) [Don Muehlenbeck](#) [Don McCoy](#)
7-7-06
1st Designed For BURNS & MCDONNELL
Kansas City, MO - CHRIS COURTRIGHT - Phone: 816-333-9400
UNDERGROUND DEVICES, INC. 90-4150
NORTHBROOK, ILLINOIS 60062 - PHONE: (847) 205-9000 PAGE 2 OF 3

ITEM NUMBER	QTY REQ'D	DESCRIPTION
①	18	3/8-16 HEX NUT (GRADE 2, CENTERLOCK LOCKING NUT, ZINC PLATED STEEL)
②	36	3/8 FLAT WASHER (.438 ID X 1.000 OD X .078 THK, USS STANDARD, ZINC PLATED STEEL)
③	2	UDI 90-4150 BLANK BORE SPACER
④	18	UDI 90-803 SPACER BUSHING (TYPE 1 PVC DARK GRAY)
⑤	18	3/8-16 X 6" LG HEX HEAD CAP SCREW (GRADE 2, ZINC PLATED LOW CARBON STEEL)

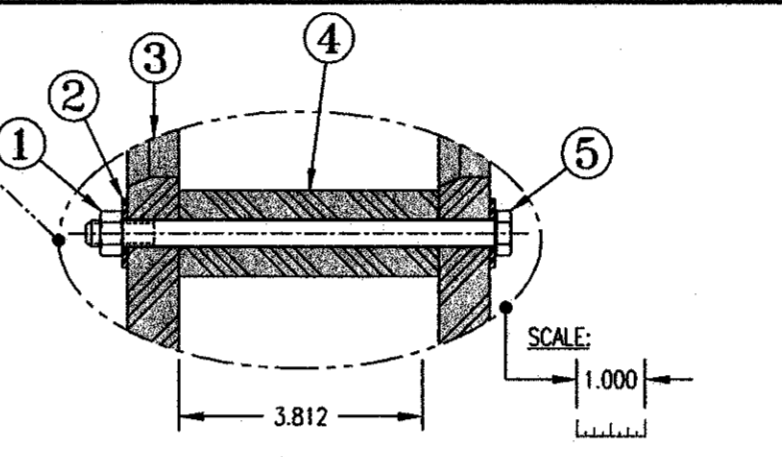

CONDUIT OD	CONDUIT WALL THICKNESS	FULL HOLE DIAMETER	PARTIAL HOLE DIAMETER
2"	2.500	2.620	---
4"	4.500	4.653	---
8"	8.900	9.015	8.920

DOUBLE WALL, FULL COMPLEMENT BORE SPACER
With 8 Ea. 8", 2 Ea. 4" & 2 Ea. 2" RTRC-XHW (Bullet-Resistant, Extra Heavy Wall Fiberglass) Conduits Per NEMA TC-2002 in a 60,000 OD X 2,130 Min. Wall HOBAS (Centrifugally Cast Fiberglass Reinforced Polymer Mortar) Casing.
See At Left: [Don Armstrong](#) [Don Muehlenbeck](#) [Don McCoy](#)
7-7-06
1st Designed For BURNS & MCDONNELL
Kansas City, MO - CHRIS COURTRIGHT - Phone: 816-333-9400
UNDERGROUND DEVICES, INC. 90-4150
NORTHBROOK, ILLINOIS 60062 - PHONE: (847) 205-9000 PAGE 2 OF 3

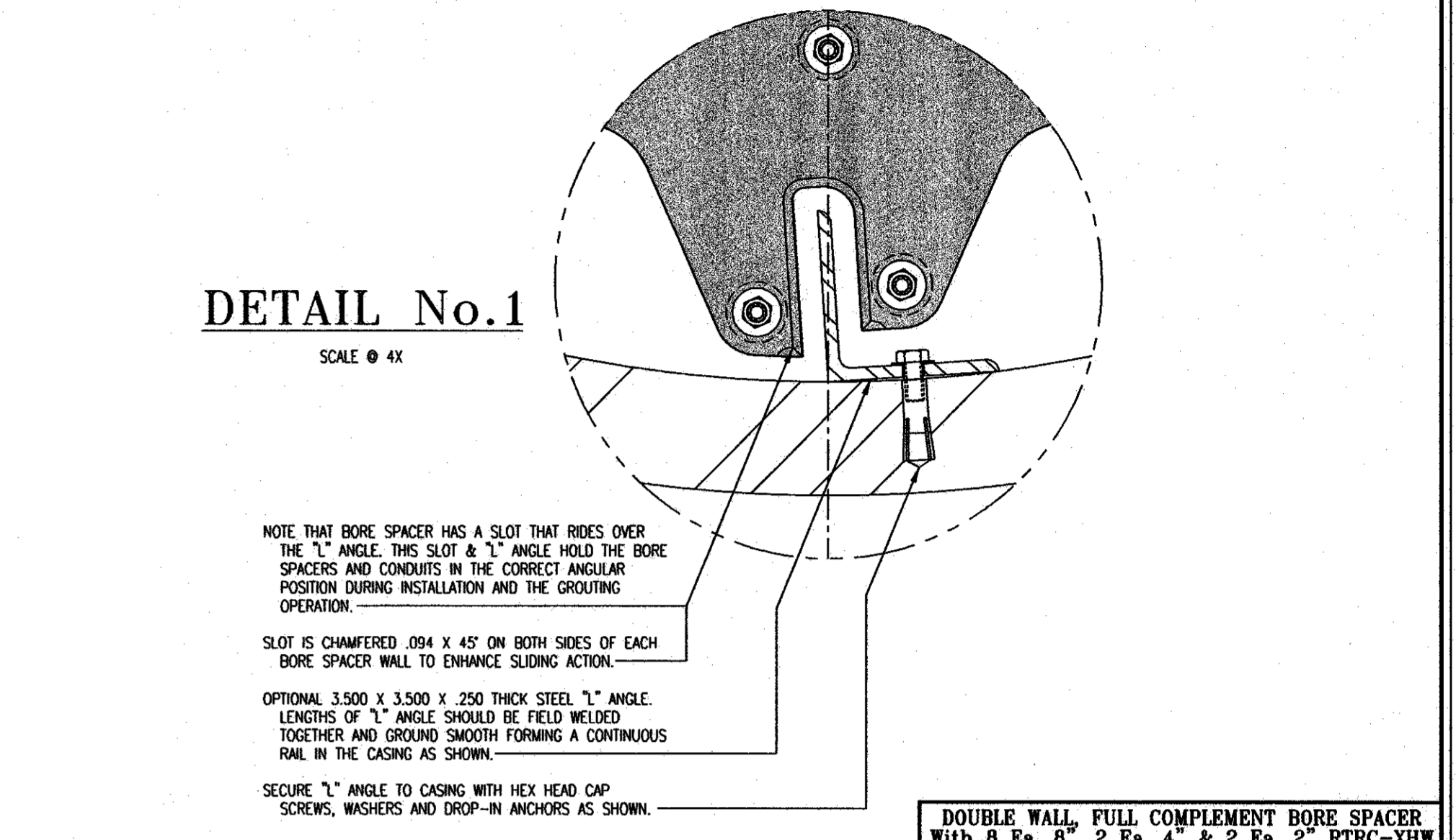

DOUBLE WALL, FULL COMPLEMENT BORE SPACER
With 8 Ea. 8", 2 Ea. 4" & 2 Ea. 2" RTRC-XHW (Bullet-Resistant, Extra Heavy Wall Fiberglass) Conduits Per NEMA TC-2002 in a 60,000 OD X 2,130 Min. Wall HOBAS (Centrifugally Cast Fiberglass Reinforced Polymer Mortar) Casing.
See At Left: [Don Armstrong](#) [Don Muehlenbeck](#) [Don McCoy](#)
7-7-06
1st Designed For BURNS & MCDONNELL
Kansas City, MO - CHRIS COURTRIGHT - Phone: 816-333-9400
UNDERGROUND DEVICES, INC. 90-4150
NORTHBROOK, ILLINOIS 60062 - PHONE: (847) 205-9000 PAGE 3 OF 3

© JULY 7, 2006 - ALL RIGHTS RESERVED BY UNDERGROUND DEVICES, INC. (180)

© JULY 7, 2006 - ALL RIGHTS RESERVED BY UNDERGROUND DEVICES, INC.

© JULY 7, 2006 - ALL RIGHTS RESERVED BY UNDERGROUND DEVICES, INC.

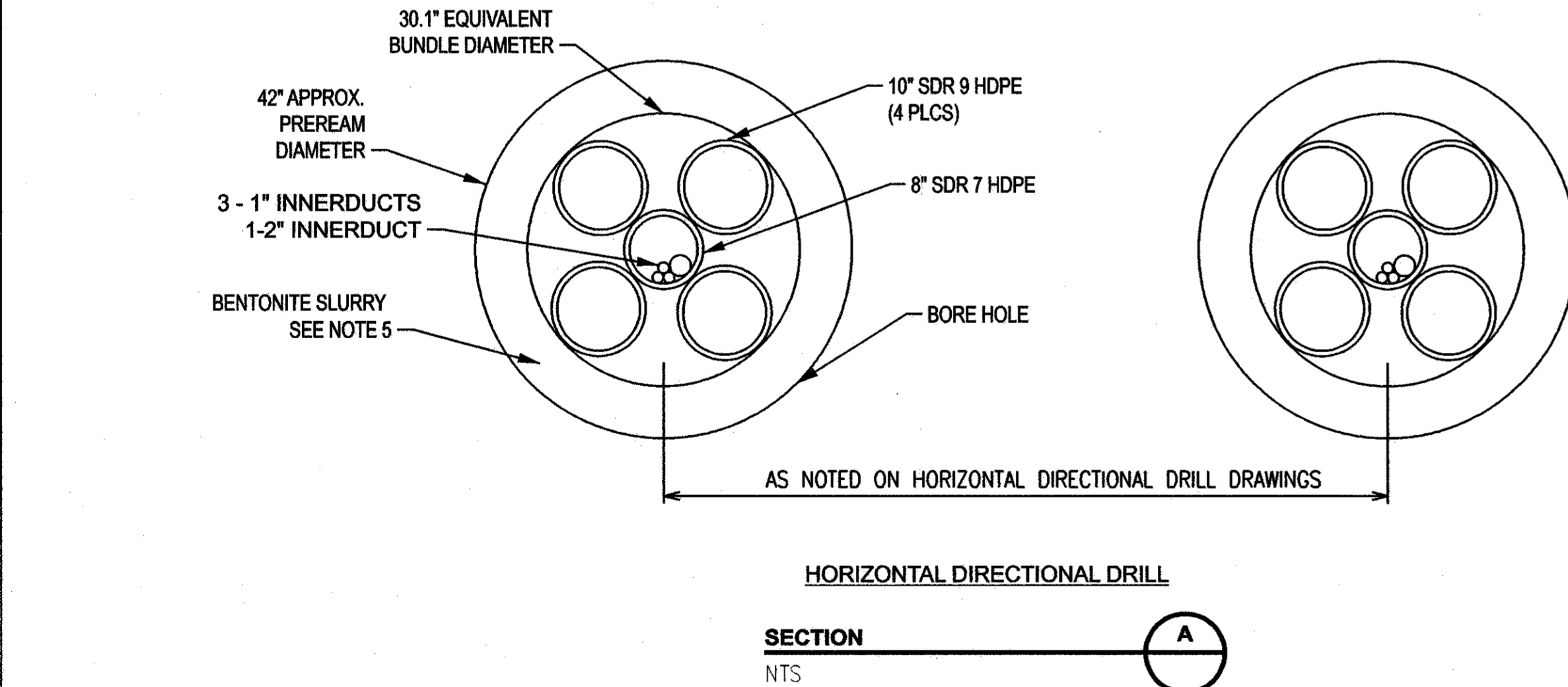

UNDERGROUND DEVICES
CATALOG NUMBER:
BS4150W4

UNDERGROUND DEVICES
CATALOG NUMBER:
BS4150W4

UNDERGROUND DEVICES
CATALOG NUMBER:
BS4150W4

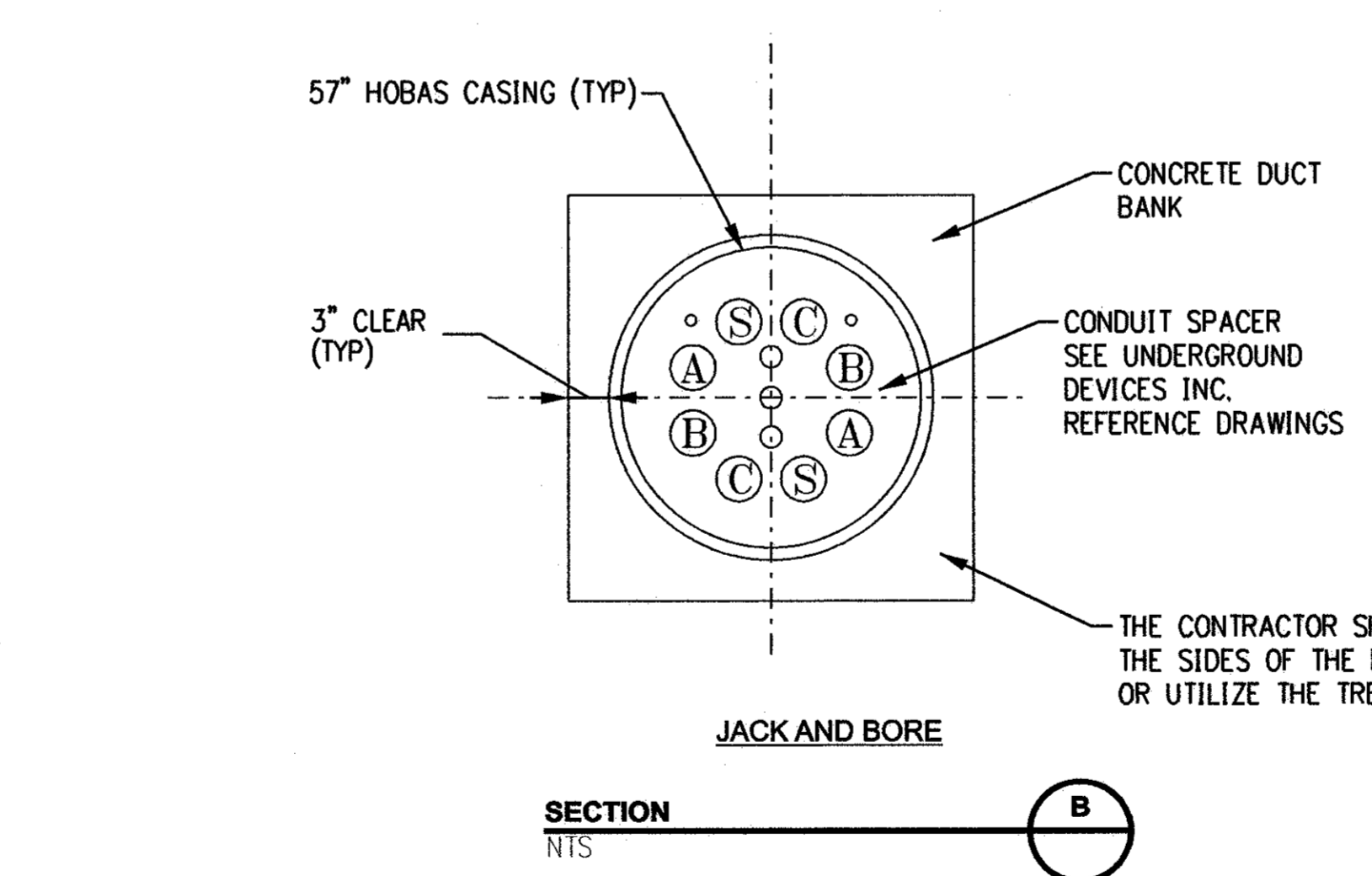

UNDERGROUND DEVICES
CATALOG NUMBER:
BS4150W4

UNDERGROUND DEVICES
CATALOG NUMBER:
BS4150W4

UNDERGROUND DEVICES
CATALOG NUMBER:
BS4150W4

- NOTES:**
- ALL CASING SHALL BE COMPLETELY FILLED WITH A THERMALLY ACCEPTABLE GROUT. GROUT MIX DESIGN SHALL MEET PROJECT SPECIFICATIONS.
 - GROUT SAMPLES SHALL BE SUBMITTED TO THE TEST COMPANY (CONTACT TEST COMPANY FOR APPROPRIATE SIZE & METHOD OF TRANSPORTATION) IN ACCORDANCE WITH THE SPECIFICATIONS.
 - CONTRACTOR SHALL FURNISH AND INSTALL CASING PIPE SPACER. SPACERS SHALL BE INSTALLED A MAXIMUM DISTANCE OF 5 FEET APART. SPACERS SHALL BE INSTALLED PER MANUFACTURERS RECOMMENDATIONS.
 - CONTRACTOR SHALL SUBMIT DETAILED DESIGN OF EACH BORED CROSSING FOR REVIEW, INCLUDING AS A MINIMUM WORK PLAN, EQUIPMENT AND MATERIALS TO BE USED, WORK AREAS, BORE PIT SIZES AND LOCATIONS.
 - BENTONITE SLURRY SAMPLES SHALL BE SUBMITTED TO THE TEST COMPANY (CONTACT TEST COMPANY FOR APPROPRIATE SIZE & METHOD OF TRANSPORTATION) IN ACCORDANCE WITH THE SPECIFICATIONS.

UNDERGROUND DEVICES
CATALOG NUMBER:
BS4150W4

UNDERGROUND DEVICES
CATALOG NUMBER:
BS4150W4

UNDERGROUND DEVICES
CATALOG NUMBER:
BS4150W4

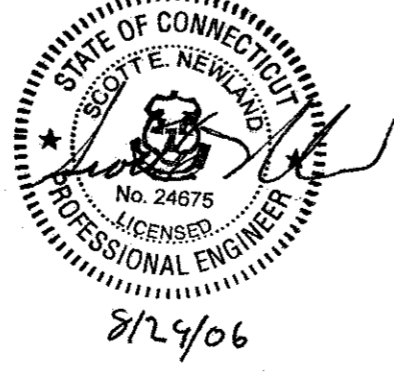

ISSUED FOR CONSTRUCTION

no.	date	revisions	by	chk
1	8/29/06	ISSUED FOR CONSTRUCTION	CTC	



date 6/15/06
designed C. COURTRIGHT
detailed L. ROWSE
checked S. NEWLAND

NORTHEAST UTILITIES SERVICE CO.			
FOR THE CONNECTICUT LIGHT & POWER COMPANY			
TITLE MIDDLETOWN-NORWALK 345KV TRANSMISSION PROJECT			
HORIZONTAL DIRECTIONAL DRILL AND JACK AND BORE SECTIONS			
BY SEN-BMCD	CHKD	APP	APP
DATE 6/15/06	DATE	DATE	DATE
SCALE AS NOTED		DWG. NO.	
	D	01223-46003	PG 006

COPYRIGHT © 2006 BURNS & MCDONNELL ENGINEERING COMPANY, INC.

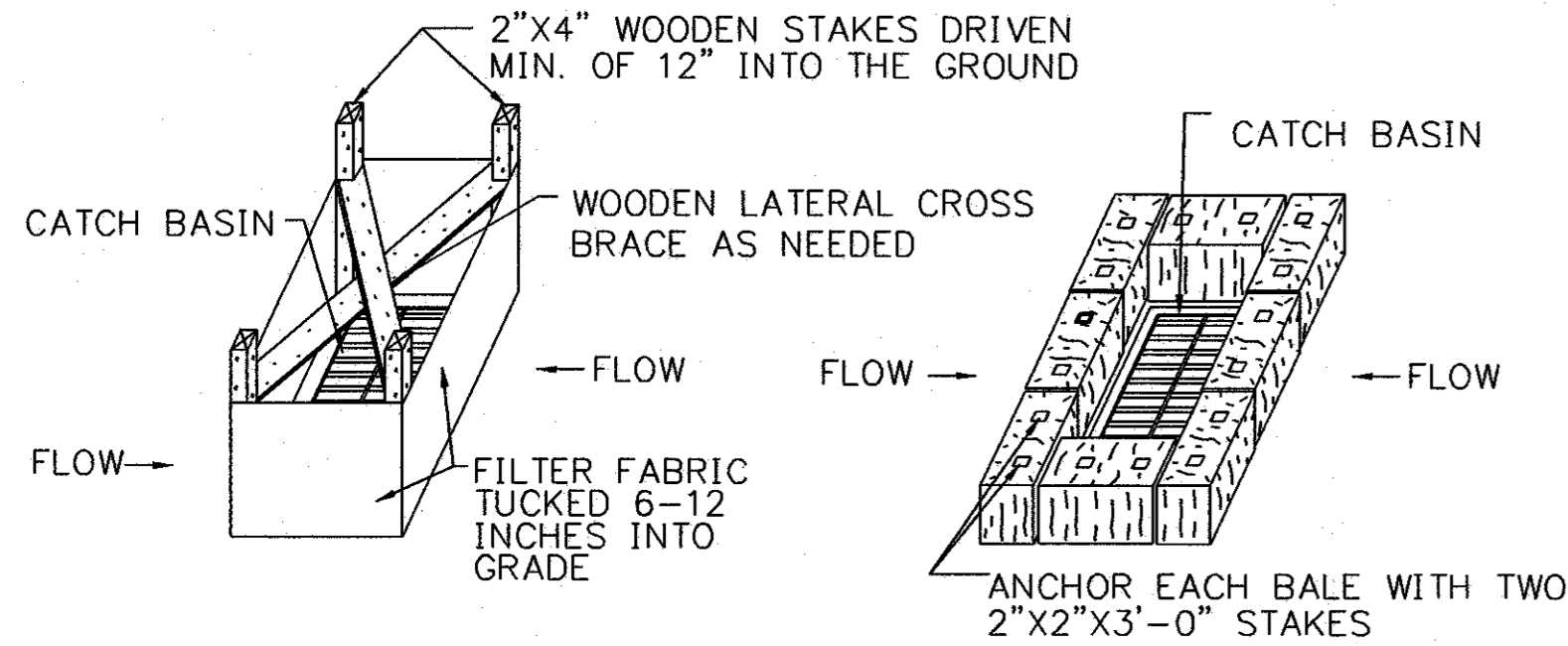

SILT FENCE INSTALLATION AT CATCH BASINS AT LOW POINTS

HAY BALE FILTER INSTALLATION AT CATCH BASIN AT LOW POINTS

STORMWATER INLETS WHICH DO NOT DISCHARGE TO SEDIMENT TRAPS OR BASINS, SHALL BE PROTECTED UNTIL THE TRIBUTARY AREAS ARE STABILIZED. SEDIMENT SHALL BE REMOVED FROM INLET PROTECTION AFTER EACH STORM EVENT.

CATCH BASIN EROSION CONTROL

DETAIL NTS 1

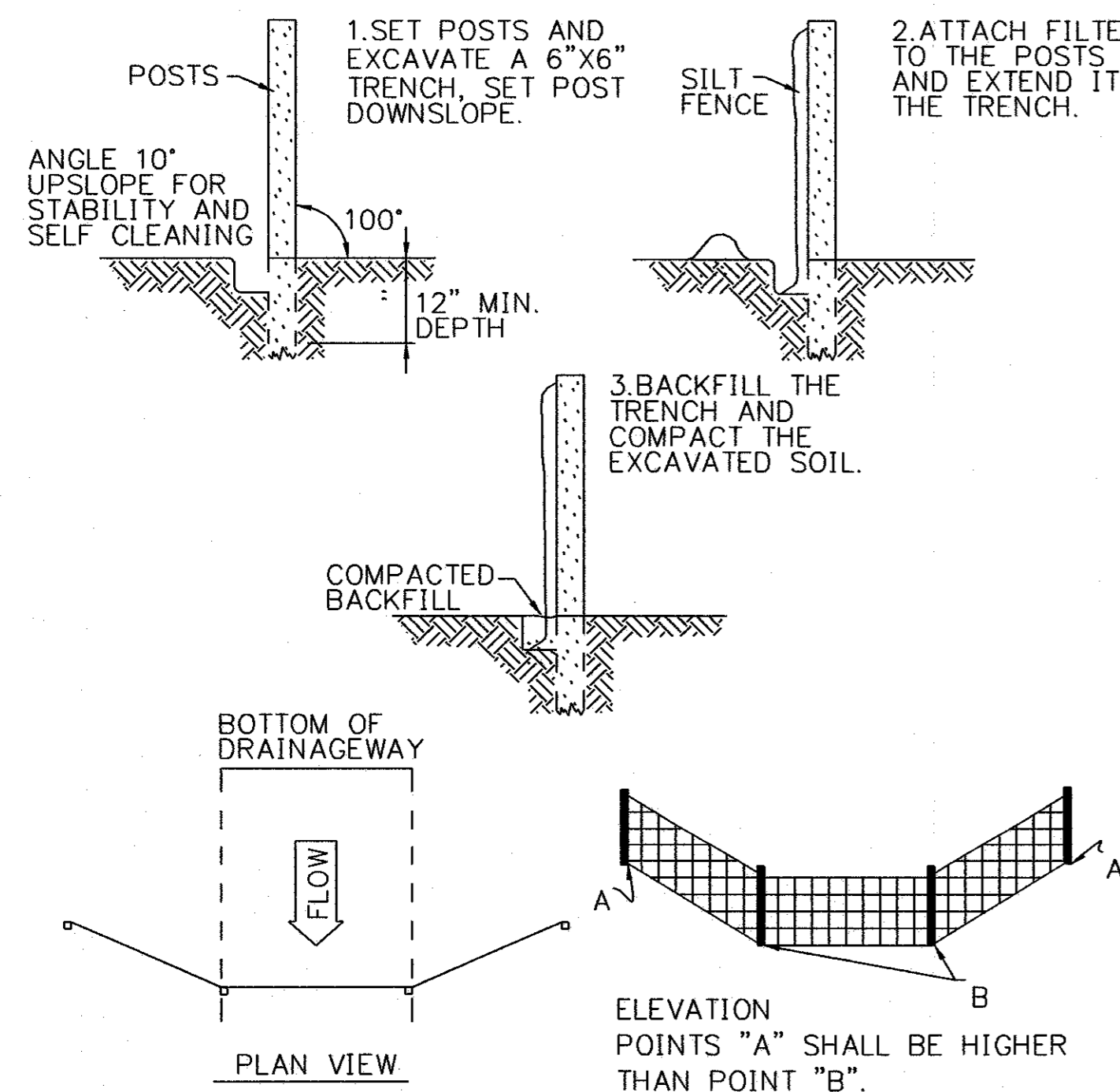

GEOTEXTILE SILT FENCE BARRIER W/OUT HAYBALES

DETAIL NTS 6

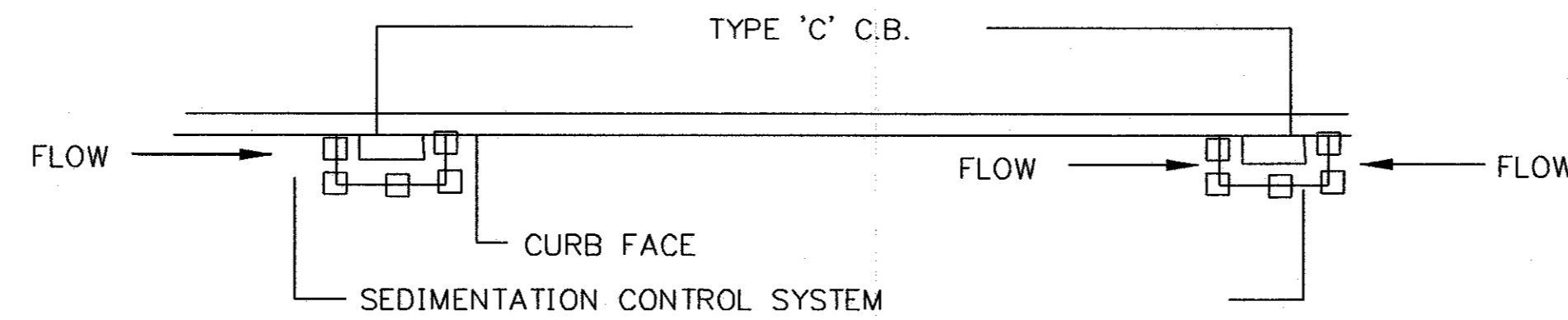

PLAN FOR TYPE 'C' C.B. (ON GRADE)

PLAN FOR TYPE 'C' CB (AT LOW POINT)

NOTE: SEDIMENTATION CONTROL SYSTEMS SHALL BE LOCATED AT ALL EXISTING OR PROPOSED BASINS WHICH ACCEPT FLOW FROM THE CONSTRUCTION AREA UNTIL TURF ESTABLISHMENT OR AS DIRECTED BY THE ENGINEER.

DETAIL NTS 2

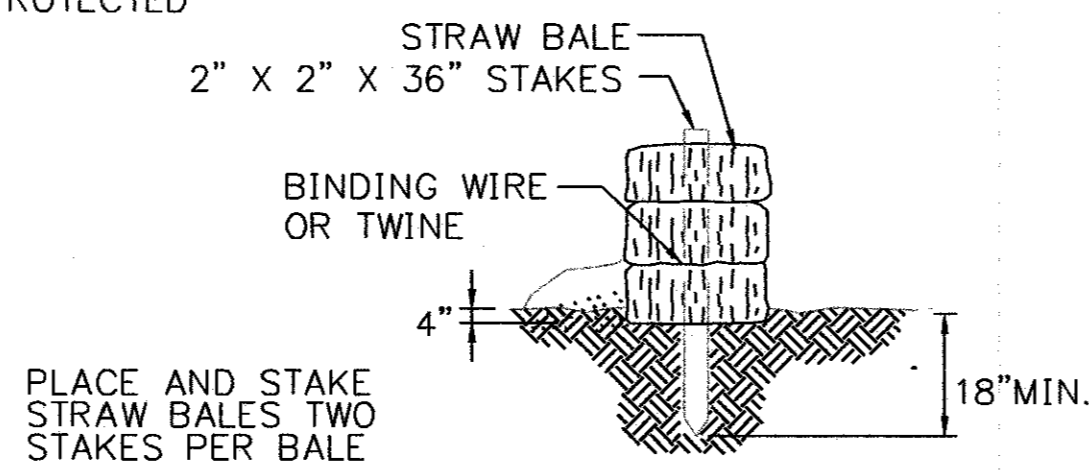

STRAW BALE BARRIERS SHALL NOT BE USED FOR MORE THAN 3 MONTHS

SEDIMENT SHALL BE REMOVED WHEN ACCUMULATIONS REACH 1/3 THE ABOVE GROUND HEIGHT OF THE BARRIER.

ANY SECTION OF STRAW BALE BARRIER WHICH HAS BEEN UNDERMINED OR TOPPED SHALL BE IMMEDIATELY REPLACED WITH A ROCK FILTER OUTLET.

HAYBALE BARRIER

DETAIL NTS 4

SEE "PLACEMENT & CONSTRUCTION OF HAY BALE BARRIER"

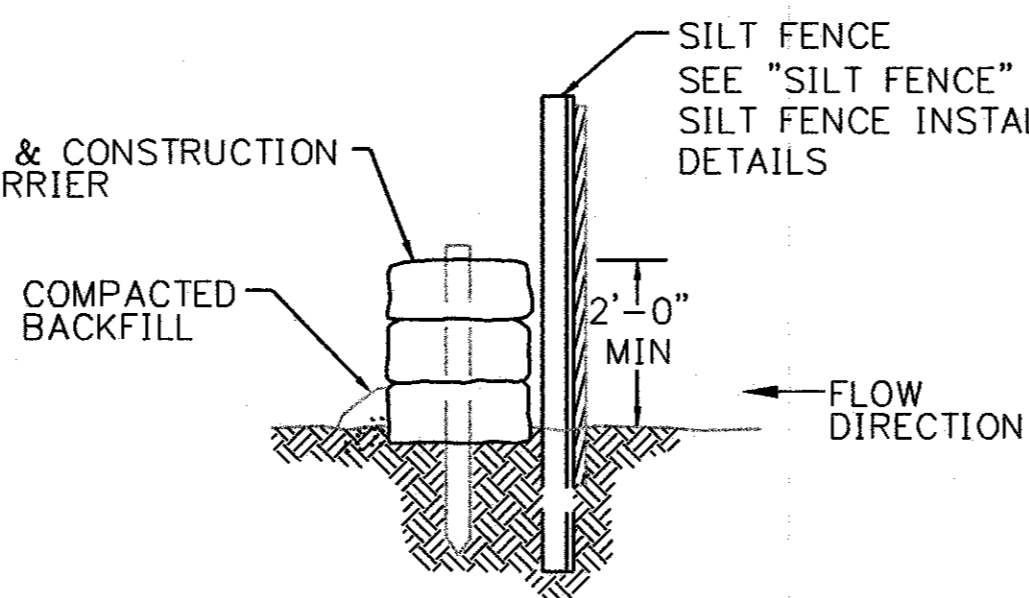

BACKFILL AND COMPACT THE EXCAVATED SOIL AS SHOWN ON THE UPHILL SIDE OF THE BARRIER TO PREVENT PIPING

GEOTEXTILE SILT FENCE BARRIER W/ HAYBALES

DETAIL NTS 7

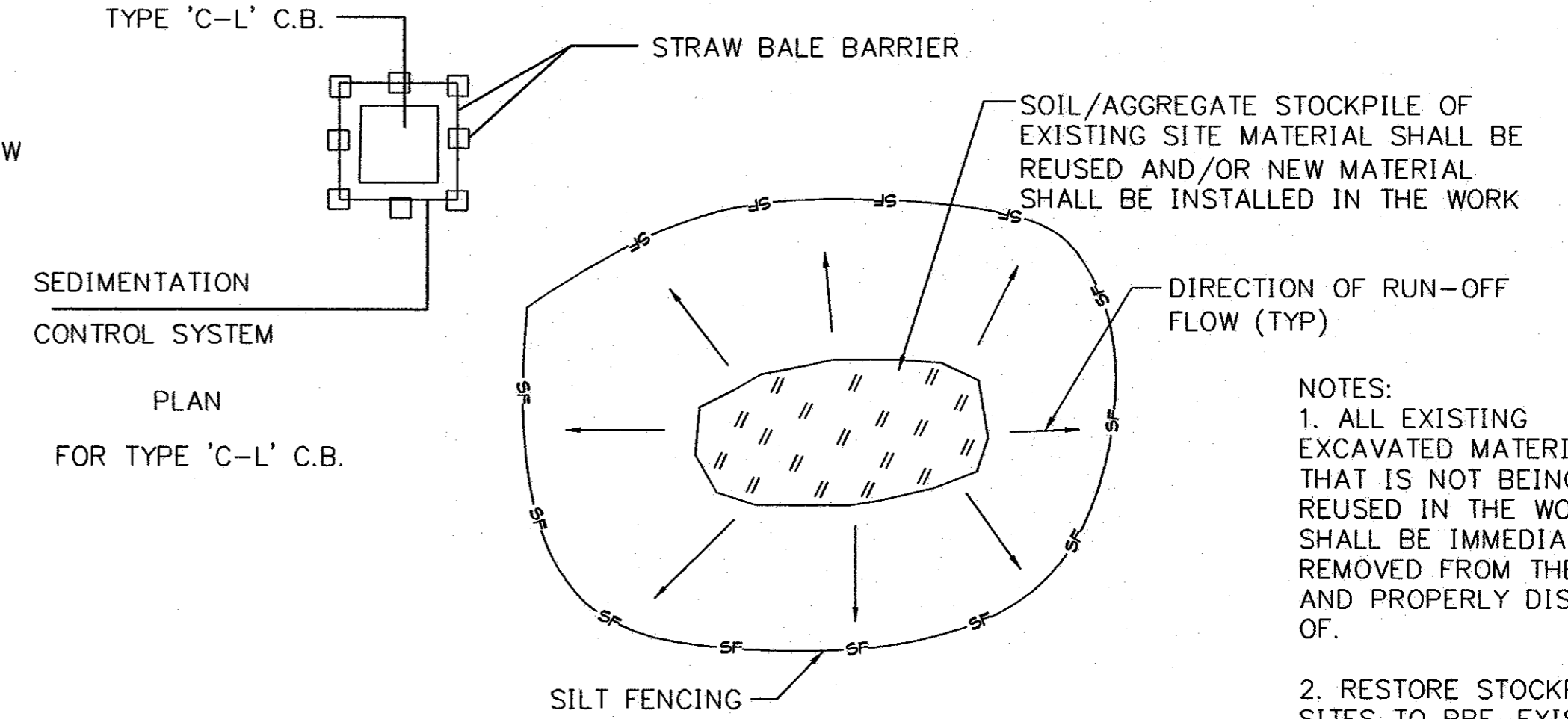

MATERIALS STOCKPILE

DETAIL NTS 3

NOTES:
1. ALL EXISTING EXCAVATED MATERIAL THAT IS NOT BEING REUSED IN THE WORK SHALL BE IMMEDIATELY REMOVED FROM THE SITE AND PROPERLY DISPOSED OF.

2. RESTORE STOCKPILE SITES TO PRE-EXISTING PROJECT CONDITION AND RESEED AS REQUIRED.

3. STOCKPILE HEIGHTS SHALL NOT EXCEED 35'. STOCKPILE SLOPES SHALL BE 2:1 OR FLATTER.

NOTE: USE FOR IN-STREAM OR SWALE SEDIMENT INTERCEPTION. LOCATE NOT TO BACKWATER ON TO WORK AREA.

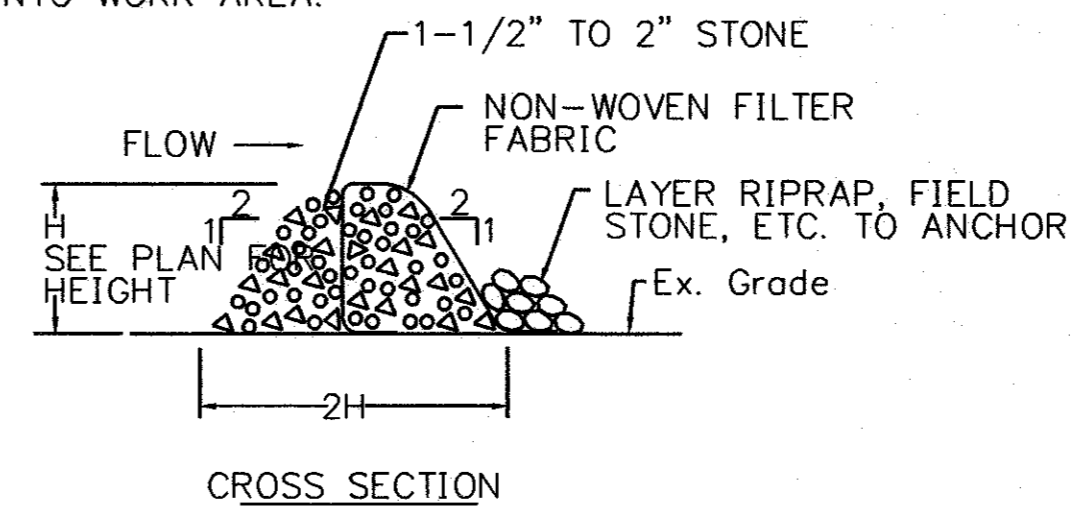

STONE FILTER BERM W/ FILTER FABRIC

DETAIL NTS 5

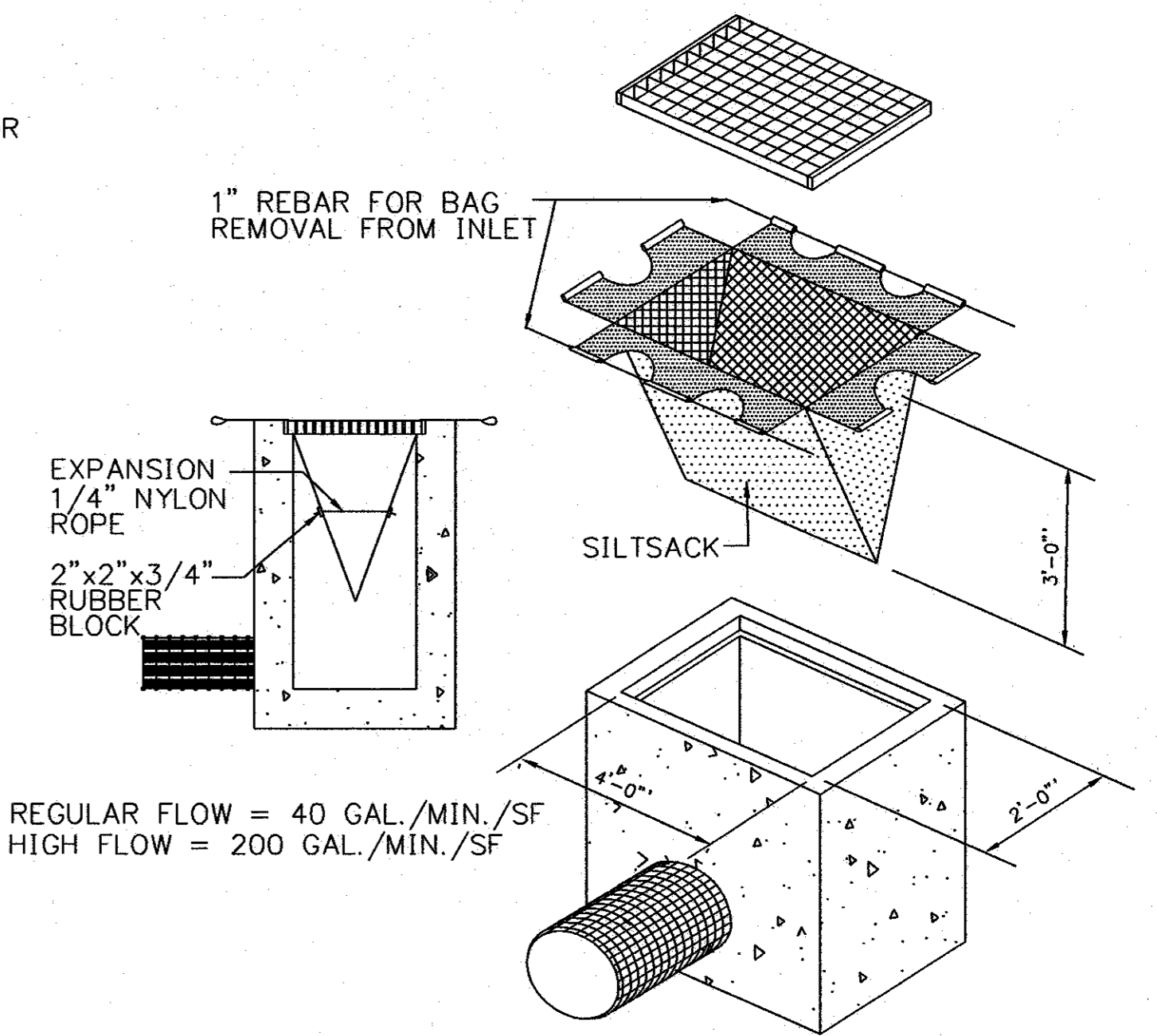

SILTSACK

DETAIL NTS 9

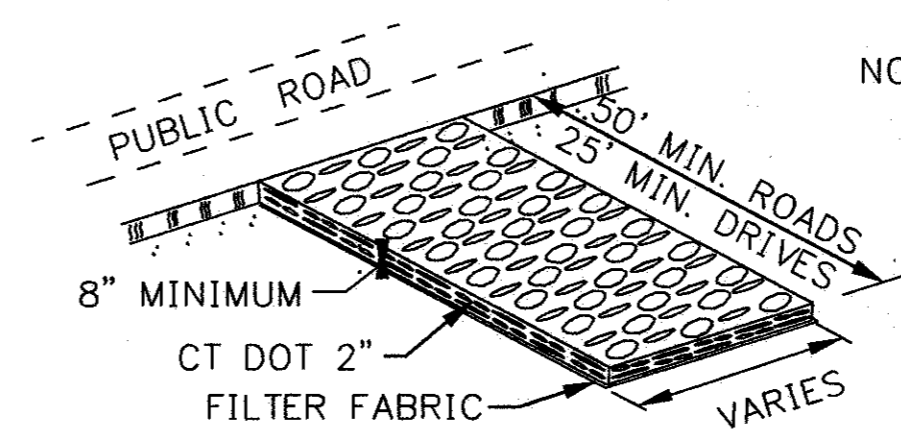

CONSTRUCTION ENTRANCE

DETAIL NTS 8

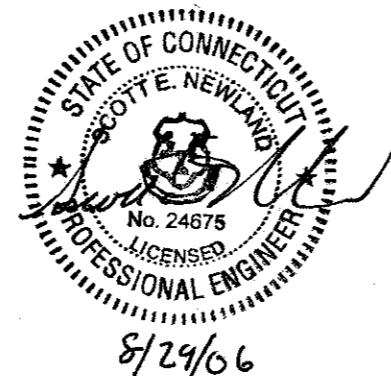

ISSUED FOR CONSTRUCTION



date 10/11/05
designed BL COMPANIES
detailed BL COMPANIES
checked S. NEWLAND

no.	date	revisions	by	chk
1	8/29/06	ISSUED FOR CONSTRUCTION	CTC	

MF	NO.	DATE	REVISIONS	BY	CHK	APP	APP

NORTHEAST UTILITIES SERVICE CO.			
FOR THE CONNECTICUT LIGHT & POWER COMPANY			
TITLE MIDDLETOWN-NORWALK 345KV TRANSMISSION PROJECT			
EROSION CONTROL DETAILS			
BY SEN-BMCD	CHKD	APP	APP
DATE 10-11-05	DATE	DATE	DATE
SCALE AS NOTED		DWG. NO.	
	D	01223-15003	PG 001

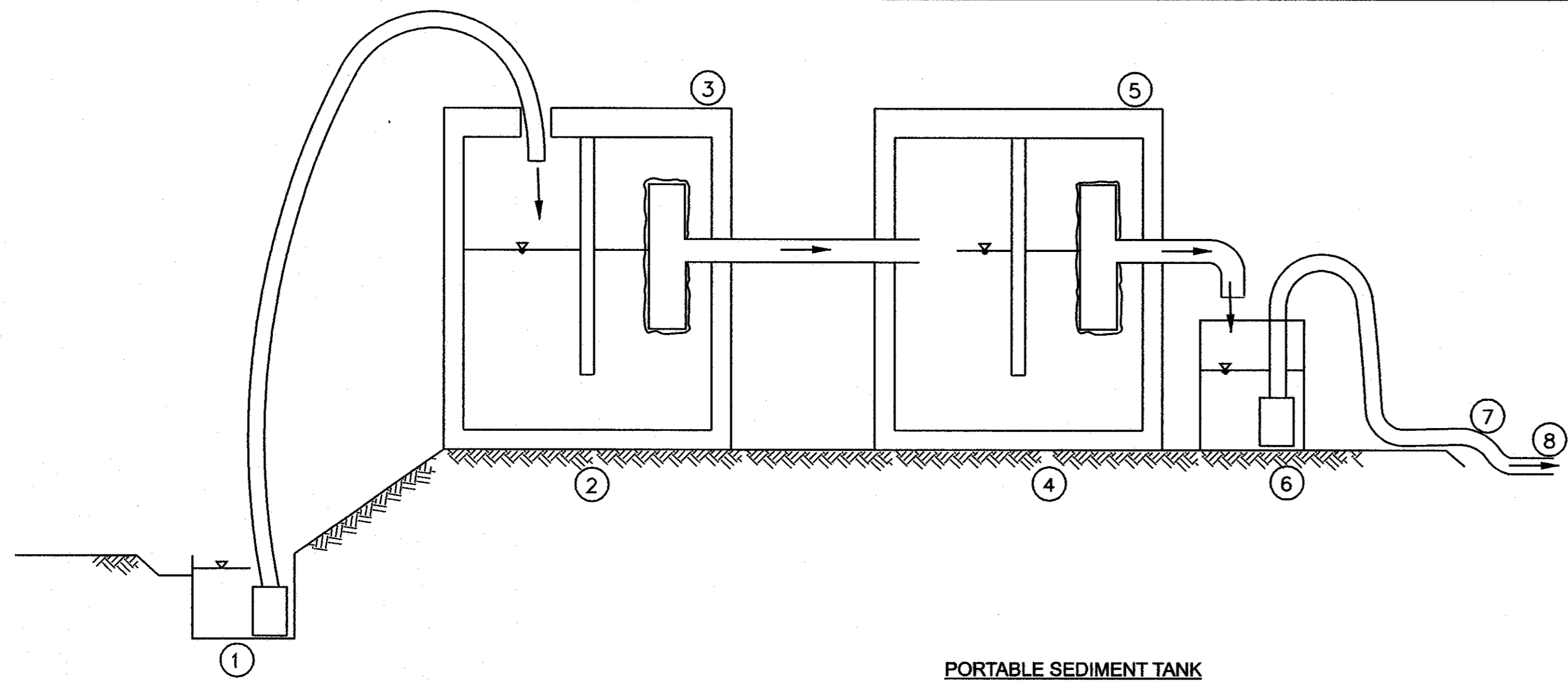

- NOTES
- ① 20 GPM TRASH PUMP DEWATERS FOUNDATION EXCAVATION
 - ② MUDDY WATER DISCHARGES TO 1,250 GAL SEPTIC TANK (OR DET. OUTLET STRUCTURE)
 - ③ 4" TEE OUTLET WRAPPED W/ FILTER FABRIC
 - ④ 1,250 GAL CLEAR WELL
 - ⑤ 2ND 4" TEE OUTLET WRAPPED W/ FILTER FABRIC
 - ⑥ 2ND PUMP IN 55 GAL DRUM (OR GRAVITY HOSE) DRAINS SYSTEM
 - ⑦ TEMP. OUTLET TO CATCH BASIN IN STREET
 - ⑧ 2-1,250 GAL. TANKS = 2,500 GAL. CAPACITY TOTAL

PORTABLE SEDIMENT TANK
 DETAIL NTS ①

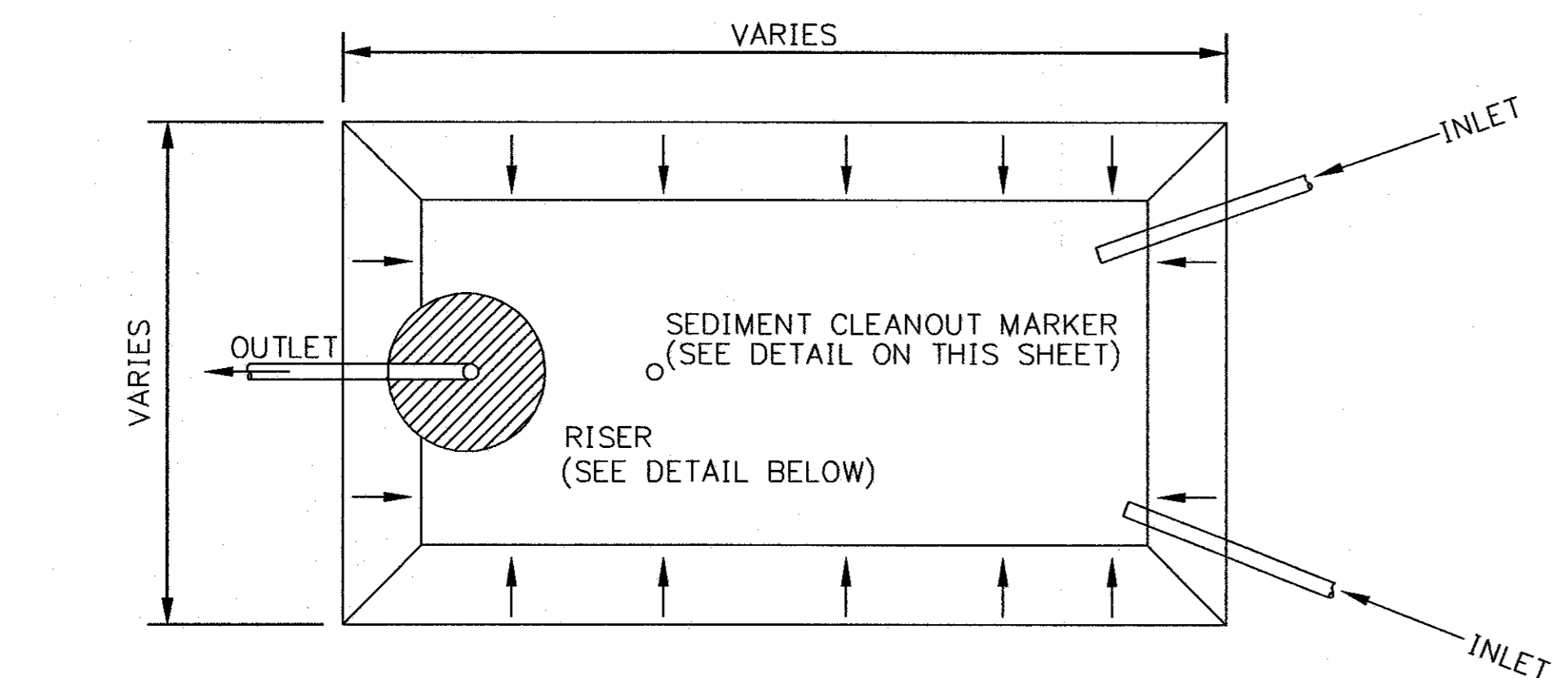

TEMPORARY SEDIMENT TRAP
 DETAIL NTS ②

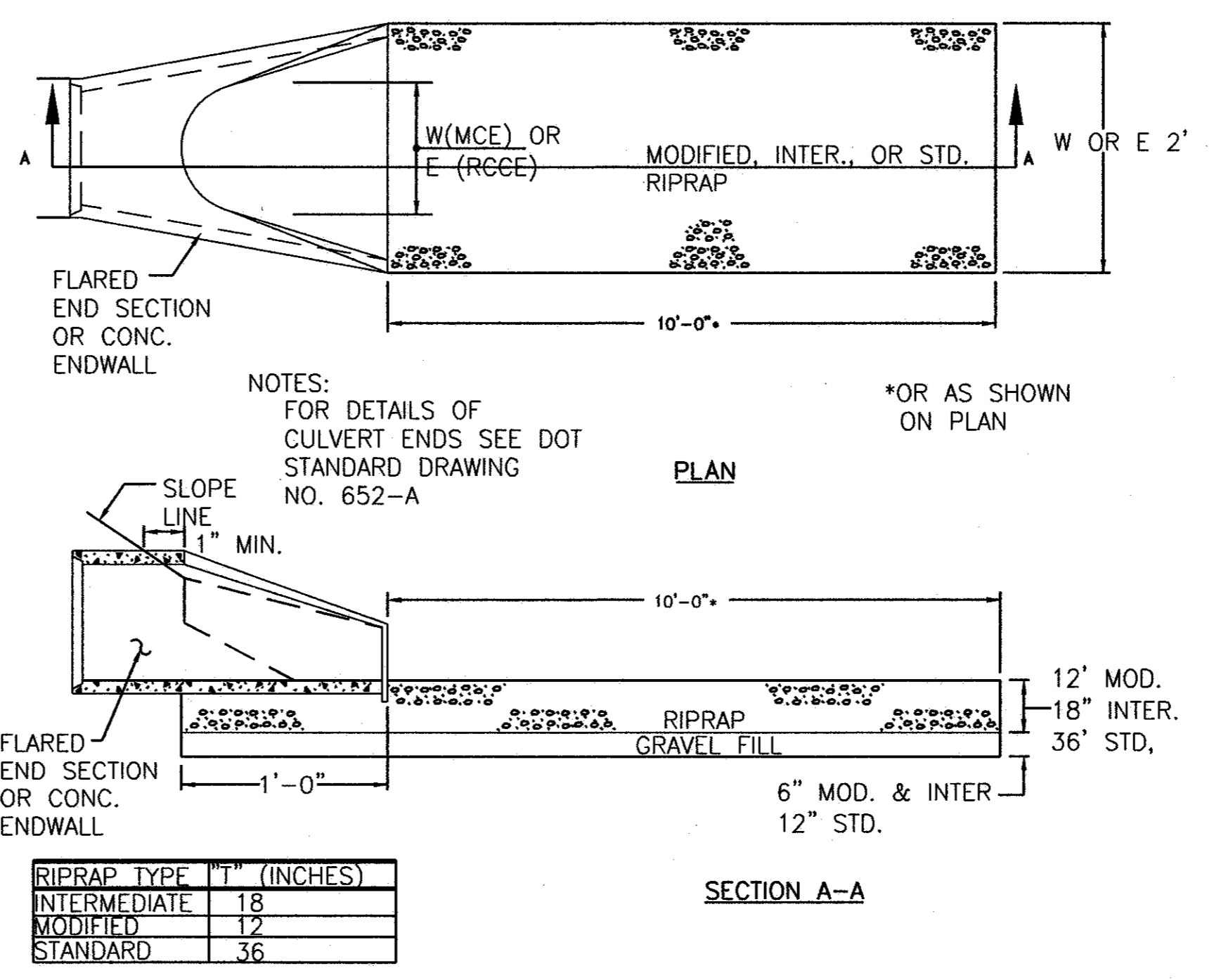
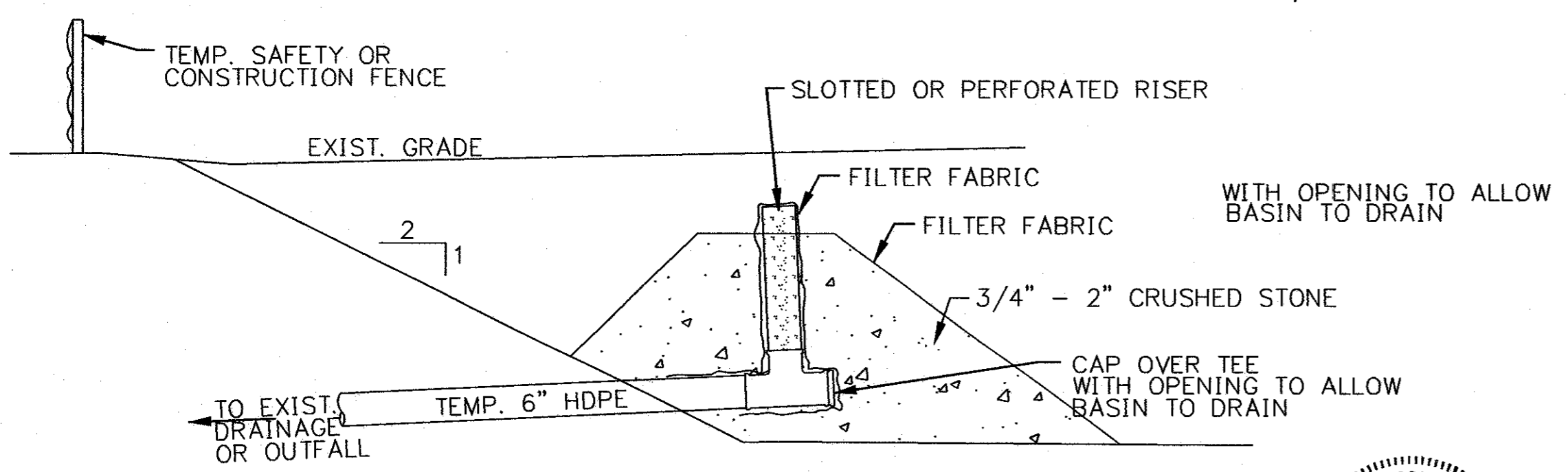

LEVEL SPREADER
 DETAIL NTS ③

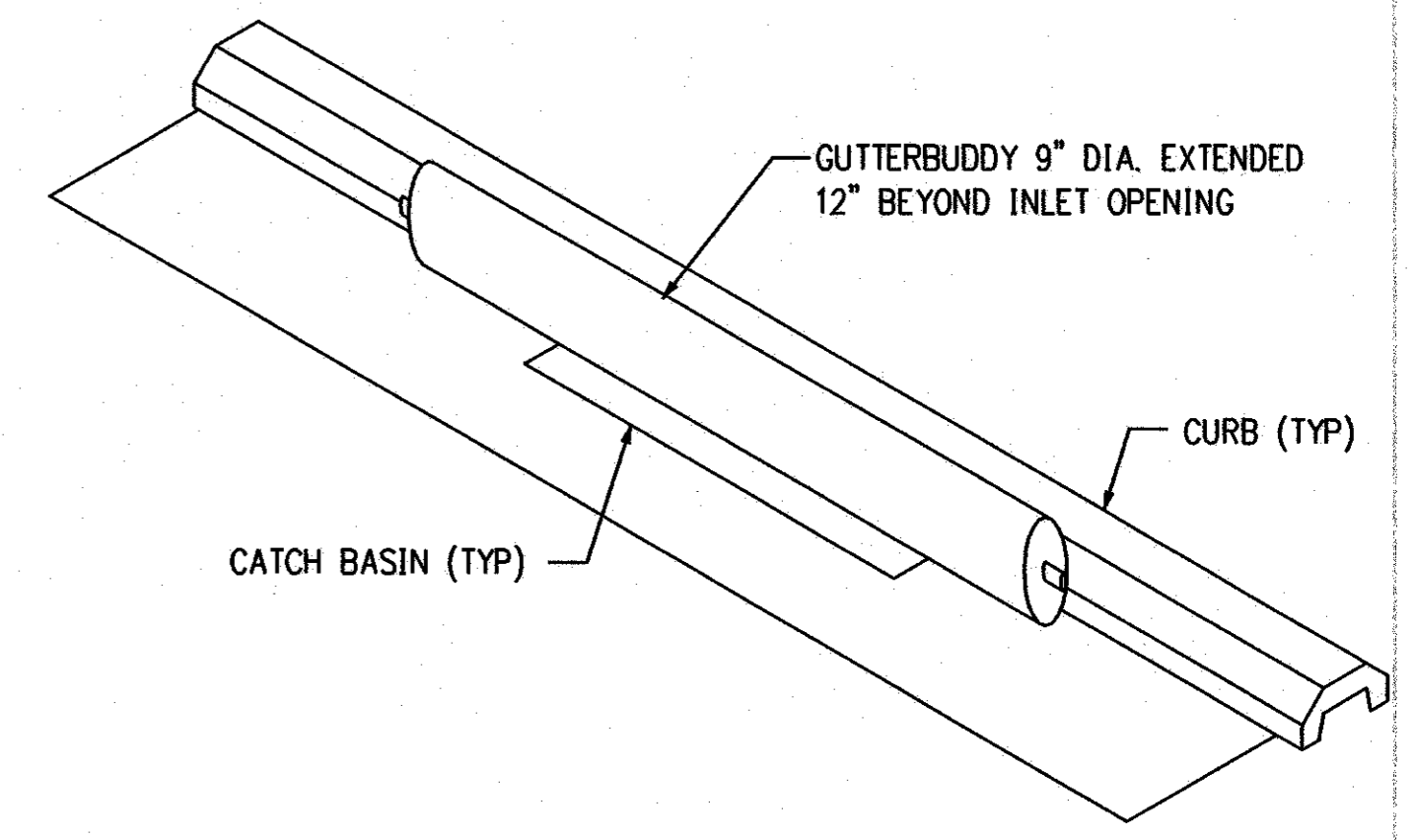

GUTTERBUDDY STORM DRAIN
 DETAIL NTS ④

COPYRIGHT © 2006 BURNS & MCDONNELL ENGINEERING COMPANY, INC.

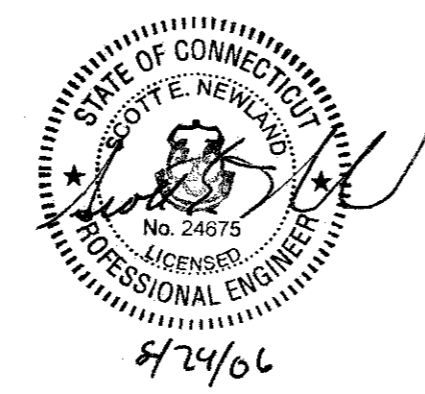

ISSUED FOR CONSTRUCTION

DOCKET No. 272

				NORTHEAST UTILITIES SERVICE CO. FOR THE CONNECTICUT LIGHT & POWER COMPANY TITLE MIDDLETOWN-NORWALK 345KV TRANSMISSION PROJECT EROSION CONTROL DETAILS			
				date 10/11/05 designed BL COMPANIES detailed S. NEWLAND	checked S. NEWLAND	BY SEN-BMCD DATE 10-11-05 SCALE AS NOTED	CHKD DATE APP DATE DWG. NO. 01223-15003 PG 002
1 8/29/06 ISSUED FOR CONSTRUCTION CTC no. date revisions by chk	MF NO. DATE REVISIONS	BY CHK APP APP	D	01223-15003 PG 002			

COPYRIGHT © 2006 BURNS & MCDONNELL ENGINEERING COMPANY, INC.

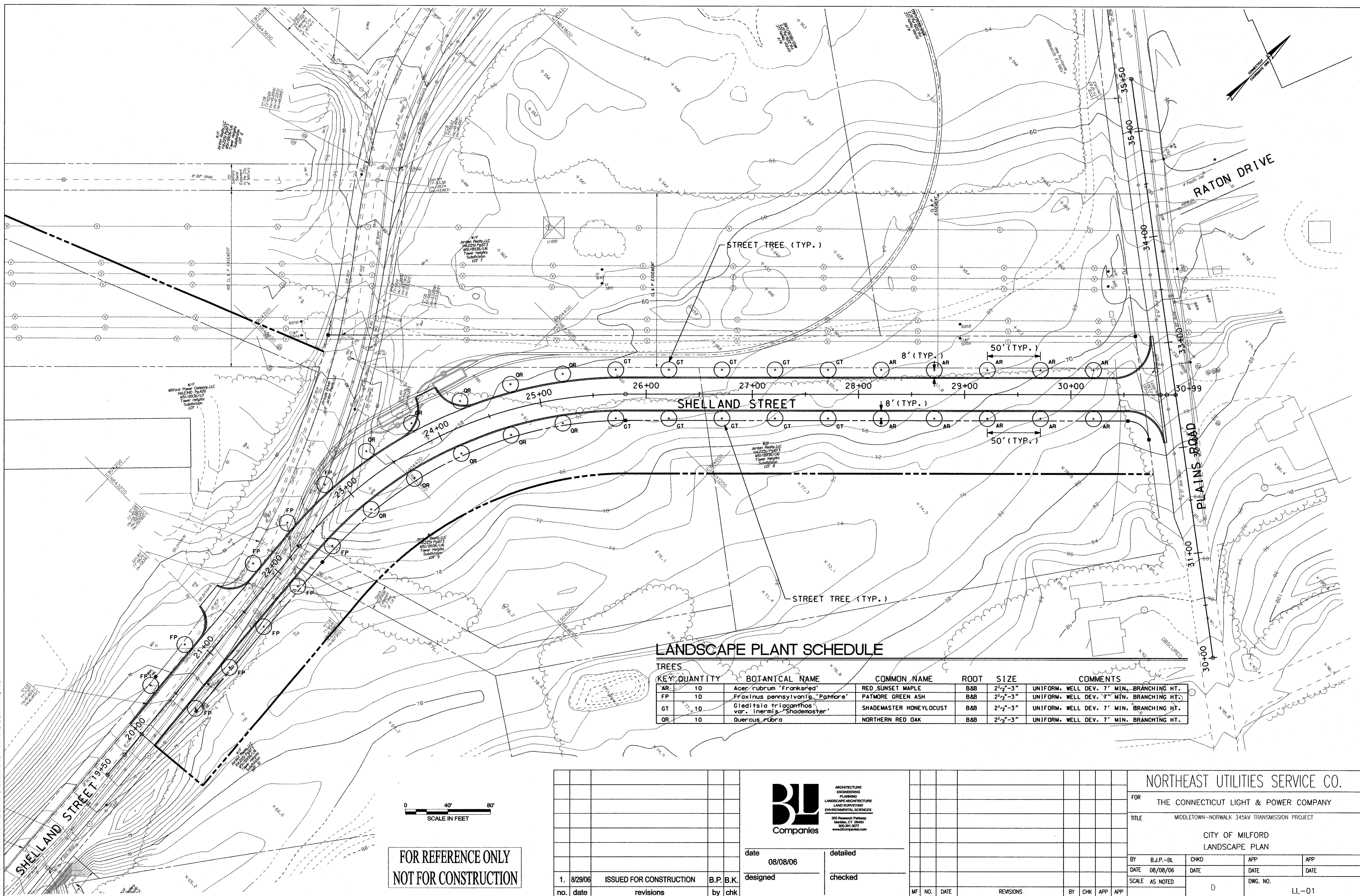

LANDSCAPE PLANT SCHEDULE

TREES						
KEY	QUANTITY	BOTANICAL NAME	COMMON NAME	ROOT SIZE	SIZE	COMMENTS
AR	10	<i>Acer rubrum</i> 'Franksred'	RED SUNSET MAPLE	B&B	2 1/2"-3"	UNIFORM. WELL DEV. 7' MIN. BRANCHING HT.
FP	10	<i>Fraxinus pennsylvanica</i> 'Patmore'	PATMORE GREEN ASH	B&B	2 1/2"-3"	UNIFORM. WELL DEV. 7' MIN. BRANCHING HT.
GT	10	<i>Gleditsia triacanthos</i> var. <i>inermis</i> 'Shademaster'	SHADEMASTER HONEYLOCUST	B&B	2 1/2"-3"	UNIFORM. WELL DEV. 7' MIN. BRANCHING HT.
OR	10	<i>Quercus rubra</i>	NORTHERN RED OAK	B&B	2 1/2"-3"	UNIFORM. WELL DEV. 7' MIN. BRANCHING HT.

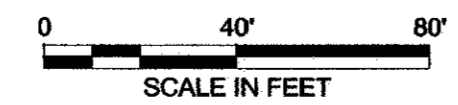

**FOR REFERENCE ONLY
NOT FOR CONSTRUCTION**

no.	date	revisions	by	chk
1.	8/29/06	ISSUED FOR CONSTRUCTION	B.P.	B.K.

**ARCHITECTURE
ENGINEERING
PLANNING
LANDSCAPE ARCHITECTURE
LAND SURVEYING
ENVIRONMENTAL SCIENCES**
 355 Research Parkway
Meriden, CT 06460
860.261.5077
www.blcompanies.com

date 08/08/06 detailed
 designed checked

MF	NO.	DATE	REVISIONS	BY	CHK	APP	APP

NORTHEAST UTILITIES SERVICE CO.

FOR THE CONNECTICUT LIGHT & POWER COMPANY

TITLE MIDDLETOWN-NORWALK 345KV TRANSMISSION PROJECT

CITY OF MILFORD
LANDSCAPE PLAN

BY B.J.P.-BL	CHKD	APP	APP
DATE 08/08/06	DATE	DATE	DATE
SCALE AS NOTED		DWG. NO.	LL-01

GENERAL NOTES

1. A) THIS MAP HAS BEEN PREPARED IN ACCORDANCE WITH THE REGULATIONS OF CONNECTICUT STATE AGENCIES, SECTIONS 20-300b-1 THROUGH 20-300b-20 AND THE "STANDARDS FOR SURVEYS AND MAPS IN THE STATE OF CONNECTICUT" AS ADOPTED BY THE CONNECTICUT ASSOCIATION OF LAND SURVEYORS, INC. ON SEPTEMBER 26, 1996.
- B) THIS PLAN CONFORMS TO HORIZONTAL ACCURACY CLASS A-2.
- C) BOUNDARY DETERMINATION OF THE NEW LOT LINES IS BASED UPON AN ORIGINAL SURVEY. BOUNDARY DETERMINATION OF THE EXISTING RIGHT OF WAY AND PERIMETER PROPERTY LINES BASED UPON A DEPENDENT RESURVEY OF MAP REFERENCE 4A.
- D) THE TYPE OF SURVEY PERFORMED IS A RESUBDIVISION MAP AND IS INTENDED TO DEPICT THE POSITION OF THE NEW BOUNDARIES WITH RESPECT TO MONUMENTATION FOUND, EASEMENTS, ENCROACHMENTS, STRUCTURES AND ROADWAYS.
2. NORTH ARROW AND BEARINGS BASED ON MAP REFERENCE 4A AND REFER TO NAD 83.
3. THE UNDERGROUND UTILITIES SHOWN HAVE BEEN LOCATED FROM FIELD SURVEY INFORMATION AND EXISTING DRAWINGS. THE SURVEYOR MAKES NO GUARANTEES THAT THE UNDERGROUND UTILITIES SHOWN COMPRISE ALL SUCH UTILITIES IN THE AREA, EITHER IN SERVICE OR ABANDONED. THE SURVEYOR FURTHER DOES NOT WARRANT THAT THE UNDERGROUND UTILITIES SHOWN ARE IN THE EXACT LOCATION INDICATED THOUGH THEY ARE LOCATED AS ACCURATELY AS POSSIBLE FROM INFORMATION AVAILABLE. THE SURVEYOR HAS NOT PHYSICALLY LOCATED THE UNDERGROUND UTILITIES. THE CONTRACTOR SHALL CONFIRM THE LOCATION OF ALL UTILITIES PRIOR TO THE COMMENCEMENT OF EXCAVATION.
4. REFERENCE IS MADE TO THE FOLLOWING MAP:
 - A. "SUBDIVISION MAP TOWER HEIGHTS SUBDIVISION PREPARED FOR JORDAN REALTY, LLC SHELLAND STREET MILFORD, CONNECTICUT" DATE 2/13/98 REV. 2/5/99 SCALE 1"=100' SHEET 2 PREPARED BY CODESPOTI & ASSOCIATES P.C. AND RECORDED IN THE MILFORD CLERKS OFFICE AS MAP #A82472.

LEGEND

- Proposed R.O.W. Line
- Existing Property Line
- Easement Line
- Utility Pole
- Utility Pole w/ Light

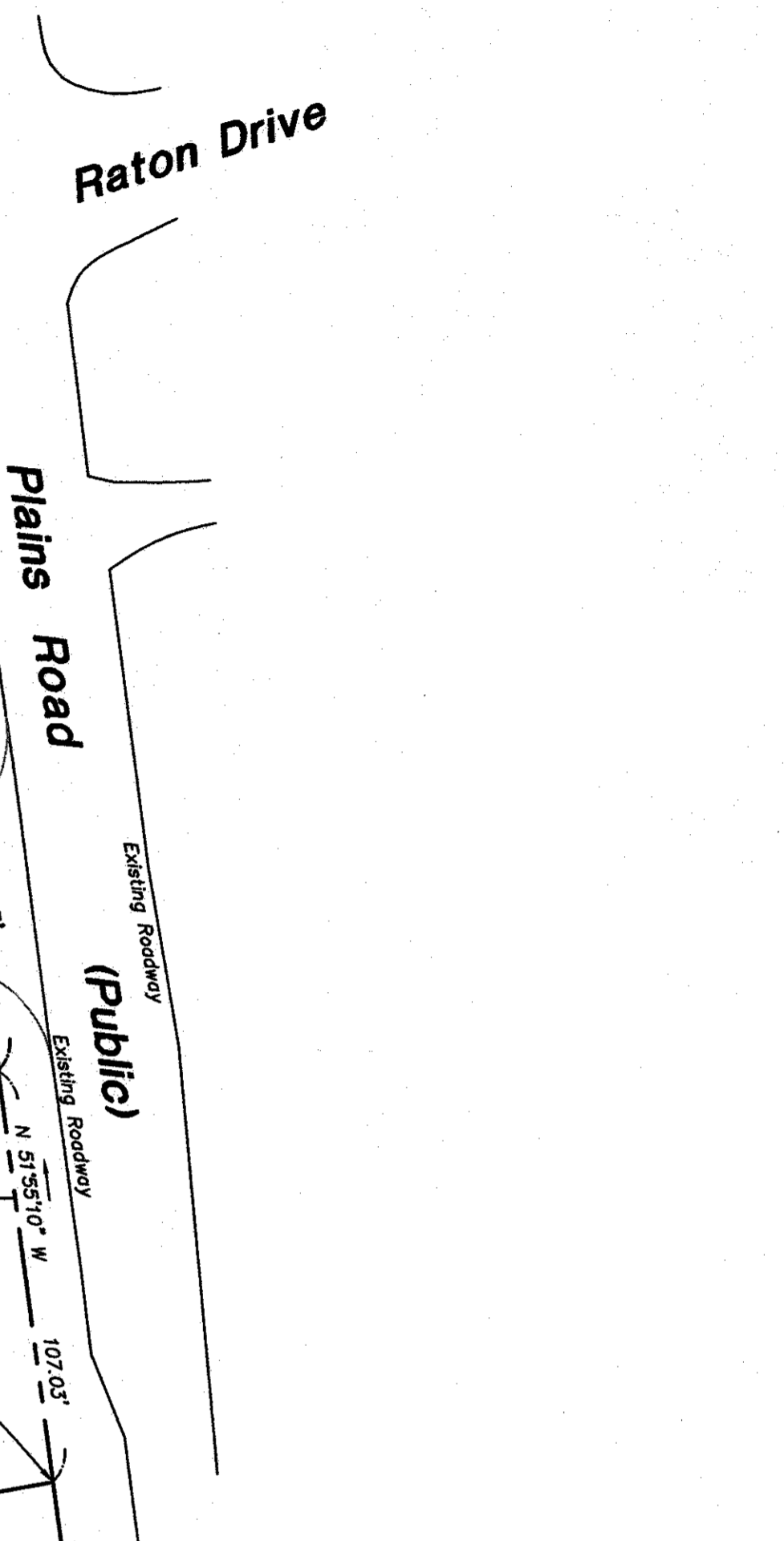
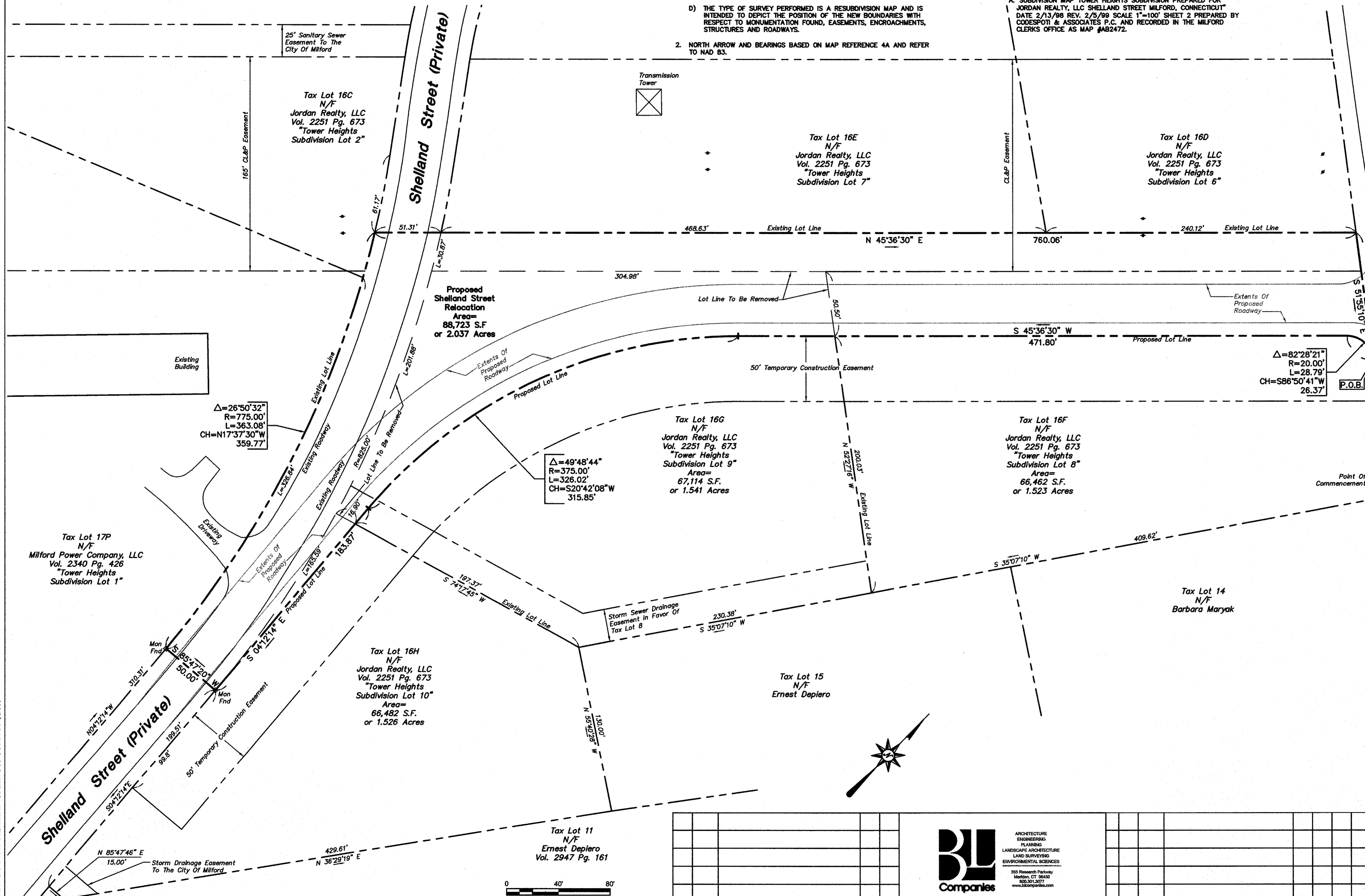

COPYRIGHT © 2006 BURNS & MCDONNELL ENGINEERING COMPANY, INC.

SCALE IN FEET
FOR REFERENCE ONLY
NOT FOR CONSTRUCTION

 ARCHITECTURE ENGINEERING PLANNING LANDSCAPE ARCHITECTURE LAND SURVEYING ENVIRONMENTAL SCIENCES 355 Research Parkway Meriden, CT 06450 800.301.3077 www.bmcom.com				
date	08/08/06	detailed		
designed		checked		
no.	date	revisions	by	chk
1.	8/29/06	ISSUED FOR CONSTRUCTION	B.P.	B.K.

NORTHEAST UTILITIES SERVICE CO.			
FOR THE CONNECTICUT LIGHT & POWER COMPANY			
TITLE MIDDLETOWN-NORWALK 345KV TRANSMISSION PROJECT			
CITY OF MILFORD LOT LINE ADJUSTMENT PLAN			
BY	B.J.P.-BL	CHKD	APP
DATE	08/08/06	DATE	DATE
SCALE	AS NOTED	D	DWG. NO. SB-01

NOTES

1. THE PROPOSED SANITARY SEWER SYSTEM SHALL BE CONSTRUCTED TO THE LIMITS AND DEPTHS AS SHOWN ON THE PLANS. IF, DURING CONSTRUCTION, CONFLICTS ARISE BETWEEN EXISTING AND PROPOSED INVERTS, EXISTING INVERTS SHALL BE HELD UNLESS OTHERWISE DIRECTED BY THE ENGINEER.
2. SEE SHEET NO. DRN-01 AND PRO-02 FOR TRUNKLINE LAYOUT PLAN AND PROFILE RESPECTIVELY.

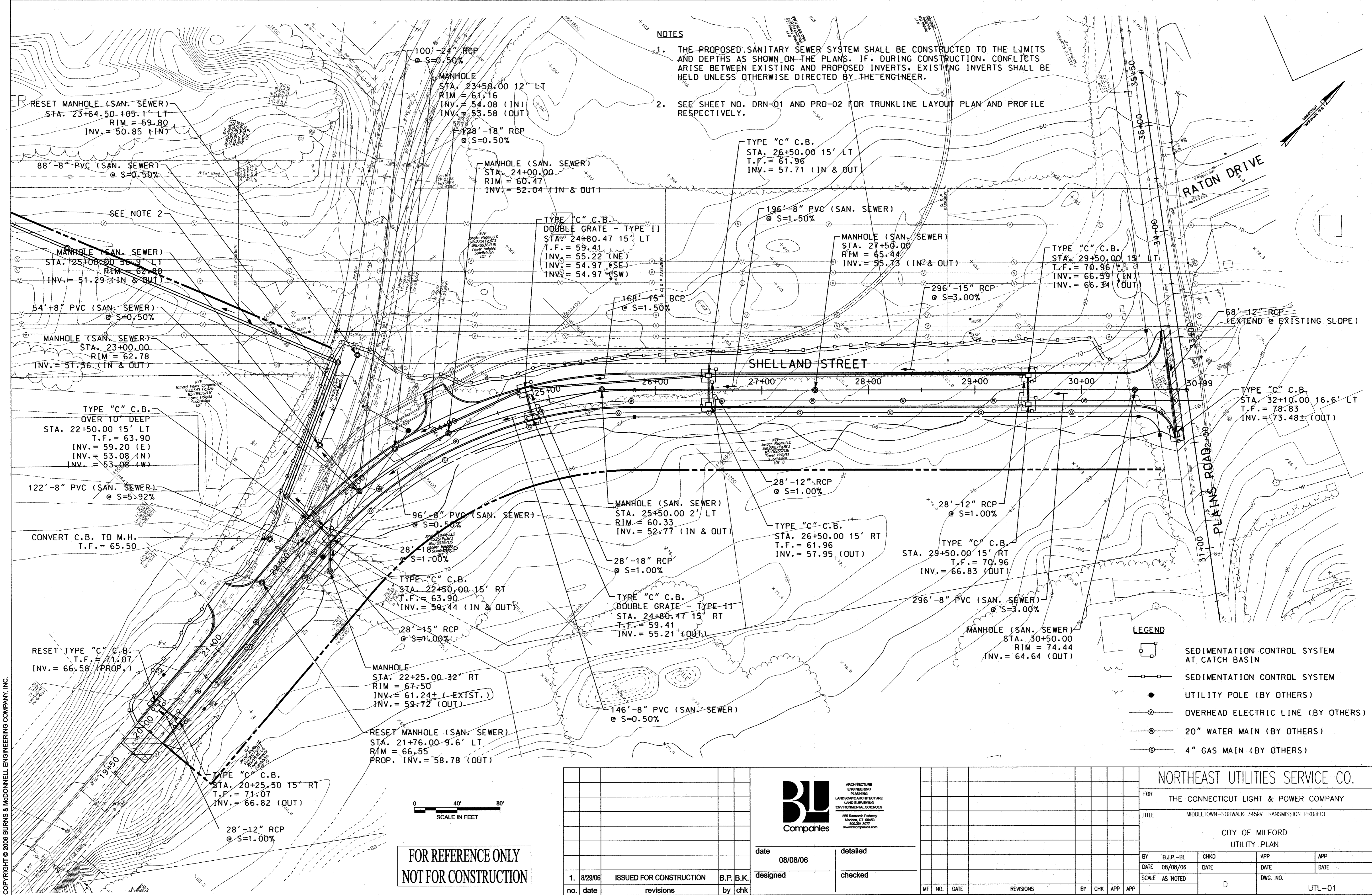

LEGEND

- SEDIMENTATION CONTROL SYSTEM AT CATCH BASIN
- SEDIMENTATION CONTROL SYSTEM
- UTILITY POLE (BY OTHERS)
- OVERHEAD ELECTRIC LINE (BY OTHERS)
- 20" WATER MAIN (BY OTHERS)
- 4" GAS MAIN (BY OTHERS)

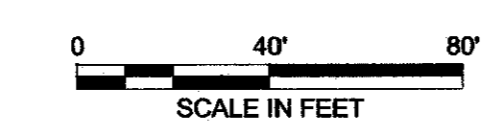

**FOR REFERENCE ONLY
NOT FOR CONSTRUCTION**



ARCHITECTURE
ENGINEERING
PLANNING
LANDSCAPE ARCHITECTURE
LAND SURVEYING
ENVIRONMENTAL SCIENCES
355 Research Parkway
Middletown, CT 06450
603.931.5077
www.blcompanies.com

date 08/08/06 detailed
designed checked

no.	date	revisions	by	chk
1.	8/29/06	ISSUED FOR CONSTRUCTION	B.P.	B.K.

NORTHEAST UTILITIES SERVICE CO.

FOR	THE CONNECTICUT LIGHT & POWER COMPANY		
TITLE	MIDDLETOWN-NORWALK 345KV TRANSMISSION PROJECT		
CITY OF MILFORD UTILITY PLAN			
BY	B.J.P.-BL	CHKD	APP
DATE	08/08/06	DATE	DATE
SCALE	AS NOTED	DWG. NO.	UTL-01

COPYRIGHT © 2006 BURNS & MCDONNELL ENGINEERING COMPANY, INC.