

TELECOMMUNICATIONS FACILITIES

AN ILLUSTRATED PRIMER ON THE SITING OF
FACILITIES WITHIN CONNECTICUT AND
THROUGHOUT THE NATION



TOWER TYPES

Lattice (or Free Standing) - - - - -	1
Monopole - - - - -	5
Guyed - - - - -	7
Repeaters - - - - -	9
Alternative Structures - - - - -	10
Rooftops - - - - -	16
Negative Visual Impact - - - - -	18
Camouflaged – Alternative Structures - - - - -	21
Free Standing - - - - -	26
Rooftop Structures - - - - -	37
Landscaping & Fencing - - - - -	46
Tower Antennas and Mounting Types - - - - -	50
Tower Construction - - - - -	55
Tower Diagram - - - - -	56
Tower Anatomy - - - - -	57
Glossary - - - - -	58
Index - - - - -	62

LATTICE or free-standing towers can accommodate heavy loading of antennas and microwave dishes. The most common cause of failure among those towers is overloading that can make the structure vulnerable to high-winds when loaded with excess amounts equipment or too much ice and snow mixed with heavy winds.



Figure-1. 168 Catoona Lane in Stamford, CT. Photograph taken in October of 2004.



Figure-2. Route 80 in Killingworth, CT. Photograph taken in November of 2004.



Figure-3. 11 Willard Road in Norwalk, CT. Photograph taken in April of 2004.

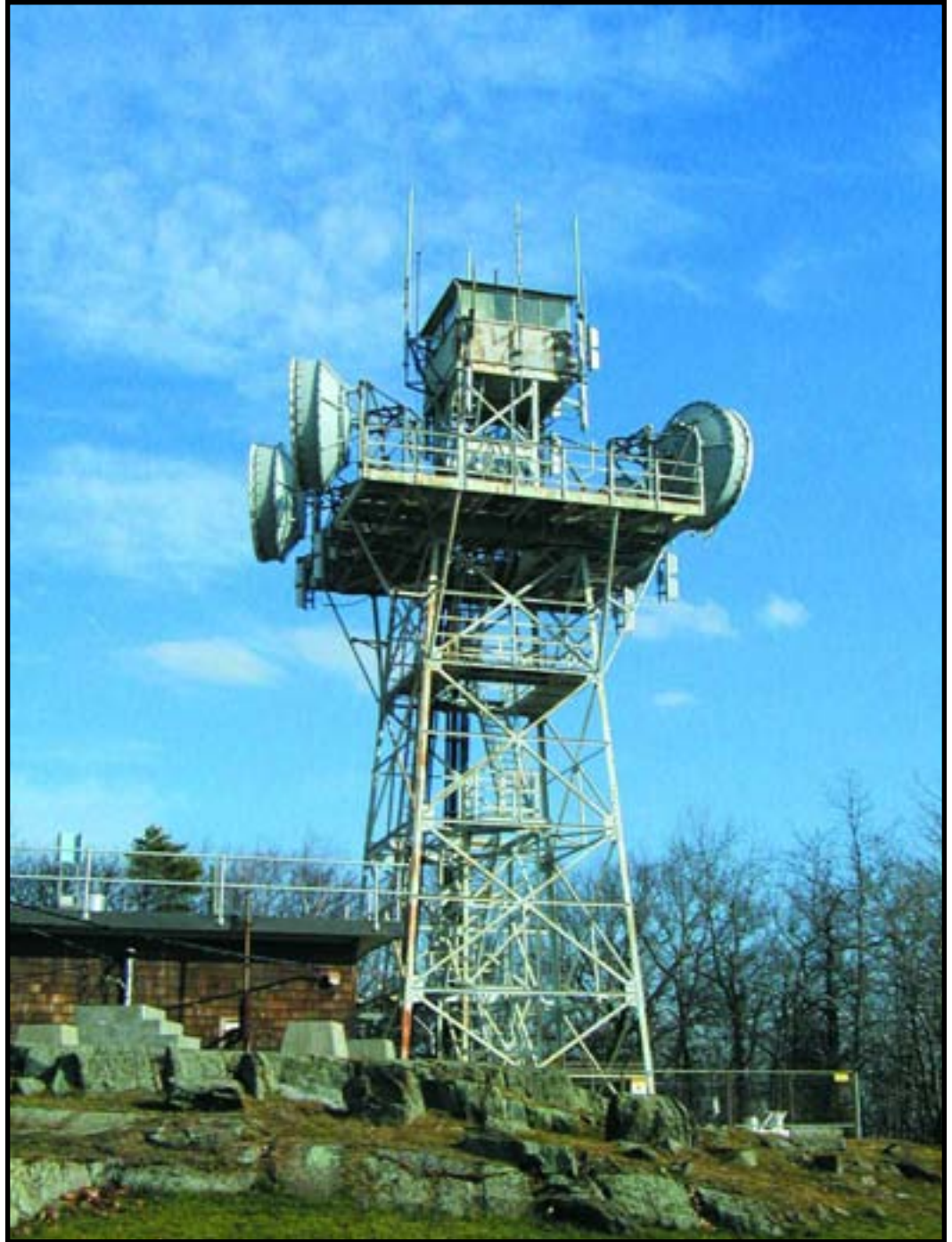

Figure-4. Mohawk Mountain in Cornwall, CT. Photograph taken in December of 2001.

MONOPOLE towers are the least expensive and require the least amount of space for construction. Antennas are usually mounted on a monopole with a vertical separation of 10 foot to 15 foot increments.

Antennas can be installed within, flush mounted to, or installed on a platform on a monopole. A regular antenna platform is shaped as a triangle with antennas mounted on each side of the triangle. A low-profile antenna platform is the same as a regular antenna platform; however the metal sides of the triangle are thinner and therefore less visible. A t-bar antenna platform consists of three arms extending from the monopole facing different directions with antennas mounted straight across the other end of the arm.



Figure-5. 528 Wheelers Farms Road in Milford, CT. Photograph taken in January of 2004.



Figure-6. 78 Route 81 in Killingworth, CT. Photograph taken in December of 2003.

GUYED lattice towers are supported by guy wires and can range from 50 feet to 2,100 feet in height. Guyed lattice towers rest on a point to allow for sway and eliminate torque in the legs of the structure.

Guyed lattice towers are sometime are referred to by critics as “bird killer” towers due to reports of migratory birds flying into the cables. Some techniques used to deter birds from flying into the guy wires include owl screech recordings, bright yellow balls strung on the guy wires and sound and light emissions.



Figure-7. 99 Briar Hill Road in Groton, CT. Photograph taken in April of 2004.



Figure-8. Tolland Avenue in Stafford Springs, CT. Photograph taken in February of 2004.

Passive **REPEATERS** are used to change the direction of a microwave path to overcome obstructions, reduce the number of active repeaters installed and allow more convenient locations for active repeaters near existing roads and power lines. A passive repeater requires no access or power supply and virtually no maintenance.



Figure-9. A passive microwave reflector is located at 652 Glenbrook Road in Stamford, CT. Photograph taken in December of 2006.

Potential locations for wireless telecommunications antennas on alternative structures include water towers, smokestacks, billboards, telephone poles and electric transmission structures.



Figure-10. Buckingham Street in Watertown, CT. Photograph taken in December of 2001.

BILLBOARDS

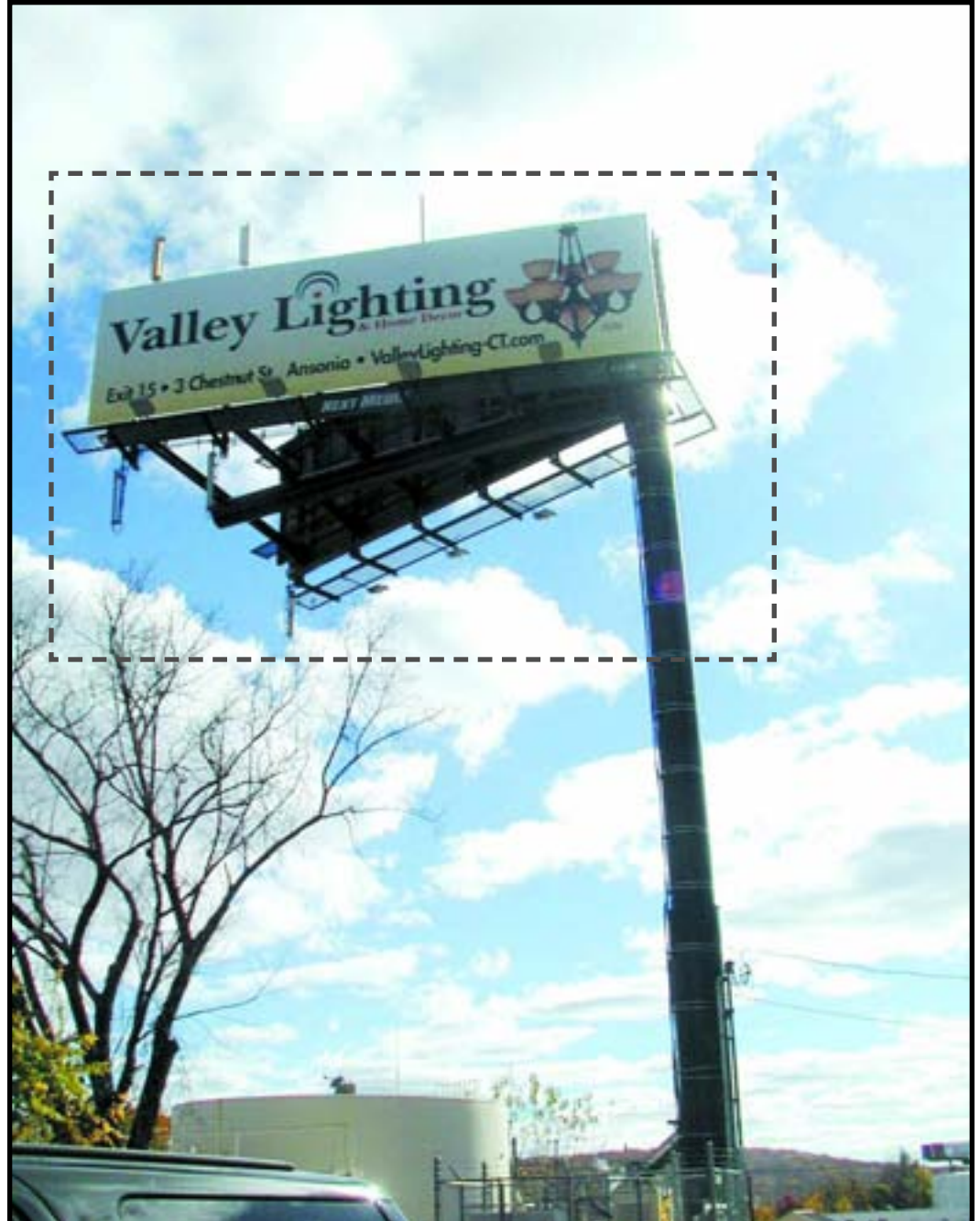

Figure-11. Wireless telecommunications antennas attached to a billboard located at 521 South Leonard Street in Waterbury. Photograph taken in October of 2006.

SMOKESTACKS

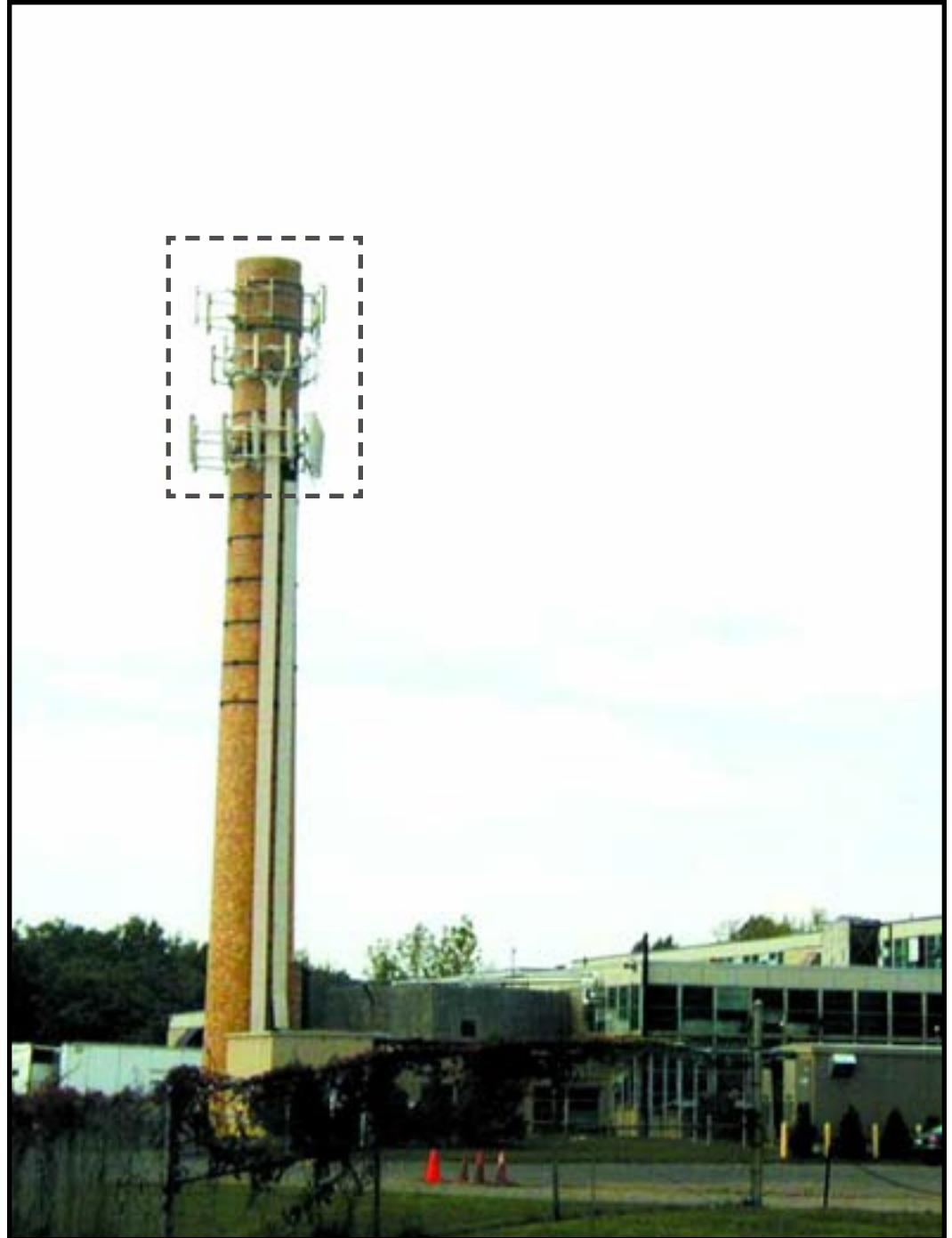

Figure-12. Antennas attached to a smokestack located at 500 South Broad Street in Meriden. Photograph taken in October of 2006

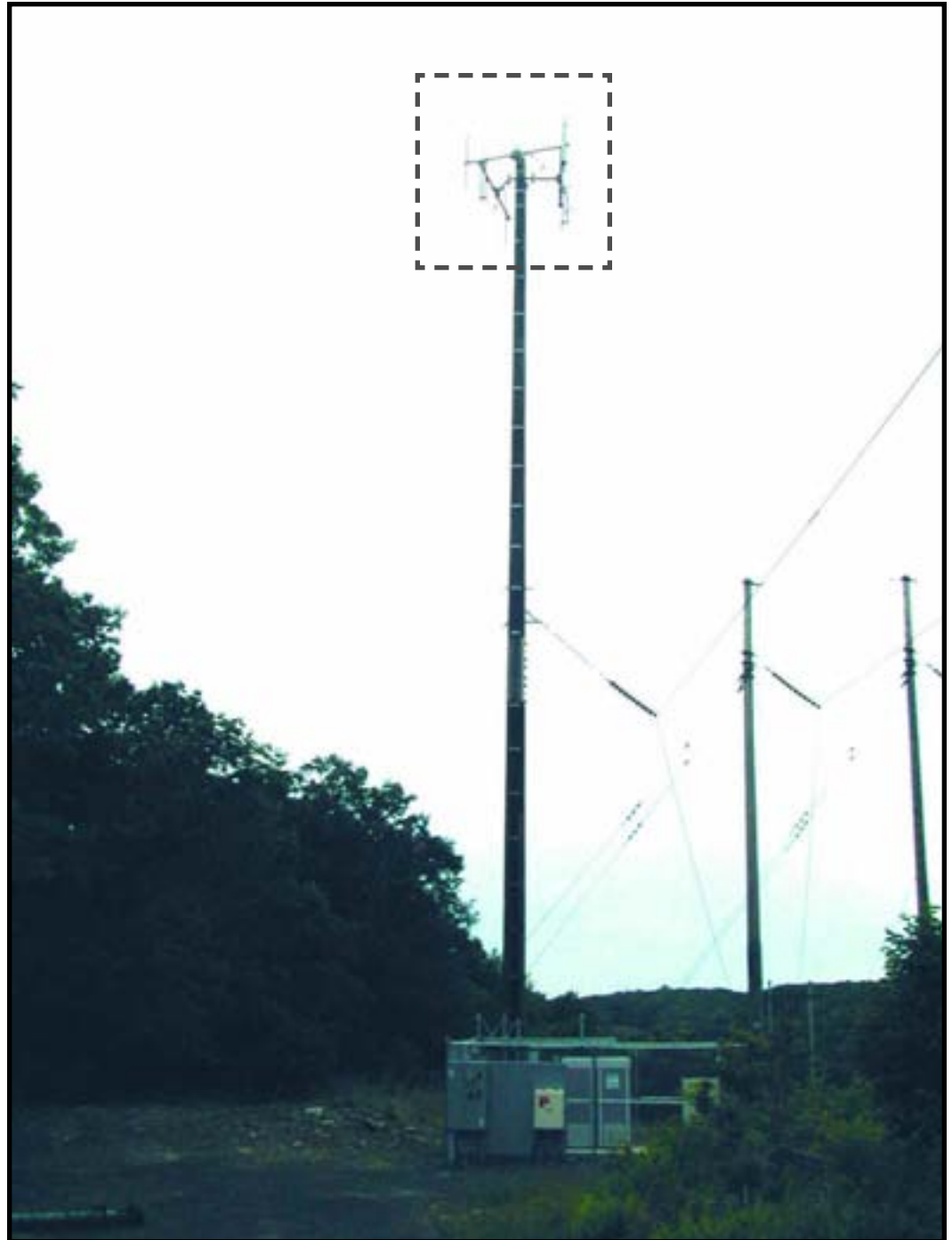

Figure-13. Co-location on an extended electric transmission pole on Bartholomew Road in Middletown, CT. Photograph taken in June of 2004.

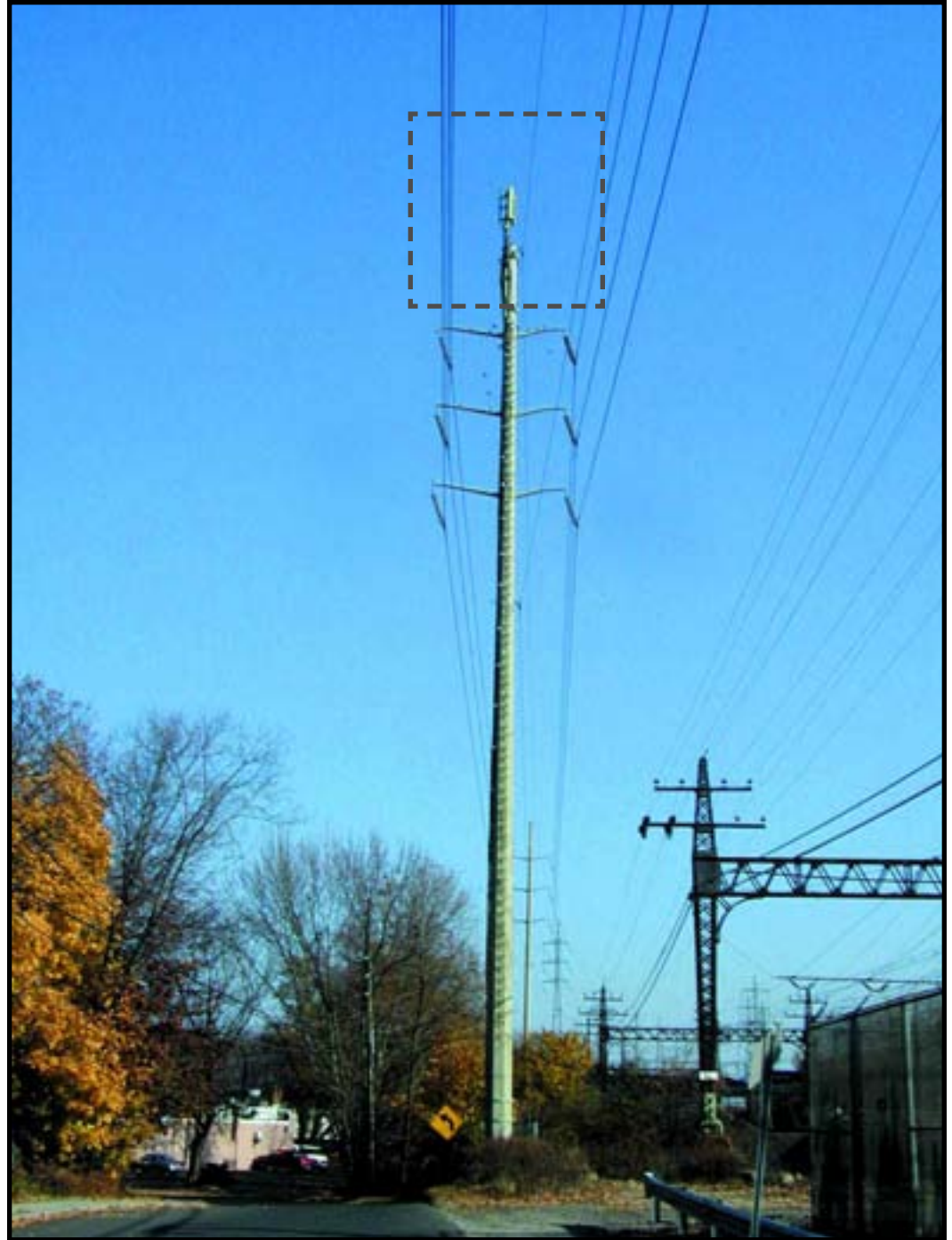

Figure-14. Co-location on an electric transmission structure located on 3 Mechanic Street in Darien, CT. Photograph taken in November of 2001.



Figure-15. Park lights share a structure with wireless telecommunications antennas at Chelsey Park in New Britain, CT. Photograph taken in September of 2006.

ROOFTOP placement of antennas represents almost half of all cellular, microwave, paging and two-way placements. Rooftop mounts can be concentrated on a mast with vertical separation of antennas (as seen below) or along a rooftop with horizontal separation of the antennas. Where directional coverage is needed, antenna panels can be mounted on the side of buildings.

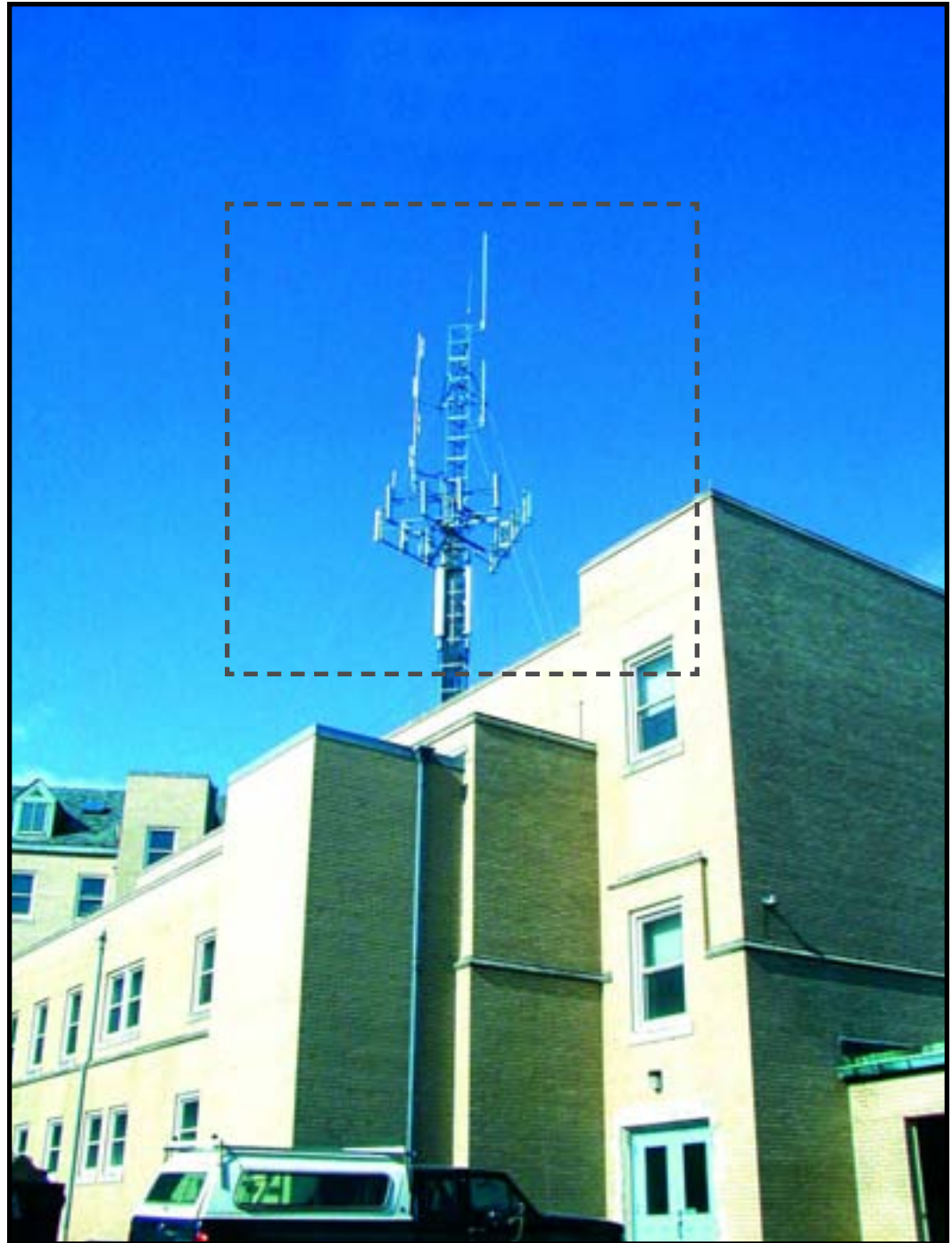

Figure-16. 265 Benham Street in Hamden, CT. Photograph taken in February of 2004.

ROOFTOP Ballast Frame for Two Wireless Antennas Supports two wireless antennas on a single Frame and provides a maximum 6' 1" antenna separation. The Frame is modular and multiple units may be bolted together to support more antennas and provide greater outside antenna separation. The Frame's footprint is 7'-3/8" wide and 7' 11" deep.

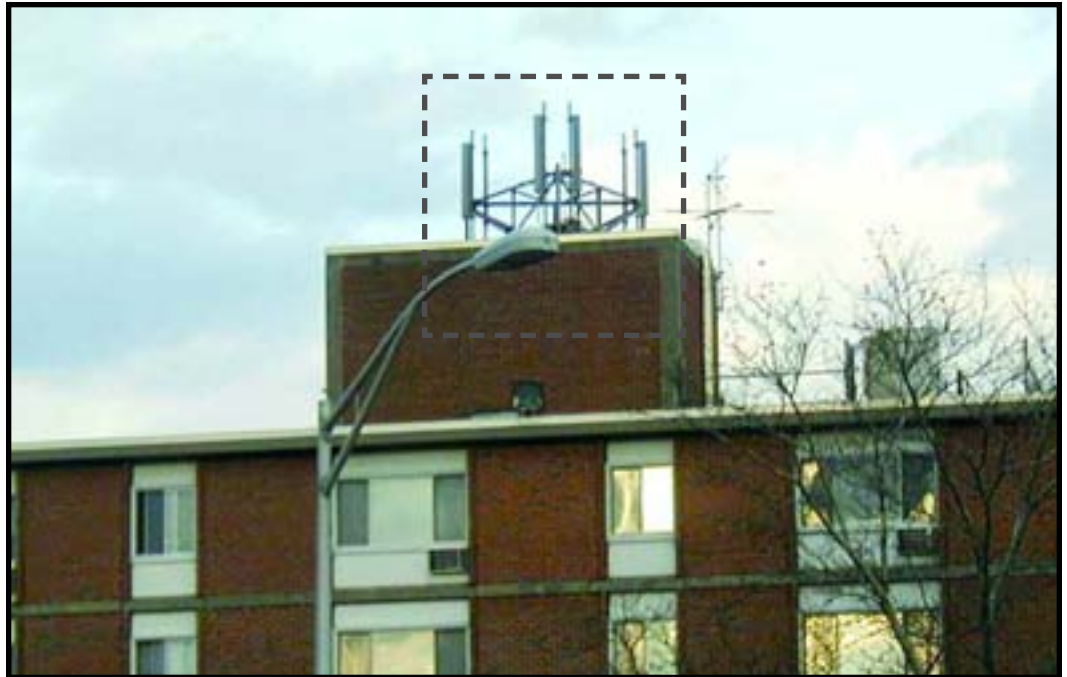
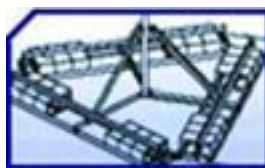

Figure-17. A ballast frame rooftop mounted antenna is located on Winter Street in New Britain, CT. Photograph taken in December of 2006.

EXAMPLES OF ROOFTOP MOUNTING EQUIPMENT



Towers in close proximity to residential areas, playgrounds or historical areas are sometimes seen as unfortunate tower locations.



Figure-18. 151 Sand Hill Road in Windsor, CT. Photograph taken in September of 2006.



Figure-19. 23 Kelleher Court in Wethersfield, CT. Photograph taken in September of 2006.



Figure-20. 1320 Chopsey Hill Road in Bridgeport, CT. Photograph taken in October of 2006.



Figure-21. 1445 Forbes Avenue in East Hartford, CT. Photograph taken December of 2000.



Figure-22. 1320 Chopsey Hill Road in Bridgeport, CT. Photograph taken in October of 2006.



Figure-23. A 120-foot telecommunications facility, disguised as a tree, located at 477 Route 7 in Sharon, CT. Photographed in January of 2007.



Figure-24. A 110-foot telecommunications facility disguised as a tree located at 70 Herb Road in Sharon, CT. Photographed in February of 2007.



Figure-25. A 125-foot telecommunications facility disguised as a bell tower located at the Harvest Baptist Church at 1440 Litchfield Turnpike in New Hartford, CT. Photographed in February of 2007.



Figure-26. An 80-foot wood laminate pole located at 41 Padanaram Road in Danbury, CT. Photographed in May of 2006.



Figure-27. A 55-foot wooden pole located at 111 Middle Turnpike in Mansfield, CT (also known as a “brown stick”). Photographed in October of 2004.

FREE STANDING

Towers can be disguised as trees, flagpoles, grain silos, clock towers, observation stations among other things. Camouflaged towers make up approximately four percent of new tower construction. Construction of camouflaged towers is more expensive than other tower types.

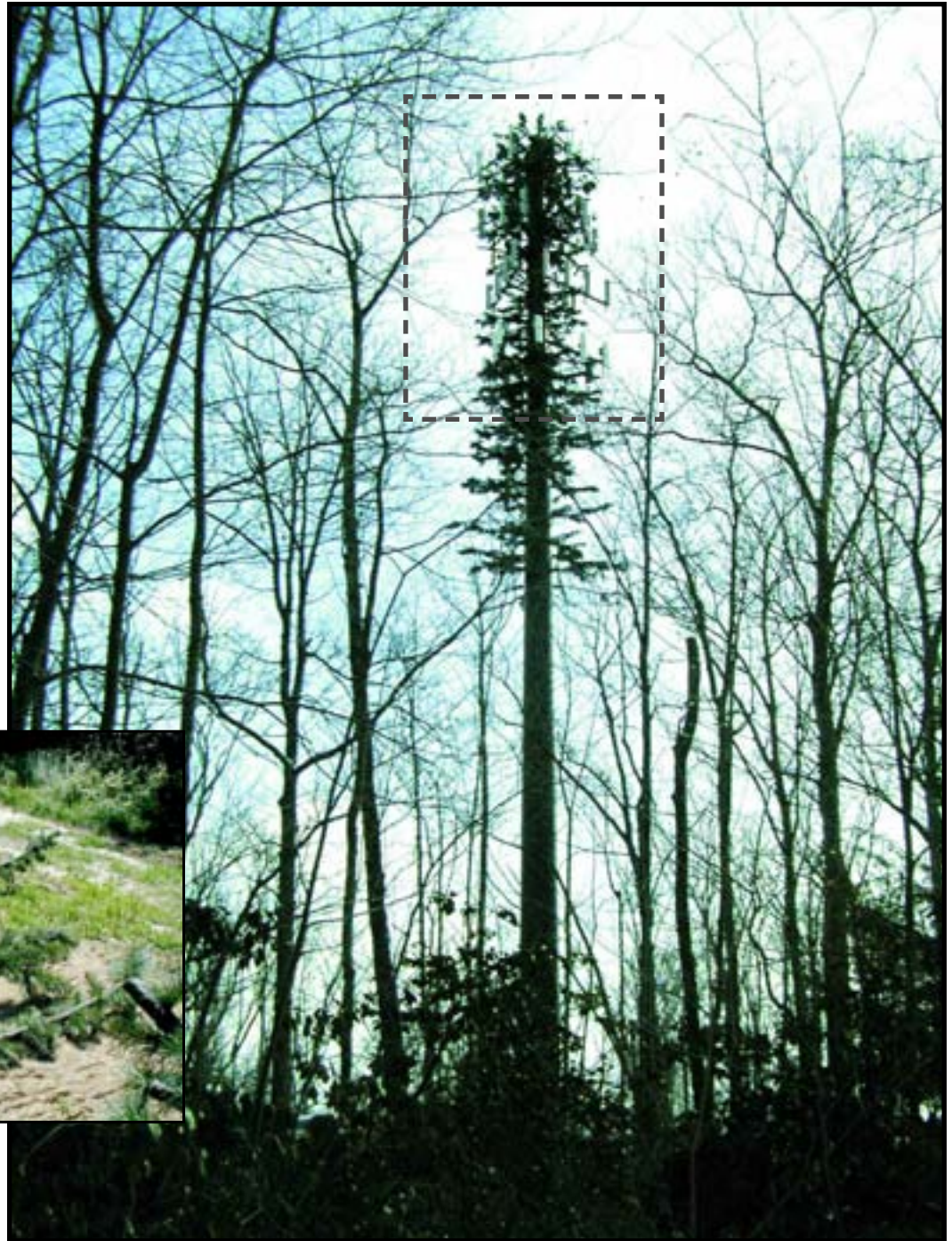

Figure-28. 127 New Hartford Road in Barkhamsted, CT. Photograph taken in January of 2004.



Figure-29. Near Interstate 405 and Long Beach Boulevard in Long Beach, CA.



Figure-30. Pacifica Mormandie in Torrance, CA. The structure is 62 feet tall. Antennas are located at 55 feet agl.



Figure-31. Pacifica Mormandie in Torrance, CA. The structure is 62 feet tall. Antennas are located at 55 feet agl.



Figure-32. 100 Pond Lily Avenue in New Haven, CT. Antennas are located within the flagpole structure and equipment is housed within a brick façade that matches the building. Photograph taken in June of 2006.



Figure-33. 985 Farmington Avenue in Bristol, CT. Antennas are located within the flagpole structure and equipment is at the base of the structure.



Figure-34. Vista, CA. The structure is 45 feet tall. Antennas are located at 41.5 feet agl and 35 feet agl.



Figure-35. 890 Evergreen Avenue in Hamden, CT. Photograph taken in July of 2001.



Figure-36. Betteravia Properties in Santa Maria, CA. The structure is 50 feet tall. Antennas are located at 48 feet agl.



Figure-37. Lamb of God in Anaheim, CA. The structure is 60 feet tall.



Figure-38. City of Lynwood, CA. Dimensions of the structure are 60 feet tall by 8 feet wide.



Figure-39. Magnolia Park in Upland, CA. The structure is 60 feet tall.

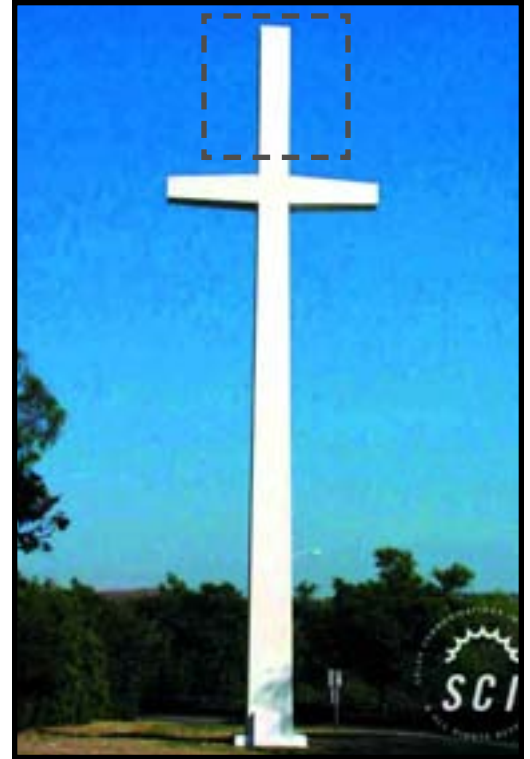

Figure-40. Mason in Irvine, CA. The structure is 60 feet tall.



Figure-41. Promenade in Corona, CA. The structure is 40 feet tall.

WATER TOWERS

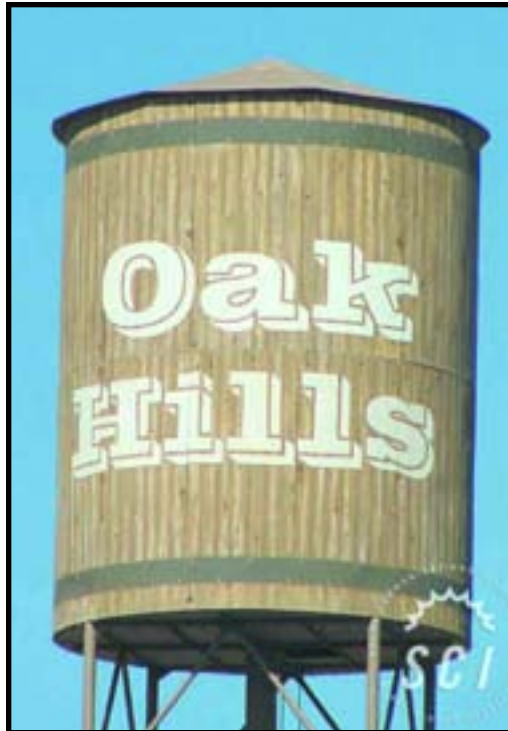

Figure-42. Cajon Pass in Oak Hills, CA. The structure is 90 feet tall. Antennas are within the water tank structure at 80 feet 8 inches agl and 70 feet agl.



Figure-43. Via Verde in San Dimas, CA. The structure is 60 feet tall. Antennas are mounted within the water tank at 58 feet agl and 47 feet agl.



Figure-44. Highway 38 Wabash in Mentone, CA. The structure is 60 feet tall. Antennas are located at 56 feet agl and 48.5 feet agl.



Figure-45. Baron Brothers' Nursery in Camarillo, CA. Antennas are located inside of the structure, which is made of a radio frequency transparent material. Dimensions of the structure are 25 feet wide by 12 feet high.

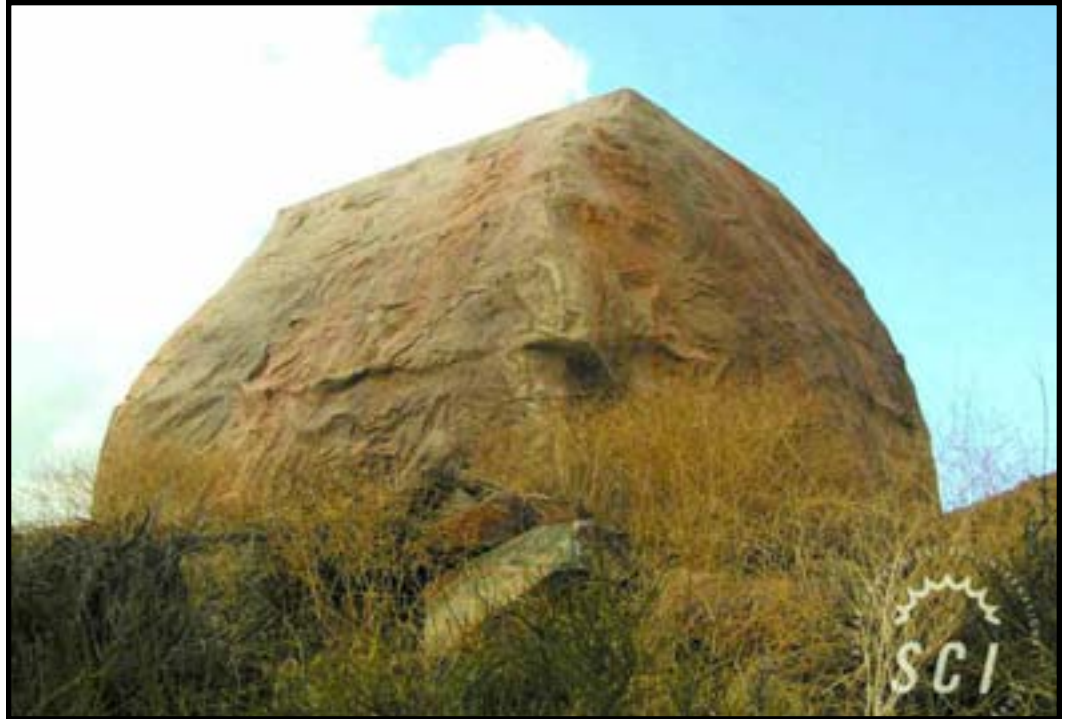

Figure-46. Chico Hills and Bundy in Menifee, CA. Antennas are located inside of the structure, which is made of a radio frequency transparent material. Dimensions of the structure are 15 feet wide by 47 feet long by 17 feet high.

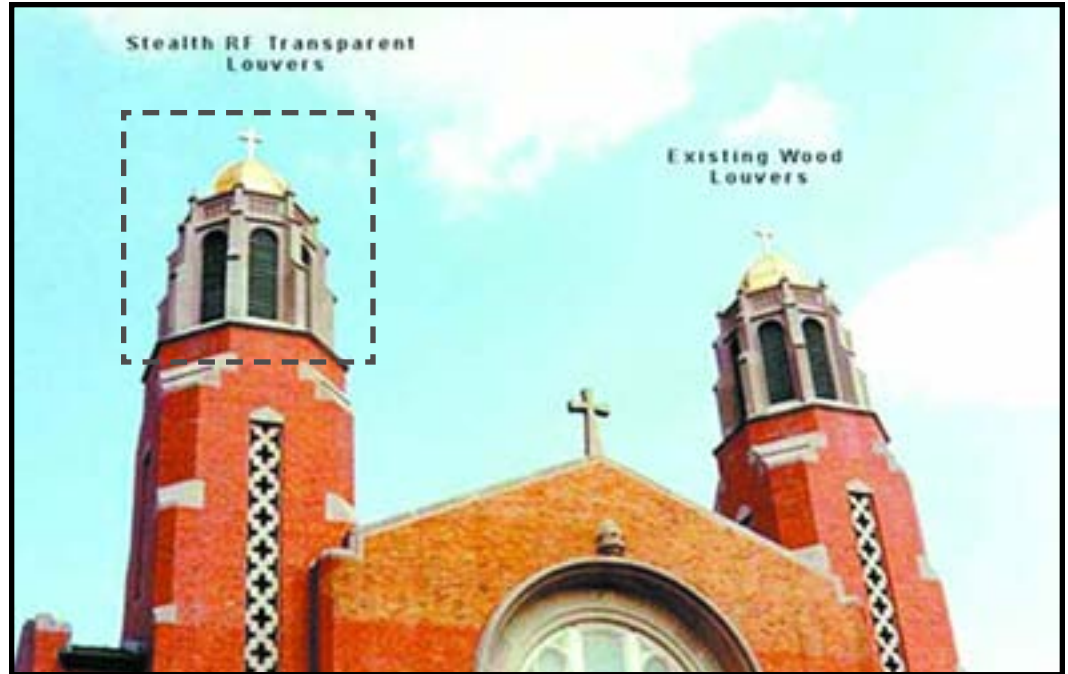

Figure-47. Rocky Peak Church in Chatsworth, CA. Antennas are located inside of the structure, which is made of a radio frequency transparent material. Dimensions of the structure are 11 feet 6 inches tall by 8 feet in diameter.

CAMOUFLAGED — ROOFTOP STRUCTURES

CT SITING COUNCIL

Wireless telecommunication antennas can be installed in or on buildings and camouflaged to appear as though they are part of the building.



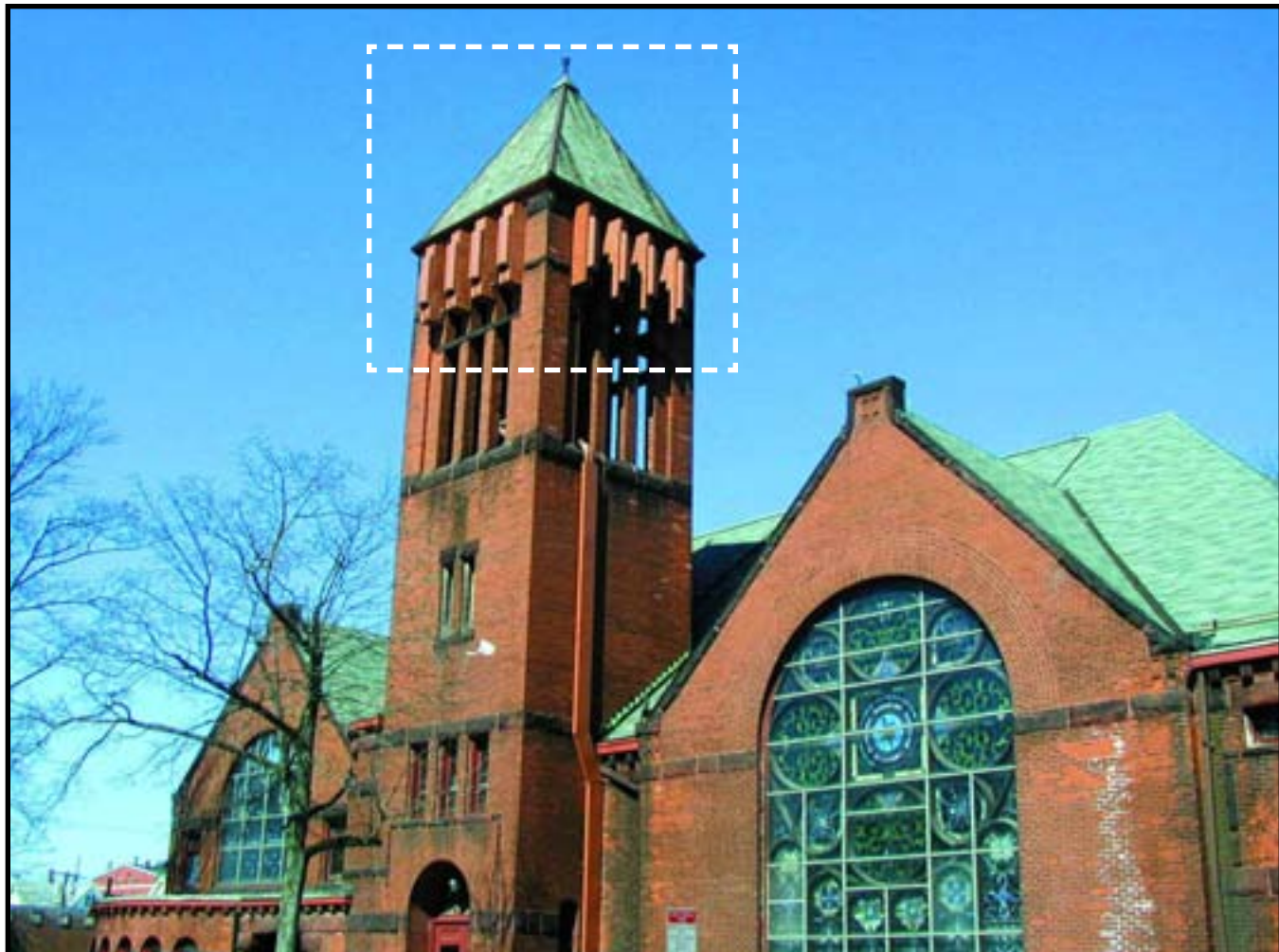

Figure-48. 5th Street in Derby, CT. Photograph taken in March of 2001.

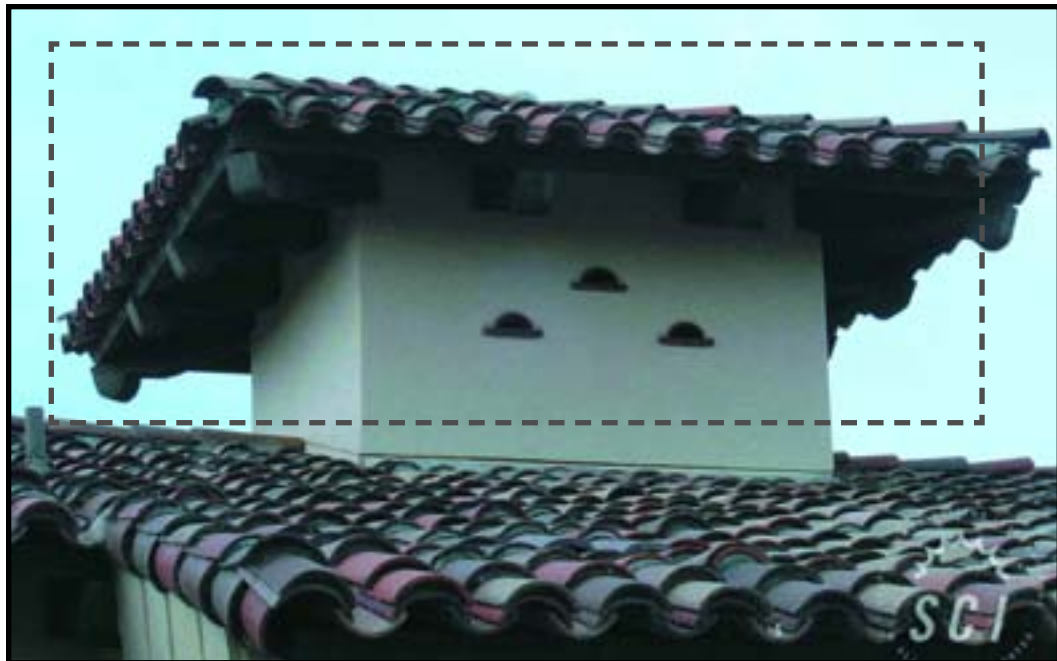

Figure-49. Shady Canyon Driving Range in Irvine, CA. The height of the structure is 21 feet 2 inches. Antennas are located at 17 feet 2 inches agl.



Figure-50. Elizabeth Street in Derby, CT. Photograph taken in March of 2001.



Figure-51. Carpinteria Best Western in Carpinteria, CA. The structure extends to 56 feet 8 inches.

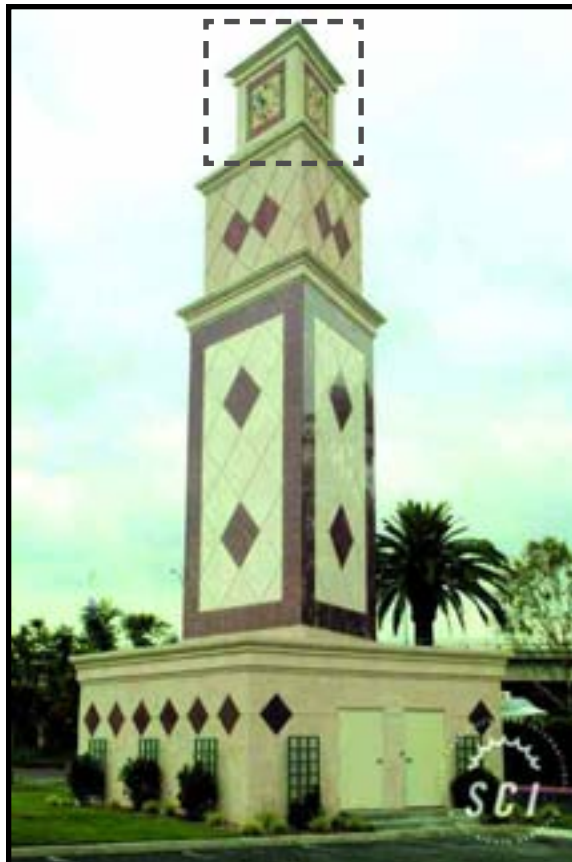

Figure-52. Cerritos Town Center in Cerritos, CA. The structure is 68 feet 6 inches tall. Antennas are located at 61 feet 8 inches agl and 50 feet agl.



Figure-53. Lantern Bay in Dana Point, CA. The height of the structure is 54 feet 11 inches. The antennas are located at 50 feet 11 inches agl.

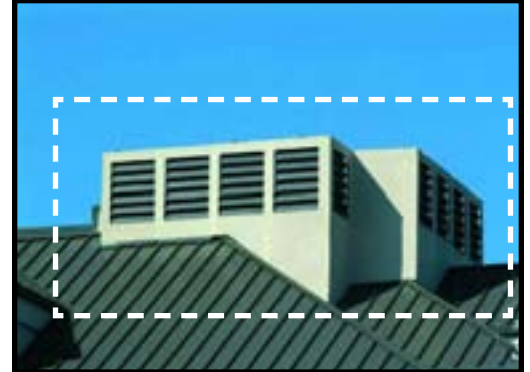

Figure-54. Highway 101 and 12 in Santa Rosa, CA. The structure is 61 feet 9 inches. Antennas are located at 59 feet agl.

CLOCK TOWERS



Figure-55. Ontario Convention Center in Ontario, CA. Structure is 86 feet 10 inches.



Figure-56. Gordon Square Shopping Center in Buena Park, CA. The structure is 51 feet tall. Antennas are located at 44 feet agl.

**RELIGIOUS
TOWERS**



Figure-57. St. George Church Cross in Upland, CA. The structure is 35 feet tall. The top of the antennas extend to 34.5 feet agl.

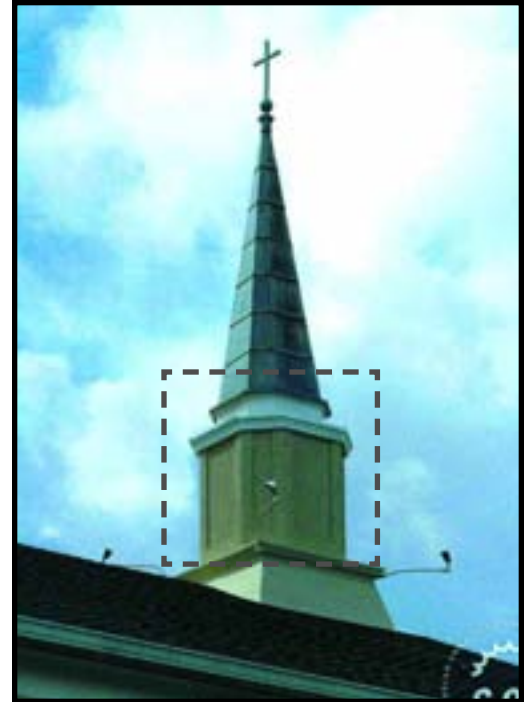

Figure-58. First United Methodist Church of Lakewood in Lakewood, CA. The structure is 56 feet 6 inches. Antennas are located at 40 feet 6 inches agl.



Figure-59. Nexte Del Mar Heights in San Diego, CA. Structure is 6 feet 8 inches from the top of the building.



Figure-60. Montfort Church in Santa Maria, CA. She structure is 50 feet tall. Antennas are located at 50 feet and 42 feet agl.

**RELIGIOUS
TOWERS**

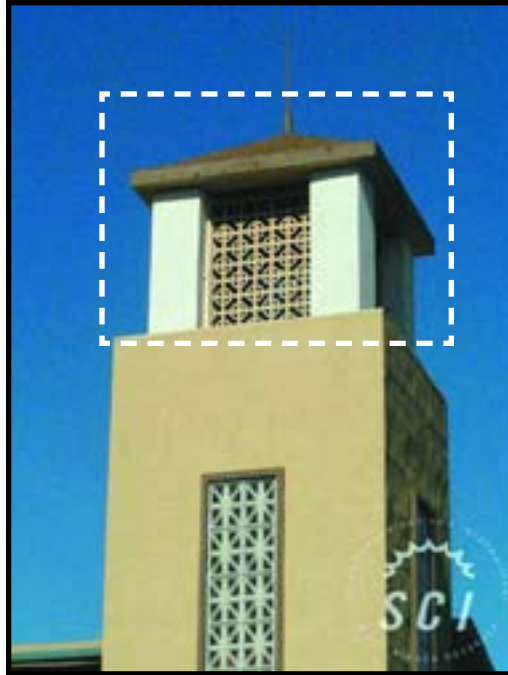

Figure-61. Peralta Park in Oakland, CA. The antennas are located at 54 feet 2 inches agl.

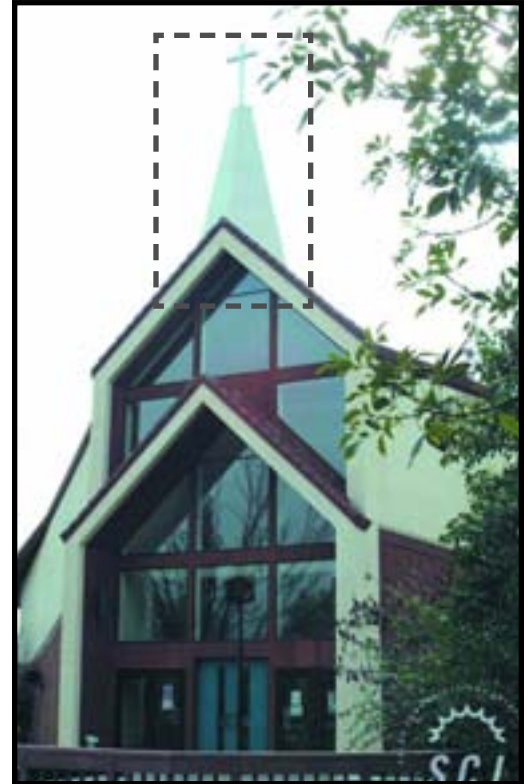

Figure-62. San Ramon-Montevideo in San Ramon, CA.

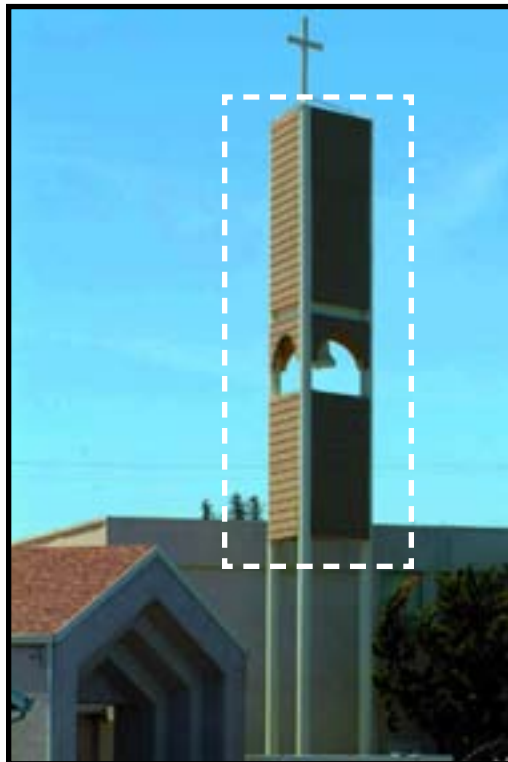

Figure-63. Rosemont in Sacramento, CA. The structure is 69 feet 9 inches. The antennas are located between 42 feet and 60 feet and between 26 feet and 38 feet agl.

Fencing and landscaping are often used to screen the compound of a wireless telecommunications site.



Figure-64. 17 West Rocks Road Norwalk, CT. Photograph taken in April of 2004.



Figure-65. 300 Governor's Highway in South Windsor, CT. Photograph taken in May of 2004.



Figure-66. 1725 Stafford Road in Mansfield, CT. Photograph taken in June of 2004.



Figure-67. 281 Woodhouse Road in Fairfield, CT. Photograph taken in June of 2000.

Antennas can be installed within, flush mounted to, or installed on a platform on a monopole. A regular antenna platform is shaped as a triangle with antennas mounted on each side of the triangle. A low-profile antenna platform is the same as a regular antenna platform; however the metal sides of the triangle are thinner and therefore less visible. A t-bar antenna platform consists of three arms extending from the monopole facing different directions with antennas mounted straight across the other end of the arm.

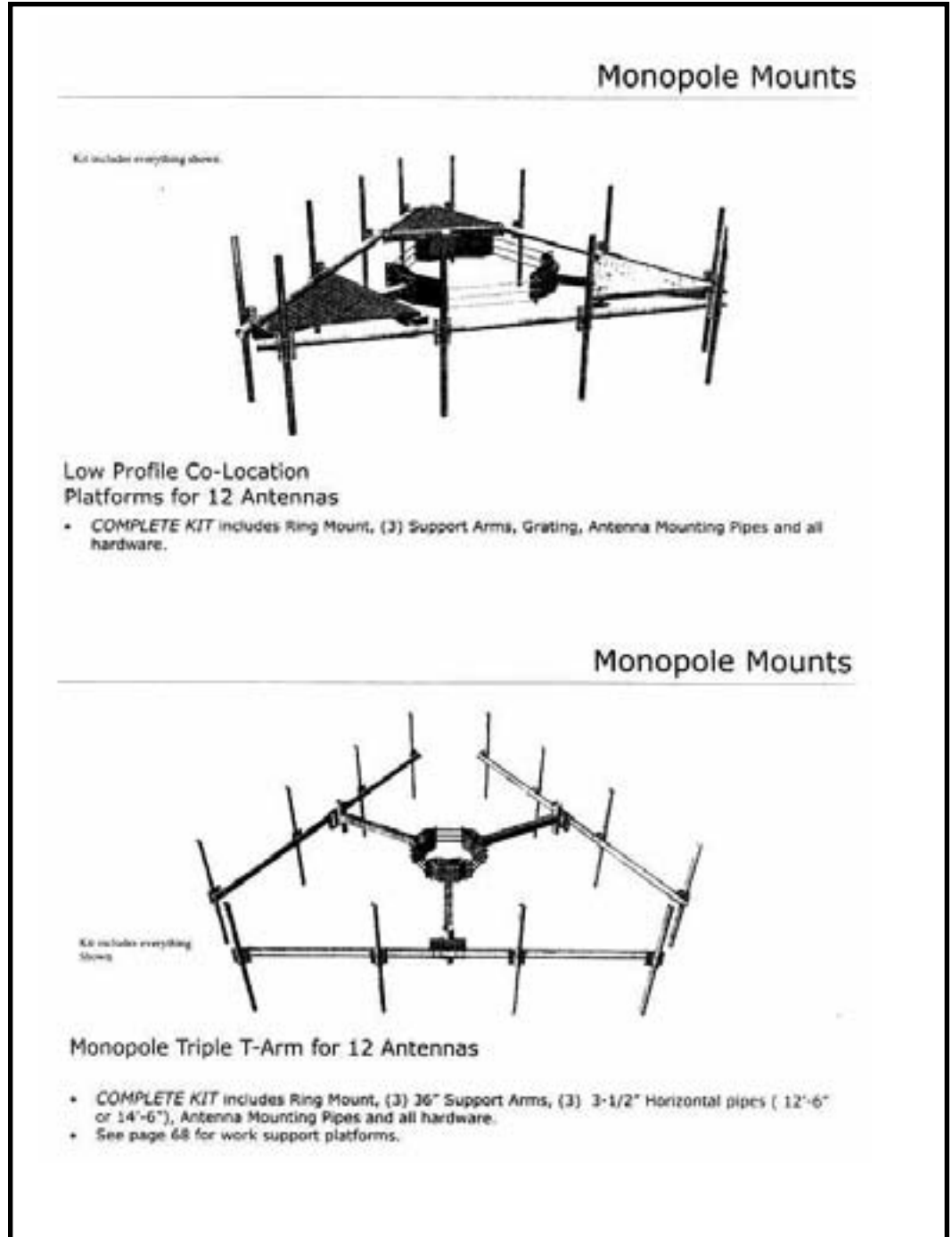

Figure-68. Two examples of antenna mounting types on a monopole. The top drawing is an example of a low-profile antenna mount. The bottom drawing is an example of a t-arm antenna mount.

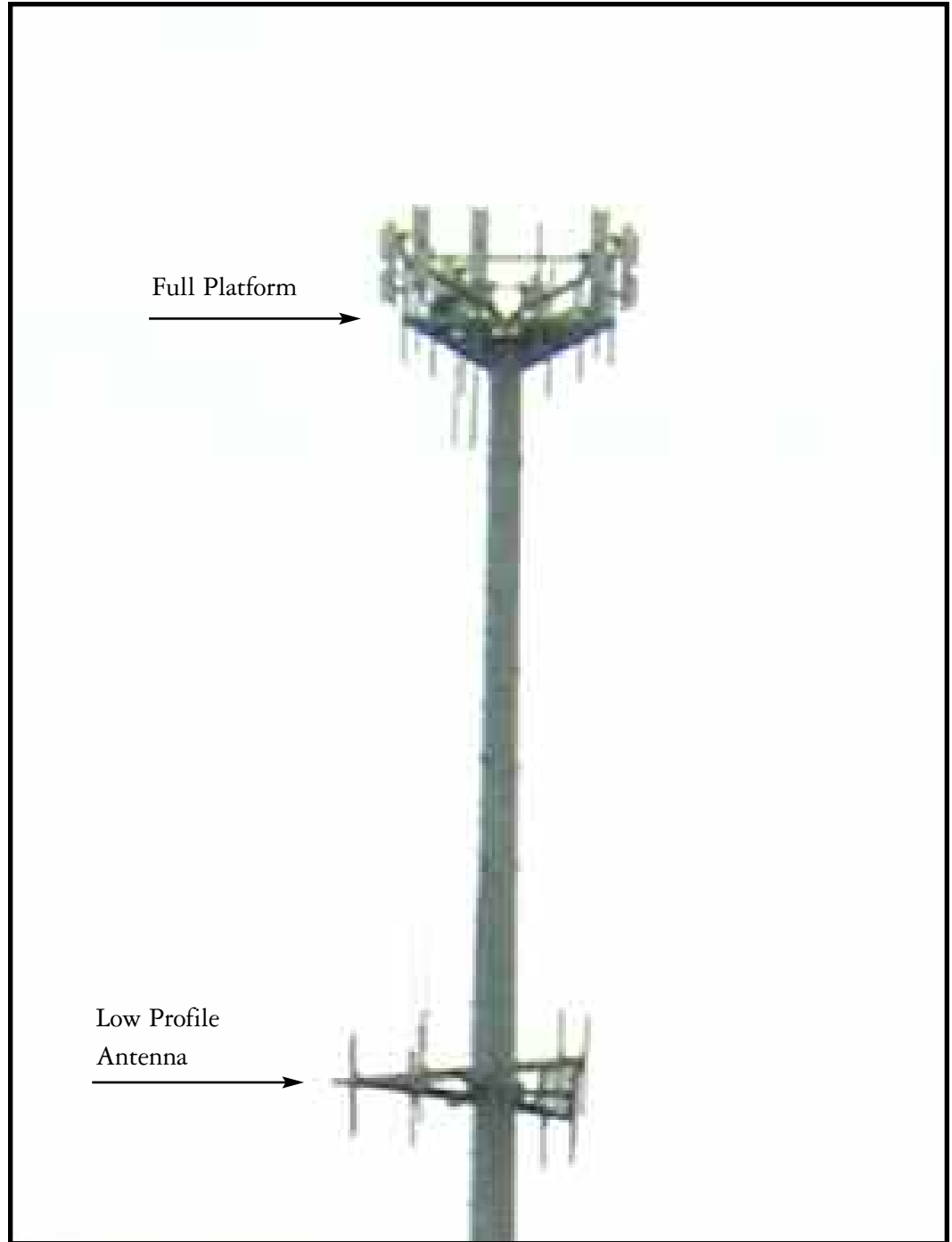

Figure-69. 393 Jackson Hill Road, Middlefield, CT. Photograph taken in April of 2003.

TOWERS — ANTENNAS AND MOUNTING TYPES CT SITING COUNCIL

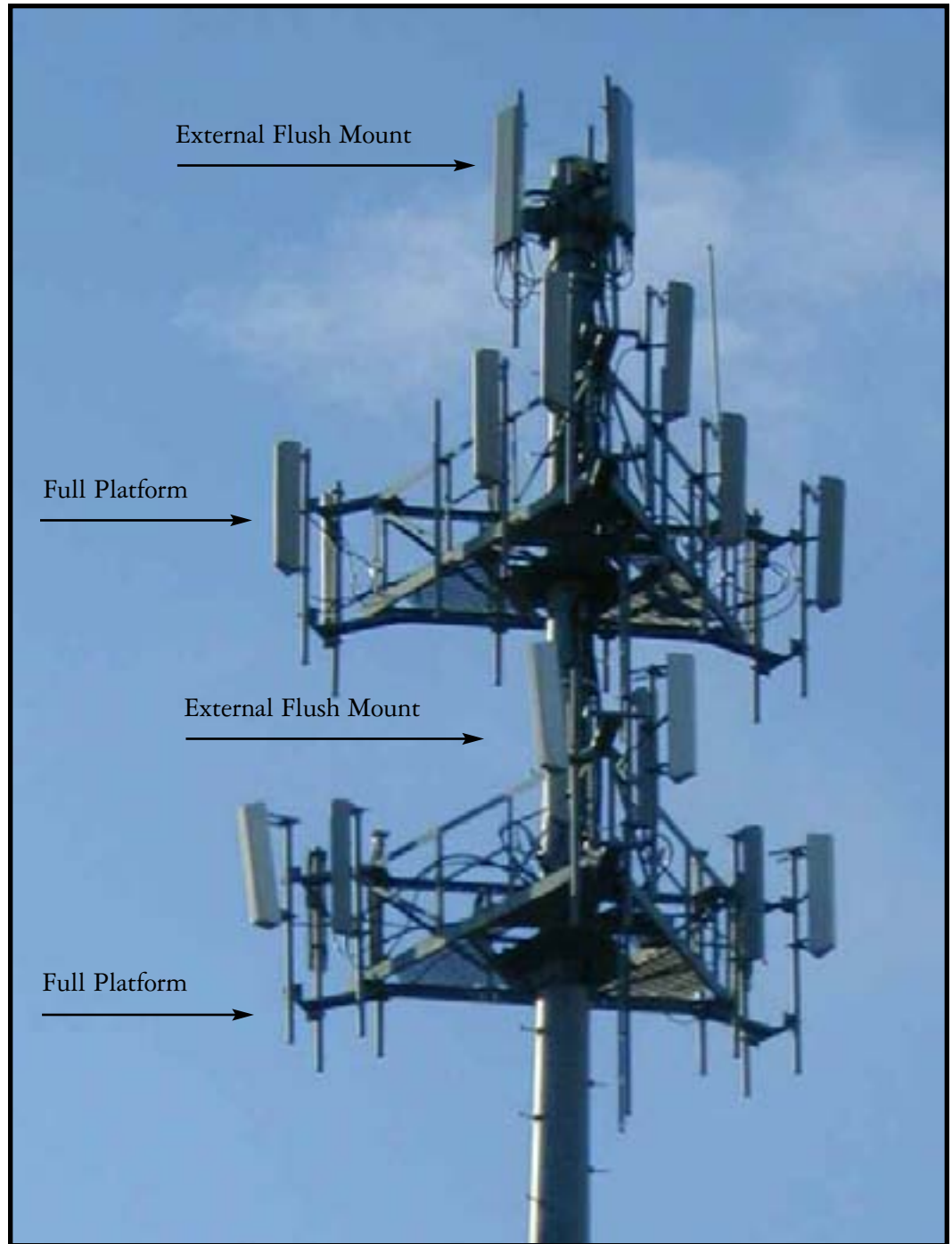

Figure-70. 627 Honey Spot Road, Stratford, CT. Photograph taken in November of 2004.

TOWERS — ANTENNAS AND MOUNTING TYPES CT SITING COUNCIL

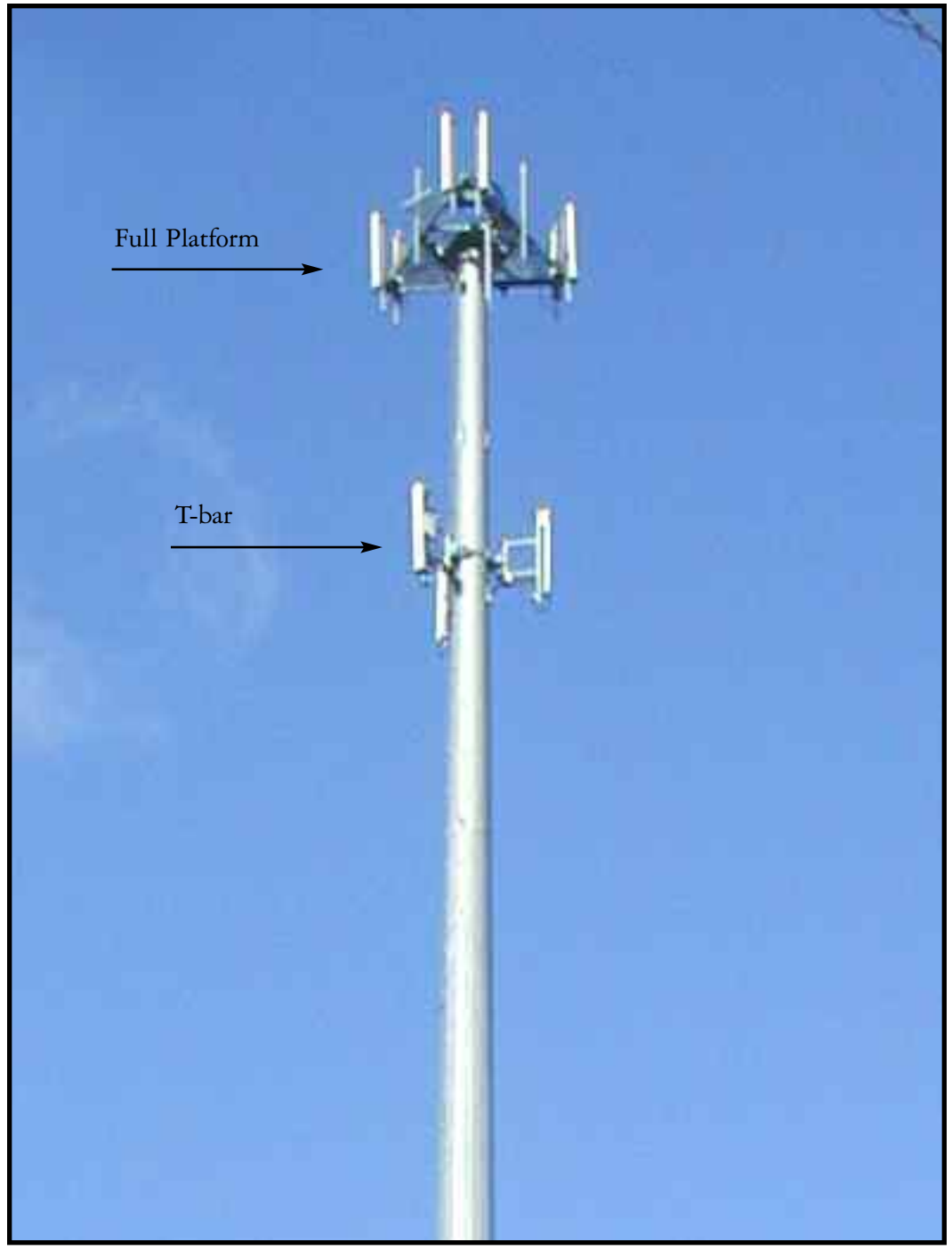

Figure-71. 78 Route 81 Killingsworth, CT. Photograph taken in December of 2004.

TOWERS — ANTENNAS AND MOUNTING TYPES CT SITING COUNCIL

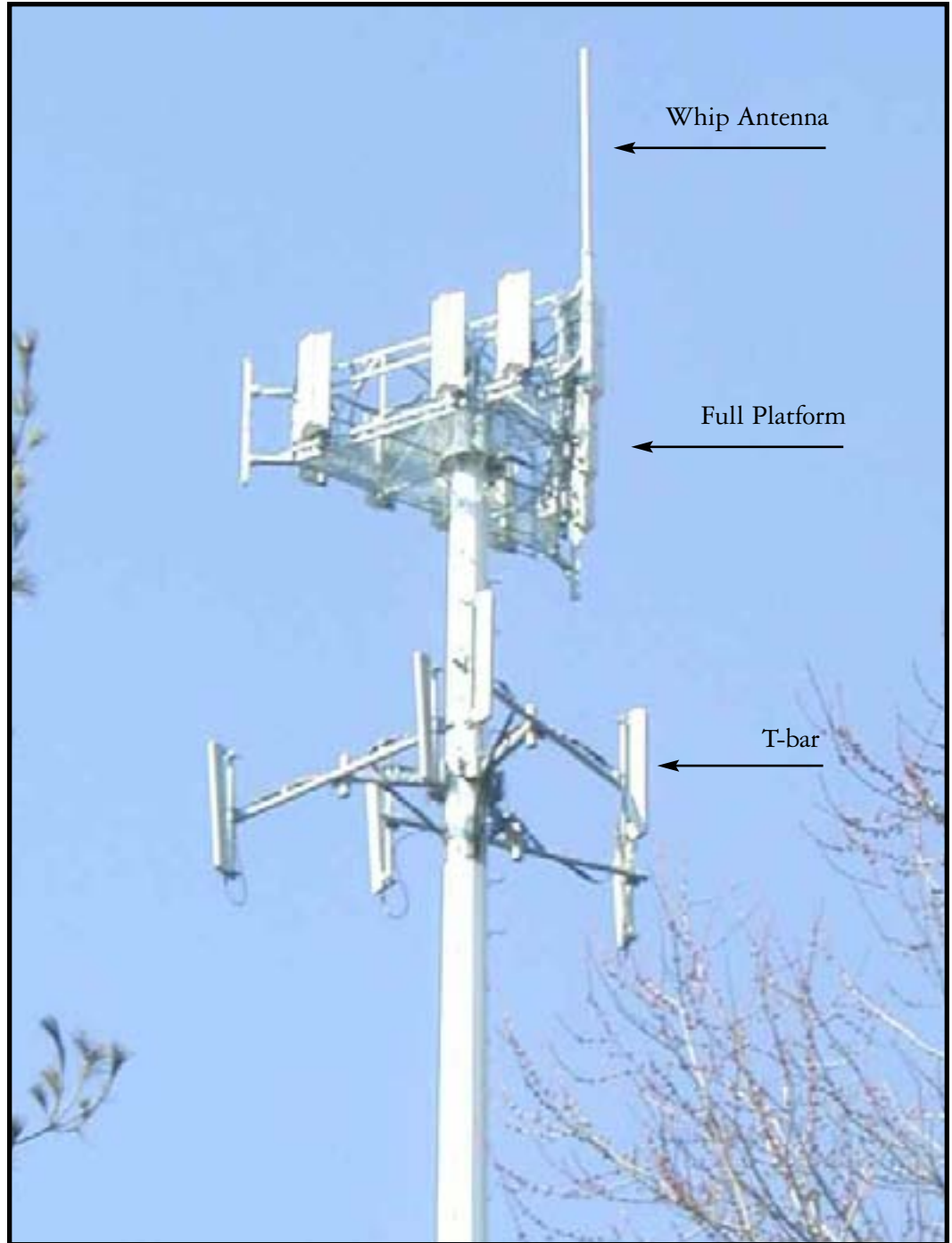

Figure-72. 2 Prestigue park Road, East Hartford, CT. Photograph taken in March of 2004.

PICTURED:

1. The stub for a guyed tower
2. Setting the stub
3. Hoisting the "gin pole" (used as a pulley attached to the side of the tower to haul additional sections, equipment and antennae up to the crew)
4. Hoisting a tower section,
5. A tower section is brought up the gin pole then finally bolted to the section preceding it.



1



2



3



4



5

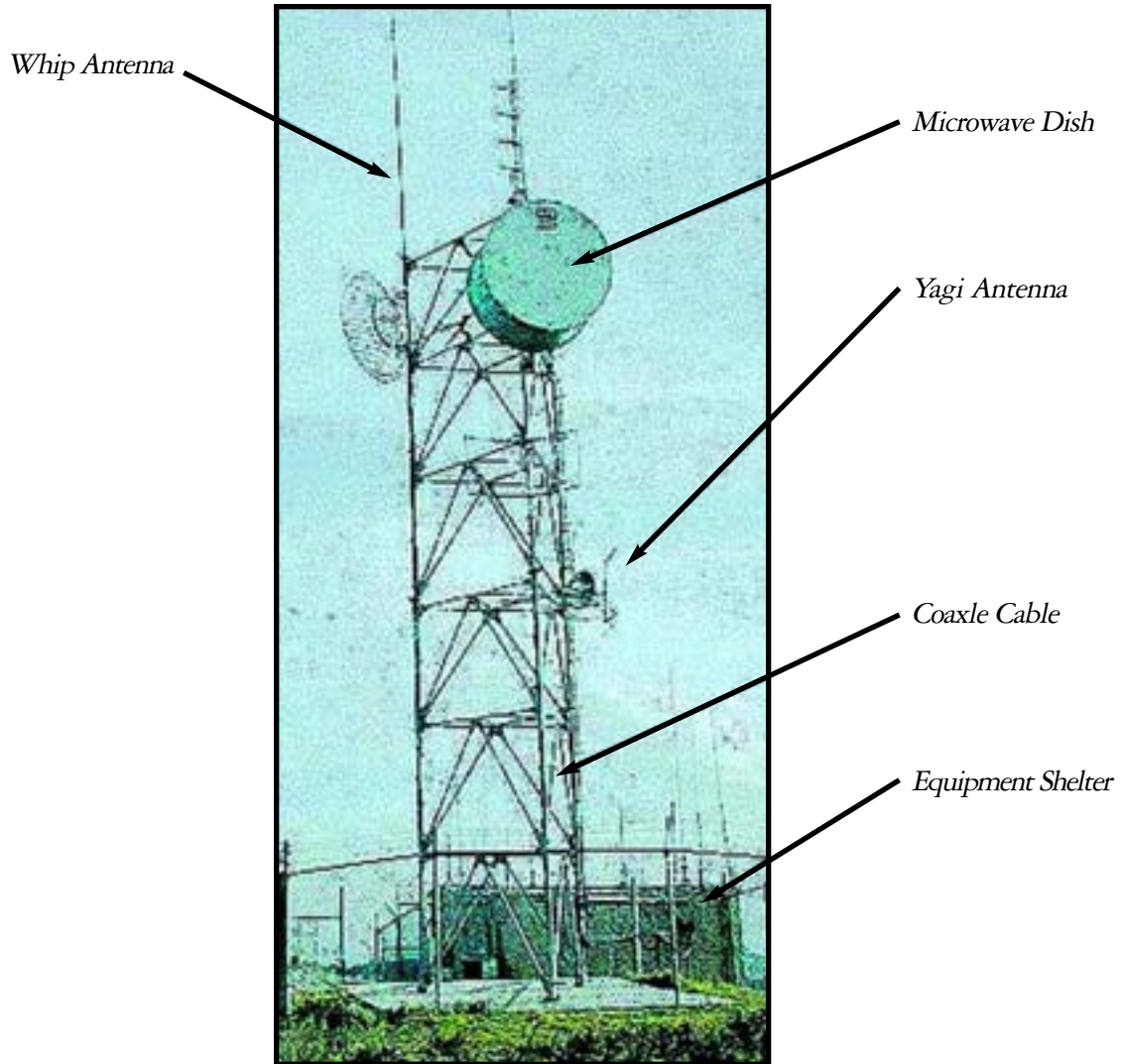

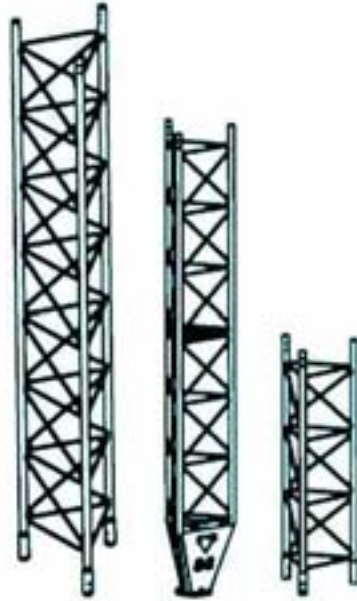

Sections



Cross-Sections



Right-Hand Lay



Left-Hand Lay

Guy Wire



Anchors for Guy Wires

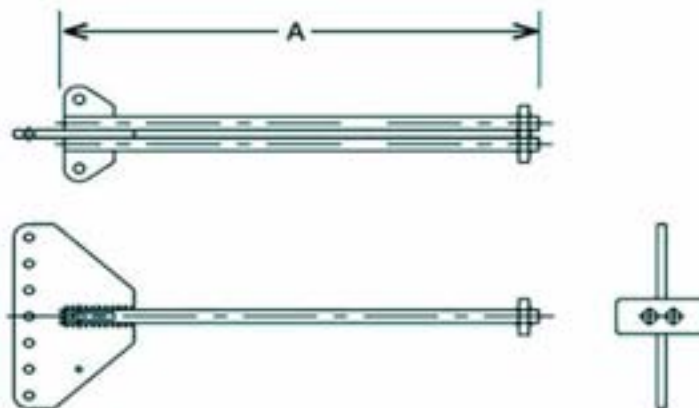

- ABSORPTION:** The reduction of signal strength by the presence of foliage.
- ABOVE GROUND LEVEL:** (AGL) Height above ground level of a structure.
- ABOVE MEAN SEA LEVEL:** (AMSL) referring to the height of the ground compared with sea level.
- ACCESS EASEMENT:** The right to cross over land to reach the parcel upon which a tower is located.
- AMERICAN NATIONAL STANDARDS INSTITUTE:** (ANSI) which creates standards for design and operation of telecommunications facilities.
- ANALOG:** The original method of modifying radio signals to enable them to carry information.
- ANCHORS:** Hardware set in ground to hold guy wires.
- ANTENNA:** A device that is used to transmit and receive radio frequency signals.
- ANTENNA FARM:** A term referring to a site with multiple towers in close proximity.
- BASE STATION:** "A central radio transmitter/receiver that communicates with mobile telephones within a given range."
- BLOCKAGE:** The prevention of a radio signal path due to an object or terrain.
- BROADBAND:** A transmitter that has a sufficient bandwidth to carry multiple voice, video or data channels simultaneously.
- CARRIER:** A service provider or operator that provides customers with service for their wireless phones.
- CELL:** A central transmission/reception point of an interconnected, 2-way radio system employing frequency hand off. Or a geographic unit of coverage.
- CELL SITE:** "The location where a wireless antenna and network communications equipment is placed in order to provide wireless service in a geographic area."
- CELL SPLITTING:** A method to increase the capacity of a wireless system by dividing one cell into two or more smaller cells.
- COAX:** Cable used for connecting transmitters and antennas which can add to the wind load on a tower.
- CODE DIVISION MULTIPLE ACCESS:** (CDMA) "A technology used to transmit wireless calls by assigning them codes."
- CO-LOCATION:** The placement of more than one carrier's equipment upon a single site.
- COORDINATES:** Referring to geographic coordinates (N. Latitude and W. Longitude).
- CELLULAR SITE ON WHEELS:** (COW) resembling a truck trailer.

- DIRECTIONAL:** A type of antenna that places a signal toward a particular direction.
- DIGITAL:** The method that converts signals into binary digits. Digital technology has largely replaced analog technology.
- DISH:** A microwave dish for transmission or reception, usually varying in size from one to three meters
- DOWN TILT:** A type of antenna that aims the signal down from the tower, rather than toward the horizon.
- DUAL BAND:** "A wireless handset that works on more than one spectrum frequency."
- DUAL MODE:** "A wireless handset that works on analog and digital networks."
- ENCLOSURE:** A shelter for housing telecommunications equipment.
- FACE(S):** The side(s) of a tower, usually three or four.
- FEDERAL AVIATION ADMINISTRATION:** (FAA) government office that regulates the location and height of towers
- FEDERAL COMMUNICATIONS COMMISSION:** (FCC) government office that regulates the use of radio facilities.
- GAIN:** The increase in wattage on a radio signal usually created via antenna design.
- GLOBAL POSITIONING SYSTEM:** The use of satellite-based system and receiver to determine exact location on earth.
- GUY WIRES:** Steel cable extending from positions on the tower to the ground to support the structure.
- GUYED TOWER:** A tower which is supported by the use of guy wires.
- HANDOFF:** The process by which a wireless network automatically switches a mobile call to an adjacent cell site.
- LATTICE:** A style of tower employing multiple, intercrossing steel supports.
- LIGHTING:** General reference to strobe lighting of a tower to alert night aviation traffic.
- LIGHTNING ARRESTER:** A device for guiding lightning strikes to ground for use on towers.
- LINE OF SIGHT:** Ability to receive a signal without blockage or shadowing due to the location of transmitter and receiver.
- LOSS:** The loss in wattage on a radio signal usually caused by the length and girth of the coax cable
- MASTER ANTENNA:** An antenna shared by more than one operator.
- MEGAHERTZ:** (MHz) A unit of frequency that is equal to one million hertz (cycles) per second.

- MONOPOLE:** A free standing tower in the shape of a pole.
- MOUNTING:** The placement of hardware, including antennas, on a structure
- NAD 27:** A method for calculating geographic coordinates created in 1927
- NAD 83:** A method for calculating geographic coordinates, revising NAD 27, and created in 1983.
- OMNIDIRECTIONAL:** A type of antenna that produces a signal in a 360 degree pattern.
- ORIENTATION:** Positioning of the legs of a tower in relation to true north.
- PAD:** Concrete pad for construction of towers or enclosures.
- PAINTING:** General reference to stripe marking on a tower to alert aviation traffic.
- PANEL ANTENNA:** An antenna shaped like a panel normally employed for cell operations
- PATH:** Course of a radio signal between points
- PATH LOSS:** Amount of power lost in a radio signal as it moves through the air.
- PERSONAL COMMUNICATIONS SERVICES:** (PCS) licensed in the 1900 MHz band.
- PROPAGATION:** The quality of a signal for the purpose of being usable across a given geographic area.
- RADIO LICENSE:** Authority granted by FCC to operate a radio facility.
- REFLECTION:** The bouncing of a radio signal off an object.
- REPEATER:** A transceiver used to "repeat" incoming signals and retransmit them in a different direction to increase range of coverage.
- RADIO FREQUENCY:** (RF) employed as a general term referring to any use of the radio spectrum.
- RF EXPOSURE:** Refers to the potential hazard from human exposure to RF radiation.
- RF DESIGN:** A general term for the design of a radio system.
- ROAMING:** A process used when traveling outside of a carrier's local service area. Users can make and receive calls through operation on another carrier's service coverage area.
- ROOFTOP SITE:** An antenna mounted on the roof of a building, with the transmitter housed within the building.
- SELF SUPPORTING LATTICE:** A tower which relies on footings for support, rather than guy wires.
- SHADOWING:** The reduction of a radio signal path due to an object or terrain.
- SHELTER:** An enclosure for housing telecommunications equipment.

SIDE MOUNTED: Any position for an antenna that is not at the top.

SITE ACQUISITION: The act of identifying and/or securing the use of a site for a carrier.

STRUCTURAL INTEGRITY: General strength of a tower under present conditions, related to wind load.

TIME DIVISION

MULTIPLE ACCESS: (TDMA) A technology that allows the transmission of information by dividing calls into time slots that last approximately a fraction of a second.

UPLINK: A radio path going up toward a satellite.

UTILITY ACCESS: The right to run electricity and telephone lines across a parcel of land.

WHIP ANTENNA: An antenna that is a single pole.

WIND LOAD: The amount of weight (at given positions) that the tower can withstand under wind conditions.

WIRELESS: A general term referring to use of radio over air.

YAGI: A type of directional antenna similar to a UHF television reception antenna.

- PAGE 1:** *Figure-1. 168 Catoona Lane in Stamford, CT. Photograph taken in October of*
- PAGE 2:** *Figure-2. Route 80 in Killingworth, CT. Photograph taken in November of 2004.*
- PAGE 3:** *Figure-3. 11 Willard Road in Norwalk, CT. Photograph taken in April of 2004.*
- PAGE 4:** *Figure-4. Mohawk Mountain in Cornwall, CT. Photograph taken in December of 2001.*
- PAGE 5:** *Figure-5. 528 Wheelers Farms Road in Milford, CT. Photograph taken in January of*
- PAGE 6:** *Figure-6. 78 Route 81 in Killingworth, CT. Photograph taken in December of 2003.*
- PAGE 7:** *Figure-7. 99 Briar Hill Road in Groton, CT. Photograph taken in April of 2004.*
- PAGE 8:** *Figure-8. Tolland Avenue in Stafford Springs, CT. Photograph taken in February of 2004.*
- PAGE 9:** *Figure-9. A passive microwave reflector is located at 652 Glenbrook Road in Stamford, CT. Photograph taken in December of 2006.*
- PAGE 10:** *Figure-10. Buckingham Street in Watertown, CT. Photograph taken in December of 2001.*
- PAGE 11:** *Figure-11. Wireless telecommunications antennas attached to a billboard located at 521 South Leonard Street in Waterbury. Photograph taken in October of 2006.*
- PAGE 12:** *Figure-12. Antennas attached to a smokestack located at 500 South Broad Street in Meriden. Photograph taken in October of 2006*
- PAGE 13:** *Figure-13. Co-location on an extended electric transmission pole on Bartholomew Road in Middletown, CT. Photograph taken in June of 2004.*
- PAGE 14:** *Figure-14. Co-location on an electric transmission structure located on 3 Mechanic Street in Darien, CT. Photograph taken in November of 2001.*
- PAGE 15:** *Figure-15. Park lights share a structure with wireless telecommunications antennas at Chelsey Park in New Britain, CT. Photograph taken in September of 2006.*
- PAGE 16:** *Figure-16. 265 Benham Street in Hamden, CT. Photograph taken in February of 2004.*

- PAGE 17:** *Figure-17. A ballast frame rooftop mounted antenna is located on Winter Street in New Britain, CT. Photograph taken in December of 2006.*
- PAGE 18:** *Figure-18. 151 Sand Hill Road in Windsor, CT. Photograph taken in September of 2006.
Figure-19. 23 Kelleher Court in Wethersfield, CT. Photograph taken in September of 2006.*
- PAGE 19:** *Figure-20. 1320 Chopsey Hill Road in Bridgeport, CT. Photograph taken in October of 2006.*
- PAGE 20:** *Figure-21. 1445 Forbes Avenue in East Hartford, CT. Photograph taken December of 2000.
Figure-22. 1320 Chopsey Hill Road in Bridgeport, CT. Photograph taken in October of 2006.*
- PAGE 21:** *Figure-23. A 120-foot telecommunications facility, disguised as a tree, located at 477 Route 7 in Sharon, CT. Photographed in January of 2007.*
- PAGE 22:** *Figure-24. A 110-foot telecommunications facility disguised as a tree located at 70 Herb Road in Sharon, CT. Photographed in February of 2007.*
- PAGE 23:** *Figure-25. A 125-foot telecommunications facility disguised as a bell tower located at the Harvest Baptist Church at 1440 Litchfield Turnpike in New Hartford, CT. Photographed in February of 2007.*
- PAGE 24:** *Figure-26. An 80-foot wood laminate pole located at 41 Padanaram Road in Danbury, CT. Photographed in May of 2006.*
- PAGE 25:** *Figure-27. A 55-foot wooden pole located at 111 Middle Turnpike in Mansfield, CT (also known as a "brown stick"). Photographed in October of 2004.*
- PAGE 26:** *Figure-28. 127 New Hartford Road in Barkhamsted, CT. Photograph taken in January of 2004.*
- PAGE 27:** *Figure-29. Near Interstate 405 and Long Beach Boulevard in Long Beach, CA.*
- PAGE 28:** *Figure-30. Pacifica Mormandie in Torrance, CA. The structure is 62 feet tall. Antennas are located at 55 feet agl.

Figure-31. Pacifica Mormandie in Torrance, CA. The structure is 62 feet tall. Antennas are located at 55 feet agl.*

PAGE 29: *Figure-32. 100 Pond Lily Avenue in New Haven, CT. Antennas are located within the flag-pole structure and equipment is housed within a brick façade that matches the building. Photograph taken in June of 2006.*

Figure-33. 985 Farmington Avenue in Bristol, CT. Antennas are located within the flagpole structure and equipment is at the base of the structure.

PAGE 30: *Figure-34. Vista, CA. The structure is 45 feet tall. Antennas are located at 41.5 feet agl and 35 feet agl.*

PAGE 31: *Figure-35. 890 Evergreen Avenue in Hamden, CT. Photograph taken in July of 2001.*

PAGE 32: *Figure-36. Betteravia Properties in Santa Maria, CA. The structure is 50 feet tall. Antennas are located at 48 feet agl.*

Figure-37. Lamb of God in Anaheim, CA. The structure is 60 feet tall.

Figure-38. City of Lynwood, CA. Dimensions of the structure are 60 feet tall by 8 feet wide.

PAGE 33: *Figure-39. Magnolia Park in Upland, CA. The structure is 60 feet tall.*

Figure-40. Mason in Irvine, CA. The structure is 60 feet tall.

Figure-41. Promenade in Corona, CA. The structure is 40 feet tall.

PAGE 34: *Figure-42. Cajon Pass in Oak Hills, CA. The structure is 90 feet tall. Antennas are within the water tank structure at 80 feet 8 inches agl and 70 feet agl.*

Figure-43. Via Verde in San Dimas, CA. The structure is 60 feet tall. Antennas are mounted within the water tank at 58 feet agl and 47 feet agl.

Figure-44. Highway 38 Wabash in Mentone, CA. The structure is 60 feet tall. Antennas are located at 56 feet agl and 48.5 feet agl.

PAGE 35: *Figure-45. Baron Brothers' Nursery in Camarillo, CA. Antennas are located inside of the structure, which is made of a radio frequency transparent material. Dimensions of the structure are 25 feet wide by 12 feet high.*

PAGE 36: *Figure-46. Chico Hills and Bundy in Menifee, CA. Antennas are located inside of the structure, which is made of a radio frequency transparent material. Dimensions of the structure are 15 feet wide by 47 feet long by 17 feet high.*

Figure-47. Rocky Peak Church in Chatsworth, CA. Antennas are located inside of the structure, which is made of a radio frequency transparent material. Dimensions of the structure are 11 feet 6 inches tall by 8 feet in diameter.

PAGE 37: NA

PAGE 38: *Figure-48. 5th Street in Derby, CT. Photograph taken in March of 2001.*

PAGE 39: *Figure-49. Shady Canyon Driving Range in Irvine, CA. The height of the structure is 21 feet 2 inches. Antennas are located at 17 feet 2 inches agl.*

PAGE 40: *Figure-50. Elizabeth Street in Derby, CT. Photograph taken in March of 2001.*

PAGE 41: *Figure-51. Carpinteria Best Western in Carpinteria, CA. The structure extends to 56 feet 8 inches.*

Figure-52. Cerritos Town Center in Cerritos, CA. The structure is 68 feet 6 inches tall. Antennas are located at 61 feet 8 inches agl and 50 feet agl.

PAGE 42: *Figure-53. Lantern Bay in Dana Point, CA. The height of the structure is 54 feet 11 inches. The antennas are located at 50 feet 11 inches agl.*

Figure-54. Highway 101 and 12 in Santa Rosa, CA. The structure is 61 feet 9 inches. Antennas are located at 59 feet agl.

PAGE 43: *Figure-55. Ontario Convention Center in Ontario, CA. Structure is 86 feet 10 inches.*

Figure-56. Gordon Square Shopping Center in Buena Park, CA. The structure is 51 feet tall. Antennas are located at 44 feet agl.

- PAGE 44:** *Figure-57. St. George Church Cross in Upland, CA. The structure is 35 feet tall. The top of the antennas extend to 34.5 feet agl.*
- Figure-58. First United Methodist Church of Lakewood in Lakewood, CA. The structure is 56 feet 6 inches. Antennas are located at 40 feet 6 inches agl.*
- Figure-59. Nexte Del Mar Heights in San Diego, CA. Structure is 6 feet 8 inches from the top of the building.*
- Figure-60. Montfort Church in Santa Maria, CA. She structure is 50 feet tall. Antennas are located at 50 feet and 42 feet agl.*
- PAGE 45:** *Figure-61. Peralta Park in Oakland, CA. The antennas are located at 54 feet 2 inches agl.*
- Figure-62. San Ramon-Montevideo in San Ramon, CA.*
- Figure-63. Rosemont in Sacramento, CA. The structure is 69 feet 9 inches. The antennas are located between 42 feet and 60 feet and between 26 feet and 38 feet agl.*
- PAGE 46:** *Figure-64. 17 West Rocks Road Norwalk, CT. Photograph taken in April of 2004.*
- PAGE 47:** *Figure-65. 300 Governor's Highway in South Windsor, CT. Photograph taken in May of 2004.*
- PAGE 48:** *Figure-66. 1725 Stafford Road in Mansfield, CT. Photograph taken in June of 2004.*
- PAGE 49:** *Figure-67. 281 Woodhouse Road in Fairfield, CT. Photograph taken in June of 2000.*
- PAGE 50:** *Figure-68. Mounting Illustrations*
- PAGE 51:** *Figure-69. 393 Jackson Hill Road, Middlefield, CT. Photograph taken in April of 2003.*
- PAGE 52:** *Figure-70. 627 Honey Spot Road, Stratford, CT. Photograph taken in November of 2004.*
- PAGE 53:** *Figure-71. 78 Route 81 Killingsworth, CT. Photograph taken in December of 2004.*
- PAGE 54:** *Figure-72. 2 Prestigie park Road, East Hartford, CT. Photograph taken in March of 2004.*