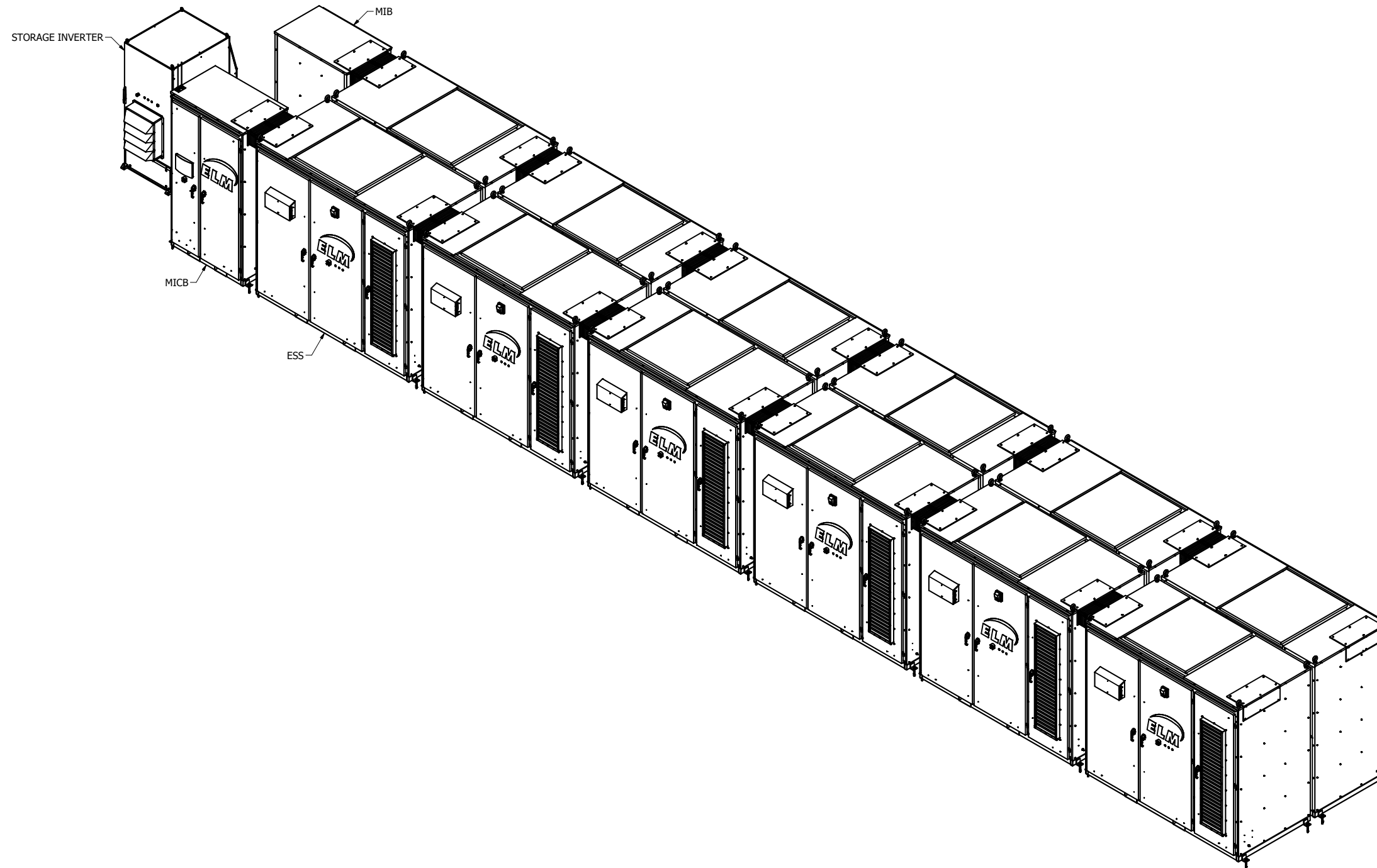

Exhibit J

ELM BESS Mechanical
Drawings

NOTES:

1. MAXIMUM ESS CONFIGURATION WITH 1 STORAGE INVERTER, CONSULT WITH ELM FOR DIFFERENT CAPACITY/CONFIGURATION

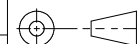

ISOMETRIC VIEW
SCALE 1 : 35

WELDMENT/ASSY TOLERANCE 2 PLACE DECIMALS ± .06 3 PLACE DECIMALS ± .005 ANGLE DIM ± 1° CONCENTRICITY .005 TIR ⊥ & // SURFACES .005 TIR 125 MICRO FINISH ON MACH SURFACES MILLIMETER DIMENSIONS WHOLE NUMBERS ± 1 1 PLACE DECIMALS ± .1		PART TOLERANCE 2 PLACE DECIMALS ± .03 3 PLACE DECIMALS ± .005 ANGLE DIM ± 1° CONCENTRICITY .005 TIR ⊥ & // SURFACES .005 TIR 125 MICRO FINISH ON MACH SURFACES INTERNAL STOCK NUMBER		MATERIAL FINISH PROJECT NAME MASS N/A		PROPERTY OF  PART NAME SITE LAYOUT			
THIS PRINT CONTAINS CONFIDENTIAL AND PROPRIETARY INFORMATION OF ISSUING COMPANY WHICH MAY NOT BE USED, DUPLICATED OR DISCLOSED TO THIRD PARTIES IN WHOLE OR IN PART EXCEPT WITH THE EXPRESSED WRITTEN PERMISSION OF ISSUING COMPANY. THIS PRINT (INCLUDING ALL COPIES THEREOF) MUST BE RETURNED IMMEDIATELY AFTER SERVING ITS INTENDED PURPOSE TO ISSUING COMPANY.				DRAWING UNITS: INCH THIRD ANGLE PROJECTION		DESIGN ENGR L BOREL DATE 9/30/2025 DRAWN BY L BOREL DATE 9/30/2025 DWG CHECKER R WOODY ENGR MGR R OJEN DATE 9/30/2025		DRAWING TITLE MG2.1 SERIES SITE MECHANICAL DRAWING NO. MG2.1-SITE-MECH-0001	
© ELM FIELDSIGHT						SHEET 1 OF 13 SCALE 1 : 35 SIZE D			

NOTES:

1. PLACEMENT OF STORAGE INVERTER IS FOR REFERENCE ONLY
2. DIMENSIONS GIVEN ARE FOR TYPICAL CONTAINER SPACING, CONSULT ELM FOR CONTAINER SPACING IN HIGH SEISMIC REGIONS

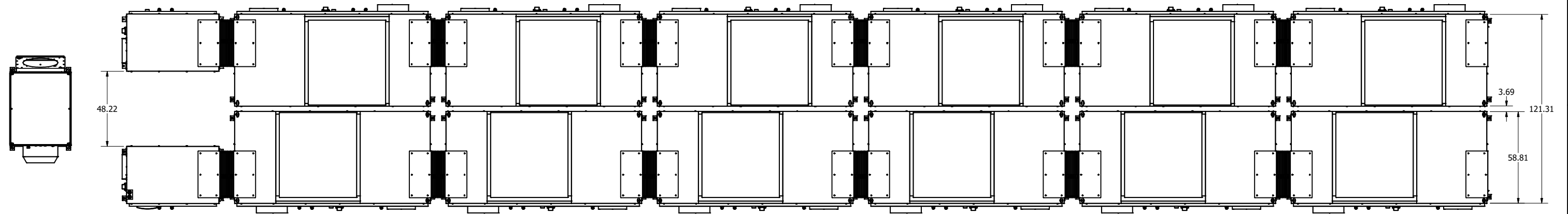

TOP VIEW
SCALE 1 : 32

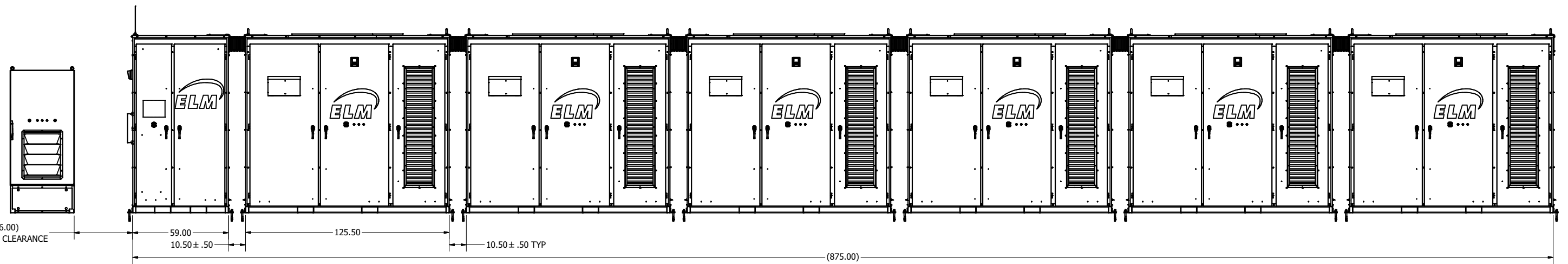

FRONT VIEW
SCALE 1 : 32

WELDMENT/ASSY TOLERANCE 2 PLACE DECIMALS ± .06 3 PLACE DECIMALS ± .005 ANGLE DIM ± 1° CONCENTRICITY .005 TIR ⊥ & // SURFACES .005 TIR 125 MICRO FINISH ON MACH SURFACES MILLIMETER DIMENSIONS WHOLE NUMBERS ± 1 1 PLACE DECIMALS ± .1		PART TOLERANCE 2 PLACE DECIMALS ± .03 3 PLACE DECIMALS ± .005 ANGLE DIM ± 1° CONCENTRICITY .005 TIR ⊥ & // SURFACES .005 TIR 125 MICRO FINISH ON MACH SURFACES INTERNAL STOCK NUMBER		MATERIAL FINISH PROJECT NAME MASS N/A		PROPERTY OF PART NAME SITE LAYOUT	
THIS PRINT CONTAINS CONFIDENTIAL AND PROPRIETARY INFORMATION OF ISSUING COMPANY WHICH MAY NOT BE USED, DUPLICATED OR DISCLOSED TO THIRD PARTIES IN WHOLE OR IN PART EXCEPT WITH THE EXPRESSED WRITTEN PERMISSION OF ISSUING. THIS PRINT (INCLUDING ALL COPIES THEREOF) MUST BE RETURNED IMMEDIATELY AFTER SERVING ITS INTENDED PURPOSE TO ISSUING COMPANY.				DRAWING UNITS: INCH THIRD ANGLE PROJECTION		DESIGN ENGR L BOREL DATE 9/30/2025 DRAWN BY L BOREL DATE 9/30/2025 DWG CHECKER R WOODY ENGR MGR R OJEN DATE 9/30/2025	
DRAWING TITLE MG2.1 SERIES SITE MECHANICAL		DRAWING NO. MG2.1-SITE-MECH-0001		SHEET 2		OF 13	
SCALE 1 : 32		SIZE D		© ELM FIELDSIGHT			

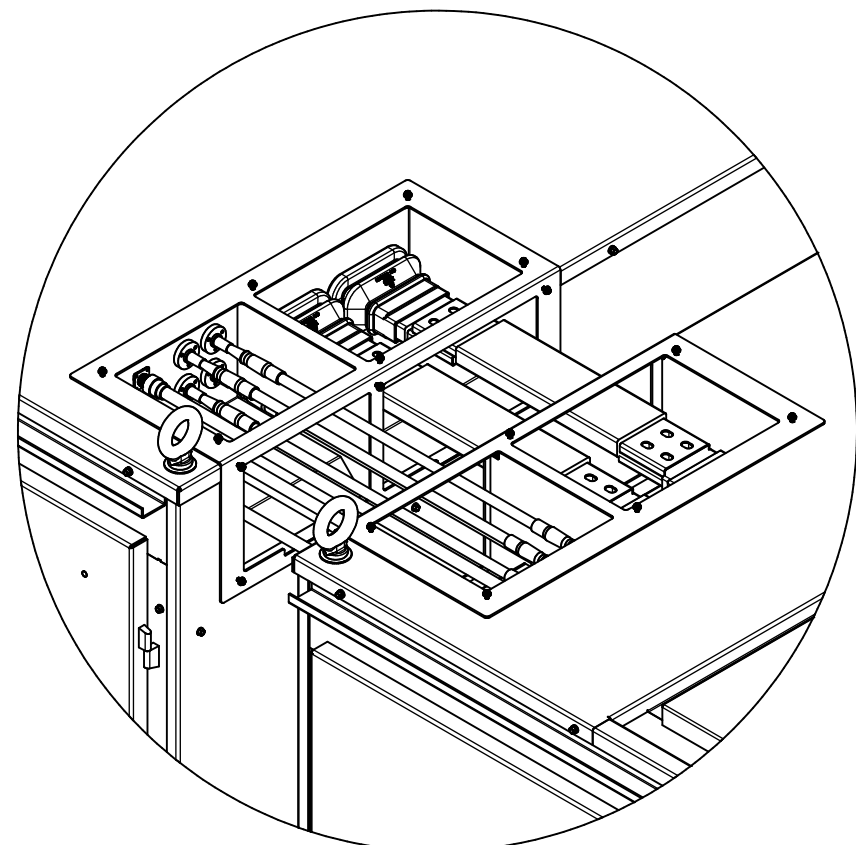

DETAIL A
SCALE 1 : 6
COVERS AND BELLOWS REMOVED

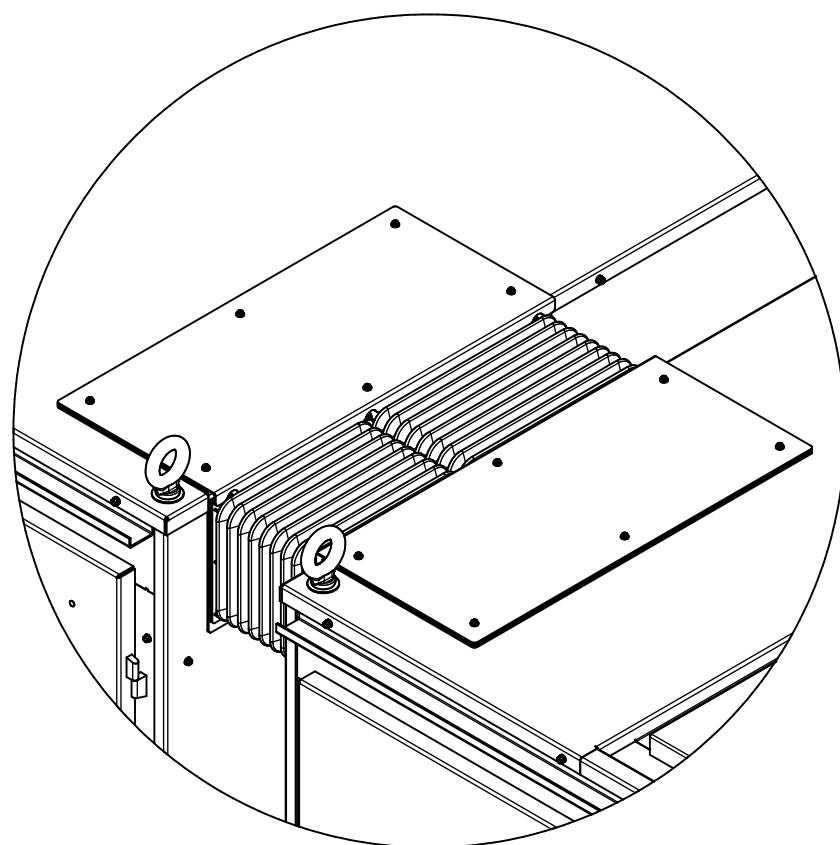

DETAIL B
SCALE 1 : 6
EPDM BELLOWS CONNECT CONTAINERS

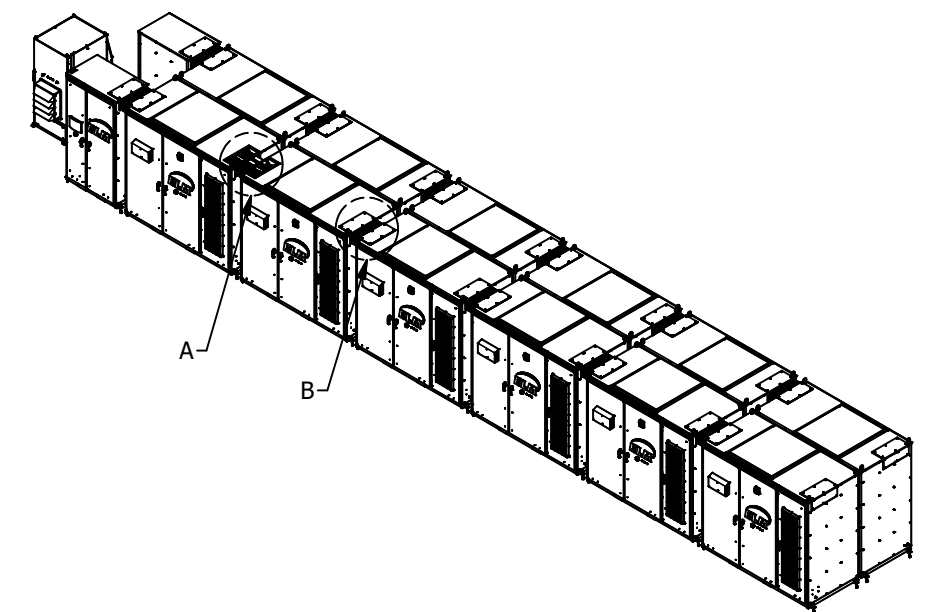

ISOMETRIC VIEW
SCALE 1 : 80

WELDMENT/ASSY TOLERANCE 2 PLACE DECIMALS ± .06 3 PLACE DECIMALS ± .005 ANGLE DIM ± 1° CONCENTRICITY .005 TIR ⊥ & // SURFACES .005 TIR 125 MICRO FINISH ON MACH SURFACES MILLIMETER DIMENSIONS WHOLE NUMBERS ± 1 1 PLACE DECIMALS ± .1		PART TOLERANCE 2 PLACE DECIMALS ± .03 3 PLACE DECIMALS ± .005 ANGLE DIM ± 1° CONCENTRICITY .005 TIR ⊥ & // SURFACES .005 TIR 125 MICRO FINISH ON MACH SURFACES INTERNAL STOCK NUMBER		MATERIAL FINISH PROJECT NAME MASS INTERNAL STOCK NUMBER		PROPERTY OF  PART NAME SITE LAYOUT	
THIS PRINT CONTAINS CONFIDENTIAL AND PROPRIETARY INFORMATION OF ISSUING COMPANY WHICH MAY NOT BE USED, DUPLICATED OR DISCLOSED TO THIRD PARTIES IN WHOLE OR IN PART EXCEPT WITH THE EXPRESSED WRITTEN PERMISSION OF ISSUING. THIS PRINT (INCLUDING ALL COPIES THEREOF) MUST BE RETURNED IMMEDIATELY AFTER SERVING ITS INTENDED PURPOSE TO ISSUING COMPANY.		DRAWING UNITS: INCH THIRD ANGLE PROJECTION		DESIGN ENGR L BOREL DATE 9/30/2025 DRAWN BY L BOREL DATE 9/30/2025 DWG CHECKER R WOODY ENGR MGR R OJEN DATE 9/30/2025		DRAWING TITLE MG2.1 SERIES SITE MECHANICAL DRAWING NO. MG2.1-SITE-MECH-0001 SHEET 3 OF 13 SCALE 1 : 80 SIZE D	

NOTES:

1. ONLY 3 CONCRETE ANCHORS ARE TYPICALLY REQUIRED, CONSULT ELM FOR SITE SPECIFIC SEISMIC REQUIREMENTS

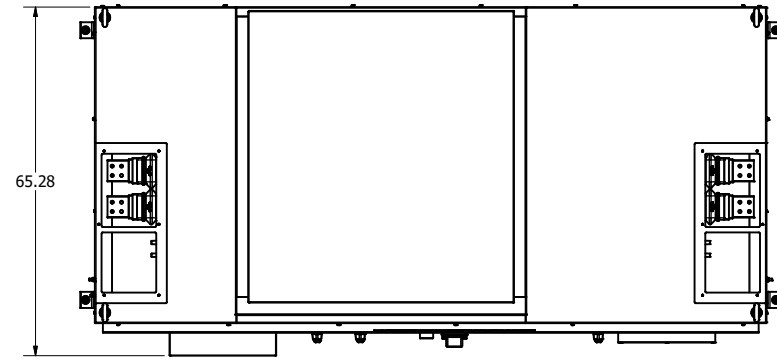

TOP VIEW
SCALE 1 : 18

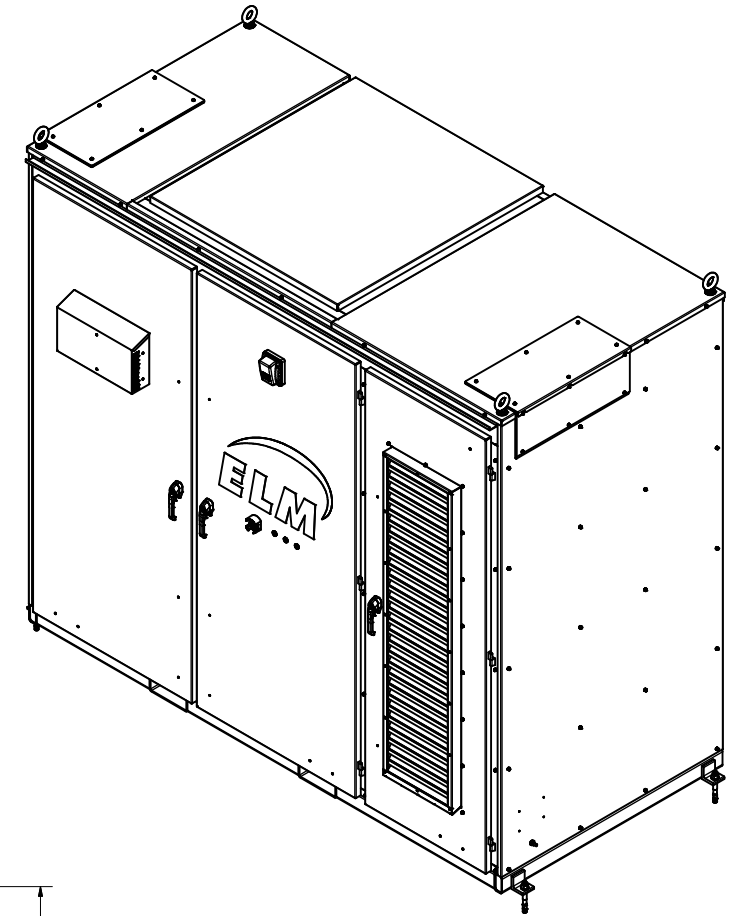

ISOMETRIC VIEW
SCALE 1 : 18

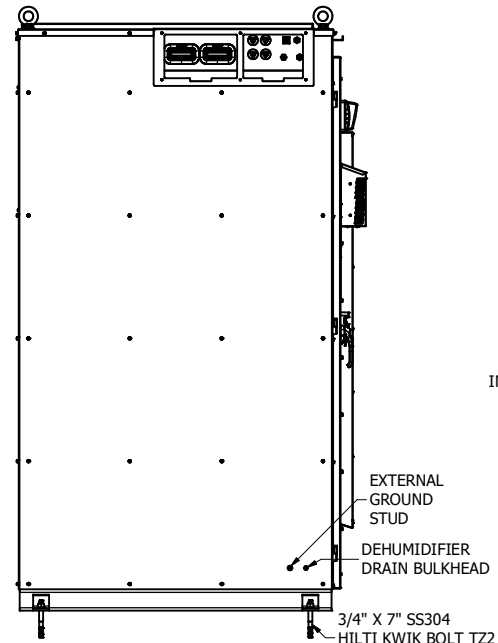

LEFT VIEW
SCALE 1 : 18

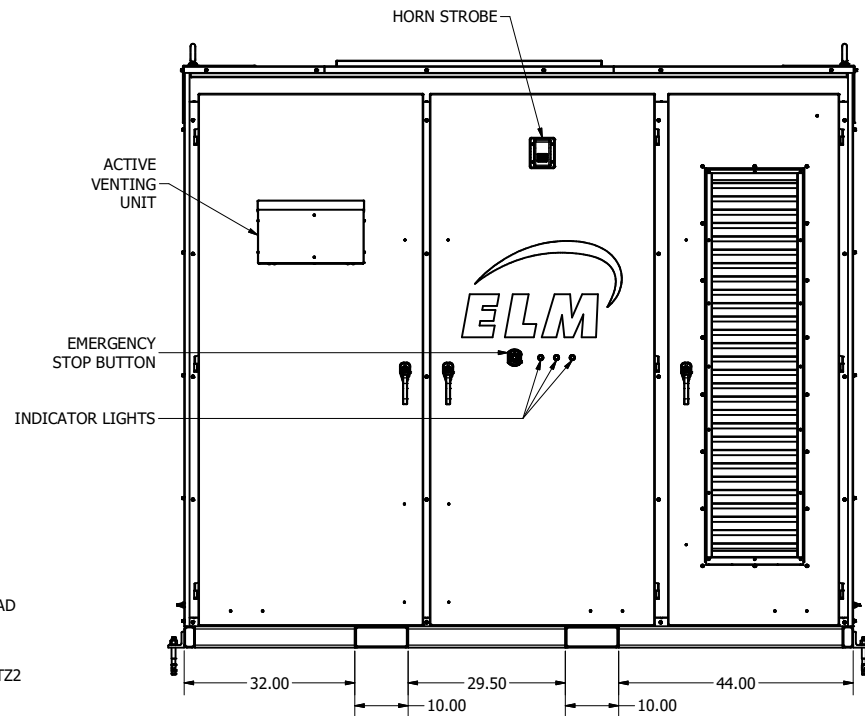

FRONT VIEW
SCALE 1 : 18

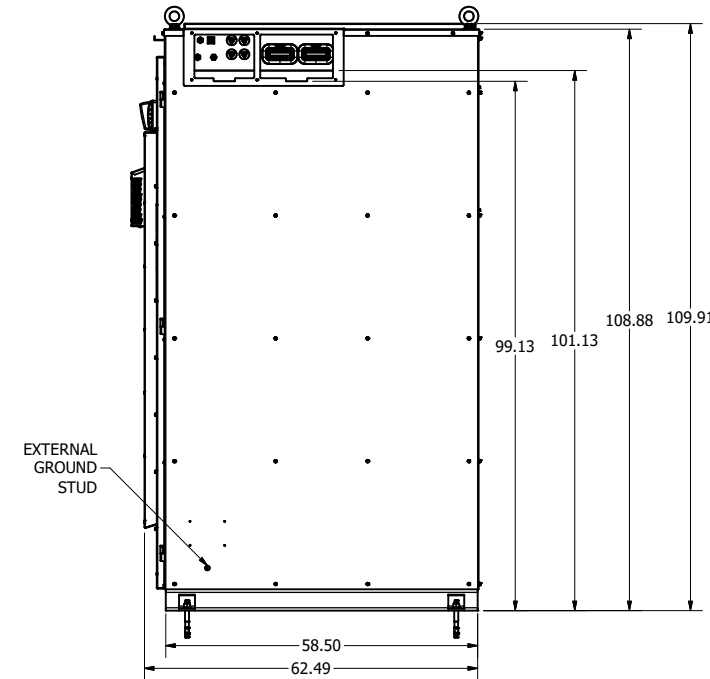

RIGHT VIEW
SCALE 1 : 18

WELDMENT/ASSY TOLERANCE 2 PLACE DECIMALS ± .06 3 PLACE DECIMALS ± .005 ANGLE DIM ± 1° CONCENTRICITY .005 TIR ⊥ & // SURFACES .005 TIR 125 MICRO FINISH ON MACH SURFACES MILLIMETER DIMENSIONS WHOLE NUMBERS ± 1 1 PLACE DECIMALS ± .1	PART TOLERANCE 2 PLACE DECIMALS ± .03 3 PLACE DECIMALS ± .005 ANGLE DIM ± 1° CONCENTRICITY .005 TIR ⊥ & // SURFACES .005 TIR 125 MICRO FINISH ON MACH SURFACES INTERNAL STOCK NUMBER	MATERIAL FINISH PROJECT NAME MG2.1 MASS 18052.8 lbmass	PROPERTY OF 	REVISION -
			THIS PRINT CONTAINS CONFIDENTIAL AND PROPRIETARY INFORMATION OF ISSUING COMPANY WHICH MAY NOT BE USED, DUPLICATED OR DISCLOSED TO THIRD PARTIES IN WHOLE OR IN PART EXCEPT WITH THE EXPRESSED WRITTEN PERMISSION OF ISSUING. THIS PRINT (INCLUDING ALL COPIES THEREOF) MUST BE RETURNED IMMEDIATELY AFTER SERVING ITS INTENDED PURPOSE TO ISSUING COMPANY.	

© ELM FIELDSIGHT

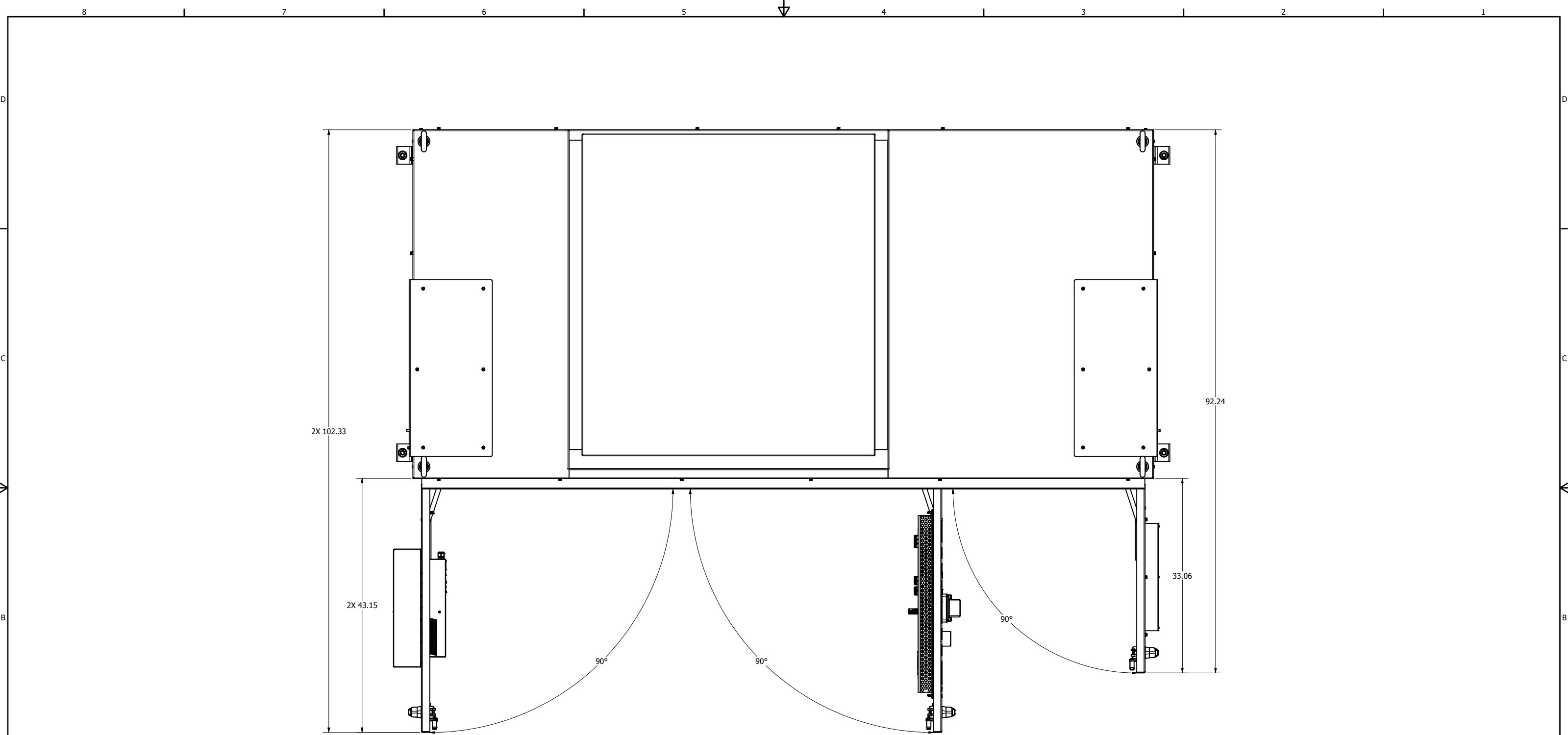

TOP VIEW (DOORS OPEN)
SCALE 1 : 8

WELDMENT/ASSY TOLERANCE 2 PLACE DECIMALS ± .06 3 PLACE DECIMALS ± .005 ANGLE DIM ± 1° CONCENTRICITY .005 TIR ⊥ & // SURFACES .005 TIR 125 MICRO FINISH ON MACH SURFACES MILLIMETER DIMENSIONS WHOLE NUMBERS ± 1 1 PLACE DECIMALS ± .1		PART TOLERANCE 2 PLACE DECIMALS ± .03 3 PLACE DECIMALS ± .005 ANGLE DIM ± 1° CONCENTRICITY .005 TIR ⊥ & // SURFACES .005 TIR 125 MICRO FINISH ON MACH SURFACES INTERNAL STOCK NUMBER		MATERIAL FINISH PROJECT NAME MASS 18052.8 lbmass		PROPERTY OF REVISION -	
THIS PRINT CONTAINS CONFIDENTIAL AND PROPRIETARY INFORMATION OF ISSUING COMPANY WHICH MAY NOT BE USED, DUPLICATED OR DISCLOSED TO THIRD PARTIES IN WHOLE OR IN PART EXCEPT WITH THE EXPRESSED WRITTEN PERMISSION OF ISSUING. THIS PRINT (INCLUDING ALL COPIES THEREOF) MUST BE RETURNED IMMEDIATELY AFTER SERVING ITS INTENDED PURPOSE TO ISSUING COMPANY.				DRAWING UNITS: INCH THIRD ANGLE PROJECTION		DESIGN ENGR L BOREL DATE 9/30/2025 DRAWN BY L BOREL DATE 9/30/2025 DWG CHECKER R WOODY ENGR MGR R OJEN DATE 9/30/2025	
DRAWING TITLE MG2.1 SERIES SITE MECHANICAL						DRAWING NO. MG2.1-SITE-MECH-0001	
SHEET 5 OF 13 SCALE 1 : 8 SIZE D						©ELM FIELDSIGHT	

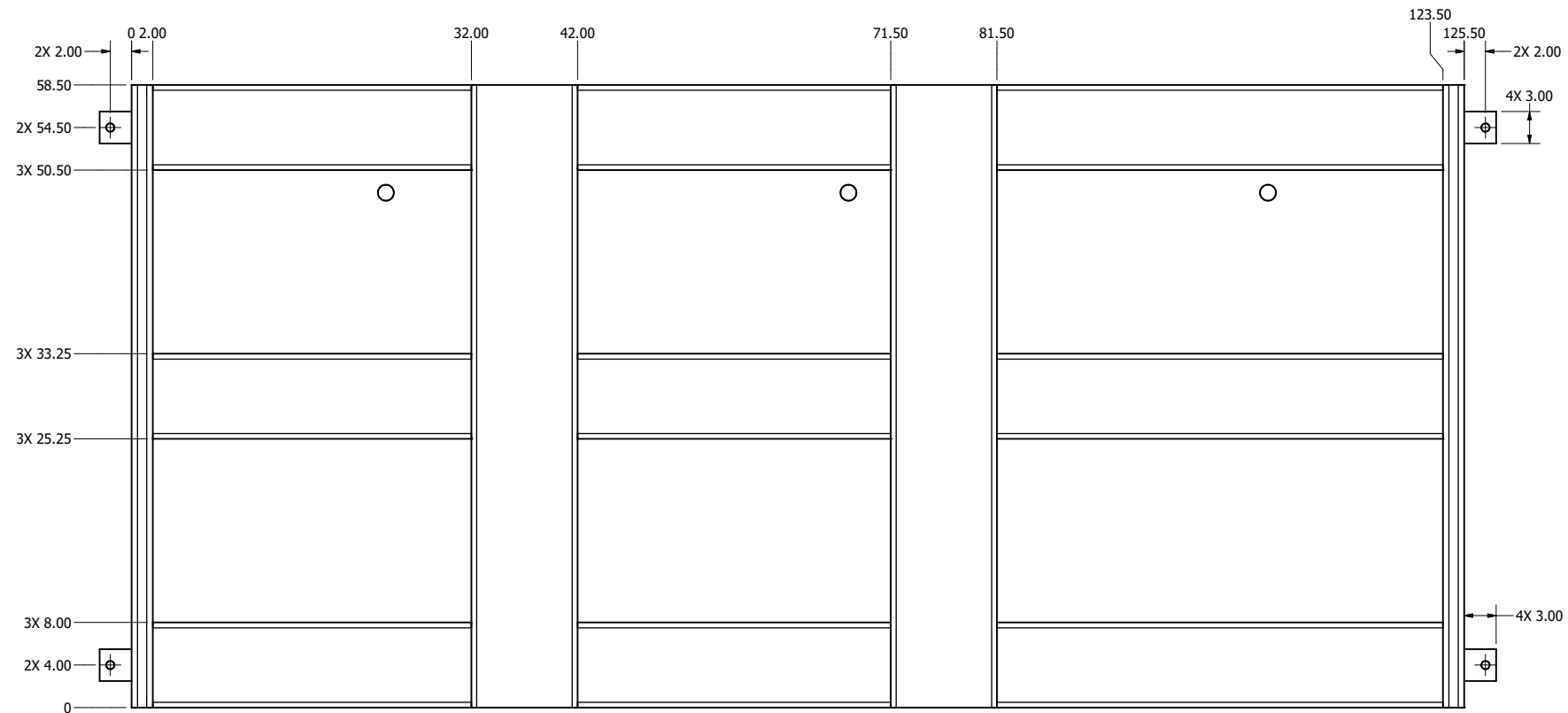

ESS SKID BOTTOM VIEW
SCALE 1 : 8

WELDMENT/ASSY TOLERANCE 2 PLACE DECIMALS ± .06 3 PLACE DECIMALS ± .005 ANGLE DIM ± 1° CONCENTRICITY .005 TIR ⊥ & // SURFACES .005 TIR 125 MICRO FINISH ON MACH SURFACES MILLIMETER DIMENSIONS WHOLE NUMBERS ± 1 1 PLACE DECIMALS ± .1		PART TOLERANCE 2 PLACE DECIMALS ± .03 3 PLACE DECIMALS ± .005 ANGLE DIM ± 1° CONCENTRICITY .005 TIR ⊥ & // SURFACES .005 TIR 125 MICRO FINISH ON MACH SURFACES INTERNAL STOCK NUMBER		MATERIAL Steel FINISH PROJECT NAME MG2.1 MASS 1626.3 lbmass		PROPERTY OF REVISION - PART NAME SKID WELDMENT	
THIS PRINT CONTAINS CONFIDENTIAL AND PROPRIETARY INFORMATION OF ISSUING COMPANY WHICH MAY NOT BE USED, DUPLICATED OR DISCLOSED TO THIRD PARTIES IN WHOLE OR IN PART EXCEPT WITH THE EXPRESSED WRITTEN PERMISSION OF ISSUING. THIS PRINT (INCLUDING ALL COPIES THEREOF) MUST BE RETURNED IMMEDIATELY AFTER SERVING ITS INTENDED PURPOSE TO ISSUING COMPANY.		DRAWING UNITS: INCH THIRD ANGLE PROJECTION		DESIGN ENGR L BOREL DATE 9/30/2025 DRAWN BY L BOREL DATE 9/30/2025 DWG CHECKER R WOODY ENGR MGR R OJEN		DATE 9/30/2025 DATE 9/30/2025 DATE 9/30/2025 DRAWING TITLE MG2.1 SERIES SITE MECHANICAL DRAWING NO. MG2.1-SITE-MECH-0001 SHEET 6 OF 13 SCALE 1 : 8 SIZE D	
©ELM FIELDSIGHT							

NOTES:

1 DIMENSIONS IDENTIFIED ARE TAKEN FROM THE INSIDE FACE OF ENCLOSURE WALLS

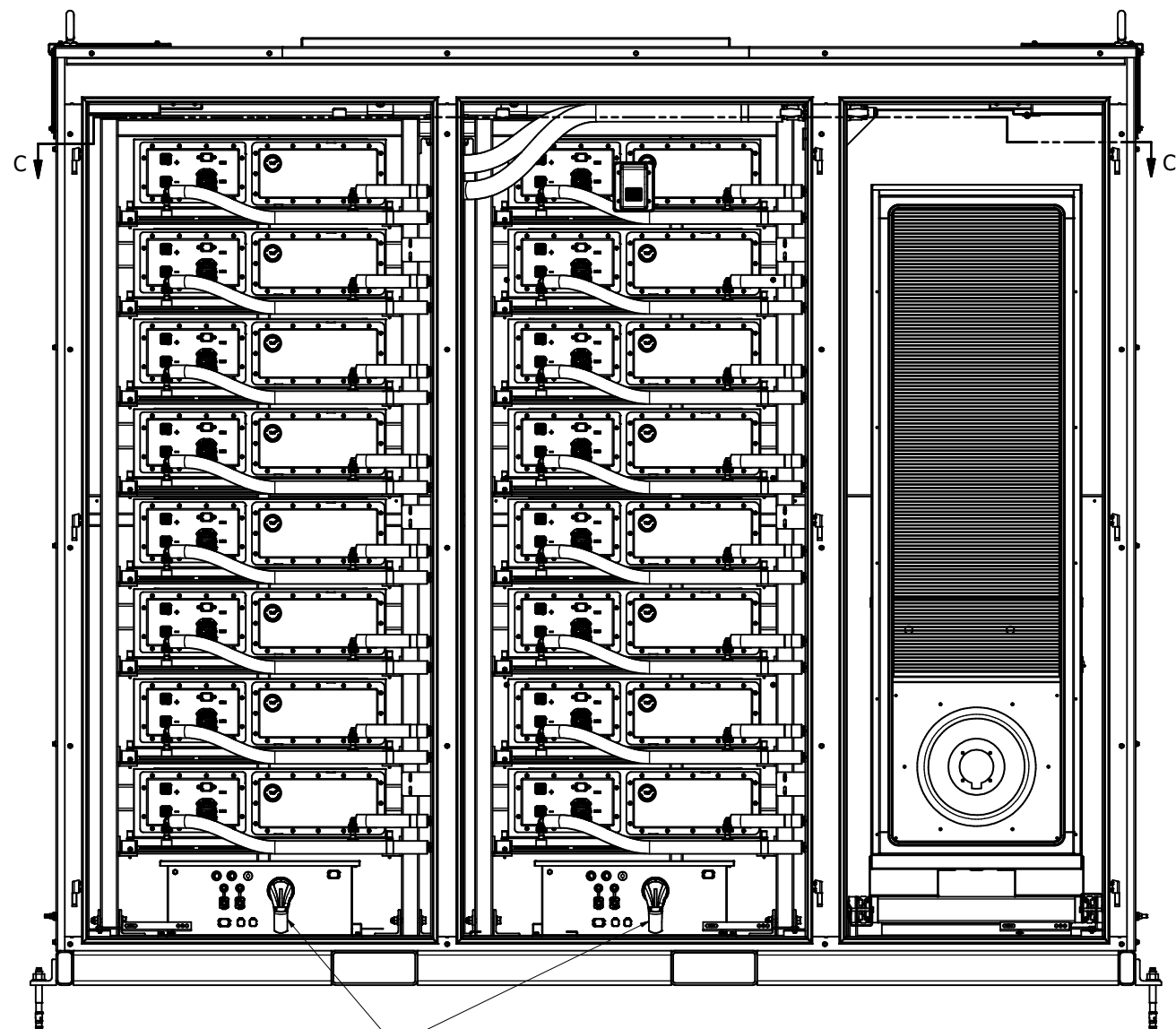

BATTERY RACK
DC DISCONNECT

FRONT VIEW (DOORS REMOVED)
SCALE 1 : 10

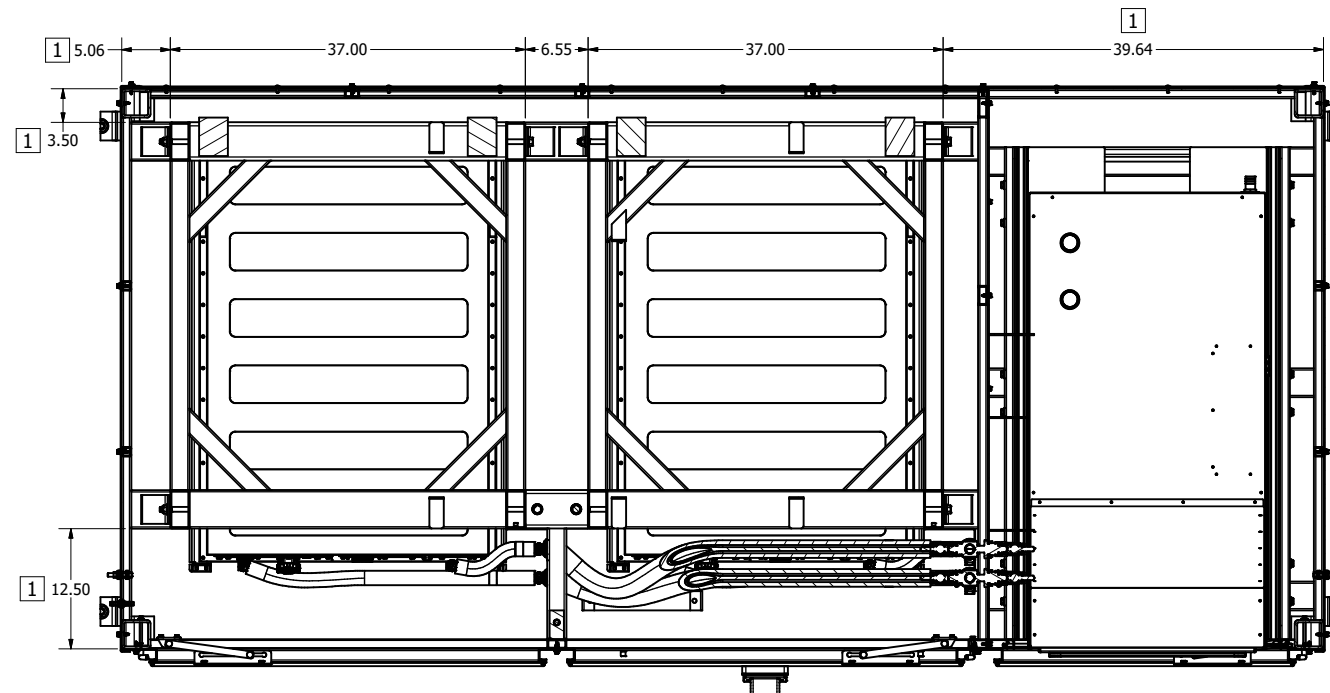

SECTION C-C
SCALE 1 : 10

WELDMENT/ASSY TOLERANCE 2 PLACE DECIMALS ± .06 3 PLACE DECIMALS ± .005 ANGLE DIM ± 1° CONCENTRICITY .005 TIR ⊥ & // SURFACES .005 TIR 125 MICRO FINISH ON MACH SURFACES MILLIMETER DIMENSIONS WHOLE NUMBERS ± 1 1 PLACE DECIMALS ± .1		PART TOLERANCE 2 PLACE DECIMALS ± .03 3 PLACE DECIMALS ± .005 ANGLE DIM ± 1° CONCENTRICITY .005 TIR ⊥ & // SURFACES .005 TIR 125 MICRO FINISH ON MACH SURFACES INTERNAL STOCK NUMBER		MATERIAL FINISH PROJECT NAME MG2.1 MASS 18052.8 lbmass		PROPERTY OF PART NAME DRAWING TITLE MG2.1 SERIES SITE MECHANICAL DRAWING NO. MG2.1-SITE-MECH-0001	
THIS PRINT CONTAINS CONFIDENTIAL AND PROPRIETARY INFORMATION OF ISSUING COMPANY WHICH MAY NOT BE USED, DUPLICATED OR DISCLOSED TO THIRD PARTIES IN WHOLE OR IN PART EXCEPT WITH THE EXPRESSED WRITTEN PERMISSION OF ISSUING COMPANY. THIS PRINT (INCLUDING ALL COPIES THEREOF) MUST BE RETURNED IMMEDIATELY AFTER SERVING ITS INTENDED PURPOSE TO ISSUING COMPANY.				DESIGN ENGR L BOREL DATE 9/30/2025		DRAWING UNITS: INCH THIRD ANGLE PROJECTION	
DRAWN BY L BOREL DATE 9/30/2025		DWG CHECKER R WOODY ENGR MGR R OJEN DATE 9/30/2025		SHEET 7 OF 13 SCALE 1 : 10 SIZE D			

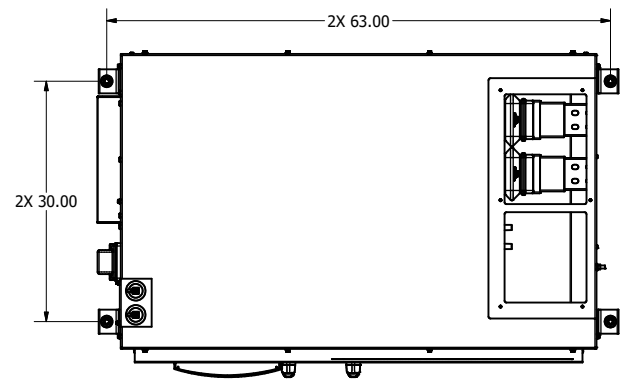

TOP VIEW
SCALE 1 : 12

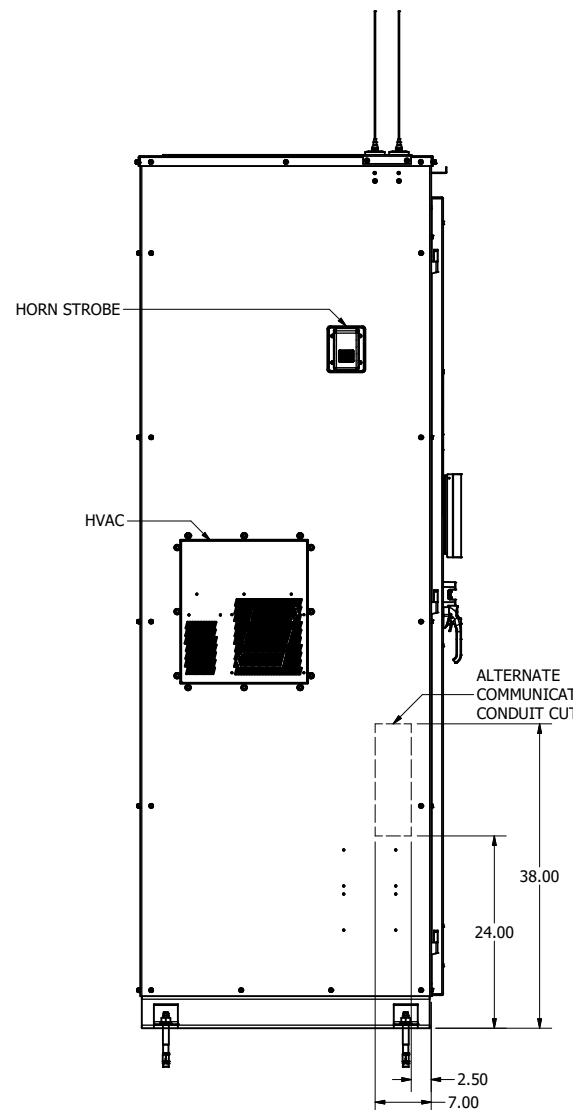

LEFT VIEW
SCALE 1 : 12

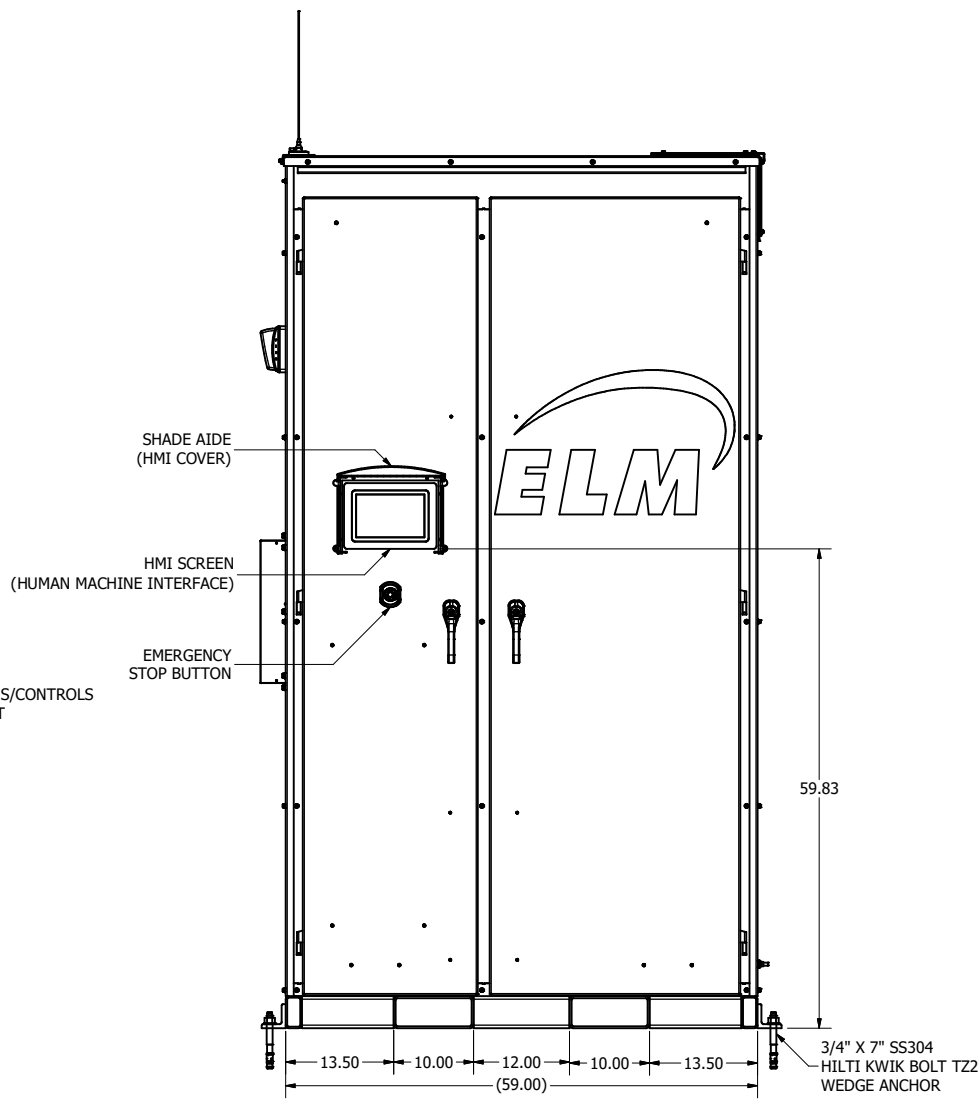

FRONT VIEW
SCALE 1 : 12

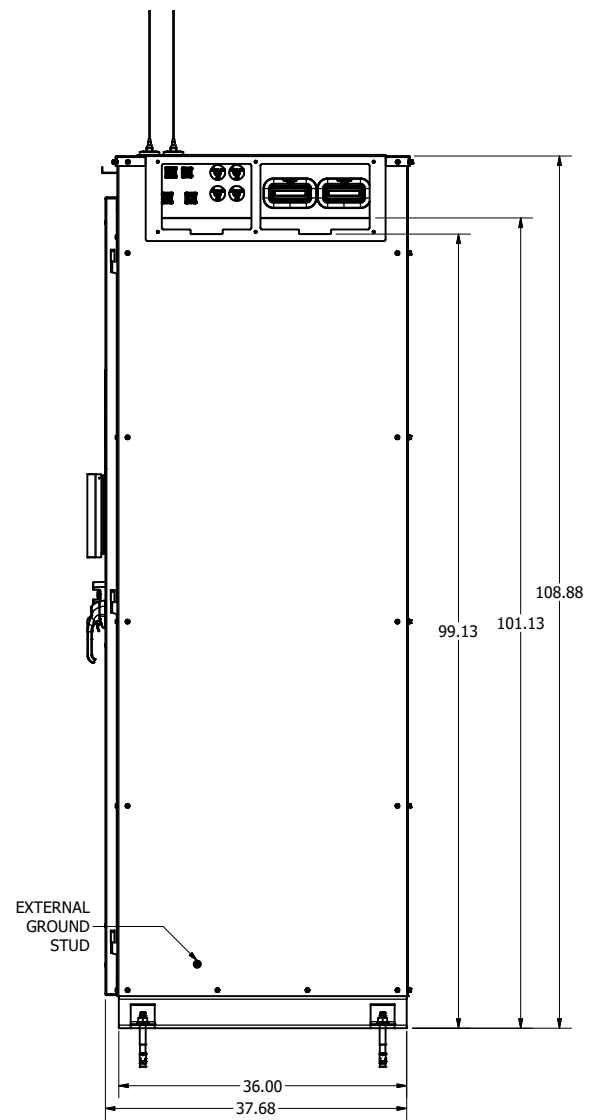

RIGHT VIEW
SCALE 1 : 12

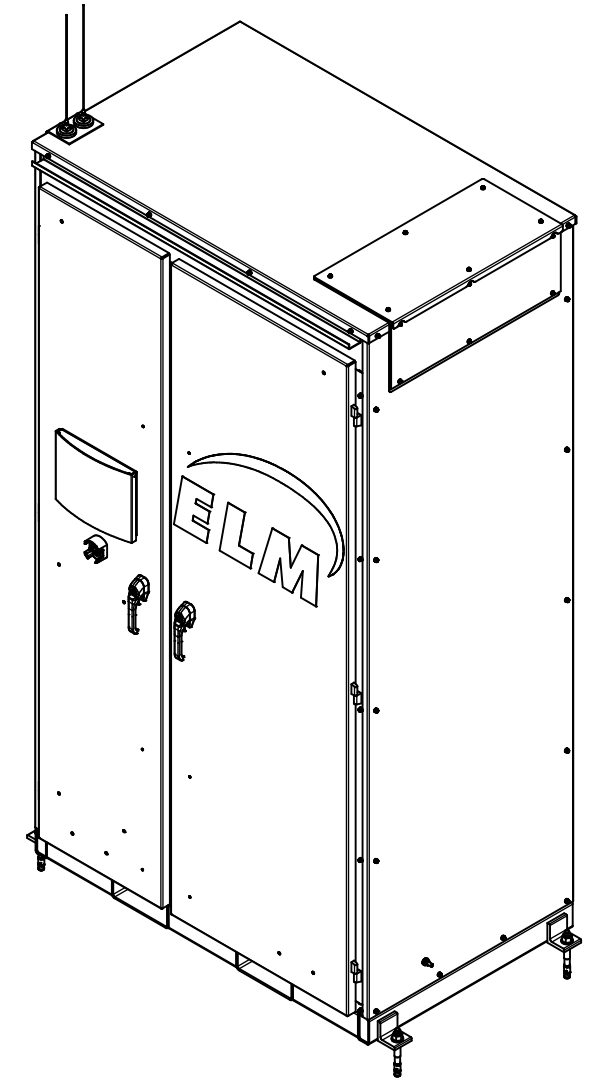

ISOMETRIC VIEW
SCALE 1 : 12

WELDMENT/ASSY TOLERANCE 2 PLACE DECIMALS ± .06 3 PLACE DECIMALS ± .005 ANGLE DIM ± 1° CONCENTRICITY .005 TIR ⊥ & // SURFACES .005 TIR 125 MICRO FINISH ON MACH SURFACES MILLIMETER DIMENSIONS WHOLE NUMBERS ± 1 1 PLACE DECIMALS ± .1		PART TOLERANCE 2 PLACE DECIMALS ± .03 3 PLACE DECIMALS ± .005 ANGLE DIM ± 1° CONCENTRICITY .005 TIR ⊥ & // SURFACES .005 TIR 125 MICRO FINISH ON MACH SURFACES INTERNAL STOCK NUMBER		MATERIAL FINISH PROJECT NAME MASS 1915.3 lbmass		PROPERTY OF PART NAME MICB FINAL ASSEMBLY			
THIS PRINT CONTAINS CONFIDENTIAL AND PROPRIETARY INFORMATION OF ISSUING COMPANY WHICH MAY NOT BE USED, DUPLICATED OR DISCLOSED TO THIRD PARTIES IN WHOLE OR IN PART EXCEPT WITH THE EXPRESSED WRITTEN PERMISSION OF ISSUING. THIS PRINT (INCLUDING ALL COPIES THEREOF) MUST BE RETURNED IMMEDIATELY AFTER SERVING ITS INTENDED PURPOSE TO ISSUING COMPANY.				DRAWING UNITS: INCH THIRD ANGLE PROJECTION		DESIGN ENGR C ONEY DATE 9/30/2025 DRAWN BY L BOREL DATE 9/30/2025 DWG CHECKER R WOODY DATE 9/30/2025 ENGR MGR R OJEN DATE 9/30/2025		DRAWING TITLE MG2.1 SERIES SITE MECHANICAL DRAWING NO. MG2.1-SITE-MECH-0001 SHEET 8 OF 13 SCALE 1 : 12 SIZE D	
© ELM FIELDSIGHT									

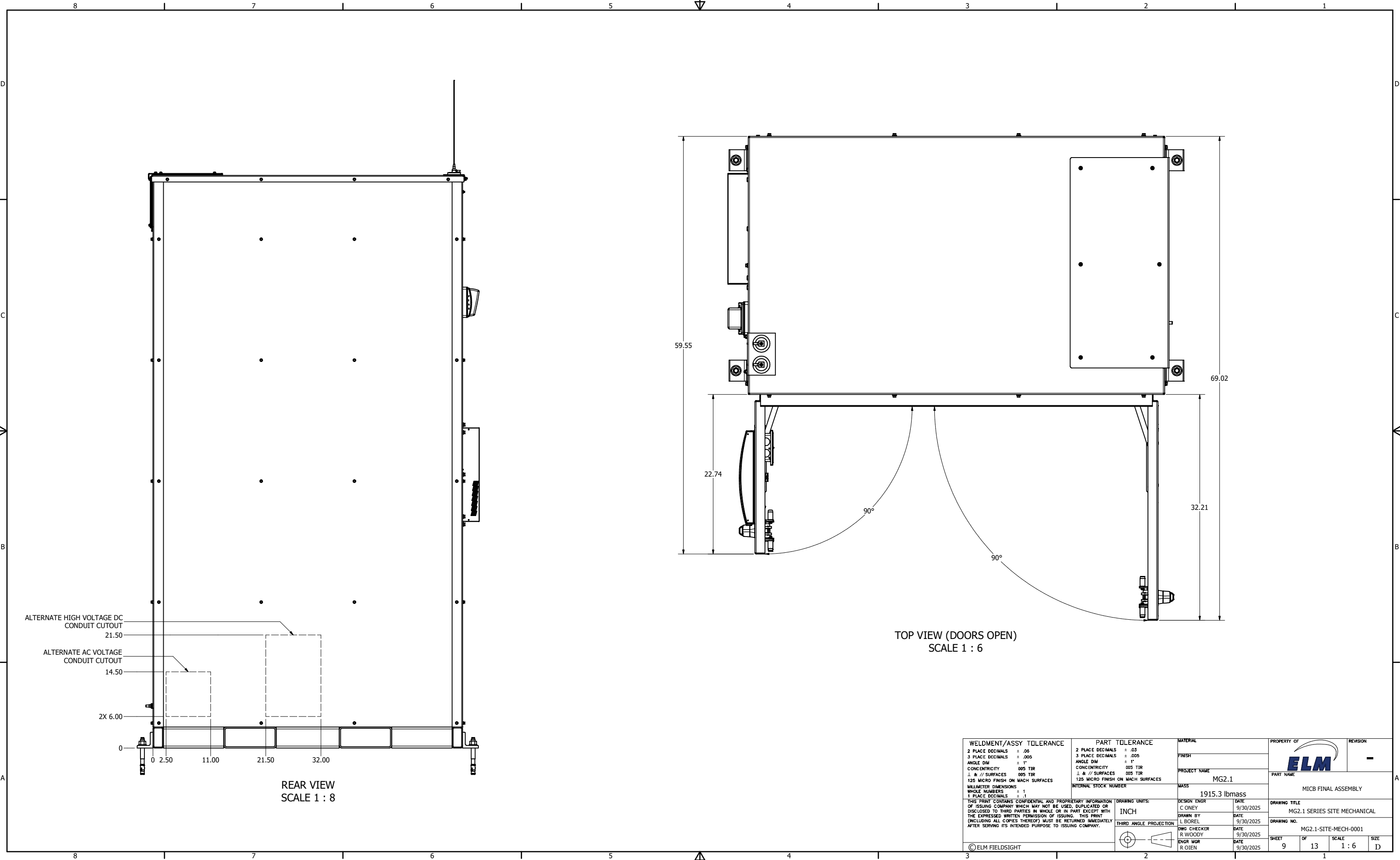

ALTERNATE HIGH VOLTAGE DC
CONDUIT CUTOUT
21.50

ALTERNATE AC VOLTAGE
CONDUIT CUTOUT
14.50

2X 6.00

0 2.50 11.00 21.50 32.00

REAR VIEW
SCALE 1 : 8

TOP VIEW (DOORS OPEN)
SCALE 1 : 6

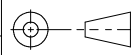
WELDMENT/ASSY TOLERANCE 2 PLACE DECIMALS ± .06 3 PLACE DECIMALS ± .005 ANGLE DIM ± 1° CONCENTRICITY .005 TIR ⊥ & // SURFACES .005 TIR 125 MICRO FINISH ON MACH SURFACES MILLIMETER DIMENSIONS WHOLE NUMBERS ± 1 1 PLACE DECIMALS ± .1		PART TOLERANCE 2 PLACE DECIMALS ± .03 3 PLACE DECIMALS ± .005 ANGLE DIM ± 1° CONCENTRICITY .005 TIR ⊥ & // SURFACES .005 TIR 125 MICRO FINISH ON MACH SURFACES INTERNAL STOCK NUMBER		MATERIAL FINISH PROJECT NAME MG2.1 MASS 1915.3 lbmass		PROPERTY OF  REVISION - PART NAME MICB FINAL ASSEMBLY			
THIS PRINT CONTAINS CONFIDENTIAL AND PROPRIETARY INFORMATION OF ISSUING COMPANY WHICH MAY NOT BE USED, DUPLICATED OR DISCLOSED TO THIRD PARTIES IN WHOLE OR IN PART EXCEPT WITH THE EXPRESSED WRITTEN PERMISSION OF ISSUING. THIS PRINT (INCLUDING ALL COPIES THEREOF) MUST BE RETURNED IMMEDIATELY AFTER SERVING ITS INTENDED PURPOSE TO ISSUING COMPANY.				DRAWING UNITS: INCH THIRD ANGLE PROJECTION		DESIGN ENGR C ONEY DATE 9/30/2025 DRAWN BY L BOREL DATE 9/30/2025 DWG CHECKER R WOODY ENGR MGR R OJEN DATE 9/30/2025		DRAWING TITLE MG2.1 SERIES SITE MECHANICAL DRAWING NO. MG2.1-SITE-MECH-0001 SHEET 9 OF 13 SCALE 1 : 6 SIZE D	
© ELM FIELDSIGHT									

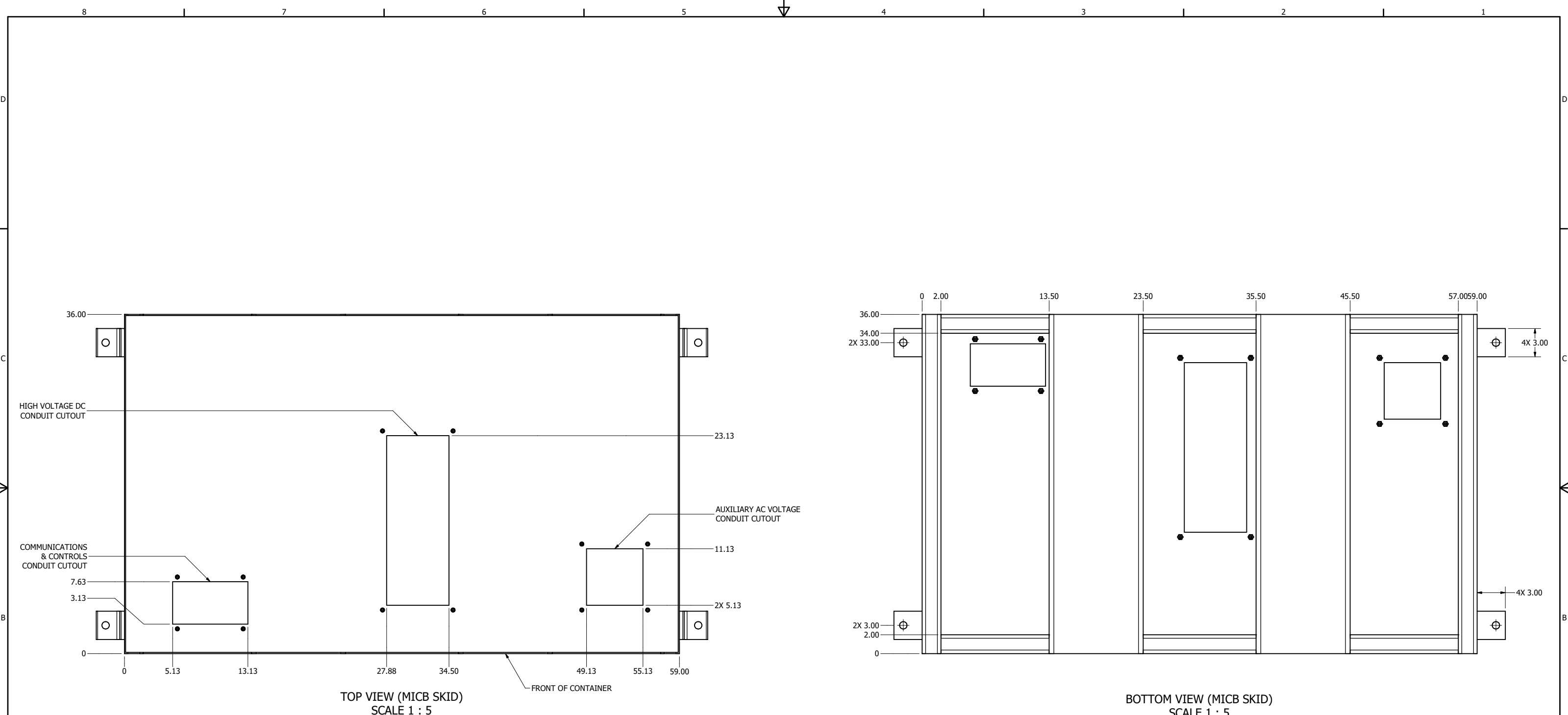

WELDMENT/ASSY TOLERANCE 2 PLACE DECIMALS ± .06 3 PLACE DECIMALS ± .005 ANGLE DIM ± 1° CONCENTRICITY .005 TIR ⊥ & // SURFACES .005 TIR 125 MICRO FINISH ON MACH SURFACES MILLIMETER DIMENSIONS WHOLE NUMBERS ± 1 1 PLACE DECIMALS ± .1		PART TOLERANCE 2 PLACE DECIMALS ± .03 3 PLACE DECIMALS ± .005 ANGLE DIM ± 1° CONCENTRICITY .005 TIR ⊥ & // SURFACES .005 TIR 125 MICRO FINISH ON MACH SURFACES INTERNAL STOCK NUMBER		MATERIAL Steel FINISH PROJECT NAME MG2.1 MASS 360.8 lbmass		PROPERTY OF REVISION - PART NAME SKID WELDMENT			
THIS PRINT CONTAINS CONFIDENTIAL AND PROPRIETARY INFORMATION OF ISSUING COMPANY WHICH MAY NOT BE USED, DUPLICATED OR DISCLOSED TO THIRD PARTIES IN WHOLE OR IN PART EXCEPT WITH THE EXPRESSED WRITTEN PERMISSION OF ISSUING. THIS PRINT (INCLUDING ALL COPIES THEREOF) MUST BE RETURNED IMMEDIATELY AFTER SERVING ITS INTENDED PURPOSE TO ISSUING COMPANY.				DRAWING UNITS: INCH THIRD ANGLE PROJECTION		DESIGN ENGR C ONEY DATE 9/30/2025 DRAWN BY L BOREL DATE 9/30/2025 DWG CHECKER R WOODY ENGR MGR R OJEN		DATE 9/30/2025 DRAWING TITLE MG2.1 SERIES SITE MECHANICAL DRAWING NO. MG2.1-SITE-MECH-0001 SHEET 10 OF 13 SCALE 1 : 5 SIZE D	
© ELM FIELDSIGHT									

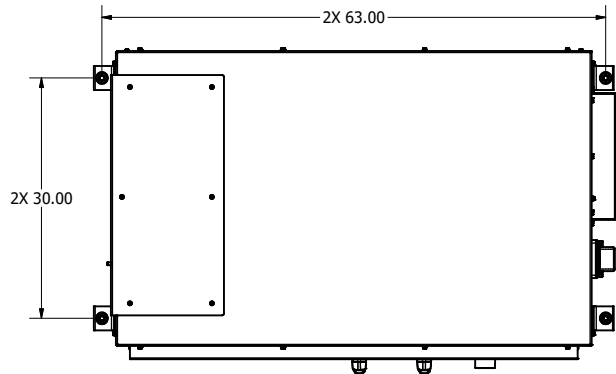

TOP VIEW
SCALE 1 : 12

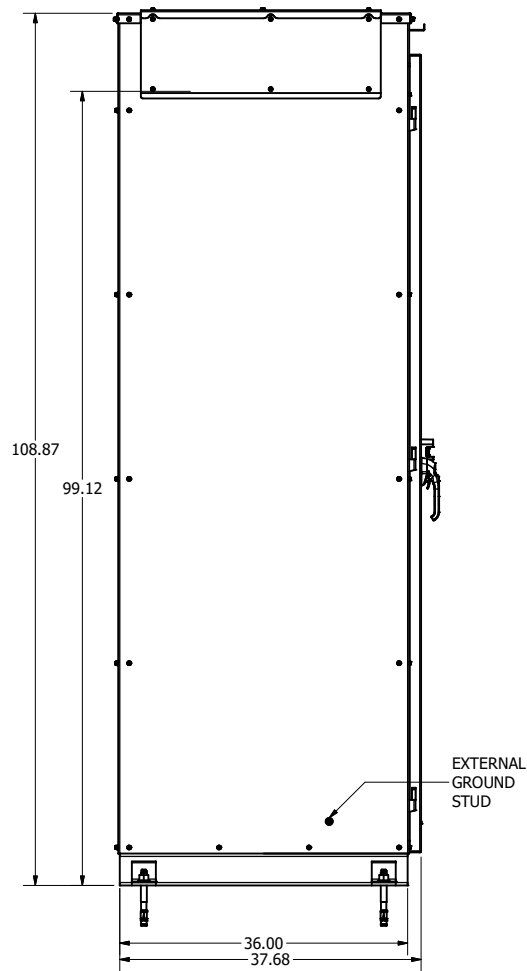

LEFT VIEW
SCALE 1 : 12

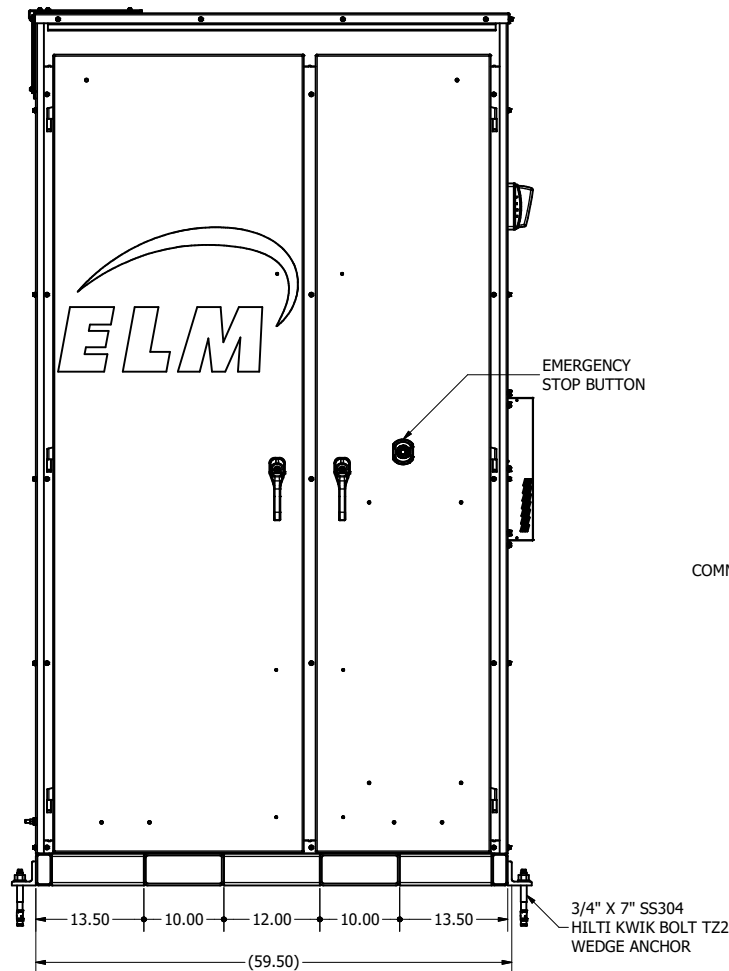

FRONT VIEW
SCALE 1 : 12

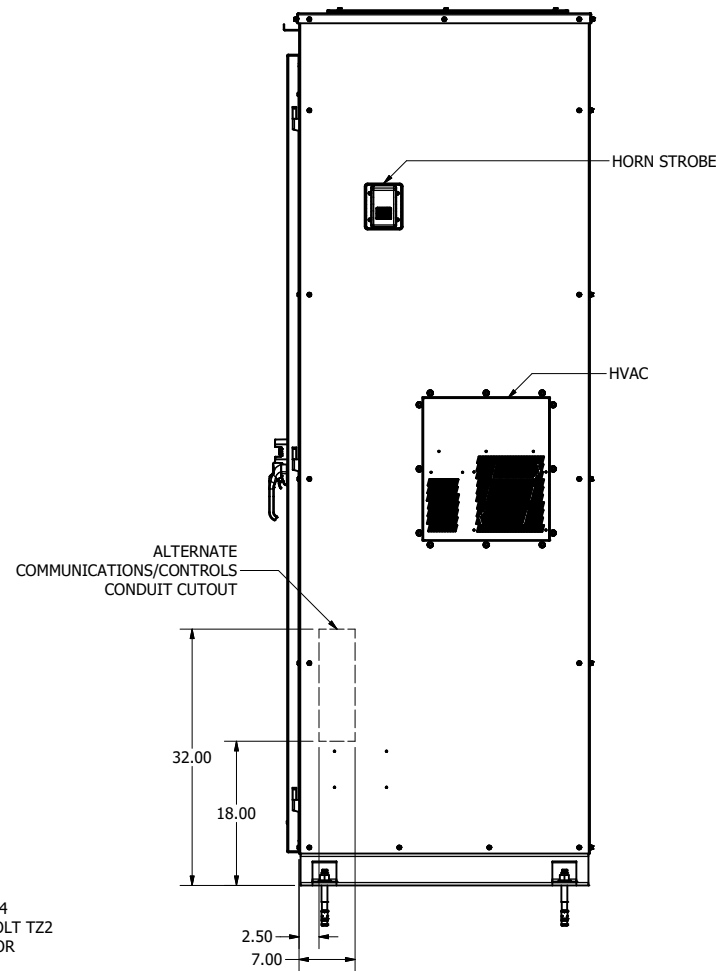

RIGHT VIEW
SCALE 1 : 12

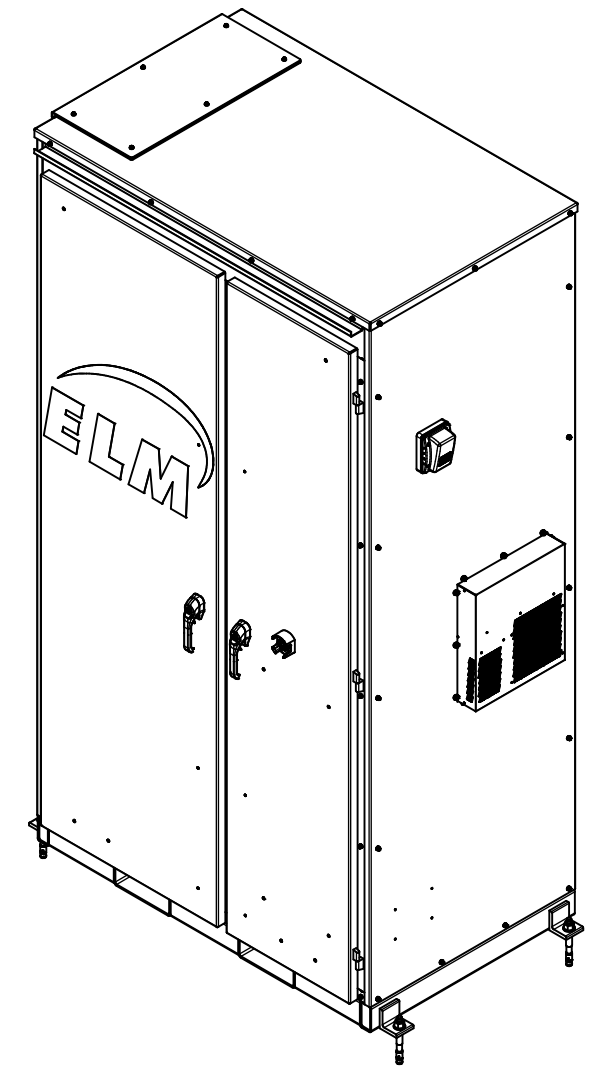

ISOMETRIC VIEW
SCALE 1 : 12

WELDMENT/ASSY TOLERANCE 2 PLACE DECIMALS ± .06 3 PLACE DECIMALS ± .005 ANGLE DIM ± 1° CONCENTRICITY .005 TIR ⊥ & // SURFACES .005 TIR 125 MICRO FINISH ON MACH SURFACES MILLIMETER DIMENSIONS WHOLE NUMBERS ± 1 1 PLACE DECIMALS ± .1		PART TOLERANCE 2 PLACE DECIMALS ± .03 3 PLACE DECIMALS ± .005 ANGLE DIM ± 1° CONCENTRICITY .005 TIR ⊥ & // SURFACES .005 TIR 125 MICRO FINISH ON MACH SURFACES INTERNAL STOCK NUMBER		MATERIAL FINISH PROJECT NAME MASS INTERNAL STOCK NUMBER		PROPERTY OF PART NAME MIB FINAL ASSEMBLY	
THIS PRINT CONTAINS CONFIDENTIAL AND PROPRIETARY INFORMATION OF ISSUING COMPANY WHICH MAY NOT BE USED, DUPLICATED OR DISCLOSED TO THIRD PARTIES IN WHOLE OR IN PART EXCEPT WITH THE EXPRESSED WRITTEN PERMISSION OF ISSUING. THIS PRINT (INCLUDING ALL COPIES THEREOF) MUST BE RETURNED IMMEDIATELY AFTER SERVING ITS INTENDED PURPOSE TO ISSUING COMPANY.		DRAWING UNITS: INCH THIRD ANGLE PROJECTION		DESIGN ENGR L BOREL DATE 9/30/2025		DRAWING TITLE MG2.1 SERIES SITE MECHANICAL	
© ELM FIELDSIGHT		MECH-0220 1768.5 lbmass		DRAWN BY L BOREL DATE 9/30/2025		DRAWING NO. MG2.1-SITE-MECH-0001	
		DWG CHECKER R WOODY ENGR MGR R OJEN DATE 9/30/2025		SHEET 11 OF 13 SCALE 1 : 12 SIZE D			

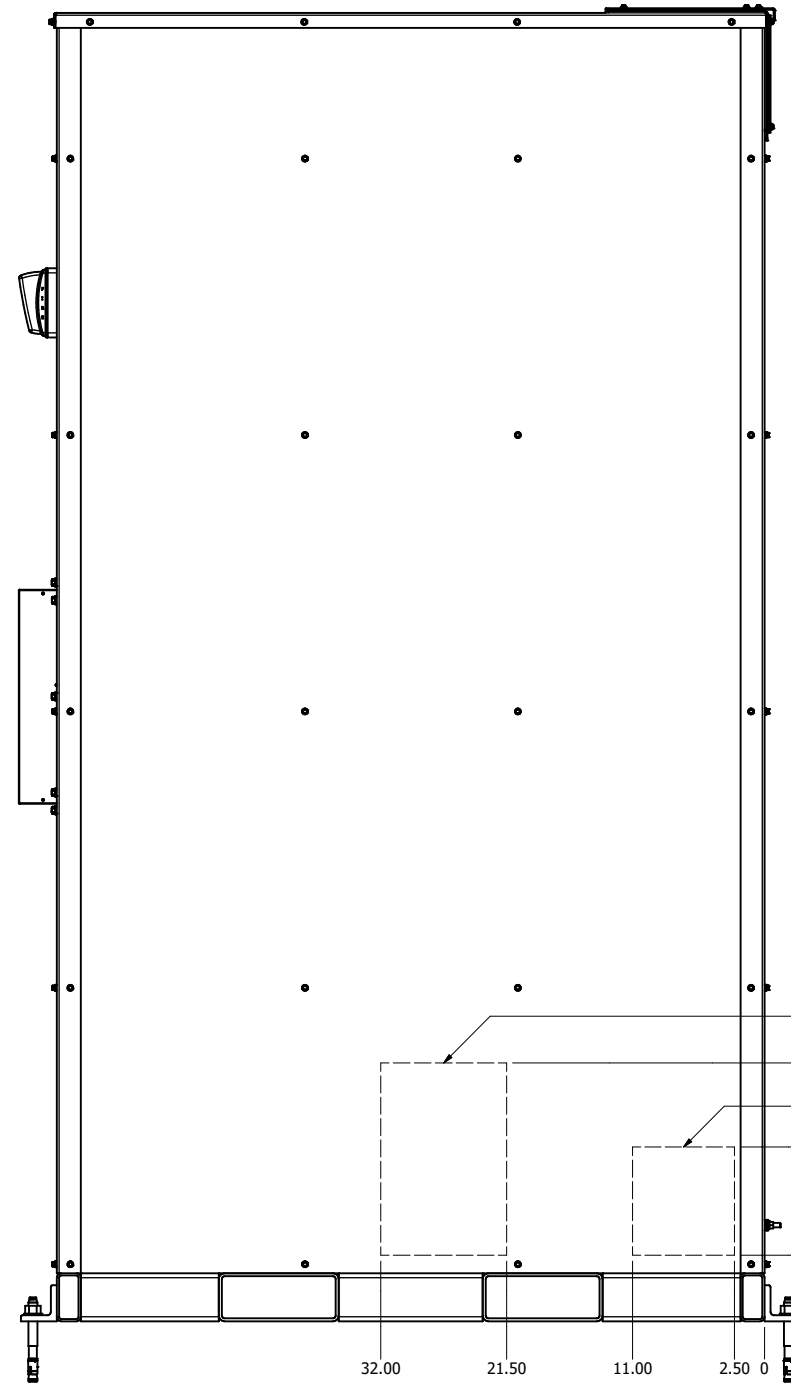

REAR VIEW
SCALE 1 : 8

ALTERNATE HIGH VOLTAGE DC
CONDUIT CUTOUT

ALTERNATE AC VOLTAGE
CONDUIT CUTOUT

32.00 21.50 11.00 2.50 0

2X 5.50

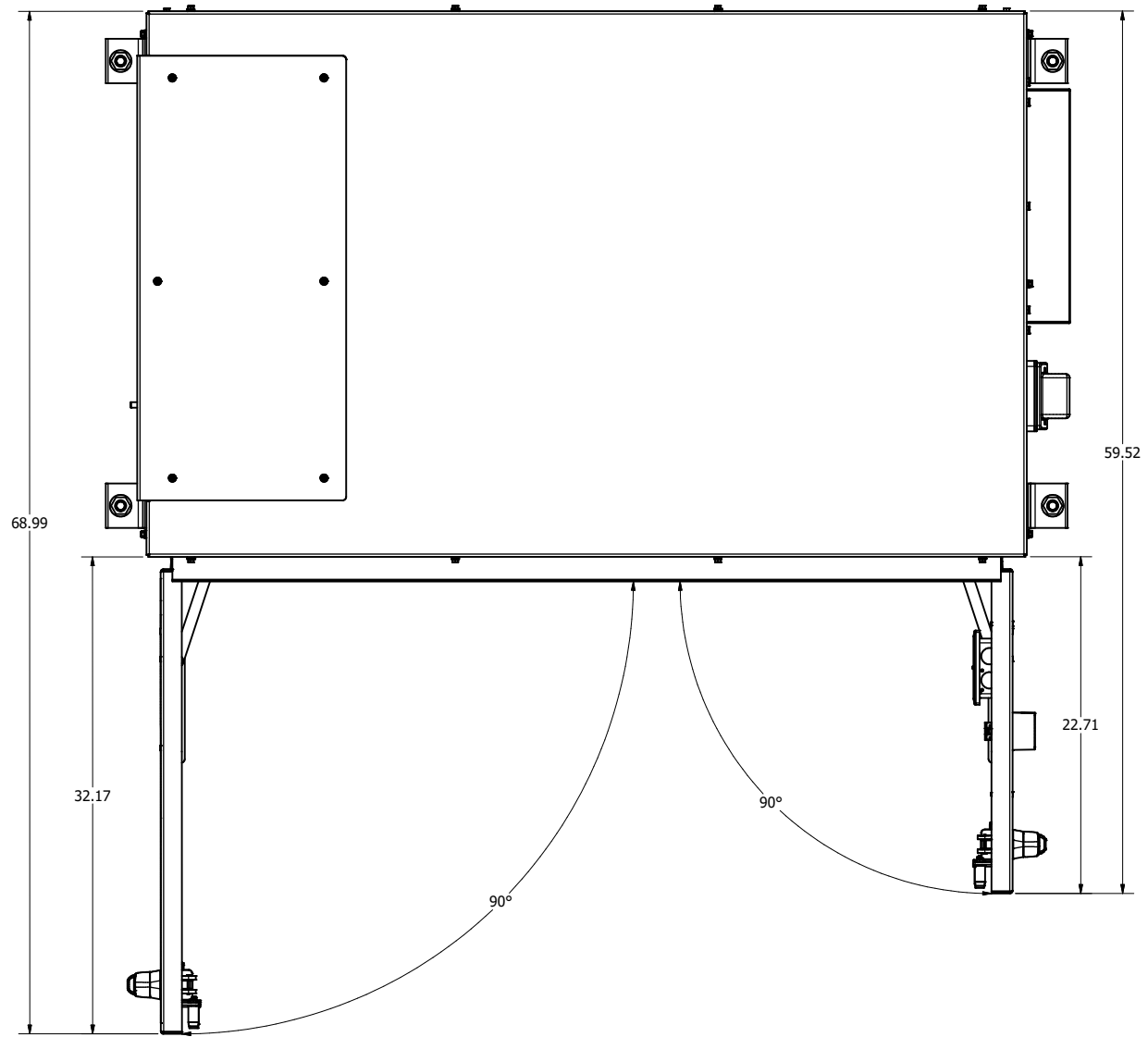

TOP VIEW (DOORS OPEN)
SCALE 1 : 6

WELDMENT/ASSY TOLERANCE 2 PLACE DECIMALS ± .06 3 PLACE DECIMALS ± .005 ANGLE DIM ± 1° CONCENTRICITY .005 TIR ⊥ & // SURFACES .005 TIR 125 MICRO FINISH ON MACH SURFACES MILLIMETER DIMENSIONS WHOLE NUMBERS ± 1 1 PLACE DECIMALS ± .1		PART TOLERANCE 2 PLACE DECIMALS ± .03 3 PLACE DECIMALS ± .005 ANGLE DIM ± 1° CONCENTRICITY .005 TIR ⊥ & // SURFACES .005 TIR 125 MICRO FINISH ON MACH SURFACES INTERNAL STOCK NUMBER MECH-0220		MATERIAL FINISH PROJECT NAME MG2.1 MASS 1768.5 lbmass		PROPERTY OF PART NAME MIB FINAL ASSEMBLY			
THIS PRINT CONTAINS CONFIDENTIAL AND PROPRIETARY INFORMATION OF ISSUING COMPANY WHICH MAY NOT BE USED, DUPLICATED OR DISCLOSED TO THIRD PARTIES IN WHOLE OR IN PART EXCEPT WITH THE EXPRESSED WRITTEN PERMISSION OF ISSUING. THIS PRINT (INCLUDING ALL COPIES THEREOF) MUST BE RETURNED IMMEDIATELY AFTER SERVING ITS INTENDED PURPOSE TO ISSUING COMPANY.				DRAWING UNITS: INCH THIRD ANGLE PROJECTION		DESIGN ENGR L BOREL DATE 9/30/2025 DRAWN BY L BOREL DATE 9/30/2025 DWG CHECKER R WOODY ENGR MGR R OJEN DATE 9/30/2025		DRAWING TITLE MG2.1 SERIES SITE MECHANICAL DRAWING NO. MG2.1-SITE-MECH-0001	
© ELM FIELDSIGHT						SHEET 12 OF 13 SCALE 1 : 6 SIZE D			

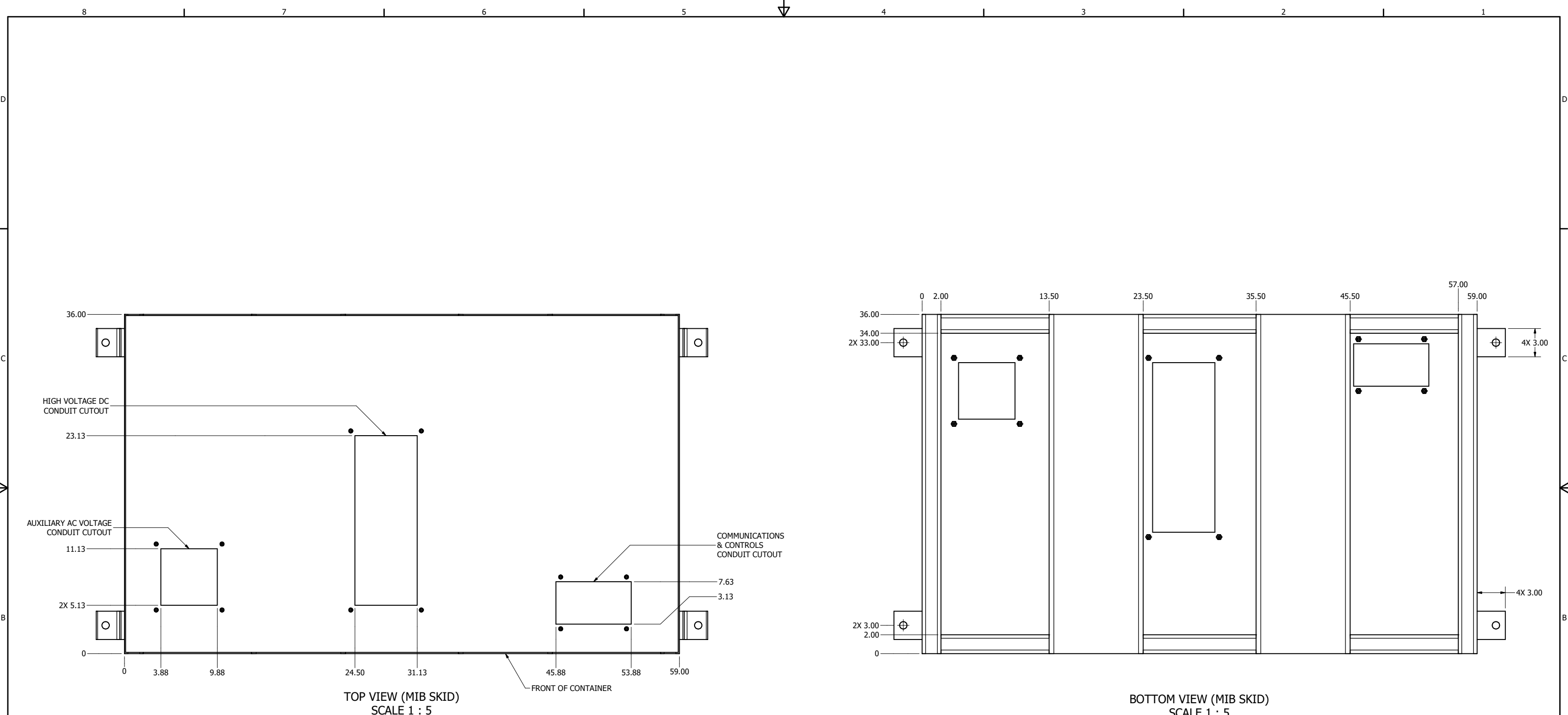

TOP VIEW (MIB SKID)
SCALE 1 : 5

BOTTOM VIEW (MIB SKID)
SCALE 1 : 5

WELDMENT/ASSY TOLERANCE 2 PLACE DECIMALS ± .06 3 PLACE DECIMALS ± .005 ANGLE DIM ± 1° CONCENTRICITY .005 TIR ⊥ & // SURFACES .005 TIR 125 MICRO FINISH ON MACH SURFACES MILLIMETER DIMENSIONS WHOLE NUMBERS ± 1 1 PLACE DECIMALS ± .1		PART TOLERANCE 2 PLACE DECIMALS ± .03 3 PLACE DECIMALS ± .005 ANGLE DIM ± 1° CONCENTRICITY .005 TIR ⊥ & // SURFACES .005 TIR 125 MICRO FINISH ON MACH SURFACES INTERNAL STOCK NUMBER		MATERIAL Steel FINISH PROJECT NAME MG2.1 MASS 360.8 lbmass		PROPERTY OF REVISION - PART NAME SKID WELDMENT					
THIS PRINT CONTAINS CONFIDENTIAL AND PROPRIETARY INFORMATION OF ISSUING COMPANY WHICH MAY NOT BE USED, DUPLICATED OR DISCLOSED TO THIRD PARTIES IN WHOLE OR IN PART EXCEPT WITH THE EXPRESSED WRITTEN PERMISSION OF ISSUING. THIS PRINT (INCLUDING ALL COPIES THEREOF) MUST BE RETURNED IMMEDIATELY AFTER SERVING ITS INTENDED PURPOSE TO ISSUING COMPANY.				DRAWING UNITS: INCH THIRD ANGLE PROJECTION		DESIGN ENGR C ONEY DATE 9/30/2025 DRAWN BY L BOREL DATE 9/30/2025 DWG CHECKER R WOODY ENGR MGR R OJEN		DATE 9/30/2025 DATE 9/30/2025		DRAWING TITLE MG2.1 SERIES SITE MECHANICAL DRAWING NO. MG2.1-SITE-MECH-0001	
© ELM FIELDSIGHT						SHEET 13 OF 13 SCALE 1 : 5 SIZE D					