

Brian T. Henebry
Partner
Direct: 203.575.2601
Fax: 203.575.2600
bhenebry@carmodylaw.com

50 Leavenworth Street
P.O. Box 1110
Waterbury, CT 06721

April 9, 2026

Via Hand-Delivery and Electronic Mail (Melanie.Bachman@ct.gov)

Melanie A. Bachman, Esq.
Executive Director
Connecticut Siting Council
10 Franklin Square
New Britain, CT 06051

Re: Shepaug LLC petition for a declaratory ruling, pursuant to Connecticut General Statutes §4-176 and §16-50k, for the construction, maintenance and operation of a 1.99-megawatt AC solar photovoltaic electric generating facility and associated equipment located adjacent to FirstLight Power, Inc.'s Shepaug Generating Station, 2225 River Road, Southbury, Connecticut, and associated electrical interconnection.

Dear Attorney Bachman:

On behalf of Shepaug LLC (the "Petitioner"), we hereby submit to the Connecticut Siting Council the original and fifteen (15) copies of Petitioner's Responses to Council's Interrogatories for the above-referenced Petition. Electronic copies of these responses will also be provided as of today's date.

Please contact me if you have any questions regarding this submission.

Very truly yours,

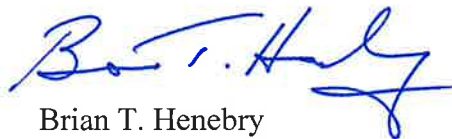
Brian T. Henebry

BTH/dma
Enclosures

cc: Service List

**LIST OF PARTIES AND INTERVENORS
SERVICE LIST**

Status Granted	Document Service	Status Holder (name, address & phone number)	Representative (name, address & phone number)
Petitioner	<input checked="" type="checkbox"/> E-mail	Shepaug LLC	<p>Brian T. Henebry, Esq. Janie L. McDermott, Esq. Carmody Torrance Sandak & Hennessey LLP 50 Leavenworth Street Waterbury, CT 06702 (203) 573-1200 bhenebry@carmodylaw.com jmcdermott@carmodylaw.com</p> <p>Tory Hanna Davis Hill Development LLC 105 Prospect St. Greenwich, CT 06830 (413) 522-7460 tory.hanna@dhd solar.com</p> <p>Sandra Brown FirstLight Energy 100 District Avenue, Suite 102 Burlington, MA 01803 (404) 695-0555 Sandra.Brown@firstlight.energy</p> <p>Michael Libertine All-Points Technology Corporation, P.C. 567 Vauxhall Street Ext. Suite 311 Waterford, CT 06385 (860) 552-2238 mibertine@allpointstech.com</p>

**Petition No. 1701 Shepaug
LLC
2225 River Road, Southbury**

Interrogatories

Notice

1. Referencing Petition Exhibit 7, has Shepaug LLC (Shepaug) directly received any comments since the petition was submitted to the Council? If yes, summarize the comments and state how these comments were addressed.

Response: The development team has engaged in the following correspondence with our stakeholders since the initial submission:

Jordan Marcinko, Land Use Administrator with the Town of Southbury, reached out on December 4, 2025 to confirm Southbury received the notification letter, and noted that proposed facility was anticipated and consistent with what Shepaug previously presented to the community. Mr. Marcinko indicated the Town was supportive of the facility, and very excited for the apiary aspect. Mr. Marcinko asked about our experience and approach with regards to the apiary, and Shepaug confirmed we have knowledge on bee keeping as a service for solar projects, which is becoming more widely implemented, and that Sami Ghantous, an employee of FirstLight on the Development team, has prior experience keeping bees and working on beehives at a solar apiary. Mr. Marcinko noted that there are local beekeepers, and that it would be great to involve local beekeepers if at all possible. Shepaug agreed to include local beekeepers in those we consider for services at the facility in the future. Shepaug also indicated that there would be necessary safety, insurance standards, and operational requirements that any beekeeper would need to adhere to, which may limit our ability to contract for services with local beekeepers, and Mr. Marcinko acknowledged that requirement and restriction. Since the conversation with Mr. Marcinko, and as part of continued development work at the facility, Shepaug has been in conversations with potential providers of apiary/ beekeeping services, and associated environmental monitoring, noting that we would appreciate if local beekeepers could be included as potential sources. We anticipate moving forward with contracting this work following security permits for the facility, and obtaining a notice to proceed.

FirstLight's Director of Community Relations, Andy Brydges, and Senior Land Manager, Brian Wood, meet with of Bent of the River Audubon Center Director, Robin Ladouceur, on December 2, 2025. During the meeting, details of the facility were discussed. No further request for information has been received.

FirstLight's Director of Community Relations, Andy Brydges, and Senior Land Manager, Brian Wood, also met with Robert Mitchell, the farm-owner of property that abuts' the Shepaug property, on December 2, 2025. During the meeting, details of the facility were discussed. Mr. Mitchell asked if logging would occur as part of the work, whether FirstLight would be open to providing any log-length wood for his firewood business. FirstLight agreed to provide him an undetermined portion of log-length wood.

Public Benefit

2. Referencing Petition p. 3, is the Shared Clean Energy Facility (SCEF) Program Agreement with Eversource Energy (Eversource) for the entire facility output? Would Eversource purchase the electricity, capacity and renewable energy certificates for the facility?

Response: Under the SCEF contract, the entire facility output is contracted to Eversource. This includes electricity, capacity, and renewable energy certificates through the 20-year Delivery Term, commencing on the In-Service Date.

3. When is the contractual in-service date for the facility?

Response: Per the SCEF contract, the PURA Tariff Terms Agreement Approval Date was July 7, 2025. The In-Service Date must be no later than 3 years from that date, or July 7, 2028.

4. If the facility operates beyond the terms of the SCEF contract, will Shepaug decommission the facility or seek other revenue mechanisms for the power produced by the facility?

Response: The facility is anticipated to have a useful life between 30 – 40 years. Following the end of the Delivery Term of the SCEF contract, FirstLight anticipates the facility will either operate as a Qualifying Facility, or participate in ISO-NE markets, and will monetize energy, capacity, and renewable energy certificates, or equivalent, within the anticipated future market. Following the end of the facility’s useful life, the facility will be decommissioned.

Facility Development

5. Is the facility, or any portion of the facility, proposed to be undertaken by state departments, institutions or agencies, or to be funded in whole or in part by the state through any contract or grant?

Response: The facility is not anticipated to be funded by any grants or rebates issued by the State of Connecticut. The facility is anticipated to participate in Connecticut renewable energy programs, including participation in the Share Clean Energy Facility program administered by Eversource, and potentially receiving debt financing through the Connecticut Green Bank.

6. What is the estimated cost of the facility?

Response: The current estimated cost of the facility is \$5,400,000, inclusive of all fees and expenses associated with the facility’s development.

7. If Shepaug transfers the facility to another entity, would Shepaug provide the Council with a written agreement as to the entity responsible for any outstanding conditions of the Declaratory Ruling and quarterly assessment charges under CGS §16-50v(b)(2) that may be associated with this facility, including contact information for the individual acting on behalf of the transferee?

Response: If the project company or its affiliates transfers ownership of the facility to another entity, Shepaug will provide notice to the Council of the change in ownership, and provide updated contact information for the facility’s owner. Shepaug will also provide a copy of any rulings made by the CSC, including but not limited to all conditions in the Council’s Final Decision, and request acknowledgement by the new owner of the facility that responsibility for any outstanding conditions including quarterly assessment charges under CGS §16-50v(b)(2) associated with the facility are the obligation of the new owner, as well as providing the Council with all written agreements regarding quarterly assessment charges.

8. Referencing Petition pp. 10-11, what is the status of construction of the 250-kW Shepaug Station Solar array? Would the Shepaug Station Solar array interconnect with the proposed facility? Explain.

Response: The 250-kW Shepaug Station Solar array and Shepaug LLC's proposed 1.99-MW Shepaug Station Solar array are two separate facilities located on FirstLight's property at 2225 River Road. They have separate interconnection agreements, both executed with Eversource, and distinct points of interconnection. The Shepaug Station 250-kW facility, or little Shepaug will be interconnected behind the main panel of Shepaug Hydrogeneration Station. The hydro facility, which is currently operated using electricity from Eversource, in the future will be powered in large part by the 250-kW facility . The "little Shepaug" project has reached mechanical completion, and is in the process of commissioning. We anticipate Commercial Operations will commence by April 30, 2026.

Proposed Site

9. Is the host parcel subject to any contracts or restrictive covenants related to any private rights to a view or vista?

Response: The host parcel is not subject to any contracts or restrictive covenants related to private rights to a view or vista.

10. Referencing Petition p. 8, provide the following information for the agricultural activity area:

- a. If the facility is sold and/or transferred to another entity, would the sale and/or transfer include management and maintenance of the agricultural activity area?

Response: Yes, the Petitioner's plan is that, if the facility is sold and/or transferred to another entity, the transferee would assume responsibility for the management and maintenance of the agricultural activity area pursuant to the Agrivoltaics Farm Plan ("Farm Plan") approved by the Connecticut Department of Agriculture (CT DOAG), which serves as the governing authorization for such activities. The Farm Plan establishes the ongoing obligation to maintain agricultural operations for the life of the facility, and compliance with its requirements would be binding on any subsequent owner or operator.

In connection with any future transfer, all relevant agreements necessary to implement the Farm Plan, including, as applicable, farm management agreements, apiary or pollinator habitat management contracts, and any related operations and maintenance obligations specific to the agricultural activity area, would be assigned or otherwise transferred to the new owner or managing entity, subject to the terms of the sale or transfer agreement.

- b. Who would be responsible for the maintenance of the agricultural activity area? What type of maintenance is necessary for the agricultural activity area and how frequently would maintenance activities occur?

Response: The agricultural activity area, including the apiary and pollinator habitat, will be managed through a coordinated effort between Shepaug and the beekeeper operator. The purpose of this collaboration is to support pollinator health, maintain safe site operations, and ensure proper land stewardship in accordance with facility Operations and Maintenance (O&M) requirements.

Site Owner Responsibilities will include providing and maintaining safe and reliable access for the beekeeper to conduct apiary operations. Shepaug's land management and maintenance team

will maintain the area surrounding the apiary in accordance with the facility's O&M standard procedures. Shepaug will also be responsible for planting pollinator seed mixes as recommended by the biodiversity monitoring performed by the beekeeper to support pollinator habitat and overall site biodiversity.

Beekeeper Responsibilities will include maintaining the apiary, including hive management, monitoring colony health, performing treatments as necessary, and conducting honey extraction. Apiary management best practices depend on the time of year and weather conditions; however, a beekeeper typically performs routine hive inspections and maintenance during the growing season approximately one to two times per month.

- c. Who would be responsible for responding to concerns and/or complaints related to these agricultural activities?

Response: The beekeeper/operator managing the apiary would be responsible for addressing any concerns or complaints related specifically to the beekeeping operations, including hive management, bee activity, treatments, inspections, and honey extraction.

Shepaug will coordinate with the beekeeper to ensure any site-related concerns are addressed promptly and appropriately. The contract for the beekeeper would require him/her to follow any safety and reporting requirements that are applicable to the wider site.

- d. What entity would manage the apiary? Would the apiary be registered with the State Entomologist?

Response: The apiary will be managed by a third party qualified and insured local beekeeper, who will be registered with the State of Connecticut Department of Agriculture, Office of the State Entomologist, in accordance with Connecticut beekeeping regulations. We are in the process of contracting HiveTracks, a company that supports the contracting process for a qualified beekeeper and provides transparent tracking of apiary activities.

Proposed Facility and Associated Equipment

11. Provide the dimensions of the concrete pad and the approximate dimensions (LxWxH) of the transformers and switchgear that would be installed on each concrete pad.

Response: Three (3) concrete pads are associated with the Shepaug facility. The first will serve as the foundation for the facility-owned equipment, and the latter two will serve as foundations for Eversource-owned equipment required for the interconnection of the facility.

The Facility-owned concrete pad dimensions are 58' by 40', as shown and labeled as "PROP. EQUIPMENT PAD" on SP-0 and DN-1, Note 5 of the original Petition, Exhibit 1a – Environmental Assessment part one (see sheets 55 and 64). Specification sheets for the equipment planned to be located at the pad are included as attachments to this filing. The equipment includes:

- 1) A JCL Switchboard with dimensions of 56.5"(L) x 29.5"(W) x 80"(H), (Exhibit 1).**
- 2) The Facility-owned JCL Transformer with dimensions of 84.5"(L) x 84.5"(W) x 80"(H), (Exhibit 2).**

Eversource will construct and own two (2) additional concrete pads, as show on sheet SP-4 of the original Petition (Exhibit 1a – Environmental Assessment, part one sheet 59) and labeled "PROP.

CONCRETE UTILITY EQUIPMENT PADS". These pads will serve as foundations for Eversource's Pad-Mounted Primary Meter at the Point of Common Coupling (POCO). Eversource has explained that their dimensions will be determined during the final design and construction phase of their work.

12. Referencing Site Plan Sheet SP-0, are the inverters mounted on posts or attached to the solar array racking system?

Response: The inverters are attached directly to the solar array racking system, at the terminus of each row. On SP-0 of the original Petition (Exhibit 1a – Environmental Assessment, part one sheet 55), this is shown on the eastern side of the array, along each eastern solar row terminus. Please see the label "PROP INVERTOR AT EACH END ROW TYP."

13. What is the anticipated lifespan of the inverters, transformers and switchgear?

Response: The anticipated lifespan for the Transformer, Invertors, and Medium Voltage Gear is 10 years, and 20 years for the switchboards.

14. Is the wiring from panels to the inverters installed on the racking system? If wiring is external, how would it be protected from potential damage from weather exposure, vegetation maintenance, or animal contact?

Response: Any conductors leaving the racking structure will be fully encased in Schedule 80 conduit, until the point at which they transition to Schedule 40 conduit underground.

15. Referencing Petition pp. 5 and 23, what is the address and direction of the closest residence to the facility limit of disturbance?

Response: The closest address is 31 Purchase Brook Road in Southbury (Zoned R80). The Limit of Disturbance (LOD) is approximately 2,770' to the existing residential structure at this address, and 369' to the residential property line.

Energy Output

16. Would Shepaug participate in an ISO-NE Forward Capacity Auction? If yes, which auction(s) and capacity commitment period(s)?

Response: In Section 7.1.4 of the SCEF Year 6 Tariff Terms Agreement, the capacity rights are transferred to the appropriate Electric Distribution Company (EDC), in this case Eversource ("SCEF capacity rights shall be transferred to the appropriate EDC, as all SCEFs are treated as load reducers and may not own capacity rights and participate in the ISO-NE capacity market.") If capacity rights revert to the facility at the end of the SCEF program, FirstLight will enter the facility into the ISO-NE Forward Capacity Auction, or the then-equivalent program.

17. If one section of the solar array experiences electrical problems causing the section to shut down, could other sections of the system still operate and transmit power to the grid?

Response: Yes, the facility is configured with multiple string inverters feeding a common alternating-current (AC) switchboard, so a localized issue would typically isolate only the affected inverter/section, while the remaining inverters continue operating.

18. What is the projected annual capacity factor of the proposed facility? What is the estimated annual degradation of the solar facility output?

Response: Using the PVsyst annual energy of 3,601.3 megawatt-hours (MWh) and the POI grid limit of 1,999 kW AC, the projected annual capacity factor is about 20.6%. First-year degradation is estimated to be not more than 1% and subsequent annual degradation is estimated to be not more than 0.4%.

19. Have electrical loss assumptions been factored into the output of the facility? What is the output (MW AC) at the point of interconnection?

Response: Yes. The PVsyst model includes electrical and system losses, including direct-current (DC) wiring loss, inverter losses, AC ohmic loss, transformer loss, medium voltage (MV) line loss, soiling, mismatch, light-induced degradation (LID), and system unavailability. The AC output at the point of interconnection is 1.999 MW AC, and the modeled annual energy injected into the grid is estimated to be 3,601.3 MWh per year.

Electrical Interconnection

20. Referencing Petition p. 14, does the interconnection require a review from Eversource and /or ISO-NE? If yes, what was the result?

Response: Yes, Eversource completed a distribution impact study for the facility. The study concluded that no voltage issues would be observed at full AC output, power quality was acceptable, direct transfer trip was not necessary. They also observed that reverse power flow at the Shepaug 13A2 breaker would be substantial following the interconnection of the facility, and as result required additional Eversource-owned protection and controls for the interconnection, as outlined under Question 21.

21. Referencing Petition p. 14, what additional interconnection infrastructure is required?

Response: The distribution impact study conducted by Eversource identified a new three-phase service consisting of a new primary meter and recloser. The interconnection set also shows a new utility riser pole with radial recloser, pad-mounted primary utility metering cabinet, customer transformer, grounding transformer, customer load-break switch, and associated protection/metering equipment. The study also notes the 13A2 feeder-head voltage regulators will need to be upgraded to accommodate reverse power flow.

22. Referencing Petition p. 13,

- a. what is the approximate height of the proposed interconnection utility poles?

Response: The interconnection documents issued by Eversource do not specify a pole height. That would likely come from Eversource's final utility construction package, but typical pole heights range from 40-45 feet above ground level.

- b. describe the feasibility of undergrounding the electrical interconnection line to the concrete utility pads.

Response: The selection of an aerial interconnection is driven by its superior cost-efficiency and minimal subsurface disruption, avoiding the significant expense and environmental risks associated with trenching through the existing terrain. By utilizing overhead lines, the facility maintains unobstructed site access for heavy machinery, ensuring a safer and more streamlined

construction timeline. The proposed design minimizes aerial installation where practical, either to reduce visibility of the poles, or to avoid conflicts with overhead transmission lines. The development team received quotes for the cost of running the electrical interconnection line entirely underground, which would consist of a number of concrete sections and would require the demolition of the existing access road, drainage system, and engineered stormwater features (recently installed to support better drainage). This underground route was evaluated by the Petitioner and deemed economically unfeasible and technically disadvantageous for the facility and site.

c. what is the width of cleared area to maintain the overhead interconnection line?

Response: The Minimum Approach Distance (MAD) will be maintained to industry standards for distributed energy voltage, as our proposed interconnection run is anticipated to be 13.8 kV during operations. The MAD is anticipated to be approximately 8-15' from the line, or a maximum of 16-30' clearance.

d. would an overhead utility line be susceptible to outages caused by periodic tree fall?

Response: The risk of outages is anticipated to be minimal, and will be mitigated as FirstLight conducts annual inspections and maintenance to ensure the MAD is maintained.

e. how often would inspections occur along the overhead line to identify diseased or dying trees that may require removal?

Response: FirstLight conducts annual inspections along the overhead line to identify any diseased or dying trees that may require removal. We remove dead, diseased, and dying trees that have the potential to impact staff or facilities.

Public Health and Safety

23. Referencing Petition 29, describe the features integrated within the remote monitoring system (RMS) to ensure safe operation of the facility. Can the RMS automatically de-energize the system during abnormal events? At what location/component would de-energization occur?

Response: Our RMS platform will monitor the following parameters continuously to detect abnormal conditions:

- **A DC string current and voltage at each combiner box will detect string faults, open circuits, and ground faults;**
- **AC output voltage, current, frequency, and power factor at each inverter;**
- **Inverter status and fault codes, including over/under voltage, over/under frequency, overcurrent, ground fault, and arc fault detection;**
- **Revenue-grade production metering at the point of interconnection;**
- **Recloser status (open/closed/fault/lockout) via Schweitzer Engineering Laboratories (SEL) relay communications (typically Distributed Network Protocol 3 (DNP3) or International Electrotechnical Commission (IEC) 61850). Additionally, the Utility requires recloser testing to ensure auto-shutdown on many criteria;**

- **Gang Operated Air-Break (GOAB) switch status (if equipped with position indicators);**
- **Meteorological data: Irradiance, ambient temperature, module temperature, and wind speed for performance benchmarking and anomaly detection;**
- **Security: Gate status, intrusion detection, and camera feeds.**

24. In the event of a shut-down, would the panels still produce and send power to the inverters? Can energized components pose a safety risk to emergency responders?

Response:

1. In the event of a shutdown, would the solar modules still produce power and send power to the inverters?

Yes, the solar modules will continue energizing the DC wiring through the string inverter inputs, including busbars, fuses, and combiner boxes. If the inverters were shut down via grid disconnect, anti-islanding trip, or emergency stop, DC conductors located between the solar modules and the inverter's DC input terminals would remain live at full open-circuit voltage (Voc).

2. Can energized components pose a safety risk to emergency responders?

Yes, DC-components cannot be de-energized without physically covering the modules or disconnecting strings at the combiner box. High-voltage DC arc flash is dangerous and can present a risk to emergency responders. Arc flash and electrical hazards will be mitigated through code-compliant system design and equipment isolation measures. Shepaug will incorporate multiple safety features, including properly rated and clearly labeled DC and AC disconnects to isolate the array, inverters, and interconnection equipment, together with coordinated overcurrent protection, grounding and bonding, and listed equipment installed per applicable electrical and utility standards. Appropriate warning labels, access clearances, and operating procedures will be provided. Shepaug will also coordinate with local emergency responders and provide site-specific training before seeking a building permit to ensure familiarity with the system layout, hazards, and emergency procedures. Collectively, these measures significantly reduce the likelihood and severity of electrical hazards to emergency personnel.

25. Are there manual facility shut-off switches that can be operated by emergency personnel? If yes, in what location(s)? Are the switches locked? If yes, how would emergency response personnel be able to operate the switch?

Response: Yes, there are multiple Manual Shutdown Switches on the site. The primary full-system disconnect is the pole-mounted GOAB Switch, a utility-side isolation point and the most visible switch for emergency responders. It will be located at the utility POI and should be operated with a hot stick by qualified personnel. The GOAB will be locked via a padlock on the operating handle to prevent unauthorized operation. The utility typically holds the key, or a Knox Box system may be used so that fire departments can access the key without utility personnel on-site.

The second manual disconnect is the Recloser which will be located at the utility riser pole, at the POI. The Recloser can be operated manually in the field or remotely via Supervisory Control and Data Acquisition (SCADA) by Eversource.

Within the facility site there are additional disconnects located at both the POI and with the array. At the POI, there are disconnects located at the PV Switchboard and an additional customer-side lockable disconnect located between the POI and the facility's transformer. Either can be used to isolate the facility from providing power to the local distribution grid. Additionally, inverter-integrated disconnects are also located throughout the array that can be operated independently to isolate sections of the array. DC Combiner boxes are also equipped with switches that are able to open the DC feeders from the combiner box back, prior to the inverters.

26. In the event of a brush fire between panel rows, how would fire equipment be able to access the area? What types of emergency vehicles can access the vegetated aisle area between the panel rows? If none, what is the minimum aisle width necessary to accommodate such vehicles?

Response: In the unlikely event of an electrical or brush fire that threatens the electrical equipment, the proper response to mitigate further risk to spray water around the fire area to reduce or prevent spreading of fire. The equipment used by emergency responders would be able to access the site via the proposed access road, and established perimeter around the solar array, which is designed to accommodate emergency vehicular access. It is not recommended that emergency responders enter the areas between array rows. This information will be included during the training of emergency responders.

Interrow spacing for the facility is 14.5', which would likely accommodate most emergency response vehicles, including fire trucks.

27. Describe how the proposed facility would comply with the current Connecticut State Fire Prevention Code.

Response: The facility designs meet Connecticut Fire Prevention Code, specifically sections of Chapter 11.12 that are applicable to ground-mounted systems. Petitioner confirms that all the requirements outlined will be met, and Petitioner will work with the local Fire Departments to address any solar-specific requirements.

28. Referencing Petition Site Plan C2.00, what is the width of the interrow spacing and perimeter aisle spacing? Does this spacing conform to the Connecticut State Fire Prevention Code?

Response: The facility design specifies 14.5' interrow spacing, and a perimeter aisle clearance of not less than 15', which exceeds the standard outlined in the Connecticut State Fire Prevention Code of 10' under Section 11.12.1.4.

29. In the event of a brush fire, what components of the solar array could catch fire (e.g. panels, conduit, wiring)?

Response: In the event of a brush fire, all components of a solar array are conceivably at risk; however, many components will not actively "catch" fire, and instead will melt. The following equipment or portions thereof could potentially catch fire or melt: DC cabling and insulation, Conduit, Combiner boxes, Circuit boards, Inverters

30. Are there any sources of water for use by emergency responders within 0.25 mile of the site? If not, what alternative water sources are available to the fire department?

Response: The bank of Lake Lillinonah is approximately 920' via existing access ways from the solar array, and 1,050' from the equipment pad.

31. Would facility maintenance vehicles be equipped with fire extinguishers? Who ensures maintenance personnel follow emergency response procedures?

Response: The Petitioner's Operations & Maintenance work will conform to FirstLight's operational requirements. FirstLight requires all maintenance vehicles be equipped with fire extinguishers, and FirstLight's Operations and Maintenance team requires personnel compliance with emergency response procedures.

32. With regard to emergency response:

a. Would outreach and/or training necessary for local emergency responders or FirstLight personnel? in the event of a fire or other emergency at the site?

Response: Yes, Petitioner will offer training to the following groups as part of the facility development: FirstLight personnel, Local fire departments, Police/sheriff's department, EMS/paramedics.

b. How would site access be ensured for emergency responders?

Response: A Knox Box system will be used so that fire departments and other emergency responders can access the key without utility personnel on-site.

c. In the event of a brush or electrical fire, how would potential electric hazards that could be encountered by emergency response personnel be mitigated?

Response: The following mitigation steps would be taken by Petitioner's personnel onsite, or outlined for emergency responders to use:

- 1) **Physically opening the recloser and GOAB so AC power is not present within the site;**
- 2) **Physically opening all breakers and inverter disconnects as additional AC power disconnects;**
- 3) **Physically opening all DC combiner box switches so that DC power does not flow into the inverters. DC voltage will still exist in the field at the solar module and string level. The next steps to mitigate would be covering the solar modules so no sun hits or waiting until sun is down to completely eliminate the DC hazard.**

d. Could the entire facility be shut down and de-energized in the event of a fire? If so, how?

Response: Yes, the steps to deenergize the solar facility are as follows:

- 1) **Press open on the site's recloser, which will electronically move a motor that opens the AC feed into the site. The recloser would get lock-out-tag-out (LOTO) to ensure no one accidentally closes the AC feed back into the site.**
- 2) **Physically opening the GOAB as a secondary disconnect of the AC feed into the site. The GOAB should get lock-out-tag-out (LOTO) to ensure no one accidentally closes the AC feed back into the site.**

- 3) **The equipment pads typically have a panelboard that feeds the string inverters with AC power; the main breaker and all individual inverter breakers can be flipped open, providing an additional AC disconnect point.**
- 4) **DC Combiner boxes have switches that can be opened in order to remove the DC feed to the inverters. Once this is done, DC voltage will still exist in the field at the module and string level.**

e. What type of media and/or specialized equipment would be necessary to extinguish a solar panel/electrical component fire?

Response: In the unlikely event of an electrical or brush fire, the proper response to mitigate further risk is to spray water around the fire area to reduce or prevent the spread of fire. Additionally, all electrical equipment would be shut down via the main switch. If the main switch is not accessible, first responders would also be able to turn off the electricity on the utility side at the POI.

Alternative suppression media can also be considered and discussed with the local fire department include, along with establishing specific plans for emergency response as outlined in question 33.

33. Referencing Petition Exhibit 5, does FirstLight have an Emergency Response Plan for the host parcel and hydroelectric generating facility site? If yes, does it or could it include methods for fire response, procedures for contacting the fire department and municipal officials based on the type(s) of emergency, post-incident inspections and reporting, and notification to state and municipal officials regarding site re-energization for Shepaug Station Solar and the proposed facility?

Response: FirstLight follows established health, safety, and environmental (HS&E) protocols that address fire, medical, and environmental emergency scenarios. FirstLight does not currently maintain an Emergency Response Plan (ERP) specific to the host parcel and hydroelectric generating facility, as such a plan is not required by the Occupational Safety and Health Administration (OSHA) for sites with fewer than 10 employees. FirstLight's Emergency Action Plan (EAP) pertains to water retaining or controlling structures, such as the Shepaug dam or spillway gates. The solar facility is not anticipated to be included in the FERC EAP at this time. Relevant emergency response procedures and expectations are communicated to FirstLight employees by their supervisors as part of onboarding training. Historically, this information has been delivered verbally; however, FirstLight is in the process of implementing an updated HS&E orientation program that will include more formalized written documentation.

FirstLight also coordinates periodic site visits with the Southbury Fire Department to ensure familiarity with site conditions and access points. All employees receive annual classroom and hands-on fire extinguisher training. In the event of an emergency, designated muster locations are utilized for personnel accountability, and site access gates can be opened remotely or locally to facilitate entry by emergency responders. For medical emergencies, site personnel contact 911 and meet responders at the facility entrance to escort them to the location of the incident.

The Petitioner will work with FirstLight personnel, Davis Hill Development, and local stakeholders to finalize an ERP for the Shepaug solar facility prior to the facility seeking a building permit. The plan will document Solar-specific operational and emergency response requirements once the design and configuration of the facility is finalized. The plan will include methods for:

- **Fire and emergency response**

- **Contacting and community with local fire department(s) and municipal officials based on the type of emergency, and**
- **Any required post-incident inspections and reporting. Petitioner will also outline what additional notifications are required following incidents for both solar Facilities as part of the plan.**

34. Referencing Petition Exhibit 5, provide a Spill Prevention and Response Plan to include spill response and notification procedures.

Response: FirstLight maintains a Spill Prevention, Control, and Countermeasure (SPCC) Plan for the Shepaug hydrogeneration facility, which outlines procedures for spill prevention, response, and notification. The SPCC Plan is attached as Exhibit 3, for review as part of this response. The Petitioner will update the existing plan to include solar-specific measures and requirements following final design for the facility, concurrent with finalization of the ERP.

35. Would the facility have lightning protection? If yes, describe. If not, could lightning strikes cause electrical fires and damage facility equipment?

Response: Shepaug is not currently planning to include a dedicated lightning protection system. A lightning strike could damage the equipment, but it is very unlikely to create an electrical fire. Even with lightning protection equipment a direct lightning strike could damage the electrical equipment. The system will be designed in accordance with applicable electrical codes, including proper grounding and bonding, which help reduce the risk of damage from a lightning event.

36. Identify the FERC physical security standards that apply to the host parcel.

Response: FirstLight adheres to FERC guidelines provided in the Division of Dam Safety and Inspections (D2SI)'s "FERC Security Program for Hydropower Projects" for Security Group 1 facilities at the Shepaug Hydrogeneration Station. The solar facility will be included in the hydrogeneration stations' Security Plan and Assessment but will not be subject to the same level of security as the hydrogeneration station under FERC's guideline, as solar facility will not be considered a Critical Asset. The solar facility will comply with all applicable FERC physical security requirements, including installation of appropriate fencing to restrict public access to the site.

The Security Plan and FERC guideline outline industry standards and encompass ways to delay, detect, and respond to unauthorized entry for various threat vectors. FirstLight has an established security Plan and Assessments that cover the five Design Basis Threats and mitigation. The Security Plan is reviewed annually by FirstLight and FERC, and inspections occur approximately every 5 years.

37. Describe how the proposed facility would comply with the Council's Docket No. 346 - White Paper on the Security of Siting Energy Facilities.

Response: The Shepaug facility will incorporate security measures and protocols in alignment with the Council's White Paper on Security of Siting Energy Facilities across the categories of Planning, Preparedness, Response and recovery. In addition, it would comply with the governing regulations from the Federal Energy Regulatory Commission (FERC) and the North American Electric Reliability Corporation (NERC). FirstLight's existing portfolio of operational assets includes facilities that fall under FERC and NERC jurisdiction, and includes projects identified as Critical Energy Infrastructure. FirstLight mandates training for employees working on NERC

Critical Infrastructure Protection (CIP) projects, and Cyber Security training for all employees, and appropriate safety and security training for identified Operation and Commercial team members.

The facility would be integrated into FirstLight's existing Enterprise Risk Management (ERM), addressing security planning, preparedness, response and recovery. Key elements, specific to the facility, would include:

- **Perimeter fencing and access controls to restrict unauthorized entry, along with on-site surveillance to monitor access, and 24/7 operational staff situated at the Shepaug Hydrogeneration Station available to address any operational concerns.**
- **Close working relationship between FirstLight and local fire departments to ensure planning and response preparation are comprehensive prior to seeking a building permit.**
- **Use of FirstLight's notification system to provide prompt messaging to emergency responders and impacted neighbors if an adverse event occurs.**
- **In the unlikely event of a system failure, recovery measures include site-specific remediation plans to restore the land and protect local ecosystems and proper disposal and recycling of damaged components.**
- **Participation in post-incident assessments, working with local emergency responders to evaluate response effectiveness and implement improvements as necessary.**

38. How does the proposed facility comply with industry Best Management Practices for Electric and Magnetic Fields at solar facilities?

Response: The Petitioner is not aware of any industry Best Management Practices for Electric and Magnetic Fields at solar facilities that connect to the existing distribution system. The facility will meet industry standard code compliant solar design, including proper grounding, use of quality components, conductor management, and utility compliant installation. Quality components, referred to as Tier 1, across the system, but specifically within the inverter circuit will reduce EMFs. In addition, the Petitioner will implement appropriate filtering in the inverter circuit to further reduce any EMFs.

Electric and Magnetic Fields (EMF) produced from solar facility electrical components are expected to dissipate quickly with distance. The Limit of Disturbance is approximately 2,770' to the closest residential structure (31 Purchase Brook Road in Southbury), and 369' to the property line of that residence.

39. Referencing Petition pp. 29-30, in what locations/intervals would safety signs be installed on the perimeter fence?

Response: Warning Signs compliant with Connecticut Electrical Code will be placed along the perimeter fence at each corner, gate, and approximately every 200'.

40. Referencing Petition p. 29, is Shepaug Generating Station currently illuminated for security and/or maintenance purposes? Describe the lighting system that would be installed at the site.

Response: The Shepaug Hydrogeneration Station is illuminated as part of standard operations. Lighting is installed across the top of the dam, on the downstream face of the dam, and at the

entrance of the powerhouse. No exterior lighting is planned for the facility. There will be some small, non-intrusive lighting fixtures within the equipment to aid in maintenance.

Environmental Effects and Mitigation Measures

41. Referencing Petition p. 12, would the transformer include a leak detection and/or secondary fluid containment system?

Response: Our transformers will be equipped with oil level gauges to provide leak detection. We will not be installing secondary containment. This is not commonplace; the oil that would leak is a FR3 oil, which is akin to vegetable oil and is non-toxic.

42. Has Shepaug met with DEEP to discuss the proposed stormwater management system? If yes, on what date? What concerns did DEEP have, if any, and how were these concerns addressed?

Response: No, Shepaug has not conducted a pre-application meeting with DEEP, but plans to do so prior to submittal of an application for a General Permit for the Discharge of Stormwater and Dewatering Wastewaters from Construction Activities. The Petitioner notes that the design of the stormwater management system complies with the requirements of the Connecticut Stormwater Quality Manual and Connecticut Guidelines for Soil Erosion and Sediment Control (both effective as of March 30, 2024); as well as Appendix I, Stormwater Management at Solar Array Construction Projects of the General Permit.

43. Referencing Petition p. 35, has Shepaug submitted an application for a General Permit for the Discharge of Stormwater and Dewatering Wastewaters from Construction Activities to DEEP? If yes, when was it filed and what is the status of the permit?

Response: No, the General Permit application process has not been initiated yet. It is common practice to wait to submit the application once the siting process is nearer to completion to ensure any applicable Council comments are incorporated into the final plans.

44. Pursuant to DEEP General Permit Section 3 (b) (15), is the construction limit of disturbance within 100 feet of any Cold Water Stream Habitat? If yes, how would impacts to cold water stream habitat be mitigated?

Response: No, the construction LOD is not within 100 feet of any Cold Water Stream Habitat. The nearest such resource is 0.75-mile away.

45. Referencing Petition page 22, were the Phase 1A and Phase 1B Cultural Resource Surveys submitted to the State Historic Preservation Office (SHPO) for review? If yes, submit a determination letter from SHPO if available. If not, when would the surveys be submitted?

Response: The results of the Phase 1A and 1B Cultural Resource Surveys were submitted to the SHPO in November, 2025 upon completion of the surveys. The Petitioner is awaiting SHPO's determination letter.

Facility Construction

46. Is blasting anticipated to install site infrastructure? If not, how will rock be removed if encountered?

Response: A number of the borings from the geotechnical report found evidence of ledge. Removal of ledge, if necessary, would be done by jack and hammer. At present, we do not anticipate blasting will be required to complete construction of the facility.

47. Have comprehensive geotechnical studies been completed to determine if site conditions support the overall facility design? If so, summarize the results. If not, has Shepaug anticipated and designed the facility with assumed subsurface conditions? What are these assumed conditions?

Response: Yes, a comprehensive geotechnical study was completed. The geotechnical report indicates that the subsurface conditions for the proposed solar array at Shepaug Dam are favorable for ground-mounted PV development, provided specific foundation and environmental factors are addressed.

48. If erosion control blankets are used to stabilize disturbed areas, can net-less or 100 percent natural fiber erosion control blankets be specified to reduce the potential for wildlife entanglement?

Response: Yes.

Facility Maintenance

49. Referencing Petition p. 12, would snow be removed from the access drive to the electrical pads? If not, how would access be facilitated?

Response: Snow will be removed from the access drive as necessary to facilitate safe access for winter maintenance and inspection activities.

50. Referencing Petition p. 28 and Exhibit 5, can the final version of the Operations and Maintenance Plan include inspection and repair protocols for the stormwater basin, spillway, and outlet structure?

Response: Yes, the Operations and Maintenance Plan will include provisions to inspect and, if necessary, repair the components of the entire stormwater management system associated with the solar facility (including the stormwater basin, spillway, and outlet structure). Once construction is complete and the facility area is fully stabilized, we anticipate minimal maintenance of the stormwater management system will be necessary. We plan to conduct bi-annual inspections to identify potentially compromised areas (e.g., displaced rip-rap, clogged drainage, etc.).

Decommissioning

51. Referencing Petition p. 31 and Exhibit 4, would decommissioning include the removal of the stormwater management basin/outlet structure?

Response: The current plan is that the stormwater basin management system would not be removed because removal would result in additional, unnecessary disturbances to stabilize the area.

52. Has the manufacturer of the proposed solar panels conducted Toxicity Characteristic Leaching Procedure (TCLP) testing to determine if the panels would be characterized as hazardous waste at the time of disposal under current regulatory criteria? If yes, submit information that indicates the proposed solar modules would not be characterized as hazardous waste. If not, would Shepaug agree to install solar panels that are not classified as hazardous waste through TCLP testing?

Response: The plan is to use solar modules made by All Canadian. All Canadian Solar modules undergo Toxicity Characteristic Leaching Procedure (TCLP) testing to monitor the presence of any toxic metal substances (arsenic, barium, cadmium, chromium, lead, mercury, selenium, silver) in accordance with TCLP Standard EPA Test Method 1311, as issued by the U.S.

Environmental Protection Agency (EPA) under the Toxic Substances Control Act (TSCA) for landfill disposal of modules.

Canadian Solar's modules have successfully passed TCLP testing for 37 potentially hazardous materials, including the RCRA 8 metals. This means that a Canadian Solar module—during normal operations as well as in the event a solar module is damaged—will not exceed any toxic contaminant leaching limits as governed by EPA guidelines and are therefore deemed non-hazardous.

If Canadian Solar modules are not ultimately selected for the facility, Shepaug will ensure that any selected solar modules have undergone TCLP testing and are certified to not be classified as hazardous waste under current EPA regulatory criteria. The Petitioner agrees to install only solar modules that meet EPA TCLP non-hazardous waste standards.

EXHIBITS

- 1. JCL Switchboard Design Approval Drawings**
- 2. JCL Transformer Design Approval Drawings**
- 3. Spill Prevention, Control, and Countermeasure (SPCC) Plan**

Exhibit 1. JCL Switchboard Design Approval Drawings

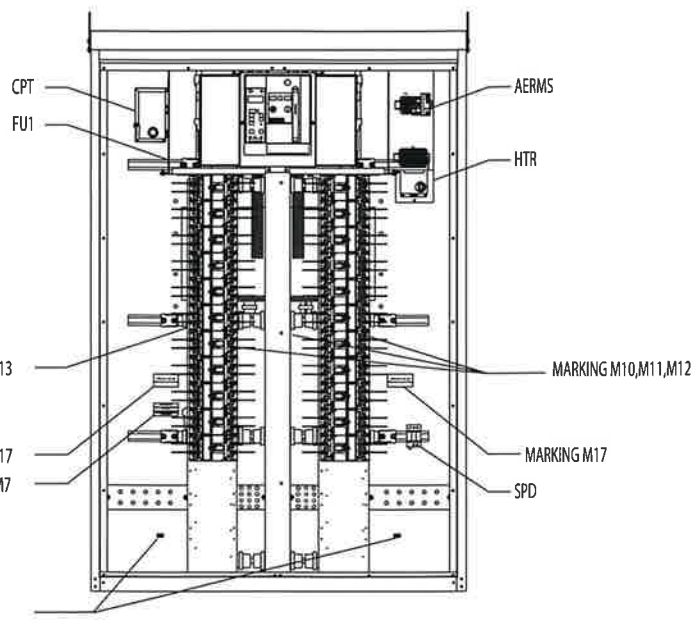

VIEW SHOWN WITHOUT DOORS OR DEADFRONT

MARKING M4 AND M5
(x2)

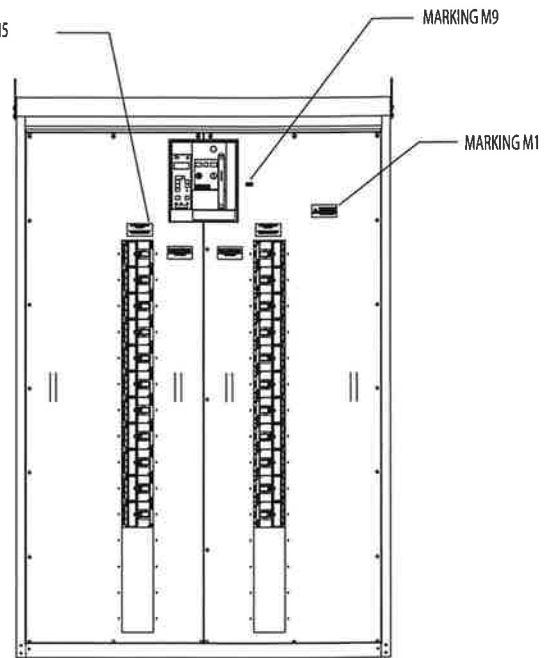

VIEW SHOWN WITHOUT DOORS

NOTES

REV	DESCRIPTION	BY	DATE
01	ISSUED FOR APPROVAL	AJ	01/19/18

Project: ST. CROIX
 Customer: JCL ENERGY

JCLENERGY
 Drawing Title: JCL ENERGY - NEW VOLT
 Drawing Number: 2018-01-0001-01-000-001
 Project # 230399

DATE: AJ
 DRAWN: AJ
 DATE: 01-19-18
 SHEET 2 OF 3
 REV: 0

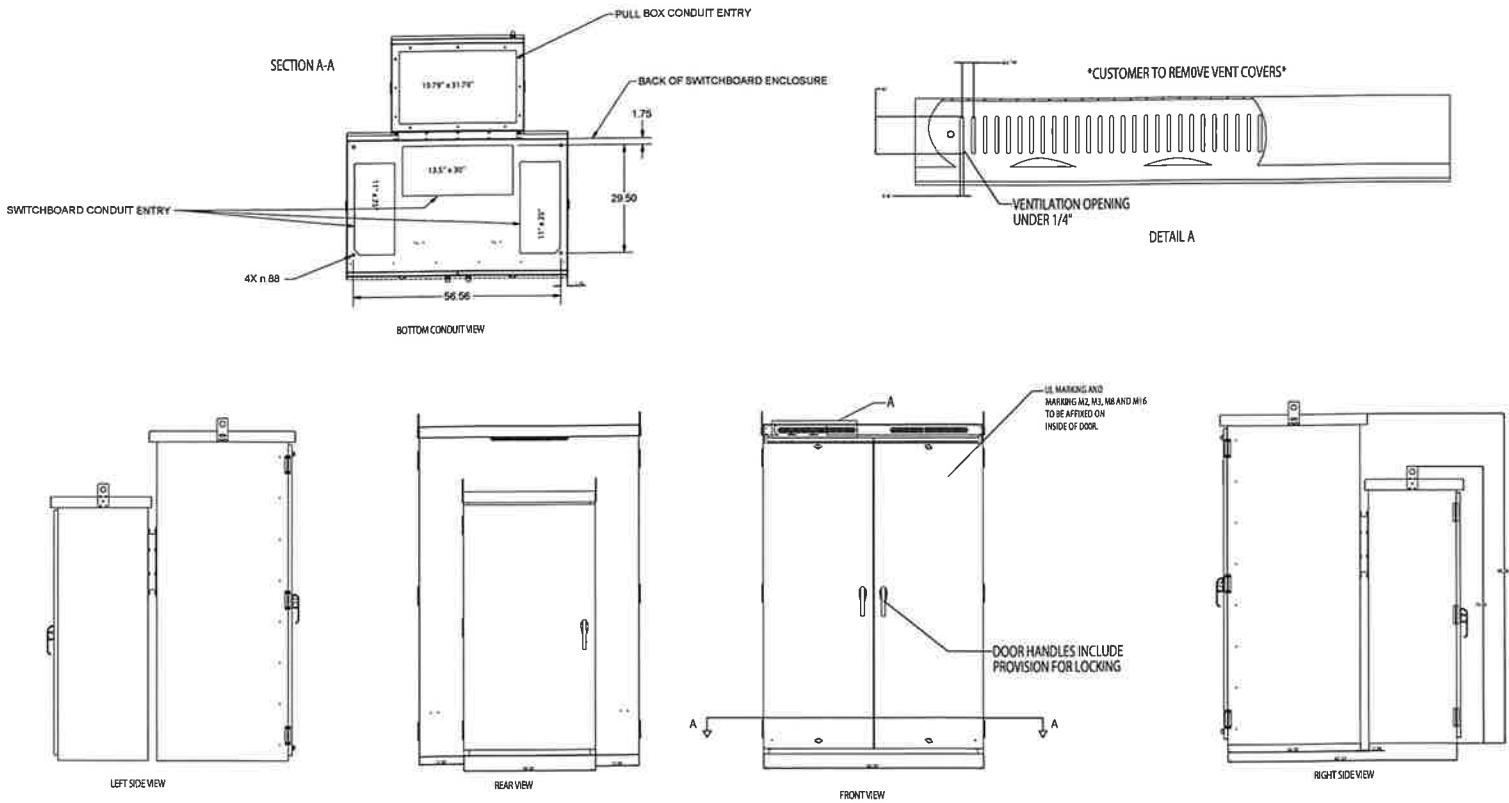

NOTES:

REV	DESCRIPTION	BY	DATE
01	PRINTED FOR APPROVAL	AL	8/20/24

Project: ST. CROIX
 Customer: JCL ENERGY

JCL ENERGY

Sheet No: 010-000-000-000-0000
 Title: 2024 BILMOUNTY TRUCK AREA
 Project: 090798

DATE: 8/20/24
 SHEET 3 OF 3

 = STICKYBACK

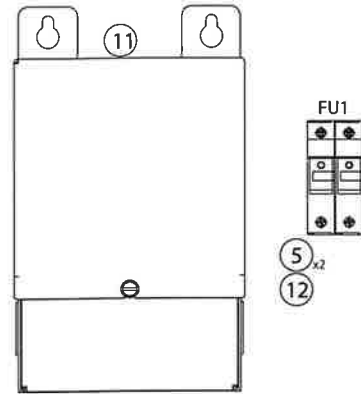
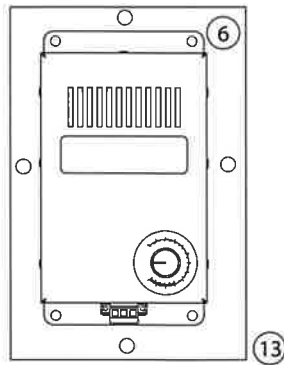
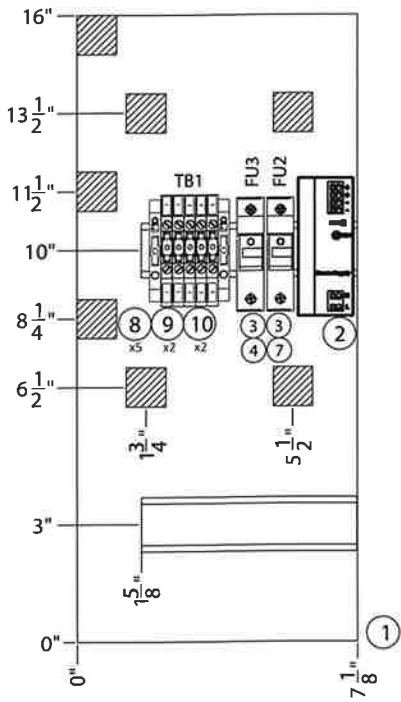

ITEM	QUANTITY	MANUFACTURER	CATALOG #	DESCRIPTION
1	1	EVANS	CUSTOM	AERMS PLATE
2	1	PULS	PIM60.241	120VAC/24VDC PS 2.5A
3	2	MERSEN	USCC1	1POLE FUSE HOLDER
4	1	MERSEN	ATDR1	1A FUSE
5	2	MERSEN	ATDR5	5A FUSE
6	1	HOFFMAN	DAH8001B	800W HEATER
7	1	MERSEN	ATDR8	8A FUSE
8	5	WEIDMULLER	1020100000	WDU4 32A TERMINAL
9	2	WEIDMULLER	1061200000	END ANCHOR
10	2	WEIDMULLER	1054560000	3POLE JUMPER
11	1	HAMMOND	Q1C5LEKF	1.5KVA 480V/120
12	1	MERSEN	USCC2	2POLE FUSE HOLDER
13	1	EVANS	CUSTOM	6X9 HEATER PLATE

- NOTES:
1. CPT & PRIMARY FUSING MOUNTED ON LEFT SIDE OF MAIN BREAKER.
 2. AERMS PLATED MOUNTED ON RIGHT SIDE OF MAIN BREAKER.
 3. HEATER MOUNTED ON BACK WALL WITH STB ON RIGHT WALL.

REV.	DESCRIPTION	BY	DATE	Project
1	UPDATED CPT	ME	5/27/23	
2	UPDATED FU1	ME	5/28/23	
3	UPDATED MAIN BREAKER	ME	6/15/23	

JCLEENERGY

1000 WILKINSON DR. SUITE 100
 WILKINSON, NC 27691
 (919) 781-1111

DATE: 6/15/23
 SHEET: 3 OF 3
 PROJECT #

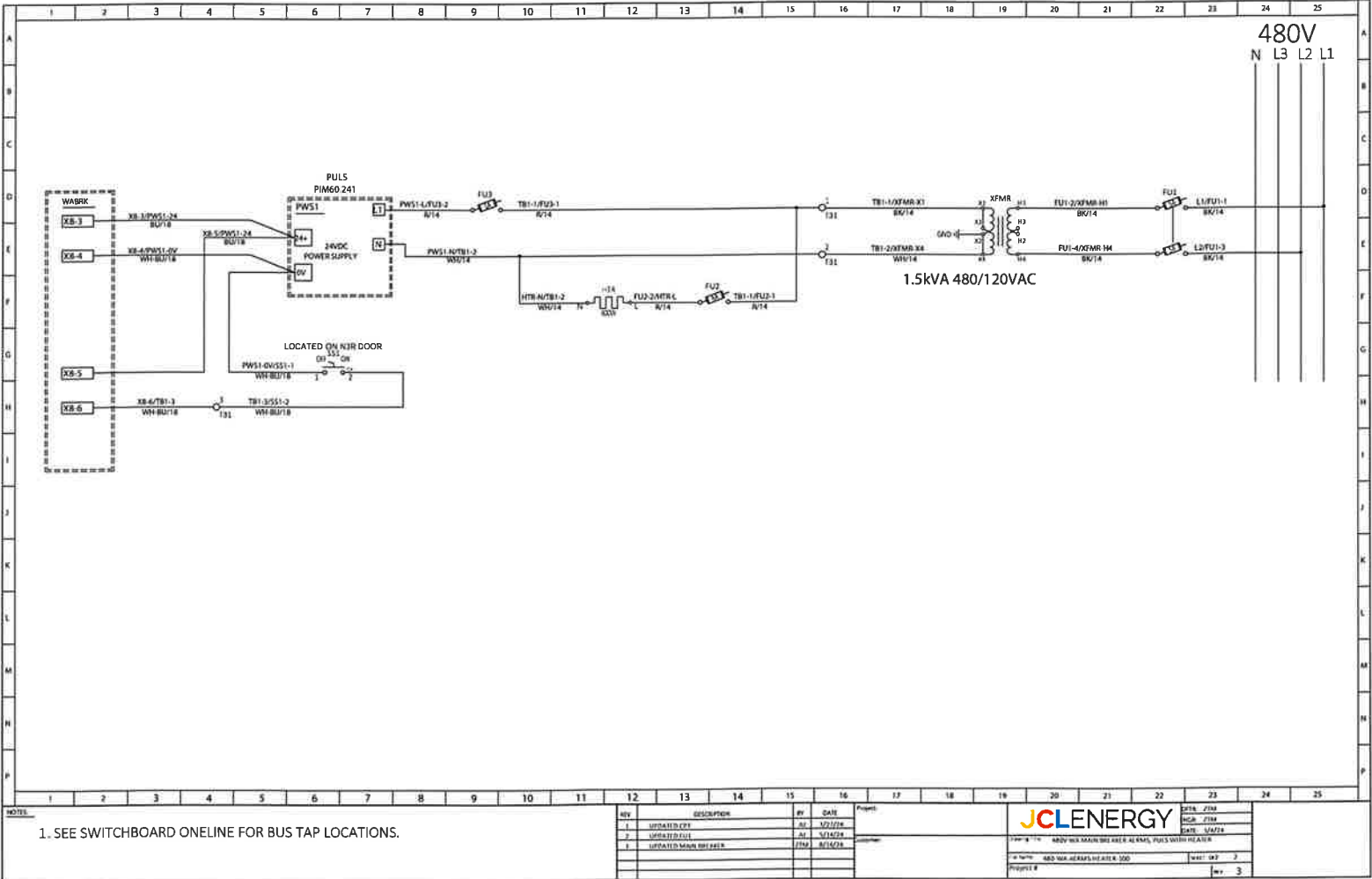

NOTE
1. SEE SWITCHBOARD ONLINE FOR BUS TAP LOCATIONS.

REV	DESCRIPTION	BY	DATE
1	UPDATED CPT	AR	12/1/18
2	UPDATED FUSE	AR	5/14/19
3	UPDATED MAIN BUS DATA	TRM	8/14/19

JCLEENERGY

480V NGR MAINS BREAKER ALARMS, PULS WITH RELAYS

480V NGR MAINS BREAKER ALARMS, PULS WITH RELAYS

Project #

Rev 3

PULL BOX BOLTS TO SWITCHBOARD FROM INSIDE OF SWITCHBOARD.

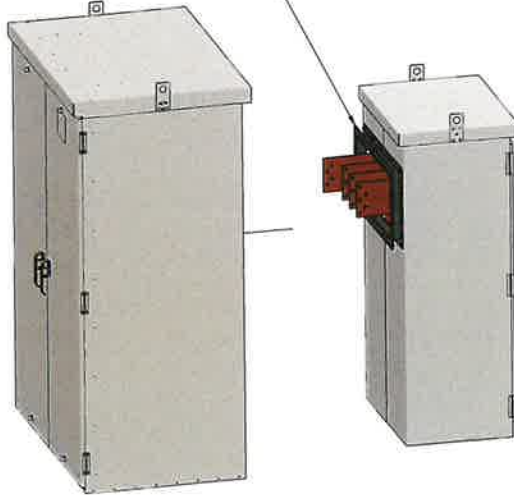

PARTS LIST			
ITEM	QTY	PART NUMBER	DESCRIPTION
1	1	A72R3624FSLP	PULL BOX ENCLOSURE
2	3	QT-00131	HORZ. TRANSITION BUS, 4000A PULLBOX
3	1	QT-00132	HORZ. TRANSITION NEUTRAL BUS, 4000A PULLBOX
4	4	QT-00133	VERT. TRANSITION BUS, 4000A PULLBOX
5	1	QT-A00047	PULL BOX TRANSITION, TOP SECTION
6	2	QTIS-00008	STANDOFF BRACKET, 4.81" lg.
7	1	QTIS-00011	GROUNDING BUS
8	3	559680	ISO LOW VOLTAGE INS, 3/8-16 X 2"lg.
9	14	559694	ISO LOW VOLTAGE INS., 3/8-16 X 3"lg.
10	2	SRJB-00002	CUSTOM BRACKET
11	1	STRUT-35 in	UNISTRUT, 35" lg.
12	2	STRUT-36 in	UNISTRUT, 36" lg.
13	2		Strut Channel Bracket
14	2		1/4" ALUMINUM SPACER
15	6		3/8-16 SET SCREW, 1"lg.
16	9		3/8-16 SET SCREW, 1.5"lg.
17	2		3/8-16 STEEL COUPLING NUT, 1.75"
18	34		CIRCULAR WASHER, 3/8
19	34		LOCK WASHER, 3/8
20	3		HEX BOLT, 3/8-16 UNC - 0.75 L.
21	21		HEX BOLT, 3/8-16 UNC - 1 L.
22	10		HEX BOLT, 3/8-16 UNC - 1.25 L.
23	32		CIRCULAR WASHER, 1/2
24	16		LOCK WASHER, 1/2
25	16		HEX NUT, 1/2-13 UNC
26	16		HEX BOLT, 1/2-13 UNC - 2.5 L.

ALL DIMENSIONS ARE IN INCHES			
DATE	SCALE	CLENERGY	
DRAWN	CHECKED	DESCRIPTION	
PROJECT		4000A PULL BOX ASSEMBLY	
4000A PULL BOX		PNL NO.	R00002
CUSTOMER		SHEET	B
		REV	0
		SHEET 1 of 4	

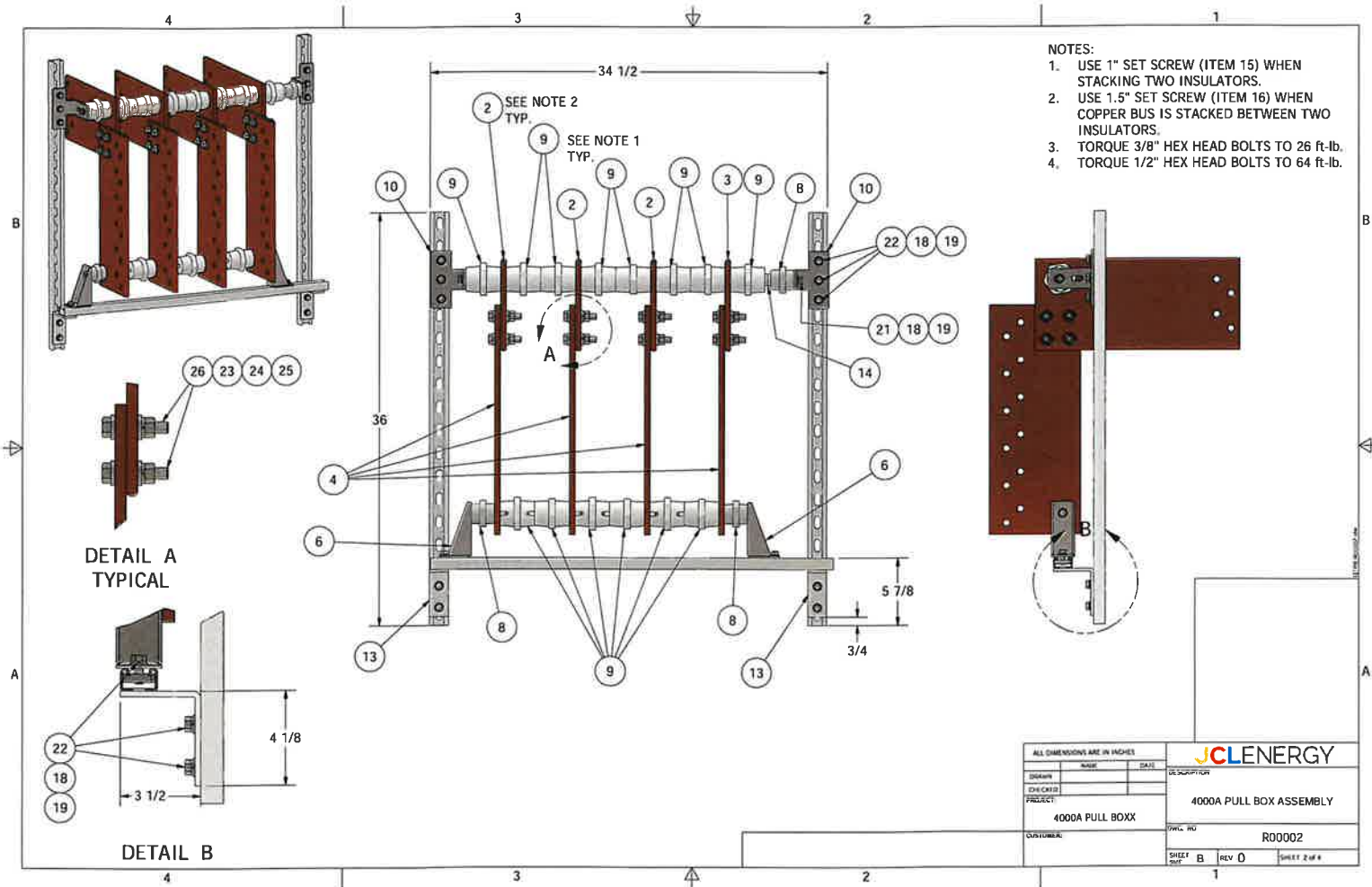

- NOTES:
1. USE 1" SET SCREW (ITEM 15) WHEN STACKING TWO INSULATORS.
 2. USE 1.5" SET SCREW (ITEM 16) WHEN COPPER BUS IS STACKED BETWEEN TWO INSULATORS.
 3. TORQUE 3/8" HEX HEAD BOLTS TO 26 ft.-lb.
 4. TORQUE 1/2" HEX HEAD BOLTS TO 64 ft.-lb.

ALL DIMENSIONS ARE IN INCHES		JCLENERGY	
DATE	REVISED	DESCRIPTION	
		4000A PULL BOX ASSEMBLY	
PROJECT		4000A PULL BOX	
CUSTOMER		REV. NO.	R00002
SHEET NO.	B	REV	D
		SHEET 2 of 4	

TYPICAL BREAK DOWN OF INSULATOR STACK UP

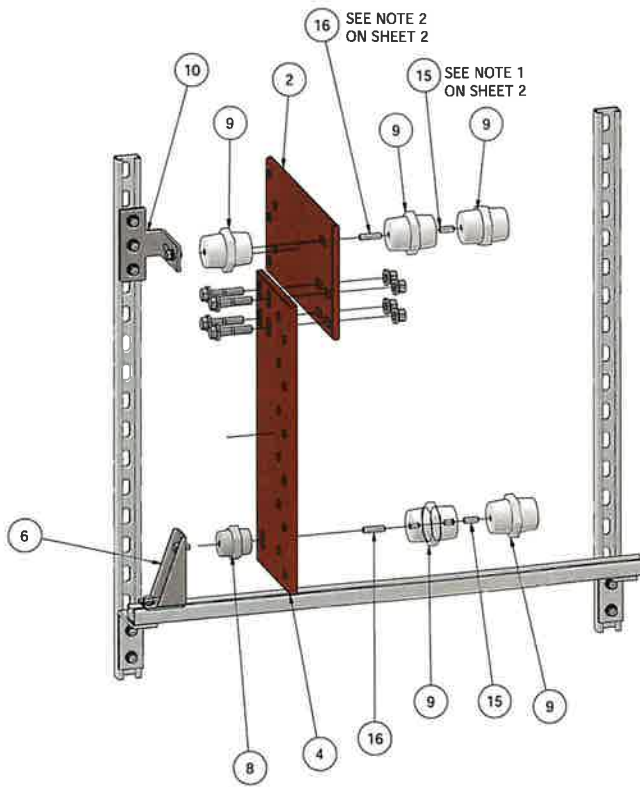

ALL DIMENSIONS ARE IN INCHES			JCLEENERGY	
DESIGNED BY	NAME	DATE	DESCRIPTION	
CHECKED BY			4000A PULL BOX ASSEMBLY	
PROJECT	4000A PULL BOX		DRAWING NO. R00002	
CUSTOMER			SHEET	B
			REV	0
			SHEET	3 of 4

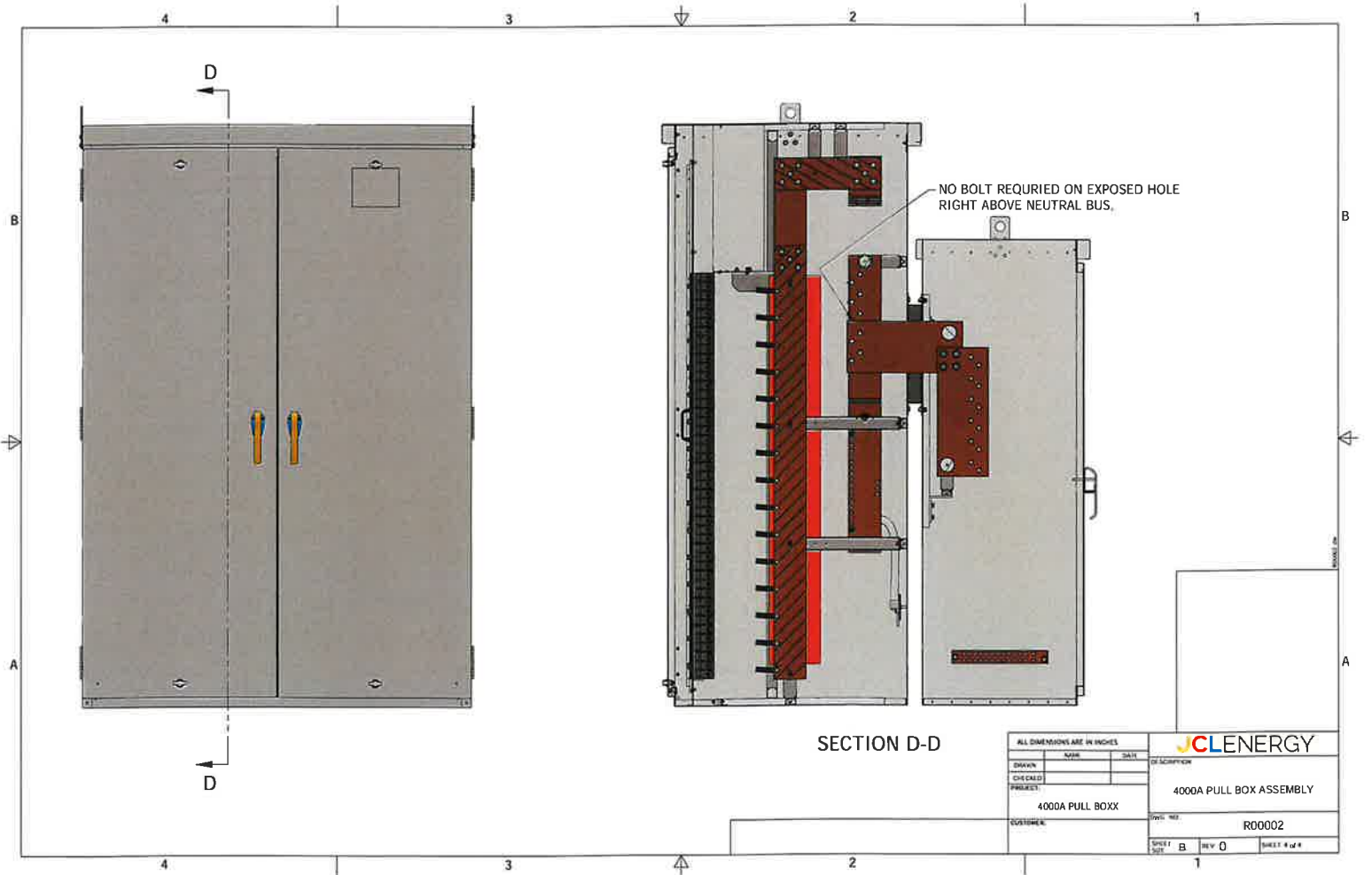

ALL DIMENSIONS ARE IN INCHES				JCLEENERGY	
DRAWN	NAME	DATE	BY DESCRIPTION		
CHECKED			4000A PULL BOX ASSEMBLY		
PROJECT	4000A PULL BOX		REV: 002 R00002		
DATE/REV:			SHEET	REV	SHEET # OF #
			B	0	4

Exhibit 2. JCL Transformer Design Approval Drawings

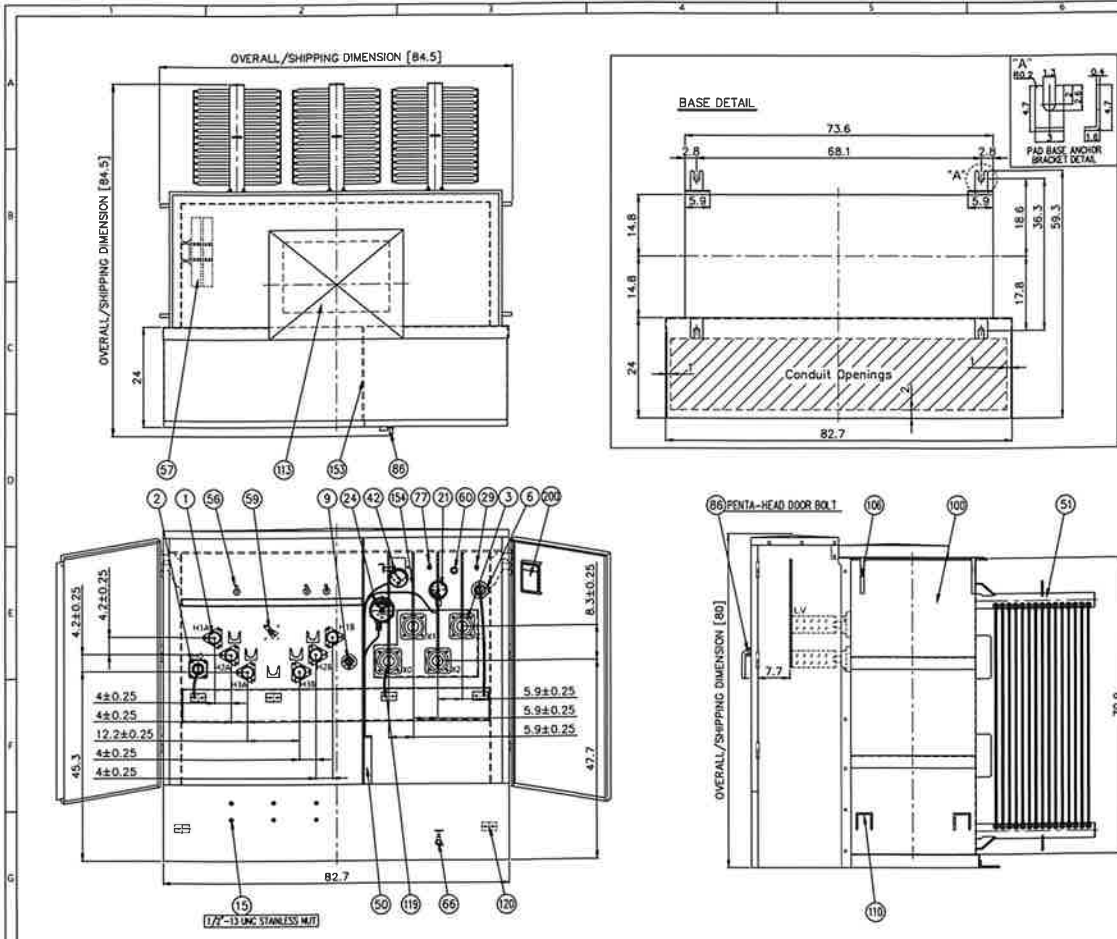

NO.	DESCRIPTION	SPECIFICATIONS	QTY
1	H V BUSHING WELL (CM 70191972) & INSERTS (HUBBELL HU215B)	15kV, 200A	6
2	H V N BUSHING (H) AS1422-007, 2HOLES	15kV, 196A	1
3	L V N BUSHING (H) 10-510-103, 10HOLES	2.5kV, 3300A	4
6	ELECTROSTATIC SHIELD GROUND BUSHING (LB-0250, 1HOLE)	0.6kV 250A	1
9	DE-ENERGIZED TAP CHANGER(DETC) (CM 7033433)	STAP, 150A	1
15	NUT FOR H V SURGE ARRESTER -SURGE ARRESTER PROVISION		6
21	OIL LEVEL GAUGE (DRTO D126 2A)	2C Contact	1
24	OIL TEMPERATURE INDICATOR (DRTO Q256 2A)	2C Contact	1
29	PRESSURE RELIEF VALVE (HEARTLAND HPV-1201)		1
42	PRESSURE VACUUM GAUGE (DRTO Q320 A10)	2C Contact	1
50	TERMINAL BLOCK		1
51	RADIATORS (WELDING)		3
56	BAY-O-NET FUSE (COOPER 4038361COSCB)	125A	3
57	CURRENT LIMITING FUSE (H) 9F59(BD123)	15.5/17.2kV 125A	6
59	LOAD BREAK SWITCH T-BLADE (COOPER LS48H31M8)	4 Position	1
60	OIL UPPER FILL PLUG	1 Inch	1
66	DRAIN VALVE WITH 3/8" SAMPLER (H) DV1000-001-F8)	1 Inch	1
77	GAS SAMPLE VALVE (HEARTLAND TW-10102045)		1
86	PAD LOCKABLE DOOR HANDLE		1
100	TANK		1
106	LIFTING HOOK FOR COMPLETE TRANSFORMER		4
110	JACK PAD WITH PULLING EYES		4
113	HAND HOLE OF TOP		1
119	REMOVABLE GROUND STRAP		3
120	2 HOLE GROUND PAD FOR MAIN BODY		6
133	METAL LV-HV BARRIER		1
154	LV BUSHING SUPPORT		4
200	NAME PLATE (ON LOCAL DOOR)	Internal	1

OVERALL DIMENSION	84.5 (13 x 84.5 (W) x 80 (H))
SHIPPING DIMENSION	84.5 (13 x 84.5 (W) x 80 (H))
CORE & COIL	5,270 lb
TANK & FITTINGS	3,685 lb
INSULATION OIL (FR3)	4,100 lb (540GAL)
TOTAL WEIGHT	13,055 lb
COLOR	ANSI 70 LIGHT GRAY

NOTE
 1. DIMENSION TOLERANCE : DIMENSION TOLERANCE FOR UNMARKED PART IN ±3%
 2. THE POSITION OF RELAY & PART ACCESSORIES WOULD BE CHANGED SLIGHTLY IN THIS DRAWING DURING DETAIL DESIGNING.

5					
4					
3					
2					
1					
REV.	DATE	REMARKS	DSGN	CHKD	APPD

JCL ENERGY

CLASS : 2000kVA (KNAN, 3PH, 60Hz, FR3 FILLED)
 HV : 13800Y/7967V, 95kV BIL
 LV : 480Y/277V, 30kV BIL
 TEMP. RISE : 65°C RISE

DSGN	CHKD	APPD	UNIT	inch
			TOL.	±3%
SHEET	DWG NO.		SCALE	N / S
1 / 1	3545-A001		DATE	
	TITLE		OUT LINE	2025.08.12

ON TRANSFORMER

71Q
OIL LEVEL
INDICATOR

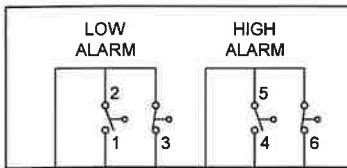

X1 : 1 2 3 6

26Q
OIL TEMP.
INDICATOR

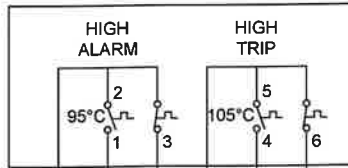

X4 : 7 8 9 10 11 12

63G
PRESSURE VACUUM
GAUGE

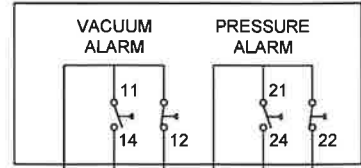

X2 : 1 2 3 4 5 6

5					
4					
3					
2					
1					
REV.	DATE	REMARKS	DSGN	CHKD	APPD

JCL ENERGY

CLASS : 2000kVA (KNAN, 3PH, 60Hz, FR3 FILLED)
 HV : 13800Y/7967V , 95kV BIL
 LV : 480Y/277V , 30kV BIL
 TEMP RISE : 65° RISE

SHEET	DSGN	CHKD	APPD	UNIT	INCH
1 / 2				TOL.	±0.25"
DWG No.			3545 - A20	SCALE	N / S
TITLE				REV.	0
				DATE	2025.08.12
PROTECTION DIAGRAM					

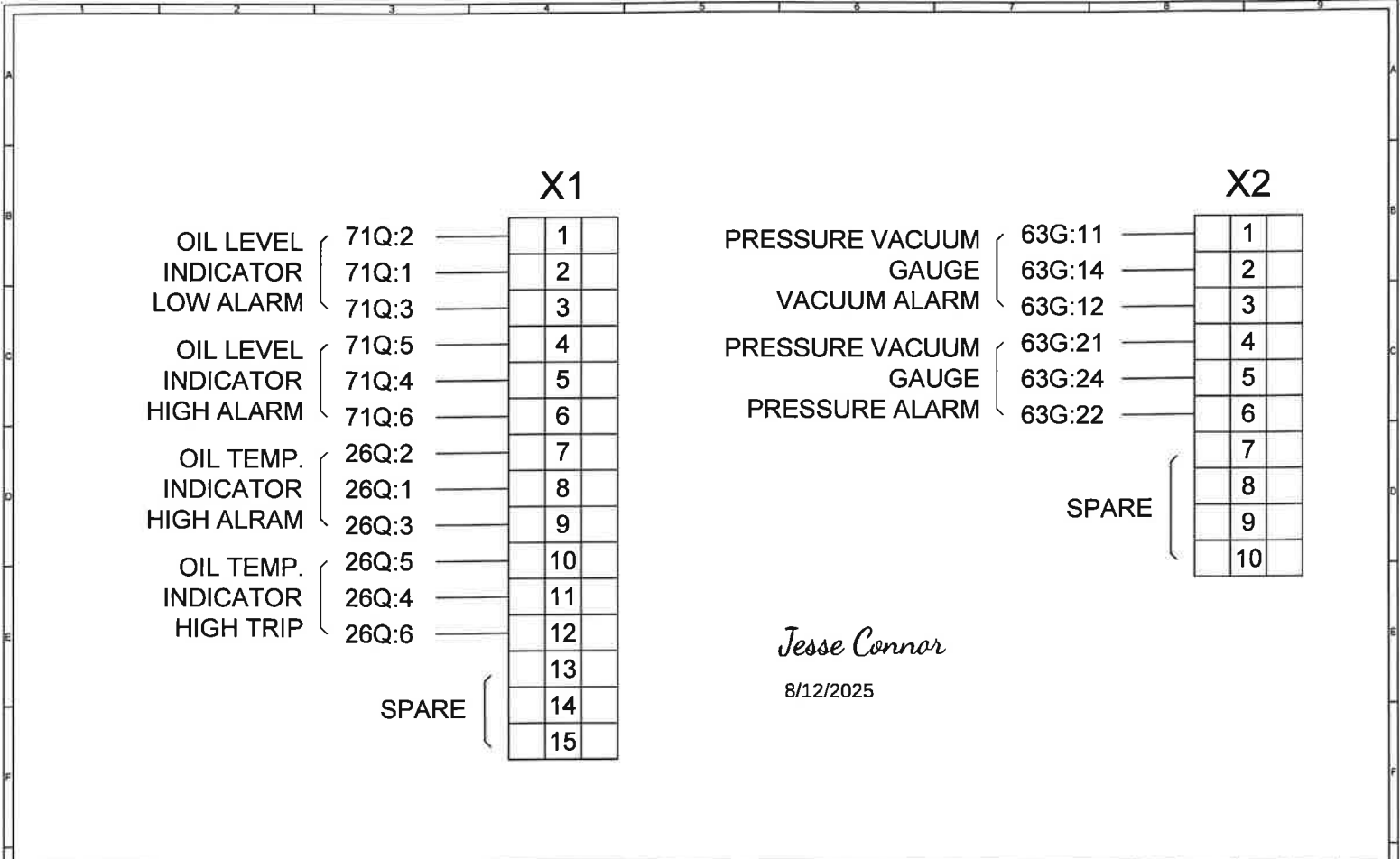

Jesse Connor

8/12/2025

5						JCL ENERGY	SHEET	DSGN	CHKD	APPD	UNIT	INCH
4					CLASS : 2000kVA (KNAN, 3PH, 60Hz, FR3 FILLED)		2 / 2				TOL	±0.25"
3					HV : 13800Y/7967V, 95kV BIL		DWG No.				SCALE	N / S
2					LV : 480Y/277V, 30kV BIL			3545 - A21			REV.	0
1					TEMP. RISE : 65° RISE		TITLE				DATE	
REV.	DATE	REMARKS	DSGN	CHKD	APPD		TERMINAL BLOCK DIAGRAM				2025.08.12	

Exhibit 3. Spill Prevention, Control, and Countermeasure (SPCC) Plan

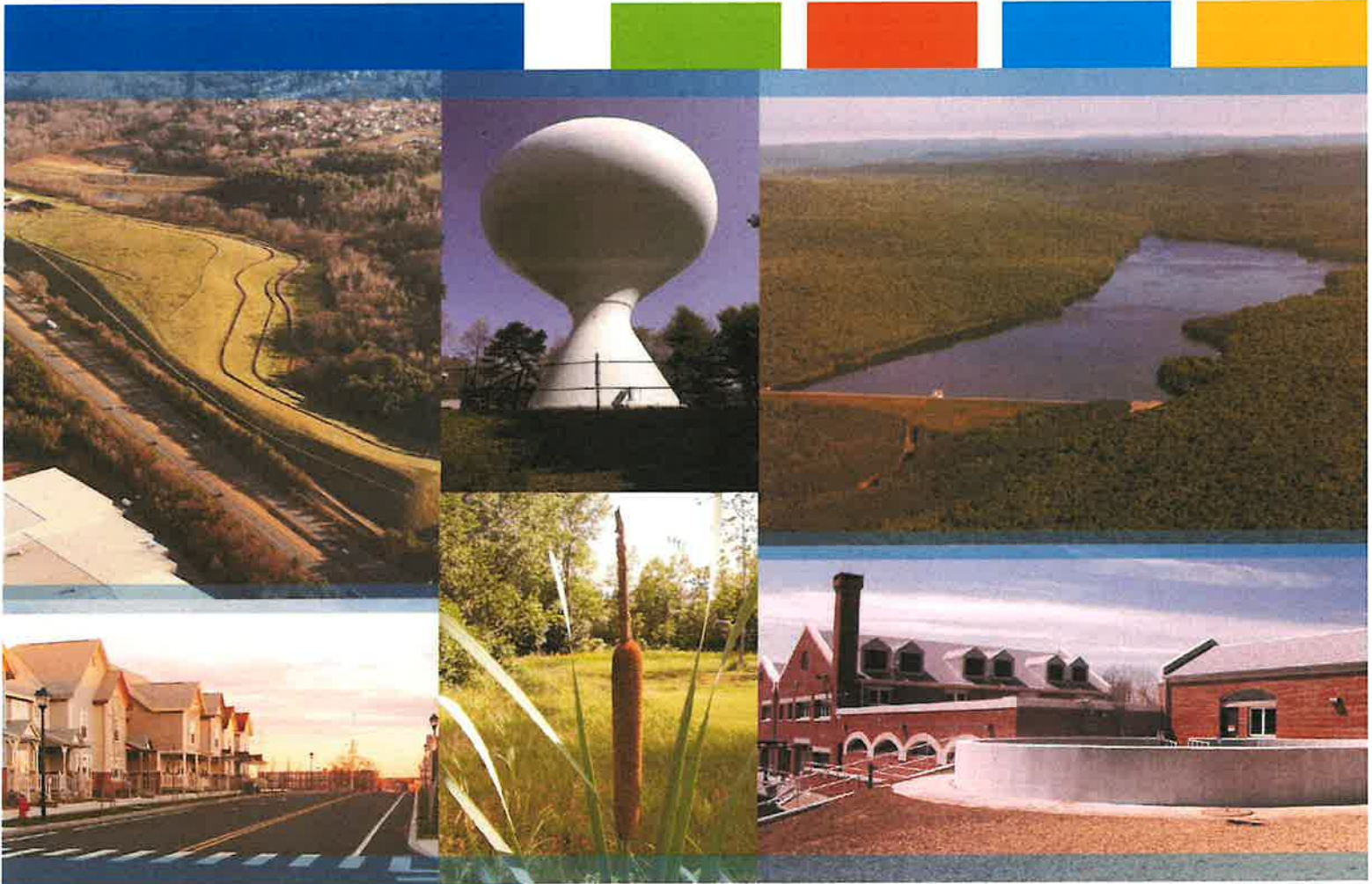

Spill Prevention, Control, and Countermeasure Plan

Shepaug Station
2225 River Road
Southbury, CT

November 2024

Tighe&Bond

FirstLight CT Housatonic LLC, Shepaug Station Management Commitment

I have the authority to commit the necessary resources to implement this Spill Prevention, Control, and Countermeasure (SPCC) Plan.

SPCC Revision Date: 12/3/2024
Name: Daniel Timlake Title: Senior Operations Manager
Signature: Daniel Timlake Date: 12/3/2024

Professional Engineer (PE) Certification

I hereby certify that this SPCC Plan has been prepared under my direct supervision by Tighe & Bond staff who have inspected this facility, and being familiar with the provisions of Environmental Protection Agency (EPA) Regulations 40 CFR Part 112 attest that the Plan has been prepared in accordance with good engineering practice, including consideration of applicable industry standards, and with the requirements of this part; that procedures for required inspections and testing have been established; and that the Plan is adequate for the facility. This certification remains in effect only if the recommendations throughout this report are implemented within the recommended timeframe.

Name: David P. Horowitz, PE, CSP Firm: Tighe & Bond, Inc.
Registration Number: 33748 Date: 11-25-2024
State: CT

Stamp/Signature:



Revisions

Changes To Facility Design, Construction, Operation, Or Maintenance

This SPCC must be revised when there is a change in the facility design, construction, operation, or maintenance that materially affects its potential for a discharge (see Section 1.4). A revision made under this situation must be prepared within six months, and implemented as soon as possible, but not later than six months following preparation of the amendment.

Technical amendments (as described in Section 1.4) shall be certified by a Professional Engineer and documented as described below.

Routine SPCC Plan Review and Evaluation

A review of this SPCC Plan shall be performed at intervals no less than every five (5) years. The review must include an evaluation to determine if more effective prevention and control technology is possible, if the technology has been field-proven at the time of the review and will significantly reduce the likelihood of a discharge. Should amendments be necessary, all amendments shall be made within six months of the evaluation.

Documentation of Routine Reviews and Evaluations

Person Performing Evaluation:

Name: _____	Title: _____
Signature: _____	Evaluation Date: _____
	Amendment Date: _____

Attestation

I have completed a review and evaluation of the SPCC Plan for the FirstLight CT Housatonic LLC, Shepaug Station as of the date indicated below and:

- will amend the Plan as a result.
- will not amend the Plan as a result

Name: _____	Title: _____
Signature: _____	Date: _____

SPCC Plan Revision Documentation

Revision history shall be summarized in the table below. Technical amendments shall be certified by the Professional Engineer using the Management Approval form on the previous page.

Date	Technical Amendment?	Description	Pages
11/24	No	5-Year SPCC Plan Update	All

Tighe&Bond

CONTENTS

Section 1 Purpose and Applicability

1.1 Applicability.....1-1
1.2 Plan Purpose.....1-1
1.3 Plan Administration and Contacts1-1
1.4 Plan Amendments and Review1-2
 1.4.1 Amendments1-2
 1.4.2 Review.....1-2
 1.4.3 Reportable Spills1-2

Section 2 112.7 - General Requirements for SPCC Plans

112.7(a)(1) - Compliance with General Requirements.....2-1
112.7(a)(2) - Deviation from Specific Requirements2-1
112.7(a)(3) - Physical Layout Description.....2-1
 (i) - Type of Oil, Container and Storage Capacity.....2-2
 (ii) - Discharge Prevention Measures2-7
 (iii) - Discharge or Drainage Controls.....2-7
 (iv) - Countermeasures for Discharge Discovery, Response,
 and Cleanup2-7
 (v) - Disposal of Recovered Materials.....2-7
 (vi) Emergency Contact List.....2-7
112.7(a)(4) & (5) - Discharge Reporting and Emergency Response Procedures 2-7
112.7(b) - Prediction of Release Source, Direction, Rate of Flow, and Discharge
 Quantity.....2-7
112.7(c) - Containment and/or Diversionary Structures or Equipment2-8
112.7(c)(1) - Discharge Prevention Systems2-8
 (i) - Sufficiently Impervious Containment2-9
 (ii) - Curbing2-9
 (iii) - Sumps and Collection Systems2-9
 (iv) - Culverts and Gutters2-9
 (v) - Weirs, Booms or other Barriers2-9
 (vi) - Spill Diversion Ponds2-9
 (vii) - Retention Ponds2-9
 (vii) - Sorbent Materials, Spill Response Supplies and Equipment2-9
112.7(d) - Impracticable Installation of Structures Listed in 40 CFR Part 112.8 2-9
112.7(e) - Inspections, Tests, and Records.....2-9
112.7(f) - Personnel, Training, and Discharge Prevention Procedures.....2-10
 (f)(1) - Employee Training.....2-10
 (f)(2) - Designated Discharge Prevention Person.....2-10
 (f)(3) - Discharge Prevention Briefings.....2-10
112.7(g) - Security.....2-11
112.7(h) - Facility Tank Car and Tank Truck Loading/Unloading Rack2-11
112.7(i) - Brittle Fracture or Other Catastrophic Failure Testing2-11
112.7(j) - State and Local Conformance with Requirements and Procedures ..2-11

112.7(k) - Oil Filled Operational Equipment2-11
 (k)(1) - Qualification Criteria 2-11
 (k)(2) - Alternative Requirements to General Secondary Containment 2-12

Section 3 112.8 - SPCC Plan Requirements For Onshore Facilities

112.8(a) - General Requirements and Specific Discharge Prevention and Containment..... 3-1
112.8(b) - Facility Drainage.....3-1
 (b)(1) - Dike Drainage3-1
 (b)(2) - Dike Drainage Valves3-1
 (b)(3) - Undiked Area Drainage.....3-1
 (b)(4) - Diversion system.....3-1
 (b)(5) - Drainage Water Treatment Units3-1
112.8(c) - Bulk Storage Containers3-1
 (c)(1) - Material and Construction Compatibility3-2
 (c)(2) - Secondary Containment.....3-2
 (c)(3) - Secondary Containment Drainage3-2
 (c)(4) - Coatings & Cathodic Protection for Buried Metallic Tank.....3-2
 (c)(5) - Coatings & Cathodic Protection for Partially Buried or Bunkered Metallic Tanks.....3-2
 (c)(6) - Inspections and Integrity Testing of Aboveground Storage Containers..... 3-2
 (c)(7) - Internal Heating Coils.....3-3
 (c)(8) - Liquid Level Sensing Devices.....3-3
 (c)(9) - Effluent Treatment Facilities3-3
 (c)(10) - Visual Discharges.....3-4
 (c)(11) - Mobile or Portable Oil Storage Containers.....3-4
112.8(d) - Facility Transfer Operations, Pumping, and Facility Process3-4
 (d)(1) - Buried Piping3-4
 (d)(2) - Out of Service Piping3-4
 (d)(3) - Pipe Supports3-4
 (d)(4) - Inspection of Aboveground Piping, Valves and Appurtenances..3-4
 (d)(5) - Aboveground Piping3-4

List of Appendices

- Appendix A Page 1 of 2 – Facility Site Plan
Page 2 of 2 – Interior of Powerhouse
- Appendix B Glossary of Terms
- Appendix C Spill Response Equipment
- Appendix D Oil Incident Report Form
- Appendix E Inspection Forms
- Appendix F Oil Spill Response Procedure
- Appendix G Certificate of Applicability Substantial Harm Criteria
- Appendix H Integrity Testing

Tighe&Bond

SECTION 1

Section 1

Purpose and Applicability

1.1 Applicability

In accordance with 40 CFR Part 112, an owner of an AST and/or UST facility must prepare and implement a Spill Prevention, Control, and Countermeasure (SPCC) Plan which must be a written document establishing release prevention and response procedures for releases from the tank or tank systems. The SPCC Plan must be prepared in accordance with 40 CFR Part 112.

SPCC Plans are required for any facility engaged in drilling, producing, gathering, storing, processing, refining, transferring or consuming oil and oil products, providing that all three of the following conditions are met:

- The facility is non-transportation-related
- The aggregate aboveground storage capacity is greater than 1,320 gallons (includes containers 55 gallons or greater) or the total underground storage capacity is greater than 42,000 gallons
- Due to its location, oil spilled at the facility could reasonably be expected to reach navigable waters of the United States or adjoining shorelines

Since the aboveground aggregate storage capacity exceeds the regulatory threshold, the FirstLight CT Housatonic LLC, Shepaug Station (the Station) is subject to the regulatory requirements related to the development and implementation of an SPCC Plan. As such, this Plan is required to be reviewed and approved by a Professional Engineer.

Appendix A contains figures that identify the facility's aboveground storage tanks (ASTs) and site features pertinent to the implementation of this SPCC Plan.

1.2 Plan Purpose

The purpose of this Plan is to outline procedures adopted by the facility to prevent the discharge of oil to surface waters, groundwater table, or adjacent water bodies. This document also summarizes procedures to be implemented by facility personnel in the event of an oil release and documents management's commitment to provide the necessary resources to implement the Plan. These procedures are intended to minimize the threat to public health and safety, and/or the environment and meet the applicable requirements of 40 CFR Parts 109 and 112, United State Environmental Protection Agency (EPA) Regulations, "Oil Pollution Prevention" and Steel Tank Institute's (STI) SP001 Inspection Standard.

The procedures, methods, and equipment described in this document meet the applicable requirements of the EPA, 40 CFR Parts 109 and 112.

1.3 Plan Administration and Contacts

The Health, Safety and Environmental (HS&E) Department is responsible for the implementation and management of this SPCC Plan and has been identified as the facility's

SPCC Coordinator. The responsibilities include confirming that the appropriate facility personnel are properly trained to implement this SPCC Plan and that personnel are familiar with and follow the procedures presented in this Plan. A copy of the SPCC Plan is kept at the facility. The plan will be available to the Regional Administrator of EPA for on-site review during normal working hours. The HS&E ensures that the necessary cleanup equipment and supplies are maintained at the designated areas as described in this SPCC Plan.

1.4 Plan Amendments and Review

1.4.1 Amendments

Federal SPCC regulations (40 CFR §112.5) require that the SPCC Plan be amended or reviewed under specific conditions, as described in this paragraph. Owners or operators must amend the SPCC Plan in accordance with 40 CFR §112.7 whenever there is a change in facility design, operation, construction, or maintenance, which affects the facility's potential for the discharge of oil into or upon the navigable waters of the United States or adjoining shorelines. Facility personnel have identified the tanks and containers of oil referenced in Section 2 of this Plan. The addition of any containers of oil (at or above the de-minimis level of 55-gallons) subsequent to the writing of this Plan should be added to this Plan accordingly with all appropriate controls and countermeasures. The amendments must be fully implemented as soon as possible but no later than six months after the facility changes have occurred.

1.4.2 Review

In addition to any amendments required above, owners or operators must complete a review and evaluation of the SPCC Plan at least once every five years. The SPCC Plan must then be amended within six months of the review to include more effective prevention and control technology if that technology is a proven technology and will significantly reduce the likelihood of a spill event from the facility. The next scheduled review and evaluation is November 2029. The review must be documented and a statement must be signed attesting to whether the plan was or was not amended (refer to certification front of document).

This plan was developed to comply with the most recent EPA requirements.

The facility will review and amend this SPCC Plan in accordance with the above requirements. All technical amendments will be certified by a Professional Engineer in accordance with 40 CFR §112.3(d) and 40 CFR §112.5(c).

1.4.3 Reportable Spills

If the facility has a reportable spill, the facility will submit a copy of this SPCC Plan to the Regional Administrator of the EPA for review. The Regional Administrator may require that the facility revise the SPCC Plan to address the requirements under the regulation and to prevent further reoccurrence of oil spills.

Tighe&Bond

SECTION 2

Section 2

112.7 - General Requirements for SPCC Plans

112.7(a)(1) - Compliance with General Requirements

This SPCC Plan has been prepared for the FirstLight CT Housatonic LLC, Shepaug Station to facilitate compliance with applicable requirements of EPA regulations under 40 CFR Parts 109, 110, and 112.

112.7(a)(2) - Deviation from Specific Requirements

This SPCC Plan is in conformance with all applicable requirements. Allowable deviations from the rule requirements are identified in their appropriate sections within this Plan.

112.7(a)(3) - Physical Layout Description

The Station is located at 2225 River Road, Southbury, Connecticut (See Appendix A for figures of the facility). Shepaug Station, situated on the Housatonic River, was first placed in operation in 1955. Shepaug is remotely monitored and dispatched from the Rocky River Station control room, which is staffed 24 hours a day, 7 days a week. Shepaug has employees on site on a regular schedule, though not full time. If Shepaug Station is unattended when a critical alarm is sounded at the Rocky River Station, an employee is dispatched to Shepaug Station to investigate.

(i) - Type of Oil, Container and Storage Capacity

TABLE 112.7(a)(3)(i)

Tank Tables
Shepaug Station

General Area: Generator Hall

Equipment	Location	Containment Method	Individual Capacity	Number of Units	Total Volume (gallons)
Emergency Generator Fuel Tank	Emerg. Gen. Room	Berm	275 gallons	1	275 gallons
Used Oil Storage	Gen. Hall	Pallet	55 gallons	4	220 gallons
				Total:	495 gallons

General Area: Sump Pump Floor

Equipment	Location	Containment Method	Individual Capacity	Number of Units	Total Volume (gallons)
Governor Oil System	Sump Pump Floor	Bermed	950 gallons	1	950 gallons
Oil/Water Separator	Sump Pump Floor	Bermed	1,000 gallons	1	1,000 gallons
Upper & Lower Bearing Oil	Sump Pump Floor	Bermed	Upper: 3,650 gallons Lower: 77 gallons	1	3,727 gallons
Total:					5,677 gallons

General Area: Sump Pump Floor

Equipment	Location	Containment Method	Individual Capacity	Number of Units	Total Volume (gallons)
Used Oil (from OWS)	Oil Room	Bermed	1,300 gallons	1	1,300 gallons
Clean Lube Oil Tank	Oil Room	Bermed	5,300 gallons	1	5,300 gallons
Dirty Lube Oil Tank	Oil Room	Bermed	5,300 gallons	1	5,300 gallons
				Total:	11,900 gallons

General Area: Outside Station

Equipment	Location	Containment Method	Individual Capacity	Number of Units	Total Volume (gallons)
13A-1X1-2 Transformers	Transformer Yard	Underground Basin	765 gallons	1	2,295 gallons
13A-1X Transformer	Transformer Yard	Underground Basin	6,100 gallons	1	6,100 gallons
13A-1S Transformer	Transformer Yard	Underground Basin	1,250 gallons	1	1,250 gallons
				Total:	9,645 gallons

Oil-Filled Equipment Below Threshold

Equipment	Location	Containment Method	Individual Capacity	Number of Units	Total Volume (gallons)
13A-1U-1H Transformer	Transformer Yard	NA	Dry	1	Dry
13A-1U-2H Transformer	Transformer Yard	NA	Dry	1	Dry
13A-1U-3H Transformer	Transformer Yard	NA	Dry	1	Dry
13A-1Y - Neutral	Transformer Yard	NA	Dry	1	Dry
13A-1U-1K - Capacitor	Transformer Yard	NA	6 gallons	1	6 gallons
13A-1U-2 - Outdoor Breaker	Transformer Yard	NA	Dry	1	Dry
13a-1X1-2 - Outdoor Breaker Bushings (6)	Transformer Yard	NA	4 gallons	6	24 gallons
				Total:	30 gallons

(ii) - Discharge Prevention Measures

Refer to section 112.7(c) of this plan for a complete list of discharge prevention measures.

(iii) - Discharge or Drainage Controls

Refer to section 112.7(c) of this plan for a complete list of discharge and drainage controls.

(iv) - Countermeasures for Discharge Discovery, Response, and Cleanup

If a discharge occurs, refer to Appendix D for the Oil Incident Report Form and Appendix F for the Oil Spill Response Procedure, which includes the following details:

- Spill Response Flow Chart;
- What to do when finding a spill;
- Steps to address small and large spills; and
- Spill response contractor contact information.

(v) - Disposal of Recovered Materials

Material generated during a cleanup effort would be disposed of in accordance with applicable State and Federal Laws and regulations and waste minimization would be practiced to the extent practical.

(vi) Emergency Contact List

An emergency contact list, including phone numbers for cleanup contractors and all appropriate Federal, State, and local agencies who must be contacted in case of a discharge as described in 40 CFR §112.1(b) is provided in Appendix F (Oil Spill Response Procedure Flow Chart). This emergency contact list includes the contact number for the National Response Center.

Facility/company personnel to be contacted in the event of an emergency, including but not limited to the SPCC Coordinator, is provided in Appendix F.

112.7(a)(4) & (5) - Discharge Reporting and Emergency Response Procedures

Procedures for discharge reporting and emergency response to discharges are presented in the Oil Spill Response Procedure in Appendix F.

112.7(b) - Prediction of Release Source, Direction, Rate of Flow, and Discharge Quantity

General experience in industry indicates a reasonable potential for equipment failures from loading and unloading, tank overflow, and piping leaks. At the Station, such failures could result in a discharge from bulk storage containers listed in the Tables found in 112.7(a)(3).

Failures or releases from containers for maintenance supplies, electrical transformers, oil filled process equipment, and mobile equipment presented in the tables found in 112.7(a)(3) are relatively rare. In addition, due to the locations and volumes involved, a release to navigable waters from these sources is unlikely. Thus, predictions of rate

and direction of releases from such equipment are not presented. Mobile equipment, by its nature is moved from one location to another. Thus, a meaningful prediction of rate and direction of releases is not possible.

112.7(c) - Containment and/or Diversionary Structures or Equipment

Containment and/or diversionary structures or equipment is in place to prevent a discharge from qualified oil-filled operational equipment. For bulk storage containers, containment, diversionary structures, container storage practices, and/or procedures are utilized to minimize the potential for releases.

Transformers – The Station has several transformers which are completely enclosed in the transformer yard. The yard includes specially constructed underground retention basins to provide for spilled oil retention in the case of an oil spill.

Oil Storage Drums – When oil storage drums are used within the Station for dispensing lubricants and cleaners in the drum storage area, drip pans are used to contain spillage during transfer operations.

Sorbent Materials – Sorbent materials and drip pans are generally used throughout the facility where oil filled equipment is located and spill kits are strategically placed in the powerhouse and outlying support buildings.

112.7(c)(1) - Discharge Prevention Systems

A list of tanks is summarized in the tables found in 112.7(a)(3). In addition, measures to prevent a discharge of oil from reaching a navigable watercourse include:

- secondary containment structures and/or located within a building (112.8(c)(2));
- loading/unloading pads (112.7(h));
- liquid-level gauges (112.8(c)(8));
- high-level alarms (112.8(c)(8));
- spill boxes and direct-fill into top of tanks (112.7(h));
- written tank truck unloading procedures (112.7(h));
- completely sealed oil-filled equipment (112.7(a)(3));
- inspection and general secondary containment procedures (112.8(c)(2) and Appendix E);
- readily available sorbent material and spill containment supplies (Appendix C); and
- training for oil-handling personnel (112.7(f)).

(i) - Sufficiently Impervious Containment

Where used, the secondary spill containment structures are sufficiently impervious to oil and fuel.

(ii) – Curbing

None.

(iii) - Sumps and Collection Systems

None.

(iv) - Culverts and Gutters

None.

(v) - Weirs, Booms or other Barriers

The facility is equipped to install oil slick barriers/booms, oil absorbent material to contain spillage, and pumping capabilities to handle a release should one occur.

(vi) - Spill Diversion Ponds

None.

(vii) - Retention Ponds

None.

(vii) - Sorbent Materials, Spill Response Supplies and Equipment

Sorbent materials and drip pans are generally used throughout the facility where oil filled equipment is located and spill kits are strategically placed in the power house and outlying support buildings. Appendix C includes details associated with the monthly inspection of spill response materials at the facility.

112.7(d) - Impracticable Installation of Structures Listed in 40 CFR Part 112.8

Not applicable.

112.7(e) - Inspections, Tests, and Records

Routine Inspections – Inspections required by the regulations are made weekly; inspection log sheets are completed and signed by the person doing the inspection. These inspections are submitted to EH&S and reviewed for malfunctions or leaks. If a malfunction is identified, a work order is placed to address the issue. See Appendix E for a copy of the weekly SPCC inspection form.

Integrity Testing Inspections – Emergency generator tank, used oil tank, and dirty and clean turbine oil storage tanks are subject to integrity testing requirements of 40 CFR §112.8 (c)(6). Refer to Appendix H of this Plan for the specifics of what is required under the applicable industry standard for these types of tanks (Steel Tank Institute’s STI SP001 standard).

Visual Inspection – All storage tanks are monitored and observed by visual inspection on a monthly basis (see Appendix E for a copy of the inspection form).

Records for all facility inspections are maintained on-site for at least three years.

112.7(f) - Personnel, Training, and Discharge Prevention Procedures

FirstLight management instructs oil-handling facility personnel in the:

- Operation and maintenance of equipment to prevent discharges;
- Discharge procedure protocols;
- Applicable pollution control laws, rules, and regulations;
- General facility operations; and
- The contents of the facility SPCC plan.

The facility schedules and conducts discharge prevention briefings for oil-handling personnel at least once a year to assure adequate understanding of the SPCC Plan for that facility.

(f)(1) - Employee Training

Annual classroom training for oil-handling facility personnel is typically led by the Station EH&S, and focuses on environmental rules, regulations, and laws, general facility operations, a general overview of this SPCC Plan, spill reporting requirements, and each person's responsibility in regards to the above.

(f)(2) - Designated Discharge Prevention Person

The primary designated person accountable for oil spill prevention and the primary SPCC Coordinator at the site is the EH&S.

In the event of their absence, the Maintenance Manager shall serve as back-up SPCC Coordinator.

(f)(3) - Discharge Prevention Briefings

Annual training at the facility serves as briefings and are held by the designated/responsible person, for all facility personnel involved in oil operations. This training is aimed at ensuring continued understanding and adherence to the discharge prevention procedures presented in the SPCC Plan. The briefings will focus on the maintenance and operation of equipment, locations of spill cleanup material and spill booms, and the location of the SPCC Plan. The briefings will also highlight and describe known discharge events or failures, malfunctioning components, and recently implemented precautionary measures and best practices. Facility personnel will have the opportunity during the briefings to share recommendations concerning health, safety, and environmental issues encountered during facility operations.

112.7(g) - Security

All entrances to the Station are fully fenced and locked, and remotely controlled from a central location. When facility personnel are not present, the station is monitored remotely from the Rocky River facility. Lighting levels are appropriate for operational and security purposes.

112.7(h) - Facility Tank Car and Tank Truck Loading/Unloading Rack

Normally, tank trucks are not loaded or unloaded at this facility. The only routine tank truck unloading is delivery of diesel fuel (not more than 275 gallons per delivery). Diesel fuel is supplied by truck and unloading would be by hoses carried by the truck. There is a single fill pipe outside the powerhouse wall leading directly to the tank. This fuel delivery is by contracted DOT licensed oil suppliers. A silicone mat is placed over the nearest storm drain to protect from a spill during unloading.

Infrequently, large amounts of transformer oil may be delivered to and from the transformers by truck. Unloading would be by hoses carried by the truck. The truck would be in conformance with applicable DOT standards. A company trained employee would also be in attendance to respond to spills.

Rarely large amounts of lubricating oil would be delivered or transferred by truck. Unloading would be by hoses carried by the truck. There are three separate fill pipes in a concrete slab immediately outside the powerhouse.

If tank trucks are used and are not empty when they leave the facility, prior to departing, the truck driver examines all drains and outlets to assure there will be no leakage while in transit.

112.7(i) - Brittle Fracture or Other Catastrophic Failure Testing

There are no field constructed bulk storage tanks at this site and therefore no requirements under this section to provide fracture potential evaluation as would be required under 40 CFR §112.7(i).

112.7(j) - State and Local Conformance with Requirements and Procedures

In accordance with 40 CFR §112.7(j), all Rules of the State of Connecticut are followed in the handling and storage of oil and the spill reporting requirements.

112.7(k) - Oil Filled Operational Equipment

Oil-filled operational equipment is provided in the Tables found in 112.7(a)(3).

(k)(1) - Qualification Criteria

The Station has not had a single discharge greater than 1,000 gallons to a navigable water from any oil-filled operational equipment, or two spills greater than 42 gallons to a navigable water from any oil-filled operational equipment. As such, the facility meets

the qualification criteria in order to not need alternative requirements to general secondary containment.

(k)(2) - Alternative Requirements to General Secondary Containment

Not applicable.

(i) - Inspection Procedures and Monitoring Program

See 112.7(e) for a description of inspection procedures and monitoring program.

(ii) - Response Plan

The facility has not submitted a response plan under 40 CFR §112.20. Therefore, the facility has implemented provisions 112.7(k)(2)(ii)(A) and (B) below:

(ii)(A) - Oil Spill Contingency Plan

An oil spill contingency plan has been developed for the facility. Refer to Sections 112.7(a)(3)(iv) through 112.7(a)(5).

(ii)(B) - Written Commitment of Manpower, Equipment and Materials

Under the Management Approval and Commitment section of the SPCC Plan (on Page i), the management of the Station has made a written commitment of manpower, equipment and materials to expeditiously control and remove any quantity of discharged oil that may be harmful.

Tighe&Bond

SECTION 3

Section 3

112.8 - SPCC Plan Requirements For Onshore Facilities

112.8(a) - General Requirements and Specific Discharge Prevention and Containment

The Station meets the general requirements for the SPCC Plan listed under Section 112.7 and the specific discharge prevention and containment procedures listed in this Section, 112.8.

112.8(b) - Facility Drainage

(b)(1) - Dike Drainage

The facility does not operate with the use of dikes as drainage structures.

(b)(2) - Dike Drainage Valves

The facility does not operate with the use of dikes as drainage structures.

(b)(3) - Undiked Area Drainage

Stormwater catch basins are present outdoors along the road. Discharges from oil filled equipment are not believed to occur in this area, and as such releases to these catch basins have not been identified.

(b)(4) - Diversion system

None.

(b)(5) - Drainage Water Treatment Units

None.

112.8(c) - Bulk Storage Containers

Bulk storage tanks are defined as a tank or container of 55-gallons or greater capacity that has the intended sole use to store oil or other petroleum products (i.e. tanks that are part of an operating system such as hydraulic systems are not to be considered bulk storage in this rule).

TABLE 112.8(c)
Bulk Storage Containers
Shepaug Station

BULK STORAGE CONTAINERS

Equipment	Description
Emergency Generator Fuel Tank	The station maintains an emergency generator fuel tank on the Generator Hall floor. The tank has secondary containment.
Various Drums	55-gallon drums are stored throughout the station for dispensing dielectric oil, lubricants or collecting used oil. Used and new oil drums are located in the oil storage room.
Used Oil Tank	A used oil tank is maintained in the oil room which captures oil from the Oil Water Separator system in the adjacent room. The oil room is bermed and provides adequate secondary containment.
Clean & Dirty Turbine Oil Tanks	A clean and dirty turbine tank are maintained in the oil room. The oil room is bermed and provides adequate secondary containment.

(c)(1) - Material and Construction Compatibility

The material and construction for all containers for the storage of oil are compatible with the oil stored and conditions of storage, including pressure and temperature.

(c)(2) - Secondary Containment

Secondary containment structures are provided for bulk storage containers listed in Tables under section 112.7(c). The volume of containment is sufficient to contain the contents of the tank or transformer with adequate freeboard for precipitation. Precipitation is not an issue for structures located within buildings.

(c)(3) - Secondary Containment Drainage

Refer to Section 112.8(b)(1).

(c)(4) - Coatings & Cathodic Protection for Buried Metallic Tank

There are no buried metallic tanks for oil storage at the Station.

(c)(5) - Coatings & Cathodic Protection for Partially Buried or Bunkered Metallic Tanks

There are no partially buried or bunkered metallic tanks for oil storage at the facility.

(c)(6) - Inspections and Integrity Testing of Aboveground Storage Containers

Aboveground Storage Tanks (Applies to the emergency generator tank, used oil tank, and clean and dirty turbine oil tanks)

There is one tank at this facility that come under the jurisdiction of 112.8(c)(6) for tank integrity testing requirements. The tank is double walled and meets the criteria of

“continuous release detection method” described in STI SP001. Because of it’s size, this tank requires only a “Periodic AST Inspection” as defined in the Standard.

The periodic inspections are defined in Section 6 of the STI Standard (see Appendix H) to include:

- Periodic AST inspections are to be conducted by owner’s inspector. Checklists for periodic AST inspections are found in Appendix C of the STI standard. These are to be used as a guide for recording inspection data.
- The owner’s inspector must meet the requirements of paragraph 4.1 of STI SP001, i.e. ... [t]he personnel performing these inspections shall be knowledgeable of storage facility operations, the type of AST and its associated components, and characteristics of the liquid stored.
- Review prior inspection, repair, and alteration data before each inspection. Note special conditions for a particular AST.
- The owner’s inspector is to complete the STI SP001 AST Record for each AST or tank site as designated in the checklists. Note special conditions and changes or alterations to the tank.
- The owner’s inspector is to complete the STI SP001 Monthly Inspection Checklist each month. Take note of instructions on the checklist. Note special conditions.
- The owner’s inspector is to complete the STI SP001 Annual Inspection Checklist each year. Take note of instructions on the checklist. Note special conditions.
- By removing water or taking other corrective action on a regular basis, harmful Microbiological Influenced Corrosion (MIC) is prevented. Monitor for water accumulation monthly. If corrosion is found due to MIC, treat the AST with a proper biocide or otherwise sterilize the fuel in the AST. In addition, take necessary steps to repair or remove the AST from service, if warranted by the extent of the corrosion.

(c)(7) - Internal Heating Coils

Internal heating coils are not installed on storage containers at this facility.

(c)(8) - Liquid Level Sensing Devices

Pursuant to this section, one of the following devices must be installed on the bulk storage containers to avoid discharges of oil from overfills:

- High level alarm (c)(8)(i); or
- High level pump cutoff to stop flow(c)(8)(ii); or
- Direct audible or code signal between tank gauger and pumping station(c)(8)(iii); or
- Fast response system for determining liquid level (a person must be present to monitor tank gauges and overall overfilling of tank (c)(8)(iv).

Additional details regarding tank overfill can be found in section 112.8(c).

(c)(9) - Effluent Treatment Facilities

None.

(c)(10) - Visual Discharges

Visible discharges of oil from containers or piping systems are corrected upon discovery. Accumulations of oil in diked areas are promptly removed by Station personnel or a contractor for proper off-site management.

(c)(11) - Mobile or Portable Oil Storage Containers

There are no mobile or portable oil storage containers located outside at the Station facility. Oil-filled mobile equipment does not fall under this category.

112.8(d) - Facility Transfer Operations, Pumping, and Facility Process

(d)(1) - Buried Piping

There is no buried piping at the facility.

(d)(2) - Out of Service Piping

There is no out of service or standby piping at the Station.

(d)(3) - Pipe Supports

Pipe supports are properly designed to minimize abrasion and corrosion and to allow for expansion and contraction.

(d)(4) - Inspection of Aboveground Piping, Valves and Appurtenances

Aboveground piping is inspected for the general condition of piping and components such as flange joint, expansion joints, valve glands and bodies, catch pans, and pipeline supports. Bulk storage inspections are carried out according to written procedures on a frequency as presented in Section 112.8 (c)(6).

(d)(5) - Aboveground Piping

There is no aboveground piping that is vulnerable to vehicle traffic at the Station.

Tighe&Bond

APPENDIX A

Appendix A
Figures

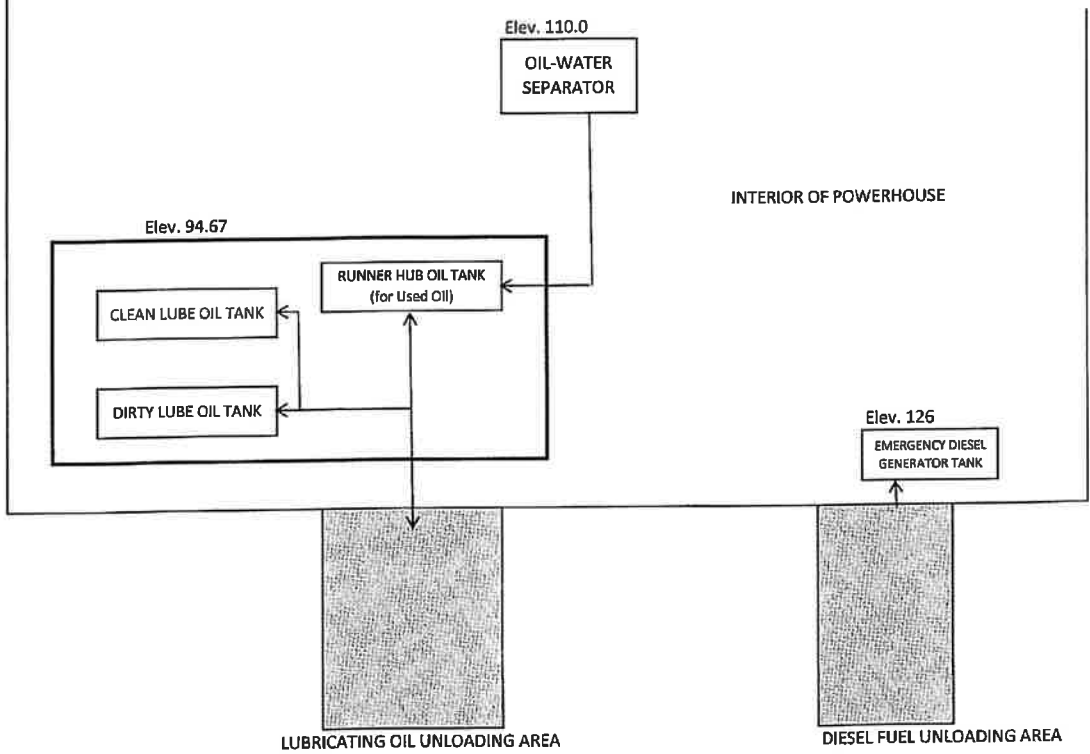

Detail of transfer lines from exterior of powerhouse building to tanks within the building (elevations of levels indicated).

Tighe&Bond

APPENDIX B

Appendix B
Glossary of Terms

Berm:

An earthen mound used to direct the flow of runoff around or through a structure.

Best Management Practice (BMP):

Schedules of activities, prohibitions of practices, maintenance procedures, and other management practices to prevent or reduce the pollution of waters of the United States. BMPs also include treatment requirements, operating procedures, and practices to control facility site runoff, spillage or leaks, sludge or waste disposal, or drainage from raw material storage.

Biodegradable:

Having the ability to break down or decompose under natural conditions and processes.

Boom:

1. A floating device used to contain oil on a body of water.
2. A piece of equipment used to apply pesticides from ground equipment such as a tractor or truck.

Buffer Strip or Zone:

Strips of grass or other erosion-resistant vegetation between a waterway and an area of more intensive land use.

By-product:

Material, other than the principal product, that is generated as a consequence of an industrial process.

CERCLA:

Comprehensive Environmental Response, Compensation, and Liability Act.

Conduit:

Any channel or pipe for transporting the flow of water.

Conveyance:

Any natural or manmade channel or pipe in which concentrated water flows.

Corrosion:

The dissolving and wearing away of metal caused by a chemical reaction such as between water and the pipes that the water contacts, chemicals touching a metal surface, or contact between two metals.

Culvert:

A covered channel or a large-diameter pipe that directs water flow below the ground level.

CWA:

Clean Water Act (formerly referred to as the Federal Water Pollution Control Act or Federal Water Pollution Control Act Amendments of 1972).

Dike:

An embankment to confine or control water, often built along the banks of a river to prevent overflow of lowlands; a levee.

Discharge:

A release or flow of stormwater or other substance from a conveyance or storage container.

Emission:

Pollution discharged into the atmosphere from smokestacks, other vents, and surface areas of commercial or industrial facilities and from motor vehicle, locomotive, or aircraft exhausts.

Emulsion:

A mixture of two or more liquids that are normally immiscible (unmixable or unblendable)

Erosion:

The wearing away of land surface by wind or water. Erosion occurs naturally from weather or runoff, but can be intensified by land-clearing practices related to farming, residential or industrial development, road building, or timber cutting.

Excavation:

The process of removing earth, stone, or other materials.

Fertilizer:

Materials such as nitrogen and phosphorus that provide nutrients for plants. Commercially sold fertilizers may contain other chemicals or may be in the form of processed sewage sludge.

Filter Fabric:

Textile of relatively small mesh or pore size that is used to allow water to pass through while keeping sediment out (permeable), or (b) prevent both runoff and sediment from passing through (impermeable).

Filter Strip:

Usually long, relatively narrow area of undisturbed or planted vegetation used to retard or collect sediment for the protection of watercourses, reservoirs, or adjacent properties.

General Permit:

A permit issued under the NPDES program to cover a certain class or category of stormwater discharges. These permits allow for a reduction in the administrative burden associated with permitting stormwater discharges associated with industrial activities. For example, EPA is planning to issue two general permits:

1. NPDES General Permits for Stormwater Discharges from Construction Activities that are classified as "Associated with Industrial Activity" and
2. NPDES General Permits for Stormwater Discharges from Industrial Activities that are classified as "Associated with Industrial Activities."

EPA is also encouraging delegated states that have an approved general permits program to issue general permits.

Grading:

The cutting and/or filling of the land surface to a desired slope or elevation.

Hazardous Substance:

1. Any material that poses a threat to human health and/or the environment. Hazardous substances can be toxic, corrosive, ignitable, explosive, or chemically reactive.
2. Any substance required by EPA to be reported if a designated quantity of the substance is spilled in the waters of the United States or if otherwise emitted into the environment.

Hazardous Waste:

A by-product of human activities that can pose a substantial or potential hazard to human health or the environment when improperly managed. Possesses at least

one of four characteristics (ignitability, corrosivity, reactivity, or toxicity), or appears on special EPA lists.

Holding Pond:

A pond or reservoir, usually made of earth, built to store polluted runoff for a limited time.

Illicit Connection:

Any discharge to a municipal separate storm sewer that is not composed entirely of stormwater except discharges authorized by an NPDES permit (other than the NPDES permit for discharges from the municipal separate storm sewer) and discharges resulting from fire fighting activities.

Infiltration:

1. The penetration of water through the ground surface into sub-surface soil or the penetration of water from the soil into sewer or other pipes through defective joints, connections, or manhole walls.
2. A land application technique where large volumes of wastewater are applied to land, allowed to penetrate the surface, and percolate through the underlying soil.

Inlet:

An entrance into a ditch, storm sewer, or other waterway.

Intermediate:

A chemical compound formed during the making of a product.

Lagoon:

A shallow pond where sunlight, bacterial action, and oxygen work to purify wastewater.

Landfill:

An area of land or an excavation in which wastes are placed for permanent disposal, and which is not a land application unit, surface impoundment, injection well, or waste pile.

Large and Medium Municipal Separate Storm Sewer System:

All municipal separate storm sewers that are either:

- i. Located in an incorporated place (city) with a population of 100,000 or more as determined by the latest Decennial Census by the Bureau of Census (these cities are listed in Appendices F and G of 40 CFR Part 122); or
- ii. Located in the counties with unincorporated urbanized populations of 100,000 or more, except municipal separate storm sewers that are located in the incorporated places, townships, or towns within such counties (these counties are listed in Appendices H and I of 40 CFR Part 122); or
- iii. Owned or operated by a municipality other than those described in paragraph (i) or (ii) and that are designated by the Director as part of the large or medium municipal separate storm sewer system.

Leaching:

The processes by which soluble constituents are dissolved in a solvent such as water and carried down through the soil.

Material Storage Areas:

On-site locations where raw materials, products, final products, by-products, or waste materials are stored.

Mobile Equipment:

While the SPCC rule does not specifically define "mobile" containers, such containers may include 55-gallon drums, skid tanks, totes, Intermediate Bulk Containers (IBCs), and other small containers put into place and later moved.

Mulch:

A natural or artificial layer of plant residue or other materials covering the land surface that conserves moisture, holds soil in place, aids in establishing plant cover, and minimizes temperature fluctuations.

Non-contact Cooling Water:

Water used to cool machinery or other materials without directly contacting process chemicals or materials.

Notice of Intent (NOI):

An application to notify the permitting authority of a facility's intention to be covered by a general permit; exempts a facility from having to submit an individual or group application.

NPDES:

EPA's program to control the discharge of pollutants to waters of the United States. See the definition of "National Pollutant Discharge Elimination System" in 40 CFR 122.2 for further guidance.

NPDES Permit:

An authorization, license, or equivalent control document issued by EPA or an approved state agency to implement the requirements of the NPDES program.

Oil Sheen:

A thin, glistening layer of oil on water.

Oil/Water Separator:

A device installed, usually at the entrance to a drain, which removes oil and grease from water flows entering the drain.

Organic Pollutants:

Substances containing carbon which may cause pollution problems in receiving streams.

Organic Solvents:

Liquid organic compounds capable of dissolving solids, gases, or liquids.

Outfall:

The point, location, or structure where wastewater or drainage discharges from a sewer pipe, ditch, or other conveyance to a receiving body of water.

Permeability:

The quality of soil that enables water or air to move through it. Usually expressed in inches/hour or inches/day.

Permit:

An authorization, license, or equivalent control document issued by EPA or an approved state agency to implement the requirements of an environmental regulation; e.g., a permit to operate a waste-water treatment plant or to operate a facility that may generate harmful emissions.

Permit Issuing Authority (or Permitting Authority):

The state agency or EPA regional office that issues environmental permits to regulated facilities.

Point Source:

Any discernible, confined, and discrete conveyance, including but not limited to any pipe, ditch, channel, tunnel, conduit, well, discrete fissure, container, rolling stock, concentrated animal feeding operation, or vessel or other floating craft, from which pollutants are or may be discharged. This term does not include return flows from irrigated agriculture or agricultural stormwater runoff.

Pollutant:

Any dredged spoil, solid waste, incinerator residue, filter backwash, sewage, garbage, sewage sludge, munitions, chemical wastes, biological materials, radioactive materials (except those regulated under the Atomic Energy Act of 1954, as amended (42 [U.S.C. 2011 et seq.]), heat, wrecked or discharged equipment, rocks, and, cellar dirt, and industrial, municipal, and agricultural waste discharged into water. It does not mean:

- i. Sewage from vessels; or
- ii. Water, gas, or other material which is injected into a well to facilitate production of oil or gas, or water derived in association with oil and gas production and disposed of in a well, if the well used either to facilitate

production or for disposal purposes is approved by the authority of the state in which the well is located, and if the state determines that the injection or disposal will not result in the degradation of ground or surface water resources [Section 502(6) of the CWA] Radioactive materials covered by the Atomic Energy Act are those encompassed in its definition of source, byproduct, or special nuclear materials. Examples of materials not covered include radium and accelerator-produced isotopes. See *Train v. Colorado Public Interest Research Group, Inc.*, 426 U.S. 1 (1976).

Porous Pavement:

A human-made surface that will allow water to penetrate through and percolate into soil (as in porous asphalt pavement or concrete). Porous asphalt pavement is comprised of irregular shaped crush rock pre-coated with asphalt binder. Water seeps through into lower layers of gravel for temporary storage, then filters naturally into the soil.

Precipitation:

Any form of rain or snow.

Preventive Maintenance Program:

A schedule of inspections and testing at regular intervals intended to prevent equipment failures and deterioration.

Process Wastewater:

Water that comes into direct contact with or results from the production or use of any raw material, intermediate product, finished product, by-product, waste products, or wastewater.

Raw Material:

Any product or material that is converted into another material by processing or manufacturing.

RCRA:

Resource Conservation and Recovery Act.

Recycle:

The process of minimizing the generation of waste by recovering usable products that might otherwise become waste; e.g., recycling of aluminum cans, wastepaper, and bottles.

Reportable Quantity (RQ):

The quantity of a hazardous substance or oil that triggers reporting requirements under CERCLA or the Clean Water Act. If a substance is released in amounts exceeding its RQ, the release must be reported to the National Response Center, the State Emergency

Response Commission, and community emergency coordinators for areas likely to be affected.

Residual:

Amount of pollutant remaining in the environment after a natural or technological process has taken place; e.g., the sludge remaining after initial wastewater treatment, or particulates remaining in air after the air passes through a scrubbing or other pollutant removal process.

Retention:

The holding of runoff in a basin without release except by means of evaporation, infiltration, or emergency bypass.

Runoff:

That part of precipitation, snowmelt, or irrigation water that runs off the land into streams or other surface water. It can carry pollutants from the air and land into the receiving waters.

Sanitary Sewer:

A system of underground pipes that carries sanitary waste or process wastewater to a treatment plant.

SARA:

Superfund Amendments and Reauthorization Act.

Secondary Containment:

Structures, usually dikes or berms, surrounding tanks or other storage containers and designed to catch spilled material from the storage containers.

Sediment Trap:

A device for removing sediment from water flows; usually installed at outfall points.

Sedimentation:

The process of depositing soil particles, clays, sands or other sediments that were picked up by flowing water.

Sediments:

Soil, sand, and minerals washed from land into water, usually after rain. They pile up in reservoirs, rivers, and harbors, destroying fish-nesting areas and holes of water animals and cloud the water so that needed sunlight might not reach aquatic plants. Careless farming, mining, and building activities will expose sediment materials, allowing them to be washed off the land after rainfalls.

Significant Materials:

Include, but are not limited to:

- Raw materials;
- Fuels;
- Materials such as solvents, detergents, and plastic pellets;
- Finished materials such as metallic products;
- Raw materials used in food processing or production;
- Hazardous substances designated under section 101(14) of CERCLA;
- Any chemical the facility is required to report pursuant to Section 313 of Title III of SARA;
- Fertilizers;
- Pesticides; and
- Waste products such as ashes, slag, and sludge that have a potential to be released with stormwater discharges [122.26(b 12)].

Significant Spills:

Include, but are not limited to: releases of oil or hazardous substances in excess of reportable quantities under Section 311 of the CWA (see 40 CFR 110.10 and CFR 117.21) or Section 102 of CERCLA (see 40 CFR 302.4).

Sludge:

A semi-solid residue from any of a number of air or water treatment processes. Sludge can be a hazardous waste.

Soil:

The unconsolidated mineral and organic material on the immediate surface of the earth that serves as a natural medium for the growth of plants.

Spill Prevention Control and Countermeasures Plan (SPCC):

Plan consisting of structures, such as curbing, and action plans to prevent and respond to spills of hazardous substances as defined in the Clean Water Act.

Spill to the Environment:

A spill occurring outdoors which is not captured entirely by structural secondary containment.

Stopcock Valve:

A small valve for stopping or controlling the flow of water or other liquid through a pipe.

Storm Drain:

A slotted opening leading to an underground pipe or an open ditch for carrying surface runoff.

Stormwater:

Runoff from a storm event, snowmelt runoff, and surface runoff and drainage.

Subsoil:

The bed or stratum of earth lying below the surface soil.

Sump:

A pit or tank that catches liquid runoff for drainage or disposal.

Surface Impoundment:

Treatment, storage, or disposal of liquid wastes in ponds.

Surface Water:

All water naturally open to the atmosphere (rivers, lakes, reservoirs, streams, wetlands impoundments, seas, estuaries, etc.); also refers to springs, wells, or other collectors which are directly influenced by surface water.

Swale:

An elongated depression in the land surface that is at least seasonally wet, is usually heavily vegetated, and is normally without flowing water. Swales direct stormwater flows into primary drainage channels and allow some of the stormwater to infiltrate into the ground surface.

Tarp:

A sheet of waterproof canvas or other material used to cover and protect materials, equipment, or vehicles.

Topography:

The physical features of a surface area including relative elevations and the position of natural and human-made features.

Tributary:

A river or stream that flows into a larger river or stream.

Underground Storage Tanks (USTs):

Storage tanks with at least 10 percent or more of its storage capacity underground (the complete regulatory definition is at 40 CFR Part 280.12).

Waste:

Unwanted materials left over from a manufacturing or other process.

Waters of the United States:

1. All waters, which are currently used, were used in the past, or may be susceptible to use in interstate or foreign commerce, including all waters which are subject to the ebb and flow of the tide;
2. All interstate waters, including interstate "wetlands;"
3. All other waters such as intrastate lakes, rivers, streams (including intermittent streams), mudflats, sandflats, "wetlands," sloughs, prairie potholes, wet meadows, playa lakes, or natural ponds, the use, degradation, or destruction of which would affect or could affect interstate or foreign commerce including any such waters:
 - a. Which are or could be used by interstate or foreign travelers for recreational or other purposes;
 - b. From which fish or shellfish are or could be taken and sold in interstate or foreign commerce; or
 - c. Which are used or could be used for industrial purposes by industries in interstate commerce;
4. All impoundments of waters otherwise defined as waters of the United States under this definition;
5. Tributaries of waters identified in paragraphs (a) through (d) of this definition;
6. The territorial sea; and
7. Wetlands" adjacent to waters (other than waters that are themselves wetlands) identified in paragraphs (a) through (f) of this definition.

Waterway:

A channel for the passage or flow of water.

Wet Well:

A chamber used to collect water or other liquid and to which a pump is attached.

Wetlands:

An area that is regularly saturated by surface or ground water and subsequently is characterized by a prevalence of vegetation that is adapted for life in saturated soil conditions. Examples include: swamps, bogs, fens, marshes, and estuaries.

Tighe&Bond

APPENDIX C

Appendix C
Spill Response Equipment

Firstlight - Shepaug Station

MONTHLY SPILL CONTROL EQUIPMENT INSPECTIONS

Is the Spill Kit Sealed

Yes*

No

*If yes, do not open to inspect

Inspection Item	Generator Hall	Sump Pump Floor	Oil Room	Outside Station
Absorbent Material				
Pads				
Booms				
Towels/Rags				
Pillows				
Containers				
30-50 Gallon Plastic Container				
Plastic Bags				
Misc.				
Personnal Protective Equipment				
No extraneous material in kit				
Drain cover				
Sign is posted and visible				
Kit is sealed				
Shovels and Squeejies				
Resealed Date				

Name _____

Signature

Date

Replenish material as necessary

Check each box after verifying contents or after replenishing

Sign form when all kits have been checked. File form in SPCC

***Outside**

Tighe&Bond

APPENDIX D

Appendix D
Oil Incident Report Form

**** REFER TO THE OIL SPILL REPORTING SCENARIO IN APPENDIX C TO DETERMINE IF AN OIL SPILL NEEDS TO BE REPORTED TO THE STATE - DOCUMENTATION IS ONLY REQUIRED TO BE MAINTAINED AT THE FACILITY ****

1. Location of Release: _____

2. Date, Time & Duration of Release: _____

3. Description of Release: _____

4. Quantity Released: _____

5. Nature of Cleanup Performed: _____

6. Environmental Contractor Used (if any): _____

7. Environmental Consultant Used (if any): _____

8. Fuel Oil Released to Surface Water Groundwater Land Pavement

9. Release Notification Status
- in-house only
 - reported as an oil spill
 - reported as a release to water

10. Agency Notification
- National Response Center
 - time contacted: _____ person contacted: _____
 - reporting number: _____
 - CT DEEP (Refer to Appendix F for additional details)
 - time contacted: _____ person contacted: _____
 - comments: _____
 - Other (name) _____
 - time contacted: _____ person contacted: _____
 - comments: _____

Name of Preparer: _____ Date: _____

Signature: _____

Copies to: _____

Tighe&Bond

APPENDIX E

Appendix E
Inspection Forms

**Firstlight - Shepaug Station
SPCC Plan
Inspection Checklist**

		Generator Hall		Sump Pump Floor	Oil Room			Transformer Yard
		Emerg. Gen. Tank	Used Oil Drums	OWS	Used Oil (from OWS)	Clean Lube Oil Tank	Dirty Lube Oil Tank	Transformers
Tanks/Drums/Transformers	Surfaces show signs of leakage	Yes / No	Yes / No	Yes / No	Yes / No	Yes / No	Yes / No	Yes / No
	Tanks are damaged, rusted, or deteriorated	Yes / No	Yes / No	Yes / No	Yes / No	Yes / No	Yes / No	Yes / No
	Bolts, rivets, or seams are damaged	Yes / No	Yes / No	Yes / No	Yes / No	Yes / No	Yes / No	Yes / No
	Supports are deteriorated or buckled	Yes / No	Yes / No	Yes / No	Yes / No	Yes / No	Yes / No	Yes / No
	Foundations have eroded or settled	Yes / No	Yes / No	Yes / No	Yes / No	Yes / No	Yes / No	Yes / No
	Level gauges or alarms are inoperative	Yes / No	Yes / No	Yes / No	Yes / No	Yes / No	Yes / No	Yes / No
	Vents are obstructed	Yes / No	Yes / No	Yes / No	Yes / No	Yes / No	Yes / No	Yes / No
	Secondary containment is damaged or stained	Yes / No	Yes / No	Yes / No	Yes / No	Yes / No	Yes / No	Yes / No
	Water/product in interstice of double-walled tank	Yes / No	Yes / No	Yes / No	Yes / No	Yes / No	Yes / No	Yes / No
	Dike drainage valve is open or is not locked	Yes / No	Yes / No	Yes / No	Yes / No	Yes / No	Yes / No	Yes / No
Piping (Inspect at Connections)	Valve seals, gaskets, or other appurtenances are leaking	Yes / No	--	Yes / No	Yes / No	Yes / No	Yes / No	--
	Pipelines or supports are damaged or deteriorated	Yes / No	--	Yes / No	Yes / No	Yes / No	Yes / No	--
	Joints, valves and other appurtenances are leaking	Yes / No	--	Yes / No	Yes / No	Yes / No	Yes / No	--
	Buried piping is exposed	Yes / No	--	Yes / No	Yes / No	Yes / No	Yes / No	--
Loading/Unloading and Transfer Equipment	Loading/unloading rack is damaged or deteriorated	--	--	--	--	--	--	--
	Connections are not capped or blank-flanged	--	--	--	--	--	--	--
	Secondary containment is damaged or stained	--	--	--	--	--	--	--
	Berm drainage valve is open or is not locked	--	--	--	--	--	--	--
Oil/Water Separator	Dil/water separator > 2 inches of accumulated oil	--	--	Yes / No	--	--	--	--
	Dil/water separator effluent has a sheen	--	--	Yes / No	--	--	--	--
Security	Fencing, gates, or lighting is non-functional	--	--	--	--	--	--	--
	Pumps and valves are locked if not in use	Yes / No	Yes / No	Yes / No	Yes / No	Yes / No	Yes / No	Yes / No
Response Equipment	Response equipment inventory is complete	Yes / No	Yes / No	Yes / No	Yes / No	Yes / No	Yes / No	Yes / No

Comments: _____

Inspectors Name _____

Date: _____

Tighe&Bond

APPENDIX F

Appendix F
Oil Spill Response Procedure

OIL SPILL RESPONSE PROCEDURE

If a spill has occurred, follow the steps in the flow chart below to determine how to proceed and who to contact.

CT DEEP – Oil Spill Reporting Scenarios

Spill Volume	In Containment?	Removed within 2-Hours?	Report
<5 Gallons	YES	YES	NO
	YES	NO	YES
	NO	YES	NO
	NO	NO	YES
5-15 Gallons	YES	YES	NO
	YES	NO	YES
	NO	YES	YES
	NO	NO	YES
>15 Gallons	YES	YES	YES
	YES	NO	YES
	NO	YES	YES
	NO	NO	YES

When Finding a Spill:

Step	Action	Who
1.	Determine the source and type of spill	Employee
2.	Stop spill at source and contain if possible, and if it can be done safely	Employee
3.	Divert spills from entering storm water drains or waterways if safe	Employee
4.	Were any damages or injuries caused? Will an evacuation be necessary?	Employee
5.	Report and obtain help by calling the control room at extension	Employee
6.	Contact appropriate site personnel <ul style="list-style-type: none">• Primary Contact HS&E, Kevin Gerardi Cell: (203) 470-8366 Office: (860) 350-3631Backup Maintenance Manager, Cliff Esmiol Cell: (203) 927-8683 Office: (860) 915-1154	Supervisor on shift
7.	Complete incident report (form F-8)	HS&E
8.	Notify appropriate agencies CT DEEP: 1-866-337-7745 NRC: 1-800-424-8802	HS&E
9.	Contact LEP (see following page)	HS&E
10.	Contact clean up resources, if large spill. (see following page)	HS&E

Release notification forms are completed over the phone with CT DEEP's Spill Response Hotline. As such, a spill notification form is not required to be developed by the responder

The Station HS&E will also contact the Licensed Environmental Professional (LEP) as soon as possible after notification to the CT DEEP. This will ensure that appropriate actions are taken.

Start Cleanup:

For small spills (less than 10 gallons):

Clean up with absorbents. Ensure cleanup materials are disposed in accordance with applicable regulations.

For large spills (greater than 10 gallons):

Call spill response contractors as in the attached list (or other known locally) who will perform expedient containment and cleanup. If safe and practicable, try to contain the spill while reaching out to a spill contractor.

SPILL CLEANUP RESOURCES

SPILL CLEANUP CONTRACTOR

Moran Environmental Recovery, LLC
20 Commerce Road
Newtown, CT 06470

Daytime: (203) 270-0095
After Hours: (800) 562-7611
Fax: (203) 270-0096

LICENSED ENVIRONMENTAL PROFESSIONAL

Tighe & Bond Consulting Engineers
Attn: Harley Langford
213 Court Street
Middletown, CT. 06457

Office: (860) 704-4781
Cell: (860) 878-2943

Tighe&Bond

APPENDIX G

Appendix G

Certification of Applicability Substantial Harm Criteria

**CERTIFICATION OF THE APPLICABILITY
OF THE SUBSTANTIAL HARM CRITERIA CHECKLIST**Facility Name: Shepaug StationFacility Address: 2225 River RoadSouthbury, CT 06488**Questionnaire**

This questionnaire is excerpted from Attachment C-II of 40 CFR 112 Appendix C. The questionnaire must be completed and signed for all facilities applicable to SPCC Plan requirements, even if they do not meet the substantial harm criteria (per 40 CFR 112 Appendix C Section 3.0). This certification must be present within the SPCC Plan and available for examination by the EPA Regional Administrator or his delegates.

- Yes No 1. Does the facility transfer oil over water to or from vessels and does the facility have a total oil storage capacity greater than or equal to 42,000 gallons?
- Yes No 2. Does the facility have a total oil storage capacity greater than or equal to 1 million gallons and does the facility lack secondary containment that is sufficiently large to contain the capacity of the largest aboveground oil storage tank plus sufficient freeboard to allow for precipitation within any aboveground oil storage tank area?
- Yes No 3. Does the facility have a total oil storage capacity greater than or equal to 1 million gallons and is the facility located at a distance (as calculated using the formula in Attachment C-III, Appendix C, 40 CFR 112 or a comparable formula¹) such that a discharge from the facility could cause injury to fish and wildlife and sensitive environments? For further description of fish and wildlife and sensitive environments, see Appendices I, II and III to DOC/NOAA's "Guidance for Facility and Vessel Response Environments" (Section 10, Appendix E, 40 CFR 112 for availability) and the applicable Area Contingency Plan.
- Yes No 4. Does the facility have a total oil storage capacity greater than or equal to 1 million gallons and is the facility located at a distance, as calculated using the appropriate formula (Attachment C-III, Appendix C, 40 CFR 112 or a comparable formula), such that a discharge from the facility would shut down a public drinking water intake²?

¹ If a comparable formula is used, documentation of the reliability and analytical soundness of the comparable formula must be attached to this form.

² For the purposes of 40 CFR part 112, public drinking water intakes are analogous to public water systems as described at 40 CFR 143.2(c).

Substantial Harm Criteria Certification

Tighe&Bond

- Yes No 5. Does the facility have a total oil storage capacity greater than or equal to 1 million gallons and has the facility experienced a reportable oil spill in an amount greater than or equal to 10,000 gallons within the last 5 years?

Certification

I certify under penalty of law that I have personally examined and am familiar with the information submitted in this document, and that based on my inquiry of those individuals responsible for obtaining this information, I believe that the submitted information is true, accurate and complete.

Daniel Timlake

Name (please type or print)

Daniel Timlake

Signature

Senior Operations Manager

Title

12/3/2024

Date

Tighe&Bond

APPENDIX H

Appendix H
Integrity Testing

INTEGRITY TESTING OF BULK TANKS

Aboveground Storage Tanks

- Emergency generator tank
- Used oil tank
- Clean and dirty turbine oil tanks

There is one tank at this facility that come under the jurisdiction of 112.8(c)(6) for tank integrity testing requirements. All tanks are double wall aboveground storage tanks or fully contained and therefore meet the criteria of "continuous release detection method" described in STI SP001. Because of their size, all three will require only "Periodic AST Inspection" as defined in the Standard rather than formal certified tester inspections.

The periodic inspections are defined in Section 6 of the Standard to include:

- Periodic AST inspections are to be conducted by owner's inspector. Checklists for periodic AST inspections are found in Appendix C of the STI standard. These are to be used as a guide for recording inspection data.
- The owner's inspector must meet the requirements of paragraph 4.1 of STI SP001, i.e. ... [t]he personnel performing these inspections shall be knowledgeable of storage facility operations, the type of AST and its associated components, and characteristics of the liquid stored.
- Review prior inspection, repair, and alteration data before each inspection. Note special conditions for a particular AST.
- The owner's inspector is to complete the STI SP001 AST Record for each AST or tank site as designated in the checklists. Note special conditions and changes or alterations to the tank.
- The owner's inspector is to complete the STI SP001 Monthly Inspection Checklist each month. Take note of instructions on the checklist. Note special conditions.
- The owner's inspector is to complete the STI SP001 Annual Inspection Checklist each year. Take note of instructions on the checklist. Note special conditions.
- By removing water or taking other corrective action on a regular basis, harmful Microbiological Influenced Corrosion (MIC) is prevented. Monitor for water accumulation monthly. If corrosion is found due to MIC, treat the AST with a proper biocide or otherwise sterilize the AST. In addition, take necessary steps to repair or remove the AST from service, if warranted by the extent of the corrosion.



100% Recyclable 

www.tighebond.com