



DAVID SHERRY, ATTORNEY  
Michaud Law Group LLC  
515 Centerpoint Drive, Suite 503  
Middletown, Connecticut 06457  
E-Mail: [dsherry@michaud.law](mailto:dsherry@michaud.law)  
Website: <https://www.michaud.law>

April 15, 2026

Connecticut Siting Council  
Attn: Executive Director Melanie Bachman  
10 Franklin Square  
New Britain, CT 06051

**PETITION NO. 1665 – TRITEC Energy Development, LLC (TRITEC Americas, LLC) petition for a declaratory ruling, pursuant to Connecticut General Statutes §4-176 and §16-50k, for the proposed construction, maintenance and operation of a 1.0-megawatt solar photovoltaic electric generating facility and associated equipment to be located at 74 Bokum Road, Old Saybrook, Connecticut, and associated electrical interconnection. Final Decision.**

Dear Executive Director Bachman:

On behalf of TRITEC Americas, LLC (“Petitioner”), Michaud Law Group submits this letter to the Connecticut Siting Council (the “Council”) regarding the Council’s Final Decision dated October 17, 2025, in the above-referenced petition. Specifically, this letter addresses Condition #3, which states:

3. Submit the final structural design for the racking system stamped by a Professional Engineer duly licensed in the State of Connecticut prior to commencement of construction.

I write to provide the required racking system design stamped by a Connecticut Professional Engineer. Please note that due to the size of the document, electronic access will be provided via separate e-mails to the Siting Council and Council staff. I respectfully request the Siting Council consider this condition from the Final Decision satisfied.

Very Truly Yours,

A handwritten signature in blue ink that reads 'D.M. Sherry'.

David M. Sherry, Esq.

**PRP index for 17419 Customer Project:**

Sheet #	Drawing Part #	Description
1	17419-901	DuraTrack® HZ Project: 17419 Title Page
2	17419-901	Foundation Layout
3	17419-901	Torque Beam Config
4	17419-901	Assembly Sequence
5	17419-901	Detail Views
6	17419-901	Center Gap Detail Views 2
7	17419-901	Elevation Detail Views 3
8	-	Night Snow Stow
9	-	Bearing Housing Perpendicularity Callout
10	20264-901	Site Data Controller
11	20436-901	GPS
12	20583-901	DTHZ Motor Electronics
13	20591-901	6X Motor Controller 1
14	20591-901	6X Motor Controller 2
15	20262-901	4X Motor Controller
16	21000-901	Bearing & Bracket STD/HW w/wo Set Screw - Field Assembly 1
17	21000-901	Bearing & Bracket STD/HW w/wo Set Screw - Field Assembly 2
18	21000-901	Bearing & Bracket STD/HW w/wo Set Screw - Field Assembly 3
19	20721-901	Column Bracket, 8 mm
20	21131-901	Field Assembly, Steel Bearing & Bracket, SPI, L/M/H 1
21	21131-901	Field Assembly, Steel Bearing & Bracket, SPI, L/M/H 2
22	21131-901	Field Assembly, Steel Bearing & Bracket, SPI, L/M/H 3
23	21020-901	Field Assembly, Steel Bearing Housing, Standard/HW Brackets w/wo Set Screws, L/M/H 1
24	21020-901	Field Assembly, Steel Bearing Housing, Standard/HW Brackets w/wo Set Screws, L/M/H 2
25	21020-901	Field Assembly, Steel Bearing Housing, Standard/HW Brackets w/wo Set Screws, L/M/H 3
26	20613-901	Torque Tube and Coupler
27	20759-901	Torque Beam, Single Piece, Coupler
28	20504-901	Full PTO Tube Driveline
29	20722-901	Assembly, Driveline Aluminum Tube
30	21013-901	Full Driveline Tube, Aluminum 1
31	21013-901	Full Driveline Tube, Aluminum 2
32	25236-901	Full Driveline Tube, Aluminum Measurements
33	20745-901	Steel Driveline
34	20726-XX-901	Global Center Structure 1
35	20726-XX-901	Global Center Structure 2
36	20726-XX-901	Global Center Structure 3
37	20726-XX-901	Global Center Structure 4
38	20726-XX-901	Global Center Structure 5
39	20726-XX-901	Global Center Structure 6
40	20999-903	GCS Motor, STD Wiring, Gearbox - Field Assembly
41	20999-903	GCS Motor, STD Wiring, Gearbox - Field Assembly
42	20999-903	GCS Motor, STD Wiring, Gearbox - Field Assembly
43	20999-903	GCS Motor, STD Wiring, Gearbox - Field Assembly
44	20727-901	Global Center Field Assembly 1
45	20727-901	Global Center Field Assembly 2
46	20727-901	Global Center Field Assembly 3
47	20727-901	Global Center Field Assembly 4
48	20844-901	400mm Clamp - Field Assembly
49	20872-901	FS6 Rapid Clamp 1
50	20872-901	FS6 Rapid Clamp 2
51	20993-901	RapidClamp, 400mm Hi Rise, 10mm 1
52	20993-901	RapidClamp, 400mm Hi Rise, 10mm 2
53	21025-901	Clamp, 3-Bolt Slot 800mm 1
54	21025-901	Clamp, 3-Bolt Slot 800mm 2
55	21011-901	Assembly, Thru-Bolt Clamp, 400mm, L/M/H
56	21016-901	400mm Thru-Bolt Clamp - Field Assembly 1
57	21016-901	400mm Thru-Bolt Clamp - Field Assembly 2
58	21016-901	400mm Thru-Bolt Clamp - Field Assembly 3
59	20893-901	Thru-Bolt Clamp 1300mm
60	20916-901	Thru-Bolt Clamp 1400mm
61	20895-901	Thru-Bolt Field Assembly 1
62	20895-901	Thru-Bolt Field Assembly 2
63	20895-901	Thru-Bolt Field Assembly 3
64	20895-901	Thru-Bolt Field Assembly 4
65	20895-901	Thru-Bolt Field Assembly 5
66	20895-901	Thru-Bolt Field Assembly 6
67	21014-901	Assembly, FS7 Clamp, 200mm, L/M/H
68	21015-901	Field Assembly, FS7 Clamp, 200mm, L/M/H
69	21030-901	Assembly, Coil Over Damper w/ Upper Bracket Kit, Wedged, L/M
70	21032-901	Field Assembly, Coil Over Damper, Wedged, L/M 1
71	21032-901	Field Assembly, Coil Over Damper, Wedged, L/M 2
72	21032-901	Field Assembly, Coil Over Damper, Wedged, L/M 3
73	21032-901	Field Assembly, Coil Over Damper, Wedged, L/M 4
74	25242-901	Kit, Coil Over Damper, Upper Bracket, Hardware, Wedged, L/M
75	25096-000	Translation Clamp
76	71005-901	Test Fixture, Damper Assembly, Go Gauge
77	33000-XX-901	STD Bearing Post
78	33002-XX-901	HD Bearing Post
79	33001-XX-901	Center Post



Exp 01/31/2027  
04/13/2026

# PHOTOVOLTAIC ARRAY PROJECT: 17419

MODULE: TSM-DEG19C.20

POWER: APPROX. 1.399 MW DC

UP TO 32 LINKED ROWS

## PROJECT NOTES:

### 1. DESIGN CRITERIA:

- A. 120 MPH WIND SPEED, ASCE 7-22, CAT I
- B. 52 PSF GROUND SNOW
- C. EXPOSURE C
- D. ISO 9223 C2 CORROSION CONDITIONS
- E. SEISMIC:  $S_{Ds} = 0.17$

### 2. MODULE SPECIFICATIONS:

- A. TSM-DEG19C.20
- B. 35 IN SERIES
- C. MOUNTED WITH 1400mm Thru-Bolt CLAMPS MOUNTED USING HUCK BOLTS

### 3. TRACKER SPECIFICATIONS:

- A. 4.0° MAX N-S TILT FROM HORIZONTAL WITHOUT MODIFICATION
- B.  $\pm 52^\circ$  TRACKER RANGE OF MOTION
- C. 10.0° MAX E/W SLOPE
- D. 480V MOTORS

④ MOTOR IS INSTALLED AT THE WEST OR EAST SIDE OF THE BLOCK.

⑤  INDICATES E/W EXTERIOR ROW UNLESS ADJACENT TO ANOTHER BLOCK.

⑥ IF THE CLEAR DISTANCE BETWEEN BLOCKS EXCEEDS 2 TIMES THE ROW SPACING, THE FIRST TWO EXPOSED ROWS ARE EXTERIOR.

7. SEE DETAIL A ON SHEET 8 FOR EXTERIOR ROW DESIGNATION DUE TO ELEVATION DIFFERENCES BETWEEN ROWS.

8. MINIMUM SITE DESIGN TEMPERATURE: -20.56°C

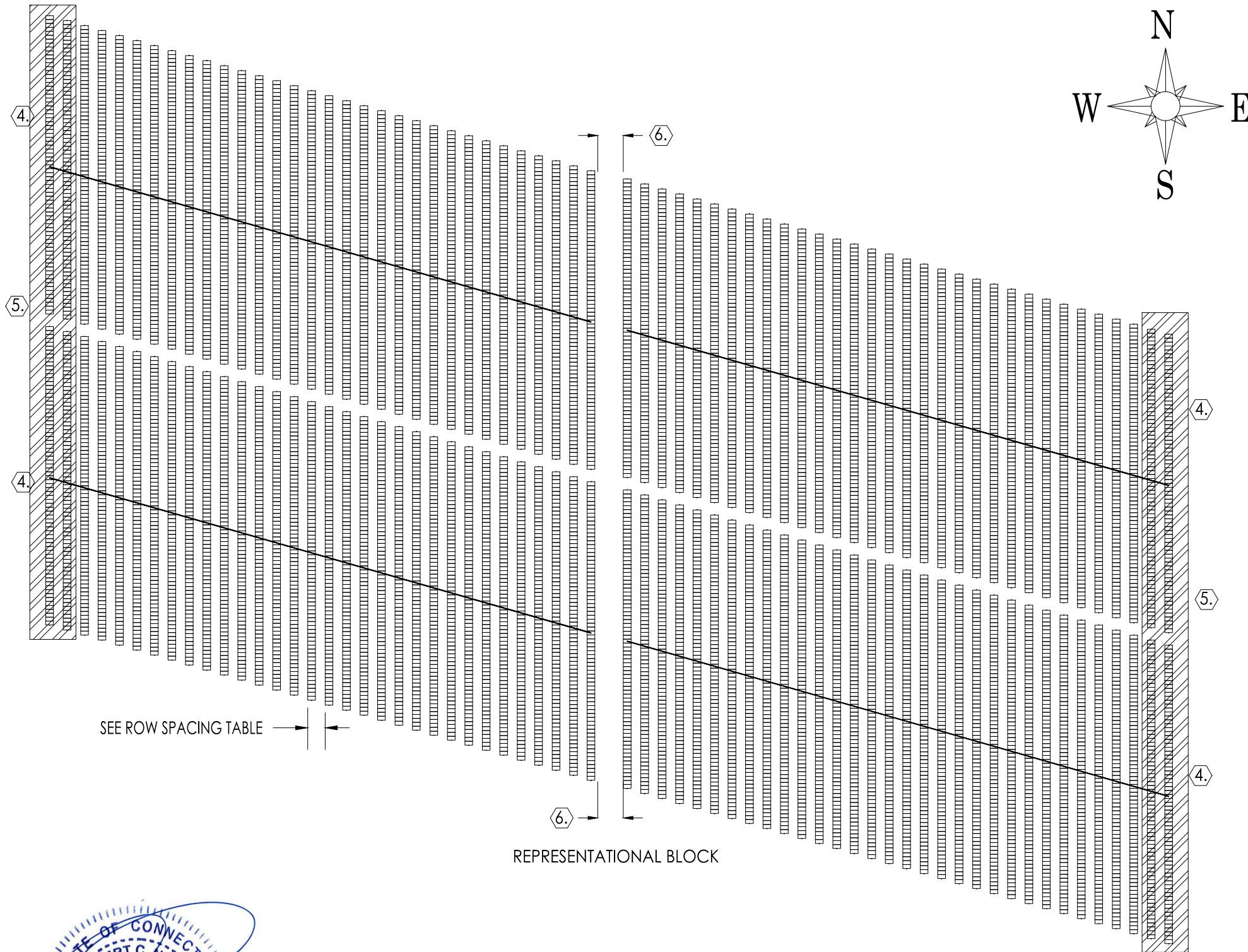

SEE ROW SPACING TABLE →

ROW SPACING TABLE

SPACING	BLOCK ANGLE	ROWS/MOTOR
4.57M [15']	0°	32
4.57M [15']	25°	27

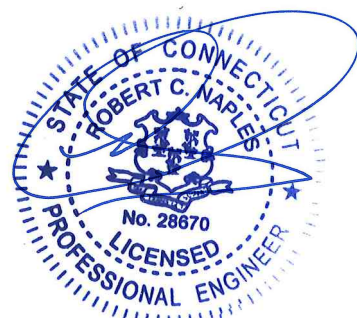

Exp 01/31/2027  
04/13/2026

17419 74 Bokum  
Approx. 1.399 MWDC  
Old Saybrook, CT 06420  
Horton Electric

PROPRIETARY AND CONFIDENTIAL  
THE INFORMATION CONTAINED IN THIS DRAWING IS THE SOLE PROPERTY OF ARRAY TECHNOLOGIES. ANY REPRODUCTION IN PART OR AS A WHOLE WITHOUT THE WRITTEN PERMISSION FROM ARRAY TECHNOLOGIES IS PROHIBITED.



DRAWING STATUS		Final	
PRODUCT STATUS		Final	
	NAME	DATE	
DRAWN	MP	04/09/2026	
CHECKED	Ampacity	04/09/2026	
APPROVED	---	---	

REV	INITIAL RELEASE	DATE
A	INITIAL RELEASE	04/09/2026
REV	DESCRIPTION	DATE

**ARRAY TECHNOLOGIES**  
3901 Midway Place NE, Albuquerque, NM 87109  
(505) 881-7567

**ARRAY TECHNOLOGIES**

TITLE  
**OmniTrack® HZ Project: 17419 74 Bokum**

SIZE	PRODUCT NUMBER	REVISION
B	17419	A

SCALE	DWG NO.	U.S. PATENT NO.
NTS	17419-901	#8,459,249; # 9,281,778

1 OF 10

**NOTES:**

1. GEAR RACK COLUMN

2. ALL COLUMNS NOT IDENTIFIED AS "GEAR RACK COLUMN" ARE BEARING COLUMNS.

3. ALL BEAMS SHOULD BE CONSTRUCTED WITH ASTM A992 GRADE 50 STEEL WITH CONSIDERATION FOR CORROSION. REFER TO FOUNDATION DESIGN, BY OTHERS, FOR DETAILS.

4. FOR COLUMN LENGTH, REFERENCE CUSTOMER PROVIDED FOUNDATION DESIGNS.

5. COLUMN TOLERANCES

- A. PILE HEIGHT TOLERANCE  $\pm 0.625"$  (16mm) FROM INSTALL PLANE
- B. PLAN LOCATION
  - 1. E/W:  $\pm 0.625"$  (16mm)
  - 2. N/S:  $\pm 1.375"$  (35mm)
- C. ROTATIONAL TWIST GEAR RACK:  $\pm 1.5^\circ$  FROM AXIS BEARING COLUMN:  $\pm 5^\circ$  FROM AXIS
- D. PLUMB:
  - 1. E/W:  $\pm 1.0^\circ$
  - 2. N/S:  $\pm 3.0^\circ$

NOTE: THESE TOLERANCES ARE NOT CUMULATIVE AND ARE DEFINED AT THE TOP OF THE COLUMN RELATIVE TO THE COLUMN PLANE AND PLAN LOCATION.

6. SEE DETAIL B ON SHEET 8 FOR MINIMUM COLUMN HEIGHTS

7. ARRAY BRACKETS ARE COMPATIBLE WITH (TBD) I-BEAMS FOR BEARING COLUMNS. IF A DIFFERENT COLUMN SIZE IS REQUIRED, CONTACT ARRAY.

8. SEE FIELD ASSEMBLY DRAWINGS FOR GEAR RACK COLUMN AND BEARING COLUMN HOLE REQUIREMENTS.

9. COLUMN SPACINGS SHOWN ARE BEARING TO BEARING ALONG TRACKER AXIS, WHICH MATCHES PILE SPACING ON A FLAT PLANE. FOR HIGH-SLOPE TRACKER INSTALLATION, REFER TO CONSTRUCTION SUPPLEMENT 901 10-000.

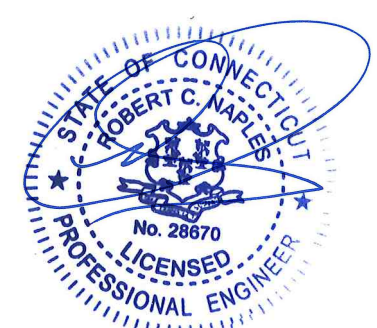
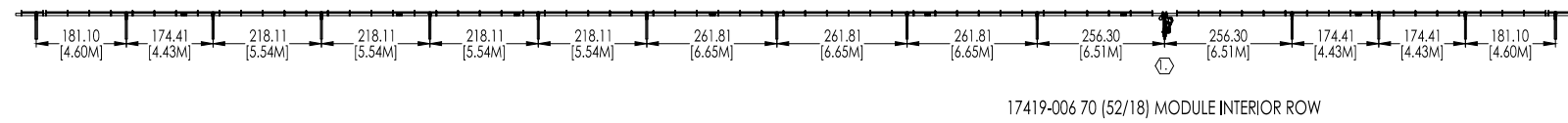
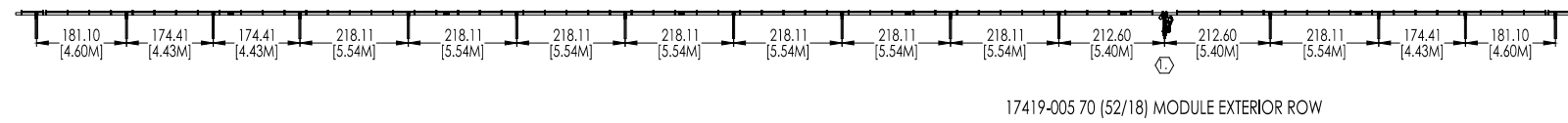
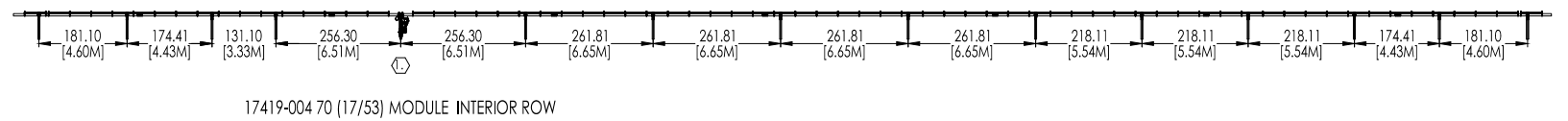
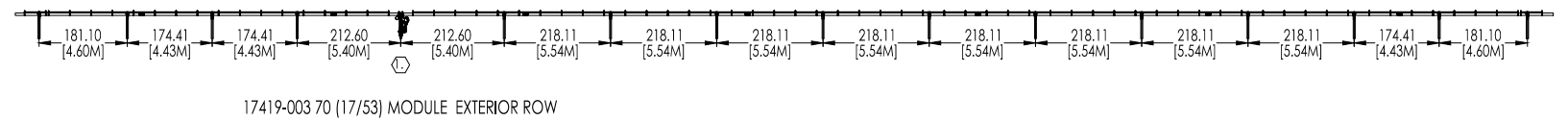
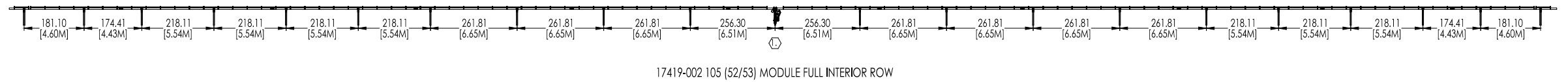
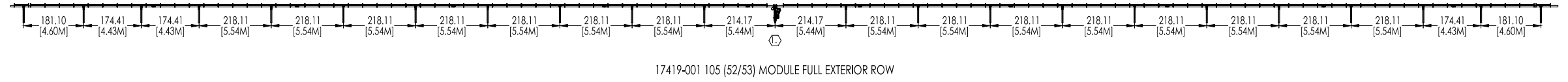

Exp 01/31/2027  
04/13/2026

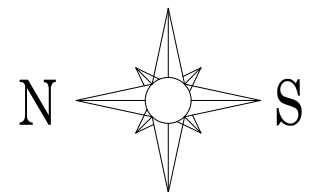

BEARING STRENGTH	HOLE DIAMETER	BEARING TYPE
HIGH WIND	[0.813] 20.7	STEEL

17419 74 Bokum  
Approx. 1.399 MWDC  
Old Saybrook, CT 06420  
Horton Electric

PROPRIETARY AND CONFIDENTIAL  
THE INFORMATION CONTAINED IN THIS DRAWING IS THE SOLE PROPERTY OF ARRAY TECHNOLOGIES. ANY REPRODUCTION IN PART OR AS A WHOLE WITHOUT THE WRITTEN PERMISSION FROM ARRAY TECHNOLOGIES IS PROHIBITED.

AMPACITY RENEWABLES QUANTA ARRAY TECHNOLOGIES	DRAWING STATUS		Final
	PRODUCT STATUS		Final
	NAME	DATE	
	DRAWN	MP	04/09/2026
	CHECKED	Ampacity	04/09/2026
	APPROVED	---	---

A	INITIAL RELEASE	04/09/2026
REV	DESCRIPTION	DATE
ARRAY TECHNOLOGIES 3901 Midway Place NE, Albuquerque, NM 87109 (505) 881-7567		
TITLE <b>OmniTrack® HZ Project: 17419 74 Bokum Foundation Layout</b>		
SIZE	PRODUCT NUMBER	REVISION
B	17419	A
SCALE	DWG NO.	U.S. PATENT NO.
NTS	17419-901	#8,459,249; # 9,281,778
		2 OF 10

**NOTES:**

① GEAR RACK COLUMN

2. ALL COLUMNS NOT IDENTIFIED AS "GEAR RACK COLUMN" ARE BEARING COLUMNS.
3. ALL BEAMS SHOULD BE CONSTRUCTED WITH ASTM A992 GRADE 50 STEEL WITH CONSIDERATION FOR CORROSION. REFER TO FOUNDATION DESIGN, BY OTHERS, FOR DETAILS.
4. FOR COLUMN LENGTH, REFERENCE CUSTOMER PROVIDED FOUNDATION DESIGNS.
5. COLUMN TOLERANCES
  - A. PILE HEIGHT TOLERANCE  $\pm 0.625"$  (16mm) FROM INSTALL PLANE
  - B. PLAN LOCATION
    1. E/W:  $\pm 0.625"$  (16mm)
    2. N/S:  $\pm 1.375"$  (35mm)
  - C. ROTATIONAL TWIST GEAR RACK:
    - $\pm 1.5^\circ$  FROM AXIS BEARING
    - COLUMN:  $\pm 5^\circ$  FROM AXIS
  - D. PLUMB:
    1. E/W:  $\pm 1.0^\circ$
    2. N/S:  $\pm 3.0^\circ$

NOTE: THESE TOLERANCES ARE NOT CUMULATIVE AND ARE DEFINED AT THE TOP OF THE COLUMN RELATIVE TO THE COLUMN PLANE AND PLAN LOCATION.

6. SEE DETAIL B ON SHEET 8 FOR MINIMUM COLUMN HEIGHTS
7. ARRAY BRACKETS ARE COMPATIBLE WITH (TBD) I-BEAMS FOR BEARING COLUMNS. IF A DIFFERENT COLUMN SIZE IS REQUIRED, CONTACT ARRAY.
8. SEE FIELD ASSEMBLY DRAWINGS FOR GEAR RACK COLUMN AND BEARING COLUMN HOLE REQUIREMENTS.
9. COLUMN SPACINGS SHOWN ARE BEARING TO BEARING ALONG TRACKER AXIS, WHICH MATCHES PILE SPACING ON A FLAT PLANE. FOR HIGH-SLOPE TRACKER INSTALLATION, REFER TO CONSTRUCTION SUPPLEMENT 901 10-000.

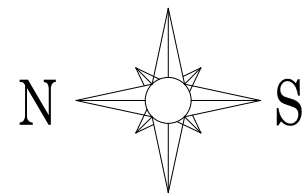

BEARING STRENGTH	HOLE DIAMETER	BEARING TYPE
HIGH WIND	[0.813] 20.7	STEEL

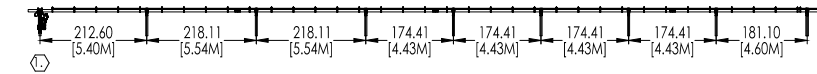

17419-007 35 (0/35) MODULE EXTERIOR ROW

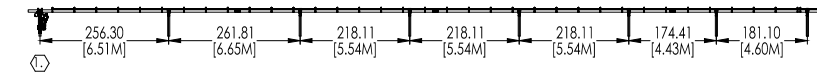

17419-008 35 (0/35) MODULE INTERIOR ROW

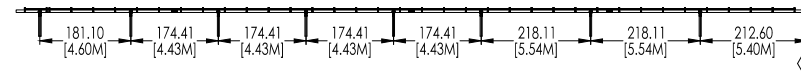

17419-009 35 (35/0) MODULE EXTERIOR ROW

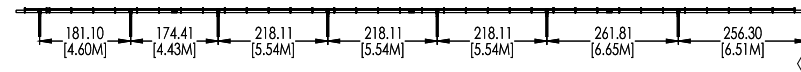

17419-010 35 (35/0) MODULE INTERIOR ROW

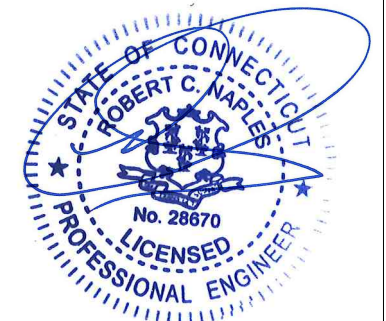

Exp 01/31/2027  
04/13/2026

17419 74 Bokum  
Approx. 1.399 MWDC  
Old Saybrook, CT 06420  
Horton Electric



DRAWING STATUS Final		
PRODUCT STATUS Final		
NAME	DATE	
DRAWN MP	04/09/2026	
CHECKED Ampacity	04/09/2026	
APPROVED ---	---	

A	INITIAL RELEASE	04/09/2026
REV	DESCRIPTION	DATE
<b>ARRAY TECHNOLOGIES</b> 3901 Midway Place NE, Albuquerque, NM 87109 (505) 881-7567		
<b>OmniTrack® HZ Project: 17419 74 Bokum Foundation Layout</b>		
SIZE B	PRODUCT NUMBER 17419	REVISION A
SCALE NTS	DWG NO. 17419-901	U.S. PATENT NO. #8,459,249; # 9,281,778
		3 OF 10

PROPRIETARY AND CONFIDENTIAL  
THE INFORMATION CONTAINED IN THIS DRAWING IS THE SOLE PROPERTY OF ARRAY TECHNOLOGIES. ANY REPRODUCTION IN PART OR AS A WHOLE WITHOUT THE WRITTEN PERMISSION FROM ARRAY TECHNOLOGIES IS PROHIBITED.

**NOTES:**

- ① LOCATION OF DAMPER
- 2. THERE IS 0.49" (12.4MM) OF SPACE BETWEEN MODULES
- 3. DO NOT ATTACH NON- ARRAY SUPPLIED MATERIALS WITHOUT ARRAY APPROVAL.
- 4. PREGALVANIZED TUBE, PN 30811, MAY BE SUBSTITUTED WITH STRUCTURAL EQUIVALENT HDG, PN 30662/30810
- 5. OVERHANG IS MEASURED FROM MODULE EDGE. THE DISTANCE BETWEEN MODULE EDGE AND CLAMP EDGE IS APPROX. 0.75".
- ⑥ MODULE GAP: BEGIN MODULE INSTALLATION AT CENTER STRUCTURE. FOR CENTER GAP DIMENSIONS SEE DETAIL F ON SHEET 9.

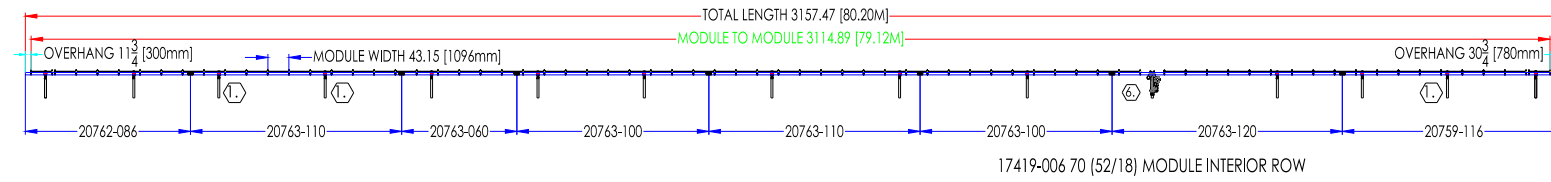
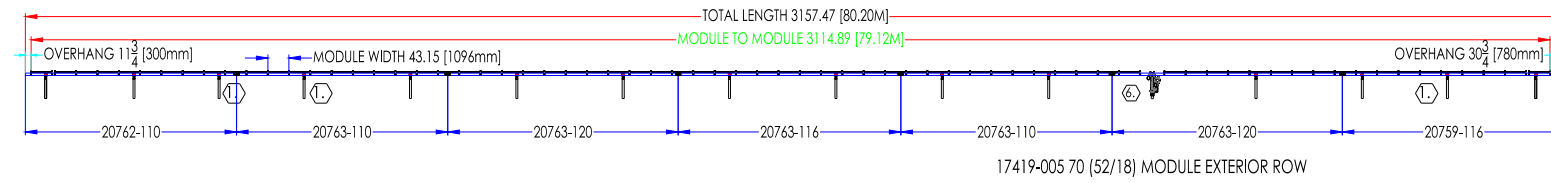
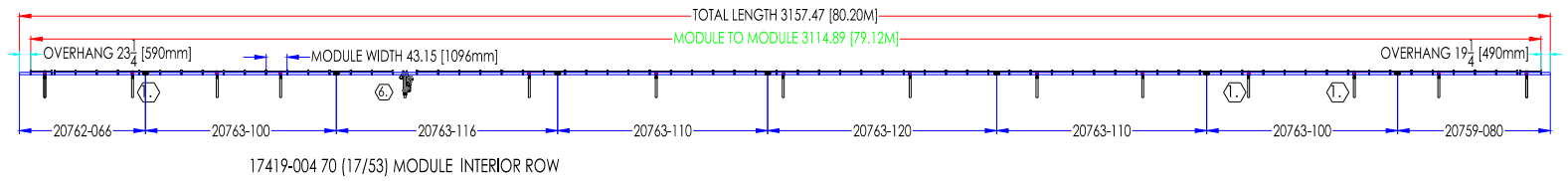
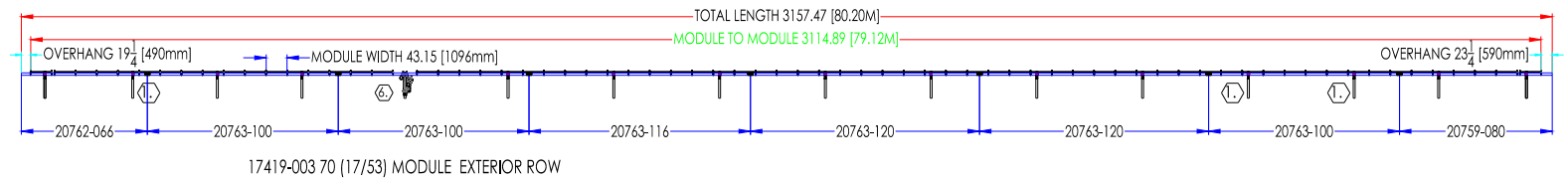
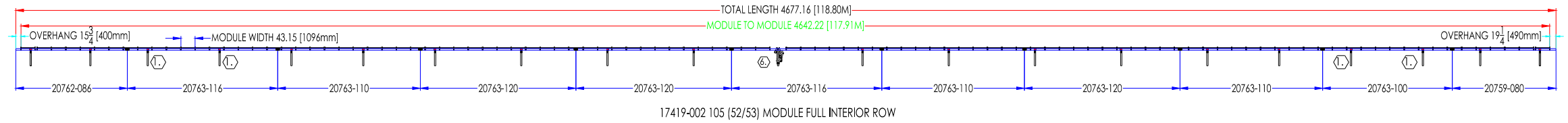
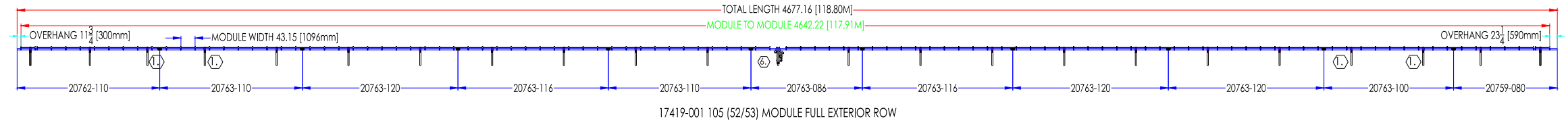

12ga TORQUE TUBE PART NOS. (L CONDITION)					
FT	M	BEAM/ COUPLER	BEAM/ CAP	BEAM/ COUPLER+ CAP	TUBE
19.68	6	20763-060	20762-060	20759-060	30811-060
20.67	6.3	20763-063	20762-063	20759-063	30811-063
21.65	6.6	20763-066	20762-066	20759-066	30811-066
26.25	8	20763-080	20762-080	20759-080	30811-080
27.23	8.3	20763-083	20762-083	20759-083	30811-083
28.21	8.6	20763-086	20762-086	20759-086	30811-086
32.81	10	20763-100	20762-100	20759-100	30811-100
34.78	10.6	20763-106	20762-106	20759-106	30811-106
36.09	11.0	20763-110	20762-110	20759-110	30811-110
38.06	11.6	20763-116	20762-116	20759-116	30811-116
39.37	12.0	20763-120	20762-120	20759-120	30811-120

NOTE: TORQUE TUBE/BEAM ASSEMBLY TABLE FOR INFORMATION PURPOSES ONLY. NOT ALL BEAM CONFIGURATIONS MAY BE REPRESENTED IN ROW LAYOUTS.

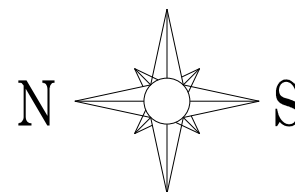

17419 74 Bokum  
Approx. 1.399 MWDC  
Old Saybrook, CT 06420  
Horton Electric

PROPRIETARY AND CONFIDENTIAL  
THE INFORMATION CONTAINED IN THIS DRAWING IS THE SOLE PROPERTY OF ARRAY TECHNOLOGIES. ANY REPRODUCTION IN PART OR AS A WHOLE WITHOUT THE WRITTEN PERMISSION FROM ARRAY TECHNOLOGIES IS PROHIBITED.



DRAWING STATUS <b>Final</b>		
PRODUCT STATUS <b>Final</b>		
DRAWN	MP	04/09/2026
CHECKED	Ampacity	04/09/2026
APPROVED	---	---

A	INITIAL RELEASE	04/09/2026
REV	DESCRIPTION	DATE
<b>ARRAY TECHNOLOGIES</b> 3901 Midway Place NE, Albuquerque, NM 87109 (505) 881-7567		
TITLE <b>OmniTrack® HZ Project:                  17419 74 Bokum                  Torque Tube Configurations</b>		
SIZE B	PRODUCT NUMBER 17419	REVISION A
SCALE NTS	DWG NO. 17419-901	U.S. PATENT NO. #8,459,249; # 9,281,778
		4 OF 10

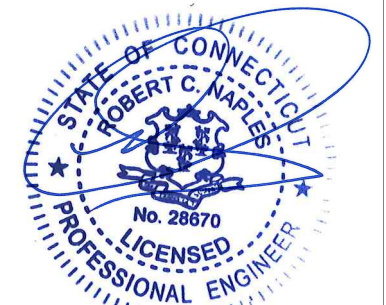

Exp 01/31/2027  
04/13/2026

**NOTES:**

1. LOCATION OF DAMPER
2. THERE IS 0.49" (12.4MM) OF SPACE BETWEEN MODULES
3. DO NOT ATTACH NON- ARRAY SUPPLIED MATERIALS WITHOUT ARRAY APPROVAL.
4. PREGALVANIZED TUBE, PN 30811, MAY BE SUBSTITUTED WITH STRUCTURAL EQUIVALENT HDG, PN 30662/30810
5. OVERHANG IS MEASURED FROM MODULE EDGE. THE DISTANCE BETWEEN MODULE EDGE AND CLAMP EDGE IS APPROX. 0.75".
6. MODULE GAP: BEGIN MODULE INSTALLATION AT CENTER STRUCTURE. FOR CENTER GAP DIMENSIONS SEE DETAIL F ON SHEET 9.

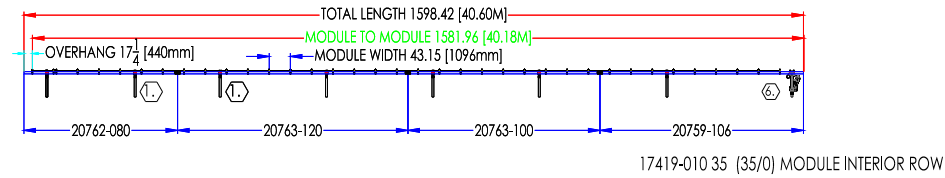
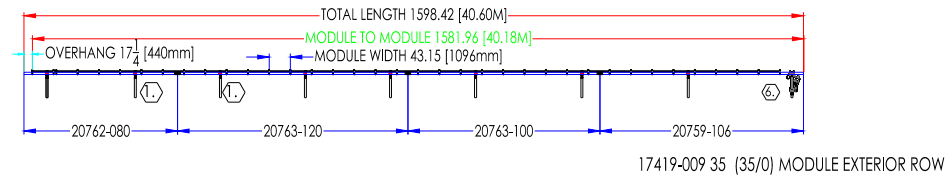
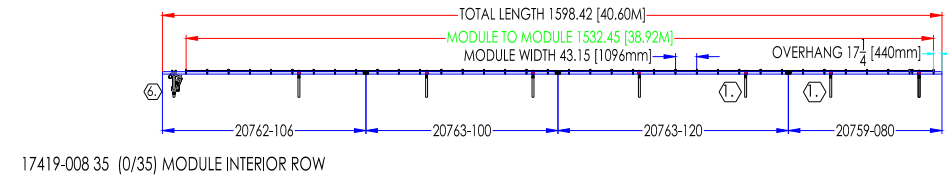
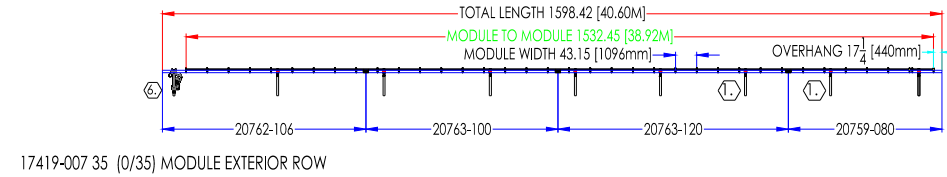

12ga TORQUE TUBE PART NOS. (L CONDITION)					
FT	M	BEAM/ COUPLER	BEAM/ CAP	BEAM/ COUPLER+ CAP	TUBE
19.68	6	20763-060	20762-060	20759-060	30811-060
20.67	6.3	20763-063	20762-063	20759-063	30811-063
21.65	6.6	20763-066	20762-066	20759-066	30811-066
26.25	8	20763-080	20762-080	20759-080	30811-080
27.23	8.3	20763-083	20762-083	20759-083	30811-083
28.21	8.6	20763-086	20762-086	20759-086	30811-086
32.81	10	20763-100	20762-100	20759-100	30811-100
34.78	10.6	20763-106	20762-106	20759-106	30811-106
36.09	11.0	20763-110	20762-110	20759-110	30811-110
38.06	11.6	20763-116	20762-116	20759-116	30811-116
39.37	12.0	20763-120	20762-120	20759-120	30811-120

NOTE: TORQUE TUBE/BEAM ASSEMBLY TABLE FOR INFORMATION PURPOSES ONLY. NOT ALL BEAM CONFIGURATIONS MAY BE REPRESENTED IN ROW LAYOUTS.

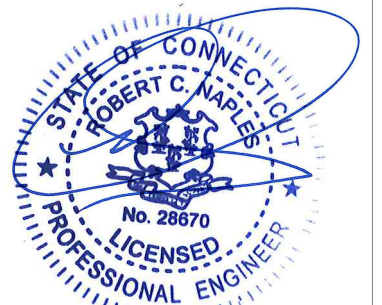

Exp 01/31/2027  
04/13/2026

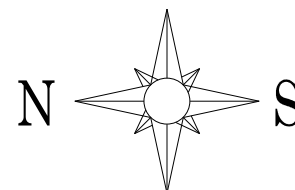

17419 74 Bokum  
Approx. 1.399 MWDC  
Old Saybrook, CT 06420  
Horton Electric

PROPRIETARY AND CONFIDENTIAL  
THE INFORMATION CONTAINED IN THIS DRAWING IS THE SOLE PROPERTY OF ARRAY TECHNOLOGIES. ANY REPRODUCTION IN PART OR AS A WHOLE WITHOUT THE WRITTEN PERMISSION FROM ARRAY TECHNOLOGIES IS PROHIBITED.



DRAWING STATUS <b>Final</b>		
PRODUCT STATUS <b>Final</b>		
NAME	DATE	
DRAWN MP	04/09/2026	
CHECKED Ampacity	04/09/2026	
APPROVED	---	---

A	INITIAL RELEASE	04/09/2026
REV	DESCRIPTION	DATE
<b>ARRAY TECHNOLOGIES</b> 3901 Midway Place NE, Albuquerque, NM 87109 (505) 881-7567		
TITLE <b>OmniTrack® HZ Project:                  17419 74 Bokum                  Torque Tube Configurations</b>		
SIZE <b>B</b>	PRODUCT NUMBER <b>17419</b>	REVISION <b>A</b>
SCALE NTS	DWG NO. 17419-901	U.S. PATENT NO. #8,459,249; # 9,281,778
		5 OF 10

**NOTES:**

1. LOWER NUMBER INDICATES NUMBER OF CLAMPS BETWEEN TWO POINTS(COLUMN TO COLUMN OR COLUMN TO TORQUE TUBE END

2. FOR EASE OF ASSEMBLY, ARRAY RECOMMENDS, BUT DOES NOT REQUIRE, THE FOLLOWING INSTALLATION SEQUENCE:  
 A: INSTALLED FIRST  
 B : INSTALLED SECOND  
 C: INSTALLED LAST

③. COUPLER IS LOCATED BETWEEN ALL TORQUE TUBE

④. LOCATION OF BEARING HOUSING WITH SET SCREWS. REFER 21000-901 FIELD ASSEMBLY DRAWING FOR DETAILS.

⑤. TRANSLATION CLAMP PAIR LOCATION. CLAMPS TO BE INSTALLED ON NORTH AND SOUTH SIDES OF BEARING POST. REFER 25096-000 FIELD ASSEMBLY DRAWING FOR DETAILS.

6. NIGHT SNOW STOW SYSTEM SETTING MUST BE TURNED ON UPON COMMISSIONING.

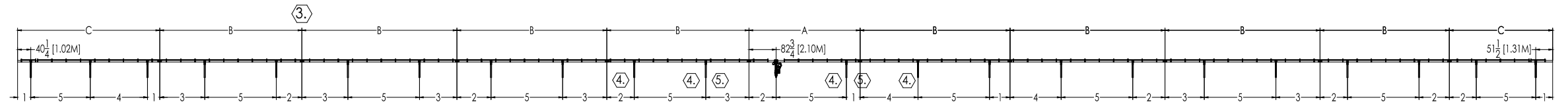

17419-001 105 (52/53) MODULE FULL EXTERIOR ROW  
109 CLAMPS

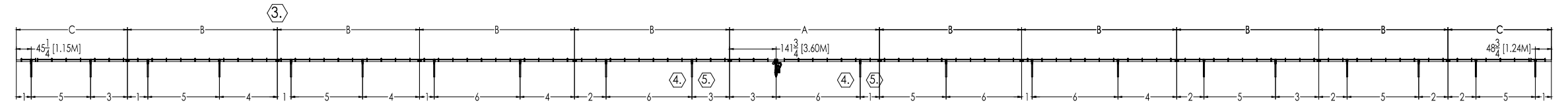

17419-002 105 (52/53) MODULE FULL INTERIOR ROW  
109 CLAMPS

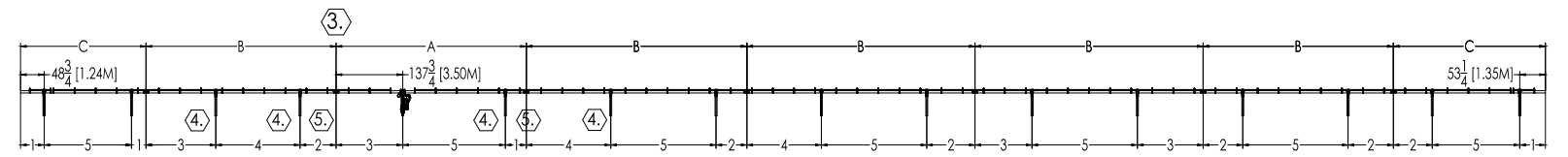

17419-003 70 (17/53) MODULE EXTERIOR ROW  
74 CLAMPS

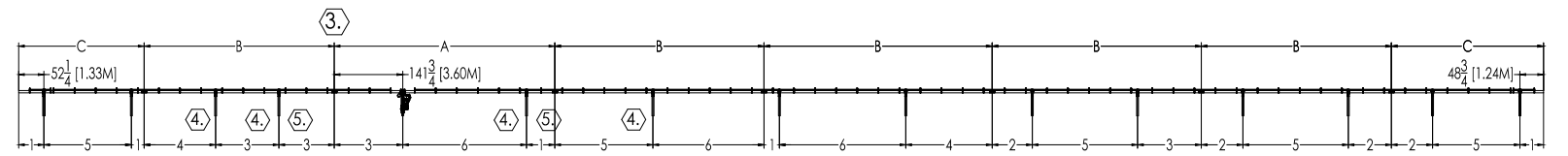

17419-004 70 (17/53) MODULE INTERIOR ROW  
74 CLAMPS

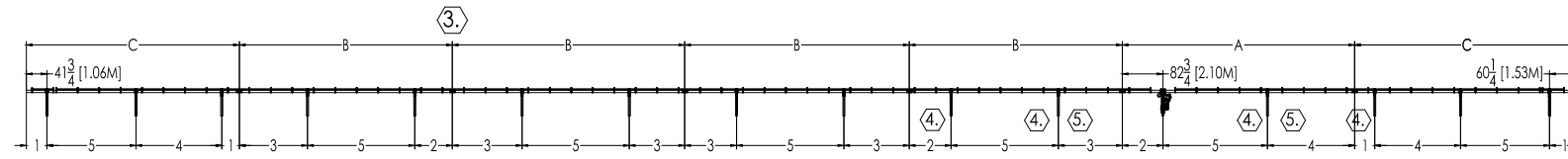

17419-005 70 (52/18) MODULE EXTERIOR ROW  
74 CLAMPS

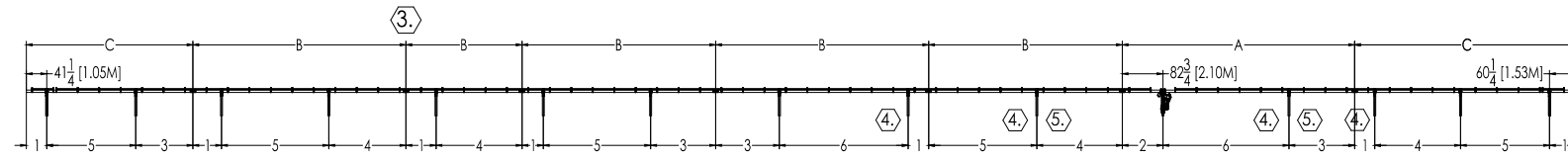

17419-006 70 (52/18) MODULE INTERIOR ROW  
74 CLAMPS

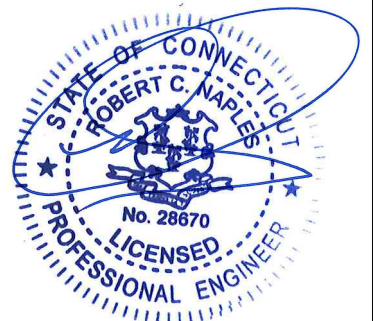

Exp 01/31/2027  
04/13/2026

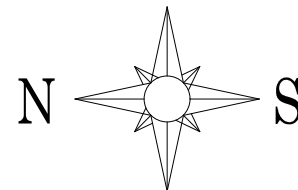

17419 74 Bokum  
Approx. 1.399 MWDC  
Old Saybrook, CT 06420  
Horton Electric

PROPRIETARY AND CONFIDENTIAL  
THE INFORMATION CONTAINED IN THIS DRAWING IS THE SOLE PROPERTY OF ARRAY TECHNOLOGIES. ANY REPRODUCTION IN PART OR AS A WHOLE WITHOUT THE WRITTEN PERMISSION FROM ARRAY TECHNOLOGIES IS PROHIBITED.



DRAWING STATUS Final		
PRODUCT STATUS Final		
	NAME	DATE
DRAWN	MP	04/09/2026
CHECKED	Ampacity	04/09/2026
APPROVED	---	---

A	INITIAL RELEASE	04/09/2026
REV	DESCRIPTION	DATE
<b>ARRAY TECHNOLOGIES</b> 3901 Midway Place NE, Albuquerque, NM 87109 (505) 881-7567		
<b>TITLE</b> OmniTrack® HZ Project: 17419 74 Bokum Assembly Sequence		
SIZE B	PRODUCT NUMBER 17419	REVISION A
SCALE NTS	DWG NO. 17419-901	U.S. PATENT NO. #8,459,249; # 9,281,778
		6 OF 10

**NOTES:**

1. LOWER NUMBER INDICATES NUMBER OF CLAMPS BETWEEN TWO POINTS(COLUMN TO COLUMN OR COLUMN TO TORQUE TUBE END
2. FOR EASE OF ASSEMBLY, ARRAY RECOMMENDS, BUT DOES NOT REQUIRE, THE FOLLOWING INSTALLATION SEQUENCE:  
 A: INSTALLED FIRST  
 B : INSTALLED SECOND  
 C: INSTALLED LAST
3. COUPLER IS LOCATED BETWEEN ALL TORQUE TUBE
4. LOCATION OF BEARING HOUSING WITH SET SCREWS. REFER 21000-901 FIELD ASSEMBLY DRAWING FOR DETAILS.
5. TRANSLATION CLAMP PAIR LOCATION. CLAMPS TO BE INSTALLED ON NORTH AND SOUTH SIDES OF BEARING POST. REFER 25096-000 FIELD ASSEMBLY DRAWING FOR DETAILS.
6. NIGHT SNOW STOW SYSTEM SETTING MUST BE TURNED ON UPON COMMISSIONING.

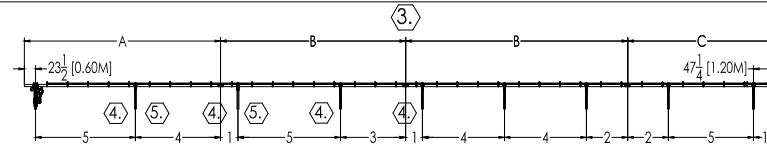

17419-007 35 (0/35) MODULE EXTERIOR ROW  
37 CLAMPS

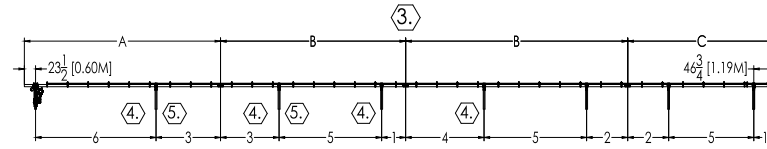

17419-008 35 (0/35) MODULE INTERIOR ROW  
37 CLAMPS

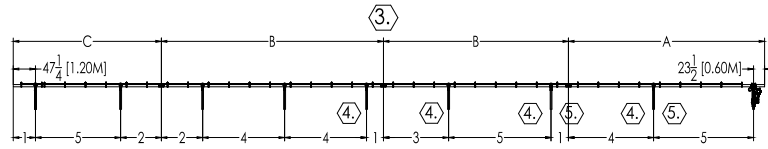

17419-009 35 (35/0) MODULE EXTERIOR ROW  
37 CLAMPS

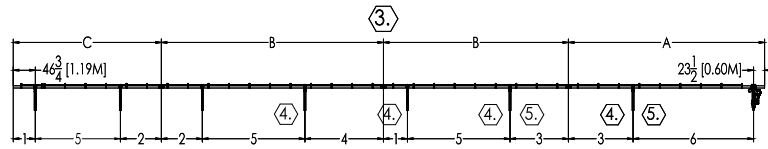

17419-010 35 (35/0) MODULE INTERIOR ROW  
37 CLAMPS

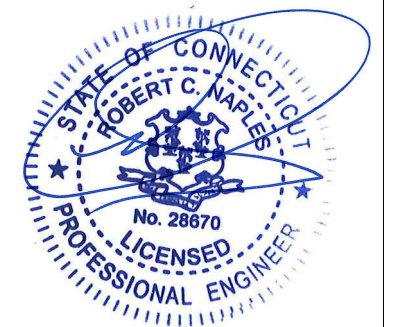

Exp 01/31/2027  
04/13/2026

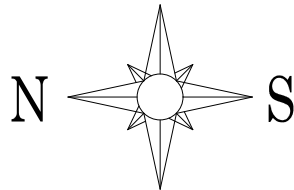

17419 74 Bokum  
Approx. 1,399 MWDC  
Old Saybrook, CT 06420  
Horton Electric

PROPRIETARY AND CONFIDENTIAL  
THE INFORMATION CONTAINED IN THIS DRAWING IS THE SOLE PROPERTY OF ARRAY TECHNOLOGIES. ANY REPRODUCTION IN PART OR AS A WHOLE WITHOUT THE WRITTEN PERMISSION FROM ARRAY TECHNOLOGIES IS PROHIBITED.

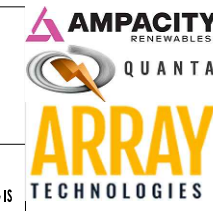

DRAWING STATUS Final		
PRODUCT STATUS Final		
	NAME	DATE
DRAWN	MP	04/09/2026
CHECKED	Ampacity	04/09/2026
APPROVED	---	---

A	INITIAL RELEASE	04/09/2026
REV	DESCRIPTION	DATE
<b>ARRAY TECHNOLOGIES</b>		
3901 Midway Place NE, Albuquerque, NM 87109 (505) 881-7567		
<b>OmniTrack® HZ Project: 17419 74 Bokum Assembly Sequence</b>		
SIZE B	PRODUCT NUMBER 17419	REVISION A
SCALE NTS	DWG NO. 17419-901	U.S. PATENT NO. #8,459,249; # 9,281,778
		7 OF 10

**NOTE:**

- IF THE HEIGHT DIFFERENCE AVERAGED AT ROW EXTREMITIES EXCEEDS THE DISTANCE NOTED, ROW ON HIGHER PLANE IS AN EXTERIOR ROW.

EXTERIOR ROW HEIGHT PARAMETER

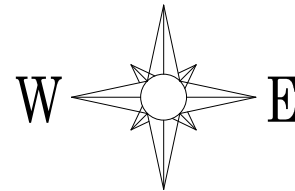
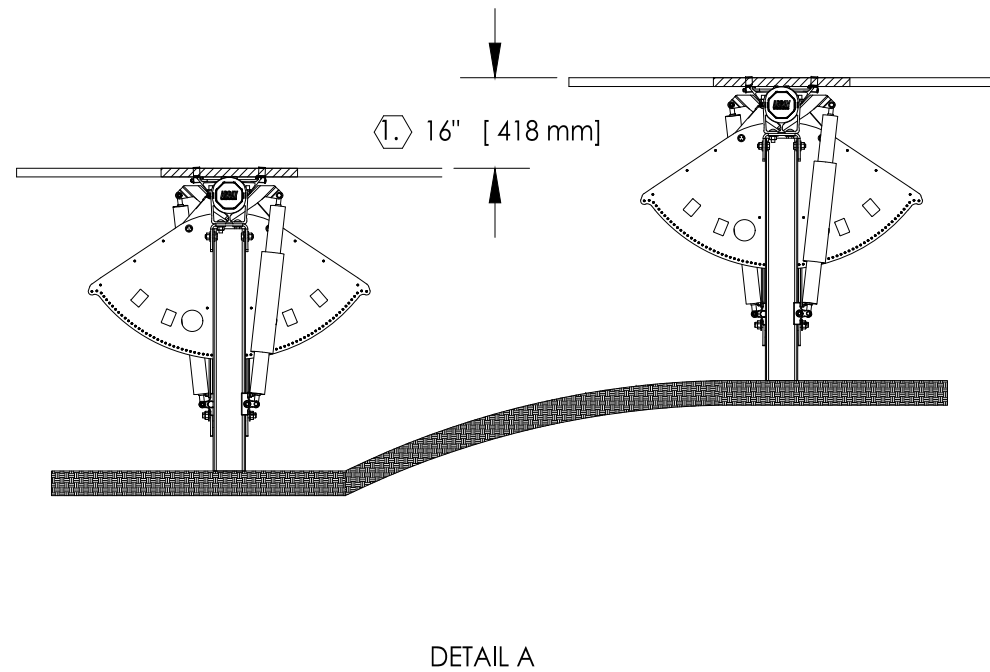

**NOTE:**

- REFERENCE INDIVIDUAL FIELD ASSEMBLY DRAWINGS FOR DETAILS.  
INSTALL END CLAMP SPACER ON END CLAMPS.  
INSTALL END CAP AT END OF TUBE.

MINIMUM DISTANCES AND MODULE DATA

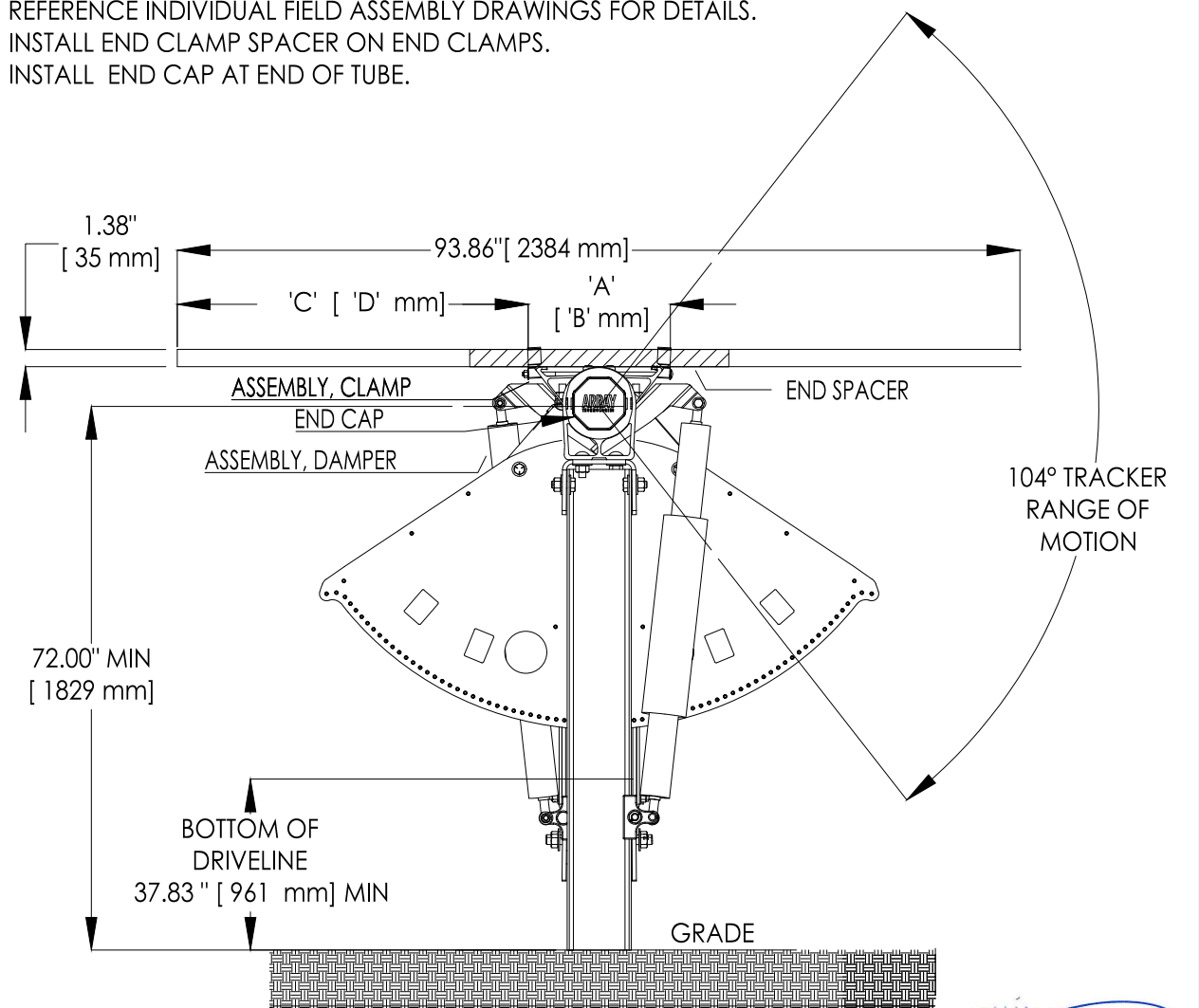

MODULE WIDTH = 43.15" [1096 mm]

DETAIL C

CLAMP TYPE	DIM 'A' [IN]	DIM 'B' [mm]	DIM 'C' [IN]	DIM 'D' [mm]
1400mm THRU BOLT	56.97	1447.0	16.36	415.5

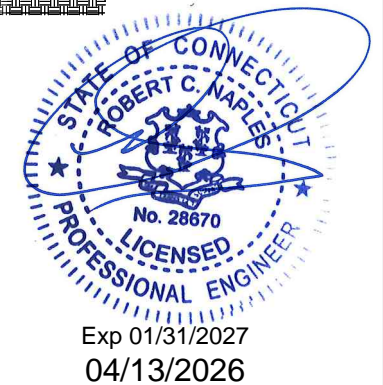

**NOTES:**

- GEAR RACK COLUMN TOP TO BEARING COLUMN TOP HEIGHT DIFFERENCE: 33.0" (REFER TO KEYED NOTE 5 ON PAGE 2 FOR ACCEPTED TOLERANCES.)
- GEAR RACK COLUMN BRACKET TOP TO BEARING COLUMN BRACKET TOP HEIGHT DIFFERENCE.
- MAX COLUMN HEIGHT IS DETERMINED BY FOUNDATION ENGINEER

COLUMN HEIGHT REQUIREMENTS

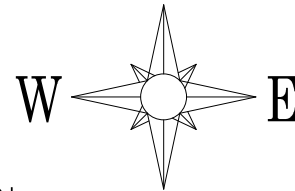
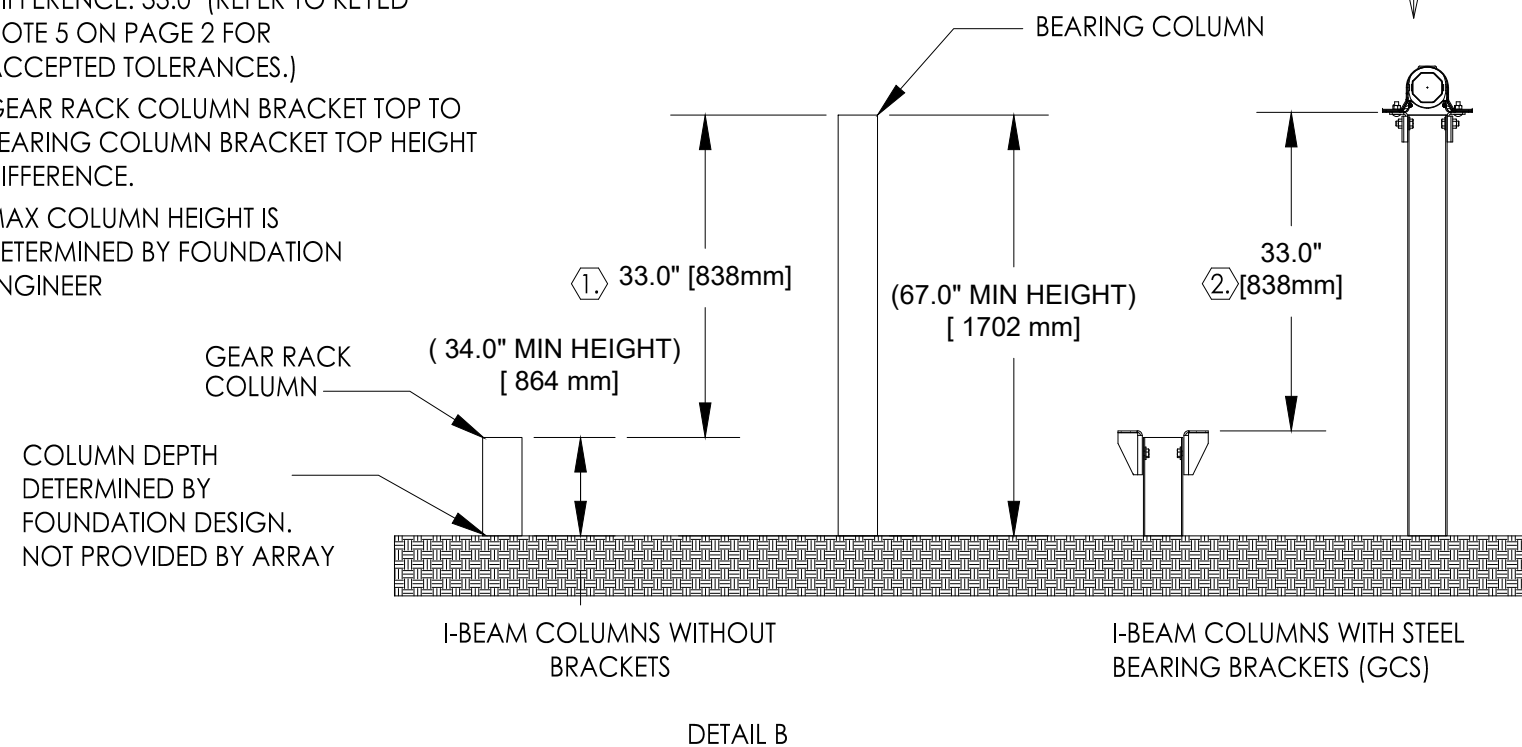

17419 74 Bokum  
Approx. 1.399 MWDC  
Old Saybrook, CT 06420  
Horton Electric

**AMPACITY RENEWABLES**  
**QUANTA**  
DRAWING STATUS: Final  
PRODUCT STATUS: Final

	NAME	DATE
DRAWN	MP	04/09/2026
CHECKED	Ampacity	04/09/2026
APPROVED	---	---

PROPRIETARY AND CONFIDENTIAL  
THE INFORMATION CONTAINED IN THIS DRAWING IS THE SOLE PROPERTY OF ARRAY TECHNOLOGIES. ANY REPRODUCTION IN PART OR AS A WHOLE WITHOUT THE WRITTEN PERMISSION FROM ARRAY TECHNOLOGIES IS PROHIBITED.

REV	DESCRIPTION	DATE
A	INITIAL RELEASE	04/09/2026

**ARRAY TECHNOLOGIES**  
3901 Midway Place NE, Albuquerque, NM 87109  
(505) 881-7567

**OmniTrack® HZ Project:**  
**17419 74 Bokum**  
**Detail Views**

SIZE B	PRODUCT NUMBER 17419	REVISION A
--------	----------------------	------------

SCALE NTS DWG NO. 17419-901 U.S. PATENT NO. #8,459,249; # 9,281,778 8 OF 10

**NOTES:**

1. THE GLOBAL CENTER STRUCTURE MOTOR IS MOUNTED OPPOSITE OF CAB SYSTEM.
2. THE GLOBAL CENTER STRUCTURE MOTOR CAN BE MOUNTED ON EITHER WEST SIDE OR EAST SIDE OF GEAR RACK.

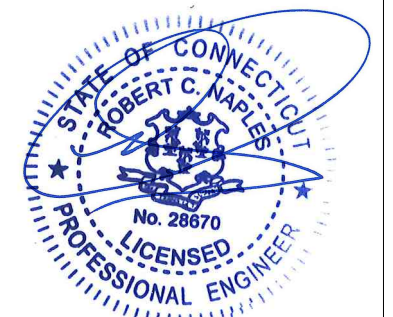
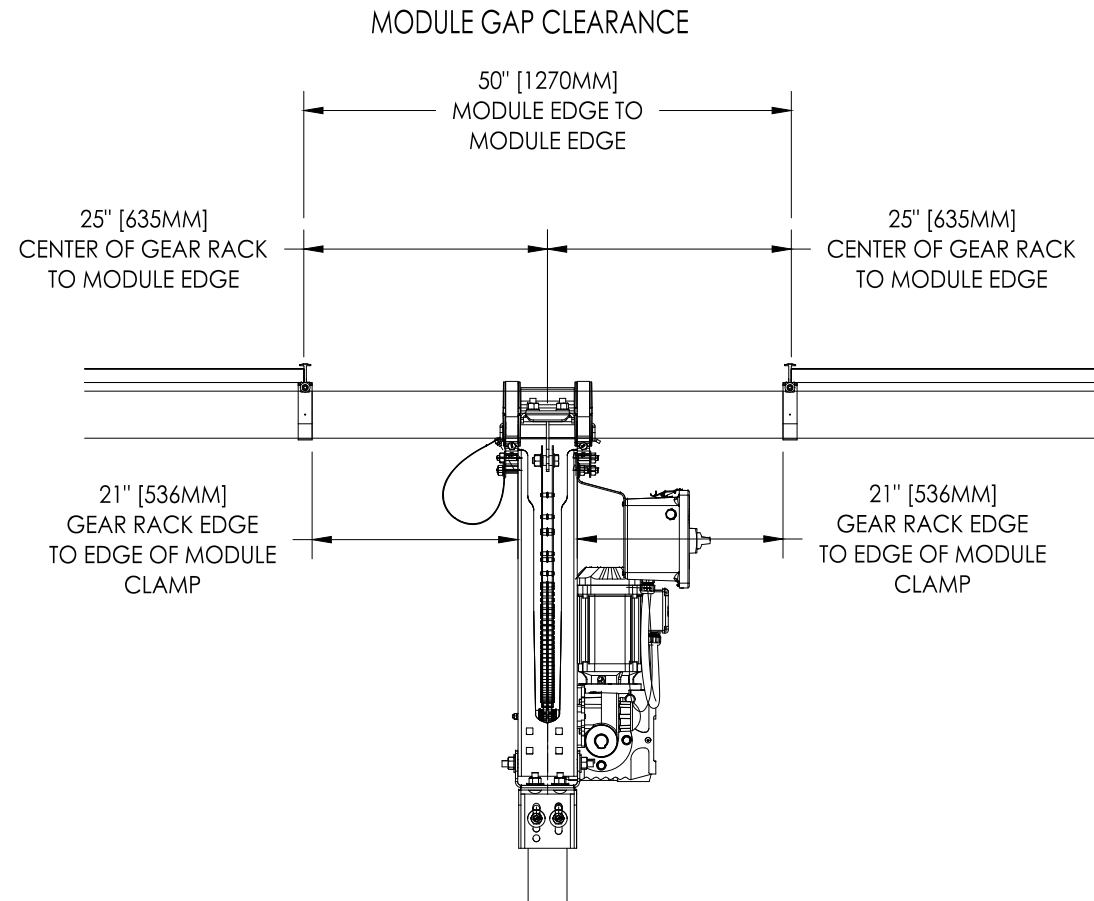

Exp 01/31/2027  
04/13/2026

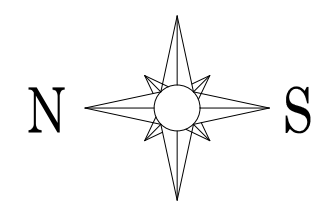

17419 74 Bokum  
Approx. 1.399 MWDC  
Old Saybrook, CT 06420  
Horton Electric

PROPRIETARY AND CONFIDENTIAL  
THE INFORMATION CONTAINED IN THIS DRAWING IS  
THE SOLE PROPERTY OF ARRAY TECHNOLOGIES.  
ANY REPRODUCTION IN PART OR AS A WHOLE  
WITHOUT THE WRITTEN PERMISSION FROM  
ARRAY TECHNOLOGIES IS PROHIBITED.

DRAWING STATUS Final	
PRODUCT STATUS Final	
NAME	DATE
DRAWN MP	04/09/2026
CHECKED Ampacity	04/09/2026
APPROVED ---	---

A	INITIAL RELEASE	04/09/2026
REV	DESCRIPTION	DATE
<b>ARRAY TECHNOLOGIES</b>		
3901 Midway Place NE, Albuquerque, NM 87109 (505) 881-7567		
<b>OmniTrack® HZ Project: 17419 74 Bokum Detail Views</b>		
SIZE B	PRODUCT NUMBER 17419	REVISION A
SCALE NTS	DWG NO. 17419-901	U.S. PATENT NO. #8,459,249; # 9,281,778
		9 OF 10

**AMPACITY RENEWABLES**

**QUANTA**

**ARRAY TECHNOLOGIES**

1. DIMENSIONS PROVIDED IN TABLE ARE FOR REFERENCE ONLY. REFER TO DETAILS A, B AND C ON SHEET 8 FOR PILE REVEAL MINIMA.

GCS DIMENSIONS FROM GRADE - 2384mm

TRACKER HEIGHT	72.00" [ 1.829 m]		84.00" [ 2.134 m]		96.00" [ 2.438 m]		108.00" [ 2.743 m]		120.00" [ 3.048 m]	
MODULE EDGE TO GRADE	37.48	0.952m	49.48"	1.257m	61.48"	1.562m	73.48"	1.866m	85.48"	2.171m
GEAR RACK PILE	33.25"	0.845m	45.25"	1.149m	57.25"	1.454m	69.25"	1.759m	81.25"	2.064m
BOTTOM OF DRIVELINE	37.83"	0.961m	49.83"	1.266m	61.83"	1.570m	73.83"	1.875m	85.83"	2.180m
MOTOR FLANGE	43.57"	1.107m	55.57"	1.411m	67.57"	1.716m	79.57"	2.021m	91.57"	2.326m
MOTOR ELECTRONICS	54.42"	1.382m	66.42"	1.687m	78.42"	1.992m	90.4"	2.297m	102.42"	2.601m
TOP OF MODULE	112.29	2.852	124.29"	3.157m	136.29"	3.462m	148.29"	3.766m	160.29"	4.071m

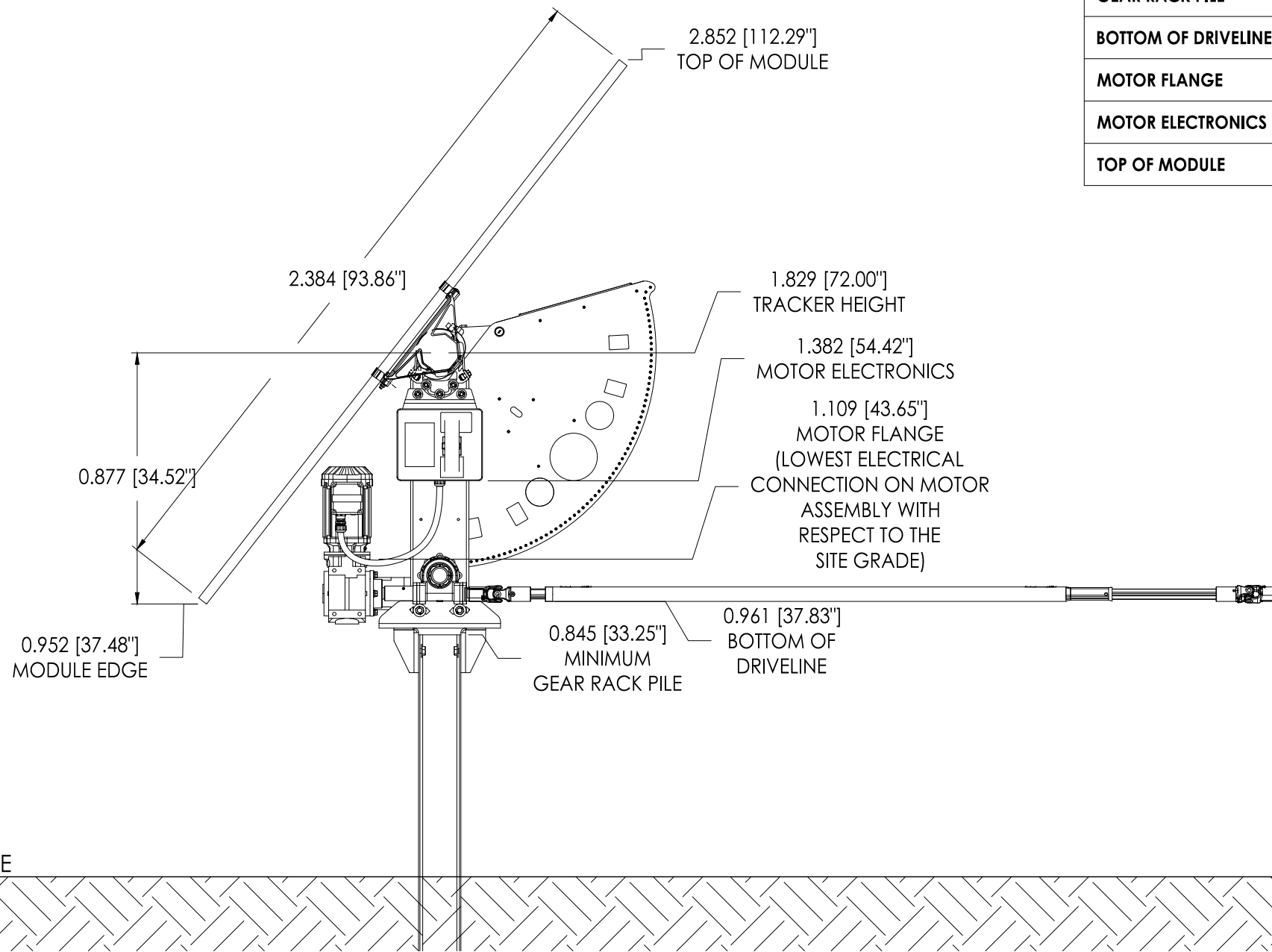

DETAIL F  
72.00" TRACKER HEIGHT

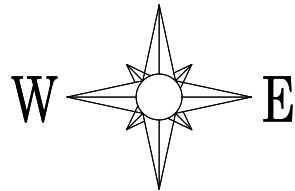

17419 74 Bokum  
Approx. 1.399 MWDC  
Old Saybrook, CT 06420  
Horton Electric

PROPRIETARY AND CONFIDENTIAL  
THE INFORMATION CONTAINED IN THIS DRAWING IS THE SOLE PROPERTY OF ARRAY TECHNOLOGIES. ANY REPRODUCTION IN PART OR AS A WHOLE WITHOUT THE WRITTEN PERMISSION FROM ARRAY TECHNOLOGIES IS PROHIBITED.

DRAWING STATUS		Final
PRODUCT STATUS		Final
DRAWN	NAME	DATE
CHECKED	Ampacity	04/09/2026
APPROVED	---	---

A	INITIAL RELEASE	04/09/2026
REV	DESCRIPTION	DATE
<b>ARRAY TECHNOLOGIES</b> 3901 Midway Place NE, Albuquerque, NM 87109 (505) 881-7567		
<b>OmniTrack® HZ Project:</b> <b>17419 74 Bokum</b> <b>Detail Views</b>		
SIZE	PRODUCT NUMBER	REVISION
B	17419	A
SCALE	DWG NO.	U.S. PATENT NO.
NTS	17419-901	#8,459,249; # 9,281,778
		10 OF 10

NOTES:

1. THE NOMINAL GAP SHOWN MAY BE ALTERED +/- 6IN.

OMNITRACK NOMINAL  
MODULE GAP CLEARANCE

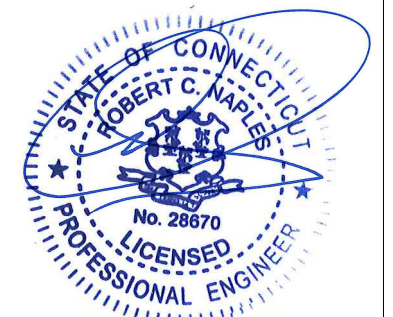
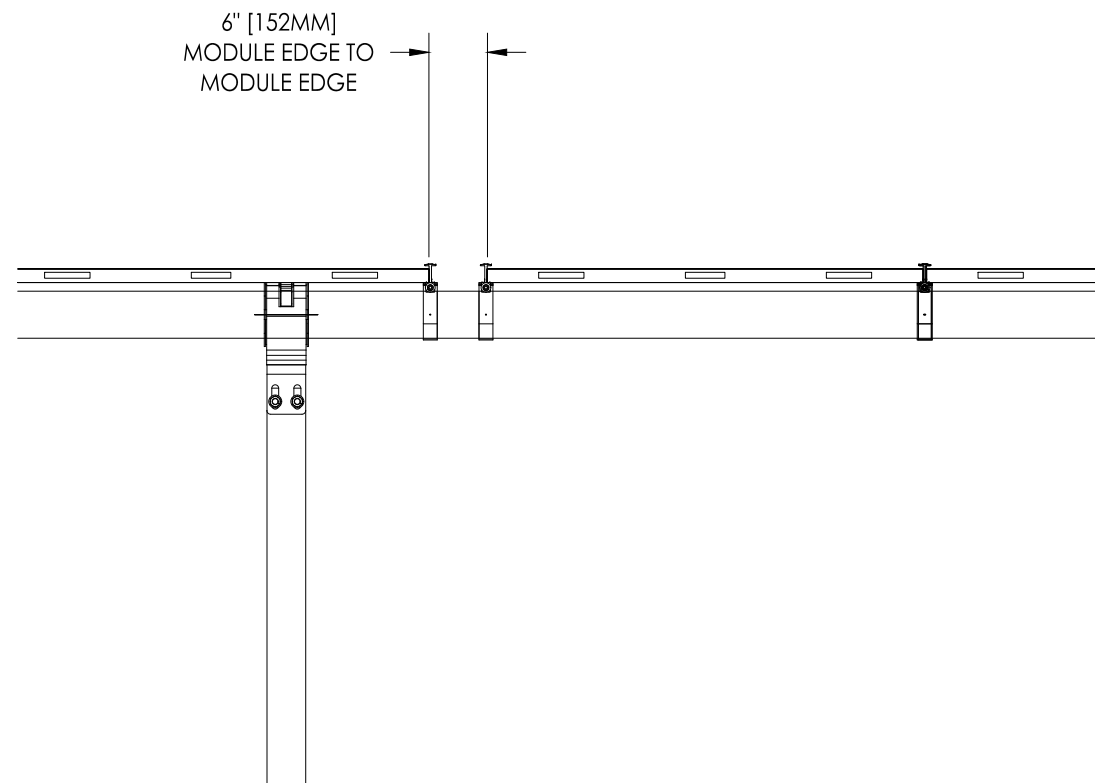

Exp 01/31/2027  
04/13/2026

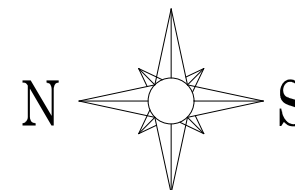

74 Bokum  
Approx. 1.399 MWDC  
Old Saybrook, CT 06420  
Horton Electric

PROPRIETARY AND CONFIDENTIAL  
THE INFORMATION CONTAINED IN THIS DRAWING IS THE SOLE PROPERTY OF ARRAY TECHNOLOGIES. ANY REPRODUCTION IN PART OR AS A WHOLE WITHOUT THE WRITTEN PERMISSION FROM ARRAY TECHNOLOGIES IS PROHIBITED.



DRAWING STATUS Final		
PRODUCT STATUS Final		
	NAME	DATE
DRAWN	MP	04/09/2026
CHECKED	Ampacity	04/09/2026
APPROVED	---	---

A	INITIAL RELEASE	04/09/2026
REV	DESCRIPTION	DATE
<b>ARRAY TECHNOLOGIES</b> 3901 Midway Place NE, Albuquerque, NM 87109 (505) 881-7567		
<b>TITLE</b> OmniTrack® HZ Project: 74 Bokum Detail Views		
SIZE B	PRODUCT NUMBER 17419	REVISION A
SCALE NTS	DWG NO. 17419-901	U.S. PATENT NO. #8,459,249; # 9,281,778
		7B OF 7

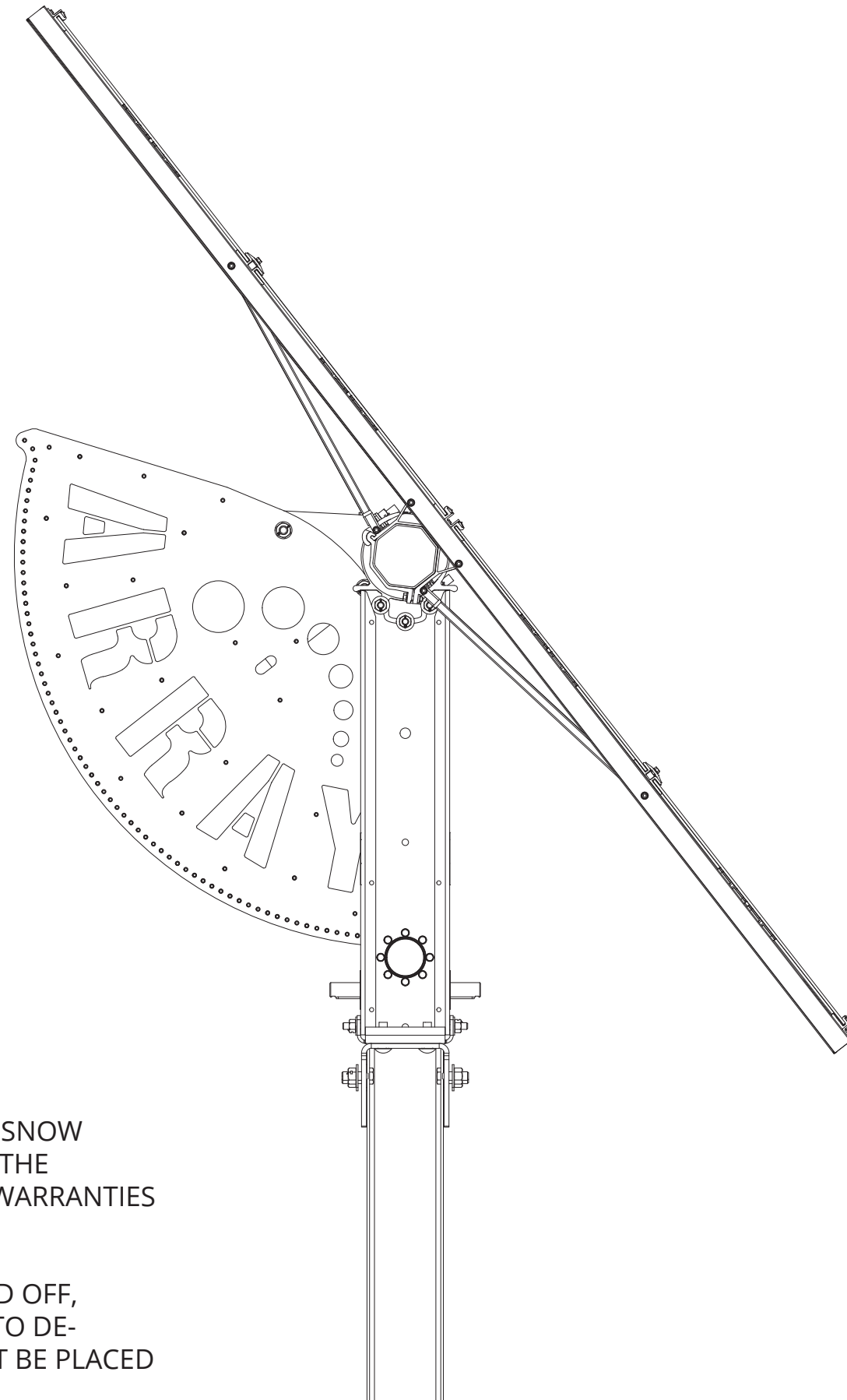

TO PROTECT MODULES FROM DAMAGE DURING A HEAVY SNOW EVENT, THE TRACKER SYSTEM HAS BEEN ENGINEERED AND DESIGNED TO BE STOWED AT NIGHT IN A MAXIMUM TILT POSITION CALLED NIGHT SNOW STOW. THE TRACKER IS REQUIRED TO BE PLACED AND REMAIN IN NIGHT SNOW STOW POSITION AT TIME OF MODULE MOUNTING AND MUST REMAIN IN SUCH POSITION UNTIL SYSTEM COMMISSIONING. PROGRAMMING OF AUTOMATED NIGHT SNOW STOW WILL OCCUR AT TIME OF COMMISSIONING.

FAILURE TO PLACE THE SYSTEM INTO NIGHT SNOW STOW COULD RESULT IN DAMAGE TO BOTH THE MODULES AND TRACKER SYSTEM, VOIDING WARRANTIES OF EACH RESPECTIVELY.

IF AT ANY TIME THE SYSTEM IS TO BE TURNED OFF, IT IS EXPRESSLY UNDERSTOOD THAT PRIOR TO DE-ENERGIZING THE SYSTEM, THE SYSTEM MUST BE PLACED IN NIGHT SNOW STOW.

DRAWING STATUS FINAL

PRODUCT STATUS FINAL

**PROPRIETARY AND CONFIDENTIAL**  
 THE INFORMATION CONTAINED IN THIS DRAWING IS THE SOLE PROPERTY OF ARRAY TECHNOLOGIES. ANY REPRODUCTIONS IN PART OR AS A WHOLE WITHOUT THE WRITTEN PERMISSION FROM ARRAY TECHNOLOGIES IS PROHIBITED.

B	CHANGED MATERIAL GRADE PER ECR 17124	10/31/2017
A	INITIAL RELEASE	10/11/2017
REV		DATE

**ARRAY TECHNOLOGIES**  
 3901 MIDWAY PLACE NE, ALBUQUERQUE, NM 87109  
 (505)881-7567



SIZE B	PRODUCT NUMBER	REVISION B	SAVED v24 11/6/2017	SHEET 1 OF 1
--------	----------------	------------	---------------------	--------------

**NOTES:**

1. ENSURE PERPENDICULARITY BETWEEN TORQUE TUBE AND BEARING HOUSING.

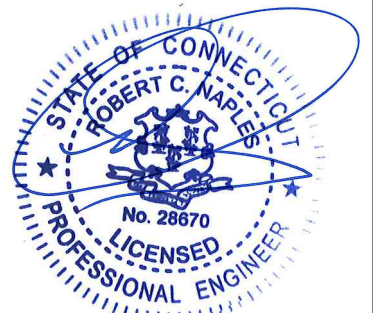
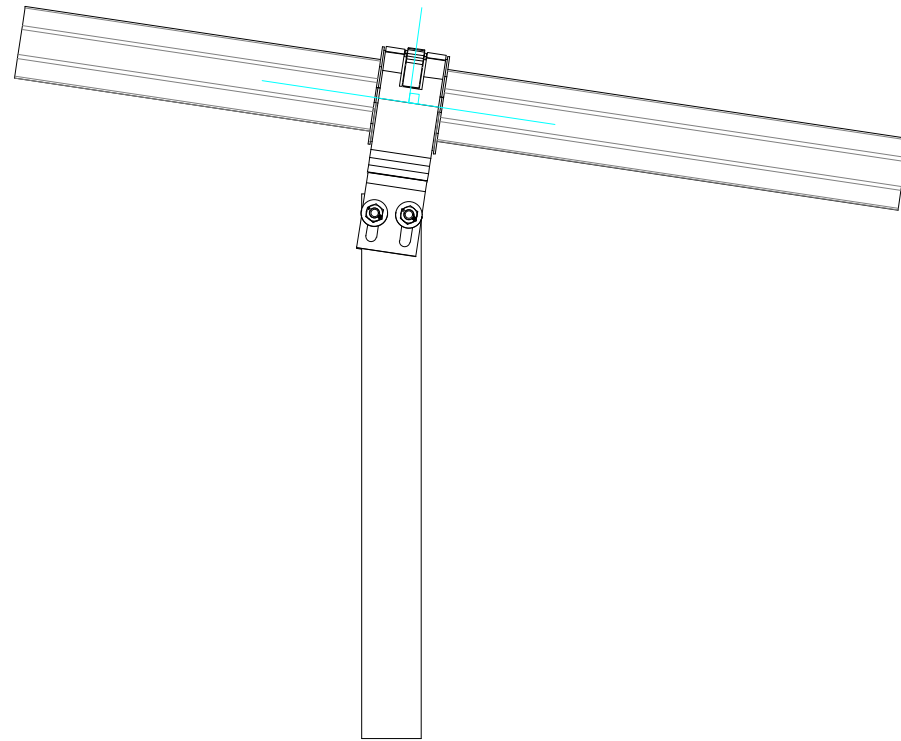

Exp 01/31/2027  
04/13/2026

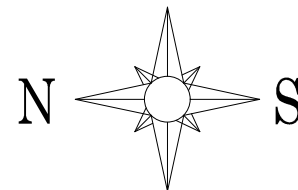

PROPRIETARY AND CONFIDENTIAL  
THE INFORMATION CONTAINED IN THIS DRAWING IS THE SOLE PROPERTY OF ARRAY TECHNOLOGIES. ANY REPRODUCTION IN PART OR AS A WHOLE WITHOUT THE WRITTEN PERMISSION FROM ARRAY TECHNOLOGIES IS PROHIBITED.



DRAWING STATUS <b>Final</b>		
PRODUCT STATUS <b>Final</b>		
	NAME	DATE
DRAWN	TH	01/24/2025
CHECKED	RPCS	01/24/2025
APPROVED	---	---

A	INITIAL RELEASE	01/24/2025
REV	DESCRIPTION	DATE
<b>ARRAY TECHNOLOGIES</b> 3901 Midway Place NE, Albuquerque, NM 87109 (505) 881-7567		
TITLE <b>DuraTrack® HZ</b> ----		
SIZE <b>B</b>	PRODUCT NUMBER	REVISION <b>A</b>
SCALE NTS	DWG NO. ---	U.S. PATENT NO. #8,459,249; # 9,281,778
		1 OF 1

**NOTES:**

- 1. REFER TO DURATRACK INSTALLATION GUIDE
- 2. NORMALLY JUMPERED, CAN BE REMOVED AND OPTIONAL STOW INSTALLED. JUMPER CAN BE USED FOR TESTING.
- 3. CONNECTION FOR GPS ANTENNA, DO NOT INSERT DEVICE OTHER THAN ARRAY GPS ANTENNA. (I.E. ETHERNET)

WIRE GAUGE AND TORQUE SPECIFICATIONS		
COMPONENT DESCRIPTION	WIRE GAUGE MAX/MIN	TORQUE SPECIFICATIONS
CIRCUIT BREAKER	5.2/1.6 $\phi$ mm [4/14 AWG]	2.48 to 2.93 N-m [22 to 26 IN-LBS]

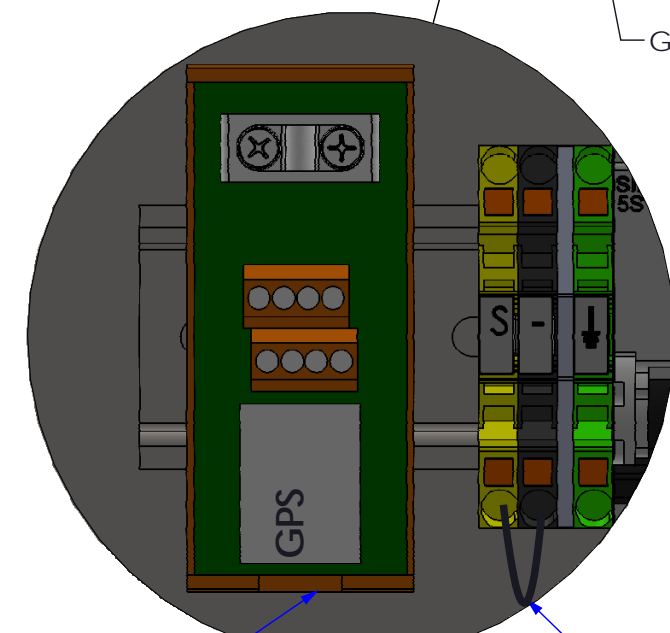
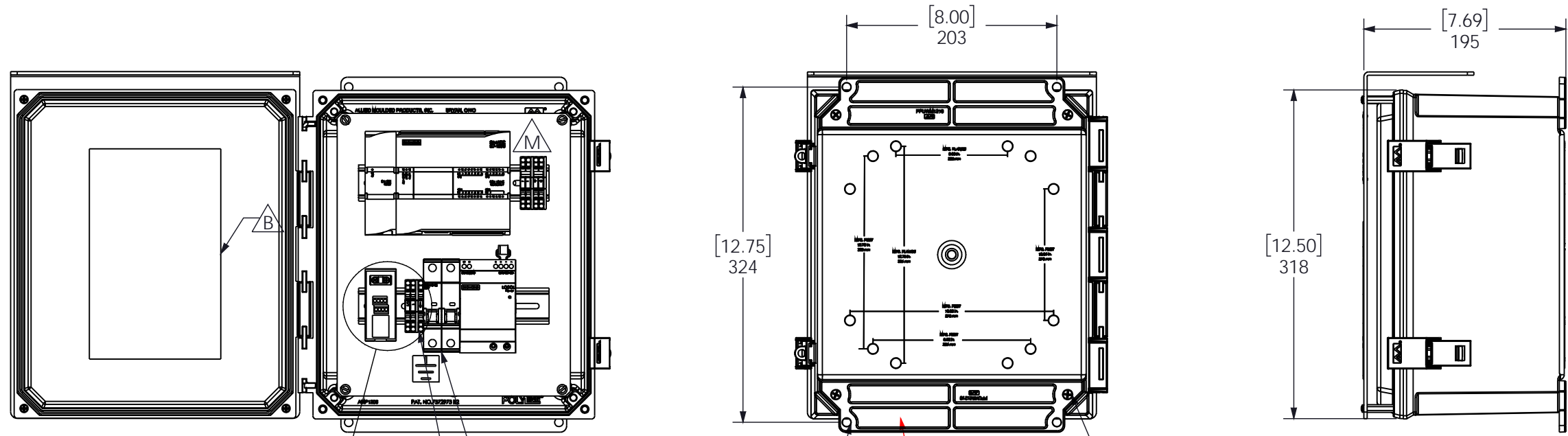
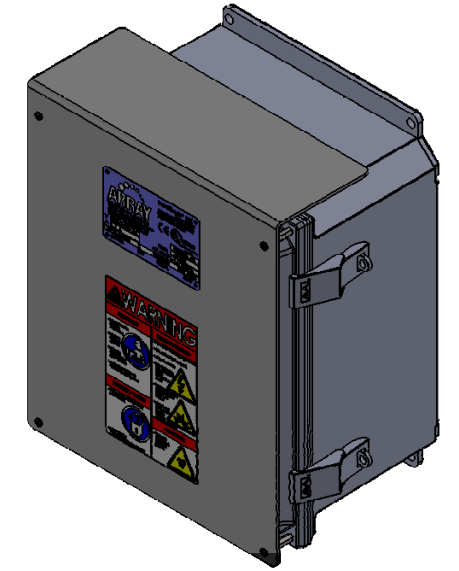

REV	DESCRIPTION	DATE
M	REMOVED COMPONENT PER ECR 18116	7/29/2018
L	MATCH ASSY REV PER ECR 18072	5/31/2018
K	MATCH ASSY REV PER ECR 17057	11/1/2017
J	REPLACED COMPONENTS PER ECR 17057	7/19/2017
H	MATCH ASSY REV PER ECR 16178	12/22/2016
G	MATCH ASSY REV PER ECR 16171	11/23/2016
F	MATCH ASSY REV PER 15075	11/5/2015
E	MATCH ASSY REV PER 15027	6/9/2015
D	EDITED PER ECR 15034	5/21/2015
C	MATCH ASSY REV PER 14073	3/5/2015
B	EDIT PER ECR #14073	2/10/2015
A	INITIAL RELEASE	11/14/2014



<p>PROPRIETARY AND CONFIDENTIAL</p> <p>THE INFORMATION CONTAINED IN THIS DRAWING IS THE SOLE PROPERTY OF ARRAY TECHNOLOGIES. ANY REPRODUCTION IN PART OR AS A WHOLE WITHOUT THE WRITTEN PERMISSION FROM ARRAY TECHNOLOGIES IS PROHIBITED.</p>	<p>UNLESS OTHERWISE SPECIFIED DIMS ARE DUAL UNITS: MILLIMETER [INCH]</p> <p>TOLERANCES, mm [in]:</p> <p>X = <math>\pm 1.25</math> [<math>\pm 0.050</math>"]</p> <p>.X = <math>\pm 0.4</math> [<math>\pm 0.015</math>"]</p> <p>.XX = <math>\pm 0.1</math> [<math>\pm 0.004</math>"]</p> <p>TOLERANCES, m [in]:</p> <p>X.XX = <math>\pm 0.013</math> [<math>\pm 0.5</math>"]</p> <p>X.XXX = <math>\pm 0.006</math> [<math>\pm 0.25</math>"]</p> <p>ANGULAR:</p> <p>X = <math>\pm 1.0^\circ</math></p> <p>X = <math>\pm 1^\circ</math></p>	<p>DRAWING STATUS</p> <p><b>Final</b></p> <p>PRODUCT STATUS</p> <p><b>Final</b></p>	<p><b>ARRAY TECHNOLOGIES</b></p> <p>3901 Midway Place NE, Albuquerque, NM 87109 (505) 881-7567</p>			
	<p>TITLE</p> <p><b>Assembly, Site Data Controller, V3, 100-240 V, w/ ethernet</b></p>		<p>SIZE</p> <p><b>B</b></p>	<p>PRODUCT NUMBER</p> <p><b>20264-000</b></p>	<p>REVISION</p> <p><b>M</b></p>	<p>SAVED v63</p> <p>7/29/2018</p>
	<p>DRAWN</p> <p>AM</p> <p>09/24/2014</p>	<p>CHECKED</p> <p>AB</p> <p>7/30/2018</p>	<p>APPROVED</p> <p>SR</p> <p>7/30/2018</p>	<p>SCALE</p> <p>1:5</p>	<p>DWG NO.</p> <p>20264-901</p>	<p>WT: 3.465 KG [7.70LB]</p>
	<p>SHEET</p> <p>1 OF 1</p>			<p>DATE</p>		

**NOTES:**

1. THE GPS ANTENNA IS PRE-ROUTED WITH A 15' [4.6 M] WIRE THAT IS PLUGGED INTO THE SITE DATA ASSEMBLY.
2. REFER TO PROVIDED INSTALLATION GUIDE FOR ADDITIONAL INSTALLATION INSTRUCTIONS.
3. MODIFY ASSEMBLY AS NEEDED TO MEET LOCAL INSPECTION CRITERIA.

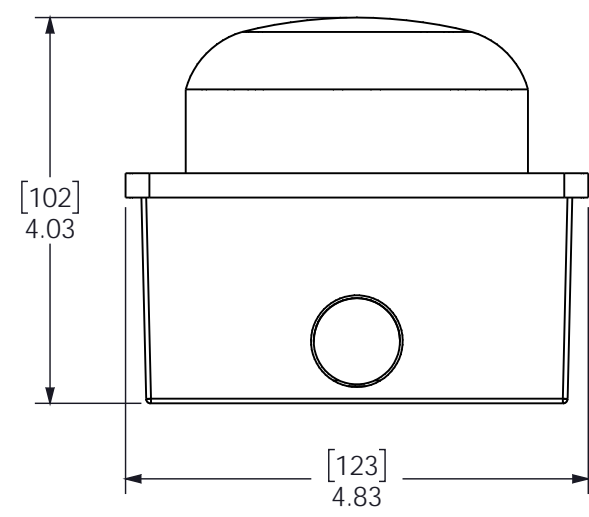
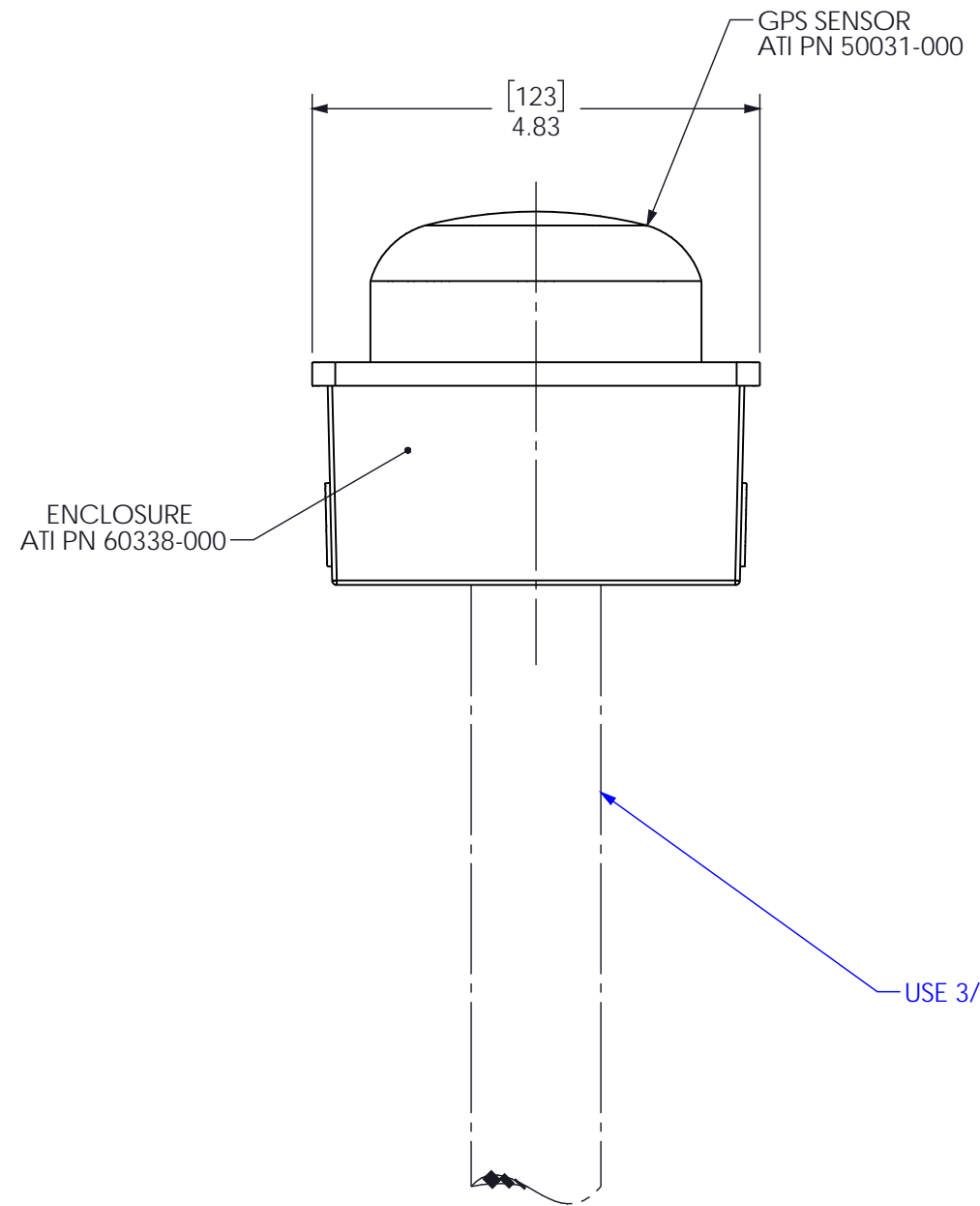
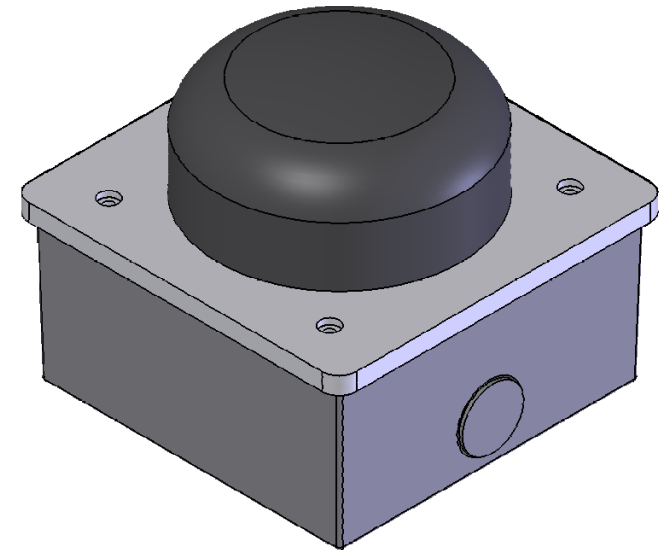

USE 3/4 INCH RIGID CONDUIT, NOT PROVIDED BY ATI.

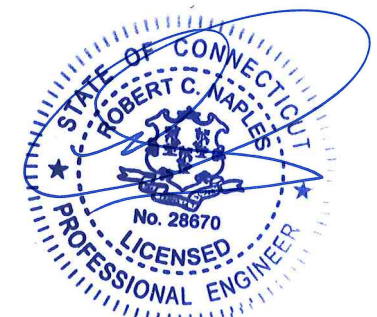

Exp 01/31/2027  
04/13/2026

A	INITIAL RELEASE	3/12/2015
REV	DESCRIPTION	DATE

**ARRAY TECHNOLOGIES**  
3901 Midway Place NE, Albuquerque, NM 87109  
(505) 881-7567

DRAWING STATUS		<b>Final</b>	
DRAWN INITIALS: AM DATE: 03/12/2015	DRAWING CHECK INITIALS: KT DATE: 4/7/2015	TITLE	
ENG. CHECK INITIALS: DATE:	FINAL APPROVAL INITIALS: CB DATE: 4/7/2015	Assembly, GPS	
THIRD ANGLE PROJECTION		ALL DIMS ARE DUAL UNITS: INCH [MILLIMETER]	
TOLERANCES UNLESS OTHERWISE SPECIFIED		SIZE B	
INCHES [MM]: .X = ±0.250 [6.00] .XX = ±0.050 [1.25] .XXX = ±0.015 [0.40]		DRAWING NUMBER 20436-901	
ANGULAR: .X = ±1.0° .X = ±0.1°		REVISION A	
PROPRIETARY AND CONFIDENTIAL THE INFORMATION CONTAINED IN THIS DRAWING IS THE SOLE PROPERTY OF ARRAY TECHNOLOGIES. ANY REPRODUCTION IN PART OR AS A WHOLE WITHOUT THE WRITTEN PERMISSION FROM ARRAY TECHNOLOGIES IS PROHIBITED.		SCALE 1:2	
		WT: 0.96 KG	
		SHEET 1 OF 1	

SAVED v13 7/25/2019	REVISION A	DRAWING NUMBER 20436-901	TITLE Assembly, GPS
SCALE 1:2		SHEET 1 OF 1	

**NOTES:**

1. REFER TO DURATRACK INSTALLATION GUIDE.
2. ALL PENETRATIONS DONE IN FIELD MUST BE PLUGGED WITH COMPONENT WHICH MAINTAINS THE IP RATING OF THE ENCLOSURE.

WIRE GAUGE AND TORQUE SPECS		
COMPONENT DESCRIPTION	WIRE GAUGE MAX/MIN	TORQUE SPECIFICATIONS
Manual Motor Protector	1.63 to 2.59 $\phi$ mm [14 to 10 AWG]	0.8 to 1.2 N-m [7 to 10.3 IN-LBS]

INPUT GROUND  
INPUT VOLTAGE 400/480 V, 3.45/3.00A

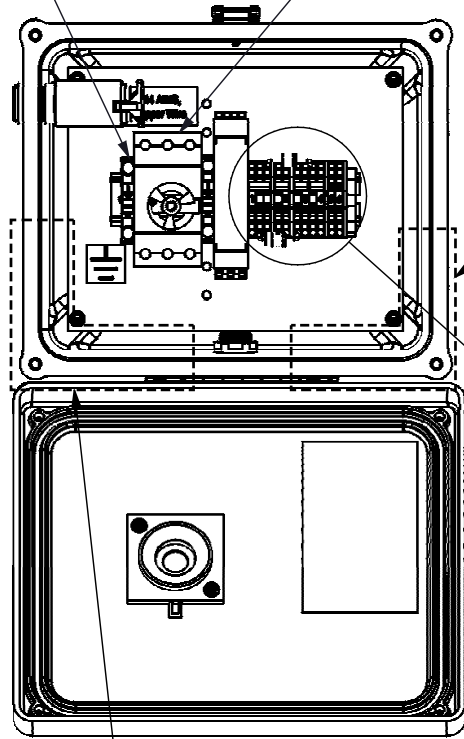

ARRAY RECOMMENDS THAT ALL LOW VOLTAGE WIRE PENETRATIONS ARE MADE IN THIS AREA.

ARRAY RECOMMENDS THAT ALL HIGH VOLTAGE WIRE PENETRATIONS ARE MADE IN THIS AREA.

DETAIL A

VOLTAGE SUPPRESSION DIODE ENSURE CORRECT POLARITY UPON INSTALLATION

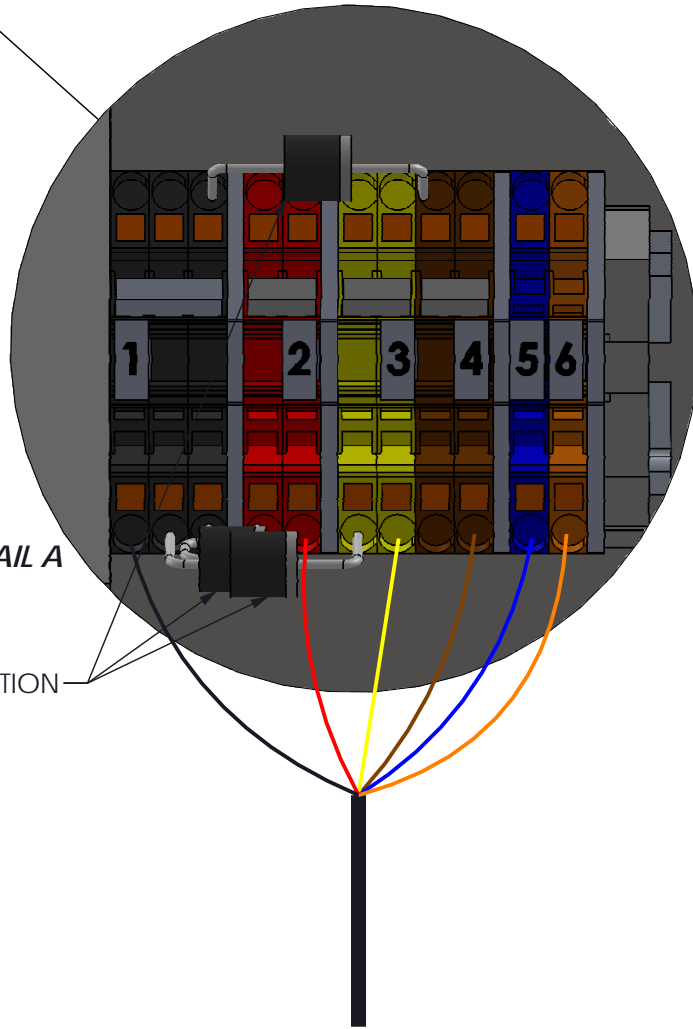

FROM 4X/6X CONTROLLER ASSY

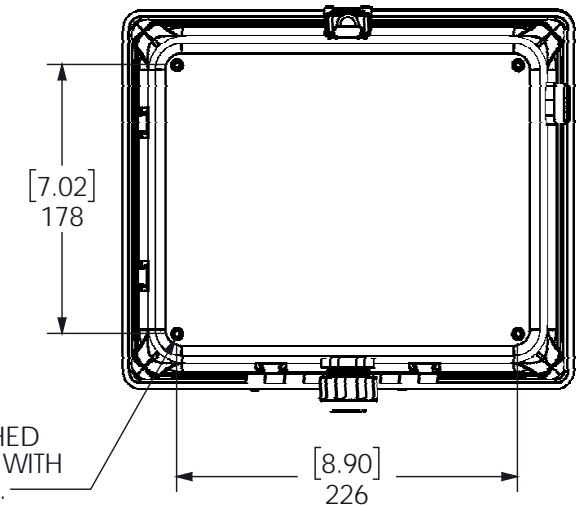
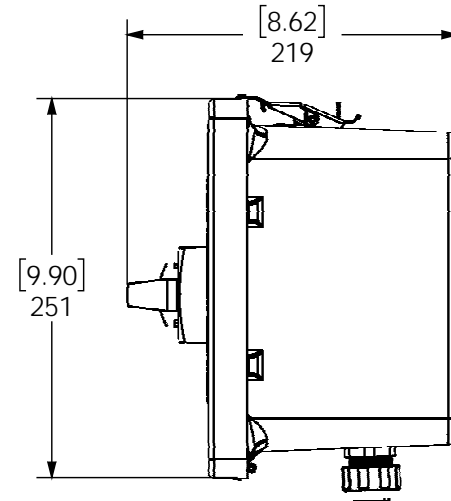

MOUNT ATTACHED TO ENCLOSURE WITH #10-32 SCREWS.

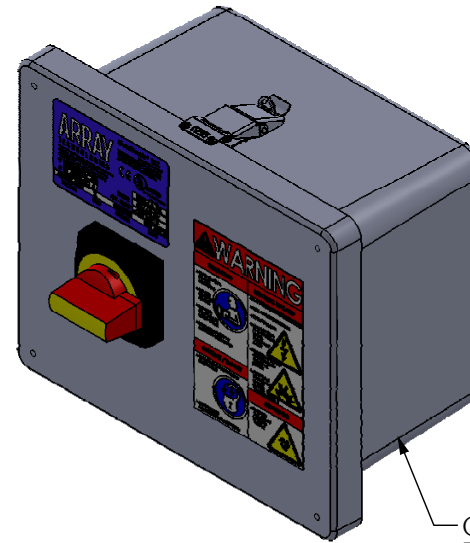

CONDUIT/WIRES HIDDEN FOR CLARITY

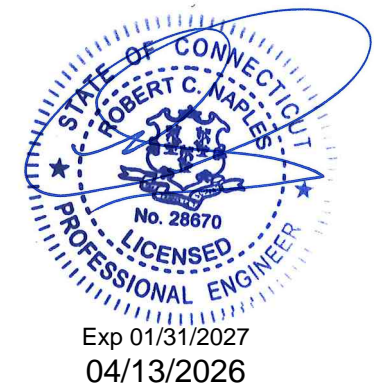

REV	DESCRIPTION	DATE
N	MATCH ASSY REV PER ECR 20180	3/19/2020
M	MATCH ASSY REV, REFERENCE (-903) PER ECR-19137	11/19/2019
L	ADDED IEC TO DESCRIPTION PER ECR 18123 REMOVED FINGER GUARD PER ECR 19005 ADDED STOP BLOCK PER ECR 19038	3/4/2019

CONFIGURATION TABLE	
PART NUMBER	DESCRIPTION
20583-000	Assembly, DTHZ Motor Electronics, V3, Dual Voltage, VMS, IEC
20583-001	Assembly, DTHZ Motor Electronics, V3, Dual Voltage, VMS, IEC, Snow Mode

DRAWING STATUS: <b>Final</b>		<b>ARRAY TECHNOLOGIES</b> 3901 Midway Place NE, Albuquerque, NM 87109 (505) 881-7567	
DRAWN INITIALS: AM DATE: 11/02/2016	DRAWING CHECK INITIALS: RM DATE: 4/17/2020	TITLE: <b>Assembly, DTHZ Motor Electronics, V3, Dual Voltage, VMS, IEC</b>	
ENG. CHECK INITIALS: DO DATE: 04/17/2020	FINAL APPROVAL INITIALS: SB DATE: 4/22/2020	SIZE: <b>B</b>	DRAWING NUMBER: 20583-901
PROPRIETARY AND CONFIDENTIAL THE INFORMATION CONTAINED IN THIS DRAWING IS THE SOLE PROPERTY OF ARRAY TECHNOLOGIES. ANY REPRODUCTION IN PART OR AS A WHOLE WITHOUT THE WRITTEN PERMISSION FROM ARRAY TECHNOLOGIES IS PROHIBITED.		REVISION: N-01	SAVED v108 4/7/2020
ALL DIMS ARE DUAL UNITS: MILLIMETER [INCH] TOLERANCES UNLESS OTHERWISE SPECIFIED MM [INCH]: X = ±1.25 [0.050] X.X = ±0.4 [0.015] XX = ±0.1 [0.004]		SCALE: 1:5	WEIGHT: 13.1kg [lb]
METER [INCH]: X.XXX = ±0.013 [0.500] X.XXX = ±0.006 [0.250]		SHEET: 1 OF 1	

8 7 6 5 4 3 2 1

**NOTES:**

- 1. REFER TO DURATRACK INSTALLATION GUIDE
- 2. NORMALLY JUMPERED, SHOULD ONLY BE REMOVED IF OPTIONAL STOW DEVICE INSTALLED.
- 3. USE GROUND WIRE FROM 50001-000, AS SHOWN. DO NOT CONNECT GROUND WIRE IN MOTOR CONTROL BOX.

WIRE GAUGE AND TORQUE SPECIFICATIONS		
COMPONENT DESCRIPTIONS	WIRE GAUGE MAX/MIN	TORQUE SPECIFICATIONS
CIRCUIT BREAKER	4/14 AWG [5.2/1.6 Ø mm]	22 to 26 IN-LBS[2.48 to 2.93 N-m]

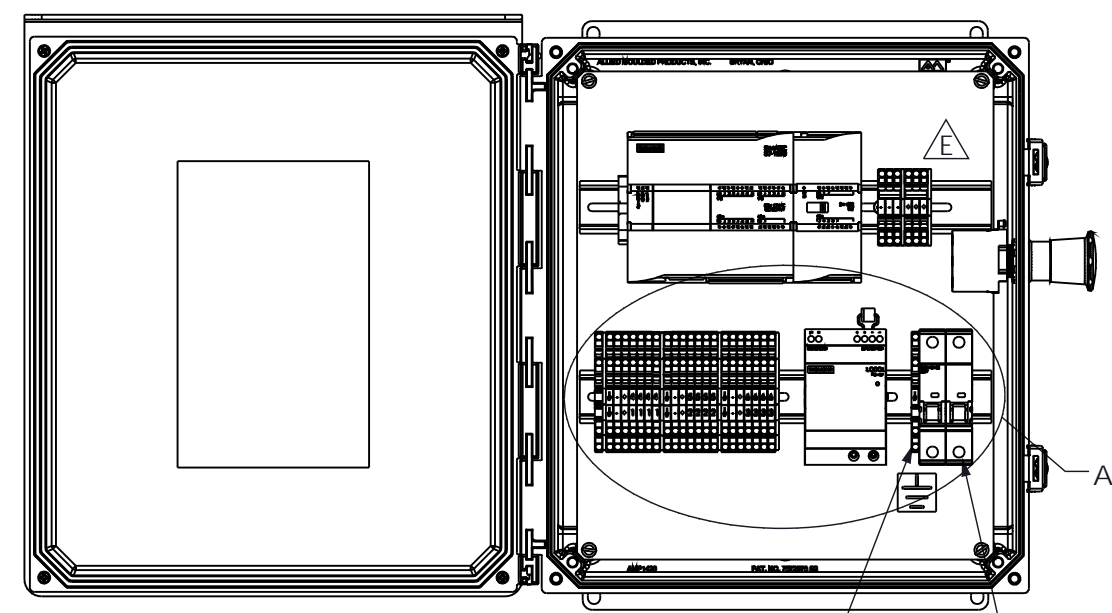
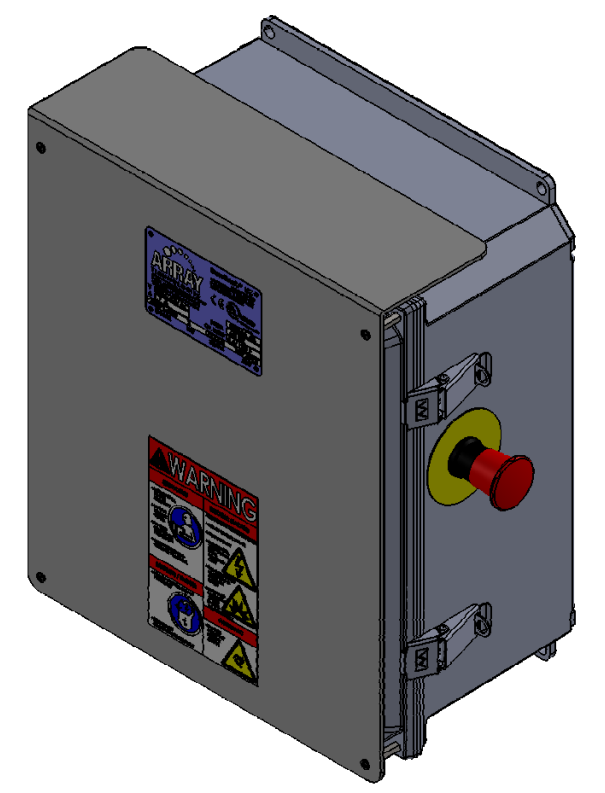

GROUND  
120/240V SINGLE PHASE

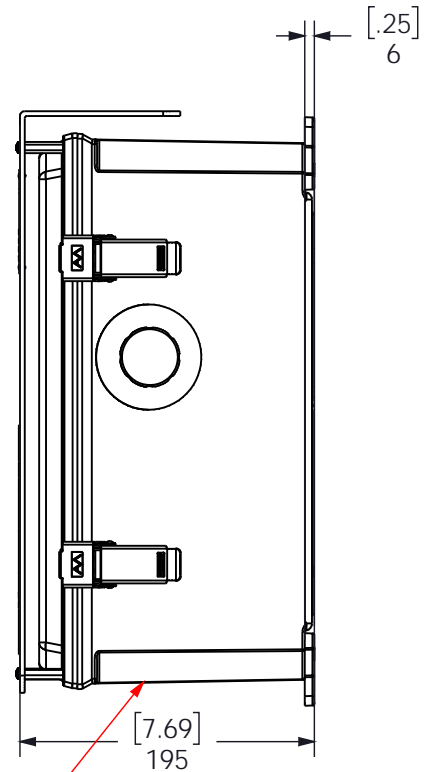

ALL PENETRATIONS INTO THE ENCLOSURE TO BE IN BOTTOM SIDE AND MUST BE PLUGGED WITH COMPONENTS WHICH MAINTAIN THE 4X RATING OF THE ENCLOSURE.

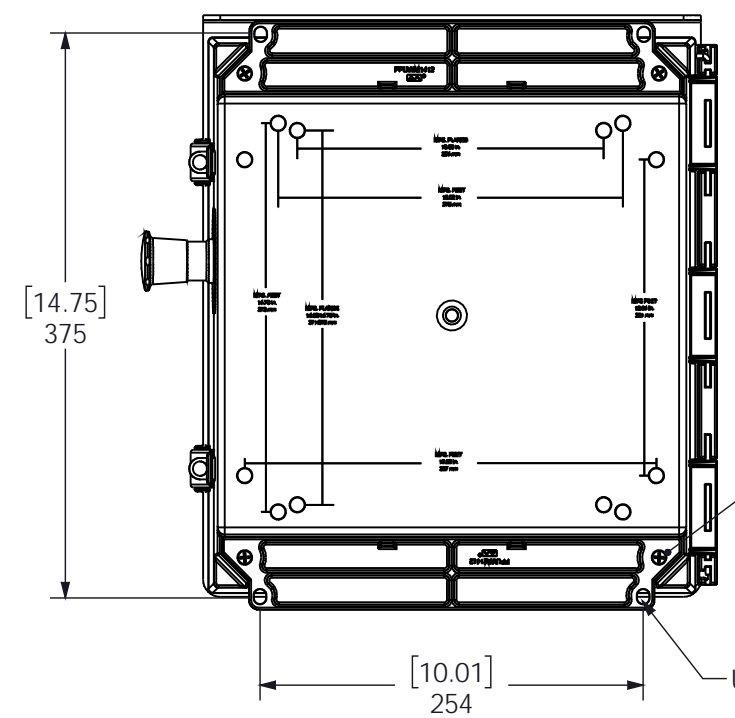

MOUNT ATTACHED TO ENCLOSURE WITH #10-32 SCREWS.  
USE 5/16-18 NUT/BOLT FOR FOOT MOUNT (OPTIONAL)

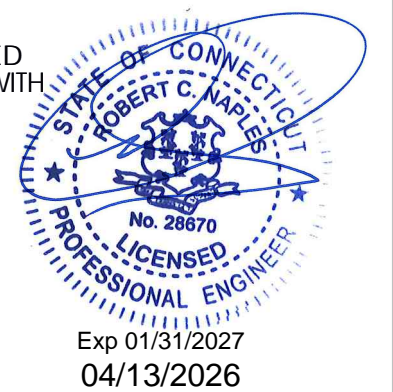

REV	DESCRIPTION	DATE
G	MATCH ASSY REV PER ECR 20180	3/19/2020
F	ADDED SNOW MODE PER ECR 18124	3/28/2019
E	REMOVED COMPONENT PER ECR 18116	7/29/2018

CONFIGURATION TABLE	
PART NUMBER	DESCRIPTION
20591-000	Assembly, 6X Motor Controller, V3, 100-240 V, w/ ethernet
20591-001	Assembly, 6X Motor Controller, V3, 100-240 V, w/ ethernet, Snow Mode

DRAWING STATUS: <b>Final</b>		
DRAWN INITIALS: AM DATE: 01/18/2017	DRAWING CHECK INITIALS: RM DATE: 4/17/2020	
ENG. CHECK INITIALS: DO DATE: 04/20/2020	FINAL APPROVAL INITIALS: SB DATE: 4/22/2020	
THIRD ANGLE PROJECTION		
TOLERANCES UNLESS OTHERWISE SPECIFIED		
MM [INCH]: X = ±1.25 [0.050] X.X = ±0.4 [0.015] X.XX = ±0.1 [0.004]	METER [INCH]: X.XX = ±0.013 [0.500] X.XXX = ±0.006 [0.250]	ANGULAR: X = ±1.0° X = ±0.1°

**ARRAY TECHNOLOGIES**  
3901 Midway Place NE, Albuquerque, NM 87109  
(505) 881-7567

TITLE: **Assembly, 6X Motor Controller, V3, 100-240 V, w/ ethernet**

SIZE B	DRAWING NUMBER: 20591-901	REVISION: H-01	SAVED v55: 4/6/2020
SCALE 1:5	WT: 5.67 KG [12.5874 LB]	SHEET 1 OF 2	

8 7 6 5 4 3 2 1

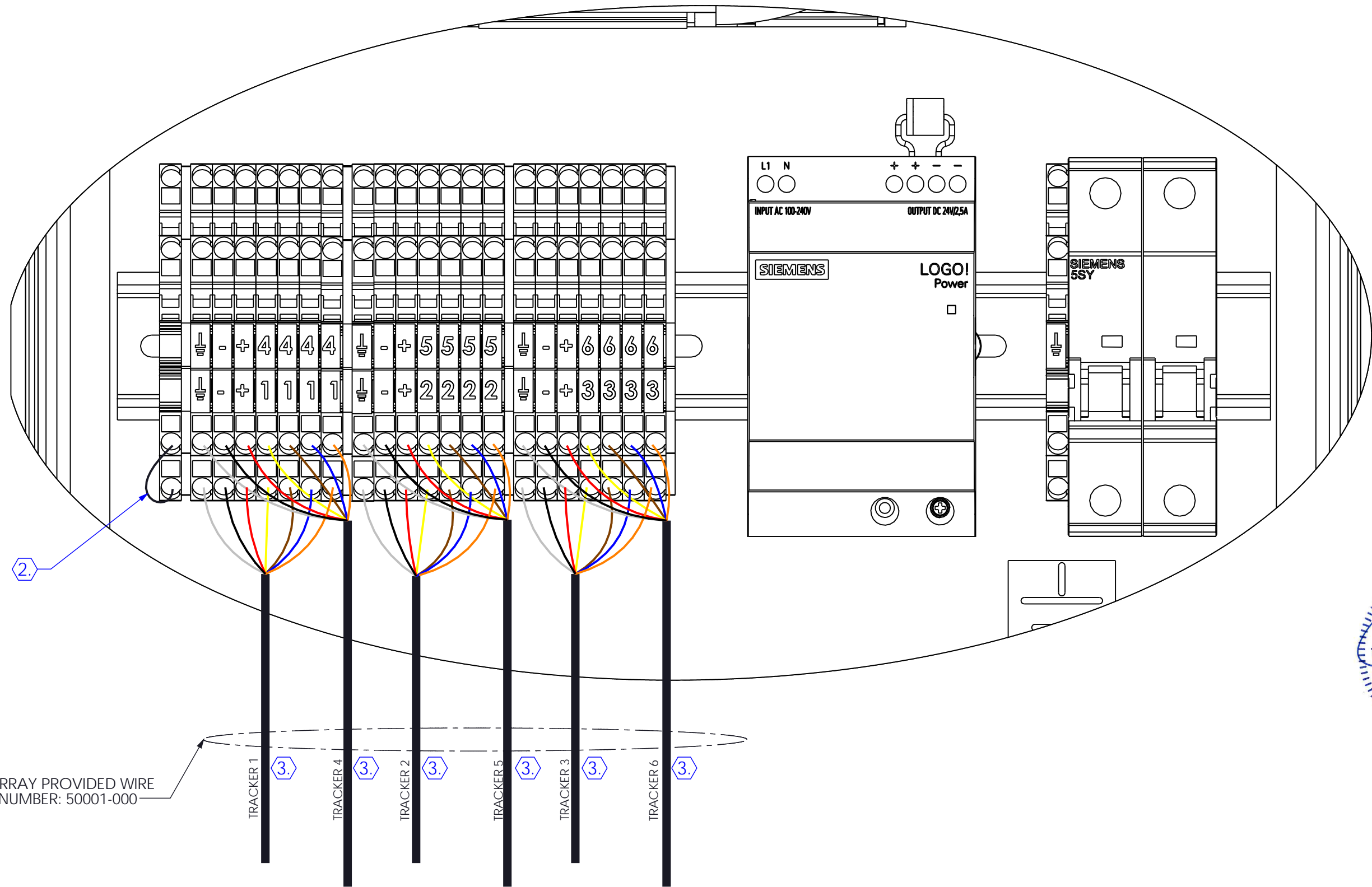

USE ARRAY PROVIDED WIRE  
PART NUMBER: 50001-000

TRACKER 1 (3)  
TRACKER 4 (3)  
TRACKER 2 (3)  
TRACKER 5 (3)  
TRACKER 3 (3)  
TRACKER 6 (3)

DETAIL A

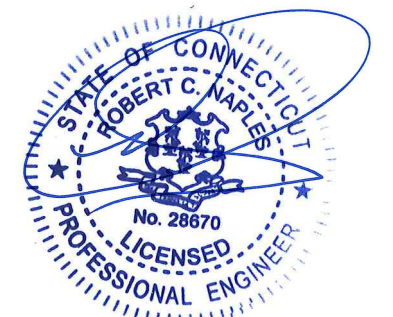

Exp 01/31/2027  
04/13/2026

SIZE B	DRAWING NUMBER 20591-901	REVISION H-01	SAVED v55 4/6/2020
SCALE 1:5	WT: 5.67 KG [12.5874 LB]		SHEET 2 OF 2

**NOTES:**

1. REFER TO DURATRACK INSTALLATION GUIDE.
2. NORMALLY JUMPERED, SHOULD ONLY BE REMOVED IF OPTIONAL WINDSTOW INSTALLED.
3. USE GROUND WIRE FROM 50001-000, AS SHOWN. DO NOT CONNECT GROUND WIRE IN MOTOR CONTROL BOX.

WIRE GAUGE AND TORQUE SPECIFICATIONS		
COMPONENT DESCRIPTIONS	WIRE GAUGE MAX/MIN	TORQUE SPECIFICATIONS
CIRCUIT BREAKER	4/14 AWG [5.2/1.6 Ø mm]	22 to 26 IN-LBS[2.48 to 2.93 N-m]

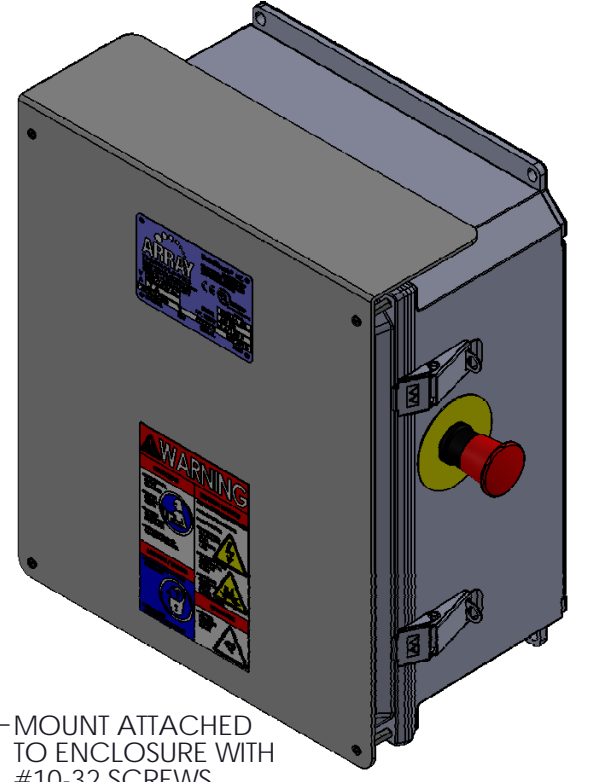

MOUNT ATTACHED TO ENCLOSURE WITH #10-32 SCREWS.

ALL PENETRATIONS INTO THE ENCLOSURE TO BE IN BOTTOM SIDE AND MUST BE PLUGGED WITH COMPONENTS WHICH MAINTAIN THE 4X RATING OF THE ENCLOSURE.

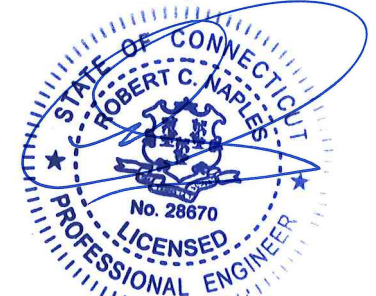
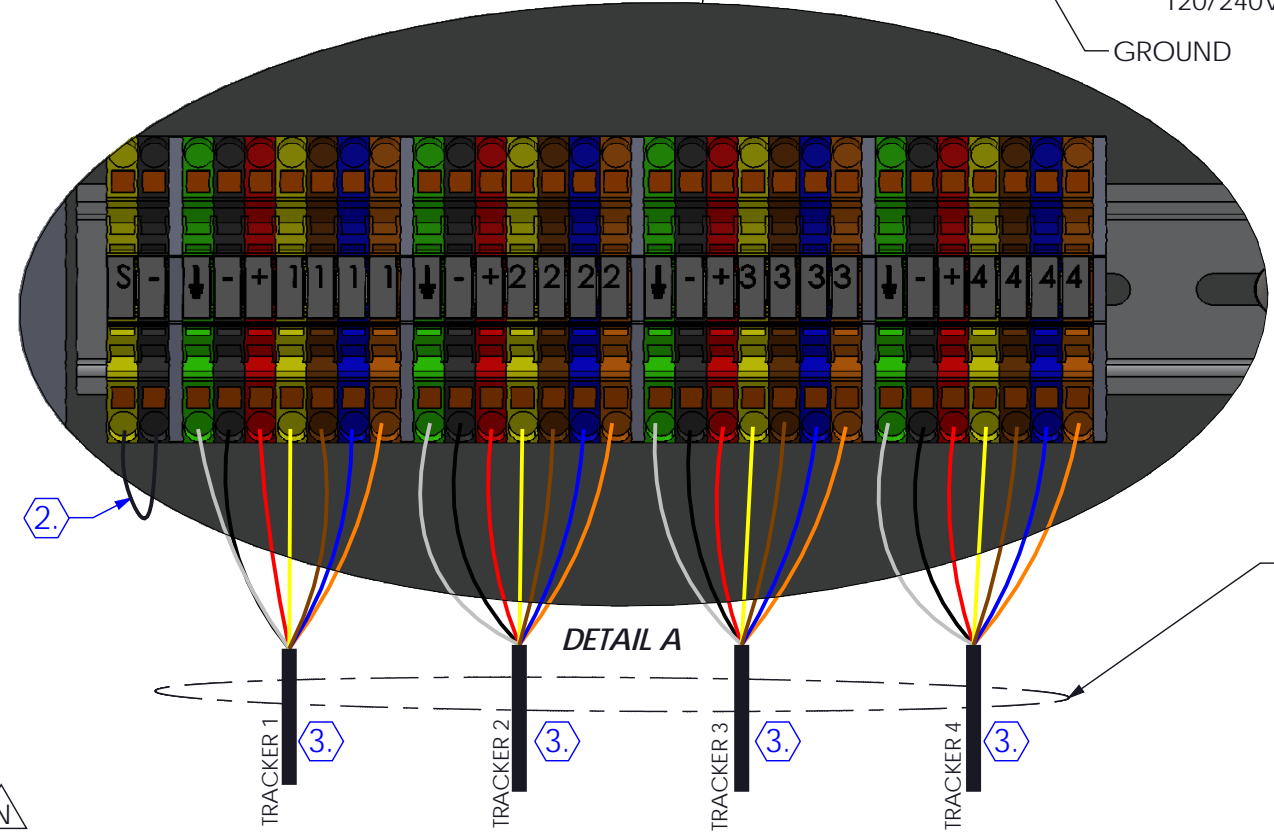
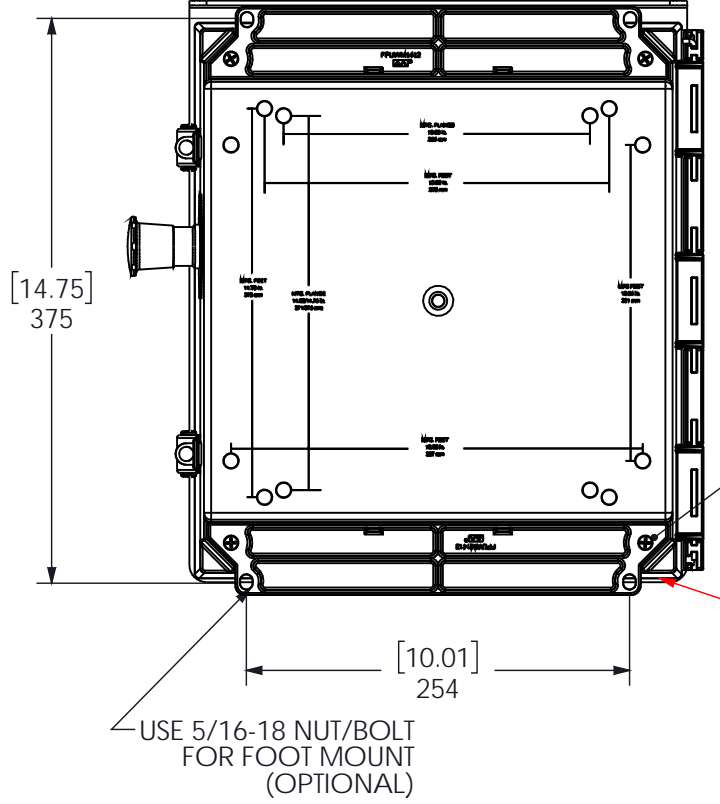
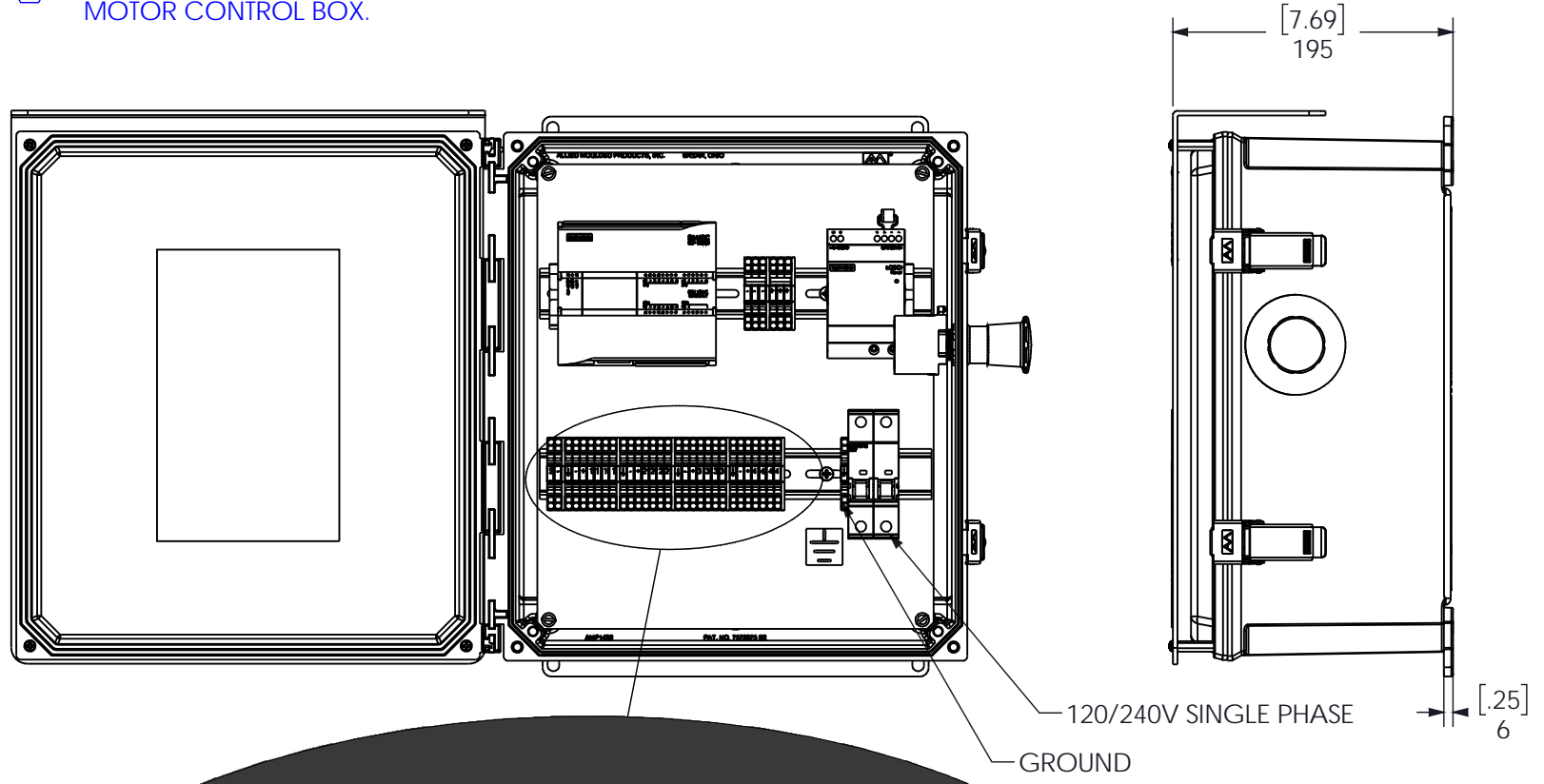

Exp 01/31/2027  
04/13/2026

REV	DESCRIPTION	DATE
N	ADDED SNOW STOW PER ECR 18124	3/19/2019
M	REMOVED COMPONENT PER ECR 18116	7/28/2018
L	MATCH ASSY REV PER ECR 18072	5/31/2018

CONFIGURATION TABLE	
PART NUMBER	DESCRIPTION
20262-000	Assembly, 4X Motor Controller, V3, 100-240 V, w/ ethernet
20262-001	Assembly, 4X Motor Controller, V3, 100-240 V, w/ ethernet, Snow Stow

PROPRIETARY AND CONFIDENTIAL THE INFORMATION CONTAINED IN THIS DRAWING IS THE SOLE PROPERTY OF ARRAY TECHNOLOGIES. ANY REPRODUCTION IN PART OR AS A WHOLE WITHOUT THE WRITTEN PERMISSION FROM ARRAY TECHNOLOGIES IS PROHIBITED.	DRAWING STATUS: <b>Final</b>		
	DRAWN: AM DATE: 09/24/2014	DRAWING CHECK: RA DATE: 6/13/2019	
	ENG. CHECK: SB DATE: 6/14/2019	FINAL APPROVAL: SB DATE: 6/14/2019	
	ALL DIMS ARE DUAL UNITS: MILLIMETER [INCH] TOLERANCES UNLESS OTHERWISE SPECIFIED MM [INCH]: X = ±1.25 [0.050] .X = ±0.4 [0.015] .XX = ±0.1 [0.004]		

<b>ARRAY TECHNOLOGIES</b> 3901 Midway Place NE, Albuquerque, NM 87109 (505) 881-7567			
TITLE: <b>Assembly, 4X Motor Controller, V3, 100-240 V, w/ ethernet</b>			
SIZE: B	DRAWING NUMBER: 20262-901	REVISION: O-01	SAVED v82: 4/16/2019
SCALE: 1:5	WT: 0.00 KG [0 LB]	SHEET: 1 OF 1	

ITEM NO.	PART NUMBER	DESCRIPTION	STANDARD	STANDARD (SET SCREWS)	HIGH WIND - RADIAL BRKT	HIGH WIND - RADIAL BRKT (SET SCREWS)	HIGH WIND - STRAIGHT SLOT BRKT	HIGH WIND - STRAIGHT SLOT BRKT (SET SCREWS)
1	20936-XXX	Assembly, Center Stop Bearing, 6.142" ID, XXX Finish	1	-	-	-	-	-
2	20937-XXX	Assembly, Center Stop Bearing, Set Screws, 6.142" ID, XXX Finish	-	1	-	-	-	-
3	20938-XXX	Assembly, Center Stop Bearing, High Wind, 6.142" ID, XXX Finish	-	-	1	-	-	-
4	20939-XXX	Assembly, Center Stop Bearing, High Wind, Set Screws, 6.142" ID, XXX Finish	-	-	-	1	-	-
5	20956-XXX	Assembly, Center Stop Bearing, Radial Slots, HW, 6.142" ID, XXX Finish	-	-	-	-	1	-
6	20957-XXX	Assembly, Center Stop Bearing, Radial Slots, HW, Set Screws, 6.142" ID, XXX Finish	-	-	-	-	-	1
7	25050-001	Kit, 0.625"-11 x 2" Structural Bolt, Large Washers, Pin Lock Nut, HDG	4	4	-	-	-	-
8	25056-001	Kit, 0.625"-11 x 2" Carriage Bolt, Large Washers, Pin Lock Nut, HDG	2	2	4	4	4	4
9	25123-001	Kit, 0.75"-10 x 2.25" Structural Bolt, Large Washers, Pin Lock Nut, HDG	-	-	4	4	4	4
10	30959-XXX	Bracket, I-Beam Bushing Housing, Std Load, 8 mm, HDG, WX x XX, XXX mm	1	1	-	-	-	-
11	30960-XXX	Bracket, I-Beam Bushing Housing, HW Radial Slots, 9.5 mm, HDG, WX x XX, XXX mm	-	-	1	1	-	-
12	30961-XXX	Bracket, I-Beam Bushing Housing, HW Straight Slots, 8 mm, HDG, WX x XX, XXX mm	-	-	-	-	1	1

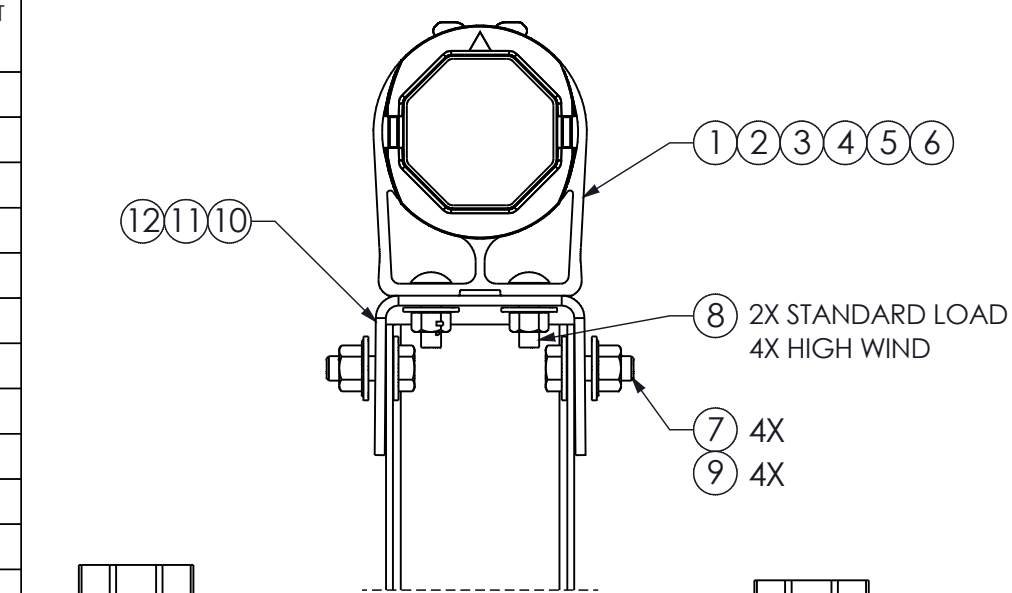

**NOTES:**

- REFER TO INSTALLATION MANUAL FOR DETAILS.
- LOOSEN JAM NUT ON SET SCREWS PRIOR TO TORQUING. ENSURE THAT THE SET SCREWS DO NOT PROTRUDE FROM THE CENTER STOP PRIOR TO SLIDING ON TORQUE TUBE.
- TORQUE SPECIFICATION:
  - 3A. SET SCREWS TORQUED TO 12±1.5 N-M [9±1 FT-LBS] [108±12 IN-LBS] BOTH TORQUED TWICE WITH ALTERNATING PATTERN.
  - 3B. JAM NUTS TORQUED TO 16±1.5 N-M [12±1 FT-LBS] [144±12 IN-LBS] BOTH TORQUED TWICE WITH ALTERNATING PATTERN.
  - 3C. 108±14 N-M [80±10 FT-LBS]
  - 3D. 169±14 N-M [125±10 FT-LBS]
  - 3E. 285±14 N-M [210±10 FT-LBS]
- MARK ALL TORQUED CONNECTIONS USING PAINT MARKER OF CONTRASTING COLOR ACROSS IMMOBILE BASE AND ALL PARTS SUBJECT TO LOOSENING.
- CARRIAGE BOLTS ARE 0.625" DIAMETER, SAE GRADE 5, HDG PER ASTM F2329.
- HOUSING IS MADE FROM ALUMINUM ALLOY 6005A/T61 PER ASTM B221 OR EQUIVALENT PER ARRAY DOCUMENT #90050-000. IF PROVIDED, POWDER COAT IS 27419 POLYESTER SD. TEFLON GREY OR ARRAY APPROVED ALTERNATE.
- STOP IS MADE FROM ALUMINUM ALLOY 6005A/T61 PER ASTM B221 OR EQUIVALENT PER ARRAY DOCUMENT #90050-000 WITH PLAIN FINISH.
8. SET SCREW BEARING HOUSING ASSEMBLY TO BE USED ON FIRST BEARING COLUMN NORTH AND SOUTH OF GEAR RACK CENTER STRUCTURE AT MINIMUM. REFER TO ADP FOR LAYOUT OF BEARING HOUSING WITH SET SCREWS PER ROW.
9. ALIGN BOLT HEAD FLAT EDGE AND CLIPPED WASHER FLAT EDGE TO THE WEB DURING INSTALLATION.
10. REFER TO I-BEAM DRAWING 33XXX-XX-901 INCLUDED IN ADP FOR DIMENSIONAL REQUIREMENTS OF NON-STANDARD PILE SIZES: W6X7, W6X7.75, W6X10.4, W6X10.5.
11. ENSURE WASHERS ARE NOT OVERLAPPING IN HIGH WIND APPLICATIONS.
12. IF BRACKET GAP EXCEEDS 4mm [0.15 in] A SHIM MUST BE INSTALLED. BRACKET GAP TO BE MEASURED ACROSS FROM TOP OF PILE.

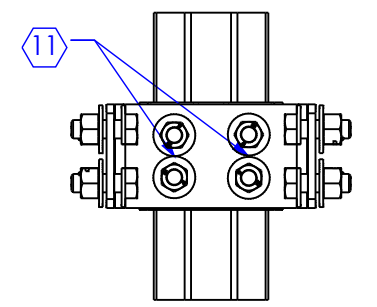
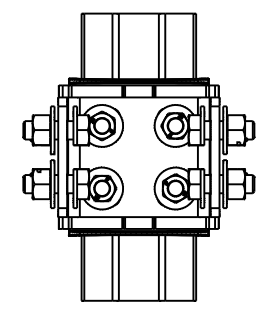
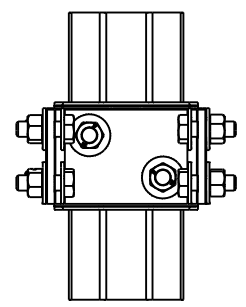
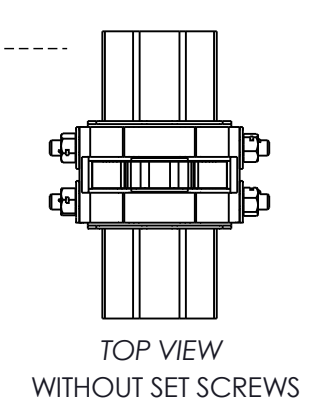
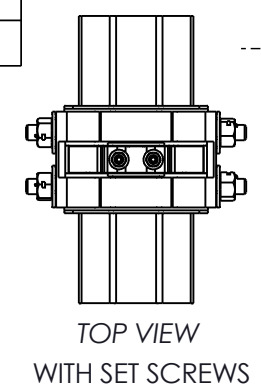
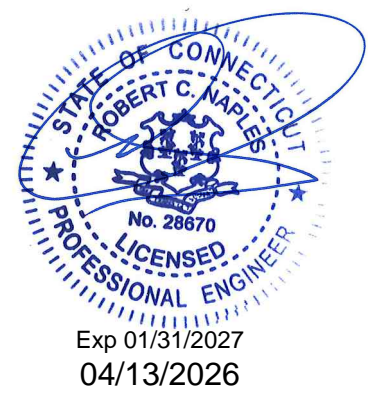

ZONE	REV	ECR #	DESCRIPTION	DATE
A3	D	US-23015	ADDED APPLICABLE TRACKER SYSTEMS	2/10/2023
B1, B2, C3, C4, C5, 2-A5, 2-C1, 2-C3, 2-C5, 2-D5	C	22189	RENAMED COLUMN HEADERS IN THE BOM, ADDED DESCRIPTIONS TO VIEWS AND 30959-176, UPDATED SELECTION CRITERIA DESCRIPTIONS IN BEARING ASSY CONFIG TABLE AND BEARING BRKT CONFIG TABLE	12/19/2022
A4, 2-A2, 2-A4	B	22168	ADDED NOTE 12 AND PILE/BRACKET VIEWS	11/4/2022

APPLICABLE TRACKER SYSTEMS: DuraTrack OmniTrack	DRAWING STATUS <b>Final</b>	<b>ARRAY TECHNOLOGIES</b> 3901 Midway Place NE, Albuquerque, NM 87109 (505) 881-7567 <b>ARRAY TECHNOLOGIES</b>	
PROPRIETARY AND CONFIDENTIAL: THE INFORMATION CONTAINED IN THIS DRAWING IS THE SOLE PROPERTY OF ARRAY TECHNOLOGIES. ANY REPRODUCTION IN PART OR AS A WHOLE WITHOUT THE WRITTEN PERMISSION FROM ARRAY TECHNOLOGIES IS PROHIBITED.	DRAWN: NC DATE: 04/08/2022 ENG. CHECK: NMS MK DATE: 02/14/2023 DRAWING CHECK: NMS DS DATE: 2/13/2023 FINAL APPROVAL: INTLS SB DATE: 2/14/2023	TITLE: <b>Field Assembly, Bearing &amp; Bracket, STD/HW, w/wo Set Screw, XXX Finish</b> DRAWING NUMBER: 21000-901 REVISION: D SAVED v43: 2/10/2023 SHEET: 1 OF 3	
THIRD ANGLE PROJECTION TOLERANCES UNLESS OTHERWISE SPECIFIED MM [INCH]: X = ±1.25 [0.049] .X = ±0.4 [0.016] .XX = ±0.1 [0.004]		ALL DIMS ARE DUAL UNITS: MILLIMETER [INCH]. DIMENSIONS IN BRACKETS ARE FOR REFERENCE ONLY. METER [INCH]: X.XX = ±0.013 [0.512] X.XXX = ±0.006 [0.236] ANGULAR: X = ±1.0° .X = ±0.1°	
SIZE B SCALE 1:20			

**IMPORTANT!  
ENSURE BEARING AND BRACKETS ARE CORRECTLY PAIRED.  
ALL BEARING AND BRACKET SLOTS MUST BE UTILIZED.**

STANDARD LOAD  
BEARING ASSEMBLY

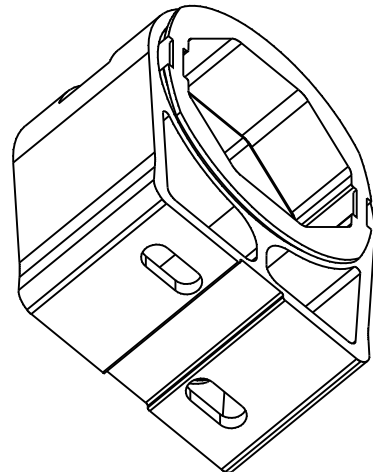

20936-XXX/20937-XXX

HIGH WIND  
BEARING ASSEMBLY

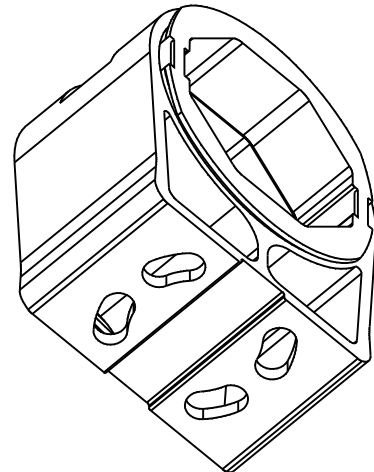

20956-XXX/20957-XXX

W6 HIGH WIND  
BEARING ASSEMBLY

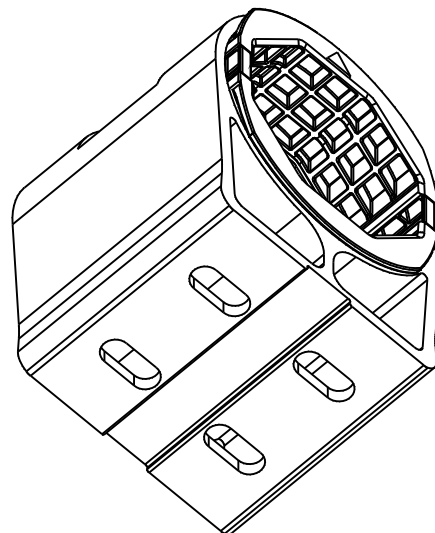

20938-XXX/20939-XXX

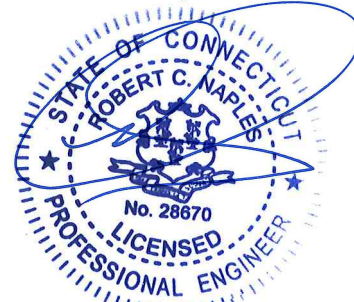

Exp 01/31/2027  
04/13/2026

STANDARD LOAD  
BRACKET INSTALLATION

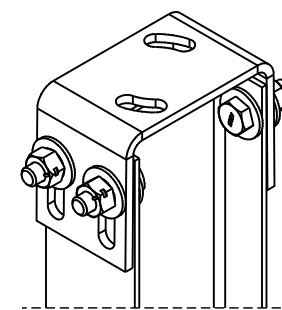

30959-XXX

HIGH WIND - RADIAL  
BRACKET INSTALLATION

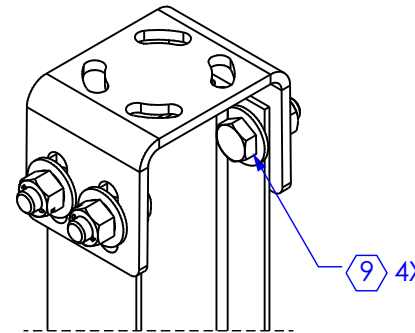

30960-XXX

HIGH WIND - STRAIGHT SLOT  
BRACKET INSTALLATION

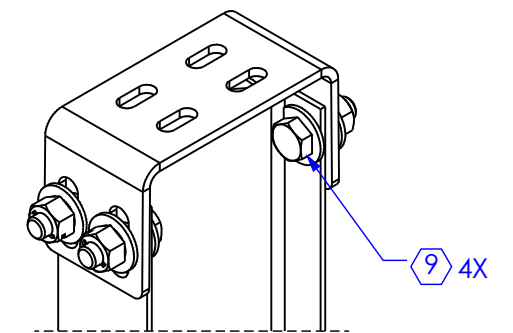

30961-XXX

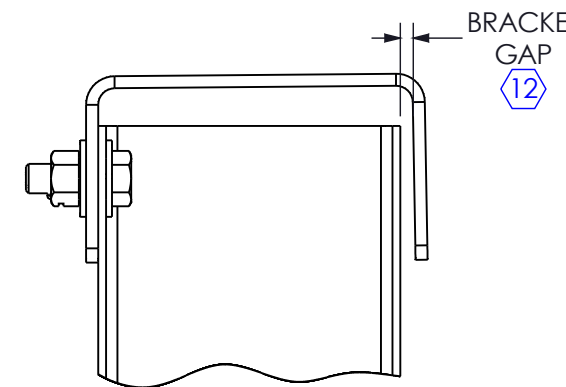

BRACKET  
GAP  
12

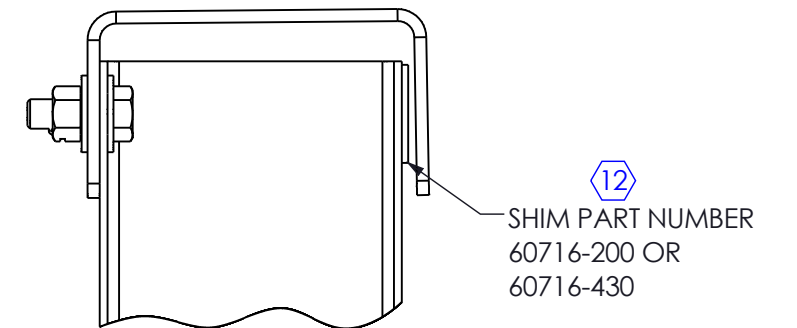

SHIM PART NUMBER  
60716-200 OR  
60716-430

**BEARING BRACKET CONFIGURATION TABLE**

BRACKET PART NUMBER	BRACKET DESCRIPTION	SELECTION CRITERIA	
		STANDARD/HIGH WIND	COMPATIBLE PILE SIZE
30959-150	Bracket, I-Beam Bushing Housing, Std Load, 8 mm, HDG, W6 x 7, W6 x 7.75, W6 x 8.5, 150 mm	STANDARD LOAD	W6X7, W6X7.75, W6X8.5
30959-152	Bracket, I-Beam Bushing Housing, Std Load, 8 mm, HDG, W6 x 9, W6 x 10.4, 152 mm	STANDARD LOAD	W6X9, W6X10.4
30959-155	Bracket, I-Beam Bushing Housing, Std Load, 8 mm, HDG, W6 x 10.5, W6 x 12, W6 x 15, 155 mm	STANDARD LOAD	W6X10.5, W6X12, W6X15
30959-161	Bracket, I-Beam Bushing Housing, Std Load, 8 mm, HDG, W6 x 16, W6 x 20, 161 mm	STANDARD LOAD	W6X16, W6X20
30959-176	Bracket, I-Beam Bushing Housing, Std Load, 8 mm, HDG, 176 mm	STANDARD LOAD	180UB16.1, 180UB18.1
30959-204	Bracket, I-Beam Bushing Housing, Std Load, 8 mm, HDG, W8 x 10, W8 x 13, 204 mm	STANDARD LOAD	W8X10, W8X13, 200UB18.2, 200UB22.3, 200UB25.4
30959-209	Bracket, I-Beam Bushing Housing, Std Load, 8 mm, HDG, W8 x 15, W8 x 18, 209 mm	STANDARD LOAD	W8X15, W8X18, 200UB29.8
30959-213	Bracket, I-Beam Bushing Housing, Std Load, 8 mm, HDG, W8 x 21, 213 mm	STANDARD LOAD	W8X21
30960-150	Bracket, I-Beam Bushing Housing, HW Radial Slots, 9.5 mm, HDG, W6x7, W6x7.75, W6x8.5, 150mm	HIGH WIND	W6X7, W6X7.75, W6X8.5
30960-152	Bracket, I-Beam Bushing Housing, HW Radial Slots, 9.5 mm, HDG, W6x9, W6x10.4, 152mm	HIGH WIND	W6X9, W6X10.4
30960-155	Bracket, I-Beam Bushing Housing, HW Radial Slots, 9.5 mm, HDG, W6x10.5, W6x12, W6x15, 155mm	HIGH WIND	W6X10.5, W6X12, W6X15
30960-161	Bracket, I-Beam Bushing Housing, HW Radial Slots, 9.5 mm, HDG, W6x16, W6x20, 161mm	HIGH WIND	W6X16, W6X20
30961-204	Bracket, I-Beam Bushing Housing, HW Straight Slots, 8 mm, HDG, W8 x 10, W8 x 13, 204 mm	HIGH WIND	W8X10, W8X13, 200UB18.2, 200UB22.3, 200UB25.4
30961-209	Bracket, I-Beam Bushing Housing, HW Straight Slots, 8 mm, HDG, W8 x 15, W8 x 18, 209 mm	HIGH WIND	W8X15, W8X18, 200UB29.8
30961-213	Bracket, I-Beam Bushing Housing, HW Straight Slots, 8 mm, HDG, W8 x 21, 213 mm	HIGH WIND	W8X21

**BEARING ASSEMBLY CONFIGURATION TABLE**

BEARING PART NUMBER	BRACKET DESCRIPTION	SELECTION CRITERIA
		STANDARD/HIGH LOAD
20936-000	Assembly, Center Stop Bearing, 6.142" ID, Powder Coat	STANDARD LOAD
20936-001	Assembly, Center Stop Bearing, 6.142" ID, Uncoated	STANDARD LOAD
20937-000	Assembly, Center Stop Bearing, Set Screws, 6.142" ID, Powder Coat	STANDARD LOAD
20937-001	Assembly, Center Stop Bearing, Set Screws, 6.142" ID, Uncoated	STANDARD LOAD
20938-000	Assembly, Center Stop Bearing, High Wind, 6.142" ID, Powder Coat	HIGH WIND - RADIAL BRKT
20938-001	Assembly, Center Stop Bearing, High Wind, 6.142" ID, Uncoated	HIGH WIND - RADIAL BRKT
20939-000	Assembly, Center Stop Bearing, High Wind, Set Screws, 6.142" ID, Powder Coat	HIGH WIND - RADIAL BRKT
20939-001	Assembly, Center Stop Bearing, High Wind, Set Screws, 6.142" ID, Uncoated	HIGH WIND - RADIAL BRKT
20956-000	Assembly, Center Stop Bearing, Radial Slots, HW, 6.142" ID, Powder Coat	HIGH WIND - STRAIGHT SLOT BRKT
20956-001	Assembly, Center Stop Bearing, Radial Slots, HW, 6.142" ID, Uncoated	HIGH WIND - STRAIGHT SLOT BRKT
20957-000	Assembly, Center Stop Bearing, Radial Slots, HW, Set Screws, 6.142" ID, Powder Coat	HIGH WIND - STRAIGHT SLOT BRKT
20957-001	Assembly, Center Stop Bearing, Radial Slots, HW, Set Screws, 6.142" ID, Uncoated	HIGH WIND - STRAIGHT SLOT BRKT

SIZE B	DRAWING NUMBER 21000-901	REVISION D	SAVED v43 2/10/2023
SCALE 1:96	SHEET		2 OF 3

8 7 6 5 4 3 2 1

D

D

C

C

B

B

A

A

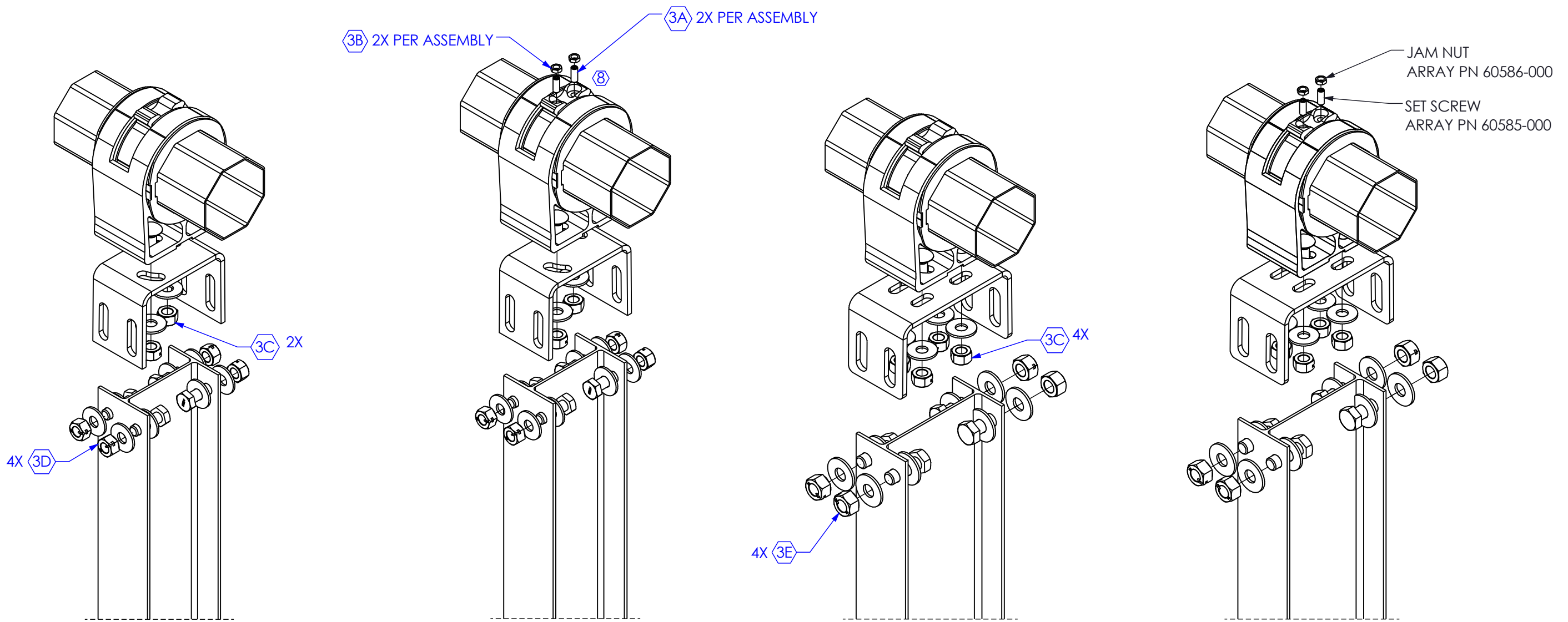

STANDARD LOAD

STANDARD LOAD WITH SET SCREWS

HIGH WIND

HIGH WIND WITH SET SCREWS

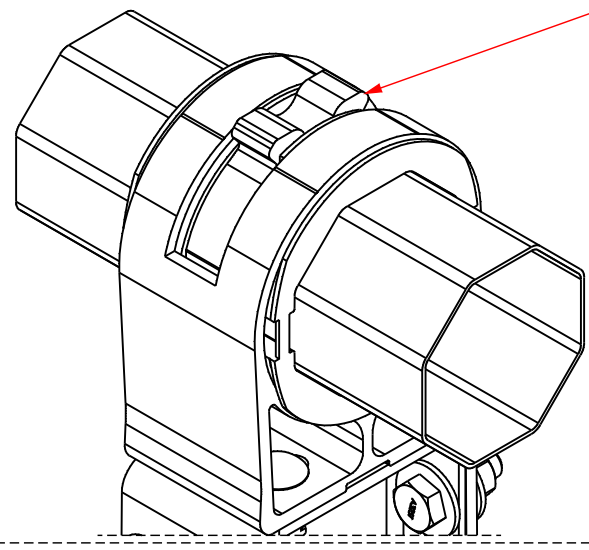

**CAUTION!**  
 BEARING HOUSING STOP MUST BE  
 IN PLANE WITH MODULE CLAMPS  
 WHEN INSTALLED ONTO TORQUE  
 TUBE. INCORRECT INSTALLATION  
 CAN RESULT IN DAMAGE TO  
 TRACKER COMPONENTS

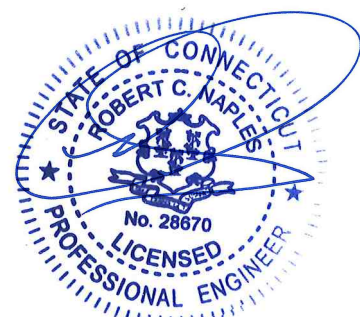

Exp 01/31/2027  
 04/13/2026

SIZE B	DRAWING NUMBER 21000-901	REVISION D	SAVED v43 2/10/2023
SCALE 1:2	SHEET 3 OF 3		

8 7 6 5 4 3 2 1

Template\_CF Drawing\_rmm\_v6

**NOTES:**

- REFER TO INSTALLATION MANUAL FOR DETAILS.
- TORQUE SPECIFICATION:  
2A 169 ± 14 N-M [125 ± 10 FT-LBS]
- MARK ALL TORQUED CONNECTIONS USING PAINT MARKER OF CONTRASTING COLOR ACROSS IMMOBILE BASE AND ALL PARTS SUBJECT TO LOOSENING.
- ALL STRUCTURAL BOLTS ARE 0.625" DIAMETER, ASTM A325, HDG PER ASTM F2329.
- I-BEAM BRACKET IS MADE FROM GRADE 80 STEEL PER ASTM A656 AND HDG PER ASTM A123. G
- 6 IF THE MOUNTING HOLE PROXIMITY TO I-BEAM WEB CAUSES THE INTERIOR FLAT WASHERS TO DEFORM DURING INSTALL, ALIGN BOLT HEAD FLAT EDGE TO THE WEB AND USE CLIPPED WASHERS, ARRAY PN 60590-000.
- 25159-000 MAY BE SUPPLIED AS 30770-XXX AND EITHER 25050-000, 25191-000, OR 25191-001.

ARRAY PART NUMBER DESIGNATION

**20721-152**

ARRAY PART NUMBER EXTENSION NUMBER INDICATES APPROXIMATE LENGTH OF DIM "A" IN MM  
 ARRAY PART NUMBER

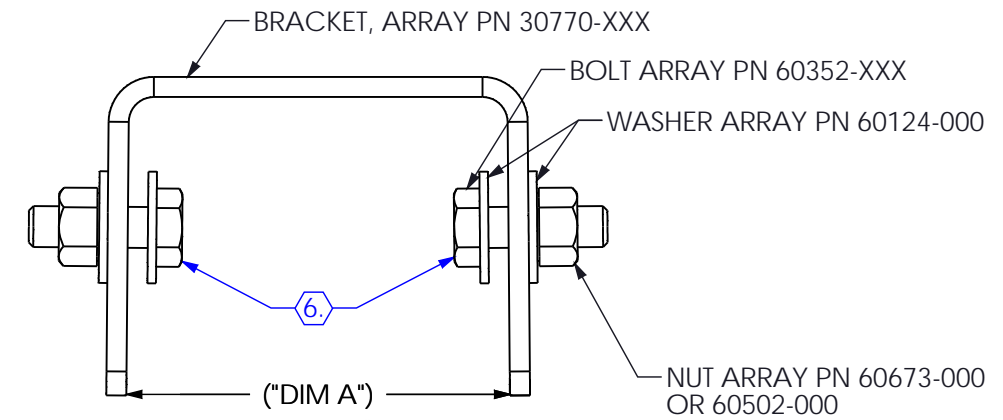
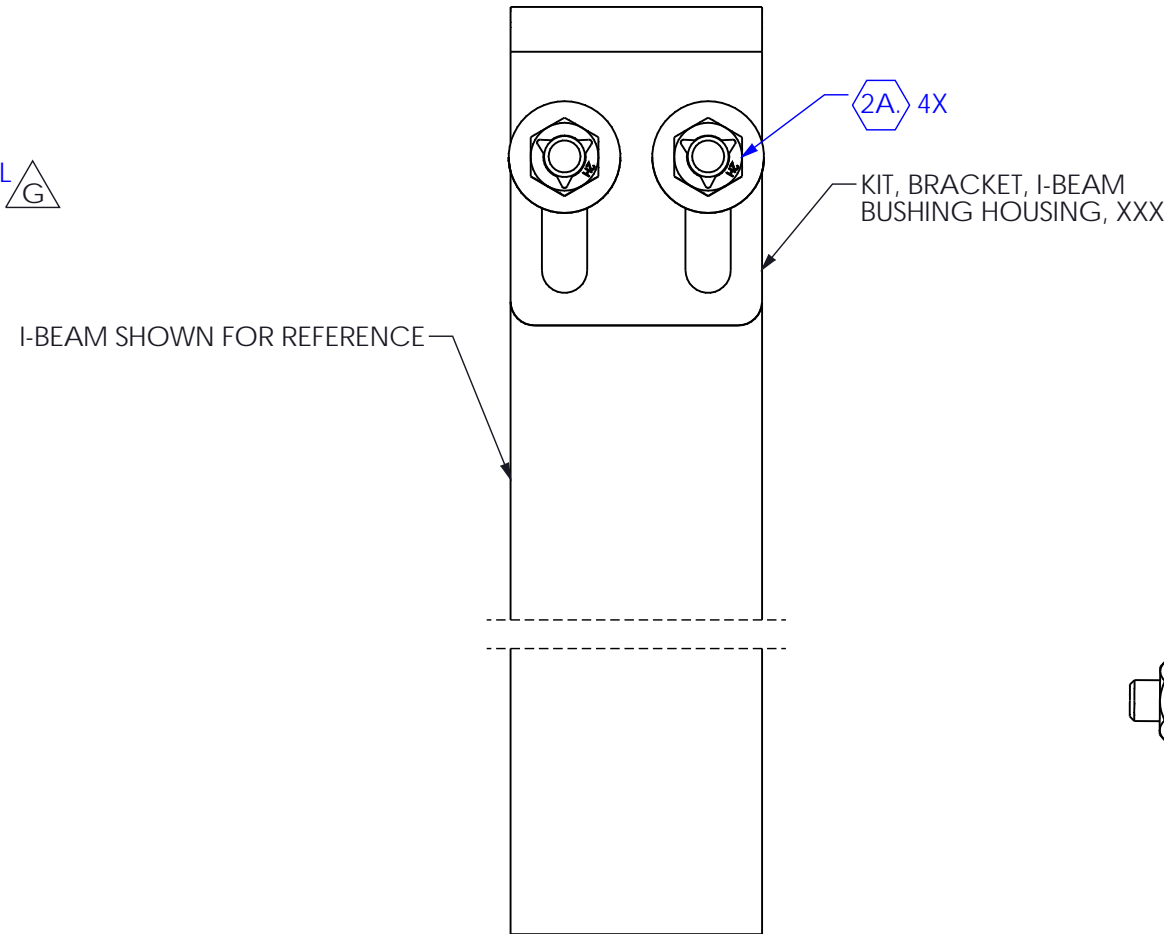
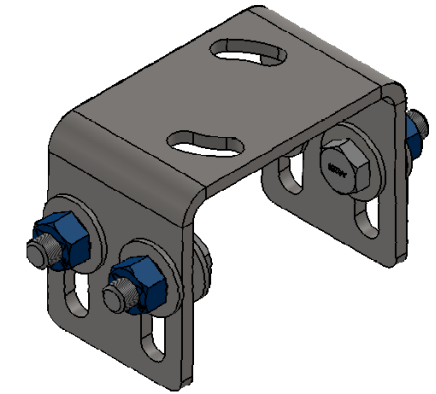

Exp 01/31/2027  
 04/13/2026

**General Table  
 CONFIGURATION TABLE**

ASSEMBLY EXTENSION	PART DESCRIPTION	PART CONFIGURATION	COMPATIBLE I-BEAM SIZE	DIM "A" mm ["]	WEIGHT KG [LB]
20721-149	Field Assembly, Column Bracket, 8 mm, 149 mm	25159-149	W6X7	151 [5.93]	2.61 [5.76]
20721-152	Field Assembly, Column Bracket, 8 mm, 152 mm	25159-152	W6X8.5, W6X9	153 [6.01]	2.61 [5.76]
20721-156	Field Assembly, Column Bracket, 8 mm, 156 mm	25159-156	W6X12, W6X15	158 [6.21]	2.61 [5.76]
20721-162	Field Assembly, Column Bracket, 8 mm, 162 mm	25159-162	W6X16, W6X20, W6X25	164 [6.46]	2.61 [5.76]
20721-203	Field Assembly, Column Bracket, 8 mm, 203 mm	25159-203	W8X10	205 [8.07]	2.94 [6.48]
20721-209	Field Assembly, Column Bracket, 8 mm, 209 mm	25159-209	W8X13, W8X15	211 [8.30]	2.94 [6.48]

REV	DESCRIPTION	DATE
G	MODIFIED NOTE PER ECR-19070	5/15/2019
F	CLARIFIED NOTE PER ECR 19068	5/6/2019
E	MODIFIED NOTE PER ECR 19043	3/19/2019
D	CHANGED KITS PER ECR 19026	2/22/2019
C	CHANGED NUT PER ECR 18118	9/4/2018

ITEM NO.	PART NUMBER	DESCRIPTION	QTY
1	25159-XXX	Kit, Bracket, 8 mm, I-beam Bushing Housing, XXX	1

PROPRIETARY AND CONFIDENTIAL THE INFORMATION CONTAINED IN THIS DRAWING IS THE SOLE PROPERTY OF ARRAY TECHNOLOGIES. ANY REPRODUCTION IN PART OR AS A WHOLE WITHOUT THE WRITTEN PERMISSION FROM ARRAY TECHNOLOGIES IS PROHIBITED.		DRAWING STATUS: <b>Final</b> DRAWN: MB DATE: 10/11/2017 ENG. CHECK: DATE: DATE: INITIALS: DATE: DATE:		DRAWING CHECK: CD DATE: 5/15/2019 FINAL APPROVAL: AH DATE: 5/15/2019		<b>ARRAY TECHNOLOGIES</b> 3901 Midway Place NE, Albuquerque, NM 87109 (505) 881-7567	
THIRD ANGLE PROJECTION MILLIMETER [INCH]		ALL DIMS ARE DUAL UNITS: TOLERANCES UNLESS OTHERWISE SPECIFIED		TITLE: <b>Field Assembly, Column Bracket, 8 mm, XXX mm</b>		SIZE: B SCALE: 1:96	
MM [INCH]: X = ±1.25 [0.050] .X = ±0.4 [0.015] .XX = ±0.1 [0.004]		METER [INCH]: X.XX = ±0.013 [0.500] X.XXX = ±0.006 [0.250]		ANGULAR: X = ±1.0° .X = ±0.1°		DRAWING NUMBER: 20721-901 REVISION: G-01 SHEET: 1 OF 1	
WT: 17.43 KG [38.6946 LB]				SAVED v60 7/29/2019			

ITEM NO.	PART NUMBER	DESCRIPTION	SPI STD	SPI STD (SET SCREW)	SPI HW	SPI HW (SET SCREW)
1	21022-XXX	ASSY, STL BRG, SSCR, L/M/H	-	1	-	1
2	21023-XXX	ASSY, STL BRG, L/M/H	1	-	1	-
3	25244-000	Kit, 0.625"-11 x 2" Carriage Bolt, SAE Washer, Pin Lock Nut, HDG	2	2	2	2
4	25245-000	Kit, 0.625"-11 x 2" Bracket to Pile Hardware, HDG, SPI	4	4	-	-
5	25279-000	Kit, 0.625"-11x2" BRKT-Pile, GR8, SPI, H	-	-	4	4
6	30968-000	BRKT, STL BRG HSG, 48.0mm, 5/8", STD	2	2	-	-
7	31071-000	BRKT, STL BRG HSG, 48.0mm, 5/8", HW	-	-	2	2

**NOTES:**

- REFER TO APPROPRIATE INSTALLATION MANUAL FOR ADDITIONAL INSTALL PROCEDURE DETAILS AND GUIDANCE.
- LOOSEN JAM NUT ON SET SCREWS PRIOR TO TORQUING. ENSURE THAT THE SET SCREWS DO NOT PROTRUDE FROM THE CENTER STOP PRIOR TO SLIDING ON TORQUE TUBE.
- TORQUE SPECIFICATION:
  - 3A. SET SCREWS TORQUED TO 12±1.5 N-M [9±1 FT-LBS] [108±12 IN-LBS]  
BOTH TORQUED TWICE WITH ALTERNATING PATTERN.
  - 3B. JAM NUTS TORQUED TO 16±1.5 N-M [12±1 FT-LBS] [144±12 IN-LBS]  
BOTH TORQUED TWICE WITH ALTERNATING PATTERN.
  - 3C. 169±14 N-M [125±10 FT-LBS]
  - 3D. 237±14 N-M [175±10 FT-LBS]
- MARK ALL TORQUED CONNECTIONS USING PAINT MARKER OF CONTRASTING COLOR ACROSS IMMOBILE BASE AND ALL PARTS SUBJECT TO LOOSENING.
5. SET SCREW BEARING HOUSING ASSEMBLY TO BE USED ON FIRST BEARING COLUMN NORTH AND SOUTH OF GEAR RACK CENTER STRUCTURE AT MINIMUM. REFER TO ADP FOR LAYOUT OF BEARING HOUSING WITH SET SCREWS PER ROW.
6. RECOMMENDED SEQUENCE FOR PROPER TIGHTENING OF SET SCREW AND NUT; STARTING WITH THE SET SCREWS TORQUE TO SPECIFICATION. NEXT TORQUE NUT TO SPECIFICATION UNTIL ALL HARDWARE IS MAINTAINING TORQUE IN THE REQUIRED RANGE. 2 TO 3 PASSES ARE OFTEN REQUIRED.
7. PILE CAP PROVIDED BY SPI AND NOT PART OF ARRAY BOM.

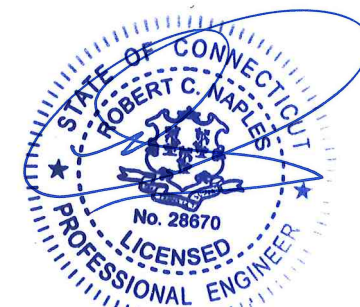
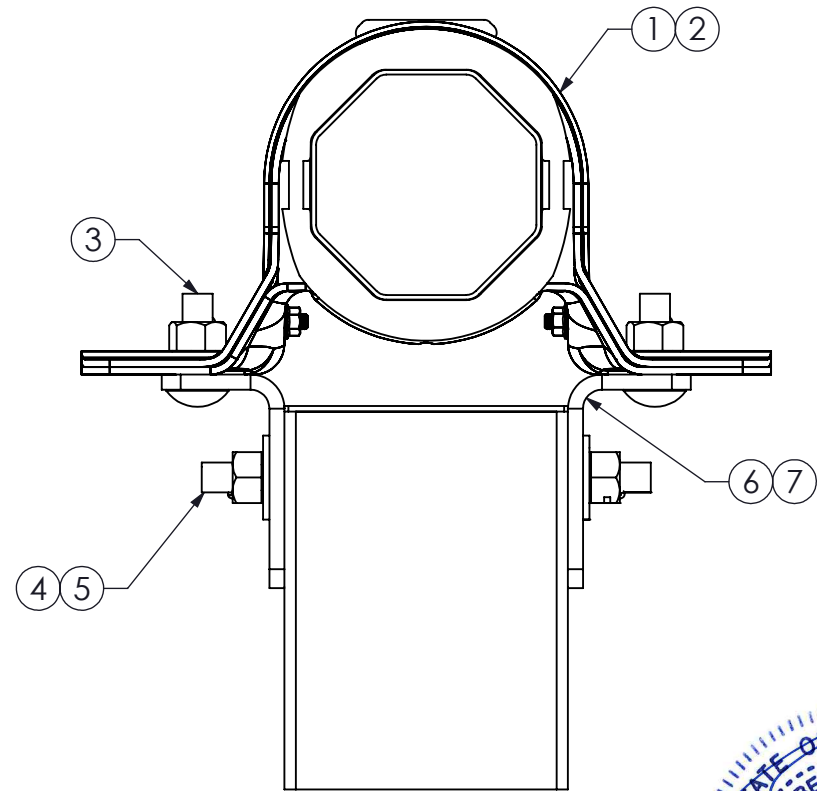

Exp 01/31/2027  
04/13/2026

STEEL BEARING ASSEMBLY CORROSION CONFIGURATION TABLE		SELECTION CRITERIA	
STEEL BEARING ASSEMBLY PART NUMBER	DESCRIPTION	SET SCREWS	CORROSION REQUIREMENTS
21022-200	Assembly, Steel Bearing, Set Screws, L	YES	L
21022-300	Assembly, Steel Bearing, Set Screws, M	YES	M
21022-400	Assembly, Steel Bearing, Set Screws, H	YES	H
21023-200	Assembly, Steel Bearing, L	NO	L
21023-300	Assembly, Steel Bearing, M	NO	M
21023-400	Assembly, Steel Bearing, H	NO	H

APPLICABLE TRACKER SYSTEMS: DuraTrack, Omnitrack

DRAWING STATUS: **Final**

DRAWN INITIALS: DS DATE: 10/29/2024 ENGR APPROVAL INITIALS: JS DATE: 11/14/2024

PROPRIETY AND CONFIDENTIAL: THE INFORMATION CONTAINED IN THIS DRAWING IS THE SOLE PROPERTY OF ARRAY TECHNOLOGIES. ANY REPRODUCTION IN PART OR AS A WHOLE WITHOUT THE WRITTEN PERMISSION FROM ARRAY TECHNOLOGIES IS PROHIBITED.

THIRD ANGLE PROJECTION

ALL DIMS ARE IN MILLIMETERS

TOLERANCES UNLESS OTHERWISE SPECIFIED

GEOMETRICAL SPECIFICATIONS PER ISO 8015 AND 22081. GENERAL LINEAR AND ANGULAR TOLERANCING PER THE TABLE BELOW:

NOMINAL DIMS	d<=6	6<d<=10	10<d<=25	25<d<=50	50<d<=100	100<d<=250	250<d<=500	d>500
f2(mm)	±0.1	±0.2	±0.3	±0.4	±0.5	±0.75	±1	±2
f3(°)	±1	±1	±0.5	±0.5	±0.5	±0.25	±0.25	±0.25

LINEAR TOL: (±12Ⓢ) | ANGLE TOL: (±13)

DIMENSIONS IN ( ) ARE FOR REFERENCE ONLY

INITIAL RELEASE	JS	11/18/2024
ZONE REV	ENGR	DATE
ECR #	DESCRIPTION	
<b>ARRAY TECHNOLOGIES</b> 3901 Midway Place NE Albuquerque, NM 87109   (505) 881-7567 <b>ARRAY</b>		
<b>TITLE</b> Field Assembly, Steel Bearing & Bracket, SPI, L/M/H		
SIZE B	DRAWING NUMBER	CODE
1:10	21131-901	A
REVISION	SAVED v23	
A	12/3/2024	
SHEET	1 OF 3	

8

7

6

5

4

3

2

1

STEEL BEARING HOUSING BRACKET CONFIGURATION TABLE		SELECTION CRITERIA			
PART NUMBER	DESCRIPTION	STANDARD/HIGH WIND	COMPATIBLE PILE TYPE	DIM "A" mm [in]	DIM "B" mm [in]
30968-000	Bracket, Steel Bearing Housing, 48mm, Std	STANDARD LOAD	SPI BEAM	90 MIN [3.54 MIN]	145 - 220 [5.71 - 8.66]
31071-000	Bracket, Steel Bearing Housing, 48mm, HW	HIGH WIND LOAD	SPI BEAM	90 MIN [3.54 MIN]	145 - 220 [5.71 - 8.66]

2 PER ASSEMBLY  
ARRAY P/N: 60586-000  
3B

2 PER ASSEMBLY  
ARRAY P/N: 60585-000  
3A

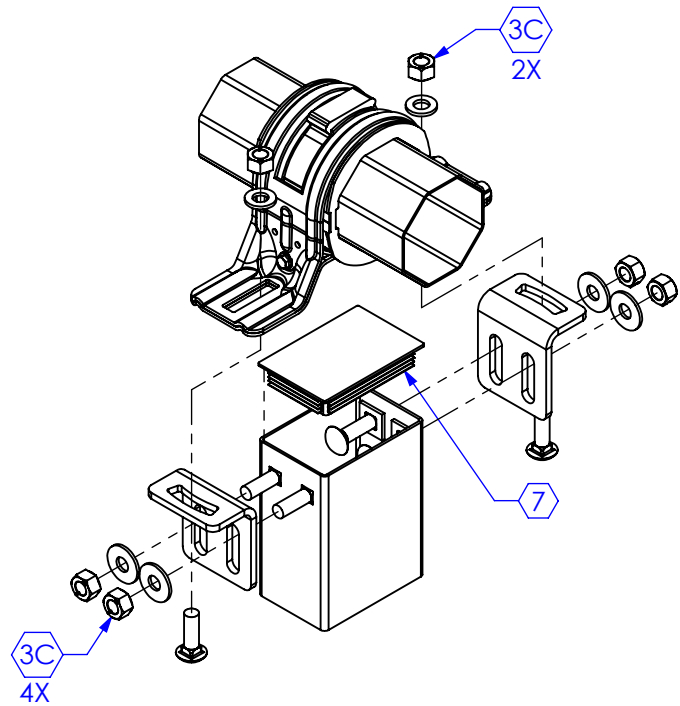

STANDARD BRACKETS  
WITHOUT SET SCREW ASSEMBLY

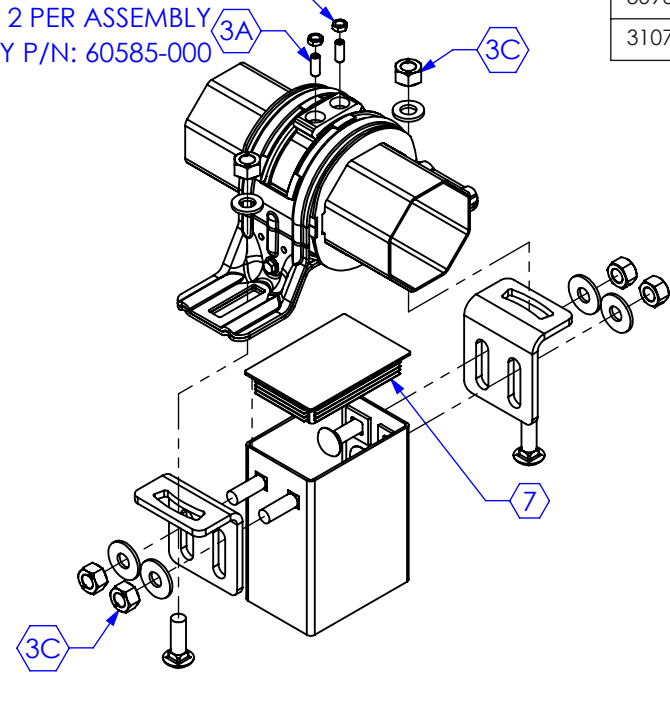

STANDARD BRACKETS  
WITH SET SCREW ASSEMBLY

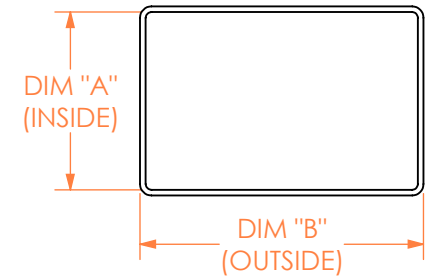
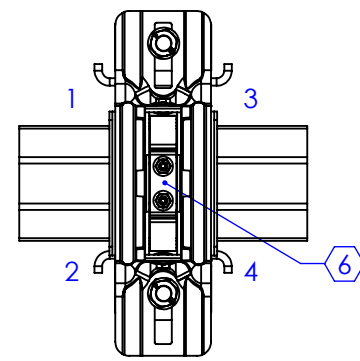

**CAUTION!**  
BEARING HOUSING STOP MUST BE IN  
PLANE WITH MODULE CLAMPS WHEN  
INSTALLED ONTO TORQUE TUBE.  
INCORRECT INSTALLATION CAN RESULT IN  
DAMAGE TO TRACKER COMPONENTS.

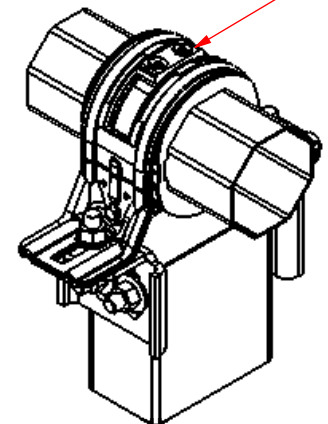

2 PER ASSEMBLY  
ARRAY P/N: 60585-000  
3A

2 PER ASSEMBLY  
ARRAY P/N: 60586-000  
3B

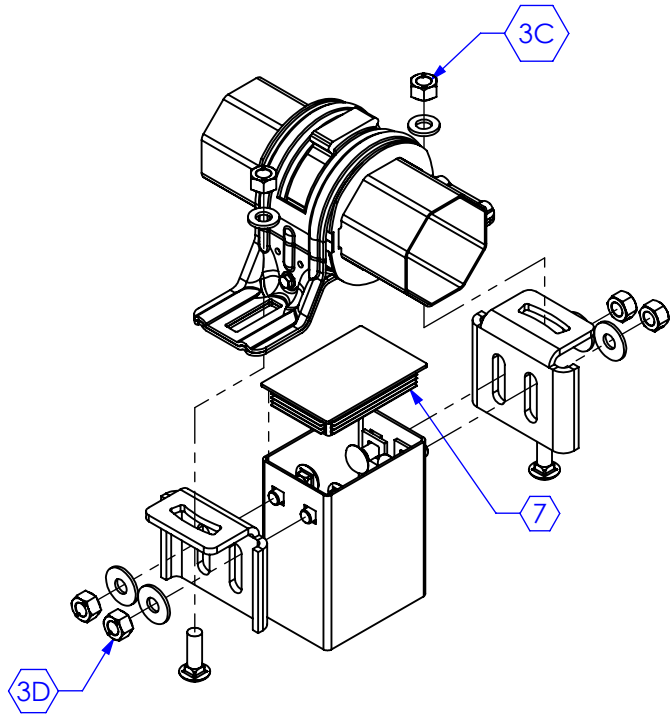

HIGH WIND BRACKETS  
WITHOUT SET SCREW ASSEMBLY

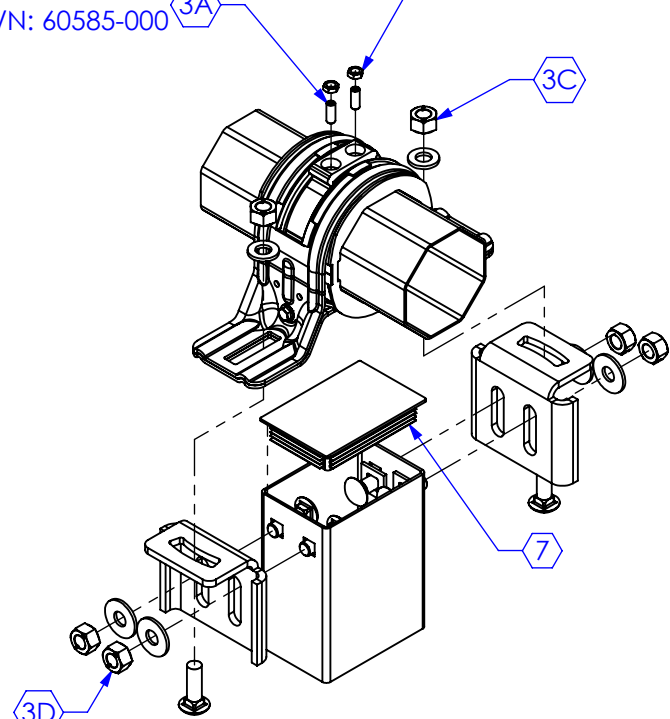

HIGH WIND BRACKETS  
WITH SET SCREW ASSEMBLY

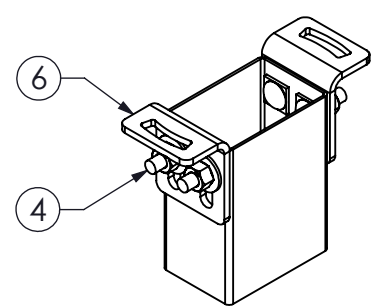

SPI STANDARD LOAD  
BRACKET INSTALLATION

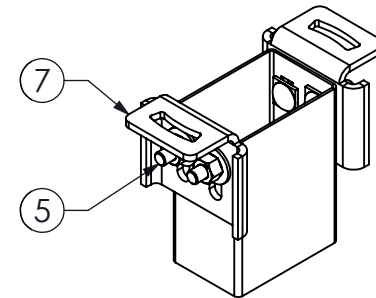
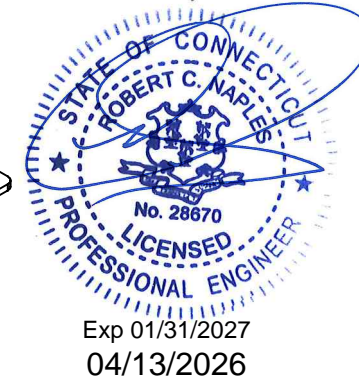

SPI HIGH WIND  
BRACKET INSTALLATION

SIZE B	DRAWING NUMBER 21131-901	REVISION A	SAVED v23 12/3/2024
SCALE 1:10	SHEET		2 OF 3

8

7

6

5

4

3

2

1

Sheet2+\_w4

8 7 6 5 4 3 2 1

← HOUSING SHIFTED E/W

15.9 MAX [0.625" MAX] ALLOWABLE HOUSING SHIFT IN EAST OR WEST DIRECTION FROM THE CENTERLINE OF THE PILE/BEAM

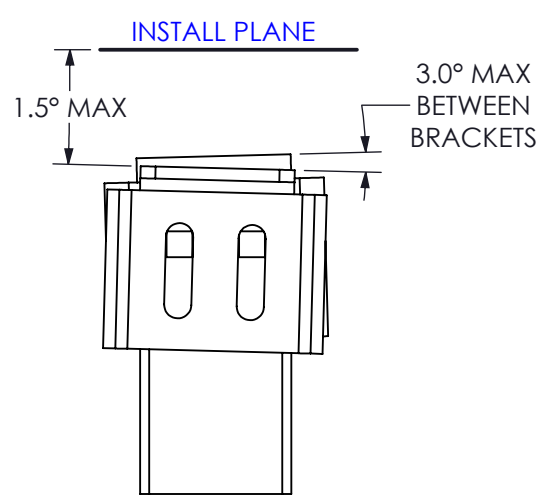
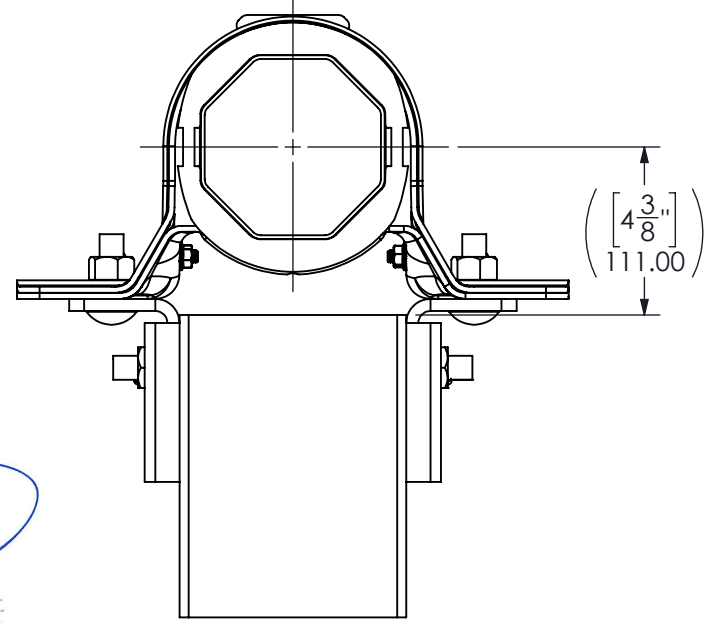
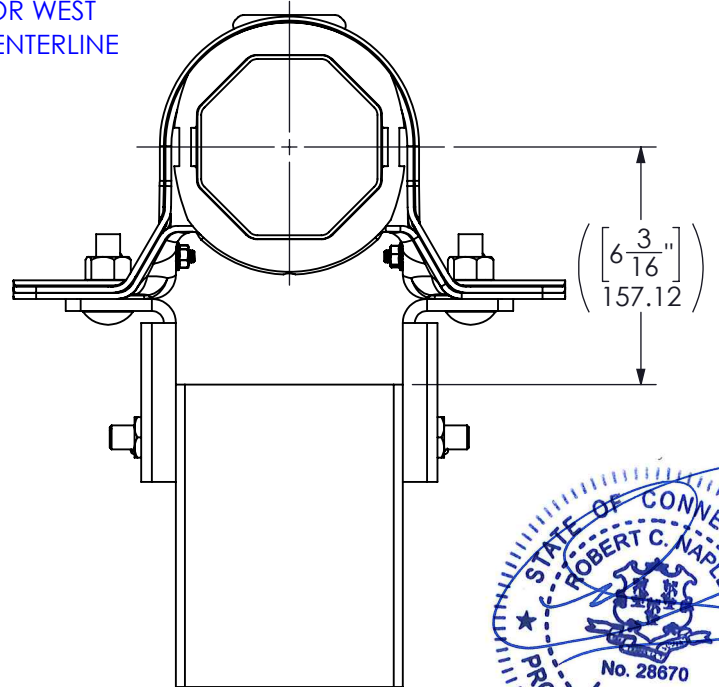
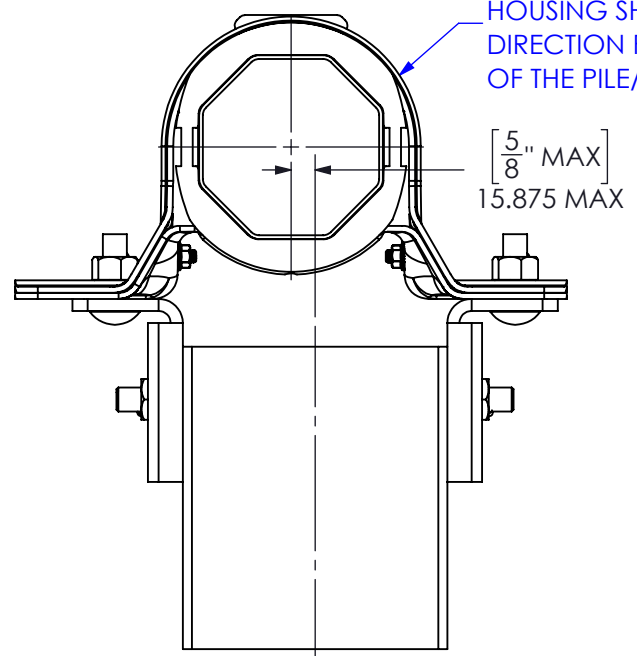

BEARING HOUSING EXTENDS UP

BEARING HOUSING EXTENDS DOWN

OFFSET BRACKET ANGLE ± 1.5° FROM INSTALL PLANE (UP TO 3.0° MAX OFFSET BETWEEN BRACKETS)

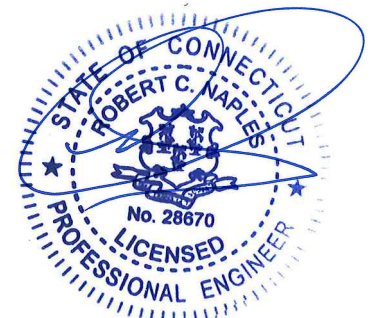

Exp 01/31/2027 04/13/2026

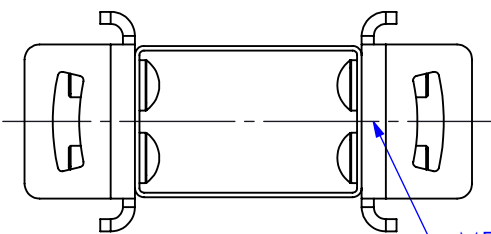

MEASURE HEIGHT ALONG CENTERLINE

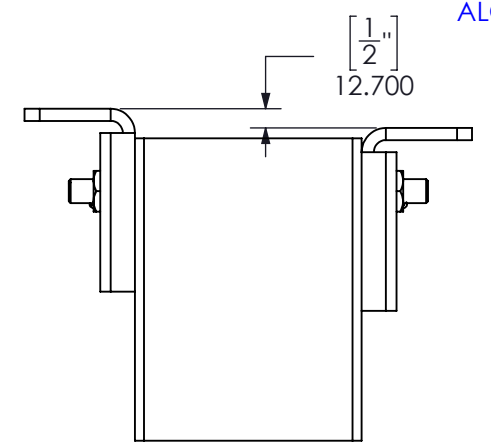

OFFSET BRACKET HEIGHT

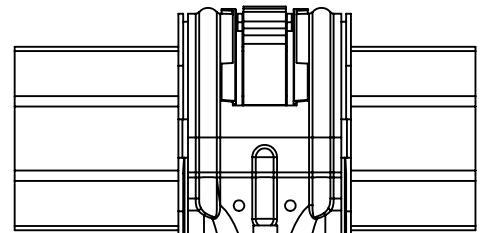

[1/2] MAX 12.70 MAX

HOUSING OVERHANG

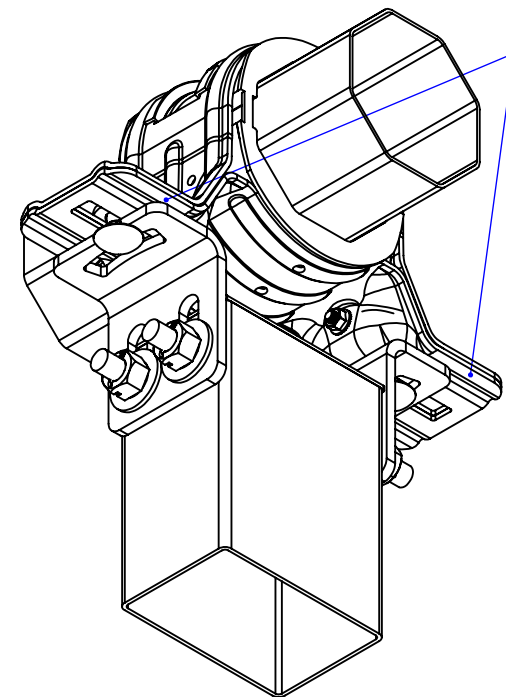

12.7 MAX [0.500" MAX] OVERHANG WHEN BOTH SIDES OF THE HOUSING ARE SHIFTED

OVERHANG REQUIREMENT NOT APPLICABLE FOR ROTATED (YAW) HOUSING WHERE OVERHANG OCCURS ON OPPOSITE SIDES

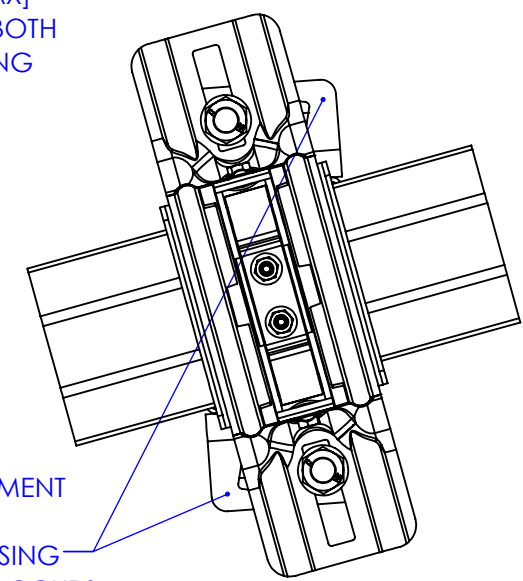

ROTATIONAL OVERHANG

SIZE B	DRAWING NUMBER 21131-901	REVISION A	SAVED v23 12/3/2024
SCALE 1:10	SHEET 3 OF 3		

8 7 6 5 4 3 2 1

Sheet2+\_w4

ITEM NO.	PART NUMBER	DESCRIPTION	W/UB STD	W/UB STD (SET SCREW)	W/UB HW	W/UB HW (SET SCREW)	IPE STD	IPE STD (SET SCREW)	IPE HW	IPE HW (SET SCREW)
1	21022-XXX	ASSY, STL BRG, SSCR, L/M/H	-	1	-	1	-	1	-	1
2	21023-XXX	ASSY, STL BRG, L/M/H	1	-	1	-	1	-	1	-
3	25050-001	Kit, 0.625"-11 x 2" Structural Bolt, Large Washers, Pin Lock Nut, HDG	4	4	-	-	-	-	-	-
4	25123-001	Kit, 0.75"-10 x 2.25" Structural Bolt, Large Washers, Pin Lock Nut, HDG	-	-	4	4	-	-	-	-
5	25140-001	Kit, 0.625"-11 x 2" Structural Bolt, Clipped Washers, Pin Lock Nut, HDG	-	-	-	-	4	4	-	-
6	25244-000	Kit, 0.625"-11 x 2" Carriage Bolt, Large Washers, Pin Lock Nut, HDG	2	2	2	2	2	2	2	2
7	25267-000	Kit, .75-10x2.25, STRL, CLPD WSHRS, PL, HDG	-	-	-	-	-	-	4	4
8	30966-000	BRKT, STL BRG HSG, 57.2mm, 5/8", STD	2	2	-	-	-	-	-	-
9	30967-000	BRKT, STL BRG HSG, 57.2mm, 3/4", HW	-	-	2	2	-	-	-	-
10	30968-000	BRKT, STL BRG HSG, 48.0mm, 5/8", STD	-	-	-	-	2	2	-	-
11	30969-000	BRKT, STL BRG HSG, 48.0mm, 3/4", HW	-	-	-	-	-	-	2	2

**NOTES:**

- REFER TO APPROPRIATE INSTALLATION MANUAL FOR ADDITIONAL INSTALL PROCEDURE DETAILS AND GUIDANCE.
- LOOSEN JAM NUT ON SET SCREWS PRIOR TO TORQUING. ENSURE THAT THE SET SCREWS DO NOT PROTRUDE FROM THE CENTER STOP PRIOR TO SLIDING ON TORQUE TUBE.
- TORQUE SPECIFICATION:
  - 3A. SET SCREWS TORQUED TO 12±1.5 N-M [9±1 FT-LBS] [108±12 IN-LBS] BOTH TORQUED TWICE WITH ALTERNATING PATTERN.
  - 3B. JAM NUTS TORQUED TO 16±1.5 N-M [12±1 FT-LBS] [144±12 IN-LBS] BOTH TORQUED TWICE WITH ALTERNATING PATTERN.
  - 3C. 169±14 N-M [125±10 FT-LBS]
  - 3D. 285±14 N-M [210±10 FT-LBS]
- MARK ALL TORQUED CONNECTIONS USING PAINT MARKER OF CONTRASTING COLOR ACROSS IMMOBILE BASE AND ALL PARTS SUBJECT TO LOOSENING.
5. SET SCREW BEARING HOUSING ASSEMBLY TO BE USED ON FIRST BEARING COLUMN NORTH AND SOUTH OF GEAR RACK CENTER STRUCTURE AT MINIMUM. REFER TO ADP FOR LAYOUT OF BEARING HOUSING WITH SET SCREWS PER ROW.
6. ALIGN BOLT HEAD FLAT EDGE AND CLIPPED WASHER FLAT EDGE TO THE WEB DURING INSTALLATION FOR THE INTERIOR WASHERS. ALIGN CLIPPED WASHER FLAT EDGES TO THE INSIDE FOR THE EXTERIOR WASHERS TO AVOID POTENTIAL OVERLAP.
7. RECOMMENDED SEQUENCE FOR PROPER TIGHTENING OF SET SCREW AND NUT; STARTING WITH THE SET SCREWS TORQUE TO SPECIFICATION. NEXT TORQUE NUT TO SPECIFICATION UNTIL ALL HARDWARE IS MAINTAINING TORQUE IN THE REQUIRED RANGE. 2 TO 3 PASSES ARE OFTEN REQUIRED.

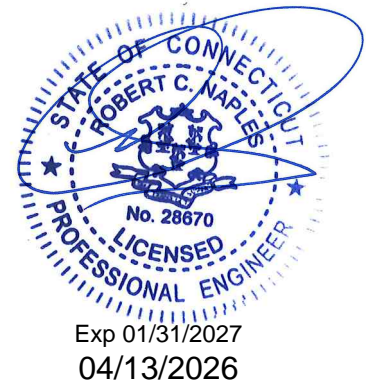
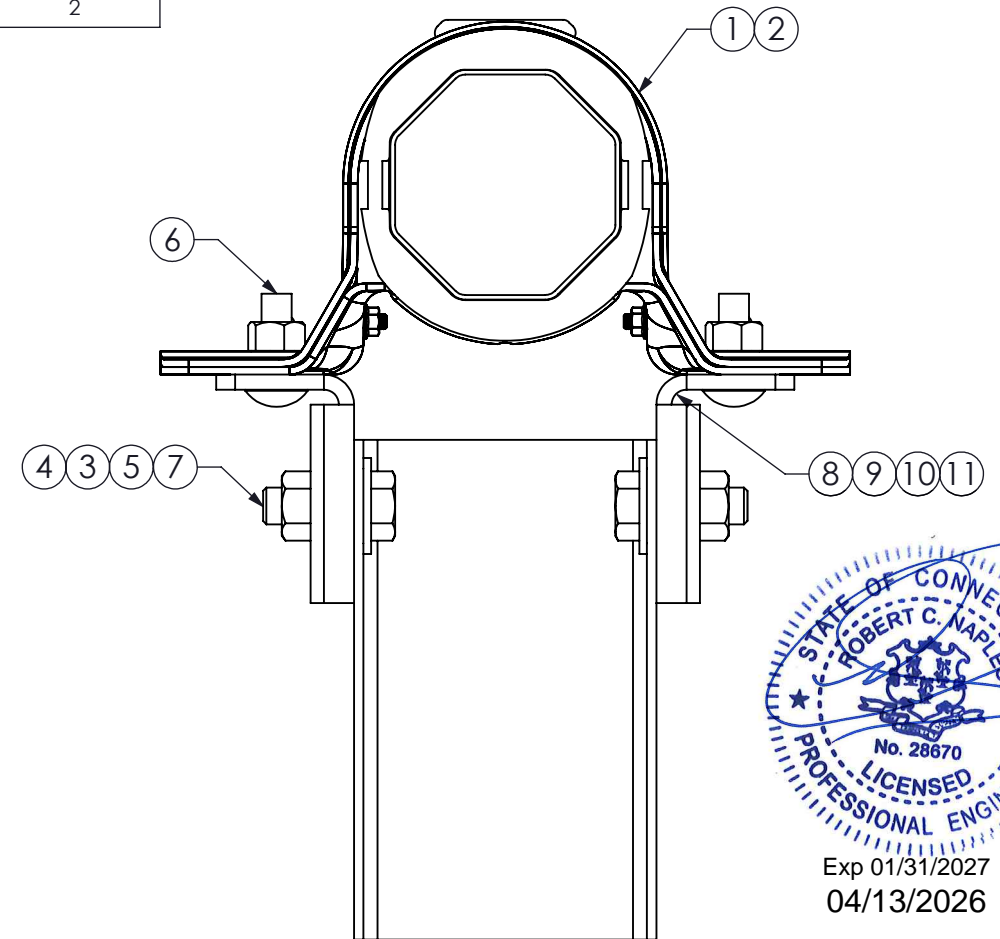

STEEL BEARING HOUSING CORROSION CONFIGURATION TABLE		SELECTION CRITERIA	
STEEL BEARING HOUSING PART NUMBER	DESCRIPTION	SET SCREWS	CORROSION REQUIREMENTS
21022-200	Assembly, Steel Bearing, Set Screws, 2-Piece, L	YES	L
21022-300	Assembly, Steel Bearing, Set Screws, 2-Piece, M	YES	M
21022-400	Assembly, Steel Bearing, Set Screws, 2-Piece, H	YES	H
21023-200	Assembly, Steel Bearing, 2-Piece, L	NO	L
21023-300	Assembly, Steel Bearing, 2-Piece, M	NO	M
21023-400	Assembly, Steel Bearing, 2-Piece, H	NO	H

ZONE	REV	ECR #	DESCRIPTION	ENGR	DATE
A2, B4, C5, D3, 2-A1, 2-A2, 2-A3, 2-C1, 2-D1, 2-D2, 2-D5, 3-A5, 3-A7, 3-B5, 3-D1, 3-D2	C	US-24068	UPDATED AND REMOVED NOTES, UPDATED TITLE, BRACKET CONFIG TABLE, VIEW CALLOUTS, COLUMN HEADERS, ADDED 25267-000	JS	07/25/2024
	B	US-23115	WEAR SLEEVE DESIGN UPDATE		8/14/2023
	A		INITIAL RELEASE		6/26/2023

APPLICABLE TRACKER SYSTEMS: DuraTrack OmniTrack	DRAWING STATUS <b>Final</b>	<b>ARRAY TECHNOLOGIES</b>			
PROPRIETARY AND CONFIDENTIAL: THE INFORMATION CONTAINED IN THIS DRAWING IS THE SOLE PROPERTY OF ARRAY TECHNOLOGIES. ANY REPRODUCTION IN PART OR AS A WHOLE WITHOUT THE WRITTEN PERMISSION FROM ARRAY TECHNOLOGIES IS PROHIBITED.	DRAWN INITIALS: RM DATE: 07/19/2023 ENG. CHECK INITIALS: JS DATE: 08/14/2023	DRAWING CHECK INITIALS: NC DATE: 7/31/2023 FINAL APPROVAL INITIALS: SB DATE: 8/13/2023	3901 Midway Place NE Albuquerque, NM 87109   (505) 881-7567		
THIRD ANGLE PROJECTION	ALL DIMS ARE IN MILLIMETERS	TITLE <b>Field Assembly, Steel Bearing Housing, Standard/High Wind Brackets, w/wo Set Screws, L/M/H</b>			
TOLERANCES UNLESS OTHERWISE SPECIFIED	ANGLE AND LINEAR TOLERANCES PER: ISO 2768-m	GEOMETRIC TOLERANCES PER: ISO 2768-K	SIZE B	DRAWING NUMBER 21020-901	CODE
			SCALE 1:10	REVISION C	SAVED v50 7/25/2024
				SHEET	1 OF 3

**STEEL BEARING HOUSING BRACKET CONFIGURATION TABLE**

**SELECTION CRITERIA**

PART NUMBER	DESCRIPTION	STANDARD/HIGH WIND	COMPATIBLE PILE TYPE	DIM "A" mm [in]	DIM "B" mm [in]
30966-000	Bracket, I-Beam Steel Bearing Housing, 57.2mm, Std	STANDARD LOAD	W/UB BEAMS	90 MIN [3.54 MIN]	145 - 220 [5.71 - 8.66]
30967-000	Bracket, I-Beam Steel Bearing Housing, 57.2mm, HW	HIGH WIND LOAD	W/UB BEAMS	90 MIN [3.54 MIN]	145 - 220 [5.71 - 8.66]
30968-000	Bracket, I-Beam Steel Bearing Housing, 48.0mm, Std	STANDARD LOAD	IPE BEAMS	80 MIN [3.15 MIN]	145 - 220 [5.71 - 8.66]
30969-000	Bracket, I-Beam Steel Bearing Housing, 48.0mm, HW	HIGH WIND LOAD	IPE BEAMS	80 MIN [3.15 MIN]	145 - 220 [5.71 - 8.66]

2 PER ASSEMBLY  
ARRAY P/N: 60586-000 (3B)  
2 PER ASSEMBLY  
ARRAY P/N: 60585-000 (3A)

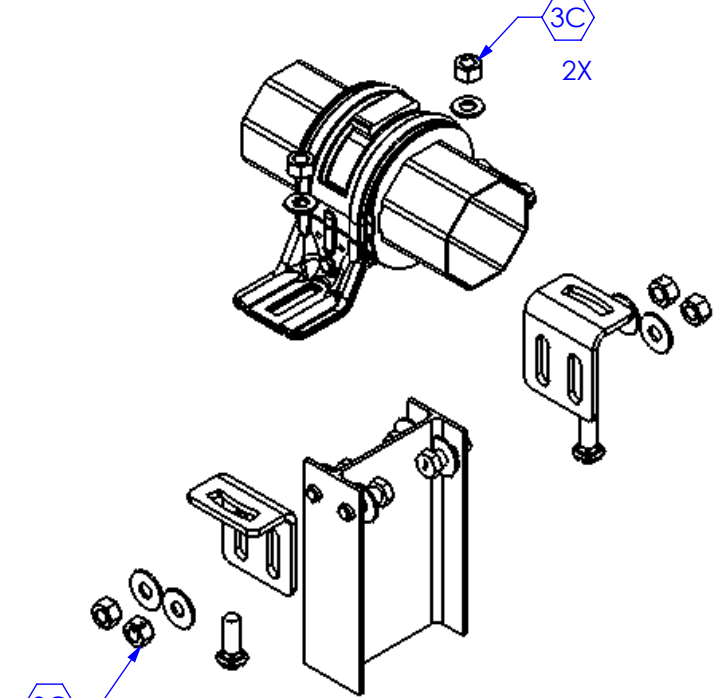

STANDARD BRACKETS WITHOUT SET SCREW ASSEMBLY

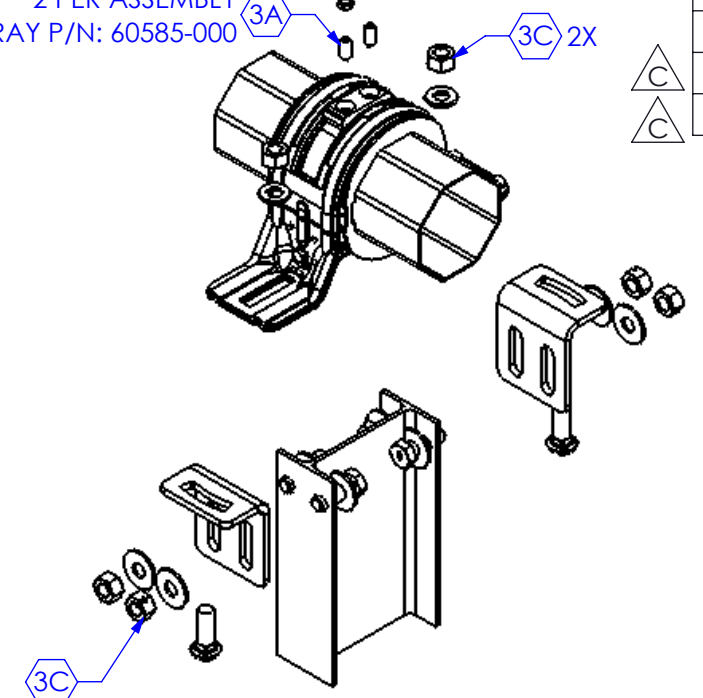

STANDARD BRACKETS WITH SET SCREW ASSEMBLY

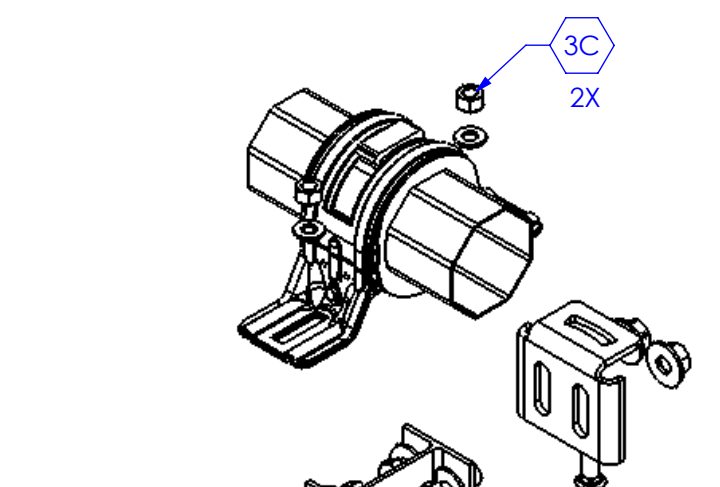

HIGH WIND BRACKETS WITHOUT SET SCREW ASSEMBLY

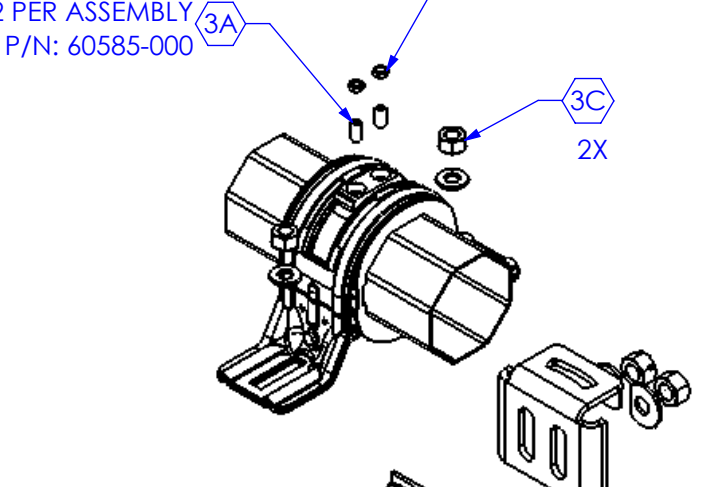

HIGH WIND BRACKETS WITH SET SCREW ASSEMBLY

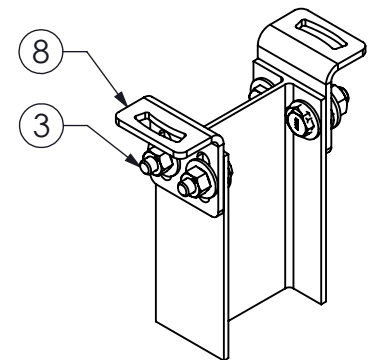
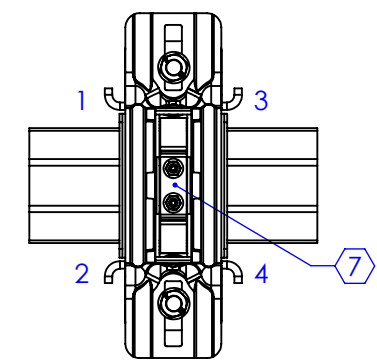

W/UB STANDARD LOAD BRACKET INSTALLATION

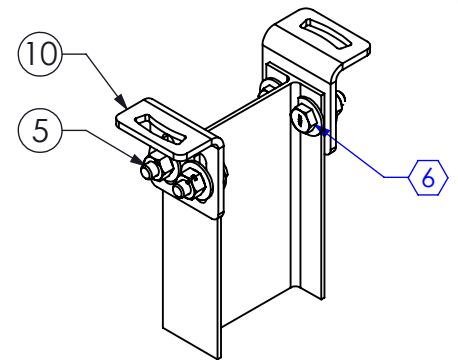

IPE STANDARD LOAD BRACKET INSTALLATION

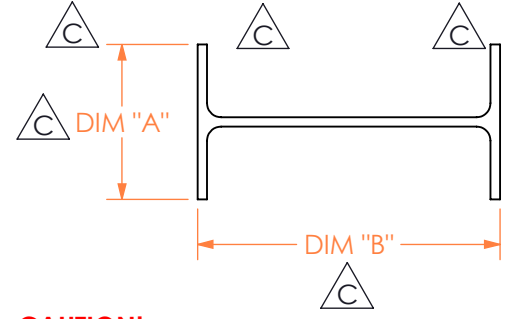
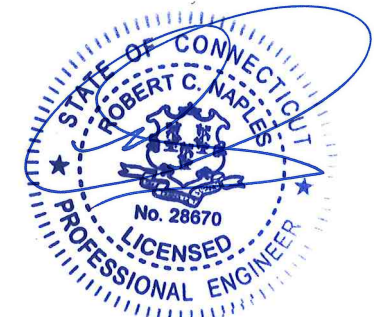

**CAUTION!**  
BEARING HOUSING STOP MUST BE IN PLANE WITH MODULE CLAMPS WHEN INSTALLED ONTO TORQUE TUBE. INCORRECT INSTALLATION CAN RESULT IN DAMAGE TO TRACKER COMPONENTS.

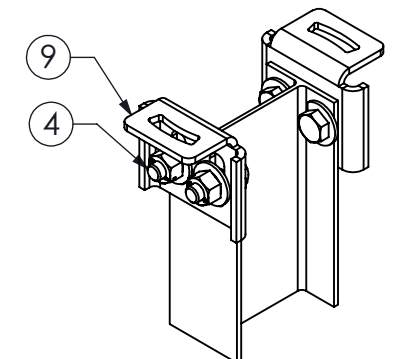

W/UB HIGH WIND BRACKET INSTALLATION

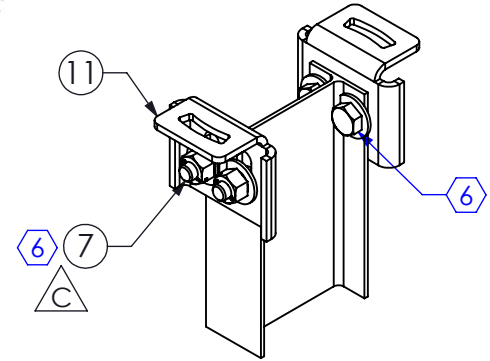

IPE HIGH WIND BRACKET INSTALLATION

SIZE B	DRAWING NUMBER 21020-901	REVISION C	SAVED v50 7/25/2024
SCALE 1:10	SHEET 2 OF 3		

8

7

6

5

4

3

2

1

← HOUSING SHIFTED E/W

15.9 MAX [0.625" MAX] ALLOWABLE HOUSING SHIFT IN EAST OR WEST DIRECTION FROM THE CENTERLINE OF THE PILE/BEAM

$\left[ \frac{5}{8} \right]$  MAX  
15.875 MAX

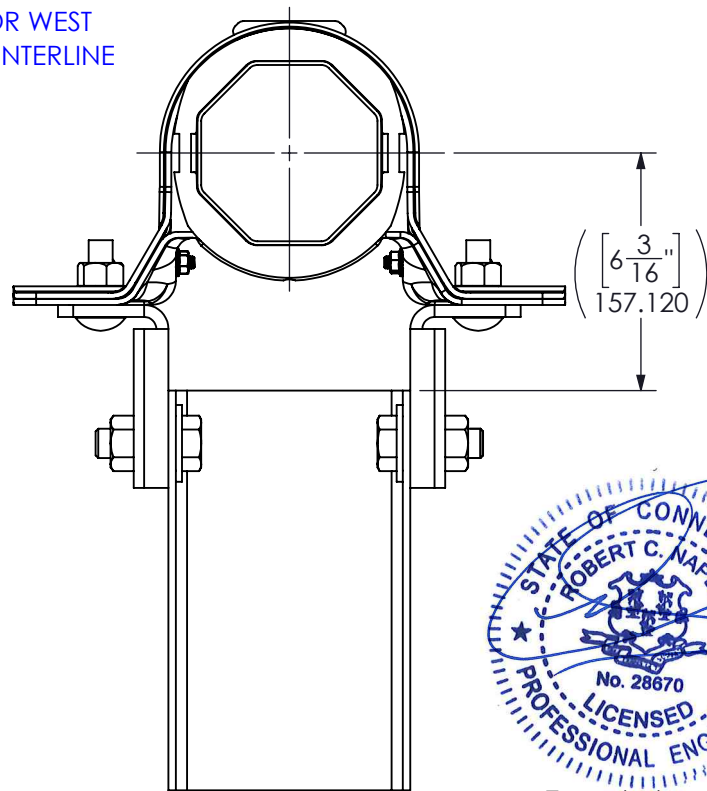
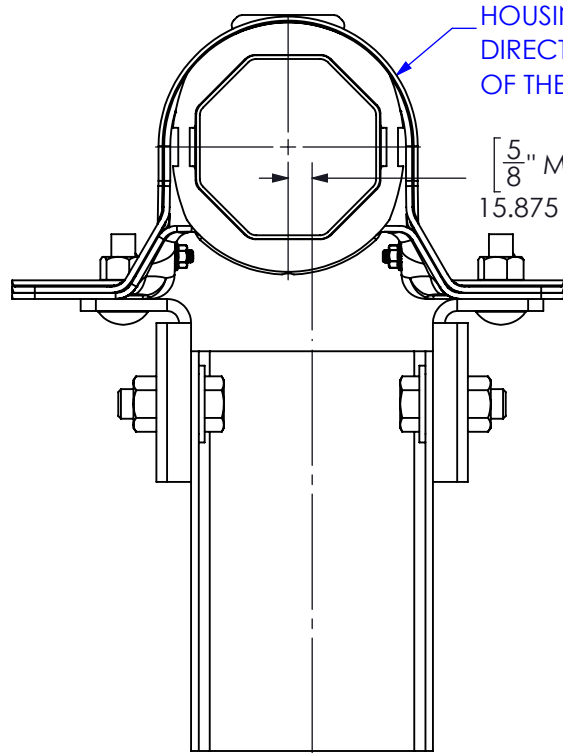

BEARING HOUSING EXTENDS UP

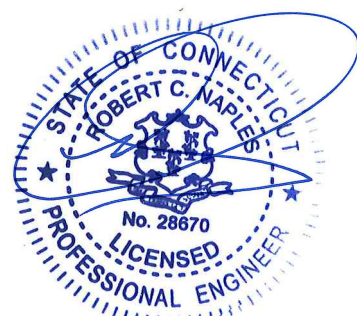

Exp 01/31/2027  
04/13/2026

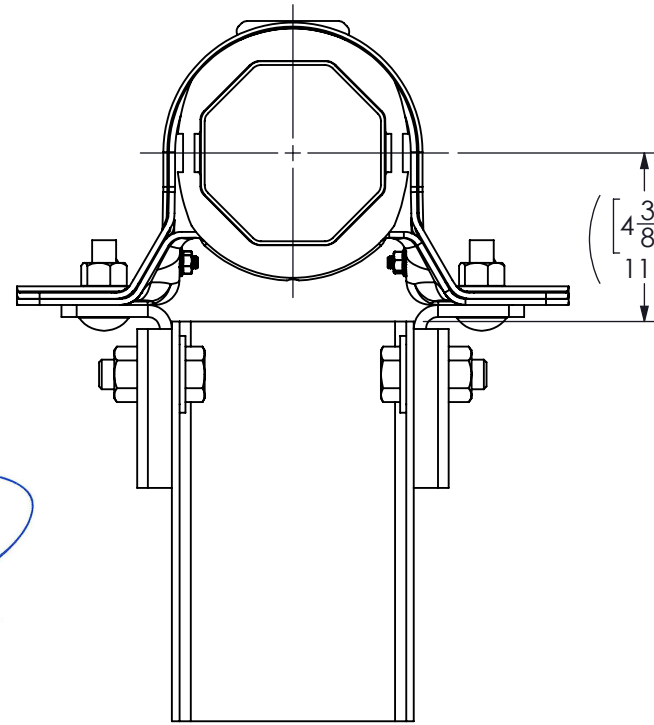

BEARING HOUSING EXTENDS DOWN

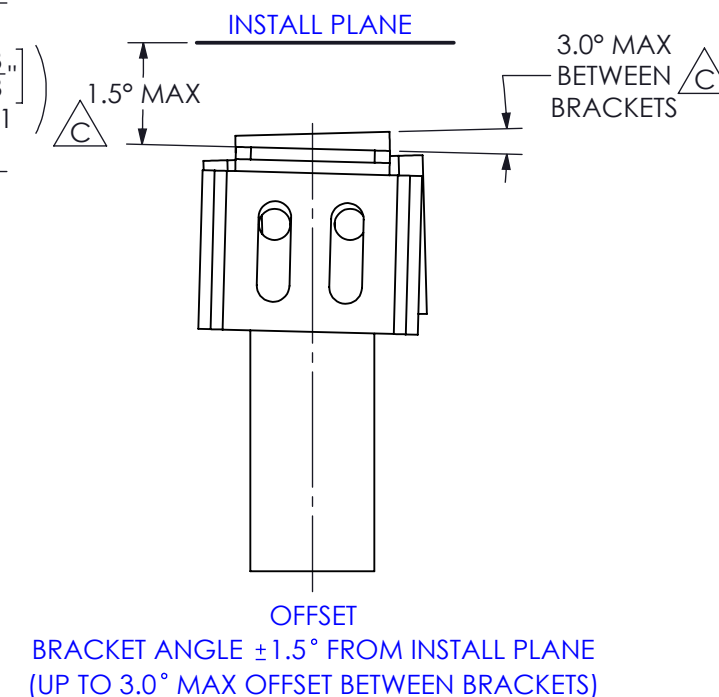

INSTALL PLANE  
OFFSET BRACKET ANGLE ±1.5° FROM INSTALL PLANE (UP TO 3.0° MAX OFFSET BETWEEN BRACKETS)

3.0° MAX BETWEEN BRACKETS

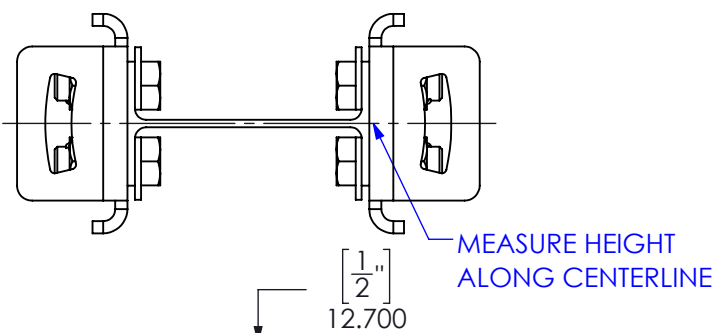

MEASURE HEIGHT ALONG CENTERLINE

$\left[ \frac{1}{2} \right]$   
12.700

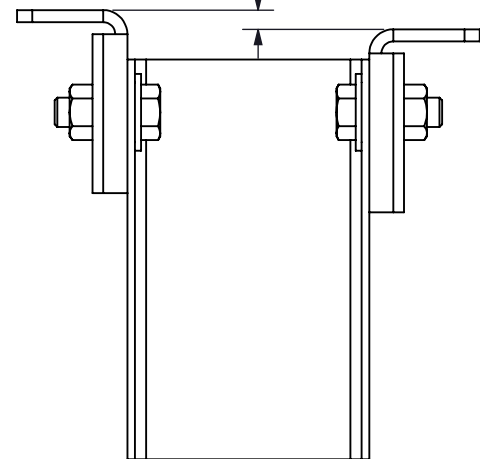

OFFSET BRACKET HEIGHT

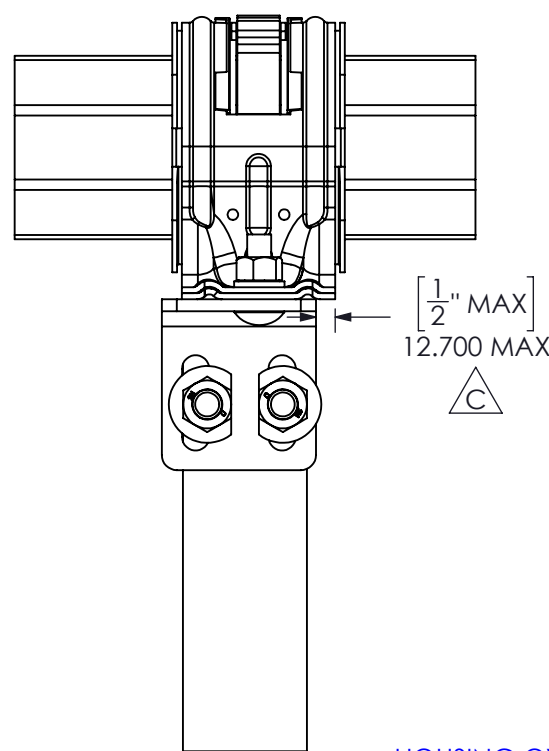

HOUSING OVERHANG

$\left[ \frac{1}{2} \right]$  MAX  
12.700 MAX

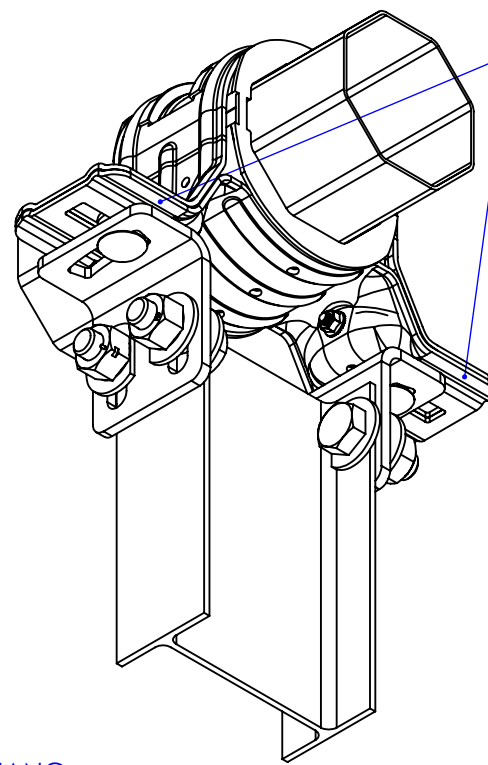

12.7 MAX [0.500" MAX] OVERHANG WHEN BOTH SIDES OF THE HOUSING ARE SHIFTED

OVERHANG REQUIREMENT NOT APPLICABLE FOR ROTATED (YAW) HOUSING WHERE OVERHANG OCCURS ON OPPOSITE SIDES

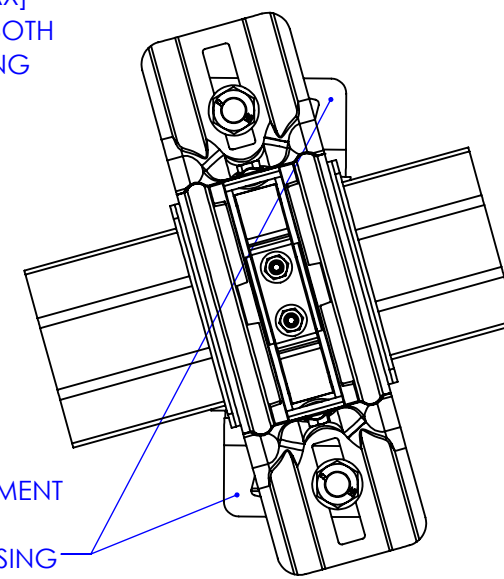

ROTATIONAL OVERHANG

SIZE B	DRAWING NUMBER 21020-901	REVISION C	SAVED v50 7/25/2024
SCALE 1:10	SHEET 3 OF 3		

8

7

6

5

4

3

2

1

**NOTES:**

- REFER TO INSTALLATION MANUAL FOR DETAILS.
- TORQUE SPECIFICATION:  
2A 108±14 N-M [80±10 FT-LBS]
- MARK ALL TORQUED CONNECTIONS USING PAINT MARKER OF CONTRASTING COLOR ACROSS IMMOBILE BASE AND ALL PARTS SUBJECT TO LOOSENING.
- 4 THE RECOMMENDED SEQUENCE FOR PROPER TIGHTENING OF BOLTS IS A CRISS-CROSS PATTERN STARTING IN THE CENTER AND WORKING OUT.
- CARRIAGE BOLTS ARE 0.625" DIAMETER, GRADE 5, SAE J429-2011, HDG.
- 6 REFER TO PROJECT ADP.
- 7 REFER TO SHIPMENT MANIFEST.

ARRAY PART NUMBER DESIGNATION

**20613-XXX**

ARRAY PART NUMBER EXTENSION NUMBER INDICATES LENGTH OF DIM "A" IN METERS  
 ARRAY PART NUMBER

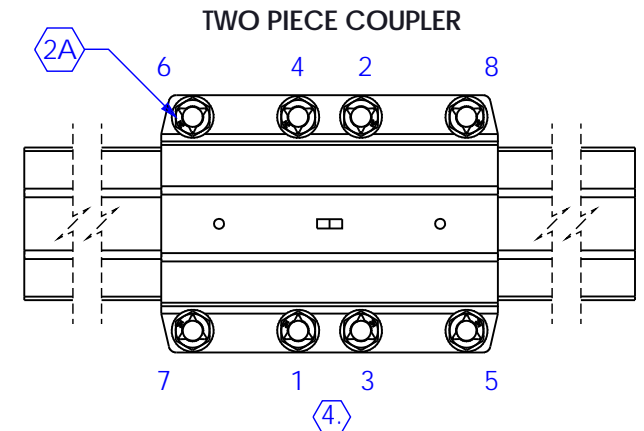
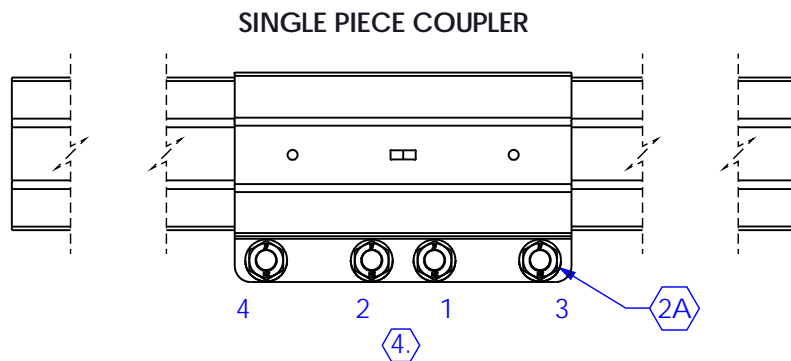
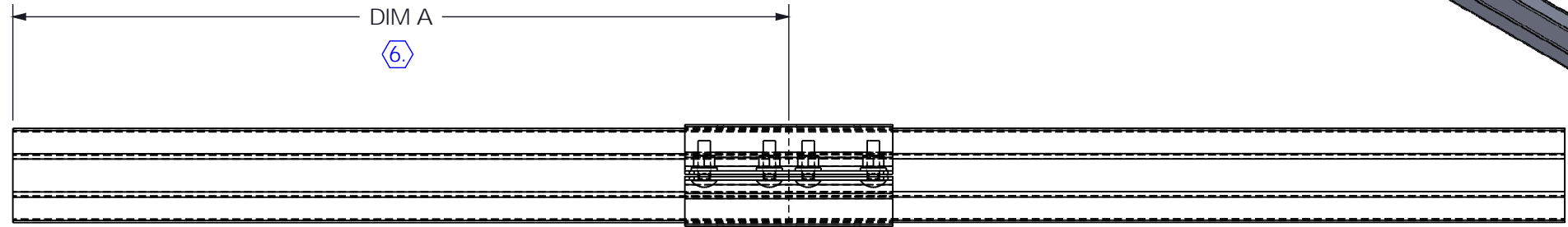
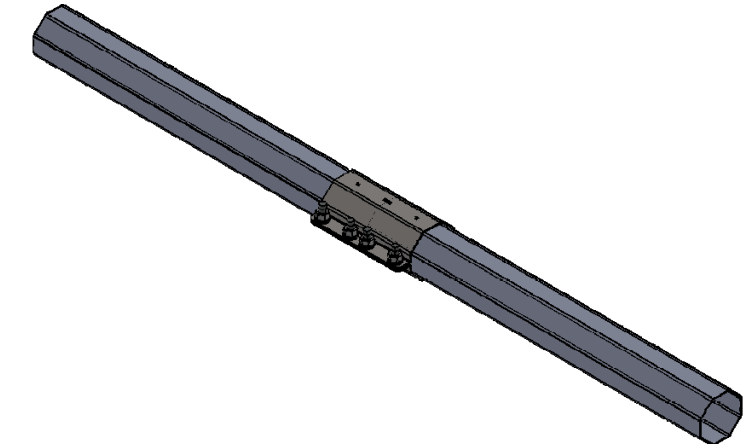

PART NUMBER	DESCRIPTION	MATERIAL	SURFACE COAT	WEIGHT
25031-000	Kit, Coupler, Octagonal Tube	Steel, ASTM A572	HDG, ASTM A123	6.24 KG [14.25 LBS]
25052-000	Kit, Coupler, Octagonal Tube, 1 Piece	Steel, ASTM A572	Pre-Galv, G-90, ASTM A653	4.83 KG [10.72 LBS]
25084-000	Kit, Coupler, Octagonal Tube	Steel, ASTM A572	Pre-Galv, G-90, ASTM A653	6.02 KG [13.36 LBS]
25145-000	Kit, Coupler, Octagon Tube Adaptor, Single Piece, HDG	Steel, ASTM A572	HDG, ASTM A123	4.66 KG [10.35 LBS]
25158-000	Kit, Coupler, Octagon Tube Adaptor, Single Piece, ZAM	Steel, EN 10346 S350GD	ZAM, ZM310, EN 10346	4.66 KG [10.35 LBS]
30301-XXX	Tube, 121.5mm, Octagon, 10 Ga.	Steel, ASTM A500C	ZT50 Galv, ASTM 1057	9.94 KG/M [6.68 LB/FT]
30302-XXX	Tube, 121.5mm, Octagon, 10 Ga.	Steel, ASTM A500C	HDG, Grade 65, ASTM A123	9.94 KG/M [6.68 LB/FT]
30502-XXX	Tube, 121.5mm, Octagon, 11 Ga.	Steel, ASTM A500C	ZT50 Galv, ASTM 1057	9.94 KG/M [6.68 LB/FT]
30503-XXX	Tube, 121.5mm, Octagon, 10 Ga.	Steel, ASTM A500C	Pre-Galv, G-115, ASTM A653	9.94 KG/M [6.68 LB/FT]
30526-XXX	Tube, 121.5mm, Octagon, 11 Ga.	Steel, ASTM A500C	Pre-Galv, G-115, ASTM A653	8.81 KG/M [5.92 LB/FT]
30527-XXX	Tube, 121.5mm, Octagon, 11 Ga.	Steel, ASTM A500C	HDG, Grade 65, ASTM A123	8.81 KG/M [5.92 LB/FT]
30548-XXX	Tube, 121.5mm, Octagon, 9 Ga.	Steel, ASTM A500C	HDG, Grade 65, ASTM A123	12.05 KG/M [8.09 LB/FT]
30661-XXX	Tube, 121.5mm, Octagon, 12 Ga.	Steel, ASTM A500C	Pre-Galv, G-115, ASTM A653	7.59 KG/M [5.10 LB/FT]
30662-XXX	Tube, 121.5mm, Octagon, 12 Ga.	Steel, ASTM A500C	HDG, Grade 65, ASTM A123	7.59 KG/M [5.10 LB/FT]
30810-XXX	Tube, 121.5mm, Octagon, 12 Ga.	Steel, ASTM A500C	HDG, Grade 45, ASTM A123	7.59 KG/M [5.10 LB/FT]
30811-XXX	Tube, 121.5mm, Octagon, 12 Ga.	Steel, ASTM A500C	Pre-Galv, G-90, ASTM A653	7.93 KG/M [5.33 LB/FT]



REV	DESCRIPTION	DATE
E	REMOVE LABELS PER ECR 20201	4/28/2020
D	ADDED TUBES PER ECR 18114	4/18/2019
C	ADDED ZAM SINGLE PIECE COUPLER AND OCTAGONAL TUBES PER ECR 17086	10/3/2017

PROPRIETARY AND CONFIDENTIAL  
 THE INFORMATION CONTAINED IN THIS DRAWING IS THE SOLE PROPERTY OF ARRAY TECHNOLOGIES. ANY REPRODUCTION IN PART OR AS A WHOLE WITHOUT THE WRITTEN PERMISSION FROM ARRAY TECHNOLOGIES IS PROHIBITED.

DRAWING STATUS: **Final**

DRAWN: MB DATE: 02/24/2017  
 ENG. CHECK: DO DATE: 05/07/2020

DRAWING CHECK: MK DATE: 4/28/2020  
 FINAL APPROVAL: SB DATE: 5/7/2020

THIRD ANGLE PROJECTION  
 MILLIMETER [INCH]  
 TOLERANCES UNLESS OTHERWISE SPECIFIED

MM [INCH]:  
 X = ±1.25 [0.050]  
 X.X = ±0.4 [0.015]  
 .XX = ±0.1 [0.004]

METER [INCH]:  
 X.XX = ±0.013 [0.500]  
 X.XXX = ±0.006 [0.250]

ANGULAR:  
 X = ±1.0°  
 .X = ±0.1°

ALL DIMS ARE DUAL UNITS.

**ARRAY TECHNOLOGIES**  
 3901 Midway Place NE, Albuquerque, NM 87109  
 (505) 881-7567

TITLE: **Field Assembly, Torque Tube and Coupler**

SIZE: B  
 SCALE: 1:96

DRAWING NUMBER: 20613-901

REVISION: E-01

SAVED v36: 4/28/2020

WT: 20.35kg [45.177lb]

SHEET: 1 OF 1

**NOTES:** 

1. CARRIAGE BOLTS ARE 0.625" DIAMETER, GRADE 5 SAE J429-2011, HDG.
- ② TORQUE SPECIFICATIONS:  
TIGHTEN NO MORE THAN 1/2 TURN PAST INITIAL LOCKING FEATURE ENGAGEMENT.
3. CLAMP ASSEMBLY (OR USE JIG) FOR WELDING. COUPLER AND TUBE SURFACES MUST BE PARALLEL AND FLUSH WHEN COUPLER IS IN CLOSED POSITION.
4. INTERPRET WELD SYMBOLS PER AWS A2.4:2007, STANDARD SYMBOLS FOR WELDING.
5. VISUALLY INSPECT COMPLETED WELDS FOR SOUNDNESS, SIZE, LENGTH, AND LOCATION PER AWS D1.1:2008, CLAUSE 6.9 AND TABLE 6.1.
6. FINISH:  
AFTER ANY SECONDARY OPERATIONS SUCH AS MACHINING, PUNCHING, GRINDING, OR WELDING, REPAIR AFFECTED AREA PER ASTM A780 AT MANUFACTURER OR PER ATIWI-07-02-28.
- ⑦ 25052-000 MAY BE REPLACED WITH 25158-000 OR 25145-000
- ⑧ 30811-XXX MAY BE REPLACED WITH 30662-XXX OR 30810-XXX

ARRAY PART NUMBER DESIGNATION

**20759-XXX**

ARRAY PART NUMBER EXTENSION NUMBER INDICATES LENGTH OF DIM "A" IN XX.X METERS  
 ARRAY PART NUMBER FOR OCTAGONAL TORQUE TUBE

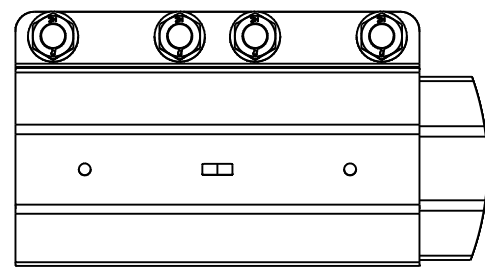
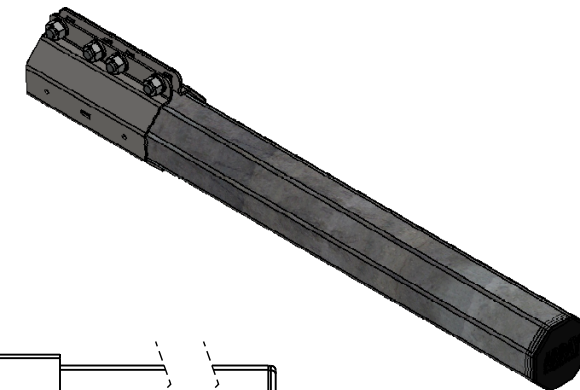

$5.28^{+0}_{-.25}$   
134.0  
-6

**DETAIL A**

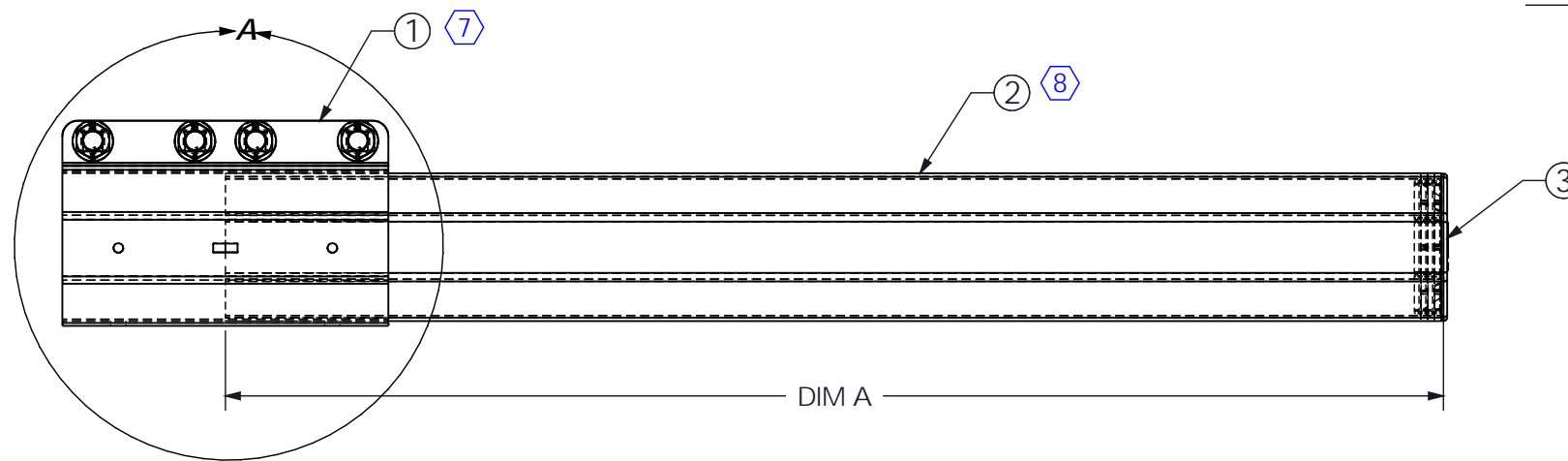
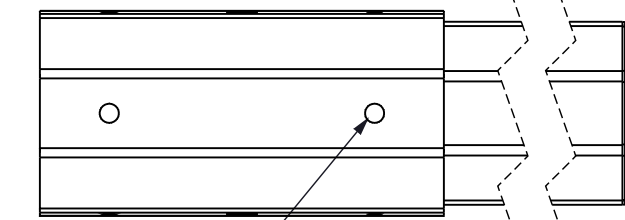
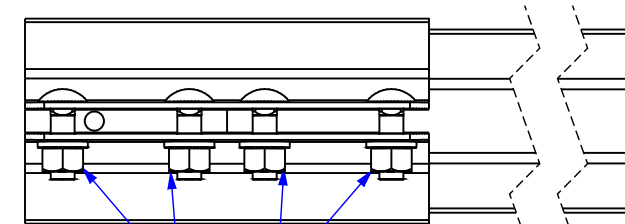

Exp 01/31/2027  
04/13/2026

F	UPDATED NOTES PER ECR 20201	4/28/2020
E	ADJUSTED CORROSION REFERENCE PER ECR-20195	4/15/2020
D	DELETED NOTE AND CHANGED WELD SYMBOL PER ECR 18154	11/15/2018
REV	DESCRIPTION	DATE

ITEM NO.	PART NUMBER	DESCRIPTION	QTY	WEIGHT
1	25052-000	Kit, Coupler, Octagon Tube Adaptor, Single Piece	1	4.83 KG [10.72 LB]
2	30811-XXX	Tube, 121.5mm Octagon, 12ga, A500 65 KSI, G90 Pre-Galv, (xx.x m)	1	7.52 KG/M [5.05 LB/FT]
3	60459-000	Plug, End, Torque Tube, Octagon, Polyethylene	1	0.17 KG [0.37 LB]

DRAWING STATUS <b>Final</b>		<b>ARRAY TECHNOLOGIES</b> 3901 Midway Place NE, Albuquerque, NM 87109 (505) 881-7567	
DRAWN INITIALS: MB DATE: 07/30/2018	DRAWING CHECK INITIALS: MK DATE: 4/28/2020	TITLE <b>Assembly, Torque Beam, Single Piece Coupler, End Cap L, XX.Xm</b>	
ENG. CHECK INITIALS: DO DATE: 04/29/2020	FINAL APPROVAL INITIALS: SB DATE: 5/7/2020		
PROPRIETARY AND CONFIDENTIAL THE INFORMATION CONTAINED IN THIS DRAWING IS THE SOLE PROPERTY OF ARRAY TECHNOLOGIES. ANY REPRODUCTION IN PART OR AS A WHOLE WITHOUT THE WRITTEN PERMISSION FROM ARRAY TECHNOLOGIES IS PROHIBITED.		ALL DIMS ARE DUAL UNITS: THIRD ANGLE PROJECTION MILLIMETER [INCH]	SIZE B SCALE 1:6 WT: 12.91kg [28.6602lb]
TOLERANCES UNLESS OTHERWISE SPECIFIED MM [INCH]: X = ±1.25 [0.050] .X = ±0.4 [0.015] .XX = ±0.1 [0.004]	METER [INCH]: X.XX = ±0.013 [0.500] X.XXX = ±0.006 [0.250]	ANGULAR: X = ±1.0° .X = ±0.1°	DRAWING NUMBER <b>20759-901</b>
		REVISION F-01	SAVED v43 4/28/2020
		SHEET 1 OF 1	

**CONFIGURATION TABLE (STANDARD)**

**DESCRIPTION: FIELD ASSEMBLY, DRIVELINE, DTHZ v3, HDG**

ASSEMBLY NUMBER	DIM "A" IN mm ["]	EXTENDED OPERATING LENGTH	ROW SPACING IN M ['] @ NOMINAL LENGTH
20504-XXX	XXXX [XXX.XX]	XXXX [XXX.XX]	X.XX [XX.X]
20504-287	2870 [113.00]	3251.2 [128.0]	3.05 [10.0]
20504-318	3175 [125.00]	3556.0 [140.0]	3.35 [11.0]
20504-348	3480 [137.00]	3860.8 [152.0]	3.66 [12.0]
20504-378	3785 [149.00]	4165.6 [164.0]	3.96 [13.0]
20504-409	4089 [161.00]	4470.4 [176.0]	4.27 [14.0]
20504-439	4394 [173.00]	4775.2 [188.0]	4.57 [15.0]
20504-470	4699 [185.00]	5080.0 [200.0]	4.88 [16.0]
20504-500	5004 [197.00]	5384.8 [212.0]	5.18 [17.0]
20504-531	5309 [209.00]	5689.6 [224.0]	5.49 [18.0]
20504-561	5613 [221.00]	5994.4 [236.0]	5.79 [19.0]
20504-592	5918 [233.00]	6299.2 [248.0]	6.10 [20.0]
20504-622	6223 [245.00]	6604.0 [260.0]	6.40 [21.0]
20504-652	6528 [257.00]	6908.8 [272.0]	6.71 [22.0]
20504-683	6833 [269.00]	7213.6 [284.0]	7.01 [23.0]
20504-714	7137 [281.00]	7518.4 [296.0]	7.32 [24.0]
20504-744	7442 [293.00]	7823.2 [308.0]	7.62 [25.0]

**NOTES:**

**1. ARRAY TORQUE SPECIFICATIONS:**

1A M8 SET SCREW 16±1 N-M [12±1 FT-LB][144±12 IN-LB]

2. ALL SET SCREWS WILL HAVE NYLON THREAD LOCKER TO BE ND INDUSTRIES ND PATCH OR ARRAY APPROVED EQUIVALENT. THREAD LOCKER TO BE APPLIED TO HALF ROUND OF SCREW FOR 4-6 THREADS.

3. MARK ALL TORQUED CONNECTIONS USING PAINT MARKER OF CONTRASTING COLOR ACROSS IMMOBILE BASE AND ALL PARTS SUBJECT TO LOOSENING.

4. ROW SPACING IS BASED ON LEVEL GRADE BETWEEN ROWS AND CENTER STRUCTURES IN ALIGNMENT.

5. REFER TO SHIPPING MANIFEST FOR PART NUMBER.

E 20504-XXX FIELD ASSEMBLY INTERCHANGEABILITY 5	
PART NUMBER	DESCRIPTION
20420-XXX	ASSEMBLY, DRIVELINE, WELDED PTO 1000 SERIES, (XXXXMM)
20509-XXX	ASSEMBLY, DRIVELINE, FULL PTO TUBE, (XXXXmm), STAKE PLUG

ARRAY PART NUMBER DESIGNATION

**20504 - XXX**

ARRAY PART NUMBER

ARRAY PART NUMBER EXTENSION NUMBER INDICATES DIM "A"

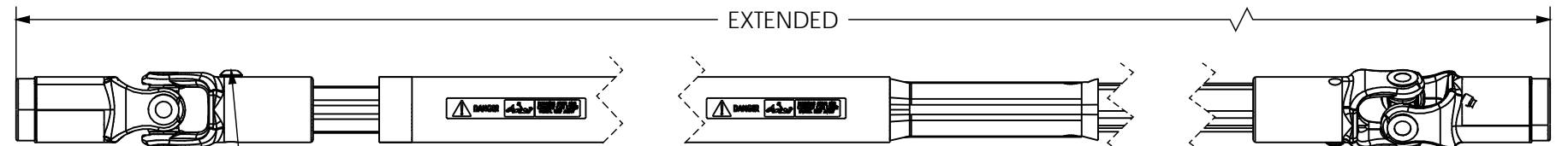
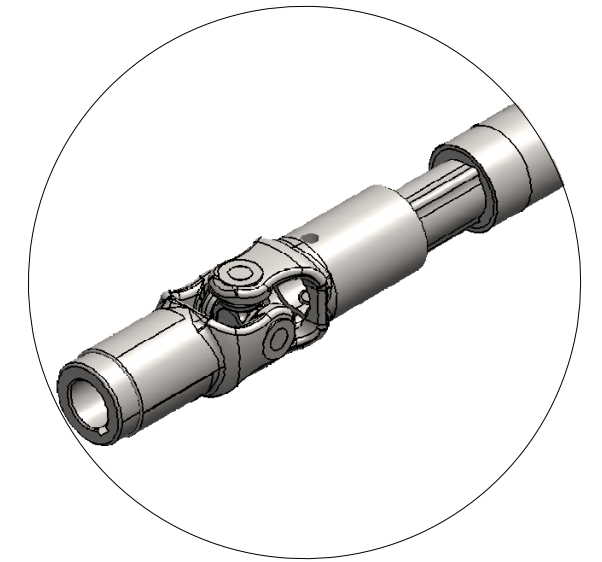

3/8"-16 X 1/2" SHBHS, SST THREAD LOCKER - 60571-050  
DO NOT REMOVE. NOT ON ALL ASSEMBLIES

3/8"-16 X 1/2" SHBHS, SST THREADLOCKER- 60571-050  
DO NOT REMOVE. NOT ON ALL ASSEMBLIES

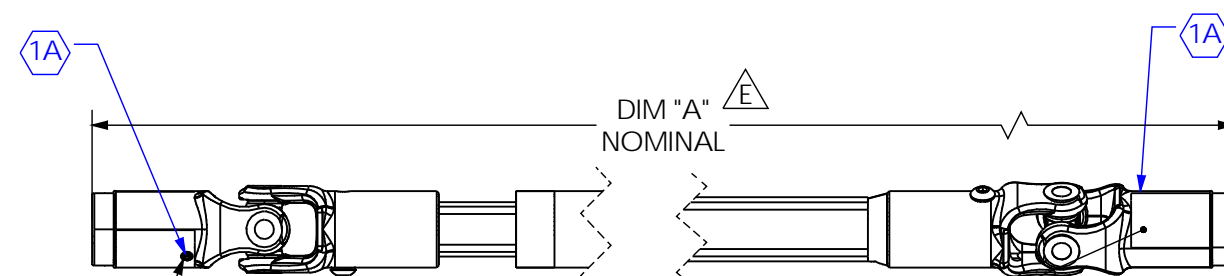

M8-1.25 X 16 MM SET SCREW - 60575-016

M8-1.25 X 16 MM SET SCREW - 60575-016

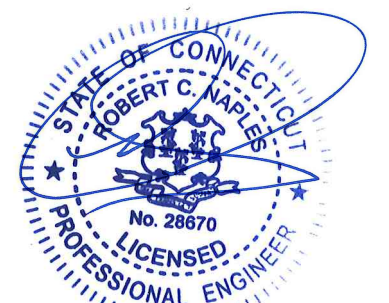

Exp 01/31/2027  
04/13/2026

REV	DESCRIPTION	DATE
E	NOMINAL LENGTH PER ECR 18046	9/19/2018
D	CHANGED SET SCREW PER ECR 16144	10/20/2016
C	CORRECT SET SCREW PART NUMBER AND CONFIG TABLE PER ECR 16001	3/2/2016

DRAWING STATUS: <b>Final</b>		DRAWN: CG DATE: 11/23/2015		DRAWING CHECK: KB DATE: 9/21/2018	
ENG. CHECK: SR DATE: 9/21/2018		FINAL APPROVAL: SR DATE: 9/21/2018		ARRAY TECHNOLOGIES	
THIRD ANGLE PROJECTION		MILLIMETER [INCH]		TITLE: Field Assembly, Driveline, DTHZ, Telescoping, HDG	
TOLERANCES UNLESS OTHERWISE SPECIFIED		ALL DIMS ARE DUAL UNITS:		3901 Midway Place NE, Albuquerque, NM 87109 (505) 881-7567	
MM [INCH]: X = ±1.25 [0.050] X.XX = ±0.013 [0.500] X.XXX = ±0.006 [0.250]		METER [INCH]: X = ±1.0* X.X = ±0.1*		SIZE B	
X = ±0.4 [0.015] X.X = ±0.1 [0.004]		X.XXX = ±0.006 [0.250]		DRAWING NUMBER: 20504-901	
X.XXX = ±0.1 [0.004]		X.XXX = ±0.006 [0.250]		REVISION: E	
X.XXX = ±0.1 [0.004]		X.XXX = ±0.006 [0.250]		SAVED v52 7/25/2019	
X.XXX = ±0.1 [0.004]		X.XXX = ±0.006 [0.250]		SCALE: 1:33.3	
X.XXX = ±0.1 [0.004]		X.XXX = ±0.006 [0.250]		WT: 12.99 KG [28.8378 LB]	
X.XXX = ±0.1 [0.004]		X.XXX = ±0.006 [0.250]		SHEET: 1 OF 1	

**CONFIGURATION TABLE (STANDARD)**

ASSEMBLY NUMBER	DESCRIPTION	DIM "A" mm [in]	DIM "B" mm [in]	FEMALE TUBE PART NUMBER	DRIVELINE LENGTH M [ft]	WEIGHT kg [lbs]
20722-251	Assembly, Driveline, Aluminum, Tube, 2508mm	2120 [83.46]	2889 [113.75]	30774-208	3.05 [10.0]	4.3 [9.53]
20722-281	Assembly, Driveline, Aluminum, Tube, 2813mm	2425 [95.47]	3194 [125.75]	30774-238	3.35 [11.0]	4.7 [10.43]
20722-312	Assembly, Driveline, Aluminum, Tube, 3118mm	2730 [107.48]	3499 [137.75]	30774-269	3.66 [12.0]	5.1 [11.32]
20722-342	Assembly, Driveline, Aluminum, Tube, 3423mm	3035 [119.49]	3804 [149.75]	30774-299	3.96 [13.0]	5.5 [12.22]
20722-373	Assembly, Driveline, Aluminum, Tube, 3727mm	3339[131.46]	4108 [161.75]	30774-330	4.27 [14.0]	5.9 [13.11]
20722-403	Assembly, Driveline, Aluminum, Tube, 4032mm	3644 [143.46]	4413 [173.75]	30774-360	4.57 [15.0]	6.4 [14.01]
20722-434	Assembly, Driveline, Aluminum, Tube, 4337mm	3949 [155.47]	4718 [185.75]	30774-391	4.88 [16.0]	6.8 [14.91]
20722-464	Assembly, Driveline, Aluminum, Tube, 4642mm	4254[167.48]	5023 [197.75]	30774-421	5.18 [17.0]	7.2 [15.80]
20722-495	Assembly, Driveline, Aluminum, Tube, 4947mm	4559 [179.49]	5328 [209.75]	30774-452	5.49 [18.0]	7.6 [16.70]
20722-525	Assembly, Driveline, Aluminum, Tube, 5251mm	4863 [191.46]	5632 [221.75]	30774-482	5.79 [19.0]	8.0 [17.60]
20722-556	Assembly, Driveline, Aluminum, Tube, 5556mm	5168 [203.46]	5937 [233.75]	30774-512	6.10 [20.0]	8.4 [18.49]
20722-586	Assembly, Driveline, Aluminum, Tube, 5861mm	5473 [215.47]	6242 [245.75]	30774-543	6.40 [21.0]	8.8 [19.39]
20722-617	Assembly, Driveline, Aluminum, Tube, 6166mm	5778 [227.48]	6547 [257.75]	30774-573	6.71 [22.0]	9.2 [20.29]
20722-647	Assembly, Driveline, Aluminum, Tube, 6471mm	6083 [239.49]	6852 [269.75]	30774-604	7.01 [23.0]	9.6 [21.18]
20722-678	Assembly, Driveline, Aluminum, Tube, 6775mm	6387 [251.46]	7156 [281.75]	30774-634	7.32 [24.0]	10.0 [22.08]
20722-708	Assembly, Driveline, Aluminum, Tube, 7080mm	6692 [263.46]	7461 [293.75]	30774-665	7.62 [25.0]	10.4 [22.98]
20722-739	Assembly, Driveline, Aluminum, Tube, 7385mm	6997 [275.47]	7766 [305.75]	30774-695	7.92 [26.0]	10.8 [23.81]
20722-769	Assembly, Driveline, Aluminum, Tube, 7690mm	7302 [287.48]	8071 [317.75]	30774-726	8.23 [27.0]	11.2 [24.77]
20722-800	Assembly, Driveline, Aluminum, Tube, 7995mm	7607 [299.49]	8376 [329.75]	30774-756	8.54 [28.0]	11.7 [25.79]

ARRAY PART NUMBER DESIGNATION  
**20722 - XXX**

ARRAY PART NUMBER EXTENSION INDICATES NOMINAL LENGTH

ARRAY PART NUMBER

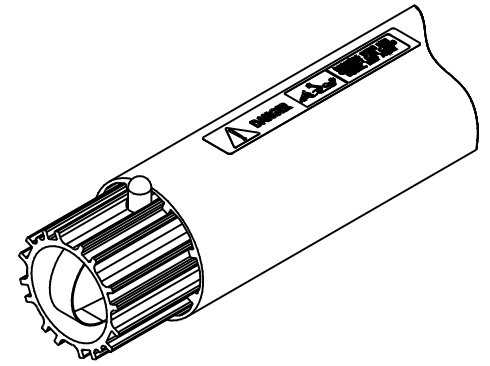

**ARRAY PN: 20722-XXX**

**NOTES:**

- OVERALL SHAFT LENGTH TELESCOPES 769mm [30"] RANGE.
- PARTS ARE TO BE CLEARLY MARKED WITH PART NUMBER. MARKING TO LAST AT LEAST 6 MONTHS IN OUTSIDE ENVIRONMENT. MARKINGS MUST BE APPROVED BY ARRAY ENGINEERING AND QUALITY.
- DRIVELINE TUBES SHOULD BE ABLE TO SLIDE FREELY WITH RESPECT TO EACH OTHER WHEN APPLYING FORCE BY HAND.
- CAUTION STICKER TO BE PLACED ON OPPOSITE ENDS OF FEMALE DRIVELINE.
- HOLES FOR SNAP BUTTONS TO BE ON THE SAME SIDE.
- SUPPLIER IDENTIFICATION MARK REQUIRED. ARRAY TO APPROVE LOCATION AND DESIGN AT TIME OF ORDER.
- MUST MEET SPECIFICATION 901 18-000 AND PASS TESTING WITH DRIVELINE U-JOINTS, ACCORDING TO AOS-45-TP-0003. IF VENDOR CANNOT PERFORM TESTING, TESTING MAY BE COORDINATED WITH THE ARRAY DESIGN VALIDATION TESTING LABORATORY.

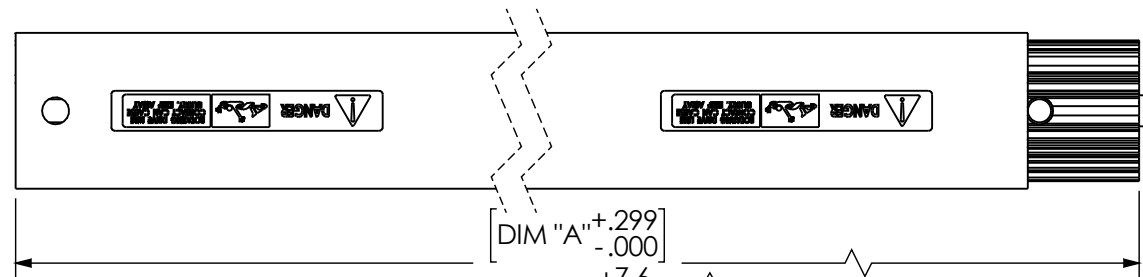

**FULLY COLLAPSED**

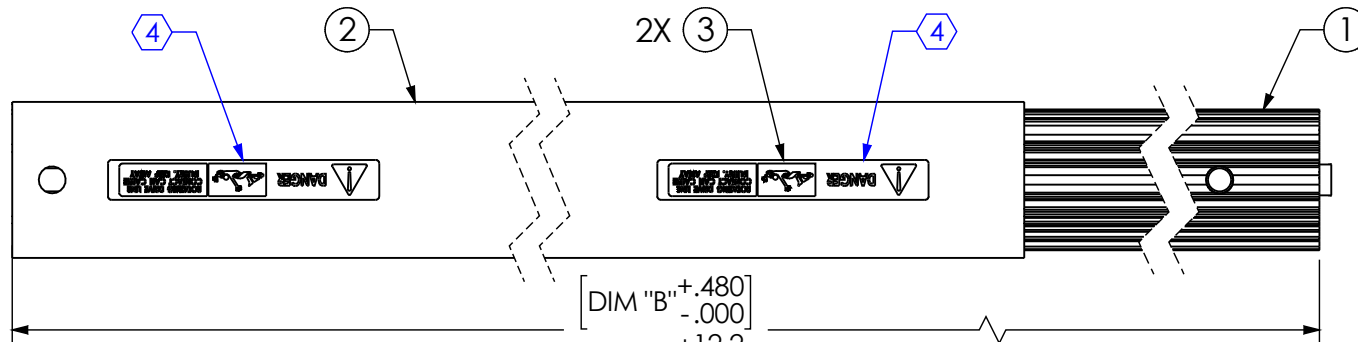

**EXTENDED WITH 6" MINIMUM ENGAGEMENT**

SNAP BUTTON TO ENGAGE WITH TUBE WALL ONLY, NOT GROOVE

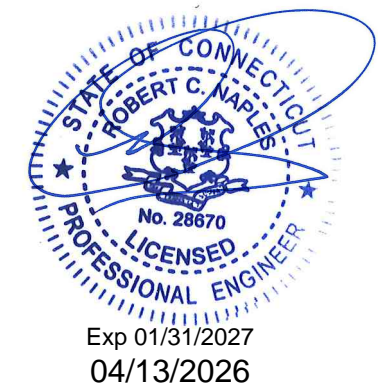
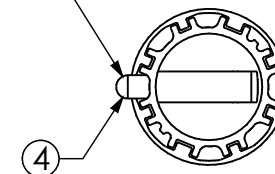

ZONE	REV	ECR #	DESCRIPTION	DATE
A6, B6	J	22180	ADDED TOLERANCE TO DIM "A" AND DIM "B"	12/2/2022
A6, B2, B6, C2, D3, D5, D6, D7	H	22129	UPDATED NOTES 1 AND 2, ADDED NEW VIEW AND NOTE 7, CHANGED DIM "A" TO DIM "B" AND COLUMNS IN TABLE	8/24/2022
A3, A6, C1	G	21082	UPDATED VIEWS FOR NEW HOLE LOCATIONS IN TUBES	5/4/2021

ITEM NO.	PART NUMBER	DESCRIPTION	QTY
1	30773-100	Tube, Aluminum Driveline Tube, Male, 1000mm, Service Part	1
2	30774-XXX	Tube, Aluminum Driveline Tube, Female, 7258 mm, Service Part	1
3	60568-000	Sticker, Driveline Danger, 4.25" X 0.625", English	2
4	60683-000	Snap Button, Aluminum Driveline, Service Part	1

DRAWING STATUS: <b>Final</b>		<b>ARRAY TECHNOLOGIES</b>	
DRAWN: AH DATE: 01/09/2018	DRAWING CHECK: DS DATE: 12/5/2022	3901 Midway Place NE, Albuquerque, NM 87109 (505) 881-7567	
ENG. CHECK: CP DATE: 12/05/2022	FINAL APPROVAL: SB DATE: 12/5/2022	TITLE: <b>Assembly, Driveline, Aluminum, Tube, XXXXmm</b>	
THIRD ANGLE PROJECTION		SIZE: B	SAVED v115: 12/5/2022
TOLERANCES UNLESS OTHERWISE SPECIFIED		SCALE: 1:3	WT: 4.330kg [9.546lb]
MM [INCH]: X = ±1.25 [0.049], X.X = ±0.4 [0.016], .XX = ±0.1 [0.004]	METER [INCH]: X.XX = ±0.013 [0.512], X.XXX = ±0.006 [0.236]	REVISION: J	SHEET: 1 OF 1
ANGULAR: X = ±1.0°, X = ±0.1°		PROPRIETARY AND CONFIDENTIAL	
THE INFORMATION CONTAINED IN THIS DRAWING IS THE SOLE PROPERTY OF ARRAY TECHNOLOGIES. ANY REPRODUCTION IN PART OR AS A WHOLE WITHOUT THE WRITTEN PERMISSION FROM ARRAY TECHNOLOGIES IS PROHIBITED.			

**NOTES:**

1. DIM "A" IS MINIMUM USABLE LENGTH. OVERALL SHAFT LENGTH TELESCOPES 660mm [26"].
2. FORCE NECESSARY FOR MOVEMENT MUST NOT EXCEED 4.5 KGF [10 LBF].
- ③ M8 SET SCREW 16±1 N-M [12±1 FT-LB] [144±12 IN-LB]
4. MARK ALL TORQUED CONNECTIONS USING PAINT MARKER OF CONTRASTING COLOR ACROSS IMMOBILE BASE AND ALL PARTS SUBJECT TO LOOSENING.
5. ROW SPACING IS BASED ON LEVEL GRADE BETWEEN ROWS AND CENTER STRUCTURE IN ALIGNMENT.
- ⑥ WHEN MOUNTING DRIVELINE ONTO SHAFT, TRAP KEY INTO SLOTS AND TIGHTEN SET SCREW ONTO FLAT REGION OF DRIVESHAFT.
- ⑦ ROW PITCH IS THE COMBINED DRIVELINE LENGTH, PLUS ASSOCIATED GEARBOX DISTANCES, TO CREATE A CENTER TO CENTER NOMINAL ROW SPACING DISTANCE, AT A 0 DEGREE ANGLE.

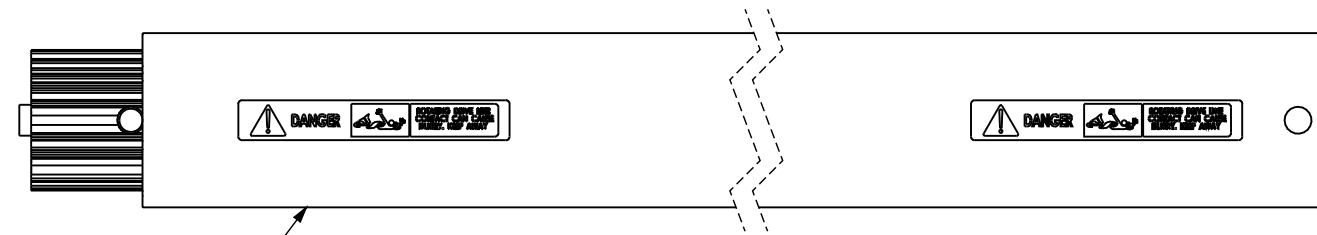

**SHIPPING CONFIGURATION**

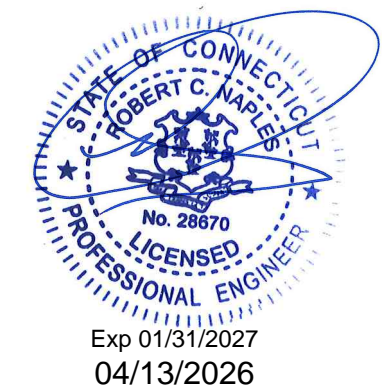
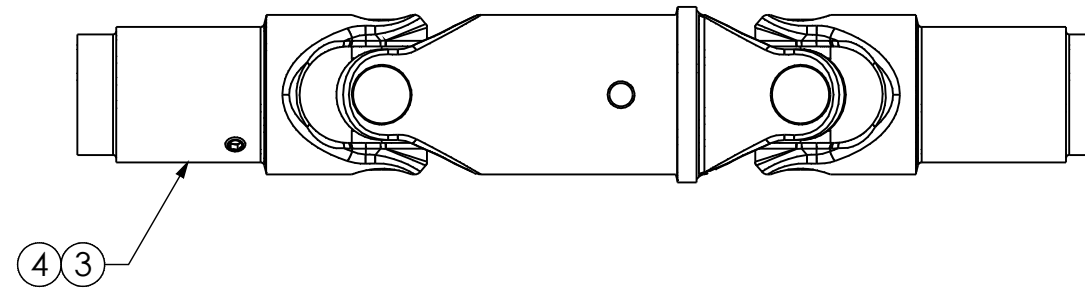

ITEM NO.	PART NUMBER	DESCRIPTION	STANDARD DIAMETER	LARGE DIAMETER
1	20722-XXX	Assembly, Driveline, Aluminum, Tube, XXXmm	1	-
2	20984-XXX	Assembly, Driveline, Aluminum, Tube, XXXXmm, 69.3mm OD	-	1
3	25236-000	Kit, U-Joint, Driveline, Aluminum, Single Slot	1	-
4	25237-000	Kit, U-Joint, Driveline, Aluminum, Large OD, Single Slot	-	1

DRAWING STATUS		Final		INITIAL RELEASE		8/2/2022	
DRAWN INITIALS: DS DATE: 08/01/2022		DRAWING CHECK INITIALS: NC DATE: 8/1/2022		REV		DESCRIPTION	
ENG. CHECK INITIALS: CP DATE: 08/01/2022		FINAL APPROVAL INITIALS: SB DATE: 8/2/2022		ECR #		DATE	
THIRD ANGLE PROJECTION		ALL DIMS ARE DUAL UNITS: MILLIMETER [INCH], DIMENSIONS IN BRACKETS ARE FOR REFERENCE ONLY.		<b>ARRAY TECHNOLOGIES</b> 3901 Midway Place NE, Albuquerque, NM 87109 (505) 881-7567			
PROPRIETARY AND CONFIDENTIAL THE INFORMATION CONTAINED IN THIS DRAWING IS THE SOLE PROPERTY OF ARRAY TECHNOLOGIES. ANY REPRODUCTION IN PART OR AS A WHOLE WITHOUT THE WRITTEN PERMISSION FROM ARRAY TECHNOLOGIES IS PROHIBITED.		TOLERANCES UNLESS OTHERWISE SPECIFIED MM [INCH]: X = ±1.25 [0.049] .X = ±0.4 [0.016] .XX = ±0.1 [0.004]		METER [INCH]: X.XX = ±0.013 [0.512] X.XXX = ±0.006 [0.236]		TITLE <b>Field Assembly, Full Driveline Tube, Aluminum, Single Slot</b>	
X = ±1.0° .X = ±0.1°		SIZE B		DRAWING NUMBER 21013-901		REVISION A	
SCALE 1:3		SHEET 1 OF 2		SAVED v10 8/19/2022			

Template\_CF Drawing\_mm\_v5

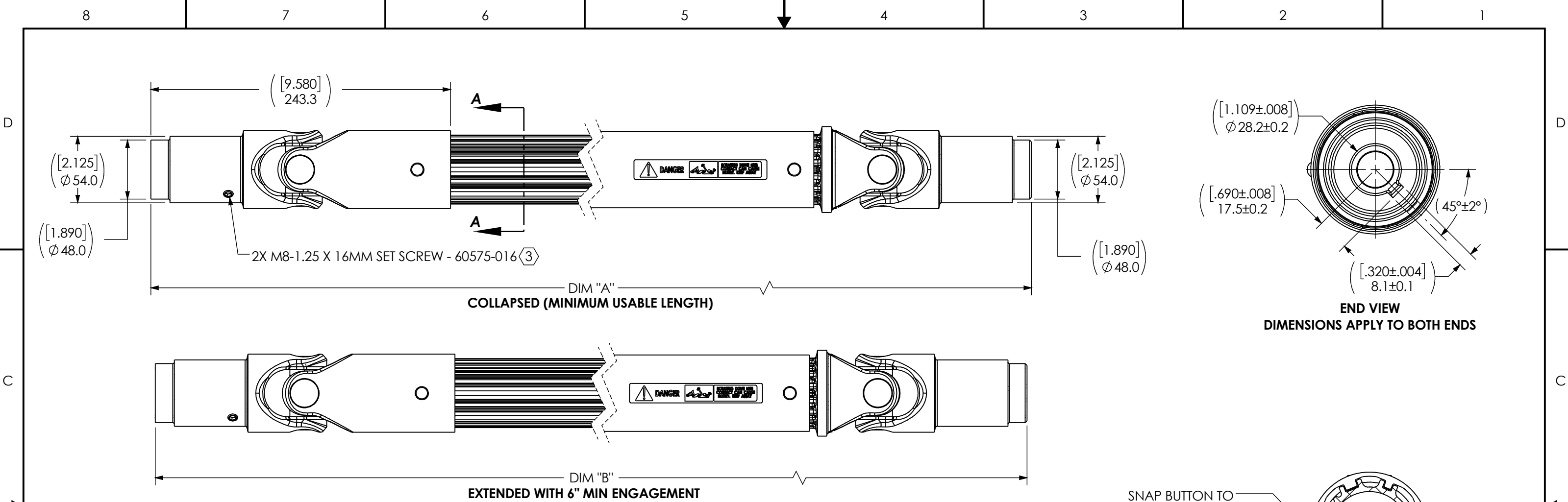

**DRIVELINE ASSEMBLY CONFIGURATION TABLE**

ASSEMBLY NUMBER	DESCRIPTION	ROW PITCH M [ft] <sup>(7)</sup>	STANDARD DIAMETER	LARGE DIAMETER	DIM "A" mm [in]	DIM "B" mm [in]
20722-251	Assembly, Driveline, Aluminum, Tube, 2508mm	3.05 [10.0]	X		2591 [102.00]	3251 [128.00]
20722-281	Assembly, Driveline, Aluminum, Tube, 2813mm	3.35 [11.0]	X		2896 [114.00]	3556 [140.00]
20722-312	Assembly, Driveline, Aluminum, Tube, 3118mm	3.66 [12.0]	X		3200 [126.00]	3861 [152.00]
20722-342	Assembly, Driveline, Aluminum, Tube, 3423mm	3.96 [13.0]	X		3505 [138.00]	4166 [164.00]
20722-373	Assembly, Driveline, Aluminum, Tube, 3727mm	4.27 [14.0]	X		3810 [150.00]	4470 [176.00]
20722-403	Assembly, Driveline, Aluminum, Tube, 4032mm	4.57 [15.0]	X		4115 [162.00]	4775 [188.00]
20722-434	Assembly, Driveline, Aluminum, Tube, 4337mm	4.88 [16.0]	X		4420 [174.00]	5080 [200.00]
20722-464	Assembly, Driveline, Aluminum, Tube, 4642mm	5.18 [17.0]	X		4724 [186.00]	5385 [212.00]
20722-495	Assembly, Driveline, Aluminum, Tube, 4947mm	5.49 [18.0]	X		5029 [198.00]	5690 [224.00]
20722-525	Assembly, Driveline, Aluminum, Tube, 5251mm	5.79 [19.0]	X		5334 [210.00]	5994 [236.00]
20722-556	Assembly, Driveline, Aluminum, Tube, 5556mm	6.10 [20.0]	X		5639 [222.00]	6299 [248.00]
20722-586	Assembly, Driveline, Aluminum, Tube, 5861mm	6.40 [21.0]	X		5944 [234.00]	6604 [260.00]
20722-617	Assembly, Driveline, Aluminum, Tube, 6166mm	6.71 [22.0]	X		6248 [246.00]	6909 [272.00]
20722-647	Assembly, Driveline, Aluminum, Tube, 6471mm	7.01 [23.0]	X		6553 [258.00]	7214 [284.00]
20722-678	Assembly, Driveline, Aluminum, Tube, 6775mm	7.32 [24.0]	X		6858 [270.00]	7518 [296.00]
20722-708	Assembly, Driveline, Aluminum, Tube, 7080mm	7.62 [25.0]	X		7163 [282.00]	7823 [308.00]
20722-739	Assembly, Driveline, Aluminum, Tube, 7385mm	7.92 [26.0]	X		7468 [294.00]	8128 [320.00]
20722-769	Assembly, Driveline, Aluminum, Tube, 7690mm	8.23 [27.0]	X		7772 [306.00]	8433 [332.00]
20722-800	Assembly, Driveline, Aluminum, Tube, 7995mm	8.54 [28.0]	X		8077 [318.00]	8738 [344.00]
20984-868	Assembly, Driveline, Aluminum, Tube, 8680mm, 69.3 ODmm	8.84 [29.0]		X	8382 [330.00]	9042 [356.00]
20984-899	Assembly, Driveline, Aluminum, Tube, 8985mm, 69.3 ODmm	9.14 [30.0]		X	8687 [342.00]	9347 [368.00]

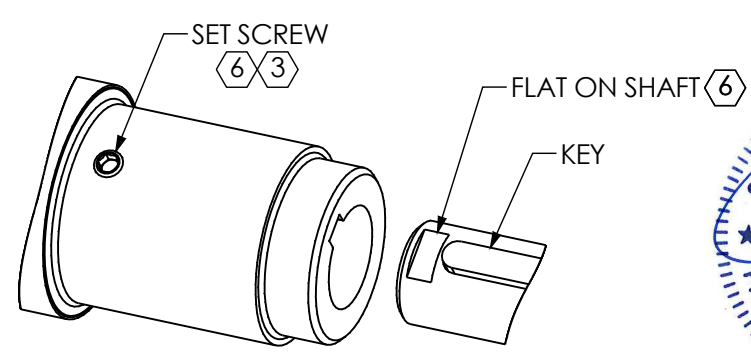

**DRIVELINE TO DRIVESHAFT ASSEMBLY**

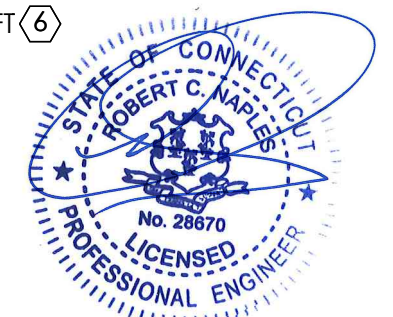

Exp 01/31/2027  
04/13/2026

SIZE B	DRAWING NUMBER 21013-901	REVISION A	SAVED v10 8/19/2022
SCALE 1:5	SHEET		2 OF 2

**NOTES:**

1. FORCE NECESSARY FOR MOVEMENT MUST NOT EXCEED 4.5 KGF [10 LBF]
2. ALL SET SCREWS WILL HAVE NYLON THREAD LOCKER TO BE ND PATCH OR ARRAY APPROVED EQUIVALENT. THREAD LOCKER TO BE APPLIED TO HALF ROUND OF SCREW FOR 4-6 THREADS.
- ③ SNAP BUTTON TO ENGAGE YOKE WALL ONLY, NOT TOOTH.

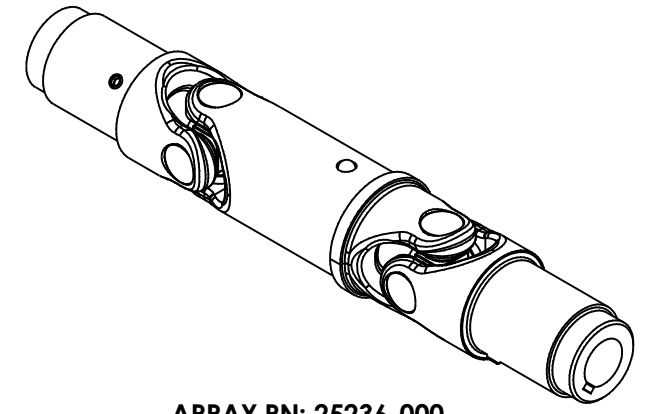

ARRAY PN: 25236-000

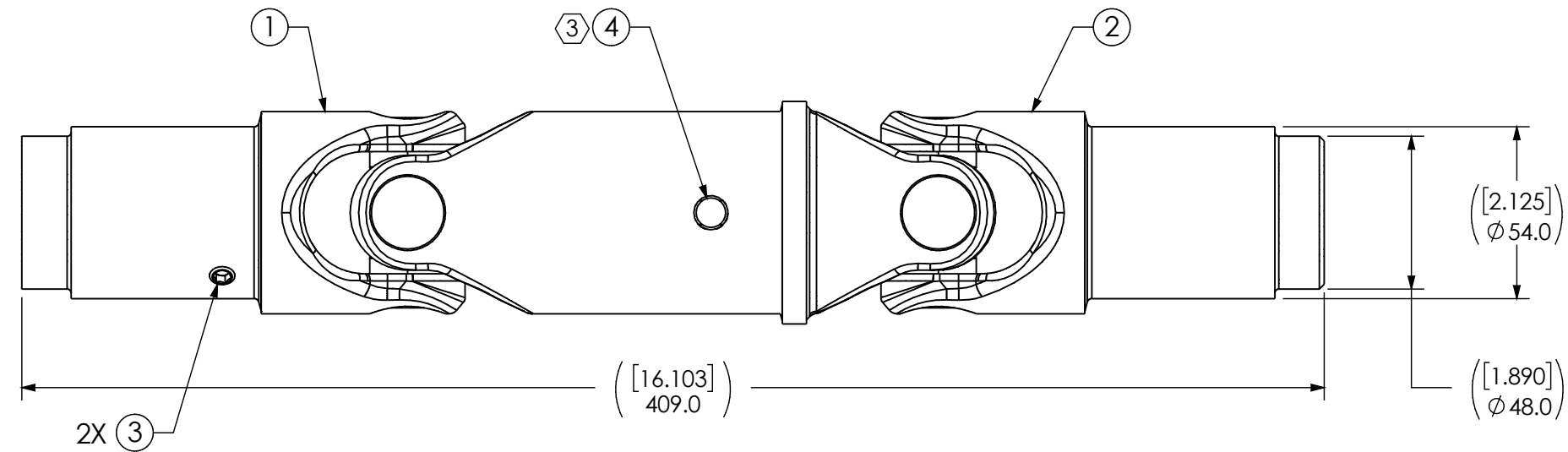

ITEM NO.	PART NUMBER	DESCRIPTION	QTY
1	40228-000	U-Joint, Aluminum, Single Slot, Female	1
2	40229-000	U-Joint, Aluminum, Single Slot, Male	1
3	60575-016	Set Screw, Dog Point, Hex Socket, Nylon Patch, SS M8-1.25 x 16	2
4	60683-000	Snap Button, Aluminum Driveline, Service Part	1

DRAWING STATUS		<b>Final</b>		INITIAL RELEASE		8/1/2022	
DRAWN INITIALS: DS DATE: 07/28/2022		DRAWING CHECK INITIALS: NC DATE: 8/1/2022		REV		DATE	
ENG. CHECK INITIALS: CP DATE: 08/01/2022		FINAL APPROVAL INITIALS: SB DATE: 8/1/2022		ECR #		DESCRIPTION	
THIRD ANGLE PROJECTION		ALL DIMS ARE DUAL UNITS: MILLIMETER [INCH], DIMENSIONS IN BRACKETS ARE FOR REFERENCE ONLY.		TITLE			
<p>PROPRIETARY AND CONFIDENTIAL</p> <p>THE INFORMATION CONTAINED IN THIS DRAWING IS THE SOLE PROPERTY OF ARRAY TECHNOLOGIES. ANY REPRODUCTION IN PART OR AS A WHOLE WITHOUT THE WRITTEN PERMISSION FROM ARRAY TECHNOLOGIES IS PROHIBITED.</p>		<p>TOLERANCES UNLESS OTHERWISE SPECIFIED</p> <p>MM [INCH]: X = ±1.25 [0.049] .X = ±0.4 [0.016] .XX = ±0.1 [0.004]</p>		<p>METER [INCH]: X.XX = ±0.013 [0.512] X.XXX = ±0.006 [0.236]</p>		<p>ARRAY TECHNOLOGIES</p> <p>3901 Midway Place NE, Albuquerque, NM 87109 (505) 881-7567</p>	
SIZE B		DRAWING NUMBER		REVISION		SAVED v10	
SCALE 1:2		25236-901		A		8/1/2022	
WT: 2.37kg [5.2614lb]				SHEET		1 OF 1	

Template\_Drawing\_mm\_v5

**CONFIGURATION TABLE**

ASSEMBLY NUMBER	DESCRIPTION	DIM "A" IN mm ["]	DIM "B" IN mm ["]	FEMALE ASSEMBLY NUMBER	WEIGHT KG [LB]	ROW SPACING IN M [']
20745-XXX	Field Assembly, Full Driveline Tube, Steel, Detachable, XXXmm	XXXX [XXX.XX]	XXXX [XXX.XX]	20773-XXX	XX.X [XX.XX]	X.XX M [XX.X']
20745-287	Field Assembly, Full Driveline Tube, Steel, Detachable, 2870mm	2870 [113.00]	3277 [129.00]	20773-202	17.72 [39.24]	3.05 M [10.0']
20745-318	Field Assembly, Full Driveline Tube, Steel, Detachable, 3175mm	3175 [125.00]	3581 [141.00]	20773-232	18.65 [41.29]	3.35 M [11.0']
20745-348	Field Assembly, Full Driveline Tube, Steel, Detachable, 3480mm	3480 [137.00]	3886 [153.00]	20773-262	19.58 [43.34]	3.66 M [12.0']
20745-378	Field Assembly, Full Driveline Tube, Steel, Detachable, 3785mm	3785 [149.00]	4191 [165.00]	20773-293	20.51 [45.39]	3.96 M [13.0']
20745-409	Field Assembly, Full Driveline Tube, Steel, Detachable, 4089mm	4089 [161.00]	4496 [177.00]	20773-323	21.44 [47.44]	4.27 M [14.0']
20745-439	Field Assembly, Full Driveline Tube, Steel, Detachable, 4394mm	4394 [173.00]	4801 [189.00]	20773-354	22.37 [49.50]	4.57 M [15.0']
20745-470	Field Assembly, Full Driveline Tube, Steel, Detachable, 4699mm	4699 [185.00]	5105 [201.00]	20773-384	23.30 [51.55]	4.88 M [16.0']
20745-500	Field Assembly, Full Driveline Tube, Steel, Detachable, 5004mm	5004 [197.00]	5410 [213.00]	20773-415	24.23 [53.60]	5.18 M [17.0']
20745-531	Field Assembly, Full Driveline Tube, Steel, Detachable, 5309mm	5309 [209.00]	5715 [225.00]	20773-445	25.16 [55.65]	5.49 M [18.0']
20745-561	Field Assembly, Full Driveline Tube, Steel, Detachable, 5613mm	5613 [221.00]	6020 [237.00]	20773-476	26.09 [57.70]	5.79 M [19.0']
20745-592	Field Assembly, Full Driveline Tube, Steel, Detachable, 5918mm	5918 [233.00]	6325 [249.00]	20773-506	27.02 [59.75]	6.10 M [20.0']
20745-622	Field Assembly, Full Driveline Tube, Steel, Detachable, 6223mm	6223 [245.00]	6629 [261.00]	20773-537	27.95 [61.80]	6.40 M [21.0']
20745-652	Field Assembly, Full Driveline Tube, Steel, Detachable, 6528mm	6528 [257.00]	6934 [273.00]	20773-567	28.88 [63.85]	6.71 M [22.0']
20745-683	Field Assembly, Full Driveline Tube, Steel, Detachable, 6833mm	6833 [269.00]	7239 [285.00]	20773-598	29.81 [65.90]	7.01 M [23.0']
20745-714	Field Assembly, Full Driveline Tube, Steel, Detachable, 7137mm	7137 [281.00]	7544 [297.00]	20773-628	30.74 [67.95]	7.32 M [24.0']
20745-744	Field Assembly, Full Driveline Tube, Steel, Detachable, 7442mm	7442 [293.00]	7849 [309.00]	20773-659	31.67 [70.00]	7.62 M [25.0']

**NOTES:**

- DIM "A" IS A NOMINAL DIMENSION. OVERALL SHAFT LENGTH TELESCOPES  $\pm 406.4\text{MM}$  [ $\pm 16"$ ]
- PARTS ARE TO BE CLEARLY MARKED WITH PART NUMBER EXTENSION, I.E. 531. MARKING TO LAST AT LEAST 6 MONTHS IN OUTSIDE ENVIRONMENT. MARKINGS MUST BE APPROVED BY ARRAY ENGINEERING AND QUALITY.
- FORCE NECESSARY FOR MOVEMENT MUST NOT EXCEED 4.5 KGF [10 LBF].
- M8 SET SCREW  $16\pm 1$  N-M [ $12\pm 1$  FT-LB][ $14\pm 12$  IN-LB].
- MARK ALL TORQUED CONNECTIONS USING PAINT MARKERS OF CONTRASTING COLOR ACROSS IMMOBILE BASE AND ALL PARTS SUBJECT TO LOOSENING.
- ROW SPACING IS BASED ON LEVEL GRADE BETWEEN ROWS AND CENTER STRUCTURES IN ALIGNMENT.

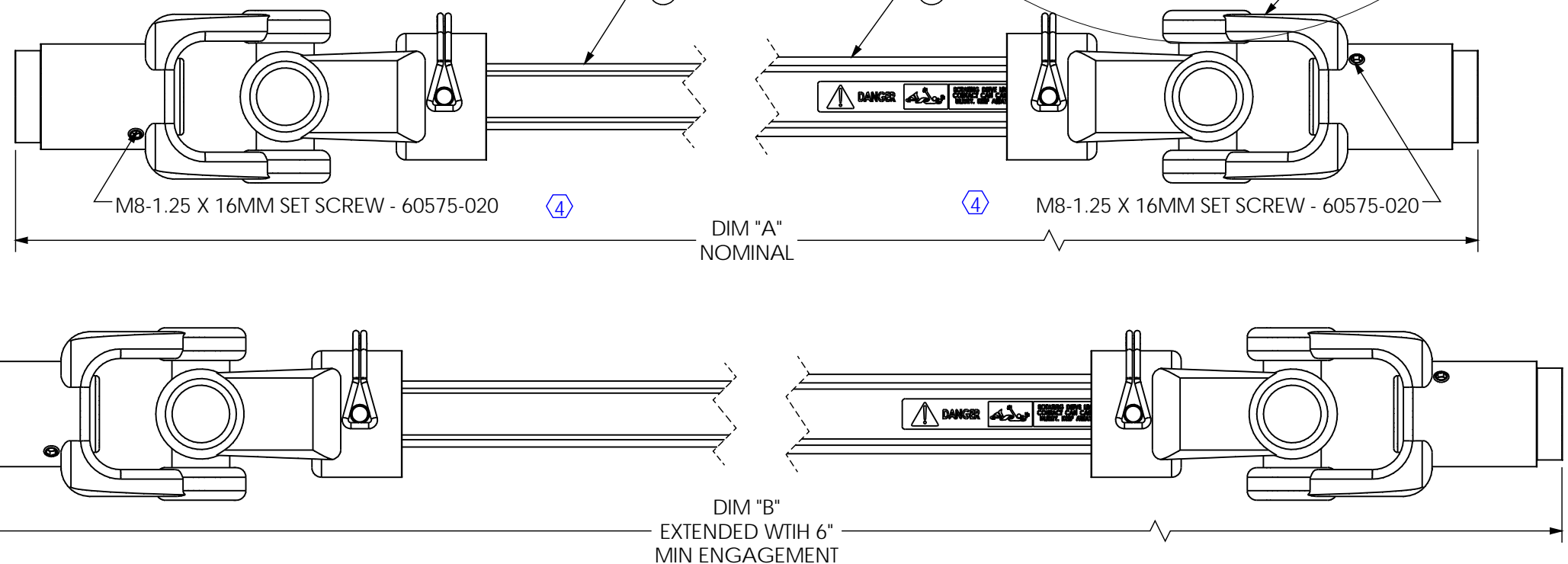

ARRAY PART NUMBER DESIGNATION  
**20745 - XXX**  
 ARRAY PART NUMBER EXTENSION NUMBER INDICATES DIM "A"  
 ARRAY PART NUMBER  
 STATE OF CONNECTICUT  
 ROBERT C. NAPLES  
 No. 28670  
 LICENSED PROFESSIONAL ENGINEER  
 Exp 01/31/2027  
 04/13/2026

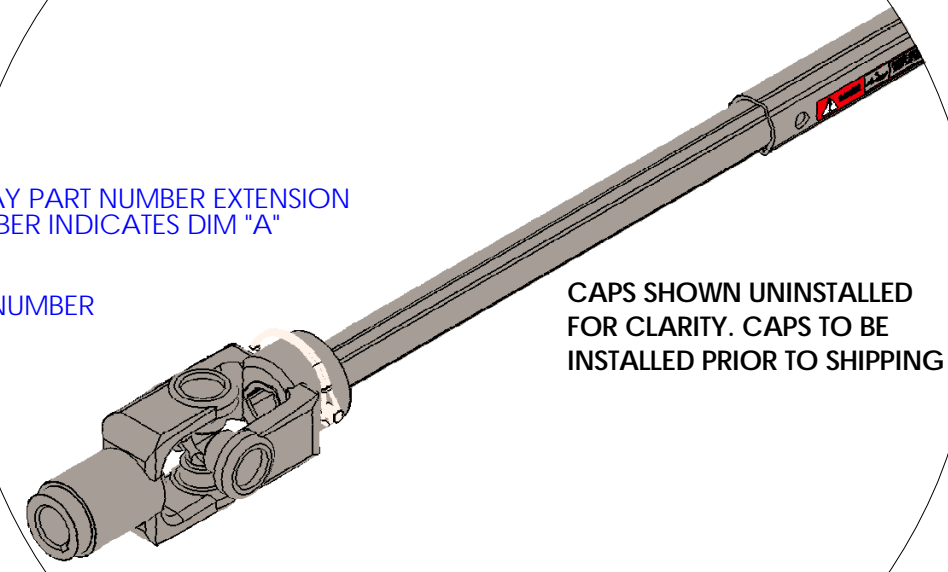

STEEL DRIVELINE SPECIFICATIONS	
OPERATING TORQUE	515 N-M [380 FT-LB]
MAXIMUM TORQUE	712 N-M [525 FT-LB]
MAX. OPERATING ANGLE	45°
U-JOINT LIFETIME	30 years min
OPERATING SPEED	30 rpm
ENVIRONMENTAL CONDITION	Severe Weather
MAINTENANCE	None Required
MAX. ANGULAR BACKLASH	5°
TORSIONAL DEFLECTION AT 325 FT-LBS	10.2° @ 125" OAL W/ 14" ENGAGEMENT. ADD .65° PER FOOT FOR LONGER LENGTHS

ITEM NO.	PART NUMBER	DESCRIPTION	QTY
1	20744-000	Assembly, Driveline, Steel, Detachable, Male	1
2	20772-000	Assembly, U-Joint, Steel, Female, Detachable	1
3	20773-XXX	Assembly, Tube, Driveline, Steel, Female, XXXX mm	1

DRAWING STATUS <b>Final</b>		
DRAWN INITIALS: AH DATE: 8/6/2018	DRAWING CHECK INITIALS: KB DATE: 8/20/2018	
ENG. CHECK INITIALS: SR DATE: 9/10/2018	FINAL APPROVAL	
THIRD ANGLE PROJECTION MILLIMETER [INCH] TOLERANCES UNLESS OTHERWISE SPECIFIED		
MM [INCH]: X = ±1.25 [0.050] X = ±0.4 [0.015] XX = ±0.1 [0.004]	METER [INCH]: X.XX = ±0.013 [0.500] X.XXX = ±0.006 [0.250]	ANGULAR: X = ±1.0° X = ±0.1°
PROPRIETARY AND CONFIDENTIAL THE INFORMATION CONTAINED IN THIS DRAWING IS THE SOLE PROPERTY OF ARRAY TECHNOLOGIES. ANY REPRODUCTION IN PART OR AS A WHOLE WITHOUT THE WRITTEN PERMISSION FROM ARRAY TECHNOLOGIES IS PROHIBITED.		

A	INITIAL RELEASE	8/20/2018
REV	DESCRIPTION	DATE

<b>ARRAY TECHNOLOGIES</b> 3901 Midway Place NE, Albuquerque, NM 87109 (505) 881-7567			
TITLE: <b>Field Assembly, Full Driveline Tube, Steel, Detachable, XXXXmm</b>			
SIZE B	DRAWING NUMBER 20745-901	REVISION A	SAVED v14 4/1/2019
SCALE 1:3	WT: SEE CONFIG. TABLE	SHEET 1 OF 1	

**NOTES:**

- ① DIMENSION ADJUSTABLE BASED UPON I-BEAM USED.
- 2. SEE PAGE 3 & 4 FOR TORQUE SPECIFICATIONS AND HARDWARE IDENTIFICATION.
- 3. CAB AND THE MOTOR MUST ALWAYS BE MOUNTED ON OPPOSITE SIDES OF THE CENTER STRUCTURE.
- 4. ALTERNATE LOGO GEAR RACK ASSEMBLY 20728-XXX MAY BE USED IN PLACE OF 20878-XXX WITH EQUIVALENT CORROSION LEVEL. ⚠
- 5. UNDER CERTAIN CIRCUMSTANCES, 20729-XX-XXX MAY BE SUBSTITUTED FOR 25215-XX-XXX.

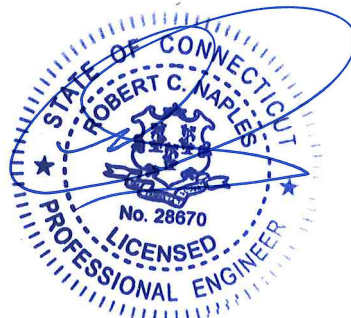
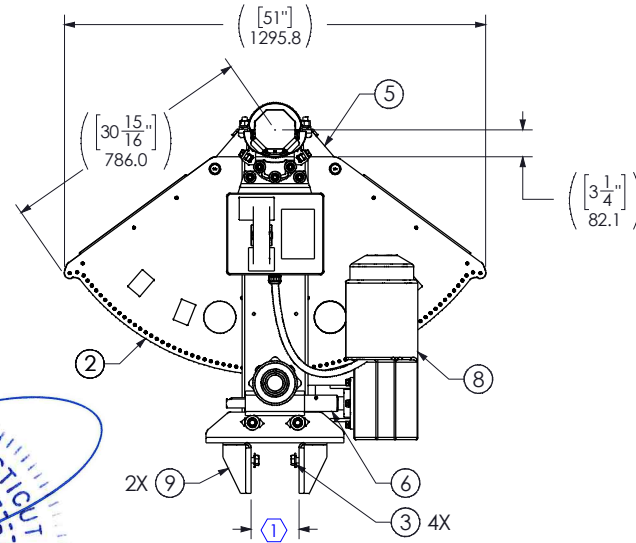
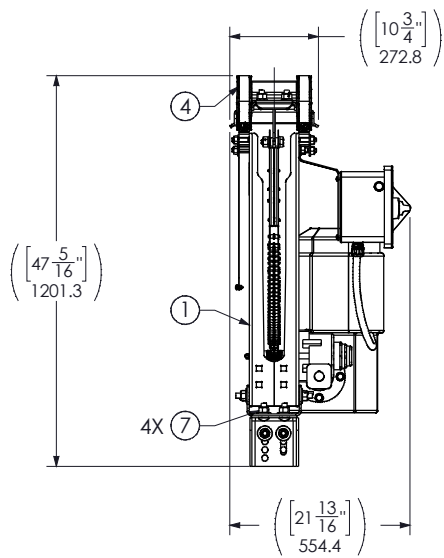

Exp 01/31/2027  
04/13/2026

ITEM NO.	PART NUMBER	DESCRIPTION	QTY
1	20725-XXX	Assembly, Center Structure, Drive Column, GCS, L/M/H, Gearbox XX	1
2	20878-XXX	Assembly, Gear Rack, No Logo, GCS 52 deg, 14 Gauge, 90 Flange, L/M/H	1
3	25050-001	Kit, 0.625"-11 x 2" Structural Bolt, Large Washers, Pin Lock Nut, HDG	4
4	25162-000	Kit, Center Structure Bearing, GCS	1
5	25163-000	Kit, Weldment, Gear Rack Coupler, GCS	1
6	25164-000	Kit, Motor Assembly, Drive Column, GCS, 345.4mm Shaft	1
7	25165-001	Kit, 0.625"-11 x 1.75" Carriage Bolt, Large Washers, Pin Lock Nut, HDG	4
8	25215-XX-XXX	Kit, Motor Assembly, Dual Voltage, 6.3A, GCS, Motor XX, M/H, Controller XX	1
9	30698-000	Bracket I-beam, GCS	2

ZONE	REV	ECR #	DESCRIPTION	DATE
A5, D5, 2-C1, 2-C6, 2-D6, 2-D7, 5-C2, 5-C4, 5-C5, 5-D4, 5-D5	T	21100 21103 21114	REMOVED CONFIGURATIONS 20729-XX-X04 THRU 20729-XX-X06, ADDED WIRE MANAGEMENT HOLE DIMENSIONS, REPLACED GEAR RACK 20728 WITH 20878, ADJUSTED GEAR RACK CONFIG TABLE, UPDATED NOTE 4	6/16/2021
2-C6	S	21093	REMOVED CONFIGURATIONS 20729-02-401 THRU 20729-02-406	5/21/2021
B7, D5, 2-A1, 5-A3, 5-A5, 5-B3	R	21033 21073	ADDED NOTE 5, BOM AND SHEET 2 (INTEGRATED -906), REMOVED NOTE 2, UPDATED FLOOD INFORMATION	4/30/2021

PROPRIETARY AND CONFIDENTIAL THE INFORMATION CONTAINED IN THIS DRAWING IS THE SOLE PROPERTY OF ARRAY TECHNOLOGIES. ANY REPRODUCTION IN PART OR AS A WHOLE WITHOUT THE WRITTEN PERMISSION FROM ARRAY TECHNOLOGIES IS PROHIBITED.		DRAWING STATUS <b>Final</b> DRAWN: KB DATE: 01/03/2018 ENG. CHECK: JS DATE: 07/12/2021 REDESIGN: NC DATE: 6/29/2021 FINAL APPROVAL: SB DATE: 7/13/2021		ALL DIMS ARE DUAL UNITS: MILLIMETER (INCH). DIMENSIONS IN BRACKETS ARE FOR REFERENCE ONLY.	
THIRD ANGLE PROJECTION TOLERANCES UNLESS OTHERWISE SPECIFIED: MM (INCH): X = ±1.25 (0.050) X = ±0.4 (0.015) XX = ±0.1 (0.004)		METER (INCH): XXX = ±0.013 (0.500) XXXX = ±0.006 (0.250)		ANGULAR: X = ±1.0° X = ±0.1°	
TITLE <b>Field Assembly, GCS, Motorized, XX Deg, L/M/H, Motor XX, Gearbox XX</b>		ARRAY TECHNOLOGIES 3901 Midway Place NE, Albuquerque, NM 87109 (505) 881-7567		SIZE B SCALE 1:15	
DRAWING NUMBER <b>20726-XX-901</b>		REVISION T		SAVED V203 7/12/2021	
SHEET 1 OF 6		SHEET 1 OF 6		SHEET 1 OF 6	

GEAR RACK CONFIGURATION TABLE	
GEAR RACK PART NUMBER	DESCRIPTION
20878-002	Assembly, Gear Rack, No Logo, GCS 52 deg, 14 Gauge, 90 Flange, L
20878-004	Assembly, Gear Rack, No Logo, GCS 52 deg, 14 Gauge, 90 Flange, M/H

MOTOR KIT CONFIGURATION TABLE	
MOTOR KIT PART NUMBER	MOTOR KIT DESCRIPTION
20729-01-301	Assembly, Dual Voltage, GCS, Motor 01, M, Controller 01
20729-01-302	Assembly, Dual Voltage, GCS, Motor 01, M, Controller 02
20729-01-303	Assembly, Dual Voltage, GCS, Motor 01, M, Controller 03
20729-01-311	Assembly, Dual Voltage, GCS, Motor 01, M, Controller 01
20729-01-401	Assembly, Dual Voltage, GCS, Motor 01, H, Controller 01
20729-01-402	Assembly, Dual Voltage, GCS, Motor 01, H, Controller 02
20729-01-403	Assembly, Dual Voltage, GCS, Motor 01, H, Controller 03
20729-03-401	Assembly, Dual Voltage, GCS, Motor 03, H, Controller 01
20729-03-402	Assembly, Dual Voltage, GCS, Motor 03, H, Controller 02
20729-03-403	Assembly, Dual Voltage, GCS, Motor 03, H, Controller 03

MOTOR KIT CONFIGURATION TABLE	
MOTOR KIT PART NUMBER	MOTOR KIT DESCRIPTION (6.3A)
25215-01-301	Kit, Motor Assembly, GCS, 6.3A, SEW Motor, L/M, IEC STD
25215-01-302	Kit, Motor Assembly, GCS, 6.3A, SEW Motor, L/M, IEC EUR
25215-01-303	Kit, Motor Assembly, GCS, 6.3A, SEW Motor, L/M, IEC AUS
25215-01-311	Kit, Motor Assembly, GCS, 6.3A, SEW Motor, M/H, IEC STD, PP
25215-01-401	Kit, Motor Assembly, GCS, 6.3A, SEW Motor, H, IEC STD
25215-01-402	Kit, Motor Assembly, GCS, 6.3A, SEW Motor, H, IEC EUR
25215-01-403	Kit, Motor Assembly, GCS, 6.3A, SEW Motor, H, IEC AUS
25215-02-401	Kit, Motor Assembly, GCS, 6.3A, Regal Motor, H, IEC STD
25215-02-402	Kit, Motor Assembly, GCS, 6.3A, Regal Motor, H, IEC EUR
25215-02-403	Kit, Motor Assembly, GCS, 6.3A, Regal Motor, H, IEC AUS
25215-03-401	Kit, Motor Assembly, GCS, 6.3A, Bonfiglioli Motor, H, IEC STD
25215-03-402	Kit, Motor Assembly, GCS, 6.3A, Bonfiglioli Motor, H, IEC EUR
25215-03-403	Kit, Motor Assembly, GCS, 6.3A, Bonfiglioli Motor, H, IEC AUS

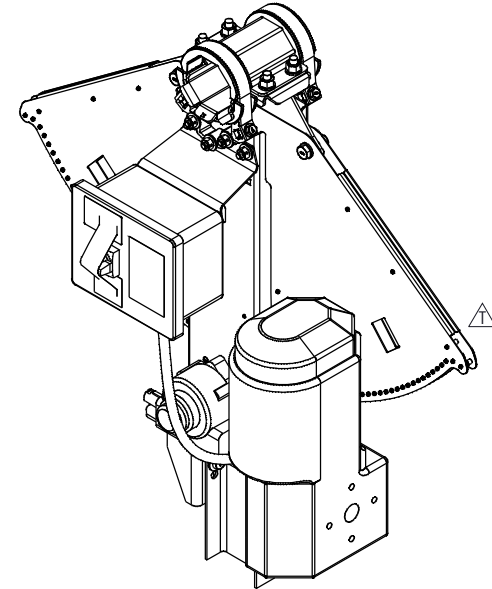

CENTER STRUCTURE CONFIGURATION TABLE		SELECTION CRITERIA	
CENTER STRUCTURE PART NUMBER	DESCRIPTION	GEARBOX SELECTION	CORROSION REQUIREMENTS
20725-201	Assembly, Center Structure, Drive Column, GCS, L, Gearbox 01	REGAL	L
20725-202	Assembly, Center Structure, Drive Column, GCS, L, Gearbox 02	KMI	L
20725-301	Assembly, Center Structure, Drive Column, GCS, M, Gearbox 01	REGAL	M
20725-302	Assembly, Center Structure, Drive Column, GCS, M, Gearbox 02	KMI	M
20725-401	Assembly, Center Structure, Drive Column, GCS, H, Gearbox 01	REGAL	H
20725-402	Assembly, Center Structure, Drive Column, GCS, H, Gearbox 02	KMI	H

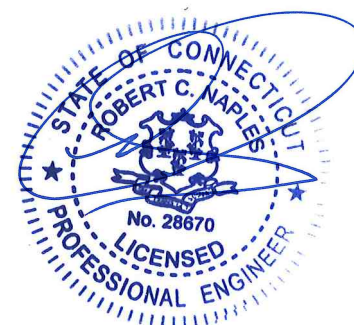

Exp 01/31/2027  
04/13/2026

SIZE B	DRAWING NUMBER 20726-XX-901	REVISION T	SAVED v203 7/12/2021
SCALE 1:10	SHEET 2 OF 6		

**NOTES:**

6. ARRAY TORQUE SPECIFICATIONS:

- 6A.  $\varnothing 5/8"$  HEX BOLT  $169 \pm 14$  N-M [ $125 \pm 10$  FT-LBS]
- 6B.  $\varnothing 5/8"$  CARRIAGE BOLT  $108 \pm 14$  N-M [ $80 \pm 10$  FT-LBS]
- 6C.  $\varnothing 5/8"$  GEAR RACK HEX BOLT  $108 \pm 14$  N-M [ $80 \pm 10$  FT-LBS]
- 6D.  $\varnothing 1/2"$  HEX BOLT  $81 \pm 7$  N-M [ $60 \pm 5$  FT-LBS]
- 6E.  $\varnothing 1/4"$  CARRIAGE BOLT  $8.5 \pm 5$  N-M [ $75 \pm 5$  IN-LBS]

7. MARK ALL TORQUED CONNECTIONS USING PAINT MARKER OF CONTRASTING COLOR ACROSS IMMOBILE BASE AND ALL PARTS SUBJECT TO LOOSENING.

8. THE RECOMMENDED SEQUENCE FOR PROPER TIGHTENING OF BOLTS IS CRISS-CROSS PATTERN.

9. CARRIAGE BOLTS ARE SAE GRADE 5 MATERIAL. FINISH - HDG

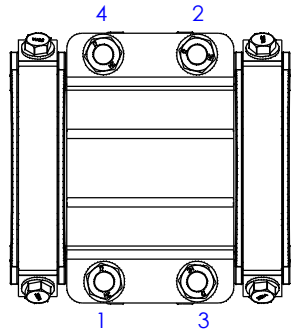

6B  $\varnothing 5/8" \times 2.00"$  CARRIAGE BOLT: 60490-200  
WASHER: 60451-000  
NUT: 60502-000

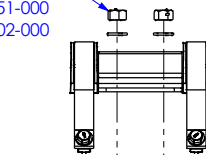

6D  $\varnothing 1/2" \times 2.50"$  HEX BOLT: 60445-250  
WASHER: 60007-000  
NUT: 60503-000

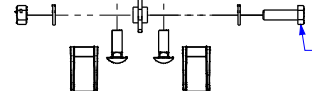

2X HARDWARE KIT: 25170-001 6C  
 $\varnothing 5/8" \times 2.25"$  GEAR RACK HEX BOLT: 60125-225  
WASHER: 60451-000  
NUT: 60502-000

**PER ARRAY DIRECTIVE  
DO NOT USE WASHER  
WITH 25170 BOLT**

6E GROUNDING STRAP: 50263-000  
 $\varnothing 1/4" \times 0.75"$  CARRIAGE BOLT: 60061-075  
NUT: 60069-000

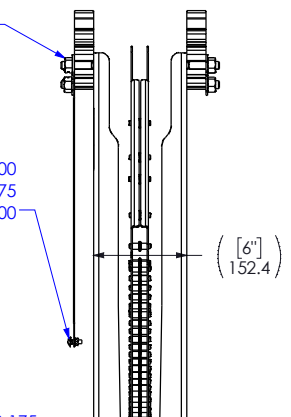

(6")  
152.4

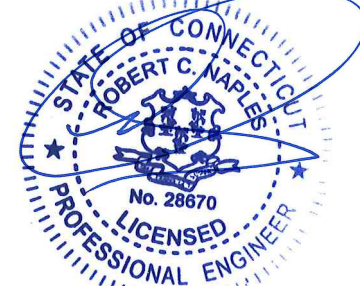

Exp 01/31/2027  
04/13/2026

6B  $\varnothing 5/8" \times 1.75"$  CARRIAGE BOLT: 60490-175  
WASHER: 60124-000  
NUT: 60502-000

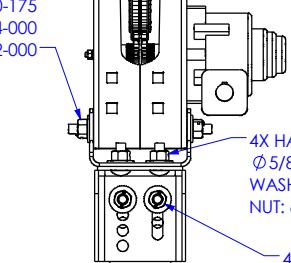

4X HARDWARE KIT: 25165-001 6B  
 $\varnothing 5/8" \times 1.75"$  CARRIAGE BOLT: 60490-175  
WASHER: 60124-000  
NUT: 60502-000

4X HARDWARE KIT: 25050-001 6A  
 $\varnothing 5/8" \times 2.00"$  HEX BOLT: 60352-200  
WASHER: 60124-000  
NUT: 60502-000

MOTOR AND ELECTRICAL COMPONENTS REMOVED FOR CLARITY

6D  $\varnothing 1/2" \times 1.25"$  HEX BOLT: 60358-125  
WASHER: 60006-000  
NUT: 60680-000

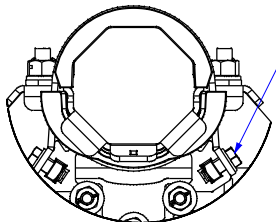

DETAIL A

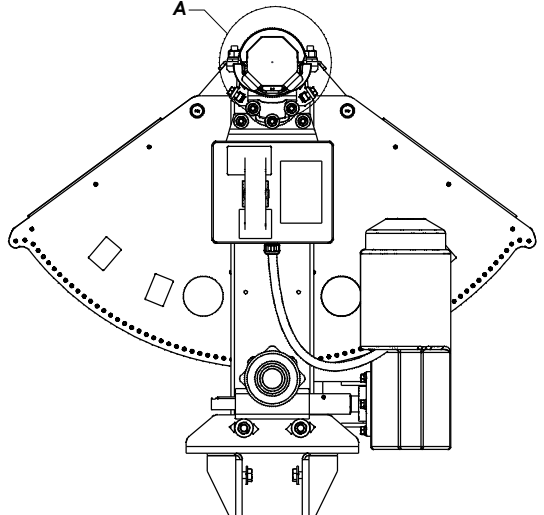

SIZE B	DRAWING NUMBER 20726-XX-901	REVISION T	SAVED v203 7/12/2021
SCALE 1:16	SHEET 3 OF 6		

8 7 6 5 4 3 2 1

**NOTES:**

10. ARRAY TORQUE SPECIFICATIONS:

- 10A. 1/2" CARRIAGE BOLT 60 ±7 N-M [45 ±5 FT-LBS]
- 10B. M12 HEX BOLT 81 ±7 N-M [60 ±5 FT-LBS]
- 10C. M8 SET SCREW 16 ±1 N-M [12 ±1 FT-LBS][144 ±12 IN-LBS]

11. GEAR RACK AND WELDMENT NOT SHOWN FOR CLARITY

10A. Ø 1/2" x 1.25" CARRIAGE BOLT: 60445-125  
 WASHER: 60007-000  
 NUT: 60502-000

10B. Ø M12 x 30 HEX BOLT: 60057-030  
 LOCK WASHER: 60483-000  
 WASHER: 60298-000

10C. M8 SET SCREW: 60573-012

10B (SEE TORQUE NOTES SHEET 3)  
 Ø 5/8" x 1.75" CARRIAGE BOLT: 60490-175  
 WASHER: 60451-000  
 NUT: 60502-000

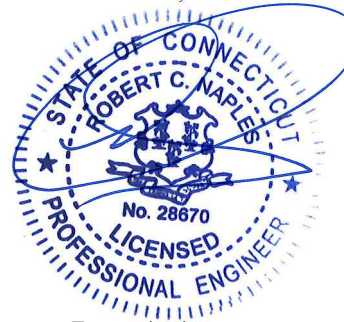

Exp 01/31/2027  
 04/13/2026

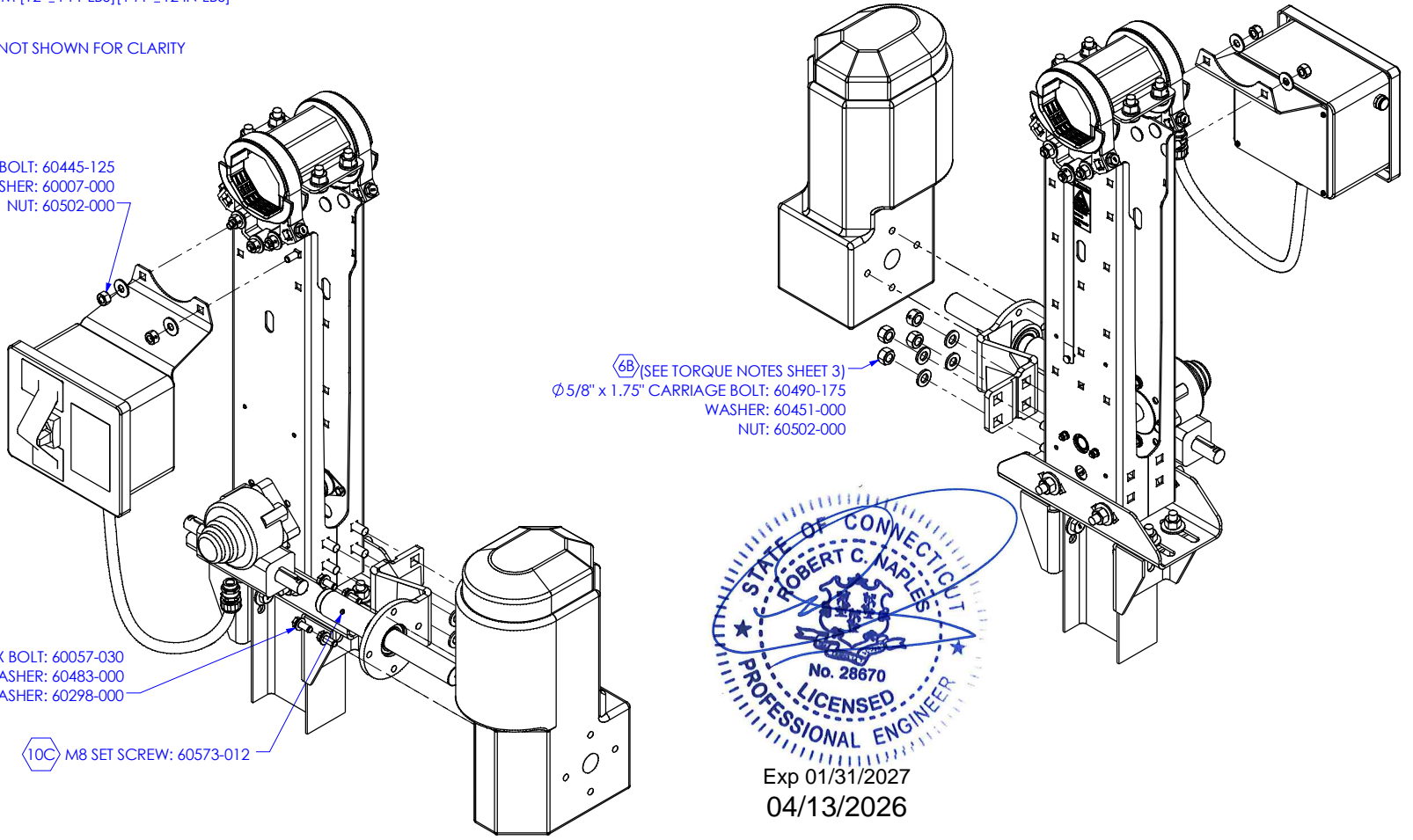

SIZE B	DRAWING NUMBER 20726-XX-901	REVISION T	SAVED v203 7/12/2021
SCALE 1:16	SHEET 4 OF 6		

8 7 6 5 4 3 2 1

**NOTES:**

- 12. THE MAXIMUM FLOOD DEPTH BELOW BOTTOM FACE OF GCS BASE.
- 13. LEADING EDGE OF THE MODULE AT 52° TILT IS LOWER THAN TRACKER ELECTRICAL CONNECTION.

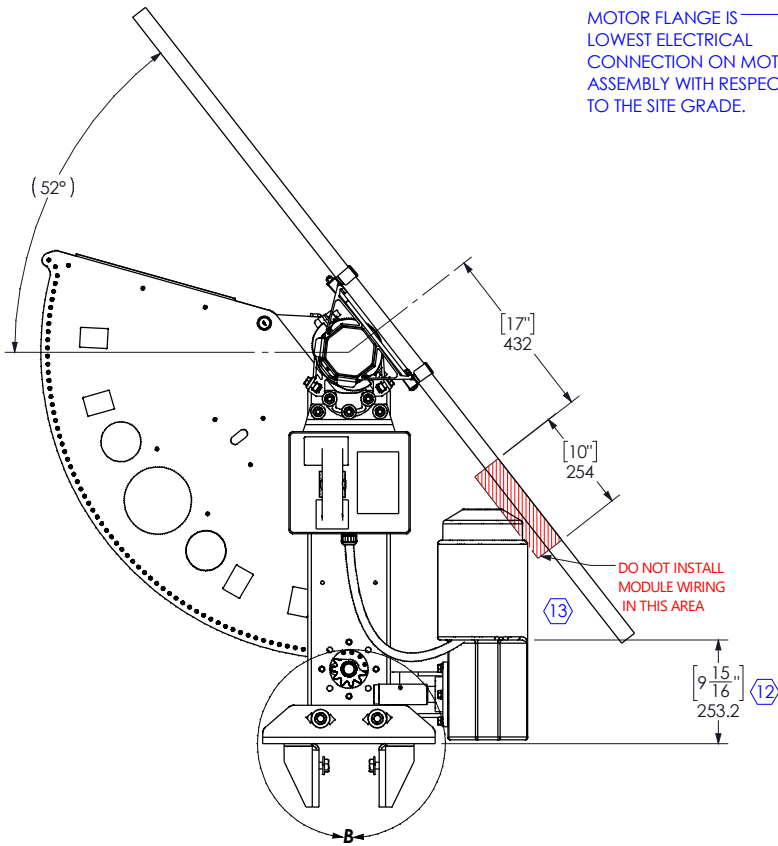

MOTOR FLANGE IS LOWEST ELECTRICAL CONNECTION ON MOTOR ASSEMBLY WITH RESPECT TO THE SITE GRADE.

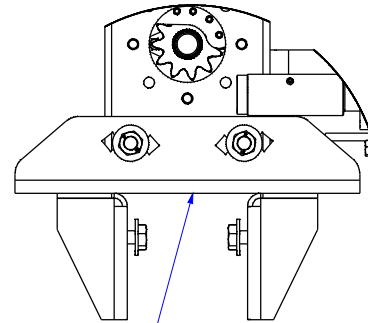
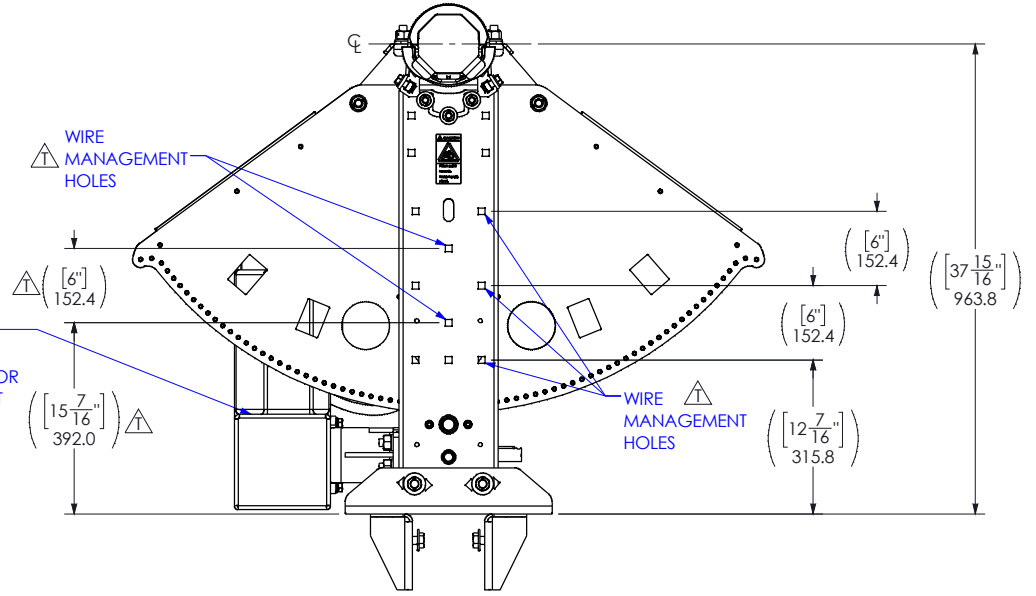

12  
**DETAIL B**

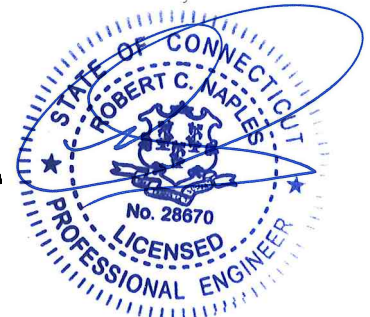

Exp 01/31/2027  
04/13/2026

SIZE B	DRAWING NUMBER 20726-XX-901	REVISION T	SAVED v203 7/12/2021
SCALE 1:16	SHEET		5 OF 6

**NOTES:**

- 14. DIMENSIONS FROM CENTER OF I-BEAM ACCOUNT FOR VARIATIONS IN WEB THICKNESS.
- 15. ALL PENETRATIONS DONE IN FIELD MUST BE PLUGGED WITH COMPONENT WHICH MAINTAINS THE 4X RATING OF THE ENCLOSURE.
- 16. ONCE CONDUIT AND CABLING IS INSTALLED MOTOR ENCLOSURES MUST BE SEALED TO PREVENT INFESTATION.
- 17. HATCHED AREA REPRESENTS USABLE SURFACE ON BOTTOM OF MOTOR ENCLOSURE IN REFERENCE TO CONDUIT STUB-UPS.
- 18. ENSURE TO LEAVE ENOUGH CLEARANCE AT STUB-UP LOCATIONS FOR INTERNAL NUTS ON ENCLOSURE.

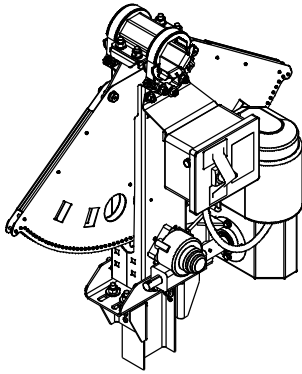
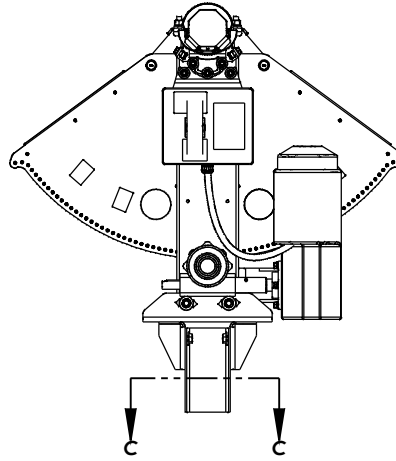

LOCATIONS FOR CONDUIT STUB-UPS

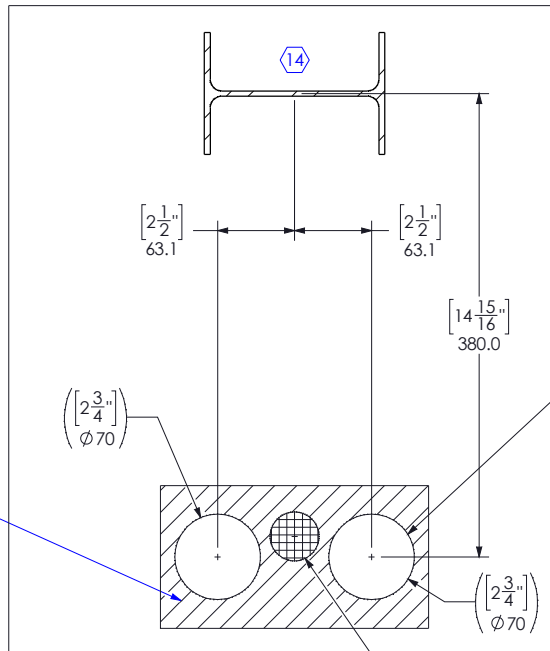

**SECTION C-C**

AREA UNUSABLE DUE TO PRE-EXISTING CONDUIT ON ARRAY ENCLOSURE.

LOCATE STUB-UP FOR CONTROL CABLE WITHIN THIS AREA. SIZE DETERMINED BY LOCAL SITE REQUIREMENTS.

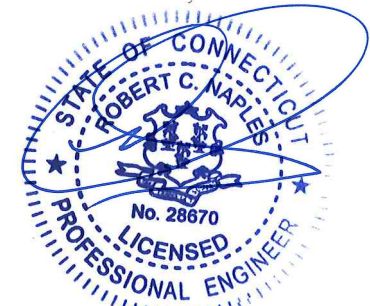

Exp 01/31/2027  
04/13/2026

SIZE B	DRAWING NUMBER 20726-XX-901	REVISION T	SAVED v203 7/12/2021
SCALE 1:16	SHEET 6 OF 6		

**NOTES:**

- SEE 20999-901 FOR BOM AND CONFIGURATION TABLES.
- ARRAY TORQUE SPECIFICATIONS:
  - 2A.  $\phi 5/8"$  HEX BOLT  $169 \pm 14$  N-M [ $125 \pm 10$  FT-LBS]
  - 2B.  $\phi 5/8"$  CARRIAGE BOLT  $108 \pm 14$  N-M [ $80 \pm 10$  FT-LBS]
  - 2C.  $\phi 5/8"$  GEAR RACK HEX BOLT  $108 \pm 14$  N-M [ $80 \pm 10$  FT-LBS]
  - 2D.  $\phi 1/2"$  HEX BOLT  $81 \pm 7$  N-M [ $60 \pm 5$  FT-LBS]
  - 2E.  $\phi 1/4"$  CARRIAGE BOLT  $8.5 \pm .5$  N-M [ $75 \pm 5$  IN-LBS]
- MARK ALL TORQUED CONNECTIONS USING PAINT MARKER OF CONTRASTING COLOR ACROSS IMMOBILE BASE AND ALL PARTS SUBJECT TO LOOSENING.
- THE RECOMMENDED SEQUENCE FOR PROPER TIGHTENING OF BOLTS IS CRISS-CROSS PATTERN.

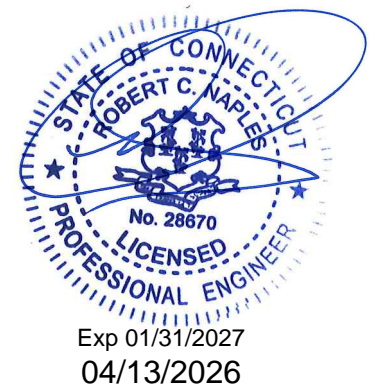

2D  $\phi 1/2" \times 1.25"$  HEX BOLT: 60358-125  
 WASHER: 60006-000  
 NUT: 60680-000

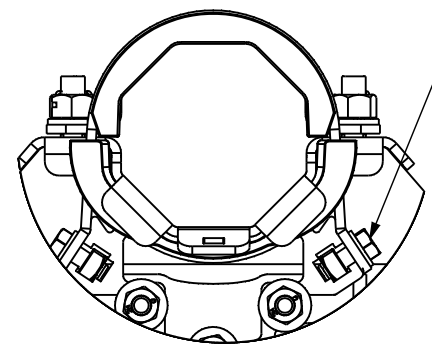

**DETAIL A**

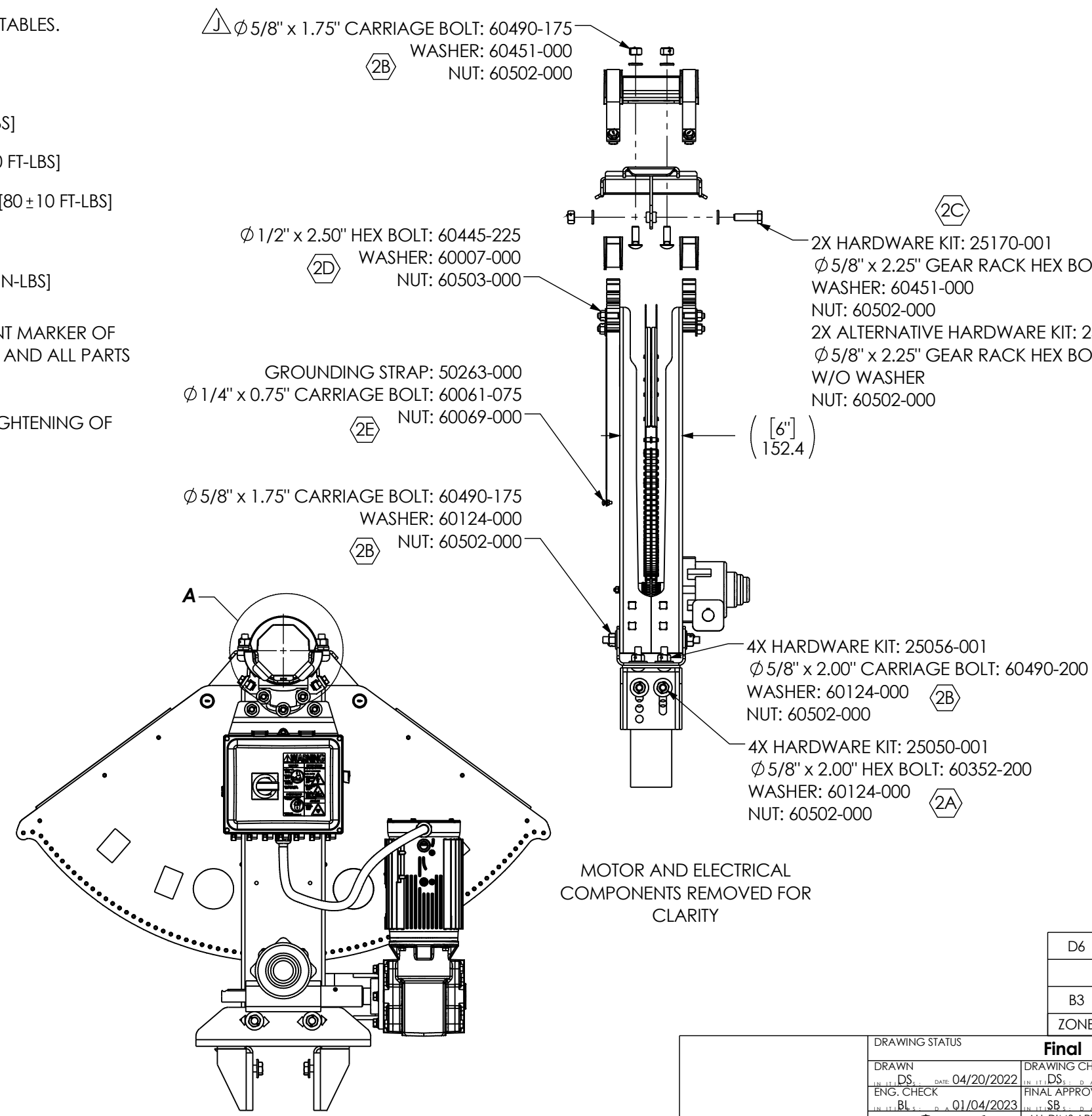

MOTOR AND ELECTRICAL COMPONENTS REMOVED FOR CLARITY

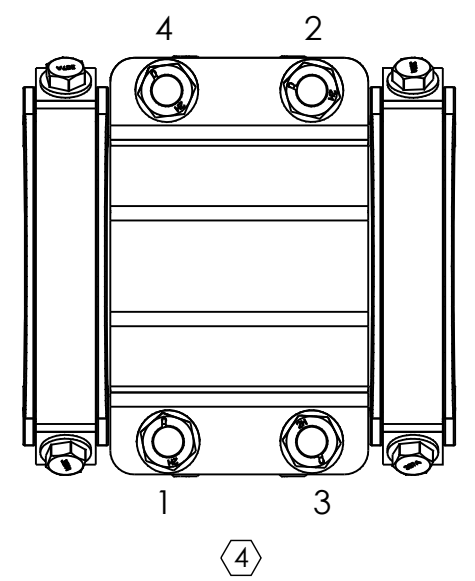

ZONE	REV	ECR #	DESCRIPTION	DATE
D6	J	22191	CORRECTED 60490 BOLT LENGTH	12/19/2022
	H	22154	UPDATED TO MATCH ASSEMBLY REVISION	10/12/2022
B3	G	22143	REPLACED 25165-001 WITH 25056-001	9/8/2022

PROPRIETARY AND CONFIDENTIAL THE INFORMATION CONTAINED IN THIS DRAWING IS THE SOLE PROPERTY OF ARRAY TECHNOLOGIES. ANY REPRODUCTION IN PART OR AS A WHOLE WITHOUT THE WRITTEN PERMISSION FROM ARRAY TECHNOLOGIES IS PROHIBITED.	DRAWING STATUS: <b>Final</b>		<b>ARRAY TECHNOLOGIES</b> 3901 Midway Place NE, Albuquerque, NM 87109 (505) 881-7567 <b>ARRAY TECHNOLOGIES</b>
	DRAWN IN: IT, DS: DATE: 04/20/2022	DRAWING CHECK IN: IT, DS: DATE: 12/19/2022	
	ENG. CHECK IN: IT, BL: DATE: 01/04/2023	FINAL APPROVAL IN: IT, SB: DATE: 1/4/2023	
	ALL DIMS ARE DUAL UNITS: MILLIMETER [INCH]. DIMENSIONS IN BRACKETS ARE FOR REFERENCE ONLY.		
THIRD ANGLE PROJECTION <b>TOLERANCES UNLESS OTHERWISE SPECIFIED</b>		TITLE: <b>Field Assembly, GCS, Motorized, XX Motor, L/M/H, STD Wiring, Gearbox XX, Regal</b>	SIZE B DRAWING NUMBER: 20999-903 REVISION: J SAVED v69: 12/19/2022 SCALE: 1:15 SHEET: 1 OF 4
MM [INCH]: X = ±1.25 [0.049] X.X = ±0.4 [0.016] X.XX = ±0.1 [0.004]	METER [INCH]: X.XX = ±0.013 [0.512] X.XXX = ±0.006 [0.236]	ANGULAR: X = ±1.0° X.X = ±0.1°	

8

7

6

5

4

3

2

1

**NOTES:**

5. ARRAY TORQUE SPECIFICATIONS:

5A. 1/2" CARRIAGE BOLT 60 ±7 N-M [45 ±5 FT-LBS]

5B. M12 HEX BOLT 81 ±7 N-M [60 ±5 FT-LBS]

5C. M8 SET SCREW 16 ±1 N-M [12 ±1 FT-LBS][144 ±12 IN-LBS]

6. GEAR RACK AND WELDMENT NOT SHOWN FOR CLARITY

Ø 1/2" x 1.25" CARRIAGE BOLT: 60445-125  
WASHER: 60007-000  
5A NUT: 60502-000

(SEE TORQUE NOTES SHEET 3)  
Ø 5/8" x 1.75" CARRIAGE BOLT: 60490-175  
WASHER: 60451-000  
2B NUT: 60502-000

Ø M12 x 30 HEX BOLT: 60057-030  
LOCK WASHER: 60483-000  
5B WASHER: 60298-000

5C M8 SET SCREW: 60573-012

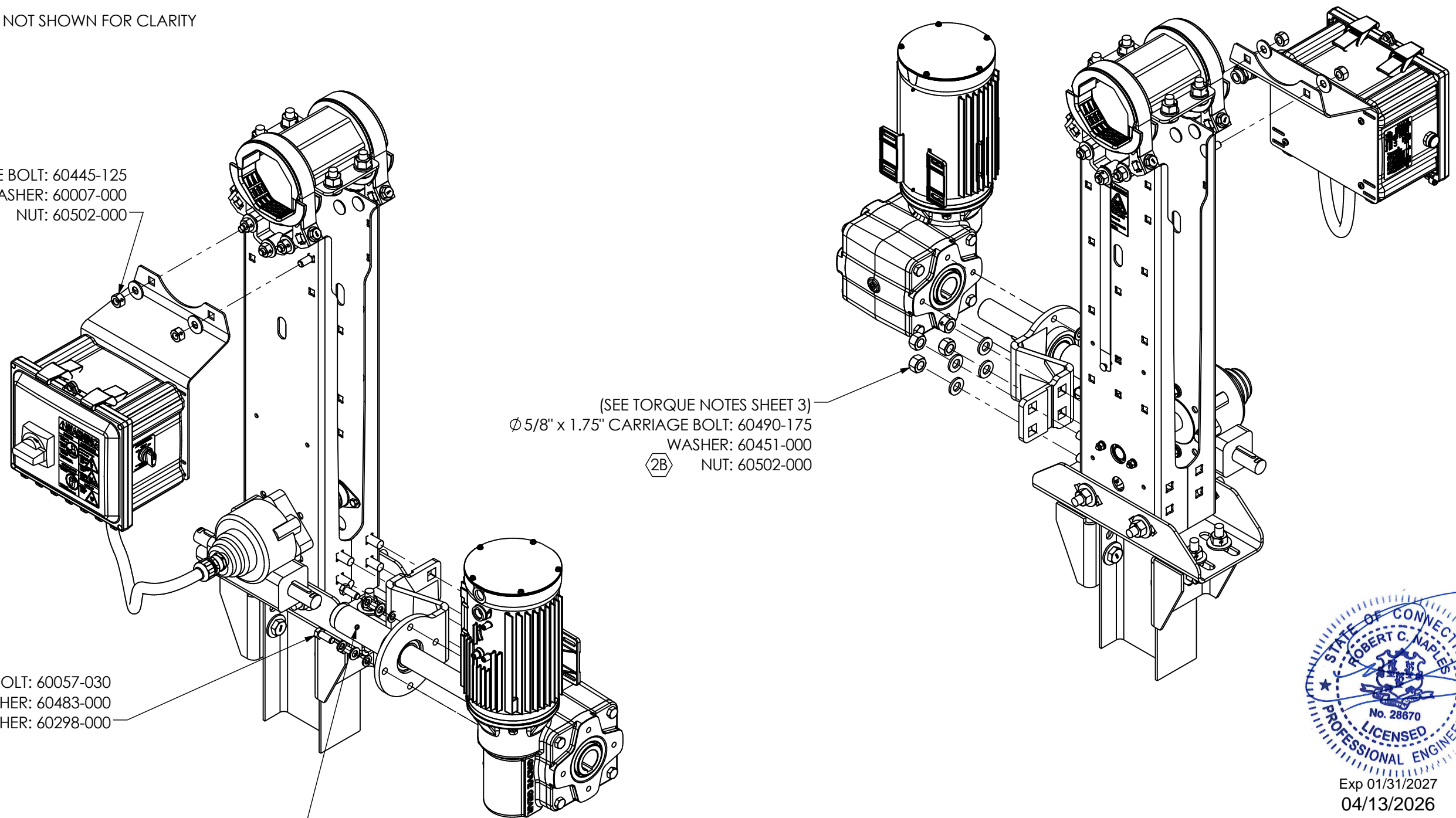

SIZE B	DRAWING NUMBER 20999-903	REVISION J	SAVED v69 12/19/2022
SCALE 1:16	SHEET 2 OF 4		

8

7

6

5

4

3

2

1

**NOTES:**

⑦ LEADING EDGE OF THE MODULE AT 52° TILT IS LOWER THAN TRACKER ELECTRICAL CONNECTION.

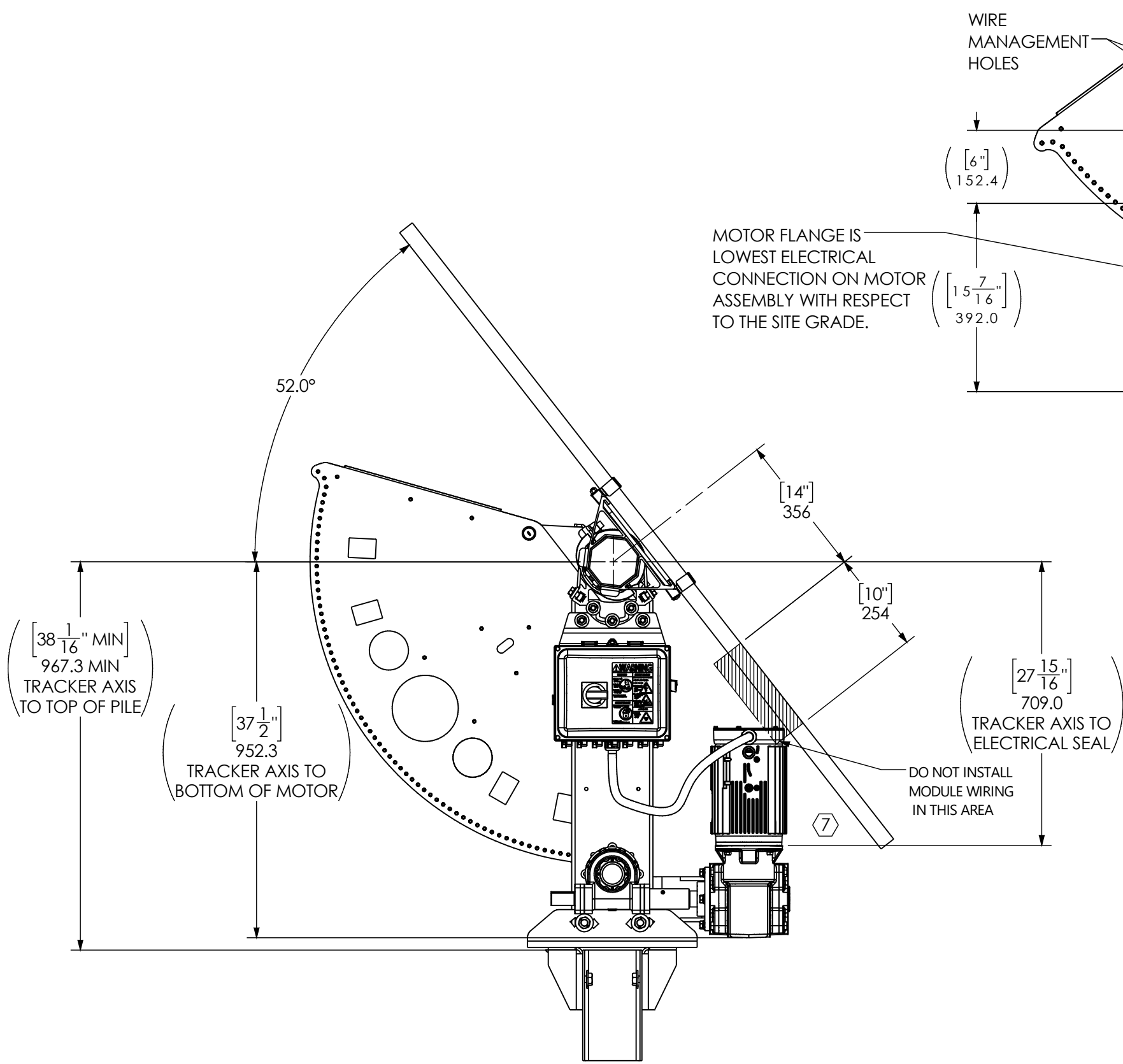

$\left[38 \frac{1}{16}'' \text{ MIN}\right]$   
967.3 MIN  
TRACKER AXIS  
TO TOP OF PILE

$\left[37 \frac{1}{2}''\right]$   
952.3  
TRACKER AXIS TO  
BOTTOM OF MOTOR

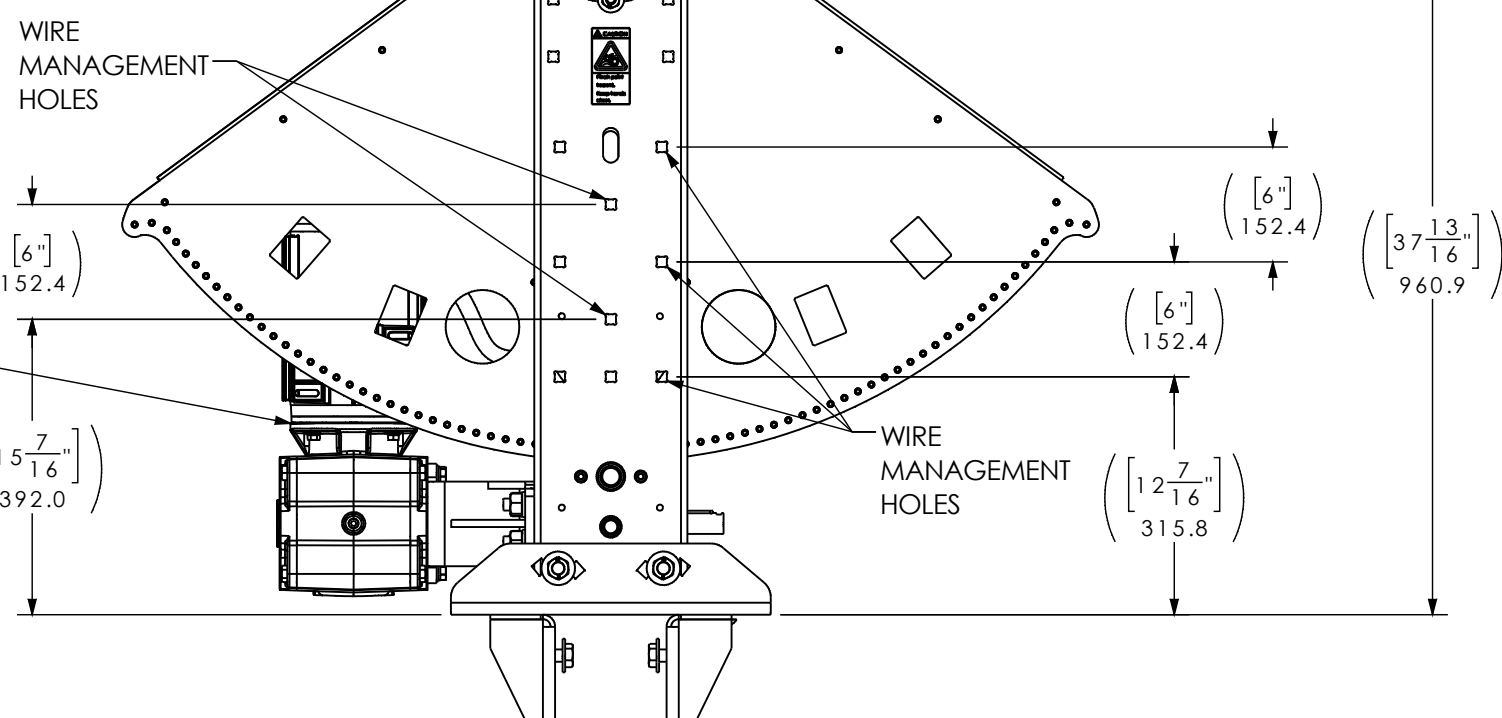

**WIRE MANAGEMENT SYSTEM AND THE MOTOR  
MUST ALWAYS BE MOUNTED ON OPPOSITE  
SIDES OF THE CENTER STRUCTURE**

$\left[27 \frac{15}{16}''\right]$   
709.0  
TRACKER AXIS TO  
ELECTRICAL SEAL

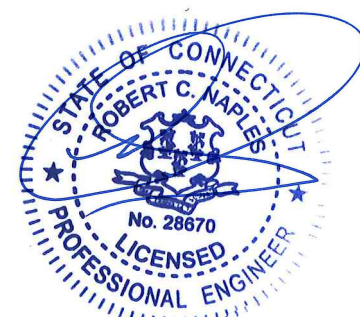

Exp 01/31/2027  
04/13/2026

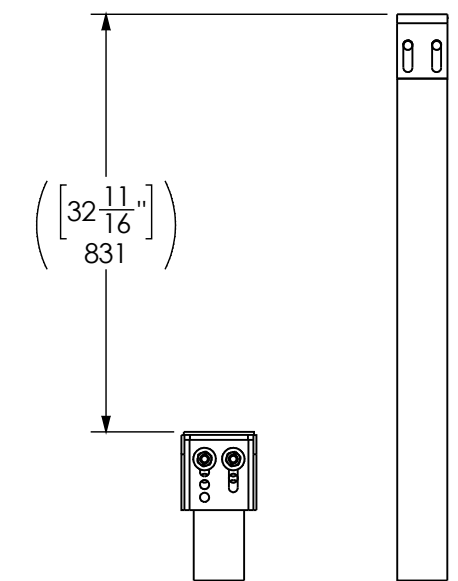

**GEAR RACK COLUMN BRACKET TOP TO  
BEARING COLUMN BRACKET TOP**

SIZE B	DRAWING NUMBER 20999-903	REVISION J	SAVED v69 12/19/2022
SCALE 1:16	SHEET 3 OF 4		

**NOTES:**

- 8. DIMENSIONS FROM CENTER OF I-BEAM ACCOUNT FOR VARIATIONS IN WEB THICKNESS.
- 9. ALL PENETRATIONS DONE IN FIELD MUST BE PLUGGED WITH COMPONENT WHICH MAINTAINS THE 4X RATING OF THE ENCLOSURE.
- 10. ONCE CONDUIT AND CABLING IS INSTALLED MOTOR ENCLOSURES MUST BE SEALED TO PREVENT INFESTATION.
- 11. HATCHED AREA REPRESENTS USABLE SURFACE ON BOTTOM OF MOTOR ENCLOSURE IN REFERENCE TO CONDUIT STUB-UPS.
- 12. ENSURE TO LEAVE ENOUGH CLEARANCE AT STUB-UP LOCATIONS FOR INTERNAL NUTS ON ENCLOSURE.

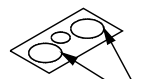
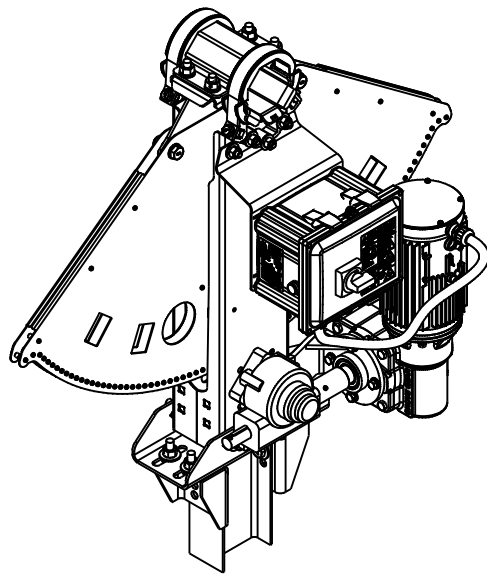
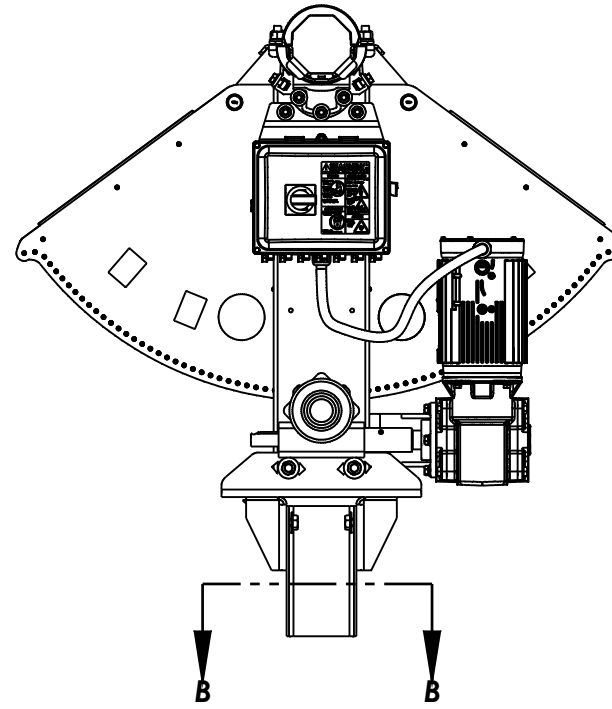

LOCATIONS FOR CONDUIT STUB-UPS

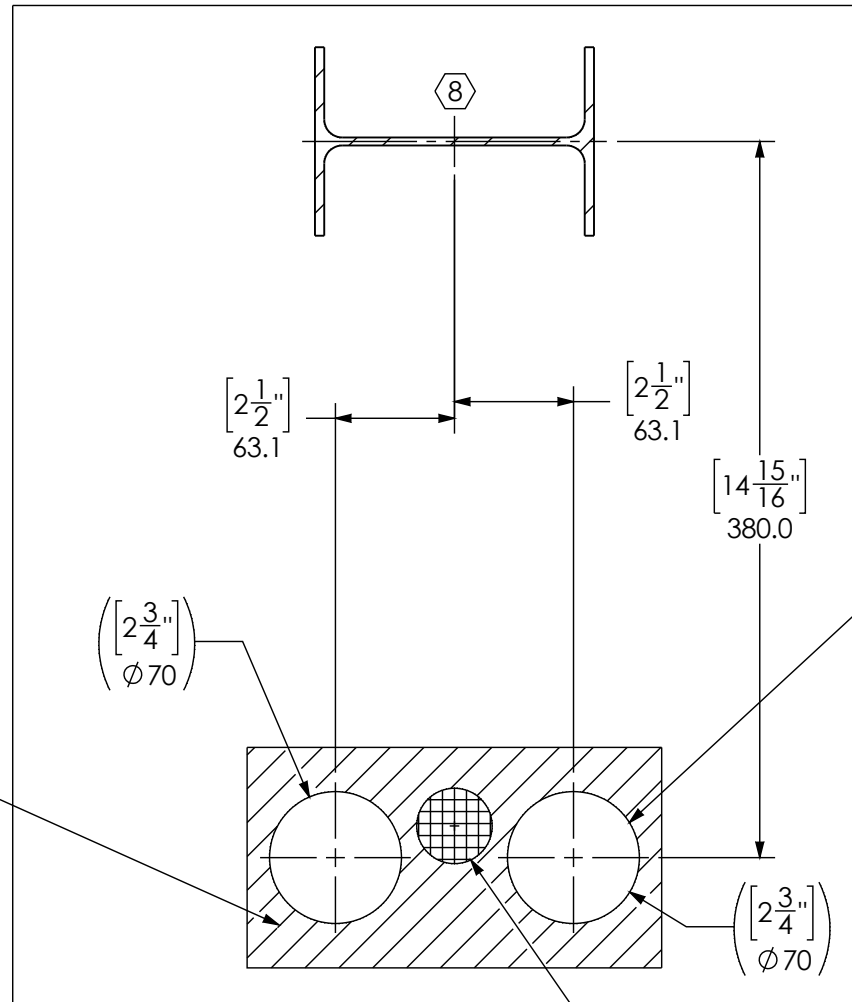

**SECTION B-B**

AREA UNUSABLE DUE TO PRE-EXISTING CONDUIT ON ARRAY ENCLOSURE.

LOCATE STUB-UP FOR CONTROL CABLE WITHIN THIS AREA. SIZE DETERMINED BY LOCAL SITE REQUIREMENTS.

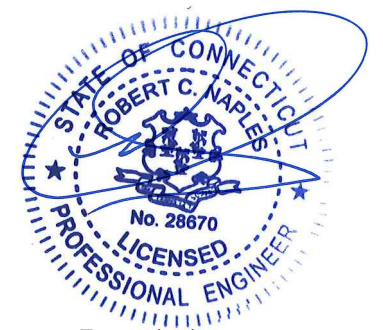

Exp 01/31/2027  
04/13/2026

SIZE <b>B</b>	DRAWING NUMBER 20999-903	REVISION J	SAVED v69 12/19/2022
SCALE 1:16	SHEET 4 OF 4		

8

7

6

5

4

3

2

1

**NOTES:**

- ① DIMENSION ADJUSTABLE BASED UPON I-BEAM USED.
- 2. SEE PAGE 3 FOR TORQUE SPECIFICATIONS.
- 3. SEE SHEET 4 FOR HARDWARE IDENTIFICATION.
- 4. ALTERNATE LOGO GEAR RACK ASSEMBLY 20728-XXX MAY BE USED IN PLACE OF 20878-XXX WITH EQUIVALENT CORROSION LEVEL.

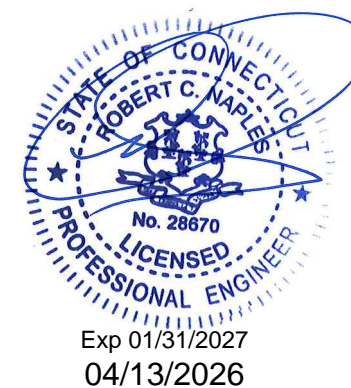
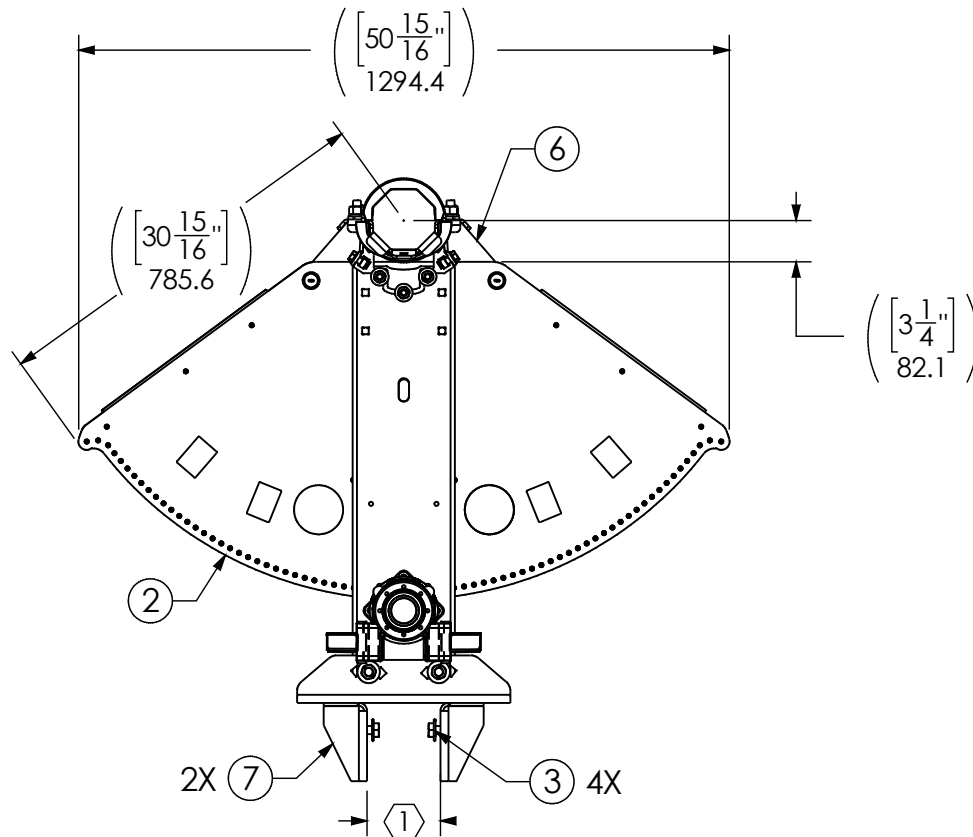
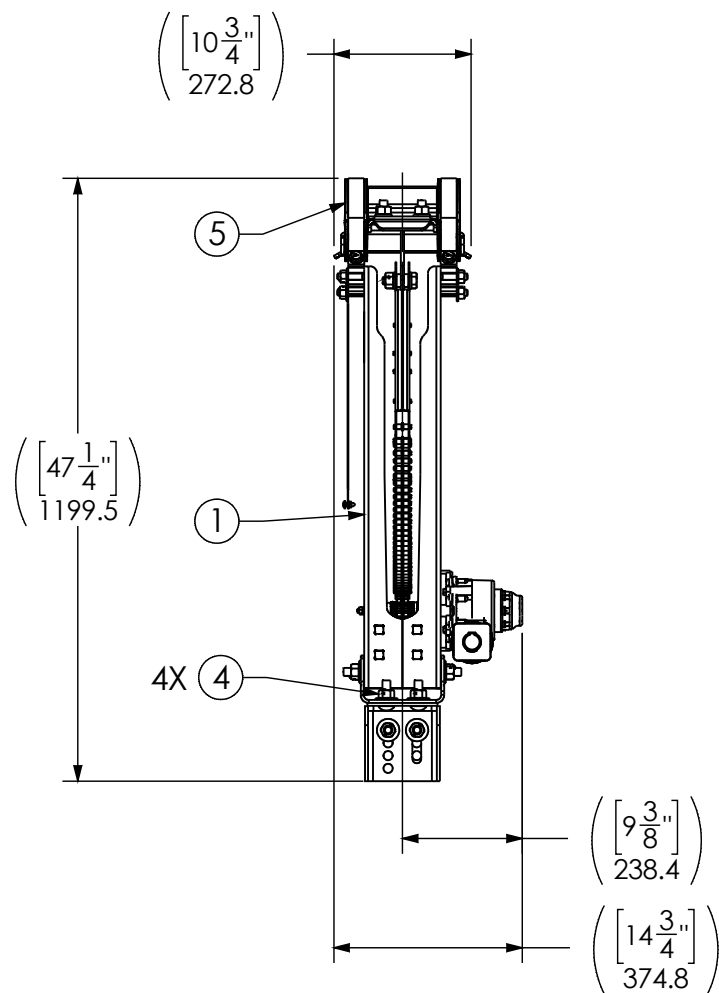
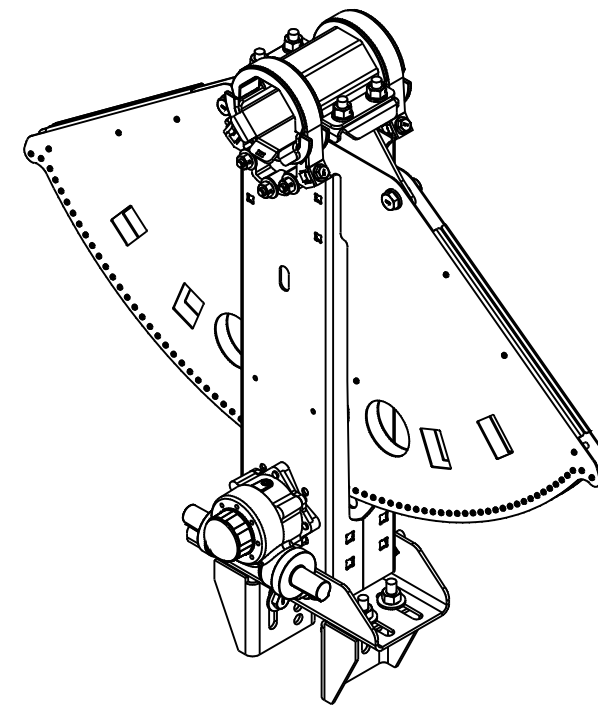

ITEM NO.	PART NUMBER	DESCRIPTION	QTY
1	20725-XXX	Assembly, Center Structure, Drive Column, GCS, L/M/H, Gearbox XX	1
2	20878-XXX	Assembly, Gear Rack, No Logo, GCS 52 deg, 14 Gauge, 90 Flange, L/M/H	1
3	25050-001	Kit, 0.625"-11 x 2" Structural Bolt, Large Washers, Pin Lock Nut, HDG	4
4	25056-001	Kit, 0.625"-11 x 2" Carriage Bolt, Large Washers, Pin Lock Nut, HDG	4
5	25162-000	Kit, Center Structure Bearing, GCS	1
6	25163-XXX	Kit, Weldment, Gear Rack Coupler, XXX, GCS	1
7	30698-000	Bracket I-beam, GCS	2

ZONE	REV	ECR #	DESCRIPTION	DATE
4-D2	W	22191	CORRECTED 60490 BOLT LENGTH	12/19/2022
A6, B6, 4-B3	V	22143	REPLACED 25165-001 WITH 25056-001, UPDATED BOM	9/28/2022
A5, 2-B7, 3-C2, 3-C6, 4-C2	U	22106	UPDATED 25163 FOR -XXX, ADDED WELDMENT CONFIG TABLE AND NOTE 8	7/27/2022

PROPRIETARY AND CONFIDENTIAL THE INFORMATION CONTAINED IN THIS DRAWING IS THE SOLE PROPERTY OF ARRAY TECHNOLOGIES. ANY REPRODUCTION IN PART OR AS A WHOLE WITHOUT THE WRITTEN PERMISSION FROM ARRAY TECHNOLOGIES IS PROHIBITED.	DRAWING STATUS: <b>Final</b>		<b>ARRAY TECHNOLOGIES</b> 3901 Midway Place NE, Albuquerque, NM 87109 (505) 881-7567		
	DRAWN IN: IT, KB, DATE: 01/03/2018 ENG. CHECK IN: IT, BL, DATE: 01/04/2023	DRAWING CHECK IN: IT, DS, DATE: 12/19/2022 FINAL APPROVAL IN: IT, SB, DATE: 1/4/2023	TITLE: <b>Field Assembly, GCS, XX Deg, L/M/H, Gearbox XX</b>		
	THIRD ANGLE PROJECTION <b>TOLERANCES UNLESS OTHERWISE SPECIFIED</b>		ALL DIMS ARE DUAL UNITS: MILLIMETER [INCH], DIMENSIONS IN BRACKETS ARE FOR REFERENCE ONLY.	SIZE B SCALE 1:10	DRAWING NUMBER: 20727-901 REVISION: W SAVED v181: 12/19/2022 SHEET 1 OF 4
	MM [INCH]: X = ±1.25 [0.049] X.X = ±0.4 [0.016] XX = ±0.1 [0.004]	METER [INCH]: X.XXX = ±0.013 [0.512] X.XXX = ±0.006 [0.236]	ANGULAR: X = ±1.0° X = ±0.1°		

8

7

6

5

4

3

2

1

Template\_CF Drawing\_mm\_v5

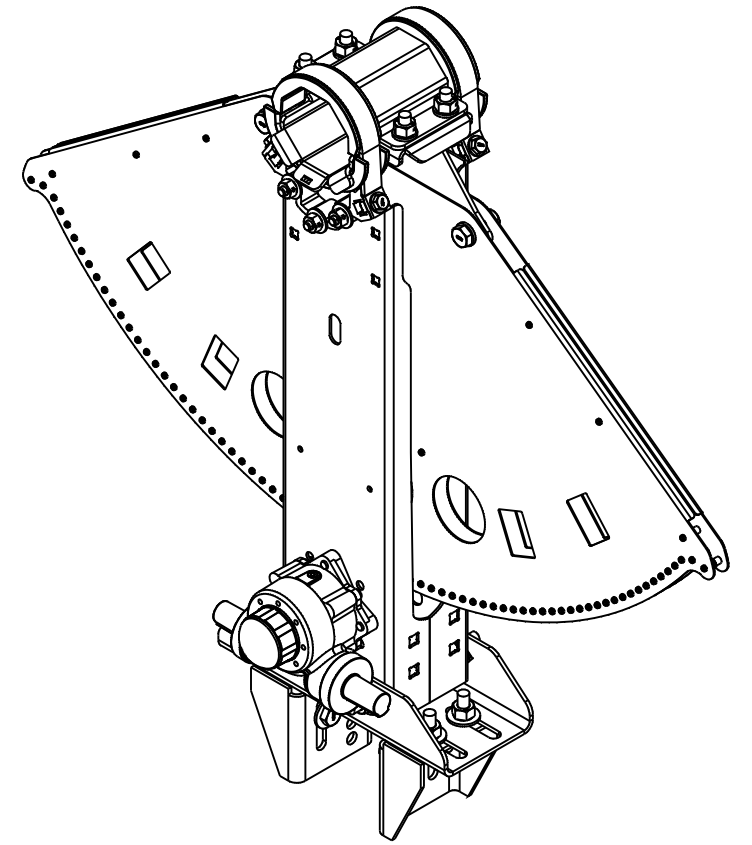

**WELDMENT KIT CONFIGURATION TABLE**

WELDMENT KIT PART NUMBER	WELDMENT KIT DESCRIPTION
25163-000	Kit, Weldment, Gear Rack Coupler, Washers, GCS
25163-001	Kit, Weldment, Gear Rack Coupler, W/O Washers, GCS

**GEAR RACK CONFIGURATION TABLE**

GEAR RACK PART NUMBER	DESCRIPTION
20878-002	Assembly, Gear Rack, No Logo, GCS 52 deg, 14 Gauge, 90 Flange, L
20878-004	Assembly, Gear Rack, No Logo, GCS 52 deg, 14 Gauge, 90 Flange, M/H

**CENTER STRUCTURE CONFIGURATION TABLE**

CENTER STRUCTURE PART NUMBER	DESCRIPTION	SELECTION CRITERIA	
		GEARBOX SELECTION	CORROSION REQUIREMENTS
20725-201	Assembly, Center Structure, Drive Column, GCS, L, Gearbox 01	REGAL	L
20725-202	Assembly, Center Structure, Drive Column, GCS, L, Gearbox 02	KMI	L
20725-301	Assembly, Center Structure, Drive Column, GCS, M, Gearbox 01	REGAL	M
20725-302	Assembly, Center Structure, Drive Column, GCS, M, Gearbox 02	KMI	M
20725-401	Assembly, Center Structure, Drive Column, GCS, H, Gearbox 01	REGAL	H
20725-402	Assembly, Center Structure, Drive Column, GCS, H, Gearbox 02	KMI	H

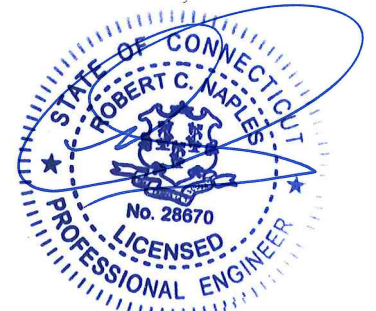

Exp 01/31/2027  
04/13/2026

SIZE B	DRAWING NUMBER 20727-901	REVISION W	SAVED v181 12/19/2022
SCALE 1:25	SHEET		2 OF 4

**NOTES:**

5. ARRAY TORQUE SPECIFICATIONS:

- 5A. 5/8" HEX BOLT 169 ± 14 N-M [125 ± 10 FT-LBS]
- 5B. 5/8" CARRIAGE BOLT 108 ± 14 N-M [80 ± 10 FT-LBS]
- 5C. 5/8" GEAR RACK HEX BOLT 108 ± 14 N-M [80 ± 10 FT-LBS]
- 5D. 1/2" HEX BOLT 81 ± 7 N-M [60 ± 5 FT-LBS]
- 5E. 1/4" CARRIAGE BOLT 8.5 ± 0.5 N-M [75 ± 5 IN-LBS]

6. MARK ALL TORQUED CONNECTIONS USING PAINT MARKER OF CONTRASTING COLOR ACROSS IMMOBILE BASE AND ALL PARTS SUBJECT TO LOOSENING.

7. THE RECOMMENDED SEQUENCE FOR PROPER TIGHTENING OF BOLTS IS CRISS-CROSS PATTERN.

8. HARDWARE KIT CAN BE SUBSTITUTED WITH ALTERNATIVE HARDWARE KIT 25170-002 FOR USE W/O WASHERS.

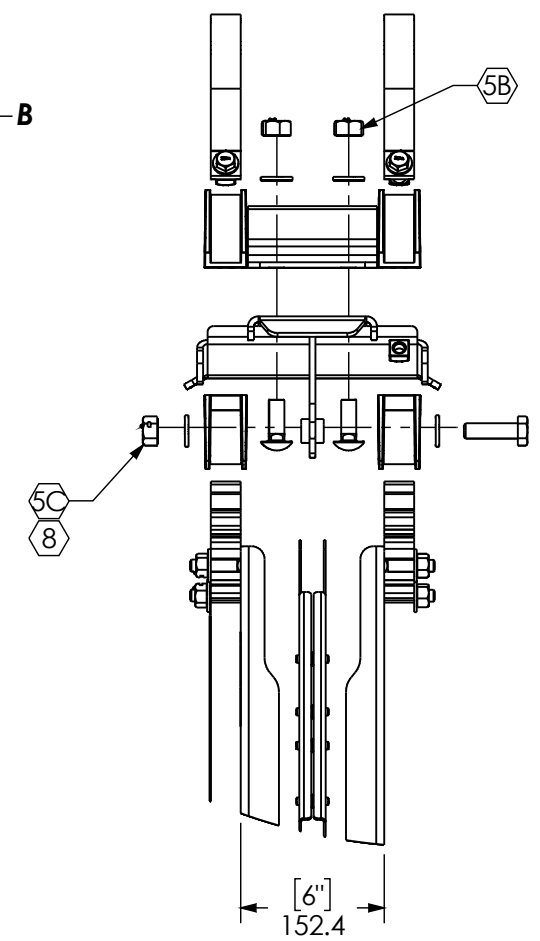
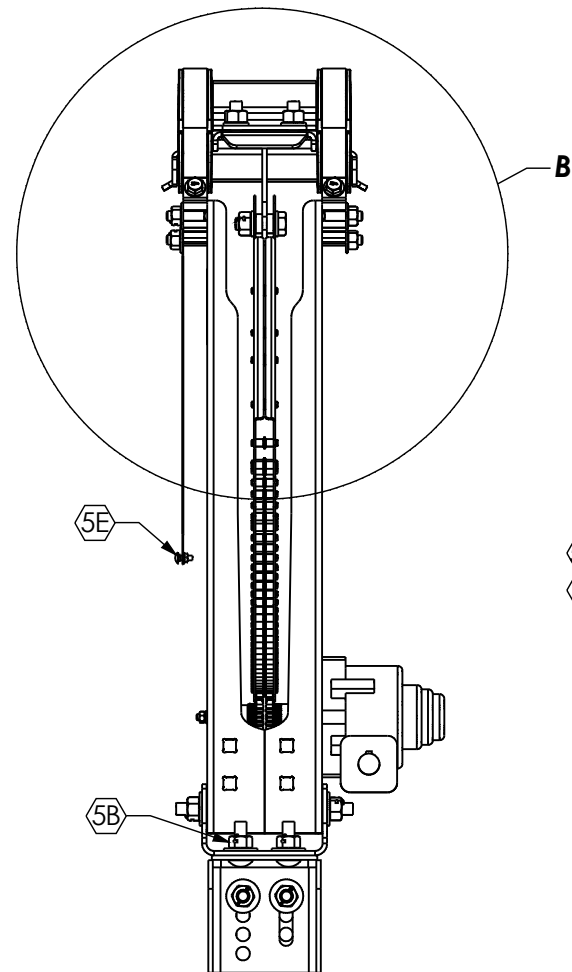
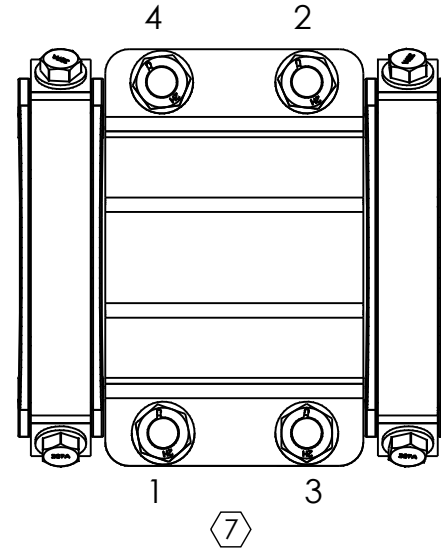

**DETAIL B**

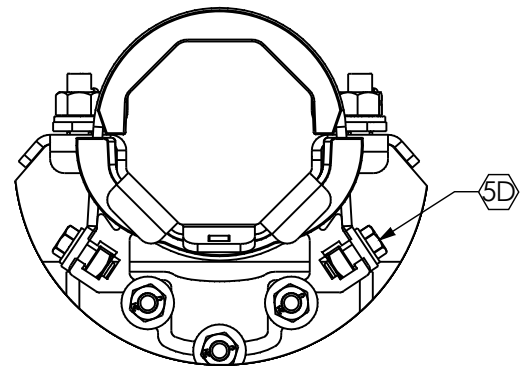

**DETAIL C**

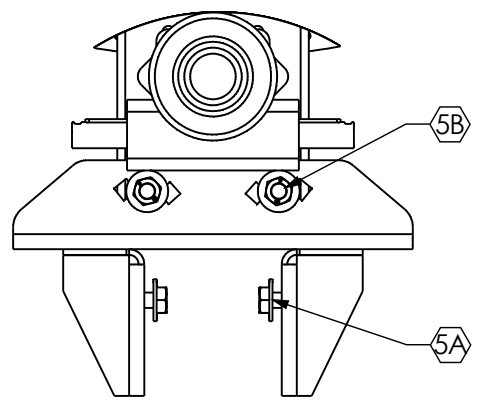

**DETAIL A**

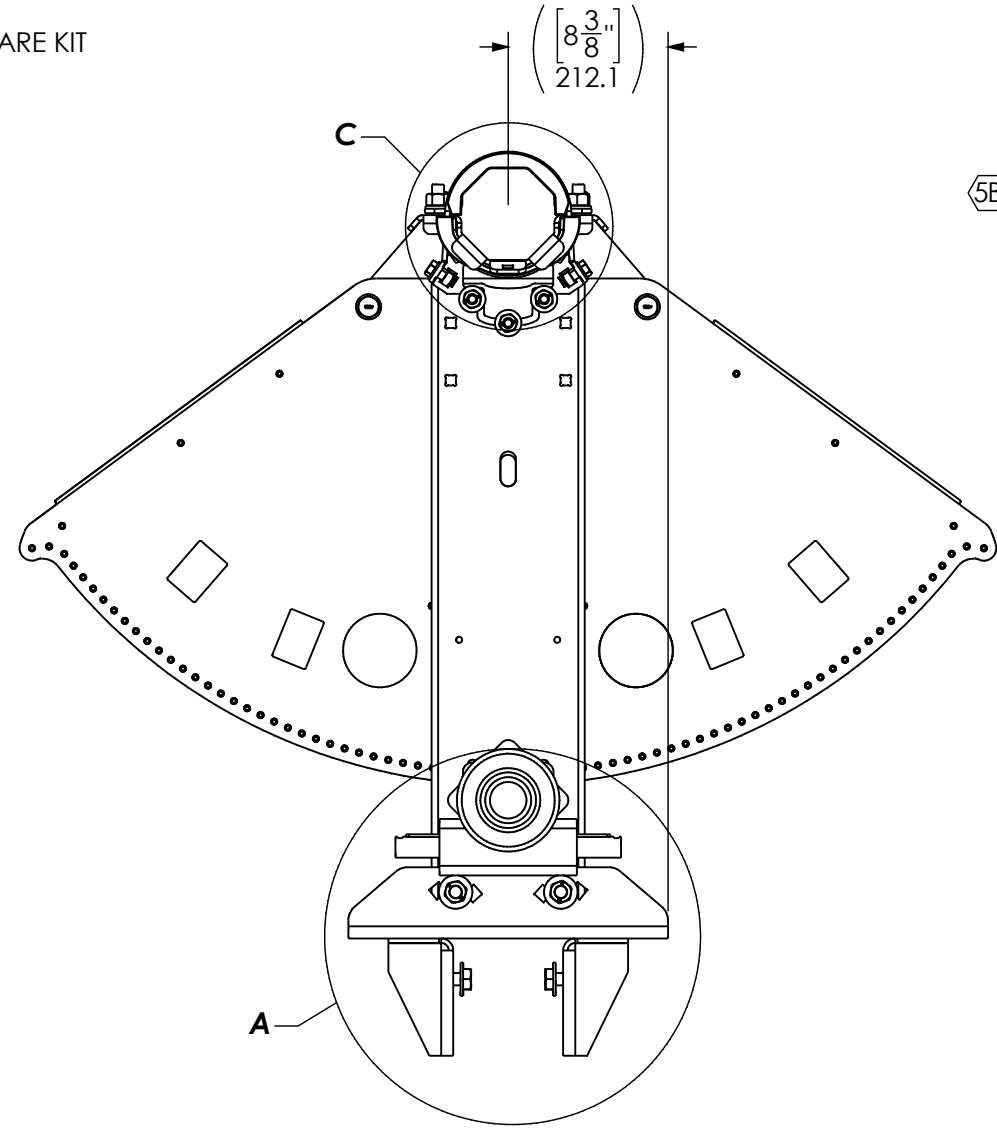

SIZE B	DRAWING NUMBER 20727-901	REVISION W	SAVED v181 12/19/2022
SCALE 1:10	SHEET 3 OF 4		

**NOTES:**

9. CARRIAGE BOLTS ARE SAE GRADE 5 MATERIAL.  
FINISH - HDG

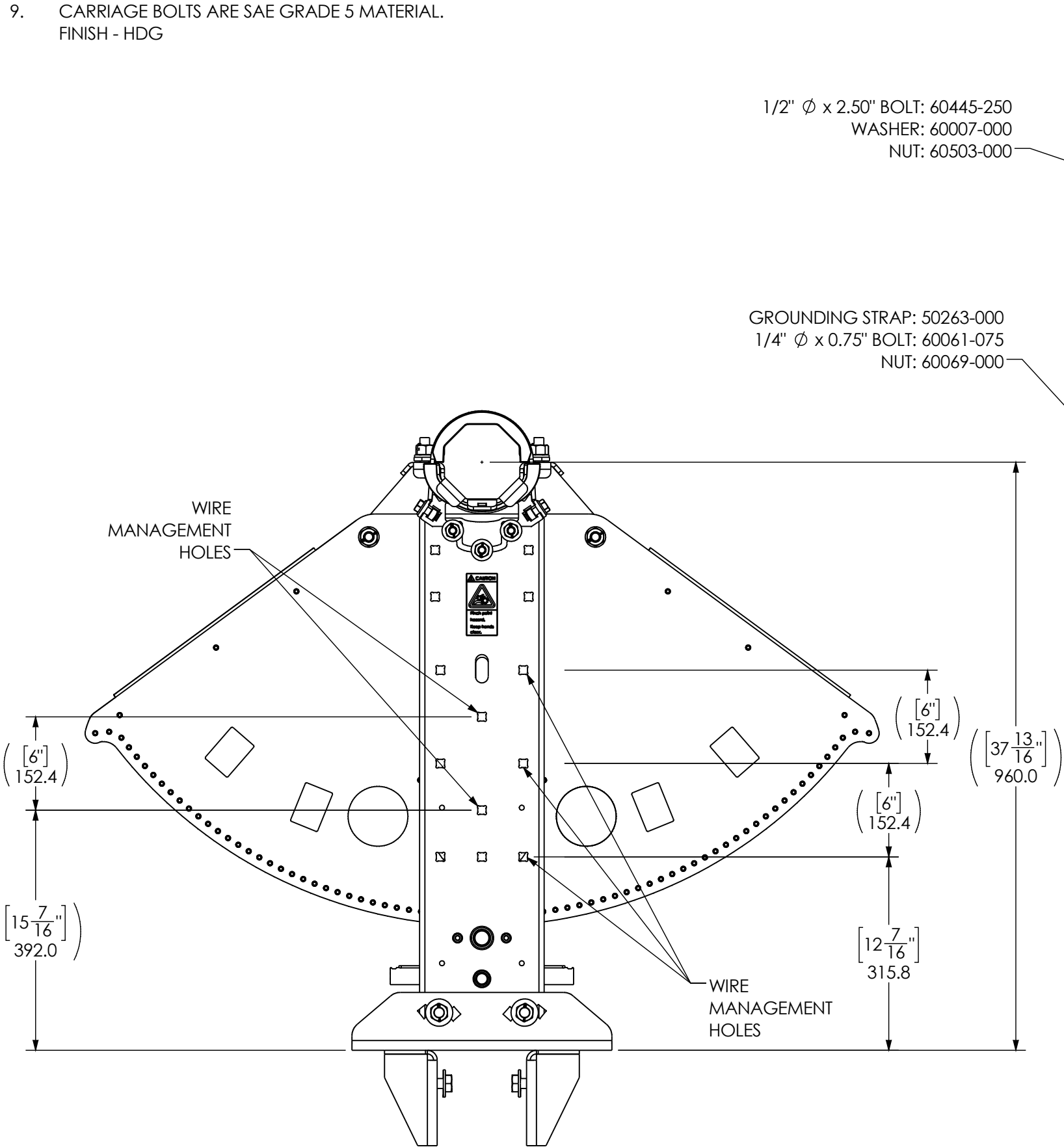

1/2"  $\phi$  x 2.50" BOLT: 60445-250  
WASHER: 60007-000  
NUT: 60503-000

GROUNDING STRAP: 50263-000  
1/4"  $\phi$  x 0.75" BOLT: 60061-075  
NUT: 60069-000

5/8"  $\phi$  x 1.75" BOLT: 60490-175  $\triangle W$   
WASHER: 60451-000  
NUT: 60502-000

1/2"  $\phi$  x 1.25" BOLT: 60358-125  
WASHER: 60006-000  
NUT: 60680-000

2X HARDWARE KIT 25170-001  
5/8"  $\phi$  x 2.25" BOLT: 60125-225  
WASHER: 60451-000  
NUT: 60502-000  
2X ALTERNATIVE HARDWARE KIT: 25170-002  
 $\phi$  5/8" x 2.25" BOLT: 60125-225  
W/O WASHER  
NUT: 60502-000

PER ARRAY DIRECTIVE  
DO NOT USE WASHER  
WITH 25170 BOLT

5/8"  $\phi$  x 2.00" BOLT: 60490-200  
WASHER: 60124-000  
NUT: 60502-000

5/8"  $\phi$  x 2.00" BOLT: 60352-200  
WASHER: 60124-000  
NUT: 60502-000

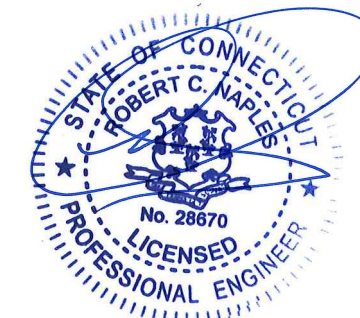

Exp 01/31/2027  
04/13/2026

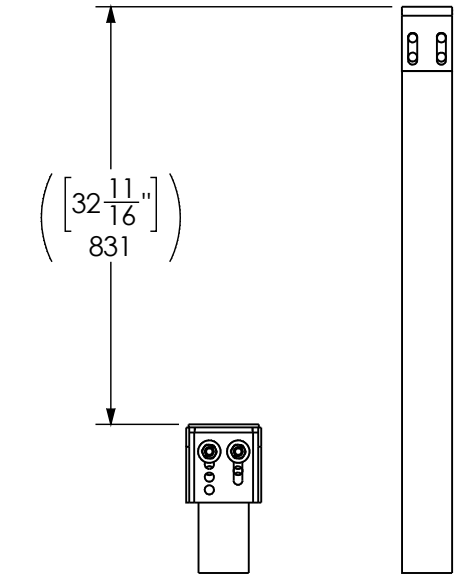
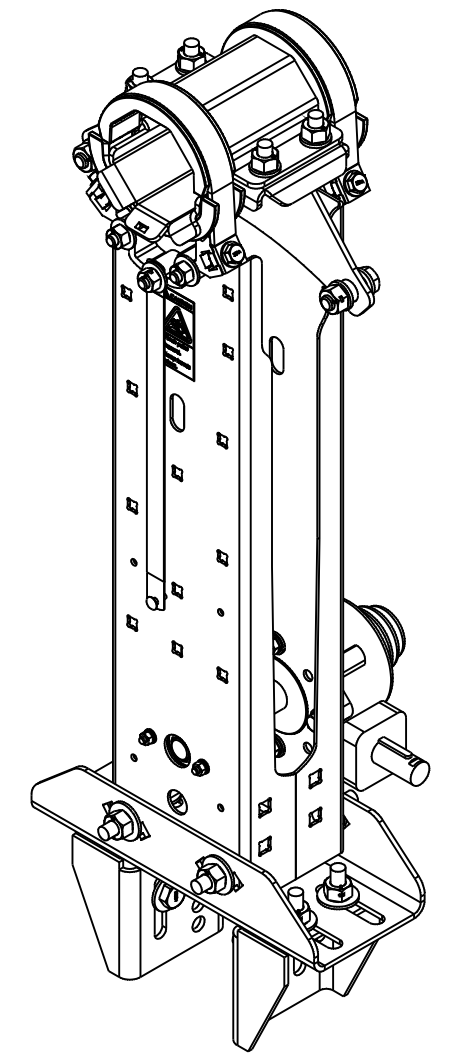

**GEAR RACK COLUMN BRACKET TOP TO BEARING COLUMN BRACKET TOP**

SIZE B	DRAWING NUMBER 20727-901	REVISION W	SAVED v181 12/19/2022
SCALE 1:8	SHEET 4 OF 4		

**NOTES:**

1. REFER TO INSTALLATION MANUAL FOR DETAILS.

2. TORQUE SPECIFICATION:

2A.  $22 \pm 3$  N-M [16  $\pm$  2 FT-LBS]

3. MARK ALL TORQUED CONNECTIONS USING PAINT MARKER OF CONTRASTING COLOR ACROSS IMMOBILE BASE AND ALL PARTS SUBJECT TO LOOSENING.

4. CARRIAGE BOLT FOR CLAMP IS 0.375" DIAMETER, GRADE 2, SAE J429-2011, HDG.

5. CLAMP BRACKETS, EARS, AND END CLAMP SPACERS ARE MADE FROM ALUMINUM ALLOY 6005A/T61 PER ASTM B221 (OR EQUIVALENT PER ARRAY DOCUMENT #90050-000) WITH PLAIN FINISH.

6. TORQUE TUBE END PLUGS MADE FROM LDPE, PE100LD-2M ARE OPTIONAL.

7. REFER TO SHIPPING MANIFEST FOR CORRECT END CLAMP SPACER PART NUMBER.

ARRAY PART NUMBER DESIGNATION

**20844-XXX**

ARRAY PART NUMBER EXTENSION NUMBER INDICATES MODULE THICKNESS IN MM

ARRAY PART NUMBER

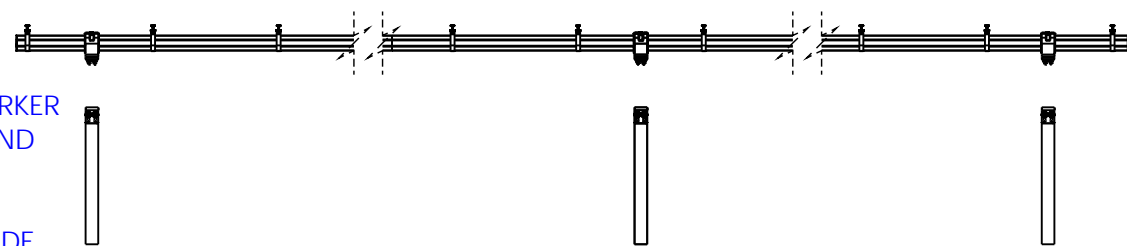

EXPLODED VIEW

7. END CLAMP SPACER 2A. 1X PER CLAMP

OPTIONAL END PLUG

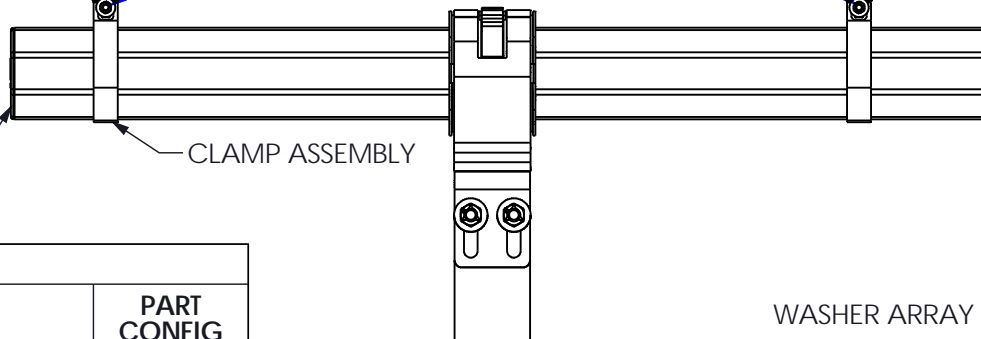

INSTALLED DETAIL

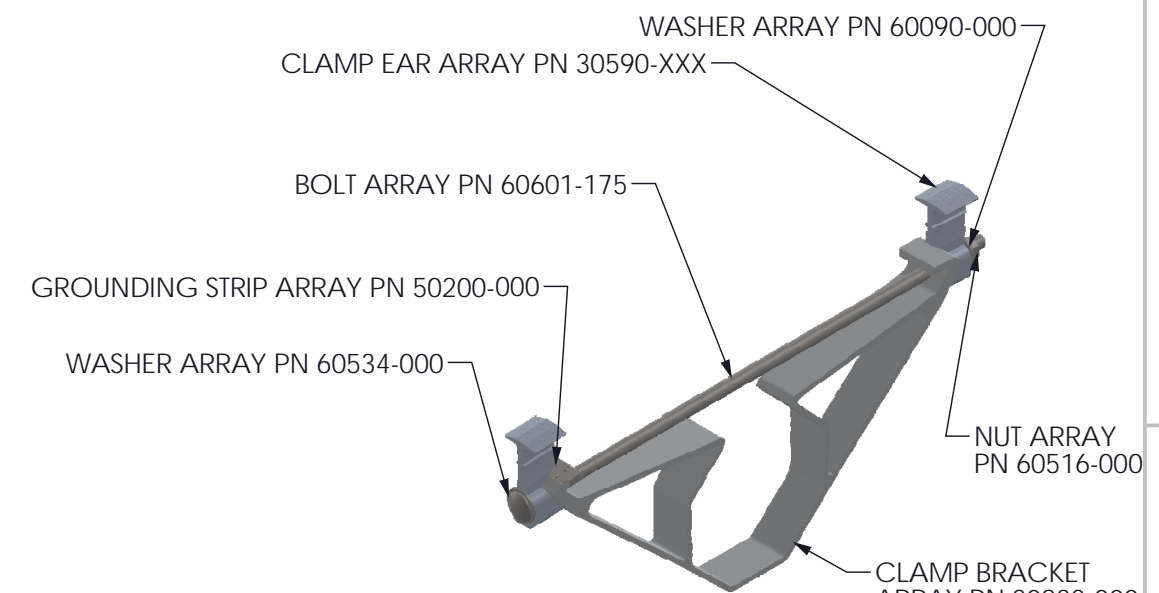

C1 THRU C3 CLAMP ASSEMBLY ARRAY PN 20834-XXX

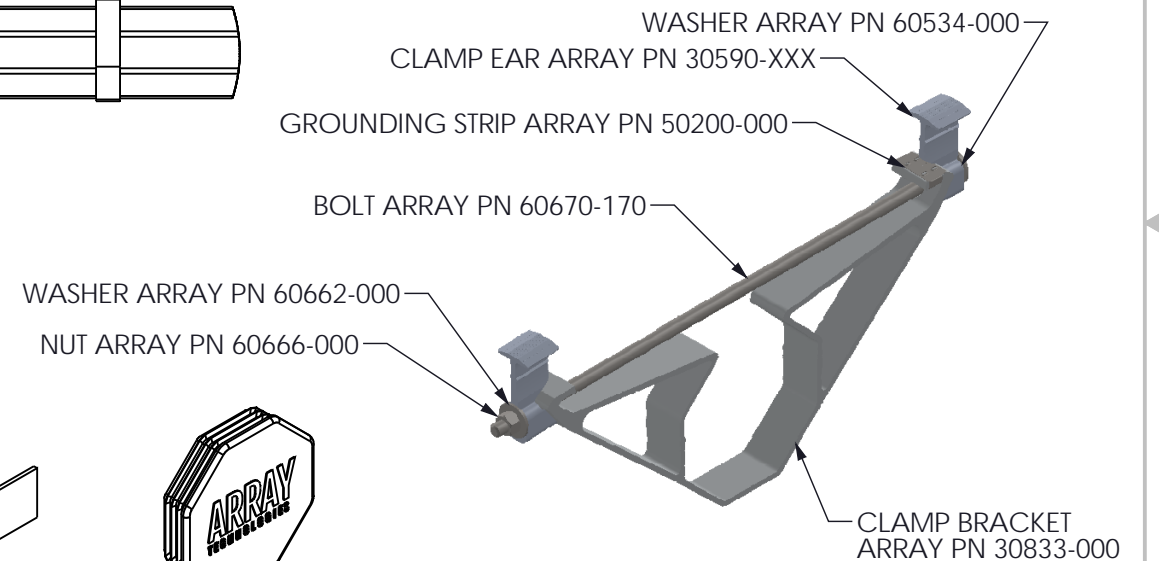

C4 CLAMP ASSEMBLY ARRAY PN 20849-XXX

**CONFIGURATION TABLE**

ASSEMBLY EXTENSION	PART DESCRIPTION	PART CONFIG
20844-025	Field Assembly, Octagonal Clamp, Thin, 400mm High Rises x 21-25mm Wide Range Module Ear, Grounded	20834-025
20844-030	Field Assembly, Octagonal Clamp, Thin, 400mm High Rises x 26-30mm Wide Range Module Ear, Grounded	20834-030
20844-035	Field Assembly, Octagonal Clamp, Thin, 400mm High Rises x 31-35mm Wide Range Module Ear, Grounded	20834-035
20844-040	Field Assembly, Octagonal Clamp, Thin, 400mm High Rises x 36-40mm Wide Range Module Ear, Grounded	20834-040
20844-045	Field Assembly, Octagonal Clamp, Thin, 400mm High Rises x 41-45mm Wide Range Module Ear, Grounded	20834-045
20844-050	Field Assembly, Octagonal Clamp, Thin, 400mm High Rises x 46-50mm Wide Range Module Ear, Grounded	20834-050
20844-055	Field Assembly, Octagonal Clamp, Thin, 400mm High Rises x 51-55mm Wide Range Module Ear, Grounded	20834-055
20844-125	Field Assembly, Octagonal Clamp, Thin, 400mm High Rises x 21-25mm Wide Range Module Ear, Grounded, C4	20849-025
20844-130	Field Assembly, Octagonal Clamp, Thin, 400mm High Rises x 26-30mm Wide Range Module Ear, Grounded, C4	20849-030
20844-135	Field Assembly, Octagonal Clamp, Thin, 400mm High Rises x 31-35mm Wide Range Module Ear, Grounded, C4	20849-035
20844-140	Field Assembly, Octagonal Clamp, Thin, 400mm High Rises x 36-40mm Wide Range Module Ear, Grounded, C4	20849-040
20844-145	Field Assembly, Octagonal Clamp, Thin, 400mm High Rises x 41-45mm Wide Range Module Ear, Grounded, C4	20849-045
20844-150	Field Assembly, Octagonal Clamp, Thin, 400mm High Rises x 46-50mm Wide Range Module Ear, Grounded, C4	20849-050
20844-155	Field Assembly, Octagonal Clamp, Thin, 400mm High Rises x 51-55mm Wide Range Module Ear, Grounded, C4	20849-055

ITEM NO.	PART NUMBER	DESCRIPTION	20844-0XX	20844-1XX
1	60459-000	Plug, End, Torque Tube, Octagon, Polyethylene (Optional)	1	1
2	20834-XXX	Assembly, Octagonal Clamp, Thin, 400mm Hi Rise, x XXmm Wide Range Module Ear, Grounded	1	
3	20849-XXX	Assembly, Octagonal Clamp, Thin, 400mm Hi Rise, x XXmm Wide Range Module Ear, Grounded, C4		1

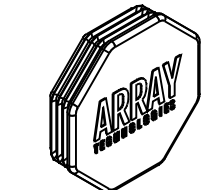
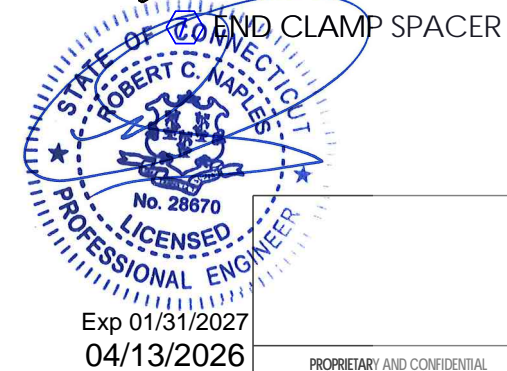

OPTIONAL END PLUG ARRAY PN 60459-000

DRAWING STATUS: <b>Final</b>	
DRAWN: KM DATE: 03/12/2019	DRAWING CHECK: DO DATE: 1/29/2020
ENG. CHECK: SB DATE: 1/29/2020	FINAL APPROVAL: SB DATE: 1/29/2020
THIRD ANGLE PROJECTION	
TOLERANCES UNLESS OTHERWISE SPECIFIED	
MM [INCH]: X = ±1.25 [0.050], X.X = ±0.4 [0.015], .XX = ±0.1 [0.004]	METER [INCH]: X.XX = ±0.013 [0.500], X.XXX = ±0.006 [0.250]
ANGULAR: X = ±1.0°, .X = ±0.1°	

ZONE	REV	ECR #	DESCRIPTION	DATE
A2, B3, B4	D	19154	END PLUG OPTIONAL	1/20/2020
A3	C	19092	CORRECTED CONFIGS C4 125 THRU 155	7/25/2019
A1, A3	B	19057	ADDED CONFIGURATION C4	4/25/2019
A	A	19040	INITIAL RELEASE	3/13/2019

**ARRAY TECHNOLOGIES**  
3901 Midway Place NE, Albuquerque, NM 87109  
(505) 881-7567

**Field Assembly, Octagonal Clamp, 400mm, x XXmm Wide Range Module Ear, Grounded**

SIZE B	DRAWING NUMBER: 20844-901	REVISION: D-01	SAVED v41: 1/20/2020
SCALE: 1:96	WT: 545.06 KG [1210.03 LB]	SHEET 1 OF 1	

PROPRIETARY AND CONFIDENTIAL  
THE INFORMATION CONTAINED IN THIS DRAWING IS THE SOLE PROPERTY OF ARRAY TECHNOLOGIES. ANY REPRODUCTION IN PART OR AS A WHOLE WITHOUT THE WRITTEN PERMISSION FROM ARRAY TECHNOLOGIES IS PROHIBITED.

**NOTES:**

- REFER TO INSTALLATION MANUAL FOR DETAILS.
- TORQUE SPECIFICATION:  
2A 22±3 N-M [16±2 FT-LBS]
- MARK ALL TORQUED CONNECTIONS USING PAINT MARKER OF CONTRASTING COLOR ACROSS IMMOBILE BASE AND ALL PARTS SUBJECT TO LOOSENING.
- CARRIAGE BOLT FOR CLAMP IS 0.375" DIAMETER, GRADE 2, SAE J429-2011.
- CLAMP BRACKETS AND RAPIDCLAMP EARS ARE MADE FROM ALUMINUM ALLOY 6005A/T61 PER ASTM B221 (OR EQUIVALENT PER ARRAY DOCUMENT #90050-000) WITH PLAIN FINISH.
- REFER TO ARRAY DOCUMENT 90103-000 FOR ADDITIONAL MODULE INSTALLATION INSTRUCTIONS.

\*\*Rapid Clamps do NOT require a Grounding Clip

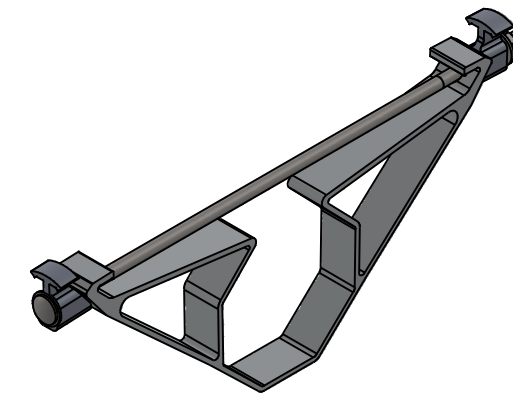
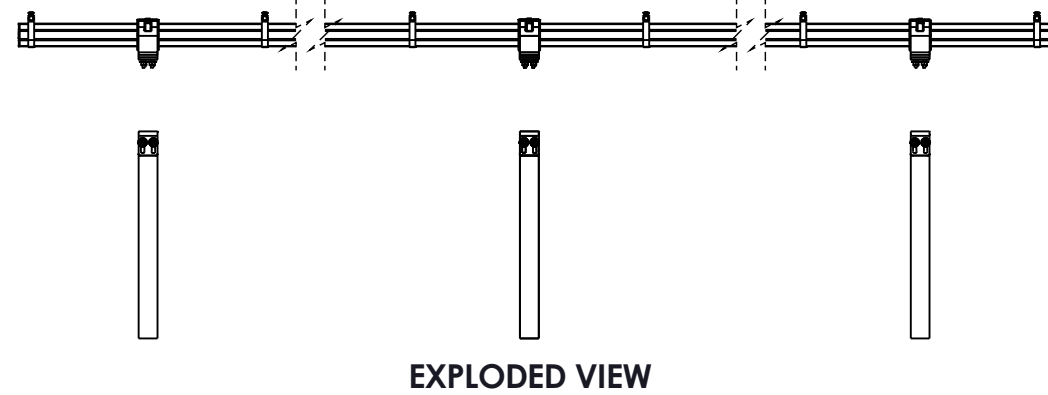

**RAPIDCLAMP ASSEMBLY  
ARRAY PN 20871-XXX (L/M/H)**

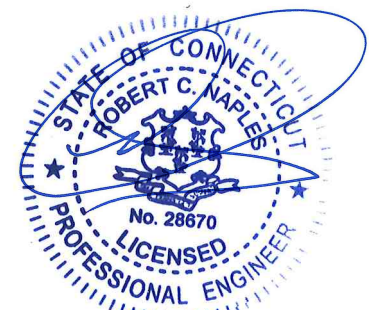

Exp 01/31/2027  
04/13/2026

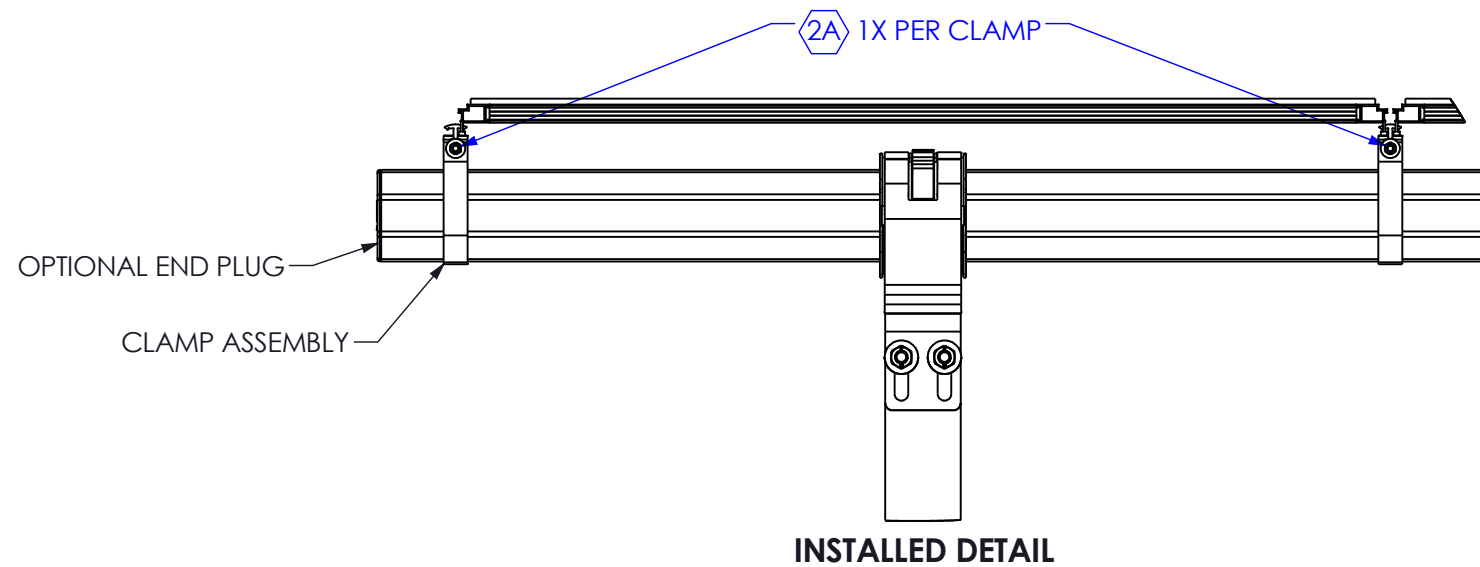

ZONE	REV	ECR #	DESCRIPTION	DATE
2-A1	D	21131	ADDED SHEET 2 AND ALL NEW VIEWS	8/24/2021
A4	C	20160 20264	WASHER REPLACED IN SUBASSEMBLY. END PLUG PN REMOVED. MODULE CORRECTED	11/23/2020
A1, A3	B	20220	CORROSION DESIGNATION UPDATE	5/20/2020

CONFIGURATION TABLE	
PART NUMBER	DESCRIPTION
20871-300	Assembly, Octagonal RapidClamp, 400mm Hi Rise, FS6, L/M
20871-400	Assembly, Octagonal RapidClamp, 400mm Hi Rise, FS6, H

PROPRIETARY AND CONFIDENTIAL THE INFORMATION CONTAINED IN THIS DRAWING IS THE SOLE PROPERTY OF ARRAY TECHNOLOGIES. ANY REPRODUCTION IN PART OR AS A WHOLE WITHOUT THE WRITTEN PERMISSION FROM ARRAY TECHNOLOGIES IS PROHIBITED.		DRAWING STATUS: <b>Final</b> DRAWN: RM DATE: 01/24/2020 ENG. CHECK: DO DATE: 10/05/2021 DRAWING CHECK: NC DATE: 9/2/2021 FINAL APPROVAL: SB DATE: 10/5/2021		ARRAY TECHNOLOGIES 3901 Midway Place NE, Albuquerque, NM 87109 (505) 881-7567	
THIRD ANGLE PROJECTION TOLERANCES UNLESS OTHERWISE SPECIFIED MM [INCH]: X = ±1.25 [0.049] .X = ±0.4 [0.016] .XX = ±0.1 [0.004]		ALL DIMS ARE DUAL UNITS: MILLIMETER [INCH]. DIMENSIONS IN BRACKETS ARE FOR REFERENCE ONLY. METER [INCH]: X.XX = ±0.013 [0.512] X.XXX = ±0.006 [0.236]		TITLE: <b>Field Assembly, Octagonal RapidClamp, 400mm Hi Rise, FS6, L/M/H</b> SIZE: B DRAWING NUMBER: 20872-901 REVISION: D SAVED v40: 9/22/2021 SCALE: 1:96 SHEET: 1 OF 2	

4 4 3 3 2 2 1 1

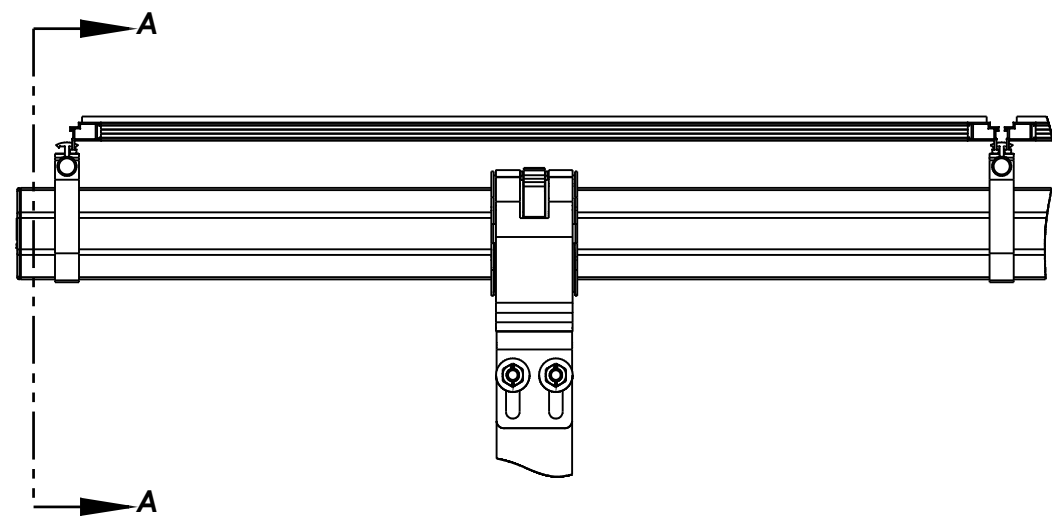

MOUNTING HOLE FLAT SURFACE IN FRAME IS TO SIT AGAINST THE FLAT SURFACE UNDER THE EAR

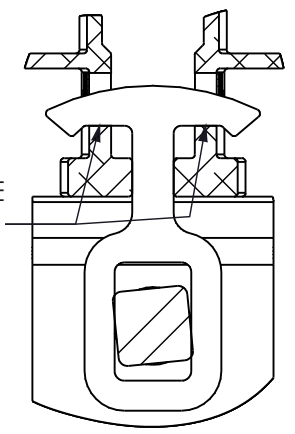

SECTION B-B

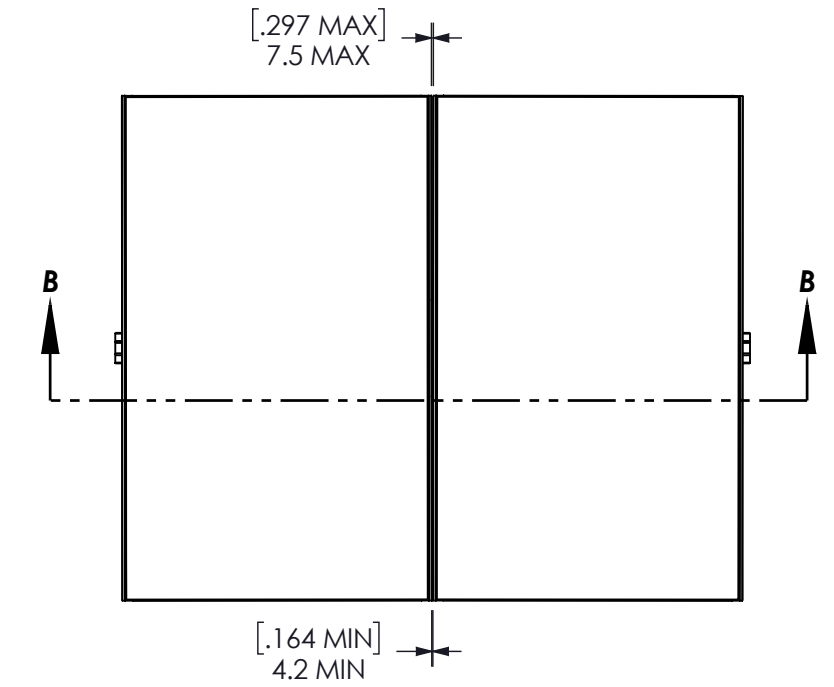

FS6 MODULE FRAME  
NON-PARALLEL MOUNTING ALLOWANCE

BRACKET IS TO COMPRESS EVENLY AROUND TORQUE TUBE. SLIGHT GAPS BETWEEN CERTAIN CLAMP ARMS ARE POSSIBLE.

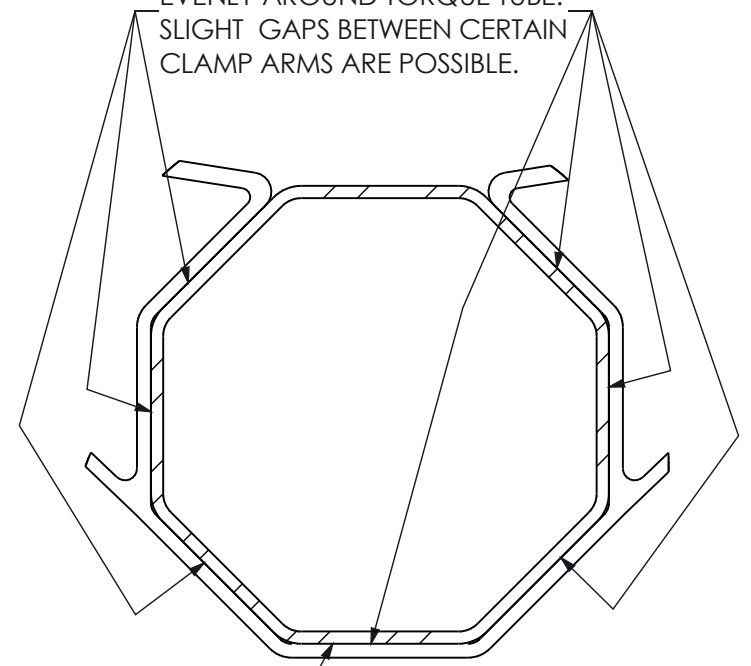

CLAMP AND TORQUE TUBE FACE MUST BE PARALLEL IF NOT IN FULL CONTACT

SECTION A-A  
COMPONENTS REMOVED FOR CLARITY

MOUNTING HOLE FLAT SURFACE IN FRAME IS TO SIT AGAINST THE FLAT SURFACE UNDER THE EAR

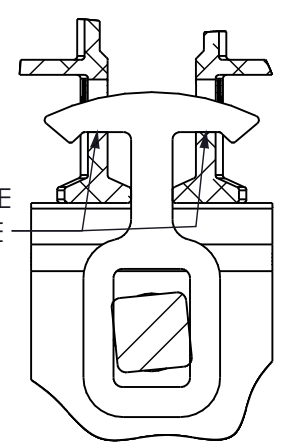

SECTION C-C

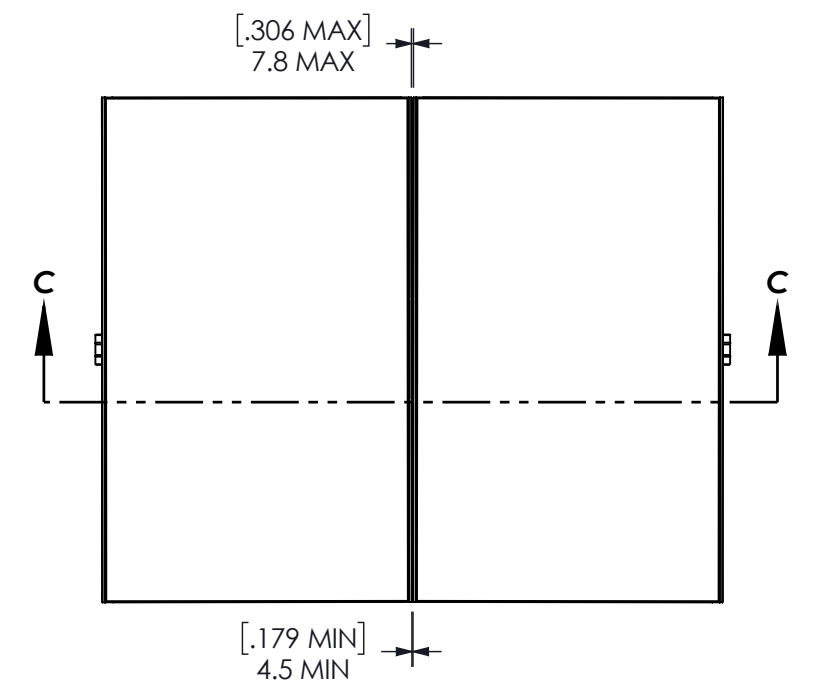

FS6+ MODULE FRAME  
NON-PARALLEL MOUNTING ALLOWANCE



Exp 01/31/2027  
04/13/2026

SIZE B	DRAWING NUMBER 20872-901	REVISION D	SAVED v40 9/22/2021
SCALE 1:30	SHEET 2 OF 2		

4 4 3 3 2 2 1 1

**NOTES:**

1. REFER TO INSTALLATION MANUAL ADDENDUM 90129-000 FOR ADDITIONAL DETAILS.
2. TORQUE SPECIFICATION:
  - 2A. INSTALLATION TORQUE: 19.0 +/- 1.5 N-M [14.0 +/- 1.0 FT-LBS]
  - INSPECTION TORQUE: MUST STAY ABOVE 12.2 N-M [9.0 FT-LBS]
  - TORQUE INSPECTION MUST OCCUR 24 HRS (MINIMUM) AFTER INITIAL INSTALLATION.
3. MARK ALL TORQUED CONNECTIONS USING PAINT MARKER OF CONTRASTING COLOR ACROSS IMMOBILE BASE AND ALL PARTS SUBJECT TO LOOSENING.
4. CARRIAGE BOLT FOR CLAMP IS 0.375" DIAMETER, GRADE 2, SAE J429-2011.
5. CLAMP BRACKETS AND EARS ARE MADE FROM ALUMINUM ALLOY 6005A/T61 PER ASTM B221 (OR EQUIVALENT PER ARRAY DOCUMENT #90050-000) WITH PLAIN FINISH.
6. THE EAR IS DESIGNED TO HOLD FS6, FS6+ INTERIOR, AND FS6+ EXTERIOR MODULES.
7. END CLAMP SPACER REQUIRED AT THE ENDS OF EVERY ROW AND AT ANY MODULE GAPS WITHIN THE ROW.

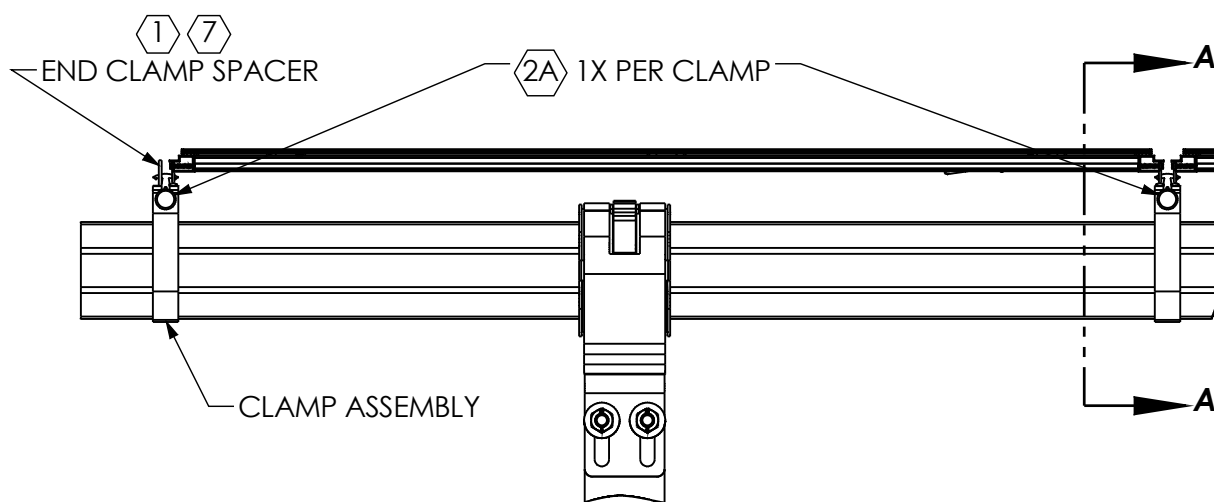

**INSTALLED DETAIL**

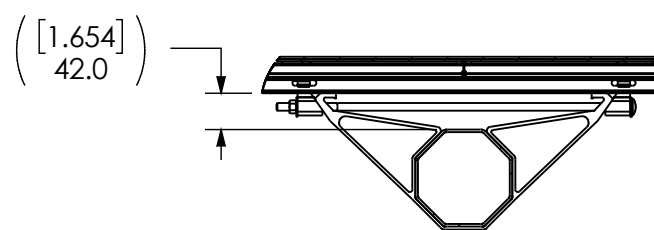

**SECTION A-A  
42mm DESIGN OFFSET**

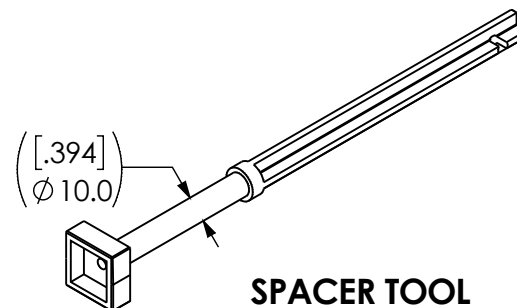

**SPACER TOOL  
60909-100**

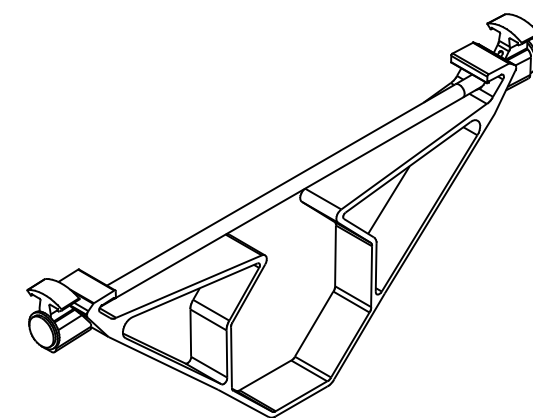

**RAPIDCLAMP ASSEMBLY (L/M/H)  
20992-XXX**

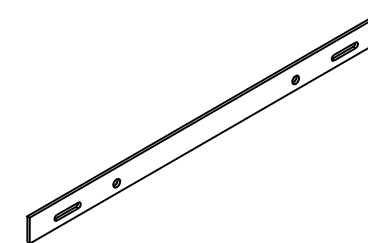

**END CLAMP SPACER  
30956-XXX**



**RAPID CLAMP ALIGNMENT TOOL  
60868-000**

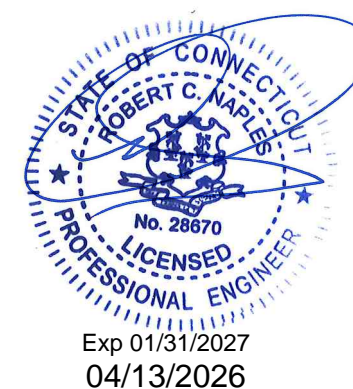

END CLAMP SPACER CONFIGURATION TABLE		
PART NUMBER	DESCRIPTION	SELECTION CRITERIA CORROSION GROUP
30956-200	Plate, End Clamp Spacer, RapidClamp, L	L
30956-400	Plate, End Clamp Spacer, RapidClamp, M/H	M/H

MODULE CLAMP CONFIGURATION TABLE		
PART NUMBER	DESCRIPTION	SELECTION CRITERIA CORROSION GROUP
20992-300	Assembly, Octagonal Clamp, RapidClamp, 400mm Hi Rise, 10mm, L/M	L/M
20992-400	Assembly, Octagonal Clamp, RapidClamp, 400mm Hi Rise, 10mm, H	H

ZONE	REV	ECR #	DESCRIPTION	ENGR	DATE
2-A2, 2-C2, 2-C3	G	US-24171	UPDATED DIMS ON SHEET 2	MK	12/16/2024
A7, B1, B4, B8, C6	F	US-24039	UPDATED NOTE 6 AND TABLE, ADDED VIEWS AND TABLE	MK	04/09/2024
2-A2, 2-C2, 2-C3	E	US-23015	ADDED APPLICABLE TRACKER SYSTEM, ADDED TRACKER SYSTEM SPECIFIC MODULE MOUNTING ALLOWANCE VALUES		2/14/2023

**APPLICABLE TRACKER SYSTEMS:**  
DuraTrack  
OmniTrack

**PROPRIETARY AND CONFIDENTIAL:**  
THE INFORMATION CONTAINED IN THIS DRAWING IS THE SOLE PROPERTY OF ARRAY TECHNOLOGIES. ANY REPRODUCTION IN PART OR AS A WHOLE WITHOUT THE WRITTEN PERMISSION FROM ARRAY TECHNOLOGIES IS PROHIBITED.

**DRAWING STATUS**  
**Final**

DRAWN: DS DATE: 03/18/2022  
ENG. CHECK: DS DATE: 03/08/2023  
DRAWING CHECK: DS DATE: 3/7/2023  
FINAL APPROVAL: SB DATE: 3/7/2023

THIRD ANGLE PROJECTION

TOLERANCES UNLESS OTHERWISE SPECIFIED

MM [INCH]: X = ±1.25 [0.049] .X = ±0.4 [0.016] .XX = ±0.1 [0.004]	METER [INCH]: X.XX = ±0.013 [0.512] X.XXX = ±0.006 [0.236]	ANGULAR: X = ±1.0° .X = ±0.1°
----------------------------------------------------------------------------	------------------------------------------------------------------	-------------------------------------

**ARRAY TECHNOLOGIES**  
3901 Midway Place NE, Albuquerque, NM 87109  
(505) 881-7567

**TITLE**  
**Field Assembly, Octagonal Clamp, RapidClamp, 400mm Hi Rise, 10mm, L/M/H**

SIZE <b>B</b>	DRAWING NUMBER 20993-901	REVISION G	SAVED v72 12/16/2024
SCALE 1:96	SHEET 1 OF 2		

Template\_CF Drawing\_mm\_v6

8 7 6 5 4 3 2 1

D

D

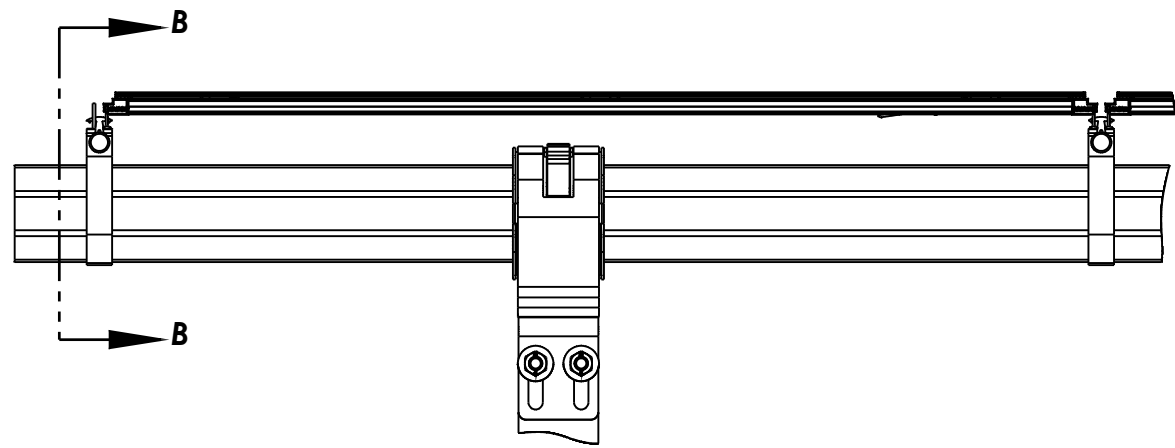

CLAMP EAR FLAT MUST FULLY SIT ON THE FLAT OF THE MODULE SLOT

① ⑥

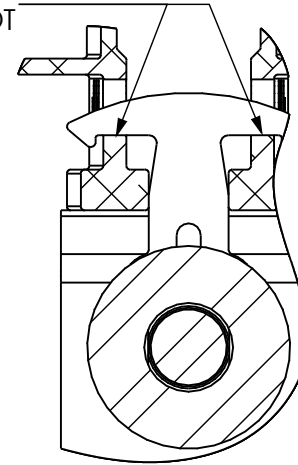

SECTION C-C

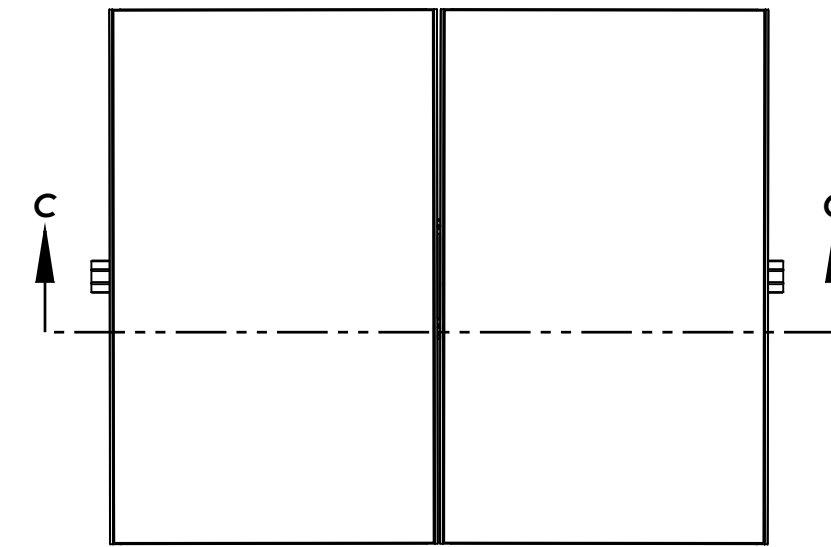

① DIM "A" MIN

FS6 MODULE FRAME  
NON-PARALLEL MOUNTING ALLOWANCE

BRACKET IS TO COMPRESS EVENLY AROUND TORQUE TUBE. SLIGHT GAPS BETWEEN CERTAIN CLAMP ARMS ARE POSSIBLE.

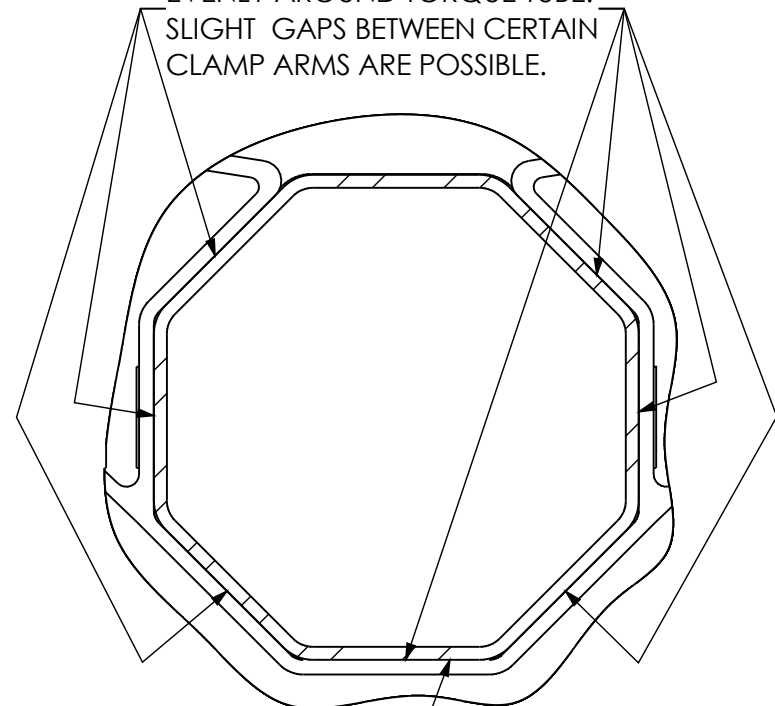

CLAMP AND TORQUE TUBE FACE MUST BE PARALLEL IF NOT IN FULL CONTACT

SECTION B-B  
COMPONENTS REMOVED FOR CLARITY

CLAMP EAR FLAT MUST FULLY SIT ON THE FLAT OF THE MODULE SLOT

① ⑥

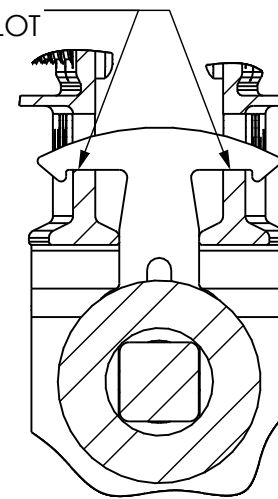

SECTION D-D

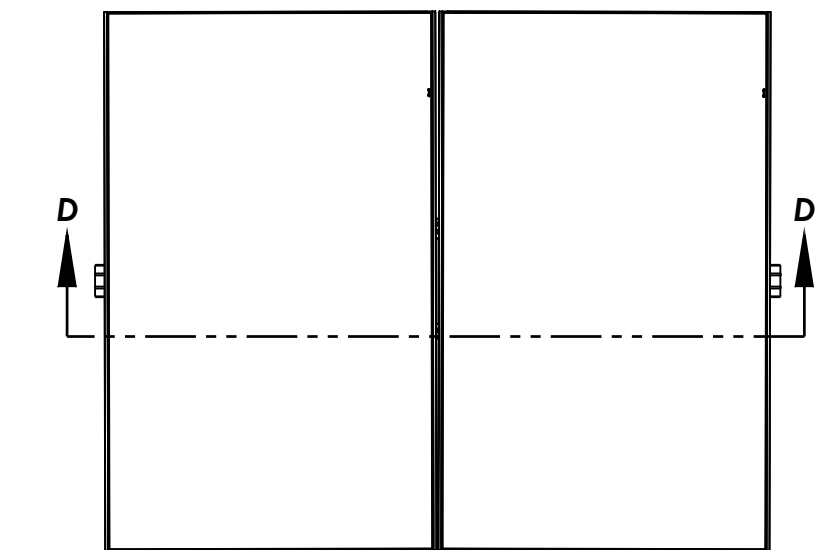

① DIM "A" MIN

FS6+ MODULE FRAME  
NON-PARALLEL MOUNTING ALLOWANCE

TRACKER SYSTEM	DIM "A" MIN mm [in]
DURATRACK	5.0 [0.197]
OMNITRACK	7.0 [0.276]

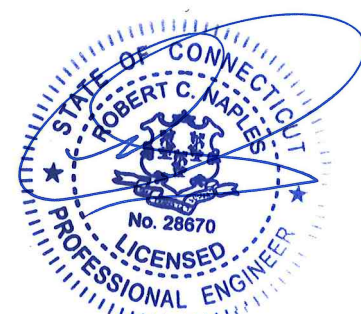

Exp 01/31/2027  
04/13/2026

C

C

B

B

A

A

8 7 6 5 4 3 2 1

SIZE B	DRAWING NUMBER 20993-901	REVISION G	SAVED v72 12/16/2024
SCALE 1:30	SHEET 2 OF 2		

**NOTES:**

- REFER TO INSTALLATION MANUAL FOR DETAILS.
- TORQUE SPECIFICATION:
  - 2A. 25.8±1.5 N-M [19.0±1.0 FT-LBS]
  - 2B. 17.5±1.5 N-M [12.9±1.0 FT-LBS]
- MARK ALL TORQUED CONNECTIONS USING PAINT MARKER OF CONTRASTING COLOR ACROSS IMMOBILE BASE AND ALL PARTS SUBJECT TO LOOSENING.
- REFER TO ARRAY INSTALLATION ADDENDUM 90140-000 FOR ADDITIONAL MODULE INSTALLATION INSTRUCTIONS.
- THE EAR IS DESIGNED TO HOLD FS6 AND FS6+ EXTERIOR MODULES.
- END CLAMP SPACER 30976-XXX REQUIRED AT THE ENDS OF EVERY ROW AND AT ANY MODULE GAPS WITHIN THE ROW; REFER TO INSTALLATION ADDENDEUM 90140-000 FOR INSTALLATION.
- REFER TO INSTALLATION ADDENDUM 90140-000 FOR INFORMATION ON MODULE GAP ALIGNMENT TOOLS AND THEIR USAGE.

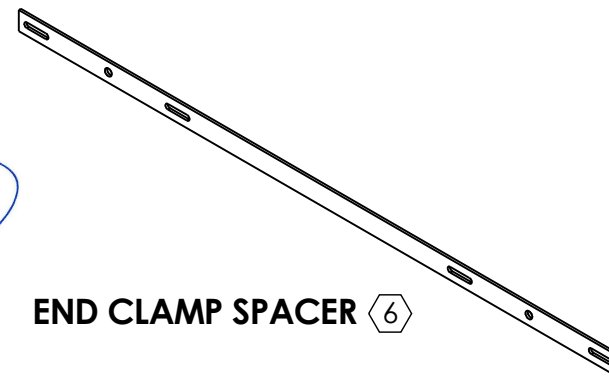
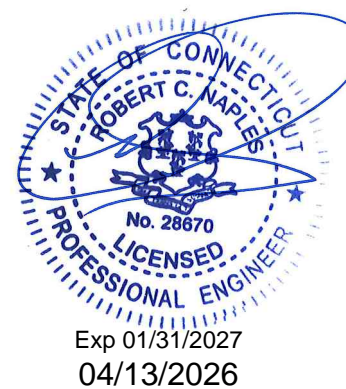
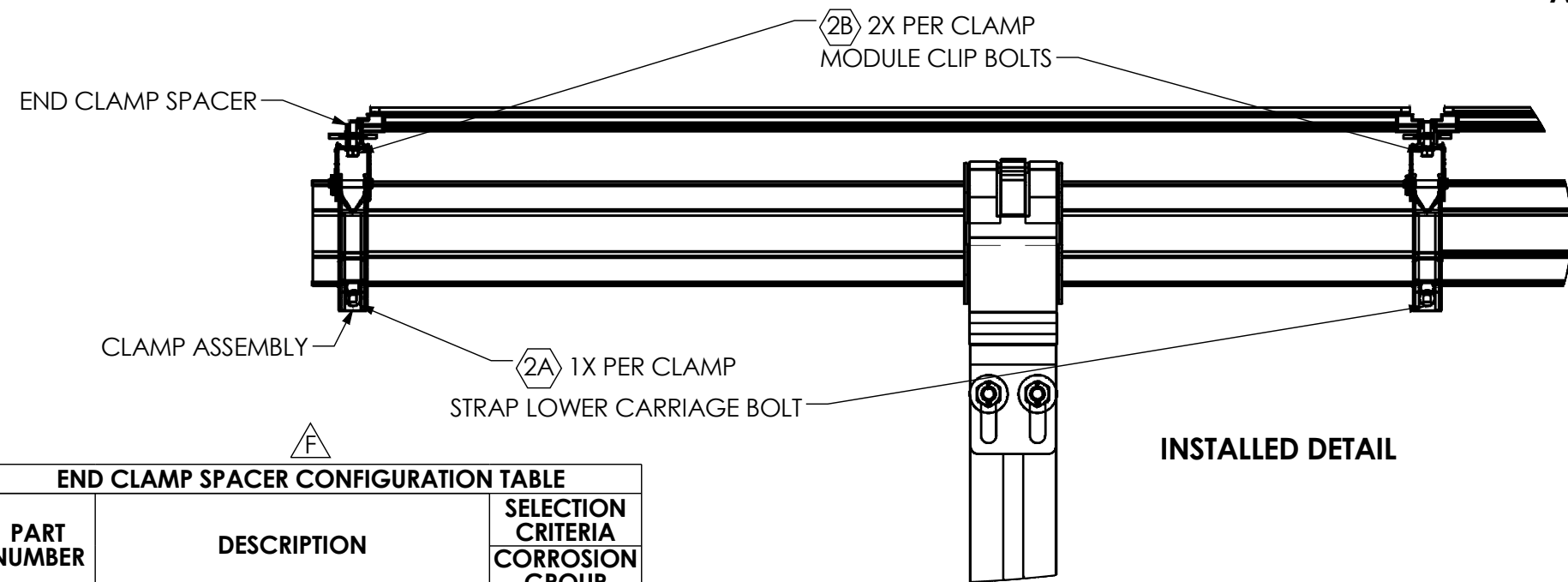
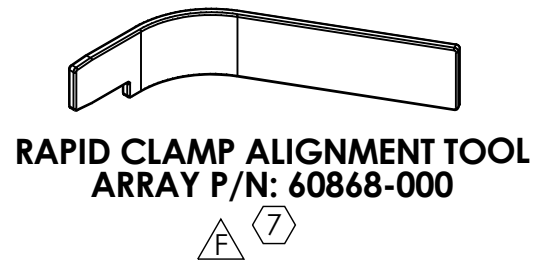
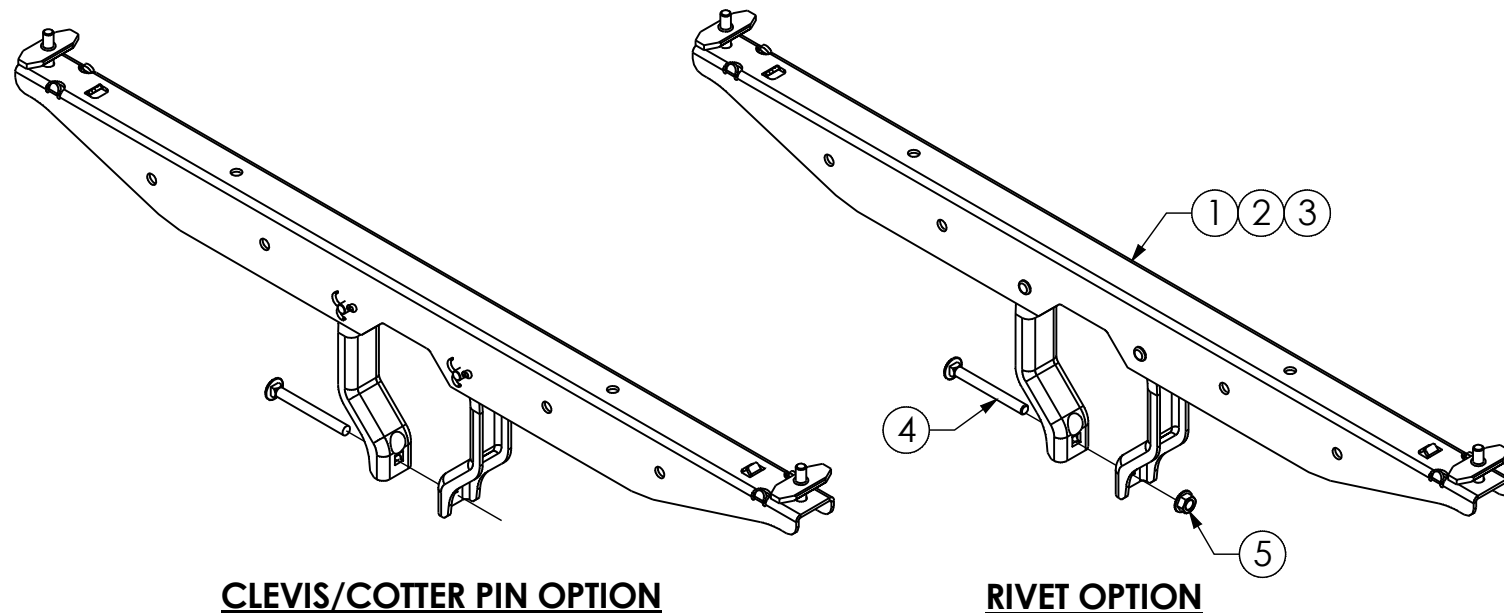
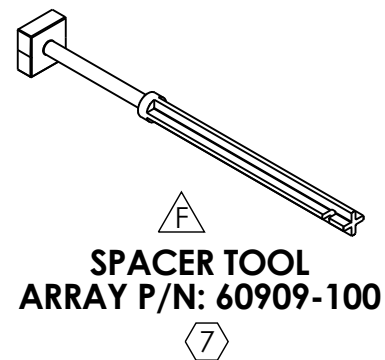

PART NUMBER	DESCRIPTION	SELECTION CRITERIA CORROSION GROUP
30976-200	Plate, End CLMP, 800mm, 3-Bolt Slot, L	L
30976-400	Plate, End CLMP, 800mm, 3-Bolt Slot, M/H	M/H

ITEM NO.	PART NUMBER	DESCRIPTION	L	M	H
1	21024-200	ASSY, Clamp, 3-Bolt, 800mm, Slot, L	1	-	-
2	21024-300	ASSY, Clamp, 3-Bolt, 800mm, Slot, M	-	1	-
3	21024-400	ASSY, Clamp, 3-Bolt, 800mm, Slot, H	-	-	1
4	60825-300	Bolt, Carriage, Grade 8, 5/16-18 x 3.000, H	1	1	1
5	60852-000	Nut, Serrated Hex Flange, Grade 8, 5/16-18, H	1	1	1

ITEM NO.	PART NUMBER	DESCRIPTION	L	M	H
1	21024-200	ASSY, Clamp, 3-Bolt, 800mm, Slot, L	1	-	-
2	21024-300	ASSY, Clamp, 3-Bolt, 800mm, Slot, M	-	1	-
3	21024-400	ASSY, Clamp, 3-Bolt, 800mm, Slot, H	-	-	1
4	60825-300	Bolt, Carriage, Grade 8, 5/16-18 x 3.000, H	1	1	1
5	60852-000	Nut, Serrated Hex Flange, Grade 8, 5/16-18, H	1	1	1

ZONE	REV	ECR #	DESCRIPTION	ENGR	DATE
A7, B8, C4, C5, 2-A3, 2-C3	F	US-25037	REMOVED L/M HDW FROM CONFIGS, UPDATED VIEW LABELS, ADDED SPACER CONFIGURATION TABLE	MK	04/24/2025
A8	E	US-24037	REMOVED REV COLUMN IN BOM	AD	04/05/2024
A2, A7, C2, C3, C4, C6, 2-A2, 2-B2	D	US-24011	ADDED BOM, NOTE 8, TEXT TO VIEWS, 60824-300, 60825-300, 60851-000, 60852-000, UPDATED NOTE 5 AND 7, VIEWS, TITLE, REMOVED END CAP VIEW AND CONFIGURATION TABLE	SB	02/02/2024

<b>APPLICABLE TRACKER SYSTEMS:</b> Duratrack OmniTrack	<b>DRAWING STATUS</b> Final DRAWN: NC DATE: 12/13/2022 ENG. CHECK: SB DATE: 09/05/2023 DRAWING CHECK: DS DATE: 7/27/2023 FINAL APPROVAL: SB DATE: 9/5/2023	<b>ARRAY TECHNOLOGIES</b> 3901 Midway Place NE, Albuquerque, NM 87109 (505) 881-7567
<b>PROPRIETARY AND CONFIDENTIAL:</b> THE INFORMATION CONTAINED IN THIS DRAWING IS THE SOLE PROPERTY OF ARRAY TECHNOLOGIES. ANY REPRODUCTION IN PART OR AS A WHOLE WITHOUT THE WRITTEN PERMISSION FROM ARRAY TECHNOLOGIES IS PROHIBITED.	ALL DIMS ARE DUAL UNITS: MILLIMETER [INCH]. DIMENSIONS IN BRACKETS ARE FOR REFERENCE ONLY. TOLERANCES UNLESS OTHERWISE SPECIFIED mm [INCH]: X = ±1.25 [0.049] .X = ±0.4 [0.016] .XX = ±0.1 [0.004]	<b>TITLE</b> Field Assembly, Clamp, 3-Bolt Slot, 800mm, L/M/H
SIZE B SCALE 1:96	DRAWING NUMBER 21025-901	REVISION F
SHEET 1 OF 2		SAVED v70 4/24/2025

8 7 6 5 4 3 2 1

D D

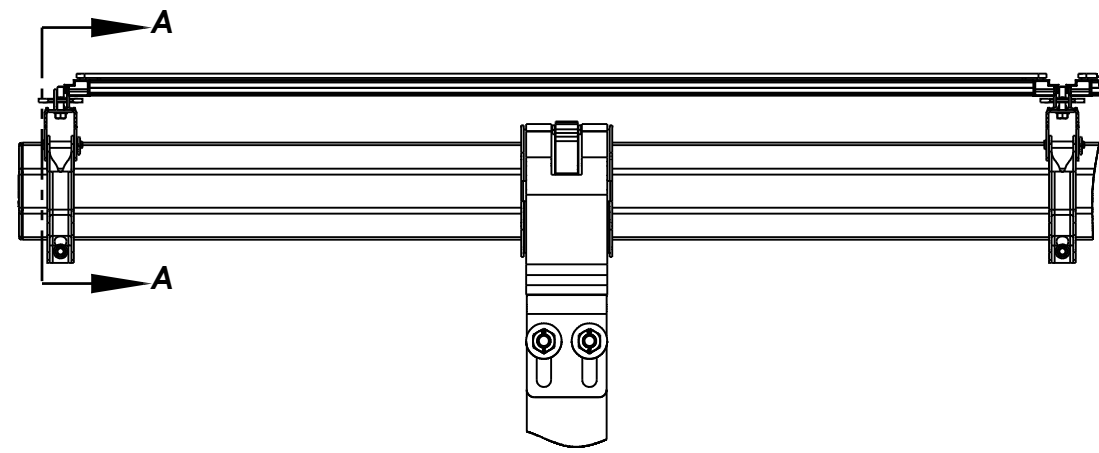

CLAMP EAR FLAT MUST FULLY SIT ON THE FLAT OF THE MODULE SLOT

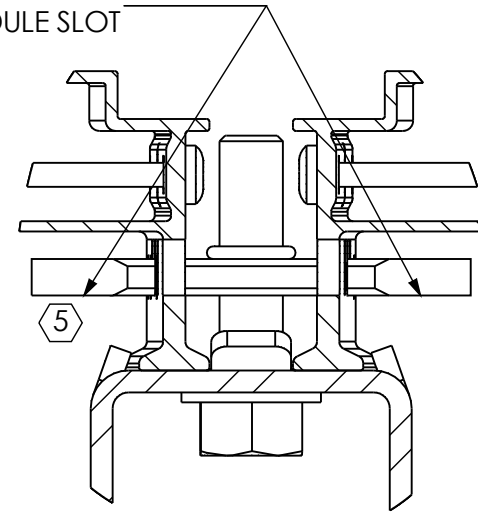

SECTION B-B

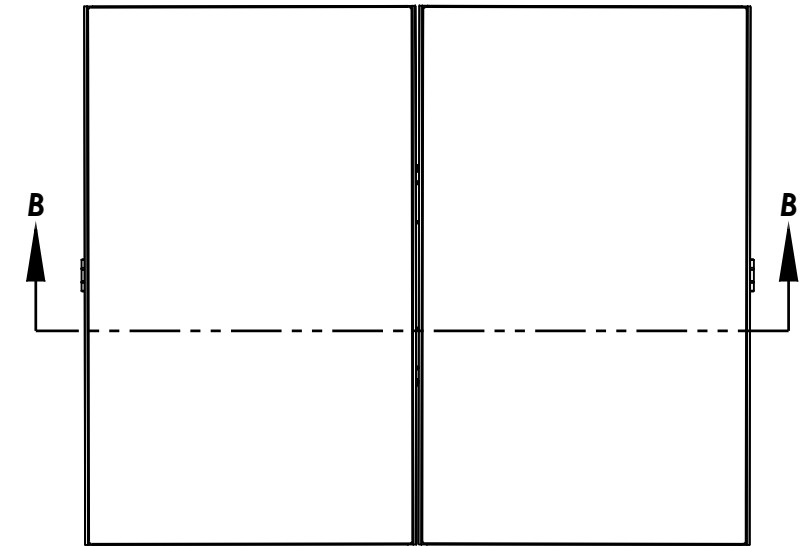

$\Delta F$   $\left[ \frac{3}{16} \text{ MIN} \right]$   
5.0 MIN

FS6/FS6+ MODULE FRAME  
NON-PARALLEL MOUNTING ALLOWANCE  
FOR DURATRACK

BRACKET IS TO COMPRESS EVENLY AROUND TORQUE TUBE. SLIGHT GAPS BETWEEN CERTAIN CLAMP ARMS ARE POSSIBLE.

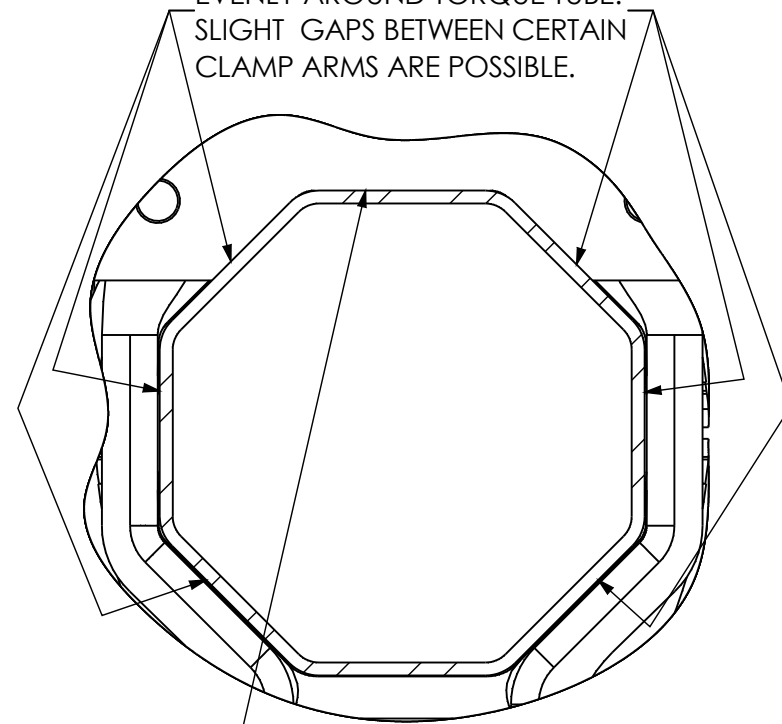

CLAMP AND TORQUE TUBE FACE MUST BE PARALLEL IF NOT IN FULL CONTACT

SECTION A-A  
COMPONENTS REMOVED FOR CLARITY

CLAMP EAR FLAT MUST FULLY SIT ON THE FLAT OF THE MODULE SLOT

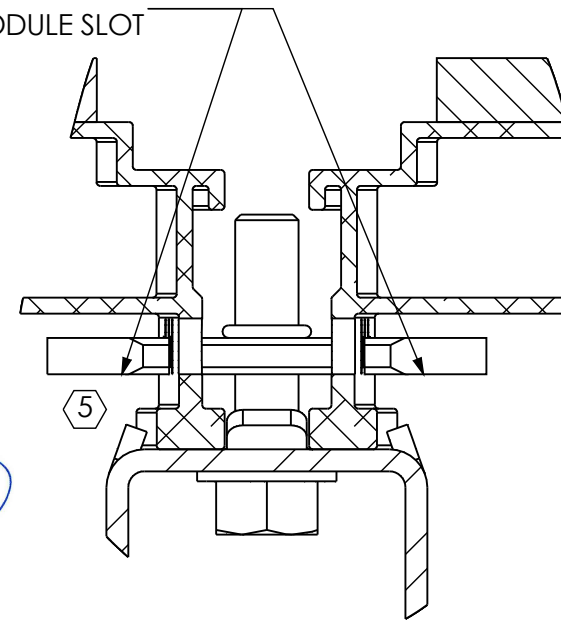

SECTION C-C

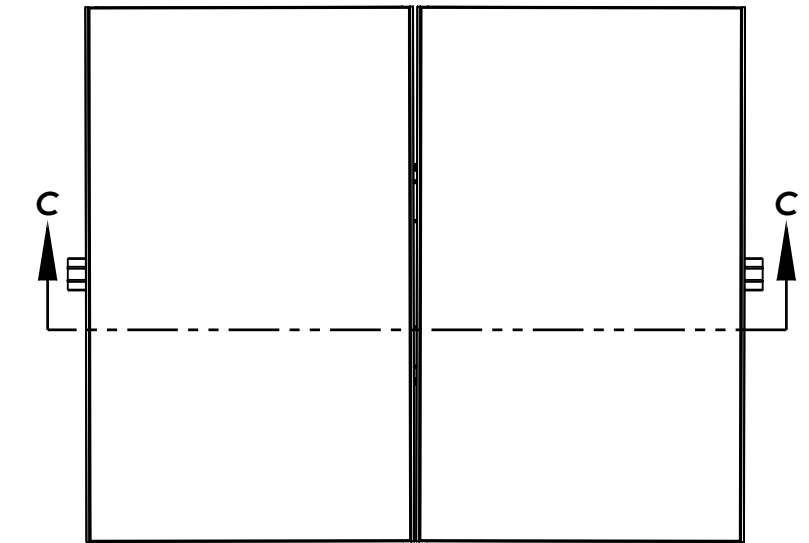

$\Delta F$   $\left[ \frac{1}{4} \text{ MIN} \right]$   
7.0 MIN

FS6/FS6+ MODULE FRAME  
NON-PARALLEL MOUNTING ALLOWANCE  
FOR OMNITRACK

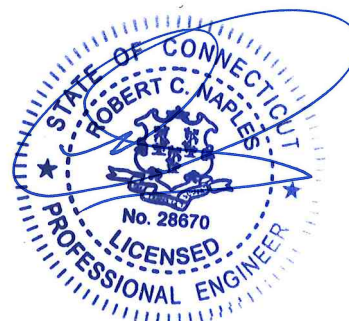

Exp 01/31/2027  
04/13/2026

B B

A A

8 7 6 5 4 3 2 1

SIZE B	DRAWING NUMBER 21025-901	REVISION F	SAVED v70 4/24/2025
SCALE 1:30	SHEET 2 OF 2		

**NOTES:**

FORM PAN HEAD BY ORBITAL RIVETING PROCESS. HINGE MUST PIVOT FREELY BY HAND AFTER ASSEMBLY.

ARRAY PART NUMBER DESIGNATION

21011-XXX

ARRAY PART NUMBER EXTENSION INDICATES CORROSION LEVEL  
 -200 INDICATES LOW CORROSION  
 -300 INDICATES MEDIUM CORROSION  
 -400 INDICATES HIGH CORROSION

ARRAY PART NUMBER

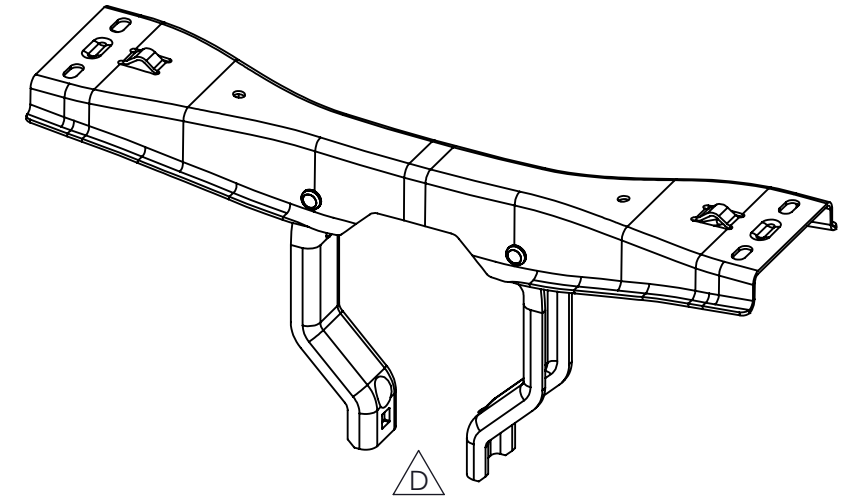
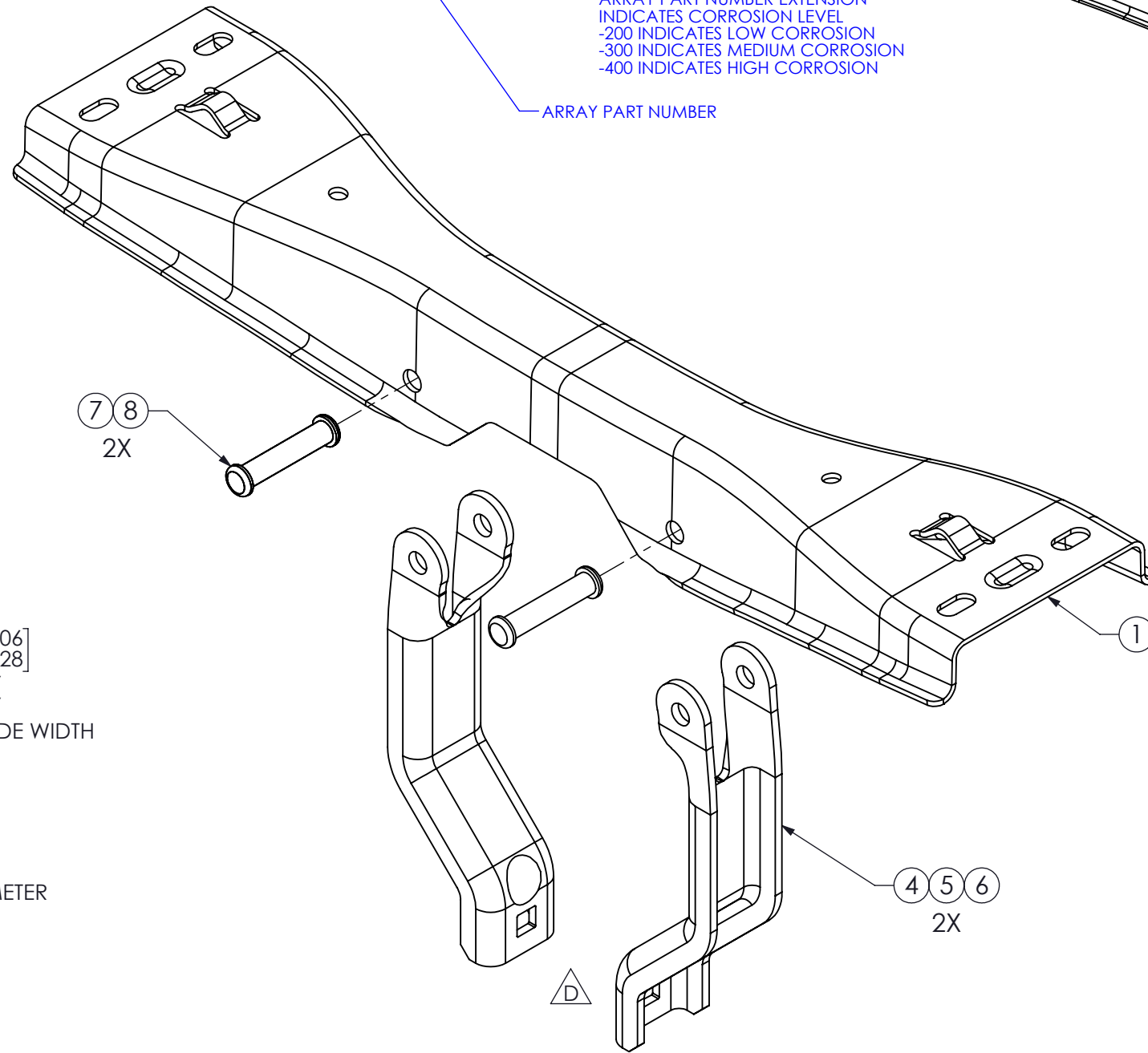
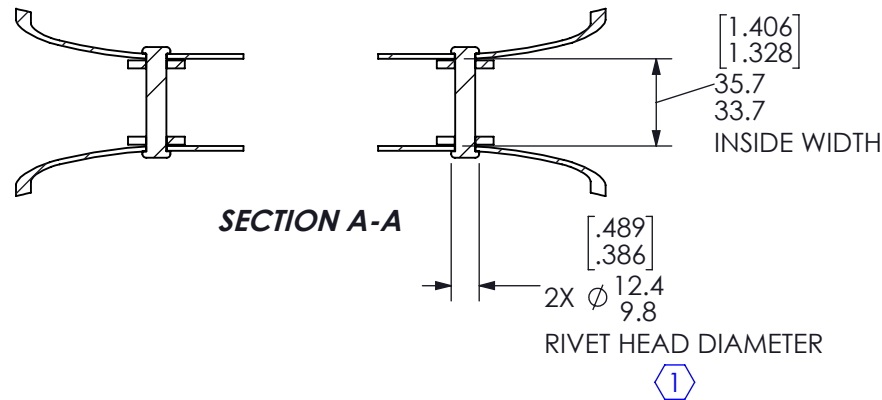
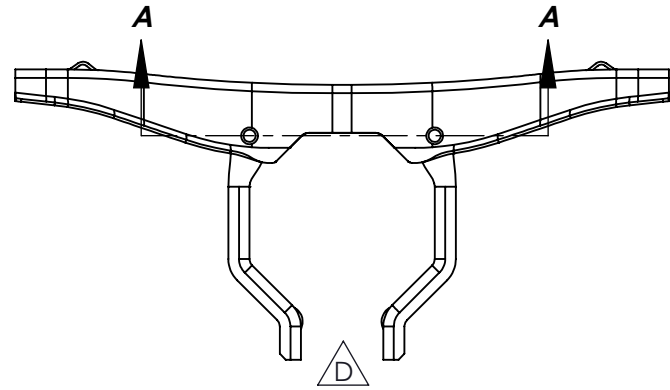

ARRAY P/N: 21011-XXX

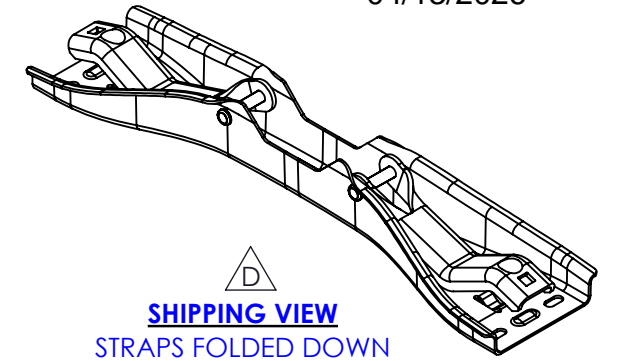

ITEM NO.	PART NUMBER	DESCRIPTION	-200	-300	-400
1	30962-200	Rail, Stamped, 400mm Thru-Bolt Clamp, 14Ga, L	1	-	-
2	30962-300	Rail, Stamped, 400mm Thru-Bolt Clamp, 14Ga, M	-	1	-
3	30962-400	Rail, Stamped, 400mm Thru-Bolt Clamp, 14Ga, H	-	-	1
4	30963-200	Strap, Stamped, 400mm Thru-Bolt Clamp, 11Ga, L	2	-	-
5	30963-300	Strap, Stamped, 400mm Thru-Bolt Clamp, 11Ga, M	-	2	-
6	30963-400	Strap, Stamped, 400mm Thru-Bolt Clamp, 11Ga, H	-	-	2
7	60874-170	Rivet, Pan Head, Steel, 0.313", 1.70, L/M	2	2	-
8	60875-170	Rivet, Pan Head, Stainless, 0.313", 1.70, H	-	-	2

ZONE	REV	ECR #	DESCRIPTION	DATE
B2, B4, C2, C7, D8	D	US-23118	REMOVED HARDWARE AND NOTE 2, ADDED SHIPPING VIEW	8/24/2023
A6	C	US-23112	ADDED L/M RIVET TO L/M CONFIGS	7/27/2023
C6	B	US-23054	CHANGED DIMENSION TO INSIDE WIDTH	4/4/2023

APPLICABLE TRACKER SYSTEMS:	DRAWING STATUS: <b>Final</b>	<b>ARRAY TECHNOLOGIES</b> 3901 Midway Place NE, Albuquerque, NM 87109 (505) 881-7567	
PROPRIETARY AND CONFIDENTIAL: THE INFORMATION CONTAINED IN THIS DRAWING IS THE SOLE PROPERTY OF ARRAY TECHNOLOGIES. ANY REPRODUCTION IN PART OR AS A WHOLE WITHOUT THE WRITTEN PERMISSION FROM ARRAY TECHNOLOGIES IS PROHIBITED.	DRAWN: RM DATE: 07/19/2022	DRAWING CHECK: RM DATE: 8/31/2023	TITLE: <b>Assembly, Thru-Bolt Clamp, 400mm, L/M/H</b>
	ENG. CHECK: BCDF DATE: 08/14/2023	FINAL APPROVAL: SB DATE: 8/14/2023	
THIRD ANGLE PROJECTION		ALL DIMS ARE DUAL UNITS: MILLIMETER [INCH], DIMENSIONS IN BRACKETS ARE FOR REFERENCE ONLY.	
TOLERANCES UNLESS OTHERWISE SPECIFIED		SIZE: B	DRAWING NUMBER: 21011-901
mm [INCH]: X = ±1.25 [0.049], .X = ±0.4 [0.016], .XX = ±0.1 [0.004]		METER [INCH]: X.XX = ±0.013 [0.512], X.XXX = ±0.006 [0.236]	REVISION: D
		ANGULAR: X = ±1.0°, .X = ±0.1°	SAVED v45: 10/9/2023
		SCALE: 1:3	WT: 1.325kg [2.921Lbs]
			SHEET: 1 OF 1

**NOTES:**

1. BOM FASTENER QUANTITY IS PER MODULE.
- ② PREFERRED BOLT ORIENTATION IS DROPPING DOWN FROM TOP OF HOLE.
3. TORQUE SPECIFICATIONS:
  - ③A. 12.2 ± 1.4 N-M [9 ± 1 FT-LBS]
  - ③B. 25.5 ± 2.7 N-M [19 ± 2 FT-LBS]
4. MARK ALL TORQUED CONNECTIONS USING A PAINT MARKER OF CONTRASTING COLOR ACROSS IMMOBILE BASE AND ALL PARTS SUBJECT TO LOOSENING.
- ⑤ MODULE INTERFACE HOLE TO EDGE OF MODULE DISTANCE LESS THAN 17.5mm WILL RESULT IN A MODULE GAP OF GREATER THAN 10mm.

6. MODULE ATTACHMENT METHODS: SELECT APPROPRIATE HARDWARE BOM - CARBON STEEL HARDWARE (TABLE 1), OR ALUMINUM SWAGE HARDWARE (TABLE 2). MIXING HARDWARE TYPES IS NOT ALLOWED.
  - ⑥.1 SWAGE FASTENERS REQUIREMENTS:  
SWAGE FASTENERS REQUIRE SWAGING TOOL TO INSTALL. SWAGE FASTENERS CAN BE INSTALLED ON MODULES WHERE THE PROFILE HEIGHT IS 30mm OR GREATER. FOR MODULES WHERE THE HEIGHT IS LESS THAN 30mm, THE DISTANCE BETWEEN THE GLASS AND THE MODULE FLANGE MUST BE CHECKED TO ENSURE A MINIMUM OF 20mm.
- ⑦ REFER TO 90133-000 INSTALLATION ADDENDUM FOR DURATRACK AND OMNITRACK INSTALLATION PROCEDURES USING THE REQUIRED 60909-000 INSTALLATION TOOL TO IMPROVE ALIGNMENT AND GAP OF THE MODULES.

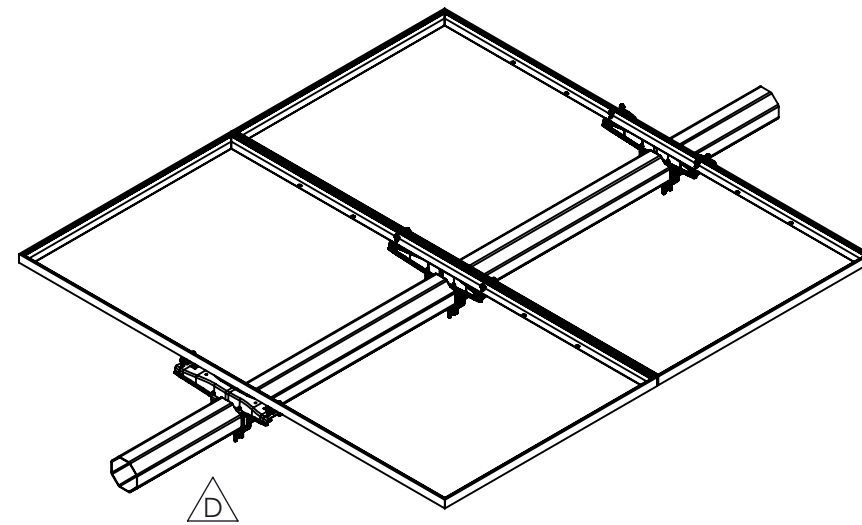

MOUNT CONFIGURATION TABLE	
21011-200	Assembly, Thru-Bolt Clamp, 400mm, L
21011-300	Assembly, Thru-Bolt Clamp, 400mm, M
21011-400	Assembly, Thru-Bolt Clamp, 400mm, H

TABLE 1: CARBON STEEL HARDWARE BOM			
ITEM NO	PART NUMBER	DESCRIPTION	QTY
1	21011-XXX	Assembly, Thru-Bolt Clamp, 400mm, L/M/H	1
2	60816-000	Nut, Serrated Hex Flange, 1/4"-20, H	4
3	60819-063	Bolt, Serrated Hex Flange, IFI 111, SAE J429, Steel, H, 1/4"-20, 0.63"	4
4	60825-300	Bolt, Carriage, Grade 8, 5/16-18 x 3.000, H	1
5	60852-000	Nut, Serrated Hex Flange, Grade 8, 5/16-18, H	1

TABLE 2: ALUMINUM SWAGE HARDWARE BOM			
ITEM NO.	PART NUMBER	DESCRIPTION	QTY
1	21011-XXX	Assembly, Thru-Bolt Clamp, 400mm, L/M/H	1
4	60825-300	Bolt, Carriage, Grade 8, 5/16-18 x 3.000, H	1
5	60852-000	Nut, Serrated Hex Flange, Grade 8, 5/16-18, H	1
6	60881-875	Bolt, Huck, Bobtail, 0.25" x 0.875", Aluminum	4
7	60882-000	Collar, Huck, 6061 Al, 0.25"	4

ZONE	REV	ECR #	DESCRIPTION	ENGR	DATE
A6, B4, D5, 2-A5, 2-A6, 3-A5	D	US-23118	ADDED 60825-300 AND 60852-000, MOVED VIEWS TO NEW SHEET 2, UPDATED NOTES	JM	11/03/2023
A7, B7, C4, C5, 2-B2, 3-A1	C	US-23075	ADDED NOTES 7 AND 8, ADDED SWAGE HARDWARE BOM, ADDED SHEET 2, ADDED LABEL FOR SECTION VIEWS		5/10/2023
A3	B	US-23015	ADDED APPLICABLE TRACKER SYSTEMS		2/14/2023

APPLICABLE TRACKER SYSTEMS: DuraTrack OmniTrack	DRAWING STATUS <b>Final</b>		<b>ARRAY TECHNOLOGIES</b> 3901 Midway Place NE, Albuquerque, NM 87109 (505) 881-7567 <b>ARRAY</b> TECHNOLOGIES	
	DRAWN INITIALS: NC DATE: 9/20/2023	DRAWING CHECK INITIALS: NC DATE: 9/20/2023		
PROPRIETARY AND CONFIDENTIAL: THE INFORMATION CONTAINED IN THIS DRAWING IS THE SOLE PROPERTY OF ARRAY TECHNOLOGIES. ANY REPRODUCTION IN PART OR AS A WHOLE WITHOUT THE WRITTEN PERMISSION FROM ARRAY TECHNOLOGIES IS PROHIBITED.	ENG. CHECK INITIALS: BCDF DATE: 05/24/2023	FINAL APPROVAL INITIALS: SB DATE: 5/24/2023	TITLE <b>Field Assembly, 400mm Thru-Bolt Clamp, L/M/H</b>	
	THIRD ANGLE PROJECTION			
	TOLERANCES UNLESS OTHERWISE SPECIFIED MM [INCH]: X = ±1.25 [0.049] .X = ±0.4 [0.016] .XX = ±0.1 [0.004]	METER [INCH]: X.XX = ±0.013 [0.512] X.XXX = ±0.006 [0.236]		ANGULAR: X = ±1.0° .X = ±0.1°
	SIZE <b>B</b>	DRAWING NUMBER <b>21016-901</b>		REVISION <b>D</b>
SCALE 1:25			SHEET <b>1 OF 3</b>	

8

7

6

5

4

3

2

1

EDGE OF  
MODULE FRAME

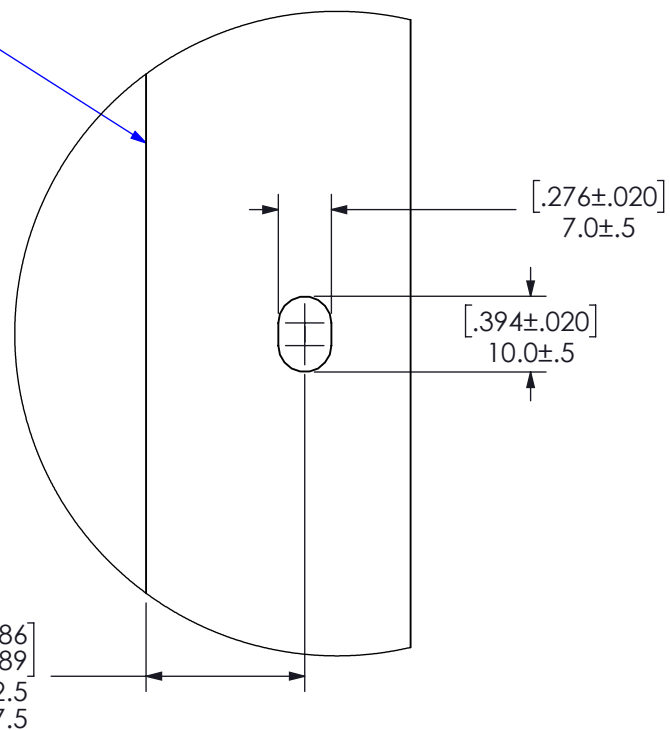

BOTTOM VIEW  
MODULE INTERFACE CRITERIA

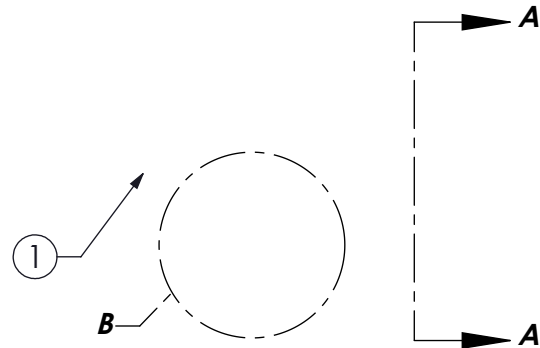

GAP BETWEEN STRAP OR MODULE  
INTERFACE BRACKET AND TORQUE TUBE

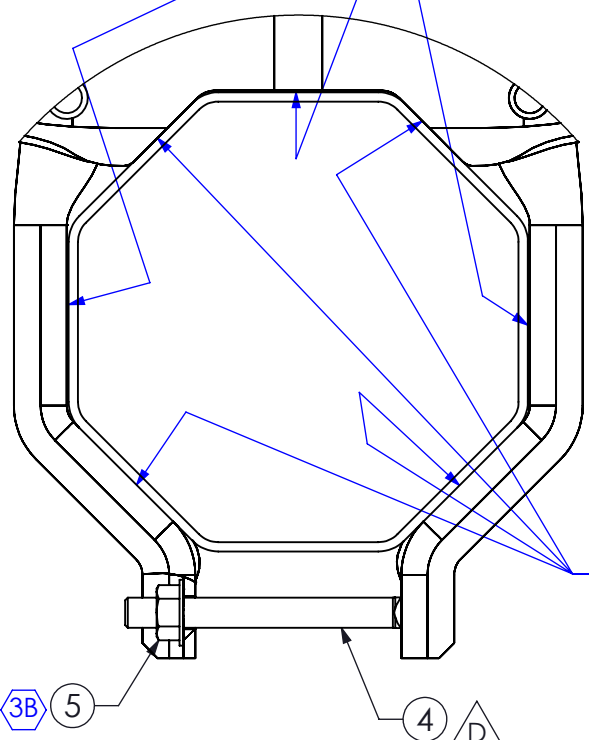

NO GAP BETWEEN STRAP OR  
MODULE INTERFACE  
BRACKET AND TORQUE TUBE

DETAIL B

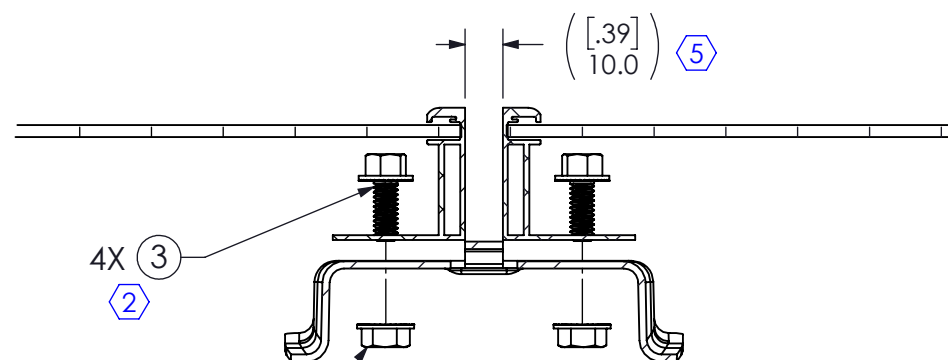

SECTION A-A  
CARBON STEEL HARDWARE

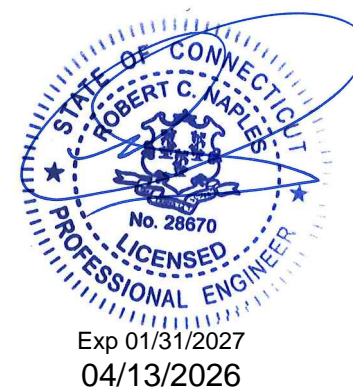

SIZE B	DRAWING NUMBER 21016-901	REVISION D	SAVED v50 11/3/2023
SCALE 1:25	SHEET 2 OF 3		

8

7

6

5

4

3

2

1

8

7

6

5

4

3

2

1

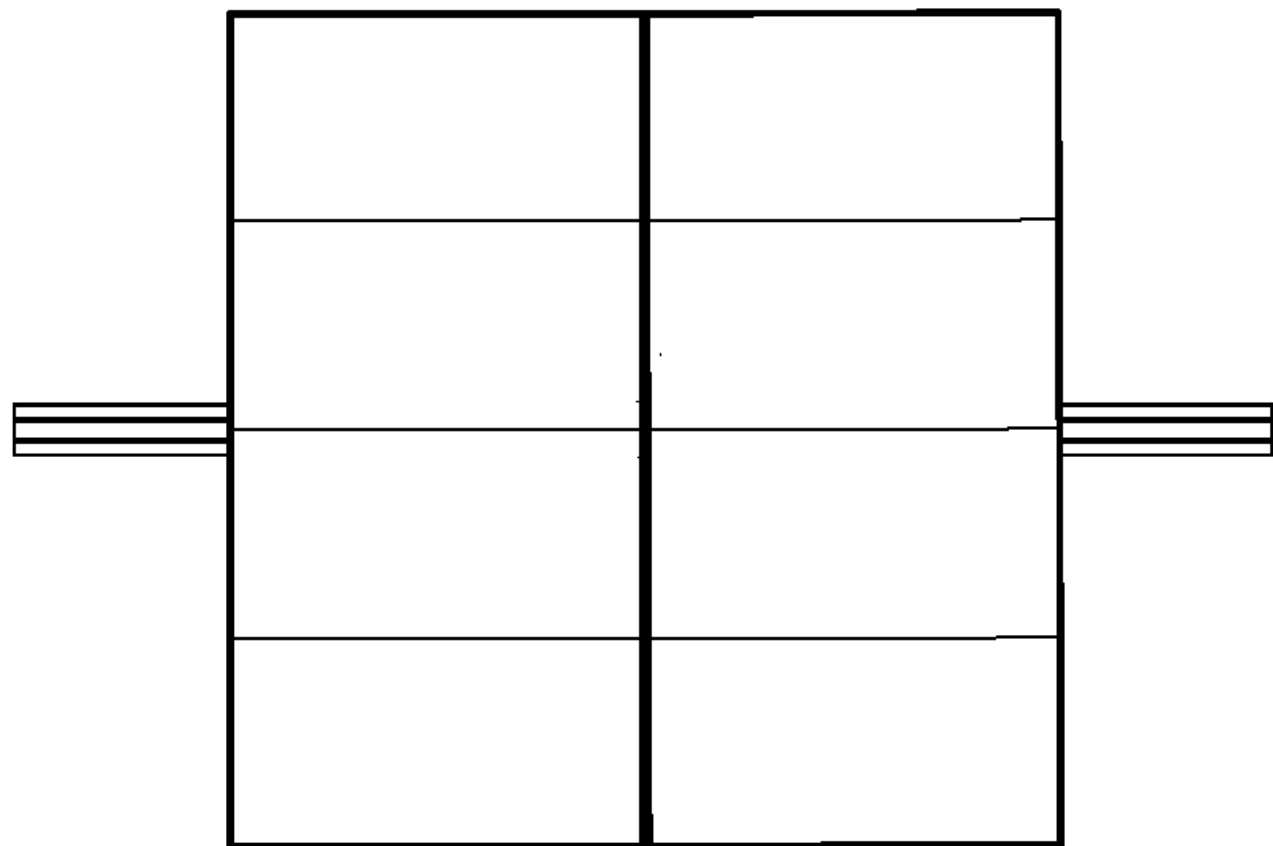

[.197 MIN]  
5.0 MIN

MINIMUM CORNER ALLOWANCE FOR DURATRACK

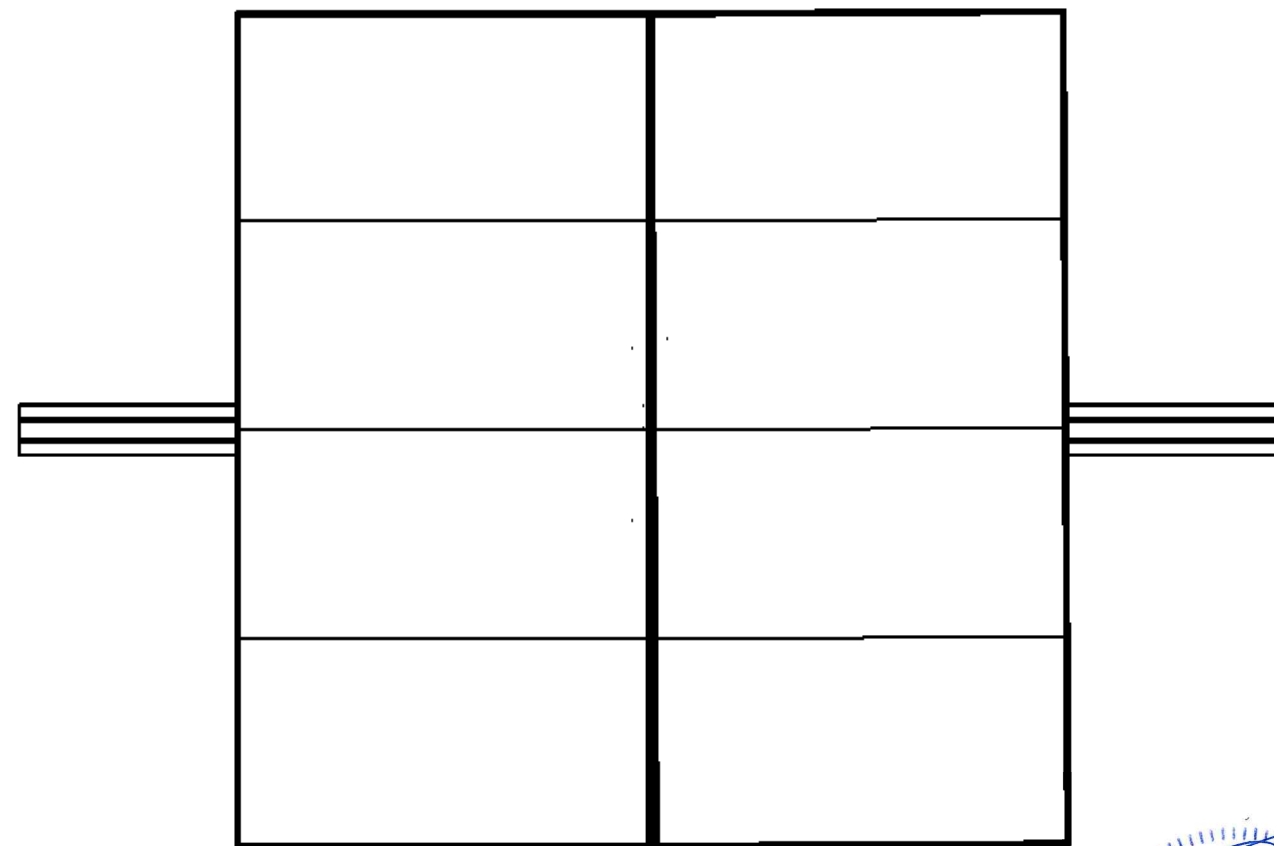

[.276 MIN]  
7.0 MIN

MINIMUM CORNER ALLOWANCE FOR OMNITRACK

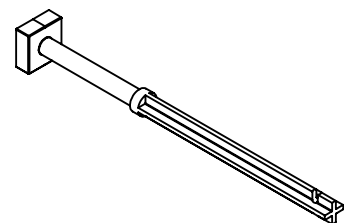

ARRAY P/N: 60909-000



Exp 01/31/2027  
04/13/2026

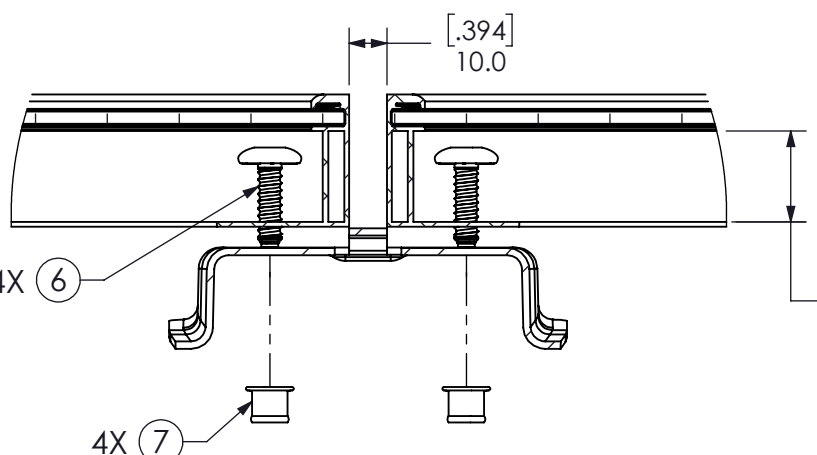

SECTION C-C  
ALUMINUM SWAGE HARDWARE

[.787 MIN]  
20.0 MIN

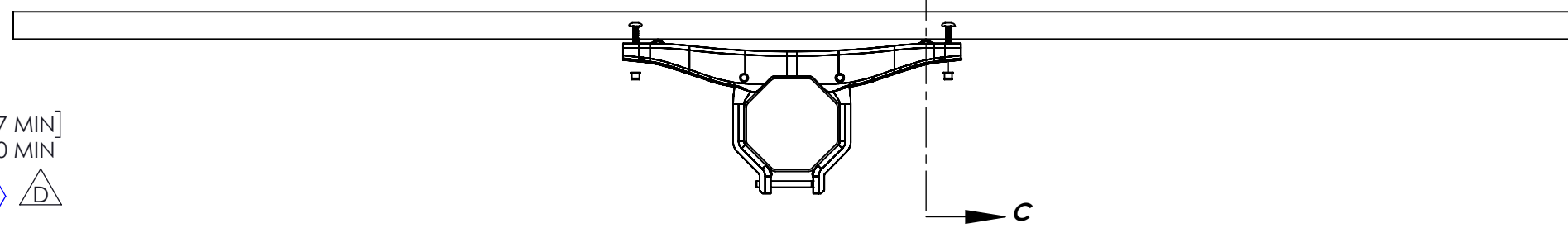

C  
C

SIZE B	DRAWING NUMBER 21016-901	REVISION D	SAVED v50 11/3/2023
SCALE 1:18	SHEET 3 OF 3		

8

7

6

5

4

3

2

1

**NOTES:**

1. ARRAY TORQUE SPECIFICATIONS

1A. 1/4" HEX BOLT 12 ± 1 N-M [9 ± 1 FT-LBS]

1B. HAND TIGHTEN UNTIL 2 THREADS SHOWING BELOW NUT. NUTS TO BE RESTRAINED DURING SHIPPING. RESTRAINING METHOD MUST BE APPROVED BY ARRAY.

2. GRADE 5 HIGHER CORROSION COMPONENTS MAY BE USED IN -002 AND -003 CONFIGURATIONS; GRADE 8 HIGHER CORROSION COMPONENTS MAY BE USED IN -102 AND -103 CONFIGURATIONS GRADE 8 COMPONENTS MAY BE USED IN PLACE OF GRADE 5 COMPONENTS.

ARRAY PART NUMBER DESIGNATION

**20893-YXX**

ARRAY PART NUMBER

ARRAY PART NUMBER EXTENSION WHERE:  
Y INDICATES HARDWARE SELECTION  
0: GRADE 5 HARDWARE  
1: GRADE 8 HARDWARE  
XX INDICATES CORROSION GROUP

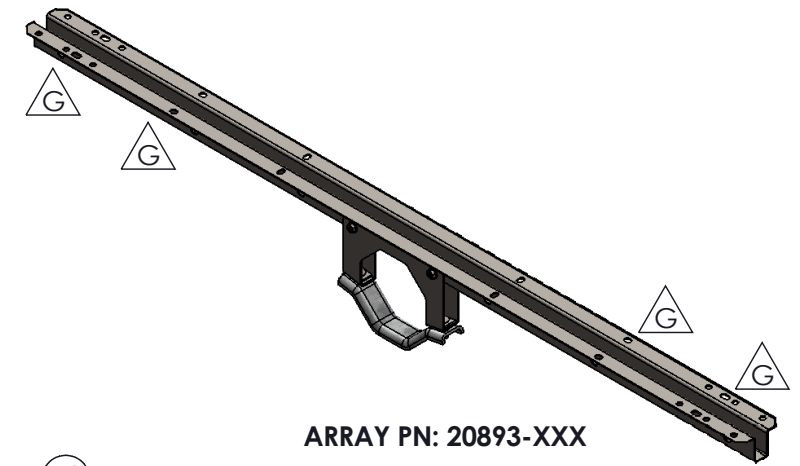

ARRAY PN: 20893-XXX

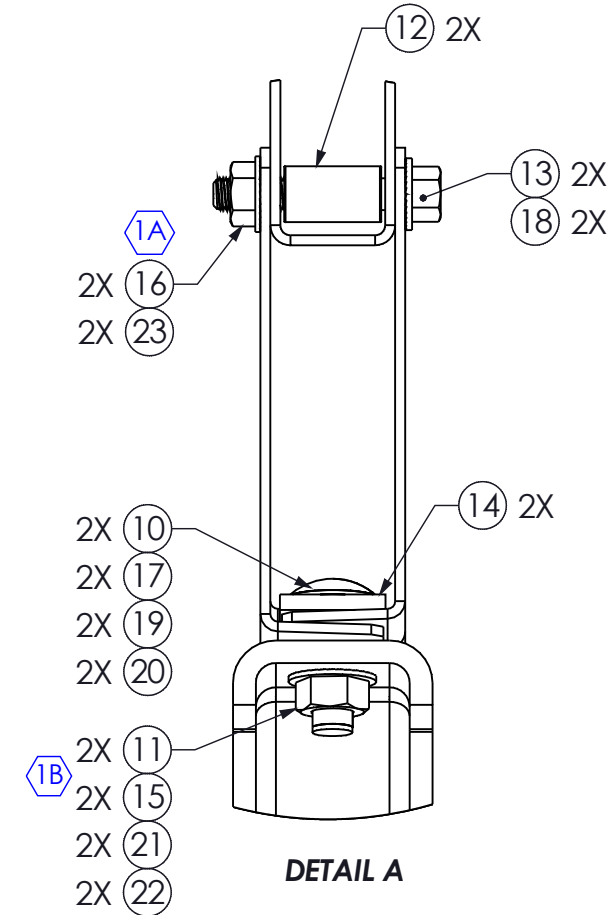
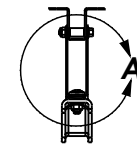
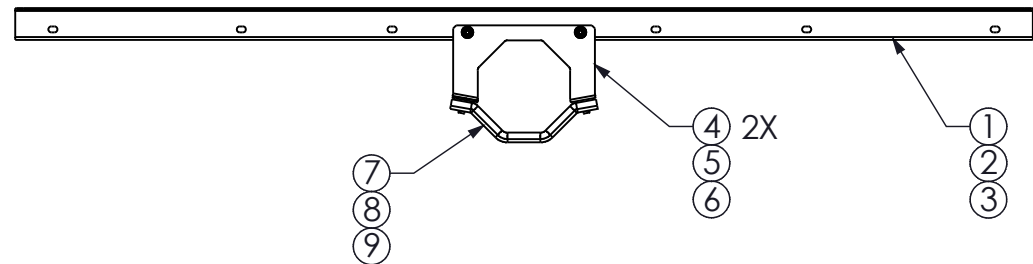

DETAIL A

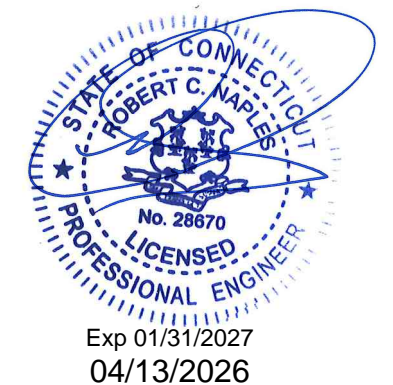

ITEM NO.	PART NUMBER	DESCRIPTION	-002	-003	-004	-102	-103	-104
1	30882-002	Rail, Thru-Bolt Mount, 1300 mm, 14 Ga, L	1	-	-	1	-	-
2	30882-003	Rail, Thru-Bolt Mount, 1300 mm, 14 Ga, M	-	1	-	-	1	-
3	30882-004	Rail, Thru-Bolt Mount, 1300 mm, 14 Ga, H	-	-	1	-	-	1
4	30884-002	Bracket, Thru-Bolt Mount, 2 Piece, Steel Gr80, 14 Ga, L	2	-	-	2	-	-
5	30884-003	Bracket, Thru-Bolt Mount, 2 Piece, Steel Gr80, 14 Ga, M	-	2	-	-	2	-
6	30884-004	Bracket, Thru-Bolt Mount, 2 Piece, Steel Gr80, 14 Ga, H	-	-	2	-	-	2
7	30906-002	Strap, Thru-Bolt Mount, Steel Gr80, .179", L	1	-	-	1	-	-
8	30906-003	Strap, Thru-Bolt Mount, Steel Gr80, .179", M	-	1	-	-	1	-
9	30906-004	Strap, Thru-Bolt Mount, Steel Gr80, .179", H	-	-	1	-	-	1
10	60693-100	Bolt, Carriage, Grade 5, H, .313-18 x 1.00	-	-	2	-	-	-
11	60696-000	Nut, Serrated Flange, H .313"-18"	-	-	2	-	-	-
12	60797-000	Collar, 1300mm Purlin, 19.3mm, H	2	2	2	2	2	2
13	60803-150	Bolt, Serrated Hex Flange, IFI 111, SAE J429, Steel, ASTM F1941M Zn-Ni 5C, 1/4"-20, 1.50"	2	2	-	2	2	-
14	60807-000	Plate, Carriage Bolt, 9mm Square, H	2	2	2	2	2	2
15	60815-000	Nut, Serrated Hex Flange, 5/16-18, L/M	2	2	-	-	-	-
16	60816-000	Nut, Serrated Hex Flange, 1/4"-20, H	-	-	2	-	-	2
17	60817-100	Bolt, Carriage, Grade 5, L/M, 5/16-18 x 1.000	2	2	-	-	-	-
18	60819-150	Bolt, Serrated Hex Flange, IFI 111, SAE J429, Steel, H, 1/4"-20, 1.50"	-	-	2	-	-	2
19	60824-100	Bolt, Carriage, Grade 8, 5/16-18 x 1.000, L/M	-	-	-	2	2	-
20	60825-100	Bolt, Carriage, Grade 8, 5/16-18 x 1.000, H	-	-	-	-	-	2
21	60851-000	Nut, Serrated Hex Flange, Grade 8, 5/16-18, L/M	-	-	-	2	2	-
22	60852-000	Nut, Serrated Hex Flange, Grade 8, 5/16-18, H	-	-	-	-	-	2
23	60860-000	Nut, Serrated Hex Flange, Grade 5, 1/4"-20, L/M	2	2	-	2	2	-

ZONE	REV	ECR #	DESCRIPTION	DATE
D1, D2, D3	G	21141	UPDATED REVISION OF 30882-XXX, ALTERED HOLES TO BE SLOTS	10/1/2021
A4, C2, C3, D5	F	21092	REMOVED 60854-000, 60855-000, 60856-000 AND 60857-000; ADDED 60803-150 AND 60860-000; ADJUSTED BOM QUANTITIES; UPDATED NOTE 2	8/23/2021
A4, B3, C2, C3, D5	E	21092	ADDED 60815-000, 60817-100, 60824-100, 60825-100, 60851-000, 60852-000, 60854-000, 60855-000, 60856-150 & 60857-150; UPDATED NOTE 2	6/10/2021

PROPRIETARY AND CONFIDENTIAL THE INFORMATION CONTAINED IN THIS DRAWING IS THE SOLE PROPERTY OF ARRAY TECHNOLOGIES. ANY REPRODUCTION IN PART OR AS A WHOLE WITHOUT THE WRITTEN PERMISSION FROM ARRAY TECHNOLOGIES IS PROHIBITED.	DRAWING STATUS <b>Final</b>	<b>ARRAY TECHNOLOGIES</b> 3901 Midway Place NE, Albuquerque, NM 87109 (505) 881-7567
	DRAWN: MK DATE: 07/14/2020 ENG. CHECK: SB DATE: 10/05/2021 DRAWING CHECK: NC DATE: 10/3/2021 FINAL APPROVAL: SB DATE: 10/4/2021	
THIRD ANGLE PROJECTION TOLERANCES UNLESS OTHERWISE SPECIFIED MM [INCH]: X = ±1.25 [0.049] .X = ±0.4 [0.016] .XX = ±0.1 [0.004]		TITLE <b>Assembly, Thru-Bolt Mount, 1300 mm, 14 Ga, Gr X HW, L/M/H</b>
ALL DIMS ARE DUAL UNITS: MILLIMETER [INCH], DIMENSIONS IN BRACKETS ARE FOR REFERENCE ONLY.		SIZE B DRAWING NUMBER: 20893-901 REVISION: G SAVED v75: 10/14/2021 SCALE: 1:10 WT: 3.977kg [8.768lb]
SHEET 1 OF 1		SHEET 1 OF 1

Template\_Drawing\_mm\_v5

**NOTES:**

1. ARRAY TORQUE SPECIFICATIONS

1A. 1/4" HEX BOLT 12 ± 1 N-M [9 ± 1 FT-LBS]

1B. HAND TIGHTEN UNTIL 2 THREADS SHOWING BELOW NUT. NUTS TO BE RESTRAINED DURING SHIPPING. RESTRAINING METHOD MUST BE APPROVED BY ARRAY.

2. GRADE 5 HIGHER CORROSION COMPONENTS MAY BE USED IN -002 AND -003 CONFIGURATIONS; GRADE 8 HIGHER CORROSION COMPONENTS MAY BE USED IN -102 AND -103 CONFIGURATIONS; GRADE 8 COMPONENTS MAY BE USED IN PLACE OF GRADE 5 COMPONENTS.

3. SILFAB MODULES MUST INCLUDE WASHER PN98180A110 AT 1400MM HOLE LOCATIONS.

ARRAY PART NUMBER DESIGNATION

20916-YXX

ARRAY PART NUMBER

ARRAY PART NUMBER EXTENSION WHERE:  
Y INDICATES HARDWARE SELECTION  
0: GRADE 5 HARDWARE  
1: GRADE 8 HARDWARE  
XX INDICATES CORROSION GROUP

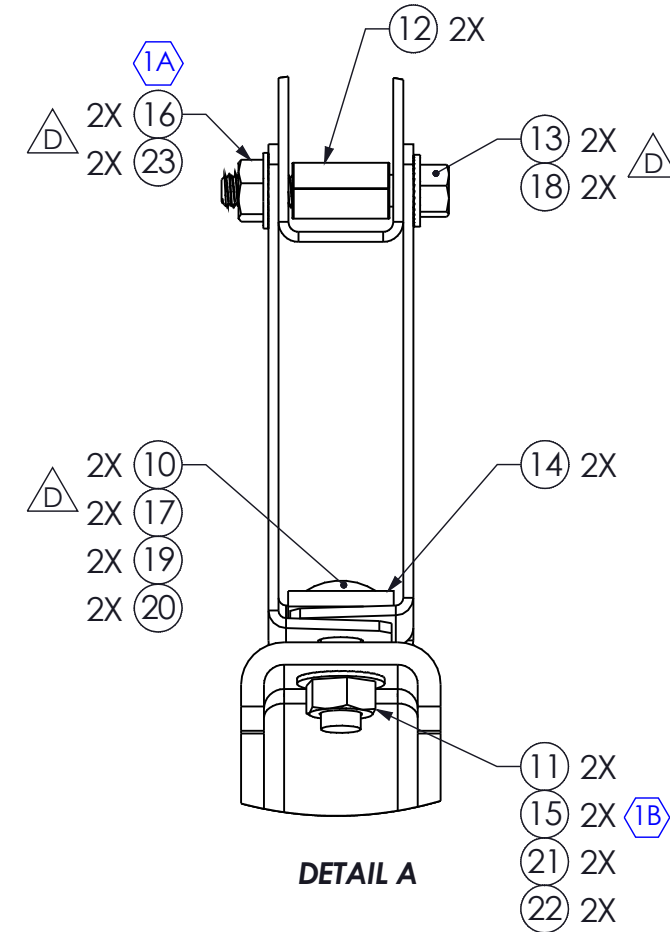
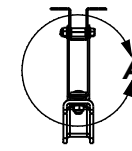
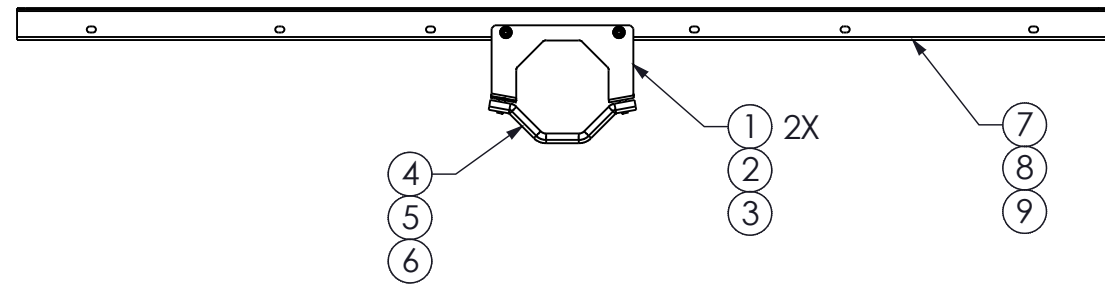

ARRAY PN: 20916-XXX

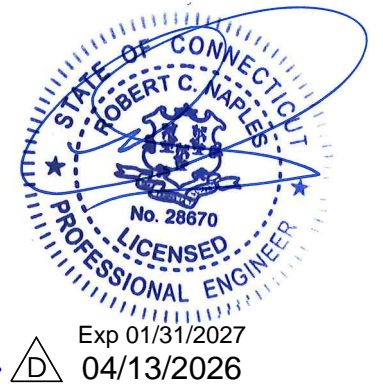

ITEM NO.	PART NUMBER	DESCRIPTION	CONFIGURATION						
			-002	-003	-004	-102	-103	-104	
1	30884-002	Bracket, Thru-Bolt Mount, 2 Piece, Steel Gr80, 14 Ga, L	2	-	-	2	-	-	
2	30884-003	Bracket, Thru-Bolt Mount, 2 Piece, Steel Gr80, 14 Ga, M	-	2	-	-	2	-	
3	30884-004	Bracket, Thru-Bolt Mount, 2 Piece, Steel Gr80, 14 Ga, H	-	-	2	-	-	2	
4	30906-002	Strap, Thru-Bolt Mount, Steel Gr80, .179", L	1	-	-	1	-	-	
5	30906-003	Strap, Thru-Bolt Mount, Steel Gr80, .179", M	-	1	-	-	1	-	
6	30906-004	Strap, Thru-Bolt Mount, Steel Gr80, .179", H	-	-	1	-	-	1	
7	30908-002	Rail, Thru-Bolt Mount, 1400 mm, 14 Ga, L	1	-	-	1	-	-	
8	30908-003	Rail, Thru-Bolt Mount, 1400 mm, 14 Ga, M	-	1	-	-	1	-	
9	30908-004	Rail, Thru-Bolt Mount, 1400 mm, 14 Ga, H	-	-	1	-	-	1	
10	60693-100	Bolt, Carriage, Grade 5, H, .313-18 x 1.00	-	-	2	-	-	-	
11	60696-000	Nut, Serrated Flange, H .313"-18"	-	-	2	-	-	-	
12	60797-000	Collar, 1300mm Purlin, 19.3mm, H	2	2	2	2	2	2	
13	60803-150	Bolt, Serrated Hex Flange, IFI 111, SAE J429, Steel, ASTM F1941M Zn-Ni 5C, 1/4"-20, 1.50"	2	2	-	2	2	-	
14	60807-000	Plate, Carriage Bolt, 9mm Square, H	2	2	2	2	2	2	
15	60815-000	Nut, Serrated Hex Flange, 5/16-18, L/M	2	2	-	-	-	-	
16	60816-000	Nut, Serrated Hex Flange, 1/4"-20, H	-	-	2	-	-	2	
17	60817-100	Bolt, Carriage, Grade 5, L/M, 5/16-18 x 1.000	2	2	-	-	-	-	
18	60819-150	Bolt, Serrated Hex Flange, IFI 111, SAE J429, Steel, H, 1/4"-20, 1.50"	-	-	2	-	-	2	
19	60824-100	Bolt, Carriage, Grade 8, 5/16-18 x 1.000, L/M	-	-	-	2	2	-	
20	60825-100	Bolt, Carriage, Grade 8, 5/16-18 x 1.000, H	-	-	-	-	-	2	
21	60851-000	Nut, Serrated Hex Flange, Grade 8, 5/16-18, L/M	-	-	-	2	2	-	
22	60852-000	Nut, Serrated Hex Flange, Grade 8, 5/16-18, H	-	-	-	-	-	2	
23	60860-000	Nut, Serrated Hex Flange, Grade 5, 1/4"-20, L/M	2	2	-	2	2	-	

ZONE	REV	ECR #	DESCRIPTION	DATE
A1, A4, B2, B4, C2, C4, C5, D4, D5	D	21092	ADDED CONFIGURATIONS -102, -103, -104, COMPONENT 60693-100, 60803-150, 60815-000, 60817-100, 60824-100, 60851-000, 60852-000, 60860-000; UPDATED NOTE 2, TITLE AND PART NUMBER DESIGNATION; ADJUSTED BOM QUANTITIES	7/6/2021
D5	C	21052	UPDATED NOTE 1B	3/30/2021
A2, B6	B	20301	M CONFIGURATION ADDED. DESCRIPTION MODIFIED	11/5/2020

DRAWING STATUS		<b>Final</b>		<b>ARRAY TECHNOLOGIES</b>	
DRAWN INITIALS: MK DATE: 09/09/2020	DRAWING CHECK INITIALS: NS DATE: 9/22/2021	3901 Midway Place NE, Albuquerque, NM 87109 (505) 881-7567		<b>ARRAY TECHNOLOGIES</b>	
ENG. CHECK INITIALS: BCDF DATE: 04/06/2021	FINAL APPROVAL INITIALS: SB DATE: 9/22/2021	ALL DIMS ARE DUAL UNITS: MILLIMETER [INCH], DIMENSIONS IN BRACKETS ARE FOR REFERENCE ONLY.		TITLE <b>Assembly, Thru-Bolt Mount, 1400 mm, 14 Ga, Gr X, L/M/H</b>	
THIRD ANGLE PROJECTION		TOLERANCES UNLESS OTHERWISE SPECIFIED		SIZE B	DRAWING NUMBER 20916-901
MM [INCH]: X = ±1.25 [0.049] .X = ±0.4 [0.016] .XX = ±0.1 [0.004]	METER [INCH]: X.XX = ±0.013 [0.512] X.XXX = ±0.006 [0.236]	ANGULAR: X = ±1.0° .X = ±0.1°	SCALE 1:10	REVISION D	SAVED v51 9/16/2021
PROPRIETARY AND CONFIDENTIAL THE INFORMATION CONTAINED IN THIS DRAWING IS THE SOLE PROPERTY OF ARRAY TECHNOLOGIES. ANY REPRODUCTION IN PART OR AS A WHOLE WITHOUT THE WRITTEN PERMISSION FROM ARRAY TECHNOLOGIES IS PROHIBITED.			WT: 4.148kg [9.145lb]	SHEET 1 OF 1	

NOTES:

- ① BOM FASTENER QTY IS PER MODULE
- ② PREFERRED BOLT ORIENTATION IS DROPPING DOWN FROM TOP OF HOLE
- 3. TORQUE SPECIFICATIONS
  - ③A. 12.2±1.4 N-M [9±1 ft-Lbs]
  - ③B. 25.5±1.5 N-M [19±1 ft-Lbs]
  - ③C. 25.5±1.5 N-M [19±1 ft-Lbs]

TIGHTEN NUTS PROGRESSIVELY ON EACH SIDE OF STRAP TO ENSURE UNIFORM CLOSING OF GAP BETWEEN MATING PARTS. GAP MEASUREMENT ON EACH SIDE MUST BE WITHIN 1mm [.04"] OF EACH OTHER.
- 4. MARK ALL TORQUED CONNECTIONS USING PAINT MARKER OF CONTRASTING COLOR ACROSS IMMOBILE BASE AND ALL PARTS SUBJECT TO LOOSENING.
- 5. USE MODULE APPROVAL LISTINGS TO DETERMINE REQUIRED MOUNT AND ATTACHMENT METHOD
- 6. USE THE CONFIGURATION TABLE TO SELECT THE MOUNT WITH THE APPROPRIATE LENGTH, MATERIAL, AND CORROSION CLASS

MOUNT CONFIGURATION TABLE	
20893-002	Assembly, Thru-Bolt Mount, 1300 mm, 14 Ga, G5 HW, L
20893-003	Assembly, Thru-Bolt Mount, 1300 mm, 14 Ga, G5 HW, M
20893-004	Assembly, Thru-Bolt Mount, 1300 mm, 14 Ga, G5 HW, H
20893-102	Assembly, Thru-Bolt Mount, 1300 mm, 14 Ga, G8 HW, L
20893-103	Assembly, Thru-Bolt Mount, 1300 mm, 14 Ga, G8 HW, M
20893-104	Assembly, Thru-Bolt Mount, 1300 mm, 14 Ga, G8 HW, H
20916-002	Assembly, Thru-Bolt Mount, 1400 mm, 14 Ga, G5, L
20916-003	Assembly, Thru-Bolt Mount, 1400 mm, 14 Ga, G5, M
20916-004	Assembly, Thru-Bolt Mount, 1400 mm, 14 Ga, G5, H
20916-102	Assembly, Thru-Bolt Mount, 1400 mm, 14 Ga, G8, L
20916-103	Assembly, Thru-Bolt Mount, 1400 mm, 14 Ga, G8, M
20916-104	Assembly, Thru-Bolt Mount, 1400 mm, 14 Ga, G8, H

SEE NOTE 7 FOR HARDWARE SPECIFICATION

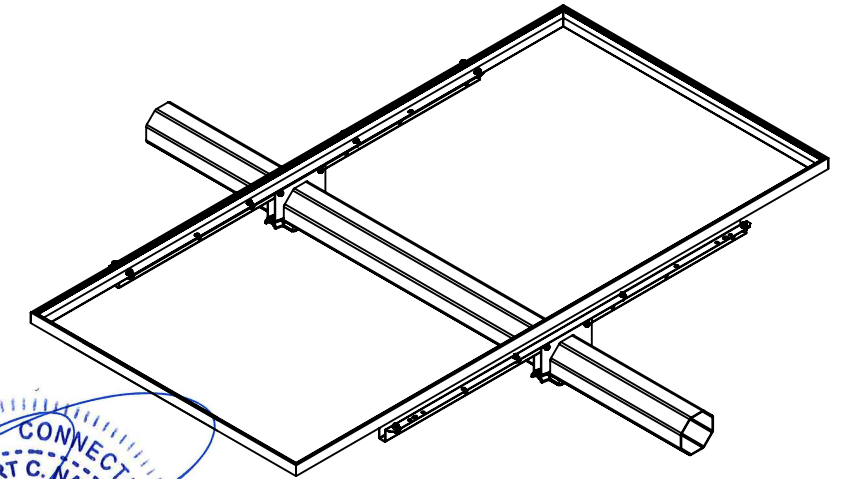
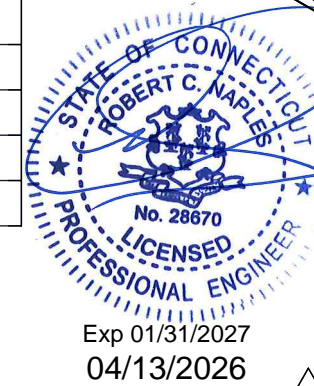

TABLE 3: ALUMINUM SWAGE HARDWARE BOM			MODULE ATTACHMENT METHODS							
ITEM NO.	PART NUMBER	DESCRIPTION	A	B	C	D	E	F	G	H
1	MOUNT	Assembly, Thru-Bolt Mount, XXXX mm, 14 Ga, Gr X HW, L/M/H	1	1	1	1	1	1	1	1
11	60881-875	Bolt, Huck, Bobtail, 0.25" x 0.875", Aluminum	-	-	-	-	-	-	-	8
12	60882-000	Collar, Huck, 6061 Al, 0.25"	-	-	-	-	-	-	-	8

TABLE 1: CARBON STEEL HARDWARE BOM			MODULE ATTACHMENT METHODS							
ITEM NO.	PART NUMBER	DESCRIPTION	A	B	C	D	E	F	G	H
1	MOUNT	Assembly, Thru-Bolt Mount, XXXX mm, 14 Ga, Gr X HW, L/M/H	1	1	1	1	1	1	1	1
2	50291-000	Washer, Grounding, SST, 5/16"	-	-	-	1	1	1	-	-
7	60696-000	Nut, Serrated Flange, H .313"-18"	4	4	8	4	4	8	4	-
8	60816-000	Nut, Serrated Hex Flange, 1/4"-20, H	4	-	-	4	-	-	4	-
9	60818-063	Bolt, Serrated Hex Flange, IFI 111, SAE J429, 5/16"-18, 0.63", H	4	4	8	4	4	8	4	-
10	60819-063	Bolt, Serrated Hex Flange, IFI 111, SAE J429, Steel, H, 1/4"-20, 0.63"	4	-	-	4	-	-	4	-

TABLE 2: STAINLESS STEEL HARDWARE BOM			MODULE ATTACHMENT METHODS							
ITEM NO.	PART NUMBER	DESCRIPTION	A	B	C	D	E	F	G	H
1	MOUNT	Assembly, Thru-Bolt Mount, XXXX mm, 14 Ga, Gr X HW, L/M/H	1	1	1	1	1	1	1	1
2	50291-000	Washer, Grounding, SST, 5/16"	-	-	-	1	1	1	-	-
3	60069-000	Nut, Serrated Flange .250-20, SST	4	-	-	4	-	-	4	-
4	60137-063	Screw, Hex Serrated, 304 SS, .250-20 x .625	4	-	-	4	-	-	4	-
5	60159-000	Nut, Lock Serrated SS 304, 0.3125"-18	4	4	8	4	4	8	4	-
6	60166-063	Screw, Hex Serrated, 304SS, 0.3125"-18 x 0.625"	4	4	8	4	4	8	4	-

C3, 2-A3, 2-A7, 2-B1, 2-B5, 2-C6, 2-D5, 2-D8, 3-B6, 4-B6, 5-B6, 5-C3, 6-A1	G	22061	UPDATED NOTE 7 AND NAMES OF DETAIL/SECTION VIEWS, ADDED ATTACHMENT METHOD "H", SHEET 6 AND TABLE 3	10/24/2022
A4, A7, B4, B7, C5, 2-A4, 2-B2, 2-B3, 2-B4, 2-C1, 2-D1, 2-D7, 3-B6, 3-C6, 4-B6, 4-C7, 5-B6, 5-C3, 5-C6, 5-D3	F	22007	ADDED STAINLESS STEEL HARDWARE TABLE 2 AND TITLE FOR TABLE 1, UPDATED NOTE 7 AND MOVED TO SHEET 2 WITH CLAMP ZONE DEFINITION VIEW	1/14/2022
A5, 2-C6, 5-A1	E	21141	ADDED ATTACHMENT METHOD "G" TO NOTE 7, CONFIGURATION "G" IN TABLE AND SHEET 5	10/28/2021
ZONE	REV	ECR #	DESCRIPTION	DATE

PROPRIETARY AND CONFIDENTIAL THE INFORMATION CONTAINED IN THIS DRAWING IS THE SOLE PROPERTY OF ARRAY TECHNOLOGIES. ANY REPRODUCTION IN PART OR AS A WHOLE WITHOUT THE WRITTEN PERMISSION FROM ARRAY TECHNOLOGIES IS PROHIBITED.	DRAWING STATUS: <b>Final</b>		<b>ARRAY TECHNOLOGIES</b> 3901 Midway Place NE, Albuquerque, NM 87109 (505) 881-7567		
	DRAWN: _____ ENG. CHECK: _____ INITIALS: FS DATE: 11/23/2022	DRAWING CHECK: _____ FINAL APPROVAL: _____ INITIALS: NC DATE: 11/14/2022 INITIALS: SB DATE: 11/23/2022	TITLE: Field Assembly, Thru-Bolt Mount, X mm, X Ga, Gr X, L/M/H		
	THIRD ANGLE PROJECTION TOLERANCES UNLESS OTHERWISE SPECIFIED MM [INCH]: X ±1.25 [0.049] .X ±0.4 [0.016] .XX ±0.1 [0.004]		METER [INCH]: X.XX ±±0.013 [0.512] X.XXX ±±0.006 [0.236]	ANGULAR: X = ±1.0° .X = ±0.1°	SIZE: B SCALE: 1:20 DRAWING NUMBER: 20895-901 REVISION: G SHEET: 1 OF 6

Template\_CF Drawing\_mm\_v5

NOTES:

- ⑦ MODULE ATTACHMENT METHODS: SELECT APPROPRIATE HARDWARE BOM - CARBON STEEL HARDWARE BOM (TABLE 1), STAINLESS-STEEL BOM (TABLE 2), OR ALUMINUM HUCK BOM (TABLE 3). NOTE: ONLY ONE HARDWARE BOM CAN BE CHOSEN (TABLE 1, TABLE 2, OR TABLE 3) MIXING CARBON STEEL HARDWARE WITH STAINLESS STEEL HARDWARE OR USING HUCK ALUMINUM HARDWARE WITH CARBON STEEL/ STAINLESS STEEL HARDWARE IS NOT ALLOWED. NOTE: SWAGE FASTENERS REQUIRE SWAGING TOOL TO INSTALL SWAGE FASTENERS AND SWAGE FASTENERS CAN ONLY BE USED WHERE THE BOTTOM OF THE GLASS OF THE MODULE TO THE MODULE FLANGE SURFACE IS EQUAL TO OR GREATER THAN 17mm

- |                                                                             |                                                                              |
|-----------------------------------------------------------------------------|------------------------------------------------------------------------------|
| A. ZONE 1: 1/4"-20<br>ZONE 2: NA<br>ZONE 3: 5/16"-18                        | E. ZONE 1: NA<br>ZONE 2: NA<br>ZONE 3: 5/16"-18, WITH GROUNDING WASHER       |
| B. ZONE 1: NA<br>ZONE 2: NA<br>ZONE 3: 5/16"-18                             | F. ZONE 1: NA<br>ZONE 2: 5/16"-18<br>ZONE 3: 5/16"-18, WITH GROUNDING WASHER |
| C. ZONE 1: NA<br>ZONE 2: 5/16"-18<br>ZONE 3: 5/16"-18                       | G. ZONE 1: 1/4"-20<br>ZONE 2: 5/16"-18<br>ZONE 3: NA                         |
| D. ZONE 1: 1/4"-20<br>ZONE 2: NA<br>ZONE 3: 5/16"-18, WITH GROUNDING WASHER | H. ZONE 1: 1/4" SWAGE BOLT<br>ZONE 2: NA<br>ZONE 3: 1/4" SWAGE BOLT          |

8. REFER TO ARRAY DOCUMENT 90115-000 FOR ADDITIONAL MODULE INSTALLATION INSTRUCTIONS.

- ⑨ WHEN TRACKER IS IN THE HORIZONTAL POSITION, MODULE GAPS ON EITHER SIDE MUST BE EQUAL WITHIN ±1mm.

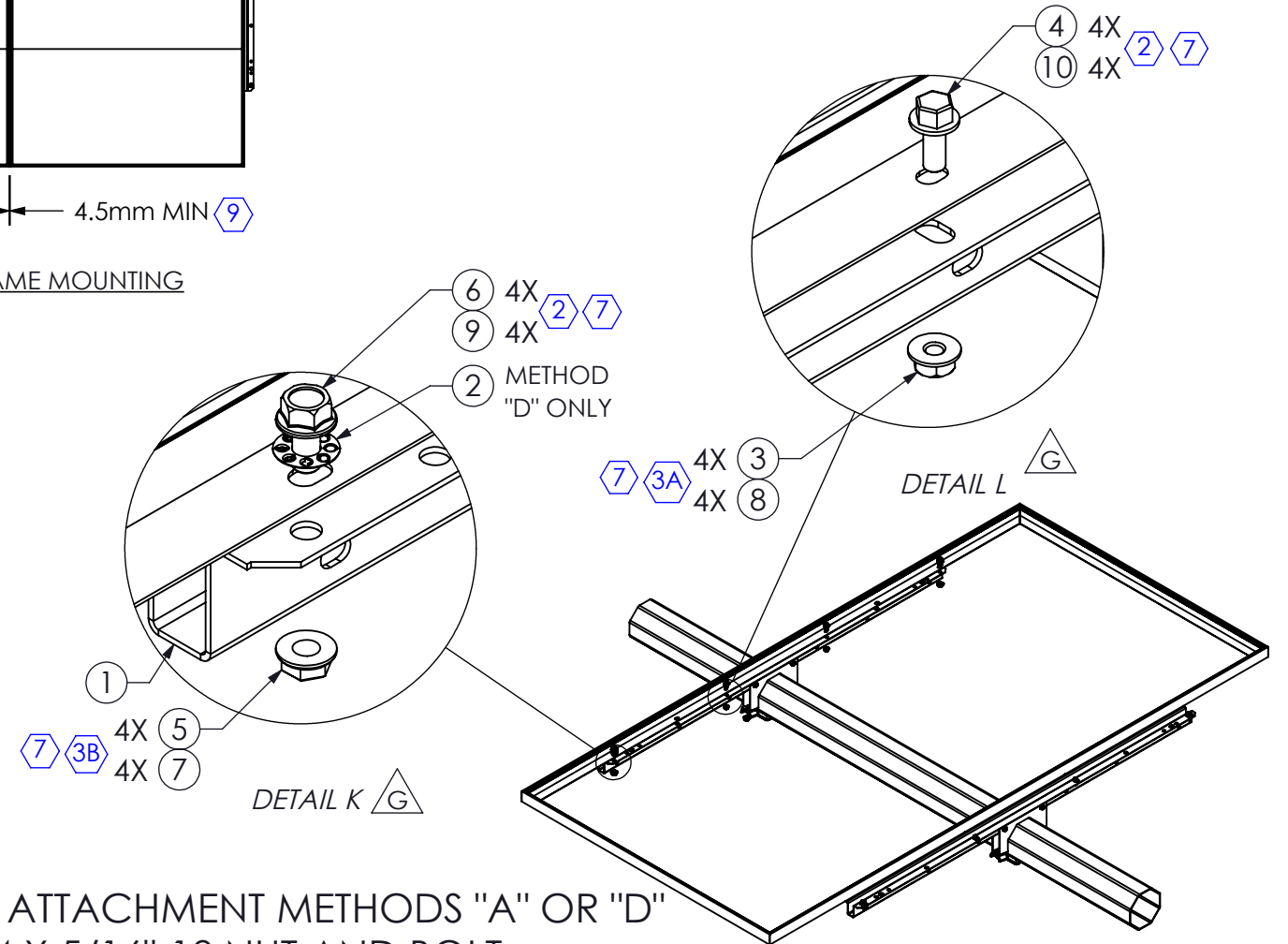
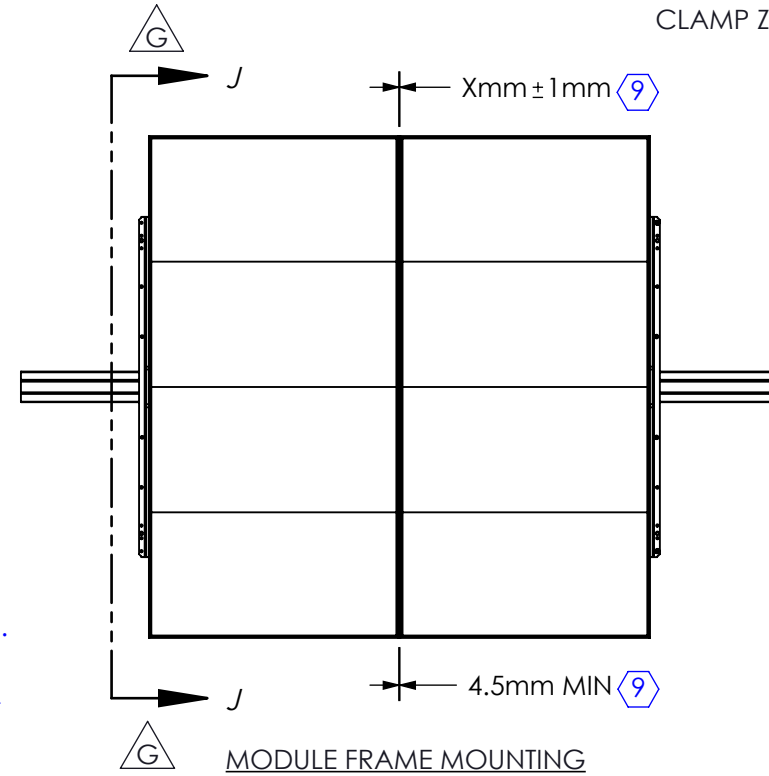
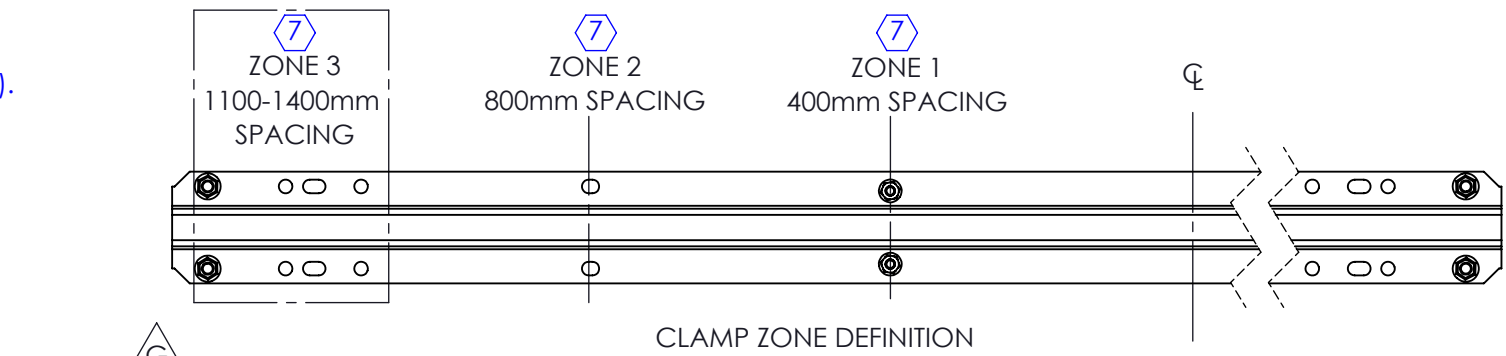
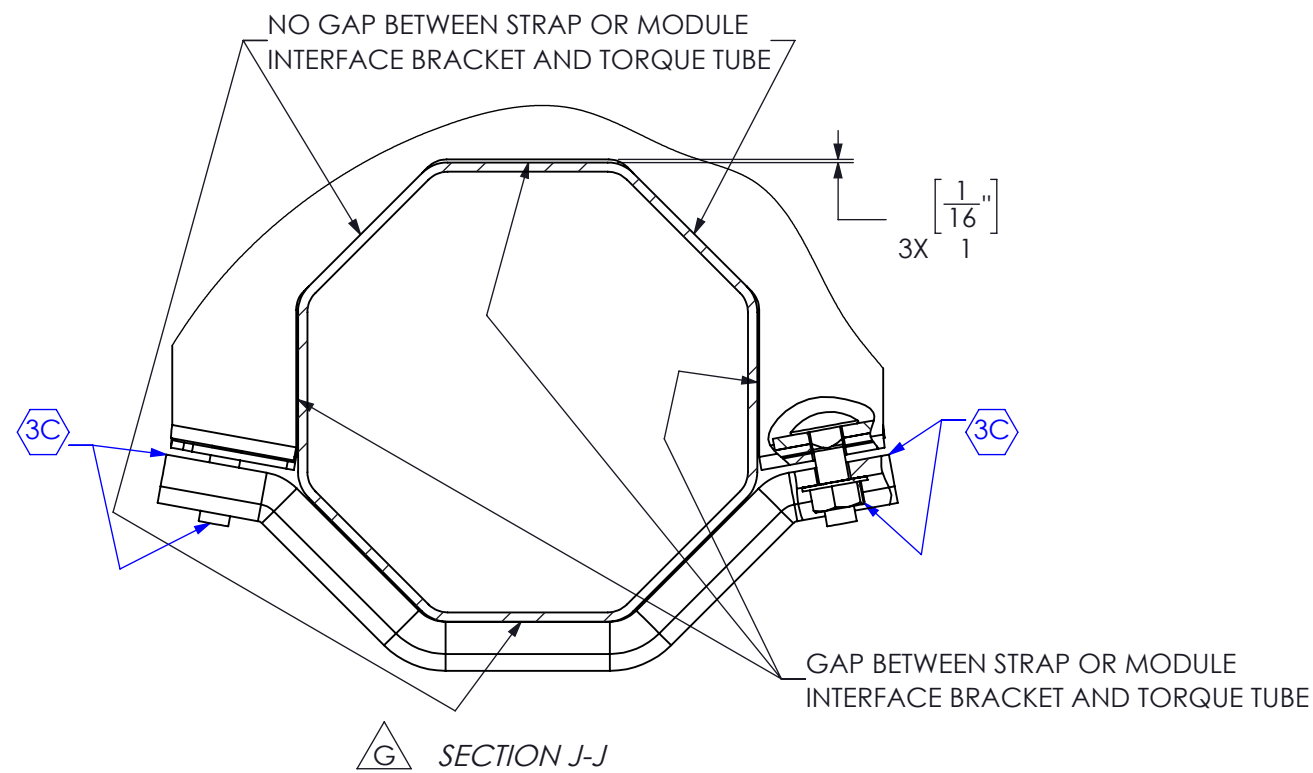

MODULE ATTACHMENT METHODS "A" OR "D"  
4 X 5/16"-18 NUT AND BOLT  
4 X 1/4"-20 NUT AND BOLT

SIZE B	DRAWING NUMBER 20895-901	REVISION G	SAVED v127 11/23/2022
SCALE 1:2	SHEET 2 OF 6		

8

7

6

5

4

3

2

1

D

D

C

C

B

B

A

A

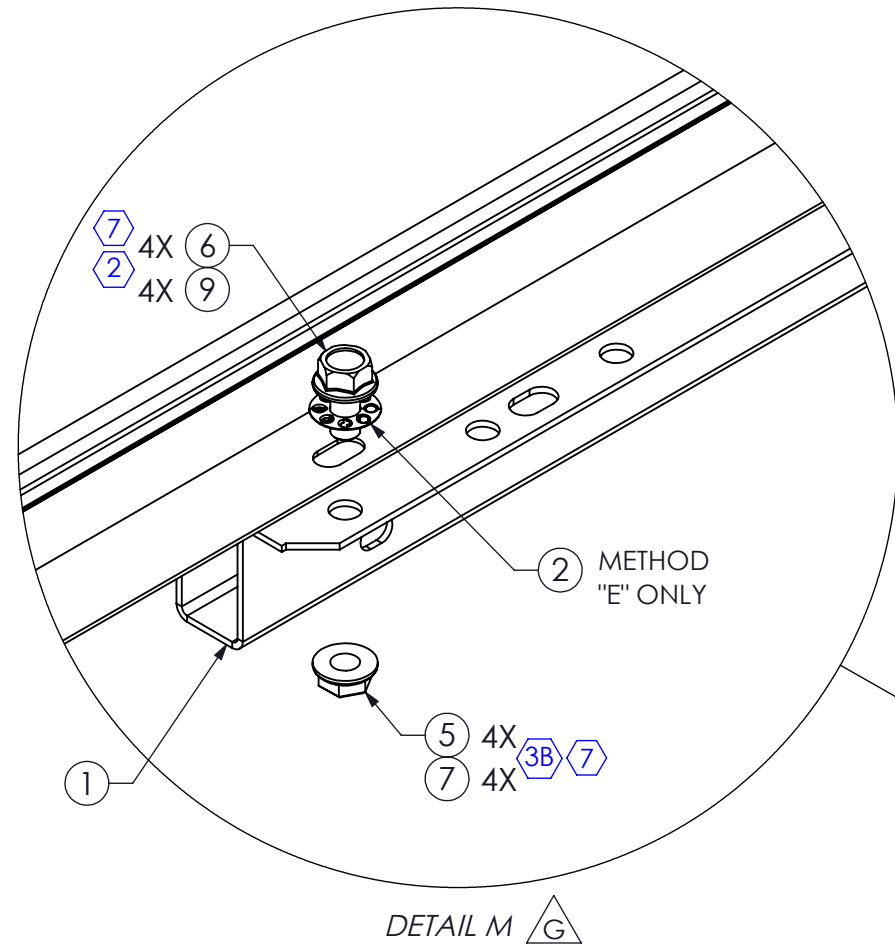

MODULE ATTACHMENT METHODS "B" OR "E"  
4 X 5/16"-18 NUT AND BOLT

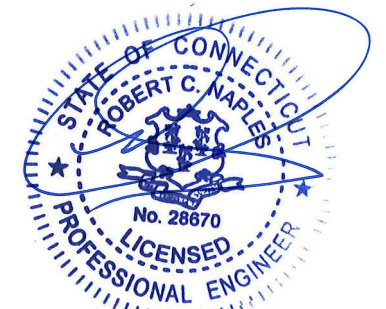
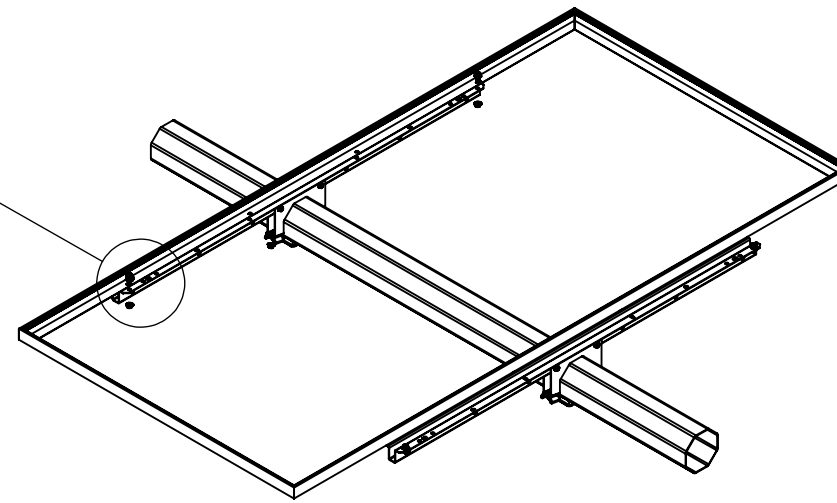

Exp 01/31/2027  
04/13/2026

SIZE B	DRAWING NUMBER 20895-901	REVISION G	SAVED v127 11/23/2022
SCALE 1:2	SHEET 3 OF 6		

8

7

6

5

4

3

2

1

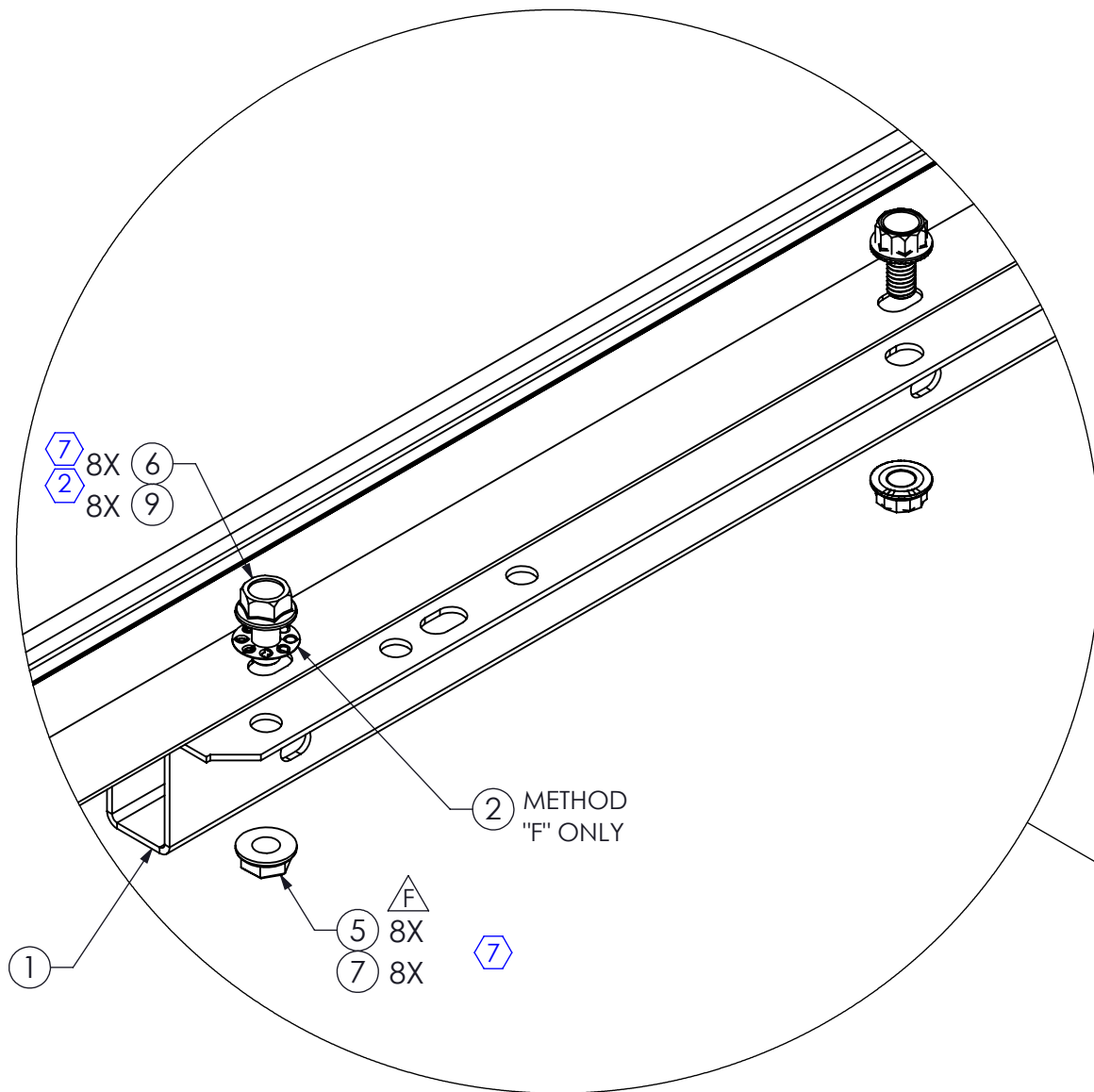

△ G DETAIL N

MODULE ATTACHMENT METHODS "C" OR "F"  
8 X 5/16"-18 NUT AND BOLT

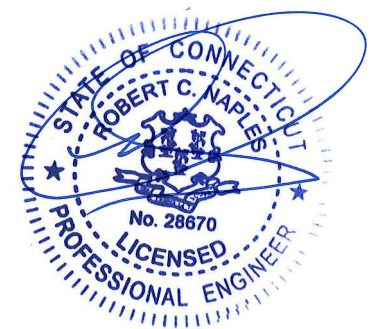
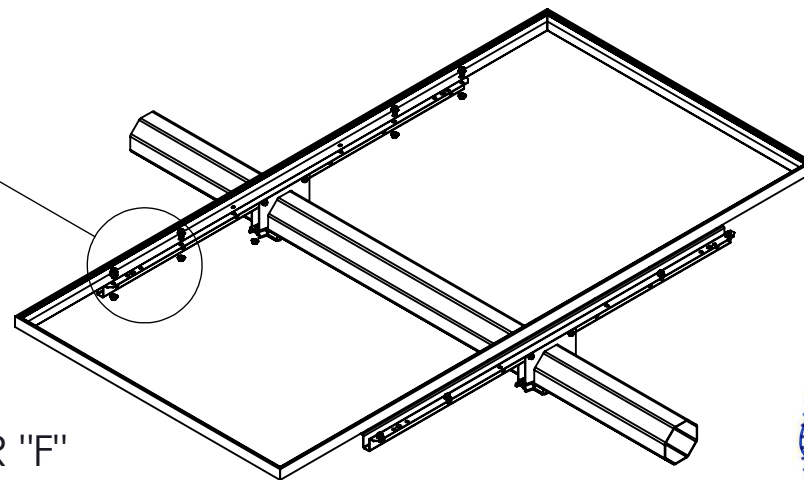

Exp 01/31/2027  
04/13/2026

SIZE B	DRAWING NUMBER 20895-901	REVISION G	SAVED v127 11/23/2022
SCALE 1:2	SHEET 4 OF 6		

8

7

6

5

4

3

2

1

D

D

C

C

B

B

A

A

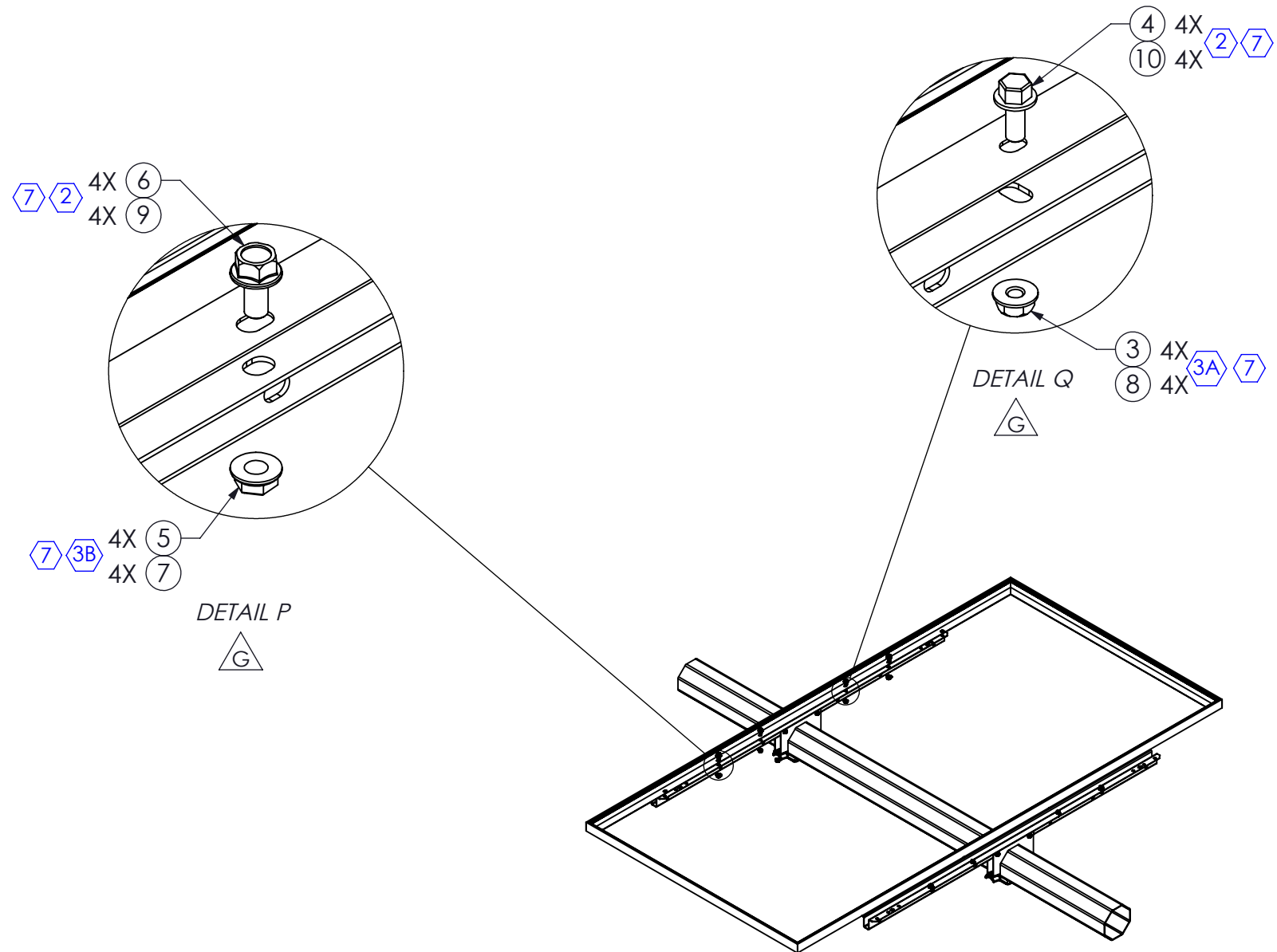

MODULE ATTACHMENT METHODS "G"  
 4 X 5/16"-18 NUT AND BOLT  
 4 X 1/4"-20 NUT AND BOLT

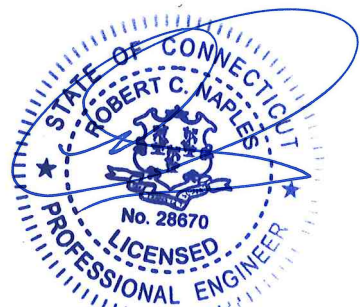

Exp 01/31/2027  
 04/13/2026

SIZE B	DRAWING NUMBER 20895-901	REVISION G	SAVED v127 11/23/2022
SCALE 1:20	SHEET 5 OF 6		

Template\_CF Drawing\_mm\_v5

8

7

6

5

4

3

2

1

8

7

6

5

4

3

2

1

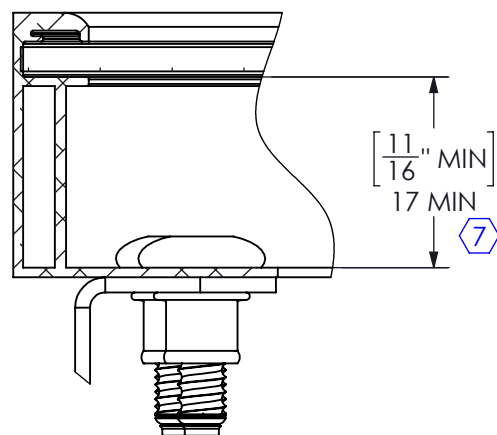
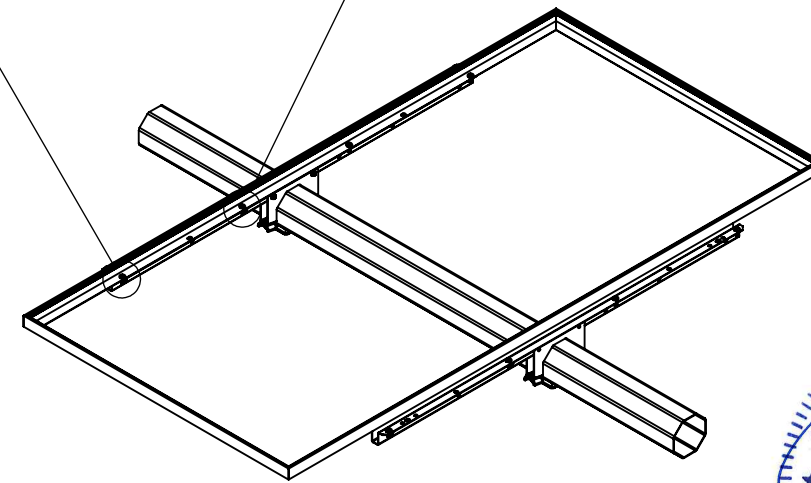
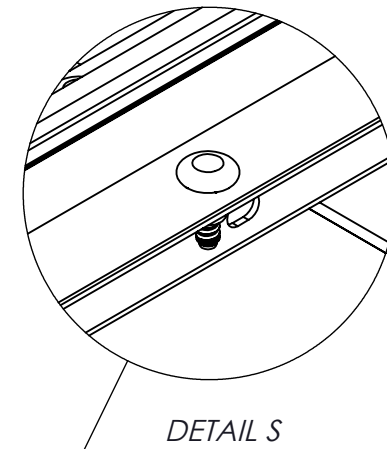
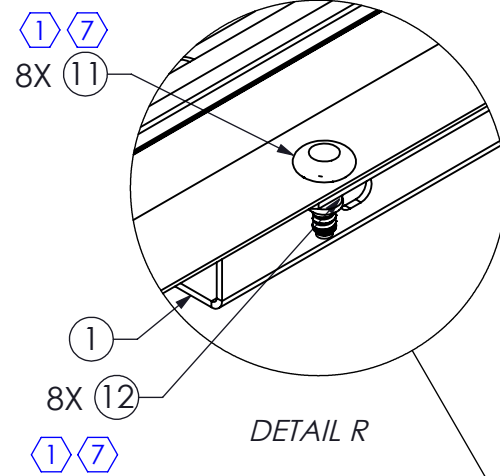
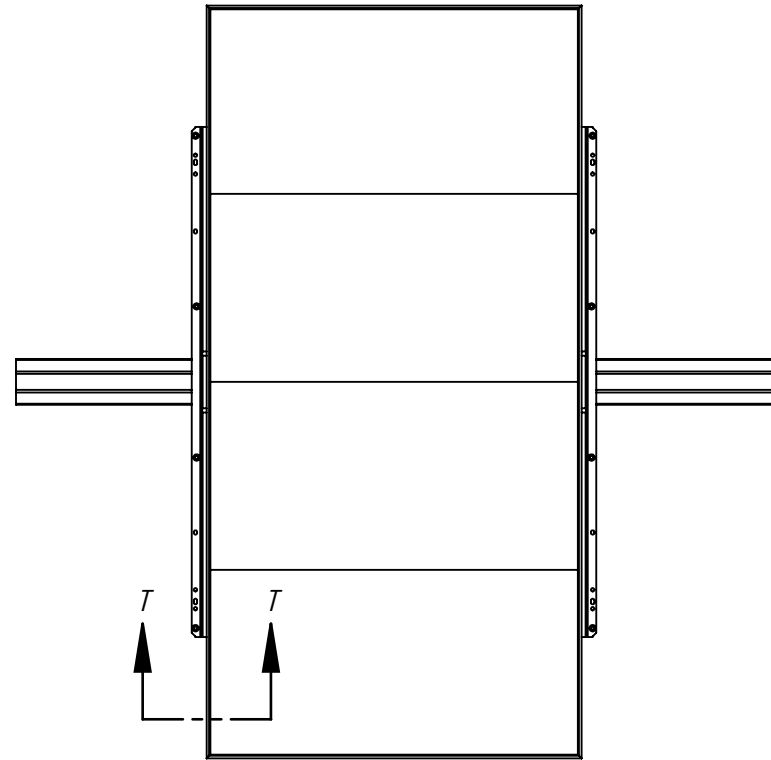

SECTION T-T

MODULE ATTACHMENT METHODS "H"  
8 X 1/4" SWAGE BOLT AND COLLAR

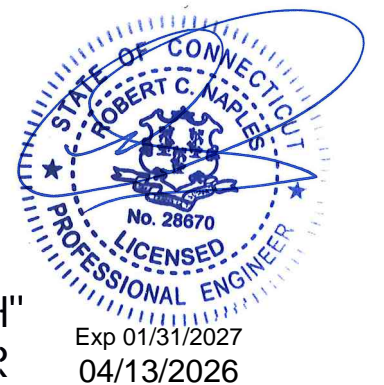

Exp 01/31/2027  
04/13/2026

SIZE B	DRAWING NUMBER	REVISION	SAVED v127
	20895-901	G	11/23/2022
SCALE 1:2	SHEET		6 OF 6



**NOTES:**

- ① FORM RIVET HEAD BY ORBITAL RIVETING PROCESS. RIVET HEAD SHAPE TO BE APPROVED BY ARRAY. HINGE MUST PIVOT FREELY BY HAND AFTER FORMING.
- ② OPTIONAL ASSEMBLY DATE MARKING WHERE SHOWN.

ARRAY PART NUMBER DESIGNATION

**21014-XXX**

ARRAY PART NUMBER EXTENSION INDICATES CORROSION GROUP  
 -200 INDICATES LOW CORROSION  
 -300 INDICATES MEDIUM CORROSION  
 -400 INDICATES HIGH CORROSION

ARRAY PART NUMBER

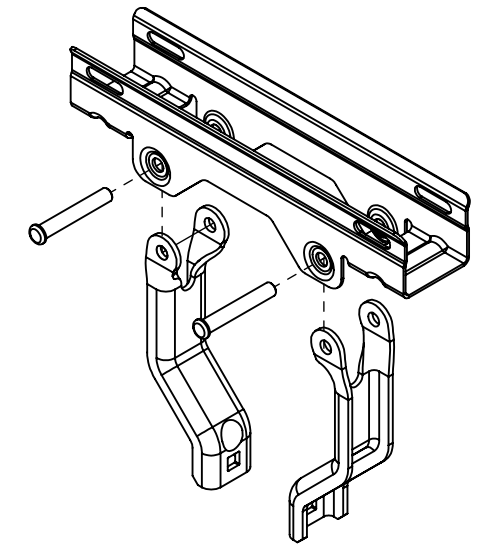

ARRAY P/N: 21014-XXX

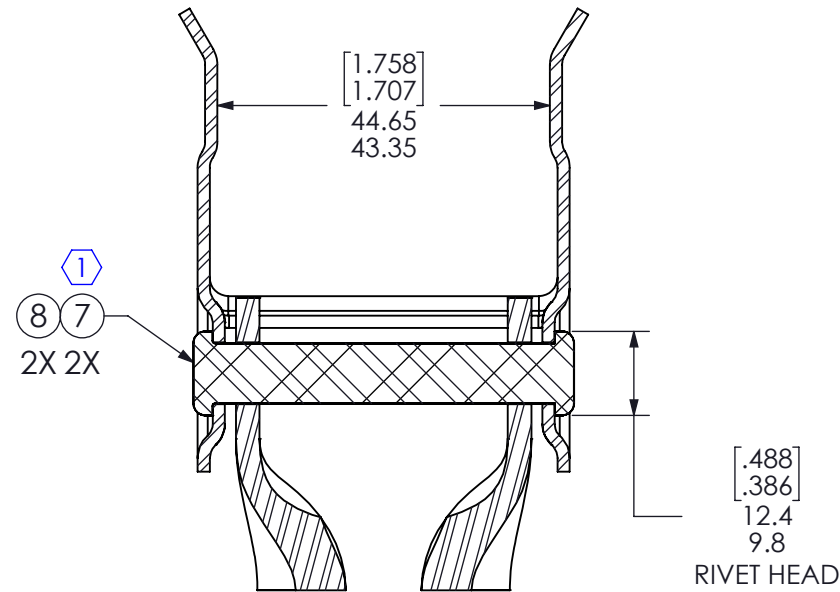

SECTION A-A

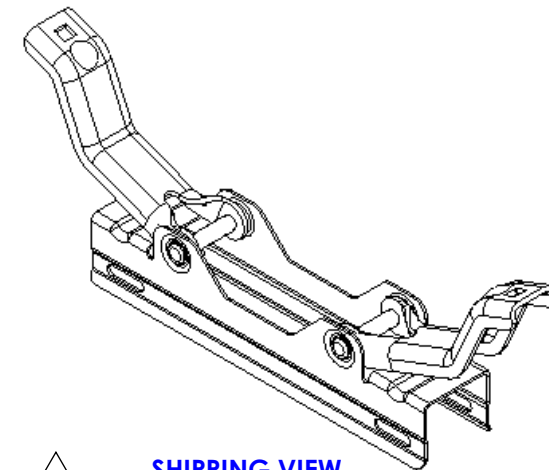
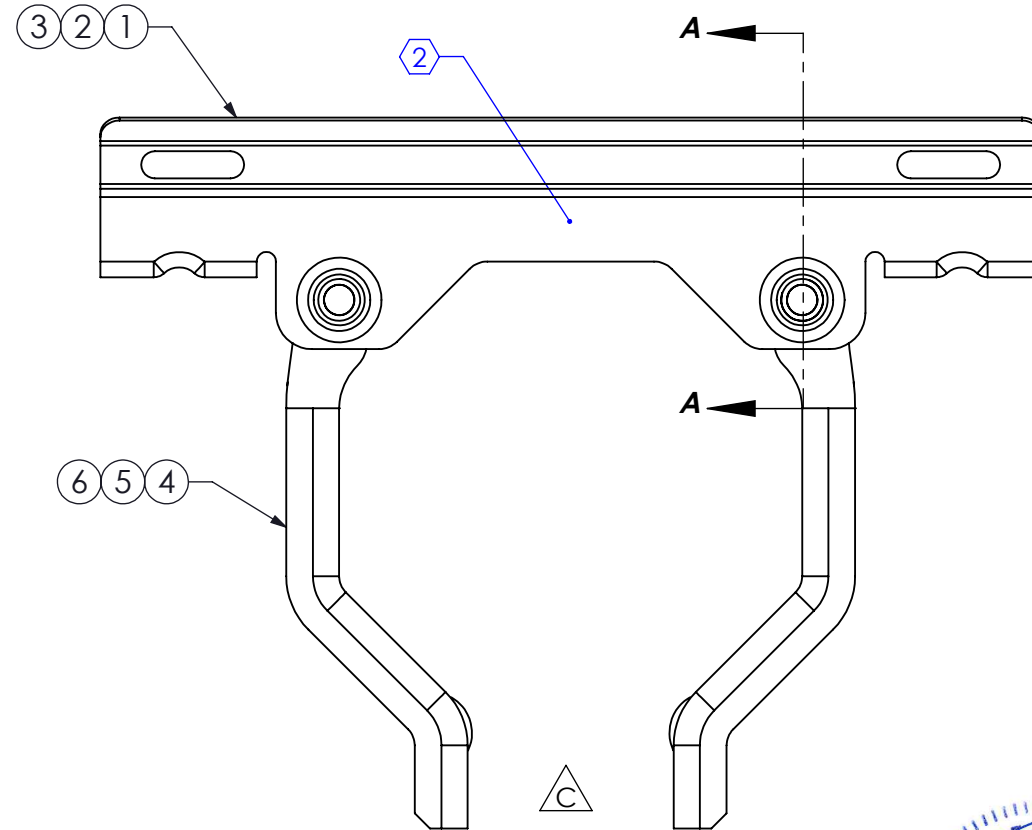

SHIPPING VIEW  
STRAPS FOLDED DOWN

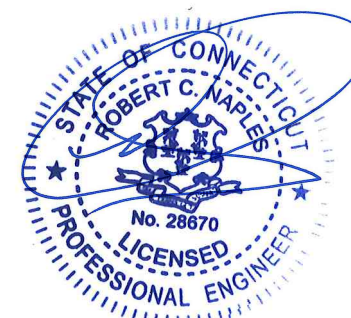

Exp 01/31/2027  
04/13/2026

ITEM NO.	PART NUMBER	DESCRIPTION	-200	-300	-400
1	30938-200	Rail, Stamped, 200mm FS7 Clamp, 16Ga, L	1	-	-
2	30938-300	Rail, Stamped, 200mm FS7 Clamp, 16Ga, M	-	1	-
3	30938-400	Rail, Stamped, 200mm FS7 Clamp, 16Ga, H	-	-	1
4	30939-200	Strap, Stamped, Short, 11Ga, L	2	-	-
5	30939-300	Strap, Stamped, Short, 11Ga, M	-	2	-
6	30939-400	Strap, Stamped, Short, 11Ga, H	-	-	2
7	60874-202	Rivet, Pan Head, Steel, 0.313", 2.02, L/M	2	2	-
8	60875-202	Rivet, Pan Head, Stainless, 0.313", 2.02, H	-	-	2

ZONE	REV	ECR #	DESCRIPTION	DATE
B3, B5	C	US-23125	REMOVED NOTE 2, 60825-300 AND 60852-000, ADDED SHIPPING VIEW	8/25/2023
A6, C7, C8	B	US-23112	ADDED L/M RIVETS TO L/M CONFIGS, ADJUSTED DIMENSIONS	7/27/2023
	A		INITIAL RELEASE	12/12/2022

APPLICABLE TRACKER SYSTEMS:	DRAWING STATUS: <b>Final</b>	<b>ARRAY TECHNOLOGIES</b> 3901 Midway Place NE, Albuquerque, NM 87109 (505) 881-7567		
PROPRIETARY AND CONFIDENTIAL: THE INFORMATION CONTAINED IN THIS DRAWING IS THE SOLE PROPERTY OF ARRAY TECHNOLOGIES. ANY REPRODUCTION IN PART OR AS A WHOLE WITHOUT THE WRITTEN PERMISSION FROM ARRAY TECHNOLOGIES IS PROHIBITED.	DRAWN: RM DATE: 09/20/2022 ENG. CHECK: SB DATE: 09/01/2023	DRAWING CHECK: RM DATE: 9/1/2023 FINAL APPROVAL: SB DATE: 9/1/2023	TITLE: <b>Assembly, FS7 Clamp, 200mm, L/M/H</b>	
	THIRD ANGLE PROJECTION TOLERANCES UNLESS OTHERWISE SPECIFIED mm [INCH]: X = ±1.25 [0.049] .X = ±0.4 [0.016] .XX = ±0.1 [0.004]		ALL DIMS ARE DUAL UNITS: MILLIMETER [INCH]. DIMENSIONS IN BRACKETS ARE FOR REFERENCE ONLY. METER [INCH]: X.XX = ±0.013 [0.512] X.XXX = ±0.006 [0.236]	ANGLAR: X = ±1.0° .X = ±0.1°
			REVISION: C SHEET: 1 OF 1	SAVED v31: 9/1/2023

**NOTES:** C

1. QUANTITY OF COMPONENTS SHOWN IN BOM IS PER MODULE.
2. REFER TO 90139-000 INSTALLATION ADDENDUM FOR DETAILS.
3. TORQUE SPECIFICATION:  
3A 23±1.5 N-M [17±2 FT-LBS]
4. MARK ALL TORQUED CONNECTIONS USING PAINT MARKER OF CONTRASTING COLOR ACROSS IMMOBILE BASE AND ALL PARTS SUBJECT TO LOOSENING.
5. STRAP HARDWARE ARE SHIPPED SEPARATELY.
6. ALTERNATE PART # 60877-000 MAY BE SUBSTITUTED FOR 60956-XXX.

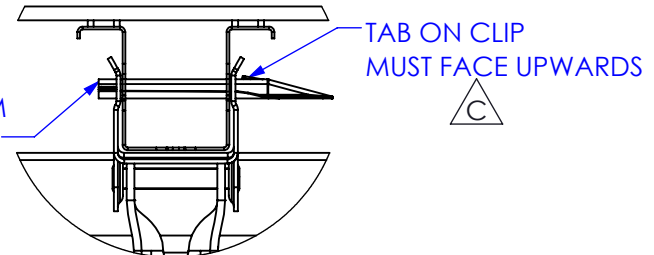
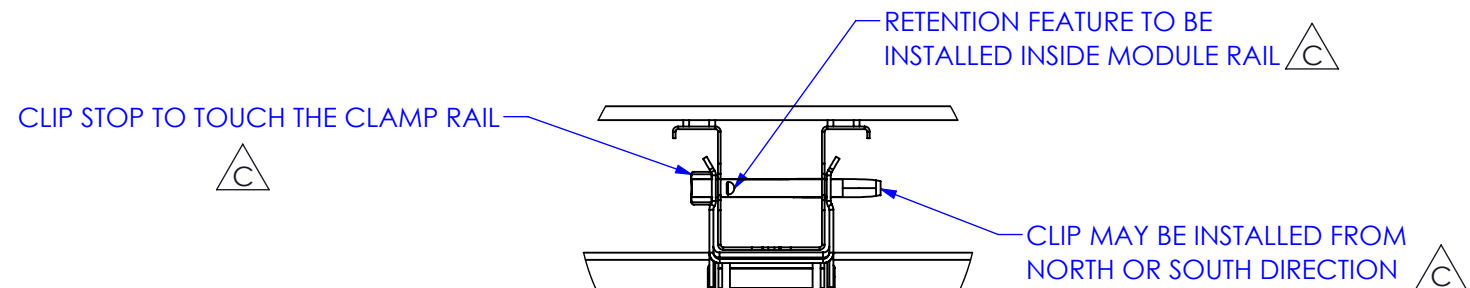

**6** *DETAIL B*  
**60877-000 CLIP**

**DETAIL A**  
**60956-XXX CLIP**

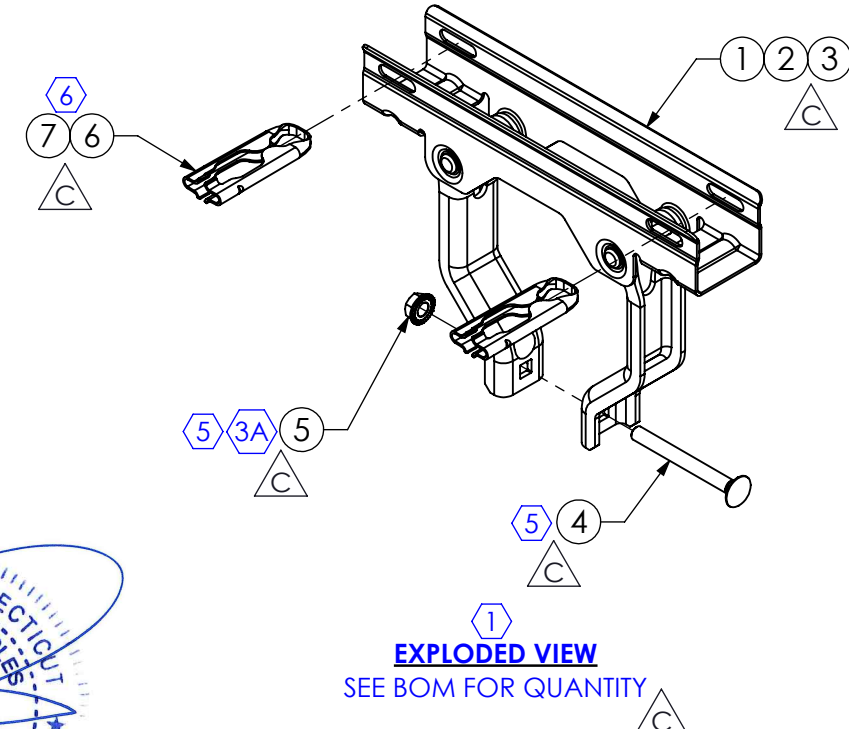
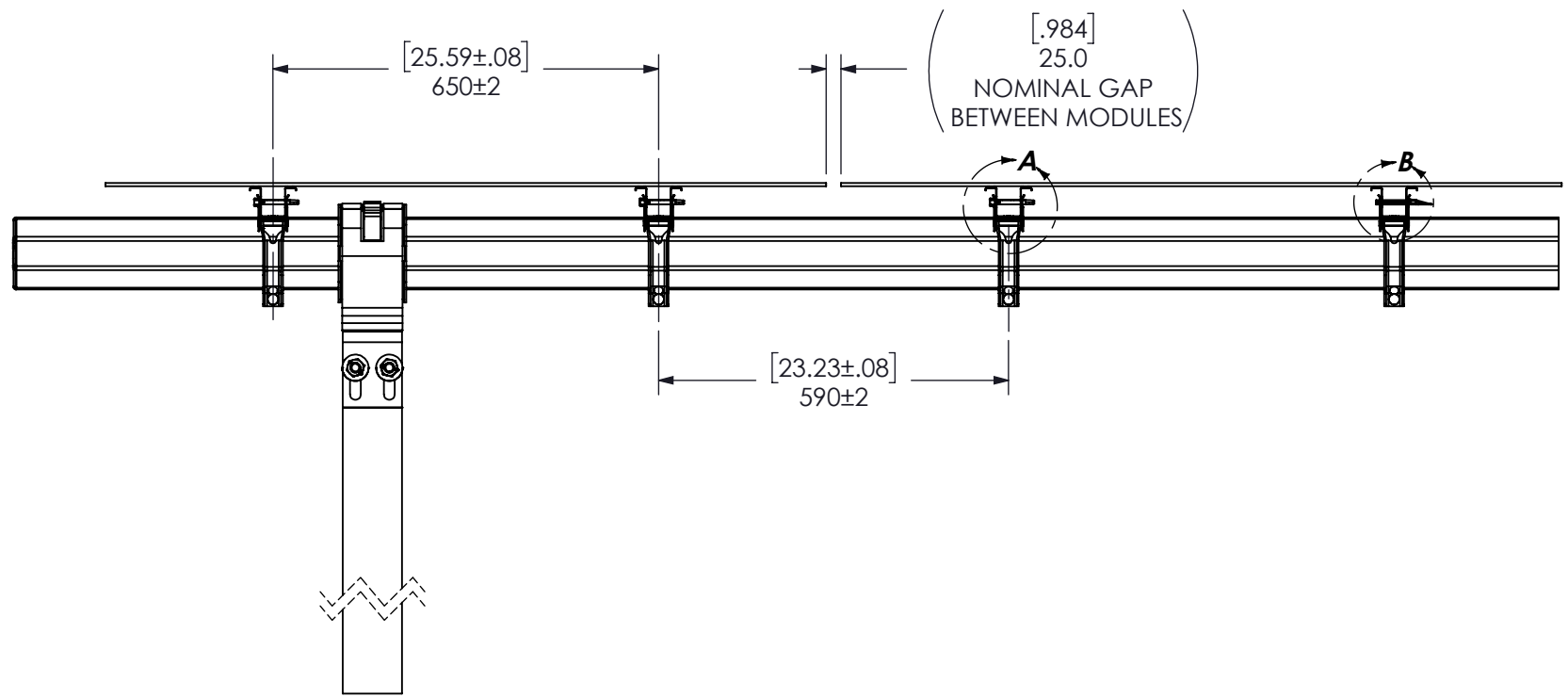

**1** **EXPLODED VIEW**  
SEE BOM FOR QUANTITY



ITEM NO.	PART NUMBER	DESCRIPTION	-200	-300	-400
1	21014-200	Assembly, FS7 Clamp, 200mm, L	2	-	-
2	21014-300	Assembly, FS7 Clamp, 200mm, M	-	2	-
3	21014-400	Assembly, FS7 Clamp, 200mm, H	-	-	2
4	60825-300	Bolt, Carriage, Grade 8, 5/16-18 x 3.000, H	2	2	2
5	60852-000	Nut, Serrated Hex Flange, Grade 8, 5/16-18, H	2	2	2
6	60956-300	Clip, Stamped, FS7 Clamp, L/M	4	4	-
7	60956-400	Clip, Stamped, FS7 Clamp, H	-	-	4

ZONE	REV	ECR #	DESCRIPTION	DATE
A6, B2, B3, C1, C3, D1, D4, D5, D8	C	US-23125	UPDATED NOTES, REMOVED DESIGNATION, REPLACED CLIP, ADDED HARDWARE AND PREV CLIP VIEW	8/25/2023
A3	B	US-23015	ADDED APPLICABLE TRACKER SYSTEM	2/14/2023
	A		INITIAL RELEASE	1/26/2023

APPLICABLE TRACKER SYSTEMS: DuraTrack OmniTrack	DRAWING STATUS <b>Final</b>	<b>ARRAY TECHNOLOGIES</b> 3901 Midway Place NE, Albuquerque, NM 87109 (505) 881-7567													
PROPRIETARY AND CONFIDENTIAL: THE INFORMATION CONTAINED IN THIS DRAWING IS THE SOLE PROPERTY OF ARRAY TECHNOLOGIES. ANY REPRODUCTION IN PART OR AS A WHOLE WITHOUT THE WRITTEN PERMISSION FROM ARRAY TECHNOLOGIES IS PROHIBITED.	DRAWN: RM DATE: 10/25/2022 ENG. CHECK: SB DATE: 09/07/2023 FINAL APPROVAL: DS DATE: 9/7/2023 FINAL APPROVAL: SB DATE: 9/7/2023	<table border="1"> <tr> <th>SIZE</th> <th>DRAWING NUMBER</th> <th>REVISION</th> <th>SAVED v35</th> </tr> <tr> <td>B</td> <td>21015-901</td> <td>C</td> <td>9/7/2023</td> </tr> <tr> <td>SCALE 1:12</td> <td colspan="2">SHEET</td> <td>1 OF 1</td> </tr> </table>		SIZE	DRAWING NUMBER	REVISION	SAVED v35	B	21015-901	C	9/7/2023	SCALE 1:12	SHEET		1 OF 1
SIZE	DRAWING NUMBER	REVISION	SAVED v35												
B	21015-901	C	9/7/2023												
SCALE 1:12	SHEET		1 OF 1												
<p>THIRD ANGLE PROJECTION</p> <p>TOLERANCES UNLESS OTHERWISE SPECIFIED</p> <p>MM [INCH]: X = ±1.25 [0.049] .X = ±0.4 [0.016] .XX = ±0.1 [0.004]</p> <p>METER [INCH]: X.XX = ±0.013 [0.512] X.XXX = ±0.006 [0.236]</p> <p>ANGULAR: X = ±1.0° .X = ±0.1°</p>		<p>ALL DIMS ARE DUAL UNITS: MILLIMETER [INCH]. DIMENSIONS IN BRACKETS ARE FOR REFERENCE ONLY.</p>													

**NOTES:**

1. TORQUE SPECIFICATION:

1A) 61 ±7 N-M [45 ±5 FT-LBS]

1B) UPPER BRACKET ASSEMBLY AND FIT CHECK TO BE PERFORMED PER WORK INSTRUCTION AOS-53-WI-0021 ON 71005-000.

2) SUPPLIER IDENTIFICATION MARK TO BE LOCATED ON THIS SIDE OF THE ASSEMBLY FOR PROPER OPERATION.

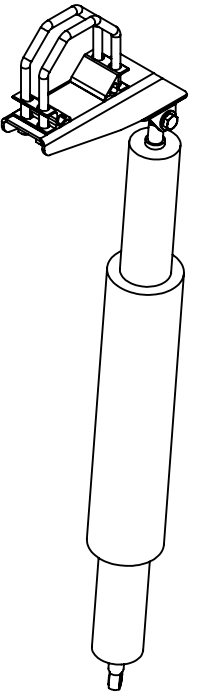
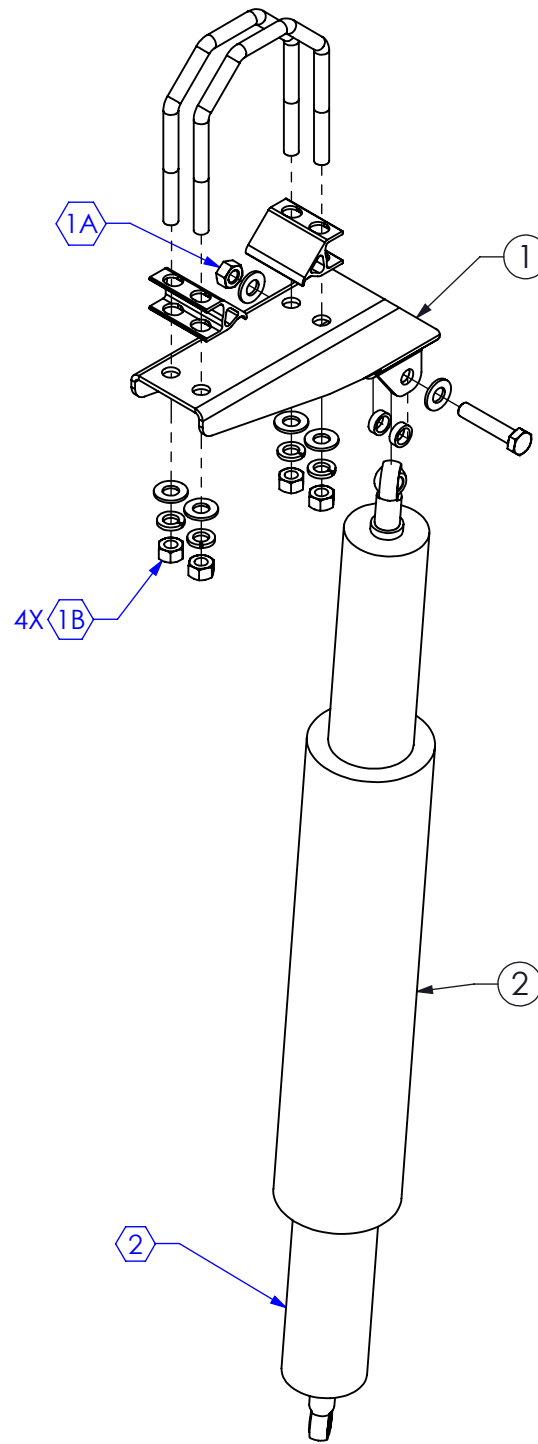

ARRAY PN: 21030-000

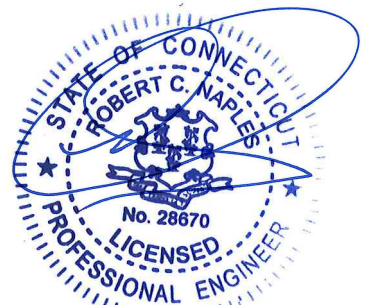

Exp 01/31/2027  
04/13/2026

ITEM NO.	PART NUMBER	DESCRIPTION	QTY
1	25242-000	Kit, Coil Over Damper, Upper Bracket, Hardware, Wedged, L/M	1
2	40195-000	Harmonic, Coil Over Damper, 381 mm Stroke, Rod End, L/M	1

APPLICABLE TRACKER SYSTEMS:		DRAWING STATUS: <b>Final</b>		INITIAL RELEASE: MK 10/27/2023	
PROPRIETARY AND CONFIDENTIAL: THE INFORMATION CONTAINED IN THIS DRAWING IS THE SOLE PROPERTY OF ARRAY TECHNOLOGIES. ANY REPRODUCTION IN PART OR AS A WHOLE WITHOUT THE WRITTEN PERMISSION FROM ARRAY TECHNOLOGIES IS PROHIBITED.		DRAWN: RM DATE: 02/23/2023 ENG. CHECK: MK DATE: 09/26/2023		DRAWING CHECK: RM DATE: 8/28/2023 FINAL APPROVAL: SB DATE: 10/27/2023	
THIRD ANGLE PROJECTION		TOLERANCES UNLESS OTHERWISE SPECIFIED		TITLE: <b>Assembly, Coil Over Damper, w/ Upper Bracket Kit, Wedged, L/M</b>	
MM [INCH]: X = ±1.25 [0.049] .X = ±0.4 [0.016] .XX = ±0.1 [0.004]		METER [INCH]: X.XX = ±0.013 [0.512] X.XXX = ±0.006 [0.236]		ANGULAR: X = ±1.0° .X = ±0.1°	
SIZE B		DRAWING NUMBER: 21030-901		REVISION: A	
SCALE: 1:6		WT: 8.519kg [18.781lb]		SHARED: 10/27/2023	
				SHEET 1 OF 1	

**NOTES:**

1. ARRAY TORQUE SPECIFICATIONS:

- 1A) 217±13 N-M [160±10 FT-LBS.]  
FOR TULLOCH ROUND PILE ADAPTER - 257±13 N-M [190±10 FT-LBS]  
TORQUE MUST BE APPLIED TO THE NUT.
- 1B) 61±7 N-M [45±5 FT-LBS.]
- 1C) 41±3 N-M [30±2.5 FT-LBS.] EACH STEP MUST BE DONE BY TIGHTENING EACH BOLT IN THE 1,2,3,4 SEQUENCE INDICATED

2. MARK ALL TORQUED CONNECTIONS USING PAINT MARKER OF CONTRASTING COLOR ACROSS IMMOBILE BASE AND ALL PARTS SUBJECT TO LOOSENING.

3. SUPPLIER IDENTIFICATION MARK TO BE LOCATED AT THE BOTTOM OF THE DAMPER DURING INSTALLATION FOR PROPER OPERATION.

4. DAMPER ASSEMBLIES ON THE SAME ROW ARE TO ALTERNATE EAST/WEST STARTING AT THE END OF THE ROW.

5. OCTAGONAL U-BOLTS MUST BE TIGHTENED EVENLY DURING INSTALLATION TO PROVIDE FLUSH AND EVEN CONTACT BETWEEN THE DAMPER BRACKET AND TORQUE TUBE.

6. THE POSITION OF THE UPPER DAMPER BRACKET IS MEASURED RELATIVE TO THE OUTERMOST SURFACE OF THE BEARING PILE ASSEMBLY, WHICH MAY BE THE PILE ITSELF, THE BRACKET OR THE BEARING. TOLERANCE SHOWN APPLIES TO INITIAL INSTALLATION. FOR QC, O&M OR COMMISSIONING PURPOSES THE PERMISSIBLE DISTANCE IS BETWEEN 13mm(MIN) AND 64mm(MAX) DUE TO THERMAL EXPANSION/CONTRACTION.

7. MEASUREMENT MUST BE TAKEN WHILE TORQUE TUBE IS IN THE ZERO DEGREE (FLAT) POSITION.

8. INSTALL DAMPER ASSEMBLY ON DOWNHILL SIDE OF THE PILE WHEN THE NORTH/SOUTH SLOPE OF THE TORQUE TUBE EXCEEDS 1.5 DEGREES (3.0%).

9. USE DIGITAL ANGLE FINDER TO DETERMINE ANGLE "A" ON THE TORQUE TUBE. ANGLE "A" IS MEASURED FROM TORQUE TUBE TO HORIZONTAL. MAX ANGLE IS 8.5 DEGREES.

10. FOR PROPER INSTALLATION INSTRUCTIONS REFER TO THE TRACKER INSTALLATION GUIDE.

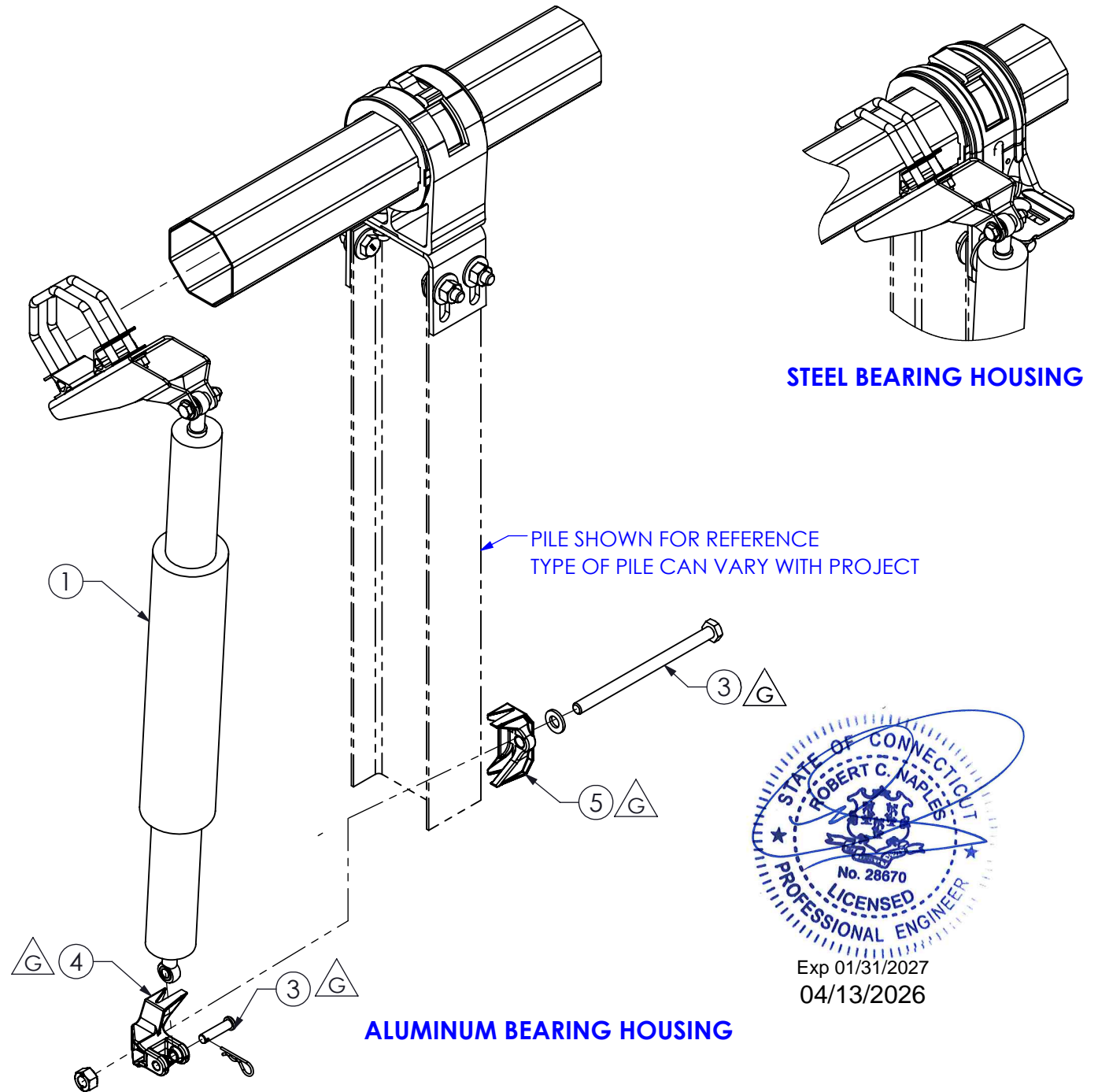

ZONE	REV	ECR #	DESCRIPTION	ENGR	DATE
A5, B2, B3, B4, B6, C2, 2-A5, 2-C3, 2-C4, 3-C4	G	US-25134	UPDATED NOTE 9, REPLACED 25233-001 WITH 25288-000, 30836-000 WITH 31112-000 AND 31113-000, 60811-XXX WITH 60811-115, FLIPPED BOLT ORIENTATION	RK	11/18/2025
B3, C1, C5, D6, 2-A1, 2-A3, 2-A7, 2-B3, 2-B4, 3-A6	F	US-25095	ADDED STEEL BEARING AND VIEWS FOR CLARITY, UPDATED NOTE 6, ADDED TORQUE SPEC 1A FOR TULLOCH ADAPTER.	RK	06/25/2025
A5, B3, B5, 2-B1, 3-B7	E	US-24153	ADDED CONFIGURATIONS, VIEW AND 25270-000, REPLACED 25233-000 WITH 25233-001, REMOVE APA 2.0 FROM TABLE, UPDATED CALLOUTS.	RK	01/13/2025

ITEM NO.	PART NUMBER	DESCRIPTION	W, UB, TULLOCH, APA 1.0	APA 2.0
1	21030-000	Assembly, Coil Over Damper, w/ Upper Bracket Kit, Wedged, L/M	1	1
2	25270-000	Kit, COD, Lower BRKT, HDWR, APA	-	1
3	25288-000	Kit, HDW, Lower Damper, Universal, H	1	-
4	31112-000	BRKT, Claw, W Damper Mount, H	1	-
5	31113-000	BRKT, Claw, W/O Damper Mount, H	1	-

APPLICABLE TRACKER SYSTEMS: DuraTrack OmniTrack		DRAWING STATUS: <b>Final</b> DRAWN: RM DATE: 02/27/2023 ENG. CHECK: MK DATE: 10/18/2023 FINAL APPROVAL: SB DATE: 10/26/2023		<b>ARRAY TECHNOLOGIES</b> 3901 Midway Place NE, Albuquerque, NM 87109 (505) 881-7567	
PROPRIETARY AND CONFIDENTIAL: THE INFORMATION CONTAINED IN THIS DRAWING IS THE SOLE PROPERTY OF ARRAY TECHNOLOGIES. ANY REPRODUCTION IN PART OR AS A WHOLE WITHOUT THE WRITTEN PERMISSION FROM ARRAY TECHNOLOGIES IS PROHIBITED.		THIRD ANGLE PROJECTION		ALL DIMS ARE DUAL UNITS: MILLIMETER (INCH). DIMENSIONS IN BRACKETS ARE FOR REFERENCE ONLY.	
TOLERANCES UNLESS OTHERWISE SPECIFIED: MM (INCH): X = ±1.25 [0.049] .X = ±0.4 [0.016] .XX = ±0.1 [0.004]		METER (INCH): X.XX = ±0.013 [0.512] X.XXX = ±0.006 [0.236]		ANGULAR: X = ±1.0° .X = ±0.1°	
TITLE: <b>Field Assembly, Coil Over Damper, Wedged, L/M</b>		SIZE: <b>B</b> SCALE: 1:10		DRAWING NUMBER: 21032-901 REVISION: G SHEET: 1 OF 4	

**NOTES:**

11. CAUTION: INCORRECT INSTALLATION OF THE FOLLOWING ITEMS CAN RESULT IN DAMAGE TO TRACKER COMPONENTS:

- 11.1 BEARING HOUSING STOP MUST BE IN PLANE WITH MODULE CLAMPS.
- 11.2 INDICATED FACE OF DAMPER BRACKET MUST BE IN PLANE WITH BEARING HOUSING STOP.

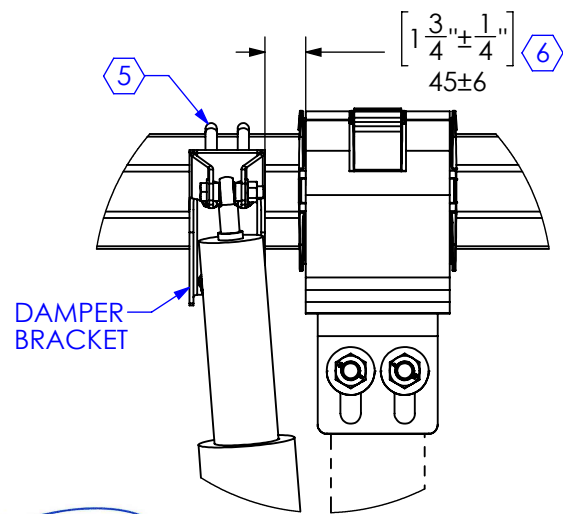

**DETAIL D  
HIGH-WIND ALUMINUM BEARING**

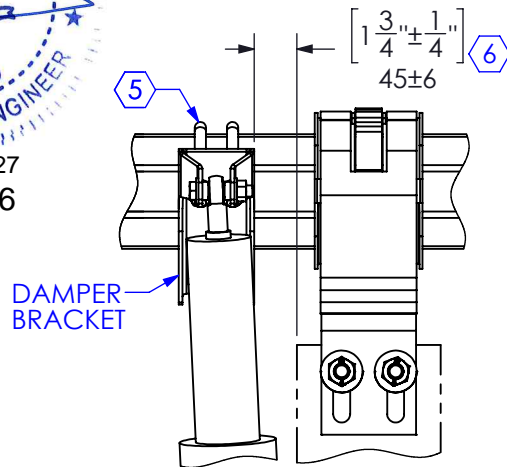
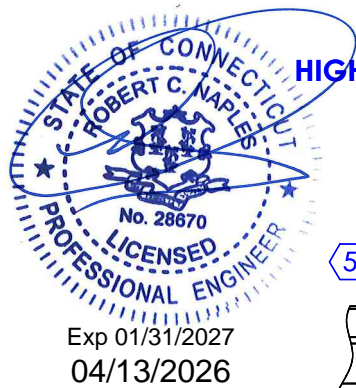

**DETAIL D  
STANDARD ALUMINUM BEARING  
WIDER PILE**

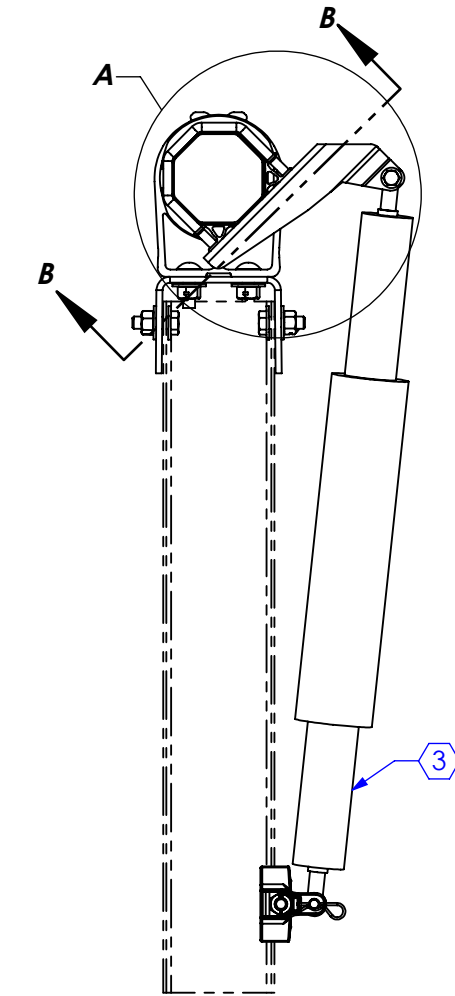

**ALUMINUM BEARING HOUSING**

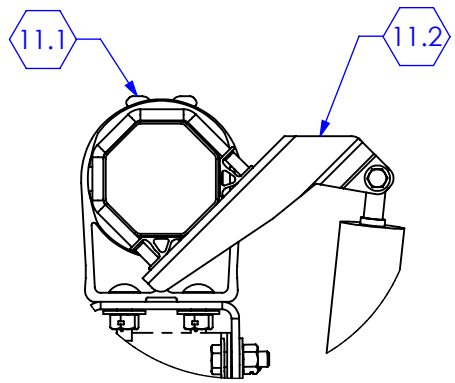

**STEEL BEARING HOUSING**

**TORQUE SEQUENCE  
FOR EACH TIGHTENING STEP**

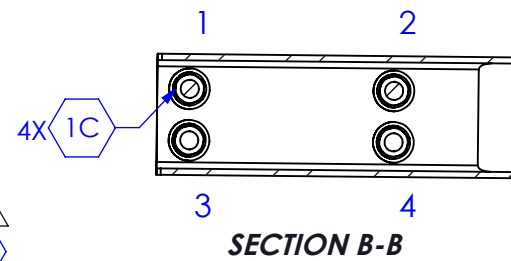

TIGHTENING STEP	TORQUE LEVEL
0	SNUG TIGHT
1	10 N-m [7.5 ft-lbs]
2	20 N-m [15 ft-lbs]
3	31 N-m [22.5 ft-lbs]
4	41 N-m [30 ft-lbs]

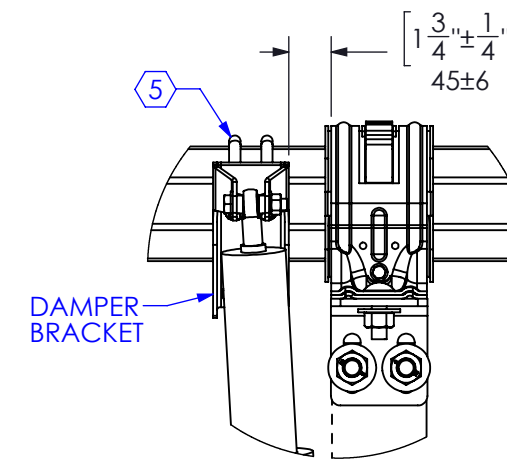

**DETAIL E  
STANDARD STEEL BEARING**

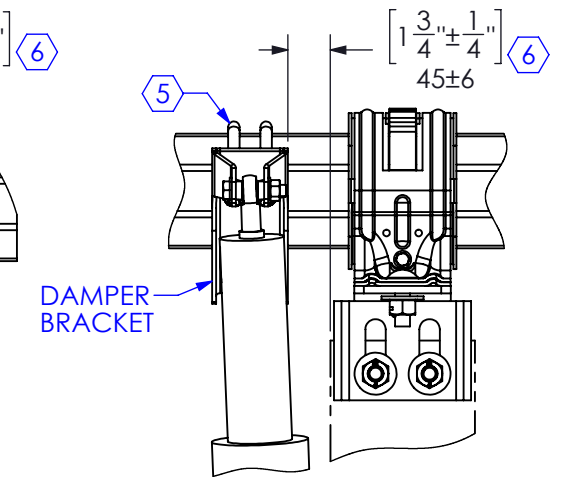

**DETAIL E  
HIGH-WIND STEEL BEARING  
WIDER PILE**

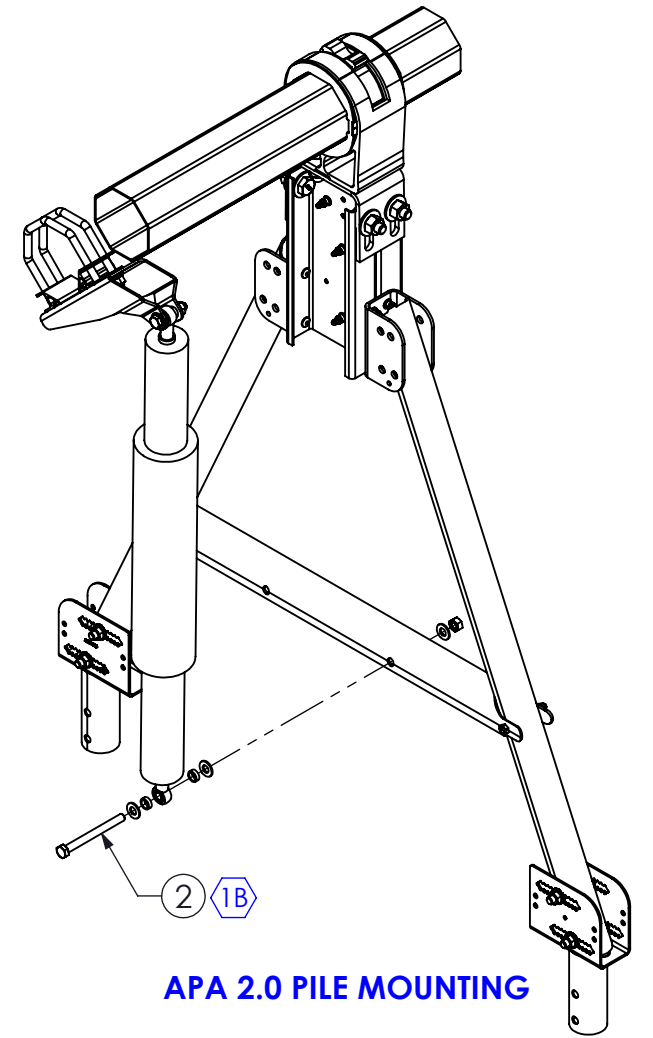

**APA 2.0 PILE MOUNTING**

SIZE B	DRAWING NUMBER 21032-901	REVISION G	SAVED v123 11/18/2025
SCALE 1:10	SHEET		2 OF 4

8

7

6

5

4

3

2

1

D

D

C

C

B

B

A

A

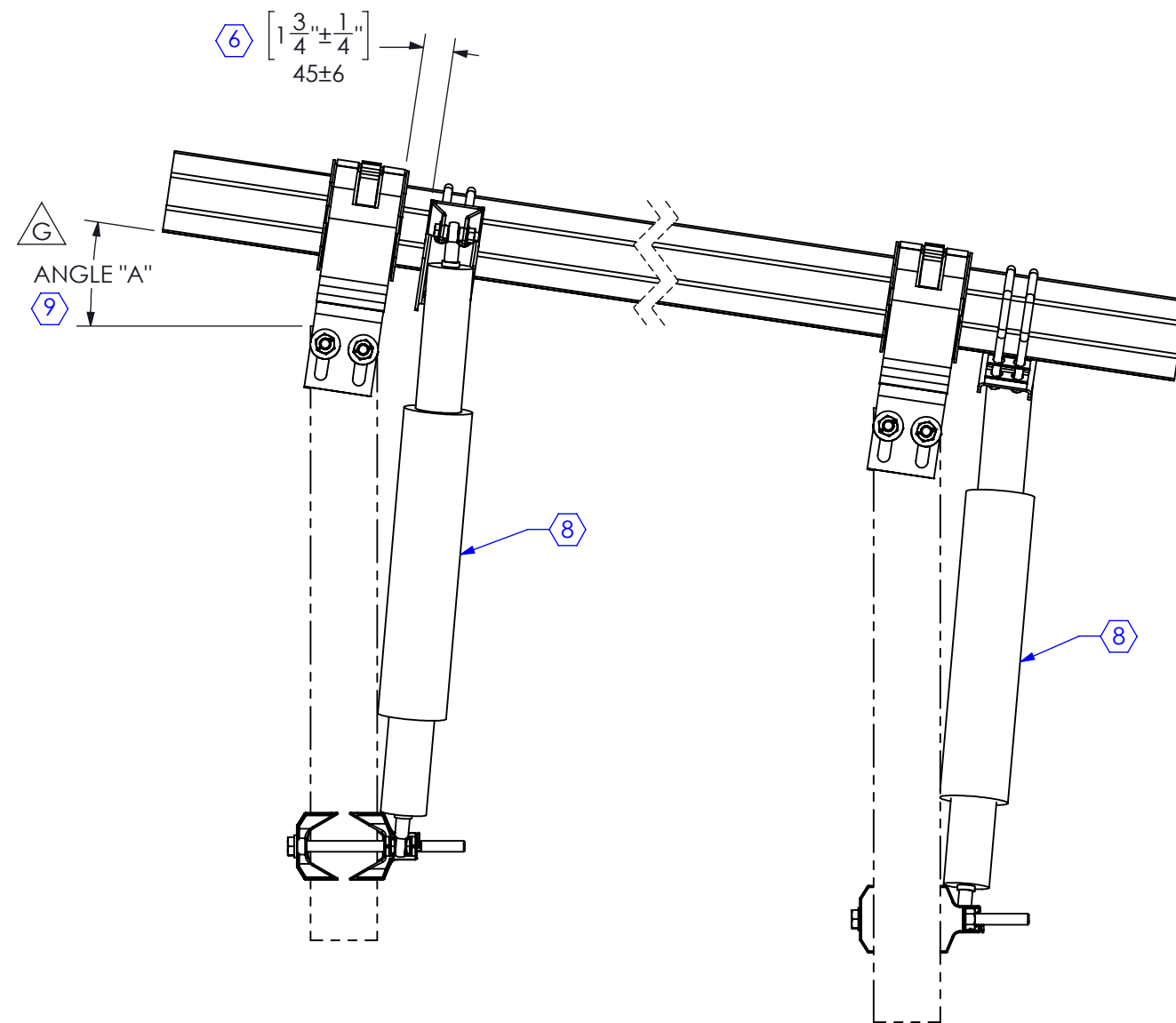
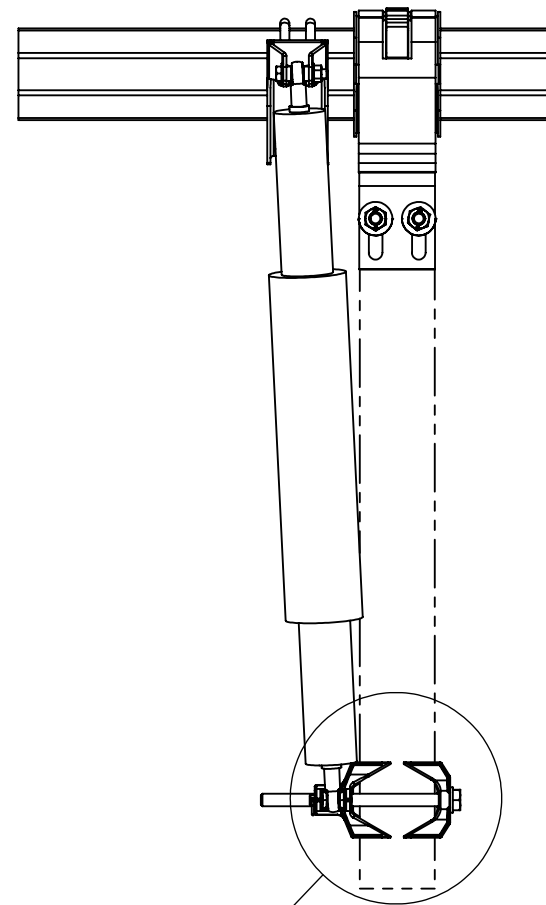
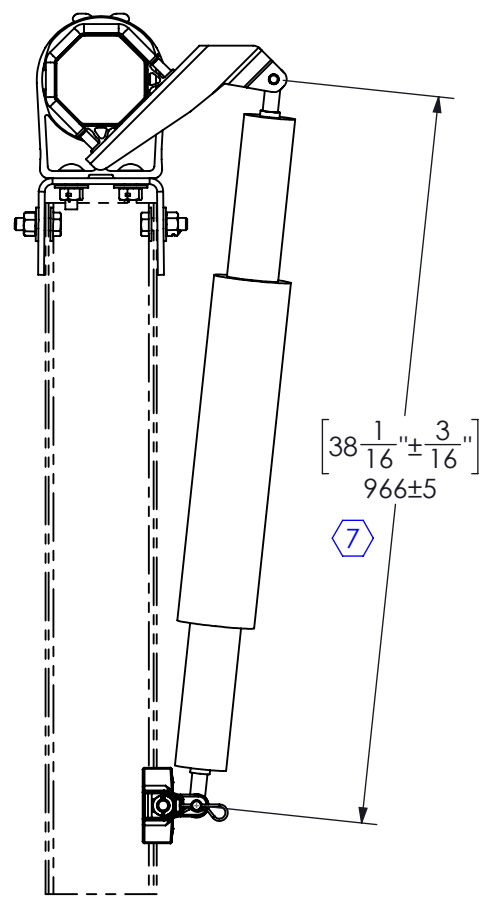

THESE BRACKET SURFACES TO BE LEVEL WITH EACH OTHER. ALLOWABLE OFFSET BETWEEN THESE SURFACES OF BRACKETS SHALL NOT EXCEED 3.2mm.

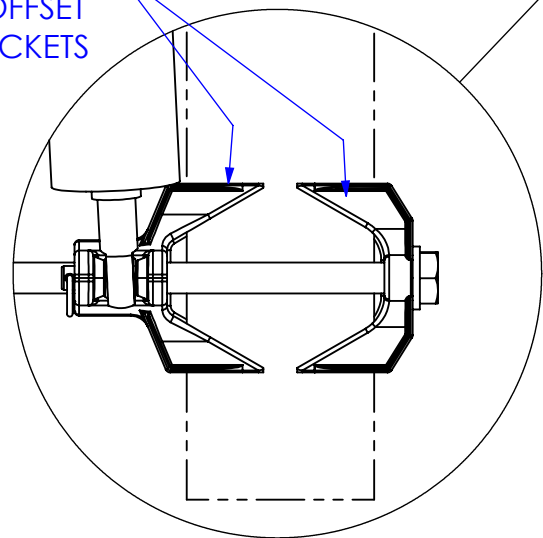

DETAIL F

ANGLE INSTALLATION



Exp 01/31/2027  
04/13/2026

SIZE B	DRAWING NUMBER 21032-901	REVISION G	SAVED v123 11/18/2025
SCALE 1:15	SHEET 3 OF 4		

8

7

6

5

4

3

2

1

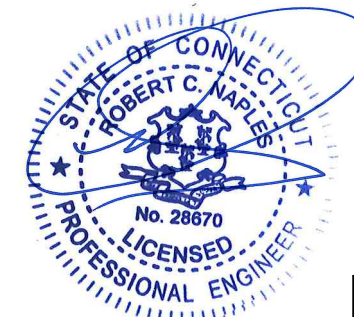

Exp 01/31/2027  
04/13/2026

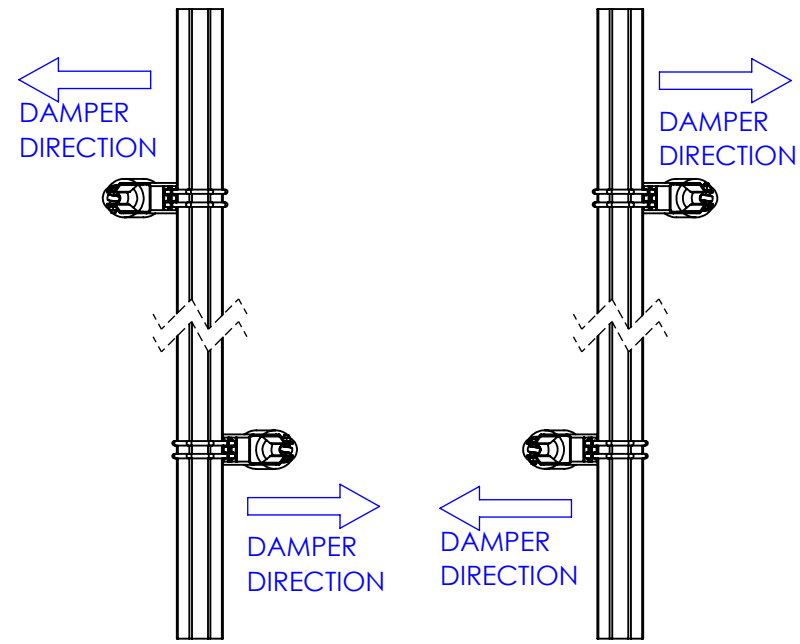

**2 DAMPER ROW  
DEMONSTRATION  
PILES AND BEARINGS REMOVED**

4

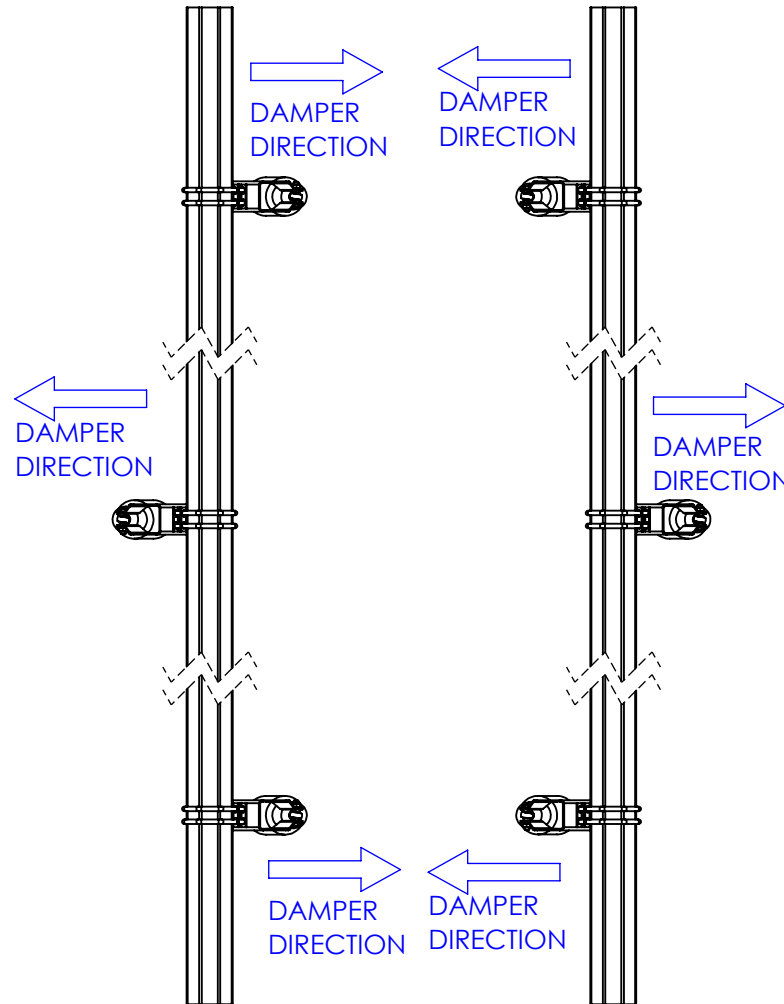

**3 DAMPER ROW  
DEMONSTRATION  
PILES AND BEARINGS REMOVED**

4

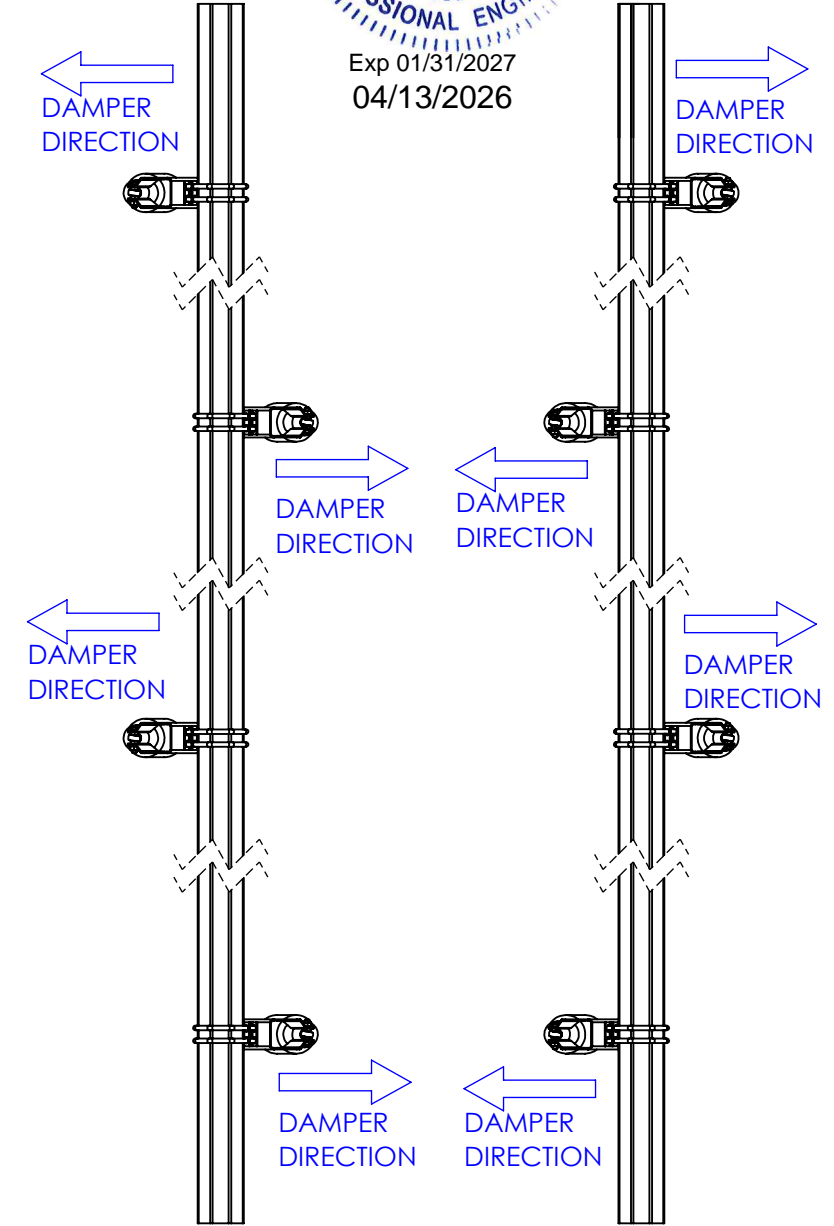

**4 DAMPER ROW  
DEMONSTRATION  
PILES AND BEARINGS REMOVED**

4

SIZE B	DRAWING NUMBER 21032-901	REVISION G	SAVED v123 11/18/2025
SCALE 1:75	SHEET 4 OF 4		

**NOTES:**

- HARDWARE TO BE PACKAGED SEPARATELY.

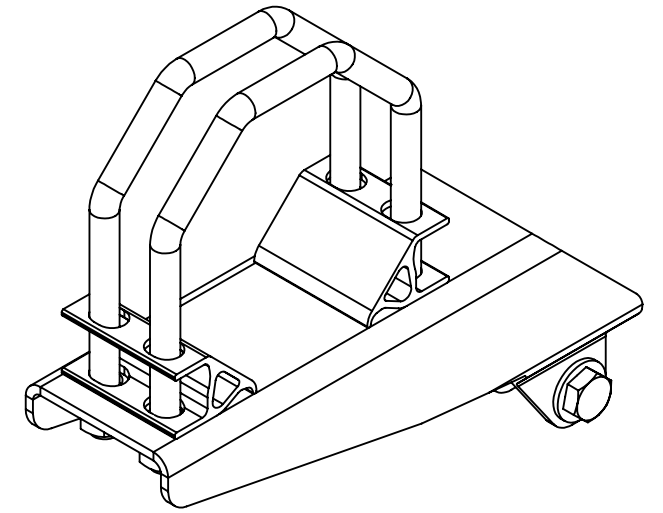
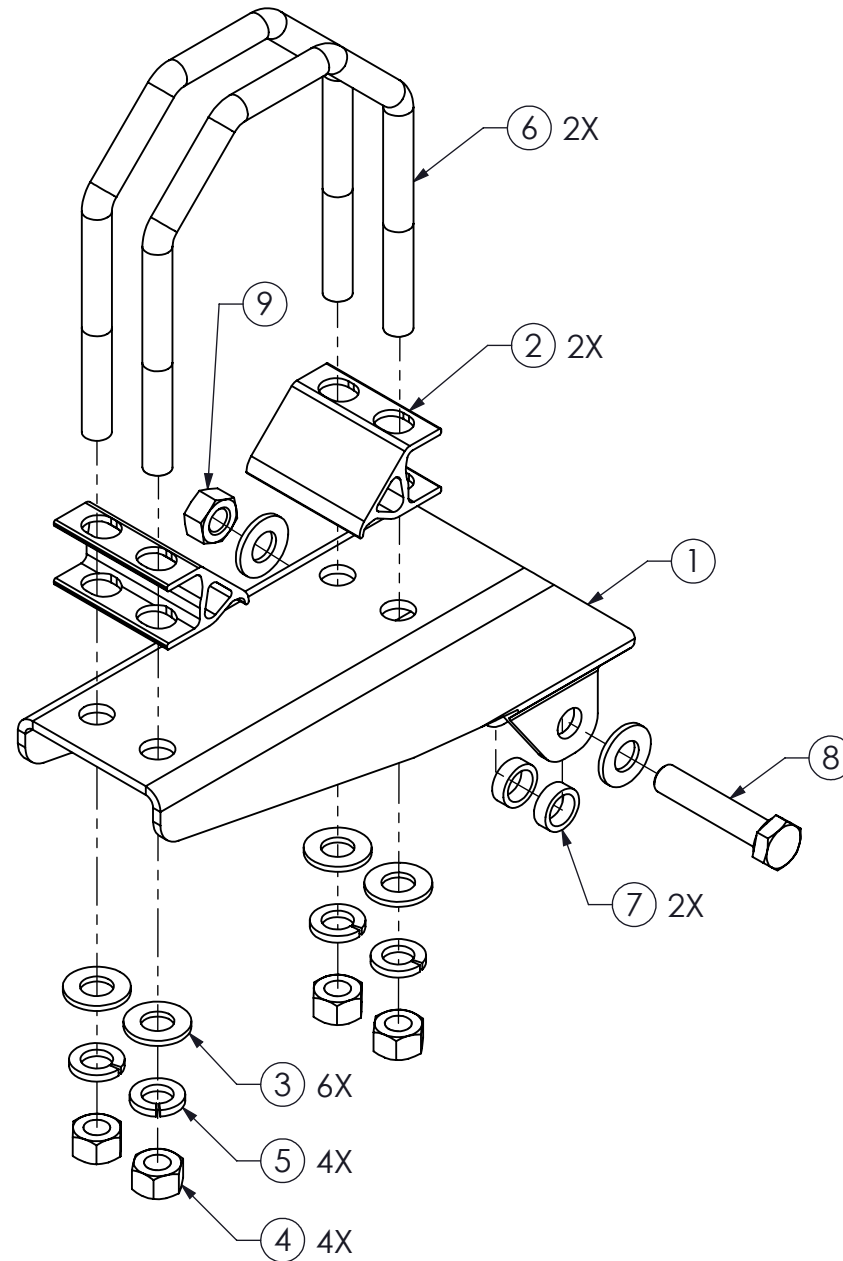

ARRAY PN: 25242-000

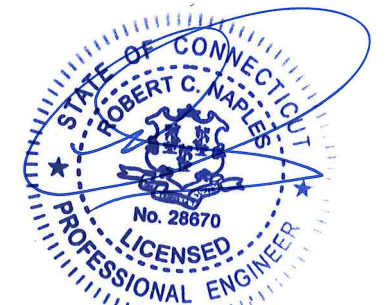

Exp 01/31/2027  
04/13/2026

ITEM NO.	PART NUMBER	DESCRIPTION	QTY
1	30835-000	Bracket, Coil Over Damper, Upper, HDG, .164"	1
2	30978-000	Wedge, Upper Damper Bracket, Aluminum	2
3	60006-000	Washer, Flat SAE F436 HDG, .500	6
4	60010-000	Nut, Hex, Grade 5, HDG, .500-13	4
5	60017-000	Washer, Split Lock HDG, .500	4
6	60448-575	U-bolt, Octagon, Grade 5 HDG, .500-13 x 5.75	2
7	60655-000	Spacer, 18-8 Stainless Steel, 0.75" OD X 0.25"	2
8	60782-060	Screw, Structural Hex Head, DIN 931, Grade 10.9, Fe/Zn-Ni 5C, M12-1.75 x 60	1
9	60783-000	Nut, Hex, DIN 934, Fe/Zn-Ni 5C, M12-1.75, Lubricated	1

APPLICABLE TRACKER SYSTEMS:	DRAWING STATUS: <b>Final</b>		<b>ARRAY TECHNOLOGIES</b> 3901 Midway Place NE, Albuquerque, NM 87109 (505) 881-7567 <b>ARRAY TECHNOLOGIES</b>	
PROPRIETARY AND CONFIDENTIAL: THE INFORMATION CONTAINED IN THIS DRAWING IS THE SOLE PROPERTY OF ARRAY TECHNOLOGIES. ANY REPRODUCTION IN PART OR AS A WHOLE WITHOUT THE WRITTEN PERMISSION FROM ARRAY TECHNOLOGIES IS PROHIBITED.	DRAWN: RM DATE: 02/23/2023 ENG. CHECK: MK DATE: 08/30/2023	DRAWING CHECK: DS DATE: 5/12/2023 FINAL APPROVAL: SB DATE: 10/27/2023	TITLE: <b>Kit, Coil Over Damper, Upper Bracket, Hardware, Wedged, L/M</b>	
	THIRD ANGLE PROJECTION		ALL DIMS ARE DUAL UNITS: MILLIMETER [INCH]. DIMENSIONS IN BRACKETS ARE FOR REFERENCE ONLY.	
	MM [INCH]: X = ±1.25 [0.049] .X = ±0.4 [0.016] .XX = ±0.1 [0.004]	METER [INCH]: X.XX = ±0.013 [0.512] X.XXX = ±0.006 [0.236]	ANGULAR: X = ±1.0° .X = ±0.1°	SIZE B SCALE 1:3

ZONE	A	INITIAL RELEASE	MK	10/27/2023
REV	ECR #	DESCRIPTION	ENGR	DATE

**NOTES:**

1. TORQUE SPECIFICATION:

①A 51.5±3N-M [38(±)3 FT-LBS]

② ALTERNATE CARRIAGE BOLT USAGE:

60572-650 BOLT, CARRIAGE, HDG, .500-13, GRADE 2, 6.50"

60445-650 BOLT, CARRIAGE, HDG, .500-13, GRADE 5, 6.50"

60445-600 BOLT, CARRIAGE, HDG, .500-13, GRADE 5, 6.00" △B

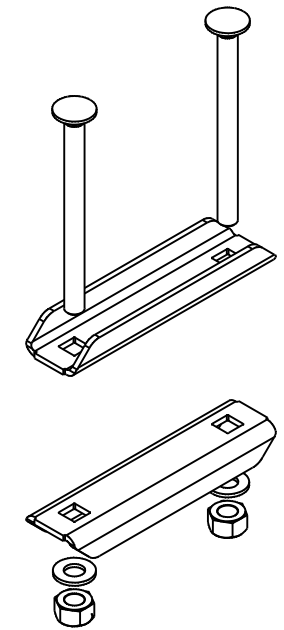
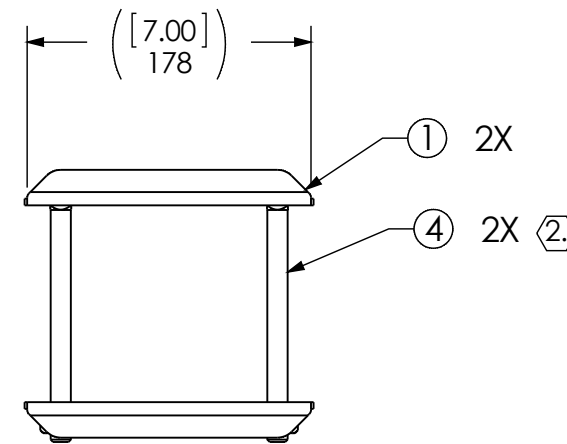
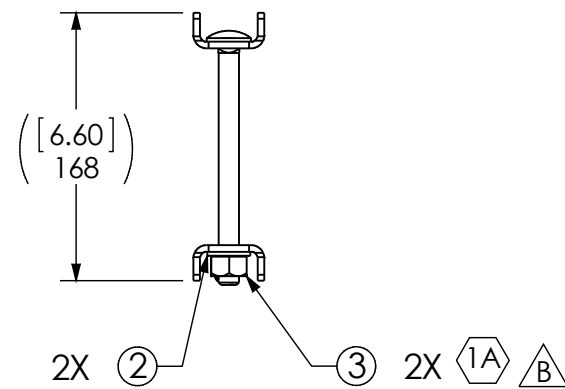
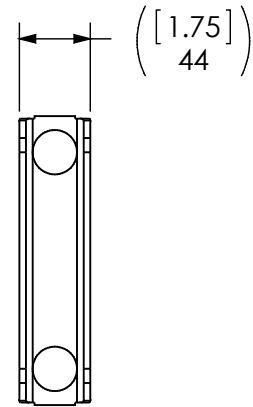
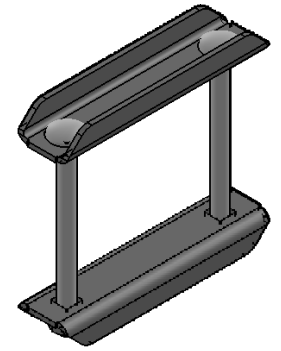



B	ALT BOLTS ADDED HW UPDATED PER ECR-16004	1/28/2016
A	INITIAL RELEASE	1/14/2016
REV	DESCRIPTION	DATE

ITEM NO.	PART NUMBER	DESCRIPTION	QTY
1	30540-000	Channel, Torque Tube Clamp, A653, G90, 1.75" x 0.875" x 0.164"	2
2	60006-000	Washer, Flat SAE F436 HDG, .500	2
3	60503-000	Nut, Pin Lock, Heavy Hex Grade 2H HDG, Lubricated, 0.5"-13	2
4	60572-600	Bolt, Carriage, HDG, .500-13, Grade 2, 6.00"	2 <span style="float: right;">△B</span>

PROPRIETARY AND CONFIDENTIAL THE INFORMATION CONTAINED IN THIS DRAWING IS THE SOLE PROPERTY OF ARRAY TECHNOLOGIES. ANY REPRODUCTION IN PART OR AS A WHOLE WITHOUT THE WRITTEN PERMISSION FROM ARRAY TECHNOLOGIES IS PROHIBITED.	UNLESS OTHERWISE SPECIFIED DIMS ARE DUAL UNITS: MILLIMETER [INCH]		DRAWING STATUS Retire - Superseded		<b>ARRAY TECHNOLOGIES</b> 3901 Midway Place NE, Albuquerque, NM 87109 (505) 881-7567	
	TOLERANCES, mm [in]: X = ±1.25 [±0.050"] .X = ±0.4 [±0.015"] .XX = ±0.1 [±0.004"]		PRODUCT STATUS Review			
	TOLERANCES, m [in]: X.XX = ±0.013 [±0.5"] X.XXX = ±0.006 [±0.25"]		NAME KT	DATE 01/15/2016		<b>Kit, Clamp, Torque Tube, Octagon, Standard</b>
	ANGULAR: X = ±1.0° .X = ±.1°		CHECKED JW	DATE 2/5/2016		
		APPROVED CB	DATE 2/4/2016			
		SIZE B	PRODUCT NUMBER 25096-000	REVISION B	SAVED v18 2/5/2016	
		SCALE 1:10	DWG NO. 25096-901	WT: 1.25 KG [2.775LB]	SHEET 1 OF 1	

**NOTES:**

- MATERIAL: D2 TOOL STEEL, RC 60 OR AISI 4140 STEEL OR EQUIVALENT. HEAT TREAT AND OIL QUENCH HARDENING MIN HRC 60.  
ALTERNATE MATERIAL OF RC/HRC 60 MAY BE APPROVED, CONSULT WITH ARRAY FOR APPROVAL.
  - FINISH: PLAIN
  - TEXT CONTAINED WITHIN THIS SYMBOL  ARE CRITICAL DIMENSIONS, REQUIRING SPC (#) AT ARRAY'S DISCRETION. MINIMUM INSPECTION FREQUENCY 6 MONTHS.
  - REMOVE ALL BURRS IN EXCESS OF .25mm [.010"]
-  NON-CRITICAL DIMENSION FOR WEIGHT SAVINGS ONLY. NOT REQUIRED FOR INSPECTION OF THE GAUGE.

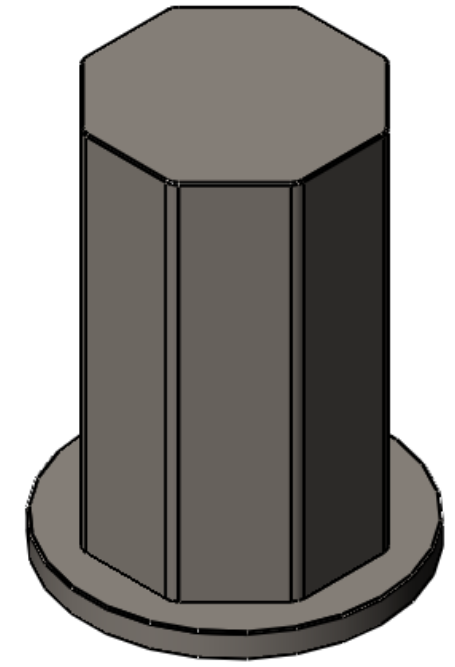
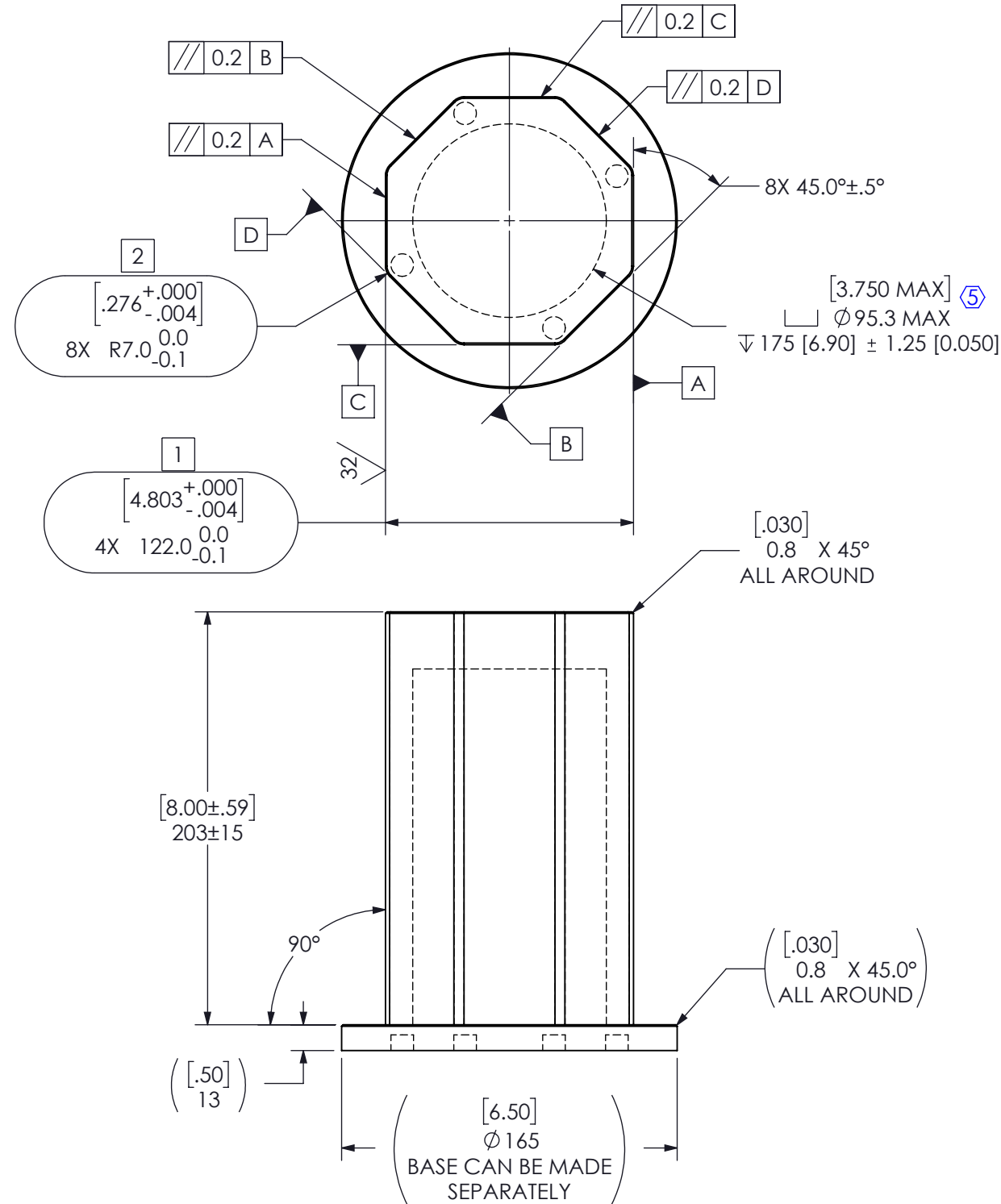

ARRAY P/N: 71005-000

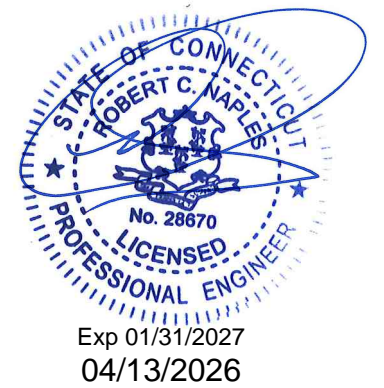

INITIALS: MK	DATE: 04/07/2023	INITIALS: NC	DATE: 7/31/2023
INITIALS: MK	DATE: 10/03/2023	INITIALS: SB	DATE: 10/27/2023

APPLICABLE TRACKER SYSTEMS:		DRAWING STATUS: <b>Final</b>		ARRAY TECHNOLOGIES	
DRAWN: INITIALS: MK DATE: 04/07/2023		DRAWING CHECK: INITIALS: NC DATE: 7/31/2023		3901 Midway Place NE, Albuquerque, NM 87109 (505) 881-7567	
ENG. CHECK: INITIALS: MK DATE: 10/03/2023		FINAL APPROVAL: INITIALS: SB DATE: 10/27/2023		TITLE: <b>Test Fixture, Damper Assembly, Go Gauge</b>	
<p>PROPRIETARY AND CONFIDENTIAL:</p> <p>THE INFORMATION CONTAINED IN THIS DRAWING IS THE SOLE PROPERTY OF ARRAY TECHNOLOGIES. ANY REPRODUCTION IN PART OR AS A WHOLE WITHOUT THE WRITTEN PERMISSION FROM ARRAY TECHNOLOGIES IS PROHIBITED.</p>		<p>THIRD ANGLE PROJECTION</p> <p>TOLERANCES UNLESS OTHERWISE SPECIFIED</p> <p>mm [INCH]: X = ±1.25 [0.049] .X = ±0.4 [0.016] .XX = ±0.1 [0.004]</p> <p>METER [INCH]: X.XX = ±0.013 [0.512] X.XXX = ±0.006 [0.236]</p> <p>ANGULAR: X = ±1.0° .X = ±0.1°</p>		<p>SIZE: B</p> <p>SCALE: 1:3</p> <p>DRAWING NUMBER: 71005-901</p> <p>REVISION: A</p> <p>SAVED v13: 10/27/2023</p> <p>WT: 11.98kg [26.411Lbs]</p> <p>SHEET: 1 OF 1</p>	

CONFIGURATION TABLE						
PART NUMBER	DESCRIPTION	DIM B MM [IN]	DIM C MM [IN]	DIM D MM [IN]	DIM E MM [IN]	WEIGHT KG/M [LB/FT]
33000-01-XXX	I-Beam, W6 X 7, STD Bearing, X.XXm (XXX")	147.1 [5.790]	3.4 [0.135]	99.2 [3.905]	4.1 [0.160]	10.4 [7.000]
33000-02-XXX	I-Beam, W6 X 7.75, STD Bearing, X.XXm (XXX")	147.8 [5.820]	3.8 [0.151]	99.6 [3.921]	4.5 [0.177]	11.5 [7.750]
33000-03-XXX	I-Beam, W6 X 8.5, STD Bearing, X.XXm (XXX")	148.1 [5.830]	4.3 [0.170]	100.1 [3.940]	5.0 [0.195]	12.6 [8.500]
33000-04-XXX	I-Beam, W6 X 9, STD Bearing, X.XXm (XXX")	149.9 [5.900]	4.3 [0.170]	100.1 [3.940]	5.5 [0.215]	13.4 [9.000]
33000-05-XXX	I-Beam, W6 X 10.4, STD Bearing, X.XXm (XXX")	151.4 [5.960]	5.1 [0.200]	100.8 [3.970]	6.3 [0.247]	15.5 [10.400]
33000-06-XXX	I-Beam, W6 X 12, STD Bearing, X.XXm (XXX")	153.2 [6.030]	5.8 [0.230]	101.6 [4.000]	7.1 [0.280]	17.9 [12.000]
33000-07-XXX	I-Beam, W6 X 15, STD Bearing, X.XXm (XXX")	152.1 [5.990]	5.8 [0.230]	152.1 [5.990]	6.6 [0.260]	22.3 [15.000]
33000-08-XXX	I-Beam, W6 X 16, STD Bearing, X.XXm (XXX")	159.5 [6.280]	6.6 [0.260]	102.4 [4.030]	10.3 [0.405]	23.8 [16.000]
33000-09-XXX	I-Beam, W6 X 20, STD Bearing, X.XXm (XXX")	157.5 [6.200]	6.6 [0.260]	152.9 [6.020]	9.3 [0.365]	29.8 [20.000]
33000-10-XXX	I-Beam, W6 X 25, STD Bearing, X.XXm (XXX")	162.1 [6.380]	8.1 [0.320]	154.4 [6.080]	11.6 [0.455]	37.2 [25.000]
33000-11-XXX	I-Beam, W8 X 10, STD Bearing, X.XXm (XXX")	200.4 [7.890]	4.3 [0.170]	100.1 [3.940]	5.2 [0.205]	14.9 [10.000]
33000-12-XXX	I-Beam, W8 X 13, STD Bearing, X.XXm (XXX")	202.9 [7.990]	5.8 [0.230]	101.6 [4.000]	6.5 [0.255]	19.3 [13.000]
33000-13-XXX	I-Beam, W8 X 15, STD Bearing, X.XXm (XXX")	206.0 [8.110]	6.2 [0.245]	102.1 [4.020]	8.0 [0.315]	22.3 [15.000]
33000-14-XXX	I-Beam, W8 X 18, STD Bearing, X.XXm (XXX")	206.8 [8.140]	5.8 [0.230]	133.4 [5.250]	8.4 [0.330]	26.8 [18.000]
33000-15-XXX	I-Beam, W6 X 10.5, STD Bearing, X.XXm (XXX")	151.6 [5.970]	4.6 [0.181]	101.6 [4.000]	6.4 [0.250]	15.6 [10.500]

**NOTES:**

- ALL FABRICATION AND OVERALL DIMS POST FINISH.
- MATERIAL:  
STEEL, ASTM A572 GRADE 50 OR ASTM A992 GRADE 50 OR WITH EQUAL/GREATER STRUCTURAL PROPERTIES.
- FINISH:  
REMOVE MILL SCALE, HOT DIP GALVANIZE (HDG), MIN GRADE 65 PER ASTM A123, OR OTHER APPROVED COATING BY THE FOUNDATION ENGINEER OF RECORD. REPAIR ANY DAMGED AREA PER ASTM A780.
- ALL UNSPECIFIED TOLERANCES AND QUALITY REQUIREMENTS PER ASTM A6 OR EQUIVALENT STANDARD.
- REMOVE ALL BURRS AND SHARP EDGES PRIOR TO HOT DIP GALVANIZING.
- ALL FABRICATION SHALL BE PERFORMED PRIOR TO HOT DIP GALVANIZING.
- HOLE PATTERN DIMENSIONS REMAIN THE SAME REGARDLESS OF COLUMN HEIGHT.
- ARRAY MUST BE NOTIFIED OF ALL CHANGES TO PILES FROM ORIGINAL SPEC.
- SUPPLIER IDENTIFICATION MARK REQUIRED. ARRAY TO APPROVE LOCATION AND DESIGN AT TIME OF ORDER.

ARRAY PART NUMBER DESIGNATION

33000-XX-XXX

INDICATES LENGTH OF DIM "A" IN X.XX METERS  
EXAMPLE: W6 X 9, 2.51M ARRAY PN: 33000-04-251

INDICATES CONFIGURATION NUMBER

ARRAY PART NUMBER

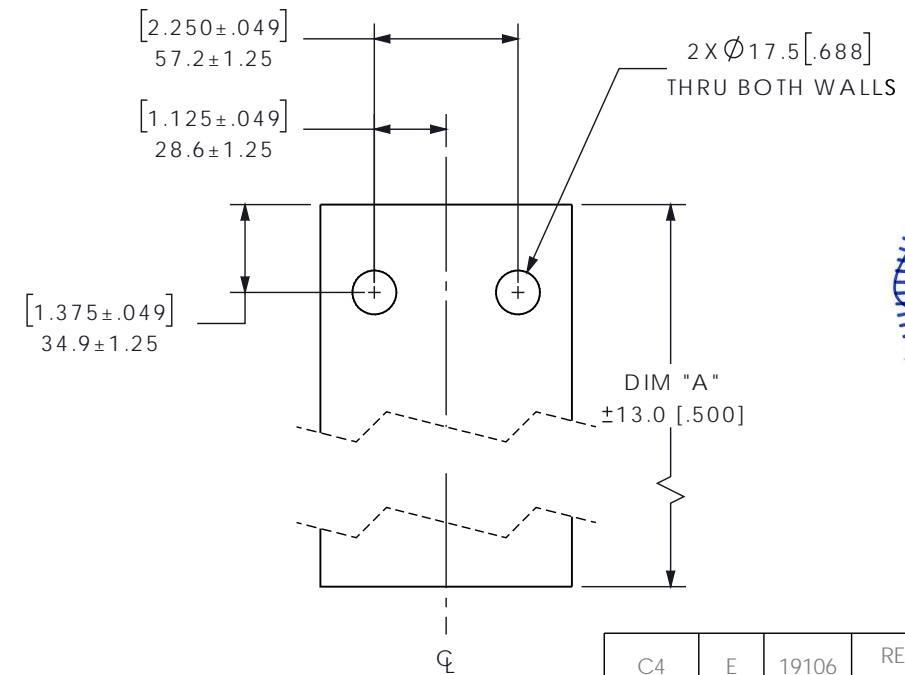
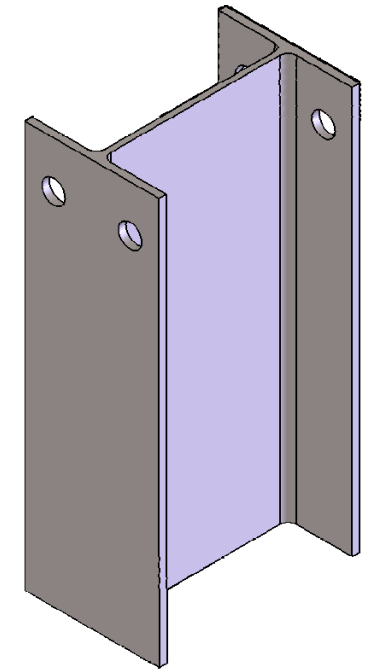
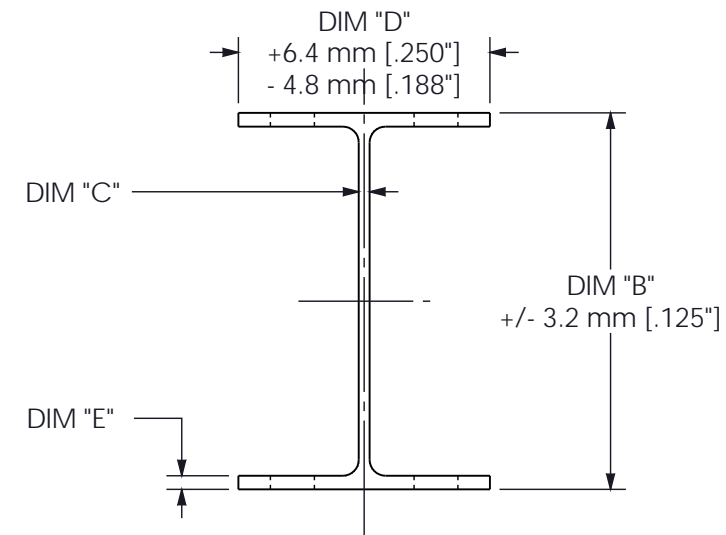

**ACTUAL I-BEAM SIZE AND LENGTH TO BE DETERMINED BY FOUNDATION ENGINEER.**

ZONE	REV	ECR #	DESCRIPTION	DATE
C4	E	19106	REVISED CONFIG TABLE; ADDED 33000-15-XXX	9/6/2019
	D	19050	REVISED TOLERANCE AND NOTE	04/03/2019
	C	19011	REVISED HOLE TOLERANCE	02/26/2019

PROPRIETARY AND CONFIDENTIAL THE INFORMATION CONTAINED IN THIS DRAWING IS THE SOLE PROPERTY OF ARRAY TECHNOLOGIES. ANY REPRODUCTION IN PART OR AS A WHOLE WITHOUT THE WRITTEN PERMISSION FROM ARRAY TECHNOLOGIES IS PROHIBITED.	DRAWING STATUS: <b>Final</b> DRAWN: INITIALS: KB DATE: 07/24/2018 ENG. CHECK: INITIALS: SB DATE: 9/10/2019 DRAWING CHECK: INITIALS: RM DATE: 9/10/2019 FINAL APPROVAL: INITIALS: SB DATE: 9/10/2019	<b>ARRAY TECHNOLOGIES</b> 3901 Midway Place NE, Albuquerque, NM 87109 (505) 881-7567
	THIRD ANGLE PROJECTION MILLIMETER [INCH] TOLERANCES UNLESS OTHERWISE SPECIFIED MM [INCH]: X = ±1.25 [0.050] X = ±0.4 [0.015] XX = ±0.1 [0.004]	ALL DIMS ARE DUAL UNITS: METER [INCH]: X.XX = ±0.013 [0.500] X.XXX = ±0.006 [0.250]

**CONFIGURATION TABLE**

PART NUMBER	DESCRIPTION	DIM B MM [IN]	DIM C MM [IN]	DIM D MM [IN]	DIM E MM [IN]	WEIGHT KG/M [LB/FT]
33002-01-XXX	I-Beam, W6 X 7, LRG Bearing, X.XXm (XXX")	147.1 [5.790]	3.4 [0.135]	99.2 [3.905]	4.1 [0.160]	10.4 [7.000]
33002-02-XXX	I-Beam, W6 X 7.75, LRG Bearing, X.XXm (XXX")	147.8 [5.820]	3.8 [0.151]	99.6 [3.921]	4.5 [0.177]	11.5 [7.750]
33002-03-XXX	I-Beam, W6 X 8.5, LRG Bearing, X.XXm (XXX")	148.1 [5.830]	4.3 [0.170]	100.1 [3.940]	5.0 [0.195]	12.6 [8.500]
33002-04-XXX	I-Beam, W6 X 9, LRG Bearing, X.XXm (XXX")	149.9 [5.900]	4.3 [0.170]	100.1 [3.940]	5.5 [0.215]	13.4 [9.000]
33002-05-XXX	I-Beam, W6 X 10.4, LRG Bearing, X.XXm (XXX")	151.4 [5.960]	5.1 [0.200]	100.8 [3.970]	6.3 [0.247]	15.5 [10.400]
33002-06-XXX	I-Beam, W6 X 12, LRG Bearing, X.XXm (XXX")	153.2 [6.030]	5.8 [0.230]	101.6 [4.000]	7.1 [0.280]	17.9 [12.000]
33002-07-XXX	I-Beam, W6 X 15, LRG Bearing, X.XXm (XXX")	152.1 [5.990]	5.8 [0.230]	152.1 [5.990]	6.6 [0.260]	22.3 [15.000]
33002-08-XXX	I-Beam, W6 X 16, LRG Bearing, X.XXm (XXX")	159.5 [6.280]	6.6 [0.260]	102.4 [4.030]	10.3 [0.405]	23.8 [16.000]
33002-09-XXX	I-Beam, W6 X 20, LRG Bearing, X.XXm (XXX")	157.5 [6.200]	6.6 [0.260]	152.9 [6.020]	9.3 [0.365]	29.8 [20.000]
33002-10-XXX	I-Beam, W6 X 25, LRG Bearing, X.XXm (XXX")	162.1 [6.380]	8.1 [0.320]	154.4 [6.080]	11.6 [0.455]	37.2 [25.000]
33002-11-XXX	I-Beam, W8 X 10, LRG Bearing, X.XXm (XXX")	200.4 [7.890]	4.3 [0.170]	100.1 [3.940]	5.2 [0.205]	14.9 [10.000]
33002-12-XXX	I-Beam, W8 X 13, LRG Bearing, X.XXm (XXX")	202.9 [7.990]	5.8 [0.230]	101.6 [4.000]	6.5 [0.255]	19.3 [13.000]
33002-13-XXX	I-Beam, W8 X 15, LRG Bearing, X.XXm (XXX")	206.0 [8.110]	6.2 [0.245]	102.1 [4.020]	8.0 [0.315]	22.3 [15.000]
33002-14-XXX	I-Beam, W8 X 18, LRG Bearing, X.XXm (XXX")	206.8 [8.140]	5.8 [0.230]	133.4 [5.250]	8.4 [0.330]	26.8 [18.000]

**NOTES:**

- ALL FABRICATION AND OVERALL DIMS POST FINISH.
- MATERIAL:**  
STEEL, ASTM A572 GRADE 50 OR ASTM A992 GRADE 50 OR WITH EQUAL/GREATER STRUCTURAL PROPERTIES.
- FINISH:**  
REMOVE MILL SCALE, HOT DIP GALVANIZE (HDG), MIN GRADE 65 PER ASTM A123, OR OTHER APPROVED COATING BY THE FOUNDATION ENGINEER OF RECORD. REPAIR ANY DAMGED AREA PER ASTM A780.
- ALL UNSPECIFIED TOLERANCES AND QUALITY REQUIREMENTS PER ASTM A6 OR EQUIVALENT STANDARD. 
- REMOVE ALL BURRS AND SHARP EDGES PRIOR TO HOT DIP GALVANIZING.
- ALL FABRICATION SHALL BE PERFORMED PRIOR TO HOT DIP GALVANIZING.
- HOLE PATTERN DIMENSIONS REMAIN THE SAME REGARDLESS OF COLUMN HEIGHT.
- ARRAY MUST BE NOTIFIED OF ALL CHANGES TO PILES FROM ORIGINAL SPEC.
- SUPPLIER IDENTIFICATION MARK REQUIRED. ARRAY TO APPROVE LOCATION AND DESIGN AT TIME OF ORDER.
- THIS PAGE APPLIES TO HIGH WIND BEARINGS ONLY**

ARRAY PART NUMBER DESIGNATION

**33002-XX-XXX**

**\*HIGH WIND BEARING ONLY\***

INDICATES LENGTH OF DIM "A" IN X.XX METERS  
EXAMPLE: W6 X 9, 2.51M ARRAY PN: 33002-04-251

INDICATES CONFIGURATION NUMBER

ARRAY PART NUMBER

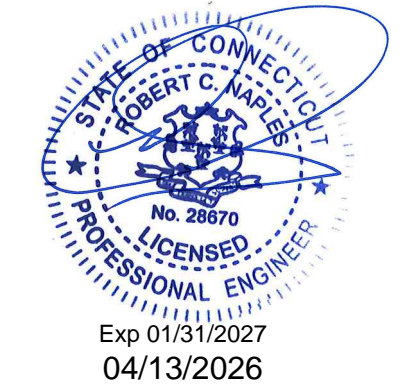
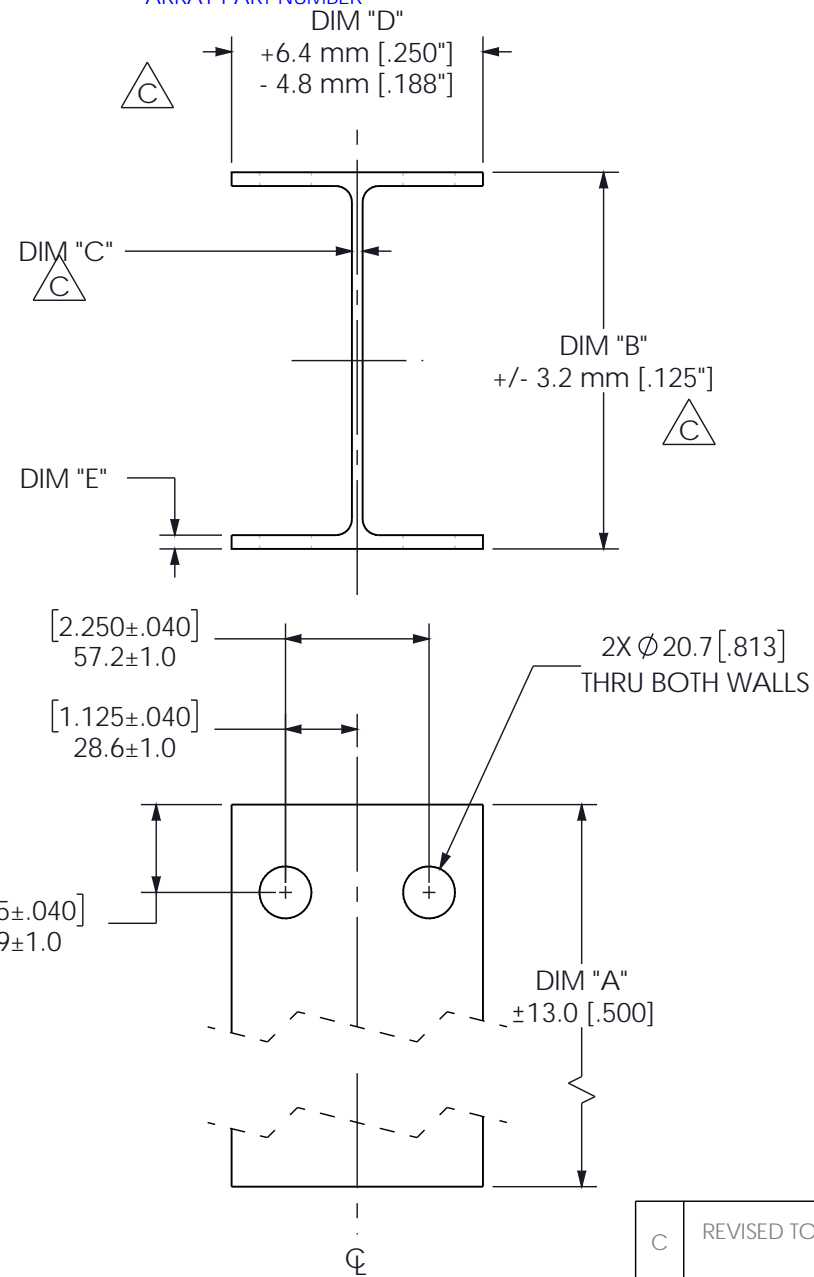

**ACTUAL I-BEAM SIZE AND LENGTH TO BE DETERMINED BY FOUNDATION ENGINEER.**

REV	DESCRIPTION	DATE
C	REVISED TOLERANCE AND NOTE PER ECR 19050	4/3/2019
B	CHANGED LENGTH TO METERS AND CHANGED DESCRIPTION PER ECR 18096	8/21/2018
A	INITIAL RELEASE	7/27/2018

PROPRIETARY AND CONFIDENTIAL THE INFORMATION CONTAINED IN THIS DRAWING IS THE SOLE PROPERTY OF ARRAY TECHNOLOGIES. ANY REPRODUCTION IN PART OR AS A WHOLE WITHOUT THE WRITTEN PERMISSION FROM ARRAY TECHNOLOGIES IS PROHIBITED.	DRAWING STATUS: <b>Final</b> DRAWN: INITIALS: KB DATE: 07/24/2018 ENG. CHECK: INITIALS: DATE: DRAWING CHECK: INITIALS: CD DATE: 4/3/2019 FINAL APPROVAL: INITIALS: AH DATE: 4/3/2019	ARRAY TECHNOLOGIES 3901 Midway Place NE, Albuquerque, NM 87109 (505) 881-7567
	ALL DIMS ARE DUAL UNITS: THIRD ANGLE PROJECTION MILLIMETER [INCH]	TITLE: <b>I-beam, XXX, LRG Bearing, X.XXm (XXX")</b>
TOLERANCES UNLESS OTHERWISE SPECIFIED: MM [INCH]: X = ±1.25 [0.050] .X = ±0.4 [0.015] .XX = ±0.1 [0.004]	METER [INCH]: X.XX = ±0.013 [0.500] X.XXX = ±0.006 [0.250]	ANGULAR: X = ±1.0° .X = ±0.1°
SCALE: 1:3 WT: 4.08 KG [*weight - convert kg@30712500SLDPRCLB] 1		TITLE: <b>I-beam, XXX, LRG Bearing, X.XXm (XXX")</b>

### CONFIGURATION TABLE

PART NUMBER	DESCRIPTION	DIM B MM [IN]	DIM C MM [IN]	DIM D MM [IN]	DIM E MM [IN]	WEIGHT KG/M [LB/FT]
33001-01-XXX	I-Beam, W6 X 7, Center Structure, X.XXm (XXX")	147.1 [5.790]	3.4 [0.135]	99.2 [3.905]	4.1 [0.160]	10.4 [7.000]
33001-02-XXX	I-Beam, W6 X 7.75, Center Structure, X.XXm (XXX")	147.8 [5.820]	3.8 [0.151]	99.6 [3.921]	4.5 [0.177]	11.5 [7.750]
33001-03-XXX	I-Beam, W6 X 8.5, Center Structure, X.XXm (XXX")	148.1 [5.830]	4.3 [0.170]	100.1 [3.940]	5.0 [0.195]	12.6 [8.500]
33001-04-XXX	I-Beam, W6 X 9, Center Structure, X.XXm (XXX")	149.9 [5.900]	4.3 [0.170]	100.1 [3.940]	5.5 [0.215]	13.4 [9.000]
33001-05-XXX	I-Beam, W6 X 10.4, Center Structure, X.XXm (XXX")	151.4 [5.960]	5.1 [0.200]	100.8 [3.970]	6.3 [0.247]	15.5 [10.400]
33001-06-XXX	I-Beam, W6 X 12, Center Structure, X.XXm (XXX")	153.2 [6.030]	5.8 [0.230]	101.6 [4.000]	7.1 [0.280]	17.9 [12.000]
33001-07-XXX	I-Beam, W6 X 15, Center Structure, X.XXm (XXX")	152.1 [5.990]	5.8 [0.230]	152.1 [5.990]	6.6 [0.260]	22.3 [15.000]
33001-08-XXX	I-Beam, W6 X 16, Center Structure, X.XXm (XXX")	159.5 [6.280]	6.6 [0.260]	102.4 [4.030]	10.3 [0.405]	23.8 [16.000]
33001-09-XXX	I-Beam, W6 X 20, Center Structure, X.XXm (XXX")	157.5 [6.200]	6.6 [0.260]	152.9 [6.020]	9.3 [0.365]	29.8 [20.000]
33001-10-XXX	I-Beam, W6 X 25, Center Structure, X.XXm (XXX")	162.1 [6.380]	8.1 [0.320]	154.4 [6.080]	11.6 [0.455]	37.2 [25.000]
33001-11-XXX	I-Beam, W8 X 10, Center Structure, X.XXm (XXX")	200.4 [7.890]	4.3 [0.170]	100.1 [3.940]	5.2 [0.205]	14.9 [10.000]
33001-12-XXX	I-Beam, W8 X 13, Center Structure, X.XXm (XXX")	202.9 [7.990]	5.8 [0.230]	101.6 [4.000]	6.5 [0.255]	19.3 [13.000]
33001-13-XXX	I-Beam, W8 X 15, Center Structure, X.XXm (XXX")	206.0 [8.110]	6.2 [0.245]	102.1 [4.020]	8.0 [0.315]	22.3 [15.000]
33001-14-XXX	I-Beam, W8 X 18, Center Structure, X.XXm (XXX")	206.8 [8.140]	5.8 [0.230]	133.4 [5.250]	8.4 [0.330]	26.8 [18.000]
33001-15-XXX	I-Beam, W6 X 10.5, Center Structure, X.XXm (XXX")	151.6 [5.970]	4.6 [0.181]	101.6 [4.000]	6.4 [0.250]	15.6 [10.500]

**NOTES:**

- ALL FABRICATION AND OVERALL DIMS POST FINISH.
- MATERIAL:**  
STEEL, ASTM A572 GRADE 50 OR ASTM A992 GRADE 50 OR WITH EQUAL/GREATER STRUCTURAL PROPERTIES.
- FINISH:**  
REMOVE MILL SCALE, HOT DIP GALVANIZE (HDG), MIN GRADE 65 PER ASTM A123, OR OTHER APPROVED COATING BY THE FOUNDATION ENGINEER OF RECORD. REPAIR ANY DAMGED AREA PER ASTM A780.
- ALL UNSPECIFIED TOLERANCES AND QUALITY REQUIREMENTS PER ASTM A6 OR EQUIVALENT STANDARD.
- REMOVE ALL BURRS AND SHARP EDGES PRIOR TO HOT DIP GALVANIZING.
- ALL FABRICATION SHALL BE PERFORMED PRIOR TO HOT DIP GALVANIZING.
- HOLE PATTERN DIMENSIONS REMAIN THE SAME REGARDLESS OF COLUMN HEIGHT.
- ARRAY MUST BE NOTIFIED OF ALL CHANGES TO PILES FROM ORIGINAL SPEC.
- SUPPLIER IDENTIFICATION MARK REQUIRED. ARRAY TO APPROVE LOCATION AND DESIGN AT TIME OF ORDER.
- THIS HOLE PATTERN CAN ALSO BE USED ON STANDARD BEARING POSTS

ARRAY PART NUMBER DESIGNATION

**33001-XX-XXX**

INDICATES LENGTH OF DIM "A" IN X.XX METERS  
EXAMPLE: W6 X 9, 2.51M ARRAY PN: 33001-04-251

INDICATES CONFIGURATION NUMBER

ARRAY PART NUMBER

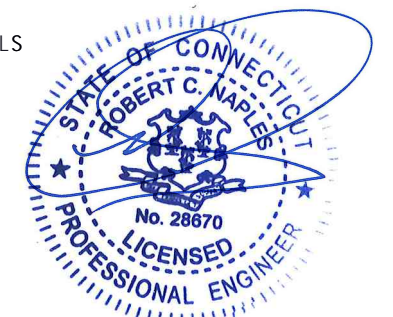
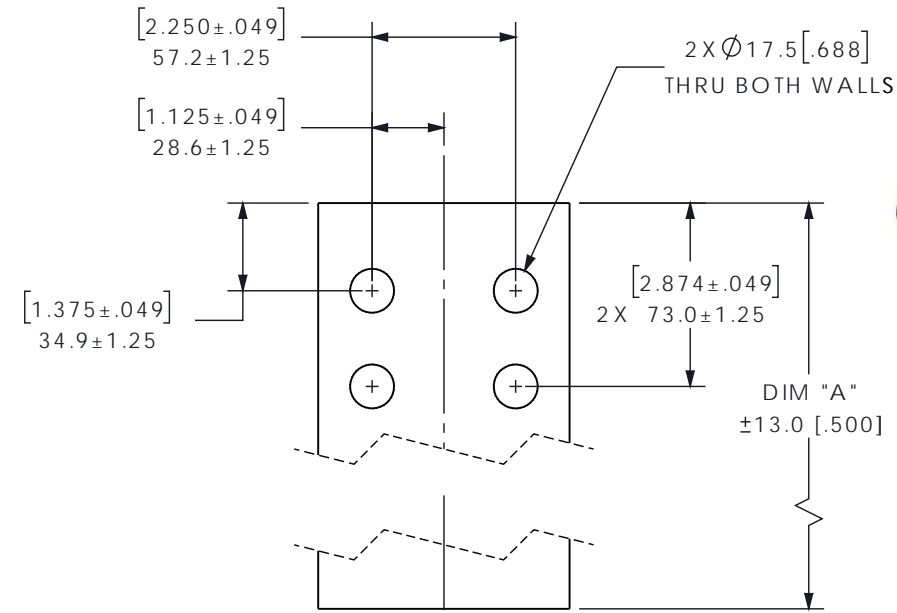
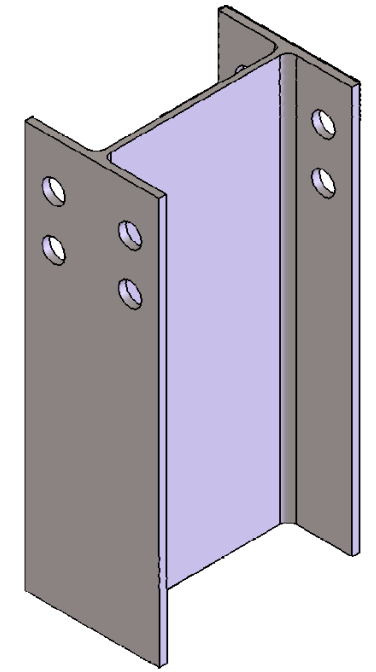
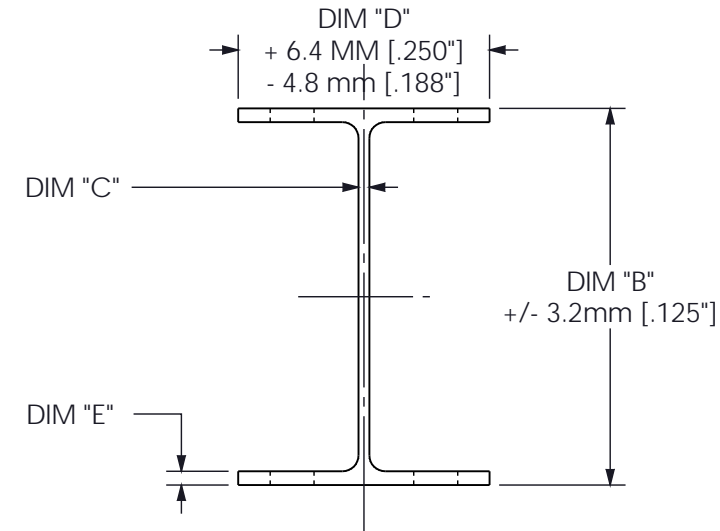

Exp 01/31/2027  
04/13/2026

**ACTUAL I-BEAM SIZE AND LENGTH TO BE DETERMINED BY FOUNDATION ENGINEER.**

ZONE	REV	ECR #	DESCRIPTION	DATE
C4	E	19106	REVISED CONFIG TABLE; ADDED 33001-15-XXX	9/6/2019
	D	19050	REVISED TOLERANCE AND NOTE	04/03/2019
	C	19011	REVISED HOLE TOLERANCE	2/26/2019

PROPRIETARY AND CONFIDENTIAL THE INFORMATION CONTAINED IN THIS DRAWING IS THE SOLE PROPERTY OF ARRAY TECHNOLOGIES. ANY REPRODUCTION IN PART OR AS A WHOLE WITHOUT THE WRITTEN PERMISSION FROM ARRAY TECHNOLOGIES IS PROHIBITED.	DRAWING STATUS: <b>Final</b> DRAWN: INITIALS: KB DATE: 07/24/2018 ENG. CHECK: INITIALS: SB DATE: 9/10/2019 DRAWING CHECK: INITIALS: RM DATE: 9/10/2019 FINAL APPROVAL: INITIALS: SB DATE: 9/10/2019	<b>ARRAY TECHNOLOGIES</b> 3901 Midway Place NE, Albuquerque, NM 87109 (505) 881-7567
	ALL DIMS ARE DUAL UNITS: MILLIMETER [INCH] THIRD ANGLE PROJECTION TOLERANCES UNLESS OTHERWISE SPECIFIED MM [INCH]: X = ±1.25 [0.050] X = ±0.4 [0.015] XX = ±0.1 [0.004]	METER [INCH]: X.XX = ±0.013 [0.500] X.XXX = ±0.006 [0.250]
TITLE: <b>I-beam, XXX, Center Structure, X.XXm (XXX")</b>		SIZE B: DRAWING NUMBER: 33001-XX-901 REVISION: E-01 SAVED v42: 9/10/2019 SCALE: 1:3 SHEET: 1 OF 1