

**STATE OF CONNECTICUT
CONNECTICUT SITING COUNCIL**

PETITION OF HYAXIOM, INC. : PETITION NO.
FOR A DECLARATORY :
RULING FOR THE LOCATION AND :
CONSTRUCTION OF A 1.84 MEGAWATT :
FUEL CELL CUSTOMER-SIDE DISTRIBUTED :
ENERGY RESOURCE AT UNIVERSITY OF :
HARTFORD 200 BLOOMFIELD AVE., :
WEST HARTFORD, CONNECTICUT :

PETITION OF HYAXIOM, INC. AS AN AGENT
FOR A DECLARATORY RULING

Pursuant to Conn. Gen. Stat. §§ 4-176 and 16-50k(a) and Conn. Agencies Regs. § 16-50j-38 et seq., HyAxiom, Inc. a Doosan company (“HyAxiom”), as an agent for and on behalf of its Customer University of Hartford (“UHart”), requests that the Connecticut Siting Council (“Council”) approve by declaratory ruling the location and construction of a Customer-side distributed resources project comprised of Four (4) new natural-gas fueled PureCell[®] Model 400 phosphoric acid fuel cells (“Fuel Cell”) and associated building and equipment (the “Facility”), providing 1.84-megawatts (“MW”) (net) of power to the University owned substation located at 200 Bloomfield Ave., West Hartford, CT (*See Attachment 1*). The Facility will be installed by HyAxiom, Inc. and owned operated and maintained by Doosan Energy Services America, Inc..

Conn. Gen. Stat. § 16-50k(a) provides that:

Notwithstanding the provisions of this chapter or title 16a, the council shall, in the exercise of its jurisdiction over the siting of generating facilities, approve by declaratory ruling . . . (B) the construction or location of any fuel cell, unless the

council finds a substantial adverse environmental effect or of any customer-side distributed resources project or facility . . . with a capacity of not more than sixty-five megawatts, as long as such project meets air and water quality standards of the Department of Energy and Environmental Projection.”

I. INTRODUCTION

The proposed Facility will be a Customer side distributed resource under 65 MW that complies with the air and water quality standards of the Department of Energy and Environmental Protection (“DEEP”). Doosan submits that no Certificate of Environmental Compatibility and Public Need is required because the proposed installation will not have a substantial adverse environmental effect.

II. DESCRIPTION AND PURPOSE OF THE PROJECT

The Facility will be a customer-side installed distributed generation resource with interconnection at the University of Hartford Substation owned and operated by the University. The Facility at 200 Bloomfield Ave. will consist of an elevated concrete structure located in parking lot “C”. (See attachment #2 Rendering). The area will be secured with a 6’ chain link fence. The proposed installation consists of four (4) 460KW Model 400+ Fuel Cells manufactured by HyAxiom, Inc. in South Windsor, Connecticut (See Attachment #3 for Model 400 Data Sheets). The overall dimension of the individual Fuel Cells is eight feet four inches wide by twenty-seven feet four inches long by nine feet eleven inches tall. The Fuel Cells are totally enclosed and factory-assembled and tested prior to shipment. The associated cooling modules will be ground mounted directly adjacent to the fuel cells. The overall dimensions for the fenced area containing the fuel cells is 108’ x 58’.

The proposed Facility will feed power through a dedicated power cable to the University owned Substation at medium voltage. The completed facility will deliver 1.84 mw of clean reliable power to the University.

The Fuel Cells are designed to have a minimum 20-year product life. This requires overhaul or replacement of major components after 10 years of operation. Components requiring overhaul include the cell stack assemblies and components in the fuel processing system.

III. SAFETY

The Fuel Cell is certified by CSA international to meet strict ANSI/CSA FC-1 2014 safety standards to protect against risks from electrical, mechanical, chemical, and combustion safety hazards. The Fuel Cell will be installed in accordance with NFPA 853. In accordance with Public Act 11-101, the fuel line pipe cleaning procedure uses inert nitrogen gas or atmospheric air. The following items are a few of the safety measures incorporated into the design. Please also refer to the Emergency Response Plan in *Attachment #4*.

A. Fire Protection

The Fuel Cell design incorporates a combustible gas sensor and thermal fuses located throughout the Fuel Cell cabinet. The detection of a potential combustible gas mixture, a fire, or the failure of this detection circuit will result in a Fuel Cell shutdown, closing of the natural gas supply valves, and a subsequent inert gas (nitrogen) purge of the Fuel Cell stack and fuel processing system. This event will also result in an alarm callout notification to HyAxiom service personnel. The Fuel Cell is designed with an integral stop button on the outside of the enclosure to enable

immediate shutdown in the event of an emergency. There is also a site-installed manual gas shut-off valve and electrical disconnect switch easily accessible to emergency personnel.

B. Gas Leak

The Fuel Cell is designed with a physical barrier that separates the equipment handling combustible gases (fuel compartment) from electrical or potential spark-creating equipment (motor compartment). The fuel compartment is maintained at a negative pressure relative to both ambient and the motor compartment in order to ensure that any gas leaks do not reach the electrical equipment in the motor compartment. The cabinet ventilation system ("CVS") is designed to dilute a potential gas leak in the fuel compartment to non-combustible levels.

C. Cell Stacks and Hydrogen

The Fuel Cell operates by converting hydrogen to DC electricity. Hydrogen is lighter than air and thus does not pool like other fuels and will readily dissipate with proper ventilation, making it less likely to ignite. Also, the Fuel Cell does not store hydrogen; instead, it produces hydrogen-rich gas at a rate equal to what it requires to produce power. The Fuel Cell stack is wrapped in a fire-retardant blanket. There are no materials inside the unit that would sustain a flame. There is no large volume of gas or any ignition that occurs within the cell stack.

D. Phosphoric Acid

Phosphoric acid is an integral part of the fuel cell system, acting as the electrolyte within the fuel cell stack. Phosphoric acid is a surprisingly common substance that is contained in common cola drinks. A leak of phosphoric acid is not possible because there is no reservoir of liquid:

phosphoric acid is constrained within the porous structure of the fuel cell stack material by capillary action.

E. Fluid Leak

The only fluid source is water. All piping systems and pressurized water vessels are designed and fabricated to the appropriate ASME codes. Water produced through the electrochemical process is “pure” water and is reclaimed and reused by the process. Water mixed with propylene glycol and a rust inhibitor (to prevent rust and freezing in colder climates) is also used in the external cooling module.

IV. HAZARDOUS MATERIALS

The Fuel Cells are capable of delivering 460 kW of electric power each. As with other fuel cell technologies, hydrogen and oxygen combine in the presence of a catalyst, which causes an electrochemical reaction to produce an electric current. A phosphoric acid fuel cell uses an inorganic, concentrated phosphoric acid as the electrolyte, allowing the electrochemical reaction to take place. The Fuel Cell also employs on-board natural gas reforming as part of the balance of plant to provide hydrogen to the fuel cell. Within this Fuel Cell, there are only two components that contain hazardous material: the Cell Stack Assembly (“CSA”) and the Integrated Low-Temperature Shift Converter (“ILS”). Neither of these components present risk when servicing the Fuel Cell. The material in both the CSA and the ILS is classified as hazardous material for the purposes of shipping. The CSA is classified as a “bulk bin,” made from the repeating elements of the Fuel Cell stack. Some of these repeating elements are porous carbon graphite plates. The phosphoric acid used as the electrolyte is contained by capillary

action within the pores of these plates. The ILS is a tank containing a self-heating solid catalyst composed of copper, zinc oxide, and alumina. Safety Data Sheets (“SDS”) are available in the y Response Plan (*See Attachment #4*).

A. Shipping of Hazardous Material

The Fuel Cell is classified as “hazardous in transportation” under the U.S. Department of Transportation (“DOT”) 49CFR regulations, and likewise as dangerous goods under the International Maritime Dangerous Goods (“IMDG”) regulations. The description of hazardous materials contained within each Fuel Cell are listed in subsections B and C below.

B. Integrated Low Shift Converter

The tank, a non-DOT specification container as described below, is a SELF HEATING SOLID INORGANIC N.O.S. (contains metallic copper on zinc oxide and alumina), CLASS 4.2, UN3190, PGII, 900 lb. net wt of hazardous material.

C. Cell Stack Assembly

The bulk bin, a non-DOT specification container as described below, is a SOLIDS CONTAINING CORROSIVE LIQUID N.O.S. (contains phosphoric acid), Class 8, UN3244, PGII, 1200 lb. net of hazardous material. The amount of phosphoric acid in the Fuel Cell complies with all applicable state and federal regulations. The exact amount of phosphoric acid is proprietary technical information and is less than the 5,000 lb. reportable quantity under 40 CFR 117.3.

D. Integration into Fuel Cell Power Plant

The above items are individual components assembled side by side, with other non-hazardous components, to form one complete Fuel Cell. The containers holding the hazardous material are non-DOT specification containers. DOT regulations allow for the transportation of the hazardous material noted above in non-DOT specification portable tanks and closed bulk bins, as used for the shipment of the Fuel Cell. IMDG regulations require United Nations (“UN”) specified containers or an exemption for international ocean transport.

E. Servicing of Product with Hazardous Material Present

The hazardous material contained within the CSA and the ILS presents no danger to installation and service personnel because direct exposure to the material is not possible. Under normal operating conditions, each container, as defined above, will contain its hazardous material for the life of the component. When end of life requires replacement of either component, no special precautions need to be employed with respect to handling because hazardous material will not come in contact with service personnel.

F. Hazardous Waste

The Fuel Cell does not produce any hazardous waste.

V. **THE SITE**

The Facility is proposed to be located entirely on the Site. The University is located both in the Town of West Hartford and the City of Hartford. The proposed location is located in Hartford and zoned “MX-2, Campus Overlay Area” under the zoning regulations of the City of Hartford (the “City”). The surrounding parcels bordering the west of the host property are zoned

for R-20 use (West Hartford) and to the North MX-2 (Hartford) (*See Attachment #5 and 5a*). Attachment #6 shows an aerial map of the location of Facility on the Site. The nearest residential properties are West of the property and over 1400 feet from the Facility. No trees are required to be removed for the installation of the Facility. Brainard Airport, the nearest airport, is over 5 miles from the proposed facility. The proposed Facility will be a maximum of 16 feet above ground level and does not fall under the FAA notification requirement of 14 CFR Part 77.9 (Attachment 7).

VI. PROJECT BENEFITS

Fuel cell technology represents an important step in advancing Connecticut's goal of diversifying its energy supply through the use of renewable energy, as expressed in Connecticut General Statutes Section 16-244 *et seq.* The Facility will serve as a cost-effective clean energy source while also reducing the demand for grid electricity from this location. Further, this Fuel Cell installation will support the efforts of the State of Connecticut to be a leader in the utilization of fuel cell technology.

Because a fuel cell does not burn fuel, the system will significantly reduce air emissions associated with acid rain and smog. Emissions standards of Connecticut will further be discussed in the next section. The Facility is designed to operate in total water balance – no make-up water is normally required after start-up and no water discharges to the environment will occur under normal operating circumstances.

VII. ENVIRONMENTAL EFFECTS

1. Water, Heat and Air Emissions

The proposed installation will have no substantial adverse environmental effect. The installation and operation of the Fuel Cell will meet all air and water quality standards of DEEP.

Section 22a-174-42 of the Regulations of Connecticut State Agencies (“RCSA”) governing air emissions from new distributed generators exempts fuel cells from air permitting requirements. Notwithstanding this exemption, the Fuel Cell meets the Connecticut emissions standards for a new distributed generator as shown in Table 1 below, and no permits, registrations or applications are required under rules based on the actual emissions of the Fuel Cell. Furthermore, the Fuel Cell is certified by the California Air Resources Board to meet the Distributed Generation Certification Regulation 2007 Fossil Fuel Emissions Standards (*See Attachment #8*).

Table 1: CT Emissions Standards for a New Distributed Generator

Air Pollutant	CT Emissions Standard (lbs/MWh)	PureCell Model 400 Fuel Cell System at Rated Power (lbs/MWh)
Oxides of Nitrogen	0.15	.01
Carbon Monoxide	1	.02
Carbon Dioxide	1650	1,049

With respect to water discharges, the Fuel Cell is designed to operate without water discharge under normal operating conditions. To the extent that minimal water overflow may occasionally occur, such discharges will consist of de-ionized water and will be directed to a site dry well. This discharge will be incorporated into the overall site design. The Fuel Cell operates in water balance below 86°F. The initial fill requires 350 gallons of water. The amount of make-up water above 86°F increases linearly from 0gpm to 1gpm at 110°F.

The Facility will also meet state criteria thresholds and projected emissions for all greenhouse gases defined in as Section 22a-174-1(49) as shown in Table 2. Section 22a-174-1(49) states the following: “Greenhouse gases” or “GHGs” means the aggregate of the following six components gases: carbon dioxide (CO2), methane (CH4), nitrous oxide (N2O), sulfur hexa fluoride (SF6), any hydrofluorocarbon (HFC) or any perfluorocarbon (PFC).” There is no defined criteria threshold for these compounds, however Section 22a-174-1(21) provides a method for computing carbon dioxide equivalent emissions “CO2e.” The proposed Facility will have no emissions of SF6, HFC, and PFC. Emissions of CH4 and N2O will be very low and will not contribute significantly to the GWP of the proposed facility.

Table 2: PureCell® Model Emissions Data

Emission Type	Projected Emissions	GWP in 40 CFR 98, Table A-1	Projected CO2e
CO2	2025 ton/yr	1	2025 ton/yr
CH4	<0.02 ton/yr	25	<0.5 ton/yr
N2O	<0.01 ton/yr	298	<3 ton/yr
SF6	N/A	22,800	N/A
HFC	N/A	12 to 14,900*	N/A
PFC	N/A	7,390 to 17,340	N/A

Current control technologies are not commercially available to reduce the greenhouse gas emissions from the Facility.

2. Wildlife and Habitat

According to the relevant portion of the CT DEEP West Hartford/Hartford Natural Diverse Database Areas Map (*See attachments #9*), the proposed Site is not located within the West Hartford/Hartford Natural Diversity Data Base Areas.

3. Noise Analysis

Based on the engineering study results conducted by a professional acoustic engineer of the proposed Site dated November 17, 2022 the noise level of the Facility will not exceed local and state noise level ordinance levels. Please review the attached Acoustic Survey Report and Recommendations in *Attachments #10*.

4. Visual Impact

The Facility will not cause any significant visual effects. The proposed site is in a parking lot situated behind an academic building. The Facility would be visible only from the Site driveways while on site.

5. Public Notice

Notice was provided via certified mail to all property owners, abutters and state and local officials pursuant to Conn. Agencies Regs. §16-50j-40(a). HyAxiom's copy of the notice letter, Abutters list and Abutters' Map are included in *Attachments 11, 12 and 13*. Prior to filing this Petition, HyAxiom sent notices to all applicable Federal, State and Municipal officials of West Hartford/Hartford as listed in *Attachments 14, 15 & 16*, which shows the certified mail receipts for State and Municipal officials and Abutters.

Project Decommissioning Plan

Following the 20-year operational life of the Facility, the decommissioning plan is as follows:

- A) Isolate, lock out and disconnect all piping for cooling module at the power module. Remove gas piping to the unit. Disconnect nitrogen purge system at power module.
- B) Disconnect all electrical conductors and conduit at the Fuel Cell to include electrical power, cooling module power, and nitrogen pressure switch. Shore power to be maintained to the unit to maintain temperature as needed.
- C) Contractor will work in concert with Doosan's Service Department personnel during decommissioning and shutdown.
- D) Return Site to original condition with the exception of the concrete pads.
- E) The decommissioned Fuel Cell will be stripped, the parts are separated and either recycled, reclaimed or transported to landfill.

7. Aquifer Protection Area, Coastal Boundaries, and Flood Zones

Based on an analysis of the Federal Emergency Management Agency's ("FEMA") National Flood Insurance Program ("NFIP") flood mapping data for Hartford (*See Attachment #17*), the proposed Facility is situated in a 100 year flood zone which is approximately elevation 37'. The fuel cells and associated electrical equipment will be installed at elevation 40'. The Site is in already disturbed area with existing construction on the Site. The Town of West Hartford/Hartford have no Aquifer Protection Areas near the Site and there is no wetland close to the proposed installation site with the nearest watercourse over 250' feet away from the proposed Site. No negative impact to the watercourses and wetlands is anticipated throughout the construction or operation of the Fuel Cell.

8. Cultural Resources.

The proposed Facility will be located in an already developed vicinity, consequently construction and operation of the Fuel Cell will have no unpleasant effect on any cultural (historical and archaeological) resources in the area.

9. Natural Gas Desulfurization Process

Sulfur is present in pipeline natural gas. It is primarily used as an odorant so leaks can be easily detected. Unfortunately, sulfur is also a poison to fuel cell systems and must be removed by the Fuel Cell. For further details of desulfurization please refer to the attached Desulfurization Memo (*See Attachment #18*).

VIII. CONSTRUCTION AND MAINTENANCE

Doosan plans to start construction work by February 2023. Construction will take approximately sixteen weeks, followed by approximately four weeks of testing and startup. Regular working hours for the proposed project are Monday through Friday from 8:00 am to 5:00 pm. HyAxiom and its contractors will fully cooperate with the City Inspector and will follow all City of Hartford and Connecticut State construction policies and codes.

IX. LOCAL INPUT AND STATE FUNDING

HyAxiom has shared plans for the project with the local officials and plans to present the plans for the installation of the Facility. This project has been awarded a contract to sell Low Emission

Renewable Energy Credits (LREC) to Eversource through the CT Low and Zero Emission Renewable Energy Credit Program. Doosan will complete all necessary permitting before installing the Fuel Cell.

X. CONCLUSION

As set forth above, HyAxiom requests that the Council issue a determination, in the form of a declaratory ruling, that the proposed installation above is not one that would have a substantial adverse effect, and, therefore, that a Certificate is not needed.

Respectfully submitted,

A handwritten signature in dark ink, appearing to read 'Walter Bonola', is written over a horizontal dotted line. The signature is fluid and cursive.

Walter Bonola

Installation Manager

Doosan Fuel Cell America, Inc.

LIST OF ATTACHMENTS

- Attachment 1: Site Plan with one line drawing
- Attachment 2: Rendering
- Attachment 3: Doosan PurcCell® Model 400 Datasheet
- Attachment 4: Emergency Response Plan
- Attachment 5: Town Zoning Map (West Hartford)
- Attachment 5a: City Zoning Map (Hartford)
- Attachment 6: Aerial Map
- Attachment 7: 14CFR Part 77.9
- Attachment 8: California Air Resources Board Emission Certification
- Attachment 9: National Diversity Database Map (West Hartford)
- Attachment 10: Acoustic Site Survey Report
- Attachment 11: Abutters Notification Letter
- Attachment 12: Abutters List
- Attachment 13: Abutters Map
- Attachment 14: Notice List (West Hartford)

Attachment 15: Notice List (Hartford)

**Attachment 16: Copy of Certified Mail receipts for letters to Abutters, State/Town
Officials**

Attachment 17: FEMA Flood Map

Attachment 18: Desulpherization Memo

Attachment #2

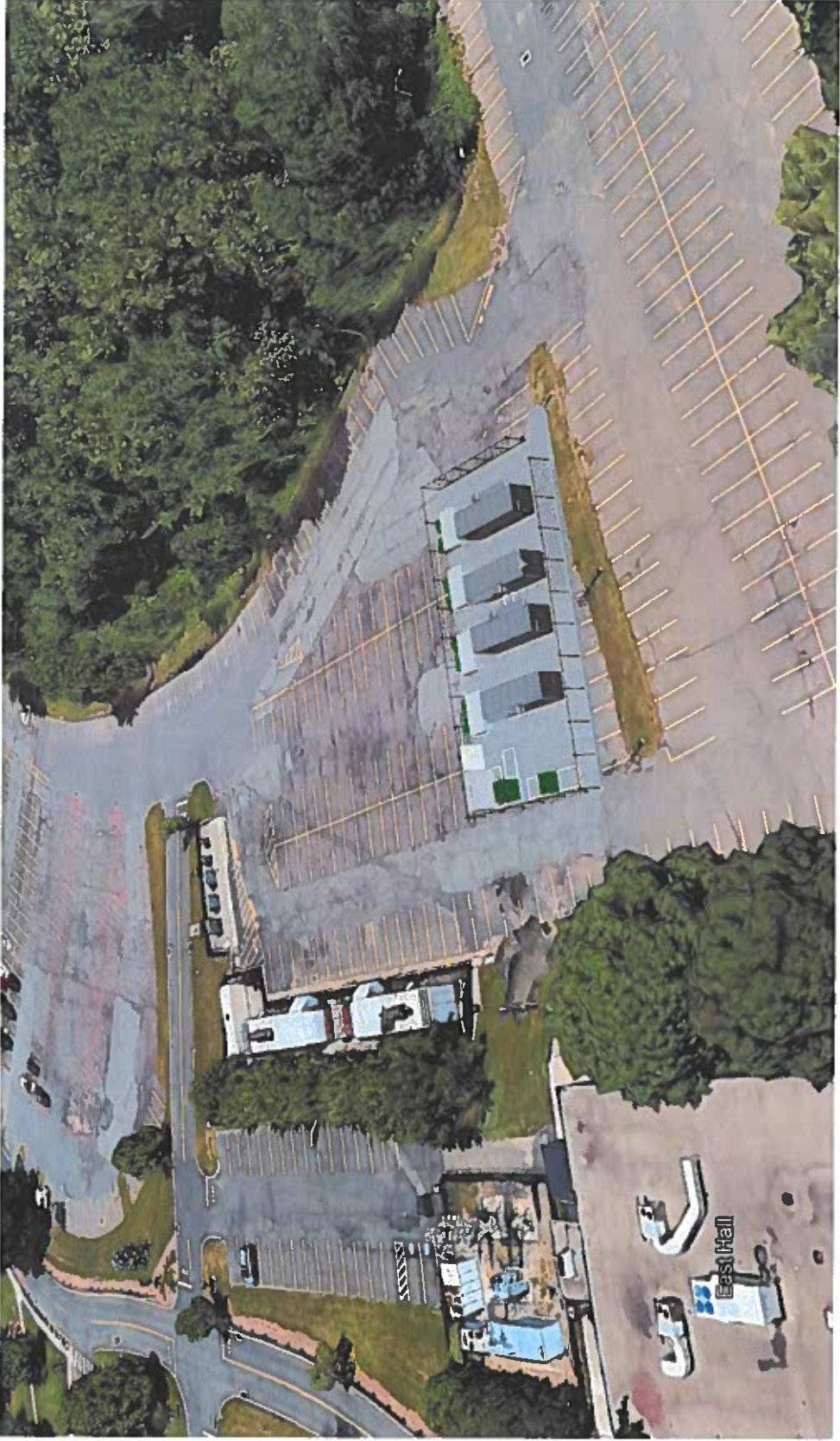

PURECELL SYSTEM BENEFITS

Energy Security

Proven PAFC fuel cell technology that is setting durability records

Energy Productivity

Increased efficiency and continuous on-site generation reduces energy costs

Energy Responsibility

Ultra-low emissions equals sustainability

PURECELL SYSTEM COMPETITIVE ADVANTAGES

Long Life

Industry leading 10-year cell stack life assures high availability and low service cost

Modular & Scalable

Solutions for multi-megawatt applications to meet growing energy demand

Experience

Most knowledgeable and experienced team in the industry

High Efficiency

Up to 90% total CHP Efficiency

Grid-Independence

Proven performance delivering power when the utility grid fails

Load Following

Capable of dispatching power to match building needs

Small Footprint

Highest power density among clean generation technologies

Flexible Siting

Indoor, outdoor, rooftop, multi-unit

RATED POWER OUTPUT: 460KW, 480VAC, 60HZ

Characteristic	Units	Operating Mode	
		Power 460kW	Eco 440kW
Electric Power Output ¹	kW/kVA	460/532	440/517
Electrical Efficiency	%, LHV	43.5%	44.4%
Peak Overall Efficiency	%, LHV	90%	90%
Gas Consumption ¹	MMBtu/h, HHV (kW)	4.04 (1,185)	3.78 (1,108)
Gas Consumption ^{1,2}	SCFH (Nm ³ /h)	3,941 (106)	3,688 (98.7)
High Grade Heat Output @ up to 250°F ¹	MMBtu/h (kW)	1.30 (382)	1.16 (341)
Low Grade Heat Output @ up to 140°F ^{1,6}	MMBtu/h (kW)	1.68 (492)	1.54 (452)



FUEL

Supply..... Natural Gas
Inlet Pressure 10 to 14 in. water (2.5 - 3.5 mbar)

EMISSIONS^{3,4}

NOx 0.02 lbs/MWh (0.009 kg/MWh)
CO 0.01 lbs/MWh (0.005 kg/MWh)
VOC 0.01 lbs/MWh (0.005 kg/MWh)
SO₂ Negligible
Particulate Matter Negligible
CO₂¹ (electric only) 1,006 lbs/MWh (456 kg/MWh)
(with High-Grade heat recovery) 567 lbs/MWh⁵ (257 kg/MWh)
(with full heat recovery) 496 lbs/MWh⁵ (225 kg/MWh)

OTHER

Ambient Operating Temp -20°F to 104°F (-29°C to 40°C)
Relative Humidity 0 to 95% (non-condensing)
Sound Level <65 dBA⁶ @ 33 ft. (10m)
Water Consumption None (up to 86°F (30°C) Ambient Temp.)
Water Discharge None (Normal Operating Conditions)

CODES AND STANDARDS

ANSI/CSA FC1-2014: Stationary Fuel Cell Power Systems
UL1741 SA: Inverters for Use With Distributed Energy Resources

NOTES

1. Average performance during 1st year of operation.
2. Based on natural gas higher heating value of 1025 Btu/SCF (40.4 MJ/Nm³)
3. Emissions based on 440 kW operation.
4. Fuel cells are exempt from air permitting in many U.S. states.
5. Includes CO₂ emissions savings due to reduced on-site boiler gas consumption
6. With optional equipment

HyAxiom, Inc.

Corporate Headquarters
101 East River Drive
East Hartford, CT 06108
(860)727-2253
www.hyaxiom.com
email: fuelcells@doosan.com

SYSTEM DIMENSIONS

Power Module

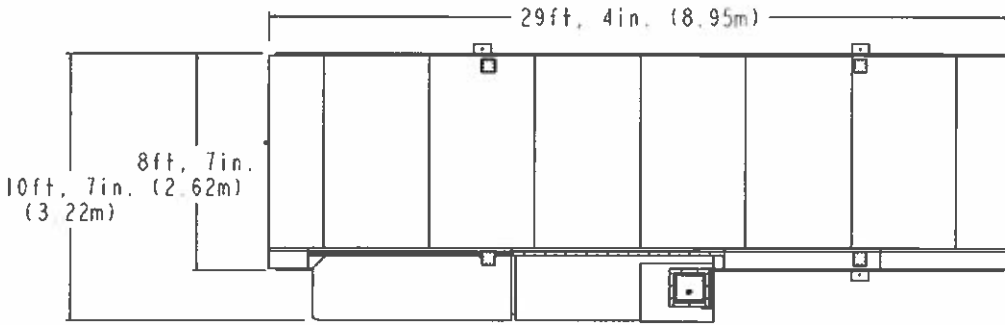

Top View

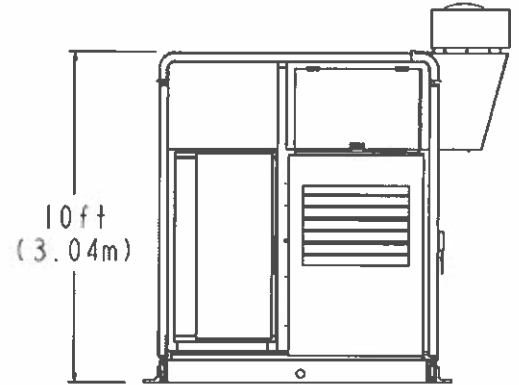

Side View

Cooling Module

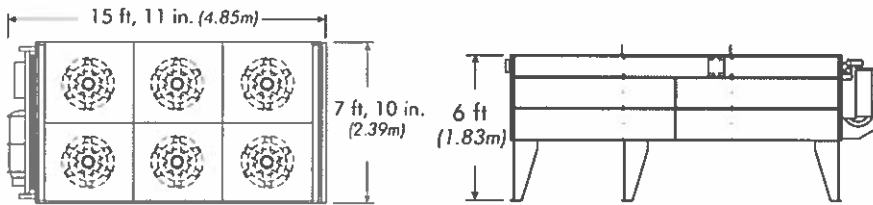

Top View

Side View

PHYSICAL SPECIFICATIONS

	Power Module	Cooling Module
Length	29' 4" (8.95m)	15' 11" (4.85m)
Width	8' 7" (2.62m)	7' 10" (2.39m)
Height	10' (3.02m)	6' 0" (1.83m)
Weight	57,000 lb (27,216 kg)	3,190lb (1,447 kg)

PURECELL ADVANTAGE

OFFSET 3x MORE CO₂



CAPACITY FACTOR



CO₂ OFFSET



USE LESS LAND

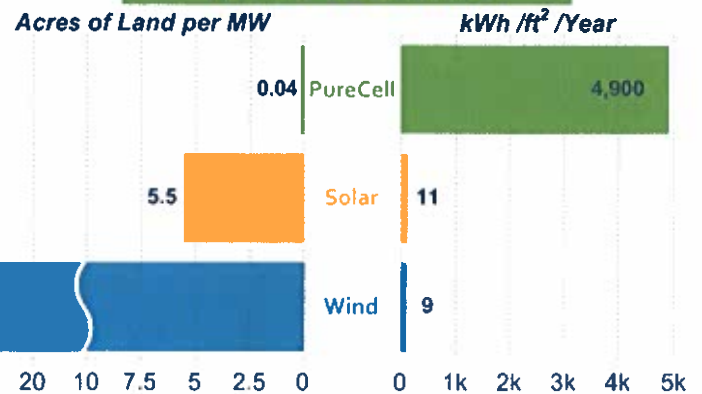

HyAxiom, Inc.
Corporate Headquarters
101 East River Drive
East Hartford, CT 06108
(860)727-2253
www.hyaxiom.com
email: fuelcells@doosan.com

The manufacturer reserves the right to change or modify, without notice, the design or equipment specifications without incurring any obligation either with respect to equipment previously sold or in the process of construction. The manufacturer does not warrant the data on this document.

HyAxiom, Inc., A Doosan Company

Fuel Cell Emergency Response Guide

University Of Hartford

200 Bloomfield Ave.

West Hartford, CT 06117



DISCLAIMER

HyAxiom reserves the right to change or modify, without notice, the design or equipment specifications of the PureCell® system Model 400 without obligation with respect to equipment either previously sold or to be sold. This guide is provided by HyAxiom, and no liability will accrue to HyAxiom based on the information or specifications included herein. No warranties or representations are made by this guide and no warranties or representations shall apply to the equipment except as stated in HyAxiom's standard terms and conditions of sale applicable at the time of purchase, a copy of which will be provided upon request. The Model 400 is designed to provide safe and reliable service when operated within design specifications, according to all

COPYRIGHTED WORK © HYAXIOM. THIS DOCUMENT CONTAINS THE PROPERTY OF HYAXIOM. YOU MAY NOT POSSESS, USE, COPY OR DISCLOSE THIS DOCUMENT OR ANY INFORMATION IN IT FOR ANY PURPOSE, INCLUDING WITHOUT LIMITATION TO DESIGN, MANUFACTURE, OR REPAIR PARTS, WITHOUT EXPRESS WRITTEN PERMISSION. NEITHER RECEIPT FROM ANY SOURCE, NOR POSSESSION OF THIS DOCUMENT, CONSTITUTES SUCH PERMISSION. POSSESSION, USE, COPYING OR DISCLOSURE BY ANYONE WITHOUT EXPRESS WRITTEN PERMISSION OF HYAXIOM CORPORATION IS NOT AUTHORIZED AND MAY RESULT IN CIVIL LIABILITY.



applicable instructions, and with the appropriate operating materials. When operating this equipment, use good judgment and follow safety precautions to avoid damage to equipment and property or injury to personnel. Be sure to understand and follow the procedures and safety precautions contained in all applicable instructions, operating materials, and those listed in this guide. All information in this document is as of January 25, 2016.

Policy

The following plan has been developed to minimize the severity of damage to human health, the environment, and property in the event of an unexpected failure.

Scope

This Emergency Response Guide shall be integrated into the site Emergency Response Plan. Information contained in this document shall be customized to meet local requirements and shall be shared with local responders as necessary. This guide is only a template and in no way assumes or transfers liability or ownership. HyAxiom should be contacted if clarification is needed.

Emergency Contacts and Numbers

COPYRIGHTED WORK © HYAXIOM. THIS DOCUMENT CONTAINS THE PROPERTY OF HYAXIOM. YOU MAY NOT POSSESS, USE, COPY OR DISCLOSE THIS DOCUMENT OR ANY INFORMATION IN IT FOR ANY PURPOSE, INCLUDING WITHOUT LIMITATION TO DESIGN, MANUFACTURE, OR REPAIR PARTS, WITHOUT EXPRESS WRITTEN PERMISSION. NEITHER RECEIPT FROM ANY SOURCE, NOR POSSESSION OF THIS DOCUMENT, CONSTITUTES SUCH PERMISSION. POSSESSION, USE, COPYING OR DISCLOSURE BY ANYONE WITHOUT EXPRESS WRITTEN PERMISSION OF HYAXIOM CORPORATION IS NOT AUTHORIZED AND MAY RESULT IN CIVIL LIABILITY.



Local Emergency Number	911
HyAxiom Control Center	(860) 727-2847
Fire Department – Non-emergency number	Town of West Hartford Fire Department (860) 523.5263
Hospital – Non-emergency number	St. Francis Hospital 114 Woodland St Hartford, CT (860) 714.4000
Electric Utility Name: Eversource Energy	888-783-6617
Gas Utility Name: Eversource	888-688-7267 *Gas Leaks Only: 877- 944-5323
Local Oil & Chemical Spill Response Division	800-645-8265
Connecticut Oil & Chemical Spill Response Division	860-424-3338
EPA - Environmental Protection Agency Region 1	(800) 424-8802 Environmental Emergency
OSHA - Occupational Safety and Health Admin. Emergency Number	(800) 321-6742 National Emergency Number
Poison Control Center	(800) 222-1222 National Emergency Number

Fuel Cell Hazard Overview

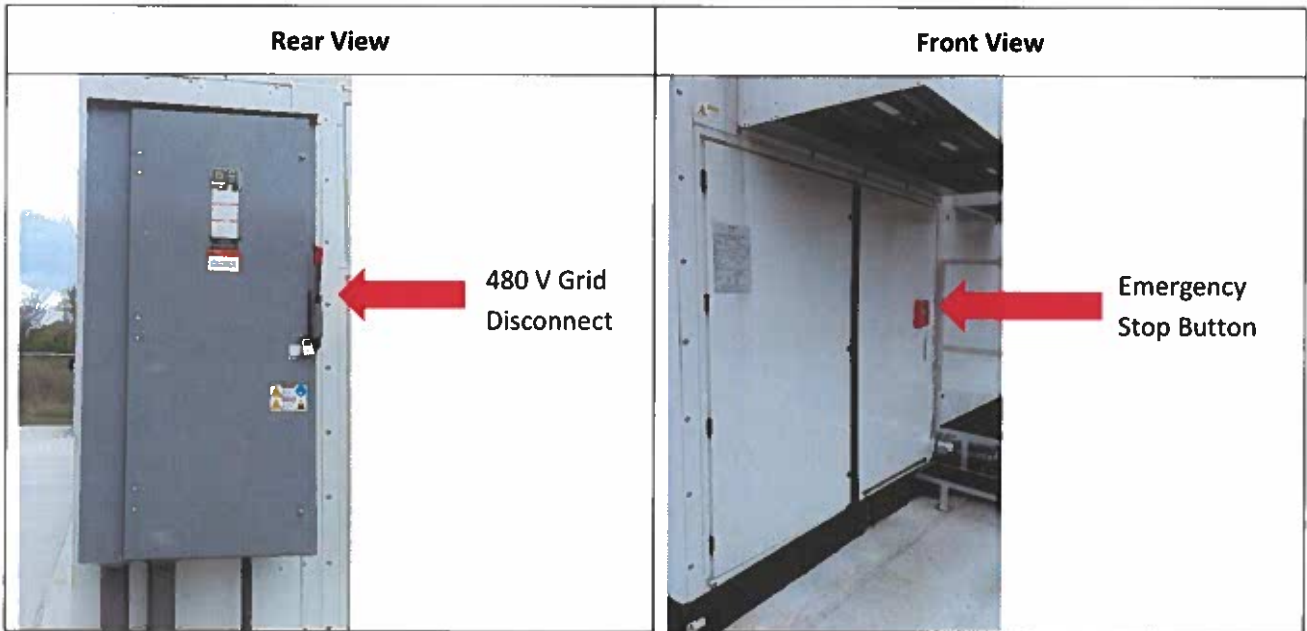
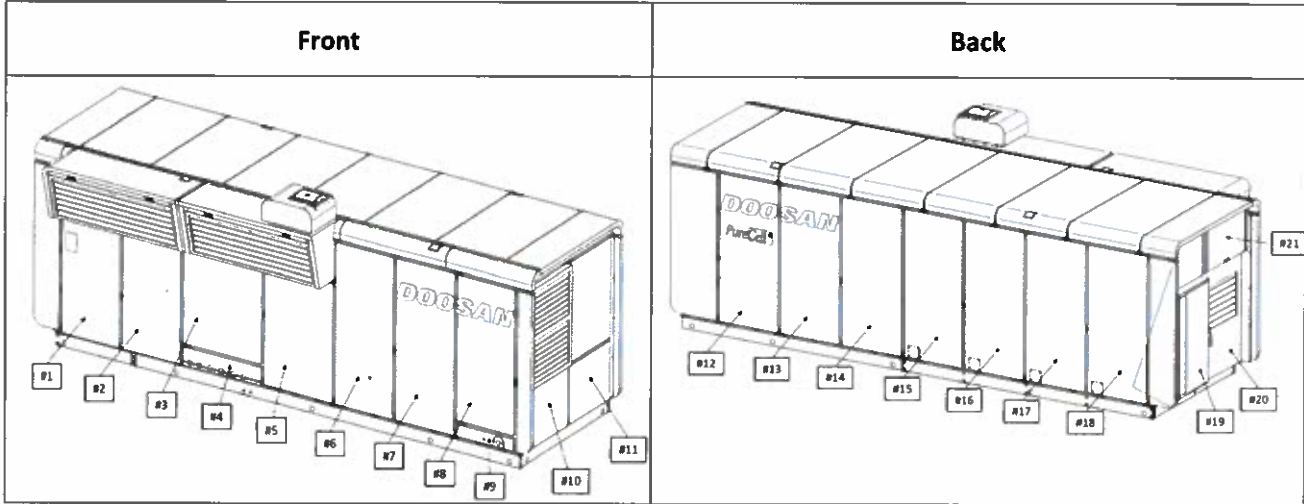

Rear View Panel	Primary Hazard	Front View Panel	Primary Hazard
1 (Computer Terminal)	Electrical = 120 VAC	12 (Reformer)	Electrical = 480 VAC Chemical = Air sensitive catalyst / combustibles Thermal = 600°F Reformer Pressure = 150 psi steam
		13 (Reformer)	Electrical = 480 VAC Chemical = Air sensitive catalyst / combustibles Thermal = 600°F Reformer Pressure = 150 psi steam
2 (Swing Door)	Electrical = 480 VAC	14 (Reformer)	Electrical = 480 VAC Chemical = Air sensitive catalyst / combustibles Thermal = 600°F Reformer Pressure = 150 psi steam
3 (Mechanical Entry)	Electrical = 480 VAC Chemical = Propylene Glycol Thermal = 350°F Steam Pressure = 150 psi Steam	15 (DC Cell Stack)	Electrical = 300 VDC Chemical = Solid phosphoric acid / combustibles
4 (Mechanical Entry)	Chemical = Propylene Glycol Thermal = 350°F Steam Pressure = 150 psi Steam	16 (DC Cell Stack)	Electrical = 300 VDC Chemical = Solid phosphoric acid / combustibles
5 (TMS)	Electrical = 480 VAC Chemical = Propylene Glycol / Deionized Water / Resin Thermal = 350°F Steam Pressure = 150 psi Steam	17 (DC Cell Stack)	Electrical = 300 VDC Chemical = Solid phosphoric acid / combustibles
6 (ILS)	Electrical = 480 VAC Chemical = Air sensitive catalyst / combustibles Thermal = 600°F Reformer Pressure = 150 psi steam	18 (DC Cell Stack)	Electrical = 300 VDC Chemical = Solid phosphoric acid / combustibles
7 (Fuel Processing Area)	Electrical = 480 VAC Chemical = Air sensitive catalyst / combustibles Thermal = 600°F Reformer Pressure = 150 psi steam	19	Not accessible
8 (Fuel Processing Area)	Electrical = 480 VAC Chemical = Air sensitive catalyst / combustibles Thermal = 600°F Reformer Pressure = 150 psi steam	20 (Grid Connect Disconnect)	Electrical = 480 VAC
9 (Gas/Nitrogen Inlet)	Chemical = combustibles	21 (Blower 110)	Electrical = 300 VDC Mechanical = Blower
10 (Reformer)	Electrical = 480 VAC Chemical = Air sensitive catalyst / combustibles Thermal = 600°F Reformer Pressure = 150 psi steam	22	Electrical = 1400 VDC / 480 VAC
11 (Reformer)	Electrical = 480 VAC Chemical = Air sensitive catalyst / combustibles Thermal = 600°F Reformer Pressure = 150 psi steam	ALL Roof Panels	Multiple Hazards DO NOT WALK ON ROOF!

Conditional Assessment

Normal Condition	Potential Abnormal Condition	Response
<p>Fuel Cell</p> <p>White steam exiting power plant at exhaust chimney, above panel #6 (It can be a large amount of white steam depending on ambient conditions)</p>	<p>Dark colored smoke exiting chimney or any other part of enclosure</p> <p>Observable fire or heavy smoke at any point on fuel cell</p>	<ol style="list-style-type: none"> 1. Establish safe perimeter 2. Contact HyAxiom Control Center (860) 727-2847 1. Press Fuel Cell 'Stop Button' – Only if safely accessible! 2. Dial 911 or Local Emergency Response Number 3. Establish safe perimeter 4. Contact HyAxiom Control Center (860) 727-2847
<p>Fuel Cell</p> <p>Moderate humming, clicking and fan sounds</p>	<p>Grinding or loud intermittent noises</p> <p>Observable fire or heavy smoke at any point on fuel cell</p>	<ol style="list-style-type: none"> 1. Contact HyAxiom Control Center (860) 727-2847 1. Press Fuel Cell 'Stop Button' – Only if safely accessible! 2. Dial 911 or Local Emergency Response Number 3. Establish safe perimeter 4. Contact HyAxiom Control Center (860) 727-2847
<p>Cooling Module</p> <p>Fan humming</p>	<p>Smoke or fire coming from module</p>	<ol style="list-style-type: none"> 1. Press Fuel Cell 'Stop Button' – Only if safely accessible! 2. Dial 911 or Local Emergency Response Number 3. Establish safe perimeter 4. Contact HyAxiom Control Center (860) 727-2847

	Grinding or loud noise coming from fans	1. Contact HyAxiom Control Center (860) 727-2847
Cooling Module	Small leak dripping from joint, valve or connection	1. Contact HyAxiom Control Center (860) 727-2847
No leaking from cooling loop piping or coils	Medium to large leak	1. Follow local spill response protocol or contact Clean Harbors Emergency Cleanup Response (800) 645-8265 2. Contact HyAxiom Control Center (860) 727-2847
Mechanical Hi/Lo Grade Piping	Small leak dripping from joint, valve or connection	1. Contact HyAxiom Control Center (860) 727-2847
Small amounts of condensate dripping from piping	Medium to large leak	1. Follow local spill response protocol or contact Clean Harbors Emergency Cleanup Response (800) 645-8265 2. Contact HyAxiom Control Center (860) 727-2847
Disconnects/Other Equipment	Smoke or fire coming from equipment	1. Dial 911 or Local Emergency Response Number 2. Establish safe perimeter 3. Contact HyAxiom Control Center (860) 727-2847
No leaks or smoke		
Compressed Gas Manifold (N2/H2)	Leaks – may be able to hear hissing sound.	1. If Indoors – Evacuate Immediately! Dial 911 or Local Emergency Response Number 2. Establish safe perimeter 3. Contact HyAxiom Control Center (860) 727-2847
No leaks, May hear intermittent gas flow during purges		



Fuel Cell Related Safety Data Sheets (SDS)

1	Propylene Glycol – DowFrost®
2	Phosphoric Acid – Solid
3	Reformer/ILS Catalysts
4	Anion/Cation Resin
5	Nitrogen / Hydrogen Compressed Gas Mixture (non-flammable)

Inspections

Inspection Type	Equipment Requirements	Frequency Required
General Maintenance	Laptop, Service Vehicle	Monthly
General Housekeeping	N/A	Monthly
Waste and Chemical Storage*	N/A	Weekly
Internal Combustible Gas Monitor	AT-160 Calibration Kit	Annual
Fire Prevention	N/A	Monthly

*When applicable

Fuel Cell operation is monitored and controlled remotely 24 hours a day 7 days a week by the HyAxiom Control Center. Upset or abnormal occurrences outside of normal operating parameters are immediately identified and service technicians are dispatched within 24 hours to respond when required.

Emergency Procedures

Alarms	There are no audible or visual alarms on Fuel Cell. Alarm conditions are relayed immediately to the HyAxiom Control Center. The HyAxiom Control Center will then contact the appropriate site personnel on the site’s emergency contact list.
Emergency Shut Down Onsite	Actuate Fuel Cell Stop Button
Emergency Area Egress - Gas Odor	Evacuate 330 Feet in all directions
Emergency Area Egress - Fire	Evacuate 330 Feet in all directions – CV000 automatic natural gas supply shut off
Emergency Egress - General	Fuel cell is unmanned remotely monitored and controlled. No HyAxiom employees attending unit unless service or maintenance is required.

Signage and labeling

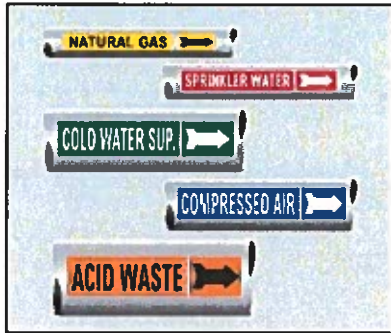

General:

Safety Hazard Analysis

The PureCell® Model 400 fuel cell system has been designed to meet strict ANSI/CSA safety standards to protect against risks from electrical, mechanical, chemical, and combustion safety hazards. The following items are a few of the safety measures incorporated into the design.

Fire Detection and Protection:

The power plant design incorporates a combustible gas sensor as well as thermal fuses located throughout the power module cabinet to detect fire. The detection of a potential flammable gas mixture, a fire, or the failure of this detection circuit will result in a power plant shutdown and a subsequent inert gas (nitrogen) purge of the fuel cell stack and fuel processing system. This event will also result in an alarm callout notification to HyAxiom service personnel. The power plant is designed with an integral emergency-stop button on the outside of the enclosure to enable immediate shutdown in the event of an emergency. There is also a gas shut-off valve and electrical disconnect switch easily accessible to emergency personnel. There are no restrictions for type of fire suppression equipment.

Gas Leak:

Augmenting the internal combustible gas sensor, the power plant also monitors the flow rate of natural gas. If the gas flow rate exceeds the equivalent power production of the power plant then a shutdown will result. The largest possible accumulation from a leak prior to shutdown is below combustible limits. Fuel valves inside the power plant are “fail safe” and will return to their normally closed position upon loss of power. The power plant is designed to have a physical barrier that separates the equipment handling combustible gases (fuel compartment) from electrical or potential spark-creating equipment (motor compartment). The fuel compartment is kept at a negative pressure to contain and remove any potential gas leaks, whereas the motor compartment is pressurized by a fan source to prevent combustible gases from entering.

Hydrogen:

Hydrogen is lighter than air and thus does not pool like other fuels and will readily dissipate with proper ventilation making it less likely to ignite. Although hydrogen has low self-ignition characteristics, the fuel in the power plant is not pure hydrogen. Also, the power plant is not producing or storing hydrogen, it consumes hydrogen-rich gas equal to what it requires to produce power. The fuel cell stack is wrapped in a fire retardant blanket. There are no materials inside the unit that would sustain a flame. There is no large volume of gas or any ignition that occurs within the cell stack.

Phosphoric Acid:

Phosphoric acid is integral part of the fuel cell system, acting as the electrolyte within the fuel cell stack. Phosphoric acid is a surprisingly common substance that is contained in common cola drinks. A leak of phosphoric acid is not possible because phosphoric acid is not in liquid form once applied in the equipment. There is no reservoir of liquid. Phosphoric acid is contained in the porous structure of the fuel cell stack material by capillary action, similar to how ink is absorbed into a blotter.

Fluid Leak:

The only fluid source is water. All pressurized water vessels are designed to ASME boiler codes and inspected annually. All piping, welds, etc. meet pressurized piping standards. Water produced through the electrochemical process is "pure" water and is reclaimed and reused by the process. The other source of water is water used in the external cooling module, which is mixed with a polypropylene glycol and a rust inhibitor to prevent rust and freezing in colder climates.

Hazardous Waste:

The fuel cell does not produce any hazardous waste. Standard Material Safety Data Sheets (MSDS) are available upon request.

APPENDIX 1 – SAFETY DATA SHEETS

SAFETY DATA SHEET

1. Identification

Product identifier: PHOSPHORIC ACID

Other means of identification

Synonyms: Ortho-Phosphoric Acid, White Phosphoric Acid
Product No.: 0240, 6908, 2798, 2797, 5854, 2796, 5804, 2788, 0259, 5372, 0274, 0269, 0268, 0265, 0264, 0262, 0260, 0255, 0251

Recommended use and restriction on use

Recommended use: Not available.
Restrictions on use: Not known.

Manufacturer/Importer/Supplier/Distributor information

Manufacturer

Company Name: Avantor Performance Materials, Inc.
Address: 3477 Corporate Parkway, Suite 200
Center Valley, PA 18034

Telephone: Customer Service: 855-282-6867

Fax:
Contact Person: Environmental Health & Safety
e-mail: info@avantormaterials.com

Emergency telephone number:
24 Hour Emergency: 908-859-2151

Chemtec: 800-424-9300

2. Hazard(s) identification

Hazard classification

Physical hazards

Corrosive to metals Category 1

Health hazards

Acute toxicity (Oral) Category 4

Skin corrosion/irritation Category 1

Serious eye damage/eye irritation Category 1

Specific target organ toxicity - single exposure Category 3

Unknown toxicity

Acute toxicity, oral 0 %

Acute toxicity, dermal 0 %

Acute toxicity, inhalation, vapor 100 %

Acute toxicity, inhalation, dust or mist 100 %

Unknown toxicity

Acute hazards to the aquatic environment 84 %

Chronic hazards to the aquatic environment 84 %

Hazard symbol:



Signal word: Danger

Hazard statement: May be corrosive to metals.
Harmful if swallowed.
Causes severe skin burns and eye damage.
May cause respiratory irritation.

Precautionary statement

Prevention: Keep only in original container. Do not breathe dust/fume/mist/vapors. Do not eat, drink or smoke when using this product. Use only outdoors or in a well-ventilated area. Wear protective gloves/protective clothing/eye protection/face protection. Wash thoroughly after handling.

Response: Absorb spillage to prevent material damage. IF SWALLOWED: Rinse mouth. Do NOT induce vomiting. IF ON SKIN (or hair): Remove/take off immediately all contaminated clothing. Rinse skin with water/shower. Wash contaminated clothing before reuse. IF IN EYES: Rinse cautiously with water for several minutes. Remove contact lenses, if present and easy to do. Continue rinsing. IF INHALED: Remove victim to fresh air and keep at rest in a position comfortable for breathing. Immediately call a POISON CENTER or doctor/physician.

Storage: Store locked up. Store in a well-ventilated place. Keep container tightly closed. Store in corrosive resistant container with a resistant inner liner.

Disposal: Dispose of contents/container to an appropriate treatment and disposal facility in accordance with applicable laws and regulations, and product characteristics at time of disposal.

Other hazards which do not result in GHS classification: None.

3. Composition/information on ingredients

Mixtures

Chemical identity	Common name and synonyms	CAS number	Content in percent (%) [*]
PHOSPHORIC ACID		7664-38-2	80 - 90%

^{*} All concentrations are percent by weight unless ingredient is a gas. Gas concentrations are in percent by volume.

4. First-aid measures

General information: Get medical advice/attention if you feel unwell. Show this safety data sheet to the doctor in attendance.

Ingestion:	Do NOT induce vomiting. Call a physician or poison control center immediately. If vomiting occurs, keep head low so that stomach content doesn't get into the lungs.
Inhalation:	Move to fresh air. Call a physician or poison control center immediately. Apply artificial respiration if victim is not breathing. If breathing is difficult, give oxygen.
Skin contact:	Immediately flush with plenty of water for at least 15 minutes while removing contaminated clothing and shoes. Call a physician or poison control center immediately. Wash contaminated clothing before reuse. Destroy or thoroughly clean contaminated shoes.
Eye contact:	Immediately flush with plenty of water for at least 15 minutes. If easy to do, remove contact lenses. Call a physician or poison control center immediately. In case of irritation from airborne exposure, move to fresh air. Get medical attention immediately.

Most important symptoms/effects, acute and delayed

Symptoms: Causes severe skin and eye burns. Causes digestive tract burns.

Indication of immediate medical attention and special treatment needed

Treatment: Treat symptomatically. Symptoms may be delayed.

5. Fire-fighting measures

General fire hazards:	No data available.
Suitable (and unsuitable) extinguishing media	
Suitable extinguishing media:	The product is non-combustible. Use fire-extinguishing media appropriate for surrounding materials.
Unsuitable extinguishing media:	None known.
Specific hazards arising from the chemical:	Not combustible, but if involved in a fire decomposes to produce toxic gases.
Special protective equipment and precautions for firefighters	
Special fire fighting procedures:	Move containers from fire area if you can do so without risk. Use water spray to keep fire-exposed containers cool.
Special protective equipment for fire-fighters:	Firefighters must use standard protective equipment including flame retardant coat, helmet with face shield, gloves, rubber boots, and in enclosed spaces, SCBA. Product is highly acidic. Wear protective gear if spilled during fire fighting.

6. Accidental release measures

Personal precautions, protective equipment and emergency procedures:	See Section 8 of the MSDS for Personal Protective Equipment. Do not touch damaged containers or spilled material unless wearing appropriate protective clothing. Keep unauthorized personnel away. Keep upwind. Ventilate closed spaces before entering them.
---	---

Methods and material for containment and cleaning up: Neutralize with lime or soda ash. Absorb spill with vermiculite or other inert material, then place in a container for chemical waste. Clean surface thoroughly to remove residual contamination. Dike far ahead of larger spill for later recovery and disposal.

Notification Procedures: Inform authorities if large amounts are involved

Environmental precautions: Do not contaminate water sources or sewer. Prevent further leakage or spillage if safe to do so.

7. Handling and storage

Precautions for safe handling: Do not get in eyes, on skin, on clothing. Do not taste or swallow. Wash thoroughly after handling. Do not eat, drink or smoke when using the product. Use caution when adding this material to water. Add material slowly when mixing with water. Do not add water to the material; instead, add the material to the water.

Conditions for safe storage, including any incompatibilities: Do not store in metal containers. Keep container tightly closed. Store in a well-ventilated place

8. Exposure controls/personal protection

Control parameters

Occupational exposure limits

Chemical identity	Type	Exposure Limit values	Source
PHOSPHORIC ACID	TWA	1 mg/m ³	US ACGIH Threshold Limit Values (2011)
	STEL	3 mg/m ³	US ACGIH Threshold Limit Values (2011)
	REL	1 mg/m ³	US NIOSH Pocket Guide to Chemical Hazards (2010)
	STEL	3 mg/m ³	US NIOSH Pocket Guide to Chemical Hazards (2010)
	PEL	1 mg/m ³	US OSHA Table Z-1 Limits for Air Contaminants (29 CFR 1910.1000) (02 2008)
	TWA	1 mg/m ³	US OSHA Table Z-1-A (29 CFR 1910.1000) (1989)
	STEL	3 mg/m ³	US OSHA Table Z-1-A (29 CFR 1910.1000) (1989)
	TWA	1 mg/m ³	US Tennessee OELs Occupational Exposure Limits, Table Z1A (06 2008)
	STEL	3 mg/m ³	US Tennessee OELs Occupational Exposure Limits, Table Z1A (06 2008)
	ST ESL	10 µg/m ³	US Texas Effects Screening Levels (Texas Commission on Environmental Quality) (12 2010)
	AN ESL	1 µg/m ³	US Texas Effects Screening Levels (Texas Commission on Environmental Quality) (12 2010)
	TWA PEL	1 mg/m ³	US California Code of Regulations Title 8, Section 5155 Airborne Contaminants (08 2010)
STEL	3 mg/m ³	US California Code of Regulations Title 8, Section 5155 Airborne Contaminants (08 2010)	

Appropriate engineering controls No data available

Individual protection measures, such as personal protective equipment

General information:	Good general ventilation (typically 10 air changes per hour) should be used. Ventilation rates should be matched to conditions. If applicable, use process enclosures, local exhaust ventilation, or other engineering controls to maintain airborne levels below recommended exposure limits. If exposure limits have not been established, maintain airborne levels to an acceptable level. An eye wash and safety shower must be available in the immediate work area.
Eye/face protection:	Wear safety glasses with side shields (or goggles) and a face shield.
Skin protection	
Hand protection:	Chemical resistant gloves
Other:	Wear suitable protective clothing and gloves.
Respiratory protection:	In case of inadequate ventilation use suitable respirator. Respirator type: Chemical respirator with acid gas cartridge.
Hygiene measures:	Provide eyewash station and safety shower. Observe good industrial hygiene practices. Wash hands before breaks and immediately after handling the product. Wash contaminated clothing before reuse. Avoid contact with eyes. Avoid contact with skin.

9. Physical and chemical properties

Appearance

Physical state:	Liquid
Form:	Liquid
Color:	Colorless
Odor:	Odorless
Odor threshold:	No data available
pH:	1.5-0.1 N Aqueous solution
Melting point/freezing point:	21.1 °C
Initial boiling point and boiling range:	158 °C
Flash Point:	Not applicable
Evaporation rate:	No data available.
Flammability (solid, gas):	No data available.
Upper/lower limit on flammability or explosive limits	
Flammability limit - upper (%):	No data available.
Flammability limit - lower (%):	No data available.
Explosive limit - upper (%):	No data available.
Explosive limit - lower (%):	No data available.
Vapor pressure:	0.3 kPa
Vapor density:	No data available.
Relative density:	1.69 (20 °C)
Solubility(ies)	
Solubility in water:	Miscible with water.
Solubility (other):	No data available
Partition coefficient (n-octanol/water):	No data available
Auto-ignition temperature:	No data available
Decomposition temperature:	No data available
Viscosity:	No data available

10. Stability and reactivity

Reactivity:	No dangerous reaction known under conditions of normal use.
Chemical stability:	Material is stable under normal conditions.
Possibility of hazardous reactions:	Hazardous polymerization does not occur.
Conditions to avoid:	Avoid contact with oxidizing agents. Avoid contact with strong reducing agents. Contact with alkalis.
Incompatible materials:	Strong reducing agents. Alkalies. Strong oxidizing agents. Metals.
Hazardous decomposition products:	oxides of phosphorus

11. Toxicological information

Information on likely routes of exposure

Ingestion:	Harmful if swallowed.
Inhalation:	Severely irritating to respiratory system.
Skin contact:	Causes severe skin burns.
Eye contact:	Causes serious eye damage.

Information on toxicological effects

Acute toxicity (list all possible routes of exposure)

Oral	
Product:	ATEmix (Rat) 1.700 mg/kg
Dermal	
Product:	ATEmix (i) 3.044.44 mg/kg

Inhalation	
Product:	No data available.

Repeated dose toxicity	
Product:	No data available.

Skin corrosion/irritation	
Product:	Causes severe skin burns.

Serious eye damage/eye irritation	
Product:	Causes serious eye damage.

Respiratory or skin sensitization	
Product:	Not a skin sensitizer.

Carcinogenicity	
Product:	This substance has no evidence of carcinogenic properties.

IARC Monographs on the Evaluation of Carcinogenic Risks to Humans:
No carcinogenic components identified

US. National Toxicology Program (NTP) Report on Carcinogens:
No carcinogenic components identified

U.S. OSHA Specifically Regulated Substances (29 CFR 1910.1001-1050):
No carcinogenic components identified

Germ cell mutagenicity

In vitro
Product: No mutagenic components identified

In vivo
Product: No mutagenic components identified

Reproductive toxicity

Product: No components toxic to reproduction

Specific target organ toxicity - single exposure

Product: None known

Specific target organ toxicity - repeated exposure

Product: None known

Aspiration hazard

Product: Not classified

Other effects: Not known

12. Ecological information

Ecotoxicity:

Acute hazards to the aquatic environment:

Fish
Product: No data available.

Aquatic invertebrates
Product: No data available.

Chronic hazards to the aquatic environment:

Fish
Product: No data available.

Aquatic invertebrates
Product: No data available.

Toxicity to Aquatic Plants
Product: No data available.

Persistence and degradability

Biodegradation
Product: Expected to be readily biodegradable.

BOD/COD ratio
Product: No data available

Bioaccumulative potential

Bioconcentration factor (BCF)
Product: No data available on bioaccumulation

Partition coefficient n-octanol / water (log Kow)
Product: No data available

Mobility in soil: The product is water soluble and may spread in water systems

Other adverse effects: The product may affect the acidity (pH-factor) in water with risk of harmful effects to aquatic organisms

13. Disposal considerations

Disposal instructions: Discharge, treatment, or disposal may be subject to national, state, or local laws

Contaminated packaging: Since emptied containers retain product residue, follow label warnings even after container is emptied.

14. Transport information

DOT

UN number:	UN 1805
UN proper shipping name:	Phosphoric acid solution
Transport hazard class(es)	
Class(es):	8
Label(s):	8
Packing group:	III
Marine Pollutant:	No

IMDG

UN number:	UN 1805
UN proper shipping name:	PHOSPHORIC ACID SOLUTION
Transport hazard class(es)	
Class(es):	8
Label(s):	8
EmS No.:	F-A, S-B
Packing group:	III
Marine Pollutant:	No

IATA

UN number:	UN 1805
Proper Shipping Name:	Phosphoric acid, solution
Transport hazard class(es):	
Class(es):	8
Label(s):	8
Marine Pollutant:	No
Packing group:	III

15. Regulatory information

US federal regulations

TSCA Section 12(b) Export Notification (40 CFR 707, Subpt. D)
US. OSHA Specifically Regulated Substances (29 CFR 1910.1001-1050)
 None present or none present in regulated quantities

CERCLA Hazardous Substance List (40 CFR 302.4):
PHOSPHORIC ACID Reportable quantity: 5000 lbs.

Superfund amendments and reauthorization act of 1986 (SARA)

Hazard categories

Acute (Immediate) Chronic (Delayed) Fire Reactive Pressure Generating

SARA 302 Extremely hazardous substance
None present or none present in regulated quantities.

SARA 304 Emergency release notification

Chemical Identity	RQ
PHOSPHORIC ACID	5000 lbs

SARA 311/312 Hazardous chemical

Chemical Identity	Threshold Planning Quantity
PHOSPHORIC ACID	500 lbs

SARA 313 (TRI reporting)
None present or none present in regulated quantities

Clean Water Act Section 311 Hazardous Substances (40 CFR 117.3)
PHOSPHORIC ACID Reportable quantity: 5000 lbs.

Clean Air Act (CAA) Section 112(r) Accidental Release Prevention (40 CFR 68.130):
None present or none present in regulated quantities.

US state regulations

US. California Proposition 65
No ingredient regulated by CA Prop 65 present

US. New Jersey Worker and Community Right-to-Know Act
PHOSPHORIC ACID Listed

US. Massachusetts RTK - Substance List
PHOSPHORIC ACID Listed

US. Pennsylvania RTK - Hazardous Substances
PHOSPHORIC ACID Listed

US. Rhode Island RTK
PHOSPHORIC ACID Listed

Inventory Status:

Australia AICS:	On or in compliance with the inventory
Canada DSL Inventory List	On or in compliance with the inventory
EINECS, ELINCS or NLP:	On or in compliance with the inventory
Japan (ENCS) List	On or in compliance with the inventory
China Inv. Existing Chemical Substances	Not in compliance with the inventory.
Korea Existing Chemicals Inv. (KECI)	On or in compliance with the inventory
Canada NDSL Inventory:	Not in compliance with the inventory.
Philippines PICCS	On or in compliance with the inventory
US TSCA Inventory:	On or in compliance with the inventory
New Zealand Inventory of Chemicals	On or in compliance with the inventory
Japan ISHL Listing	Not in compliance with the inventory.
Japan Pharmacopoeia Listing	Not in compliance with the inventory.

16. Other information, including date of preparation or last revision

NFPA Hazard ID



Hazard rating: 0 - Minimal; 1 - Slight; 2 - Moderate; 3 - Serious; 4 - Severe

Issue date: 04-07-2014
Revision date: No data available
Version #: 1.0
Further information: No data available.

Disclaimer: THE INFORMATION PRESENTED IN THIS MATERIAL SAFETY DATA SHEET (MSDS/SDS) WAS PREPARED BY TECHNICAL PERSONNEL BASED ON DATA THAT THEY BELIEVE IN THEIR GOOD FAITH JUDGMENT IS ACCURATE. HOWEVER, THE INFORMATION PROVIDED HEREIN IS PROVIDED "AS IS," AND AVANTOR PERFORMANCE MATERIALS MAKES AND GIVES NO REPRESENTATIONS OR WARRANTIES WHATSOEVER, AND EXPRESSLY DISCLAIMS ALL WARRANTIES REGARDING SUCH INFORMATION AND THE PRODUCT TO WHICH IT RELATES, WHETHER EXPRESS, IMPLIED, OR STATUTORY, INCLUDING WITHOUT LIMITATION, WARRANTIES OF ACCURACY, COMPLETENESS, MERCHANTABILITY, NON-INFRINGEMENT, PERFORMANCE, SAFETY, SUITABILITY, STABILITY, AND FITNESS FOR A PARTICULAR PURPOSE, AND ANY WARRANTIES ARISING FROM COURSE OF DEALING, COURSE OF PERFORMANCE, OR USAGE OF TRADE. THIS MSDS/SDS IS INTENDED ONLY AS A GUIDE TO THE APPROPRIATE PRECAUTIONARY HANDLING OF THE MATERIAL BY A PROPERLY TRAINED PERSON USING THIS PRODUCT, AND IS NOT INTENDED TO BE COMPREHENSIVE AS TO THE MANNER AND CONDITIONS OF USE, HANDLING, STORAGE, OR DISPOSAL OF THE PRODUCT. INDIVIDUALS RECEIVING THIS MSDS/SDS MUST ALWAYS EXERCISE THEIR OWN INDEPENDENT JUDGMENT IN DETERMINING THE APPROPRIATENESS OF SUCH ISSUES. ACCORDINGLY, AVANTOR PERFORMANCE MATERIALS ASSUMES NO LIABILITY WHATSOEVER FOR THE USE OF OR RELIANCE UPON THIS INFORMATION. NO SUGGESTIONS FOR USE ARE INTENDED AS, AND NOTHING HEREIN SHALL BE CONSTRUED AS, A RECOMMENDATION TO INFRINGE ANY EXISTING PATENTS OR TO VIOLATE ANY FEDERAL, STATE, LOCAL, OR FOREIGN LAWS. AVANTOR PERFORMANCE MATERIALS REMINDS YOU THAT IT IS YOUR LEGAL DUTY TO MAKE ALL INFORMATION IN THIS MSDS/SDS AVAILABLE TO YOUR EMPLOYEES.

NN53

MATERIAL SAFETY DATA SHEET

PRODUCT NAME: Shift Max 230, Reduced Heterogeneous Catalyst, FC72372

SECTION 1. CHEMICAL PRODUCT AND COMPANY IDENTIFICATION

Doosan Fuel Cell America, Inc. TELEPHONE: 24 HOUR EMERGENCY: 1-800-424-8300 (CHEMTREC)
195 Governors Hwy. PRODUCT INFORMATION: 860-727-2300
South Windsor, CT 06074
USA

MSDS NO: NN53 INITIAL RELEASE DATE: 4/23/2009 REVISION DATE:

GENERIC DESCRIPTION: Reduced catalyst
PHYSICAL FORM: Cylindrical tablets
COLOR: Dark brown
ODOR: None

NFPA 704 CODES: HEALTH: 1 FLAMMABILITY: 4 REACTIVITY: 2

NOTE: NFPA = NATIONAL FIRE PROTECTION ASSOCIATION

SECTION 2. COMPOSITION / INFORMATION ON INGREDIENTS

CAS NUMBER	%WT/VOL	COMPONENTS	EXPOSURE LIMITS	
			OSHA	ACGIH

The following is the composition of the packed tablets:

1344-28-1	9-12	Aluminum oxide	15 mg/m ³ 5 mg/m ³ (respirable)	1 mg/m ³ (respirable)
7440-50-8	55-62	Copper	1 mg/m ³	1 mg/m ³ (dust)
1314-13-2	28-33	Zinc oxide	15 mg/m ³ 5 mg/m ³ (respirable)	2 mg/m ³ (respirable)

MATERIAL SAFETY DATA SHEET

PRODUCT NAME: Shift Max 230, Reduced Heterogeneous Catalyst, FC72372

SECTION 3. EFFECTS OF OVEREXPOSURE

ACUTE EFFECTS:

- EYE:** May cause irritation
- SKIN:** Frequent or prolonged contact may irritate the skin and cause a skin rash (dermatitis).
- INHALATION:** Prolonged or repeated inhalation may cause lung damage. Prolonged or excessive inhalation may cause respiratory tract irritation.
- ORAL:** Moderately toxic and may be harmful if swallowed; may damage the liver, pancreas, kidney or nervous systems.

REPEATED EXPOSURE EFFECTS:

- EYE:** Signs and symptoms of overexposure may include scratch or abrasion, damage to cornea (necrosis).
- SKIN:** Overexposure may cause skin rash, dermatitis and or itching.
- INHALATION:** Overexposure may cause coughing, wheezing, shortness of breath, difficult breathing, chest pain.
- ORAL:** Ingestion may cause upset stomach and intestinal distress.

SECTION 3. EFFECTS OF OVEREXPOSURE

NOTE TO PHYSICIANS: N/A

THIS MATERIAL CONTAINS THE FOLLOWING COMPONENTS WITH THE SPECIAL HAZARDS LISTED BELOW.

- CARCINOGENS** N/A
- MUTAGENS** N/A
- REPRODUCTIVE TOXINS** N/A
- SENSITIZERS** N/A

COMMENTS: None

NTP CLASSIFICATION: N/A

IARC CLASSIFICATION: N/A

OSHA CLASSIFICATION: N/A

MATERIAL SAFETY DATA SHEET

PRODUCT NAME: Shift Max 230, Reduced Heterogeneous Catalyst, FC72372

SECTION 4. FIRST AID MEASURES

EYE: Immediately flush eyes with plenty of water for at least 30 minutes. Get immediate medical attention.

SKIN: Wash with plenty of soap and water. Get medical attention if irritation develops or persists.

INHALATION: Remove to fresh air. If breathing is difficult seek immediate medical attention.

ORAL: If swallowed, do NOT induce vomiting. Give victim large quantities of water. Call a physician or poison control center immediately. Never give anything by mouth to an unconscious person.

COMMENTS: Exposure to fumes of the metal oxides may cause metal fume fever including irritation of eyes and respiratory tract and flu-like symptoms.

SECTION 5. FIRE FIGHTING MEASURES

FLASH POINT (METHOD): N/A

AUTOIGNITION TEMPERATURE: N/A

FLAMMABILITY LIMITS IN AIR: N/A

EXTINGUISHING MEDIA: Protect exposures; cool with water fog. For small fires use Class D extinguishing media.

UNSUITABLE EXTINGUISHING MEDIA: ND

FIRE FIGHTING PROCEDURES: Wear full protective clothing and SCBA's.

UNUSUAL FIRE HAZARDS: Packed material will spontaneously oxidize in air, producing significant heat. Keep away from combustible materials.

HAZARDOUS DECOMPOSITION PRODUCTS: Toxic metal fumes may be emitted if thermally decomposed.

SECTION 6. ACCIDENTAL RELEASE MEASURES

CONTAINMENT / CLEAN UP:

Small spill With shovel or scoop, place material onto clean, dry non-flammable surface to allow catalyst to oxidize. Place oxidized catalyst into container and cover loosely. Remove containers from spill area. Protect against inhalation of dusts or fumes. Wear eye protection.

Large spill Wet methods of cleanup are preferred. Keep airborne particulates to a minimum. Protect against inhalation of dusts or fumes. Wear eye protection. Place in appropriate containers for disposal.

MATERIAL SAFETY DATA SHEET

PRODUCT NAME: Shift Max 230, Reduced Heterogeneous Catalyst, FC72372

SECTION 7. HANDLING AND STORAGE

HANDLING: No special precautions for intact containers.

STORAGE: Store in dry area. Prevent exposure to air by maintaining under an inert gas atmosphere such as nitrogen. Use additional precautions to prevent asphyxiant hazards due to inert gas usage.

SECTION 8. EXPOSURE CONTROLS / PERSONAL PROTECTION

ENGINEERING CONTROLS

LOCAL EXHAUST: If user operations generate dust or fume, use ventilation to keep exposure to airborne contaminants below the exposure limits.

GENERAL VENTILATION: N/A

PERSONAL PROTECTIVE EQUIPMENT FOR ROUTINE HANDLING

EYES: Wear safety glasses with side shields or goggles.

SKIN: Wear protective clothing, including long sleeves and gloves to prevent skin contact.

SUITABLE GLOVES: Impermeable, such as latex, Nitrile, etc.

INHALATION: Wear NIOSH approved respirator with particulate filter.

PERSONAL PROTECTIVE EQUIPMENT FOR SPILLS

EYES: Chemical goggles

SKIN: Chemical resistant gloves

INHALATION / SUITABLE RESPIRATOR: (Min) Use NIOSH-approved respirator with particulate filter

PRECAUTIONARY MEASURES: N/D

MATERIAL SAFETY DATA SHEET

PRODUCT NAME: Shift Max 230, Reduced Heterogeneous Catalyst, FC72372

SECTION 9. PHYSICAL AND CHEMICAL PROPERTIES

TYPICAL PHYSICAL PROPERTIES ARE GIVEN BELOW.

APPEARANCE: Cylindrical tablets	POUR POINT C (F): N/A
COLOR: Dark brown	FREEZING POINT C (F): N/A
ODOR: None	VOLATILE ORGANIC COMPOUND:
ODOR THRESHOLD: N/A	SPECIFIC GRAVITY: (H₂O = 1) >8
pH: N/A	VAPOR PRESSURE - mmHg: N/A
BOILING POINT C (F): N/A	VAPOR DENSITY @ TEMP: _____: N/A
MELTING POINT C (F): N/A	EVAPORATION RATE RELATIVE TO _____: N/A
SOLUBILITY IN WATER: Insoluble	EXPLOSIVE PROPERTIES: WB not explode
VISCOSITY AT _____: N/A	OXIDIZING PROPERTIES: Not an oxidizer
VISCOSITY AT _____:	
RELATIVE DENSITY TO: 65-85 lb./CF (bulk)	

SECTION 10. STABILITY AND REACTIVITY

STABILITY (THERMAL, LIGHT, ETC.): Generally considered stable when contained under an inert atmosphere.

CONDITIONS TO AVOID: Exposure to air.

INCOMPATIBILITY (MATERIALS TO AVOID): Combustible materials.

HAZARDOUS DECOMPOSITION PRODUCTS: Thermal decomposition may produce metal oxide fumes.

HAZARDOUS POLYMERIZATION: Not expected to occur.

MATERIAL SAFETY DATA SHEET

PRODUCT NAME: Shift Max 230, Reduced Heterogeneous Catalyst, FC72372

SECTION 11. TOXICOLOGICAL DATA

Exposure to metal oxide fume may produce "metal fume fever" which is characterized by flu-like symptoms including fever, chills and general aches.

SECTION 12. ECOLOGICAL INFORMATION

No data available.

SECTION 13. DISPOSAL CONSIDERATIONS

Local regulations may vary; all waste must be disposed/recycled/reclaimed in accordance with federal, state and local environmental control regulations.

SECTION 14. TRANSPORT INFORMATION

PROPER SHIPPING NAME: Self-heating solid, inorganic, N.O.S.
HAZARD TECHNICAL NAME: Reduced copper catalysts.
HAZARD CLASS: 4.2
UN NUMBER: 3190
PACKING GROUP: II

SECTION 15. REGULATORY INFORMATION

TSCA STATUS: Component materials are in the TSCA Inventory.
EPA SARA TITLE III CHEMICAL LISTINGS:
SECTION 302 HAZARDOUS SUBSTANCES: No
SECTION 305 EXTREMELY HAZARDOUS SUBSTANCES: No

MATERIAL SAFETY DATA SHEET

PRODUCT NAME: Shift Max 230, Reduced Heterogeneous Catalyst, FC72372

SECTION 15. REGULATORY INFORMATION, CONTINUED

SECTION 312 HAZARD CLASS:

ACUTE: Yes
CHRONIC: Yes
FIRE: Yes
PRESSURE: No
REACTIVE: No

SECTION 372 TOXIC CHEMICALS: Copper.

SECTION 16. OTHER INFORMATION

COMMENTS: N/D = Not Determined
N/A = Not Applicable

As a unit, the materials do not pose a hazard. However, should the container be compromised and the packed catalyst become available, measures must be taken to prevent exposure to air.

PREPARED BY: D. Black, J. Preston
Revision By:

DATE: 4/23/2009

INFORMATION GIVEN HEREIN IS OFFERED IN GOOD FAITH AS ACCURATE, BUT WITHOUT GUARANTEE. CONDITIONS OF USE AND SUITABILITY OF THE PRODUCT FOR PARTICULAR USES ARE BEYOND OUR CONTROL. ALL RISKS OF USE OF THE PRODUCT ARE THEREFORE ASSUMED BY THE USER AND WE EXPRESSLY DISCLAIM ALL WARRANTIES OF EVERY KIND AND NATURE, INCLUDING WARRANTIES OF MERCHANTABILITY AND FITNESS FOR A PARTICULAR PURPOSE IN RESPECT TO THE USE OR SUITABILITY OF THE PRODUCT. NOTHING IS INTENDED AS A RECOMMENDATION FOR USES WHICH INFRINGE VALID PATENTS OR AS EXTENDING LICENSE UNDER VALID PATENTS. APPROPRIATE WARNINGS AND SAFE HANDLING PROCEDURES SHOULD BE PROVIDED TO HANDLERS AND USERS.

ZONING MAP OF WEST HARTFORD

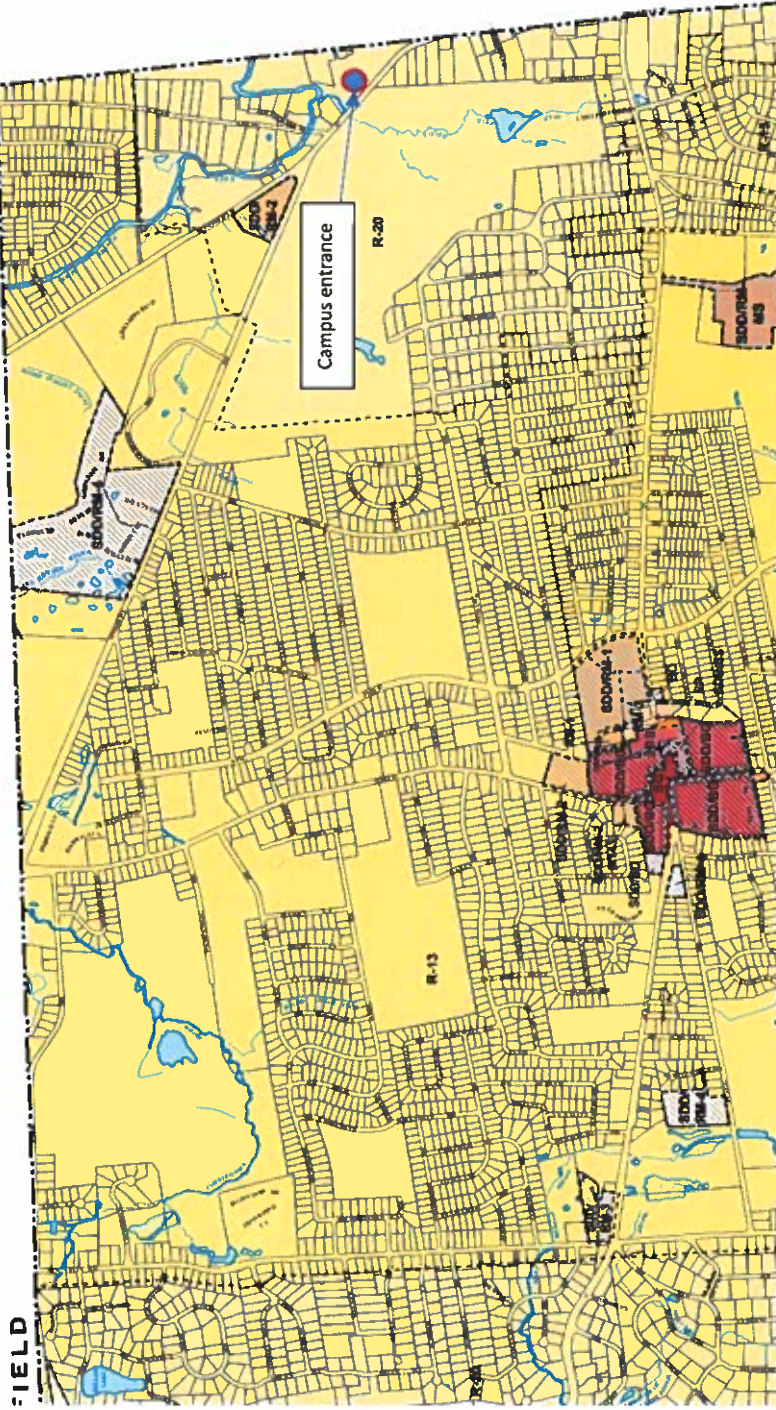

Attachment #5a



Attachment #6



This content is from the eCFR and is authoritative but unofficial.



Displaying title 14, up to date as of 11/14/2022. Title 14 was last amended 11/14/2022.

Title 14 - Aeronautics and Space

**Chapter I - Federal Aviation Administration, Department of Transportation
Subchapter E - Airspace**

Part 77 - Safe, Efficient Use, and Preservation of the Navigable Airspace

Subpart B - Notice Requirements

§ 77.9 Construction or alteration requiring notice.

If requested by the FAA, or if you propose any of the following types of construction or alteration, you must file notice with the FAA of:

- (a) Any construction or alteration that is more than 200 ft. AGL at its site.
- (b) Any construction or alteration that exceeds an imaginary surface extending outward and upward at any of the following slopes:
 - (1) 100 to 1 for a horizontal distance of 20,000 ft. from the nearest point of the nearest runway of each airport described in paragraph (d) of this section with its longest runway more than 3,200 ft. in actual length, excluding heliports.
 - (2) 50 to 1 for a horizontal distance of 10,000 ft. from the nearest point of the nearest runway of each airport described in paragraph (d) of this section with its longest runway no more than 3,200 ft. in actual length, excluding heliports.
 - (3) 25 to 1 for a horizontal distance of 5,000 ft. from the nearest point of the nearest landing and takeoff area of each heliport described in paragraph (d) of this section.
- (c) Any highway, railroad, or other traverse way for mobile objects, of a height which, if adjusted upward 17 feet for an Interstate Highway that is part of the National System of Military and Interstate Highways where overcrossings are designed for a minimum of 17 feet vertical distance, 15 feet for any other public roadway, 10 feet or the height of the highest mobile object that would normally traverse the road, whichever is greater, for a private road, 23 feet for a railroad, and for a waterway or any other traverse way not previously mentioned, an amount equal to the height of the highest mobile object that would normally traverse it, would exceed a standard of paragraph (a) or (b) of this section.
- (d) Any construction or alteration on any of the following airports and heliports:
 - (1) A public use airport listed in the Airport/Facility Directory, Alaska Supplement, or Pacific Chart Supplement of the U.S. Government Flight Information Publications;
 - (2) A military airport under construction, or an airport under construction that will be available for public use;
 - (3) An airport operated by a Federal agency or the DOD.
 - (4) An airport or heliport with at least one FAA-approved instrument approach procedure.
- (e) You do not need to file notice for construction or alteration of:

- (1) Any object that will be shielded by existing structures of a permanent and substantial nature or by natural terrain or topographic features of equal or greater height, and will be located in the congested area of a city, town, or settlement where the shielded structure will not adversely affect safety in air navigation;
- (2) Any air navigation facility, airport visual approach or landing aid, aircraft arresting device, or meteorological device meeting FAA-approved siting criteria or an appropriate military service siting criteria on military airports, the location and height of which are fixed by its functional purpose;
- (3) Any construction or alteration for which notice is required by any other FAA regulation.
- (4) Any antenna structure of 20 feet or less in height, except one that would increase the height of another antenna structure.

Attachment #8

State of California
AIR RESOURCES BOARD
Executive Order DG-047
Distributed Generation Certification of
Doosan Fuel Cell America, Inc.
460 kW PureCell Model 400

WHEREAS, the Air Resources Board (ARB) was given the authority under California Health and Safety Code section 41514.9 to establish a statewide Distributed Generation (DG) Certification Program to certify electrical generation technologies that are exempt from the permit requirements of air pollution control or air quality management districts;

WHEREAS, this DG Certification does not constitute an air pollution permit or eliminate the responsibility of the end user to comply with all federal, state, and local laws, rules and regulations;

WHEREAS, on October 26, 2017, Doosan Fuel Cell America, Inc. applied for a DG Certification of its 460 kW PureCell Model 400 fuel cell power plant and whose application was deemed complete on February 7, 2018;

WHEREAS, Doosan Fuel Cell America, Inc. has demonstrated, according to test methods specified in title 17, California Code of Regulations (CCR), section 94207, that its natural-gas-fueled 460 kW PureCell Model 400 fuel cell power plant has complied with the following emission standards:

1. Emissions of oxides of nitrogen no greater than 0.07 pounds per megawatt-hour; and
2. Emissions of carbon monoxide no greater than 0.10 pounds per megawatt-hour; and
3. Emissions of volatile organic compounds no greater than 0.02 pounds per megawatt-hour.

WHEREAS, Doosan Fuel Cell America, Inc. has demonstrated that its 460 kW PureCell Model 400 fuel cell power plant complies with the emission durability requirements in title 17, CCR, section 94203 (d);

WHEREAS, I find that the Applicant, Doosan Fuel Cell America, Inc., has met the requirements specified in article 3, title 17, CCR, and has satisfactorily demonstrated that the 460 kW PureCell Model 400 fuel cell power plant meets the DG Certification Regulation 2007 Fossil Fuel Emission Standards;

NOW THEREFORE, IT IS HEREBY ORDERED, that a DG Certification, Executive Order DG-047 is granted.

This DG Certification:

- 1) is subject to all conditions and requirements of the ARB's DG Certification Program, article 3, title 17, CCR, including the provisions relating to inspection, denial, suspension, and revocation; and
- 2) shall be void if any manufacturer's modification results in an increase in emissions or changes the efficiency or operating conditions of a model, such that the model no longer meets the DG Certification Regulation 2007 Fossil Fuel Emission Standards; and
- 3) shall expire on the 5th day of April, 2023.

Executed at Sacramento, California, this 6th day of April 2018.

/S/

Floyd V. Vergara, Esq., P.E.
Chief, Industrial Strategies Division

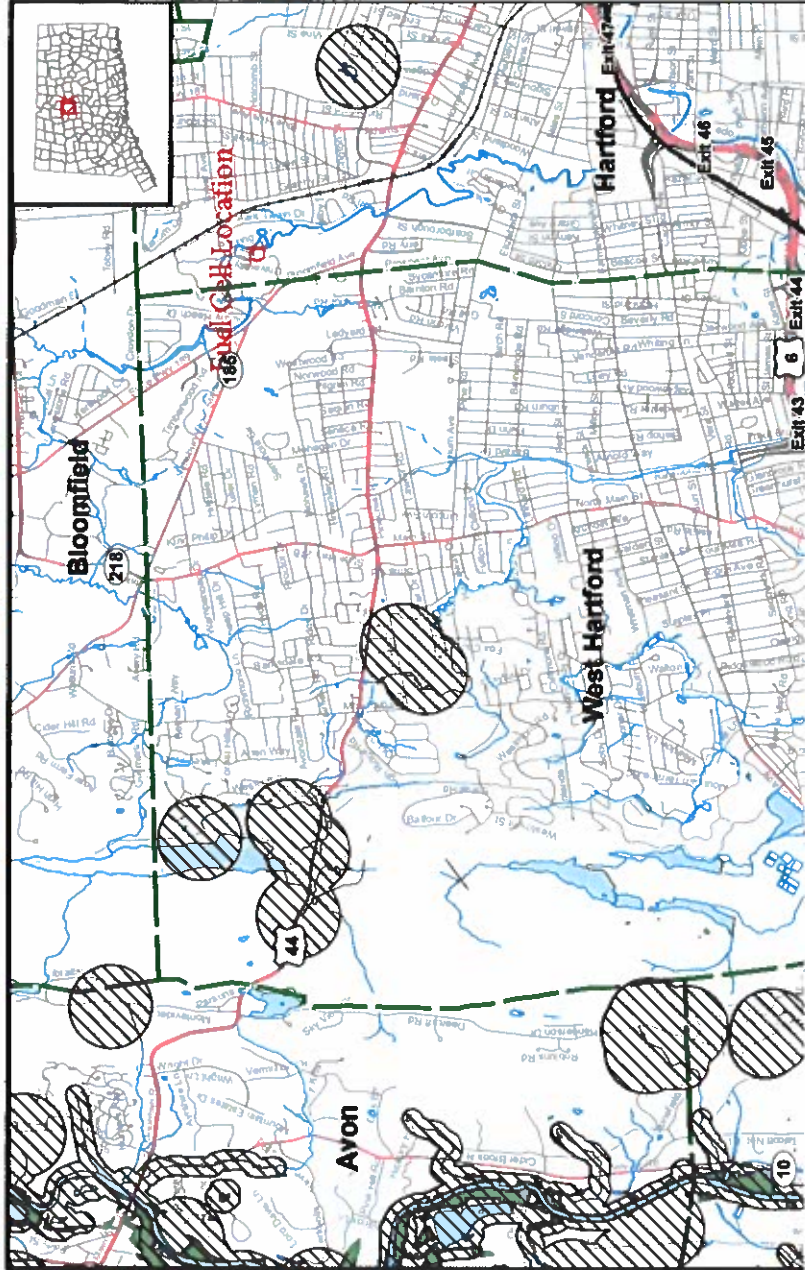

Natural Diversity Data Base Areas
WEST HARTFORD, CT
 June 2022

-  State and Federal Listed Species Critical Habitat
-  Critical Habitat
-  Town Boundary

NOTE: This map shows general locations of State and Federal Listed Species and Critical Habitats. Information on listed species is collected and compiled by the Natural Diversity Data Base (NDDB) from a variety of data sources. Exact locations of species have been buffered to produce the generalized locations.

This map is intended for use as a preliminary screening tool for conducting a Natural Diversity Data Base Review Request. To use the map, locate the project boundaries and any additional affected areas if the project is within a hatched area there may be a potential conflict with a listed species. For more information, complete a Request for Natural Diversity Data Base State Listed Species Review form (DEP-APP-007), and submit it to the NDDB

Attachment #10

Prepared For: HiAxiom, Inc.

Point of Contact: Walter Bonola

**Prepared by: Acoustical Technologies Inc.
50 Myrock Avenue
Waterford, CT 06385-3008**

**Subject: University of Hartford
Airborne Noise Assessment
At 200 Bloomfield Avenue**

Author: Carl Cascio

Date: November 17, 2022

Revision: 1

Table of Contents

	Page
Summary	3
Introduction	4
Development of the Acoustic Assessment Plan	4
Acoustic Measurement Program	5
Data Analysis	9
Allowable Noise Levels	13
Impulse Noise	15
Prominent Discrete Tones	16
Infrasonic and Ultrasonic Noise	18
Overall Sound Pressure Levels	18
Conclusions	20
References	20

Summary

This document makes a positive acoustic assessment that should assist in meeting any acoustic noise concerns during the operation of four HiAxiom 460 KW fuel cells at the University of Hartford site at 200 Bloomfield Road in West Hartford, CT. An acoustic assessment plan was developed and executed to acquire airborne acoustic information useful in explaining and mitigating the potential airborne noise issues during operation of four HiAxiom 460 KW fuel cells. It is important to show that the airborne noise generated by the fuel cells will not significantly impact the facility's neighbors.

The airborne noise levels expected to be generated by the HiAxiom fuel cells operating at the Hartford site were simulated by exciting a set of six co-located speakers at the fuel cell Cooling and Power Module positions. (The Cooling Module is the dominant noise source.) The six speakers produced an overall airborne noise level that was 19 to 22 dB higher than the levels measured for a single HiAxiom fuel cell installed at Montville, CT. One-third octave band analysis showed the speakers' level to be near the Montville fuel cell airborne noise levels at low frequencies where the airborne noise levels were low and to exceed the fuel cell signature by 10 to 20 dB at higher frequencies where the fuel cell signature was higher in noise level.

Airborne noise levels with the speakers operating were measured at distances from 5 to 180 meters from the proposed fuel cell location behind East Hall. The six speakers produced overall A-weighted sound pressure levels of approximately 87 to 92 dBA at 5 meters and 83 to 86 dBA at 10 meters (reference 20 microPascals) at the proposed fuel cells' location. The airborne noise levels from the speakers received at nearby properties on campus were measured at noise levels of 46 to 72 dBA. Residential measurement locations to the east and west were too far away to be able to measure the airborne noise with the speakers on. Analysis of the speaker data indicated propagation losses of at least 12 to 37 dB from the fuel cells' location to the nearby properties on campus. The source level at 10 meters from the operation of a HiAxiom fuel cell at Montville, CT was then used as a basis for making the Hartford fuel cell airborne noise estimates.

Operation of the four HiAxiom fuel cells should produce airborne noise levels well below the Commercial Zone noise limit (62 dBA) at all of the nearby campus properties. The highest expected airborne noise level of 58 dBA will be at the back of East Hall about 42 meters from the fuel cells. Commercial properties in nearby zones should see airborne noise levels no higher than 40 dBA. All of the nearby residential property lines are expected to be below both the day time and night time residential noise limits because of the very large distances to the homes. The closest homes on Bloomfield Avenue and Granby Street should have noise levels below 20 dBA. There should be no acoustic issues present during operation of four HiAxiom 460 KW fuel cells.

The Connecticut's Noise Code (Reference 1) also calls for review of acoustic issues associated with impulse noise, prominent discrete tones, infrasonic and ultrasonic noise. Operation of the fuel cells is expected to meet all of these requirements at all of the nearby property lines. The City of Hartford Noise Ordinance uses the same noise limits as the State of Connecticut while adding an additional condition that the fuel cells not be audible. While the fuel cells may be audible on nearby properties on campus there should be no audible issues off campus.

Acoustical Technologies Inc.

Introduction

Acoustical Technologies Inc. was tasked as part of a HiAxiom site permitting process with an assessment of potential acoustic issues associated with fuel cell airborne noise reaching the properties adjacent to the University of Hartford at 200 Bloomfield Road in West Hartford, CT. Responding to a request from Walter Bonola, a site visit was made on October 30, 2022. During the visit, a survey of the airborne noise levels produced by a set of six speakers simulating the airborne noise produced by four HiAxiom Fuel Cells was made in order to identify potential airborne noise issues. Airborne noise measurements were taken to quantify the propagation of the simulated fuel cell airborne noise to the adjacent properties. Background airborne noise levels were also made with the speakers off. This document provides an acoustic assessment to assist in meeting acoustic noise concerns during the permitting process for the siting of four HiAxiom fuel cells at the University of Hartford. While the University mailing address is West Hartford the four fuel cells will be located in a parking lot behind East Hall in Hartford, CT.

Development of the Acoustic Assessment Plan

The purpose of this effort is to acquire acoustic information useful in explaining the potential airborne noise issues associated with the operation of four HiAxiom 460 KW fuel cells at the University of Hartford site in Hartford, CT. The school at 200 Bloomfield Road is located in a Mixed Use (MX-2) Campus Overlay Zone on the Hartford – West Hartford border. This Commercial – Residential Zone is surrounded by Residential NX-1 and N-4-1 Zones to the north, northeast, east and southeast, Open Space to the south and R-20 Residential Zones to the west in West Hartford. Figure 1 shows the Hartford zoning map. It is important to determine whether the airborne noise generated by the four HiAxiom fuel cells will impact these neighbors.

The acoustic impact is assessed in the following way. The fuel cell is yet to be installed so there is no way to measure fuel cell operating airborne noise levels at the new site. The fuel cell airborne noise has been measured at other sites and both overall and one-thirtieth octave band airborne noise data of a typical HiAxiom 460 KW fuel cell is available (Reference 3). Using this data, a set of six speakers have been programmed through a set of octave and one-third octave band filters to generate a noise spectrum similar to that of the 460 KW fuel cell. (It is assumed that the Cooling and Power Module noise in the existing measured 460 KW fuel cell are similar to the new units.) This spectrum will then be played through an audio amplifier to create the electrical voltage necessary to drive the six speakers. In order to overcome the potentially high background noise at the University of Hartford site the speaker output will be increased to a level more than 15 dB higher than the overall dBA noise level measured on a single 460 KW fuel cell at a distance of 10 meters. With the speakers on, this approach then follows the traditional “What is the airborne noise level at the neighbor’s property line?”. The six speakers will be run and airborne measurements made near the proposed fuel cell locations and at several of the nearest neighbor’s properties. This measured site data can also be used to estimate noise levels at other neighbor’s property lines. The State of Connecticut’s Noise Ordinance¹ and the City of Hartford Noise Ordinance² will then be consulted to assess the impact of the measured and estimated acoustic levels. Because of the closeness of the proposed fuel cell site to the nearest properties noise mitigation may be recommended if the airborne noise estimated for four fuel cells comes near or exceeds the noise requirements at the neighbors’ property lines.

Acoustical Technologies Inc.

Figure 1. Northwest Corner of the Hartford Zoning Map Showing the Area near the Fuel Cells

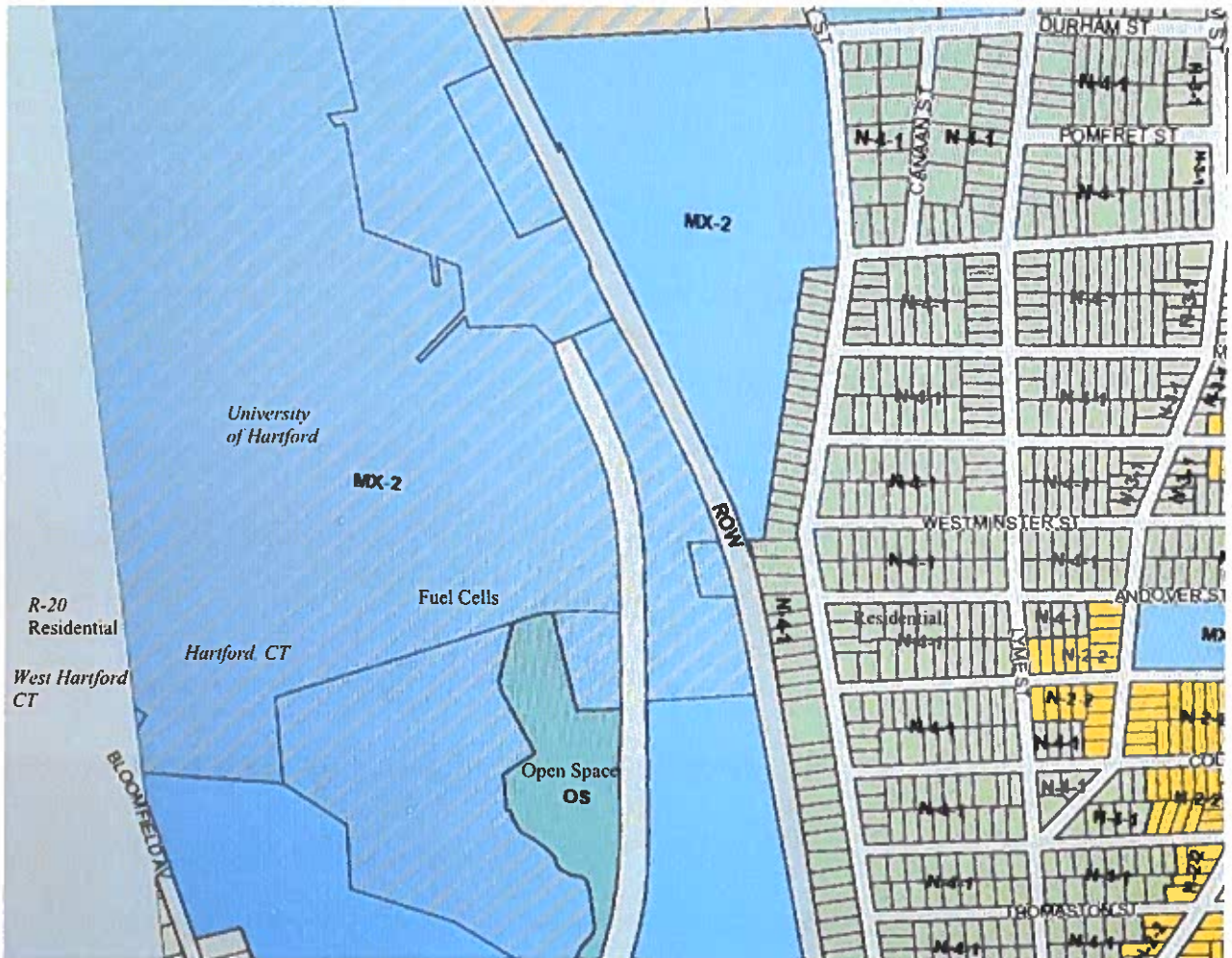

Acoustic Measurement Program

The acoustic data necessary to assess the impact of four 460 KW HiAxiom Fuel Cells are described below: Airborne sound pressure measurements were conducted at the University of Hartford near 200 Bloomfield Road on October 30, 2022 during the morning hours. This testing established both background airborne noise levels and simulated airborne noise levels with the speakers operating. The overall A-weighted airborne noise measurements were made with an ExTech model 407780A Digital Sound Level Meter (s/n 140401544) that had been calibrated prior to and just after the test with a Quest model QC-10 Calibrator (s/n Q19080194). Measurements were taken with A-weighting (frequency filtering that corresponds to human hearing) and with the sound level meter in a Slow response mode. For reference, a noise level increase of 1 dB is equal to an airborne sound pressure increase of 12.2 per cent. All measurements were made with the microphone at a height above ground between five and six feet. The sound pressure data reported herein are all given in dB reference 20 microPascals.

Acoustical Technologies Inc.

In Hartford “speaker on” and background airborne noise measurements were taken at 5 and 10 meters from the proposed 460 KW fuel cell site and at the following six nearby properties.

Location	Business	Distance	Zone	Type
1 – Fuel Cells to the East	U of Hartford	5 meters	MX-2	Mixed Use
2 – Fuel Cells to the East	U of Hartford	10 meters	MX-2	Mixed Use
3 – Fuel Cells to the South	U of Hartford	5 meters	MX-2	Mixed Use
4 – Fuel Cells to the South	U of Hartford	10 meters	MX-2	Mixed Use
5 – Fuel Cells to the North	U of Hartford	5 meters	MX-2	Mixed Use
6 – Fuel Cells to the North	U of Hartford	10 meters	MX-2	Mixed Use
7 – Fuel Cells to the West	U of Hartford	5 meters	MX-2	Mixed Use
8 – Fuel Cells to the West	U of Hartford	10 meters	MX-2	Mixed Use
P1 – 351 Mark Twain Drive	Univ. High School	190 meters	MX-2	Mixed Use
P2 – 196 Bloomfield Avenue	Magnet School	180 meters	MX-2	Mixed Use
P3 – 196 Bloomfield Avenue	School Playground	135 meters	MX-2	Mixed Use
P4 – 200 Bloomfield Avenue	East Hall	42 meters	MX-2	Mixed Use
P5 – 200 Bloomfield Avenue	Student Union	138 meters	MX-2	Mixed Use
P6 – 200 Bloomfield Avenue	Hillyer Hall	168 meters	MX-2	Mixed Use

See the Google satellite map in Figure 2 for the approximate measurement locations. Measurements were made in each compass direction near the proposed operating Power and Cooling Module sites. Sound pressure data were taken with the ExTech sound level meter. Figures 3 and 4 provide photographs of the speaker locations for the East and West directions, respectively. At these locations, a one-minute record of the acoustic noise was analyzed for the speakers in the “on” condition. One minute of background noise data was also analyzed at 5 and 10 meters with the same four speaker directions. Similar data were taken at the six properties.

Airborne noise measurements taken outside are corrupted by rain and wind so a day was selected when the winds were expected to be 10 miles per hour or less. Table 1 provides the weather data in Hartford for the acoustic measurements on October 30, 2022. Measurements were taken over the period from 8:50 am until 12:30 pm. Table 1 shows the temperature and wind speeds in hourly intervals. Wind conditions were very good during all the testing. Also, there was no rain during the testing. Vehicle traffic along the nearby roads was light and very few of the measurements had to be delayed until traffic was absent. Background noise levels at all of the measurement positions were low with levels from 41 to 50 dBA. At all of the measurement locations it was possible to audibly hear the airborne noise from the six speakers over the background noise. Airborne noise loss versus range was then determined at these locations.

These transfer functions were then applied to the 460 KW data from Montville³ in order to estimate the received levels for the new 460 KW fuel cells in Hartford. Four fuel cells will make as much as 6 dB more noise than one fuel cell. Reasonable estimates were calculated by looking at the relative distances for each of the four fuel cells. For properties to the north the four cooling modules are side by side so the distance to the property is the same for each fuel cell. The noise at the properties to the north is $10 \cdot \log(4)$ or 6 dB higher than the noise from one cooling module when four cooling modules are operating. This is also true for the properties to the south where the four side to side power modules generate 6 dB more than one power module.

Acoustical Technologies Inc.

Figure 5 shows that the east and west directions require a combination of cooling module and power module noise. This is done by combining one power module and four cooling modules. Noise from the other three power modules is effectively blocked by the first power module. The cooling module noise is also adjusted a bit according to the different distances to each property.

Table 1. Hartford Weather Data on October 30, 2022

https://www.wunderground.com/history/daily/us/ct/h_windsor-locks/KHFD/date/2022-10-30

Time (EST)	Temp. (°F)	Humidity (%)	Dew Point (°F)	Barometer (in HG)	Wind Speed (mph)	Wind Direction	Condition
6:53 AM	32 °F	30 °F	92 %	30.28 in	0 mph	CALM	Fair
7:53 AM	35 °F	34 °F	96 %	30.30 in	0 mph	CALM	Fair
8:53 AM	42 °F	33 °F	70 %	30.29 in	5 mph	NNE	Fair
9:53 AM	46 °F	35 °F	66 %	30.28 in	0 mph	CALM	Fair
10:53 AM	50 °F	35 °F	57 %	30.26 in	0 mph	CALM	Fair
11:53 AM	57 °F	35 °F	44 %	30.22 in	0 mph	CALM	Fair
12:53 PM	61 °F	35 °F	38 %	30.19 in	0 mph	CALM	Fair
1:53 PM	65 °F	31 °F	28 %	30.17 in	0 mph	CALM	Fair
2:53 PM	66 °F	24 °F	20 %	30.14 in	3 mph	S	Fair

Figure 2. University of Hartford Map from Google Maps

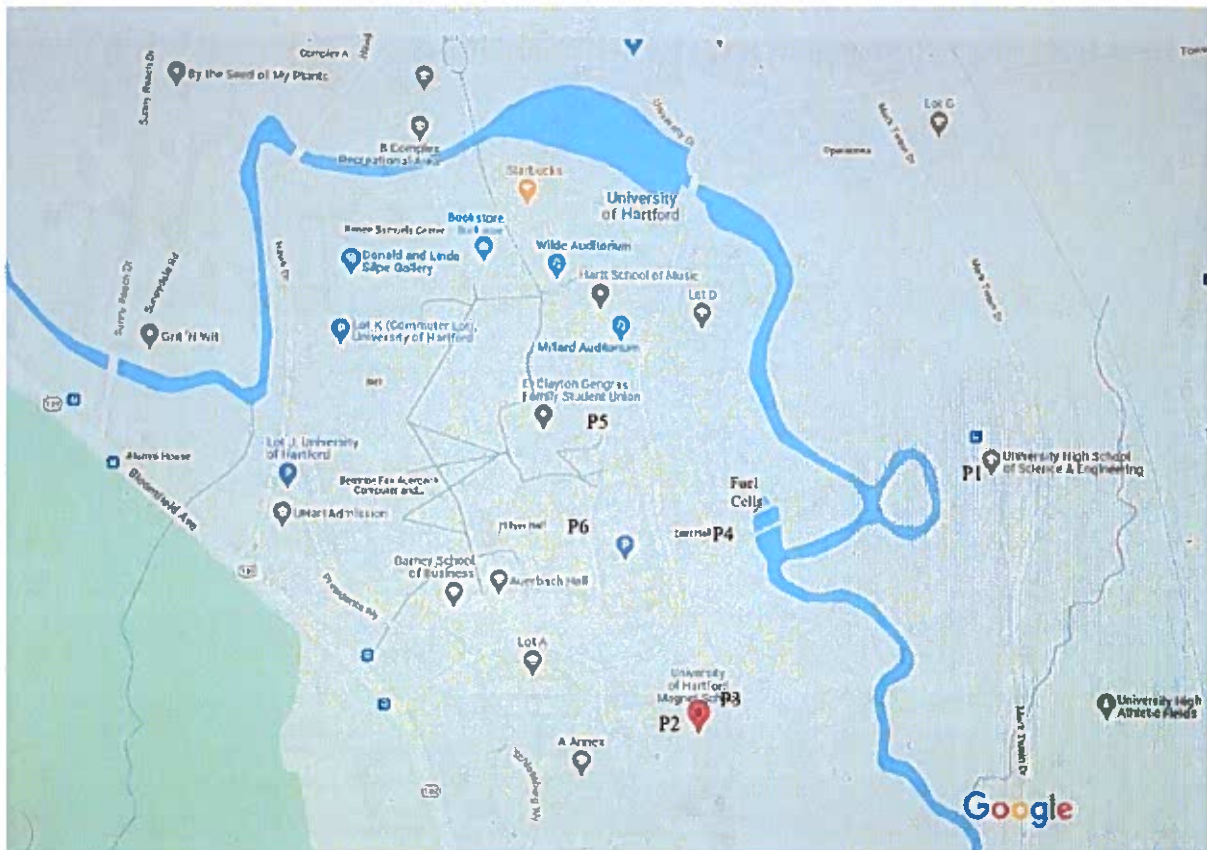

Acoustical Technologies Inc.

Figure 3. HiAxiom Fuel Location Looking East at the University of Hartford Site



Figure 4. HiAxiom Fuel Location Looking West at the University of Hartford Site



Figure 5. Proposed 460 KW Fuel Cell Installation at the University of Hartford



Data Analysis

This section analyzes the airborne noise levels measured at the Hartford site and then estimates the received level and transmission loss to nearby properties expected during actual fuel cell operation. These estimated levels will be compared to the noise limits in the Connecticut and Hartford noise ordinances. Speaker operating noise levels at the Hartford site are reported in Table 2. Background noise levels at the Hartford site are reported in Table 3. The background data are used to correct the speaker levels providing estimates in Table 4 of only the speaker noise contribution at each location. Table 5 compares the Montville 460 KW 10-meter sound levels with the speaker 10-meter levels in Hartford. Table 6 then reports the operating noise levels estimated for the four new 460 KW fuel cells. Comparing these Hartford fuel cell estimated levels with the state and city noise limits will identify which nearby locations do or do not meet the airborne noise requirements.

Figure 1 is a map showing the Hartford zoning districts in the University of Hartford area. The position locations and distances were calculated using Google Maps. These estimates of the range in meters to each location are given in Tables 2, 3, 4 and 6. The closest measurement location is P4, which places the first cooling and power module 42 meters west to East Hall. The 2nd, 3rd and 4th cooling modules are 48.9, 55.8 and 62.7 meters away. The next closest measurement location is P3 at the University of Hartford Magnet School playground, which is about 138 meters southwest. Other campus facilities (P2, P5 and P6) are 180, 138 and 168

Acoustical Technologies Inc.

meters away. The University High School of Science and Engineering is 190 meters to the east on Mark Twain drive for the first cooling and power modules. (Speaker data was taken at 90 meters and corrected to the 190-meter distance.) The 2nd, 3rd and 4th cooling modules are 196.9, 203.8 and 210.7 meters away. The closest residential properties are 425 meters away on Bloomfield Avenue to the west and Granby Street to the east. Because of this great distance airborne noise at these residential locations is not heard with the speakers on. Nonetheless, “speaker on” noise levels exceeded background noise at all six campus measurement locations.

Table 2. Measured Overall Sound Pressure Levels in dBA ref. 20 microPascals with Speakers On

Location	Range in Meters	Direction	Leq	Max	Min	L10	L90
Speakers	5	East	92.6	93.7	91.8	93.4	92.0
Speakers	10	East	86.0	86.6	85.5	86.4	85.8
Speakers	5	South	88.2	88.6	85.5	88.4	88.1
Speakers	10	South	83.2	83.9	82.9	83.6	83.1
Speakers	5	North	87.5	88	87.1	87.8	87.3
Speakers	10	North	83.0	83.4	82.8	83.2	83.0
Speakers	5	West	88.8	89.3	88.4	89.1	88.6
Speakers	10	West	83.9	84.5	83.7	84.1	83.8
Univ. High School	90	East	66.0	66.8	65.1	66.5	65.3
Magnet School	180	Southwest	50.6	52.5	48.4	51.6	49.5
Magnet School Playground	135	Southwest	52.9	55.0	50.5	54.6	51.3
East Hall	42	West	71.7	72.1	71.3	71.9	71.5
Student Union	138	Northwest	47.6	66.1	47.0	48.0	47.3
Hillyer Hall	168	West	51.7	54.0	51.0	52.4	51.2

A comparison of the airborne noise produced at 10 meters by the HiAxiom fuel cell on the Montville site with the airborne noise produced by the speakers at the Hartford site is shown in Table 5. The speakers roughly match the fuel cell airborne noise for frequencies below 200 Hertz and greatly exceed the fuel cell airborne noise at higher frequencies where the fuel cell airborne noise levels are the highest. The overall airborne noise levels are 19 dB to 23 dB higher for the speakers as compared to what was measured from the single HiAxiom 460 KW fuel cell at Montville, CT. These 19 to 23 dB differences in level (Column 5 in Table 6) were subtracted from the Hartford measured levels (Column 4 in Table 6) to estimate the expected fuel cell acoustic signature for one fuel cell in each direction (Column 6 in Table 6). Column 7 provides the corrections for four fuel cells which when added to column 6, result in the four fuel cell estimate in column 8. These calculations are displayed in Table 6 below. The 10-meter Montville airborne noise levels were used with the Hartford transmission loss data to estimate the expected four fuel cell airborne noise at the nearby neighbors.

Acoustical Technologies Inc.

Table 3 Measured Overall Sound Pressure Levels in dBA ref. 20 microPascals with Speakers Off

Location	Range in Meters	Direction	Leq	Max	Min	L10	L90
Speakers	5	East	46.4	48.6	45.6	46.9	46.0
Speakers	10	East	46.1	54.7	45.0	46.4	45.4
Speakers	5	South	45.5	50.8	44.6	47.0	44.2
Speakers	10	South	46.2	50.8	44.8	47.0	45.4
Speakers	5	North	44.3	45.8	43.7	45.0	43.9
Speakers	10	North	44.1	45.2	43.6	44.9	43.8
Speakers	5	West	46.9	50.1	45.2	47.9	45.7
Speakers	10	West	45.7	48.1	44.8	46.5	45.2
Univ. High School	90	East	47.1	49.7	45.5	48.3	46.9
Magnet School	180	Southwest	39.4	42.1	37.9	40.9	38.2
Magnet School Playground	135	Southwest	39.4	43.6	36.7	41.5	37.3
East Hall	42	West	51.2	59.1	49.7	52.2	50.1
Student Union	138	Northwest	43.4	78.8	41.3	45.2	41.7
Hillyer Hall	168	West	43.1	55.1	42	43.7	42.2

Table 4 Background Corrected L90 Sound Pressure Levels in dBA ref. 20 microPascals

Location	Range in Meters	Direction	L90	L90 Bkgd	Bkgd Corr	Xfer F
Speakers Cooling	10	East	85.8	45.4	85.8	
Speakers Power	10	South	83.1	45.4	83.1	
Speakers Cooling	10	North	83.0	43.8	83.0	
Speakers Cooling	10	West	83.8	45.2	83.8	
Univ. High School	90	East	65.3	46.9	65.2	-20.6
Magnet School	180	Southwest	49.5	38.2	49.2	-34.2
Magnet School Playground	135	Southwest	51.3	37.3	51.1	-32.3
East Hall	42	West	71.5	50.1	71.5	-12.3
Student Union	138	Northwest	47.3	41.7	45.9	-37.5
Hillyer Hall	168	West	51.2	42.2	50.6	-33.2

Table 5. Comparison of Overall Sound Pressure Levels in dBA reference 20 microPascals (Speaker Levels are about 20 dB Higher than the levels from one 460 KW Fuel Cell)

Location	Range in Meters	Direction	Leq	Min	L10	L90	Correct by Subtract
Cooling 1 unit ³	5	West	69.7	69.1	70.1	69.4	
Hartford Speaker	5	North	87.5	87.1	87.8	87.3	
		Difference	17.8	18.0	17.7	17.9	17.9
Cooling 1 unit ³	10	West	64.2	63.7	64.4	64.0	
Hartford Speaker	10	North	83.0	82.8	83.2	83.0	
		Difference	18.8	19.1	18.8	19.0	19
Power 1 unit ³	5	South	61.8	61.4	62.1	61.7	
Hartford Speaker	5	South	88.2	85.5	88.4	88.1	
		Difference	26.4	24.1	26.3	26.4	26.4
Power 1 unit ³	10	South	61.2	60.5	61.9	60.8	
Hartford Speaker	10	South	83.2	82.9	83.6	83.1	
		Difference	22.0	22.4	21.7	22.3	22.3
Power 1 unit ³	5	East & South	67.4	66.8	67.7	67.1	
Hartford Speaker	5	East	92.6	91.8	93.4	92.0	
		Difference	25.2	25.0	25.7	24.9	24.9
Power 1 unit ³	10	West	64.2	63.7	64.4	64.0	
Hartford Speaker	10	East	86.0	85.5	86.4	85.8	
		Difference	21.8	21.8	22.0	21.8	21.8
Power 1 unit ³	5	West	69.7	69.1	70.1	69.4	
Hartford Speaker	5	West	88.8	88.4	89.1	88.6	
		Difference	19.1	19.3	19.0	19.2	19.2
Power 1 unit ³	10	West	64.2	63.7	64.4	64.0	
Hartford Speaker	10	West	83.9	83.7	84.1	83.8	
		Difference	19.7	20.0	19.7	19.8	19.8

The airborne noise levels to be produced by the HiAxiom fuel cells are shown in Table 6. For each of the ten locations the Hartford measurements are corrected to account for the higher speaker levels. The fuel cell noise correction for the Cooling Module is estimated to be 19 dB in the North direction because the speaker levels are that much higher than the Montville Cooling Module levels. The speakers at the Power Module location were estimated to be 22.3 dB higher than the Montville Power Module levels in the South direction. In the East and West directions, the airborne noise was calculated using a power sum of four distance corrected cooling modules and one power module to estimate the airborne noise radiated to properties in those directions.

Acoustical Technologies Inc.

The measurements at the University of Hartford were taken at various distances from the speakers and then corrected to estimate the expected noise from four fuel cells. Except for East Hall the expected airborne noise levels are all below 45 dBA, the lowest residential noise limit. The back side of East Hall should see airborne noise levels of about 58 dBA, below the 62 dBA noise limit in a commercial zone. The other school properties on campus are expected to be below 37 dBA depending on how close the locations are to the fuel cell. Because they are so far away, the off campus residential properties are all expected to have airborne noise levels due to the four fuel cells that are below 20 dBA. The other nearby property, University High School on Mark Twain Drive should see airborne noise levels below 45 dBA.

Table 6. Estimated Hartford Overall Sound Pressure Levels in dBA ref. 20 microPascals

Location	Range in Meters	Direction	Measured Level	Speaker Correction	One Unit Level	Four Unit Correction	Four Unit Level
P1 Univ. High School	190	East	65.2 - 5.2	-21.8	38.2	6.1	44.3
P2 Magnet School	180	Southwest	49.2	-21	28.2	6.5	34.7
P3 Magnet School Playground	135	Southwest	51.1	-21	30.1	6.5	36.6
P4 East Hall	42	West	71.5	-19.8	51.7	6.5	58.2
P5 Student Union	138	Northwest	45.9	-19	26.9	7.8	34.7
P6 Hillyer Hall	168	West	50.6	-19.8	30.8	6.5	37.3
Bloomfield Avenue - 201	425	West	32.9	-19.8	13.1	6.5	19.6
Bloomfield Avenue - 207	430	West	32.8	-19.8	13	6.5	19.5
Granby Street - 309	425	East	31.3	-21.8	9.5	6.5	16.0
Granby Street - 305	430	East	31.2	-21.8	9.4	6.5	15.9

A 5.2 dB reduction for the distance correction from 90 to 190 meters was made for P1 – school.⁴

Allowable Noise Levels

Connecticut’s regulation for the control of noise provides in *CT section 22a-69-3*¹ the requirements for noise emission in Connecticut. *Section 22a-69-3.1* states that no person shall cause or allow the emission of excessive noise beyond the boundaries of his/her Noise Zone so as to violate any provisions of these Regulations. The CT ordinance will be used to evaluate the noise generated by the HiAxiom 460 KW Fuel Cells. (The Hartford noise ordinance has the same noise limits but also employs an additional criterion that will also be evaluated.) Following sections discuss each type of noise using the results obtained from the October 30, 2022 speaker measurements in Hartford and the HiAxiom 460 KW fuel cell test in Montville, CT reported on July 13, 2020.

Acoustical Technologies Inc.

As stated above, the University of Hartford is located in a Mixed-Use Zone on Bloomfield Avenue and is surrounded by Residential and Open Space Zones. The closest residential zones are 425 meters away. Based on the analysis resulting in Table 6 the airborne noise from the four new fuel cells should be below 20 dBA in the 200 block of Bloomfield Avenue and the 300 block of Granby Street. Other nearby residential properties at greater distances are also expected to be well below the day time and night time Residential Zone noise limits for an emitter in either a residential or commercial (mixed use) zone. The airborne noise estimated at all the University of Hartford properties (besides East Hall) in the mixed-use zone are below the allowable residential night time noise limit of 45 dBA. The rear of East Hall is below the commercial noise limit of 62 dBA. The four fuel cells will not exceed either the State of Connecticut or City of Hartford noise limits

The Hartford Noise Ordinance² also states in section 23-3 (4 c) that *“In the absence of a sound level meter, any noise plainly audible pursuant to subsection 23-2 (b) constitutes prima facie evidence of a violation of this section.”* The measured data from October 30, 2022 at the University of Hartford indicate that the lowest measured background noise level was 37.3 dBA at the Magnet School playground. The new fuel cells’ airborne noise would have to be below at least 37 dBA to be inaudible at the Magnet School playground. Experience suggests a noise level 5 to 10 dB lower would not be heard since the fuel cells generate mostly random noise. Since the expected level at the Magnet School is 36.6 dBA it is likely that the fuel cells would be audible at a very low level. The results for other campus locations are given in Table 7. The difference in levels varies from -0.7 dB to -4.9 dB on campus indicating the four fuel cells would probably be heard at low level. East Hall being next to the fuel cells is the only location where the fuel cell noise is higher in level than the background noise. Off campus in the residential areas on Bloomfield Avenue and Granby Street the fuel cells would definitely **not** be heard.

Table 7. Comparison of Background and Estimated Hartford Fuel Cell Sound Pressure Levels

Location	Range in Meters	Direction	Bkgd Level	Four Unit Level	Difference in Level
P1 Univ. High School	190	East	46.9	44.3	-2.6
P2 Magnet School	180	Southwest	38.2	34.7	-3.5
P3 Magnet School Playground	135	Southwest	37.3	36.6	-0.7
P4 East Hall	42	West	50.1	58.2	8.1
P5 Student Union	138	Northwest	41.7	34.7	-7
P6 Hillyer Hall	168	West	42.2	37.3	-4.9
201 Bloomfield Ave	425	West	45	19.6	-25.4
207 Bloomfield Ave	430	West	45	19.5	-25.5
309 Granby Street	425	East	45	16.0	-29
305 Granby Street	430	East	45	15.9	-29.1

Impulse Noise

The Connecticut noise code states in *CT section 22a-69-3.2 (part a) Impulse Noise* that no person shall cause or allow the emission of impulse noise in excess of 80 dB peak sound pressure level during the night time to any class A Noise Zone. Night time is defined as 10 pm to 7 am. *CT section 22a-69-3.2 (part b) Impulse Noise* states that no person shall cause or allow the emission of impulse noise in excess of 100 dB peak sound pressure level at any time to any Noise Zone. The Hartford noise ordinance sets the same limits for Impulse Noise.

Figure 6. Acoustic Airborne Noise Weighting Curves

[http://upload.wikimedia.org/wikipedia/commons/3/39/Acoustic_weighting_curves_\(1\).svg](http://upload.wikimedia.org/wikipedia/commons/3/39/Acoustic_weighting_curves_(1).svg)

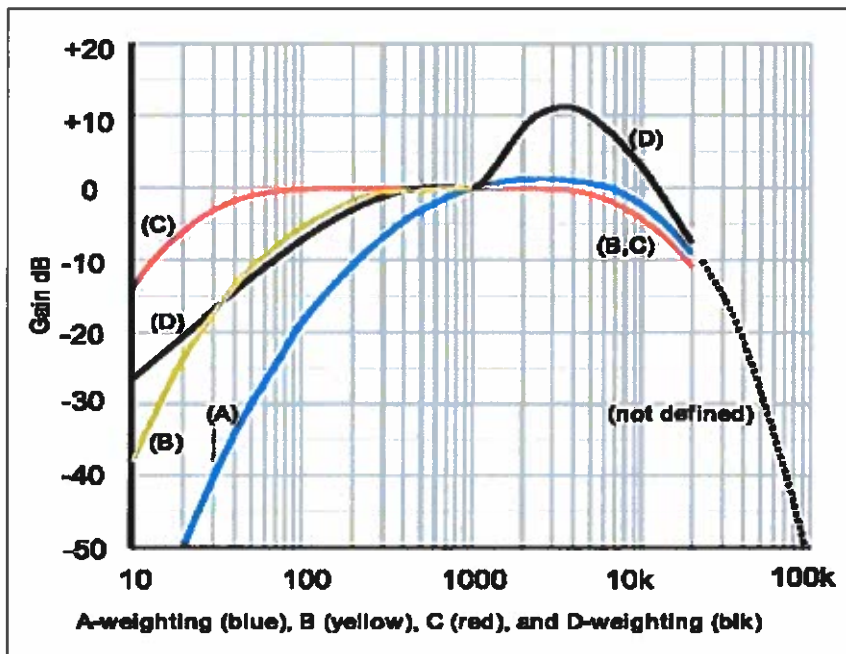

1 of 1

1/25/2013 9:35 PM

Impulse noise in excess of 80 dBA was not observed during any of the ten property line measurements of the HiAxiom 460 KW fuel cell made at the Montville site on 7 July, 2020³. The maximum level measured was 79.7 dBA at location P2 using the ExTech sound level meter. This and the other levels above 70 dBA were caused by vehicle traffic and not by the fuel cell. Unweighted impulse noise levels were determined using a Hewlett Packard HP3561A spectrum analyzer. (The maximum level ten meters from the fuel cell was 77 dBA.) The closest Hartford property showed 12 dB of transmission loss so the highest expected level would be below 66 dB. Given the steady state nature of the fuel cell's noise signature there should be no acoustic issues with the State of Connecticut's or the City of Hartford's impulse noise requirements.

A few words are in order to discuss the difference between A-weighted and un-weighted impulse noise. A-weighting emphasizes the middle and higher frequencies while reducing the influence of the low frequencies. Figure 6 above plots the A-weighting curve versus frequency in blue.

Acoustical Technologies Inc.

Below a frequency of 1 kiloHertz the acoustic level is attenuated by increasing amounts. The reduction is about 10 dB at 200 Hertz, 20 dB at 90 Hertz and 30 dB at 50 Hertz. It also reduces the level at very high frequency being down in level by 10 dB at 20 kiloHertz. The fuel cell measurements show the unweighted overall levels to be about 9 dB higher than the A-weighted noise levels. Adding 9 dB to the measured levels brings the peak impulse up to about 75 dB reference 20 microPascals for the East Hall location. The transfer functions to the closest nearby residential properties are more than 35 dB so these neighbors should see levels less than 52 dB impulse noise, well below the 80 dB night time limit. The impulse noise levels on campus should be no higher than 62 dB reference 20 microPascals, well below the 100 dB limit.

Prominent Discrete Tones

The Connecticut regulation for the control of noise states in *CT section 22a-69-3.3 Prominent discrete tones*: Continuous noise measured beyond the boundary of the Noise Zone of the noise emitter in any other Noise Zone which possesses one or more audible discrete tones shall be considered excessive noise when a level of 5 dBA below the levels specified in section 3 of these Regulations is exceeded. The CT Regulations establish different noise limits for different land use zones. Residential (homes and condominiums) and hotel uses are in Class A. Schools, business, parks, recreational activities and government services are in Class B. Forestry and related services are in Class C. By my reading of the regulations the University of Hartford is a Class B emitter in a Business or Commercial Zone. The noise zone standards in *CT section 22a-69-3.5* state that a Class B emitter cannot exceed the following overall sound pressure levels:

To Class C 62 dBA To Class B 62 dBA To Class A 55 dBA (day) 45 dBA (night)

The discrete tones limits are 5 dBA lower so that no tone may be higher than the following:

To Class C 57 dBA To Class B 57 dBA To Class A 50 dBA (day) 40 dBA (night)

The Hartford noise ordinance does not discuss discrete tones so the CT Noise Ordinance will be used. To address the discrete tone issue, we use measured spectral data from the Reference 3 Montville testing. The data is the maximum level received in 1/30 octave bands for frequencies from 0.32 to 100,000 Hz. Figure 7 plots the airborne noise measured 10 meters from the Cooling and Power Modules in 1-30th octave bands. This figure shows some discrete tones in the middle frequencies produced by the HiAxiom Fuel Cell Cooling and Power Modules. The eight largest tones are given in Table 8. The highest is 55.1 dB reference 20 microPascals at 302 Hz. The second highest tone is at 213.8 Hz at a level of 54.3 dB reference 20 microPascals. All the remaining tones are below 53 dBA. The A-weighted discrete tone corrections are given in the 4th row of Table 8. Incorporating the transmission loss to the properties gives the A-weighted levels in the last three rows of Table 8 after the 6.5 dB correction for four units is added. All the frequencies at the two nearest residences on Bloomfield Avenue and Granby Street have levels that are below the 40 dBA requirement in a Residential Zone by at least 22 dB. All the nearby residential properties should meet all the discrete tone requirements. The discrete tones at University High School should be below the 40 dBA night time limit by at least 4 dB. There should be no acoustic issue with the CT discrete tone noise requirements at any of the nearby properties outside the Hartford campus. The discrete tone limit in a commercial zone is 57 dB.

Acoustical Technologies Inc.

On the campus the highest expected discrete sound level is 49 dB at East Hall 8 dB below the limit. Other locations on the Hartford campus will have even lower discrete sound levels.

Figure 7. Montville Tones 460 KW Fuel Cell Cooling & Power Modules in 1-30th octave bands

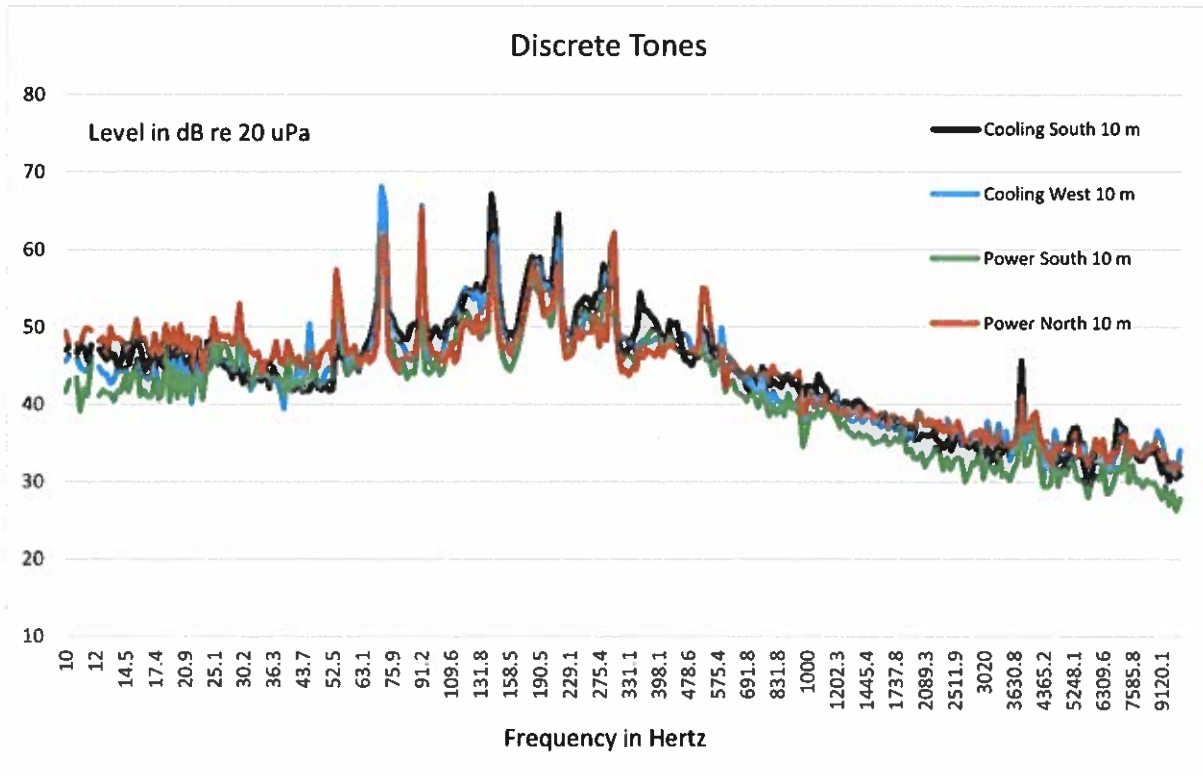

Table 8. Peak Discrete Sound Pressure Level Estimates in dB ref. 20 microPascals

Location	Range Meters	53.7 Hz	70.8 Hz	91.2 Hz	141.3 Hz	213.8 Hz	302 Hz	3801 Hz	4169 Hz
Allowed Level		40	40	40	40	40	40	40	40
Montville	10	57.3	68.1	65.6	67.1	64.5	62.1	45.6	39
A Weighting		-29.0	-24.3	-20.5	-14.7	-10.2	-7.0	1.0	0.9
Hartford 1 unit	10	28.3	43.8	45.1	52.4	54.3	55.1	46.6	39.9
4 Fuel Cells	10	34.8	50.3	51.6	58.9	60.8	61.6	53.1	46.4
U High School	190	9.0	24.5	25.8	33.1	35.0	35.8	27.3	20.6
East Hall	42	22.5	38.0	39.3	46.6	48.5	49.3	40.8	34.1
Bloomfield Av	425	-9.6	5.9	7.2	14.5	16.4	17.2	8.7	2.0
Granby Street	425	-13.2	2.3	3.6	10.9	12.8	13.6	5.1	1.6

Acoustical Technologies Inc.

Infrasonic and Ultrasonic Noise

The Connecticut regulation for the control of noise states in *CT section 22a-69-3.4 Infrasonic and Ultrasonic* that no person shall emit beyond his/her property infrasonic or ultrasonic sound in excess of 100 dB at any time. 100 dB with respect to the reference of 20 microPascals is a sound pressure of 2 Pascals or 0.00029 psi. Infrasonic sounds are sound pressure fluctuations below a frequency of 20 Hertz. Ultrasonic sounds are sound pressure fluctuations at frequencies above 20,000 Hertz. There is no mention in the Hartford Noise Ordinance that limits infrasonic or ultrasonic noise so the State of CT Noise Ordinance will be used.

Narrow bandwidth sound pressure spectrums in dB reference 20 microPascals made at the Montville western 10-meter Cooling Module location can be used to compare with the infrasonic and ultrasonic noise requirements. The Montville airborne noise data were processed in the 0 to 200 Hertz and 0 to 100,000 Hertz frequency ranges. The bandwidth of each data point is 0.75 Hertz for the 200 Hertz range and 375 Hertz for the 100,000 Hertz frequency range. The infrasonic noise for frequencies up to 20 Hertz is shown in Figure 8 for the 460 KW unit at Montville³. The maximum level at 10 meters is 48 dB reference 20 microPascals. The entire 20 Hertz band can be power summed and never exceeds 70 dB reference 20 microPascals at 10 meters in Montville. After subtracting 5.8 dB for the maximum correction at East Hall (12.3 dB transmission loss - 6.5 dB gain for 4 units), the 64.2 dB level is well below the requirement of 100 dB for the Hartford campus. The minimum transmission loss to the nearest residential property line is at least 38 dB so the maximum possible infrasonic noise at Bloomfield Avenue and Granby Street would be less than 39 dB., well below the 100 dB limit. There should be no issue with the infrasonic noise requirement at any of the neighboring residential properties.

The ultrasonic noise for frequencies up to 100 KiloHertz is given in Figure 9. The Montville data uses a microphone with flat high frequency performance and provides a good estimate for the 460 KW fuel cell. The entire 80 KiloHertz band from 20 to 100 kiloHertz has been power summed and never exceeds a noise level of 62 dB reference 20 microPascals 10 meters from the fuel cell at Montville. After subtracting 5.8 dB for the maximum correction at East Hall, the ultrasonic level of 56.2 dB is well below the requirement of 100 dB for the Hartford campus. Adding the minimum transmission loss to the nearest residential property line of 38 dB leads to a maximum possible ultrasonic noise at Bloomfield Avenue and Granby Street of 24 dB. The noise levels at all the other nearby residential neighbors will be lower and there should be no issue with ultrasonic noise at any of the neighboring properties.

Overall Sound Pressure Levels

The Connecticut regulations for the control of noise state that

(a) No person in a Class B Noise Zone shall emit noise exceeding the levels below:

To Class C 62 dBA To Class B 62 dBA To Class A 55 dBA (day) 45 dBA (night)

The Hartford site is in a Mixed-Use Zone that has surrounding Residential Zones. The nearby neighbors in NX-1, N-4-1 and R-20 zones are classified as residential with residential noise

Acoustical Technologies Inc.

limits of 55 dBA during the day and 45 dBA at night. The State of Connecticut and City of Hartford consider universities to be in a commercial zone with a noise limit of 62 dBA.

Figure 8. Infrasonic Noise from Montville Fuel Cell Cooling Modules in 1-30th octave bands

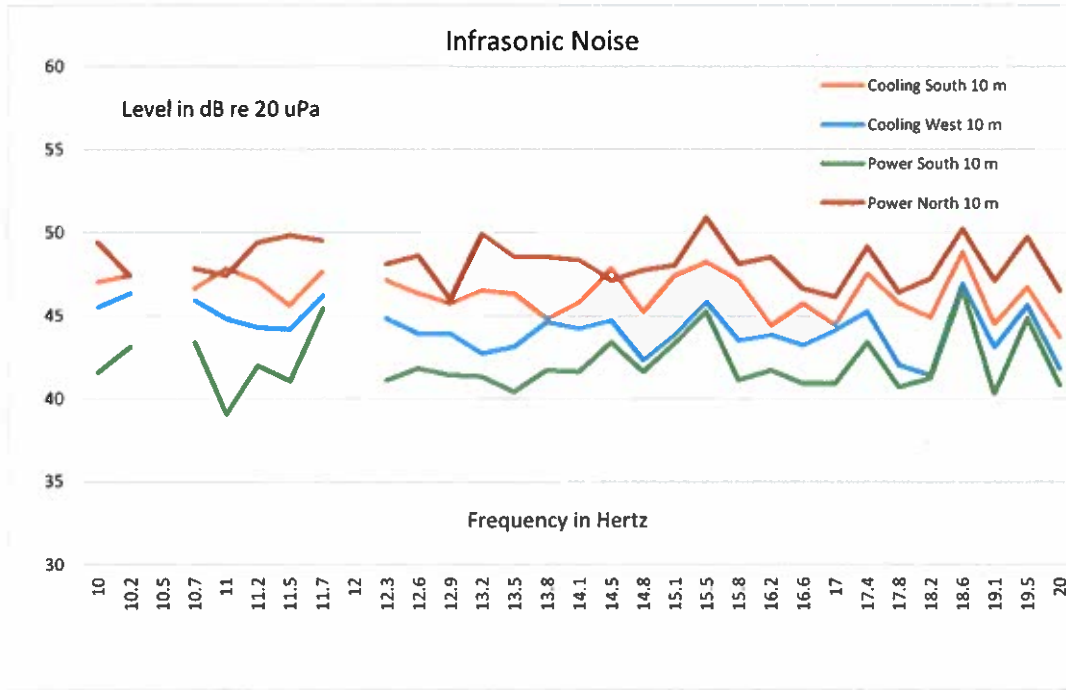
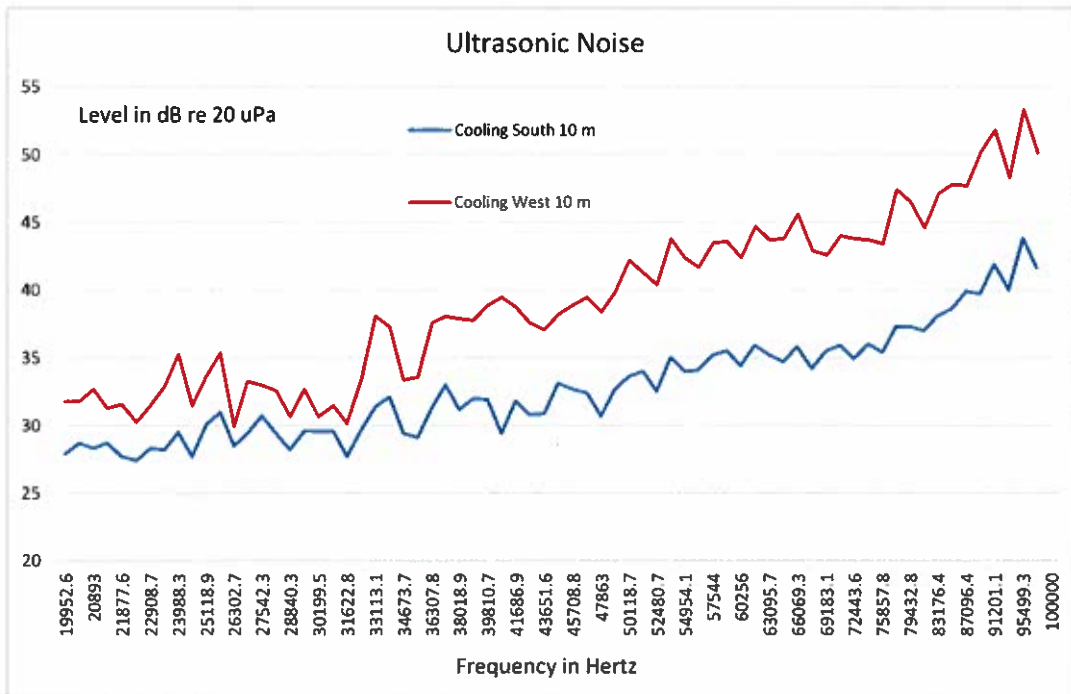

Figure 9. Ultrasonic Noise from Montville Fuel Cell Cooling Modules in 1-30th octave bands



Acoustical Technologies Inc.

The estimated overall A-weighted sound pressure level fuel cell estimates in dBA reference 20 microPascals are given in Table 6 above using the background corrected measurements made on October 30, 2022. The second column gives the approximate distance from the fuel cell to the measurement location, with locations identified by a P number in Figure 2. Column 3 gives the direction from the fuel cell to the property. The airborne noise values given in column 6 are the estimated fuel cell received level for one 460 KW fuel cell. The values in column 8 provide the estimated airborne noise levels with four fuel cells operating. The values are all below the commercial zone noise limit on the Hartford campus and below the residential noise limits off the Hartford campus. Because of the increasing loss with distance the surrounding residential properties should all be lower than 45 dBA.

Operation of the four HiAxiom fuel cells will have no significant acoustic impact at all of the nearby properties adjacent to the HiAxiom fuel cell site on Bloomfield Avenue. The campus properties close to the fuel cells should see overall airborne noise levels from the fuel cell below the 62 dBA airborne noise requirement. Some of these campus facilities may be able to hear the fuel cells at noise levels below the background noise. Commercial and residential properties further away from the fuel cell in the Mixed Use and Residential Zones are not expected to hear the fuel cells. All of the nearby residential properties should not be affected by the operation of the four fuel cells.

Conclusions

The purpose of this effort is to evaluate the acoustical environment at the University of Hartford during operation of the four HiAxiom 460 KW fuel cells. This effort has been accomplished and the results show that the operation of the four HiAxiom 460 KW fuel cells will meet all of the State of Connecticut and City of Hartford airborne noise requirements at all the nearby properties. Residences in all directions are expected to meet all the noise requirements because they are far enough away from the new fuel cells with airborne noise levels below 45 dBA. Locations at distances greater than 200 meters should not hear the operating 460 KW fuel cells. On the Hartford campus all the buildings including East Hall should see airborne noise levels below the 62 dBA commercial noise limit.

References

- 1) CT DE&EP *Noise Control Regulation RCSA Section 22a-69-1 to 22a-69-7.4*
<http://www.ct.gov/dep/lib/dep/regulations/22a/22a-69-1through7.pdf>
- 2) Hartford Noise Ordinance,
https://library.municode.com/ct/hartford/codes/code_of_ordinances?nodeId=PTIIMUCO_CH23NO
- 3) Town of Montville Water Pollution Control Authority Airborne Noise Test
At 83 Pink Row, Acoustical Technologies Inc., July 13, 2020
- 4) <https://noisetools.net/barriercalculator> was used in the sound pressure calculations



HyAxiom Inc,
A Doosan Company
101 East River Drive
East Hartford, CT 06108

November 28, 2022

RE: Petition for a Declaratory Ruling That No Certificate of Environmental Compatibility and Public Need is Required ("Petition") for the Installation of Four (4) 460 kW Fuel Cells on site at 200 Bloomfield Ave., West Hartford, CT 06117.

Dear Recipient,

Pursuant to Section 16-50j-40 of the Connecticut Siting Council's (the "Council") Rules of Practice, we are notifying you that HyAxiom, Inc. intends to file a petition for declaratory ruling with the Connecticut Siting Council ("Council") on or about December 1, 2022. The petition will request the Council's approval of the installation of Four (4) 460kW fuel cells and ancillary equipment in support of a customer-side, distributed generation project at 200 Bloomfield Ave., West Hartford, CT 06117. The fuel cells will be powered by natural gas and the generated electricity will be distributed to the University of Hartford.

The proposed placement of the fuel cells is located within the confines of the University of Hartford campus property adjacent to East Hall. The fuel cells will be arranged in a fenced area to the rear of East Hall in parking lot "C".

If you have any questions regarding the proposed work, please contact any of the following:

HyAxiom, Inc.	University of Hartford	Connecticut Siting Council
Walter Bonola	Chris Dupuis, AVP Capital Planning & Mgt.	10 Franklin Square
101 Riverside Drive	200 Bloomfield Ave., West Hartford, CT	New Britain, CT 06051
East Hartford, Ct 06108	Tel: (860) 768-7866	(860) 827-2935
Tel: (860) 250-3776	cdupuis@hartford.edu	
walter.bonola@doosan.com		

Sincerely,

Walter Bonola

Install Project Manager

HyAxiom, Inc.

Attachment #12

LUSTER, DEBORAH A + MARK R

80 SUNNY REACH DRIVE

West Hartford, CT 06117

JEFFERSON D JELLY TR

74 SUNNY REACH DRIVE

West Hartford, CT 06117

PRINCE, TROY S

68 SUNNY REACH DRIVE

West Hartford, CT 06117

GUZMAN, LAZARO E + NITYA

64 SUNNY REACH DRIVE

West Hartford, CT 06117

WEINTRAUB, BETTY S

60 SUNNY REACH DRIVE

West Hartford, CT 06117

SEAVER, GREGORY J

56 SUNNY REACH DRIVE

West Hartford, CT 06117

Bittel, Thomas J.

46 Sunny reach Drive

West Hartford, CT 06117

CASS, HOWARD + BASIA KRAUL

2 SUNNY REACH DRIVE

West Hartford, CT 06117

TRAGER, MERLE J + DAVID S

12 SUNNYDALE ROAD

West Hartford, CT 06117

WEED, TRACY K

8 SUNNYDALE ROAD

West Hartford, CT 06117

SMALL, DAVID J

6 SUNNYDALE ROAD

West Hartford, CT 06117

MATHEWS, GRACIE L + I CHARLES

4 SUNNYDALE ROAD

West Hartford, CT 06117

CERMOLA, MATTHEW P + JILLIAN

2 SUNNYDALE ROAD

West Hartford, CT 06117

THE HARTFORD ROMAN CATHOLIC

207 BLOOMFIELD AVENUE

West Hartford, CT 06117

MITRA, SUMIT + SUDAKSHINA

148 SUNNY REACH DRIVE

West Hartford, CT 06117

VALACHOVIC, MATTHEW DAVID + KATHLEEN
ANN

144 SUNNY REACH DRIVE

West Hartford, CT 06117

LAHIR,I BIMALIN + GERTRUD

140 SUNNY REACH DRIVE

West Hartford, CT 06117

KIM, MYUNG CHAN

136 SUNNY REACH DRIVE

West Hartford, CT 06117

SILVERMAN, ISAAC E + LAURIE C

130 SUNNY REACH DRIVE

West Hartford, CT 06117

MENE, ABHAY S + GAYATRI A

126 SUNNY REACH DRIVE

West Hartford, CT 06117

BRYDEN, ELIZABETH

120 SUNNY REACH DRIVE

West Hartford, CT 06117

SANFORD, RICHARD J + CHRISTINE M

114 SUNNY REACH DRIVE

West Hartford, CT 06117

WANG, HIN-CHENG +

110 SUNNY REACH DRIVE

West Hartford, CT 06117

BROWN, LEWIS R + MICHELLE A

104 SUNNY REACH DRIVE

West Hartford, CT 06117

LEVINE, ROBERT B + JULIE R

98 SUNNY REACH DRIVE

West Hartford, CT 06117

SCHANER, ELANA

94 SUNNY REACH DRIVE

West Hartford, CT 06117

MEAD, LINDA J

90 SUNNY REACH DRIVE

West Hartford, CT 06117

LEBOW, ALAN J + SUSAN L

86 SUNNY REACH DRIVE

West Hartford, CT 06117

MOEMEKA, EDWARD
201 BLOOMFIELD AVENUE
West Hartford, CT 06117

PENFIELD JARVIS TR
195 BLOOMFIELD AVENUE
West Hartford, CT 06117

CASCIANI, CHRISTOPHER J + CARRIE M
183 BLOOMFIELD AVENUE
West Hartford, CT 06117

PIMENTEL, VERONICA MARIA
173 BLOOMFIELD AVENUE
West Hartford, CT 06117

TERRION, PATRICK A + MARTHA A
171 BLOOMFIELD AVENUE
West Hartford, CT 06117

PIHL,, JEFFREY J + AMANDA L
159 BLOOMFIELD AVENUE
West Hartford, CT 06117

KIEFER LOUIS + SHERYL M
HOROWITZ
250 BLOOMFIELD AVENUE
West Hartford, CT 06117

SINGER, CLAUDE + CONSTANCE BOSWORTH
SING
145 BLOOMFIELD AVENUE
West Hartford, CT 06117

WATKINSON SCHOOL
180 BLOOMFIELD AVE
Hartford, CT 06105

HOUSING AUTHORITY-CITY OF HTFD
1550 ALBANY AVE
Hartford, CT 06105

NATIONAL RAILROAD PASSENGER CO
450 WINDSOR ST
Hartford, CT 06105

UNIVERSITY HOUSING ASSOC LP
947 TOWER AVE
Hartford, CT 06105

Attachment #13
Part A

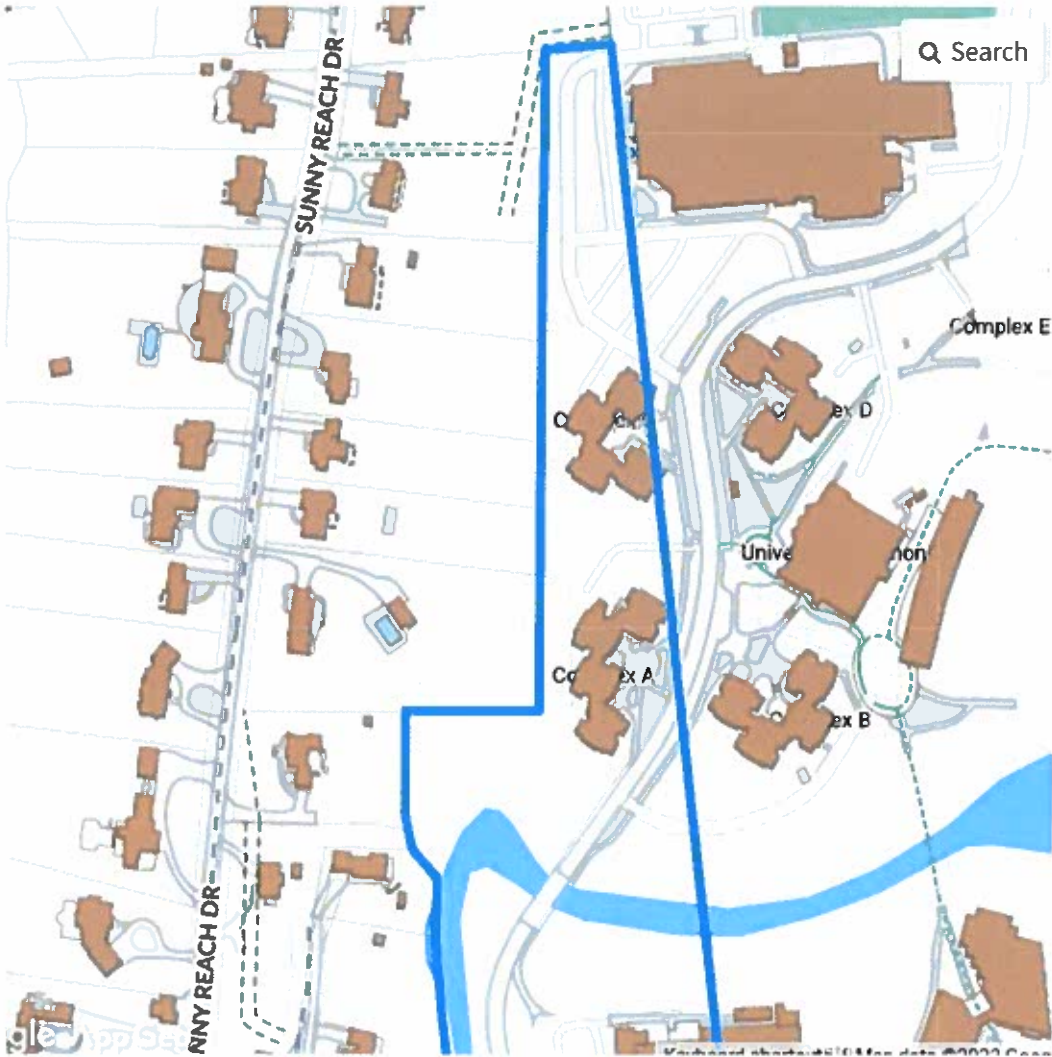

Part B

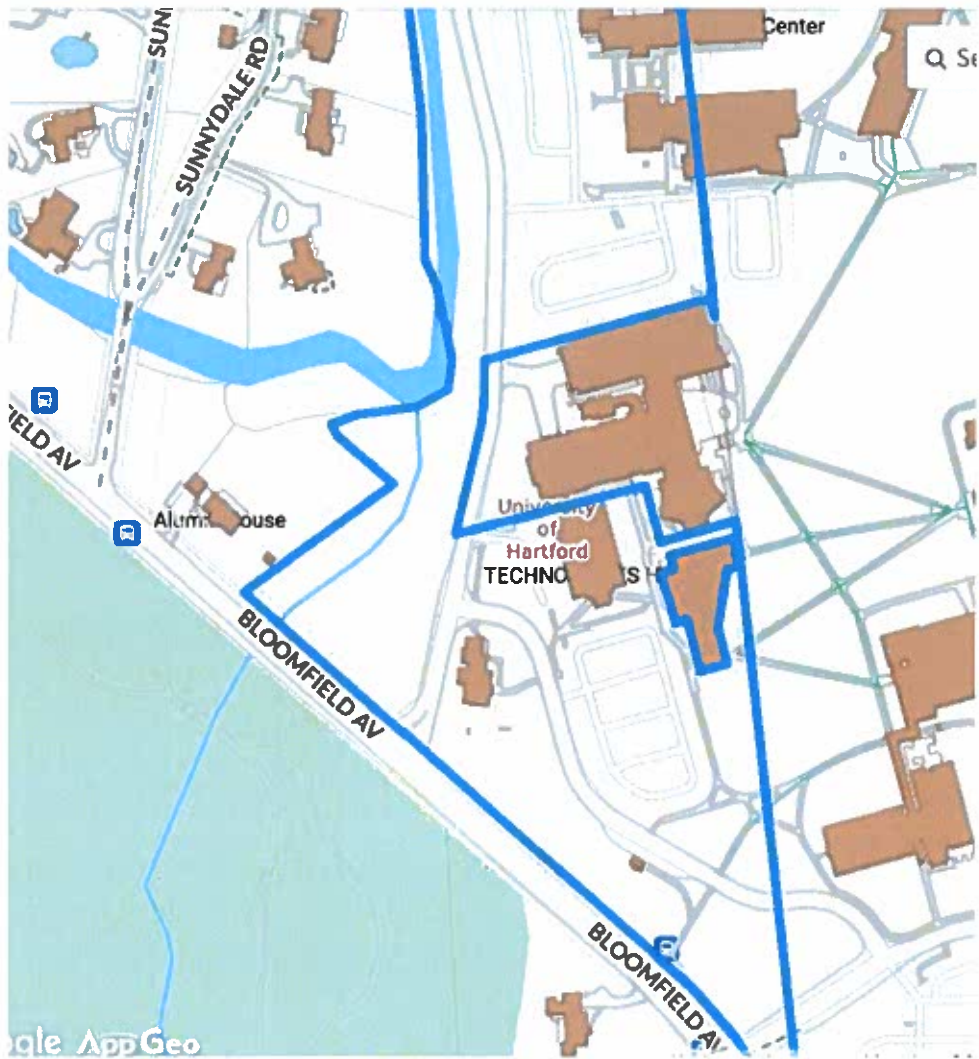

Attachment #14

RICK LEDWITH

Town of West Hartford

Town Manager

50 S Main St

West Hartford, CT 06107

JOSEPH DAKERS SR.

Town of West Hartford

Town Assessor

50 S Main St

West Hartford, CT 06107

TODD DUMAIS

Town Planner

50 S Main St

West Hartford, CT 06107

ESSIE LABROT

Town Clerk

50 S Main St

West Hartford, CT 06107

DUANE MARTIN

Director of Community Development

50 S Main St

West Hartford, CT 06107

Alberto Cortes

West Hartford Town Council

50 S Main St

West Hartford, CT 06107

Leon Davidoff

West Hartford Town Council

50 S Main St

West Hartford, CT 06107

Mary Fay

West Hartford Minority Leader

50 S Main St

West Hartford, CT 06107

Debra Polun

West Hartford Town Council

50 S Main St

West Hartford, CT 06107

Ben Wenograd

West Hartford Town Council

50 S Main St

West Hartford, CT 06107

Mark Zydanowicz

West Hartford Town Council

50 S Main St

West Hartford, CT 06107

MITRA, SUMIT + SUDAKSHINA

148 SUNNY REACH DRIVE

West Hartford, CT 06117

VALACHOVIC, MATTHEW DAVID + KATHLEEN
ANN

144 SUNNY REACH DRIVE

West Hartford, CT 06117

LAHIR,I BIMALIN + GERTRUD

140 SUNNY REACH DRIVE

West Hartford, CT 06117

KIM, MYUNG CHAN

136 SUNNY REACH DRIVE

West Hartford, CT 06117

SILVERMAN, ISAAC E + LAURIE C

130 SUNNY REACH DRIVE

West Hartford, CT 06117

MENE, ABHAY S + GAYATRI A

126 SUNNY REACH DRIVE

West Hartford, CT 06117

BRYDEN, ELIZABETH

120 SUNNY REACH DRIVE

West Hartford, CT 06117

SANFORD, RICHARD J + CHRISTINE M

114 SUNNY REACH DRIVE

West Hartford, CT 06117

WANG, HIN-CHENG +

110 SUNNY REACH DRIVE

West Hartford, CT 06117

BROWN, LEWIS R + MICHELLE A

104 SUNNY REACH DRIVE

West Hartford, CT 06117

LEVINE, ROBERT B + JULIE R

98 SUNNY REACH DRIVE

West Hartford, CT 06117

SCHANER, ELANA

94 SUNNY REACH DRIVE

West Hartford, CT 06117

MEAD, LINDA J

90 SUNNY REACH DRIVE

West Hartford, CT 06117

LEBOW, ALAN J + SUSAN L

86 SUNNY REACH DRIVE

West Hartford, CT 06117

LUSTER, DEBORAH A + MARK R
80 SUNNY REACH DRIVE
West Hartford, CT 06117

CASS, HOWARD + BASIA KRAUL
2 SUNNY REACH DRIVE
West Hartford, CT 06117

JEFFERSON D JELLY TR
74 SUNNY REACH DRIVE
West Hartford, CT 06117

TRAGER, MERLE J + DAVID S
12 SUNNYDALE ROAD
West Hartford, CT 06117

PRINCE, TROY S
68 SUNNY REACH DRIVE
West Hartford, CT 06117

WEED, TRACY K
8 SUNNYDALE ROAD
West Hartford, CT 06117

GUZMAN, LAZARO E + NITYA
64 SUNNY REACH DRIVE
West Hartford, CT 06117

SMALL, DAVID J
6 SUNNYDALE ROAD
West Hartford, CT 06117

WEINTRAUB, BETTY S
60 SUNNY REACH DRIVE
West Hartford, CT 06117

MATHEWS, GRACIE L + I CHARLES
4 SUNNYDALE ROAD
West Hartford, CT 06117

SEAVER, GREGORY J
56 SUNNY REACH DRIVE
West Hartford, CT 06117

CERMOLA, MATTHEW P + JILLIAN
2 SUNNYDALE ROAD
West Hartford, CT 06117

BITTEL, THOMAS J
46 SUNNY REACH DRIVE
West Hartford, CT 06117

HOROWITZ

250 BLOOMFIELD AVENUE

West Hartford, CT 06117

MOEMEKA, EDWARD

201 BLOOMFIELD AVENUE

West Hartford, CT 06117

PENFIELD JARVIS TR

195 BLOOMFIELD AVENUE

West Hartford, CT 06117

CASCIANI, CHRISTOPHER J + CARRIE M

183 BLOOMFIELD AVENUE

West Hartford, CT 06117

PIMENTEL, VERONICA MARIA

173 BLOOMFIELD AVENUE

West Hartford, CT 06117

TERRION, PATRICK A + MARTHA A

171 BLOOMFIELD AVENUE

West Hartford, CT 06117

PIHL,, JEFFREY J + AMANDA L

159 BLOOMFIELD AVENUE

West Hartford, CT 06117

SINGER, CLAUDE + CONSTANCE BOSWORTH
SING

145 BLOOMFIELD AVENUE

West Hartford, CT 06117

WATKINSON SCHOOL

180 BLOOMFIELD AVE

Hartford, CT 06105

HOUSING AUTHORITY-CITY OF HTFD

1550 ALBANY AVE

Hartford, CT 06105

NATIONAL RAILROAD PASSENGER CO

450 WINDSOR ST

Hartford, CT 06105

UNIVERSITY HOUSING ASSOC LP

947 TOWER AVE

Hartford, CT 06105

Attachment #15

Maly Rosado
City of Hartford Council President

550 Main St.
Hartford CT 06103

Thomas Clarke II
City of Hartford Majority Leader

550 Main St.
Hartford CT 06103

Tiana Hercules
City of Hartford Councilwoman

550 Main St.
Hartford CT 06103

John Gale
City of Hartford Councilman

550 Main St.
Hartford CT 06103

Nick Lebron
City of Hartford Councilman

550 Main St.
Hartford CT 06103

Joshua Michtom
City of Hartford Councilman

550 Main St.
Hartford CT 06103

Marilyn Rossetti
City of Hartford Councilwoman

550 Main St.
Hartford CT 06103

James Sánchez
City of Hartford Councilman

550 Main St.
Hartford CT 06103

Shirley Surgeon
City of Hartford Councilwoman

550 Main St.
Hartford CT 06103

Mayor Luke Bronin

550 Main St.
Hartford CT 06103

Richard Blumenthal

655 Dirksen Senate Office Bldg.
Washington, D.C. 20510

Chris Murphy
303 Hart Senate Office Bldg.
Washington, D.C. 20510

John B. Larson

Rm. 1419 Long Worth Office Bldg.,
Washington, D.C. 20515

Secretary of State
Denise Merrill
210 Capitol Ave.,
Hartford, CT 06106

Connecticut State Senator
5th Senatorial District
Derek Slap
Legislative Office Building
Room 3100
Hartford, CT 06106-1591

Connecticut State Representatives
District 6
Edwin Vargas
Legislative Office Building
Room 1003
Hartford, CT 06106-1591

District 15
Bobby Gibson
Legislative Office Building
Room 4022
Hartford, CT 06106-1591

District 18
Jillian Gilchrest
Legislative Office Building
Room 3101
Hartford, CT 06106-1591

District 19
Tammy Exum
Legislative Office Building
Room 4036
Hartford, CT 06106-1591

District 20
Kate Farrar
Legislative Office Building
Room 4043
Hartford, CT 06106-1591

U.S. Postal Service
CERTIFIED MAIL® RECEIPT
 Domestic Mail Only

For delivery information, visit our website at www.usps.com®

OFFICIAL USE

Certified Mail Fee \$
 Extra Services & Fees (check box, add fee as appropriate)
 Return Receipt (hardcopy) \$
 Return Receipt (electronic) \$
 Certified Mail Restricted Delivery \$
 Adult Signature Required \$
 Adult Signature Restricted Delivery \$
 Postage \$
 Total Postage and Fees \$



Sent To
 Levine, Robert B + Julie B
 Street and Apt. No., or PO Box No.
 98 Sunny Beach Dr
 City, State, ZIP+4®
 West Hartford, CT 06117

U.S. Postal Service™
CERTIFIED MAIL® RECEIPT
 Domestic Mail Only

For delivery information, visit our website at www.usps.com®

OFFICIAL USE

Certified Mail Fee \$
 Extra Services & Fees (check box, add fee as appropriate)
 Return Receipt (hardcopy) \$
 Return Receipt (electronic) \$
 Certified Mail Restricted Delivery \$
 Adult Signature Required \$
 Adult Signature Restricted Delivery \$
 Postage \$
 Total Postage and Fees \$

Sent To
 Cermola, Matthew P + Jillian
 Street and Apt. No., or PO Box No.
 2 Sunnydale Rd
 City, State, ZIP+4®
 West Hartford, CT 06117

U.S. Postal Service™
CERTIFIED MAIL® RECEIPT
 Domestic Mail Only

For delivery information, visit our website at www.usps.com®

OFFICIAL USE

Certified Mail Fee \$
 Extra Services & Fees (check box, add fee as appropriate)
 Return Receipt (hardcopy) \$
 Return Receipt (electronic) \$
 Certified Mail Restricted Delivery \$
 Adult Signature Required \$
 Adult Signature Restricted Delivery \$
 Postage \$
 Total Postage and Fees \$



Sent To
 Mitra, Sumit + Sudakshina
 Street and Apt. No., or PO Box No.
 140 Sunny Beach Dr
 City, State, ZIP+4®
 West Hartford, CT 06117

PS Form 3800, April 2015 PSN 7530-02 000-9047 See Reverse for Instructions

7022 2410 0002 4759 8146

U.S. Postal Service
CERTIFIED MAIL® RECEIPT
 Domestic Mail Only

For delivery information, visit our website at www.usps.com®

OFFICIAL USE

Certified Mail Fee \$
 Extra Services & Fees (check box, add fee as appropriate)
 Return Receipt (hardcopy) \$
 Return Receipt (electronic) \$
 Certified Mail Restricted Delivery \$
 Adult Signature Required \$
 Adult Signature Restricted Delivery \$
 Postage \$
 Total Postage and Fees \$



Sent To
 Lahir, Bimalin + Gertrude
 Street and Apt. No., or PO Box No.
 140 Sunny Beach Dr
 City, State, ZIP+4®
 West Hartford, CT 06117

U.S. Postal Service™
CERTIFIED MAIL® RECEIPT
 Domestic Mail Only

For delivery information, visit our website at www.usps.com®

OFFICIAL USE

Certified Mail Fee \$
 Extra Services & Fees (check box, add fee as appropriate)
 Return Receipt (hardcopy) \$
 Return Receipt (electronic) \$
 Certified Mail Restricted Delivery \$
 Adult Signature Required \$
 Adult Signature Restricted Delivery \$
 Postage \$
 Total Postage and Fees \$



Sent To
 Small, David J
 Street and Apt. No., or PO Box No.
 6 Sunnydale Rd
 City, State, ZIP+4®
 West Hartford, CT 06117

U.S. Postal Service™
CERTIFIED MAIL® RECEIPT
 Domestic Mail Only

For delivery information, visit our website at www.usps.com®

OFFICIAL USE

Certified Mail Fee \$
 Extra Services & Fees (check box, add fee as appropriate)
 Return Receipt (hardcopy) \$
 Return Receipt (electronic) \$
 Certified Mail Restricted Delivery \$
 Adult Signature Required \$
 Adult Signature Restricted Delivery \$
 Postage \$
 Total Postage and Fees \$



Sent To
 Weintraub, Betty S
 Street and Apt. No., or PO Box No.
 140 Sunny Beach Dr.
 City, State, ZIP+4®
 West Hartford, CT 06117

PS Form 3800, April 2015 PSN 7530-02 000-9047 See Reverse for Instructions

7022 2410 0002 4759 8146

1 2 3 4 5 6 7 8 9 10 11 12 13 14 15 16 17 18 19 20 21 22 23 24 25 26 27 28 29 30 31 32 33 34 35 36 37 38 39 40 41 42 43 44 45 46 47 48 49 50 51 52 53 54 55 56 57 58 59 60 61 62 63 64 65 66 67 68 69 70 71 72 73 74 75 76 77 78 79 80 81 82 83 84 85 86 87 88 89 90 91 92 93 94 95 96 97 98 99 100

U.S. Postal Service
CERTIFIED MAIL® RECEIPT
 Domestic Mail Only

For delivery information, visit our website at www.usps.com®

OFFICIAL USE

Certified Mail Fee
 \$

Extra Services & Fees (check box, add fee as appropriate)

Return Receipt (hardcopy) \$

Return Receipt (electronic) \$

Certified Mail Restricted Delivery \$

Adult Signature Required \$

Adult Signature Restricted Delivery \$

Postage
 \$

Total Postage and Fees
 \$

Sent To
 Matthews Grace L + Charles
 Street and Apt. No., or PO Box No.
 4 Sunny Reach Rd
 City, State, ZIP+4®
 West Hartford CT 06117

PS Form 3800, April 2015 PSN 7530 02-000-9047 See Reverse for Instructions

7022 2410 0002 4759 7842

U.S. Postal Service
CERTIFIED MAIL® RECEIPT
 Domestic Mail Only

For delivery information, visit our website at www.usps.com®

OFFICIAL USE

Certified Mail Fee
 \$

Extra Services & Fees (check box, add fee as appropriate)

Return Receipt (hardcopy) \$

Return Receipt (electronic) \$

Certified Mail Restricted Delivery \$

Adult Signature Required \$

Adult Signature Restricted Delivery \$

Postage
 \$

Total Postage and Fees
 \$

Sent To
 Valerich, Matthew David, Kathleen
 Street and Apt. No., or PO Box No.
 140 Sunny Reach Dr.
 City, State, ZIP+4®
 West Hartford, CT 06117

PS Form 3800, April 2015 PSN 7530 02-000-9047 See Reverse for Instructions

U.S. Postal Service™
CERTIFIED MAIL® RECEIPT
 Domestic Mail Only

For delivery information, visit our website at www.usps.com®

OFFICIAL USE

Certified Mail Fee
 \$

Extra Services & Fees (check box, add fee as appropriate)

Return Receipt (hardcopy) \$

Return Receipt (electronic) \$

Certified Mail Restricted Delivery \$

Adult Signature Required \$

Adult Signature Restricted Delivery \$

Postage
 \$

Total Postage and Fees
 \$

Sent To
 Seaver Gregory J
 Street and Apt. No., or PO Box No.
 56 Sunny Reach Dr.
 City, State, ZIP+4®
 West Hartford CT 06117

PS Form 3800, April 2015 PSN 7530 02-000-9047 See Reverse for Instructions

7022 2410 0002 4759 7910

U.S. Postal Service™
CERTIFIED MAIL® RECEIPT
 Domestic Mail Only

For delivery information, visit our website at www.usps.com®

OFFICIAL USE

Certified Mail Fee
 \$

Extra Services & Fees (check box, add fee as appropriate)

Return Receipt (hardcopy) \$

Return Receipt (electronic) \$

Certified Mail Restricted Delivery \$

Adult Signature Required \$

Adult Signature Restricted Delivery \$

Postage
 \$

Total Postage and Fees
 \$

Sent To
 Wang Hin-cheng
 Street and Apt. No., or PO Box No.
 110 Sunny Reach Dr.
 City, State, ZIP+4®
 West Hartford, CT 06117

PS Form 3800, April 2015 PSN 7530 02-000-9047 See Reverse for Instructions

U.S. Postal Service™
CERTIFIED MAIL® RECEIPT
 Domestic Mail Only

For delivery information, visit our website at www.usps.com®

OFFICIAL USE

Certified Mail Fee
 \$

Extra Services & Fees (check box, add fee as appropriate)

Return Receipt (hardcopy) \$

Return Receipt (electronic) \$

Certified Mail Restricted Delivery \$

Adult Signature Required \$

Adult Signature Restricted Delivery \$

Postage
 \$

Total Postage and Fees
 \$

Sent To
 Sanford Richard + Christina M
 Street and Apt. No., or PO Box No.
 114 Sunny Reach Dr
 City, State, ZIP+4®
 West Hartford CT 06117

PS Form 3800, April 2015 PSN 7530 02-000-9047 See Reverse for Instructions

7022 2410 0002 4759 7972

U.S. Postal Service™
CERTIFIED MAIL® RECEIPT
 Domestic Mail Only

For delivery information, visit our website at www.usps.com®

OFFICIAL USE

Certified Mail Fee
 \$

Extra Services & Fees (check box, add fee as appropriate)

Return Receipt (hardcopy) \$

Return Receipt (electronic) \$

Certified Mail Restricted Delivery \$

Adult Signature Required \$

Adult Signature Restricted Delivery \$

Postage
 \$

Total Postage and Fees
 \$

Sent To
 Luster Deborah A + Mark R
 Street and Apt. No., or PO Box No.
 80 Sunny Reach Dr
 City, State, ZIP+4®
 West Hartford, CT 06117

PS Form 3800, April 2015 PSN 7530 02-000-9047 See Reverse for Instructions

RUCC 6740 0002 4759 7811

U.S. Postal Service
CERTIFIED MAIL® RECEIPT
Domestic Mail Only

For delivery information, visit our website at www.usps.com®

OFFICIAL USE

Certified Mail Fee \$

Extra Services & Fees (check box, add fee as appropriate)

Return Receipt (hardcopy) \$

Return Receipt (electronic) \$

Certified Mail Restricted Delivery \$

Adult Signature Required \$

Adult Signature Restricted Delivery \$

Postage \$

Total Postage and Fees \$

USPS



Sent To
Bryden, Elizabeth
Street and Apt. No., or PO Box No.
120 Sunny Reach Dr
City, State, ZIP+4®
West Hartford, CT 06117

U.S. Postal Service™
CERTIFIED MAIL® RECEIPT
Domestic Mail Only

For delivery information, visit our website at www.usps.com®

OFFICIAL USE

Certified Mail Fee \$

Extra Services & Fees (check box, add fee as appropriate)

Return Receipt (hardcopy) \$

Return Receipt (electronic) \$

Certified Mail Restricted Delivery \$

Adult Signature Required \$

Adult Signature Restricted Delivery \$

Postage \$

Total Postage and Fees \$

USPS



Sent To
Head, Linda J
Street and Apt. No., or PO Box No.
90 Sunny Reach Dr.
City, State, ZIP+4®
West Hartford, CT 06107

U.S. Postal Service™
CERTIFIED MAIL® RECEIPT
Domestic Mail Only

For delivery information, visit our website at www.usps.com®

OFFICIAL USE

Certified Mail Fee \$

Extra Services & Fees (check box, add fee as appropriate)

Return Receipt (hardcopy) \$

Return Receipt (electronic) \$

Certified Mail Restricted Delivery \$

Adult Signature Required \$

Adult Signature Restricted Delivery \$

Postage \$

Total Postage and Fees \$

USPS



Sent To
Watkinson School
Street and Apt. No., or PO Box No.
1805 Bloomfield Ave
City, State, ZIP+4®
West Hartford, CT 06105

RUCC 6740 0002 4759 8085

U.S. Postal Service
CERTIFIED MAIL® RECEIPT
Domestic Mail Only

For delivery information, visit our website at www.usps.com®

OFFICIAL USE

Certified Mail Fee \$

Extra Services & Fees (check box, add fee as appropriate)

Return Receipt (hardcopy) \$

Return Receipt (electronic) \$

Certified Mail Restricted Delivery \$

Adult Signature Required \$

Adult Signature Restricted Delivery \$

Postage \$

Total Postage and Fees \$

USPS



Sent To
Daddy Eklun
Street and Apt. No., or PO Box No.
LOB Room 4036
City, State, ZIP+4®
West Hartford, CT 06106-1591

U.S. Postal Service™
CERTIFIED MAIL® RECEIPT
Domestic Mail Only

For delivery information, visit our website at www.usps.com®

OFFICIAL USE

Certified Mail Fee \$

Extra Services & Fees (check box, add fee as appropriate)

Return Receipt (hardcopy) \$

Return Receipt (electronic) \$

Certified Mail Restricted Delivery \$

Adult Signature Required \$

Adult Signature Restricted Delivery \$

Postage \$

Total Postage and Fees \$

USPS

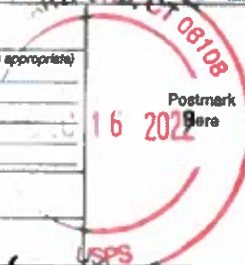

Sent To
Jarvis Parfield Trust
Street and Apt. No., or PO Box No.
195 Bloomfield Avenue
City, State, ZIP+4®
West Hartford, CT 06117

U.S. Postal Service™
CERTIFIED MAIL® RECEIPT
Domestic Mail Only

For delivery information, visit our website at www.usps.com®

OFFICIAL USE

Certified Mail Fee \$

Extra Services & Fees (check box, add fee as appropriate)

Return Receipt (hardcopy) \$

Return Receipt (electronic) \$

Certified Mail Restricted Delivery \$

Adult Signature Required \$

Adult Signature Restricted Delivery \$

Postage \$

Total Postage and Fees \$

USPS



Sent To
Edward Moeneka
Street and Apt. No., or PO Box No.
201 Bloomfield Ave
City, State, ZIP+4®
West Hartford, CT 06117

RUCC 6740 0002 4759 7811

RUCC 6740 0002 4759 8308

RUCC 6740 0002 4759 8085

1 2 3 4 5 6 7 8 9 10 11 12 13 14 15 16 17 18 19 20 21 22 23 24 25 26 27 28 29 30 31 32 33 34 35 36 37 38 39 40 41 42 43 44 45 46 47 48 49 50 51 52 53 54 55 56 57 58 59 60 61 62 63 64 65 66 67 68 69 70 71 72 73 74 75 76 77 78 79 80 81 82 83 84 85 86 87 88 89 90 91 92 93 94 95 96 97 98 99 100

U.S. Postal Service™
CERTIFIED MAIL™ RECEIPT
 (Domestic Mail Only; No Insurance Coverage Provided)
 For delivery information, visit our website at www.usps.com

OFFICIAL USE

Postage	\$
Certified Fee	
Return Receipt Fee (Endorsement Required)	
Restricted Delivery Fee (Endorsement Required)	
Total Postage & Fees	\$

Sent To: **Maly Rosado**
 Street, Apt. No., or PO Box No.: **550 Main St.**
 City, State, ZIP+4: **Hartford CT 06103**

PS Form 3800, August 2006 See Reverse for Instructions

7022 2410 0002 4759 7729

U.S. Postal Service
CERTIFIED MAIL® RECEIPT
 Domestic Mail Only
 For delivery information, visit our website at www.usps.com

OFFICIAL USE

Certified Mail Fee	\$
Extra Services & Fees (check box, add fee as appropriate)	
<input type="checkbox"/> Return Receipt (hardcopy)	\$
<input type="checkbox"/> Return Receipt (electronic)	\$
<input type="checkbox"/> Certified Mail Restricted Delivery	\$
<input type="checkbox"/> Adult Signature Required	\$
<input type="checkbox"/> Adult Signature Restricted Delivery	\$
Postage	\$
Total Postage and Fees	\$

Sent To: **Diana Vargas**
 Street and Apt. No., or PO Box No.: **100**
 City, State, ZIP+4: **Hartford CT 06106**

PS Form 3800, April 2015 PSN 7530-02-000-9047 See Reverse for Instructions

1 2 3 4 5 6 7 8 9 10 11 12 13 14 15 16 17 18 19 20 21 22 23 24 25 26 27 28 29 30 31 32 33 34 35 36 37 38 39 40 41 42 43 44 45 46 47 48 49 50 51 52 53 54 55 56 57 58 59 60 61 62 63 64 65 66 67 68 69 70 71 72 73 74 75 76 77 78 79 80 81 82 83 84 85 86 87 88 89 90 91 92 93 94 95 96 97 98 99 100

U.S. Postal Service™
CERTIFIED MAIL® RECEIPT
 Domestic Mail Only
 For delivery information, visit our website at www.usps.com

OFFICIAL USE

Certified Mail Fee	\$
Extra Services & Fees (check box, add fee as appropriate)	
<input type="checkbox"/> Return Receipt (hardcopy)	\$
<input type="checkbox"/> Return Receipt (electronic)	\$
<input type="checkbox"/> Certified Mail Restricted Delivery	\$
<input type="checkbox"/> Adult Signature Required	\$
<input type="checkbox"/> Adult Signature Restricted Delivery	\$
Postage	\$
Total Postage and Fees	\$

Sent To: **National Railroad Passenger Co.**
 Street and Apt. No., or PO Box No.: **250 Windsor St.**
 City, State, ZIP+4: **Hartford CT 06105**

PS Form 3800, April 2015 PSN 7530-02-000-9047 See Reverse for Instructions

7022 2410 0002 4759 7675

U.S. Postal Service™
CERTIFIED MAIL® RECEIPT
 Domestic Mail Only
 For delivery information, visit our website at www.usps.com

OFFICIAL USE

Certified Mail Fee	\$
Extra Services & Fees (check box, add fee as appropriate)	
<input type="checkbox"/> Return Receipt (hardcopy)	\$
<input type="checkbox"/> Return Receipt (electronic)	\$
<input type="checkbox"/> Certified Mail Restricted Delivery	\$
<input type="checkbox"/> Adult Signature Required	\$
<input type="checkbox"/> Adult Signature Restricted Delivery	\$
Postage	\$
Total Postage and Fees	\$

Sent To: **William Long**
 Street and Apt. No., or PO Box No.: **53 Elm St.**
 City, State, ZIP+4: **Hartford CT 06106**

PS Form 3800, April 2015 PSN 7530-02-000-9047 See Reverse for Instructions

1 2 3 4 5 6 7 8 9 10 11 12 13 14 15 16 17 18 19 20 21 22 23 24 25 26 27 28 29 30 31 32 33 34 35 36 37 38 39 40 41 42 43 44 45 46 47 48 49 50 51 52 53 54 55 56 57 58 59 60 61 62 63 64 65 66 67 68 69 70 71 72 73 74 75 76 77 78 79 80 81 82 83 84 85 86 87 88 89 90 91 92 93 94 95 96 97 98 99 100

U.S. Postal Service™
CERTIFIED MAIL® RECEIPT
 Domestic Mail Only
 For delivery information, visit our website at www.usps.com

OFFICIAL USE

Certified Mail Fee	\$
Extra Services & Fees (check box, add fee as appropriate)	
<input type="checkbox"/> Return Receipt (hardcopy)	\$
<input type="checkbox"/> Return Receipt (electronic)	\$
<input type="checkbox"/> Certified Mail Restricted Delivery	\$
<input type="checkbox"/> Adult Signature Required	\$
<input type="checkbox"/> Adult Signature Restricted Delivery	\$
Postage	\$
Total Postage and Fees	\$

Sent To: **City of Hartford Housing Authority**
 Street and Apt. No., or PO Box No.: **1530 Albany Ave**
 City, State, ZIP+4: **Hartford CT 06105**

PS Form 3800, April 2015 PSN 7530-02-000-9047 See Reverse for Instructions

7022 2410 0002 4759 7668

U.S. Postal Service™
CERTIFIED MAIL® RECEIPT
 Domestic Mail Only
 For delivery information, visit our website at www.usps.com

OFFICIAL USE

Certified Mail Fee	\$
Extra Services & Fees (check box, add fee as appropriate)	
<input type="checkbox"/> Return Receipt (hardcopy)	\$
<input type="checkbox"/> Return Receipt (electronic)	\$
<input type="checkbox"/> Certified Mail Restricted Delivery	\$
<input type="checkbox"/> Adult Signature Required	\$
<input type="checkbox"/> Adult Signature Restricted Delivery	\$
Postage	\$
Total Postage and Fees	\$

Sent To: **Comptroller Natalie Braswell**
 Street and Apt. No., or PO Box No.: **1600 4th Ave**
 City, State, ZIP+4: **Hartford CT 06106**

PS Form 3800, April 2015 PSN 7530-02-000-9047 See Reverse for Instructions

1 2 3 4 5 6 7 8 9 10 11 12 13 14 15 16 17 18 19 20 21 22 23 24 25 26 27 28 29 30 31 32 33 34 35 36 37 38 39 40 41 42 43 44 45 46 47 48 49 50 51 52 53 54 55 56 57 58 59 60 61 62 63 64 65 66 67 68 69 70 71 72 73 74 75 76 77 78 79 80 81 82 83 84 85 86 87 88 89 90 91 92 93 94 95 96 97 98 99 100

U.S. Postal Service
CERTIFIED MAIL® RECEIPT
 Domestic Mail Only

For delivery information, visit our website at www.usps.com®

OFFICIAL USE

Certified Mail Fee \$

Extra Services & Fees (check box, add fee as appropriate)

Return Receipt (hardcopy) \$

Return Receipt (electronic) \$

Certified Mail Restricted Delivery \$

Adult Signature Required \$

Adult Signature Restricted Delivery \$

Postage \$

Total Postage and Fees \$

Sent To
 The Hartford Financial Services Group, Inc.
 200 Bloomfield Ave.
 West Hartford, CT 06117

Postmark Here
 DEC 16 2022

PS Form 3800, April 2015 PSN 7530-02-000-9047 See Reverse for Instructions

7022 2430 0002 4759 7651

U.S. Postal Service
CERTIFIED MAIL® RECEIPT
 Domestic Mail Only

For delivery information, visit our website at www.usps.com®

OFFICIAL USE

Certified Mail Fee \$

Extra Services & Fees (check box, add fee as appropriate)

Return Receipt (hardcopy) \$

Return Receipt (electronic) \$

Certified Mail Restricted Delivery \$

Adult Signature Required \$

Adult Signature Restricted Delivery \$

Postage \$

Total Postage and Fees \$

Sent To
 Shawn J. Wroden
 35 Elm St
 West Hartford, CT 06106

Postmark Here
 DEC 16 2022

PS Form 3800, April 2015 PSN 7530-02-000-9047 See Reverse for Instructions

1 2 3 4 5 6 7 8 9 10 11 12 13 14 15 16 17 18 19 20 21 22 23 24 25 26 27 28 29 30 31 32 33 34 35 36 37 38 39 40 41 42 43 44 45 46 47 48 49 50 51 52 53 54 55 56 57 58 59 60 61 62 63 64 65 66 67 68 69 70 71 72 73 74 75 76 77 78 79 80 81 82 83 84 85 86 87 88 89 90 91 92 93 94 95 96 97 98 99 100

U.S. Postal Service™
CERTIFIED MAIL® RECEIPT
 Domestic Mail Only

For delivery information, visit our website at www.usps.com®

OFFICIAL USE

Certified Mail Fee \$

Extra Services & Fees (check box, add fee as appropriate)

Return Receipt (hardcopy) \$

Return Receipt (electronic) \$

Certified Mail Restricted Delivery \$

Adult Signature Required \$

Adult Signature Restricted Delivery \$

Postage \$

Total Postage and Fees \$

Sent To
 USPS
 Virginia Marie Terriotti
 123 Bloomfield Ave
 West Hartford, CT 06117

Postmark Here
 DEC 16 2022

PS Form 3800, April 2015 PSN 7530-02-000-9047 See Reverse for Instructions

7022 2430 0002 4759 7583

U.S. Postal Service™
CERTIFIED MAIL® RECEIPT
 Domestic Mail Only

For delivery information, visit our website at www.usps.com®

OFFICIAL USE

Certified Mail Fee \$

Extra Services & Fees (check box, add fee as appropriate)

Return Receipt (hardcopy) \$

Return Receipt (electronic) \$

Certified Mail Restricted Delivery \$

Adult Signature Required \$

Adult Signature Restricted Delivery \$

Postage \$

Total Postage and Fees \$

Sent To
 John Larson
 221 Main St
 West Hartford, CT 06106

Postmark Here
 DEC 16 2022

PS Form 3800, April 2015 PSN 7530-02-000-9047 See Reverse for Instructions

1 2 3 4 5 6 7 8 9 10 11 12 13 14 15 16 17 18 19 20 21 22 23 24 25 26 27 28 29 30 31 32 33 34 35 36 37 38 39 40 41 42 43 44 45 46 47 48 49 50 51 52 53 54 55 56 57 58 59 60 61 62 63 64 65 66 67 68 69 70 71 72 73 74 75 76 77 78 79 80 81 82 83 84 85 86 87 88 89 90 91 92 93 94 95 96 97 98 99 100

U.S. Postal Service™
CERTIFIED MAIL® RECEIPT
 Domestic Mail Only

For delivery information, visit our website at www.usps.com®

OFFICIAL USE

Certified Mail Fee \$

Extra Services & Fees (check box, add fee as appropriate)

Return Receipt (hardcopy) \$

Return Receipt (electronic) \$

Certified Mail Restricted Delivery \$

Adult Signature Required \$

Adult Signature Restricted Delivery \$

Postage \$

Total Postage and Fees \$

Sent To
 Veronica Pimental
 123 Bloomfield Ave
 West Hartford, CT 06117

Postmark Here
 DEC 16 2022

PS Form 3800, April 2015 PSN 7530-02-000-9047 See Reverse for Instructions

7020 0640 0000 3748 4045

U.S. Postal Service™
CERTIFIED MAIL® RECEIPT
 Domestic Mail Only

For delivery information, visit our website at www.usps.com®

OFFICIAL USE

Certified Mail Fee \$

Extra Services & Fees (check box, add fee as appropriate)

Return Receipt (hardcopy) \$

Return Receipt (electronic) \$

Certified Mail Restricted Delivery \$

Adult Signature Required \$

Adult Signature Restricted Delivery \$

Postage \$

Total Postage and Fees \$

Sent To
 RICK LEDWITH
 90 SOUTH MAIN ST
 WEST HARTFORD CT 06107

Postmark Here
 DEC 16 2022

PS Form 3800, April 2015 PSN 7530-02-000-9047 See Reverse for Instructions

RUCC 2740 0002 4759 7596

U.S. Postal Service
CERTIFIED MAIL® RECEIPT
Domestic Mail Only

For delivery information, visit our website at www.usps.com®

OFFICIAL USE

Certified Mail Fee \$

Extra Services & Fees (check box, add fee as appropriate)

Return Receipt (hardcopy) \$

Return Receipt (electronic) \$

Certified Mail Restricted Delivery \$

Adult Signature Required \$

Adult Signature Restricted Delivery \$

Postage \$

Total Postage and Fees \$



Send To
 Street and Apt. No., or PO Box No.
Jillion Gilchrist
Legislative Office Bldg Room 310
Hartford CT 06106-1594
 City, State, ZIP+4®

PS Form 3800, April 2015 PSN 7502-02-000-9017 See Reverse for Instructions

U.S. Postal Service™
CERTIFIED MAIL® RECEIPT
Domestic Mail Only

For delivery information, visit our website at www.usps.com®

OFFICIAL USE

Certified Mail Fee \$

Extra Services & Fees (check box, add fee as appropriate)

Return Receipt (hardcopy) \$

Return Receipt (electronic) \$

Certified Mail Restricted Delivery \$

Adult Signature Required \$

Adult Signature Restricted Delivery \$

Postage \$

Total Postage and Fees \$



Send To
 Street and Apt. No., or PO Box No.
Kate Farrer
LOB Room 4043
Hartford CT 06106-1594
 City, State, ZIP+4®

PS Form 3800, April 2015 PSN 7502-02-000-9017 See Reverse for Instructions

U.S. Postal Service™
CERTIFIED MAIL® RECEIPT
Domestic Mail Only

For delivery information, visit our website at www.usps.com®

OFFICIAL USE

Certified Mail Fee \$

Extra Services & Fees (check box, add fee as appropriate)

Return Receipt (hardcopy) \$

Return Receipt (electronic) \$

Certified Mail Restricted Delivery \$

Adult Signature Required \$

Adult Signature Restricted Delivery \$

Postage \$

Total Postage and Fees \$



Send To
 Street and Apt. No., or PO Box No.
Thomas Clarke II
550 Main St
Hartford CT 06103
 City, State, ZIP+4®

PS Form 3800, April 2015 PSN 7502-02-000-9017 See Reverse for Instructions

RUCC 2740 0002 4759 7576

U.S. Postal Service
CERTIFIED MAIL® RECEIPT
Domestic Mail Only

For delivery information, visit our website at www.usps.com®

OFFICIAL USE

Certified Mail Fee \$

Extra Services & Fees (check box, add fee as appropriate)

Return Receipt (hardcopy) \$

Return Receipt (electronic) \$

Certified Mail Restricted Delivery \$

Adult Signature Required \$

Adult Signature Restricted Delivery \$

Postage \$

Total Postage and Fees \$



Send To
 Street and Apt. No., or PO Box No.
Nick Lebron
550 Main St
Hartford CT 06103
 City, State, ZIP+4®

PS Form 3800, April 2015 PSN 7502-02-000-9017 See Reverse for Instructions

U.S. Postal Service™
CERTIFIED MAIL® RECEIPT
Domestic Mail Only

For delivery information, visit our website at www.usps.com®

OFFICIAL USE

Certified Mail Fee \$

Extra Services & Fees (check box, add fee as appropriate)

Return Receipt (hardcopy) \$

Return Receipt (electronic) \$

Certified Mail Restricted Delivery \$

Adult Signature Required \$

Adult Signature Restricted Delivery \$

Postage \$

Total Postage and Fees \$



Send To
 Street and Apt. No., or PO Box No.
Alana Hercules
550 Main St
Hartford CT 06103
 City, State, ZIP+4®

PS Form 3800, April 2015 PSN 7502-02-000-9017 See Reverse for Instructions

U.S. Postal Service™
CERTIFIED MAIL® RECEIPT
Domestic Mail Only

For delivery information, visit our website at www.usps.com®

OFFICIAL USE

Certified Mail Fee \$

Extra Services & Fees (check box, add fee as appropriate)

Return Receipt (hardcopy) \$

Return Receipt (electronic) \$

Certified Mail Restricted Delivery \$

Adult Signature Required \$

Adult Signature Restricted Delivery \$

Postage \$

Total Postage and Fees \$



Send To
 Street and Apt. No., or PO Box No.
John Gale
550 Main St.
Hartford CT 06103
 City, State, ZIP+4®

PS Form 3800, April 2015 PSN 7502-02-000-9017 See Reverse for Instructions

7022 2410 0002 4759 7596

7022 2410 0002 4759 7569

7022 2410 0002 4759 7576

7020 0640 0000 3748 4052
7020 0640 0000 3748 4586
7020 0640 0000 3748 4267

U.S. Postal Service
CERTIFIED MAIL® RECEIPT
Domestic Mail Only

For delivery information, visit our website at www.usps.com®.

OFFICIAL USE

Certified Mail Fee	\$
Extra Services & Fees (check box, add fee as appropriate)	
<input type="checkbox"/> Return Receipt (hardcopy)	\$
<input type="checkbox"/> Return Receipt (electronic)	\$
<input type="checkbox"/> Certified Mail Restricted Delivery	\$
<input type="checkbox"/> Adult Signature Required	\$
<input type="checkbox"/> Adult Signature Restricted Delivery	\$
Postage	\$
Total Postage and Fees	\$

Sent to **Mark Zydanowicz** USPS
Street and Apt. No., or PO Box No.
50 S. Main St.
City, State, ZIP+4®
West Hartford CT 06107

U.S. Postal Service™
CERTIFIED MAIL® RECEIPT
Domestic Mail Only

For delivery information, visit our website at www.usps.com®.

OFFICIAL USE

Certified Mail Fee	\$
Extra Services & Fees (check box, add fee as appropriate)	
<input type="checkbox"/> Return Receipt (hardcopy)	\$
<input type="checkbox"/> Return Receipt (electronic)	\$
<input type="checkbox"/> Certified Mail Restricted Delivery	\$
<input type="checkbox"/> Adult Signature Required	\$
<input type="checkbox"/> Adult Signature Restricted Delivery	\$
Postage	\$
Total Postage and Fees	\$

Sent to **Shirley Surgeon**
Street and Apt. No., or PO Box No.
550 Main St
City, State, ZIP+4®
Hartford CT 06103

U.S. Postal Service™
CERTIFIED MAIL® RECEIPT
Domestic Mail Only

For delivery information, visit our website at www.usps.com®.

OFFICIAL USE

Certified Mail Fee	\$
Extra Services & Fees (check box, add fee as appropriate)	
<input type="checkbox"/> Return Receipt (hardcopy)	\$
<input type="checkbox"/> Return Receipt (electronic)	\$
<input type="checkbox"/> Certified Mail Restricted Delivery	\$
<input type="checkbox"/> Adult Signature Required	\$
<input type="checkbox"/> Adult Signature Restricted Delivery	\$
Postage	\$
Total Postage and Fees	\$

Sent to **Mary Fay** USPS
Street and Apt. No., or PO Box No.
50 SOUTH MAIN ST
City, State, ZIP+4®
WEST HARTFORD CT 06107

PS Form 3800, April 2015 PSN 7530-02-000-9747 See Reverse for Instructions

U.S. Postal Service
CERTIFIED MAIL® RECEIPT
Domestic Mail Only

For delivery information, visit our website at www.usps.com®.

OFFICIAL USE

Certified Mail Fee	\$
Extra Services & Fees (check box, add fee as appropriate)	
<input type="checkbox"/> Return Receipt (hardcopy)	\$
<input type="checkbox"/> Return Receipt (electronic)	\$
<input type="checkbox"/> Certified Mail Restricted Delivery	\$
<input type="checkbox"/> Adult Signature Required	\$
<input type="checkbox"/> Adult Signature Restricted Delivery	\$
Postage	\$
Total Postage and Fees	\$

Sent to **DURNE MARTIN** USPS
Street and Apt. No., or PO Box No.
50 SOUTH MAIN ST
City, State, ZIP+4®
WEST HARTFORD CT 06107

U.S. Postal Service™
CERTIFIED MAIL® RECEIPT
Domestic Mail Only

For delivery information, visit our website at www.usps.com®.

OFFICIAL USE

Certified Mail Fee	\$
Extra Services & Fees (check box, add fee as appropriate)	
<input type="checkbox"/> Return Receipt (hardcopy)	\$
<input type="checkbox"/> Return Receipt (electronic)	\$
<input type="checkbox"/> Certified Mail Restricted Delivery	\$
<input type="checkbox"/> Adult Signature Required	\$
<input type="checkbox"/> Adult Signature Restricted Delivery	\$
Postage	\$
Total Postage and Fees	\$

Sent to **Don Wondral**
Street and Apt. No., or PO Box No.
50 S. Main St
City, State, ZIP+4®
West Hartford, CT 06107

U.S. Postal Service™
CERTIFIED MAIL® RECEIPT
Domestic Mail Only

For delivery information, visit our website at www.usps.com®.

OFFICIAL USE

Certified Mail Fee	\$
Extra Services & Fees (check box, add fee as appropriate)	
<input type="checkbox"/> Return Receipt (hardcopy)	\$
<input type="checkbox"/> Return Receipt (electronic)	\$
<input type="checkbox"/> Certified Mail Restricted Delivery	\$
<input type="checkbox"/> Adult Signature Required	\$
<input type="checkbox"/> Adult Signature Restricted Delivery	\$
Postage	\$
Total Postage and Fees	\$

Sent to **Joseph Dakers** USPS
Street and Apt. No., or PO Box No.
50 S. Main St
City, State, ZIP+4®
West Hartford, CT 06107

PS Form 3800, April 2015 PSN 7530-02-000-9747 See Reverse for Instructions

7017 0190 0001 1555 6356

U.S. Postal Service
CERTIFIED MAIL® RECEIPT
 Domestic Mail Only

For delivery information, visit our website at www.usps.com®.

OFFICIAL USE

Certified Mail Fee
 \$

Extra Services & Fees (check box, add fee as appropriate)

<input type="checkbox"/> Return Receipt (hardcopy)	\$
<input type="checkbox"/> Return Receipt (electronic)	\$
<input type="checkbox"/> Certified Mail Restricted Delivery	\$
<input type="checkbox"/> Adult Signature Required	\$
<input type="checkbox"/> Adult Signature Restricted Delivery	\$

Postage
 \$

Total Postage and Fees
 \$

Postmark Here
 DEC 16 2022

HARTFORD, CT 06108

USPS

To
 Todd Domais
 Street and Apt. No., or PO Box No.
 50 S. Main St
 West Hartford, CT 06117

PS Form 3800, April 2015 PSN 7530-02-000-90-7 See Reverse for Instructions

7020 0640 0000 3748 4571

U.S. Postal Service™
CERTIFIED MAIL® RECEIPT
 Domestic Mail Only

For delivery information, visit our website at www.usps.com®.

OFFICIAL USE

Certified Mail Fee
 \$

Extra Services & Fees (check box, add fee as appropriate)

<input type="checkbox"/> Return Receipt (hardcopy)	\$
<input type="checkbox"/> Return Receipt (electronic)	\$
<input type="checkbox"/> Certified Mail Restricted Delivery	\$
<input type="checkbox"/> Adult Signature Required	\$
<input type="checkbox"/> Adult Signature Restricted Delivery	\$

Postage
 \$

Total Postage and Fees
 \$

Postmark Here
 DEC 16 2022

HARTFORD, CT 06108

USPS

To
 Alberto Cortez
 Street and Apt. No., or PO Box No.
 50 S. Main St
 West Hartford, CT 06117

PS Form 3800, April 2015 PSN 7530-02-000-90-7 See Reverse for Instructions

Attachment #17

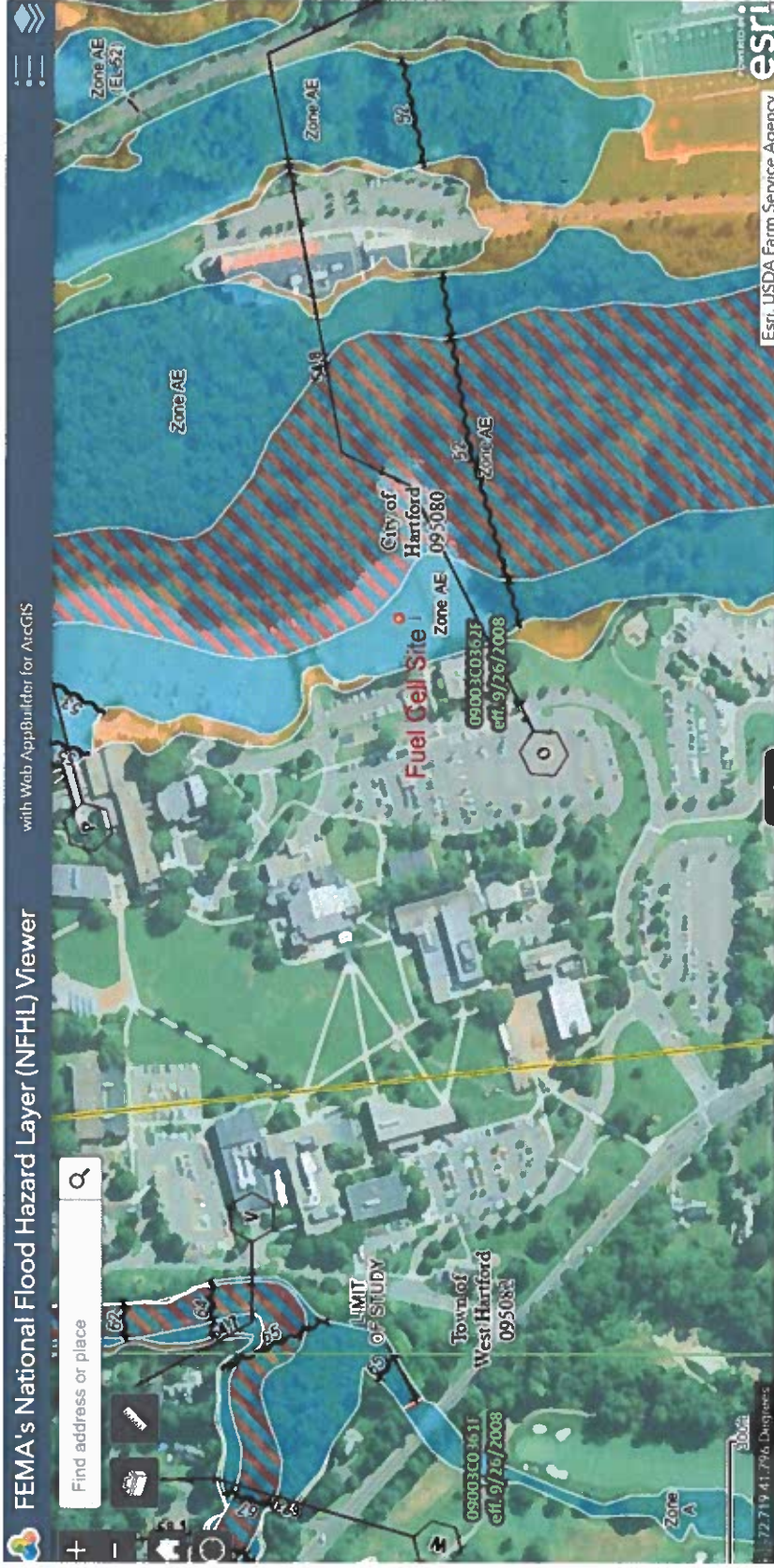

PureCell Model 400 Fuel Processing System (FPS)

The FPS converts pipeline-quality natural gas into hydrogen reformato – a hydrogen-rich gas that is delivered to the anode side of the fuel cell stacks. This module includes a condenser to recover water generated in the fuel cell reaction by condensing water vapor from the process exhaust. This eliminates the need for makeup water under most operating conditions. The recovered water is used in the steam reformation process. The main components of the FPS include the following:

Hydro-Desulfurizer

The desulfurizer system removes sulfur used as an odorant in natural gas, which is a poison to the catalysts used in the fuel cell systems. Sulfur is converted to zinc-sulfide, a non-hazardous waste, within the desulfurizer and remains there until an overhaul is required, nominally after 10 years. This system will also remove small amounts of oxygen in the gas.

Steam Reformer

Steam (H₂O) generated in the cell stack cooling loop of the TMS is combined in the reformer with methane (CH₄) in the natural gas to generate a gas composed of hydrogen (H₂), carbon monoxide (CO), and carbon dioxide (CO₂)

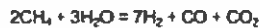

Equation 1

Integrated Low-Temperature Shift Converter

The integrated low-temperature shift converter (ILS) generates additional hydrogen through a water-gas reaction in which CO and water is converted to hydrogen and CO₂. The reduced CO content minimizes its adverse effect on fuel cell stack performance.



Equation 2

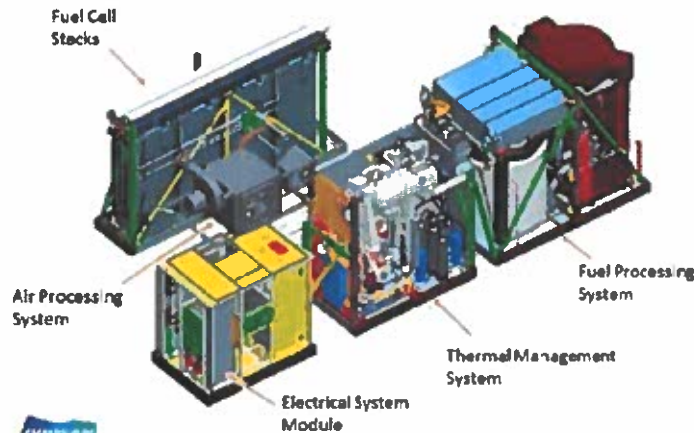

Figure 1. PureCell Model 400 Subsystems