



STATE OF CONNECTICUT
CONNECTICUT SITING COUNCIL

Ten Franklin Square, New Britain, CT 06051

Phone: (860) 827-2935 Fax: (860) 827-2950

E-Mail: siting.council@ct.gov

Web Site: portal.ct.gov/csc

VIA ELECTRONIC MAIL

March 30, 2023

Kristen Grillo
Bloom Energy Corporation
4353 North First Street
San Jose, CA 95134
Kristen.Grillo@bloomenergy.com

RE: **PETITION NO. 1509** - Bloom Energy Corporation declaratory ruling, pursuant to Connecticut General Statutes §4-176 and §16-50k, for the proposed construction, maintenance and operation of a customer-side 300-kilowatt fuel cell facility and associated equipment to be located at Park Avenue Medical Center, 5520 Park Avenue, Trumbull, Connecticut.

Dear Kristen Grillo:

The Connecticut Siting Council (Council) is in receipt of the notification for pipe cleaning procedure dated March 29, 2023 regarding compliance with Condition No. 5 of the Council's Declaratory Ruling of June 24, 2022 for the above-referenced facility.

The Council acknowledges that the condition has been satisfied. This acknowledgment applies only to the condition satisfied by the March 29, 2023 correspondence.

Please be advised that deviations from the standards established by the Council in the Declaratory Ruling are enforceable under the provisions of Connecticut General Statutes §16-50u.

Thank you for your attention and cooperation.

Sincerely,

Melanie A. Bachman
Executive Director

MB/RDM/laf

From: Kristen Grillo <Kristen.Grillo@bloomenergy.com>
Sent: Wednesday, March 29, 2023 11:35 AM
To: CSC-DL Siting Council <Siting.Council@ct.gov>
Subject: PE1509 - Bloom Energy Fuel Cell Installation, 5520 Park Avenue, TrumbullCT- Letter of Notification for Pipe Cleaning Procedures

Good morning,

Per condition #4 & #5 cited in Siting Council Declaratory Ruling Letter for Petition #PE1509, please find the attached Letter of Notification for pipe cleaning procedures to be performed at the Park Avenue Medical Center's Bloom Energy Fuel Cell Installation site, located at 5520 Park Avenue in Trumbull, CT.

If you should have any questions or require further information, please don't hesitate to contact me.

Thank you for your time.



Kristen Grillo

Senior Permitting Specialist | East Coast Field Office
Customer Installations Group | North America
(917) 803-4511

Kristen.Grillo@bloomenergy.com

Bloom Energy Corporation
4353 North First Street, San Jose, CA 95134
(408) 543-1500
www.bloomenergy.com

March 29th, 2023

Melanie Bachman, Esq.
Executive Director
Connecticut Siting Council
10 Franklin Square
New Britain, CT 06051

RE: PETITION NO. 1509 - Bloom Energy Corporation petition for a declaratory ruling, pursuant to Connecticut General Statutes §4-176 and §16-50k, for the proposed construction, maintenance and operation of a customer-side 300-kilowatt fuel cell facility and associated equipment to be located at Park Avenue Medical Center, 5520 Park Avenue, Trumbull, Connecticut.

Dear Ms. Bachman:

At a public meeting held on June 23, 2022, the Connecticut Siting Council (Council) considered and ruled that the above-referenced proposal meets air and water quality standards of the Department of Energy and Environmental Protection and would not have a substantial adverse environmental effect, and pursuant to Connecticut General Statutes § 16-50k would not require a Certificate of Environmental Compatibility and Public Need with certain conditions. As requested in the declaratory ruling, the following information is being provided not less than 15 days prior to any fuel pipe cleaning operations related to the fuel cell construction, installation, or modification:

4. The use of natural gas as a fuel system cleaning medium during fuel cell construction, installation or modification shall be prohibited;

- Bloom Energy uses an inert gas (Nitrogen) to handle cleaning the fuel system during construction, installation, or modification of its fuel cell projects.

5. Submit the following information to the Council 15 days prior to any fuel pipe cleaning operations related to fuel cell construction, installation, or modification:

- Pipe cleaning operations occur during the commissioning state of the project. A copy of the “Gas System Commissioning” standard operating procedure (SOP) is provided as Exhibit 1. The information below derives from this SOP.

a. Identification of the cleaning media to be used;

Nitrogen is the cleaning media to be used.



Bloom Energy Corporation
4353 North First Street, San Jose, CA 95134
408 543 1500
www.bloomenergy.com

What Powers You

- b. **Identification of any known hazards through use of the selected cleaning media;**
Nitrogen is selected as a cleaning media as it is inherently safe, however there are hazards in dealing with any high pressure gas including operating the equipment, debris existing in the lines during the cleaning process, high noise, and typical construction site hazards.
- c. **Description of how known hazards will be mitigated, including identification of any applicable state or federal regulations concerning hazard mitigation measures for such media;**
Bloom Energy and its contractors will proceed in accordance to the provided method of procedure in addition to compliance with OSHA and NFPA Standards. Compressed Nitrogen will be transported and handled in compliance with all federal, state, and local codes, PPE will be worn at all times and areas of hazard will be barricaded off.
- d. **Identification and description of accepted industry practices or relevant regulations concerning the proper use of such media;**
OSHA, NFPA 54, NFPA 56, NFPA 853, ASME B31 and DOT Title 49.
- e. **Provide detailed specifications (narratives/drawings) indicating the location and procedures to be used during the pipe cleaning process, including any necessary worker safety exclusion zones;**
- Ensure all PPE is in place:
Min requirements: Safety glasses, gloves, hardhat, high visibility clothing, safety shoes, hearing protection, combustible gas monitor, and oxygen monitor.
 - Set up barricades around all above ground points of the fuel line to be cleaned and ensure all non-essential personal removed. Areas to be barricaded and where cleaning to take place shown on the below fuel piping schematic.

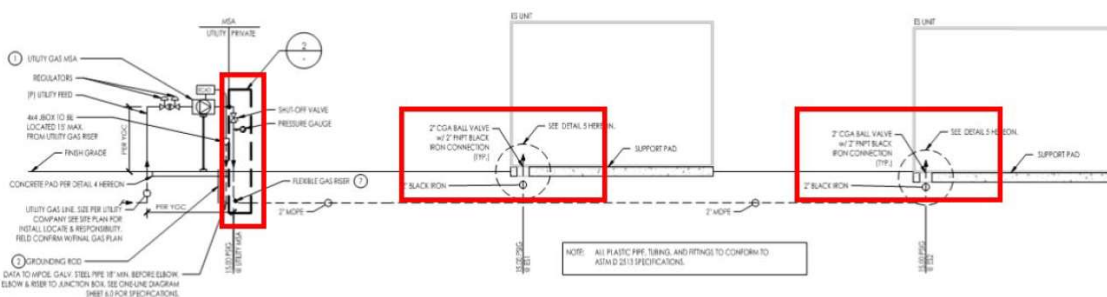

CLEAN ENERGY SERVER NATURAL GAS SUPPLY DIAGRAM



Bloom Energy Corporation
4353 North First Street, San Jose, CA 95134
408 543 1500
www.bloomenergy.com

What Powers You

- Ensure all fuel system valves closed and isolate the incoming utility gas valve and the fuel cell gas meter.
- Connect Nitrogen gas bottle through a regulator downstream of the incoming gas utility valve at the fuel cell gas meter.
- Connect vent hoses at the fuel cell gas connections and open valves as required to allow flow from the Nitrogen gas bottle through the fuel system plumbing to clean out system of moisture and residual debris.
- Monitor combustible gas levels and oxygen levels on all personal during cleaning process. Closes valves and halt the cleaning process and notify the process supervisor if the combustible gas levels exceed 25% of LEL (Lower Explosive Limit) or if the oxygen levels fall below 19.5%.
- Remove vent hoses from the fuel cell gas connection and close the valves at the fuel cell connections.
- Remove the Nitrogen gas bottle and regulator from the fuel cell gas meter.

f. Identification of the contractor or personnel performing the work, including a description of past project experience and the level of training and qualifications necessary for performance of the work;

Employees of Bloom Energy will oversee and perform the procedures detailed in the Gas System Commissioning procedure. Bloom Energy has safely commissioned more than 200 fuel cell installation projects in California, New York, New Jersey, Delaware and Connecticut. The required safety trainings to complete this procedure include:

- Natural Gas Safety
- Compressed Nitrogen Safety
- Fire Extinguisher Safety
- Combustible Gas Indicator Operation
- Corporate Control of Hazardous Energies

g. Contact information for a special inspector hired by the project developer who is a Connecticut Registered Engineer with specific knowledge and experience regarding electric generating facilities or a National Board of Boiler and Pressure Vessel Inspector and written approval of such special inspector by the local fire marshal and building inspector; and

- Richard Gregoire, P.E.
IDEA Engineering, Inc.
612 Wheelers Farms Road, 1st Fl
Milford CT 06464
T: (203) 671-7021
CT License No. 16221



Bloom Energy Corporation
4353 North First Street, San Jose, CA 95134
408 543 1500
www.bloomenergy.com

What Powers You

- h. Certification of notice regarding pipe cleaning operations to all state agencies listed in General Statutes § 16-50j(h) and to the Department of Consumer Protection, Department of Labor, Department of Public Safety, Department of Public Works, and the Department of Emergency Management and Homeland Security;

Bloom Energy has provided notice via Certified Mail (Exhibit 3) to the following agencies:

- Department of Energy and Environmental Protection
- Department of Public Utility Regulatory Authority
- Department of Public Health Protection
- Council on Environmental Quality
- Department of Agriculture
- Office of Policy and Management
- Department of Transportation
- Department of Economic and Community Development
- Division of Emergency Management and Homeland Security (DEMHS)
- Department of Consumer Protection
- Department of Administrative Services
- Department of Labor

Respectfully,



Kristen Grillo

Senior Permitting Specialist | East Coast Field Office

Customer Installations Group | North America

(917) 803-4511

Kristen.Grillo@bloomenergy.com



Bloom Energy Corporation
4353 North First Street, San Jose, CA 95134
408 543 1500
www.bloomenergy.com

Exhibit 1

Gas System Commissioning – N2

DOC-1010208

Revision A

Estimated Evolution Time: 2 hrs

Number of Personnel: 2 Total

1 Inlet Attendant &

1 Discharge Attendant

Gas System Commissioning - Nitrogen



DOC-1010208 Rev A

Purpose

- This procedure intends to provide a clear process for CIG field workers ensuring natural gas delivery to site within Bloom Energy Specifications. More specifically, the objective of this procedure is to:
 - Ensure Compliance with:
 - NFPA 54 National Fuel Gas Code
 - OSHA and CalOSHA construction safety standards
 - Title 49 of the Code of Federal Regulations (DOT) safety standards
 - Regional Air Quality Management Board Regulations
 - Bloom Energy's Critical to Quality Standards, especially regarding
 - Gas piping system blow-down and purging standards
 - Only valid in the state of CT

Scope

- This procedure applies to all US BE construction sites in Connecticut.

Audience

- 1 CDA Input attendant (general or sub-contractor)
- 1 Discharge Attendant (Bloom Qualified Gas Personnel)

Applicable Documents

- NFPA 54
- DOC-1007152 SVC
- DOC-1009468 – Gas System Commissioning - CDA

Gas System Commissioning - Nitrogen



DOC-1010208 Rev A

Preliminary Requirements

Required Safety Trainings

- Bloom personnel on site must be documented as Bloom Energy (BE) Qualified Gas System Personnel, which includes:
 - Pipeline Safety
 - Compressed Gas Safety
 - LOTO
 - Valve Safety

Required Personal Protection Equipment (PPE)

- Safety glasses
- Gloves
- Hard hat
- High visibility clothing
- Work boots with safety toe protection

Special Precautions and Potential Hazards

- Verify fuel plumbing has been pressure tested for leaks by the utility and general contractor before executing this SOP (House Line Release).
- Oxygen monitoring is required for this operation.

Required Tools, Materials, and Equipment

- YFP Purge Hose (124422)
- House line installed
- Multi-Gas Monitor: minimum detection of Oxygen and Methane LEL
- Adjustable Wrench Set and/or two (2) Pipe Wrenches
- Gas Sampling Kit (BE# 131263)
- Caution tape and delineators
- Fire Extinguisher (2A or better).
 - This should already be on site.
- Filled Nitrogen Tank
 - QTY 1 approximately 75 Cu. Ft tank per 250 linear feet of 2" gas line (Praxair part NI-Q or equivalent)
 - QTY 1 approximately 140 Cu. Ft tank per 500 linear feet of 2" gas line (Praxair part NI-S or equivalent)

Gas System Commissioning - Nitrogen

Section A: Nitrogen Purge of Construction Plumbing

1. Site Setup

- 1.1. Ensure all customer protocols are met and scheduled accordingly
 - 1.1.1. Multiple RSA on the same site requires a dedicated MOP, using this procedure as a guide.
- 1.2. Put On PPE.
- 1.3. Turn on personal gas monitor(s) and attach to the person(s) at the discharge location.
- 1.4. Set up cones and caution tape to establish a discharge area around the fuel stub up farthest from the MSA with a 10 foot radius around the point of discharge. Remove all non-essential personnel.
 - 1.4.1. Ensure that there will be no open flame within 50 ft
- 1.5. Ensure a 2A or better fire extinguisher is located within 50 feet of the discharge area.
- 1.6. Verify Each Fuel stub up valve is in the closed position (at YFP, and Upstream facilities valve, where applicable and shut each fuel stub up valve. See Figure 1.

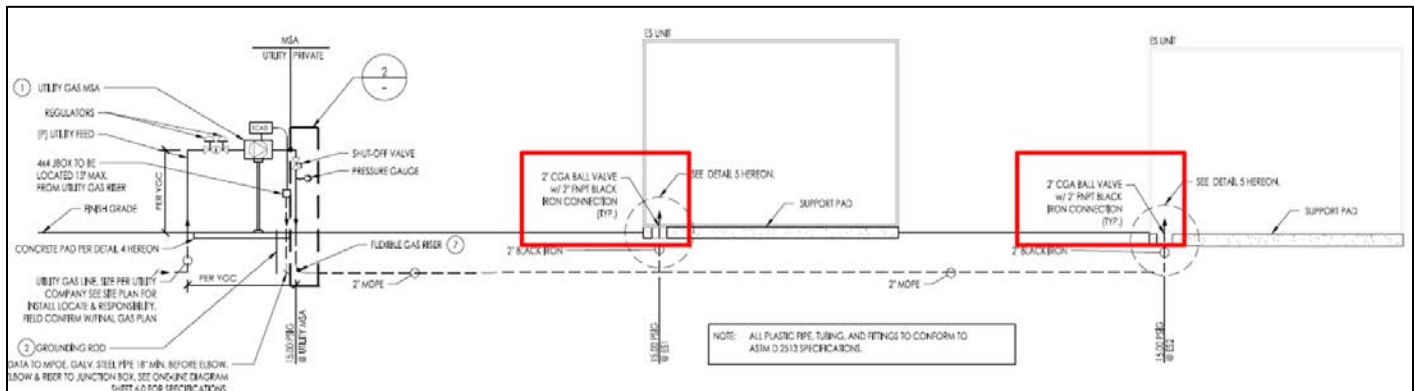

Figure 1

Gas System Commissioning - Nitrogen

1.7. Identify Isolation valves on meter assembly.

1.8. Ensure all shut off valves are open between MSA and ESS and the stub-up valves are closed.

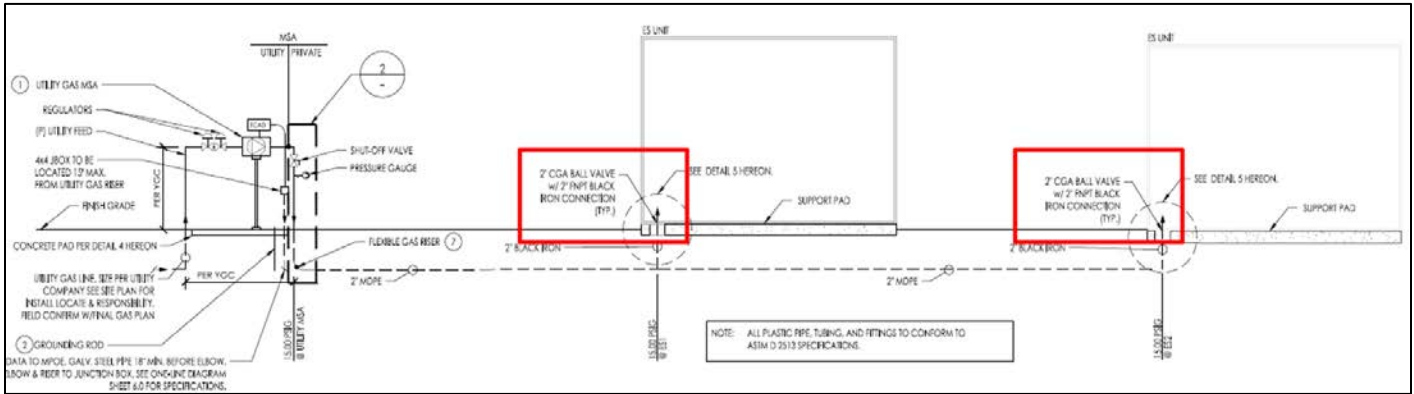

Figure 2

a. If a YBB, reach out to the Construction Program Manager. Future instructions will go here. See Figure 3.

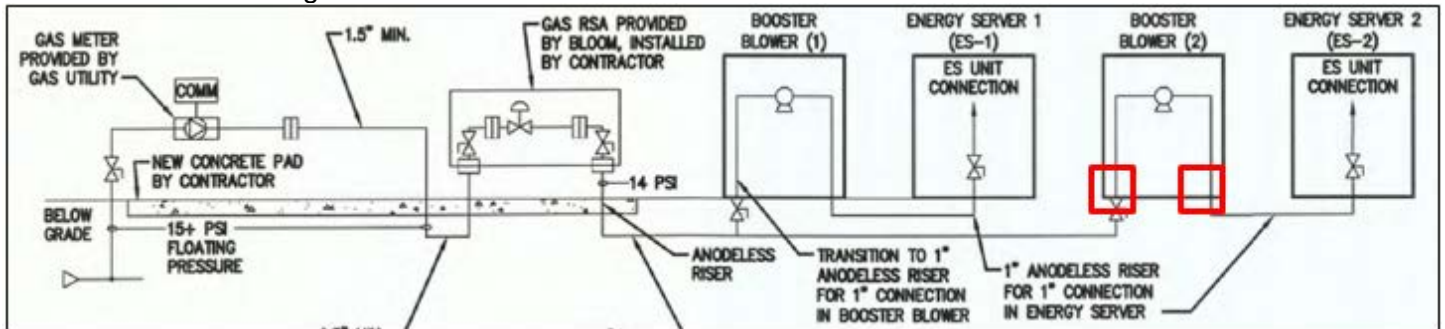

Figure 3

Gas System Commissioning - Nitrogen

2. Follow the gas line from the MSA (or MSA gap) to the isolation valve on the stub up.
 - 2.1. Identify Isolation valve on meter assembly.
 - 2.2. Determine if gas pressure is available to the plumbing being purged, apply a LOTO to isolate gas if required.
 - 2.3. Perform a valve lineup to achieve the following:
 - 2.3.1. Meter Isolation valve is shut
 - 2.3.2. System gas stub up valve is shut
 - 2.3.3. All other valves between the meter isolation and system gas stub up are open
 - 2.3.3.1. If Parallel regulators, ensure only one set open, close isolations to the other set of regulators

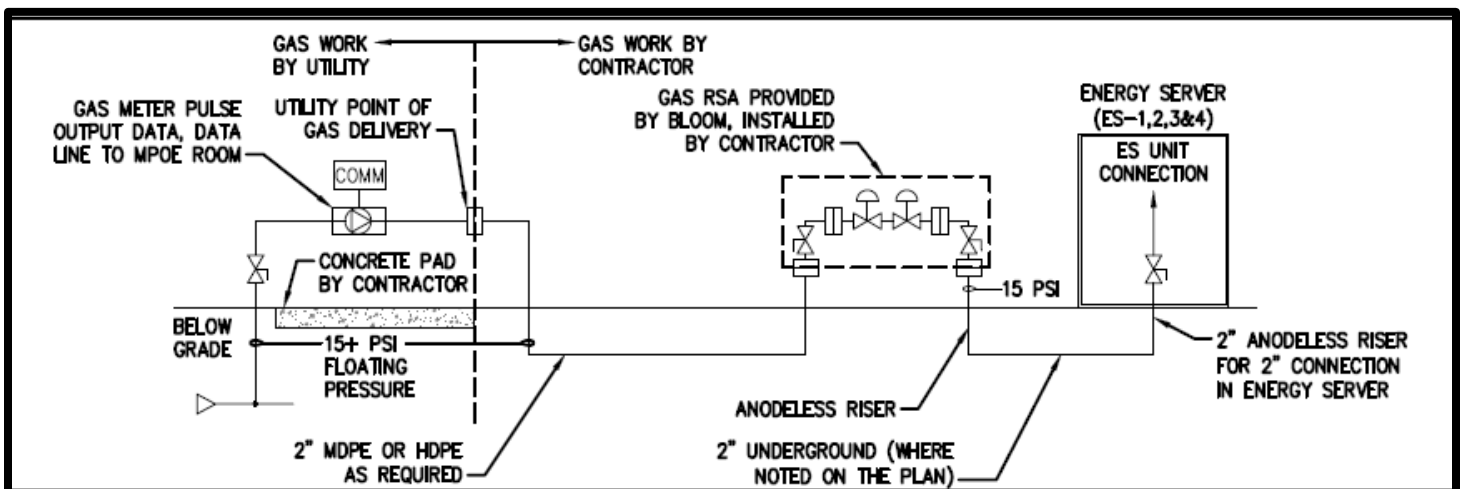

Figure 4

3. General/Subcontractor connects the supply of Nitrogen to the furthest point upstream without interfering with the Gas Utility scope of work.
4. Position Discharge Attendant with air monitor at the point of discharge.

Gas System Commissioning - Nitrogen



DOC-1010208 Rev A

5. Connect YFP Purge Hose.
 - 5.1. Disconnect YFP from the fuel stub up, if connected
 - 5.2. Attach YFP purge hose to fuel stub up
 - 5.3. Attach YFP purge hose to overhead QDC
6. Inlet attendant supplies intended operational system pressure (min of 60 PSI) to plumbing and corrects any leaks.
7. Once pressure holds, the Discharge Attendant slowly opens all valves between the Nitrogen supply and the discharge assembly
8. Discharge attendant then opens the discharge assembly full open
 - 8.1. Continuously monitor the discharge area for the following and create an incident report if any are found:
 - 8.1.1. Debris
 - 8.1.2. Liquid water
 - 8.1.3. Gas other than compressed air
 - 8.1.4. Discharge attendant shall continuously monitor the discharge area and be prepared to secure the flow.
9. Let Nitrogen flow through the purge assembly for 60 seconds, then secure for 60 seconds.
 - 9.1. Perform at least 6 on/off cycles (6 cycles per 200 ft. of underground pipe)
10. Close the stub up isolation valve
11. If part of the assembly, remove the purge hose Y strainer
 - 11.1. If debris found, take pictures, clean and log an incident.
12. Reinstall "y" strainer.
13. If the Gas stick is provided by Bloom, perform Section B, if it is provided by the utility (fixed pressure) Move to Section C

Section B: Setting the Bloom Gas Regulators

1. Possible Bloom Gas Stick Setups:

1.1. Dual Regulator (two regulators on a single run of pipe)

1.1.1. Perform Section B as written

1.2. Dual Parallel (four regulators on two runs of pipe)

1.2.1. Perform Section B once for each set

1.2.2. Ensure that the set not being used is isolated

1.3. Single Regulator (one regulator on a single run of pipe)

1.3.1. Follow instructions for the upstream regulator only

2. Di Discharge Attendant throttles open the discharge valve as little as possible while still discharging air.

3. Contract Plumber will throttle the compressed gas regulator to achieve delivery pressure (min of 60PSI) on pressure gauge upstream of the regulator set.

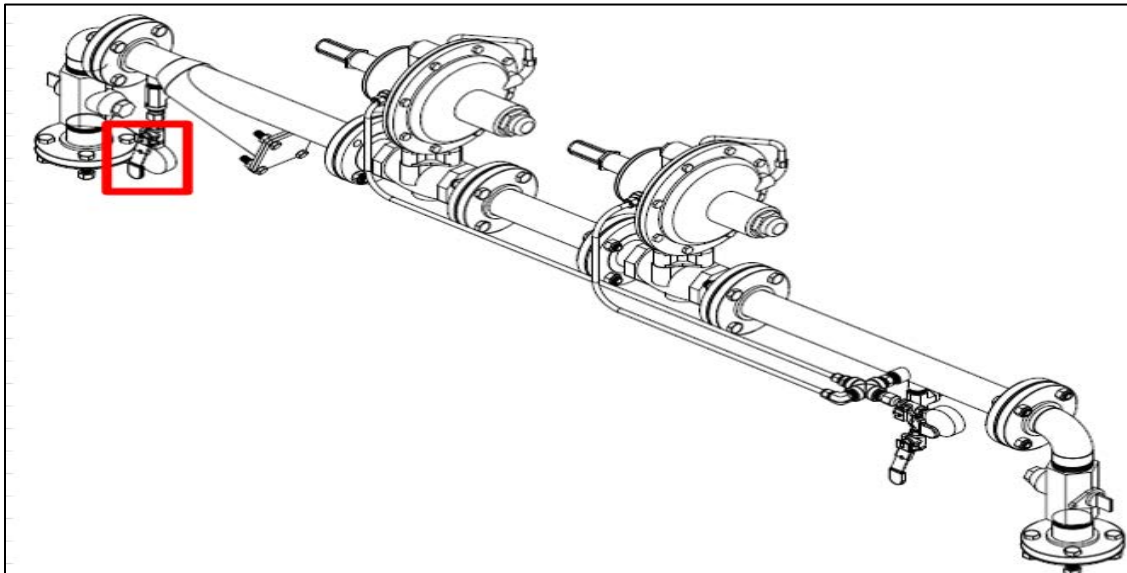

Figure 10

Gas System Commissioning - Nitrogen

4. Discharge Attendant closes the valve on the vent assembly.
5. Remove the gray plastic covers from the Main Body Pilot adjustment screw from both regulators. Leave the cover on the small independent series 67 pilot assembly alone. See Figure 11.

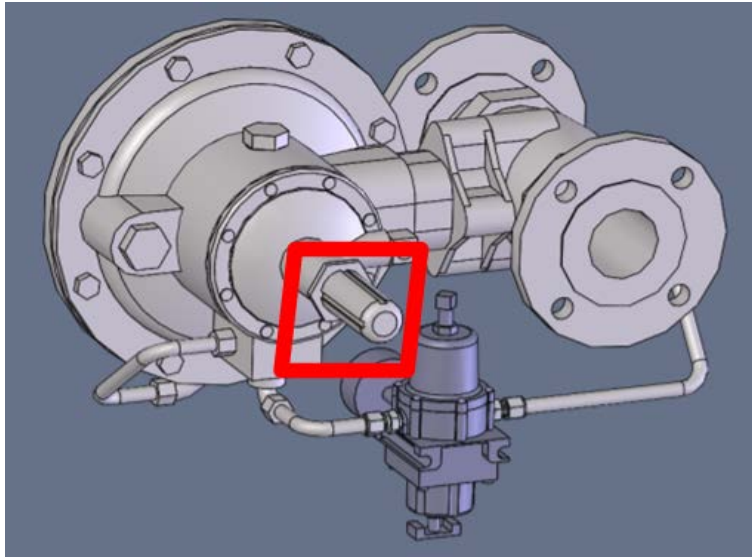

Figure 11

6. Turn the **Main Body Pilot** on the **upstream** regulator fully counter clockwise to stop any flow of gas.
 7. Turn the **Main Body Pilot** on the **downstream** regulator clockwise so the regulator is fully open.
- 7.1. If single regulator, ignore all **downstream** regulator instructions

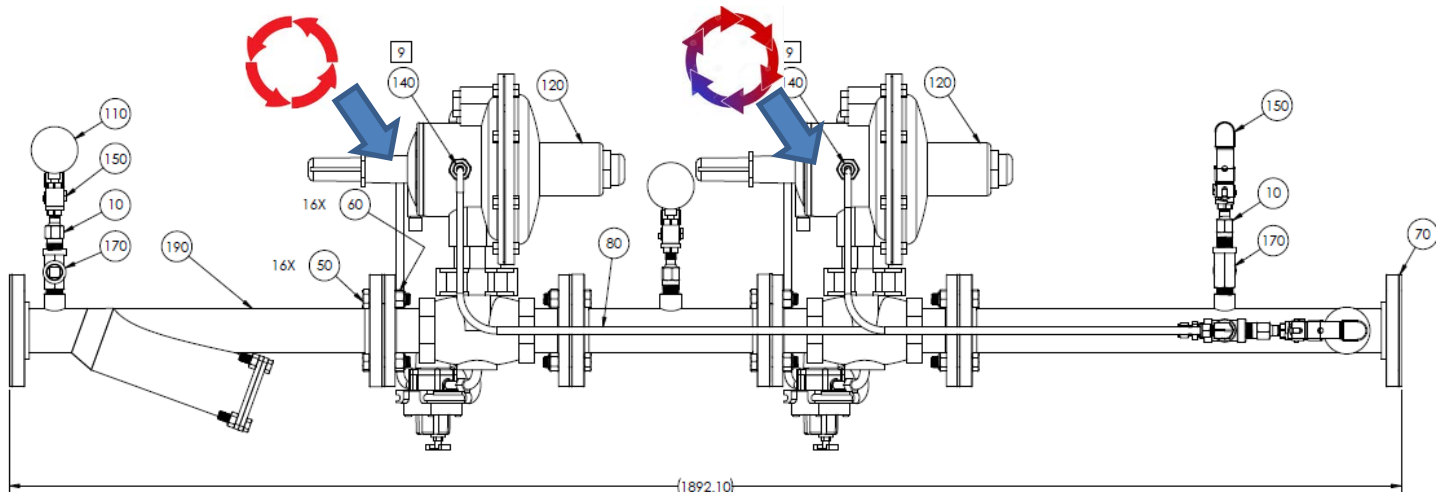

Figure 12

Gas System Commissioning - Nitrogen

8. Crack open the discharge valve just enough so that the flow of air can be heard or felt.



Figure 13

9. Adjust the **Upstream** regulator first.

10. On the **Main Body Pilot** assembly, turn the adjusting screw clockwise to increase outlet pressure to achieve **18** psi as read on a gauge as far downstream as possible.

- 10.1. Be sure to adjust slowly to allow system pressure to stabilize after adjustment.

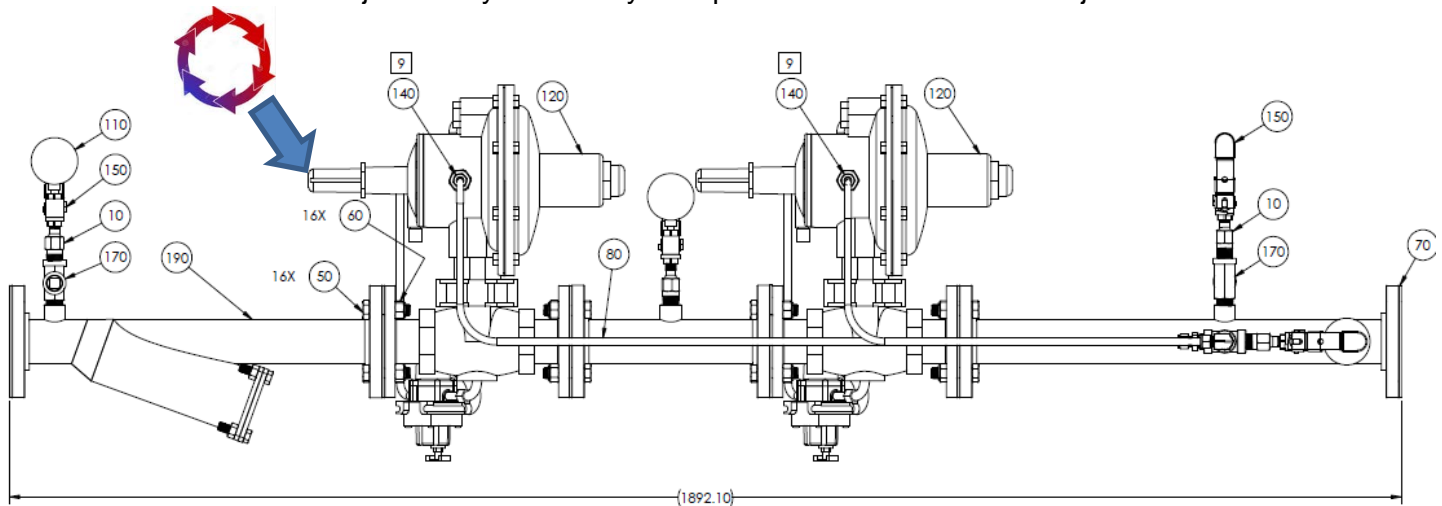

Figure 14

Gas System Commissioning - Nitrogen

11. Adjust the **downstream** regulator second

11.1. On the **Main Body Pilot** assembly, turn the adjusting screw clockwise to increase outlet pressure or counterclockwise to decrease outlet pressure to achieve **15 psi** as read as far downstream as possible.

11.2. Be sure to wait for system pressure to change.

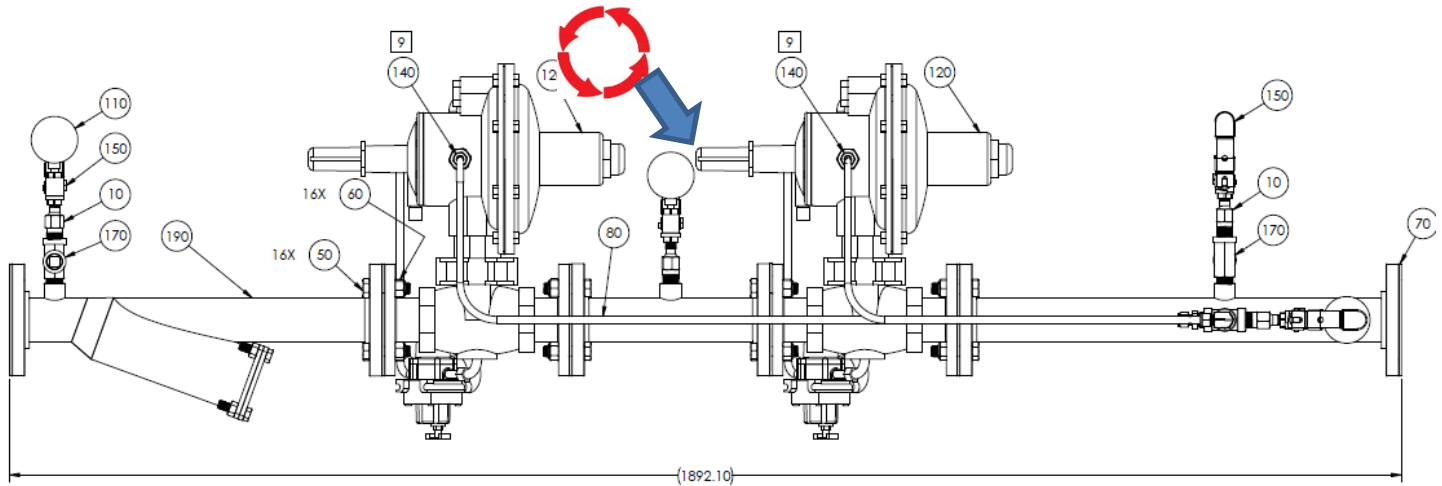

Figure 15

12. If the pressure on the upstream RSA riser gauge drops below expected delivery pressure at any time during the procedure, **STOP**, and re-pressurize the line and consider throttling down on the discharge valve.

13. Close the vent assembly valve.

Gas System Commissioning - Nitrogen

14. If the gas stick is a dual parallel set and this is the first set dialed in, do the following (skip to next step if not):
 - 14.1. Isolate the dialed in set with the valves provided on the turndown
 - 14.2. Open the isolation valves for the pair that has not yet been set
 - 14.3. Repeat Section B for the second set of regulators

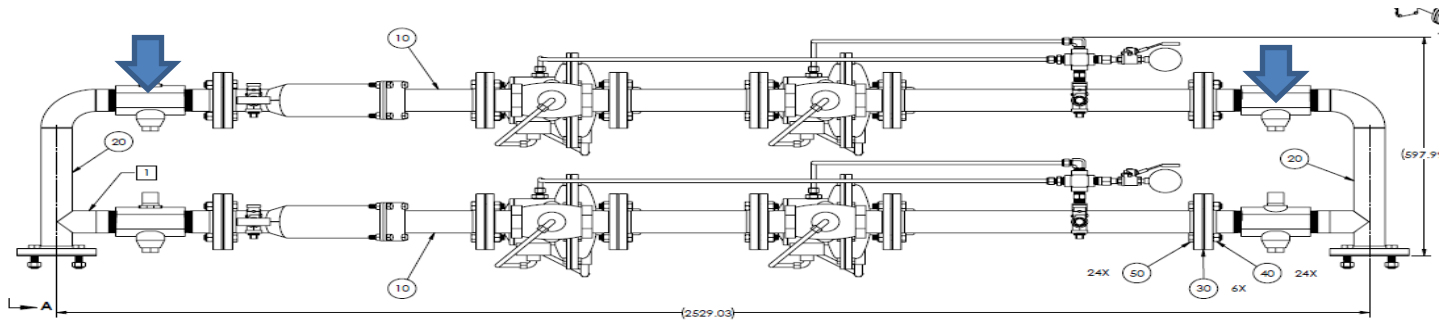

Figure 16

Section C: Process closeout

1. Restore system Conditions

- 1.1. Turn off the air compressor
- 1.2. Isolate the test equipment from the system
- 1.3. Remove all test equipment
 - 1.3.1. Air Compressor
 - 1.3.2. Purge Hose
- 1.4. Close all fuel stub up valves and reconnect YFP to fuel stub up
- 1.5. Leave meter isolation valves open
 - 1.5.1. If dual parallel, leave only one set open, isolate the second set

Gas System Commissioning - Nitrogen



DOC-1010208 Rev A

Version History

Revision	Date	Process Owner	Change Description	Training Required
A		Andy Blakeslee	Initial Release	<input type="checkbox"/> Yes <input checked="" type="checkbox"/> No
A	4/27/17	Shane Peters	Reformatted into Standard Template, suggested edits	<input type="checkbox"/> Yes <input type="checkbox"/> No
A	6/8/17	Shane Peters	Thomas Sipe updates, with Shane's reformatting.	<input type="checkbox"/> Yes <input type="checkbox"/> No
A	2/20/18	Thomas Sipe	Split CDA, N2 and Moisture Sample	<input checked="" type="checkbox"/> Yes <input type="checkbox"/> No
				<input type="checkbox"/> Yes <input type="checkbox"/> No

Electronic Signature approvals are on file in Agile.

NITROGEN, COMPRESSED

Safety Data Sheet



1. IDENTIFICATION

Product identifier

Product Name NITROGEN, COMPRESSED

Other means of identification

Safety data sheet number LIND-P086

UN/ID no. UN1066

Trade name Lasline N2 4.8; Lasline N2 5.0; Gourmet N; Grade 6.0, VOC Free, Emission Grade, Zero 0.2

Recommended use of the chemical and restrictions on use

Recommended Use Industrial and professional use. Food and Beverage. Calibration/test gas.

Uses advised against Consumer use

Details of the supplier of the safety data sheet

Messer Canada Inc.

5860 Chedworth Way

Mississauga, Ontario L5R 0A2

Phone: 905-501-2500

Email: service@messer-ca.com

Website: www.messer-ca.com

Customer Service: 888-256-7359

Emergency telephone number

Company Phone Number +1 905-501-0802

FOR TRANSPORTATION EMERGENCIES ONLY: CANUTEC +1 613-996-6666 OR +1-888-226-8832

2. HAZARDS IDENTIFICATION

Gases under pressure	Compressed gas
Simple asphyxiants	Yes / Category 1

Label elements

Signal word

Warning

Hazard Statements

Contains gas under pressure; may explode if heated

May displace oxygen and cause rapid suffocation

Precautionary Statements - Prevention

Do not handle until all safety precautions have been read and understood
 Use and store only outdoors or in a well ventilated place
 Use a backflow preventive device in piping
 Use only with equipment rated for cylinder pressure
 Close valve after each use and when empty

Precautionary Statements - Response

IF INHALED: Remove person to fresh air and keep comfortable for breathing. Get medical attention/advice.

Precautionary Statements - Storage

Protect from sunlight when ambient temperature exceeds 52°C/125°F

Hazards not otherwise classified (HNOC)

Not applicable

3. COMPOSITION/INFORMATION ON INGREDIENTS

Pure Gas

Chemical Name	Common names/synonyms	CAS No.	Volume %	Chemical Formula
NITROGEN	Not available	7727-37-9	>99	N ₂

4. FIRST AID MEASURES

Description of first aid measures

General advice	Show this safety data sheet to the doctor in attendance.
Inhalation	Remove to fresh air and keep comfortable for breathing. If breathing is difficult, give oxygen. If breathing has stopped, give artificial respiration. Get medical attention immediately.
Skin contact	None under normal use. Get medical attention if symptoms occur.
Eye contact	None under normal use. Get medical attention if symptoms occur.
Ingestion	Not an expected route of exposure.
Self-protection of the first aider	RESCUE PERSONNEL SHOULD BE EQUIPPED WITH SELF-CONTAINED BREATHING APPARATUS.

Most important symptoms and effects, both acute and delayed

Symptoms	Simple asphyxiant. May cause suffocation by displacing the oxygen in the air. Exposure to oxygen-deficient atmosphere (<19.5%) may cause dizziness, drowsiness, nausea, vomiting, excess salivation, diminished mental alertness, loss of consciousness and death. Exposure to atmospheres containing 8-10% or less oxygen will bring about unconsciousness without warning and so quickly that the individuals cannot help or protect themselves. Lack of sufficient oxygen may cause serious injury or death.
-----------------	---

Indication of any immediate medical attention and special treatment needed

Note to physicians	Treat symptomatically.
---------------------------	------------------------

5. FIRE-FIGHTING MEASURES

Suitable extinguishing media

Use extinguishing measures that are appropriate to local circumstances and the surrounding environment.

Unsuitable extinguishing media None.

Specific extinguishing methods

Continue to cool fire exposed cylinders until flames are extinguished. Damaged cylinders should be handled only by specialists.

Specific hazards arising from the chemical

Non-flammable gas. Cylinders may rupture under extreme heat.

Protective equipment and precautions for firefighters

As in any fire, wear self-contained breathing apparatus pressure-demand, NIOSH (approved or equivalent) and full protective gear.

6. ACCIDENTAL RELEASE MEASURES

Personal precautions, protective equipment and emergency procedures

Personal precautions

Evacuate personnel to safe areas. Ensure adequate ventilation, especially in confined areas. Monitor oxygen level. Wear self-contained breathing apparatus when entering area unless atmosphere is proved to be safe.

Environmental precautions

Environmental precautions

Prevent spreading of vapors through sewers, ventilation systems and confined areas.

Methods and material for containment and cleaning up

Methods for containment

Stop the flow of gas or remove cylinder to outdoor location if this can be done without risk. If leak is in container or container valve, contact the appropriate emergency telephone number in Section 1 or call your closest Messer location.

Methods for cleaning up

Return cylinder to Messer or an authorized distributor.

7. HANDLING AND STORAGE

Precautions for safe handling

Advice on safe handling

Protect cylinders from physical damage; do not drag, roll, slide or drop. When moving cylinders, even for short distance, use a cart designed to transport cylinders. Never attempt to lift a cylinder by its valve protection cap. Never insert an object (e.g. wrench, screwdriver, pry bar, etc.) into valve cap openings. Doing so may damage valve, causing leak to occur. Use an adjustable strap wrench to remove over-tight or rusted caps. Use only with adequate ventilation. Use a backflow preventive device in piping. Close valve after each use and when empty. If user experiences any difficulty operating cylinder valve discontinue use and contact supplier. Ensure the complete gas system has been checked for leaks before use.

Never put cylinders into trunks of cars or unventilated areas of passenger vehicles. Never attempt to refill a compressed gas cylinder without the owner's written consent. Never strike an arc on a compressed gas cylinder or make a cylinder a part of an electrical circuit.

Only experienced and properly instructed persons should handle gases under pressure. Always store and handle compressed gas cylinders in accordance with Compressed Gas Association publication CGA-P1, Safe Handling of Compressed Gases in Containers. Use only with equipment rated for cylinder pressure.

For additional recommendations consult CGA P-76 Hazards of Oxygen-Deficient Atmospheres.

Conditions for safe storage, including any incompatibilities

Storage Conditions Store in cool, dry, well-ventilated area of non-combustible construction away from heavily trafficked areas and emergency exits. Keep at temperatures below 52°C / 125°F. Cylinders should be stored upright with valve protection cap in place and firmly secured to prevent falling. Full and empty cylinders should be segregated. Use a "first in-first out" inventory system to prevent full cylinders from being stored for excessive periods of time. Stored containers should be periodically checked for general condition and leakage.

Incompatible materials None known.

8. EXPOSURE CONTROLS/PERSONAL PROTECTION

Control parameters

Exposure Guidelines

Chemical Name	ACGIH TLV	OSHA PEL	NIOSH IDLH
NITROGEN 7727-37-9	: See Appendix F: Minimal Oxygen Content	None	None

ACGIH TLV: American Conference of Governmental Industrial Hygienists - Threshold Limit Value. OSHA PEL: Occupational Safety and Health Administration - Permissible Exposure Limits. NIOSH IDLH: Immediately Dangerous to Life or Health

Appropriate engineering controls

Engineering Controls Provide general ventilation, local exhaust ventilation, process enclosure or other engineering controls to maintain airborne levels below recommended exposure limits and to maintain oxygen levels above 19.5%. Oxygen detectors should be used when asphyxiating gases may be released. Systems under pressure should be regularly checked for leakages.

Individual protection measures, such as personal protective equipment

Eye/face protection Wear safety glasses with side shields (or goggles).

Skin and body protection Work gloves and safety shoes are recommended when handling cylinders.

Respiratory protection Use positive pressure airline respirator with escape cylinder or self contained breathing apparatus for oxygen-deficient atmospheres (<19.5%).

General Hygiene Considerations Handle in accordance with good industrial hygiene and safety practice.

9. PHYSICAL AND CHEMICAL PROPERTIES

Information on basic physical and chemical properties

Physical state	Gas
Appearance	Colorless
Odor	Odorless
Odor threshold	Not applicable
pH	Not applicable
Melting/freezing point	Not applicable
Boiling point / boiling range	-196 °C / -321 °F
Evaporation rate	Not applicable
Flammability (solid, gas)	Non-flammable gas
Lower flammability limit:	Not applicable
Upper flammability limit:	Not applicable
Flash point	Not applicable
Autoignition temperature	Not available

Decomposition temperature	Not available
Water solubility	Slightly soluble
Partition coefficient	Not available
Kinematic viscosity	Not applicable

Component Level Information:

Chemical Name	Molecular weight	Boiling point/range	Vapor Pressure	Vapor density (air =1)	Gas Density kg/m ³ @20°C	Critical Temperature
NITROGEN	28.01	-196 °C	Above critical temperature	0.97	1.153	-146.9 °C

10. STABILITY AND REACTIVITY

Reactivity

Not reactive under normal conditions

Chemical stability

Stable under normal conditions.

Explosion data

Sensitivity to Mechanical Impact None.

Sensitivity to Static Discharge None.

Possibility of Hazardous Reactions

None under normal processing.

Conditions to avoid

None under recommended storage and handling conditions (see Section 7).

Incompatible materials

None known.

Hazardous Decomposition Products

None known.

11. TOXICOLOGICAL INFORMATION

Information on likely routes of exposure

Inhalation	Product is a simple asphyxiant.
Skin contact	Not available
Eye contact	Not available
Ingestion	Not an expected route of exposure.

Information on toxicological effects**Symptoms**

Simple asphyxiant. May cause suffocation by displacing the oxygen in the air. Exposure to oxygen-deficient atmosphere (<=19.5%) may cause dizziness, drowsiness, nausea, vomiting, excess salivation, diminished mental alertness, loss of consciousness and death. Exposure to atmospheres containing 8-10% or less oxygen will bring about unconsciousness without warning and so quickly that the individuals cannot help or protect themselves. Lack of sufficient oxygen may cause serious injury or death.

Delayed and immediate effects as well as chronic effects from short and long-term exposure

Skin corrosion/irritation	Not classified.
Serious eye damage/eye irritation	Not classified.
Irritation	Not classified.
Sensitization	Not classified.
Germ cell mutagenicity	Not classified.
Carcinogenicity	This product does not contain any carcinogens or potential carcinogens listed by OSHA, IARC or NTP.
Reproductive toxicity	Not classified.
Developmental Toxicity	Not classified.
STOT - single exposure	Not classified.
STOT - repeated exposure	Not classified.
Chronic toxicity	None known.
Aspiration hazard	Not applicable.

Numerical measures of toxicity

Product Information	
Oral LD50	Not available
Dermal LD50	Not available
Inhalation LC50	Not available

12. ECOLOGICAL INFORMATION**Ecotoxicity**

No known effect.

Persistence and degradability

Not applicable.

Bioaccumulation

No known effect.

13. DISPOSAL CONSIDERATIONS**Waste treatment methods**

Disposal of wastes Do not attempt to dispose of residual waste or unused quantities. Return in the shipping container PROPERLY LABELED WITH ANY VALVE OUTLET PLUGS OR CAPS SECURED AND VALVE PROTECTION CAP IN PLACE to Messer for proper disposal.

14. TRANSPORT INFORMATION**TDG**

UN/ID no.	UN1066
Proper shipping name	Nitrogen, compressed
Hazard Class	2.2
Description	UN1066, Nitrogen, compressed, 2.2

IATA

UN/ID no.	UN1066
Proper shipping name	Nitrogen, compressed
Hazard Class	2.2
ERG Code	2L
Special Provisions	A69

IMDG

UN/ID no.	UN1066
Proper shipping name	Nitrogen, compressed
Hazard Class	2.2
EmS-No.	F-C, S-V

15. REGULATORY INFORMATION**INTERNATIONAL INVENTORIES**

TSCA	Complies
DSL/NDL	Complies
EINECS/ELINCS	Complies

Legend:

TSCA - United States Toxic Substances Control Act Section 8(b) Inventory

DSL/NDL - Canadian Domestic Substances List/Non-Domestic Substances List

EINECS/ELINCS - European Inventory of Existing Chemical Substances/European List of Notified Chemical Substances

16. OTHER INFORMATION

NFPA	Health hazards 0	Flammability 0	Instability 0	Physical and Chemical Properties Simple asphyxiant
-------------	-------------------------	-----------------------	----------------------	---

Note: Ratings were assigned in accordance with Compressed Gas Association (CGA) guidelines as published in CGA Pamphlet P-19-2019, CGA Recommended Hazard Ratings for Compressed Gases, 4th Edition.

Issue Date	07-Apr-2017
Revision Date	27-Sep-2021
Revision Note:	SDS sections updated; 3

LIND-P086

General Disclaimer

For terms and conditions, including limitation of liability, please refer to the purchase agreement in effect between Messer LLC, Messer Merchant Production LLC, Messer North America, Inc., Messer Gas Puerto Rico, Inc. or Messer Canada Inc. (or any of their affiliates and subsidiaries) and the purchaser.

DISCLAIMER OF EXPRESSED AND IMPLIED WARRANTIES

Although reasonable care has been taken in the preparation of this document, we extend no warranties and make no representations as to the accuracy or completeness of the information contained herein, and assume no responsibility regarding the suitability of this information for the user's intended purposes or for the consequences of its use. Each individual should make a determination as to the suitability of the information for their particular purpose(s).

End of Safety Data Sheet

Exhibit 2

Experience:

Mr. Gregoire holds a Masters Degree in Chemical Engineering with over 25 years of experience in specialty & hazardous chemicals, solids handling, pharmaceutical, bio-pharmaceutical, high purity systems, environmental and polymer industries. His background encompasses the full range of process engineering activities, code and safety reviews / evaluations, as well as project engineering and business development work at several major engineering firms. Mr. Gregoire has lectured at Interphex on "Controlling Solvent Emissions from Process Vents". He is a registered Professional Engineer in 13 U.S. states. He is also a registered NCEES member. Mr. Gregoire has responsibility for various process/project engineering activities and technical leadership at **IDEA**.

RELEVANT PROJECTS:

Fuel Cell Gas Line Purge Special Inspections

Witness and Special Inspections of various pre-start-up fuel line purges using nitrogen for A/Z Corp., ENCON and Bloom Energy.

Generation Bridge II, LLC

New Haven Harbor Power Station, New Haven, CT

Fuel Oil Dock engineering services including preparation of Electrical Area Classification Maps at barge dock.

Bedoukian Research, Inc. – Danbury, CT

500 gal. Still System - Schematic Design Package for a 45' high process structure including 2 reactors/stills, condensers and associated support systems.

Vent KO Tank Project – 200 gal. Vent KO Tank detailed design to decouple relief and vent header systems.

Safety and Environmental Upgrade Project – Evaluation and design for 13 reactor/vessel systems involving relief system upgrades and N₂ padding modifications for enhanced safety and environmental control.

Synthetic chemistry scale-up project including bulk solids addition system, reactor & overheads system and high alloy vertical axis, top discharge centrifuge.

A/Z Corporation – Stamford, CT

Fuel Cell Gas Line Purge Witness

Co-witness to a Special Inspection for several Bloom energy fuel cell gas line purges at NBC Sports Group in Stamford, CT

Rust-Oleum – Attleboro, MA

PHA Addendum Safety Review including flammable liquids, combustible dust, equipment, electrical classification, containment and egress reviews.

BD Biosciences – Miami, FL

Advanced Bioprocessing Media Manufacturing Facility Solids Processing Lines - Weighing/Dispensing, N₂ Recycle Milling System, Blending, Multiple Container Size Packaging System. Liquids Processing Line – Up to 3000L compounding, Bulk and Bottle Sterile Filling Lines Utilities expansion including a new WPI POU's and a new UPW sub-loop.

Hamilton Sundstrand – Windsor Locks, CT

Advanced Pneumatic Testing Lab Project with state-of-the-art controls and utilities including -70° to 800°F pneumatic temperature capabilities.

ASPEN AEROGELS – E. Providence, RI

Facility RTO and dust/fume scrubber systems for misc. process and drying ovens emission & fume environmental control.

Boston University Medical Center – Boston, MA

Commissioning of a national emerging infectious diseases laboratory and research center consisting of a seven (7) story building (194,000 sq. ft.) with Biosafety Level 2, 3, and 4 Laboratories, associated MEP systems and administrative offices.

U.S. Surgical Corp. (div. of TYCO Healthcare) – North Haven, CT

Monomer area expansion of cracking reactor, crystallizer & solvent recovery systems including hot oil & steam utilities studies.

Sandoz Pharmaceuticals - East Hanover, NJ

Environmental summary package for a state-of-the-art solvent recovery system.
Comparison study of various fluid bed and pan coater systems for a solids dosage development facility.

Lockheed Martin / Sikorsky – Stratford, CT
Multiple PHA reviews including flammable liquids, autoclaves, steam systems, as well as as-builts of applicable processes.

RAS-TECH – Brentwood, NH
Dust safety and process code study for a recycle asphalt shingle process.

MACDERMID ENTHONE – West Haven, CT
Multiple specialty high purity process upgrades.
Site utilities as-builts.

King Industries – Norwalk, CT
Code and Engineering Evaluation reviews for a new grass roots Specialty Chemical Manufacturing Facility.

The Lee Company – Westbrook, CT
Utilities upgrades, fume and dust safety studies.

DSM Pharmaceuticals – Greenville, NC
Major pharmaceuticals Dust Remediation Safety Study including code reviews, evaluations and estimates for 95+ Dust Collector systems.

Confidential Client – Long Island, NY
Agent for insurance investigations and code reviews pertaining to a dust collector system metal dust fire.

BALCHEM Corporation – Slate Hill, NY
Nutraceutical Encapsulation Process blending, cooling and conveying study.

NEXEO SOLUTIONS – Various Corporate Sites
Flammable bulk chemical and EH&S upgrade projects including ventilation, submerged fill & bottom loading.

BALCHEM Corporation – Slate Hill, NY
Probiotics & Flavor Containment Area Study
Wyeth-Ayerst - Rouses Point, NY.
Solvent recovery and tank farm expansion
Chem. development facility emissions reduction project
Granulation and fluid bed drying expansion projects (3)
Chemical development expansion
Solvent emissions control and plant utilities upgrade
Solvent emissions reduction scheme for a pharma spray drying process including permitting assistance.
Solvent coating system estimate package.

Sabic Innovative Plastics - Mt. Vernon, IN
Specials solids handling BEP including supersack unloading, recycle N2 solids transfer, solids storage, and batch weigh systems.

Procter & Gamble Pharmaceuticals – Norwich, NY
Hydrazine Analyzer Project
Reactor Chiller Installation

Sterling Pharmaceuticals, Inc. - Barceloneta, PR
Bulk pharmaceutical expansion project
Debottlenecking study and estimate for an existing, fine organic chemical manufacturing facility.
Hi purity water system and SIP for tumble dryer system.

Wyeth BioPharma - Andover, MA
Biopharmaceutical advanced development facility
field commissioning lead for 35 field engineers.

Wyeth-Ayerst - Montreal, Canada
Chemical development expansion

Merial, Ltd. – Athens, GA
Bio-pharmaceutical animal health facility - Site Utilities & Master Plan Scoping

GE Plastics – Burkville, AL
Lexan Facility Major Capacity Expansions

FMC Corporation - Baltimore, MD
Herbicide plant retrofit including wiped film still.

General Electric Company - Waterford, NY.
Silicone polymer plant capacity stretch.
Grassroots silicone polymer project definitive estimate.

General Electric Company - South Korea.
Multi-product polymer compounding facility

General Electric (GEM Polymers) - Osaka, Japan
Basic engineering package for a PPO facility.

Arch Chemical – North Kingston, RI
New HP Photo Resist Facility

GE Plastics - Mt. Vernon, IN
Specialty resin and resin drying system expansion
Specialty Resin CIP System with first-of-a-kind equipment.
Haz-Op and Dryer Focus Team
Bulk/specialty compounding and pkg. facility expansion
Solvent recovery revamp to reduce Methylene Chloride in wastewaters
Solvent recovery pilot plant
Methylene Chloride Loss Reduction Project
Phosgene Capacity Study

Olin Microelectronic Materials - Quonset Point, RI
High Purity Bulk Electronics Chemicals Facility incl. Packaging, High Purity Chemical Reactor & Vacuum Still System

Plaskon Electronics Materials, Ltd. (subsidiary of Rohm & Haas, Inc.) Jurong, Singapore.

Plant operating procedures with subsequent computer sequence descriptions, system startup and debugging of an electronics grade epoxy molding compound plant
Specialty chemical debottlenecking and start-up

Pfizer Inc. - Groton, CT

Refrigeration retrofit estimate & const. sequencing pkg.
Vent emissions calculation packages and end-of-line device evaluations including estimates.

Nycomed Amersham - Rensselaer, NY

Bulk Chem. Retrofit Conceptual Design Pkg. & Estimate
Pilot Plant Upgrades & Modifications

Analog Devices - Wilmington, MA

Wafer Fabrication Facility
Utilities Retrofit
Multiple Chilled Water System Integration

Syntex – Springfield, MO

Bulk Chemical Upgrade
Vent Emissions & Thermal Oxidizer Project
Cities Service Company - Mont Belvieu, TX
Natural gas liquids fractionation plant.

Searle Food Resources, Inc. - Augusta, GA

ASPERTAME (NUTRASWEET) product recov. system.
Static Cryst. simulation. Site waste treatment facility

Harris/Fairchild Semiconductor - Mountaintop, PA

HP Chemical Distribution Systems

Sanders – Nashua, NH

Piping & utilities systems modifications and documentation.

Shell Oil Company - Argo, IL

Batch custom resin solutions plant

MAJOR CAREER ASSIGNMENTS:

IDEA, Inc., Milford, CT

Principal / Manager, Process Engineering

SKANSKA E&C, Shelton, CT (formerly CPI PLANTS, Inc.)

Manager, Process Engineering
Process Manager
Senior Process Engineer

KVAERNER / JOHN BROWN E&C (formerly CRAWFORD & RUSSELL, INC.), Stamford, CT)

Process Engineer

EDUCATION:

RENSSELAER POLYTECHNIC INSTITUTE

B.S., Chemical Engineering - 1978

MANHATTAN COLLEGE

M.S., Chemical Engineering - 1983

SOCIETIES:

American Institute of Chemical Engineers; International Society for Pharmaceutical Engineering

LICENSES:

Licensed Professional Engineer, States of Connecticut, New York, Massachusetts, Rhode Island, Vermont, New Hampshire, Maine, Texas, California, North Carolina, Florida, Virginia and Arizona.

NCEES Registered Professional Engineer

PUBLICATIONS:

ISPE course leader for a workshop entitled "Controlling Solvent Emissions from Process Vents"

Exhibit 3

What Powers You

VIA ELECTRONIC MAIL

March 29, 2023

RE: PETITION NO. 1509 - Bloom Energy Corporation petition for a declaratory ruling, pursuant to Connecticut General Statutes §4-176 and §16-50k, for the proposed construction, maintenance and operation of a customer-side 300-kilowatt fuel cell facility and associated equipment to be located at Park Avenue Medical Center, 5520 Park Avenue, Trumbull, Connecticut.

Dear Ladies and Gentlemen:

At a public meeting held on June 23, 2022, the Connecticut Siting Council (Council) considered and ruled that the above-referenced proposal meets air and water quality standards of the Department of Energy and Environmental Protection and would not have a substantial adverse environmental effect, and pursuant to Connecticut General Statutes § 16-50k would not require a Certificate of Environmental Compatibility and Public Need with certain conditions. As requested in the declaratory ruling, the following information is being provided not less than 15 days prior to any fuel pipe cleaning operations related to the fuel cell construction, installation, or modification.

Employees of Bloom Energy will oversee and perform the procedures detailed in their “Gas System Commissioning” procedure. Bloom Energy has safely commissioned more than 200 fuel cell installation projects in California, New York, New Jersey, Delaware, and Connecticut. During fuel pipe cleaning operations, a third-party Connecticut licensed mechanical engineer with specific knowledge and experience regarding generating facilities will inspect the work.

Additional information regarding the pipe cleaning procedures will be posted under Petition No. 1509 on the Council website.

Respectfully,

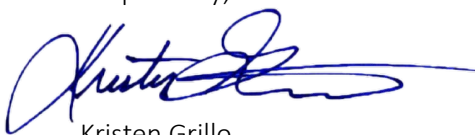

Kristen Grillo
Senior Permitting Specialist | East Coast Field Office
Customer Installations Group | North America
(917) 803-4511
Kristen.Grillo@bloomenergy.com



Bloom Energy Corporation
4353 North First Street, San Jose, CA 95134
408 543 1500
www.bloomenergy.com