

STATE OF CONNECTICUT
CONNECTICUT SITING COUNCIL

IN RE:

NEW CINGULAR WIRELESS PCS, LLC (AT&T)
PETITION FOR A DECLARATORY RULING,
PURSUANT TO CONNECTICUT GENERAL
STATUTES §4-176 AND §16-50K, FOR THE
INSTALLATION OF A WIRELESS
TELECOMMUNICATIONS FACILITY ON
PROPERTY LOCATED AT 97 HAMILTON AVENUE,
STAMFORD, CONNECTICUT.

PETITION NO. _____

March 10, 2022

PETITION FOR A DECLARATORY RULING:
INSTALLATION HAVING
NO SUBSTANTIAL ADVERSE ENVIRONMENTAL EFFECT

I. Introduction

Pursuant to Section 16-50j-38 and 16-50j-39 of the regulations of Connecticut State Agencies (“R.C.S.A.”), New Cingular Wireless PCS LLC (“AT&T”) hereby petitions the Connecticut Siting Council (the “Council”) for a declaratory ruling (“Petition”) that no Certificate of Environmental Compatibility and Public Need (“Certificate”) is required under Section 16-50k(a) of the Connecticut General Statutes (“C.G.S.”) to install a new wireless telecommunications facility at 97 Hamilton Avenue, Stamford, Connecticut (the “Site”). AT&T proposes to install two small panel antennas at the top of a new utility pole and an equipment cabinet with remote radio head units (“RRH”) lower on the new pole. The property is owned by the State and controlled by the Department of Transportation (“DOT”). DOT’s authorization for AT&T to file this Petition is included in **Attachment 1**.

II. Factual Background

a. AT&T’s Need for the Proposed Facility

AT&T identified a need for additional coverage and/or capacity relief in its network in this area of Stamford. The proposed Facility is designed to assure reliable wireless service to AT&T customers and emergency service providers in the area of the Facility location as well as travelers along the adjacent Amtrak railway. A new pole is proposed as the existing utility poles in the area where service is needed are unavailable for use by the electric utility due to the utility attachments on these poles.

b. The Site and AT&T's Proposed Tower Facility

The Site is DOT property in the vicinity of the Amtrak railway on the overpass on Hamilton Avenue. It is classified in the Light Industrial zoning district. Surrounding land uses include utility, commercial, and the railroad.

AT&T's proposed Facility consists of two small square panel antennas mounted at the top of a new class 2 utility pole at a centerline height of approximately 42' above grade level ("AGL"). An equipment cabinet with one RRH will be mounted lower on the pole so that the bottom of the equipment cabinet will be approximately 12'-9" AGL. Each panel antenna is 23.3" x 23.3" x 6.0" wide. AT&T will deploy their 700MHz, 1900 MHz and AWS frequencies which will be shared between the two antennas. Specifications and details of AT&T's proposed Facility are shown on the drawings included in **Attachment 2**. Also, included in **Attachment 3** is a structural analysis report confirming that AT&T's proposed Facility can be structurally accommodated.

No back-up power for AT&T's proposed Facility is proposed. Construction will take place five (5) days a week, only during weekdays (Monday – Friday). The total duration of construction and facility integration is 90 days. The approximate cost is \$50,000.

c. Council Jurisdiction

Connecticut law confers jurisdiction to the Council over certain "facilities", including "telecommunication towers." C.G.S. §16-50i(a)(6). State regulations define "tower" as a "structure, whether free standing or attached to a building or another structure... used principally to support one or more antennas for receiving or sending radio frequency signals...." R.C.S.A. §16-50j-2a(30)(A). Utility structures used to support electric distribution lines located within the public right-of-way fall under PURA's jurisdiction. Thus, PURA has jurisdiction over small cell facility attachments to utility poles that are part of the electric utility distribution system located within the public right-of-way. PURA, Docket 16-06-38.

Here, the proposed utility pole will be "used principally to support one or more antennas for receiving or sending radio frequency signals" and the pole will not, for the foreseeable future, be used as a part of the existing electric distribution system. Thus, the proposed utility pole along with AT&T's wireless equipment constitutes a "facility" over which the Council has jurisdiction. This jurisdiction is consistent with the Council's November 5, 2007 Opinion in Petition No. 809.

III. Discussion

a. The Proposed Small Cell Facility Will Not Have A Substantial Environmental Impact

For the reasons set forth below, AT&T respectfully submits that its proposed Facility will not have a substantial environmental impact and as such a Certificate pursuant to C.G.S. Section 16-50k(a) is not required.

i. Physical Environmental Effects

AT&T's proposed Facility will not result in any significant physical or environmental change to the Site or any adjacent parcels. Minimal disturbance is associated with the proposed Facility.

ii. Visual Effects

The photosimulation included in **Attachment 4** demonstrates that the limited nature of AT&T's proposed Facility will not result in any significant visual impacts to the area. Indeed, compared to the existing utility infrastructure in the area, AT&T's proposed Facility results in negligible visibility.

iii. FCC Compliance

The operation of AT&T's antenna will not increase the total radio frequency electromagnetic power density at the site to a level at or above applicable standards. A power density report is included in **Attachment 5**. The total radio frequency power density will be well within standards adopted by the Connecticut Department of Environmental Protection as set forth in Section 22a-162 of the Connecticut General Statutes and the MPE limits established by the Federal Communications Commission.

b. Notice of Petition Filing

Pursuant to R.C.S.A. Section 16-50j-40(a), notice of AT&T's intent to file this Petition was sent to each person appearing of record as an owner of property that abuts the site, as well as the appropriate municipal officials and government agencies as required by Section 16-50l of the C.G.S. Certification of such notice, a copy of the notice and the list of property owners is included in **Attachment 6** along with the map from the Town's GIS website used to identify abutting property owners. **Attachment 6** also includes a certification of service to municipal officials and government agencies to whom notice was sent.

IV. Conclusion

As set forth above, AT&T's proposed Facility will not result in any known adverse environmental effects. Therefore, and for all the foregoing reasons, AT&T petitions the Council for a determination that the proposed Facility does not require a Certificate of Environmental Compatibility and Public Need and that the Council issue an order approving same.

Respectfully submitted,



Lucia Chiochio
On behalf of the Petitioner

cc: Mayor Caroline Simmons, City of Stamford
Ralph Blessing, Land Use Bureau, City of Stamford
AT&T
Nexius
Meyling Nunez, Cuddy & Feder, LLP

ATTACHMENT 1



STATE OF CONNECTICUT

DEPARTMENT OF TRANSPORTATION
2800 BERLIN TURNPIKE, P.O. BOX 317546
NEWINGTON, CONNECTICUT 06131-7546
Phone: (203) 497-3344



February 17, 2022

Kelly Fay
Site Acquisition Specialist
Nexius Solutions, Inc
300 Apollo Drive, 2nd Floor
Chelmsford, MA 01824

Subject: Letter of "No Objection"

AT&T Small Cellular Sites in Greenwich and Stamford
55 Henry Street, Greenwich – CRAN_RCTB_AMTRK_001
Davis Avenue, Greenwich – CRAN_RCTB_AMTRK_002
101 Indian Field Road, Greenwich – CRAN_RCTB_AMTRK_007
97 Hamilton Avenue, Greenwich – CRAN_RCTB_AMTRK_051

Dear Ms. Fay:

This is to confirm the Connecticut Department of Transportation ("Department") has reviewed the subject AT&T Small Cellular Site locations and has "no objection" to the locations proposed by AT&T for cellular facilities construction within the limits of State Rail Right-of-Way as described in the following plans submitted to the Department on October 27, 2021:

'AT&T New England_Nexius_CRAN, CRAN_RCTB_AMTRK_001, USID 291841, 55 Henry Street, Greenwich, CT; Date: October 25, 2021; Map Author: Nexius Solutions, Inc.'; 'AT&T New England_Nexius_CRAN, CRAN_RCTB_AMTRK_002, USID 291392, Davis Avenue, Greenwich, CT; Date: October 27, 2021; Map Author: Nexius Solutions, Inc.'; 'AT&T New England_Nexius_CRAN, CRAN_RCTB_AMTRK_007, USID 291844, 101 Indian Field Road, Greenwich, CT; Date: October 25, 2021; Map Author: Nexius Solutions, Inc.'; and 'AT&T New England_Nexius_CRAN, CRAN_RCTB_AMTRK_051, USID 291384, 97 Hamilton Avenue, Stamford, CT; Date: October 19, 2021; Map Author: Nexius Solutions, Inc.' referred to as "the Plans".

AT&T must continue to coordinate with the Department and Metro-North Railroad ("Railroad") for approval of all future engineering plan submissions and for master license agreement requirements and entry upon State-owned rail property.

If you have any questions please contact Ms. Julie Thomas, Supervising Rail Officer, by phone at (203) 497-3383 or by email at Julie.Thomas@ct.gov.

Respectfully,

Eric Bergeron
Assistant Rail Administrator
Bureau of Public Transportation

Digitally signed by Bergeron, Eric
DN: E=Eric.Bergeron@ct.gov, CN="Bergeron,
Eric", OU=GCO, OU=District-3,
OU=DOT-Users, DC=DOT, DC=CT, DC=GOV
Date: 2022.02.22 10:42:11-05'00'

ATTACHMENT 2



AT&T

PROJECT: NEW ENGLAND_NEXIUS_CRAN
 SITE NAME: CRAN_RCTB_AMTRK_051
 USID: 291384
 PACE NUMBER: MRCTB045148
 FA NUMBER: 15122383
 PTN NUMBER: 2051A0SRPH
 COORDINATES: 41.063400°, -73.520600°
 SITE ADDRESS: 97 HAMILTON AVENUE
 STAMFORD, CONNECTICUT 06902

PREPARED BY:

nexius

ENABLING SMARTER CONNECTIONS

A&E OFFICE:
 2595 NORTH DALLAS PARKWAY, SUITE 300
 FRISCO, TX 75034
 (972) 581-9888

CLIENT:



AT&T
 550 COCHITUATE ROAD,
 FRAMINGHAM, MA 01701

FOR ZONING

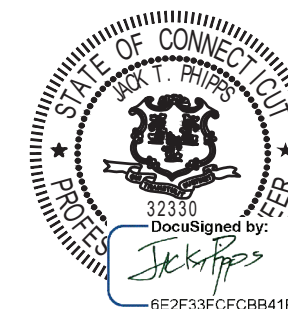

DATE SIGNED: 02/10/22

NEXIUS SOLUTIONS, INC.
 CONNECTICUT FIRM NO. PEC.0001571
 FIRM REGISTRATION RENEWAL 3/17/22.
 PE LICENSE RENEWAL 1/31/23

PROJECT INFORMATION

PROJECT:	NEW ENGLAND_NEXIUS_CRAN
SITE NAME:	CRAN_RCTB_AMTRK_051
USID:	291384
PACE NUMBER:	MRCTB045148
LATITUDE:	41.063400°
LONGITUDE:	-73.520600°
SITE ADDRESS:	97 HAMILTON AVENUE
CITY, STATE ZIP:	STAMFORD, CONNECTICUT 06902
COUNTY:	FAIRFIELD
JURISDICTION:	CITY OF STAMFORD
STRUCTURE TYPE:	PROPOSED UTILITY POLE
STRUCTURE OWNER:	CT DOT
GROUND ELEVATION:	33'± AMSL
APPLICANT:	NEXIUS SOLUTIONS, INC. 300 APOLLO DRIVE, 2ND FLOOR CHELMSFORD, MA 01824 SITE ACQUISITION: NICOLE CAPLANMASON EMAIL: nicole.caplanmason@nexius.com
SITE ACQUISITION:	NEXIUS SOLUTIONS, INC. 300 APOLLO DRIVE, 2ND FLOOR CHELMSFORD, MA 01824
ENGINEERING SERVICES:	NEXIUS SOLUTIONS, INC. 2595 NORTH DALLAS PARKWAY, SUITE 300 FRISCO, TX 75034 EMAIL: JACK.PHIPPS@nexius.com

AERIAL PHOTO



SHEET INDEX

SHEET #	SHEET TITLE
T-1	TITLE SHEET
GN-1	GENERAL NOTES
C-1	POLE ELEVATION
C-2	AERIAL MAP TO SCALE
C-3	SITE PLAN
C-4	SITE SURVEY
C-5	ENLARGED SITE PLAN
EQ-1	EQUIPMENT DETAILS
EQ-2	EQUIPMENT DETAILS
EQ-3	EQUIPMENT DETAILS
E-1	ELECTRICAL AND GROUNDING DETAILS

CODE COMPLIANCE

ALL WORK SHALL BE PERFORMED AND MATERIALS INSTALLED IN ACCORDANCE WITH CURRENT EDITIONS OF THE FOLLOWING APPLICABLE CODES AS ADOPTED BY THE LOCAL GOVERNING AUTHORITIES.

- 2018 INTERNATIONAL BUILDING CODE
- 2020 NATIONAL ELECTRICAL CODE

THESE DRAWINGS ARE DESIGNED TO THE LATEST CODES. THEY ALSO MEET THE ADOPTED CODE REQUIREMENTS OF THE JURISDICTION LISTED ABOVE.

THIS DOCUMENT IS THE DESIGN PROPERTY AND COPYRIGHT OF NEXIUS AND FOR THE EXCLUSIVE USE BY THE TITLE CLIENT. DUPLICATION OR USE WITHOUT THE EXPRESS WRITTEN CONSENT OF THE CREATOR IS STRICTLY PROHIBITED.

SUBMITTALS

REV	DATE	DESCRIPTION	BY
A	05/05/21	FOR REVIEW	GS
B	10/19/21	FOR REVIEW	PM
0	11/02/21	FINAL ZD	GS
1	01/25/22	REVISED FINAL ZD	GS
2	02/10/22	REVISED FINAL ZD	GS

CHECKED BY: GS
 CHECKED DATE: 02/10/22

SITE INFORMATION:
 SITE NAME: CRAN_RCTB_AMTRK_051
 USID: 291384
 SITE ADDRESS: 97 HAMILTON AVENUE
 STAMFORD, CONNECTICUT 06902

SCOPE OF WORK

1. INSTALL NEW 50'-0" CLASS 2 (43'-0" A.G.L.) WOOD POLE.
 2. INSTALL (2) PROPOSED ANTENNAS SIDE MOUNTED ON PROPOSED POLE PER MANUFACTURER'S SPECIFICATIONS.
 3. INSTALL (1) EQUIPMENT ENCLOSURE CONTAINING (1) RRU8843 AND (2) PSU AC 08 ON PROPOSED POLE PER MANUFACTURER'S SPECIFICATIONS.
 4. INSTALL (1) METER AND (1) AC DISTRIBUTION BOX/SERVICE DISCONNECT ON PROPOSED POLE PER MANUFACTURER'S SPECIFICATIONS AND PER UTILITY AND NEC REQUIREMENTS.
- ANY DEVIATION THAT DIFFERS SUBSTANTIALLY FROM WHAT IS SHOWN ON THE CONSTRUCTION DRAWINGS MUST BE APPROVED BY THE ENGINEER OF RECORD. NO CHANGES THAT ALTER THE CHARACTER OF THE WORK CAN BE MADE DURING CONSTRUCTION WITHOUT ISSUING A CHANGE ORDER.
- DRAWING SCALES ARE INTENDED FOR 11" X 17" SIZE PRINTED MEDIA ONLY. ALL OTHER SIZES ARE DEEMED "NOT TO SCALE".

STRUCTURE PHOTO



ONE CALL

TO OBTAIN LOCATION OF PARTICIPANTS UNDERGROUND FACILITIES BEFORE YOU DIG IN CONNECTICUT, CONTACT CALL BEFORE YOU DIG TOLL FREE: 1-800-922-4455 OR www.cbyd.com

CONNECTICUT STATUTE REQUIRES MIN OF 2 WORKING DAYS NOTICE BEFORE YOU EXCAVATE

Know what's below.
 Call before you dig.

SHEET TITLE: TITLE SHEET

SHEET NUMBER: T-1

GENERAL CONSTRUCTION

1. ALL SITE WORK SHALL BE COMPLETED AS INDICATED ON THE DRAWINGS AND PROJECT SPECIFICATIONS.
2. GENERAL CONTRACTOR SHALL VISIT THE SITE AND FAMILIARIZE HIMSELF WITH ALL CONDITIONS AFFECTING THE PROPOSED WORK. GENERAL CONTRACTOR IS RESPONSIBLE FOR FAMILIARIZING HIMSELF WITH ALL CONTRACT DOCUMENTS, FIELD CONDITIONS, DIMENSIONS, AND CONFIRMING THAT THE WORK MAY BE ACCOMPLISHED AS SHOWN PRIOR TO PROCEEDING WITH CONSTRUCTION. ANY DISCREPANCIES SHALL BE BROUGHT TO THE ATTENTION OF THE ENGINEER PRIOR TO THE COMMENCEMENT OF WORK.
3. ALL MATERIALS FURNISHED AND INSTALLED SHALL BE IN STRICT ACCORDANCE WITH ALL APPLICABLE CODES, REGULATIONS, ORDINANCES, AND ISSUE ALL APPROPRIATE NOTICES.
4. ALL WORK CARRIED OUT SHALL COMPLY WITH ALL APPLICABLE MUNICIPAL AND UTILITY COMPANY SPECIFICATIONS AND LOCAL JURISDICTIONAL CODES, ORDINANCES, AND APPLICABLE REGULATIONS.
5. PLANS ARE NOT TO BE SCALED. SPACING BETWEEN EQUIPMENT IS THE MINIMUM REQUIRED CLEARANCE. THEREFORE, IT IS CRITICAL TO FIELD VERIFY DIMENSIONS, SHOULD THERE BE ANY QUESTIONS REGARDING THE CONTRACT DOCUMENTS, THE CONTRACTOR SHALL BE RESPONSIBLE FOR OBTAINING A CLARIFICATION FROM THE ENGINEER PRIOR TO PROCEEDING WITH THE WORK. DETAILS ARE INTENDED TO SHOW DESIGN INTENT. MODIFICATIONS MAY BE REQUIRED TO SUIT JOB DIMENSIONS OR CONDITIONS AND SUCH MODIFICATIONS SHALL BE INCLUDED AS PART OF WORK AND PREPARED BY THE ENGINEER PRIOR TO PROCEEDING WITH WORK.
6. THE CONTRACTOR SHALL INSTALL ALL EQUIPMENT AND MATERIALS IN ACCORDANCE WITH MANUFACTURER'S RECOMMENDATIONS UNLESS SPECIFICALLY STATED OTHERWISE.
7. IF THE SPECIFIED EQUIPMENT CANNOT BE INSTALLED AS SHOWN ON THESE DRAWINGS, THE CONTRACTOR SHALL PROPOSE AN ALTERNATIVE INSTALLATION SPACE FOR APPROVAL BY THE ENGINEER PRIOR TO PROCEEDING.
8. CONTRACTOR SHALL NOTIFY THE GENERAL CONTRACTOR OF ANY EXISTING CONDITIONS THAT DEVIATE FROM THE DRAWINGS PRIOR TO BEGINNING CONSTRUCTION.
9. GENERAL CONTRACTOR SHALL BE RESPONSIBLE FOR THE SAFETY OF WORK AREA, ADJACENT AREAS AND BUILDING OCCUPANTS THAT ARE LIKELY TO BE AFFECTED BY THE WORK UNDER THIS CONTRACT. WORK SHALL CONFIRM TO ALL OSHA REQUIREMENTS AND THE LOCAL JURISDICTION.
10. GENERAL CONTRACTOR SHALL COORDINATE WORK AND SCHEDULE WORK ACTIVITIES WITH OTHER DISCIPLINES.
11. WORK SHALL BE DONE IN A PROFESSIONAL MANNER BY COMPETENT EXPERIENCED PERSONNEL IN ACCORDANCE WITH APPLICABLE CODES AND THE BEST ACCEPTED PRACTICE.
12. SEAL PENETRATIONS THROUGH FIRE RATED AREAS WITH UL LISTED MATERIALS APPROVED BY LOCAL JURISDICTION. CONTRACTOR SHALL KEEP AREA CLEAN, HAZARD FREE, AND DISPOSE OF ALL DEBRIS.
13. CONTRACTOR SHALL PROVIDE WRITTEN NOTICE TO THE CONSTRUCTION MANAGER 48 HOURS PRIOR TO COMMENCEMENT OF WORK.
14. THE CONTRACTOR SHALL PROTECT EXISTING IMPROVEMENTS, PAVEMENTS, CURBS, LANDSCAPING AND STRUCTURES. ANY DAMAGED PART SHALL BE REPAIRED AT CONTRACTOR'S EXPENSE TO THE SATISFACTION OF THE OWNER.
15. THE CONTRACTOR SHALL CONTACT UTILITY LOCATING SERVICES PRIOR TO THE START OF CONSTRUCTION.
16. GENERAL CONTRACTOR SHALL COORDINATE AND MAINTAIN ACCESS FOR ALL TRADES AND CONTRACTORS TO THE SITE AND/OR BUILDING.
17. THE GENERAL CONTRACTOR SHALL BE RESPONSIBLE FOR SECURITY OF THE SITE FOR THE DURATION OF CONSTRUCTION UNTIL JOB COMPLETION.
18. CONTRACTORS SHALL BE RESPONSIBLE FOR OBTAINING ALL PERMITS AND INSPECTIONS REQUIRED FOR CONSTRUCTION. IF CONTRACTOR CANNOT OBTAIN A PERMIT, THEY MUST NOTIFY THE GENERAL CONTRACTOR IMMEDIATELY.
19. THE GENERAL CONTRACTOR SHALL MAINTAIN IN GOOD CONDITION ONE COMPLETE SET OF PLANS WITH ALL REVISIONS, ADDENDA, AND CHANGE ORDERS ON THE PREMISES AT ALL TIMES.
20. THE GENERAL CONTRACTOR SHALL PROVIDE PORTABLE FIRE EXTINGUISHERS WITH A RATING OF NOT LESS THAN 2-A TO 2-A:10-B:C AND SHALL BE WITHIN 25 FEET OF TRAVEL DISTANCE TO ALL PORTIONS OF WHERE THE WORK IS BEING COMPLETED DURING CONSTRUCTION.
21. ALL EXISTING ACTIVE SEWER, WATER, GAS, ELECTRIC, COMMUNICATIONS, AND OTHER UTILITIES SHALL BE PROTECTED AT ALL TIMES, AND WHERE REQUIRED FOR THE PROPER EXECUTION OF THE WORK, SHALL BE RELOCATED AS DIRECTED BY THE ENGINEER. EXTREME CAUTION SHOULD BE USED BY THE CONTRACTOR WHEN EXCAVATING OR DRILLING PIERS AROUND OR NEAR UTILITIES. CONTRACTOR SHALL PROVIDE SAFETY TRAINING FOR THE WORKING CREW. THIS SHALL INCLUDE BUT NOT BE LIMITED TO: FALL PROTECTION, CONFINED SPACE, ELECTRICAL SAFETY, AND TRENCHING / EXCAVATION.
22. ALL EXISTING INACTIVE SEWER, WATER, GAS, ELECTRIC, AND OTHER UTILITIES WHICH INTERFERE WITH THE EXECUTION OF THE WORK, SHALL BE REMOVED, CAPPED, PLUGGED OR OTHERWISE DISCONNECTED AT POINTS WHICH WILL NOT INTERFERE WITH THE EXECUTION OF THE WORK, AS DIRECTED BY THE RESPONSIBLE ENGINEER, AND SUBJECT TO THE APPROVAL OF THE OWNER AND/OR LOCAL UTILITIES.

23. CONTRACTOR SHALL MINIMIZE DISTURBANCE TO THE EXISTING SITE DURING CONSTRUCTION. EROSION CONTROL MEASURES, IF REQUIRED DURING CONSTRUCTION, SHALL BE IN CONFORMANCE WITH THE FEDERAL AND LOCAL JURISDICTION FOR EROSION AND SEDIMENT CONTROL.
24. THE AREAS OF THE OWNER'S PROPERTY DISTURBED BY THE WORK SHALL BE GRADED TO A UNIFORM SLOPE AND STABILIZED TO PREVENT EROSION.
25. NO FILL OR EMBANKMENT MATERIAL SHALL BE PLACED ON FROZEN GROUNDING. FROZEN MATERIALS, SNOW OR ICE SHALL NOT BE PLACED IN ANY FILL OR EMBANKMENT.
26. THE SUBGRADE SHALL BE BROUGHT TO A SMOOTH UNIFORM GRADE AND COMPACTED TO 95 PERCENT STANDARD PROCTOR DENSITY UNDER PAVEMENT AND STRUCTURES AND 80 PERCENT STANDARD PROCTOR DENSITY IN OPEN SPACE.
27. ALL TRENCHES IN PUBLIC RIGHT OF WAY SHALL BE BACKFILLED WITH FLOWABLE FILL OR OTHER MATERIAL PRE-APPROVED BY THE LOCAL JURISDICTION.
28. ALL NECESSARY RUBBISH, STUMPS, DEBRIS, STICKS, STONES, AND OTHER REFUSE SHALL BE REMOVED FROM THE SITE AND DISPOSED OF IN A LAWFUL MANNER.
29. ALL BROCHURES, OPERATING AND MAINTENANCE MANUALS, CATALOGS, SHOP DRAWINGS, AND OTHER DOCUMENTS SHALL BE TURNED OVER TO THE GENERAL CONTRACTOR AT COMPLETION OF CONSTRUCTION AND PRIOR TO PAYMENT.
30. CONTRACTOR SHALL SUBMIT A COMPLETE SET OF AS-BUILT REDLINES TO THE GENERAL CONTRACTOR UPON COMPLETION OF PROJECT AND PRIOR TO FINAL PAYMENT.
31. NO OUTDOOR STORAGE OR SOLID WASTE CONTAINERS ARE PROPOSED.
32. ALL MATERIAL SHALL BE FURNISHED AND WORK SHALL BE PERFORMED IN ACCORDANCE WITH THE LATEST GROUNDING STANDARD.
33. CONTRACTOR SHALL REMOVE ALL TRASH AND DEBRIS FROM THE SITE ON A DAILY BASIS.
34. INFORMATION SHOWN ON THESE DRAWINGS WAS OBTAINED FROM SITE VISITS AND/OR DRAWINGS PROVIDED BY THE SITE OWNER.
35. CONTRACTORS SHALL NOTIFY THE ENGINEER OF ANY DISCREPANCIES PRIOR TO ORDERING MATERIAL OR PROCEEDING WITH CONSTRUCTION.
36. ALL CABLE INSTALLATIONS TO FOLLOW MANUFACTURER'S INSTRUCTIONS AND RECOMMENDATIONS.

ANTENNA MOUNTING

1. DESIGN AND CONSTRUCTION OF ANTENNA SUPPORTS SHALL CONFORM TO CURRENT ANSI/TIA-222 OR APPLICABLE LOCAL CODES.
2. ALL STEEL MATERIALS SHALL BE GALVANIZED AFTER FABRICATION IN ACCORDANCE WITH ASTM A123 "ZINC (HOT-DIP GALVANIZED) COATINGS ON IRON AND STEEL PRODUCTS", UNLESS NOTED OTHERWISE.
3. ALL BOLTS, ANCHORS AND MISCELLANEOUS HARDWARE SHALL BE GALVANIZED IN ACCORDANCE WITH ASTM A153 "ZINC-COATING (HOT-DIP) ON IRON AND STEEL HARDWARE", UNLESS NOTED OTHERWISE.
4. DAMAGED GALVANIZED SURFACES SHALL BE REPAIRED BY COLD GALVANIZING IN ACCORDANCE WITH ASTM A780.
5. ALL ANTENNA MOUNTS SHALL BE INSTALLED WITH LOCK NUTS, DOUBLE NUTS AND SHALL BE TORQUED TO MANUFACTURER'S RECOMMENDATIONS.
6. CONTRACTOR SHALL INSTALL ANTENNA PER MANUFACTURER'S RECOMMENDATION FOR INSTALLATION AND GROUNDING.
7. PRIOR TO SETTING ANTENNA AZIMUTHS AND DOWNTILTS, ANTENNA CONTRACTOR SHALL CHECK THE ANTENNA MOUNT FOR TIGHTNESS AND ENSURE THAT THEY ARE PLUMB. ANTENNA AZIMUTHS SHALL BE SET FROM TRUE NORTH AND BE ORIENTED WITHIN +/- 5% AS DEFINED BY THE RFDS. ANTENNA DOWNTILTS SHALL BE WITHIN +/- 0.5% AS DEFINED BY THE RFDS. REFER TO ND-00246.

TORQUE REQUIREMENTS

1. ALL RF CONNECTIONS SHALL BE TIGHTENED WITH A TORQUE WRENCH AND A TORQUE MARK INDICATED ON BOTH SIDES OF THE CONNECTION.
2. ALL GROUNDING AND ANTENNA HARDWARE SHALL ALL BE TIGHTENED WITH A TORQUE WRENCH AND A TORQUE MARK INDICATED ON THE NUT SIDE STARTING FROM THE THREADS TO THE SOLID SURFACE. TORQUE TO THE FOLLOWING VALUES:
 - 2.1. ALL 5/16" ANTENNA HARDWARE TIGHTENED TO 9 FT-LBS.
 - 2.2. ALL 1/2" ANTENNA HARDWARE TIGHTENED TO 43 FT-LBS.
 - 2.3. ALL DIN-TYPE CONNECTIONS TIGHTENED TO 18-22 FT-LBS.
 - 2.4. ALL N-TYPE CONNECTIONS TIGHTENED TO 15-20 IN-LBS.

COAXIAL CABLE NOTES

1. TYPES AND SIZES OF THE ANTENNA CABLE ARE BASED ON ESTIMATED LENGTHS. PRIOR TO ORDERING CABLE, CONTRACTOR SHALL VERIFY ACTUAL LENGTH BASED ON CONSTRUCTION LAYOUT AND NOTIFY THE PROJECT MANAGER IF ACTUAL LENGTHS EXCEED ESTIMATED LENGTHS.

2. CONTRACTOR SHALL VERIFY THE DOWNTILT OF EACH ANTENNA WITH A DIGITAL LEVEL.
3. CONTRACTOR SHALL CONFIRM COAX COLOR CODING PRIOR TO CONSTRUCTION. REFER TO "ANTENNA SYSTEM LABELING STANDARD" ND-00027 LATEST VERSION.
4. USE 1/2" COAX ON ANTENNAS UNLESS OTHERWISE SPECIFIED.
5. FILL VOID AROUND CABLES AT CONDUIT OPENING WITH FOAM SEALANT TO PREVENT WATER INTRUSION.
6. ALL COAXIAL CABLE SHALL BE SECURED TO THE DESIGNED SUPPORT STRUCTURE, IN AN APPROVED MANNER, AT DISTANCES NOT TO EXCEED 4'-0".
7. CONTRACTOR SHALL FOLLOW ALL MANUFACTURER'S RECOMMENDATIONS REGARDING BOTH THE INSTALLATION AND GROUNDING OF ALL COAXIAL CABLES, CONNECTORS, ANTENNAS, AND ALL OTHER EQUIPMENT.
8. ALL OUTDOOR RF CONNECTIONS SHALL BE WEATHERPROOFED USING COLD SHRINK OR HEAT SHRINK ON ALL ANTENNA AND RADIO CONNECTIONS,

GENERAL CABLE AND EQUIPMENT NOTES

1. PRIOR TO INSTALLATION CONTRACTOR SHALL VERIFY MAKE AND MODEL OF ANTENNA, DIPLEXERS, AND COAX CONFIGURATION.
2. ALL CONNECTIONS FOR HANGERS, SUPPORTS, BRACING, ETC. SHALL BE INSTALLED PER MANUFACTURER'S RECOMMENDATIONS.
3. CONTRACTOR SHALL REFERENCE THE STRUCTURAL ANALYSIS/DESIGN DRAWINGS FOR DIRECTIONS ON CABLE DISTRIBUTION/ROUTING.
4. IF REQUIRED TO PAINT ANTENNAS AND/OR COAX:
 - 4.1. TEMPERATURE SHALL BE ABOVE 50° F.
 - 4.2. PAINT COLOR MUST BE APPROVED BY BUILDING OWNER/LANDLORD.
 - 4.3. FOR REGULATED TOWERS, FAA/FCC APPROVED PAINT IS REQUIRED.
 - 4.4. DO NOT PAINT OVER COLOR CODING OR ON EQUIPMENT MODEL NUMBERS.
5. ALL PROPOSED GROUND BAR DOWNLEADS ARE TO BE TERMINATED TO THE EXISTING ADJACENT GROUND BAR DOWNLEADS A MINIMUM DISTANCE OF 4'-0" BELOW GROUND BAR. TERMINATIONS MAY BE EXOTHERMIC OR COMPRESSION.
6. NO BOLT THREADS TO PROTRUDE MORE THAN 1-1/2".

NOTES REVISION 20200526

PREPARED BY:

nexus

ENABLING SMARTER CONNECTIONS

A&E OFFICE:
2595 NORTH DALLAS PARKWAY, SUITE 300
FRISCO, TX 75034
(972) 581-9888

CLIENT:



AT&T
550 COCHITUATE ROAD,
FRAMINGHAM, MA 01701

FOR ZONING

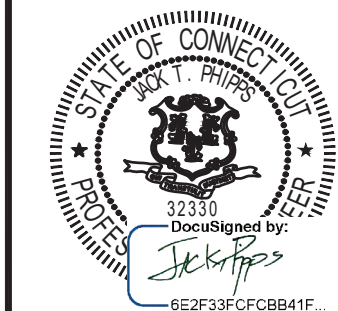

DATE SIGNED: 02/10/22

NEXIUS SOLUTIONS, INC.
CONNECTICUT FIRM NO. PEC.0001571
FIRM REGISTRATION RENEWAL 3/17/22.
PE LICENSE RENEWAL 1/31/23

THIS DOCUMENT IS THE DESIGN PROPERTY AND COPYRIGHT OF NEXIUS AND FOR THE EXCLUSIVE USE BY THE TITLE CLIENT. DUPLICATION OR USE WITHOUT THE EXPRESS WRITTEN CONSENT OF THE CREATOR IS STRICTLY PROHIBITED.

SUBMITTALS			
REV	DATE	DESCRIPTION	BY
A	05/05/21	FOR REVIEW	GS
B	10/19/21	FOR REVIEW	PM
0	11/02/21	FINAL ZD	GS
1	01/25/22	REVISED FINAL ZD	GS
2	02/10/22	REVISED FINAL ZD	GS

CHECKED BY: GS CHECKED DATE: 02/10/22

SITE INFORMATION: SITE NAME:
CRAN_RCTB_AMTRK_051
USID:
291384
SITE ADDRESS:
**97 HAMILTON AVENUE
STAMFORD, CONNECTICUT 06902**

SHEET TITLE: **GENERAL NOTES**

SHEET NUMBER: **GN-1**

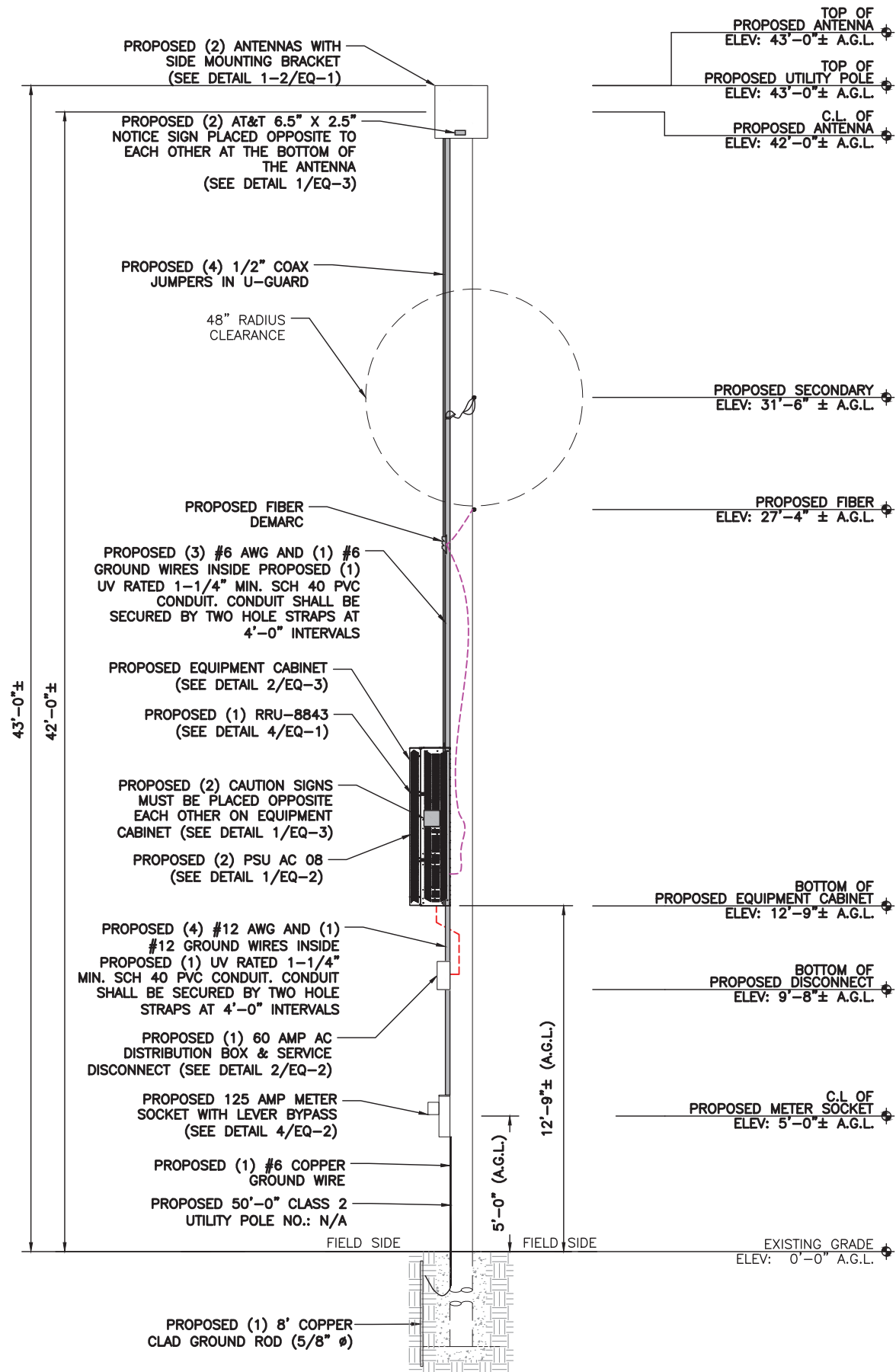

NOTES:

1. AN ANALYSIS OF THE CAPACITY OF THE EXISTING STRUCTURE TO SUPPORT THE PROPOSED LOADING HAS NOT BEEN COMPLETED BY NEXIUS. DRAWINGS ARE SUBJECT TO CHANGE PENDING OUTCOME OF A STRUCTURAL ANALYSIS.
2. AT&T SHALL MAKE ARRANGEMENTS WITH THE LOCAL ELECTRICAL UTILITY, TO ADJUST THE POSITION OF THE EXISTING OVERHEAD COMMUNICATION LINES AT SUBJECT UTILITY POLE TO PROVIDE THE REQUIRED CLEARANCE FOR THE INSTALLATION OF THE PROPOSED AT&T ANTENNA. THE PROPOSED INSTALLATION OF THE ANTENNA AND ALL APPURTENANCES SHALL MEET THE REQUIREMENTS OF THE POWER COMPANY AND THE 2020 NATIONAL ELECTRICAL SAFETY CODE.
3. VERIFY EQUIPMENT B.O.M. AGAINST RFDS TO ENSURE YOU HAVE THE RIGHT ANTENNA. NOTIFY YOUR PROJECT PM IF THERE IS A DISCREPANCY IN THE ANTENNA OR MOUNTING BRACKET.
4. IT IS THE RESPONSIBILITY OF THE CONTRACTOR TO VERIFY, PRIOR TO THE ONSET OF CONSTRUCTION, THAT THE SUPPORTING STRUCTURE(S) AND MOUNTING SYSTEM(S) HAVE BEEN DEEMED STRUCTURALLY ADEQUATE BY A LICENSED PROFESSIONAL ENGINEER TO SUPPORT THE EXISTING AND PROPOSED EQUIPMENT AND ASSOCIATED CONSTRUCTION LOADS, INCLUDING BUT NOT LIMITED TO THOSE DEPICTED, HEREIN. THE CONTRACTOR SHALL ASSUME THE FULL-LIABILITY AND RISK ASSOCIATED WITH THE INSTALLATION OF THE PROPOSED EQUIPMENT AND/OR APPURTENANCES IF PERFORMED WITHOUT SAID PASSING STRUCTURAL ANALYSIS OR EVALUATION. IF THE RESULT OF THE ANALYSIS REQUIRES THE STRUCTURE BE STRENGTHENED OR MODIFIED; SUCH MODIFICATIONS SHALL BE PROPERLY INSTALLED AND COMPLETED PRIOR TO THE ONSET OF CONSTRUCTION.



② PHOTO SIMULATION
N.T.S.

PREPARED BY:

nexius

ENABLING SMARTER CONNECTIONS

A&E OFFICE:
2595 NORTH DALLAS PARKWAY, SUITE 300
FRISCO, TX 75034
(972) 581-9888

CLIENT:



AT&T
550 COCHITUATE ROAD,
FRAMINGHAM, MA 01701

FOR ZONING



DATE SIGNED: 02/10/22

NEXIUS SOLUTIONS, INC.
CONNECTICUT FIRM NO. PEC.0001571
FIRM REGISTRATION RENEWAL 3/17/22.
PE LICENSE RENEWAL 1/31/23

THIS DOCUMENT IS THE DESIGN PROPERTY AND COPYRIGHT OF NEXIUS AND FOR THE EXCLUSIVE USE BY THE TITLE CLIENT. DUPLICATION OR USE WITHOUT THE EXPRESS WRITTEN CONSENT OF THE CREATOR IS STRICTLY PROHIBITED.

SUBMITTALS			
REV	DATE	DESCRIPTION	BY
A	05/05/21	FOR REVIEW	GS
B	10/19/21	FOR REVIEW	PM
0	11/02/21	FINAL ZD	GS
1	01/25/22	REVISED FINAL ZD	GS
2	02/10/22	REVISED FINAL ZD	GS

CHECKED BY: GS
CHECKED DATE: 02/10/22

SITE INFORMATION:
SITE NAME:
CRAN_RCTB_AMTRK_051
USID:
291384
SITE ADDRESS:
**97 HAMILTON AVENUE
STAMFORD, CONNECTICUT 06902**

SHEET TITLE:
POLE ELEVATIONS

SHEET NUMBER:
C-1

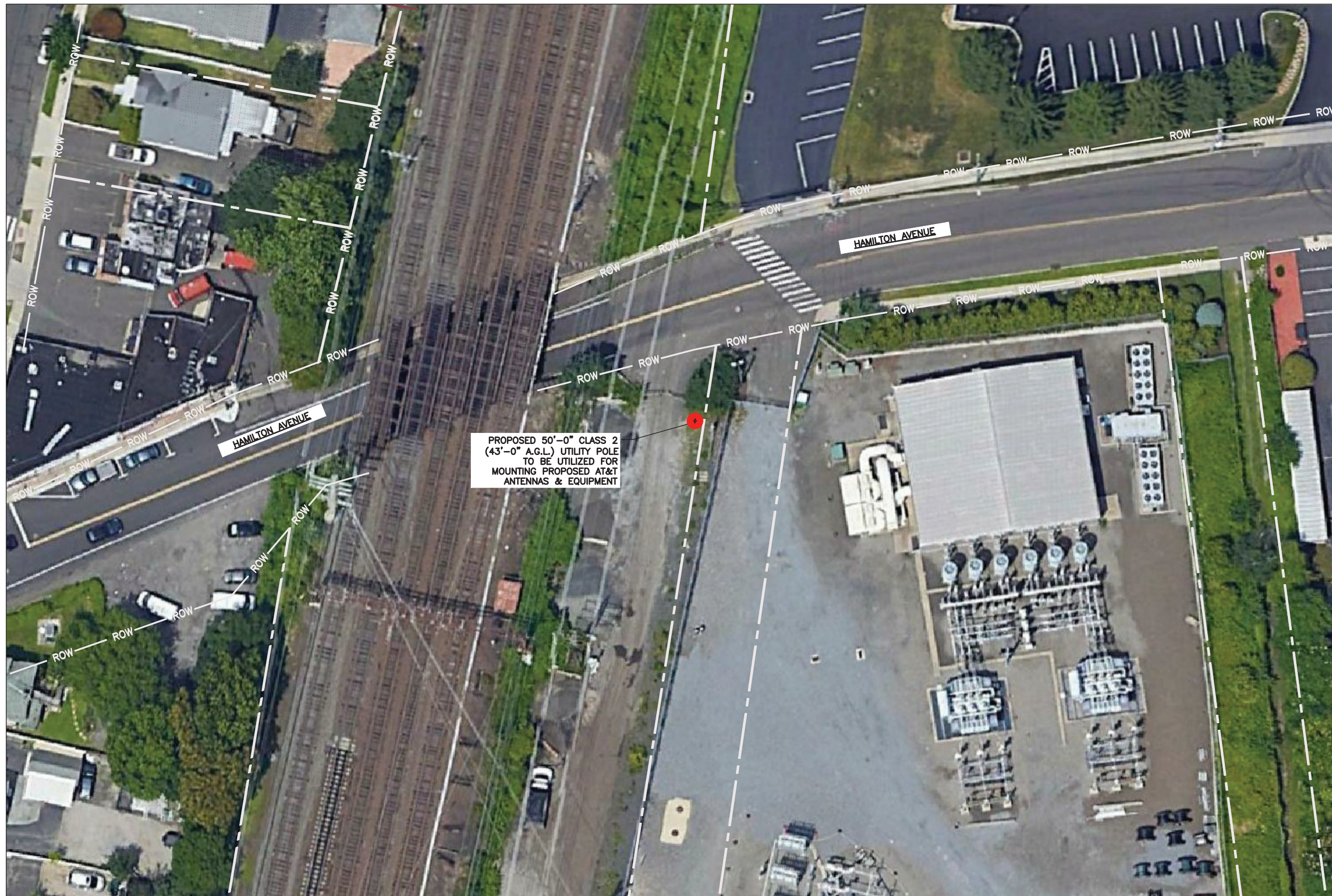

PROPOSED 50'-0" CLASS 2 (43'-0" A.G.L.) UTILITY POLE TO BE UTILIZED FOR MOUNTING PROPOSED AT&T ANTENNAS & EQUIPMENT

1 AERIAL MAP
SCALE: 1:40

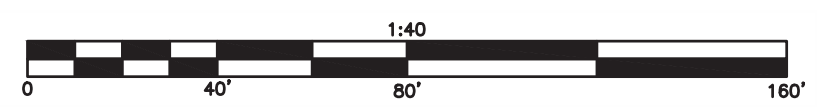
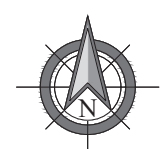

PREPARED BY:

nexus

ENABLING SMARTER CONNECTIONS

A&E OFFICE:
2595 NORTH DALLAS PARKWAY, SUITE 300
FRISCO, TX 75034
(972) 581-9888

CLIENT:



AT&T
550 COCHITUATE ROAD,
FRAMINGHAM, MA 01701

FOR ZONING



DATE SIGNED: 02/10/22

NEXIUS SOLUTIONS, INC.
CONNECTICUT FIRM NO. PEC.0001571
FIRM REGISTRATION RENEWAL 3/17/22.
PE LICENSE RENEWAL 1/31/23

THIS DOCUMENT IS THE DESIGN PROPERTY AND COPYRIGHT OF NEXIUS AND FOR THE EXCLUSIVE USE BY THE TITLE CLIENT. DUPLICATION OR USE WITHOUT THE EXPRESS WRITTEN CONSENT OF THE CREATOR IS STRICTLY PROHIBITED.

SUBMITTALS			
REV	DATE	DESCRIPTION	BY
A	05/05/21	FOR REVIEW	GS
B	10/19/21	FOR REVIEW	PM
0	11/02/21	FINAL ZD	GS
1	01/25/22	REVISED FINAL ZD	GS
2	02/10/22	REVISED FINAL ZD	GS

CHECKED BY: GS CHECKED DATE: 02/10/22

SITE INFORMATION:
SITE NAME:
CRAN_RCTB_AMTRK_051
USID:
291384
SITE ADDRESS:
**97 HAMILTON AVENUE
STAMFORD, CONNECTICUT 06902**

SHEET TITLE:
AERIAL MAP TO SCALE

SHEET NUMBER:
C-2

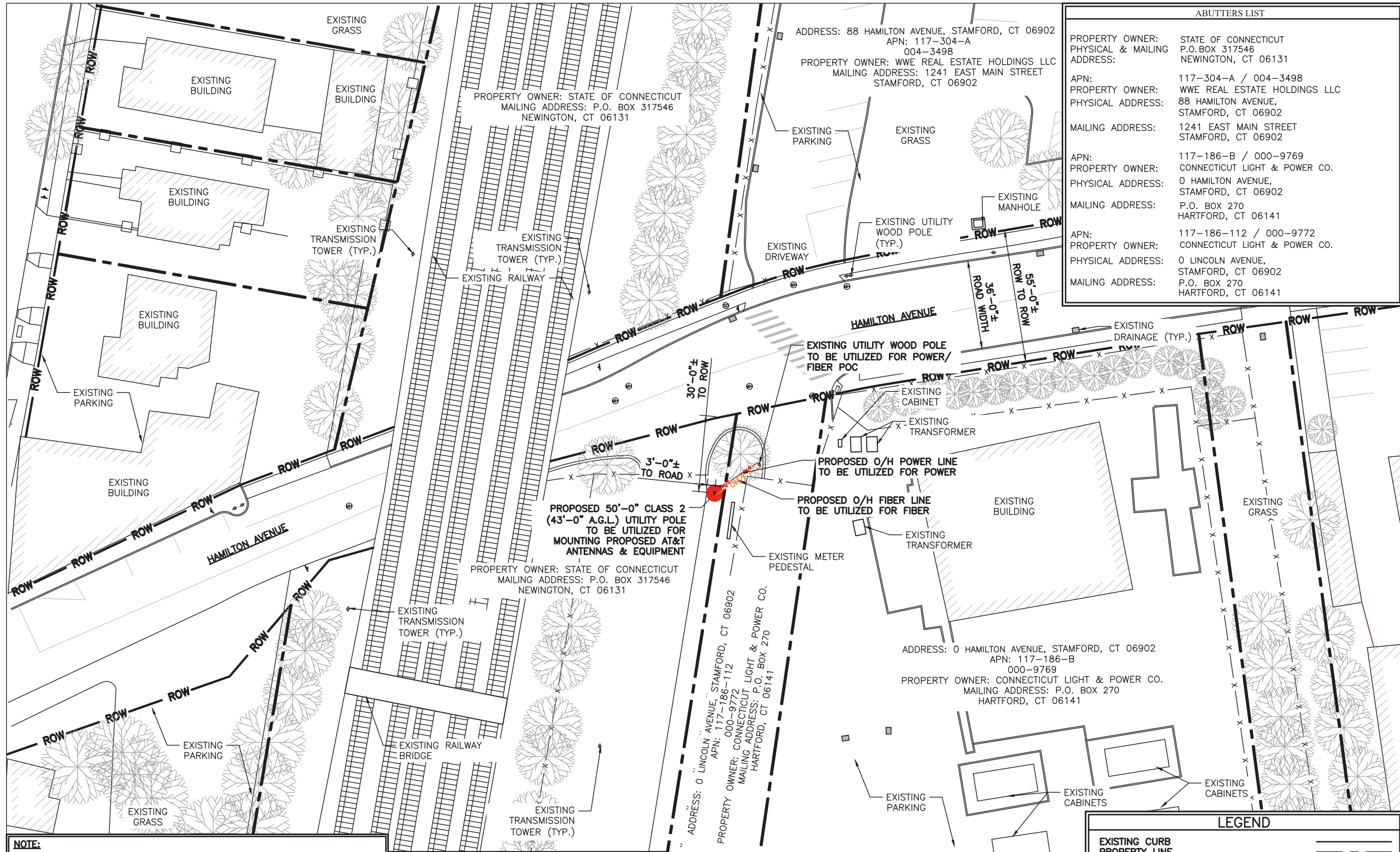

ABUTTERS LIST	
PROPERTY OWNER:	STATE OF CONNECTICUT
PHYSICAL & MAILING ADDRESS:	P.O. BOX 317546 NEWINGTON, CT 06131
APN:	117-304-A / 004-3498
PROPERTY OWNER:	WWE REAL ESTATE HOLDINGS LLC
PHYSICAL ADDRESS:	88 HAMILTON AVENUE, STAMFORD, CT 06902
MAILING ADDRESS:	1241 EAST MAIN STREET STAMFORD, CT 06902
APN:	117-186-B / 000-9769
PROPERTY OWNER:	CONNECTICUT LIGHT & POWER CO.
PHYSICAL ADDRESS:	0 HAMILTON AVENUE, STAMFORD, CT 06902
MAILING ADDRESS:	P.O. BOX 270 HARTFORD, CT 06141
APN:	117-186-112 / 000-9772
PROPERTY OWNER:	CONNECTICUT LIGHT & POWER CO.
PHYSICAL ADDRESS:	0 LINCOLN AVENUE, STAMFORD, CT 06902
MAILING ADDRESS:	P.O. BOX 270 HARTFORD, CT 06141

PREPARED BY:

nexus

ENABLING SMARTER CONNECTIONS

A&E OFFICE:
2595 NORTH DALLAS PARKWAY, SUITE 300
FRISCO, TX 75034
(972) 581-9888

CLIENT:



AT&T
550 COCHITUATE ROAD,
FRAMINGHAM, MA 01701

FOR ZONING

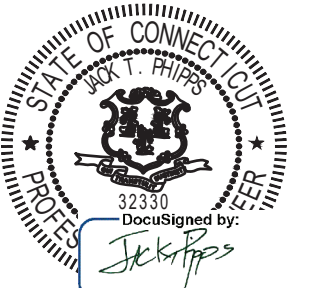

DATE SIGNED: 02/10/22

NEXIUS SOLUTIONS, INC.
CONNECTICUT FIRM NO. PEC.0001571
FIRM REGISTRATION RENEWAL 3/17/22.
PE LICENSE RENEWAL 1/31/23

THIS DOCUMENT IS THE DESIGN PROPERTY AND COPYRIGHT OF NEXIUS AND FOR THE EXCLUSIVE USE BY THE TITLE CLIENT. DUPLICATION OR USE WITHOUT THE EXPRESS WRITTEN CONSENT OF THE CREATOR IS STRICTLY PROHIBITED.

SUBMITTALS

REV	DATE	DESCRIPTION	BY
A	05/05/21	FOR REVIEW	GS
B	10/19/21	FOR REVIEW	PM
0	11/02/21	FINAL ZD	GS
1	01/25/22	REVISED FINAL ZD	GS
2	02/10/22	REVISED FINAL ZD	GS

CHECKED BY: GS
CHECKED DATE: 02/10/22

SITE INFORMATION:
SITE NAME:
CRAN_RCTB_AMTRK_051
USID:
291384
SITE ADDRESS:
**97 HAMILTON AVENUE
STAMFORD, CONNECTICUT 06902**

SHEET TITLE:
SITE PLAN FOR ZONING

SHEET NUMBER:
C-3

NOTE:
PLEASE REFER TO THE SURVEY DATED 08-23-2021 FOR ADDITIONAL INFORMATION. THE CONTRACTOR SHALL VERIFY THAT THE PROPOSED WORK AREA IS LOCATED WITHIN THE PUBLIC RIGHT OF WAY. ANY DISCREPANCIES SHALL BE BROUGHT TO THE ATTENTION OF THE PROJECT MANAGER AND ENGINEER FOR RESOLUTION. THE CONTRACTOR SHALL BE RESPONSIBLE FOR THE RELOCATION AND REPAIR OF ANY CONSTRUCTION PERFORMED OUTSIDE THE PUBLIC OF THE PUBLIC RIGHT OF WAY.

NOTE:
THIS PLAN WAS CREATED BASED ON INFORMATION GATHERED FROM AERIAL PHOTOGRAPHY, GIS DATA, AND/OR ASSESSORS MAPS PROVIDED BY LOCAL SOURCES. THIS PLAN IS IN NO WAY INTENDED TO BE USED AS A BOUNDARY SURVEY.

- NOTE:**
- POC TO BE DETERMINED BY LOCAL UTILITY COMPANY.
 - CONTRACTOR TO FIELD VERIFY ALL EXISTING UNDERGROUND UTILITIES WHERE WORK IS TO BE PERFORMED.

LEGEND	
EXISTING CURB	---
PROPERTY LINE	---
ROW LINE	---
OVERHEAD ELECTRIC LINE	— OH/E —
OVERHEAD FIBER LINE	— OH/F —
UTILITY POLE	⊙
STREET LIGHT	★
MANHOLE	⊕
STORM DRAIN MANHOLE	⊖

1 SITE PLAN
SCALE: 1:40

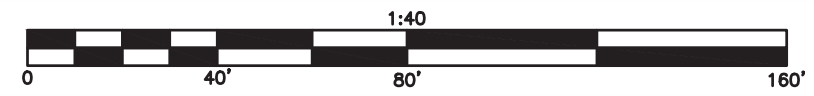

117-304-A
004-3498
N/F
WWE REAL ESTATE HOLDINGS LLC
121 EAST MAIN STREET
STAMFORD, CT 06902

N/F
STATE OF CONNECTICUT
P.O. BOX 317546
NEWINGTON, CT 06131

HAMILTON AVENUE
1924 CITY LAYOUT - 50' WIDE

CENTER OF PROPOSED POLE
LAT: 41°03'48.24"
LON: 73°31'14.16"
N: 584774.44
E: 787491.81
GROUND EL: 29'±

R=647.07' L=56.69'
CHD=N73°23'27"E
CHD L=56.67'

N/F
STATE OF CONNECTICUT
P.O. BOX 317546
NEWINGTON, CT 06131

117-186-B
000-9769
N/F
CONNECTICUT LIGHT & POWER CO.
P.O. BOX 270
HARTFORD, CT 06141

117-186-112
000-9772
N/F
CONNECTICUT LIGHT & POWER CO.
P.O. BOX 270
HARTFORD, CT 06141

VARIABLE WIDTH EASEMENT TO
CONNECTICUT LIGHT & POWER CO.
SEE DEED 3688-173



LEGEND:

- N/F NOW OR FORMERLY
- 117-186-112 ASSESSOR'S ID
- ▲ CALCULATED POINT
- ⊙ ELECTRIC METER
- ⊙ UTILITY POLE
- ⊙ POST
- LOCUS PROPERTY LINE
- - - ABUTTERS PROPERTY LINE (±)
- - - EASEMENT LINE
- OVERHEAD WIRES
- ○ ○ CHAIN LINK FENCE

SITE SPECIFIC NOTES:

1. FIELD SURVEY DATE: 7-19-2021
2. HORIZONTAL DATUM: NORTH AMERICAN DATUM OF 1983 (NAD83)
3. VERTICAL DATUM: NORTH AMERICAN VERTICAL DATUM OF 1988 (NAVD88)
4. OWNER: STATE OF CONNECTICUT
P.O. BOX 317546
NEWINGTON, CT 06131
5. SITE NAME: AMTRAK_SITES_CT_16_D
6. SITE ADDRESS: 97 HAMILTON AVENUE
STAMFORD, CT 06902
7. APPLICANT: AT&T
550 COCHITUATE ROAD
FRAMINGHAM, MA 01701
8. JURISDICTION: CITY OF STAMFORD
FAIRFIELD COUNTY
9. TAX ID: N/A
10. DEED REFERENCE: DEED BOOK 276 PAGE 272
11. PLAN REFERENCE: PLAN 3923
12. ZONING DISTRICT: M-L (LIGHT INDUSTRIAL)
13. THE HORIZONTAL DATUM AND VERTICAL DATUM WERE DERIVED FROM AN RTK GPS SURVEY.
14. ALL UNDERGROUND UTILITY INFORMATION PRESENTED HEREON WAS DETERMINED FROM SURFACE EVIDENCE AND PLANS OF RECORD. ALL UNDERGROUND UTILITIES SHOULD BE LOCATED IN THE FIELD PRIOR TO COMMENCEMENT OF ALL SITE WORK. CALL DISSAFE 1-800-322-4844 A MINIMUM OF 72 HOURS PRIOR TO PLANNED ACTIVITY.
15. ACCORDING TO FEDERAL EMERGENCY MANAGEMENT AGENCY MAPS, THE PROPOSED IMPROVEMENTS ON THIS PROPERTY ARE LOCATED IN AN AREA DESIGNATED AS ZONE X (UNSHADED), AREAS DETERMINED TO BE OUTSIDE THE 0.2% ANNUAL CHANCE FLOODPLAIN. COMMUNITY PANEL NO. 09001C 0509 F EFFECTIVE DATE: 06-18-2010
16. FIELD SURVEY BY RTK GPS.
17. ALL PROPERTY LINES SHOWN ARE FROM DEEDS AND PLANS OF RECORD AND GIS DATA.



PREPARED BY:

nexius

TRANSFORM YOUR BUSINESS...THROUGH WIRELESS

A&E OFFICE:
300 APOLLO DRIVE, SUITE 7
CHELMSFORD, MA 01824
1 (978) 923-7965

APPLICANT:



550 COCHITUATE ROAD
FRAMINGHAM, MA 01701

SUBMITTALS

REV	DATE	DESCRIPTION	BY
1	8/23/2021	SUBMITTED FOR REVIEW	JDG

SITE INFO:

SITE NAME:
AMTRAK_SITES_CT_16_D
LOCATION CODE:

SITE ADDRESS:
**97 HAMILTON AVENUE
STAMFORD, CT 06902**

SHEET TITLE:

**ABUTTERS PLAN &
EXISTING CONDITIONS**

NEXIUS PROJ. NO: - SHEET NUMBER:

CHECKED BY:
BCF

8/23/2021

C-1

THIS SURVEY HAS BEEN PREPARED PURSUANT TO THE REGULATIONS OF CONNECTICUT STATE AGENCIES SECTIONS 20-300B-1 THROUGH 20-300B-20 AND THE "STANDARDS FOR SURVEYS AND MAPS IN THE STATE OF CONNECTICUT" AS ADOPTED BY THE CONNECTICUT ASSOCIATION OF LAND SURVEYORS INC. ON SEPTEMBER 26, 1997.

TYPE OF SURVEY: LOCATION SURVEY
BOUNDARY SURVEY CATEGORY: DEPENDENT RESURVEY

CLASS OF ACCURACY: HORIZONTAL CLASS: D
VERTICAL CLASS: N/A
PURPOSE OF SURVEY: DETERMINE LOCATION OF PROPOSED UTILITY POLE

THIS DOCUMENT AND COPIES THEREOF ARE VALID ONLY IF THEY BEAR THE LIVE SIGNATURE AND EMBOSSED SEAL OF THE DESIGNATED PROFESSIONAL. UNAUTHORIZED ALTERATIONS RENDER ANY DECLARATION NULL AND VOID.

TO THE BEST OF MY KNOWLEDGE AND BELIEF, THIS MAP IS SUBSTANTIALLY CORRECT AS NOTED HEREON.

Charles G. Gidman
CHARLES G. GIDMAN, P.L.S. #70103

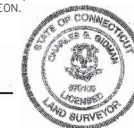

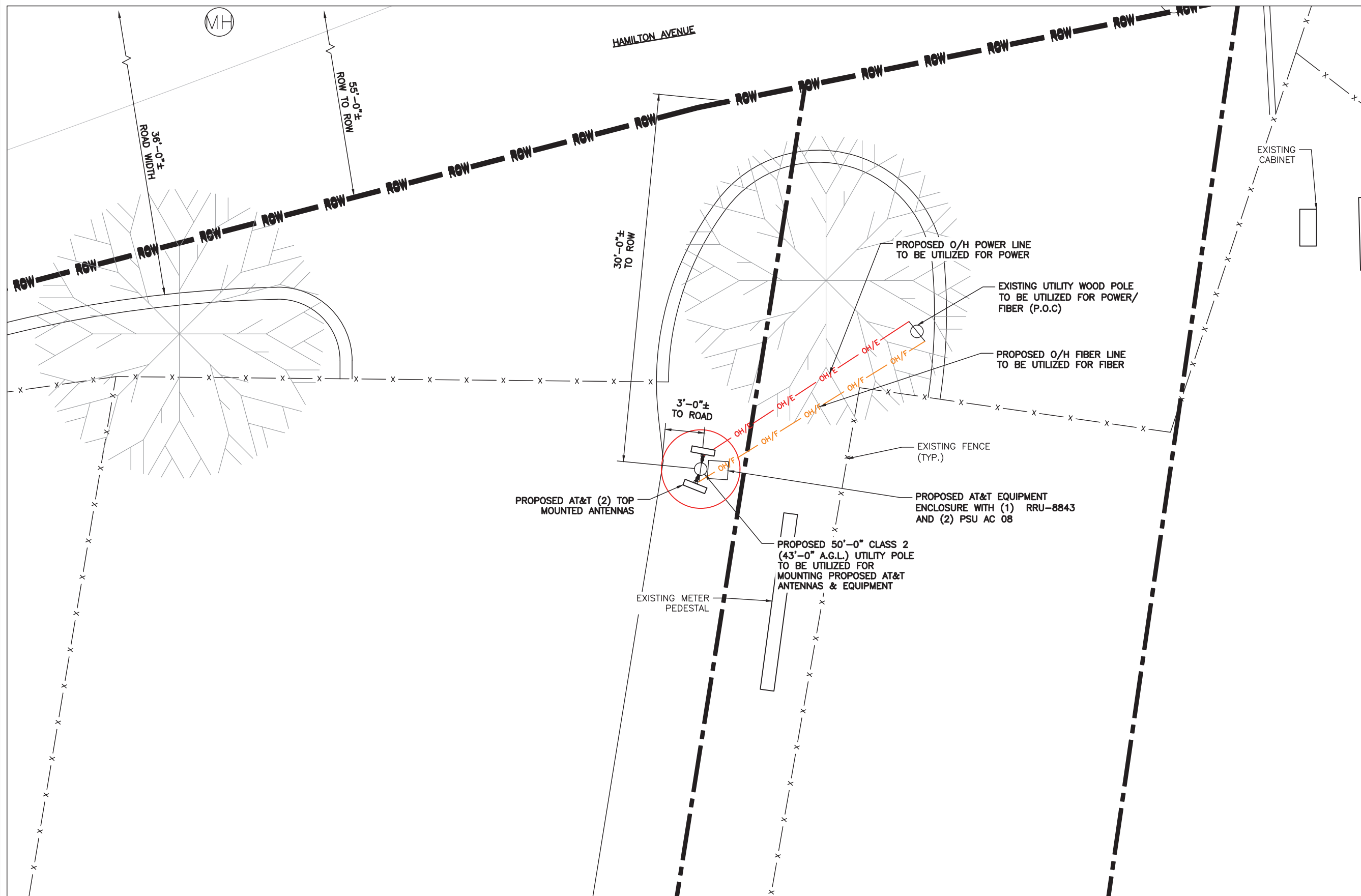

1 ENLARGED SITE PLAN
SCALE: 1/8" = 1'-0"

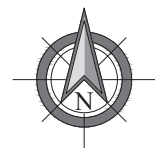

PREPARED BY:

nexus

ENABLING SMARTER CONNECTIONS

A&E OFFICE:
2595 NORTH DALLAS PARKWAY, SUITE 300
FRISCO, TX 75034
(972) 581-9888

CLIENT:



AT&T
550 COCHITUATE ROAD,
FRAMINGHAM, MA 01701

FOR ZONING

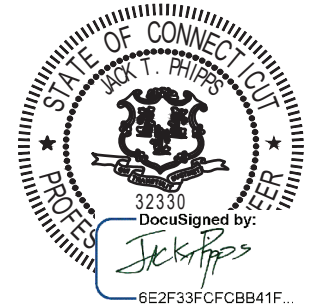

DATE SIGNED: 02/10/22

NEXIUS SOLUTIONS, INC.
CONNECTICUT FIRM NO. PEC.0001571
FIRM REGISTRATION RENEWAL 3/17/22.
PE LICENSE RENEWAL 1/31/23

THIS DOCUMENT IS THE DESIGN PROPERTY AND COPYRIGHT OF NEXIUS AND FOR THE EXCLUSIVE USE BY THE TITLE CLIENT. DUPLICATION OR USE WITHOUT THE EXPRESS WRITTEN CONSENT OF THE CREATOR IS STRICTLY PROHIBITED.

SUBMITTALS			
REV	DATE	DESCRIPTION	BY
A	05/05/21	FOR REVIEW	GS
B	10/19/21	FOR REVIEW	PM
0	11/02/21	FINAL ZD	GS
1	01/25/22	REVISED FINAL ZD	GS
2	02/10/22	REVISED FINAL ZD	GS

CHECKED BY: GS
CHECKED DATE: 02/10/22

SITE INFORMATION:
SITE NAME:
CRAN_RCTB_AMTRK_051
USID:
291384
SITE ADDRESS:
**97 HAMILTON AVENUE
STAMFORD, CONNECTICUT 06902**

SHEET TITLE:
ENLARGED SITE PLAN

SHEET NUMBER:
C-5

ANTENNA SPECIFICATIONS	
MANUFACTURER	GALTRONICS
MODEL NUMBER	GP2406-06670
HEIGHT	23.3"
WIDTH	23.3"
DEPTH	6.0"
WEIGHT	26.5 LBS.

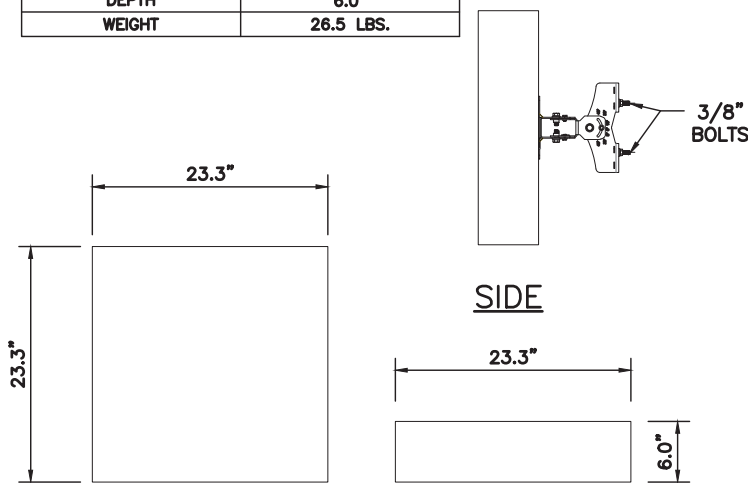

FRONT

BOTTOM

① ANTENNA DETAIL
SCALE: N.T.S.

ANTENNA BRACKET SPECIFICATIONS	
MANUFACTURER	GALTRONICS
MODEL NUMBER	62-45-09
HEIGHT	6.3"
WIDTH	8.9"
LENGTH	8.0"
WEIGHT	5.4 LBS.
ITEM NUMBER	ANT.16455

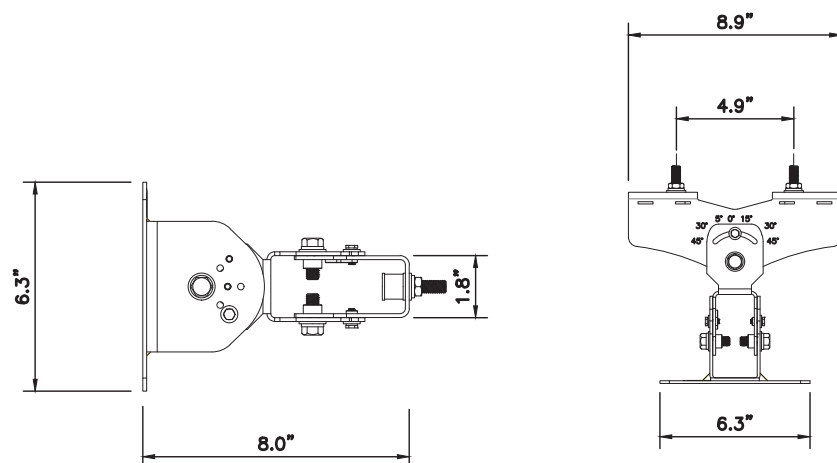

SIDE

TOP

② ANTENNA BRACKET DETAIL
SCALE: N.T.S.

③ NOT USED
SCALE: N.T.S.

RADIO SPECIFICATIONS	
MANUFACTURER	ERICSSON
MODEL NUMBER	RRU 8843
HEIGHT	14.9"
WIDTH	13.2"
DEPTH	10.9"
WEIGHT	72 LBS.

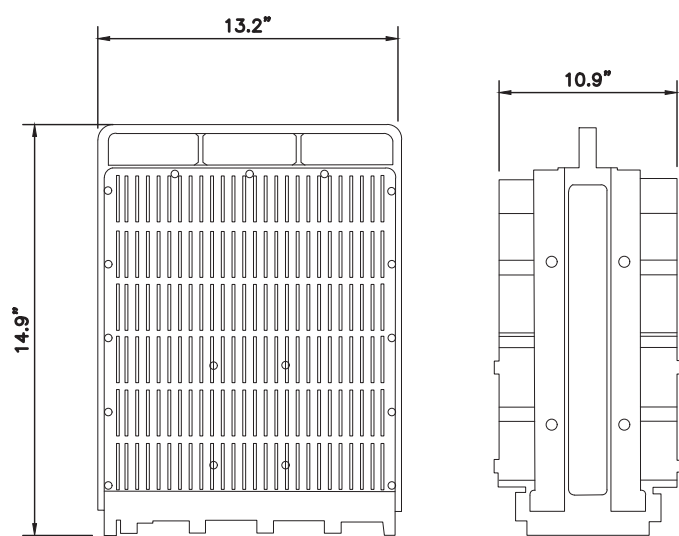

FRONT

SIDE

④ RRU 8843 DETAIL
SCALE: N.T.S.

⑤ NOT USED
SCALE: N.T.S.

⑥ NOT USED
SCALE: N.T.S.

PREPARED BY:

nexius

ENABLING SMARTER CONNECTIONS

A&E OFFICE:
2595 NORTH DALLAS PARKWAY, SUITE 300
FRISCO, TX 75034
(972) 581-9888

CLIENT:



AT&T
550 COCHITUATE ROAD,
FRAMINGHAM, MA 01701

FOR ZONING

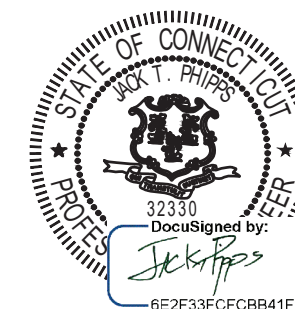

DATE SIGNED: 02/10/22

NEXIUS SOLUTIONS, INC.
CONNECTICUT FIRM NO. PEC.0001571
FIRM REGISTRATION RENEWAL 3/17/22.
PE LICENSE RENEWAL 1/31/23

THIS DOCUMENT IS THE DESIGN PROPERTY AND COPYRIGHT OF NEXIUS AND FOR THE EXCLUSIVE USE BY THE TITLE CLIENT. DUPLICATION OR USE WITHOUT THE EXPRESS WRITTEN CONSENT OF THE CREATOR IS STRICTLY PROHIBITED.

SUBMITTALS			
REV	DATE	DESCRIPTION	BY
A	05/05/21	FOR REVIEW	GS
B	10/19/21	FOR REVIEW	PM
0	11/02/21	FINAL ZD	GS
1	01/25/22	REVISED FINAL ZD	GS
2	02/10/22	REVISED FINAL ZD	GS

CHECKED BY: GS
CHECKED DATE: 02/10/22

SITE INFORMATION:
SITE NAME:
CRAN_RCTB_AMTRK_051
USID:
291384
SITE ADDRESS:
**97 HAMILTON AVENUE
STAMFORD, CONNECTICUT 06902**

SHEET TITLE:
EQUIPMENT DETAILS

SHEET NUMBER:
EQ-1

PSU SPECIFICATIONS	
MANUFACTURER	ERICSSON
MODEL NUMBER	PSU AC 08
HEIGHT	7.1"
WIDTH	10.8"
DEPTH	2.7"
WEIGHT	11.5 LBS.

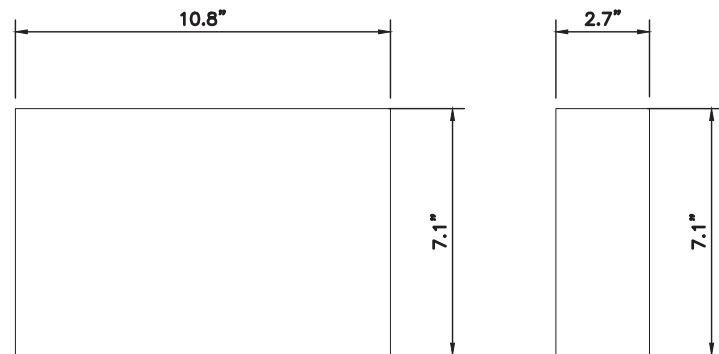

① PSU AC 08 DETAIL
SCALE: N.T.S.

AC DISTRIBUTION BOX SPECIFICATIONS	
MANUFACTURER	RAYCAP
MODEL NUMBER	RSCAC-9556-P-240-D
HEIGHT	12.39"
WIDTH	8.59"
DEPTH	5.65"
WEIGHT	8.0 LBS.
ITEM NUMBER	CEQ.21617

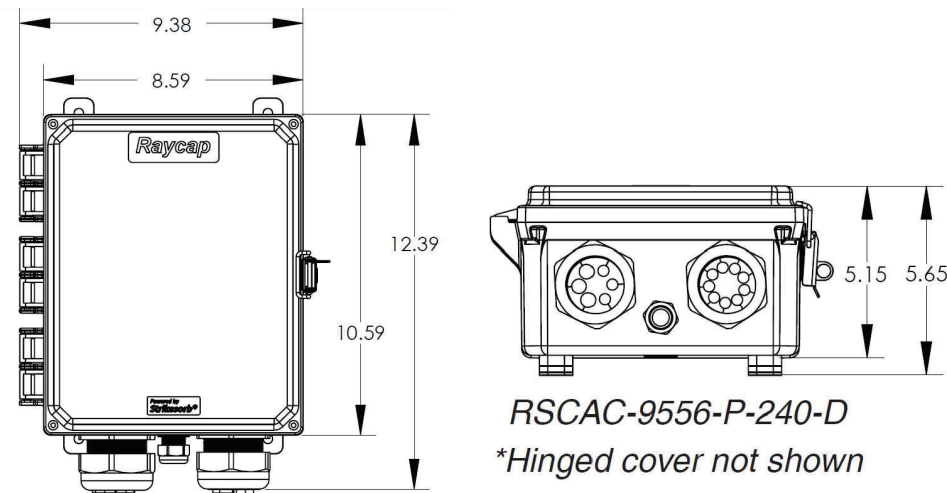

RSCAC-9556-P-240-D
*Hinged cover not shown

② AC DISTRIBUTION BOX DETAIL
SCALE: N.T.S.



RSCAC-9556-P-240-D

INSIDE

METER SPECIFICATIONS	
MANUFACTURER	MILBANK
MODEL NUMBER	U2272-RL-5T9-BL
HEIGHT	18.5"
WIDTH	10.0"
DEPTH	4.84"

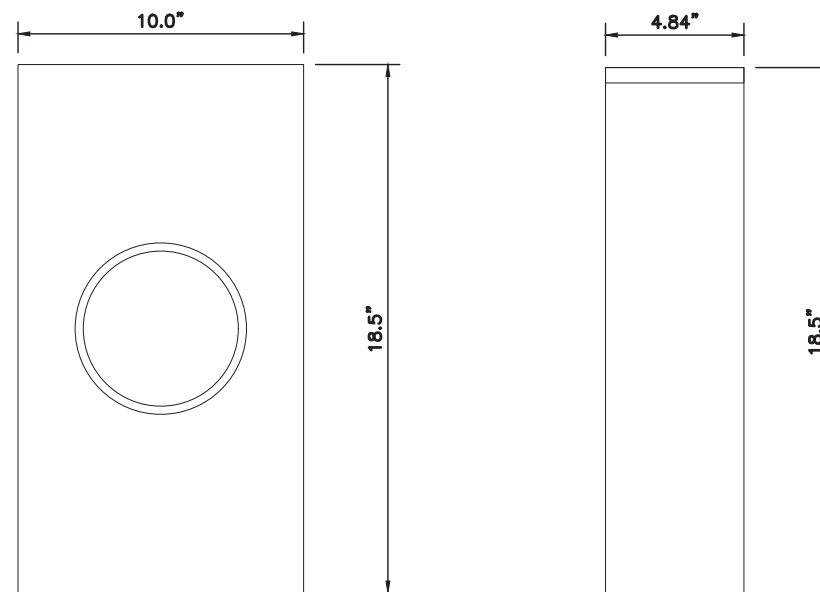

FRONT

SIDE

④ METER MAIN WITH BYPASS DETAIL
SCALE: N.T.S.

③ NOT USED
SCALE: N.T.S.

PREPARED BY:

nexus

ENABLING SMARTER CONNECTIONS

A&E OFFICE:
2595 NORTH DALLAS PARKWAY, SUITE 300
FRISCO, TX 75034
(972) 581-9888

CLIENT:



AT&T
550 COCHITUATE ROAD,
FRAMINGHAM, MA 01701

FOR ZONING

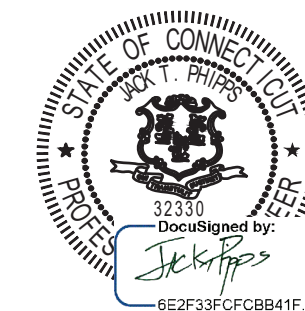

DATE SIGNED: 02/10/22

NEXIUS SOLUTIONS, INC.
CONNECTICUT FIRM NO. PEC.0001571
FIRM REGISTRATION RENEWAL 3/17/22.
PE LICENSE RENEWAL 1/31/23

THIS DOCUMENT IS THE DESIGN PROPERTY AND COPYRIGHT OF NEXIUS AND FOR THE EXCLUSIVE USE BY THE TITLE CLIENT. DUPLICATION OR USE WITHOUT THE EXPRESS WRITTEN CONSENT OF THE CREATOR IS STRICTLY PROHIBITED.

SUBMITTALS			
REV	DATE	DESCRIPTION	BY
A	05/05/21	FOR REVIEW	GS
B	10/19/21	FOR REVIEW	PM
0	11/02/21	FINAL ZD	GS
1	01/25/22	REVISED FINAL ZD	GS
2	02/10/22	REVISED FINAL ZD	GS

CHECKED BY: GS
CHECKED DATE: 02/10/22

SITE INFORMATION:
SITE NAME:
CRAN_RCTB_AMTRK_051
USID:
291384
SITE ADDRESS:
**97 HAMILTON AVENUE
STAMFORD, CONNECTICUT 06902**

SHEET TITLE:
EQUIPMENT DETAILS

SHEET NUMBER:
EQ-2

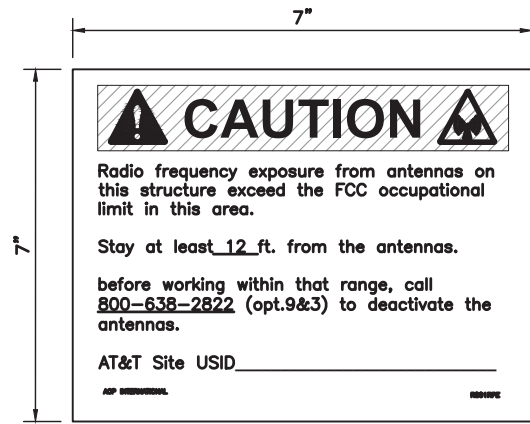

AT&T YELLOW CAUTION SIGN MOUNTED ON THE EQUIPMENT SHROUD

NOTE:
 SIGNAGE MUST BE ORDERED FROM ACP INTL SIGNS INC., ACCORDING TO THE GUIDANCE IN SECTION 6.2 'ACPT INTL SIGNS ORDERING PROCESS (CRAN) IN ATT-790-202-062 DAS (DISTRIBUTED ANTENNA SYSTEM) AND CRAN (CENTRALIZED RADIO ACCESS NETWORK) SIGNAGE STANDARD.
<http://apex.web.att.com/bookview/bookview.jsp?bookname=att-790-202-062&fulltext>
 1. ORDERING PART NUMBER FOR THIS SIGN IS: ABOVE R801RPE
 2. SIGN DIMENSIONS ARE: HEIGHT= 7', WIDTH=7'
 3. USE THE SUPPLIED NUMBER PAD TO ENTER THE NUMBER 12. INTO THE BLANK SPACE AS SHOWN IN THE SIGN DIAGRAM.

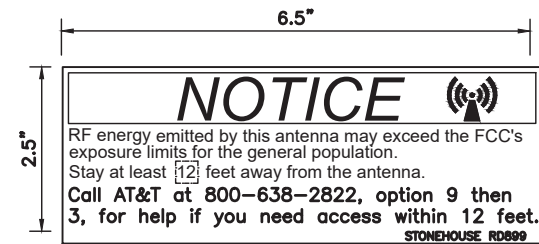

AT&T NOTICE SIGN (TOTAL OF 2) TO BE PLACED (1) NOTICE STICKER AT THE BOTTOM OF EACH ANTENNA.

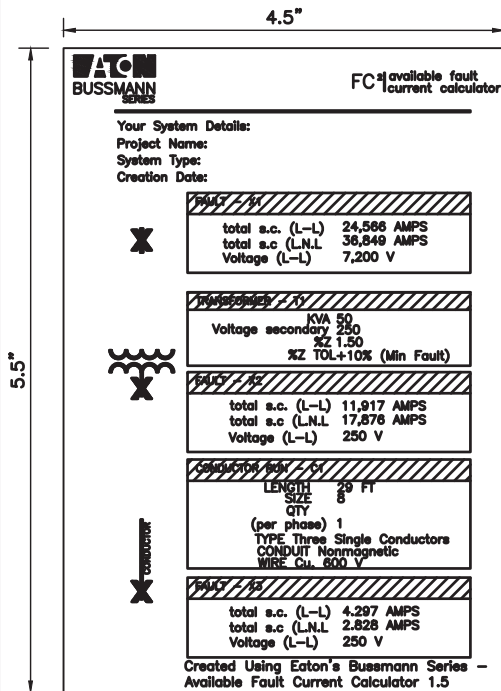

AT&T FAULT CURRENT SIGN MOUNTED ON THE DISCONNECT

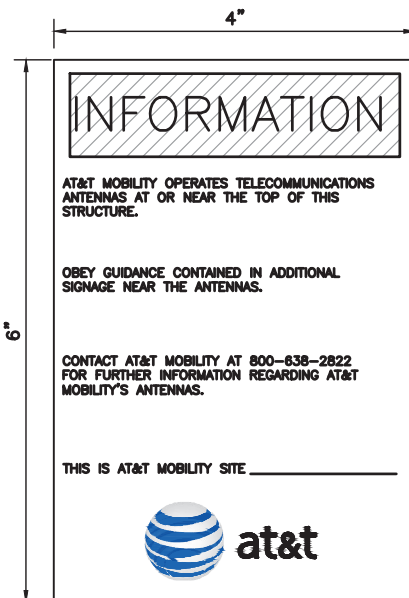

AT&T INFORMATION SIGN TO BE MOUNTED TO FRONT OF AC DISTRIBUTION BOX

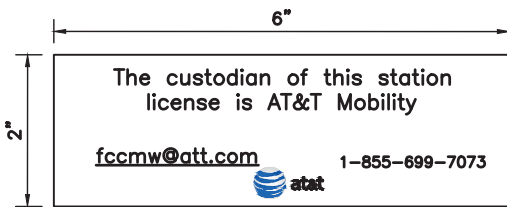

AT&T CUSTODIAN SIGN TO BE MOUNTED TO FRONT OF AC DISTRIBUTION BOX

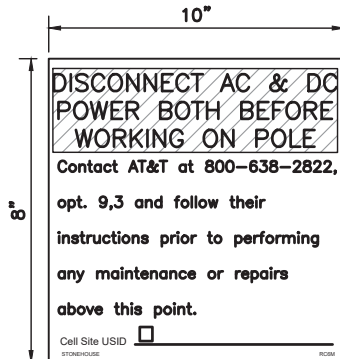

POLE OWNER DISCONNECT SIGN TO BE PLACED AT THE DISCONNECT

EQUIPMENT ENCLOSURE SPECIFICATIONS	
MANUFACTURER	CHARLES
MODEL NUMBER	SH60-702018DNE7
HEIGHT	70.0"
WIDTH	20.0"
DEPTH	18.0"
WEIGHT	181.0 LBS.
ITEM NUMBER	CEQ.43918

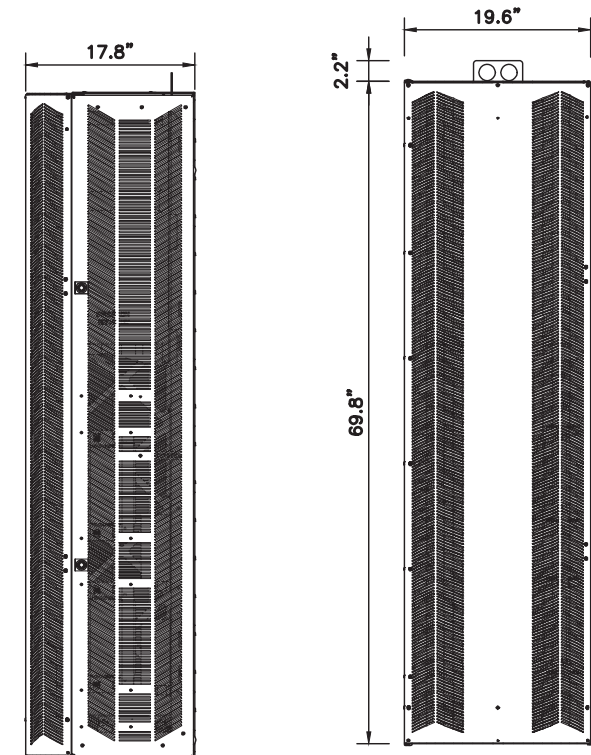

SIDE

FRONT

2 EQUIPMENT CABINET DETAIL SCALE: N.T.S.

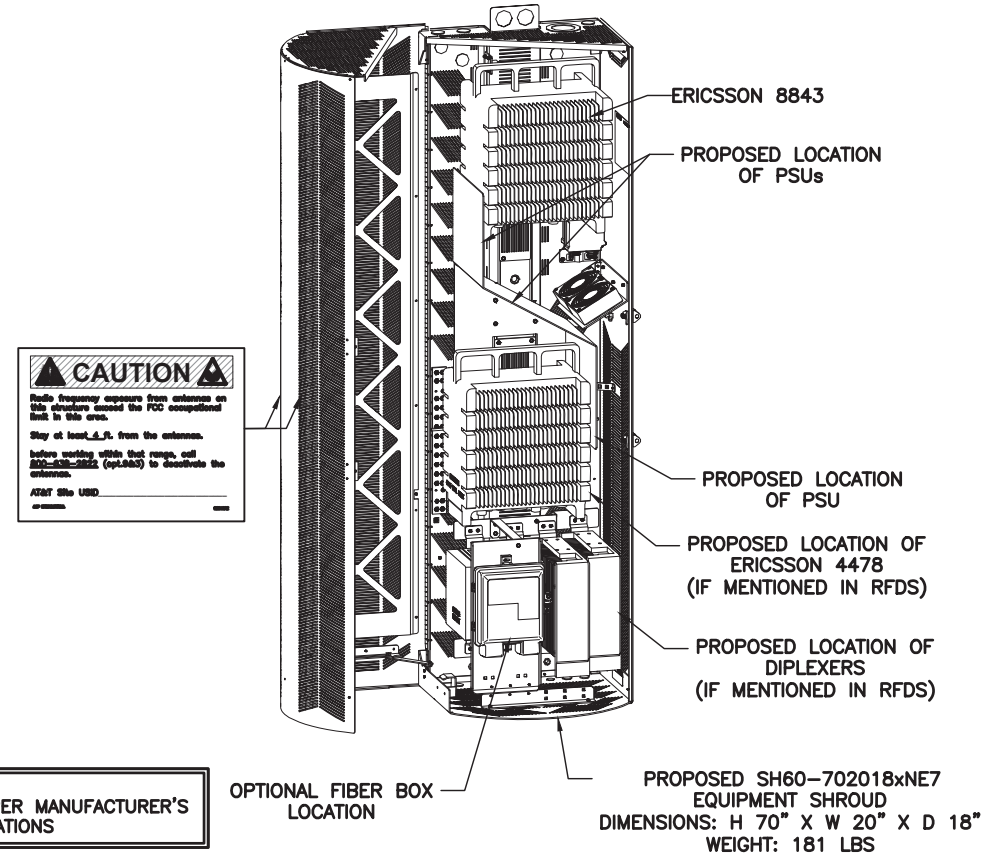

NOTE:
 MOUNT PER MANUFACTURER'S SPECIFICATIONS

3 EQUIPMENT CABINET DETAIL SCALE: N.T.S.

PREPARED BY:

nexius

ENABLING SMARTER CONNECTIONS

A&E OFFICE:
 2595 NORTH DALLAS PARKWAY, SUITE 300
 FRISCO, TX 75034
 (972) 581-9888

CLIENT:



AT&T
 550 COCHITUATE ROAD,
 FRAMINGHAM, MA 01701

FOR ZONING



DATE SIGNED: 02/10/22

NEXIUS SOLUTIONS, INC.
 CONNECTICUT FIRM NO. PEC.0001571
 FIRM REGISTRATION RENEWAL 3/17/22.
 PE LICENSE RENEWAL 1/31/23

THIS DOCUMENT IS THE DESIGN PROPERTY AND COPYRIGHT OF NEXIUS AND FOR THE EXCLUSIVE USE BY THE TITLE CLIENT. DUPLICATION OR USE WITHOUT THE EXPRESS WRITTEN CONSENT OF THE CREATOR IS STRICTLY PROHIBITED.

SUBMITTALS			
REV	DATE	DESCRIPTION	BY
A	05/05/21	FOR REVIEW	GS
B	10/19/21	FOR REVIEW	PM
0	11/02/21	FINAL ZD	GS
1	01/25/22	REVISED FINAL ZD	GS
2	02/10/22	REVISED FINAL ZD	GS

CHECKED BY: GS CHECKED DATE: 02/10/22

SITE INFORMATION: SITE NAME: CRAN_RCTB_AMTRK_051
 USID: 291384
 SITE ADDRESS: 97 HAMILTON AVENUE
 STAMFORD, CONNECTICUT 06902

SHEET TITLE: EQUIPMENT DETAILS

SHEET NUMBER: EQ-3

1 SIGNAGE DETAILS SCALE: N.T.S.

NOTES:

- EQUIPMENT AND LAYOUT SHOWN IS FOR DIAGRAMMATIC PURPOSES ONLY. REFER TO PROPOSED SITE PLAN AND POLE ELEVATION FOR ACTUAL EQUIPMENT LOCATIONS AND CONDITIONS.
- ALL ELECTRICAL WORK MUST MEET THE REQUIREMENTS OF THE NATIONAL ELECTRICAL CODE AND THE NATIONAL ELECTRICAL SAFETY CODE.
- BONDING AND GROUNDING TO MEET APPLICABLE NEC REQUIREMENTS.

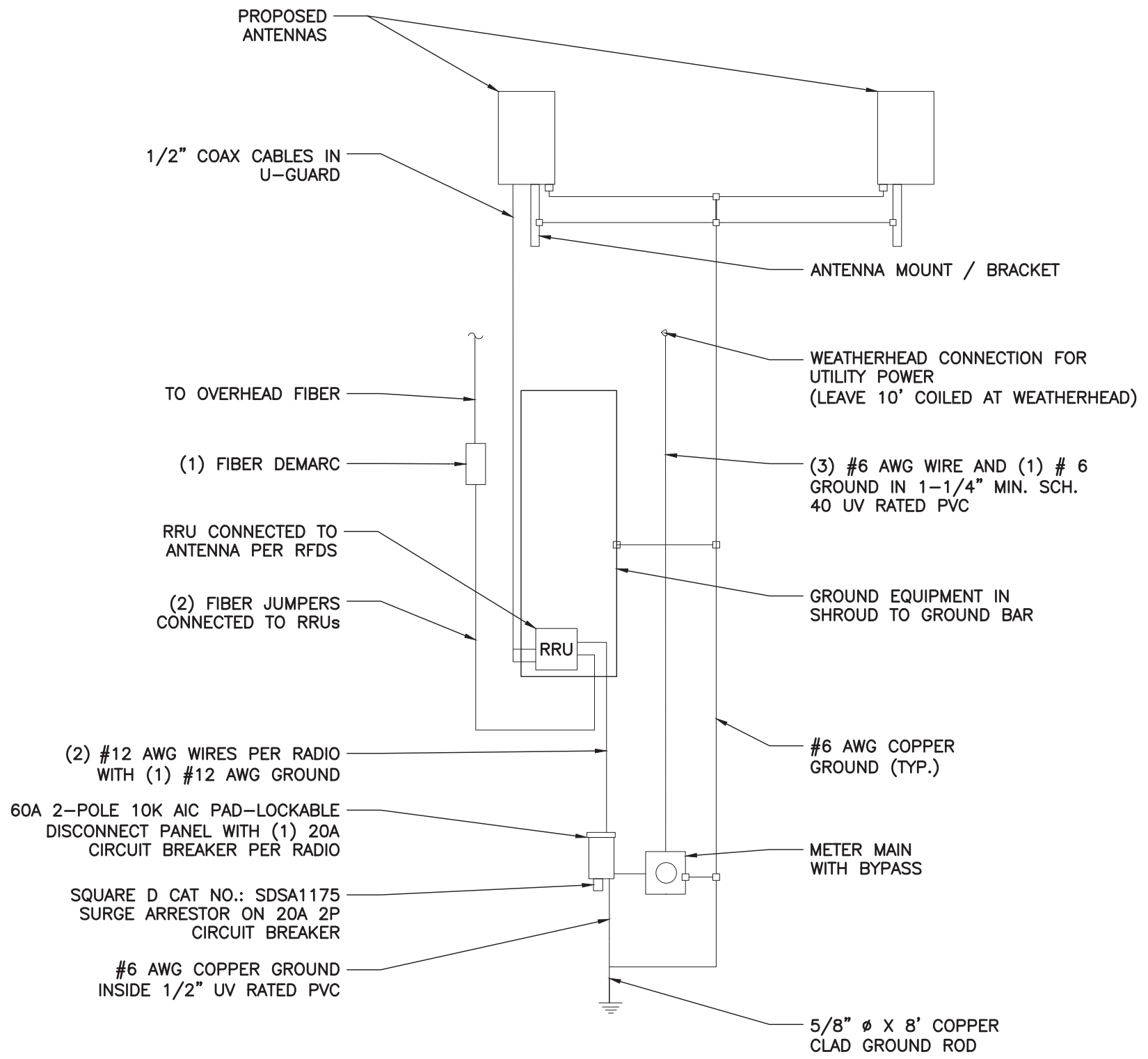

1 GENERAL WIRING DIAGRAM
SCALE: N.T.S.

PREPARED BY:
nexus
ENABLING SMARTER CONNECTIONS
A&E OFFICE:
2595 NORTH DALLAS PARKWAY, SUITE 300
FRISCO, TX 75034
(972) 581-9888

CLIENT:

AT&T
550 COCHITUATE ROAD,
FRAMINGHAM, MA 01701

FOR ZONING

32330
DocuSigned by:
Jack Phipps
6E2F33FCFCBB41F...

DATE SIGNED: 02/10/22
NEXIUS SOLUTIONS, INC.
CONNECTICUT FIRM NO. PEC.0001571
FIRM REGISTRATION RENEWAL 3/17/22.
PE LICENSE RENEWAL 1/31/23

THIS DOCUMENT IS THE DESIGN PROPERTY AND COPYRIGHT OF NEXIUS AND FOR THE EXCLUSIVE USE BY THE TITLE CLIENT. DUPLICATION OR USE WITHOUT THE EXPRESS WRITTEN CONSENT OF THE CREATOR IS STRICTLY PROHIBITED.

SUBMITTALS

REV	DATE	DESCRIPTION	BY
A	05/05/21	FOR REVIEW	GS
B	10/19/21	FOR REVIEW	PM
0	11/02/21	FINAL ZD	GS
1	01/25/22	REVISED FINAL ZD	GS
2	02/10/22	REVISED FINAL ZD	GS

CHECKED BY: GS
CHECKED DATE: 02/10/22

SITE INFORMATION:
SITE NAME:
CRAN_RCTB_AMTRK_051
USID:
291384
SITE ADDRESS:
**97 HAMILTON AVENUE
STAMFORD, CONNECTICUT 06902**

SHEET TITLE:
ELECTRICAL AND GROUNDING DETAILS

SHEET NUMBER:
E-1

ATTACHMENT 3

n e x i u s

Engineering Structural Analysis Report

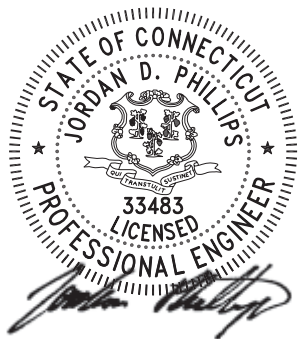

Jordan D Phillips PE

Digitally signed by Jordan D Phillips
PE
DN: C=US,
E=jordan.phillips@nexius.com,
O="Nexius Solutions, Inc.", OU=A/E
Group - Structural Engineering,
CN=Jordan D Phillips PE
Location: Sylvan Lake, MI
Reason: I am the author of this
document
Contact Info: (248) 709-3642
Date: 2022.01.26 15:06:43-05'00'

CRAN_RCTB_AMTRK_051

Proposed

MRCTB045148

1/26/2022

ADEQUATE

Engineering Structural Analysis Report

Reference: Assessment of the **Proposed** 50-ft Class 2 Wooden Pole.
Cascade ID - Candidate: CRAN_RCTB_AMTRK_051
Site Address: 97 HAMILTON AVENUE, STAMFORD, CT 06902

We are pleased to provide you with our engineering assessment of the 50-ft Wooden Pole located at 97 HAMILTON AVENUE, STAMFORD, CT 06902.

The pole analyzed for this project is a 50-ft tall, Class 2 pole. The program calculates an applied wind load on the surface area of the attachments and multiplies that by the height of the attachment to determine a bending moment in the pole (WL load and BM). It also calculates the vertical loads applied and adds the moment due to the applied gravity loads. The calculated moment is compared to the pole capacity and capacity utilization is calculated. The final calculations for this pole indicate a capacity utilization is 64.4%. This is below the maximum allowable capacity utilization, 100%, so it is determined that the applied loads and configuration is acceptable for this pole.

Existing information such as pole height, line types, line heights and depth of set are based on site photographs gathered by Nexius staff. Line and equipment heights are determined based on standard spacing requirements set forth by the pole owner and standard industry practices. If any of these assumptions are not valid or made in error, the conclusion of this assessment may be affected and NEXIUS should review the effect on the structural integrity of the pole.

To the best of our knowledge and based on the result of this pole loading calculation, the additional loadings to the existing pole will not compromise the structural integrity of this utility/streetlight pole. This pole loading calculation satisfies the minimum requirements set forth by the National Electric Code, National Electric Safety Code, ANSI O5 utility pole standards, and the pole owner's attachment standards. If any of these assumptions are not valid or made in error, the conclusion of this assessment may be affected and NEXIUS should review the effect on the structural integrity of the pole.

Please contact us if you have any questions.

ASSUMPTIONS AND LIMITATIONS OF ANALYSIS

Please note the following assumptions and limitations inherent in this analysis and report:

A) The equipment configuration is as per “15122383.AE201.220125.REV 1” Drawings by NEXIUS, dated 01/25/2022.

If any of these assumptions are not valid or made in error, the conclusion of this assessment may be affected and NEXIUS should review the effect on the structural integrity of the pole.

<u>Proposed Final Equipment</u>		
Item	Model	Quantity
Antenna	Galtronics GP2406-06670 w/ Mount Bracket	2
125-Amp Meter	MILBANK U2272-RL-5T9-BL	1
AC Distribution Box	RAYCAP RSCAC-9556-P-240-D	1
Equipment Enclosure	Charles SH60-702018DNE7	1
Radio	Ericsson 8843	1*
PSU	Ericsson PSU AC 08	2*

*Located inside Equipment Enclosure

CONCLUSIONS & RECOMMENDATIONS:

The **proposed** 50-ft wooden pole has been found **ADEQUATE** to support its overall and total load subject to the attached Standard Conditions on **page 4** and the above-mentioned assumptions and limitations.

Please note that the soils report for the foundation were not available to us at the time of this analysis, therefore, the soil conditions have been assumed.

Should you have any questions, comments or require additional information, please do not hesitate to call.

Sincerely,

Analysis by: Salman Al Jurdi

Reviewed by: Jordan Phillips, PE

Standard Conditions for Providing Structural Consulting Services on Existing Structures

1. If the existing conditions are not as represented in this structural report or attached sketches, we should be contacted to evaluate the significance of the deviation and revise the structural assessment accordingly.
2. The structural analysis has been performed assuming that the structure is in “like new” condition. No allowance was made for excessive corrosion, damaged or missing structural members, loose bolts, etc. If there are any known deficiencies in the structure that potentially compromise structural integrity, we should be made aware of the deficiencies. If we are aware of a deficiency that exists in a structure at the time of our analysis, a general explanation of the structural concern due to the deficiency will be included in the structural report, but the deficiency will not be reflected in capacity calculations.
3. The structural analysis provided is an assessment of the primary load carrying capacity of the structure. We provide a limited scope of service, in that we have not verified the capacity of every weld, plate, connection detail, etc. In most cases, structural fabrication details are unknown at the time of our analysis, and the detailed field measurement of this information is beyond the scope of our services. In instances where we have not performed connection/component capacity calculations, it is assumed that existing manufactured connection/component develop the full capacity of the primary members being calculated.
4. We will not accept any liability for the adequacy of the existing foundation system unless accurate structural foundation drawings are provided with a site-specific geotechnical report. Foundations will be assumed installed per the drawings with no construction deficiency due to initial installation or age.
5. Miscellaneous items such as antenna mounts, coax supports, etc. have not been designed, detailed, or specified as part of our work. It is assumed that material of adequate size and strength will be purchased from a reputable component manufacturer. The attached report and sketches are schematic in nature and should not be used to fabricate or purchase hardware and accessories to be attached to the structure. We recommend field measurement of the structure before fabricating or purchasing new hardware and accessories. We are not responsible for proper fit and clearance of hardware and accessory items in the field.
6. The structural analysis has been performed considering minimum code requirements or recommendations. If alternate wind, ice, or deflection criteria are to be considered, then we shall be made aware of the alternate criteria.

Pole Num:	N/A	Pole Length / Class:	50 / 2	Code:	Structure Type:	Deadend
Customer:	AT&T	Species:	SOUTHERN PINE	NESC Rule:	Status	Unguyed
PACE #:	MRCTB045148	Setting Depth (ft):	7.00	Construction Grade:	Rule 250B	0.65
USID:	291384	G/L Circumference (in):	41.61	Loading District:	Heavy	2.50
Site Address:	97 Hamilton Ave	G/L Fiber Stress (psi):	8,000	Ice Thickness (in):	0.50	1.65
Pole Owner:	CT DOT	Allowable Stress (psi):	5,200	Wind Speed (mph):	39.53	1.50
Proposed RAD Center (AGL):	42'-0"	Fiber Stress Ht. Reduc:	No	Wind Pressure (psf):	4.00	
Latitude:		Longitude:	41.063400 Deg	Elevation:	-73.520600 Deg	33 Feet

Pole Capacity Utilization (%)	Height (ft)	Wind Angle (deg)
Maximum	64.4	51.2
Groundline	64.4	51.2
Vertical	5.5	51.2

Pole Moments (ft-lb)	Load Angle (deg)	Wind Angle (deg)
Max Cap Util	63,230	51.2
Groundline	63,230	51.2
GL Allowable	98,873	

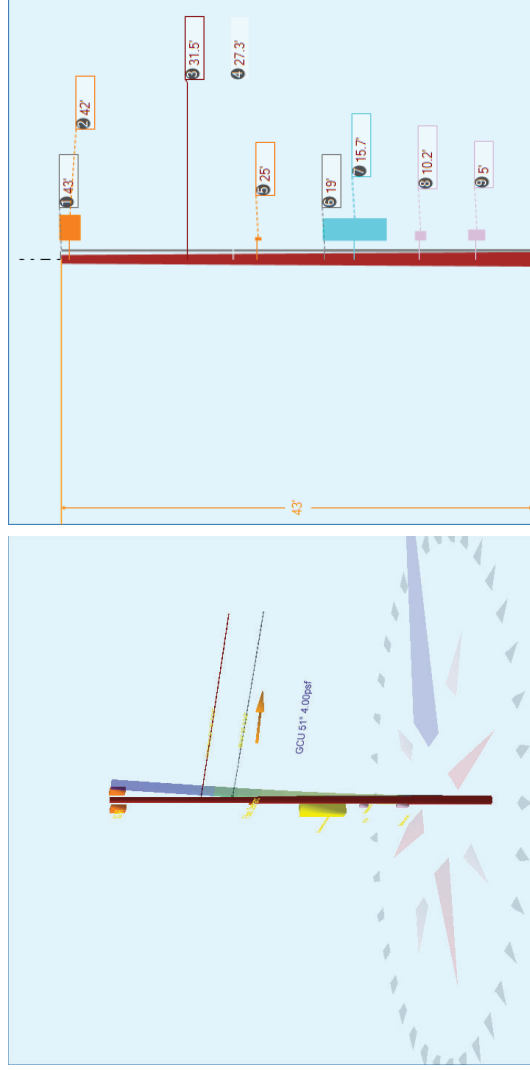

Groundline Load Summary - Reporting Angle Mode: Load - Reporting Angle: 59.4°										
	Shear Load* (lbs)	Applied Load (%)	Bending Moment (ft-lb)	Applied Moment (%)	Pole Capacity (%)	Bending Stress (+/- psi)	Vertical Load (lbs)	Vertical Stress (psi)	Total Stress (psi)	Pole Capacity (%)
Powers	823	35.2	25,909	41.0	26.2	1,363	16	0	1,363	26.2
Comms	823	35.2	22,485	35.6	22.7	1,183	29	0	1,183	22.8
GenericEquipments	61	2.6	2,538	4.0	2.6	134	103	1	134	2.6
PowerEquipments	186	8.0	2,357	3.7	2.4	124	464	3	127	2.4
Pole	376	16.1	7,990	12.6	8.1	420	2,422	18	438	8.4
Risers	70	3.0	1,936	3.1	2.0	102	93	1	103	2.0
Insulators	0	0.0	15	0.0	0.0	1	9	0	1	0.0
Pole Load	2,339	100.0	63,230	100.0	64.0	3,327	3,136	23	3,350	64.4
Pole Reserve Capacity			35,643		36.0	1,873			1,850	35.6

Load Summary by Owner - Reporting Angle Mode: Load - Reporting Angle: 59.4°										
	Shear Load* (lbs)	Applied Load (%)	Bending Moment (ft-lb)	Applied Moment (%)	Pole Capacity (%)	Bending Stress (+/- psi)	Vertical Load (lbs)	Vertical Stress (psi)	Total Stress (psi)	Pole Capacity (%)
<Undefined>	1,963	83.9	55,240	87.4	55.9	2,907	714	5	2,912	56.0
CT DOT	376	16.1	7,990	12.6	8.1	420	2,422	18	438	8.4
Totals:	2,339	100.0	63,230	100.0	64.0	3,327	3,136	23	3,350	64.4

Detailed Load Components:

Power	Owner	Height (ft)	Horiz. Offset (in)	Cable Diameter (in)	Sag at Max Temp (ft)	Cable Weight (lbs/ft)	Lead/Span Length (ft)	Span Angle (deg)	Wire Length (ft)	Tension (lbs)	Tension Moment* (ft-lb)	Offset Moment* (ft-lb)	Wind Moment* (ft-lb)	Moment at GL* (ft-lb)
Secondary	DUPLEX 6 AWG	31.50	6.94	0.5370	0.27	0.071	30.0	64.0	30.0	500	25,904	8	11	25,923
Totals:											25,904	8	11	25,923

Comm	Owner	Height (ft)	Horiz. Offset (in)	Cable Diameter (in)	Sag at Max Temp (ft)	Cable Weight (lbs/ft)	Lead/Span Length (ft)	Span Angle (deg)	Wire Length (ft)	Tension (lbs)	Tension Moment* (ft-lb)	Offset Moment* (ft-lb)	Wind Moment* (ft-lb)	Moment at GL* (ft-lb)
Overlashed Bundle	6M	27.33	7.44	0.2420	0.01	0.104	30.0	64.0	30.0	500	22,475	4	9	22,489
Telco	BELOPTIX AT072 - 72 FIBERS - ARMORED (0.657)	27.28	7.44	0.6570		0.190	30.0	64.0	30.0			5	3	8
Totals:											22,475	9	13	22,497

Generic Equipment		Owner	Height (ft)	Horiz. Offset (in)	Offset Angle (deg)	Rotate Angle (deg)	Unit Weight (lbs)	Unit Height (in)	Unit Depth (in)	Unit Diameter (in)	Unit Length (in)	Offset Moment* (ft-lb)	Wind Moment* (ft-lb)	Moment at GL* (ft-lb)
Box	5G NR		42.00	14.04	0.0	0.0	31.90	23.30	6.00	--	23.30	28	1,245	1,273
Box	5G NR		42.00	14.04	180.0	0.0	31.90	23.30	6.00	--	23.30	-28	1,245	1,216
Box	Fiber Demarc		25.00	6.34	180.0	0.0	5.00	7.00	2.50	--	3.00	-2	51	49
Totals:												-2	2,541	2,539

Power Equipment		Owner	Height (ft)	Horiz. Offset (in)	Offset Angle (deg)	Rotate Angle (deg)	Unit Weight (lbs)	Unit Height (in)	Unit Depth (in)	Unit Diameter (in)	Unit Length (in)	Offset Moment* (ft-lb)	Wind Moment* (ft-lb)	Moment at GL* (ft-lb)
Box	Equipment Enclosure		15.67	15.66	180.0	180.0	276.00	70.00	18.00	--	20.00	-257	2,413	2,156
Box	RAYCAP		10.18	10.29	180.0	180.0	8.00	12.39	5.65	--	8.59	-4	119	115
Box	Meter socket		5.00	11.32	180.0	180.0	25.00	18.50	4.84	--	10.00	-14	102	88
Totals:												-276	2,634	2,358

Riser		Owner	Height (ft)	Horiz. Offset (in)	Offset Angle (deg)	Rotate Angle (deg)	Unit Weight (lbs)	Unit Height (in)	Unit Depth (in)	Unit Diameter (in)	Unit Length (in)	Offset Moment* (ft-lb)	Wind Moment* (ft-lb)	Moment at GL* (ft-lb)
Riser- 2" 45.0°			19.00	6.81	45.0	45.0	19.00	228.00	2.00	2.00	228.00	10	43	53
Riser- 2" 300.0°			43.00	6.81	300.0	300.0	43.00	516.00	2.00	2.00	516.00	-12	1,895	1,884
Totals:												-1	1,939	1,937

Insulator		Owner	Height (ft)	Horiz. Offset (in)	Offset Angle (deg)	Rotate Angle (deg)	Unit Weight (lbs)	Unit Height (in)	Unit Diameter (in)	Unit Length (in)	Offset Moment* (ft-lb)	Wind Moment* (ft-lb)	Moment at GL* (ft-lb)	
Spool	Spool 2.5"		31.50	0.00	90.0	0.0	1.00	1.00	2.50	2.12	1	11	12	
Bolt	Single Bolt		27.33	0.00	0.0	0.0	5.00	5.00	3.00	0.00	2	0	2	
Totals:												3	11	15

Pole Buckling													
Buckling Constant	Buckling Column Height* (ft)	Buckling Section Height (% Buckling Col. Hgt.)	Buckling Section Diameter (in)	Minimum Buckling Diameter at GL (in)	Diameter at Tip (in)	Diameter at GL (in)	Modulus of Elasticity (psi)	Pole Density (pcf)	Ice Density (pcf)	Pole Tip Height (ft)	Buckling Capacity at Height (lbs)	Buckling Load Applied at Height (lbs)	Buckling Load Factor of Safety
2.00	19.27	32.68	12.47	14.24	7.96	13.25	1.60e+6	60.00	57.00	43.00	56,994	570.17	18.18

O-Calc® Pro Schematic View

Pole Identification: N/A

Report Created: 1/26/2022

File: MRCTB045148.pplx

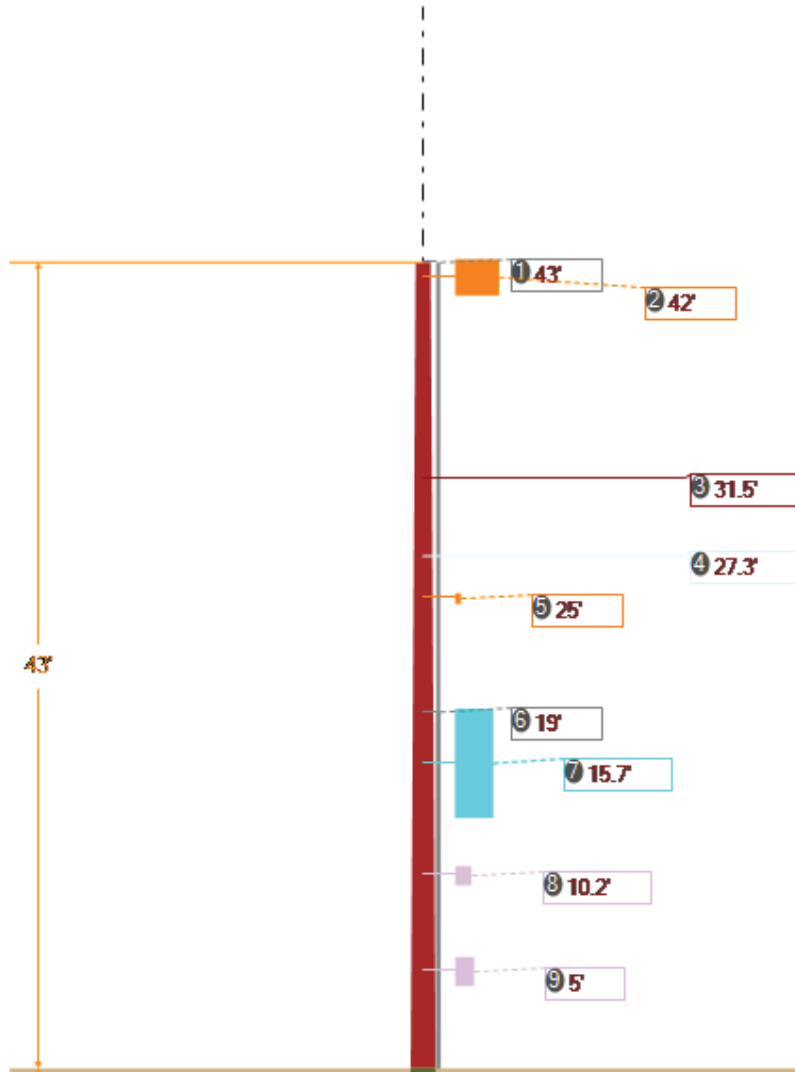

1 - 43' (516")	Riser- 2" 300.0°
2 - 42' (504")	Equipment Equipment
3 - 31.5' (378")	Secondary 64° 30' 0.537" (DUPLIX 6 AWG)
4 - 27.3' (328")	6M 64° 30' Msgr:0.242"
5 - 25' (300")	Equipment
6 - 19' (228")	Riser- 2" 45.0°
7 - 15.7' (188")	Box Equipment Enclosure

8 - 10.2' (122.2")
Box meter socket
9 - 5' (60")
Box meter socket

ATTACHMENT 4



AT&T

CRAN_RCTB_AMTRK_051
MRCTB045148
97 HAMILTON AVENUE,
STAMFORD, CT 06902
Photo-simulation produced on 01/25/2022

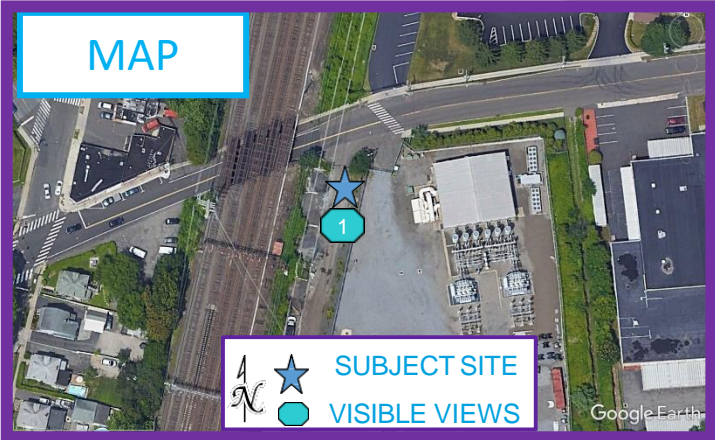

ATTACHMENT 5

Radio Frequency – Electromagnetic Energy (RF-EME) Compliance Report

Site No. CRAN_RCTB_AMTRK_051
MRCTB045148
CRAN_RCTB_AMTRK_051
97 Hamilton Avenue
Stamford, Connecticut 06902
Fairfield County
41.06340000; -73.52060000 NAD83
Utility Pole

The proposed AT&T installation will be in compliance with FCC regulations upon proper installation of recommended signage.

EBI Project No. 6222000610
February 4, 2022

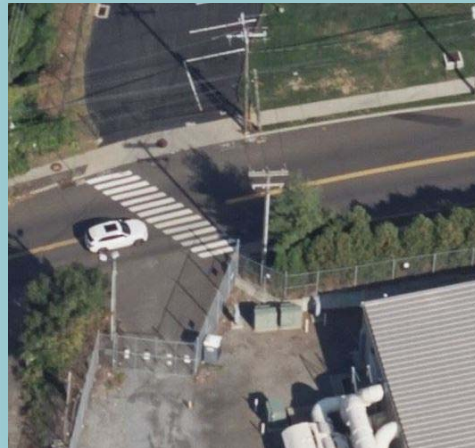

Prepared for:
AT&T Mobility, LLC
c/o Nexius
2999 Oak Road, Suite 110
Walnut Creek, California 94597

Prepared by:
 **EBI Consulting**
environmental | engineering | due diligence

TABLE OF CONTENTS

EXECUTIVE SUMMARY.....	1
1.0 FEDERAL COMMUNICATIONS COMMISSION (FCC) REQUIREMENTS	3
2.0 AT&T RF EXPOSURE POLICY REQUIREMENTS	5
3.0 WORST-CASE PREDICTIVE MODELING.....	5
4.0 RECOMMENDED SIGNAGE/COMPLIANCE PLAN	7
5.0 SUMMARY AND CONCLUSIONS.....	8
6.0 LIMITATIONS	8

APPENDICES

- Appendix A Personnel Certifications**
- Appendix B Compliance/Signage Plan**

EXECUTIVE SUMMARY

Purpose of Report

EnviroBusiness Inc. (dba EBI Consulting) has been contracted by AT&T Mobility, LLC to conduct radio frequency electromagnetic (RF-EME) modeling for AT&T Site CRAN_RCTB_AMTRK_051 located at 97 Hamilton Avenue in Stamford, Connecticut to determine RF-EME exposure levels from proposed AT&T wireless communications equipment at this site. As described in greater detail in Section 1.0 of this report, the Federal Communications Commission (FCC) has developed Maximum Permissible Exposure (MPE) Limits for general public exposures and occupational exposures. This report summarizes the results of RF-EME modeling in relation to relevant FCC RF-EME compliance standards for limiting human exposure to RF-EME fields.

This report contains the RF EME analysis for the site, including the following:

- Site Plan with antenna locations
- Graphical representation of theoretical MPE fields based on modeling
- Graphical representation of recommended signage and/or barriers

This document addresses the compliance of AT&T's transmitting facilities independently and in relation to all collocated facilities at the site.

Statement of Compliance

A site is considered out of compliance with FCC regulations if there are areas that exceed the FCC exposure limits and there are no RF hazard mitigation measures in place. Any carrier which has an installation that contributes more than 5% of the applicable MPE must participate in mitigating these RF hazards.

As presented in the sections below, based on worst-case predictive modeling, there are no modeled exposures on any accessible utility line level and ground walking/working surface related to ATT's proposed antennas that exceed the FCC's occupational and/or general public exposure limits at this site.

As such, the proposed AT&T installation is in compliance with FCC regulations upon proper installation of recommended signage and/or barriers.

AT&T Recommended Signage/Compliance Plan

AT&T's RF Exposure: Responsibilities, Procedures & Guidelines document, dated October 28, 2014, requires that:

1. All sites must be analyzed for RF exposure compliance;
2. All sites must have that analysis documented; and
3. All sites must have any necessary signage and barriers installed.

Site compliance recommendations have been developed based upon protocols presented in AT&T's RF Exposure: Responsibilities, Procedures & Guidelines document, dated October 28, 2014, additional guidance provided by AT&T, EBI's understanding of FCC and OSHA requirements, and common industry practice. Barrier locations have been identified (when required) based on guidance presented in AT&T's RF Exposure: Responsibilities, Procedures & Guidelines document, dated October 28, 2014.

The following signage is recommended at this site:

- Install 7 by 7-inch CAUTION signs on the equipment cabinet on the side of the utility pole.

The signage proposed for installation at this site complies with AT&T's RF Exposure: Responsibilities, Procedures & Guidelines document and therefore complies with FCC and OSHA requirements. Barriers are not recommended on this site. To reduce the risk of exposure and/or injury, EBI recommends that access to the utility pole or areas associated with the active antenna installation be restricted and secured where possible. More detailed information concerning site compliance recommendations is presented in Section 4.0 and Appendix B of this report.

1.0 FEDERAL COMMUNICATIONS COMMISSION (FCC) REQUIREMENTS

The FCC has established Maximum Permissible Exposure (MPE) limits for human exposure to Radiofrequency Electromagnetic (RF-EME) energy fields, based on exposure limits recommended by the National Council on Radiation Protection and Measurements (NCRP) and, over a wide range of frequencies, the exposure limits developed by the Institute of Electrical and Electronics Engineers, Inc. (IEEE) and adopted by the American National Standards Institute (ANSI) to replace the 1982 ANSI guidelines. Limits for localized absorption are based on recommendations of both ANSI/IEEE and NCRP.

The FCC guidelines incorporate two separate tiers of exposure limits that are based upon occupational/controlled exposure limits (for workers) and general public/uncontrolled exposure limits for members of the general public.

Occupational/controlled exposure limits apply to situations in which persons are exposed as a consequence of their employment and in which those persons who are exposed have been made fully aware of the potential for exposure and can exercise control over their exposure. Occupational/controlled exposure limits also apply where exposure is of a transient nature as a result of incidental passage through a location where exposure levels may be above general public/uncontrolled limits (see below), as long as the exposed person has been made fully aware of the potential for exposure and can exercise control over his or her exposure by leaving the area or by some other appropriate means.

General public/uncontrolled exposure limits apply to situations in which the general public may be exposed or in which persons who are exposed as a consequence of their employment may not be made fully aware of the potential for exposure or cannot exercise control over their exposure. Therefore, members of the general public would always be considered under this category when exposure is not employment-related, for example, in the case of a telecommunications tower that exposes persons in a nearby residential area.

Table I and Figure I (below), which are included within the FCC's OET Bulletin 65, summarize the MPE limits for RF emissions. These limits are designed to provide a substantial margin of safety. They vary by frequency to take into account the different types of equipment that may be in operation at a particular facility and are "time-averaged" limits to reflect different durations resulting from controlled and uncontrolled exposures.

The FCC's MPEs are measured in terms of power (mW) over a unit surface area (cm²). Known as the power density, the FCC has established an occupational MPE of 5 milliwatts per square centimeter (mW/cm²) and an uncontrolled MPE of 1 mW/cm² for equipment operating in the 1900 MHz frequency range. For the AT&T equipment operating at 850 MHz, the FCC's occupational MPE is 2.83 mW/cm² and an uncontrolled MPE of 0.57 mW/cm². For the AT&T equipment operating at 700 MHz, the FCC's occupational MPE is 2.33 mW/cm² and an uncontrolled MPE of 0.47 mW/cm². These limits are considered protective of these populations.

Table I: Limits for Maximum Permissible Exposure (MPE)				
(A) Limits for Occupational/Controlled Exposure				
Frequency Range (MHz)	Electric Field Strength (E) (V/m)	Magnetic Field Strength (H) (A/m)	Power Density (S) (mW/cm ²)	Averaging Time [E] ² , [H] ² , or S (minutes)
0.3-3.0	614	1.63	(100)*	6
3.0-30	1842/f	4.89/f	(900/f ²)*	6
30-300	61.4	0.163	1.0	6
300-1,500	--	--	f/300	6
1,500-100,000	--	--	5	6

(B) Limits for General Public/Uncontrolled Exposure				
Frequency Range (MHz)	Electric Field Strength (E) (V/m)	Magnetic Field Strength (H) (A/m)	Power Density (S) (mW/cm²)	Averaging Time [E]², [H]², or S (minutes)
0.3-1.34	614	1.63	(100)*	30
1.34-30	824/f	2.19/f	(180/f ²)*	30
30-300	27.5	0.073	0.2	30
300-1,500	--	--	f/1,500	30
1,500-100,000	--	--	1.0	30

f = Frequency in (MHz)

* Plane-wave equivalent power density

Figure 1. FCC Limits for Maximum Permissible Exposure (MPE)
 Plane-wave Equivalent Power Density

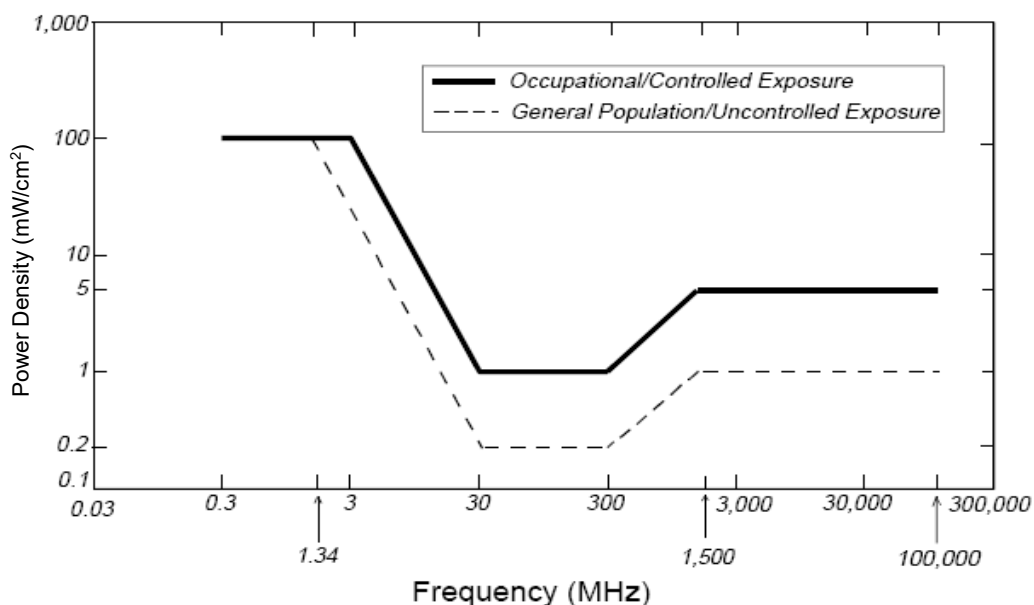

Based on the above, the most restrictive thresholds for exposures of unlimited duration to RF energy for several personal wireless services are summarized below:

Personal Wireless Service	Approximate Frequency	Occupational MPE	Public MPE
Microwave (Point-to-Point)	5,000 - 80,000 MHz	5.00 mW/cm ²	1.00 mW/cm ²
Broadband Radio (BRS)	2,600 MHz	5.00 mW/cm ²	1.00 mW/cm ²
Wireless Communication (WCS)	2,300 MHz	5.00 mW/cm ²	1.00 mW/cm ²
Advanced Wireless (AWS)	2,100 MHz	5.00 mW/cm ²	1.00 mW/cm ²
Personal Communication (PCS)	1,950 MHz	5.00 mW/cm ²	1.00 mW/cm ²
Cellular Telephone	870 MHz	2.90 mW/cm ²	0.58 mW/cm ²
Specialized Mobile Radio (SMR)	855 MHz	2.85 mW/cm ²	0.57 mW/cm ²
Long Term Evolution (LTE)	700 MHz	2.33 mW/cm ²	0.47 mW/cm ²
Most Restrictive Frequency Range	30-300 MHz	1.00 mW/cm ²	0.20 mW/cm ²

MPE limits are designed to provide a substantial margin of safety. These limits apply for continuous exposures and are intended to provide a prudent margin of safety for all persons, regardless of age, gender, size, or health.

Personal Communication (PCS) facilities used by AT&T in this area operate within a frequency range of 700-1900 MHz. Facilities typically consist of: 1) electronic transceivers (the radios or cabinets) connected to wired telephone lines; and 2) antennas that send the wireless signals created by the transceivers to be received by individual subscriber units (PCS telephones). Transceivers are typically connected to antennas by coaxial cables.

Because of the short wavelength of PCS services, the antennas require line-of-site paths for good propagation, and are typically installed above ground level. Antennas are constructed to concentrate energy towards the horizon, with as little energy as possible scattered towards the ground or the sky. This design, combined with the low power of PCS facilities, generally results in no possibility for exposure to approach Maximum Permissible Exposure (MPE) levels, with the exception of areas directly in front of the antennas.

2.0 AT&T RF EXPOSURE POLICY REQUIREMENTS

AT&T's RF Exposure: Responsibilities, Procedures & Guidelines document, dated October 28, 2014, requires that:

1. All sites must be analyzed for RF exposure compliance;
2. All sites must have that analysis documented; and
3. All sites must have any necessary signage and barriers installed.

Pursuant to this guidance, worst-case predictive modeling was performed for the site. This modeling is described below in Section 3.0. Lastly, based on the modeling and survey data, EBI has produced a Compliance Plan for this site that outlines the recommended signage and barriers. The recommended Compliance Plan for this site is described in Section 4.0.

3.0 WORST-CASE PREDICTIVE MODELING

In accordance with AT&T's RF Exposure policy, EBI performed theoretical modeling using RoofMaster™ software to estimate the worst-case power density at the site utility line level and ground-level and/or nearby rooftops resulting from operation of the antennas. RoofMaster™ is a widely-used predictive modeling program that has been developed to predict RF power density values for rooftop and tower telecommunications sites produced by vertical collinear antennas that are typically used in the cellular, PCS, paging and other communications services. Using the computational methods set forth in Federal Communications (FCC) Office of Engineering & Technology (OET) Bulletin 65, "Evaluating Compliance with FCC Guidelines for Human Exposure to Radiofrequency Electromagnetic Fields" (OET-65), RoofMaster™ calculates predicted power density in a scalable grid based on the contributions of all RF sources characterized in the study scenario. At each grid location, the cumulative power density is expressed as a percentage of the FCC limits. Manufacturer antenna pattern data is utilized in these calculations. RoofMaster™ models consist of the Far Field model as specified in OET-65 and an implementation of the OET-65 Cylindrical Model (Sula9). The models utilize several operational specifications for different types of antennas to produce a plot of spatially-averaged power densities that can be expressed as a percentage of the applicable exposure limit. A statistical power factor may be applied to the antenna system based on guidance from the carrier and system manufacturers.

For this report, EBI utilized antenna and power data provided by AT&T and compared the resultant worst-case MPE levels to the FCC's occupational/controlled exposure limits outlined in OET Bulletin 65.

The assumptions used in the modeling are based upon information provided by AT&T and information gathered from other sources. There are no other wireless carriers with equipment installed at this site.

Based on worst-case predictive modeling, there are no modeled exposures on any accessible utility line level and ground walking/working surface related to ATT's proposed antennas that exceed the FCC's occupational and/or general public exposure limits at this site.

Modeling indicates that the worst-case emitted power density may exceed the FCC's general public limit within approximately 25 feet of the antenna face and the occupational limit within approximately 11 feet of the antenna face. Modeling also indicates that the worst-case emitted power density may exceed the FCC's general population limit within approximately 7 feet below the bottom of the AT&T antenna.

At the nearest walking/working surfaces to the AT&T antennas on the utility line level, the maximum power density generated by the AT&T antennas is approximately 24.40 percent of the FCC's general public limit (4.88 percent of the FCC's occupational limit). The composite exposure level from all carriers on this site is approximately 24.40 percent of the FCC's general public limit (4.88 percent of the FCC's occupational limit) at the nearest walking/working surface to each antenna. It should be noted that percentage of MPE is based on spatially-averaged power densities over a height of six feet, with the height of the utility line being centered within that spatial range. Based on worst-case predictive modeling, there are no areas at ground/street level related to the proposed AT&T antennas that exceed the FCC's occupational or general public exposure limits at this site. At ground/street level, the maximum power density generated by the antennas is approximately 1.18 percent of the FCC's general public limit (0.236 percent of the FCC's occupational limit).

A graphical representation of the RoofMaster™ modeling results is presented in Appendix B.











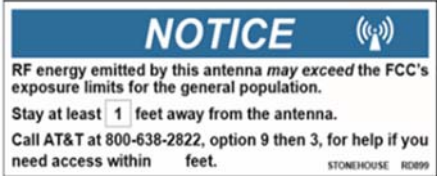

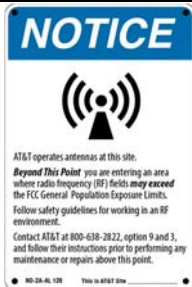
Microwave dish antennas are designed for point-to-point operations at the elevations of the installed equipment rather than ground-level coverage. Based on AT&T's RF Exposure: Responsibilities, Procedures & Guidelines document, dated October 28, 2014, microwave antennas are considered compliant if they are higher than 20 feet above any accessible walking/working surface. There are no microwaves installed at this site.

4.0 RECOMMENDED SIGNAGE/COMPLIANCE PLAN

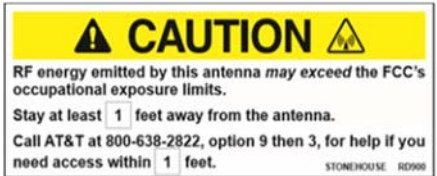
Signs are the primary means for control of access to areas where RF exposure levels may potentially exceed the MPE. As presented in the AT&T guidance document, the signs must:

- Be posted at a conspicuous point;
- Be posted at the appropriate locations;
- Be readily visible; and
- Make the reader aware of the potential risks prior to entering the affected area.

The table below presents the signs that may be used for AT&T installations.

CRAN / HETNET Small Cell Decals / Signs		Alerting Signs	
	<p>NOTICE DECAL</p>		
	<p>NOTICE SIGN</p>		
	<p>CAUTION DECAL</p>		
	<p>CAUTION SIGN</p>		

Based upon protocols presented in AT&T's RF Exposure: Responsibilities, Procedures & Guidelines document, dated October 28, 2014, and additional guidance provided by AT&T, the following signage is recommended on the site:

- Install 7 by 7-inch CAUTION signs on the equipment cabinet on the side of the utility pole.

No barriers are required for this site. Barriers should be constructed of weather-resistant plastic or wood fencing. Barriers may consist of railing, rope, chain, or weather-resistant plastic if no other types are permitted or are feasible. Painted stripes should only be used as a last resort and only in regions where there is little chance of snowfall. If painted stripes are selected as barriers, it is recommended that the stripes and signage be illuminated. The signage and any barriers are graphically represented in the Signage Plan presented in Appendix B.

5.0 SUMMARY AND CONCLUSIONS

EBI has prepared this Radiofrequency Emissions Compliance Report for the proposed AT&T telecommunications equipment at the site located at 97 Hamilton Avenue in Stamford, Connecticut.

EBI has conducted theoretical modeling to estimate the worst-case power density from AT&T antennas to document potential MPE levels at this location and ensure that site control measures are adequate to meet FCC and OSHA requirements, as well as AT&T's corporate RF safety policies. As presented in the preceding sections, based on worst-case predictive modeling, there are no modeled exposures on any accessible utility line level and ground walking/working surface related to ATT's proposed antennas that exceed the FCC's occupational and/or general public exposure limits at this site.

To reduce the risk of exposure and/or injury, EBI recommends that access to the utility pole or areas associated with the active antenna installation be restricted and secured where possible. Signage is recommended at the site as presented in Section 4.0 and Appendix B. Posting of the signage brings the site into compliance with FCC rules and regulations and AT&T's corporate RF safety policies.

6.0 LIMITATIONS

This report was prepared for the use of AT&T Mobility, LLC to meet requirements outlined in AT&T's corporate RF safety guidelines. It was performed in accordance with generally accepted practices of other consultants undertaking similar studies at the same time and in the same locale under like circumstances. The conclusions provided by EBI and its partners are based solely on information supplied by AT&T. The observations in this report are valid on the date of the investigation. Any additional information that becomes available concerning the site should be provided to EBI so that our conclusions may be revised and modified, if necessary. This report has been prepared in accordance with Standard Conditions for Engagement and authorized proposal, both of which are integral parts of this report. No other warranty, expressed or implied, is made.

Appendix A

Personnel Certifications

Preparer Certification

I, Andrew Simpson, state that:

- I am an employee of EnviroBusiness Inc. (d/b/a EBI Consulting), which provides RF-EME safety and compliance services to the wireless communications industry.
- I have successfully completed RF-EME safety training, and I am aware of the potential hazards from RF-EME and would be classified “occupational” under the FCC regulations.
- I am fully aware of and familiar with the Rules and Regulations of both the Federal Communications Commissions (FCC) and the Occupational Safety and Health Administration (OSHA) with regard to Human Exposure to Radio Frequency Radiation.
- I have been trained in on the procedures outlined in AT&T’s RF Exposure: Responsibilities, Procedures & Guidelines document (dated October 28, 2014) and on RF-EME modeling using RoofMaster™ modeling software.
- I have reviewed the data provided by the client and incorporated it into this Site Compliance Report such that the information contained in this report is true and accurate to the best of my knowledge.

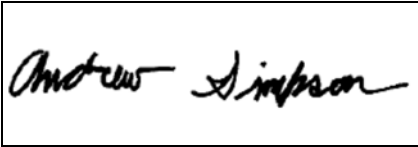
A rectangular box containing a handwritten signature in black ink that reads "Andrew Simpson".

Appendix B

Compliance/Signage Plan

Elevation Simulation

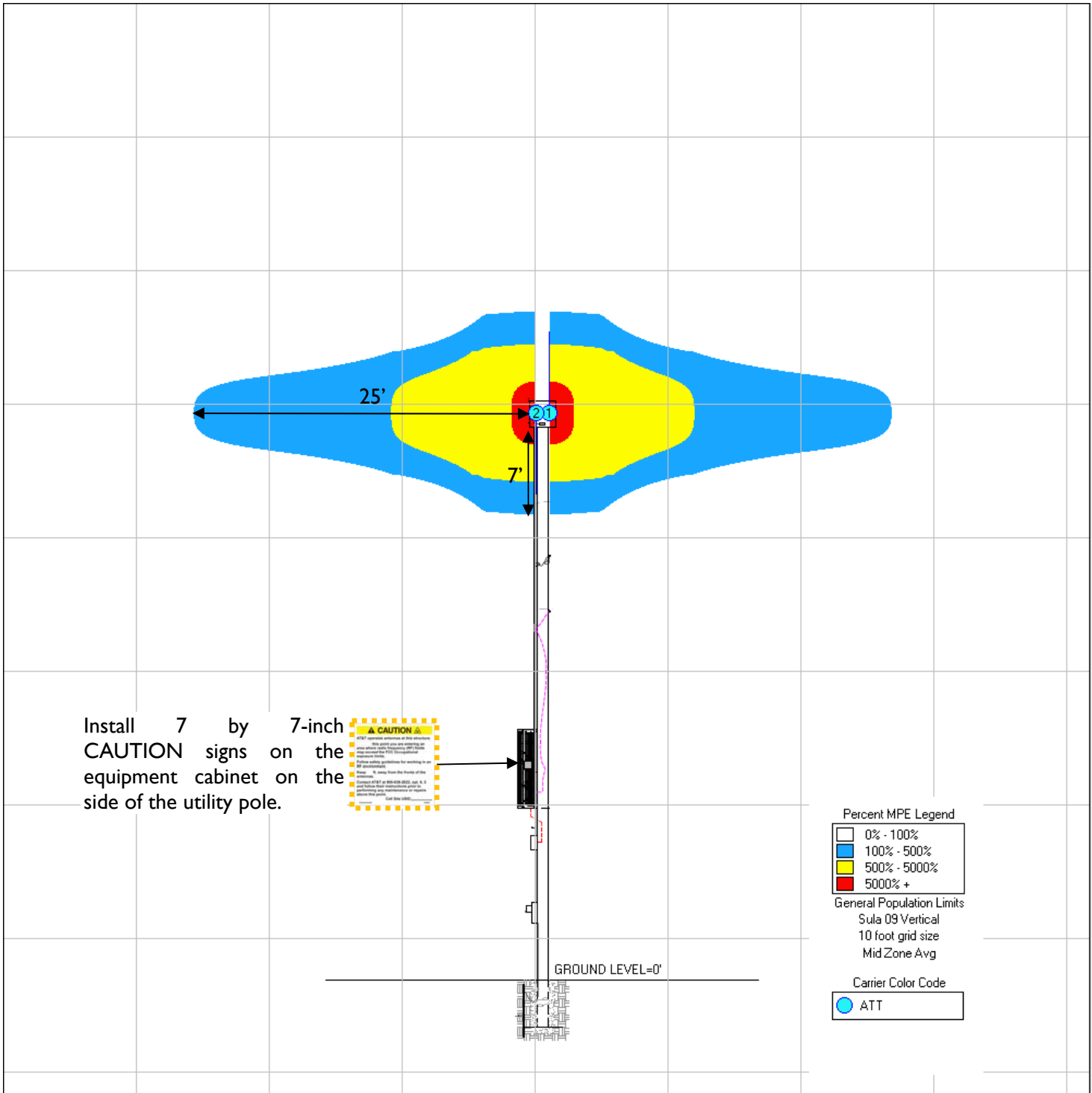

	Existing Sign
	Proposed Sign
	Installed Sign

SIGN IDENTIFICATION LEGEND			
	AT&T NOTICE 2 Sign		AT&T CAUTION 2 – Rooftop Sign
	AT&T WARNING 1B and 2A Signs		AT&T CAUTION 2B – Tower Sign
	AT&T NOTICE Small Cell Signs		AT&T CAUTION 2C – Parapet Sign
	AT&T CAUTION Small Cell Signs		AT&T TRILINGUAL NOTICE Sign

ATTACHMENT 6

CERTIFICATION OF SERVICE

I hereby certify that on March 8, 2022 a copy of the following notice of the intended filing of a Petition with the Connecticut Siting Council for a declaratory ruling was sent by certified mail, return receipt requested, to the list below:



Dated: March 8, 2022

Cuddy & Feder LLP
45 Hamilton Avenue, 14th Floor
White Plains, New York 10601
Attorneys for:
New Cingular Wireless PCS, LLC (AT&T)

State

THE HONORABLE WILLIAM TONG ATTORNEY GENERAL OFFICE OF THE ATTORNEY GENERAL 165 CAPITOL AVENUE HARTFORD, CT 06106	DEPARTMENT OF ECONOMIC AND COMMUNITY DEVELOPMENT DAVID LEHMAN, COMMISSIONER 450 COLUMBUS BLVD HARTFORD, CT 06103
DEPARTMENT OF PUBLIC HEALTH DR. MANISHA JUTHANI, MD, ACTING COMMISSIONER 410 CAPITOL AVENUE HARTFORD, CT 06134	PUBLIC UTILITIES REGULATORY AUTHORITY MARISSA P. GILLETT, CHAIRMAN 10 FRANKLIN SQUARE NEW BRITAIN, CT 06051
COUNCIL ON ENVIRONMENTAL QUALITY PETER B. HEARN, EXECUTIVE DIRECTOR 79 ELM STREET, 6 th FLOOR HARTFORD, CT 06106	DEPARTMENT OF TRANSPORTATION JOSEPH GIULIETTI, COMMISSIONER 2800 BERLIN TURNPIKE, P.O. BOX 317546 NEWINGTON, CT 06131
DEPARTMENT OF ENERGY & ENVIRONMENTAL PROTECTION KATIE DYKES, COMMISSIONER 79 ELM STREET HARTFORD, CT 06106	DEPARTMENT OF AGRICULTURE BRYAN P. HURLBURT, COMMISSIONER 450 COLUMBUS BOULEVARD SUITE 701 HARTFORD, CT 06103
OFFICE OF POLICY AND MANAGEMENT MELISSA MCCAWE, SECRETARY 450 CAPITOL AVENUE HARTFORD, CT 06106	SECRETARY OF THE STATE DENISE W. MERRILL 165 CAPITOL AVENUE, SUITE 1000 P.O. BOX 150470 HARTFORD, CT 06106
WESTERN CONNECTICUT COUNCIL OF GOVERNMENTS 1 RIVERSIDE ROAD SANDY HOOK, CT 06482	DEPARTMENT OF EMERGENCY SERVICES & PUBLIC PROTECTION DIVISION OF EMERGENCY MANAGEMENT AND HOMELAND SECURITY

	JAMES C. ROVELLA, COMMISSIONER 1111 COUNTRY CLUB ROAD MIDDLETOWN, CT 06457
STATE HISTORIC PRESERVATION OFFICE DEPARTMENT OF ECONOMIC AND COMMUNITY DEVELOPMENT 450 COLUMBUS BLVD., 5 TH FLOOR HARTFORD, CT 06103	STATE REPRESENTATIVE- 146 TH DISTRICT DAVID MICHEL LEGISLATIVE OFFICE BUILDING 300 CAPITOL AVENUE ROOM 4037 HARTFORD, CT 06106
STATE SENATOR – 27 TH DISTRICT PATRICIA BILLIE MILLER LEGISLATIVE OFFICE BUILDING 300 CAPITOL AVENUE ROOM 3300 HARTFORD, CT 06106	STATE SENATOR – 36 TH DISTRICT RYAN FAZIO LEGISLATIVE OFFICE BUILDING 300 CAPITOL AVENUE ROOM 3400 HARTFORD, CT 06106

Federal

FEDERAL COMMUNICATIONS COMMISSION 45 L STREET NE WASHINGTON, DC 20554	FEDERAL AVIATION ADMINISTRATION 800 INDEPENDENCE AVENUE, SW WASHINGTON, DC 20591
U.S. SENATOR CHRIS MURPHY COLT GATEWAY 120 HUYSHOPE AVENUE SUITE 401 HARTFORD, CT 06106	U.S. SENATOR RICHARD BLUMENTHAL 90 STATE HOUSE SQUARE, 10 TH FLOOR HARTFORD, CT 06103
U.S. CONGRESSMAN – 4 TH DISTRICT JIM HIMES 888 WASHINGTON BOULEVARD 10 TH FLOOR STAMFORD, CT 06901	

City of Stamford

CAROLINE SIMMONS, MAYOR OFFICE OF THE MAYOR STAMFORD GOVERNMENT CENTER 888 WASHINGTON BOULEVARD 10 TH FLOOR STAMFORD, CT 06901	THERESA DELL CHAIR OF PLANNING BOARD PLANNING BOARD STAMFORD GOVERNMENT CENTER 888 WASHINGTON BOULEVARD 7 TH FLOOR STAMFORD, CT 06901
GARY STONE, CHAIRMAN OF ENVIRONMENTAL PROTECTION BOARD STAMFORD GOVERNMENT CENTER 888 WASHINGTON BOULEVARD 7 TH FLOOR STAMFORD, CT 06901	LYDA RUIJTER, CITY & TOWN CLERK TOWN CLERK'S OFFICE STAMFORD GOVERNMENT CENTER 888 WASHINGTON BOULEVARD GROUND FLOOR STAMFORD, CT 06901

DAVID STEIN CHAIR OF ZONING BOARD ZONING BOARD STAMFORD GOVERNMENT CENTER 888 WASHINGTON BOULEVARD 7 TH FLOOR STAMFORD, CT 06901	
---	--

NOTICE

Notice is hereby given, pursuant to Section 16-50j-40(a) of the Regulations of Connecticut State Agencies of a Petition being filed with the Connecticut Siting Council (“Siting Council”) on or after March 10, 2022 by New Cingular Wireless PCS, LLC (“AT&T”). AT&T seeks a declaratory ruling that no Certificate of Environmental Compatibility and Public Need (“Certificate”) is required under Section 16-50k(a) of the Connecticut General Statutes (“C.G.S.”) to install a new “small cell” wireless telecommunications facility on a new pole within the public right-of-way.

The proposed telecommunications facility will be in the public right-of-way located adjacent to 97 Hamilton Avenue, Stamford, Connecticut. AT&T proposes to install an approximately 50’-tall Class 2 utility pole. The proposed pole will stand approximately 43’0”-tall above grade level (“AGL”). AT&T proposes to mount two small cell antennas to the top of the new utility pole at a centerline height of 42’0”AGL with a total height of 43’0” AGL to the top of the antennas and mount. A new equipment cabinet is proposed on the side of the pole.

The Petition will provide additional details of the proposal and explain why AT&T submits that this proposed small cell facility presents no significant adverse environmental effects. The location, height, and other features of the proposal are subject to review and potential change under the provisions of Connecticut General Statutes Sections 16-50g *et. seq.*

Copies of the Petition will be on file with the following on or after March 10, 2022:

Connecticut Siting Council	City and Town Clerk
10 Franklin Square	888 Washington Boulevard – Ground Floor
New Britain, Connecticut 06051	Stamford, CT 06901

or the offices of the undersigned. A copy of the Petition will also be available on the Connecticut Siting Council website: <https://www.ct.gov/cSc/site/default.asp> under Pending Matters. All inquiries should be addressed to the Connecticut Siting Council or to the undersigned.

Lucia Chiocchio, Esq.
Daniel Patrick, Esq.
Cuddy & Feder LLP
445 Hamilton Ave, 14th Floor
White Plains, New York 10601
(914) 761-1300
Attorneys for the Petitioner

CERTIFICATION OF SERVICE

I hereby certify that on March 8, 2022 a copy of the following letter and notice of the intended filing of a Petition with the Connecticut Siting Council for a declaratory ruling was sent by certified mail, return receipt requested, to the attached list of abutting property owners:



Dated: March 8, 2022

Cuddy & Feder LLP
45 Hamilton Avenue, 14th Floor
White Plains, New York 10601
Attorneys for:
New Cingular Wireless PCS, LLC (AT&T)

STATE OF CONNECTICUT P.O. BOX 317546 NEWINGTON, CT 06131	WWE REAL ESTATE HOLDINGS LLC 88 HAMILTON AVENUE STAMFORD, CT 06902
WWE REAL ESTATE HOLDINGS LLC 1241 EAST MAIN STREET STAMFORD, CT 06902	CONNECTICUT LIGHT & POWER CO. 0 HAMILTON AVENUE STAMFORD, CT 06902
CONNECTICUT LIGHT & POWER CO. P.O. BOX 270 HARTFORD, CT 06141	CONNECTICUT LIGHT & POWER CO. 0 LINCOLN AVENUE STAMFORD, CT 06902

March 8, 2022

**VIA CERTIFIED MAIL/
RETURN RECEIPT REQUESTED**

Re: New Cingular Wireless PCS, LLC (“AT&T”)
Installation of A Small Cell Wireless Telecommunication Facility
97 Hamilton Avenue, Stamford, Connecticut

Dear Sir or Madam:

We are writing to you on behalf of our client New Cingular Wireless PCS, LLC (“AT&T”) with respect to the above referenced matter and our client’s intent to file a petition for a declaratory ruling with the State of Connecticut Siting Council for approval of installation of a small cell wireless telecommunication facility on a new pole (the “Facility”) to be installed in the public right-of-way near the above-captioned property.

State law requires that record owners of property abutting a parcel on which a facility is proposed be sent notice of an applicant’s intent to file a petition with the Siting Council.

Included with this letter please find a Notice of this submission and details of the proposal. The location, height and other features of the Facility are subject to review and potential change by the Connecticut Siting Council under the provisions of Connecticut General Statutes §16-50g *et seq.*

If you have any questions concerning this petition, please contact the Connecticut Siting Council or the undersigned after March 10, 2022 which is the date that the petition is expected to be on file.

Very truly yours,

Lucia Chiochio
Enclosure

cc: Daniel Patrick, Esq., Cuddy & Feder LLP

NOTICE

Notice is hereby given, pursuant to Section 16-50j-40(a) of the Regulations of Connecticut State Agencies of a Petition being filed with the Connecticut Siting Council (“Siting Council”) on or after March 10, 2022 by New Cingular Wireless PCS, LLC (“AT&T”). AT&T seeks a declaratory ruling that no Certificate of Environmental Compatibility and Public Need (“Certificate”) is required under Section 16-50k(a) of the Connecticut General Statutes (“C.G.S.”) to install a new “small cell” wireless telecommunications facility on a new pole within the public right-of-way.

The proposed telecommunications facility will be in the public right-of-way located adjacent to 97 Hamilton Avenue, Stamford, Connecticut. AT&T proposes to install an approximately 50’-tall Class 2 utility pole. The proposed pole will stand approximately 43’0”-tall above grade level (“AGL”). AT&T proposes to mount two small cell antennas to the top of the new utility pole at a centerline height of 42’0”AGL with a total height of 43’0” AGL to the top of the antennas and mount. A new equipment cabinet is proposed on the side of the pole.

The Petition will provide additional details of the proposal and explain why AT&T submits that this proposed small cell facility presents no significant adverse environmental effects. The location, height, and other features of the proposal are subject to review and potential change under the provisions of Connecticut General Statutes Sections 16-50g *et. seq.*

Copies of the Petition will be on file with the following on or after March 10, 2022:

Connecticut Siting Council	City and Town Clerk
10 Franklin Square	888 Washington Boulevard – Ground Floor
New Britain, Connecticut 06051	Stamford, CT 06901

or the offices of the undersigned. A copy of the Petition will also be available on the Connecticut Siting Council website: <https://www.ct.gov/cSc/site/default.asp> under Pending Matters. All inquiries should be addressed to the Connecticut Siting Council or to the undersigned.

Lucia Chiocchio, Esq.
Daniel Patrick, Esq.
Cuddy & Feder LLP
445 Hamilton Ave, 14th Floor
White Plains, New York 10601
(914) 761-1300
Attorneys for the Petitioner

97 Hamilton Avenue, Stamford, CT



ABUTTERS LIST

Parcel ID	Site Address	Owner Name	Mailing Address	City	State	Zip
	State of Connecticut	State of Connecticut	P.O. Box 317546	Newington	CT	06131
004-3498	88 Hamilton Avenue, Stamford	WWE Real Estate Holdings, LLC	1241 East Main Street	Stamford	CT	06902
000-9769	0 Hamilton Avenue, Stamford	Connecticut Light & Power Co.	P.O. Box 270	Hartford	CT	06141
000-9772	0 Lincoln Avenue, Stamford	Connecticut Light & Power Co.	P.O. Box 270	Hartford	CT	06141