



STATE OF CONNECTICUT  
CONNECTICUT SITING COUNCIL

Ten Franklin Square, New Britain, CT 06051  
Phone: (860) 827-2935 Fax: (860) 827-2950  
E-Mail: [siting.council@ct.gov](mailto:siting.council@ct.gov)  
Web Site: [portal.ct.gov/csc](http://portal.ct.gov/csc)

**VIA ELECTRONIC MAIL**

February 1, 2023

David W. Bogan, Esq.  
Day Pitney LLP  
242 Trumbull Street  
Hartford, CT 06103  
[dbogan@daypitney.com](mailto:dbogan@daypitney.com)

RE: **PETITION NO. 1352** – Nutmeg Solar, LLC, declaratory ruling, pursuant to Connecticut General Statutes §4-176 and §16-50k, for the proposed construction, maintenance and operation of a 19.6-megawatt AC solar photovoltaic electric generating facility on approximately 162 acres comprised of 9 separate parcels located generally south of Bailey Road and east of Route 191 (Broad Brook Road), and associated electrical interconnection to Eversource Energy's Scitico Substation at 20 Bailey Road in Enfield, Connecticut.  
**D&M Plan Revision.**

Dear Attorney Bogan:

The Connecticut Siting Council (Council) is in receipt of your correspondence dated January 30, 2023 regarding the revision to the Development and Management (D&M) Plan for the above-referenced site that was approved by the Council on January 17, 2020.

Pursuant to Regulations of Connecticut State Agencies (RCSA) §16-50j-62(b), your request to install a new approximately 16-foot wide by 314-foot long gravel access road and a 2,788 square foot parking and turnaround area on part of the former laydown area from the operations and maintenance (O&M) building to connect to existing access is hereby approved. This will provide safe vehicle access to the O&M building.

This approval applies only to the D&M Plan revision dated January 30, 2023.

Please be advised that deviations from the Council's D&M Plan approvals are enforceable under the provisions of Connecticut General Statutes § 16-50u. Furthermore, the facility owner/operator is responsible for reporting requirements pursuant to RCSA §16-50j-62.

Thank you for your attention and cooperation.

Sincerely,

Melanie A. Bachman  
Executive Director

MB/MP

**DAVID W. BOGAN**  
Attorney at Law

242 Trumbull Street  
Hartford, CT 06103-1212  
T: (860) 275-0187 F: (617) 326-3035  
dbogan@daypitney.com

January 30, 2023

**VIA ELECTRONIC MAIL & FIRST CLASS MAIL**

Melanie A. Bachman, Esq.  
Executive Director  
Connecticut Siting Council  
10 Franklin Square  
New Britain, CT 06051

Re: ***Petition 1352*** - Nutmeg Solar, LLC, petition for a declaratory ruling, pursuant to Connecticut General Statutes §4-176 and §16-50k, for the proposed construction, maintenance and operation of a 19.6-megawatt AC solar photovoltaic electric generating facility on approximately 162 acres comprised of 9 separate parcels located generally south of Bailey Road and east of Route 191 (Broad Brook Road), and associated electrical interconnection to Eversource Energy's Scitico Substation at 20 Bailey Road in Enfield, Connecticut - ***Request for D&M Plan Modification***

Dear Ms. Bachman:

On April 26, 2019, the Connecticut Siting Council ("Council") approved the above-referenced Petition, permitting the establishment of a 19.6 MWac solar photovoltaic electric generating facility in Enfield, Connecticut. The Council approved the facility's Development and Management Plan ("D&M Plan") on January 17, 2020, wherein it delegated approval of any changes to the D&M Plan to Council staff in accordance with Regulations of Connecticut State Agencies ("RCSA") §16-50j-62(b).

In the Petition and D&M Plan, a temporary construction laydown area was approved and used adjacent to the proposed collector substation and an existing house and horse barn. The laydown area was used for Project component delivery, off-loading, and storage. As provided in the D&M Plan revision approved by the Council on October 19, 2020, the Project decided to use the existing house and barn as an Operations and Maintenance (O&M) Building. In nearing construction completion, the Project recognized that it would need a continued access point to deliver and unload Project components to the O&M building for operation and maintenance purposes. There is no engineered access to the O&M Building and safety issues were identified with using the preexisting driveway to the O&M building based on the steep slope. The grade of

Melanie A. Bachman, Esq.  
January 30, 2023  
Page 2

the original driveway prevented access by certain vehicles and became a greater safety issue during winter months. Therefore, Petitioner determined that an alternative permanent access road was necessary to access the O&M Building. The Petitioner is requesting that part of the originally approved laydown area be converted to a gravel access road for the O&M building. This is a flat area that can safely be accessed by all needed vehicles at all times of year. See attached Tighe & Bond Memorandum for additional details.

This proposed change will provide safe year-round access to the O&M building and will have no impact on the stormwater flows across the Project site. The laydown area has already been disturbed due to use during construction. The access road is proposed to be gravel and engineered consistent with previously approved access roads on site, and the balance of the laydown area will be reseeded as proposed in the Petition.

Accordingly, pursuant to RCSA §16 50j 62(b), the Petitioner requests Council staff approval to add a gravel access road as depicted in the Tighe & Bond Memorandum.

Please do not hesitate to contact the undersigned should you require further information.

Very truly yours,



David W. Bogan

DWB/  
Attachment  
Tighe & Bond Memorandum

## CERTIFICATION

I hereby certify that on January 30, 2023, the foregoing was delivered by email in accordance with §16-50j-12 of the Regulations of Connecticut State Agencies, to all parties and intervenors of record, as follows:

James N. Tallberg, Esq.  
Town Attorney  
Town of Enfield  
820 Enfield Street  
Enfield, CT 06082  
[townattorney@enfield.org](mailto:townattorney@enfield.org)



---

David W. Bogan  
Commissioner of the Superior Court

## Nutmeg Solar Project – Proposed Office Building Access

**To:** Natalie Flinn, Nutmeg Solar, LLC  
**FROM:** Brian S. Huntley, PE, Tighe & Bond  
**COPY:** Linda Rivard, Tetra Tech  
**DATE:** January 26, 2023

During construction of the Nutmeg Solar Project in Enfield, Connecticut, an existing building within the project property has been utilized for operational purposes of the array and as a maintenance building. There is no engineered access to the building, which has resulted in vehicles driving on grass areas to access the building. As noted by Nutmeg Solar, LLC, a more permanent solution is desired to prevent erosion and rutting issues and provide long-term access to the building.

### Access Road Design

A 16-foot-wide gravel access road with a 41-foot by 68-foot turnaround area has been designed for the building. The design includes topography suitable for vehicular access. The proposed road connects with the existing gravel access road located near the office building. The proposed road is positioned in the general location of the route that has been used for access to the building throughout construction. A figure containing the proposed road layout and a detail of the proposed cross-section is attached to this memorandum.

### Stormwater Considerations

The proposed access road will modify the ground covers as originally proposed for the project, which has the potential to impact peak rates of runoff in the stormwater management design. Tighe & Bond reviewed the impact of the additional gravel cover on the project's peak rates of runoff and determined there will be no significant increase as a result of the proposed access road. Table 1, below, includes the peak rates of runoff for the approved design and for the modified design with the office building access road.

**Table 1**

Peak Rates of Runoff Comparison

<b>Storm Event</b>	<b>Approved Peak Rate to Design Point 1 (cfs)</b>	<b>Modified Peak Rate to Design Point 1 (cfs)</b>
2-Year	2.0	2.0
10-Year	7.7	7.7
25-Year	12.8	12.8
100-Year	23.7	23.7

Peak rates of runoff are not significantly impacted in the 2-, 10-, 25-, or 100-year storm events. We do not believe any additional stormwater management features are required as a result of the proposed office building access.

FIGURE 1

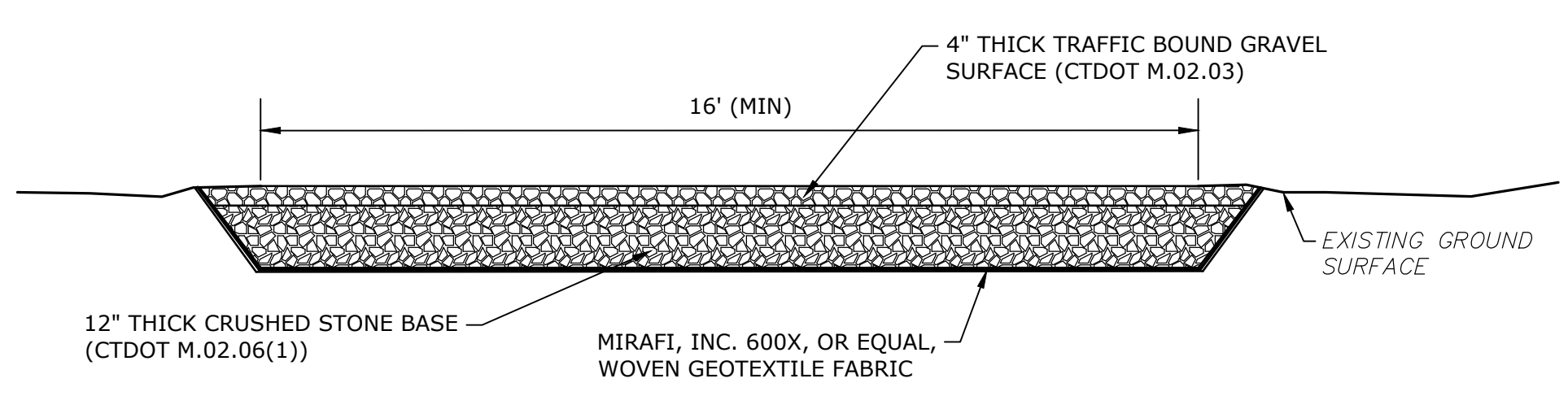
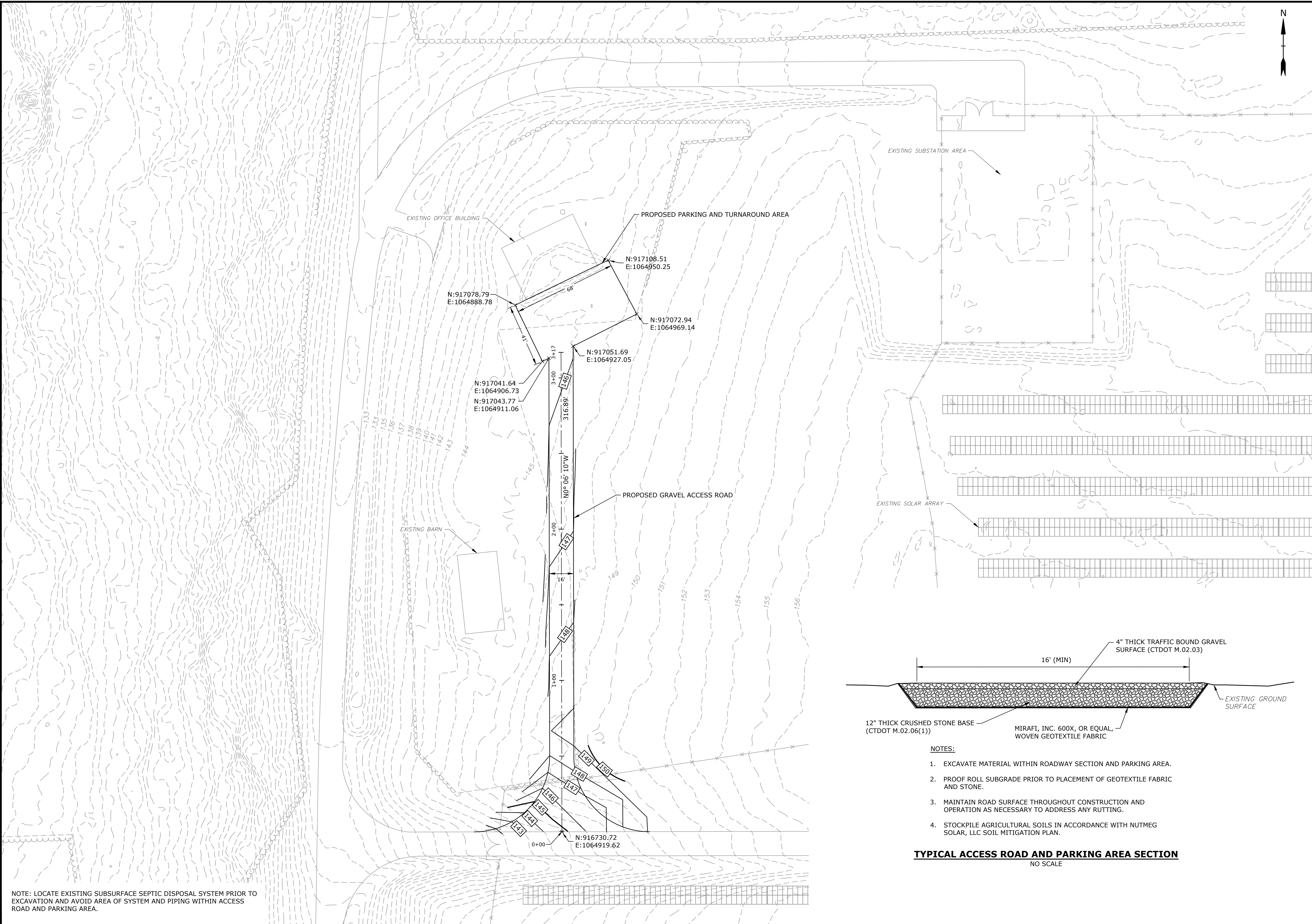
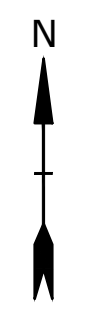

- NOTES:**
1. EXCAVATE MATERIAL WITHIN ROADWAY SECTION AND PARKING AREA.
  2. PROOF ROLL SUBGRADE PRIOR TO PLACEMENT OF GEOTEXTILE FABRIC AND STONE.
  3. MAINTAIN ROAD SURFACE THROUGHOUT CONSTRUCTION AND OPERATION AS NECESSARY TO ADDRESS ANY RUTTING.
  4. STOCKPILE AGRICULTURAL SOILS IN ACCORDANCE WITH NUTMEG SOLAR, LLC SOIL MITIGATION PLAN.

**TYPICAL ACCESS ROAD AND PARKING AREA SECTION**  
NO SCALE

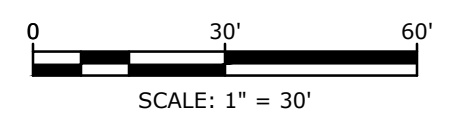

THIS DOCUMENT IS INCOMPLETE AND IS RELEASED TEMPORARILY FOR PROGRESS REVIEW ONLY. IT IS NOT INTENDED FOR BIDDING OR CONSTRUCTION PURPOSES.

**Nutmeg Solar Project**

Nutmeg Solar, LLC

Enfield, CT

MARK	DATE	DESCRIPTION
PROJECT NO:	R0317-4	
DATE:	12/2022	
FILE:	R0317 - Nutmeg Access Road.dwg	
DRAWN BY:	TAL/ALG	
DESIGNED/CHECKED BY:	JMC	
APPROVED BY:	BSH	

OFFICE ACCESS ROAD GRADING PLAN

SCALE: 1" = 30'

FIGURE 1

Last Saved: 12/19/2022 11:32am By: AGL/rlh  
 Plotted On: Dec 21, 2022 11:32am  
 Tighe & Bond | 1140317 - Nutmeg Solar | 1140317 - Nutmeg Access Road.dwg

NOTE: LOCATE EXISTING SUBSURFACE SEPTIC DISPOSAL SYSTEM PRIOR TO EXCAVATION AND AVOID AREA OF SYSTEM AND PIPING WITHIN ACCESS ROAD AND PARKING AREA.