

Stormwater Pollution Control Plan, Stonington Solar Project North Stonington, Connecticut



Prepared for:



2045 Lincoln Highway
Edison, NJ 08817

Prepared by:



SIERRA OVERHEAD ANALYTICS

P.O. Box 1716
Twain Harte, CA 95383



Table of Contents

1. Introduction 1

 1.1. Purpose 1

 1.2. Amendments 1

 1.3. Relevant Documents 1

2. Signatures and Certifications 1

 2.1. Registrant Certification 1

 2.2. Professional Engineer Certification 1

 2.3. Contractor/Subcontractor Certification 2

3. Contact Information/Responsible Parties 3

4. Contractor Training 3

5. Project and Site Description 3

 5.1. Project Location and Description 3

 5.2. Existing Conditions 3

 5.3. Endangered and Threatened Species 4

 5.4. Historic Preservation/Cultural Resources 4

 5.5. Developed Conditions 4

 5.6. Nature of Construction Activity and Schedule 5

 5.7. Limit of Disturbance 6

 5.8. Total Disturbed Area 6

 5.9. Site Soils 6

 5.10. Wetlands 6

 5.11. Flood Zone 6

 5.12. Receiving Water Bodies 7

6. Inspections, Monitoring, Reporting, & Record Keeping 1

 6.1. Site Inspector 1

 6.2. Inspection Frequency and Record Keeping 1

 6.3. Monitoring and Sampling Frequency 2

 6.4. Sample Collection 3

 6.5. Sampling Locations 3

 6.6. Reporting 3

 6.7. Record Keeping 4

7. Temporary Best Management Practices 4

 7.1. BMP Matrix 1

 7.2. Erosion, Sediment and Non-Structural Controls 4

 7.3. Special Conditions and Requirements 5

8. Post Construction Stormwater Control Measures 5

 8.1. Post Construction Stormwater Control Measure Maintenance 6

 8.2. Post Construction Stormwater Control Measure Inspections 6

9. Pollution Prevention 6

 9.1. Potential Sources of Pollution 6



9.2.	Emergency Response Plan Spill Prevention and Response	6
9.3.	Fueling and Maintenance of Equipment and Vehicles	7
9.4.	Washing of Equipment and Vehicles	7
9.5.	Storage, Handling, and Disposal of Construction Products, Materials, and Wastes	8
9.6.	Hazardous and/or Toxic Waste.....	8
9.7.	Washing of Applicators and Containers used for Paint, Concrete, or Other Materials...	8
9.8.	Construction and Domestic Waste	8
9.9.	Other Pollution Prevention Practices	9
10.	Final Permanent Stabilization	9

Appendices

- Appendix A – Construction General Permit
- Appendix B – USDA Soils Data
- Appendix C – ESC Plan Drawings
- Appendix D – FEMA FIRM Panel No. 09011C0412G
- Appendix E – BMP Inspection and Reporting Forms
- Appendix F – Calculation Sheets
- Appendix G – BMP Fact Sheets



1. Introduction

In 1972, the Federal Water Pollution Control Act (also known as the Clean Water Act [CWA]) was amended to regulate the discharge of pollutants from any point source into Waters of the United States. Pollutant discharges were thereby prohibited without a National Pollutant Discharge Elimination System (NPDES) permit administered by the Environmental Protection Agency (EPA; Title 40 of the Code of Federal Regulations [CFR] Section 122). The EPA maintains authority to grant delegation of permit administration to state or local governments. Municipal, industrial, construction, or any other activities that produce pollutant discharges, are required to operate and comply with a permit issued by the approving authority.

The Connecticut Department of Energy & Environmental Protection (DEEP) administers the Construction General Permit for the Discharge of Stormwater and Dewatering Wastewaters from Construction Activities (CGP) for the State of Connecticut. The CGP regulates stormwater runoff to surface waters from construction activities that disturb one or more acres. A copy of the CGP is included as **Appendix A**.

The Stonington Solar Project (Project) is a proposed 162-acre photovoltaic (PV) solar power generation facility located in North Stonington, Connecticut. Compliance with the CGP is required for all construction activities associated with the Project.

1.1. Purpose

This Stormwater Pollution Control Plan (SWPCP) and Erosion & Sediment Control Plan drawings were prepared to assist construction activities associated with the Project, in order to protect waters of the state and US and comply with federal and local requirements.

1.2. Amendments

This SWPCP represents the minimum requirements to protect surface waters and critical habitats based on proposed construction activities. If sediment discharge to a receiving water body occurs, this SWPCP shall be revised by the responsible party to meet current conditions.

1.3. Relevant Documents

Relevant documents reviewed for the preparation of this SWPC include:

All-Points Technology Corporation. (2017). *Phase I Environmental Site Assessment*. Killingsworth, CT: All-Points Technology Corporation.

All-Points Technology Corporation. (2018). *Environmental Assessment*. Killingsworth, CT: All-Points Technology Corporation.

All-Points Technology Corporation. (2019). *Jurisdictional Determination*. Killingsworth, CT: All-Points Technology Corporation.



- All-Points Technology Corporation. (2019). *Jurisdictional Determination Supplemental*. Killingsworth, CT: All-Points Technology Corporation.
- Connecticut Siting Council. (2018). *Petition No. 1345*. New Britain, CT: State of Connecticut, Connecticut Siting Council.
- Coronal Energy. (2018). *Stormwater Engineering Concept Report, Pawcatuck Solar Center*. Davis, CA: Coronal Energy.
- DEEP. (2019). *General Permit for the Discharge of Stormwater and Dewatering Wastewaters from Construction Activities*. Hartford, CT: Connecticut Department of Energy & Environmental Protection.
- DEEP. (2020). *NDDB Final Determination No.: 201908729 (Preliminary Assessment No. 201607723)*. Hartford, CT: Connecticut Department of Energy & Environmental Protection.
- SOA. (2020). *Hydrology & Hydraulics Report, Stonington Solar Project*. Sonoma, California: Sierra Overhead Analytics, Inc.
- SWC. (2002). *2002 Connecticut Guidelines for Soil Erosion and Sediment Control, DEP Bulletin 34 (ISBN 0-942085-10-8)*. Hartford, CT: Connecticut Council on Soil and Water Conservation in Cooperation with the Department of Energy & Environmental Protection.
- Terracon. (2018). *Geotechnical Engineering Report, Pawcatuck Solar Center*. Rocky Hill, CT: Terracon Consultants, Inc.
- USDA. (2020, 03 10). *SSURGO*. Retrieved from Web Soil Survey: <https://websoilsurvey.sc.egov.usda.gov/App/WebSoilSurvey.aspx>



2. Signatures and Certifications

2.1. Registrant Certification

I hereby certify that I am making this certification in connection with a registration under such general permit, submitted to the commissioner by CS ENERGY for an activity located at Ella Wheeler Road, North Stonington, Connecticut 06359 (41.42°N, 71.084°W) and that all terms and conditions of the general permit are being met for all discharges which have been initiated and such activity is eligible for authorization under such permit. I further certify that a system is in place to ensure that all terms and conditions of this general permit will continue to be met for all discharges authorized by this general permit at the site. I certify that the registration filed pursuant to this general permit is on complete and accurate forms as prescribed by the commissioner without alteration of their text. I certify that I have personally examined and am familiar with the information that provides the basis for this certification, including but not limited to all information described in Section 3(b)(8)(A) of such general permit, and I certify, based on reasonable investigation, including my inquiry of those individuals responsible for obtaining such information, that the information upon which this certification is based is true, accurate and complete to the best of my knowledge and belief. I certify that I have made an affirmative determination in accordance with Section 3(b)(8)(B) of this general permit. I understand that the registration filed in connection with such general permit is submitted in accordance with and shall comply with the requirements of Section 22a-430b of Connecticut General Statutes. I also understand that knowingly making any false statement made in the submitted information and in this certification may be punishable as a criminal offense, including the possibility of fine and imprisonment, under section 53a-157b of the Connecticut General Statutes and any other applicable law.

Registrant: CS Energy

Signature: Jacob Weiser

Date: 5/22/2020

Printed Name: Jacob Weiser

Title: Assistant Project Manager

2.2. Professional Engineer Certification

I hereby certify that I am a professional engineer licensed in the State of Connecticut. I am making this certification in connection with a registration under such general permit, submitted to the commissioner by CS ENERGY for an activity located at Ella Wheeler Road, North Stonington, Connecticut 06359 (41.42°N, 71.084°W). I certify that I have thoroughly and completely reviewed the Stormwater Pollution Control Plan for the project or activity covered by this certification. I further certify, based on such review and on the standard of care for such projects, that the Stormwater Pollution Control Plan has been prepared in accordance with the



Connecticut Guidelines for Soil Erosion and Sediment Control, as amended, the Stormwater Quality Manual, as amended, and the conditions of the general permit, and that the controls required for such Plan are appropriate for the site. I further certify, based on reasonable investigation, including my inquiry of those individuals responsible for obtaining such information, that the information upon which this certification is based is true, accurate and complete to the best of my knowledge and belief. I also understand that knowingly making any false statement in this certification may subject me to sanction by the Department and/or be punishable as a criminal offense, including the possibility of fine and imprisonment, under section 53a-157b of the Connecticut General Statutes and any other applicable law."

Preparer: Sierra Overhead Analytics, Inc.

Signature: *Darin Galloway* Date: 05/22/2020
Printed Name: Darin Galloway Title: Principal Engineer
License No.: 34152 Exp. Date: 1/31/2021

2.3. Contractor/Subcontractor Certification

I certify under penalty of the law that I have read and understand the terms and conditions of the CGP for the Discharge of Stormwater and Dewatering Wastewaters from Construction Activities. I understand that as a contractor or subcontractor at the site, I am authorized by this CGP, and must comply with the terms and conditions of this CGP, including, but not limited to, the requirements of the Stormwater Pollution Control Plan prepared for the site.

Contractor:

Signature: *Jacob Weiser* Date: 5/22/2020
Printed Name: Jacob Weiser Title: Assistant Project Manager

Subcontractor: TBD pending contract award

Signature: _____ Date: _____
Printed Name: _____ Title: _____

Subcontractor: TBD pending contract award

Signature: _____ Date: _____
Printed Name: _____ Title: _____



3. Contact Information/Responsible Parties

Owner Contact Information:

Contact Name: David Fitzgerald
Company Name: Enerparc, Inc.
Company Address: 1999 Harrison St, Ste 830
City, State, Zip Code: Oakland, California 94612
Contact Phone Number: (415) 823-9673

Primary Operator/Contractor Contact Information:

Contact Name: Jacob Weiser
Company Name: CS Energy
Company Address: 2045 Lincoln Highway
City, State, Zip Code: Edison, New Jersey 08817
Contact Phone Number: (732) 520-5000

Secondary Contractor Information:

Contact Name: Wayne Seaman
Company Name: CS Energy
Company Address: 2045 Lincoln Highway
City, State, Zip Code: Edison, New Jersey 08817
Contact Phone Number: (732) 266-6645

4. Contractor Training

Contractors, subcontractors, builders, installers, regular suppliers, support service companies or others who are involved in construction activities at the Project must be trained on and adhere to the CGP and special requirements included in this SWPCP and ESC Drawings.

5. Project and Site Description

5.1. Project Location and Description

The Project is located south of Interstate 95, east of Pendleton Hill Road (Route 49), and west of Boombridge Road, in Stonington, Connecticut. The total project size is approximately 162 acres and located in New London County at approximately Latitude/Longitude: 41.42° North, 71.84° West.

5.2. Existing Conditions

The site limit of disturbance (LOD) encompasses ±142 acres of agricultural use land located approximately 2.8 miles southeast of North Stonington, CT. The vegetative cover consists of



native flora in the form of low-lying scrub brush and trees, and is an agricultural field used for corn production.

The terrain is predominantly composed of mild slopes between 1-6% in open areas and greater than 10% along the sides of the natural drainages. The drainage ditches range in depth from 2-10 feet and have a gradual slope ($\pm 3\%$).

The Project area currently does not have impervious surfaces.

5.3. Endangered and Threatened Species

Four endangered or threatened species are listed in the Environmental Report as present within the Project boundaries (All-Points Technology Corporation, 2018):

- Eastern Spadefoot Toad (State Endangered)
- Hoary Bat (State Special Concern)
- Sparkling Jewelwing (Threatened)
- Eastern Pearlshell (Special Concern)

The overall project and tree clearing activities have been reviewed and approved by DEEP (DEEP, 2020).

5.4. Historic Preservation/Cultural Resources

Historic preservation/cultural resources areas were identified at the Project area. Two cemeteries and a prehistoric cultural site were documented (All-Points Technology Corporation, 2018). All historic preservation/cultural resources are outside of the Project Limit of Disturbance and are depicted on the ESC Drawings in **Appendix C**.

5.5. Developed Conditions

Developed conditions for the scope of this SWPCP include installation of the following:

- Site access roads
- Security fence
- Laydown area (temporary, to be removed and stabilized post construction)
- Equipment pads, transformers, and switchgear
- Pile, racking, and modules
- Underground conductor wires

Array structural, racking tolerance, and power production requirements necessitate spot grading at select locations around the site. Grading areas are depicted on Grading & Drainage sheets included in **Appendix C**. Grading activities will reduce slopes in select areas, but will not create impervious surfaces. A Hydrology & Hydraulics (H&H) Report was prepared by SOA to model water quality and water quantity requirements for the Project based on post-construction design. The H&H Report was prepared in accordance with the 2004 Connecticut Stormwater



Quality Manual and the 2020 Guidance Regarding Solar Arrays and the General Permit for the Discharge of Stormwater and Dewatering Wastewaters from Construction Activities prepared by DEEP. Permanent and temporary BMPs for construction and post-construction activities at the site are selected and/or designed based on conclusions in the H&H Report.

All disturbed areas, except for roads and equipment pads, will be reclaimed with a low ground cover consisting of native vegetation. Runoff coefficients for the Project area will not move out of the 0.1-0.3 range for unimproved areas based on construction activities. Hydrologic Soil Groups (HSG) for the graded areas will see a reduction by one HSG type.

5.6. Nature of Construction Activity and Schedule

Construction Activity	Estimated Begin Date	Estimated End Date
Tree Clearing BMP Installation	4/6/2020	4/12/2020
Tree Clearing	4/13/2020	4/30/2020
Construction Activity BMP Installation	7/1/2020	7/15/2020
Mowing/Clearing	7/1/2020	8/1/2020
Temporary Laydown Yard Installation	7/15/2020	7/20/2020
Security Fence Installation	8/1/2020	9/15/2020
Site Access Road Installation	7/10/2020	8/15/2020
Grading	7/1/2020	8/1/2020
Pile, Racking, and Module Installation	7/20/2020	10/10/2020
Trenching for Underground Conductor Installation	7/25/2020	8/14/2020
Equipment Pad Construction	8/15/2020	9/10/2020
Transformer and Switchgear Installation	9/10/2020	9/15/2020
Overhead Pole Line Installation	7/15/2020	8/15/2020
Reclamation and Final Stabilization	7/1/2020	1/15/2021

5.7. Limit of Disturbance

- Limit of Disturbance (LOD) = ±142-acres
 - LOD is the total area within the project fence.

5.8. Total Disturbed Area

- Total Disturbed Area (TDA) = ±110-acres

TDA calculation assumes the entire site within the fenced area is disturbed. TDA includes preparation/installation of the following:

- Grading
- Road
- Equipment pad
- Pile
- Fence

5.9. Site Soils

The US Natural Resources Conservation Service, Web Soil Survey was reviewed for site soil properties and compositions. Site soils consist predominantly of sandy-loams and loamy-sands. Site soils HSG mainly fall in groups A and B with high to moderate infiltration rates. HSG C and D also exist on the site. Areas that are to be graded will see a reduction of one HSG type. Site soil erosion factors, whole soil, (K_w) ranges from 0.15 to 0.28. Values of soil erosion factors can range from 0.02 to 0.69. Typically, the higher the factor, higher potential exists for sheet and rill erosion by water to occur. Soils data is included in **Appendix B**. The Revised Universal Soil Loss Equation (RUSLE) was prepared to estimate soil loss due to construction activities and duration. The RUSLE calculation sheet is included in **Appendix F**.

5.10. Wetlands

Wetlands have been delineated in relation to the Project site (All-Points Technology Corporation, 2018). Wetland delineation is described in a report titled *Environmental Assessment, Solar Facility Installation, Pawcatuck Solar Center, Ella Wheeler Drive, North Stonington, Connecticut* (Environmental Assessment) prepared by All-Points Technology Corporation, P.C. Based on the environmental assessment, 12 wetlands are located on or bordering the Project area. Wetland locations are depicted on ESC Drawings in **Appendix C**.

5.11. Flood Zone

Based on Federal Emergency Management Administration (FEMA) FIRM Flood Zone Map for the Project area (Firm Panel No. 09011C0412G Effective 7/18/2011), the Project is located in Zone X outside the 0.2% (500-year) flood event. The 100-year and 500-year flood zones are included on ESC Drawings in **Appendix C** and FEMA Flood Panel No. 09011C0412G located in **Appendix D**.

5.12. Receiving Water Bodies

- Pawcatuck River – ±220 feet minimum to the South
 - 303d listed
 - TMDL for Escherichia Coli (E.coli)

- Unnamed tributary – ±400 feet minimum to the East

- Shunock River – ±2,800 feet minimum to the Southwest
 - 305b assessed
 - Recreation impaired



6. Inspections, Monitoring, Reporting, & Record Keeping

6.1. Site Inspector

Contact Name: Devin Howe
 Company Name: Beals Associates
 Company Address: 2 Park Plaza, Suite 200
 City, State, Zip Code: Boston, MA 02116
 Contact Phone Number: (508) 250-7545

The site inspector shall install a rain gauge at the site in accordance with requirements in the CGP. The rain gauge shall be installed in a location free of overhead vegetation and structures and out of the path of tree clearing equipment. The rain gauge shall be monitored routinely and reported on the BMP inspection forms.

6.2. Inspection Frequency and Record Keeping

Within the first 30 days following commencement of the construction activity on the site, the permittee shall contact: (1) the appropriate District; or (2) a qualified soil erosion and sediment control professional or a qualified professional engineer to inspect the site. The site shall be inspected at least once and no more than three times during the first 90 days to confirm compliance with the CGP and proper initial implementation of all control measures designated in this SWPCP for the Project for the initial phase of construction. Visual inspection is required for compliance with the CGP. Minimum monitoring and record keeping requirements are presented in the CGP (**Appendix A**) and summarize below:

Site Condition	Minimum Frequency
1. Active period	<p>Within 24-hours following a storm event that generates discharge.</p> <p>At least once every 7 days, regardless of whether stormwater runoff is occurring.</p>
2. Weekend, Holiday, or other period outside of normal working hours	<p>Within 24-hours for storms equal to or greater than 0.5 inches.</p> <p>Immediately upon start of normal working hours for storms less than 0.5 inches.</p>
3. Following temporary or final stabilization	Once per month for three months.



The qualified inspector shall inspect, at a minimum, the following:

- Disturbed areas of the construction activity that have not been finally stabilized
- All erosion and sedimentation control measures
- All structural control measures
- Soil stockpile areas
- Washout areas
- Locations where vehicles enter or exit the site

These areas shall be inspected for evidence of, or the potential for, pollutants entering the drainage system and impacts to the receiving waters. Locations where vehicles enter or exit the site shall also be inspected for evidence of off-site sediment tracking. A site inspection form is included in **Appendix E**.

6.3. Monitoring and Sampling Frequency

On sites that disturb 5-acres or more, monthly monitoring of turbidity is required. Turbidity shall be monitored in accordance with 40 CFR Part 136.

Sampling frequency shall be in accordance with the following:

1. Sampling shall be conducted at least once every month while the Project is active, when there is a discharge of stormwater from the site, or until final stabilization of the drainage area associated with each outfall is achieved.
2. Sampling shall only occur during normal working hours. If sampling is discontinued due to the end of normal working hours, it shall resume the following morning or the morning of the next working day following a weekend or holiday, as long as the discharge continues.
3. Sampling may be temporarily suspended any time conditions exist that may reasonably pose a threat to the safety of the person taking the sample. Such conditions may include high winds, lightning, impinging wave or tidal activity, intense rainfall, or other hazardous condition. Once the unsafe condition is no longer present, sampling shall resume.
4. If there is no stormwater discharge during a month, sampling is not required.

6.4. Sample Collection

Sample collection shall be performed in accordance with the following:

1. All samples shall be collected from discharges resulting from a storm event that occurs at least 24 hours after any previous storm event generating a stormwater discharge. Any sample containing snow or ice melt must be identified on the Stormwater Monitoring Report form. Sampling of snow or ice melt in the absence of a storm event is not a valid sample.
2. Samples shall be grab samples taken at least three separate times during a storm event and shall be representative of the flow and characteristics of the discharge(s). Samples may be taken manually or by an in-situ turbidity probe or other automatic sampling device equipped to take individual turbidity readings (i.e. not composite). The first sample shall be taken within the first hour of stormwater discharge from the site. In cases where samples are collected manually and the discharge begins outside of normal working hours, the first sample shall be taken at the start of normal working hours.

6.5. Sampling Locations

Sampling is required at all point source discharges of stormwater from disturbed areas. Where there are two or more discharge points that discharge substantially identical runoff, based on similarities of the exposed soils, slope, and type of stormwater controls used, a sample may be taken from just one of the discharge points. No substantially identical runoff discharge areas are identified for the Project area.

Sampling locations are depicted on the ESC Drawings in **Appendix C**.

6.6. Reporting

Stormwater monitoring reports shall be prepared and submitted in accordance with the following:

1. Within thirty (30) days following the end of each month, enter the stormwater sampling result(s) on the Stormwater Monitoring Report (SMR) form (available at www.ct.gov/deep/stormwater) and submit it in accordance with NetDMR provisions. The SMR form is included in **Appendix E**.
2. If there was no discharge during any given monitoring period, submit the form as required with the words “no discharge” entered in place of the monitoring results.

3. If monitoring of any discharge more frequently than required by this general permit occurs, the results of this monitoring shall be included in additional SMRs for the month in which the samples were collected.
4. If sampling protocols are modified due to the limitations of normal working hours or unsafe conditions in accordance with the CGP, a description of and reason for the modifications shall be included with the SMR.
5. If a discharge is sampled that is representative of two or more substantially identical discharge points, the permittee shall include the names or locations of the other discharge points.
6. Prior to 180 days following issuance of the permit, SMRs shall be uploaded to NetDMR.

6.7. Record Keeping

Record Keeping shall be in accordance with the following:

1. For a period of at least five years from the date that construction is complete, the permittee shall retain copies of the Plan and all reports required by this general permit, and records of all data used to complete the registration for the CGP, unless the commissioner specifies another time period in writing. Inspection records must be retained as part of the Plan for a period of five (5) years after the date of inspection.
2. The permittee shall retain an updated copy of the Plan required by this general permit at the construction site from the date construction is initiated at the site until the date construction at the site is completed.

7. Temporary Best Management Practices

Site and construction conditions have been evaluated for potential contributions of pollutants to surface waters. The following Best Management Practices (BMPs) have been selected to mitigate impact from construction activities. Proper implementation and maintenance instructions for each BMP can be found in the Connecticut Guidelines for Soil Erosion and Sediment Control (SWC, 2002). BMP fact sheets are included in **Appendix G**. BMP locations and details are depicted on ESC Drawings in **Appendix C**.

7.1. BMP Matrix

BMPs	Project Phase		
	Construction	Final Stabilization	Wet Season (Oct. 1 - May 31)
Biobags			
Bioswales			
Check Dams			
Compost Berm			
Compost Blankets			
Compost Socks			
Concrete Truck Washout	X		X
Construction Entrance	X		X
Dewatering (treatment location, schematic, & sampling plan required)			
Drainage Swales			
Earth Dikes (Stabilized)			
Energy Dissipaters	X		X
Erosion Control Blankets & Mats (Specify type)	X		X
Seeding (no-till drill, hand spread, hydroseeding)	X	X	X
Inlet Protection			
Mulches (Specify Type)			
Mycorrhizae/ Biofertilizers			
Natural Buffer Zone	X	X	X
Orange fencing (protecting sensitive/preserved areas)			
Outlet Protection	X	X	X
Permanent Seeding and Planting		X	
Pipe Slope Drains			
Plastic Sheeting			
Preserve Existing Vegetation	X	X	X
Sediment Fencing/Silt Fencing	X		X
Sediment Barrier/Straw Bale Barrier	X		X
Sediment Trap	X		X
Sodding			
Soil Tackifiers			
Storm Drain Inlet Protection			
Temporary Diversion Dikes			
Temporary or Permanent Sedimentation Basins	X	X	X
Temporary Seeding and Planting	X		X
Treatment System (O & M plan required)			
Unpaved roads graveled (except temp. const. path)	X	X	X
Vegetative Buffer Strips			
Use Designated Staging/Laydown Areas Only (per plan)	X		X
Tire wash entering site			

* = BMP must be installed prior to any ground disturbance.

- Concrete truck washout: Cleaning of concrete trucks shall only occur in designated washouts. Temporary concrete washout basins are located near the equipment pad pouring locations. Concrete washouts shall be removed and disposed of prior to final stabilization of the site.

- Construction entrance: A construction entrance shall be installed and maintained at the site entrance from Ella Wheeler Road. If the construction entrance fails to control sediment tracking off-site, either a tire wash shall be installed or a redesign of the construction entrance will be needed.
- Dust Control: Perform dust control measures, such as street sweeping and water spraying, when fugitive dust becomes evident.
- Energy dissipators/Outlet Protection: Energy dissipators and/or outlet protection shall be installed at all culvert and stormwater drainpipe outlets. Inspect energy dissipators for erosion and repair/replace as needed.
- Erosion control mats: Erosion control matting shall be placed on cut/fill slopes of graded areas immediately following establishment of final grade and topsoil cover. Erosion control matting shall be inspected in accordance with the requirements in **Section 6**. Erosion control matting has failed when the following occur:
 - Soils and/or seed have washed away from beneath the mat and the surface has started eroding at an accelerated rate.
 - Matting has come dislodged from the soil surface
 - Matting is torn

If washouts or breakouts occur, regrade and reseed prior to reinstallation of the matting. If repetitive failures occur at the same location(s), a hay bale barrier and temporary slope drainpipe may be placed to divert stormwater from the top of the slope to the bottom without damaging the matting or slope.

- Temporary Seeding: Seed graded areas within 7-days following establishment of final grade and placement of topsoil cover.
- Permanent Seeding:
 - Initial Establishment: Inspect seeded area at least once a week and within 24-hours of the end of a storm with a rainfall amount of 0.5-inch or greater during the first growing season. Where seed has been moved or where soil erosion has occurred determine the cause of the failure. Bird damage may be a problem if mulch was applied too thinly to protect seed. Re-seed and re-mulch. If movement was the result of wind, repair erosion damage (if any), re-apply seed and mulch, and apply mulch anchoring. If failure was caused by concentrated water, (1) install additional measures to control water and sediment movement, (2) repair erosion damage, (3) re-seed and (4) re-apply mulch with anchoring or use Temporary Erosion Control Blanket measure and/or Permanent Turf Reinforcement Mat measure). If there is no erosion, but seed survival is less than 100 plants per square foot after 4 weeks of growth, re-seed as planting season allows. Continue inspections until at least 100 plants per square foot have grown at least 6 inches tall or until the first mowing.
 - First Mowing: Allow the majority of plants to achieve a height of least 6-inches before mowing it the first time. Do not cut while the surface is wet. Cutting while the surface is still wet may pull many seedlings from the soil and often leaves a series of unnecessary ruts. The first mowing should

remove approximately one-third of the growth, depending upon the type of grass and where it is being used. Do not mow grass below 3-inches. If the seeding was mulched, do not attempt to rake out the mulching material. Normal mowing will gradually remove all unwanted debris.

- Long Term Maintenance: Mow and fertilize at a rate that sustains the area in a condition that supports the intended use. If appropriate the height of cut may be adjusted downward, by degrees, as new plants become established. Carry out any fertilization program in accordance with approved soil tests that determine the proper amount of lime and fertilizer needed to maintain a vigorous sod yet prevent excessive leaching of nutrients to the groundwater or runoff to surface waters. Although weeds may appear to be a problem, they shade the new seedlings and help conserve surface moisture. Do not apply weed control until the new seeding has been mowed at least four times.
- Natural Buffer Zones: Natural buffer zones shall be maintained around all wetlands and sensitive areas. Additionally, existing vegetation shall be preserved where possible. The contractor shall not damage or remove existing vegetation unless it is infeasible.
- Silt Fence: Silt fence was placed at locations downslope and cross-slope of disturbed areas where other measures were impractical. Additionally, to protect wetlands, a double row of silt fence, spaced 5-feet apart, is located between the site and the wetlands. Silt fence placed on slopes should have J-hooks placed on the side facing the site to break up concentrated flow along the silt fence. Inspect all silt fence in accordance with the requirements in **Section 6**. Remove sediment deposits when they reach one half the height of the silt fence. Replace or repair the silt fence within 24-hours of observation of failure. Failure of a silt fence has occurred when sediment fails to be retained due to:
 - Overtopping, undercutting, bypass
 - Moved out of position or knocked over
 - Geotextile fabric has decomposed or has been damaged
- Hay Bale Barrier: One hay bale barrier was designed into the erosion and sediment control plan on the southwestern side of the northeast area. Inspect the hay bale barrier in accordance with the requirements in **Section 6**. Remove sediment deposits or install a secondary barrier upslope from the existing barrier when sediment deposits reach approximately one half the height of the barrier. Replace or repair the barrier within 24-hours of observed failure. Failure of the barrier has occurred when sediment fails to be retained by the barrier due to:
 - overtopping, undercutting, bypass
 - moved out of position
 - deterioration or damage to the hay bales
- Sediment Trap: Sediment traps were sized based on the Revised Universal Soil Loss Equation (RUSLE). Sediment traps were typically placed down slope of graded or otherwise highly disturbed areas. Sediment

traps shall be inspected in accordance with the requirements in **Section 6**. Sediment traps should be cleaned when sediment accumulation exceeds one half the wet storage capacity of the trap.

- Sedimentation Basins: Sediment basins were sized based on the Revised Universal Soil Loss Equation (RUSLE). Sediment basins were typically placed down slope of graded or otherwise highly disturbed areas. Sediment basins shall be inspected in accordance with the requirements in **Section 6**. Sediment basins should be cleaned when sediment accumulation exceeds one half the wet storage capacity of the basin or when the depth of available pool is reduced to 18-inches, whichever is achieved first.

7.2. Erosion, Sediment and Non-Structural Controls

Erosion and sediment controls are required by the CGP to provide effective reduction or elimination of sediment related pollutants in stormwater discharges and authorized non-stormwater discharges from the Site. Applicable BMPs are identified in **Section 7.1** for erosion control, sediment control, tracking control, and wind erosion control.

Erosion control, also referred to as soil stabilization, consists of source control measures that are designed to prevent soil particles from detaching and becoming transported in stormwater runoff. Erosion control BMPs protect the soil surface by covering and/or binding soil particles. The Project will implement the following practices to provide effective temporary and final erosion control during construction:

1. Preserve existing vegetation where required and when feasible.
2. The area of soil disturbing operations shall be controlled such that the Contractor is able to implement erosion control BMPs quickly and effectively.
3. Stabilize non-active areas within 14 days of cessation of construction activities or sooner if stipulated by local requirements.
4. Control erosion in concentrated flow paths by applying erosion control blankets, check dams, erosion control seeding or alternate methods.
5. Prior to the completion of construction, apply permanent erosion control to remaining disturbed soil areas.

Enough erosion control materials shall be maintained onsite to allow implementation in conformance with this SWPCP and the ESC drawings.

Sediment controls are temporary or permanent structural measures that are intended to complement the selected erosion control measures and reduce sediment discharges from active construction areas. Sediment controls are designed to intercept and settle out soil particles that have been detached and transported by the force of water.

Non-stormwater discharges into storm drainage systems or waterways, which are not authorized under the CGP, are prohibited. Non-stormwater discharges for which a separate NPDES permit is required by DEEP are prohibited unless coverage under the separate NPDES



permit has been obtained for the discharge. The selection of non-stormwater BMPs is based on construction activities with a potential for non-stormwater discharges.

These temporary erosion, sediment, and non-stormwater control BMPs shall be implemented in conformance with the BMP Factsheets provided in **Appendix G**. If there is a conflict between documents, design drawings will prevail over narrative in the BMP Fact Sheets. Site specific details in the design drawings prevail over standard details included in the BMP Fact Sheets. The narrative in the body of the SWPCP prevails over guidance in the BMP Fact Sheets. The CGP prevails over the SWPCP, design drawings, and BMP fact sheets.

7.3. Special Conditions and Requirements

Additional stormwater, erosion, and sediment control requirements include, but are not limited to, the following:

- Equipment maintenance will not occur on site.
- All equipment staging must occur at designated areas only.
- All equipment fueling must be completed within secondary containment (drip pans) at designated staging areas only and proper spill response measures must be at hand.
- All fuel storage must be located within secondary containment at designated staging areas only.
- If dusty conditions occur, dust abatement using water trucks is required. Water spraying will only be used to the point of dust abatement without creating any ponded water.
- Portable toilets will only be located at the designated areas, secured to the ground with stakes and placed within secondary containment.

8. Post Construction Stormwater Control Measures

Permanent best management practices have been designed for the site in accordance with the CGP Section 2,C,i and 2,C,ii. Water quality and water quantity control calculations are included in a separate stormwater control calculation package (available on request). Stormwater quality measures consist of grass lined roadside swales and vegetated areas. Stormwater quantity measures consist of detention basins.

Detention basin sizing and outlet design are based on the 2-year, 10-year, and 25-year storm events. Detention basin spillway design is based on the 100-year storm event. Stormwater quantity control measure locations are depicted on Grading & Drainage design sheets G&D 200 through 205. Stormwater quantity control measure details are depicted on Grading & Drainage design sheets G&D 300 through 303.

8.1. Post Construction Stormwater Control Measure Maintenance

All post construction stormwater control measures (basins, trash racks, spillways, etc.) shall be cleaned of construction sediment and debris upon final stabilization of the site.

8.2. Post Construction Stormwater Control Measure Inspections

Following installation and cleaning of all post-construction stormwater measures, the permittee shall contact the appropriate Conservation District or a qualified soil erosion and sediment control professional and/or a qualified professional engineer, as appropriate, who will inspect the site to confirm compliance with these post-construction stormwater measures. This person(s) shall not be an employee of the permittee and shall have no ownership interest of any kind in the project for which the site's registration was submitted.

Following final stabilization of the site and termination of the CGP coverage, operations and maintenance of stormwater control measures shall be performed by the site owner's O&M personnel. All above ground embankments shall be routinely inspected for rodent burrow, piping, and erosion. If repairs are required, a qualified engineer shall evaluate the structure first. Repairs shall be made based on the engineer's recommendations. .

9. Pollution Prevention

9.1. Potential Sources of Pollution

Potential sources of pollution are:

- Total petroleum hydrocarbons (TPH) consisting of diesel, gasoline, anti-freeze, hydraulic fluid, motor oil, gear oil, and transmission oil;
- Septic waste and sanitary fluids (sodium sulfate, soap, fragrance, nonphenol ethoxylate, 1,4 Dioxane and Ethylene Oxide);
- Sediment; and
- Trash, debris, and other solids.

If additional potential pollutants are brought onsite, an evaluation of containment and response measures must be completed before work is initiated.

9.2. Emergency Response Plan Spill Prevention and Response

Spill cleanup kits and absorbent materials will be stored on-site and readily available. If a spill occurs, clean-up measures are required immediately. Spill cleanup, reporting, and documentation shall be performed in accordance with the following:

- Separate contaminated soils from other stockpiled material. Contaminated soils are never to be added to stockpiled material or backfill and other contaminated material

- Dispose of contaminated soils in accordance with local, state and federal regulations
- Report the spill, if equal to or greater than the reportable quantity as defined in 40 CFR Part 110 and/or 40CFR Part 302, immediately to the following:
 - Primary Operator/Contractor
 - Emergency Response:

Contractors will notify the Fire Department by dialing 911.

Contractors will also notify the primary operator prior to making any regulatory notifications of spills.

- Document the spill, within 7 days, with the description, circumstances, and date of the release
- Modify the SWPCP AND ESC Drawings within 14 calendar days of the release including the description, circumstances, and date of the release
- Review the SWPCP and ESC Drawings to identify measures to prevent the reoccurrence of such releases and to respond to such releases

9.3. Fueling and Maintenance of Equipment and Vehicles

No equipment maintenance will be performed onsite. Equipment refueling will be performed only in the designated staging areas with absorbent material and drip pans underneath to collect spilled material. Any fluids drained from equipment during servicing will be collected and in leak-proof, properly labeled containers and disposed of in accordance with local, state and federal regulations.

Store chemicals in water-tight containers and provide either cover (e.g., plastic sheeting or temporary roofs) to prevent these containers from coming into contact with rainwater, or a similarly effective means designed to prevent the discharge of pollutants from these areas (e.g., spill kits), or provide secondary containment (e.g., spill berms, decks, spill containment pallets). Spills shall be cleaned up immediately, using dry clean-up methods where possible, and dispose of used materials properly. Do not clean surfaces or spills by hosing the area down. Eliminate the source of the spill to prevent a discharge or a continuation of an ongoing discharge.

9.4. Washing of Equipment and Vehicles

Washing of equipment and vehicles will not be permitted at the Project area.

9.5. Storage, Handling, and Disposal of Construction Products, Materials, and Wastes

In storage areas, provide either cover (e.g., plastic sheeting or temporary roofs) to prevent these products from encountering rainwater, or a similarly effective means designed to prevent the discharge of pollutants from these areas.

9.6. Hazardous and/or Toxic Waste

Hazardous or toxic waste (e.g., paints, solvents, petroleum-based products, wood preservatives, additives, curing compounds, acids) shall be separated from construction and domestic waste.

Hazardous or toxic waste shall be stored in sealed containers, which are constructed of suitable materials to prevent leakage and corrosion, and which are labeled in accordance with applicable Resource Conservation and Recovery Act (RCRA) requirements and all other applicable federal, state, or local requirements.

Hazardous or toxic waste containers stored outside will be placed within appropriately-sized secondary containment (e.g., spill berms, decks, spill containment pallets) to prevent spills from being discharged, or provide a similarly effective means designed to prevent the discharge of pollutants from these areas (e.g., storing chemicals in covered areas or having a spill kit available on site).

Hazardous or toxic waste will be disposed of in accordance with the manufacturer's recommended methods of disposal and in compliance with federal, state, and local requirements.

Clean up spills of hazardous or toxic waste immediately, using dry clean-up methods where possible, and dispose of used materials properly. Do not clean surfaces or spills by hosing the area down. Eliminate the source of the spill to prevent a discharge or a furtherance of an ongoing discharge.

9.7. Washing of Applicators and Containers used for Paint, Concrete, or Other Materials

Washing of applicators and containers used for paint, concrete, or other materials will not be permitted at the construction site.

9.8. Construction and Domestic Waste

Construction and domestic waste (e.g., packaging materials, scrap construction materials, masonry products, timber, pipe and electrical cuttings, plastics, Styrofoam, concrete, and other trash or building materials) will be disposed of in waste containers (e.g., dumpster or trash receptacle) of sufficient size and number to contain construction and domestic wastes. All waste containers must be covered at the completion of work each day.



9.9. Other Pollution Prevention Practices

All containers must be properly labeled with the identity of the chemical and appropriate hazard warnings, the name and address of the manufacturer, importer or other responsible party. Container labeling and hazard communication will be conducted in accordance with 40 CFR 1910.

10. Final Permanent Stabilization

All disturbed areas, with exception of impervious surfaces, will be reclaimed by surface roughening and application of low ground cover, native seed mix. Once all soil disturbing activities at the site have been completed, all construction materials, waste, and equipment will be removed and properly disposed of, if required. Temporary erosion and sediment control measures shall be removed.

Final stabilization shall be achieved when the site has an average of 100 plants per square foot, 6" tall before the first mowing.

Once the site has been stabilized for at least three months, the permittee shall have the site inspected by a qualified inspector to confirm final stabilization. The permittee shall indicate compliance with this requirement on the Notice of Termination form.



APPENDIX A

**CONSTRUCTION GENERAL
PERMIT**

SWPCP and ESCP
Stonington Solar Project
New London County, Connecticut

General Permit for the Discharge of Stormwater and Dewatering Wastewaters from Construction Activities

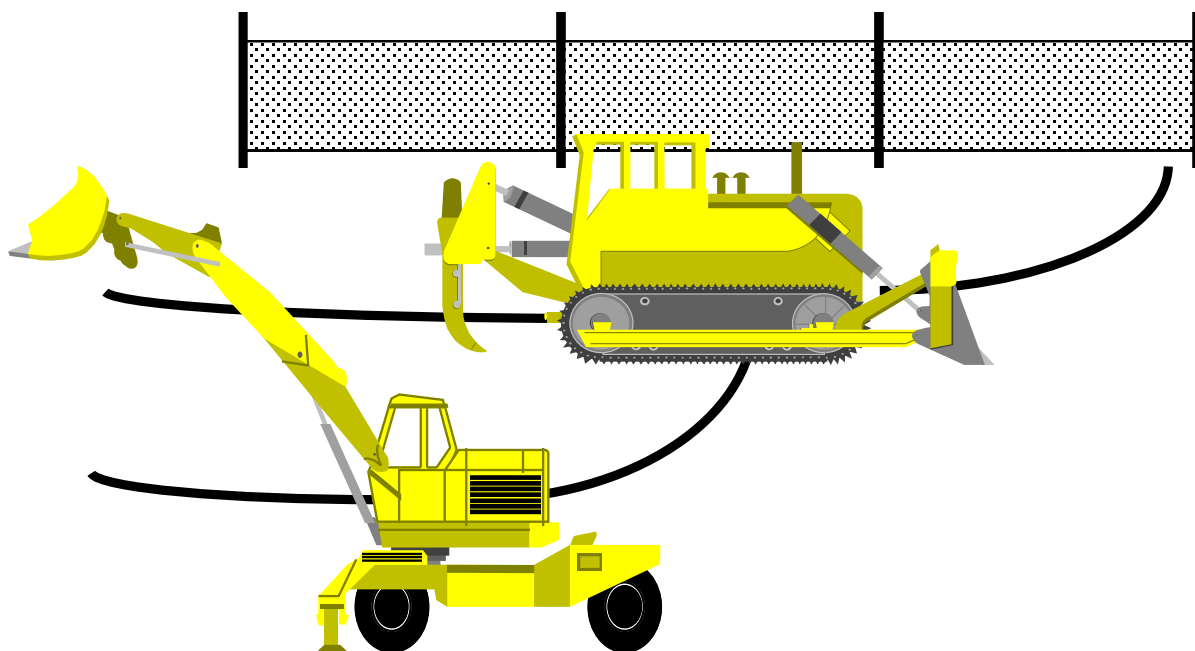

Effective Date: October 1, 2019

Printed on recycled paper

General Permit for Discharge of Stormwater and Dewatering Wastewaters from Construction Activities

Table of Contents

Section 1.	Authority	4
Section 2.	Definitions	4
Section 3.	Authorization Under This General Permit	9
	(a) Eligible Activities	9
	(b) Requirements for Authorization	9
	(c) Registration.....	15
	(d) Small Construction	16
	(e) Geographic Area.....	17
	(f) Effective Date and Expiration Date of this General Permit.....	17
	(g) Effective Date of Authorization.....	17
	(h) Revocation of an Individual Permit	18
	(i) Issuance of an Individual Permit.....	18
Section 4.	Registration Requirements	18
	(a) Who Must File a Registration.....	18
	(b) Scope of Registration.....	18
	(c) Contents of Registration	18
	(d) Where to File a Registration	21
	(e) Availability of Registration and Plan.....	21
	(f) Additional Information	22
	(g) Additional Notification	22
	(h) Action by Commissioner	22
	(i) Latest Date to Submit a Registration Under this General Permit	23
Section 5.	Conditions of this General Permit	23
	(a) Conditions Applicable to Certain Discharges.....	23
	(b) Stormwater Pollution Control Plan.....	24
	(c) Monitoring.....	36
	(d) Reporting and Record Keeping Requirements.....	39
	(e) Regulations of Connecticut State Agencies Incorporated into this General Permit	39
	(f) Reliance on Registration	40
	(g) Duty to Correct and Report Violations	40
	(h) Duty to Provide Information.....	40
	(i) Certification of Documents.....	40
	(j) Date of Filing.....	40
	(k) False Statements	40
	(l) Correction of Inaccuracies	41
	(m) Transfer of Authorization	41
	(n) Reopener	41
	(o) Other Applicable Law.....	41
	(p) Other Rights.....	41
Section 6.	Termination Requirements.....	41
	(a) Notice of Termination.....	41
	(b) Termination Form.....	42

	(c) Where to File a Termination Form	42
Section 7.	Commissioner's Powers	43
	(a) Abatement of Violations	43
	(b) General Permit Revocation, Suspension, or Modification.....	43
	(c) Filing of an Individual Application.....	43
Appendix A	Endangered and Threatened Species	
Appendix B	Low Impact Development Guidance Information and Fact Sheet	
Appendix C	Aquifer Protection Guidance Information	
Appendix D	Coastal Management Act Determination Form	
Appendix E	Conservation Districts of Connecticut	
Appendix F	Memorandum of Agreement Between DEEP and Conservation Districts	
Appendix G	Historic Preservation Review	
Appendix H	Wild & Scenic Rivers Guidance	

General Permit for the Discharge of Stormwater and Dewatering Wastewaters from Construction Activities

Section 1. Authority

This general permit is issued under the authority of section 22a-430b of the Connecticut General Statutes.

Section 2. Definitions

The definitions of terms used in this general permit shall be the same as the definitions contained in section 22a-423 of the Connecticut General Statutes and section 22a-430-3(a) of the Regulations of Connecticut State Agencies. As used in this general permit, the following definitions shall apply:

“x-year, 24-hour rainfall event” means the maximum 24-hour precipitation event with a probable recurrence interval of once in the given number of years (i.e. x=2, 25 or 100), as defined by the National Weather Service in Technical Paper Number 40, “Rainfall Frequency Atlas of the United States,” May 1961, and subsequent amendments, or equivalent regional or state rainfall probability information developed therefrom.

“Annual sediment load” means the total amount of sediment carried by stormwater runoff on an annualized basis.

“Aquifer protection area” means aquifer protection area as defined in section 22a-354h of the Connecticut General Statutes.

“Best engineering practices” means the design of engineered control measures to control pollution to the maximum extent achievable using measures that are technologically available and economically practicable.

“CFR” means the Code of Federal Regulations.

“Coastal area” means coastal area as defined in section 22a-93(3) of the Connecticut General Statutes.

“Coastal waters” means coastal waters as defined in section 22a-93(5) of the Connecticut General Statutes.

“Commissioner” means commissioner as defined in section 22a-2(b) of the Connecticut General Statutes.

“Construction activity” means any activity associated with construction at a site including, but not limited to, clearing and grubbing, grading, excavation, and dewatering.

“Department” means the Department of Energy & Environmental Protection.

“Developer” means a person who or municipality which is responsible, either solely or partially through contract, for the design and construction of a project site.

“Dewatering wastewater” means wastewater associated with the construction activity generated from the lowering of the groundwater table, the pumping of accumulated stormwater or uncontaminated groundwater from an excavation, the pumping of surface water from a cofferdam, or pumping of other surface water that has been diverted into a construction site.

“District” means a soil and water conservation district established pursuant to section 22a-315 of the Connecticut General Statutes. Appendix E lists the Districts, their geographic delineations, and contact information.

“*Disturbance*” means the execution of any of the construction activity(ies) defined in this general permit.

“*Effective Impervious Cover*” is the total area of a site with a Rational Method runoff coefficient of 0.7 or greater (or other equivalent methodology) from which stormwater discharges directly to a surface water or to a storm sewer system.

“*Engineered stormwater management system*” means any control measure and related appurtenances which requires engineering analysis and/or design by a professional engineer.

“*Erosion*” means the detachment and movement of soil or rock fragments by water, wind, ice and gravity.

“*Fresh-tidal wetland*” means a tidal wetland with an average salinity level of less than 0.5 parts per thousand.

“*Grab sample*” means an individual sample collected in less than fifteen minutes.

“*Groundwater*” means those waters of the state that naturally exist or flow below the surface of the ground.

“*Guidelines*” means the 2002 Connecticut Guidelines for Soil Erosion and Sediment Control, as amended, established pursuant to section 22a-328 of the Connecticut General Statutes.

“*High Quality Waters*” means those waters defined as high quality waters in the Connecticut Water Quality Standards published by the Department, as may be amended.

“*Impaired water(s)*” means those surface waters of the state designated by the commissioner as impaired pursuant to Section 303(d) of the Clean Water Act and as identified in the most recent State of Connecticut Integrated Water Quality Report.

“*In Responsible charge*” means professional experience for which the Commissioner determines that a professional’s primary duties consistently involve a high level of responsibility and decision making in the planning and designing of engineered stormwater management systems or in the planning and designing of soil erosion and sediment controls for residential and commercial construction projects. The Commissioner shall consider the following in determining whether a professional’s experience qualifies as responsible charge experience:

- (i) the level of independent decision-making exercised;
- (ii) the number of individuals and the disciplines of the other professionals that the professional supervised or coordinated;
- (iii) the extent to which a professional’s responsibilities consistently involved the review of work performed by other professionals involved the planning and designing of engineered stormwater management systems or the planning and designing of soil erosion and sediment controls for residential and commercial construction projects;
- (iv) the extent to which a professional’s responsibilities consistently involved the planning and designing of engineered stormwater management systems or the planning and designing of soil erosion and sediment controls for residential and commercial construction projects and whether such responsibilities were an integral and substantial component of the professional’s position;
- (v) the nature of a professional’s employer’s primary business interests and the relation of those interests to planning and designing of engineered stormwater management systems or to planning and designing of soil erosion and sediment controls for residential and commercial construction projects;

- (vi) the extent to which a professional has engaged in the evaluation and selection of scientific or technical methodologies for planning and designing of engineered stormwater management systems or for planning and designing of soil erosion and sediment controls for residential and commercial construction projects;
- (vii) the extent to which a professional drew technical conclusions, made recommendations, and issued opinions based on the results of planning and designing of engineered stormwater management systems or of planning and designing of soil erosion and sediment controls for residential and commercial construction projects; or
- (viii) any other factor that the Commissioner deems relevant.

“*Individual permit*” means a permit issued to a specific permittee under section 22a-430 of the Connecticut General Statutes.

“*Inland wetland*” means wetlands as defined in section 22a-38 of the Connecticut General Statutes.

“*Landscape Architect*” means a person with a currently effective license issued in accordance with chapter 396 of the Connecticut General Statutes.

“*Linear Project*” includes the construction of roads, railways, bridges, bikeways, conduits, substructures, pipelines, sewer lines, towers, poles, cables, wires, connectors, switching, regulating and transforming equipment and associated ancillary facilities in a long, narrow area.

“*Locally approvable project*” means a construction activity for which the registration is not for a municipal, state or federal project and is required to obtain municipal approval for the project.

“*Locally exempt project*” means a construction activity for which the registration is for a project authorized under municipal, state or federal authority and may not be required to obtain municipal approval for the project.

“*Low Impact Development*” or “*LID*” means a site design strategy that maintains, mimics or replicates pre-development hydrology through the use of numerous site design principles and small-scale treatment practices distributed throughout a site to manage runoff volume and water quality at the source.

“*Minimize*”, for purposes of implementing the control measures in Section 5(b)(2) of this general permit, means to reduce and/or eliminate to the extent achievable using control measures that are technologically available and economically practicable and achievable in light of best industry practice.

“*Municipal separate storm sewer system*” or “*MS4*” means conveyances for stormwater (including roads with drainage systems, municipal streets, catch basins, curbs, gutters, ditches, man-made channels or storm drains) owned or operated by any municipality and discharging to surface waters of the state.

“*Municipality*” means a city, town or borough of the state as defined in section 22a-423 of the Connecticut General Statutes.

“*Nephelometric Turbidity Unit*” or “*NTU*” means a unit measure of turbidity from a calibrated nephelometer.

“*Normal Working Hours*”, for the purposes of monitoring under Section 5(c) of this general permit, are considered to be, at a minimum, Monday through Friday, between the hours of 8:00 am and 6:00 pm, unless additional working hours are specified by the permittee.

“*Permittee*” means any person who or municipality which initiates, creates or maintains a discharge in accordance with Section 3 of this general permit.

“*Person*” means person as defined in section 22a-423 of the Connecticut General Statutes.

“*Phase*” means a portion of a project possessing a distinct and complete set of activities that have a specific functional goal wherein the work to be completed in the phase is not dependent upon the execution of work in a later phase in order to make it functional.

“*Point Source*” means any discernible, confined and discrete stormwater conveyance (including but not limited to, any pipe, ditch, channel, tunnel, conduit, discrete fissure, container, rolling stock, concentrated animal feeding operation, landfill leachate collection system, vessel or other floating craft) from which pollutants are or may be discharged.

“*Professional Engineer*” or “*P.E.*” means a person with a currently effective license issued in accordance with chapter 391 of the Connecticut General Statutes.

“*Qualified Inspector*” means an individual possessing either (1) a professional license or certification by a professional organization recognized by the commissioner related to agronomy, civil engineering, landscape architecture, soil science, and two years of demonstrable and focused experience in erosion and sediment control plan reading, installation, inspection and/or report writing for residential and commercial construction projects in accordance with the Guidelines; or (2) five years of demonstrable and focused experience in erosion and sediment control plan reading, installation, inspection and/or report writing for residential and commercial construction projects in accordance with the Guidelines; or (3) certification by the Connecticut Department of Transportation (DOT).

“*Qualified professional engineer*” means a professional engineer who has, for a minimum of eight years, engaged in the planning and designing of engineered stormwater management systems for residential and commercial construction projects in accordance with the Guidelines and the Stormwater Quality Manual including, but not limited to, a minimum of four years in responsible charge of the planning and designing of engineered stormwater management systems for such projects.

“*Qualified soil erosion and sediment control professional*” means a landscape architect or a professional engineer who: (1) has for a minimum of eight years engaged in the planning and designing of soil erosion and sediment controls for residential and commercial construction projects in accordance with the Guidelines including, but not limited to, a minimum of four years in responsible charge of the planning and designing of soil erosion and sediment controls for such projects; or (2) is currently certified as a professional in erosion and sediment control as designated by EnviroCert International, Incorporated (or other certifying organization acceptable to the commissioner) and has for a minimum of six years experience engaged in the planning and designing of soil erosion and sediment controls for residential and commercial construction projects in accordance with the Guidelines including, but not limited to, a minimum of four years in responsible charge in the planning and designing of soil erosion and sediment controls for such projects.

“*Registrant*” means a person or municipality that files a registration.

“*Registration*” means a registration form filed with the commissioner pursuant to Section 4 of this general permit.

“*Regulated Municipal Separate Storm Sewer System*” or “*Regulated MS4*” means the separate storm sewer system of the City of Stamford or any municipally-owned or -operated separate storm sewer system (as defined above) authorized by the most recently issued General Permit for the Discharge of Stormwater from Small Municipal Separate Storm Sewer Systems (MS4 general permit) including all those located partially

or entirely within an Urbanized Area and those additional municipally-owned or municipally-operated Small MS4s located outside an Urbanized Area as may be designated by the commissioner.

“*Retain*” means to hold runoff on-site to promote vegetative uptake and groundwater recharge through the use of runoff reduction or LID practices or other measures. In addition, it means there shall be no subsequent point source release to surface waters from a storm event defined in this general permit or as approved by the commissioner.

“*Runoff reduction practices*” means those post-construction stormwater management practices used to reduce post-development runoff volume delivered to the receiving water, as defined by retaining the volume of runoff from a storm up to the first half inch or one inch of rainfall in accordance with Sections 5(b)(2)(C)(i)(a) or (b), respectively. Runoff reduction is quantified as the total annual post-development runoff volume reduced through canopy interception, soil amendments, evaporation, rainfall harvesting, engineered infiltration, extended filtration or evapo-transpiration.

“*Sediment*” means solid material, either mineral or organic, that is in suspension, is transported, or has been moved from its site of origin by erosion.

“*Site*” means geographically contiguous land on which a construction activity takes place or on which a construction activity for which authorization is sought under this general permit is proposed to take place. Non-contiguous land or water owned by the same person shall be deemed the same site if such land is part of a linear project (as defined in this section) or is otherwise connected by a right-of-way, which such person controls.

“*Soil*” means any unconsolidated mineral and organic material of any origin.

“*Stabilize*” means the use of measures as outlined in the 2002 Connecticut Guidelines for Soil Erosion and Sediment Control, as amended, or as approved by the commissioner, to prevent the visible movement of soil particles and development of rills.

“*Structural measure*” means a measure constructed for the temporary storage and/or treatment of stormwater runoff.

“*Standard Industrial Classification Code*” or “*SIC Code*” means those codes provided in the Standard Industrial Classification Manual, Executive Office of the President, Office of Management and Budget 1987.

“*Standard of care*”, as used in Section 3(b), means to endeavor to perform in a manner consistent with that degree of care and skill ordinarily exercised by members of the same profession currently practicing under similar circumstances.

“*Stormwater*” means waters consisting of rainfall runoff, including snow or ice melt during a rain event.

“*Stormwater Quality Manual*” means the 2004 Connecticut Stormwater Quality Manual published by the Connecticut Department of Energy & Environmental Protection, as amended.

“*Surface water*” means that portion of waters, as the term “waters” is defined in section 22a-423 of the Connecticut General Statutes, located above the ground surface.

“*Tidal wetland*” means a wetland as that term is defined in section 22a-29(2) of the Connecticut General Statutes.

“*Total disturbance*” means the total area on a site where soil will be exposed or susceptible to erosion during the course of all phases of a project.

“*Total Maximum Daily Load*” or “*TMDL*” means the maximum capacity of a surface water to assimilate a pollutant as established by the commissioner, including pollutants contributed by point and non-point sources and a margin of safety.

“*Upland soils*” means soils which are not designated as poorly drained, very poorly drained, alluvial, or flood plain by the National Cooperative Soils Survey, as may be amended, of the Natural Resources Conservation Service of the United States Department of Agriculture and/or the inland wetlands agency of the municipality in which the project will take place.

“*Water company*” means water company as defined in section 25-32a of the Connecticut General Statutes.

“*Water Quality Standards or Classifications*” means those water quality standards or classifications contained in the Connecticut Water Quality Standards published by the Department, as may be amended.

“*Water Quality Volume*” or “*WQV*” means the volume of runoff generated by one inch of rainfall on a site as defined in the 2004 Connecticut Stormwater Quality Manual, as amended.

Section 3. Authorization Under This General Permit

(a) Eligible Activities

This general permit authorizes the discharge of stormwater and dewatering wastewaters to surface waters from construction activities on a site, as defined in this general permit, with a total disturbance of one or more acres of land area on a site, *regardless of project phasing*.

In the case of a larger plan of development (such as a subdivision), the estimate of total acres of site disturbance shall include, but is not limited to, road and utility construction, individual lot construction (e.g. house, driveway, septic system, etc.), and all other construction associated with the overall plan, regardless of the individual parties responsible for construction of these various elements.

(b) Requirements for Authorization

This general permit authorizes the construction activity listed in the “Eligible Activities” section (Section 3(a)) of this general permit provided:

(1) Coastal Management Act

Such construction activity must be consistent with all applicable goals and policies in section 22a-92 of the Connecticut General Statutes, and must not cause adverse impacts to coastal resources as defined in section 22a-93(15) of the Connecticut General Statutes. Please refer to the Appendix D for additional guidance.

(2) Endangered and Threatened Species

Such activity must not threaten the continued existence of any species listed pursuant to section 26-306 of the Connecticut General Statutes as endangered or threatened and must not result in the destruction or adverse modification of habitat designated as essential to such species. See Appendix A.

(3) Aquifer Protection Areas

Such construction activity, if it is located within an aquifer protection area as mapped under section 22a-354b of the General Statutes, must comply with regulations adopted pursuant to section 22a-354i of the General Statutes. Please refer to the Appendix C for additional guidance.

For any construction activity regulated pursuant to sections 8(c) and 9(b) of the Aquifer Protection Regulations (section 22a-354i(1)-(10) of the Regulations of Connecticut State Agencies), the Stormwater Pollution Control Plan (Plan) must assure that stormwater run-off generated from the regulated construction activity (i) is managed in a manner so as to prevent pollution of groundwater, and (ii) complies with all the requirements of this general permit.

(4) Mining Operations Exception

The stormwater discharge resulting from an activity classified as Standard Industrial Classification 10 through 14 (the mining industry) is not authorized by this general permit and is regulated under the most recently issued General Permit for the Discharge of Stormwater Associated with Industrial Activity.

(5) Discharge to POTW

The stormwater is *not* discharged to a Publicly Owned Treatment Works (POTW).

(6) Discharge to Groundwater

The stormwater is *not* discharged entirely to groundwater, meaning a stormwater discharge to a surface water will not occur up to a 100-year, 24-hour rainfall event.

(7) Such construction activity must be consistent with the Wild and Scenic Rivers Act (16 U.S.C. 1271-1287) for those river components and tributaries which have been designated as Wild and Scenic by the United States Congress. Further, such construction activities must not have a direct and adverse effect on the values for which such river designation was established. Please refer to Appendix H for additional guidance.

(8) Certification Requirements for Registrants and other Individuals

As part of the registration for this general permit, the registrant and any other individual or individuals responsible for preparing the registration submits to the commissioner a written certification which, at a minimum, complies with the following requirements:

- (A) The registrant and any other individual or individuals responsible for preparing the registration and signing the certification has completely and thoroughly reviewed, at a minimum, this general permit and the following regarding the activities to be authorized under such general permit:
 - (i) all registration information provided in accordance with Section 4(c)(2) of such general permit;
 - (ii) the project site, based on a site inspection;
 - (iii) the Stormwater Pollution Control Plan; and
 - (iv) any plans and specifications and any Department approvals regarding such Stormwater Pollution Control Plan;

- (B) The registrant and any other individual or individuals responsible for preparing the registration and signing the certification pursuant to this general permit has, based on the review described in section 3(b)(8)(A) of this general permit, made an affirmative determination to:
- (i) comply with the terms and conditions of this general permit;
 - (ii) maintain compliance with all plans and documents prepared pursuant to this general permit including, but not limited to, the Stormwater Pollution Control Plan;
 - (iii) properly implement and maintain the elements of the Stormwater Pollution Control Plan; and
 - (iv) properly operate and maintain all stormwater management systems in compliance with the terms and conditions of this general permit to protect the waters of the state from pollution;
- (C) Such registrant and any other individual or individuals responsible for preparing the registration certifies to the following statement: "I hereby certify that I am making this certification in connection with a registration under such general permit, submitted to the commissioner by [INSERT NAME OF REGISTRANT] for an activity located at [INSERT ADDRESS OF PROJECT OR ACTIVITY] and that all terms and conditions of the general permit are being met for all discharges which have been initiated and such activity is eligible for authorization under such permit. I further certify that a system is in place to ensure that all terms and conditions of this general permit will continue to be met for all discharges authorized by this general permit at the site. I certify that the registration filed pursuant to this general permit is on complete and accurate forms as prescribed by the commissioner without alteration of their text. I certify that I have personally examined and am familiar with the information that provides the basis for this certification, including but not limited to all information described in Section 3(b)(8)(A) of such general permit, and I certify, based on reasonable investigation, including my inquiry of those individuals responsible for obtaining such information, that the information upon which this certification is based is true, accurate and complete to the best of my knowledge and belief. I certify that I have made an affirmative determination in accordance with Section 3(b)(8)(B) of this general permit. I understand that the registration filed in connection with such general permit is submitted in accordance with and shall comply with the requirements of Section 22a-430b of Connecticut General Statutes. I also understand that knowingly making any false statement made in the submitted information and in this certification may be punishable as a criminal offense, including the possibility of fine and imprisonment, under section 53a-157b of the Connecticut General Statutes and any other applicable law."
- (9) The registrant has submitted to the commissioner a written certification by a professional engineer or, where appropriate, a landscape architect licensed in the State of Connecticut for the preparation, planning and design of the Stormwater Pollution Control Plan and stormwater management systems:
- (A) The professional engineer or landscape architect shall certify to the following statement:
- "I hereby certify that I am a [professional engineer][landscape architect] licensed in the State of Connecticut. I am making this certification in connection with a registration under such general permit, submitted to the commissioner by [INSERT NAME OF REGISTRANT] for an activity located at [INSERT ADDRESS OF PROJECT OR ACTIVITY]. I certify that I have thoroughly and completely reviewed the Stormwater

Pollution Control Plan for the project or activity covered by this certification. I further certify, based on such review and on the standard of care for such projects, that the Stormwater Pollution Control Plan has been prepared in accordance with the Connecticut Guidelines for Soil Erosion and Sediment Control, as amended, the Stormwater Quality Manual, as amended, and the conditions of the general permit, and that the controls required for such Plan are appropriate for the site. I further certify, based on reasonable investigation, including my inquiry of those individuals responsible for obtaining such information, that the information upon which this certification is based is true, accurate and complete to the best of my knowledge and belief. I also understand that knowingly making any false statement in this certification may subject me to sanction by the Department and/or be punishable as a criminal offense, including the possibility of fine and imprisonment, under section 53a-157b of the Connecticut General Statutes and any other applicable law."

- (B) Nothing in this section shall be construed to authorize a professional engineer or a landscape architect to engage in any profession or occupation requiring a license under any other provision of the general statutes without such license.

(10) Plan Review and Certification by a District for Locally Approvable Projects

For those Plans not reviewed in accordance with Section 3(b)(11), below, the registrant has submitted to the commissioner a written certification by the appropriate regional District for the review of the Stormwater Pollution Control Plan pursuant to Appendix F, which, at a minimum, complies with the following requirements:

- (A) the Plan Review Certification must be signed by the District. Information on the District review process is outlined in the Memorandum of Agreement provided in Appendix F. In cases where the District is unable to complete review of the Plan within the time limits specified in the Memorandum of Agreement in Appendix F, a notice to that effect signed by the District may be submitted in lieu of the certification.
- (B) the Stormwater Pollution Control Plan has been prepared in accordance with the requirements of Section 5(b) of the general permit.
- (C) Nothing in this subsection shall be construed to authorize District personnel to engage in any profession or occupation requiring a license under any other provision of the general statutes without such license.

(11) Plan Review and Certification by a Qualified Soil Erosion and Sediment Control Professional and Qualified Professional Engineer for Locally Approvable Projects

For those Plans not reviewed in accordance with Section 3(b)(10), above, the registrant has submitted to the commissioner a written certification by a qualified professional engineer or a qualified soil erosion and sediment control professional in accordance with the following requirements:

- (A) for projects disturbing more than one acre and less than fifteen (15) acres, such qualified soil erosion and sediment control professional or qualified professional engineer:
 - (i) is not an employee, as defined by the Internal Revenue Service in the Internal Revenue Code of 1986, of the registrant; and
 - (ii) has no ownership interest of any kind in the project for which the registration is being submitted.

- (B) for projects disturbing fifteen (15) acres or more, such qualified soil erosion and sediment control professional or qualified professional engineer:
 - (i) is not an employee, as defined by the Internal Revenue Service in the Internal Revenue Code of 1986, of the registrant;
 - (ii) did not engage in any activities associated with the preparation, planning, designing or engineering of such plan for soil erosion and sediment control or plan for stormwater management systems on behalf of such registrant;
 - (iii) is not under the same employ as any person who engaged in any activities associated with the preparation, planning, designing or engineering of such plans and specifications for soil erosion and sediment control or plans and specifications for stormwater management systems on behalf of such registrant; and
 - (iv) has no ownership interest of any kind in the project for which the registration is being submitted.
- (C) The qualified professional engineer or qualified soil erosion and sediment control professional signing the certification has, at a minimum, completely and thoroughly reviewed this general permit and the following regarding the discharges to be authorized under such general permit:
 - (i) all registration information provided in accordance with Section 4(c)(2) of such general permit;
 - (ii) the site, based on a site inspection;
 - (iii) the Stormwater Pollution Control Plan;
 - (iv) the Guidelines;
 - (v) the Stormwater Quality Manual, if applicable; and
 - (vi) all non-engineered and engineered stormwater management systems, including any plans and specifications and any Department approvals regarding such stormwater management systems.
- (D) Affirmative Determination
 - (i) The qualified soil erosion and sediment control professional signing the certification must have made an affirmative determination, based on the review described in section 3(b)(11)(C) of this general permit that:
 - (a) the Stormwater Pollution Control Plan prepared and certified pursuant to the registration is adequate to assure that the project or activity authorized under this general permit, if implemented in accordance with the Stormwater Pollution Control Plan, will comply with the terms and conditions of such general permit; and
 - (b) all non-engineered stormwater management systems:
 - (1) have been designed to control pollution to the maximum extent achievable using measures that are technologically available and economically

practicable and that conform to those in the Guidelines and the Stormwater Quality Manual;

- (2) will function properly as designed;
- (3) are adequate to ensure compliance with the terms and conditions of this general permit; and
- (4) will protect the waters of the state from pollution.

(ii) The qualified professional engineer signing the certification must have made an affirmative determination, based on the review described in section 3(b)(11)(C) of this general permit that:

- (a) the Stormwater Pollution Control Plan prepared and certified pursuant to the registration is adequate to assure that the activity authorized under this general permit, if implemented in accordance with the Stormwater Pollution Control Plan, will comply with the terms and conditions of such general permit; and
- (b) all non-engineered and engineered stormwater management systems:
 - (1) have been designed to control pollution to the maximum extent achievable using measures that are technologically available and economically practicable and that conform to those in the Guidelines and the Stormwater Quality Manual;
 - (2) will function properly as designed;
 - (3) are adequate to ensure compliance with the terms and conditions of this general permit; and
 - (4) will protect the waters of the state from pollution.

(E) The qualified professional engineer or qualified soil erosion and sediment control professional shall, provided it is true and accurate, certify to the following statement:

"I hereby certify that I am a qualified professional engineer or qualified soil erosion and sediment control professional, or both, as defined in the General Permit for Discharge of Stormwater and Dewatering Wastewaters from Construction Activities and as further specified in sections 3(b)(11)(A) and (B) of such general permit. I am making this certification in connection with a registration under such general permit, submitted to the commissioner by [INSERT NAME OF REGISTRANT] for an activity located at [INSERT ADDRESS OF PROJECT OR ACTIVITY]. I have personally examined and am familiar with the information that provides the basis for this certification, including but not limited to all information described in Section 3(b)(11)(C) of such general permit, and I certify, based on reasonable investigation, including my inquiry of those individuals responsible for obtaining such information, that the information upon which this certification is based is true, accurate and complete to the best of my knowledge and belief. I further certify that I have made the affirmative determination in accordance with Sections 3(b)(11)(D)(i) and (ii) of this general permit. I understand that this certification is part of a registration submitted in accordance with Section 22a-430b of Connecticut General Statutes and is subject to the requirements and responsibilities for a qualified professional in such statute. I also understand that knowingly making any false statement in this certification may be

punishable as a criminal offense, including the possibility of fine and imprisonment, under section 53a-157b of the Connecticut General Statutes and any other applicable law."

- (F) Nothing in this subsection shall be construed to authorize a qualified soil erosion and sediment control professional or a qualified professional engineer to engage in any profession or occupation requiring a license under any other provision of the general statutes without such license.

(12) New Discharges to Impaired Waters

New stormwater discharges directly to an impaired water, as indicated in the State's Integrated Water Quality Report, must be in accordance with the following conditions:

- (A) Stormwater discharges that go directly to impaired waters seeking authorization under this general permit shall comply with the requirements of this subsection (B) below if the indicated cause or potential cause of the impairment is one of the following:
- Site Clearance (Land Development or Redevelopment)
 - Post-Development Erosion and Sedimentation
 - Source Unknown (if cause of impairment is Sedimentation/Siltation)
- (B) Such stormwater discharge is authorized if the permittee complies with the requirements of Section 5(b)(3) of this permit and receives a written affirmative determination from the commissioner that the discharge meets the requirements of that section. In such case, the permittee must keep a copy of the written determination onsite with the Plan. If the permittee does not receive such affirmative determination, the construction activity is not authorized by this general permit and must obtain an individual permit.

(c) **Registration**

Pursuant to the "Registration Requirements" section (Section 4) of this general permit, a completed registration with respect to the construction activity shall be filed with the commissioner as follows:

(1) Locally Approvable Projects

The registration must:

- (A) Be electronically submitted, along with all required elements in subsections (B), (C) and (D), below, at least sixty (60) days prior to the planned commencement of the construction activity.
- (B) Include the Registration Form (available at www.ct.gov/deep/stormwater).
- (C) Include any additional forms and information regarding compliance and/or consistency with the Coastal Management Act, Impaired Waters (including TMDL requirements), Endangered and Threatened Species, and Aquifer Protection Areas that may be required pursuant to the "Requirements of Authorization" section (Section 3(b)).
- (D) Include a Plan Review Certification in accordance with the "Plan Review Certification" (Section 5(b)(8)).

Locally Approvable projects may also choose to make their Plan electronically available in accordance with Section 4(c)(2)(N) of this general permit. The 60 day period cited in subsection

(A), above, will not begin until all required elements have been submitted. Failure to include any of these required submissions shall be grounds to reject the registration.

(2) Locally Exempt Projects

The registration must:

- (A) Be electronically submitted, along with all required elements in subsections (B), (C) and (D), below, at least:
- (i) sixty (60) days prior to the planned commencement of the construction activity if the site has a total disturbed area of between one (1) and twenty (20) acres; *or*
 - (ii) ninety (90) days prior to the planned commencement of construction activity if the site:
 - (a) has a total disturbed area greater than twenty (20) acres;
 - (b) discharges to a tidal wetland (that is not a fresh-tidal wetland) within 500 feet of the discharge point; *or*
 - (c) is subject to the impaired waters provisions of Section 3(b)(12).
- (B) Include the Registration Form (available at www.ct.gov/deep/stormwater).
- (C) Include any additional forms and information regarding compliance and/or consistency with the Coastal Management Act, Impaired Waters (including TMDL requirements), Endangered and Threatened Species, and Aquifer Protection that may be required pursuant to the “Requirements of Authorization” section (Section 3(b)).
- (D) Include an electronic copy of the Stormwater Pollution Control Plan (Plan) (or a web address where the electronic Plan can be downloaded) for the commissioner’s review. The electronic Plan shall be in Adobe™ PDF format or similar publicly available format in common use. **DO NOT INCLUDE** in this electronic copy any pages or other material that do not pertain to stormwater management or erosion and sedimentation control (such as electrical and lighting plans, boundary or lot surveys, building plans, non-stormwater related detail sheets, etc.).

The 60 or 90 day periods cited in subsections (A), above, will not begin until all required elements have been submitted. Failure to include any of these required submissions shall be grounds to reject the registration.

(3) Re-Registration of Existing Projects

For sites previously registered under any previous version of the General Permit for the Discharge of Stormwater and Dewatering Wastewaters from Construction Activities and for which no Notice of Termination has been submitted pursuant to the “Termination Requirements” section (Section 6), no re-registration or fee is required to maintain permit authorization. Resubmission of the permittee’s Plan is not required unless specifically requested by the commissioner.

(d) Small Construction

For construction projects with a total disturbance of between one and five acres, the permittee shall adhere to the erosion and sediment control land use regulations of the municipality in which the construction activity is conducted, as well as the Guidelines and the Stormwater Quality Manual.

No registration or Plan review and certification shall be required for such construction activity provided a land-use commission of the municipality (i.e. planning/zoning, wetland, conservation, etc) reviews and issues a written approval of the proposed erosion and sediment control measures, pursuant to the requirements of section 22a-329 of the Connecticut General Statutes. In the absence of such municipal commission approval, the permittee shall register with the DEEP under the requirements for a Locally Exempt Project and comply with all applicable conditions of this general permit.

(e) *Geographic Area*

This general permit applies throughout the State of Connecticut.

(f) *Effective Date and Expiration Date of this General Permit*

The registration provisions of Section 3(c) and 4 of this General Permit, including any applicable definitions or provisions referred to in those sections insofar as they facilitate submission of a registration, shall be effective September 1, 2013. All remaining provisions of this General Permit shall be effective on October 1, 2013. The provisions of this General Permit shall expire on September 30, 2020.

(g) *Effective Date of Authorization*

A construction activity is authorized by this general permit at such time as specified in subsections (1) and (2), below.

(1) Authorization Timelines

The activity is authorized based on the following timelines unless superseded by subsection (2), below:

- (A) for locally approvable projects, sixty (60) days after the submission of the registration form required by Section 4(c), or
- (B) for locally exempt projects under 20 acres, sixty (60) days after the submission of the registration form required by Section 4(c), or
- (C) for locally exempt projects over 20 acres, ninety (90) days after the submission of the registration form required by Section 4(c).

(2) Alternate Authorization Timelines

If one of the following conditions for authorization applies, that condition shall supersede those of subsection (1), above:

- (A) for sites for which the registration and Plan availability and review provisions of Section 4(e) are completed prior to the authorization periods in subsection (1), above, the commissioner may authorize the activity upon such completion, or
- (B) for sites subject to the conditions of Section 3(b)(2), 3(b)(12) and/or Section 5(a)(2), the activity is authorized on the date of the commissioner's affirmative determination and/or approval, or

(h) *Revocation of an Individual Permit*

If a construction activity is eligible for authorization under this general permit and such activity is presently authorized by an individual permit, the existing individual permit may be revoked by the commissioner upon a written request by the permittee. If the commissioner revokes such individual permit in writing, such revocation shall take effect on the effective date of authorization of such activity under this general permit.

(i) *Issuance of an Individual Permit*

If the commissioner issues an individual permit under section 22a-430 of the Connecticut General Statutes, authorizing a construction activity authorized by this general permit, this general permit shall cease to authorize that activity beginning on the date such individual permit is issued.

Section 4. Registration Requirements

(a) *Who Must File a Registration*

With the exception noted in the “Small Construction” section (Section 3(d)) of this general permit, any person or municipality which initiates, creates, originates or maintains a discharge described in the “Eligible Activities” section (Section 3(a)) of this general permit shall file with the commissioner a registration form that meets the requirements of the “Contents of Registration” section (Section 4(c)) of this general permit and the applicable fee within the timeframes and in the amounts specified in Sections 3(c) and 4(c)(1)(A), respectively. Any such person or municipality filing a registration remains responsible for maintaining compliance with this general permit.

(b) *Scope of Registration*

Each registration shall be limited to the discharge at or from one site; no registration shall cover discharges at or from more than one site.

(c) *Contents of Registration*

(1) Fees

(A) Registration Fee

A registration, if required, shall not be deemed complete unless the registration fee has been paid in full.

(i) Locally Approvable Projects

A registration fee of \$625.00 shall be submitted to the Department with the registration form.

(ii) Locally Exempt Projects

A registration fee shall be submitted with a registration form as follows:

- (a)** For sites with total disturbance of between one (1) and twenty (20) acres, the fee shall be \$3,000.

- (b) For sites with total disturbance equal to or greater than twenty (20) acres and less than fifty (50) acres, the fee shall be \$4,000.
- (c) For sites with total disturbance equal to or greater than fifty (50) acres, the fee shall be \$5,000.

The fees for municipalities shall be half of those indicated in subsections (a), (b) and (c) above pursuant to section 22a-6(b) of the Connecticut General Statutes. State and Federal agencies shall pay the full fees specified in this subsection.

- (B) The registration fee shall be paid electronically or by check or money order payable to the Department of Energy & Environmental Protection.
- (C) The registration fee is non-refundable.

(2) Registration Form

A registration shall be filed electronically on forms prescribed and provided by the commissioner (available at: www.ct.gov/deep/stormwater) and shall include, but not be limited to, the following:

- (A) Legal name, address, and telephone number of the registrant. If the registrant is a person (as defined in Section 2 of this permit) transacting business in Connecticut and is registered with the Connecticut Secretary of the State, provide the exact name as registered with the Connecticut Secretary of the State.
- (B) Legal name, address and telephone number of the owner of the property on which the construction activity will take place.
- (C) Legal name, address and telephone number of the primary contact for departmental correspondence and inquiries, if different from the registrant.
- (D) Legal name, address and telephone number of the developer of the property on which the construction activity is to take place.
- (E) Legal name, address and daytime and off-hours telephone numbers of the general contractor(s) or other representative(s), if different from the developer.
- (F) Legal name, address and telephone number of any consultant(s), engineer(s) or landscape architect(s) retained by the permittee to prepare the registration and Stormwater Pollution Control Plan.
- (G) Location address or description of the site for which the registration is filed.
- (H) The estimated duration of the construction activity.
- (I) Indication of the normal working hours of the site.
- (J) A brief description of the construction activity, including, but not limited to:
 - (i) Total number of acres to be disturbed, regardless of phasing.
 - (ii) Assurance that construction is in accordance with the Guidelines and local erosion and sediment control ordinances, where applicable.

- (iii) For sites in the Coastal Boundary, documentation that the DEEP Office of Long Island Sound Programs or local governing authority has issued a coastal site plan approval or a determination that the project is exempt from coastal site plan review (see Appendix D) in accordance with section 22a-92 and 22a-93(15) of the Connecticut General Statutes.
 - (iv) Documentation that the construction activity will not threaten the continued existence of any species listed pursuant to section 26-306 of the Connecticut General Statutes as endangered or threatened and will not result in the destruction or adverse modification of habitat designated as essential to such species (see Appendix A).
 - (v) For sites discharging to certain impaired waters, as specified in Section 3(b)(12), documentation that the construction activity meets the requirements of that section and Section 5(b)(3) for authorization under this general permit.
 - (vi) Assurance that the construction activity is not located within an aquifer protection area (see Appendix C) as mapped under section 22a-354b of the Connecticut General Statutes or, if it is located within an aquifer protection area, that the construction activity will comply with regulations adopted pursuant to section 22a-354i of the Connecticut General Statutes.
 - (vii) For a proposed locally approvable project, a plan review certification from the appropriate District, qualified soil erosion and sediment control professional, and/or qualified professional engineer in accordance with Section 5(b)(10) or (11) or a notice from the District that they were unable to complete the Plan review within the time limits specified in the Memorandum of Agreement in Appendix F.
- (K) A brief description of the stormwater discharge, including:
- (i) The name of the municipal separate storm sewer system or immediate surface water body or wetland to which the stormwater runoff will discharge;
 - (ii) Verification of whether or not the site discharges to a tidal wetland (that is not a fresh-tidal wetland) within 500 feet of the discharge point, to a high quality water or to an impaired water with or without a TMDL;
 - (iii) The name of the watershed or nearest waterbody to which the site discharges.
 - (iv) Location of the stormwater discharge(s) including latitude and longitude.
- (L) The total effective impervious cover for the site before and after the proposed construction activity.
- (M) Documentation that the proposed construction activity has been reviewed for consistency with state Historic Preservation statutes, regulations, and policies including identification of any potential impacts on property listed or eligible for listing on the Connecticut Register of Historic Places. A review conducted for an Army Corps of Engineers Section 404 wetland permit would meet this qualification. Refer to Appendix G for guidance on conducting the required review.
- (N) Registrants for locally approvable projects may, if they choose, attach an electronic copy of their Plan to their registration or provide a web address where their Plan may be downloaded. If an electronic plan is not provided, the registrant is still subject to the

requirements for submission of a Plan to the commissioner or a member of the public pursuant to the “Plan Availability” section (Section 4(e)(2)). An electronic Plan shall be in Adobe™ PDF format or similar publicly available format in common use. **DO NOT INCLUDE** in the Plan any pages or other material that do not pertain to stormwater management or erosion and sedimentation control (such as electrical and lighting plans, boundary or lot surveys, building plans, non-stormwater related detail sheets, etc.).

- (O) Registrants for all locally exempt projects must submit an electronic copy of their Plan or a web address where the electronic Plan can be downloaded. The electronic Plan shall be in Adobe™ PDF format or similar publicly available format in common use. **DO NOT INCLUDE** in this Plan any pages or other material that do not pertain to stormwater management or erosion and sedimentation control (such as electrical and lighting plans, boundary or lot surveys, building plans, non-stormwater related detail sheets, etc.).
- (P) The certification of the registrant and of the individual or individuals responsible for actually preparing the registration, in accordance with Section 3(b)(8).
- (Q) For all registrations, a design certification must be signed by a professional engineer in accordance with Section 3(b)(9):.
- (R) For registrations for locally approvable projects a review certification must be signed by either: (i) a District in accordance with Section 3(b)(10), or (ii) a qualified soil erosion and sediment control professional and/or qualified professional engineer in accordance with either Section 3(b)(11).

If the registrant is not capable of submitting electronically, a paper form may be submitted in accordance with Section 4(d).

(d) Where to File a Registration

A registration (available at: www.ct.gov/deep/stormwater) shall be filed electronically with the commissioner in accordance with Section 3(c)(2) or (3). If the registrant does not have the capability to submit electronically, a paper registration may be filed at the following address:

CENTRAL PERMIT PROCESSING UNIT
DEPARTMENT OF ENERGY & ENVIRONMENTAL PROTECTION
79 ELM STREET
HARTFORD, CT 06106-5127

(e) Availability of Registration and Plan

By the fifteenth (15th) day of each month, the commissioner shall post on the DEEP website a list of registrations submitted in the previous month.

(1) Registration Availability

On or before fifteen (15) days from the date of posting by the commissioner, members of the public may review and comment on a registration. Any electronically available Plans will be posted with the corresponding registration.

(2) Plan Availability

(A) Electronic Plan Availability

For an electronically available Plan, on or before fifteen (15) days from the date of posting by the commissioner, members of the public may review and comment on a registrant's Plan.

(B) Non-Electronic Plan Availability

For any Plan that is not electronically available, on or before fifteen (15) days from the date of a registration posting by the commissioner, members of the public may submit a written request to the commissioner to obtain a copy of a registrant's Plan. The commissioner shall inform the registrant of the request and the name of the requesting party. If the commissioner does not already have access to a copy of the requested Plan, the registrant shall submit a copy of their Plan to the commissioner within seven (7) days of their receipt of such request. On or before fifteen (15) days from the date the commissioner makes a Plan available to the requesting party, they may submit written comments on the Plan to the commissioner.

(f) Additional Information

The commissioner may require a permittee to submit additional information that the commissioner reasonably deems necessary to evaluate the consistency of the subject construction activity with the requirements for authorization under this general permit.

(g) Additional Notification

For discharges authorized by this general permit to a regulated municipal separate storm sewer system, a copy of the registration and all attachments thereto shall also be submitted to the owner and operator of that system.

For discharges authorized by this general permit to a DOT separate storm sewer system, a copy of the registration and all attachments thereto shall also be submitted to the DOT upon request.

For discharges within a public drinking water supply watershed or aquifer area, a copy of the registration and the Plan described in subsection 5(b) of this general permit shall be submitted to the water company.

For discharges to river components and tributaries which have been designated as Wild and Scenic under the Wild and Scenic Rivers Act, a copy of the registration and the Plan described in 5(b) of this general permit shall be submitted to the applicable Wild and Scenic Coordinating Committee. Please refer to Appendix H for additional guidance

In addition, a copy of this registration and the Plan shall be available upon request to the local inland wetlands agency established pursuant to section 22a-42 of the Connecticut General Statutes, or its duly authorized agent.

(h) Action by Commissioner

(1) The commissioner may reject without prejudice a registration if it does not satisfy the requirements of the "Contents of Registration" section (subsection 4(c)) of this general permit. Any registration refiled after such a rejection shall be accompanied by the fee specified in the "Fees" subsection (subsection 4(c)(1)) of this general permit.

- (2) The commissioner may disapprove a registration if is inconsistent with the requirements for authorization under the “Requirements for Registration” section (Section 3(b)) of this general permit, or for any other reason provided by law.
- (3) Disapproval of a registration under this subsection shall constitute notice to the registrant that the subject construction activity must be authorized under an individual permit.
- (4) Rejection or disapproval of a registration shall be in writing.

(i) ***Latest Date to Submit a Registration Under this General Permit***

No person shall submit a registration under this general permit after June 30, 2020.

Section 5. Conditions of this General Permit

The permittee shall meet all requirements of this general permit at all times. In addition, a permittee shall be responsible for conducting authorized construction activities in accordance with the following conditions:

(a) ***Conditions Applicable to Certain Discharges***

- (1) Structures and Dredging in Coastal and Tidal Areas

Any person who or municipality that discharges stormwater into coastal tidal waters for which a permit is required under section 22a-361 of the Connecticut General Statutes (structures and dredging) or section 22a-32 of the Connecticut General Statutes (Tidal Wetlands Act), shall obtain such permit(s) from the commissioner. A tidal wetland permit is required for the placement of any sediment upon a tidal wetland, whether it is deposited directly or indirectly.

- (2) Discharges to Tidal Wetlands

Any site which has a post-construction stormwater discharge to a tidal wetland (that is not a fresh-tidal wetland) where such discharge is within 500 feet of the tidal wetland, shall discharge such stormwater through a system designed to retain and infiltrate the volume of stormwater runoff generated by 1 inch of rainfall on the site. If there are site constraints that would prevent retention of this volume on-site (e.g., brownfields, capped landfills, bedrock, elevated groundwater, etc.), documentation must be submitted, for the commissioner’s review and written approval, which explains the site limitations and offers an alternative retention volume. In such cases, the portion of 1 inch that cannot be retained must be provided with additional stormwater treatment so as to protect water quality. Any such treatment shall be designed, installed and maintained in accordance with the Stormwater Quality Manual.

For sites unable to comply with this section, the commissioner, at the commissioner’s sole discretion, may require the submission of an individual permit in lieu of authorization under this general permit.

- (3) Toxicity to Aquatic and Marine Life

The discharge shall not cause pollution due to acute or chronic toxicity to aquatic and marine life, impair the biological integrity of aquatic or marine ecosystems, or result in an unacceptable risk to human health.

(4) Water Quality Standards

The stormwater discharge shall not cause or contribute to an exceedance of the applicable Water Quality Standards in the receiving water.

(5) High Quality Waters

Any new or increased stormwater discharge to high quality waters shall be discharged in accordance with the Connecticut Anti-Degradation Implementation Policy in the Water Quality Standards.

(b) Stormwater Pollution Control Plan

All registrants shall develop and maintain on-site a Stormwater Pollution Control Plan (Plan) for the construction activity authorized by this general permit. Once the construction activity begins, the permittee shall perform all actions required by such Plan and shall maintain compliance with the Plan thereafter. The Plan shall be designed to minimize (as defined in Section 2): (1) pollution caused by soil erosion and sedimentation during and after construction; and (2) stormwater pollution caused by use of the site after construction is completed.

(1) Development and Contents of Plan

(A) The Plan shall consist of site plan drawings and a narrative. The Plan shall be prepared in accordance with sound engineering practices, and shall be consistent with the Guidelines and the 2004 Connecticut Stormwater Quality Manual (available at <http://www.ct.gov/deep/stormwater>). The Plan shall also be consistent with any remedial action plan, closure plan or other plan required by any other DEEP permit.

(B) The Plan shall include, at a minimum, the following items:

(i) Site Plan

Site drawings indicating drainage patterns and approximate slopes anticipated after major grading activities, areas of soil disturbance, the location of major structural and non-structural controls (as specified in subsection 5(b)(2), below), the location of areas where stabilization practices are expected to occur, areas which will be vegetated following construction, monitored outfalls, surface waters, impaired waters (identifying those with and without a TMDL), high quality waters, inland wetlands, tidal wetlands, fresh-tidal wetlands, and locations where stormwater will be discharged to a surface water (both during and post-construction);

(ii) Site Description

(a) A narrative description of the nature of the construction activity;

(b) An estimate of the total area of the site and the total area of the site that is expected to be disturbed by construction activities;

(c) An estimate of the average runoff coefficient of the site after construction activities are completed;

(d) The name of the immediate receiving water(s) and the ultimate receiving water(s) of the discharges authorized by this general permit; and

(e) Extent of wetland acreage on the site.

(iii) Construction Sequencing

The Plan shall clearly identify the expected sequence of major construction activities on the site and corresponding erosion and sediment controls and shall include an estimated timetable for all construction activities, which shall be revised as necessary to keep the Plan current. Wherever possible, the site shall be phased to avoid the disturbance of over five acres at one time (or a lesser area of disturbance as required in the “Impaired Waters” section (Section 5(b)(3)). The Plan shall clearly show the limits of disturbance for the entire construction activity and for each phase.

(iv) Control Measures

The Plan shall include a description, in narrative and on the site plan drawings, of appropriate control measures that will be performed at the site to minimize the discharge of pollutants to waters of the state. Control measures shall be implemented in accordance with Section 5(b)(2) below. In addition, the following information shall be provided:

- (a) Calculations supporting the design of sediment and floatables removal controls pursuant to Section 5(b)(2)(C)(ii)(b).
- (b) Calculations supporting the design of velocity dissipation controls pursuant to Section 5(b)(2)(C)(ii)(c).

(v) Runoff Reduction and Low Impact Development (LID) Information

Where runoff reduction practices and/or LID measures are utilized, the following information shall be included in the site plan and narrative:

- (a) The location of the site’s streams, floodplains, all wetlands, riparian buffers, slopes 3:1 and steeper, and vegetation identified for preservation and non-disturbance during construction such as forested areas, hay fields, and old fields;
- (b) Natural drainage patterns, swales, and other drainage ways, that are not streams, floodplains, or wetland areas;
- (c) The location of all areas with soils suitable for infiltration¹ and areas of the site best suited for infiltration for the siting of runoff reduction practices and LID design measures;
- (d) The location of all areas unsuitable or least suitable for infiltration for the siting of areas of development/building;
- (e) The location of all post-construction stormwater management measures, runoff reduction practices and LID design measures developed pursuant to subsection 5(b)(2)(C)(i) below;
- (f) Identification of areas inappropriate for the infiltration of stormwater runoff from land uses with a significant potential for groundwater pollution;

¹ Infiltration rates must be measured by a field permeability test. The measured field design infiltration rate is equal to one-half the field-measured infiltration rate.

- (g) A narrative describing the nature, purpose, implementation and long-term maintenance of the post-construction measures, runoff reduction practices and LID design measures;
- (h) Calculations, for measures developed pursuant to Section 5(b)(2)(C)(i), illustrating the retention of the water quality volume or half the water quality volume for the site, as applicable, including a discussion of the impact of any runoff reduction and/or LID practices on these calculations.
- (i) A narrative describing any site constraints that prevent retention of the appropriate volume specified in Section 5(b)(2)(C)(i) including: an explanation of the site limitations; a description of the runoff reduction practices implemented; an explanation of why the amount retained constitutes the maximum extent achievable; an alternative retention volume; and a description of the measures used to provide additional stormwater treatment for sediment, floatables and nutrients above the alternate volume up to the water quality volume.
- (j) Calculations showing the proposed effective impervious cover for the site and, where necessary or appropriate for measures developed for linear projects pursuant to Section 5(b)(2)(C)(i), each outfall drainage area.

(vi) Inspections

The Plan shall include a narrative of all inspection personnel conducting the routine inspections, their responsibilities and procedures pursuant to subsection 5(b)(4)(B) below. The Plan shall also include documentation of the qualifications of the inspector(s) and the findings, actions and results of all inspections conducted at the site.

(vii) Monitoring

The Plan shall provide a narrative of the stormwater monitoring procedures pursuant to Section 5(c). This narrative shall include documentation of the monitoring frequency, personnel conducting monitoring, identification of monitored outfalls, methodology for monitoring, provisions for monitoring a linear project (if applicable), the site's normal working hours, the method for measuring turbidity and a copy of all monitoring records.

(viii) Contractors

- (a) The Plan shall clearly identify each contractor and subcontractor that will perform construction activities on the site that have the potential to cause pollution of the waters of the State. The Plan shall include a copy of the certification statement in the "Contractor Certification Statement" section, below, signed by each such contractor and subcontractor.

(b) Contractor Certification Statement

The Plan shall include the following certification signed by each contractor and subcontractor identified in the Plan as described above:

"I certify under penalty of the law that I have read and understand the terms and conditions of the General Permit for the Discharge of Stormwater and Dewatering Wastewaters from Construction Activities. I understand that as a contractor or

subcontractor at the site, I am authorized by this general permit, and must comply with the terms and conditions of this general permit, including, but not limited to, the requirements of the Stormwater Pollution Control Plan prepared for the site.”

The certification shall include the name and title of the person providing the signature; the name, address and telephone number of the contracting firm; the address (or other identifying description) of the site; and the date the certification is made.

(c) Subdivisions

Where individual lots in a subdivision or other common plan of development are conveyed or otherwise the responsibility of another person or municipality, those individual lot contractors shall be required to comply with the provisions of this general permit and the Stormwater Pollution Control Plan, and shall sign the certification statement in the “Contractor Certification Statement” section, above, regardless of lot size or disturbed area. In such cases, the permittee shall provide a copy of the Plan to each individual lot contractor, obtain signed certifications from such contractors and retain all signed certifications in the Plan.

(ix) Impaired Waters

For construction activities that discharge to impaired waters, as specified in “New Discharges to Impaired Waters” (Section 3(b)(12)), the Plan shall include a description of the provisions for controlling the construction and post-construction stormwater discharges to these waters pursuant to subsection 5(b)(3) below.

(2) Stormwater Control Measures

Control Measures are required Best Management Practices (BMPs) that the permittee must implement to minimize the discharge of pollutants from the permitted activity. The term “minimize” means reduce and/or eliminate to the extent achievable using control measures that are technologically available and economically practicable and achievable in light of best industry practice.

Control Measures shall be designed in accordance with the Guidelines, the Stormwater Quality Manual or the DOT Qualified Products List (http://www.ct.gov/dot/lib/dot/documents/dresearch/conndot_qpl.pdf). Use of controls to comply with the “Erosion and Sediment Controls” section (subsection (A) below) of this general permit that are not included in those resources must be approved by the commissioner or the commissioner’s designated agent. The narrative and drawings of controls shall address the following minimum components:

(A) Erosion and Sediment Controls

(i) Soil Stabilization and Protection

The Plan shall include a narrative and drawings of interim and permanent soil stabilization practices for managing disturbed areas and soil stockpiles, including a schedule for implementing the practices. The Permittee shall ensure that existing vegetation is preserved to the maximum extent practicable and that disturbed portions of the site are minimized and stabilized.

Where construction activities have permanently ceased or when final grades are reached in any portion of the site, stabilization and protection practices as specified in Chapter 5 of the Guidelines or as approved by the commissioner or his/ her designated agent shall be implemented within seven days. Areas that will remain disturbed but inactive for at least thirty days shall receive temporary seeding or soil protection within seven days in accordance with the Guidelines.

Areas that will remain disturbed beyond the seeding season as identified in the Guidelines, shall receive long-term, non-vegetative stabilization and protection sufficient to protect the site through the winter. In all cases, stabilization and protection measures shall be implemented as soon as possible in accordance with the Guidelines or as approved by the commissioner or his/ her designated agent.

A reverse slope bench is required for any slope steeper than 3:1 (horizontal: vertical) that exceeds 15 feet vertically, except when engineered slope stabilization structures or measures are included or a detailed soil mechanics analysis has been conducted to verify stability. Engineered analyses and measures must be designed by a CT licensed Professional Engineer with experience in geotechnical engineering or soil mechanics.

(ii) Structural Measures

The Plan shall include a narrative and drawings of structural measures to divert flows away from exposed soils, store flows or otherwise limit runoff and minimize the discharge of pollutants from the site. Unless otherwise specifically approved in writing by the commissioner or his/ her designated agent, or if otherwise authorized by another state or federal permit, structural measures shall be installed on upland soils.

For points of discharge from disturbed sites with a total contributing drainage area of between two to five acres, a temporary sediment trap must be installed in accordance with the Guidelines. For points of discharge from disturbed sites with a total contributing drainage area greater than five acres, a temporary basin must be designed and installed in accordance with the Guidelines. Such trap(s) or basin(s) must be maintained until final stabilization of the contributing area as defined in "Notice of Termination" (Section 6(a)).

The requirement for sediment traps or basins shall not apply to flows from off-site areas and flows from the site that are either undisturbed or have undergone final stabilization where such flows are diverted around the temporary sediment trap or basin. Any exceptions must be approved in writing by the commissioner or his/ her designated agent.

(iii) Maintenance

The Plan shall include a narrative of the procedures to maintain in good and effective operating conditions all erosion and sediment control measures, including vegetation, and all other protective measures identified in the site plan. Maintenance of all erosion and sediment controls shall be performed in accordance with the Guidelines, or more frequently as necessary, to protect the waters of the state from pollution.

(B) Dewatering Wastewaters

Dewatering wastewaters shall be managed in accordance with the Guidelines. Dewatering wastewaters discharged to surface waters shall be discharged in a manner that minimizes the discoloration of the receiving waters. The Plan shall include a narrative and drawings of the

operational and structural measures that will be used to ensure that all dewatering wastewaters will not cause scouring or erosion or contain suspended solids in amounts that could reasonably be expected to cause pollution of surface waters of the State. Unless otherwise specifically approved in writing by the commissioner or his/ her designated agent, or if otherwise authorized by another state or federal permit, dewatering measures shall be installed on upland soils.

No discharge of dewatering wastewater(s) shall contain or cause a visible oil sheen, floating solids, or foaming in the receiving water.

(C) Post-Construction Stormwater Management

The Plan shall include a narrative and drawings of measures that will be installed during the construction process to minimize the discharge of pollutants in stormwater discharges that will occur after construction operations have been completed. Post-construction stormwater management measures shall be designed and implemented in accordance with the Stormwater Quality Manual, the DOT Qualified Products List or as approved by the commissioner or his/ her designated agent in writing. Unless otherwise specifically provided by the commissioner in writing, or authorized by another state or federal permit, structural measures shall be placed on upland soils. The Plan shall include provisions to address the long-term maintenance of any post-construction stormwater management measure installed.

(i) Post-Construction Performance Standards

The permittee shall utilize runoff reduction practices (as defined in Section 2) to meet runoff volume requirements based on the conditions below. For sites unable to comply with these conditions, the commissioner, at the commissioner's sole discretion, may require the submission of an individual permit in lieu of authorization under this general permit.

(a) Redevelopment

For sites that are currently developed with an effective impervious cover of forty percent or more and for which the permittee is proposing redevelopment, the permittee shall design the site in such a manner as to retain on-site half the water quality volume (as defined in Section 2) for the site and provide additional stormwater treatment without retention for discharges up to the full water quality volume for sediment, floatables and nutrients to the maximum extent achievable using control measures that are technologically available and economically practicable and achievable in light of best industry practice. In cases where the permittee is not able to retain half the water quality volume, the permittee shall design the redevelopment to retain runoff volume to the maximum extent achievable using control measures that are technologically available and economically practicable and achievable in light of best industry practice. In such cases, additional stormwater treatment up to the full water quality volume is still required. Any such treatment shall be designed, installed and maintained in accordance with the Stormwater Quality Manual. If retention of the half the water quality volume is not achieved, the permittee shall submit a report to the commissioner describing: the measures taken to maximize runoff reduction practices on the site; the reasons why those practices constitute the maximum extent achievable; the alternative retention volume; and a description of the measures used to provide additional stormwater treatment above the alternate volume up to the water quality volume. In the case of linear redevelopment projects (e.g. roadway reconstruction or widening) for the developed portion of

the right of way: (1) for projects that may be unable to comply with the full retention standard, the alternate retention and treatment provisions may also be applied as specified above, or (2) for projects that will not increase the effective impervious cover within a given watershed, the permittee shall implement the additional stormwater treatment measures referenced above, but will not be required to retain half of the water quality volume.

(b) Other Development

The following performance standard applies to all sites that are currently undeveloped or are currently developed with less than forty percent effective impervious cover. For these sites, the permittee shall design the site to retain the water quality volume for the site. If there are site constraints that would prevent retention of this volume on-site (e.g., brownfields, capped landfills, bedrock, elevated groundwater, etc.), documentation must be submitted, for the commissioner's review and written approval, which: explains the site limitations; provides a description of the runoff reduction practices implemented; provides an explanation of why this constitutes the maximum extent achievable; offers an alternative retention volume; and provides a description of the measures used to provide additional stormwater treatment for sediment, floatables and nutrients above the alternate volume up to the water quality volume. Any such treatment shall be designed, installed and maintained in accordance with the Stormwater Quality Manual. In the case of linear projects that do not involve impervious surfaces (e.g. electrical transmission rights-of-way or natural gas pipelines), retention of the water quality volume is not required as long as the post-development runoff characteristics do not differ significantly from pre-development conditions.

(ii) Post-Construction Control Measures

(a) Runoff Reduction and Low Impact Development ("LID") Practices

The site design shall incorporate runoff reduction practices, low impact development ("LID") practices or other measures to meet the performance standards in subsection (i) above, promote groundwater recharge and minimize post-construction impacts to water quality. Please refer to Appendix B for additional guidance information.

(b) Suspended Solids and Floatables Removal

The permittee shall install post-construction stormwater management measures designed to minimize the discharge of suspended solids and floatables (e.g. oil and grease, other floatable liquids, floatable solids, trash, etc.) from stormwater. A goal of 80 percent removal of the annual sediment load from the stormwater discharge shall be used in designing and installing stormwater management measures. The Plan shall provide calculations supporting the capability of such measures in achieving this goal and any third-party verification, as applicable, of the sediment removal efficiencies of such measures. This goal is not intended to limit local approval authorities from requiring a higher standard pursuant to local requirements.

(c) Velocity Dissipation

Velocity dissipation devices shall be placed at discharge locations and along the length of any outfall channel as necessary to provide a non-erosive velocity flow to the receiving watercourse so that the natural physical and biological characteristics and functions are maintained and protected.

(D) Other Controls

The following additional controls shall be implemented:

(i) Waste Disposal: Best management practices shall be implemented to minimize the discharge of litter, debris, building materials, hardened concrete waste, or similar materials to waters of the State. A narrative of these practices shall be provided in the Plan.

(ii) Washout Areas

Washout of applicators, containers, vehicles and equipment for concrete, paint and other materials shall be conducted in a designated washout area. There shall be no surface discharge of washout wastewaters from this area. Such washout shall be conducted: (1) outside of any buffers and at least 50 feet from any stream, wetland or other sensitive resource; or (2) in an entirely self-contained washout system. The permittee shall clearly flag off and designate areas to be used for washing and conduct such activities only in these areas. The permittee shall direct all washwater into a container or pit designed such that no overflows can occur during rainfall or after snowmelt.

In addition, dumping of liquid wastes in storm sewers is prohibited. The permittee shall remove and dispose of hardened concrete waste consistent with practices developed for the "Waste Disposal" section (subparagraph 5(b)(2)(D)(i), above). At least once per week, the permittee must inspect any containers or pits used for washout to ensure structural integrity, adequate holding capacity, and to check for leaks or overflows. If there are signs of leaks, holes or overflows in the containers or pits that could lead to a discharge, the permittee shall repair them prior to further use. For concrete washout areas, the permittee shall remove hardened concrete waste whenever the hardened concrete has accumulated to a height of ½ of the container or pit or as necessary to avoid overflows. A narrative of maintenance procedures and a record of maintenance and inspections shall be included in the Plan.

(iii) Off-site vehicle tracking of sediments and the generation of dust shall be minimized. Wet dust suppression shall be used, in accordance with section 22a-174-18(b) of the Connecticut General Statutes, for any construction activity that causes airborne particulates. The volume of water sprayed for controlling dust shall be minimized so as to prevent the runoff of water. No discharge of dust control water shall contain or cause a visible oil sheen, floating solids, visible discoloration, or foaming in the receiving stream.

(iv) All post-construction stormwater structures shall be cleaned of construction sediment and any remaining silt fence shall be removed upon stabilization of the site.

(v) All chemical and petroleum product containers stored on the site (excluding those contained within vehicles and equipment) shall be provided with impermeable containment which will hold at least 110% of the volume of the largest container, or

10% of the total volume of all containers in the area, whichever is larger, without overflow from the containment area. All chemicals and their containers shall be stored under a roofed area except for those chemicals stored in containers of 100 gallon capacity or more, in which case a roof is not required. Double-walled tanks satisfy this requirement.

(3) Additional Control Measures for Impaired Waters

For construction activities that discharge directly to impaired waters, as specified in “New Discharges to Impaired Waters” (Section 3(b)(12)), the Plan shall include the following provisions:

- (A) In lieu of the provisions of “Construction Sequencing” (Section 5(b)(1)(B)(iii)), no more than 3 acres may be disturbed at any one time. For those areas for which construction activity will be temporarily suspended for a period of greater than 14 days, temporary stabilization measures shall be implemented within 3 days of such suspension of activity. For all areas, permanent stabilization shall be implemented within 30 days of disturbance; *or*
- (B) The Plan shall document that measures are in place to ensure that there will be no discharge to the impaired water from rain events up to a 2-year, 24-hour rain event while construction activity is occurring; *or*
- (C) For discharges to impaired waters with an established TMDL:
 - (i) the Plan shall document that there is sufficient remaining Waste Load Allocation (WLA) in the TMDL to allow the discharge, *and*
 - (ii) measures shall be implemented to ensure the WLA will not be exceeded, *and*
 - (iii) stormwater discharges shall be monitored, if applicable, for any indicator pollutant identified in the TMDL for every rain event that produces a discharge to ensure compliance with the WLA. Such monitoring shall be in addition to the requirements specified in Section 5(c), *or*
 - (iv) the specific requirements for stormwater discharges specified in the TMDL are met.

Construction activities discharging to impaired waters that do not comply with this subsection are not authorized by this general permit.

(4) Inspections

All construction activities submitting a registration for this general permit shall be inspected initially for Plan implementation and then weekly for routine inspections.

(A) Plan Implementation Inspections

Within the first 30 days following commencement of the construction activity on the site, the permittee shall contact: (1) the appropriate District; or (2) a qualified soil erosion and sediment control professional or a qualified professional engineer to inspect the site. The site shall be inspected at least once and no more than three times during the first 90 days to confirm compliance with the general permit and proper initial implementation of all controls measures designated in the Plan for the site for the initial phase of construction. For sites not inspected by District personnel, the following conditions shall apply:

- (i) for projects disturbing more than one acre and less than fifteen (15) acres, the inspector shall be someone who:
 - (a) is not an employee, as defined by the Internal Revenue Service in the Internal Revenue Code of 1986, of the registrant, and
 - (b) has no ownership interest of any kind in the project for which the registration is being submitted.
- (ii) for projects disturbing fifteen (15) acres or more, the inspector shall be someone who:
 - (a) is not an employee, as defined by the Internal Revenue Service in the Internal Revenue Code of 1986, of the registrant, and
 - (b) has not engaged in any activities associated with the preparation, planning, designing or engineering of such plan for soil erosion and sediment control or plan for engineered stormwater management systems on behalf of such registrant, and
 - (c) is not under the same employ as any person who engaged in any activities associated with the preparation, planning, designing or engineering of such plans and specifications for soil erosion and sediment control or plans and specifications for engineered stormwater management systems on behalf of such registrant, and
 - (d) has no ownership interest of any kind in the project for which the registration is being submitted.

The permittee may use, if they wish, the same person(s) that provided the Plan Review Certification pursuant to Section 5(b)(11).

(B) Routine Inspections

The permittee shall routinely inspect the site for compliance with the general permit and the Plan for the site until a Notice of Termination has been submitted. Inspection procedures for these routine inspections shall be addressed and implemented in the following manner:

- (i) The permittee shall maintain a rain gauge on-site to document rainfall amounts. At least once a week and within 24 hours of the end of a storm that generates a discharge, a qualified inspector (provided by the permittee), as defined in the “Definitions” section (Section 2) of this general permit, shall inspect, at a minimum, the following: disturbed areas of the construction activity that have not been finally stabilized; all erosion and sedimentation control measures; all structural control measures; soil stockpile areas; washout areas and locations where vehicles enter or exit the site. These areas shall be inspected for evidence of, or the potential for, pollutants entering the drainage system and impacts to the receiving waters. Locations where vehicles enter or exit the site shall also be inspected for evidence of off-site sediment tracking. For storms that end on a weekend, holiday or other time after which normal working hours will not commence within 24 hours, an inspection is required within 24 hours only for storms that equal or exceed 0.5 inches. For storms of less than 0.5 inches, an inspection shall occur immediately upon the start of the subsequent normal working hours. Where sites have been temporarily or finally stabilized, such inspection shall be conducted at least once every month for three months.
- (ii) The qualified inspector(s) shall evaluate the effectiveness of erosion and sediment controls, structural controls, stabilization practices, and any other controls implemented

to prevent pollution and determine if it is necessary to install, maintain, or repair such controls and/or practices to improve the quality of stormwater discharge(s).

- (iii) A report shall be prepared and retained as part of the Plan. This report shall summarize: the scope of the inspection; name(s) and qualifications of personnel making the inspection; the date(s) of the inspection; weather conditions including precipitation information; major observations relating to erosion and sediment controls and the implementation of the Plan; a description of the stormwater discharge(s) from the site; and any water quality monitoring performed during the inspection. The report shall be signed by the permittee or his/her authorized representative in accordance with the “Certification of Documents” section (subsection 5(i)) of this general permit.

The report shall include a statement that, in the judgment of the qualified inspector(s) conducting the site inspection, the site is either in compliance or out of compliance with the terms and conditions of the Plan and permit. If the site inspection indicates that the site is out of compliance, the inspection report shall include a summary of the remedial actions required to bring the site back into compliance. Non-engineered corrective actions (as identified in the Guidelines) shall be implemented on site within 24 hours and incorporated into a revised Plan within three (3) calendar days of the date of inspection unless another schedule is specified in the Guidelines. Engineered corrective actions (as identified in the Guidelines) shall be implemented on site within seven (7) days and incorporated into a revised Plan within ten (10) days of the date of inspection, unless another schedule is specified in the Guidelines or is approved by the commissioner. During the period in which any corrective actions are being developed and have not yet been fully implemented, interim measures shall be implemented to minimize the potential for the discharge of pollutants from the site.

- (iv) Inspectors from the DEEP and the appropriate District may inspect the site for compliance with this general permit at any time construction activities are ongoing and upon completion of construction activities to verify the final stabilization of the site and/or the installation of post-construction stormwater management measures pursuant to Section 6(a).
- (v) Additional inspections, reports and documentation may also be required to comply with the “Monitoring Requirements” section (Section 5(c)).

(5) Keeping Plans Current

The Permittee is responsible for keeping their Plan in compliance with this general permit at all times. This may involve any or all of the following:

- (A) The permittee shall amend the Plan if the actions required by the Plan fail to prevent pollution or fail to otherwise comply with any other provision of this general permit. The Plan shall also be amended whenever there is a change in contractors or subcontractors at the site, or a change in design, construction, operation, or maintenance at the site which has the potential for the discharge of pollutants to the waters of the state and which has not otherwise been addressed in the Plan.
- (B) The commissioner may notify the permittee at any time that the Plan and/or the site do not meet one or more of the minimum requirements of this general permit. Within 7 days of such notice, or such other time as the commissioner may allow, the permittee shall make the required changes to the Plan and perform all actions required by such revised Plan. Within 15 days of such notice, or such other time as the commissioner may allow, the permittee shall submit to the commissioner a written certification that the requested changes have been

made and implemented and such other information as the commissioner requires, in accordance with the ‘Duty to Provide Information’ and ‘Certification of Documents’ sections (subsections 5(h) and 5(i)) of this general permit.

- (C) For any stormwater discharges authorized under any previous version of this general permit, the existing Plan shall be updated by February 1, 2014, as applicable, in accordance with the “Development and Contents of the Plan” (subsection 5(b)(1)), “Stormwater Control Measures” (subsection 5(b)(2)), “Routine Inspections” (subsection 5(b)(4)(B)), and “Monitoring” (subsection 5(c)) sections of this general permit, except for the post-construction measures in subsection 5(b)(2)(C)(i)(a) & (b) and 5(b)(2)(C)(ii)(a). The permittee shall maintain compliance with such Plan thereafter. For previously authorized sites discharging to impaired waters or other sensitive areas, the commissioner may require additional control measures or provide authorization under an individual permit pursuant to Sections 4(h) and 3(i).

(6) Failure to Prepare, Maintain or Amend Plan

In no event shall failure to complete, maintain or update a Plan, in accordance with the “Development of Contents of the Plan” and “Keeping Plans Current” sections (subsections 5(b)(1) and 5(b)(5)) of this general permit, relieve a permittee of responsibility to implement any actions required to protect the waters of the state and to comply with all conditions of the permit.

(7) Plan Signature

The Plan shall be signed and certified as follows:

- (A) The Plan shall be signed by the permittee in accordance with the “Certification of Documents” section (subsection 5(i)) of this general permit.
- (B) The Plan shall include certification by all contractors and subcontractors in accordance with the “Contractors” section (subsection 5(b)(1)(B)(viii)) of this general permit.
- (C) The Plan shall include a copy of the certification by a professional engineer or landscape architect made in accordance with Section 3(b)(9) of this general permit.

(8) Plan Review Certification

For a locally approvable project pursuant to Section 3(c) of this general permit, a copy of the Plan review certification made in accordance with either Section 3(b)(10) or (11) shall be maintained with the Plan. Note that construction activities reviewed and certified pursuant to those sections are still subject to the local erosion and sediment control and stormwater management regulations of the municipality in which the activity is conducted.

(9) Plan Submittal

The Plan shall be submitted to the commissioner and other certain parties under the following conditions:

- (A) All Locally Exempt Projects with greater than one acre of soil disturbance shall submit an electronic copy of the Plan and a completed Registration Form to the commissioner.
- (B) For all other projects, the permittee shall provide a copy of the Plan, and a completed Registration Form for this general permit to the following persons immediately upon request:

- (i) The commissioner at his or her request or at the request of a member of the public during the registration and Plan availability period pursuant to Section 4(e);
- (ii) The municipal planning commission, zoning commission and/or inland wetlands agency, or its respective enforcement officer or designated agent;
- (iii) In the case of a stormwater discharge through a municipal separate storm sewer system, the municipal operator of the system;
- (iv) In the case of a stormwater discharge located within a public drinking water supply watershed or aquifer area, the water company responsible for that water supply.

DO NOT SUBMIT any pages or other material that do not pertain to stormwater management or erosion and sedimentation control (such as electrical and lighting plans, boundary or lot surveys, building plans, non-stormwater related detail sheets, etc.).

(c) Monitoring Requirements

The primary requirements for monitoring turbidity are summarized in the table below:

Table 1

<i>Area of Soil Disturbance</i>	<i>Monitoring Required?</i>	<i>Monitoring Frequency</i>	<i>Sample Method</i>
Sites which disturb 1 acre or more, but less than 5 acres	Only IF a Registration is required	Monthly IF a Registration is required	Procedure consistent with 40 CFR Part 136
Sites which disturb 5 acres or more	Yes	Monthly	Procedure consistent with 40 CFR Part 136

(1) Turbidity Monitoring Requirements

(A) Monitoring Frequency

- (i) Sampling shall be conducted in accordance with Table 1, above, at least once every month, when there is a discharge of stormwater from the site while construction activity is ongoing, until final stabilization of the drainage area associated with each outfall is achieved.
- (ii) The permittee is only required to take samples during normal working hours as defined in Section 2. The site’s normal working hours must be identified in the Plan pursuant to Section 5(b)(1)(B)(vii). If sampling is discontinued due to the end of normal working hours, the permittee shall resume sampling the following morning or the morning of the next working day following a weekend or holiday, as long as the discharge continues.
- (iii) Sampling may be temporarily suspended any time conditions exist that may reasonably pose a threat to the safety of the person taking the sample. Such conditions may include high winds, lightning, impinging wave or tidal activity, intense rainfall or other

hazardous condition. Once the unsafe condition is no longer present, sampling shall resume.

(iv) If there is no stormwater discharge during a month, sampling is not required.

(B) Sample Collection

(i) All samples shall be collected from discharges resulting from a storm event that occurs at least 24 hours after any previous storm event generating a stormwater discharge. Any sample containing snow or ice melt must be identified on the Stormwater Monitoring Report form. Sampling of snow or ice melt in the absence of a storm event is not a valid sample.

(ii) Samples shall be grab samples taken *at least* three separate times during a storm event and shall be *representative* of the flow and characteristics of the discharge(s). Samples may be taken manually or by an in-situ turbidity probe or other automatic sampling device equipped to take individual turbidity readings (i.e. not composite). The first sample shall be taken within the first hour of stormwater discharge from the site. In cases where samples are collected manually and the discharge begins outside of normal working hours, the first sample shall be taken at the start of normal working hours.

(C) Sampling Locations

(i) Sampling is required of all point source discharges of stormwater from disturbed areas except as may be modified for linear projects under subparagraph (ii) below. Where there are two or more discharge points that discharge substantially identical runoff, based on similarities of the exposed soils, slope, and type of stormwater controls used, a sample may be taken from just one of the discharge points. In such case, the permittee shall report that the results also apply to the substantially identical discharge point(s). No more than 5 substantially identical outfalls may be identified for one representative discharge. If such project is planned to continue for more than one year, the permittee shall rotate twice per year the location where samples are taken so that a different discharge point is sampled every six months. The Plan must identify each outfall authorized by this permit and describe the rationale for any substantially identical outfall determinations.

(ii) Linear Projects

For a linear project, as defined in Section 2, the protocols of subparagraph (i), above, shall apply except that up to 10 substantially identical outfalls may be identified for one representative discharge.

(iii) All sampling point(s) shall be identified in the Plan and be clearly marked in the field with a flag, stake, or other visible marker.

(D) Sampling and analysis shall be prescribed by 40 CFR Part 136.

(E) Turbidity Values

The stormwater discharge turbidity value for each sampling point shall be determined by taking the average of the turbidity values of all samples taken at that sampling point during a given storm.

(2) Stormwater Monitoring Reports

- (A) Within thirty (30) days following the end of each month, permittees shall enter the stormwater sampling result(s) on the Stormwater Monitoring Report (SMR) form (available at www.ct.gov/deep/stormwater) and submit it in accordance with the NetDMR provisions in subsection F, below, or, if the permittee has opted out of NetDMR, to the following address:

Bureau of Materials Management and Compliance Assurance
Water Permitting and Enforcement Division (Attn: DMR Processing)
Connecticut Department of Energy and Environmental Protection
79 Elm Street
Hartford, CT 06106-5127

- (B) If there was no discharge during any given monitoring period, the permittee shall submit the form as required with the words “no discharge” entered in place of the monitoring results.
- (C) If the permittee monitors any discharge more frequently than required by this general permit, the results of this monitoring shall be included in additional SMRs for the month in which the samples were collected.
- (D) If sampling protocols are modified due to the limitations of normal working hours or unsafe conditions in accordance with Section 5(c)(1)(A)(ii) or (iii) above, a description of and reason for the modifications shall be included with the SMR.
- (E) If the permittee samples a discharge that is representative of two or more substantially identical discharge points, the permittee shall include the names or locations of the other discharge points.
- (F) NetDMR Reporting Requirements
- (i) Prior to one-hundred and eighty (180) days after the issuance of this permit, the Permittee may either submit monitoring data and other reports to the Department in hard copy form or electronically using NetDMR, a web-based tool that allows Permittees to electronically submit stormwater monitoring reports through a secure internet connection. Unless otherwise approved in writing by the commissioner, no later than one-hundred and eighty (180) days after the issuance of this permit the Permittee shall begin reporting electronically using NetDMR. Specific requirements regarding subscription to NetDMR and submittal of data and reports in hard copy form and for submittal using NetDMR are described below:

(a) Submittal of NetDMR Subscriber Agreement

On or before fifteen (15) days after the issuance of this permit, the Permittee and/or the person authorized to sign the Permittee’s discharge monitoring reports (“Signatory Authority”) as described in RCSA Section 22a-430-3(b)(2) shall contact the Department at deep.netdmr@ct.gov and initiate the NetDMR subscription process for electronic submission of Stormwater Monitoring Report information. Information on NetDMR is available on the Department’s website at www.ct.gov/deep/netdmr. On or before ninety (90) days after issuance of this permit the Permittee shall submit a signed and notarized copy of the *Connecticut DEEP NetDMR Subscriber Agreement* to the Department.

(b) Submittal of Reports Using NetDMR

Unless otherwise approved by the commissioner, on or before one-hundred and eighty (180) days after issuance of this permit, the Permittee and/or the Signatory Authority shall electronically submit SMRs required under this permit to the Department using NetDMR in satisfaction of the SMR submission requirements of Sections 5(c)(2)(A) of this permit.

SMRs shall be submitted electronically to the Department no later than the 30th day of the month following the completed reporting period. Any additional monitoring conducted in accordance with 40 CFR 136 shall be submitted to the Department as an electronic attachment to the SMR in NetDMR. Once a Permittee begins submitting reports using NetDMR, it will no longer be required to submit hard copies of SMRs to the Department. NetDMR is accessed from: <http://www.epa.gov/netdmr>.

(c) Submittal of NetDMR Opt-Out Requests

If the Permittee is able to demonstrate a reasonable basis, such as technical or administrative infeasibility, that precludes the use of NetDMR for electronically submitting SMRs, the commissioner may approve the submission of SMRs in hard copy form (“opt-out request”). Opt-out requests must be submitted in writing to the Department for written approval on or before fifteen (15) days prior to the date a Permittee would be required under this permit to begin filing SMRs using NetDMR. This demonstration shall be valid for twelve (12) months from the date of the Department’s approval and shall thereupon expire. At such time, SMRs shall be submitted electronically to the Department using NetDMR unless the Permittee submits a renewed opt-out request and such request is approved by the Department.

All opt-out requests and requests for the NetDMR subscriber form should be sent to the following address or by email at deep.netdmr@ct.gov:

Attn: NetDMR Coordinator
Connecticut Department of Energy and Environmental Protection
79 Elm Street
Hartford, CT 06106-5127

(d) Reporting and Record Keeping Requirements

- (1) For a period of at least five years from the date that construction is complete, the permittee shall retain copies of the Plan and all reports required by this general permit, and records of all data used to complete the registration for this general permit, unless the commissioner specifies another time period in writing. Inspection records must be retained as part of the Plan for a period of five (5) years after the date of inspection.
- (2) The permittee shall retain an updated copy of the Plan required by this general permit at the construction site from the date construction is initiated at the site until the date construction at the site is completed.

(e) Regulations of Connecticut State Agencies Incorporated into this General Permit

The permittee shall comply with sections 22a-430-3 and 22a-430-4 of the Regulations of Connecticut State Agencies which are hereby incorporated into this general permit, as if fully set forth herein.

(f) *Reliance on Registration*

In evaluating the registrant's registration, the commissioner has relied on information provided by the registrant. If such information proves to be false or incomplete, any authorization reliant on such information may be suspended or revoked in accordance with law, and the commissioner may take any other legal action provided by law.

(g) *Duty to Correct and Report Violations*

Upon learning of a violation of a condition of this general permit, unless otherwise specified in this general permit, a permittee shall immediately take all reasonable action to determine the cause of such violation, correct and mitigate the results of such violation, prevent further such violation, and report in writing such violation and such corrective action to the commissioner within five (5) days of the permittee's learning of such violation. Such information shall be filed in accordance with the "Certification of Documents" section (Section 5(i)) of this general permit.

(h) *Duty to Provide Information*

If the commissioner requests any information pertinent to the construction activity or to compliance with this general permit or with the permittee's authorization under this general permit, the permittee shall provide such information within fifteen (15) days of such request or other time period as may be specified in writing by the commissioner. Such information shall be filed in accordance with the "Certification of Documents" section (Section 5(i)) of this general permit.

(i) *Certification of Documents*

Unless otherwise specified in this general permit, any document, including but not limited to any notice, information or report, which is submitted to the commissioner under this general permit shall be signed by the permittee, or a duly authorized representative of the permittee, and by the individual or individuals responsible for actually preparing such document, each of whom shall certify in writing as follows:

"I have personally examined and am familiar with the information submitted in this document and all attachments thereto, and I certify that, based on reasonable investigation, including my inquiry of those individuals responsible for obtaining the information, the submitted information is true, accurate and complete to the best of my knowledge and belief. I understand that a false statement made in this document or its attachments may be punishable as a criminal offense, in accordance with section 22a-6 of the Connecticut General Statutes, pursuant to section 53a-157b of the Connecticut General Statutes, and in accordance with any other applicable statute."

(j) *Date of Filing*

For purposes of this general permit, the date of filing with the commissioner of any document is the date such document is received by the commissioner. The word "day" as used in this general permit means the calendar day; if any date specified in the general permit falls on a Saturday, Sunday, or legal holiday, such deadline shall be the next business day thereafter.

(k) *False Statements*

Any false statement in any information submitted pursuant to this general permit may be punishable as a criminal offense, in accordance with section 22a-6 of the Connecticut General Statutes, pursuant to section 53a-157b of the Connecticut General Statutes.

(l) Correction of Inaccuracies

Within fifteen (15) days after the date a permittee becomes aware of a change in any information in any material submitted pursuant to this general permit, or becomes aware that any such information is inaccurate or misleading or that any relevant information has been omitted, such permittee shall correct the inaccurate or misleading information or supply the omitted information in writing to the commissioner. Such information shall be filed in accordance with the certification requirements prescribed in Section 5(i) of this general permit.

(m) Transfer of Authorization

Any authorization issued by the commissioner under this general permit is transferable only in accordance with the provisions of section 22a-60 of the General Statutes. Any person or municipality proposing to transfer any such authorization shall submit a license transfer form to the commissioner. The transferee is not authorized to conduct any activities under this general permit until the transfer is approved by the commissioner (typically 30 days). The transferee may adopt by reference the Plan developed by the transferor. The transferee shall amend the Plan as required by the “Keeping Plans Current” Section 5(b)(5) of this general permit).

(n) Reopener

At such time as the USEPA may institute a new rule for post-construction stormwater management or modify the requirements for their National Pollutant Discharge Elimination System (NPDES) General Permit for Discharges from Construction Activities (CGP) to institute a numeric Effluent Limitation Guideline (ELG) for turbidity in stormwater discharges from construction activities, the commissioner may reopen this general permit pursuant to the Section 40 Part 122.62(a) of the Code of Federal Regulations for implementation of these elements.

(o) Other Applicable Law

Nothing in this general permit shall relieve the permittee of the obligation to comply with any other applicable federal, state and local law, including but not limited to the obligation to obtain any other authorizations required by such law.

(p) Other Rights

This general permit is subject to and does not derogate any present or future rights or powers of the State of Connecticut and conveys no rights in real or personal property nor any exclusive privileges, and is subject to all public and private rights and to any federal, state, and local laws pertinent to the property or construction activity affected by such general permit. In conducting any construction activity authorized hereunder, the permittee may not cause pollution, impairment, or destruction of the air, water, or other natural resources of this state. The issuance of this general permit shall not create any presumption that this general permit should or will be renewed.

Section 6. Termination Requirements

(a) Notice of Termination

At the completion of a construction project registered pursuant to the “Registration Requirements” section (Section 4) of this general permit, a Notice of Termination must be filed with the commissioner. A project shall be considered complete after all post-construction measures are installed, cleaned and functioning and the site has been stabilized for at least three months following the cessation of construction activities. A site is considered stabilized when there is no active erosion or sedimentation present and no disturbed areas remain exposed **for all phases**.

(1) Post-Construction Inspection

For locally approvable projects, once all post-construction stormwater measures have been installed in accordance with the Post-Construction Stormwater Management section (subsection 5(b)(2)(C)) and cleaned of any construction sediment or debris, the registrant shall contact the appropriate Conservation District or a qualified soil erosion and sediment control professional and/or a qualified professional engineer, as appropriate, who will inspect the site to confirm compliance with these post-construction stormwater measures. This person(s) shall not be an employee, as defined by the Internal Revenue Service in the Internal Revenue Code of 1986, of the permittee and shall have no ownership interest of any kind in the project for which the site's registration was submitted.

(2) Final Stabilization Inspection

For all projects, once the site has been stabilized for at least three months, the registrant shall have the site inspected by a qualified inspector to confirm final stabilization. The registrant shall indicate compliance with this requirement on the Notice of Termination form.

(b) Termination Form

A termination notice shall be filed on forms prescribed and provided by the commissioner and shall include the following:

- (1) The permit number as provided to the permittee on the permit certificate.
- (2) The name of the registrant as reported on the general permit registration form (DEEP-PED-REG-015).
- (3) The address of the completed construction site.
- (4) The dates when:
 - (A) All storm drainage structures were cleaned of construction debris pursuant to the "Other Controls" section (subsection 5(b)(2)(D)) of this general permit; and
 - (B) The post-construction inspection was conducted pursuant to subsection 6(a)(1), above; and
 - (C) The date of completion of construction; and
 - (D) The date of the final stabilization inspection pursuant to subsection 6(a)(2), above.
- (5) A description of the post-construction activities at the site.
- (6) Signatures of:
 - (A) The permittee; and
 - (B) The person certifying the post-construction inspection pursuant to subsection 6(a)(1), above.

(c) Where to File a Termination Form

A termination form shall be filed with the commissioner at the following address:

Section 7. Commissioner's Powers

(a) Abatement of Violations

The commissioner may take any action provided by law to abate a violation of this general permit, including but not limited to penalties of up to \$25,000 per violation per day under Chapter 446k of the Connecticut General Statutes, for such violation. The commissioner may, by summary proceedings or otherwise and for any reason provided by law, including violation of this general permit, revoke a permittee's authorization hereunder in accordance with sections 22a-3a-2 through 22a-3a-6, inclusive, of the Regulations of Connecticut State Agencies. Nothing herein shall be construed to affect any remedy available to the commissioner by law.

(b) General Permit Revocation, Suspension, or Modification

The commissioner may, for any reason provided by law, by summary proceedings or otherwise, revoke or suspend this general permit or modify to establish any appropriate conditions, schedules of compliance, or other provisions which may be necessary to protect human health or the environment.

(c) Filing of an Individual Permit Application

If the commissioner notifies a permittee in writing that such permittee must obtain an individual permit if he wishes to continue lawfully conducting the construction activity, the permittee shall file an application for an individual permit within thirty (30) days of receiving the commissioner's notice. While such application is pending before the commissioner, the permittee shall continue to comply with the terms and conditions of this general permit. Nothing herein shall affect the commissioner's power to revoke a permittee's authorization under this general permit at any time.

Issued: 9/30/19

/s/ Betsey Wingfield

Betsey Wingfield
Deputy Commissioner

This is a true and accurate copy of the general permit executed on **09/30/2019** by the Department of Energy and Environmental Protection.

General Permit for the Discharge of Stormwater and Dewatering Wastewaters from Construction Activities

APPENDIX A

Endangered and Threatened Species

In order to be eligible for coverage under the General Permit for the Discharge of Stormwater and Dewatering Wastewaters from Construction Activities (“GP” or “the GP”), under section 3(b)(2) of the GP, a registrant must ensure that the construction activity, which includes, but is not limited to, excavation, site development or other ground disturbance activities, and stormwater flow, discharges and control measures (“construction activity”), does not threaten the continued existence of any state or federal species listed as endangered or threatened (“listed species”) or result in the destruction or adverse modification of any habitat associated with such species.

In order to prevent significant, unforeseen delays in the processing of a registration under the GP, registrants should assess compliance with section 3(b)(2) early in the planning stages of a project. The Department of Energy and Environmental Protection (“the Department”) strongly recommends that this assessment *be initiated up to one year, or more*, prior to the projected construction initiation date, and even before the purchase of the site of the construction activity. At a minimum, registrants must assess compliance with section 3(b)(2) prior to submission of the Registration Form for the GP.

This Appendix describes the ways that a registrant can comply with section 3(b)(2) of the GP. In connection with the filing of a registration a registrant can perform a self-assessment described in Section 1, seek a limited one-year determination or a safe harbor determination from the Department’s Wildlife Division under Sections 2 or 3, respectively, or stipulate in writing to the presence of listed species or any habitat associated with such species and develop a mitigation plan pursuant to Section 5 of this Appendix. While some means of compliance are more limited than others, the options set out in this Appendix are not mutually exclusive and all options remain available to a registrant. For example, a registrant may perform a self-assessment under Section 1 and seek a safe harbor determination under Section 3 of this Appendix. Provided the requirements of this Appendix are met, the choice of how to proceed is the registrant’s.

Section 1. Self Assessment through Natural Diversity Database Map Review and Screening

Before submission of a registration for coverage under this GP, a registrant must review the current versions of the Department’s Natural Diversity Data Base (“NDDB”) maps. Except as provided for in Sections 2, 3 or 5 of this Appendix, such review must occur no more than six months before such submission. Such review provides a method for screening whether the Department is already aware of listed species that may be present on the site of the construction activity. These maps can be viewed at the following locations:

1. Online at the following links:

[CT DEEP Natural Diversity Data Base Maps](#)
[CTECO Webpage](#) (in the interactive Simple Map Viewer)

2. At the DEEP Public File Room at 79 Elm Street in Hartford.

Screening

The site of the construction activity must be compared to the shaded areas depicted on the NDDDB map to determine if the site is entirely, partially, or within ¼ mile of a shaded area. If the site is entirely, partially or within a ¼ mile of a shaded area for a listed species a registrant can only achieve compliance with section 3(b)(2) of the GP by obtaining a limited one-year determination under Section 2, a safe harbor determination under Section 3, or an approved mitigation plan under Section 5 of this Appendix from the Department's Wildlife Division.

If the site of the construction activity is not entirely, partially or within ¼ mile of a shaded area, then the Department is not aware of any listed species at the site of the construction activity. Based upon this screening, and provided the registrant has no reasonably available verifiable, scientific or other credible information that the construction activity could reasonably be expected to violate section 3(b)(2) of the GP, when completing the Registration Form for this GP a registrant may check the box that indicates that the construction activity will not impact federal or state listed species.

A registrant using only self-assessment under this section may utilize the results of any such self assessment for up to, but no more than, six months from the date of such assessment. Note, however, that the NDDDB maps are not the result of comprehensive state-wide field investigations, but rather serve as a screening tool. Using such maps as a screening tool does not provide a registrant with an assurance that listed species or their associated habitat may not be encountered at the site of the construction activity. Notwithstanding the NDDDB screening results, if a listed species is encountered at the site of the construction activity, the registrant shall promptly contact the Department and may need to take additional action to ensure that the registrant does not violate section 3(b)(2) of the GP.

Section 2. Obtaining a Limited One-Year Determination

A registrant may seek a written determination from the Department's Wildlife Division, good for one-year, that the proposed construction activity complies with section 3(b)(2) of the GP. To obtain this limited one-year determination, a registrant must, in addition to conducting the NDDDB map review in Section 1 of this Appendix, provide the Department's Wildlife Division with (1) any reasonably available verifiable, scientific or other credible information about whether the construction activity could reasonably be expected to result in a violation of section 3(b)(2) of the GP, and (2) limited information about the site of the proposed construction activity, but less information than would be necessary for a safe harbor determination under Section 3 of this Appendix. The limited information necessary for a one-year determination is on the current "Request for Natural Diversity Database (NDDDB) State Listed Species Review" form on the Department's website. The form and instructions for seeking such a limited one-year determination are available at www.ct.gov/DEEP/nddbrequest.

Provided the registrant's information is accurate and the Department's Wildlife Division determines that the construction activity will not violate section 3(b)(2) of the GP, the registrant shall receive a limited one-year determination from the Department. Any such determination may indicate that the construction activity will not impact listed species or their associated habitat, or it may include specific conditions to be implemented to avoid or significantly minimize any impacts that may be encountered at the site of the construction activity. For purposes of submitting a registration for the GP, any such limited one-year determination can be relied upon by the person receiving such determination for one-year from the date of such determination. Like, however, the NDDDB screening procedure in Section 1 of this Appendix, a limited one-year determination does not provide a registrant with an assurance that listed species or their associated habitat may not be encountered at the site of the construction activity. If a listed species is encountered, the registrant shall promptly contact the Department

and may need to take additional action to ensure that the construction activity does not violate section 3(b)(2) of the GP.

If a registrant receives a limited one-year determination from the Department, the registrant should check the limited one-year determination box on the GP registration form and include the Department's one-year limited determination letter if requested on the GP Registration form. Checking the limited one-year determination box on the registration form and failing to provide the determination letter from the Department's Wildlife Division, if requested on the GP Registration form, will delay and may prevent processing of a registration.

If based upon the information provided by a registrant seeking a limited one-year determination the Department's Wildlife Division determines that the construction activity could impact listed species or their associated habitat, or that the Department needs additional information to make a limited one-year determination, the registrant may still achieve compliance with section 3(b)(2) of the GP through providing additional information pursuant to Section 4 or developing a mitigation plan pursuant to Section 5 of this Appendix.

A registrant may request one or more one-year extensions to a limited one-year determination under this section. If the Department's Wildlife Division has prescribed a form for requesting an extension, any such request shall be made using the prescribed form. There is a presumption that requests for a one-year extension of a limited one-year determination shall be granted. However, this presumption can be rebutted if the Department determines that a change in any of the following has occurred since an initial limited one-year determination or any extension was granted: the construction activity affecting or potentially affecting listed species or their associated habitat; the NDDB maps for the site of the construction activity; the limited information upon which a limited one-year determination or any extension was granted; or other information indicative of a change in circumstance affecting listed species or their associated habitat. Any one-year extension granted under this paragraph shall run from the date the Department's Wildlife Division issues its determination to grant an extension and shall be treated as a limited one-year determination as provided for in this section. Any letter granting a one-year extension shall be included with a registration along with the original limited one-year determination as provided for in this section.

Section 3. Obtaining a Safe Harbor Determination

A registrant may seek a written determination from the Department's Wildlife Division, good for three years, with the potential to be extended for an additional year, that proposed construction activity complies with section 3(b)(2) of the GP. Any such determination shall constitute a "safe harbor" for purposes of section 3(b)(2) of the GP.

To obtain a safe harbor determination, a registrant must, in addition to conducting the NDDB review in section 1 of this Appendix, provide the Department's Wildlife Division with any reasonably available verifiable, scientific or other credible information about whether the construction activity could reasonably be expected to result in a violation of section 3(b)(2) of the GP and specific information about the site of the construction activity. The specific information necessary for a safe harbor determination is listed in Attachment A to this Appendix. This information must be sufficient to allow the Wildlife Division to adequately assess the site for potential risks to listed species and their associated habitat. While the Department recognizes certain information is necessary to make a safe harbor determination, it also recognizes that a registrant may need to obtain a safe harbor determination early in its project's approval process in order to make prudent business decisions about purchasing a site or proceeding to final project designs. The form and instructions for seeking a safe harbor determination are available at www.ct.gov/DEEP/nddbrequest.

Provided the registrant's information is accurate and the Department's Wildlife Division determines that the construction activity will not violate section 3(b)(2) of the GP, the registrant shall receive a safe harbor determination from the Department. A safe harbor determination may indicate that the construction activity will not impact listed species or their associated habitat, or it may include specific conditions to be implemented to avoid or significantly minimize any impacts that may be encountered at the site of the construction activity. The Department shall honor the safe harbor determination for three years from the date it is issued, meaning that unlike the NDDB review in Section 1 or the limited one-year determination in Section 2 of this Appendix, if the Department makes a safe harbor determination and a registrant remains in compliance with any conditions in any such determination, irrespective of what may be found at the site of the construction activity, a registrant shall be considered in compliance with section 3(b)(2) of the GP. However, a safe harbor determination shall not be effective if a construction activity may threaten the continued existence of any federally listed species or its critical habitat under federal law. If a federally listed species or its critical habitat is encountered on the site of the construction activity, the registrant shall promptly contact the Department and may need to take additional action to ensure that the construction activity does not violate federal law or section 3(b)(2) of the GP.

If a registrant receives a safe harbor determination from the Department, the registrant should check the safe harbor determination box on the GP registration form and include the Department's safe harbor determination if requested on the GP Registration form. Checking the safe harbor box on the registration form and failing to provide the safe harbor determination letter from the Department's Wildlife Division, if requested on the GP Registration form, will delay and may prevent processing of a registration.

If based upon the information provided by a registrant seeking a safe harbor determination the Department's Wildlife Division determines that the construction activity could impact listed species or their associated habitat, or that the Department needs additional information to make a safe harbor determination, the registrant may still achieve compliance with section 3(b)(2) of the GP through providing additional information pursuant to Section 4 or developing a mitigation plan pursuant to Section 5 of this Appendix.

If a registrant receives a safe harbor determination from the Department's Wildlife Division, anytime during the third year of such safe harbor, a registrant may request a one-year extension of that safe harbor. If the Department's Wildlife Division has prescribed a form for requesting an extension, any such request shall be made using the prescribed form. There is a presumption that a request for a one-year extension of a safe harbor shall be granted. However, this presumption can be rebutted if the Department determines that a change in any of the following has occurred since the safe harbor was granted: the construction activity affecting or potentially affecting listed species or their associated habitat; the NDDB maps for the site of the construction activity; the information upon which the safe harbor was granted; or other information indicative of a change in circumstance affecting listed species or their associated habitat. A registrant may seek only one extension, for one-year, to a safe harbor determination. Any one-year extension granted under this paragraph shall run from the date of the Department's Wildlife Division issues its determination to grant an extension and shall be honored by the Department in the same manner as a safe harbor determination noted above. Any letter granting a one-year extension shall be included with a registration along with the original limited safe harbor determination as provided for in this section.

Section 4. Providing Additional Information

For the Department's Wildlife Division to make a limited one-year determination under Section 2 or a safe harbor determination under section 3 of this Appendix, limited additional information may be required to determine if the construction activity would impact listed species or their associated habitat. If the species in question is a state listed endangered or threatened species under section 26-306 of the general statutes, a registrant shall, in consultation with the Department's Wildlife Division, provide the limited additional

information requested by the Department's Wildlife Division. Such information may include, but is not limited to, a survey of specific listed species in question. If the species in question is a federally listed threatened or endangered species, in addition to the Department's Wildlife Division, a registrant shall also consult with the U.S. Fish and Wildlife Service and shall provide any additional information requested by that agency. A registrant that initially sought or obtained a limited one-year determination may, after providing the additional information required under this section request a safe harbor determination under Section 3 of this Appendix.

At any time, as an alternative to proceeding under Section 2, 3 or 4 of this Appendix, a registrant may stipulate, in writing, to the presence of one or more listed species or their associated habitat. A registrant choosing this alternative shall proceed to develop a mitigation plan under Section 5 of this Appendix.

If based upon any additional information provided to the Department's Wildlife Division, and as applicable, the U.S. Fish & Wildlife Service, the Department's Wildlife division determines that construction activity will be in compliance with section 3(b)(2) of the GP, a registrant shall receive a limited one-year determination under Section 2 or a safe harbor determination under Section 3 of this Appendix, as applicable.

If the Department's Wildlife Division determines that additional information is necessary to determine if the construction activity has the potential to impact listed species or their associated habitat, and a registrant chooses to not provide such information, a registrant shall proceed with the self assessment through an NDDB review under Section 1 of this Appendix, or stipulate to the existence of a listed species or associated habitat and develop a mitigation plan under Section 5 or such registrant shall not be eligible to register under the GP.

Section 5. Developing a Mitigation Plan

The Department's Wildlife Division may determine that the construction activity has the potential to adversely impact listed species or their associated habitat. However, it may be possible to modify the construction activity or undertake certain on-site measures to avoid or significantly minimize such impacts. If the species or associated habitat in question is a state listed endangered or threatened species under section 26-306 of the general statutes, a registrant shall consult with the Department's Wildlife Division to determine if an acceptable mitigation plan can be developed so impacts can be avoided or minimized such that a registrant remains in compliance with section 3(b)(2). If the species in question is a federally listed threatened or endangered species, any such consultation shall also include the U.S. Fish and Wildlife Service.

If a registrant in consultation with the Department's Wildlife Division, and as applicable, the U.S. Fish & Wildlife Service, develops a mitigation plan that is approved by the Department's Wildlife Division, or as applicable, the U.S. Fish & Wildlife Service, the registrant shall receive a limited one-year determination under Section 2 or a safe harbor determination under Section 3 of this Appendix. In this situation, in addition to checking the one-year determination box or the safe harbor determination box, as applicable, on the registration form, the registrant shall also check the box on the registration form indicating that it has an approved mitigation plan and provide a status update on the registration form as to whether it has completed or is still in the process of implementing the approved mitigation plan.

If an approved mitigation plan has not been fully implemented by the time a registration is submitted, completing all remaining tasks in the plan shall become an enforceable condition of any registration issued to the registrant.

If the Department determines that the construction activity has the potential to adversely impact listed species or their associated habitat and the registrant and the Department, and as applicable, the U.S. Fish & Wildlife Service, are not able to agree on an acceptable mitigation plan that is approved by the Department, and as applicable, the U.S. Fish & Wildlife Service, any such registrant shall not be eligible to register under the GP.

APPENDIX A
ATTACHMENT A

Specific Information Needed to Apply for a Safe Harbor Determination

A Safe Harbor Determination will be made upon the submission of a detailed report that fully addresses the matters noted below. For the Department's Wildlife Division to make a safe harbor determination, the report should synthesize and analyze this information, not simply compile information. Those providing synthesis and analysis need appropriate qualifications and experience. A request for a safe harbor determination shall include:

1) Habitat Information, including GIS mapping overlays, identifying:

- wetlands, including wetland cover types;
- plant community types;
- topography;
- soils;
- bedrock geology;
- floodplains, if any;
- land use history; and
- water quality classifications/criteria.

2) Photographs - The report should also include photographs of the site, including all reasonably available aerial or satellite photographs and an analysis of such photographs.

3) Inspection - The report should include a visual inspection(s) of the site, preferably when the ground is visible. This inspection can also be helpful in confirming or further evaluating the items noted above.

4) Biological Surveys - The report should include all biological surveys of the site where construction activity will take place that are reasonably available to a registrant. A registrant shall notify the Department's Wildlife Division of biological studies of the site where construction activity will take place that a registrant is aware of but are not reasonably available to the registrant.

5) Based on items #1 through 4 above, the report shall include a Natural Resources Inventory of the site of the construction activity. This inventory should also include a review of reasonably available scientific literature and any recommendations for minimizing adverse impacts from the proposed construction activity on listed species or their associated habitat.

6) In addition, to the extent the following is available at the time a safe harbor determination is requested, a request for a safe harbor determination shall include and assess:

- Information on Site Disturbance Estimates/Site Alteration information
- Vehicular Use
- Construction Activity Phasing Schedules, if any; and
- Alternation of Drainage Patterns

General Permit for the Discharge of Stormwater and Dewatering Wastewaters from Construction Activities

APPENDIX B

Connecticut Department of Energy & Environmental Protection Inland Water Resources Division Fact Sheet Considering Low Impact Development Principles in Site Design

In order to reduce the impact of development and address stormwater quality issues, the Department strongly encourages the use of Low Impact Development (LID) measures. LID is a site design strategy intended to maintain or replicate predevelopment hydrology through the use of small-scale controls, integrated throughout the site, to manage stormwater runoff as close to its source as possible. Infiltration of stormwater through LID helps to remove sediments, nutrients, heavy metals, and other types of pollutants from runoff.

Key Strategies for LID

Key strategies for effective LID include: infiltrating, filtering, and storing as much stormwater as feasible, managing stormwater close to where the rain/snow falls, managing stormwater at multiple locations throughout the landscape, conserving and restoring natural vegetation and soils, preserving open space and minimizing land disturbance, designing the site to minimize impervious surfaces, and providing for maintenance and education. Water quality and quantity benefits are maximized when multiple techniques are grouped together. In areas of compacted and/or possibly contaminated soils, soil suitability should be further investigated prior to selecting optimum treatment and/or remediation measures. Where soil conditions permit, the DEEP encourages the utilization of one, or a combination of, the following measures:

- the use of pervious pavement or grid pavers (which are very compatible for parking lot and fire lane applications), or impervious pavement without curbs or with notched curbs to direct runoff to properly designed and installed infiltration areas;
- the use of vegetated swales, tree box filters, and/or infiltration islands to infiltrate and treat stormwater runoff (from building roofs, roads, and parking lots);
- the minimization of access road widths and parking lot areas to the maximum extent possible to reduce the area of impervious surface;
- the use of dry wells to manage runoff from building roofs;
- incorporation of proper physical barriers or operational procedures for special activity areas where pollutants could potentially be released (e.g. loading docks, maintenance and service areas, dumpsters, etc.);
- the installation of rainwater harvesting systems to capture stormwater from building roofs for the purpose of reuse for irrigation (i.e. - rain barrels for residential use and cisterns for larger developments);
- the use of residential rain gardens to manage runoff from roofs and driveways;
- the use of vegetated roofs (green roofs) to detain, absorb, and reduce the volume of roof runoff; and
- providing for pollution prevention measures to reduce the introduction of pollutants to the environment.

The [2004 Stormwater Quality Manual LID Appendix](#) and the [2002 Erosion and Sediment Control Guidelines LID Appendix](#) both provide guidance on implementing LID measures. A guide to LID resources can also be found in the [DEEP Low Impact Development Resources Factsheet](#) (PDF).

LID in Urban Areas

If the proposed site is located in a highly urbanized area, it is likely underlain by urban land complex soils. The Natural Resources Conservation Service (NRCS) Soil Web Survey (<http://websoilsurvey.nrcs.usda.gov/app/HomePage.htm>) provides information on soil textures, parent materials, slopes, height of seasonal high water table, depth to restrictive layer, and permeability. In highly developed areas, infiltration may be limited due to the high percentage of impervious cover. However, infiltration practices may be suitable at urban sites depending on:

- Potential contamination of soils in historically industrialized areas. The siting of areas for infiltration must consider any existing soil or groundwater contamination.
- Site specific soil conditions. NRCS mapping consists of a minimum 3 acres map unit and soils may vary substantially within each mapping unit. Test pits should be dug in areas
- planned for infiltration practices to verify soil suitability and/or limitations.
- Investigation of areas of compacted soils and the utilization of proper construction staging. Planning should insure that areas to be used for infiltration are not compacted during the construction process by vehicles or machinery.

Even if infiltration is limited at a site, it is still possible to implement LID practices. Specifically, potential exists for the installation of green roofs on buildings and/or the use of cisterns to capture and reuse rainwater.

LID in Areas with a High Seasonal Water Table or Hardpan Layer

- The impact of stormwater runoff to any streams and/or wetlands near the site should be considered. Water quality treatment is influenced by hydraulic conductivity and time of travel. If stormwater infiltration is limited by an impermeable layer close to the surface, the water may run laterally through the ground and discharge to the stream or wetlands, providing limited water quality treatment. However, a longer time of travel may provide sufficient treatment. Proper soil testing for infiltration potential will increase the likelihood of successful BMP design.
- In areas with a high seasonal water table, bioretention areas/rain gardens should be planted with water tolerant/wetland plants. The presence of a high seasonal water table suggests that water may drain slowly or not at all during certain parts of the year. Planting native wetland vegetation will help to ensure plant survival and increase the effectiveness of bioretention practices. Information on native plantings that are both drought tolerant and tolerant of wet conditions can be found in The UConn Cooperative Extension System’s guide to building a rain garden at http://nemo.uconn.edu/publications/rain_garden_broch.pdf. Native plant lists for Connecticut can also be found at <http://www.fhwa.dot.gov/environment/rdsduse/ct.htm>.

LID Guidance for Federal Projects

- LID techniques have been utilized by Department of Defense (DoD) agencies during the last several years. The effectiveness of these projects in managing runoff as well as reducing construction and maintenance costs has created significant interest in LID. The DoD has created a Unified Facilities Criteria document, Low Impact Development that provides guidelines for integrating LID planning and design into a facility’s regulatory and resource protection programs. It is available on-line at: http://www.wbdg.org/ccb/DOD/UFC/ufc_3_210_10.pdf.
- Section 438 of the Energy Independence and Security Act (EISA) of 2007 requires federal agencies to reduce stormwater runoff from federal development projects to protect water resources. In December 2009, the EPA developed a technical guidance document on implementing the stormwater runoff requirements for federal projects under Section 438 of EISA. The document contains guidance on how compliance with Section 438 can be achieved, measured and evaluated and can be found at: http://www.epa.gov/owow/NPS/lid/section438/pdf/final_sec438_eisa.pdf.

For more information contact the CT DEEP Watershed Management/Low Impact Development Program:

Name	Area	Telephone
MaryAnn Nusom Haverstock	Program Oversight/ Low Impact Development	(860) 424-3347
Chris Malik	Watershed Manager	(860) 424-3959
Susan Peterson	Watershed Manager	(860) 424-3854
Eric Thomas	Watershed Manager	(860) 424-3548

List of Runoff Reduction/LID Practices

Re-Forestation
Disconnection of Rooftop Runoff
Disconnection of Non-Rooftop Runoff
Sheetflow to Conservation Areas
Green Roof
Permeable Pavement
Rainwater Harvesting
Submerged Gravel Wetlands
Micro-Infiltration
Rain Gardens
Bioretention
Landscape Infiltration
Grass Swales
Bio-swales
Wet Swales
Stormwater Ponds
Stormwater Wetlands
Stormwater Filtering Systems
Stormwater Infiltration



General Permit for the Discharge of Stormwater and Dewatering Wastewaters from Construction Activities

APPENDIX C

AQUIFER PROTECTION AREAS AND OTHER GROUNDWATER DRINKING SUPPLY AREAS GUIDANCE INFORMATION

The Pollution Control Plan (“the Plan”) should consider measures to reduce or mitigate potential impacts to both ground water (aquifers) and surface waters, taking into consideration both quantity and quality of the runoff. The emphasis should be to minimize, to the extent possible, changes between pre-development and post-development runoff rates and volumes.

The basic stormwater principals for Aquifer Protection Areas (and other groundwater drinking supply areas) are to prevent inadvertent pollution discharges/releases to the ground, while encouraging recharge of stormwater where it does not endanger groundwater quality. Measures include:

- prevent illicit discharges to storm water, including fuel/chemical pollution releases to the ground;
- minimize impervious coverage and disconnect large impervious areas with natural or landscape areas;
- direct paved surface runoff to aboveground type land treatment structures – sheet flow, surface swales, depressed grass islands, detention/retention and infiltration basins, and wet basins. These provide an opportunity for volatilization of volatile organic compounds to the extent possible before the stormwater can infiltrate into the ground;
- provide necessary impervious pavement in high potential pollutant release areas. These “storm water hot spots” include certain land use types or storage and loading areas, fueling areas, intensive parking areas and roadways (see table below);
- only use subsurface recharge structures such as dry wells, galleries, or leaching trenches, to directly infiltrate clean runoff such as rooftops, or other clean surfaces. These structures do not adequately allow for attenuation of salts, solvents, fuels or other soluble compounds in groundwater that may be contained in runoff; and
- restrict pavement deicing chemicals, or use an environmentally suitable substitute such as sand only, or alternative de-icing agents such as calcium chloride or calcium magnesium.

Infiltration of stormwater should be **restricted** under the following site conditions:

- **Land Uses or Activities with Potential for Higher Pollutant Loads:** Infiltration of stormwater from these land uses or activities (refer to Table 7-5 below), also referred to as stormwater “hotspots,” can contaminate public and private groundwater supplies. Infiltration of stormwater from these land uses or activities may be allowed by the review authority with appropriate pretreatment. Pretreatment could consist of one or a combination of the primary or secondary treatment practices described in the Stormwater Quality Manual provided that the treatment practice is designed to remove the stormwater contaminants of concern.
- **Subsurface Contamination:** Infiltration of stormwater in areas with soil or groundwater contamination such as brownfield sites and urban redevelopment areas can mobilize contaminants.
- **Groundwater Supply and Wellhead Areas:** Infiltration of stormwater can potentially contaminate groundwater drinking water supplies in immediate public drinking water wellhead areas.

Land Uses or Activities with Potential for Higher Pollutant Loads
 Table 7-5 of the 2004 Stormwater Quality Manual

<u>Land Use/Activities</u>	
<ul style="list-style-type: none"> • Industrial facilities subject to the DEEP Industrial Stormwater General Permit or the U.S. EPA National Pollution Discharge Elimination System (NPDES) Stormwater Permit Program • Vehicle salvage yards and recycling facilities • Vehicle fueling facilities (gas stations and other facilities with on-site vehicle fueling) • Vehicle service, maintenance, and equipment cleaning facilities • Fleet storage areas (cars, buses, trucks, public works) • Commercial parking lots with high intensity use (shopping malls, fast food restaurants, convenience stores, supermarkets, etc.) • Public works storage areas 	<ul style="list-style-type: none"> • Road salt storage facilities (if exposed to rainfall) • Commercial nurseries • Flat metal rooftops of industrial facilities • Facilities with outdoor storage and loading/unloading of hazardous substances or materials, regardless of the primary land use of the facility or development • Facilities subject to chemical inventory reporting under Section 312 of the Superfund Amendments and Reauthorization Act of 1986 (SARA), if materials or containers are exposed to rainfall • Marinas (service and maintenance) • Other land uses and activities as designated by the review authority

For further information regarding the design of stormwater collection systems in Aquifer Protection Areas, contact the Aquifer Protection Area Program at (860) 424-3020 or visit www.ct.gov/deep/aquiferprotection.



General Permit for the Discharge of Stormwater and Dewatering Wastewaters from Construction Activities

APPENDIX D

Coastal Management Act Determination Form

For sites within the Coastal Boundary, please attach this form and written approval from the local governing authority (or verification of exemption) to the Registration Form for the Discharge of Stormwater and Dewatering Wastewaters From Construction Activities.

SITE INFORMATION

Future Permittee _____
Mailing Address _____
Business Phone _____ ext.: _____ Fax: _____
Contact Person _____ Title: _____
Site Name _____
Site Address/ Location _____
Site Latitude and Longitude _____
Receiving Water (name, basin) _____
Project Description _____

STATEMENT OF REVIEW:

<p>The above referenced project is consistent with the goals and policies in section 22a-92 of the Connecticut General Statutes and will not cause adverse impacts to coastal resources as defined in section 22a-93(15) of the Connecticut General Statutes.</p> <p>Date of Coastal Site Plan Approval: _____</p> <p><input type="checkbox"/> Copy of written approval attached, or</p> <p><input type="checkbox"/> Verification of exemption attached</p>

APPENDIX E
(Exhibit 3 of District/DEEP Memorandum of Agreement)

Conservation Districts of Connecticut
Regional Delineations and Contact Information

Northwest Conservation District
1185 New Litchfield Street
Torrington, CT 06790
Ph: 860-626-7222
Fax: 860-626-7222
Email: ncd@conservect.org

Eastern Connecticut Conservation District
238 West Town Street
Norwich, CT 06360-2111
Ph: 860-887-4163 x 400 Fax: 860-887-4082
Email: kate.johnson.eccd@comcast.net

Connecticut River Coastal Conservation District, Inc.
deKoven House Community Center
27 Washington Street
Middletown, CT 06457
Ph: 860-346-3282 Fax: 860-346-3284
Email: ctrivercoastal@conservect.org

Southwest Conservation District
51 Mill Pond Road
Hamden, CT 06514
Ph: 203-287-8179 Fax: 203-288-5077
Email: swcd43@sbcglobal.net

North Central Conservation District
24 Hyde Avenue
Vernon, CT 06066
Ph: 860-875-3881 Fax: 860-870-8973
Email: tollandc@snet.net

NORTHWEST	SOUTHWEST	NORTH CENTRAL	CT RIVER COASTAL	EASTERN
Barkhamsted	Ansonia	Avon	Berlin	Andover
Bethel	Beacon Falls	Bloomfield	Chester	Ashford
Bethlehem	Bethany	Bolton	Clinton	Bozrah
Bridgewater	Branford	Bristol	Colchester	Brooklyn
Brookfield	Bridgeport	Burlington	Cromwell	Canterbury
Canaan	Cheshire	Canton	Deep River	Chaplin
Colebrook	Darien	Coventry	Durham	Columbia
Cornwall	Derby	East Granby	East Haddam	Eastford
Danbury	East Haven	East Hartford	East Hampton	East Lyme
Goshen	Easton	East Windsor	Essex	Franklin
Hartland	Fairfield	Ellington	Haddam	Griswold
Harwinton	Greenwich	Enfield	Hebron	Groton
Kent	Guilford	Farmington	Killingworth	Hampton
Litchfield	Hamden	Glastonbury	Lyme	Killingly
Morris	Meriden	Granby	Madison	Lebanon
New Fairfield	Middlebury	Hartford	Marlborough	Ledyard
New Hartford	Milford	Manchester	Middlefield	Lisbon
New Milford	Monroe	Plainville	Middletown	Mansfield
Newtown	Naugatuck	Simsbury	Newington	Montville
Norfolk	New Canaan	Somers	New Britain	New
North Canaan	New Haven	South Windsor	Old Lyme	London
Plymouth	North Branford	Stafford	Old Saybrook	North
Roxbury	North Haven	Suffield	Portland	Stonington
Salisbury	Norwalk	Tolland	Rocky Hill	Norwich
Sharon	Orange	Vernon	Salem	Plainfield
Sherman	Oxford	West Hartford	Westbrook	Pomfret
Southbury	Prospect	Wethersfield		Preston
Thomaston	Redding	Willington		Putnam
Torrington	Ridgefield	Windsor		Scotland
Warren	Seymour	Windsor Locks		Sprague
Washington	Shelton			Sterling
Watertown	Southington			Stonington
Winchester	Stamford			Thompson
Woodbury	Stratford			Union
	Trumbull			Voluntown
	Wallingford			Waterford
	Waterbury			Windham
	West Haven			Woodstock
	Weston			
	Westport			
	Wilton			
	Wolcott			
	Woodbridge			

APPENDIX F

Memorandum of Agreement Between The Connecticut Department of Energy & Environmental Protection and the Conservation Districts of Connecticut

WHEREAS, the Commissioner of the Department of Energy and Environmental Protection (“Department” or “DEEP”) is authorized by section 22a-6(2)(3) and (4) of the Connecticut General Statutes (“CGS”) to enter into this Agreement; and

WHEREAS, the five Conservation Districts of Connecticut (collectively, the “Districts”), are not-for-profit corporations duly authorized, organized and existing under the laws of the State of Connecticut and are authorized by section 22a-315 of the CGS and section 22a-315-14 of the Regulations of Connecticut State Agencies to enter into this Agreement; and

WHEREAS, section 22a-430b of the Connecticut General Statutes requires the Department to regulate stormwater discharges from construction activities under the General Permit for the Discharge of Stormwater and Dewatering Wastewaters Associated with Construction Activities (“the Construction General Permit” or “CGP”), which has been or shall be issued on October 1, 2013. The Construction General Permit requires the implementation of erosion and sedimentation controls to control the discharge of sediment from construction and post-construction discharges; and

WHEREAS, Construction General Permits require the preparation and implementation of a Stormwater Pollution Control Plan (“Plan” or “SWPCP”) to prevent erosion and the discharge of sediment to the waters of the state; and

WHEREAS, pursuant to section 22a-315 of the CGS, soil and water conservation districts and boards were established to advise the Commissioner on matters of soil and water conservation and erosion and sedimentation control and to assist the Commissioner in implementing programs related to soil and water conservation and erosion and sediment control; and

WHEREAS, pursuant to section 22a-315 of the CGS, the soil and water conservation districts and boards may receive funds from private sources for services provided to promote soil and water conservation and to assist the Commissioner in the implementation of related programs; and

WHEREAS, section 22a-326 of the CGS declares the policy of the state “to strengthen and extend its erosion and sediment control activities and programs and to establish and implement, through the Council on Soil and Water Conservation, soil and water conservation districts, the municipalities and the Commissioner of Energy and Environmental Protection, a state-wide coordinated erosion and sediment control program which shall reduce the danger from storm water runoff, minimize nonpoint sediment pollution from land being developed and conserve and protect the land, water, air and other environmental resources of the state;” and

WHEREAS, the Districts have understanding and experience in reviewing erosion and sediment control plans because of their longstanding participation in the municipal approval process, as required by section 22a-329 of the CGS; and

WHEREAS, DEEP and the Districts are jointly dedicated to protecting the waters of the state by controlling the discharge of sediment and the pollution resulting from stormwater runoff.

NOW, THEREFORE, in consideration of the mutual covenants and conditions hereinafter stated, the Parties agree as follows:

I. RESPONSIBILITIES OF THE CONSERVATION DISTRICTS.

For locally approvable projects, as defined in the Construction General Permit, with five (5) or more acres of soil disturbance, the appropriate District (as specified in Appendix E of the Construction General Permit, appended hereto as Exhibit 3) shall review Stormwater Pollution Control Plans submitted to the District in accordance with Section 3(b)(10) of the CGP, shall determine whether each such SWPCP is consistent with the requirements of the CGP, and shall advise the Commissioner in writing of its determination regarding the SWPCP's consistency.

A. Components of the SWPCP Review by the Districts

1. Requirements for Conducting a Review:

(a) SWPCP review shall be conducted by a District representative having one or more of the following minimum qualifications: (i) a bachelor's degree in hydrology, engineering (agricultural, civil, environmental, or chemical), landscape architecture, geology, soil science, environmental science, natural resources management, or a related field and two years of professional and field experience, or (ii) the EnviroCert International, Inc. designation as a Certified Professional in Erosion and Sediment Control, or a Certified Professional in Storm Water Quality.

(b) All SWPCP reviews undertaken by a District shall be conducted in accordance with the guidelines and procedures established by DEEP in consultation with the Districts, as further described below, and shall include at least one inspection, and no more than 3 inspections, of the project site.

(c) The District shall begin a SWPCP review upon the receipt of the all of following: the developer's request for review, two copies of the proposed SWPCP, the payment of required fee in the amount specified in Exhibit 1 and the written permission of the developer to enter onto and inspect the project site. Once the District is in receipt of all the documents and the fee as delineated above, the developer's SWPCP shall be considered submitted to the District.

2. Determinations of Consistency by the District after Review of the SWPCP and Subsequent Procedures

(a) If the District determines the developer's SWPCP is:

(i) Consistent with the requirements of the Construction General Permit, the District shall issue an affirmative determination notice to both the developer or such developer's designee and to DEEP in order to advise them of the adequacy of the SWPCP. The District shall also provide a copy of the SWPCP to DEEP if requested by the Commissioner.

(ii) Not consistent with the requirements of the Construction General Permit, the District shall provide a written notice of such inconsistency to the developer or such developer's designee; such notice shall include a list of the SWPCP's deficiencies and any appropriate explanatory comments.

(b) If the developer's SWPCP is found to be inconsistent with the CGP, the developer may revise the SWPCP (the "Revised SWPCP") to address any deficiencies noted by the District and resubmit its Revised SWPCP to the District for review.

(c) If the District receives a Revised SWPCP in accordance with subsection (b) above, the District shall perform a review of the Revised SWPCP. If the Revised SWPCP is deemed:

(i) Consistent with the requirements of the Construction General Permit, the District shall (1) issue an affirmative determination notice to both the project developer or such project developer's designee and to DEEP to advise them of the adequacy of the SWPCP and (2) provide a copy of the SWPCP to the DEEP if requested by the Commissioner; or

(ii) Not consistent with the requirements of the CGP after this review, the District shall provide a written notice of such inconsistency to the developer or such developer's designee. This notice shall include a list of all remaining SWPCP deficiencies and any explanatory comments as appropriate.

(d) In the event the District determines after review of the Revised SWPCP in accordance with subsection (c), above, that the Revised SWPCP remains inconsistent with the requirements of the Construction General Permit, and the developer resubmits its Revised SWPCP *within 180 calendar days* of the District's original determination of inconsistency, the resubmitted Revised SWPCP shall be considered a Resubmission. As such, the resubmitted Revised SWPCP shall be reviewed by the District in accordance with the timeframes set forth in Section I.B., and other applicable sections of this document, and the fee shall be in accordance with Section II, below, and the Resubmission Fee in Exhibit 1.

(e) In the event the District determines after review of the Revised SWPCP in accordance with subsection (c), above, that the Revised SWPCP remains inconsistent with the requirements of the Construction General Permit, and the developer resubmits its Revised SWPCP *more than 180 calendar days after* the District's original determination of inconsistency, the resubmitted Revised SWPCP shall be considered a new submission. The newly submitted Revised SWPCP shall be reviewed by the District in accordance with the timeframes set forth in Section I.B., and other applicable sections of this document, and the fee shall be in accordance with Section II, below, and the SWPCP Review Fee in Exhibit 1.

(f) Revisions to a SWPCP subsequent to the District's prior approval of developer's SWPCP

(i) In the event the developer revises a SWPCP after the District has determined that the developer's SWPCP, prior to this revision, was consistent with the requirements of the Construction General Permit, and the developer submits the revised SWPCP to the District for review *within 180 calendar days* of the District's original determination of consistency, the SWPCP shall be considered a Post-Approval Resubmission. As a Post-Approval Resubmission, the SWPCP shall be reviewed by the District in accordance with the timeframes set forth in Section I.B., and other applicable sections of this document, and the fee shall be in accordance with Section II, below, and the Post-Approval Resubmission Fee in Exhibit 1.

(ii) In the event the developer revises a SWPCP after the District has determined that the developer's SWPCP, prior to this revision, was consistent with the requirements of the Construction General Permit, and the developer submits the revised SWPCP to the District for review *more than 180 calendar days after* the District's original determination of consistency, the SWPCP shall be considered a new submission. The newly submitted SWPCP shall be reviewed by the District in accordance with the timeframes set forth in Section I.B., and other applicable sections of this document, and the fee shall be in accordance with Section II, below, and the SWPCP Review Fee in Exhibit 1.

B. Plan Review Timeframes

1. The District shall review a new submission of a SWPCP submitted by a developer or such developer's designee and provide review comments within thirty (30) calendar days of the date of a complete submission as specified in Section I.A.1.(c).
2. If the District identifies deficiencies in the SWPCP, the District shall allow the developer or such developer's designee the opportunity to revise their SWPCP and resubmit it to the District within fifteen (15) calendar days after the date of mailing or delivery of the District's written comments to the developer or such developer's designee.
3. The District shall review any SWPCP revised in accordance with subsection I.B.2., above, and provide a written determination of the SWPCP's consistency or inconsistency within fifteen (15) calendar days after the submission of the revised SWPCP.
4. At the request of the District or the developer and with the agreement of both the District and the developer, the deadlines stated in subsections 1. – 3., above, may be extended. However, any such extensions shall be limited to no more than double the original amount of time allowed above for the relevant action.
5. Express review of a SWPCP may be requested by a developer. However, the Districts shall have complete discretion to accept or decline such request for an express review based on the District's circumstances, including, but not limited to: their existing workload, vacation schedules and staffing. If a District grants an express review, the timeframe shall be reduced to no more than one third of the timeframes noted in subsection 1. – 3., above, and the fee shall be in accordance with the Express Reviews fee in Exhibit 1.
6. In the event a District does not complete the review of the SWPCP within sixty (60) days (or within the time allowed under any authorized extension pursuant to subsection B.4, above, but in no circumstance later than 120 days) of the date the SWPCP was initially submitted to the District, and provided such delay is not the result of the developer's or such developer's designee's failure to address SWPCP deficiencies as noted in subsection B.2, above, the District shall:
 - (a) not later than three (3) days after the District's deadline, notify the DEEP that the developer shall be initiating the registration process for the Construction General Permit in accordance with section I.B of this Agreement, for completion of the SWPCP review, and;
 - (b) provide to the DEEP, upon request, the District's complete file, including supporting documentation the developer's SWPCP consistency determination, including, but not limited to, the SWPCP, any other documentation submitted to the District by or on behalf of a developer, and any analysis already performed by the District; and
 - (c) not later than seven (7) days after the District's deadline, in accordance with section I.B of this Agreement, for completion of the SWPCP review, transfer to the DEEP, up to a maximum of \$4,500, the fees that were originally submitted by the developer.

C. Inspections of the Project Site

1. Prior to the commencement of project construction and during the course of the SWPCP review process, the District shall conduct at least one inspection of the project site.
2. Once the construction of the project has begun, a District shall make at least one, but not more than three, inspection(s) of the project site to verify that the developer's SWPCP is being

implemented as approved by the District. A District shall report the results of the inspection(s) to the developer or such developer's designee and to DEEP in a manner prescribed by the Commissioner.

3. Upon notification from the developer or developer's designee, in accordance with Section 6(a)(1) of the CGP, that construction of the stormwater collection and management system is complete, the District shall conduct one inspection of the project site to verify that the post-construction stormwater management measures were completed in accordance with the approved SWPCP. The District shall report the results of this inspection to DEEP in a manner prescribed by the Commissioner.

D. Audits

The District agrees that all records pertaining to this Agreement shall be maintained for a period of not less than five (5) years. Such records shall be made available to the DEEP and to the state auditors upon request. For the purposes of this Agreement, "Records" are all working papers and such information and materials as may have been accumulated by the District in performing the Agreement, including, but not limited to, documents, data, analysis, plans, books, computations, drawings, specifications, notes, reports, records, estimates, summaries and correspondence, kept or stored in any form.

II. FEE SCHEDULE.

A. A District may assess fees for the services it renders in conjunction with its SWPCP reviews. Such fees shall be paid as follows:

1. All fees, except those described in subsection II.A.2, below, shall be submitted by the developer to the District with the developer's request for review. These fees are non refundable.
2. The fee for Post-Approval Resubmission, as designated in Exhibit 1, shall be submitted by the developer to the District upon completion of the District's review, prior to release of the determination notice, and is non refundable.

B. The Fee Schedule shall be reviewed annually by the Parties. The Fee Schedule may be adjusted as warranted, without a formal amendment to this Agreement, by mutual agreement between the Districts and the Commissioner.

III. RESPONSIBILITIES OF DEEP.

A. In accordance with the Construction General Permit requirements for SWPCP reviews by a third party, DEEP shall conduct outreach to inform the development community that a District may review SWPCPs for consistency with the requirements of the Construction General Permit. DEEP shall also inform the development community that a registration form for authorization under the Construction General Permit may only be submitted to DEEP if: the District, or other third party in accordance with Section 3(b)(11) of the CGP, determines that the SWPCP is consistent with the requirements of the CGP, or in the event the time schedule is exceeded for a District review as described in section I.B.6, above.

B. In order to institute standard SWPCP review guidelines and procedures, DEEP shall coordinate with the Districts to prepare a SWPCP checklist. The standard review guidelines and procedures established shall be consistent with the requirements of the Construction General Permit, the 2002 CT Guidelines for Soil Erosion and Sedimentation Control, and the 2004 Stormwater Quality Manual. The Commissioner shall have final approval of the review guidelines and procedures.

C. DEEP shall provide initial training regarding SWPCP requirements for District staff involved in SWPCP reviews. The frequency of subsequent training shall be determined by the Commissioner.

D. DEEP shall retain final decision making authority regarding the determination that a SWPCP is or is not consistent with the requirements of the Construction General Permit and shall oversee the permitting process for Construction General Permit coverage.

E. Once a SWPCP has been approved, DEEP shall oversee any subsequent compliance and/or enforcement matters related to a developer's adherence to the requirements of the Construction General Permit.

F. DEEP shall have the discretion to review any of the Districts' records pertaining to any aspect this Agreement.

IV. POINTS OF CONTACT.

The following shall be points of contact for this Agreement unless otherwise agreed to by all Parties, notwithstanding section VI. All notices, demands, requests, consents, approvals or other communications required or permitted to be given or which are given with respect to this Agreement (for the purpose of this section collectively called "Notices") shall be deemed to have been effected at such time as the notice is placed in the U.S. mail, first class and postage prepaid, return receipt requested, or, placed with a recognized, overnight express delivery service that provides for a return receipt. All such Notices shall be in writing and shall be addressed as follows:

A. DEEP

Director
Water Permitting & Enforcement Division
Bureau of Material Management & Compliance Assurance
Department of Energy & Environmental Protection
79 Elm St.
Hartford, CT 06106
Phone: 860-424-3018
Fax: 860-424-4074

B. Conservation District

Board Chairperson
Address & Phone of appropriate District:

Northwest Conservation District
1185 New Litchfield Street
Torrington, CT 06790
Ph: 860-626-7222
Fax: 860-626-7222
Email: ncd@conservect.org

Eastern Connecticut Conservation District
238 West Town Street
Norwich, CT 06360-2111
Ph: 860-887-4163 x 400 Fax: 860-887-4082
Email: kate.johnson.eccd@comcast.net

Connecticut River Coastal Conservation District, Inc.
deKoven House Community Center
27 Washington Street
Middletown, CT 06457
Ph: 860-346-3282 Fax 860-346-3284
Email: ctrivercoastal@conservect.org

Southwest Conservation District
51 Mill Pond Road
Hamden, CT 06514
Ph: 203-287-8179 Fax: 203-288-5077
Email: swcd43@sbcglobal.net

North Central Conservation District
24 Hyde Avenue
Vernon, CT 06066
Ph: 860-875-3881 Fax: 860-870-8973
Email: tollandc@snet.net

V. EXECUTIVE ORDERS AND ANTI-DISCRIMINATION. The Districts shall comply with the additional terms and conditions hereto attached as Exhibit 2.

VI. AMENDMENTS. Either the DEEP or the Districts may recommend revisions to this Agreement as circumstances may warrant; however, any revisions must be upon mutual agreement of DEEP and all five Conservation Districts. Unless otherwise stated in this Agreement, formal written amendment is required for changes to any of the terms and conditions specifically stated in the Agreement, including Exhibit 2 of the Agreement, any prior amendments to the Agreement, and any other Agreement revisions determined material by the Department.

VII. SEVERABILITY. The provisions of this Agreement are severable. If any part of it is found unenforceable, all other provisions shall remain fully valid and enforceable, unless the unenforceable provision is an essential element of the bargain.

VIII. SOVEREIGN IMMUNITY. The Parties acknowledge and agree that nothing in the Agreement shall be construed as a modification, compromise or waiver by the State of any rights or defenses of any immunities provided by federal law or the laws of the State of Connecticut to the State or any of the State's, which they may have had, now have or shall have with respect to all matters arising out of the Agreement. To the extent that this section conflicts with any other section, this section shall govern.

IX. FORUM AND CHOICE OF LAW. The Agreement shall be deemed to have been made in the City of Hartford, State of Connecticut. Both Parties agree that it is fair and reasonable for the validity and construction of the Agreement to be, and it shall be, governed by the laws and court decisions of the State of Connecticut, without giving effect to its principles of conflicts of laws. To the extent that any immunities provided by federal law or the laws of the State of Connecticut do not bar an action against the State or the Districts, and to the extent that these courts are courts of competent jurisdiction, for the purpose of venue, the complaint shall be made returnable to the Judicial District of Hartford only or shall be brought in the United States District Court for the District of Connecticut only, and shall not be transferred to any other court, provided, however, that nothing here constitutes a waiver or compromise of the sovereign immunity of the State of Connecticut. The Districts waive any objection which they may now have or shall have to the laying of venue of any Claims in any forum and further irrevocably submits to such jurisdiction in any suit, action or proceeding.

X. TERMINATION. Notwithstanding any provisions in this Agreement, DEEP, through a duly

authorized employee, may terminate the Agreement whenever the Agency makes a written determination that such Termination is in the best interests of the State. The Agency shall notify the Districts in writing sent by certified mail, return receipt requested, which notice shall specify the effective date of Termination and the extent to which the Districts must complete its Performance under the Agreement prior to such date; or (b) The Districts may terminate the Agreement for good cause. The Districts shall notify DEEP by written notice at least one hundred eighty (180) days prior to the effective date of termination. In order for the Districts to terminate this Agreement, (1) there must be a consensus between all five Conservation Districts that each District shall be terminating this Agreement with the DEEP; (2) such proof of consensus shall be submitted to the DEEP in the form of a letter signed by the duly authorized agent for each District by certified mail, return receipt requested, at least one hundred eighty (180) days prior to the Districts' intention to cancel or terminate. Upon the Termination of this Agreement by either Party, the Districts shall deliver to the Agency copies of all Records no later than thirty (30) days after the Termination of the Agreement, or fifteen (15) days after the Non-terminating Party receives a written request from the Terminating Party for the Records. The Districts shall deliver those Records that exist in electronic, magnetic or other intangible form in a non-proprietary format, such as, but not limited to, PDF, ASCII or .TXT. Upon receipt of a written notice of Termination from the Agency, the Districts shall cease operations as the Agency directs in the notice, and take all actions that are necessary or appropriate, or that the Agency may reasonably direct, for the protection, and preservation of records. Except for any work which the Agency directs the Districts to Perform in the notice prior to the effective date of Termination, and except as otherwise provided in the notice, the Districts shall terminate or conclude all existing subcontracts and purchase orders and shall not enter into any further subcontracts, purchase orders or commitments. Upon Termination of the Agreement, all rights and obligations shall be null and void, so that no Party shall have any further rights or obligations to any other Party, except with respect to the sections which survive Termination. All representations, warranties, agreements and rights of the Parties under the Agreement shall survive such Termination to the extent not otherwise limited in the Agreement and without each one of them having to be specifically mentioned in the Agreement. Termination of the Agreement pursuant to this section shall not be deemed to be a breach of Agreement by the Agency.

XI. DURATION OF AGREEMENT. This Agreement shall be effective on July 1, 2013 or on the date of the last signature below, whichever is later, and shall continue in force unless canceled or terminated by either party in accordance with paragraph X above.

XII. VOID AB INITIO. Notwithstanding paragraphs X and XI, the Agreement shall be void *ab initio* if the Construction General Permit is reissued, revoked or modified to eliminate the need for the Districts to review the SWPCP pursuant to such general permit's terms and conditions or if the Construction General Permit expires and is not reissued.

XIII. INTERPRETATION. The Agreement contains numerous references to statutes and regulations. For purposes of interpretation, conflict resolution and otherwise, the content of those statutes and regulations shall govern over the content of the reference in the Agreement to those statutes and regulations.

XIV. ENTIRETY OF AGREEMENT. This Agreement is the entire agreement between the Parties with respect to its subject matter, and supersedes all prior agreements, proposals, offers, counteroffers and understandings of the Parties, whether written or oral. The Agreement has been entered into after full investigation, neither Party relying upon any statement or representation by the other unless such statement or representation is specifically embodied in the Agreement.

XV. PROTECTION OF STATE CONFIDENTIAL INFORMATION.

A. The Districts or District Parties, at their own expense, have a duty to and shall protect from a Confidential Information Breach any and all Confidential Information which they come to possess or

control, wherever and however stored or maintained, in a commercially reasonable manner in accordance with current industry standards.

B. Each District or District Party shall develop, implement and maintain a comprehensive data-security program for the protection of Confidential Information. The safeguards contained in such program shall be consistent with and comply with the safeguards for protection of Confidential Information, and information of a similar character, as set forth in all applicable federal and state law and written policy of the Department or State concerning the confidentiality of Confidential Information. Such data-security program shall include, but not be limited to, the following:

1. A security policy for employees related to the storage, access and transportation of data containing Confidential Information;
2. Reasonable restrictions on access to records containing Confidential Information, including access to any locked storage where such records are kept;
3. A process for reviewing policies and security measures at least annually;
4. Creating secure access controls to Confidential Information, including but not limited to passwords; and
5. Encrypting of Confidential Information that is stored on laptops, portable devices or being transmitted electronically.

C. The District and District Parties shall notify the Department and the Connecticut Office of the Attorney General as soon as practical, but no later than twenty-four (24) hours, after they become aware of or suspect that any Confidential Information which Parties have come to possess or control has been subject to a Confidential Information Breach. If a Confidential Information Breach has occurred, the District shall, within three (3) business days after the notification, present a credit monitoring and protection plan to the Commissioner of Administrative Services, the Department and the Connecticut Office of the Attorney General, for review and approval. Such credit monitoring or protection plan shall be made available by the District at its own cost and expense to all individuals affected by the Confidential Information Breach. Such credit monitoring or protection plan shall include, but is not limited to, reimbursement for the cost of placing and lifting one (1) security freeze per credit file pursuant to Connecticut General Statutes §36a-701a. Such credit monitoring or protection plans shall be approved by the State in accordance with this Section and shall cover a length of time commensurate with the circumstances of the Confidential Information Breach. The District's costs and expenses for the credit monitoring and protection plan shall not be recoverable from the Department, any State of Connecticut entity or any affected individuals.

D. The District shall incorporate the requirements of this Section in all subAgreements requiring each District Party to safeguard Confidential Information in the same manner as provided for in this Section.

E. Nothing in this Section shall supersede in any manner the District's and/ or the District Parties' obligations pursuant to HIPAA or the provisions of this Agreement concerning the obligations of the District as a Business Associate of the Department.

XVI. AMERICANS WITH DISABILITIES ACT. The Districts shall be and remain in compliance with the Americans with Disabilities Act of 1990 ("Act"), to the extent applicable, during the term of the Agreement. The DEEP may cancel the Agreement if the District and District Parties fail to comply with the Act.

XVII. ADA PUBLICATION STATEMENT. The following statement shall be incorporated into all **publications** prepared under the terms of this Agreement:

“The Department of Energy and Environmental Protection is an affirmative action/equal opportunity employer and service provider. In conformance with the Americans with Disabilities Act, DEEP makes every effort to provide equally effective services for persons with disabilities. Individuals with disabilities who need this information in an alternative format, to allow them to benefit and/or participate in the agency’s programs and services, should call DEEP’s Human Resources Office at (860) 424-3006, send a fax to (860) 424-3896, or email DEEP.MedRecs@ct.gov. Persons who are hearing impaired should call the State of Connecticut relay number 711.”

When advertising any **public meetings** conducted under the terms of this Agreement, the above publications language should be used as well as the following statement:

“Requests for accommodations must be made at least two weeks prior to the program date.”

All **videos** produced under the terms of this Agreement must be made available with closed captioning.

XVIII. PUBLICATION OF MATERIALS. The District must obtain written approval from the State of Connecticut prior to distribution or publication of any printed material prepared under the terms of this Agreement. Unless specifically authorized in writing by the State, on a case by case basis, the District shall have no right to use, and shall not use, the name of the State of Connecticut, its officials, agencies, or employees or the seal of the State of Connecticut or its agencies: (1) in any advertising, publicity, promotion; or (2) to express or to imply any endorsement of District’s products or services; or (3) to use the name of the State of Connecticut, its officials agencies, or employees or the seal of the State of Connecticut or its agencies in any other manner (whether or not similar to uses prohibited by (1) and (2) above), except only to manufacture and deliver in accordance with this Agreement such items as are hereby contracted for by the State. In no event may the Districts use the State Seal in any way without the express written consent of the Secretary of State.

XIX. CHANGES IN PRINCIPAL PROJECT STAFF. Any changes in the principal project staff must be requested in writing and approved in writing by the Commissioner at the Commissioner’s sole discretion. In the event of any unapproved change in principal project staff, the Commissioner may, in the Commissioner’s sole discretion, terminate this Agreement.

XX. FURTHER ASSURANCES. The Parties shall provide such information, execute and deliver any instruments and documents and take such other actions as may be necessary or reasonably requested by the other Party which are not inconsistent with the provisions of this Agreement and which do not involve the vesting of rights or assumption of obligations other than those provided for in the Agreement, in order to give full effect to the Agreement and to carry out the intent of the Agreement.

XXI. ASSIGNMENT. The Districts shall not assign any of their rights or obligations under the Agreement, voluntarily or otherwise, in any manner without the prior written consent of the Agency. The Agency may void any purported assignment in violation of this section and declare the District in breach of this Agreement. Any termination by the Agency for a breach is without prejudice to the Agency’s or the State’s rights or possible Claims.

XXII. EXHIBITS. All exhibits referred to in, and attached to, this Agreement are incorporated in this Agreement by such reference and shall be deemed to be a part of it as if they had been fully set forth in it.

XXIII. FORCE MAJEUR. Events that materially affect the cost of the Goods or Services or the time schedule within which to Perform and are outside the control of the party asserting that such an event has occurred, including, but not limited to, labor troubles unrelated to District(s), failure of or inadequate

permanent power, unavoidable casualties, fire not caused by a District, extraordinary weather conditions, disasters, riots, acts of God, insurrection or war.

XXIV. INDEMNIFICATION. The Districts shall indemnify, defend and hold harmless the State and its officers, representatives, agents, servants, employees, successors and assigns from and against any and all (1) Claims arising, directly or indirectly, in connection with the Agreement, including the acts of commission or omission (collectively, the "Acts") of the District or District Parties; and (2) liabilities, damages, losses, costs and expenses, including but not limited to, attorneys' and other professionals' fees, arising, directly or indirectly, in connection with Claims, Acts or the Agreement. The Districts obligations under this section to indemnify, defend and hold harmless against Claims includes Claims concerning confidentiality of any part of or all of the Districts' Records, any intellectual property rights, other proprietary rights of any person or entity, copyrighted or uncopyrighted compositions, secret processes, patented or unpatented inventions, articles or appliances furnished or used in the Performance. The Districts shall not be responsible for indemnifying or holding the State harmless from any liability arising due to the negligence of the State or any other person or entity acting under the direct control or supervision of the State. The Districts shall reimburse the State for any and all damages to the real or personal property of the State caused by the Acts of the Districts or any District Parties. The State shall give the Districts reasonable notice of any such Claims. The Districts shall carry and maintain at all times during the term of the Agreement, and during the time that any provisions survive the term of the Agreement, sufficient general liability insurance to satisfy its obligations under this Agreement. The Districts shall name the State as an additional insured on the policy and shall provide a copy of the policy to the Agency prior to the effective date of the Agreement. The Districts shall not begin Performance until the delivery of the policy to the Agency. The Agency shall be entitled to recover under the insurance policy even if a body of competent jurisdiction determines that the Agency or the State is contributorily negligent. This section shall survive the Termination of the Agreement and shall not be limited by reason of any insurance coverage.

XXV. DISTRICT PARTIES. A District's members, directors, officers, shareholders, partners, managers, principal officers, representatives, agents, servants, consultants, employees or any one of them or any other person or entity with whom the District is in privity of oral or written contract and the District intends for such other person or entity to Perform under the Agreement in any capacity

XXVI. CAMPAIGN CONTRIBUTION RESTRICTION. For all State contracts as defined in P.A. 07-1 having a value in a calendar year of \$50,000 or more or a combination or series of such agreements or contracts having a value of \$100,000 or more, the authorized signatory to this Agreement expressly acknowledges receipt of the State Elections Enforcement Commission's notice advising state contractors of state campaign contribution and solicitation prohibitions, and will inform its principals of the contents of the notice. See SEEC Form 11.

Authorizing Signatures

For DEEP: _____
Commissioner Date

For Northwest Conservation District: _____
Signature Date

Title

For Eastern Connecticut Conservation District: _____
Signature Date

Title

For Connecticut River Coastal Conservation District, Inc.: _____
Signature Date

Title

For Southwest Conservation District: _____
Signature Date

Title

For North Central Conservation District: _____
Signature Date

Title

EXHIBIT 1

**Connecticut Conservation District
Stormwater Pollution Control Plan Review Fee Schedule**

Single Family Residential Developments Disturbing 5 or more Acres

Number of Lots	Standard Fee	Number of Lots	Standard Fee
1	\$1,500	26	\$5,625
2	\$1,665	27	\$5,790
3	\$1,830	28	\$5,955
4	\$1,995	29	\$6,120
5	\$2,160	30	\$6,285
6	\$2,325	31	\$6,450
7	\$2,490	32	\$6,615
8	\$2,655	33	\$6,780
9	\$2,820	34	\$6,945
10	\$2,985	35	\$7,110
11	\$3,150	36	\$7,275
12	\$3,315	37	\$7,440
13	\$3,480	38	\$7,605
14	\$3,645	39	\$7,770
15	\$3,810	40	\$7,935
16	\$3,975	41	\$8,100
17	\$4,140	42	\$8,265
18	\$4,305	43	\$8,430
19	\$4,470	44	\$8,595
20	\$4,635	45	\$8,760
21	\$4,800	46	\$8,925
22	\$4,965	47	\$9,090
23	\$5,130	48	\$9,255
24	\$5,295	49	\$9,420
25	\$5,460	50	\$9,585

Over 50 lots:

\$9,585 + \$20 x number of lots over 50

SW PCP Review: Standard Fee (as shown above)

Resubmission: Standard Fee minus 50%

Post-Approval Resubmission: \$85 per hour, up to a maximum of the Standard Fee minus 50%

Express Reviews: The specified fee for an SW PCP Review, a Resubmission, or a Post-Approval Resubmission; plus 50% of the applicable fee and/or limit

Policies:

1. Payment due upon submission of SW PCP, with the exception of Post-Approval Resubmissions.
2. Payment for Post-Approval Resubmission review is due upon completion of review.
3. Written permission to enter onto and inspect the site: Due upon submission of SW PCP.

EXHIBIT 1

**Connecticut Conservation District
Stormwater Pollution Control Plan Review Fee Schedule**

Commercial and Multi Family Developments

Number of Disturbed Standard Acres Fee		Number of Disturbed Standard Acres Fee	
5	\$2,200	28	\$5,995
6	\$2,365	29	\$6,160
7	\$2,530	30	\$6,325
8	\$2,695	31	\$6,490
9	\$2,860	32	\$6,655
10	\$3,025	33	\$6,820
11	\$3,190	34	\$6,985
12	\$3,355	35	\$7,150
13	\$3,520	36	\$7,315
14	\$3,685	37	\$7,480
15	\$3,850	38	\$7,645
16	\$4,015	39	\$7,810
17	\$4,180	40	\$7,975
18	\$4,345	41	\$8,140
19	\$4,510	42	\$8,305
20	\$4,675	43	\$8,470
21	\$4,840	44	\$8,635
22	\$5,005	45	\$8,800
23	\$5,170	46	\$8,965
24	\$5,335	47	\$9,130
25	\$5,500	48	\$9,295
26	\$5,665	49	\$9,460
27	\$5,830	50	\$9,625

Over 50 acres:

\$9,625 + \$25 x number of disturbed acres over 50

SW PCP Review: Standard Fee (as shown above)

Resubmission: Standard Fee minus 50%

Post-Approval Resubmission: \$85 per hour, up to a maximum of the Standard Fee minus 50%

Express Reviews: The specified fee for an SW PCP Review, a Resubmission, or a Post-Approval Resubmission; plus 50% of the applicable fee and/or limit

Policies:

1. Payment due upon submission of SW PCP, with the exception of Post-Approval Resubmissions.
2. Payment for Post-Approval Resubmission review is due upon completion of review.
3. Written permission to enter onto and inspect the site: Due upon submission of SW PCP.

EXHIBIT 2

EXECUTIVE ORDERS

The Agreement is subject to the provisions of Executive Order No. Three of Governor Thomas J. Meskill, promulgated June 16, 1971, concerning labor employment practices, Executive Order No. Seventeen of Governor Thomas J. Meskill, promulgated February 15, 1973, concerning the listing of employment openings and Executive Order No. Sixteen of Governor John G. Rowland promulgated August 4, 1999, concerning violence in the workplace, all of which are incorporated into and are made a part of the Contract as if they had been fully set forth in it. At the Districts' request, the Client Agency shall provide a copy of these orders to the Districts. The Agreement may also be subject to Executive Order No. 7C of Governor M. Jodi Rell, promulgated July 13, 2006, concerning contracting reforms and Executive Order No. 14 of Governor M. Jodi Rell, promulgated April 17, 2006, concerning procurement of cleaning products and services, in accordance with their respective terms and conditions.

NONDISCRIMINATION

(a) For purposes of this Section, the following terms are defined as follows:

- i. "Commission" means the Commission on Human Rights and Opportunities;
- ii. "Contract" and "contract" include any extension or modification of this Agreement or contract;
- iii. "Districts" and "districts" include the Districts and any successors or assigns of the Districts or districts;
- iv. "Gender identity or expression" means a person's gender-related identity, appearance or behavior, whether or not that gender-related identity, appearance or behavior is different from that traditionally associated with the person's physiology or assigned sex at birth, which gender-related identity can be shown by providing evidence including, but not limited to, medical history, care or treatment of the gender-related identity, consistent and uniform assertion of the gender-related identity or any other evidence that the gender-related identity is sincerely held, part of a person's core identity or not being asserted for an improper purpose.
- v. "good faith" means that degree of diligence which a reasonable person would exercise in the performance of legal duties and obligations;
- vi. "good faith efforts" shall include, but not be limited to, those reasonable initial efforts necessary to comply with statutory or regulatory requirements and additional or substituted efforts when it is determined that such initial efforts will not be sufficient to comply with such requirements;
- vii. "marital status" means being single, married as recognized by the State of Connecticut, widowed, separated or divorced;
- viii. "mental disability" means one or more mental disorders, as defined in the most recent edition of the American Psychiatric Association's "Diagnostic and Statistical Manual of Mental Disorders", or a record of or regarding a person as having one or more such disorders;
- ix. "minority business enterprise" means any small contractor, District or supplier of materials fifty-one percent or more of the capital stock, if any, or assets of which is owned by a person or persons: (1) who are active in the daily affairs of the enterprise, (2) who have the power to direct the management and policies of the enterprise, and (3) who are members of a minority, as such term is defined in subsection (a) of Connecticut General Statutes § 32-9n; and
- x. "public works contract" means any agreement between any individual, firm or corporation and the State or any political subdivision of the State other than a municipality for construction, rehabilitation, conversion, extension, demolition or repair of a public building, highway or other changes or improvements in real property, or which is financed in whole or in part by the State, including, but not limited to, matching expenditures, grants, loans, insurance or guarantees.

For purposes of this Section, the terms "Contract" and "contract" do not include a contract where each District is (1) a political subdivision of the state, including, but not limited to, a municipality, (2) a quasi-public agency, as defined in Conn. Gen. Stat. Section 1-120, (3) any other state, including but not limited to any federally recognized Indian tribal governments, as defined in Conn. Gen. Stat. Section 1-267, (4) the federal government, (5) a foreign government, or (6) an agency of a subdivision, agency, state or government described in the immediately preceding enumerated items (1), (2), (3), (4) or (5).

(b) (1) The Districts agree and warrant that in the performance of the Agreement such Districts will not discriminate or permit discrimination against any person or group of persons on the grounds of race, color, religious creed, age, marital status, national origin, ancestry, sex, gender identity or expression, mental retardation, mental disability or physical disability, including, but not limited to, blindness, unless it is shown by such Districts that such disability prevents performance of the work involved, in any manner prohibited by the laws of the United States or of the State of Connecticut; and the Districts further agree to take affirmative action to insure that applicants with job-related qualifications are employed and that employees are treated when employed without regard to their race, color, religious creed, age, marital status, national origin, ancestry, sex, gender identity or expression, mental retardation, mental disability or physical disability, including, but not limited to, blindness, unless it is shown by the Districts that such disability prevents performance of the work involved; (2) the Districts agree, in all solicitations or advertisements for employees placed by or on behalf of the Districts, to state that it is

an "affirmative action-equal opportunity employer" in accordance with regulations adopted by the Commission; (3) the Districts agree to provide each labor union or representative of workers with which the Districts have a collective bargaining Agreement or other contract or understanding and each vendor with which the Districts have a contract or understanding, a notice to be provided by the Commission, advising the labor union or workers' representative of the Districts' commitments under this section and to post copies of the notice in conspicuous places available to employees and applicants for employment; (4) the Districts agree to comply with each provision of this Section and Connecticut General Statutes §§ 46a-68e and 46a-68f and with each regulation or relevant order issued by said Commission pursuant to Connecticut General Statutes §§ 46a-56, 46a-68e and 46a-68f; and (5) the Districts agree to provide the Commission on Human Rights and Opportunities with such information requested by the Commission, and permit access to pertinent books, records and accounts, concerning the employment practices and procedures of the Districts as relate to the provisions of this Section and Connecticut General Statutes § 46a-56. If the contract is a public works contract, the Districts agree and warrant that they will make good faith efforts to employ minority business enterprises as Districts and suppliers of materials on such public works projects.

(c) Determination of the Districts' good faith efforts shall include, but shall not be limited to, the following factors: The Districts' employment and subcontracting policies, patterns and practices; affirmative advertising, recruitment and training; technical assistance activities and such other reasonable activities or efforts as the Commission may prescribe that are designed to ensure the participation of minority business enterprises in public works projects.

(d) The Districts shall develop and maintain adequate documentation, in a manner prescribed by the Commission, of its good faith efforts.

(e) The Districts shall include the provisions of subsection (b) of this Section in every subcontract or purchase order entered into in order to fulfill any obligation of a contract with the State and such provisions shall be binding on the Districts, vendor or manufacturer unless exempted by regulations or orders of the Commission. The Districts shall take such action with respect to any such subcontract or purchase order as the Commission may direct as a means of enforcing such provisions including sanctions for noncompliance in accordance with Connecticut General Statutes §46a-56; provided if such Districts become involved in, or is threatened with, litigation with the Districts or vendor as a result of such direction by the Commission, the Districts may request the State of Connecticut to enter into any such litigation or negotiation prior thereto to protect the interests of the State and the State may so enter.

(f) The Districts agree to comply with the regulations referred to in this Section as they exist on the date of this Agreement and as they may be adopted or amended from time to time during the term of this Agreement and any amendments thereto.

(g) (1) The Districts agree and warrant that in the performance of the Agreement such Districts will not discriminate or permit discrimination against any person or group of persons on the grounds of sexual orientation, in any manner prohibited by the laws of the United States or the State of Connecticut, and that employees are treated when employed without regard to their sexual orientation; (2) the Districts agree to provide each labor union or representative of workers with which such Districts have a collective bargaining Agreement or other contract or understanding and each vendor with which such Districts have a contract or understanding, a notice to be provided by the Commission on Human Rights and Opportunities advising the labor union or workers' representative of the Districts' commitments under this section, and to post copies of the notice in conspicuous places available to employees and applicants for employment; (3) the Districts agree to comply with each provision of this section and with each regulation or relevant order issued by said Commission pursuant to Connecticut General Statutes § 46a-56; and (4) the Districts agree to provide the Commission on Human Rights and Opportunities with such information requested by the Commission, and permit access to pertinent books, records and accounts, concerning the employment practices and procedures of the Districts which relate to the provisions of this Section and Connecticut General Statutes § 46a-56.

(h) The Districts shall include the provisions of the foregoing paragraph in every subcontract or purchase order entered into in order to fulfill any obligation of a contract with the State and such provisions shall be binding on the Districts, vendor or manufacturer unless exempted by regulations or orders of the Commission. The Districts shall take such action with respect to any such subcontract or purchase order as the Commission may direct as a means of enforcing such provisions including sanctions for noncompliance in accordance with Connecticut General Statutes § 46a-56; provided, if such Districts become involved in, or is threatened with, litigation with the Districts or vendor as a result of such direction by the Commission, the Districts may request the State of Connecticut to enter into any such litigation or negotiation prior thereto to the Connecticut Department of Energy and Environmental Protection (DEEP)."

Note: Place on official Letterhead. Need to document registered name with CT Secretary of State C.O.N.C.O.R.D.

CERTIFICATION

I, **XXXXXXXXXXXXXXXXXX**, Chair of the **XXXXXXXXXXXXXXXXXX** an entity lawfully organized and existing under the laws of Connecticut, do hereby certify that the following is a true and correct copy of a resolution adopted on the **>>>>**day of **>>>>**, 2011, by the governing body of the **XXXXXX** in accordance with all of its documents of governance and management and the laws of Connecticut and further certify that such resolution has not been modified, rescinded or revoked, and is a present in full force and effect.

RESOLVED: That the **XXXXXXXXXXXXXXXXXX** hereby adopts as its policy to support the nondiscrimination agreements and warranties required under Conn. Gen. Stat. § 4a-60(a)(1) and § 4a-60a(a)(1), as amended in State of Connecticut Public Act 07-245 and sections 9(a)(1) and 10(a)(1) of Public Act 07-142, as those statutes may be amended from time to time.

IN WITNESS WHEREOF, the undersigned has executed this certificate **this >>>>day of >>>>**, 2013.

Signature

Date

CONSERVATION DISTRICT PLAN REVIEW CERTIFICATION

Registrations submitted to DEEP for which a Conservation District has performed the Plan review pursuant to Section 3(b)(10) of the General Permit for the Discharge of Stormwater and Dewatering Wastewaters from Construction Activities shall include the following certification:

"I hereby certify that I am an employee of the [INSERT NAME OF DISTRICT] Conservation District and that I meet the qualifications to review Stormwater Pollution Control Plans as specified in the Memorandum of Agreement between the Connecticut Department of Energy & Environmental Protection and the Connecticut Conservation Districts. I am making this certification in connection with a registration under the General Permit for the Discharge of Stormwater and Dewatering Wastewaters from Construction Activities, submitted to the commissioner by [INSERT NAME OF REGISTRANT] for an activity located at [INSERT ADDRESS OF PROJECT OR ACTIVITY]. I have personally examined and am familiar with the information that provides the basis for this certification, including but not limited to all information described in such general permit, and I certify, based on reasonable investigation, including my inquiry of those individuals responsible for obtaining such information, that the information upon which this certification is based is true, accurate and complete to the best of my knowledge and belief. I certify, based on my review of the requirements of such general permit and on the standard of care for such projects, that the Plan is in compliance with the requirements of the general permit. I understand that knowingly making any false statement in this certification may be punishable as a criminal offense, including the possibility of fine and imprisonment, under section 53a-157b of the Connecticut General Statutes and any other applicable law."

Registrations submitted to DEEP for which the District review was begun but ***could not be completed*** within the time limits specified in the Memorandum of Agreement shall include the following statement:

"I hereby certify that I am an employee of the [INSERT NAME OF DISTRICT] Conservation District and that I meet the qualifications to review Stormwater Pollution Control Plans as specified in the Memorandum of Agreement between the Connecticut Department of Energy & Environmental Protection and the Connecticut Conservation Districts. I am making this statement in connection with a registration under the General Permit for the Discharge of Stormwater and Dewatering Wastewaters from Construction Activities, submitted to the commissioner by [INSERT NAME OF REGISTRANT] for an activity located at [INSERT ADDRESS OF PROJECT OR ACTIVITY]. I hereby state that the review of the Stormwater Pollution Control Plan (Plan) for such registration was not completed within the time frames specified in the Memorandum of Agreement. Consequently, I cannot certify that the Plan is in compliance with the requirements of the general permit."



General Permit for the Discharge of Stormwater and Dewatering Wastewaters Associated with Construction Activities

APPENDIX G

Historic Preservation Review

Pursuant to Chapter 184a, Section 10-387 of the Connecticut General Statutes, the Department of Energy & Environmental Protection (DEEP) shall review, in consultation with the Connecticut Commission on Culture and Tourism, its policies and practices for consistency with the preservation and study of CT's archaeological and historical sites. Pursuant to this requirement, DEEP has outlined the following process for assessing the potential for and the presence of historic and/or archaeological resources at a proposed development site. DEEP advises a review for the resources identified below *be initiated up to one year* prior to registration for this permit (*or prior to property purchase if possible*) and in conjunction with the local project approval process. However, a review conducted for an Army Corps of Engineers Section 404 wetland permit would meet this requirement.

Step 1: Determine if the proposed site is within an area of significance by consulting the following resources:

1. CT Register of Historic Places found at the link below:
<http://www.nationalregisterofhistoricplaces.com/CT/state.html#pickem>
2. The municipality of the proposed development site for its designations of local historic districts, including but not limited to, local Historic District and/or Property Statutes.

Step 2: Assess site characteristics to determine the presence of a potential archaeological site, sacred site, and/ or sacred object as described below:

Definitions:

1. "Archaeological site" means a location where there exists material evidence that is not less than fifty years old of the past life and culture of human beings in the state.
2. "Sacred site" or "sacred land" means any space, including an archaeological site, of ritual or traditional significance in the culture and religion of Native Americans that is listed or eligible for listing on the National Register of Historic Places (16 USC 470a, as amended) or the state register of historic places defined in section 10-410, including, but not limited to, marked and unmarked human burials, burial areas and cemeteries, monumental geological or natural features with sacred meaning or a meaning central to a group's oral traditions; sites of ceremonial structures, including sweat lodges; rock art sites, and sites of great historical significance to a tribe native to this state.
3. "Sacred object" means any archaeological artifact or other object associated with a sacred site.

Site Prescreening Criteria:

1. Does the proposed development site include lands within 300 feet of surface water features, such as streams, brooks, lakes, or marshes?

If "yes", proceed to Criterion 2. If the answer to Criterion 1 is "no", then there is a low potential for prehistoric period archaeological resources - Proceed to Criterion 3.

2. Does the area of anticipated construction or ground disturbance include soils classified by the Natural Resource Conservation Service as "Sandy Loam/ Loamy sand" or "Sandy Gravel Loam" not including "Fine Sandy Loam/ Loamy sand" with slopes less than or equal to 15%? (Soil mapping information is available for free from:
<http://websoilsurvey.nrcs.usda.gov/app/WebSoilSurvey.aspx>)

If the answer to Criterion 2 is no, then there is a low potential for prehistoric period archaeological resources - Proceed to Criterion 3. If yes, the project site may contain significant prehistoric period archaeological resources

– assess all other criteria and proceed to Step 3.

3. Are there buildings or structures over 150 years in age with the project site?

If no, proceed to Criterion 4. If yes, the project site may contain significant historic period archaeological resources – assess all other criteria and proceed to Step 3.

4. Are there buildings or structures shown within or immediately adjacent to the project site on the 1850's Connecticut County maps?

Historic County maps are here:

Fairfield - <http://www.flickr.com/photos/uconnlibrariesmagic/3387034755/>

Hartford - <http://www.flickr.com/photos/uconnlibrariesmagic/3386955421/>

Litchfield - <http://www.flickr.com/photos/uconnlibrariesmagic/3387765290/>

Middlesex - <http://www.flickr.com/photos/uconnlibrariesmagic/3386956185/>

New Haven - <http://www.flickr.com/photos/uconnlibrariesmagic/3386956345/>

New London - <http://www.flickr.com/photos/uconnlibrariesmagic/3387766080/>

Tolland - <http://www.flickr.com/photos/uconnlibrariesmagic/3386957013/>

Windham - <http://www.flickr.com/photos/uconnlibrariesmagic/3387766950/>

To look for buildings and structures click on the appropriate county map link. From the “Actions” drop-down menu choose “View all sizes”. On the “Photo/All sizes” page, choose “Original” to view the county map at an enlarged scale.

If no, there is a low potential for significant historic period archaeological resources. If yes, the site may contain significant historic period archaeological resources- assess all other criteria and proceed to Step 3.

Step 3: If you answered yes to Criterion 2, 3, or 4, please contact Daniel Forrest (860-256-2761 or daniel.forrest@ct.gov) or the current environmental review coordinator at the State Historic Preservation Office, Department of Economic and Community Development for additional guidance.

Step 4: Report in the Registration Form for the General Permit for the Discharge of Stormwater and Dewatering Wastewaters Associated with Construction Activities that a review has been conducted and the results of the review (i.e. the proposed site does not have the potential for historic/ archaeological resources, or that such potential exists and is being or has been reviewed by the Connecticut Commission on Culture and Tourism).

Please note that DEEP will refer all proposed sites with a historic/ archaeological resource potential (as identified in Steps 1 & 2 above) to the State Historic Preservation Office at the Department of Economic and Community Development..

Appendix H

Wild & Scenic Rivers Guidance

Overview: Wild and Scenic Rivers Act

The Wild and Scenic Rivers Act (WSRA) charges administration of rivers in the National Wild and Scenic Rivers System (National System) to four federal land management agencies (Bureau of Land Management, National Park Service, U.S. Fish and Wildlife Service, and U.S. Forest Service). However, to protect and enhance river values as directed in the WSRA, it is essential to use the authorities of a number of other federal agencies in administering the water column, river bed/bank, and upland river corridor.

Congress declared a policy to protect selected rivers in the nation through the WSRA. The river-administering agencies are to protect the river's identified values, free-flowing condition, and associated water quality. Specifically, each component is to be "administered in such manner as to protect and enhance the (outstandingly remarkable) values (**ORVs**) which caused it to be included in said system. . . ."

The WSRA also directs other federal agencies to protect river values. It explicitly recognizes the Federal Energy Regulatory Commission, Environmental Protection Agency, Army Corps of Engineers and any other federal department or agency with lands on or adjacent to designated (or congressionally authorized study) rivers or that permit or assist in the construction of water resources projects.

Pertinent Sections of the Wild and Scenic Rivers Act

The full Wild and Scenic Rivers Act can be found at the website: www.rivers.gov

Pertinent Sections related to the mandate to protect river values through coordinated federal actions is found in several sections of the WSRA:

Section 1(b)	Section 7(a)	Section 10(a)
Section 12(a)	Section 12(c)	

Designated Rivers under the Wild and Scenic Rivers Act and Contact Information

The full listing of designated rivers can be found on the website www.rivers.gov

As of the date of this publication, there are two designated rivers in Connecticut, both of which are managed under the Partnership Wild and Scenic Rivers Program, through a Coordinating Committee consisting of representatives from local communities and organizations, state government and the National Park Service. More information about these rivers, their watersheds, approved management plans, the Wild and Scenic Coordinating Committees and specific contact information can be found on the websites.

1. West Branch of the Farmington River: www.farmingtonriver.org
2. Eightmile River: www.eightmileriver.org



APPENDIX B

USDA SOILS REPORTS

SWPCP and ESCP

Stonington Solar Project
New London County, Connecticut

Soil Map—State of Connecticut
(Stonington Solar)

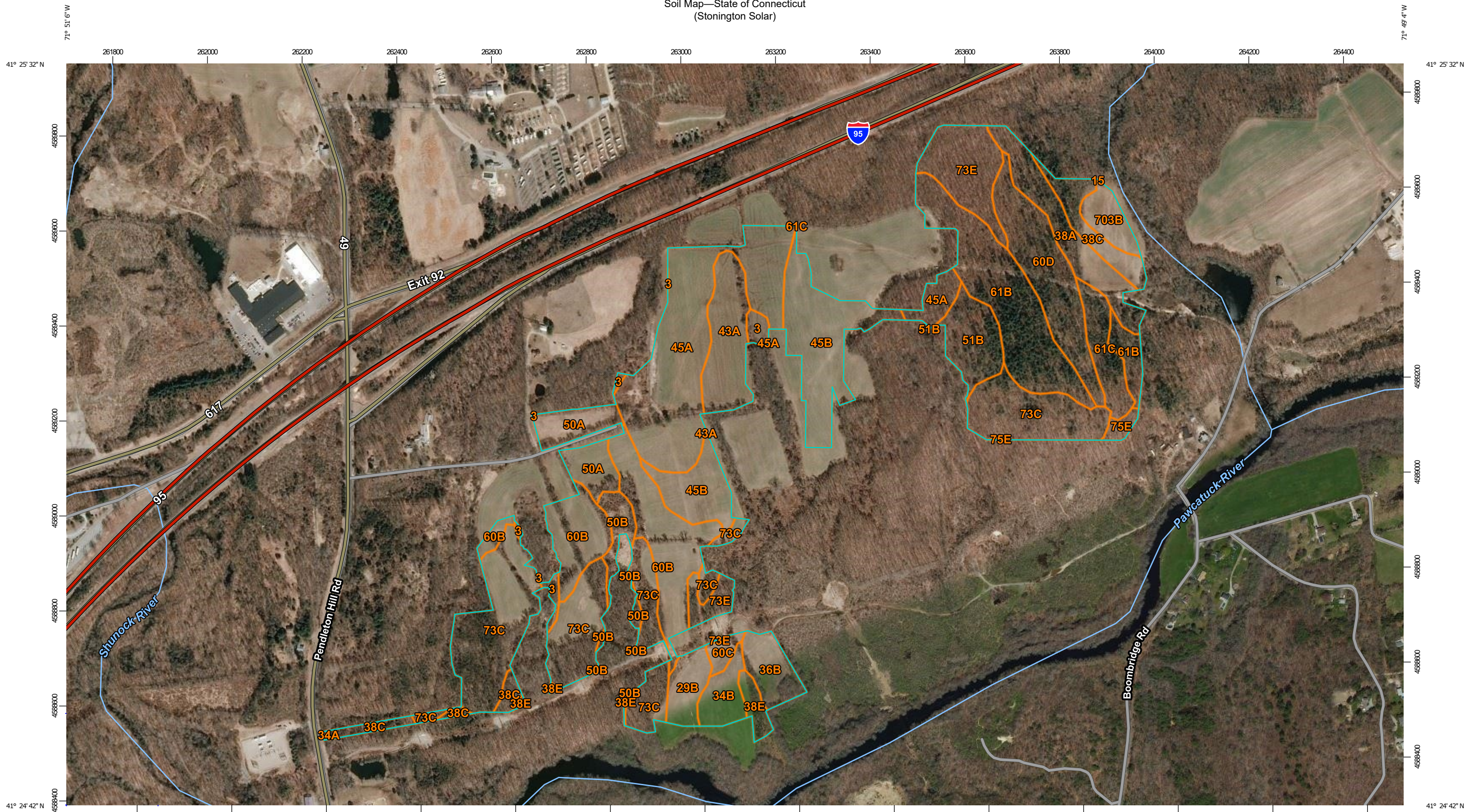

Map Scale: 1:7,610 if printed on B landscape (17" x 11") sheet.
0 100 200 400 600 Meters
0 350 700 1400 2100 Feet
Map projection: Web Mercator Corner coordinates: WGS84 Edge tics: UTM Zone 19N WGS84

MAP LEGEND

Area of Interest (AOI)

 Area of Interest (AOI)



















Soils





 Soil Map Unit Polygons

 Soil Map Unit Lines

 Soil Map Unit Points

Special Point Features



-  Blowout
-  Borrow Pit
-  Clay Spot
-  Closed Depression
-  Gravel Pit
-  Gravelly Spot
-  Landfill
-  Lava Flow
-  Marsh or swamp
-  Mine or Quarry
-  Miscellaneous Water
-  Perennial Water
-  Rock Outcrop
-  Saline Spot
-  Sandy Spot
-  Severely Eroded Spot
-  Sinkhole
-  Slide or Slip
-  Sodic Spot

-  Spoil Area
-  Stony Spot
-  Very Stony Spot
-  Wet Spot
-  Other
-  Special Line Features

Water Features

 Streams and Canals

Transportation

-  Rails
-  Interstate Highways
-  US Routes
-  Major Roads
-  Local Roads

Background

 Aerial Photography

MAP INFORMATION

The soil surveys that comprise your AOI were mapped at 1:12,000.

Please rely on the bar scale on each map sheet for map measurements.

Source of Map: Natural Resources Conservation Service
Web Soil Survey URL:
Coordinate System: Web Mercator (EPSG:3857)

Maps from the Web Soil Survey are based on the Web Mercator projection, which preserves direction and shape but distorts distance and area. A projection that preserves area, such as the Albers equal-area conic projection, should be used if more accurate calculations of distance or area are required.

This product is generated from the USDA-NRCS certified data as of the version date(s) listed below.

Soil Survey Area: State of Connecticut
Survey Area Data: Version 19, Sep 13, 2019

Soil map units are labeled (as space allows) for map scales 1:50,000 or larger.

Date(s) aerial images were photographed: Mar 30, 2011—Mar 27, 2019

The orthophoto or other base map on which the soil lines were compiled and digitized probably differs from the background imagery displayed on these maps. As a result, some minor shifting of map unit boundaries may be evident.

Map Unit Legend

Map Unit Symbol	Map Unit Name	Acres in AOI	Percent of AOI
3	Ridgebury, Leicester, and Whitman soils, 0 to 8 percent slopes, extremely stony	1.4	0.9%
15	Scarboro muck, 0 to 3 percent slopes	0.0	0.0%
29B	Agawam fine sandy loam, 3 to 8 percent slopes	2.8	1.7%
34A	Merrimac fine sandy loam, 0 to 3 percent slopes	0.1	0.1%
34B	Merrimac fine sandy loam, 3 to 8 percent slopes	2.7	1.7%
36B	Windsor loamy sand, 3 to 8 percent slopes	3.3	2.0%
38A	Hinckley loamy sand, 0 to 3 percent slopes	6.5	4.0%
38C	Hinckley loamy sand, 3 to 15 percent slopes	5.0	3.1%
38E	Hinckley loamy sand, 15 to 45 percent slopes	1.5	0.9%
43A	Rainbow silt loam, 0 to 3 percent slopes	6.6	4.0%
45A	Woodbridge fine sandy loam, 0 to 3 percent slopes	21.3	13.2%
45B	Woodbridge fine sandy loam, 3 to 8 percent slopes	14.6	9.0%
50A	Sutton fine sandy loam, 0 to 3 percent slopes	5.1	3.2%
50B	Sutton fine sandy loam, 3 to 8 percent slopes	2.3	1.4%
51B	Sutton fine sandy loam, 0 to 8 percent slopes, very stony	4.7	2.9%
60B	Canton and Charlton fine sandy loams, 3 to 8 percent slopes	14.5	9.0%
60C	Canton and Charlton fine sandy loams, 8 to 15 percent slopes	0.9	0.6%
60D	Canton and Charlton soils, 15 to 25 percent slopes	9.4	5.8%
61B	Canton and Charlton fine sandy loams, 0 to 8 percent slopes, very stony	14.9	9.2%
61C	Canton and Charlton fine sandy loams, 8 to 15 percent slopes, very stony	3.7	2.3%

Map Unit Symbol	Map Unit Name	Acres in AOI	Percent of AOI
73C	Charlton-Chatfield complex, 0 to 15 percent slopes, very rocky	29.5	18.2%
73E	Charlton-Chatfield complex, 15 to 45 percent slopes, very rocky	8.0	4.9%
75E	Hollis-Chatfield-Rock outcrop complex, 15 to 45 percent slopes	0.7	0.4%
703B	Haven silt loam, 3 to 8 percent slopes	2.4	1.5%
Totals for Area of Interest		161.9	100.0%

Hydrologic Soil Group—State of Connecticut
(Stonington Solar - Hydrologic Soil Group)

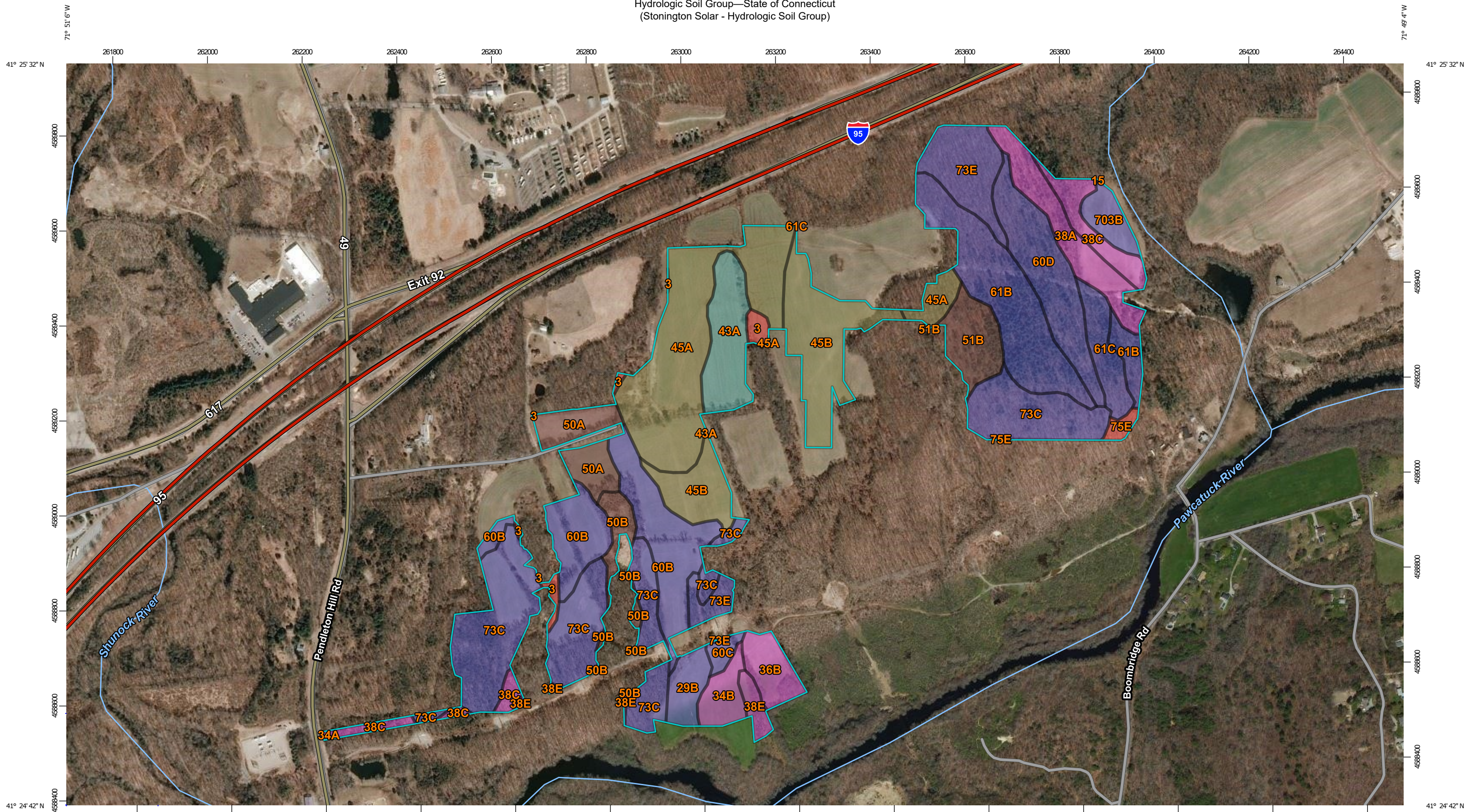

Map Scale: 1:7,610 if printed on B landscape (17" x 11") sheet.
0 100 200 400 600 Meters
0 350 700 1400 2100 Feet
Map projection: Web Mercator Corner coordinates: WGS84 Edge tics: UTM Zone 19N WGS84

MAP LEGEND

Area of Interest (AOI)









 Area of Interest (AOI)

Soils

Soil Rating Polygons





 A
 A/D
 B
 B/D
 C
 C/D
 D
 Not rated or not available

Soil Rating Lines

 A
 A/D
 B
 B/D
 C
 C/D
 D
 Not rated or not available

Soil Rating Points





 A
 A/D
 B
 B/D

 C
 C/D
 D
 Not rated or not available

Water Features

 Streams and Canals

Transportation

 Rails
 Interstate Highways
 US Routes
 Major Roads
 Local Roads

Background

 Aerial Photography

MAP INFORMATION

The soil surveys that comprise your AOI were mapped at 1:12,000.

Please rely on the bar scale on each map sheet for map measurements.

Source of Map: Natural Resources Conservation Service
 Web Soil Survey URL:
 Coordinate System: Web Mercator (EPSG:3857)

Maps from the Web Soil Survey are based on the Web Mercator projection, which preserves direction and shape but distorts distance and area. A projection that preserves area, such as the Albers equal-area conic projection, should be used if more accurate calculations of distance or area are required.

This product is generated from the USDA-NRCS certified data as of the version date(s) listed below.

Soil Survey Area: State of Connecticut
 Survey Area Data: Version 19, Sep 13, 2019

Soil map units are labeled (as space allows) for map scales 1:50,000 or larger.

Date(s) aerial images were photographed: Mar 30, 2011—Mar 27, 2019

The orthophoto or other base map on which the soil lines were compiled and digitized probably differs from the background imagery displayed on these maps. As a result, some minor shifting of map unit boundaries may be evident.

Hydrologic Soil Group

Map unit symbol	Map unit name	Rating	Acres in AOI	Percent of AOI
3	Ridgebury, Leicester, and Whitman soils, 0 to 8 percent slopes, extremely stony	D	1.4	0.9%
15	Scarboro muck, 0 to 3 percent slopes	A/D	0.0	0.0%
29B	Agawam fine sandy loam, 3 to 8 percent slopes	B	2.8	1.7%
34A	Merrimac fine sandy loam, 0 to 3 percent slopes	A	0.1	0.1%
34B	Merrimac fine sandy loam, 3 to 8 percent slopes	A	2.7	1.7%
36B	Windsor loamy sand, 3 to 8 percent slopes	A	3.3	2.0%
38A	Hinckley loamy sand, 0 to 3 percent slopes	A	6.5	4.0%
38C	Hinckley loamy sand, 3 to 15 percent slopes	A	5.0	3.1%
38E	Hinckley loamy sand, 15 to 45 percent slopes	A	1.5	0.9%
43A	Rainbow silt loam, 0 to 3 percent slopes	C	6.6	4.0%
45A	Woodbridge fine sandy loam, 0 to 3 percent slopes	C/D	21.3	13.2%
45B	Woodbridge fine sandy loam, 3 to 8 percent slopes	C/D	14.6	9.0%
50A	Sutton fine sandy loam, 0 to 3 percent slopes	B/D	5.1	3.2%
50B	Sutton fine sandy loam, 3 to 8 percent slopes	B/D	2.3	1.4%
51B	Sutton fine sandy loam, 0 to 8 percent slopes, very stony	B/D	4.7	2.9%
60B	Canton and Charlton fine sandy loams, 3 to 8 percent slopes	B	14.5	9.0%
60C	Canton and Charlton fine sandy loams, 8 to 15 percent slopes	B	0.9	0.6%

Map unit symbol	Map unit name	Rating	Acres in AOI	Percent of AOI
60D	Canton and Charlton soils, 15 to 25 percent slopes	B	9.4	5.8%
61B	Canton and Charlton fine sandy loams, 0 to 8 percent slopes, very stony	B	14.9	9.2%
61C	Canton and Charlton fine sandy loams, 8 to 15 percent slopes, very stony	B	3.7	2.3%
73C	Charlton-Chatfield complex, 0 to 15 percent slopes, very rocky	B	29.5	18.2%
73E	Charlton-Chatfield complex, 15 to 45 percent slopes, very rocky	B	8.0	4.9%
75E	Hollis-Chatfield-Rock outcrop complex, 15 to 45 percent slopes	D	0.7	0.4%
703B	Haven silt loam, 3 to 8 percent slopes	B	2.4	1.5%
Totals for Area of Interest			161.9	100.0%

Description

Hydrologic soil groups are based on estimates of runoff potential. Soils are assigned to one of four groups according to the rate of water infiltration when the soils are not protected by vegetation, are thoroughly wet, and receive precipitation from long-duration storms.

The soils in the United States are assigned to four groups (A, B, C, and D) and three dual classes (A/D, B/D, and C/D). The groups are defined as follows:

Group A. Soils having a high infiltration rate (low runoff potential) when thoroughly wet. These consist mainly of deep, well drained to excessively drained sands or gravelly sands. These soils have a high rate of water transmission.

Group B. Soils having a moderate infiltration rate when thoroughly wet. These consist chiefly of moderately deep or deep, moderately well drained or well drained soils that have moderately fine texture to moderately coarse texture. These soils have a moderate rate of water transmission.

Group C. Soils having a slow infiltration rate when thoroughly wet. These consist chiefly of soils having a layer that impedes the downward movement of water or soils of moderately fine texture or fine texture. These soils have a slow rate of water transmission.

Group D. Soils having a very slow infiltration rate (high runoff potential) when thoroughly wet. These consist chiefly of clays that have a high shrink-swell potential, soils that have a high water table, soils that have a claypan or clay layer at or near the surface, and soils that are shallow over nearly impervious material. These soils have a very slow rate of water transmission.

If a soil is assigned to a dual hydrologic group (A/D, B/D, or C/D), the first letter is for drained areas and the second is for undrained areas. Only the soils that in their natural condition are in group D are assigned to dual classes.

Rating Options

Aggregation Method: Dominant Condition

Component Percent Cutoff: None Specified

Tie-break Rule: Higher

RUSLE2 Related Attributes

This report summarizes those soil attributes used by the Revised Universal Soil Loss Equation Version 2 (RUSLE2) for the map units in the selected area. The report includes the map unit symbol, the component name, and the percent of the component in the map unit. Soil property data for each map unit component include the hydrologic soil group, erosion factor Kf for the surface horizon, erosion factor T, and the representative percentage of sand, silt, and clay in the mineral surface horizon. Missing surface data may indicate the presence of an organic layer.

Report—RUSLE2 Related Attributes

Soil properties and interpretations for erosion runoff calculations. The surface mineral horizon properties are displayed or the first mineral horizon below an organic surface horizon. Organic horizons are not displayed.

RUSLE2 Related Attributes—State of Connecticut								
Map symbol and soil name	Pct. of map unit	Slope length (ft)	Hydrologic group	Kf	T factor	Representative value		
						% Sand	% Silt	% Clay
3—Ridgebury, Leicester, and Whitman soils, 0 to 8 percent slopes, extremely stony								
Ridgebury, extremely stony	40	298	D	.37	2	61.0	32.0	7.0
Leicester, extremely stony	35	298	B/D	.24	5	58.0	32.0	10.0
Whitman, extremely stony	17	200	D	.37	2	57.0	35.0	8.0
15—Scarboro muck, 0 to 3 percent slopes								
Scarboro	80	197	A/D	.24	1	61.0	35.0	4.0
29B—Agawam fine sandy loam, 3 to 8 percent slopes								
Agawam	85	200	B	.37	3	63.0	33.0	4.0
34A—Merrimac fine sandy loam, 0 to 3 percent slopes								
Merrimac	85	200	A	.28	4	60.1	34.5	5.4
34B—Merrimac fine sandy loam, 3 to 8 percent slopes								
Merrimac	85	200	A	.28	4	60.1	34.5	5.4
36B—Windsor loamy sand, 3 to 8 percent slopes								
Windsor, loamy sand	85	197	A	.15	5	85.0	14.0	1.0
38A—Hinckley loamy sand, 0 to 3 percent slopes								
Hinckley	85	161	A	.10	3	81.0	17.0	2.0

RUSLE2 Related Attributes--State of Connecticut								
Map symbol and soil name	Pct. of map unit	Slope length (ft)	Hydrologic group	Kf	T factor	Representative value		
						% Sand	% Silt	% Clay
38C—Hinckley loamy sand, 3 to 15 percent slopes								
Hinckley	85	161	A	.10	3	81.0	17.0	2.0
38E—Hinckley loamy sand, 15 to 45 percent slopes								
Hinckley	85	161	A	.10	3	81.0	17.0	2.0
43A—Rainbow silt loam, 0 to 3 percent slopes								
Rainbow	80	174	C	.37	3	28.0	65.0	7.0
45A—Woodbridge fine sandy loam, 0 to 3 percent slopes								
Woodbridge	85	298	C/D	.28	3	61.0	32.0	7.0
45B—Woodbridge fine sandy loam, 3 to 8 percent slopes								
Woodbridge, fine sandy loam	82	151	C/D	.28	3	61.0	32.0	7.0
50A—Sutton fine sandy loam, 0 to 3 percent slopes								
Sutton	85	200	B/D	.24	5	58.0	33.0	9.0
50B—Sutton fine sandy loam, 3 to 8 percent slopes								
Sutton	80	151	B/D	.24	5	58.0	33.0	9.0
51B—Sutton fine sandy loam, 0 to 8 percent slopes, very stony								
Sutton, very stony	85	180	B/D	.24	5	58.0	33.0	9.0
60B—Canton and Charlton fine sandy loams, 3 to 8 percent slopes								
Canton	50	151	B	.24	3	61.2	31.5	7.3
Charlton	35	161	B	.24	5	57.0	34.0	9.0
60C—Canton and Charlton fine sandy loams, 8 to 15 percent slopes								
Canton	50	151	B	.24	3	61.2	31.5	7.3
Charlton	35	161	B	.24	5	57.0	34.0	9.0
60D—Canton and Charlton soils, 15 to 25 percent slopes								
Canton	45	125	B	.24	3	58.0	36.0	6.0
Charlton	35	125	B	.28	5	64.5	30.0	5.5

RUSLE2 Related Attributes--State of Connecticut								
Map symbol and soil name	Pct. of map unit	Slope length (ft)	Hydrologic group	Kf	T factor	Representative value		
						% Sand	% Silt	% Clay
61B—Canton and Charlton fine sandy loams, 0 to 8 percent slopes, very stony								
Canton, very stony	50	151	B	.24	3	61.2	31.5	7.3
Charlton, very stony	35	161	B	.24	5	57.0	34.0	9.0
61C—Canton and Charlton fine sandy loams, 8 to 15 percent slopes, very stony								
Canton, very stony	50	151	B	.24	3	61.2	31.5	7.3
Charlton, very stony	35	161	B	.24	5	57.0	34.0	9.0
73C—Charlton-Chatfield complex, 0 to 15 percent slopes, very rocky								
Charlton, very stony	50	125	B	.24	5	57.0	34.0	9.0
Chatfield, very stony	30	125	B	.28	2	58.0	33.0	9.0
73E—Charlton-Chatfield complex, 15 to 45 percent slopes, very rocky								
Charlton	45	125	B	.28	5	64.5	30.0	5.5
Chatfield	30	125	B	.15	2	67.5	20.0	12.5
75E—Hollis-Chatfield-Rock outcrop complex, 15 to 45 percent slopes								
Hollis	35	125	D	.32	1	60.5	33.0	6.5
Chatfield	30	125	B	.15	2	67.5	20.0	12.5
703B—Haven silt loam, 3 to 8 percent slopes								
Haven	85	161	B	.37	3	24.5	64.0	11.5

Data Source Information

Soil Survey Area: State of Connecticut
 Survey Area Data: Version 19, Sep 13, 2019



APPENDIX C

ESC PLAN DRAWINGS

SWPCP and ESCP

Stonington Solar Project
New London County, Connecticut



APPENDIX D

**FEMA FIRM PANEL NO.
09011C0412G**

**SWPCP and ESCP
Stonington Solar Project
New London County, Connecticut**

NOTES TO USERS

This map is for use in administering the National Flood Insurance Program. It does not necessarily identify all areas subject to flooding, particularly from local drainage sources of small size. The **community map repository** should be consulted for possible updated or additional flood hazard information.

To obtain more detailed information in areas where **Base Flood Elevations (BFEs)** and/or **flowways** have been determined, users are encouraged to consult the Flood Profiles and Floodway Data and/or Summary of Stillwater Elevations tables contained within the Flood Insurance Study (FIS) Report that accompanies this FIRM. Users should be aware that BFEs shown on the FIRM represent rounded whole-foot elevations. These BFEs are intended for flood insurance rating purposes only and should not be used as the sole source of flood elevation information. Accordingly, flood elevation data presented in the FIS Report should be utilized in conjunction with the FIRM for purposes of construction and/or floodplain management.

Coastal Base Flood Elevations shown on this map apply only landward of 0.0' North American Vertical Datum of 1988 (NAVD 88). Users of this FIRM should be aware that coastal flood elevations are also provided in the Summary of Stillwater Elevations table in the Flood Insurance Study Report for this jurisdiction. Elevations shown in the Summary of Stillwater Elevations table should be used for construction and/or floodplain management purposes when they are higher than the elevations shown on this FIRM.

Boundaries of the **flowways** were computed at cross sections and interpolated between cross sections. The flowways were based on hydraulic considerations with regard to requirements of the National Flood Insurance Program. Floodway widths and other pertinent floodway data are provided in the Flood Insurance Study Report for this jurisdiction.

Certain areas not in Special Flood Hazard Areas may be protected by **flood control structures**. Refer to Section 2.4 "Flood Protection Measures" of the Flood Insurance Study Report for information on flood control structures for this jurisdiction.

The **projection** used in the preparation of this map was Connecticut State Plane Zone (FIPS zone 0600). The **horizontal datum** was NAD 83, GRS 1980 spheroid. Differences in datum, spheroid, projection or UTM zones used in the production of FIRMs for adjacent jurisdictions may result in slight positional differences in map features across jurisdiction boundaries. These differences do not affect the accuracy of this FIRM.

Flood elevations on this map are referenced to the North American Vertical Datum of 1988. These flood elevations must be compared to structure and ground elevations referenced to the same **vertical datum**. For information regarding conversion between the National Geodetic Vertical Datum of 1929 and the North American Vertical Datum of 1988, visit the National Geodetic Survey website at <http://www.ngs.noaa.gov> or contact the National Geodetic Survey at the following address:

NGS Information Services
NOAA, NINGS12
National Geodetic Survey
SSMC-3, #9202
1315 East-West Highway
Silver Spring, Maryland 20910-3282
(301) 713-3242

To obtain current elevation, description, and/or location information for **bench marks** shown on this map, please contact the Information Services Branch of the National Geodetic Survey at (301) 713-3242, or visit its website at <http://www.ngs.noaa.gov>.

Base map information shown on this FIRM was derived from digital orthophotography provided by the Connecticut Department of Environmental Planning. This information was created from photography dated 2000, 2004 and 2005.

The **profile baselines** depicted on this map represent the hydraulic modeling baselines that match the flood profiles in the FIS report. As a result of improved topographic data, the **profile baseline**, in some cases, may deviate significantly from the channel centerline or appear outside the SFHA.

Based on updated topographic information, this map reflects more detailed and up-to-date **stream channel configurations** and **floodplain delineations** than those shown on the previous FIRM for this jurisdiction. As a result, the Flood Profiles and Floodway Data tables for multiple streams in the Flood Insurance Study Report (which contains authoritative hydraulic data) may reflect stream channel distances that differ from what is shown on the map. Also, the road to floodplain relationships for unrevised streams may differ from what is shown on previous maps.

Corporate limits shown on this map are based on the best data available at the time of publication. Because changes due to annexations or de-annexations may have occurred after this map was published, map users should contact appropriate community officials to verify current corporate limit locations.

Please refer to the separately printed **Map Index** for an overview map of the county showing the layout of map panels; community map repository addresses; and a Listing of Communities table containing National Flood Insurance Program dates for each community as well as a listing of the panels on which each community is located.

For information on available products associated with this FIRM visit the **Map Service Center (MSC)** website at <http://msc.fema.gov>. Available products may include previously issued Letters of Map Change, a Flood Insurance Study Report, and/or digital versions of this map. Many of these products can be ordered or obtained directly from the MSC website.

If you have **questions about this map**, how to order products, or the National Flood Insurance Program in general, please call the **FEMA Map Information eXchange (FMIX)** at 1-877-FEMA-MAP (1-877-336-2627) or visit the FEMA website at <http://www.fema.gov/business/rfp>.

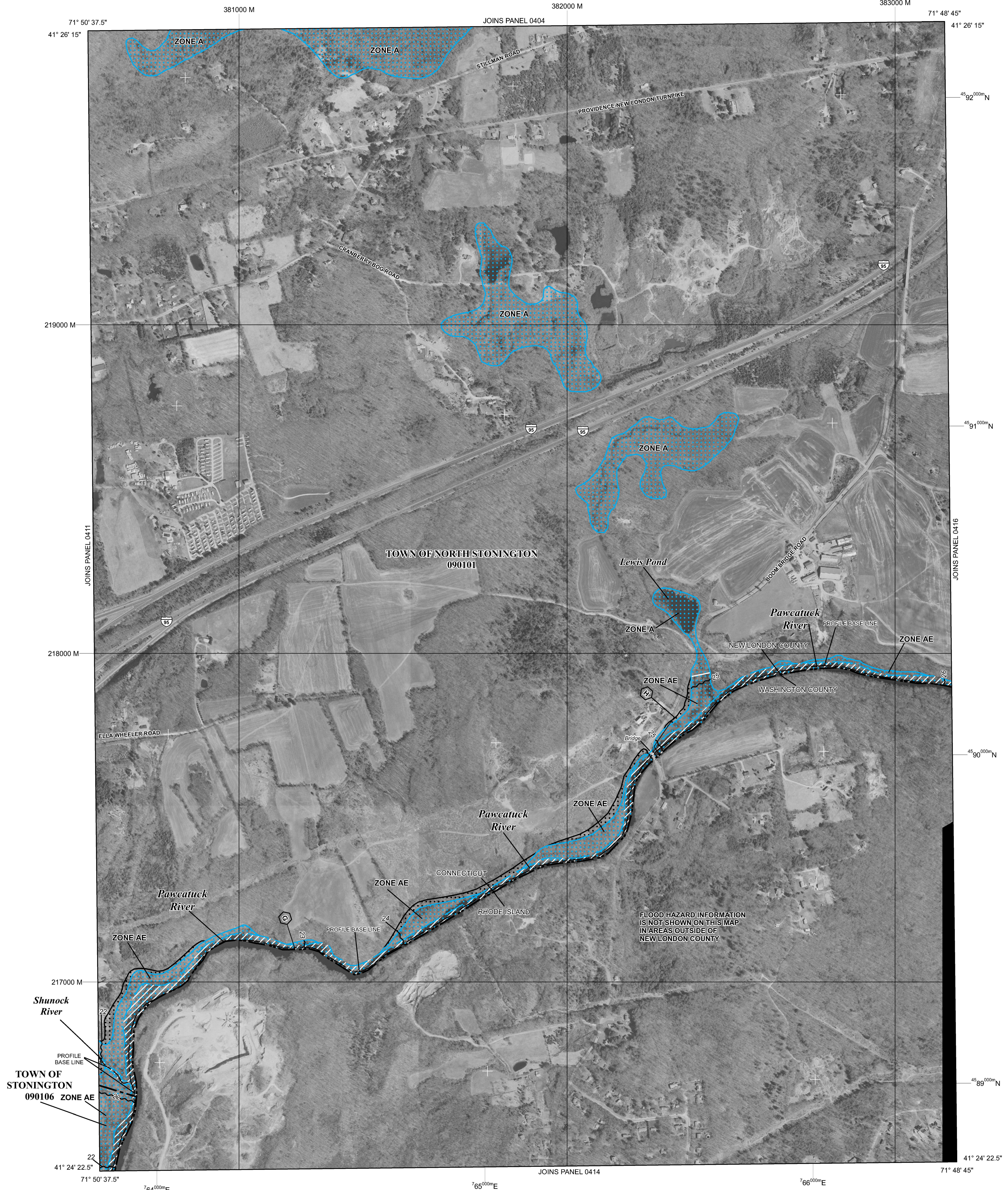

LEGEND

- SPECIAL FLOOD HAZARD AREAS (SFHAs) SUBJECT TO INUNDATION BY THE 1% ANNUAL CHANCE FLOOD
The 1% annual chance flood (100-year flood), also known as the base flood, is the flood that has a 1% chance of being equaled or exceeded in any given year. The Special Flood Hazard Area is the area subject to flooding by the 1% annual chance flood. Areas of Special Flood Hazard include Zones A, AE, AH, AO, AR, A99, and VE. The Base Flood Elevation is the water-surface elevation of the 1% annual chance flood.
- ZONE A** No Base Flood Elevations determined.
- ZONE AE** Base Flood Elevations determined.
- ZONE AH** Flood depths of 1 to 3 feet (usually areas of ponding); Base Flood Elevations determined.
- ZONE AO** Flood depths of 1 to 3 feet (usually sheet flow on sloping terrain); average depths determined. For areas of alluvial fan flooding, velocities also determined.
- ZONE AR** Special Flood Hazard Areas formerly protected from the 1% annual chance flood by a flood control system that was subsequently deteriorated. Zone AR indicates that the former flood control system is being restored to provide protection from the 1% annual chance or greater flood.
- ZONE A99** Area to be protected from 1% annual chance flood by a Federal flood protection system under construction; no Base Flood Elevations determined.
- ZONE V** Coastal flood zone with velocity hazard (wave action); no Base Flood Elevations determined.
- ZONE VE** Coastal flood zone with velocity hazard (wave action); Base Flood Elevations determined.
- FLOODWAY AREAS IN ZONE AE
The floodway is the channel of a stream plus any adjacent floodplain areas that must be kept free of encroachment so that the 1% annual chance flood can be carried without substantial increases in flood heights.
- OTHER FLOOD AREAS
- ZONE X** Areas of 0.2% annual chance flood; areas of 1% annual chance flood with average depths of less than 1 foot with drainage areas less than 1 square mile; and areas protected by levees from 1% annual chance flood.
- OTHER AREAS
- ZONE D** Areas determined to be outside the 0.2% annual chance floodplain.
- ZONE E** Areas in which flood hazards are undetermined, but possible.
- COASTAL BARRIER RESOURCES SYSTEM (CBRS) AREAS
- OTHERWISE PROTECTED AREAS (OPAs)
- CBRS areas and OPAs are normally located within or adjacent to Special Flood Hazard Areas.
- 1% Annual Chance Floodplain Boundary
- 0.2% Annual Chance Floodplain Boundary
- Floodway boundary
- Zone D boundary
- CBRS and OPA boundary
- Boundary dividing Special Flood Hazard Area Zones and boundary dividing Special Flood Hazard Areas of different Base Flood Elevations, flood depths, or flood velocities.
- Base Flood Elevation line and value; elevation in feet* (EL 987)
- Base Flood Elevation value where uniform within zone; elevation in feet*

*Referenced to the North American Vertical Datum of 1988

- Cross section line
- Transect line
- Culvert
- Bridge
- Geographic coordinates referenced to the North American Datum of 1983 (NAD 83) Western Hemisphere
- 1000-meter ticks: Connecticut State Plane Zone (FIPS Zone 0600), Lambert Conformal Conic projection
- 1000-meter Universal Transverse Mercator grid values, zone 18N
- Bench mark (see explanation in Notes to Users section of this FIRM panel)
- M1.5
River Mile
- MAP REPOSITORIES
Refer to Map Repositories list on Map Index
- EFFECTIVE DATE OF COUNTYWIDE FLOOD INSURANCE RATE MAP
July 18, 2011
- EFFECTIVE DATE(S) OF REVISION(S) TO THIS PANEL

For community map revision history prior to countywide mapping, refer to the Community Map History table located in the Flood Insurance Study report for this jurisdiction.

To determine if flood insurance is available in this community, contact your insurance agent or call the National Flood Insurance Program at 1-800-638-6620.

MAP SCALE 1" = 500'

NATIONAL FLOOD INSURANCE PROGRAM

PANEL 0412G

FIRM

FLOOD INSURANCE RATE MAP

NEW LONDON COUNTY, CONNECTICUT

ALL JURISDICTIONS

PANEL 412 OF 554
(SEE MAP INDEX FOR FIRM PANEL LAYOUT)

CONTAINS:

COMMUNITY	NUMBER	PANEL	SUFFIX
NORTH STONINGTON, TOWN OF	090101	0412	G
STONINGTON, TOWN OF	090106	0412	G

Notice to User: The **Map Number** shown below should be used when placing map orders; the **Community Number** shown above should be used on insurance applications for the subject community.

MAP NUMBER 09011C0412G
EFFECTIVE DATE JULY 18, 2011
Federal Emergency Management Agency



APPENDIX E

**BMP INSPECTION AND
REPORTING FORMS**

SWPCP and ESCP
Stonington Solar Project
New London County, Connecticut

**Risk Level 1, 2, 3
Visual Inspection Field Log Sheet**

Date and Time of Inspection:				Report Date:		
Inspection Type:	<input type="checkbox"/> Weekly	<input type="checkbox"/> Before predicted rain	<input type="checkbox"/> During rain event	<input type="checkbox"/> Following qualifying rain event	<input type="checkbox"/> Contained stormwater release	<input type="checkbox"/> Quarterly non-stormwater

Site Information

Construction Site Name:	
Construction stage and completed activities:	Approximate area of exposed site:

Weather and Observations

Date Rain Predicted to Occur:		Predicted % chance of rain:	
Estimate storm beginning: _____ (date and time)	Estimate storm duration: _____ (hours)	Estimate time since last storm: _____ (days or hours)	Rain gauge reading: _____ (inches)

Observations: If yes identify location

Odors	Yes <input type="checkbox"/>	No <input type="checkbox"/>
Floating material	Yes <input type="checkbox"/>	No <input type="checkbox"/>
Suspended Material	Yes <input type="checkbox"/>	No <input type="checkbox"/>
Sheen	Yes <input type="checkbox"/>	No <input type="checkbox"/>
Discolorations	Yes <input type="checkbox"/>	No <input type="checkbox"/>
Turbidity	Yes <input type="checkbox"/>	No <input type="checkbox"/>

Site Inspections

Outfalls or BMPs Evaluated	Deficiencies Noted
(add additional sheets or attached detailed BMP Inspection Checklists)	
Photos Taken:	Yes <input type="checkbox"/> No <input type="checkbox"/> Photo Reference IDs:

Corrective Actions Identified (note if SWPPP/REAP change is needed)

--

Inspector Information

Inspector Name:	Inspector Title:
Signature:	Date:



APPENDIX F

CALCULATION SHEETS

SWPCP and ESCP

Stonington Solar Project

New London County, Connecticut



Sierra Overhead Analytics, Inc.
 PO Box 1716
 Twain Harte, California
 sierraoverheadanalytics.com
 775-848-5540

Revised Universal Soil Loss Equation (RUSLE)

Basin ID	LOD within Basin (acres)	Rainfall-Runoff Erosivity Factor (R) ²	Soil Erodibility Factor (K)	Average Slope Length (ft)	Average Slope (ft/ft)	Topographic Factor (LS)	Cover Management Factor (C)	Erosion Control Practice Factor (P)	Average Soil Loss (A, Tons/acre/year)	Potential Soil Volume to Mitigate (yd ³) ¹
2	34.70	180	0.24	137.2	0.11	200	0.05	0.08	3.802	0.095
3	2.49	180	0.24	296.1	0.11	3.59	0.05	0.08	0.068	0.024
4	1.82	180	0.24	299.7	0.16	6.15	0.05	0.08	0.170	0.081
5	52.13	180	0.28	158.8	0.08	1.05	0.05	0.08	0.017	0.000
6	6.96	180	0.28	114.5	0.02	0.05	0.05	0.08	0.000	0.000
7	0.00	180	0.24	246.1	0.055	1.43	0.05	0.08	0.014	0.000
8	16.20	180	0.24	266.2	0.06	1.43	0.05	0.08	0.015	0.001
9	0.00	180	0.37	276.8	0.09	2.5	0.05	0.08	0.060	0.000
Total LOD: 114.30										

Notes:

1 - Assume 1 year construction duration and 85 lbs/ft³ for soil weight to volume conversion.

2 - R factor derived from EPA Rainfall Erosivity Factor Calculator, construction dates 5/1/2020 to 5/1/2021 (<https://lew.epa.gov/>)



Sierra Overhead Analytics, Inc.
 PO Box 1716
 Twain Harte, California
 sierraoverheadanalytics.com
 775-848-5540

Water Quality Control Volume (WQCV)

Basin ID	Impervious Area (ft^2)	Basin Area (ft^2)	Basin Area (acres)	Imperviousness (unitless)	Imperviousness (%)	WQV-R	Water Quality Control Volume (acre-ft)
2	5,969	4,168,391	95.69	0.001	0.14	0.05	0.41
3	32	250,440	5.75	0.000	0.01	0.05	0.02
5	53,602	7,553,874	173.41	0.007	0.71	0.06	0.81
6	25,095	2,366,341	54.32	0.011	1.06	0.06	0.27
7	9,723	1,156,101	26.54	0.008	0.84	0.06	0.13
8	40,678	1,099,302	25.24	0.037	3.70	0.08	0.18
9	8,428	402,038	9.23	0.021	2.10	0.07	0.05
Total LOD:	143,527	16,996,487	390				

Notes:



APPENDIX G

BMP FACT SHEETS

SWPCP and ESCP

Stonington Solar Project
New London County, Connecticut

Figure PS-2 Selecting Seed Mix to Match Need

Area To Be Seeded	Mixture Number ¹	
	Mowing Desired	Mowing Not Required
BORROW AREAS, ROADSIDES, DIKES, LEVEES, POND BANKS AND OTHER SLOPES AND BANKS A) Well or excessively drained soil ² B) Somewhat poorly drained soils ² C) Variable drainage soils ²	1,2,3,4,5 or 8 2 2	5, 6, 7, 8, 9, 10, 11, 12, 16, 22 5, 6 5, 6, 11
DRAINAGE DITCH AND CHANNEL BANKS A) Well or excessively drained soils ² B) Somewhat poorly drained soils ² C) Variable drainage soils ²	1, 2, 3, or 4 2 2	9, 10, 11, 12
DIVERSIONS A) Well or excessively drained soils ² B) Somewhat poorly drained soils ² C) Variable drainage soils ²	2, 3 or 4 2 2	9, 10, 11
EFFLUENT DISPOSAL		5 or 6
GRAVEL PITS ³		26, 27, 28
GULLIED AND ERODED AREAS		3, 4, 5, 8, 10, 11, 12
MINESPOIL & WASTE, AND OTHER SPOIL BANKS (If toxic substances & physical properties not limiting) ³		15, 16, 17, 18, 26, 27, 28
SHORELINES (Fluctuating water levels)		5 or 6
SKI SLOPES		4, 10
SOD WATERWAYS AND SPILLWAYS	1, 2, 3, 4, 6, 7, or 8	1, 2, 3, 4, 6, 7, or 8
SUNNY RECREATION AREAS (Picnic areas and playgrounds or driving and archery ranges, nature trails)	1, 2 or 23	
CAMPING AND PARKING, NATURE TRAILS (Shaded)	19, 21 or 23	
SAND DUNES (Blowing sand)	25	
WOODLAND ACCESS ROADS, SKID TRAILS AND LOG YARDING AREAS		9, 10, 16, 22 , 26
LAWNS AND HIGH MAINTENANCE AREAS	1, 19, 21 or 29	

¹ The numbers following in these columns refer to seed mixtures in **Figure PS-3**. Mixes for shady areas are in *bold-italics* print (including mixes 20 through 24).

² See county soil survey for drainage class. Soil surveys are available from the County Soil and Water Conservation District Office.

³ Use mix 26 when soil passing a 200 mesh sieve is less than 15% of total weight. Use mix 26 & 27 when soil passing a 200 mesh sieve is between 15 and 20% of total weight. Use mix 26, 27 & 28 when soil passing a 200 mesh sieve is above 20% of total weight.

Source: USDA-NRCS

Figure PS-3 Seed Mixtures for Permanent Seeding

No.	Seed Mixture (Variety) ⁴	Lbs/Acre	Lbs/1,000 Sq. Ft.
1 ⁵	Kentucky Bluegrass	20	.45
	Creeping Red Fescue (Pennlawn, Wintergreen)	20	.45
	Perennial Ryegrass (Norlea, Manhattan)	<u>5</u>	<u>.10</u>
	Total	45	1.00
2 ⁵	Creeping Red Fescue (Pennlawn, Wintergreen)	20	.45
	Redtop (Streeker, Common)	2	.05
	Tall Fescue (Kentucky 31) or Smooth Bromegrass (Saratoga, Lincoln)	<u>20</u>	<u>.45</u>
	Total	42	.95
3 ⁵	Creeping Red Fescue (Pennlawn, Wintergreen)	20	.45
	Bird's-foot Trefoil (Empire, Viking) with inoculant ¹	8	.20
	Tall Fescue (Kentucky 31) or Smooth Bromegrass (Saratoga, Lincoln)	<u>20</u>	<u>.45</u>
	Total	48	1.10
4 ⁵	Creeping Red Fescue (Pennlawn, Wintergreen) or Tall Fescue (Kentucky 31)	20	.45
	Redtop (Streeker, Common)	2	.05
	Bird's-foot Trefoil (Empire, Viking) with inoculant ¹	<u>8</u>	<u>.20</u>
	Total	30	.70
5 ⁵	White Clover	10	.25
	Perennial Rye Grass	<u>2</u>	<u>.05</u>
	Total	12	.30
6 ⁵	Creeping Red Fescue	20	.50
	Redtop (Streeker, Common)	2	.05
	Perennial Rye Grass	<u>20</u>	<u>.50</u>
	Total	42	1.05
7 ⁵	Smooth Bromegrass (Saratoga, Lincoln)	15	.35
	Perennial Ryegrass (Norlea, Manhattan)	5	.10
	Bird's-foot Trefoil (Empire, Viking) with inoculant ¹	<u>10</u>	<u>.25</u>
	Total	30	.79
8 ⁶	Switchgrass (Blackwell, Shelter, Cave-in-rock)	10 ¹	.25
	Weeping lovegrass	3	.07
	Little Bluestem (Blaze, Aldous, Camper)	<u>10¹</u>	<u>.25</u>
	Total	23	.57
9 ⁵	Creeping Red Fescue (Pennlawn, Wintergreen)	10	.25
	Crown Vetch (Chemung, Penngift) with inoculant ¹	15	.35
	(or Flatpea (Lathco) with inoculant ¹)	(30)	(.75)
	Tall Fescue (Kentucky 31) or Smooth Bromegrass (Saratoga, Lincoln)	15	.35
	Redtop (Streeker, Common)	<u>2</u>	<u>.05</u>
	Total	42 (or 57)	1.00 (or 1.40)
10 ⁵	Creeping Red Fescue (Pennlawn, Wintergreen)	20	.45
	Redtop (Streeker, Common)	2	.05
	Crown Vetch (Chemung, Penngift) with inoculant ¹	15	.35
	(or Flatpea (Lathco) with inoculant ¹)	(30)	(.75)
	Total	37 (or 52)	.85 (or 1.25)
	11 ⁵	Bird's-foot Trefoil (Empire, Viking) with inoculant ¹	8
Crown Vetch (Chemung, Penngift) with inoculant ¹		15	.35
Creeping Red Fescue (Pennlawn, Wintergreen) or Tall Fescue (Kentucky 31) or Smooth Bromegrass (Saratoga, Lincoln)		<u>20</u>	<u>.45</u>
Total		43	1.00

continued

Figure PS-3 Seed Mixtures for Permanent Seeding (con't)

No.	Seed Mixture (Variety) ⁴	Lbs/1,000 Lbs/Acre	No. Sq. Ft.
12 ⁶	Switchgrass (Blackwell, Shelter, Cave-in-rock) Perennial Ryegrass (Norlea, Manhattan) Crown Vetch (Chemung, Penngift) with inoculant ¹	101 5 <u>15</u> Total 45	.25 .10 <u>.35</u> 1.05
13 ⁶	Crown Vetch (Chemung, Penngift) with inoculant ¹ (or Flatpea (Lathco) with inoculant ¹) Switchgrass (Blackwell, Shelter, Cave-in-rock) Perennial Ryegrass (Norlea, Manhattan)	10 (30) 5 ¹ <u>5</u> Total 20 (or 40)	.25 (.75) .10 <u>.10</u> .45 (or .95)
14 ⁵	Crown Vetch (Chemung, Penngift) with inoculant ¹ (or Flatpea (Lathco) with inoculant ¹) Perennial Ryegrass (Norlea, Manhattan)	15 (30) <u>10</u> Total 25 (or 40)	.35 (.75) <u>.25</u> .60 (or 1.00)
15 ⁶	Switchgrass (Blackwell, Shelter, Cave-in-rock) Big Bluestem (Niagra, Kaw) or Little Bluestem (Blaze, Aldous, Camper) Perennial Ryegrass (Norlea, Manhattan) Bird's-foot Trefoil (Empire, Viking) with inoculant ¹	5 ¹ 5 ¹ 5 <u>5</u> Total 20	.10 .10 .10 <u>.10</u> .40
16 ⁵	Tall Fescue (Kentucky 31) Flatpea (Lathco) with inoculant ¹	20 <u>30</u> Total 50	.45 <u>.75</u> 1.20
17 ⁶	Deer Tongue (Tioga) with inoculant ¹ Bird's-foot Trefoil (Empire, Viking) with inoculant ¹ Perennial Ryegrass (Norlea, Manhattan)	10 ¹ 8 <u>3</u> Total 21	.25 .20 <u>.07</u> .52
18 ⁶	Deer Tongue (Tioga) with inoculant ¹ Crown Vetch (Chemung, Penngift) with inoculant ¹ Perennial Ryegrass (Norlea, Manhattan)	10 ¹ 15 <u>3</u> Total 28	.25 .35 <u>.07</u> .67
19 ³	Chewings Fescue Hard Fescue Colonial Bentgrass Bird's-foot Trefoil (Empire, Viking) with inoculant ¹ Perennial Ryegrass	35 30 5 10 <u>20</u> Total 100	.80 .70 .10 .20 <u>.50</u> 2.30
20 ⁵	Deleted due to invasive species		
21 ⁵	Creeping Red Fescue (Pennlawn, Wintergreen)	Total 60	1.35
22 ⁵	Creeping Red Fescue (Pennlawn, Wintergreen) Tall Fescue (Kentucky 31)	40 <u>20</u> Total 60	.90 <u>.45</u> 1.35
23 ⁵	Creeping Red Fescue (Pennlawn, Wintergreen) Flatpea (Lathco) with inoculant ¹	15 <u>30</u> Total 45	.35 <u>.75</u> 3.60
24 ⁵	Tall Fescue (Kentucky 31)	Total 150	3.60

Permanent Seeding (PS)

Figure PS-3 Seed Mixtures for Permanent Seeding (con't)

No.	Seed Mixture (Variety) ⁴	Lbs/Acre	Lbs/1,000 Sq. Ft.
25 ⁵	American Beachgrass (Cape)	58,500 culms/acre	1,345 culms/ 100 sq. ft.
26 ⁶	Switchgrass (Blackwell, Shelter, Cave-in-rock)	4.0	.10
	Big Bluestem (Niagra, Kaw)	4.0	.10
	Little Bluestem (Blaze, Aldous, Camper)	2.0	.05
	Sand Lovegrass (NE-27, Bend)	1.5	.03
	Bird's-foot Trefoil (Empire Viking)	<u>2.0</u>	<u>.05</u>
	Total	13.5	.33
27 ⁵	Flatpea (Lathco)	10	.20
	Perennial Pea (Lancer)	2	.05
	Crown Vetch (Chemung, Penngift)	10	.20
	Tall Fescue (Kentucky 31)	<u>2</u>	<u>.20</u>
	Total	24	.65
28 ⁵	Orchardgrass (Pennlate, Kay, Potomac)	5	.10
	Tall Fescue (Kentucky 31)	10	.20
	Redtop (Streeker, Common)	2	.05
	Birds-foot Trefoil (Empire Viking)	<u>5</u>	<u>.10</u>
	Total	22	.45
29	Turf Type Tall Fescue (Bonanza, Mustang, Rebel II, Spartan, Jaguar) or Perennial Rye ("Future 2000" mix; Fiesta II, Blazer II, and Dasher II)	175 to 250	6 to 8

¹ Use proper inoculant for legume seeds, use four times recommended rate when hydroseeding.

² Use Pure Live Seed (PLS) = $\frac{\% \text{ Germination} \times \% \text{ Purity}}{100}$

EXAMPLE: Common Bermuda seed with 70% germination and 80% purity=

$$\frac{70 \times 80}{100} \quad \text{or} \quad \frac{56}{100} \quad \text{or} \quad 56\%$$

$$\frac{10 \text{ lbs PLS/acre}}{56\%} = 17.9 \text{ lbs/acre of bagged seed}$$

³ DOT All purpose mix

⁴ Wild flower mix containing New England Aster, Baby's Breath, Black Eye Susan, Catchfly, Dwarf Columbine, Purple Coneflower, Lance-leaved Coreopsis, Cornflower, Ox-eye Daisy, Scarlet Flax, Foxglove, Gayfeather, Rocky Larkspur, Spanish Larkspur, Corn Poppy, Spurred Snapdragon, Wallflower and/or Yarrow may be added to any seed mix given. Most seed suppliers carry a wild flower mixture that is suitable for the Northeast and contains a variety of both annual and perennial flowers. Seeding rates for the specific mixtures should be followed.

⁵ Considered to be a cool season mix.

⁶ Considered to be a warm season mix.

Figure SB&F-1 Sediment Barrier and Filter Limitations

Limitation	Hay Bale	Geotextile Silt Fence	Turbidity Curtain	Vegetated Filter	Stone Check (non-engineered)
site conditions	on land	on land or standing water < 2 ft. deep	in water > 2 ft. deep	on land	on land
max. slope gradient	50% (2:1)	50% (2:1)	NA	10% (10:1)	50% (2:1)
max. slope length					
toe of slope application	100 ft.	100 ft.	NA	NA	NA
swale application	NA	depends on contributing slope gradient	NA	NA	depends on contributing slope gradient
max. drainage area	1 acre	1 acre	NA	1 acre	2 acres
expected life of control	≤ 3 months	1-3 years	per manufacturers specifications	until silted in	1 year
time of year to install	before ground freezes ¹		non-frozen water conditions	must be established before initial use	year round
location on landscape	not on pavement, bedrock or other hard surface that prevents proper trenching or anchoring		in water > 2 ft. depth	slope in filter area not steeper than 10%	on land
in still water < 2 ft. deep	no	by special design only	no	no	no
in water > 2 ft. deep	no	no	yes	no	no
sheet flows - toe of slope	on the contour 5-10 away from toe of slope	on the contour 0-10 away from toe of slope	NA	only where vegetation is adequate to filter runoff water	not advised
drainageways	not advised	"U" shaped across drainageway	NA	NA	across drainageway
catch basins in hollows	ring basin		NA	NA	ring basin
on slopes	twin "U" shaped up- and down-slope of basin		NA	NA	twin barriers, one up- and down-slope of basin
culver inlets	no	"U" shaped at least 6 ft. from inlet	yes	no	"U" shaped at least 6 ft. from inlet
culvert outlets	no	"U" shaped at least 6 ft. from outlet	yes	no	"U" shaped at least 6 ft. from outlet

¹ special case – see stone barrier measure when stone barrier and hay bale barrier are combined during frozen ground conditions

11 - Sediment Impoundments, Barriers and Filters

Temporary Sediment Basin (SB)

Definition

A temporary dam, excavated pit or dugout pond constructed across a waterway or at other suitable locations with a controlled outlet(s) such that a combination of wet and dry storage areas are created. A basin that is created by the construction of a dam is classified as an *embankment sediment basin* and a basin that is constructed by excavation is an *excavated sediment basin*. A basin that is created by a combination of dam construction and excavation is classified as an *embankment sediment basin* when the depth of water impounded against the embankment at emergency spillway elevation is three feet or more.

Purpose

- To intercept and retain sediment during construction.
- To reduce or abate water pollution.
- To prevent undesirable deposition of sediment in wetlands, on bottom lands and developed areas.
- To preserve the capacity of reservoirs, ditches, canals, diversions, storm sewers, waterways and streams.

Applicability

- Below disturbed areas with a contributing drainage areas less than 100 acres. For drainage areas less than five acres, a **Temporary Sediment Trap** may be used.
- Only for locations where failure of the temporary sediment basin will not, within reasonable expectations, result in loss of life or damage to buildings, roads, railroads or utilities.
- Not for use as a post-construction stormwater renovation system.

Planning Considerations

The preferred method of sediment control is to prevent erosion and control it near the source, rather than constructing sediment basins which only trap a portion of the sediments. However, where physical conditions, land ownership or construction operations preclude the treatment of the sediment source by the installation of erosion control measures to keep soil and other material in place, a temporary sediment basin may offer the most practical solution to the problem.

Consider sequencing construction so that the basin is located in an area that won't be developed until after the contributing watershed is stabilized. Also, sequence construction activities and locate the basin to minimize interference with other construction activities and construction of utilities.

Locate the basin outside of wetlands and try to locate it in such a way that maximum storage benefit is obtained from the existing surrounding terrain to minimize disturbance from the construction of the dam.

Regardless of the construction sequence and location, plan to provide and maintain construction equipment access for the removal of accumulated sediment.

To minimize the size of the temporary sediment basin, plan to divert clean waters around the basin and intercept only runoff from disturbed areas.

For projects which include a permanent detention basin, it is sometimes advantageous to locate the temporary sediment basin at the site of the detention basin. Sharing the same location may minimize site disturbance and cost. When this approach is used, the size requirements of both

the detention and sediment basins must be determined and the larger of the two must be in place during the construction period. After construction, the minimum size shall be that of the detention basin. One approach would be to construct the detention basin along with its berm and outlet works first, and expand the storage volume, if need be, to that required for the sediment basin. The permanent outlet works are modified during the construction period to provide the necessary wet and dry storage requirements and enhance the basin's ability to remove sediment. Upon stabilization of the contributing watershed, accumulated sediment is removed from the basin and any work, such as modifying the outlet works or installing permanent plantings, is done to complete the permanent detention basin.

Finally, the E&S plan should identify the sediment removal threshold(s), the method(s) of disposing of the sediment removed from the basin, the method of basin removal and final stabilization of the sediment basin after the contributing drainage area is stabilized.

Contact DEP Inland Water Resources Division early in the planning process to determine the potential need for a dam construction permit and/or water diversion permit. A local or state inland wetlands permit will be required if the temporary sediment basin is proposed in a wetland and/or watercourse area. Additional local permits may be required for work within floodplain and wetlands buffer areas. Check local ordinances and regulations regarding health and safety, as sediment basins may attract children and can be dangerous.

Design Criteria

Overall

Design the sediment basin to be compatible with the floodplain management and storm water management programs of the local jurisdiction and with local regulations for controlling sediment, erosion and runoff.

Attempt to locate sediment basins where:

1. Failure of the sediment basin would not, within reasonable expectations, result in loss of life, damage roads, railroads, homes, commercial and industrial properties or interrupt the use or service of utilities. (Dams which might fail and endanger life or property are regulated by the Commissioner of the Department of Environmental Protection under the CGS §§22a-401 through 22a-411.);
2. The effective height of the dam for an embankment sediment basin should be 15 feet or less. The effective height of the dam is defined as the difference in elevation in feet between the emergency spillway crest and the lowest point in the cross section taken along the centerline of the dam. If there is no emergency spillway, the top of the dam becomes the upper limit;
3. The product of the storage times the effective height of the dam should be less than 3,000. Storage is the volume in acre-feet in the reservoir below the elevation of the crest of the emergency spillway. The effective height of the dam is as defined above.

Sediment basins that exceed any one of the above conditions shall be designed to meet the criteria in Earth Dams and Reservoirs, Technical Release 60 (TR-60)

Drainage Area

The maximum allowable drainage area into a sediment basin shall be 100 acres. An emergency spillway shall be provided on all embankment sediment basins with a contributing drainage area equal to or greater than 20 acres.

Basin Capacity

The volume in the sediment basin below the crest elevation of the emergency spillway shall be at least that required for *wet storage* (which includes *sediment storage*) plus that required for *residence storage*.

Residence Storage Time and Volume: Residence time is defined as the volume weighted average time that an amount of flow will reside in a reservoir.

The sediment basin shall provide, in addition to sediment storage volume and wet storage volume, adequate volume to provide a minimum 10 hours residence time for a 10-year frequency, 24-hour duration, Type III distribution storm.

Flood routing is required to determine residence storage time. **Figure SB-13**, along with flood routing using the approximate methods in the **Detention Basin** measure, TR-55, or other generally accepted flood routing methods, will provide the minimum required residence storage volume and the maximum allowable principal spillway discharge.

Sediment Storage Volume: At least 1 year of predicted sediment load must be provided regardless of the planned frequency of sediment removal. Where it is determined that periodic removal of sediment is practical, the sediment storage volume may be proportionately reduced.

For the purpose of determining the sediment storage volume, use 80% trap efficiency. Sediment Storage Requirements for Reservoirs Technical Release No. 12 by the USDA, NRCS may be used to provide a more refined estimate of the actual trap efficiency¹ of specific sediment basin.

Sediment volume is calculated from the following formula:

$$V = \frac{(DA)(A)(DR)(TE)(2,000\text{lbs./ton})}{(\gamma)(43,560\text{sq.ft./ac})}$$

where:

V = the volume of sediment trapped in ac. ft./yr.

DA = the total drainage area in acres

A = the average annual erosion in tons per acre per year using either values from the Universal Soil Loss Equation, the Revised Universal Soil Loss Equation or the values in **Figure SB-1** for the listed land use.

DR = the delivery ratio determined from **Figure SB-12**.

TE = the trap efficiency as given above. (Use 0.8)

γ = the estimated sediment density in the sediment basin in lbs/cu. ft. (from **Figure SB-2**).

Wet Storage Volume: The volume of the wet storage shall be at least twice the volume of the sediment storage volume (see above) and shall be designed to a minimum depth of 2 feet.

Wet storage volume is the volume in the basin that is located below the invert of the lowest outlet structure for the basin. The wet storage may not provide permanent ponding of water depending on site conditions but will create a permanent pool for settling suspended sediment during a runoff event. The wet storage is intended to minimize the re-suspension of existing trapped sediments during a runoff event. To reduce sediment removal frequency, increase the volume of wet storage which will increase the sediment storage volume.

Basin Shape and Depth

The length, width, and depth of the basin are measured from the emergency spillway crest elevation.

¹Trap efficiency is the amount (expressed as a percent) of the total sediment delivered to the basin that will remain in the sediment basin. It is a function of residence time, characteristics of the sediment, nature and properties of inflow, and other factors.

Depth: The average depth shall be 4 feet or greater.

Width: The minimum width shall be:

$$W = 10 \sqrt{Q_5}$$

where: W = width in feet
 Q_5 = peak discharge from a 5-year frequency storm in cfs.

When the downstream area is highly sensitive to sediment impacts, the minimum width shall be:

$$W = 10 \sqrt{Q_{25}}$$

where: W = width in feet
 Q_{25} = peak discharge from a 25-year frequency storm in cfs.

Figure SB-1 Determining Erosion Rates	
Land Use	Ave. Annual Erosion
Wooded area	0.2 ton/ac/yr
Developed urban areas, grassed areas, pastures, hay fields, abandoned fields with good cover	1.0 ton/ac/yr
Clean tilled cropland (corn, vegetables, etc.)	10 ton/ac/yr
Construction Areas	50 ton/ac/yr

Source: USDA-SCS

Figure SB-2 Estimated Sediment Density	
Soil Texture *	γ_s Submerged (lbs/cu. ft.)
Clay	40-60
Silt	55-75
Clay-silt mixtures (equal parts)	40-65
Sand-silt mixtures (equal parts)	75-95
Clay-silt-sand mixtures (equal parts)	50-80
Sand	85-100
Gravel	85-125
Poorly sorted sand and gravel	95-130

* Use USDA soil data from county soil surveys or sieve analysis to determine soil texture.

Source: USDA-NRCS.

Length: The effective flow length shall be equal to at least two times the effective flow width. When site constraints prohibit the design of an adequate length, baffles

are required to provide for the creation of an adequate flow length. (see **Figure SB-7**)

Spillway Design

The outlets for the basin shall consist of a combination of principal and emergency spillways. These outlets must pass the peak runoff from the contributing drainage area for the design storm (see **Figure SB-5**). If, due to site conditions and basin geometry, a separate emergency spillway is not feasible, the principal spillway must pass the entire peak runoff expected from the design storm. However, an attempt to provide a separate emergency spillway should always be made (refer to “Emergency Spillway”, **Figure SB-10**). Runoff computations shall be based upon the soil cover conditions which are expected to prevail during the life of the basin. Refer to standard engineering practices for calculations of the peak rate of runoff. Notably, the flow through the dewatering orifice cannot be utilized when calculating the design storm elevation because of its potential to become clogged; therefore, available spillway storage must begin at the principal spillway crest.

The spillways designed by the procedures contained in this manual will not necessarily result in any reduction in the peak rate of runoff. If a reduction in peak runoff is desired, the appropriate hydrographs and storm routings shall be generated to choose the basin and spillway sizes.

Principal Spillway

For maximum effectiveness, the principal spillway should consist of a vertical pipe or box of corrugated metal or reinforced concrete, with a minimum diameter of 15 inches, joined by a water tight connection to a horizontal pipe (barrel) extending through the embankment and outletting beyond the downstream toe of the fill. If the principal spillway is used in conjunction with a separate emergency spillway, then the principal spillway shall be designed to pass at least the peak flow expected from a 2-year storm. If no emergency spillway is used, the principal spillway shall be designed to pass the entire peak flow expected from the design storm.

Design Elevations: The crest of the principal spillway shall be set at the elevation corresponding to the storage volume required. If a principal spillway is used in conjunction with an emergency spillway, the principal spillway crest shall be a minimum of 1.0 foot below the crest of the emergency spillway. In addition, a minimum freeboard of 1.0 foot shall be provided between the design high water elevation (design depth through the emergency spillway) and the top of the embankment. If no emergency spillway is used, the crest of the principal spillway shall be a minimum of 3 feet below the top of the embankment; in addition, a minimum freeboard of 2.0 feet shall be provided between the design high water and the top of the embankment.

Anti-Vortex Device and Trash Rack: If a riser-type principal spillway is used, an anti-vortex device and trash rack shall be attached to the top of the riser to improve the flow characteristics and prevent blockage due to

floating debris. (See **Figure SB-8** and **Figure SB-9** for examples of the anti-vortex device and trash rack.)

Base: The base of the principal spillway shall be firmly anchored to prevent floatation. If the riser height of the spillway is greater than 10 feet, computations shall be made to determine the anchoring requirements. A minimum factor of safety of 1.25 shall be used (downward forces = 1.25 x upward forces).

For risers 10 feet or less in height, the anchoring may be done in one of the two following ways:

1. A concrete base 18 inches thick and twice the width of the riser diameter shall be used and the riser shall be embedded 6 inches into the concrete.
2. A square steel plate securely attached or welded to the base of the riser, a minimum of 0.25 inch thick and having a width equal to twice the diameter of the riser shall be used; it shall be covered with stone, gravel, or compacted soil to prevent flotation.

Note: *If a steel base is used, special attention should be given to compaction so that 95% standard proctor compaction is achieved over the plate. Also, added precautions should be taken to ensure that material over the plate is not removed accidentally during removal of sediment from the basin.*

Barrel: The barrel of the principal spillway, which extends through the embankment, shall be designed to carry the flow provided by the riser of the principal spillway with the water level at the crest of the emergency spillway. The connection between the riser and the barrel shall be watertight. The outlet of the barrel shall be protected to prevent erosion or scour of downstream areas.

Seepage Control Along Principal Spillway Barrels:

Anti-Seep Collars: Anti-seep collars are designed to control seepage and piping along the barrel by increasing the flow length and thus making any flow along the barrel travel a longer distance.

Anti-seep collars shall be used along the barrel of the principal spillway within the normal saturation zone of the embankment to increase the seepage length by at least 10%, if either of the following two conditions is met:

1. The settled height of the embankment exceeds 10 feet.
2. The embankment has a low silt-clay content (Unified Soil Classes SM or GM based on sieve analysis. See Appendix H for classification specifications) and the barrel is greater than 10 inches in diameter.

Anti-seep collars shall be installed within the saturated zone. The maximum spacing between collars shall be 14 times the projection of the collars above the barrel and in no case shall exceed 25 feet. Collars shall not be closer than 2 feet from a pipe joint. Collars should be placed sufficiently far apart to allow space for hauling and compacting equipment. Precautions should be taken to ensure 95% standard proctor compaction is achieved around the collars. Connections between the collars and the barrel shall be watertight.

Filter Diaphragms: Due to the constraints that collars impose on embankment fill placement and compaction, collars may sometimes be ineffective or actually result in an increase in seepage and piping.

Alternative measures to anti-seep collars have been developed and are being incorporated into embankment designs. These measures include a structure known as a "filter or drainage diaphragm." A filter diaphragm consists of a layer of sand and fine gravel which runs through the dam embankment perpendicular to the barrel. Typically, the structure is 4 to 5 inches in width, approximately 1 foot in height, and is located at the barrel elevation at its intersection with the upper bounds of the seepage zone. The measure controls the transport of embankment fines, which is the major concern with piping and seepage. The diaphragm channels any undesirable flow through the fine-graded material, which traps any embankment material being transported. The flow is then conveyed out of the embankment through a drain.

The critical design element of the filter diaphragm is the grain-size distribution (gradation) of the filter material which is determined by the gradation of the adjacent embankment fill material. The use and design of these measures shall be based on site-specific geotechnical information and be supervised by a qualified professional.

Principal Spillway - Construction Specifications:

The riser of the principal spillway shall be securely attached to the barrel by a watertight connection. The barrel and riser shall be placed on a firmly compacted soil foundation. The base of the riser shall be firmly anchored according to design criteria to prevent its floating. With the exception of filter diaphragms, pervious materials such as sand, gravel, or crushed stone shall not be used as backfill around the barrel or anti-seep collars (compact by hand if necessary). Fill material shall be placed around the pipe in 6-inch layers and compacted until 95% standard proctor compaction is achieved. A minimum of two feet of fill shall be hand-compacted over the barrel before crossing it with construction equipment.

Pipe conduits for embankment sediment basins shall meet the following requirements:

Pipe Materials: The pipe shall be capable of withstanding external loading without yielding, buckling, or cracking. The following pipe materials are acceptable:

1. **Corrugated Steel Pipe:** Pipe gauge is not to be less than that indicated in **Figure SB-3**. The maximum principal spillway barrel size shall be 48 inches. The pipe shall be helical fabrication. Flanges with gaskets or caulking may be used. Rod and lug coupling bands with gaskets or caulking may be used.
2. **Corrugated Aluminum Pipe:** Minimum pipe gauge is shown in **Figure SB-3**. The maximum principal spillway barrel size shall be 36 inches. The pipe shall be riveted fabrication. The embankment and water shall range between pH 4 and pH 9. Inlets, coupling bands and anti-seep collars must be made of aluminum.

Fittings for aluminum pipe fabricated of metals other than aluminum or aluminized steel must be separated from the aluminum pipe at all points by at least two layers of plastic tape having a total thickness of at least 24 mils, or by other permanent insulating material that effectively prevents galvanic corrosion.

Bolts used to join aluminum and steel must be galvanized, plastic coated, or otherwise protected to prevent galvanic corrosion. Bolts used to join aluminum to aluminum, other than aluminum alloy bolts, must be galvanized, plastic coated, or otherwise protected to prevent galvanic corrosion.

Connections between pipe joints must be watertight. Flanges with gaskets or caulking may be used. Rod and lug coupling bands with gaskets or caulking may be used. Slip seam coupling bands with gaskets or caulking may be used.

3. **Plastic Pipe:** PVC pipe shall meet the requirements of **Figure SB-4**. Connections between pipe joints and anti-seep collar connections to the pipe must be watertight. Pipe joints shall be solvent welded, O-ring, or threaded. All fittings and couplings shall meet or exceed the same strength requirements as

Figure SB-4 PVC* Pipe Requirements		
Nominal Pipe Size (Inches)	Strength	Maximum Depth of Fill Over Pipe (Feet)
6, 8, 10, 12	Sched. 40	10
	Sched. 80	15
	SDR 26	10
*Polyvinyl chloride pipe, PVC 1120 or PVC 1220, conforming to ASTM D 1785 or ASTM D 2241		

Source: Adapted from Standards for Soil Erosion and Sediment Control in New Jersey, New Jersey State Conservation Committee.

that of the pipe and be made of material that is recommended for use with the pipe. Connections of plastic pipe to less flexible pipe or structures shall be designed to avoid stress concentrations that could rupture the plastic. The maximum principal spillway barrel size shall be 12 inches.

4. **Smooth Steel:** The minimum wall thickness shall be 3/16 inch. Used pipe shall be in good condition and not have deep rust pits. The maximum principal spillway barrel shall be 48 inch. Pipe joints shall be threaded or welded by a competent welder.
5. **Concrete, With Rubber Gasket Joints:** The pipe shall be laid in concrete bedding. Connections between pipe joints and anti-seep collar connections to pipe shall be watertight and remain watertight after movement caused by foundation consolidation and embankment settlement.

Inlets for Pipe Conduits: The inlet shall be structurally sound and made from materials compatible with the pipe. The inlet shall be designed to prevent floatation.

Figure SB-3 Corrugated Steel and Aluminum Pipe Requirement									
Corrugated Steel Pipe									
Pipe Diameter	8 to 21	24	30	36	42	48	Risers Only		
							54	60	66
Minimum Gauge	16	16	14	14	12	10	10	10	10
Corrugated Aluminum Pipe									
Pipe Diameter	8 to 21	24	30	36	Risers Only				
					42	48	54		
Gauge (inches)	16 (.06)	14 (0.75)	14 (0.75)	14 (0.75)	12 (.105)	10 (.135)	10 (.135)		

Source: Standards for Soil Erosion and Sediment Control in New Jersey. New Jersey State Soil Conservation Committee.

The inlets shall be designed to function satisfactorily for the full range of flow and hydraulic head anticipated. The inlet materials shall be subject to the same limitations and requirements as pipe conduits.

1. **Watertight Riser:** Risers shall be completely watertight except for the inlet.
2. **Pipe Drop Inlet:** Pipe drop inlets, where designed for pressure flow, shall meet the following conditions:
 - (a) The weir length shall be adequate to prime the pipe below the emergency spillway elevation.
 - (b) For pipe on less than critical slope, the height of the drop inlet shall be at least 2 times the conduit diameter.
 - (c) For pipe on a critical slope or steeper, the height of the drop inlet shall be at least 5 times the conduit diameter.

Anti-vortex Devices: Sediment basins with the principal spillway designed for pressure flow shall have adequate anti-vortex devices. See **Figure SB-8** and **Figure SB-9**.

Trash and Safety Guards: An appropriate guard shall be installed at the inlet. The guard shall prevent clogging of the pipe by trash and reduce the safety hazard to people. The guard shall be a type that will not plug with leaves, grass or other debris. See **Figure SB-9** and **Figure SB-9**.

Outlets for Pipe Conduits: The outlets shall be structurally sound and made from materials compatible with the pipe. The outlets shall be designed to function satisfactorily for the full range of flow and hydraulic head anticipated. Protection against scour at the discharge end of the spillway shall be provided. Measures may include impact basins, Saint Anthony Falls outlets, riprap, excavated plunge pools or other generally accepted energy dissipators.

Anti-seep Collars: Pipe conduits for embankment sediment basins shall be provided with anti-seep collars or filter diaphragms. The minimum number of anti-seep collars shall be determined by the size of the collars and the length of that part of the conduit lying in the saturated zone of earth embankment. Anti-seep collars are not required for excavated sediment basins.

The size and number of anti-seep collars is determined such that the ratio of the length of the line of seepage ($L + 2 n V$) to L is to be not less than 1.15 where

V = projection of the anti-seep collar in feet

L = length in feet of the conduit within the zone of saturation, measured from the downstream side of the riser to the toe drain or point where the phreatic line intercepts the conduit, whichever is shorter

n = number of anti-seep collars

Anti-seep collars should be equally spaced along that part of the barrel within the saturated zone at distances of not more than 25 feet. See page 5-11-8 for other criteria on seepage control which may conflict.

The anti-seep collars and their connections to the pipe shall be watertight. The collar material shall be compatible with pipe materials.

Emergency Spillway

An attempt to provide a separate emergency spillway shall always be made. However, there shall be an emergency spillway on all temporary sediment basins with a contributing drainage equal to or exceeding 20 acres. The emergency spillway acts as a safety release for a sediment basin, or any impoundment-type structure, by conveying the larger, less frequent storms through or around the basin without damage to the embankment. The emergency spillway shall consist of an open channel (earthen and vegetated) constructed adjacent to the embankment over undisturbed material (not fill).

Where conditions will not allow the construction of an emergency spillway on undisturbed material, a spillway may be constructed of a non-erodible material such as riprap. The spillway shall have a control section at least 20 feet in length. The control section is a level portion of the spillway channel at the highest elevation in the channel profile.

Where conditions require the construction of an emergency spillway on the embankment, a spillway shall be constructed of a non-erodible material such as riprap. As an alternative, a structural spillway may be installed which combines the outflow requirements of a principal (primary) spillway and emergency (auxiliary) spillway.

An evaluation of site and downstream conditions must be made to determine the feasibility and justification for the incorporation of an emergency spillway. In some cases, the site topography does not allow a spillway to be constructed in undisturbed material, and the temporary nature of the facility may not warrant the cost of disturbing more acreage to construct and armor a spillway. The principal spillway should then be sized to convey all the design storms.

Emergency Spillways for Excavated Sediment Basins:

If the downstream slope is 5:1 or flatter and has existing vegetation or is immediately protected by sodding, riprap, asphalt lining, concrete lining, or other equally effective protection, then excavated sediment basins may utilize the natural ground for the emergency spillway. Otherwise, the spillway shall meet the capacity requirement for embankment sediment basins given below.

Emergency Spillway for Embankment Sediment Basins:

Emergency spillways for embankment sediment basins shall meet the following requirements:

Capacity: The minimum capacity of the emergency spillway shall be that required to pass the peak flow expected from a design storm of the frequency and duration shown in **Figure SB-5** less any reduction creditable to principal spillway discharge and detention storage.

If routed, the flood routing shall be done using the approximate methods outlined in the **Detention Basin** measure, TR-55, or other generally accepted methods of emergency spillway flood routing. When discharge of conduit-type principal spillway system is considered in calculating outflow through the emergency spillway, the crest elevation of the inlet shall be such that full pipe flow will be generated in the conduit before there is discharge through the emergency spillway.

Figure SB-5 Design Data		
Drainage Area (acres)	Frequency (years)	Minimum Duration (hours)
Less than 50	25	24
50-100	100	24

Source: USDA-NRCS

Design Elevations: The design storm elevation through the emergency spillway shall be at least 1.0 feet below the top of the embankment. The crest of the emergency spillway channel shall be at least 1.0 feet above the crest of the principal spillway.

Location: The emergency spillway channel shall be located so that it will not be constructed over fill material. The channel shall be located so as to avoid sharp turns or bends. The channel shall return the flow of water to a defined channel downstream from the embankment.

Spillway variables (see **Figure SB-10** and **Figure SB-11**): Emergency spillways are to provide for passage of the design flow at a safe velocity to a point downstream where the embankment will not be endangered. The maximum permissible velocity in the exit channel shall be 4 feet per second for vegetated channels in soils with a plasticity index of 10 or less and 6 feet per second for vegetated channels in soils with a plasticity index greater than 10 (based on laboratory analysis). For exit channels with erosion protection other than vegetation, the velocities shall be non-erosive for the type of protection used.

The emergency spillway channel shall return the flow to the receiving channel at a non-eroding velocity.

Cross Sections: Emergency spillways shall be trapezoidal and be located in undisturbed earth. The side slopes shall be 2:1 or flatter. The bottom width shall be a minimum of 8 feet. The embankment requirements shall determine elevation differences between the crest of the emergency spillway and the settled top of dam.

Component Parts: Emergency spillways are open channels and consist of an inlet channel, control section and an exit channel. The emergency spillway shall be sufficiently long to provide protection from breaching.

Inlet Channel: The inlet channel shall be level and straight for at least 20 feet upstream of the control section. Upstream from this level area it may be graded back towards the basin to provide drainage. The alignment of the inlet channel may be curved upstream from the straight portion.

Exit Channel: The grade of the exit channel of a constructed spillway shall fall within the range established by discharge requirements and permissible velocities. The exit channel shall carry the design flow downstream to a point where the flow will not discharge onto the toe of the embankment. The design flow should be contained in the exit channel without the use of dikes. However, if a dike is necessary, it shall have 2:1 or flatter side slopes, a minimum top width of 8 feet, and be high enough to contain the design flow plus 1 foot of freeboard.

Emergency Spillway - Construction Specifications:

Do not construct vegetative emergency spillways over fill material. Design elevations, widths, entrance and exit channel slopes are critical to the successful operation of the spillway and should be adhered to closely during construction.

Structural Spillways Other Than Pipe

Structural spillways other than pipe systems will have structural designs based on sound engineering data with acceptable soil and hydrostatic loadings as determined on an individual site basis.

When used as a principal spillway, structural spillways shall meet the flow requirements for principal spillways and shall not be damaged by the emergency spillway design storm. When used as a combination principal emergency spillway, it shall pass the storm runoff from the appropriate storm in **Figure SB-5**.

Embankment Design

Height: The effective height of the dam for an embankment detention basin is 15 feet or less. The effective height of the dam is defined as the difference in elevation in feet between the emergency spillway crest and the lowest point in the cross section taken along the centerline of the dam. If there is no emergency spillway, the top of the dam becomes the upper limit. Additional design guidance can be found in the NRCS Practice Standard 378, August 1982. Sediment basins that exceed the above conditions shall be designed to meet the criteria in Earth Dams and Reservoirs Technical Release 60 (TR-60).

Embankment Cross-Section: For embankments of less than 10 feet, the embankment must have a minimum top width of 6 feet, and the side slopes shall be 2:1 or flatter. For embankments 10 to 14 feet in height, the minimum top width shall be 8 feet and the side slopes shall be 2-1/2:1 or flatter. For 15 foot high embankments (maximum allowed under this practice), the minimum top width shall be 10 feet with 2-1/2:1 side slopes or flatter.

Site Preparation: Areas under the embankment and any structural works related to the basin shall be cleared, grubbed, and stripped of topsoil to remove trees, vegetation, roots, or other unsuitable material. In order to facilitate cleanout and restoration, the area of most frequent inundation (measured from the top of the principal spillway) will be cleared of all brush and trees.

Foundation Cutoff: A foundation cutoff, constructed with relatively impermeable materials, shall be provided for all embankments. The cutoff trench shall be excavated along the centerline of the dam. The trench must extend at least 2 feet into undisturbed foundation soils. The cutoff trench shall extend up both abutments to the emergency spillway crest elevation. The width shall be wide enough to permit operation of compaction equipment (4 feet minimum). The side slopes shall be no steeper than 1:1. Compaction requirements shall be the same as those for the embankment. The trench shall be kept free from standing water during the backfilling operations.

Seepage Control: Seepage control is to be included if seepage may create swamping downstream, if needed to ensure a stable embankment, or if special problems require drainage for a stable embankment. Seepage control may be accomplished by foundation, abutment or embankment drains, reservoir blanketing or a combination of these and other measures.

Foundation: The area on which an embankment is to be placed shall consist of material that has sufficient bearing strength to support the embankment without excessive consolidation.

Earth Embankment Design

Freeboard: The minimum elevation of the top of the settled embankment shall be 1.0 foot above the water surface in the reservoir with the emergency spillway flowing at design depth.

Materials: The fill material for the embankment shall be from approved borrow areas. It shall be clean mineral soil, free of roots, woody vegetation, stumps, sod, oversized stones, rocks, man made materials, or other perishable or unsuitable material. The material selected must have enough strength for the dam to remain stable and be impervious enough, when properly compacted, to prevent excessive seepage through the dam. Impervious portions of the embankment shall consist of at least 15% clay or silt. Using the Unified Soil Classification System (See **Appendix H**), SC (clayey sand), GC (clayey gravel) and CL (“low liquid limit” clay) are among the preferred types of embankment soils. SM, ML and GM type soils may also be used. Fill material should be selected based on laboratory analysis.

Allowance for Settlement: The design height of the embankment shall be increased by the amount needed to ensure that, after all settlement and consolidation has taken place, the height of the dam will equal or exceed the design height. This increase shall not be less than 10% when compaction is by hauling equipment or 5% if controlled compaction is used, except where detailed soil testing and laboratory analysis shows that a lesser amount is adequate.

Compaction: Areas on which fill is to be placed shall be scarified prior to placement of fill. The fill material shall contain the proper amount of moisture to ensure that at least 90% – 95% standard proctor compaction will be achieved. Fill material will be placed in 9-inch continuous layers over the entire length of the fill. Compaction shall be obtained by routing the hauling equipment over the fill so that the entire surface of the fill is traversed by at least one wheel or tread track of the equipment, or by using a compactor. Special care shall be taken in compacting around the anti-seep collars and principal

spillway system to avoid damage and achieve desired compaction (compact by hand, if necessary).

Provisions for Maintenance Sediment Removal

Sediment basin designs shall include provisions for the periodic removal of accumulated sediments, including adequate access for excavating and hauling equipment, dewatering and the threshold of sediment deposition that triggers the sediment removal operation. Additionally, disposal sites for the removed sediments shall be planned. See measures found in the Dewatering Functional Group and the discussion in Chapter 4, Special Treatments (stockpiling).

Sediment Storage Markers

Detail the location and installation requirements for sediment storage stakes or other means of showing the threshold elevation for sediment cleanout.

Stabilization of Disturbed Areas

The embankment, emergency spillway, spoil and borrow areas, and other disturbed areas above normal water level shall be vegetatively stabilized in accordance with the **Permanent Seeding** or **Sodding** measures or otherwise provided with a non-erodible surface.

Construction Specifications

Construction specifications shall to be included either on the plans or contained in a supplemental document referenced by and accompanying the plans. The construction specifications identify all material and operational specifications that are required by the design. The construction specifications must include but are not limited to design requirements for site preparation, foundation cutoff, seepage control, foundation construction, materials for principal and emergency spillways, vegetation establishment and sediment storage markers.

Installation Requirements

Construct in accordance with the design plans and construction specifications.

Site Preparation

Clear, grub and strip topsoil to remove trees, vegetation, roots, or other unsuitable material from areas under the embankment or any structural works related to the basin. Clear and grub the area of most frequent inundation (measured from the top of the outlet control structure) of all brush and trees to facilitate clean out and restoration.

Install Sediment Controls for Contributing Areas

Install sediment controls to trap sediment before it enters and leaves the detention basin construction site.

Stabilize the dam and emergency spillway in accordance with the engineered design, stabilize the spoil and borrow areas, and other disturbed areas in accordance with the **Temporary Seeding** or **Permanent Seeding**

measures, whichever is applicable.

Safety

Install safety features and devices to protect humans and animals from such accidents as falling or drowning. Temporary fencing can be used until barrier plantings are established. Use protective measures such as guardrails and fences on spillways and impoundments as needed.

Maintenance

Inspect the temporary sediment basin at least once a week and within 24 hours of the end of a storm with a rainfall amount of 0.5 inch or greater to determine conditions in the basin. Clean the sediment basin of sediments when sediment accumulation exceeds one half of the wet storage capacity of the basin or when the depth of available pool is reduced to 18 inches,

whichever is achieved first. Sediment levels shall be marked within the sediment storage area by stakes or other means showing the threshold elevation for sediment cleanout.

Prior to the removal of sediments, dewater the basin through pumping or other means to the expose previously submerged sediments. Use measures found in the Dewatering Functional Group and Chapter 4, Special Treatments (Stockpiling). Do not allow accumulated sediment to flush into the stream or drainageway. Stockpile the sediment in such a manner that it will not erode from the site or into a wetland, watercourse or other sensitive area.

Sediment removal, transportation and disposal shall occur as shown on the plans as limited by the design criteria.

Figure SB-6 Sediment Basin Schematic Elevations

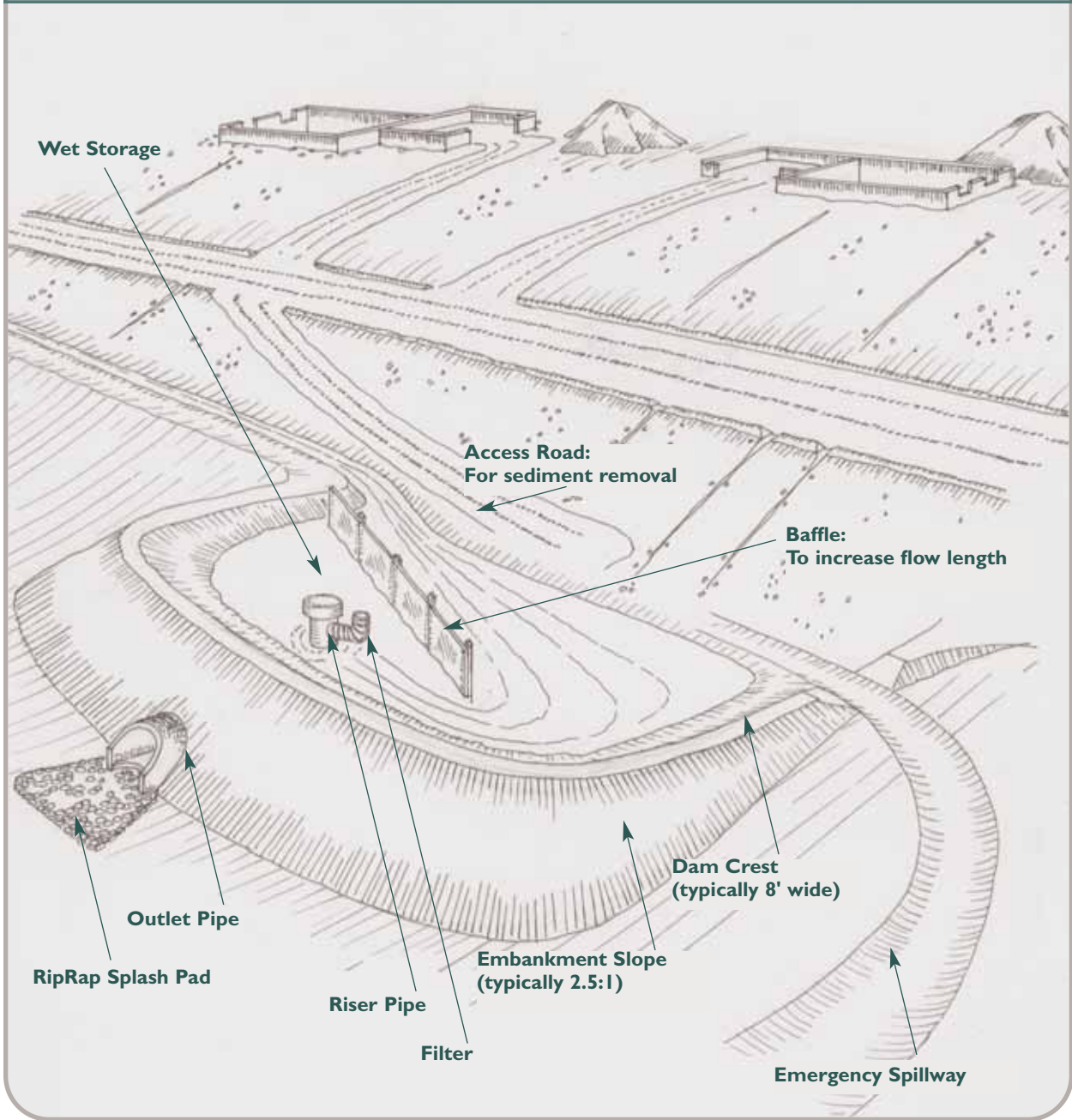

Temporary Sediment
Basin (SB)

Figure SB-7 Sediment Basin Baffle Details

Examples: Plan Views – not to scale

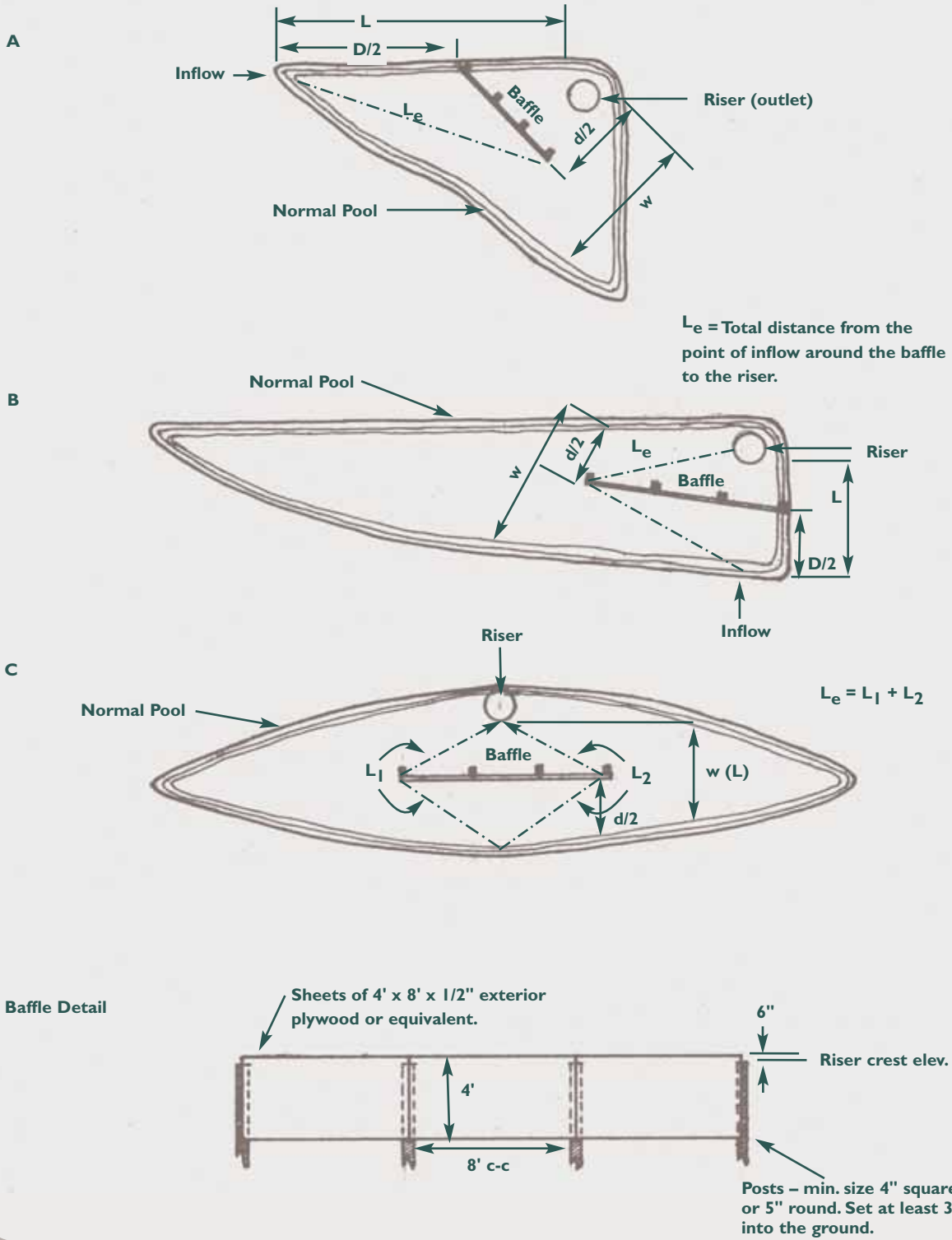

Source: USDA-NRCS

Figure SB-8 Anti-Vortex - Trash and Safety Guard Diagram

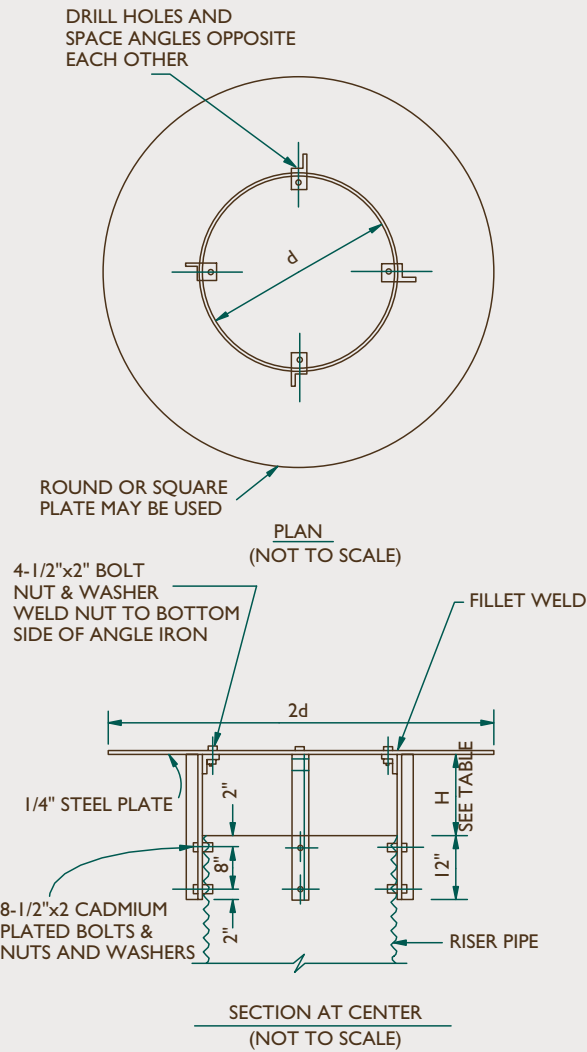

INLET d DIA. INCHES	BARREL DIA. INCHES	H INCHES
12	6	6
12	8	6
15	10	6
15	12	7
18	12	6
24	15	7 1/2
24	18	10
* 30	18	8 1/2
* 30	24	13 1/2
* 36	24	12

* USE ANGLE IRON STIFFENERS ON PLATE AS SPECIFIED.

Source: USDA-NRCS

Figure SB-9 Concentric Trash Rack and Anti-Vortex Device

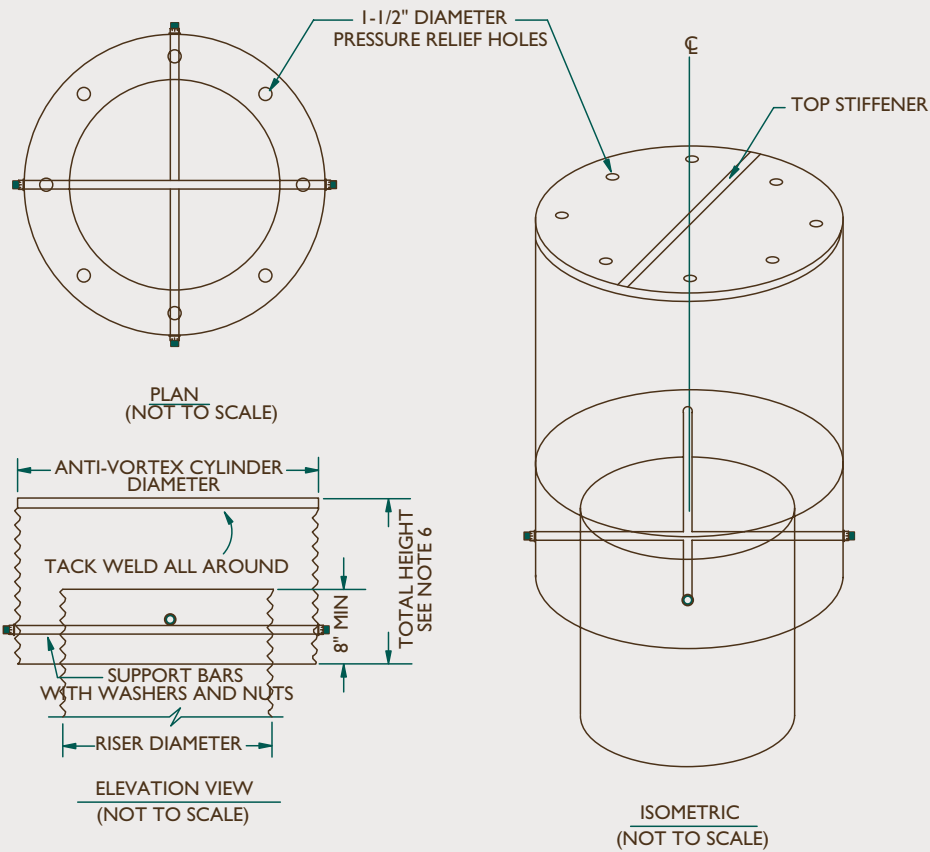

NOTES:

1. TOP STIFFENER (IF REQUIRED) IS 2" X 2" X 1/4" ANGLE WELDED TO TOP AND ORIENTED PERPENDICULAR TO CORRUGATIONS.
2. TOP IS 12 GAGE CORRUGATED METAL OR 1/8" STEEL PLATE. PRESSURE RELIEF HOLES MAY BE OMITTED IF ENDS OF CORRUGATIONS ARE LEFT FULLY OPEN WHEN CORRUGATED TOP IS WELDED TO CYLINDER.
3. CYLINDER IS 12 GAGE CORRUGATED METAL PIPE OR FABRICATED FROM STEEL PIPE WITH A MINIMUM 1/8" WALL THICKNESS.
4. SUPPORT BARS ARE 1/2" DIAM. (MIN).
5. TRASH RACK DIAMETER SHALL BE SIZED SO THE VELOCITY THROUGH THE BOTTOM OF THE RACK IS LESS THAN 2.5 FEET/SECOND.
6. THE TOP OF THE CONCENTRIC TRASH RACK SHALL BE SET AT OR ABOVE THE ELEVATION AT WHICH THE PRINCIPAL SPILLWAY BARREL FLOWS FULL (PRIMES).

Source: USDA-NRCS

Figure SB-10 Design Data for Earth Spillways

LEGEND

- n = MANNING'S COEFFICIENT OF ROUGHNESS.
- H_p = DIFFERENCE IN ELEVATION BETWEEN CREST OF EARTH SPILLWAY AT THE CONTROL SECTION | AND WATER SURFACE IN RESERVOIR, IN FEET.
- b = BOTTOM WIDTH OF EARTH SPILLWAY AT THE CONTROL SECTION, IN FEET.
- Q = TOTAL DISCHARGE, IN C.F.S.
- V = VELOCITY, IN FEET PER SECOND, THAT WILL EXIST IN CHANNEL BELOW CONTROL SECTION, AT DESIGN Q, IF CONSTRUCTED TO SLOPE (S) THAT IS SHOWN.
- S = FLATTEST SLOPE (S), IN % ALLOWABLE FOR CHANNEL BELOW CONTROL SECTION.
- X = MINIMUM LENGTH OF CHANNEL BELOW CONTROL SECTION, IN FEET.
- z = SIDE SLOPE RATIO (2:1).

NOTES:

1. FOR A GIVEN H_p A DECREASE IN THE EXIT SLOPE FROM S AS GIVEN IN THE TABLE DECREASES SPILLWAY DISCHARGE, BUT INCREASING THE EXIT SLOPE FROM S DOES NOT INCREASE DISCHARGE. IF AN EXIT SLOPE (S_e) STEEPER THAN S IS USED, THEN THE VELOCITY (V_e) IN THE EXIT CHANNEL WILL INCREASE ACCORDING TO THE FOLLOWING RELATIONSHIP:

$$V_e = V \left(\frac{S_e}{S} \right)^{0.3}$$
2. DATA TO RIGHT OF HEAVY VERTICAL ON FIGURE SB-11 SHOULD BE USED WITH CAUTION, AS THE RESULTING SECTIONS WILL BE EITHER POORLY PROPORTIONED OR HAVE VELOCITIES IN EXCESS OF 6 FT/SEC.

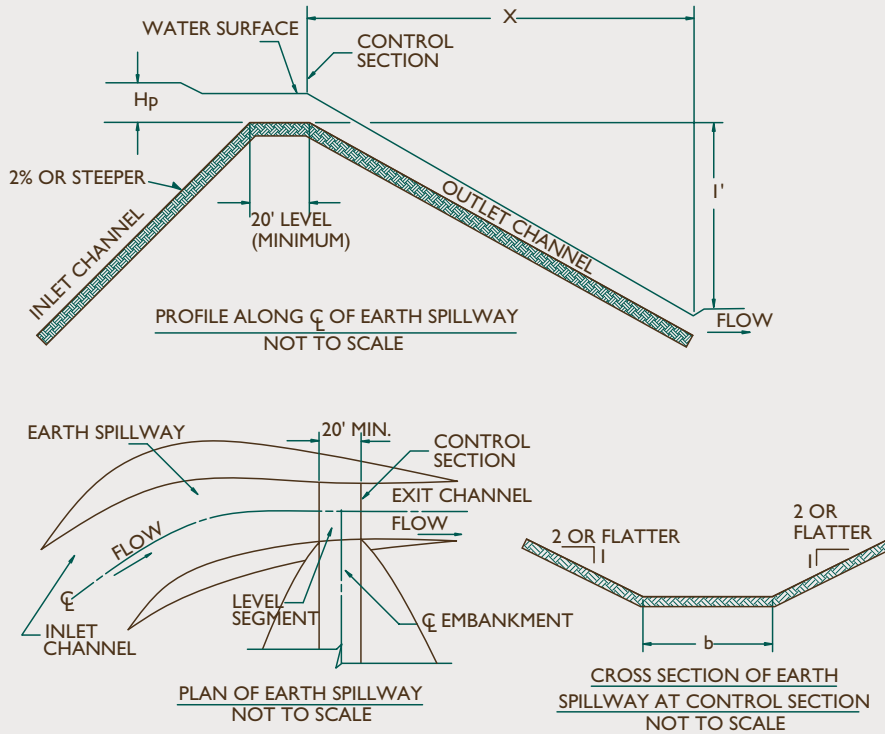

Source: USDA-NRCS

Figure SB-11 Table Containing Design Data for Earth Spillways When Used as Emergency Spillway

STAGE (H ₀) IN FEET	SPILLWAY VARIABLES	BOTTOM WIDTH (b) IN FEET																
		8	10	12	14	16	18	20	22	24	26	28	30	32	34	36	38	40
0.5	Q	6	7	8	10	11	13	14	15	17	18	20	21	22	24	25	27	28
	V	2.7	2.7	2.7	2.7	2.7	2.7	2.7	2.7	2.7	2.7	2.7	2.7	2.7	2.7	2.7	2.7	2.7
	S	3.9	3.9	3.9	3.9	3.8	3.8	3.8	3.8	3.8	3.8	3.8	3.8	3.8	3.8	3.8	3.8	3.8
	X	32	33	33	33	33	33	33	33	33	33	33	33	33	33	33	33	33
0.6	Q	8	10	12	14	16	18	20	22	24	26	28	30	32	34	35	37	39
	V	3.0	3.0	3.0	3.0	3.0	3.0	3.0	3.0	3.0	3.0	3.0	3.0	3.0	3.0	3.0	3.0	3.0
	S	3.7	3.7	3.7	3.7	3.6	3.6	3.6	3.6	3.6	3.6	3.6	3.6	3.6	3.6	3.6	3.6	3.6
	X	36	36	36	36	36	36	37	37	37	37	37	37	37	37	37	37	37
0.7	Q	11	13	16	18	20	23	25	28	30	33	35	38	41	43	44	46	48
	V	3.2	3.2	3.3	3.3	3.3	3.3	3.3	3.3	3.3	3.3	3.3	3.3	3.3	3.3	3.3	3.3	3.3
	S	3.5	3.5	3.4	3.4	3.4	3.4	3.4	3.4	3.4	3.4	3.4	3.4	3.4	3.4	3.4	3.4	3.4
	X	39	40	40	40	41	41	41	41	41	41	41	41	41	41	41	41	41
0.8	Q	13	16	19	22	26	29	32	35	38	42	45	46	48	51	54	57	60
	V	3.5	3.5	3.5	3.6	3.6	3.6	3.6	3.6	3.6	3.6	3.6	3.6	3.6	3.6	3.6	3.6	3.6
	S	3.3	3.3	3.3	3.2	3.2	3.2	3.2	3.2	3.2	3.2	3.2	3.2	3.2	3.2	3.2	3.2	3.2
	X	44	44	44	44	45	45	45	45	45	45	45	45	45	45	45	45	45
0.9	Q	17	20	24	28	32	35	39	43	47	51	53	57	60	64	68	71	75
	V	3.7	3.8	3.8	3.8	3.8	3.8	3.8	3.8	3.8	3.8	3.8	3.8	3.8	3.8	3.8	3.8	3.8
	S	3.2	3.1	3.1	3.1	3.1	3.1	3.1	3.1	3.1	3.1	3.1	3.1	3.1	3.1	3.1	3.1	3.1
	X	47	47	48	48	48	48	48	48	48	48	49	49	49	49	49	49	49
1.0	Q	20	24	29	33	38	42	47	51	56	61	63	68	72	77	81	86	90
	V	4.0	4.0	4.0	4.0	4.0	4.0	4.0	4.0	4.0	4.0	4.0	4.0	4.0	4.0	4.0	4.0	4.0
	S	3.1	3.0	3.0	3.0	3.0	3.0	3.0	3.0	3.0	3.0	3.0	3.0	3.0	3.0	3.0	3.0	3.0
	X	51	51	51	51	52	52	52	52	52	52	52	52	52	52	52	52	52
1.1	Q	23	28	34	39	44	49	54	60	65	70	74	79	84	89	95	100	105
	V	4.2	4.2	4.2	4.3	4.3	4.3	4.3	4.3	4.3	4.3	4.3	4.3	4.3	4.3	4.3	4.3	4.3
	S	2.9	2.9	2.9	2.9	2.9	2.9	2.9	2.9	2.9	2.9	2.8	2.8	2.8	2.8	2.8	2.8	2.8
	X	55	55	55	55	55	55	55	56	56	56	56	56	56	56	56	56	56
1.2	Q	28	33	40	45	51	58	64	69	76	80	86	92	98	104	110	116	122
	V	4.4	4.4	4.4	4.4	4.4	4.5	4.5	4.5	4.5	4.5	4.5	4.5	4.5	4.5	4.5	4.5	4.5
	S	2.9	2.9	2.8	2.8	2.8	2.8	2.8	2.8	2.8	2.8	2.8	2.8	2.8	2.8	2.8	2.8	2.8
	X	58	58	59	59	59	59	59	59	60	60	60	60	60	60	60	60	60
1.3	Q	32	38	46	53	58	65	73	80	86	91	99	106	112	119	125	133	140
	V	4.5	4.6	4.6	4.6	4.6	4.6	4.7	4.7	4.7	4.7	4.7	4.7	4.7	4.7	4.7	4.7	4.7
	S	2.8	2.8	2.8	2.7	2.7	2.7	2.7	2.7	2.7	2.7	2.7	2.7	2.7	2.7	2.7	2.7	2.7
	X	62	62	62	63	63	63	63	63	63	63	63	64	64	64	64	64	64
1.4	Q	37	44	51	59	66	74	82	90	96	103	111	119	127	134	142	150	158
	V	4.7	4.8	4.8	4.8	4.8	4.8	4.8	4.8	4.8	4.9	4.9	4.9	4.9	4.9	4.9	4.9	4.9
	S	2.8	2.7	2.7	2.7	2.7	2.7	2.7	2.6	2.6	2.6	2.6	2.6	2.6	2.6	2.6	2.6	2.6
	X	65	66	66	66	66	67	67	67	67	67	67	68	68	68	68	68	69
1.5	Q	41	50	58	66	75	85	92	101	108	116	125	133	142	150	160	169	178
	V	4.8	4.9	4.9	5.0	5.0	5.0	5.0	5.0	5.0	5.0	5.0	5.0	5.0	5.0	5.1	5.1	5.1
	S	2.7	2.7	2.6	2.6	2.6	2.6	2.6	2.6	2.6	2.6	2.6	2.6	2.6	2.6	2.5	2.5	2.5
	X	69	69	70	70	71	71	71	71	71	71	71	72	72	72	72	72	72
1.6	Q	46	56	65	75	84	94	104	112	122	132	142	149	158	168	178	187	197
	V	5.0	5.1	5.1	5.1	5.1	5.2	5.2	5.2	5.2	5.2	5.2	5.2	5.2	5.2	5.2	5.2	5.2
	S	2.6	2.6	2.6	2.5	2.5	2.5	2.5	2.5	2.5	2.5	2.5	2.5	2.5	2.5	2.5	2.5	2.5
	X	72	74	74	75	75	76	76	76	76	76	76	76	76	76	76	76	76
1.7	Q	52	62	72	83	94	105	115	126	135	145	156	167	175	187	196	206	217
	V	5.2	5.2	5.2	5.3	5.3	5.3	5.3	5.4	5.4	5.4	5.4	5.4	5.4	5.4	5.4	5.4	5.4
	S	2.6	2.6	2.5	2.5	2.5	2.5	2.5	2.5	2.5	2.5	2.5	2.5	2.5	2.5	2.5	2.5	2.5
	X	76	78	79	80	80	80	80	80	80	80	80	80	80	80	80	80	80
1.8	Q	58	69	81	93	104	116	127	138	150	160	171	182	194	204	214	226	233
	V	5.3	5.4	5.4	5.5	5.5	5.5	5.5	5.5	5.5	5.5	5.5	5.5	5.6	5.6	5.6	5.6	5.6
	S	2.5	2.5	2.5	2.5	2.4	2.4	2.4	2.4	2.4	2.4	2.4	2.4	2.4	2.4	2.4	2.4	2.4
	X	80	82	83	84	84	84	84	84	84	84	84	84	84	84	84	84	84
1.9	Q	64	76	88	102	114	127	140	152	164	175	188	201	213	225	235	248	260
	V	5.5	5.5	5.5	5.6	5.6	5.6	5.7	5.7	5.7	5.7	5.7	5.7	5.7	5.7	5.7	5.7	5.7
	S	2.5	2.5	2.5	2.4	2.4	2.4	2.4	2.4	2.4	2.4	2.4	2.4	2.4	2.4	2.4	2.4	2.4
	X	84	85	86	87	88	88	88	88	88	88	88	88	88	88	88	88	88
2.0	Q	71	83	97	111	125	138	153	164	178	193	204	218	232	245	256	269	283
	V	5.6	5.7	5.7	5.7	5.8	5.8	5.8	5.8	5.8	5.8	5.8	5.8	5.9	5.9	5.9	5.9	5.9
	S	2.5	2.4	2.4	2.4	2.4	2.4	2.4	2.4	2.3	2.3	2.3	2.3	2.3	2.3	2.3	2.3	2.3
	X	88	90	91	91	91	91	92	92	92	92	92	92	92	92	92	92	92
2.1	Q	77	91	107	122	135	149	162	177	192	207	220	234	250	267	276	291	305
	V	5.7	5.8	5.9	5.9	5.9	5.9	5.9	6.0	6.0	6.0	6.0	6.0	6.0	6.0	6.0	6.0	6.0
	S	2.4	2.4	2.4	2.4	2.4	2.3	2.3	2.3	2.3	2.3	2.3	2.3	2.3	2.3	2.3	2.3	2.3
	X	92	93	95	95	95	95	95	95	95	96	96	96	96	96	96	96	96
2.2	Q	84	100	116	131	146	163	177	194	210	224	238	253	269	288	301	314	330
	V	5.9	5.9	6.0	6.0	6.0	6.1	6.1	6.1	6.1	6.1	6.1	6.1	6.1	6.2	6.2	6.2	6.2
	S	2.4	2.4	2.4	2.3	2.3	2.3	2.3	2.3	2.3	2.3	2.3	2.3	2.3	2.3	2.3	2.3	2.3
	X	96	98	99	99	99	99	99	100	100	100	100	100	100	100	100	100	100
2.3	Q	90	108	124	140	158	175	193	208	226	243	258	275	292	306	323	341	354
	V	6.0	6.1	6.1	6.1	6.2	6.2	6.2	6.2	6.3	6.3	6.3	6.3	6.3	6.3	6.3	6.3	6.3
	S	2.4	2.4	2.3	2.3	2.3	2.3	2.3	2.3	2.2	2.2	2.2	2.2	2.2	2.2	2.2	2.2	2.2
	X	100	102	102	103	103	103	104	104	104	105	105	105	105	105	105	105	105
2.4	Q	99	116	136	152	170	189	206	224	241	260	275	294	312	327	346	364	378
	V	6.1	6.2	6.2	6.3	6.3	6.3	6.4	6.4	6.4	6.4	6.4	6.4	6.4	6.4	6.4	6.4	6.4
	S	2.3	2.3	2.3	2.3	2.3	2.2	2.2	2.2	2.2	2.2	2.2	2.2	2.2	2.2	2.2	2.2	2.2
	X	105	105	106	107	107	108	108	108	108	108	109	109	109	109	109	109	109

Temporary Sediment Basin (SB)

Source: USDA-NRCS

Figure SB-12 Sediment Delivery Ratio Vs. Drainage Area Graph

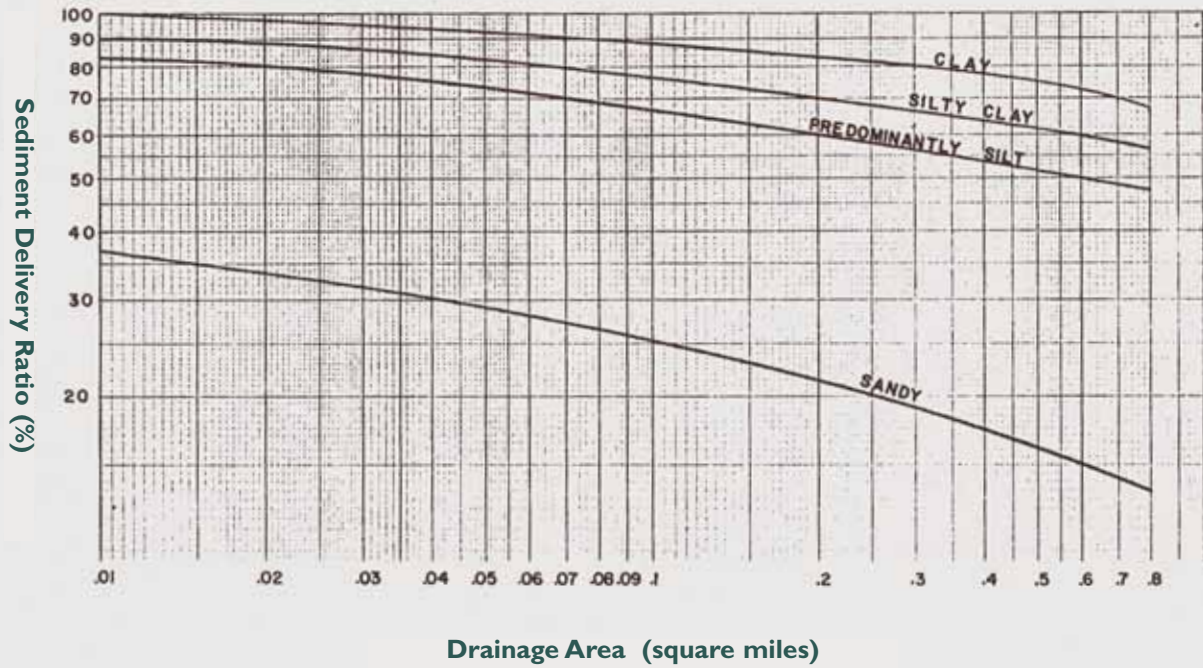

Source: USDA-NRCS

Figure SB-13 Maximum Peak Outflow for Detention Time Graph

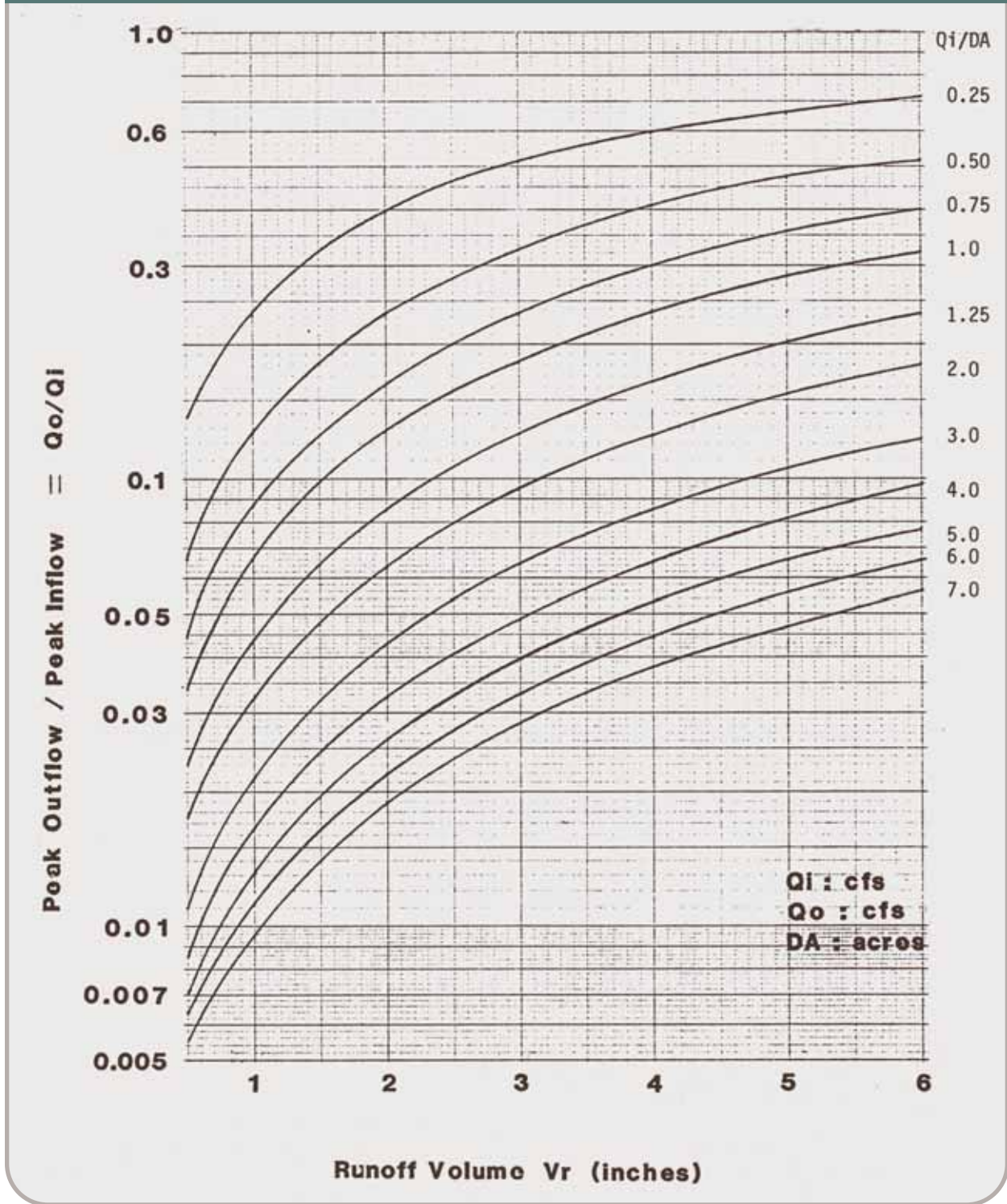

Source: USDA-NRCS

Temporary Sediment Basin: Design Example I

Determining Volume in a Sediment Basin to Meet Sediment Storage Volume and Detention Storage Volume Requirements

One-hundred acres drain into a planned sediment basin. Failure of the sediment basin at the planned site will not result in loss of life or damage to buildings, roads, railroads or utilities. Ten acres are to be cleared and developed into houses. Ninety acres are in woods and will not be disturbed during the life of the sediment basin. It is estimated it will take 18 months to develop the site. The sediment basin will be installed as the first item of construction and removed as the last item of construction. The owner estimates that the ten acres to be developed will be bare for 12 months and under roofs, pavement, and sod for the last six months of construction. The soils are Agawam fine sandy loam on a flat slope. The sediment pool will be normally dry. The 10-year, 24-hour rainfall is 5.0 inches.

Determine sediment storage volume using the following method:
Determine, DA - Drainage Area and A - Average Annual Erosion

1st year

Woods

$$(DA)(A) = 90 \text{ ac} \times 0.2 \text{ tons/ac/yr} = 18 \text{ tons/yr}$$

Construction Area

$$(DA)(A) = 10 \text{ ac} \times 50 \text{ tons} = 500 \text{ tons/yr}$$

$$(DA)(A) = 518 \text{ tons for the 1st year.}$$

2nd year

Woods

$$(DA)(A) = 90 \text{ ac} \times 0.2 \text{ tons/ac/yr} = 18 \text{ tons/yr}$$

Urban Area

$$(DA)(A) = 10 \text{ ac} \times 1.0 \text{ tons/ac/yr} = 10 \text{ tons/yr}$$

$$(DA)(A) = (18 + 10) = 14 \text{ tons for 2nd year for six month life}$$

$$(DA)(A) = 518 + 14 = 532 \text{ tons for the life of the basin.}$$

Determine DR - delivery ratio

$$100/640 = 0.16 \text{ sq mi from Figure SB-12 for a sandy soil, } DR = 24\%.$$

Determine γ - density of the sediment. From **Figure SB-1** the density of submerged sand is 85-100 lbs/cu. ft., Use $\gamma = 90$ lbs/cu. ft.

Determine TE trap efficiency. The TE is 80 % from the sediment storage volume section of the Sediment Basin measure.

Determine V - minimum volume for sediment storage for the planned life of the structure using the formula:

$$V = \frac{(DA)(A)(DR)(TE)(2,000 \text{ lbs./ton})}{(\gamma)(43,560 \text{ sq.ft./ac})}$$

$$V = (532)(0.24)(0.80)(1/90)(2,000)(1/43,560)$$

$$V = 0.052 \text{ Ac. ft. for sediment storage.}$$

Determine detention storage volume.

Given that:

$$Q_{10} = 30 \text{ cfs and}$$

$$V_r = 1.30 \text{ inches}$$

Then:

$$Q_i = 30 \text{ cfs}$$

$$V_r = 1.3$$

$$\frac{Q_{10}}{DA} = \frac{30}{100} = 0.30$$

From **Figure SB-13**

$$\frac{Q_o}{Q_i} = 0.27$$

(continued on next page)

Design Example I (continued)

$Q_o = 8.1$ cfs = maximum allowable principal spillway discharge.

$$Q_o = (0.27) (Q_i) = (0.27) (30) = 8.1 \text{ cfs}$$

$$\text{Release rate} = \frac{(8.1 \text{ cfs}) (640 \text{ Ac./sq. mi.})}{(100 \text{ Ac.})} = 51.8 \text{ csm}$$

$$V_p = 1.3 \text{ inches}$$

From the figures in the Detention Basin measure for single stage structures with release rates less than 300 csm, the minimum storage required, V_s , is 0.67 inches.

$$V_s = 0.67 \text{ inches} = \frac{(0.67 \text{ in.}) (100 \text{ Ac.})}{(12 \text{ in./ft.})} = 5.58 \text{ Ac. ft.}$$

$$V_s = 5.58 \text{ Ac. ft. for detention storage volume.}$$

The minimum volume required below the crest of the emergency spillway is 0.052 Ac. ft. plus 5.58 Ac. ft. or 5.63 Ac. ft.

Temporary Sediment Basin: Design Example 2

Same as Design Example 1 except the soil is Hollis fine sandy loam on a steep slope.

Determine sediment storage volume using method given in Example No. 1.

(DA) (A) same as in Design Example 1

(DA) (A) = 518 tons for the 1st year

(DA) (A) = 14 tons for the 2nd year

Determine, DR - delivery ratio.

The Hollis soil is a fine sandy loam. Using the Soil Survey Report, this soil would be approximately 60% sand and 40% silt. Using **Figure SB-12** with 0.16 sq. mi. drainage area and a value between the sandy and silty curves, the delivery ratio is 45%.

Determine, γ - density of sediment. $\gamma = 95$ lbs/cu.ft., using **Figure SB-1** with sand-silt mixture.

The trap efficiency is the same as Design Example No. 1 and is 80%.

Determine minimum volume for sediment storage for the planned life structure using the formula:

$$V = \frac{(DA)(A)(DR)(TE)(2,000\text{lbs./ton})}{(\gamma)(43,560\text{sq.ft./ac})}$$

$$V = (518 + 14) (0.45) (0.80) (1/95) (2,000) (1/43,560)$$

$$V = 0.093 \text{ Ac. ft. for sediment storage}$$

Determine detention storage volume.

Given that:

$$Q_i = Q_{10} = 285 \text{ cfs}$$

$$V_r = 2.89 \text{ inches and}$$

$$DA = 100 \text{ acres}$$

Then:

$$\frac{Q_i}{DA} = \frac{285}{100} = 2.89 \text{ inches}$$

From **Figure SB-13**

$$\frac{Q_o}{Q_i} = 0.066$$

$$Q_o = (0.066) (Q_i) = (0.066) (285)$$

$$Q_o = 18.8 \text{ cfs (the maximum allowable principal spillway discharge rate)}$$

$$Q_o = (\text{relative to drainage area}) = \frac{18.8\text{cfs}}{100 \text{ acres}} = \frac{(640 \text{ acres})}{(1 \text{ sq. mile})}$$

$$= 120.3 \text{ csm}$$

From **Detention Basin** measure **Figure DB-6**,

when $V_r = 2.89$ inches V_s is 1.65 inches

$$V_s = 1.65 \text{ inches} = \frac{(1.65 \text{ in.}) (100 \text{ Ac.})}{(12 \text{ in./ft.})} = 13.75 \text{ Ac. ft.}$$

$$V_s = 13.75 \text{ Ac. ft. for detention storage volume}$$

The minimum volume required below the crest of the emergency spillway is 0.093 Ac. ft. for sediment storage volume plus 13.75 Ac. ft. for detention storage volume or 13.84 Ac. ft.

Conclusions From Design Examples

To have a reasonable size sediment basin that is effective, two components are critical. The total drainage area must be small. The volume of runoff must be low. To accomplish this requires good vegetative cover and soils with high infiltration rates.

11 - Sediment Impoundments, Barriers and Filters

Temporary Sediment Trap (TST)

Definition

A temporary ponding area with a stone outlet formed by excavation and/or constructing an earthen embankment.

Purpose

To detain sediment-laden runoff from small disturbed areas long enough to allow a majority of the sediment to settle out.

Applicability

- Below disturbed areas where the contributing drainage area is 5 acres or less. For drainage areas greater than 5 acres use **Temporary Sediment Basin** measure.
- Where the intended use is 2 years or less. For uses greater than 2 years use **Temporary Sediment Basin** measure.
- When diverting sediment-laden water with temporary diversions that meet the above limitations for use.

Planning Considerations

Sequence the construction of temporary sediment traps, along with other perimeter erosion and sediment controls so that they are constructed and made functional before land disturbance in the contributing drainage area takes place.

The temporary sediment trap has two storage requirements: one for wet storage and one for dry storage. Commonly, the wet storage is created by excavation within a drainage way and the dry storage created by the construction of a pervious stone dike across the drainage way. Sometimes the trap is formed, at least in part, by the construction of an embankment. Such an embankment constitutes a dam and is therefore limited to a height of no greater than 5 feet and requires care in its construction.

E&S plans should identify the size of the contributing drainage area, wet and dry storage requirements as well as the volume of sediment accumulation that will trigger trap cleaning. Sediment is required to be removed from the trap when the sediment accumulation exceeds half of the wet storage volume of the trap. The plans should also guarantee that access is provided for sediment removal and detail how excavated sediment will be disposed (such as by use in fill areas on-site or removal to an approved off-site location).

Variations in temporary sediment trap design may be considered, but plan reviewers should ensure the minimum storage requirements and structural requirements noted below are maintained.

Specifications

Location

Locate temporary sediment traps so that they can be installed prior to conducting any grading activities in the contributing watershed. Do not locate traps in close proximity to existing or proposed building foundations if there is any concern regarding seepage of water from the temporary sediment trap into the foundations or foundation excavation area. Locate traps to obtain maximum storage benefit from the terrain, for ease of clean out and disposal of the trapped sediment.

Trap Capacity

The temporary sediment trap shall have an initial storage volume of 134 cubic yards per acre of drainage area, half of which shall be in the form of wet storage to provide a stable settling medium. The remaining storage volume shall be in the form of a drawdown (dry storage) which will provide extended settling time during less frequent, larger storm events. **Figure TST-1** contains the formulas for calculating the wet storage volume and the dry storage volume. The volume of wet storage shall be measured from the low point of the excavated area to the base of the stone outlet structure (see **Figure TST-2**). The volume of the dry storage shall be measured from the base of the stone outlet to the top of the stone outlet (overflow mechanism).

Try to provide a storage area which has a minimum 2:1 length to width ratio (measured from point of maximum runoff introduction to outlet)

Figure TST-1 Formula for Figuring Temporary Sediment Trap Storage Requirements

Wet storage volume may be approximated as follows:

$$V_w = 0.85 \times A_w \times D_w$$

where,

V_w = the wet storage volume in cubic feet

A_w = the surface area of the flooded area at the base of the stone outlet in square feet

D_w = the maximum depth in feet, measured from the low point in the trap to the base of the stone outlet.

Dry storage volume may be approximated as follows:

$$V_d = \frac{(A_w + A_d)}{2} \times D_d$$

where,

V_d = the dry storage volume

A_w = the surface area of the flooded area at the base of the stone outlet in square feet.

A_d = the surface area of the flooded area at the top of the stone outlet (over flow mechanism), in square feet

D_d = the depth in feet, measured from the base of the stone outlet to the top of the stone outlet

Note: Conversion between cubic feet and cubic yards is: cubic feet x 0.037 = cubic yards.

Slope Limitations

All cut and fill slopes shall be 2:1 or flatter except for the excavated wet storage area where slopes shall not exceed 1.5:1. The maximum depth of excavation within the wet storage area should not exceed 3 feet to facilitate clean-out and for site safety considerations.

Inlet / Outlet Configuration

The outlet shall be located at the most distant hydraulic point from the inlet. In cases where a long narrow site runs perpendicular to the direction of flow, baffles consisting of stone dikes or other structurally sufficient barriers should be added along the long axis of the trap to increase travel distance through the trap (see **Figure TST-3**).

Outlet

Plan the outlet in such a manner that the minimum wet storage and dry storage volumes are created (see Trap Capacity section above) and 1 foot of free board between the top of the outlet and the crest of the embankment is established. The outlet consists of a pervious stone dike with a core of modified riprap and faced on the upstream side with DOT #3 stone. Temporary sediment traps must outlet onto stabilized (preferably undisturbed) ground, into a watercourse, stabilized channel, or into a storm drain system. **Figure TST-4** shows an example of an outlet for a temporary sediment trap.

Embankment

The maximum height of a temporary sediment trap embankment is limited to 5 feet as measured vertically

from the crest of the embankment to the down slope base of the embankment or toe of the stone dike, whichever is lower. Minimum top widths (W) and outlet heights (Ho) for various embankment heights (H) are shown in **Figure TST-2**. Side slopes of the embankment shall be 2:1 or flatter.

Materials

Modified Riprap: shall meet the requirements of DOT Standard Specifications Section M.12.02.

DOT #3 Stone: shall meet the requirements of DOT Standard Specifications Section M.01.01 for #3 Aggregate.

Construction

Clear, grub and strip any vegetation and root mat from any proposed embankment and outlet area. Remove stones and rocks whose diameter is greater than 3 inches and other debris.

Excavate wet storage and construct the embankment and/or outlet as needed to attain the necessary storage requirements. Use only fill material for the embankment that is free from excessive organics, debris, large rocks (over 6 inches) or other unsuitable materials. Compact the embankment in 9-inch layers by traversing with equipment while it is being constructed.

Stabilize the earthen embankment using any of the following measures: **Temporary Seeding, Permanent Seeding, or Stone Slope Protection** immediately after installation.

Carry out construction operations in such a manner that erosion and water pollution are minimized.

Figure TST-2 Minimum Top Width (w) Required for Temporary Sediment Trap Embankments According to Height of Embankment (feet)

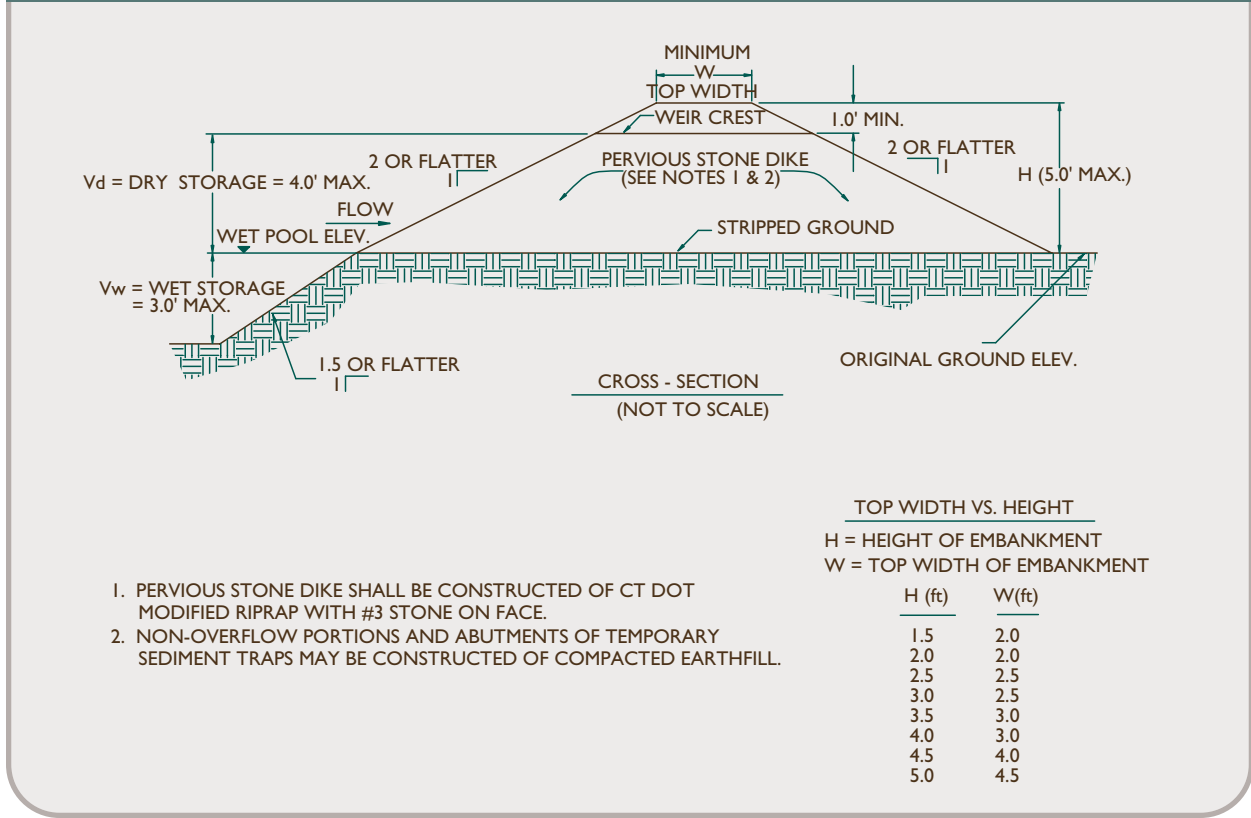

Source: USDA-NRCS

Maintenance

Inspect the temporary sediment trap at least once a week and within 24 hours of the end of a storm with a rainfall amount of 0.5 inch or greater. Check the outlet to ensure that it is structurally sound and has not been damaged by erosion or construction equipment. The height of the stone outlet should be maintained at least 1 foot below the crest of the embankment. Also check for sediment accumulation and filtration performance.

When sediments have accumulated to one half the minimum required volume of the wet storage, dewater the trap as needed, remove sediments and restore the

trap to its original dimensions. Dispose of the sediment removed from the basin in a suitable area and in such a manner that it will not erode and cause sedimentation problems.

The temporary sediment trap may be removed after the contributing drainage area is stabilized. If it is to be removed, then the plans should show how the site of the temporary sediment trap is to be graded and stabilized after removal.

Figure TST-3 Example plan Views of Baffles in Temporary Sediment Traps

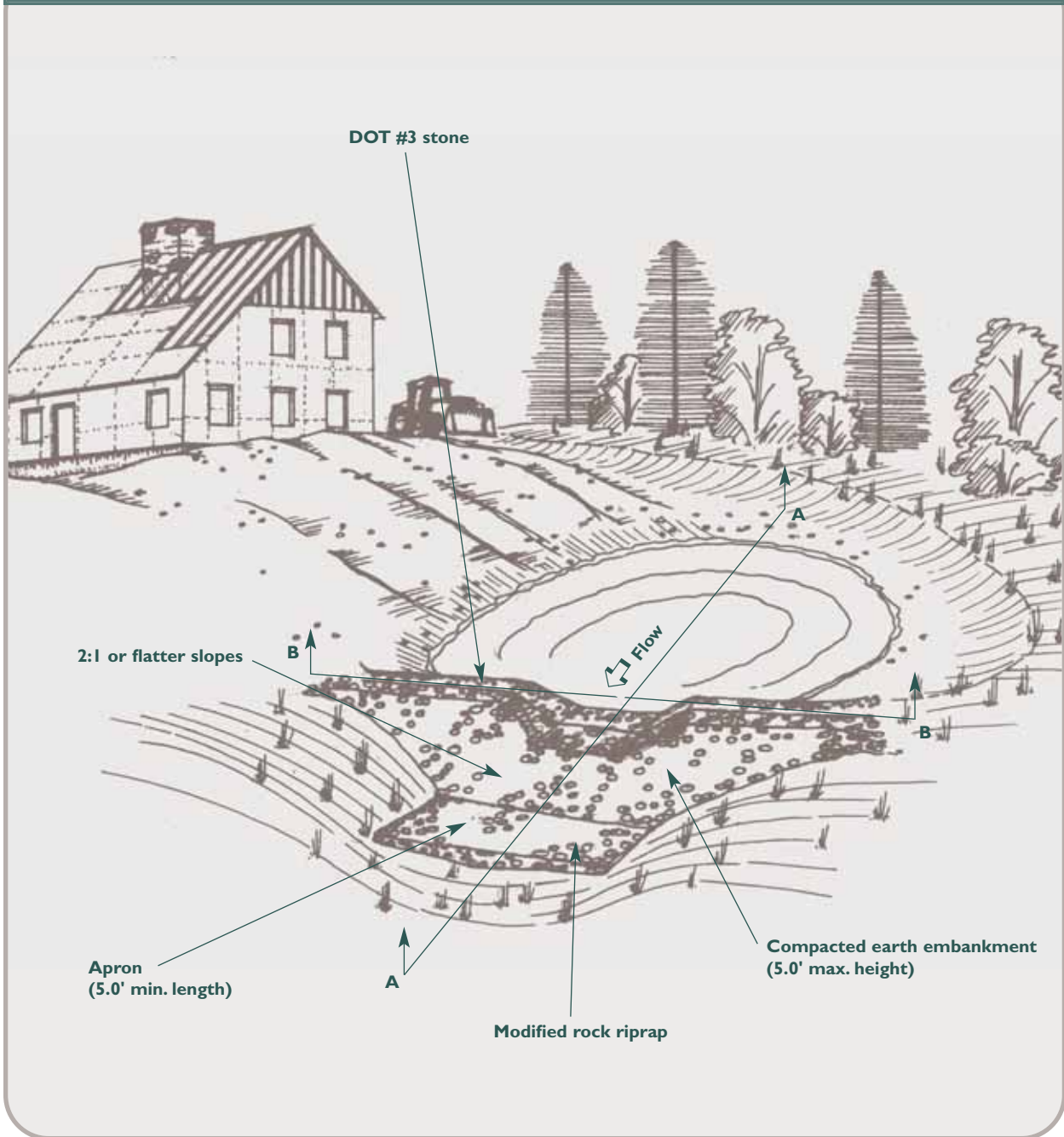

Temporary Sediment Trap (TST)

Figure TST-4 Views of a Temporary Sediment Trap Outlet

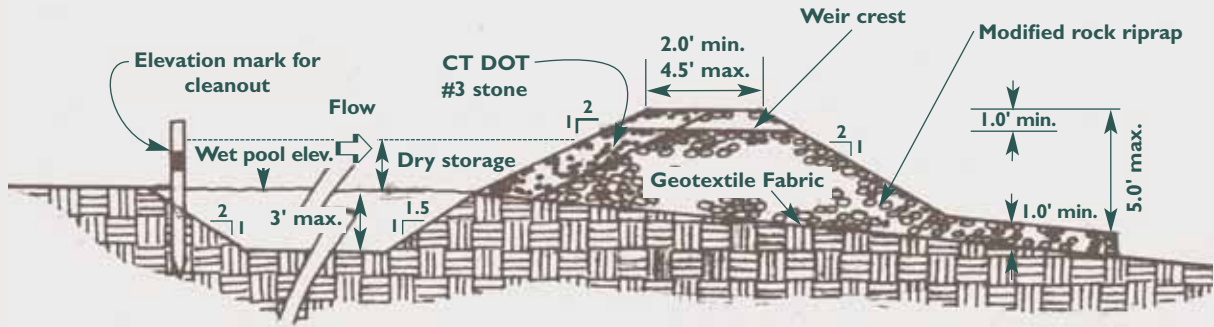

X - Section A-A
(not to scale)

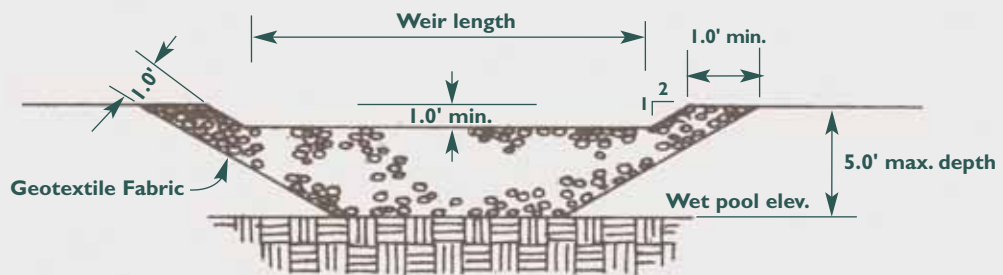

X - Section B-B
(not to scale)

11- Sediment Impoundments, Barriers and Filters

Hay Bale Barrier (HB)

Definition

A temporary sediment barrier consisting of a row of entrenched and anchored bales of hay or straw.

Purpose

- To intercept and detain small amounts of sediment from small disturbed areas.
- To decrease the velocity of sheet flows.
- To redirect small volumes of water away from erodible soils.
- To settle and assist in filtering waters discharged from pumping operations (see **Pumping Settling Basin** measure, Type I and Type II).

Applicability

- Below small disturbed areas where the drainage area (disturbed and undisturbed) is less than 1 acre in size.
- Above disturbed slopes to direct surface water away from erodible areas where the drainage area (disturbed and undisturbed) is less than 1 acre in size.
- Where protection and effectiveness is required for less than 3 months.
- Where sedimentation will reduce the capacity of storm drainage systems or adversely affect adjacent areas, watercourses and other sensitive areas.
- Not for use in drainageways, except in special cases where it is applied with other measures (see **Geotextile Silt Fence** and **Stone Check Dams** Special Cases).
- Not intended for use in streams.

Planning Considerations

See Planning Considerations for Sediment Impoundments, Barriers and Filters Function Group.

Specifications

Materials

Hay Bales: shall be made of hay or straw with 40 pounds minimum weight and 120 pounds maximum weight held together by twine or wire.

Stakes for Anchoring Hay Bales: shall be a minimum of 36 inches long and made of either hardwood with dimensions of at least 1.5 inches square or steel posts with a minimum weight of 0.5 pound per linear foot.

Placement on the Landscape

Contributing drainage area is no greater than 1 acre. Maximum slope length is as shown in **Figure HB-1**.

Toe of Slope: Locate 5-10 feet down gradient from the toe of slope (see **Figure HB-2**), generally on the contour. When the contour can not be followed, stagger the bale installation and install perpendicular wings spaced as shown in **Figure HB-1** to break the velocity of water flowing behind the bales. The barrier should be located with

sufficient distance from the toe of the slope to allow access by equipment for removal of accumulated sediments

Swales: Not recommended. See **Geotextile Silt Fence** or **Stone Check Dam** measures.

Catch Basins in Swales on Slopes: Not recommended. See **Geotextile Silt Fence** or **Stone Check Dam** measures.

Catch Basins in Depressions or Low Spots (yard drains): Encircle catchbasin (see **Figure HB-3**).

Culvert Inlets: Not recommended. See **Geotextile Silt Fence** measure.

Culvert Outlets: Not recommended. Use **Temporary Sediment Trap** and/or **Stone Check Dam** measures.

Pumping Settling Basin: See **Pumping Settling Basin** measure.

Installation (see **Figure HB-2**)

Trench excavation: Excavate a trench as wide as the bales and at least 4 inches deep. Each end of the trench should be winged upslope so that the bottom of the last bale is higher than the top of the lowest hay bale in the barrier.

Figure HB-1 Hay Bale Design Slope/Length Limitations

Slope Steepness ¹	Slope Length and Wing Spacing
5:1 or shallower	100 feet
3:1 to 5:1	75 feet
2:1 to 3:1	50 feet

¹ Where the gradient changes through the drainage area the steepest slope section shall be used.

Hay Bale Placement: Place bales in a single row in the trench, lengthwise, with ends of adjacent bales tightly abutting one another and the bindings oriented around the sides rather than along the tops and bottoms of the bales (to avoid premature rotting of the bindings).

Staking Hay Bales: Anchor each bale with at least 2 stakes, driving the first stake in each bale toward the previously laid bale to force the bales together. Stakes must be driven a minimum of 18 inches into the ground.

Fill any gaps between the bales with hay or straw to prevent water from escaping between the bales.

Backfill & Tamped: Backfill the bales with the excavated trench material to a minimum depth of 4 inches on the uphill side of the bales. Tamp by hand or machine and compact the soil. Loose hay or straw scattered over the disturbed area immediately uphill from the hay bale barrier tends to increase barrier efficiency.

Substitute Measures

Geotextile Silt Fence may be used as a substitute. When frozen or other similar ground conditions prevent the proper trenching or anchoring of hay bales, a sediment barrier consisting of a stone check dam with a hay bale core may be substituted for the hay bale barrier. See **Stone Check Dam** measure, “Special Case Combinations for Added Filtration & Frozen Ground Conditions” for details.

Maintenance

Inspect the hay bale barrier at least once a week and within 24 hours of the end of a storm with a rainfall amount of 0.5 inch or greater to determine maintenance needs. For dewatering operations, inspect frequently before, during, and after pumping operations.

Remove the sediment deposits or install a secondary barrier upslope from the existing barrier when sediment deposits reach approximately one half the height of the barrier (see **Figure HB-4**).

Replace or repair the barrier within 24 hours of observed failure. Failure of the barrier has occurred when sediment fails to be retained by the barrier because:

- the barrier has been overtopped, undercut or bypassed by runoff water,
- the barrier has been moved out of position, or
- the hay bales have deteriorated or been damaged.

When repetitive failures occur at the same location, review conditions and limitations for use and determine if additional controls (e.g. temporary stabilization of contributing area, diversions, stone barriers) are needed to reduce failure rate or replace hay bale barrier. See **Figure HB-5** for trouble shooting failures.

Maintain the hay bale barrier until the contributing area is stabilized.

After the upslope areas have been permanently stabilized, pull the stakes out of the hay bales. Unless otherwise required, no removal or regrading of accumulated sediment is necessary. The hay bales may then be left in place or broken up for ground cover.

Figure HB-2 Placement and Construction of a Hay Bale Barrier

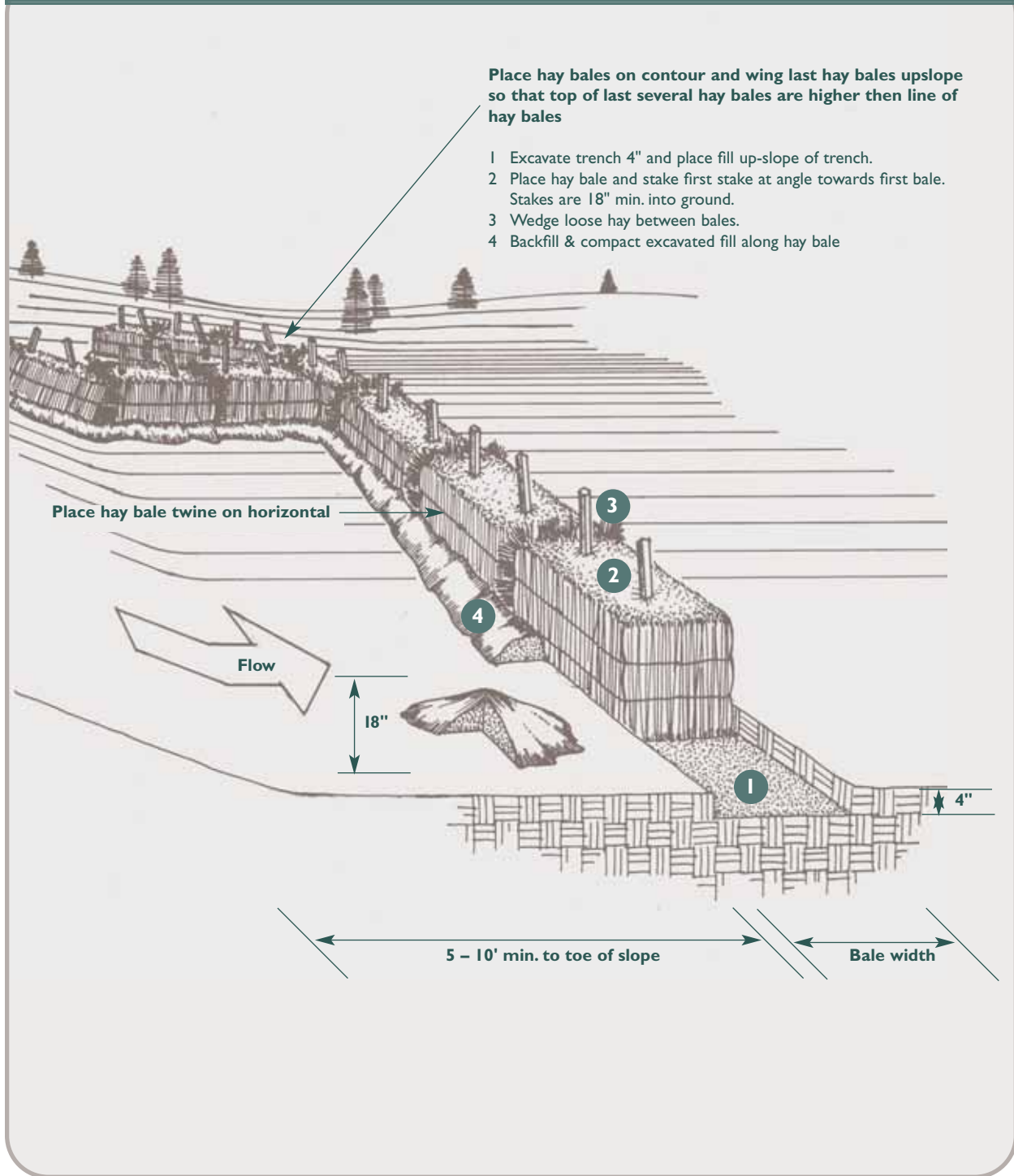

Figure HB-3 Hay Bale Barrier at Catchbasin in Hollow

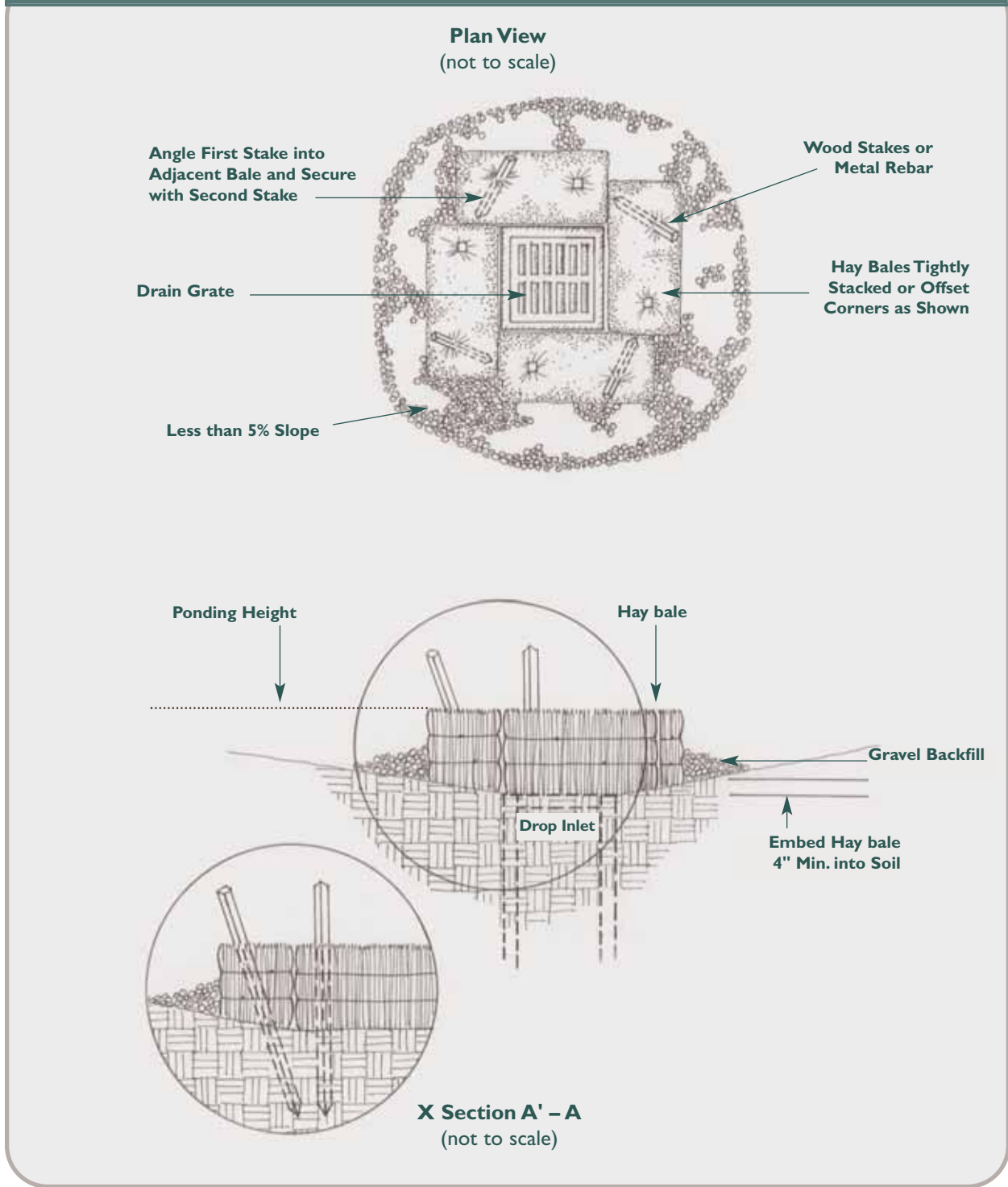

Figure HB-4 Adding Backup Hay Bale Barrier

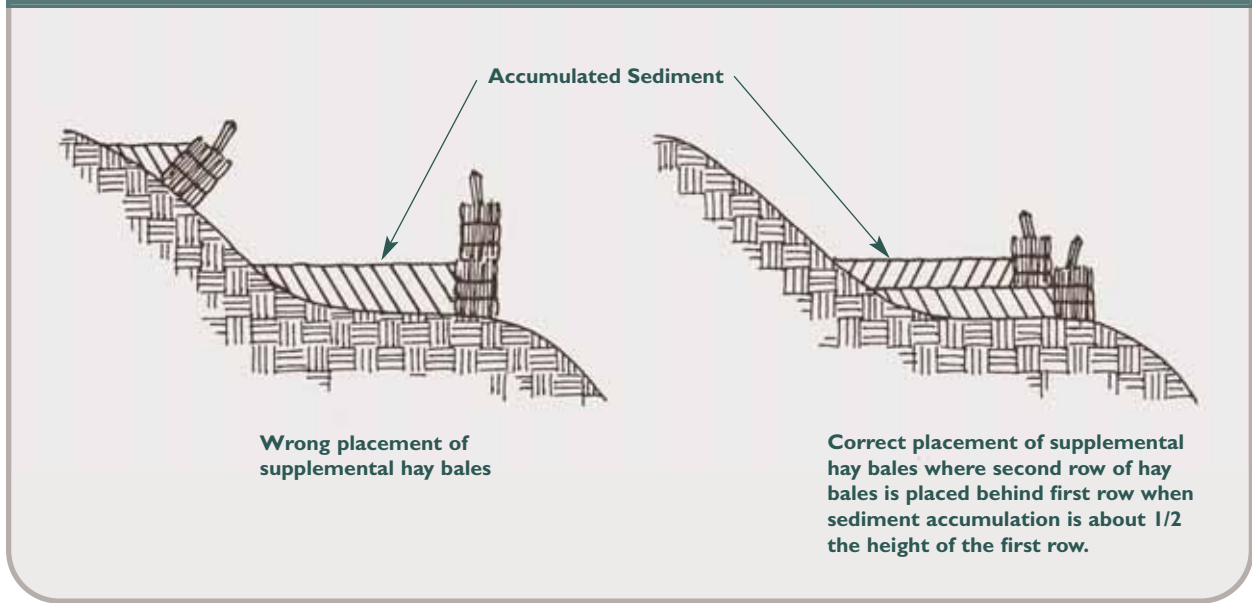

Figure HB-5 Hay Bale Barrier Trouble Shooting Guide

Problem	Cause	Fix
undercutting	inadequate trenching	reset bales properly or for small failure backfill downslope rills, fill & compact under failing bale, fill joints with hay, backfill up slope side of bale with 4" wedge of wood chips or compacted soil
	spaces between bales	
	barrier not on the contour, runoff flowing along upslope side of barrier	same as above, and install perpendicular wings to break flow line such that bottom end of wing is higher than top of barrier
rilling around end	not extending end of hay bale barrier far enough upslope	extend hay bale barrier far enough upslope so that bottom of last bale is higher than top of lowest bale
hay bales moved	watershed too large	change to stone barrier
	flows too concentrated	change to geotextile silt fence or stone barrier
	inadequately staked	fill and compact any rills at hay bale barrier, reinstall bale, fill joints, backfill and compact, increase staking depths

11 - Sediment Impoundments, Barriers and Filters

Geotextile Silt Fence (GSF)

Definition

A temporary sediment barrier consisting of a geotextile fabric pulled taut and attached to supporting posts and entrenched.

Purpose

- To intercept and retain sediment from disturbed areas.
- To decrease the velocity of sheet flows and low volume concentrated flows.

Applicability

- Below small disturbed areas where the contributing drainage area (disturbed and undisturbed) is less than 1 acre in size.
- At storm water drainage inlets and catch basins where sedimentation will reduce the capacity of storm drainage systems or adversely affect adjacent areas, water-courses and other sensitive areas.
- Not for use in areas where rock, frozen ground or other hard surface prevents proper installation of the barrier (see Special Case Combinations in **Stone Check Dam** measure).
- Prohibited from use in drainageways whose flow is supported by ground water discharge.

Planning Considerations

See Planning Considerations for Sediment Impoundments, Barriers and Filters Functional Group. When used at a culvert outlet, plan to install the geotextile silt fence before the start of construction and complete the installation of the required outlet protection before the culvert is made functional. It is preferable to control sediment at the inlets rather than at the outlet. Use at outlets should be limited to situations where inlet controls are not possible or to act as a backup to inlet controls.

Specifications

Materials

Geotextile fabric: shall be a pervious sheet of polypropylene, nylon, polyester, ethylene or similar filaments and shall be certified by the manufacturer or supplier as conforming to the requirements shown in **Figure GSF-1**. The geotextile shall be non-rotting, acid and alkali resistant and have sufficient strength and permeability for the purpose intended, including handling and backfilling operations. Filaments in the geotextile shall be resistant to absorption. The filament network must be dimensionally stable and resistant to de-lamination. The geotextile shall be free of any chemical treatment or coating that will reduce its permeability. The geotextile shall also be free of any flaws or defects which will alter its physical properties. Torn or punctured geotextiles shall not be used.

Supporting posts: shall be at least 42 inches long made of either 1.5 inch square hardwood stakes or steel posts with projections for fastening the geotextile possessing a minimum strength of 0.5 pound per linear foot.

Placement on the Landscape

Contributing drainage area 1 acre or less. Maximum slope length is as shown in **Figure GSF-2**.

For toe of slope (Figure GSF-3): Locate 5-10 feet down gradient from the toe of slope, generally on the contour with maintenance and sediment removal requirements in mind. When the contour can not be followed install the fence such that perpendicular wings are created to break the velocity of water flowing along the fence. See **Figure GSF-2** for spacing requirements.

Swales (see Figure GSF-4): Locate "U" shape across swale such that the bottom of both ends of the fence are higher than the top of the lowest section of the fence.

Catch Basins in Swale on Slopes: Locate 2 "U" shapes across swale as above: one immediately up slope from the catch basin and the other immediately down slope from the catch basin.

Catch Basins in Depressions: Encircle catch basin.

Culvert Inlets: Locate in a "U" shape approximately 6 feet from the culvert in the direction of the incoming flow.

Figure GSF-1 Geotextile Silt Fencing Minimum Requirements

Physical Property	Test Method	Minimum Requirement
filtering efficiency	ASTM 5141	75% (min)
grab tensile strength (lbs.)	ASTM D4632	100 lbs
elongation @ failure	ASTM D4632	15 %
Mullen burst strength	ASTM D3786	250 psi
puncture strength	ASTM 4833	50 lbs
apparent opening size	ASTM D4751	no greater than 0.90 mm and no less than 0.60 mm
flow rate	ASTM D4491	0.2 gal/ft ² /min
permativity	ASTM D4491	0.05 sec. -1 (min)
ultraviolet radiation stability %	ASTM-D4355	70% after 500 hours of exposure (min)

Culvert Outlets: Locate across the swale at least 6 feet from the culvert outlet.

Figure GSF-2 Geotextile Silt Fence Slope/Length Limitations

Slope Steepness ¹	Slope Length and Wing Spacing
5:1 or flatter	100 feet
3:1 to 5:1	75 feet
2:1 to 3:1	50 feet

¹ Where the gradient changes through the drainage area the steepest slope section shall be used.

Installation (see **Figure GSF-3**)

Trench excavation: Excavate a trench a minimum of 6 inches deep and 6 inches wide on the up slope side of the fence location. For slope and swale installations, extend the ends of the trench sufficiently up slope such that bottom end of the fence will be higher than the top of the lowest portion of the fence.

When the fence is not to be installed on the contour, excavate wing trenches spaced at the intervals given in **Figure GSF-2**.

When trench excavation is obstructed by an occasional stone or tree root, provide a smooth transition between the trench bottom and the obstruction.

Support Posts: Drive support posts on the down slope side of the trench to a depth of at least 12 inches into original ground.

Never install support posts more than 10 feet apart. Install support posts closer than 10 feet apart when concentrated flows are anticipated or when steep contributing slopes and soil conditions are expected to generate larger volumes of sediment. For catch basins in hollows, drive posts at each corner of

the catch basin. Whenever the geotextile filter fabric that is used exceeds the minimum material specifications contained in this measure, the spacing of the stakes shall be per manufacturer's recommendations.

Geotextile Filter Fabric: Staple or secure the geotextile to the support posts per manufacturer's instruction such that at least 6 inches of geotextile lies within the trench, the height of the fence does not exceed 30 inches² and the geotextile is taut between the posts. When the trench is obstructed by stones, tree roots, etc. allow the geotextile to lay over the obstruction such that the bottom of the geotextile points up slope.

In the absence of manufacturer's instructions, space wire staples on wooden stakes at a maximum of 4 inches apart and alternate their position from parallel to the axis of the stake to perpendicular.

Do not staple the geotextile to living trees.

Provide reinforcement for the fence when it can be exposed to high winds.

When joints in the geotextile fabric are necessary, splice together only at a support posts, and securely seal (see manufacturer's recommendations).

Backfill & Compaction: Backfill the trench with tamped soil or aggregate over the geotextile (see **Figure GSF-3**). When the trench is obstructed by a stone, tree root, etc. make sure the bottom of the geotextile lies horizontal on the ground with the resulting flap on the up slope side of the geotextile and bury the flap 6 inches of tamped soil, or aggregate.

Maintenance

Inspect the silt fence at least once a week and within 24 hours of the end of a storm with a rainfall amount of 0.5 inch or greater to determine maintenance needs. When used for dewatering operations, inspect frequently before, during and after pumping operations.

² higher barriers may impound volumes of water sufficient to push over the support posts

Remove the sediment deposits or, if room allows, install a secondary silt fence up slope of the existing fence when sediment deposits reach approximately one half the height of the existing fence.

Replace or repair the fence within 24 hours of observed failure. Failure of the fence has occurred when sediment fails to be retained by the fence because:

- (a) the fence has been overtopped, undercut or bypassed by runoff water,
- (b) the fence has been moved out of position (knocked over), or
- (c) the geotextile has decomposed or been damaged.

When repetitive failures occur at the same location, review conditions and limitations for use and determine if additional controls (e.g. temporary stabilization of contributing area, diversions, stone barriers) are needed to reduce failure rate or replace fence. See **Figure GSF-5** for trouble shooting failures.

Maintain the fence until the contributing area is stabilized.

After the contributing area is stabilized determine if sediment contained by the fence requires removal or regrading and stabilization. If the depth is greater than or equal to 6 inches, regrading or removal of the accumulated sediment is required. No removal or regrading is required if sediment depth is less than 6 inches.

Remove the fence by pulling up the support posts and cutting the geotextile at ground level. Regrade or remove sediment as needed, and stabilize disturbed soils.

Figure GSF-3 Toe of Slope Installations with Wings

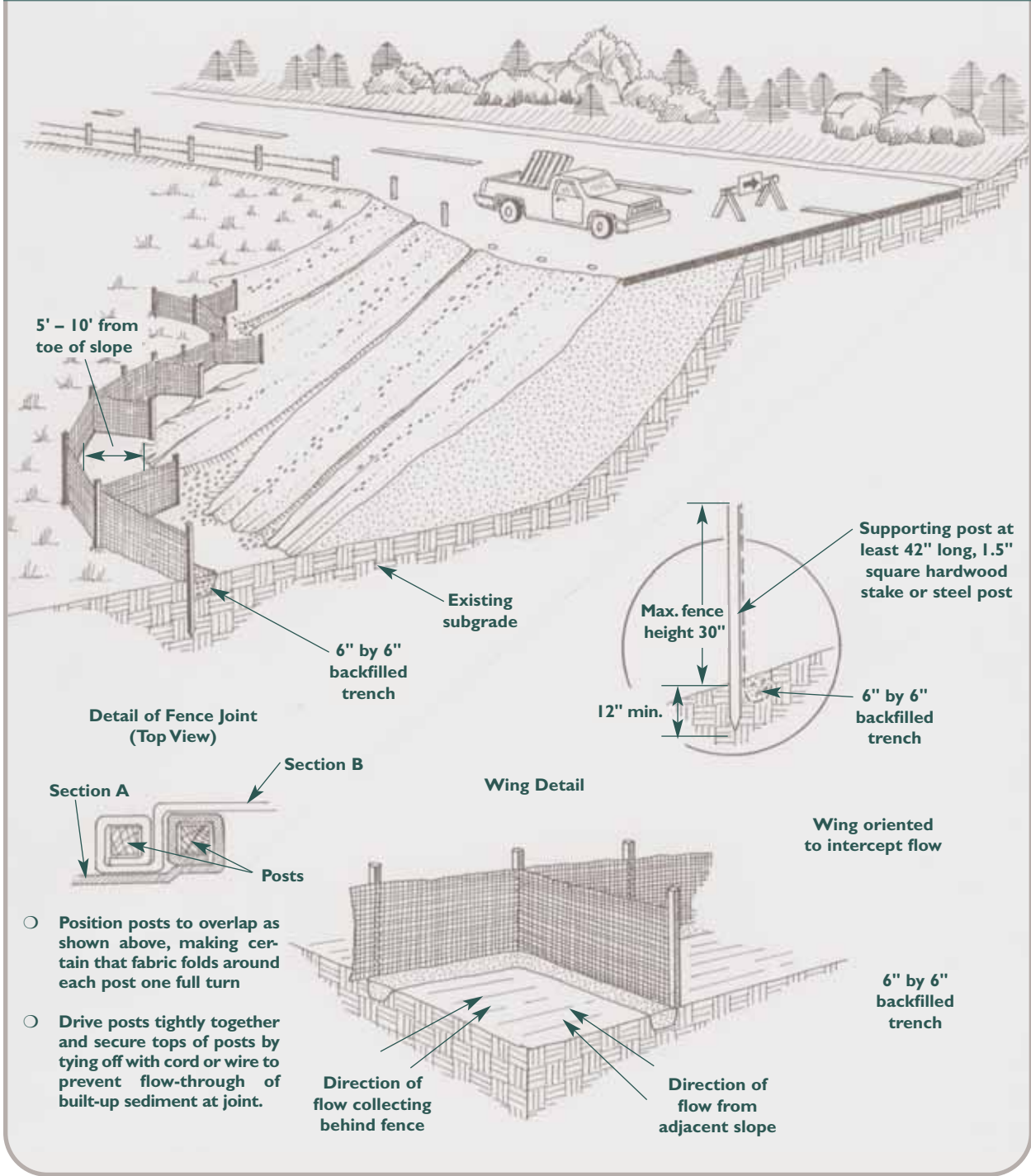

Geotextile Silt Fence (GSF)

Figure GSF-4 Swale and Catch Basin Installations

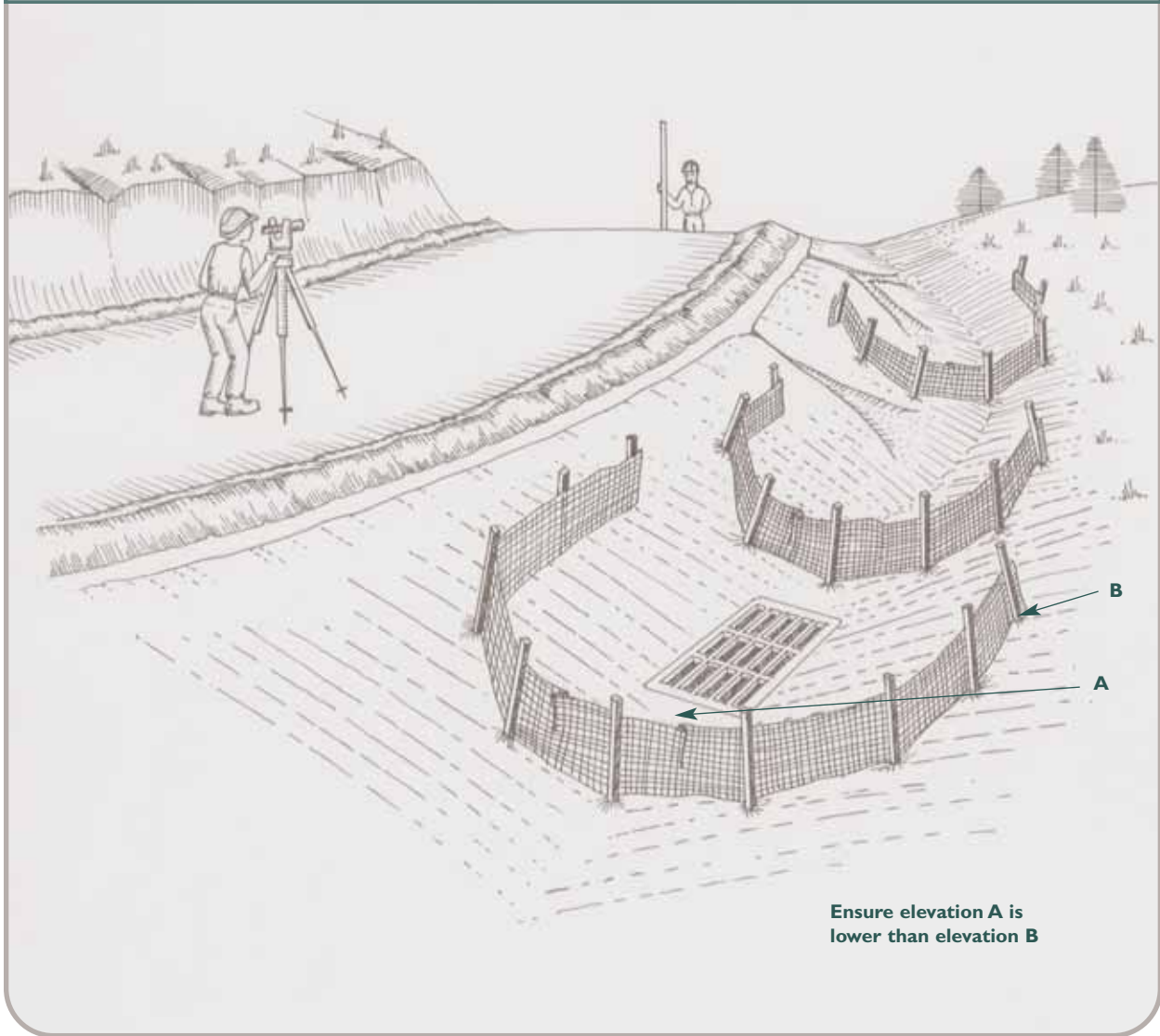

Figure GSF-5 Silt Fence Trouble Shooting Guide

Problem	Cause	Fix
fence fallen over or stakes broken from pressure of water	too large drainage area	Change to stone check dams or add additional controls up slope to reduce velocities and sediment loading (see measure matrix, Chapter 4 for other measures available).
	flows too concentrated	Repair or replace fence, increase staking frequency, angle stake up slope, consider installing hay bale barrier on the down slope side of fence in area of concentration or adding guy wire for support.
	stake not driven deep enough geotextile not properly attached to stakes	Repair or replace fence, increase stake depth. Recheck manufacturer's instructions on attachment and re-attach.
undercutting, toe failure	poor trenching or inadequate compaction, not enough geotextile buried	Install new fence properly or retrench, fill & compact rills at fence failure, drive stakes deeper as necessary to bury enough geotextile, fill & compact trench and down slope rills to provide support. For repeated failures consider installing hay bale barrier on the down slope side at the failure site after repair work is done.
	fence not on the contour, runoff eroding up slope side of barrier	Retrench, fill & compact rills at fence failure, and install perpendicular wings to break flow line such that bottom end of wing is higher than top of fence at wing joint OR install stone barriers on up slope side of fence to reduce runoff velocities. For repeated failures consider installing hay bale barrier on the down slope side at the failure site after
	poor transition from trench to obstruction at grade	Fill failed area to make smooth transition from trench to obstruction and re-bury flap of geotextile with 6 inches of tamped soil or aggregate. For repeated failures consider installing hay bale barrier on the down slope side at the failure site after repair work is done.
water running around ends	not extending end of fencing far enough up slope	Extend fence far enough up slope so that bottom of fence end is higher than top of lowest portion of fence, overlap joints at least 6 inches.

9-Detention Structures

Detention Basin (DB)

Definition

An impoundment made by constructing a dam or an embankment (embankment detention basin), or by excavating a pit or dugout (excavated detention basin). Basins resulting from both excavation and embankment construction are classified as embankment detention basins where the depth of water impounded against the embankment at emergency spillway elevation is three feet or more.

Purpose

- To regulate the rate and amount of runoff from development sites during and after construction operations.
- To minimize the effects of downstream erosion and flooding.

Applicability

Where there is a need to control or prevent downstream erosion and flooding due to site development or from other land use changes.

Planning Considerations

Increased downstream erosion, sedimentation and flooding may be caused by increased runoff volume, increased peak discharge, reduced time of concentration, or reduced natural storage.

To minimize design and regulatory approval costs, design detention basins to avoid inland wetlands and watercourses and so that they are not subject to water diversion or dam safety regulation. A local or state inland wetlands permit will be required if a detention basin is proposed in a wetland area.

A state water diversion permit from the DEP's Inland Water Resources Division will be required if the contributing drainage area to the detention basin is greater than 100 acres. If the contributing drainage is less than 100 acres and no inland wetlands or watercourses are involved, then a diversion permit will not be required. However, if wetlands or watercourses are involved, a diversion permit may be required and a permit need determination should be sought from the DEP.

The DEP also regulates all dam construction within the state. Contact DEP Inland Water Resources Division early in the planning process to determine the need for a dam construction permit. Try to keep the effective height of the dam less than 15 feet and the product of the storage volume in acre-feet times the effective height of the dam less than 3,000 (see design criteria below). If these limitations are exceeded the design criteria for the embankments of the detention basin are raised to a higher standard.

Carefully consider the visual design of detention basins in areas of high public visibility and those associated with recreation. The underlying criterion for all

visual design is appropriateness. The shape and form of basins, excavated material and plantings are to relate visually to their surroundings and to their function. See **Figure DB-1** for a schematic of a detention basin.

In planning the detention basin consider safety features to protect the public. Design and locate any safety features so as not to interfere with the hydraulic operation of the structure.

For projects which include a temporary sediment basin, it is sometimes advantageous to locate the temporary sediment basin at the site of the detention basin. Sharing the same location may minimize site disturbance and cost. When this approach is used, the size requirements of both the detention and sediment basins must be determined and the larger of the two must be in place during the construction period. After construction, the minimum size shall be that of the detention basin. The construction should be phased so increases in runoff are controlled during the development of the project. One approach would be to construct the detention basin along with its berm and outlet works first, and expand the storage volume, if need be, to that required for the sediment basin.

The permanent outlet works may have to be temporarily modified during the construction period to provide the necessary wet and dry storage requirements for the temporary sediment basin and enhance the basin's ability to remove sediment. Upon stabilization of the contributing watershed, accumulated sediment is removed from the basin and any work, such as modifying the outlet works or installing permanent plantings, is done to complete the permanent detention basin.

Figure DB-1 Schematic of a Detention Basin

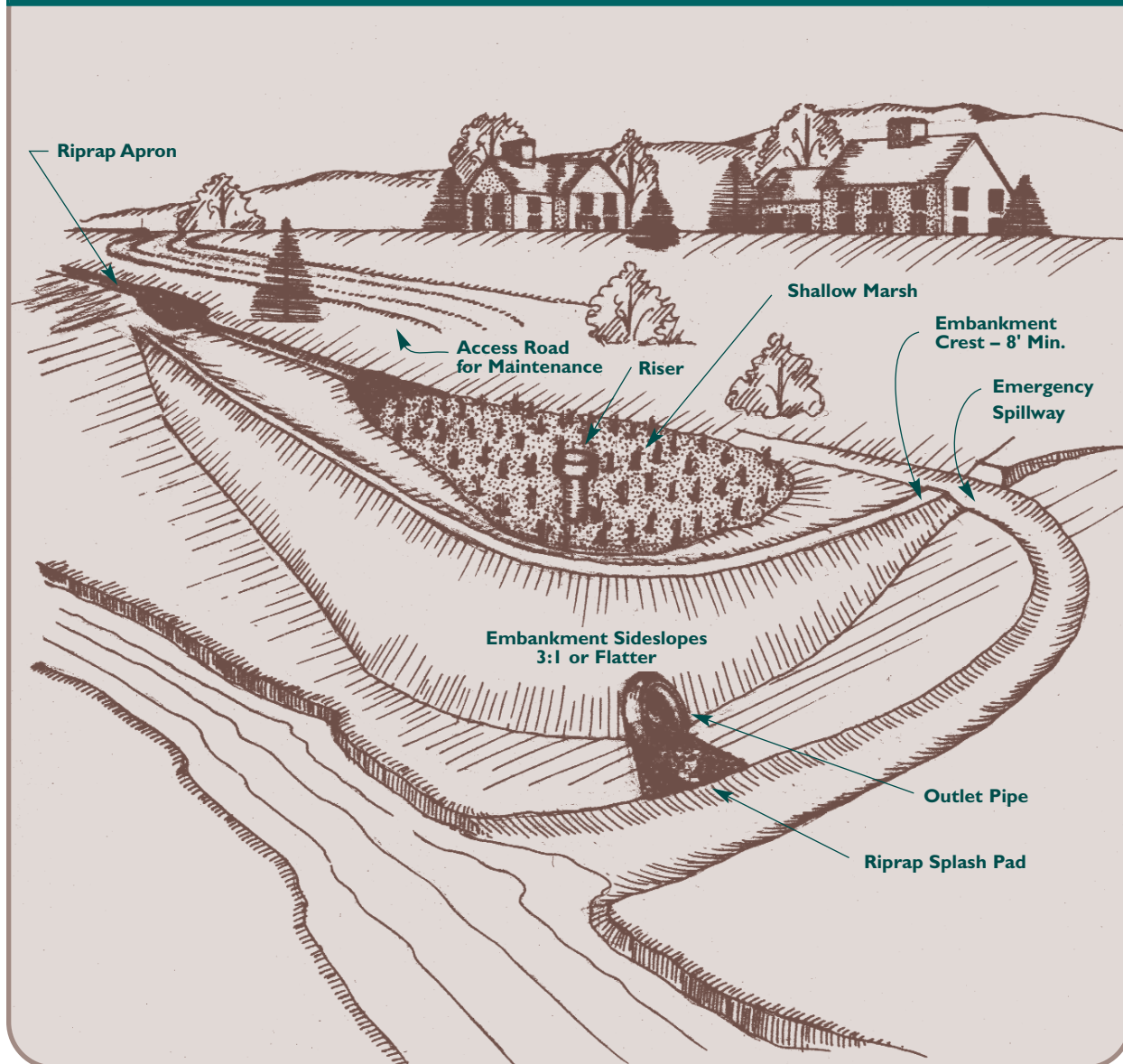

On-site detention may be undesirable when the site is located in the lower portions of a watershed before the confluence with a perennial watercourse. If detention is located in the lower reaches of a watershed, there is a risk, depending on the size and release rate of the basin, that the peak flows from the outlet control structure could combine with the peak flows from the upper reaches, thus increasing peak flows or sustaining peak flows over longer periods. These increases could result in prolonged flooding and channel erosion along and within the perennial stream course downstream of the site.

To avoid this problem a hydrologic analysis is required by an engineer. Locate the area downstream that is to be targeted for protection from additional runoff. A target area might be a flood prone road crossing, eroding stream bank or reach of stream where homes are currently endangered. Delineate the watershed to the targeted area.

Determine where the proposed detention basin is located within that watershed. Conduct a hydrograph analysis to determine the timing of peak discharges. Use the Soil Conservation Service (NRCS) Technical Releases 20 or 55, U.S. Army Corps of Engineers HEC-I or other appropriate methods which produce hydrographs to evaluate existing and post-development conditions.

If the hydrograph analysis shows that detention is detrimental to the target area, but nearby downstream concerns are present, other methods to decrease peak flows from the site will need to be utilized.

Sequence and schedule the construction of a detention basin so that it is made functional before other site construction activities cause changes in infiltration rates that can result in increases in stormwater runoff.

Finally, the ownership and responsibility for operation and maintenance of the detention basin needs to be

considered before the design process begins and should be determined by the completion of the local regulatory processes. The owner may be a homeowner, a homeowners association or a municipality.

Design Criteria¹

Overall

Design the detention basin to be compatible with the floodplain management and stormwater management programs of the local jurisdiction and with local regulations for controlling sediment, erosion and runoff. The basin shall properly regulate storm discharges from the site to a safe, adequate outlet. Consider the duration of flow as well as the peak discharge. Provide adequate erosion control measures and other water-quality practices. Plan and design the basin to ensure minimal impact on visual quality and human enjoyment of the landscape. Blend structures and materials aesthetically with their surroundings.

Attempt to locate detention basins where:

- *Failure of the detention basin would not, within reasonable expectations, result in loss of life, damage all-weather roads, railroads, homes, commercial and industrial properties or interrupt the use or service of utilities. (Dams which might fail and endanger life or property are regulated by the Commissioner of the Department of Environmental Protection under the CGS §§22a-401 through 22a-411.*
- *the effective height of the dam for an embankment detention basin should be 15 feet or less. The effective height of the dam is defined as the difference in elevation in feet between the emergency spillway crest and the lowest point in the cross section taken along the centerline of the dam.*
- *The product of the storage times the effective height of the dam should be less than 3,000. Storage is the volume in acre-feet in the reservoir below the elevation of the crest of the emergency spillway. The effective height of the dam is as defined above.*

Detention basins that exceed any one of the above conditions shall be designed to meet the criteria in Earth Dams and Reservoirs, Technical Release 60 (TR-60) by the USDA Soil Conservation Service (NRCS).

Design Storms

If the primary purpose of the detention basin is to minimize downstream erosion and subsequent sedimentation, the peak discharge from the 2-year, 10-year and 25-year storm frequency, 24-hour duration, Type III distribution storms shall be analyzed.

If the primary purpose of the detention basin is to

minimize flooding, the peak discharge from the 2-year, 10-year, and 100-year frequency, 24-hour duration, Type III distribution storms shall be analyzed.

No increase in peak flow from the 2-year, 10-year and 25-year storms shall be allowed unless downstream increases are compatible with an overall floodplain management system. Check local requirements for additional criteria that may include larger storms. Some of the items to consider in determining if increased peak flows are compatible with an overall floodplain management system are:

- *the timing of peak flows from sub-watersheds;*
- *the increased duration of high flow rates;*
- *the stability of the downstream channels; and*
- *the distance downstream that the peak discharges are increased.*

See **Figure DB-6** and **Figure DB-7** for structure routing graphs.

Spillway Design

The outlets for the basin shall consist of a combination of an outlet control structure (sometimes referred to as a principal spillway) and an emergency spillway. These outlets shall pass the peak runoff from the contributing drainage area for the design flood. If, due to site conditions and basin geometry, a separate emergency spillway is not feasible, the outlet control structure shall pass the entire routed peak runoff expected from the design storm. **However, an attempt to provide a separate emergency spillway shall always be made. An emergency spillway shall be provided on all detention basins with a contributing drainage area equal to or exceeding 20 acres. (Refer to Emergency Spillway subsection found on Page 5-9-11).** Runoff computations shall be based upon the soil cover conditions which are expected to prevail during the life of the basin. Refer to standard engineering manuals and procedures for calculations of the peak rate of runoff. Notably, the flow through any dewatering orifice or pipe shall not be utilized when calculating the design elevations because of its potential to become clogged; therefore, available spillway storage shall begin at the first stage of the outlet control structure.

Outlet Control Structure

A structural spillway may be installed which combines the outflow requirements of a principal (primary) spillway and emergency (secondary) spillway. Another type of outlet control structure may consist of a riser pipe and barrel that controls the elevation of the water and the rate of discharge for the detention basin. The barrel and riser shall be hydraulically sized such that full pipe (barrel) flow is achieved when the water level is at or below the crest of the emergency spillway. For many applications outlet control structures consist of a vertical pipe or box of corrugated metal, plastic or reinforced concrete, with a minimum diameter of 15 inches, joined by a water

¹ For structures which are regulated under CGS §22a-401, the design criteria may be more stringent than that found in the **Detention Basin DesignCriteria**.

tight connection to a horizontal pipe (barrel) extending through the embankment and outletting beyond the downstream toe of the fill. The outlet control structure and amount of storage shall be sized to prevent the emergency spillway from overtopping for a 25-year design storm. If no emergency spillway is used, the outlet control structure shall be designed to pass the entire routed peak flow expected from the design storm.

Design Elevations: The crest of the outlet control structure shall be set at the elevation corresponding to the storage volume required. If severe sedimentation is expected, the design volume should include provisions for sediment volume.

Detention basins are individual in scope and design. The following freeboard requirements shall be used when no other design requirements exist. A minimum freeboard of 1.0 foot shall be provided between the

routed water surface elevation for the design storm and the top of the embankment.

Anti-Vortex Device: An anti-vortex device and trash rack shall be attached to the top of a drop inlet control structure to improve the flow characteristics into the principal spillway and prevent blockage from floating debris. An example of an anti-vortex device is shown in **Figure DB-8**.

Trash Racks: To determine the dimensions of the trash rack, first determine the required cross-sectional area of the trash rack which will maintain a required maximum design velocity of 2 fps and then increase that area sufficiently to account for the obstruction caused by the bars.

The required cross-sectional area of the trash rack is estimated using the following formula:

$$A_{required} = \frac{Q}{V}$$

Where $A_{required}$ is the required cross-sectional opening area of the trash rack,
 Q is the design flow for the outlet control structure, and
 V is the design velocity which is required to be equal to or less than 2 fps.

Once $A_{required}$ is calculated, then it is proportionally increased to account for the obstruction of flow by the trash rack bars as follows:

$$A_{adjusted} = A_{required} \left(\frac{1}{1 - \% \text{ of area obstructed by trash rack bars}} \right)$$

Next a design for the trash rack is suggested. The area for the suggested trash rack design is then compared to $A_{adjusted}$. The suggested trash rack design is acceptable only when the suggested design area is greater than $A_{adjusted}$.

Design Examples 1 & 2 illustrate how to determine the minimum requirements for trash racks in a detention basin with a low and high stage outlets.

Detention Basin Trash Rack: Design Example 1

Figure DB-2 shows a sloped trash rack placed on the low stage outlet for the detention basin with suggested design dimensions. Given for this example is a design flow (Q) of 25 cfs for this outlet, the required maximum velocity (V) is 2 fps, and the trash rack bars obstruct 25% of the trash rack opening area.

$$A_{required} = \frac{Q}{V} = \frac{25 \text{ cfs}}{2 \text{ fps}} = 12.5 \text{ ft}^2$$

Given that the bars obstruct 25% of cross-sectional opening area, increase the opening area as follows:

$$A_{adjusted} = A_{required} \left(\frac{1}{1 - 0.25} \right) = \frac{12.5}{0.75} = 16.7 \text{ ft}^2$$

Adjusted required opening area is 16.7 ft².

A surface area of the trash rack is suggested by giving it dimensions of 3.5 ft. wide, 3.5 ft. high with its bars placed on 1:1 slope. Because the bars are sloped at a 1:1 slope, the actual length of the bars is (3.5 ft. x 1.41) or 4.94 ft. Therefore,

$$\text{Suggested Surface Area of the Rack} = (\text{width}) (\text{length}) = (3.5 \text{ ft.}) (4.94 \text{ ft.}) = 17.3 \text{ ft.}^2$$

Since the suggested surface area of the sloping trash rack (17.3 ft.²) is greater than the adjusted required opening area (16.7 ft.²), then the suggested dimensions of 3.5 ft. wide by 3.5 ft high are acceptable.

Detention Basin Trash Rack: Design Example 2

Example #2 below calculates the minimum area on a box-shaped trash rack on the high stage outlet (see **Figure DB-3**) where the design flow (Q) for this outlet is 75.0 cfs, the acceptable velocity is set at 2 fps, and the trash rack bars obstruct 25% of the trash rack opening area. Given that the bars obstruct 25% of cross-sectional opening area, increase the opening area as follows:

$$A_{required} = \frac{Q}{V} = \frac{75 \text{ cfs}}{2 \text{ fps}} = 37.5 \text{ ft}^2$$

and

$$A_{adjusted} = A_{required} \left(\frac{1}{1 - 0.25} \right) = \frac{37.5}{0.75} = 50.0 \text{ ft}^2$$

Adjusted required opening area is 50.0 ft.².

Use the following formula to check the total available area of the trash rack using the suggested design dimension given in **Figure DB-3**.

$$Area = [(side \ length) (2sides) + (front)] [(height) - (face \ of \ anti\text{-}vortex \ device)]$$

$$Area = (9.5 \text{ ft.}) (2) + (4.0 \text{ ft.}) [(2.5 \text{ ft.}) - (0.5 \text{ ft.}) (2.5 \text{ ft.} = 9.5 \text{ ft.})]$$

$$Area = [57.5 \text{ ft.}^2] - [6.0 \text{ ft.}^2] = 51.50 \text{ ft.}^2$$

Since the designed surface area of the high stage trash rack (51.50 ft.²) is greater than the adjusted required opening area (50.0 ft.²), then the trash rack design is acceptable.

Figure DB-2 Low Stage Trash Rack for Design Example 1

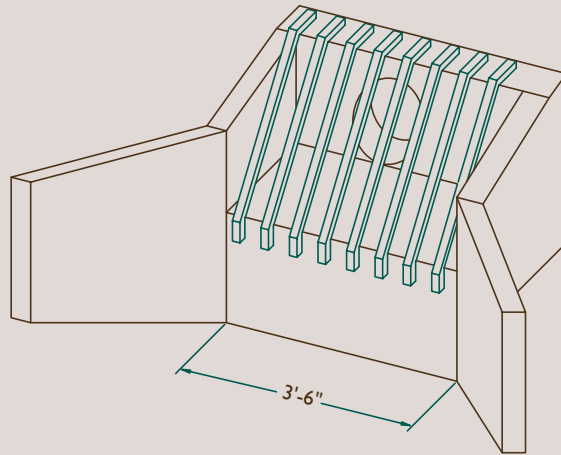

ISOMETRIC
(Not To Scale)

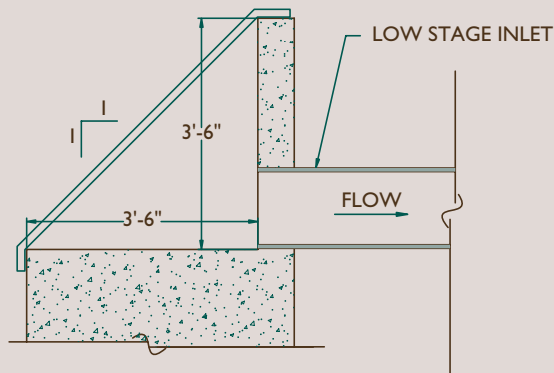

SIDE ELEVATION
(Not To Scale)

NOTES:

1. TRASH RACK SHALL BE FABRICATED OF STRUCTURAL STEEL IN CONFORMANCE WITH ASTM A-36.
2. ALL STRUCTURAL STEEL SHALL BE GALVANIZED IN ACCORDANCE WITH ASTM A-123.

Source: USDA-NRCS

Figure DB-3 High Stage Trash Rack for Design Example 2

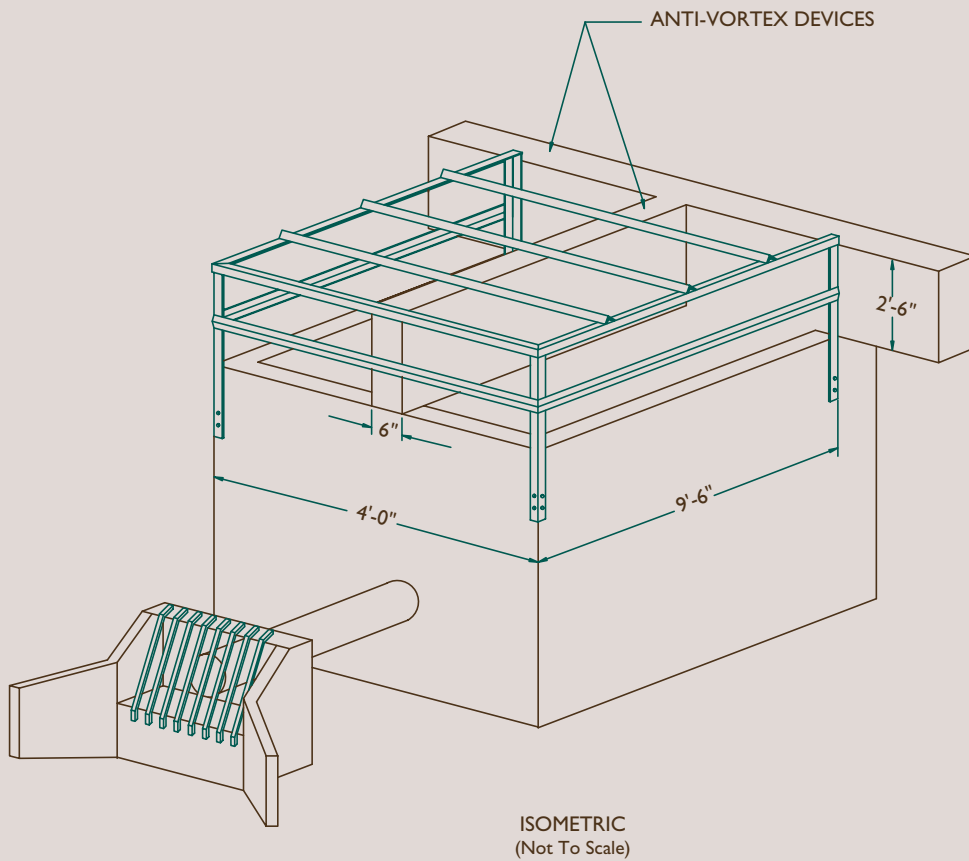

NOTES:

1. TRASH RACK SHALL BE FABRICATED OF STRUCTURAL STEEL IN CONFORMANCE WITH ASTM A-36.
2. ALL STRUCTURAL STEEL SHALL BE GALVANIZED IN ACCORDANCE WITH ASTM A-123.

Source: USDA-NRCS

Drains: If the detention basin is intended to be dry during non-storm events, subsurface drains within the bottom of the basin which outlet into the spillway system may be incorporated as a means of dewatering the basin bottom.

Base: The base of the outlet control structure shall be designed to prevent its floatation. A minimum factor of safety of 1.25 shall be used (downward forces = 1.25 x upward forces).

Barrel: If used, the barrel of the outlet control structure, which extends through the embankment, shall be designed to carry the flow provided by the riser of the outlet control structure with the water level at the crest of the emergency spillway. The connection between the riser and the barrel shall be watertight. The area surrounding the outlet of the barrel shall be protected to prevent downstream erosion or scour. See **Outlet** section for more specifics.

Pipe Materials: The pipe shall be capable of withstanding the external loading without excessive yielding, buckling, or cracking. The following pipe materials are acceptable:

Corrugated Steel Pipe: Pipe gauge shall not be less than that indicated in **Figure DB-4**. The maximum outlet control structure barrel size shall be 48 inches. If larger sizes are used then a detailed analysis is required to demonstrate the structural integrity of the pipe and suitability for placement within a dam embankment. The pipe shall be helical (spiral) fabrication. The pipe

shall be asphalt coated or aluminized. **Connections between pipe joints shall be watertight.** Flanges with gaskets or caulking may be used. Rod and lug coupling bands with gaskets or caulking may be used.

Corrugated Aluminum Pipe: Pipe gauge shall not be less than that shown in **Figure DB-4**. The maximum outlet control structure barrel size shall be 36 inches. If larger sizes are used then a detailed analysis is required to demonstrate the structural integrity of the pipe and suitability for placement within a dam embankment. The pipe shall be helical (spiral) fabrication. Riveted pipe shall be close riveted. The embankment materials and water shall range between pH4 and pH9. Inlets, coupling bands and anti-seep collars shall be made of aluminum or other non-corrosive materials.

Fittings for aluminum pipe of metals other than aluminum or aluminized steel shall be separated from the aluminum pipe at all points by at least two layers of plastic tape having a total thickness of at least 24 mils, or by other permanent insulating material that effectively prevents galvanic corrosion. Bolts used to join aluminum and steel shall be galvanized, plastic coated, or otherwise protected to prevent galvanic corrosion. Bolts used to join aluminum to aluminum, other than aluminum alloy bolts, shall be galvanized, plastic coated, or otherwise protected to prevent galvanic corrosion.

Connections between pipe joints shall be watertight. Flanges with gasket or caulking may be used. Rod and lug coupling bands with gaskets or caulking may be used. Slip seam coupling bands with gaskets or caulking may be used.

Figure DB-4 Corrugated Steel & Aluminum Pipe Requirements

Corrugated Steel Pipe										
Pipe Diameter (inches)	8 – 21	24	30	36	42	48	Risers Only			
							54	60	66	
Min. Gauge (inches)	16	16	14	14	12	10	10	10	10	
Corrugated Aluminum Pipe										
Pipe Diameter	8 – 21	24	30	36	Risers Only					
					42	48	54			
Gauge (inches)	16 (.06)	16 (.06)	14 (.075)	14 (.075)	12 (.105)	10 (.135)	10 (.135)			

PVC Pipe: The PVC shall meet the requirements of **Figure DB-5. Connections between pipe joints and anti-seep collar connections to pipe shall be watertight.** Pipe joints shall be solvent welded, O-ring, or threaded. All fittings and couplings shall meet or exceed the same strength requirements as that of the pipe and be made of material that is recommended for use with the pipe. Connections of PVC pipe to less flexible pipe or structures shall be designed to avoid stress concentrations that could rupture the PVC. When using PVC pipe the maximum outlet control structure barrel size shall be 12 inch, except a larger PVC pipe may be used if the engineering design calculations justify the use of a larger pipe.

Figure DB-5 PVC Pipe*		
Nominal Pipe Size (inches) Strength	Maximum	Depth of Fill Over Pipe (feet)
6, 8, 10, 12	Sched. 40	10
	Sched. 80	15
	SDR 26	10

*Polyvinyl chloride pipe, PVC 1120 or PVC 1220, conforming to ASTM D 1785 or ASTM D 2241

Smooth Steel: The minimum wall thickness shall be 3/16 inch. Previously used pipe may be used providing it is in good condition and does not have deep rust pits. The maximum outlet control structure barrel diameter shall be 48 inches. Pipe joints shall be threaded or welded by a competent welder. There are also several acceptable pre-engineered couplings available from pipe distributors.

Concrete Pipe With Rubber Gasket Joints: The pipe shall be designed with a concrete bedding. Connections between pipe joints and anti-seep collar connections to pipe shall be watertight and remain watertight after movement caused by foundation consolidation and embankment settlement.

Inlet: The inlet of the outlet control structure shall be structurally sound and made from materials compatible with the pipe. The inlet shall be designed to prevent floatation. The inlet shall be designed to function satisfactorily for the full range of flow and hydraulic head anticipated. The inlet materials are subject to the same limitations and requirements as the pipe materials.

Hood Inlet: If the pipe is designed for pressure flow, the minimum available head between the top of the pipe and the crest of the emergency spillway shall be adequate to prime the pipe. This head shall be at least 1.4 times the pipe diameter. See **Figure DB-9** for hood inlet detail.

Drop Inlet: If the pipe is designed for pressure flow the weir length of the drop inlet shall be adequate to prime the pipe when the water surface is at or below the emergency spillway crest. For pipe barrels placed on critical

slope or flatter, the drop inlet shall be at least 2D deep, where D is the barrel diameter. For pipe placed on steeper than critical slope, the drop inlet shall be at least 5D deep, where D is the barrel diameter.

Outlets: The outlet for the outlet control structure area shall be protected to prevent erosion. In addition, the outlet shall be designed to function satisfactorily for the full range of flow and hydraulic head anticipated. Protection against scour at the discharge end of the spillway shall be provided. Measures may include an impact basin, outlet protection, riprap, excavated plunge pools or use of other generally accepted methods.

Pipes larger than 18 inches shall have an energy dissipator such as one of the following:

- *Saint Anthony Falls type outlet;*
- *impact basin;*
- *stilling basin or plunge pool; or*
- *outlet protection in accordance with the outlet protection measure*

Anti-Seep Collars: Since very little time is spent in determining potential phreatic water surfaces within detention basins, it is accepted practice to design anti-seep controls as if the basin were always full of water. Anti-seep collars shall be designed for installation on the barrel of the outlet control structure within the normal saturation zone of the embankment to increase the seepage length by at least 10%, if either of the following two conditions exist:

1. The settled height of the embankment exceeds 10 feet.
2. The embankment soils have less than 15% passing the #200 sieve and the barrel is greater than 10 inches in diameter.

The anti-seep collars shall be installed within the saturated zone. The maximum spacing between collars shall be 14 times the projection of the collars above the barrel and in no case shall the spacing be greater than 25 feet. Collars shall not be closer than 2 feet from a pipe joint. Collars shall be placed sufficiently far apart to allow space for hauling and compacting equipment. Precautions should be taken to ensure 90%-95% standard proctor compaction is achieved around the collars. Connections between the collars and the barrel shall be watertight. See **Figure DB- 10** for details.

Alternatives to Anti-Seep Collars: Anti-seep collars are designed to control seepage and piping along the barrel by increasing the flow length and thus making any flow along the barrel travel a longer distance. However, due to the constraints that collars impose on embankment fill placement and compaction, collars may sometimes be ineffective if proper placement procedures are not followed precisely.

Alternative measures have been developed and are being incorporated into embankment designs. These measures include a structure known as a “filter diaphragm.” A filter diaphragm consists of a layer of sand and fine gravel which runs through the dam embankment perpendicular to the barrel. The measure controls the

transport of embankment fines, which is the major concern with piping and seepage. The diaphragm is designed to trap any embankment material being transported by seepage along the barrel. The flow is then conveyed out of the embankment via a pipe to the toe of the fill.

The critical design element for the filter diaphragm is the grain-size distribution of the filter material which is determined by the grain-size distribution of the embankment fill material. The use and design of filter diaphragms shall be based on site-specific geotechnical information and its construction should be supervised by a qualified professional.

Dewatering Pipe

A pipe with a suitable valve shall be provided to dewater the basin if the basin has a permanent pool. The outlet control structure may be used in conjunction with a dewatering pipe when so located to accomplish this function.

Emergency Spillway

An attempt to provide a separate emergency spillway shall always be made. However, there shall be an emergency spillway on all detention basins with a contributing drainage area equal to or exceeding 20 acres. The emergency spillway acts as a safety release for a detention basin, or any impoundment-type structure, by conveying the larger, less frequent storms through or around the basin without damage to the embankment.

The emergency spillway shall consist of an open channel (earthen and vegetated) constructed adjacent to the embankment over undisturbed material not within the embankment (not fill). The spillway shall have a control section at least 20 feet in length. The control section is a level portion of the spillway channel at the highest elevation in the spillway profile. Where conditions require the construction of an emergency spillway on the embankment, a spillway shall be constructed of a non-erodible material such as riprap. As an alternative, a structural spillway may be installed which combines the outflow requirements of a principal (primary) spillway and emergency (auxiliary) spillway.

The minimum capacity of a natural or constructed emergency spillway shall be that required to pass the peak flow expected from a design storm of 100-year frequency, 24-hour duration, Type III distribution less any reduction creditable to conduit discharge and detention storage. The capacity shall be calculated using the appropriate retardance and permissible velocities, as given in the **Vegetated Waterway** measure.

The emergency spillway shall safely pass either the peak inflow of the design storm runoff or the peak flow after routing.

Excavated Detention Basins: Excavated detention basins shall be designed with an outlet control structure constructed as described on **Page 5-9-4**. They can use the natural ground for the emergency spillway if the outlet slope is 5:1 or flatter and has existing vegetation or is immediately protected by sodding, riprap, asphalt lining, concrete lining, or other equally effective protection. The spillway shall meet the capacity requirement for embankment detention basins.

Embankment Detention Basins: Embankment detention basin spillways shall meet the following requirements:

Component Parts: Emergency spillways are open channels and consist of an inlet channel, control section and an exit channel. The emergency spillway should be as long as possible to provide protection from breaching. These emergency spillways should be constructed in natural ground whenever possible and have the discharge areas located at least 20 feet downstream of the embankment.

- **Inlet Channel:** *The inlet channel shall be level and straight for at least 20 feet upstream from the control section. Where site conditions do not allow a 20-foot long level section, armoring or sills may be utilized to prevent head cutting or breaching of the emergency spillway. Upstream from the level area the inlet channel may be graded back towards the basin to provide drainage. The alignment of the inlet channel may be curved upstream and flared out towards upstream from the straight portion.*
- **Exit Channel:** *The grade of the exit channel of an emergency spillway shall fall within the range established by discharge requirements and permissible velocities. For embankment dams the exit channel shall convey the design flow downstream to a point where the flow will not discharge to the toe of the embankment dam. Generally, the design flow should be contained in the exit channel without the use of dikes. If a dike is necessary, it shall have 2:1 or flatter side slopes, a top width minimum of 8 feet, and be high enough to contain the design flow plus one foot of freeboard.*

Velocity: The maximum permissible velocity in the exit channel shall be 4 feet per second for vegetated channels in soils with a plasticity index of 10 or less and 6 feet per second for vegetated channels in soils with a plasticity index greater than 10. For exit channels with erosion protection other than vegetation, the velocities shall be in the acceptable range for the type of protection used.

Cross Sections: Emergency spillways shall be trapezoidal and be located in undisturbed earth whenever practical. The side slopes shall be 2:1 or flatter. The minimum bottom width shall be 10 feet. The hydraulic requirements determine the elevation differences between the crest of the emergency spillway and the top of dam.

Structural Spillways Other Than Pipe

Structural spillways other than pipe shall be designed based on sound engineering data with acceptable soil and hydrostatic loadings as determined on an individual site basis.

When used as an outlet control structure, these structural spillways shall otherwise meet the flow requirements for outlet control structures and shall not

be damaged by the emergency spillway design storm. When used as an emergency spillway, these structural spillways shall meet the capacity requirements for emergency spillways.



Earth Embankment

Freeboard: A minimum freeboard of 1.0 foot shall be provided between the routed water surface elevation for the design storm and the top of the embankment of the 100 year storm.

Top Width: The minimum top width of the embankment shall be 8 feet.

Side Slopes: For embankment stability the combined upstream and downstream side slopes of the settled embankment when added together shall not be less than 5:1 with neither slope steeper than 2:1. Slopes shall be designed to be stable in all cases.

Materials: The fill material for the embankment shall be taken from approved borrow areas. It shall be clean mineral soil, free of roots, woody vegetation, stumps, sod, oversized stones, rocks, or other organic or unsuitable material. The material selected shall have enough strength for the embankment to remain stable and be tight enough, when properly compacted, to prevent excessive seepage of water through the dam. Fill containing particles ranging from small gravel or coarse sand to fine sand and clay in desired proportions is appropriate. Embankment material should contain at least 15% passing the #200 sieve and not more than 50% passing the # 200 sieve.

No stones larger than 6 inches shall be allowed within the compacted embankment. Within two feet of any structure, the maximum size shall be 3 inches. Construction shall not take place during cold periods where temperatures are consistently lower than 40 degrees Fahrenheit. The soil intended for the embankment shall be laboratory tested with a written report by a professional engineer licensed to practice in Connecticut, experienced in the field of soil mechanics. The report shall carry the engineer's findings and suggested design parameters if at variance with those proposed in the design.

Compaction: Areas on which fill is to be placed shall be scarified prior to placement of fill. The fill material shall contain the proper amount of moisture to ensure that 90%-95% standard proctor compaction will be achieved. Fill material will be placed in 9-inch continuous layers over the entire length of the fill. Compaction shall be obtained by routing the hauling equipment over the fill so that the entire surface of the fill is traversed by at least one wheel or tread track of the equipment, or by using a compactor. Special care shall be taken in compacting around the anti-seep collars, conduits, and structures to avoid damage and achieve desired compaction.

Foundation Cutoff for Embankment Detention Basin: A foundation cutoff constructed with relatively impermeable materials shall be provided for all embankments. The minimum depth of the cutoff shall be 2 feet. The cutoff trench, as a minimum, shall extend up both

abutments to the emergency spillway crest elevation. The minimum bottom width shall be 4 feet and wide enough to permit operation of compaction equipment. The side slopes shall be no steeper than 1:1. Compaction requirements shall be the same as those for the embankment. The trench shall be kept free from standing water during the backfilling operations.

Seepage Control: Seepage control is to be included if seepage may create swamping downstream, if needed to ensure a stable embankment, or if special problems require drainage for a stable embankment. Seepage control may be accomplished by foundation, abutment or embankment drains, reservoir blanketing or a combination of these and other measures.

Foundation: The area on which an embankment is to be placed shall consist of material that has sufficient bearing strength to support the earthfill and structures without excessive consolidation. Any unsuitable materials shall be removed from the foundation area before construction.

Installation Requirements

Construct the detention basin in accordance with the engineered design.

Site Preparation

Clear, grub, and strip topsoil to remove trees, vegetation, roots, or other unsuitable material from areas under the embankment or any structural works related to the basin. Clear and grub the area of most frequent inundation (measured from the top of the outlet control structure) of all brush and trees to facilitate clean out and restoration.

Install Sediment Controls for Contributing Areas

Install sediment controls to trap sediment before it enters and leaves the detention basin construction site.

Stabilize the dam and emergency spillway in accordance with the engineered design, stabilize the spoil and borrow areas, and other disturbed areas in accordance with the **Temporary Seeding** or **Permanent Seeding measures**, whichever is applicable.

Safety

Install safety features and devices to protect humans and animals from such accidents as falling or drowning. Temporary fencing can be used until barrier plantings are established. Use protective measures such as guardrails and fences on spillways and impoundments as needed.

Operation and Maintenance

Ownership

The ownership and responsibility for operation and maintenance of the detention basins should have been determined by the completion of the local regulatory processes. The owner may be a homeowner, a homeowners association or a municipality.

There should be a legally binding and easily

Figure DB-6 Structure Routing Graph

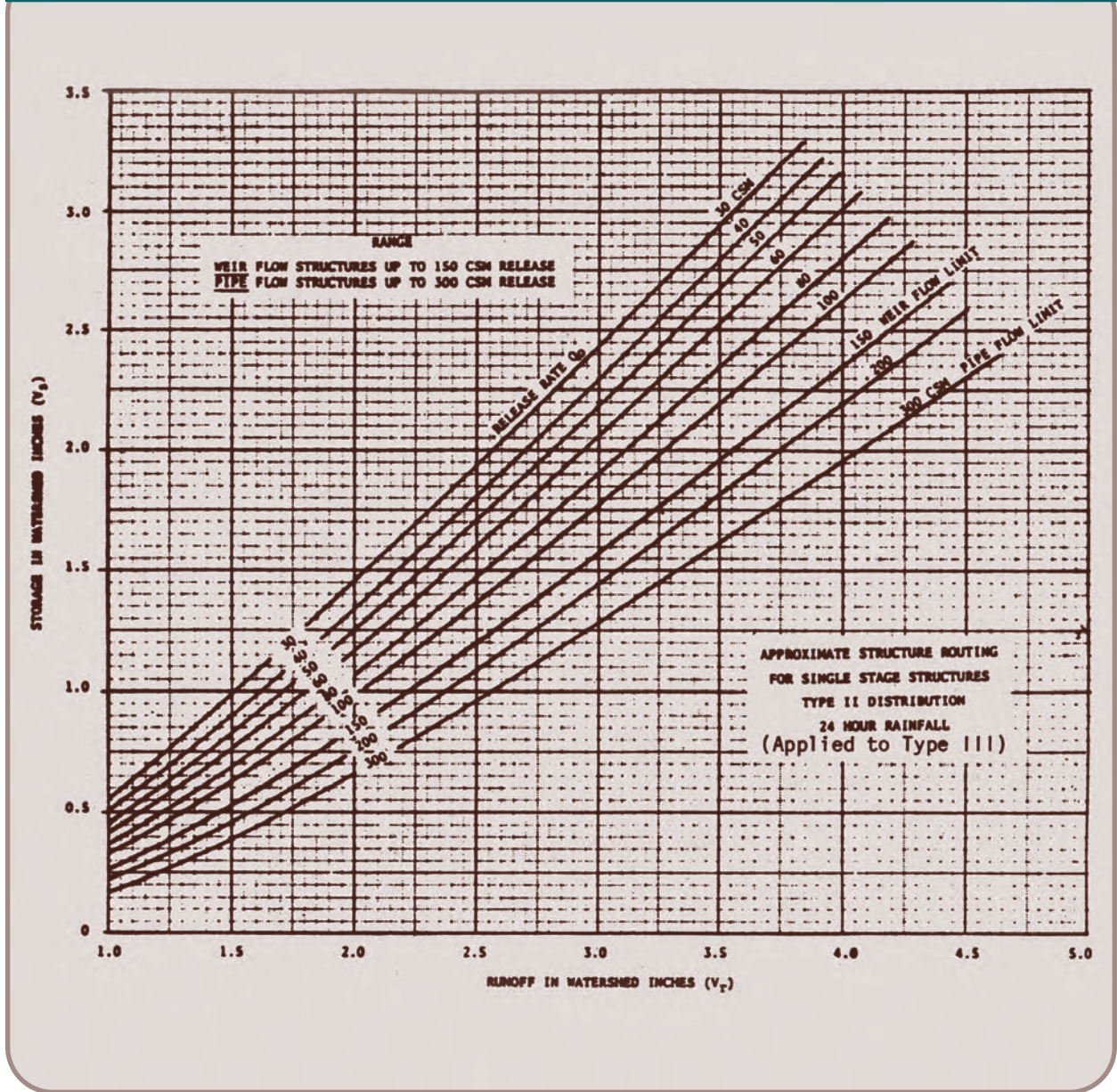

Source: USDA-NRCS

Figure DB-7 Structure Routing Graph for Type III Distributions

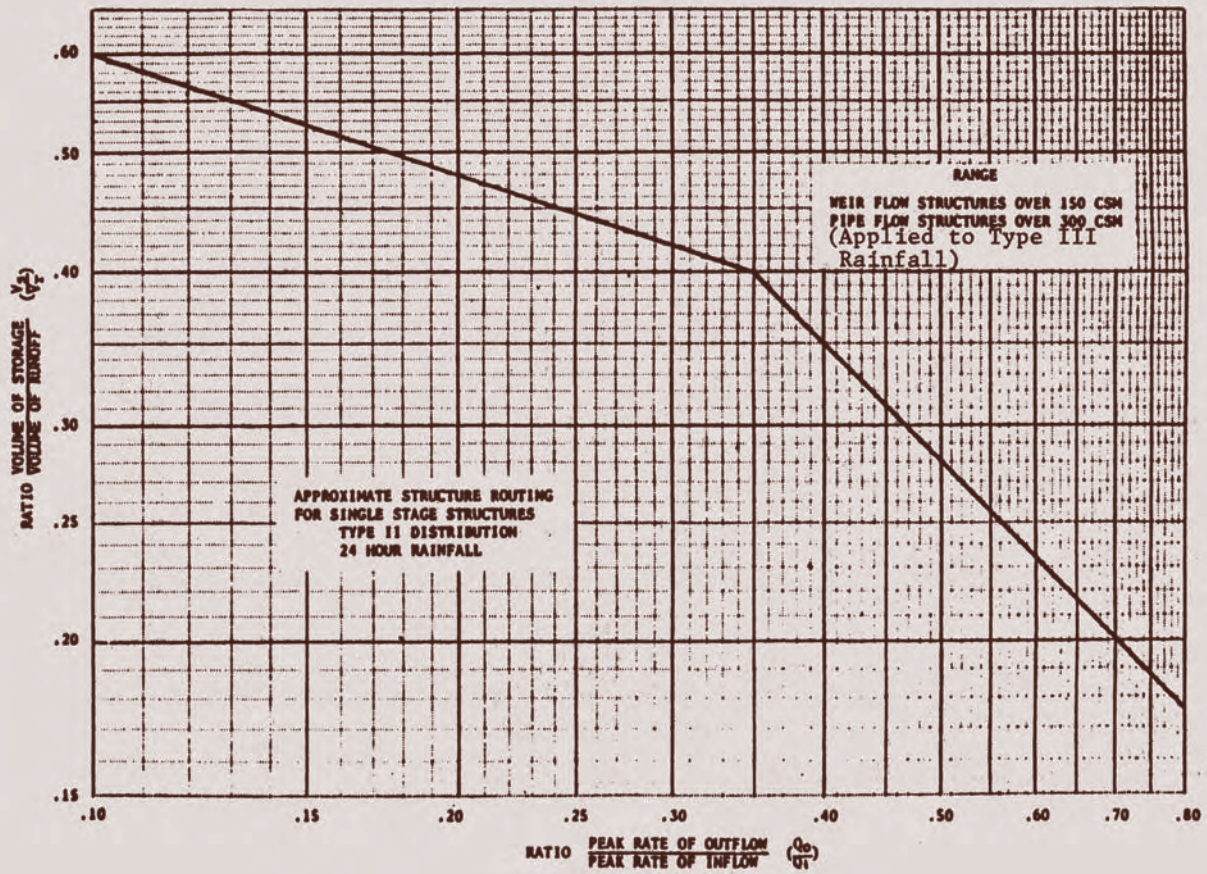

Source: USDA-NRCS

Figure DB-8 Example of Anti-Vortex with Trash and Safety Guard Diagram

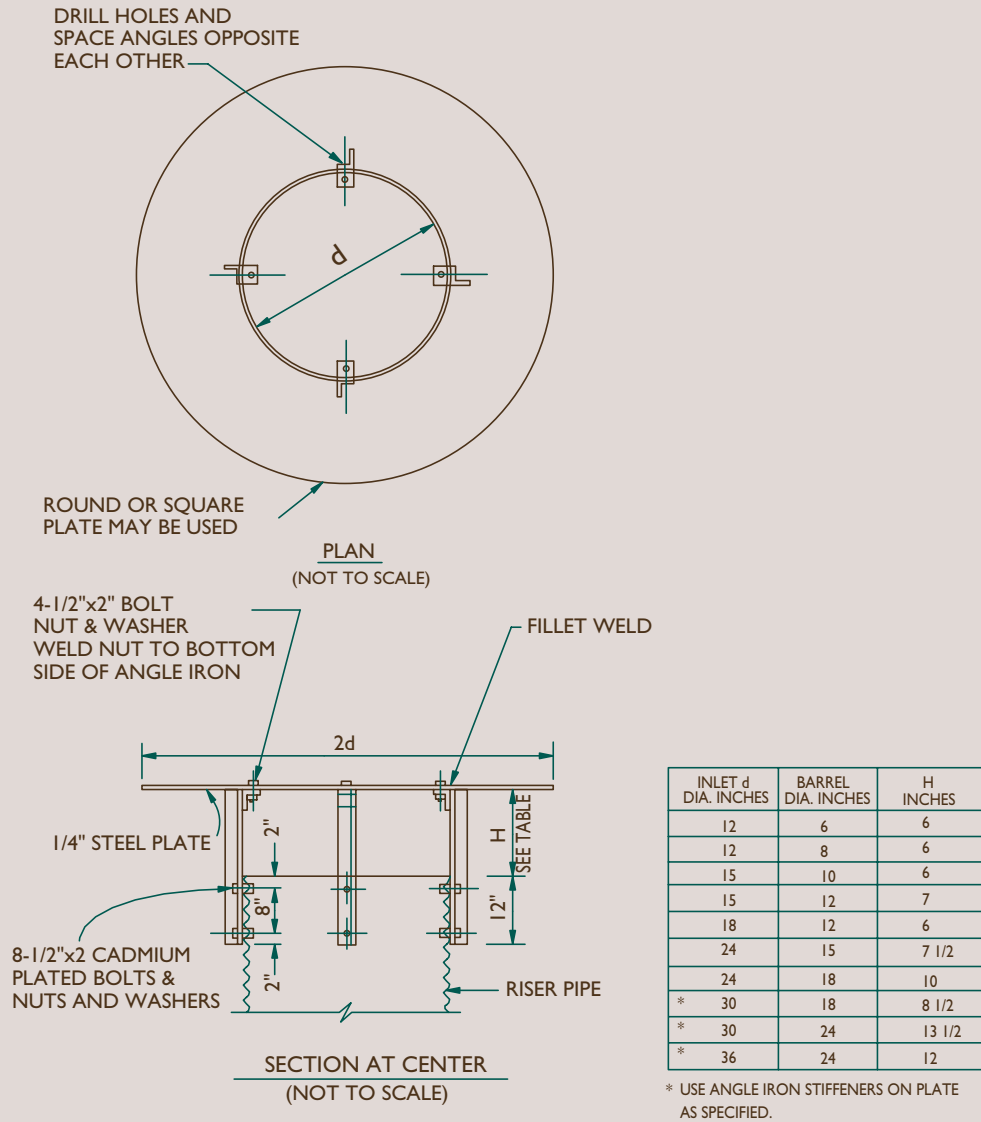

Source: USDA-NRCS

Figure DB-9 Hood Inlet Detail

TABLE OF QUANTITIES MATERIAL LIST & WEIGHTS FOR ANTI-VORTEX PLATE

PIPE DIA. INCHES	PLATE GAUGE	PLATE SIZE INCHES	2" X 2" X 1/4" STEEL ANGLE BRACES (ONE RIGHT AND ONE LEFT) INCHES					REQD. NO.	2" X 2" X 1/4" STEEL ANGLE SUPPORT FEET AND INCHES	REQD. NO.	1/2" X 1 1/2" STEEL MACHINE BOLT WITH NUT AND WASHER NO. REQUIRED	TOTAL WEIGHT LBS.
			a	b	c	d	e					
15	16	22 1/2 x 22 1/2	8	7 7/8	8	6 3/8	5 1/3	2	1 - 11 1/2	1	12	30
18	16	27 x 27	10	9	9	7 7/8	5 1/3	2	2 - 4	1	13	39
21	16	31 1/2 x 31 1/2	10	11 7/8	9	9 1/2	5 1/3	2	2 - 8 1/2	1	14	47
24	14	36 x 36	13	13 3/4	12	11 1/4	8	2	3 - 1	1	15	65
30	14	45 x 45	13	17 3/8	12	13 7/8	8	2	3 - 10	1	16	88
36	12	54 x 54	13	21 1/8	12	17	8	2	4 - 7	2	31	163

METAL BAFFLE SHALL HAVE THE SAME COATING AS THE PIPE TO WHICH IT IS ATTACHED.
 WHERE METAL BAFFLE IS FABRICATED OF MORE THAN ONE PIECE OF METAL,
 THE SEPARATE PIECES SHALL BE SECURELY FASTENED TO EACH OTHER.
 SHARP CORNERS SHALL BE REMOVED. METAL BAFFLE MAY BE MADE OF
 CORRUGATED OR SMOOTH SHEET METAL AND SHAPED CIRCULAR, SQUARE OR AS SHOWN.

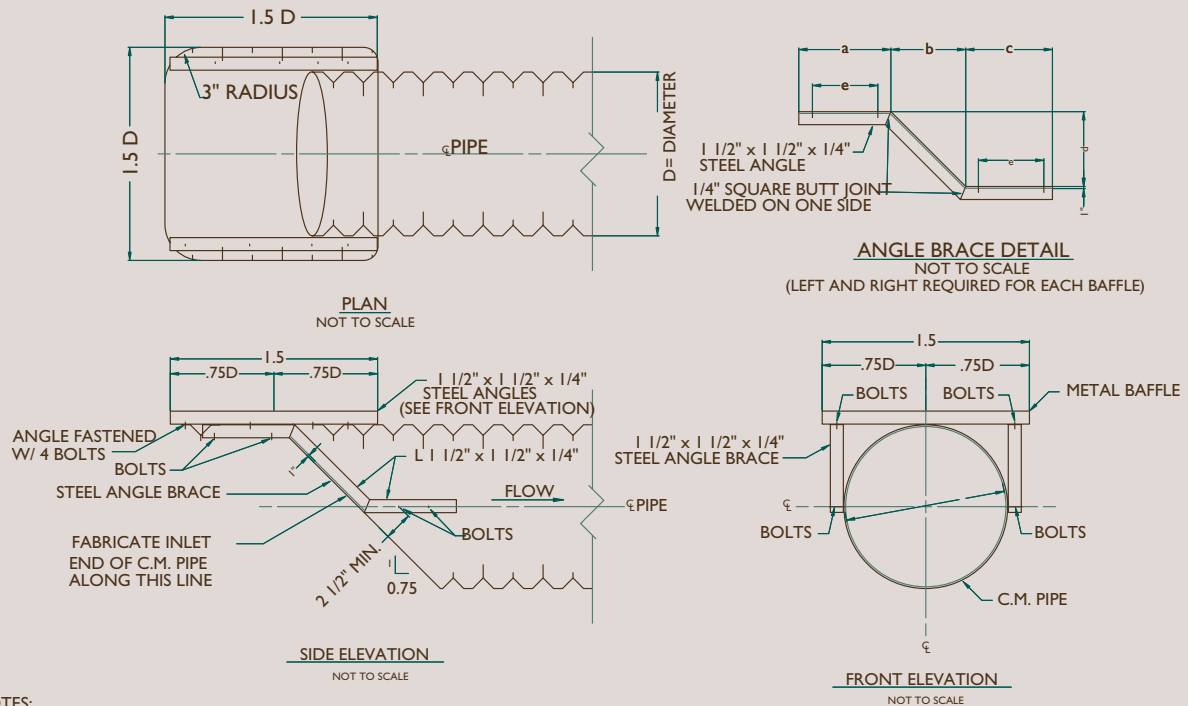

NOTES:

1. ALL BOLTS SHALL BE 3/8" X 1 1/2" WITH NUT AND SPLIT WASHERS.
2. ALL HOLES FOR BOLTS SHALL BE DRILLED 7/16" DIAMETER.
3. ALL NUTS, BOLTS AND WASHERS SHALL BE GALVANIZED, CADMIUM PLATED OR STAINLESS STEEL.
4. ALL CUTS SHALL BE SAW OR SHEAR CUTS.
5. HOLES IN THE ANGLE BRACE SHALL BE SPACED AND LOCATED TO MATCH CORRUGATIONS IN PIPE AND BAFFLE.
6. STEEL ANGLES SHALL BE GALVANIZED.
7. ALL GALVANIZING DAMAGED BY CUTTING, DRILLING OR WELDING SHALL BE REPAIRED BY PAINTING WITH TWO (2) COATS OF ZINC DUST - ZINC OXIDE PRIMER.

Source: USDA-NRCS

Figure DB-10 Anti-Seep Collar

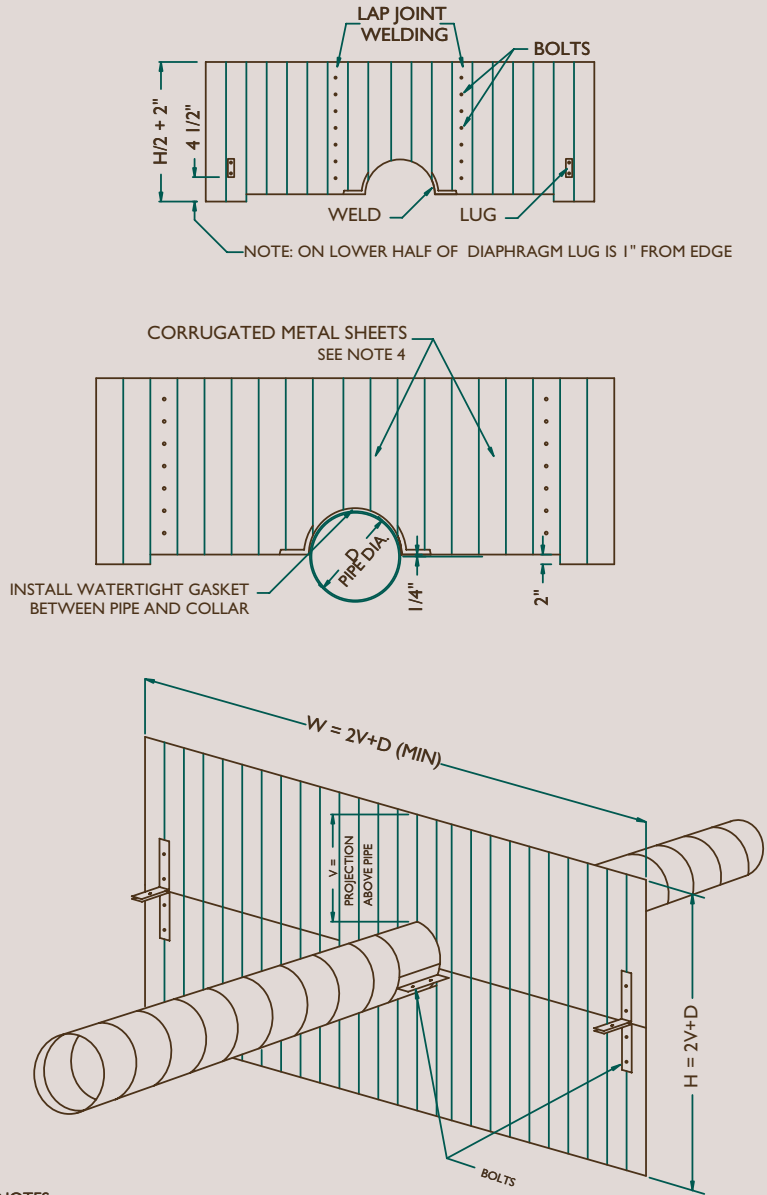

- NOTES:**
1. ANTI-SEEP COLLARS TO BE FULLY BITUMINOUS COATED.
 2. THE MAXIMUM SPACING OF ANTI-SEEP COLLARS ALONG THE CONDUIT SHALL BE NO GREATER THAN 14V, AND IN NO CASE GREATER THAN 25 FEET.
 3. ANTI-SEEP COLLARS SHALL BE PLACED AT LEAST 2 FEET FROM PIPE JOINTS.
 4. SEE FIGURE DB-4 FOR GAUGE.

Source: USDA-NRCS

5-Stabilization Structures

Temporary Lined Chute (TC)

Definition

A temporary channel constructed with a non-erosive material, such as concrete, bituminous concrete, riprap, sacked concrete, gabions, half round pipes, revetment erosion control mats with cement grout or similar materials used to carry concentrated runoff down a slope.

Purpose

To temporarily convey concentrated storm water runoff down a slope without causing erosion problems on or below the slope.

Applicability

- For drainage areas less than or equal to 36 acres.
- Where the intended use is less than one year.
- For protection of disturbed cut or fill slopes where planned vegetative cover is not established and/or permanent drainage controls have not been completed.
- On slopes no steeper than 1.5:1 and no flatter than 5:1. For slopes flatter than 5:1 use **Temporary Lined Channel**, **Vegetated Waterway** or **Permanent Lined Waterway** where appropriate.

Planning Considerations

Temporary lined chutes should be planned and installed along with, or as part of, other erosion control practices in an overall surface water control plan. If the chute is anticipated to be needed for more than 1 year use Permanent Lined Waterway measure, **Permanent Slope Drain** measure, or consider revising the sequence of construction to eliminate the need for a temporary lined chute. For drainage areas less than 5 acres the **Temporary Pipe Slope Drain** measure may be used as an alternative to a temporary lined chute. If the drainage area exceeds 36 acres then either split the drainage area or use alternate measures such as Permanent Lined Waterway measure.

Design Criteria

Slope Limitations

Temporary lined chutes shall be designed for placement on undisturbed or well compacted slopes that are not steeper than 1:1.5 and not less than 5:1.

Sizing Limitations

Design criteria are divided into two groups depending on the size of the drainage area. Group A is limited to a maximum area of 18 acres, and Group B may be used for drainage areas between 14 and 36 acres. Within each group the height of the lining at the entrance, depth of the chute down the slope, and length of the inlet and outlet sections are constant (See **Figure TC-1**). These are determined by the selection of a bottom width. The bottom width of the chute is dependent upon the size of the drainage area involved.

Use **Figure TC-1** to determine the sizing requirements for chute and associated group based on drainage area and proposed bottom width.

The selected size shall be identified in the E&S plan. For dimensions, grades, and construction details of concrete chutes see **Figure TC-2**.

Channel Linings

The lining shall consist of riprap, bituminous concrete or other comparable non-erodible material as described below. Design temporary chute linings with inlet and outlet protection to prevent erosion, to withstand the loading imposed by site conditions, and to meet durability requirements for the proposed maintenance program. Provide for adequate filter blankets, geotextile, or both, for these types of channel linings.

- (a) **Riprap** shall be designed in accordance with the **Riprap** measure.
- (b) **Bituminous concrete** linings shall be designed with a minimum thickness of 2 inches and in accordance with accepted engineering practices for structural adequacy.
- (c) **Portland Cement Concrete** shall be 2500 PSI minimum with 2.5 inches minimum thickness.
- (d) **Sacked concrete** shall be designed for both structural and hydraulic stability.
- (e) **Gabions** shall be designed in accordance with the **Gabions** measure.

Figure TC-1 Chute Size Determination

Group A			Group B		
Size	Bottom Width b (ft)	Maximum Drainage Area ¹ (acres)	Size	Bottom Width b (ft)	Maximum Drainage Area ¹ (acres)
A-2	2	5	B-4	4	14
A-4	4	8	B-6	6	20
A-6	6	11	B-8	8	25
A-8	8	14	B-10	10	31
A-10	10	18	B-12	12	36
Height at entrance (H) = 1.5 feet Depth of Chute (d) = 8 inches Length of inlet & outlet section (L) = 6 feet			Height at entrance (h) = 2 feet Depth of Chute (d) = 10 inches Length of inlet & outlet section (L) = 10 feet		

¹ Criteria for extending the maximum allowable drainage area listed above:

If good mulch cover (equivalent to landscape mulch or temporary soil protection) is maintained over a minimum of 75% of the drainage area throughout the life of the structure, then the drainage areas listed above may be increased by 25%, providing the 36 acres drainage area limit is not exceeded.

If good grass cover (i.e. well established turf) or woodland cover is maintained over a minimum of 75% of the drainage area throughout the life of the structure, then the drainage areas listed above may be increased by 50%, providing the 26 acre drainage area limit is not exceeded.

Source: USDA-NRCS

- (f) **Erosion control blankets and turf reinforcement mats**, when used, shall be designed in accordance with manufacture’s recommendations.

Inlet Design

- (a) The top of the earth lining at the entrance to the chute shall not be lower at any point than the top of the lining at the entrance of the chute (“H” as shown in **Figure TC-2**).
- (b) The lining of the side slopes at the chute entrance shall extend the distance H above the lining invert as shown in **Figure TC-2**.
- (c) The entrance floor at the upper end of the chute shall have a minimum slope toward the outlet of 0.25 inch per foot.
- (d) Design the cutoff wall at the entrance so that it is continuous with the lining.

Outlet Design

The minimum requirements for outlet protection are shown in **Figure TC-2**. Verify adequacy of outlet stabilization using **Outlet Protection** measure. Design the cutoff wall at end of the discharge aprons so that it is continuous with the lining.

Installation Requirements

1. Install the chute on undisturbed soil, if possible, or if not possible, on well compacted fill.
2. Begin construction of the chute at its lower end. Compact or place the lining so that it is free of voids and reasonably smooth.
3. Construct the cutoff walls at the entrance and at the end of the discharge aprons so that they are continuous with the lining.
4. Stabilize all areas disturbed by construction immediately after work is completed.

Maintenance

Inspect the temporary lined chute at least once a week and within 24 hours of the end of a storm with a rainfall amount of 0.5 inch or greater for erosion damage. Repair as needed. If repeated failure occurs, check design limitations and installation requirements. Correct deficiencies as needed.

Prevent construction traffic across the chute and avoid the placement of any material on the chute.

Figure TC-2 Temporary Paved Chute Plan and Profile

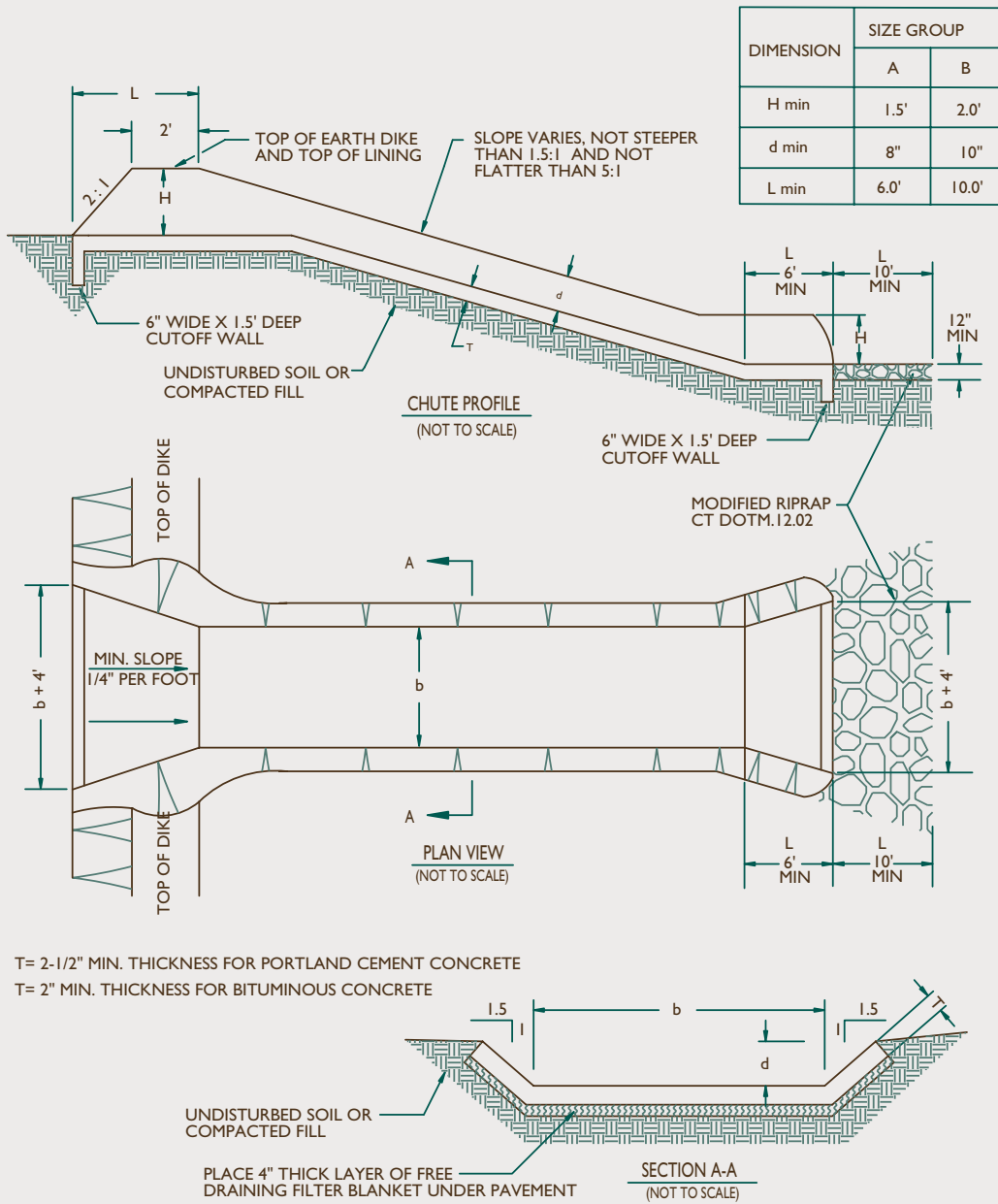

Source: USDA-NRCS

5-Stabilization Structures

Temporary Pipe Slope Drain (TSD)

Definition

A flexible or rigid pipe used to conduct water from the top of a slope to the toe of the slope.

Purpose

- To convey water over excessive grade changes.
- To convey concentrated stormwater runoff flows down the face of a slope without causing erosion problems either on or at the toe of the slope.

Applicability

- On cut or fill slopes where the soil or existing vegetative cover will not withstand concentrated runoff flows.
- For use less than 6 months.
- Where the contributing drainage area is 5 acres or less.

Planning Considerations

Temporary pipe slope drains should be planned and installed along with, or as part of, other conservation practices in an overall surface water disposal system. This measure should be used only for the temporary conveyance of water and consideration should be given to the final stabilization of the area during the initial planning stages. Temporary pipe slope drains are commonly used in conjunction with temporary diversions (see Diversion Functional Group) which direct water to the drain.

Design Criteria

The maximum allowable drainage area per drain is 5 acres.

Material used in the temporary pipe slope drain shall be heavy duty flexible (see **Figure TSD-2**) or rigid conduit (see **Figure TSD-3**) designed for the purpose with hold down grommets or rigid pipe supplied with anchors. Additionally, use only one size pipe for any single installation.

The bottom of the pipe slope drain shall be flush with the toe of the diversion berm (see **Figure TSD-3**).

The pipe slope drains shall be sized according to **Figure TSD-1** and shall be provided with watertight fittings.

Water directed into the temporary slope drain shall be in accordance with temporary diversion measures found in the Diversion Functional Group, where applicable. However, at a minimum, the height of the berm at the centerline of the inlet shall be equal to the diameter of the pipe (D) plus 12 inches. Where the berm height is greater than 18 inches at the inlet, it shall be sloped 3:1 or flatter.

The area immediately below the outlet of the pipe slope drain shall be protected from erosive discharges with appropriate energy dissipators. For drainage areas

Figure TSD-1 Size of Slope Drain

Maximum Drainage Area (Acres)	Pipe Diameter, D (in.)
0.5	12
2.5	18
5.0	24

Source: USDA-NRCS

greater than 1 acre, hay bale check dams and geotextile silt fences are not appropriate.

Installation Requirements

1. Install a temporary pipe slope drain on a cut or a stable fill slope during or immediately after construction of diversion berms.
2. Stabilize the area from the top of the berm, around and under the entrance section of the drain to prevent erosion and piping failure at the inlet.
3. Anchor the pipe slope drain securely. Space anchors a maximum of 10 feet on center.
4. Securely fasten the sections of pipe together with watertight fittings.

Maintenance

Inspect the temporary pipe slope drain at least once a week and within 24 hours of the end of a storm with a rainfall amount of 0.5 inch or greater to determine maintenance needs. Repair damage as necessary. Avoid the placement of any material on top of the pipe and prevent vehicular traffic from crossing the slope drain.

Figure TSD-2 Example of Temporary Pipe Slope Drain

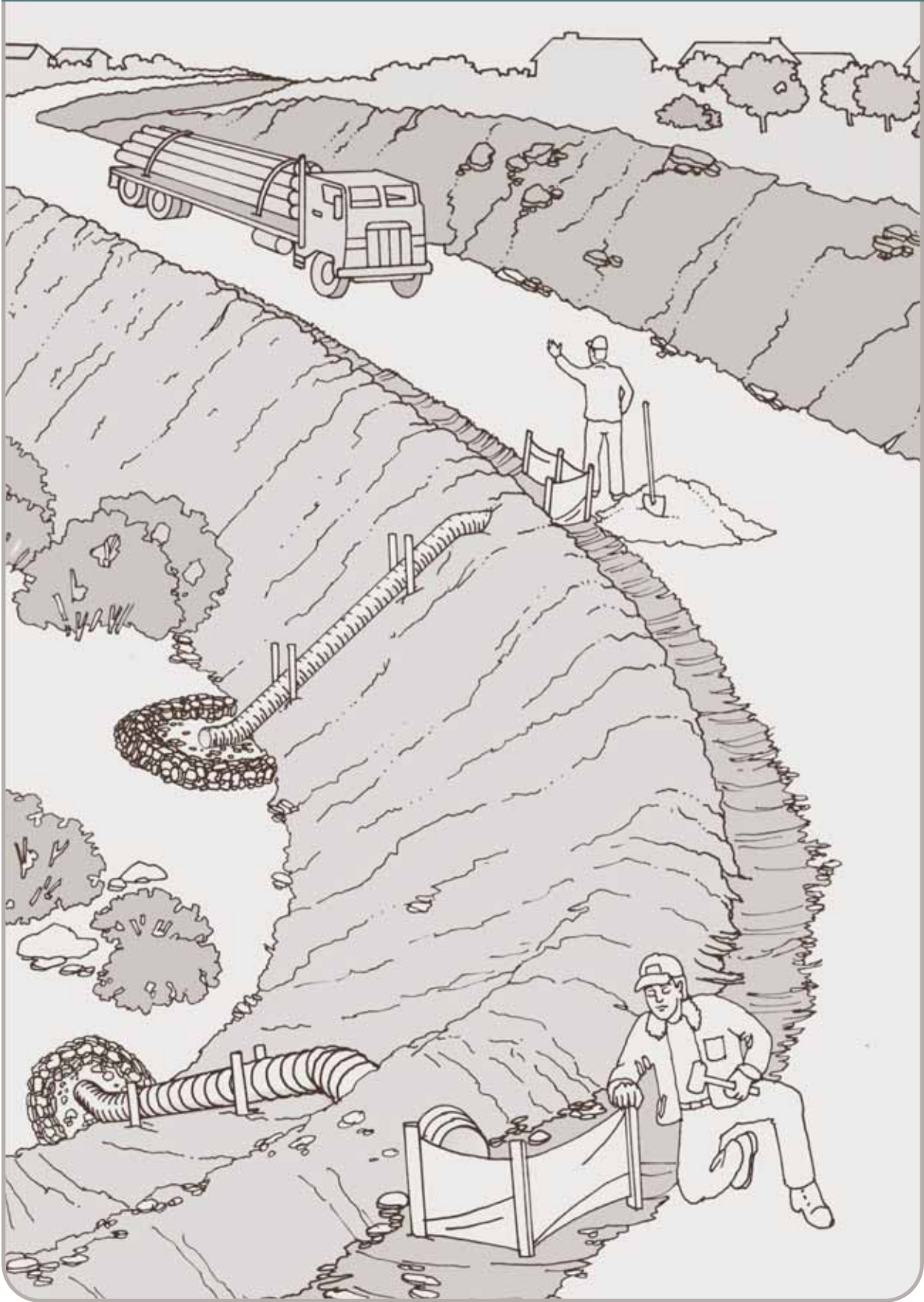

Temporary Pipe
Slope Drain (TSD)

Figure TSD-3 Example of Temporary Pipe Slope Drain

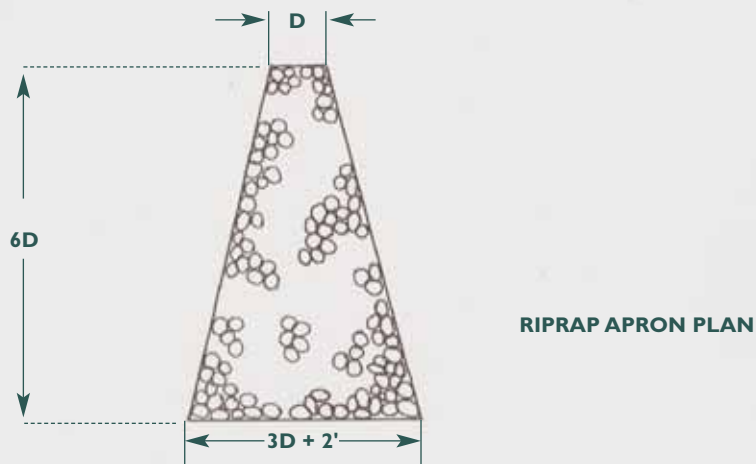
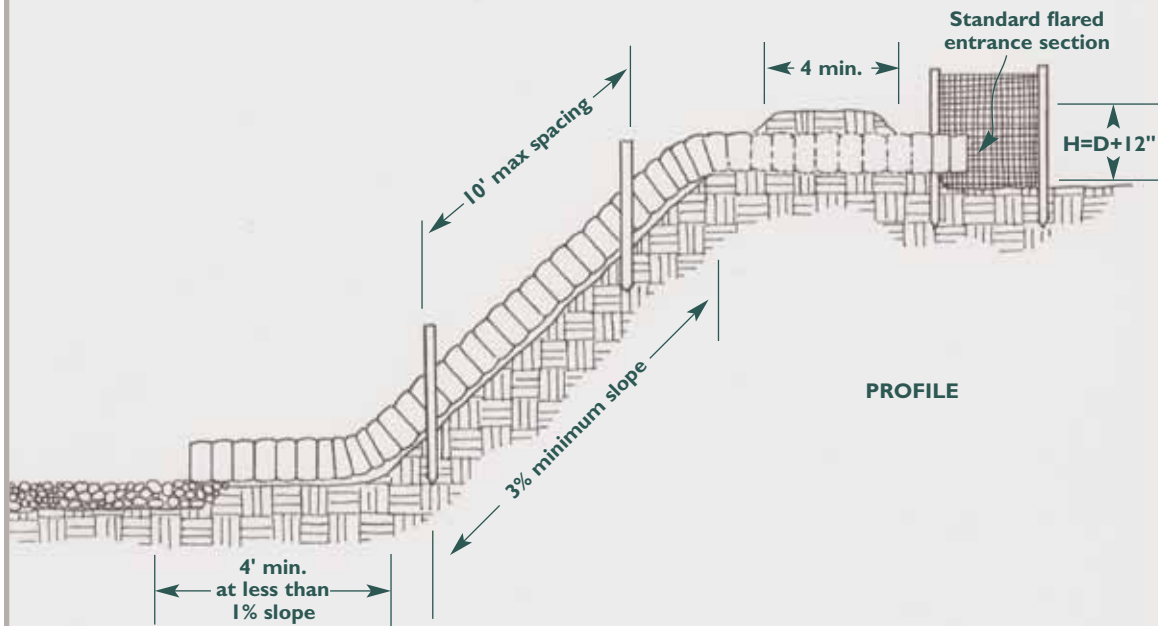

CONSTRUCTION SPECIFICATIONS

1. The pipe slope drain shall have a slope of 3% or steeper.
2. Top of the earth dike over the inlet pipe and all dikes carrying water to the pipe shall be at least 1 foot higher than the top of the pipe.
3. Add 0.3 foot to dike height for settlement.
4. Soil around and under the slope pipe shall be hand tempered in 4-inch lifts.
5. The pipe shall be plastic or corrugated metal pipe with watertight 12-inch wide connecting bands or flange connections.
6. Pipe anchors to be placed at 10-foot maximum spacing.
7. Riprap to be 6 inches in a layer at least 12 inches thickness and pressed into the soil.
8. Periodic inspection and required maintenance must be provided after each rain event.

Temporary Pipe Slope Drain (TSD)

Figure Planning I Mulching Section Chart

Mulch Type	Exposure Period	How Applied	Limitations / Considerations
Temporary Soil Protection - temporary soil cover when seeding dates cannot be met			
straw/hay	0-6 months	by hand or blown by machine	<ul style="list-style-type: none"> • preferred over other mulches • requires anchoring in windy areas • hay will typically supply weed seeds, straw will not
cellulose fiber*	not recommended	not recommended	<ul style="list-style-type: none"> • used only as a tackifier for other mulch material
wood chips	> 1 year	by hand or graded by machine	<ul style="list-style-type: none"> • restricted to slopes 3 on 1 or flatter • must be removed or tilled into ground before seeding or planting • may reduce soil fertility during decay process requiring subsequent fertilization for plant growth • lasts longer than straw/hay • no anchoring required
bark chips / shredded bark	0-1 year	by hand	<ul style="list-style-type: none"> • same as wood chips
Mulch for Seed - temporary soil cover until seeds germinate and grow sufficiently to stabilize soil			
straw/hay	0-6 months	by hand or blown by machine	<ul style="list-style-type: none"> • requires anchoring in windy areas • hay will supply weed seeds, straw will not • may provide better shading against hot summer sun for seeding done at the beginning of summer
cellulose fiber*	0-6 months	sprayed in slurry with water	<ul style="list-style-type: none"> • no volunteer weed seeds, lawn seeding • wood fiber per unit cost generally more expensive than paper fiber, but requires less product for equivalent coverage • may be used in summer with seed only if adequate irrigation is planned
wood chips	not recommended	not recommended	not recommended
bark chips/ shredded bark	not recommended	not recommended	not recommended
Landscape Mulch - soil cover inhibiting weed growth around planted trees, shrubs & vines			
straw/hay	not recommended	not recommended	not recommended
cellulose fiber*	not recommended	not recommended	not recommended
wood chips	> 1 year	by hand or graded by machine	<ul style="list-style-type: none"> • may reduce soil fertility during decay process, requiring application of nitrogen • slippage may occur on steeper slopes if wood chips are applied over a large area
bark chips/ shredded bark	0-1 year	by hand	<ul style="list-style-type: none"> • same as wood chips

* see Specifications text on special concerns of various cellulose mulches

4-Short Term Non-living Soil Protection

Temporary Soil Protection (TSP)

Definition

Application of a degradable material that will protect the soil surface on a temporary basis without the intention of promoting plant growth.

Purpose

To prevent erosion by dissipating the erosive energy of raindrops and encouraging sheet flow over the soil surface.

Applicability

- When grading of the disturbed area will be suspended for a period of 30 or more consecutive days, but less than 5 months, stabilize the site within 7 days of the suspension of grading through the use of mulch or other materials appropriate for use as a temporary soil protector.
- For surfaces that are not to be reworked within 5 months but will be reworked within 1 year, use **Temporary Seeding, Mulch for Seed** or when slopes are less than 3:1, wood chips, bark chips or shredded bark.
- For surfaces that are to be reworked after 1 year, use **Permanent Seeding** and **Mulch for Seed**

Planning Considerations

See Mulching Selection Chart found in the Group Planning Considerations.

Specifications

Materials

Temporary soil protection materials include but are not limited to mulches, tackifiers, and nettings and shall be:

- *biodegradable or photo-degradable within 2 years but without substantial degradation for 5 months;*
- *free of contaminants that pollute the air or waters of the State when properly applied;*
- *free of foreign material, coarse stems and any substance toxic to plant growth or which interferes with seed germination; and*
- *capable of being applied evenly such that it provides 100% initial soil coverage and still adheres to the soil surface, does not slip on slopes when it rains or is watered, does not blow off site, and dissipates rain-drop splash.*

Mulches within this specification include, but are not limited to:

Hay: The dried stems and leafy parts of plants cut and harvested, such as alfalfa, clovers, other forage legumes and the finer stemmed, leafy grasses. The average stem length should not be less than 4 inches. Hay that can be windblown should be anchored to hold it in place.

Straw: Cut and dried stems of herbaceous plants, such as wheat, barley, cereal rye, or brome. The average stem length should not be less than 4 inches. Straw that can be windblown should be anchored to hold it in place.

Wood Chips: Chipped wood material from logs, stumps, brush or trimmings including bark, stems and leaves having a general maximum size of 0.5 inch by 2 inches and free of excessively fine or long stringy particles as well as stones, soil and other debris. No anchoring is required. If seeding is performed where wood chips have been previously applied, prior to the seeding the wood chips should be removed or tilled into the ground and additional nitrogen applied. Nitrogen application rate is determined by soil test at time of seeding (anticipate 12 lbs. nitrogen per ton of wood chips).

Bark Chips, Shredded Bark: Tree bark shredded as a by product of timber processing having a general maximum size of 4 inches and free of excessively fine or long stringy particles as well as stone and other debris. Material use is the same as wood chips.

May also include corn stalks, leaves and other similar materials provided they meet the requirements of the materials section within this specification.

Note: *Wood and bark by-products may generate contaminated runoff if improperly stored for extended periods. These materials should only be stored on free draining, gently sloping soils, and only for short periods of time.*

If subsequent seeding is performed where cellulose dense mulches (e.g. leaves, excelsior, woodchips, barkchips) have been applied, then prior to seeding either remove the mulch or till it into the ground with the application of nitrogen.

Cellulose fiber is not recommended for use, except as a tackifier for other mulch materials.

Tackifiers within this specification include, but are not limited to:

Water soluble materials that cause mulch particles to adhere to one another, generally consisting of either a natural vegetable gum blended with gelling and hardening agents or a blend of hydrophilic polymers, resins, viscosifiers, sticking aids and gums. **Emulsified asphalts are specifically prohibited for use as tackifiers due to their potential for causing water pollution following its application.**

Nettings within this specification include but are not limited to:

Prefabricated openwork fabrics made of cellulose cords, ropes, threads, or biodegradable synthetic material that is woven, knotted or molded in such a manner that it holds mulch in place until temporary soil protection is no longer needed. Examples of netting are tobacco netting (used where flows are not concentrated) and jute netting (typically used in drainageways).

Substitute Measures

Where tackifiers or nettings are needed to anchor mulch, a **Temporary Erosion Control Blanket** or **Stone Slope Protection** may be substituted, providing 100% of the disturbed soil is covered.

Site Preparation

Prior to mulching, complete the required grading and install and/or repair other sediment control measures needed to control water movement within the area to be mulched.

Application

Spreading: Spread mulch material uniformly by hand or machine resulting in 100% coverage of the disturbed soil.

When spreading hay mulch by hand, divide the area to be mulched into approximately 1,000 square feet and place 2 to 3 bales of hay in each section to facilitate uniform distribution.

When spreading woodchips on slopes, it is particularly important not to spread the chips too thick. Excessive applications tend to slip or slump when saturated.

See **Figure TSP-1** for suggested application rates of specific mulches when used as temporary soil protection.

Figure TSP-1 Suggested Temporary Soil Protection Application Rates for 100% Cover	
Mulch	Rate
Hay/Straw	2 – 3 Tons/acre
Wood Chips/Shredded Bark	6 cu. yds./1000 sq. ft.

Anchoring: Apply tackifiers and/or netting either with the mulch or immediately following mulch application. Expect the need for tackifiers or netting along the shoulders of actively traveled roads, hill tops and long open slopes not protected by wind breaks.

When using netting the most critical aspect is to ensure that the netting maintains substantial contact with the mulch and the mulch, in turn, maintains continuous contact with the soil surface. Without such contact, the material is useless and erosion can be expected to occur. Install in accordance with manufacturer's recommendations.

Maintenance

Inspect temporary soil protection area at least once a week and within 24 hours of the end of a storm with a rainfall amount of 0.5 inch or greater for mulch movement and rill erosion.

Where soil protection falls below 100%, reapply soil protection within 48 hours. Determine the cause of the failure. If mulch failure was the result of wind, consider applying a tackifier or netting. If mulch failure was caused by concentrating water, install additional measures to control water and sediment movement, repair erosion damage, re-apply mulch with anchoring or use Temporary Erosion Control Blankets.

Inspections should take place until work resumes.

4-Short Term Non-living Soil Protection

Mulch For Seed (MS)

Definition

Application of a mulch that will protect the soil surface on a temporary basis and promote the establishment of temporary or permanent seedings.

Purpose

- To prevent erosion by dissipating the erosive energy of raindrops and encourage a sheet flow over the soil surface.
- To aid in the growth of herbaceous vegetation by reducing evaporation of water, enhancing absorption of water, helping to anchor seed in place, providing protection against extreme heat and cold and improving soil texture as it decomposes.

Applicability

Used with **Temporary Seeding** and **Permanent Seeding** measures.

Planning Considerations

See Mulching Selection Chart found in the Group Planning Considerations.

Specifications

Materials

Mulch for seed, including tackifiers and nettings used to anchor much, shall be:

- *biodegradable or photo-degradable within 2 years but without substantial degradation over a period of 6 weeks,*
- *free of contaminants that pollute the air or waters of the State when properly applied,*
- *free of foreign material, coarse stems and any substance toxic to plant growth or which interferes with seed germination, and*
- *capable of being applied evenly such that it provides 80%-95% soil coverage and still adheres to the soil surface, does not slip on slopes when it rains or is watered, does not blow off site, dissipates raindrop splash, holds soil moisture, moderates soil temperatures and does not interfere with seed growth.*

Types of mulches within this specification include, but are not limited to:

Hay: The dried stems and leafy parts of plants cut and harvested, such as alfalfa, clovers, other forage legumes and the finer stemmed, leafy grasses. Stem length should not average less than 4 inches. Hay that can be windblown must be anchored. Preferred mulch when seeding occurs outside of the recommended seeding dates.

Straw: Cut and dried stems of herbaceous plants, such as wheat barley, cereal rye, or broom. The average stem length should not be less than 4 inches. Straw that can be windblown should be anchored to hold it in place.

Cellulose Fiber: Fiber origin is either virgin wood, post-industrial/pre-consumer wood or post consumer wood complying with materials specification (collectively referred to as “wood fiber”), newspaper, kraft paper, cardboard (collectively referred to as “paper fiber”) or a combination of wood and paper fiber. Paper fiber, in particular, shall not contain boron, which inhibits seed germination. The cellulose fiber must be manufactured in such a manner that after the addition to and agitation in slurry tanks with water, the fibers in the slurry become uniformly

suspended to form a homogeneous product. Subsequent to hydraulic spraying on the ground, the mulch shall allow for the absorption and percolation of moisture and shall not form a tough crust such that it interferes with seed germination or growth. Generally applied with tackifier and fertilizer. Refer to manufacturer's specifications for application rates needed to attain 80%-95% coverage without interfering with seed germination or plant growth. Not recommended as a mulch for use when seeding occurs outside of the recommended seeding dates.

Other mulches also include corn stalks and other similar organic materials provided they meet the requirements listed in the first paragraph of this section. Does not include materials such as wood chips, bark chips or cocoa hulls.

Tackifiers within this specification include, but are not limited to:

Water soluble materials that cause mulch particles to adhere to one another, generally consisting of either a natural vegetable gum blended with gelling and hardening agents or a blend of hydrophilic polymers, resins, viscosifiers, sticking aids and gums. Good for areas intended to be mowed. Cellulose fiber mulch may be applied as a tackifier to other mulches, provided the application is sufficient to cause the other mulches to adhere to one another. **Emulsified asphalt is specifically prohibited for use as tackifier due to its potential for causing water pollution following its application.**

Nettings within this specification include, but are not limited to:

Prefabricated openwork fabrics made of cellulose cords, ropes, threads, or biodegradable synthetic material that is woven, knotted or molded in such a manner that it holds mulch in place until vegetation growth is sufficient to stabilize the soil. Generally used in areas where no mowing is planned. Examples of netting are tobacco netting (used where flows are not concentrated) and jute netting (typically used in drainageways).

Substitute Measures

Where mulch anchoring is required a **Temporary Erosion Control Blanket** may be used.

Site Preparation

Follow requirements of **Permanent Seeding** or **Temporary Seeding**.

Application

Timing: Applied immediately following seeding. Some cellulose fiber may be applied with seed to assist in marking where seed has been sprayed, but expect to apply a second application of cellulose fiber to meet the requirements of **Mulch for Seed**.

Spreading: Mulch material shall be spread uniformly by hand or machine resulting in 80%-95% coverage of the disturbed soil when seeding within the recommended seeding dates. Applications that are uneven can result in excessive mulch smothering the germinating seeds. For hay or straw anticipate an application rate of 2 tons per acre. For cellulose fiber follow manufacturer's recommended application rates

Figure MS-I Estimating Mulch Cover

The following procedure was adapted from the pamphlet entitled "Farming with Residues" by the U.S. Department of Agriculture Soil Conservation Service dated September 1991.

1. Use any line that is equally divided into 100 parts. Fifty foot cable transect lines are available for this purpose. Another tool is a 50-foot tape measure using the 6-inch and foot marks also works well.
2. Stretch the line across the area to be sampled. Count the number of marks (tabs or knots) that have mulch showing under them when sighting directly above one end of the mark. It is important to use the same point on each mark for accuracy.
3. Walk the entire length of the rope or wire. The total number of marks with mulch under them is the percent cover.
4. Repeat the procedure at least 3 times in different areas and average the findings.

to provide 80%-95% coverage.

When seeding outside the recommended seeding dates, increase mulch application rate to provide between 95%-100% coverage of the disturbed soil. For hay or straw anticipate an application rate of 2.5 to 3 tons per acre.

See **Figure MS-1** for a procedure to estimate the adequacy of mulch coverage.

When spreading hay mulch by hand, divide the area to be mulched into approximately 1,000 square feet and place 1.5-2 bales of hay in each section to facilitate uniform distribution.

For cellulose fiber mulch, expect several spray passes to attain adequate coverage, to eliminate shadowing, and to avoid slippage (similar to spraying with paint).

Machine clogging can occur if product is improperly loaded or if leftover product is left in machine without cleaning. Comply with the manufacturer's recommendations for application requirements and mulch material specifications.

Anchoring: When needed, mulch anchoring is applied either with the mulch as with cellulose fiber or applied immediately following mulch application. Expect the need for mulch anchoring along the shoulders of actively traveled roads, hill tops and long open slopes not protected by wind breaks.

When using netting, the most critical aspect is to ensure that the netting maintains substantial contact with the underlying mulch and the mulch, in turn, maintains continuous contact with the soil surface. Without such contact, the material is useless and erosion occurs. Install in accordance with manufacturer's recommendations.

Maintenance

Inspect mulched areas at least once a week and within 24 hours of the end of a storm with a rainfall amount of 0.5 inch or greater until the grass has germinated to determine maintenance needs

Where mulch has been moved or where soil erosion has occurred, determine the cause of the failure. If it was the result of wind, then repair erosion damage (if any), re-apply mulch (and seed as needed) and consider applying a netting or tackifier. If mulch failure was caused by concentrating water, install additional measures to control water and sediment movement, repair erosion damage, re-apply mulch and consider applying a netting or tackifier or use the **Temporary Erosion Control Blanket** measure.

Once grass has germinated, inspections should continue as required by **Temporary Seeding** and **Permanent Seeding**.

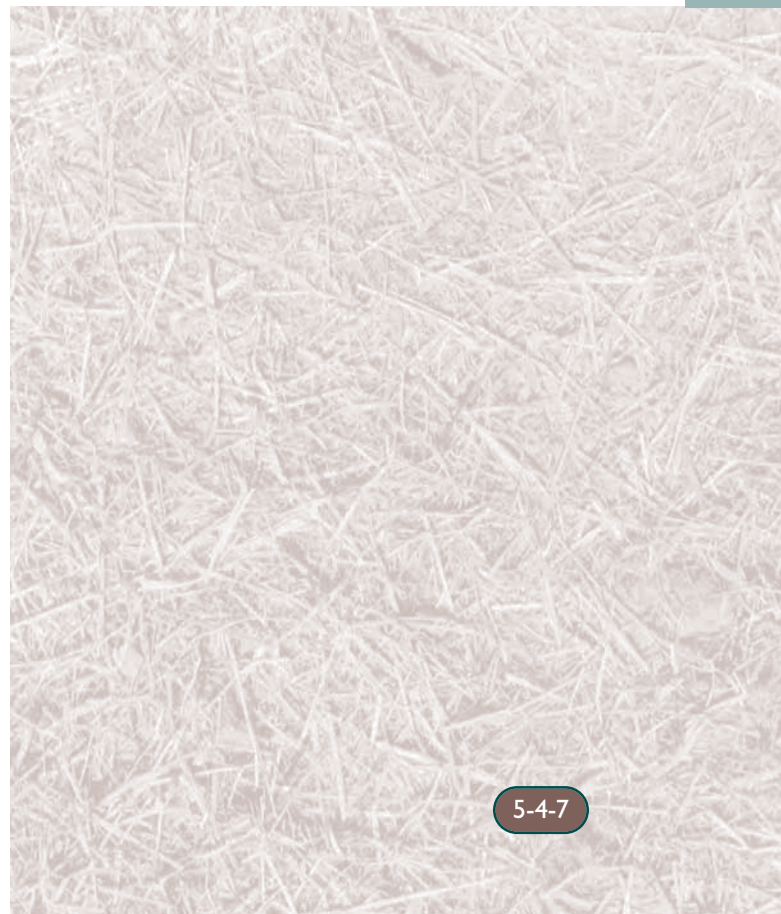

4-Short Term Non-living Soil Protection

Landscape Mulch (LM)

Definition

Application of a mulch that protects the soil surface on a long term basis and promotes the growth of landscape plantings.

Purpose

- To prevent erosion by dissipating the erosive energy of raindrops and encouraging infiltration.
- To promote growth of plantings and woody vegetation by reducing evaporation of water, enhancing absorption of water, controlling weeds, providing protection against extreme heat and cold and improving soil texture.
- To provide a temporary cover for disturbed soil.

Applicability

Used only with landscape plantings (see **Landscape Planting** measure) and existing woody vegetation.

Planning Considerations

Providing adequate organic mulch will enable a newly transplanted tree to become established and grow faster than an equivalent tree which is not mulched during the establishment period.

Plan mulch to be of sufficient depth to block the light that triggers weed seed germination and to prevent those that germinate deep under the mulch from surviving. Since weeds become established within the mulch matrix a barrier under the mulch is of limited value. The use of black plastic under landscape mulch is not advised because the plastic impedes water and gas exchange in the soil, often creating a soil environment that is more conducive to disease organisms. However, woven geotextiles that are manufactured specifically for use as a weed barrier may be used, particularly when the Stone Slope Protection measure is used as a substitute for landscape mulch.

See Mulching Selection Chart found in the Group Planning Considerations.

Specifications

Materials

Mulch materials must be:

- *biodegradable over a period of several years but without substantial degradation within 1 year;*

- *free of contaminants that pollute the air or waters of the State when applied;*
- *free of foreign material, and any substance toxic to plant growth; and*
- *capable of being applied evenly such that it provides 100% soil coverage and still adheres to the soil surface without a mulch anchor, does not slip on slopes when it rains or is watered, does not blow off site, dissipates raindrop splash, retains soil moisture, moderates soil temperatures and inhibits the growth of herbaceous plants.*

Types of mulches within this specification include, but are not limited to:

Wood Chips: Chipped wood material from logs, stumps, brush or trimmings including bark, stems and leaves having a general maximum size of 0.5 inch by 2 inches and free of excessively fine or long stringy particles as well as stones, soil and other debris.

Bark Chips, Shredded Bark: Tree bark shredded as a by product of timber processing having a general maximum size of 4 inches and free of excessively fine or long stringy particles as well as stone and other debris.

Note: *Wood and bark by-products may generate contaminated runoff if improperly stored for extended periods. These materials should only be stored on free draining, gently sloping soils, and only for short periods of time.*

May also include cocoa hulls and other similar materials provided they meet the requirements listed in the first paragraph of this section.

Does not include materials such as hay or cellulose fiber that is used in Mulch for Seed measure.

Substitute Measures

Stone Slope Protection measure may be used as a substitute for **Landscape Mulch**. Use with caution due to concerns about heat absorption and light reflection.

Site Preparation

Follow requirements of **Landscape Planting** measure and/or **Tree Protection** measure.

Application

Timing: For trees and shrubs apply after the installation of any weed barrier and within 7 days after planting. For vines and ground covers apply after the installation of any weed barrier either before planting or within 7 days after planting. Periodic reapplication is necessary when the mulch has decayed sufficiently to expose underlying soil or when it no longer inhibits herbaceous growth.

Spreading: Spread the mulch materials uniformly to a depth of at least 4 inches over the area disturbed by the hole excavated for planting the tree / shrub or over the entire area that has been or will be planted with vines or ground covers. See **Figure LMu-1** for suggested application rates for wood chips and shredded bark. Do not pile mulch against any tree or shrub trunk. Avoid excessive depths on slopes where mulch could slip when saturated.

Figure LMu-1 Suggested Landscape Mulch Application Rates for 100% Cover

Mulch	Rate
Wood Chips/ Shredded Bark	10 cu yds./1000 sq. ft.

Maintenance

Inspect 2 to 3 months after the first application and then once a year for mulch movement, rill erosion and decay.

Where mulch has been moved by concentrated waters, install additional measures to control water and sediment movement, repair erosion damage, remove any unwanted vegetation and re-apply mulch.

If mulch has decayed exposing underlying soil, repair any erosion damage, remove any unwanted vegetation and reapply mulch.

4-Short Term Non-living Soil Protection

Temporary Erosion Control Blanket (ECB)

Definition

A manufactured blanket composed of biodegradable / photodegradable natural or polymer fibers and/or filaments that have been mechanically, structurally or chemically bound together to form a continuous matrix.

Purpose

To provide temporary surface protection to newly seeded and/or disturbed soils to absorb raindrop impact and to reduce sheet and rill erosion and to enhance the establishment of vegetation.

Applicability

- On disturbed soils where slopes are 2:1 or flatter.
- Where wind and traffic generated air flow may dislodge standard, unarmored mulches.
- May be used as a substitute for **Temporary Soil Protection**.
- May be used as a substitute for **Mulch for Seed**.

Planning Considerations

When considering the use of ECB keep in mind the blanket's capability to conform to ground surface irregularities. If the blanket is not capable of developing a continuous contact with the soil then it must be applied to a fine graded surface. Some blankets will soften and when wetted reconfirm to the ground. Also, when the ground is frozen, proper anchoring can be difficult, if not impossible.

Care must be taken to choose the type of blanket which is most appropriate for the specific need of the project. With the abundance of erosion control blankets available, it is impossible to cover all of the advantages, disadvantages and specifications of all manufactured blankets. There is no substitute for a thorough understanding of the manufacturer's instructions and recommendations in conjunction with a site visit by the erosion and sedimentation plan designer prior to and during installation to verify a product's appropriateness.

The success of temporary erosion control blankets is dependent upon strict adherence to the manufacturer's installation recommendations. As such, a final inspection should be planned to ensure that the lap joints are secure, all edges are properly anchored and all staking/stapling patterns follow the manufacturer's recommendations.

Specifications

Materials

Temporary erosion control blankets shall be composed of fibers and/or filaments that:

- *are biodegradable or photodegradable within two years but without substantial degradation over the period of intended usage (five months maximum);*
- *are mechanically, structurally or chemically bound together to form a continuous matrix of even thickness and distribution that resist raindrop splash and when used with seedings allows vegetation to penetrate the blanket;*
- *are of sufficient structural strength to withstand stretching or movement by wind or water when installed in accordance with the manufacturer's recommendations;*
- *are free of any substance toxic to plant growth and unprotected human skin or which interferes with seed germination;*
- *contain no contaminants that pollute the air or waters of the State when properly applied; and*

- provide either 80%-95% soil coverage when used as a substitute for **Mulch for Seed** or 100% initial soil coverage when used as a substitute for **Temporary Soil Protection** measure.

Materials shall be selected as appropriate for the specific site conditions in accordance with manufacturer's recommendations. Use of any particular temporary erosion control blanket should be supported by manufacturer's test data that confirms the blanket meets these material specifications and will provide the short term erosion control capabilities necessary for the specific project.

Site Preparation and Installation

(see **Figure ECB-1**)

Prepare the surface, remove protruding objects and install temporary erosion control blankets in accordance with the manufacturer's recommendations. Ensure that the orientation and anchoring of the blanket is appropriate for the site.

The blanket can be laid over areas where sprigged grass seedlings have been inserted into the soil. Where landscape plantings are planned, lay the blanket first and then plant through the blanket in accordance with Landscape Planting measure.

Inspect the installation to insure that all lap joints are secure, all edges are properly anchored and all staking or stapling patterns follow manufacturer's recommendations.

Maintenance

Inspect temporary erosion control blankets at least once a week and within 24 hours of the end of a storm with a rainfall amount of 0.5 inch or greater for failures. Blanket failure has occurred when (1) soils and/or seed have washed away from beneath the blanket and the soil surface can be expected to continue to erode at an accelerated rate, and/or (2) the blanket has become dislodged from the soil surface or is torn.

If washouts or breakouts occur, re-install the blanket after regrading and re-seeding, ensuring that blanket installation still meets design specifications. When repetitive failures occur at the same location, review conditions and limitations for use and determine if diversions, stone check dams or other measures are needed to reduce failure rate.

Repair any dislodged or failed blankets immediately.

When used as a substitute for **Mulch for Seed**, continue to inspect as required by the seeding measure. When used as a substitute for **Temporary Soil Protection**, continue to inspect until it is replaced by other erosion control measures or until work resumes.

Figure ECB-1
Example of Temporary Erosion Control Blanket Installation

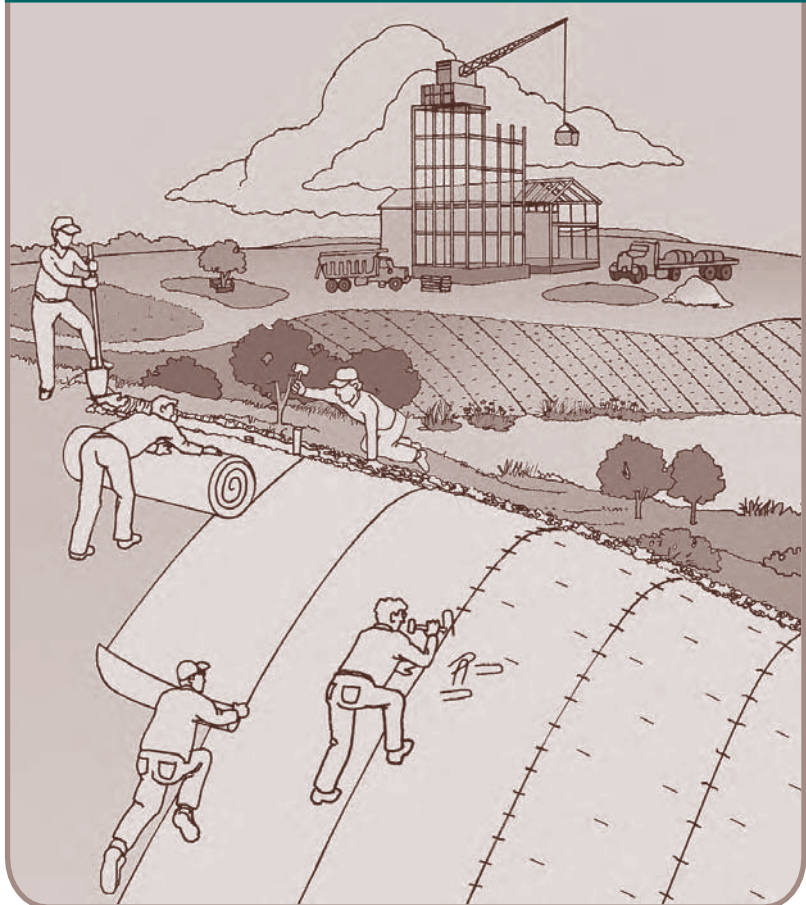

4-Short Term Non-living Soil Protection

Permanent Turf Reinforcement Mat (TRM)

Definition

A manufactured mat composed of non-biodegradable polymer or synthetic fibers mechanically, structurally or chemically bound together to form a continuous matrix.

Purpose

- To provide permanent turf reinforcement where design flows exceed the stability of the soils and/or proposed vegetation.
- To enhance the establishment of vegetation as the final surface protection.

Applicability

- In channels where design velocities exceed the stability limits of the soil and/or vegetation, and a soft-armored approach is desired.
- On unstable soils where intermittent flow exists.
- On disturbed soils with slopes 2:1 or flatter. On shorelines above a protected or stable toe to reduce soil erosion.

Planning Considerations

As a rule of thumb, when flows over exposed soils exceed 2 feet per second and flows over proposed turf areas exceed 5-6 feet per second, then soil erosion can be expected. Permanent turf reinforcement mats can be one way to reduce the erosion potential, and can be used in conjunction with other erosion control measures such as **Vegetated Waterway** and **Permanent Diversion**.

Permanent turf reinforcement mats are manufactured in several styles. They can be flat or three dimensional matrixes, laid either on top of or within the soil surface layer. Where permanent turf reinforcement mats are primarily used in areas of concentrated flows, an engineered design is required. Permanent turf reinforcement mats require the application of vegetative soil cover measures.

The requirement for permanent turf reinforcement mats should be identified during the development of the erosion and sediment control plan. Also, permanent turf reinforcement mats may be used as a corrective measure in areas of concentrated flows where repeated failures of vegetative cover have occurred.

Some permanent turf reinforcement mats are manufactured with a temporary erosion control blanket attached to them and do not require a separate mulch

application. Permanent turf reinforcement mats should be expected to last the life expectancy specified in the manufacturer's recommendations. Care must be taken to choose the type of mats which are most appropriate for the specific need of the project. A thorough understanding of the manufacturer's instructions and recommendations is needed to verify a product's appropriateness.

Design Criteria

Where turf reinforcement mats are used in areas of concentrated flows an engineered design is required. For other applications refer to the manufacturer's recommendations.

Materials

Permanent turf reinforcement mats shall:

- *consist of ultraviolet light resistant polymer or synthetic fibers mechanically, structurally, and/or chemically bound together for a continuous matrix of consistent thickness;*
- *contain no contaminants that pollute the air or waters of the state when properly installed; and*

- *be free of any substance toxic to plant growth and unprotected human skin or which interferes with seed germination.*

Materials shall be selected as appropriate for the specific site conditions in accordance with manufacturer's recommendations. Use of any particular permanent turf reinforcement mat should be supported by manufacturer's test data that confirms the mat will provide the long term erosion control capabilities necessary for the specific project.

Installation Requirements

Prepare site and install in accordance with manufacturer's requirements. **Figure TRM-1** shows a typical installation for a grass-lined channel.

Establish vegetative cover in accordance with the applicable measure found in the Vegetative Soil Cover Control Measure Group of these Guidelines. Modify the sequence of application to meet the manufacturer's requirements for the specific installation.

Inspect the installation to ensure that the mat is in

direct contact with the prepared soil surface, all lap joints are secure, all edges and interior mats are properly anchored and/or treated, backfilling follows the manufacturer's requirements, and the vegetative soil measures used have been correctly applied.

Maintenance

Inspect permanent turf reinforcement mats at least once a week and within 24 hours of the end of a storm with a rainfall amount of 0.5 inch or greater for failures until the turf has become established. Mat failure has occurred when soils and/or seed have washed away from beneath or within the mat resulting in a soil surface that can be expected to continue to erode or when the mat has become dislodged from the soil surface. When repetitive failures occur at the same location, review conditions and limitations of turf reinforcement mats and determine if additional controls, (e.g. diversions, stone barriers) are needed to ensure success. Repair mat failures within one work day.

After the turf has become established, inspect annually or after major storm events.

Figure TRM-1 Example of TRM Channel Application

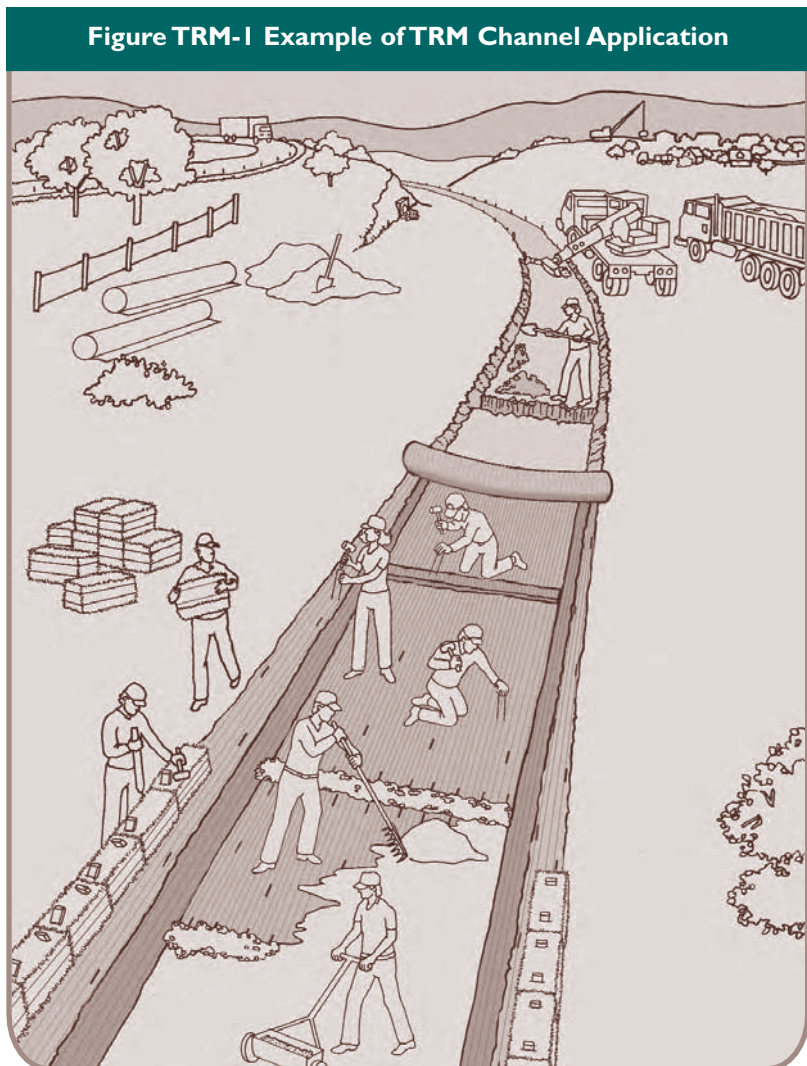

4-Short Term Non-living Soil Protection

Stone Slope Protection (SSP)

Definition

Applying stone aggregates for permanent protection on slopes where vegetative soil cover measures are either impractical or difficult to establish.

Purpose

To permanently reduce runoff and erosion, prevent soil compaction and prevent shallow surface slope failures by providing a non-vegetative stone cover over the soil surface.

Applicability

- Where highly erodible soils provide for unfavorable conditions for plant establishment and growth. Where herbaceous plant growth is to be discouraged or controlled.
- Not for use in concentrated flow areas or as a replacement for riprap or other measures designed to control slope stability. Use slope stabilization measures in the Stabilization Structures Functional Group and **Subsurface Drain** measure. May be used in combination with other slope stabilization measures and subsurface drains.
- For use on slopes 2:1 or flatter. For slopes steeper than 2:1 and for slopes with excessive seepage, an engineer's review of slope stability is required (see **Riprap** measure).

Planning Considerations

Typically, stone slope protection is used when there has been difficulty in establishing vegetation caused by adverse soil conditions or where competing vegetation is to be discouraged, as with landscape plants. It may take the place of Landscape Mulch, thus requiring less maintenance.

An engineering review is required when the slope to be protected is steeper than 2:1 or when excessive seepage is expected. If the engineering review results in a concern about slope stability, then other slope stabilization measures shall be utilized, possibly in combination with this measure.

Specifications

Materials

Stone used in stone slope protection shall consist of crushed stone or gravel that meets the gradations for DOT #3 coarse aggregate (see **Figure SP-1**) conforming to the DOT Standard Specifications Section M.01.01.

Site Preparation

Bring areas to be stabilized to final grade in accordance with the approved plan. Install and/or repair other sediment control measures as needed to control water movement into the area to be covered with stone.

Application

Slope the area on which the stone is to be placed to a reasonably true surface prior to placing any stone. Spread the stone by any suitable means which will not

crush the stone. Shape the stone to a smooth uniform finished grade. Provide 100% coverage of the disturbed soil with the stone.

Figure SP-1 DOT #3 Coarse Aggregate

Square Mesh Sieves	% Passing by Weight
2.5"	100
2.0"	90-100
1.5"	35-70
1.0"	0-15
0.5"	0-5

Maintenance

Coarse aggregate conforming to DOT Standard Specifications Section M.01.01 will not deteriorate, but may fail by slippage or displacement. If slippage or displacement occur, conduct an engineering analysis to determine the cause. Overland water flow, excessive seepage, deep slope failure or surficial structural failure should be investigated by an engineer. Repair failed areas and/or implement alternate measures to obtain stability.

3-Vegetative Soil Cover

Temporary Seeding (TS)

Definition

Establishment of temporary stand of grass and/or legumes by seeding and mulching soils that will be exposed for a period greater than 1 month but less than 12 months.

Purpose

To temporarily stabilize the soil and reduce damage from wind and/or water erosion and sedimentation until permanent stabilization is accomplished.

Applicability

- Within the first 7 days of suspending work on a grading operation that exposes erodible soils where such suspension is expected to last for 1 to 12 months. Such areas include soil stockpiles, borrow pits, road banks and other disturbed or unstable areas.
- Not for use on areas that are to be left dormant for more than 1 year. Use permanent vegetative measures in those situations.

Specifications

Seed Selection

Select grass species appropriate for the season and site conditions from **Figure TS-2**.

Timing Considerations

Seed with a temporary seed mixture within 7 days after the suspension of grading work in disturbed areas where the suspension of work is expected to be more than 30 days but less than 1 year. Seeding outside the optimum seeding dates given in **Figure TS-2** may result in either inadequate germination or low plant survival rates, reducing erosion control effectiveness.

Site Preparation

Install needed erosion control measures such as diversions, grade stabilization structures, sediment basins and grassed waterways in accordance with the approved plan.

Grade according to plans and allow for the use of appropriate equipment for seedbed preparation, seeding, mulch application, and mulch anchoring. All grading should be done in accordance with the **Land Grading** measure.

Seedbed Preparation

Loosen the soil to a depth of 3-4 inches with a slightly roughened surface. If the area has been recently loosened or disturbed, no further roughening is required. Soil preparation can be accomplished by tracking with a bulldozer, discing, harrowing, raking or dragging with a section of chain link fence. Avoid excessive compaction of the surface by equipment traveling back and forth

over the surface. If the slope is tracked, the cleat marks shall be perpendicular to the anticipated direction of the flow of surface water (see **Surface Roughening** measure).

Apply ground limestone and fertilizer according to soil test recommendations (such as those offered by the University of Connecticut Soil Testing Laboratory or other reliable source). Soil sample mailers are available from the local Cooperative Extension System office. Appendix E contains a listing of the Cooperative Extension System offices.

If soil testing is not feasible on small or variable sites, or where timing is critical, fertilizer may be applied at the rate of 300 pounds per acre or 7.5 pounds per 1,000 square feet of 10-10-10 or equivalent. Additionally, lime may be applied using rates given in **Figure TS-1**.

Figure TS-1 Soil Texture vs. Liming Rates

Soil Texture	Tons / Acre of Lime	Lbs / 1000 ft ² of Lime
Clay, clay loam and high organic soil	3	135
Sandy loam, loam, silt loam	2	90
Loamy sand, sand	1	45

Seeding

Apply seed uniformly by hand, cyclone seeder, drill, cultipacker type seeder or hydroseeder at a minimum rate for the selected seed identified in **Figure TS-2**. Increase

seeding rates by 10% when hydroseeding.

Mulching

Temporary seedings made during optimum seeding dates shall be mulched according to the **Mulch for Seed** measure. Note when seeding outside of the optimum seeding dates, increase the application of mulch to provide 95%-100% coverage.

Maintenance

Inspect seeded area at least once a week and within 24 hours of the end of a storm with a rainfall amount of 0.5 inch or greater for seed and mulch movement and rill erosion.

Where seed has moved or where soil erosion has occurred, determine the cause of the failure. Bird feeding may be a problem if mulch was applied too thinly to protect seed. Re-seed and re-mulch. If movement was the result of wind, then repair erosion damage (if any), reapply seed and mulch and apply mulch anchoring. If failure was caused by concentrated runoff, install additional measures to control water and sediment movement, repair erosion damage, re-seed and re-apply mulch with anchoring or use **Temporary Erosion Control Blanket** measure.

Continue inspections until the grasses are firmly established. Grasses shall not be considered established until a ground cover is achieved which is mature enough to control soil erosion and to survive severe weather conditions (approximately 80% vegetative surface cover).

3-Vegetative Soil Cover

Permanent Seeding (PS)

Definition

Establishment of permanent stand of grass and/or legumes by seeding and mulching exposed soils with a seed mixture appropriate for long term stabilization.

Purpose

To permanently stabilize the soil with a vegetative cover that will prevent damage from wind and/or water erosion and sedimentation.

Applicability

- On disturbed or erodible soils have been brought to final grade or where the suspension of work is expected to exceed 1 year, and
- Where slopes gradients are no steeper than 2:1. For slopes steeper than 2:1, use slope stabilization measures from the Stabilization Structures Functional Group.

Planning Considerations

There are several factors that should be considered when evaluating a site for the establishment of permanent vegetation.

Time Of Year

Seeding dates in Connecticut are normally April 1 through June 15 and August 15 through October 1. Spring seedings give the best results and spring seedings of all mixes with legumes is recommended. There are two exceptions to the above dates. The first exception is when seedings will be made in the areas of Connecticut known as the Coastal Slope and the Connecticut River Valley. The Coastal Slope includes the coastal towns of New London, Middlesex, New Haven, and Fairfield counties. In these areas, with the exception of crown vetch¹, the final fall seeding dates can be extended an additional 15 days. The second exception is frost crack or dormant seeding. In this type of seeding, the seed is applied during the time of year when no germination can be expected, normally November through February. Germination will take place when weather conditions improve. In this type of seeding, mulching is extremely important to protect the seed from wind and surface erosion and to provide erosion protection until the seeding becomes established.

Topsoiling Needs

The need to topsoil is determined by a combination of existing soil fertility and intended use. The poorer the site is in terms of natural fertility and soil texture, the greater the need for topsoil. This is especially true on sites where a high quality vegetative cover is needed either for erosion control or aesthetics.

Soil Texture

Soil texture (ratio of gravel, sand, silt, clay and organic matter) can affect the choice of a seed mixture for vegetating disturbed areas. For example, sites which have soils with a large percentage of sands and gravels will tend to be droughty and therefore require a drought tolerant mixture. Conversely, sites that exhibit somewhat poorly or poorly drained characteristics will require a mixture that will tolerate wet conditions. Soil texture of the site may warrant consideration for the use of topsoil (see **Topsoiling** measure) or sodding (see **Sodding** measure).

Intended Use

Referring to **Figure PS-2**, consider the ultimate use and maintenance requirements of the area when choosing a seed mixture to be used. There are two levels of maintenance: areas that will be mowed and areas that will not.

Areas that will be mowed can have different levels of maintenance and mowing. Golf courses and recreation areas will require more intensive management than roadside banks and medians.

Areas such as spoil banks, gravel pits and steep roadbanks once seeded and established will require no further mowing and little, if any, maintenance.

Topography or Finished Grade

Do not use permanent seeding on slopes steeper than 2:1. Under saturated conditions slopes could develop deep or shallow surface failures. In cases such as this, maintenance can be a constant problem and there can be danger to structures. A thorough site investigation is needed to determine if alternatives such as benching or

¹ When crown vetch is seeded in late summer, at least 35% of the seed should be hard seed (unscarified).

other structural methods are needed to ensure soil stability before seeding is done.

Cool Season versus Warm Season Grasses

Cool season grasses are those species that normally begin growth very early in the spring (late March to early April) and will continue to grow until warm weather sets in mid-June. At the onset of hot weather, cool season grasses will enter a stage of dormancy and exhibit little growth. They will maintain that dormant state until the cooler weather of the fall (end of August) and will then begin to grow again until late fall (end of October). Warm season grasses on the other hand, do not begin vigorous growth until warm weather (late May) and will continue growth until cool weather in the late fall (mid-September). Cool season grasses generally are the sod formers, such as bluegrass, while the warm season grasses, such as the perennial ryes, do not form sod.

Presence of Mulch

Sometimes seeding will occur after a previous application of mulch. If wood chips, bark or similar materials were used on the seeding area, plan on either removing the mulch or incorporating it into the soil and applying more nitrogen (see **Seed Bed Preparation**). Previously applied hay and straw mulch can be incorporated into the soil without adding supplemental nitrogen.

Specifications

Seed Selection and Quantity

Select a seed mixture appropriate to the intended use and soil conditions from **Figure PS-2** and **Figure PS-3** or use mixture recommended by the NRCS. For seed mixtures containing legumes, select the type and amount of inoculant that is specific for the legume to be used.

When buying seed make sure the quality of the seed is given for pure live seed and germination rate. Ask the supplier for an affidavit of purity and germination rate if there is any question. Expect a purity between of 95% and 98% and a germination rate between 70% and 90%. Some seeding mixtures call for pure live seed. An example of calculating pure live seed is given in **Figure PS-3**.

Increase seeding rates 10% when using frost crack seeding² or hydroseeding.

Timing

Seed with a permanent seed mixture within 7 days after establishing final grades or when grading work within a disturbed area is to be suspended for a period of more than 1 year. Seeding is recommended from April 1 through June 15 and August 15 through October 1, with the following exceptions:

- for the coastal towns and in the Connecticut River

Valley final fall seeding dates can be extended an additional 15 days, and

- *dormant or frost crack seeding is done after the ground is frozen.*

Site Preparation

Grade in accordance with the **Land Grading** measure.

Install all necessary surface water controls.

For areas to be mowed remove all surface stones 2 inches or larger. Remove all other debris such as wire, cable, tree roots, pieces of concrete, clods, lumps or other unsuitable material.

Note: *On areas where wood chips and/or bark mulch was previously applied, either remove the mulch or incorporate it into the soil with a nitrogen fertilizer added. Nitrogen application rate is determined by soil test at time of seeding; anticipate 12 lbs nitrogen per ton of wood chips and/or bark mulch.*

Seedbed Preparation

Apply topsoil, if necessary, in accordance with the **Topsoiling** measure.

Apply fertilizer and ground limestone according to soil tests conducted by the University of Connecticut Soil Testing Laboratory or other reliable source. A pH range of 6.2 to 7.0 is optimal for plant growth of most grass species.

Where soil testing is not feasible on small or variable sites, or where timing is critical, fertilizer may be applied at the rate of 300 pounds per acre or 7.5 pounds per 1,000 square feet using 10-10-10 or equivalent and limestone at 4 tons per acre or 200 pounds per 1,000 square feet. Additionally, lime may be applied using rates given in **Figure PS-1**. A pH of 6.2 to 7.0 is optimal.

For areas that were previously mulched with wood chips or bark and the wood chips or bark are to be incorporated into the soil, apply additional nitrogen at a rate that is determined by soil tests at time of seeding.

Figure PS-1 Soil Texture vs. Liming Rates

Soil Texture	Tons / Acre of Lime	Lbs / 1000 ft ² of Lime
Clay, clay loam and high organic soil	3	135
Sandy loam, loam, silt loam	2	90
Loamy sand, sand	1	45

²Frost crack or dormant seeding is a method used to establish a seeding during the off season and should be used only in extreme cases as there is a smaller chance of success. It can be an effective way to plant grass seed during late winter or early spring. This method is most effective on frozen ground where a seedbed has been prepared, or on areas that have been disturbed and where topsoil exists but vegetation has not been established. Frost crack or dormant seeding can also be used to re-seed or over-seed an area previously seeded, but where the survival was poor. The existing plants will remain undamaged, while the frost works the seed into the soil in bare areas. In all cases, seedings of this type need to be mulched to protect the seed from wind and water until satisfactory growing conditions occur (See Mulch for Seed measure). This method works particularly well with legumes, such as crown vetch and flat pea, which have a hard seed coat and the freezing action breaks down the seed coat to allow for germination.

Work lime and fertilizer into the soil to a depth of 3 to 4 inches with a disc or other suitable equipment.

Continue tillage until a reasonably uniform, fine seedbed is prepared. For areas to be mowed the final soil loosening and surface roughening operation is by hand, harrow or disk. If done by harrow or disc, it is generally done on the contour. Areas not to be mowed can be tracked with cleated earthmoving equipment perpendicular to the slope (see **Surface Roughening** measure). However, for areas where **Temporary Erosion Control Blankets** are to be used instead of **Mulch for Seed** prepare the seed bed in accordance with blanket manufacturer's recommendations.

Inspect seedbed just before seeding. If the soil is compacted, crusted or hardened, scarify the area prior to seeding.

Seed Application

Apply selected seed at rates provided in **Figure PS-3** uniformly by hand, cyclone seeder, drill, cultipacker type seeder or hydroseeder (slurry including seed, fertilizer.). Normal seeding depth is from 0.25 to 0.5 inch. Increase seeding rates by 10% when hydroseeding or frost crack seeding.

Seed warm season grasses during the spring period only.

Apply mulch according to the **Mulch for Seed** measure.

Irrigation for Summer Seeding

When seeding outside of the recommended seeding dates in the summer months, watering may be essential to the establish a new seeding. Irrigation is a specialized practice and care needs to be taken not to exceed the infiltration rate of the soil. Each application must be uniformly applied with 1 to 2 inches of water applied per application, soaking the ground to a depth of 4 inches.

Maintenance

Initial Establishment

Inspect seeded area at least once a week and within 24 hours of the end of a storm with a rainfall amount of 0.5 inch or greater during the first growing season.

Where seed has been moved or where soil erosion has occurred determine the cause of the failure. Bird damage may be a problem if mulch was applied too thinly to protect seed. Re-seed and re-mulch. If movement was the result of wind, repair erosion damage (if any), re-apply seed and mulch, and apply mulch anchoring. If failure was caused by concentrated water, (1) install additional measures to control water and sediment movement, (2) repair erosion damage, (3) re-seed and (4) re-apply mulch with anchoring or use **Temporary Erosion Control Blanket** measure and/or **Permanent**

Turf Reinforcement Mat measure).

If there is no erosion, but seed survival is less than 100 plants per square foot after 4 weeks of growth, re-seed as planting season allows.

Continue inspections until at least 100 plants per square foot have grown at least 6 inches tall or until the first mowing.

First Mowing

Allow the majority of plants to achieve a height of least 6 inches before mowing it the first time. Do not mow while the surface is wet. Mowing while the surface is still wet may pull many seedlings from the soil and often leaves a series of unnecessary ruts. The first mowing should remove approximately one third of the growth, depending upon the type of grass and where it is being used. Do not mow grass below 3 inches.

If the seeding was mulched, do not attempt to rake out the mulching material. Normal mowing will gradually remove all unwanted debris.

Long Term Maintenance

Mow and fertilize at a rate that sustains the area in a condition that supports the intended use. If appropriate the height of cut may be adjusted downward, by degrees, as new plants become established. Carry out any fertilization program in accordance with approved soil tests that determine the proper amount of lime and fertilizer needed to maintain a vigorous sod yet prevent excessive leaching of nutrients to the groundwater or runoff to surface waters.

Although weeds may appear to be a problem, they shade the new seedlings and help conserve surface moisture. Do not apply weed control until the new seeding has been mowed at least four times.

Figure PS-2 Selecting Seed Mix to Match Need

Area To Be Seeded	Mixture Number ¹	
	Mowing Desired	Mowing Not Required
BORROW AREAS, ROADSIDES, DIKES, LEVEES, POND BANKS AND OTHER SLOPES AND BANKS A) Well or excessively drained soil ² B) Somewhat poorly drained soils ² C) Variable drainage soils ²	1,2,3,4,5 or 8 2 2	5, 6, 7, 8, 9, 10, 11, 12, 16, 22 5, 6 5, 6, 11
DRAINAGE DITCH AND CHANNEL BANKS A) Well or excessively drained soils ² B) Somewhat poorly drained soils ² C) Variable drainage soils ²	1, 2, 3, or 4 2 2	9, 10, 11, 12
DIVERSIONS A) Well or excessively drained soils ² B) Somewhat poorly drained soils ² C) Variable drainage soils ²	2, 3 or 4 2 2	9, 10, 11
EFFLUENT DISPOSAL		5 or 6
GRAVEL PITS ³		26, 27, 28
GULLIED AND ERODED AREAS		3, 4, 5, 8, 10, 11, 12
MINESPOIL & WASTE, AND OTHER SPOIL BANKS (If toxic substances & physical properties not limiting) ³		15, 16, 17, 18, 26, 27, 28
SHORELINES (Fluctuating water levels)		5 or 6
SKI SLOPES		4, 10
SOD WATERWAYS AND SPILLWAYS	1, 2, 3, 4, 6, 7, or 8	1, 2, 3, 4, 6, 7, or 8
SUNNY RECREATION AREAS (Picnic areas and playgrounds or driving and archery ranges, nature trails)	1, 2 or 23	
CAMPING AND PARKING, NATURE TRAILS (Shaded)	19, 21 or 23	
SAND DUNES (Blowing sand)	25	
WOODLAND ACCESS ROADS, SKID TRAILS AND LOG YARDING AREAS		9, 10, 16, 22 , 26
LAWNS AND HIGH MAINTENANCE AREAS	1, 19, 21 or 29	

¹ The numbers following in these columns refer to seed mixtures in **Figure PS-3**. Mixes for shady areas are in *bold-italics* print (including mixes 20 through 24).

² See county soil survey for drainage class. Soil surveys are available from the County Soil and Water Conservation District Office.

³ Use mix 26 when soil passing a 200 mesh sieve is less than 15% of total weight. Use mix 26 & 27 when soil passing a 200 mesh sieve is between 15 and 20% of total weight. Use mix 26, 27 & 28 when soil passing a 200 mesh sieve is above 20% of total weight.

Source: USDA-NRCS

Figure PS-3 Seed Mixtures for Permanent Seeding

No.	Seed Mixture (Variety) ⁴	Lbs/Acre	Lbs/1,000 Sq. Ft.
1 ⁵	Kentucky Bluegrass	20	.45
	Creeping Red Fescue (Pennlawn, Wintergreen)	20	.45
	Perennial Ryegrass (Norlea, Manhattan)	<u>5</u>	<u>.10</u>
	Total	45	1.00
2 ⁵	Creeping Red Fescue (Pennlawn, Wintergreen)	20	.45
	Redtop (Streeker, Common)	2	.05
	Tall Fescue (Kentucky 31) or Smooth Bromegrass (Saratoga, Lincoln)	<u>20</u>	<u>.45</u>
	Total	42	.95
3 ⁵	Creeping Red Fescue (Pennlawn, Wintergreen)	20	.45
	Bird's-foot Trefoil (Empire, Viking) with inoculant ¹	8	.20
	Tall Fescue (Kentucky 31) or Smooth Bromegrass (Saratoga, Lincoln)	<u>20</u>	<u>.45</u>
	Total	48	1.10
4 ⁵	Creeping Red Fescue (Pennlawn, Wintergreen) or Tall Fescue (Kentucky 31)	20	.45
	Redtop (Streeker, Common)	2	.05
	Bird's-foot Trefoil (Empire, Viking) with inoculant ¹	<u>8</u>	<u>.20</u>
	Total	30	.70
5 ⁵	White Clover	10	.25
	Perennial Rye Grass	<u>2</u>	<u>.05</u>
	Total	12	.30
6 ⁵	Creeping Red Fescue	20	.50
	Redtop (Streeker, Common)	2	.05
	Perennial Rye Grass	<u>20</u>	<u>.50</u>
	Total	42	1.05
7 ⁵	Smooth Bromegrass (Saratoga, Lincoln)	15	.35
	Perennial Ryegrass (Norlea, Manhattan)	5	.10
	Bird's-foot Trefoil (Empire, Viking) with inoculant ¹	<u>10</u>	<u>.25</u>
	Total	30	.79
8 ⁶	Switchgrass (Blackwell, Shelter, Cave-in-rock)	10 ¹	.25
	Weeping lovegrass	3	.07
	Little Bluestem (Blaze, Aldous, Camper)	<u>10¹</u>	<u>.25</u>
	Total	23	.57
9 ⁵	Creeping Red Fescue (Pennlawn, Wintergreen)	10	.25
	Crown Vetch (Chemung, Penngift) with inoculant ¹	15	.35
	(or Flatpea (Lathco) with inoculant ¹)	(30)	(.75)
	Tall Fescue (Kentucky 31) or Smooth Bromegrass (Saratoga, Lincoln)	15	.35
	Redtop (Streeker, Common)	<u>2</u>	<u>.05</u>
	Total	42 (or 57)	1.00 (or 1.40)
10 ⁵	Creeping Red Fescue (Pennlawn, Wintergreen)	20	.45
	Redtop (Streeker, Common)	2	.05
	Crown Vetch (Chemung, Penngift) with inoculant ¹	15	.35
	(or Flatpea (Lathco) with inoculant ¹)	(30)	(.75)
	Total	37 (or 52)	.85 (or 1.25)
	11 ⁵	Bird's-foot Trefoil (Empire, Viking) with inoculant ¹	8
Crown Vetch (Chemung, Penngift) with inoculant ¹		15	.35
Creeping Red Fescue (Pennlawn, Wintergreen) or Tall Fescue (Kentucky 31) or Smooth Bromegrass (Saratoga, Lincoln)		<u>20</u>	<u>.45</u>
Total		43	1.00

continued

Figure PS-3 Seed Mixtures for Permanent Seeding (con't)

No.	Seed Mixture (Variety) ⁴	Lbs/1,000 Lbs/Acre	No. Sq. Ft.
12 ⁶	Switchgrass (Blackwell, Shelter, Cave-in-rock) Perennial Ryegrass (Norlea, Manhattan) Crown Vetch (Chemung, Penngift) with inoculant ¹	101 5 <u>15</u> Total 45	.25 .10 <u>.35</u> 1.05
13 ⁶	Crown Vetch (Chemung, Penngift) with inoculant ¹ (or Flatpea (Lathco) with inoculant ¹) Switchgrass (Blackwell, Shelter, Cave-in-rock) Perennial Ryegrass (Norlea, Manhattan)	10 (30) 5 ¹ <u>5</u> Total 20 (or 40)	.25 (.75) .10 <u>.10</u> .45 (or .95)
14 ⁵	Crown Vetch (Chemung, Penngift) with inoculant ¹ (or Flatpea (Lathco) with inoculant ¹) Perennial Ryegrass (Norlea, Manhattan)	15 (30) <u>10</u> Total 25 (or 40)	.35 (.75) <u>.25</u> .60 (or 1.00)
15 ⁶	Switchgrass (Blackwell, Shelter, Cave-in-rock) Big Bluestem (Niagra, Kaw) or Little Bluestem (Blaze, Aldous, Camper) Perennial Ryegrass (Norlea, Manhattan) Bird's-foot Trefoil (Empire, Viking) with inoculant ¹	5 ¹ 5 ¹ 5 <u>5</u> Total 20	.10 .10 .10 <u>.10</u> .40
16 ⁵	Tall Fescue (Kentucky 31) Flatpea (Lathco) with inoculant ¹	20 <u>30</u> Total 50	.45 <u>.75</u> 1.20
17 ⁶	Deer Tongue (Tioga) with inoculant ¹ Bird's-foot Trefoil (Empire, Viking) with inoculant ¹ Perennial Ryegrass (Norlea, Manhattan)	10 ¹ 8 <u>3</u> Total 21	.25 .20 <u>.07</u> .52
18 ⁶	Deer Tongue (Tioga) with inoculant ¹ Crown Vetch (Chemung, Penngift) with inoculant ¹ Perennial Ryegrass (Norlea, Manhattan)	10 ¹ 15 <u>3</u> Total 28	.25 .35 <u>.07</u> .67
19 ³	Chewings Fescue Hard Fescue Colonial Bentgrass Bird's-foot Trefoil (Empire, Viking) with inoculant ¹ Perennial Ryegrass	35 30 5 10 <u>20</u> Total 100	.80 .70 .10 .20 <u>.50</u> 2.30
20 ⁵	Deleted due to invasive species		
21 ⁵	Creeping Red Fescue (Pennlawn, Wintergreen)	Total 60	1.35
22 ⁵	Creeping Red Fescue (Pennlawn, Wintergreen) Tall Fescue (Kentucky 31)	40 <u>20</u> Total 60	.90 <u>.45</u> 1.35
23 ⁵	Creeping Red Fescue (Pennlawn, Wintergreen) Flatpea (Lathco) with inoculant ¹	15 <u>30</u> Total 45	.35 <u>.75</u> 3.60
24 ⁵	Tall Fescue (Kentucky 31)	Total 150	3.60

Figure PS-3 Seed Mixtures for Permanent Seeding (con't)

No.	Seed Mixture (Variety) ⁴	Lbs/Acre	Lbs/1,000 Sq. Ft.
25 ⁵	American Beachgrass (Cape)	58,500 culms/acre	1,345 culms/ 100 sq. ft.
26 ⁶	Switchgrass (Blackwell, Shelter, Cave-in-rock)	4.0	.10
	Big Bluestem (Niagra, Kaw)	4.0	.10
	Little Bluestem (Blaze, Aldous, Camper)	2.0	.05
	Sand Lovegrass (NE-27, Bend)	1.5	.03
	Bird's-foot Trefoil (Empire Viking)	<u>2.0</u>	<u>.05</u>
	Total	13.5	.33
27 ⁵	Flatpea (Lathco)	10	.20
	Perennial Pea (Lancer)	2	.05
	Crown Vetch (Chemung, Penngift)	10	.20
	Tall Fescue (Kentucky 31)	<u>2</u>	<u>.20</u>
	Total	24	.65
28 ⁵	Orchardgrass (Pennlate, Kay, Potomac)	5	.10
	Tall Fescue (Kentucky 31)	10	.20
	Redtop (Streeker, Common)	2	.05
	Birds-foot Trefoil (Empire Viking)	<u>5</u>	<u>.10</u>
	Total	22	.45
29	Turf Type Tall Fescue (Bonanza, Mustang, Rebel II, Spartan, Jaguar) or Perennial Rye ("Future 2000" mix; Fiesta II, Blazer II, and Dasher II)	175 to 250	6 to 8

¹ Use proper inoculant for legume seeds, use four times recommended rate when hydroseeding.

² Use Pure Live Seed (PLS) = $\frac{\% \text{ Germination} \times \% \text{ Purity}}{100}$

EXAMPLE: Common Bermuda seed with 70% germination and 80% purity=

$$\frac{70 \times 80}{100} \quad \text{or} \quad \frac{56}{100} \quad \text{or} \quad 56\%$$

$$\frac{10 \text{ lbs PLS/acre}}{56\%} = 17.9 \text{ lbs/acre of bagged seed}$$

³ DOT All purpose mix

⁴ Wild flower mix containing New England Aster, Baby's Breath, Black Eye Susan, Catchfly, Dwarf Columbine, Purple Coneflower, Lance-leaved Coreopsis, Cornflower, Ox-eye Daisy, Scarlet Flax, Foxglove, Gayfeather, Rocky Larkspur, Spanish Larkspur, Corn Poppy, Spurred Snapdragon, Wallflower and/or Yarrow may be added to any seed mix given. Most seed suppliers carry a wild flower mixture that is suitable for the Northeast and contains a variety of both annual and perennial flowers. Seeding rates for the specific mixtures should be followed.

⁵ Considered to be a cool season mix.

⁶ Considered to be a warm season mix.

2-Preserve and Conserve Soils

Topsoiling (TO)

Definition

The application of topsoil to promote the growth of vegetation following the establishment of final grades.

Purpose

To provide a suitable growth medium for final site stabilization with vegetation.

Applicability

- Where the texture, pH, or nutrient balance of the available soil (sands, gravels or other unconsolidated materials) cannot be modified by reasonable means to provide an adequate growth medium.
- Where the existing soil material is too shallow to provide an adequate root zone and to supply necessary moisture and nutrients for plant growth.
- Where high quality turf is desirable to prevent erosion and withstand intensive use and/or meet aesthetic requirements.
- Where landscape plantings are planned.
- Where extensive filling and cutting of slopes has occurred.
- Only on slopes no steeper than 2:1.

Planning Considerations

Topsoil is the surface layer of a soil profile (known as the A horizon of a soil), generally characterized as being darker than the subsoil due to the presence of organic matter. This layer is the major zone of root development, containing most of the nutrients available to plants, and supplying a large amount of the water used by plants, and is the zone where the respiration of plant roots occurs.

Consider the following:

- *Need – Vegetative growth is more rapid on sites with at least 4 inches of topsoil. Also, the health and quality of vegetation is better when topsoil is present. Topsoiling is strongly recommended where landscape plantings or high-maintenance turf will be grown. Topsoiling is required when establishing vegetation on shallow soils, and soils with a pH of 4 or below (acidic).*
- *Availability - Determine if sufficient volume of topsoil exists on the site. If not, it will be necessary to identify additional sources of topsoil.*
- *Costs - Compare the cost of topsoiling to the cost of preparing a seedbed in subsoil (See **Permanent Seeding, Sodding and Landscape Planting** measures). Limed and fertilized subsoils with proper seedbed preparation may provide an adequate growth medium if moisture is not limiting. Stripping, stockpiling, and reapplying topsoil, or importing topsoil can be expensive. Additionally, imported topsoils may contain weed seeds or invasive plants that are objectionable to the establishment of the permanent vegetation and may require additional treatments.*
- *Scheduling - The application of topsoil must be scheduled so as not to delay seeding or sodding operations. This delay increases the exposure time of critical areas, thereby increasing maintenance cost of existing controls.*
- *Stockpiles Management - Topsoil stockpiles need to be located away from construction activities. If topsoil is to be*

stockpiled longer than 30 days, it must be protected with a temporary seeding, matting or other acceptable means of preventing erosion. (See *Stockpile Management, Chapter 4, Special Treatments*).

- *Application Limitations - Care must be taken when applying topsoil to subsoil if the two soils have contrasting textures or strongly contrasting density (i.e. hardpan). Topsoil applied to a compacted subsoil can result in water flows between the two soil layers, causing the topsoil to slough. Where hardpan exists, it must be loosened with appropriate equipment such as a disk or harrow prior to spreading topsoil to ensure adequate bonding. Additionally, for slopes 2:1 through 5:1 slope tracking is required prior to the placement of topsoil to improve bonding (see **Surface Roughening** measure).*

Specifications

Materials

Topsoil shall inclusively mean a soil:

- *meeting one of the following soil textural classes established by the United States Department of Agriculture Classification System based upon the proportion of sand, silt, and clay size particles after passing a 2 millimeter (mm) sieve and subjected to a particle size analysis:*
 - loamy sand, including coarse, loamy fine, and loamy very fine sand,
 - sandy loam, including coarse, fine and very fine sandy loam,
 - loam, or
 - silt loam with not more than 60% silt;
- *containing not less than 6% and not more than 20% organic matter as determined by loss-on-ignition of oven dried samples dried at 105 degrees centigrade;*
- *possessing a pH range of 6.0-7.5, except if the vegetative practice being used specifically requires a lower pH, then pH may be adjusted accordingly;*
- *having soluble salts not exceeding 500 ppm; and*
- *that is loose and friable and free from refuse, stumps, roots, brush, weeds, frozen particles, rocks, and stones over 1.25 inches in diameter, and any material that will prevent the formation of a suitable seedbed or prevent seed germination and plant growth.*

Topsoil may be of natural origin or manufactured by blending composted organic materials with organic deficient soils, mineral soils, sand and lime such that the

resulting soil meets the material specifications listed above.

All topsoil shall be analyzed by a recognized soil testing laboratory for organic content, pH and soluble salts requirements given above.

Calculating Topsoil Needs

Topsoiling needs can be calculated by using the values given in **Figure TO-1**. Calculate topsoil needs in advance of stripping to determine if there is sufficient topsoil of good quality to justify stripping.

Stripping

Stripping shall be confined to the immediate construction area. A 4- to 6-inch stripping depth is common, but depth may vary depending on the particular soil. Place all perimeter dikes, basins, and other sediment controls

Figure TO-1 Topsoil Required for Application of Various Depths

Depth in Inches	Cu. Yds / 1,000 ft ²	Cu. Yds/ Acre
4	12.4	537
5	15.5	672
6	18.6	806

prior to stripping.

Stockpiling

Stockpile topsoil that is stripped from the site in such a manner that natural site drainage is not obstructed and no off-site sediment damage results. In all cases, locate stockpiles to maximize distance from wetlands and/or watercourses.

The side slopes of all stockpiles shall not exceed 2:1.

Install a sediment barrier down slope to trap sediments eroding from the stockpile. Stabilize the stockpiled material if it is to remain for a period of 30 day or longer (see **Temporary Soil Protection, Temporary Seeding, Permanent Seeding,** and **Mulch for Seed** measures for application timing requirements).

Application of Topsoil

Site Preparation: Install and/or repair erosion and sediment control measures such as diversions, grade stabilization structures, waterways, silt fence and sediment basins before topsoiling. Maintain these measures during topsoiling.

Bonding: After bringing the subsoil to grade (and immediately prior to spreading the topsoil), the subgrade shall be loosened by discing, scarifying or tracking to a depth of a least 4 inches to ensure bonding of the topsoil and subsoil. For a tracking description, see **Surface Roughening** measure.

Applying Topsoil: Distribute the topsoil uniformly to a minimum depth of 4 inches. Maintain approved grades when spreading topsoil. Correct any irregularities in the surface resulting from topsoiling or other operations in order to prevent the formation of depressions or water pockets.

Note: *Do not place topsoil if the subgrade or the topsoil is frozen or excessively wet.*

Ensure good contact with the underlying soil and obtain a uniform firm seedbed for the establishment of vegetation. Avoid excessive compaction as it increases runoff velocity and volume, and inhibits seed germination.

Liming: Where the pH of the subsoil is 6.0 or less, ground agricultural limestone shall be spread in accordance with the soil test to attain a pH of 6.0 to 6.5 or to attain a pH as required by the vegetative establishment practice being used.

Stabilizing Applied Topsoil: Immediately following topsoil applications, protect the topsoil from erosion by either sodding, seeding and/or mulching (see measures in the Short Term Non-Living Soil Protection Group and the Vegetative Soil Cover Group).

Maintenance

Inspect and maintain in accordance with the surface protection measure(s) used.

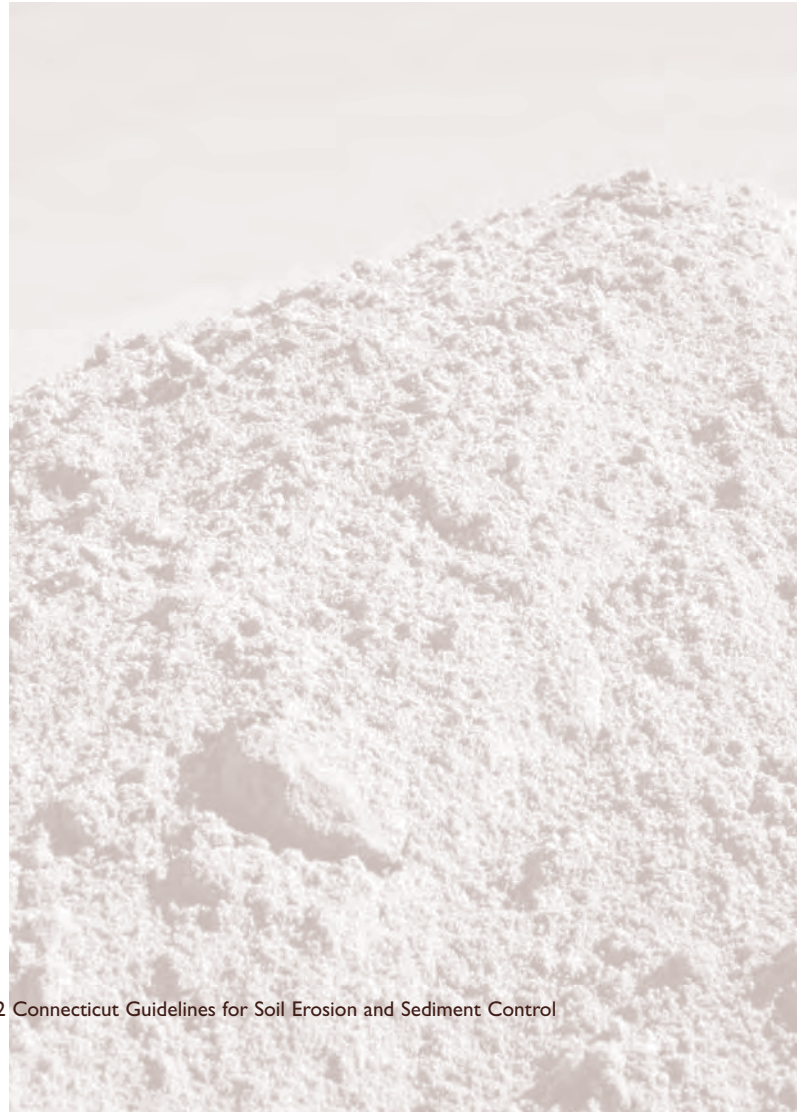

2-Preserve and Conserve Soils

Land Grading (LG)

Definition

Reshaping of the ground surface by excavation or filling or both, to obtain planned grades.

Purpose

- To control surface runoff and reduce erosion potential.
- To prepare for the establishment of a vegetative cover on those areas where the existing land surface is to be reshaped by grading.

Applicability

- Where grading to planned elevations is practical for the purposes set forth above.
- On slopes no steeper than 2:1. For slopes steeper than 2:1, see the slope stabilization measures in the Stabilization Structures Functional Group.
- Does not apply to bedrock cuts or faces.

Planning Considerations

Utilize the existing topography and natural features as much as possible when developing a grading plan. This minimizes the degree of land disturbance and avoids extreme grade modifications within a site development.

The two primary factors that determine the potential for excessive erosion on any site are length of slope and steepness. Long slopes without provisions for surface water diversions are much more susceptible to erosion than shorter slopes. As slopes become steeper, the potential for erosion also increases.

Obtain sufficient topographic, soils, hydrologic and geologic information to determine what limitations, if any, are to be considered in a development plan and grading operation. Final slope stability, the impact of the grading operations on adjacent properties and drainage patterns, and the effect of land disturbance on existing vegetation, ground and surface water resources are examples of concerns that must be addressed during planning for land grading.

In situations where geologic and hydrologic conditions clearly indicate a potential stability problem, structural measures shall be considered. Consider the presence of bedrock. Seepage combined with steep slopes and the close proximity of bedrock very often result in an unstable condition. Surface and subsurface drains may be needed to remove excess water.

For fill slopes that will take more than 1 day to construct, consider requiring the use of a **Temporary Fill Berm** and associated **Temporary Pipe Slope Drain**, as may be needed. At the end of the work day divert erosive stormwater runoff away from the unstable slope to a stable discharge point.

Design Criteria

Slope Defined

Slope is the relationship of horizontal distance to vertical distance and is referenced as either horizontal to vertical, a ratio of horizontal:vertical or a percentage of the vertical divided by the horizontal. **Figure LG-1** identifies the methods by which slope is determined.

Slope Gradient Limitations

Vegetated Mowed Slopes: Where a slope is to be vegetated and mowed, the slope shall not be steeper than 3:1; flatter slopes are preferred because of safety factors related to the operation of equipment.

Vegetated Unmowed Slopes: Where a slope is to be vegetated but not mowed, the slope shall not be steeper than 2:1.

Structurally Stabilized Slopes: For slopes steeper than 2:1, or when slopes are steeper than 3:1 and the change in elevation exceeds 15 feet without a cross slope bench, engineered structural design features shall be incorporated. Applicable engineered measures may include those found in the Stabilization Structures Functional Group (see **Figure 3-2**, Selection Matrix) or other structural measures designed by the engineer.

Exceptions: Slope limitations may be increased providing detailed soil mechanics analysis calculations are performed which confirm an acceptable safety factor for the finished slope.

Figure LG-1 Determining Slope

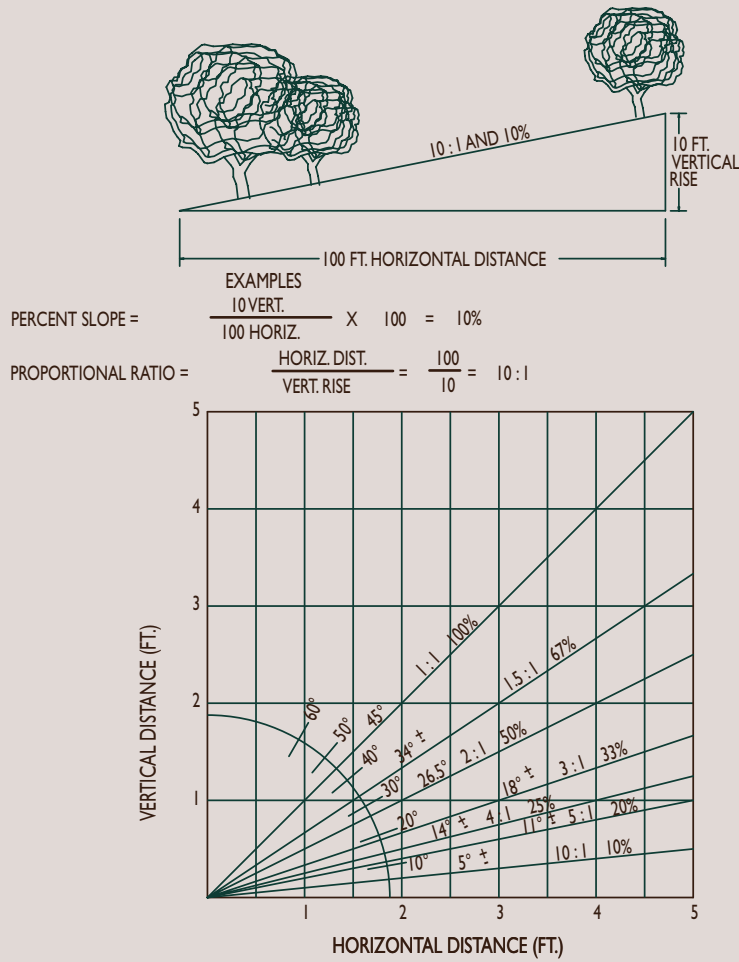

Source: USDA-NRCS

Figure LG-2 Example of Formula for Top Slope Diversions

Example: Determine the maximum allowable overland flow distance, A, for a 3:1 side slope with a vertical interval of 7 feet.

Given: X = 3 Y = 7

Solution: A = X(15-Y)
 A = 3(15-7)
 A = 24'

Summary: A = 24'
 B = 15(X) Since X=3 then 15'(3') = 45'

Therefore: If the overland flow distance is <24, then A+XY<B and no diversion or cross slope bench is required.

Slope Length Limitations and Reverse Slope Benches

Reverse slope benches are required whenever the vertical height of any **slope steeper than 3:1 exceeds 15 feet** (see **Figure LG-3**), except when engineered slope stabilization structures measures are included in the slope and/or a detailed soil mechanics analysis calculation has confirmed an acceptable factor of safety exists for the finished slope. Using the following design criteria provide:

- *spacing between benches into nearly equal segments and convey the surface and subsurface water to a stable outlet while still considering soils, seeps, rock outcrops, and other site conditions;*
- *bench width(s) of at least 6 feet (or sufficient to accommodate construction and long term maintenance equipment);*
- *reverse slope(s) of 5:1 or flatter between the outer edge of the bench and the toe of the upper slope;*
- *a minimum bench depth of 1 foot;*
- *bench gradient(s) to a stable outlet of at least 1% but not greater than 2%; and*
- *no total flow length(s) within the bench exceeding 800 feet unless accompanied by appropriate design and computations to demonstrate adequate capacity and stability.*

Controlling Water Movement

Make provisions to safely conduct surface runoff to storm drains, protected outlets or to stable watercourses to ensure that runoff will not damage slopes or other graded areas. See measures in the Stabilization Structures Group, **Vegetated Waterway**, **Permanent Diversion**, **Outlet Protection** and related measures. For slope designs that include engineered slope stabilization measures and where the change in elevation exceeds 15 feet without the inclusion of a reverse slope bench, perform an engineering analysis to determine the measures required to insure runoff will not damage the slope or other graded areas. For all other slopes perform the following analysis.

Surface Water: Maximum allowable overland flow distance in feet to the top of the designed slope with no diversion of surface water is determined by use of the formula:

$$A=X (15-Y)$$

- A** = Maximum overland flow distance in feet above the crest of the designed slope
- B** = Maximum horizontal distance in feet shall not exceed 15X.
- X** = Side slope; horizontal distance in feet to one-foot vertical (e.g., = 2 for designed slope 2:1)
- Y** = Height of designed slope in feet measured vertically from toe elevation of the designed slope to top of cut or fill for the designed slope.

Either divert surface water from the face of all cut and fill slopes by the use of diversions, ditches and drainage ways or otherwise convey it down the slope by the use of other appropriate measures. Surface water may be allowed to flow down cut and fill slopes when all of the following conditions exist:

- *the length of overland flow (in feet) to the crest of the designed slope does not exceed the distance "A";*
- *the face of the slope is already stable or the face of the slope is protected from surface runoff until it is stabilized (stability can be predicted by applying the Revised Universal Soil Loss Equation. See Appendix D);*
- *the face of the slope is not subjected to any concentrated flows of surface water from natural drainage ways and structures such as graded drainageways and downspouts; and*
- *the maximum total horizontal overland flow (A) plus slope distance (B) does not exceed 15 times the side slope (X) of the cut or fill slopes.*

Figure LG-2 contains an example that uses the formula referenced above.

Subsurface Water: Subsurface drainage shall be provided where necessary to intercept groundwater seepage that would otherwise adversely affect slope stability or create excessively wet site conditions that would hinder or prohibit desired vegetative growth. (See **Subsurface Drain** measure).

Other Design Limitations

Slopes shall not be created close to property lines so as to endanger adjoining properties without adequately protecting such properties against erosion, sedimentation, slippage, settlement, subsidence or other related damage.

Soil material used for earth fill shall be obtained from an approved borrow pit or other designated area. The fill material shall be free of brush, rubbish, large rocks, logs, stumps, building debris, and other objectionable material that would interfere with, or prevent construction of, satisfactory fills. It should be free of stones over 2 inches in diameter where compacted by hand or mechanical tampers or over 6 inches in diameter where compacted by rollers or other equipment. Frozen material shall not be placed in the fill nor shall the fill material be placed on a frozen foundation.

Stockpiles, borrow areas and spoil areas shall be located away from steep slopes and surface waters and shall be shown on the plans. Soil stockpiles shall be subject to the provisions of this measure.

All disturbed areas shall be stabilized in accordance with the E&S measures contained in these Guidelines.

Installation Requirements

1. Protect all graded or disturbed areas including slopes during clearing and construction in accordance with the approved erosion and sediment control plan until they are permanently stabilized.
2. Construct and maintain all erosion and sediment controls in accordance with the approved erosion and sediment control plan.
3. Clear and grub area to be graded. In filled areas where fill exceeds 5 feet in depth, grubbing may not be required.
4. Strip and stockpile topsoil required for the establishment of vegetation in amounts necessary to complete finished grading of all exposed areas. (See Chapter 4, Special Treatments, Stockpile Management)
5. Use only fill materials that are free of brush, rubbish, rocks, logs, stumps, building debris and other objectionable materials that would interfere with or prevent construction of satisfactory fills. Frozen material or soft, saturated or highly compressible materials shall not be incorporated into fills. Rock fill and other clean fill¹ may be used providing it does not interfere with the construction of structures.
6. Place and compact all fill in layers not exceeding 1 foot in thickness. No embankment layer shall be deposited on surfaces of snow or ice nor shall it be placed on frozen or unstable surfaces. Where embankments are to be constructed on slopes steeper than 3:1, deeply scarify the existing slope or cut into steps before filling is begun. If fill placement is not completed within 1 day, then install temporary erosion and sediment controls, such as Temporary Fill Berm, as necessary to redirect runoff water away from the unstable slope until fill placement resumes.
7. Compact all fills as required to reduce erosion, slippage, settlement, subsidence or other related problems. Fill that is intended to support buildings, structures, conduits and other facilities shall be compacted in accordance with the design specifications.
8. Prior to final seeding, roughen slopes 2:1 through 5:1 to reduce runoff velocities unless the engineer directs otherwise. (See Surface Roughening measure)
9. If areas are to be topsoiled, refer to the **Topsoiling** measure.
10. During all phases of construction keep reverse slope benches free of sediment.
11. The treatment of seeps or springs encountered during construction shall be reviewed and addressed by the engineer in accordance with generally accepted engineering standards.
12. Apply permanent soil stabilization measures to all graded areas within 7 days of establishing final grade. (See measures in the Vegetative Soil Cover Functional Group.) If final grading is to be delayed for more than 30 days after land disturbance activities cease, temporary soil stabilization measures shall be applied in accordance with the **Temporary Seeding** measure and associated measures in the Short Term Non-Living Soil Protection Functional Group.

Maintenance

Inspect and maintain all erosion and sediment measures implemented during land grading operations according to their respective requirements.

¹ Clean fill is defined by CGS § 22a-209-1.

Figure LG-3 Illustration of Reverse Slope Bench

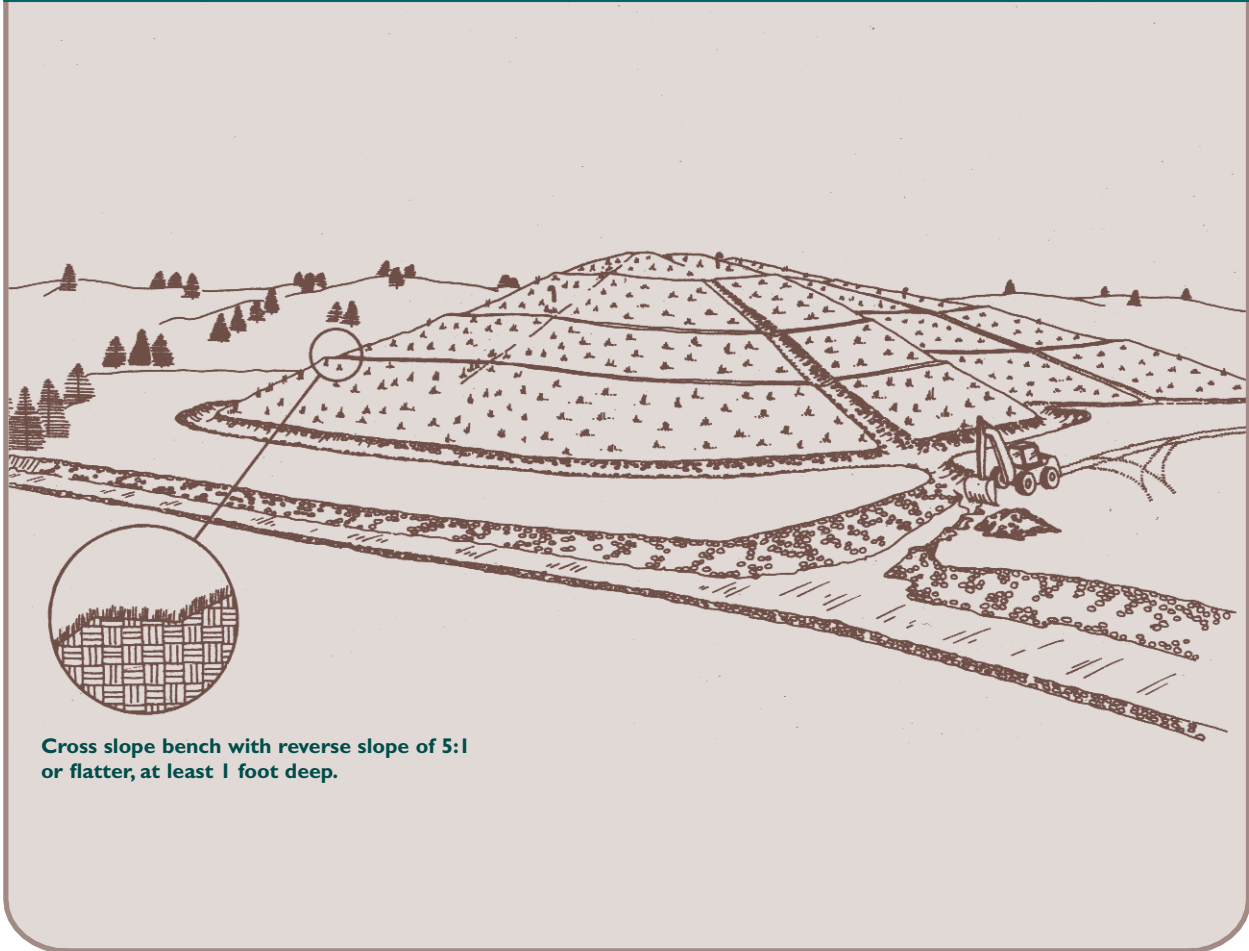

2-Preserve and Conserve Soils

Surface Roughening (SR)

Definition

A rough soil surface with horizontal depressions created by operating a tillage or other suitable implement on the contour, or by leaving slopes in a roughened condition by not fine-grading them.

Purpose

- To promote the establishment of vegetative cover with seed.
- To reduce storm water runoff velocity and increase infiltration.
- To reduce sheet erosion and provide for sediment trapping.

Applicability

- On disturbed slopes whose gradients are between 2:1 and 4:1, inclusive.
- Not for slopes that are to be finished with a stable rock face, stone slope protection, or sod.

Planning Considerations

It is difficult to establish vegetation on smooth, hard surfaces. Roughened slope surfaces with uneven soil and rocks left in place may appear unattractive or unfinished at first, however this encourages water infiltration, speeds the establishment of vegetation, and decreases runoff velocity.

Roughened loose soil surfaces give lime, fertilizer and seed protection from the erosive effects of rainfall and wind. Depressions in the surface provide microclimates which generally provide a cooler and more favorable moisture level than hard flat surfaces; this microclimate aids seed germination.

Different methods can be used for achieving a roughened soil surface on a slope. The selection of an appropriate method depends upon the type of slope. Roughening methods include grooving, and tracking. Factors to be considered in choosing a method are slope steepness, mowing requirements, and whether it is a cut or fill slope.

It is important to avoid excessive compaction of the soil surface when roughening the surface. Tracking with bulldozer treads is preferable to not roughening at all, but is not as effective as other forms of roughening, as the soil surface is severely compacted and runoff may be increased.

Specifications

For Areas Which Will Not Be Mowed

Cut Slope Applications: Cut slopes between 2:1 and 4:1, inclusive, shall be tracked or grooved (see **Figure SR-1**). Grooving or tracking consists of using machinery to create a series of ridges and depressions which run perpendicular to the direction of the slope (on the contour). Grooves may be made with any appropriate implement which can be safely operated on the slope and which will not cause undue compaction. Suggested implements include discs, tillers, springtooth harrows, dozer track cleats or the teeth on a front-end loader bucket. Such grooves shall not be less than 3 inches deep nor further than 15 inches apart.

Fill Slope Applications: Fill slopes between 2:1 to 4:1, inclusive, shall be grooved or allowed to remain rough as they are constructed. As lifts of the fill are constructed, soil and rock materials may be allowed to fall naturally onto the slope surface after filling is completed if the surface is not sufficiently roughened. After filling is completed, if the surface is not sufficiently roughened groove or track surface the same as for cut slopes. Slopes shall not be bladed or scraped to produce a smooth, hard surface, except where slopes are meant to be used as a travelway for vehicles and additional erosion and sediment controls are installed.

Areas Which Will Be Mowed

Mowed slopes should not be steeper than 3:1. Excessive roughness is undesirable where mowing is planned. Surface roughening is not recommended for areas to be sodded (See Sodding measure). Areas to be seeded and mowed may be roughened with shallow depressions such as those that remain after harrowing, raking, or using a cultipacker-seeder. Depressions formed by such equipment should be at least 1 inch deep and not further than 12 inches apart. The final pass of any equipment shall be on the contour (perpendicular to the direction of the slope).

Roughening With Tracked Machinery

(see **Figure SR-1**)

Roughening with tracked machinery on soils with a high clay content is not recommended unless no alternatives are available. Undue compaction of surface soil results from this practice. Sandy soils do not compact severely, and may be tracked. In sandy soils tracking may not be as effective as the other roughening methods described.

When tracking is the chosen surface roughening technique, it shall be done by operating tracked machinery up and down the slope to leave horizontal depressions in the soil. As few passes as possible of the machinery should be made to minimize compaction.

Stabilizing with Seed and/or Mulch

Immediately following surface roughening, protect the soil from erosion by seeding and/or mulching (See measures in the Short Term Non-Living Soil Protection Functional Group and the Vegetative Soil Cover Functional Group).

Maintenance

Inspect and maintain in accordance with the surface protection measure(s) used.

Figure SR-1 Tracking Slopes

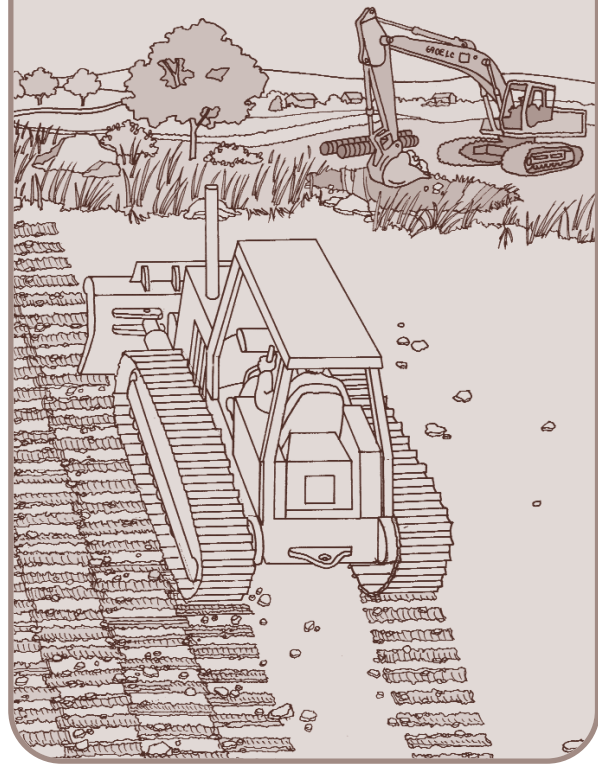

2-Preserve and Conserve Soils

Dust Control (DC)

Definition

The control of dust on construction sites, construction roads and other areas where dust is generated.

Purpose

To prevent the movement of dust from exposed soil surfaces, which may cause both off-site and on-site damage, be a health hazard to humans, wildlife and plant life, or create a safety hazard by reducing traffic visibility.

Applicability

- On unstable soils subject to construction traffic.
- Where unstable soils are located on hill tops or long reaches of open ground and can be exposed to high winds.

Planning Considerations

When construction activities expose soils, fugitive dust is emitted both during these activities (i.e., excavation, demolition, vehicle traffic, rock drilling and other human activities) and as a result of wind erosion of the exposed earth surfaces. Large quantities of dust can be generated during “heavy” construction activities, such as road and street construction, subdivision, commercial or industrial development.

In planning for dust controls:

- *Limit the amount of exposed soil by phasing construction to reduce the area of land disturbed at any one time and by using, as soon as possible, stabilization measures such as anchored **Temporary Soil Protection, Temporary Seeding** or **Permanent Seeding** with anchored **Mulch for Seed, Landscape Plantings** with **Landscape Mulch, Sodding** or **Stone Slope Protection**.*
- *Maintain as much natural vegetation as is practicable. Undisturbed vegetative buffers (minimum of 50-foot width) left between graded areas and area to be protected can be very effective.*
- *Identify and address sources of dust generated by construction activities. Limit construction traffic to predetermined routes. Paved surfaces require mechanical sweepers to remove soil that has been deposited or tracked onto the pavement. On unpaved travelways and temporary haul roads, use*

road construction stabilization measures and/or water as needed to keep surface damp. Stationary sources of dust, such as rock crushers, use fine water sprays to control dust. If water is expected to be needed for dust control, identify the source of water in advance. Pumping from streams, pond and similar waterbodies may require approval from the municipal inland wetland agency.

- *Identify and address sources of wind generated dust. Provide special consideration to hill tops and long reaches of open ground where slopes may be exposed to high winds. Consider breaking up long reaches with temporary windbreaks constructed from brush piles, geotextile silt fences or hay bales. Plan on stabilizing slopes early. Mulch for seed will require anchoring when used.*
- *Consider water quality when selecting the method and/or materials used for dust control. When considering the use of calcium chloride, be aware of the following: the receiving soil's permeability so as to prevent groundwater contamination; the timing of the application to rainfall to prevent washing of salts into sensitive areas such as wetlands and watercourses; and proximity to sensitive areas such as watercourses, ponds, established or soon to be established area of plantings, where salts could impair or destroy plant and animal life. Additionally, some materials used for dust control may be rendered ineffective by degraded water quality if it is used for mixing.*

Consider using dust control measures only after it is determined that other measures for soil stabilization cannot be practically applied.

dust becomes evident.

Specifications

Mechanical Sweeping

Use mechanical sweeping on paved areas where dust and fine materials accumulate as a result of truck traffic, pavement saw cutting spillage, and wind or water deposition from adjacent disturbed areas. Sweep daily in heavily trafficked areas.

Water

Periodically moisten exposed soil surfaces on unpaved travelways to keep the travelway damp.

Non-Asphaltic Soil Tackifier

Non-asphaltic soil tackifier consists of an emulsified liquid soil stabilizer of organic, inorganic or mineral origin, including, but not limited to the following: modified resins, calcium chloride, complex surfactant, copolymers or high grade latex acrylics. The solutions shall be non-asphaltic, nontoxic to human, animal and plant life, non-corrosive and nonflammable. Materials used shall meet local, state and federal guidelines for intended use. All materials are to be applied according to the manufacturer's recommendations and all safety guidelines shall be followed in storing, handling and applying materials.

Maintenance

Repeat application of dust control measures when fugitive

12-Tire Tracked Soils

Construction Entrance (CE)

Definition

A stone stabilized pad sometimes associated with a mud rack, automotive spray, or other measures located at points of vehicular ingress and egress on a construction site.

Purpose

To reduce the tracking of sediment off site onto paved surfaces.

Applicability

At points of construction vehicle ingress and egress where sediment may be tracked onto adjoining paved surfaces by vehicles.

Planning Considerations

The construction entrance is intended to cause sediment to drop off of vehicle tires and prevent it from being tracked onto adjoining paved areas. Its design and maintenance requirements are dependent upon how intensely the entrance is used and the nature of the sediments that can be tracked. Consider the texture of the sediments to be retained by the construction entrance. The minimum construction entrance is 50 feet, but where the soils subject to tracking contain less than 80% sand, then the minimum length of the construction entrance is 100 feet (see textural triangle in Appendix H). For sites containing clay or silty soils consider developing a construction access road with a gravel base. (See Chapter 4, Special Treatments, Construction Access Roads). The length of the construction entrance may be reduced by the establishment of an access road with a stable surface that is not subject to soil tracking.

If the construction entrance drains to a paved surface and its grade exceeds 2%, then plan on installing a water bar within the construction entrance to divert water away from the paved surface. For access roads that slope down to the construction entrance, consider installing a water bar and associated sediment barrier to protect the construction entrance from unnecessary siltation during storm events.

Placing a geotextile beneath the stone pad of the construction entrance can reduce the pumping of subsoil into the stone by construction traffic and reduce maintenance costs.

Select the site of the construction entrance to avoid poorly drained soils where possible. Where lateral flows of water must be maintained through the construction entrance, consider having an engineer design subsurface drainage or other drainage facilities to eliminate the obstruction to flow.

Consider requiring the installation of construction access fencing to restrict construction traffic to the construction entrance.

When the construction entrance is installed to the minimum standards and is properly maintained, but is still unable to prevent the majority of sediments from being tracked off site, the entrance must either be extended or a washing rack installed. If a washing rack or similar device is to be used to wash sediment from tires, make provisions to intercept the wash water and trap the sediment before it is carried off-site. Determine the sizing requirements for the sediment trapping facility so that it will hold the maximum volume of water that would be used over a 2-hour period. (See **Pumping Settling Basin** measure for formula on pumping rate and storage requirements).

The use of a construction entrance may not eliminate the need for periodic street sweeping, but if properly maintain it should significantly reduce the need.

Specifications

Materials

Stone: Use angular stone sized according to the standards set by ASTM C-33, size No. 2 or 3, or DOT Standard Specifications section M.01.01, size #3. See **Figure SP-1 on page 5-4-14** for stone sizing requirements.

Geotextile: Fibers used in the geotextile shall consist of synthetic polymers composed of at least 85% by weight polypropylenes, polyesters, polyamides, polyethylene, polyolefins or polyvinylidene-chlorides. The fibers shall be formed into a stable network of filaments or yarns retaining dimensional stability relative to each other. The geotextile used shall be specifically intended for "road stabilization" applications and shall be consistent with the manufacturer's recommendations for the intended use.

Location

Locate the entrance to provide maximum utilization by construction vehicles. Avoid poorly drained soils, where possible.

Construction Entrance Dimensions (see **Figure CE-2**)
Stone Thickness: not less than 6 inches.

Width: A 12-foot minimum with points of ingress or egress flared sufficiently to accommodate the turning radius of the construction vehicles used.

Length: A 50-foot minimum except where the tracked sediments contain less than 80% sand, a 100-foot minimum is required. If the traveled length is less than the minimum, then the construction entrance shall be the traveled length. On a site specific basis increase lengths as needed to prevent the tracking of sediment onto paved surfaces.

Construction

Clear the area of the entrance of all vegetation, roots, and other objectionable material. At poorly drained locations install subsurface drainage insuring the outlet to the drains are free flowing.

If using a geotextile in place of free draining material, unroll the geotextile in a direction parallel to the roadway centerline in a loose manner permitting it to conform to the surface irregularities when the stone is placed. Unless otherwise specified by the manufacturer, the minimum overlap of geotextile panels joined without sewing according to the manufacturer's recommendations. The geotextile may be temporarily secured with pins recommended or provided by the manufacturer but they shall be removed prior to placement of the stone.

Place the stone to the specified dimensions. Keep

additional stone available or stockpile for future use. If the grade of the construction entrance drains to the paved surface and it exceeds 2%, construct a water bar within the construction entrance at least 15 feet from its entrance on the paved surface diverting runoff water to a settling or filtering area.

Construct any drainage and settling facilities needed for washing operations. If wash racks are used, install according to the manufacturer's specifications.

Washing

If most of the sediment is not removed by travel over the stone, wash tires before vehicles enter a public road. Divert wash water away from the entrance to a settling area to remove sediment. Size settling area to hold the volume of water used during any 2-hour period. Using a wash rack may make washing more convenient and effective.

Maintenance

Maintain the entrance in a condition which will prevent tracking and washing of sediment onto paved surfaces. Provide periodic top dressing with additional stone or additional length as conditions demand. Repair any measures used to trap sediment as needed. Immediately remove all sediment spilled, dropped, washed or tracked onto paved surfaces. Roads adjacent to a construction site shall be left clean at the end of each day.

If the construction entrance is being properly maintained and the action of a vehicle traveling over the stone pad is not sufficient to remove the majority of the sediment, then either (1) increase the length of the construction entrance, (2) modify the construction access road surface, or (3) install washing racks and associated settling area or similar devices before the vehicle enters a paved surface.



Figure CE-2 Diagram of Typical Construction Entrance

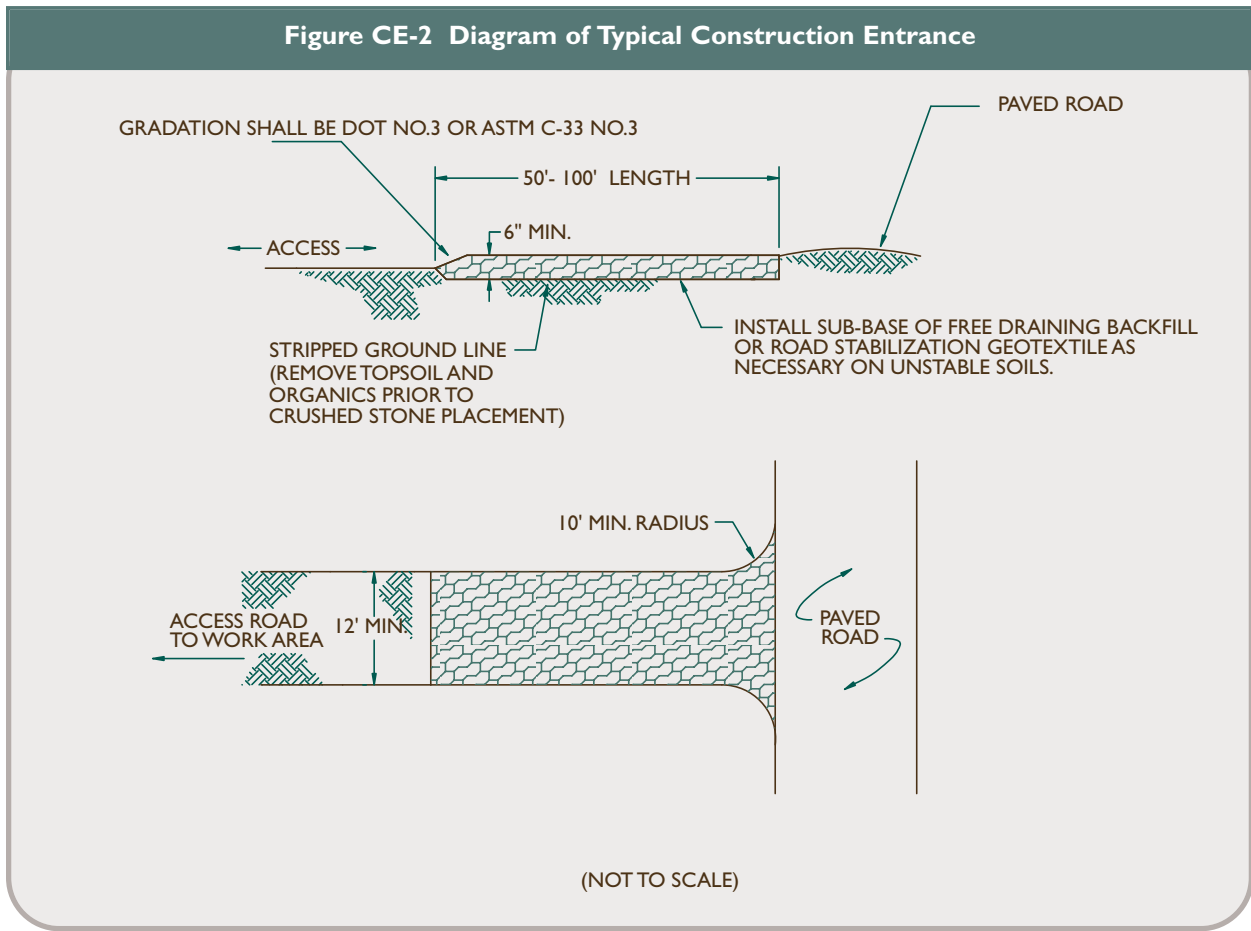

Source: USDA-NRCS

11 - Sediment Impoundments, Barriers and Filters

Geotextile Silt Fence (GSF)

Definition

A temporary sediment barrier consisting of a geotextile fabric pulled taut and attached to supporting posts and entrenched.

Purpose

- To intercept and retain sediment from disturbed areas.
- To decrease the velocity of sheet flows and low volume concentrated flows.

Applicability

- Below small disturbed areas where the contributing drainage area (disturbed and undisturbed) is less than 1 acre in size.
- At storm water drainage inlets and catch basins where sedimentation will reduce the capacity of storm drainage systems or adversely affect adjacent areas, water-courses and other sensitive areas.
- Not for use in areas where rock, frozen ground or other hard surface prevents proper installation of the barrier (see Special Case Combinations in **Stone Check Dam** measure).
- Prohibited from use in drainageways whose flow is supported by ground water discharge.

Planning Considerations

See Planning Considerations for Sediment Impoundments, Barriers and Filters Functional Group. When used at a culvert outlet, plan to install the geotextile silt fence before the start of construction and complete the installation of the required outlet protection before the culvert is made functional. It is preferable to control sediment at the inlets rather than at the outlet. Use at outlets should be limited to situations where inlet controls are not possible or to act as a backup to inlet controls.

Specifications

Materials

Geotextile fabric: shall be a pervious sheet of polypropylene, nylon, polyester, ethylene or similar filaments and shall be certified by the manufacturer or supplier as conforming to the requirements shown in **Figure GSF-1**. The geotextile shall be non-rotting, acid and alkali resistant and have sufficient strength and permeability for the purpose intended, including handling and backfilling operations. Filaments in the geotextile shall be resistant to absorption. The filament network must be dimensionally stable and resistant to de-lamination. The geotextile shall be free of any chemical treatment or coating that will reduce its permeability. The geotextile shall also be free of any flaws or defects which will alter its physical properties. Torn or punctured geotextiles shall not be used.

Supporting posts: shall be at least 42 inches long made of either 1.5 inch square hardwood stakes or steel posts with projections for fastening the geotextile possessing a minimum strength of 0.5 pound per linear foot.

Placement on the Landscape

Contributing drainage area 1 acre or less. Maximum slope length is as shown in **Figure GSF-2**.

For toe of slope (Figure GSF-3): Locate 5-10 feet down gradient from the toe of slope, generally on the contour with maintenance and sediment removal requirements in mind. When the contour can not be followed install the fence such that perpendicular wings are created to break the velocity of water flowing along the fence. See **Figure GSF-2** for spacing requirements.

Swales (see Figure GSF-4): Locate "U" shape across swale such that the bottom of both ends of the fence are higher than the top of the lowest section of the fence.

Catch Basins in Swale on Slopes: Locate 2 "U" shapes across swale as above: one immediately up slope from the catch basin and the other immediately down slope from the catch basin.

Catch Basins in Depressions: Encircle catch basin.

Culvert Inlets: Locate in a "U" shape approximately 6 feet from the culvert in the direction of the incoming flow.

Figure GSF-1 Geotextile Silt Fencing Minimum Requirements

Physical Property	Test Method	Minimum Requirement
filtering efficiency	ASTM 5141	75% (min)
grab tensile strength (lbs.)	ASTM D4632	100 lbs
elongation @ failure	ASTM D4632	15 %
Mullen burst strength	ASTM D3786	250 psi
puncture strength	ASTM 4833	50 lbs
apparent opening size	ASTM D4751	no greater than 0.90 mm and no less than 0.60 mm
flow rate	ASTM D4491	0.2 gal/ft ² /min
permativity	ASTM D4491	0.05 sec. -1 (min)
ultraviolet radiation stability %	ASTM-D4355	70% after 500 hours of exposure (min)

Culvert Outlets: Locate across the swale at least 6 feet from the culvert outlet.

Figure GSF-2 Geotextile Silt Fence Slope/Length Limitations

Slope Steepness ¹	Slope Length and Wing Spacing
5:1 or flatter	100 feet
3:1 to 5:1	75 feet
2:1 to 3:1	50 feet

¹ Where the gradient changes through the drainage area the steepest slope section shall be used.

Installation (see **Figure GSF-3**)

Trench excavation: Excavate a trench a minimum of 6 inches deep and 6 inches wide on the up slope side of the fence location. For slope and swale installations, extend the ends of the trench sufficiently up slope such that bottom end of the fence will be higher than the top of the lowest portion of the fence.

When the fence is not to be installed on the contour, excavate wing trenches spaced at the intervals given in **Figure GSF-2**.

When trench excavation is obstructed by an occasional stone or tree root, provide a smooth transition between the trench bottom and the obstruction.

Support Posts: Drive support posts on the down slope side of the trench to a depth of at least 12 inches into original ground.

Never install support posts more than 10 feet apart. Install support posts closer than 10 feet apart when concentrated flows are anticipated or when steep contributing slopes and soil conditions are expected to generate larger volumes of sediment. For catch basins in hollows, drive posts at each corner of

the catch basin. Whenever the geotextile filter fabric that is used exceeds the minimum material specifications contained in this measure, the spacing of the stakes shall be per manufacturer's recommendations.

Geotextile Filter Fabric: Staple or secure the geotextile to the support posts per manufacturer's instruction such that at least 6 inches of geotextile lies within the trench, the height of the fence does not exceed 30 inches² and the geotextile is taut between the posts. When the trench is obstructed by stones, tree roots, etc. allow the geotextile to lay over the obstruction such that the bottom of the geotextile points up slope.

In the absence of manufacturer's instructions, space wire staples on wooden stakes at a maximum of 4 inches apart and alternate their position from parallel to the axis of the stake to perpendicular.

Do not staple the geotextile to living trees.

Provide reinforcement for the fence when it can be exposed to high winds.

When joints in the geotextile fabric are necessary, splice together only at a support posts, and securely seal (see manufacturer's recommendations).

Backfill & Compaction: Backfill the trench with tamped soil or aggregate over the geotextile (see **Figure GSF-3**). When the trench is obstructed by a stone, tree root, etc. make sure the bottom of the geotextile lies horizontal on the ground with the resulting flap on the up slope side of the geotextile and bury the flap 6 inches of tamped soil, or aggregate.

Maintenance

Inspect the silt fence at least once a week and within 24 hours of the end of a storm with a rainfall amount of 0.5 inch or greater to determine maintenance needs. When used for dewatering operations, inspect frequently before, during and after pumping operations.

² higher barriers may impound volumes of water sufficient to push over the support posts

Remove the sediment deposits or, if room allows, install a secondary silt fence up slope of the existing fence when sediment deposits reach approximately one half the height of the existing fence.

Replace or repair the fence within 24 hours of observed failure. Failure of the fence has occurred when sediment fails to be retained by the fence because:

- (a) the fence has been overtopped, undercut or bypassed by runoff water,
- (b) the fence has been moved out of position (knocked over), or
- (c) the geotextile has decomposed or been damaged.

When repetitive failures occur at the same location, review conditions and limitations for use and determine if additional controls (e.g. temporary stabilization of contributing area, diversions, stone barriers) are needed to reduce failure rate or replace fence. See **Figure GSF-5** for trouble shooting failures.

Maintain the fence until the contributing area is stabilized.

After the contributing area is stabilized determine if sediment contained by the fence requires removal or regrading and stabilization. If the depth is greater than or equal to 6 inches, regrading or removal of the accumulated sediment is required. No removal or regrading is required if sediment depth is less than 6 inches.

Remove the fence by pulling up the support posts and cutting the geotextile at ground level. Regrade or remove sediment as needed, and stabilize disturbed soils.

Figure GSF-3 Toe of Slope Installations with Wings

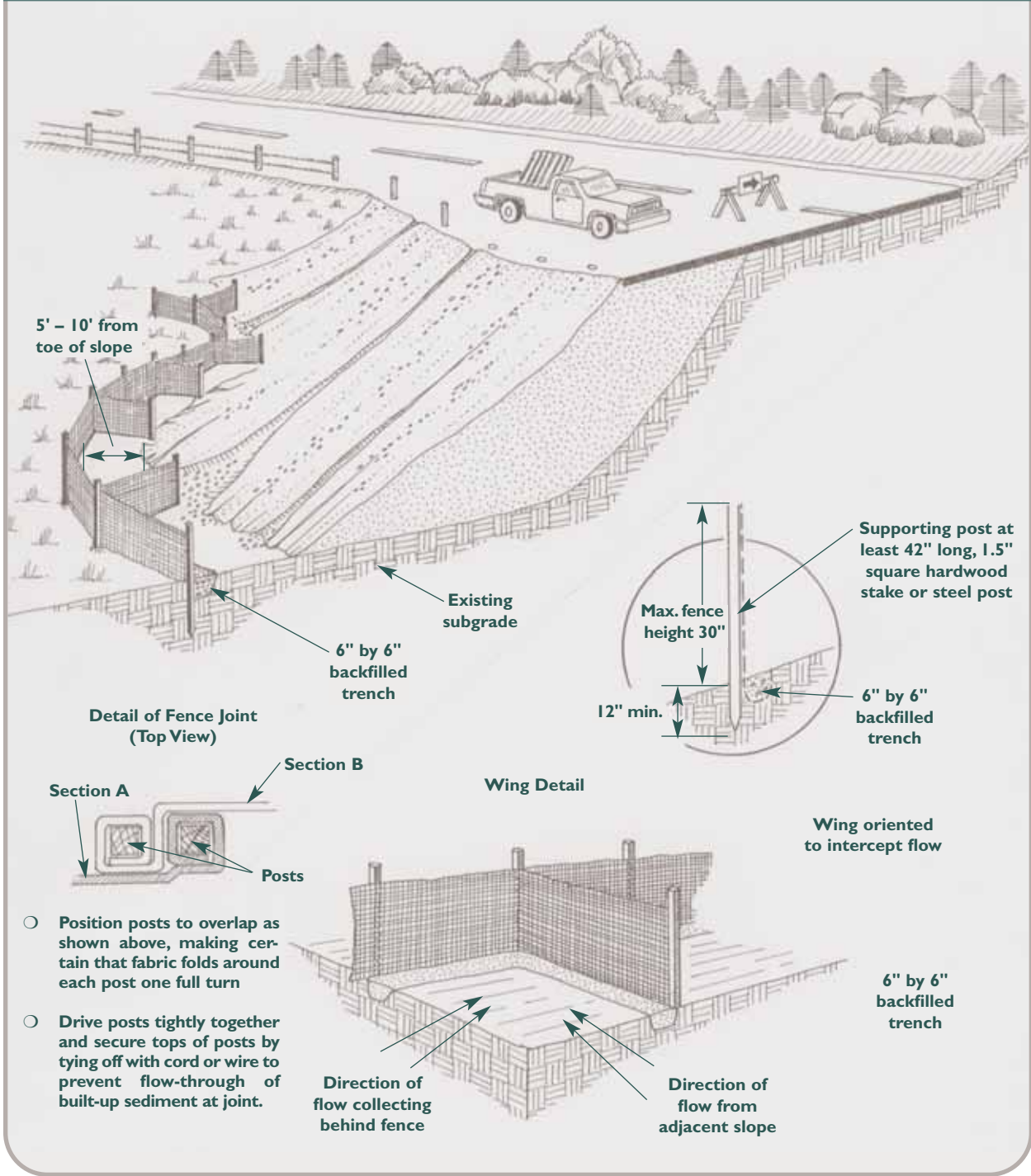

Geotextile Silt Fence (GSF)

Figure GSF-4 Swale and Catch Basin Installations

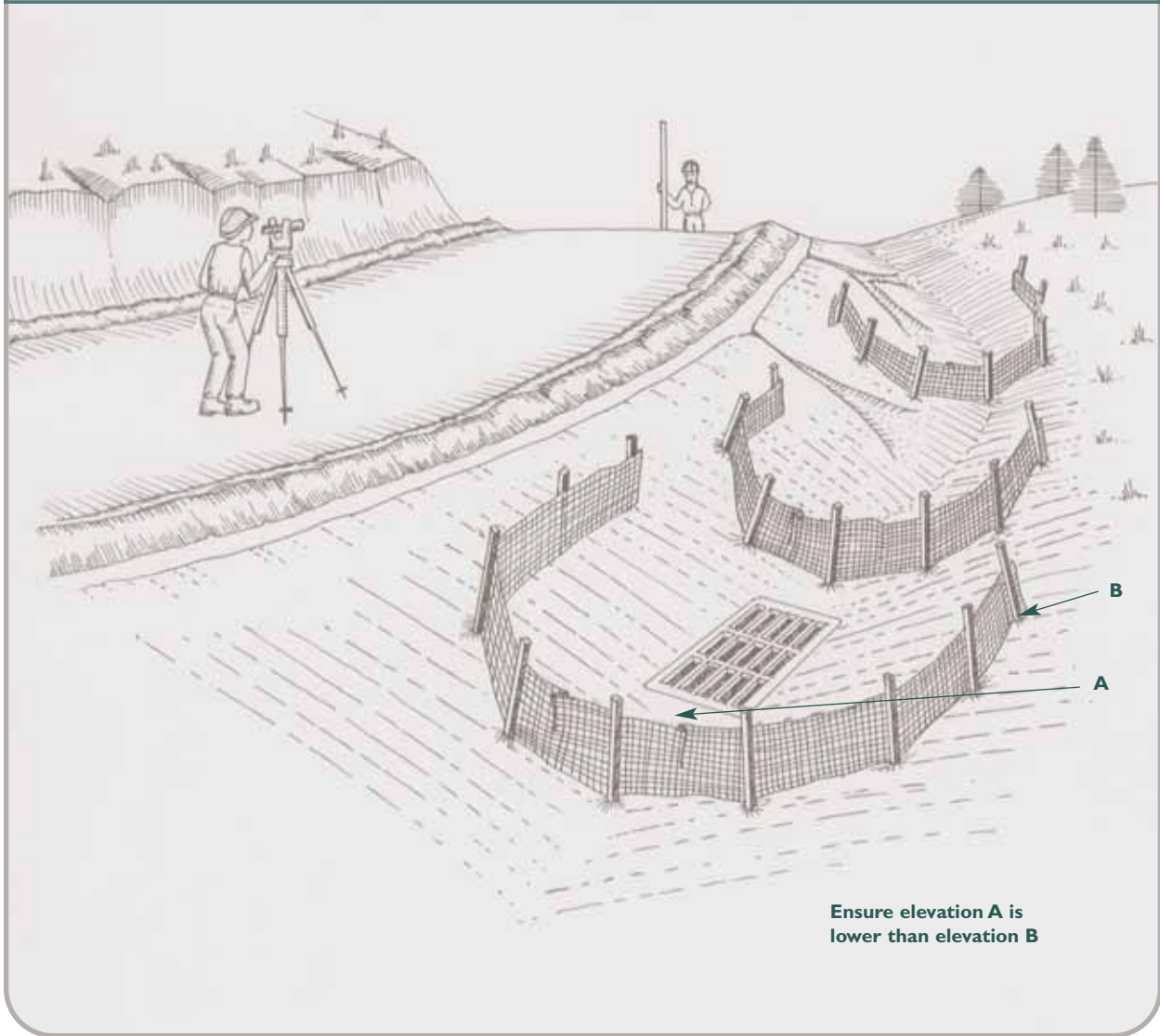

Figure GSF-5 Silt Fence Trouble Shooting Guide

Problem	Cause	Fix
fence fallen over or stakes broken from pressure of water	too large drainage area	Change to stone check dams or add additional controls up slope to reduce velocities and sediment loading (see measure matrix, Chapter 4 for other measures available).
	flows too concentrated	Repair or replace fence, increase staking frequency, angle stake up slope, consider installing hay bale barrier on the down slope side of fence in area of concentration or adding guy wire for support.
	stake not driven deep enough geotextile not properly attached to stakes	Repair or replace fence, increase stake depth. Recheck manufacturer's instructions on attachment and re-attach.
undercutting, toe failure	poor trenching or inadequate compaction, not enough geotextile buried	Install new fence properly or retrench, fill & compact rills at fence failure, drive stakes deeper as necessary to bury enough geotextile, fill & compact trench and down slope rills to provide support. For repeated failures consider installing hay bale barrier on the down slope side at the failure site after repair work is done.
	fence not on the contour, runoff eroding up slope side of barrier	Retrench, fill & compact rills at fence failure, and install perpendicular wings to break flow line such that bottom end of wing is higher than top of fence at wing joint OR install stone barriers on up slope side of fence to reduce runoff velocities. For repeated failures consider installing hay bale barrier on the down slope side at the failure site after
	poor transition from trench to obstruction at grade	Fill failed area to make smooth transition from trench to obstruction and re-bury flap of geotextile with 6 inches of tamped soil or aggregate. For repeated failures consider installing hay bale barrier on the down slope side at the failure site after repair work is done.
water running around ends	not extending end of fencing far enough up slope	Extend fence far enough up slope so that bottom of fence end is higher than top of lowest portion of fence, overlap joints at least 6 inches.