



Crown Castle
3 Corporate Park Drive, Suite 101
Clifton Park, NY 12065

September 26, 2017

Melanie A. Bachman
Acting Executive Director
Connecticut Siting Council
10 Franklin Square
New Britain, CT 06051

RE: Notice of Exempt Modification for Sprint 2.5 Rework Crown Site BU: 876405
AT&T Site ID: CT54XC771
186 Minortown Road, Woodbury, CT 06798
Latitude: 41° 34' 4.79"/ Longitude: -73° 10' 46.85"

Dear Ms. Bachman:

Sprint currently maintains three (3) antennas at the 103-foot level of the existing 110-foot monopole tower at 186 Minortown Road in Woodbury, CT. The tower is owned by Crown Castle. The property is owned by Raymond Hardisty. Sprint now intends to replace install three (3) antennas, one (1) hybrid, and three (3) new RRHs.

This facility was approved by the by the Connecticut Siting Council in Docket No. 235 on June 19, 2003 and on July 13, 2004 in Petition No. 678 approved an extension to the tower (100 feet to 110 feet). This approval included the conditions that:

1. The tower shall be constructed no taller than necessary to provide the proposed telecommunications services, sufficient to accommodate the antennas of Sprint PCS, AT&T Wireless PCS, LLC and other entities, both public and private, but such tower shall not exceed a height of 110 feet above ground level.
2. The Certificate Holder shall prepare a Development and Management (D&M) Plan for this site in compliance with Sections 16-50j-75 through 16-50j-77 of the Regulations of Connecticut State Agencies. The D&M Plan shall be submitted to and approved by the Council prior to the commencement of facility construction and shall include:
 - a. Visual simulations of the monopole and stealth options for a 110-foot tower at the site including a flagpole and tree tower;
 - b. a final site plan(s) of site development to include specifications for the tower, tower foundation, antennas, equipment building, access road, utility line, and landscaping; and

The Foundation for a Wireless World.

CrownCastle.com

- c. construction plans for site clearing, water drainage, and erosion and sedimentation control consistent with the 2002 Connecticut Guidelines for Soil Erosion and Sediment Control, as amended.

7. Any antenna that becomes obsolete and ceases to function shall be removed within 60 days after such antennas become obsolete and cease to function.

This modification complies with the aforementioned condition(s).

Please accept this letter as notification pursuant to Regulations of Connecticut State Agencies § 16-50j-73, for construction that constitutes an exempt modification pursuant to R.C.S.A. § 16-50j-72(b)(2). In accordance with R.S.C.A. § 16-50j-73, a copy of this letter is being sent to Mr. William J. Butterly Jr., First Selectman, Town of Woodbury, as well as the property owner, and Crown Castle is the tower owner.

1. The proposed modifications will not result in an increase in the height of the existing tower.
2. The proposed modifications will not require the extension of the site boundary.
3. The proposed modification will not increase noise levels at the facility by six decibels or more, or to levels that exceed state and local criteria.
4. The operation of the replacement antennas will not increase radio frequency emissions at the facility to a level at or above the Federal Communication Commission safety standard.
5. The proposed modifications will not cause a change or alteration in the physical or environmental characteristics of the site.
6. The existing structure and its foundation can support the proposed loading.

For the foregoing reasons, AT&T respectfully submits that the proposed modifications to the above-reference telecommunications facility constitutes an exempt modification under R.C.S.A. § 16-50j-72(b)(2). Please send approval/rejection letter to Attn: Jeffrey Barbadora.

Sincerely,

Jeffrey Barbadora
Real Estate Specialist
12 Gill Street, Suite 5800, Woburn, MA 01801
781-729-0053
Jeff.Barbadora@crowncastle.com

Melanie A. Bachman

September 26, 2017

Page 3

Attachments:

Tab 1: Exhibit-1: Compound plan and elevation depicting the planned changes

Tab 2: Exhibit-2: Structural Modification Report

Tab 3: Exhibit-3: General Power Density Table Report (RF Emissions Analysis Report)

cc: Mr. William J. Butterly Jr.
Town of Woodbury
281 Main Street South
Woodbury, CT 06798

Planning and Zoning
Town of Woodbury
281 Main Street South
Woodbury, CT 06798

Raymond Hardisty
200 Minortown Road
Woodbury, CT 06798

Connecticut Siting Council

Decisions

DOCKET NO. 235 - Sprint Spectrum L.P. application for a } Connecticut
Certificate of Environmental Compatibility and Public Need }
for the construction, maintenance and operation of a } Siting
wireless telecommunications facility at 186 Minortown }
Road or Main Street North, North Woodbury, Connecticut. } Council

June 19, 2003

Decision and Order

Pursuant to the foregoing Findings of Fact and Opinion, the Connecticut Siting Council (Council) finds that the effects associated with the construction, operation, and maintenance of a telecommunications facility including effects on the natural environment; ecological integrity and balance; public health and safety; scenic, historic, and recreational values; forests and parks; air and water purity; and fish and wildlife are not disproportionate either alone or cumulatively with other effects when compared to need, are not in conflict with the policies of the State concerning such effects, and are not sufficient reason to deny the application and therefore directs that a Certificate of Environmental Compatibility and Public Need, as provided by General Statutes § 16-50k, be issued to Sprint Spectrum L.P. d/b/a Sprint PCS for the construction, maintenance and operation of a wireless telecommunications facility at 186 Minortown Road, Woodbury, Connecticut. The Council denies certification of Site B located at Main Street North, Woodbury, Connecticut.

The facility shall be constructed, operated, and maintained substantially as specified in the Council's record in this matter, and subject to the following conditions:

1. The tower shall be constructed no taller than necessary to provide the proposed telecommunications services, sufficient to accommodate the antennas of Sprint PCS, AT&T Wireless PCS, LLC and other entities, both public and private, but such tower shall not exceed a height of 100 feet above ground level.
2. The Certificate Holder shall prepare a Development and Management (D&M) Plan for this site in compliance with Sections 16-50j-75 through 16-50j-77 of the Regulations of Connecticut State Agencies. The D&M Plan shall be submitted to and approved by the Council prior to the commencement of facility construction and shall include:
 - a. Visual simulations of the monopole and stealth options for a 100-foot tower at the site including a flagpole and tree tower;
 - b. a final site plan(s) of site development to include specifications for the tower, tower foundation, antennas, equipment building, access road, utility line, and landscaping; and
 - c. construction plans for site clearing, water drainage, and erosion and sedimentation control consistent with the 2002 Connecticut Guidelines for Soil Erosion and Sediment Control, as amended.
3. The Certificate Holder shall, prior to the commencement of operation, provide the Council worst-case modeling of electromagnetic radio frequency power density of all proposed entities' antennas at the closest point of uncontrolled access to the tower base, consistent with Federal Communications Commission, Office of Engineering and Technology, Bulletin No. 65, August 1997. The Certificate Holder shall ensure a recalculated report of electromagnetic radio frequency power density is submitted to the Council if and when circumstances in operation cause a change in power density above the levels calculated and provided pursuant to this Decision and Order.
4. Upon the establishment of any new State or federal radio frequency standards applicable to frequencies of this facility, the facility granted herein shall be brought into compliance with such standards.
5. The Certificate Holder shall permit public or private entities to share space on the proposed tower for fair consideration, or shall provide any requesting entity with specific legal, technical, environmental, or

economic reasons precluding such tower sharing.

6. If the facility does not initially provide wireless services within one year of completion of construction or ceases to provide wireless services for a period of one year, this Decision and Order shall be void, and the Certificate Holder shall dismantle the tower and remove all associated equipment or reapply for any continued or new use to the Council before any such use is made.
7. Any antenna that becomes obsolete and ceases to function shall be removed within 60 days after such antennas become obsolete and cease to function.
8. Unless otherwise approved by the Council, this Decision and Order shall be void if the facility authorized herein is not operational within one year of the effective date of this Decision and Order or within one year after all appeals to this Decision and Order have been resolved.

Pursuant to General Statutes § 16-50p, we hereby direct that a copy of the Findings of Fact, Opinion, and Decision and Order be served on each person listed below, and notice of issuance shall be published in the Waterbury Republican American, and Voices Sunday – The Weekly Star.

By this Decision and Order, the Council disposes of the legal rights, duties, and privileges of each party named or admitted to the proceeding in accordance with Section 16-50j-17 of the Regulations of Connecticut State Agencies.

The parties and intervenors to this proceeding are:

Applicant

Sprint Spectrum L.P. d/b/a Sprint PCS

Its Representative

Thomas J. Regan, Esq.
Brown Rudnick Berlack Israels LLP
CityPlace I, 38th Floor
185 Asylum Street
Hartford, CT 06103-6522
860-509-6522

Intervenor

AT&T Wireless PCS, LLC d/b/a AT&T Wireless

Its Representative

Daniel F. Leary, Esq.
Cuddy & Feder LLP
90 Maple Avenue
White Plains, New York 10601
(914) 761-1300

Party

Anthony J. Vallillo

Connecticut Siting Council

Petition Staff Reports

Petition No. 678 - Project Summary

Cellco Partnership

North Woodbury, Connecticut

July 13, 2004

Introduction

Cellco Partnership d/b/a as Verizon Wireless (Cellco) seeks to extend the height of a Sprint Spectrum L.P. (Sprint) owned 100-foot monopole located in North Woodbury, Connecticut. The existing tower was approved by the Council on June 19, 2003 under Docket 235. The tower currently supports the antennas of Sprint (100-foot centerline) and AT&T Wireless PCS LLC (90-foot centerline). Cellco is seeking a declaratory ruling that no Certificate of Environmental Compatibility and Public Need is required for the tower extension. A copy of the Petition was provided to the Town. Additionally, Cellco contacted the First Selectman to discuss the proposal. The Town has no comment on the proposed tower extension. Abutting property owners were also notified of the proposed extension. No abutters commented on the proposal.

Proposed Modification

Cellco seeks to extend the height of the approved tower from 100 feet to 110 feet. Cellco would install three flush mounted PCS panel antennas a centerline height of 110 feet, bringing the total height of the facility to 112 feet above ground level. Cellco would expand the compound by 20 feet to the north to accommodate a 12-foot by 30-foot equipment shelter. The proposed compound expansion is within Sprint's 100-foot by 100-foot lease area and would require minimal grading. Additional site clearing would not be required.

Visibility Impact

Extending the tower from 100 feet agl to 110 feet agl would increase visibility from 27-acres to 34-acres within a two-mile radius of the site, mainly as a result of the expansion of existing areas with visibility. In addition, approximately 4 acres of seasonal visibility would occur from the open areas immediately southeast of the site. The extended tower would be seasonally visible from 0.2 miles of North Main Street, 0.1 miles of Minortown Road, and 0.2 miles of Middle Road Turnpike.

Power Density

The conservative worst-case approximation of electromagnetic radiofrequency emissions for telecommunications operations at the site would increase from 22.4% to 24.2% of the applicable standard for uncontrolled environments.

The Assessor's office is responsible for the maintenance of records on the ownership of properties. Assessments are computed at 70% of the estimated market value of real property at the time of the last revaluation which was 2013.

Town of Woodbury

First Deed from the Indians 1659



Information on the Property Records for the Municipality of Woodbury was last updated on 9/23/2017.

Parcel Information

Location:	186 MINORTOWN RD	Property Use:	Industrial	Primary Use:	Broadcasting Facility
Unique ID:	346710	Map Block Lot:	025-036	Acres:	1.38
490 Acres:	0.00	Zone:	OS60	Volume / Page:	281/ 769
Developers Map / Lot:	32/82	Census:	3621		

Value Information

	Appraised Value	70% Assessed Value
Land	138,000	96,600
Buildings	0	0
Detached Outbuildings	277,415	194,190
Total	415,415	290,790

Owner's Information

Owner's Data

HARDISTY RAYMOND A
GLOBAL SIGNAL ACQUISITIONS II LLC
PMB 331
4017 WASHINGTON RD

Detached Outbuildings

Type:	Year Built:	Length:	Width:	Area:
Building/Equipment Cell Towers	2005			160
Building/Equipment Cell Towers	2010			320
Fencing Cell Towers	2010			200
Mono Pole Cell Towers	2005			100
Pad Cell Towers	2010			120

Owner History - Sales

Owner Name	Volume	Page	Sale Date	Deed Type	Valid Sale	Sale Price
HARDISTY RAYMOND A	281	769	10/22/2002		No	\$0

Building Permits

Permit Number	Permit Type	Date Opened	Date Closed	Permit Status	Reason
B208-14	Commercial Addition	11/14/2014		Closed	TMOBILE TO ADD 3 ATENNAS TO EXISTING ARAY NO GROUND WORK
B026-13	Comm Renovations	02/25/2013		Closed	DRILL 2- 1/2 INCH HOLE DEPTH OF 7'2" INTO EXISITING OUNATION AND EPOXY 3 (9') ANCHOPR BOLTS INTO HO
B002-13	Comm Renovations	01/02/2013		Closed	CELL TOWER- ADD CABINET TO SHELTER INSTALL 3 NEW ANTENNAS & 6 RRUS TO EXISTING TOWER

Town of Woodbury, Connecticut - Assessment Parcel Map

Parcel: 025-036

Address: 186 MINORTOWN RD

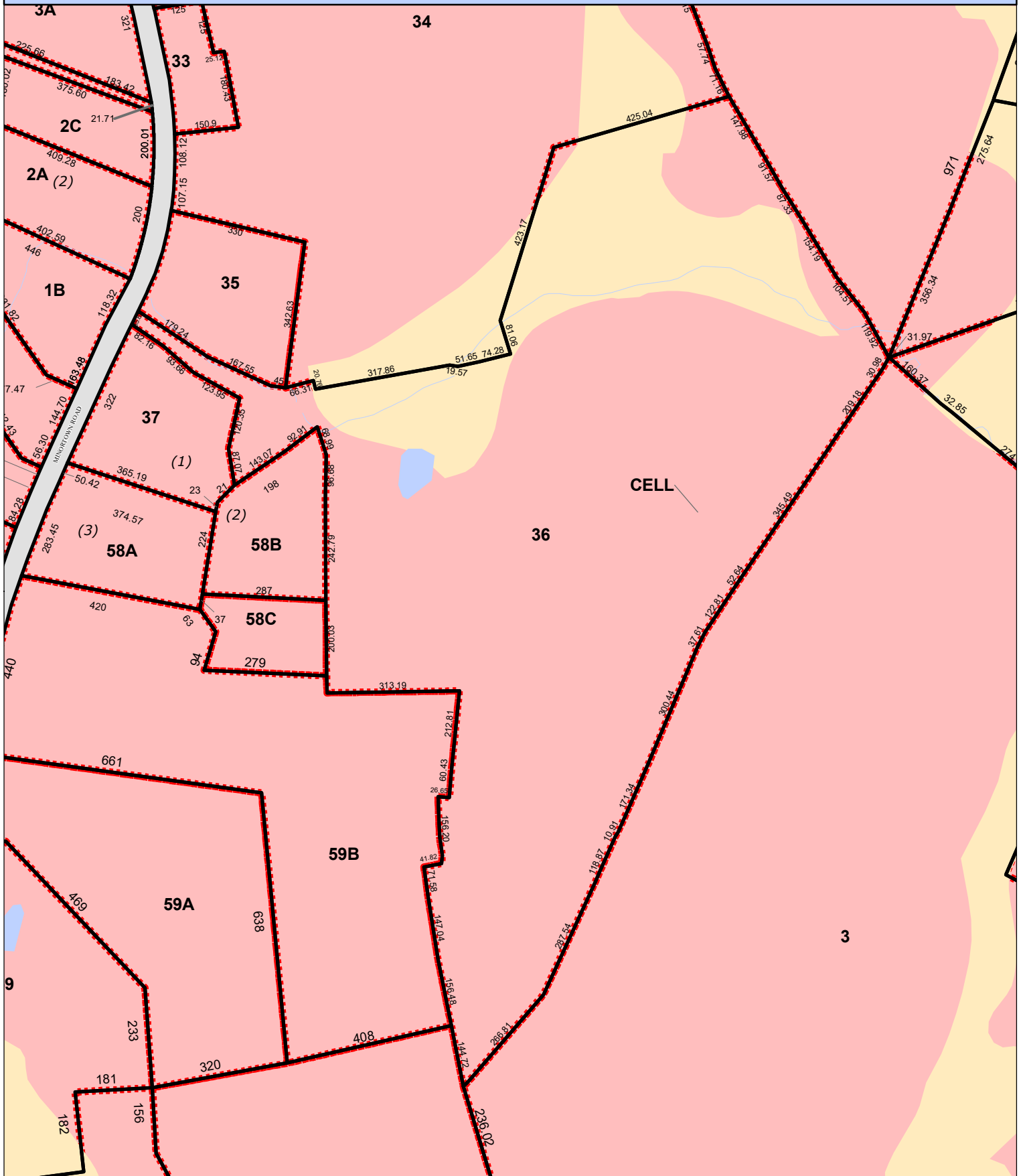
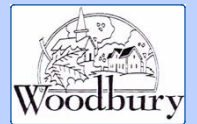

Approximate Scale: 1 inch = 300 feet

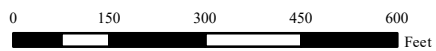

Map Produced: 2/14/2017

Disclaimer: This map is for informational purposes only. All information is subject to verification by any user. The Town of Woodbury and its mapping contractors assume no legal responsibility for the information contained herein.



2.5 EQUIPMENT DEPLOYMENT

SITE NUMBER:
CT54XC771

SITE NAME:
WOODBURY NORTH

SITE ADDRESS:
186 MINORTOWN ROAD
WOODBURY, CT 06798

APPROVED
By Craig Koppang at 11:46 am, Aug 09, 2017

APPROVED
By Jeff Barbadora at 10:04 pm, Aug 02, 2014

CROWN ID#: 876405
CROWN SITE NAME: WOODBURY NORTH

Sprint
2.5 EQUIPMENT DEPLOYMENT
6580 SPRINT PARKWAY
OVERLAND PARK, KS 66251



TECTONIC
PLANNING
ENGINEERING
SURVEYING
CONSTRUCTION
MANAGEMENT
TECTONIC Engineering & Surveying
Consultants P.C.
1279 Route 300
Newburgh, NY 12550
Phone: (845) 567-6656
Fax: (845) 567-8703
www.tectonicengineering.com

SHEET INFORMATION

SITE NUMBER:	CT54XC771	LANDLORD:	CROWN CASTLE USA 2000 CORPORATE DRIVE CANONSBURG, PA
SITE NAME:	WOODBURY NORTH	LOCAL POWER COMPANY:	CONNECTICUT LIGHT AND POWER CONTACT CUSTOMER SERVICE (800) 288-2000
SITE ADDRESS:	186 MINORTOWN ROAD WOODBURY, CT 06798	APPLICANT:	SPRINT 6580 SPRINT PARKWAY OVERLAND PARK, KA 66251
COUNTY:	LITCHFIELD	ENGINEER:	JAMES QUICKSELL (845) 567-6656 EXT. 2835 jquicksell@tectonicengineering.com
COORDINATES: (NAD 83)	41° 34' 4.79"N 73° 10' 46.85"W	SPRINT CM:	GARY WOOD (860) 940-9188 gary.wood@sprint.com
GROUND ELEV:	456'± AMSL	CROWN CM:	JASON D'AMICO (860) 209-0104 jason.d'amico@crowncastle.com
STRUCTURE TYPE:	MONOPOLE	AAV:	CHARTER
STRUCTURE HEIGHT:	110'-0"± AGL		
STRUCTURE RAD CENTER:	103'-0"± AGL		
ZONING CLASSIFICATION:	OS80		
PARCEL ID:	025-036		

VICINITY MAP (NOT TO SCALE)



SHEET INDEX

SHT. NO.	SHEET DESCRIPTION
T-1	TITLE SHEET
SP-1	GENERAL NOTES
SP-2	GENERAL NOTES
A-1	SITE PLAN
A-2	ELEVATION
A-3	ENLARGED EQUIPMENT LAYOUT PLANS
A-4	ANTENNA LAYOUT PLANS
A-5	RAN WIRING DIAGRAM
A-6	CABLE DETAILS
S-1	EQUIPMENT DETAILS
S-2	EQUIPMENT SCHEMATIC DETAILS
E-1	ELECTRICAL & GROUNDING PLANS
E-2	GROUNDING DETAILS & NOTES

THIS DOCUMENT IS THE CREATION, DESIGN, PROPERTY AND COPYRIGHTED WORK OF SPRINT COMMUNICATIONS, INC. ANY DUPLICATION OR USE WITHOUT EXPRESS WRITTEN CONSENT IS STRICTLY PROHIBITED. DUPLICATION AND USE BY GOVERNMENT AGENCIES FOR THE PURPOSES OF CONDUCTING THEIR LAWFULLY AUTHORIZED REGULATORY AND ADMINISTRATIVE FUNCTIONS IS SPECIFICALLY ALLOWED.

SUBMITTALS

PROJECT NO: 7225.CT54XC771

NO	DATE	DESCRIPTION	BY
0	6/23/14	FOR COMMENT	JT
1	7/29/14	FOR CONSTRUCTION	KA
2	8/1/14	PER COMMENTS	KA

DATE: 8/1/14
REVIEWED BY: JMG

GENERAL NOTES

- THIS IS AN UNMANNED TELECOMMUNICATION FACILITY AND NOT FOR HUMAN HABITATION. HANDICAP ACCESS REQUIREMENTS ARE NOT REQUIRED. FACILITY HAS NO PLUMBING OR REFRIGERANTS. THIS FACILITY SHALL MEET OR EXCEED ALL FAA AND FCC REGULATOR REQUIREMENTS.
- CONTRACTOR SHALL VERIFY ALL PLANS AND EXISTING DIMENSIONS AND CONDITIONS ON THE JOB SITE AND SHALL IMMEDIATELY NOTIFY THE PROJECT OWNER'S REPRESENTATIVE IN WRITING OF DISCREPANCIES BEFORE PROCEEDING WITH THE WORK OR BE RESPONSIBLE FOR SAME.
- DEVELOPMENT AND USE OF THIS SITE WILL CONFORM TO ALL APPLICABLE CODES AND ORDINANCES.
 - BUILDING CODE OF CONNECTICUT, LATEST EDITION.
 - ANSI/TIA/EIA-222-F-1996.
 - NATIONAL ELECTRICAL CODE, LATEST EDITION.

AERIAL VIEW (NOT TO SCALE)



APPROVALS

THE FOLLOWING PARTIES HEREBY APPROVE AND ACCEPT THESE DOCUMENTS AND AUTHORIZE THE CONTRACTOR TO PROCEED WITH THE CONSTRUCTION DESCRIBED HEREIN. ALL DOCUMENTS ARE SUBJECT TO REVIEW BY THE LOCAL BUILDING DEPARTMENT AND MAY IMPOSE CHANGES OR MODIFICATIONS.

CONSTRUCTION: _____ DATE: _____
 LEASING/SITE ACQUISITION: _____ DATE: _____
 LANDLORD/PROPERTY OWNER: _____ DATE: _____
 R.F. ENGINEER: _____ DATE: _____

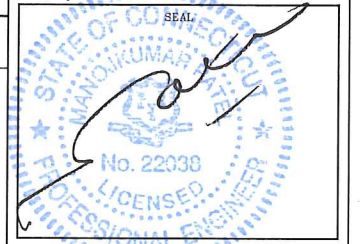

PROJECT DESCRIPTION

- (1) NEW ALU 9929 EXPANSION CABINET
- (3) NEW RFS APXVTM14-C-120 ANTENNAS.
- (3) NEW TD-RRH8x20-25 RRH.
- (1) NEW 5/8" FIBER CABLE.

SITE NUMBER:
CT54XC771
SITE NAME:
WOODBURY NORTH
SITE ADDRESS:
186 MINORTOWN ROAD
WOODBURY, CT 06798

SHEET TITLE:
TITLE SHEET

SHEET NO:
T-1



DIVISION 01000—GENERAL NOTES

- THE CONTRACTOR SHALL GIVE ALL NOTICES AND COMPLY WITH ALL LAWS, ORDINANCES, RULES, REGULATIONS AND LAWFUL ORDERS OF ANY PUBLIC AUTHORITY, MUNICIPAL AND UTILITY COMPANY SPECIFICATIONS, AND LOCAL AND STATE JURISDICTIONAL CODES BEARING ON THE PERFORMANCE OF THE WORK. THE WORK PERFORMED ON THE PROJECT AND THE MATERIALS INSTALLED SHALL BE IN STRICT ACCORDANCE WITH ALL APPLICABLE CODES, REGULATIONS, AND ORDINANCES.
- THE ARCHITECT/ENGINEER HAVE MADE EVERY EFFORT TO SET FORTH IN THE CONSTRUCTION AND CONTRACT DOCUMENTS THE COMPLETE SCOPE OF WORK. THE CONTRACTOR BIDDING THE JOB IS NEVERTHELESS CAUTIONED THAT MINOR OMISSIONS OR ERRORS IN THE DRAWINGS AND OR SPECIFICATIONS SHALL NOT EXCUSE SAID CONTRACTOR FROM COMPLETING THE PROJECT AND IMPROVEMENTS IN ACCORDANCE WITH THE INTENT OF THESE DOCUMENTS.
- THE CONTRACTOR OR BIDDER SHALL BEAR THE RESPONSIBILITY OF NOTIFYING (IN WRITING) THE PROJECT OWNER'S REPRESENTATIVE OF ANY CONFLICTS, ERRORS, OR OMISSIONS PRIOR TO THE SUBMISSION OF CONTRACTOR'S PROPOSAL OR PERFORMANCE OF WORK.
- THE SCOPE OF WORK SHALL INCLUDE FURNISHING ALL MATERIALS, EQUIPMENT, LABOR AND ALL OTHER MATERIALS AND LABOR DEEMED NECESSARY TO COMPLETE THE WORK/PROJECT AS DESCRIBED HEREIN.
- THE CONTRACTOR SHALL VISIT THE JOB SITE PRIOR TO THE SUBMISSION OF BIDS OR PERFORMING WORK TO FAMILIARIZE HIMSELF WITH THE FIELD CONDITIONS AND TO VERIFY THAT THE PROJECT CAN BE CONSTRUCTED IN ACCORDANCE WITH THE CONTRACT DOCUMENTS.
- ONCE THE CONTRACTOR HAS RECEIVED AND ACCEPTED THE NOTICE TO PROCEED, CONTRACTOR WILL CONTACT THE CROWN CASTLE CONSTRUCTION MANAGER OF RECORD (NOTED ON THE FIRST PAGE ON THIS CONSTRUCTION DRAWING) A MINIMUM OF 48 HOURS PRIOR TO WORK START. UPON ARRIVAL TO THE JOB SITE, CONTRACTOR CREW IS REQUIRED TO CALL 1-800-788-7011 TO NOTIFY THE CROWN CASTLE NOC WORK HAS BEGUN.
- THE CONTRACTOR SHALL INSTALL ALL EQUIPMENT AND MATERIALS ACCORDING TO THE MANUFACTURER'S/VENDOR'S SPECIFICATIONS UNLESS NOTED OTHERWISE OR WHERE LOCAL CODES OR ORDINANCES TAKE PRECEDENCE.
- THE CONTRACTOR SHALL PROVIDE A FULL SET OF CONSTRUCTION DOCUMENTS AT THE SITE UPDATED WITH THE LATEST REVISIONS AND ADDENDUMS OR CLARIFICATIONS AVAILABLE FOR THE USE BY ALL PERSONNEL INVOLVED WITH THE PROJECT.
- THE CONTRACTOR SHALL SUPERVISE AND DIRECT THE PROJECT DESCRIBED HEREIN. THE CONTRACTOR SHALL BE SOLELY RESPONSIBLE FOR ALL CONSTRUCTION MEANS, METHODS, TECHNIQUES, SEQUENCES AND PROCEDURES AND FOR COORDINATING ALL PORTIONS OF THE WORK UNDER THE CONTRACT.
- THE CONTRACTOR SHALL BE RESPONSIBLE FOR OBTAINING ALL PERMITS AND INSPECTIONS WHICH MAY BE REQUIRED FOR THE WORK BY THE ARCHITECT/ENGINEER, THE STATE, COUNTY OR LOCAL GOVERNMENT AUTHORITY.
- THE CONTRACTOR SHALL MAKE NECESSARY PROVISIONS TO PROTECT EXISTING IMPROVEMENTS, EASEMENTS, PAVING, CURBING, ETC. DURING CONSTRUCTION. UPON COMPLETION OF WORK, THE CONTRACTOR SHALL REPAIR ANY DAMAGE THAT MAY HAVE OCCURRED DUE TO CONSTRUCTION ON OR ABOUT THE PROPERTY.
- THE CONTRACTOR SHALL KEEP THE GENERAL WORK AREA CLEAN AND HAZARD FREE DURING CONSTRUCTION AND DISPOSE OF ALL DIRT, DEBRIS, RUBBISH AND REMOVE EQUIPMENT NOT SPECIFIED AS REMAINING ON THE PROPERTY. PREMISES SHALL BE LEFT IN CLEAN CONDITION AND FREE FROM PAINT SPOTS, DUST, OR SMUDGES OF ANY NATURE.
- THE CONTRACTOR SHALL COMPLY WITH ALL PERTINENT SECTIONS OF THE BASIC STATE BUILDING CODE, LATEST EDITION, AND ALL OSHA REQUIREMENTS AS THEY APPLY TO THIS PROJECT. ALL EXISTING ACTIVE SEWER, WATER, GAS, ELECTRIC, AND OTHER UTILITIES WHERE ENCOUNTERED IN THE WORK SHALL BE PROTECTED AT ALL TIMES, AND WHERE REQUIRED FOR THE PROPER EXECUTION OF THE WORK SHALL BE RELOCATED AS DIRECTED BY THE ARCHITECT/ENGINEER. EXTREME CAUTION SHOULD BE USED BY THE CONTRACTOR WHEN EXCAVATING OR PIER DRILLING AROUND OR NEAR UTILITIES. THE CONTRACTOR SHALL PROVIDE SAFETY TRAINING FOR THE WORKING CREW. THIS WILL INCLUDE BUT NOT LIMITED TO A) FALL PROTECTION, B) CONFINED SPACE, C) ELECTRICAL SAFETY, D) TRENCHING AND EXCAVATION OF ALL EXISTING INACTIVE SEWER, WATER, GAS, ELECTRIC AND OTHER UTILITIES WHICH INTERFERE WITH THE EXECUTION OF THE WORK SHALL BE REMOVED AND OR CAPPED, PLUGGED OR OTHERWISE DISCONTINUED AT THE POINTS WHICH WILL NOT INTERFERE WITH THE EXECUTION OF THE WORK SUBJECT TO THE APPROVAL OF THE ARCHITECT/ENGINEER.
- THE CONTRACTOR SHALL NOTIFY THE PROJECT OWNER'S REPRESENTATIVE IN WRITING WHERE A CONFLICT OCCURS ON ANY OF THE CONTRACT DOCUMENTS. THE CONTRACTOR IS NOT TO ORDER MATERIAL OR CONSTRUCT ANY PORTION OF THE WORK THAT IS IN CONFLICT UNTIL CONFLICT IS RESOLVED BY THE LESSEE/LICENSEE REPRESENTATIVE.
- THE CONTRACTOR SHALL VERIFY ALL DIMENSIONS, ELEVATIONS, PROPERTY LINES, ETC. ON THE JOB.
- THE CONTRACTOR SHALL NOTIFY THE THE RF ENGINEER FOR ANTENNA AZIMUTH VERIFICATION (DURING ANTENNA INSTALLATION) PRIOR TO CONDUCTING SWEEP TESTS.
- THE CONTRACTOR SHALL SUBMIT AT THE END OF THE PROJECT A COMPLETE SET OF AS-BUILT DRAWINGS TO THE CLIENT REPRESENTATIVE.
- REFER TO: CONSTRUCTION STANDARDS—SPRINT DOCUMENT EXHIBIT A—STANDARD CONSTRUCTION SPECIFICATIONS FOR WIRELESS SITES REV. 4.0— 02.15.2011.DOCM.
- REFER TO: WEATHER PROOFING SPECS: EXCERPT EXH A—WIHRPRF—STD CONSTR SPECS_157201110421855492.DOCM.
- REFER TO: COLOR CODING—SPRINT NEXTEL ANT AND LINE COLOR CODING (DRAFT) V3 09-08-11.PDF
- REFER TO LATEST DOCUMENTATION REVISION.

DIVISION 03000—CONCRETE

- APPLICABLE STANDARDS (USE LATEST EDITIONS)
 - ACI-301 — SPECIFICATIONS FOR STRUCTURAL CONCRETE FOR BUILDINGS.
 - ACI-347 GUIDE TO FORM WORK FOR CONCRETE.
 - ASTM C33— CONCRETE AGGREGATE
 - ASTM C94 — READY MIXED CONCRETE e. ASTM C150 — PORTLAND CEMENT.
 - ASTM C260 — AIR-ENTRAINING ADMIXTURES FOR CONCRETE
 - ASTM C309— LIQUID MEMBRANE FORMING COMPOUNDS FOR CURING CONCRETE.
 - ASTM C494 — CHEMICAL ADMIXTURES FOR CONCRETE
 - ASTM A615— DEFORMED AND PLAIN BILLET-STEEL BARS FOR CONCRETE REINFORCEMENT
 - ASTM A185— STEEL WELDED WIRE FABRIC (PLAIN) FOR CONCRETE REINFORCEMENT
- QUALITY ASSURANCE
CONCRETE MATERIALS AND OPERATIONS SHALL BE TESTED AND INSPECTED BY THE ARCHITECT/ENGINEER AS DIRECTED BY THE CLIENT'S REPRESENTATIVE.
- SURFACE FINISHES
 - SURFACES AGAINST WHICH BACKFILL OR CONCRETE SHALL BE PLACED REQUIRE NO TREATMENT EXCEPT REPAIR OF DEFECTIVE AREAS.
 - SURFACES THAT WILL BE PERMANENTLY EXPOSED SHALL PRESENT A UNIFORM FINISH PROVIDED BY THE REMOVAL OF FINIS AND THE FILLING HOLES AND OTHER IRREGULARITIES WITH DRY PACK GROUT, OR BY SACKING WITH UTILITY OR ORDINARY GROUT.
 - SURFACES THAT WOULD NORMALLY BE LEVEL AND WHICH WILL BE PERMANENTLY EXPOSED TO THE WEATHER SHALL BE SLOPED FOR DRAINAGE. UNLESS ENGINEER'S DESIGN DRAWING SPECIFIES A HORIZONTAL SURFACE OR SURFACES SUCH AS STAIR TREADS, WALLS, CURBS, AND PARAPETS SHALL BE SLOPED APPROXIMATELY 1/4" PER FOOT.
 - SURFACES THAT WILL BE COVERED BY BACKFILL OR CONCRETE SHALL BE SMOOTH SCREENED.
 - EXPOSED SLAB SURFACES SHALL BE CONSOLIDATED, SCREENED, FLOATED, AND STEEL TROWELED. HAND OR POWER-DRIVEN EQUIPMENT MAY BE USED FOR FLOATING. FLOATING SHALL BE STARTED AS SOON AS THE SCREENED SURFACE HAS ATTAINED A STIFFNESS TO PERMIT FINISHING OPERATIONS. OPERATIONS. ALL EDGES MUST HAVE A 3/4" CHAMFER.
- QUALITY ASSURANCE CONCRETE MATERIALS AND OPERATIONS SHALL BE TESTED AND INSPECTED BY THE ENGINEER.
- PATCHING
THE CONTRACTOR SHALL NOTIFY THE ENGINEER IMMEDIATELY UPON REMOVAL OF THE FORMS TO OBSERVE CONCRETE SURFACE CONDITIONS. IMPERFECTIONS SHALL BE PATCHED ACCORDING TO THE ENGINEER'S DIRECTION.
- DEFECTIVE CONCRETE
THE CONTRACTOR SHALL NOTIFY OR REPLACE CONCRETE NOT CONFORMING TO REQUIRED LEVELS AND LINES, DETAILS, AND ELEVATIONS AS SPECIFIED IN ACI 301.
- PROTECTION
 - IMMEDIATELY AFTER PLACEMENT. THE CONTRACTOR SHALL PROTECT THE CONCRETE FROM PREMATURE DRYING, EXCESSIVELY HOT OR COLD TEMPERATURES, AND MECHANICAL INJURY. FINISHED WORK SHALL BE PROTECTED.
 - CONCRETE SHALL BE MAINTAINED WITH MINIMAL MOISTURE LOSS AT RELATIVELY CONSTANT TEMPERATURE FOR PERIOD NECESSARY FOR HYDRATION OF CEMENT AND HARDENING OF CONCRETE.
 - ALL CONCRETE SHALL BE WATER CURED PER ACCEPTABLE PRACTICES SPECIFIED BY ACI CODE (LATEST EDITION)

DIVISION 05000 — METALS

- GENERAL
 - WORK INCLUDED
 - THE WORK CONSISTS OF THE FABRICATION AND INSTALLATION OF ALL MATERIALS TO BE FURNISHED. AND WITHOUT LIMITING THE GENERALITY THEREOF, INCLUDING ALL EQUIPMENT, LABOR AND SERVICES REQUIRED FOR ALL STRUCTURAL STEEL WORK AND ALL ITEMS INCIDENTAL AS SPECIFIED AND AS SHOWN ON THE DRAWINGS:
 - STEEL FRAMING INCLUDING BEAMS, ANGLES, CHANNELS AND PLATES. WELDING AND BOLTING OF ATTACHMENTS.
 - REFERENCE STANDARDS
 - THE WORK SHALL CONFORM TO THE CODES AND STANDARDS OF THE FOLLOWING AGENCIES AS FURTHER CITED HEREIN:
 - ASTM: AMERICAN SOCIETY FOR TESTING AND MATERIALS AS PUBLISHED IN "COMPILATION OF ASTM STANDARDS IN BUILDING CODES" OR LATEST EDITION.
 - AWS: AMERICAN WELDING SOCIETY CODE OR LATEST EDITION.
 - AISC: AMERICAN INSTITUTE OF STEEL CONSTRUCTION, "SPECIFICATION FOR THE DESIGN, FABRICATION AND ERECTION OF STRUCTURAL STEEL FOR BUILDINGS" (LATEST EDITION).
 - PRODUCTS
 - MATERIALS
 - STRUCTURAL STEEL: SHALL COMPLY WITH THE REQUIREMENTS OF ASTM A36 AND A992 FOR STRUCTURAL STEEL.

ALL PROPOSED STRUCTURAL STEEL SHALL BE FABRICATED AND ERECTED IN ACCORDANCE WITH AISC CODE AND ASTM SPECIFICATIONS (LATEST EDITION) ALL NEW STEEL SHALL CONFORM TO THE FOLLOWING.

 - STRUCTURAL WIDE FLANGE: ASTM A992 Fy=50KSI.
 - MISCELLANEOUS STEEL (PLATES), CHANNELS, ANGLES, ETC): ASTM A36 (Fy=36KSI).
 - STRUCTURAL TUBING: ASTM A500 Gr. B (Fy=46KSI).
 - STEEL PIPE: ASTM A53 Gr B (Fy=35KSI).
 - WELDING
 - ALL WELDING SHALL BE DONE BY CERTIFIED WELDERS. CERTIFICATION DOCUMENTS SHALL BE MADE AVAILABLE FOR ENGINEER'S AND/OR OWNER'S REVIEW IF REQUESTED.
 - WELDING ELECTRODES FOR MANUAL SHIELDED METAL ARC WELDING SHALL CONFORM TO ASTM 1-233, E70 SERIES. BARE ELECTRODES AND GRANULAR FLUX USED IN THE SUBMERGED ARC PROCESS SHALL CONFORM TO AISC SPECIFICATIONS.
 - FIELD WELDING SHALL BE DONE AS PER AWS D1.1 REQUIREMENTS VISUAL INSPECTION IS ACCEPTABLE.
 - STUD WELDING SHALL BE ACCOMPLISHED BY CAPACITOR DISCHARGE (CD) WELDING TECHNIQUE USING CAPACITOR DISCHARGE STUD WELDER.
 - PROVIDE STUD FASTENERS OF MATERIALS AND SIZES SHOWN ON DRAWINGS OR AS RECOMMENDED BY THE MANUFACTURER FOR STRUCTURAL LOADINGS REQUIRED.
 - FOLLOW MANUFACTURERS SPECIFICATIONS AND INSTRUCTIONS TO PROPERLY SELECT AND INSTALL STUD WELDS.
 - BOLTING
 - BOLTS SHALL BE CONFORMING TO ASTM A35 HIGH STRENGTH HOT DIP GALVANIZED WITH ASTM A153 HEAVY HEX TYPE NUTS.
 - BOLTS SHALL BE 3/4" (MINIMUM) CONFORMING TO ASTM A325, HOT DIP GALVANIZED, ASTM A153 NUTS SHALL BE HEAVY HEX TYPE.
 - ALL CONNECTIONS SHALL BE 2 BOLTS MINIMUM.
 - EXCEPT WHERE SHOWN, ALL BEAM TO BEAM AND BEAM TO COLUMN CONNECTIONS TO BE DOUBLE ANGLED CONNECTIONS WITH HIGH STRENGTH BOLTS (THREADS EXCLUDED FROM SHEAR PLANE) AND HARDENED WASHERS.
 - STANDARD, OVERSIZED OR HORIZONTAL SHORT SLOTTED HOLES.
 - SNUG-TIGHT STRENGTH BEARING BOLTS MAY BE USED IN STANDARD HOLES CONFORMING TO ACIS, USING THE TURN OF THE NUT METHOD.
 - FULLY-TENSIONED HIGH STRENGTH (SLIP CRITICAL) SHALL BE USED IN OVERSIZED SLOT HOLES (RESPECTIVE OF SLOT ORIENTATION).
 - ALL BRACED CONNECTION, MOMENT CONNECTION AND CONNECTIONS NOTED AS "SLIP CRITICAL" SHALL BE BE SLIP CRITICAL JOINTS WITH CLASS A SURFACE CONDITIONS, UNLESS OTHERWISE NOTED.
 - EPOXY ANCHOR ASSEMBLIES SHALL BE AS MANUFACTURED BY HILTI OR ENGINEER APPROVED EQUAL, AS FOLLOWS:

BASE MATERIAL	ANCHOR SYSTEM
CONCRETE	HILTI HIT-HY 200
HOLLOW & GROUTED CMU OR BRICK	HILTI HIT-HY 70
 - FABRICATION
 - FABRICATION OF STEEL SHALL CONFORM TO THE AISC AND AWS

- FINISH
 - STRUCTURAL STEEL EXPOSED TO WEATHER SHALL BE HOT-DIP GALVANIZED AFTER FABRICATION IN ACCORDANCE WITH ASTM A123. (LATEST EDITION) UNLESS OTHERWISE NOTED.
- PROTECTION
 - UPON COMPLETION OF ERECTION, INSPECT ALL GALVANIZED STEEL AND PAINT ANY FIELD CUTS, WELDS OR GALVANIZED BREAKS WITH (2) COATS OF ZINC-RICH COLD GALVANIZING PAINT.
- ERECTION
 - PROVIDE ALL ERECTION, EQUIPMENT, BRACING, PLANKING, FIELD BOLTS, NUTS, WASHERS, DRIFT PINS, AND SIMILAR MATERIALS WHICH DO NOT FORM A PART OF THE COMPLETED CONSTRUCTION, BUT ARE NECESSARY FOR ITS PROPER ERECTION.
 - ERECT AND ANCHOR ALL STRUCTURAL STEEL IN ACCORDANCE WITH AISC REFERENCE STANDARDS. ALL WORK SHALL BE ACCURATELY SET TO ESTABLISHED SUITABLE ATTACHMENTS TO THE CONSTRUCTION OF THE BUILDING
 - TEMPORARY BRACING, GUYING, AND SUPPORT SHALL BE PROVIDED TO KEEP THE STRUCTURE SET AND ALIGNED AT ALL TIMES DURING CONSTRUCTION, AND TO PREVENT DANGER TO PERSONS AND PROPERTY. CHECK ALL TEMPORARY LOADS AND STAY WITHIN SAFE CAPACITY OF ALL BUILDING COMPONENTS.



TECTONIC Engineering & Surveying Consultants P.C.

1279 Route 300
Newburgh, NY 12550
Phone: (845) 567-6656
Fax: (845) 567-8703
www.tectonicengineering.com

THIS DOCUMENT IS THE CREATION, DESIGN, PROPERTY AND COPYRIGHTED WORK OF SPRINT COMMUNICATIONS, INC. ANY DUPLICATION OR USE WITHOUT EXPRESS WRITTEN CONSENT IS STRICTLY PROHIBITED. DUPLICATION AND USE BY GOVERNMENT AGENCIES FOR THE PURPOSES OF CONDUCTING THEIR LAWFULLY AUTHORIZED REGULATORY AND ADMINISTRATIVE FUNCTIONS IS SPECIFICALLY ALLOWED.

SUBMITTALS			
PROJECT NO: 7225.CT54XC771			
NO	DATE	DESCRIPTION	BY
0	6/23/14	FOR COMMENT	JT
1	7/29/14	FOR CONSTRUCTION	KA
2	8/1/14	PER COMMENTS	KA

DATE	REVIEWED BY
8/1/14	SMG

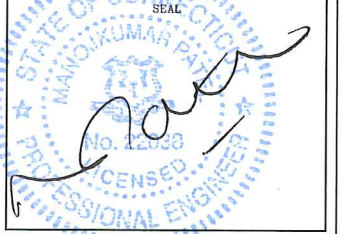

SITE NUMBER:
CT54XC771

SITE NAME:
WOODBURY NORTH

SITE ADDRESS:
186 MINORTOWN ROAD
WOODBURY, CT 06798

SHEET TITLE:
GENERAL NOTES

SHEET NO:
SP-1

DIVISION 13000--SPECIAL CONSTRUCTION ANTENNA INSTALLATION

PART 1 - GENERAL

1.01 WORK INCLUDED

A. ANTENNAS AND HYBRIFLEX CABLES ARE FURNISHED BY CLIENT'S REPRESENTATIVE UNDER SEPARATE CONTRACT. THE CONTRACTOR SHALL ASSIST ANTENNA INSTALLATION CONTRACTOR IN TERMS OF COORDINATION AND SITE ACCESS. ERECTION SUBCONTRACTOR SHALL BE RESPONSIBLE FOR THE PROPERTY.

B. INSTALL ANTENNAS AS INDICATED ON DRAWINGS AND CLIENT'S REPRESENTATIVE SPECIFICATIONS.

C. INSTALL GALVANIZED STEEL ANTENNA MOUNTS AS INDICATED ON DRAWINGS.

D. INSTALL FURNISHED GALVANIZED STEEL OR ALUMINUM WAVEGUIDE AND PROVIDE PRINTOUT OF THAT RESULT

F. INSTALL HYBRIFLEX CABLES AND TERMINATIONS BETWEEN ANTENNAS AND EQUIPMENT PER MANUFACTURER'S RECOMMENDATIONS. WEATHERPROOF ALL CONNECTORS BETWEEN THE ANTENNA AND EQUIPMENT PER MANUFACTURER'S REQUIREMENTS.

G. ANTENNA AND HYBRIFLEX CABLE GROUNDING:

1. ALL EXTERIOR #6 GREEN GROUND WIRE DAISY CHAIN CONNECTIONS ARE TO BE WEATHER SEALED WITH ANDREWS CONNECTOR/SPLICE WEATHERPROOFING KIT TYPE 3221213 OR EQUIVALENT.

2. ALL HYBRIFLEX CABLE GROUNDING KITS ARE TO BE INSTALLED ON STRAIGHT RUNS OF HYBRIFLEX CABLE (NOT WITHIN BENDS). 1.02 RELATED WORK FURNISH THE FOLLOWING WORK AS SPECIFIED UNDER CONSTRUCTION DOCUMENTS, BUT COORDINATE WITH OTHER TRADES PRIOR TO BID:

1. FLASHING OF OPENING INTO OUTSIDE WALLS.
2. SEALING AND CAULKING ALL OPENINGS.
3. PAINTING.
4. CUTTING AND PATCHING.

1.03 REQUIREMENTS OF REGULATOR AGENCIES

A. FURNISH U.L. LISTED EQUIPMENT WHERE SUCH LABEL IS AVAILABLE. INSTALL IN CONFORMANCE WITH U.L. STANDARDS WHERE APPLICABLE.

B. INSTALL ANTENNA, ANTENNA CABLES, GROUNDING SYSTEM IN ACCORDANCE WITH DRAWINGS AND SPECIFICATIONS IN EFFECT AT PROJECT LOCATION AND RECOMMENDATIONS OF STATE AND LOCAL BUILDING CODES HAVING JURISDICTION OVER SPECIFIC PORTIONS OF WORK. THIS WORK INCLUDES, BUT IS NOT LIMITED TO THE FOLLOWING:

1. EIA - ELECTRONIC INDUSTRIES ASSOCIATION RS-22. STRUCTURAL STANDARDS FOR STEEL ANTENNA TOWERS AND ANTENNA SUPPORTING STRUCTURES.

2. FAA - FEDERAL AVIATION ADMINISTRATION ADVISORY CIRCULAR AC 70/7480-IH, CONSTRUCTION MARKING AND LIGHTING.

3. FCC - FEDERAL COMMUNICATION COMMISSION RULES AND REGULATIONS FORM 715, OBSTRUCTION MARKING AND LIGHTING SPECIFICATION FOR ANTENNA STRUCTURES

4. AISC - AMERICAN INSTITUTE OF STEEL CONSTRUCTION FOR STRUCTURAL JOINTS USING ASTM 1325 OR A490 BOLTS.

5. NEC - NATIONAL ELECTRIC CODE - ON TOWER LIGHTING KITS.

6. UL - UNDERWRITER'S LABORATORIES APPROVED ELECTRICAL PRODUCTS.

7. IN ALL CASES, PART 77 OF THE FAA RULES AND PARTS 17 AND 22 OF THE FCC RULES ARE APPLICABLE AND IN THE EVENT OF CONFLICT, SUPERSEDE ANY OTHER STANDARDS OR SPECIFICATIONS.

8. LIFE SAFETY CODE NFPA, LATEST EDITION.

DIVISION 13000--EARTHWORK

PART 1 GENERAL

1.01 WORK INCLUDED: REFER TO SURVEY AND SITE PLAN FOR WORK INCLUDED.

1.02 RELATED WORK

A. CONSTRUCTION OF EQUIPMENT FOUNDATIONS
B. INSTALLATION OF ANTENNA SYSTEM

PART 2 PRODUCTS

2.01 MATERIALS

A. ROAD AND SITE MATERIALS; FILL MATERIAL SHALL BE ACCEPTABLE, SELECT FILL SHALL BE IN ACCORDANCE WITH LOCAL DEPARTMENT OF HIGHWAY AND PUBLIC TRANSPORTATION STANDARD SPECIFICATIONS.

B. SOIL STERILIZER SHALL BE EPA REGISTERED OF LIQUID COMPOSITION AND OF PRE-EMERGENCE DESIGN.

C. SOIL STABILIZER FABRIC SHALL BE MIRAFI OR EQUAL - 600X AT ACCESS ROAD AND COMPOUND.

D. GRAVEL FILL; WELL GRADED, HARD, DURABLE, NATURAL SAND AND GRAVEL, FREE FROM ICE AND SNOW, ROOTS, SOD RUBBISH, AND OTHER DELETERIOUS OR ORGANIC MATTER.

MATERIAL SHALL CONFORM TO THE FOLLOWING GRADATION REQUIREMENTS.

GRAVEL FILL TO BE PLACED IN LIFTS OF 9" MAXIMUM THICKNESS AND 90 % DENSITY. COMPACTED TO 95

E. NO FILL OR EMBANKMENT MATERIALS SHALL BE PLACED ON FROZEN GROUND. FROZEN MATERIALS SNOW OR ICE SHALL NOT BE PLACED IN ANY FILL OF EMBANKMENT

2.02 EQUIPMENT

A. COMPACTION SHALL BE ACCOMPLISHED BY MECHANICAL MEANS. LARGER AREAS SHALL BE COMPACTED BY SHEEPS FOOT, VIBRATORY OR RUBBER TIED ROLLERS WEIGHING AT LEAST FIVE TONS. SMALLER AREAS SHALL BE COMPACTED BY POWER-DRIVER, HAND HELD TAMPERS.

B. PRIOR TO OTHER EXCAVATION AND CONSTRUCTION EFFORTS GRUB ORGANIC MATERIAL TO A MINIMUM OF 6" BELOW ORIGINAL GROUND LEVEL.

C. UNLESS OTHERWISE INSTRUCTED BY CLIENT'S REPRESENTATIVE. REMOVE TREES, BRUSH AND DEBRIS FROM THE PROPERTY TO AN AUTHORIZED DISPOSAL LOCATION.

D. PRIOR TO PLACEMENT OF FILL OR BASE MATERIALS, ROLL THE SOIL.

E. WHERE UNSTABLE SOIL CONDITIONS ARE ENCOUNTERED, LINE THE GRUBBED AREAS WITH STABILIZER MAT PRIOR TO PLACEMENT OF FILL OR BASE MATERIAL.

3.03 INSTALLATION

A. THE SITE AND TURNAROUND AREAS SHALL BE AT THE SUB-BASE COURSE ELEVATION PRIOR TO FORMING FOUNDATIONS. GRADE OR FILL THE SITE AND ACCESS ROAD AS REQUIRED TO PRODUCE EVEN DISTRIBUTION OF SPOILS RESULTING FROM FOUNDATION EXCAVATIONS. THE RESULTING GRADE SHALL CORRESPOND WITH SAID SUB-BASE COURSE, ELEVATIONS ARE TO BE CALCULATED FROM FINISHED GRADES OR SLOPES INDICATED.

B. THE ACCESS ROAD SHALL BE BROUGHT TO BASE COURSE ELEVATION PRIOR TO FOUNDATION CONSTRUCTION.

C. DO NOT CREATE DEPRESSIONS WHERE WATER MAY POND.

D. THE CONTRACT INCLUDES ALL NECESSARY GRADING, BANKING, DITCHING AND COMPLETE SURFACE COURSE FOR ACCESS ROAD. ALL ROADS OR ROUTES UTILIZED FOR ACCESS TO PUBLIC THOROUGHFARE IS INCLUDED IN SCOPE OF WORK UNLESS OTHERWISE INDICATED.

E. WHEN IMPROVING AN EXISTING ACCESS ROAD, GRADE THE EXISTING ROAD TO REMOVE ANY ORGANIC MATTER AND SMOOTH THE SURFACE BEFORE PLACING FILL OR STONE.

F. PLACE FILL OR STONE IN 3" MAXIMUM LIFTS AND COMPACT BEFORE PLACING NEXT LIFT.

G. THE FINISH GRADE, INCLUDING TOP SURFACE COURSE, SHALL EXTEND A MINIMUM OF 12" BEYOND THE SITE FENCE AND SHALL COVER THE AREA AS INDICATED.

H. RIPRAP SHALL BE APPLIED TO THE SIDE SLOPES OF ALL FENCED AREAS, PARKING AREAS AND TO ALL OTHER SLOPES GREATER THAN 2:1.

I. RIPRAP SHALL BE APPLIED TO THE SIDES OF DITCHES OR DRAINAGE SWALES AS INDICATED ON PLANS.

J. RIPRAP ENTIRE DITCH FOR 6'-0" IN ALL DIRECTIONS AT CULVERT OPENINGS.

K. SEED, FERTILIZER AND STRAW COVER SHALL BE APPLIED TO ALL OTHER DISTURBED AREAS AND DITCHES, DRAINAGE, SWALES, NOT OTHERWISE RIP-RAPPED.

L. UNDER NO CIRCUMSTANCES SHALL DITCHES, SWALES OR CULVERTS BE PLACED SO THEY DIRECT WATER TOWARDS, OR PERMIT STANDING WATER IMMEDIATELY ADJACENT TO SITE. IF OWNER DESIGNS OR IF DESIGN ELEVATIONS CONFLICT WITH THIS GUIDANCE ADVISE THE OWNER IMMEDIATELY.

M. IF A DITCH LIES WITH SLOPE GREATER THAN TEN PERCENT, MOUND DIVERSIONARY HEADWALL IN THE DITCH AT CULVERT ENTRANCES. RIP-RAP THE UPSTREAM SIDE OF THE HEADWALL AS WELL AS THE DITCH FOR 6'-0" ABOVE THE CULVERT.

N. IF A DITCH LIES WITH SLOPES GREATER THAN TEN PERCENT, MOUND DIVERSIONARY HEADWALLS IN THE DITCH FOR 6'-0" ABOVE THE CULVERT ENTRANCE.

O. SEED AND FERTILIZER SHALL BE APPLIED TO SURFACE CONDITIONS WHICH WILL ENCOURAGE ROOTING. RAKE AREAS TO BE SEEDED TO EVEN THE SURFACE AND TO LOOSEN THE SOIL.

P. SOW SEED IN TWO DIRECTIONS IN TWICE THE QUANTITY RECOMMENDED BY THE SEED PRODUCER.

Q. IT IS THE CONTRACTOR'S RESPONSIBILITY TO ENSURE GROWTH OF SEEDED AND LANDSCAPED AREAS BY WATERING UP TO THE POINT OF RELEASE FROM THE CONTRACT. CONTINUE TO REWORK BARE AREAS UNTIL COMPLETE COVERAGE IS OBTAINED.

3.04 FIELD QUALITY CONTROL

A. COMPACTION SHALL BE D-1557 FOR SITE WORK AND 95 % MAXIMUM DENSITY UNDER SLAB AREAS. AREAS OF SETTLEMENT WILL BE EXCAVATED AND REFILLED AT CONTRACTOR'S EXPENSE. REQUIRED. USE OF EROSION CONTROL MESH OR MULCH NET SHALL BE AN ACCEPTABLE ALTERNATIVE.

B. THE COMPACTION TEST RESULTS SHALL BE AVAILABLE PRIOR TO THE CONCRETE POUR.

3.05 PROTECTION

A. PROTECT SEEDED AREAS FORM EROSION BY SPREADING STRAW TO A UNIFORM LOOSE DEPTH OF 1"-2". STAKE AND TIE DOWN AS REQUIRED. USE OF EROSION CONTROL MESH OR MULCH NET SHALL BE AN ACCEPTABLE ALTERNATIVE.

B. ALL TREES PLACED IN CONJUNCTION WITH A LANDSCAPE CONTRACT SHALL BE WRAPPED, TIED WITH HOSE PROTECTED WIRE AND SECURED TO STAKES EXTENDING 2'-0" INTO THE GROUND ON FOUR SIDES OF THE TREE.

C. ALL EXPOSED AREAS SHALL BE PROTECTED AGAINST WASHOUTS AND SOIL EROSION. STRAW BALES SHALL BE PLACED AT THE INLET APPROACH TO ALL NEW OR EXISTING CULVERTS. REFER TO DETAILS ON DRAWINGS

SYMBOLS	ABBREVIATIONS
--- g --- g ---	GROUND WIRE
--- E --- E ---	ELECTRIC
--- T --- T ---	TELEPHONE
--- O --- O --- O --- O ---	OVERHEAD WIRE
---	PROPERTY LINE
-x-x-x-x-	CHAIN LINK FENCE
A-1	ANTENNA MARK
(E)	EXISTING
(P)	PROPOSED DETAIL
	REFERENCE
	SURFACE ELEVATION

2.5 EQUIPMENT DEPLOYMENT
6580 SPRINT PARKWAY
OVERLAND PARK, KS 66251

TECTONIC Engineering & Surveying Consultants P.C.
1279 Route 300
Newburgh, NY 12550
Phone: (845) 567-6656
Fax: (845) 567-8703
www.tectonicengineering.com

THIS DOCUMENT IS THE CREATION, DESIGN, PROPERTY AND COPYRIGHTED WORK OF SPRINT COMMUNICATIONS, INC. ANY DUPLICATION OR USE WITHOUT EXPRESS WRITTEN CONSENT IS STRICTLY PROHIBITED. DUPLICATION AND USE BY GOVERNMENT AGENCIES FOR THE PURPOSES OF CONDUCTING THEIR LAWFULLY AUTHORIZED REGULATORY AND ADMINISTRATIVE FUNCTIONS IS SPECIFICALLY ALLOWED.

SUBMITTALS			
NO	DATE	DESCRIPTION	BY
0	6/23/14	FOR COMMENT	JT
1	7/29/14	FOR CONSTRUCTION	KA
2	8/1/14	PER COMMENTS	KA

PROJECT NO: 7225.CT54XC771

DATE: 8/1/14 REVIEWED BY: JMG

SITE NUMBER:
CT54XC771

SITE NAME:
WOODBURY NORTH

SITE ADDRESS:
186 MINORTOWN ROAD
WOODBURY, CT 06798

SHEET TITLE:
GENERAL NOTES

SHEET NO:
SP-2

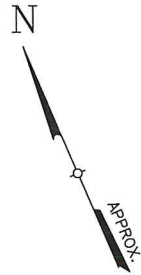

NORTH NOTE:
 NORTH SHOWN HAS BEEN
 ESTABLISHED USING THE USGS
 QUADRANGLE 7.5 MINUTE MAPS
 AND IS APPROXIMATE. VERIFY
 TRUE NORTH PRIOR TO
 INSTALLATION OF ANTENNAS.

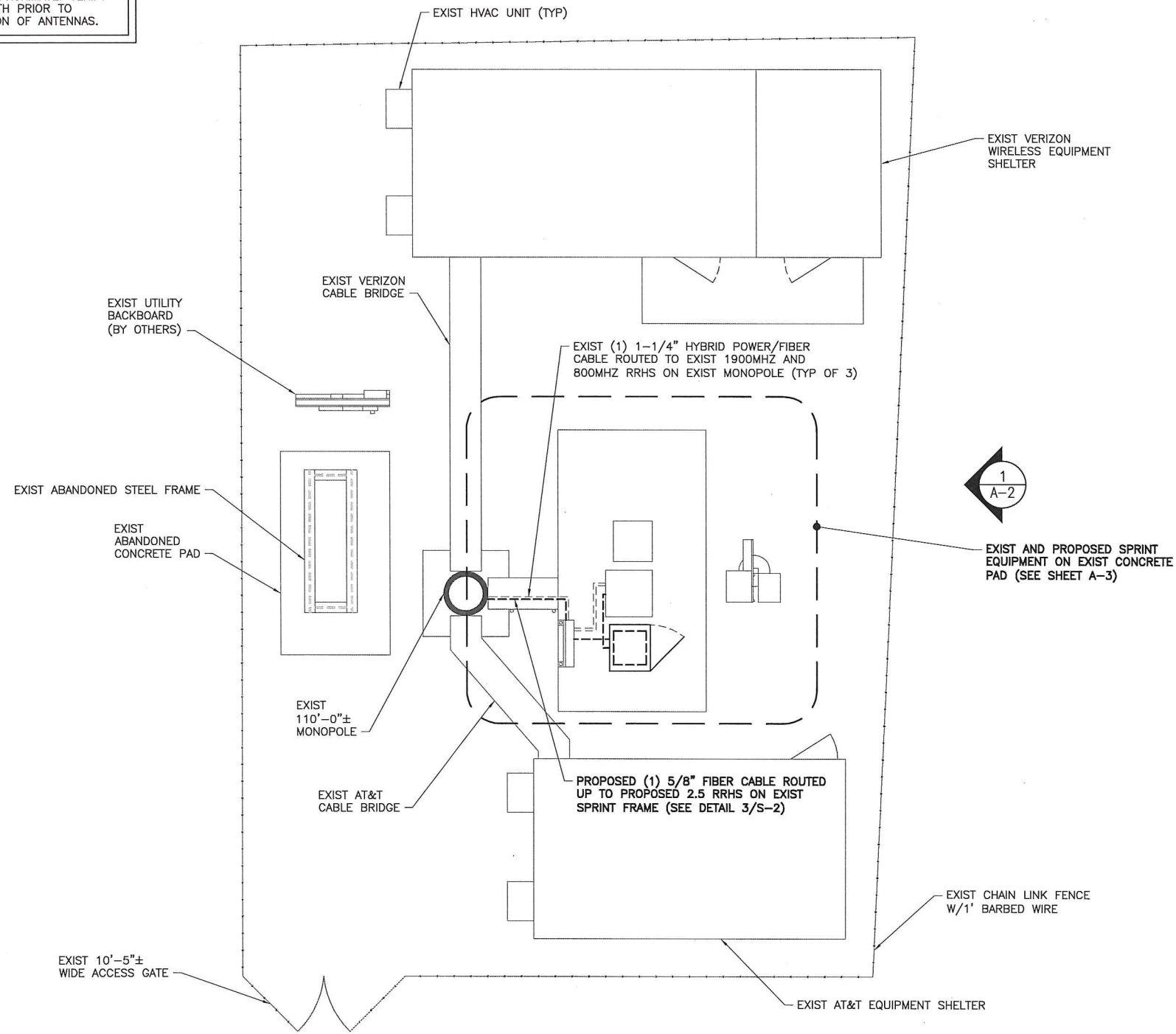

1 SITE PLAN
 A-1 SCALE: 1/4" = 1'-0"

Sprint
 2.5 EQUIPMENT DEPLOYMENT
 6580 SPRINT PARKWAY
 OVERLAND PARK, KS 66251



TECTONIC
 PLANNING
 ENGINEERING
 SURVEYING
 CONSTRUCTION
 MANAGEMENT
TECTONIC Engineering & Surveying
 Consultants P.C.
 1279 Route 300
 Newburgh, NY 12550
 Phone: (845) 567-6656
 Fax: (845) 567-8703
 www.tectoniceengineering.com

THIS DOCUMENT IS THE CREATION,
 DESIGN, PROPERTY AND COPYRIGHTED
 WORK OF SPRINT COMMUNICATIONS, INC.
 ANY DUPLICATION OR USE WITHOUT
 EXPRESS WRITTEN CONSENT IS STRICTLY
 PROHIBITED. DUPLICATION AND USE BY
 GOVERNMENT AGENCIES FOR THE
 PURPOSES OF CONDUCTING THEIR
 LAWFULLY AUTHORIZED REGULATORY AND
 ADMINISTRATIVE FUNCTIONS IS
 SPECIFICALLY ALLOWED.

SUBMITTALS

PROJECT NO: 7225.CT54XC771

NO	DATE	DESCRIPTION	BY
0	6/23/14	FOR COMMENT	JT
1	7/29/14	FOR CONSTRUCTION	KA
2	8/1/14	PER COMMENTS	KA

DATE: 8/1/14 REVIEWED BY: JMG

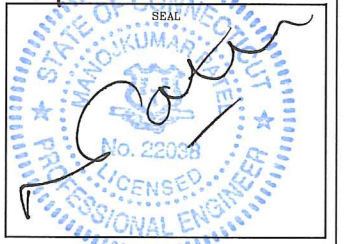

SITE NUMBER:
 CT54XC771
 SITE NAME:
 WOODBURY NORTH
 SITE ADDRESS:
 186 MINORTOWN ROAD
 WOODBURY, CT 06798

SHEET TITLE:
 SITE PLAN

SHEET NO:
 A-1

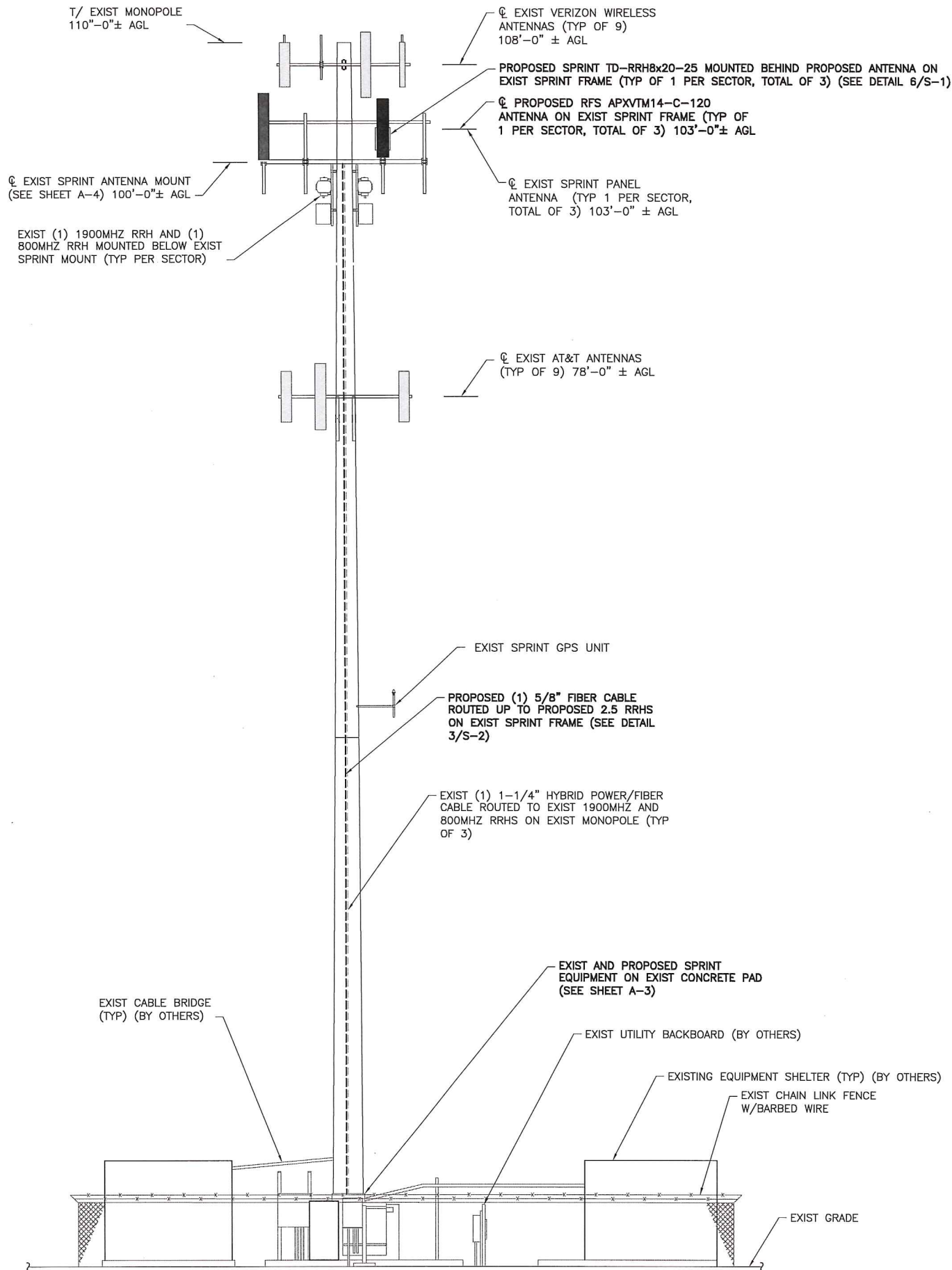

THE EXISTING MOUNT HAS BEEN ANALYZED BY TECTONIC ENGINEERING AND FOUND TO BE ADEQUATE TO SUPPORT THE PROPOSED SPRINT UPGRADE AS DETAILED IN THE STRUCTURAL ANALYSIS EVALUATION LETTER DATED 7/29/14.

THE MONOPOLE SHALL BE ANALYZED BY A PROFESSIONAL ENGINEER LICENSED IN THE STATE OF CONNECTICUT (TO BE COORDINATED BY OTHERS)



Sprint
2.5 EQUIPMENT DEPLOYMENT
6580 SPRINT PARKWAY
OVERLAND PARK, KS 66251

CROWN CASTLE

TECTONIC
• PLANNING
• ENGINEERING
• SURVEYING
• CONSTRUCTION MANAGEMENT

TECTONIC Engineering & Surveying Consultants P.C.
1279 Route 300
Newburgh, NY 12550
Phone: (845) 567-6656
Fax: (845) 567-8703
www.tectonicengineering.com

THIS DOCUMENT IS THE CREATION, DESIGN, PROPERTY AND COPYRIGHTED WORK OF SPRINT COMMUNICATIONS, INC. ANY DUPLICATION OR USE WITHOUT EXPRESS WRITTEN CONSENT IS STRICTLY PROHIBITED. DUPLICATION AND USE BY GOVERNMENT AGENCIES FOR THE PURPOSES OF CONDUCTING THEIR LAWFULLY AUTHORIZED REGULATORY AND ADMINISTRATIVE FUNCTIONS IS SPECIFICALLY ALLOWED.

SUBMITTALS

PROJECT NO: 7225.CT54XC771

NO	DATE	DESCRIPTION	BY
0	6/23/14	FOR COMMENT	JT
1	7/29/14	FOR CONSTRUCTION	KA
2	8/1/14	PER COMMENTS	KA

DATE: 8/1/14
REVIEWED BY: JMG

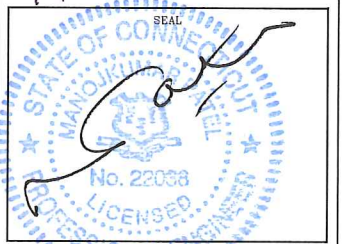

SITE NUMBER:
CT54XC771

SITE NAME:
WOODBURY NORTH

SITE ADDRESS:
186 MINORTOWN ROAD
WOODBURY, CT 06798

SHEET TITLE:
ELEVATION

SHEET NO:
A-2

1 ELEVATION
A-2 SCALE: 1/8" = 1'-0"

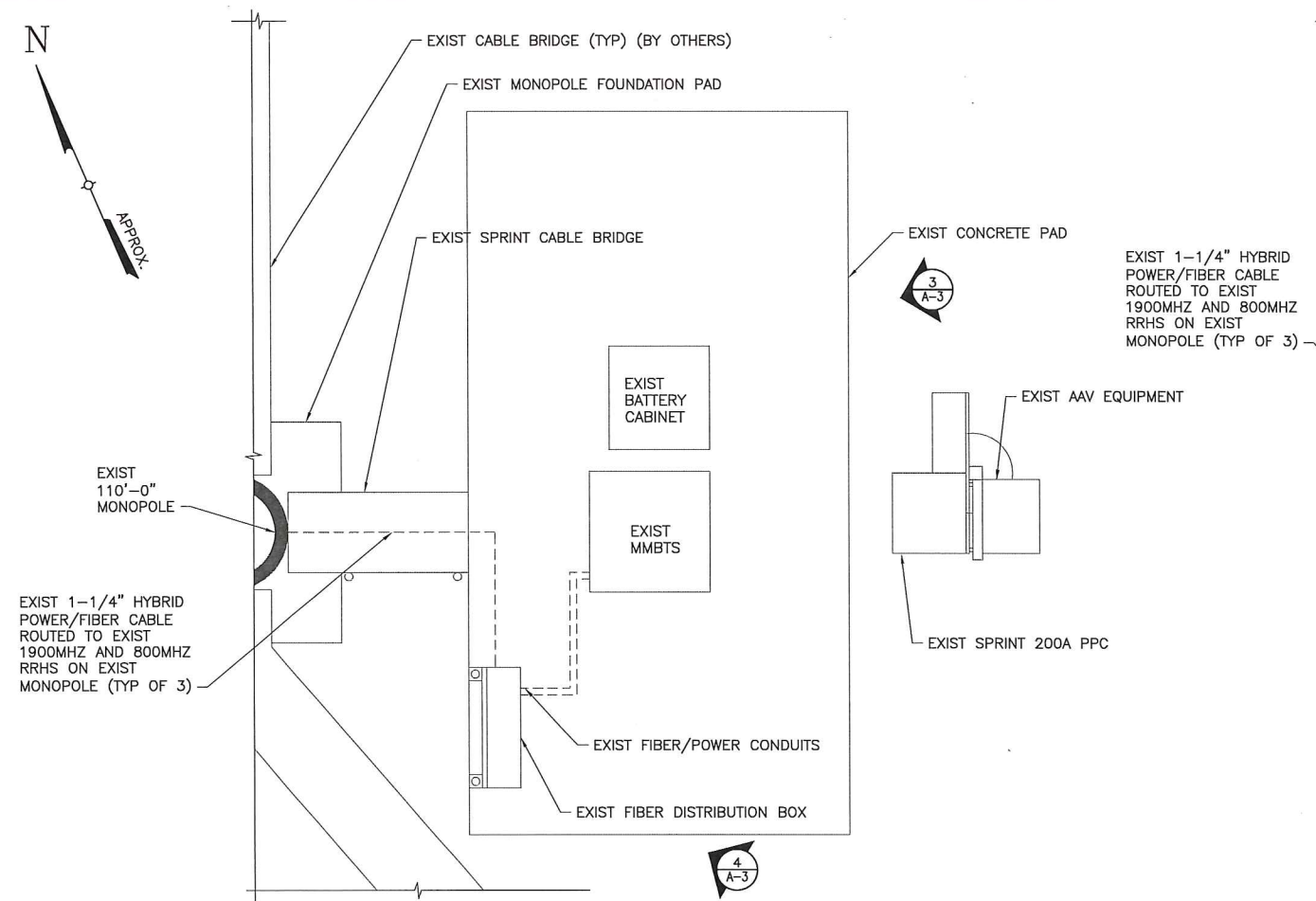
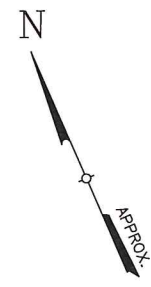

1 EQUIPMENT PLAN (EXIST)
A-3 SCALE: 1/2" = 1'-0"

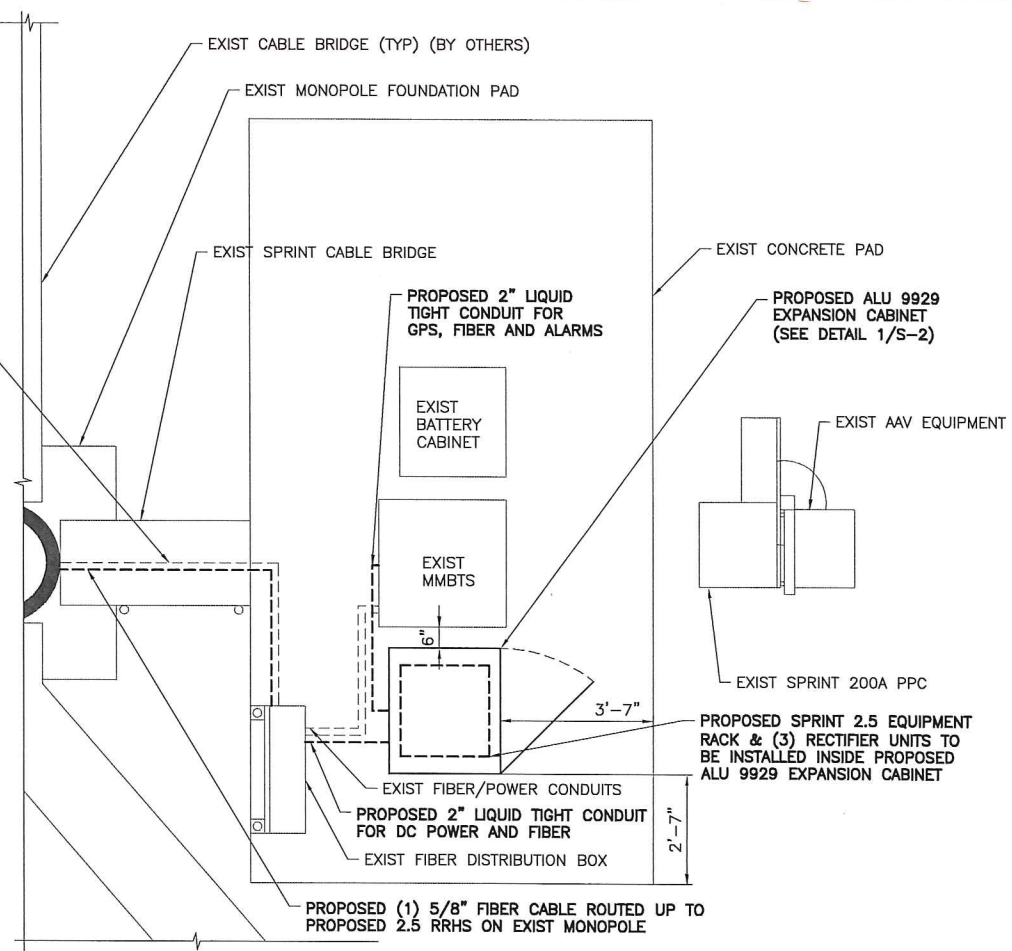

2 EQUIPMENT PLAN (FINAL)
A-3 SCALE: 1/2" = 1'-0"



3 EXIST EQUIPMENT PAD
A-3 SCALE: N.T.S.



4 EXIST FIBER DISTRIBUTION BOX
A-3 SCALE: N.T.S.

Sprint
2.5 EQUIPMENT DEPLOYMENT
6580 SPRINT PARKWAY
OVERLAND PARK, KS 66251

CROWN CASTLE

TECTONIC
PLANNING
ENGINEERING
SURVEYING
CONSTRUCTION MANAGEMENT
TECTONIC Engineering & Surveying Consultants P.C.
1279 Route 300
Newburgh, NY 12550
Phone: (845) 567-6656
Fax: (845) 567-8703
www.tectonicengineering.com

THIS DOCUMENT IS THE CREATION, DESIGN, PROPERTY AND COPYRIGHTED WORK OF SPRINT COMMUNICATIONS, INC. ANY DUPLICATION OR USE WITHOUT EXPRESS WRITTEN CONSENT IS STRICTLY PROHIBITED. DUPLICATION AND USE BY GOVERNMENT AGENCIES FOR THE PURPOSES OF CONDUCTING THEIR LAWFULLY AUTHORIZED REGULATORY AND ADMINISTRATIVE FUNCTIONS IS SPECIFICALLY ALLOWED.

SUBMITTALS			
PROJECT NO: 7225.CT54XC771			
NO	DATE	DESCRIPTION	BY
0	6/23/14	FOR COMMENT	JT
1	7/29/14	FOR CONSTRUCTION	KA
2	8/1/14	PER COMMENTS	KA

DATE	REVIEWED BY
8/1/14	JMG

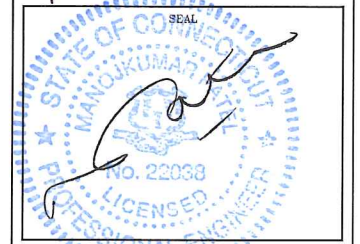

SITE NUMBER:
CT54XC771
SITE NAME:
WOODBURY NORTH
SITE ADDRESS:
186 MINORTOWN ROAD
WOODBURY, CT 06798

SHEET TITLE:
ENLARGED EQUIPMENT LAYOUT PLANS

SHEET NO:
A-3

N
APPROX.

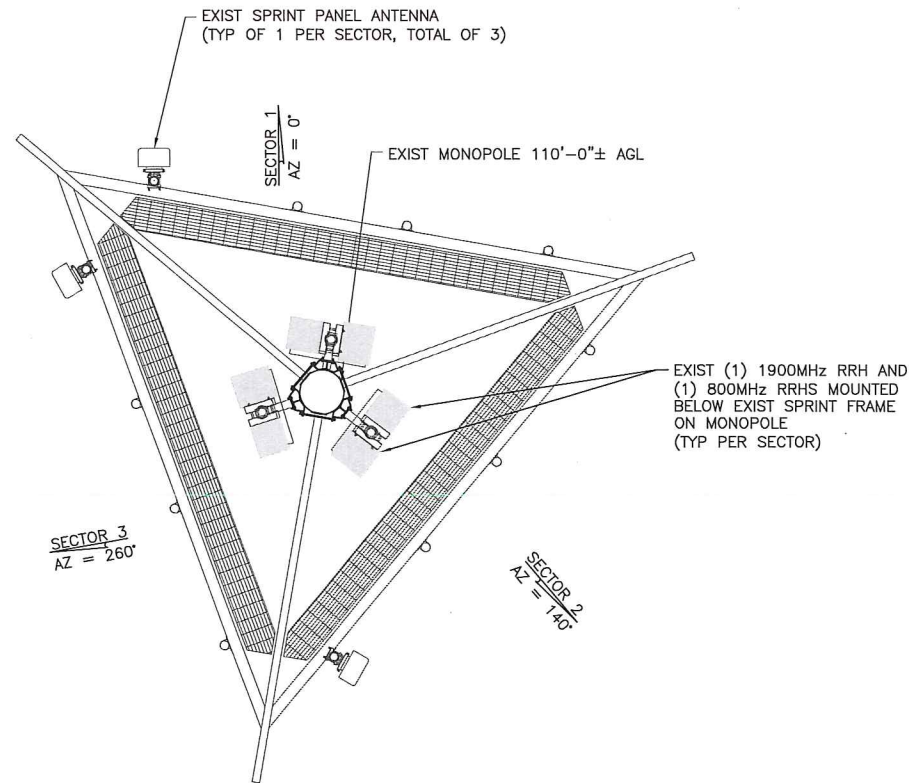

1 ANTENNA LAYOUT PLAN (EXIST)
SCALE: 3/8" = 1'-0"

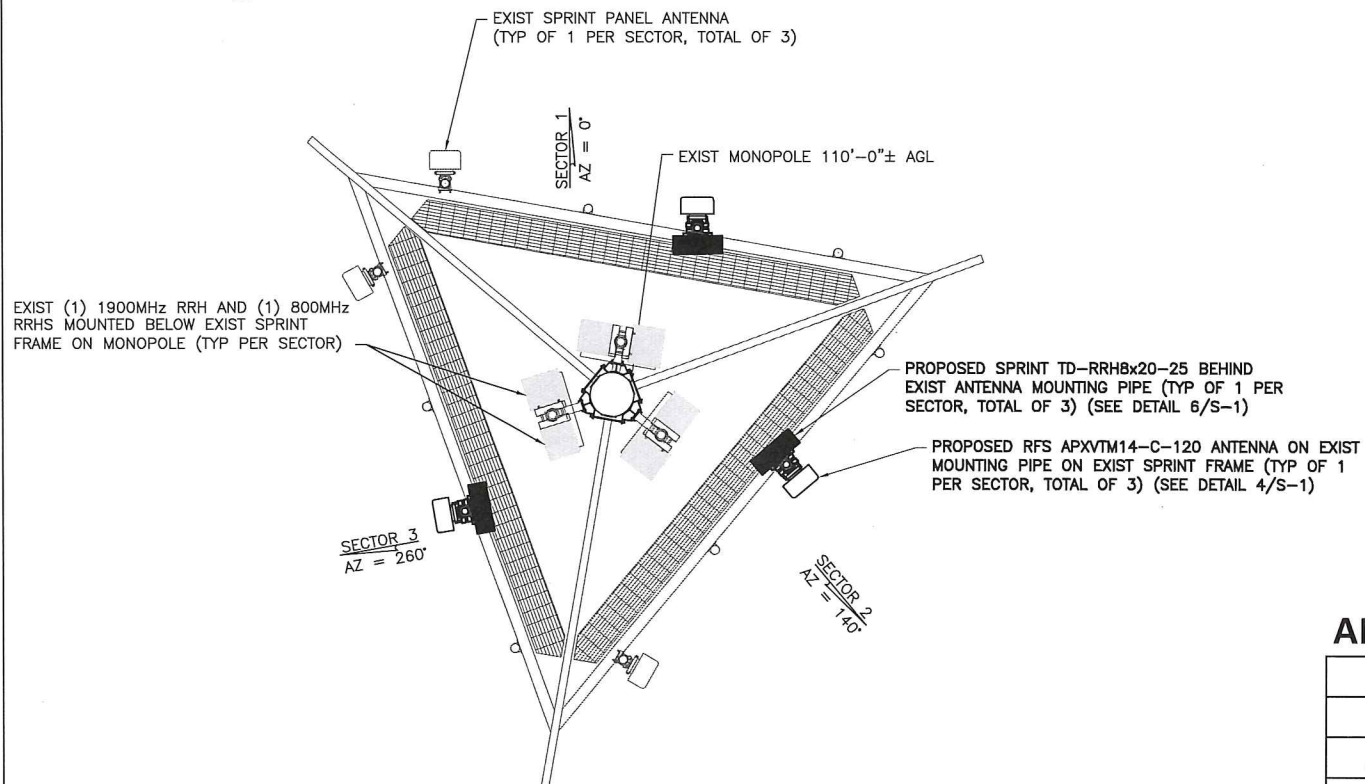

2 ANTENNA LAYOUT PLAN (FINAL)
SCALE: 3/8" = 1'-0"

THE EXISTING MOUNT HAS BEEN ANALYZED BY TECTONIC ENGINEERING AND FOUND TO BE ADEQUATE TO SUPPORT THE PROPOSED SPRINT UPGRADE AS DETAILED IN THE STRUCTURAL ANALYSIS EVALUATION LETTER DATED 7/29/14.

THE EXISTING MONOPOLE SHALL BE ANALYZED BY A PROFESSIONAL ENGINEER LICENSED IN THE STATE OF CONNECTICUT (TO BE COORDINATED BY OTHERS)

EXIST SPRINT PANEL ANTENNA TO REMAIN (TYP OF 1 PER SECTOR, TOTAL OF 3)



EXIST (1) 1900MHz RRH AND (1) 800MHz RRH MOUNTED BELOW ON EXIST SPRINT FRAME ON MONOPOLE (TYP PER SECTOR)

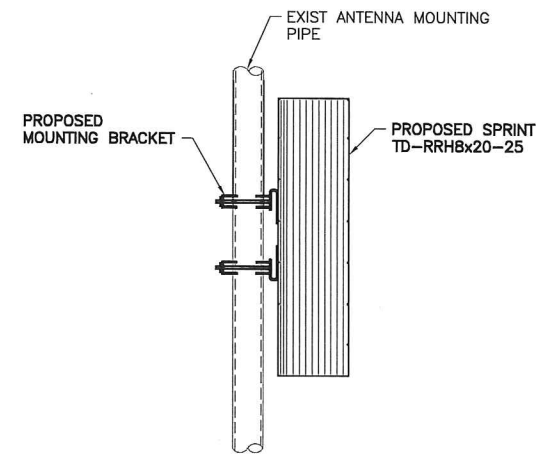

3 RRH MOUNTING DETAIL
SCALE: 1 1/2" = 1'-0"

ANTENNA DATA

Status	Exist	Proposed
Antenna Manufacturer	RFS-CELWAVE	RFS-CELWAVE
Antenna Model Number	APXVSP18-C-A20/APXV9ERR18-C-A20	APXV9TM14-ALV-120
Number of Antennas	3	3
Antenna RAD Center	103'	103'
Antenna Azimuth	0/140/260	0/140/160
Antenna RRH Model Number	800MHz/1900MHz	TD-RRH8x20-25
Number of RRH	6	3

Sprint
2.5 EQUIPMENT DEPLOYMENT
6580 SPRINT PARKWAY
OVERLAND PARK, KS 66251

CROWN CASTLE

TECTONIC
PLANNING
ENGINEERING
SURVEYING
CONSTRUCTION MANAGEMENT
TECTONIC Engineering & Surveying Consultants P.C.
1279 Route 300
Newburgh, NY 12550
Phone: (845) 567-6656
Fax: (845) 567-8703
www.tectonicengineering.com

THIS DOCUMENT IS THE CREATION, DESIGN, PROPERTY AND COPYRIGHTED WORK OF SPRINT COMMUNICATIONS, INC. ANY DUPLICATION OR USE WITHOUT EXPRESS WRITTEN CONSENT IS STRICTLY PROHIBITED. DUPLICATION AND USE BY GOVERNMENT AGENCIES FOR THE PURPOSES OF CONDUCTING THEIR LAWFULLY AUTHORIZED REGULATORY AND ADMINISTRATIVE FUNCTIONS IS SPECIFICALLY ALLOWED.

SUBMITTALS

PROJECT NO: 7225.CT54XC771

NO	DATE	DESCRIPTION	BY
0	6/23/14	FOR COMMENT	JT
1	7/29/14	FOR CONSTRUCTION	KA
2	8/1/14	PER COMMENTS	KA

DATE	REVIEWED BY
8/1/14	JMA

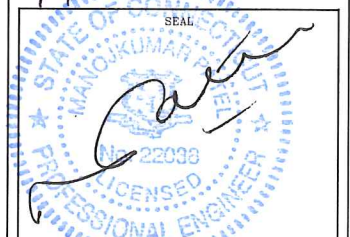

SITE NUMBER:
CT54XC771

SITE NAME:
WOODBURY NORTH

SITE ADDRESS:
186 MINORTOWN ROAD
WOODBURY, CT 06798

SHEET TITLE:
ANTENNA LAYOUT PLANS

SHEET NO:
A-4

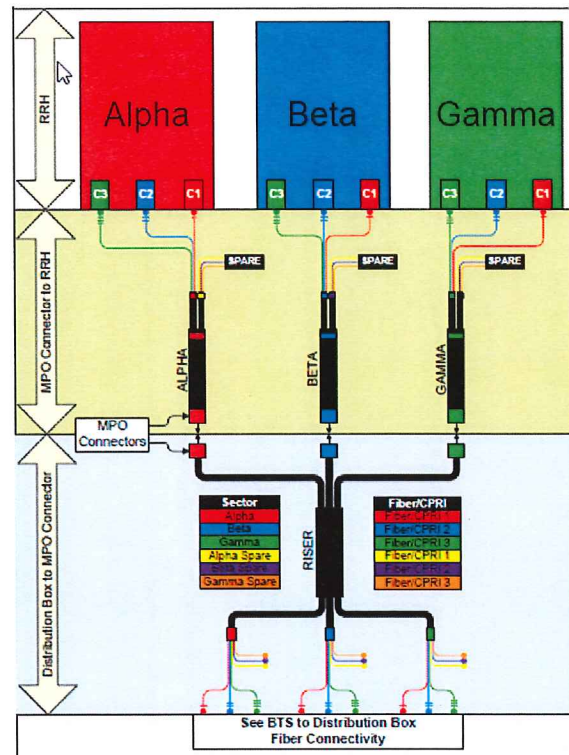

1 2.5 CABLE COLOR CODING
A-5 SCALE: N.T.S.

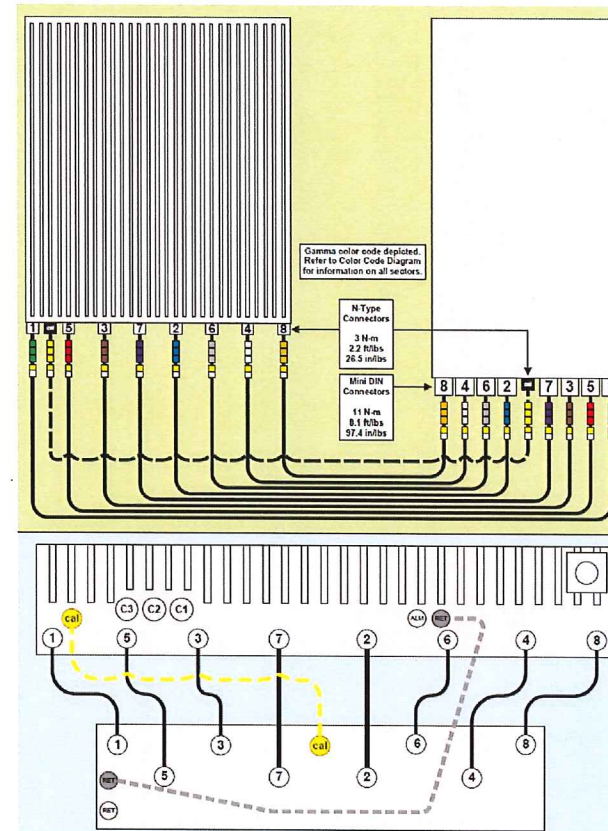

2 RRH CONNECTIVITY
A-5 SCALE: N.T.S.

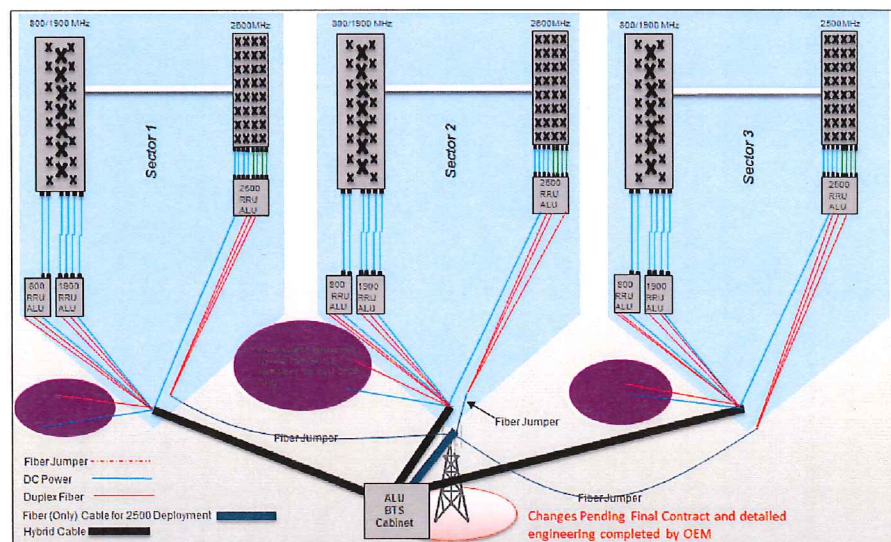

3 RAN WIRING
A-5 SCALE: N.T.S.

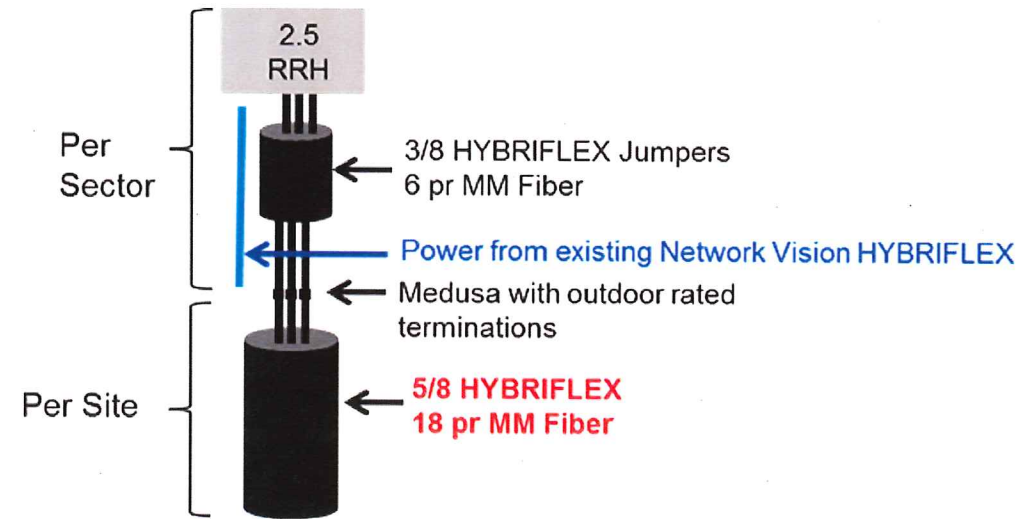

4 CABLE SCENARIO
A-5 SCALE: N.T.S.

Sprint
2.5 EQUIPMENT DEPLOYMENT
6580 SPRINT PARKWAY
OVERLAND PARK, KS 66251

CROWN CASTLE

TECTONIC
PLANNING
ENGINEERING
SURVEYING
CONSTRUCTION MANAGEMENT
TECTONIC Engineering & Surveying
Consultants P.C.
1279 Route 300
Newburgh, NY 12550
Phone: (845) 567-6656
Fax: (845) 567-8703
www.tectoniceengineering.com

THIS DOCUMENT IS THE CREATION, DESIGN, PROPERTY AND COPYRIGHTED WORK OF SPRINT COMMUNICATIONS, INC. ANY DUPLICATION OR USE WITHOUT EXPRESS WRITTEN CONSENT IS STRICTLY PROHIBITED. DUPLICATION AND USE BY GOVERNMENT AGENCIES FOR THE PURPOSES OF CONDUCTING THEIR LAWFULLY AUTHORIZED REGULATORY AND ADMINISTRATIVE FUNCTIONS IS SPECIFICALLY ALLOWED.

SUBMITTALS			
PROJECT NO: 7225.CT54XC771			
NO	DATE	DESCRIPTION	BY
0	6/23/14	FOR COMMENT	JT
1	7/29/14	FOR CONSTRUCTION	KA
2	8/1/14	PER COMMENTS	KA

DATE	REVIEWED BY
8/1/14	SMG



SITE NUMBER:
CT54XC771
SITE NAME:
WOODBURY NORTH
SITE ADDRESS:
186 MINORTOWN ROAD
WOODBURY, CT 06798

SHEET TITLE:
RAN WIRING DIAGRAM

SHEET NO:
A-5

IMPORTANT!! LINE UP WHITE MARKINGS ON JUMPER AND RISER IP-MPO CONNECTOR. PUSH THE WHITE MARK ON THE JUMPER CONNECTOR FLUSH AGAINST THE RED SEAL ON THE RISER CONNECTION



IMPORTANT!! ROTATE THE BAYONET HOUSING CLOCKWISE UNTIL A CLICK SOUND IS HEARD TO ENSURE A GOOD CONNECTION

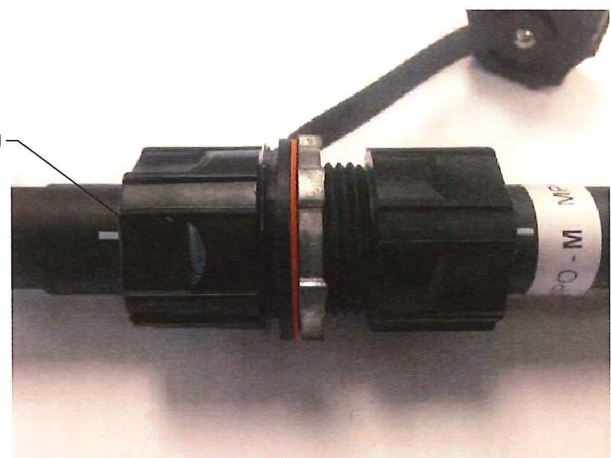

1 HYBRIFLEX RISER/JUMPER CONNECTION DETAILS
A-6 SCALE: N.T.S.

TRUNK-LINE TO JUMPER CONNECTION (MPO) TO BE INSTALLED PER MANUFACTURER REQUIREMENTS. SEE DETAIL.

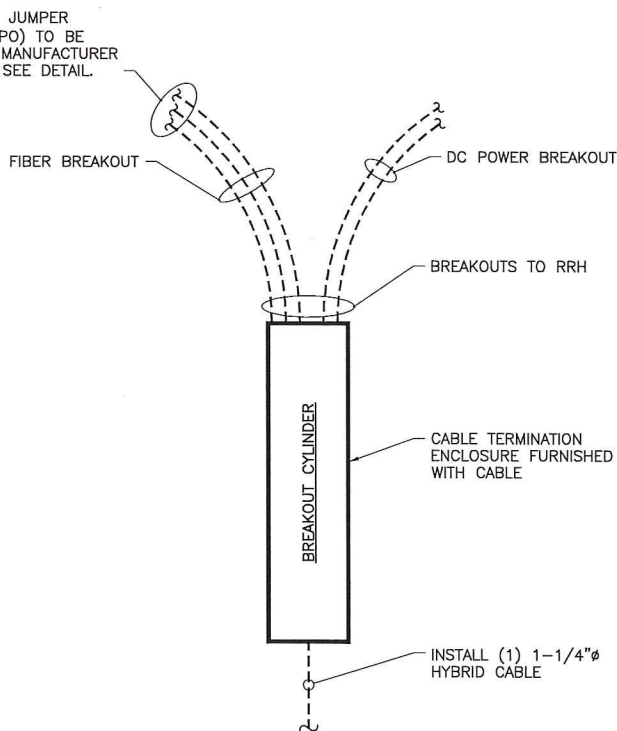

2.5 HYBRID CABLE W/FIBER & DC FEEDERS

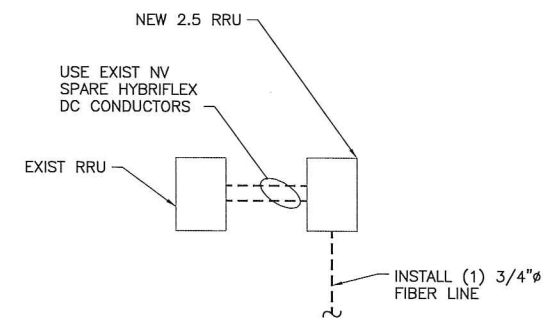

FIBER ONLY TRUNK LINES

2 TRUNK LINE DETAILS (TYPICAL)
A-6 SCALE: N.T.S.

SPECIAL NOTES: CABLE MARKINGS AT RAD CENTER AND ALL WALL/BLDG. PENETRATIONS

- ALL COLOR CODE TAPE SHALL BE 3M-35 AND SHALL BE INSTALLED USING A MINIMUM OF (3) WRAPS OF TAPE.
- ALL COLOR BANDS INSTALLED AT THE TOWER TOP SHALL BE A MINIMUM OF 3" WIDE AND SHALL HAVE A MINIMUM OF 3/4" OF SPACING BETWEEN EACH COLOR.
- ALL COLOR BANDS INSTALLED AT OR NEAR THE GROUND MAY BE ONLY 3/4" WIDE. EACH TOP-JUMPER SHALL BE COLOR CODED WITH (1) SET OF 3" WIDE BANDS.
- EACH MAIN COAX SHALL BE COLOR CODED WITH (1) SET OF 3" BANDS NEAR THE TOP-JUMPER CONNECTION AND WITH 3/4" COLOR BANDS JUST PRIOR TO ENTERING THE BTS OR TRANSMITTER BUILDING.
- ALL BOTTOM JUMPERS SHALL BE COLOR CODED WITH (1) SET OF 3/4" BANDS ON EACH END OF THE BOTTOM JUMPER.
- ALL COLOR CODES SHALL BE INSTALLED SO AS TO ALIGN NEATLY WITH ONE ANOTHER FROM SIDE-TO-SIDE.
- EACH COLOR BAND SHALL HAVE A MINIMUM OF (3) WRAPS AND SHALL BE NEATLY TRIMMED AND SMOOTHED OUT AS TO AVOID UNRAVELING.
- X-POLE ANTENNAS SHOULD USE "XX-1" FOR THE "+45" PORT, "XX-2" FOR THE "-45" PORT.
- COLOR BAND #4 REFERS TO THE FREQUENCY BAND: ORANGE=850, VIOLET=1900. USED ON JUMPERS ONLY.
- RF FEEDLINE SHALL BE IDENTIFIED WITH A METAL TAG (STAINLESS OR BRASS) AND STAMPED WITH THE SECTOR, ANTENNA POSITION, AND CABLE NUMBER.
- ANTENNAS MUST BE IDENTIFIED, USING THE SECTOR LETTER AND ANTENNA NUMBER, WITH A BLACK MARKER PRIOR TO INSTALLATION.

Sprint
2.5 EQUIPMENT DEPLOYMENT
6580 SPRINT PARKWAY
OVERLAND PARK, KS 66251

CROWN CASTLE

TECTONIC ENGINEERING & SURVEYING CONSULTANTS P.C.
1279 Route 300
Newburgh, NY 12550
Phone: (845) 567-6656
Fax: (845) 567-8703
www.tectonicengineering.com

THIS DOCUMENT IS THE CREATION, DESIGN, PROPERTY AND COPYRIGHTED WORK OF SPRINT COMMUNICATIONS, INC. ANY DUPLICATION OR USE WITHOUT EXPRESS WRITTEN CONSENT IS STRICTLY PROHIBITED. DUPLICATION AND USE BY GOVERNMENT AGENCIES FOR THE PURPOSES OF CONDUCTING THEIR LAWFULLY AUTHORIZED REGULATORY AND ADMINISTRATIVE FUNCTIONS IS SPECIFICALLY ALLOWED.

SUBMITTALS

PROJECT NO: 7225.CT54XC771

NO	DATE	DESCRIPTION	BY
0	6/23/14	FOR COMMENT	JT
1	7/29/14	FOR CONSTRUCTION	KA
2	8/1/14	PER COMMENTS	KA

DATE: 8/1/14
REVIEWED BY: JMA

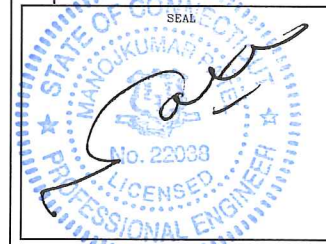

SITE NUMBER: CT54XC771
SITE NAME: WOODBURY NORTH
SITE ADDRESS: 186 MINORTOWN ROAD WOODBURY, CT 06798

SHEET TITLE: CABLE DETAILS

SHEET NO: A-6

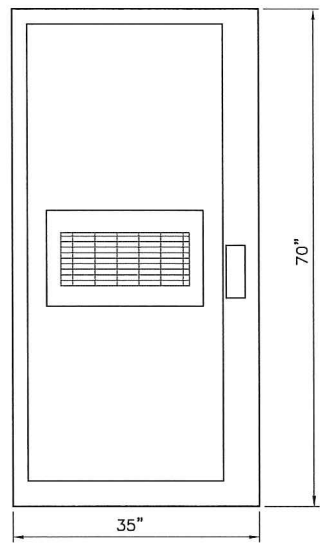

CABINET FRONT 9928 MMBTS MODULAR CELL	
SPECIFICATIONS:	
HEIGHT:	70"
WIDTH:	35"
DEPTH:	37.8"
WEIGHT:	1090 LBS.

FRONT

1 (EXIST) MMBTS CABINET
S-1 SCALE: 1" = 1'-0"

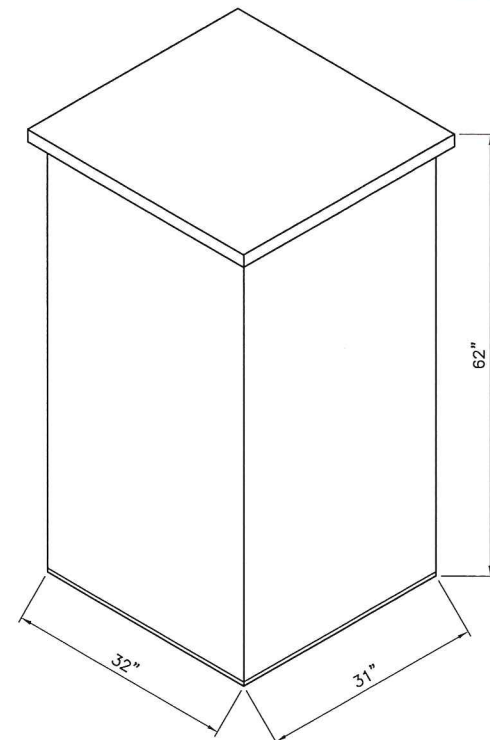

ANDREW 60ECv2	
SPECIFICATIONS:	
HEIGHT:	60"
WIDTH:	31"
DEPTH:	30"
WEIGHT:	2430 LBS.

2 (EXIST) BATTERY CABINET
S-1 SCALE: 1" = 1'-0"

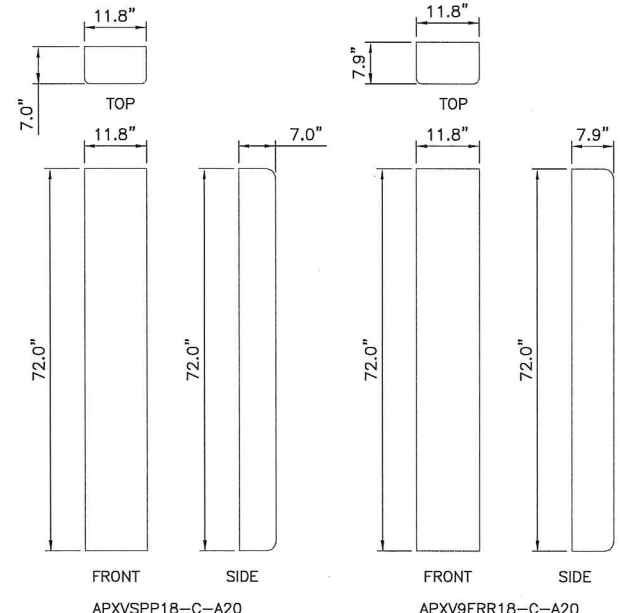

APXVSP18-C-A20

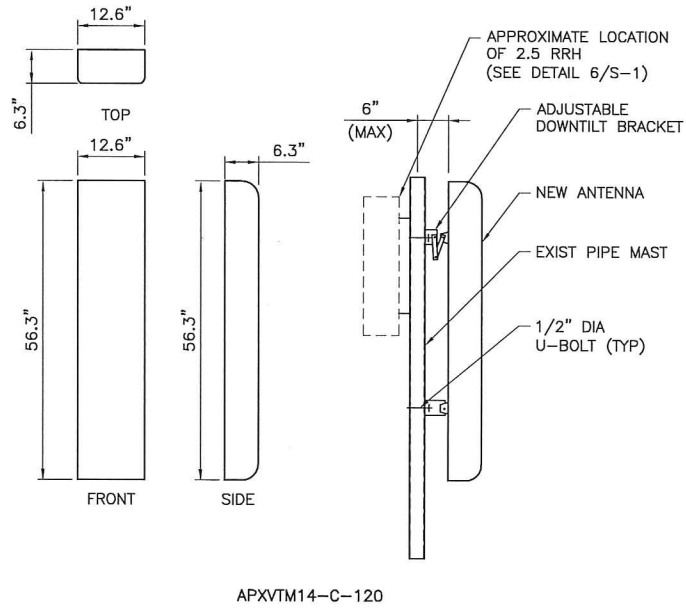

APXVTM14-C-120

3 (EXIST) ANTENNA DETAILS
S-1 SCALE: 3/4" = 1'-0"

4 (PROPOSED) ANTENNA DETAIL
S-1 SCALE: 3/4" = 1'-0"

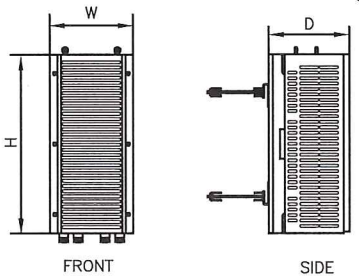

TYPE:	1900 MHz 4x45W
MODEL #:	RRH 1900 4X45 65MHz
HEIGHT:	25.0"
WIDTH:	11.1"
DEPTH:	11.4"
WEIGHT:	±60 LBS.

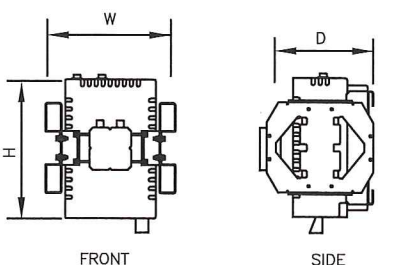

TYPE:	800 MHz 2x50W
MODEL #:	FD-RRH-2x50-800
HEIGHT:	19.7"
WIDTH:	13"
DEPTH:	10.8"
WEIGHT:	±53 LBS

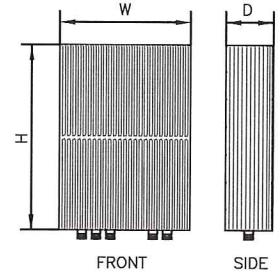

TYPE:	2.5 RRH
MODEL #:	TD-RRHx20-25
HEIGHT:	26.1"
WIDTH:	18.6"
DEPTH:	6.71"
WEIGHT:	±70 LBS

5 (EXIST) RRH DETAILS
S-1 SCALE: 1 1/2" = 1'-0"

6 (PROPOSED) RRH DETAIL
S-1 SCALE: N.T.S.

Sprint
2.5 EQUIPMENT DEPLOYMENT
6580 SPRINT PARKWAY
OVERLAND PARK, KS 66251

CROWN CASTLE

TECTONIC ENGINEERING & SURVEYING CONSULTANTS P.C.
1279 Route 300
Newburgh, NY 12550
Phone: (845) 567-6656
Fax: (845) 567-8703
www.tectonicengineering.com

THIS DOCUMENT IS THE CREATION, DESIGN, PROPERTY AND COPYRIGHTED WORK OF SPRINT COMMUNICATIONS, INC. ANY DUPLICATION OR USE WITHOUT EXPRESS WRITTEN CONSENT IS STRICTLY PROHIBITED. DUPLICATION AND USE BY GOVERNMENT AGENCIES FOR THE PURPOSES OF CONDUCTING THEIR LAWFULLY AUTHORIZED REGULATORY AND ADMINISTRATIVE FUNCTIONS IS SPECIFICALLY ALLOWED.

SUBMITTALS			
PROJECT NO: 7225.CT54XC771			
NO	DATE	DESCRIPTION	BY
0	6/23/14	FOR COMMENT	JT
1	7/29/14	FOR CONSTRUCTION	KA
2	8/1/14	PER COMMENTS	KA

DATE REVIEWED BY
8/1/14 JMG

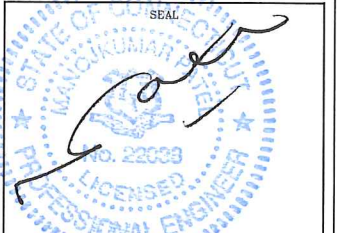

SITE NUMBER:
CT54XC771

SITE NAME:
WOODBURY NORTH

SITE ADDRESS:
186 MINORTOWN ROAD
WOODBURY, CT 06798

SHEET TITLE:
EQUIPMENT DETAILS

SHEET NO:
S-1

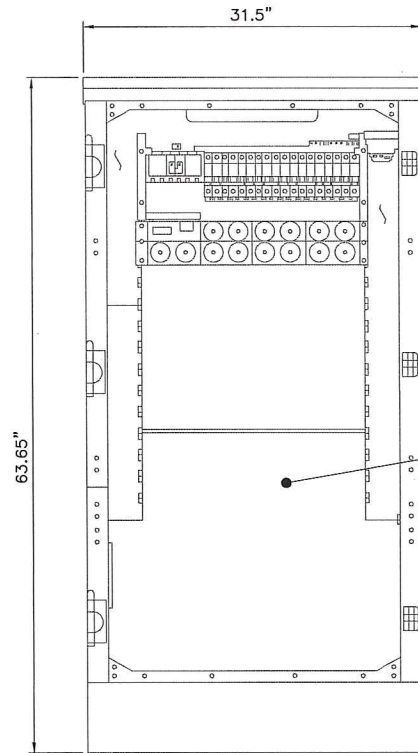

9929 EXPANSION CABINET	
CABINET SPECIFICATIONS	
EXPANSION CABINET:	
- HEIGHT	- 63.65"
- WIDTH	- 31.5"
- DEPTH	- 35.5"
WEIGHT: 1,600 LBS.	

INSTALL NEW 2.5 EQUIPMENT IN PROPOSED 9929 EXPANSION CABINET INCLUDING BUT NOT LIMITED TO BASE BAND UNIT, CELL SITE ROUTER AND SURGE ARRESTORS. GROUND EQUIPMENT TO PROPOSED INTERIOR CABINET GROUND BAR

FRONT ELEVATION
(CABINET INTERIOR)

1 9929 INTERIOR DETAIL
S-2 SCALE: N.T.S.

- LEGEND:**
1. P1000T-HG UNISTRUT, 12" LONG.
 2. 6" PIPE HANGER.
 3. EXISTING SUPPORT PIPE.
 4. NEW STANDOFF BRACKET, ANDREW PART# 30848-4.
 5. NEW ROUND MEMBER ADAPTER SIZED FOR EXISTING PIPE SUPPORT.
 6. BREAKOUT UNIT.
 7. CABLE.

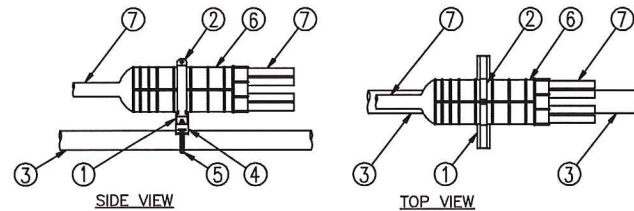

3 MEDUSA HEAD DETAIL
S-2 SCALE: NTS

RFS HYBRIFLEX RISER CABLES SCHEDULE

Cable Type	Manufacturer / Model	Length
Fiber Only (Existing DC Power)	Hybrid cable MN: HB058-M12-050F	50 ft
	12x multi-mode fiber pairs, Top: Outdoor protected connectors, Bottom: LC Connectors, 5/8 cable, 50ft	
	MN: HB058-M12-075F	75 ft
	MN: HB058-M12-100F	100 ft
	MN: HB058-M12-125F	125 ft
	MN: HB058-M12-150F	150 ft
8 AWG Power	Hybrid cable MN: HB114-08U3M12-050F	50 ft
	3x 8 AWG power pairs, 12x multi-mode fiber pairs, Outdoor rated connectors & LC Connectors, 1 1/4 cable, 50ft	
	MN: HB114-08U3M12-075F	75 ft
	MN: HB114-08U3M12-100F	100 ft
	MN: HB114-08U3M12-125F	125 ft
	MN: HB114-08U3M12-150F	150 ft
6 AWG Power	Hybrid cable MN: HB114-13U3M12-225F	225 ft
	3x 6 AWG power pairs, 12x multi-mode fiber pairs, Outdoor rated connectors & LC Connectors, 1 1/4 cable, 225ft	
	MN: HB114-13U3M12-250F	250 ft
	MN: HB114-13U3M12-275F	275 ft
	MN: HB114-13U3M12-300F	300 ft
	4 AWG Power	Hybrid cable MN: HB114-21U3M12-225F
3x 4 AWG power pairs, 12x multi-mode fiber pairs, Outdoor rated connectors & LC Connectors, 1 1/4 cable, 225ft		
MN: HB114-21U3M12-350F		350 ft
MN: HB114-21U3M12-375F		375 ft

RFS HYBRIFLEX JUMPER CABLE SCHEDULE

Cable Type	Manufacturer / Model	Length
Fiber Only	Hybrid Jumper cable MN: HBF012-M3-5F1	5 ft
	5 ft, 3x multi-mode fiber pairs, Outdoor & LC connectors, 1/2 cable	
	MN: HBF012-M3-10F1	10 ft
	MN: HBF012-M3-15F1	15 ft
	MN: HBF012-M3-20F1	20 ft
	MN: HBF012-M3-25F1	25 ft
8 AWG Power	Hybrid Jumper cable MN: HBF058-08U1M3-5F1	5 ft
	5 ft, 1x 8 AWG power pair, 3x multi-mode fiber pairs, Outdoor & LC Connectors, 5/8 cable	
	MN: HBF058-08U1M3-10F1	10 ft
	MN: HBF058-08U1M3-15F1	15 ft
	MN: HBF058-08U1M3-20F1	20 ft
	MN: HBF058-08U1M3-25F1	25 ft
6 AWG Power	Hybrid Jumper cable MN: HBF058-13U1M3-5F1	5 ft
	5 ft, 1x 6 AWG power pair, 3x multi-mode fiber pairs, Outdoor & LC Connectors, 5/8 cable	
	MN: HBF058-13U1M3-10F1	10 ft
	MN: HBF058-13U1M3-15F1	15 ft
	MN: HBF058-13U1M3-20F1	20 ft
	MN: HBF058-13U1M3-25F1	25 ft
4 AWG Power	Hybrid Jumper cable MN: HBF078-21U1M3-5F1	5 ft
	5 ft, 1x 4 AWG power pair, 3x multi-mode fiber pairs, Outdoor & LC Connectors, 7/8 cable	
	MN: HBF078-21U1M3-10F1	10 ft
	MN: HBF078-21U1M3-15F1	15 ft
	MN: HBF078-21U1M3-20F1	20 ft
	MN: HBF078-21U1M3-25F1	25 ft

HYBRID CABLE DC CONDUCTOR SIZE GUIDELINE

CABLE	LENGTH	DC CONDUCTOR	CABLE DIAMETER
FIBER ONLY	VARIABLES	USE NV HYBRIFLEX	7/8"
HYBRIFLEX	<200'	8 AWG	1-1/4"
HYBRIFLEX	225-300'	6 AWG	1-1/4"
HYBRIFLEX	325-375'	4 AWG	1-1/4"

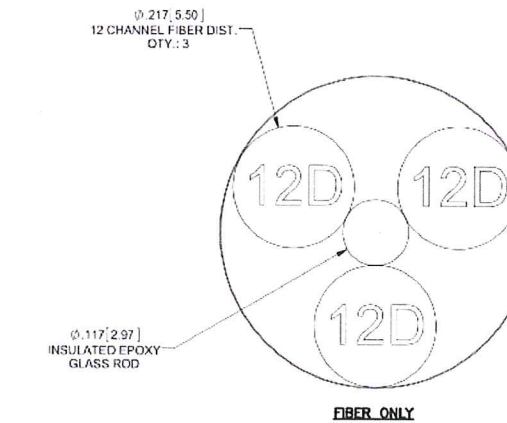
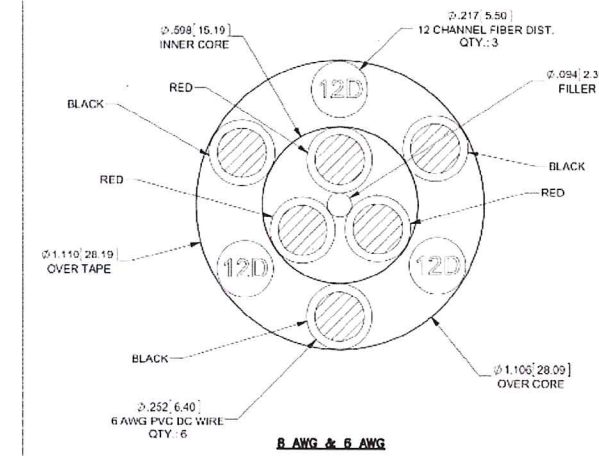
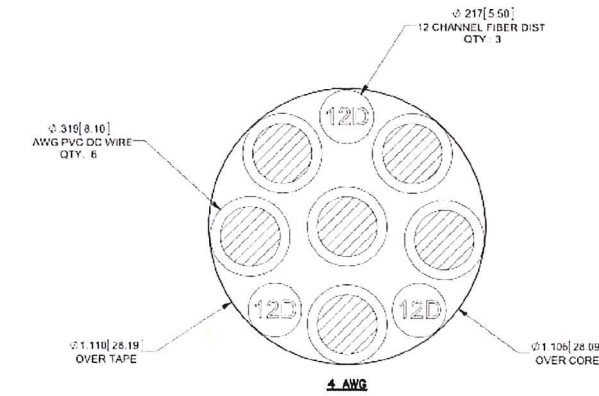

2 2.5 HYBRID CABLE X-SECTION AND DATA
S-2 SCALE: NTS

Sprint
2.5 EQUIPMENT DEPLOYMENT
6580 SPRINT PARKWAY
OVERLAND PARK, KS 66251

CROWN CASTLE

TECTONIC ENGINEERING & SURVEYING CONSULTANTS P.C.
1279 Route 300
Newburgh, NY 12550
Phone: (845) 567-6656
Fax: (845) 567-8703
www.tectonicengineering.com

THIS DOCUMENT IS THE CREATION, DESIGN, PROPERTY AND COPYRIGHTED WORK OF SPRINT COMMUNICATIONS, INC. ANY DUPLICATION OR USE WITHOUT EXPRESS WRITTEN CONSENT IS STRICTLY PROHIBITED. DUPLICATION AND USE BY GOVERNMENT AGENCIES FOR THE PURPOSES OF CONDUCTING THEIR LAWFULLY AUTHORIZED REGULATORY AND ADMINISTRATIVE FUNCTIONS IS SPECIFICALLY ALLOWED.

SUBMITTALS

PROJECT NO: 7225.CT54XC771

NO	DATE	DESCRIPTION	BY
0	6/23/14	FOR COMMENT	JT
1	7/29/14	FOR CONSTRUCTION	KA
2	8/1/14	PER COMMENTS	KA

DATE	REVIEWED BY
8/1/14	JMA

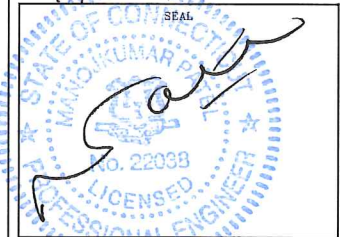

SITE NUMBER:
CT54XC771

SITE NAME:
WOODBURY NORTH

SITE ADDRESS:
186 MINORTOWN ROAD
WOODBURY, CT 06798

SHEET TITLE:
EQUIPMENT
SCHEMATIC DETAILS

SHEET NO:
S-2

THIS DOCUMENT IS THE CREATION, DESIGN, PROPERTY AND COPYRIGHTED WORK OF SPRINT COMMUNICATIONS, INC. ANY DUPLICATION OR USE WITHOUT EXPRESS WRITTEN CONSENT IS STRICTLY PROHIBITED. DUPLICATION AND USE BY GOVERNMENT AGENCIES FOR THE PURPOSES OF CONDUCTING THEIR LAWFULLY AUTHORIZED REGULATORY AND ADMINISTRATIVE FUNCTIONS IS SPECIFICALLY ALLOWED.

SUBMITTALS

PROJECT NO: 7225.CT54XC771

NO	DATE	DESCRIPTION	BY
0	6/23/14	FOR COMMENT	JT
1	7/29/14	FOR CONSTRUCTION	KA
2	8/1/14	PER COMMENTS	KA

DATE: 8/1/14 REVIEWED BY: JMG
 SEAL: PROFESSIONAL ENGINEER 22033

SITE NUMBER: CT54XC771
 SITE NAME: WOODBURY NORTH
 SITE ADDRESS: 186 MINORTOWN ROAD WOODBURY, CT 06798

SHEET TITLE: ELECTRICAL & GROUNDING PLANS

SHEET NO: E-1

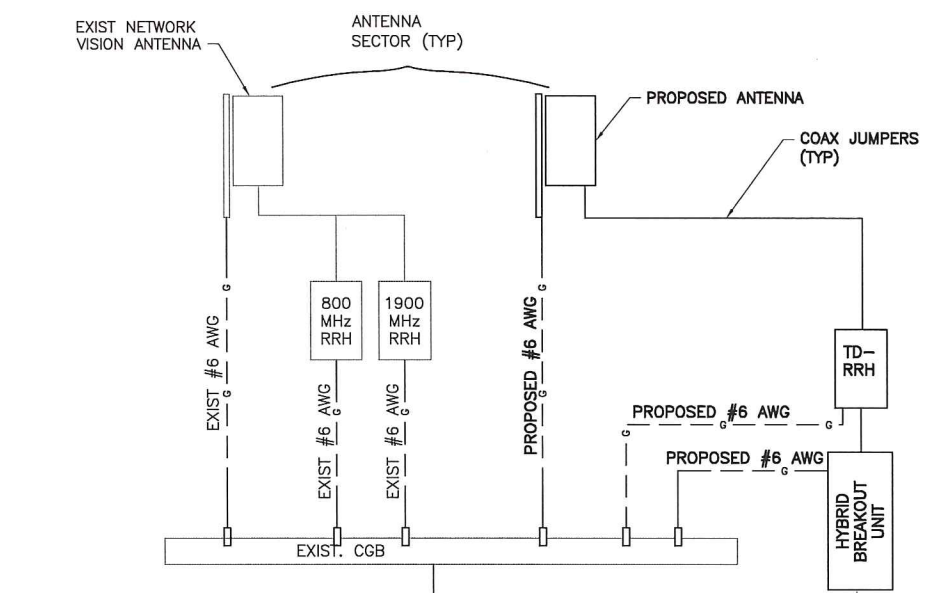

NOTE: ALL CONDUCTORS SHALL BE #6 AWG SOLID TINNED UNLESS OTHERWISE NOTED.

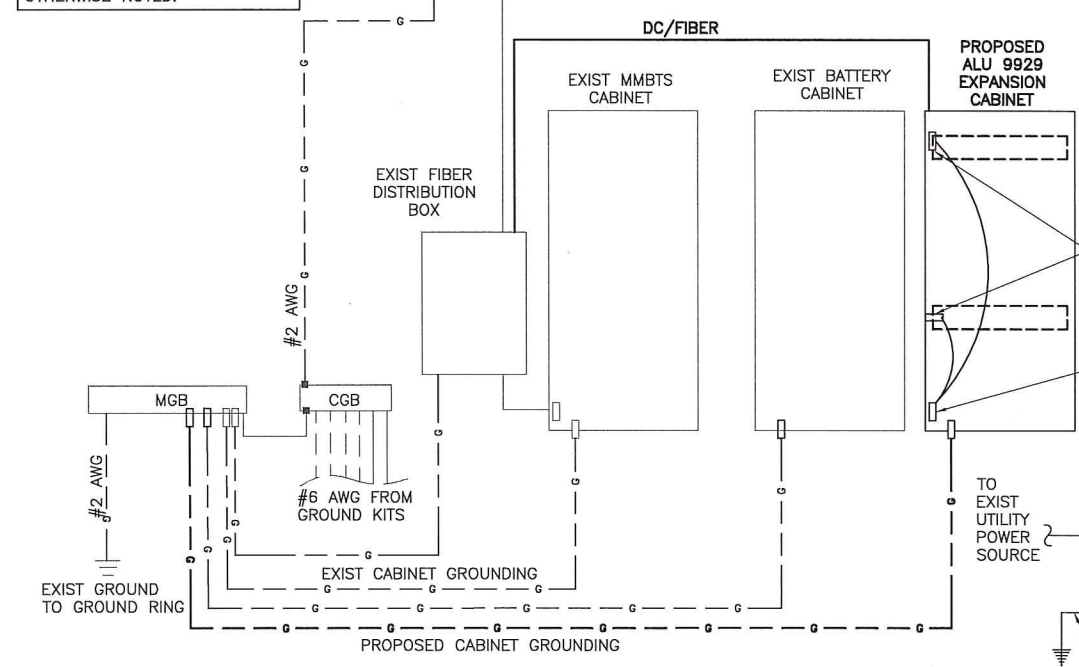

LEGEND
 ■ CADWELD CONNECTION
 □ MECHANICAL CONNECTION
 ● COMPRESSION CONNECTION

1 TYPICAL GROUNDING ONE LINE DIAGRAM
 E-1 SCALE: NTS

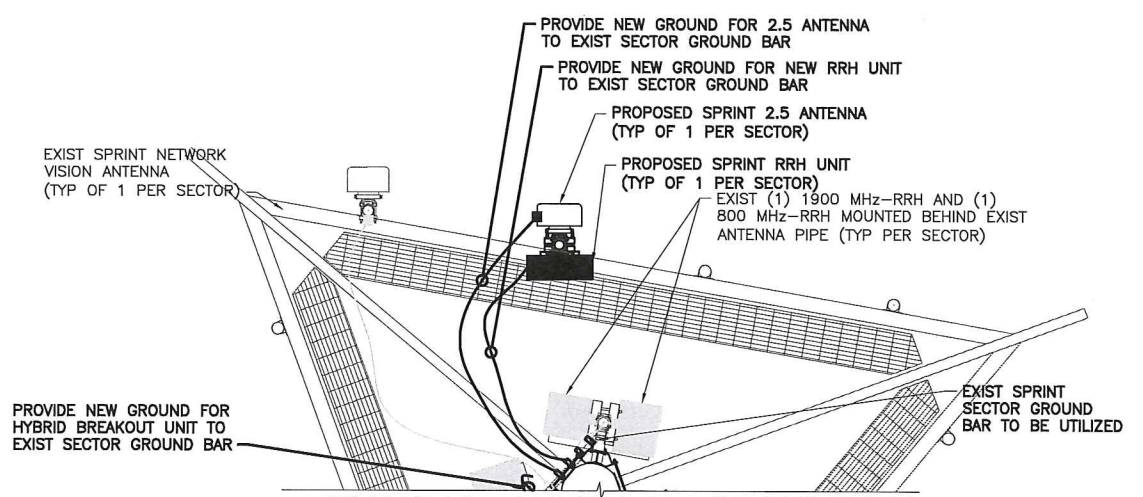

2 TYPICAL ANTENNA GROUNDING PLAN
 E-1 SCALE: NTS

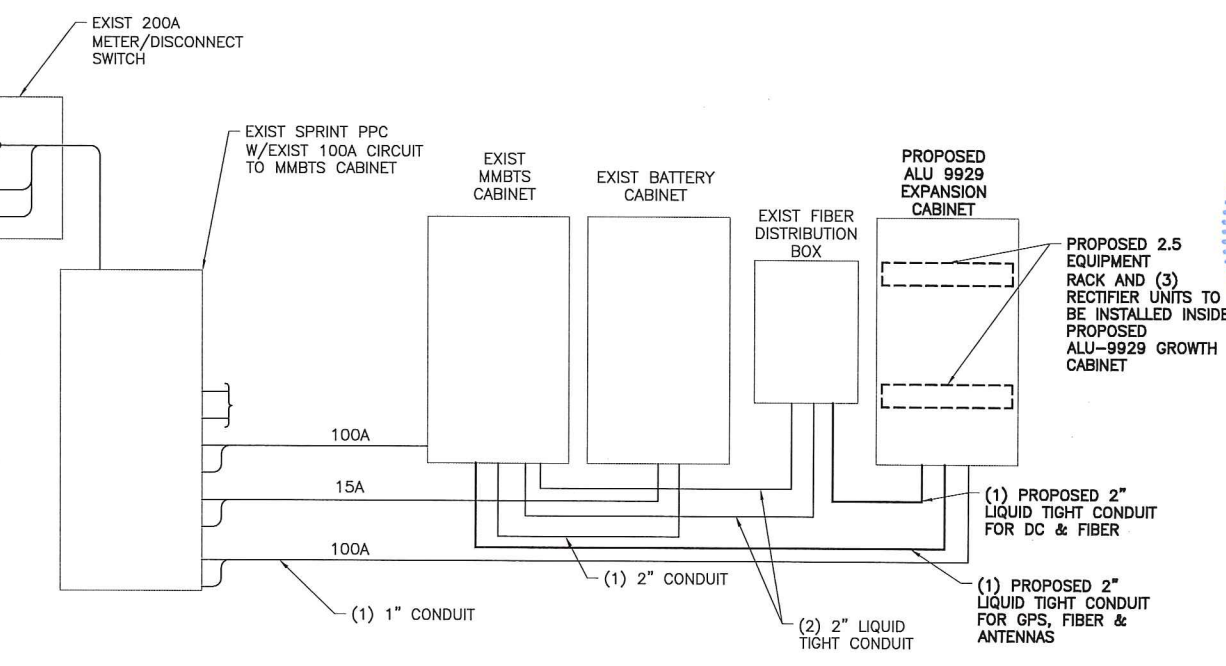

NOTE: FINAL ELECTRICAL DESIGN TO BE DETERMINED BY OTHER.
3 TYPICAL ELECTRICAL & TELCO PLAN
 E-1 SCALE: NTS

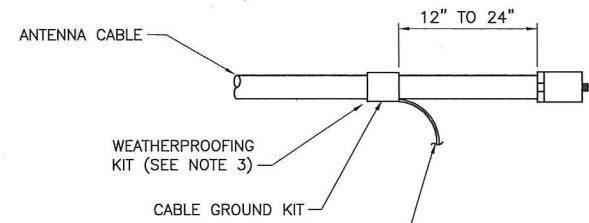

6 AWG STRANDED Cu WIRE WITH GREEN, 600V, THWN INSULATION OR BLACK, MARKED AS REQUIRED BY THE NEC (GROUNDED TO GROUND BAR) (SEE NOTES 1 & 2)

CONNECTION OF CABLE GROUND KIT TO ANTENNA CABLE

NOTES:

DO NOT INSTALL CABLE GROUND KIT AT A BEND AND ALWAYS DIRECT GROUND WIRE DOWN TO GROUND BAR.

GROUNDING KIT SHALL BE TYPE AND PART NUMBER AS SUPPLIED OR RECOMMENDED BY CABLE MANUFACTURER.

WEATHER PROOFING SHALL BE (TYPE AND PART NUMBER) AS SUPPLIED OR RECOMMENDED BY CABLE MANUFACTURER AND APPROVED BY CONTRACTOR.

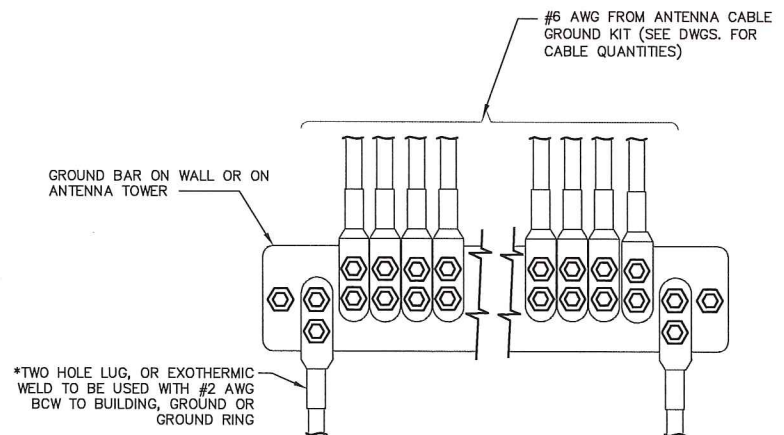

*TWO HOLE LUG, OR EXOTHERMIC WELD TO BE USED WITH #2 AWG BCW TO BUILDING, GROUND OR GROUND RING

* - GROUND BARS AT THE BOTTOM OF TOWERS/MONOPOLES SHALL ONLY USE EXOTHERMIC WELDS.

- ATTACH "DO NOT DISCONNECT" LABELS TO GROUND BARS. CAN USE BRASS TAG "DO NOT DISCONNECT" AT EACH HYBRID GROUND POINT OR BACK-A-LITE PLATE LABEL ON GROUND BAR.

- CONNECT SEQUENCE- BOLT/WASHER/NO-OX/GROUND BAR/NO-OX/WASHER/LOCK-WASHER/NUT. THIS IS REPEATED FOR EACH LUG CONNECTION POINT.

ELECTRICAL AND GROUNDING NOTES

- ALL ELECTRICAL WORK SHALL CONFORM TO THE REQUIREMENTS OF THE NATIONAL ELECTRICAL CODE (NEC) AS WELL AS APPLICABLE STATE AND LOCAL CODES.
- ALL ELECTRICAL ITEMS SHALL BE U.L. APPROVED OR LISTED AND PROCURED PER SPECIFICATION REQUIREMENTS.
- ELECTRICAL AND TELCO WIRING OUTSIDE A BUILDING AND EXPOSED TO WEATHER SHALL BE IN WATER TIGHT GALVANIZED RIGID STEEL CONDUITS OR SCHEDULE 80 PVC (AS PERMITTED BY CODE) AND WHERE REQUIRED IN LIQUID TIGHT FLEXIBLE METAL OR NONMETALLIC CONDUITS.
- BURIED CONDUIT SHALL BE SCHEDULE 40 PVC.
- ELECTRICAL WIRING SHALL BE COPPER WITH TYPE XHHW, THWN, OR THNN INSULATION.
- RUN TELCO CONDUIT OR CABLE BETWEEN TELEPHONE UTILITY DEMARCATION POINT AND PROJECT OWNER CELL SITE TELCO CABINET AND BTS CABINET AS INDICATED ON THIS DRAWING PROVIDE FULL LENGTH PULL ROPE IN INSTALLED TELCO CONDUIT. PROVIDE GREENLEE CONDUIT MEASURING TAPE AT EACH END.
- WHERE CONDUIT BETWEEN BTS AND PROJECT OWNER CELL SITE PPC AND BETWEEN BTS AND PROJECT OWNER CELL SITE TELCO SERVICE CABINET ARE UNDERGROUND USE PVC, SCHEDULE 40 CONDUIT. ABOVE THE GROUND PORTION OF THESE CONDUITS SHALL BE PVC CONDUIT.
- ALL EQUIPMENT LOCATED OUTSIDE SHALL HAVE NEMA 3R ENCLOSURE.
- GROUNDING SHALL COMPLY WITH NEC ART. 250.
- GROUND HYBRID CABLE SHIELDS AT 3 LOCATIONS USING MANUFACTURER'S HYBRID CABLE GROUNDING KITS SUPPLIED BY PROJECT OWNER.
- USE #2 COPPER STRANDED WIRE WITH GREEN COLOR INSULATION FOR ABOVE GRADE GROUNDING (UNLESS OTHERWISE SPECIFIED) AND #2 SOLID TINNED BARE COPPER WIRE FOR BELOW GRADE GROUNDING AS INDICATED ON THE DRAWING.
- ALL GROUND CONNECTIONS TO BE BURNDY HYGROUND COMPRESSION TYPE CONNECTORS OR CADWELD EXOTHERMIC WELD. DO NOT ALLOW BARE COPPER WIRE TO BE IN CONTACT WITH GALVANIZED STEEL.
- ROUTE GROUNDING CONDUCTORS ALONG THE SHORTEST AND STRAIGHTEST PATH POSSIBLE, EXCEPT AS OTHERWISE INDICATED. GROUNDING LEADS SHOULD NEVER BE BENT AT RIGHT ANGLE. ALWAYS MAKE AT LEAST 12" RADIUS BENDS. #2 WIRE CAN BE BENT AT 6" RADIUS WHEN NECESSARY. BOND ANY METAL OBJECTS WITHIN 6 FEET OF PROJECT OWNER EQUIPMENT OR CABINET TO MASTER GROUND BAR OR GROUNDING RING.
- CONNECTIONS TO GROUND BARS SHALL BE MADE WITH TWO HOLE COMPRESSION TYPE COPPER LUGS. APPLY OXIDE INHIBITING COMPOUND TO ALL LOCATIONS.
- APPLY OXIDE INHIBITING COMPOUND TO ALL COMPRESSION TYPE GROUND CONNECTIONS.
- BOND ANTENNA MOUNTING BRACKETS, HYBRID CABLE GROUND KITS, AND RRHs TO EGB PLACED NEAR THE ANTENNA LOCATION.
- BOND ANTENNA EGB'S AND MGB TO GROUND RING.
- CONTRACTOR SHALL TEST COMPLETED GROUND SYSTEM AND RECORD RESULT FOR PROJECT CLOSE-OUT DOCUMENTATION. 5 OHMS MINIMUM RESISTANCE REQUIRED.
- CONTRACTOR SHALL CONDUCT ANTENNA, HYBRID CABLES, GPS COAX AND RRH RETURN-LOSS AND DISTANCE- TO-FAULT MEASUREMENTS (SWEEP TESTS) AND RECORD RESULTS FOR PROJECT CLOSE OUT.
- CONTRACTOR SHALL CHECK CAPACITY OF EXISTING SERVICE & PANEL ON SITE TO DETERMINE IF CAPACITY EXISTS TO ACCOMMODATE THE ADDED LOAD OF THIS PROJECT. ADVISE ENGINEER OF ANY DISCREPANCY.
- LOCATION OF ALL OUTLET, BOXES, ETC, AND THE TYPE OF CONNECTION (PLUG OR DIRECT) SHALL BE CONFIRMED WITH THE OWNER'S REPRESENTATIVE PRIOR TO ROUGH-IN.
- ELECTRICAL CHARACTERISTICS OF ALL EQUIPMENT (NEW AND EXISTING) SHALL BE FIELD VERIFIED WITH THE OWNERS REPRESENTATIVE AND EQUIPMENT SUPPLIER PRIOR TO ROUGH-IN OF CONDUIT AND WIRE. ALL EQUIPMENT SHALL BE PROPERLY CONNECTED ACCORDING TO THE NAMEPLATE DATA FURNISHED ON THE EQUIPMENT.

1 CABLE GROUNDING KIT DETAIL
E-2 SCALE: N.T.S.

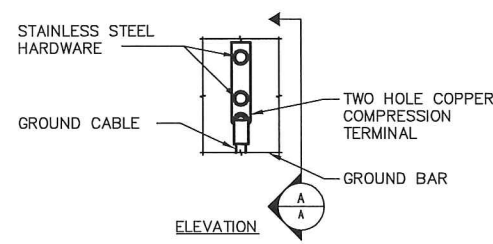

NOTE:
1. "DOUBLING UP" OR "STACKING" OF CONNECTION IS NOT PERMITTED.
2. OXIDE INHIBITING COMPOUND TO BE USED AT ALL LOCATIONS.
3. CADWELD DOWNLOADS FROM UPPER EGB, LOWER EGB AND MGB.

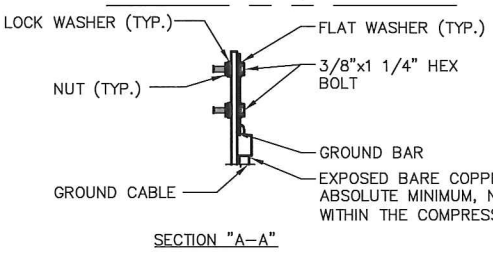

SECTION "A-A"

2 GROUNDING BAR CONN. DETAIL
E-2 SCALE: NTS

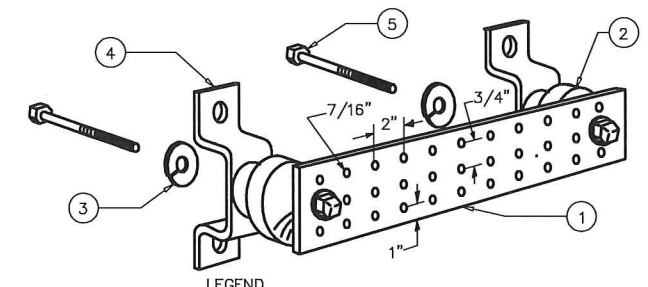

- LEGEND
- COPPER TINNED GROUND BAR, 1/4" X 4" X 20", OR OTHER LENGTH AS REQUIRED, HOLE CENTERS TO MATCH NEMA DOUBLE LUG CONFIGURATION
 - INSULATORS, NEWTON INSTRUMENT CAT. NO. 3061-4 OR EQUAL
 - 5/8" LOCKWASHERS OR EQUAL
 - WALL MOUNTING BRACKET, NEWTON INSTRUMENT CO. CAT NO. A-6056 OR EQUAL
 - 5/8-11 X 1" H.H.C.S.BOLTS

NOTE:
ALL BOLTS, NUTS, WASHERS AND LOCK WASHERS SHALL BE 18-8 STAINLESS STEEL.

3 GROUNDING BAR DETAIL
E-2 SCALE: NTS

4 ANTENNA GROUND BAR DETAIL
E-2 SCALE: NTS

GROUNDING NOTES:

- GROUNDING SHALL BE IN ACCORDANCE WITH NEC ARTICLE 250-GROUNDING AND BONDING.
- ALL GROUND WIRES SHALL BE #2 AWG UNLESS NOTED OTHERWISE.
- ALL GROUNDING WIRES SHALL PROVIDE A STRAIGHT, DOWNWARD PATH TO GROUND WITH GRADUAL BENDS AS REQUIRED. GROUND WIRES SHALL NOT BE LOOPED OR SHARPLY BENT.
- EACH EQUIPMENT CABINET SHALL BE CONNECTED TO THE MASTER ISOLATION GROUND BAR (MGB) WITH #2 AWG INSULATED STRANDED COPPER WIRE. EQUIPMENT CABINETS WALL HAVE (2) CONNECTIONS.
- PROVIDE DEDICATED #2 AWG COPPER GROUND WIRE FROM EACH ANTENNA MOUNTING PIPE TO ASSOCIATED CIGBE.
- THE CONTRACTOR SHALL VERIFY THAT THE EXISTING GROUND BARS HAVE ENOUGH SPACE/HOLES FOR ADDITIONAL TWO HOLE LUGS.
- ALL CONDUITS SHALL BE RIGID GALVANIZED STEEL AND SHALL BE PROVIDED WITH GROUNDING BUSHINGS.
- PROVIDE GROUND CONNECTIONS FOR ALL METALLIC STRUCTURES, ENCLOSURES, RACEWAYS AND OTHER CONDUCTIVE ITEMS ASSOCIATED WITH THE INSTALLATION OF CARRIER'S EQUIPMENT.
- WHEN CABLE LENGTH IS OVER 20' THE MANUFACTURERS GROUND KIT MUST BE INSTALLED PER THE MANUFACTURERS SPECIFICATIONS.
- REFER TO "ANTI-THEFT UPDATE TO SPRINT GROUNDING 082412.PDF" FOR GUIDELINE TO SUSPECTED OR ACTUAL THEFT OF GROUNDING.
- HOME RUN GROUNDS ARE NOT APPROVED BY CROWN CASTLE CONSTRUCTION STANDARDS AND THAT ANTENNA BUSS BARS SHOULD BE INSTALLED DIRECTLY TO TOWER STEEL WITHOUT INSULATORS OR DOWN CONDUCTORS.

PROTECTIVE GROUNDING SYSTEM GENERAL NOTES:

- AT ALL TERMINATIONS AT EQUIPMENT ENCLOSURES, PANEL, AND FRAMES OF EQUIPMENT AND WHERE EXPOSED FOR GROUNDING. CONDUCTOR TERMINATION SHALL BE PERFORMED UTILIZING TWO HOLE BOLTED TONGUE COMPRESSION TYPE LUGS WITH STAINLESS STEEL SELF-TAPPING SCREWS.
- ALL CLAMPS AND SUPPORTS USED TO SUPPORT THE GROUNDING SYSTEM CONDUCTORS AND PVC CONDUITS SHALL BE PVC TYPE (NON CONDUCTIVE). DO NOT USE METAL BRACKETS OR SUPPORTS WHICH WOULD FORM A COMPLETE RING AROUND ANY GROUNDING CONDUCTOR.
- ALL GROUNDING CONNECTIONS SHALL BE COATED WITH A COPPER SHIELD ANTI-CORROSIVE AGENT SUCH AS T&B KOPR SHIELD. VERIFY PRODUCT WITH PROJECT MANAGER.
- ALL BOLTS, WASHERS, AND NUTS USED ON GROUNDING CONNECTIONS SHALL BE STAINLESS STEEL.
- INSTALL GROUND BUSHING ON ALL METALLIC CONDUITS AND BOND TO THE EQUIPMENT GROUND BUS IN THE PANEL BOARD.
- GROUND ANTENNA BASES, FRAMES, CABLE RACKS, AND OTHER METALLIC COMPONENTS WITH #2 INSULATED TINNED STRANDED COPPER GROUNDING CONDUCTORS AND CONNECT TO INSULATED SURFACE MOUNTED GROUND BARS. CONNECTION DETAILS SHALL FOLLOW MANUFACTURER'S SPECIFICATIONS FOR GROUNDING.
- GROUND HYBRID CABLE SHIELD AT BOTH ENDS USING MANUFACTURER'S GUIDELINES.

Sprint
2.5 EQUIPMENT DEPLOYMENT
6580 SPRINT PARKWAY
OVERLAND PARK, KS 66251

CROWN CASTLE

TECTONIC
PLANNING
ENGINEERING
SURVEYING
CONSTRUCTION MANAGEMENT
TECTONIC Engineering & Surveying Consultants P.C.
1279 Route 300
Newburgh, NY 12550
Phone: (845) 567-6656
Fax: (845) 567-8703
www.tectonicengineering.com

THIS DOCUMENT IS THE CREATION, DESIGN, PROPERTY AND COPYRIGHTED WORK OF SPRINT COMMUNICATIONS, INC. ANY DUPLICATION OR USE WITHOUT EXPRESS WRITTEN CONSENT IS STRICTLY PROHIBITED. DUPLICATION AND USE BY GOVERNMENT AGENCIES FOR THE PURPOSES OF CONDUCTING THEIR LAWFULLY AUTHORIZED REGULATORY AND ADMINISTRATIVE FUNCTIONS IS SPECIFICALLY ALLOWED.

SUBMITTALS

PROJECT NO: 7225.CT54XC771

NO	DATE	DESCRIPTION	BY
0	6/23/14	FOR COMMENT	JT
1	7/29/14	FOR CONSTRUCTION	KA
2	8/1/14	PER COMMENTS	KA

DATE	REVIEWED BY
8/1/14	shel

SEAL
MAJOR STATE ENGINEER
22030
PROFESSIONAL ENGINEER

SITE NUMBER:
CT54XC771
SITE NAME:
WOODBURY NORTH
SITE ADDRESS:
186 MINORTOWN ROAD
WOODBURY, CT 06798

SHEET TITLE:
GROUNDING DETAILS & NOTES

SHEET NO:
E-2

Date: **August 02, 2017**

Marianne Dunst
Crown Castle
3530 Toringdon Way, Suite 300
Charlotte, NC 28277
704.405.6580

Paul J Ford and Company
250 E. Broad Street, Suite 600
Columbus, OH 43215
614.221.6679
rferrante@pjfweb.com

Subject: Structural Analysis Report

Carrier Designation:

Sprint PCS Co-Locate

Carrier Site Number:

CT54XC771

Carrier Site Name:

CT54XC771

Crown Castle Designation:

Crown Castle BU Number:

876405

Crown Castle Site Name:

WOODBURY NORTH

Crown Castle JDE Job Number:

450839

Crown Castle Work Order Number:

1436644

Crown Castle Application Number:

399494 Rev. 2

Engineering Firm Designation:

Paul J Ford and Company Project Number: 37517-2700.001.7805

Site Data:

186 MinorTown, WOODBURY, Litchfield County, CT

Latitude 41° 34' 4.79", Longitude -73° 10' 46.85"

109.86 Foot - Monopole Tower

Dear Marianne Dunst,

Paul J Ford and Company is pleased to submit this "**Structural Analysis Report**" to determine the structural integrity of the above mentioned tower. This analysis has been performed in accordance with the Crown Castle Structural 'Statement of Work' and the terms of Crown Castle Purchase Order Number 1064313, in accordance with application 399494, revision 2.

The purpose of the analysis is to determine acceptability of the tower stress level. Based on our analysis we have determined the tower stress level for the structure and foundation, under the following load case, to be:

LC5: Existing + Proposed Equipment

Sufficient Capacity

Note: See Table I and Table II for the proposed and existing loading, respectively.

This analysis has been performed in accordance with the 2016 Connecticut State Building Code based upon an ultimate 3-second gust wind speed of 120 mph converted to a nominal 3-second gust wind speed of 93 mph per Section 1609.3 and Appendix N as required for use in the ANSI/TIA-222-G-2005 Standard, "Structural Standard for Antenna Supporting Structures and Antennas", with ANSI/TIA-222-G-1-2007 and ANSI/TIA-222-G-2-2009 Addenda per Exception #5 of Section 1609.1.1. Risk Category II, Exposure Category C and Topographic Category 1 with a maximum Topographic Factor, Kzt, of 1.0 were used in this analysis.

We at *Paul J Ford and Company* appreciate the opportunity of providing our continuing professional services to you and Crown Castle. If you have any questions or need further assistance on this or any other projects please give us a call.

Respectfully submitted by:

Ryan Ferrante, EI
Structural Designer

TABLE OF CONTENTS

1) INTRODUCTION

2) ANALYSIS CRITERIA

Table 1 - Proposed Antenna and Cable Information

Table 2 - Existing Antenna and Cable Information

3) ANALYSIS PROCEDURE

Table 3 - Documents Provided

3.1) Analysis Method

3.2) Assumptions

4) ANALYSIS RESULTS

Table 4 - Section Capacity (Summary)

Table 5 - Tower Components vs. Capacity

4.1) Recommendations

5) APPENDIX A

tnxTower Output

6) APPENDIX B

Base Level Drawing

7) APPENDIX C

Additional Calculations

1) INTRODUCTION

This tower is a 109.86 ft Monopole tower designed by ENGINEERED ENDEAVORS, INC. in April of 2003. The tower was originally designed for a wind speed of 85 mph per TIA/EIA-222-F.

2) ANALYSIS CRITERIA

This analysis has been performed in accordance with the 2016 Connecticut State Building Code based upon an ultimate 3-second gust wind speed of 120 mph converted to a nominal 3-second gust wind speed of 93 mph per Section 1609.3 and Appendix N as required for use in the ANSI/TIA-222-G-2005 Standard, "Structural Standard for Antenna Supporting Structures and Antennas", with ANSI/TIA-222-G-1-2007 and ANSI/TIA-222-G-2-2009 Addenda per Exception #5 of Section 1609.1.1. Risk Category II, Exposure Category C and Topographic Category 1 with a maximum Topographic Factor, Kzt, of 1.0 were used in this analysis.

Table 1 - Proposed Antenna and Cable Information

Mounting Level (ft)	Center Line Elevation (ft)	Number of Antennas	Antenna Manufacturer	Antenna Model	Number of Feed Lines	Feed Line Size (in)	Note
100.0	103.0	3	alcatel lucent	TD-RRH8x20-25	1	1-1/4	-
		3	rfs celwave	APXVTM14-C-120 w/ Mount Pipe			

Table 2 - Existing Antenna and Cable Information

Mounting Level (ft)	Center Line Elevation (ft)	Number of Antennas	Antenna Manufacturer	Antenna Model	Number of Feed Lines	Feed Line Size (in)	Note
108.0	108.0	1	antel	BXA-171063-8BF-2 w/ Mount Pipe	12	1-5/8	1
		2	antel	BXA-171085-8BF-EDIN-2 w/ Mount Pipe			
		3	antel	BXA-70063/6CF-2 w/ Mount Pipe			
		1	antel	BXA-80063/4CFx5 w/ Mount Pipe			
		2	antel	BXA-80080/4CF w/ Mount Pipe			
		6	rfs celwave	FD9R6004/2C-3L			
		1	tower mounts	T-Arm Mount [TA 602-3]			
100.0	103.0	9	rfs celwave	ACU-A20-N	3	1-1/4	1
		1	rfs celwave	APXV9ERR18-C-A20 w/ Mount Pipe			
		2	rfs celwave	APXVSPP18-C-A20 w/ Mount Pipe			
	100.0	1	tower mounts	Miscellaneous [NA 507-1]			
		1	tower mounts	Platform Mount [LP 601-1]			
98.0	99.0	3	alcatel lucent	800MHZ RRH	-	-	1
	98.0	1	tower mounts	Side Arm Mount [SO 701-3]			
	97.0	3	alcatel lucent	1900MHZ RRH (65MHz)			

Mounting Level (ft)	Center Line Elevation (ft)	Number of Antennas	Antenna Manufacturer	Antenna Model	Number of Feed Lines	Feed Line Size (in)	Note
78.0	78.0	1	kmw communications	AM-X-CD-14-65-00T-RET w/ Mount Pipe	12 2 1	1-5/8 7/16 3/8	1
		2	kmw communications	AM-X-CD-16-65-00T-RET w/ Mount Pipe			
		12	lgp telecom	TMA-DD 1900			
		6	powerwave technologies	7770.00 w/ Mount Pipe			
		1	raycap	DC6-48-60-18-8F			
		1	tower mounts	T-Arm Mount [TA 602-3]			
76.0	76.0	6	ericsson	RRUS 11	-	-	1
		1	tower mounts	Side Arm Mount [SO 701-3]			
50.0	51.0	1	lucent	KS24019-L112A	1	1/2	1
	50.0	1	tower mounts	Side Arm Mount [SO 701-1]			

Notes:
 1) Existing Equipment

3) ANALYSIS PROCEDURE

Table 3 - Documents Provided

Document	Remarks	Reference	Source
GEOTECHNICAL REPORTS	Clarence Welti Assoc., 3/20/2003	2158106	CCISITES
POST-MODIFICATION INSPECTION	TEP, 05A1056, 12/6/2005	1956156	CCISITES
POST-MODIFICATION INSPECTION	PJF, 41708-0085, 7/24/2008	2309564	CCISITES
POST-MODIFICATION INSPECTION	TEP, 131001.876405, 5/6/2013	3849745	CCISITES
TOWER FOUNDATION DRAWINGS/DESIGN/SPECS	EEI, 11560, 4/24/2003	1613643	CCISITES
TOWER MANUFACTURER DRAWINGS	EEI, 11560, 4/21/2003	1614551	CCISITES

3.1) Analysis Method

tnxTower (version 7.0.5.1), a commercially available analysis software package, was used to create a three-dimensional model of the tower and calculate member stresses for various loading cases. Selected output from the analysis is included in Appendix A.

3.2) Assumptions

- 1) Tower and structures were built in accordance with the manufacturer's specifications.
- 2) The tower and structures have been maintained in accordance with the manufacturer's specification.
- 3) The configuration of antennas, transmission cables, mounts and other appurtenances are as specified in Tables 1 and 2 and the referenced drawings.
- 4) Monopole has been modified in conformance with the referenced modification drawings.

This analysis may be affected if any assumptions are not valid or have been made in error. Paul J Ford and Company should be notified to determine the effect on the structural integrity of the tower.

4) ANALYSIS RESULTS

Table 4 - Section Capacity (Summary)

Section No.	Elevation (ft)	Component Type	Size	Critical Element	P (K)	SF*P_allow (K)	% Capacity	Pass / Fail
L1	109.86 - 99	Pole	TP14.9843x12.7x0.1875	1	-3.83	654.24	18.5	Pass
L2	99 - 98.5	Pole	TP15.5x14.9843x0.1875	2	-3.86	677.04	19.0	Pass
L3	98.5 - 79.33	Pole	TP19.246x15.5x0.1875	3	-5.75	839.32	61.4	Pass
L4	79.33 - 47.12	Pole	TP25.54x19.246x0.4458	4	-12.74	1693.49	68.7	Pass
L5	47.12 - 14.83	Pole	TP31.3878x23.9156x0.4471	5	-20.66	2183.17	83.2	Pass
L6	14.83 - 13.83	Pole	TP31.5808x31.3878x0.5465	6	-20.93	2496.75	73.9	Pass
L7	13.83 - 6	Pole	TP33.092x31.5808x0.4413	7	-22.73	2236.52	87.1	Pass
L8	6 - 3.33	Pole	TP33.6073x33.092x0.5251	8	-23.45	2573.66	77.6	Pass
L9	3.33 - 0	Pole	TP34.25x33.6073x0.4279	9	-24.23	2294.34	88.6	Pass
							Summary	
						Pole (L9)	88.6	Pass
						Rating =	88.6	Pass

Table 5 - Tower Component Stresses vs. Capacity

Notes	Component	Elevation (ft)	% Capacity	Pass / Fail
1	Anchor Rods	0	56.4	Pass
1	Base Plate	0	65.9	Pass
1	Base Foundation Structural Steel	0	45.0	Pass
1	Base Foundation Soil Interaction	0	33.8	Pass
1	Flange Connection	98.5	46.3	Pass

Structure Rating (max from all components) =	88.6%
---	--------------

Notes:

- 1) See additional documentation in "Appendix C – Additional Calculations" for calculations supporting the % capacity consumed.

4.1) Recommendations

The monopole and its foundation have sufficient capacity to carry the proposed loading configuration. No modifications are required at this time.

APPENDIX A
TNXTOWER OUTPUT

Tower Input Data

There is a pole section.

This tower is designed using the TIA-222-G standard.

The following design criteria apply:

- 1) Tower is located in Litchfield County, Connecticut.
- 2) ASCE 7-10 Wind Data is used (wind speeds converted to nominal values).
- 3) Basic wind speed of 93 mph.
- 4) Structure Class II.
- 5) Exposure Category C.
- 6) Topographic Category 1.
- 7) Crest Height 0.00 ft.
- 8) Nominal ice thickness of 1.0000 in.
- 9) Ice thickness is considered to increase with height.
- 10) Ice density of 56.00 pcf.
- 11) A wind speed of 40 mph is used in combination with ice.
- 12) Temperature drop of 50 °F.
- 13) Deflections calculated using a wind speed of 60 mph.
- 14) A non-linear (P-delta) analysis was used.
- 15) Pressures are calculated at each section.
- 16) Stress ratio used in pole design is 1.
- 17) Local bending stresses due to climbing loads, feed line supports, and appurtenance mounts are not considered.

Options

Consider Moments - Legs Consider Moments - Horizontals Consider Moments - Diagonals Use Moment Magnification ✓ Use Code Stress Ratios ✓ Use Code Safety Factors - Guys Escalate Ice Always Use Max Kz Use Special Wind Profile Include Bolts In Member Capacity Leg Bolts Are At Top Of Section Secondary Horizontal Braces Leg Use Diamond Inner Bracing (4 Sided) SR Members Have Cut Ends SR Members Are Concentric	Distribute Leg Loads As Uniform Assume Legs Pinned ✓ Assume Rigid Index Plate ✓ Use Clear Spans For Wind Area Use Clear Spans For KL/r Retension Guys To Initial Tension ✓ Bypass Mast Stability Checks ✓ Use Azimuth Dish Coefficients ✓ Project Wind Area of Appurt. Autocalc Torque Arm Areas Add IBC .6D+W Combination Sort Capacity Reports By Component Triangulate Diamond Inner Bracing Treat Feed Line Bundles As Cylinder	Use ASCE 10 X-Brace Ly Rules Calculate Redundant Bracing Forces Ignore Redundant Members in FEA SR Leg Bolts Resist Compression All Leg Panels Have Same Allowable Offset Girt At Foundation ✓ Consider Feed Line Torque Include Angle Block Shear Check Use TIA-222-G Bracing Resist. Exemption Use TIA-222-G Tension Splice Exemption Poles ✓ Include Shear-Torsion Interaction Always Use Sub-Critical Flow Use Top Mounted Sockets
--	--	---

Tapered Pole Section Geometry

Section	Elevation ft	Section Length ft	Splice Length ft	Number of Sides	Top Diameter in	Bottom Diameter in	Wall Thickness in	Bend Radius in	Pole Grade
L1	109.86-99.00	10.86	0.00	18	12.7000	14.9843	0.1875	0.7500	A572-65 (65 ksi)
L2	99.00-98.50	0.50	0.00	18	14.9843	15.5000	0.1875	0.7500	A572-65 (65 ksi)
L3	98.50-79.33	19.17	0.00	18	15.5000	19.2460	0.1875	0.7500	A572-65 (65 ksi)
L4	79.33-47.12	32.21	3.75	18	19.2460	25.5400	0.4458	1.7833	Reinf 42.98 ksi (43 ksi)
L5	47.12-14.83	36.04	0.00	18	23.9156	31.3878	0.4471	1.7884	Reinf 43.50 ksi (44 ksi)
L6	14.83-13.83	1.00	0.00	18	31.3878	31.5808	0.5465	2.1859	Reinf 40.58 ksi (41 ksi)
L7	13.83-6.00	7.83	0.00	18	31.5808	33.0920	0.4412	1.7650	Reinf 42.79 ksi (43 ksi)

Section	Elevation ft	Section Length ft	Splice Length ft	Number of Sides	Top Diameter in	Bottom Diameter in	Wall Thickness in	Bend Radius in	Pole Grade
L8	6.00-3.33	2.67	0.00	18	33.0920	33.6073	0.5251	2.1003	Reinf 40.84 ksi (41 ksi)
L9	3.33-0.00	3.33		18	33.6073	34.2500	0.4279	1.7115	Reinf 43.70 ksi (44 ksi)

Tapered Pole Properties

Section	Tip Dia. in	Area in ²	I in ⁴	r in	C in	I/C in ³	J in ⁴	It/Q in ²	w in	w/t
L1	12.8959	7.4465	147.2916	4.4419	6.4516	22.8302	294.7770	3.7240	1.9052	10.161
	15.2155	8.8059	243.5842	5.2529	7.6120	31.9999	487.4888	4.4038	2.3072	12.305
L2	15.2155	8.8059	243.5842	5.2529	7.6120	31.9999	487.4888	4.4038	2.3072	12.305
	15.7391	9.1129	269.9504	5.4359	7.8740	34.2838	540.2560	4.5573	2.3980	12.789
L3	15.7391	9.1129	269.9504	5.4359	7.8740	34.2838	540.2560	4.5573	2.3980	12.789
	19.5428	11.3422	520.4852	6.7657	9.7769	53.2360	1041.6552	5.6722	3.0573	16.306
L4	19.5428	26.6028	1187.9180	6.6740	9.7769	121.5020	2377.3992	13.3039	2.6026	5.838
	25.9340	35.5091	2825.0292	8.9084	12.9743	217.7401	5653.7757	17.7579	3.7104	8.323
L5	25.0740	33.3047	2317.4659	8.3313	12.1491	190.7518	4637.9812	16.6555	3.4222	7.654
	31.8720	43.9088	5310.6836	10.9840	15.9450	333.0622	10628.3550	21.9586	4.7373	10.595
L6	31.8720	53.4942	6428.5301	10.9487	15.9450	403.1685	12865.5190	26.7522	4.5625	8.349
	32.0680	53.8290	6549.9728	11.0172	16.0431	408.2744	13108.5643	26.9196	4.5964	8.411
L7	32.0680	43.6119	5342.7858	11.0546	16.0431	333.0277	10692.6017	21.8101	4.7816	10.837
	33.6025	45.7283	6158.9826	11.5910	16.8107	366.3719	12326.0693	22.8685	5.0476	11.439
L8	33.6025	54.2752	7272.6459	11.5613	16.8107	432.6190	14554.8613	27.1427	4.9001	9.332
	34.1258	55.1340	7623.3647	11.7442	17.0725	446.5284	15256.7604	27.5722	4.9908	9.505
L9	34.1258	45.0607	6267.1994	11.7787	17.0725	367.0928	12542.6454	22.5346	5.1618	12.064
	34.7784	45.9335	6638.4829	12.0069	17.3990	381.5439	13285.7008	22.9711	5.2749	12.328

Feed Line/Linear Appurtenances - Entered As Area

Description	Face or Leg	Allow Shield	Component Type	Placement ft	Total Number		C _A A _A ft ² /ft	Weight plf
LDF7-50A(1-5/8)	C	No	Inside Pole	108.00 - 0.00	12	No Ice	0.00	0.82
						1/2" Ice	0.00	0.82
						1" Ice	0.00	0.82
**								
HB114-1-0813U4-M5J(1-1/4)	C	No	Inside Pole	100.00 - 0.00	3	No Ice	0.00	1.20
						1/2" Ice	0.00	1.20
						1" Ice	0.00	1.20
HB114-21U3M12-XXXF(1-1/4)	C	No	Inside Pole	100.00 - 0.00	1	No Ice	0.00	1.22
						1/2" Ice	0.00	1.22
						1" Ice	0.00	1.22

LDF7-50A(1-5/8)	C	No	Inside Pole	78.00 - 0.00	12	No Ice	0.00	0.82
						1/2" Ice	0.00	0.82
						1" Ice	0.00	0.82
FB-L98B-002-75000(3/8)	C	No	Inside Pole	78.00 - 0.00	1	No Ice	0.00	0.06
						1/2" Ice	0.00	0.06
						1" Ice	0.00	0.06
WR-VG122ST-BRDA(7/16)	C	No	Inside Pole	78.00 - 0.00	2	No Ice	0.00	0.14
						1/2" Ice	0.00	0.14
						1" Ice	0.00	0.14
2" (Nominal) Conduit	C	No	Inside Pole	78.00 - 0.00	1	No Ice	0.00	0.72
						1/2" Ice	0.00	0.72
						1" Ice	0.00	0.72
**								
LDF4-50A(1/2)	C	No	CaAa (Out Of Face)	50.00 - 0.00	1	No Ice	0.06	0.15
						1/2" Ice	0.16	0.84
						1" Ice	0.26	2.14
**								
Aero MP3-05	C	No	CaAa (Out Of Face)	81.58 - 0.00	1	No Ice	0.35	0.00
						1/2" Ice	0.40	0.00
						1" Ice	0.66	0.00

Feed Line/Linear Appurtenances Section Areas

Tower Section	Tower Elevation ft	Face	A_R ft ²	A_F ft ²	C_{AA} In Face ft ²	C_{AA} Out Face ft ²	Weight K
L1	109.86-99.00	A	0.000	0.000	0.000	0.000	0.00
		B	0.000	0.000	0.000	0.000	0.00
		C	0.000	0.000	0.000	0.000	0.09
L2	99.00-98.50	A	0.000	0.000	0.000	0.000	0.00
		B	0.000	0.000	0.000	0.000	0.00
		C	0.000	0.000	0.000	0.000	0.01
L3	98.50-79.33	A	0.000	0.000	0.000	0.000	0.00
		B	0.000	0.000	0.000	0.000	0.00
		C	0.000	0.000	0.000	0.783	0.28
L4	79.33-47.12	A	0.000	0.000	0.000	0.000	0.00
		B	0.000	0.000	0.000	0.000	0.00
		C	0.000	0.000	0.000	11.383	0.81
L5	47.12-14.83	A	0.000	0.000	0.000	0.000	0.00
		B	0.000	0.000	0.000	0.000	0.00
		C	0.000	0.000	0.000	13.248	0.83
L6	14.83-13.83	A	0.000	0.000	0.000	0.000	0.00
		B	0.000	0.000	0.000	0.000	0.00
		C	0.000	0.000	0.000	0.410	0.03
L7	13.83-6.00	A	0.000	0.000	0.000	0.000	0.00
		B	0.000	0.000	0.000	0.000	0.00
		C	0.000	0.000	0.000	3.213	0.20
L8	6.00-3.33	A	0.000	0.000	0.000	0.000	0.00
		B	0.000	0.000	0.000	0.000	0.00
		C	0.000	0.000	0.000	1.095	0.07
L9	3.33-0.00	A	0.000	0.000	0.000	0.000	0.00
		B	0.000	0.000	0.000	0.000	0.00
		C	0.000	0.000	0.000	1.366	0.09

Feed Line/Linear Appurtenances Section Areas - With Ice

Tower Section	Tower Elevation ft	Face or Leg	Ice Thickness in	A_R ft ²	A_F ft ²	C_{AA} In Face ft ²	C_{AA} Out Face ft ²	Weight K
L1	109.86-99.00	A	2.244	0.000	0.000	0.000	0.000	0.00
		B		0.000	0.000	0.000	0.000	0.00
		C		0.000	0.000	0.000	0.000	0.09
L2	99.00-98.50	A	2.232	0.000	0.000	0.000	0.000	0.00
		B		0.000	0.000	0.000	0.000	0.00
		C		0.000	0.000	0.000	0.000	0.01
L3	98.50-79.33	A	2.208	0.000	0.000	0.000	0.000	0.00
		B		0.000	0.000	0.000	0.000	0.00
		C		0.000	0.000	0.000	2.081	0.28
L4	79.33-47.12	A	2.133	0.000	0.000	0.000	0.000	0.00
		B		0.000	0.000	0.000	0.000	0.00
		C		0.000	0.000	0.000	30.662	0.83
L5	47.12-14.83	A	1.986	0.000	0.000	0.000	0.000	0.00
		B		0.000	0.000	0.000	0.000	0.00
		C		0.000	0.000	0.000	45.117	1.07
L6	14.83-13.83	A	1.840	0.000	0.000	0.000	0.000	0.00
		B		0.000	0.000	0.000	0.000	0.00
		C		0.000	0.000	0.000	1.274	0.03
L7	13.83-6.00	A	1.773	0.000	0.000	0.000	0.000	0.00
		B		0.000	0.000	0.000	0.000	0.00
		C		0.000	0.000	0.000	9.751	0.24
L8	6.00-3.33	A	1.644	0.000	0.000	0.000	0.000	0.00
		B		0.000	0.000	0.000	0.000	0.00
		C		0.000	0.000	0.000	3.180	0.08
L9	3.33-0.00	A	1.483	0.000	0.000	0.000	0.000	0.00
		B		0.000	0.000	0.000	0.000	0.00
		C		0.000	0.000	0.000	3.740	0.10

Feed Line Center of Pressure

Section	Elevation	CP _x	CP _z	CP _x Ice	CP _z Ice
	ft	in	in	in	in
L1	109.86-99.00	0.0000	0.0000	0.0000	0.0000
L2	99.00-98.50	0.0000	0.0000	0.0000	0.0000
L3	98.50-79.33	-0.0556	0.0321	-0.1149	0.0663
L4	79.33-47.12	-0.3818	0.2204	-0.7249	0.4185
L5	47.12-14.83	-0.4475	0.2584	-1.0281	0.5936
L6	14.83-13.83	-0.4548	0.2626	-1.0228	0.5905
L7	13.83-6.00	-0.4564	0.2635	-1.0192	0.5885
L8	6.00-3.33	-0.4583	0.2646	-1.0031	0.5791
L9	3.33-0.00	-0.4593	0.2652	-0.9726	0.5615

Discrete Tower Loads

Description	Face or Leg	Offset Type	Offsets: Horz Lateral Vert ft ft ft	Azimuth Adjustment °	Placement ft	C _{AA} Front ft ²	C _{AA} Side ft ²	Weight K	
BXA-171085-8BF-EDIN-2 w/ Mount Pipe	A	From Leg	4.00	0.00	108.00	No Ice	3.18	3.35	0.03
			0.00			1/2" Ice	3.56	3.97	0.06
			0.00			1" Ice	3.93	4.60	0.10
BXA-171085-8BF-EDIN-2 w/ Mount Pipe	B	From Leg	4.00	0.00	108.00	No Ice	3.18	3.35	0.03
			0.00			1/2" Ice	3.56	3.97	0.06
			0.00			1" Ice	3.93	4.60	0.10
BXA-171063-8BF-2 w/ Mount Pipe	C	From Leg	4.00	0.00	108.00	No Ice	3.18	3.35	0.03
			0.00			1/2" Ice	3.56	3.97	0.06
			0.00			1" Ice	3.93	4.60	0.10
BXA-70063/6CF-2 w/ Mount Pipe	A	From Leg	4.00	0.00	108.00	No Ice	7.81	5.40	0.04
			0.00			1/2" Ice	8.36	6.55	0.10
			0.00			1" Ice	8.87	7.41	0.17
BXA-70063/6CF-2 w/ Mount Pipe	B	From Leg	4.00	0.00	108.00	No Ice	7.81	5.40	0.04
			0.00			1/2" Ice	8.36	6.55	0.10
			0.00			1" Ice	8.87	7.41	0.17
BXA-70063/6CF-2 w/ Mount Pipe	C	From Leg	4.00	0.00	108.00	No Ice	7.81	5.40	0.04
			0.00			1/2" Ice	8.36	6.55	0.10
			0.00			1" Ice	8.87	7.41	0.17
BXA-80080/4CF w/ Mount Pipe	A	From Leg	4.00	0.00	108.00	No Ice	5.04	4.03	0.03
			0.00			1/2" Ice	5.42	4.65	0.08
			0.00			1" Ice	5.81	5.28	0.13
BXA-80080/4CF w/ Mount Pipe	B	From Leg	4.00	0.00	108.00	No Ice	5.04	4.03	0.03
			0.00			1/2" Ice	5.42	4.65	0.08
			0.00			1" Ice	5.81	5.28	0.13
BXA-80063/4CFx5 w/ Mount Pipe	C	From Leg	4.00	0.00	108.00	No Ice	4.95	3.62	0.03
			0.00			1/2" Ice	5.32	4.22	0.07
			0.00			1" Ice	5.71	4.83	0.12
(2) FD9R6004/2C-3L	A	From Leg	4.00	0.00	108.00	No Ice	0.31	0.08	0.00
			0.00			1/2" Ice	0.39	0.12	0.01
			0.00			1" Ice	0.47	0.17	0.01
(2) FD9R6004/2C-3L	B	From Leg	4.00	0.00	108.00	No Ice	0.31	0.08	0.00
			0.00			1/2" Ice	0.39	0.12	0.01
			0.00			1" Ice	0.47	0.17	0.01
(2) FD9R6004/2C-3L	C	From Leg	4.00	0.00	108.00	No Ice	0.31	0.08	0.00
			0.00			1/2" Ice	0.39	0.12	0.01
			0.00			1" Ice	0.47	0.17	0.01
2.375" OD x 6' Mount Pipe	A	From Leg	4.00	0.00	108.00	No Ice	1.43	1.43	0.03
			0.00			1/2" Ice	1.92	1.92	0.04
			0.00			1" Ice	2.29	2.29	0.05
2.375" OD x 6' Mount Pipe	B	From Leg	4.00	0.00	108.00	No Ice	1.43	1.43	0.03
			0.00			1/2" Ice	1.92	1.92	0.04
			0.00			1" Ice	2.29	2.29	0.05
2.375" OD x 6' Mount Pipe	C	From Leg	4.00	0.00	108.00	No Ice	1.43	1.43	0.03
			0.00			1/2" Ice	1.92	1.92	0.04
			0.00			1" Ice	2.29	2.29	0.05

Description	Face or Leg	Offset Type	Offsets:			Azimuth Adjustment	Placement	C _{AA} _{Front}	C _{AA} _{Side}	Weight	
			Horz	Lateral	Vert						°
			ft	ft	ft						
T-Arm Mount [TA 602-3]	C	None				0.00	108.00	No Ice 1/2" Ice 1" Ice	11.59 15.44 19.29	11.59 15.44 19.29	0.77 0.99 1.21

APXVSP18-C-A20 w/ Mount Pipe	A	From Leg	4.00 0.00 3.00			0.00	100.00	No Ice 1/2" Ice 1" Ice	8.26 8.82 9.35	6.95 8.13 9.02	0.08 0.15 0.23
APXV9ERR18-C-A20 w/ Mount Pipe	B	From Leg	4.00 0.00 3.00			0.00	100.00	No Ice 1/2" Ice 1" Ice	8.26 8.82 9.35	7.47 8.66 9.56	0.09 0.16 0.24
APXVSP18-C-A20 w/ Mount Pipe	C	From Leg	4.00 0.00 3.00			0.00	100.00	No Ice 1/2" Ice 1" Ice	8.26 8.82 9.35	6.95 8.13 9.02	0.08 0.15 0.23
(3) ACU-A20-N	A	From Leg	4.00 0.00 3.00			0.00	100.00	No Ice 1/2" Ice 1" Ice	0.07 0.10 0.15	0.12 0.16 0.21	0.00 0.00 0.00
(3) ACU-A20-N	B	From Leg	4.00 0.00 3.00			0.00	100.00	No Ice 1/2" Ice 1" Ice	0.07 0.10 0.15	0.12 0.16 0.21	0.00 0.00 0.00
(3) ACU-A20-N	C	From Leg	4.00 0.00 3.00			0.00	100.00	No Ice 1/2" Ice 1" Ice	0.07 0.10 0.15	0.12 0.16 0.21	0.00 0.00 0.00
APXVTM14-C-120 w/ Mount Pipe	A	From Leg	4.00 0.00 3.00			0.00	100.00	No Ice 1/2" Ice 1" Ice	6.58 7.03 7.47	4.96 5.75 6.47	0.08 0.13 0.19
APXVTM14-C-120 w/ Mount Pipe	B	From Leg	4.00 0.00 3.00			0.00	100.00	No Ice 1/2" Ice 1" Ice	6.58 7.03 7.47	4.96 5.75 6.47	0.08 0.13 0.19
APXVTM14-C-120 w/ Mount Pipe	C	From Leg	4.00 0.00 3.00			0.00	100.00	No Ice 1/2" Ice 1" Ice	6.58 7.03 7.47	4.96 5.75 6.47	0.08 0.13 0.19
TD-RRH8x20-25	A	From Leg	4.00 0.00 3.00			0.00	100.00	No Ice 1/2" Ice 1" Ice	4.05 4.30 4.56	1.53 1.71 1.90	0.07 0.10 0.13
TD-RRH8x20-25	B	From Leg	4.00 0.00 3.00			0.00	100.00	No Ice 1/2" Ice 1" Ice	4.05 4.30 4.56	1.53 1.71 1.90	0.07 0.10 0.13
TD-RRH8x20-25	C	From Leg	4.00 0.00 3.00			0.00	100.00	No Ice 1/2" Ice 1" Ice	4.05 4.30 4.56	1.53 1.71 1.90	0.07 0.10 0.13
(2) 2.375" OD x 6' Mount Pipe	A	From Leg	4.00 0.00 0.00			0.00	100.00	No Ice 1/2" Ice 1" Ice	1.43 1.92 2.29	1.43 1.92 2.29	0.03 0.04 0.05
(2) 2.375" OD x 6' Mount Pipe	B	From Leg	4.00 0.00 0.00			0.00	100.00	No Ice 1/2" Ice 1" Ice	1.43 1.92 2.29	1.43 1.92 2.29	0.03 0.04 0.05
(2) 2.375" OD x 6' Mount Pipe	C	From Leg	4.00 0.00 0.00			0.00	100.00	No Ice 1/2" Ice 1" Ice	1.43 1.92 2.29	1.43 1.92 2.29	0.03 0.04 0.05
Platform Mount [LP 601-1]	C	None				0.00	100.00	No Ice 1/2" Ice 1" Ice	28.47 33.59 38.71	28.47 33.59 38.71	1.12 1.51 1.91
Miscellaneous [NA 507-1]	C	None				0.00	100.00	No Ice 1/2" Ice 1" Ice	4.80 6.70 8.60	4.80 6.70 8.60	0.25 0.29 0.34

1900MHz RRH (65MHz)	A	From Leg	2.00 0.00 -1.00			0.00	98.00	No Ice 1/2" Ice 1" Ice	2.32 2.53 2.74	2.24 2.44 2.65	0.06 0.08 0.11
1900MHz RRH (65MHz)	B	From Leg	2.00 0.00 -1.00			0.00	98.00	No Ice 1/2" Ice 1" Ice	2.32 2.53 2.74	2.24 2.44 2.65	0.06 0.08 0.11
1900MHz RRH (65MHz)	C	From Leg	2.00 0.00 -1.00			0.00	98.00	No Ice 1/2" Ice 1" Ice	2.32 2.53 2.74	2.24 2.44 2.65	0.06 0.08 0.11

Description	Face or Leg	Offset Type	Offsets:		Azimuth Adjustment	Placement	C _{AA} _{Front}	C _{AA} _{Side}	Weight
			Horz	Lateral					
			ft	ft					
800MHZ RRH	A	From Leg	2.00	0.00	98.00	No Ice	2.13	1.77	0.05
			0.00			1/2" Ice	2.32	1.95	0.07
			1.00			1" Ice	2.51	2.13	0.10
800MHZ RRH	B	From Leg	2.00	0.00	98.00	No Ice	2.13	1.77	0.05
			0.00			1/2" Ice	2.32	1.95	0.07
			1.00			1" Ice	2.51	2.13	0.10
800MHZ RRH	C	From Leg	2.00	0.00	98.00	No Ice	2.13	1.77	0.05
			0.00			1/2" Ice	2.32	1.95	0.07
			1.00			1" Ice	2.51	2.13	0.10
2.375" OD x 4' Mount Pipe	A	From Leg	2.00	0.00	98.00	No Ice	0.87	0.87	0.02
			0.00			1/2" Ice	1.11	1.11	0.03
			0.00			1" Ice	1.36	1.36	0.04
2.375" OD x 4' Mount Pipe	B	From Leg	2.00	0.00	98.00	No Ice	0.87	0.87	0.02
			0.00			1/2" Ice	1.11	1.11	0.03
			0.00			1" Ice	1.36	1.36	0.04
2.375" OD x 4' Mount Pipe	C	From Leg	2.00	0.00	98.00	No Ice	0.87	0.87	0.02
			0.00			1/2" Ice	1.11	1.11	0.03
			0.00			1" Ice	1.36	1.36	0.04
Side Arm Mount [SO 701-3]	C	None		0.00	98.00	No Ice	2.83	2.83	0.20
						1/2" Ice	3.92	3.92	0.24
						1" Ice	5.01	5.01	0.28

(2) 7770.00 w/ Mount Pipe	A	From Leg	4.00	0.00	78.00	No Ice	5.83	4.73	0.09
			0.00			1/2" Ice	6.27	5.51	0.14
			0.00			1" Ice	6.70	6.21	0.21
(2) 7770.00 w/ Mount Pipe	B	From Leg	4.00	0.00	78.00	No Ice	5.83	4.73	0.09
			0.00			1/2" Ice	6.27	5.51	0.14
			0.00			1" Ice	6.70	6.21	0.21
(2) 7770.00 w/ Mount Pipe	C	From Leg	4.00	0.00	78.00	No Ice	5.83	4.73	0.09
			0.00			1/2" Ice	6.27	5.51	0.14
			0.00			1" Ice	6.70	6.21	0.21
AM-X-CD-16-65-00T-RET w/ Mount Pipe	A	From Leg	4.00	0.00	78.00	No Ice	8.26	6.30	0.07
			0.00			1/2" Ice	8.82	7.48	0.14
			0.00			1" Ice	9.35	8.37	0.21
AM-X-CD-14-65-00T-RET w/ Mount Pipe	B	From Leg	4.00	0.00	78.00	No Ice	5.23	4.02	0.05
			0.00			1/2" Ice	5.62	4.63	0.10
			0.00			1" Ice	6.01	5.26	0.15
AM-X-CD-16-65-00T-RET w/ Mount Pipe	C	From Leg	4.00	0.00	78.00	No Ice	8.26	6.30	0.07
			0.00			1/2" Ice	8.82	7.48	0.14
			0.00			1" Ice	9.35	8.37	0.21
(4) TMA-DD 1900	A	From Leg	4.00	0.00	78.00	No Ice	0.50	0.24	0.01
			0.00			1/2" Ice	0.59	0.31	0.01
			0.00			1" Ice	0.69	0.39	0.02
(4) TMA-DD 1900	B	From Leg	4.00	0.00	78.00	No Ice	0.50	0.24	0.01
			0.00			1/2" Ice	0.59	0.31	0.01
			0.00			1" Ice	0.69	0.39	0.02
(4) TMA-DD 1900	C	From Leg	4.00	0.00	78.00	No Ice	0.50	0.24	0.01
			0.00			1/2" Ice	0.59	0.31	0.01
			0.00			1" Ice	0.69	0.39	0.02
DC6-48-60-18-8F	B	From Leg	4.00	0.00	78.00	No Ice	0.92	0.92	0.02
			0.00			1/2" Ice	1.46	1.46	0.04
			0.00			1" Ice	1.64	1.64	0.06
T-Arm Mount [TA 602-3]	C	None		0.00	78.00	No Ice	11.59	11.59	0.77
						1/2" Ice	15.44	15.44	0.99
						1" Ice	19.29	19.29	1.21

(2) RRUS 11	A	From Leg	2.00	0.00	76.00	No Ice	2.79	1.19	0.05
			0.00			1/2" Ice	3.00	1.34	0.07
			0.00			1" Ice	3.21	1.50	0.10
(2) RRUS 11	B	From Leg	2.00	0.00	76.00	No Ice	2.79	1.19	0.05
			0.00			1/2" Ice	3.00	1.34	0.07
			0.00			1" Ice	3.21	1.50	0.10
(2) RRUS 11	C	From Leg	2.00	0.00	76.00	No Ice	2.79	1.19	0.05
			0.00			1/2" Ice	3.00	1.34	0.07
			0.00			1" Ice	3.21	1.50	0.10

Description	Face or Leg	Offset Type	Offsets:		Azimuth Adjustment	Placement	C _{AA} _{Front}	C _{AA} _{Side}	Weight	
			Horz	Lateral						Vert
			ft	ft	°	ft	ft ²	ft ²	K	
2.375" OD x 4' Mount Pipe	A	From Leg	2.00	0.00	0.00	76.00	No Ice	0.87	0.87	0.02
			0.00	0.00			1/2" Ice	1.11	1.11	0.03
			0.00	0.00			1" Ice	1.36	1.36	0.04
2.375" OD x 4' Mount Pipe	B	From Leg	2.00	0.00	0.00	76.00	No Ice	0.87	0.87	0.02
			0.00	0.00			1/2" Ice	1.11	1.11	0.03
			0.00	0.00			1" Ice	1.36	1.36	0.04
2.375" OD x 4' Mount Pipe	C	From Leg	2.00	0.00	0.00	76.00	No Ice	0.87	0.87	0.02
			0.00	0.00			1/2" Ice	1.11	1.11	0.03
			0.00	0.00			1" Ice	1.36	1.36	0.04
Side Arm Mount [SO 701-3]	C	None			0.00	76.00	No Ice	2.83	2.83	0.20
							1/2" Ice	3.92	3.92	0.24
							1" Ice	5.01	5.01	0.28

KS24019-L112A	B	From Leg	3.00	0.00	0.00	50.00	No Ice	0.14	0.14	0.01
			0.00	0.00			1/2" Ice	0.20	0.20	0.01
			1.00	0.00			1" Ice	0.26	0.26	0.01
Side Arm Mount [SO 701-1]	B	From Leg	1.50	0.00	0.00	50.00	No Ice	0.85	1.67	0.07
			0.00	0.00			1/2" Ice	1.14	2.34	0.08
			0.00	0.00			1" Ice	1.43	3.01	0.09

Tower Pressures - No Ice

$G_H = 1.100$

Section Elevation	z	K _z	q _z	A _G	F a c e	A _F	A _R	A _{leg}	Leg %	C _{AA} _{In} Face	C _{AA} _{Out} Face
ft	ft		psf	ft ²		ft ²	ft ²	ft ²		ft ²	ft ²
L1 109.86-99.00	104.28	1.277	26.86	12.720	A	0.000	12.720	12.720	100.00	0.000	0.000
					B	0.000	12.720	100.00	0.000	0.000	
					C	0.000	12.720	100.00	0.000	0.000	
L2 99.00-98.50	98.75	1.262	26.55	0.645	A	0.000	0.645	0.645	100.00	0.000	0.000
					B	0.000	0.645	100.00	0.000	0.000	
					C	0.000	0.645	100.00	0.000	0.000	
L3 98.50-79.33	88.57	1.234	25.95	28.181	A	0.000	28.181	28.181	100.00	0.000	0.000
					B	0.000	28.181	100.00	0.000	0.000	
					C	0.000	28.181	100.00	0.000	0.783	
L4 79.33-47.12	62.69	1.147	24.08	61.034	A	0.000	61.034	61.034	100.00	0.000	0.000
					B	0.000	61.034	100.00	0.000	0.000	
					C	0.000	61.034	100.00	0.000	11.383	
L5 47.12-14.83	30.79	0.988	20.59	76.616	A	0.000	76.616	76.616	100.00	0.000	0.000
					B	0.000	76.616	100.00	0.000	0.000	
					C	0.000	76.616	100.00	0.000	13.248	
L6 14.83-13.83	14.33	0.85	17.88	2.664	A	0.000	2.664	2.664	100.00	0.000	0.000
					B	0.000	2.664	100.00	0.000	0.000	
					C	0.000	2.664	100.00	0.000	0.410	
L7 13.83-6.00	9.88	0.85	17.88	21.425	A	0.000	21.425	21.425	100.00	0.000	0.000
					B	0.000	21.425	100.00	0.000	0.000	
					C	0.000	21.425	100.00	0.000	3.213	
L8 6.00-3.33	4.66	0.85	17.88	7.535	A	0.000	7.535	7.535	100.00	0.000	0.000
					B	0.000	7.535	100.00	0.000	0.000	
					C	0.000	7.535	100.00	0.000	1.095	
L9 3.33-0.00	1.66	0.85	17.88	9.560	A	0.000	9.560	9.560	100.00	0.000	0.000
					B	0.000	9.560	100.00	0.000	0.000	
					C	0.000	9.560	100.00	0.000	1.366	

Tower Pressure - With Ice

$G_H = 1.100$

Section Elevation ft	z ft	K_z	q_z psf	t_z in	A_G ft ²	F a c e	A_F ft ²	A_R ft ²	A_{leg} ft ²	Leg %	$C_A A_A$ In Face ft ²	$C_A A_A$ Out Face ft ²
L1 109.86-99.00	104.28	1.277	4.97	2.2439	16.782	A	0.000	16.782	16.782	100.00	0.000	0.000
						B	0.000	16.782	100.00	0.000	0.000	
						C	0.000	16.782	100.00	0.000	0.000	
L2 99.00-98.50	98.75	1.262	4.91	2.2317	0.831	A	0.000	0.831	0.831	100.00	0.000	0.000
						B	0.000	0.831	100.00	0.000	0.000	
						C	0.000	0.831	100.00	0.000	0.000	
L3 98.50-79.33	88.57	1.234	4.80	2.2075	35.235	A	0.000	35.235	35.235	100.00	0.000	0.000
						B	0.000	35.235	100.00	0.000	0.000	
						C	0.000	35.235	100.00	0.000	2.081	
L4 79.33-47.12	62.69	1.147	4.45	2.1325	72.482	A	0.000	72.482	72.482	100.00	0.000	0.000
						B	0.000	72.482	100.00	0.000	0.000	
						C	0.000	72.482	100.00	0.000	30.662	
L5 47.12-14.83	30.79	0.988	3.81	1.9862	88.093	A	0.000	88.093	88.093	100.00	0.000	0.000
						B	0.000	88.093	100.00	0.000	0.000	
						C	0.000	88.093	100.00	0.000	45.117	
L6 14.83-13.83	14.33	0.85	3.31	1.8399	2.971	A	0.000	2.971	2.971	100.00	0.000	0.000
						B	0.000	2.971	100.00	0.000	0.000	
						C	0.000	2.971	100.00	0.000	1.274	
L7 13.83-6.00	9.88	0.85	3.31	1.7729	23.739	A	0.000	23.739	23.739	100.00	0.000	0.000
						B	0.000	23.739	100.00	0.000	0.000	
						C	0.000	23.739	100.00	0.000	9.751	
L8 6.00-3.33	4.66	0.85	3.31	1.6445	8.267	A	0.000	8.267	8.267	100.00	0.000	0.000
						B	0.000	8.267	100.00	0.000	0.000	
						C	0.000	8.267	100.00	0.000	3.180	
L9 3.33-0.00	1.66	0.85	3.31	1.4831	10.384	A	0.000	10.384	10.384	100.00	0.000	0.000
						B	0.000	10.384	100.00	0.000	0.000	
						C	0.000	10.384	100.00	0.000	3.740	

Tower Pressure - Service

$G_H = 1.100$

Section Elevation ft	z ft	K_z	q_z psf	A_G ft ²	F a c e	A_F ft ²	A_R ft ²	A_{leg} ft ²	Leg %	$C_A A_A$ In Face ft ²	$C_A A_A$ Out Face ft ²
L1 109.86-99.00	104.28	1.277	10.00	12.720	A	0.000	12.720	12.720	100.00	0.000	0.000
					B	0.000	12.720	100.00	0.000	0.000	
					C	0.000	12.720	100.00	0.000	0.000	
L2 99.00-98.50	98.75	1.262	9.89	0.645	A	0.000	0.645	0.645	100.00	0.000	0.000
					B	0.000	0.645	100.00	0.000	0.000	
					C	0.000	0.645	100.00	0.000	0.000	
L3 98.50-79.33	88.57	1.234	9.66	28.181	A	0.000	28.181	28.181	100.00	0.000	0.000
					B	0.000	28.181	100.00	0.000	0.000	
					C	0.000	28.181	100.00	0.000	0.783	
L4 79.33-47.12	62.69	1.147	8.97	61.034	A	0.000	61.034	61.034	100.00	0.000	0.000
					B	0.000	61.034	100.00	0.000	0.000	
					C	0.000	61.034	100.00	0.000	11.383	
L5 47.12-14.83	30.79	0.988	7.67	76.616	A	0.000	76.616	76.616	100.00	0.000	0.000
					B	0.000	76.616	100.00	0.000	0.000	
					C	0.000	76.616	100.00	0.000	13.248	
L6 14.83-13.83	14.33	0.85	6.66	2.664	A	0.000	2.664	2.664	100.00	0.000	0.000
					B	0.000	2.664	100.00	0.000	0.000	
					C	0.000	2.664	100.00	0.000	0.410	
L7 13.83-6.00	9.88	0.85	6.66	21.425	A	0.000	21.425	21.425	100.00	0.000	0.000
					B	0.000	21.425	100.00	0.000	0.000	
					C	0.000	21.425	100.00	0.000	3.213	
L8 6.00-3.33	4.66	0.85	6.66	7.535	A	0.000	7.535	7.535	100.00	0.000	0.000
					B	0.000	7.535	100.00	0.000	0.000	
					C	0.000	7.535	100.00	0.000	1.095	

Section Elevation ft	z ft	K_z	q_z psf	A_G ft ²	F a c e	A_F ft ²	A_R ft ²	A_{leg} ft ²	Leg %	$C_A A_A$ In Face ft ²	$C_A A_A$ Out Face ft ²
L9 3.33-0.00	1.66	0.85	6.66	9.560	A	0.000	9.560	9.560	100.00	0.000	0.000
					B	0.000	9.560		100.00	0.000	0.000
					C	0.000	9.560		100.00	0.000	1.366

Load Combinations

Comb. No.	Description
1	Dead Only
2	1.2 Dead+1.6 Wind 0 deg - No Ice
3	0.9 Dead+1.6 Wind 0 deg - No Ice
4	1.2 Dead+1.6 Wind 30 deg - No Ice
5	0.9 Dead+1.6 Wind 30 deg - No Ice
6	1.2 Dead+1.6 Wind 60 deg - No Ice
7	0.9 Dead+1.6 Wind 60 deg - No Ice
8	1.2 Dead+1.6 Wind 90 deg - No Ice
9	0.9 Dead+1.6 Wind 90 deg - No Ice
10	1.2 Dead+1.6 Wind 120 deg - No Ice
11	0.9 Dead+1.6 Wind 120 deg - No Ice
12	1.2 Dead+1.6 Wind 150 deg - No Ice
13	0.9 Dead+1.6 Wind 150 deg - No Ice
14	1.2 Dead+1.6 Wind 180 deg - No Ice
15	0.9 Dead+1.6 Wind 180 deg - No Ice
16	1.2 Dead+1.6 Wind 210 deg - No Ice
17	0.9 Dead+1.6 Wind 210 deg - No Ice
18	1.2 Dead+1.6 Wind 240 deg - No Ice
19	0.9 Dead+1.6 Wind 240 deg - No Ice
20	1.2 Dead+1.6 Wind 270 deg - No Ice
21	0.9 Dead+1.6 Wind 270 deg - No Ice
22	1.2 Dead+1.6 Wind 300 deg - No Ice
23	0.9 Dead+1.6 Wind 300 deg - No Ice
24	1.2 Dead+1.6 Wind 330 deg - No Ice
25	0.9 Dead+1.6 Wind 330 deg - No Ice
26	1.2 Dead+1.0 Ice+1.0 Temp
27	1.2 Dead+1.0 Wind 0 deg+1.0 Ice+1.0 Temp
28	1.2 Dead+1.0 Wind 30 deg+1.0 Ice+1.0 Temp
29	1.2 Dead+1.0 Wind 60 deg+1.0 Ice+1.0 Temp
30	1.2 Dead+1.0 Wind 90 deg+1.0 Ice+1.0 Temp
31	1.2 Dead+1.0 Wind 120 deg+1.0 Ice+1.0 Temp
32	1.2 Dead+1.0 Wind 150 deg+1.0 Ice+1.0 Temp
33	1.2 Dead+1.0 Wind 180 deg+1.0 Ice+1.0 Temp
34	1.2 Dead+1.0 Wind 210 deg+1.0 Ice+1.0 Temp
35	1.2 Dead+1.0 Wind 240 deg+1.0 Ice+1.0 Temp
36	1.2 Dead+1.0 Wind 270 deg+1.0 Ice+1.0 Temp
37	1.2 Dead+1.0 Wind 300 deg+1.0 Ice+1.0 Temp
38	1.2 Dead+1.0 Wind 330 deg+1.0 Ice+1.0 Temp
39	Dead+Wind 0 deg - Service
40	Dead+Wind 30 deg - Service
41	Dead+Wind 60 deg - Service
42	Dead+Wind 90 deg - Service
43	Dead+Wind 120 deg - Service
44	Dead+Wind 150 deg - Service
45	Dead+Wind 180 deg - Service
46	Dead+Wind 210 deg - Service
47	Dead+Wind 240 deg - Service
48	Dead+Wind 270 deg - Service
49	Dead+Wind 300 deg - Service
50	Dead+Wind 330 deg - Service

Maximum Member Forces

Section No.	Elevation ft	Component Type	Condition	Gov. Load Comb.	Axial K	Major Axis Moment kip-ft	Minor Axis Moment kip-ft
L1	109.86 - 99	Pole	Max Tension	14	0.00	-0.00	0.00
			Max. Compression	26	-13.96	-0.14	-0.00
			Max. Mx	8	-3.83	-35.31	0.06
			Max. My	14	-3.83	0.05	-35.27
			Max. Vy	8	7.12	-35.31	0.06
			Max. Vx	14	7.13	0.05	-35.27
			Max. Torque	2			-0.14
L2	99 - 98.5	Pole	Max Tension	1	0.00	0.00	0.00
			Max. Compression	26	-14.02	-0.14	-0.00
			Max. Mx	8	-3.86	-38.87	0.07
			Max. My	14	-3.86	0.06	-38.84
			Max. Vy	8	7.14	-38.87	0.07
			Max. Vx	14	7.15	0.06	-38.84
			Max. Torque	2			-0.14
L3	98.5 - 79.33	Pole	Max Tension	1	0.00	0.00	0.00
			Max. Compression	26	-18.01	-0.14	-0.00
			Max. Mx	8	-5.75	-198.65	0.35
			Max. My	14	-5.75	0.36	-198.69
			Max. Vy	8	8.78	-198.65	0.35
			Max. Vx	14	8.79	0.36	-198.69
			Max. Torque	2			-0.14
L4	79.33 - 47.12	Pole	Max Tension	1	0.00	0.00	0.00
			Max. Compression	26	-32.16	-0.10	-0.00
			Max. Mx	8	-12.75	-568.76	1.09
			Max. My	14	-12.75	1.08	-569.29
			Max. Vy	8	14.30	-568.76	1.09
			Max. Vx	14	14.32	1.08	-569.29
			Max. Torque	15			-0.42
L5	47.12 - 14.83	Pole	Max Tension	1	0.00	0.00	0.00
			Max. Compression	26	-42.78	-0.22	-0.36
			Max. Mx	8	-20.66	-1131.53	2.45
			Max. My	14	-20.66	2.36	-1133.22
			Max. Vy	8	16.79	-1131.53	2.45
			Max. Vx	14	16.82	2.36	-1133.22
			Max. Torque	13			-0.94
L6	14.83 - 13.83	Pole	Max Tension	1	0.00	0.00	0.00
			Max. Compression	26	-43.11	-0.21	-0.37
			Max. Mx	8	-20.93	-1148.33	2.49
			Max. My	14	-20.93	2.40	-1150.05
			Max. Vy	8	16.84	-1148.33	2.49
			Max. Vx	14	16.87	2.40	-1150.05
			Max. Torque	13			-0.95
L7	13.83 - 6	Pole	Max Tension	1	0.00	0.00	0.00
			Max. Compression	26	-45.41	-0.16	-0.40
			Max. Mx	8	-22.73	-1281.68	2.81
			Max. My	14	-22.73	2.71	-1283.67
			Max. Vy	8	17.25	-1281.68	2.81
			Max. Vx	14	17.28	2.71	-1283.67
			Max. Torque	13			-1.09
L8	6 - 3.33	Pole	Max Tension	1	0.00	0.00	0.00
			Max. Compression	26	-46.29	-0.14	-0.41
			Max. Mx	8	-23.45	-1327.90	2.91
			Max. My	14	-23.45	2.82	-1329.97
			Max. Vy	8	17.40	-1327.90	2.91
			Max. Vx	14	17.43	2.82	-1329.97
			Max. Torque	13			-1.14
L9	3.33 - 0	Pole	Max Tension	1	0.00	0.00	0.00
			Max. Compression	26	-47.24	-0.13	-0.42
			Max. Mx	8	-24.23	-1386.07	3.05
			Max. My	14	-24.23	2.95	-1388.25
			Max. Vy	8	17.57	-1386.07	3.05
			Max. Vx	14	17.60	2.95	-1388.25
			Max. Torque	13			-1.20

Maximum Reactions

Location	Condition	Gov. Load Comb.	Vertical K	Horizontal, X K	Horizontal, Z K
Pole	Max. Vert	26	47.24	-0.00	-0.00
	Max. H _x	21	18.18	17.55	-0.04
	Max. H _z	3	18.18	-0.04	17.59
	Max. M _x	2	1387.95	-0.04	17.59
	Max. M _z	8	1386.07	-17.55	0.04
	Max. Torsion	25	1.20	8.74	15.21
	Min. Vert	15	18.18	0.04	-17.59
	Min. H _x	9	18.18	-17.55	0.04
	Min. H _z	15	18.18	0.04	-17.59
	Min. M _x	14	-1388.25	0.04	-17.59
	Min. M _z	20	-1385.58	17.55	-0.04
	Min. Torsion	13	-1.20	-8.74	-15.21

Tower Mast Reaction Summary

Load Combination	Vertical K	Shear _x K	Shear _z K	Overturning Moment, M _x kip-ft	Overturning Moment, M _z kip-ft	Torque kip-ft
Dead Only	20.20	0.00	0.00	0.12	-0.19	0.00
1.2 Dead+1.6 Wind 0 deg - No Ice	24.24	0.04	-17.59	-1387.95	-3.45	-1.01
0.9 Dead+1.6 Wind 0 deg - No Ice	18.18	0.04	-17.59	-1373.01	-3.35	-1.01
1.2 Dead+1.6 Wind 30 deg - No Ice	24.24	8.81	-15.25	-1203.76	-696.03	-0.56
0.9 Dead+1.6 Wind 30 deg - No Ice	18.18	8.81	-15.25	-1190.74	-688.42	-0.56
1.2 Dead+1.6 Wind 60 deg - No Ice	24.24	15.22	-8.83	-696.78	-1202.18	0.05
0.9 Dead+1.6 Wind 60 deg - No Ice	18.18	15.22	-8.83	-689.26	-1189.08	0.05
1.2 Dead+1.6 Wind 90 deg - No Ice	24.24	17.55	-0.04	-3.05	-1386.07	0.64
0.9 Dead+1.6 Wind 90 deg - No Ice	18.18	17.55	-0.04	-3.05	-1371.04	0.64
1.2 Dead+1.6 Wind 120 deg - No Ice	24.24	15.18	8.76	691.55	-1199.00	1.06
0.9 Dead+1.6 Wind 120 deg - No Ice	18.18	15.18	8.76	684.01	-1185.93	1.06
1.2 Dead+1.6 Wind 150 deg - No Ice	24.24	8.74	15.21	1200.88	-690.50	1.20
0.9 Dead+1.6 Wind 150 deg - No Ice	18.18	8.74	15.21	1187.81	-682.95	1.20
1.2 Dead+1.6 Wind 180 deg - No Ice	24.24	-0.04	17.59	1388.25	2.95	1.01
0.9 Dead+1.6 Wind 180 deg - No Ice	18.18	-0.04	17.59	1373.23	2.98	1.02
1.2 Dead+1.6 Wind 210 deg - No Ice	24.24	-8.81	15.25	1204.07	695.54	0.56
0.9 Dead+1.6 Wind 210 deg - No Ice	18.18	-8.81	15.25	1190.97	688.05	0.56
1.2 Dead+1.6 Wind 240 deg - No Ice	24.24	-15.22	8.83	697.08	1201.70	-0.05
0.9 Dead+1.6 Wind 240 deg - No Ice	18.18	-15.22	8.83	689.48	1188.72	-0.05
1.2 Dead+1.6 Wind 270 deg - No Ice	24.24	-17.55	0.04	3.35	1385.58	-0.64
0.9 Dead+1.6 Wind 270 deg - No Ice	18.18	-17.55	0.04	3.28	1370.68	-0.64
1.2 Dead+1.6 Wind 300 deg - No Ice	24.24	-15.18	-8.76	-691.25	1198.51	-1.06
0.9 Dead+1.6 Wind 300 deg - No Ice	18.18	-15.18	-8.76	-683.79	1185.56	-1.06
1.2 Dead+1.6 Wind 330 deg - No Ice	24.24	-8.74	-15.21	-1200.58	690.01	-1.20
0.9 Dead+1.6 Wind 330 deg - No Ice	18.18	-8.74	-15.21	-1187.59	682.58	-1.20
1.2 Dead+1.0 Ice+1.0 Temp	47.24	0.00	0.00	0.42	-0.13	0.00
1.2 Dead+1.0 Wind 0 deg+1.0 Ice+1.0 Temp	47.24	0.01	-4.21	-355.24	-0.68	-0.36
1.2 Dead+1.0 Wind 30 deg+1.0 Ice+1.0 Temp	47.24	2.11	-3.65	-307.83	-178.30	-0.19
1.2 Dead+1.0 Wind 60 deg+1.0 Ice+1.0 Temp	47.24	3.65	-2.11	-177.82	-308.19	0.03
1.2 Dead+1.0 Wind 90 deg+1.0 Ice+1.0 Temp	47.24	4.21	-0.01	-0.04	-355.55	0.24
1.2 Dead+1.0 Wind 120 deg+1.0 Ice+1.0 Temp	47.24	3.64	2.10	177.88	-307.70	0.39
1.2 Dead+1.0 Wind 150 deg+1.0 Ice+1.0 Temp	47.24	2.10	3.65	308.26	-177.44	0.43
1.2 Dead+1.0 Wind 180 deg+1.0 Ice+1.0 Temp	47.24	-0.01	4.21	356.16	0.31	0.36
1.2 Dead+1.0 Wind 210 deg+1.0 Ice+1.0 Temp	47.24	-2.11	3.65	308.75	177.93	0.19
1.2 Dead+1.0 Wind 240 deg+1.0 Ice+1.0 Temp	47.24	-3.65	2.11	178.74	307.82	-0.03
1.2 Dead+1.0 Wind 270 deg+1.0 Ice+1.0 Temp	47.24	-4.21	0.01	0.95	355.18	-0.24
1.2 Dead+1.0 Wind 300 deg+1.0 Ice+1.0 Temp	47.24	-3.64	-2.10	-176.96	307.33	-0.39
1.2 Dead+1.0 Wind 330 deg+1.0 Ice+1.0 Temp	47.24	-2.10	-3.65	-307.34	177.07	-0.43
Dead+Wind 0 deg - Service	20.20	0.01	-4.09	-321.08	-0.94	0.03
Dead+Wind 30 deg - Service	20.20	2.05	-3.55	-278.42	-161.18	0.02
Dead+Wind 60 deg - Service	20.20	3.54	-2.05	-161.12	-278.29	0.01
Dead+Wind 90 deg - Service	20.20	4.09	-0.01	-0.61	-320.88	-0.00
Dead+Wind 120 deg - Service	20.20	3.53	2.04	160.09	-277.55	-0.01
Dead+Wind 150 deg - Service	20.20	2.03	3.54	277.93	-159.90	-0.02
Dead+Wind 180 deg - Service	20.20	-0.01	4.09	321.34	0.54	-0.03

Load Combination	Vertical	Shear _x	Shear _z	Overtuning Moment, M _x	Overtuning Moment, M _z	Torque
	K	K	K	kip-ft	kip-ft	kip-ft
Dead+Wind 210 deg - Service	20.20	-2.05	3.55	278.67	160.78	-0.02
Dead+Wind 240 deg - Service	20.20	-3.54	2.05	161.37	277.89	-0.01
Dead+Wind 270 deg - Service	20.20	-4.09	0.01	0.87	320.48	0.00
Dead+Wind 300 deg - Service	20.20	-3.53	-2.04	-159.84	277.15	0.01
Dead+Wind 330 deg - Service	20.20	-2.03	-3.54	-277.68	159.50	0.02

Solution Summary

Load Comb.	Sum of Applied Forces			Sum of Reactions			% Error
	PX K	PY K	PZ K	PX K	PY K	PZ K	
1	0.00	-20.20	0.00	-0.00	20.20	-0.00	0.000%
2	0.04	-24.24	-17.59	-0.04	24.24	17.59	0.008%
3	0.04	-18.18	-17.59	-0.04	18.18	17.59	0.006%
4	8.81	-24.24	-15.25	-8.81	24.24	15.25	0.000%
5	8.81	-18.18	-15.25	-8.81	18.18	15.25	0.000%
6	15.22	-24.24	-8.83	-15.22	24.24	8.83	0.000%
7	15.22	-18.18	-8.83	-15.22	18.18	8.83	0.000%
8	17.55	-24.24	-0.04	-17.55	24.24	0.04	0.008%
9	17.55	-18.18	-0.04	-17.55	18.18	0.04	0.006%
10	15.18	-24.24	8.76	-15.18	24.24	-8.76	0.000%
11	15.18	-18.18	8.76	-15.18	18.18	-8.76	0.000%
12	8.74	-24.24	15.21	-8.74	24.24	-15.21	0.000%
13	8.74	-18.18	15.21	-8.74	18.18	-15.21	0.000%
14	-0.04	-24.24	17.59	0.04	24.24	-17.59	0.008%
15	-0.04	-18.18	17.59	0.04	18.18	-17.59	0.006%
16	-8.81	-24.24	15.25	8.81	24.24	-15.25	0.000%
17	-8.81	-18.18	15.25	8.81	18.18	-15.25	0.000%
18	-15.22	-24.24	8.83	15.22	24.24	-8.83	0.000%
19	-15.22	-18.18	8.83	15.22	18.18	-8.83	0.000%
20	-17.55	-24.24	0.04	17.55	24.24	-0.04	0.008%
21	-17.55	-18.18	0.04	17.55	18.18	-0.04	0.006%
22	-15.18	-24.24	-8.76	15.18	24.24	8.76	0.000%
23	-15.18	-18.18	-8.76	15.18	18.18	8.76	0.000%
24	-8.74	-24.24	-15.21	8.74	24.24	15.21	0.000%
25	-8.74	-18.18	-15.21	8.74	18.18	15.21	0.000%
26	0.00	-47.24	0.00	-0.00	47.24	-0.00	0.000%
27	0.01	-47.24	-4.21	-0.01	47.24	4.21	0.001%
28	2.11	-47.24	-3.65	-2.11	47.24	3.65	0.001%
29	3.65	-47.24	-2.11	-3.65	47.24	2.11	0.001%
30	4.21	-47.24	-0.01	-4.21	47.24	0.01	0.001%
31	3.64	-47.24	2.10	-3.64	47.24	-2.10	0.001%
32	2.10	-47.24	3.65	-2.10	47.24	-3.65	0.001%
33	-0.01	-47.24	4.21	0.01	47.24	-4.21	0.001%
34	-2.11	-47.24	3.65	2.11	47.24	-3.65	0.001%
35	-3.65	-47.24	2.11	3.65	47.24	-2.11	0.001%
36	-4.21	-47.24	0.01	4.21	47.24	-0.01	0.001%
37	-3.64	-47.24	-2.10	3.64	47.24	2.10	0.001%
38	-2.10	-47.24	-3.65	2.10	47.24	3.65	0.001%
39	0.01	-20.20	-4.09	-0.01	20.20	4.09	0.004%
40	2.05	-20.20	-3.55	-2.05	20.20	3.55	0.004%
41	3.54	-20.20	-2.05	-3.54	20.20	2.05	0.004%
42	4.09	-20.20	-0.01	-4.09	20.20	0.01	0.004%
43	3.53	-20.20	2.04	-3.53	20.20	-2.04	0.004%
44	2.03	-20.20	3.54	-2.03	20.20	-3.54	0.004%
45	-0.01	-20.20	4.09	0.01	20.20	-4.09	0.004%
46	-2.05	-20.20	3.55	2.05	20.20	-3.55	0.004%
47	-3.54	-20.20	2.05	3.54	20.20	-2.05	0.004%
48	-4.09	-20.20	0.01	4.09	20.20	-0.01	0.004%
49	-3.53	-20.20	-2.04	3.53	20.20	2.04	0.004%
50	-2.03	-20.20	-3.54	2.03	20.20	3.54	0.004%

Non-Linear Convergence Results

Load Combination	Converged?	Number of Cycles	Displacement Tolerance	Force Tolerance
1	Yes	6	0.00000001	0.00000001
2	Yes	16	0.00008494	0.00010323
3	Yes	16	0.00005752	0.00008346
4	Yes	21	0.00000001	0.00007856
5	Yes	20	0.00000001	0.00011637
6	Yes	21	0.00000001	0.00007874
7	Yes	20	0.00000001	0.00011668
8	Yes	16	0.00008495	0.00010006
9	Yes	16	0.00005752	0.00008085
10	Yes	21	0.00000001	0.00007861
11	Yes	20	0.00000001	0.00011656
12	Yes	21	0.00000001	0.00007737
13	Yes	20	0.00000001	0.00011463
14	Yes	16	0.00008493	0.00010979
15	Yes	16	0.00005752	0.00008862
16	Yes	21	0.00000001	0.00007904
17	Yes	20	0.00000001	0.00011713
18	Yes	21	0.00000001	0.00007886
19	Yes	20	0.00000001	0.00011686
20	Yes	16	0.00008495	0.00010540
21	Yes	16	0.00005753	0.00008494
22	Yes	21	0.00000001	0.00007729
23	Yes	20	0.00000001	0.00011458
24	Yes	21	0.00000001	0.00007852
25	Yes	20	0.00000001	0.00011647
26	Yes	6	0.00000001	0.00000001
27	Yes	18	0.00013095	0.00004318
28	Yes	18	0.00013079	0.00007309
29	Yes	18	0.00013079	0.00007320
30	Yes	18	0.00013096	0.00004443
31	Yes	18	0.00013079	0.00007389
32	Yes	18	0.00013078	0.00007255
33	Yes	18	0.00013093	0.00004328
34	Yes	18	0.00013075	0.00007340
35	Yes	18	0.00013075	0.00007325
36	Yes	18	0.00013093	0.00004311
37	Yes	18	0.00013077	0.00007200
38	Yes	18	0.00013078	0.00007337
39	Yes	15	0.00013932	0.00005855
40	Yes	15	0.00013913	0.00007025
41	Yes	15	0.00013914	0.00006916
42	Yes	15	0.00013933	0.00005851
43	Yes	15	0.00013915	0.00006805
44	Yes	15	0.00013914	0.00007011
45	Yes	15	0.00013933	0.00005859
46	Yes	15	0.00013913	0.00006860
47	Yes	15	0.00013914	0.00006956
48	Yes	15	0.00013933	0.00005839
49	Yes	15	0.00013915	0.00006941
50	Yes	15	0.00013914	0.00006749

Maximum Tower Deflections - Service Wind

Section No.	Elevation ft	Horz. Deflection in	Gov. Load Comb.	Tilt °	Twist °
L1	109.86 - 99	18.05	46	1.51	0.00
L2	99 - 98.5	14.65	46	1.47	0.00
L3	98.5 - 79.33	14.50	46	1.46	0.00
L4	79.33 - 47.12	9.26	46	1.10	0.00
L5	50.87 - 14.83	3.81	46	0.72	0.00
L6	14.83 - 13.83	0.31	46	0.20	0.00
L7	13.83 - 6	0.27	46	0.19	0.00
L8	6 - 3.33	0.05	46	0.08	0.00
L9	3.33 - 0	0.02	46	0.05	0.00

Critical Deflections and Radius of Curvature - Service Wind

Elevation ft	Appurtenance	Gov. Load Comb.	Deflection in	Tilt °	Twist °	Radius of Curvature ft
108.00	BXA-171085-8BF-EDIN-2 w/ Mount Pipe	46	17.46	1.50	0.00	17001
100.00	APXVSPP18-C-A20 w/ Mount Pipe	46	14.96	1.48	0.00	6483
98.00	1900MHz RRH (65MHz)	46	14.35	1.46	0.00	4516
78.00	(2) 7770.00 w/ Mount Pipe	46	8.95	1.07	0.00	3327
76.00	(2) RRUS 11	46	8.49	1.03	0.00	3380
50.00	KS24019-L112A	46	3.69	0.70	0.00	4465

Maximum Tower Deflections - Design Wind

Section No.	Elevation ft	Horz. Deflection in	Gov. Load Comb.	Tilt °	Twist °
L1	109.86 - 99	77.95	16	6.51	0.00
L2	99 - 98.5	63.29	16	6.35	0.00
L3	98.5 - 79.33	62.63	16	6.33	0.00
L4	79.33 - 47.12	40.04	16	4.74	0.00
L5	50.87 - 14.83	16.49	16	3.10	0.00
L6	14.83 - 13.83	1.33	16	0.86	0.00
L7	13.83 - 6	1.15	16	0.81	0.00
L8	6 - 3.33	0.22	16	0.33	0.00
L9	3.33 - 0	0.07	16	0.20	0.00

Critical Deflections and Radius of Curvature - Design Wind

Elevation ft	Appurtenance	Gov. Load Comb.	Deflection in	Tilt °	Twist °	Radius of Curvature ft
108.00	BXA-171085-8BF-EDIN-2 w/ Mount Pipe	16	75.42	6.51	0.00	4038
100.00	APXVSPP18-C-A20 w/ Mount Pipe	16	64.62	6.39	0.00	1539
98.00	1900MHz RRH (65MHz)	16	61.97	6.31	0.00	1071
78.00	(2) 7770.00 w/ Mount Pipe	16	38.68	4.63	0.00	781
76.00	(2) RRUS 11	16	36.69	4.48	0.00	792
50.00	KS24019-L112A	16	15.94	3.05	0.00	1037

Compression Checks

Pole Design Data

Section No.	Elevation ft	Size	L ft	L _u ft	KI/r	A in ²	P _u K	φP _n K	Ratio $\frac{P_u}{\phi P_n}$
L1	109.86 - 99 (1)	TP14.9843x12.7x0.1875	10.86	0.00	0.0	8.8060	-3.83	654.24	0.006
L2	99 - 98.5 (2)	TP15.5x14.9843x0.1875	0.50	0.00	0.0	9.1129	-3.86	677.04	0.006
L3	98.5 - 79.33 (3)	TP19.246x15.5x0.1875	19.17	0.00	0.0	11.3422	-5.75	839.32	0.007
L4	79.33 - 47.12 (4)	TP25.54x19.246x0.4458	32.21	0.00	0.0	34.4722	-12.74	1693.49	0.008
L5	47.12 - 14.83 (5)	TP31.3878x23.9156x0.4471	36.04	0.00	0.0	43.9088	-20.66	2183.17	0.009
L6	14.83 - 13.83 (6)	TP31.5808x31.3878x0.5465	1.00	0.00	0.0	53.8290	-20.93	2496.75	0.008
L7	13.83 - 6 (7)	TP33.092x31.5808x0.4413	7.83	0.00	0.0	45.7283	-22.73	2236.52	0.010
L8	6 - 3.33 (8)	TP33.6073x33.092x0.5251	2.67	0.00	0.0	55.1340	-23.45	2573.66	0.009
L9	3.33 - 0 (9)	TP34.25x33.6073x0.4279	3.33	0.00	0.0	45.9335	-24.23	2294.34	0.011

Pole Bending Design Data

Section No.	Elevation ft	Size	M_{ux}	ϕM_{nx}	Ratio	M_{uy}	ϕM_{ny}	Ratio
			kip-ft	kip-ft	$\frac{M_{ux}}{\phi M_{nx}}$	kip-ft	kip-ft	$\frac{M_{uy}}{\phi M_{ny}}$
L1	109.86 - 99 (1)	TP14.9843x12.7x0.1875	35.36	198.12	0.178	0.00	198.12	0.000
L2	99 - 98.5 (2)	TP15.5x14.9843x0.1875	38.94	212.26	0.183	0.00	212.26	0.000
L3	98.5 - 79.33 (3)	TP19.246x15.5x0.1875	199.01	328.29	0.606	0.00	328.29	0.000
L4	79.33 - 47.12 (4)	TP25.54x19.246x0.4458	570.19	839.65	0.679	0.00	839.65	0.000
L5	47.12 - 14.83 (5)	TP31.3878x23.9156x0.4471	1135.06	1380.00	0.823	0.00	1380.00	0.000
L6	14.83 - 13.83 (6)	TP31.5808x31.3878x0.5465	1151.92	1578.08	0.730	0.00	1578.08	0.000
L7	13.83 - 6 (7)	TP33.092x31.5808x0.4413	1285.77	1493.24	0.861	0.00	1493.24	0.000
L8	6 - 3.33 (8)	TP33.6073x33.092x0.5251	1332.15	1737.00	0.767	0.00	1737.00	0.000
L9	3.33 - 0 (9)	TP34.25x33.6073x0.4279	1390.53	1588.15	0.876	0.00	1588.15	0.000

Pole Shear Design Data

Section No.	Elevation ft	Size	Actual V_u	ϕV_n	Ratio	Actual T_u	ϕT_n	Ratio
			K	K	$\frac{V_u}{\phi V_n}$	kip-ft	kip-ft	$\frac{T_u}{\phi T_n}$
L1	109.86 - 99 (1)	TP14.9843x12.7x0.1875	7.14	327.12	0.022	0.08	396.72	0.000
L2	99 - 98.5 (2)	TP15.5x14.9843x0.1875	7.16	338.52	0.021	0.08	425.04	0.000
L3	98.5 - 79.33 (3)	TP19.246x15.5x0.1875	8.80	419.66	0.021	0.12	657.38	0.000
L4	79.33 - 47.12 (4)	TP25.54x19.246x0.4458	14.34	846.74	0.017	0.31	1681.36	0.000
L5	47.12 - 14.83 (5)	TP31.3878x23.9156x0.4471	16.85	1091.58	0.015	0.43	2763.38	0.000
L6	14.83 - 13.83 (6)	TP31.5808x31.3878x0.5465	16.90	1248.37	0.014	0.44	3160.02	0.000
L7	13.83 - 6 (7)	TP33.092x31.5808x0.4413	17.31	1118.26	0.015	0.50	2990.13	0.000
L8	6 - 3.33 (8)	TP33.6073x33.092x0.5251	17.46	1286.83	0.014	0.53	3478.25	0.000
L9	3.33 - 0 (9)	TP34.25x33.6073x0.4279	17.63	1147.17	0.015	0.56	3180.18	0.000

Pole Interaction Design Data

Section No.	Elevation ft	Ratio P_u	Ratio M_{ux}	Ratio M_{uy}	Ratio V_u	Ratio T_u	Comb. Stress Ratio	Allow. Stress Ratio	Criteria
		ϕP_n	ϕM_{nx}	ϕM_{ny}	ϕV_n	ϕT_n			
L1	109.86 - 99 (1)	0.006	0.178	0.000	0.022	0.000	0.185	1.000	4.8.2
L2	99 - 98.5 (2)	0.006	0.183	0.000	0.021	0.000	0.190	1.000	4.8.2
L3	98.5 - 79.33 (3)	0.007	0.606	0.000	0.021	0.000	0.614	1.000	4.8.2
L4	79.33 - 47.12 (4)	0.008	0.679	0.000	0.017	0.000	0.687	1.000	4.8.2
L5	47.12 - 14.83 (5)	0.009	0.823	0.000	0.015	0.000	0.832	1.000	4.8.2
L6	14.83 - 13.83 (6)	0.008	0.730	0.000	0.014	0.000	0.739	1.000	4.8.2
L7	13.83 - 6 (7)	0.010	0.861	0.000	0.015	0.000	0.871	1.000	4.8.2
L8	6 - 3.33 (8)	0.009	0.767	0.000	0.014	0.000	0.776	1.000	4.8.2
L9	3.33 - 0 (9)	0.011	0.876	0.000	0.015	0.000	0.886	1.000	4.8.2

Section Capacity Table

Section No.	Elevation ft	Component Type	Size	Critical Element	P K	ϕP_{allow} K	% Capacity	Pass Fail	
L1	109.86 - 99	Pole	TP14.9843x12.7x0.1875	1	-3.83	654.24	18.5	Pass	
L2	99 - 98.5	Pole	TP15.5x14.9843x0.1875	2	-3.86	677.04	19.0	Pass	
L3	98.5 - 79.33	Pole	TP19.246x15.5x0.1875	3	-5.75	839.32	61.4	Pass	
L4	79.33 - 47.12	Pole	TP25.54x19.246x0.4458	4	-12.74	1693.49	68.7	Pass	
L5	47.12 - 14.83	Pole	TP31.3878x23.9156x0.4471	5	-20.66	2183.17	83.2	Pass	
L6	14.83 - 13.83	Pole	TP31.5808x31.3878x0.5465	6	-20.93	2496.75	73.9	Pass	
L7	13.83 - 6	Pole	TP33.092x31.5808x0.4413	7	-22.73	2236.52	87.1	Pass	
L8	6 - 3.33	Pole	TP33.6073x33.092x0.5251	8	-23.45	2573.66	77.6	Pass	
L9	3.33 - 0	Pole	TP34.25x33.6073x0.4279	9	-24.23	2294.34	88.6	Pass	
							Summary		
							Pole (L9)	88.6	Pass
							RATING =	88.6	Pass

APPENDIX B BASE LEVEL DRAWING

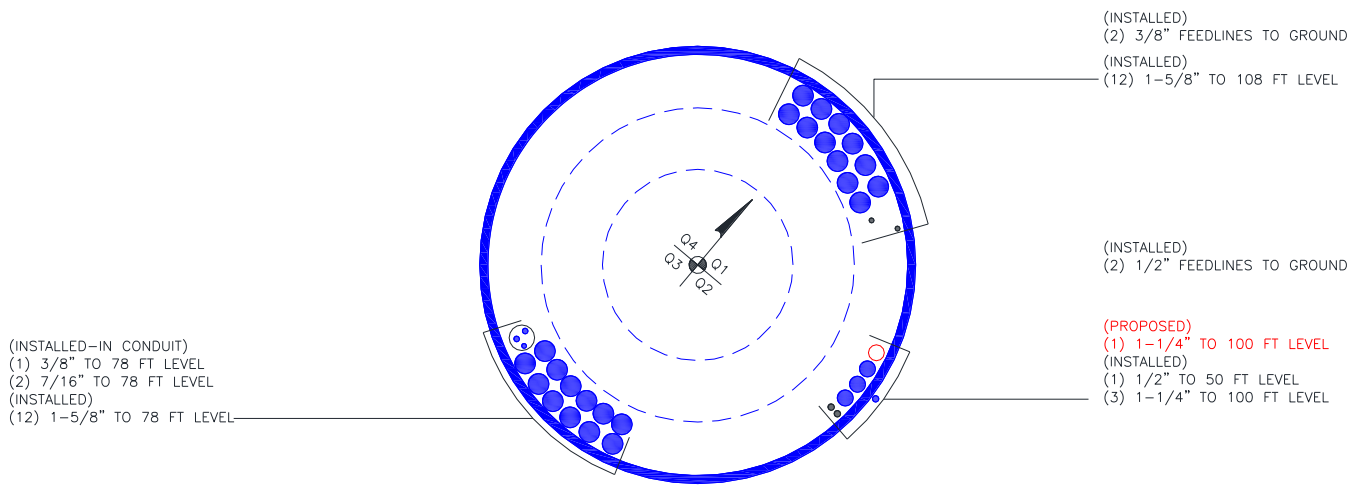

APPENDIX C
ADDITIONAL CALCULATIONS

Section	1	2	3	4	5	6	7	8	9
Length (ft)	10.86	0.50	19.17	32.21	36.04	1.00	7.83	2.67	3.33
Number of Sides	18	18	18	18	18	18	18	18	18
Thickness (in)	0.1875	0.1875	0.1875	0.4458	0.4471	0.5465	0.4412	0.4279	0.5251
Socket Length (ft)				3.75					
Top Dia (in)	12.7000	14.9843	15.5000	19.2460	23.9156	31.3878	31.5808	33.0920	34.2503
Bot Dia (in)	14.9843	15.5000	19.2460	25.5400	31.3878	31.5808	33.0920	34.2503	34.2503
Grade	A572-65	A572-65	A572-65	A572-65	A572-65	A572-65	A572-65	A572-65	A572-65
Weight (K)	0.3	0.0	0.7	3.4	4.7	0.2	1.2	0.5	0.5
Reinf	42.98 ksi	42.98 ksi	42.98 ksi	42.98 ksi	42.98 ksi	42.98 ksi	42.98 ksi	42.98 ksi	42.98 ksi

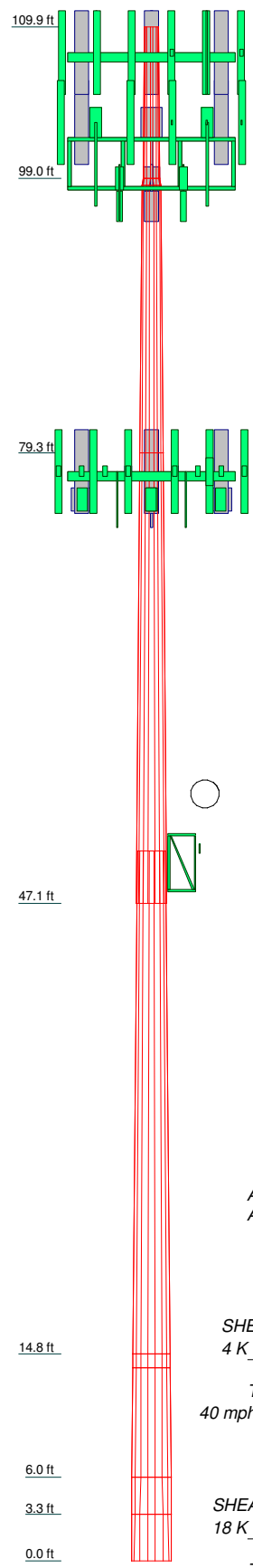

DESIGNED APPURTENANCE LOADING

TYPE	ELEVATION	TYPE	ELEVATION
BXA-171085-8BF-EDIN-2 w/ Mount Pipe	108	Miscellaneous [NA 507-1]	100
BXA-171085-8BF-EDIN-2 w/ Mount Pipe	108	1900MHz RRH (65MHz)	98
BXA-171063-8BF-2 w/ Mount Pipe	108	1900MHz RRH (65MHz)	98
BXA-70063/6CF-2 w/ Mount Pipe	108	1900MHz RRH (65MHz)	98
BXA-70063/6CF-2 w/ Mount Pipe	108	800MHz RRH	98
BXA-70063/6CF-2 w/ Mount Pipe	108	800MHz RRH	98
BXA-70063/6CF-2 w/ Mount Pipe	108	800MHz RRH	98
BXA-80080/4CF w/ Mount Pipe	108	2.375" OD x 4' Mount Pipe	98
BXA-80080/4CF w/ Mount Pipe	108	2.375" OD x 4' Mount Pipe	98
BXA-80080/4CF w/ Mount Pipe	108	2.375" OD x 4' Mount Pipe	98
BXA-80063/4CFx5 w/ Mount Pipe	108	2.375" OD x 4' Mount Pipe	98
(2) FD9R6004/2C-3L	108	Side Arm Mount [SO 701-3]	98
(2) FD9R6004/2C-3L	108	(2) 7770.00 w/ Mount Pipe	78
(2) FD9R6004/2C-3L	108	(2) 7770.00 w/ Mount Pipe	78
(2) FD9R6004/2C-3L	108	(2) 7770.00 w/ Mount Pipe	78
2.375" OD x 6' Mount Pipe	108	AM-X-CD-16-65-00T-RET w/ Mount Pipe	78
2.375" OD x 6' Mount Pipe	108	AM-X-CD-16-65-00T-RET w/ Mount Pipe	78
2.375" OD x 6' Mount Pipe	108	AM-X-CD-14-65-00T-RET w/ Mount Pipe	78
T-Arm Mount [TA 602-3]	108	AM-X-CD-16-65-00T-RET w/ Mount Pipe	78
APXVSP18-C-A20 w/ Mount Pipe	100	AM-X-CD-16-65-00T-RET w/ Mount Pipe	78
APXVSP18-C-A20 w/ Mount Pipe	100	(4) TMA-DD 1900	78
(3) ACU-A20-N	100	(4) TMA-DD 1900	78
(3) ACU-A20-N	100	(4) TMA-DD 1900	78
(3) ACU-A20-N	100	DC6-48-60-18-8F	78
APXVTM14-C-120 w/ Mount Pipe	100	T-Arm Mount [TA 602-3]	78
APXVTM14-C-120 w/ Mount Pipe	100	(2) RRU 11	76
APXVTM14-C-120 w/ Mount Pipe	100	(2) RRU 11	76
APXVTM14-C-120 w/ Mount Pipe	100	(2) RRU 11	76
TD-RRH8x20-25	100	2.375" OD x 4' Mount Pipe	76
TD-RRH8x20-25	100	2.375" OD x 4' Mount Pipe	76
TD-RRH8x20-25	100	2.375" OD x 4' Mount Pipe	76
(2) 2.375" OD x 6' Mount Pipe	100	Side Arm Mount [SO 701-3]	76
(2) 2.375" OD x 6' Mount Pipe	100	Side Arm Mount [SO 701-3]	76
(2) 2.375" OD x 6' Mount Pipe	100	KS24019-L112A	50
Platform Mount [LP 601-1]	100	Side Arm Mount [SO 701-1]	50

MATERIAL STRENGTH

GRADE	Fy	Fu	GRADE	Fy	Fu
A572-65	65 ksi	80 ksi	Reinf 42.79 ksi	43 ksi	54 ksi
Reinf 42.98 ksi	43 ksi	54 ksi	Reinf 40.84 ksi	41 ksi	52 ksi
Reinf 43.50 ksi	44 ksi	55 ksi	Reinf 43.70 ksi	44 ksi	55 ksi
Reinf 40.58 ksi	41 ksi	51 ksi			

TOWER DESIGN NOTES

1. Tower is located in Litchfield County, Connecticut.
2. Tower designed for Exposure C to the TIA-222-G Standard.
3. Tower designed for a 93 mph basic wind in accordance with the TIA-222-G Standard.
4. Tower is also designed for a 40 mph basic wind with 1.00 in ice. Ice is considered to increase in thickness with height.
5. Deflections are based upon a 60 mph wind.
6. Tower Structure Class II.
7. Topographic Category 1 with Crest Height of 0.00 ft
8. TOWER RATING: 88.6%

ALL REACTIONS ARE FACTORED

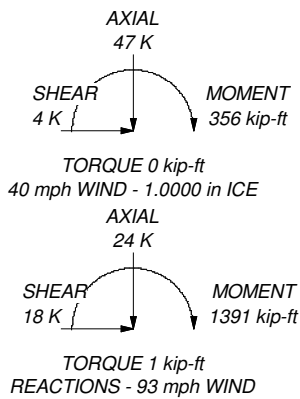

Paul J Ford and Company
 250 E. Broad Street Suite 600
 Columbus, OH 43215
 Phone: 614.221.6679
 FAX: 614.448.4105

Job: **110 Ft. Monopole / Woodbury, CT**
 Project: **PJF 37517-2700.001 / BU 876405**
 Client: Crown Castle
 Code: TIA-222-G
 Path: G:\CWERR\375_Crown_Castle\2017\07\17-2700_876405_Woodbury\09\37517-2700.001\BU 876405_SA_1438644\37517-2700.001_Reinf.dwg
 Drawn by: Ryan Ferrante
 Date: 08/02/17
 App'd:
 Scale: NTS
 Dwg No. E-1

v4.4 - Effective 7-12-13

Asymmetric Bolt Analysis

Moment = 39 k-ft
 Axial = 3.9 kips
 Shear = 7.2 kips
 Anchor Qty = 15

TIA Ref. = G
 ASIF = N/A
 Max Ratio = 105.0%

Location = Flange Plate
 η = N/A for BP, Rev. G Sect. 4.9.9
 Threads = X-Excluded for FP, Rev. G

**** For Flange Plates: Prying action is not considered in the bolt loads. ****

Item	Nominal Bolt Dia, in	Spec	Fy, ksi	Fu, ksi	Location, degrees	Bolt Circle, in	Area Override, in ²	Area, in ²	Max Net Compression, kips	Max Net Tension, kips	Load for Capacity Calc, kips	Capacity Override, kips	Capacity, kips	Capacity Ratio
1	1.000	A325	92	120	0.0	25.75	0.00	0.79	5.10	4.58	4.58	0.00	54.54	8.4%
2	1.000	A325	92	120	15.0	25.75	0.00	0.79	5.10	4.58	4.58	0.00	54.54	8.4%
3	1.000	A325	92	120	30.0	25.75	0.00	0.79	5.10	4.58	4.58	0.00	54.54	8.4%
4	1.000	A325	92	120	90.0	25.75	0.00	0.79	5.10	4.58	4.58	0.00	54.54	8.4%
5	1.000	A325	92	120	105.0	25.75	0.00	0.79	5.10	4.58	4.58	0.00	54.54	8.4%
6	1.000	A325	92	120	120.0	25.75	0.00	0.79	5.10	4.58	4.58	0.00	54.54	8.4%
7	1.000	A325	92	120	135.0	25.75	0.00	0.79	5.10	4.58	4.58	0.00	54.54	8.4%
8	1.000	A325	92	120	150.0	25.75	0.00	0.79	5.10	4.58	4.58	0.00	54.54	8.4%
9	1.000	A325	92	120	210.0	25.75	0.00	0.79	5.10	4.58	4.58	0.00	54.54	8.4%
10	1.000	A325	92	120	225.0	25.75	0.00	0.79	5.10	4.58	4.58	0.00	54.54	8.4%
11	1.000	A325	92	120	240.0	25.75	0.00	0.79	5.10	4.58	4.58	0.00	54.54	8.4%
12	1.000	A325	92	120	255.0	25.75	0.00	0.79	5.10	4.58	4.58	0.00	54.54	8.4%
13	1.000	A325	92	120	270.0	25.75	0.00	0.79	5.10	4.58	4.58	0.00	54.54	8.4%
14	1.000	A325	92	120	330.0	25.75	0.00	0.79	5.10	4.58	4.58	0.00	54.54	8.4%
15	1.000	A325	92	120	345.0	25.75	0.00	0.79	5.10	4.58	4.58	0.00	54.54	8.4%

11.78

Stiffened or Unstiffened, Exterior Flange Plate - Any Bolt Material TIA Rev G

Site Data	
BU#:	
Site Name:	
App #:	

Reactions and bolt qty. adjusted to account for bolt layout.

Reactions		
Mu	61.05969	ft-kips
Axial, Pu:	3.9	kips
Shear, Vu:	7.2	kips
Elevation:	98.5	feet

Bolt Threads:
X-Excluded
$\phi V_n = \phi(0.55 A_b F_u)$
$\phi = 0.75, \phi^* V_n$ (kips):
38.88

Pole Manufacturer:	Other
--------------------	-------

If No stiffeners, Criteria:	TIA G
-----------------------------	-------

<-Only Applicable to Unstiffened Cases

Bolt Data		
Qty:	24	
Diameter (in.):	1	Bolt Fu: 120
Bolt Material:	A325	Bolt Fy: 92
N/A:	75	<-- Disregard
N/A:	55	<-- Disregard
Circle (in.):	25.75	

Flange Bolt Results

Bolt Tension Capacity, $\phi^* T_n, B1$:	54.54 kips
Adjusted $\phi^* T_n$ (due to $V_u = V_u / Q_t$), B :	54.54 kips
Max Bolt directly applied T_u :	4.58 Kips
Min. PL "tc" for B cap. w/o Pry:	2.835 in
Min PL "treq" for actual T w/ Pry:	0.680 in
Min PL "t1" for actual T w/o Pry:	0.822 in
T allowable with Prying:	9.90 kips $\alpha > 1$ case
Prying Force, q:	0.00 kips
Total Bolt Tension = $T_u + q$:	4.58 kips
Prying Bolt Stress Ratio = $(T_u + q) / (B)$:	8.4% Pass

Non-Rigid
$\phi^* T_n$
$\phi T_n [(1 - (V_u / \phi V_n)^2)^{0.5}]$

Plate Data		
Diam:	28.5	in
Thick, t:	1	in
Grade (Fy):	60	ksi
Strength, Fu:	75	ksi
Single-Rod B-eff:	1.98	in

Exterior Flange Plate Results

Flexural Check	
Compression Side Plate Stress:	22.1 ksi
Allowable Plate Stress:	54.0 ksi
Compression Plate Stress Ratio:	41.0% Pass
No Prying	
Tension Side Stress Ratio, $(t_{req}/t)^2$:	46.3% Pass

Non-Rigid
TIA G
$\phi^* F_y$
Comp. Y.L. Length:
20.94

Stiffener Data (Welding at Both Sides)		
Config:	0	*
Weld Type:		
Groove Depth:		in **
Groove Angle:		degrees
Fillet H. Weld:		<-- Disregard
Fillet V. Weld:		in
Width:		in
Height:		in
Thick:		in
Notch:		in
Grade:		ksi
Weld str.:		ksi

n/a

Stiffener Results

Horizontal Weld :	n/a
Vertical Weld:	n/a
Plate Flex+Shear, $f_b / F_b + (f_v / F_v)^2$:	n/a
Plate Tension+Shear, $f_t / F_t + (f_v / F_v)^2$:	n/a
Plate Comp. (AISC Bracket):	n/a

Pole Results

Pole Punching Shear Check:	n/a
----------------------------	-----

Pole Data		
Diam:	14.9843	in
Thick:	0.1875	in
Grade:	65	ksi
# of Sides:	18	"0" IF Round
Fu	80	ksi
Reinf. Fillet Weld	0	"0" if None

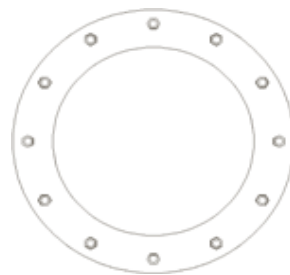

* 0 = none, 1 = every bolt, 2 = every 2 bolts, 3 = 2 per bolt

** Note: for complete joint penetration groove welds the groove depth must be exactly 1/2 the stiffener thickness for calculation purposes

v4.4 - Effective 7-12-13

Asymmetric Anchor Rod Analysis

Moment = 1391 k-ft
 Axial = 24.0 kips
 Shear = 18.0 kips
 Anchor Qty = 11

TIA Ref. = G
 ASIF = N/A
 Max Ratio = 105.0%

Location = Base Plate
 η = 0.50 for BP, Rev. G Sect. 4.9.9
 Threads = N/A for FP, Rev. G

**** For Post Installed Anchors: Check anchors for embedment, epoxy/grout bond, and capacity based on proof load. ****

Item	Nominal Anchor Dia, in	Spec	Fy, ksi	Fu, ksi	Location, degrees	Anchor Circle, in	Area Override, in ²	Area, in ²	Max Net Compression, kips	Max Net Tension, kips	Load for Capacity Calc, kips	Capacity Override, kips	Capacity, kips	Capacity Ratio
1	2.250	#18J A615 Gr 75	75	100	25.0	42.00	0.00	3.98	135.72	131.35	138.99	0.00	260.00	53.5%
2	2.250	#18J A615 Gr 75	75	100	70.0	42.00	0.00	3.98	134.90	130.54	138.17	0.00	260.00	53.1%
3	2.250	#18J A615 Gr 75	75	100	115.0	42.00	0.00	3.98	142.40	138.04	145.67	0.00	260.00	56.0%
4	2.250	#18J A615 Gr 75	75	100	160.0	42.00	0.00	3.98	141.06	136.70	144.33	0.00	260.00	55.5%
5	2.250	#18J A615 Gr 75	75	100	205.0	42.00	0.00	3.98	130.61	126.24	133.88	0.00	260.00	51.5%
6	2.250	#18J A615 Gr 75	75	100	250.0	42.00	0.00	3.98	130.26	125.89	133.53	0.00	260.00	51.4%
7	2.250	#18J A615 Gr 75	75	100	295.0	42.00	0.00	3.98	141.06	136.70	144.33	0.00	260.00	55.5%
8	2.250	#18J A615 Gr 75	75	100	340.0	42.00	0.00	3.98	143.50	139.13	146.77	0.00	260.00	56.4%
9	2.250	A193 Gr B7	105	125	48.0	47.25	0.00	3.98	149.51	145.15	152.78	0.00	325.00	47.0%
10	2.250	A193 Gr B7	105	125	174.0	47.25	0.00	3.98	155.07	150.71	158.34	0.00	325.00	48.7%
11	2.250	A193 Gr B7	105	125	280.0	47.25	0.00	3.98	154.42	150.06	157.69	0.00	325.00	48.5%

43.77

Stiffened or Unstiffened, UngROUTed, Circular Base Plate - Any Rod Material

TIA Rev G

Assumption: Clear space between bottom of leveling nut and top of concrete **not** exceeding (1)*(Rod Diameter)

Site Data	
BU#:	
Site Name:	
App #:	
Pole Manufacturer:	Other

Anchor Rod Data	
Qty:	8
Diam:	2.25 in
Rod Material:	A615-J
Strength (Fu):	100 ksi
Yield (Fy):	75 ksi
Bolt Circle:	42 in

Plate Data	
Diam:	48 in
Thick:	1.5 in
Grade:	60 ksi
Single-Rod B-eff:	13.59 in

Stiffener Data (Welding at both sides)	
Config:	3 *
Weld Type:	Fillet
Groove Depth:	<-- Disregard
Groove Angle:	<-- Disregard
Fillet H. Weld:	0.375 in
Fillet V. Weld:	0.25 in
Width:	6.5 in
Height:	18 in
Thick:	0.5 in
Notch:	1 in
Grade:	36 ksi
Weld str.:	70 ksi
Clear Space between Stiffeners (b):	5 in

Pole Data	
Diam:	34.25 in
Thick:	0.25 in
Grade:	65 ksi
# of Sides:	18 "0" IF Round
Fu	80 ksi
Reinf. Fillet Weld	0 "0" if None

Reactions		
Mu:	989.2	ft-kips
Axial, Pu:	17.5	kips
Shear, Vu:	13.1	kips
Eta Factor, η	0.5	TIA G (Fig. 4-4)

Reactions adjusted to account for post installed anchors.

If No stiffeners, Criteria: AISC LRFD <-Only Applicable to Unstiffened Cases

Anchor Rod Results

Max Rod (Cu+ Vu/η): 146.8 Kips
 Allowable Axial, Φ*Fu*Anet: 260.0 Kips
 Anchor Rod Stress Ratio: 56.4% **Pass**

Stiffened
AISC LRFD
φ*Tn

Base Plate Results

Base Plate Stress: 7.4 ksi
 Allowable Plate Stress: 32.4 ksi
 Base Plate Stress Ratio: 22.7% **Pass**

Shear Check Only

Stiffened
AISC LRFD
φ*Fy
Y.L. Length:
N/A, Roark

Stiffener Results

Horizontal Weld : 58.0% **Pass**
 Vertical Weld: 31.2% **Pass**
 Plate Flex+Shear, fb/Fb+(fv/Fv)^2: 20.4% **Pass**
 Plate Tension+Shear, ft/Ft+(fv/Fv)^2: 65.9% **Pass**
 Plate Comp. (AISC Bracket): 64.4% **Pass**

Pole Results

Pole Punching Shear Check: 10.1% **Pass**

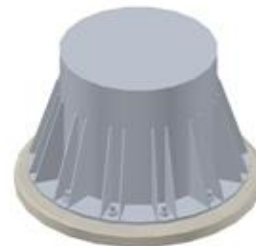
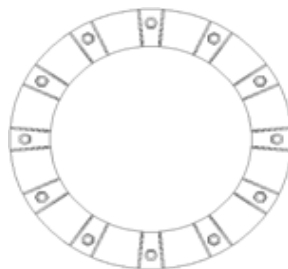

* 0 = none, 1 = every bolt, 2 = every 2 bolts, 3 = 2 per bolt

** Note: for complete joint penetration groove welds the groove depth must be exactly 1/2 the stiffener thickness for calculation purposes

Factored Foundation Loads:

	LC1	LC2	
Factored Axial Load (+Comp, -Ten) =	24	18	kips
Factored Horiz. Load at Top of Pier =	18	18	kips
Factored OTM at Top of Pier =	1391	1391	k-ft

LRFD Resistance and Load Factors:

	Φ	Dead Load Factors	
Soil Bearing =	0.75		
Soil Weight =	0.75	1.2	0.9
Concrete Weight =	0.75	1.2	0.9

Soil Properties:

Depth to Water Table =	99 ft
Uplift Cone from	Top of footing

Layer Thk ft	Soil Density pcf	Cohesion ksf	Friction Angle degrees	Ult Bearing ksf	Depth ft
7	125	0	34	12	7.00

Dimensions:

Pier Shape =	Square
Pier Width =	5.5 ft Square
Pier Height above Grade =	1 ft
Depth to Bottom of Footing =	6.5 ft
Footing Thickness =	3 ft
Footing Width, B =	16.5 ft
Footing Length, L =	16.5 ft

Concrete:

Concrete Strength =	4 ksi
Rebar Strength =	60 ksi

Summary Results:

	Required	Available
Maximum Net Soil Bearing =	3.043 ksf	9.000 ksf
Uplift =	0.0 kips	214.6 kips
Punching Shear Stress =	0.023 ksi	0.190 ksi
Bending Shear Stress =	141.9 kips	591.7 kips
Bending Moment =	661.45 k-ft	1867.5 k-ft
Conc Pier Reinforcing Steel =	1472.0 k-ft	3274.3 k-ft

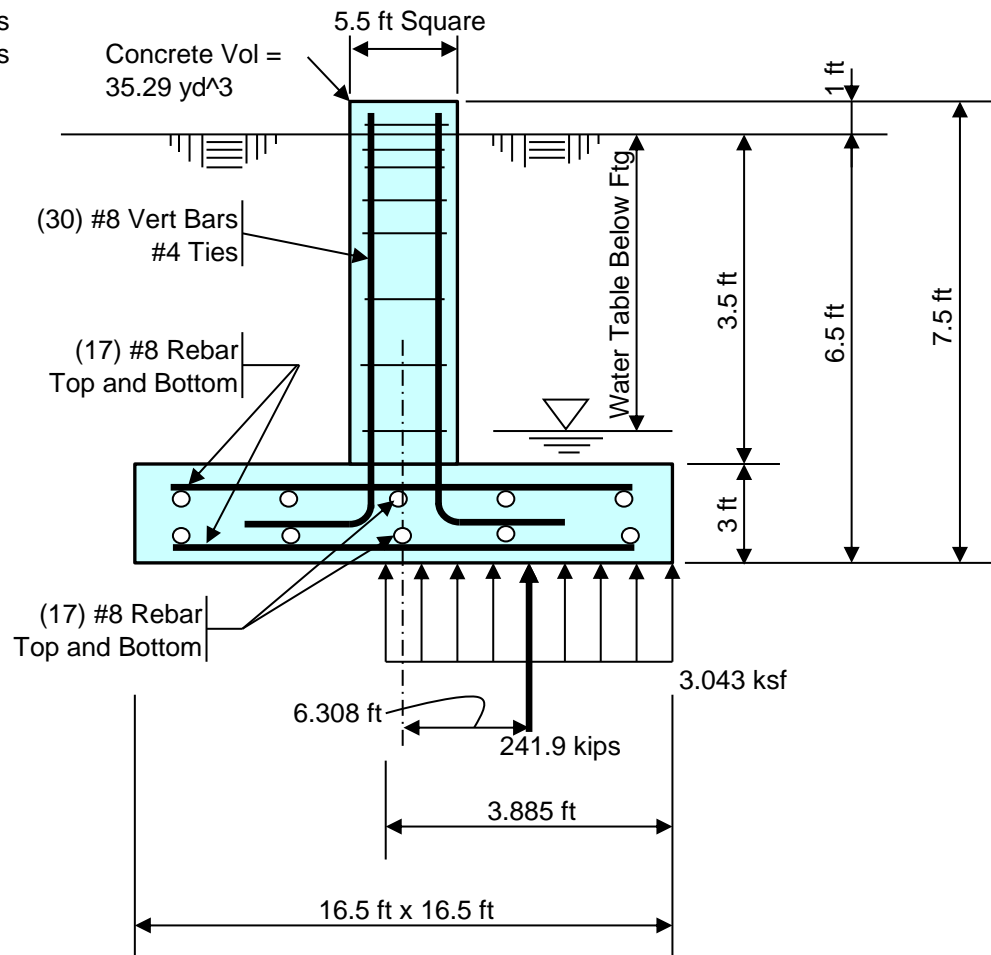

Total Pad Reinf Stl =	26.86 in ² >= 12.83 in ² = Min Stl, OK
Total Pier Reinf Stl =	23.70 in ² >= 21.78 in ² = Min Stl, OK
Footing Thickness =	3.00 ft >= 1.36 ft = Min Ftg Thk, OK

Stress Ratio =	33.8% in Soil Bearing
Stress Ratio =	0.0% in Uplift
Stress Ratio =	12.0% in Punching Shear
Stress Ratio =	24.0% in Bending Shear
Stress Ratio =	35.4% in Bending Moment
Stress Ratio =	45.0% in Pier Rebar



RADIO FREQUENCY EMISSIONS ANALYSIS REPORT EVALUATION OF HUMAN EXPOSURE POTENTIAL TO NON-IONIZING EMISSIONS

SPRINT Existing Facility

Site ID: CT54XC771

Woodbury North
186 Minortown Road
Woodbury, CT 06798

September 16, 2017

EBI Project Number: 6217004103

Site Compliance Summary	
Compliance Status:	COMPLIANT
Site total MPE% of FCC general population allowable limit:	15.19 %



September 16, 2017

SPRINT

Attn: RF Engineering Manager
1 International Boulevard, Suite 800
Mahwah, NJ 07495

Emissions Analysis for Site: **CT54XC771 – Woodbury North**

EBI Consulting was directed to analyze the proposed SPRINT facility located at **186 Minortown Road, Woodbury, CT**, for the purpose of determining whether the emissions from the Proposed SPRINT Antenna Installation located on this property are within specified federal limits.

All information used in this report was analyzed as a percentage of current Maximum Permissible Exposure (% MPE) as listed in the FCC OET Bulletin 65 Edition 97-01 and ANSI/IEEE Std C95.1. The FCC regulates Maximum Permissible Exposure in units of microwatts per square centimeter ($\mu\text{W}/\text{cm}^2$). The number of $\mu\text{W}/\text{cm}^2$ calculated at each sample point is called the power density. The exposure limit for power density varies depending upon the frequencies being utilized. Wireless Carriers and Paging Services use different frequency bands each with different exposure limits, therefore it is necessary to report results and limits in terms of percent MPE rather than power density.

All results were compared to the FCC (Federal Communications Commission) radio frequency exposure rules, 47 CFR 1.1307(b)(1) – (b)(3), to determine compliance with the Maximum Permissible Exposure (MPE) limits for General Population/Uncontrolled environments as defined below.

General population/uncontrolled exposure limits apply to situations in which the general population may be exposed or in which persons who are exposed as a consequence of their employment may not be made fully aware of the potential for exposure or cannot exercise control over their exposure. Therefore, members of the general population would always be considered under this category when exposure is not employment related, for example, in the case of a telecommunications tower that exposes persons in a nearby residential area.

Population exposure to radio frequencies is regulated and enforced in units of microwatts per square centimeter ($\mu\text{W}/\text{cm}^2$). The general population exposure limits for the 850 MHz Band is approximately $567 \mu\text{W}/\text{cm}^2$. The general population exposure limit for the 1900 MHz (PCS) and 2500 MHz (BRS) bands is $1000 \mu\text{W}/\text{cm}^2$. Because each carrier will be using different frequency bands, and each frequency band has different exposure limits, it is necessary to report percent of MPE rather than power density.



Occupational/controlled exposure limits apply to situations in which persons are exposed as a consequence of their employment and in which those persons who are exposed have been made fully aware of the potential for exposure and can exercise control over their exposure. Occupational/controlled exposure limits also apply where exposure is of a transient nature as a result of incidental passage through a location where exposure levels may be above general population/uncontrolled limits (see below), as long as the exposed person has been made fully aware of the potential for exposure and can exercise control over his or her exposure by leaving the area or by some other appropriate means.

Additional details can be found in FCC OET 65.

CALCULATIONS

Calculations were done for the proposed SPRINT Wireless antenna facility located at **186 Minortown Road, Woodbury, CT**, using the equipment information listed below. All calculations were performed per the specifications under FCC OET 65. Since SPRINT is proposing highly focused directional panel antennas, which project most of the emitted energy out toward the horizon, all calculations were performed assuming a lobe representing the maximum gain of the antenna per the antenna manufactures supplied specifications, minus 10 dB, was focused at the base of the tower. For this report the sample point is the top of a 6-foot person standing at the base of the tower.

For all calculations, all equipment was calculated using the following assumptions:

- 1) 1 CDMA channels (850 MHz) were considered for each sector of the proposed installation. These Channels have a transmit power of 20 Watts per Channel.
- 2) 2 LTE channels (850 MHz) were considered for each sector of the proposed installation. These Channels have a transmit power of 20 Watts per Channel.
- 3) 5 CDMA channels (1900 MHz (PCS)) were considered for each sector of the proposed installation. These Channels have a transmit power of 16 Watts per Channel.
- 4) 2 LTE channels (1900 MHz (PCS)) were considered for each sector of the proposed installation. These Channels have a transmit power of 40 Watts per Channel.
- 5) 8 LTE channels (2500 MHz (BRS)) were considered for each sector of the proposed installation. These Channels have a transmit power of 20 Watts per Channel.



- 6) All radios at the proposed installation were considered to be running at full power and were uncombined in their RF transmissions paths per carrier prescribed configuration. Per FCC OET Bulletin No. 65 - Edition 97-01 recommendations to achieve the maximum anticipated value at each sample point, all power levels emitting from the proposed antenna installation are increased by a factor of 2.56 to account for possible in-phase reflections from the surrounding environment. This is rarely the case, and if so, is never continuous.
- 7) For the following calculations, the sample point was the top of a 6-foot person standing at the base of the tower. The maximum gain of the antenna per the antenna manufactures supplied specifications minus 10 dB was used in this direction. This value is a very conservative estimate as gain reductions for these particular antennas are typically much higher in this direction.
- 8) The antennas used in this modeling are the **RFS APXVSP18-C-A20, RFS APXV9ERR18-C-A20 and the RFS APXVTM14-C-120** for transmission in the 850 MHz, 1900 MHz (PCS) and 2500 MHz (BRS) frequency bands. This is based on feedback from the carrier with regards to anticipated antenna selection. Maximum gain values for all antennas are listed in the Inventory and Power Data table below. The maximum gain of the antenna per the antenna manufactures supplied specifications, minus 10 dB, was used for all calculations. This value is a very conservative estimate as gain reductions for these particular antennas are typically much higher in this direction.
- 9) The antenna mounting height centerlines of the proposed antennas are **103 feet** above ground level (AGL) for **Sector A**, **103 feet** above ground level (AGL) for **Sector B** and **103 feet** above ground level (AGL) for Sector C.
- 10) Emissions values for additional carriers were taken from the Connecticut Siting Council active database. Values in this database are provided by the individual carriers themselves.

All calculations were done with respect to uncontrolled / general population threshold limits.



SPRINT Site Inventory and Power Data by Antenna

Sector:	A	Sector:	B	Sector:	C
Antenna #:	1	Antenna #:	1	Antenna #:	1
Make / Model:	RFS APXV9ERR18-C-A20	Make / Model:	RFS APXVSPPI8-C-A20	Make / Model:	RFS APXVSPPI8-C-A20
Gain:	13.4 / 15.9 dBd	Gain:	13.4 / 15.9 dBd	Gain:	13.4 / 15.9 dBd
Height (AGL):	103 feet	Height (AGL):	103 feet	Height (AGL):	103 feet
Frequency Bands	850 MHz / 1900 MHz (PCS)	Frequency Bands	850 MHz / 1900 MHz (PCS)	Frequency Bands	850 MHz / 1900 MHz (PCS)
Channel Count	10	Channel Count	10	Channel Count	10
Total TX Power(W):	220 Watts	Total TX Power(W):	220 Watts	Total TX Power(W):	220 Watts
ERP (W):	5,873.76	ERP (W):	7,537.38	ERP (W):	7,537.38
Antenna A1 MPE%	2.52 %	Antenna B1 MPE%	3.26 %	Antenna C1 MPE%	3.26 %
Antenna #:	2	Antenna #:	2	Antenna #:	2
Make / Model:	RFS APXVTM14-C-120	Make / Model:	RFS APXVTM14-C-120	Make / Model:	RFS APXVTM14-C-120
Gain:	15.9 dBd	Gain:	15.9 dBd	Gain:	15.9 dBd
Height (AGL):	103 feet	Height (AGL):	103 feet	Height (AGL):	103 feet
Frequency Bands	2500 MHz (BRS)	Frequency Bands	2500 MHz (BRS)	Frequency Bands	2500 MHz (BRS)
Channel Count	8	Channel Count	8	Channel Count	8
Total TX Power(W):	160 Watts	Total TX Power(W):	160 Watts	Total TX Power(W):	160 Watts
ERP (W):	6,224.72	ERP (W):	6,224.72	ERP (W):	6,224.72
Antenna A2 MPE%	2.38 %	Antenna B2 MPE%	2.38 %	Antenna C2 MPE%	2.38 %

Site Composite MPE%	
Carrier	MPE%
SPRINT – Max per sector	5.64 %
Verizon Wireless	3.35 %
AT&T	6.20 %
Site Total MPE %:	15.19 %

SPRINT Sector A Total:	4.89 %
SPRINT Sector B Total:	5.64 %
SPRINT Sector C Total:	5.64 %
Site Total:	15.19 %

SPRINT _ Max Values per Frequency Band / Technology Per Sector (Sectors B & C)	# Channels	Watts ERP (Per Channel)	Height (feet)	Total Power Density ($\mu\text{W}/\text{cm}^2$)	Frequency (MHz)	Allowable MPE ($\mu\text{W}/\text{cm}^2$)	Calculated % MPE
Sprint 850 MHz CDMA	1	437.55	103	1.67	850 MHz	567	0.29%
Sprint 850 MHz LTE	2	437.55	103	3.34	850 MHz	567	0.59%
Sprint 1900 MHz (PCS) CDMA	5	622.47	103	11.89	1900 MHz (PCS)	1000	1.19%
Sprint 1900 MHz (PCS) LTE	2	1,556.18	103	11.89	1900 MHz (PCS)	1000	1.19%
Sprint 2500 MHz (BRS) LTE	8	778.09	103	23.78	2500 MHz (BRS)	1000	2.38%
						Total:	5.64%



Summary

All calculations performed for this analysis yielded results that were **within** the allowable limits for general population exposure to RF Emissions.

The anticipated maximum composite contributions from the SPRINT facility as well as the site composite emissions value with regards to compliance with FCC's allowable limits for general population exposure to RF Emissions are shown here:

SPRINT Sector	Power Density Value (%)
Sector A:	4.89 %
Sector B:	5.64 %
Sector C:	5.64 %
SPRINT Maximum Total (per sector):	5.64 %
Site Total:	15.19 %
Site Compliance Status:	COMPLIANT

The anticipated composite MPE value for this site assuming all carriers present is **15.19 %** of the allowable FCC established general population limit sampled at the ground level. This is based upon values listed in the Connecticut Siting Council database for existing carrier emissions.

FCC guidelines state that if a site is found to be out of compliance (over allowable thresholds), that carriers over a 5% contribution to the composite value will require measures to bring the site into compliance. For this facility, the composite values calculated were well within the allowable 100% threshold standard per the federal government.