



**Gamma Purchasing
L.L.C. ("DISH")**

Alex Murshteyn
Real Estate Consultant
750 W. Center St, Suite 301
W. Bridgewater, MA 02379
Phone: (508) 821-0159
amurshteyn@clinellc.com

November 20, 2018

Honorable Robert Stein, Chairman
and Members of the Connecticut Siting Council
Connecticut Siting Council
10 Franklin Square
New Britain, Connecticut 06051

Re: **Request for Tower Share
Gamma Purchasing L.L.C. ("DISH" a/k/a "Dish" f/k/a "Dish Network") Request for
Approval of the Shared Use of an Existing Tower at 1233 Wolcott Road, Wolcott, CT.
DISH site number: CT0100001A (SBA: CT20021-A)**

Dear Chairman Stein and Members of the Council:

Dish proposes to share an existing telecommunications tower located at 1233 Wolcott Road, Wolcott, CT (the facility). The subject parcel is identified by the Town of Wolcott as Map 119, Block 3 and Lot 7. The property is owned by Edward F. Cleary. The tower is owned by SBA Communications. The property is roughly 7.04± acres and accommodates an existing one-story industrial building plus the self-supporting lattice tower with its chain-link fenced compound, with two utility buildings plus two empty and one covered/occupied concrete pad within. The facility is and will continue to be owned and operated by SBA Communications.

Pursuant to Connecticut General Statutes Section 16-50aa (the Statute), Dish requests a finding from the Connecticut Siting Council that the shared use of this facility is technically, legally, environmentally and economically feasible, will meet safety concerns, will avoid the unnecessary proliferation of towers and is in the public interest. Dish further requests an order approving the shared use of this facility.

The purpose of this request is to use an existing tower to develop Dish's wireless network to provide high speed wireless data and to develop wireless service within the State of Connecticut and in this part of Wolcott, CT: thus avoiding the need for an additional tower in Wolcott.

Dish is licensed by the Federal Communications Commission ("FCC") to provide multiple technologies, including NB-IoT, PCS and AWS (1900 MHz and 2000-2020 MHz) in New Haven

County. Dish is building and enhancing its network to take advantage of its licensed spectrum, and improve its Personal Carrier Services (PCS) and other FCC-licensed wireless data services.

Existing Facility & Proposed Modification

The existing facility is and will continue to be a 350' lattice tower located at 1233 Wolcott Road. Site coordinates (NAD83) are N41° 37' 17.7" and W72° 58' 25.1". Currently there are approximately ten other commercial wireless carriers licensed on this tower, including two existing major carriers, whereby Dish now intends to use the vacant space near the tower top. The site plan of the facility is included in the proposed Construction Drawings, prepared by Hudson Design Group, LLC dated November 1, 2018 and enclosed herewith.

Dish intends to install three (3) ODI2-065R18K-GQ Comba panel antennas and five (5) Ericsson RRUs on an antenna sector frame to be attached to the lattice tower at the 341' mount level. Dish will also install one (1) 1-1/4" hybrid fiber cable on the tower. Down below, it will remove one (1) of the existing vacant concrete pads and replace it with one smaller (1) platform-level 3' dish antenna,

Dish intends to enter into a new agreement, at this tower height, in order to license the portion of space within the existing fenced compound for new 5'-0" x 7'-0" platform on concrete piers that will replace an existing 6'-0" x 10'-0" concrete pad. It will install one (1) new 5'-3" stacked cabinet beneath an ice canopy, along with one (1) telco and one (1) power cabinet on an H-frame thereon. Equipment will thus remain within the existing fenced compound. A new ice bridge will also be installed near the ice canopy in order to connect the equipment with the tower. A GPS antenna with a 3' satellite dish will be located on the platform canopy near the ice bridge.

Consistent with the requirements of the Statute, it is feasible for Dish to collocate at this facility. Dish is proposing to collocate on the existing lattice tower that will continue to remain the ownership of SBA Communications. Included with this application is a Structural Analysis Report from All Pro Consulting Group, Inc. dated August 22, 2018 that shows that the existing tower can support Dish's proposed equipment, as well as one (1) additional RRU later canceled from the planned initial deployment (i.e. only the aforementioned 5 will be installed).

The Proposal is Legally Feasible.

The Council has authority, pursuant to statute, to issue an order approving of the shared use of this tower. By issuing an order approving Dish's shared use of this tower, Dish will be able to proceed with obtaining a building permit for the proposed installation. SBA Communications has executed a Letter of Authorization that approved Dish's Request for Tower Share filing on November 20, 2018, which approval is included with this application. Dish's proposal is legally feasible.

Dish is a telecommunication provider licensed by the FCC to provide service in the State of Connecticut, including but not limited to New London County. Dish will enter into an agreement with the owner of this facility, American Tower, for the location of this proposed equipment on the existing tower so that it may provide telecommunications services to the surrounding community. Consequently, the proposal is legally feasible.

The Proposal is Environmentally Feasible.

Pursuant to the Statute, the proposal will be environmentally feasible for the following reasons:

- The overall impact on the Town of Wolcott will be decreased with the sharing of a single tower versus the proliferation of multiple towers.
- There will be no material increase in the visibility of the tower with the addition of the antennas and associated equipment on the tower.
- There will be no increased impact on air quality because no air pollutants will be generated during normal operation of the facility.
- There will only be a brief, slight increase in noise pollution while the site is under construction.
- During construction, the proposed project will generate a small amount of traffic as construction takes place. Upon completion, traffic will be limited to an average of one trip per month for maintenance and inspections.
- There will be no adverse impact to the health and safety of the surrounding community or workers at the facility due to the addition of Dish’s new antennas to the tower. Dish has performed an analysis of the radio frequency field emanating from the transmitting antennas on the tower to ensure compliance with the National Council on Radiation Protection and measurements (NCRP) standard for maximum permissible exposure (MPE) adopted by the FCC. The analysis dated November 15, 2018 indicates that Dish and other antennas on the tower will cumulatively emit 5.93% of the NCRP standard for maximum permissible exposure. The report indicates that maximum level of exposure will be well below the FCC’s mandated radio frequency exposure limits. The report is enclosed herewith and the calculations are below.

Antenna ID	Antenna Make / Model	Frequency Bands	Antenna Gain (dBi)	Channel Count	Total TX Power (W)	ERP (W)	MPE %
Antenna A1	Comba ODD-06/R18K-GQ	1900 MHz (PCS) - H Block / Band 70 (2000 to 2020 MHz)	15.65	4	160	5,876.52	0.19
Sector A Composite MPE%							0.19
Antenna B1	Comba ODD-06/R18K-GQ	1900 MHz (PCS) - H Block / Band 70 (2000 to 2020 MHz)	15.65	4	160	5,876.52	0.19
Sector B Composite MPE%							0.19
Antenna C1	Comba ODD-06/R18K-GQ	1900 MHz (PCS) - H Block / Band 70 (2000 to 2020 MHz)	15.65	4	160	5,876.52	0.19
Sector C Composite MPE%							0.19
Site Composite MPE %							
Carrier							MPE%
Dish Wireless - Max Sector Value							0.19 %
Loluck							0.00 %
TSP Wireless							0.03 %
Highlink Wireless							0.29 %
Wolcott Ambulance							0.06 %
Norstel							0.15 %
Sprint							0.46 %
Clearnet							0.04 %
Marsan							2.63 %
AT&T							1.85 %
NewPCS							0.17 %
Site Total MPE %:							5.93 %

Dish Wireless Sector A Total:	0.19 %
Dish Wireless Sector B Total:	0.19 %
Dish Wireless Sector C Total:	0.19 %
Site Total:	5.93 %

- Dish expects to enhance safety in this portion of Wolcott by improving wireless telecommunications for local residents and travelers. Dish is currently developing its network to provide its customers with quality and reliable coverage to comply with their FCC license, the site is a necessary part of Dish's network development.
- Specifically, this proposal is designed to provide reliable wireless coverage for this section of Wolcott, CT.

Conclusions:

For the reasons stated above, the attachment of Dish's antennas and associated equipment to the tower would meet all the requirements set forth in the Statute. The proposal is legally, technically, economically and environmentally feasible and meets all public safety concerns. Therefore, Dish respectfully requests that the Council approve this request for the shared use of this tower located at 1233 Wolcott Road, Wolcott, CT.

Respectfully yours,

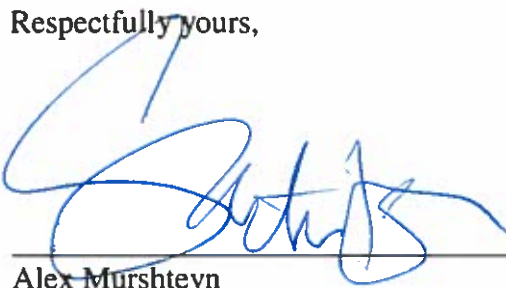

Alex Murshteyn
Real Estate Consultant – Site Acquisition
c/o Gamma Purchasing L.L.C. (Dish)
Centerline Communications, LLC
750 West Center Street, Floor 3 / Suite 301
West Bridgewater, MA 02379
Mobile: (508) 821-0159
AMurshteyn@centerlinecommunications.com

Enclosures (7)

cc: Thomas G. Dunn, Town of Wolcott, Mayor of Wolcott - chief elected official
David Kalinowski, Zoning Inspector, Zoning Department Office - P&Z official
Edward F. Cleary - property owner
SBA Communications - tower owner
DISH (e-mail)

ALEX MURSHTEYN
508-821-0159
CENTERLINE COMMUNICATIONS, LLC
750 WEST CENTER STREET
WEST BRIDGEWATER MA 023791518

1 LBS

1 OF 1

DWT: 14,10,1

SHIP TO:

TOWN HALL
MAYOR THOMAS G. DUNN
MAYOR'S OFFICE
10 KENEA AVE
WOLCOTT CT 06716-2114

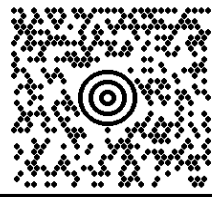

CT 067 9-05



UPS GROUND

TRACKING #: 1Z 9Y4 503 03 3343 6508

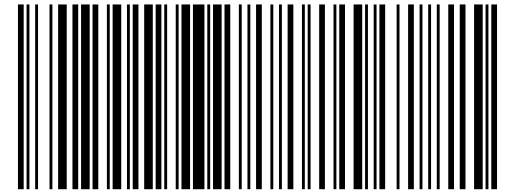

BILLING: P/P

Reference#1: CT0100001A
Reference#2: CSC TS - CEO

UIS 20.6.13. WNTNV50 06.0A 10/2018



ALEX MURSHTEYN
508-821-0159
CENTERLINE COMMUNICATIONS, LLC
750 WEST CENTER STREET
WEST BRIDGEWATER MA 023791518

1 LBS

1 OF 1

DWT: 14,11,1

SHIP TO:

TOWN HALL
DAVID KALINOWSKI, ZONING INSPECTOR
ZONING DEPARTMENT OFFICE
10 KENEA AVE
WOLCOTT CT 06716-2114

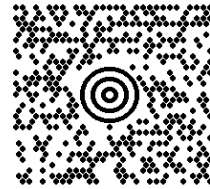

CT 067 9-05



UPS 3 DAY SELECT

3

TRACKING #: 1Z 9Y4 503 12 2090 6114

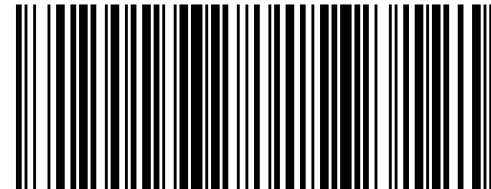

BILLING: P/P

Reference#1: CT0100001A
Reference#2: CSC TS - P&Z

UIS 20.6.13. WNTNV50 06.0A 10/2018



ALEX MURSHTEYN
508-821-0159
CENTERLINE COMMUNICATIONS, LLC
750 WEST CENTER STREET
WEST BRIDGEWATER MA 023791518

1 LBS

1 OF 1

DWT: 14,10,1

SHIP TO:

SHAWN NOTTAGE, SITE MARKETING MGR
401-533-6434
SBA COMMUNICATIONS CORPORATION
8051 CONGRESS AVENUE
BOCA RATON FL 33487-1307

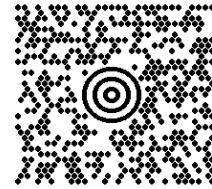

FL 332 6-07



UPS GROUND

TRACKING #: 1Z 9Y4 503 03 3886 8720



BILLING: P/P

Reference#1: CT0100001A
Reference#2: CSC TS - TO

UIS 20.6.13. WNTNV50 06.0A 10/2018



ALEX MURSHTEYN
508-821-0159
CENTERLINE COMMUNICATIONS, LLC
750 WEST CENTER STREET
WEST BRIDGEWATER MA 023791518

1 LBS

1 OF 1

DWT: 14,10,1

SHIP TO:

EDWARD F. CLEARY
50 BEACH RD
WOLCOTT CT 06716-1902

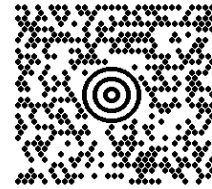

CT 067 9-05



UPS GROUND

TRACKING #: 1Z 9Y4 503 03 2822 4336

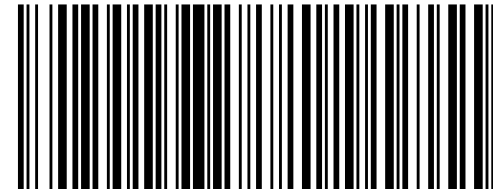

BILLING: P/P

Reference#1: CT0100001A
Reference#2: CSC TS - PO

UIS 20.6.13. WNTNV50 06.0A 10/2018





SBA Communications Corporation
8051 Congress Avenue
Boca Raton, FL 33487-1307

T + 561.995.7670
F + 561.995.7626

sbasite.com

LETTER OF AUTHORIZATION

SBA Site ID: CT20021-A, Cleary Tower (Edward)

Property Located at: 1233 Wolcott Road (Rt-69), Wolcott, CT, 06716

THE CITY/COUNTY OF: Wolcott / New Haven/Wolcott

APPLICATION FOR ZONING/USE/BUILDING PERMIT

This letter authorizes Dish Network and its authorized agents to file for all necessary zoning, planning and building permits (local, state and federal) for the purposes of installing, operating and maintaining a telecommunications facility on the existing tower on the property referenced above on behalf of Edward F. Cleary.

All approval conditions that may be granted to Dish Network in connection with above referenced facility relating to this specific application are the sole responsibility of Dish Network.

SBA Structures, LLC

A handwritten signature in black ink, appearing to read "Jason Silberstein", is written over a light blue horizontal line.

Jason Silberstein

Executive VP, Site Leasing

Date: 11/20/2018



CONSULTING GROUP, INC.

9221 Lyndon B. Johnson Freeway, #204, Dallas, TX 75243 ★ PHONE 972-231-8893 ★ FAX 1-866-364-8375
www.allprocgi.com ★ e-mail: info@allprocgi.com

**Tower Structural Analysis Report for
SBA Network Services, Inc.**



Existing 350' Self Support Tower

SBA Site Name: Cleary Tower (Edward)
SBA Site ID: CT20021-A-11
Carrier Name: Dish Network
Carrier Site ID/Name: CT0100001A / EA010
App # 93365, v1

Site Location: 1233 Wolcott Road (Rt-69)
Wolcott, CT 06716
New Haven County
Latitude: 41.621581°
Longitude: -72.973633°

ACGI Job # 18-5441

(Refer to Previous ACGI Job # 17-0832 Rev.2, dated 07/14/2017)

ANALYSIS RESULTS		
Tower Components	98.4 %	Pass
Tower Foundation	41.8 %	Pass
Net change in tower stress	+6.8 %	Change from previous SA by Allpro Consulting Group, Inc. ACGI#17-0832 Rev.2 dated 07/14/2017.

Prepared By:
Binod Paudel, EIT
Staff Engineer

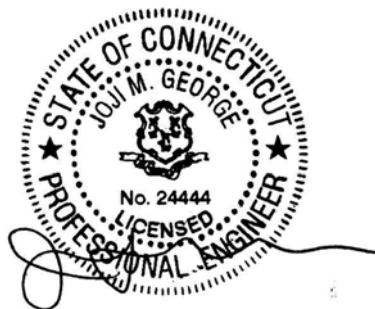

08/22/2018
Approved By:
Joji M. George, P.E.
CT PE # 24444

TABLE OF CONTENTS

ANALYSIS SUMMARY	3
SCOPE & SOURCE OF INFORMATION.....	3
SOURCE OF INFORMATION.....	3
ANALYSIS METHODS & DATA.....	4
SITE DATA.....	4
TOWER DATA	4
TOWER HISTORY	4
CONCLUSIONS.....	5
RESULT SUMMARY.....	5
MAXIMUM DISH ROTATION AT SERVICE WIND SPEED	5
ASSUMPTIONS	6
DISCLAIMER.....	6
APPURTENANCE LISTING	7
EXISTING LOAD DESCRIPTION.....	7
FINAL DISH NETWORK LOAD DESCRIPTION.....	7
SUMMARY OF WORKING PERCENTAGE OF STRUCTURAL COMPONENTS	8
APPENDIX.....	10

1. ANALYSIS SUMMARY

The existing 350' Self-Supported Tower located in Wolcott, Connecticut was analyzed by Allpro Consulting Group, Inc. (ACGI) for the existing loads and the proposed Dish Network antennas, dishes and coaxes per application#93365, v1 as authorized by SBA Communication Corp. Based on the results of the analysis, the existing tower with below mentioned proposed and existing loading is found to be **in compliance** with TIA-222-G, *Structural Standards for Steel Antenna Towers and Antenna Supporting Structures* and *International Building Code 2012*.

2. SCOPE & SOURCE OF INFORMATION

The purpose of this structural analysis is to determine whether the existing structure is capable of supporting additional proposed loads.

SOURCE OF INFORMATION		
Tower Data:	Paul J. Ford & Co.	Structural analysis by Paul J. Ford & Co., Job No. A03-T143 dated 12/22/2003.
	FDH Engineering	Previous structural analysis by FDH Engineering, project #1462GQ1400, dated 04/09/2014.
	Allpro Consulting Group, Inc.	Previous structural analysis by Allpro Consulting Group, Inc., ACGI Job #16-4376, dated 12/14/2016.
		Previous modification design by Allpro Consulting Group, Inc., ACGI#17-0832 Rev.2 dated 07/14/2017.
Foundation Data:	Paul J. Ford & Co.	Structural analysis by Paul J. Ford & Co., Job No. A03-T143 dated 12/22/2003.
Geotechnical Report:	Osman Pekin	Soil report by Osman Pekin, Ph.D., P.E. dated 12/12/1991.
Loading Data:	Allpro Consulting Group, Inc.	Previous modification design SA by Allpro Consulting Group, Inc., ACGI#17-0832 Rev.2 dated 07/14/2017.
	sbsite.com	SBA site summary dated 7/26/2018. Proposed final loading for Dish Network as per sbsite.com, Application ID 93365, v1.
Authorization:	SBA Communication Corp.	

3. ANALYSIS METHODS & DATA

The analysis was performed in accordance with Telecommunication Industry Association specification TIA-222-G-Addendum 2. The tower was modeled using TNX Tower, a 3-D finite element program. TNX Tower is a general-purpose modeling, analysis, and design program created specifically for communication towers using the EIA-222-C, EIA-222-D, TIA/EIA-222-F or TIA-222-G standards. The 3-D model included the tower, with existing appurtenances and all proposed loads.

SITE DATA	
SBA Site Name:	Cleary Tower (Edward)
SBA Site Number:	CT20021-A-11
Carrier Site Name:	Dish Network: CT0100001A / EA010
City, State:	Wolcott, CT
County:	New Haven
Code Wind Load Requirement:	TIA-222-G & 2012 International Building Code (Ultimate wind speed of 125 mph 3 sec gust equivalent to Nominal design wind speed of 97 mph)
Wind Load Used:	TIA-222-G Code: <ul style="list-style-type: none"> • Nominal wind speed of 97 mph (3 second gust wind speed) • Structure Class II*. • Exposure Category B. • Topographic Category 1. • A wind speed of 50 mph is used in combination with 0.75 in ice thickness.
Seismic Check:	Spectral Response Acceleration at Short Period (Ss) is 0.186 g which less than 1.000 g. Therefore, no seismic check is required as per TIA-222-G section 2.7.3

*This structural analysis is based upon the tower being classified as a class II; however, if a different classification is required subsequent to the date hereof, the tower classification will be changed to meet such requirement and a new structural analysis will be run.

TOWER DATA	
Tower Type:	Self-Supported Tower
Height:	350'
Cross Section:	Triangular
Steel Strength:	Legs – 50 ksi, Braces – 36ksi
Type of Foundation:	Pad and Pier Foundation

TOWER HISTORY	
Tower Manufacturer / Model:	FWT, Inc.
Date of Original Design:	1992
Previous Modifications:	Previous modification design by Allpro Consulting Group, Inc., ACGI#17-0832 Rev.2 dated 07/14/2017.
Original Design Code Reqt:	EIA/TIA 222-E, 85mph basic wind speed without ice and 74 mph basic wind speed with 0.5" thick ice

4. CONCLUSIONS

RESULT SUMMARY		
MEMBER	% Capacity	Pass/Fail
Leg	46.1 %	Pass
Diagonal	51.6 %	Pass
Horizontal	50.3 %	Pass
Top Girt	3.2 %	Pass
Redundant Horizontal Bracing	98.4 %	Pass
Redundant Diagonal Bracing	69.1 %	Pass
Inner Bracing	0.9 %	Pass
Bolts	48.1 %	Pass
Anchor Bolts	46.5 %	Pass

Foundation Type	Reaction Direction	Current Analysis Reaction (TIA-222-G)	Original Design Reaction (EIA/TIA-222-E)	Original Design Reaction equivalent to TIA-222-G (multiply by 1.35)	% Capacity
Individual Foundation	Uplift	308 k	631 k	851.8 k	36.2%
	Compression	424 k	751 k	1013.8 k	41.8%

*Note: Soil data available as per Soil report by Osman Pekin, Ph.D., P.E. dated 12/12/1991 is not sufficient for the detail analysis of the foundation. Therefore, reactions are compared based upon the original tower design. Foundation is estimated to be acceptable based on the tower member loads and stresses. However, it is recommended to provide detailed geotechnical investigation report for rigorous analysis of the tower foundation.

MAXIMUM DISH ROTATION AT SERVICE WIND SPEED				
Twist and Sway (deg), 10 dB degradation limit*				
Elev. (ft)	MW Dish	Tilt (deg)	Twist (deg)	Allowable (deg)
165±	SPD3-2.4	0.0670	0.0029	Carrier to verify

As per the results of the analysis, the existing tower **is in code compliance** for the proposed and existing antenna loads.

Maximum tower member stress **is less than allowable making it in code compliance** under the TIA-222-G code and International Building Code 2012 requirements.

Overall tower stress ratio increased by 6.8% compared to previous SA by Allpro Consulting Group, Inc. ACGI#17-0832 Rev.2 dated 07/14/2017 due to addition of Dish Network loadings (new carrier).

5.

ASSUMPTIONS

This analysis was completed based on the following assumptions:

- Tower has been properly maintained
- Tower erection was in accordance to manufacturer drawings
- Leg flanges have been properly designed by manufacturer to not be a limiting reaction
- Welds have been properly designed and installed by manufacturer to not be a limiting reaction
- Foundation was constructed in accordance to manufacturer drawings
- Foundation does not have structural damage
- Bolts have been properly tightened according to manufacturer specifications
- Appurtenance, mount and transmission line sizes and weights are best estimates using the tnxTower database and manufacturer information

6.

DISCLAIMER

Installation procedures and related loading are not within the scope of this analysis. A contractor experienced in similar work should perform all installation work. The engineering services provided by Allpro Consulting Group, Inc. (ACGI) are limited to the computer analysis and calculations of the structure with the proposed and existing loads. This analysis is considered void if the loading mentioned in this report is changed or is different as installed. It is assumed that the existing structure is properly maintained and is in good condition free of any defects. Scope of this analysis does not include existing connections, except as noted in this report.

ACGI does not make any warranties, expressed or implied in connection with this engineering analysis report and disclaims any liability arising from deficiencies or any existing conditions of the original structure. ACGI will not be responsible for consequential or incidental damages sustained by any parties as a result of any data or conclusions included in this Report. The maximum liability of ACGI pursuant to this report shall be limited to the consulting fee received for the preparation of the report.

7.

APPURTENANCE LISTING

EXISTING LOAD DESCRIPTION					
<u>ELEV (ft.)</u>	<u>Qty.</u>	<u>Antenna Description</u>	<u>Mount Type & Qty.</u>	<u>TX. LINE (in)</u>	<u>TENANT</u>
350±	1	Celwave PD200 Omni	(1) Star Mount w/ (9) Standoffs	(1) 7/8"	LoJack
350±	1	101 Omni		(1) 1 1/4"	Marcus
320±	2	101 Omni	(2) 6' Standoffs	(2) 1 1/4"	Marcus
186±	3	Powerwave 7770 Antenna	(3) 13.5' T-Frames	(12) 1-5/8" (2) 3/4" DC Power (1) 1/2" Fiber [DC Power & Fiber inside 2" interduct]	AT&T
	4	KMW AM-X-CD-16-65-00T-RET Antenna			
	2	Kathrein 800 10121 Antenna			
	3	CCI HPA-65R-BUU-H6 Antenna			
	6	CCI DTMABP7819VG12A TMA			
	4	Kathrein 860 10025 RET			
	3	Ericsson RRUS 11 Remote Radio			
	3	Ericsson RRUS 32 Remote Radio			
	6	Powerwave LGP 13519 Diplexer			
1	Raycap DC6-48-60-18-8F Surge				
165±	3	SPD3-2.4 Radiowaves Dish	Pipe Mount	(6) 1/2"	Marcus
	3	SPD2-5.8 Radiowaves Dish	Pipe Mount		
158±	1	Decibel DB408 Omni	(1) 17" Standoff	(1) 7/8"	Wolcott
134±	3	APXVTM14-C-I20	(3) 15' T-Frames	(4) 1-1/4"	Sprint
	3	RFS APXVSP18			
	3	RRH 1900 MHz			
	3	RRH 800 MHz			
	3	RRH TD-8x20-25			
	3	RRH 800 MHz Filter			
	4	RFS ACU-A20-N			

FINAL DISH NETWORK LOAD DESCRIPTION					
<u>ELEV (ft.)</u>	<u>Qty.</u>	<u>Antenna Description</u>	<u>Mount Type & Qty.</u>	<u>TX. LINE (in)</u>	<u>TENANT</u>
341±	3	Kathrein 800 10622 Antenna	(3) Commscope SF-SU7-2-96 Sector Frame	(1) 1-1/4" Hybrid	Dish Network
	3	Ericsson 4415 Radio			
	3	Ericsson 0208 Radio			

Notes:

1. ACGI should be notified of any discrepancies found in the data listed in this report.
2. Notify ACGI if any potential physical and other interference with existing antennas for a redesign.

8. SUMMARY OF WORKING PERCENTAGE OF STRUCTURAL COMPONENTS

Section Capacity Table

Section No.	Elevation ft	Component Type	Size	Critical Element	P K	ϕP_{allow} K	% Capacity	Pass Fail
T1	350 - 340	Leg	2	3	-6.389	49.286	13.0	Pass
		Diagonal	L2x1 1/2x3/16	9	-2.174	10.346	21.0	Pass
		Top Girt	L3x3x1/4	4	-0.325	28.598	1.1	Pass
							31.7 (b)	
							3.2 (b)	
T2	340 - 320	Leg	2	21	-32.850	72.063	45.6	Pass
		Diagonal	L2x1 1/2x3/16	24	-3.350	11.584	28.9	Pass
							45.8 (b)	
T3	320 - 300	Leg	2 1/2	54	-51.804	112.346	46.1	Pass
		Diagonal	L2x2x3/16	75	-2.765	13.174	21.0	Pass
							36.6 (b)	
T4	300 - 280	Leg	3 1/4	81	-66.554	183.313	36.3	Pass
		Diagonal	L2-1/2x2-1/2x3/16	84	-2.330	13.474	17.3	Pass
							28.2 (b)	
T5	280 - 260	Leg	3 1/4	102	-82.027	183.313	44.7	Pass
		Diagonal	L2-1/2x2-1/2x3/16	108	-2.519	10.341	24.4	Pass
							31.5 (b)	
T6	260 - 240	Leg	3 1/2	123	-98.359	234.484	41.9	Pass
		Diagonal	L3x3x3/16	128	-2.981	13.820	21.6	Pass
							37.6 (b)	
T7	240 - 220	Leg	3 1/2	144	-114.326	306.641	37.3	Pass
		Diagonal	2L2 1/2x2 1/2x3/16x3/8	152	-3.882	25.202	15.4	Pass
							24.3 (b)	
		Horizontal	L2 1/2x2 1/2x3/16	148	-2.174	8.246	26.4	Pass
							27.8 (b)	
T8	220 - 200	Inner Bracing	L2 1/2x2 1/2x3/16	154	-0.012	7.609	0.6	Pass
		Leg	3 3/4	183	-132.471	368.015	36.0	Pass
		Diagonal	2L2 1/2x2 1/2x3/16x3/8	191	-4.388	21.196	20.7	Pass
							23.9 (b)	
		Horizontal	L2 1/2x2 1/2x3/16	190	-2.402	6.207	38.7	Pass
		Inner Bracing	L2 1/2x2 1/2x3/16	194	-0.014	5.772	0.7	Pass
T9	200 - 180	Leg	4	222	-152.651	434.236	35.2	Pass
		Diagonal	2L3x3x3/16x3/8	230	-6.349	30.555	20.8	Pass
							32.1 (b)	
		Horizontal	L3x3x3/16	226	-2.650	8.488	31.2	Pass
							33.8 (b)	
T10	180 - 160	Inner Bracing	L3x3x3/16	233	-0.017	7.941	0.7	Pass
		Leg	4 1/4	261	-177.754	505.220	35.2	Pass
		Diagonal	2L3x3x3/16x3/8	269	-7.303	26.278	27.8	Pass
							37.1 (b)	
		Horizontal	L3x3x3/16	265	-3.083	6.804	45.3	Pass
		Inner Bracing	L3x3x3/16	272	-0.018	6.396	0.8	Pass
T11	160 - 140	Leg	4 1/4	300	-204.825	505.220	40.5	Pass
		Diagonal	2L3x3x3/16x3/8	308	-8.157	22.339	36.5	Pass
							43.0 (b)	
		Horizontal	L3 1/2x3 1/2x1/4	304	-3.552	11.687	30.4	Pass
							34.0 (b)	
T12	140 - 120	Inner Bracing	L3 1/2x3 1/2x1/4	312	-0.021	11.050	0.7	Pass
		Leg	4 1/2	339	-225.945	580.902	38.9	Pass
		Diagonal	2L3x3x1/4x3/8	358	-12.140	31.416	38.6	Pass
							43.4 (b)	
		Horizontal	2L2 1/2x2 1/2x3/16x3/8	347	-3.918	13.682	28.6	Pass
		Redund Horz 1 Bracing	L2x2x3/16	352	-3.918	5.620	69.7	Pass
		Redund Diag 1 Bracing	L2-1/2x2-1/2x3/16	375	-2.662	6.069	43.9	Pass
T13	120 - 100	Inner Bracing	L3 1/2x3 1/2x1/4	362	-0.030	9.656	0.7	Pass
		Leg	4 3/4	384	-257.203	661.231	38.9	Pass
		Diagonal	2L3x3x1/4x3/8	400	-12.136	28.916	42.0	Pass
							47.2 (b)	
		Horizontal	2L2 1/2x2 1/2x3/16x3/8	392	-4.460	11.547	38.6	Pass
		Redund Horz 1 Bracing	L2x2x3/16	397	-4.460	4.748	93.9	Pass

CT20021-A-11/Cleary Tower (Edward) -350' SST

Section No.	Elevation ft	Component Type	Size	Critical Element	P K	ϕP_{allow} K	% Capacity	Pass Fail	
T14	100 - 80	Redund Diag 1 Bracing	L2-1/2x2-1/2x3/16	420	-2.927	5.494	53.3	Pass	
		Inner Bracing	L4x4x1/4	407	-0.031	12.311	0.8	Pass	
		Leg	4 3/4	429	-286.135	661.231	43.3	Pass	
		Diagonal	2L3x3x1/4x3/8	448	-13.238	26.593	49.8	Pass	
		Horizontal	2L2 1/2x2 1/2x3/16x3/8	437	-4.962	9.860	50.3	Pass	
		Redund Horz 1 Bracing	L2x2x3/8	442	-4.962	7.521	66.0	Pass	
		Redund Diag 1 Bracing	L2-1/2x2-1/2x3/16	465	-3.162	4.968	63.7	Pass	
T15	80 - 60	Inner Bracing	L4x4x1/4	452	-0.033	10.555	0.8	Pass	
		Leg	5	474	-317.199	746.168	42.5	Pass	
		Diagonal	2L3 1/2x3 1/2x1/4x3/8	490	-13.340	38.008	35.1	Pass	
							43.4 (b)		
		Horizontal	2L3x3x3/16x3/8	482	-5.501	15.048	36.6	Pass	
		Redund Horz 1 Bracing	L2-1/2x2-1/2x3/16	487	-5.501	6.992	78.7	Pass	
		Redund Diag 1 Bracing	L3x3x3/16	510	-3.420	7.925	43.2	Pass	
T16	60 - 40	Inner Bracing	2L3x3x3/16x3/8	496	-0.038	14.343	0.8	Pass	
		Leg	5 1/4	519	-346.925	835.679	41.5	Pass	
		Diagonal	2L3 1/2x3 1/2x1/4x3/8	538	-14.578	35.047	41.6	Pass	
							44.7 (b)		
		Horizontal	2L3x3x3/16x3/8	527	-6.016	13.146	45.8	Pass	
		Redund Horz 1 Bracing	L2-1/2x2-1/2x3/16	532	-6.016	6.113	98.4	Pass	
		Redund Diag 1 Bracing	L3x3x3/16	555	-3.662	7.227	50.7	Pass	
T17	40 - 20	Inner Bracing	2L3x3x3/16x3/8	541	-0.039	12.552	0.9	Pass	
		Leg	5 1/4	564	-378.276	835.679	45.3	Pass	
		Diagonal	2L3 1/2x3 1/2x1/4x3/8	580	-14.543	32.326	45.0	Pass	
							46.9 (b)		
		Horizontal	2L3 1/2x3 1/2x1/4x3/8	572	-6.560	24.167	27.1	Pass	
		Redund Horz 1 Bracing	L2.5x2.5x3/16 + L2.5x2.5x1/4 (C-Shape) - Cleary Tower	577	-6.560	14.963	43.8	Pass	
		Redund Diag 1 Bracing	L3x3x3/16	600	-3.921	6.591	59.5	Pass	
T18	20 - 0	Inner Bracing	2L3 1/2x3 1/2x1/4x3/8	587	-0.044	23.141	0.7	Pass	
		Leg	5 1/2	607	-409.462	929.740	44.0	Pass	
		Diagonal	2L3 1/2x3 1/2x1/4x3/8	628	-15.426	29.896	51.6	Pass	
		Horizontal	2L3 1/2x3 1/2x1/4x3/8	610	-7.101	21.456	33.1	Pass	
		Redund Horz 1 Bracing	L3x3x3/16	629	-7.101	8.374	84.8	Pass	
		Redund Diag 1 Bracing	L3x3x3/16	636	-4.178	6.043	69.1	Pass	
		Inner Bracing	2L3 1/2x3 1/2x1/4x3/8	631	-0.043	20.572	0.7	Pass	
							Summary		
							Leg (T3)	46.1	Pass
							Diagonal (T18)	51.6	Pass
					Horizontal (T14)	50.3	Pass		
					Top Girt (T1)	3.2	Pass		
					Redund Horz 1 Bracing (T16)	98.4	Pass		
					Redund Diag 1 Bracing (T18)	69.1	Pass		
					Inner Bracing (T16)	0.9	Pass		
					Bolt Checks	48.1	Pass		
					RATING =	98.4	Pass		

APPENDIX

SITE DATA

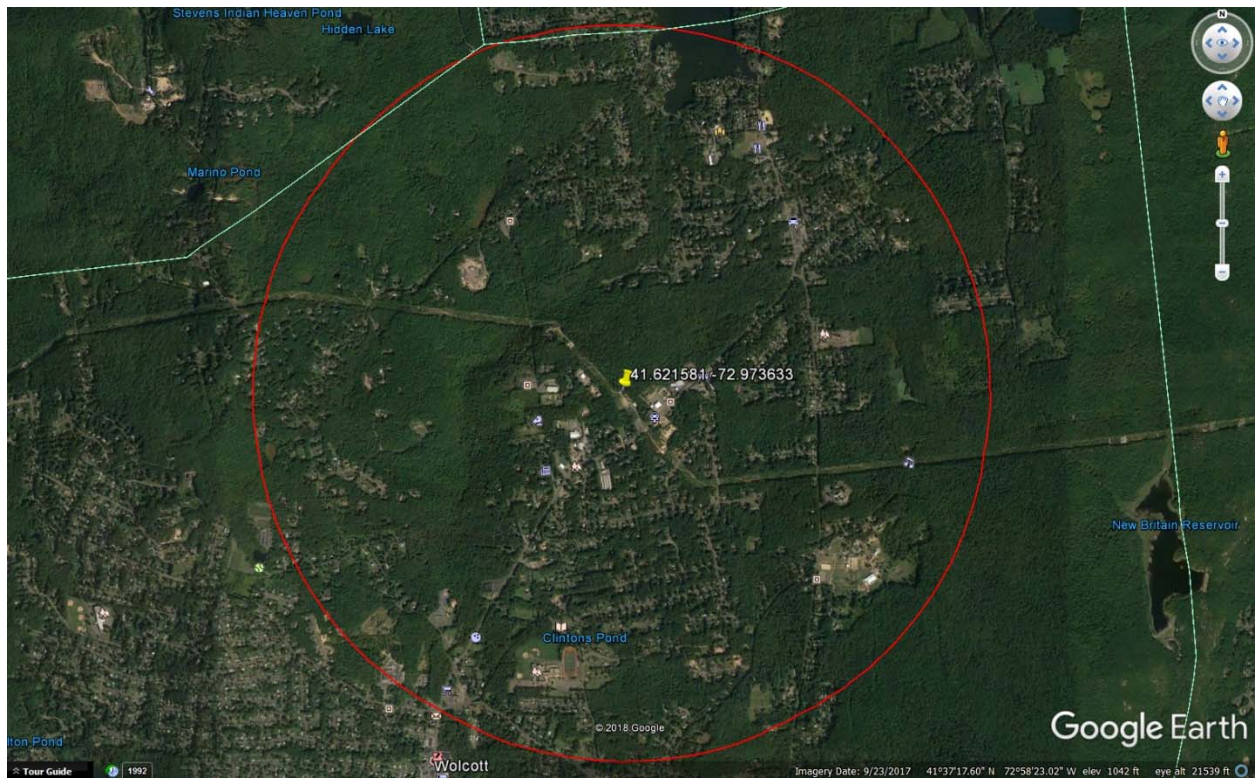

Exposure "B"

REFERENCE FROM CONNECTICUT STATE BUILDING CODE

(APPENDIX N) MUNICIPALITY - SPECIFIC STRUCTURAL DESIGN PARAMETERS												
Municipality	Ground Snow Load	MCE Spectral Accelerations (%g)		Wind Design Parameters								
				Ultimate Design Wind Speeds, V_{ult} (mph)			Nominal Design Wind Speeds, V_{asd} (mph)			Wind-Borne Debris Regions ¹		
		S_s	S_1	Risk Cat. I	Risk Cat. II	Risk Cat III-IV	Risk Cat. I	Risk Cat. II	Risk Cat. III-IV	Risk Cat. II & III except Occup I-2	Risk Cat III Occup I-2 & Risk Cat. IV	
New Haven	30	0.186	0.062	115	125	135	89	97	105		Type C	Yes
Newington	30	0.182	0.064	115	125	135	89	97	105			
New London	30	0.161	0.058	125	135	145	97	105	112	Type B	Type A	Yes
New Milford	35	0.198	0.066	105	115	125	81	89	97			
Newtown	30	0.208	0.066	110	120	130	85	93	101			Yes
Norfolk	40	0.175	0.065	105	115	125	81	89	97			
North Branford	30	0.179	0.061	120	130	140	93	101	108			Yes
North Canaan	40	0.173	0.065	105	115	120	81	89	93			
North Haven	30	0.184	0.062	115	125	135	89	97	105			Yes
North Stonington	30	0.163	0.059	125	135	145	97	105	112		Type A	Yes
Norwalk	30	0.232	0.067	110	120	130	85	93	101			Yes
Norwich	30	0.168	0.060	125	135	145	97	105	112		Type A	Yes
Old Lyme	30	0.164	0.059	125	135	145	97	105	112	Type B	Type A	Yes
Old Saybrook	30	0.164	0.059	125	135	145	97	105	112	Type B	Type A	Yes
Orange	30	0.192	0.063	115	125	135	89	97	105			Yes
Oxford	30	0.196	0.064	110	125	130	85	97	101			Yes
Plainfield	35	0.170	0.061	125	135	145	97	105	112		Type A	Yes
Plainville	35	0.184	0.064	115	125	135	89	97	105			Yes
Plymouth	35	0.186	0.064	110	120	130	85	93	101			Yes
Pomfret	40	0.172	0.063	120	130	140	93	101	108			Yes
Portland	30	0.180	0.063	115	130	135	89	101	105			Yes
Preston	30	0.167	0.060	125	135	145	97	105	112		Type A	Yes
Prospect	30	0.188	0.064	115	125	135	89	97	105			Yes
Putnam	40	0.172	0.063	120	130	140	93	101	108			Yes
Redding	30	0.220	0.067	110	120	130	85	93	101			Yes
Ridgefield	30	0.230	0.068	110	120	125	85	93	97			Yes
Rocky Hill	30	0.181	0.063	115	125	135	89	97	105			Yes
Roxbury	35	0.197	0.065	110	120	125	85	93	97			Yes
Salem	30	0.170	0.060	120	135	140	93	105	108		Type A	Yes
Salisbury	40	0.173	0.065	105	115	120	81	89	93			
Scotland	30	0.172	0.061	120	130	140	93	101	108			Yes
Seymour	30	0.194	0.064	115	125	135	89	97	105			Yes
Sharon	40	0.179	0.065	105	115	120	81	89	93			
Shelton	30	0.199	0.064	115	125	135	89	97	105			Yes
Sherman	35	0.202	0.066	105	115	120	81	89	93			
Simsbury	35	0.179	0.064	110	120	130	85	93	101			Yes
Somers	35	0.174	0.064	115	125	135	89	97	105			Yes
Southbury	35	0.198	0.065	110	120	130	85	93	101			Yes
Southington	30	0.185	0.064	115	125	135	89	97	105			Yes
South Windsor	30	0.178	0.064	115	125	135	89	97	105			Yes

USGS Design Maps Summary Report

User-Specified Input

Building Code Reference Document 2012/2015 International Building Code
 (which utilizes USGS hazard data available in 2008)

Site Coordinates 41.62158°N, 72.97363°W

Site Soil Classification Site Class D – “Stiff Soil”

Risk Category I/II/III

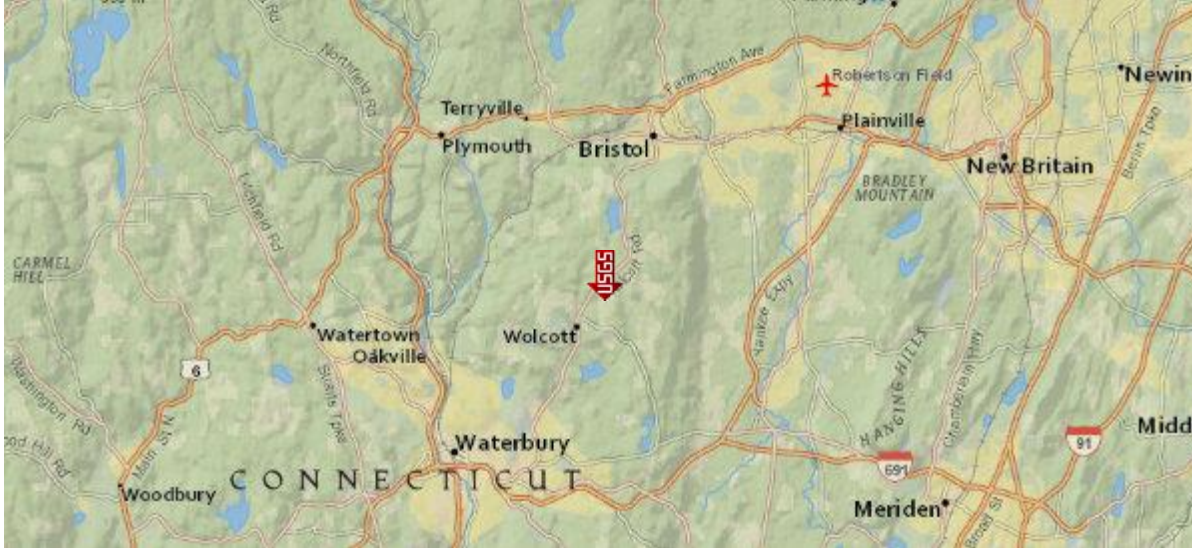

USGS-Provided Output

$S_S = 0.186 \text{ g}$	$S_{MS} = 0.297 \text{ g}$	$S_{DS} = 0.198 \text{ g}$
$S_1 = 0.064 \text{ g}$	$S_{M1} = 0.154 \text{ g}$	$S_{D1} = 0.102 \text{ g}$

For information on how the S_S and S_1 values above have been calculated from probabilistic (risk-targeted) and deterministic ground motions in the direction of maximum horizontal response, please return to the application and select the “2009 NEHRP” building code reference document.

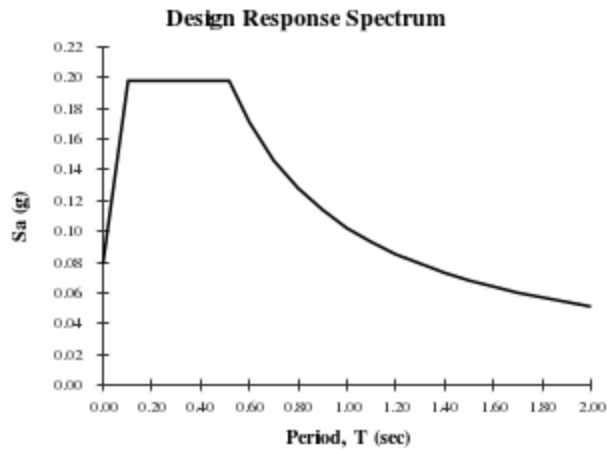
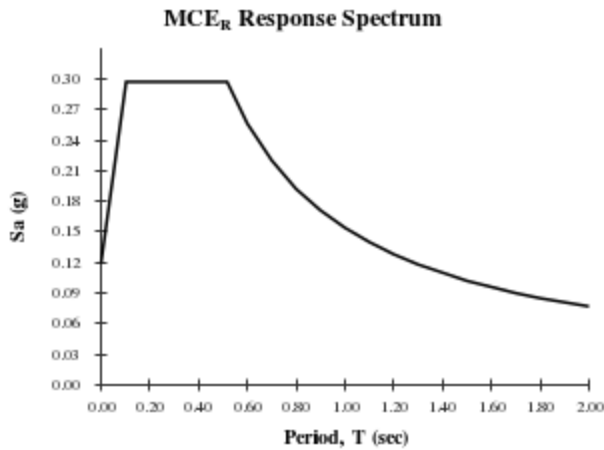

Although this information is a product of the U.S. Geological Survey, we provide no warranty, expressed or implied, as to the accuracy of the data contained therein. This tool is not a substitute for technical subject-matter knowledge.

COAX LAYOUT

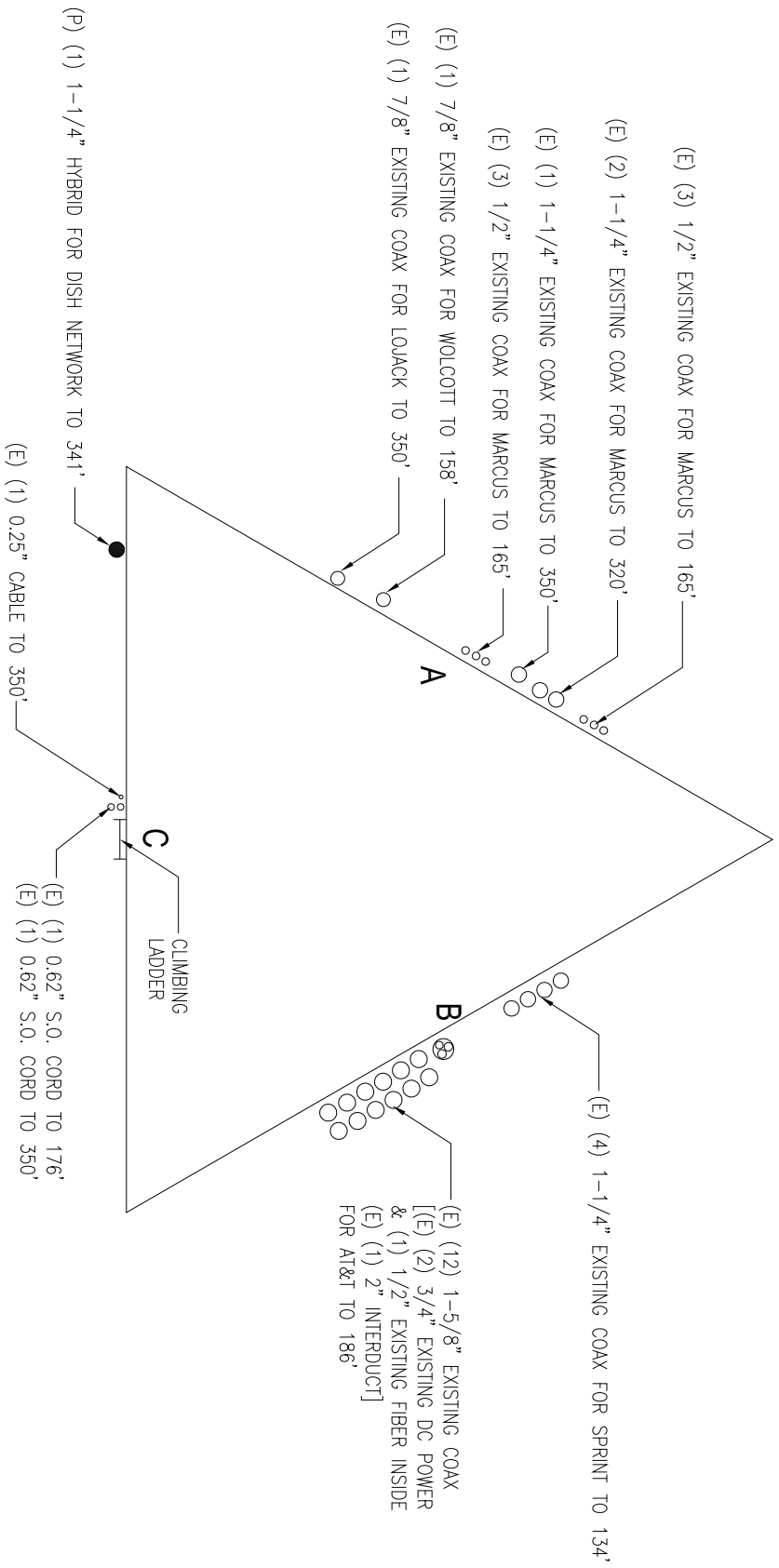

COAX LAYOUT

N.T.S

TOWER ELEVATION DRAWING

Section	T18	T17	T16	T15	T14	T13	T12	T11	T10	T9	T8	T7	T6	T5	T4	T3	T2	T1	
Legs	SR 5 1/2	SR 5 1/4	SR 5	SR 4 3/4	SR 4 3/4	SR 4 1/4	SR 4 1/2	SR 4 1/4	A572-50	SR 4	SR 3 3/4	SR 3 1/2	SR 3 1/2	SR 3 1/4	SR 2 1/2	SR 2	SR 2		
Leg Grade	2L3 1/2x3 1/2x1/4x3/8																		
Diagonals	2L3x3x3/16x3/8																		
Diagonal Grade	A36																		
Top Girts	N.A.																		
Horizontals	2L3 1/2x3 1/2x1/4x3/8																		
Red. Horizontals	L3x3x3/16																		
Red. Diagonals	L2 1/2x2 1/2x3/16																		
Inner Bracing	2L3x3x3/16x3/8																		
Face Width (ft)	36	34	32	30	28	26	24	22	20	18	16	14	12	10	8	6	5 @ 4	2 @ 5	
# Panels @ (ft)	36	34	32	30	28	26	24	22	20	18	16	14	12	10	8	6	5 @ 4	2 @ 5	
Weight (K)	95.3	100.8	101.1	99.1	85	74	70	64	64	57	51	42	37	30	24	23	1.5	1.1	0.6

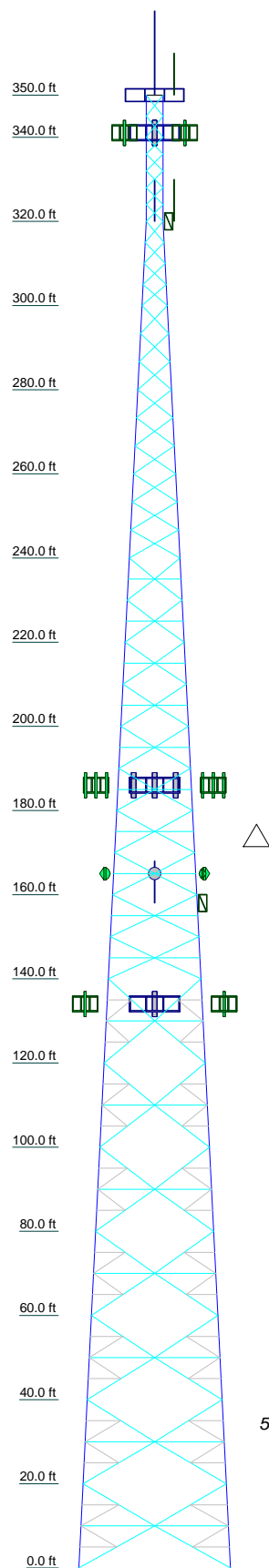

SYMBOL LIST

MARK	SIZE	MARK	SIZE
A	L3x3x1/4	C	L2.5x2.5x3/16 + L2.5x2.5x1/4 (C-Shape) - Cleary Tower
B	L3 1/2x3 1/2x1/4		

MATERIAL STRENGTH

GRADE	Fy	Fu	GRADE	Fy	Fu
A572-50	50 ksi	65 ksi	A36	36 ksi	58 ksi

TOWER DESIGN NOTES

1. Tower designed for Exposure B to the TIA-222-G Standard.
2. Tower designed for a 97 mph basic wind in accordance with the TIA-222-G Standard.
3. Tower is also designed for a 50 mph basic wind with 0.75 in ice. Ice is considered to increase in thickness with height.
4. Deflections are based upon a 60 mph wind.
5. Tower Structure Class II.
6. Topographic Category 1 with Crest Height of 0.00 ft
7. TOWER RATING: 98.4%

ALL REACTIONS ARE FACTORED

MAX. CORNER REACTIONS AT BASE:

DOWN: 424 K
SHEAR: 47 K

UPLIFT: -308 K
SHEAR: 36 K

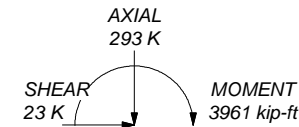

TORQUE 10 kip-ft
50 mph WIND - 0.7500 in ICE

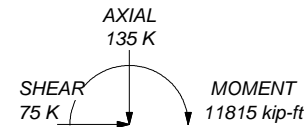

TORQUE 29 kip-ft
REACTIONS - 97 mph WIND

Allpro Consulting Group, Inc.			Job: 18-5441
9221 Lyndon B. Johnson Fwy, Suite #204			Project: CT20021-A-11 Cleary Tower (Edward)
Dallas, TX 75243	Client: SBA	Drawn by: Binod Paudel	App'd:
Phone: 972-231-8893	Code: TIA-222-G	Date: 08/22/18	Scale: NTS
FAX: 866-364-8375	Path:		Dwg No. E-1

DESIGNED APPURTENANCE LOADING

TYPE	ELEVATION	TYPE	ELEVATION
Celwave PD200 Omni (LoJack)	350	800-10121 (ATI)	186
101 Omni (Marcus)	350	HPA-65R-BUU-H6 (ATI)	186
Star Mount w/ (9) Standoffs (Marcus/LoJack)	350	HPA-65R-BUU-H6 (ATI)	186
800 10622 (Dish Network)	341	(2) CCI DTMA-BP7819VG12A (ATI)	186
800 10622 (Dish Network)	341	(2) CCI DTMA-BP7819VG12A (ATI)	186
800 10622 (Dish Network)	341	(2) CCI DTMA-BP7819VG12A (ATI)	186
4415 (Dish Network)	341	860 10025 RET (ATI)	186
4415 (Dish Network)	341	(2) Pipe Mounts (5.25' x 4.5") (Marcus)	165
4415 (Dish Network)	341	(2) Pipe Mounts (5.25' x 4.5") (Marcus)	165
0208 (Dish Network)	341	(2) Pipe Mounts (5.25' x 4.5") (Marcus)	165
0208 (Dish Network)	341	Radiowaves SPD3-2.4 Dish (Marcus)	165
0208 (Dish Network)	341	Radiowaves SPD3-2.4 Dish (Marcus)	165
Commscope SF-SU7-2-96 Sector Frame (Dish Network)	341	Radiowaves SPD2-5.8 Dish (Marcus)	165
Commscope SF-SU7-2-96 Sector Frame (Dish Network)	341	Radiowaves SPD2-5.8 Dish (Marcus)	165
Commscope SF-SU7-2-96 Sector Frame (Dish Network)	341	Radiowaves SPD2-5.8 Dish (Marcus)	165
101 Omni (Marcus)	320	Decibel DB408 Omni (Wolcott Ambulance)	158
101 Omni (Marcus)	320	17" Standoff Mount (Wolcott)	158
6' Standoff (Marcus)	320	15' T-Frames (Sprint)	134
6' Standoff (Marcus)	320	15' T-Frames (Sprint)	134
RRUS 11 (ATI)	186	15' T-Frames (Sprint)	134
RRUS 32 (ATI)	186	RRH 800 MHz (Sprint)	134
RRUS 32 (ATI)	186	RRH 800 MHz (Sprint)	134
RRUS 32 (ATI)	186	RRH 800 MHz (Sprint)	134
(2) LGP13519 Diplexer (ATI)	186	TD-RRH8x20-25 (Sprint)	134
(2) LGP13519 Diplexer (ATI)	186	ACU-A20-N (Sprint)	134
(2) LGP13519 Diplexer (ATI)	186	ACU-A20-N (Sprint)	134
DC6-48-60-18-8F (ATI)	186	APXVTM14-C-120 (Sprint)	134
13.5' T-Frames (ATI)	186	APXVTM14-C-120 (Sprint)	134
13.5' T-Frames (ATI)	186	APXVTM14-C-120 (Sprint)	134
13.5' T-Frames (ATI)	186	RFS APXVSP18 (Sprint)	134
7770 (ATI)	186	RFS APXVSP18 (Sprint)	134
7770 (ATI)	186	RFS APXVSP18 (Sprint)	134
7770 (ATI)	186	RRH 1900 MHz (Sprint)	134
(2) 860 10025 RET (ATI)	186	RRH 1900 MHz (Sprint)	134
860 10025 RET (ATI)	186	RRH 1900 MHz (Sprint)	134
RRUS 11 (ATI)	186	RRH 800 MHz (Sprint)	134
RRUS 11 (ATI)	186	TD-RRH8x20-25 (Sprint)	134
AM-X-CD-16-65-00T-RET (ATI)	186	TD-RRH8x20-25 (Sprint)	134
AM-X-CD-16-65-00T-RET (ATI)	186	RRH 800 MHz Filter (Sprint)	134
(2) AM-X-CD-16-65-00T-RET (ATI)	186	RRH 800 MHz Filter (Sprint)	134
800-10121 (ATI)	186	RRH 800 MHz Filter (Sprint)	134
		(2) ACU-A20-N (Sprint)	134

SYMBOL LIST

MARK	SIZE	MARK	SIZE
A	L3x3x1/4	C	L2.5x2.5x3/16 + L2.5x2.5x1/4 (C-Shape) - Cleary Tower
B	L3 1/2x3 1/2x1/4		

MATERIAL STRENGTH

GRADE	Fy	Fu	GRADE	Fy	Fu
A572-50	50 ksi	65 ksi	A36	36 ksi	58 ksi

TOWER DESIGN NOTES

1. Tower designed for Exposure B to the TIA-222-G Standard.
2. Tower designed for a 97 mph basic wind in accordance with the TIA-222-G Standard.
3. Tower is also designed for a 50 mph basic wind with 0.75 in ice. Ice is considered to increase in thickness with height.
4. Deflections are based upon a 60 mph wind.
5. Tower Structure Class II.
6. Topographic Category 1 with Crest Height of 0.00 ft

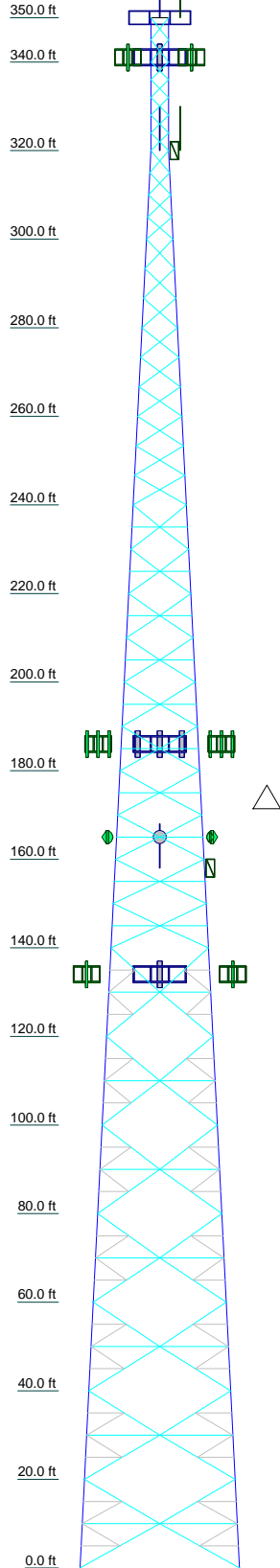

Section	T18	T17	T16	T15	T14	T13	T12	T11	T10	T9	T8	T7	T6	T5	T4	T3	T2	T1
Legs	SR 5 1/2	SR 5 1/4	SR 5 1/4	SR 5	SR 4 3/4	SR 4 3/4	SR 4 1/2	SR 4 1/4	SR 4	SR 3 3/4	SR 3 3/4	SR 3 1/2	SR 3 1/2	SR 3 1/4	SR 2 1/2	SR 2	SR 2	
Leg Grade	2L3 1/2x3 1/2x1/4x3/8																	
Diagonals	2L3x3x1/4x3/8																	
Diagonal Grade	A36																	
Top Girts	N.A.																	
Horizontals	2L2 1/2x2 1/2x3/16x3/8																	
Red. Horizontals	L3x3x3/16	L2x2x3/8																
Red. Diagonals	L3x3x3/16	L2-1/2x2-1/2x3/16																
Inner Bracing	2L3 1/2x3 1/2x1/4x3/8	L4x4x1/4																
Face Width (ft)	36	34	32	30	28	26	24	22	20	18	16	14	12	10	8	6	5 @ 4	2 @ 5
# Panels @ (ft)	95.3	10.8	10.1	9.1	8.5	7.4	6.4	6.4	5.1	5.1	4.2	3.7	3.0	2.4	2.3	1.5	1.1	0.6
Weight (K)																		

Allpro Consulting Group, Inc.		Job: 18-5441	
9221 Lyndon B. Johnson Fwy, Suite #204		Project: CT20021-A-11 Cleary Tower (Edward)	
Dallas, TX 75243	Phone: 972-231-8893	Client: SBA	Drawn by: Binod Paudel
Phone: 972-231-8893	FAX: 866-364-8375	Code: TIA-222-G	Date: 08/22/18
		Path:	App'd: _____
			Scale: NTS
			Dwg No. E-1

MISCELLANEOUS PLOTS

TIA-222-G - 97 mph/50 mph 0.7500 in Ice Exposure B

Leg Capacity ——— Leg Compression (K)

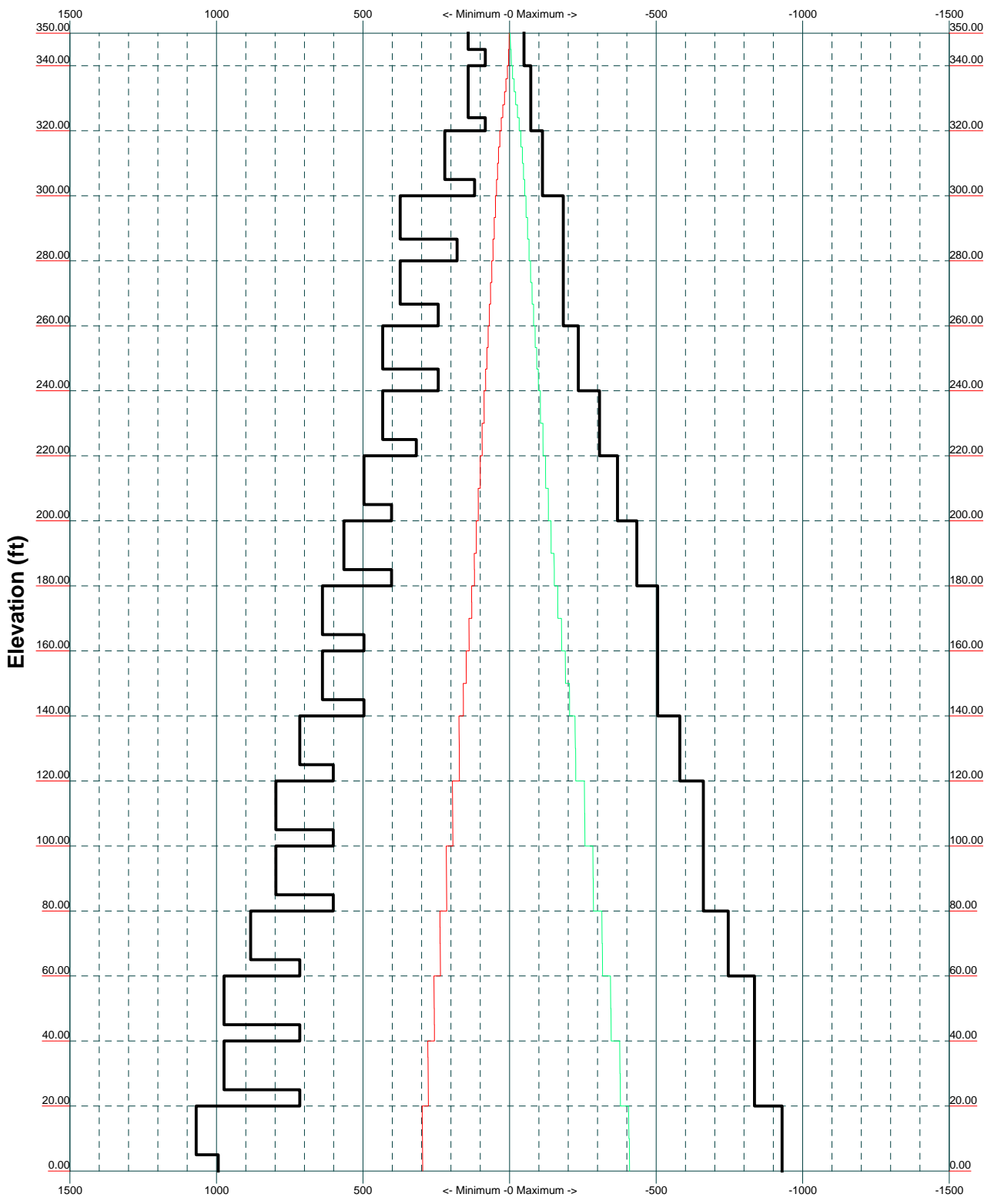

Allpro Consulting Group, Inc.		
9221 Lyndon B. Johnson Fwy, Suite #204		
Dallas, TX 75243		
Phone: 972-231-8893		
FAX: 866-364-8375		
Job: 18-5441	Project: CT20021-A-11 Cleary Tower (Edward)	
Client: SBA	Drawn by: Binod Paudel	App'd:
Code: TIA-222-G	Date: 08/22/18	Scale: NTS
Path:		Dwg No. E-3

Vx

Vz

Mx

Mz

Global Mast Shear (K)

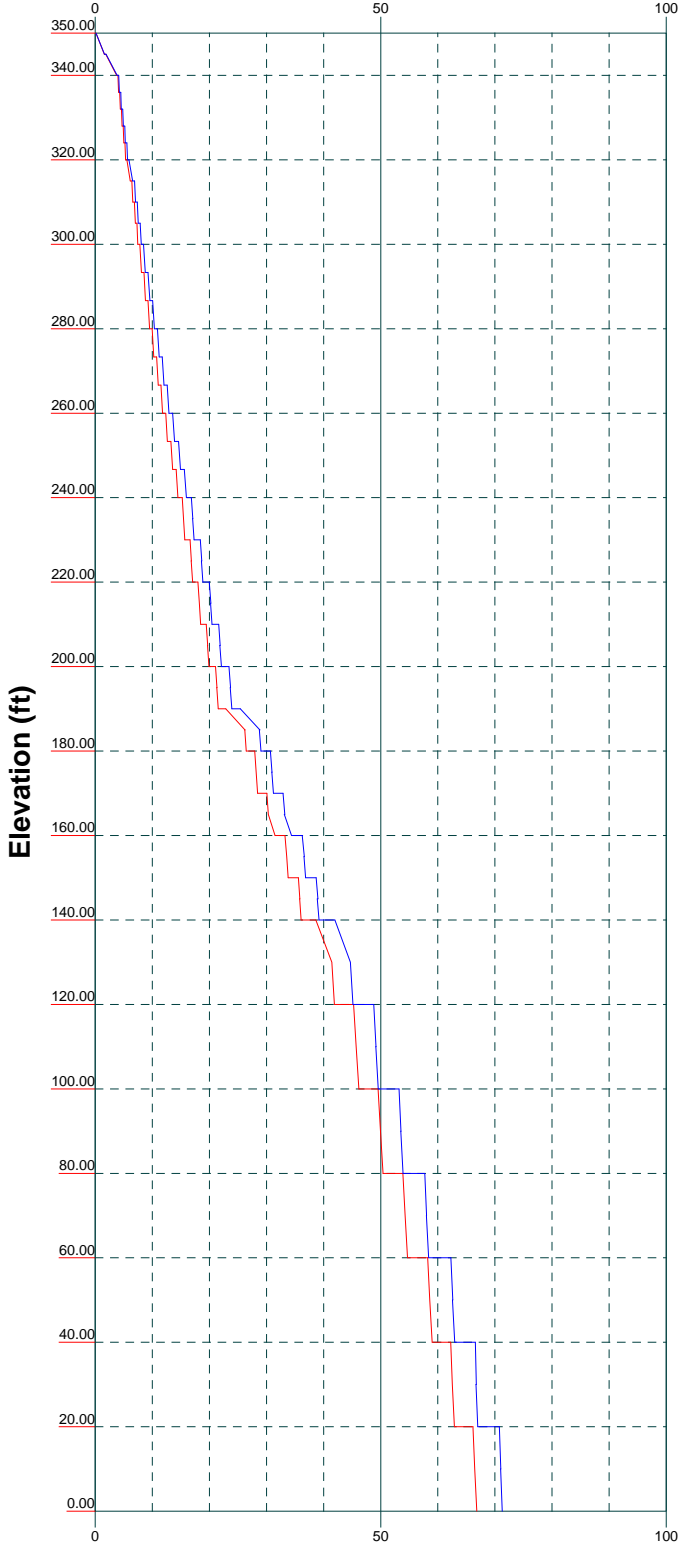

Global Mast Moment (kip-ft)

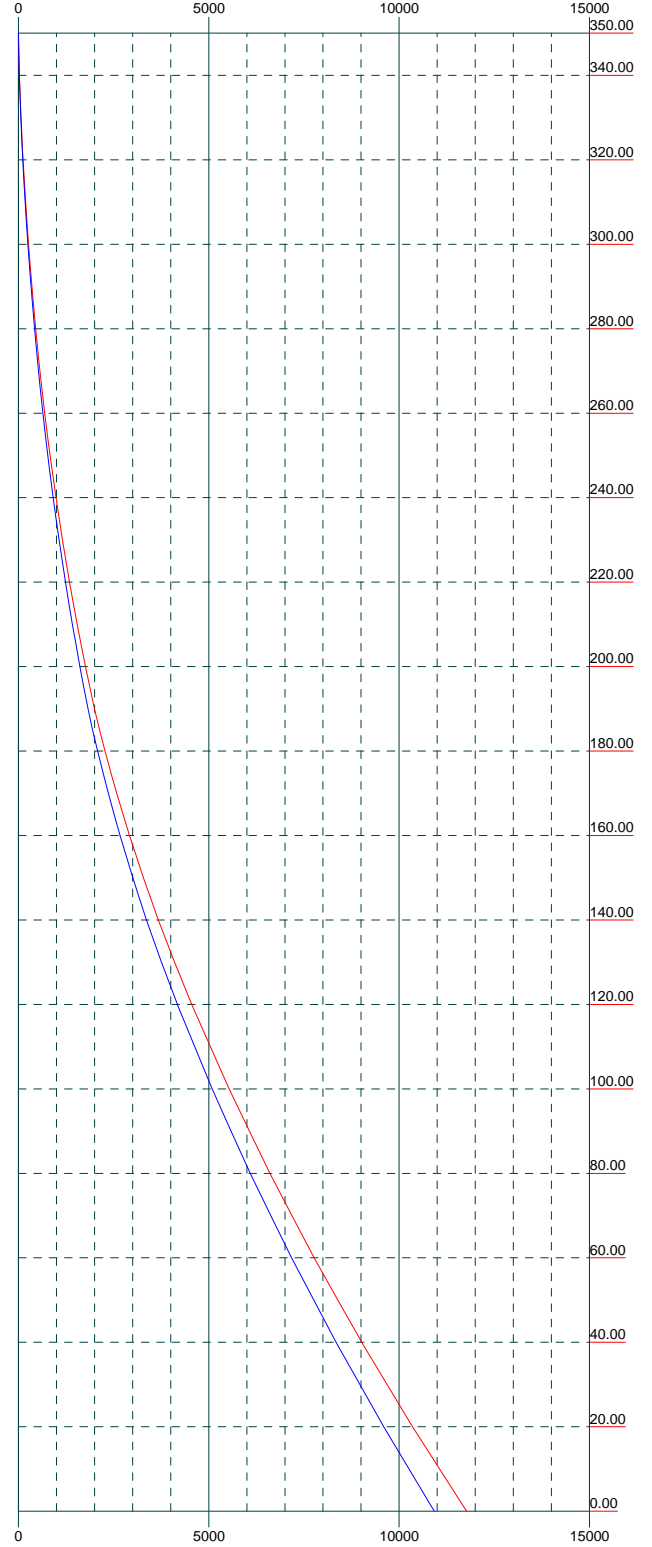

Allpro Consulting Group, Inc.		
9221 Lyndon B. Johnson Fwy, Suite #204		
Dallas, TX 75243		
Phone: 972-231-8893		
FAX: 866-364-8375		
Job: 18-5441	Project: CT20021-A-11 Cleary Tower (Edward)	
Client: SBA	Drawn by: Binod Paudel	App'd:
Code: TIA-222-G	Date: 08/22/18	Scale: NTS
Path:		Dwg No. E-4

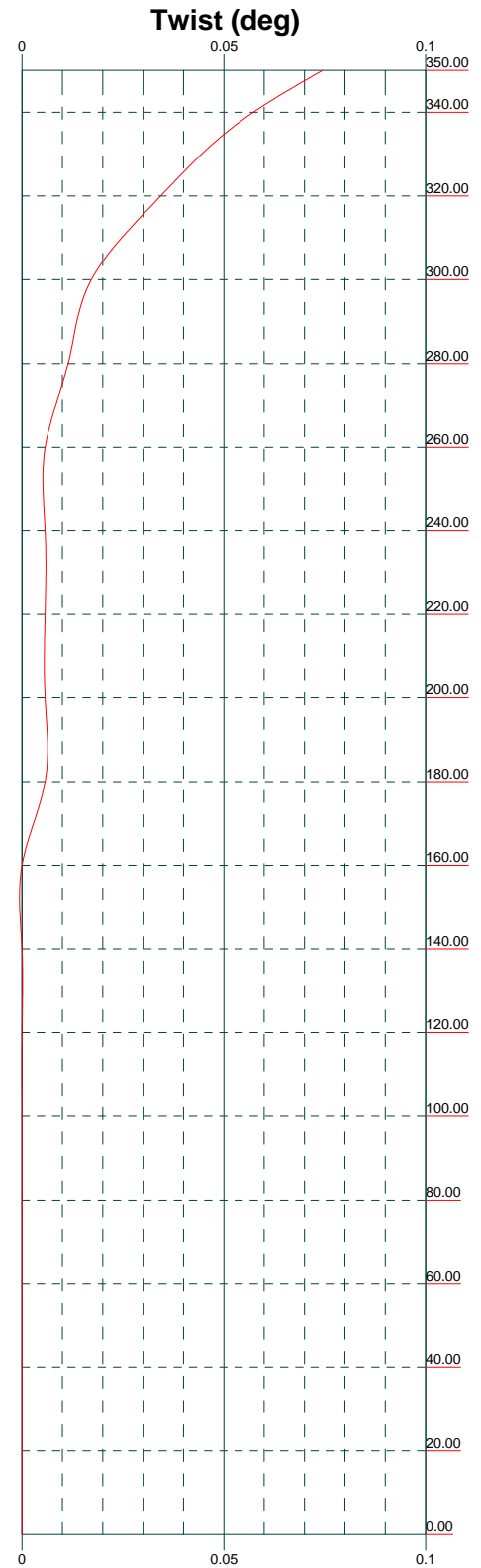
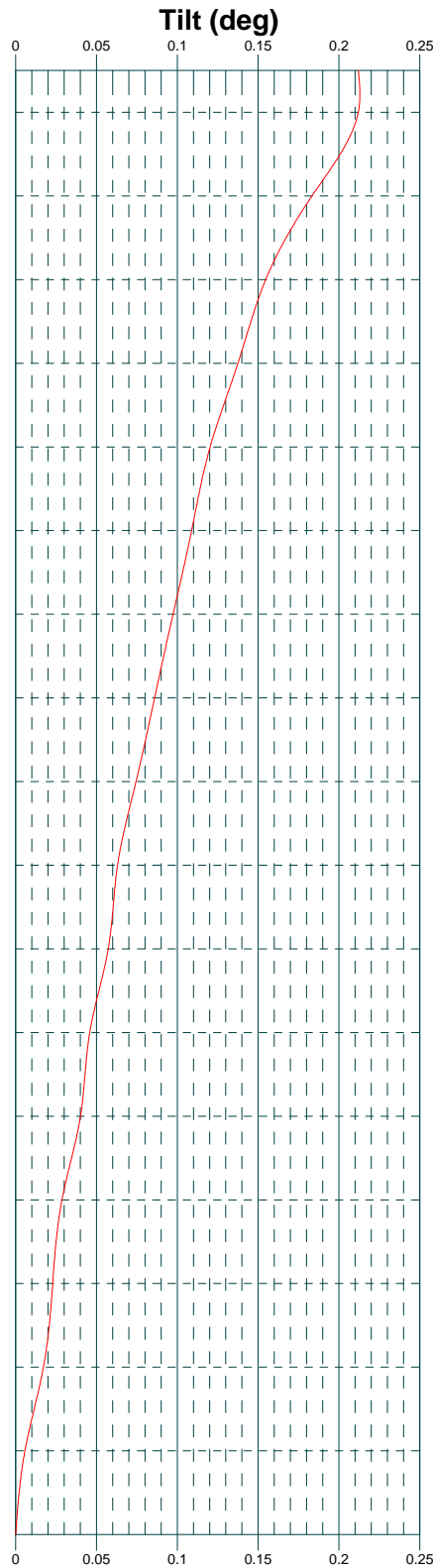
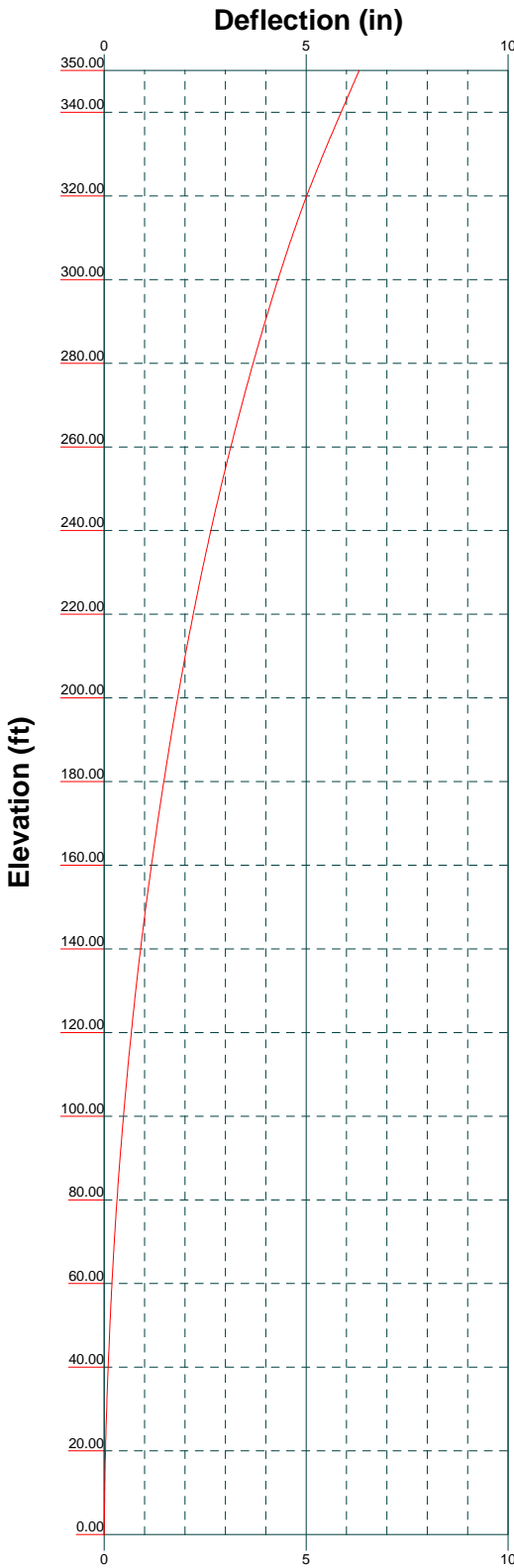

Allpro Consulting Group, Inc. 9221 Lyndon B. Johnson Fwy, Suite #204 Dallas, TX 75243 Phone: 972-231-8893 FAX: 866-364-8375			Job: 18-5441		
			Project: CT20021-A-11 Cleary Tower (Edward)		
Client: SBA		Drawn by: Binod Paudel		App'd:	
Code: TIA-222-G		Date: 08/22/18		Scale: NTS	
Path:			Dwg No. E-5		

CALCULATION PRINTOUT

tnxTower Allpro Consulting Group, Inc. 9221 Lyndon B. Johnson Fwy, Suite #204 Dallas, TX 75243 Phone: 972-231-8893 FAX: 866-364-8375	Job	18-5441	Page	1 of 38	
	Project	CT20021-A-11 Cleary Tower (Edward)		Date	15:43:40 08/22/18
	Client	SBA		Designed by	Binod Paudel

Tower Input Data

The main tower is a 3x free standing tower with an overall height of 350.00 ft above the ground line.

The base of the tower is set at an elevation of 0.00 ft above the ground line.

The face width of the tower is 4.00 ft at the top and 36.00 ft at the base.

This tower is designed using the TIA-222-G standard.

The following design criteria apply:

ASCE 7-10 Wind Data is used (wind speeds converted to nominal values).

Basic wind speed of 97 mph.

Structure Class II.

Exposure Category B.

Topographic Category 1.

Crest Height 0.00 ft.

Nominal ice thickness of 0.7500 in.

Ice thickness is considered to increase with height.

Ice density of 56 pcf.

A wind speed of 50 mph is used in combination with ice.

Temperature drop of 50 °F.

Deflections calculated using a wind speed of 60 mph.

A non-linear (P-delta) analysis was used.

Pressures are calculated at each section.

Stress ratio used in tower member design is 1.

Local bending stresses due to climbing loads, feed line supports, and appurtenance mounts are not considered.

Options

- | | | |
|--|--|--|
| <ul style="list-style-type: none"> Consider Moments - Legs Consider Moments - Horizontals Consider Moments - Diagonals Use Moment Magnification √ Use Code Stress Ratios √ Use Code Safety Factors - Guys Escalate Ice Always Use Max Kz Use Special Wind Profile √ Include Bolts In Member Capacity Leg Bolts Are At Top Of Section √ Secondary Horizontal Braces Leg Use Diamond Inner Bracing (4 Sided) SR Members Have Cut Ends SR Members Are Concentric | <ul style="list-style-type: none"> Distribute Leg Loads As Uniform Assume Legs Pinned √ Assume Rigid Index Plate √ Use Clear Spans For Wind Area √ Use Clear Spans For KL/r √ Retension Guys To Initial Tension √ Bypass Mast Stability Checks √ Use Azimuth Dish Coefficients √ Project Wind Area of Appurt. √ Autocalc Torque Arm Areas Add IBC .6D+W Combination Sort Capacity Reports By Component √ Triangulate Diamond Inner Bracing Treat Feed Line Bundles As Cylinder | <ul style="list-style-type: none"> Use ASCE 10 X-Brace Ly Rules √ Calculate Redundant Bracing Forces Ignore Redundant Members in FEA SR Leg Bolts Resist Compression All Leg Panels Have Same Allowable Offset Girt At Foundation √ Consider Feed Line Torque √ Include Angle Block Shear Check Use TIA-222-G Bracing Resist. Exemption Use TIA-222-G Tension Splice Exemption <li style="background-color: #e0e0e0;">Poles Include Shear-Torsion Interaction Always Use Sub-Critical Flow Use Top Mounted Sockets Pole Without Linear Attachments Pole With Shroud Or No Appurtenances Outside and Inside Corner Radii Are Known |
|--|--|--|

tnxTower Allpro Consulting Group, Inc. 9221 Lyndon B. Johnson Fwy, Suite #204 Dallas, TX 75243 Phone: 972-231-8893 FAX: 866-364-8375	Job 18-5441	Page 2 of 38
	Project CT20021-A-11 Cleary Tower (Edward)	Date 15:43:40 08/22/18
	Client SBA	Designed by Binod Paudel

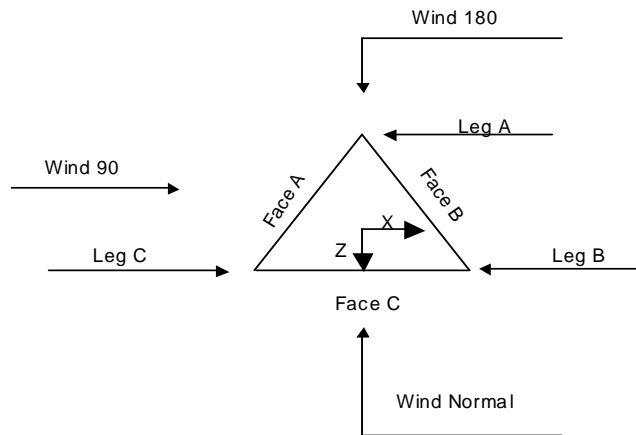

Triangular Tower

Tower Section Geometry

Tower Section	Tower Elevation	Assembly Database	Description	Section Width	Number of Sections	Section Length
	ft			ft		ft
T1	350.00-340.00			4.00	1	10.00
T2	340.00-320.00			4.00	1	20.00
T3	320.00-300.00			4.00	1	20.00
T4	300.00-280.00			6.00	1	20.00
T5	280.00-260.00			8.00	1	20.00
T6	260.00-240.00			10.00	1	20.00
T7	240.00-220.00			12.00	1	20.00
T8	220.00-200.00			14.00	1	20.00
T9	200.00-180.00			16.00	1	20.00
T10	180.00-160.00			18.00	1	20.00
T11	160.00-140.00			20.00	1	20.00
T12	140.00-120.00			22.00	1	20.00
T13	120.00-100.00			24.00	1	20.00
T14	100.00-80.00			26.00	1	20.00
T15	80.00-60.00			28.00	1	20.00
T16	60.00-40.00			30.00	1	20.00
T17	40.00-20.00			32.00	1	20.00
T18	20.00-0.00			34.00	1	20.00

Tower Section Geometry (cont'd)

tnxTower Allpro Consulting Group, Inc. 9221 Lyndon B. Johnson Fwy, Suite #204 Dallas, TX 75243 Phone: 972-231-8893 FAX: 866-364-8375	Job	18-5441	Page	3 of 38
	Project	CT20021-A-11 Cleary Tower (Edward)	Date	15:43:40 08/22/18
	Client	SBA	Designed by	Binod Paudel

Tower Section	Tower Elevation <i>ft</i>	Diagonal Spacing <i>ft</i>	Bracing Type	Has K Brace End Panels	Has Horizontals	Top Girt Offset <i>in</i>	Bottom Girt Offset <i>in</i>
T1	350.00-340.00	5.00	X Brace	No	No	0.0000	0.0000
T2	340.00-320.00	4.00	X Brace	No	No	0.0000	0.0000
T3	320.00-300.00	5.00	X Brace	No	No	0.0000	0.0000
T4	300.00-280.00	6.67	X Brace	No	No	0.0000	0.0000
T5	280.00-260.00	6.67	X Brace	No	No	0.0000	0.0000
T6	260.00-240.00	6.67	X Brace	No	No	0.0000	0.0000
T7	240.00-220.00	5.00	Double K	No	Yes	0.0000	0.0000
T8	220.00-200.00	5.00	Double K	No	Yes	0.0000	0.0000
T9	200.00-180.00	5.00	Double K	No	Yes	0.0000	0.0000
T10	180.00-160.00	5.00	Double K	No	Yes	0.0000	0.0000
T11	160.00-140.00	5.00	Double K	No	Yes	0.0000	0.0000
T12	140.00-120.00	10.00	Double K1	No	Yes	0.0000	0.0000
T13	120.00-100.00	10.00	Double K1	No	Yes	0.0000	0.0000
T14	100.00-80.00	10.00	Double K1	No	Yes	0.0000	0.0000
T15	80.00-60.00	10.00	Double K1	No	Yes	0.0000	0.0000
T16	60.00-40.00	10.00	Double K1	No	Yes	0.0000	0.0000
T17	40.00-20.00	10.00	Double K1	No	Yes	0.0000	0.0000
T18	20.00-0.00	10.00	Double K1	No	Yes	0.0000	0.0000

Tower Section Geometry (cont'd)

Tower Elevation <i>ft</i>	Leg Type	Leg Size	Leg Grade	Diagonal Type	Diagonal Size	Diagonal Grade
T1 350.00-340.00	Solid Round	2	A572-50 (50 ksi)	Single Angle	L2x1 1/2x3/16	A36 (36 ksi)
T2 340.00-320.00	Solid Round	2	A572-50 (50 ksi)	Single Angle	L2x1 1/2x3/16	A36 (36 ksi)
T3 320.00-300.00	Solid Round	2 1/2	A572-50 (50 ksi)	Equal Angle	L2x2x3/16	A36 (36 ksi)
T4 300.00-280.00	Solid Round	3 1/4	A572-50 (50 ksi)	Equal Angle	L2-1/2x2-1/2x3/16	A36 (36 ksi)
T5 280.00-260.00	Solid Round	3 1/4	A572-50 (50 ksi)	Equal Angle	L2-1/2x2-1/2x3/16	A36 (36 ksi)
T6 260.00-240.00	Solid Round	3 1/2	A572-50 (50 ksi)	Equal Angle	L3x3x3/16	A36 (36 ksi)
T7 240.00-220.00	Solid Round	3 1/2	A572-50 (50 ksi)	Double Equal Angle	2L2 1/2x2 1/2x3/16x3/8	A36 (36 ksi)
T8 220.00-200.00	Solid Round	3 3/4	A572-50 (50 ksi)	Double Equal Angle	2L2 1/2x2 1/2x3/16x3/8	A36 (36 ksi)
T9 200.00-180.00	Solid Round	4	A572-50 (50 ksi)	Double Equal Angle	2L3x3x3/16x3/8	A36 (36 ksi)
T10 180.00-160.00	Solid Round	4 1/4	A572-50 (50 ksi)	Double Equal Angle	2L3x3x3/16x3/8	A36 (36 ksi)
T11 160.00-140.00	Solid Round	4 1/4	A572-50 (50 ksi)	Double Equal Angle	2L3x3x3/16x3/8	A36 (36 ksi)
T12 140.00-120.00	Solid Round	4 1/2	A572-50 (50 ksi)	Double Equal Angle	2L3x3x1/4x3/8	A36 (36 ksi)
T13 120.00-100.00	Solid Round	4 3/4	A572-50 (50 ksi)	Double Equal Angle	2L3x3x1/4x3/8	A36 (36 ksi)
T14 100.00-80.00	Solid Round	4 3/4	A572-50 (50 ksi)	Double Equal Angle	2L3x3x1/4x3/8	A36 (36 ksi)
T15 80.00-60.00	Solid Round	5	A572-50 (50 ksi)	Double Equal Angle	2L3 1/2x3 1/2x1/4x3/8	A36 (36 ksi)
T16 60.00-40.00	Solid Round	5 1/4	A572-50 (50 ksi)	Double Equal Angle	2L3 1/2x3 1/2x1/4x3/8	A36 (36 ksi)
T17 40.00-20.00	Solid Round	5 1/4	A572-50	Double Equal Angle	2L3 1/2x3 1/2x1/4x3/8	A36

tnxTower Allpro Consulting Group, Inc. 9221 Lyndon B. Johnson Fwy, Suite #204 Dallas, TX 75243 Phone: 972-231-8893 FAX: 866-364-8375	Job	18-5441	Page	4 of 38
	Project	CT20021-A-11 Cleary Tower (Edward)	Date	15:43:40 08/22/18
	Client	SBA	Designed by	Binod Paudel

Tower Elevation ft	Leg Type	Leg Size	Leg Grade	Diagonal Type	Diagonal Size	Diagonal Grade
T18 20.00-0.00	Solid Round	5 1/2	(50 ksi) A572-50 (50 ksi)	Angle Double Equal Angle	2L3 1/2x3 1/2x1/4x3/8	(36 ksi) A36 (36 ksi)

Tower Section Geometry (cont'd)

Tower Elevation ft	No. of Mid Girts	Mid Girt Type	Mid Girt Size	Mid Girt Grade	Horizontal Type	Horizontal Size	Horizontal Grade
T7 240.00-220.00	None	Flat Bar		A36 (36 ksi)	Equal Angle	L2 1/2x2 1/2x3/16	A36 (36 ksi)
T8 220.00-200.00	None	Flat Bar		A36 (36 ksi)	Equal Angle	L2 1/2x2 1/2x3/16	A36 (36 ksi)
T9 200.00-180.00	None	Flat Bar		A36 (36 ksi)	Equal Angle	L3x3x3/16	A36 (36 ksi)
T10 180.00-160.00	None	Flat Bar		A36 (36 ksi)	Equal Angle	L3x3x3/16	A36 (36 ksi)
T11 160.00-140.00	None	Flat Bar		A36 (36 ksi)	Equal Angle	L3 1/2x3 1/2x1/4	A36 (36 ksi)
T12 140.00-120.00	None	Flat Bar		A36 (36 ksi)	Double Equal Angle	2L2 1/2x2 1/2x3/16x3/8	A36 (36 ksi)
T13 120.00-100.00	None	Flat Bar		A36 (36 ksi)	Double Equal Angle	2L2 1/2x2 1/2x3/16x3/8	A36 (36 ksi)
T14 100.00-80.00	None	Flat Bar		A36 (36 ksi)	Double Equal Angle	2L2 1/2x2 1/2x3/16x3/8	A36 (36 ksi)
T15 80.00-60.00	None	Flat Bar		A36 (36 ksi)	Double Equal Angle	2L3x3x3/16x3/8	A36 (36 ksi)
T16 60.00-40.00	None	Flat Bar		A36 (36 ksi)	Double Equal Angle	2L3x3x3/16x3/8	A36 (36 ksi)
T17 40.00-20.00	None	Flat Bar		A36 (36 ksi)	Double Equal Angle	2L3 1/2x3 1/2x1/4x3/8	A36 (36 ksi)
T18 20.00-0.00	None	Flat Bar		A36 (36 ksi)	Double Equal Angle	2L3 1/2x3 1/2x1/4x3/8	A36 (36 ksi)

Tower Section Geometry (cont'd)

Tower Elevation ft	Secondary Horizontal Type	Secondary Horizontal Size	Secondary Horizontal Grade	Inner Bracing Type	Inner Bracing Size	Inner Bracing Grade
T7 240.00-220.00	Equal Angle		A36 (36 ksi)	Equal Angle	L2 1/2x2 1/2x3/16	A36 (36 ksi)
T8 220.00-200.00	Equal Angle		A36 (36 ksi)	Equal Angle	L2 1/2x2 1/2x3/16	A36 (36 ksi)
T9 200.00-180.00	Equal Angle		A36 (36 ksi)	Equal Angle	L3x3x3/16	A36 (36 ksi)
T10 180.00-160.00	Equal Angle		A36 (36 ksi)	Equal Angle	L3x3x3/16	A36 (36 ksi)
T11 160.00-140.00	Equal Angle		A36 (36 ksi)	Equal Angle	L3 1/2x3 1/2x1/4	A36 (36 ksi)

tnxTower Allpro Consulting Group, Inc. 9221 Lyndon B. Johnson Fwy, Suite #204 Dallas, TX 75243 Phone: 972-231-8893 FAX: 866-364-8375	Job 18-5441	Page 5 of 38
	Project CT20021-A-11 Cleary Tower (Edward)	Date 15:43:40 08/22/18
	Client SBA	Designed by Binod Paudel

Tower Elevation	Secondary Horizontal Type	Secondary Horizontal Size	Secondary Horizontal Grade	Inner Bracing Type	Inner Bracing Size	Inner Bracing Grade
<i>ft</i>						
T12 140.00-120.00	Equal Angle		A36 (36 ksi)	Equal Angle	L3 1/2x3 1/2x1/4	A36 (36 ksi)
T13 120.00-100.00	Equal Angle		A36 (36 ksi)	Equal Angle	L4x4x1/4	A36 (36 ksi)
T14 100.00-80.00	Equal Angle		A36 (36 ksi)	Equal Angle	L4x4x1/4	A36 (36 ksi)
T15 80.00-60.00	Equal Angle		A36 (36 ksi)	Double Equal Angle	2L3x3x3/16x3/8	A36 (36 ksi)
T16 60.00-40.00	Equal Angle		A36 (36 ksi)	Double Equal Angle	2L3x3x3/16x3/8	A36 (36 ksi)
T17 40.00-20.00	Equal Angle		A36 (36 ksi)	Double Equal Angle	2L3 1/2x3 1/2x1/4x3/8	A36 (36 ksi)
T18 20.00-0.00	Equal Angle		A36 (36 ksi)	Double Equal Angle	2L3 1/2x3 1/2x1/4x3/8	A36 (36 ksi)

Tower Section Geometry (cont'd)

Tower Elevation	Redundant Bracing Grade	Redundant Type	Redundant Type	Redundant Size	K Factor
<i>ft</i>					
T12 140.00-120.00	A36 (36 ksi)	Horizontal (1) Diagonal (1)	Equal Angle	L2x2x3/16 L2-1/2x2-1/2x3/16	1 1
T13 120.00-100.00	A36 (36 ksi)	Horizontal (1) Diagonal (1)	Equal Angle	L2x2x3/16 L2-1/2x2-1/2x3/16	1 1
T14 100.00-80.00	A36 (36 ksi)	Horizontal (1) Diagonal (1)	Equal Angle	L2x2x3/8 L2-1/2x2-1/2x3/16	1 1
T15 80.00-60.00	A36 (36 ksi)	Horizontal (1) Diagonal (1)	Equal Angle	L2-1/2x2-1/2x3/16 L2-1/2x2-1/2x3/16	1 1
T16 60.00-40.00	A36 (36 ksi)	Horizontal (1) Diagonal (1)	Equal Angle	L3x3x3/16 L2-1/2x2-1/2x3/16	1 1
T17 40.00-20.00	A36 (36 ksi)	Horizontal (1) Diagonal (1)	Arbitrary Shape Equal Angle	L2.5x2.5x3/16 + L2.5x2.5x1/4 (C-Shape) - Cleary Tower L3x3x3/16	1 1
T18 20.00-0.00	A36 (36 ksi)	Horizontal (1) Diagonal (1)	Equal Angle	L3x3x3/16 L3x3x3/16	1 1

Tower Section Geometry (cont'd)

Tower Elevation	Gusset Area (per face)	Gusset Thickness	Gusset Grade	Adjust. Factor A_f	Adjust. Factor A_r	Weight Mult.	Double Angle Stitch Bolt Spacing Diagonals	Double Angle Stitch Bolt Spacing Horizontals	Double Angle Stitch Bolt Spacing Redundants
<i>ft</i>	ft^2	<i>in</i>					<i>in</i>	<i>in</i>	<i>in</i>
T1 350.00-340.00	0.00	0.0000	A36 (36 ksi)	1	1	1.05	36.0000	36.0000	36.0000
T2 340.00-320.00	0.00	0.0000	A36 (36 ksi)	1	1	1.05	36.0000	36.0000	36.0000
T3 320.00-300.00	0.00	0.0000	A36 (36 ksi)	1	1	1.05	36.0000	36.0000	36.0000
T4	0.00	0.0000	A36	1	1	1.05	36.0000	36.0000	36.0000

Job	18-5441	Page	8 of 38
Project	CT20021-A-11 Cleary Tower (Edward)	Date	15:43:40 08/22/18
Client	SBA	Designed by	Binod Paudel

Tower Elevation ft	Leg		Diagonal		Top Girt		Bottom Girt		Mid Girt		Long Horizontal		Short Horizontal	
	Net Width Deduct in	U	Net Width Deduct in	U	Net Width Deduct in	U	Net Width Deduct in	U	Net Width Deduct in	U	Net Width Deduct in	U	Net Width Deduct in	U
T12 140.00-120.00	0.0000	1	0.0000	0.75	0.0000	0.75	0.0000	0.75	0.0000	0.75	0.0000	0.75	0.0000	0.75
T13 120.00-100.00	0.0000	1	0.0000	0.75	0.0000	0.75	0.0000	0.75	0.0000	0.75	0.0000	0.75	0.0000	0.75
T14 100.00-80.00	0.0000	1	0.0000	0.75	0.0000	0.75	0.0000	0.75	0.0000	0.75	0.0000	0.75	0.0000	0.75
T15 80.00-60.00	0.0000	1	0.0000	0.75	0.0000	0.75	0.0000	0.75	0.0000	0.75	0.0000	0.75	0.0000	0.75
T16 60.00-40.00	0.0000	1	0.0000	0.75	0.0000	0.75	0.0000	0.75	0.0000	0.75	0.0000	0.75	0.0000	0.75
T17 40.00-20.00	0.0000	1	0.0000	0.75	0.0000	0.75	0.0000	0.75	0.0000	0.75	0.0000	0.75	0.0000	0.75
T18 20.00-0.00	0.0000	1	0.0000	0.75	0.0000	0.75	0.0000	0.75	0.0000	0.75	0.0000	0.75	0.0000	0.75

Tower Section Geometry (cont'd)

Tower Elevation ft	Leg Connection Type	Leg		Diagonal		Top Girt		Bottom Girt		Mid Girt		Long Horizontal		Short Horizontal	
		Bolt Size in	No.	Bolt Size in	No.	Bolt Size in	No.	Bolt Size in	No.	Bolt Size in	No.	Bolt Size in	No.	Bolt Size in	No.
T1 350.00-340.00	Flange	0.6250	4	0.6250	1	0.6250	1	0.0000	0	0.6250	0	0.6250	0	0.6250	0
T2 340.00-320.00	Flange	0.6250	4	0.6250	1	0.6250	0	0.0000	0	0.6250	0	0.6250	0	0.6250	0
T3 320.00-300.00	Flange	0.7500	4	0.6250	1	0.6250	0	0.0000	0	0.6250	0	0.6250	0	0.6250	0
T4 300.00-280.00	Flange	0.7500	6	0.6250	1	0.6250	0	0.6250	0	0.6250	0	0.6250	0	0.6250	0
T5 280.00-260.00	Flange	0.8750	6	0.6250	1	0.6250	0	0.6250	0	0.6250	0	0.6250	0	0.6250	0
T6 260.00-240.00	Flange	0.8750	6	0.6250	1	0.6250	0	0.6250	0	0.6250	0	0.6250	0	0.6250	0
T7 240.00-220.00	Flange	1.0000	6	0.6250	1	0.6250	0	0.0000	0	0.6250	0	0.6250	1	0.6250	0
T8 220.00-200.00	Flange	1.1250	6	0.7500	1	0.6250	0	0.0000	0	0.6250	0	0.6250	1	0.6250	1
T9 200.00-180.00	Flange	1.1250	6	0.7500	1	0.6250	0	0.0000	0	0.6250	0	0.6250	1	0.6250	1
T10 180.00-160.00	Flange	1.2500	6	0.7500	1	0.6250	0	0.0000	0	0.6250	0	0.6250	1	0.6250	1
T11 160.00-140.00	Flange	1.2500	6	0.7500	1	0.6250	0	0.0000	0	0.6250	0	0.6250	1	0.6250	1
T12 140.00-120.00	Flange	1.3750	6	0.7500	1	0.6250	0	0.0000	0	0.6250	0	0.7500	1	0.6250	1
T13 120.00-100.00	Flange	1.3750	6	0.7500	1	0.6250	0	0.0000	0	0.6250	0	0.7500	1	0.6250	1
T14 100.00-80.00	Flange	1.3750	6	0.7500	1	0.6250	0	0.0000	0	0.6250	0	0.7500	1	0.6250	1
T15 80.00-60.00	Flange	1.5000	6	0.8750	1	0.6250	0	0.0000	0	0.6250	0	0.7500	1	0.6250	1

tnxTower Allpro Consulting Group, Inc. 9221 Lyndon B. Johnson Fwy, Suite #204 Dallas, TX 75243 Phone: 972-231-8893 FAX: 866-364-8375	Job	18-5441	Page	9 of 38	
	Project	CT20021-A-11 Cleary Tower (Edward)		Date	15:43:40 08/22/18
	Client	SBA		Designed by	Binod Paudel

Tower Elevation ft	Leg Connection Type	Leg		Diagonal		Top Girt		Bottom Girt		Mid Girt		Long Horizontal		Short Horizontal	
		Bolt Size in	No.	Bolt Size in	No.	Bolt Size in	No.	Bolt Size in	No.	Bolt Size in	No.	Bolt Size in	No.	Bolt Size in	No.
T16 60.00-40.00	Flange	1.5000 A325N	6	0.8750 A325N	1	0.6250 A325N	0	0.0000 A325N	0	0.6250 A325N	0	0.7500 A325N	1	0.6250 A325N	1
T17 40.00-20.00	Flange	1.5000 A325N	6	0.8750 A325N	1	0.6250 A325N	0	0.0000 A325N	0	0.6250 A325N	0	0.7500 A325N	1	0.6250 A325N	1
T18 20.00-0.00	Flange	2.5000 A307	6	0.8750 A325N	1	0.6250 A325N	0	0.0000 A325N	0	0.6250 A325N	0	0.7500 A325N	1	0.6250 A325N	1

Feed Line/Linear Appurtenances - Entered As Round Or Flat

Description	Face or Leg	Allow Shield	Component Type	Placement ft	Face Offset in	Lateral Offset (Frac FW)	#	# Per Row	Clear Spacing in	Width or Diameter in	Perimeter in	Weight plf
7/8 (LoJack)	A	No	Ar (CaAa)	350.00 - 0.00	0.0000	-0.15	1	1	0.5000	1.1100		0.54
7/8 (Wolcott Ambulance)	A	No	Ar (CaAa)	158.00 - 0.00	0.0000	-0.1	1	1	0.5000	1.1100		0.54
1/2 (Marcus)	A	No	Ar (CaAa)	165.00 - 0.00	0.0000	0.05	3	3	0.5000	0.5800		0.25
1 1/4 (Marcus)	A	No	Ar (CaAa)	350.00 - 0.00	0.0000	0.1	1	1	0.5000	1.5500		0.66
1 1/4 (Marcus)	A	No	Ar (CaAa)	320.00 - 0.00	0.0000	0.12	2	2	0.5000	1.5500		0.66
1/2 (Marcus)	A	No	Ar (CaAa)	165.00 - 0.00	0.0000	0.15	3	3	0.5000	0.5800		0.25
Feedline Ladder (Af)	A	No	Af (CaAa)	350.00 - 0.00	0.0000	0	1	1	1.5000	1.5000		4.20

1-5/8" (AT&T)	B	No	Ar (CaAa)	186.00 - 0.00	0.0000	0.15	12	6	0.5000	1.9800		0.82
3/4" DC Power (AT&T)	B	No	Ar (CaAa)	186.00 - 0.00	0.0000	0.05	2	1	0.5000	0.8650		0.15
1/2" Fiber (AT&T)	B	No	Ar (CaAa)	186.00 - 0.00	0.0000	0.05	1	1	0.5000	0.6400		0.11
2" Interduct (AT&T)	B	No	Ar (CaAa)	186.00 - 0.00	0.0000	0.05	1	1	0.0000	2.0000		0.00
Feedline Ladder (Af) (AT&T)	B	No	Af (CaAa)	186.00 - 0.00	0.0000	0	1	1	1.5000	1.5000		4.20

1 1/4 (Sprint)	B	No	Ar (CaAa)	134.00 - 0.00	0.0000	-0.15	4	4	0.5000	1.5500		0.66

Climbing Ladder ****	C	No	Af (CaAa)	350.00 - 0.00	0.0000	0	1	1	0.5000	1.5000		7.90

1 1/4 (Dish Network)	C	No	Ar (CaAa)	341.00 - 0.00	0.0000	0.4	1	1	0.5000	1.5500		0.66
Feedline Ladder (Af) (Dish Network)	C	No	Af (CaAa)	341.00 - 0.00	0.0000	0.4	1	1	1.5000	1.5000		4.20

tnxTower Allpro Consulting Group, Inc. 9221 Lyndon B. Johnson Fwy, Suite #204 Dallas, TX 75243 Phone: 972-231-8893 FAX: 866-364-8375	Job 18-5441	Page 10 of 38
	Project CT20021-A-11 Cleary Tower (Edward)	Date 15:43:40 08/22/18
	Client SBA	Designed by Binod Paudel

Description	Face or Leg	Allow Shield	Component Type	Placement ft	Face Offset in	Lateral Offset (Frac FW)	#	# Per Row	Clear Spacing in	Width or Diameter in	Perimeter in	Weight plf

0.62" S.O. Cord	C	No	Ar (CaAa)	176.00 - 0.00	0.0000	0	2	2	0.0000	0.6200		0.31
0.62" S.O. Cord	C	No	Ar (CaAa)	350.00 - 176.00	0.0000	0	1	1	0.0000	0.6200		0.31
0.25" Cable	C	No	Ar (CaAa)	350.00 - 0.00	0.0000	0	1	1	0.5000	0.2500		0.13

Feed Line/Linear Appurtenances Section Areas

Tower Section	Tower Elevation ft	Face	A _R ft ²	A _F ft ²	C _{A_A} In Face ft ²	C _{A_A} Out Face ft ²	Weight K
T1	350.00-340.00	A	0.000	0.000	5.160	0.000	0.054
		B	0.000	0.000	0.000	0.000	0.000
		C	0.000	0.000	3.775	0.000	0.088
T2	340.00-320.00	A	0.000	0.000	10.320	0.000	0.108
		B	0.000	0.000	0.000	0.000	0.000
		C	0.000	0.000	14.840	0.000	0.264
T3	320.00-300.00	A	0.000	0.000	16.520	0.000	0.134
		B	0.000	0.000	0.000	0.000	0.000
		C	0.000	0.000	14.840	0.000	0.264
T4	300.00-280.00	A	0.000	0.000	16.520	0.000	0.134
		B	0.000	0.000	0.000	0.000	0.000
		C	0.000	0.000	14.840	0.000	0.264
T5	280.00-260.00	A	0.000	0.000	16.520	0.000	0.134
		B	0.000	0.000	0.000	0.000	0.000
		C	0.000	0.000	14.840	0.000	0.264
T6	260.00-240.00	A	0.000	0.000	16.520	0.000	0.134
		B	0.000	0.000	0.000	0.000	0.000
		C	0.000	0.000	14.840	0.000	0.264
T7	240.00-220.00	A	0.000	0.000	16.520	0.000	0.134
		B	0.000	0.000	0.000	0.000	0.000
		C	0.000	0.000	14.840	0.000	0.264
T8	220.00-200.00	A	0.000	0.000	16.520	0.000	0.134
		B	0.000	0.000	0.000	0.000	0.000
		C	0.000	0.000	14.840	0.000	0.264
T9	200.00-180.00	A	0.000	0.000	16.520	0.000	0.134
		B	0.000	0.000	18.378	0.000	0.087
		C	0.000	0.000	14.840	0.000	0.264
T10	180.00-160.00	A	0.000	0.000	18.260	0.000	0.142
		B	0.000	0.000	61.260	0.000	0.289
		C	0.000	0.000	15.832	0.000	0.269
T11	160.00-140.00	A	0.000	0.000	25.478	0.000	0.174
		B	0.000	0.000	61.260	0.000	0.289
		C	0.000	0.000	16.080	0.000	0.270
T12	140.00-120.00	A	0.000	0.000	25.700	0.000	0.175
		B	0.000	0.000	69.940	0.000	0.326
		C	0.000	0.000	16.080	0.000	0.270
T13	120.00-100.00	A	0.000	0.000	25.700	0.000	0.175
		B	0.000	0.000	73.660	0.000	0.342
		C	0.000	0.000	16.080	0.000	0.270
T14	100.00-80.00	A	0.000	0.000	25.700	0.000	0.175
		B	0.000	0.000	73.660	0.000	0.342
		C	0.000	0.000	16.080	0.000	0.270
T15	80.00-60.00	A	0.000	0.000	25.700	0.000	0.175
		B	0.000	0.000	73.660	0.000	0.342
		C	0.000	0.000	16.080	0.000	0.270

<p style="text-align: center;">tnxTower</p> <p>Allpro Consulting Group, Inc. 9221 Lyndon B. Johnson Fwy, Suite #204 Dallas, TX 75243 Phone: 972-231-8893 FAX: 866-364-8375</p>	Job	18-5441	Page	11 of 38
	Project	CT20021-A-11 Cleary Tower (Edward)	Date	15:43:40 08/22/18
	Client	SBA	Designed by	Binod Paudel

Tower Section	Tower Elevation ft	Face	A_R ft ²	A_F ft ²	C_{AA} In Face ft ²	C_{AA} Out Face ft ²	Weight K
T16	60.00-40.00	A	0.000	0.000	25.700	0.000	0.175
		B	0.000	0.000	73.660	0.000	0.342
		C	0.000	0.000	16.080	0.000	0.270
T17	40.00-20.00	A	0.000	0.000	25.700	0.000	0.175
		B	0.000	0.000	73.660	0.000	0.342
		C	0.000	0.000	16.080	0.000	0.270
T18	20.00-0.00	A	0.000	0.000	25.700	0.000	0.175
		B	0.000	0.000	73.660	0.000	0.342
		C	0.000	0.000	16.080	0.000	0.270

Feed Line/Linear Appurtenances Section Areas - With Ice

Tower Section	Tower Elevation ft	Face or Leg	Ice Thickness in	A_R ft ²	A_F ft ²	C_{AA} In Face ft ²	C_{AA} Out Face ft ²	Weight K
T1	350.00-340.00	A	1.897	0.000	0.000	16.541	0.000	0.282
		B		0.000	0.000	0.000	0.000	0.000
		C		0.000	0.000	15.915	0.000	0.291
T2	340.00-320.00	A	1.888	0.000	0.000	32.981	0.000	0.561
		B		0.000	0.000	0.000	0.000	0.000
		C		0.000	0.000	52.608	0.000	0.950
T3	320.00-300.00	A	1.877	0.000	0.000	55.505	0.000	0.810
		B		0.000	0.000	0.000	0.000	0.000
		C		0.000	0.000	52.372	0.000	0.943
T4	300.00-280.00	A	1.864	0.000	0.000	55.268	0.000	0.803
		B		0.000	0.000	0.000	0.000	0.000
		C		0.000	0.000	52.123	0.000	0.935
T5	280.00-260.00	A	1.851	0.000	0.000	55.016	0.000	0.796
		B		0.000	0.000	0.000	0.000	0.000
		C		0.000	0.000	51.857	0.000	0.927
T6	260.00-240.00	A	1.837	0.000	0.000	54.747	0.000	0.789
		B		0.000	0.000	0.000	0.000	0.000
		C		0.000	0.000	51.574	0.000	0.919
T7	240.00-220.00	A	1.821	0.000	0.000	54.457	0.000	0.780
		B		0.000	0.000	0.000	0.000	0.000
		C		0.000	0.000	51.269	0.000	0.909
T8	220.00-200.00	A	1.805	0.000	0.000	54.144	0.000	0.772
		B		0.000	0.000	0.000	0.000	0.000
		C		0.000	0.000	50.939	0.000	0.900
T9	200.00-180.00	A	1.787	0.000	0.000	53.803	0.000	0.762
		B		0.000	0.000	29.749	0.000	0.515
		C		0.000	0.000	50.579	0.000	0.889
T10	180.00-160.00	A	1.767	0.000	0.000	62.807	0.000	0.842
		B		0.000	0.000	98.658	0.000	1.699
		C		0.000	0.000	56.195	0.000	0.897
T11	160.00-140.00	A	1.745	0.000	0.000	98.503	0.000	1.216
		B		0.000	0.000	98.095	0.000	1.678
		C		0.000	0.000	57.190	0.000	0.889
T12	140.00-120.00	A	1.720	0.000	0.000	98.510	0.000	1.207
		B		0.000	0.000	118.823	0.000	1.924
		C		0.000	0.000	56.619	0.000	0.874
T13	120.00-100.00	A	1.692	0.000	0.000	97.461	0.000	1.182
		B		0.000	0.000	127.061	0.000	2.007
		C		0.000	0.000	55.962	0.000	0.858
T14	100.00-80.00	A	1.658	0.000	0.000	96.225	0.000	1.153
		B		0.000	0.000	125.979	0.000	1.969
		C		0.000	0.000	55.187	0.000	0.839
T15	80.00-60.00	A	1.617	0.000	0.000	94.711	0.000	1.117

tnxTower Allpro Consulting Group, Inc. 9221 Lyndon B. Johnson Fwy, Suite #204 Dallas, TX 75243 Phone: 972-231-8893 FAX: 866-364-8375	Job 18-5441	Page 12 of 38
	Project CT20021-A-11 Cleary Tower (Edward)	Date 15:43:40 08/22/18
	Client SBA	Designed by Binod Paudel

Tower Section	Tower Elevation ft	Face or Leg	Ice Thickness in	A _R ft ²	A _F ft ²	C _{AA} In Face ft ²	C _{AA} Out Face ft ²	Weight K
T16	60.00-40.00	B	1.564	0.000	0.000	124.655	0.000	1.922
		C		0.000	0.000	54.238	0.000	0.816
		A		0.000	0.000	92.744	0.000	1.072
T17	40.00-20.00	B	1.486	0.000	0.000	122.934	0.000	1.863
		C		0.000	0.000	53.005	0.000	0.787
		A		0.000	0.000	89.883	0.000	1.008
T18	20.00-0.00	B	1.331	0.000	0.000	120.432	0.000	1.779
		C		0.000	0.000	51.210	0.000	0.746
		A		0.000	0.000	84.211	0.000	0.887
		B		0.000	0.000	115.474	0.000	1.617
		C		0.000	0.000	47.647	0.000	0.669

Feed Line Center of Pressure

Section	Elevation ft	CP _x in	CP _z in	CP _x Ice in	CP _z Ice in
T1	350.00-340.00	-1.3372	-0.3057	-2.1515	0.9539
T2	340.00-320.00	-2.8616	0.4458	-3.9371	2.2178
T3	320.00-300.00	-3.8281	-0.7662	-5.6618	1.4449
T4	300.00-280.00	-4.3542	-0.8678	-7.3378	1.8853
T5	280.00-260.00	-5.0290	-1.0051	-8.6858	2.2377
T6	260.00-240.00	-5.0100	-1.0061	-9.4059	2.4364
T7	240.00-220.00	-5.8037	-1.1649	-10.5384	2.7177
T8	220.00-200.00	-6.1329	-1.2319	-11.3049	2.9100
T9	200.00-180.00	-3.2441	-1.5962	-8.4081	2.1229
T10	180.00-160.00	1.4817	-2.8076	-3.2712	-0.0807
T11	160.00-140.00	0.0638	-4.0768	-6.3264	-2.8964
T12	140.00-120.00	1.0708	-7.3816	-5.8157	-5.8520
T13	120.00-100.00	1.5483	-8.7512	-5.4707	-7.2267
T14	100.00-80.00	1.5965	-9.1063	-5.6470	-7.6001
T15	80.00-60.00	1.4801	-8.6054	-5.4996	-7.6346
T16	60.00-40.00	1.5081	-8.8292	-5.5452	-7.9465
T17	40.00-20.00	1.5087	-8.9064	-5.4126	-8.2066
T18	20.00-0.00	1.5076	-8.9672	-5.1049	-8.5587

Shielding Factor Ka

Tower Section	Feed Line Record No.	Description	Feed Line Segment Elev.	K _a No Ice	K _a Ice
T1	1		7/8 340.00 - 350.00	0.6000	0.4718
T1	4		1 1/4 340.00 - 350.00	0.6000	0.4718
T1	7	Feedline Ladder (Af)	340.00 - 350.00	0.6000	0.4718
T1	17	Climbing Ladder	340.00 - 350.00	0.6000	0.4718
T1	19		1 1/4 340.00 - 341.00	0.6000	0.4718
T1	20	Feedline Ladder (Af)	340.00 -	0.6000	0.4718

tnxTower Allpro Consulting Group, Inc. 9221 Lyndon B. Johnson Fwy, Suite #204 Dallas, TX 75243 Phone: 972-231-8893 FAX: 866-364-8375	Job 18-5441	Page 13 of 38
	Project CT20021-A-11 Cleary Tower (Edward)	Date 15:43:40 08/22/18
	Client SBA	Designed by Binod Paudel

Tower Section	Feed Line Record No.	Description	Feed Line Segment Elev.	K _a No Ice	K _a Ice
			341.00		
T1	23	0.62" S.O. Cord	340.00 -	0.6000	0.4718
			350.00		
T1	24	0.25" Cable	340.00 -	0.6000	0.4718
			350.00		
T2	1	7/8	320.00 -	0.6000	0.4940
			340.00		
T2	4	1 1/4	320.00 -	0.6000	0.4940
			340.00		
T2	7	Feedline Ladder (Af)	320.00 -	0.6000	0.4940
			340.00		
T2	17	Climbing Ladder	320.00 -	0.6000	0.4940
			340.00		
T2	19	1 1/4	320.00 -	0.6000	0.4940
			340.00		
T2	20	Feedline Ladder (Af)	320.00 -	0.6000	0.4940
			340.00		
T2	23	0.62" S.O. Cord	320.00 -	0.6000	0.4940
			340.00		
T2	24	0.25" Cable	320.00 -	0.6000	0.4940
			340.00		
T3	1	7/8	300.00 -	0.6000	0.5750
			320.00		
T3	4	1 1/4	300.00 -	0.6000	0.5750
			320.00		
T3	5	1 1/4	300.00 -	0.6000	0.5750
			320.00		
T3	7	Feedline Ladder (Af)	300.00 -	0.6000	0.5750
			320.00		
T3	17	Climbing Ladder	300.00 -	0.6000	0.5750
			320.00		
T3	19	1 1/4	300.00 -	0.6000	0.5750
			320.00		
T3	20	Feedline Ladder (Af)	300.00 -	0.6000	0.5750
			320.00		
T3	23	0.62" S.O. Cord	300.00 -	0.6000	0.5750
			320.00		
T3	24	0.25" Cable	300.00 -	0.6000	0.5750
			320.00		
T4	1	7/8	280.00 -	0.6000	0.6000
			300.00		
T4	4	1 1/4	280.00 -	0.6000	0.6000
			300.00		
T4	5	1 1/4	280.00 -	0.6000	0.6000
			300.00		
T4	7	Feedline Ladder (Af)	280.00 -	0.6000	0.6000
			300.00		
T4	17	Climbing Ladder	280.00 -	0.6000	0.6000
			300.00		
T4	19	1 1/4	280.00 -	0.6000	0.6000
			300.00		
T4	20	Feedline Ladder (Af)	280.00 -	0.6000	0.6000
			300.00		
T4	23	0.62" S.O. Cord	280.00 -	0.6000	0.6000
			300.00		
T4	24	0.25" Cable	280.00 -	0.6000	0.6000
			300.00		
T5	1	7/8	260.00 -	0.6000	0.6000
			280.00		
T5	4	1 1/4	260.00 -	0.6000	0.6000
			280.00		
T5	5	1 1/4	260.00 -	0.6000	0.6000

tnxTower Allpro Consulting Group, Inc. 9221 Lyndon B. Johnson Fwy, Suite #204 Dallas, TX 75243 Phone: 972-231-8893 FAX: 866-364-8375	Job 18-5441	Page 14 of 38
	Project CT20021-A-11 Cleary Tower (Edward)	Date 15:43:40 08/22/18
	Client SBA	Designed by Binod Paudel

Tower Section	Feed Line Record No.	Description	Feed Line Segment Elev.	K _a No Ice	K _a Ice
			280.00		
T5	7	Feedline Ladder (Af)	260.00 - 280.00	0.6000	0.6000
T5	17	Climbing Ladder	260.00 - 280.00	0.6000	0.6000
T5	19	1 1/4	260.00 - 280.00	0.6000	0.6000
T5	20	Feedline Ladder (Af)	260.00 - 280.00	0.6000	0.6000
T5	23	0.62" S.O. Cord	260.00 - 280.00	0.6000	0.6000
T5	24	0.25" Cable	260.00 - 280.00	0.6000	0.6000
T6	1	7/8	240.00 - 260.00	0.6000	0.6000
T6	4	1 1/4	240.00 - 260.00	0.6000	0.6000
T6	5	1 1/4	240.00 - 260.00	0.6000	0.6000
T6	7	Feedline Ladder (Af)	240.00 - 260.00	0.6000	0.6000
T6	17	Climbing Ladder	240.00 - 260.00	0.6000	0.6000
T6	19	1 1/4	240.00 - 260.00	0.6000	0.6000
T6	20	Feedline Ladder (Af)	240.00 - 260.00	0.6000	0.6000
T6	23	0.62" S.O. Cord	240.00 - 260.00	0.6000	0.6000
T6	24	0.25" Cable	240.00 - 260.00	0.6000	0.6000
T7	1	7/8	220.00 - 240.00	0.6000	0.6000
T7	4	1 1/4	220.00 - 240.00	0.6000	0.6000
T7	5	1 1/4	220.00 - 240.00	0.6000	0.6000
T7	7	Feedline Ladder (Af)	220.00 - 240.00	0.6000	0.6000
T7	17	Climbing Ladder	220.00 - 240.00	0.6000	0.6000
T7	19	1 1/4	220.00 - 240.00	0.6000	0.6000
T7	20	Feedline Ladder (Af)	220.00 - 240.00	0.6000	0.6000
T7	23	0.62" S.O. Cord	220.00 - 240.00	0.6000	0.6000
T7	24	0.25" Cable	220.00 - 240.00	0.6000	0.6000
T8	1	7/8	200.00 - 220.00	0.6000	0.6000
T8	4	1 1/4	200.00 - 220.00	0.6000	0.6000
T8	5	1 1/4	200.00 - 220.00	0.6000	0.6000
T8	7	Feedline Ladder (Af)	200.00 - 220.00	0.6000	0.6000
T8	17	Climbing Ladder	200.00 - 220.00	0.6000	0.6000
T8	19	1 1/4	200.00 - 220.00	0.6000	0.6000
T8	20	Feedline Ladder (Af)	200.00 -	0.6000	0.6000

Job	18-5441	Page	15 of 38
Project	CT20021-A-11 Cleary Tower (Edward)	Date	15:43:40 08/22/18
Client	SBA	Designed by	Binod Paudel

Tower Section	Feed Line Record No.	Description	Feed Line Segment Elev.	K_a No Ice	K_a Ice
			220.00		
T8	23	0.62" S.O. Cord	200.00 -	0.6000	0.6000
			220.00		
T8	24	0.25" Cable	200.00 -	0.6000	0.6000
			220.00		
T9	1	7/8	180.00 -	0.6000	0.6000
			200.00		
T9	4	1 1/4	180.00 -	0.6000	0.6000
			200.00		
T9	5	1 1/4	180.00 -	0.6000	0.6000
			200.00		
T9	7	Feedline Ladder (Af)	180.00 -	0.6000	0.6000
			200.00		
T9	9	1-5/8"	180.00 -	0.6000	0.6000
			186.00		
T9	10	3/4" DC Power	180.00 -	0.0000	0.0000
			186.00		
T9	11	1/2" Fiber	180.00 -	0.0000	0.0000
			186.00		
T9	12	2" Interduct	180.00 -	0.6000	0.6000
			186.00		
T9	13	Feedline Ladder (Af)	180.00 -	0.6000	0.6000
			186.00		
T9	17	Climbing Ladder	180.00 -	0.6000	0.6000
			200.00		
T9	19	1 1/4	180.00 -	0.6000	0.6000
			200.00		
T9	20	Feedline Ladder (Af)	180.00 -	0.6000	0.6000
			200.00		
T9	23	0.62" S.O. Cord	180.00 -	0.6000	0.6000
			200.00		
T9	24	0.25" Cable	180.00 -	0.6000	0.6000
			200.00		
T10	1	7/8	160.00 -	0.6000	0.6000
			180.00		
T10	3	1/2	160.00 -	0.6000	0.6000
			165.00		
T10	4	1 1/4	160.00 -	0.6000	0.6000
			180.00		
T10	5	1 1/4	160.00 -	0.6000	0.6000
			180.00		
T10	6	1/2	160.00 -	0.6000	0.6000
			165.00		
T10	7	Feedline Ladder (Af)	160.00 -	0.6000	0.6000
			180.00		
T10	9	1-5/8"	160.00 -	0.6000	0.6000
			180.00		
T10	10	3/4" DC Power	160.00 -	0.0000	0.0000
			180.00		
T10	11	1/2" Fiber	160.00 -	0.0000	0.0000
			180.00		
T10	12	2" Interduct	160.00 -	0.6000	0.6000
			180.00		
T10	13	Feedline Ladder (Af)	160.00 -	0.6000	0.6000
			180.00		
T10	17	Climbing Ladder	160.00 -	0.6000	0.6000
			180.00		
T10	19	1 1/4	160.00 -	0.6000	0.6000
			180.00		
T10	20	Feedline Ladder (Af)	160.00 -	0.6000	0.6000
			180.00		
T10	22	0.62" S.O. Cord	160.00 -	0.6000	0.6000

tnxTower

Allpro Consulting Group, Inc.
 9221 Lyndon B. Johnson Fwy, Suite #204
 Dallas, TX 75243
 Phone: 972-231-8893
 FAX: 866-364-8375

Job	18-5441	Page	16 of 38
Project	CT20021-A-11 Cleary Tower (Edward)	Date	15:43:40 08/22/18
Client	SBA	Designed by	Binod Paudel

Tower Section	Feed Line Record No.	Description	Feed Line Segment Elev.	K_a No Ice	K_a Ice
			176.00		
T10	23	0.62" S.O. Cord	176.00 -	0.6000	0.6000
			180.00		
T10	24	0.25" Cable	160.00 -	0.6000	0.6000
			180.00		
T11	1	7/8	140.00 -	0.6000	0.6000
			160.00		
T11	2	7/8	140.00 -	0.6000	0.6000
			158.00		
T11	3	1/2	140.00 -	0.6000	0.6000
			160.00		
T11	4	1 1/4	140.00 -	0.6000	0.6000
			160.00		
T11	5	1 1/4	140.00 -	0.6000	0.6000
			160.00		
T11	6	1/2	140.00 -	0.6000	0.6000
			160.00		
T11	7	Feedline Ladder (Af)	140.00 -	0.6000	0.6000
			160.00		
T11	9	1-5/8"	140.00 -	0.6000	0.6000
			160.00		
T11	10	3/4" DC Power	140.00 -	0.0000	0.0000
			160.00		
T11	11	1/2" Fiber	140.00 -	0.0000	0.0000
			160.00		
T11	12	2" Interduct	140.00 -	0.6000	0.6000
			160.00		
T11	13	Feedline Ladder (Af)	140.00 -	0.6000	0.6000
			160.00		
T11	17	Climbing Ladder	140.00 -	0.6000	0.6000
			160.00		
T11	19	1 1/4	140.00 -	0.6000	0.6000
			160.00		
T11	20	Feedline Ladder (Af)	140.00 -	0.6000	0.6000
			160.00		
T11	22	0.62" S.O. Cord	140.00 -	0.6000	0.6000
			160.00		
T11	24	0.25" Cable	140.00 -	0.6000	0.6000
			160.00		
T12	1	7/8	120.00 -	0.6000	0.6000
			140.00		
T12	2	7/8	120.00 -	0.6000	0.6000
			140.00		
T12	3	1/2	120.00 -	0.6000	0.6000
			140.00		
T12	4	1 1/4	120.00 -	0.6000	0.6000
			140.00		
T12	5	1 1/4	120.00 -	0.6000	0.6000
			140.00		
T12	6	1/2	120.00 -	0.6000	0.6000
			140.00		
T12	7	Feedline Ladder (Af)	120.00 -	0.6000	0.6000
			140.00		
T12	9	1-5/8"	120.00 -	0.6000	0.6000
			140.00		
T12	10	3/4" DC Power	120.00 -	0.0000	0.0000
			140.00		
T12	11	1/2" Fiber	120.00 -	0.0000	0.0000
			140.00		
T12	12	2" Interduct	120.00 -	0.6000	0.6000
			140.00		
T12	13	Feedline Ladder (Af)	120.00 -	0.6000	0.6000

tnxTower

Allpro Consulting Group, Inc.
9221 Lyndon B. Johnson Fwy, Suite #204
Dallas, TX 75243
Phone: 972-231-8893
FAX: 866-364-8375

Job	18-5441	Page	17 of 38
Project	CT20021-A-11 Cleary Tower (Edward)	Date	15:43:40 08/22/18
Client	SBA	Designed by	Binod Paudel

Tower Section	Feed Line Record No.	Description	Feed Line Segment Elev.	K_a No Ice	K_a Ice
T12	15	1 1/4	140.00 120.00 - 134.00	0.6000	0.6000
T12	17	Climbing Ladder	120.00 - 140.00	0.6000	0.6000
T12	19	1 1/4	120.00 - 140.00	0.6000	0.6000
T12	20	Feedline Ladder (Af)	120.00 - 140.00	0.6000	0.6000
T12	22	0.62" S.O. Cord	120.00 - 140.00	0.6000	0.6000
T12	24	0.25" Cable	120.00 - 140.00	0.6000	0.6000
T13	1	7/8	100.00 - 120.00	0.6000	0.6000
T13	2	7/8	100.00 - 120.00	0.6000	0.6000
T13	3	1/2	100.00 - 120.00	0.6000	0.6000
T13	4	1 1/4	100.00 - 120.00	0.6000	0.6000
T13	5	1 1/4	100.00 - 120.00	0.6000	0.6000
T13	6	1/2	100.00 - 120.00	0.6000	0.6000
T13	7	Feedline Ladder (Af)	100.00 - 120.00	0.6000	0.6000
T13	9	1-5/8"	100.00 - 120.00	0.6000	0.6000
T13	10	3/4" DC Power	100.00 - 120.00	0.0000	0.0000
T13	11	1/2" Fiber	100.00 - 120.00	0.0000	0.0000
T13	12	2" Interduct	100.00 - 120.00	0.6000	0.6000
T13	13	Feedline Ladder (Af)	100.00 - 120.00	0.6000	0.6000
T13	15	1 1/4	100.00 - 120.00	0.6000	0.6000
T13	17	Climbing Ladder	100.00 - 120.00	0.6000	0.6000
T13	19	1 1/4	100.00 - 120.00	0.6000	0.6000
T13	20	Feedline Ladder (Af)	100.00 - 120.00	0.6000	0.6000
T13	22	0.62" S.O. Cord	100.00 - 120.00	0.6000	0.6000
T13	24	0.25" Cable	100.00 - 120.00	0.6000	0.6000
T14	1	7/8	80.00 - 100.00	0.6000	0.6000
T14	2	7/8	80.00 - 100.00	0.6000	0.6000
T14	3	1/2	80.00 - 100.00	0.6000	0.6000
T14	4	1 1/4	80.00 - 100.00	0.6000	0.6000
T14	5	1 1/4	80.00 - 100.00	0.6000	0.6000
T14	6	1/2	80.00 - 100.00	0.6000	0.6000
T14	7	Feedline Ladder (Af)	80.00 - 100.00	0.6000	0.6000
T14	9	1-5/8"	80.00 - 100.00	0.6000	0.6000
T14	10	3/4" DC Power	80.00 - 100.00	0.0000	0.0000
T14	11	1/2" Fiber	80.00 - 100.00	0.0000	0.0000
T14	12	2" Interduct	80.00 - 100.00	0.6000	0.6000
T14	13	Feedline Ladder (Af)	80.00 - 100.00	0.6000	0.6000
T14	15	1 1/4	80.00 - 100.00	0.6000	0.6000

Job	18-5441	Page	18 of 38
Project	CT20021-A-11 Cleary Tower (Edward)	Date	15:43:40 08/22/18
Client	SBA	Designed by	Binod Paudel

Tower Section	Feed Line Record No.	Description	Feed Line Segment Elev.	K _a No Ice	K _a Ice
T14	17	Climbing Ladder	80.00 - 100.00	0.6000	0.6000
T14	19	1 1/4	80.00 - 100.00	0.6000	0.6000
T14	20	Feedline Ladder (Af)	80.00 - 100.00	0.6000	0.6000
T14	22	0.62" S.O. Cord	80.00 - 100.00	0.6000	0.6000
T14	24	0.25" Cable	80.00 - 100.00	0.6000	0.6000
T15	1	7/8	60.00 - 80.00	0.6000	0.6000
T15	2	7/8	60.00 - 80.00	0.6000	0.6000
T15	3	1/2	60.00 - 80.00	0.6000	0.6000
T15	4	1 1/4	60.00 - 80.00	0.6000	0.6000
T15	5	1 1/4	60.00 - 80.00	0.6000	0.6000
T15	6	1/2	60.00 - 80.00	0.6000	0.6000
T15	7	Feedline Ladder (Af)	60.00 - 80.00	0.6000	0.6000
T15	9	1-5/8"	60.00 - 80.00	0.6000	0.6000
T15	10	3/4" DC Power	60.00 - 80.00	0.0000	0.0000
T15	11	1/2" Fiber	60.00 - 80.00	0.0000	0.0000
T15	12	2" Interduct	60.00 - 80.00	0.6000	0.6000
T15	13	Feedline Ladder (Af)	60.00 - 80.00	0.6000	0.6000
T15	15	1 1/4	60.00 - 80.00	0.6000	0.6000
T15	17	Climbing Ladder	60.00 - 80.00	0.6000	0.6000
T15	19	1 1/4	60.00 - 80.00	0.6000	0.6000
T15	20	Feedline Ladder (Af)	60.00 - 80.00	0.6000	0.6000
T15	22	0.62" S.O. Cord	60.00 - 80.00	0.6000	0.6000
T15	24	0.25" Cable	60.00 - 80.00	0.6000	0.6000
T16	1	7/8	40.00 - 60.00	0.6000	0.6000
T16	2	7/8	40.00 - 60.00	0.6000	0.6000
T16	3	1/2	40.00 - 60.00	0.6000	0.6000
T16	4	1 1/4	40.00 - 60.00	0.6000	0.6000
T16	5	1 1/4	40.00 - 60.00	0.6000	0.6000
T16	6	1/2	40.00 - 60.00	0.6000	0.6000
T16	7	Feedline Ladder (Af)	40.00 - 60.00	0.6000	0.6000
T16	9	1-5/8"	40.00 - 60.00	0.6000	0.6000
T16	10	3/4" DC Power	40.00 - 60.00	0.0000	0.0000
T16	11	1/2" Fiber	40.00 - 60.00	0.0000	0.0000
T16	12	2" Interduct	40.00 - 60.00	0.6000	0.6000
T16	13	Feedline Ladder (Af)	40.00 - 60.00	0.6000	0.6000
T16	15	1 1/4	40.00 - 60.00	0.6000	0.6000
T16	17	Climbing Ladder	40.00 - 60.00	0.6000	0.6000
T16	19	1 1/4	40.00 - 60.00	0.6000	0.6000
T16	20	Feedline Ladder (Af)	40.00 - 60.00	0.6000	0.6000
T16	22	0.62" S.O. Cord	40.00 - 60.00	0.6000	0.6000
T16	24	0.25" Cable	40.00 - 60.00	0.6000	0.6000
T17	1	7/8	20.00 - 40.00	0.6000	0.6000
T17	2	7/8	20.00 - 40.00	0.6000	0.6000
T17	3	1/2	20.00 - 40.00	0.6000	0.6000
T17	4	1 1/4	20.00 - 40.00	0.6000	0.6000
T17	5	1 1/4	20.00 - 40.00	0.6000	0.6000
T17	6	1/2	20.00 - 40.00	0.6000	0.6000
T17	7	Feedline Ladder (Af)	20.00 - 40.00	0.6000	0.6000
T17	9	1-5/8"	20.00 - 40.00	0.6000	0.6000
T17	10	3/4" DC Power	20.00 - 40.00	0.0000	0.0000
T17	11	1/2" Fiber	20.00 - 40.00	0.0000	0.0000
T17	12	2" Interduct	20.00 - 40.00	0.6000	0.6000
T17	13	Feedline Ladder (Af)	20.00 - 40.00	0.6000	0.6000
T17	15	1 1/4	20.00 - 40.00	0.6000	0.6000
T17	17	Climbing Ladder	20.00 - 40.00	0.6000	0.6000
T17	19	1 1/4	20.00 - 40.00	0.6000	0.6000
T17	20	Feedline Ladder (Af)	20.00 - 40.00	0.6000	0.6000
T17	22	0.62" S.O. Cord	20.00 - 40.00	0.6000	0.6000
T17	24	0.25" Cable	20.00 - 40.00	0.6000	0.6000
T18	1	7/8	0.00 - 20.00	0.6000	0.6000
T18	2	7/8	0.00 - 20.00	0.6000	0.6000
T18	3	1/2	0.00 - 20.00	0.6000	0.6000

tnxTower Allpro Consulting Group, Inc. 9221 Lyndon B. Johnson Fwy, Suite #204 Dallas, TX 75243 Phone: 972-231-8893 FAX: 866-364-8375	Job	18-5441	Page	19 of 38	
	Project	CT20021-A-11 Cleary Tower (Edward)		Date	15:43:40 08/22/18
	Client	SBA		Designed by	Binod Paudel

Tower Section	Feed Line Record No.	Description	Feed Line Segment Elev.	K_a No Ice	K_a Ice
T18	4	1 1/4	0.00 - 20.00	0.6000	0.6000
T18	5	1 1/4	0.00 - 20.00	0.6000	0.6000
T18	6	1/2	0.00 - 20.00	0.6000	0.6000
T18	7	Feedline Ladder (Af)	0.00 - 20.00	0.6000	0.6000
T18	9	1-5/8"	0.00 - 20.00	0.6000	0.6000
T18	10	3/4" DC Power	0.00 - 20.00	0.0000	0.0000
T18	11	1/2" Fiber	0.00 - 20.00	0.0000	0.0000
T18	12	2" Interduct	0.00 - 20.00	0.6000	0.6000
T18	13	Feedline Ladder (Af)	0.00 - 20.00	0.6000	0.6000
T18	15	1 1/4	0.00 - 20.00	0.6000	0.6000
T18	17	Climbing Ladder	0.00 - 20.00	0.6000	0.6000
T18	19	1 1/4	0.00 - 20.00	0.6000	0.6000
T18	20	Feedline Ladder (Af)	0.00 - 20.00	0.6000	0.6000
T18	22	0.62" S.O. Cord	0.00 - 20.00	0.6000	0.6000
T18	24	0.25" Cable	0.00 - 20.00	0.6000	0.6000

Discrete Tower Loads

Description	Face or Leg	Offset Type	Offsets: Horz Lateral Vert	Azimuth Adjustment	Placement	C_{AA} Front	C_{AA} Side	Weight	
			ft	°	ft	ft ²	ft ²	K	
7770 (AT&T)	A	From Leg	3.00	0.0000	186.00	No Ice	5.51	2.93	0.035
			0.00			1/2" Ice	5.87	3.27	0.068
			0.00			1" Ice	6.23	3.63	0.105
7770 (AT&T)	B	From Leg	3.00	0.0000	186.00	No Ice	5.51	2.93	0.035
			0.00			1/2" Ice	5.87	3.27	0.068
			0.00			1" Ice	6.23	3.63	0.105
7770 (AT&T)	C	From Leg	3.00	0.0000	186.00	No Ice	5.51	2.93	0.035
			0.00			1/2" Ice	5.87	3.27	0.068
			0.00			1" Ice	6.23	3.63	0.105
AM-X-CD-16-65-00T-RET (AT&T)	A	From Leg	3.00	0.0000	186.00	No Ice	6.04	4.11	0.033
			0.00			1/2" Ice	6.41	4.45	0.074
			0.00			1" Ice	6.77	4.80	0.121
AM-X-CD-16-65-00T-RET (AT&T)	B	From Leg	3.00	0.0000	186.00	No Ice	6.04	4.11	0.033
			0.00			1/2" Ice	6.41	4.45	0.074
			0.00			1" Ice	6.77	4.80	0.121
(2) AM-X-CD-16-65-00T-RET (AT&T)	C	From Leg	3.00	0.0000	186.00	No Ice	6.04	4.11	0.033
			0.00			1/2" Ice	6.41	4.45	0.074
			0.00			1" Ice	6.77	4.80	0.121
800-10121 (AT&T)	A	From Leg	3.00	0.0000	186.00	No Ice	5.16	3.29	0.046
			0.00			1/2" Ice	5.51	3.64	0.079
			0.00			1" Ice	5.87	3.99	0.117
800-10121 (AT&T)	B	From Leg	3.00	0.0000	186.00	No Ice	5.16	3.29	0.046
			0.00			1/2" Ice	5.51	3.64	0.079
			0.00			1" Ice	5.87	3.99	0.117
HPA-65R-BUU-H6 (AT&T)	A	From Leg	3.00	0.0000	186.00	No Ice	9.49	5.49	0.043
			0.00			1/2" Ice	9.96	5.94	0.100
			0.00			1" Ice	10.43	6.41	0.164
HPA-65R-BUU-H6 (AT&T)	B	From Leg	3.00	0.0000	186.00	No Ice	9.49	5.49	0.043
			0.00			1/2" Ice	9.96	5.94	0.100
			0.00			1" Ice	10.43	6.41	0.164

tnxTower Allpro Consulting Group, Inc. 9221 Lyndon B. Johnson Fwy, Suite #204 Dallas, TX 75243 Phone: 972-231-8893 FAX: 866-364-8375	Job	18-5441	Page	20 of 38
	Project	CT20021-A-11 Cleary Tower (Edward)	Date	15:43:40 08/22/18
	Client	SBA	Designed by	Binod Paudel

Description	Face or Leg	Offset Type	Offsets:		Azimuth Adjustment	Placement	CAAA Front	CAAA Side	Weight
			Horz	Vert					
			ft	ft	°	ft	ft ²	ft ²	K
HPA-65R-BUU-H6 (AT&T)	C	From Leg	3.00	0.0000	186.00	No Ice	9.49	5.49	0.043
			0.00			1/2" Ice	9.96	5.94	0.100
			0.00			1" Ice	10.43	6.41	0.164
(2) CCI DTMA-BP7819VG12A (AT&T)	A	From Leg	3.00	0.0000	186.00	No Ice	0.56	0.34	0.020
			0.00			1/2" Ice	0.66	0.43	0.025
			0.00			1" Ice	0.77	0.52	0.030
(2) CCI DTMA-BP7819VG12A (AT&T)	B	From Leg	3.00	0.0000	186.00	No Ice	0.56	0.34	0.020
			0.00			1/2" Ice	0.66	0.43	0.025
			0.00			1" Ice	0.77	0.52	0.030
(2) CCI DTMA-BP7819VG12A (AT&T)	C	From Leg	3.00	0.0000	186.00	No Ice	0.56	0.34	0.020
			0.00			1/2" Ice	0.66	0.43	0.025
			0.00			1" Ice	0.77	0.52	0.030
860 10025 RET (AT&T)	A	From Leg	3.00	0.0000	186.00	No Ice	0.14	0.12	0.001
			0.00			1/2" Ice	0.20	0.17	0.003
			0.00			1" Ice	0.26	0.23	0.005
(2) 860 10025 RET (AT&T)	A	From Leg	3.00	0.0000	186.00	No Ice	0.14	0.12	0.001
			0.00			1/2" Ice	0.20	0.17	0.003
			0.00			1" Ice	0.26	0.23	0.005
860 10025 RET (AT&T)	A	From Leg	3.00	0.0000	186.00	No Ice	0.14	0.12	0.001
			0.00			1/2" Ice	0.20	0.17	0.003
			0.00			1" Ice	0.26	0.23	0.005
RRUS 11 (AT&T)	A	From Leg	3.00	0.0000	186.00	No Ice	2.52	1.02	0.055
			0.00			1/2" Ice	2.72	1.16	0.074
			0.00			1" Ice	2.92	1.30	0.097
RRUS 11 (AT&T)	B	From Leg	3.00	0.0000	186.00	No Ice	2.52	1.02	0.055
			0.00			1/2" Ice	2.72	1.16	0.074
			0.00			1" Ice	2.92	1.30	0.097
RRUS 11 (AT&T)	C	From Leg	3.00	0.0000	186.00	No Ice	2.52	1.02	0.055
			0.00			1/2" Ice	2.72	1.16	0.074
			0.00			1" Ice	2.92	1.30	0.097
RRUS 32 (AT&T)	A	From Leg	3.00	0.0000	186.00	No Ice	2.32	1.65	0.077
			0.00			1/2" Ice	2.51	1.83	0.098
			0.00			1" Ice	2.71	2.01	0.122
RRUS 32 (AT&T)	B	From Leg	3.00	0.0000	186.00	No Ice	2.32	1.65	0.077
			0.00			1/2" Ice	2.51	1.83	0.098
			0.00			1" Ice	2.71	2.01	0.122
RRUS 32 (AT&T)	C	From Leg	3.00	0.0000	186.00	No Ice	2.32	1.65	0.077
			0.00			1/2" Ice	2.51	1.83	0.098
			0.00			1" Ice	2.71	2.01	0.122
(2) LGP13519 Diplexer (AT&T)	A	From Leg	3.00	0.0000	186.00	No Ice	0.29	0.18	0.005
			0.00			1/2" Ice	0.36	0.24	0.008
			0.00			1" Ice	0.44	0.31	0.012
(2) LGP13519 Diplexer (AT&T)	B	From Leg	3.00	0.0000	186.00	No Ice	0.29	0.18	0.005
			0.00			1/2" Ice	0.36	0.24	0.008
			0.00			1" Ice	0.44	0.31	0.012
(2) LGP13519 Diplexer (AT&T)	C	From Leg	3.00	0.0000	186.00	No Ice	0.29	0.18	0.005
			0.00			1/2" Ice	0.36	0.24	0.008
			0.00			1" Ice	0.44	0.31	0.012
DC6-48-60-18-8F (AT&T)	C	From Leg	3.00	0.0000	186.00	No Ice	2.20	3.70	0.020
			0.00			1/2" Ice	2.40	3.94	0.030
			0.00			1" Ice	2.60	4.19	0.040
13.5' T-Frames (AT&T)	A	From Leg	1.50	0.0000	186.00	No Ice	10.12	9.05	0.240
			0.00			1/2" Ice	14.43	11.89	0.340
			0.00			1" Ice	18.74	14.73	0.440
13.5' T-Frames (AT&T)	B	From Leg	1.50	0.0000	186.00	No Ice	10.12	9.05	0.240
			0.00			1/2" Ice	14.43	11.89	0.340
			0.00			1" Ice	18.74	14.73	0.440

tnxTower Allpro Consulting Group, Inc. 9221 Lyndon B. Johnson Fwy, Suite #204 Dallas, TX 75243 Phone: 972-231-8893 FAX: 866-364-8375	Job	18-5441	Page	21 of 38
	Project	CT20021-A-11 Cleary Tower (Edward)	Date	15:43:40 08/22/18
	Client	SBA	Designed by	Binod Paudel

<i>Description</i>	<i>Face or Leg</i>	<i>Offset Type</i>	<i>Offsets: Horz Lateral Vert</i> <i>ft ft ft</i>	<i>Azimuth Adjustment</i> <i>°</i>	<i>Placement</i> <i>ft</i>	<i>CAAA Front</i> <i>ft²</i>	<i>CAAA Side</i> <i>ft²</i>	<i>Weight</i> <i>K</i>	
13.5' T-Frames (AT&T)	C	From Leg	1.50 0.00 0.00	0.0000	186.00	No Ice 1/2" Ice 1" Ice	10.12 14.43 14.73	9.05 11.89 14.73	0.240 0.340 0.440

Celwave PD200 Omni (LoJack)	A	From Leg	3.00 0.00 10.00	0.0000	350.00	No Ice 1/2" Ice 1" Ice	2.73 3.91 5.09	2.73 3.91 5.10	0.020 0.040 0.068
101 Omni (Marcus)	B	From Leg	3.00 0.00 5.00	0.0000	350.00	No Ice 1/2" Ice 1" Ice	2.14 3.06 5.10	2.14 3.06 3.99	0.020 0.040 0.068
Star Mount w/ (9) Standoffs (Marcus/LoJack)	A	From Leg	1.50 0.00 0.00	0.0000	350.00	No Ice 1/2" Ice 1" Ice	28.57 35.34 42.11	28.57 35.34 42.11	0.568 0.863 1.158

101 Omni (Marcus)	A	From Leg	3.00 0.00 5.00	0.0000	320.00	No Ice 1/2" Ice 1" Ice	2.14 3.06 5.10	2.14 3.06 3.99	0.020 0.040 0.068
101 Omni (Marcus)	B	From Leg	3.00 0.00 5.00	0.0000	320.00	No Ice 1/2" Ice 1" Ice	2.14 3.06 5.10	2.14 3.06 3.99	0.020 0.040 0.068
6' Standoff (Marcus)	A	From Leg	1.50 0.00 0.00	0.0000	320.00	No Ice 1/2" Ice 1" Ice	4.97 6.12 7.27	3.20 5.12 7.04	0.070 0.130 0.190
6' Standoff (Marcus)	B	From Leg	1.50 0.00 0.00	0.0000	320.00	No Ice 1/2" Ice 1" Ice	4.97 6.12 7.27	3.20 5.12 7.04	0.070 0.130 0.190

Decibel DB408 Omni (Wolcott Ambulance)	A	From Leg	3.00 0.00 5.00	0.0000	158.00	No Ice 1/2" Ice 1" Ice	1.60 2.42 3.24	1.60 2.42 3.24	0.020 0.032 0.050
17" Standoff Mount (Wolcott)	B	From Leg	1.50 0.00 0.00	0.0000	158.00	No Ice 1/2" Ice 1" Ice	0.73 0.91 1.09	0.73 0.91 1.09	0.027 0.035 0.046

APXVTM14-C-I20 (Sprint)	A	From Leg	3.00 0.00 0.00	0.0000	134.00	No Ice 1/2" Ice 1" Ice	6.34 6.72 7.10	3.61 3.97 4.33	0.056 0.096 0.140
APXVTM14-C-I20 (Sprint)	B	From Leg	3.00 0.00 0.00	0.0000	134.00	No Ice 1/2" Ice 1" Ice	6.34 6.72 7.10	3.61 3.97 4.33	0.056 0.096 0.140
APXVTM14-C-I20 (Sprint)	C	From Leg	3.00 0.00 0.00	0.0000	134.00	No Ice 1/2" Ice 1" Ice	6.34 6.72 7.10	3.61 3.97 4.33	0.056 0.096 0.140
RFS APXVSPP18 (Sprint)	A	From Leg	3.00 0.00 0.00	0.0000	134.00	No Ice 1/2" Ice 1" Ice	8.02 8.48 8.94	5.28 5.74 6.20	0.057 0.107 0.162
RFS APXVSPP18 (Sprint)	B	From Leg	3.00 0.00 0.00	0.0000	134.00	No Ice 1/2" Ice 1" Ice	8.02 8.48 8.94	5.28 5.74 6.20	0.057 0.107 0.162
RFS APXVSPP18 (Sprint)	C	From Leg	3.00 0.00 0.00	0.0000	134.00	No Ice 1/2" Ice 1" Ice	8.02 8.48 8.94	5.28 5.74 6.20	0.057 0.107 0.162
RRH 1900 MHz (Sprint)	A	From Leg	3.00 0.00 0.00	0.0000	134.00	No Ice 1/2" Ice 1" Ice	1.22 1.37 1.52	1.87 2.05 2.24	0.043 0.059 0.077
RRH 1900 MHz (Sprint)	B	From Leg	3.00 0.00 0.00	0.0000	134.00	No Ice 1/2" Ice	1.22 1.37	1.87 2.05	0.043 0.059

tnxTower Allpro Consulting Group, Inc. 9221 Lyndon B. Johnson Fwy, Suite #204 Dallas, TX 75243 Phone: 972-231-8893 FAX: 866-364-8375	Job		18-5441		Page		22 of 38	
	Project		CT20021-A-11 Cleary Tower (Edward)		Date		15:43:40 08/22/18	
	Client		SBA		Designed by		Binod Paudel	

Description	Face or Leg	Offset Type	Offsets:		Azimuth Adjustment	Placement	CAAA Front	CAAA Side	Weight	
			Horz	Vert						
			ft	ft	°	ft	ft ²	ft ²	K	
RRH 1900 MHz (Sprint)	C	From Leg	0.00		0.0000	134.00	1" Ice	1.52	2.24	0.077
			3.00				No Ice	1.22	1.87	0.043
			0.00				1/2" Ice	1.37	2.05	0.059
RRH 800 MHz (Sprint)	A	From Leg	0.00		0.0000	134.00	1" Ice	1.52	2.24	0.077
			3.00				No Ice	1.73	1.37	0.048
			0.00				1/2" Ice	1.90	1.52	0.065
RRH 800 MHz (Sprint)	B	From Leg	0.00		0.0000	134.00	1" Ice	2.07	1.68	0.084
			3.00				No Ice	1.73	1.37	0.048
			0.00				1/2" Ice	1.90	1.52	0.065
RRH 800 MHz (Sprint)	C	From Leg	0.00		0.0000	134.00	1" Ice	2.07	1.68	0.084
			3.00				No Ice	1.73	1.37	0.048
			0.00				1/2" Ice	1.90	1.52	0.065
TD-RRH8x20-25 (Sprint)	A	From Leg	0.00		0.0000	134.00	1" Ice	2.07	1.68	0.084
			3.00				No Ice	1.73	1.37	0.048
			0.00				1/2" Ice	1.90	1.52	0.065
TD-RRH8x20-25 (Sprint)	B	From Leg	0.00		0.0000	134.00	1" Ice	2.07	1.68	0.084
			3.00				No Ice	1.73	1.37	0.048
			0.00				1/2" Ice	1.90	1.52	0.065
TD-RRH8x20-25 (Sprint)	C	From Leg	0.00		0.0000	134.00	1" Ice	2.07	1.68	0.084
			3.00				No Ice	1.73	1.37	0.048
			0.00				1/2" Ice	1.90	1.52	0.065
RRH 800 MHz Filter (Sprint)	A	From Leg	0.00		0.0000	134.00	1" Ice	2.07	1.68	0.084
			3.00				No Ice	1.73	1.37	0.048
			0.00				1/2" Ice	1.90	1.52	0.065
RRH 800 MHz Filter (Sprint)	B	From Leg	0.00		0.0000	134.00	1" Ice	2.07	1.68	0.084
			3.00				No Ice	1.73	1.37	0.048
			0.00				1/2" Ice	1.90	1.52	0.065
RRH 800 MHz Filter (Sprint)	C	From Leg	0.00		0.0000	134.00	1" Ice	2.07	1.68	0.084
			3.00				No Ice	1.73	1.37	0.048
			0.00				1/2" Ice	1.90	1.52	0.065
(2) ACU-A20-N (Sprint)	A	From Leg	0.00		0.0000	134.00	1" Ice	0.15	0.21	0.004
			3.00				No Ice	0.07	0.12	0.001
			0.00				1/2" Ice	0.10	0.16	0.002
ACU-A20-N (Sprint)	B	From Leg	0.00		0.0000	134.00	1" Ice	0.15	0.21	0.004
			3.00				No Ice	0.07	0.12	0.001
			0.00				1/2" Ice	0.10	0.16	0.002
ACU-A20-N (Sprint)	C	From Leg	0.00		0.0000	134.00	1" Ice	0.15	0.21	0.004
			3.00				No Ice	0.07	0.12	0.001
			0.00				1/2" Ice	0.10	0.16	0.002
15' T-Frames (Sprint)	A	From Leg	0.00		0.0000	134.00	1" Ice	20.18	19.08	0.690
			1.50				No Ice	11.22	10.08	0.370
			0.00				1/2" Ice	15.70	14.58	0.530
15' T-Frames (Sprint)	B	From Leg	0.00		0.0000	134.00	1" Ice	20.18	19.08	0.690
			1.50				No Ice	11.22	10.08	0.370
			0.00				1/2" Ice	15.70	14.58	0.530
15' T-Frames (Sprint)	C	From Leg	0.00		0.0000	134.00	1" Ice	20.18	19.08	0.690
			1.50				No Ice	11.22	10.08	0.370
			0.00				1/2" Ice	15.70	14.58	0.530

(2) Pipe Mounts (5.25' x 4.5") (Marcus)	A	From Leg	0.00		0.0000	165.00	1" Ice	2.54	2.54	0.094
			0.50				No Ice	1.69	1.69	0.057
			0.00				1/2" Ice	2.21	2.21	0.074
(2) Pipe Mounts (5.25' x 4.5") (Marcus)	B	From Leg	0.00		0.0000	165.00	1" Ice	2.54	2.54	0.094
			0.50				No Ice	1.69	1.69	0.057
			0.00				1/2" Ice	2.21	2.21	0.074
(2) Pipe Mounts (5.25' x 4.5") (Marcus)	C	From Leg	0.00		0.0000	165.00	1" Ice	2.54	2.54	0.094
			0.50				No Ice	1.69	1.69	0.057
			0.00				1/2" Ice	2.21	2.21	0.074

tnxTower Allpro Consulting Group, Inc. 9221 Lyndon B. Johnson Fwy, Suite #204 Dallas, TX 75243 Phone: 972-231-8893 FAX: 866-364-8375	Job	18-5441	Page	23 of 38
	Project	CT20021-A-11 Cleary Tower (Edward)	Date	15:43:40 08/22/18
	Client	SBA	Designed by	Binod Paudel

Description	Face or Leg	Offset Type	Offsets:		Azimuth Adjustment	Placement	CAAA Front	CAAA Side	Weight	
			Horz	Lateral						Vert
(Marcus)			0.00			1/2" Ice	2.21	2.21	0.074	
****			0.00			1" Ice	2.54	2.54	0.094	
800 10622 (Dish Network)	A	From Leg	3.00		0.0000	341.00	No Ice	6.31	1.98	0.052
			0.00				1/2" Ice	6.68	2.32	0.083
			0.00				1" Ice	7.06	2.66	0.119
800 10622 (Dish Network)	B	From Leg	3.00		0.0000	341.00	No Ice	6.31	1.98	0.052
			0.00				1/2" Ice	6.68	2.32	0.083
			0.00				1" Ice	7.06	2.66	0.119
800 10622 (Dish Network)	C	From Leg	3.00		0.0000	341.00	No Ice	6.31	1.98	0.052
			0.00				1/2" Ice	6.68	2.32	0.083
			0.00				1" Ice	7.06	2.66	0.119
4415 (Dish Network)	A	From Leg	3.00		0.0000	341.00	No Ice	1.86	0.83	0.046
			0.00				1/2" Ice	2.03	0.96	0.061
			0.00				1" Ice	2.20	1.09	0.077
4415 (Dish Network)	B	From Leg	3.00		0.0000	341.00	No Ice	1.86	0.83	0.046
			0.00				1/2" Ice	2.03	0.96	0.061
			0.00				1" Ice	2.20	1.09	0.077
4415 (Dish Network)	C	From Leg	3.00		0.0000	341.00	No Ice	1.86	0.83	0.046
			0.00				1/2" Ice	2.03	0.96	0.061
			0.00				1" Ice	2.20	1.09	0.077
0208 (Dish Network)	A	From Leg	3.00		0.0000	341.00	No Ice	1.36	0.48	0.020
			0.00				1/2" Ice	1.50	0.58	0.029
			0.00				1" Ice	1.66	0.68	0.041
0208 (Dish Network)	B	From Leg	3.00		0.0000	341.00	No Ice	1.36	0.48	0.020
			0.00				1/2" Ice	1.50	0.58	0.029
			0.00				1" Ice	1.66	0.68	0.041
0208 (Dish Network)	C	From Leg	3.00		0.0000	341.00	No Ice	1.36	0.48	0.020
			0.00				1/2" Ice	1.50	0.58	0.029
			0.00				1" Ice	1.66	0.68	0.041
Commscope SF-SU7-2-96 Sector Frame (Dish Network)	A	From Leg	1.50		0.0000	341.00	No Ice	11.06	8.76	0.395
			0.00				1/2" Ice	17.63	14.51	0.553
			0.00				1" Ice	24.20	20.26	0.711
Commscope SF-SU7-2-96 Sector Frame (Dish Network)	B	From Leg	1.50		0.0000	341.00	No Ice	11.06	8.76	0.395
			0.00				1/2" Ice	17.63	14.51	0.553
			0.00				1" Ice	24.20	20.26	0.711
Commscope SF-SU7-2-96 Sector Frame (Dish Network)	C	From Leg	1.50		0.0000	341.00	No Ice	11.06	8.76	0.395
			0.00				1/2" Ice	17.63	14.51	0.553
			0.00				1" Ice	24.20	20.26	0.711

Dishes

Description	Face or Leg	Dish Type	Offset Type	Offsets:		Azimuth Adjustment	3 dB Beam Width	Elevation	Outside Diameter	Aperture Area	Weight	
				Horz	Lateral							Vert
Radiowaves SPD3-2.4 Dish (Marcus)	A	Paraboloid w/Radome	From Leg	1.00		0.0000		165.00	3.00	No Ice	7.10	0.035
				0.00						1/2" Ice	7.46	0.073
				0.00						1" Ice	7.83	0.112
Radiowaves	B	Paraboloid	From	1.00		0.0000		165.00	3.00	No Ice	7.10	0.035

tnxTower Allpro Consulting Group, Inc. 9221 Lyndon B. Johnson Fwy, Suite #204 Dallas, TX 75243 Phone: 972-231-8893 FAX: 866-364-8375	Job	18-5441	Page	24 of 38
	Project	CT20021-A-11 Cleary Tower (Edward)	Date	15:43:40 08/22/18
	Client	SBA	Designed by	Binod Paudel

Description	Face or Leg	Dish Type	Offset Type	Offsets: Horz Lateral Vert ft	Azimuth Adjustment °	3 dB Beam Width °	Elevation ft	Outside Diameter ft	Aperture Area ft ²	Weight K
SPD3-2.4 Dish (Marcus)		w/Radome	Leg	0.00					1/2" Ice 7.46	0.073
Radiowaves	C	Paraboloid	From	0.00	0.0000		165.00	3.00	1" Ice 7.83	0.112
SPD3-2.4 Dish (Marcus)		w/Radome	Leg	0.00					No Ice 7.10	0.035
Radiowaves	A	Paraboloid	From	0.00	0.0000		165.00	2.00	1/2" Ice 7.46	0.073
SPD2-5.8 Dish (Marcus)		w/Radome	Leg	0.00					1" Ice 7.83	0.112
Radiowaves	B	Paraboloid	From	0.00	0.0000		165.00	2.00	No Ice 3.14	0.022
SPD2-5.8 Dish (Marcus)		w/Radome	Leg	0.00					1/2" Ice 3.41	0.039
Radiowaves	C	Paraboloid	From	0.00	0.0000		165.00	2.00	1" Ice 3.67	0.057
SPD2-5.8 Dish (Marcus)		w/Radome	Leg	0.00					No Ice 3.14	0.022
Radiowaves				0.00					1/2" Ice 3.41	0.039
SPD2-5.8 Dish (Marcus)		w/Radome	Leg	0.00					1" Ice 3.67	0.057

Load Combinations

Comb. No.	Description
1	Dead Only
2	1.2 Dead+1.6 Wind 0 deg - No Ice
3	0.9 Dead+1.6 Wind 0 deg - No Ice
4	1.2 Dead+1.6 Wind 30 deg - No Ice
5	0.9 Dead+1.6 Wind 30 deg - No Ice
6	1.2 Dead+1.6 Wind 60 deg - No Ice
7	0.9 Dead+1.6 Wind 60 deg - No Ice
8	1.2 Dead+1.6 Wind 90 deg - No Ice
9	0.9 Dead+1.6 Wind 90 deg - No Ice
10	1.2 Dead+1.6 Wind 120 deg - No Ice
11	0.9 Dead+1.6 Wind 120 deg - No Ice
12	1.2 Dead+1.6 Wind 150 deg - No Ice
13	0.9 Dead+1.6 Wind 150 deg - No Ice
14	1.2 Dead+1.6 Wind 180 deg - No Ice
15	0.9 Dead+1.6 Wind 180 deg - No Ice
16	1.2 Dead+1.6 Wind 210 deg - No Ice
17	0.9 Dead+1.6 Wind 210 deg - No Ice
18	1.2 Dead+1.6 Wind 240 deg - No Ice
19	0.9 Dead+1.6 Wind 240 deg - No Ice
20	1.2 Dead+1.6 Wind 270 deg - No Ice
21	0.9 Dead+1.6 Wind 270 deg - No Ice
22	1.2 Dead+1.6 Wind 300 deg - No Ice
23	0.9 Dead+1.6 Wind 300 deg - No Ice
24	1.2 Dead+1.6 Wind 330 deg - No Ice
25	0.9 Dead+1.6 Wind 330 deg - No Ice
26	1.2 Dead+1.0 Ice+1.0 Temp
27	1.2 Dead+1.0 Wind 0 deg+1.0 Ice+1.0 Temp
28	1.2 Dead+1.0 Wind 30 deg+1.0 Ice+1.0 Temp
29	1.2 Dead+1.0 Wind 60 deg+1.0 Ice+1.0 Temp
30	1.2 Dead+1.0 Wind 90 deg+1.0 Ice+1.0 Temp
31	1.2 Dead+1.0 Wind 120 deg+1.0 Ice+1.0 Temp
32	1.2 Dead+1.0 Wind 150 deg+1.0 Ice+1.0 Temp
33	1.2 Dead+1.0 Wind 180 deg+1.0 Ice+1.0 Temp
34	1.2 Dead+1.0 Wind 210 deg+1.0 Ice+1.0 Temp
35	1.2 Dead+1.0 Wind 240 deg+1.0 Ice+1.0 Temp
36	1.2 Dead+1.0 Wind 270 deg+1.0 Ice+1.0 Temp
37	1.2 Dead+1.0 Wind 300 deg+1.0 Ice+1.0 Temp

tnxTower Allpro Consulting Group, Inc. 9221 Lyndon B. Johnson Fwy, Suite #204 Dallas, TX 75243 Phone: 972-231-8893 FAX: 866-364-8375	Job 18-5441	Page 25 of 38
	Project CT20021-A-11 Cleary Tower (Edward)	Date 15:43:40 08/22/18
	Client SBA	Designed by Binod Paudel

Comb. No.	Description
38	1.2 Dead+1.0 Wind 330 deg+1.0 Ice+1.0 Temp
39	Dead+Wind 0 deg - Service
40	Dead+Wind 30 deg - Service
41	Dead+Wind 60 deg - Service
42	Dead+Wind 90 deg - Service
43	Dead+Wind 120 deg - Service
44	Dead+Wind 150 deg - Service
45	Dead+Wind 180 deg - Service
46	Dead+Wind 210 deg - Service
47	Dead+Wind 240 deg - Service
48	Dead+Wind 270 deg - Service
49	Dead+Wind 300 deg - Service
50	Dead+Wind 330 deg - Service

Maximum Tower Deflections - Service Wind

Section No.	Elevation ft	Horz. Deflection in	Gov. Load Comb.	Tilt °	Twist °
T1	350 - 340	6.313	39	0.2141	0.0733
T2	340 - 320	5.865	39	0.2106	0.0588
T3	320 - 300	5.015	39	0.1825	0.0338
T4	300 - 280	4.303	39	0.1533	0.0175
T5	280 - 260	3.687	39	0.1371	0.0112
T6	260 - 240	3.135	39	0.1216	0.0075
T7	240 - 220	2.641	39	0.1086	0.0054
T8	220 - 200	2.205	39	0.0954	0.0044
T9	200 - 180	1.819	39	0.0840	0.0037
T10	180 - 160	1.477	39	0.0739	0.0032
T11	160 - 140	1.171	47	0.0647	0.0028
T12	140 - 120	0.901	47	0.0552	0.0023
T13	120 - 100	0.672	47	0.0464	0.0020
T14	100 - 80	0.478	47	0.0381	0.0017
T15	80 - 60	0.317	47	0.0296	0.0013
T16	60 - 40	0.192	47	0.0217	0.0010
T17	40 - 20	0.099	47	0.0144	0.0007
T18	20 - 0	0.032	47	0.0069	0.0003

Critical Deflections and Radius of Curvature - Service Wind

Elevation ft	Appurtenance	Gov. Load Comb.	Deflection in	Tilt °	Twist °	Radius of Curvature ft
350.00	Celwave PD200 Omni	39	6.313	0.2141	0.0733	291469
341.00	800 10622	39	5.909	0.2112	0.0602	153102
320.00	101 Omni	39	5.015	0.1825	0.0338	28435
186.00	7770	39	1.575	0.0768	0.0033	128204
165.00	Radiowaves SPD3-2.4 Dish	39	1.244	0.0670	0.0029	142622
158.00	Decibel DB408 Omni	47	1.142	0.0638	0.0027	138938
134.00	APXVTM14-C-120	47	0.828	0.0525	0.0022	116809

tnxTower Allpro Consulting Group, Inc. 9221 Lyndon B. Johnson Fwy, Suite #204 Dallas, TX 75243 Phone: 972-231-8893 FAX: 866-364-8375	Job 18-5441	Page 26 of 38
	Project CT20021-A-11 Cleary Tower (Edward)	Date 15:43:40 08/22/18
	Client SBA	Designed by Binod Paudel

Maximum Tower Deflections - Design Wind

Section No.	Elevation ft	Horz. Deflection in	Gov. Load Comb.	Tilt °	Twist °
T1	350 - 340	26.377	2	0.8771	0.3069
T2	340 - 320	24.536	2	0.8675	0.2460
T3	320 - 300	21.015	2	0.7593	0.1415
T4	300 - 280	18.045	2	0.6411	0.0734
T5	280 - 260	15.464	2	0.5746	0.0468
T6	260 - 240	13.149	2	0.5101	0.0314
T7	240 - 220	11.079	2	0.4555	0.0225
T8	220 - 200	9.249	2	0.4004	0.0185
T9	200 - 180	7.628	2	0.3525	0.0154
T10	180 - 160	6.193	2	0.3101	0.0133
T11	160 - 140	4.908	2	0.2717	0.0115
T12	140 - 120	3.771	2	0.2318	0.0098
T13	120 - 100	2.807	18	0.1946	0.0085
T14	100 - 80	2.000	18	0.1600	0.0071
T15	80 - 60	1.326	18	0.1242	0.0055
T16	60 - 40	0.803	18	0.0909	0.0042
T17	40 - 20	0.413	18	0.0603	0.0028
T18	20 - 0	0.134	19	0.0287	0.0014

Critical Deflections and Radius of Curvature - Design Wind

Elevation ft	Appurtenance	Gov. Load Comb.	Deflection in	Tilt °	Twist °	Radius of Curvature ft
350.00	Celwave PD200 Omni	2	26.377	0.8771	0.3069	112137
341.00	800 10622	2	24.719	0.8698	0.2519	55251
320.00	101 Omni	2	21.015	0.7593	0.1415	7106
186.00	7770	2	6.606	0.3222	0.0138	30524
165.00	Radiowaves SPD3-2.4 Dish	2	5.216	0.2813	0.0120	33923
158.00	Decibel DB408 Omni	2	4.788	0.2678	0.0113	33059
134.00	APXVTM14-C-I20	2	3.462	0.2202	0.0094	27844

Bolt Design Data

Section No.	Elevation ft	Component Type	Bolt Grade	Bolt Size in	Number Of Bolts	Maximum Load per Bolt K	Allowable Load per Bolt K	Ratio Load Allowable	Allowable Ratio	Criteria	
T1	350	Leg	A325N	0.6250	4	0.949	20.709	0.046	✓	1	Bolt Tension
		Diagonal	A325N	0.6250	1	2.165	6.831	0.317	✓	1	Member Block Shear
		Top Girt	A325N	0.6250	1	0.336	10.440	0.032	✓	1	Member Bearing
T2	340	Leg	A325N	0.6250	4	7.095	20.709	0.343	✓	1	Bolt Tension
		Diagonal	A325N	0.6250	1	3.131	6.831	0.458	✓	1	Member Block Shear
T3	320	Leg	A325N	0.7500	4	11.154	29.821	0.374	✓	1	Bolt Tension
		Diagonal	A325N	0.6250	1	2.503	6.831	0.366	✓	1	Member Block

tnxTower Allpro Consulting Group, Inc. 9221 Lyndon B. Johnson Fwy, Suite #204 Dallas, TX 75243 Phone: 972-231-8893 FAX: 866-364-8375	Job 18-5441	Page 27 of 38
	Project CT20021-A-11 Cleary Tower (Edward)	Date 15:43:40 08/22/18
	Client SBA	Designed by Binod Paudel

Section No.	Elevation ft	Component Type	Bolt Grade	Bolt Size in	Number Of Bolts	Maximum Load per Bolt K	Allowable Load per Bolt K	Ratio Load Allowable	Allowable Ratio	Criteria	
T4	300	Leg	A325N	0.7500	6	9.445	29.821	0.317	✓	1	Shear Bolt Tension
		Diagonal	A325N	0.6250	1	2.205	7.830	0.282	✓	1	Member Bearing
T5	280	Leg	A325N	0.8750	6	11.514	40.589	0.284	✓	1	Bolt Tension
		Diagonal	A325N	0.6250	1	2.464	7.830	0.315	✓	1	Member Bearing
T6	260	Leg	A325N	0.8750	6	13.629	40.589	0.336	✓	1	Bolt Tension
		Diagonal	A325N	0.6250	1	2.942	7.830	0.376	✓	1	Member Bearing
T7	240	Leg	A325N	1.0000	6	15.592	53.014	0.294	✓	1	Bolt Tension
		Diagonal	A325N	0.6250	1	3.801	15.660	0.243	✓	1	Member Bearing
		Horizontal	A325N	0.6250	1	2.174	7.830	0.278	✓	1	Member Bearing
T8	220	Leg	A325N	1.1250	6	17.802	67.096	0.265	✓	1	Bolt Tension
		Diagonal	A325N	0.7500	1	4.280	17.944	0.239	✓	1	Member Block Shear
		Horizontal	A325N	0.6250	1	2.402	7.830	0.307	✓	1	Member Bearing
T9	200	Leg	A325N	1.1250	6	20.004	67.096	0.298	✓	1	Bolt Tension
		Diagonal	A325N	0.7500	1	6.076	18.922	0.321	✓	1	Member Bearing
		Horizontal	A325N	0.6250	1	2.650	7.830	0.338	✓	1	Member Bearing
T10	180	Leg	A325N	1.2500	6	23.027	82.835	0.278	✓	1	Bolt Tension
		Diagonal	A325N	0.7500	1	7.017	18.922	0.371	✓	1	Member Bearing
		Horizontal	A325N	0.6250	1	3.083	7.830	0.394	✓	1	Member Bearing
T11	160	Leg	A325N	1.2500	6	26.279	82.835	0.317	✓	1	Bolt Tension
		Diagonal	A325N	0.7500	1	8.133	18.922	0.430	✓	1	Member Bearing
		Horizontal	A325N	0.6250	1	3.552	10.440	0.340	✓	1	Member Bearing
T12	140	Leg	A325N	1.3750	6	28.554	100.230	0.285	✓	1	Bolt Tension
		Diagonal	A325N	0.7500	1	10.942	25.230	0.434	✓	1	Member Bearing
		Horizontal	A325N	0.7500	1	3.918	17.944	0.218	✓	1	Member Block Shear
T13	120	Leg	A325N	1.3750	6	32.295	100.230	0.322	✓	1	Bolt Tension
		Diagonal	A325N	0.7500	1	11.907	25.230	0.472	✓	1	Member Bearing
		Horizontal	A325N	0.7500	1	4.460	17.944	0.249	✓	1	Member Block Shear
T14	100	Leg	A325N	1.3750	6	35.801	100.230	0.357	✓	1	Bolt Tension
		Diagonal	A325N	0.7500	1	12.084	25.230	0.479	✓	1	Member Bearing
		Horizontal	A325N	0.7500	1	4.962	17.944	0.277	✓	1	Member Block Shear
T15	80	Leg	A325N	1.5000	6	39.378	119.282	0.330	✓	1	Bolt Tension
		Diagonal	A325N	0.8750	1	12.847	29.580	0.434	✓	1	Member Bearing
		Horizontal	A325N	0.7500	1	5.501	18.922	0.291	✓	1	Member Bearing
T16	60	Leg	A325N	1.5000	6	42.762	119.282	0.358	✓	1	Bolt Tension
		Diagonal	A325N	0.8750	1	13.214	29.580	0.447	✓	1	Member Bearing
		Horizontal	A325N	0.7500	1	6.016	18.922	0.318	✓	1	Member Bearing
T17	40	Leg	A325N	1.5000	6	46.222	119.282	0.387	✓	1	Bolt Tension
		Diagonal	A325N	0.8750	1	13.862	29.580	0.469	✓	1	Member Bearing

tnxTower Allpro Consulting Group, Inc. 9221 Lyndon B. Johnson Fwy, Suite #204 Dallas, TX 75243 Phone: 972-231-8893 FAX: 866-364-8375	Job 18-5441	Page 28 of 38
	Project CT20021-A-11 Cleary Tower (Edward)	Date 15:43:40 08/22/18
	Client SBA	Designed by Binod Paudel

Section No.	Elevation ft	Component Type	Bolt Grade	Bolt Size in	Number Of Bolts	Maximum Load per Bolt K	Allowable Load per Bolt K	Ratio Load Allowable	Allowable Ratio	Criteria
T18	20	Horizontal	A325N	0.7500	1	6.560	25.230	0.260 ✓	1	Member Bearing
		Leg	A307	2.5000	6	49.462	165.670	0.299 ✓	1	Bolt Tension
		Diagonal	A325N	0.8750	1	14.231	29.580	0.481 ✓	1	Member Bearing
		Horizontal	A325N	0.7500	1	7.101	25.230	0.281 ✓	1	Member Bearing

Compression Checks

Leg Design Data (Compression)

Section No.	Elevation ft	Size	L ft	L _u ft	Kl/r	A in ²	P _u K	φP _n K	Ratio $\frac{P_u}{\phi P_n}$
T1	350 - 340	2	10.00	5.00	120.0 K=1.00	3.1416	-6.389	49.286	0.130 ¹ ✓
T2	340 - 320	2	20.00	4.00	96.0 K=1.00	3.1416	-32.850	72.063	0.456 ¹ ✓
T3	320 - 300	2 1/2	20.03	5.01	96.2 K=1.00	4.9087	-51.804	112.346	0.461 ¹ ✓
T4	300 - 280	3 1/4	20.03	6.68	98.6 K=1.00	8.2958	-66.554	183.313	0.363 ¹ ✓
T5	280 - 260	3 1/4	20.03	6.68	98.6 K=1.00	8.2958	-82.027	183.313	0.447 ¹ ✓
T6	260 - 240	3 1/2	20.03	6.68	91.6 K=1.00	9.6211	-98.359	234.484	0.419 ¹ ✓
T7	240 - 220	3 1/2	20.03	5.01	68.7 K=1.00	9.6211	-114.326	306.641	0.373 ¹ ✓
T8	220 - 200	3 3/4	20.03	5.01	64.1 K=1.00	11.0447	-132.471	368.015	0.360 ¹ ✓
T9	200 - 180	4	20.03	5.01	60.1 K=1.00	12.5664	-152.651	434.236	0.352 ¹ ✓
T10	180 - 160	4 1/4	20.03	5.01	56.6 K=1.00	14.1863	-177.754	505.220	0.352 ¹ ✓
T11	160 - 140	4 1/4	20.03	5.01	56.6 K=1.00	14.1863	-204.825	505.220	0.405 ¹ ✓
T12	140 - 120	4 1/2	20.03	5.01	53.4 K=1.00	15.9043	-225.945	580.902	0.389 ¹ ✓
T13	120 - 100	4 3/4	20.03	5.01	50.6 K=1.00	17.7205	-257.203	661.231	0.389 ¹ ✓
T14	100 - 80	4 3/4	20.03	5.01	50.6 K=1.00	17.7205	-286.135	661.231	0.433 ¹ ✓
T15	80 - 60	5	20.03	5.01	48.1 K=1.00	19.6350	-317.199	746.168	0.425 ¹ ✓
T16	60 - 40	5 1/4	20.03	5.01	45.8 K=1.00	21.6475	-346.925	835.679	0.415 ¹ ✓
T17	40 - 20	5 1/4	20.03	5.01	45.8	21.6475	-378.276	835.679	0.453 ¹ ✓

tnxTower Allpro Consulting Group, Inc. 9221 Lyndon B. Johnson Fwy, Suite #204 Dallas, TX 75243 Phone: 972-231-8893 FAX: 866-364-8375	Job 18-5441	Page 29 of 38
	Project CT20021-A-11 Cleary Tower (Edward)	Date 15:43:40 08/22/18
	Client SBA	Designed by Binod Paudel

Section No.	Elevation ft	Size	L ft	L _u ft	Kl/r	A in ²	P _u K	φP _n K	Ratio $\frac{P_u}{\phi P_n}$
T18	20 - 0	5 1/2	20.03	5.01	K=1.00 43.7 K=1.00	23.7583	-409.462	929.740	0.440 ¹ ✓ ✓

¹ P_u / φP_n controls

Diagonal Design Data (Compression)

Section No.	Elevation ft	Size	L ft	L _u ft	Kl/r	A in ²	P _u K	φP _n K	Ratio $\frac{P_u}{\phi P_n}$
T1	350 - 340	L2x1 1/2x3/16	6.40	2.95	112.4 K=1.02	0.6211	-2.174	10.346	0.210 ¹ ✓
T2	340 - 320	L2x1 1/2x3/16	5.66	2.59	102.4 K=1.06	0.6211	-3.350	11.584	0.289 ¹ ✓
T3	320 - 300	L2x2x3/16	6.56	3.22	103.5 K=1.06	0.7148	-2.765	13.174	0.210 ¹ ✓
T4	300 - 280	L2-1/2x2-1/2x3/16	10.16	5.00	121.3 K=1.00	0.9023	-2.330	13.474	0.173 ¹ ✓
T5	280 - 260	L2-1/2x2-1/2x3/16	11.74	5.79	140.4 K=1.00	0.9023	-2.519	10.341	0.244 ¹ ✓
T6	260 - 240	L3x3x3/16	13.44	6.62	133.3 K=1.00	1.0898	-2.981	13.820	0.216 ¹ ✓
T7	240 - 220	2L2 1/2x2 1/2x3/16x3/8	8.60	8.18	126.2 K=1.00	1.8000	-3.882	25.202	0.154 ¹ ✓
T8	220 - 200	2L2 1/2x2 1/2x3/16x3/8	9.44	8.98	138.5 K=1.00	1.8000	-4.388	21.196	0.207 ¹ ✓
T9	200 - 180	2L3x3x3/16x3/8	10.30	9.84	125.7 K=1.00	2.1800	-6.349	30.555	0.208 ¹ ✓
T10	180 - 160	2L3x3x3/16x3/8	11.18	10.71	136.9 K=1.00	2.1800	-7.303	26.278	0.278 ¹ ✓
T11	160 - 140	2L3x3x3/16x3/8	12.08	11.62	148.5 K=1.00	2.1800	-8.157	22.339	0.365 ¹ ✓
T12	140 - 120	2L3x3x1/4x3/8	15.62	15.11	143.9 K=1.00	2.8800	-12.140	31.416	0.386 ¹ ✓
T13	120 - 100	2L3x3x1/4x3/8	16.40	15.88	150.0 K=1.00	2.8800	-12.136	28.916	0.420 ¹ ✓
T14	100 - 80	2L3x3x1/4x3/8	17.21	16.69	156.4 K=1.00	2.8800	-13.238	26.593	0.498 ¹ ✓
T15	80 - 60	2L3 1/2x3 1/2x1/4x3/8	18.03	17.48	141.7 K=1.00	3.3800	-13.340	38.008	0.351 ¹ ✓
T16	60 - 40	2L3 1/2x3 1/2x1/4x3/8	18.87	18.31	147.6 K=1.00	3.3800	-14.578	35.047	0.416 ¹ ✓
T17	40 - 20	2L3 1/2x3 1/2x1/4x3/8	19.73	19.17	153.7 K=1.00	3.3800	-14.543	32.326	0.450 ¹ ✓
T18	20 - 0	2L3 1/2x3 1/2x1/4x3/8	20.59	20.03	159.8 K=1.00	3.3800	-15.426	29.896	0.516 ¹ ✓

tnxTower Allpro Consulting Group, Inc. 9221 Lyndon B. Johnson Fwy, Suite #204 Dallas, TX 75243 Phone: 972-231-8893 FAX: 866-364-8375	Job 18-5441	Page 30 of 38
	Project CT20021-A-11 Cleary Tower (Edward)	Date 15:43:40 08/22/18
	Client SBA	Designed by Binod Paudel

¹ $P_u / \phi P_n$ controls

Horizontal Design Data (Compression)

Section No.	Elevation ft	Size	L ft	L_u ft	Kl/r	A in^2	P_u K	ϕP_n K	Ratio $\frac{P_u}{\phi P_n}$
T7	240 - 220	L2 1/2x2 1/2x3/16	13.50	6.48	157.2 K=1.00	0.9023	-2.174	8.246	0.264 ¹ ✓
T8	220 - 200	L2 1/2x2 1/2x3/16	15.50	7.47	181.2 K=1.00	0.9023	-2.402	6.207	0.387 ¹ ✓
T9	200 - 180	L3x3x3/16	17.50	8.46	170.3 K=1.00	1.0898	-2.650	8.488	0.312 ¹ ✓
T10	180 - 160	L3x3x3/16	19.50	9.45	190.2 K=1.00	1.0898	-3.083	6.804	0.453 ¹ ✓
T11	160 - 140	L3 1/2x3 1/2x1/4	21.50	10.45	180.7 K=1.00	1.6900	-3.552	11.687	0.304 ¹ ✓
T12	140 - 120	2L2 1/2x2 1/2x3/16x3/8	23.00	11.18	172.4 K=1.00	1.8000	-3.918	13.682	0.286 ¹ ✓
T13	120 - 100	2L2 1/2x2 1/2x3/16x3/8	25.00	12.17	187.7 K=1.00	1.8000	-4.460	11.547	0.386 ¹ ✓
T14	100 - 80	2L2 1/2x2 1/2x3/16x3/8	27.00	13.17	203.1 K=1.00	1.8000	-4.962	9.860	0.503 ¹ ✓
T15	80 - 60	2L3x3x3/16x3/8	29.00	14.16	180.9 K=1.00	2.1800	-5.501	15.048	0.366 ¹ ✓
T16	60 - 40	2L3x3x3/16x3/8	31.00	15.15	193.6 K=1.00	2.1800	-6.016	13.146	0.458 ¹ ✓
T17	40 - 20	2L3 1/2x3 1/2x1/4x3/8	33.00	16.15	177.8 K=1.00	3.3800	-6.560	24.167	0.271 ¹ ✓
T18	20 - 0	2L3 1/2x3 1/2x1/4x3/8	35.00	17.14	188.6 K=1.00	3.3800	-7.101	21.456	0.331 ¹ ✓

¹ $P_u / \phi P_n$ controls

Top Girt Design Data (Compression)

Section No.	Elevation ft	Size	L ft	L_u ft	Kl/r	A in^2	P_u K	ϕP_n K	Ratio $\frac{P_u}{\phi P_n}$
T1	350 - 340	L3x3x1/4	4.00	3.59	96.4 K=1.32	1.4400	-0.325	28.598	0.011 ¹ ✓

¹ $P_u / \phi P_n$ controls

Redundant Horizontal (1) Design Data (Compression)

tnxTower Allpro Consulting Group, Inc. 9221 Lyndon B. Johnson Fwy, Suite #204 Dallas, TX 75243 Phone: 972-231-8893 FAX: 866-364-8375	Job	18-5441	Page	31 of 38
	Project	CT20021-A-11 Cleary Tower (Edward)	Date	15:43:40 08/22/18
	Client	SBA	Designed by	Binod Paudel

Section No.	Elevation ft	Size	L ft	L _u ft	Kl/r	A in ²	P _u K	φP _n K	Ratio $\frac{P_u}{\phi P_n}$
T12	140 - 120	L2x2x3/16	5.75	5.56	169.5 K=1.00	0.7148	-3.918	5.620	0.697 ¹ ✓
T13	120 - 100	L2x2x3/16	6.25	6.05	184.4 K=1.00	0.7148	-4.460	4.748	0.939 ¹ ✓
T14	100 - 80	L2x2x3/8	6.75	6.55	202.1 K=1.00	1.3600	-4.962	7.521	0.660 ¹ ✓
T15	80 - 60	L2-1/2x2-1/2x3/16	7.25	7.04	170.7 K=1.00	0.9023	-5.501	6.992	0.787 ¹ ✓
T16	60 - 40	L2-1/2x2-1/2x3/16	7.75	7.53	182.6 K=1.00	0.9023	-6.016	6.113	0.984 ¹ ✓
T17	40 - 20	L2.5x2.5x3/16 + L2.5x2.5x1/4 (C-Shape) - Cleary Tower	8.25	8.03	125.4 K=1.00	1.0565	-6.560	14.963	0.438 ¹ ✓
T18	20 - 0	L3x3x3/16	8.75	8.52	171.5 K=1.00	1.0898	-7.101	8.374	0.848 ¹ ✓

¹ P_u / φP_n controls

Redundant Diagonal (1) Design Data (Compression)

Section No.	Elevation ft	Size	L ft	L _u ft	Kl/r	A in ²	P _u K	φP _n K	Ratio $\frac{P_u}{\phi P_n}$
T12	140 - 120	L2-1/2x2-1/2x3/16	7.81	7.56	183.3 K=1.00	0.9023	-2.662	6.069	0.439 ¹ ✓
T13	120 - 100	L2-1/2x2-1/2x3/16	8.20	7.94	192.6 K=1.00	0.9023	-2.927	5.494	0.533 ¹ ✓
T14	100 - 80	L2-1/2x2-1/2x3/16	8.60	8.35	202.6 K=1.00	0.9023	-3.162	4.968	0.637 ¹ ✓
T15	80 - 60	L3x3x3/16	9.02	8.76	176.3 K=1.00	1.0898	-3.420	7.925	0.432 ¹ ✓
T16	60 - 40	L3x3x3/16	9.44	9.17	184.6 K=1.00	1.0898	-3.662	7.227	0.507 ¹ ✓
T17	40 - 20	L3x3x3/16	9.86	9.60	193.3 K=1.00	1.0898	-3.921	6.591	0.595 ¹ ✓
T18	20 - 0	L3x3x3/16	10.30	10.03	201.9 K=1.00	1.0898	-4.178	6.043	0.691 ¹ ✓

¹ P_u / φP_n controls

Inner Bracing Design Data (Compression)

Section No.	Elevation ft	Size	L ft	L _u ft	Kl/r	A in ²	P _u K	φP _n K	Ratio $\frac{P_u}{\phi P_n}$
T7	240 - 220	L2 1/2x2 1/2x3/16	6.75	6.75	163.7 K=1.00	0.9023	-0.012	7.609	0.002 ¹ ✓

tnxTower Allpro Consulting Group, Inc. 9221 Lyndon B. Johnson Fwy, Suite #204 Dallas, TX 75243 Phone: 972-231-8893 FAX: 866-364-8375	Job	18-5441	Page	32 of 38
	Project	CT20021-A-11 Cleary Tower (Edward)	Date	15:43:40 08/22/18
	Client	SBA	Designed by	Binod Paudel

Section No.	Elevation ft	Size	L ft	L _u ft	Kl/r	A in ²	P _u K	φP _n K	Ratio $\frac{P_u}{\phi P_n}$
T8	220 - 200	L2 1/2x2 1/2x3/16	7.75	7.75	187.9 K=1.00	0.9023	-0.014	5.772	0.002 ¹ ✓
T9	200 - 180	L3x3x3/16	8.75	8.75	176.1 K=1.00	1.0898	-0.017	7.941	0.002 ¹ ✓
T10	180 - 160	L3x3x3/16	9.75	9.75	196.2 K=1.00	1.0898	-0.018	6.396	0.003 ¹ ✓
T11	160 - 140	L3 1/2x3 1/2x1/4	10.75	10.75	185.9 K=1.00	1.6900	-0.021	11.050	0.002 ¹ ✓
T12	140 - 120	L3 1/2x3 1/2x1/4	11.50	11.50	198.8 K=1.00	1.6900	-0.030	9.656	0.003 ¹ ✓
T13	120 - 100	L4x4x1/4	12.50	12.50	188.7 K=1.00	1.9400	-0.031	12.311	0.003 ¹ ✓
T14	100 - 80	L4x4x1/4	13.50	13.50	203.8 K=1.00	1.9400	-0.033	10.555	0.003 ¹ ✓
T15	80 - 60	2L3x3x3/16x3/8	14.50	14.50	185.3 K=1.00	2.1800	-0.038	14.343	0.003 ¹ ✓
T16	60 - 40	2L3x3x3/16x3/8	15.50	15.50	198.1 K=1.00	2.1800	-0.039	12.552	0.003 ¹ ✓
T17	40 - 20	2L3 1/2x3 1/2x1/4x3/8	16.50	16.50	181.7 K=1.00	3.3800	-0.044	23.141	0.002 ¹ ✓
T18	20 - 0	2L3 1/2x3 1/2x1/4x3/8	17.50	17.50	192.7 K=1.00	3.3800	-0.043	20.572	0.002 ¹ ✓

¹ P_u / φP_n controls

Tension Checks

Leg Design Data (Tension)

Section No.	Elevation ft	Size	L ft	L _u ft	Kl/r	A in ²	P _u K	φP _n K	Ratio $\frac{P_u}{\phi P_n}$
T1	350 - 340	2	10.00	5.00	120.0	3.1416	3.794	141.372	0.027 ¹ ✓
T2	340 - 320	2	20.00	4.00	96.0	3.1416	28.378	141.372	0.201 ¹ ✓
T3	320 - 300	2 1/2	20.03	5.01	96.2	4.9087	44.617	220.893	0.202 ¹ ✓
T4	300 - 280	3 1/4	20.03	6.68	98.6	8.2958	56.672	373.310	0.152 ¹ ✓
T5	280 - 260	3 1/4	20.03	6.68	98.6	8.2958	69.086	373.310	0.185 ¹ ✓
T6	260 - 240	3 1/2	20.03	6.68	91.6	9.6211	81.771	432.951	0.189 ¹ ✓
T7	240 - 220	3 1/2	20.03	5.01	68.7	9.6211	93.721	432.951	0.216 ¹ ✓
T8	220 - 200	3 3/4	20.03	5.01	64.1	11.0447	107.010	497.010	0.215 ¹ ✓

tnxTower Allpro Consulting Group, Inc. 9221 Lyndon B. Johnson Fwy, Suite #204 Dallas, TX 75243 Phone: 972-231-8893 FAX: 866-364-8375	Job	18-5441	Page	33 of 38
	Project	CT20021-A-11 Cleary Tower (Edward)	Date	15:43:40 08/22/18
	Client	SBA	Designed by	Binod Paudel

Section No.	Elevation ft	Size	L ft	L _u ft	Kl/r	A in ²	P _u K	φP _n K	Ratio $\frac{P_u}{\phi P_n}$
T9	200 - 180	4	20.03	5.01	60.1	12.5664	120.767	565.487	0.214 ¹
T10	180 - 160	4 1/4	20.03	5.01	56.6	14.1863	138.575	638.381	0.217 ¹
T11	160 - 140	4 1/4	20.03	5.01	56.6	14.1863	157.966	638.381	0.247 ¹
T12	140 - 120	4 1/2	20.03	5.01	53.4	15.9043	172.687	715.694	0.241 ¹
T13	120 - 100	4 3/4	20.03	5.01	50.6	17.7205	194.866	797.425	0.244 ¹
T14	100 - 80	4 3/4	20.03	5.01	50.6	17.7205	215.971	797.425	0.271 ¹
T15	80 - 60	5	20.03	5.01	48.1	19.6350	237.596	883.573	0.269 ¹
T16	60 - 40	5 1/4	20.03	5.01	45.8	21.6475	257.984	974.139	0.265 ¹
T17	40 - 20	5 1/4	20.03	5.01	45.8	21.6475	278.850	974.139	0.286 ¹
T18	20 - 0	5 1/2	20.03	5.01	43.7	23.7583	298.155	1069.120	0.279 ¹

¹ P_u / φP_n controls

Diagonal Design Data (Tension)

Section No.	Elevation ft	Size	L ft	L _u ft	Kl/r	A in ²	P _u K	φP _n K	Ratio $\frac{P_u}{\phi P_n}$
T1	350 - 340	L2x1 1/2x3/16	6.40	2.95	83.8	0.3604	2.165	15.675	0.138 ¹
T2	340 - 320	L2x1 1/2x3/16	5.66	2.59	74.0	0.3604	3.131	15.675	0.200 ¹
T3	320 - 300	L2x2x3/16	6.56	3.22	64.9	0.4307	2.503	18.734	0.134 ¹
T4	300 - 280	L2-1/2x2-1/2x3/16	9.67	4.77	75.3	0.5713	2.205	24.851	0.089 ¹
T5	280 - 260	L2-1/2x2-1/2x3/16	11.74	5.79	91.1	0.5713	2.464	24.851	0.099 ¹
T6	260 - 240	L3x3x3/16	13.44	6.62	86.1	0.7119	2.942	30.968	0.095 ¹
T7	240 - 220	2L2 1/2x2 1/2x3/16x3/8	8.20	7.78	123.7	1.1391	3.801	49.549	0.077 ¹
T8	220 - 200	2L2 1/2x2 1/2x3/16x3/8	9.02	8.56	136.2	1.1039	4.280	48.020	0.089 ¹
T9	200 - 180	2L3x3x3/16x3/8	10.30	9.84	129.1	1.3889	6.076	60.417	0.101 ¹
T10	180 - 160	2L3x3x3/16x3/8	11.18	10.71	140.4	1.3889	7.017	60.417	0.116 ¹
T11	160 - 140	2L3x3x3/16x3/8	11.63	11.17	146.1	1.3889	8.133	60.417	0.135 ¹

tnxTower Allpro Consulting Group, Inc. 9221 Lyndon B. Johnson Fwy, Suite #204 Dallas, TX 75243 Phone: 972-231-8893 FAX: 866-364-8375	Job 18-5441	Page 34 of 38
	Project CT20021-A-11 Cleary Tower (Edward)	Date 15:43:40 08/22/18
	Client SBA	Designed by Binod Paudel

Section No.	Elevation ft	Size	L ft	L _u ft	Kl/r	A in ²	P _u K	φP _n K	Ratio $\frac{P_u}{\phi P_n}$
T12	140 - 120	2L3x3x1/4x3/8	15.62	15.11	132.8	1.8319	10.942	79.687	0.137 ¹
T13	120 - 100	2L3x3x1/4x3/8	15.62	15.10	132.7	1.8319	11.907	79.687	0.149 ¹
T14	100 - 80	2L3x3x1/4x3/8	16.40	15.89	139.5	1.8319	12.084	79.687	0.152 ¹
T15	80 - 60	2L3 1/2x3 1/2x1/4x3/8	17.21	16.65	128.0	2.1600	12.847	93.960	0.137 ¹
T16	60 - 40	2L3 1/2x3 1/2x1/4x3/8	18.03	17.47	134.1	2.1600	13.214	93.960	0.141 ¹
T17	40 - 20	2L3 1/2x3 1/2x1/4x3/8	18.87	18.31	140.5	2.1600	13.862	93.960	0.148 ¹
T18	20 - 0	2L3 1/2x3 1/2x1/4x3/8	19.73	19.16	146.9	2.1600	14.231	93.960	0.151 ¹

¹ P_u / φP_n controls

Horizontal Design Data (Tension)

Section No.	Elevation ft	Size	L ft	L _u ft	Kl/r	A in ²	P _u K	φP _n K	Ratio $\frac{P_u}{\phi P_n}$
T7	240 - 220	L2 1/2x2 1/2x3/16	13.50	6.48	101.8	0.5713	2.174	24.851	0.087 ¹
T8	220 - 200	L2 1/2x2 1/2x3/16	15.50	7.47	117.1	0.5713	2.402	24.851	0.097 ¹
T9	200 - 180	L3x3x3/16	17.50	8.46	109.7	0.7119	2.650	30.968	0.086 ¹
T10	180 - 160	L3x3x3/16	19.50	9.45	122.3	0.7119	3.083	30.968	0.100 ¹
T11	160 - 140	L3 1/2x3 1/2x1/4	21.50	10.45	116.4	1.1269	3.552	49.019	0.072 ¹
T12	140 - 120	2L2 1/2x2 1/2x3/16x3/8	23.00	11.18	174.5	1.1039	3.918	48.020	0.082 ¹
T13	120 - 100	2L2 1/2x2 1/2x3/16x3/8	25.00	12.17	189.7	1.1039	4.460	48.020	0.093 ¹
T14	100 - 80	2L2 1/2x2 1/2x3/16x3/8	27.00	13.17	205.2	1.1039	4.962	48.020	0.103 ¹
T15	80 - 60	2L3x3x3/16x3/8	29.00	14.16	182.6	1.3889	5.501	60.417	0.091 ¹
T16	60 - 40	2L3x3x3/16x3/8	31.00	15.15	195.3	1.3889	6.016	60.417	0.100 ¹
T17	40 - 20	2L3 1/2x3 1/2x1/4x3/8	33.00	16.15	179.2	2.2069	6.560	95.999	0.068 ¹
T18	20 - 0	2L3 1/2x3 1/2x1/4x3/8	35.00	17.14	190.1	2.2069	7.101	95.999	0.074 ¹

tnxTower Allpro Consulting Group, Inc. 9221 Lyndon B. Johnson Fwy, Suite #204 Dallas, TX 75243 Phone: 972-231-8893 FAX: 866-364-8375	Job 18-5441	Page 35 of 38
	Project CT20021-A-11 Cleary Tower (Edward)	Date 15:43:40 08/22/18
	Client SBA	Designed by Binod Paudel

¹ $P_u / \phi P_n$ controls

Top Girt Design Data (Tension)

Section No.	Elevation ft	Size	L ft	L_u ft	Kl/r	A in ²	P_u K	ϕP_n K	Ratio $\frac{P_u}{\phi P_n}$
T1	350 - 340	L3x3x1/4	4.00	3.59	49.5	0.9394	0.336	40.863	0.008 ¹

¹ $P_u / \phi P_n$ controls

Redundant Horizontal (1) Design Data (Tension)

Section No.	Elevation ft	Size	L ft	L_u ft	Kl/r	A in ²	P_u K	ϕP_n K	Ratio $\frac{P_u}{\phi P_n}$
T12	140 - 120	L2x2x3/16	5.75	5.56	108.1	0.7148	3.918	23.161	0.169 ¹
T13	120 - 100	L2x2x3/16	6.25	6.05	117.6	0.7148	4.460	23.161	0.193 ¹
T14	100 - 80	L2x2x3/8	6.75	6.55	132.4	1.3600	4.962	44.064	0.113 ¹
T15	80 - 60	L2-1/2x2-1/2x3/16	7.25	7.04	108.6	0.9023	5.501	29.236	0.188 ¹
T16	60 - 40	L2-1/2x2-1/2x3/16	7.75	7.53	116.1	0.9023	6.016	29.236	0.206 ¹
T17	40 - 20	L2.5x2.5x3/16 + L2.5x2.5x1/4 (C-Shape) - Cleary Tower	8.25	8.03	125.4	1.0565	6.560	34.229	0.192 ¹
T18	20 - 0	L3x3x3/16	8.75	8.52	108.9	1.0898	7.101	35.311	0.201 ¹

¹ $P_u / \phi P_n$ controls

Redundant Diagonal (1) Design Data (Tension)

Section No.	Elevation ft	Size	L ft	L_u ft	Kl/r	A in ²	P_u K	ϕP_n K	Ratio $\frac{P_u}{\phi P_n}$
T12	140 - 120	L2-1/2x2-1/2x3/16	7.81	7.56	116.5	0.9023	2.662	29.236	0.091 ¹
T13	120 - 100	L2-1/2x2-1/2x3/16	8.20	7.94	122.5	0.9023	2.927	29.236	0.100 ¹
T14	100 - 80	L2-1/2x2-1/2x3/16	8.60	8.35	128.8	0.9023	3.162	29.236	0.108 ¹
T15	80 - 60	L3x3x3/16	9.02	8.76	111.9	1.0898	3.420	35.311	0.097 ¹

tnxTower Allpro Consulting Group, Inc. 9221 Lyndon B. Johnson Fwy, Suite #204 Dallas, TX 75243 Phone: 972-231-8893 FAX: 866-364-8375	Job 18-5441	Page 36 of 38
	Project CT20021-A-11 Cleary Tower (Edward)	Date 15:43:40 08/22/18
	Client SBA	Designed by Binod Paudel

Section No.	Elevation ft	Size	L ft	L _u ft	Kl/r	A in ²	P _u K	φP _n K	Ratio P _u / φP _n
T16	60 - 40	L3x3x3/16	9.44	9.17	117.2	1.0898	3.662	35.311	0.104 ¹
T17	40 - 20	L3x3x3/16	9.86	9.60	122.7	1.0898	3.921	35.311	0.111 ¹ ✓
T18	20 - 0	L3x3x3/16	10.30	10.03	128.1	1.0898	4.178	35.311	0.118 ¹ ✓

¹ P_u / φP_n controls

Section Capacity Table

Section No.	Elevation ft	Component Type	Size	Critical Element	P K	φP _{allow} K	% Capacity	Pass Fail
T1	350 - 340	Leg	2	3	-6.389	49.286	13.0	Pass
		Diagonal	L2x1 1/2x3/16	9	-2.174	10.346	21.0	Pass
		Top Girt	L3x3x1/4	4	-0.325	28.598	31.7 (b) 1.1	Pass
T2	340 - 320	Leg	2	21	-32.850	72.063	45.6	Pass
		Diagonal	L2x1 1/2x3/16	24	-3.350	11.584	28.9 45.8 (b)	Pass
T3	320 - 300	Leg	2 1/2	54	-51.804	112.346	46.1	Pass
		Diagonal	L2x2x3/16	75	-2.765	13.174	21.0 36.6 (b)	Pass
T4	300 - 280	Leg	3 1/4	81	-66.554	183.313	36.3	Pass
		Diagonal	L2-1/2x2-1/2x3/16	84	-2.330	13.474	17.3 28.2 (b)	Pass
T5	280 - 260	Leg	3 1/4	102	-82.027	183.313	44.7	Pass
		Diagonal	L2-1/2x2-1/2x3/16	108	-2.519	10.341	24.4 31.5 (b)	Pass
T6	260 - 240	Leg	3 1/2	123	-98.359	234.484	41.9	Pass
		Diagonal	L3x3x3/16	128	-2.981	13.820	21.6 37.6 (b)	Pass
T7	240 - 220	Leg	3 1/2	144	-114.326	306.641	37.3	Pass
		Diagonal	2L2 1/2x2 1/2x3/16x3/8	152	-3.882	25.202	15.4 24.3 (b)	Pass
		Horizontal	L2 1/2x2 1/2x3/16	148	-2.174	8.246	26.4 27.8 (b)	Pass
T8	220 - 200	Inner Bracing	L2 1/2x2 1/2x3/16	154	-0.012	7.609	0.6	Pass
		Leg	3 3/4	183	-132.471	368.015	36.0	Pass
		Diagonal	2L2 1/2x2 1/2x3/16x3/8	191	-4.388	21.196	20.7 23.9 (b)	Pass
T9	200 - 180	Horizontal	L2 1/2x2 1/2x3/16	190	-2.402	6.207	38.7	Pass
		Inner Bracing	L2 1/2x2 1/2x3/16	194	-0.014	5.772	0.7	Pass
		Leg	4	222	-152.651	434.236	35.2	Pass
T10	180 - 160	Diagonal	2L3x3x3/16x3/8	230	-6.349	30.555	20.8 32.1 (b)	Pass
		Horizontal	L3x3x3/16	226	-2.650	8.488	31.2 33.8 (b)	Pass
		Inner Bracing	L3x3x3/16	233	-0.017	7.941	0.7	Pass
T10	180 - 160	Leg	4 1/4	261	-177.754	505.220	35.2	Pass
		Diagonal	2L3x3x3/16x3/8	269	-7.303	26.278	27.8 37.1 (b)	Pass
		Horizontal	L3x3x3/16	265	-3.083	6.804	45.3	Pass
		Inner Bracing	L3x3x3/16	272	-0.018	6.396	0.8	Pass

tnxTower Allpro Consulting Group, Inc. 9221 Lyndon B. Johnson Fwy, Suite #204 Dallas, TX 75243 Phone: 972-231-8893 FAX: 866-364-8375	Job	18-5441	Page	37 of 38
	Project	CT20021-A-11 Cleary Tower (Edward)	Date	15:43:40 08/22/18
	Client	SBA	Designed by	Binod Paudel

Section No.	Elevation ft	Component Type	Size	Critical Element	P K	ϕP_{allow} K	% Capacity	Pass Fail
T11	160 - 140	Leg	4 1/4	300	-204.825	505.220	40.5	Pass
		Diagonal	2L3x3x3/16x3/8	308	-8.157	22.339	36.5	Pass
		Horizontal	L3 1/2x3 1/2x1/4	304	-3.552	11.687	43.0 (b) 30.4	Pass
T12	140 - 120	Inner Bracing	L3 1/2x3 1/2x1/4	312	-0.021	11.050	0.7	Pass
		Leg	4 1/2	339	-225.945	580.902	38.9	Pass
		Diagonal	2L3x3x1/4x3/8	358	-12.140	31.416	38.6	Pass
		Horizontal	2L2 1/2x2 1/2x3/16x3/8	347	-3.918	13.682	28.6	Pass
		Redund Horz 1 Bracing	L2x2x3/16	352	-3.918	5.620	69.7	Pass
		Redund Diag 1 Bracing	L2-1/2x2-1/2x3/16	375	-2.662	6.069	43.9	Pass
T13	120 - 100	Inner Bracing	L3 1/2x3 1/2x1/4	362	-0.030	9.656	0.7	Pass
		Leg	4 3/4	384	-257.203	661.231	38.9	Pass
		Diagonal	2L3x3x1/4x3/8	400	-12.136	28.916	42.0	Pass
		Horizontal	2L2 1/2x2 1/2x3/16x3/8	392	-4.460	11.547	38.6	Pass
		Redund Horz 1 Bracing	L2x2x3/16	397	-4.460	4.748	93.9	Pass
		Redund Diag 1 Bracing	L2-1/2x2-1/2x3/16	420	-2.927	5.494	53.3	Pass
T14	100 - 80	Inner Bracing	L4x4x1/4	407	-0.031	12.311	0.8	Pass
		Leg	4 3/4	429	-286.135	661.231	43.3	Pass
		Diagonal	2L3x3x1/4x3/8	448	-13.238	26.593	49.8	Pass
		Horizontal	2L2 1/2x2 1/2x3/16x3/8	437	-4.962	9.860	50.3	Pass
		Redund Horz 1 Bracing	L2x2x3/8	442	-4.962	7.521	66.0	Pass
		Redund Diag 1 Bracing	L2-1/2x2-1/2x3/16	465	-3.162	4.968	63.7	Pass
T15	80 - 60	Inner Bracing	L4x4x1/4	452	-0.033	10.555	0.8	Pass
		Leg	5	474	-317.199	746.168	42.5	Pass
		Diagonal	2L3 1/2x3 1/2x1/4x3/8	490	-13.340	38.008	35.1	Pass
		Horizontal	2L3x3x3/16x3/8	482	-5.501	15.048	36.6	Pass
		Redund Horz 1 Bracing	L2-1/2x2-1/2x3/16	487	-5.501	6.992	78.7	Pass
		Redund Diag 1 Bracing	L3x3x3/16	510	-3.420	7.925	43.2	Pass
T16	60 - 40	Inner Bracing	2L3x3x3/16x3/8	496	-0.038	14.343	0.8	Pass
		Leg	5 1/4	519	-346.925	835.679	41.5	Pass
		Diagonal	2L3 1/2x3 1/2x1/4x3/8	538	-14.578	35.047	41.6	Pass
		Horizontal	2L3x3x3/16x3/8	527	-6.016	13.146	45.8	Pass
		Redund Horz 1 Bracing	L2-1/2x2-1/2x3/16	532	-6.016	6.113	98.4	Pass
		Redund Diag 1 Bracing	L3x3x3/16	555	-3.662	7.227	50.7	Pass
T17	40 - 20	Inner Bracing	2L3x3x3/16x3/8	541	-0.039	12.552	0.9	Pass
		Leg	5 1/4	564	-378.276	835.679	45.3	Pass
		Diagonal	2L3 1/2x3 1/2x1/4x3/8	580	-14.543	32.326	45.0	Pass
		Horizontal	2L3 1/2x3 1/2x1/4x3/8	572	-6.560	24.167	27.1	Pass
		Redund Horz 1 Bracing	L2.5x2.5x3/16 + L2.5x2.5x1/4 (C-Shape) - Cleary Tower	577	-6.560	14.963	43.8	Pass
		Redund Diag 1 Bracing	L3x3x3/16	600	-3.921	6.591	59.5	Pass
T18	20 - 0	Inner Bracing	2L3 1/2x3 1/2x1/4x3/8	587	-0.044	23.141	0.7	Pass
		Leg	5 1/2	607	-409.462	929.740	44.0	Pass
		Diagonal	2L3 1/2x3 1/2x1/4x3/8	628	-15.426	29.896	51.6	Pass

tnxTower Allpro Consulting Group, Inc. 9221 Lyndon B. Johnson Fwy, Suite #204 Dallas, TX 75243 Phone: 972-231-8893 FAX: 866-364-8375	Job	18-5441	Page	38 of 38
	Project	CT20021-A-11 Cleary Tower (Edward)	Date	15:43:40 08/22/18
	Client	SBA	Designed by	Binod Paudel

Section No.	Elevation ft	Component Type	Size	Critical Element	P K	ϕP_{allow} K	% Capacity	Pass Fail
		Horizontal	2L3 1/2x3 1/2x1/4x3/8	610	-7.101	21.456	33.1	Pass
		Redund Horz 1 Bracing	L3x3x3/16	629	-7.101	8.374	84.8	Pass
		Redund Diag 1 Bracing	L3x3x3/16	636	-4.178	6.043	69.1	Pass
		Inner Bracing	2L3 1/2x3 1/2x1/4x3/8	631	-0.043	20.572	0.7	Pass
							Summary	
						Leg (T3)	46.1	Pass
						Diagonal (T18)	51.6	Pass
						Horizontal (T14)	50.3	Pass
						Top Girt (T1)	3.2	Pass
						Redund Horz 1 Bracing (T16)	98.4	Pass
						Redund Diag 1 Bracing (T18)	69.1	Pass
						Inner Bracing (T16)	0.9	Pass
						Bolt Checks	48.1	Pass
						RATING =	98.4	Pass

MATHCAD CALCULATION PRINTOUT

EXISTING 350' SELF SUPPORT TOWER ANCHOR BOLT CHECK**REACTIONS ON THE FOUNDATION**

As per Tnx output (see attached)

Down load; $P_v := 424 \cdot \text{kips}$ Shear; $V_u := 47 \cdot \text{kips}$ Uplift load; $P_{up} := 308 \cdot \text{kips}$ Moment; $M := 0 \cdot \text{kips} \cdot \text{ft}$

Anchor Rod Data is as per Structural Analysis by Paul J. Ford & Co., Job No. A03-T143 dated 12/22/2003.

Number of Anchor Rods: $N_{\text{anchors}} := 6$ Diameter of Anchors: $D_{\text{anchors}} := 2.5 \text{in}$ $n := 4 \text{in}^{-1}$ Area of anchor bolts
$$A_b := \frac{\pi \cdot (D_{\text{anchors}})^2}{4} = 4.909 \cdot \text{in}^2$$
Net Tensile Area of Anchors:
$$A_{\text{net}} := \frac{\pi}{4} \cdot \left(D_{\text{anchors}} - \frac{0.9743}{n} \right)^2 = 3.999 \cdot \text{in}^2$$
Minimum Yield Stress $F_{Y\text{anchors}} := 36 \text{ksi}$ (Grade A36)Ultimate Tensile Stress: $F_{U\text{anchors}} := 58 \text{ksi}$ Safety Factor for Anchor: $\phi_t := 0.8$ (Section 4.9.9, TIA-222-G Addendum 2)Allowable Axial Load per Anchor:
$$T_{\text{cap}} := \phi_t \cdot F_{U\text{anchors}} \cdot A_{\text{net}}$$

 $T_{\text{cap}} = 185.545 \cdot \text{kips}$

Interaction Equation for Anchor Rods as per Section 4.9.9, TIA-222-G Addendum 1 and Figure 4.4

For detail type (D) as per Figure 4.4 $\eta := 0.50$ $P_u := \text{if}(\eta > 0.5, P_{up}, P_v) = 424 \cdot \text{kips}$ Maximum Load on Anchor:
$$T_{\text{max}} := \frac{P_u + \frac{V_u}{\eta}}{N_{\text{anchors}}}$$
 $T_{\text{max}} = 86.333 \cdot \text{kips}$ Anchor Rod Capacity:
$$\frac{T_{\text{max}}}{T_{\text{cap}}} = 46.53\% \quad \text{OK!}$$
Anchor_Rod_Check := $\text{if}(T_{\text{max}} < T_{\text{cap}}, \text{"OK"}, \text{"Not OK"})$ **Anchor_Rod_Check = "OK"**

For detail type (d), when the clear distance from top of concrete to the bottom of leveling nut exceeds 1.0 times the diameter of the anchor rod, the interaction equation as per section 4.9.9., TIA-222-G Addendum 1 shall also be satisfied.

Clear distance: $I_{ar} := 2.0\text{in}$ (estimated from photo)

Clear distance: $I_{ar} = 2 \cdot \text{in} < \text{Diameter of Anchors: } D_{anchors} = 2.5 \cdot \text{in}$ OK!

Summary

-Foundation Reactions from Tower Base-

Shear $V_u = 47 \cdot \text{kips}$

Down load $P_v = 424 \cdot \text{kips}$

Uplift load $P_{up} = 308 \cdot \text{kips}$

Moment $M = 0 \cdot \text{ft} \cdot \text{kip}$

Anchor Rod Check $T_{max} = 86.333 \cdot \text{kips} < T_{cap} = 185.545 \cdot \text{kips}$

Anchor_Rod_Check := if($T_{max} < T_{cap}$, "OK", "Not OK")

Anchor_Rod_Check = "OK"

ANSI/TIA-222-G

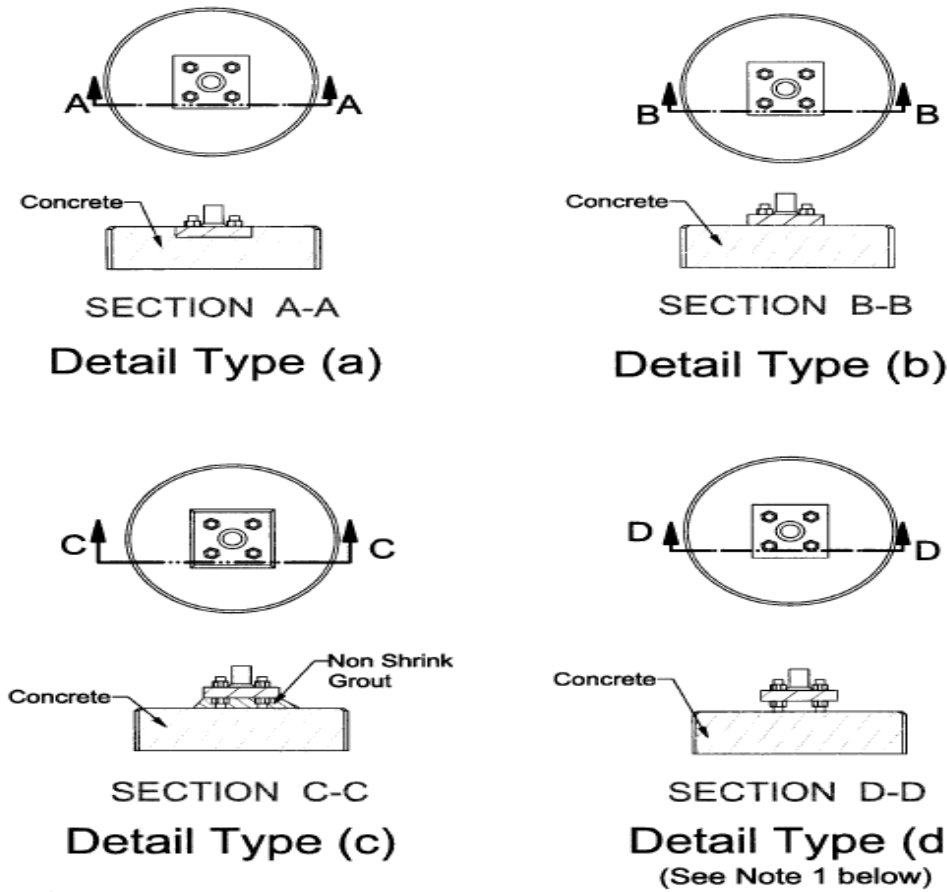

Note:

1. When clear distance from top of concrete to the bottom face of the leveling nut exceeds 1.5 times the diameter of the anchor rod, bending of the anchor rod shall be considered (refer to 4.9.9).

Figure 4-4: Anchor Rod Detail Types

4.9.9 Anchor Rods

For anchor rods, the following interaction equation shall be satisfied:

$$\left(\frac{P_u + \frac{V_u}{\eta}}{\phi R_{nt}} \right) \leq 1$$

where:

$$\phi = 0.80$$

P_u = tension force for detail types (a), (b) & (c) and larger of compression or tension force for type (d) as depicted in Figure 4-4.

V_u = shear force (direct shear and torsion components) corresponding to P_u

R_{nt} = nominal tensile strength of anchor rod as per 4.9.6.1

η = 0.90 for detail type (a)
 = 0.70 for detail type (b)
 = 0.55 for detail type (c)
 = 0.50 for detail type (d)

For detail type (d), when the clear distance from the top of concrete to the bottom leveling nut exceeds 1.0 times the diameter of the anchor rod, the following interaction equation shall also be satisfied:

$$\left(\frac{V_u}{\phi R_{nv}} \right)^2 + \left(\left| \frac{P_u}{\phi R_{nt}} \right| + \left| \frac{M_u}{\phi R_{nm}} \right| \right)^2 \leq 1$$

where:

M_u = bending moment corresponding to V_u
 = $0.65 l_{ar} V_u$

l_{ar} = length from top of concrete to bottom of anchor rod leveling nut

Addendum 1

ϕR_{nv} = design shear strength of anchor rod as per 4.9.6.3

ϕR_{nm} = design flexural strength of anchor rod in accordance with 4.7.1 using the tensile root diameter for the determination of z

d_r = tensile root diameter of rod, in [mm]
 = $d - 0.9743/n$ inches
 = $d - 0.9382(p)$ mm

d = nominal rod diameter, in [mm]

n = number of threads per inch

p = pitch of threads, mm

4.9.6.3 Design Shear Strength

The design shear strength of a bolt, ϕR_{nv} , shall be taken as:

$$\phi = 0.75$$

(a) When threads are excluded from the shear plane:

$$R_{nv} = 0.55 F_{ub} A_b$$

(b) When threads are included in the shear plane:

$$R_{nv} = 0.45 F_{ub} A_b$$

where:

F_{ub} = Specified minimum tensile strength of bolt

A_b = nominal unthreaded area of bolt

4.7.1 Solid Round Members

For solid round members, M_n shall be determined as follows:

$$M_n = F_y' Z$$

where:

F_y' = effective yield stress as determined from 4.5.4.1

Z = plastic section modulus

4.5.4.1 Effective Yield Stress

For 60° and 90° angle members, the effective yield stress for axial compression, F_y' , shall be determined as follows:

$$w/t \leq 0.47 \sqrt{\frac{E}{F_y}}$$

$$F_y' = F_y$$

$$0.47 \sqrt{\frac{E}{F_y}} < w/t \leq 0.85 \sqrt{\frac{E}{F_y}}$$

$$F_y' = \left[1.677 - 0.677 \left(\frac{w/t}{0.47 \sqrt{E/F_y}} \right) \right] F_y$$

$$0.85 \sqrt{\frac{E}{F_y}} < w/t \leq 25$$

$$F_y' = [0.0332 \pi^2 E / (w/t)^2]$$

The width to thickness ratio (w/t) shall not exceed 25 for angle members (refer to Figure 4-3).

For solid round members, the effective yield stress, F_y' , shall be equal to F_y .

For tubular round members, the diameter to thickness ratio (D/t) shall not exceed 400. The effective yield stress, F_y' , shall be determined as follows:

$$D/t \leq 0.114 E/F_y$$

$$F_y' = F_y$$

$$0.114 E/F_y < D/t \leq 0.448 E/F_y$$

$$F_y' = \left(\frac{0.0379E}{(D/t)F_y} + \frac{2}{3} \right) F_y$$

$$0.448 E/F_y < D/t \leq 400$$

$$F_y' = \frac{0.337E}{(D/t)}$$



Radio Frequency Emissions Analysis Report

Dish Wireless Proposed Facility

Site ID: CT0100001A

Cleary Tower
Wolcott Road
Wolcott, CT 6719

November 15, 2018

Centerline Communications Project Number: 950033-001

Site Compliance Summary	
Compliance Status:	COMPLIANT
Site total MPE% of FCC general population allowable limit:	5.93 %



November 15, 2018

Dish Wireless
9601 South Meriden Blvd
Englewood, CO 80112

Emissions Analysis for Site: **CT0100001A – Cleary Tower**

Centerline Communications, LLC (“Centerline”) was directed to analyze the proposed Dish Wireless facility located at **Wolcott Road, Wolcott, CT**, for the purpose of determining whether the emissions from the Proposed Dish Wireless Antenna Installation located on this property are within specified federal limits.

All information used in this report was analyzed as a percentage of current Maximum Permissible Exposure (% MPE) as listed in the FCC OET Bulletin 65 Edition 97-01 and ANSI/IEEE Std C95.1. The FCC regulates Maximum Permissible Exposure in units of microwatts per square centimeter ($\mu\text{W}/\text{cm}^2$). The number of $\mu\text{W}/\text{cm}^2$ calculated at each sample point is called the power density. The exposure limit for power density varies depending upon the frequencies being utilized. Wireless Carriers and Paging Services use different frequency bands each with different exposure limits, therefore it is necessary to report results and limits in terms of percent MPE rather than power density.

All results were compared to the FCC (Federal Communications Commission) radio frequency exposure rules, 47 CFR 1.1307(b)(1) – (b)(3), to determine compliance with the Maximum Permissible Exposure (MPE) limits for General Population/Uncontrolled environments as defined below.

General population/uncontrolled exposure limits apply to situations in which the general population may be exposed or in which persons who are exposed as a consequence of their employment may not be made fully aware of the potential for exposure or cannot exercise control over their exposure. Therefore, members of the general population would always be considered under this category when exposure is not employment related, for example, in the case of a telecommunications tower that exposes persons in a nearby residential area.

Population exposure to radio frequencies is regulated and enforced in units of microwatts per square centimeter ($\mu\text{W}/\text{cm}^2$). The general population exposure limit for the 1900 MHz (PCS) – H Block and Band 70 (2000 to 2020 MHz) is $1000 \mu\text{W}/\text{cm}^2$.



Occupational/controlled exposure limits apply to situations in which persons are exposed as a consequence of their employment and in which those persons who are exposed have been made fully aware of the potential for exposure and can exercise control over their exposure. Occupational/controlled exposure limits also apply where exposure is of a transient nature as a result of incidental passage through a location where exposure levels may be above general population/uncontrolled limits (see below), as long as the exposed person has been made fully aware of the potential for exposure and can exercise control over his or her exposure by leaving the area or by some other appropriate means.

Additional details can be found in FCC OET 65.



CALCULATIONS

Calculations were performed for the proposed Dish Wireless antenna facility located at **Wolcott Road, Wolcott, CT**, using the equipment information listed below. All calculations were performed per the specifications under FCC OET 65. Since Dish Wireless is proposing highly focused directional panel antennas, which project most of the emitted energy out toward the horizon, all calculations were performed assuming a lobe representing the maximum gain of the antenna per the antenna manufactures supplied specifications, minus 10 dB, was focused at the base of the tower. For this report the sample point is the top of a 6-foot person standing at the base of the tower.

Per FCC OET Bulletin No. 65 - Edition 97-01 recommendations to achieve the maximum anticipated value at each sample point, all power levels emitting from the proposed antenna installation are increased by a factor of 2.56 to account for possible in-phase reflections from the surrounding environment. All power values expressed and analyzed are maximum power levels expected to be used on all radios.

All emissions values for additional carriers were taken from the Connecticut Siting Council (CSC) active MPE database. Values in this database are provided by the individual carriers themselves

For each sector the following channel counts, frequency bands and power levels were utilized as shown in *Table 1*:

Technology	Frequency Band	Channel Count	Transmit Power per Channel (W)
NB-IoT	1900 MHz (PCS) - H Block	2	40
NB-IoT	Band 70 (2000 to 2020 MHz)	2	40

Table 1: Channel Data Table



The following antennas listed in *Table 2* were used in the modeling for transmission in the 1900 MHz (PCS) – H Block and Band 70 (2000 to 2020 MHz) frequency bands. This is based on feedback from the carrier with regards to anticipated antenna selection. Maximum gain values for all antennas are listed in the Inventory and Power Data table below. The maximum gain of the antenna per the antenna manufactures supplied specifications, minus 10 dB, was used for all calculations. This value is a very conservative estimate as gain reductions for these particular antennas are typically much higher in this direction.

Sector	Antenna Number	Antenna Make / Model	Antenna Centerline (ft)
A	1	Comba ODI2-065R18K-GQ	341
B	1	Comba ODI2-065R18K-GQ	341
C	1	Comba ODI2-065R18K-GQ	341

Table 2: Antenna Data

All calculations were done with respect to uncontrolled / general population threshold limits.



RESULTS

Per the calculations completed for the proposed Dish Wireless configurations *Table 3* shows resulting emissions power levels and percentages of the FCC’s allowable general population limit.

Antenna ID	Antenna Make / Model	Frequency Bands	Antenna Gain (dBd)	Channel Count	Total TX Power (W)	ERP (W)	MPE %
Antenna A1	Comba ODI2-065R18K-GQ	1900 MHz (PCS) - H Block / Band 70 (2000 to 2020 MHz)	15.65	4	160	5,876.52	0.19
Sector A Composite MPE%							0.19
Antenna B1	Comba ODI2-065R18K-GQ	1900 MHz (PCS) - H Block / Band 70 (2000 to 2020 MHz)	15.65	4	160	5,876.52	0.19
Sector B Composite MPE%							0.19
Antenna C1	Comba ODI2-065R18K-GQ	1900 MHz (PCS) - H Block / Band 70 (2000 to 2020 MHz)	15.65	4	160	5,876.52	0.19
Sector C Composite MPE%							0.19

Table 3: Dish Wireless Emissions Levels



The Following table (*table 4*) shows all additional carriers on site and their MPE% as recorded in the CSC active MPE database for this facility along with the newly calculated maximum Dish Wireless MPE contributions per this report. FCC OET 65 specifies that for carriers utilizing directional antennas that the highest recorded sector value be used for composite site MPE values due to their greatly reduced emissions contributions in the directions of the adjacent sectors. For this site, all three sectors have the same configuration yielding the same results on all three sectors. *Table 5* below shows a summary for each Dish Wireless Sector as well as the composite MPE value for the site.

Site Composite MPE%	
Carrier	MPE%
Dish Wireless – Max Sector Value	0.19 %
LoJack	0.00 %
TSR Wireless	0.05 %
Weblink Wireless	0.29 %
Wolcott Ambulance	0.06 %
Nextel	0.15 %
Sprint	0.46 %
Clearwire	0.04 %
Marcus	2.64 %
AT&T	1.88 %
MetroPCS	0.17 %
Site Total MPE %:	5.93 %

Table 4: All Carrier MPE Contributions

Dish Wireless Sector A Total:	0.19 %
Dish Wireless Sector B Total:	0.19 %
Dish Wireless Sector C Total:	0.19 %
Site Total:	5.93 %

Table 5: Site MPE Summary



FCC OET 65 specifies that for carriers utilizing directional antennas that the highest recorded sector value be used for composite site MPE values due to their greatly reduced emissions contributions in the directions of the adjacent sectors. *Table 6* below details a breakdown by frequency band and technology for the MPE power values for the maximum calculated Dish Wireless sector(s). For this site, all three sectors have the same configuration yielding the same results on all three sectors.

Dish Wireless _ Frequency Band / Technology Max Power Values (Per Sector)	# Channels	Watts ERP (Per Channel)	Height (feet)	Total Power Density ($\mu\text{W}/\text{cm}^2$)	Frequency (MHz)	Allowable MPE ($\mu\text{W}/\text{cm}^2$)	Calculated % MPE
Dish Network 1900 MHz (PCS) - H Block NB-IoT	2	1,469.13	341	0.94	1900 MHz (PCS) - H Block	1000	0.09%
Dish Network Band 70 (2000 to 2020 MHz) NB-IoT	2	1,469.13	341	0.94	Band 70 (2000 to 2020 MHz)	1000	0.09%
						Total:	0.19%

Table 6: Dish Wireless Maximum Sector MPE Power Values



Summary

All calculations performed for this analysis yielded results that were **within** the allowable limits for general population exposure to RF Emissions.

The anticipated maximum composite contributions from the Dish Wireless facility as well as the site composite emissions value with regards to compliance with FCC's allowable limits for general population exposure to RF Emissions are shown here:

Dish Wireless Sector	Power Density Value (%)
Sector A:	0.19 %
Sector B:	0.19 %
Sector C:	0.19 %
Dish Wireless Maximum Total (per sector):	0.19 %
Site Total:	5.93 %
Site Compliance Status:	COMPLIANT

The anticipated composite MPE value for this site assuming all carriers present is **5.93 %** of the allowable FCC established general population limit sampled at the ground level. This is based upon values listed in the Connecticut Siting Council database for existing carrier emissions.

FCC guidelines state that if a site is found to be out of compliance (over allowable thresholds), that carriers over a 5% contribution to the composite value will require measures to bring the site into compliance. For this facility, the composite values calculated were well within the allowable 100% threshold standard per the federal government.

A handwritten signature in black ink, appearing to read 'Scott Heffernan', is written over a light blue horizontal line.

Scott Heffernan

RF Engineering Director

Centerline Communications, LLC

95 Ryan Drive, Suite 1

Raynham, MA 02767

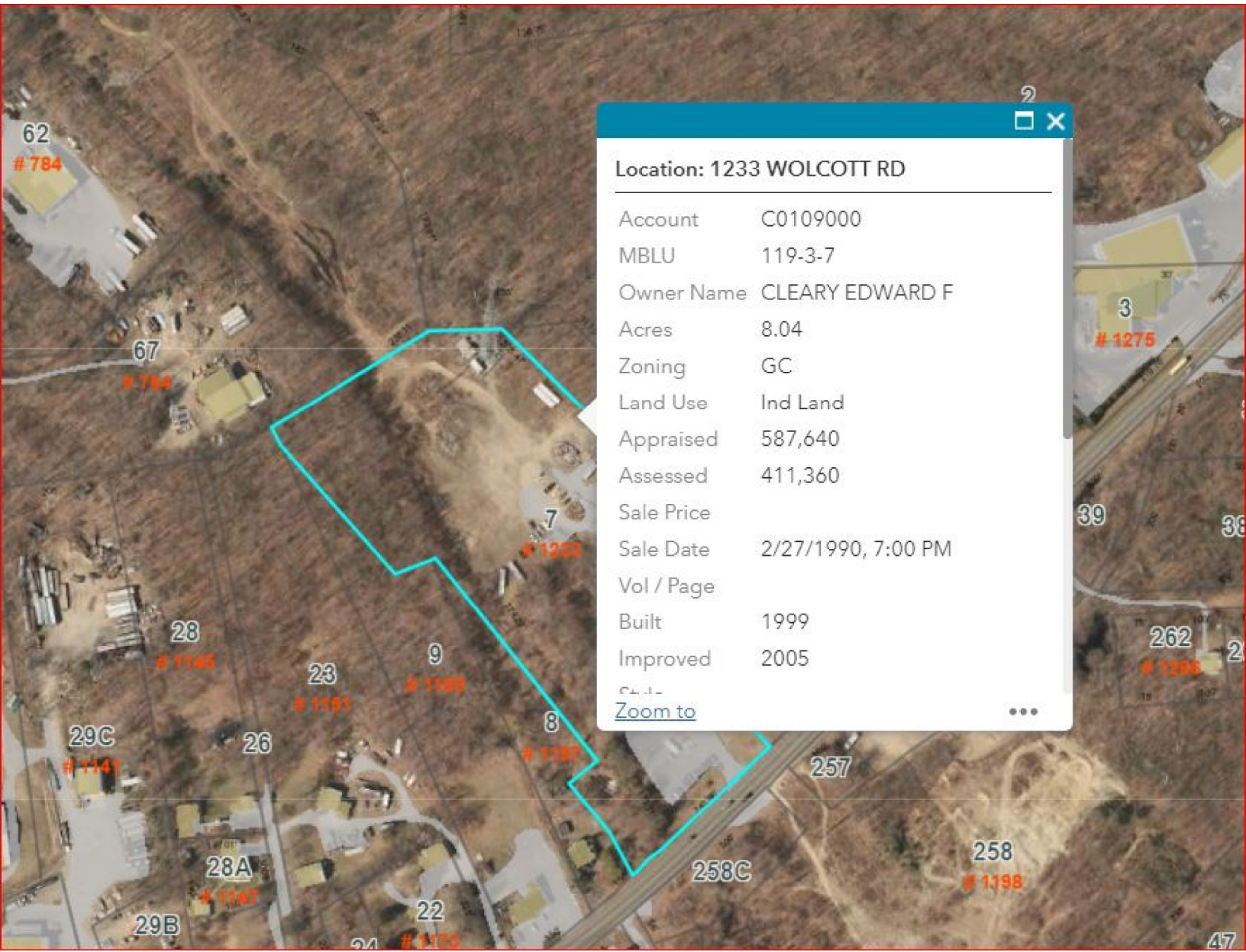

Location: 1233 WOLCOTT RD

Account	C0109000
MBLU	119-3-7
Owner Name	CLEARY EDWARD F
Acres	8.04
Zoning	GC
Land Use	Ind Land
Appraised	587,640
Assessed	411,360
Sale Price	
Sale Date	2/27/1990, 7:00 PM
Vol / Page	
Built	1999
Improved	2005

[Zoom to](#) ⋮

Town of Wolcott, Connecticut - Assessment Parcel Map

Parcel: C0109000

Address: 1233 WOLCOTT RD

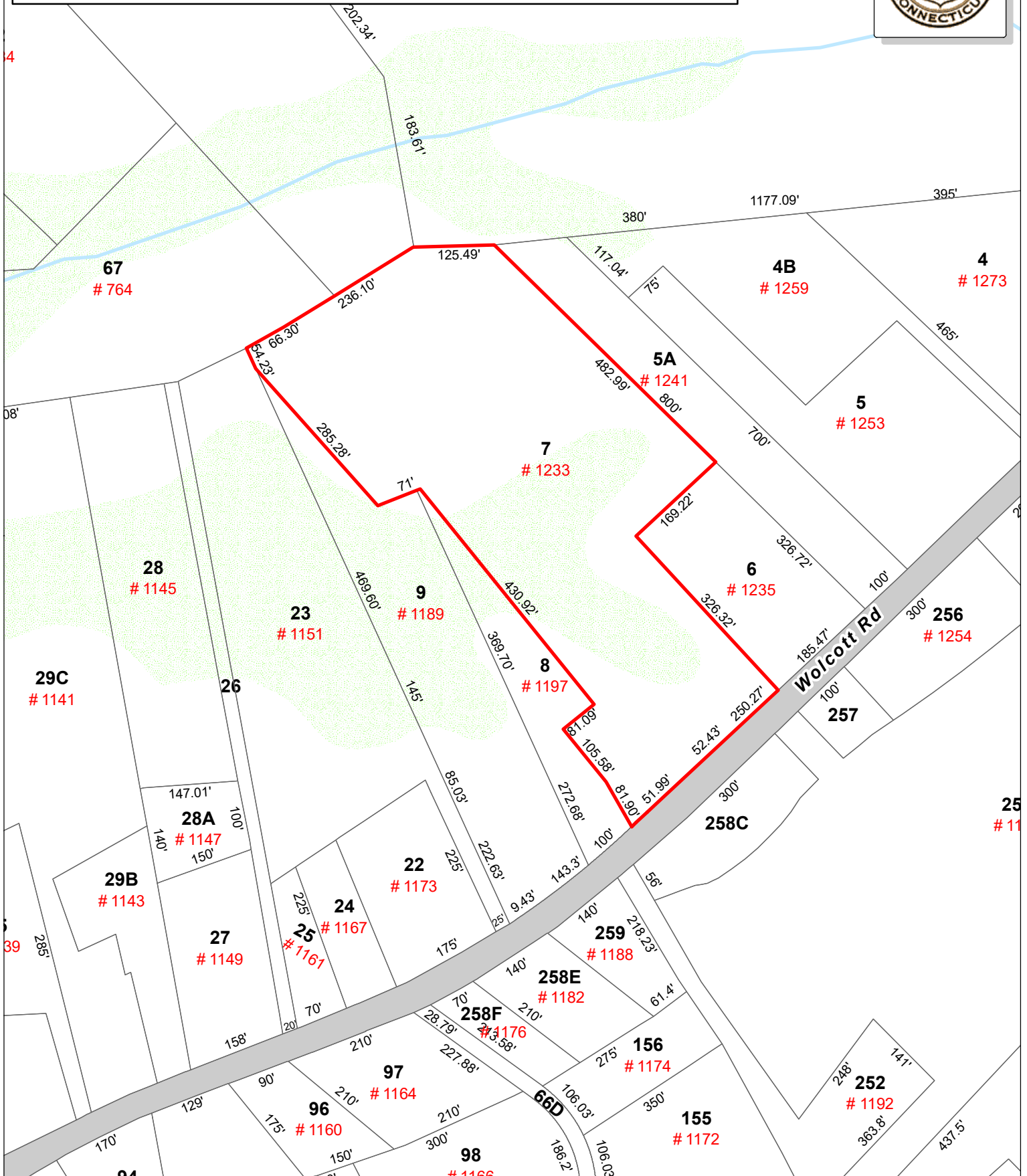

Map Produced Aug 2018

Approximate Scale: 1 inch = 200 feet

Disclaimer: This map is for informational purposes only. All information is subject to verification by any user. The Town of Wolcott and its mapping contractors assume no legal responsibility for the information contained herein.

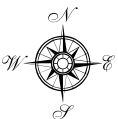

1233 WOLCOTT RD

Location 1233 WOLCOTT RD

Mblu 119/ 3/ 7/ /

Acct# C0109000

Owner CLEARY EDWARD F

Assessment \$411,360

Appraisal \$587,640

PID 1226

Building Count 1

Current Value

Appraisal			
Valuation Year	Improvements	Land	Total
2016	\$255,360	\$332,280	\$587,640

Assessment			
Valuation Year	Improvements	Land	Total
2016	\$178,760	\$232,600	\$411,360

Owner of Record

Owner CLEARY EDWARD F
Co-Owner
Address 50 BEACH RD
WOLCOTT, CT 06716

Sale Price \$0
Certificate
Book & Page 192/ 18
Sale Date 02/28/1990
Instrument 25

Ownership History

Ownership History					
Owner	Sale Price	Certificate	Book & Page	Instrument	Sale Date
CLEARY EDWARD F	\$0		192/ 18	25	02/28/1990

Building Information

Building 1 : Section 1

Year Built: 1999
Living Area: 4,000
Replacement Cost: \$154,800
Building Percent 89
Good:
Replacement Cost
Less Depreciation: \$137,770

Building Attributes	
Field	Description

STYLE	Comm Garage
MODEL	Comm/Ind
Grade	D
Stories:	1
Occupancy	3
Exterior Wall 1	Pre-finish Metl
Exterior Wall 2	
Roof Structure	Gable
Roof Cover	Metal
Interior Wall 1	Minimum
Interior Wall 2	
Interior Floor 1	Concrete
Interior Floor 2	
Heating Fuel	Oil
Heating Type	Forced Hot Air
AC %	0
Foundation	Poured Conc
Bldg Use	Commercial
Total Rooms	0
Total Bedrms	0
Total Fixtures	0
Perimeter	260
SF Fin Bsmt	0
1st Floor Use:	
Heat/AC	NONE
Frame Type	STEEL
Baths/Plumbing	LIGHT
Ceiling/Wall	NONE
Rooms/Prtns	LIGHT
Wall Height	14
% Comn Wall	

Building Photo



(<http://images.vgsi.com/photos/WolcottCTPhotos//\00\01\12\49>).

Building Layout



Building Sub-Areas (sq ft)			<u>Legend</u>
Code	Description	Gross Area	Living Area
BAS	First Floor	4,000	4,000
SLB	Slab	4,000	0
		8,000	4,000

Building 1 : Section 1

Year Built: 1999
Living Area: 0
Replacement Cost: \$154,800
Building Percent Good: 89
Replacement Cost Less Depreciation: \$137,770

Building Attributes	
Field	Description

Style	Outbuildings
Model	
Grade:	
Stories	
Occupancy	
Exterior Wall 1	
Exterior Wall 2	
Roof Structure	
Roof Cover	
Interior Wall 1	
Interior Wall 2	
Interior Flr 1	
Interior Flr 2	
Heat Fuel	
Heat Type:	
AC Percent	
Total Bedrooms:	
Full Bthrms:	
Half Baths:	
Extra Fixtures	
Total Rooms:	
Bath Style:	
Kitchen Style:	
Num Kitchens	
Fireplace(s)	
% Attic Fin	
LF Dormer	
Foundation	
Bsmt Gar(s)	
Bsmt %	
SF FBM	
Fin Bsmt Qual	
Bsmt Access	

Building Photo



(<http://images.vgsi.com/photos/WolcottCTPhotos/\00\01\12\50>).

Building Layout

Building Layout

Building Sub-Areas (sq ft)	Legend
No Data for Building Sub-Areas	

Extra Features

Extra Features	Legend
No Data for Extra Features	

Land

Land Use

Use Code 201
Description Commercial
Zone GC
Neighborhood C150
Alt Land Appr No
Category

Land Line Valuation

Size (Acres) 7.04
Frontage
Depth
Assessed Value \$232,600
Appraised Value \$332,280

Outbuildings

Outbuildings						Legend
Code	Description	Sub Code	Sub Description	Size	Value	Bldg #
CELL	Cell	SH	Cell Shed	450 S.F.	\$60,750	1
CELL	Cell	SH	Cell Shed	200 S.F.	\$27,000	1
PAV1	Paving	AS	Asphalt	31500 S.F.	\$27,560	1
FN4	FENCE-8' CHAIN			240 L.F.	\$2,280	1

Valuation History

Appraisal			
Valuation Year	Improvements	Land	Total
2017	\$255,360	\$332,280	\$587,640
2015	\$182,320	\$330,320	\$512,640
2014	\$182,320	\$330,320	\$512,640

Assessment			
Valuation Year	Improvements	Land	Total
2017	\$178,760	\$232,600	\$411,360
2015	\$127,630	\$231,220	\$358,850
2014	\$127,630	\$231,220	\$358,850



PROJECT: NEW SITE BUILD
 SITE NAME: CLEARY TOWER
 SITE NUMBER: CT0100001A
 SBA SITE NAME: CLEARY TOWER
 SBA SITE #: CT20021-A

PLANS PREPARED FOR:



PLANS PREPARED BY:



PRE-CONSTRUCTION APPROVALS:

DISH WIRELESS CONS. MANAGER	DATE
DISH WIRELESS OPS. MANAGER	DATE
DISH WIRELESS RF ENGINEER	DATE

POST-CONSTRUCTION APPROVALS:

DISH WIRELESS CONS. MANAGER	DATE
DISH WIRELESS OPS. MANAGER	DATE
DISH WIRELESS RF ENGINEER	DATE

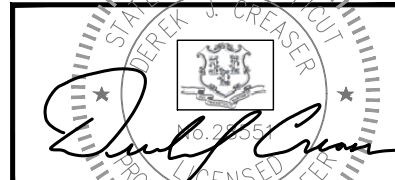

DRAWING NOTICE:
 THIS DRAWING HAS NOT BEEN PUBLISHED AND IS THE SOLE PROPERTY OF HDG, LLC, AND IS LENT TO THE BORROWER FOR THEIR CONFIDENTIAL USE ONLY, AND IN CONSIDERATION OF THE LOAN OF THIS DRAWING, THE BORROWER PROMISES AND AGREES TO RETURN IT UPON REQUEST AND AGREES THAT IT WILL NOT BE REPRODUCED, COPIED, LENT OR OTHERWISE DISPOSED OF DIRECTLY OR INDIRECTLY, NOR USED FOR ANY PURPOSE OTHER THAN FOR WHICH IT IS FURNISHED.

SUBMITTALS:				
DESCRIPTION	DATE	BY	REV	
ISSUED FOR REVIEW	11/01/18	ET	0	

APPLICANT SITE NAME:

CLEARY TOWER

APPLICANT SITE NUMBER:

CT0100001A

SITE ADDRESS:

CLEARY TOWER (EDWARD)
 WOLCOTT, CT 06716

SHEET DESCRIPTION:

TITLE SHEET

DWG INFORMATION:

DRAWN BY:	ET
CHECKED BY:	HC

SHEET NUMBER:

T-1.0

AERIAL MAP



SITE INFORMATION

SITE ADDRESS: CLEARY TOWER (EDWARD)
 WOLCOTT, CT 06716
COUNTY: NEW HAVEN COUNTY
ZONING JURISDICTION: TOWN OF WOLCOTT, CT
POWER COMPANY: EVERSOURCE
AAV PROVIDER: FRONTIER
STRUCTURE INFORMATION:
 OWNER: SBA
 LATITUDE: 44° 3' 41.148"N (NAD 83)
 44.06143
 LONGITUDE: -75° 50' 22.992"W (NAD 83)
 -75.83972
 GROUND ELEVATION: 970.0'
 STRUCTURE HEIGHT: 350' AGL
 STRUCTURE TYPE: GUYED TOWER
 ANTENNA CENTERLINE: 341'-0" AGL

APPLICANT: DISH WIRELESS
DISH WIRELESS CM: JOSH REYNOLDS
 PHONE: (206) 701-4123
 JOSH.REYNOLDS@DISH.COM

DRAWING INDEX

SHEET No.	SHEET TITLE	REV
T-1.0	TITLE SHEET	0
SP-1.0	SPECIFICATIONS (1 OF 3)	0
SP-2.0	SPECIFICATIONS (2 OF 3)	0
SP-2.1	SPECIFICATIONS (3 OF 3)	0
RF-1.0	RF DATA SHEET	0
RF-1.1	RFDS PLUMBING DIAGRAM	0
A-1.0	OVERALL SITE PLAN	0
A-1.1	EQUIPMENT PLAN	0
A-2.0	TOWER ELEVATIONS & ANTENNA PLAN	0
A-3.0	ANTENNA SCHEDULE & DIAGRAM	0
A-4.0	EQUIPMENT DETAILS (1 OF 3)	0
A-4.1	EQUIPMENT DETAILS (2 OF 3)	0
A-4.2	EQUIPMENT DETAILS (3 OF 3)	0
E-1.0	ELECTRICAL DETAILS & ONE-LINE DIAGRAM	0
G-1.0	GROUNDING PLAN	0
G-2.0	GROUNDING DETAILS (1 OF 2)	0
G-2.1	GROUNDING DETAILS (2 OF 2)	0

PROJECT INFORMATION

THIS IS NOT AN ALL-INCLUSIVE LIST. CONTRACTOR SHALL UTILIZE SPECIFIED EQUIPMENT PART OR ENGINEER APPROVED EQUIVALENT. CONTRACTOR SHALL VERIFY ALL NEEDED EQUIPMENT TO PROVIDE A FUNCTIONAL SITE. THE PROJECT GENERALLY CONSISTS OF THE FOLLOWING:

- INSTALL (3) NEW PROPOSED PANEL ANTENNAS (1 PER SECTOR)
- INSTALL (3) NEW RET'S
- INSTALL (3) NEW PROPOSED ANTENNA MOUNTS & ASSOCIATED JUMPERS (1 PER SECTOR)
- INSTALL (5) NEW PROPOSED RRU'S AND ASSOCIATED JUMPERS
- INSTALL (1) NEW HYBRID CABLE
- INSTALL (1) NEW PROPOSED METAL PLATFORM WITH CANOPY
- INSTALL (1) NEW PROPOSED ICE BRIDGE (PER DESIGN)
- INSTALL (1) NEW PROPOSED BATTERY BACKUP SYSTEM IN CABINET
- INSTALL (1) NEW PPC CABINET MOUNTED TO NEW H-FRAME
- INSTALL (1) NEW EQUIPMENT CABINET
- INSTALL (1) NEW RBS CHASSIS IN NEW EQUIPMENT CABINET
- INSTALL (1) NEW BASEBAND UNIT IN NEW CHASSIS
- INSTALL (1) NEW POWER CONDUIT FROM PLATFORM TO DESIGNATED MEET POINT DESIGNATED BY POWER COMPANY
- INSTALL (1) (IF REQUIRED) METER BASE FOR POWER METER ON NEW H-FRAME
- INSTALL (1) NEW TELCO CONDUIT FROM PLATFORM TO DESIGNATED MEET POINT ALLOCATED BY TELCO PROVIDER
- INSTALL (1) NEW NEMA4 TELCO-FIBER BOX MOUNTED TO H-FRAME
- INSTALL (1) NEW GPS ANTENNA WITH CABLE IN CONDUIT
- INSTALL (1) NEW DISH WIRELESS 3'-0" DISH ANTENNA FACING SOUTH ON NEW PIPE MAST
- INSTALL (1) NEW PIPE MAST FOR DISH ANTENNA
- THE SIZE, HEIGHT AND DIRECTION OF ALL ANTENNAS SHALL BE ADJUSTED TO MEET SYSTEM REQUIREMENT DEPICTED BY THE LATEST APPROVED RFDS.

JURISDICTION COMPLIANCE

ALL WORK SHALL BE PERFORMED AND MATERIALS INSTALLED IN ACCORDANCE WITH THE CURRENT EDITIONS OF THE FOLLOWING CODES AS ADOPTED BY THE LOCAL GOVERNING AUTHORITIES. NOTHING IN THESE PLANS IS TO BE CONSTRUED TO PERMIT WORK NOT CONFORMING TO THESE CODES.

1. INTERNATIONAL BUILDING CODE
2. INTERNATIONAL MECHANICAL CODE
3. ANSI/TIA-222 STRUCTURAL STANDARD
4. NFPA 780 - LIGHTNING PROTECTION CODE
5. NATIONAL ELECTRICAL CODE

CONSULTING TEAM

ENGINEERING: HUDSON DESIGN GROUP, LLC.
 45 BEECHWOOD DRIVE
 NORTH ANDOVER, MA 01845
 PHONE: (978) 557-5553
 FAX: (978) 336-5586



Know what's below.
 Call before you dig.
 www.call811.com

THE UTILITIES AS SHOWN ON THIS SET OF DRAWINGS WERE DEVELOPED FROM THE INFORMATION AVAILABLE. THE INFORMATION PROVIDED IS NOT IMPLIED NOR INTENDED TO BE THE COMPLETE INVENTORY OF UTILITIES IN THIS AREA. IT IS THE CONTRACTOR'S RESPONSIBILITY TO VERIFY THE LOCATION OF ALL UTILITIES (WHETHER SHOWN OR NOT) AND PROTECT SAID UTILITIES FROM ANY DAMAGE CAUSED BY CONTRACTOR'S ACTIVITIES.

GENERAL REQUIREMENTS SECTION 01 10 00

PART 1: GENERAL

1.1 INTENT:

- A. THESE SPECIFICATIONS AND CONSTRUCTION DRAWINGS DESCRIBE THE WORK TO BE DONE AND THE MATERIALS TO BE FURNISHED FOR CONSTRUCTION. PLANS ARE NOT TO BE SCALED.
- B. THE DRAWINGS AND SPECIFICATIONS ARE INTENDED TO BE FULLY EXPLANATORY AND SUPPLEMENTARY, HOWEVER, SHOULD ANYTHING BE SHOWN, INDICATED OR SPECIFIED ON ONE AND NOT THE OTHER, IT SHALL BE DONE THE SAME AS IF SHOWN, INDICATED OR SPECIFIED IN BOTH.
- C. THE INTENTION OF DOCUMENTS IS TO INCLUDE ALL LABOR AND MATERIALS REASONABLY NECESSARY FOR THE PROPER EXECUTION AND COMPLETION OF THE WORK AS STIPULATED IN THE CONTRACT.
- D. CONFLICTS: THE CONTRACTOR SHALL BE RESPONSIBLE FOR VERIFICATION OF ALL MEASUREMENTS AT THE SITE BEFORE ORDERING MATERIALS OR DOING ANY WORK. NO COMPENSATION SHALL BE ALLOWED DUE TO DIFFERENCES BETWEEN ACTUAL DIMENSIONS AND THOSE ON THE DOCUMENTS. ANY DISCREPANCY SHALL BE REPORTED TO THE OWNER OR HIS AGENT FOR CONSIDERATION.

1.2 LICENSING REQUIREMENTS:

- A. THE CONTRACTOR IS RESPONSIBLE FOR PROCUREMENT AND MAINTAINING ALL APPLICABLE LICENSES AND BONDS.

1.3 STORAGE:

- A. ALL MATERIALS MUST BE STORED IN A LEVEL AND DRY FASHION THAT DOES NOT OBSTRUCT THE FLOW OF OTHER WORK. ANY STORAGE METHOD MUST MEET ALL RECOMMENDATIONS OF THE ASSOCIATED MANUFACTURER.

1.4 CLEAN UP:

- A. THE CONTRACTOR SHALL KEEP THE SITE FREE FROM ACCUMULATION OF WASTE MATERIALS OR RUBBISH AT ALL TIMES.

1.5 QUALITY ASSURANCE:

- A. ALL WORK SHALL BE IN ACCORDANCE WITH APPLICABLE LOCAL, STATE, AND FEDERAL REGULATIONS.

PART 2: PRODUCTS – NOT APPLICABLE TO THIS SECTION

PART 3: EXECUTION – NOT APPLICABLE TO THIS SECTION

END OF SECTION

CAST-IN-PLACE-CONCRETE SECTION 03 30 00

PART 1: GENERAL

1.1 SUMMARY:

- A. FURNISH AND INSTALL ALL CAST-IN-PLACE CONCRETE, REINFORCING AND ACCESSORIES, AS SPECIFIED HEREIN AND AS SHOWN ON THE DRAWINGS.

1.2 SUBMITTALS:

- A. PRODUCT DATA: SUBMIT MANUFACTURER'S PRODUCT DATA AND INSTALLATION INSTRUCTIONS FOR EACH MATERIAL AND PRODUCT USED.
- B. SHOP DRAWINGS: SUBMIT SHOP DRAWINGS INDICATING MATERIAL CHARACTERISTICS, DETAILS OF CONSTRUCTION, CONNECTIONS, AND RELATIONSHIP WITH ADJACENT CONSTRUCTION.

- 1. SHOP DRAWINGS SHALL BE PREPARED AND STAMPED BY A QUALIFIED ENGINEER LICENSED IN THE JURISDICTION OF THE PROJECT.

- C. MIX DESIGN: SUBMIT FOR APPROVAL MIX DESIGN PROPOSED FOR USE.

1.3 QUALITY ASSURANCE:

- A. COMPLY WITH GOVERNING CODES AND REGULATIONS. PROVIDE PRODUCTS OF ACCEPTABLE MANUFACTURERS, WHICH HAVE BEEN IN SATISFACTORY USE IN SIMILAR SERVICE FOR A MINIMUM OF THREE YEARS. USE EXPERIENCED INSTALLERS. DELIVER, HANDLE, STORE MATERIALS IN ACCORDANCE WITH MANUFACTURER'S INSTRUCTIONS.
- B. TESTING: EMPLOY AN INDEPENDENT TESTING AGENCY ACCEPTABLE TO OWNER TO DESIGN CONCRETE MIXES AND TO PERFORM MATERIAL EVALUATION TESTS. PROVIDE 4 AND 28 DAY CYLINDER TESTS. COMPLY WITH ASTM C 143, C 173, C 31 AND C 39.
- C. STANDARDS
 - 1. ACI 301, SPECIFICATIONS FOR STRUCTURAL CONCRETE FOR BUILDINGS.
 - 2. ACI 318, BUILDING CODE REQUIREMENTS FOR REINFORCED CONCRETE, AND CRSI MANUAL OF STANDARD PRACTICE.

PART 2: PRODUCTS

2.1 MATERIALS:

- A. MATERIALS SHALL CONFORM TO THE RESPECTIVE PUBLICATIONS AND OTHER REQUIREMENTS SPECIFIED HEREIN.

- B. CEMENT: CEMENT SHALL CONFORM TO ASTM C150, TYPE 1. CEMENT MAY BE BAGGED OR BULK. CEMENT SHALL BE USED FROM ONLY ONE MILL THROUGHOUT PROJECT.
- C. FINE AGGREGATE: FINE AGGREGATE SHALL CONFORM TO ASTM C33-08 AND SHALL BE UNIFORMLY GRADED, CLEAN, SHARP, WASHED MATERIAL OR CRUSHED SAND, FREE FROM ORGANIC IMPURITIES.
- D. COURSE AGGREGATE: COURSE AGGREGATE SHALL CONFORM TO ASTM C33-08 AND SHALL BE NATURAL WASHED GRAVEL OR WASHED CRUSHED ROCK HAVING HARD, STRONG, DURABLE PIECES, FREE FORM ADHERENT COATINGS, THE MAXIMUM SIZE OF COARSE AGGREGATE SHALL BE 3/4" IN ACCORDANCE WITH THE REQUIREMENTS OF ASTM C33-08; GRADATION SIZE NO. 67.
- E. WATER: WATER USED IN THE CONCRETE MIX SHALL BE POTABLE, CLEAN, AND FREE FROM OILS, ACIDS, SALTS, CHLORIDES, ALKALI, SUGAR, VEGETABLE, OR OTHER INJURIOUS SUBSTANCES.
- F. REINFORCING STEEL: ALL BARS ARE TO BE NEW BILLET STEEL CONFORMING TO ASTM A615, GRADE 60. BENDING DETAILS ARE TO CONFORM TO THE STANDARDS OF ACI 318.
- G. FORMS: THE FORMS SHALL BE TRUE AND RIGID AND CONFORM TO SHAPE, LINE AND DIMENSIONS AS SHOWN ON THE DRAWINGS. ALL FORMS SHALL BE RIGIDLY CONSTRUCTED, BRACED AND TIED TO PREVENT ANY DEFLECTION OR DISPLACEMENT DURING PLACING OF CONCRETE. ALL EXPOSED CORNERS AND EDGES SHALL HAVE 3/4" FILLETS. ALL JOINTS SHALL BE MORTAR TIGHT; OPEN JOINTS SHALL BE SEALED AS REQUIRED.
- H. CONCRETE:

1. PROPORTIONING: CONCRETE SHALL CONFORM TO THE FOLLOWING:

- a. CEMENT-6 SACKS PER CUBIC YARD, MINIMUM
- b. WATER SHALL BE KEPT TO AN ABSOLUTE MINIMUM TO MAINTAIN SLUMP AS SPECIFIED
- c. AGGREGATE; SAND FACTOR SHALL BE AS REQUIRED TO GIVE THE BEST WORKABLE MIX WITHIN THE RANGE OF 46% TO 52% OF TOTAL AGGREGATE.
- d. STRENGTH-4,000 PSI AT 28 DAYS, UNLESS NOTED OTHERWISE
- e. ALL CONCRETE SHALL CONTAIN A WATER-REDUCING AGENT AND SHALL HAVE THREE (3) TO FIVE (5) PERCENT ENTRAINED AIR.

2.2 SLUMP:

- A. THE MAXIMUM SLUMP SHALL NOT EXCEED 3" EXCEPT FOR CONCRETE TO BE PLACED IN FORMS 8" WIDE OR LESS, WHERE THE MAXIMUM SLUMP SHALL BE 4".
- B. THE DETERMINATION OF SLUMP SHALL CONFORM TO ASTM C143.

2.3 MIXING:

- A. THE CONTRACTOR SHALL USE READY-MIXED CONCRETE, MIXED AND DELIVERED IN CONFORMANCE WITH ASTM C94.

2.4 MIXTURES:

- A. THE CONCRETE SHALL CONTAIN AN AIR-ENTRAINING ADMIXTURE COMPLYING WITH THE REQUIREMENTS OF ASTM C-260 AND ACI 212.1R AND A WATER-REDUCING ADMIXTURE COMPLYING WITH THE REQUIREMENTS OF ASTM C-494 AND ACI 212.1R. ADMIXTURES SHALL BE PURCHASE AND BATCHED IN LIQUID SOLUTION. THE USE OF CALCIUM CHLORIDE OR AN ADMIXTURE CONTAINING CALCIUM CHLORIDE IS PROHIBITED.
- B. ADMIXTURES SHALL BE OF THE SAME MANUFACTURER TO ASSURE COMPATIBILITY.
- C. ACCEPTABLE MANUFACTURERS ARE:
 - 1. W.R. GRACE 3. MASTER BUILDERS
 - 2. SIKA GROUP 4. EUCLID CHEMICAL CO

2.5 CURING COMPOUNDS:

- A. CURING COMPOUNDS SHALL CONFORM TO ASTM C309, TYPE 1, ID, CLASS A AND B AND ASTM C171 AS APPLICABLE

PART 3: EXECUTION

3.1 GENERAL:

- A. CONSTRUCT AND ERECT FORMWORK IN ACCORDANCE WITH ACI 301 ACI 347.
- B. COLD-WEATHER CONCRETING SHALL BE IN ACCORDANCE WITH ACI 306.
- C. HOT-WEATHER CONCRETING SHALL BE IN ACCORDANCE WITH ACI 305.

3.2 INSERTS, EMBEDDED COMPONENTS AND OPENINGS:

- A. CONTRACTOR SHALL CHECK ALL CIVIL, ARCHITECTURAL, STRUCTURAL, AND ELECTRICAL DRAWINGS FOR OPENINGS, SLEEVES, ANCHOR BOLTS, INSERTS AND OTHER ITEMS TO BE BUILT INTO THE CONCRETE WORK.
- B. COORDINATE THE WORK OF OTHER SECTIONS IN FORMING AND SETTING OPENINGS, RECESSES, SLOTS, CHASES, ANCHORS, INSERTS AND OTHER ITEMS TO BE EMBEDDED.
- C. EMBEDDED ITEMS SHALL BE SET ACCURATELY IN LOCATION, ALIGNMENT, ELEVATION, AND PLUMBNESS. LOCATE AND MEASURE FROM ESTABLISHED SURVEYED REFERENCE BENCHMARKS.
- D. EMBEDDED ITEMS SHALL BE ANCHORED INTO PLACE AS REQUIRED TO PREVENT MOVEMENT DURING CONCRETE PLACEMENT AND CONSOLIDATION. COMPONENTS FORMING A PART OF A COMPLETE ASSEMBLY SHALL BE ALIGNED BEFORE ANCHORING. PROVIDE TEMPORARY BRACING, ANCHORAGE, AND TEMPLATES AS REQUIRED TO MAINTAIN THE SETTING AND ALIGNMENT.

3.3 REINFORCEMENT PLACEMENT:

- A. REINFORCEMENT SHALL BE PLACED IN ACCORDANCE WITH CHECKED AND RELEASED DRAWINGS AND ACI 301 AND ACI 315; SECURELY WIRE-TIE REINFORCEMENT AT ALL INTERSECTIONS.

- B. ACCURATELY POSITION, SUPPORT AND SECURE REINFORCEMENT AGAINST DISPLACEMENT FROM FORMWORK CONSTRUCTION OR CONCRETE PLACEMENT AND CONSOLIDATION. REINFORCING SHALL BE SUPPORTED ON METAL CHAIRS, RUNNERS, BOLSTERS, SPACERS, AND HANGERS.
- C. SPLICES OF REINFORCING BARS SHALL BE CLASS B UNLESS SHOWN OTHERWISE. SPLICES SHALL BE STAGGERED. FULL DEVELOPMENT LENGTH SHALL BE PROVIDED ACROSS JOINTS.
- D. LOCATE REINFORCING TO PROVIDE CONCRETE COVER AND SPACING SHOWN ON THE DRAWINGS. MINIMUM COVER SHALL BE AS REQUIRED BY ACI 318.
- E. WELDING OF AND TO ANY REINFORCING MATERIALS INCLUDING TACK WELDING OF CROSSING BARS IS STRICTLY PROHIBITED. BARS SHALL BE FREE OF FLAKY OR SCALY RUST AT THE TIME THE CONCRETE IS PLACED.

3.4 CONCRETE PLACEMENT:

- A. PRIOR TO PLACING CONCRETE, FORMS AND REINFORCEMENT SHALL BE THOROUGHLY INSPECTED. ALL WOOD CHIPS, DIRT, ETC., AS WELL AS ALL TEMPORARY BRACING, TIES, AND CLEATS REMOVED, AND ALL OPENINGS FOR UTILITIES PROPERLY BOXED, ALL FORMS SHALL BE PROPERLY SECURED IN THEIR CORRECT POSITION AND MADE TIGHT. ALL REINFORCING AND EMBEDDED ITEMS SHALL BE SECURED IN THEIR PROPER LOCATIONS.. ALL OLD AND DRY CONCRETE AND DIRT SHALL BE CLEANED AND ALL STANDING WATER AND OTHER FOREIGN MATTER REMOVED.
- B. PLACING CONCRETE SHALL BE IN ACCORDANCE WITH ACI 301 AND ACI 304 AND SHALL BE CARRIED OUT AT SUCH A RATE THAT THE CONCRETE PREVIOUSLY PLACED IS STILL PLASTIC AND INTEGRATED WITH THE FRESHLY PLACE CONCRETE. CONCRETING, ONCE STARTED, SHALL BE CARRIED ON AS A CONTINUOUS OPERATION UNTIL THE SECTION IS COMPLETED. NO COLD JOINTS SHALL BE ALLOWED.
- C. CONSTRUCTION JOINTS: USE KEYWAYS, CONTINUE REINFORCEMENT THROUGH JOINT.
- D. EXPANSION JOINTS: FOR EXTERIOR WORK, LOCATE AT 30'-0" O.C. MAXIMUM, AT APPROVED LOCATIONS. PROVIDE SMOOTH DOWELS ACROSS JOINT WHICH PERMIT 1" HORIZONTAL MOVEMENT AND NO VERTICAL SHEAR MOVEMENT.
- E. ISOLATION JOINTS: PROVIDE BETWEEN SLABS AND VERTICAL ELEMENTS SUCH AS COLUMNS AND STRUCTURAL WALLS.
- F. CONTROL JOINTS: PROVIDE SAWN OR TOOLED JOINTS OR REMOVABLE INSERT STRIPS; DEPTH EQUAL TO 1/4" SLAB THICKNESS. SPACING SHALL BE AS REQUIRED AND APPROVED.
- G. ALL CONCRETE SHALL BE THOROUGHLY CONSOLIDATED AND COMPACTED BY VIBRATION, SPADING, RODDING, OR FORKING DURING THE OPERATION OF PLACING AND DEPOSITING IN ACCORDANCE WITH ACI 309. THE CONCRETE SHALL BE WORKED AROUND REINFORCEMENT, EMBEDDED ITEMS, AND INTO THE CORNERS OF THE FORMS SO AS TO ELIMINATE ALL AIR AND STONE POCKETS.

3.5 FINISHING:

- A. FINISHING OF ALL SLABS SHALL BE IN ACCORDANCE WITH ACI 302.1; SECTION 7.2 WITH A MINIMUM OF THREE TROWELINGS.
 - 1. INTERIOR SLAB FINISH TOLERANCE AS MEASURED IN ACCORDANCE WITH ASTM E 1155, SHALL HAVE AN OVERALL TEST F NUMBER FOR FLATNESS, FF=20 AND FOR LEVEL, FL=15. THE MINIMUM LOCAL NUMBER FOR FLATNESS, FF=15 AND FOR LEVEL, FL=10.
 - 2. EXTERIOR SLAB FINISH SHALL BE FLAT (FF=20) AND SHALL BE SLOPED A MINIMUM OF 1/8" PER FOOT TO A MAXIMUM OF 1/4" PER FOOT TO PREVENT PONDING WATER.
- B. SURFACES OF SLABS SHALL RECEIVE TWO COATS OF CLEAR SEALER/HARDNER.
- C. ABOVE GRADE WALL SURFACES SHALL HAVE A SMOOTH FORM FINISH AS DEFINED IN CHAPTER 10 OF ACI 301.

3.6 CURING:

- A. FRESHLY DEPOSITED CONCRETE SHALL BE PROTECTED FROM PREMATURE DRYING AND EXCESSIVELY HOT OR COLD TEMPERATURES AND SHALL BE MAINTAINED WITH MINIMAL MOISTURE LOSS AT A RELATIVELY CONSTANT TEMPERATURE FOR A PERIOD OF TIME NECESSARY FOR THE HYDRATION OF THE CEMENT AND PROPER HARDENING OF THE CONCRETE.
- B. CURING SHALL IMMEDIATELY FOLLOW THE FINISH OPERATION. CONCRETE SHALL BE KEPT CONTINUOUSLY MOIST AT LEAST OVERNIGHT, IMMEDIATELY FOLLOWING THE INITIAL CURING. BEFORE THE CONCRETE HAS DRIED, ADDITIONAL CURING SHALL BE ACCOMPLISHED BY ONE OF THE FOLLOWING MATERIALS OR METHODS:
 - 1. PONDING OR CONTINUOUS SPRINKLING
 - 2. ABSORPTIVE MAT OR FABRIC KEPT CONTINUOUSLY WET
 - 3. NON-ABSORPTIVE FILM (POLYETHYLENE) OVER A PREVIOUSLY SPRINKLED SURFACE
 - 4. SAND OR OTHER COVERING KEPT CONTINUOUSLY WET
 - 5. CONTINUOUS STEAM (NOT EXCEEDING 150 DEGREES F) OR VAPOR MIST BATH.
 - 6. SPRAYED-ON CURING COMPOUND APPLIED IN TWO COATES, SPRAYED IN PERPENDICULAR DIRECTIONS.
- C. THE FINAL CURING SHALL CONTINUE UNTIL THE CUMULATIVE NUMBER OF DAYS OR FRACTION THEREOF, NOT NECESSARILY CONSECUTIVE, DURING WHICH TEMPERATURE OF THE AIR IN CONTACT WITH CONCRETE IS ABOVE 50 DEGREES F HAS TOTALED SEVEN (7) DAYS. CONCRETE SHALL NOT BE PERMITTED TO FREEZE DURING THE CURING PERIOD. RAPID DRYING AT THE END OF THE CURING PERIOD SHALL BE PREVENTED.

PLANS PREPARED FOR:



PLANS PREPARED BY:



45 BEECHWOOD DRIVE TEL: (978) 557-5553
N. ANDOVER, MA 01845 FAX: (978) 336-5586

PRE-CONSTRUCTION APPROVALS:

DISH WIRELESS CONS. MANAGER	DATE
DISH WIRELESS OPS. MANAGER	DATE
DISH WIRELESS RF ENGINEER	DATE

POST-CONSTRUCTION APPROVALS:

DISH WIRELESS CONS. MANAGER	DATE
DISH WIRELESS OPS. MANAGER	DATE
DISH WIRELESS RF ENGINEER	DATE

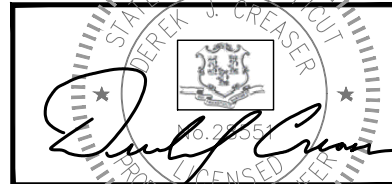

DRAWING NOTICE:
THIS DRAWING HAS NOT BEEN PUBLISHED AND IS THE SOLE PROPERTY OF HDG, LLC, AND IS LENT TO THE BORROWER FOR THEIR CONFIDENTIAL USE ONLY, AND IN CONSIDERATION OF THE LOAN OF THIS DRAWING, THE BORROWER PROMISES AND AGREES TO RETURN IT UPON REQUEST AND AGREES THAT IT WILL NOT BE REPRODUCED, COPIED, LENT OR OTHERWISE DISPOSED OF DIRECTLY OR INDIRECTLY, NOR USED FOR ANY PURPOSE OTHER THAN FOR WHICH IT IS FURNISHED.

SUBMITTALS:	DESCRIPTION	DATE	BY	REV
ISSUED FOR REVIEW		11/01/18	ET	0

APPLICANT SITE NAME:

CLEARY TOWER

APPLICANT SITE NUMBER:

CT0100001A

SITE ADDRESS:

CLEARY TOWER (EDWARD)
WOLCOTT, CT 06716

SHEET DESCRIPTION:

SPECIFICATIONS
(1 OF 3)

DWG INFORMATION:

DRAWN BY: ET
CHECKED BY: HC

SHEET NUMBER:

SP-1.0

PART 1: GENERAL

1.1 GENERAL CONDITIONS:

- A. THE CONTRACTOR SHALL INSPECT THE SITE WHERE THIS WORK IS TO BE PERFORMED AND FULLY FAMILIARIZE HIMSELF WITH ALL CONDITIONS RELATED TO THIS PROJECT.
- B. THE CONTRACTOR SHALL OBTAIN AND PAY FOR ALL PERMITS AND LICENSES AND SHALL MAKE ALL DEPOSITS AND PAY ALL FEES REQUIRED FOR THE PERFORMANCE OF WORK UNDER THIS SECTION.
- C. DRAWINGS SHOW THE GENERAL ARRANGEMENT OF ALL SYSTEMS AND COMPONENTS COVERED UNDER THIS SECTION. THE CONTRACTOR SHALL VERIFY ALL DIMENSIONS. DRAWINGS SHALL NOT BE SCALED TO DETERMINE DIMENSIONS.

1.2 LAWS, REGULATIONS, ORDINANCES, STATUTES AND CODES:

- A. ALL WORK SHALL BE INSTALLED IN ACCORDANCE WITH THE NATIONAL ELECTRICAL CODE, AND ALL APPLICABLE LOCAL LAWS, REGULATIONS, ORDINANCES, STATUTES AND CODES.

1.3 REFERENCES:

- A. THE PUBLICATIONS LISTED BELOW FORM PART OF THIS SPECIFICATION. EACH PUBLICATION SHALL BE THE LATEST REVISION AND ADDENDUM IN EFFECT ON THE DATE THIS SPECIFICATION IS ISSUED FOR CONSTRUCTION UNLESS NOTED OTHERWISE. EXCEPT AS MODIFIED BY THE REQUIREMENTS SPECIFIED HEREIN OR THE DETAILS OF THE DRAWINGS, WORK INCLUDED IN THIS SPECIFICATION SHALL CONFORM TO THE APPLICABLE PROVISIONS OF THESE PUBLICATIONS.

1. ANSI/IEEE (AMERICAN NATIONAL STANDARDS INSTITUTE)
2. IEEE (INSTITUTE OF ELECTRICAL AND ELECTRONICS ENGINEERS)
3. ASTM (AMERICAN SOCIETY FOR TESTING AND MATERIALS)
4. ICEA (INSULATED CABLE ENGINEERS ASSOCIATION)
5. NEMA (NATIONAL ELECTRICAL MANUFACTURER'S ASSOCIATION)
6. NFPA (NATIONAL FIRE PROTECTION ASSOCIATION)
7. OSHA (OCCUPATIONAL SAFETY AND HEALTH ADMINISTRATION)
8. UL (UNDERWRITERS LABORATORIES, INC.)
9. R56 MOTOROLA STANDARDS

1.4 SCOPE OF WORK:

- A. WORK UNDER THIS SECTION SHALL CONSIST OF FURNISHING ALL LABOR, MATERIAL AND ASSOCIATED SERVICES REQUIRED TO COMPLETELY CONSTRUCT AND LEAVE READY FOR OPERATION SYSTEMS AS SHOWN ON THE DRAWINGS AND HEREIN DESCRIBED.
- B. ALL ELECTRICAL EQUIPMENT UNDER THIS CONTRACT SHALL BE PROPERLY TESTED, ADJUSTED, AND ALIGNED BY THE CONTRACTOR.
- C. THE CONTRACTOR SHALL BE RESPONSIBLE FOR ALL EXCAVATING, DRAINING, TRENCHES, BACKFILLING, AND REMOVAL OF EXCESS DIRT.
- D. THE CONTRACTOR SHALL FURNISH TO THE OWNER, CERTIFICATES OF FINAL INSPECTION AND APPROVAL FROM THE INSPECTION AUTHORITIES HAVING JURISDICTION.

PART 2: PRODUCTS

2.1 GENERAL:

- A. ALL ITEMS OF MATERIALS AND EQUIPMENT SHALL BE NEW, FREE FROM DEFECTS AND OF THE BEST QUALITY NORMALLY USED FOR THE PURPOSE IN GOOD COMMERCIAL PRACTICE.
- B. ALL MATERIALS AND EQUIPMENT SHALL BE ACCEPTABLE TO THE AUTHORITY HAVING JURISDICTION AS SUITABLE FOR THE USE INTENDED.
- C. ALL EQUIPMENT SHALL BEAR THE UNDERWRITERS LABORATORIES LABEL OF APPROVAL, AND SHALL CONFORM TO REQUIREMENTS OF THE NATIONAL ELECTRICAL CODE.
- D. ALL OVERCURRENT DEVICES SHALL HAVE AN INTERRUPTING RATING EQUAL TO OR GREATER THAN THE SHORT CIRCUIT CURRENT TO WHICH THEY ARE SUBJECTED, 10,000 AIC MINIMUM. VERIFY AVAILABLE SHORT CIRCUIT CURRENT DOES NOT EXCEED THE RATING OF ELECTRICAL EQUIPMENT.

2.2 MATERIALS AND EQUIPMENT:

- A. CONDUIT:
 1. RIGID GALVANIZED STEEL CONDUIT (RGS) SHALL BE HOT-DIP GALVANIZED INSIDE AND OUTSIDE INCLUDING ENDS AND THREADS AND ENAMELED OR LACQUERED INSIDE IN ADDITION TO GALVANIZING.

2. FLEXIBLE METAL CONDUIT SHALL BE GALVANIZED, ZINC-COATED STEEL, PVC COATED FOR OUTDOOR APPLICATIONS.
 3. CONDUIT CLAMPS, STRAPS AND SUPPORTS SHALL BE STEEL OR MALLEABLE IRON. ALL FITTINGS SHALL BE COMPRESSION TYPE AND WATERTIGHT.
 4. NON-METALLIC CONDUIT AND FITTINGS SHALL BE SCHEDULE 40 PVC, HEAVY-WALL RIGID WITH SOLVENT-CEMENT-TYPE JOINTS AS RECOMMENDED BY THE MANUFACTURER.
- B. WIRE AND CABLE:
1. WIRE AND CABLE SHALL BE FLAME-RETARDANT, MOISTURE AND HEAT RESISTANT THERMOPLASTIC, SINGLE CONDUCTOR, COPPER, TYPE THHN/THWN, 600 VOLT, SIZES AS INDICATED, #12 AWG MINIMUM.
 2. #10 AWG AND SMALLER CONDUCTORS SHALL BE SOLID AND #8 AWG AND LARGER CONDUCTORS SHALL BE STRANDED.
 3. SOLDERLESS, PRESSURE-TYPE CONNECTORS CONSTRUCTED OF HIGH-STRENGTH, NON-CORRODIBLE, TIN-PLATED COPPER DESIGNED TO FURNISH HIGH-PULLOUT STRENGTH AND HIGH CONDUCTIVITY JOINTS SHALL BE USED.
 4. SUPPORT GRIPS SHALL BE SINGLE WEAVE, CLOSED MESH, HIGH-GRADE, NON-MAGNETIC, TIN-COATED BRONZE CAPABLE OF SUPPORTING TEN TIMES THE CABLE DEAD WEIGHT, HUBBELL KELLEMS OR APPROVED EQUAL.
- C. DISCONNECT SWITCHES:
1. DISCONNECT SWITCHES SHALL BE HEAVY DUTY, DEAD-FRONT, QUICK-MAKE, QUICK-BREAK, EXTERNALLY OPERABLE, HANDLE LOCKABLE AND INTERLOCKED WITH COVER IN CLOSED POSITION, RATING AS INDICATED, UL LABELED FURNISHED IN NEMA 3R ENCLOSURE, SQUARE D CLASS 3110 OR APPROVED EQUAL.
- D. SYSTEM GROUNDING:
1. BELOW GRADE GROUNDING CONDUCTORS SHALL BE BARE SOLID TINNED COPPER, SIZED AS INDICATED. ABOVE GROUND GROUNDING CONDUCTORS SHALL BE STRANDED INSULATED, UNLESS NOTED OTHERWISE.
 2. GROUND BARS SHALL BE GALVANIZED STEEL BARS OR RECTANGULAR CROSS SECTION UNLESS OTHERWISE INDICATED.
 3. CONNECTORS SHALL BE HIGH-CONDUCTIVITY, HEAVY DUTY, LISTED AND LABELED AS GROUNDING CONNECTORS FOR THE MATERIALS USED. USE TWO-HOLE COMPRESSION LUGS WITH HEAT SHRINK FOR MECHANICAL CONNECTIONS.
 4. EXOTHERMIC WELDED CONNECTIONS SHALL BE PROVIDED IN KIT FORM AND SELECTED FOR THE SPECIFIC TYPES, SIZES, AND COMBINATIONS OF CONDUCTORS AND OTHER ITEMS TO BE CONNECTED.
 5. GROUND RODS SHALL BE COPPER-CLAD STEEL WITH HIGH-STRENGTH STEEL CORE AND ELECTROLYTIC-GRADE COPPER OUTER SHEATH, MOLTEN WELDED TO CORE, 3/4" x 10'-0".
- E. OTHER MATERIALS:
1. THE CONTRACTOR SHALL PROVIDE OTHER MATERIALS, THOUGH NOT SPECIFICALLY DESCRIBED, WHICH ARE REQUIRED FOR A COMPLETELY OPERATIONAL SYSTEM AND PROPER INSTALLATION OF THE WORK.

PLANS PREPARED FOR:



PLANS PREPARED BY:



PRE-CONSTRUCTION APPROVALS:

DISH WIRELESS CONS. MANAGER	DATE
DISH WIRELESS OPS. MANAGER	DATE
DISH WIRELESS RF ENGINEER	DATE

POST-CONSTRUCTION APPROVALS:

DISH WIRELESS CONS. MANAGER	DATE
DISH WIRELESS OPS. MANAGER	DATE
DISH WIRELESS RF ENGINEER	DATE

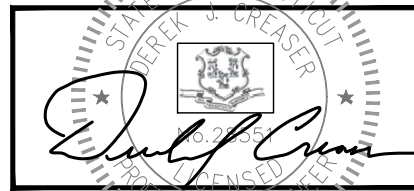

DRAWING NOTICE:
 THIS DRAWING HAS NOT BEEN PUBLISHED AND IS THE SOLE PROPERTY OF HDG, LLC, AND IS LENT TO THE BORROWER FOR THEIR CONFIDENTIAL USE ONLY, AND IN CONSIDERATION OF THE LOAN OF THIS DRAWING, THE BORROWER PROMISES AND AGREES TO RETURN IT UPON REQUEST AND AGREES THAT IT WILL NOT BE REPRODUCED, COPIED, LENT OR OTHERWISE DISPOSED OF DIRECTLY OR INDIRECTLY, NOR USED FOR ANY PURPOSE OTHER THAN FOR WHICH IT IS FURNISHED.

SUBMITTALS:

DESCRIPTION	DATE	BY	REV
ISSUED FOR REVIEW	11/01/18	ET	0

APPLICANT SITE NAME:

CLEARY TOWER

APPLICANT SITE NUMBER:

CT0100001A

SITE ADDRESS:

CLEARY TOWER (EDWARD)
 WOLCOTT, CT 06716

SHEET DESCRIPTION:

SPECIFICATIONS
 (2 OF 3)

DWG INFORMATION: SHEET NUMBER:

DRAWN BY:	ET	SP-2.0
CHECKED BY:	HC	

PART 3: EXECUTION

3.1 GENERAL:

- A. ALL MATERIALS AND EQUIPMENT SHALL BE INSTALLED IN STRICT ACCORDANCE WITH THE MANUFACTURER'S RECOMMENDATIONS.
- B. EQUIPMENT SHALL BE TIGHTLY COVERED AND PROTECTED AGAINST DIRT OR WATER, AND AGAINST CHEMICAL OR MECHANICAL INJURY DURING INSTALLATION AND CONSTRUCTION PERIODS.

3.2 LABOR AND WORKMANSHIP:

- A. ALL LABOR FOR THE INSTALLATION OF MATERIALS AND EQUIPMENT FURNISHED FOR THE ELECTRICAL SYSTEM SHALL BE DONE BY EXPERIENCED MECHANICS OF THE PROPER TRADES.
- B. ALL ELECTRICAL EQUIPMENT FURNISHED SHALL BE ADJUSTED, ALIGNED AND TESTED BY THE CONTRACTOR AS REQUIRED TO PRODUCE THE INTENDED PERFORMANCE.
- C. UPON COMPLETION OF THE WORK, THE CONTRACTOR SHALL THOROUGHLY CLEAN ALL EXPOSED EQUIPMENT, REMOVE ALL LABELS AND ANY DEBRIS, CRATING OR CARTONS AND LEAVE THE INSTALLATION FINISHED AND READY FOR OPERATION.

3.3 COORDINATION:

- A. THE CONTRACTOR SHALL COORDINATE THE INSTALLATION OF ELECTRICAL ITEMS WITH THE OWNER-FURNISHED EQUIPMENT DELIVERY SCHEDULE TO PREVENT UNNECESSARY DELAYS IN THE TOTAL WORK.

3.4 INSTALLATION:

A. CONDUIT:

1. ALL ELECTRICAL WIRING SHALL BE INSTALLED IN CONDUIT AS HEREIN SPECIFIED. NO CONDUIT OR TUBING OF LESS THAN 3/4" NOMINAL SIZE SHALL BE USED.
2. PROVIDE RGS CONDUIT FOR ALL EXPOSED, EXTERIOR CONDUIT.
3. PROVIDE SCHEDULE 40 PVC OR RGS CONDUIT BELOW GRADE, 1" MINIMUM, UNLESS NOTED OTHERWISE. ALL 90 DEGREE BENDS TO ABOVE GRADE SHALL BE RGS. MINIMUM BURIAL DEPTH SHALL BE 24" CLEAR TO TOP OF CONDUIT, UNLESS NOTED OTHERWISE.
4. USE GALVANIZED FLEXIBLE STEEL CONDUIT WHERE DIRECT CONNECTION IS NOT DESIRABLE FOR REASONS OF EQUIPMENT MOVEMENT, VIBRATION, OR FOR EASE OF MAINTENANCE. USE LIQUIDTIGHT, PVC COATED FLEXIBLE METAL CONDUIT FOR OUTDOOR APPLICATIONS.
5. INSTALL GALVANIZED FLEXIBLE STEEL CONDUIT AT ALL POINTS OF CONNECTION TO EQUIPMENT MOUNTED ON SUPPORTS TO ALLOW FOR EXPANSION AND CONTRACTION.
6. A RUN OF CONDUIT BETWEEN BOXES OR FITTINGS SHALL NOT CONTAIN MORE THAN THE EQUIVALENT OF FOUR QUARTER-BENDS INCLUDING THOSE BENDS LOCATED IMMEDIATELY AT THE BOX OR FITTING. THE RADIUS OF BENDS SHALL NEVER BE SHORTER THAN THAT OF THE CORRESPONDING TRADE ELBOW.
7. WHERE CONDUIT HAS TO BE CUT IN THE FIELD, IT SHALL BE CUT SQUARE WITH A PIPE CUTTER USING CUTTING KNIVES.
8. ALL CONDUITS SHALL BE SWABBED CLEAN BY PULLING AN APPROPRIATE SIZE MANDREL THROUGH THE CONDUIT BEFORE INSTALLATION OF WIRE OR CABLE. CLEAR ALL BLOCKAGES AND REMOVE BURRS, DIRT, AND DEBRIS.
9. INSTALL PULL STRINGS IN ALL EMPTY CONDUITS. IDENTIFY PULL STRINGS AT EACH END WITH ITS DESTINATION.
10. PROVIDE INSULATED GROUNDING BUSHINGS FOR ALL CONDUITS STUBBED INTO EQUIPMENT ENCLOSURES OR STUBBED OUT FOR FUTURE USE BY OTHERS.
11. CONTRACTOR IS RESPONSIBLE FOR PROTECTING ALL CONDUITS DURING CONSTRUCTION. TEMPORARY OPENINGS IN THE CONDUIT SYSTEM SHALL BE PLUGGED OR CAPPED TO PREVENT ENTRANCE OF MOISTURE OR FOREIGN MATTER. CONTRACTOR SHALL REPLACE ANY CONDUITS CONTAINING FOREIGN MATERIALS THAT CANNOT BE REMOVED.
12. INSTALL 2" ORANGE DETECTABLE TAPE 12" ABOVE ALL UNDERGROUND CONDUIT AND WIRE.
13. CONDUITS SHALL BE INSTALLED IN SUCH A MANNER AS TO INSURE AGAINST COLLECTION OF TRAPPED CONDENSATION.

B. WIRE AND CABLE:

1. ALL POWER WIRING SHALL BE COLOR CODED AS FOLLOWS:

DESCRIPTION	120/240V	208Y/120V	480Y/277V
PHASE A	BLACK	BLACK	BROWN
PHASE B	RED	RED	ORANGE
PHASE C		BLUE	YELLOW
NEUTRAL	WHITE	WHITE	GRAY
GROUND	GREEN	GREEN	GREEN

2. SPLICES SHALL BE MADE ONLY AT OUTLETS, JUNCTION BOXES, OR ACCESSIBLE RACEWAYS WITH PRESSURE-TYPE CONNECTORS.
3. PULLING LUBRICANTS SHALL BE SOAPSTONE POWDER, POWDERED TALC, OR A COMMERCIAL PULLING COMPOUND. NO SOAP SUDS, SOAP FLAKES, OIL, OR GREASE SHALL BE USED, AS THESE MAY BE HARMFUL TO CABLE INSULATION. CONTRACTOR SHALL USE NYLON OR HEMP ROPE FOR PULLING CABLE TO AVOID SCORING THE CONDUIT.
4. CABLES SHALL BE NEATLY TRAINED, WITHOUT INTERLACING, AND BE OF SUFFICIENT LENGTH IN ALL BOXES, EQUIPMENT, ETC. TO PERMIT MAKING A NEAT ARRANGEMENT. CABLES SHALL BE SECURED IN A MANNER TO AVOID TENSION ON CONDUCTORS OR TERMINALS, AND SHALL BE PROTECTED FROM MECHANICAL INJURY AND FROM MOISTURE. SHARP BENDS OVER CONDUIT BUSHINGS ARE PROHIBITED. DAMAGED CABLES SHALL BE REMOVED AND REPLACED AT THE CONTRACTOR'S EXPENSE.

C. DISCONNECT SWITCHES:

1. INSTALL DISCONNECT SWITCHES LEVEL AND PLUMB. CONNECT TO WIRING SYSTEM AND GROUND AS INDICATED.

D. GROUNDING:

1. ALL METALLIC PARTS OF ELECTRICAL EQUIPMENT WHICH DO NOT CARRY CURRENT SHALL BE GROUNDED IN ACCORDANCE WITH THE REQUIREMENTS OF ARTICLE 250 OF THE NATIONAL ELECTRICAL CODE.
2. PROVIDE ELECTRICAL GROUNDING AND BONDING SYSTEMS INDICATED WITH ASSEMBLY OF MATERIALS, INCLUDING GROUNDING ELECTRODES, BONDING JUMPERS AND ADDITIONAL ACCESSORIES AS REQUIRED FOR A COMPLETE INSTALLATION.
3. ROUTE GROUNDING CONNECTIONS AND CONDUCTORS TO GROUND IN THE SHORTEST AND STRAIGHTEST PATHS POSSIBLE TO MINIMIZE TRANSIENT VOLTAGE RISES.
4. TIGHTEN GROUNDING AND BONDING CONNECTORS, INCLUDING SCREWS AND BOLTS, IN ACCORDANCE WITH MANUFACTURER'S PUBLISHED TORQUE TIGHTENING VALUES FOR CONNECTORS AND BOLTS. WHERE MANUFACTURER'S TORQUING REQUIREMENTS ARE NOT AVAILABLE, TIGHTEN CONNECTIONS TO COMPLY WITH TIGHTENING TORQUE VALUES SPECIFIED IN UL 486A TO ASSURE PERMANENT AND EFFECTIVE GROUNDING.
5. ALL UNDERGROUND GROUNDING CONNECTIONS SHALL BE MADE BY THE EXOTHERMIC WELD PROCESS AND INSTALLED IN ACCORDANCE WITH THE MANUFACTURER'S INSTRUCTIONS.
6. ALL GROUND CONNECTIONS SHALL BE INSPECTED FOR TIGHTNESS. EXOTHERMIC-WELDED CONNECTIONS SHALL BE APPROVED BY THE CONSTRUCTION INSPECTOR BEFORE BEING PERMANENTLY CONCEALED.
7. APPLY CORROSION-RESISTANT FINISH TO FIELD CONNECTIONS, AND PLACES WHERE FACTORY APPLIED PROTECTIVE COATINGS HAVE BEEN DESTROYED. USE COPPER-BASED "NO-OX" OR APPROVED EQUAL.
8. A SEPARATE, CONTINUOUS, INSULATED EQUIPMENT GROUNDING CONDUCTOR SHALL BE INSTALLED IN ALL FEEDER AND BRANCH CIRCUITS
9. BOND ALL INSULATED GROUNDING BUSHINGS WITH A BARE #6 AWG GROUNDING CONDUCTOR TO A GROUND BUS OR GROUNDING LUG IN ENCLOSURE.
10. DIRECT BURIED GROUND CONDUCTORS SHALL BE INSTALLED AT A NOMINAL DEPTH OF 30" BELOW GRADE, UNLESS NOTED OTHERWISE.
11. ALL GROUNDING CONDUCTORS EMBEDDED IN OR PENETRATING CONCRETE SHALL BE INSULATED OR INSTALLED IN PVC CONDUIT.
12. INSTALL ELECTROLYTIC GROUNDING SYSTEM IN STRICT ACCORDANCE WITH MANUFACTURER'S INSTRUCTIONS. REMOVE SEALING TAPE FROM LEACHING AND BREATHER HOLES. INSTALL PROTECTIVE BOX FLUSH WITH GRADE.
13. DRIVE GROUND RODS UNTIL TOPS ARE 30" BELOW FINAL GRADE.
14. GROUNDING CONDUCTOR TO EQUIPMENT GROUND LUGS:
 - a. BOLTED TO EQUIPMENT HOUSING WITH STAINLESS STEEL BOLTS AND LOCK WASHERS.
 - b. ALL EQUIPMENT TO BE GROUNDED SHALL BE FREE OF PAINT OR ANY OTHER MATERIAL COVERING BARE METAL AT THE POINT OF CONNECTION.

3.5 ACCEPTANCE TESTING:

- A. PROVIDE PERSONNEL AND EQUIPMENT, MAKE REQUIRED TESTS, AND SUBMIT TEST REPORTS UPON COMPLETION OF TESTS.
- B. WHEN MATERIAL AND/OR WORKMANSHIP IS FOUND NOT TO COMPLY WITH THE SPECIFIED REQUIREMENTS, THE NONCOMPLYING ITEMS SHALL BE REMOVED FROM THE JOBSITE AND REPLACED WITH ITEMS COMPLYING WITH THE SPECIFIED REQUIREMENTS PROMPTLY AFTER RECEIPT OF NOTICE OF SUCH NON-COMPLIANCE.

C. TEST PROCEDURES:

1. ALL FEEDERS SHALL HAVE THEIR INSULATION TESTED AFTER INSTALLATION, BUT BEFORE CONNECTION TO DEVICES. THE CONDUCTORS SHALL TEST FREE FROM SHORT CIRCUITS AND GROUNDS. TESTING SHALL BE FOR ONE MINUTE USING 1000V DC. INVESTIGATE ANY VALUES LESS THAN 50 MEGOHMS.
2. PRIOR TO ENERGIZING CIRCUITRY, TEST WIRING DEVICES FOR ELECTRICAL CONTINUITY AND PROPER POLARITY CONNECTIONS.
3. MEASURE AND RECORD VOLTAGES BETWEEN PHASES AND BETWEEN PHASE WIRES AND NEUTRALS. SUBMIT A REPORT OF MAXIMUM AND MINIMUM VOLTAGES.
4. PERFORM GROUND TEST TO MEASURE GROUND RESISTANCE OF GROUNDING SYSTEM USING THE IEEE STANDARD 3-POINT "FALL-OF-POTENTIAL" METHOD. PROVIDE PLOTTED TEST VALUES & LOCATION SKETCH. NOTIFY THE ENGINEER IMMEDIATELY IF MEASURED VALUE IS OVER 5 OHMS.

NOTE:

1. ALL WORK SHALL BE PERFORMED IN ACCORDANCE WITH THE REQUIREMENTS STIPULATED IN THE CONSTRUCTION SCOPE OF WORK CONTRACT, REGARDLESS OF INCLUSION OR OMISSION FROM THE CONSTRUCTION.
2. GENERAL CONTRACTOR TO KNOW AND OBSERVE MANUFACTURER'S MINIMUM BEND RADIUS SPECIFICATIONS BEFORE HANDLING HYBRID CABLES, RF CABLES AND/OR FIBER OPTIC LINES.
3. ADHERENCE TO CONSTRUCTION DOCUMENTS AND CONSTRUCTION SCOPE OF WORK ARE TO BE FOLLOWED.

ANTENNA LAYOUT NOTE:

1. THIS ANTENNA ORIENTATION PLAN IS A SCHEMATIC. THE CONTRACTOR SHALL VERIFY TOWER ORIENTATION AND FIELD COORDINATE REQUIRED ADJUSTMENTS TO ACHIEVE THE DESIRED ANTENNA AZIMUTHS.
2. ANTENNA CENTERLINE HEIGHT REFERENCED FROM GROUND AT BASE OF TOWER, ASSUMING HEIGHT OF 0'-0" AT SAID REFERENCE POINT.
3. ALL ANTENNAS, CABLES AND MOUNTS SHALL BE INSTALLED IN ACCORDANCE WITH THE TOWER ENGINEER'S RECOMMENDATIONS IN A MANNER CONSISTENT WITH THE STRUCTURAL ANALYSIS REPORT.
4. ALL ANTENNA BRACKETS PER ANTENNA MANUFACTURER, OR EQUAL CONTRACTOR TO COORDINATE REQUIRED MECHANICAL DOWN TILT WITH DISH WIRELESS.
5. ALL ANTENNA INFORMATION TO BE CONFIRMED WITH DISH WIRELESS RF DESIGN PRIOR TO INSTALLATION.
6. VERIFY POSITIONS AND AZIMUTH ANTENNAS WITH DISH WIRELESS PRIOR TO INSTALLATION.
7. SECTOR FRAMES AND ANTENNAS SHOULD HAVE IDENTIFYING TORQUES MARKS SHOWN AFTER INSTALLATION.
8. ALL CLOSEOUT PHOTOS ADHERE TO CLOSE-OUT DOCUMENTATION.

EQUIPMENT TESTING:

CONTRACTOR SHALL COMPLETE THE FOLLOWING REQUIREMENTS.

1. ANTENNAS AND RF JUMPER:
 - ALL RF JUMPERS & ANTENNA PORTS MUST HAVE DOCUMENTED PASSING SYSTEM SWEEP TEST.
 - PIM TESTING IS REQUIRED FOR ALL INSTALLED ANTENNAS AND FEEDLINES.
 - SYSTEM SWEEPS SHALL BE AT A RETURN LOSS OF ≤ -16 db.
 - ALL SWEEPS MUST BE PROVIDED IN A PDF AS WELL AS ANRITSU (OR EQUAL) DATA FILE FORMAT.
2. HYBRID CABLES:
 - ALL FIBER PAIRS MUST HAVE A DOCUMENTED PASSING POWER & A FIBER INSPECTION SCOPE TEST.
 - PASSING POWER TEST SHALL BE ≤ 3 db.
 - REQUIRED FIBER TEST GEAR SHALL BE VIAVI JDSU FIT-SD103; P5000i FIBER SCOPE DIGITAL INSPECTION KIT; VIAVI 2303/11, OLS-35 OPTICAL LASER LIGHT SOURCE 1310/1550 NM, SM, INTERCHANGEABLE ADAPTER OR EQUAL.
 - ALL FIBER TEST RESULTS MUST BE PROVIDED IN PDF FORMAT.
 - ALL FIBER PAIRS MUST HAVE A DOCUMENTED PASSING POWER & A FIBER INSPECTION SCOPE TEST.
3. ADD TO EQUIPMENT TESTING:
 - FINAL ACCEPTANCE: PERFORM ALL TECHNICAL TESTS SPECIFIED IN THE CONSTRUCTION SOW, SECTION XIV.

PLANS PREPARED FOR:



PLANS PREPARED BY:



PRE-CONSTRUCTION APPROVALS:

DISH WIRELESS CONS. MANAGER	DATE
DISH WIRELESS OPS. MANAGER	DATE
DISH WIRELESS RF ENGINEER	DATE

POST-CONSTRUCTION APPROVALS:

DISH WIRELESS CONS. MANAGER	DATE
DISH WIRELESS OPS. MANAGER	DATE
DISH WIRELESS RF ENGINEER	DATE

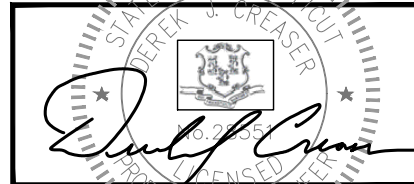

DRAWING NOTICE:
THIS DRAWING HAS NOT BEEN PUBLISHED AND IS THE SOLE PROPERTY OF HDG, LLC, AND IS LENT TO THE BORROWER FOR THEIR CONFIDENTIAL USE ONLY, AND IN CONSIDERATION OF THE LOAN OF THIS DRAWING, THE BORROWER PROMISES AND AGREES TO RETURN IT UPON REQUEST, LENT OR OTHERWISE DISPOSED OF DIRECTLY OR INDIRECTLY, NOR USED FOR ANY PURPOSE OTHER THAN FOR WHICH IT IS FURNISHED.

SUBMITTALS:

DESCRIPTION	DATE	BY	REV
ISSUED FOR REVIEW	11/01/18	ET	0

APPLICANT SITE NAME:

CLEARY TOWER

APPLICANT SITE NUMBER:

CT0100001A

SITE ADDRESS:

CLEARY TOWER (EDWARD)
WOLCOTT, CT 06716

SHEET DESCRIPTION:

SPECIFICATIONS
(3 OF 3)

DWG INFORMATION: SHEET NUMBER:

DRAWN BY:	ET	SP-2.1
CHECKED BY:	HC	



RF Design Data Sheet

Site Information

State	CT	Site ID	CT0100001A
Site Name	CT20021-A	Tower Type	Self Support
Address	Cleary Tower (Edward)	City	Wolcott
Latitude (degrees)	41.62157989	Zip	06716
Longitude (degrees)	-72.97363267	Tower Owner	SBA
RFDS Revision	0.0	Issue Date	10/9/2018
RF Engineer	Ajit Prashar		ajit.p.prashar@ericsson.com

Design Information

Technology	NB-IoT		
Vendor	Ericsson		
Site Configuration	4415-2 No Band 29		
Site Type - Equipment - Band	AWS-4		
Sector Information (Expected Configuration)	Sector-1 (Alpha)	Sector-2 (Beta)	Sector-3 (Gamma)
LTE Sector Number	CT0100001A_1	CT0100001A_2	CT0100001A_3
Antenna Center Line (ft)	341	341	341
Antenna Model Number	ODI2-065R18K-GQ	ODI2-065R18K-GQ	ODI2-065R18K-GQ
Number of Antennas / Sector	1	1	1
Antenna Dimensions (LxWxD) (In)	53.5 x 9.8 x 2.4	53.5 x 9.8 x 2.4	53.5 x 9.8 x 2.4
Antenna Weight (lbs.)	25	25	25
Antenna Manufacturer	Comba	Comba	Comba
Horizontal Beamwidth	64	64	64
Gain (dBd)	17.8	17.8	17.8
Azimuth (deg) (Relative to True North)	0	120	240
Antenna Downtilt (Mechanical)	0	0	0
Antenna Downtilt 2100 (Electrical)	1	1	3
Antenna Downtilt 700 (Electrical)			
Radio Model (Band 70)	Radio 4415	Radio 4415	-
Radio Quantity (Band 70)	1	1	-
Radio Model (H-Block)	Radio 0208	Radio 0208	Radio 0208
Radio Quantity (H-Block)	1	1	1
Radio Model (700 band)	-	-	-
Radio Quantity (700 band)	-	-	-
Number of Feeders / Sector	4	4	4
Feeder Diameter (Nominal) (in)	1/2	1/2	1/2
Feeder Length (m)	3	3	3
700 MHz Radio location	-	-	-
700 MHz Coax Cable Type (in)	-	-	-
TX/RX Diplexer Model			
TX/RX Diplexer Qty			
TX/RX Diplexer Dim (inch) / Wt (lbs)			

Description of Cabling Configuration Changes / Additions

Mandatory : Append Sketches indicating Locations of all new Antennas, Cabling, Duplexor, Diplexors (if applicable), TMA's etc....

NOTE:
CONFIRM LATEST RF DATA SHEET AND
DIAGRAM AT TIME OF CONSTRUCTION.

PLANS PREPARED FOR:



PLANS PREPARED BY:



PRE-CONSTRUCTION APPROVALS:

DISH WIRELESS CONS. MANAGER	DATE
DISH WIRELESS OPS. MANAGER	DATE
DISH WIRELESS RF ENGINEER	DATE

POST-CONSTRUCTION APPROVALS:

DISH WIRELESS CONS. MANAGER	DATE
DISH WIRELESS OPS. MANAGER	DATE
DISH WIRELESS RF ENGINEER	DATE

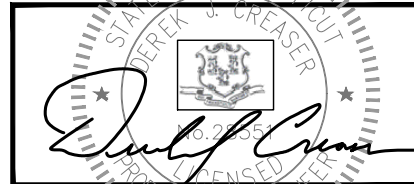

DRAWING NOTICE:
THIS DRAWING HAS NOT BEEN PUBLISHED AND IS THE SOLE PROPERTY OF HDG, LLC, AND IS LENT TO THE BORROWER FOR THEIR CONFIDENTIAL USE ONLY, AND IN CONSIDERATION OF THE LOAN OF THIS DRAWING, THE BORROWER PROMISES AND AGREES TO RETURN IT UPON REQUEST AND AGREES THAT IT WILL NOT BE REPRODUCED, COPIED, LENT OR OTHERWISE DISPOSED OF DIRECTLY OR INDIRECTLY, NOR USED FOR ANY PURPOSE OTHER THAN FOR WHICH IT IS FURNISHED.

SUBMITTALS:

DESCRIPTION	DATE	BY	REV
ISSUED FOR REVIEW	11/01/18	ET	0

APPLICANT SITE NAME:

CLEARY TOWER

APPLICANT SITE NUMBER:

CT0100001A

SITE ADDRESS:

CLEARY TOWER (EDWARD)
WOLCOTT, CT 06716

SHEET DESCRIPTION:

RF DATA SHEET

DWG INFORMATION:

DRAWN BY:	ET
CHECKED BY:	HC

SHEET NUMBER:

RF-1.0



DISH WIRELESS CONS. MANAGER	DATE
DISH WIRELESS OPS. MANAGER	DATE
DISH WIRELESS RF ENGINEER	DATE

DISH WIRELESS CONS. MANAGER	DATE
DISH WIRELESS OPS. MANAGER	DATE
DISH WIRELESS RF ENGINEER	DATE

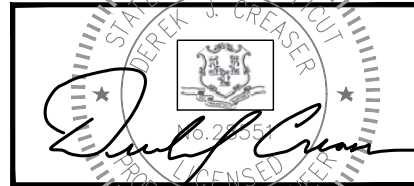

DRAWING NOTICE:
THIS DRAWING HAS NOT BEEN PUBLISHED AND IS THE SOLE PROPERTY OF HDG, LLC, AND IS LENT TO THE BORROWER FOR THEIR CONFIDENTIAL USE ONLY, AND IN CONSIDERATION OF THE LOAN OF THIS DRAWING, THE BORROWER PROMISES AND AGREES THAT IT WILL NOT BE REPRODUCED, COPIED, LENT OR OTHERWISE DISPOSED OF DIRECTLY OR INDIRECTLY, NOR USED FOR ANY PURPOSE OTHER THAN FOR WHICH IT IS FURNISHED.

SUBMITTALS:

DESCRIPTION	DATE	BY	REV
ISSUED FOR REVIEW	11/01/18	ET	0

APPLICANT SITE NAME:

CLEARY TOWER

APPLICANT SITE NUMBER:

CT0100001A

SITE ADDRESS:

CLEARY TOWER (EDWARD)
WOLCOTT, CT 06716

SHEET DESCRIPTION:

RFDS PLUMBING
DIAGRAM

DWG INFORMATION: SHEET NUMBER:

DRAWN BY: ET
CHECKED BY: HC

RF-1.1

Ericsson Antenna to RRU Diagram

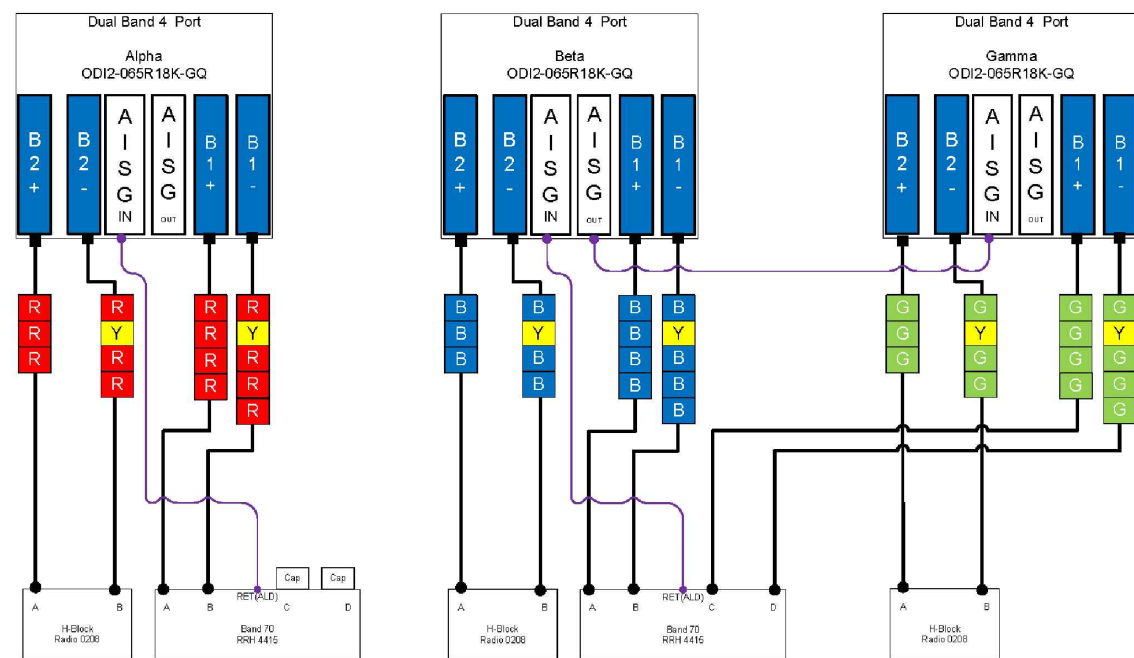

Note: This Plumbing Diagram does not represent the position of the RRU or Antenna on the mount. That is stipulated in the Construction Drawings. If there is any question please address your Construction Manager before proceeding.

Ericsson LTE BBU TO RRU Fiber and Power Diagram
(Rosenberger Hybrid cable is used when length ≤ 90m)

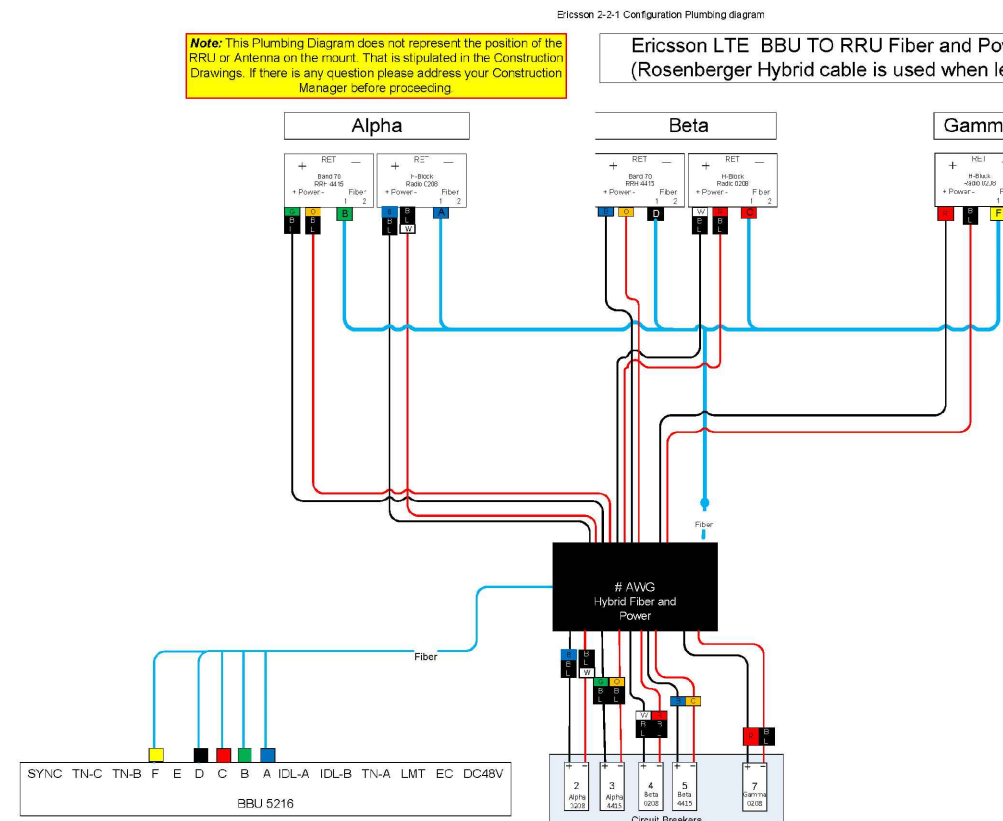

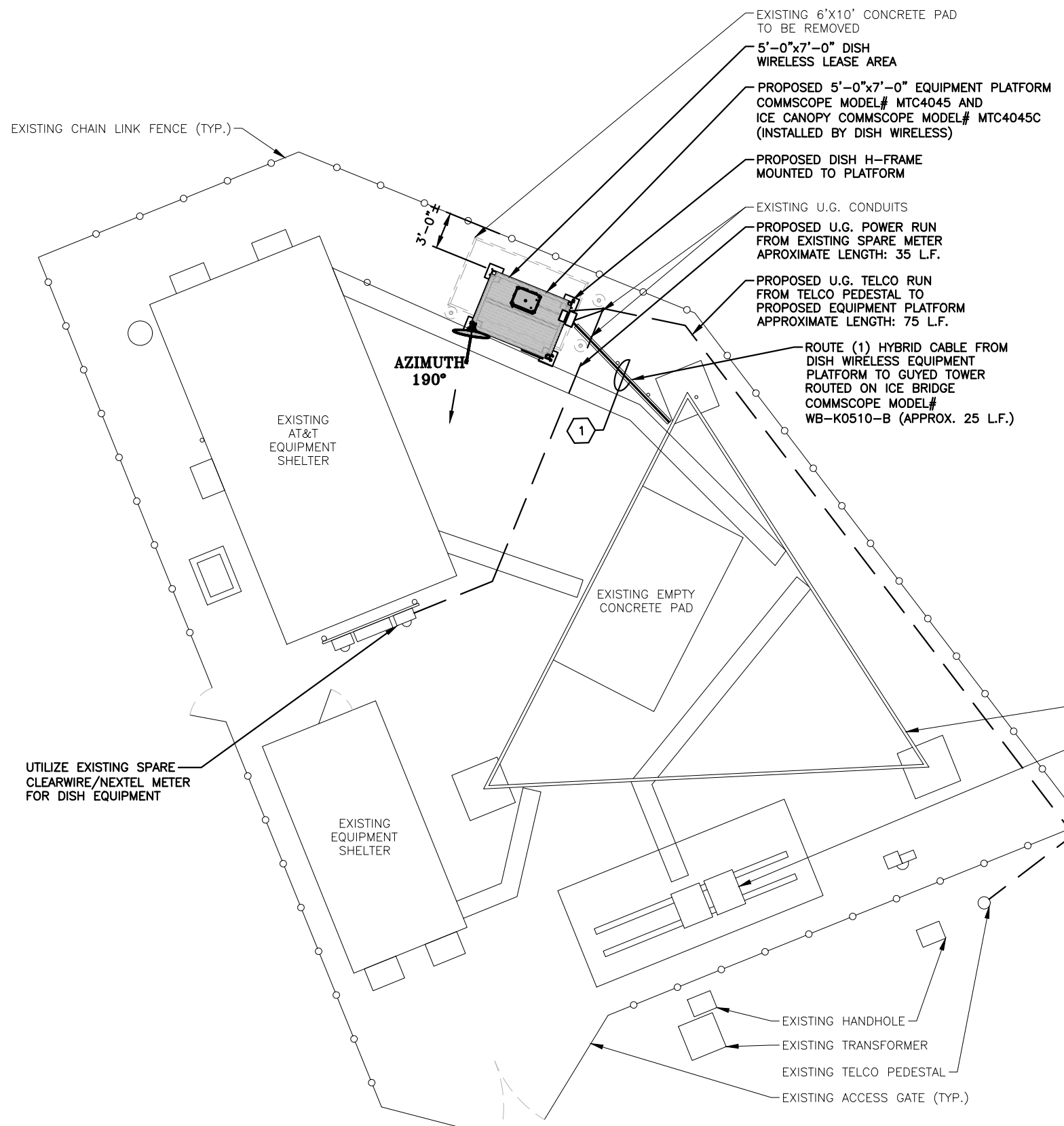

KEYED NOTES:
 ① ROUTE (1) HYBRID CABLE ROUTED ON PROPOSED ICE BRIDGE FROM EQUIPMENT PLATFORM TO TOWER. CONTRACTOR SHALL WEATHER SEAL EACH END OF CONDUIT PER DISH WIRELESS SPECIFICATIONS AND REQUIREMENTS.

LENGTHS:

TOTAL LENGTH OF CABLE ON TOWER	341'
TOTAL HYBRID FLEX RUN FROM PROPOSED EQUIPMENT PLATFORM TO TOWER	25'
TOTAL HYBRID FLEX RUN FROM PROPOSED EQUIPMENT PLATFORM TO EACH SECTOR (+10%)	405'

PLANS PREPARED FOR:

PLANS PREPARED BY:

45 BEECHWOOD DRIVE TEL: (978) 557-5553
 N. ANDOVER, MA 01845 FAX: (978) 336-5586

PRE-CONSTRUCTION APPROVALS:

DISH WIRELESS CONS. MANAGER	DATE
DISH WIRELESS OPS. MANAGER	DATE
DISH WIRELESS RF ENGINEER	DATE

POST-CONSTRUCTION APPROVALS:

DISH WIRELESS CONS. MANAGER	DATE
DISH WIRELESS OPS. MANAGER	DATE
DISH WIRELESS RF ENGINEER	DATE

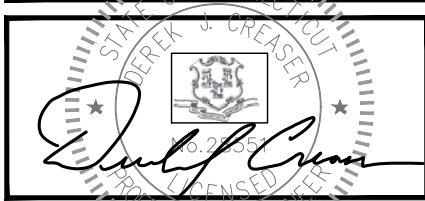

DRAWING NOTICE:
 THIS DRAWING HAS NOT BEEN PUBLISHED AND IS THE SOLE PROPERTY OF HDG, LLC, AND IS LENT TO THE BORROWER FOR THEIR CONFIDENTIAL USE ONLY, AND IN CONSIDERATION OF THE LOAN OF THIS DRAWING, THE BORROWER PROMISES AND AGREES TO RETURN IT UPON REQUEST AND AGREES THAT IT WILL NOT BE REPRODUCED, COPIED, LENT OR OTHERWISE DISPOSED OF DIRECTLY OR INDIRECTLY, NOR USED FOR ANY PURPOSE OTHER THAN FOR WHICH IT IS FURNISHED.

SUBMITTALS:

DESCRIPTION	DATE	BY	REV
ISSUED FOR REVIEW	11/01/18	ET	0

APPLICANT SITE NAME:
CLEARY TOWER

APPLICANT SITE NUMBER:
CT0100001A

SITE ADDRESS:
**CLEARY TOWER (EDWARD)
 WOLCOTT, CT 06716**

SHEET DESCRIPTION:
**OVERALL
 SITE PLAN**

DWG INFORMATION: SHEET NUMBER:

DRAWN BY: ET	A-1.0
CHECKED BY: HC	

SBA SITE NAME: CLEARY TOWER
SBA SITE #: CT20021-A

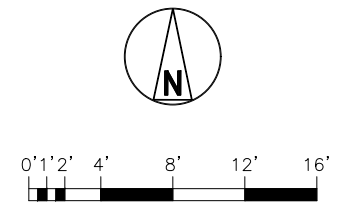

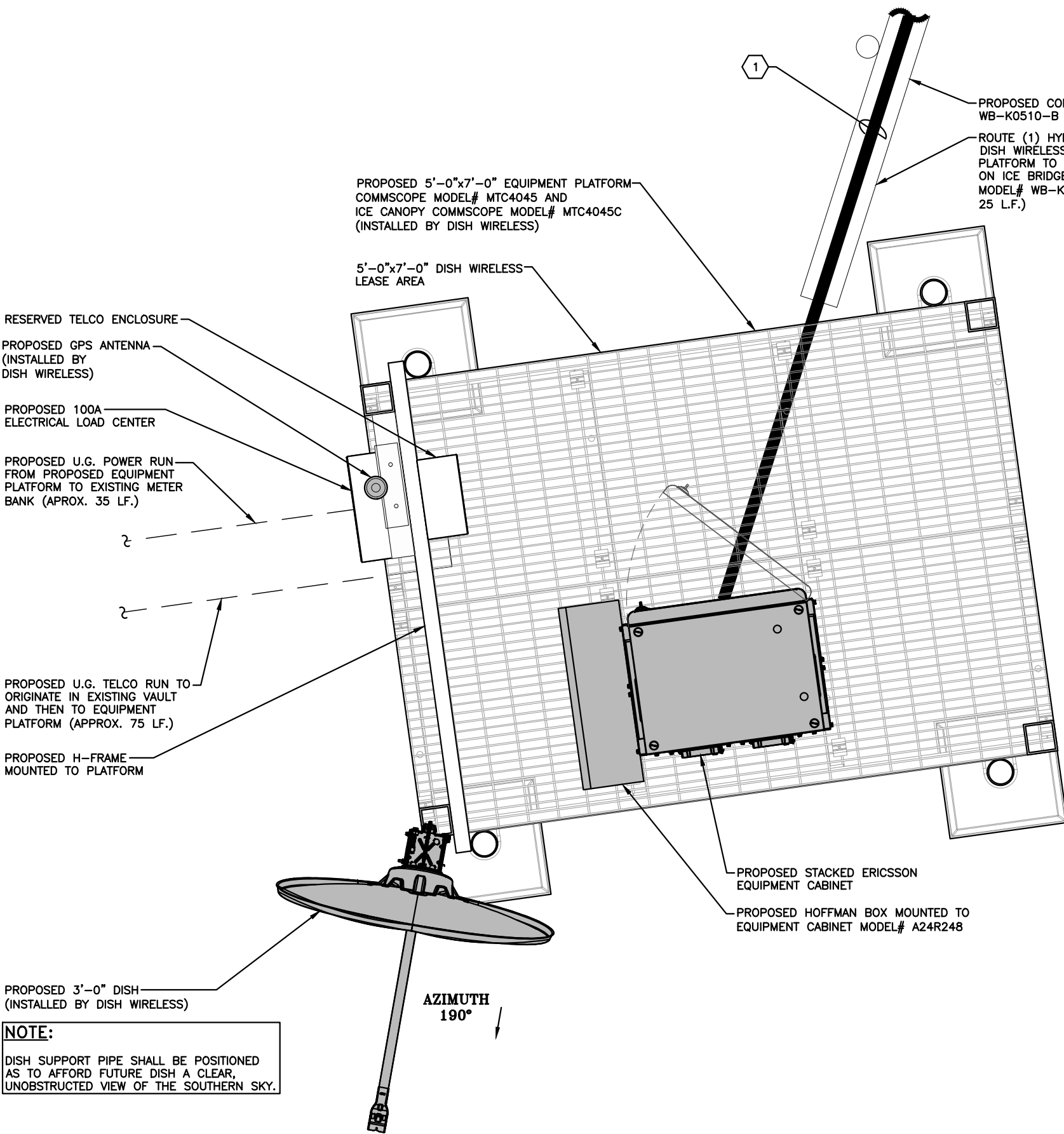

NOTE:
 DISH SUPPORT PIPE SHALL BE POSITIONED AS TO AFFORD FUTURE DISH A CLEAR, UNOBSTRUCTED VIEW OF THE SOUTHERN SKY.

KEYED NOTES:
 ① ROUTE (1) HYBRID CABLE ROUTED ON PROPOSED ICE BRIDGE FROM EQUIPMENT PLATFORM TO TOWER. CONTRACTOR SHALL WEATHER SEAL EACH END OF CONDUIT PER DISH WIRELESS SPECIFICATIONS AND REQUIREMENTS.

PROPOSED COMMSCOPE WB-K0510-B ICE BRIDGE
 ROUTE (1) HYBRID CABLE FROM DISH WIRELESS EQUIPMENT PLATFORM TO GUYED TOWER ROUTED ON ICE BRIDGE COMMSCOPE MODEL# WB-K0510-B (APPROX. 25 L.F.)

PROPOSED 5'-0"x7'-0" EQUIPMENT PLATFORM COMMSCOPE MODEL# MTC4045 AND ICE CANOPY COMMSCOPE MODEL# MTC4045C (INSTALLED BY DISH WIRELESS)

5'-0"x7'-0" DISH WIRELESS LEASE AREA

RESERVED TELCO ENCLOSURE

PROPOSED GPS ANTENNA (INSTALLED BY DISH WIRELESS)

PROPOSED 100A ELECTRICAL LOAD CENTER

PROPOSED U.G. POWER RUN FROM PROPOSED EQUIPMENT PLATFORM TO EXISTING METER BANK (APPROX. 35 L.F.)

PROPOSED U.G. TELCO RUN TO ORIGINATE IN EXISTING VAULT AND THEN TO EQUIPMENT PLATFORM (APPROX. 75 L.F.)

PROPOSED H-FRAME MOUNTED TO PLATFORM

PROPOSED STACKED ERICSSON EQUIPMENT CABINET

PROPOSED HOFFMAN BOX MOUNTED TO EQUIPMENT CABINET MODEL# A24R248

PROPOSED 3'-0" DISH (INSTALLED BY DISH WIRELESS)

AZIMUTH 190°

SBA SITE NAME: CLEARY TOWER
SBA SITE #: CT20021-A

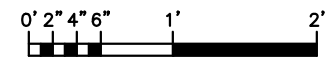

EQUIPMENT PLAN

1 1/2" = 1'-0" 1

PLANS PREPARED FOR:



PLANS PREPARED BY:



PRE-CONSTRUCTION APPROVALS:

DISH WIRELESS CONS. MANAGER	DATE
DISH WIRELESS OPS. MANAGER	DATE
DISH WIRELESS RF ENGINEER	DATE

POST-CONSTRUCTION APPROVALS:

DISH WIRELESS CONS. MANAGER	DATE
DISH WIRELESS OPS. MANAGER	DATE
DISH WIRELESS RF ENGINEER	DATE

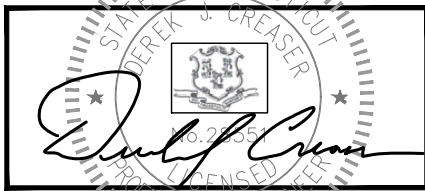

DRAWING NOTICE:
 THIS DRAWING HAS NOT BEEN PUBLISHED AND IS THE SOLE PROPERTY OF HDG, LLC, AND IS LENT TO THE BORROWER FOR THEIR CONFIDENTIAL USE ONLY, AND IN CONSIDERATION OF THE LOAN OF THIS DRAWING, THE BORROWER PROMISES AND AGREES THAT IT WILL NOT BE REPRODUCED, COPIED, LENT OR OTHERWISE DISPOSED OF DIRECTLY OR INDIRECTLY, NOR USED FOR ANY PURPOSE OTHER THAN FOR WHICH IT IS FURNISHED.

SUBMITTALS:

DESCRIPTION	DATE	BY	REV
ISSUED FOR REVIEW	11/01/18	ET	0

APPLICANT SITE NAME:
CLEARY TOWER

APPLICANT SITE NUMBER:
CT0100001A

SITE ADDRESS:
**CLEARY TOWER (EDWARD)
 WOLCOTT, CT 06716**

SHEET DESCRIPTION:
EQUIPMENT PLAN

DWG INFORMATION: SHEET NUMBER:
A-1.1

DRAWN BY: ET
 CHECKED BY: HC

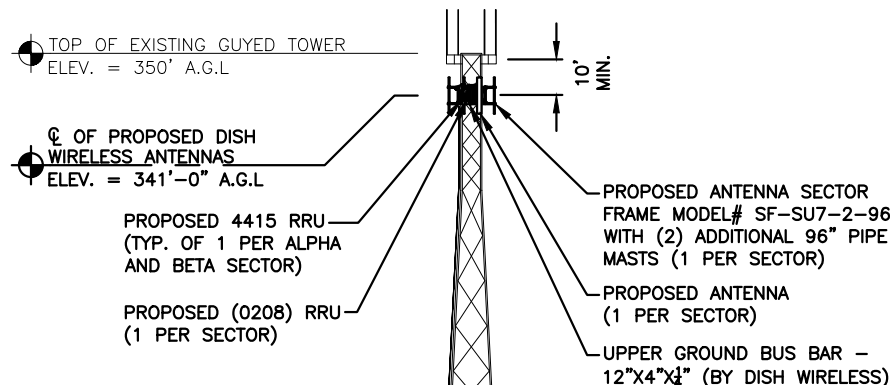

STRUCTURE INFORMATION IS SHOWN FOR ILLUSTRATIVE PURPOSES ONLY. STRUCTURAL INTEGRITY OF SUPPORTING STRUCTURES, ANTENNA MOUNTS, AND FOUNDATION SHALL BE VERIFIED AS ACCEPTABLE BY AN ENGINEER CERTIFIED STRUCTURAL ANALYSIS, UTILIZING THE NEW LOADING REPRESENTED WITHIN THESE DRAWINGS. PRIOR TO THE EXECUTION OF NEW LOADING CONTAINED IN THESE DRAWINGS CONTRACTOR SHALL OBTAIN ALL STRUCTURAL REPORTS AND FOLLOW ALL RECOMMENDATIONS.

ADDITIONAL GROUND BUS BAR - 12"x4"x1/4" @ 100' (TYP.) (BY DISH WIRELESS)

- NOTE:**
1. ALL CABLE SUPPORTS SHOULD BE BLOCKS WITH GROMMETS (NO SNAP-INS ALLOWED).
 2. SECTOR FRAMES AND ANTENNAS SHOULD HAVE IDENTIFYING TORQUE MARKS SHOWN AFTER INSTALLATION.

NOTE:
EXISTING EQUIPMENT ELEVATIONS ARE APPROXIMATE AND ARE FOR VISUAL REFERENCE ONLY. HDG RECOMMENDS A TOWER MAPPING TO BE PERFORMED TO OBTAIN EXISTING CARRIER ACCURATE RAD CENTER.

KEYED NOTES:

1. ROUTE (1) HYBRID CABLE ROUTED ON PROPOSED ICE BRIDGE FROM EQUIPMENT PLATFORM TO TOWER. CONTRACTOR SHALL WEATHER SEAL EACH END OF CONDUIT PER DISH WIRELESS SPECIFICATIONS AND REQUIREMENTS.

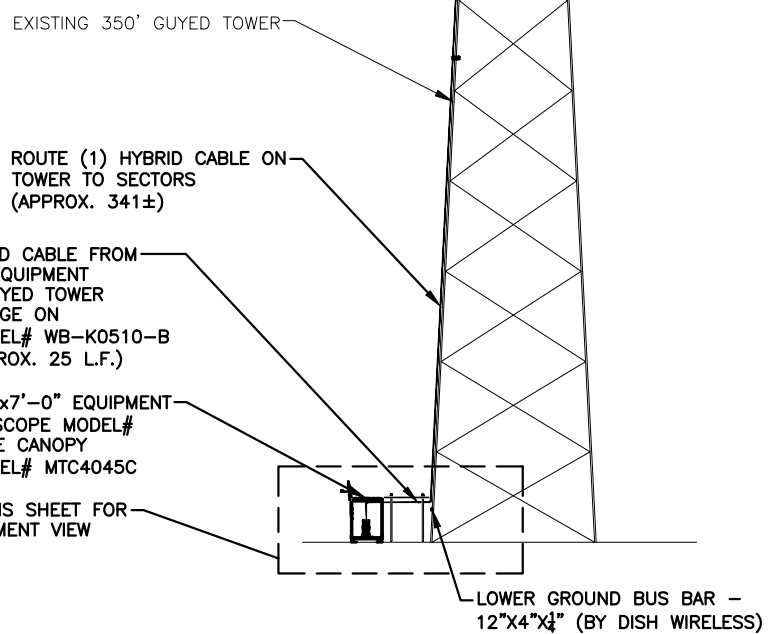

SBA SITE NAME: CLEARY TOWER
SBA SITE #: CT20021-A

RAD CENTER/FACE WIDTH:	
RAD CENTER	TOWER FACE WIDTH
341'-0"	4'-0"±

NOTE:
FACEWIDTH BASED ON SA BY: SBA,
DATED: AUGUST 22, 2018

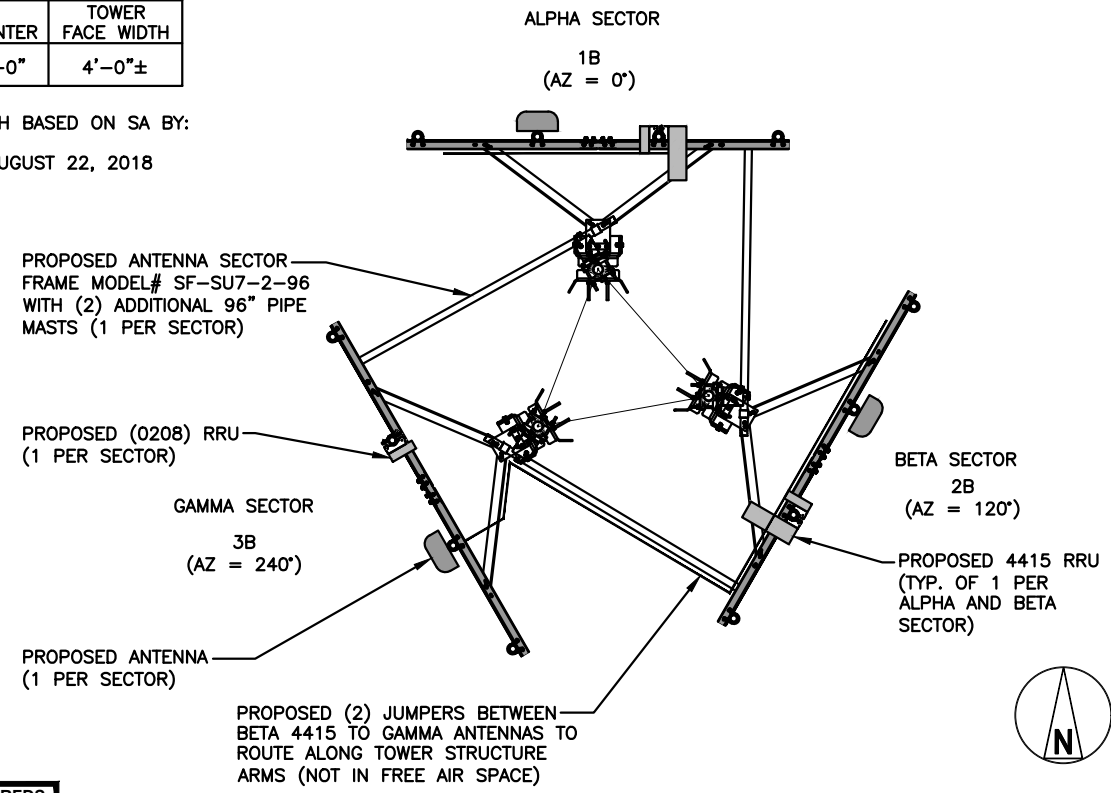

REFER TO RFDS
DATED: 10/09/18
REVISION 0.0

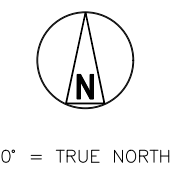

ANTENNA PLAN NO SCALE 2

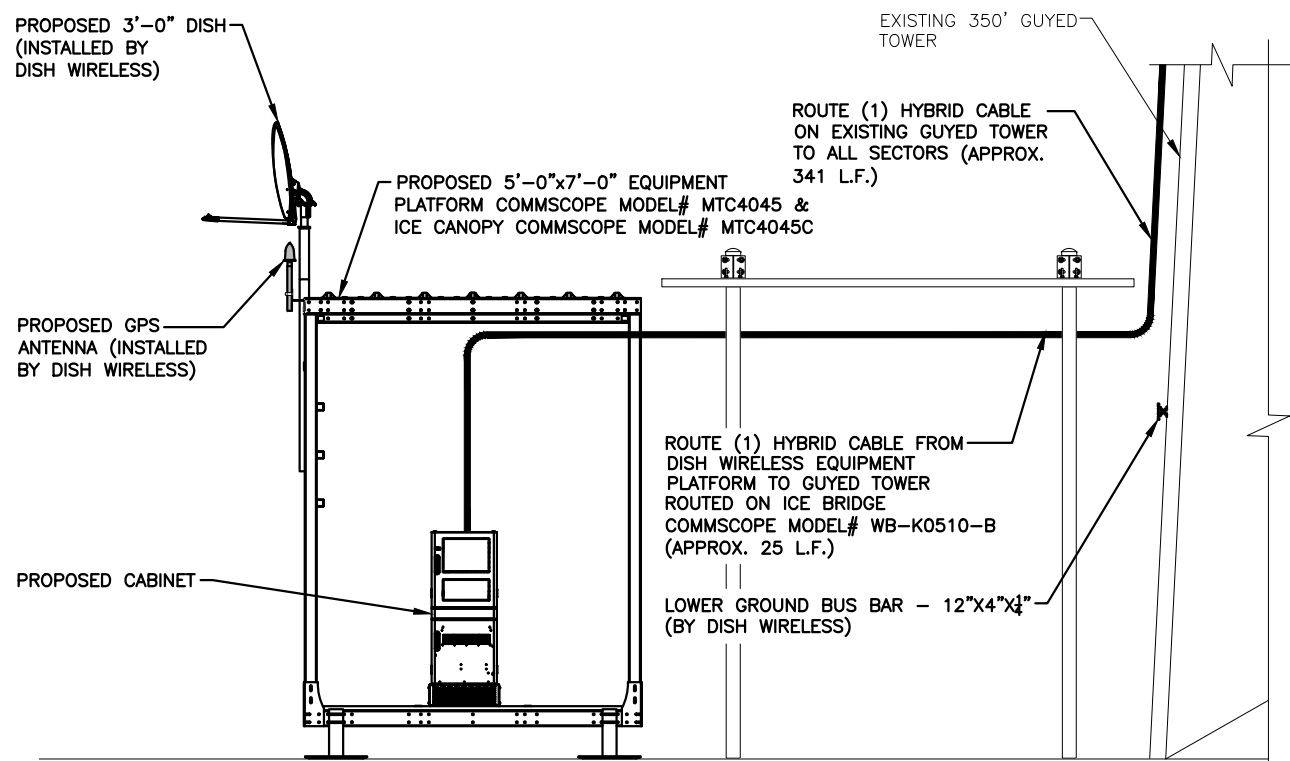

EQUIPMENT ELEVATION NO SCALE 3

PLANS PREPARED FOR:



PLANS PREPARED BY:



PRE-CONSTRUCTION APPROVALS:

DISH WIRELESS CONS. MANAGER	DATE
DISH WIRELESS OPS. MANAGER	DATE
DISH WIRELESS RF ENGINEER	DATE

POST-CONSTRUCTION APPROVALS:

DISH WIRELESS CONS. MANAGER	DATE
DISH WIRELESS OPS. MANAGER	DATE
DISH WIRELESS RF ENGINEER	DATE

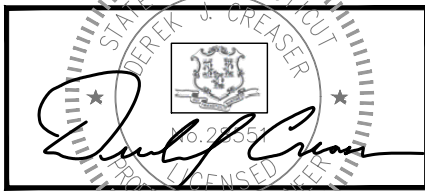

DRAWING NOTICE:
THIS DRAWING HAS NOT BEEN PUBLISHED AND IS THE SOLE PROPERTY OF HDG, LLC, AND IS LENT TO THE BORROWER FOR THEIR CONFIDENTIAL USE ONLY, AND IN CONSIDERATION OF THE LOAN OF THIS DRAWING, THE BORROWER PROMISES AND AGREES TO RETURN IT UPON REQUEST AND AGREES THAT IT WILL NOT BE REPRODUCED, COPIED, LENT OR OTHERWISE DISPOSED OF DIRECTLY OR INDIRECTLY, NOR USED FOR ANY PURPOSE OTHER THAN FOR WHICH IT IS FURNISHED.

SUBMITTALS:

DESCRIPTION	DATE	BY	REV
ISSUED FOR REVIEW	11/01/18	ET	0

APPLICANT SITE NAME:
CLEARY TOWER

APPLICANT SITE NUMBER:
CT0100001A

SITE ADDRESS:
**CLEARY TOWER (EDWARD)
WOLCOTT, CT 06716**

SHEET DESCRIPTION:
**TOWER ELEVATIONS &
ANTENNA PLAN**

DWG INFORMATION:

DRAWN BY:	ET	SHEET NUMBER:	A-2.0
CHECKED BY:	HC		

TOWER ELEVATION

NO SCALE

1

EQUIPMENT ELEVATION

NO SCALE

3

TYPICAL SECTOR

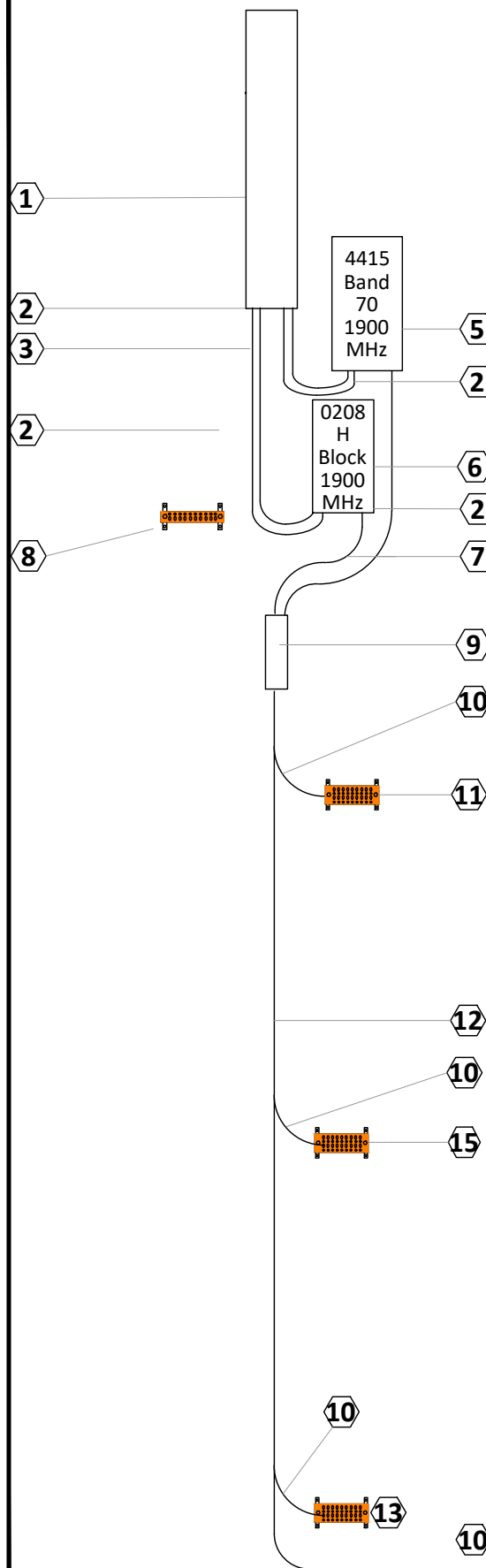

KEY NOTES

- 1 ANTENNA - COMBA OD12-065R18K-GQ- (DISH PROVIDED)
- 2 CLAMSHELL WEATHER PROOFING (CONTRACTOR PROVIDED)
- 3 PROPOSED (6 EA.) 1/2" COAX JUMPERS FROM RRUS TO ANTENNA - (DISH PROVIDED) - VARIABLE LENGTHS
- 4 RRU - E2 BAND 29 700 MHZ - NOT USED
- 5 RRU - 4415 BAND 70 1900 MHZ- (DISH PROVIDED)
- 6 RRU - 0208 H BLOCK 1900 MHZ - (DISH PROVIDED)
- 7 DC/FIBER JUMPER CABLES (BREAKOUT CYLINDER TO RRU)
- 8 SECTOR GROUND BUS BAR - 12"x2"x1/4" (DISH PROVIDED)
- 9 FIBER/POWER BREAKOUT CYLINDER
- 10 GROUND KIT ON HYBRID CABLE AND EACH RF CABLE
- 11 UPPER TOWER GROUND BUS BAR - 12"x4"x1/4" (DISH PROVIDED)
- 12 HYBRID CABLE
- 13 LOWER TOWER GROUND BUS BAR - 12"x4"x1/4" (DISH PROVIDED)
- 14 EQUIPMENT GROUND BUS BAR - 12"x4"x1/4" (DISH PROVIDED)
- 15 ADD ADDITIONAL BUS BARS AND GROUND KITS ON TOWER IN 50, 100, OR 200-FOOT INCREMENTS BASED ON TOWER HEIGHT AND LIGHTNING ZONE

ANTENNA SCHEDULE

SECTOR	ANTENNA MANUFACTURER	HYBRID CABLES	AZIMUTH	RAD CENTER	MECH D-TILT	ELECT D-TILT	RRU MANUFACTURER	RRU TECHNOLOGY	RRU LOCATION	JUMPER SIZE	JUMPER QTY	JUMPER LENGTH	RET JUMPER LENGTH
ALPHA 1	N/A	N/A	N/A	N/A	N/A	N/A	N/A	N/A	N/A	N/A	N/A	N/A	N/A
ALPHA 2	COMBA OD12-065R18K-GQ 53.5 X 9.8 X 2.4	DSHYBKIT-18612-10M - 7/8"φ	0°	341'-0"	0°	1°	N/A	N/A	N/A	N/A	N/A	N/A	N/A
ALPHA 3	N/A	N/A	N/A	N/A	N/A	N/A	(1) ERICSSON (0208) (1) ERICSSON (4415)	H BLOCK BAND 70	SECTOR SECTOR	1/2" 1/2"	2 2	6'-0" 6'-0"	N/A 4'-0"
ALPHA 4	N/A	N/A	N/A	N/A	N/A	N/A	N/A	N/A	N/A	N/A	N/A	N/A	N/A
BETA 1	N/A	N/A	N/A	N/A	N/A	N/A	N/A	N/A	N/A	N/A	N/A	N/A	N/A
BETA 2	COMBA OD12-065R18K-GQ 53.5 X 9.8 X 2.4	SHARE WITH ALPHA	120°	341'-0"	0°	1°	N/A	N/A	N/A	N/A	N/A	N/A	N/A
BETA 3	N/A	N/A	N/A	N/A	N/A	N/A	(1) ERICSSON (0208) (1) ERICSSON (4415)	H BLOCK BAND 70	SECTOR SECTOR	1/2" 1/2"	2 2	6'-0" 6'-0"	N/A 4'-0"
BETA 4	N/A	N/A	N/A	N/A	N/A	N/A	N/A	N/A	N/A	N/A	N/A	N/A	N/A
GAMMA 1	N/A	N/A	N/A	N/A	N/A	N/A	N/A	N/A	N/A	N/A	N/A	N/A	N/A
GAMMA 2	COMBA OD12-065R18K-GQ 53.5 X 9.8 X 2.4	SHARE WITH ALPHA	240°	341'-0"	0°	3°	N/A	N/A	N/A	N/A	N/A	N/A	N/A
GAMMA 3	N/A	N/A	N/A	N/A	N/A	N/A	(1) ERICSSON (0208)	H BLOCK	SECTOR	1/2"	2	6'-0"	16'-0"
GAMMA 4	N/A	N/A	N/A	N/A	N/A	N/A	N/A	N/A	N/A	N/A	N/A	N/A	N/A

TYPICAL SECTOR ANTENNA and RRU MOUNTING

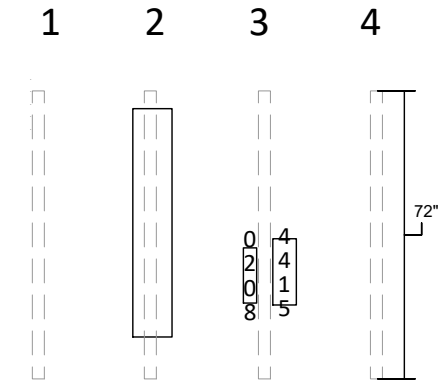
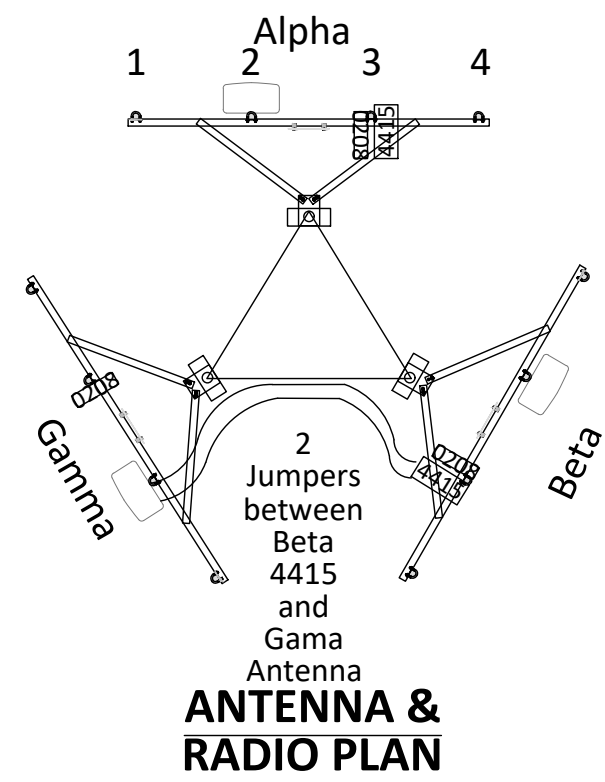

Comba OD12-065R18K-GQ
Antenna - 25.1 lbs. (11.4 kg)
Mount - 2.8 lbs. (6.2 kg)

0208 H Block 1900 MHz	4415 Band 70 1900 MHz
-----------------------------------	-----------------------------------

19.84 lbs. (9 kg) | 46 lbs. (21 kg)
Weight, excl. mounting hardware

PLANS PREPARED FOR:



PLANS PREPARED BY:



PRE-CONSTRUCTION APPROVALS:

DISH WIRELESS CONS. MANAGER	DATE
DISH WIRELESS OPS. MANAGER	DATE
DISH WIRELESS RF ENGINEER	DATE

POST-CONSTRUCTION APPROVALS:

DISH WIRELESS CONS. MANAGER	DATE
DISH WIRELESS OPS. MANAGER	DATE
DISH WIRELESS RF ENGINEER	DATE

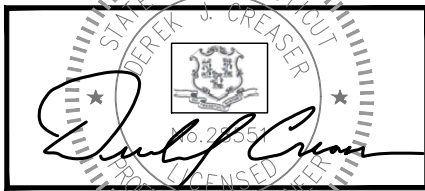

DRAWING NOTICE:
THIS DRAWING HAS NOT BEEN PUBLISHED AND IS THE SOLE PROPERTY OF HDG, LLC, AND IS LENT TO THE BORROWER FOR THEIR CONFIDENTIAL USE ONLY, AND IN CONSIDERATION OF THE LOAN OF THIS DRAWING, THE BORROWER PROMISES AND AGREES TO RETURN IT UPON REQUEST AND AGREES THAT IT WILL NOT BE REPRODUCED, COPIED, LENT OR OTHERWISE DISPOSED OF DIRECTLY OR INDIRECTLY, NOR USED FOR ANY PURPOSE OTHER THAN FOR WHICH IT IS FURNISHED.

SUBMITTALS:	DESCRIPTION	DATE	BY	REV
ISSUED FOR REVIEW		11/01/18	ET	0

APPLICANT SITE NAME:
CLEARY TOWER

APPLICANT SITE NUMBER:
CT0100001A

SITE ADDRESS:
**CLEARY TOWER (EDWARD)
WOLCOTT, CT 06716**

SHEET DESCRIPTION:
**ANTENNA SCHEDULE
& DIAGRAM**

DWG INFORMATION: DRAWN BY: ET
CHECKED BY: HC

SHEET NUMBER:
A-3.0

CABINET	DIMENSIONS	WEIGHT FULLY LOADED
CABINET	23.86"Wx18.90"Dx63.13"H	382.4 lbs
DISH	3'-0"Ø	28 lbs

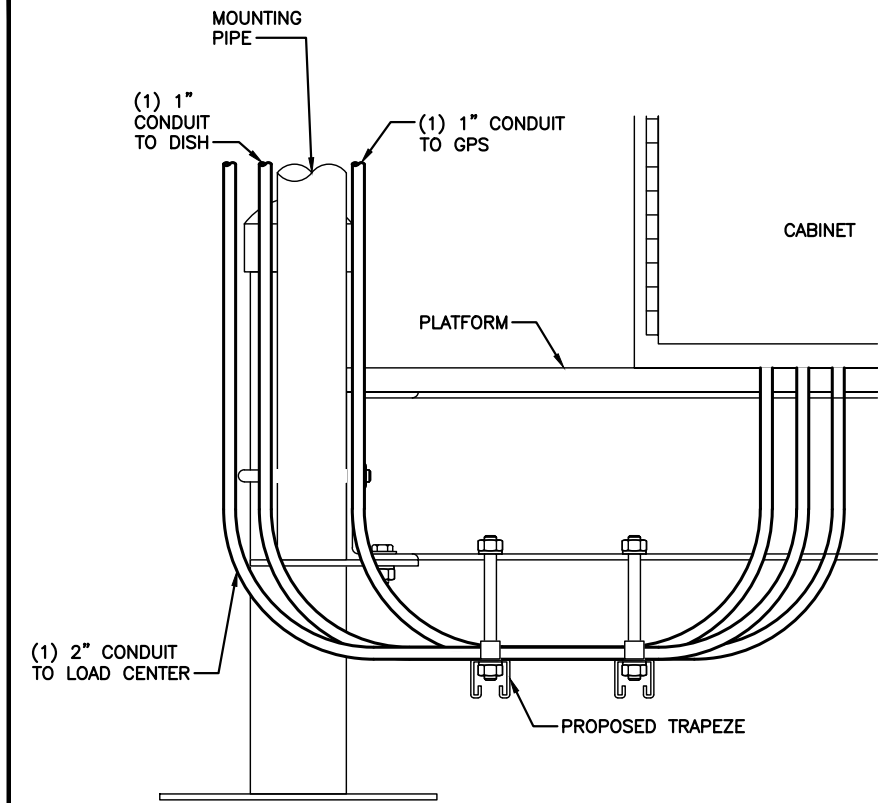
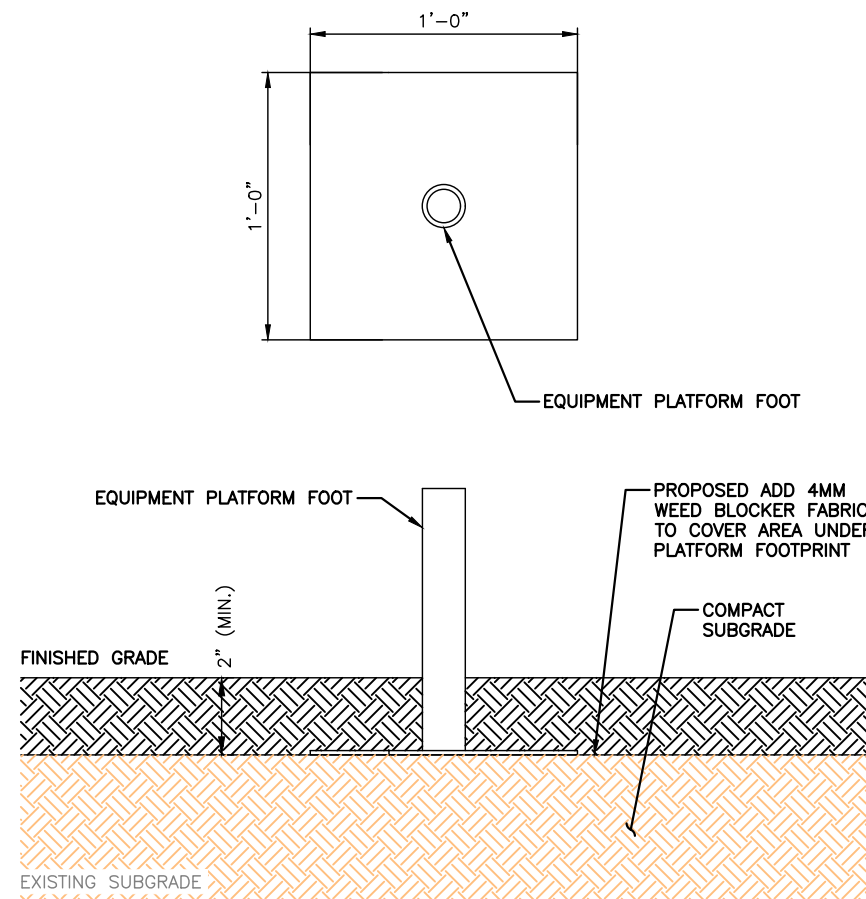

PLANS PREPARED FOR:

PLANS PREPARED BY:

 45 BEECHWOOD DRIVE TEL: (978) 557-5553
 N. ANDOVER, MA 01845 FAX: (978) 336-5586

PRE-CONSTRUCTION APPROVALS:

DISH WIRELESS CONS. MANAGER	DATE
DISH WIRELESS OPS. MANAGER	DATE
DISH WIRELESS RF ENGINEER	DATE

POST-CONSTRUCTION APPROVALS:

DISH WIRELESS CONS. MANAGER	DATE
DISH WIRELESS OPS. MANAGER	DATE
DISH WIRELESS RF ENGINEER	DATE

EQUIPMENT LOADING

NO SCALE

1

EQUIPMENT PLATFORM FOOT DETAIL

NO SCALE

2

CONDUIT RUNS UNDER PLATFORM

NO SCALE

3

Alpha Sector			Technology	
(+) Port (TX)	Technology		700 MHz	Orange
Antenna/RRH-1	600 Mhz	White	Black	White
Antenna/RRH-2	White	Black	White	Black
Antenna/RRH-3	White	Black	White	Black
(-) Port (RX)				
Antenna/RRH-1	White	Black	White	Black
Antenna/RRH-2	White	Black	White	Black
Antenna/RRH-3	White	Black	White	Black
Beta Sector				
(+) Port (TX)				
Antenna/RRH-1	White	Blue	Black	White
Antenna/RRH-2	White	Blue	Black	White
Antenna/RRH-3	White	Blue	Black	White
(-) Port (RX)				
Antenna/RRH-1	White	Blue	Black	White
Antenna/RRH-2	White	Blue	Black	White
Antenna/RRH-3	White	Blue	Black	White
Gamma Sector				
(+) Port (TX)				
Antenna/RRH-1	White	Green	Black	White
Antenna/RRH-2	White	Green	Black	White
Antenna/RRH-3	White	Green	Black	White
(-) Port (RX)				
Antenna/RRH-1	White	Green	Black	White
Antenna/RRH-2	White	Green	Black	White
Antenna/RRH-3	White	Green	Black	White

FEEDLINE/JUMPER COLOR CODE

NO SCALE

4

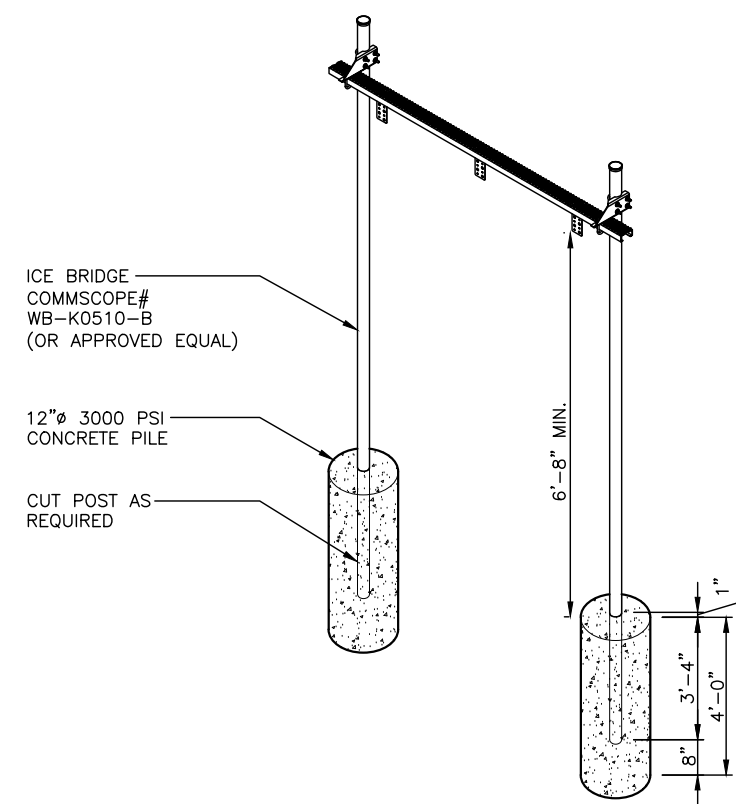

ICE BRIDGE DETAIL

NO SCALE

5

DRAWING NOTICE:
 THIS DRAWING HAS NOT BEEN PUBLISHED AND IS THE SOLE PROPERTY OF HDG, LLC, AND IS LENT TO THE BORROWER FOR THEIR CONFIDENTIAL USE ONLY, AND IN CONSIDERATION OF THE LOAN OF THIS DRAWING, THE BORROWER PROMISES AND AGREES TO RETURN IT UPON REQUEST AND AGREES THAT IT WILL NOT BE REPRODUCED, COPIED, LENT OR OTHERWISE DISPOSED OF DIRECTLY OR INDIRECTLY, NOR USED FOR ANY PURPOSE OTHER THAN FOR WHICH IT IS FURNISHED.

SUBMITTALS:

DESCRIPTION	DATE	BY	REV
ISSUED FOR REVIEW	11/01/18	ET	0

APPLICANT SITE NAME:
CLEARY TOWER

APPLICANT SITE NUMBER:
CT0100001A

SITE ADDRESS:
**CLEARY TOWER (EDWARD)
 WOLCOTT, CT 06716**

SHEET DESCRIPTION:
**EQUIPMENT DETAILS
 (1 OF 3)**

DWG INFORMATION: DRAWN BY: ET
 CHECKED BY: HC

SHEET NUMBER:
A-4.0

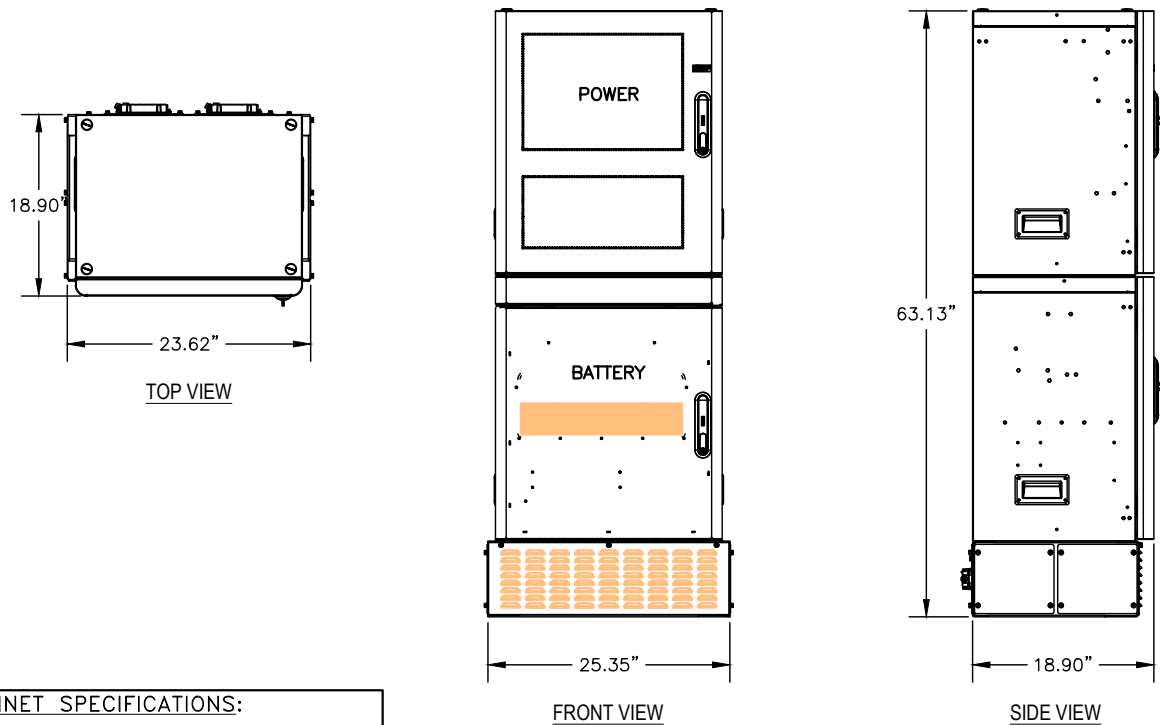

CABINET SPECIFICATIONS:
 DIMENSIONS HxWxD: 63.13"x23.86"x18.90"
 FULLY LOADED WEIGHT: 382.4lbs

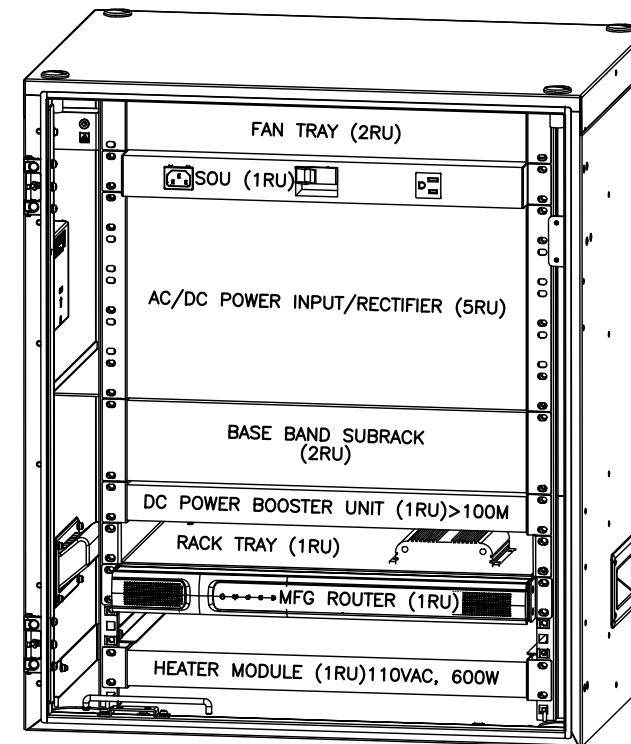

PLANS PREPARED FOR:



PLANS PREPARED BY:



45 BEECHWOOD DRIVE TEL: (978) 557-5553
 N. ANDOVER, MA 01845 FAX: (978) 336-5586

PRE-CONSTRUCTION APPROVALS:

DISH WIRELESS CONS. MANAGER DATE
 DISH WIRELESS OPS. MANAGER DATE
 DISH WIRELESS RF ENGINEER DATE

POST-CONSTRUCTION APPROVALS:

DISH WIRELESS CONS. MANAGER DATE
 DISH WIRELESS OPS. MANAGER DATE
 DISH WIRELESS RF ENGINEER DATE

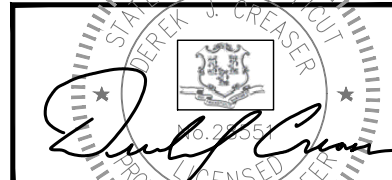

EQUIPMENT CABINET DETAIL

NO SCALE

1

EQUIPMENT CABINET - POWER

NO SCALE

2

NOTE:
 GPS TO BE MOUNTED WITH
 SOUTHWESTERN EXPOSURE,
 10' (MIN.) FROM EXISTING
 GPS ANTENNA.

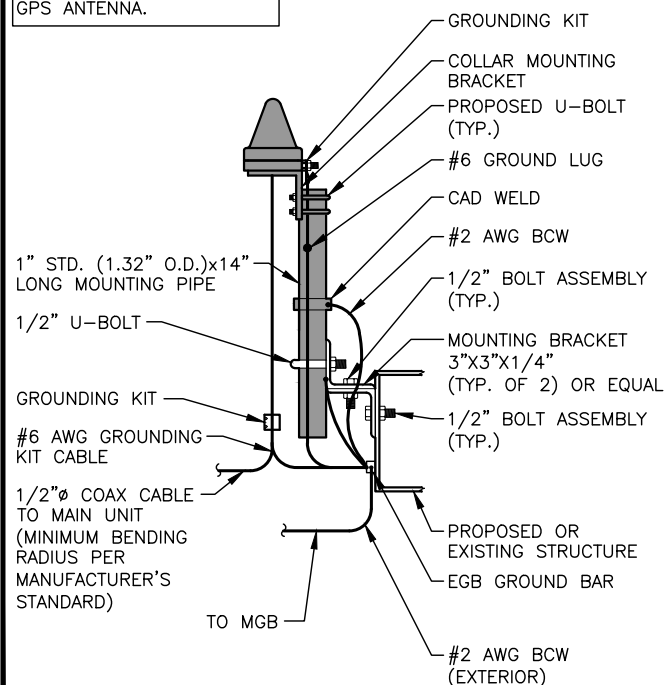

HOFFMAN BOX SPECIFICATIONS:
 DIMENSIONS HxWxD: 24.0"x24.0"x8.0"

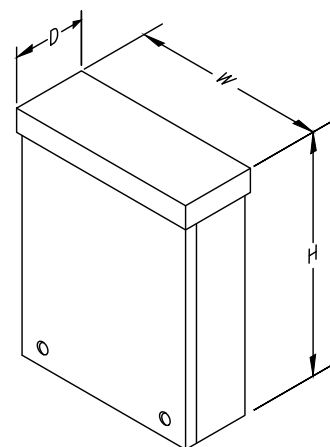

GPS MOUNTING DETAIL

NO SCALE

3

HOFFMAN BOX

NO SCALE

4

FRONT

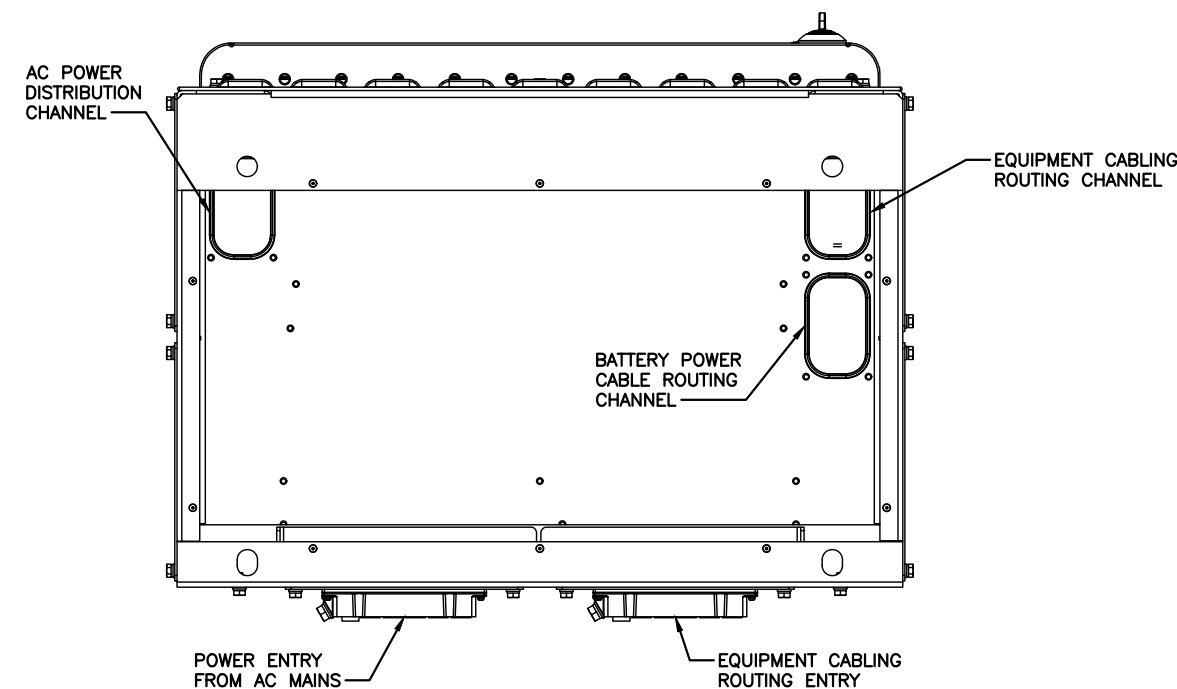

DRAWING NOTICE:
 THIS DRAWING HAS NOT BEEN PUBLISHED AND IS THE
 SOLE PROPERTY OF HDG, LLC, AND IS LENT TO THE
 BORROWER FOR THEIR CONFIDENTIAL USE ONLY, AND IN
 CONSIDERATION OF THE LOAN OF THIS DRAWING, THE
 BORROWER PROMISES AND AGREES TO RETURN IT UPON
 REQUEST AND AGREES THAT IT WILL NOT BE REPRODUCED,
 COPIED, LENT OR OTHERWISE DISPOSED OF DIRECTLY OR
 INDIRECTLY, NOR USED FOR ANY PURPOSE OTHER THAN
 FOR WHICH IT IS FURNISHED.

SUBMITTALS:	DESCRIPTION	DATE	BY	REV
ISSUED FOR REVIEW		11/01/18	ET	0

APPLICANT SITE NAME:

CLEARY TOWER

APPLICANT SITE NUMBER:

CT0100001A

SITE ADDRESS:

CLEARY TOWER (EDWARD)
 WOLCOTT, CT 06716

SHEET DESCRIPTION:

EQUIPMENT DETAILS
 (2 OF 3)

DWG INFORMATION:

DRAWN BY: ET
 CHECKED BY: HC

SHEET NUMBER:

A-4.1

EQUIPMENT CABINET BOTTOM VIEW

NO SCALE

5

ANTENNA SPECIFICATIONS:

DIMENSIONS HxWxD:
53.5 X 9.8 X 2.4
WEIGHT:
51.6lbs
CONNECTORS:
(6) 4.3-10 FEMALE

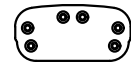

BOTTOM VIEW

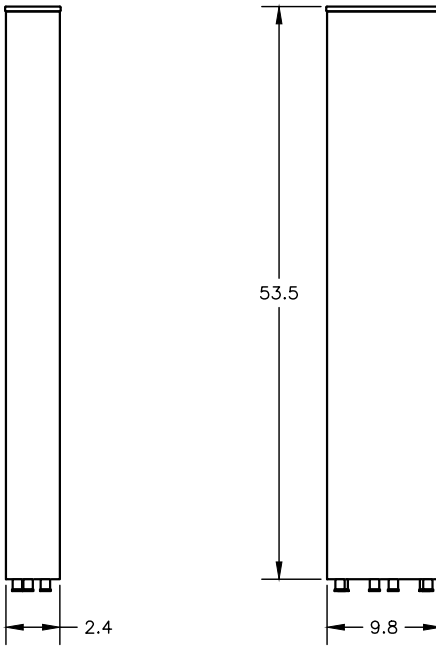

FRONT VIEW

SIDE VIEW

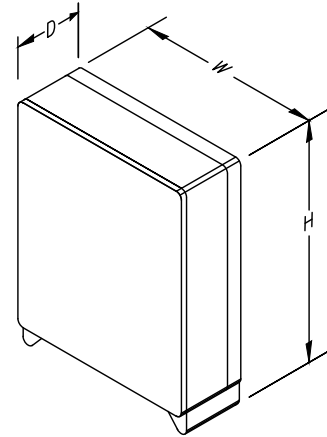

RRU SPECIFICATIONS 0208:

DIMENSIONS HxWxD: 13.8"x11.7"x3.3"
WEIGHT: 18.5lbs

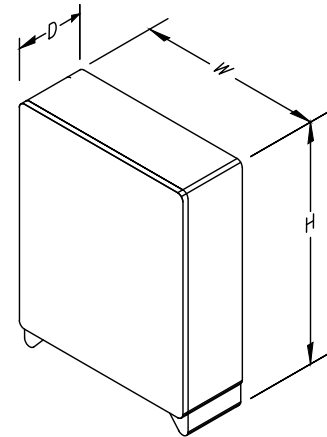

RRU SPECIFICATIONS 4415:

DIMENSIONS HxWxD: 16.5"x13.5"x6.3"
WEIGHT: 47.4lbs

PLANS PREPARED FOR:



PLANS PREPARED BY:



45 BEECHWOOD DRIVE TEL: (978) 557-5553
N. ANDOVER, MA 01845 FAX: (978) 336-5586

PRE-CONSTRUCTION APPROVALS:

DISH WIRELESS CONS. MANAGER	DATE
DISH WIRELESS OPS. MANAGER	DATE
DISH WIRELESS RF ENGINEER	DATE

POST-CONSTRUCTION APPROVALS:

DISH WIRELESS CONS. MANAGER	DATE
DISH WIRELESS OPS. MANAGER	DATE
DISH WIRELESS RF ENGINEER	DATE

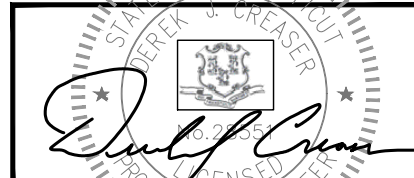

ANTENNA DETAIL

NO SCALE

1

700 RRU DETAIL

NO SCALE

2

700 RRU DETAIL

NO SCALE

3

NOT USED

4

DRAWING NOTICE:
THIS DRAWING HAS NOT BEEN PUBLISHED AND IS THE SOLE PROPERTY OF HDG, LLC, AND IS LENT TO THE BORROWER FOR THEIR CONFIDENTIAL USE ONLY, AND IN CONSIDERATION OF THE LOAN OF THIS DRAWING, THE BORROWER PROMISES AND AGREES TO RETURN IT UPON REQUEST AND AGREES THAT IT WILL NOT BE REPRODUCED, COPIED, LENT OR OTHERWISE DISPOSED OF DIRECTLY OR INDIRECTLY, NOR USED FOR ANY PURPOSE OTHER THAN FOR WHICH IT IS FURNISHED.

SUBMITTALS:

DESCRIPTION	DATE	BY	REV
ISSUED FOR REVIEW	11/01/18	ET	0

APPLICANT SITE NAME:

CLEARY TOWER

APPLICANT SITE NUMBER:

CT0100001A

SITE ADDRESS:

CLEARY TOWER (EDWARD)
WOLCOTT, CT 06716

SHEET DESCRIPTION:

EQUIPMENT DETAILS
(3 OF 3)

DWG INFORMATION:

DRAWN BY: ET
CHECKED BY: HC

SHEET NUMBER:

A-4.2

ANTENNA MOUNTING BRACKET

PROPOSED ANTENNA
SECTOR FRAME PART#
SF-SU7-2-96 WITH
(2) PIPE MASTS
(1 PER SECTOR)

EXISTING
TOWER

RRU MOUNTING KIT
ON PIPE MOUNT
ANTENNA

RRU (TYP.)

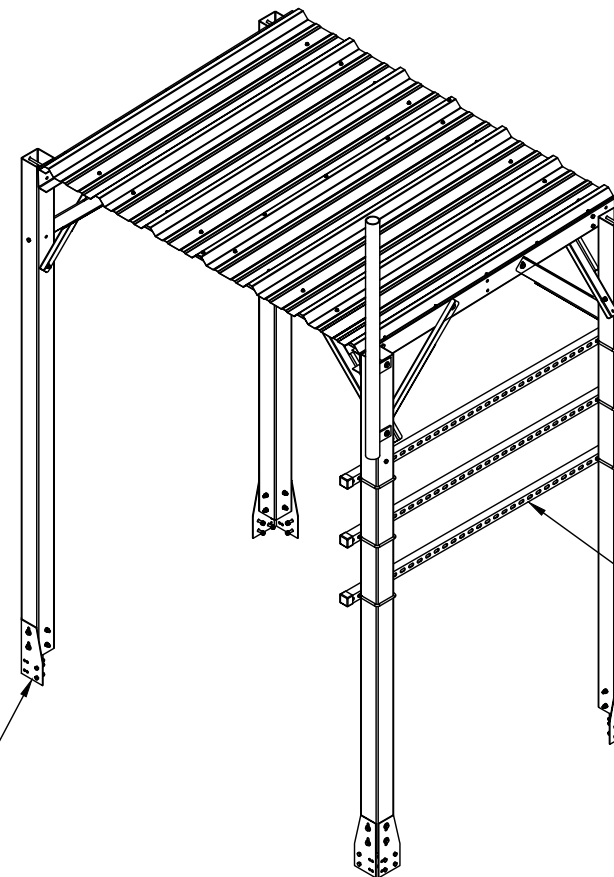
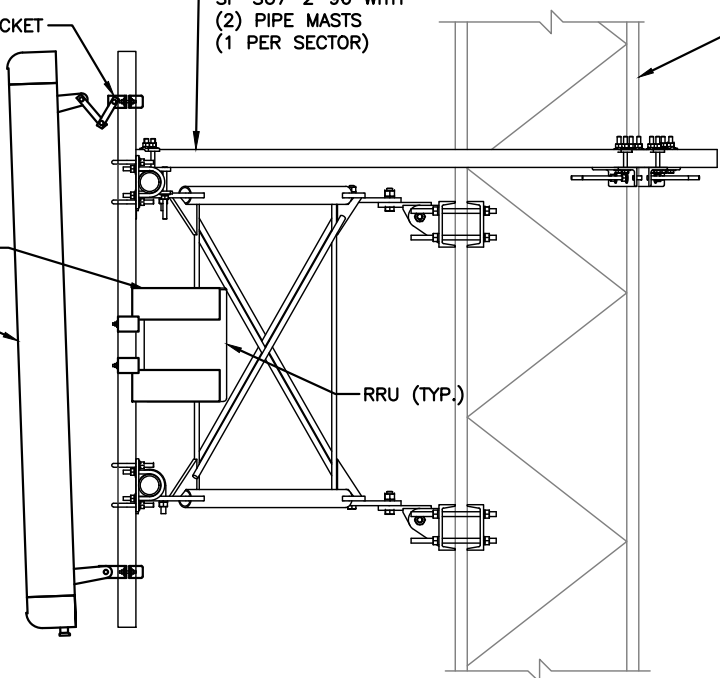

PROPOSED CANOPY

H-FRAME

CANOPY LEG SUPPORT

ANTENNA MOUNTING DETAIL

NO SCALE

5

MTC 4045C CANOPY DETAIL

NO SCALE

6

KEYED NOTES:

- 1 PROPOSED TELCO U.G. RUN TO ORIGINATE IN EXISTING VAULT TO PROPOSED EQUIPMENT
- 2 PROPOSED POWER U.G. RUN FROM EXISTING METER BANK TO PROPOSED EQUIPMENT.
- 3 PROPOSED (1) 2" CONDUITS FOR POWER FROM LOAD CENTER TO ERICSSON POWER CABINET.
- 4 PROPOSED 1" CONDUIT FROM DISH ANTENNA TO ERICSSON POWER CABINET.
- 5 PROPOSED 1" CONDUIT FROM LOAD CENTER TO ERICSSON BATTERY CABINET GFCI RECEPTACLE

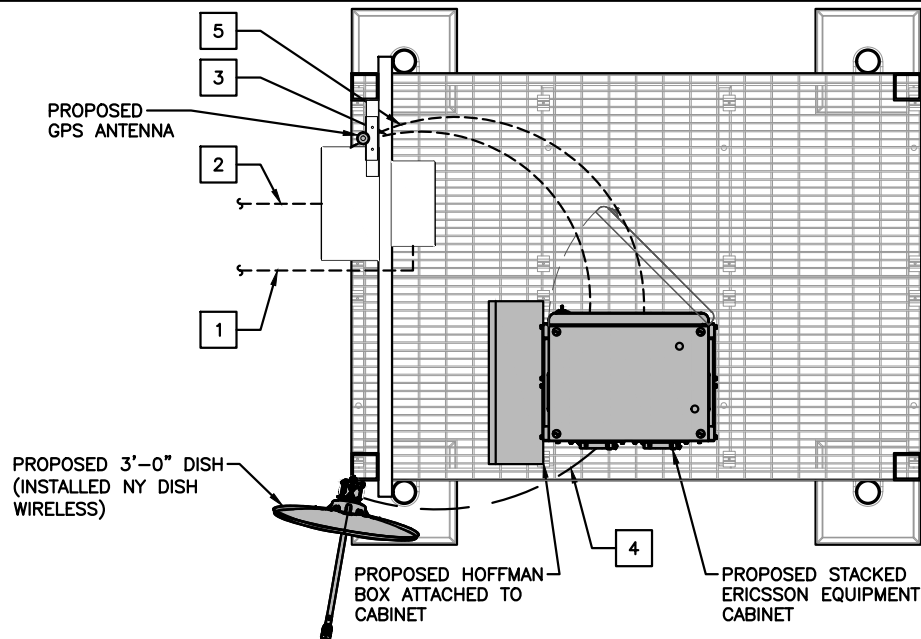

ENLARGED UTILITY EQUIPMENT PLATFORM

NO SCALE

1

EXISTING POWER SOURCE
(120/240V, 1 ϕ , 3W)

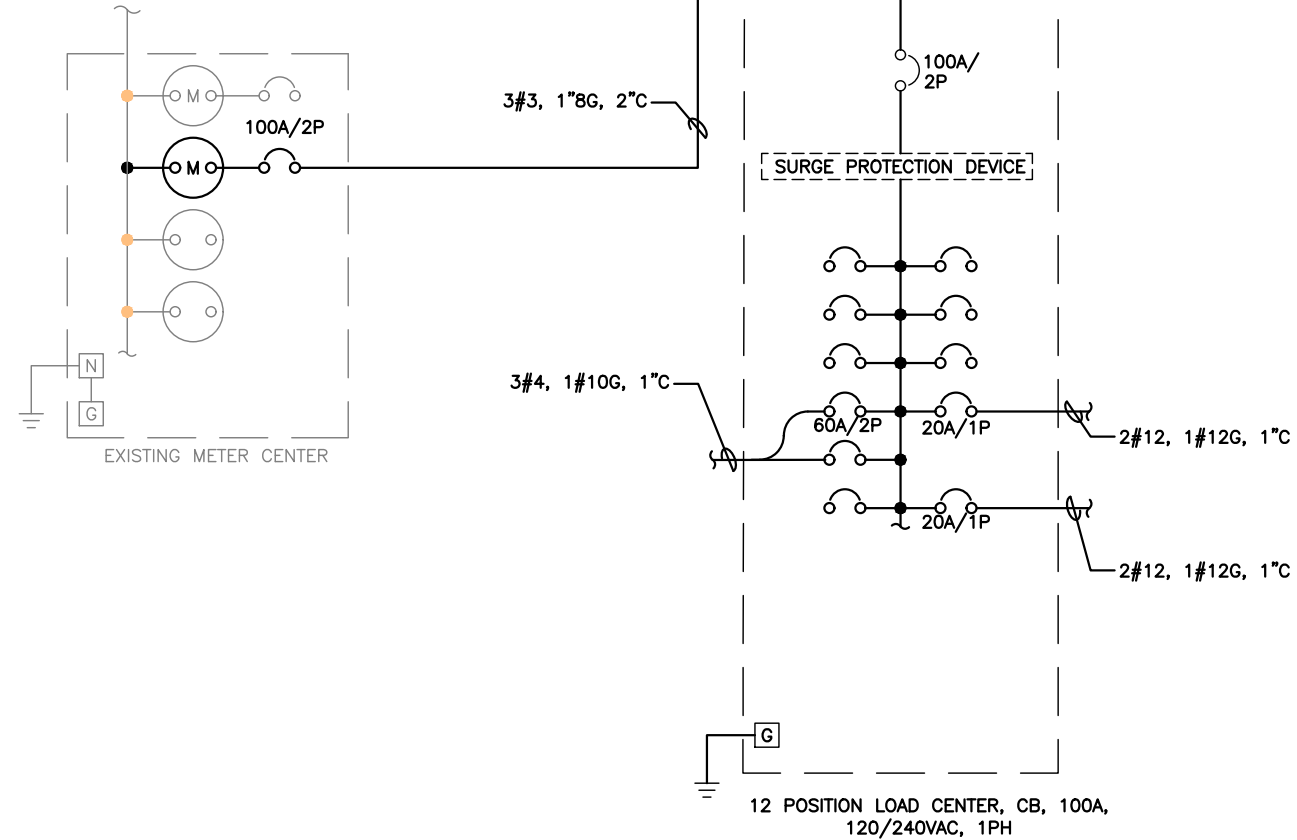

ELECTRICAL ONE-LINE DIAGRAM

NO SCALE

2

DETAIL NOT USED

NO SCALE

3

NO SCALE

4

PLANS PREPARED FOR:



PLANS PREPARED BY:



PRE-CONSTRUCTION APPROVALS:

DISH WIRELESS CONS. MANAGER	DATE
DISH WIRELESS OPS. MANAGER	DATE
DISH WIRELESS RF ENGINEER	DATE

POST-CONSTRUCTION APPROVALS:

DISH WIRELESS CONS. MANAGER	DATE
DISH WIRELESS OPS. MANAGER	DATE
DISH WIRELESS RF ENGINEER	DATE

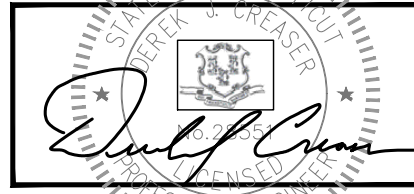

DRAWING NOTICE:
THIS DRAWING HAS NOT BEEN PUBLISHED AND IS THE SOLE PROPERTY OF HDG, LLC, AND IS LENT TO THE BORROWER FOR THEIR CONFIDENTIAL USE ONLY, AND IN CONSIDERATION OF THE LOAN OF THIS DRAWING, THE BORROWER PROMISES AND AGREES TO RETURN IT UPON REQUEST AND AGREES THAT IT WILL NOT BE REPRODUCED, COPIED, LENT OR OTHERWISE DISPOSED OF DIRECTLY OR INDIRECTLY, NOR USED FOR ANY PURPOSE OTHER THAN FOR WHICH IT IS FURNISHED.

SUBMITTALS:

DESCRIPTION	DATE	BY	REV
ISSUED FOR REVIEW	11/01/18	ET	0

APPLICANT SITE NAME:
CLEARY TOWER

APPLICANT SITE NUMBER:
CT0100001A

SITE ADDRESS:
**CLEARY TOWER (EDWARD)
WOLCOTT, CT 06716**

SHEET DESCRIPTION:
**ELECTRICAL DETAILS &
ONE-LINE DIAGRAM**

DWG INFORMATION: DRAWN BY: **ET**
CHECKED BY: **HC**

SHEET NUMBER:
E-1.0



DISH WIRELESS CONS. MANAGER	DATE
DISH WIRELESS OPS. MANAGER	DATE
DISH WIRELESS RF ENGINEER	DATE

DISH WIRELESS CONS. MANAGER	DATE
DISH WIRELESS OPS. MANAGER	DATE
DISH WIRELESS RF ENGINEER	DATE

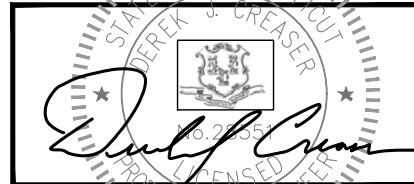

DRAWING NOTICE:
 THIS DRAWING HAS NOT BEEN PUBLISHED AND IS THE SOLE PROPERTY OF HGD, LLC, AND IS LENT TO THE BORROWER FOR THEIR CONFIDENTIAL USE ONLY, AND IN CONSIDERATION OF THE LOAN OF THIS DRAWING, THE BORROWER PROMISES AND AGREES TO RETURN IT UPON REQUEST AND AGREES THAT IT WILL NOT BE REPRODUCED, COPIED, LENT OR OTHERWISE DISPOSED OF DIRECTLY OR INDIRECTLY, NOR USED FOR ANY PURPOSE OTHER THAN FOR WHICH IT IS FURNISHED.

SUBMITTALS:

DESCRIPTION	DATE	BY	REV
ISSUED FOR REVIEW	11/01/18	ET	0

APPLICANT SITE NAME:
CLEARY TOWER

APPLICANT SITE NUMBER:
CT0100001A

SITE ADDRESS:
**CLEARY TOWER (EDWARD)
 WOLCOTT, CT 06716**

SHEET DESCRIPTION:
GROUNDING PLAN

DWG INFORMATION:	SHEET NUMBER:
DRAWN BY: ET CHECKED BY: HC	G-1.0

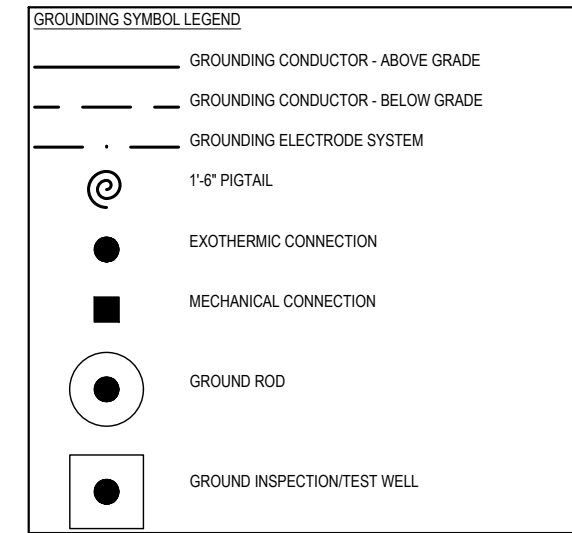

NOTE:
 ALL CONNECTIONS TO BE MECHANICAL ON TOWER.
 EXOTHERMIC WELDS ARE NOT ALLOWED.

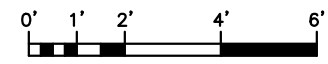
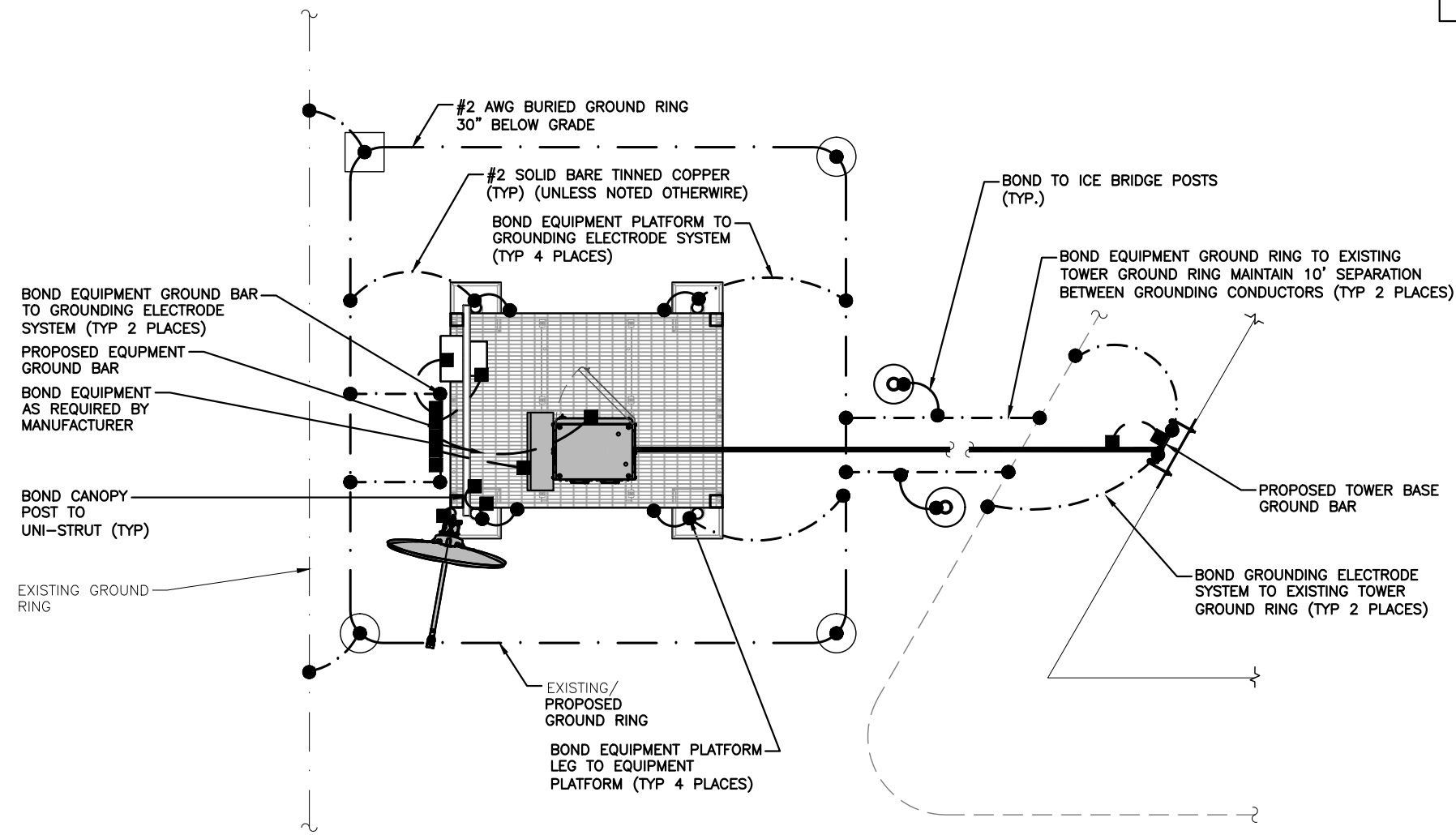

LEGEND:

—	GROUND CONDUCTOR
●	EXOTHERMIC WELD
■	MECHANICAL CONNECTION
≡	GROUND ROD

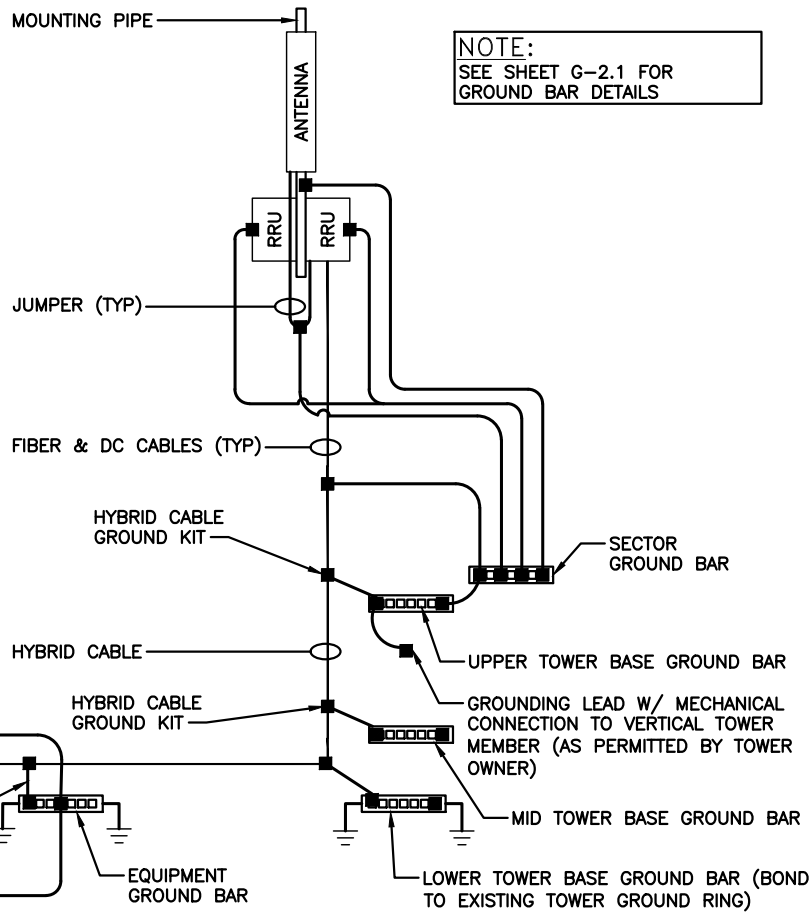

GROUNDING RISER DIAGRAM (TYPICAL SECTOR)

NO SCALE

1

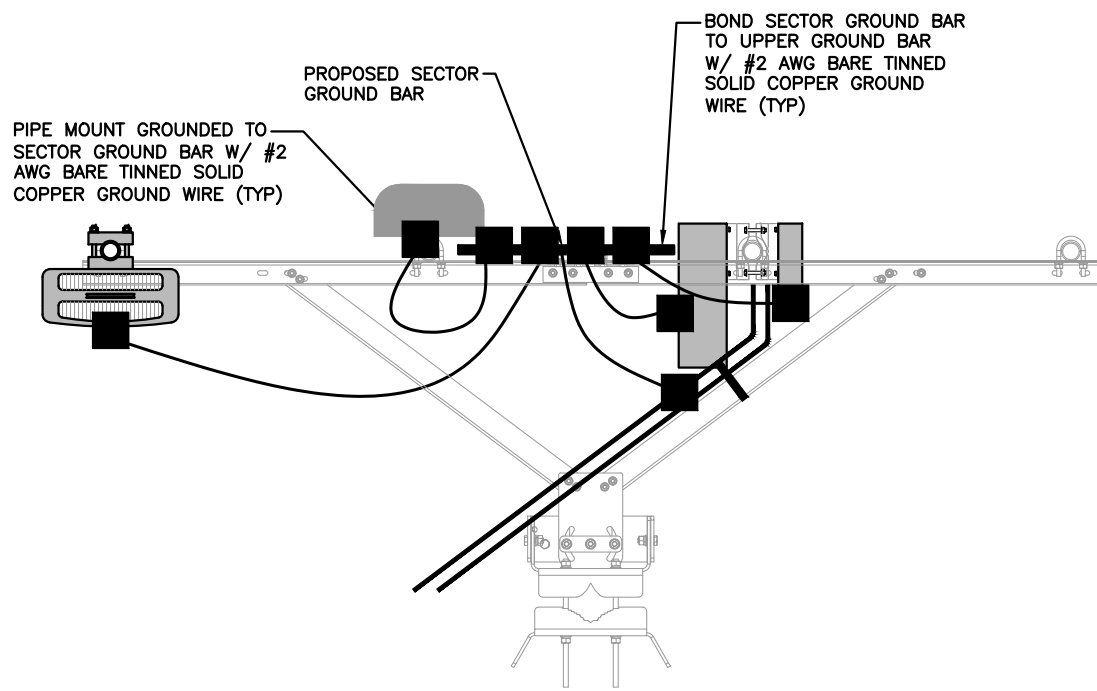

ANTENNA GROUNDING PLAN - TYPICAL SECTOR

NO SCALE

2

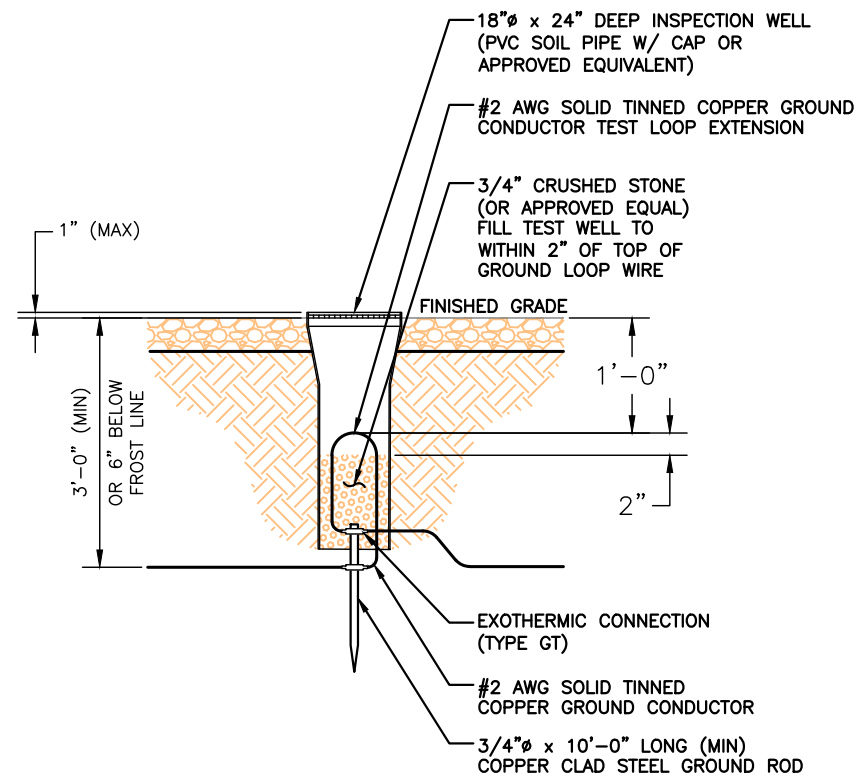

TEST WELL DETAIL

NO SCALE

3

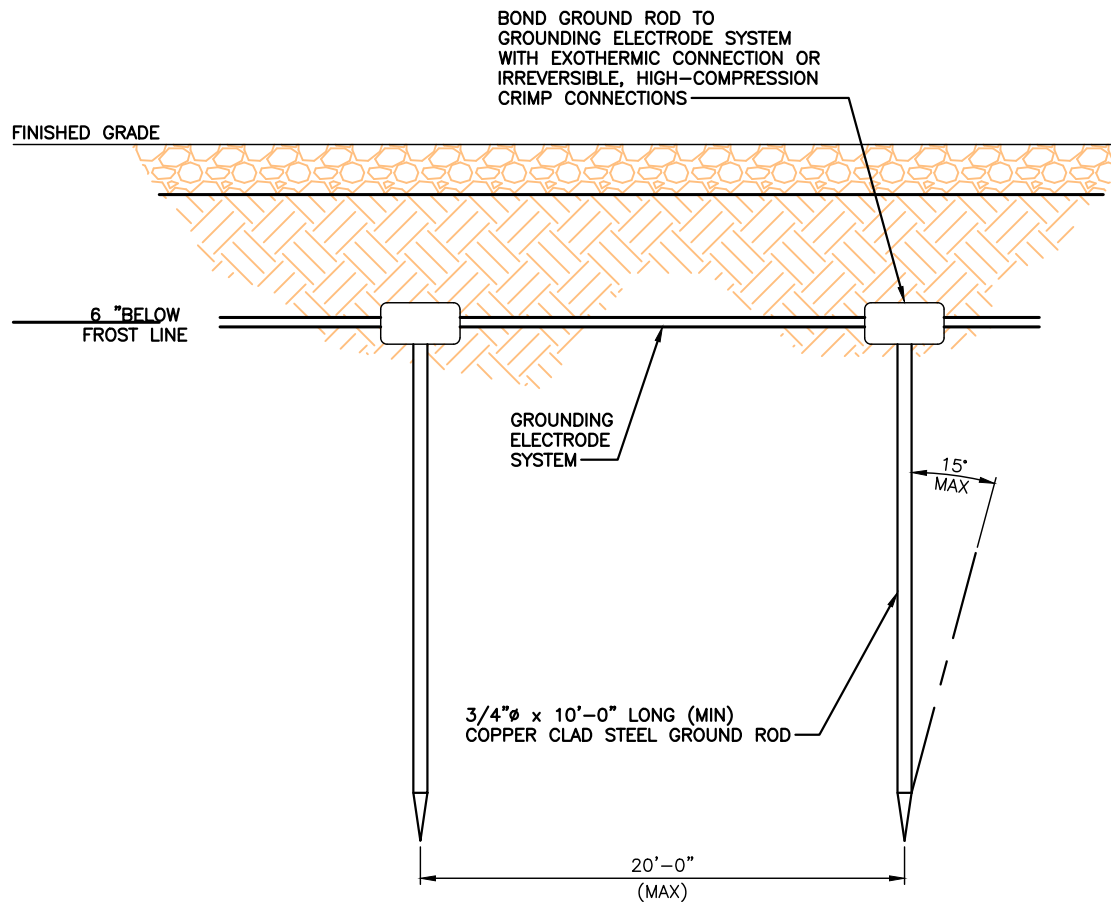

GROUND ROD DETAIL

NO SCALE

4

PLANS PREPARED FOR:



PLANS PREPARED BY:



PRE-CONSTRUCTION APPROVALS:

DISH WIRELESS CONS. MANAGER	DATE
DISH WIRELESS OPS. MANAGER	DATE
DISH WIRELESS RF ENGINEER	DATE

POST-CONSTRUCTION APPROVALS:

DISH WIRELESS CONS. MANAGER	DATE
DISH WIRELESS OPS. MANAGER	DATE
DISH WIRELESS RF ENGINEER	DATE

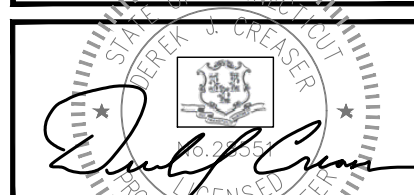

DRAWING NOTICE:
THIS DRAWING HAS NOT BEEN PUBLISHED AND IS THE SOLE PROPERTY OF HDG, LLC, AND IS LENT TO THE BORROWER FOR THEIR CONFIDENTIAL USE ONLY, AND IN CONSIDERATION OF THE LOAN OF THIS DRAWING, THE BORROWER PROMISES AND AGREES THAT IT WILL NOT BE REPRODUCED, COPIED, LENT OR OTHERWISE DISPOSED OF DIRECTLY OR INDIRECTLY, NOR USED FOR ANY PURPOSE OTHER THAN FOR WHICH IT IS FURNISHED.

SUBMITTALS:

DESCRIPTION	DATE	BY	REV
ISSUED FOR REVIEW	11/01/18	ET	0

APPLICANT SITE NAME:
CLEARY TOWER

APPLICANT SITE NUMBER:
CT0100001A

SITE ADDRESS:
**CLEARY TOWER (EDWARD)
WOLCOTT, CT 06716**

SHEET DESCRIPTION:
**GROUNDING DETAILS
(1 OF 2)**

DWG INFORMATION: DRAWN BY: ET
CHECKED BY: HC

SHEET NUMBER:
G-2.0

NOTES:

1. ALL HARDWARE SHALL BE 18-8 STAINLESS STEEL INCLUDING BELLVILLE WASHERS, COAT ALL SURFACES WITH KOPR-SHIELD BEFORE MATING.
2. IF BONDING TO STEEL: INSERT A TOOTH WASHER BETWEEN LUGH AND STEEL, COAL ALL SURFACES WITH KOPR-SHIELD.
3. USE A THIN COAT OF ANTI-CORROSION GREASE AT CONNETIONS.
4. DIMPLE OR MECHANICAL CRIMP LUGS WILL NOT BE PERMITTED.

GROUND LEAD FROM SECTOR GROUND BAR TO HYBRID CABLE USING HYBRID CABLE GROUNDING KIT PER CABLE MFR. REQUIREMENTS

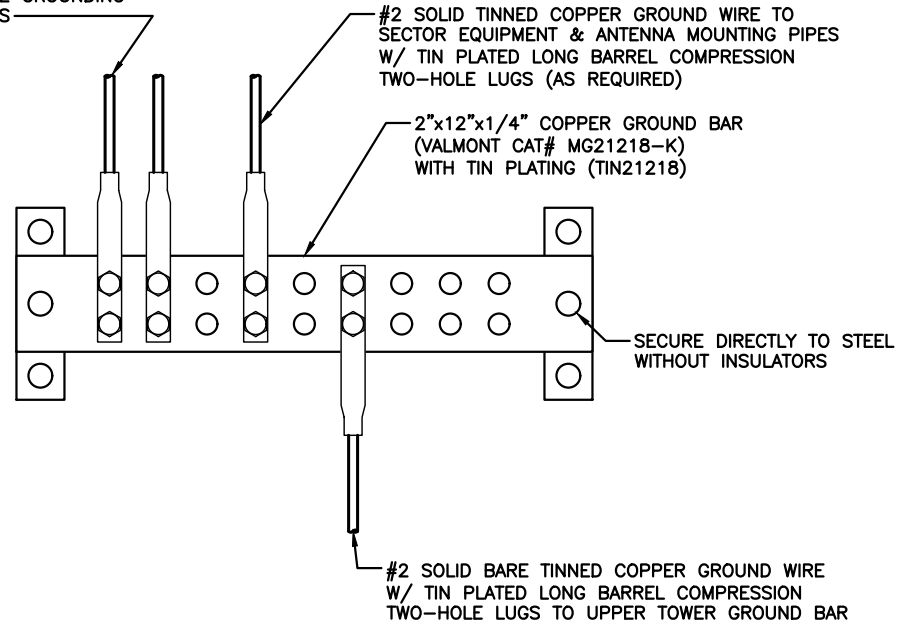

SECTOR GROUND BAR DETAIL

NO SCALE

1

NOTES:

1. ALL HARDWARE SHALL BE 18-8 STAINLESS STEEL INCLUDING BELLVILLE WASHERS, COAT ALL SURFACES WITH KOPR-SHIELD BEFORE MATING.
2. IF BONDING TO STEEL: INSERT A TOOTH WASHER BETWEEN LUGH AND STEEL, COAL ALL SURFACES WITH KOPR-SHIELD.
3. USE A THIN COAT OF ANTI-CORROSION GREASE AT CONNETIONS.
4. DIMPLE OR MECHANICAL CRIMP LUGS WILL NOT BE PERMITTED.

#2 BARE SOLID TINNED GROUND CONDUCTORS FROM SECTOR GROUND BUS BARS FEEDING FROM TOP

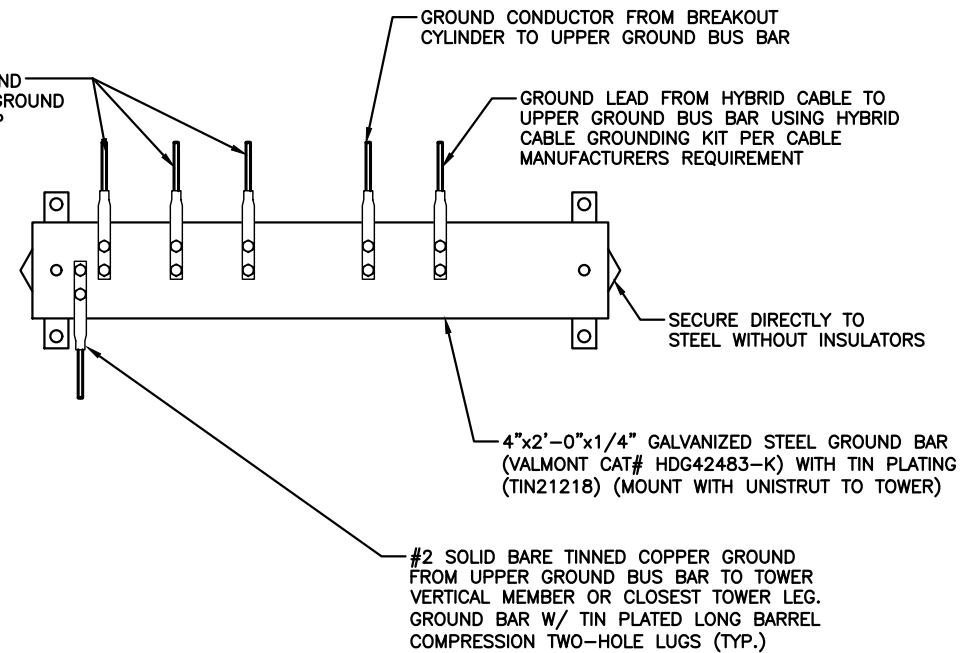

UPPER TOWER GROUND BAR DETAIL

NO SCALE

2

NOTES:

1. ALL HARDWARE SHALL BE 18-8 STAINLESS STEEL INCLUDING BELLVILLE WASHERS, COAT ALL SURFACES WITH KOPR-SHIELD BEFORE MATING.
2. IF BONDING TO STEEL: INSERT A TOOTH WASHER BETWEEN LUGH AND STEEL, COAL ALL SURFACES WITH KOPR-SHIELD.
3. USE A THIN COAT OF ANTI-CORROSION GREASE AT CONNETIONS.
4. DIMPLE OR MECHANICAL CRIMP LUGS WILL NOT BE PERMITTED.

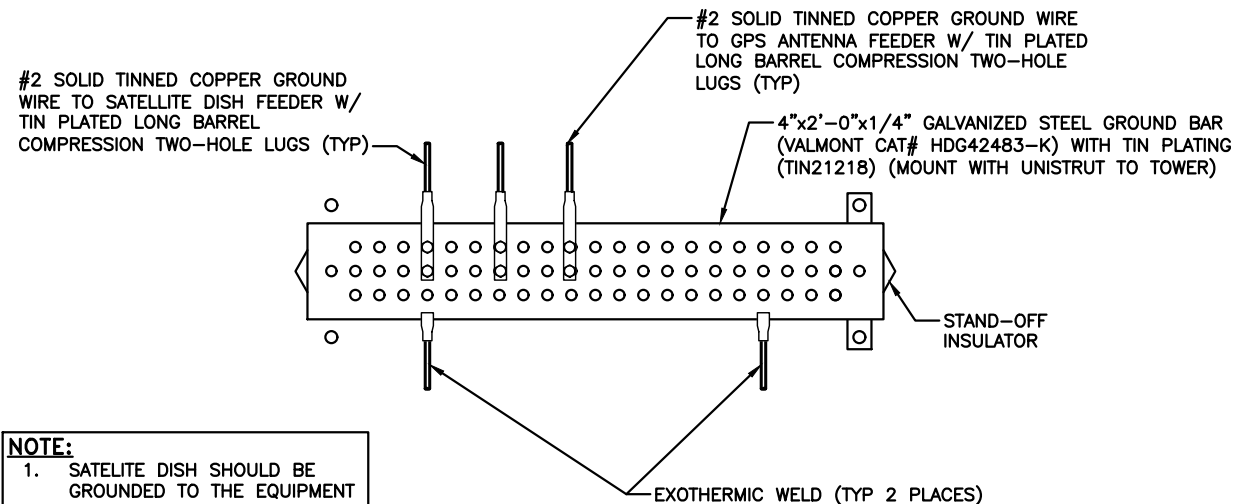

NOTE:
1. SATELITE DISH SHOULD BE GROUNDED TO THE EQUIPMENT GROUND RING.

BOND ICE BRIDGE TO EQUIPMENT GROUND RING

EQUIPMENT GROUND BAR DETAIL

NO SCALE

3

NOTES:

1. ALL HARDWARE SHALL BE 18-8 STAINLESS STEEL INCLUDING BELLVILLE WASHERS, COAT ALL SURFACES WITH KOPR-SHIELD BEFORE MATING.
2. IF BONDING TO STEEL: INSERT A TOOTH WASHER BETWEEN LUGH AND STEEL, COAL ALL SURFACES WITH KOPR-SHIELD.
3. USE A THIN COAT OF ANTI-CORROSION GREASE AT CONNETIONS.
4. DIMPLE OR MECHANICAL CRIMP LUGS WILL NOT BE PERMITTED.

4"x2'-0"x1/4" GALVANIZED STEEL GROUND BAR (VALMONT CAT# HDG42483-K) WITH TIN PLATING (TIN21218) (MOUNT WITH UNISTRUT TO TOWER)

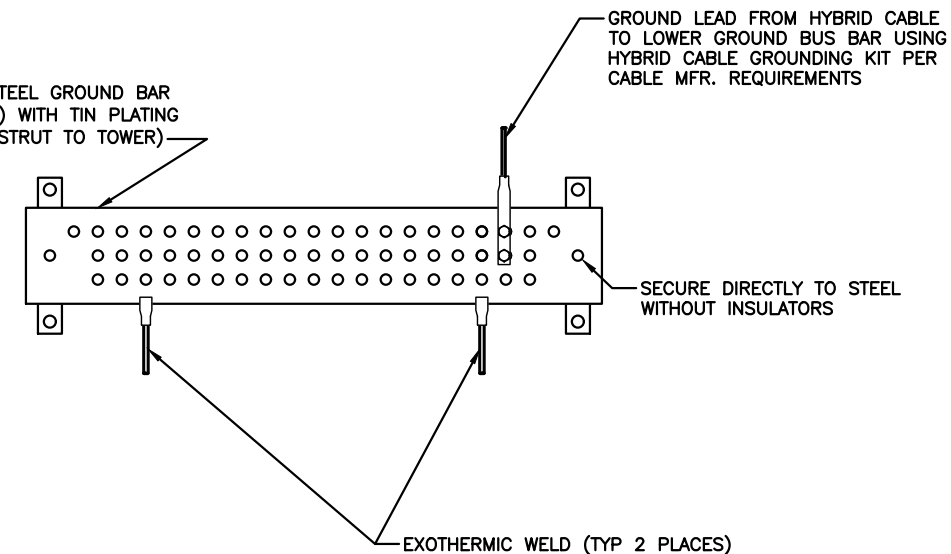

LOWER TOWER GROUND BAR DETAIL

NO SCALE

4

BOND ICE BRIDGE TO EQUIPMENT GROUND RING

PLANS PREPARED FOR:



PLANS PREPARED BY:



PRE-CONSTRUCTION APPROVALS:

DISH WIRELESS CONS. MANAGER	DATE
DISH WIRELESS OPS. MANAGER	DATE
DISH WIRELESS RF ENGINEER	DATE

POST-CONSTRUCTION APPROVALS:

DISH WIRELESS CONS. MANAGER	DATE
DISH WIRELESS OPS. MANAGER	DATE
DISH WIRELESS RF ENGINEER	DATE

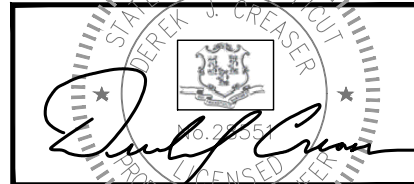

DRAWING NOTICE:
THIS DRAWING HAS NOT BEEN PUBLISHED AND IS THE SOLE PROPERTY OF HDG, LLC, AND IS LENT TO THE BORROWER FOR THEIR CONFIDENTIAL USE ONLY, AND IN CONSIDERATION OF THE LOAN OF THIS DRAWING, THE BORROWER PROMISES AND AGREES TO RETURN IT UPON REQUEST AND AGREES THAT IT WILL NOT BE REPRODUCED, COPIED, LENT OR OTHERWISE DISPOSED OF DIRECTLY OR INDIRECTLY, NOR USED FOR ANY PURPOSE OTHER THAN FOR WHICH IT IS FURNISHED.

SUBMITTALS:	DESCRIPTION	DATE	BY	REV
ISSUED FOR REVIEW		11/01/18	ET	0

APPLICANT SITE NAME:

CLEARY TOWER

APPLICANT SITE NUMBER:

CT0100001A

SITE ADDRESS:

CLEARY TOWER (EDWARD)
WOLCOTT, CT 06716

SHEET DESCRIPTION:

GROUNDING DETAILS
(2 OF 2)

DWG INFORMATION:

DRAWN BY: ET
CHECKED BY: HC

SHEET NUMBER:

G-2.1