

September 23, 2015

Melanie A. Bachman  
Acting Executive Director  
Connecticut Siting Council  
10 Franklin Square  
New Britain, CT 06051

Re: **Notice of Exempt Modification – Facility Modification  
482 Pigeon Hill Road, Windsor, Connecticut**

Dear Ms. Bachman:

On June 29, 2015, the Council acknowledged the Cellco Partnership d/b/a Verizon Wireless (“Cellco”) notice of intent to modify the above-referenced facility (EM-VER-164-150605). To date, the work described in that filing has not been completed. Cellco has now revised the scope of this modification project and submits this new notice of exempt modification.

Cellco currently maintains twelve (12) wireless telecommunications antennas at the 155-foot level on an existing 160-foot lattice tower at 482 Pigeon Hill Road in Windsor, Connecticut (the “Property”). The Property and tower are owned by Cellco. Cellco’s use of the tower was approved by the Council in 1986 (Docket No. 58). Cellco now intends to modify its facility by replacing six (6) of its existing antennas with three (3) model SBNHH-1D65B, 1900 MHz antennas and three (3) model SBNHH-1D65B, 2100 MHz antennas, at the same 155-foot level on the tower. Cellco also intends to replace six (6) remote radio heads (“RRHs”) with six (6) newer model RRHs, and install three (3) additional RRHs and one (1) HYBRIFLEX™ antenna cable. Included in Attachment 1 are specifications for Cellco’s replacement antennas, RRHs and HYBRIFLEX™ cable.

Please accept this letter as notification pursuant to R.C.S.A. § 16-50j-73, for construction that constitutes an exempt modification pursuant to R.C.S.A. § 16-50j-72(b)(2). In accordance with R.C.S.A. § 16-50j-73, a copy of this letter is being sent to Peter Souza, Town Manager for the Town of Windsor.

14165315-v1

Melanie A. Bachman  
September 23, 2015  
Page 2

The planned modifications to the facility fall squarely within those activities explicitly provided for in R.C.S.A. § 16-50j-72(b)(2).

1. The proposed modifications will not result in an increase in the height of the existing tower. The replacement antennas and RRHs will be installed at the same 155-foot level on the tower.
2. The proposed modifications will not involve any change to ground-mounted equipment and, therefore, will not require the extension of the site boundary.
3. The proposed modifications will not increase noise levels at the facility by six decibels or more, or to levels that exceed state and local criteria.
4. The operation of the replacement antennas will not increase radio frequency (RF) emissions at the facility to a level at or above the Federal Communications Commission (FCC) safety standard. A cumulative General Power Density table with Cellco's modified facility is included in Attachment 2.
5. The proposed modifications will not cause a change or alteration in the physical or environmental characteristics of the site.
6. The tower and its foundation, with certain modifications described in a structural analysis report dated March 27, 2014, to be performed by T-Mobile, can support Cellco's proposed modifications. (See Structural Analysis Report included in Attachment 3).

For the foregoing reasons, Cellco respectfully submits that the proposed modifications to the above-referenced telecommunications facility constitutes an exempt modification under R.C.S.A. § 16-50j-72(b)(2).

Sincerely,

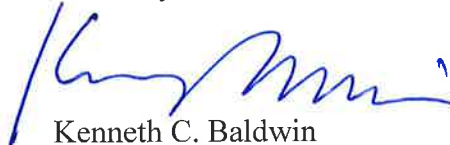

Kenneth C. Baldwin

Enclosures

Copy to:

Peter Souza, Windsor Town Manager  
Tim Parks

# **ATTACHMENT 1**

## SBNHH-1D65B

**Andrew® Tri-band Antenna, 698–896 and 2x 1695–2360 MHz, 65° horizontal beamwidth, internal RET. Both high bands share the same electrical tilt.**

- Interleaved dipole technology providing for attractive, low wind load mechanical package

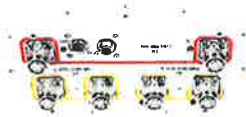

### Electrical Specifications

Frequency Band, MHz	698–806	806–896	1695–1880	1850–1990	1920–2200	2300–2360
Gain, dBi	14.9	14.7	17.7	18.2	18.6	18.6
Beamwidth, Horizontal, degrees	68	66	69	66	63	58
Beamwidth, Vertical, degrees	12.1	10.7	5.6	5.2	5.0	4.5
Beam Tilt, degrees	0–14	0–14	0–7	0–7	0–7	0–7
USLS, dB	14	13	15	15	15	13
Front-to-Back Ratio at 180°, dB	27	29	28	28	28	27
CPR at Boresight, dB	20	23	20	20	17	21
CPR at Sector, dB	14	10	12	10	9	1
Isolation, dB	25	25	25	25	25	25
Isolation, Intersystem, dB	30	30	30	30	30	30
VSWR   Return Loss, dB	1.5   14.0	1.5   14.0	1.5   14.0	1.5   14.0	1.5   14.0	1.5   14.0
PIM, 3rd Order, 2 x 20 W, dBc	-153	-153	-153	-153	-153	-153
Input Power per Port, maximum, watts	350	350	350	350	350	300
Polarization	±45°	±45°	±45°	±45°	±45°	±45°
Impedance	50 ohm	50 ohm	50 ohm	50 ohm	50 ohm	50 ohm

### Electrical Specifications, BASTA\*

Frequency Band, MHz	698–806	806–896	1695–1880	1850–1990	1920–2200	2300–2360
Gain by all Beam Tilts, average, dBi	14.5	14.3	17.4	17.9	18.2	18.3
Gain by all Beam Tilts Tolerance, dB	±0.5	±0.8	±0.4	±0.3	±0.5	±0.3
Gain by Beam Tilt, average, dBi	0°   14.6	0°   14.5	0°   17.4	0°   17.8	0°   18.1	0°   18.2
Gain by Beam Tilt, average, dBi	7°   14.6	7°   14.4	3°   17.5	3°   17.9	3°   18.3	3°   18.4
Gain by Beam Tilt, average, dBi	14°   14.2	14°   13.6	7°   17.4	7°   17.9	7°   18.2	7°   18.4
Beamwidth, Horizontal Tolerance, degrees	±2.2	±3.4	±2	±4.6	±5.7	±4.3
Beamwidth, Vertical Tolerance, degrees	±0.8	±1	±0.3	±0.2	±0.3	±0.2
USLS, dB	16	14	16	16	16	15
Front-to-Back Total Power at 180° ± 30°, dB	25	26	27	26	26	26
CPR at Boresight, dB	22	23	21	20	20	22
CPR at Sector, dB	13	11	16	12	11	4

\* CommScope® supports NGMN recommendations on Base Station Antenna Standards (BASTA). To learn more about the benefits of BASTA, [download the whitepaper Time to Raise the Bar on BSAs.](#)

### General Specifications

Antenna Brand	Andrew®
Antenna Type	DualPol® multiband with internal RET
Band	Multiband
Brand	DualPol®   Teletilt®
Operating Frequency Band	1695 – 2360 MHz   698 – 896 MHz
Performance Note	Outdoor usage

# Product Specifications

COMMScope®

SBNHH-1D65B

POWERED BY



## Mechanical Specifications

Color	Light gray
Lightning Protection	dc Ground
Radiator Material	Aluminum   Low loss circuit board
Radome Material	Fiberglass, UV resistant
Reflector Material	Aluminum
RF Connector Interface	7-16 DIN Female
RF Connector Location	Bottom
RF Connector Quantity, total	6
Wind Loading, maximum	617.7 N @ 150 km/h 138.9 lbf @ 150 km/h
Wind Speed, maximum	241.4 km/h   150.0 mph

## Dimensions

Depth	181.0 mm   7.1 in
Length	1851.0 mm   72.9 in
Width	301.0 mm   11.9 in
Net Weight	18.4 kg   40.6 lb

## Remote Electrical Tilt (RET) Information

Input Voltage	10–30 Vdc
Power Consumption, idle state, maximum	2.0 W
Power Consumption, normal conditions, maximum	13.0 W
Protocol	3GPP/AISG 2.0 (Multi-RET)
RET Interface	8-pin DIN Female   8-pin DIN Male
RET Interface, quantity	1 female   1 male
RET System	Teletilt®

## Packed Dimensions

Depth	299.0 mm   11.8 in
Length	1970.0 mm   77.6 in
Width	409.0 mm   16.1 in
Shipping Weight	31.0 kg   68.3 lb

## Regulatory Compliance/Certifications

### Agency

RoHS 2011/65/EU  
China RoHS SJ/T 11364-2006  
ISO 9001:2008

### Classification

Compliant by Exemption  
Above Maximum Concentration Value (MCV)  
Designed, manufactured and/or distributed under this quality management system



## Included Products

# Product Specifications

COMMSCOPE®

SBNHH-1D65B



**BSAMNT-1** — Wide Profile Antenna Downtilt Mounting Kit for 2.4 - 4.5 in (60 - 115 mm) OD round members. Kit contains one scissor top bracket set and one bottom bracket set.

## \* **Footnotes**

**Performance Note**      Severe environmental conditions may degrade optimum performance

# ALCATEL-LUCENT B13 RRH4X30-4R

Alcatel-Lucent B13 Remote Radio Head 4x30-4R is the newest addition of Remote Radio Head to the extended product line of Alcatel-Lucent's distributed Base Station solutions, aimed at facilitating smooth RF site acquisition and related civil engineering.

**Supporting 2Tx/4Tx MIMO and 4-way Rx diversity**, Alcatel-Lucent B13 RRH4x30-4R allows operators to have a compact radio solution to deploy LTE in the 700U band (700 MHz, 3GPP band 13), providing them with the means to achieve high capacity, high quality and high coverage with minimum site requirements.



The Alcatel-Lucent B13 RRH4x30-4R product has four transmit RF paths, offering the possibility to **select, via software only, 2Tx or 4Tx MIMO configurations** with either 2x60 W or 4x30 W RF output power. It supports also 4-way Rx diversity and up to 10MHz instantaneous bandwidth.

The Alcatel-Lucent B13 RRH4x30-4R is a near zero-footprint solution and operates noise free, simplifying negotiations with site property owners and minimizing environmental impacts.

Its compactness and slim design makes the Alcatel-Lucent B13 RRH4x30-4R easy to install close to the antenna: operators can therefore locate this Remote Radio Head where RF design conditions are deemed ideal, minimizing trade-offs between available sites and RF optimum sites, together with reducing the RF feeder needs and installation costs.

## FEATURES

- Supporting LTE in 700 MHz band (700U, 3GPP band 13)
- LTE 2Tx or 4Tx MIMO (SW switchable)
- Output power: Up to 2x60W or 4x30W
- 10MHz LTE carrier with 4Rx Diversity
- Convection-cooled (fan-less)
- Supports AISG 2.0 ALD devices (RET, TMA) through RS485 or RF ports

## BENEFITS

- Compact to reduce additional footprint when adding LTE in 700U band
- MIMO scheme operation selection (2Tx or 4Tx) by software only
- Improves downlink spectral efficiency through MIMO4
- Increases LTE coverage thanks to 4Rx diversity capability and best in class Rx sensitivity
- Flexible mounting options: Pole or Wall

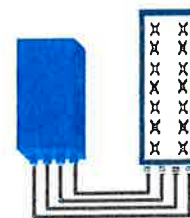

4x30W with 4T4R  
or  
2x60W with 2T4R  
Can be switched between modes via SW w/o site visit

# TECHNICAL SPECIFICATIONS

Features & performance	
Number of TX/RX paths	4 duplexed (either 4T4R or 2T4R by SW)
Frequency band	U700 (C) (3GPP bands 13): DL: 746 - 756 MHz / UL: 777 - 787 MHz
Instantaneous bandwidth - #carriers	10MHz – 1 LTE carrier (in 10MHz occupied bandwidth)
LTE carrier bandwidth	10 MHz
RF output power	2x60W or 4x30W (by SW)
Noise figure – RX Diversity scheme	2 dB typ. (<2.5 dB max) – 2 or 4 way Rx diversity
Sizes (HxWxD) in mm (in.)	550 x 305 x 230 (21.6" x 12.0" x 9") (with solar shield)
Volume in L	38 (with solar shield)
Weight in kg (lb) (w/o mounting HW)	26 (57.2) (with solar shield)
DC voltage range	-40.5 to -57V at full performance, -38 to -57V with relaxation on power consumption
DC power consumption	550W typical @100% RF load ( In 2Tx or 4TX mode)
Environmental conditions	-40°C (-40°F) / +55°C (+131°F)
Wind load (@150km/h or 93mph)	IP65 Frontal: <200N / Lateral : <150N
Antenna ports	4 ports 7/16 DIN female (50 ohms) VSWR < 1.5
CPRI ports	2 CPRI ports (HW ready for Rate7, 9.8 Gbps) SFP single mode dual fiber
AISG interfaces	1 AISG2.0 output (RS485) Integrated Smart Bias Tees (x2)
Misc. Interfaces	4 external alarms (1 connector) – 4 RF Tx & 4 RF Rx monitor ports - 1 DC connector (2 pins)
Installation conditions	Pole and wall mounting
Regulatory compliance	3GPP 36.141 / 3GPP 36.113 / GR-1089-CORE / GR-3108-CORE / UL 60950-1 / FCC Part 27

www.alcatel-lucent.com Alcatel, Lucent, Alcatel-Lucent and the Alcatel-Lucent logo are trademarks of Alcatel-Lucent. All other trademarks are the property of their respective owners. The information presented is subject to change without notice. Alcatel-Lucent assumes no responsibility for inaccuracies contained herein. Copyright © 2014 Alcatel-Lucent. All Rights Reserved



# PCS RF MODULES

## RRH1900 2X60 - HW CHARACTERISTICS

LA6.0.1/13.3

<b>RRH2x60</b>	
RF Output Power	2X60W
Instantaneous Bandwidth	20MHz
Transmitter	2 TX
Receiver	1900 HW version 1900A HW version
Features	2 Branch RX – LA6.0.1 4 Branch RX – LR13.3 AISG 2.0 for RET/TMA
Power	Internal Smart Bias-T -48VDC
CPRI Ports	2 CPRI Rate 3 Ports
External Alarms	4 External User Alarms
Monitor Ports	TX
Environmental	GR487 Compliance
RF Connectors	7/16 DIN (top mounted)

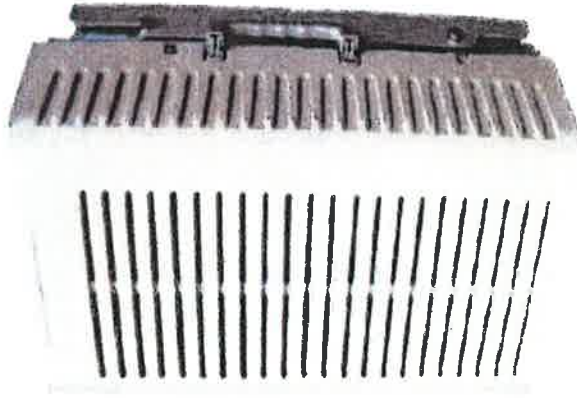

\*\* Not a Verizon Wireless deployed product

# NEW PCS RF MODULES FOR VZW

## RRH2X60 - HW CHARACTERISTICS

LR14.3

RRH2X60	
RF Output Power	2x60W (4x30W HW Ready)
Instantaneous Bandwidth	60MHz
Target Reliability (Annual Return Rate)	<2%
Receiver	4 Branch Rx
Features	AISG 2.0 for RET/TMA
Power	-48VDC
	Internal Smart Bias-T
CPRI Ports	2 CPRI Rate 5 Ports
External Alarms	4 External User Alarms
Monitor Ports	TX, RX
Environmental	GR487 Compliance
RF Connectors	7/16 DIN (downward facing)
Dimensions	22"(h) x 12"(w) x 9.4"(d)**
Weight	55lb**

\*\* - Includes solar shield but not mounting brackets (8 lbs.)

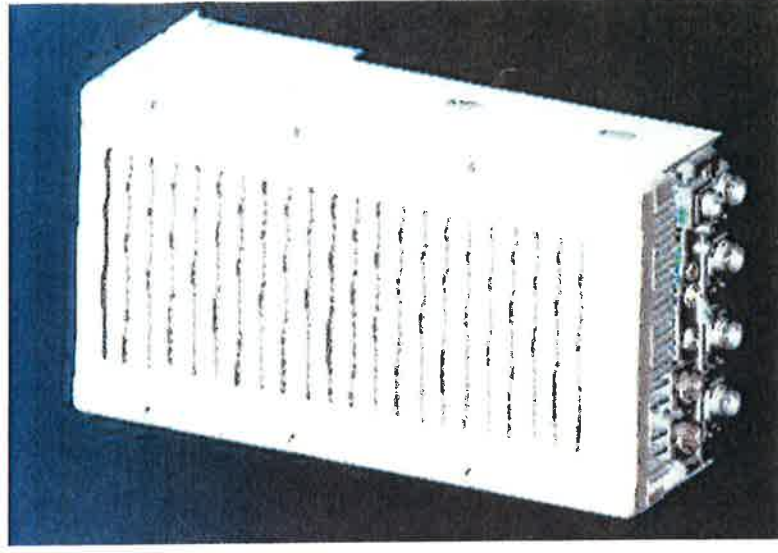

# ALCATEL-LUCENT WIRELESS PRODUCT DATASHEET RRH2X60-AWS FOR BAND 4 APPLICATIONS

The Alcatel-Lucent RRH2x60-AWS is a high power, small form factor Remote Radio Head operating in the AWS frequency band (3GPP Band 4) for LTE technology. It is designed with an eco-efficient approach, providing operators with the means to achieve high quality and high capacity coverage with minimum site requirements and efficient operation.

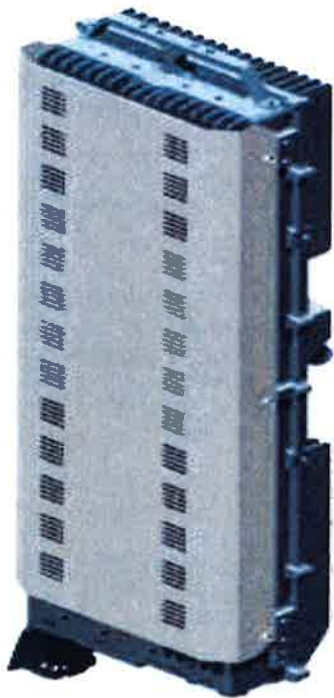

A distributed Node B expands the deployment options by using two components, a Base Band Unit (BBU) containing the digital assets and a separate RRH containing the radio-frequency (RF) elements. This modular design optimizes available space and allows the main components of a Node B to be installed separately, within the same site or several kilometers apart.

The Alcatel-Lucent RRH2x60-AWS is linked to the BBU by an optical-fiber connection carrying downlink and uplink digital radio signals

along with operations, administration and maintenance (OA&M) information.

#### SUPERIOR RF PERFORMANCE

The Alcatel-Lucent RRH2x60-AWS integrates all the latest technologies. This allows to offer best-in-class characteristics.

It delivers an outstanding 120 watts of total RF power thanks to its two transmit RF paths of 60 W each.

It is ideally suited to support multiple-input multiple-output (MIMO) 2x2 operation.

It includes four RF receivers to natively support 4-way uplink reception diversity. This improves the radio uplink coverage and this can be used to extend the cell radius commensurate with 2x2MIMO 2x60 W for the downlink.

It supports multiple discontinuous LTE carriers within an instantaneous bandwidth of 45 MHz corresponding to the entire AWS B4 spectrum.

The latest generation power amplifiers (PA) used in this product achieve high efficiency (>40%), resulting in improved power consumption figures.

#### OPTIMIZED TCO

The Alcatel-Lucent RRH2x60-AWS is designed to make available all the benefits of a distributed Node B, with excellent RF characteristics, with low capital expenditures (CAPEX) and low operating expenditures (OPEX).

The Alcatel-Lucent RRH2x60-AWS is a very cost-effective solution to deploy LTE MIMO.

#### EASY INSTALLATION

The RRH2x60-AWS includes a reversible mounting bracket which allows for ease of installation behind an antenna, or on a rooftop knee wall while providing easy access to the mid body RF connectors.

The limited space available in some sites may prevent the installation of traditional single-cabinet BTS equipment. However, many of these sites can host an Alcatel-Lucent RRH2x60-AWS installation, providing more flexible site selection and improved network quality along with greatly reduced installation time and costs.

The Alcatel-Lucent RRH2x60-AWS is a zero-footprint solution and is convection cooled without fans for silent operation, simplifying negotiations with site property owners and minimizing environmental impacts.

Installation can easily be done by a single person as the Alcatel-Lucent RRH2x60-AWS is compact and weighs about 20 kg, eliminating the need for a crane to hoist the BTS cabinet to the rooftop. A site can be in operation in less than one day.

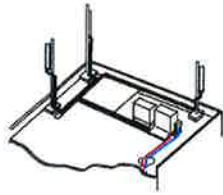

Macro

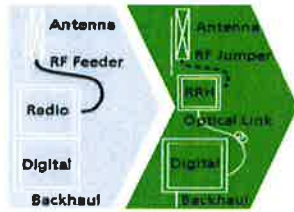

RRH for space-constrained cell sites

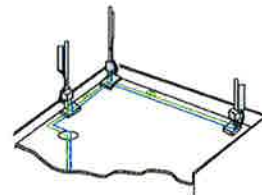

Distributed

## FEATURES

- RRH2x60-AWS integrates two power amplifiers of 60W rating (at each antenna connector)
- Support multiple carriers over the entire 3GPP band 4
- RRH2x60-AWS is optimized for LTE operation
- RRH2x60-AWS is a very compact and lightweight product
- Advanced power management techniques are embedded to provide power savings, such as PA bias control

## BENEFITS

- MIMO LTE operation with only one single unit per sector
- Improved uplink coverage with built-in 4-way receive diversity capability
- RRH can be mounted close to the antenna, eliminating nearly all losses in RF cables and thus reducing power consumption by 50% compared to conventional solutions
- Distributed configurations provide easily deployable and cost-effective solutions, near zero footprint and

silent solutions, with minimum impact on the neighborhood, which ease the deployment

- RETA and TMA support without additional hardware thanks to the AISG v2.0 port and the integrated Bias-Tees. Bias-Tees support AISG DC supply and signaling.

## TECHNICAL SPECIFICATIONS

Specifications listed are hardware capabilities. Some capabilities depend on support in a specific software release or future release.

### Dimensions and weights

- HxWxD : 510x285x186mm (27 l with solar shield)
- Weight : 20 kg (44 lbs)

### Electrical Data

- Power Supply : -48V DC (-40.5 to -57V)
- Power Consumption (ETSI average traffic load reference) : 250W @2x60W

### RF Characteristics

- Frequency band: 1710-1755, UL / 2110-2155 MHz, DL (3GPP band 4)
- Output power: 2x60W at antenna connectors
- Technology supported: LTE
- Instantaneous bandwidth: 45 MHz
- Rx diversity: 2-way and 4-way uplink reception
- Typical sensitivity without Rx diversity: -105 dBm for LTE

### Connectivity

- Two CPRI optical ports for daisy chaining and up to six RRHs per fiber
- Type of optical fiber: Single-Mode (SM) and Multi-Mode (MM) SFPs
- Optical fiber length: up to 500m using MM fiber, up to 20km using SM fiber
- TMA/RETA : AISG 2.0 (RS485 connector and internal Bias-Tee)
- Six external alarms
- Surge protection for all external ports (DC and RF)

### Environmental specifications

- Operating temperature: -40°C to 55°C including solar load
- Operating relative humidity: 8% to 100%
- Environmental Conditions : ETS 300 019-1-4 class 4.1E
- Ingress Protection : IEC 60529 IP65
- Acoustic Noise : Noiseless (natural convection cooling)

### Safety and Regulatory Data

- EMC : 3GPP 25113, EN 301 489-1, EN 301 489-23, GR 1089, GR 3108, OET-65
- Safety : IEC60950-1, EN 60825-1, UL, ANSI/NFPA 70, CAN/CSA-C22.2
- Regulatory : FCC Part 15 Class B, CE Mark – European Directive : 2002/95/EC (ROHS); 2002/96/EC (WEEE); 1999/5/EC (R&TTE)
- Health : EN 50385

www.alcatel-lucent.com Alcatel, Lucent, Alcatel-Lucent and the Alcatel-Lucent logo are trademarks of Alcatel-Lucent. All other trademarks are the property of their respective owners. The information presented is subject to change without notice. Alcatel-Lucent assumes no responsibility for inaccuracies contained herein.

Copyright © 2012 Alcatel-Lucent. All rights reserved. M2012XXXXXX (March)



**HYBRIFLEX™ RRH Hybrid Feeder Cabling Solution, 1-5/8", Single-Mode Fiber**

**Product Description**

RFS' HYBRIFLEX Remote Radio Head (RRH) hybrid feeder cabling solution combines optical fiber and DC power for RRHs in a single lightweight aluminum corrugated cable, making it the world's most innovative solution for RRH deployments.

It was developed to reduce installation complexity and costs at Cellular sites. HYBRIFLEX allows mobile operators deploying an RRH architecture to standardize the RRH installation process and eliminate the need for and cost of cable grounding. HYBRIFLEX combines optical fiber (multi-mode or single-mode) and power in a single corrugated cable. It eliminates the need for junction boxes and can connect multiple RRHs with a single feeder. Standard RFS CELLFLEX® accessories can be used with HYBRIFLEX cable. Both pre-connectorized and on-site options are available.

**Features/Benefits**

- Aluminum corrugated armor with outstanding bending characteristics - minimizes installation time and enables mechanical protection and shielding
- Same accessories as 1 5/8" coaxial cable
- Outer conductor grounding - Eliminates typical grounding requirements and saves on installation costs
- Lightweight solution and compact design - Decreases tower loading
- Robust cabling - Eliminates need for expensive cable trays and ducts
- Installation of tight bundled fiber optic cable pairs directly to the RRH - Reduces CAPEX and wind load by eliminating need for interconnection
- Optical fiber and power cables housed in single corrugated cable - Saves CAPEX by standardizing RRH cable installation and reducing installation requirements
- Outdoor polyethylene jacket - Ensures long-lasting cable protection



Figure 1: HYBRIFLEX Series

**Technical Specifications**

Outer Conductor Armor	Corrugated Aluminum	(mm (in))	46.5 (1.83)
Jacket	Polyethylene, PE	(mm (in))	50.3 (1.98)
UV-Protection	Individual and External Jacket		Yes
<b>Weight</b>			
Weight, Approximate		(kg/m (lb/ft))	1.9 (1.30)
Minimum Bending Radius, Single Bending		(mm (in))	200 (8)
Minimum Bending Radius, Repeated Bending		(mm (in))	500 (20)
Recommended/Maximum Clamp Spacing		(m (ft))	1.0 / 1.2 (3.25 / 4.0)
<b>DC-Resistance</b>			
DC-Resistance Outer Conductor Armor		(Ω/km (Ω/1000ft))	068 (0.205)
DC-Resistance Power Cable, 8.4mm <sup>2</sup> (8AWG)		(Ω/km (Ω/1000ft))	2.1 (0.307)
<b>Optical Specifications</b>			
Version			Single-mode OM3
Quantity, Fiber Count			16 (8 pairs)
Core/Clad		(μm)	50/125
Primary Coating (Acrylate)		(μm)	245
Buffer Diameter, Nominal		(μm)	900
Secondary Protection, Jacket, Nominal		(mm (in))	2.0 (0.08)
Minimum Bending Radius		(mm (in))	104 (4.1)
Insertion Loss @ wavelength 850nm		dB/km	3.0
Insertion Loss @ wavelength 1310nm		dB/km	1.0
Standards (Meets or exceeds)			UL94-V0, UL1666 RoHS Compliant
<b>DC Power Cable Specifications</b>			
Size (Power)		(mm (AWG))	8.4 (8)
Quantity, Wire Count (Power)			16 (8 pairs)
Size (Alarm)		(mm (AWG))	0.8 (18)
Quantity, Wire Count (Alarm)			4 (2 pairs)
Type			UV protected
Strands			19
Primary Jacket Diameter, Nominal		(mm (in))	6.8 (0.27)
Standards (Meets or exceeds)			NFPA 130, ICEA S-95-658 UL Type XHHW-2, UL 44 UL-LS Limited Smoke, UL VW-1 IEEE-383 (1974), IEEE1202/FT4 RoHS Compliant
<b>Operating Temp.</b>			
Installation Temperature		(°C (°F))	-40 to +65 (-40 to 149)
Operation Temperature		(°C (°F))	-40 to +65 (-40 to 149)

\* This data is provisional and subject to change

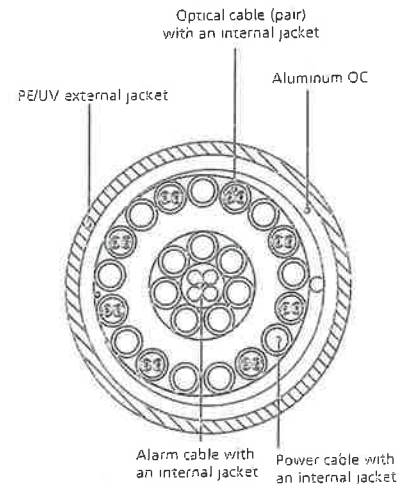

Figure 2: Construction Detail

All information contained in the present datasheet is subject to confirmation at time of ordering.

# **ATTACHMENT 2**



# **ATTACHMENT 3**



**Structural Analysis Report**

*160-ft Existing ROHN Lattice Tower*

*Proposed Verizon Wireless  
Antenna Upgrade*

*Verizon Site Ref: Windsor*

*482 Pigeon Hill Road  
Windsor, CT*

*Centek Project No. 15001.040*

~~*Date: May 21, 2015*~~

*Rev 1: September 1, 2015*

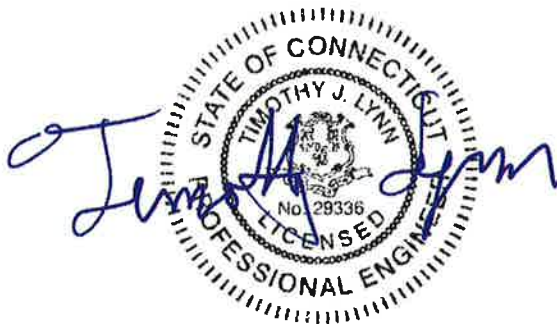

**Prepared for:**  
Verizon Wireless  
99 East River Road, 9<sup>th</sup> Floor  
East Hartford, CT 06108

## **Table of Contents**

### **SECTION 1 – REPORT**

- INTRODUCTION
- ANTENNA AND APPURTENANCE SUMMARY
- PRIMARY ASSUMPTIONS USED IN THE ANALYSIS
- ANALYSIS
- TOWER LOADING
- TOWER CAPACITY
- FOUNDATION AND ANCHORS
- CONCLUSION

### **SECTION 2 – CONDITIONS & SOFTWARE**

- STANDARD ENGINEERING CONDITIONS
- GENERAL DESCRIPTION OF STRUCTURAL ANALYSIS PROGRAM

### **SECTION 3 – CALCULATIONS**

- tnxTower INPUT/OUTPUT SUMMARY
- tnxTower FEED LINE PLAN
- tnxTower FEED LINE DISTRIBUTION
- tnxTower DETAILED OUTPUT
- FOUNDATION ANALYSIS

### **SECTION 4 – REFERENCE MATERIALS**

- VERIZON RF DATA SHEET
- EQUIPMENT CUT SHEETS

## Introduction

The purpose of this report is to summarize the results of the non-linear, P- $\Delta$  structural analysis of the antenna upgrade proposed by Verizon Wireless on the existing self-supporting lattice tower located in Windsor, Connecticut.

The host tower is a 160-ft, three legged, tapered steel lattice tower originally designed and manufactured by UNR-ROHN. The manufacturer's drawings and calculations were unavailable for use in this report. The existing tower geometry, structure member sizes and foundation information were obtained from a previous structural report prepared by Centek job no. 14033.002 dated March 27, 2014.

Antenna and appurtenance information were obtained from the aforementioned Centek structural report and a Verizon RF data sheet.

The tower consists of eight (8) tapered vertical sections consisting of structural steel pipe legs conforming to ASTM A572 Gr. 50. Diagonal lateral support bracing consists of structural steel angle shapes conforming to ASTM A36. The vertical tower sections are connected by bolted flange plates while the pipe legs and bracing are connected by welded and bolted gusset connections. The width of the tower face is 8.56-ft at the top and 22.85-ft at the base.

Verizon Wireless proposes the removal of six (6) panel antennas, six (6) diplexers and six (6) remote radio heads and the installation of six (6) panel antennas, nine (9) remote radio heads and one (1) main distribution box mounted on the existing T-Frames. Refer to the Antenna and Appurtenance Summary below for a detailed description of the proposed antenna configuration.

## Antenna and Appurtenance Summary

The existing, proposed and future loads considered in this analysis consist of the following:

- **AT&T (Existing):**  
Antennas: Six (6) KMW AM-X-CD-14-65-00T-RET panel antennas and six (6) Powerwave TT19-08DB111 TMA's mounted on three (3) 10-ft-6in T-Arms connected to one (1) 8" SCH.40 x 18-ft long mast with a RAD center elevation of  $\pm 169$ -ft above the existing tower base.  
Coax Cables: Twelve (12) 1-1/4"  $\varnothing$  coax cables running on the leg/face of the existing tower as specified within Section 3 of this report.
- **T-MOBILE (Existing):**  
Antenna: Six (6) Ericsson AIR 21 panel antennas, three (3) RFS APX16DWV-16DWVS-C-A20 panel antennas and three (3) Ericsson KRY 112 TMA's mounted on three (3) 15-ft Wireless Frames with a RAD center elevation of  $\pm 147$ -ft above the existing tower base.  
Coax Cable: Eighteen (18) 1-5/8"  $\varnothing$  coax cables and one (1) 1-5/8"  $\varnothing$  fiber cable running on a leg/face of the existing tower as specified in Section 3 of this report.
- **UNKNOWN (EXISTING):**  
Antenna: One (1) 15-ft  $\varnothing$  Omni-directional (whip) antenna mounted with an elevation of  $\pm 167.5$ -ft above the tower base.  
Coax Cable: One (1) 7/8"  $\varnothing$  coax cable running on a leg/face of the existing tower as specified in Section 3 of this report.

- UNKNOWN (EXISTING):  
Antenna: One (1) 8-ft  $\varnothing$  dish antenna on a 5-ft x 4.5-in  $\varnothing$  pipe mount with an elevation of  $\pm 111.33$ -ft above the tower base.  
Coax Cable: One (1) EW63 cable running on a leg/face of the existing tower as specified in Section 3 of this report.
- UNKNOWN (Existing):  
Antenna: One (1) 16-ft  $\varnothing$  Omni-directional (whip) antenna on a 4-ft side mount standoff with an elevation of  $\pm 108$ -ft above the tower base.  
Coax Cable: One (1) 7/8"  $\varnothing$  coax cable running on a leg/face of the existing tower as specified in Section 3 of this report.
- UNKNOWN (Existing):  
Antenna: One (1) 6-ft  $\varnothing$  dish antenna on a 5-ft x 4.5-in  $\varnothing$  pipe mount with an elevation of  $\pm 102$ -ft above the tower base.  
Coax Cable: One (1) EW90  $\varnothing$  coax cable running on a leg/face of the existing tower as specified in Section 3 of this report.
- UNKNOWN (Existing):  
Antenna: One (1) 6-ft  $\varnothing$  dish antenna on a 5-ft x 4.5-in  $\varnothing$  pipe mount with an elevation of  $\pm 94$ -ft above the tower base.  
Coax Cable: One (1) EW63 cable running on a leg/face of the existing tower as specified in Section 3 of this report.
- UNKNOWN (Existing):  
Antenna: One (1) 10-ft  $\varnothing$  dish antenna on a 6-ft 8-in x 4-in  $\varnothing$  pipe mount with an elevation of  $\pm 72$ -ft above the tower base.  
Coax Cable: One (1) EW63 cable running on a leg/face of the existing tower as specified in Section 3 of this report.
- UNKNOWN (Existing):  
Antenna: One (1) empty 4-ft side mount standoff with an elevation of  $\pm 47$ -ft above the tower base.
- UNKNOWN (Existing):  
Antenna: One (1) 12-ft  $\varnothing$  Omni-directional (whip) antenna on a 4-ft side mount standoff with an elevation of  $\pm 45.41$ -ft above the tower base.  
Coax Cable: One (1) 1/2-in  $\varnothing$  coax cable running on a leg/face of the existing tower as specified in Section 3 of this report.
- VERIZON (Existing to Remain):  
Antennas: Six (6) Antel LPA-80063-4CF, two (2) Antel BXA-70040/6CF and one (1) Antel BXA-70063/6CF panel antennas mounted on three (3) Valmont 15-ft T-Frames with a RAD center elevation of  $\pm 156.5$ -ft above the existing tower base.  
Misc Equipment: One (1) RFS DB-T1-6Z-8AB-0Z main distribution box mounted to the leg of the existing tower with a RAD center elevation of 156.5-ft above the existing tower base.  
Coax Cables: Twelve (12) 1-5/8"  $\varnothing$  coax cables and one (1) 1-5/8"  $\varnothing$  fiber cable running on the face of the existing tower configured in 2 rows of 6 cables as specified in Section 3 of this report.

- **VERIZON (Existing to Remove):**  
Antennas: Three (3) RFS APX18-206517-T2 panel antennas, three (3) Andrew HBX-6516DS-T2M panel antennas, six (6) RFS FD9R6004/2C-3L Diplexers, three (3) Alcatel-Lucent RRH2x40-AWS Remote Radio Heads and three (3) Alcatel-Lucent RRH2x40-07-L Remote Radio Heads mounted to three (3) existing 15-ft T-Frames noted above with a RAD center elevation of 156.5-ft above the existing tower base.
- **VERIZON (Proposed):**  
Antennas: Six (6) Andrew SBNHH-1D65B panel antennas, three (3) Alcatel-Lucent RRH4x30-B13 Remote Radio Heads, three (3) Alcatel-Lucent RRH2x60-PCS remote radio heads, three (3) Alcatel-Lucent RRH4x45/2x90-AWS and one (1) RFS DB-T1-6Z-8AB-0Z main distribution box mounted on three (3) Valmont 15-ft T-Frames with a RAD center elevation of  $\pm 156.5$ -ft above the existing tower base.  
Coax Cables: One (1) 1-5/8"  $\varnothing$  fiber cable running on a face of the existing tower as specified in Section 3 of this report.

### Primary Assumptions Used in the Analysis

- The tower structure's theoretical capacity not including any assessment of the condition of the tower.
- The tower carries the horizontal and vertical loads due to the weight of antennas, ice load and wind.
- Tower is properly installed and maintained.
- Tower is in plumb condition.
- Tower loading for antennas and mounts as listed in this report.
- All bolts are appropriately tightened providing the necessary connection continuity.
- All welds are fabricated with ER-70S-6 electrodes.
- All members are assumed to be as specified in the original tower design documents.
- All members are "hot dipped" galvanized in accordance with ASTM A123 and ASTM A153 Standards.
- All member protective coatings are in good condition.
- All tower members were properly designed, detailed, fabricated, installed and have been properly maintained since erection.
- Any deviation from the analyzed antenna loading will require a new analysis for verification of structural adequacy.

## A n a l y s i s

The existing tower was analyzed using a comprehensive computer program entitled *tnxTower*. The program analyzes the tower, considering the worst case loading condition. The tower is considered as loaded by concentric forces along the tower shaft, and the model assumes that the shaft members are subjected to bending, axial, and shear forces.

The existing tower was analyzed for the controlling basic wind speed (fastest mile) with no ice and a 75% reduction of wind force with ½ inch accumulative ice to determine stresses in members as per guidelines of TIA/EIA-222-F-96 entitled "Structural Standards for Steel Antenna Towers and Antenna Supporting Structures", the American Institute of Steel Construction (AISC) and the Manual of Steel Construction; Allowable Stress Design (ASD).

The controlling wind speed is determined by evaluating the local available wind speed data as provided in Appendix K of the CSBC<sup>1</sup> and the wind speed data available in the TIA/EIA-222-F-96 Standard. The higher of the two wind speeds is utilized in preparation of the tower analysis.

## T o w e r L o a d i n g

Tower loading was determined by the basic wind speed as applied to projected surface areas with modification factors per TIA/EIA-222-F, gravity loads of the tower structure and its components, and the application of ½" radial ice on the tower structure and its components.

Basic Wind Speed:	Hartford; v = 80 mph (fastest mile)	[Section 16 of TIA/EIA-222-F-96]
	Windsor; v = 95 mph (3 second gust) equivalent to v = 77.5 mph (fastest mile) <i>TIA/EIA-222 wind speed controls.</i>	[Appendix K of the 2005 CT Building Code Supplement]
Load Cases:	<u>Load Case 1</u> ; 80 mph wind speed w/ no ice plus gravity load – used in calculation of tower stresses.	[Section 2.3.16 of TIA/EIA-222-F-96]
	<u>Load Case 2</u> ; 69 mph wind speed w/ ½" radial ice plus gravity load – used in calculation of tower stresses. The 69 mph wind speed velocity represents 75% of the wind pressure generated by the 80 mph wind speed.	[Section 2.3.16 of TIA/EIA-222-F-96]
	<u>Load Case 3</u> ; Seismic – not checked	[Section 1614.5 of State Bldg. Code 2005] does not control in the design of this structure type

---

<sup>1</sup> The 2005 Connecticut State Building Code as amended by the 2009 CT State Supplement. (CSBC)

## Tower Capacity

Tower stresses were calculated utilizing the structural analysis software tnxTower. Allowable stresses were determined based on Table 5 of the TIA/EIA code with a 1/3 increase per Section 3.1.1.1 of the same code.

- Calculated stresses were found to be within allowable limits. In Load Case 2, per tnxTower "Section Capacity Table", this tower was found to be at **97.8%** of its total capacity.

Tower Section	Elevation	Stress Ratio (percentage of capacity)	Result
Leg (T7)	20'-0" - 40'-0"	97.3%	<b>PASS</b>
Diagonal (T5)	60'-0" - 80'-0"	97.8%	<b>PASS</b>

## Foundation and Anchors

The existing foundation consists of three (3) 3-ft  $\varnothing$  reinforced concrete piers on three (3) 8-ft square reinforced concrete pads subsequently reinforced with four (4) rock anchors per pad. The existing foundation locations and dimensions were taken from the aforementioned Centek structural analysis and reinforcement design documents. The sub-grade conditions used in the analysis of the existing foundation were obtained from a geo-technical soils study report prepared by Clarence Welti & Associates, Inc., dated September 20, 2010. The tower legs are connected to the three (3) reinforced concrete piers by means of six (6) 7/8"  $\varnothing$ , ASTM A354 Grade BC anchor bolts per leg, embedded into the concrete foundation structure.

- The tower reactions developed from the governing Load Case 1 of the proposed reinforced tower condition were used in the verification of the foundation and anchor bolts:

Leg Reactions	Vector	Proposed Tower Reactions
Leg	Shear	<b>24 kips</b>
	Compression	<b>203 kips</b>
	Uplift	<b>177 kips</b>
Base	Shear	<b>39 kips</b>
	Compression	<b>31 kips</b>
	Moment	<b>3808 kip-ft</b>

- The anchor bolts were found to be within allowable limits.

Tower Section	Component	Stress Ratio (percentage of capacity)	Result
Anchor Bolts	Tension	86.8%	PASS

- The foundation was found to be within allowable limits.

Foundation Type	Design Limit	Allowable Limit/FS	Proposed Loading	Result
Rock Anchored Pad and Pier (x3)	Bearing Pressure	12.00ksf	8.9ksf	PASS
	Rock Mass Uplift Resistance	2.00 <sup>(2)</sup>	5.10 <sup>(2)</sup>	PASS
	Rock Anchor Rock/Grout Bond Uplift Resistance	2.00 <sup>(2)</sup>	3.45 <sup>(2)</sup>	PASS

Note 2: Minimum required Factor of Safety (FS) of 2.0 required per IBC 2003/2005 CSBC Section 3108.4.2.

## Conclusion and Recommendations

This analysis shows that the subject tower **is adequate** to support the proposed antenna configuration with the below recommendations.

- **All reinforcements per the structural analysis report prepared by Cenetek for T-Mobile job no. 14033.002 dated March 27, 2014 must be completed prior to the Verizon Wireless antenna upgrade.**
- **All coax cables routed as specified in Section 3 of this report**

The analysis is based, in part, on the information provided to this office by Verizon Wireless. If the existing conditions are different than the information in this report, Centek Engineering, Inc. must be contacted for resolution of any potential issues.

Please feel free to call with any questions or comments.

Respectfully Submitted by:

  
 Timothy J. Lynn, PE  
 Structural Engineer

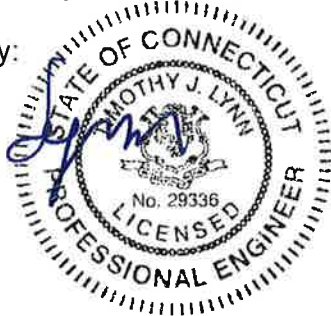



Standard Conditions for Furnishing of  
Professional Engineering Services on  
Existing Structures

All engineering services are performed on the basis that the information used is current and correct. This information may consist of, but is not necessarily limited to:

- Information supplied by the client regarding the structure itself, its foundations, the soil conditions, the antenna and feed line loading on the structure and its components, or other relevant information.
- Information from the field and/or drawings in the possession of Centek Engineering, Inc. or generated by field inspections or measurements of the structure.
- It is the responsibility of the client to ensure that the information provided to Centek Engineering, Inc. and used in the performance of our engineering services is correct and complete. In the absence of information to the contrary, we assume that all structures were constructed in accordance with the drawings and specifications and are in an uncorroded condition and have not deteriorated. It is therefore assumed that its capacity has not significantly changed from the "as new" condition.
- All services will be performed to the codes specified by the client, and we do not imply to meet any other codes or requirements unless explicitly agreed in writing. If wind and ice loads or other relevant parameters are to be different from the minimum values recommended by the codes, the client shall specify the exact requirement. In the absence of information to the contrary, all work will be performed in accordance with the latest revision of ANSI/ASCE10 & ANSI/EIA-222
- All services performed, results obtained, and recommendations made are in accordance with generally accepted engineering principles and practices. Centek Engineering, Inc. is not responsible for the conclusions, opinions and recommendations made by others based on the information we supply.

## GENERAL DESCRIPTION OF STRUCTURAL ANALYSIS PROGRAM

tnxTower, is an integrated structural analysis and design software package for Designed specifically for the telecommunications industry, tnxTower, formerly RISA Tower, automates much of the tower analysis and design required by the TIA/EIA 222 Standard.

### tnxTower Features:

- tnxTower can analyze and design 3- and 4-sided guyed towers, 3- and 4-sided self-supporting towers and either round or tapered ground mounted poles with or without guys.
- The program analyzes towers using the TIA-222-G (2005) standard or any of the previous TIA/EIA standards back to RS-222 (1959). Steel design is checked using the AISC ASD 9th Edition or the AISC LRFD specifications.
- Linear and non-linear (P-delta) analyses can be used in determining displacements and forces in the structure. Wind pressures and forces are automatically calculated.
- Extensive graphics plots include material take-off, shear-moment, leg compression, displacement, twist, feed line, guy anchor and stress plots.
- tnxTower contains unique features such as True Cable behavior, hog rod take-up, foundation stiffness and much more.

Section	T1	T2	T3	T4	T5	T6	T7	T8	T9	T10	T11	T12	T13	T14	T15
Legs	ROHN 6 EHS	ROHN 4 EH	ROHN 4 EH	ROHN 3 EH	ROHN 2.5 EH	ROHN 2.5 STD									
Leg Grade	L4x4x1/4	L3x3x1/4	L3x3x1/4	L3x3x3/16	L2 1/2x2 1/2x3/16	L2 1/2x2 1/2x3/16	L2 1/2x2 1/2x3/16	L2 1/2x2 1/2x3/16	L2 1/2x2 1/2x3/16	L2 1/2x2 1/2x3/16	L2 1/2x2 1/2x3/16	L2 1/2x2 1/2x3/16	L2 1/2x2 1/2x3/16	L2 1/2x2 1/2x3/16	L2 1/2x2 1/2x3/16
Diagonals															
Diagonal Grade															
Top Chls															
Spec. Holes/Spalls															
Face Width (ft)	22.85	16.89	16.68	14.66	12.6	10.56	8.56	6.56	4.56	2.56	0.56	0.56	0.56	0.56	0.56
# Panels @ (ft)	17.2	8 @ 10	8 @ 10	8 @ 10	8 @ 10	8 @ 10	8 @ 10	8 @ 10	8 @ 10	8 @ 10	8 @ 10	8 @ 10	8 @ 10	8 @ 10	8 @ 10
Weight (K)	17.2	3.8	3.8	3.1	1.8	1.1	0.6	0.3	0.1	0.05	0.02	0.01	0.01	0.01	0.01

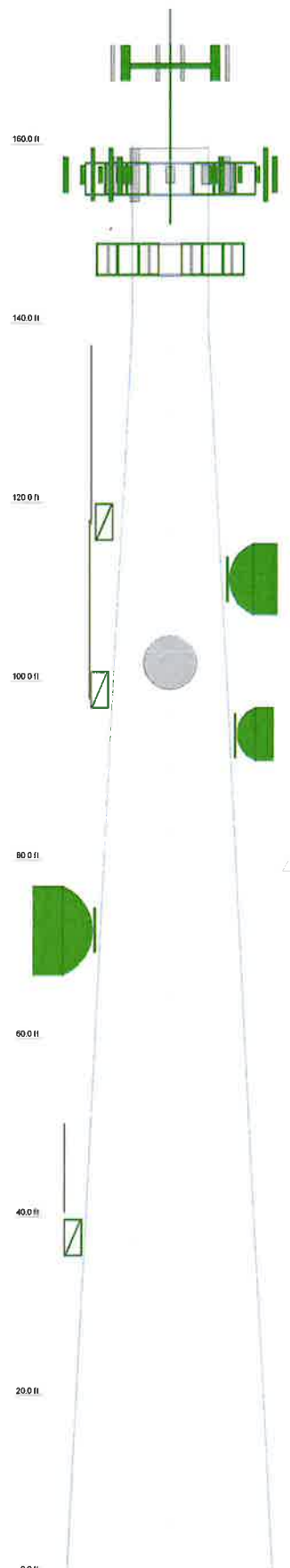

**DESIGNED APPURTENANCE LOADING**

TYPE	ELEVATION	TYPE	ELEVATION
(2) AM-X-CD-1465-00T-RET (ATI)	160	D6-T1-6Z-8AB-0Z (Verizon - Existing)	156.5
(2) AM-X-CD-1465-00T-RET (ATI)	160	D6-T1-6Z-8AB-0Z (Verizon - Proposed)	156.5
(2) AM-X-CD-1465-00T-RET (ATI)	160	LPA-80063-4CF (Verizon - Existing)	156.5
(2) TT19-086P111-001 TMA (ATI)	160	Without 15' T-Frame P111 600109 (Verizon)	156
(2) TT19-086P111-001 TMA (ATI)	160	Without 15' T-Frame P111 600109 (Verizon)	156
(2) TT19-086P111-001 TMA (ATI)	160	Without 15' T-Frame P111 600109 (Verizon)	156
Verizon 10' 6" T-Arms 3 (Cable Xs P111 602738) (ATI)	160	AFX16DWW-16DWW5-C-A20 (T-Mobile)	147
15' x 2" Dia Orns (Unknown)	160	AFX16DWW-16DWW5-C-A20 (T-Mobile)	147
P6 18ft Pipe Mast (ATI)	161	(2) AIR21 (T-Mobile)	147
SBNH-1D656 (Verizon - Proposed)	156.5	(2) AIR21 (T-Mobile)	147
BXA-700406CF (Verizon - Existing)	156.5	KRY 112 TMA (T-Mobile)	147
SBNH-1D656 (Verizon - Proposed)	156.5	KRY 112 TMA (T-Mobile)	147
LPA-80063-4CF (Verizon - Existing)	156.5	KRY 112 TMA (T-Mobile)	147
LPA-80063-4CF (Verizon - Existing)	156.5	15' Frame (T-Mobile)	147
SBNH-1D656 (Verizon - Proposed)	156.5	15' Frame (T-Mobile)	147
BXA-700406CF (Verizon - Existing)	156.5	15' Frame (T-Mobile)	147
SBNH-1D656 (Verizon - Proposed)	156.5	AFX16DWW-16DWW5-C-A20 (T-Mobile)	147
LPA-80063-4CF (Verizon - Existing)	156.5	15' x 2" Dia Orns (Unknown)	127.8
LPA-80063-4CF (Verizon - Existing)	156.5	4' Side Mount Standoff (Unknown)	117.75
SBNH-1D656 (Verizon - Proposed)	156.5	50"x4.5" Pipe Mount (Unknown)	111.33
BXA-700406CF (Verizon - Existing)	156.5	8 FT DSH (Unknown)	111.33
SBNH-1D656 (Verizon - Proposed)	156.5	16' x 2" Dia Orns (Unknown)	100
LPA-80063-4CF (Verizon - Existing)	156.5	50"x4.5" Pipe Mount (Unknown)	102.2
RRH4x452x90-AWS (Verizon - Proposed)	156.5	6 FT DSH (Unknown)	102
RRH4x452x90-AWS (Verizon - Proposed)	156.5	4' Side Mount Standoff (Unknown)	99
RRH4x452x90-AWS (Verizon - Proposed)	156.5	6 FT DSH (Unknown)	94
RRH2x60-PCS (Verizon - Proposed)	156.5	50"x4.5" Pipe Mount (Unknown)	80.83
RRH2x60-PCS (Verizon - Proposed)	156.5	50"x4.5" Pipe Mount (Unknown)	72.1
RRH2x60-PCS (Verizon - Proposed)	156.5	10 FT DSH (Unknown)	72
RRH4x30-B13 (Verizon - Proposed)	156.5	4' Side Mount Standoff (Verizon) (Unknown)	47
RRH4x30-B13 (Verizon - Proposed)	156.5	12' x 1-1/2" Dia Orns (Unknown)	45.41
RRH4x30-B13 (Verizon - Proposed)	156.5	4' Side Mount Standoff (Unknown)	37.58

**MATERIAL STRENGTH**

GRADE	Fy	Fu	GRADE	Fy	Fu
A36	50 ksi	65 ksi	A36	36 ksi	58 ksi

**TOWER DESIGN NOTES**

1. Tower designed for a 80 mph basic wind in accordance with the EIA-222-D Standard.
2. Tower is also designed for a 69 mph basic wind with 0.50 in ice.
3. Deflections are based upon a 50 mph wind.
4. Weld together tower sections have flange connections.
5. Connections use galvanized A325 bolts, nuts and locking devices. Installation per TIA/EIA-222 and AISC Specifications.
6. Tower members are "hot dipped" galvanized in accordance with ASTM A123 and ASTM A153 Standards.
7. Welds are fabricated with ER-70S-6 electrodes.
8. TOWER RATINGS: 97.8%

MAX. CORNER REACTIONS AT BASE:  
 DOWN: 203 K  
 UPLIFT: -177 K  
 SHEAR: 24 K

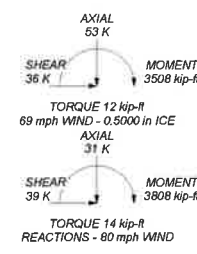

<b>Centek Engineering Inc.</b>		15001.040 - Windsor	
63-2 North Branford Rd.		Project: 160' Lattice Tower - 482 Pigeon Hill Road, Windsor, CT	
Branford, CT 06405		Client: Verizon Wireless	Drawn By: T.J.L.
Phone: (203) 488-0560		Date: 09/01/15	Scale: NTS
FAX: (203) 488-8567		Date: 09/01/15	Scale: NTS
		Date: 09/01/15	Scale: NTS
		Date: 09/01/15	Scale: NTS

Round

Flat

App In Face

App Out Face

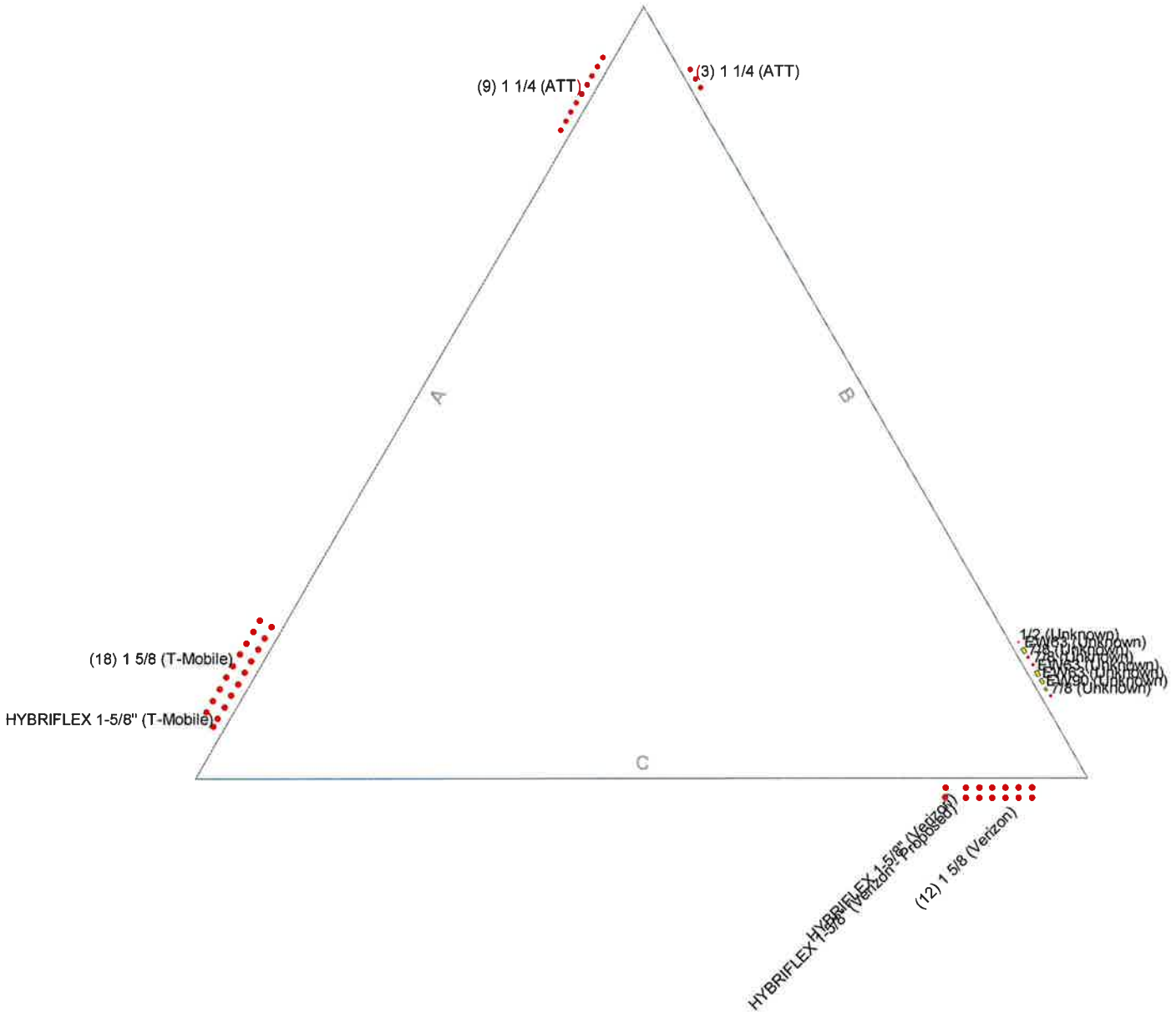

<b>Centek Engineering Inc.</b>			
63-2 North Branford Rd. Branford, CT 06405 Phone: (203) 488-0580 FAX: (203) 488-8587			
Job:	<b>15001.040 - Windsor</b>		
Project:	160' Lattice Tower - 482 Pigeon Hill Road, Windsor,		
Client:	Verizon Wireless	Drawn by:	TJL
Code:	EIA-222-D	Date:	09/01/15
Path:		Scale:	NTS
		Dwg No.:	E-7

0' - 160'

Round Flat App In Face App Out Face Truss Leg

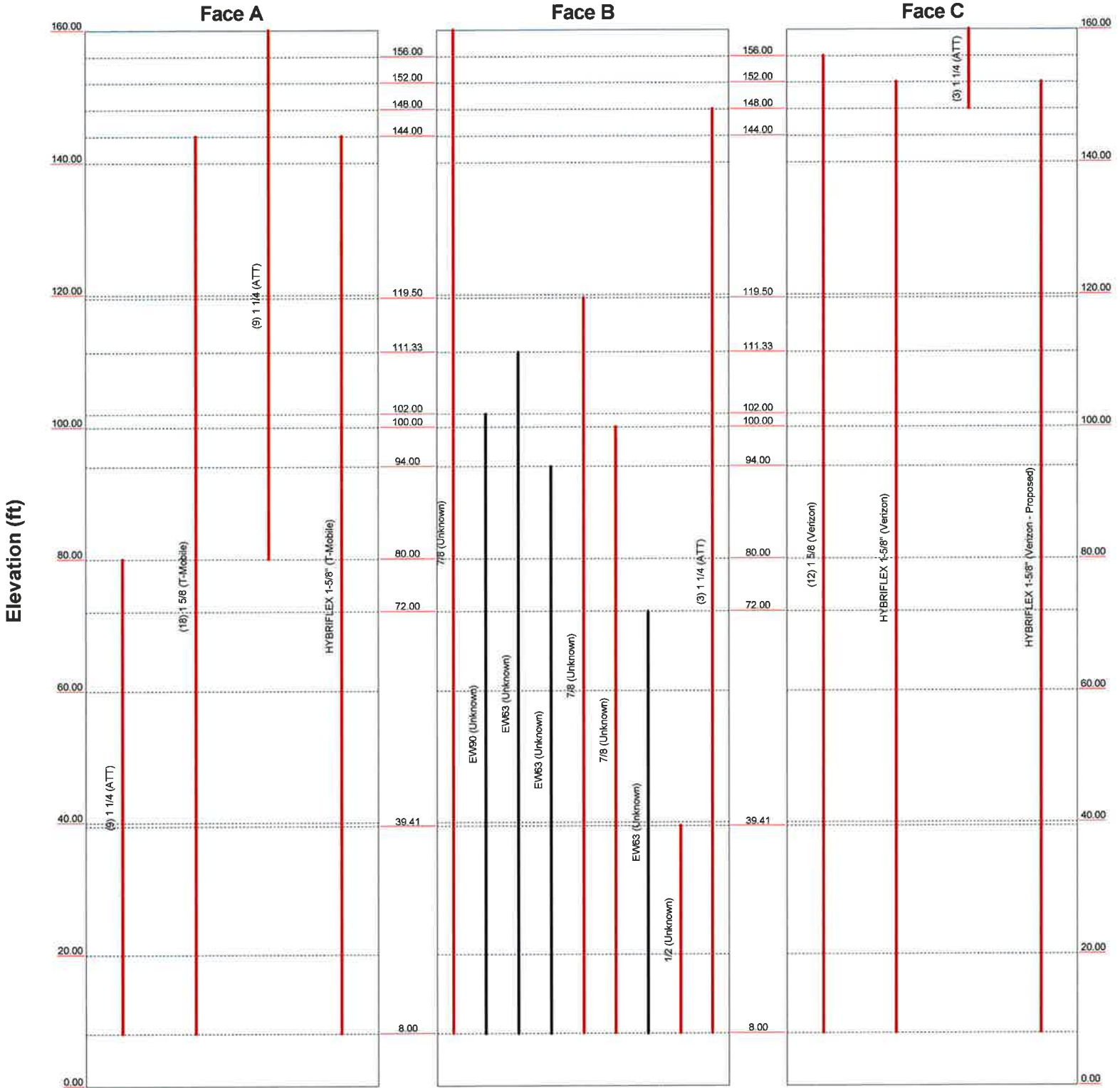

<b>Centek Engineering Inc.</b>			
63-2 North Branford Rd. Branford, CT 06405 Phone: (203) 488-0580 FAX: (203) 488-8587			
Job:	15001.040 - Windsor		
Project:	160' Lattice Tower - 482 Pigeon Hill Road, Windsor,		
Client:	Verizon Wireless	Drawn by:	T.JL
Code:	EIA-222-D	Date:	09/01/15
Path:	J:\EIA\100101\10040 - Windsor\Stack Department of Geology\160' Lattice Tower Windsor	Scale:	NTS
		Dwg No.:	E-7

<b>tnxTower</b>  <b>Centek Engineering Inc.</b> 63-2 North Branford Rd. Branford, CT 06405 Phone: (203) 488-0580 FAX: (203) 488-8587	<b>Job</b> 15001.040 - Windsor	<b>Page</b> 1 of 32
	<b>Project</b> 160' Lattice Tower - 482 Pigeon Hill Road, Windsor, CT	<b>Date</b> 15:28:01 09/01/15
	<b>Client</b> Verizon Wireless	<b>Designed by</b> TJL

## Tower Input Data

The main tower is a 3x free standing tower with an overall height of 160.00 ft above the ground line.

The base of the tower is set at an elevation of 0.00 ft above the ground line.

The face width of the tower is 8.56 ft at the top and 22.85 ft at the base.

This tower is designed using the EIA-222-D standard.

The following design criteria apply:

Basic wind speed of 80 mph.

Nominal ice thickness of 0.5000 in.

Ice density of 56 pcf.

A wind speed of 69 mph is used in combination with ice.

Temperature drop of 50 °F.

Deflections calculated using a wind speed of 50 mph.

Weld together tower sections have flange connections..

Connections use galvanized A325 bolts, nuts and locking devices. Installation per TIA/EIA-222 and AISC Specifications..

Tower members are "hot dipped" galvanized in accordance with ASTM A123 and ASTM A153 Standards..

Welds are fabricated with ER-70S-6 electrodes..

A non-linear (P-delta) analysis was used.

Pressures are calculated at each section.

Stress ratio used in tower member design is 1.333.

Local bending stresses due to climbing loads, feedline supports, and appurtenance mounts are not considered.

## Options

- |  |  |  |
|--|--|--|
| <ul style="list-style-type: none"> <li>Consider Moments - Legs</li> <li>Consider Moments - Horizontals</li> <li>Consider Moments - Diagonals</li> <li>Use Moment Magnification</li> <li>√ Use Code Stress Ratios</li> <li>√ Use Code Safety Factors - Guys</li> <li>Escalate Ice</li> <li>Always Use Max Kz</li> <li>Use Special Wind Profile</li> <li>√ Include Bolts In Member Capacity</li> <li>Leg Bolts Are At Top Of Section</li> <li>√ Secondary Horizontal Braces Leg</li> <li>Use Diamond Inner Bracing (4 Sided)</li> <li>Add IBC .6D+W Combination</li> </ul> | <ul style="list-style-type: none"> <li>Distribute Leg Loads As Uniform</li> <li>Assume Legs Pinned</li> <li>√ Assume Rigid Index Plate</li> <li>√ Use Clear Spans For Wind Area</li> <li>√ Use Clear Spans For KL/r</li> <li>Retension Guys To Initial Tension</li> <li>Bypass Mast Stability Checks</li> <li>√ Use Azimuth Dish Coefficients</li> <li>√ Project Wind Area of Appurt.</li> <li>Autocalc Torque Arm Areas</li> <li>SR Members Have Cut Ends</li> <li>√ Sort Capacity Reports By Component</li> <li>Triangulate Diamond Inner Bracing</li> </ul> | <ul style="list-style-type: none"> <li>Treat Feedline Bundles As Cylinder</li> <li>Use ASCE 10 X-Brace Ly Rules</li> <li>√ Calculate Redundant Bracing Forces</li> <li>Ignore Redundant Members in FEA</li> <li>√ SR Leg Bolts Resist Compression</li> <li>√ All Leg Panels Have Same Allowable</li> <li>Offset Girt At Foundation</li> <li>√ Consider Feedline Torque</li> <li>Include Angle Block Shear Check</li> </ul> |
|  |  | <b>Poles</b>   |
|  |  | <ul style="list-style-type: none"> <li>Include Shear-Torsion Interaction</li> <li>Always Use Sub-Critical Flow</li> <li>Use Top Mounted Sockets</li> </ul>   |

<b>tnxTower</b>  <b>Centek Engineering Inc.</b> 63-2 North Branford Rd. Branford, CT 06405 Phone: (203) 488-0580 FAX: (203) 488-8587	<b>Job</b> 15001.040 - Windsor	<b>Page</b> 2 of 32
	<b>Project</b> 160' Lattice Tower - 482 Pigeon Hill Road, Windsor, CT	<b>Date</b> 15:28:01 09/01/15
	<b>Client</b> Verizon Wireless	<b>Designed by</b> TJL

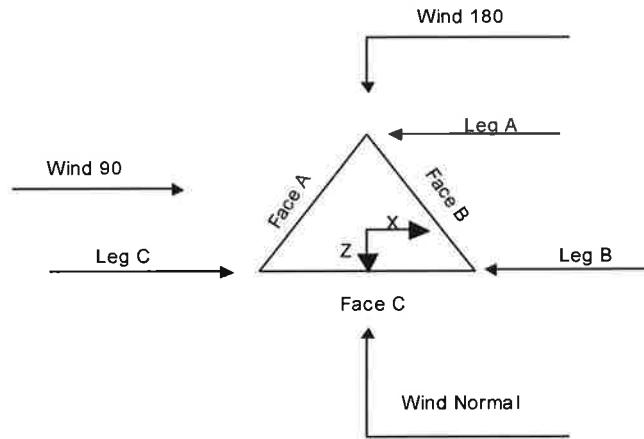

**Triangular Tower**

**Tower Section Geometry**

Tower Section	Tower Elevation	Assembly Database	Description	Section Width	Number of Sections	Section Length
	ft			ft		ft
T1	160.00-140.00			8.56	1	20.00
T2	140.00-120.00			8.56	1	20.00
T3	120.00-100.00			10.56	1	20.00
T4	100.00-80.00			12.60	1	20.00
T5	80.00-60.00			14.66	1	20.00
T6	60.00-40.00			16.69	1	20.00
T7	40.00-20.00			18.69	1	20.00
T8	20.00-0.00			20.85	1	20.00

**Tower Section Geometry (cont'd)**

Tower Section	Tower Elevation	Diagonal Spacing	Bracing Type	Has K Brace End Panels	Has Horizontals	Top Girt Offset	Bottom Girt Offset
	ft	ft				in	in
T1	160.00-140.00	4.75	X Brace	No	No	6.0000	6.0000
T2	140.00-120.00	6.67	X Brace	No	Yes	0.0000	0.0000
T3	120.00-100.00	6.67	X Brace	No	Yes	0.0000	0.0000
T4	100.00-80.00	6.67	X Brace	No	Yes	0.0000	0.0000
T5	80.00-60.00	10.00	X Brace	No	Yes	0.0000	0.0000
T6	60.00-40.00	10.00	X Brace	No	No	0.0000	0.0000
T7	40.00-20.00	10.00	X Brace	No	No	0.0000	0.0000

<b>tnxTower</b>  <b>Centek Engineering Inc.</b> 63-2 North Branford Rd. Branford, CT 06405 Phone: (203) 488-0580 FAX: (203) 488-8587	<b>Job</b> 15001.040 - Windsor	<b>Page</b> 3 of 32
	<b>Project</b> 160' Lattice Tower - 482 Pigeon Hill Road, Windsor, CT	<b>Date</b> 15:28:01 09/01/15
	<b>Client</b> Verizon Wireless	<b>Designed by</b> TJL

Tower Section	Tower Elevation	Diagonal Spacing	Bracing Type	Has K Brace End Panels	Has Horizontals	Top Girt Offset	Bottom Girt Offset
	ft	ft				in	in
T8	20.00-0.00	10.00	X Brace	No	No	0.0000	0.0000

### Tower Section Geometry (cont'd)

Tower Elevation	Leg Type	Leg Size	Leg Grade	Diagonal Type	Diagonal Size	Diagonal Grade
ft						
T1 160.00-140.00	Pipe	ROHN 2.5 STD	A572-50 (50 ksi)	Equal Angle	L1 3/4x1 3/4x1/4	A36 (36 ksi)
T2 140.00-120.00	Pipe	ROHN 2.5 STD	A572-50 (50 ksi)	Equal Angle	L2x2x1/4	A36 (36 ksi)
T3 120.00-100.00	Pipe	ROHN 2.5 EH	A572-50 (50 ksi)	Equal Angle	L2 1/2x2 1/2x3/16	A36 (36 ksi)
T4 100.00-80.00	Pipe	ROHN 3 EH	A572-50 (50 ksi)	Equal Angle	L3x3x3/16	A36 (36 ksi)
T5 80.00-60.00	Pipe	ROHN 4 EH	A572-50 (50 ksi)	Equal Angle	L3x3x1/4	A36 (36 ksi)
T6 60.00-40.00	Pipe	ROHN 5 EH	A572-50 (50 ksi)	Equal Angle	L3 1/2x3 1/2x1/4	A36 (36 ksi)
T7 40.00-20.00	Pipe	ROHN 5 EH	A572-50 (50 ksi)	Equal Angle	L3 1/2x3 1/2x1/4	A36 (36 ksi)
T8 20.00-0.00	Pipe	ROHN 6 EHS	A572-50 (50 ksi)	Equal Angle	L4x4x1/4	A36 (36 ksi)

### Tower Section Geometry (cont'd)

Tower Elevation	Top Girt Type	Top Girt Size	Top Girt Grade	Bottom Girt Type	Bottom Girt Size	Bottom Girt Grade
ft						
T1 160.00-140.00	Equal Angle	L2 1/2x2 1/2x3/8	A36 (36 ksi)	Equal Angle		A36 (36 ksi)

### Tower Section Geometry (cont'd)

Tower Elevation	Secondary Horizontal Type	Secondary Horizontal Size	Secondary Horizontal Grade	Inner Bracing Type	Inner Bracing Size	Inner Bracing Grade
ft						
T2 140.00-120.00	Equal Angle	L2x2x1/4	A36 (36 ksi)	Equal Angle		A36 (36 ksi)
T3 120.00-100.00	Equal Angle	L2 1/2x2 1/2x3/16	A36 (36 ksi)	Equal Angle		A36 (36 ksi)
T4 100.00-80.00	Equal Angle	L3x3x3/16	A36 (36 ksi)	Equal Angle		A36 (36 ksi)
T5 80.00-60.00	Equal Angle	L3x3x1/4	A36 (36 ksi)	Equal Angle		A36 (36 ksi)



<b>tnxTower</b>  <b>Centek Engineering Inc.</b> 63-2 North Branford Rd. Branford, CT 06405 Phone: (203) 488-0580 FAX: (203) 488-8587	<b>Job</b> 15001.040 - Windsor	<b>Page</b> 4 of 32
	<b>Project</b> 160' Lattice Tower - 482 Pigeon Hill Road, Windsor, CT	<b>Date</b> 15:28:01 09/01/15
	<b>Client</b> Verizon Wireless	<b>Designed by</b> TJL

**Tower Section Geometry (cont'd)**

Tower Elevation	Gusset Area (per face)	Gusset Thickness	Gusset Grade	Adjust. Factor $A_f$	Adjust. Factor $A_r$	Weight Mult.	Double Angle Stitch Bolt Spacing Diagonals in	Double Angle Stitch Bolt Spacing Horizontals in
ft	ft <sup>2</sup>	in						
T1 160.00-140.00	0.00	0.0000	A36 (36 ksi)	1	1	1	36.0000	36.0000
T2 140.00-120.00	0.00	0.0000	A36 (36 ksi)	1	1	1	36.0000	36.0000
T3 120.00-100.00	0.00	0.0000	A36 (36 ksi)	1	1	1	36.0000	36.0000
T4 100.00-80.00	0.00	0.0000	A36 (36 ksi)	1	1	1	36.0000	36.0000
T5 80.00-60.00	0.00	0.0000	A36 (36 ksi)	1	1	1	36.0000	36.0000
T6 60.00-40.00	0.00	0.0000	A36 (36 ksi)	1	1	1	36.0000	36.0000
T7 40.00-20.00	0.00	0.0000	A36 (36 ksi)	1	1	1	36.0000	36.0000
T8 20.00-0.00	0.00	0.0000	A36 (36 ksi)	1	1	1	36.0000	36.0000

**Tower Section Geometry (cont'd)**

Tower Elevation	Calc K Single Angles	Calc K Solid Rounds	K Factors <sup>1</sup>									
			Legs	X Brace Diags		K Brace Diags		Single Diags	Girts	Horiz.	Sec. Horiz.	Inner Brace
				X	Y	X	Y					
ft				X	Y	X	Y	X	Y	X	Y	
T1 160.00-140.00	Yes	Yes	1	1	1	1	1	1	1	1	1	1
T2 140.00-120.00	Yes	Yes	1	1	1	1	1	1	1	1	1	1
T3 120.00-100.00	Yes	Yes	1	1	1	1	1	1	1	1	1	1
T4 100.00-80.00	Yes	Yes	1	1	1	1	1	1	1	1	1	1
T5 80.00-60.00	Yes	Yes	1	1	1	1	1	1	1	1	1	1
T6 60.00-40.00	Yes	Yes	1	1	1	1	1	1	1	1	1	1
T7 40.00-20.00	Yes	Yes	1	1	1	1	1	1	1	1	1	1
T8 20.00-0.00	Yes	Yes	1	1	1	1	1	1	1	1	1	1

<sup>1</sup>Note: K factors are applied to member segment lengths. K-braces without inner supporting members will have the K factor in the out-of-plane direction applied to the overall length.

**Tower Section Geometry (cont'd)**

<b>tnxTower</b>  <b>Centek Engineering Inc.</b> 63-2 North Branford Rd. Branford, CT 06405 Phone: (203) 488-0580 FAX: (203) 488-8587	<b>Job</b>	15001.040 - Windsor	<b>Page</b>	5 of 32	
	<b>Project</b>	160' Lattice Tower - 482 Pigeon Hill Road, Windsor, CT		<b>Date</b>	15:28:01 09/01/15
	<b>Client</b>	Verizon Wireless		<b>Designed by</b>	TJL

Tower Elevation ft	Leg		Diagonal		Top Girt		Bottom Girt		Mid Girt		Long Horizontal		Short Horizontal	
	Net Width Deduct in	U	Net Width Deduct in	U	Net Width Deduct in	U	Net Width Deduct in	U	Net Width Deduct in	U	Net Width Deduct in	U	Net Width Deduct in	U
T1 160.00-140.00	0.0000	1	0.0000	1	0.0000	1	0.0000	1	0.0000	1	0.0000	1	0.0000	1
T2 140.00-120.00	0.0000	1	0.0000	1	0.0000	1	0.0000	1	0.0000	1	0.0000	1	0.0000	1
T3 120.00-100.00	0.0000	1	0.0000	1	0.0000	1	0.0000	1	0.0000	1	0.0000	1	0.0000	1
T4 100.00-80.00	0.0000	1	0.0000	1	0.0000	1	0.0000	1	0.0000	1	0.0000	1	0.0000	1
T5 80.00-60.00	0.0000	1	0.0000	1	0.0000	1	0.0000	1	0.0000	1	0.0000	1	0.0000	1
T6 60.00-40.00	0.0000	1	0.0000	1	0.0000	1	0.0000	1	0.0000	1	0.0000	1	0.0000	1
T7 40.00-20.00	0.0000	1	0.0000	1	0.0000	1	0.0000	1	0.0000	1	0.0000	1	0.0000	1
T8 20.00-0.00	0.0000	1	0.0000	1	0.0000	1	0.0000	1	0.0000	1	0.0000	1	0.0000	1

**Tower Section Geometry (cont'd)**

Tower Elevation ft	Leg Connection Type	Leg		Diagonal		Top Girt		Bottom Girt		Mid Girt		Long Horizontal		Short Horizontal	
		Bolt Size in	No.	Bolt Size in	No.	Bolt Size in	No.	Bolt Size in	No.	Bolt Size in	No.	Bolt Size in	No.	Bolt Size in	No.
T1 160.00-140.00	Flange	0.6250	4	0.5000	1	0.6250	0	0.6250	0	0.6250	0	0.6250	0	0.6250	0
T2 140.00-120.00	Flange	0.6250	4	0.5000	1	0.6250	0	0.6250	0	0.6250	0	0.6250	0	0.7500	0
T3 120.00-100.00	Flange	0.7500	4	0.5000	1	0.6250	0	0.6250	0	0.6250	0	0.6250	0	0.7500	2
T4 100.00-80.00	Flange	0.8750	4	0.5000	1	0.6250	0	0.6250	0	0.6250	0	0.6250	0	0.6250	2
T5 80.00-60.00	Flange	1.0000	4	0.6250	1	0.6250	0	0.6250	0	0.6250	0	0.6250	0	0.6250	2
T6 60.00-40.00	Flange	1.0000	4	0.6250	1	0.6250	0	0.6250	0	0.6250	0	0.6250	0	0.6250	0
T7 40.00-20.00	Flange	1.0000	6	0.6250	1	0.6250	0	0.6250	0	0.6250	0	0.6250	0	0.6250	0
T8 20.00-0.00	Flange	0.8750	6	0.6250	1	0.6250	0	0.6250	0	0.6250	0	0.6250	0	0.6250	0
		A354-BC		A325X		A325X		A325X		A325X		A325X		A325N	

**Feed Line/Linear Appurtenances - Entered As Round Or Flat**

Description	Face or Leg	Allow Shield	Component Type	Placement ft	Face Offset in	Lateral Offset (Frac FW)	# Per Row	# Row	Clear Spacing in	Width or Diameter in	Perimeter in	Weight plf
1 5/8 (Verizon)	C	Yes	Ar (CfAe)	156.00 - 8.00	2.0000	-0.4	12	6	1.9800 1.0000	1.9800		1.04
1 1/4 (ATT)	A	Yes	Ar (CfAe)	80.00 - 8.00	2.0000	0.38	9	9	1.5500	1.5500		0.66
7/8 (Unknown)	B	Yes	Ar (CfAe)	160.00 - 8.00	2.0000	0.4	1	1	1.1100	1.1100		0.54

<b>tnxTower</b>  <b>Centek Engineering Inc.</b> 63-2 North Branford Rd. Branford, CT 06405 Phone: (203) 488-0580 FAX: (203) 488-8587	<b>Job</b> 15001.040 - Windsor	<b>Page</b> 6 of 32
	<b>Project</b> 160' Lattice Tower - 482 Pigeon Hill Road, Windsor, CT	<b>Date</b> 15:28:01 09/01/15
	<b>Client</b> Verizon Wireless	<b>Designed by</b> TJL

Description	Face or Leg	Allow Shield	Component Type	Placement ft	Face Offset in	Lateral Offset (Frac FW)	#	# Per Row	Clear Spacing in	Width or Diameter in	Perimeter in	Weight plf
EW90 (Unknown)	B	Yes	Af (CfAe)	102.00 - 8.00	2.0000	0.39	1	1	0.9869	0.9869	3.2550	0.32
EW63 (Unknown)	B	Yes	Af (CfAe)	111.33 - 8.00	2.0000	0.38	1	1	1.5742	1.5742	5.0668	0.51
EW63 (Unknown)	B	Yes	Af (CfAe)	94.00 - 8.00	2.0000	0.37	1	1	1.5742	1.5742	5.0668	0.51
7/8 (Unknown)	B	Yes	Ar (CfAe)	119.50 - 8.00	2.0000	0.36	1	1	1.1100	1.1100		0.54
7/8 (Unknown)	B	Yes	Ar (CfAe)	100.00 - 8.00	2.0000	0.35	1	1	1.1100	1.1100		0.54
EW63 (Unknown)	B	Yes	Af (CfAe)	72.00 - 8.00	2.0000	0.34	1	1	1.5742	1.5742	5.0668	0.51
1/2 (Unknown)	B	Yes	Ar (CfAe)	39.41 - 8.00	2.0000	0.33	1	1	0.5800	0.5800		0.25
1 5/8 (T-Mobile)	A	Yes	Ar (CfAe)	144.00 - 8.00	2.0000	-0.37	18	9	1.9800	1.9800		1.04
1 1/4 (ATT)	B	Yes	Ar (CfAe)	148.00 - 8.00	2.0000	-0.4	3	3	1.5500	1.5500		0.66
HYBRIFLEX 1-5/8" (Verizon)	C	Yes	Ar (CfAe)	152.00 - 8.00	2.0000	-0.34	1	1	1.0000	1.9800		1.90
1 1/4 (ATT)	A	Yes	Ar (CfAe)	160.00 - 80.00	2.0000	0.3	9	9	1.5500	1.5500		0.66
1 1/4 (ATT)	C	Yes	Ar (CfAe)	160.00 - 148.00	-6.0000	0	3	3	1.5500	1.5500		0.66
HYBRIFLEX 1-5/8" (T-Mobile)	A	Yes	Ar (CfAe)	144.00 - 8.00	2.0000	-0.44	1	1	1.0000	1.9800		1.90
HYBRIFLEX 1-5/8" (Verizon - Proposed)	C	Yes	Ar (CfAe)	152.00 - 8.00	5.0000	-0.34	1	1	1.0000	1.9800		1.90

### Feed Line/Linear Appurtenances Section Areas

Tower Section	Tower Elevation ft	Face	A <sub>R</sub> ft <sup>2</sup>	A <sub>F</sub> ft <sup>2</sup>	C <sub>AA</sub> In Face ft <sup>2</sup>	C <sub>AA</sub> Out Face ft <sup>2</sup>	Weight K
T1	160.00-140.00	A	29.850	0.000	0.000	0.000	0.20
		B	4.950	0.000	0.000	0.000	0.03
		C	24.450	0.000	0.000	0.000	0.27
T2	140.00-120.00	A	56.250	0.000	0.000	0.000	0.53
		B	9.600	0.000	0.000	0.000	0.05
		C	26.400	0.000	0.000	0.000	0.33
T3	120.00-100.00	A	56.250	0.000	0.000	0.000	0.53
		B	11.404	1.651	0.000	0.000	0.07
		C	26.400	0.000	0.000	0.000	0.33
T4	100.00-80.00	A	56.250	0.000	0.000	0.000	0.53
		B	13.300	6.105	0.000	0.000	0.10
		C	26.400	0.000	0.000	0.000	0.33
T5	80.00-60.00	A	56.250	0.000	0.000	0.000	0.53
		B	13.300	8.466	0.000	0.000	0.10
		C	26.400	0.000	0.000	0.000	0.33
T6	60.00-40.00	A	56.250	0.000	0.000	0.000	0.53
		B	13.300	9.516	0.000	0.000	0.11
		C	26.400	0.000	0.000	0.000	0.33
T7	40.00-20.00	A	56.250	0.000	0.000	0.000	0.53

<b>tnxTower</b>  <b>Centek Engineering Inc.</b> 63-2 North Branford Rd. Branford, CT 06405 Phone: (203) 488-0580 FAX: (203) 488-8587	<b>Job</b> 15001.040 - Windsor	<b>Page</b> 7 of 32
	<b>Project</b> 160' Lattice Tower - 482 Pigeon Hill Road, Windsor, CT	<b>Date</b> 15:28:01 09/01/15
	<b>Client</b> Verizon Wireless	<b>Designed by</b> TJL

Tower Section	Tower Elevation ft	Face	$A_R$ ft <sup>2</sup>	$A_F$ ft <sup>2</sup>	$C_{AA}$ In Face ft <sup>2</sup>	$C_{AA}$ Out Face ft <sup>2</sup>	Weight K
T8	20.00-0.00	B	14.238	9.516	0.000	0.000	0.11
		C	26.400	0.000	0.000	0.000	0.33
		A	33.750	0.000	0.000	0.000	0.32
		B	8.560	5.710	0.000	0.000	0.07
		C	15.840	0.000	0.000	0.000	0.20

### Feed Line/Linear Appurtenances Section Areas - With Ice

Tower Section	Tower Elevation ft	Face or Leg	Ice Thickness in	$A_R$ ft <sup>2</sup>	$A_F$ ft <sup>2</sup>	$C_{AA}$ In Face ft <sup>2</sup>	$C_{AA}$ Out Face ft <sup>2</sup>	Weight K
T1	160.00-140.00	A	0.500	48.183	0.000	0.000	0.000	0.54
		B		8.617	0.000	0.000	0.000	0.08
		C		37.450	0.000	0.000	0.000	0.64
T2	140.00-120.00	A	0.500	87.917	0.000	0.000	0.000	1.33
		B		16.267	0.000	0.000	0.000	0.15
		C		39.733	0.000	0.000	0.000	0.75
T3	120.00-100.00	A	0.500	87.917	0.000	0.000	0.000	1.33
		B		19.695	2.391	0.000	0.000	0.20
		C		39.733	0.000	0.000	0.000	0.75
T4	100.00-80.00	A	0.500	87.917	0.000	0.000	0.000	1.33
		B		23.300	9.105	0.000	0.000	0.30
		C		39.733	0.000	0.000	0.000	0.75
T5	80.00-60.00	A	0.500	87.917	0.000	0.000	0.000	1.33
		B		23.300	12.466	0.000	0.000	0.33
		C		39.733	0.000	0.000	0.000	0.75
T6	60.00-40.00	A	0.500	87.917	0.000	0.000	0.000	1.33
		B		23.300	13.960	0.000	0.000	0.34
		C		39.733	0.000	0.000	0.000	0.75
T7	40.00-20.00	A	0.500	87.917	0.000	0.000	0.000	1.33
		B		25.856	13.960	0.000	0.000	0.36
		C		39.733	0.000	0.000	0.000	0.75
T8	20.00-0.00	A	0.500	52.750	0.000	0.000	0.000	0.80
		B		15.560	8.376	0.000	0.000	0.22
		C		23.840	0.000	0.000	0.000	0.45

### Feed Line Shielding

Section	Elevation ft	Face	$A_R$ ft <sup>2</sup>	$A_R$ Ice ft <sup>2</sup>	$A_F$ ft <sup>2</sup>	$A_F$ Ice ft <sup>2</sup>
T1	160.00-140.00	A	0.000	0.000	2.302	5.075
		B	0.000	0.000	0.382	0.908
		C	0.000	0.000	1.886	3.944
T2	140.00-120.00	A	0.000	0.000	4.840	10.086
		B	0.000	0.000	0.826	1.866
		C	0.000	0.000	2.271	4.558
T3	120.00-100.00	A	0.000	0.000	5.817	11.517
		B	0.000	0.000	1.350	2.942
		C	0.000	0.000	2.730	5.205
T4	100.00-80.00	A	0.000	0.000	6.808	13.005
		B	0.000	0.000	2.349	5.015
		C	0.000	0.000	3.195	5.877
T5	80.00-60.00	A	0.000	0.000	4.744	9.062

<b>tnxTower</b>  <b>Centek Engineering Inc.</b> 63-2 North Branford Rd. Branford, CT 06405 Phone: (203) 488-0580 FAX: (203) 488-8587	<b>Job</b> 15001.040 - Windsor	<b>Page</b> 8 of 32
	<b>Project</b> 160' Lattice Tower - 482 Pigeon Hill Road, Windsor, CT	<b>Date</b> 15:28:01 09/01/15
	<b>Client</b> Verizon Wireless	<b>Designed by</b> TJL

Section	Elevation	Face	$A_R$	$A_{R\ Ice}$	$A_F$	$A_{F\ Ice}$
	ft		ft <sup>2</sup>	ft <sup>2</sup>	ft <sup>2</sup>	ft <sup>2</sup>
T6	60.00-40.00	B	0.000	0.000	1.836	3.893
		C	0.000	0.000	2.226	4.095
		A	0.000	0.000	3.770	7.015
		B	0.000	0.000	1.529	3.150
		C	0.000	0.000	1.769	3.170
T7	40.00-20.00	A	0.000	0.000	3.678	6.843
		B	0.000	0.000	1.553	3.272
		C	0.000	0.000	1.726	3.093
T8	20.00-0.00	A	0.000	0.000	2.475	4.513
		B	0.000	0.000	1.046	2.162
		C	0.000	0.000	1.161	2.039

### Feed Line Center of Pressure

Section	Elevation	$CP_X$	$CP_Z$	$CP_X\ Ice$	$CP_Z\ Ice$
	ft	in	in	in	in
T1	160.00-140.00	2.1408	-1.7559	2.1554	-2.4563
T2	140.00-120.00	-4.4816	0.4917	-4.5605	-0.2753
T3	120.00-100.00	-3.3968	0.9132	-3.4205	0.1755
T4	100.00-80.00	-1.3194	1.5786	-1.1793	0.9712
T5	80.00-60.00	0.0347	0.9438	0.3727	-0.0096
T6	60.00-40.00	0.5007	1.1993	0.9258	0.1440
T7	40.00-20.00	0.9917	1.4332	1.8432	0.4178
T8	20.00-0.00	0.7113	0.9813	1.3758	0.3121

### Discrete Tower Loads

Description	Face or Leg	Offset Type	Offsets: Horz Lateral Vert	Azimuth Adjustment	Placement	$C_{AA}\ Front$	$C_{AA}\ Side$	Weight	
			ft	°	ft	ft <sup>2</sup>	ft <sup>2</sup>	K	
(2) AM-X-CD-14-65-00T-RET (AT&T)	A	From Face	2.00 0.00 0.00	0.0000	169.00	No Ice 1/2" Ice	5.51 5.90	2.83 3.14	0.04 0.07
(2) AM-X-CD-14-65-00T-RET (AT&T)	B	From Face	2.00 0.00 0.00	0.0000	169.00	No Ice 1/2" Ice	5.51 5.90	2.83 3.14	0.04 0.07
(2) AM-X-CD-14-65-00T-RET (AT&T)	C	From Face	2.00 0.00 0.00	0.0000	169.00	No Ice 1/2" Ice	5.51 5.90	2.83 3.14	0.04 0.07
(2) TT19-08BP111-001 TMA (AT&T)	A	From Face	2.00 0.00 0.00	0.0000	169.00	No Ice 1/2" Ice	0.00 0.00	0.52 0.62	0.02 0.02
(2) TT19-08BP111-001 TMA (AT&T)	B	From Face	2.00 0.00 0.00	0.0000	169.00	No Ice 1/2" Ice	0.00 0.00	0.52 0.62	0.02 0.02
(2) TT19-08BP111-001 TMA (AT&T)	C	From Face	2.00 0.00	0.0000	169.00	No Ice 1/2" Ice	0.00 0.00	0.52 0.62	0.02 0.02

<b>tnxTower</b>  <b>Centek Engineering Inc.</b> 63-2 North Branford Rd. Branford, CT 06405 Phone: (203) 488-0580 FAX: (203) 488-8587	<b>Job</b> 15001.040 - Windsor	<b>Page</b> 9 of 32
	<b>Project</b> 160' Lattice Tower - 482 Pigeon Hill Road, Windsor, CT	<b>Date</b> 15:28:01 09/01/15
	<b>Client</b> Verizon Wireless	<b>Designed by</b> TJL

Description	Face or Leg	Offset Type	Offsets:		Azimuth Adjustment	Placement	C <sub>A</sub> A <sub>1</sub> Front	C <sub>A</sub> A <sub>1</sub> Side	Weight	
			Horz	Vert						
			ft	ft	°	ft	ft <sup>2</sup>	ft <sup>2</sup>	K	
P8 x18-ft Pipe Mast (AT&T)	C	From Centroid-Face	0.00	0.00	0.0000	161.00	No Ice	15.53	15.53	0.51
			0.00	0.00			1/2" Ice	16.61	16.61	0.62
			0.00	0.00						
Valmont 10'-6" T-Armx 3 (Colo Kit P/N 802738) (AT&T)	C	From Centroid-Face	0.00	0.00	0.0000	169.00	No Ice	15.97	15.97	0.47
			0.00	0.00			1/2" Ice	20.77	20.77	0.59
			0.00	0.00						
LPA-80063-4CF (Verizon - Existing)	A	From Leg	5.00	0.00	0.0000	156.50	No Ice	7.00	6.04	0.02
			-6.00	0.00			1/2" Ice	7.41	6.43	0.07
			0.00	0.00						
SBNHH-1D65B (Verizon - Proposed)	A	From Leg	5.00	0.00	0.0000	156.50	No Ice	8.33	5.34	0.04
			-4.00	0.00			1/2" Ice	8.88	5.79	0.09
			0.00	0.00						
BXA-70040/6CF (Verizon - Existing)	A	From Leg	5.00	0.00	0.0000	156.50	No Ice	16.31	5.72	0.04
			0.00	0.00			1/2" Ice	16.93	6.17	0.12
			0.00	0.00						
SBNHH-1D65B (Verizon - Proposed)	A	From Leg	5.00	0.00	0.0000	156.50	No Ice	8.33	5.34	0.04
			-4.00	0.00			1/2" Ice	8.88	5.79	0.09
			0.00	0.00						
LPA-80063-4CF (Verizon - Existing)	A	From Leg	5.00	0.00	0.0000	156.50	No Ice	7.00	6.04	0.02
			6.00	0.00			1/2" Ice	7.41	6.43	0.07
			0.00	0.00						
LPA-80063-4CF (Verizon - Existing)	B	From Leg	5.00	0.00	0.0000	156.50	No Ice	7.00	6.04	0.02
			-6.00	0.00			1/2" Ice	7.41	6.43	0.07
			0.00	0.00						
SBNHH-1D65B (Verizon - Proposed)	B	From Leg	5.00	0.00	0.0000	156.50	No Ice	8.33	5.34	0.04
			-4.00	0.00			1/2" Ice	8.88	5.79	0.09
			0.00	0.00						
BXA-70040/6CF (Verizon - Existing)	B	From Leg	5.00	0.00	0.0000	156.50	No Ice	16.31	5.72	0.04
			0.00	0.00			1/2" Ice	16.93	6.17	0.12
			0.00	0.00						
SBNHH-1D65B (Verizon - Proposed)	B	From Leg	5.00	0.00	0.0000	156.50	No Ice	8.33	5.34	0.04
			-4.00	0.00			1/2" Ice	8.88	5.79	0.09
			0.00	0.00						
LPA-80063-4CF (Verizon - Existing)	B	From Leg	5.00	0.00	0.0000	156.50	No Ice	7.00	6.04	0.02
			6.00	0.00			1/2" Ice	7.41	6.43	0.07
			0.00	0.00						
LPA-80063-4CF (Verizon - Existing)	C	From Leg	5.00	0.00	0.0000	156.50	No Ice	7.00	6.04	0.02
			-6.00	0.00			1/2" Ice	7.41	6.43	0.07
			0.00	0.00						
SBNHH-1D65B (Verizon - Proposed)	C	From Leg	5.00	0.00	0.0000	156.50	No Ice	8.33	5.34	0.04
			-4.00	0.00			1/2" Ice	8.88	5.79	0.09
			0.00	0.00						
BXA-70063/6CF (Verizon - Existing)	C	From Leg	5.00	0.00	0.0000	156.50	No Ice	7.73	4.16	0.01
			0.00	0.00			1/2" Ice	8.27	4.60	0.05
			0.00	0.00						
SBNHH-1D65B (Verizon - Proposed)	C	From Leg	5.00	0.00	0.0000	156.50	No Ice	8.33	5.34	0.04
			-4.00	0.00			1/2" Ice	8.88	5.79	0.09
			0.00	0.00						
LPA-80063-4CF (Verizon - Existing)	C	From Leg	5.00	0.00	0.0000	156.50	No Ice	7.00	6.04	0.02
			6.00	0.00			1/2" Ice	7.41	6.43	0.07
			0.00	0.00						
RRH4x45/2x90-AWS (Verizon - Proposed)	A	From Leg	4.00	0.00	0.0000	156.50	No Ice	3.01	1.91	0.08
			4.00	0.00			1/2" Ice	3.26	2.13	0.10
			0.00	0.00						
RRH4x45/2x90-AWS (Verizon - Proposed)	B	From Leg	4.00	0.00	0.0000	156.50	No Ice	3.01	1.91	0.08
			4.00	0.00			1/2" Ice	3.26	2.13	0.10
			0.00	0.00						

<b>tnxTower</b>  <b>Centek Engineering Inc.</b> 63-2 North Branford Rd. Branford, CT 06405 Phone: (203) 488-0580 FAX: (203) 488-8587	<b>Job</b>		15001.040 - Windsor		<b>Page</b>		10 of 32	
	<b>Project</b>		160' Lattice Tower - 482 Pigeon Hill Road, Windsor, CT		<b>Date</b>		15:28:01 09/01/15	
	<b>Client</b>		Verizon Wireless		<b>Designed by</b>		TJL	

Description	Face or Leg	Offset Type	Offsets:		Azimuth Adjustment	Placement	C <sub>AA</sub> Front	C <sub>AA</sub> Side	Weight	
			Horz	Vert						
			ft	ft	°	ft	ft <sup>2</sup>	ft <sup>2</sup>	K	
RRH4x45/2x90-AWS (Verizon - Proposed)	C	From Leg	0.00		0.0000	156.50	No Ice	3.01	1.91	0.08
			4.00				1/2" Ice	3.26	2.13	0.10
			4.00							
RRH2x60-PCS (Verizon - Proposed)	A	From Leg	0.00		0.0000	156.50	No Ice	2.51	1.55	0.06
			4.00				1/2" Ice	2.73	1.74	0.07
			-4.00							
RRH2x60-PCS (Verizon - Proposed)	B	From Leg	0.00		0.0000	156.50	No Ice	2.51	1.55	0.06
			4.00				1/2" Ice	2.73	1.74	0.07
			-4.00							
RRH2x60-PCS (Verizon - Proposed)	C	From Leg	0.00		0.0000	156.50	No Ice	2.51	1.55	0.06
			4.00				1/2" Ice	2.73	1.74	0.07
			-4.00							
RRH4x30-B13 (Verizon - Proposed)	A	From Leg	0.00		0.0000	156.50	No Ice	2.52	1.89	0.06
			4.00				1/2" Ice	2.74	2.09	0.08
			0.00							
RRH4x30-B13 (Verizon - Proposed)	B	From Leg	0.00		0.0000	156.50	No Ice	2.52	1.89	0.06
			4.00				1/2" Ice	2.74	2.09	0.08
			0.00							
RRH4x30-B13 (Verizon - Proposed)	C	From Leg	0.00		0.0000	156.50	No Ice	2.52	1.89	0.06
			4.00				1/2" Ice	2.74	2.09	0.08
			0.00							
DB-T1-6Z-8AB-0Z (Verizon - Existing)	C	From Leg	0.00		0.0000	156.50	No Ice	5.60	2.33	0.04
			0.50				1/2" Ice	5.92	2.56	0.08
			0.00							
DB-T1-6Z-8AB-0Z (Verizon - Proposed)	B	From Leg	0.00		0.0000	156.50	No Ice	5.60	2.33	0.04
			0.50				1/2" Ice	5.92	2.56	0.08
			0.00							
Valmont 15' T-Frame P/N 860109 (Verizon)	A	From Leg	0.00		0.0000	156.00	No Ice	13.90	13.90	0.39
			2.00				1/2" Ice	20.00	20.00	0.53
			0.00							
Valmont 15' T-Frame P/N 860109 (Verizon)	B	From Leg	0.00		0.0000	156.00	No Ice	13.90	13.90	0.39
			2.00				1/2" Ice	20.00	20.00	0.53
			0.00							
Valmont 15' T-Frame P/N 860109 (Verizon)	C	From Leg	0.00		0.0000	156.00	No Ice	13.90	13.90	0.39
			2.00				1/2" Ice	20.00	20.00	0.53
			0.00							
APX16DWV-16DWVS-C-A 20 (T-Mobile)	A	From Leg	0.00		0.0000	147.00	No Ice	7.07	2.15	0.04
			4.00				1/2" Ice	7.52	2.49	0.07
			0.00							
APX16DWV-16DWVS-C-A 20 (T-Mobile)	B	From Leg	0.00		0.0000	147.00	No Ice	7.07	2.15	0.04
			4.00				1/2" Ice	7.52	2.49	0.07
			0.00							
APX16DWV-16DWVS-C-A 20 (T-Mobile)	C	From Leg	0.00		0.0000	147.00	No Ice	7.07	2.15	0.04
			4.00				1/2" Ice	7.52	2.49	0.07
			0.00							
(2) AIR21 (T-Mobile)	A	From Leg	0.00		0.0000	147.00	No Ice	6.53	4.36	0.08
			4.00				1/2" Ice	6.98	4.77	0.12
			0.00							
(2) AIR21 (T-Mobile)	A	From Leg	0.00		0.0000	147.00	No Ice	6.53	4.36	0.08
			4.00				1/2" Ice	6.98	4.77	0.12
			0.00							
(2) AIR21 (T-Mobile)	A	From Leg	0.00		0.0000	147.00	No Ice	6.53	4.36	0.08
			4.00				1/2" Ice	6.98	4.77	0.12
			0.00							
KRY 112 TMA (T-Mobile)	A	From Leg	0.00		0.0000	147.00	No Ice	0.00	0.49	0.03
			4.00				1/2" Ice	0.00	0.59	0.03
			0.00							

<b>tnxTower</b>  <b>Centek Engineering Inc.</b> 63-2 North Branford Rd. Branford, CT 06405 Phone: (203) 488-0580 FAX: (203) 488-8587	<b>Job</b>	15001.040 - Windsor	<b>Page</b>	11 of 32
	<b>Project</b>	160' Lattice Tower - 482 Pigeon Hill Road, Windsor, CT	<b>Date</b>	15:28:01 09/01/15
	<b>Client</b>	Verizon Wireless	<b>Designed by</b>	TJL

Description	Face or Leg	Offset Type	Offsets:			Azimuth Adjustment	Placement	C <sub>AA</sub> Front	C <sub>AA</sub> Side	Weight	
			Horz	Lateral	Vert						ft
KRY 112 TMA (T-Mobile)	A	From Leg	0.00			0.0000	147.00	No Ice	0.00	0.49	0.03
			4.00					1/2" Ice	0.00	0.59	0.03
			0.00								
KRY 112 TMA (T-Mobile)	A	From Leg	4.00			0.0000	147.00	No Ice	0.00	0.49	0.03
			0.00					1/2" Ice	0.00	0.59	0.03
			0.00								
15' Frame (T-Mobile)	A	From Leg	0.50			0.0000	147.00	No Ice	7.13	5.70	0.35
			0.00					1/2" Ice	9.71	8.10	0.49
			0.00								
15' Frame (T-Mobile)	B	From Leg	0.50			0.0000	147.00	No Ice	7.13	5.70	0.35
			0.00					1/2" Ice	9.71	8.10	0.49
			0.00								
15' Frame (T-Mobile)	C	From Leg	0.50			0.0000	147.00	No Ice	7.13	5.70	0.35
			0.00					1/2" Ice	9.71	8.10	0.49
			0.00								
4' Side Mount Standoff (Unknown)	C	From Leg	1.75			0.0000	99.00	No Ice	2.72	2.72	0.05
			0.00					1/2" Ice	4.91	4.91	0.09
			0.00								
16' x 2" Dia Omni (Unknown)	C	From Leg	3.50			0.0000	108.00	No Ice	3.20	3.20	0.04
			0.00					1/2" Ice	4.83	4.83	0.06
			0.00								
4' Side Mount Standoff (Unknown)	C	From Leg	2.25			0.0000	117.75	No Ice	2.72	2.72	0.05
			0.00					1/2" Ice	4.91	4.91	0.09
			0.00								
15' x 2" Dia Omni (Unknown)	C	From Leg	4.50			0.0000	127.50	No Ice	3.00	3.00	0.04
			0.00					1/2" Ice	4.53	4.53	0.06
			0.00								
5'0"x4.5" Pipe Mount (Unknown)	C	From Leg	0.75			0.0000	72.10	No Ice	1.76	1.76	0.05
			0.00					1/2" Ice	2.08	2.08	0.07
			0.00								
4' Side Mount Standoff (Unknown)	C	From Leg	1.50			0.0000	37.58	No Ice	2.72	2.72	0.05
			0.00					1/2" Ice	4.91	4.91	0.09
			0.00								
12' x 1-1/2" Dia Omni (Unknown)	C	From Leg	3.00			0.0000	45.41	No Ice	1.80	1.80	0.03
			0.00					1/2" Ice	3.02	3.02	0.04
			0.00								
15' x 2" Dia Omni (Unknown)	A	From Leg	0.75			0.0000	165.00	No Ice	3.00	3.00	0.04
			0.00					1/2" Ice	4.53	4.53	0.06
			0.00								
5'0"x4.5" Pipe Mount (Unknown)	A	From Leg	0.92			0.0000	102.20	No Ice	1.76	1.76	0.05
			0.00					1/2" Ice	2.08	2.08	0.07
			0.00								
5'0"x4.5" Pipe Mount (Unknown)	B	From Leg	0.75			0.0000	111.33	No Ice	1.76	1.76	0.05
			0.00					1/2" Ice	2.08	2.08	0.07
			0.00								
5'0"x4.5" Pipe Mount (Unknown)	B	From Leg	0.75			0.0000	93.83	No Ice	1.76	1.76	0.05
			0.00					1/2" Ice	2.08	2.08	0.07
			0.00								
4' Side Mount Standoff (Vacant) (Unknown)	A	From Leg	1.50			0.0000	47.00	No Ice	2.72	2.72	0.05
			0.00					1/2" Ice	4.91	4.91	0.09
			0.00								



<b>tnxTower</b>  <b>Centek Engineering Inc.</b> 63-2 North Branford Rd. Branford, CT 06405 Phone: (203) 488-0580 FAX: (203) 488-8587	<b>Job</b> 15001.040 - Windsor	<b>Page</b> 12 of 32
	<b>Project</b> 160' Lattice Tower - 482 Pigeon Hill Road, Windsor, CT	<b>Date</b> 15:28:01 09/01/15
	<b>Client</b> Verizon Wireless	<b>Designed by</b> TJL

**Dishes**

Description	Face or Leg	Dish Type	Offset Type	Offsets: Horz Lateral Vert	Azimuth Adjustment °	3 dB Beam Width °	Elevation ft	Outside Diameter ft	Aperture Area ft <sup>2</sup>	Weight K
10 FT DISH (Unknown)	C	Paraboloid w/Shroud (HP)	From Leg	1.00	10.0000		72.00	10.00	No Ice	0.32
				0.00					1/2" Ice	0.73
				0.00						
6 FT DISH (Unknown)	A	Paraboloid w/Radome	From Leg	1.00	-50.0000		102.00	6.00	No Ice	0.14
				0.00					1/2" Ice	0.29
				0.00						
8 FT DISH (Unknown)	B	Paraboloid w/Shroud (HP)	From Leg	1.00	-30.0000		111.33	8.00	No Ice	0.25
				0.00					1/2" Ice	0.51
				0.00						
6 FT DISH (Unknown)	B	Paraboloid w/Shroud (HP)	From Leg	1.00	0.0000		94.00	6.00	No Ice	0.14
				0.00					1/2" Ice	0.29
				0.00						

**Tower Pressures - No Ice**

$G_H = 1.129$

Section Elevation ft	z ft	K <sub>Z</sub>	q <sub>z</sub> psf	A <sub>G</sub> ft <sup>2</sup>	F a c e	A <sub>F</sub> ft <sup>2</sup>	A <sub>R</sub> ft <sup>2</sup>	A <sub>leg</sub> ft <sup>2</sup>	Leg %	C <sub>A</sub> A <sub>A</sub> In Face ft <sup>2</sup>	C <sub>A</sub> A <sub>A</sub> Out Face ft <sup>2</sup>
T1 160.00-140.00	150.00	1.541	25	175.992	A	10.533	39.433	9.583	19.18	0.000	0.000
					B	12.453	14.533		35.51	0.000	0.000
					C	10.949	34.033		21.30	0.000	0.000
T2 140.00-120.00	130.00	1.48	24	195.998	A	11.183	65.849	9.599	12.46	0.000	0.000
					B	15.197	19.199		27.91	0.000	0.000
					C	13.751	35.999		19.29	0.000	0.000
T3 120.00-100.00	110.00	1.411	23	236.398	A	17.626	65.850	9.600	11.50	0.000	0.000
					B	23.744	21.004		21.45	0.000	0.000
					C	20.713	36.000		16.93	0.000	0.000
T4 100.00-80.00	90.00	1.332	22	278.441	A	25.481	67.937	11.687	12.51	0.000	0.000
					B	36.046	24.987		19.15	0.000	0.000
					C	29.094	38.087		17.40	0.000	0.000
T5 80.00-60.00	70.00	1.24	20	321.010	A	21.076	71.276	15.026	16.27	0.000	0.000
					B	32.450	28.326		24.72	0.000	0.000
					C	23.593	41.426		23.11	0.000	0.000
T6 60.00-40.00	50.00	1.126	18	363.083	A	19.350	74.824	18.574	19.72	0.000	0.000
					B	31.107	31.874		29.49	0.000	0.000
					C	21.351	44.974		28.00	0.000	0.000
T7 40.00-20.00	30.00	1	16	404.685	A	21.568	74.829	18.579	19.27	0.000	0.000
					B	33.208	32.817		28.14	0.000	0.000
					C	23.520	44.979		27.12	0.000	0.000
T8 20.00-0.00	10.00	1	16	448.055	A	28.791	55.870	22.120	26.13	0.000	0.000
					B	35.929	30.680		33.21	0.000	0.000
					C	30.104	37.960		32.50	0.000	0.000

**Tower Pressure - With Ice**

<b>tnxTower</b>  <b>Centek Engineering Inc.</b> 63-2 North Branford Rd. Branford, CT 06405 Phone: (203) 488-0580 FAX: (203) 488-8587	<b>Job</b>	15001.040 - Windsor	<b>Page</b>	13 of 32	
	<b>Project</b>	160' Lattice Tower - 482 Pigeon Hill Road, Windsor, CT		<b>Date</b>	15:28:01 09/01/15
	<b>Client</b>	Verizon Wireless		<b>Designed by</b>	TJL

$$G_H = 1.129$$

Section Elevation ft	z ft	$K_z$	$q_z$ psf	$t_z$ in	$A_G$ ft <sup>2</sup>	F a c e	$A_F$ ft <sup>2</sup>	$A_R$ ft <sup>2</sup>	$A_{leg}$ ft <sup>2</sup>	Leg %	$C_{AA}$ In Face ft <sup>2</sup>	$C_{AA}$ Out Face ft <sup>2</sup>
T1 160.00-140.00	150.00	1.541	19	0.5000	177.658	A	12.452	61.100	12.917	17.56	0.000	0.000
						B	16.619	21.533		33.86	0.000	0.000
						C	13.582	50.367		20.20	0.000	0.000
T2 140.00-120.00	130.00	1.48	18	0.5000	197.666	A	11.278	100.855	12.938	11.54	0.000	0.000
						B	19.497	29.205		26.57	0.000	0.000
						C	16.805	52.672		18.62	0.000	0.000
T3 120.00-100.00	110.00	1.411	17	0.5000	238.067	A	18.178	100.856	12.939	10.87	0.000	0.000
						B	29.145	32.634		20.94	0.000	0.000
						C	24.490	52.672		16.77	0.000	0.000
T4 100.00-80.00	90.00	1.332	16	0.5000	280.110	A	26.460	102.943	15.026	11.61	0.000	0.000
						B	43.554	38.326		18.35	0.000	0.000
						C	33.587	54.760		17.01	0.000	0.000
T5 80.00-60.00	70.00	1.24	15	0.5000	322.678	A	22.495	106.281	18.365	14.26	0.000	0.000
						B	40.131	41.665		22.45	0.000	0.000
						C	27.462	58.098		21.46	0.000	0.000
T6 60.00-40.00	50.00	1.126	14	0.5000	364.752	A	20.509	109.830	21.913	16.81	0.000	0.000
						B	38.334	45.213		26.23	0.000	0.000
						C	24.354	61.646		25.48	0.000	0.000
T7 40.00-20.00	30.00	1	12	0.5000	406.354	A	23.211	109.836	21.919	16.47	0.000	0.000
						B	40.743	47.775		24.76	0.000	0.000
						C	26.962	61.652		24.74	0.000	0.000
T8 20.00-0.00	10.00	1	12	0.5000	449.724	A	31.964	78.209	25.459	23.11	0.000	0.000
						B	42.691	41.019		30.41	0.000	0.000
						C	34.438	49.299		30.40	0.000	0.000

### Tower Pressure - Service

$$G_H = 1.129$$

Section Elevation ft	z ft	$K_z$	$q_z$ psf	$A_G$ ft <sup>2</sup>	F a c e	$A_F$ ft <sup>2</sup>	$A_R$ ft <sup>2</sup>	$A_{leg}$ ft <sup>2</sup>	Leg %	$C_{AA}$ In Face ft <sup>2</sup>	$C_{AA}$ Out Face ft <sup>2</sup>
T1 160.00-140.00	150.00	1.541	10	175.992	A	10.533	39.433	9.583	19.18	0.000	0.000
					B	12.453	14.533		35.51	0.000	0.000
					C	10.949	34.033		21.30	0.000	0.000
T2 140.00-120.00	130.00	1.48	9	195.998	A	11.183	65.849	9.599	12.46	0.000	0.000
					B	15.197	19.199		27.91	0.000	0.000
					C	13.751	35.999		19.29	0.000	0.000
T3 120.00-100.00	110.00	1.411	9	236.398	A	17.626	65.850	9.600	11.50	0.000	0.000
					B	23.744	21.004		21.45	0.000	0.000
					C	20.713	36.000		16.93	0.000	0.000
T4 100.00-80.00	90.00	1.332	9	278.441	A	25.481	67.937	11.687	12.51	0.000	0.000
					B	36.046	24.987		19.15	0.000	0.000
					C	29.094	38.087		17.40	0.000	0.000
T5 80.00-60.00	70.00	1.24	8	321.010	A	21.076	71.276	15.026	16.27	0.000	0.000
					B	32.450	28.326		24.72	0.000	0.000
					C	23.593	41.426		23.11	0.000	0.000
T6 60.00-40.00	50.00	1.126	7	363.083	A	19.350	74.824	18.574	19.72	0.000	0.000
					B	31.107	31.874		29.49	0.000	0.000
					C	21.351	44.974		28.00	0.000	0.000
T7 40.00-20.00	30.00	1	6	404.685	A	21.568	74.829	18.579	19.27	0.000	0.000
					B	33.208	32.817		28.14	0.000	0.000

<b>tnxTower</b>  <b>Centek Engineering Inc.</b> 63-2 North Branford Rd. Branford, CT 06405 Phone: (203) 488-0580 FAX: (203) 488-8587	<b>Job</b> 15001.040 - Windsor	<b>Page</b> 14 of 32
	<b>Project</b> 160' Lattice Tower - 482 Pigeon Hill Road, Windsor, CT	<b>Date</b> 15:28:01 09/01/15
	<b>Client</b> Verizon Wireless	<b>Designed by</b> TJL

Section Elevation ft	z ft	K <sub>Z</sub>	q <sub>z</sub> psf	A <sub>G</sub> ft <sup>2</sup>	F a c e	A <sub>F</sub> ft <sup>2</sup>	A <sub>R</sub> ft <sup>2</sup>	A <sub>leg</sub> ft <sup>2</sup>	Leg %	C <sub>A</sub> A <sub>A</sub> In Face ft <sup>2</sup>	C <sub>A</sub> A <sub>A</sub> Out Face ft <sup>2</sup>
T8 20.00-0.00	10.00	1	6	448.055	C	23.520	44.979	22.120	27.12	0.000	0.000
					A	28.791	55.870		26.13	0.000	0.000
					B	35.929	30.680		33.21	0.000	0.000
					C	30.104	37.960		32.50	0.000	0.000

**Tower Forces - No Ice - Wind Normal To Face**

Section Elevation ft	Add Weight K	Self Weight K	F a c e	e	C <sub>F</sub>	R <sub>R</sub>	D <sub>F</sub>	D <sub>R</sub>	A <sub>E</sub> ft <sup>2</sup>	F K	w plf	Ctrl. Face
T1 160.00-140.00	0.50	1.15	A	0.284	2.34	0.611	1	1	34.631	2.31	115.49	A
			B	0.153	2.759	0.582	1	1	20.911			
			C	0.256	2.421	0.603	1	1	31.482			
T2 140.00-120.00	0.91	1.29	A	0.393	2.078	0.649	1	1	53.905	3.07	153.26	A
			B	0.175	2.68	0.586	1	1	26.442			
			C	0.254	2.426	0.603	1	1	35.454			
T3 120.00-100.00	0.92	1.52	A	0.353	2.164	0.634	1	1	59.348	3.35	167.55	A
			B	0.189	2.632	0.588	1	1	36.100			
			C	0.24	2.468	0.599	1	1	42.290			
T4 100.00-80.00	0.95	2.08	A	0.336	2.206	0.627	1	1	68.106	3.70	185.05	A
			B	0.219	2.533	0.595	1	1	50.901			
			C	0.241	2.464	0.6	1	1	51.935			
T5 80.00-60.00	0.96	2.46	A	0.288	2.329	0.612	1	1	64.711	3.46	172.80	A
			B	0.189	2.632	0.588	1	1	49.114			
			C	0.203	2.588	0.591	1	1	48.072			
T6 60.00-40.00	0.97	2.65	A	0.259	2.41	0.604	1	1	64.567	3.24	162.02	A
			B	0.173	2.687	0.585	1	1	49.764			
			C	0.183	2.655	0.587	1	1	47.751			
T7 40.00-20.00	0.97	2.78	A	0.238	2.473	0.599	1	1	66.386	3.04	151.84	A
			B	0.163	2.724	0.584	1	1	52.360			
			C	0.169	2.702	0.585	1	1	49.815			
T8 20.00-0.00	0.58	3.28	A	0.189	2.633	0.588	1	1	61.654	3.00	150.14	A
			B	0.149	2.776	0.581	1	1	53.763			
			C	0.152	2.764	0.582	1	1	52.188			
Sum Weight:	6.76	17.21						OTM	1971.68 kip-ft	25.16		

**Tower Forces - No Ice - Wind 60 To Face**

Section Elevation ft	Add Weight K	Self Weight K	F a c e	e	C <sub>F</sub>	R <sub>R</sub>	D <sub>F</sub>	D <sub>R</sub>	A <sub>E</sub> ft <sup>2</sup>	F K	w plf	Ctrl. Face
T1 160.00-140.00	0.50	1.15	A	0.284	2.34	0.611	0.8	1	32.524	2.17	108.46	A
			B	0.153	2.759	0.582	0.8	1	18.421			
			C	0.256	2.421	0.603	0.8	1	29.292			
T2 140.00-120.00	0.91	1.29	A	0.393	2.078	0.649	0.8	1	51.668	2.94	146.90	A
			B	0.175	2.68	0.586	0.8	1	23.402			
			C	0.254	2.426	0.603	0.8	1	32.703			
T3 120.00-100.00	0.92	1.52	A	0.353	2.164	0.634	0.8	1	55.823	3.15	157.60	A
			B	0.189	2.632	0.588	0.8	1	31.351			
			C	0.24	2.468	0.599	0.8	1	38.147			

<b>tnxTower</b>  <b>Centek Engineering Inc.</b> 63-2 North Branford Rd. Branford, CT 06405 Phone: (203) 488-0580 FAX: (203) 488-8587	<b>Job</b>	15001.040 - Windsor	<b>Page</b>	15 of 32	
	<b>Project</b>	160' Lattice Tower - 482 Pigeon Hill Road, Windsor, CT		<b>Date</b>	15:28:01 09/01/15
	<b>Client</b>	Verizon Wireless		<b>Designed by</b>	TJL

Section Elevation	Add Weight	Self Weight	F a c e	e	C <sub>F</sub>	R <sub>R</sub>	D <sub>F</sub>	D <sub>R</sub>	A <sub>E</sub>	F	w	Ctrl. Face
ft	K	K							ft <sup>2</sup>	K	plf	
T4 100.00-80.00	0.95	2.08	A	0.336	2.206	0.627	0.8	1	63.009	3.42	171.20	A
			B	0.219	2.533	0.595	0.8	1	43.692			
			C	0.241	2.464	0.6	0.8	1	46.116			
T5 80.00-60.00	0.96	2.46	A	0.288	2.329	0.612	0.8	1	60.496	3.23	161.54	A
			B	0.189	2.632	0.588	0.8	1	42.624			
			C	0.203	2.588	0.591	0.8	1	43.354			
T6 60.00-40.00	0.97	2.65	A	0.259	2.41	0.604	0.8	1	60.697	3.05	152.31	A
			B	0.173	2.687	0.585	0.8	1	43.543			
			C	0.183	2.655	0.587	0.8	1	43.481			
T7 40.00-20.00	0.97	2.78	A	0.238	2.473	0.599	0.8	1	62.072	2.84	141.98	A
			B	0.163	2.724	0.584	0.8	1	45.718			
			C	0.169	2.702	0.585	0.8	1	45.111			
T8 20.00-0.00	0.58	3.28	A	0.189	2.633	0.588	0.8	1	55.896	2.72	136.12	A
			B	0.149	2.776	0.581	0.8	1	46.577			
			C	0.152	2.764	0.582	0.8	1	46.168			
Sum Weight:	6.76	17.21						OTM	1853.07 kip-ft	23.52		

### Tower Forces - No Ice - Wind 90 To Face

Section Elevation	Add Weight	Self Weight	F a c e	e	C <sub>F</sub>	R <sub>R</sub>	D <sub>F</sub>	D <sub>R</sub>	A <sub>E</sub>	F	w	Ctrl. Face
ft	K	K							ft <sup>2</sup>	K	plf	
T1 160.00-140.00	0.50	1.15	A	0.284	2.34	0.611	0.85	1	33.051	2.20	110.22	A
			B	0.153	2.759	0.582	0.85	1	19.043			
			C	0.256	2.421	0.603	0.85	1	29.840			
T2 140.00-120.00	0.91	1.29	A	0.393	2.078	0.649	0.85	1	52.227	2.97	148.49	A
			B	0.175	2.68	0.586	0.85	1	24.162			
			C	0.254	2.426	0.603	0.85	1	33.391			
T3 120.00-100.00	0.92	1.52	A	0.353	2.164	0.634	0.85	1	56.704	3.20	160.09	A
			B	0.189	2.632	0.588	0.85	1	32.538			
			C	0.24	2.468	0.599	0.85	1	39.183			
T4 100.00-80.00	0.95	2.08	A	0.336	2.206	0.627	0.85	1	64.284	3.49	174.66	A
			B	0.219	2.533	0.595	0.85	1	45.494			
			C	0.241	2.464	0.6	0.85	1	47.570			
T5 80.00-60.00	0.96	2.46	A	0.288	2.329	0.612	0.85	1	61.550	3.29	164.36	A
			B	0.189	2.632	0.588	0.85	1	44.246			
			C	0.203	2.588	0.591	0.85	1	44.533			
T6 60.00-40.00	0.97	2.65	A	0.259	2.41	0.604	0.85	1	61.665	3.09	154.73	A
			B	0.173	2.687	0.585	0.85	1	45.098			
			C	0.183	2.655	0.587	0.85	1	44.549			
T7 40.00-20.00	0.97	2.78	A	0.238	2.473	0.599	0.85	1	63.151	2.89	144.44	A
			B	0.163	2.724	0.584	0.85	1	47.379			
			C	0.169	2.702	0.585	0.85	1	46.287			
T8 20.00-0.00	0.58	3.28	A	0.189	2.633	0.588	0.85	1	57.336	2.79	139.62	A
			B	0.149	2.776	0.581	0.85	1	48.373			
			C	0.152	2.764	0.582	0.85	1	47.673			
Sum Weight:	6.76	17.21						OTM	1882.72 kip-ft	23.93		

### Tower Forces - With Ice - Wind Normal To Face

<b>tnxTower</b>  <b>Centek Engineering Inc.</b> 63-2 North Branford Rd. Branford, CT 06405 Phone: (203) 488-0580 FAX: (203) 488-8587	<b>Job</b>	15001.040 - Windsor	<b>Page</b>	16 of 32	
	<b>Project</b>	160' Lattice Tower - 482 Pigeon Hill Road, Windsor, CT		<b>Date</b>	15:28:01 09/01/15
	<b>Client</b>	Verizon Wireless		<b>Designed by</b>	TJL

Section Elevation	Add Weight	Self Weight	F a c e	e	C <sub>F</sub>	R <sub>R</sub>	D <sub>F</sub>	D <sub>R</sub>	A <sub>E</sub>	F	w	Ctrl. Face
ft	K	K							ft <sup>2</sup>	K	plf	
T1 160.00-140.00	1.26	1.74	A	0.414	2.037	0.657	1	1	52.620	2.29	114.58	A
			B	0.215	2.547	0.594	1	1	29.399			
			C	0.36	2.149	0.636	1	1	45.619			
T2 140.00-120.00	2.23	1.99	A	0.567	1.828	0.734	1	1	85.318	3.20	160.03	A
			B	0.246	2.448	0.601	1	1	37.048			
			C	0.351	2.168	0.633	1	1	50.147			
T3 120.00-100.00	2.28	2.44	A	0.5	1.9	0.698	1	1	88.525	3.29	164.55	A
			B	0.26	2.409	0.604	1	1	48.867			
			C	0.324	2.234	0.624	1	1	57.335			
T4 100.00-80.00	2.38	3.31	A	0.462	1.954	0.679	1	1	96.342	3.48	173.94	A
			B	0.292	2.317	0.614	1	1	67.071			
			C	0.315	2.256	0.621	1	1	67.578			
T5 80.00-60.00	2.41	3.50	A	0.399	2.066	0.651	1	1	91.709	3.26	162.89	A
			B	0.253	2.427	0.603	1	1	65.245			
			C	0.265	2.393	0.606	1	1	62.661			
T6 60.00-40.00	2.43	3.63	A	0.357	2.155	0.635	1	1	90.264	3.04	151.90	A
			B	0.229	2.502	0.597	1	1	65.315			
			C	0.236	2.481	0.598	1	1	61.240			
T7 40.00-20.00	2.44	3.83	A	0.327	2.226	0.625	1	1	91.823	2.83	141.74	A
			B	0.218	2.538	0.594	1	1	69.130			
			C	0.218	2.537	0.594	1	1	63.599			
T8 20.00-0.00	1.47	4.55	A	0.245	2.453	0.601	1	1	78.937	2.69	134.28	A
			B	0.186	2.643	0.588	1	1	66.797			
			C	0.186	2.643	0.588	1	1	63.410			
Sum Weight:	16.89	24.99						OTM	1926.77 kip-ft	24.08		

### Tower Forces - With Ice - Wind 60 To Face

Section Elevation	Add Weight	Self Weight	F a c e	e	C <sub>F</sub>	R <sub>R</sub>	D <sub>F</sub>	D <sub>R</sub>	A <sub>E</sub>	F	w	Ctrl. Face
ft	K	K							ft <sup>2</sup>	K	plf	
T1 160.00-140.00	1.26	1.74	A	0.414	2.037	0.657	0.8	1	50.129	2.18	109.15	A
			B	0.215	2.547	0.594	0.8	1	26.076			
			C	0.36	2.149	0.636	0.8	1	42.903			
T2 140.00-120.00	2.23	1.99	A	0.567	1.828	0.734	0.8	1	83.062	3.12	155.80	A
			B	0.246	2.448	0.601	0.8	1	33.149			
			C	0.351	2.168	0.633	0.8	1	46.786			
T3 120.00-100.00	2.28	2.44	A	0.5	1.9	0.698	0.8	1	84.889	3.16	157.79	A
			B	0.26	2.409	0.604	0.8	1	43.038			
			C	0.324	2.234	0.624	0.8	1	52.437			
T4 100.00-80.00	2.38	3.31	A	0.462	1.954	0.679	0.8	1	91.050	3.29	164.39	A
			B	0.292	2.317	0.614	0.8	1	58.360			
			C	0.315	2.256	0.621	0.8	1	60.861			
T5 80.00-60.00	2.41	3.50	A	0.399	2.066	0.651	0.8	1	87.210	3.10	154.90	A
			B	0.253	2.427	0.603	0.8	1	57.219			
			C	0.265	2.393	0.606	0.8	1	57.168			
T6 60.00-40.00	2.43	3.63	A	0.357	2.155	0.635	0.8	1	86.163	2.90	144.99	A
			B	0.229	2.502	0.597	0.8	1	57.649			
			C	0.236	2.481	0.598	0.8	1	56.369			
T7 40.00-20.00	2.44	3.83	A	0.327	2.226	0.625	0.8	1	87.180	2.69	134.57	A
			B	0.218	2.538	0.594	0.8	1	60.982			
			C	0.218	2.537	0.594	0.8	1	58.206			
T8 20.00-0.00	1.47	4.55	A	0.245	2.453	0.601	0.8	1	72.544	2.47	123.40	A

<b>tnxTower</b>  <b>Centek Engineering Inc.</b> 63-2 North Branford Rd. Branford, CT 06405 Phone: (203) 488-0580 FAX: (203) 488-8587	<b>Job</b> 15001.040 - Windsor	<b>Page</b> 17 of 32
	<b>Project</b> 160' Lattice Tower - 482 Pigeon Hill Road, Windsor, CT	<b>Date</b> 15:28:01 09/01/15
	<b>Client</b> Verizon Wireless	<b>Designed by</b> TJL

Section Elevation ft	Add Weight K	Self Weight K	F a c e	e	C <sub>F</sub>	R <sub>R</sub>	D <sub>F</sub>	D <sub>R</sub>	A <sub>E</sub> ft <sup>2</sup>	F K	w plf	Ctrl. Face
Sum Weight:	16.89	24.99	B C	0.186 0.186	2.643 2.643	0.588 0.588	0.8 0.8	1 1 OTM	58.259 56.522 1842.87 kip-ft	22.90		

**Tower Forces - With Ice - Wind 90 To Face**

Section Elevation ft	Add Weight K	Self Weight K	F a c e	e	C <sub>F</sub>	R <sub>R</sub>	D <sub>F</sub>	D <sub>R</sub>	A <sub>E</sub> ft <sup>2</sup>	F K	w plf	Ctrl. Face
T1 160.00-140.00	1.26	1.74	A B C	0.414 0.215 0.36	2.037 2.547 2.149	0.657 0.594 0.636	0.85 0.85 0.85	1 1 1	50.752 26.906 43.582	2.21	110.51	A
T2 140.00-120.00	2.23	1.99	A B C	0.567 0.246 0.351	1.828 2.448 2.168	0.734 0.601 0.633	0.85 0.85 0.85	1 1 1	83.626 34.124 47.626	3.14	156.86	A
T3 120.00-100.00	2.28	2.44	A B C	0.5 0.26 0.324	1.9 2.409 2.234	0.698 0.604 0.624	0.85 0.85 0.85	1 1 1	85.798 44.495 53.662	3.19	159.48	A
T4 100.00-80.00	2.38	3.31	A B C	0.462 0.292 0.315	1.954 2.317 2.256	0.679 0.614 0.621	0.85 0.85 0.85	1 1 1	92.373 60.538 62.540	3.34	166.78	A
T5 80.00-60.00	2.41	3.50	A B C	0.399 0.253 0.265	2.066 2.427 2.393	0.651 0.603 0.606	0.85 0.85 0.85	1 1 1	88.334 59.225 58.541	3.14	156.90	A
T6 60.00-40.00	2.43	3.63	A B C	0.357 0.229 0.236	2.155 2.502 2.481	0.635 0.597 0.598	0.85 0.85 0.85	1 1 1	87.188 59.565 57.587	2.93	146.72	A
T7 40.00-20.00	2.44	3.83	A B C	0.327 0.218 0.218	2.226 2.538 2.537	0.625 0.594 0.594	0.85 0.85 0.85	1 1 1	88.341 63.019 59.555	2.73	136.37	A
T8 20.00-0.00	1.47	4.55	A B C	0.245 0.186 0.186	2.453 2.643 2.643	0.601 0.588 0.588	0.85 0.85 0.85	1 1 1 OTM	74.143 60.393 58.244 1863.85 kip-ft	2.52	126.12	A
Sum Weight:	16.89	24.99								23.19		

**Tower Forces - Service - Wind Normal To Face**

Section Elevation ft	Add Weight K	Self Weight K	F a c e	e	C <sub>F</sub>	R <sub>R</sub>	D <sub>F</sub>	D <sub>R</sub>	A <sub>E</sub> ft <sup>2</sup>	F K	w plf	Ctrl. Face
T1 160.00-140.00	0.50	1.15	A B C	0.284 0.153 0.256	2.34 2.759 2.421	0.611 0.582 0.603	1 1 1	1 1 1	34.631 20.911 31.482	0.90	45.11	A
T2 140.00-120.00	0.91	1.29	A B C	0.393 0.175 0.254	2.078 2.68 2.426	0.649 0.586 0.603	1 1 1	1 1 1	53.905 26.442 35.454	1.20	59.87	A
T3	0.92	1.52	A	0.353	2.164	0.634	1	1	59.348	1.31	65.45	A

<b>tnxTower</b>  <b>Centek Engineering Inc.</b> 63-2 North Branford Rd. Branford, CT 06405 Phone: (203) 488-0580 FAX: (203) 488-8587	<b>Job</b>	15001.040 - Windsor	<b>Page</b>	18 of 32	
	<b>Project</b>	160' Lattice Tower - 482 Pigeon Hill Road, Windsor, CT		<b>Date</b>	15:28:01 09/01/15
	<b>Client</b>	Verizon Wireless		<b>Designed by</b>	TJL

Section Elevation ft	Add Weight K	Self Weight K	F a c e	e	C <sub>F</sub>	R <sub>R</sub>	D <sub>F</sub>	D <sub>R</sub>	A <sub>E</sub> ft <sup>2</sup>	F K	w plf	Ctrl. Face
120.00-100.00			B	0.189	2.632	0.588	1	1	36.100			
			C	0.24	2.468	0.599	1	1	42.290			
T4	0.95	2.08	A	0.336	2.206	0.627	1	1	68.106	1.45	72.28	A
100.00-80.00			B	0.219	2.533	0.595	1	1	50.901			
			C	0.241	2.464	0.6	1	1	51.935			
T5	0.96	2.46	A	0.288	2.329	0.612	1	1	64.711	1.35	67.50	A
80.00-60.00			B	0.189	2.632	0.588	1	1	49.114			
			C	0.203	2.588	0.591	1	1	48.072			
T6	0.97	2.65	A	0.259	2.41	0.604	1	1	64.567	1.27	63.29	A
60.00-40.00			B	0.173	2.687	0.585	1	1	49.764			
			C	0.183	2.655	0.587	1	1	47.751			
T7	0.97	2.78	A	0.238	2.473	0.599	1	1	66.386	1.19	59.31	A
40.00-20.00			B	0.163	2.724	0.584	1	1	52.360			
			C	0.169	2.702	0.585	1	1	49.815			
T8	0.58	3.28	A	0.189	2.633	0.588	1	1	61.654	1.17	58.65	A
20.00-0.00			B	0.149	2.776	0.581	1	1	53.763			
			C	0.152	2.764	0.582	1	1	52.188			
Sum Weight:	6.76	17.21						OTM	770.19 kip-ft	9.83		

### Tower Forces - Service - Wind 60 To Face

Section Elevation ft	Add Weight K	Self Weight K	F a c e	e	C <sub>F</sub>	R <sub>R</sub>	D <sub>F</sub>	D <sub>R</sub>	A <sub>E</sub> ft <sup>2</sup>	F K	w plf	Ctrl. Face
160.00-140.00			A	0.284	2.34	0.611	0.8	1	32.524	0.85	42.37	A
			B	0.153	2.759	0.582	0.8	1	18.421			
			C	0.256	2.421	0.603	0.8	1	29.292			
T2	0.91	1.29	A	0.393	2.078	0.649	0.8	1	51.668	1.15	57.38	A
140.00-120.00			B	0.175	2.68	0.586	0.8	1	23.402			
			C	0.254	2.426	0.603	0.8	1	32.703			
T3	0.92	1.52	A	0.353	2.164	0.634	0.8	1	55.823	1.23	61.56	A
120.00-100.00			B	0.189	2.632	0.588	0.8	1	31.351			
			C	0.24	2.468	0.599	0.8	1	38.147			
T4	0.95	2.08	A	0.336	2.206	0.627	0.8	1	63.009	1.34	66.87	A
100.00-80.00			B	0.219	2.533	0.595	0.8	1	43.692			
			C	0.241	2.464	0.6	0.8	1	46.116			
T5	0.96	2.46	A	0.288	2.329	0.612	0.8	1	60.496	1.26	63.10	A
80.00-60.00			B	0.189	2.632	0.588	0.8	1	42.624			
			C	0.203	2.588	0.591	0.8	1	43.354			
T6	0.97	2.65	A	0.259	2.41	0.604	0.8	1	60.697	1.19	59.49	A
60.00-40.00			B	0.173	2.687	0.585	0.8	1	43.543			
			C	0.183	2.655	0.587	0.8	1	43.481			
T7	0.97	2.78	A	0.238	2.473	0.599	0.8	1	62.072	1.11	55.46	A
40.00-20.00			B	0.163	2.724	0.584	0.8	1	45.718			
			C	0.169	2.702	0.585	0.8	1	45.111			
T8	0.58	3.28	A	0.189	2.633	0.588	0.8	1	55.896	1.06	53.17	A
20.00-0.00			B	0.149	2.776	0.581	0.8	1	46.577			
			C	0.152	2.764	0.582	0.8	1	46.168			
Sum Weight:	6.76	17.21						OTM	723.85 kip-ft	9.19		

<b>tnxTower</b>  <b>Centek Engineering Inc.</b> 63-2 North Branford Rd. Branford, CT 06405 Phone: (203) 488-0580 FAX: (203) 488-8587	<b>Job</b> 15001.040 - Windsor	<b>Page</b> 19 of 32
	<b>Project</b> 160' Lattice Tower - 482 Pigeon Hill Road, Windsor, CT	<b>Date</b> 15:28:01 09/01/15
	<b>Client</b> Verizon Wireless	<b>Designed by</b> T.J.L.

**Tower Forces - Service - Wind 90 To Face**

Section Elevation	Add Weight	Self Weight	F a c e	e	C <sub>F</sub>	R <sub>R</sub>	D <sub>F</sub>	D <sub>R</sub>	A <sub>E</sub>	F	w	Ctrl. Face
ft	K	K							ft <sup>2</sup>	K	plf	
T1 160.00-140.00	0.50	1.15	A	0.284	2.34	0.611	0.85	1	33.051	0.86	43.05	A
			B	0.153	2.759	0.582	0.85	1	19.043			
			C	0.256	2.421	0.603	0.85	1	29.840			
T2 140.00-120.00	0.91	1.29	A	0.393	2.078	0.649	0.85	1	52.227	1.16	58.00	A
			B	0.175	2.68	0.586	0.85	1	24.162			
			C	0.254	2.426	0.603	0.85	1	33.391			
T3 120.00-100.00	0.92	1.52	A	0.353	2.164	0.634	0.85	1	56.704	1.25	62.53	A
			B	0.189	2.632	0.588	0.85	1	32.538			
			C	0.24	2.468	0.599	0.85	1	39.183			
T4 100.00-80.00	0.95	2.08	A	0.336	2.206	0.627	0.85	1	64.284	1.36	68.23	A
			B	0.219	2.533	0.595	0.85	1	45.494			
			C	0.241	2.464	0.6	0.85	1	47.570			
T5 80.00-60.00	0.96	2.46	A	0.288	2.329	0.612	0.85	1	61.550	1.28	64.20	A
			B	0.189	2.632	0.588	0.85	1	44.246			
			C	0.203	2.588	0.591	0.85	1	44.533			
T6 60.00-40.00	0.97	2.65	A	0.259	2.41	0.604	0.85	1	61.665	1.21	60.44	A
			B	0.173	2.687	0.585	0.85	1	45.098			
			C	0.183	2.655	0.587	0.85	1	44.549			
T7 40.00-20.00	0.97	2.78	A	0.238	2.473	0.599	0.85	1	63.151	1.13	56.42	A
			B	0.163	2.724	0.584	0.85	1	47.379			
			C	0.169	2.702	0.585	0.85	1	46.287			
T8 20.00-0.00	0.58	3.28	A	0.189	2.633	0.588	0.85	1	57.336	1.09	54.54	A
			B	0.149	2.776	0.581	0.85	1	48.373			
			C	0.152	2.764	0.582	0.85	1	47.673			
Sum Weight:	6.76	17.21						OTM	735.44 kip-ft	9.35		

**Force Totals**

Load Case	Vertical Forces	Sum of Forces X	Sum of Forces Z	Sum of Overturning Moments, M <sub>x</sub>	Sum of Overturning Moments, M <sub>z</sub>	Sum of Torques
	K	K	K	kip-ft	kip-ft	kip-ft
Leg Weight	6.55					
Bracing Weight	10.66					
Total Member Self-Weight	17.21				6.09	
Total Weight	30.74			8.92	6.09	
Wind 0 deg - No Ice		0.45	-37.69	-3688.11	-13.97	-2.44
Wind 30 deg - No Ice		19.74	-31.32	-3082.98	-1909.96	4.01
Wind 60 deg - No Ice		32.68	-17.79	-1743.06	-3199.77	3.65
Wind 90 deg - No Ice		38.02	-0.12	13.87	-3719.58	3.99
Wind 120 deg - No Ice		34.33	18.21	1817.67	-3331.66	5.42
Wind 150 deg - No Ice		19.28	31.47	3132.15	-1897.98	8.41
Wind 180 deg - No Ice		-0.02	36.25	3608.30	-13.22	4.47
Wind 210 deg - No Ice		-19.45	31.22	3096.42	1906.55	-2.56
Wind 240 deg - No Ice		-33.92	18.47	1811.71	3312.27	-2.60
Wind 270 deg - No Ice		-37.80	-0.04	-8.46	3726.07	-6.46
Wind 300 deg - No Ice		-32.90	-17.61	-1758.73	3253.53	-9.48
Wind 330 deg - No Ice		-19.76	-31.36	-3100.71	1957.66	-14.16
Member Ice	7.78					
Total Weight Ice	52.62			20.82	12.91	
Wind 0 deg - Ice		0.34	-34.83	-3392.07	-2.13	-3.36
Wind 30 deg - Ice		18.13	-29.20	-2855.18	-1748.34	1.10



<b>tnxTower</b>  <b>Centek Engineering Inc.</b> 63-2 North Branford Rd. Branford, CT 06405 Phone: (203) 488-0580 FAX: (203) 488-8587	<b>Job</b> 15001.040 - Windsor	<b>Page</b> 20 of 32
	<b>Project</b> 160' Lattice Tower - 482 Pigeon Hill Road, Windsor, CT	<b>Date</b> 15:28:01 09/01/15
	<b>Client</b> Verizon Wireless	<b>Designed by</b> TJL

Load Case	Vertical Forces K	Sum of Forces X K	Sum of Forces Z K	Sum of Overturning Moments, $M_x$ kip-ft	Sum of Overturning Moments, $M_z$ kip-ft	Sum of Torques kip-ft
Wind 60 deg - Ice		30.27	-16.65	-1615.07	-2953.00	0.94
Wind 90 deg - Ice		35.15	-0.09	24.74	-3428.42	1.77
Wind 120 deg - Ice		31.46	16.93	1697.04	-3047.98	3.73
Wind 150 deg - Ice		17.78	29.32	2921.00	-1739.38	7.10
Wind 180 deg - Ice		-0.01	33.81	3365.96	-2.06	4.94
Wind 210 deg - Ice		-17.91	29.13	2893.62	1762.14	-0.01
Wind 240 deg - Ice		-31.15	17.12	1692.14	3049.67	-0.08
Wind 270 deg - Ice		-34.98	-0.03	7.39	3449.93	-3.66
Wind 300 deg - Ice		-30.44	-16.51	-1627.35	3010.72	-6.93
Wind 330 deg - Ice		-18.15	-29.23	-2868.96	1801.51	-11.50
Total Weight	30.74			8.92	6.09	
Wind 0 deg - Service		0.17	-14.72	-1446.43	-6.00	-0.95
Wind 30 deg - Service		7.71	-12.23	-1210.05	-746.62	1.57
Wind 60 deg - Service		12.76	-6.95	-686.65	-1250.45	1.43
Wind 90 deg - Service		14.85	-0.05	-0.34	-1453.50	1.56
Wind 120 deg - Service		13.41	7.11	704.26	-1301.97	2.12
Wind 150 deg - Service		7.53	12.29	1217.73	-741.94	3.28
Wind 180 deg - Service		-0.01	14.16	1403.73	-5.70	1.74
Wind 210 deg - Service		-7.60	12.20	1203.78	744.21	-1.00
Wind 240 deg - Service		-13.25	7.21	701.94	1293.32	-1.01
Wind 270 deg - Service		-14.77	-0.02	-9.07	1454.96	-2.52
Wind 300 deg - Service		-12.85	-6.88	-692.77	1270.37	-3.70
Wind 330 deg - Service		-7.72	-12.25	-1216.98	764.17	-5.53

## Load Combinations

Comb. No.	Description
1	Dead Only
2	Dead+Wind 0 deg - No Ice
3	Dead+Wind 30 deg - No Ice
4	Dead+Wind 60 deg - No Ice
5	Dead+Wind 90 deg - No Ice
6	Dead+Wind 120 deg - No Ice
7	Dead+Wind 150 deg - No Ice
8	Dead+Wind 180 deg - No Ice
9	Dead+Wind 210 deg - No Ice
10	Dead+Wind 240 deg - No Ice
11	Dead+Wind 270 deg - No Ice
12	Dead+Wind 300 deg - No Ice
13	Dead+Wind 330 deg - No Ice
14	Dead+Ice+Temp
15	Dead+Wind 0 deg+Ice+Temp
16	Dead+Wind 30 deg+Ice+Temp
17	Dead+Wind 60 deg+Ice+Temp
18	Dead+Wind 90 deg+Ice+Temp
19	Dead+Wind 120 deg+Ice+Temp
20	Dead+Wind 150 deg+Ice+Temp
21	Dead+Wind 180 deg+Ice+Temp
22	Dead+Wind 210 deg+Ice+Temp
23	Dead+Wind 240 deg+Ice+Temp
24	Dead+Wind 270 deg+Ice+Temp
25	Dead+Wind 300 deg+Ice+Temp
26	Dead+Wind 330 deg+Ice+Temp
27	Dead+Wind 0 deg - Service
28	Dead+Wind 30 deg - Service

<b>tnxTower</b>  <b>Centek Engineering Inc.</b> 63-2 North Branford Rd. Branford, CT 06405 Phone: (203) 488-0580 FAX: (203) 488-8587	<b>Job</b> 15001.040 - Windsor	<b>Page</b> 21 of 32
	<b>Project</b> 160' Lattice Tower - 482 Pigeon Hill Road, Windsor, CT	<b>Date</b> 15:28:01 09/01/15
	<b>Client</b> Verizon Wireless	<b>Designed by</b> TJL

Comb. No.	Description
29	Dead+Wind 60 deg - Service
30	Dead+Wind 90 deg - Service
31	Dead+Wind 120 deg - Service
32	Dead+Wind 150 deg - Service
33	Dead+Wind 180 deg - Service
34	Dead+Wind 210 deg - Service
35	Dead+Wind 240 deg - Service
36	Dead+Wind 270 deg - Service
37	Dead+Wind 300 deg - Service
38	Dead+Wind 330 deg - Service

### Maximum Member Forces

Section No.	Elevation ft	Component Type	Condition	Gov. Load Comb.	Force K	Major Axis Moment kip-ft	Minor Axis Moment kip-ft
T1	160 - 140	Leg	Max Tension	12	20.47	-1.21	-0.90
			Max. Compression	2	-25.65	0.02	1.37
			Max. Mx	5	-1.34	1.30	-0.02
			Max. My	2	-25.65	-0.02	-1.63
			Max. Vy	6	4.85	-1.13	-0.75
			Max. Vx	2	-6.00	0.02	1.37
		Diagonal	Max Tension	13	5.03	0.00	0.00
			Max. Compression	7	-5.02	0.00	0.00
			Max. Mx	26	1.73	0.02	-0.00
			Max. My	7	-5.02	0.00	0.01
			Max. Vy	26	0.01	0.02	-0.00
			Max. Vx	7	-0.00	0.00	0.01
		Top Girt	Max Tension	7	0.08	0.00	0.00
			Max. Compression	19	-0.19	0.00	0.00
			Max. Mx	14	-0.07	-0.08	0.00
			Max. My	18	-0.03	0.00	0.00
			Max. Vy	14	0.04	0.00	0.00
			Max. Vx	18	-0.00	0.00	0.00
T2	140 - 120	Leg	Max Tension	12	39.46	-0.04	0.01
			Max. Compression	2	-46.21	-0.21	0.09
			Max. Mx	2	-29.83	1.37	-0.02
			Max. My	11	-3.20	0.01	-0.38
			Max. Vy	2	0.33	1.37	-0.02
			Max. Vx	13	-0.20	0.01	0.24
		Diagonal	Max Tension	7	4.46	0.00	0.00
			Max. Compression	7	-4.57	0.00	0.00
			Max. Mx	15	3.18	0.04	0.00
			Max. My	12	-4.05	0.00	-0.01
			Max. Vy	25	0.02	0.04	0.00
			Max. Vx	25	0.00	0.00	0.00
		Secondary Horizontal	Max Tension	2	0.80	0.00	0.00
			Max. Compression	2	-0.80	0.00	0.00
			Max. Mx	14	0.09	-0.07	0.00
			Max. My	14	0.08	0.00	0.00
			Max. Vy	14	0.03	0.00	0.00
			Max. Vx	14	-0.00	0.00	0.00
T3	120 - 100	Leg	Max Tension	12	61.31	-0.15	0.10
			Max. Compression	2	-70.46	-0.08	0.04
			Max. Mx	12	53.74	0.41	0.22
			Max. My	9	-4.14	0.27	-0.78
			Max. Vy	12	-0.35	-0.27	0.22
			Max. Vx	9	0.68	-0.19	0.56

<b>tnxTower</b>  <b>Centek Engineering Inc.</b> 63-2 North Branford Rd. Branford, CT 06405 Phone: (203) 488-0580 FAX: (203) 488-8587	<b>Job</b> 15001.040 - Windsor	<b>Page</b> 22 of 32
	<b>Project</b> 160' Lattice Tower - 482 Pigeon Hill Road, Windsor, CT	<b>Date</b> 15:28:01 09/01/15
	<b>Client</b> Verizon Wireless	<b>Designed by</b> TJL

Section No.	Elevation ft	Component Type	Condition	Gov. Load Comb.	Force K	Major Axis Moment kip-ft	Minor Axis Moment kip-ft	
T4	100 - 80	Diagonal	Max Tension	7	4.98	0.00	0.00	
			Max. Compression	11	-5.00	0.00	0.00	
			Max. Mx	15	3.93	0.06	0.00	
			Max. My	17	-3.52	0.01	0.01	
			Max. Vy	15	-0.03	0.06	0.00	
			Max. Vx	17	-0.00	0.00	0.00	
		Secondary Horizontal	Max Tension	2	1.22	0.00	0.00	
			Max. Compression	2	-1.22	0.00	0.00	
			Max. Mx	14	0.12	-0.10	0.00	
			Max. My	18	1.01	0.00	0.00	
			Max. Vy	14	-0.03	0.00	0.00	
			Max. Vx	18	-0.00	0.00	0.00	
		Leg	Max Tension	12	85.00	0.18	-0.05	
			Max. Compression	6	-96.07	-0.13	-0.26	
			Max. Mx	19	-92.88	0.54	-0.06	
			Max. My	13	-6.67	-0.01	0.85	
			Max. Vy	10	-0.27	0.54	-0.02	
			Max. Vx	3	0.56	-0.05	-0.58	
			Diagonal	Max Tension	7	5.79	0.00	0.00
				Max. Compression	7	-5.82	0.00	0.00
				Max. Mx	15	4.34	0.09	0.00
				Max. My	17	-4.04	0.02	0.01
				Max. Vy	15	-0.03	0.09	0.00
				Max. Vx	17	-0.00	0.00	0.00
Secondary Horizontal	Max Tension	6	1.67	0.00	0.00			
	Max. Compression	6	-1.67	0.00	0.00			
	Max. Mx	14	0.16	-0.16	0.00			
	Max. My	26	1.39	0.00	0.00			
	Max. Vy	14	-0.05	0.00	0.00			
	Max. Vx	26	-0.00	0.00	0.00			
T5	80 - 60	Leg	Max Tension	12	106.67	-0.12	0.40	
			Max. Compression	6	-120.34	-0.19	0.16	
			Max. Mx	23	-116.27	0.98	0.01	
			Max. My	13	-8.20	0.02	1.51	
			Max. Vy	4	0.56	-0.37	-0.12	
			Max. Vx	13	-1.06	0.02	1.51	
		Diagonal	Max Tension	5	7.58	0.00	0.00	
			Max. Compression	11	-7.63	0.00	0.00	
			Max. Mx	25	5.27	0.11	-0.01	
			Max. My	20	-6.30	0.04	0.01	
			Max. Vy	25	0.04	0.10	0.01	
			Max. Vx	21	-0.00	0.00	0.00	
Secondary Horizontal	Max Tension	6	2.09	0.00	0.00			
	Max. Compression	6	-2.09	0.00	0.00			
	Max. Mx	14	0.19	-0.25	0.00			
	Max. My	26	1.72	0.00	0.01			
	Max. Vy	14	0.06	0.00	0.00			
	Max. Vx	26	-0.00	0.00	0.00			
T6	60 - 40	Leg	Max Tension	12	130.48	-0.50	-0.00	
			Max. Compression	6	-147.57	0.48	-0.05	
			Max. Mx	25	114.22	-1.15	0.04	
			Max. My	13	-11.06	-0.02	0.49	
			Max. Vy	19	0.19	1.01	0.01	
			Max. Vx	11	-0.10	-0.04	-0.44	
		Diagonal	Max Tension	5	7.65	0.00	0.00	
			Max. Compression	11	-7.79	0.00	0.00	
			Max. Mx	19	5.46	0.16	-0.01	
			Max. My	26	-4.34	0.11	0.02	

<b>tnxTower</b>  <b>Centek Engineering Inc.</b> 63-2 North Branford Rd. Branford, CT 06405 Phone: (203) 488-0580 FAX: (203) 488-8587	<b>Job</b> 15001.040 - Windsor	<b>Page</b> 23 of 32
	<b>Project</b> 160' Lattice Tower - 482 Pigeon Hill Road, Windsor, CT	<b>Date</b> 15:28:01 09/01/15
	<b>Client</b> Verizon Wireless	<b>Designed by</b> TJL

Section No.	Elevation ft	Component Type	Condition	Gov. Load Comb.	Force K	Major Axis Moment kip-ft	Minor Axis Moment kip-ft
T7	40 - 20	Leg	Max. Vy	25	0.05	0.16	-0.01
			Max. Vx	26	-0.00	0.00	0.00
			Max Tension	12	151.91	-0.32	0.00
			Max. Compression	6	-172.57	0.62	-0.02
			Max. Mx	25	132.89	-1.88	0.01
			Max. My	13	-13.73	-0.05	0.64
			Max. Vy	17	0.30	-1.87	-0.00
		Diagonal	Max. Vx	13	0.11	-0.05	0.64
			Max Tension	18	7.69	0.00	0.00
			Max. Compression	18	-7.60	0.00	0.00
			Max. Mx	25	5.29	0.19	-0.02
			Max. My	25	-6.70	0.13	0.02
			Max. Vy	25	0.06	0.19	-0.02
			Max. Vx	25	-0.00	0.00	0.00
T8	20 - 0	Leg	Max Tension	12	172.22	-0.61	0.03
			Max. Compression	6	-196.51	0.00	-0.00
			Max. Mx	19	-177.09	2.13	-0.01
			Max. My	11	-9.88	-0.07	-1.27
			Max. Vy	17	-0.35	-1.87	-0.00
			Max. Vx	9	0.19	-0.08	1.25
			Diagonal	Max Tension	18	8.78	0.00
		Max. Compression		18	-8.64	0.00	0.00
		Max. Mx		25	4.22	0.30	0.02
		Max. My		25	-7.92	0.21	0.03
		Max. Vy		25	0.08	0.30	0.02
		Max. Vx		25	-0.00	0.00	0.00

### Maximum Reactions

Location	Condition	Gov. Load Comb.	Vertical K	Horizontal, X K	Horizontal, Z K
Leg C	Max. Vert	10	201.64	20.51	-11.67
	Max. H <sub>x</sub>	10	201.64	20.51	-11.67
	Max. H <sub>z</sub>	17	-153.46	-18.60	10.66
	Min. Vert	4	-174.47	-18.38	10.42
	Min. H <sub>x</sub>	17	-153.46	-18.60	10.66
	Min. H <sub>z</sub>	10	201.64	20.51	-11.67
Leg B	Max. Vert	6	202.65	-20.68	-11.63
	Max. H <sub>x</sub>	25	-156.31	18.76	10.56
	Max. H <sub>z</sub>	25	-156.31	18.76	10.56
	Min. Vert	12	-177.23	18.55	10.31
	Min. H <sub>x</sub>	6	202.65	-20.68	-11.63
	Min. H <sub>z</sub>	6	202.65	-20.68	-11.63
Leg A	Max. Vert	2	197.28	-0.11	23.05
	Max. H <sub>x</sub>	11	10.68	2.71	0.84
	Max. H <sub>z</sub>	2	197.28	-0.11	23.05
	Min. Vert	8	-172.74	0.13	-20.61
	Min. H <sub>x</sub>	5	9.54	-2.81	0.87
	Min. H <sub>z</sub>	21	-153.52	0.13	-21.07

### Tower Mast Reaction Summary

<b>tnxTower</b>  <b>Centek Engineering Inc.</b> 63-2 North Branford Rd. Branford, CT 06405 Phone: (203) 488-0580 FAX: (203) 488-8587	<b>Job</b> 15001.040 - Windsor	<b>Page</b> 24 of 32
	<b>Project</b> 160' Lattice Tower - 482 Pigeon Hill Road, Windsor, CT	<b>Date</b> 15:28:01 09/01/15
	<b>Client</b> Verizon Wireless	<b>Designed by</b> TJL

Load Combination	Vertical	Shear <sub>x</sub>	Shear <sub>y</sub>	Overturning Moment, M <sub>x</sub>	Overturning Moment, M <sub>y</sub>	Torque
	K	K	K	kip-ft	kip-ft	kip-ft
Dead Only	30.74	0.00	0.00	8.92	6.09	0.00
Dead+Wind 0 deg - No Ice	30.74	0.45	-37.69	-3701.08	-13.96	-2.46
Dead+Wind 30 deg - No Ice	30.74	19.74	-31.32	-3093.87	-1916.53	3.99
Dead+Wind 60 deg - No Ice	30.74	32.68	-17.79	-1749.23	-3210.89	3.65
Dead+Wind 90 deg - No Ice	30.74	38.02	-0.12	13.94	-3732.50	4.00
Dead+Wind 120 deg - No Ice	30.74	34.33	18.21	1824.11	-3343.17	5.44
Dead+Wind 150 deg - No Ice	30.74	19.28	31.47	3143.21	-1904.59	8.42
Dead+Wind 180 deg - No Ice	30.74	-0.02	36.25	3621.01	-13.31	4.49
Dead+Wind 210 deg - No Ice	30.74	-19.45	31.22	3107.35	1913.11	-2.54
Dead+Wind 240 deg - No Ice	30.74	-33.92	18.47	1818.05	3323.73	-2.60
Dead+Wind 270 deg - No Ice	30.74	-37.80	-0.04	-8.53	3739.04	-6.48
Dead+Wind 300 deg - No Ice	30.74	-32.90	-17.61	-1765.02	3264.86	-9.50
Dead+Wind 330 deg - No Ice	30.74	-19.76	-31.36	-3111.68	1964.46	-14.17
Dead+Ice+Temp	52.62	0.00	-0.00	20.88	12.96	0.00
Dead+Wind 0 deg+Ice+Temp	52.62	0.34	-34.83	-3411.32	-2.03	-3.41
Dead+Wind 30 deg+Ice+Temp	52.62	18.13	-29.20	-2871.40	-1758.03	1.10
Dead+Wind 60 deg+Ice+Temp	52.62	30.27	-16.65	-1624.27	-2969.53	0.96
Dead+Wind 90 deg+Ice+Temp	52.62	35.15	-0.09	24.87	-3447.61	1.82
Dead+Wind 120 deg+Ice+Temp	52.62	31.46	16.93	1706.72	-3064.95	3.80
Dead+Wind 150 deg+Ice+Temp	52.62	17.78	29.32	2937.53	-1749.13	7.17
Dead+Wind 180 deg+Ice+Temp	52.62	-0.01	33.81	3384.98	-2.14	4.99
Dead+Wind 210 deg+Ice+Temp	52.62	-17.91	29.13	2909.98	1771.92	-0.00
Dead+Wind 240 deg+Ice+Temp	52.62	-31.15	17.12	1701.67	3066.68	-0.11
Dead+Wind 270 deg+Ice+Temp	52.62	-34.98	-0.03	7.34	3469.25	-3.71
Dead+Wind 300 deg+Ice+Temp	52.62	-30.44	-16.51	-1636.71	3027.58	-6.99
Dead+Wind 330 deg+Ice+Temp	52.62	-18.15	-29.23	-2885.28	1811.58	-11.57
Dead+Wind 0 deg - Service	30.74	0.17	-14.72	-1440.32	-1.73	-0.96
Dead+Wind 30 deg - Service	30.74	7.71	-12.23	-1203.13	-744.93	1.56
Dead+Wind 60 deg - Service	30.74	12.76	-6.95	-677.86	-1250.55	1.43
Dead+Wind 90 deg - Service	30.74	14.85	-0.05	10.89	-1454.32	1.56
Dead+Wind 120 deg - Service	30.74	13.41	7.11	718.00	-1302.23	2.13
Dead+Wind 150 deg - Service	30.74	7.53	12.29	1233.28	-740.27	3.29
Dead+Wind 180 deg - Service	30.74	-0.01	14.16	1419.92	-1.48	1.75
Dead+Wind 210 deg - Service	30.74	-7.60	12.20	1219.27	751.05	-0.99
Dead+Wind 240 deg - Service	30.74	-13.25	7.21	715.63	1302.08	-1.01
Dead+Wind 270 deg - Service	30.74	-14.77	-0.02	2.11	1464.31	-2.53
Dead+Wind 300 deg - Service	30.74	-12.85	-6.88	-684.04	1279.08	-3.71
Dead+Wind 330 deg - Service	30.74	-7.72	-12.25	-1210.09	771.10	-5.54

## Solution Summary

Load Comb.	Sum of Applied Forces			Sum of Reactions			% Error
	PX K	PY K	PZ K	PX K	PY K	PZ K	
1	0.00	-30.74	0.00	0.00	30.74	0.00	0.000%
2	0.45	-30.74	-37.69	-0.45	30.74	37.69	0.000%
3	19.74	-30.74	-31.32	-19.74	30.74	31.32	0.002%
4	32.68	-30.74	-17.79	-32.68	30.74	17.79	0.000%
5	38.02	-30.74	-0.12	-38.02	30.74	0.12	0.001%
6	34.33	-30.74	18.21	-34.33	30.74	-18.21	0.000%
7	19.28	-30.74	31.47	-19.28	30.74	-31.47	0.000%
8	-0.02	-30.74	36.25	0.02	30.74	-36.25	0.000%
9	-19.45	-30.74	31.22	19.45	30.74	-31.22	0.000%
10	-33.92	-30.74	18.47	33.92	30.74	-18.47	0.000%
11	-37.80	-30.74	-0.04	37.80	30.74	0.04	0.001%
12	-32.90	-30.74	-17.61	32.90	30.74	17.61	0.000%
13	-19.76	-30.74	-31.36	19.76	30.74	31.36	0.001%
14	0.00	-52.62	0.00	0.00	52.62	0.00	0.000%

<b>tnxTower</b>  <b>Centek Engineering Inc.</b> 63-2 North Branford Rd. Branford, CT 06405 Phone: (203) 488-0580 FAX: (203) 488-8587	<b>Job</b>	15001.040 - Windsor	<b>Page</b>	25 of 32
	<b>Project</b>	160' Lattice Tower - 482 Pigeon Hill Road, Windsor, CT	<b>Date</b>	15:28:01 09/01/15
	<b>Client</b>	Verizon Wireless	<b>Designed by</b>	TJL

Load Comb.	Sum of Applied Forces			Sum of Reactions			% Error
	PX K	PY K	PZ K	PX K	PY K	PZ K	
15	0.34	-52.62	-34.83	-0.34	52.62	34.83	0.000%
16	18.13	-52.62	-29.20	-18.13	52.62	29.20	0.000%
17	30.27	-52.62	-16.65	-30.27	52.62	16.65	0.000%
18	35.15	-52.62	-0.09	-35.15	52.62	0.09	0.000%
19	31.46	-52.62	16.93	-31.46	52.62	-16.93	0.000%
20	17.78	-52.62	29.32	-17.78	52.62	-29.32	0.000%
21	-0.01	-52.62	33.81	0.01	52.62	-33.81	0.000%
22	-17.91	-52.62	29.13	17.91	52.62	-29.13	0.000%
23	-31.15	-52.62	17.12	31.15	52.62	-17.12	0.000%
24	-34.98	-52.62	-0.03	34.98	52.62	0.03	0.000%
25	-30.44	-52.62	-16.51	30.44	52.62	16.51	0.000%
26	-18.15	-52.62	-29.23	18.15	52.62	29.23	0.000%
27	0.17	-30.74	-14.72	-0.17	30.74	14.72	0.000%
28	7.71	-30.74	-12.23	-7.71	30.74	12.23	0.000%
29	12.76	-30.74	-6.95	-12.76	30.74	6.95	0.000%
30	14.85	-30.74	-0.05	-14.85	30.74	0.05	0.000%
31	13.41	-30.74	7.11	-13.41	30.74	-7.11	0.000%
32	7.53	-30.74	12.29	-7.53	30.74	-12.29	0.000%
33	-0.01	-30.74	14.16	0.01	30.74	-14.16	0.000%
34	-7.60	-30.74	12.20	7.60	30.74	-12.20	0.000%
35	-13.25	-30.74	7.21	13.25	30.74	-7.21	0.000%
36	-14.77	-30.74	-0.02	14.77	30.74	0.02	0.000%
37	-12.85	-30.74	-6.88	12.85	30.74	6.88	0.000%
38	-7.72	-30.74	-12.25	7.72	30.74	12.25	0.000%

## Non-Linear Convergence Results

Load Combination	Converged?	Number of Cycles	Displacement Tolerance	Force Tolerance
1	Yes	4	0.00000001	0.00000001
2	Yes	4	0.00000001	0.00001216
3	Yes	4	0.00000001	0.00001366
4	Yes	4	0.00000001	0.00001122
5	Yes	4	0.00000001	0.00001009
6	Yes	4	0.00000001	0.00001229
7	Yes	4	0.00000001	0.00000789
8	Yes	4	0.00000001	0.00000845
9	Yes	4	0.00000001	0.00001676
10	Yes	4	0.00000001	0.00001718
11	Yes	4	0.00000001	0.00000994
12	Yes	4	0.00000001	0.00000969
13	Yes	4	0.00000001	0.00000784
14	Yes	4	0.00000001	0.00000001
15	Yes	4	0.00000001	0.00000993
16	Yes	4	0.00000001	0.00001258
17	Yes	4	0.00000001	0.00001153
18	Yes	4	0.00000001	0.00000996
19	Yes	4	0.00000001	0.00000991
20	Yes	4	0.00000001	0.00000836
21	Yes	4	0.00000001	0.00000979
22	Yes	4	0.00000001	0.00001488
23	Yes	4	0.00000001	0.00001396
24	Yes	4	0.00000001	0.00000894
25	Yes	4	0.00000001	0.00001000
26	Yes	4	0.00000001	0.00000760
27	Yes	4	0.00000001	0.00000001

<b>tnxTower</b>  <b>Centek Engineering Inc.</b> 63-2 North Branford Rd. Branford, CT 06405 Phone: (203) 488-0580 FAX: (203) 488-8587	<b>Job</b> 15001.040 - Windsor	<b>Page</b> 26 of 32
	<b>Project</b> 160' Lattice Tower - 482 Pigeon Hill Road, Windsor, CT	<b>Date</b> 15:28:01 09/01/15
	<b>Client</b> Verizon Wireless	<b>Designed by</b> TJL

28	Yes	4	0.00000001	0.00000001
29	Yes	4	0.00000001	0.00000001
30	Yes	4	0.00000001	0.00000001
31	Yes	4	0.00000001	0.00000001
32	Yes	4	0.00000001	0.00000001
33	Yes	4	0.00000001	0.00000001
34	Yes	4	0.00000001	0.00000001
35	Yes	4	0.00000001	0.00000001
36	Yes	4	0.00000001	0.00000001
37	Yes	4	0.00000001	0.00000001
38	Yes	4	0.00000001	0.00000001

### Maximum Tower Deflections - Service Wind

Section No.	Elevation ft	Horz. Deflection in	Gov. Load Comb.	Tilt °	Twist °
T1	160 - 140	5.515	31	0.3253	0.0162
T2	140 - 120	4.155	31	0.3058	0.0106
T3	120 - 100	2.956	31	0.2492	0.0061
T4	100 - 80	1.993	31	0.1918	0.0066
T5	80 - 60	1.255	31	0.1395	0.0070
T6	60 - 40	0.720	31	0.0988	0.0053
T7	40 - 20	0.341	31	0.0665	0.0032
T8	20 - 0	0.100	31	0.0323	0.0014

### Critical Deflections and Radius of Curvature - Service Wind

Elevation ft	Appurtenance	Gov. Load Comb.	Deflection in	Tilt °	Twist °	Radius of Curvature ft
169.00	(2) AM-X-CD-14-65-00T-RET	31	5.515	0.3253	0.0162	98669
165.00	15' x 2" Dia Omni	31	5.515	0.3253	0.0162	98669
161.00	P8 x18-ft Pipe Mast	31	5.515	0.3253	0.0162	98669
156.50	LPA-80063-4CF	31	5.272	0.3236	0.0153	98669
156.00	Valmont 15' T-Frame P/N 860109	31	5.237	0.3234	0.0152	98669
147.00	APX16DWV-16DWVS-C-A20	31	4.620	0.3165	0.0128	37950
127.50	15' x 2" Dia Omni	31	3.380	0.2722	0.0059	20018
117.75	4' Side Mount Standoff	31	2.836	0.2424	0.0063	18380
111.33	8 FT DISH	31	2.510	0.2236	0.0066	19368
108.00	16' x 2" Dia Omni	31	2.350	0.2142	0.0066	19958
102.20	5'0"x4.5" Pipe Mount	31	2.088	0.1979	0.0066	21053
102.00	6 FT DISH	31	2.079	0.1974	0.0066	21089
99.00	4' Side Mount Standoff	31	1.951	0.1891	0.0066	21514
94.00	6 FT DISH	31	1.749	0.1754	0.0067	21835
93.83	5'0"x4.5" Pipe Mount	31	1.742	0.1749	0.0068	21844
72.10	5'0"x4.5" Pipe Mount	31	1.022	0.1219	0.0066	25436
72.00	10 FT DISH	31	1.019	0.1217	0.0066	25482
47.00	4' Side Mount Standoff (Vacant)	31	0.459	0.0777	0.0039	36032
45.41	12' x 1-1/2" Dia Omni	31	0.431	0.0752	0.0038	36522
37.58	4' Side Mount Standoff	31	0.305	0.0625	0.0030	36251

<b>tnxTower</b>  <b>Centek Engineering Inc.</b> 63-2 North Branford Rd. Branford, CT 06405 Phone: (203) 488-0580 FAX: (203) 488-8587	<b>Job</b> 15001.040 - Windsor	<b>Page</b> 27 of 32
	<b>Project</b> 160' Lattice Tower - 482 Pigeon Hill Road, Windsor, CT	<b>Date</b> 15:28:01 09/01/15
	<b>Client</b> Verizon Wireless	<b>Designed by</b> TJL

### Maximum Tower Deflections - Design Wind

Section No.	Elevation ft	Horz. Deflection in	Gov. Load Comb.	Tilt °	Twist °
T1	160 - 140	14.138	6	0.8274	0.0414
T2	140 - 120	10.646	6	0.7800	0.0270
T3	120 - 100	7.571	6	0.6387	0.0156
T4	100 - 80	5.105	6	0.4913	0.0168
T5	80 - 60	3.213	6	0.3574	0.0180
T6	60 - 40	1.845	6	0.2531	0.0136
T7	40 - 20	0.874	6	0.1704	0.0083
T8	20 - 0	0.257	6	0.0827	0.0035

### Critical Deflections and Radius of Curvature - Design Wind

Elevation ft	Appurtenance	Gov. Load Comb.	Deflection in	Tilt °	Twist °	Radius of Curvature ft
169.00	(2) AM-X-CD-14-65-00T-RET	6	14.138	0.8274	0.0414	40055
165.00	15' x 2" Dia Omni	6	14.138	0.8274	0.0414	40055
161.00	P8 x18-ft Pipe Mast	6	14.138	0.8274	0.0414	40055
156.50	LPA-80063-4CF	6	13.514	0.8233	0.0392	40055
156.00	Valmont 15' T-Frame P/N 860109	6	13.425	0.8226	0.0389	40055
147.00	APX16DWV-16DWVS-C-A20	6	11.839	0.8058	0.0327	15406
127.50	15' x 2" Dia Omni	6	8.658	0.6980	0.0152	7990
117.75	4' Side Mount Standoff	6	7.263	0.6212	0.0161	7274
111.33	8 FT DISH	6	6.427	0.5729	0.0168	7632
108.00	16' x 2" Dia Omni	6	6.019	0.5485	0.0168	7846
102.20	5'0"x4.5" Pipe Mount	6	5.347	0.5069	0.0168	8241
102.00	6 FT DISH	6	5.325	0.5055	0.0168	8254
99.00	4' Side Mount Standoff	6	4.997	0.4842	0.0169	8409
94.00	6 FT DISH	6	4.479	0.4492	0.0173	8533
93.83	5'0"x4.5" Pipe Mount	6	4.462	0.4480	0.0173	8537
72.10	5'0"x4.5" Pipe Mount	6	2.617	0.3123	0.0169	9944
72.00	10 FT DISH	6	2.610	0.3118	0.0168	9962
47.00	4' Side Mount Standoff (Vacant)	6	1.175	0.1990	0.0101	14069
45.41	12' x 1-1/2" Dia Omni	6	1.103	0.1926	0.0096	14258
37.58	4' Side Mount Standoff	6	0.780	0.1601	0.0077	14156

### Bolt Design Data

Section No.	Elevation ft	Component Type	Bolt Grade	Bolt Size in	Number Of Bolts	Maximum Load per Bolt K	Allowable Load K	Ratio Load Allowable	Allowable Ratio	Criteria
T1	160	Leg	A325N	0.6250	4	5.12	13.19	0.388 ✓	1.333	Bolt Tension
		Diagonal	A325N	0.5000	1	5.03	4.12	1.221 ✓	1.333	Bolt Shear
T2	140	Leg	A325N	0.6250	4	9.85	13.50	0.730 ✓	1.333	Bolt Tension
		Diagonal	A325N	0.5000	1	4.57	4.12	1.109 ✓	1.333	Bolt Shear
T3	120	Leg	A325N	0.7500	4	15.31	19.44	0.788 ✓	1.333	Bolt Tension



<b>tnxTower</b>  <b>Centek Engineering Inc.</b> 63-2 North Branford Rd. Branford, CT 06405 Phone: (203) 488-0580 FAX: (203) 488-8587	<b>Job</b> 15001.040 - Windsor	<b>Page</b> 28 of 32
	<b>Project</b> 160' Lattice Tower - 482 Pigeon Hill Road, Windsor, CT	<b>Date</b> 15:28:01 09/01/15
	<b>Client</b> Verizon Wireless	<b>Designed by</b> TJL

Section No.	Elevation ft	Component Type	Bolt Grade	Bolt Size in	Number Of Bolts	Maximum Load per Bolt K	Allowable Load K	Ratio Load/Allowable	Allowable Ratio	Criteria
T4	100	Diagonal	A325N	0.5000	1	5.00	4.12	1.212 ✓	1.333	Bolt Shear
		Secondary Horizontal	A325X	0.7500	2	0.61	9.79	0.062 ✓	1.333	Member Bearing
		Leg	A325N	0.8750	4	21.22	26.46	0.802 ✓	1.333	Bolt Tension
		Diagonal	A325X	0.5000	1	5.79	4.76	1.216 ✓	1.333	Member Bearing
T5	80	Secondary Horizontal	A325X	0.6250	2	0.83	8.16	0.102 ✓	1.333	Member Bearing
		Leg	A325N	1.0000	4	26.62	34.56	0.770 ✓	1.333	Bolt Tension
		Diagonal	A325N	0.6250	1	7.63	6.44	1.185 ✓	1.333	Bolt Shear
T6	60	Secondary Horizontal	A325X	0.6250	2	1.04	9.20	0.113 ✓	1.333	Bolt Shear
		Leg	A325N	1.0000	4	32.62	34.56	0.944 ✓	1.333	Bolt Tension
T7	40	Diagonal	A325N	0.6250	1	7.79	6.44	1.209 ✓	1.333	Bolt Shear
		Leg	A325N	1.0000	6	25.32	34.56	0.733 ✓	1.333	Bolt Tension
T8	20	Diagonal	A325N	0.6250	1	7.69	6.44	1.194 ✓	1.333	Bolt Shear
		Leg	A354-BC	0.8750	6	28.70	24.80	1.157 ✓	1.333	Bolt Tension
		Diagonal	A325X	0.6250	1	8.78	8.16	1.077 ✓	1.333	Member Bearing

### Compression Checks

### Leg Design Data (Compression)

Section No.	Elevation ft	Size	L ft	L <sub>u</sub> ft	Kl/r	F <sub>a</sub> ksi	A in <sup>2</sup>	Actual P K	Allow. P <sub>a</sub> K	Ratio P/P <sub>a</sub>
T1	160 - 140	ROHN 2.5 STD	20.00	4.75	60.2 K=1.00	22.690	1.7040	-25.65	38.66	0.663 ✓
T2	140 - 120	ROHN 2.5 STD	20.03	3.46	43.9 K=1.00	25.276	1.7040	-46.21	43.07	1.073 ✓
T3	120 - 100	ROHN 2.5 EH	20.03	3.44	44.7 K=1.00	25.153	2.2535	-70.46	56.68	1.243 ✓
T4	100 - 80	ROHN 3 EH	20.04	3.43	36.2 K=1.00	26.354	3.0159	-96.07	79.48	1.209 ✓
T5	80 - 60	ROHN 4 EH	20.03	5.18	42.1 K=1.00	25.539	4.4074	-120.34	112.56	1.069 ✓
T6	60 - 40	ROHN 5 EH	20.03	10.02	65.4 K=1.00	21.782	6.1120	-147.57	133.13	1.108 ✓
T7	40 - 20	ROHN 5 EH	20.04	10.02	65.4 K=1.00	21.778	6.1120	-172.57	133.11	1.296 ✓
T8	20 - 0	ROHN 6 EHS	20.03	10.02	54.0 K=1.00	23.713	6.7133	-196.51	159.19	1.234 ✓

<b>tnxTower</b>  <b>Centek Engineering Inc.</b> 63-2 North Branford Rd. Branford, CT 06405 Phone: (203) 488-0580 FAX: (203) 488-8587	<b>Job</b> 15001.040 - Windsor	<b>Page</b> 29 of 32
	<b>Project</b> 160' Lattice Tower - 482 Pigeon Hill Road, Windsor, CT	<b>Date</b> 15:28:01 09/01/15
	<b>Client</b> Verizon Wireless	<b>Designed by</b> TJL

**Diagonal Design Data (Compression)**

Section No.	Elevation ft	Size	L ft	L <sub>w</sub> ft	Kl/r	F <sub>a</sub> ksi	A in <sup>2</sup>	Actual P K	Allow. P <sub>a</sub> K	Ratio P/P <sub>a</sub>
T1	160 - 140	L1 3/4x1 3/4x1/4	9.79	4.64	163.2 K=1.00	5.605	0.8125	-5.02	4.55	1.103 ✓
T2	140 - 120	L2x2x1/4	12.21	6.05	185.6 K=1.00	4.337	0.9380	-4.41	4.07	1.085 ✓
T3	120 - 100	L2 1/2x2 1/2x3/16	13.96	6.92	167.8 K=1.00	5.305	0.9020	-5.00	4.78	1.045 ✓
T4	100 - 80	L3x3x3/16	15.79	7.81	157.3 K=1.00	6.038	1.0900	-5.82	6.58	0.885 ✓
T5	80 - 60	L3x3x1/4	19.03	9.46	191.7 K=1.00	4.065	1.4400	-7.63	5.85	1.304 ✓
T6	60 - 40	L3 1/2x3 1/2x1/4	20.76	10.27	177.5 K=1.00	4.740	1.6900	-7.79	8.01	0.973 ✓
T7	40 - 20	L3 1/2x3 1/2x1/4	22.64	11.23	194.1 K=1.00	3.962	1.6900	-7.58	6.70	1.132 ✓
T8	20 - 0	L4x4x1/4	24.49	12.08	182.3 K=1.00	4.492	1.9400	-8.34	8.71	0.957 ✓

**Secondary Horizontal Design Data (Compression)**

Section No.	Elevation ft	Size	L ft	L <sub>w</sub> ft	Kl/r	F <sub>a</sub> ksi	A in <sup>2</sup>	Actual P K	Allow. P <sub>a</sub> K	Ratio P/P <sub>a</sub>
T2	140 - 120	L2x2x1/4	10.22	9.98	242.6 K=0.79	2.536	0.9380	-0.80	2.38	0.337 ✓
T3	120 - 100	L2 1/2x2 1/2x3/16	12.25	11.53	224.7 K=0.80	2.956	0.9020	-1.22	2.67	0.458 ✓
T4	100 - 80	L3x3x3/16	14.31	13.59	220.7 K=0.81	3.065	1.0900	-1.67	3.34	0.499 ✓
T5	80 - 60	L3x3x1/4	16.17	15.36	246.0 K=0.79	2.467	1.4400	-2.09	3.55	0.587 ✓

**Top Girt Design Data (Compression)**

Section No.	Elevation ft	Size	L ft	L <sub>w</sub> ft	Kl/r	F <sub>a</sub> ksi	A in <sup>2</sup>	Actual P K	Allow. P <sub>a</sub> K	Ratio P/P <sub>a</sub>
T1	160 - 140	L2 1/2x2 1/2x3/8	8.56	8.32	172.3 K=0.84	5.031	1.7300	-0.19	8.70	0.021 ✓

**Tension Checks**

<b>tnxTower</b>  <b>Centek Engineering Inc.</b> 63-2 North Branford Rd. Branford, CT 06405 Phone: (203) 488-0580 FAX: (203) 488-8587	<b>Job</b> 15001.040 - Windsor	<b>Page</b> 30 of 32
	<b>Project</b> 160' Lattice Tower - 482 Pigeon Hill Road, Windsor, CT	<b>Date</b> 15:28:01 09/01/15
	<b>Client</b> Verizon Wireless	<b>Designed by</b> TJL

**Leg Design Data (Tension)**

Section No.	Elevation ft	Size	L ft	L <sub>u</sub> ft	KI/r	F <sub>a</sub> ksi	A in <sup>2</sup>	Actual P K	Allow. P <sub>a</sub> K	Ratio $\frac{P}{P_a}$
T1	160 - 140	ROHN 2.5 STD	20.00	4.75	60.2	30.000	1.7040	20.47	51.12	0.400
T2	140 - 120	ROHN 2.5 STD	20.03	3.46	43.9	30.000	1.7040	39.46	51.12	0.772
T3	120 - 100	ROHN 2.5 EH	20.03	3.44	44.7	30.000	2.2535	61.31	67.61	0.907
T4	100 - 80	ROHN 3 EH	20.04	3.43	36.2	30.000	3.0159	85.00	90.48	0.939
T5	80 - 60	ROHN 4 EH	20.03	5.18	42.1	30.000	4.4074	106.67	132.22	0.807
T6	60 - 40	ROHN 5 EH	20.03	10.02	65.4	30.000	6.1120	130.48	183.36	0.712
T7	40 - 20	ROHN 5 EH	20.04	10.02	65.4	30.000	6.1120	151.91	183.36	0.828
T8	20 - 0	ROHN 6 EHS	20.03	10.02	54.0	30.000	6.7133	172.22	201.40	0.855

**Diagonal Design Data (Tension)**

Section No.	Elevation ft	Size	L ft	L <sub>u</sub> ft	KI/r	F <sub>a</sub> ksi	A in <sup>2</sup>	Actual P K	Allow. P <sub>a</sub> K	Ratio $\frac{P}{P_a}$
T1	160 - 140	L1 3/4x1 3/4x1/4	9.79	4.64	108.0	21.600	0.8125	5.03	17.55	0.287
T2	140 - 120	L2x2x1/4	11.12	5.51	110.8	21.600	0.9380	4.46	20.26	0.220
T3	120 - 100	L2 1/2x2 1/2x3/16	13.96	6.92	108.5	21.600	0.9020	4.98	19.48	0.256
T4	100 - 80	L3x3x3/16	15.79	7.81	101.3	21.600	1.0900	5.79	23.54	0.246
T5	80 - 60	L3x3x1/4	19.03	9.46	123.7	21.600	1.4400	7.58	31.10	0.244
T6	60 - 40	L3 1/2x3 1/2x1/4	20.76	10.27	114.5	21.600	1.6900	7.65	36.50	0.210
T7	40 - 20	L3 1/2x3 1/2x1/4	22.64	11.23	125.1	21.600	1.6900	7.69	36.50	0.211
T8	20 - 0	L4x4x1/4	24.49	12.08	117.3	21.600	1.9400	8.78	41.90	0.210

**Secondary Horizontal Design Data (Tension)**

<b>tnxTower</b>  <b>Centek Engineering Inc.</b> 63-2 North Branford Rd. Branford, CT 06405 Phone: (203) 488-0580 FAX: (203) 488-8587	<b>Job</b> 15001.040 - Windsor	<b>Page</b> 31 of 32
	<b>Project</b> 160' Lattice Tower - 482 Pigeon Hill Road, Windsor, CT	<b>Date</b> 15:28:01 09/01/15
	<b>Client</b> Verizon Wireless	<b>Designed by</b> TJL

Section No.	Elevation ft	Size	L ft	L <sub>u</sub> ft	Kl/r	F <sub>a</sub> ksi	A in <sup>2</sup>	Actual P K	Allow. P <sub>a</sub> K	Ratio P P <sub>a</sub>
T2	140 - 120	L2x2x1/4	10.22	9.98	196.6	21.600	0.9380	0.80	20.26	0.040
T3	120 - 100	L2 1/2x2 1/2x3/16	12.25	11.53	185.3	21.600	0.9020	1.22	19.48	0.063
T4	100 - 80	L3x3x3/16	14.31	13.59	179.1	21.600	1.0900	1.67	23.54	0.071
T5	80 - 60	L3x3x1/4	16.17	15.36	203.8	21.600	1.4400	2.09	31.10	0.067

### Top Girt Design Data (Tension)

Section No.	Elevation ft	Size	L ft	L <sub>u</sub> ft	Kl/r	F <sub>a</sub> ksi	A in <sup>2</sup>	Actual P K	Allow. P <sub>a</sub> K	Ratio P P <sub>a</sub>
T1	160 - 140	L2 1/2x2 1/2x3/8	8.56	8.32	132.6	21.600	1.7300	0.08	37.37	0.002

### Section Capacity Table

Section No.	Elevation ft	Component Type	Size	Critical Element	P K	SF*P <sub>allow</sub> K	% Capacity	Pass Fail	
T1	160 - 140	Leg	ROHN 2.5 STD	3	-25.65	51.54	49.8	Pass	
T2	140 - 120	Leg	ROHN 2.5 STD	33	-46.21	57.42	80.5	Pass	
T3	120 - 100	Leg	ROHN 2.5 EH	63	-70.46	75.56	93.3	Pass	
T4	100 - 80	Leg	ROHN 3 EH	92	-96.07	105.95	90.7	Pass	
T5	80 - 60	Leg	ROHN 4 EH	122	-120.34	150.05	80.2	Pass	
T6	60 - 40	Leg	ROHN 5 EH	143	-147.57	177.46	83.2	Pass	
T7	40 - 20	Leg	ROHN 5 EH	158	-172.57	177.43	97.3	Pass	
T8	20 - 0	Leg	ROHN 6 EHS	173	-196.51	212.20	92.6	Pass	
T1	160 - 140	Diagonal	L1 3/4x1 3/4x1/4	9	-5.02	6.07	82.7	Pass	
T2	140 - 120	Diagonal	L2x2x1/4	38	-4.41	5.42	91.6 (b)	Pass	
T3	120 - 100	Diagonal	L2 1/2x2 1/2x3/16	64	-5.00	6.38	81.4	Pass	
T4	100 - 80	Diagonal	L3x3x3/16	96	-5.82	8.77	83.2 (b)	Pass	
T5	80 - 60	Diagonal	L3x3x1/4	124	-7.63	7.80	78.4	Pass	
T6	60 - 40	Diagonal	L3 1/2x3 1/2x1/4	145	-7.79	10.68	90.9 (b)	Pass	
T7	40 - 20	Diagonal	L3 1/2x3 1/2x1/4	160	-7.58	8.93	66.4	Pass	
T8	20 - 0	Diagonal	L4x4x1/4	176	-8.34	11.62	91.3 (b)	Pass	
T2	140 - 120	Secondary Horizontal	L2x2x1/4	41	-0.80	3.17	25.3	Pass	
T3	120 - 100	Secondary Horizontal	L2 1/2x2 1/2x3/16	71	-1.22	3.55	34.4	Pass	
T4	100 - 80	Secondary Horizontal	L3x3x3/16	100	-1.67	4.45	37.4	Pass	
T5	80 - 60	Secondary Horizontal	L3x3x1/4	130	-2.09	4.74	44.1	Pass	
T1	160 - 140	Top Girt	L2 1/2x2 1/2x3/8	6	-0.19	11.60	1.6	Pass	
							Summary		
							Leg (T7)	97.3	Pass

<b>tnxTower</b>  <b>Centek Engineering Inc.</b> 63-2 North Branford Rd. Branford, CT 06405 Phone: (203) 488-0580 FAX: (203) 488-8587	<b>Job</b> 15001.040 - Windsor	<b>Page</b> 32 of 32
	<b>Project</b> 160' Lattice Tower - 482 Pigeon Hill Road, Windsor, CT	<b>Date</b> 15:28:01 09/01/15
	<b>Client</b> Verizon Wireless	<b>Designed by</b> TJL

Section No.	Elevation ft	Component Type	Size	Critical Element	P K	SF*P <sub>allow</sub> K	% Capacity	Pass Fail
						Diagonal (T5)	97.8	Pass
						Secondary Horizontal (T5)	44.1	Pass
						Top Girt (T1)	1.6	Pass
						Bolt Checks	91.6	Pass
						<b>RATING =</b>	<b>97.8</b>	<b>Pass</b>

**Rock Anchor Foundation Analysis:**

**Input Data:**

Max Pier Reactions:

Uplift = Uplift := 177-kips *user input*  
 Shear = Shear := 24-kips *user input*  
 Compression = Axial := 203-kips *user input*

Structure:

Footing Width =  $B_{ftg} := 8.0\text{ft}$  *user input*  
 Footing Length =  $L_{ftg} := 8.0\text{ft}$  *user input*  
 Footing Thickness =  $T_{ftg} := 3.50\text{ft}$  *user input*  
 Pier Length/Width =  $L_{pier} := 3.00\text{ft}$  *user input*  
 Pier Height =  $T_{pier} := 9.50\text{ft}$  *user input*  
 Pier Projection Above Grade =  $P_p := 2.00\text{-ft}$  *user input*

Depths:

Depth to Bottom of Footing =  $D_{ftg} := 11.00\text{ft}$  *user input* (from grade line)  
 Depth to Suitable Rock =  $D_{rock} := 12.00\text{ft}$  *user input* (from grade line)  
 Depth to Suitable Earth =  $D_{earth} := 1.0\text{ft}$  *user input* (from grade line)  
 Anchor Length =  $L_{anchor} := 30.00\text{ft}$  *user input* (from grade line)  
 Depth to Top of Submerged Anchor =  $D_{anchortop} := 2.50\text{ft}$  *user input* (from grade line)  
 Anchor Depth =  $D_{anchor} := D_{anchortop} + L_{anchor}$  (from grade line)  
 $D_{anchor} = 32.5\text{ft}$

Subgrade Properties:

Internal Friction Angle =  $\phi := 30\text{deg}$  *user input*  
 Unit Weight of Earth =  $\gamma_{earth} := 110 \frac{\text{lb}}{\text{ft}^3}$  *user input*  
 Unit Weight of Rock =  $\gamma_{rock} := 165 \frac{\text{lb}}{\text{ft}^3}$  *user input*  
 Unit Weight of Conc =  $\gamma_{conc} := 150 \frac{\text{lb}}{\text{ft}^3}$  *user input*  
 Allowable Bearing = Bearing := 12000-psf *user input*

(Existing sub-grade conditions utilized in the analysis of the existing foundation system were obtained from a geo-technical soils study prepared by Clarence Welti & Assoc., P.E., P.C; dated September 20 2010.

Rock Anchor Properties:

Number of Anchors =	$N_{\text{anchor}} := 4$	<i>user input</i>	
Hole Diameter =	$\text{hole}_d := 4.00\text{in}$	<i>user input</i>	
Allowable Bond Stress Between Rock and Grout =	$\sigma_{\text{bond}} := 50\text{-psi}$	<i>user input</i>	Working bond Strength based on Weathered Rock/Sandstone
Grout Allowable Compressive Stress =	$f_{c_g} := 5000\text{-psi}$	<i>user input</i>	
Anchor Spacing* (along length) =	$S_{\text{anchor}} := 5.00\text{ft}$	<i>user input</i>	
Required Factor of Safety =	$F_S := 2.0$	<i>user input</i>	
Rock Anchor Ultimate Strength =	$F_{u_{\text{anchor}}} := 150.0\text{ksi}$	<i>user input</i>	Williams R71-11 1-3/8" dia. 150ksi
Rock Anchor Yield Strength =	$F_{y_{\text{anchor}}} := 127.7\text{ksi}$	<i>user input</i>	Per Recommendation of PTI For Prestressed Rock Anchors and Soil Anchors Section 6.6 Design Load Should not be more than 60% of Specified Minimum Tensile Strength.
Rock Anchor Diameter =	$d_{ra} := 1.250\text{in}$	<i>user input</i>	
Rock Anchor Area per Group =	$A_g := 1.250\text{in}^2$	<i>user input</i>	
Rock Anchor Ultimate Tensile Load =	$T_u := 188\text{kips}$		
Rock Anchor Allowable Tension =	$T_{\text{all}} := 0.60 \cdot T_u = 112.8\text{-kips}$		
Rock Anchor Maximum Working Load to Yield =	$T_y := 0.80 \cdot T_u = 150.4\text{-kips}$		
Rock Anchor Shear Capacity =	$S_h := 0.4 \cdot T_y = 60.16\text{-kips}$		
Total Volume of Concrete =	$V_{\text{conc}} := B_{\text{ftg}} \cdot L_{\text{ftg}} \cdot T_{\text{ftg}} + \frac{\pi \cdot L_{\text{pier}}^2}{4} \cdot T_{\text{pier}} = 291.2\text{-ft}^3$		
Weight of Pad =	$W_{\text{pad}} := (B_{\text{ftg}} \cdot L_{\text{ftg}} \cdot T_{\text{ftg}}) \cdot \gamma_{\text{conc}} = 33.6\text{-kips}$		
Weight of Pier =	$W_{\text{pier}} := (L_{\text{pier}}^2 \cdot T_{\text{pier}}) \cdot \gamma_{\text{conc}} = 12.83\text{-kips}$		
Total Weight of Concrete =	$W_{\text{conc}} := W_{\text{pad}} + W_{\text{pier}} = 46.4\text{-kips}$		

**Rock Anchor Tension/Shear Check:**

Actual Tension Force per Anchor =

$$T_a := \frac{\text{Uplift} - W_{\text{conc}}}{N_{\text{anchor}}} = 32.6\text{-kips}$$

Design Shear Force per Anchor =

$$S_a := \frac{\text{Shear}}{N_{\text{anchor}}} = 6\text{-kips}$$

Reduced Tension For Tension/Shear Combination =

$$T_{\text{allr}} := \left[ 1 - \left( \frac{S_a}{T_{\text{all}}} \right)^2 \right] \cdot T_{\text{all}} = 112.48\text{-kips}$$

Tension Check =

$$\text{TensionCheck} := \text{if}(T_{\text{allr}} \geq T_a, \text{"OK"}, \text{"IncreaseSize"}) = \text{"OK"}$$

Shear Check =

$$\text{ShearCheck} := \text{if}(S_h \geq S_a, \text{"OK"}, \text{"IncreaseSize"}) = \text{"OK"}$$

Provided Safety Factor =

$$\frac{T_{\text{allr}}}{T_a} = 3.45$$

$$\text{SafetyFactor} := \text{if}\left(\frac{T_{\text{allr}}}{T_a} \geq 1.0, \text{"OK"}, \text{"Overstressed"}\right)$$

**SafetyFactor = "OK"**

**Rock Anchor Req'd Development Length in Rock:**

Minimum Free Stress Length Required =

$$F_{\text{stressreqd}} := 10.0\text{ft}$$

(Original Centek design free stress length)

Minimum Free Stress Length Provided =

$$F_{\text{stressprov}} := 10.0\text{ft}$$

Controlling Free Stress Length:

$$L_f := \text{if}(F_{\text{stressprov}} > F_{\text{stressreqd}}, F_{\text{stressprov}}, F_{\text{stressreqd}}) \quad L_f = 10\text{ft}$$

Required Rock Anchor Proof Load (1.33x Design Load) =

$$T_p := T_a \cdot 1.33 = 43.4\text{-kips}$$

Provided Rock Anchor Proof Load (1.33x Design Load) =

$$T_{\text{pp}} := 40\text{kips} \cdot 1.33 \cdot F_S = 106.4\text{-kips}$$

$$T_{\text{PLmax}} := 0.80 \cdot T_U = 150.4\text{-kips}$$

Required Release Lock Off Load (1.10x Design Load) =

$$T_L := T_a \cdot 1.10 = 35.9\text{-kips}$$

Actual Release Lock Off Load (1.00x Design Load) =

$$T_{\text{LL}} := 40\text{kips} \cdot 1.00 \cdot F_S = 80\text{-kips}$$

$$T_{\text{LLmax}} := 0.70 \cdot T_U = 131.6\text{-kips}$$

Rock Anchor/Grout Bond Length:

$$L_d := \frac{\left( \frac{0.04}{\text{in}} T_{\text{LL}} \right)}{\sqrt{f_{c_g} \cdot \text{psi}}} \quad L_d = 3.77\text{-ft}$$

**Note:**  
 Max Allowable Tensile Load = 60% of Ultimate Strength.  
 Max Lock Off Load = 70% of Ultimate Strength.  
 Max Proof Load = 80% of Ultimate Strength.

Required Rock/Grout Bond Length:

$$L_b := \frac{T_{\text{LL}}}{\pi \cdot \text{hole}_d \cdot \sigma_{\text{bond}}} = 10.61\text{ft}$$

Controlling Length:

$$L_a := \text{if}(L_b < L_d, L_d, L_b) \quad L_a = 10.61\text{ft}$$

$$L_{\text{bprov}} := D_{\text{anchor}} - L_f - D_{\text{anchortop}} = 20\text{ft}$$

$$\text{Bond\_Length\_Check} := \text{if}\left(\frac{L_a}{L_{\text{bprov}}} \leq 1.00, \text{"OK"}, \text{"Increase Length"}\right)$$

**Bond\_Length\_Check = "OK"**



**Calculated Uplift Resistance:**

Intermediate Dimension:

Suitable Earth Height =  $H := D_{rock} - D_{earth} = 11 \text{ ft}$

Suitable Rock Height =  $Z := (D_{anchor} - D_{rock}) = 20.5 \text{ ft}$

Total Anchor Width =  $W := S_{anchor} = 5 \text{ ft}$

Volumes:

Base Area 1 of Resisting Pyramid =  $B_1 := W^2 = 25 \text{ ft}^2$

Base Area 2 of Resisting Pyramid =  $B_2 := [\tan(\phi) \cdot (Z \cdot 0.5) \cdot 2 + W]^2 = 283.4 \text{ ft}^2$

Base Area 3 of Resisting Pyramid =  $B_3 := [\tan(\phi) \cdot (Z \cdot 0.5 + H) \cdot 2 + W]^2 = 872.5 \text{ ft}^2$

Total Volume of Resisting Material =  $V_{tot} := \frac{[H + (Z \cdot 0.5)] \cdot (B_1 + B_3 + \sqrt{B_1 \cdot B_3})}{3} = 7403.1 \text{ ft}^3$

Volume of Rock =  $V_{rock} := \frac{(Z \cdot 0.5) \cdot (B_1 + B_2 + \sqrt{B_1 \cdot B_2})}{3} = 1341.4 \text{ ft}^3$

Volume of Earth =  $V_{earth} := V_{tot} - V_{rock} - V_{conc} = 5770.5 \text{ ft}^3$

Note: Rock Cone Taken At Half Suitable Rock Height - See Rock Volume Calculations.

Resisting Forces:

Resisting Rock Force =  $W_{rock} := V_{rock} \cdot \gamma_{rock} = 221.3 \text{ kips}$

Resisting Earth Force =  $W_{earth} := V_{earth} \cdot \gamma_{earth} = 634.8 \text{ kips}$

Total Resisting Force =  $W_{total} := W_{rock} + W_{earth} + W_{conc} = 902.5 \text{ kips}$

**Foundation Uplift Check:**

Factor of Safety =  $\frac{W_{total}}{\text{Uplift}} = 5.10$

$\text{Uplift\_Check} := \text{if} \left( \frac{W_{total}}{\text{Uplift}} \geq F_S, \text{"OK"}, \text{"Overstressed"} \right)$

**Uplift\_Check = "OK"**

**Rock Bearing Capacity Check:**

Bearing Force =  $\text{MaxBearing} := \left[ \frac{(Axial + W_{conc}) + (N_{anchor} T_{LL})}{B_{ftg} L_{ftg}} \right] = 8897 \text{ psf}$

$\frac{\text{MaxBearing}}{\text{Bearing}} = 0.74$

$\text{Rock\_Bearing\_Check} := \text{if} \left( \frac{\text{MaxBearing}}{\text{Bearing}} \leq 1.00, \text{"OK"}, \text{"Overstressed"} \right)$

**Rock\_Bearing\_Check = "OK"**

SITE NAME	WINDSOR CT		ECP - CELL #	8	143
LATITUDE	41-51-59.90 N		LONGITUDE	72-40-29.20 W	
RET antenna upgrade with 60W 700 and AWS RRH upgrade. The 60W 4 port 700 RRH will be connected to the low band ports on the AWS and PCS antenna. Please note the electrical tilt for 700 is on the SBNHH antennas			SAVE BUTTON		LATTICE
			STRUCTURE TYPE		
<b>700 Mhz - LTE Current Config</b>	<b>ALPHA</b>		<b>BETA</b>		<b>GAMMA</b>
EQUIPMENT TYPE	eNodeB		eNodeB		eNodeB
ANTENNA TYPE	BXA-70040-6CF-2		BXA-70040-6CF-2		BXA-70063-6CF-4
QTY OF ANTENNAS PER FACE	1		1		1
ORIENTATION (DEG)	40		230		310
DOWN TILT ( MECH/DEG )	4		5		0
RAD CTR (FT AGL)	155		155		155
TMA - QTY / MODEL					
DIPLEXER - QTY / MODEL					
MCPA BRICKS (QTY)					
RRH - QTY/MODEL	1	ALU SLI-9442 2X40-7U	1	ALU SLI-9442 2X40-7U	1 ALU SLI-9442 2X40-7U
SECTOR DISTRIBUTION BOX					
MAIN DISTRIBUTION BOX					
<b>700 Mhz - LTE Future Config</b>	<b>ALPHA</b>		<b>BETA</b>		<b>GAMMA</b>
EQUIPMENT TYPE	eNodeB		eNodeB		eNodeB
ANTENNA TYPE	BXA-70040-6CF-2		BXA-70040-6CF-2		BXA-70063-6CF-4
QTY OF ANTENNAS PER FACE	leave as placeholder		leave as placeholder		leave as placeholder
ORIENTATION (DEG)	40		230		310
DOWN TILT ( MECH/DEG )	7 elect		7 elect		5 elect
RAD CTR (FT AGL)	155		155		155
TMA - QTY / MODEL					
DIPLEXER - QTY / MODEL					
MCPA BRICKS (QTY)					
RRH - QTY/MODEL	1	ALU RH-2X60-700U	1	ALU RH-2X60-700U	1 ALU RH-2X60-700U
SECTOR DISTRIBUTION BOX					
MAIN DISTRIBUTION BOX					
<b>850 Cellular - Current Config</b>	<b>ALPHA</b>		<b>BETA</b>		<b>GAMMA</b>
EQUIPMENT TYPE	Cellular Modcell 4.0B		Cellular Modcell 4.0B		Cellular Modcell 4.0B
ANTENNA TYPE	LPA-80063-4CF		LPA-80063-4CF		LPA-80063-4CF
QTY OF ANTENNAS PER FACE	2		2		2
ORIENTATION (DEG)	40		230		310
DOWN TILT ( MECH/DEG )	5		5		4
RAD CTR (FT AGL)	155		155		155
TMA - QTY / MODEL					
DIPLEXER - QTY / MODEL	2	FD9R6004/2C-3L	2	FD9R6004/2C-3L	2 FD9R6004/2C-3L
DIPLEX WITH LTE CABLE					
MCPA BRICKS (QTY)					
<b>850 Cellular - Future Config</b>	<b>ALPHA</b>		<b>BETA</b>		<b>GAMMA</b>
EQUIPMENT TYPE	Cellular Modcell 4.0B		Cellular Modcell 4.0B		Cellular Modcell 4.0B
ANTENNA TYPE	LPA-80063-4CF		LPA-80063-4CF		LPA-80063-4CF
QTY OF ANTENNAS PER FACE	2		2		2
ORIENTATION (DEG)	40		230		310
DOWN TILT ( MECH/DEG )	5		5		4
RAD CTR (FT AGL)	155		155		155
TMA - QTY / MODEL					
DIPLEXER - QTY / MODEL	0	FD9R6004/2C-3L	0	FD9R6004/2C-3L	0 FD9R6004/2C-3L
DIPLEX WITH LTE CABLE					
MCPA BRICKS (QTY)					
<b>1900 PCS - Current Config</b>	<b>ALPHA</b>		<b>BETA</b>		<b>GAMMA</b>
EQUIPMENT TYPE	PCS Modcell 4.0B		PCS Modcell 4.0B		PCS Modcell 4.0B
ANTENNA TYPE	HBX-6516DS-T2M		HBX-6516DS-T2M		HBX-6516DS-T2M
QTY OF ANTENNAS PER FACE	1		1		1
ORIENTATION (DEG)	40		230		310
DOWN TILT ( MECH/DEG )	1		2		1
RAD CTR (FT AGL)	155		155		155
TMA - QTY / MODEL					
DIPLEXER - QTY / MODEL					
DIPLEX WITH CELLULAR CABLE	DIPLEX with Cellular Cable		DIPLEX with Cellular Cable		DIPLEX with Cellular Cable
MCPA BRICKS (QTY)					
<b>1900 PCS - Future Config</b>	<b>ALPHA</b>		<b>BETA</b>		<b>GAMMA</b>
EQUIPMENT TYPE	PCS Modcell 4.0B		PCS Modcell 4.0B		PCS Modcell 4.0B
ANTENNA TYPE	SBNHH-1D65B		SBNHH-1D65B		SBNHH-1D65B
QTY OF ANTENNAS PER FACE	1		1		1
ORIENTATION (DEG)	40		230		310
DOWN TILT ( MECH/DEG )	3 elect		4 elect		3 elect
RAD CTR (FT AGL)	155		155		155
TMA - QTY / MODEL					
DIPLEXER - QTY / MODEL					
DIPLEX WITH CELLULAR CABLE					
MCPA BRICKS (QTY)					
RRH - QTY/MODEL	1	ALU RH-2X60-PCS	1	ALU RH-2X60-PCS	1 ALU RH-2X60-PCS
SECTOR DISTRIBUTION BOX					
MAIN DISTRIBUTION BOX					

2100 Mhz - AWS Current Config				ALPHA				BETA				GAMMA							
EQUIPMENT TYPE				eNodeB				eNodeB				eNodeB							
ANTENNA TYPE				APX18-206517-T2				APX18-206517-T2				APX18-206517-T2							
QTY OF ANTENNAS PER FACE				1				1				1							
ORIENTATION (DEG)				40				230				310							
DOWN TILT ( MECH/DEG )				1				1				0							
RAD CTR ( FT AGL)				155				155				155							
TMA - QTY / MODEL																			
DIPLEXER - QTY / MODEL																			
MCPA BRICKS (QTY)																			
RRH - QTY/MODEL				1		ALU RH-2X40-AWS		1		ALU RH-2X40-AWS		1		ALU RH-2X40-AWS					
SECTOR DISTRIBUTION BOX																			
MAIN DISTRIBUTION BOX				1								DB-T1-6Z-8AB-0Z							
2100 Mhz - AWS Future Config				ALPHA				BETA				GAMMA							
EQUIPMENT TYPE				eNodeB				eNodeB				eNodeB							
ANTENNA TYPE				SBNHH-1D65B				SBNHH-1D65B				SBNHH-1D65B							
QTY OF ANTENNAS PER FACE				1				1				1							
ORIENTATION (DEG)				40				230				310							
DOWN TILT ( MECH/DEG )				3 elect				3 elect				2 elect							
RAD CTR ( FT AGL)				155				155				155							
TMA - QTY / MODEL																			
DIPLEXER - QTY / MODEL																			
MCPA BRICKS (QTY)																			
RRH - QTY/MODEL				1		ALU RH-2X60-AWS		1		ALU RH-2X60-AWS		1		ALU RH-2X60-AWS					
SECTOR DISTRIBUTION BOX																			
MAIN DISTRIBUTION BOX				1								DB-T1-6Z-8AB-0Z							
NUMBER OF CABLE'S NEEDED								Fiber Line Model Number											
Total # Fiber Lines				2				TOTAL # OF MAINLINES				12							
Total # Top Jumpers				6				TOTAL # OF TOP JUMPERS				36							
Equipment Cable Ordering				MAIN CABLE		12		+		0		TOP JUMPER #		24		+		12	
TX / RX FREQUENCIES												TX POWER OUTPUT							
Cellular A-Band				PCS F-Band				700 Mhz C - B				Cellular (Watts)							
TX - 869-880,890-891.5 MHz				TX - 1970-1975				TX - 746-757				PCS (Watts)							
RX - 824-835,845-846.5 MHz				RX - 1890-1895				RX - 776-787				LTE (Watts)							
ALPHA				BETA				GAMMA											
Ant	Freq	Func	Color Code	Ant	Freq	Func	Color Code	Ant	Freq	Func	Color Code								
A1-A	800	Tx1/Rx0	RED	A5-A	800	Tx2/Rx0	BLUE	A9-A	800	Tx3/Rx0	GREEN								
A1-B	1900	Tx1/Rx0	RED/WHITE	A5-B	1900	Tx2/Rx0	BLUE/WHITE	A9-B	1900	Tx3/Rx0	GREEN/WHITE								
A2	700	Tx1/Rx0	RED/ORANGE	A6	700	Tx2/Rx0	BLUE/ORANGE	A10	700	Tx3/Rx0	GREEN/ORANGE								
A3	700	Tx4/Rx1	RED/RED/ORANGE	A7	700	Tx5/Rx1	BLUE/BLUE/ORANGE	A11	700	Tx6/Rx1	GREEN/GREEN/ORANGE								
A4-B	1900	Tx4/Rx1	RED/RED/WHITE	A8-B	1900	Tx5/Rx1	BLUE/BLUE/WHITE	A12-B	1900	Tx6/Rx1	GREEN/GREEN/WHITE								
A4-A	800	Tx4/Rx1	RED/RED	A8-A	800	Tx5/Rx1	BLUE/BLUE	A12-A	800	Tx6/Rx1	GREEN/GREEN								
RF ENGINEER				RF MANAGER				INITIALS				DATE							
Prepared By : Mark Brauer				Robert Hesselbach				MB				3/24/2015							



## SBNHH-1D65B

**Andrew® Tri-band Antenna, 698–896 and 2 x 1710–2360 MHz, 65° horizontal beamwidth, internal RET. Both high bands share the same electrical tilt.**

- Interleaved dipole technology providing for attractive, low wind load mechanical package

### Electrical Specifications

Frequency Band, MHz	698–806	806–896	1710–1880	1850–1990	1920–2180	2300–2360
Gain, dBi	14.9	14.7	17.7	18.2	18.6	18.6
Beamwidth, Horizontal, degrees	68	66	69	66	63	58
Beamwidth, Vertical, degrees	12.1	10.7	5.6	5.2	5.0	4.5
Beam Tilt, degrees	0–14	0–14	0–7	0–7	0–7	0–7
USLS, dB	14	13	15	15	15	13
Front-to-Back Ratio at 180°, dB	27	29	28	28	28	27
CPR at Boresight, dB	20	23	20	20	17	21
CPR at Sector, dB	14	10	12	10	9	1
Isolation, dB	25	25	25	25	25	25
Isolation, Intersystem, dB	30	30	30	30	30	30
VSWR   Return Loss, dB	1.5   14.0	1.5   14.0	1.5   14.0	1.5   14.0	1.5   14.0	1.5   14.0
PIM, 3rd Order, 2 x 20 W, dBc	-153	-153	-153	-153	-153	-153
Input Power per Port, maximum, watts	350	350	350	350	350	300
Polarization	±45°	±45°	±45°	±45°	±45°	±45°
Impedance	50 ohm	50 ohm	50 ohm	50 ohm	50 ohm	50 ohm

### Electrical Specifications, BASTA\*

Frequency Band, MHz	698–806	806–896	1710–1880	1850–1990	1920–2180	2300–2360
Gain by all Beam Tilts, average, dBi	14.5	14.3	17.4	17.9	18.2	18.3
Gain by all Beam Tilts Tolerance, dB	±0.5	±0.8	±0.4	±0.3	±0.5	±0.3
	0°   14.6	0°   14.5	0°   17.4	0°   17.8	0°   18.1	0°   18.2
Gain by Beam Tilt, average, dBi	7°   14.6	7°   14.4	3°   17.5	3°   17.9	3°   18.3	3°   18.4
	14°   14.2	14°   13.6	7°   17.4	7°   17.9	7°   18.2	7°   18.4
Beamwidth, Horizontal Tolerance, degrees	±2.2	±3.4	±2	±4.6	±5.7	±4.3
Beamwidth, Vertical Tolerance, degrees	±0.8	±1	±0.3	±0.2	±0.3	±0.2
USLS, dB	16	14	16	16	16	15
Front-to-Back Total Power at 180° ± 30°, dB	25	26	27	26	26	26
CPR at Boresight, dB	22	23	21	20	20	22
CPR at Sector, dB	13	11	16	12	11	4

\* CommScope® supports NGMN recommendations on Base Station Antenna Standards (BASTA). To learn more about the benefits of BASTA, [download the whitepaper Time to Raise the Bar on BSAs.](#)

### General Specifications

Antenna Brand	Andrew®
Antenna Type	DualPol® multiband with internal RET
Band	Multiband
Brand	DualPol®   Teletilt®
Operating Frequency Band	1710 – 2360 MHz   698 – 896 MHz

### Mechanical Specifications

# Product Specifications

COMMScope®

SBNHH-1D65B

POWERED BY



Color	Light gray
Lightning Protection	dc Ground
Radiator Material	Aluminum   Low loss circuit board
Radome Material	Fiberglass, UV resistant
Reflector Material	Aluminum
RF Connector Interface	7-16 DIN Female
RF Connector Location	Bottom
RF Connector Quantity, total	6
Wind Loading, maximum	617.7 N @ 150 km/h 138.9 lbf @ 150 km/h
Wind Speed, maximum	241.4 km/h   150.0 mph

## Dimensions

Depth	181.0 mm   7.1 in
Length	1828.0 mm   72.0 in
Width	301.0 mm   11.9 in
Net Weight	18.4 kg   40.6 lb

## Remote Electrical Tilt (RET) Information

Input Voltage	10–30 Vdc
Power Consumption, idle state, maximum	2.0 W
Power Consumption, normal conditions, maximum	13.0 W
Protocol	3GPP/AISG 2.0 (Multi-RET)
RET Interface	8-pin DIN Female   8-pin DIN Male
RET Interface, quantity	1 female   1 male
RET System	Teletilt®

## Regulatory Compliance/Certifications

### Agency

RoHS 2011/65/EU  
China RoHS SJ/T 11364-2006  
ISO 9001:2008

### Classification

Compliant by Exemption  
Above Maximum Concentration Value (MCV)  
Designed, manufactured and/or distributed under this quality management system



## Included Products

BSAMNT-1 — Wide Profile Antenna Downtilt Mounting Kit for 2.4 - 4.5 in (60 - 115 mm) OD round members. Kit contains one scissor top bracket set and one bottom bracket set.

# ALCATEL-LUCENT B13 RRH4X30-4R

Alcatel-Lucent B13 Remote Radio Head 4x30-4R is the newest addition of Remote Radio Head to the extended product line of Alcatel-Lucent's distributed Base Station solutions, aimed at facilitating smooth RF site acquisition and related civil engineering.

**Supporting 2Tx/4Tx MIMO and 4-way Rx diversity**, Alcatel-Lucent B13 RRH4x30-4R allows operators to have a compact radio solution to deploy LTE in the 700U band (700 MHz, 3GPP band 13), providing them with the means to achieve high capacity, high quality and high coverage with minimum site requirements.

The Alcatel-Lucent B13 RRH4x30-4R product has four transmit RF paths, offering the possibility to **select, via software only, 2Tx or 4Tx MIMO configurations** with either 2x60 W or 4x30 W RF output power. It supports also 4-way Rx diversity and up to 10MHz instantaneous bandwidth.

The Alcatel-Lucent B13 RRH4x30-4R is a near zero-footprint solution and operates noise free, simplifying negotiations with site property owners and minimizing environmental impacts.

Its compactness and slim design makes the Alcatel-Lucent B13 RRH4x30-4R easy to install close to the antenna: operators can therefore locate this Remote Radio Head where RF design conditions are deemed ideal, minimizing trade-offs between available sites and RF optimum sites, together with reducing the RF feeder needs and installation costs.



## FEATURES

- Supporting LTE in 700 MHz band (700U, 3GPP band 13)
- LTE 2Tx or 4Tx MIMO (SW switchable)
- Output power: Up to 2x60W or 4x30W
- 10MHz LTE carrier with 4Rx Diversity
- Convection-cooled (fan-less)
- Supports AISG 2.0 ALD devices (RET, TMA) through RS485 or RF ports

## BENEFITS

- Compact to reduce additional footprint when adding LTE in 700U band
- MIMO scheme operation selection (2Tx or 4Tx) by software only
- Improves downlink spectral efficiency through MIMO4
- Increases LTE coverage thanks to 4Rx diversity capability and best in class Rx sensitivity
- Flexible mounting options: Pole or Wall

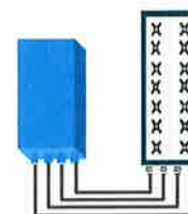

4x30W with 4T4R  
or  
2x60W with 2T4R  
Can be switched between  
modes via SW w/o site  
visit

## TECHNICAL SPECIFICATIONS

Features & performance	
<b>Number of TX/RX paths</b>	4 duplexed (either 4T4R or 2T4R by SW)
<b>Frequency band</b>	U700 (C) (3GPP bands 13): DL: 746 - 756 MHz / UL: 777 - 787 MHz
<b>Instantaneous bandwidth - #carriers</b>	10MHz – 1 LTE carrier (In 10MHz occupied bandwidth)
<b>LTE carrier bandwidth</b>	10 MHz
<b>RF output power</b>	2x60W or 4x30W (by SW)
<b>Noise figure – RX Diversity scheme</b>	2 dB typ. (<2.5 dB max) – 2 or 4 way Rx diversity
<b>Sizes (HxWxD) in mm (in.)</b>	550 x 305 x 230 (21.6" x 12.0" x 9") (with solar shield)
<b>Volume in L</b>	38 (with solar shield)
<b>Weight in kg (lb) (w/o mounting HW)</b>	26 (57.2) (with solar shield)
<b>DC voltage range</b>	-40.5 to -57V at full performance, -38 to -57V with relaxation on power consumption
<b>DC power consumption</b>	550W typical @100% RF load ( In 2Tx or 4TX mode)
<b>Environmental conditions</b>	-40°C (-40°F) / +55°C (+131°F) IP65
<b>Wind load (@150km/h or 93mph)</b>	Frontal:<200N / Lateral :<150N
<b>Antenna ports</b>	4 ports 7/16 DIN female (50 ohms) VSWR < 1.5
<b>CPRI ports</b>	2 CPRI ports (HW ready for Rate7, 9.8 Gbps) SFP single mode dual fiber
<b>AISG interfaces</b>	1 AISG2.0 output (RS485) Integrated Smart Bias Tees (x2)
<b>Misc. Interfaces</b>	4 external alarms (1 connector) – 4 RF Tx & 4 RF Rx monitor ports - 1 DC connector (2 pins)
<b>Installation conditions</b>	Pole and wall mounting
<b>Regulatory compliance</b>	3GPP 36.141 / 3GPP 36.113 / GR-1089-CORE / GR-3108-CORE / UL 60950-1 / FCC Part 27

www.alcatel-lucent.com Alcatel, Lucent, Alcatel-Lucent and the Alcatel-Lucent logo are trademarks of Alcatel-Lucent. All other trademarks are the property of their respective owners. The information presented is subject to change without notice. Alcatel-Lucent assumes no responsibility for inaccuracies contained herein.  
Copyright © 2014 Alcatel-Lucent. All Rights Reserved

# NEW PCS RF MODULES FOR VZW

## RRH2X60 - HW CHARACTERISTICS

LR14.3

RRH2x60	
RF Output Power	2x60W (4x30W HW Ready)
Instantaneous Bandwidth	60MHz
Target Reliability (Annual Return Rate)	<2%
Receiver	4 Branch Rx
Features	AISG 2.0 for RET/TMA
Power	-48VDC Internal Smart Bias-T
CPRI Ports	2 CPRI Rate 5 Ports
External Alarms	4 External User Alarms
Monitor Ports	TX, RX
Environmental	GR487 Compliance
RF Connectors	7/16 DIN (downward facing)
Dimensions	22"(h) x 12"(w) x 9.4" (d)**
Weight	55lb**



\*\* - Includes solar shield but not mounting brackets (8 lbs.)



# VZW Network Equipment Reporting Form (NERF)

<b>Vendor</b>	Alcatel-Lucent		<b>Model</b>	B66a RRH 4Tx/4Rx 4x45W or 2x 90W (SW selectable)		<b>Function</b>	RRH for distributed architecture with a CPRI interface between digital and RF processing components. The RRH has 4 Tx ports and 4 Rx ports. Can be SW configured for 2 Tx with 90W rf per port or 4 Tx with 45W rf per port. The RRH has passive cooling only.		
<b>*1)Equipment Configuration</b>	<b>*2)Heat Release @50°F Intake Temp [W]</b>		<b>*3)Airflow Rate @ 100% Activity Rate [cfm]</b>		<b>*4)Dimensions [in]</b>		<b>Non-Thermal Data</b>		
	<b>100% Activity</b>	<b>50% Activity</b>	<b>Nominal (70°F)</b>	<b>Max (95°F)</b>	<b>External (WxDxH)</b>	<b>Clear (F/R/S)</b>	<b>Installed Weight [lb]</b>	<b>*5)Sound @ Nominal [L<sub>WAS</sub>]</b>	<b>*6)Name Plate [W]</b>
<b>Minimum</b>			N/A Convection cooled	N/A Convection cooled	w/o Solar Shield W = 11.4in D = 6.7in H = 25.2in (W=290mm) (D=170mm) (H=640mm)	Front: 12" Rear: 7.5" Right: 12" Left: 12" Top: 12" Bottom: 24"			
<b>Typical</b>			N/A Convection cooled	N/A Convection cooled	with Solar Shield W = 12in D = 7.6in H = 25.8in (W=304mm) (D=193mm) (H=655mm)		62lb 72 lb(w mounting brackets)	N/A Convection cooled	
<b>Full</b>	825W (add 60W for AISG)	TBD	N/A Convection cooled	N/A Convection cooled	N/A			N/A Convection cooled	
<b>*7)Equipment EC-Class</b>	N/A Convection cooled	<b>*10)Fan Speed</b>	N/A Convection cooled	<b>*13)Fan Hot-Swap</b>	N/A Convection cooled	<b>*16)Environ. Tests</b>	N/A Convection cooled	<b>*18)Temp. Rise [°F]</b>	N/A Convection cooled
<b>*8)Non-Optimal EC-Class</b>	N/A Convection cooled	<b>*11)Fan Logic</b>	N/A Convection cooled	<b>*14)Shut-Down</b>	N/A Convection cooled	<b>*17)Allow. Max [°F]</b>	N/A Convection cooled	<b>*19)Rec. Max [°F]</b>	N/A Convection cooled
<b>*9)Exhaust Openings</b>	N/A Convection cooled	<b>*12)Fan Alarm</b>	N/A Convection cooled	<b>*15)Temp. Access</b>	N/A Convection cooled	<b>*17)Allow. Min [°F]</b>	N/A Convection cooled	<b>*19)Rec. Min [°F]</b>	N/A Convection cooled
<b>Power Reporting</b>									
<b>Power Input</b>	-48V	<b>No. Power Supplies</b>	N/A (Customer provided power plant)		<b>Number of Inputs per Power Supply</b>	1			
<b>*24)Maximum Demand (total system in Watts)</b>	825W (add 60W for AISG)	<b>Maximum Input (each power supply in Watts)</b>	N/A (Customer provided power plant)		<b>Maximum Output (each power supply in Watts)</b>	58W (to AISG port, 29V/2A)			
<b>Power Supply Connection Type</b>	DC entry via Conduit Box	<b>Power Supply Make &amp; Model</b>	N/A (Customer provided power plant)						
<b>Input Protection</b>	no input fuse	<b>Input Protection Make &amp; Model</b>	N/A (Customer provided power plant)						
<b>Redundancy Scheme</b>	N/A								
<b>Nominal Voltage</b>	-48VDC	<b>Maximum Voltage</b>	-57V		<b>Minimum Voltage</b>	-38V			
<b>*25)Max Current at Nominal Voltage</b>	17.2A (add 1.2A if AISG port loaded 2A*29V)	<b>*25)Max Current at Maximum Voltage</b>	14.5A (add 1A if AISG port loaded 2A*29V)		<b>*25)Max Current at Minimum Voltage</b>	21.7A (add 1.5A if AISG port loaded 2A*29V)			

Return completed forms to Engineering and Operations Support (EOS)  
[Richard.damiano@verizonwireless.com](mailto:Richard.damiano@verizonwireless.com)



**DC and Fiber Management Distribution Boxes for HYBRIFLEX™ Cable**

**Product Description**

The RFS Distribution Box design comes with the option for pluggable over voltage protection (OVP) for up to 6 remote radios and the connection for 6 pairs of optical fiber with LC optical fiber cable management. There is a hybrid cable input with a jumper configuration for power and optical fiber to the remote radio heads (RRHs). A custom wall, a 2-inch pole, and an H-Frame mounting bracket are included. Both the compact and standard design are available with lightning protection.

**Features/Benefits**

- Designed to accommodate varying diameters of HYBRIFLEX™ (combined power and fiber optic) cables – up to 2 inches
- Supports Single- and Multi-Mode Optical fiber
- NEMA 4x rated enclosure – allows flexibility for indoor or outdoor installation on a roof or tower top
- Weatherproof enclosure and ports – improves system reliability
- Modular design – makes replacement or addition of OVP easy without removal of other components within the box
- Strikesorb OVP technology – protects equipment from damaging surges up to 60 kA on an 8/20 waveform and up to 5 kA on a 10/350 waveform (certain models only)
- Low residual voltage and high impedance – ideally suited for RRH technology – won't shut down the RRH the way spark gap technology does (certain models only)



**Technical Specifications**

**Mechanical Specifications**

Model Number	DB-B1-6C-8AB-0Z	DB-T1-6Z-8AB-0Z
Enclosure Design	Standard, 6 OVP's	Standard without OVP
Dimensions - H x W x D, mm (in)	610 x 610 x 254 (24 x 24 x 10)	610 x 610 x 254 (24 x 24 x 10)
Weight, kg (lb)	20 (44)	20 (44)
Suppression Connection Method	Compression lug, #2-#14 AWG Copper, #2-#12 Aluminum	
Fiber Connection Method	LC-LC Single- or Multi-mode duplex	
Environmental Rating	NEMA 4x	
Operating Temperature, °C (°F)	-40 to +80 (-40 to +176)	
UV Protection	ISO 4892-2 Method A Xenon-Arc 2160 hrs	

**Electrical Specifications**

Nominal Operating Voltage	48 VDC	
Nominal Discharge Current (I <sub>n</sub> ) per UL 1449 3rd Ed	20 kA 8/20 μs	N/A
Maximum Discharge Current (I <sub>max</sub> ) per NEMA LS-1	60 kA 8/20 μs	N/A
Maximum Impulse (Lightning) Current (I <sub>imp</sub> ) per IEC 61643-1	5 kA 10/350 μs	N/A
Maximum Continuous Operating Voltage (U <sub>c</sub> )	75 VDC	N/A
Voltage Protection Rating per UL1449 3rd Ed	400 V	N/A
Protection Class as per IEC 61643-1	Class 1	N/A
Strikesorb OVP Compliance	ANSI/UL 1449-3rd Ed	N/A
	IEEE C62.41	N/A
	NEMA LS-1	N/A
	IEC 61643-1	N/A
	IEC 61643-12	N/A
	EN 61643-11	N/A

\* This data is provisional and subject to change.

All information contained in the present datasheet is subject to confirmation at time of ordering.