



10 INDUSTRIAL AVE,  
SUITE 3  
MAHWAH NJ 07430

PHONE: 201.684.0055  
FAX: 201.684.0066

October 6, 2021

Members of the Siting Council  
Connecticut Siting Council  
Ten Franklin Square  
New Britain, CT 06051

RE: Notice of Exempt Modification  
250 Derby Ave, West Haven, CT 06516  
Latitude: 41.3088500  
Longitude: -72.96000000  
T-Mobile/Sprint ID: CTNH833A-CT13XC264

Dear Ms. Bachman:

T-Mobile/Sprint currently maintains six (6) antennas at the 74-foot level of the existing 76-foot monopole tower at 250 Derby Avenue, West Haven, CT. The 76-foot monopole tower is owned and operated by Yale University. The property is owned by Yale University. T-Mobile/Sprint now intends to remove the six (6) existing antennas and add six (6) new antennas. The new antennas will be installed at the same 74-foot level of the tower and will support 5G services.

**Planned Modifications:**

**Tower:**

Remove

(3) 1-5/8" fiber cables

Remove

(3) Commscope DT465B-2XR panel antennas

(3) RFS APXVSP18 panel antennas

(6) ALU 1900 MHz RRHs

(6) ALU 800 MHz RRHs

(3) ALU TD-RRH-8X20 RRHs

Install New:

(3) Ericsson AIR6449 B41 Antennas

(3) RFS APXVAALL18\_43-U-NA20 Antennas

(3) Ericsson Radio 4460 B25+B66

(3) Ericsson Radio 4480 B71+B85

(3) 6/24 100m 4 AWG Hybrid Cables

(3) Commscope: SDX1926Q-43 Diplexers

**Ground:**

Remove

- (1) Sprint BTS Cabinet
- (2) Sprint Battery Cabinets
- (1) Hoffman Box and Frame

Install New:

- (1) Ericsson Enclosure 6160 Cabinet
- (1) Ericsson Battery B160 Cabinet
- (1) 150A Breaker in Existing 200A PPC Cabinet

Existing to Remain:

- (1) Sokva Transformer
- (1) Telco Cabinet
- (1) 200A PPC Cabinet
- (1) AAV Cabinet

There are no records of the original zoning approval, but the original Building permit for this installation was issued by the Town of West Haven on 11/19/1999. T-Mobile/Sprint has been approved for subsequent modifications at their facility. This proposed modification complies with the original approval.

Please accept this letter as notification pursuant to Regulations of Connecticut State Agencies § 16-50j-73, for construction that constitutes an exempt modification pursuant to R.C.S.A. § 16-50j-72(b)(2). In accordance with R.C.S.A. § 16-50j-73, a copy of this letter is being sent to Mayor -Nancy R. Rossi, Elected Official, and Fred A. Messoro, Acting Commissioner of Planning and Development as well as the tower and property owner.

The planned modifications to the facility fall squarely within those activities explicitly provided for in R.C.S.A. § 16-50j-72(b)(2).

1. The proposed modifications will not result in an increase in the height of the existing structure.
2. The proposed modifications will not require the extension of the site boundary.
3. The proposed modifications will not increase noise levels at the facility by six decibels or more, or to levels that exceed state and local criteria.
4. The operation of the replacement antennas will not increase radio frequency emissions at the facility to a level at or above the Federal Communications Commission safety standard.
5. The proposed modifications will not cause a change or alteration in the physical or environmental characteristics of the site.
6. The existing structure and its foundation can support the proposed loading.

For the foregoing reasons, T-Mobile/Sprint respectfully submits that the proposed modifications to the aboverferenced telecommunications facility constitute an exempt modification under R.C.S.A. § 16-50j-72(b)(2).

Sincerely,

**David DePinto**

Transcend Wireless

Cell: 973-907-3243

Email: [ddepinto@transcendwireless.com](mailto:ddepinto@transcendwireless.com)

Attachments

cc: Nancy R. Rossi – Mayor of the City of West Haven

Fred A. Messoro- Acting Commissioner of Planning and Development

Yale University- Property Owner & Tower Owner





---

## UPS Delivery Notification, Tracking Number 1ZV257424299015853

---

UPS <pkginfo@ups.com>  
To: DDEPINTO@transcendwireless.com

Fri, Oct 8, 2021 at 11:39 AM



**Hello, your package has been delivered.**

**Delivery Date:** Friday, 10/08/2021

**Delivery Time:** 11:37 AM

**Left At:** INSIDE DELIV

**Signed by:** FREDCD

### TRANSCEND WIRELESS

**Tracking Number:** [1ZV257424299015853](#)

**Ship To:** WEST HAVEN CITY HALL  
355 MAIN STREET  
1ST FLOOR  
WEST HAVEN, CT 06516  
US

**Number of Packages:** 1

**UPS Service:** UPS Ground

**Package Weight:** 1.8 LBS

**Reference Number:** CTNH833A-CT13XC264



[Download the UPS mobile app](#)

---

© 2021 United Parcel Service of America, Inc. UPS, the UPS brandmark, and the color brown are trademarks of United Parcel Service of America, Inc. All rights reserved.

All trademarks, trade names, or service marks that appear in connection with UPS's services are the property of their respective owners.

Please do not reply directly to this email. UPS will not receive any reply message.

[Review the UPS Privacy Notice](#)

[For Questions, Visit Our Help and Support Center](#)



---

## UPS Delivery Notification, Tracking Number 1ZV257424291662856

---

UPS <pkginfo@ups.com>  
To: DDEPINTO@transcendwireless.com

Fri, Oct 8, 2021 at 11:38 AM



**Hello, your package has been delivered.**

**Delivery Date:** Friday, 10/08/2021

**Delivery Time:** 11:36 AM

**Left At:** RESIDENTIAL

**Signed by:** ROSCD

### TRANSCEND WIRELESS

<b>Tracking Number:</b>	<b>1ZV257424291662856</b>
<b>Ship To:</b>	WEST HAVEN CITY HALL 355 MAIN STREET WEST HAVEN, CT 06516 US
<b>Number of Packages:</b>	1
<b>UPS Service:</b>	UPS Ground
<b>Package Weight:</b>	1.8 LBS
<b>Reference Number:</b>	CTNH833A-CT13XC264



[Download the UPS mobile app](#)

---

© 2021 United Parcel Service of America, Inc. UPS, the UPS brandmark, and the color brown are trademarks of United Parcel Service of America, Inc. All rights reserved.

All trademarks, trade names, or service marks that appear in connection with UPS's services are the property of their respective owners.

Please do not reply directly to this email. UPS will not receive any reply message.

[Review the UPS Privacy Notice](#)

[For Questions, Visit Our Help and Support Center](#)



---

## UPS Delivery Notification, Tracking Number 1ZV257424295745867

---

UPS <pkginfo@ups.com>  
To: DDEPINTO@transcendwireless.com

Fri, Oct 8, 2021 at 11:10 AM



**Hello, your package has been delivered.**

**Delivery Date:** Friday, 10/08/2021

**Delivery Time:** 11:08 AM

**Left At:** FRONT DESK

**Signed by:** ID Verified

### TRANSCEND WIRELESS

**Tracking Number:** [1ZV257424295745867](#)

**Ship To:**  
YALE UNIVERSITY  
[2 WHITNEY AVENUE](#)  
[6TH FLOOR](#)  
[NEW HAVEN, CT 06510](#)  
[US](#)

**Number of Packages:** 1

**UPS Service:** UPS Ground

**Package Weight:** 1.8 LBS

**Reference Number:** CTNH833A-CT13XC264



[Download the UPS mobile app](#)

---

© 2021 United Parcel Service of America, Inc. UPS, the UPS brandmark, and the color brown are trademarks of United Parcel Service of America, Inc. All rights reserved.

All trademarks, trade names, or service marks that appear in connection with UPS's services are the property of their respective owners.

Please do not reply directly to this email. UPS will not receive any reply message.

[Review the UPS Privacy Notice](#)

[For Questions, Visit Our Help and Support Center](#)



**City of West Haven, Connecticut - Assessment Parcel Map**

**Parcel: 073-0015-0-0000    Address: 250 DERBY AVE**

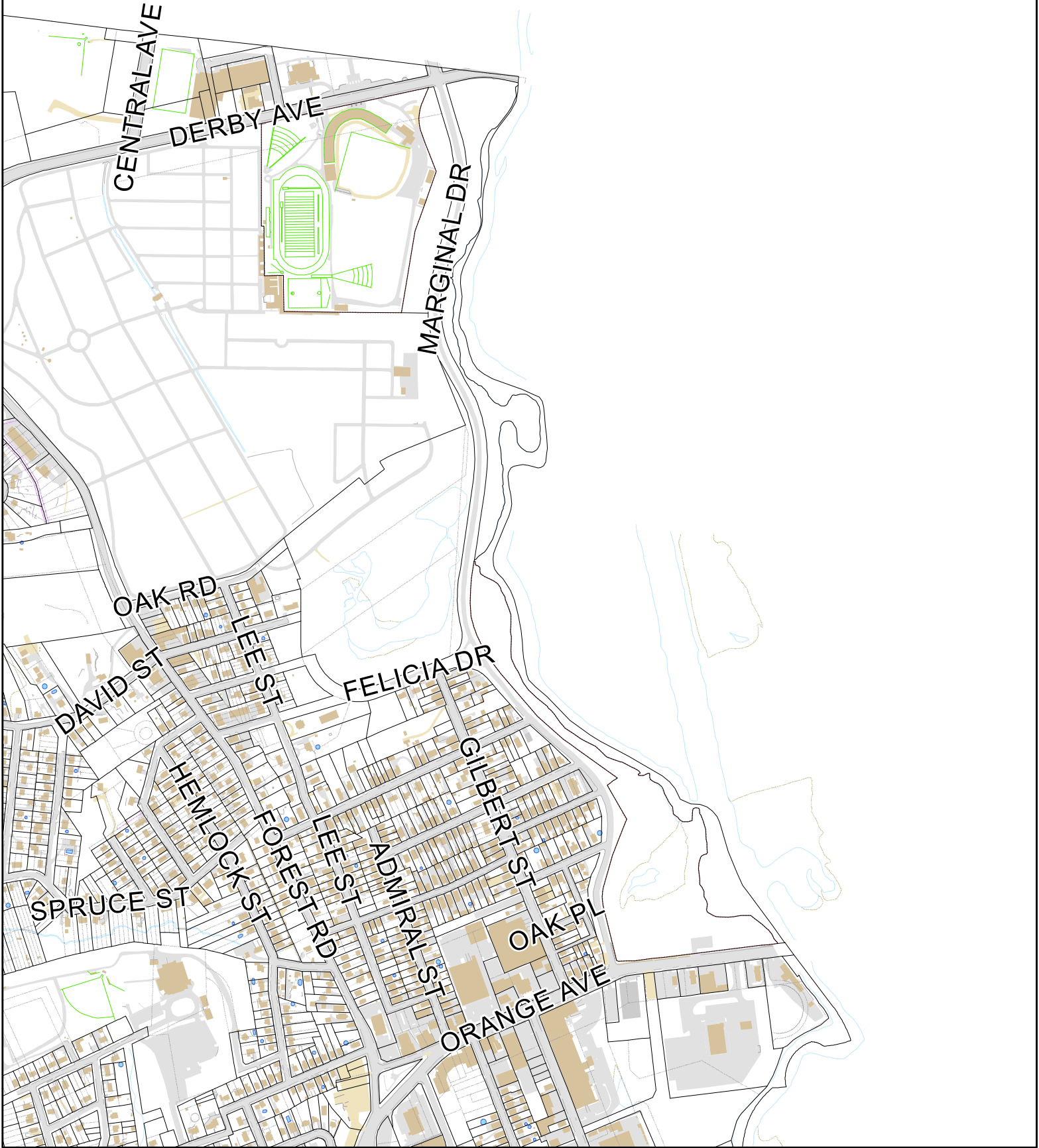

N



**Approximate Scale: 1 inch = 700 feet**

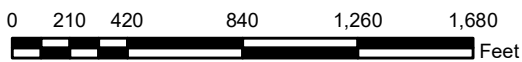

**Map Produced: April 2021**

Disclaimer: This map is for informational purposes only. All information is subject to verification by any user. The City of West Haven and its mapping contractors assume no legal responsibility for the information contained herein.

# 250 DERBY AVE

**Location** 250 DERBY AVE

**Mblu** 73/ 15/ //

**Acct#** 00015574

**Owner** YALE UNIVERSITY

**PBN**

**Assessment** \$4,971,050

**Appraisal** \$7,101,500

**PID** 17343

**Building Count** 2

## Current Value

Appraisal			
Valuation Year	Improvements	Land	Total
2020	\$2,821,200	\$4,280,300	\$7,101,500

Assessment			
Valuation Year	Improvements	Land	Total
2020	\$1,974,840	\$2,996,210	\$4,971,050

## Owner of Record

**Owner** YALE UNIVERSITY  
**Co-Owner** TAX DEPT ATTN: CYNTHIA NETHERCUT  
**Address** PO BOX 208239  
NEW HAVEN,, CT 06520

**Sale Price** \$0  
**Certificate**  
**Book & Page** 0/0  
**Sale Date** 03/05/2020

## Ownership History

Ownership History					
Owner	Sale Price	Certificate	Book & Page	Instrument	Sale Date
YALE UNIVERSITY	\$0		0/0	03	03/05/2020
YALE UNIVERSITY	\$0		0/0		

## Building Information

### Building 1 : Section 1

**Year Built:** 1930  
**Living Area:** 49,920  
**Replacement Cost:** \$4,036,406  
**Building Percent Good:** 48  
**Replacement Cost  
Less Depreciation:** \$1,937,500

Building Attributes	
Field	Description
STYLE	Auditorium
MODEL	Comm/Ind
Grade	Below Average
Stories:	1
Occupancy	1.00
Exterior Wall 1	Brick/Masonry
Exterior Wall 2	
Roof Structure	Shed
Roof Cover	Asph/F Gls/Cmp

### Building Photo



(<http://images.vgsi.com/photos/WestHavenCTPhotos/\A00\01\54\77.jpg>)

Interior Wall 1	Minim/Masonry
Interior Wall 2	
Interior Floor 1	Concr-Finished
Interior Floor 2	
Heating Fuel	None
Heating Type	None
AC Type	None
Struct Class	
Bldg Use	YALE TAXAB MDL-94
Total Rooms	
Total Bedrms	00
Total Baths	0
1st Floor Use:	3890
Heat/AC	NONE
Frame Type	MASONRY
Baths/Plumbing	AVERAGE
Ceiling/Wall	NONE
Rooms/Prtns	AVERAGE
Wall Height	20.00
% Comn Wall	0.00

## Building Layout

**BAS**  
(29,120 sf)

**FBM**  
(20,800 sf)

(ParcelSketch.ashx?pid=17343&bid=17700)

Building Sub-Areas (sq ft)			Legend
Code	Description	Gross Area	Living Area
BAS	First Floor	29,120	29,120
FBM	Basement, Finished	20,800	20,800
		49,920	49,920

## Building 2 : Section 1

**Year Built:** 1999  
**Living Area:** 5,541  
**Replacement Cost:** \$399,430  
**Building Percent Good:** 80  
**Replacement Cost**  
**Less Depreciation:** \$319,500

## Building Photo

 Building Photo

(<http://images.vgsi.com/photos/WestHavenCTPhotos//default.jpg>)

Field	Description
STYLE	Office
MODEL	Comm/Ind
Grade	Average
Stories:	1
Occupancy	1.00
Exterior Wall 1	Stucco/Masonry
Exterior Wall 2	
Roof Structure	Shed
Roof Cover	Tin
Interior Wall 1	Drywall/Sheet
Interior Wall 2	
Interior Floor 1	Concr-Finished
Interior Floor 2	Carpet
Heating Fuel	Gas
Heating Type	Forced Air-Duc
AC Type	Central
Struct Class	
Bldg Use	YALE TAXAB MDL-94
Total Rooms	
Total Bedrms	00
Total Baths	0
1st Floor Use:	3890
Heat/AC	HEAT/AC SPLIT
Frame Type	STEEL
Baths/Plumbing	AVERAGE
Ceiling/Wall	SUS-CEIL & WL

## Building Layout

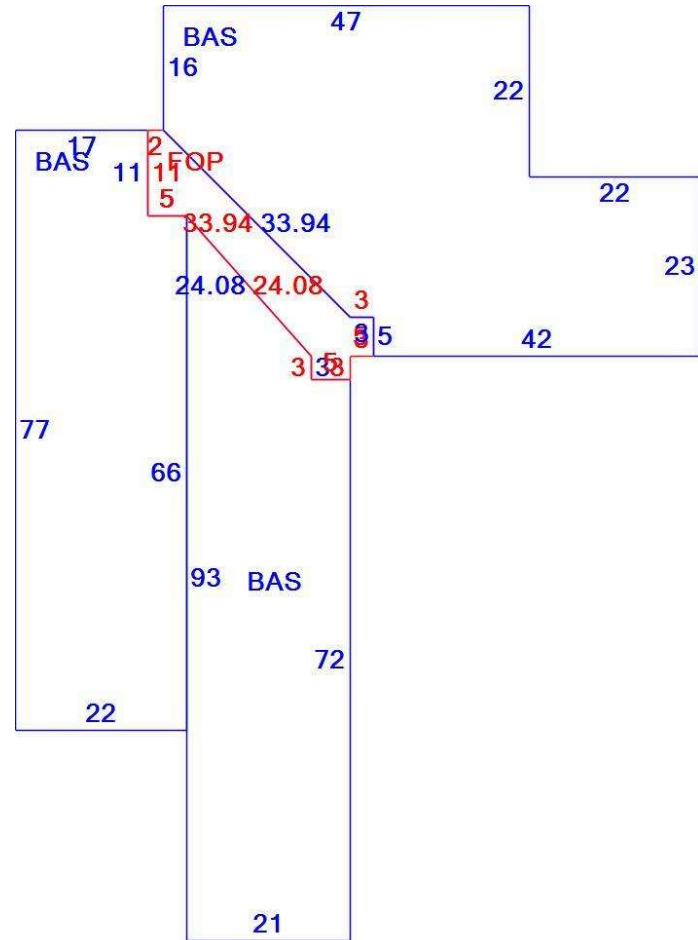

(ParcelSketch.ashx?pid=17343&bid=18103)

Building Sub-Areas (sq ft)			Legend
Code	Description	Gross Area	Living Area
BAS	First Floor	5,541	5,541
FOP	Porch, Open, Finished	262	0
		5,803	5,541

Rooms/Prtns	AVERAGE
Wall Height	14.00
% Comn Wall	0.00

### Extra Features

Extra Features					<u>Legend</u>
Code	Description	Size	Value	Assessed Value	Bldg #
SPR1	SPRINKLERS-WET	15596.00 S.F.	\$7,500	\$5,250	1
A/C	AIR COND	1500.00 S.F.	\$1,800	\$1,260	1

### Land

#### Land Use

**Use Code** 3890  
**Description** YALE TAXAB MDL-94  
**Zone** RB  
**Neighborhood** C700  
**Alt Land Appr** No  
**Category**

#### Land Line Valuation

**Size (Acres)** 21.95  
**Frontage** 940  
**Depth** 0  
**Assessed Value** \$2,996,210  
**Appraised Value** \$4,280,300

### Outbuildings

Outbuildings							<u>Legend</u>
Code	Description	Sub Code	Sub Description	Size	Value	Assessed Value	Bldg #
LT12	W/FOUR LIGHTS			6.00 UNITS	\$18,000	\$12,600	1
FN1	FENCE-4' CHAIN			700.00 L.F.	\$2,800	\$1,960	1
PAV1	PAVING-ASPHALT			8000.00 S.F.	\$8,000	\$5,600	1
FGR4	W/LOFT-AVG			2250.00 S.F.	\$32,600	\$22,820	1
FN3	FENCE-6' CHAIN			800.00 L.F.	\$2,900	\$2,030	1

SHD2	W/LIGHTS ETC			600.00 S.F.	\$9,600	\$6,720	1
CELL	SITE	SI		2.00 SITES	\$373,000	\$261,100	1
SHD7	CELL SHED			200.00 S.F.	\$54,000	\$37,800	1
SHD7	CELL SHED			200.00 S.F.	\$54,000	\$37,800	1

**Valuation History**

<b>Appraisal</b>			
<b>Valuation Year</b>	<b>Improvements</b>	<b>Land</b>	<b>Total</b>
2019	\$2,535,000	\$4,115,600	\$6,650,600

<b>Assessment</b>			
<b>Valuation Year</b>	<b>Improvements</b>	<b>Land</b>	<b>Total</b>
2019	\$1,774,500	\$2,880,920	\$4,655,420

12/19/99 .. 1/13/00 26  
1/14/00 - 4/13/00 3

1300  
4500

P.O.B 208216

# BUILDING PERMIT

023101

**THIS CARD MUST BE DISPLAYED ON THE PREMISES**

**250 Derby Ave.**

**For**

**Sprint - Mountain Bldg.**

**Issued**

**11.19.99**

**BUILDING OFFICIAL**

**WEST HAVEN, CONNECTICUT**





SPRINT ID: CT13XC264  
 SITE ID: CTNH833A  
 250 DERBY AVE  
 WEST HAVEN, CT 06516

T-MOBILE RAN TEMPLATE (PROVIDED BY RFDS)  
 67E5A998E 6160

T-MOBILE A+L TEMPLATE (PROVIDED BY RFDS)  
 67E5998E\_1xAIR+1OP

- GENERAL NOTES**
- ALL WORK SHALL BE IN ACCORDANCE WITH THE 2015 INTERNATIONAL BUILDING CODE AS MODIFIED BY THE 2018 CONNECTICUT SUPPLEMENT, INCLUDING THE TIA/EIA-222 REVISION "G" STRUCTURAL STANDARDS FOR STEEL ANTENNA TOWERS AND SUPPORTING STRUCTURES. 2017 CONNECTICUT FIRE SAFETY CODE, NATIONAL ELECTRICAL CODE AND LOCAL CODES.
  - CONTRACTOR SHALL REVIEW ALL DRAWINGS AND SPECIFICATIONS IN THE CONTRACT DOCUMENT SET. CONTRACTOR SHALL COORDINATE ALL WORK SHOWN IN THE SET OF DRAWINGS. THE CONTRACTOR SHALL PROVIDE A COMPLETE SET OF DRAWINGS TO ALL SUBCONTRACTORS AND ALL RELATED PARTIES. THE SUBCONTRACTORS SHALL EXAMINE ALL THE DRAWINGS AND SPECIFICATIONS FOR THE INFORMATION THAT AFFECTS THEIR WORK.
  - CONTRACTOR SHALL PROVIDE A COMPLETE BUILD-OUT WITH ALL FINISHES, STRUCTURAL, MECHANICAL, AND ELECTRICAL COMPONENTS AND PROVIDE ALL ITEMS AS SHOWN OR INDICATED ON THE DRAWINGS OR IN THE WRITTEN SPECIFICATIONS.
  - CONTRACTOR SHALL FURNISH ALL MATERIAL, LABOR AND EQUIPMENT TO COMPLETE THE WORK AND FURNISH A COMPLETED JOB ALL IN ACCORDANCE WITH LOCAL AND STATE GOVERNING AUTHORITIES AND OTHER AUTHORITIES HAVING LAWFUL JURISDICTION OVER THE WORK.
  - CONTRACTOR SHALL SECURE AND PAY FOR ALL PERMITS AND ALL INSPECTIONS REQUIRED AND SHALL ALSO PAY FEES REQUIRED FOR THE GENERAL CONSTRUCTION, PLUMBING, ELECTRICAL, AND HVAC. PERMITS SHALL BE PAID FOR BY THE RESPECTIVE SUBCONTRACTORS.
  - CONTRACTOR SHALL MAINTAIN A CURRENT SET OF DRAWINGS AND SPECIFICATIONS ON SITE AT ALL TIMES AND INSURE DISTRIBUTION AND SPECIFICATIONS ON SITE AT ALL TIMES AND INSURE DISTRIBUTION OF NEW DRAWINGS TO SUBCONTRACTORS AND OTHER RELEVANT PARTIES AS SOON AS THEY ARE MADE AVAILABLE. ALL OLD DRAWINGS SHALL BE MARKED VOID AND REMOVED FROM THE CONTRACT AREA. THE CONTRACTOR SHALL FURNISH AN "AS-BUILT" SET OF DRAWINGS TO OWNER UPON COMPLETION OF PROJECT.
  - LOCATION OF EQUIPMENT, AND WORK SUPPLIED BY OTHERS THAT IS DIAGRAMMATICALLY INDICATED ON THE DRAWINGS SHALL BE DETERMINED BY THE CONTRACTOR. THE CONTRACTOR SHALL DETERMINE LOCATIONS AND DIMENSIONS SUBJECT TO STRUCTURAL CONDITIONS AND WORK OF THE SUBCONTRACTORS.
  - THE CONTRACTOR IS SOLELY RESPONSIBLE TO DETERMINE CONSTRUCTION PROCEDURE AND SEQUENCE AND TO ENSURE THE SAFETY OF THE EXISTING STRUCTURES AND ITS COMPONENT PARTS DURING CONSTRUCTION. THIS INCLUDES THE ADDITION OF WHATEVER SHORING, BRACING, UNDERPINNING, ETC. THAT MAY BE NECESSARY.
  - DRAWINGS INDICATE THE MINIMUM STANDARDS, BUT IF ANY WORK SHOULD BE INDICATED TO BE SUBSTANDARD TO ANY ORDINANCES, LAWS, CODES, RULES, OR REGULATIONS BEARING ON THE WORK, THE CONTRACTOR SHALL INCLUDE IN HIS WORK AND SHALL EXECUTE THE WORK CORRECTLY IN ACCORDANCE WITH SUCH ORDINANCES, LAWS, CODES, RULES OR REGULATIONS WITH NO INCREASE IN COSTS.
  - ALL UTILITY WORK SHALL BE IN ACCORDANCE WITH LOCAL UTILITY COMPANY REQUIREMENTS AND SPECIFICATIONS.
  - ALL EQUIPMENT AND PRODUCTS PURCHASED ARE TO BE REVIEWED BY CONTRACTOR AND ALL APPLICABLE SUBCONTRACTORS FOR ANY CONDITION PER MANUFACTURER'S RECOMMENDATIONS. CONTRACTOR TO SUPPLY THESE ITEMS AT NO COST TO OWNER OR CONSTRUCTION MANAGER.
  - ANY AND ALL ERRORS, DISCREPANCIES, AND 'MISSED' ITEMS ARE TO BE BROUGHT TO THE ATTENTION OF THE T-MOBILE CONSTRUCTION MANAGER DURING THE BIDDING PROCESS BY THE CONTRACTOR. ALL THESE ITEMS ARE TO BE INCLUDED IN THE BID. NO 'EXTRA' WILL BE ALLOWED FOR MISSED ITEMS.
  - CONTRACTOR SHALL BE RESPONSIBLE FOR ALL ON-SITE SAFETY FROM THE TIME THE JOB IS AWARDED UNTIL ALL WORK IS COMPLETE AND ACCEPTED BY THE OWNER.
  - CONTRACTOR TO REVIEW ALL SHOP DRAWINGS AND SUBMIT COPY TO ENGINEER FOR APPROVAL. DRAWINGS MUST BEAR THE CHECKER'S INITIALS BEFORE SUBMITTING TO THE CONSTRUCTION MANAGER FOR REVIEW.
  - THE CONTRACTOR SHALL FIELD VERIFY ALL DIMENSIONS, ELEVATIONS, ANGLES AND EXISTING CONDITIONS AT THE SITE, PRIOR TO FABRICATION AND/OR INSTALLATION OF ANY WORK IN THE CONTRACT AREA.
  - COORDINATION, LAYOUT, FURNISHING AND INSTALLATION OF CONDUITS AND ALL APPURTENANCES REQUIRED FOR PROPER INSTALLATION OF ELECTRICAL AND TELECOMMUNICATION SERVICE SHALL BE THE SOLE RESPONSIBILITY OF THE CONTRACTOR.
  - ALL DAMAGE CAUSED TO ANY EXISTING STRUCTURE SHALL BE THE SOLE RESPONSIBILITY OF THE CONTRACTOR. THE CONTRACTOR WILL BE HELD LIABLE FOR ALL REPAIRS REQUIRED FOR EXISTING STRUCTURES IF DAMAGED DURING CONSTRUCTION ACTIVITIES.
  - THE CONTRACTOR SHALL CONTACT 'CALL BEFORE YOU DIG' AT LEAST 48 HOURS PRIOR TO ANY EXCAVATIONS AT 1-800-922-4455. ALL UTILITIES SHALL BE IDENTIFIED AND CLEARLY MARKED. CONTRACTOR SHALL MAINTAIN AND PROTECT MARKED UTILITIES THROUGHOUT PROJECT COMPLETION.
  - CONTRACTOR SHALL COMPLY WITH THE OWNER'S ENVIRONMENTAL ENGINEER ON ALL METHODS AND PROVISIONS FOR ALL EXCAVATION ACTIVITIES INCLUDING SOIL DISPOSAL. ALL BACKFILL MATERIALS TO BE PROVIDED BY THE CONTRACTOR.

**SITE DIRECTIONS**

**FROM:** 35 GRIFFIN ROAD SOUTH  
BLOOMFIELD, CT 06002

**TO:** 250 DERBY AVE  
WEST HAVEN, CT 06516

- GET ON I-91 S IN WINDSOR FROM DAY HILL RD. 4.30 MI.
- MERGE ONTO I-91 S. 7.30 MI.
- KEEP LEFT TO STAY ON I-91 S. 10.5 MI.
- KEEP RIGHT TO STAY ON I-91 S. 27.5 MI.
- USE THE RIGHT LANE TO STAY ON I-91 S. 0.20 MI.
- TAKE EXIT 1 TOWARD MLK BLVD/DOWNTOWN/NEW HAVEN. 0.30 MI.
- CONTINUE ONTO OAK STREET CONNECTOR. 0.30 MI.
- USE THE RIGHT 3 LANES TO TURN SLIGHTLY RIGHT TOWARD STATE RD 34 W. 0.07 MI.
- CONTINUE ONTO STATE RD 34 W. 0.08 MI.
- CONTINUE ONTO N FRONTAGE RD/M.L.K. JR. BLVD. 1.40 MI.
- USE THE RIGHT 2 LANES TO TURN RIGHT ONTO ELLA T GRASSO BLVD. 0.20 MI.
- USE THE LEFT LANE TO TURN LEFT ONTO CT-34 W/DERBY AVE. 0.30 MI.

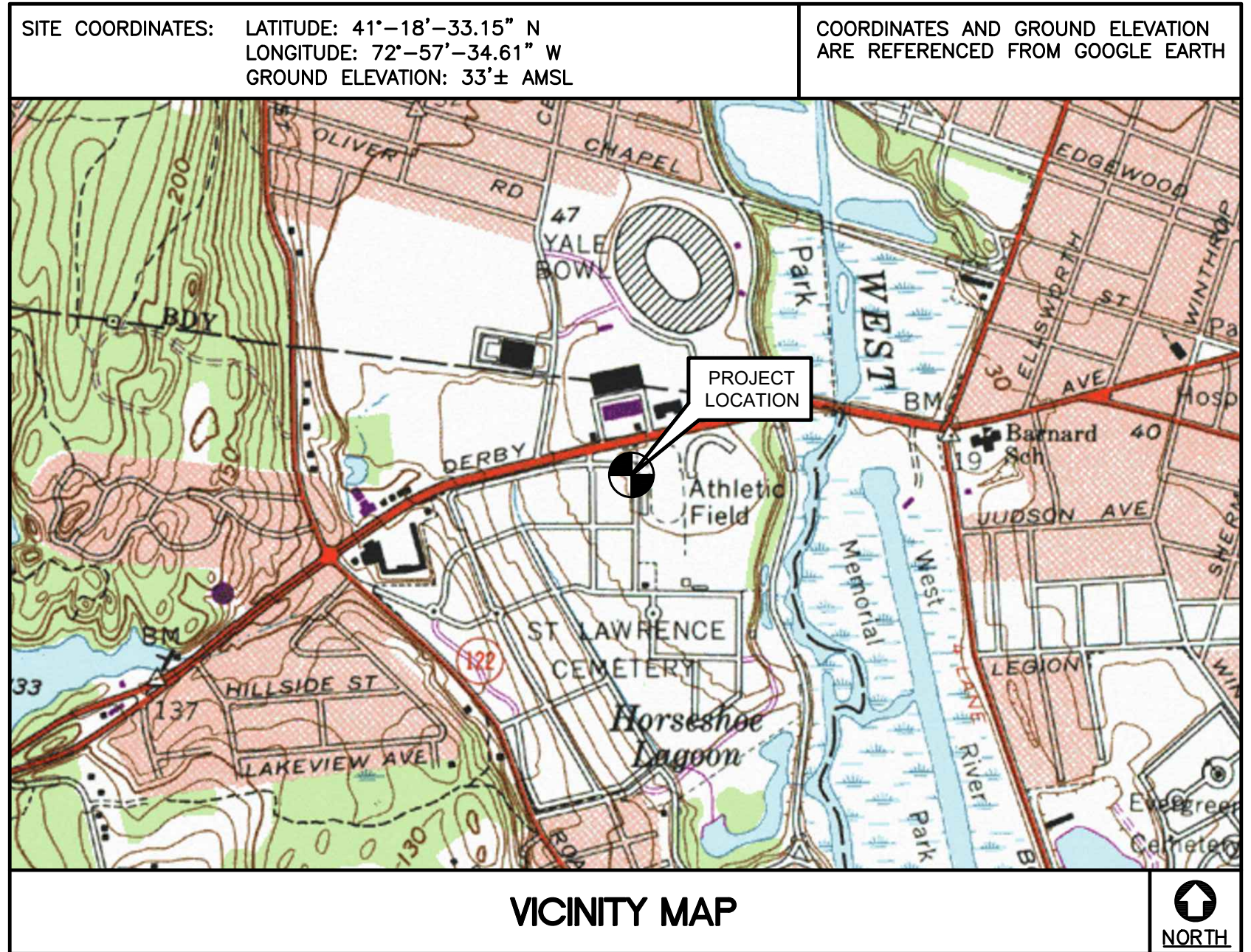

- PROJECT SUMMARY**
- THE PROPOSED SCOPE OF WORK CONSISTS OF A MODIFICATION TO THE EXISTING UNMANNED TELECOMMUNICATIONS FACILITY INCLUDING THE FOLLOWING:
- INSTALL RFS-APXVAALL18\_43-U-NA20 ANTENNA, TYP. (1) PER SECTOR. TOTAL (3)
  - INSTALL ERICSSON AIR6449 B41 ANTENNA, TYP. (1) PER SECTOR. TOTAL (3)
  - INSTALL RADIO 4480 B71+B85, TYP. (1) PER SECTOR. TOTAL (3)
  - INSTALL RADIO 4460 B25+B66, TYP. (1) PER SECTOR. TOTAL (3)
  - INSTALL (3) COMMSCOPE DIPLEXERS, TYP (1) PER SECTOR
  - INSTALL 150A BREAKER IN EXISTING 200A PPC
  - INSTALL (3) 6/24 4AWG HYBRIDS
  - INSTALL (1) T-MOBILE POWER ENCLOSURE 6160
  - INSTALL (1) T-MOBILE BATTERY CABINET B160
  - REMOVE SPRINT EQUIPMENT
  - REMOVE ALL EXISTING HYBRID CABLES

**PROJECT INFORMATION**

SPRINT ID: CT13XC264  
 SITE ID: CTNH833A  
 SITE ADDRESS: 250 DERBY AVE  
WEST HAVEN CT, 06516

APPLICANT: T-MOBILE NORTHEAST, LLC  
35 GRIFFIN ROAD SOUTH  
BLOOMFIELD, CT 06002

CONTACT PERSON: KYLE RICHERS  
TRANSCEND WIRELESS, LLC  
(908)-447-4716

ENGINEER OF RECORD: CENTEK ENGINEERING, INC.  
63-2 NORTH BRANFORD RD.  
BRANFORD, CT 06405

CARLO F. CENTORE, PE  
(203) 488-0580 EXT. 122

PROJECT COORDINATES: LATITUDE: 41°-18'-33.15" N  
LONGITUDE: 72°-57'-34.61" W  
GROUND ELEVATION: 33'± AMSL

SITE COORDINATES AND GROUND ELEVATION REFERENCED FROM GOOGLE EARTH.

**SHEET INDEX**

SHT. NO.	DESCRIPTION	REV.
T-1	TITLE SHEET	3
N-1	GENERAL NOTES AND SPECIFICATIONS	3
C-1	SITE LOCATION PLAN	3
C-2	COMPOUND PLAN AND TOWER ELEVATION	3
C-3	EQUIPMENT PLANS	3
C-4	ANTENNA PLANS AND ELEVATIONS	3
C-5	TYPICAL EQUIPMENT DETAILS	3
E-1	ELECTRICAL RISER DIAGRAM AND CONDUIT ROUTING	3
E-2	TYPICAL ELECTRICAL DETAILS	3
E-3	ELECTRICAL SPECIFICATIONS	3

PROFESSIONAL ENGINEER SEAL

SPRINT logo

T-MOBILE logo

CENTEK engineering  
Centered on Solutions  
(203) 488-0580  
(203) 488-8587 Fax  
63-2 North Branford Road  
Branford, CT 06405  
www.CentekEng.com

T-MOBILE NORTHEAST LLC  
 SPRINT ID: CT13XC264  
 SITE ID: CTNH833A  
 250 DERBY AVE  
 WEST HAVEN, CT 06516

DATE: 01/21/21  
 SCALE: AS NOTED  
 JOB NO. 21005.07

TITLE SHEET

T-1

Sheet No. 1 of 10

REV.	DATE	DESCRIPTION
3	09/07/21	CONSTRUCTION DRAWINGS - REVISED PER NEW ANTENNA AZIMUTHS
2	07/28/21	CONSTRUCTION DRAWINGS - REVISED PER NEW RFDS
1	05/07/21	CONSTRUCTION DRAWINGS - REVISED PER CLIENT COMMENTS
0	03/18/21	CONSTRUCTION DRAWINGS - ISSUED FOR CONSTRUCTION

**NOTES AND SPECIFICATIONS**

**DESIGN BASIS:**

GOVERNING CODE: 2015 INTERNATIONAL BUILDING (IBC) AS MODIFIED BY THE 2018 CONNECTICUT STATE BUILDING CODE.

- DESIGN CRITERIA:
  - RISK CATEGORY II (BASED ON IBC TABLE 1604.5)
  - ULTIMATE DESIGN SPEED (OTHER STRUCTURE): 125 MPH ( $V_{asd}$ ) (EXPOSURE B/ IMPORTANCE FACTOR 1.0 BASED ON ASCE 7-10).

**SITE NOTES**

- THE CONTRACTOR SHALL CALL UTILITIES PRIOR TO THE START OF CONSTRUCTION.
- ACTIVE EXISTING UTILITIES, WHERE ENCOUNTERED IN THE WORK, SHALL BE PROTECTED AT ALL TIMES. THE ENGINEER SHALL BE NOTIFIED IMMEDIATELY, PRIOR TO PROCEEDING, SHOULD ANY UNCOVERED EXISTING UTILITY PRECLUDE COMPLETION OF THE WORK IN ACCORDANCE WITH THE CONTRACT DOCUMENTS.
- THE AREAS OF THE COMPOUND DISTURBED BY THE WORK SHALL BE RETURNED TO THEIR ORIGINAL CONDITION.
- CONTRACTOR SHALL MINIMIZE DISTURBANCE TO EXISTING SITE DURING CONSTRUCTION. EROSION CONTROL MEASURES, SHALL BE IN CONFORMANCE WITH THE LOCAL GUIDELINES FOR EROSION AND SEDIMENT CONTROL.
- IF ANY FIELD CONDITIONS EXIST WHICH PRECLUDE COMPLIANCE WITH THE DRAWINGS, THE CONTRACTOR SHALL IMMEDIATELY NOTIFY THE ENGINEER AND SHALL PROCEED WITH AFFECTED WORK AFTER CONFLICT IS SATISFACTORILY RESOLVED.

**GENERAL NOTES**

- ALL WORK SHALL BE IN ACCORDANCE WITH THE 2015 INTERNATIONAL BUILDING CODE AS MODIFIED BY THE 2018 CONNECTICUT SUPPLEMENT, INCLUDING THE TIA/EIA-222 REVISION "G" "STRUCTURAL STANDARDS FOR STEEL ANTENNA TOWERS AND SUPPORTING STRUCTURES." 2017 CONNECTICUT FIRE SAFETY CODE, NATIONAL ELECTRICAL CODE AND LOCAL CODES.
- CONTRACTOR SHALL REVIEW ALL DRAWINGS AND SPECIFICATIONS IN THE CONTRACT DOCUMENT SET. CONTRACTOR SHALL COORDINATE ALL WORK SHOWN IN THE SET OF DRAWINGS. THE CONTRACTOR SHALL PROVIDE A COMPLETE SET OF DRAWINGS TO ALL SUBCONTRACTORS AND ALL RELATED PARTIES. THE SUBCONTRACTORS SHALL EXAMINE ALL THE DRAWINGS AND SPECIFICATIONS FOR THE INFORMATION THAT AFFECTS THEIR WORK.
- CONTRACTOR SHALL PROVIDE A COMPLETE BUILD-OUT WITH ALL FINISHES, STRUCTURAL, MECHANICAL, AND ELECTRICAL COMPONENTS AND PROVIDE ALL ITEMS AS SHOWN OR INDICATED ON THE DRAWINGS OR IN THE WRITTEN SPECIFICATIONS.
- CONTRACTOR SHALL FURNISH ALL MATERIAL, LABOR AND EQUIPMENT TO COMPLETE THE WORK AND FURNISH A COMPLETED JOB ALL IN ACCORDANCE WITH LOCAL AND STATE GOVERNING AUTHORITIES AND OTHER AUTHORITIES HAVING LAWFUL JURISDICTION OVER THE WORK.
- CONTRACTOR SHALL SECURE AND PAY FOR ALL PERMITS AND ALL INSPECTIONS REQUIRED AND SHALL ALSO PAY FEES REQUIRED FOR THE GENERAL CONSTRUCTION, PLUMBING, ELECTRICAL AND HVAC. PERMITS SHALL BE PAID FOR BY THE RESPECTIVE SUBCONTRACTORS.
- CONTRACTOR SHALL MAINTAIN A CURRENT SET OF DRAWINGS AND SPECIFICATIONS ON SITE AT ALL TIMES AND INSURE DISTRIBUTION OF NEW DRAWINGS TO SUBCONTRACTORS AND OTHER RELEVANT PARTIES AS SOON AS THEY ARE MADE AVAILABLE. ALL OLD DRAWINGS SHALL BE MARKED VOID AND REMOVED FROM THE CONTRACT AREA. THE CONTRACTOR SHALL FURNISH AN "AS-BUILT" SET OF DRAWINGS TO OWNER UPON COMPLETION OF PROJECT.
- LOCATION OF EQUIPMENT AND WORK SUPPLIED BY OTHERS THAT IS DIAGRAMMATICALLY INDICATED ON THE DRAWINGS, SHALL BE DETERMINED BY THE CONTRACTOR. THE CONTRACTOR SHALL DETERMINE LOCATIONS AND DIMENSIONS SUBJECT TO STRUCTURAL CONDITIONS AND WORK OF THE SUBCONTRACTORS.
- THE CONTRACTOR IS SOLELY RESPONSIBLE TO DETERMINE CONSTRUCTION PROCEDURE AND SEQUENCE, AND TO ENSURE THE SAFETY OF THE EXISTING STRUCTURES AND IT'S COMPONENT PARTS DURING CONSTRUCTION. THIS INCLUDES THE ADDITION OF WHATEVER SHORING, BRACING, UNDERPINNING, ETC. THAT MAY BE NECESSARY.
- DRAWINGS INDICATE THE MINIMUM STANDARDS, BUT IF ANY WORK SHOULD BE INDICATED TO BE SUBSTANDARD TO ANY ORDINANCES, LAWS, CODES, RULES, OR REGULATIONS BEARING ON THE WORK, THE CONTRACTOR SHALL INCLUDE IN HIS WORK AND SHALL EXECUTE THE WORK CORRECTLY IN ACCORDANCE WITH SUCH ORDINANCES, LAWS, CODES, RULES OR REGULATIONS WITH NO INCREASE IN COSTS.
- ALL UTILITY WORK SHALL BE IN ACCORDANCE WITH LOCAL UTILITY COMPANY REQUIREMENTS AND SPECIFICATIONS.
- ALL EQUIPMENT AND PRODUCTS PURCHASED ARE TO BE REVIEWED BY CONTRACTOR AND ALL APPLICABLE SUBCONTRACTORS FOR ANY CONDITION PER MFR.'S RECOMMENDATIONS. CONTRACTOR TO SUPPLY THESE ITEMS AT NO COST TO OWNER OR CONSTRUCTION MANAGER.
- ANY AND ALL ERRORS, DISCREPANCIES, AND "MISSED" ITEMS, ARE TO BE BROUGHT TO THE ATTENTION OF THE SITE OWNER'S CONSTRUCTION MANAGER DURING THE BIDDING PROCESS BY THE CONTRACTOR. ALL THESE ITEMS ARE TO BE INCLUDED IN THE BID. NO 'EXTRA' WILL BE ALLOWED FOR MISSED ITEMS.
- CONTRACTOR SHALL BE RESPONSIBLE FOR ALL ON-SITE SAFETY FROM THE TIME THE JOB IS AWARDED UNTIL ALL WORK IS COMPLETE AND ACCEPTED BY THE OWNER.
- CONTRACTOR TO REVIEW ALL SHOP DRAWINGS AND SUBMIT COPY TO ENGINEER FOR APPROVAL. DRAWINGS MUST BEAR THE CHECKER'S INITIALS BEFORE SUBMITTING TO THE CONSTRUCTION MANAGER FOR REVIEW.
- THE CONTRACTOR SHALL FIELD VERIFY ALL DIMENSIONS, ELEVATIONS, ANGLES, AND EXISTING CONDITIONS AT THE SITE, PRIOR TO FABRICATION AND/OR INSTALLATION OF ANY WORK IN THE CONTRACT AREA.
- COORDINATION, LAYOUT, FURNISHING AND INSTALLATION OF CONDUIT AND ALL APPURTENANCES REQUIRED FOR PROPER INSTALLATION OF ELECTRICAL AND TELECOMMUNICATION SERVICE SHALL BE THE SOLE RESPONSIBILITY OF THE CONTRACTOR.
- ALL DAMAGE CAUSED TO ANY EXISTING STRUCTURE SHALL BE THE SOLE RESPONSIBILITY OF THE CONTRACTOR. THE CONTRACTOR WILL BE HELD LIABLE FOR ALL REPAIRS REQUIRED FOR EXISTING STRUCTURES IF DAMAGED DURING CONSTRUCTION ACTIVITIES.
- THE CONTRACTOR SHALL CONTACT 'CALL BEFORE YOU DIG' AT LEAST 48 HOURS PRIOR TO ANY EXCAVATIONS AT 1-800-922-4455. ALL UTILITIES SHALL BE IDENTIFIED AND CLEARLY MARKED. CONTRACTOR SHALL MAINTAIN AND PROTECT MARKED UTILITIES THROUGHOUT PROJECT COMPLETION.
- CONTRACTOR SHALL COMPLY WITH OWNER'S ENVIRONMENTAL ENGINEER ON ALL METHODS AND PROVISIONS FOR ALL EXCAVATION ACTIVITIES INCLUDING SOIL DISPOSAL. ALL BACKFILL MATERIALS TO BE PROVIDED BY THE CONTRACTOR.
- THE COUNTY/CITY/TOWN WILL MAKE PERIODIC FIELD OBSERVATION AND INSPECTIONS TO MONITOR THE INSTALLATION, MATERIALS, WORKMANSHIP AND EQUIPMENT INCORPORATED INTO THE PROJECT TO ENSURE COMPLIANCE WITH THE DESIGN PLANS, SPECIFICATIONS, CONTRACT DOCUMENTS AND APPROVED SHOP DRAWINGS.
- THE COUNTY/CITY/TOWN MUST BE NOTIFIED (2) WORKING DAYS PRIOR TO CONCEALMENT/BURIAL OF ANY SYSTEM OR MATERIAL THAT WILL PREVENT THE DIRECT INSPECTION OF MATERIALS, METHODS OR WORKMANSHIP. EXAMPLES OF THESE PROCESSES ARE BACKFILLING A GROUND RING OR TOWER FOUNDATION, POURING TOWER FOUNDATIONS, BURYING GROUND RODS, PLATES OR GRIDS, ETC. THE CONTRACTOR MAY PROCEED WITH THE SCHEDULED PROCESS (2) WORKING DAYS AFTER PROVIDING NOTICE UNLESS NOTIFIED OTHERWISE BY THE COUNTY/CITY/TOWN.

CONSTRUCTION DRAWINGS - REVISED PER NEW ANTENNA AZIMUTHS	TJR	RTS	09/07/21	DATE	DESCRIPTION
CONSTRUCTION DRAWINGS - REVISED PER NEW RFDS	TJR	RTS	07/28/21	DATE	DESCRIPTION
CONSTRUCTION DRAWINGS - REVISED PER CLIENT COMMENTS	TJR	JLW	05/07/21	DATE	DESCRIPTION
CONSTRUCTION DRAWINGS - ISSUED FOR CONSTRUCTION	TJR	JLW	03/18/21	DATE	DESCRIPTION
REV.	0				

PROFESSIONAL ENGINEER SEAL

**CENTEX** engineering  
 Solutions  
 (203) 488-0380  
 (203) 488-8387 Fax  
 63-2 North Branford Road  
 Branford, CT 06405  
 www.CentexEng.com

**T-MOBILE NORTHEAST LLC**  
**SPRINT ID: CT13XC264**  
**SITE ID: CTNH833A**  
 250 DERBY AVE  
 WEST HAVEN, CT 06516

DATE: 01/21/21  
 SCALE: AS NOTED  
 JOB NO. 21005.07

GENERAL NOTES  
 AND  
 SPECIFICATIONS

**N-1**

Sheet No. 2 of 10

NOTE:  
ALL HCS LENGTHS TO BE MEASURED AND  
VERIFIED IN FIELD BEFORE ORDERING

ANTENNA SCHEDULE								
SECTOR	EXISTING/PROPOSED	ANTENNA	SIZE (INCHES) (L x W x D)	ANTENNA $\phi$ HEIGHT	AZIMUTH	(E/P) RRU (QTY)	(E/P) DIPLEXER (QTY)	(QTY) PROPOSED COAX
A1	PROPOSED	RFS-APXVAALL18_43-U-NA20	72 x 24 x 8.5	74'	50°	(P) RADIO 4460 B25+B66 (1), (P) RADIO 4480 B71+B85 (1)	(P) COMMSCOPE: SDX1926Q (1)	(1) 6/24 4AWG HYBRID CABLE
A2	PROPOSED	ERICSSON AIR6449 B41	33.1 x 20.6 x 8.6	74'	50°			
B1	PROPOSED	RFS-APXVAALL18_43-U-NA20	72 x 24 x 8.5	74'	120°	(P) RADIO 4460 B25+B66 (1), (P) RADIO 4480 B71+B85 (1)	(P) COMMSCOPE: SDX1926Q (1)	(1) 6/24 4AWG HYBRID CABLE
B2	PROPOSED	ERICSSON AIR6449 B41	33.1 x 20.6 x 8.6	74'	120°			
C1	PROPOSED	RFS-APXVAALL18_43-U-NA20	72 x 24 x 8.5	74'	300°	(P) RADIO 4460 B25+B66 (1), (P) RADIO 4480 B71+B85 (1)	(P) COMMSCOPE: SDX1926Q (1)	(1) 6/24 4AWG HYBRID CABLE
C2	PROPOSED	ERICSSON AIR6449 B41	33.1 x 20.6 x 8.6	74'	300°			



**1** SITE LOCATION PLAN  
C-1 SCALE: NOT TO SCALE



<p>(203) 488-0580 (203) 488-8587 Fax 63-2 North Branford Road Branford, CT 06405 www.CentekEng.com</p>	
<p><b>T-MOBILE NORTHEAST LLC</b>  <b>SPRINT ID: CT13XC264</b>  <b>SITE ID: CTNH833A</b>  <b>250 DERBY AVE</b>  <b>WEST HAVEN, CT 06516</b></p>	
DATE:	01/21/21
SCALE:	AS NOTED
JOB NO.	21005.07
<p>SITE LOCATION PLAN</p>	
<p><b>C-1</b></p>	
Sheet No. 3	of 10

REV.	DATE	DRAWN BY	CHECK'D BY	DESCRIPTION
3	09/07/21	RTS	TJR	CONSTRUCTION DRAWINGS - REVISED PER NEW ANTENNA AZIMUTHS
2	07/28/21	RTS	TJR	CONSTRUCTION DRAWINGS - REVISED PER NEW RFRS
0	05/07/21	JLW	TJR	CONSTRUCTION DRAWINGS - REVISED PER CLIENT COMMENTS
0	03/18/21	JLW	TJR	CONSTRUCTION DRAWINGS - ISSUED FOR CONSTRUCTION

**STRUCTURAL COMPLIANCE**

**ANTENNA MOUNTS**  
 A STRUCTURAL ANALYSIS OF THE ANTENNA MOUNTS WAS PERFORMED FOR THE PROPOSED EQUIPMENT INSTALLATION AND THEY WERE FOUND TO BE STRUCTURALLY SUFFICIENT TO ACCOMMODATE THE PROPOSED LOADING..  
 REFER TO THE ANTENNA MOUNT ANALYSIS REPORT PREPARED BY CENTEK ENGINEERING (PROJECT # 21005.07) DATED 08/16/21 FOR ADDITIONAL INFORMATION AND REQUIREMENTS.

**TOWER AND TOWER FOUNDATION**  
 A STRUCTURAL ANALYSIS OF THE TOWER AND TOWER FOUNDATION WAS PERFORMED FOR THE PROPOSED EQUIPMENT INSTALLATION AND THEY WERE FOUND TO BE STRUCTURALLY SUFFICIENT TO ACCOMMODATE THE PROPOSED LOADING.  
 REFER TO THE STRUCTURAL ANALYSIS REPORT PREPARED BY CENTEK ENGINEERING (PROJECT # 21005.07) DATED 08/16/21 FOR ADDITIONAL INFORMATION AND REQUIREMENTS.

**NOTE:** NO EQUIPMENT SHALL BE INSTALLED ON THE HOSTING STRUCTURE WITHOUT A PASSING STRUCTURAL ANALYSIS REPORT AND CONTRACTOR PRIOR CONFIRMATION THAT ANY AND ALL REQUISITE MODIFICATIONS HAVE BEEN COMPLETED.

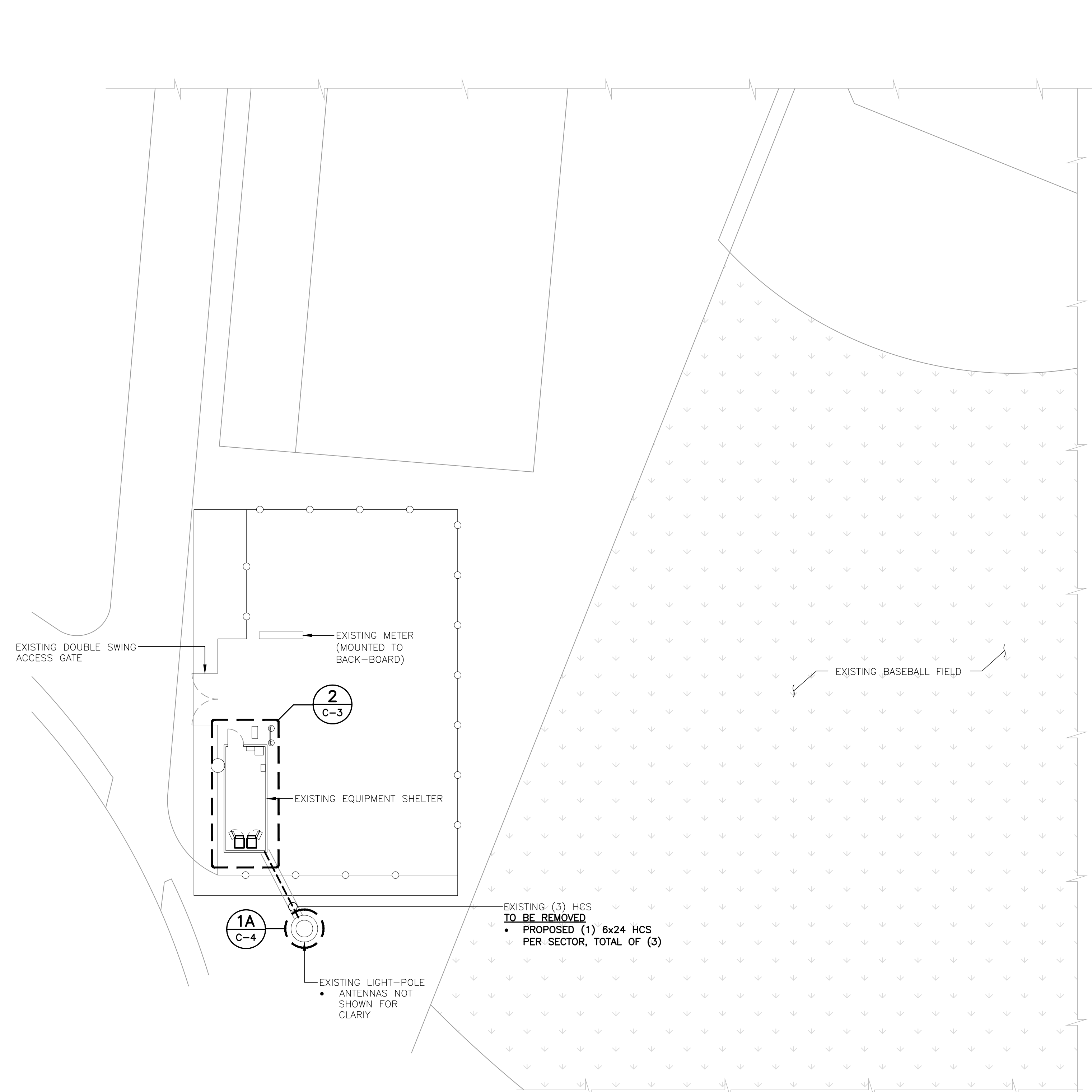

**1** COMPOUND PLAN - PROPOSED  
 SCALE: 1/16" = 1'  
 TRUE NORTH

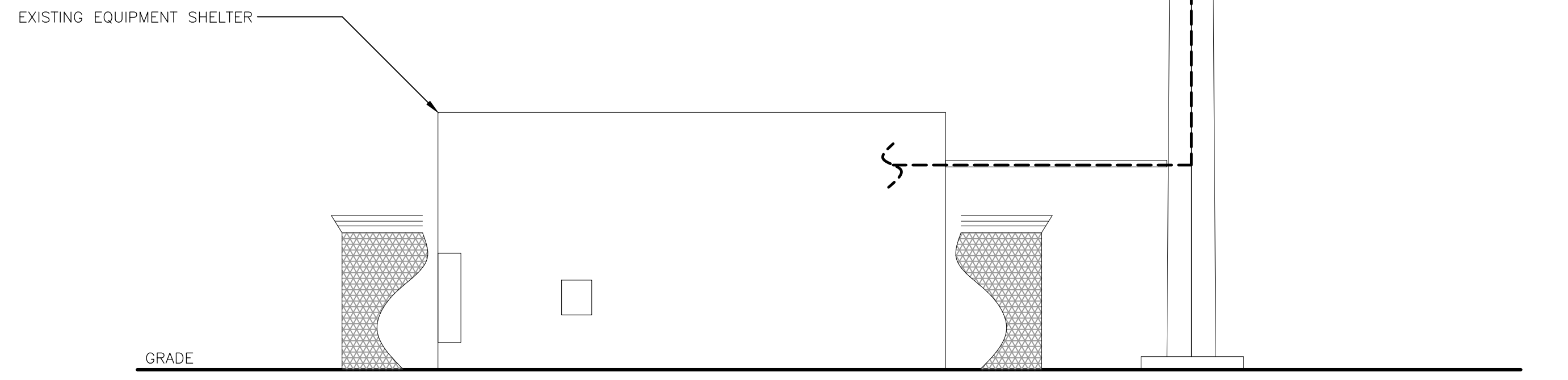
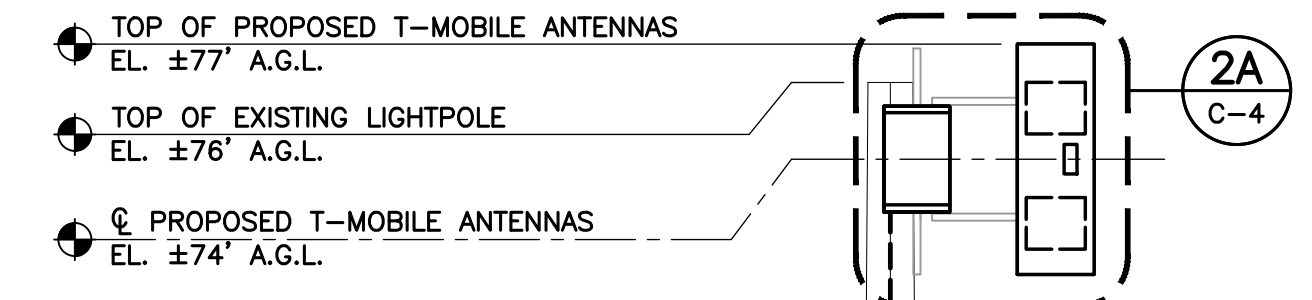

**2** TOWER ELEVATION - PROPOSED  
 SCALE: 1" = 5'  
 GRAPHIC SCALE  
 1" = 5'-0"

CONSTRUCTION DRAWINGS - REVISED PER NEW ANTENNA AZIMUTHS	TJR	09/07/21	3
CONSTRUCTION DRAWINGS - REVISED PER NEW RFDS	RTS	07/28/21	2
CONSTRUCTION DRAWINGS - REVISED PER CLIENT COMMENTS	TJR	05/07/21	0
CONSTRUCTION DRAWINGS - ISSUED FOR CONSTRUCTION	TJR	03/18/21	0
DATE	DATE	DATE	DATE
REV.	REV.	REV.	REV.
DRAWN BY: CKD		BY	

PROFESSIONAL ENGINEER SEAL

**SPRINT** **T-Mobile**

**CENTEK engineering**  
 Centered on Solutions  
 (203) 488-0580  
 (203) 488-8587 Fax  
 63-2 North Branford Road  
 Branford, CT 06405  
 www.CentekEng.com

**T-MOBILE NORTHEAST LLC**  
**SPRINT ID: CT13XC264**  
**SITE ID: CTNH833A**  
 250 DERBY AVE  
 WEST HAVEN, CT 06516

DATE: 01/21/21  
 SCALE: AS NOTED  
 JOB NO. 21005.07

COMPOUND PLAN AND TOWER ELEVATION

**C-2**

Sheet No. 4 of 10

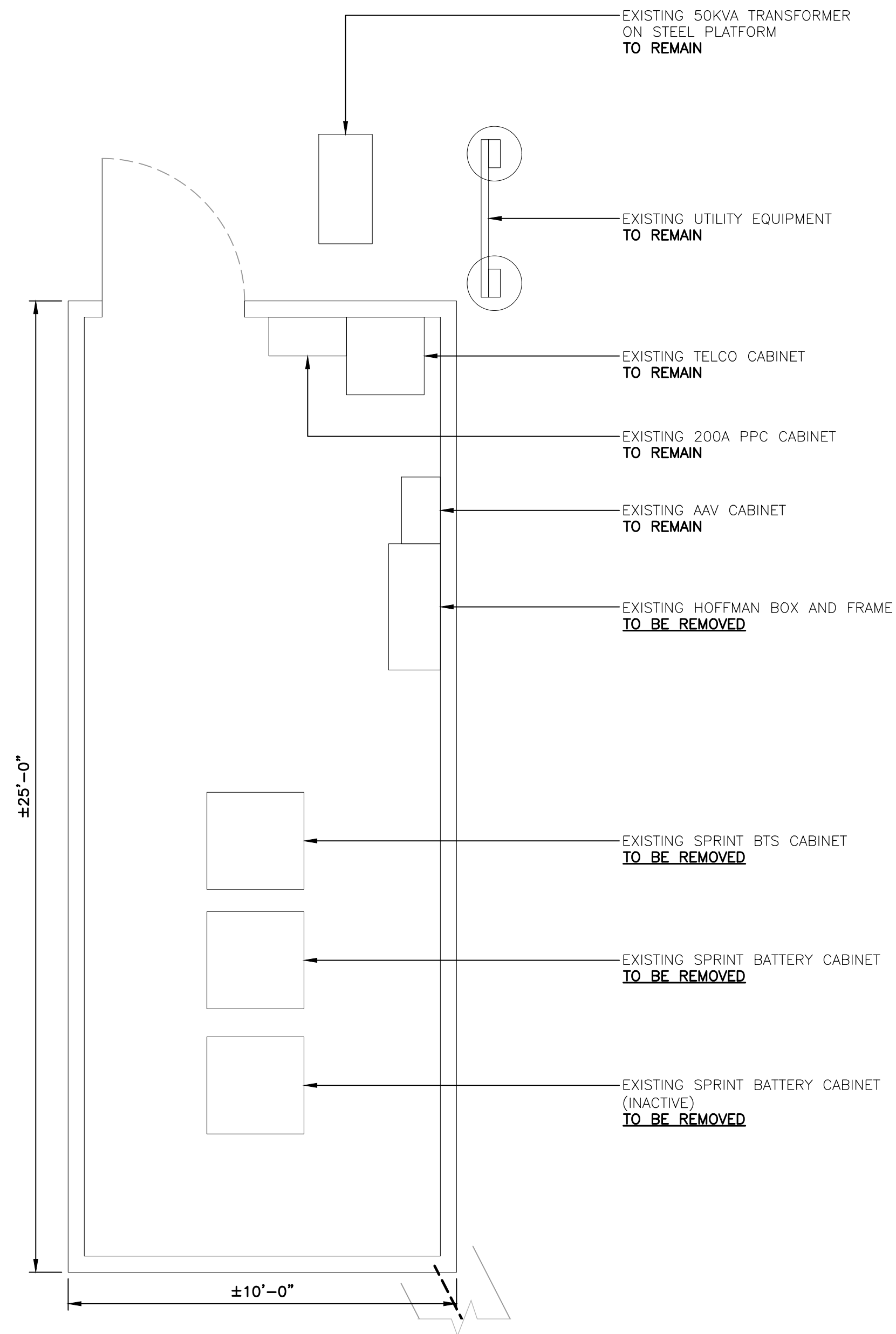

1 EQUIPMENT PLAN - EXISTING  
 C-3 SCALE: 3/8" = 1' TRUE NORTH

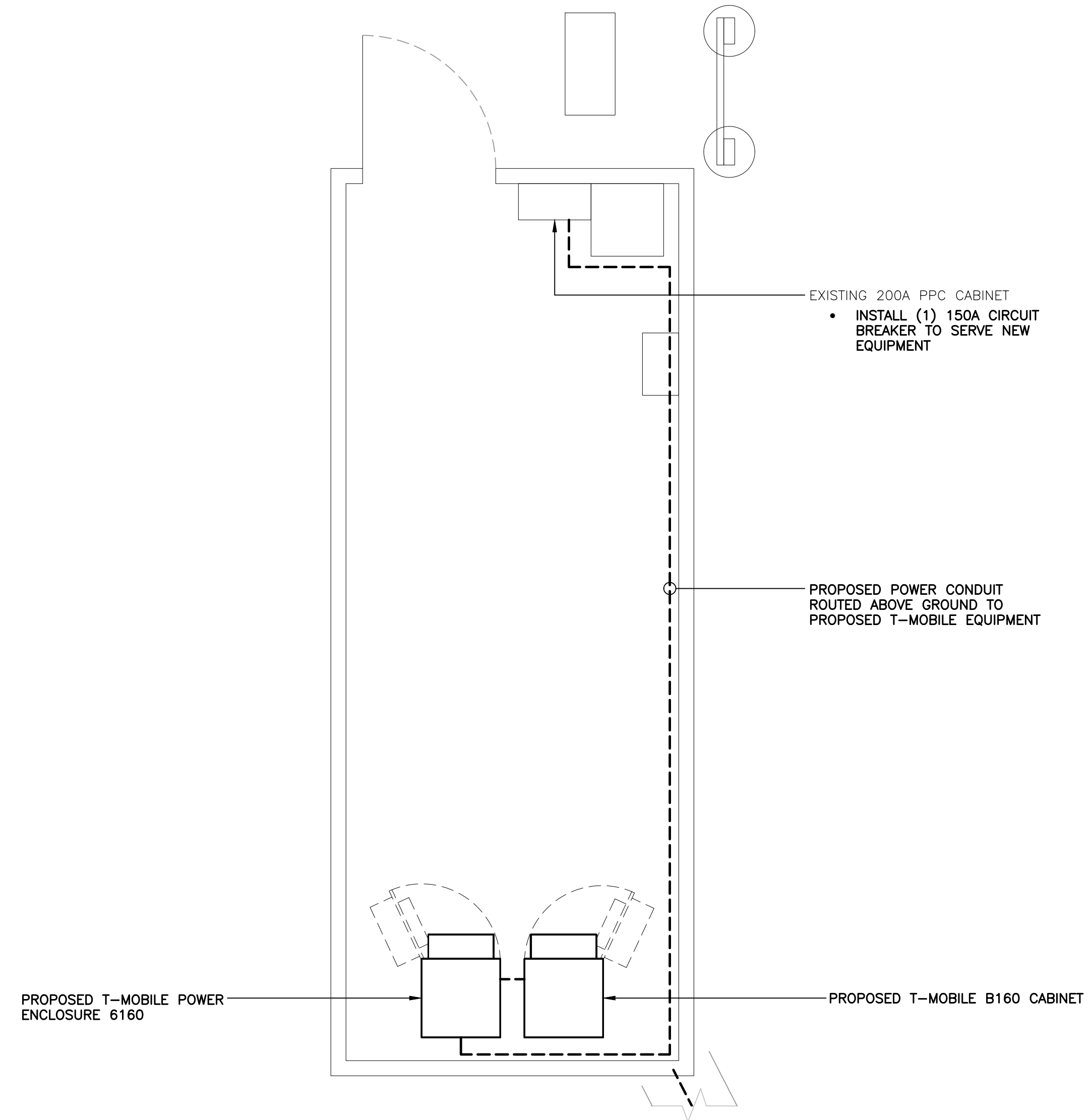

2 EQUIPMENT PLAN - PROPOSED  
 C-3 SCALE: 3/8" = 1' TRUE NORTH

(203) 488-0580 (203) 488-8587 Fax 63-2 North Branford Road Branford, CT 06405 www.CentekEng.com	
<b>T-MOBILE NORTHEAST LLC</b> <b>SPRINT ID: CT13XC264</b> <b>SITE ID: CTNH833A</b> <b>250 DERBY AVE</b> <b>WEST HAVEN, CT 06516</b>	
DATE:	01/21/21
SCALE:	AS NOTED
JOB NO.	21005.07
EQUIPMENT PLANS	
Sheet No. 5 of 10	

REV.	DATE	BY/CHK'D	DESCRIPTION
3	09/07/21	TJR	CONSTRUCTION DRAWINGS - REVISED PER NEW ANTENNA AZIMUTHS
2	07/28/21	RTS	CONSTRUCTION DRAWINGS - REVISED PER NEW RFDS
1	05/07/21	TJR	CONSTRUCTION DRAWINGS - REVISED PER CLIENT COMMENTS
0	03/18/21	JLW	CONSTRUCTION DRAWINGS - ISSUED FOR CONSTRUCTION

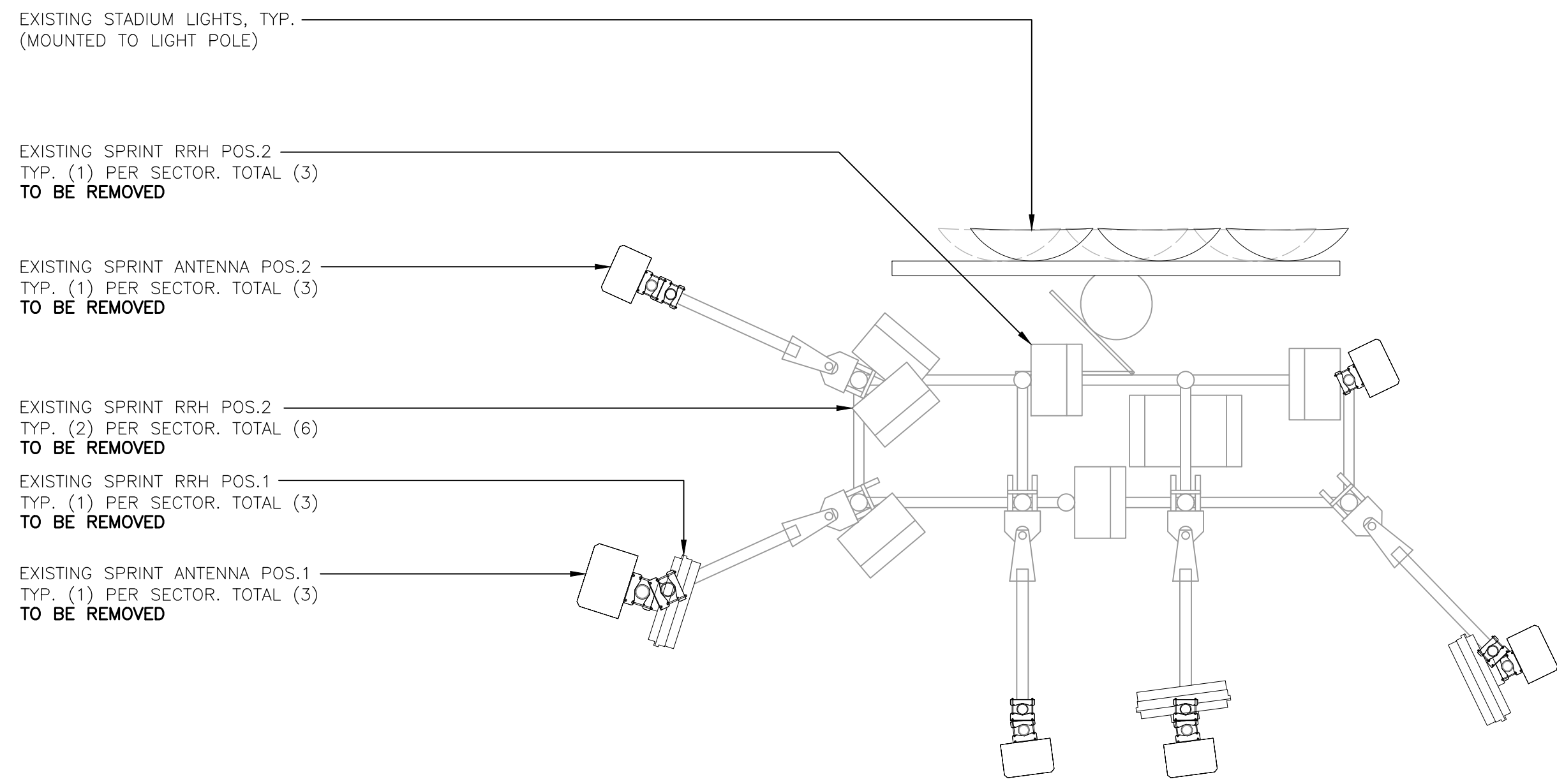

**1 ANTENNA PLAN - EXISTING**  
 C-4 SCALE: 1/2" = 1' TRUE NORTH

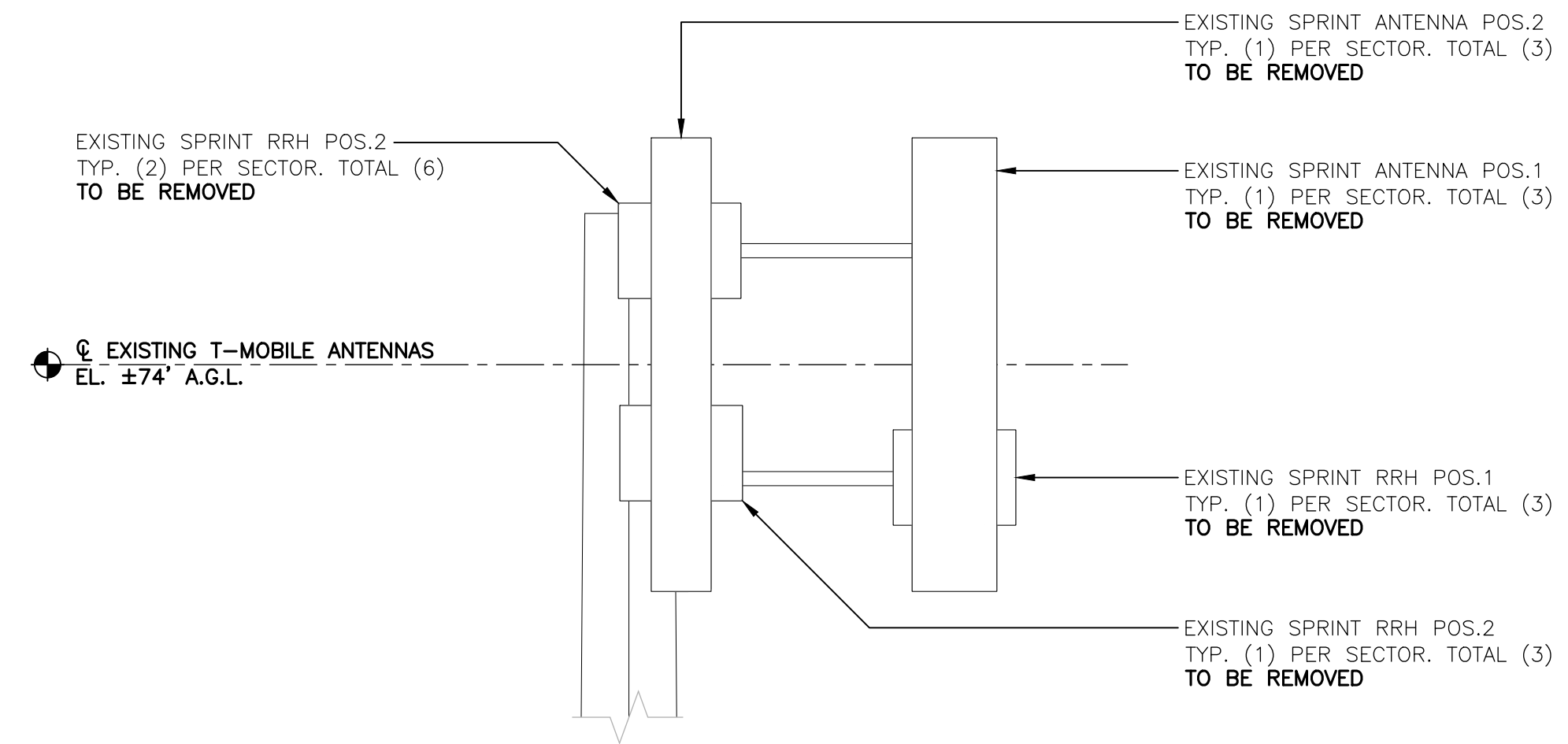

**2 ANTENNA ELEVATION - EXISTING**  
 C-4 SCALE: 1/2" = 1'

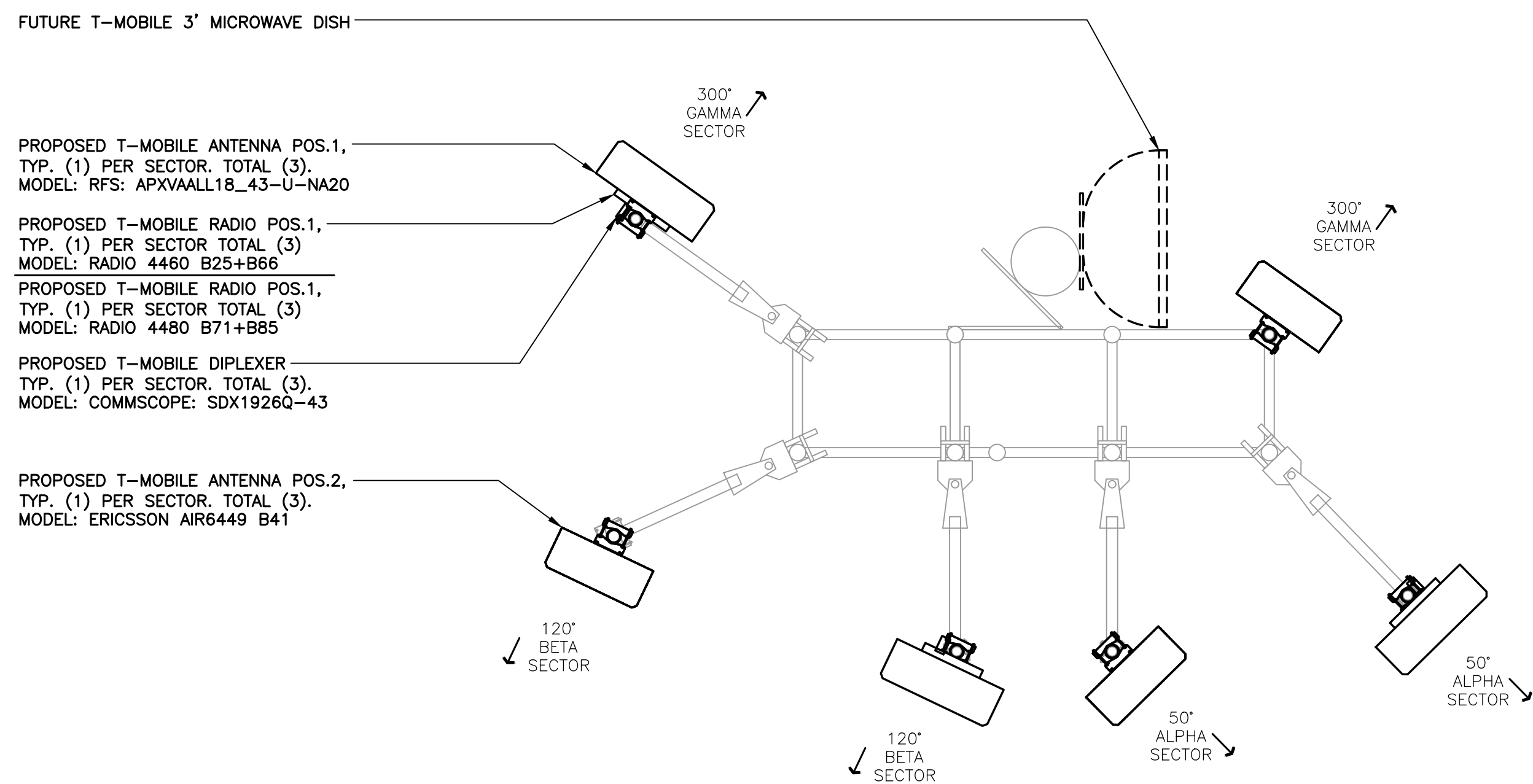

**1A ANTENNA PLAN - PROPOSED**  
 C-4 SCALE: 1/2" = 1' TRUE NORTH

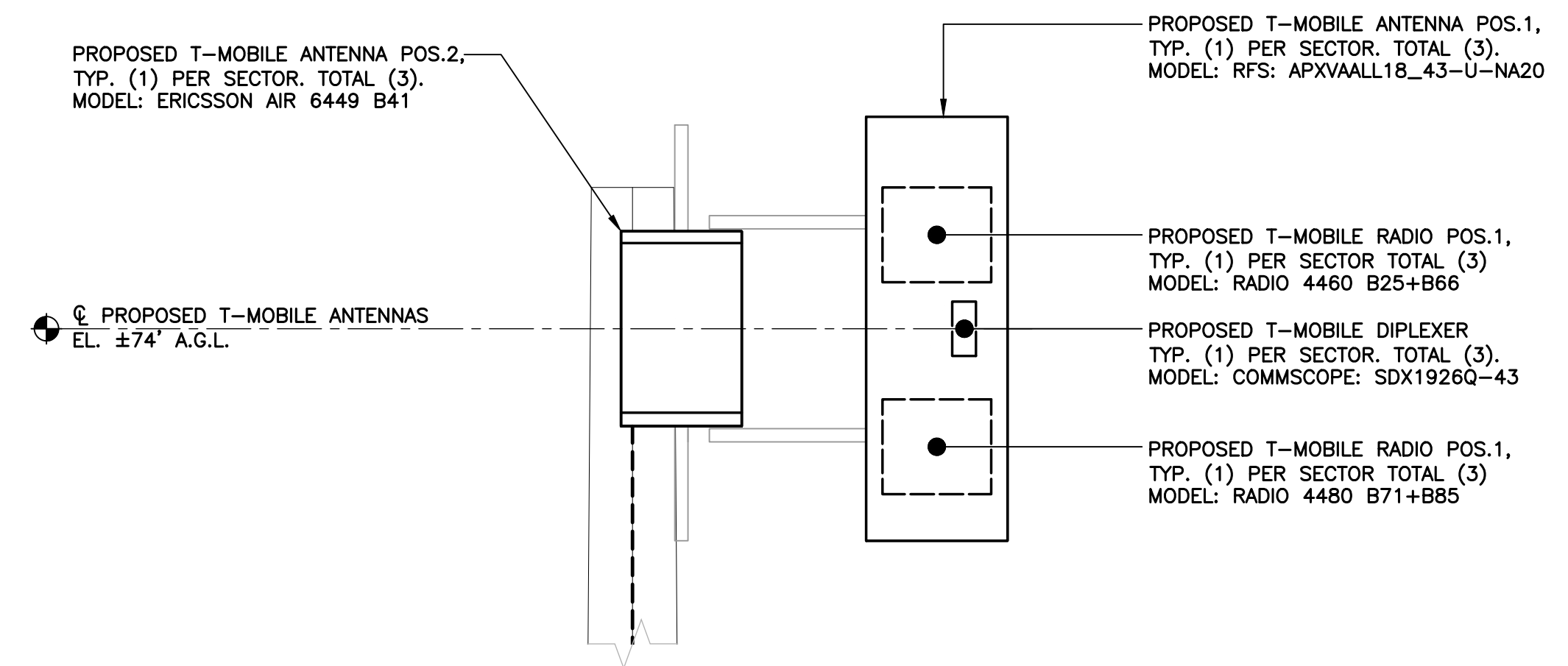

**2A ANTENNA ELEVATION - PROPOSED**  
 C-4 SCALE: 1/2" = 1'

PROFESSIONAL ENGINEER SEAL	CONSTRUCTION DRAWINGS - REVISED PER NEW ANTENNA AZIMUTHS																
	CONSTRUCTION DRAWINGS - REVISED PER NEW RFDS																
	CONSTRUCTION DRAWINGS - REVISED PER CLIENT COMMENTS																
	CONSTRUCTION DRAWINGS - ISSUED FOR CONSTRUCTION																
	DATE DRAWN BY/CHECK'D BY																
	REV. DATE																
<b>T-MOBILE NORTHEAST LLC</b> <b>SPRINT ID: CT13XC264</b> <b>SITE ID: CTNH833A</b> <b>250 DERBY AVE</b> <b>WEST HAVEN, CT 06516</b>	<table border="1"> <tr> <td>3</td> <td>09/07/21</td> <td>RTS</td> <td>TJR</td> </tr> <tr> <td>2</td> <td>07/28/21</td> <td>RTS</td> <td>TJR</td> </tr> <tr> <td>1</td> <td>05/07/21</td> <td>JLW</td> <td>TJR</td> </tr> <tr> <td>0</td> <td>03/18/21</td> <td>JLW</td> <td>TJR</td> </tr> </table>	3	09/07/21	RTS	TJR	2	07/28/21	RTS	TJR	1	05/07/21	JLW	TJR	0	03/18/21	JLW	TJR
3	09/07/21	RTS	TJR														
2	07/28/21	RTS	TJR														
1	05/07/21	JLW	TJR														
0	03/18/21	JLW	TJR														
<b>DATE:</b> 01/21/21 <b>SCALE:</b> AS NOTED <b>JOB NO.:</b> 21005.07	<b>ANTENNA PLANS AND ELEVATIONS</b>																
<b>C-4</b> Sheet No. 6 of 10																	

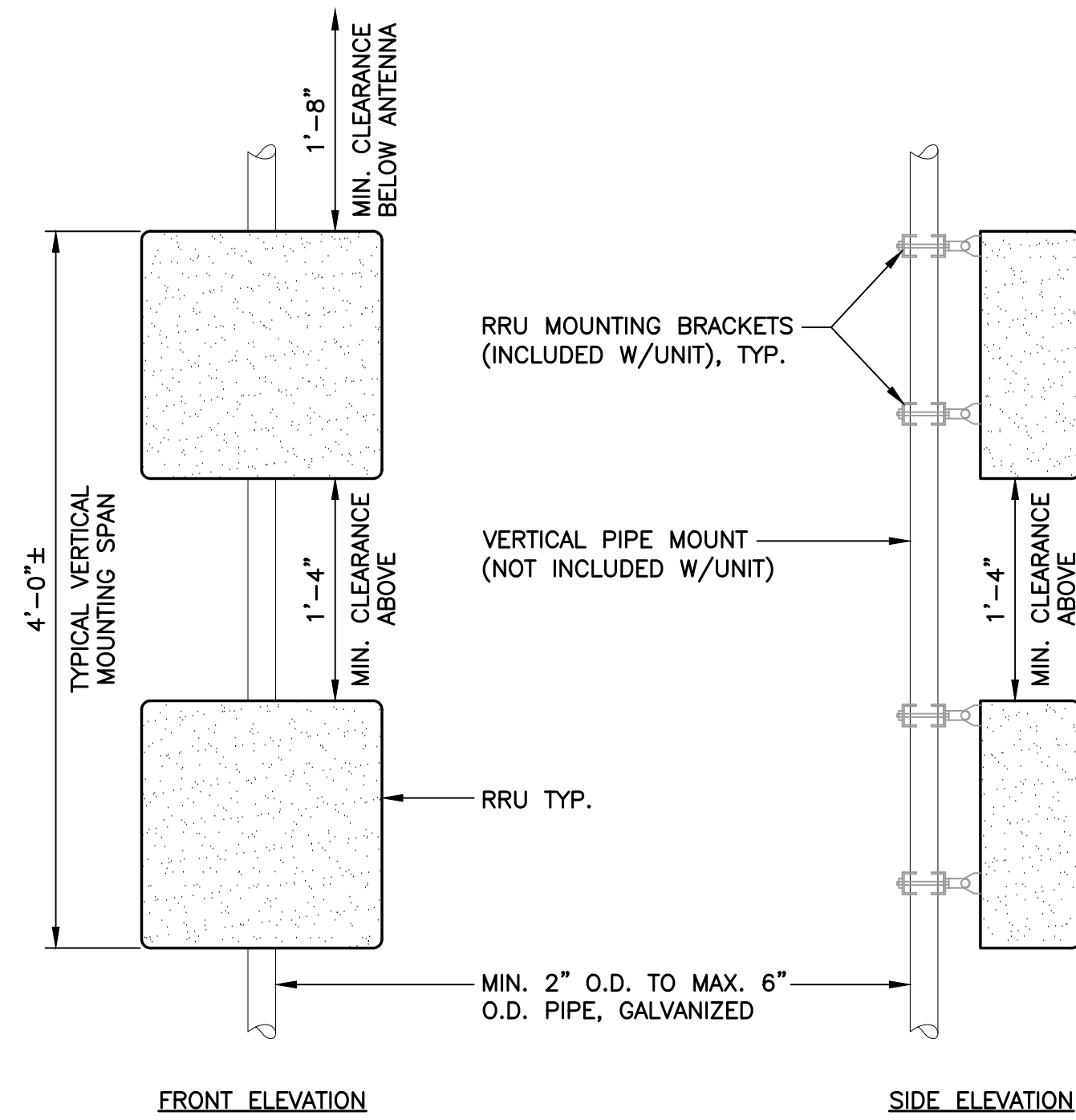

**NOTES: (PIPE MOUNTING)**

1. T-MOBILE SHALL SUPPLY RRU, AND RRU POLE-MOUNTING BRACKET. CONTRACTOR SHALL SUPPLY POLE/PIPE AND INSTALL ALL MOUNTING HARDWARE INCLUDING ERICSSON RRU POLE-MOUNTING BRACKET.
2. NO PAINTING OF THE RRU OR SOLAR SHIELD IS ALLOWED.

**1 TYPICAL RRU MOUNTING DETAIL**  
C-5 SCALE: NOT TO SCALE

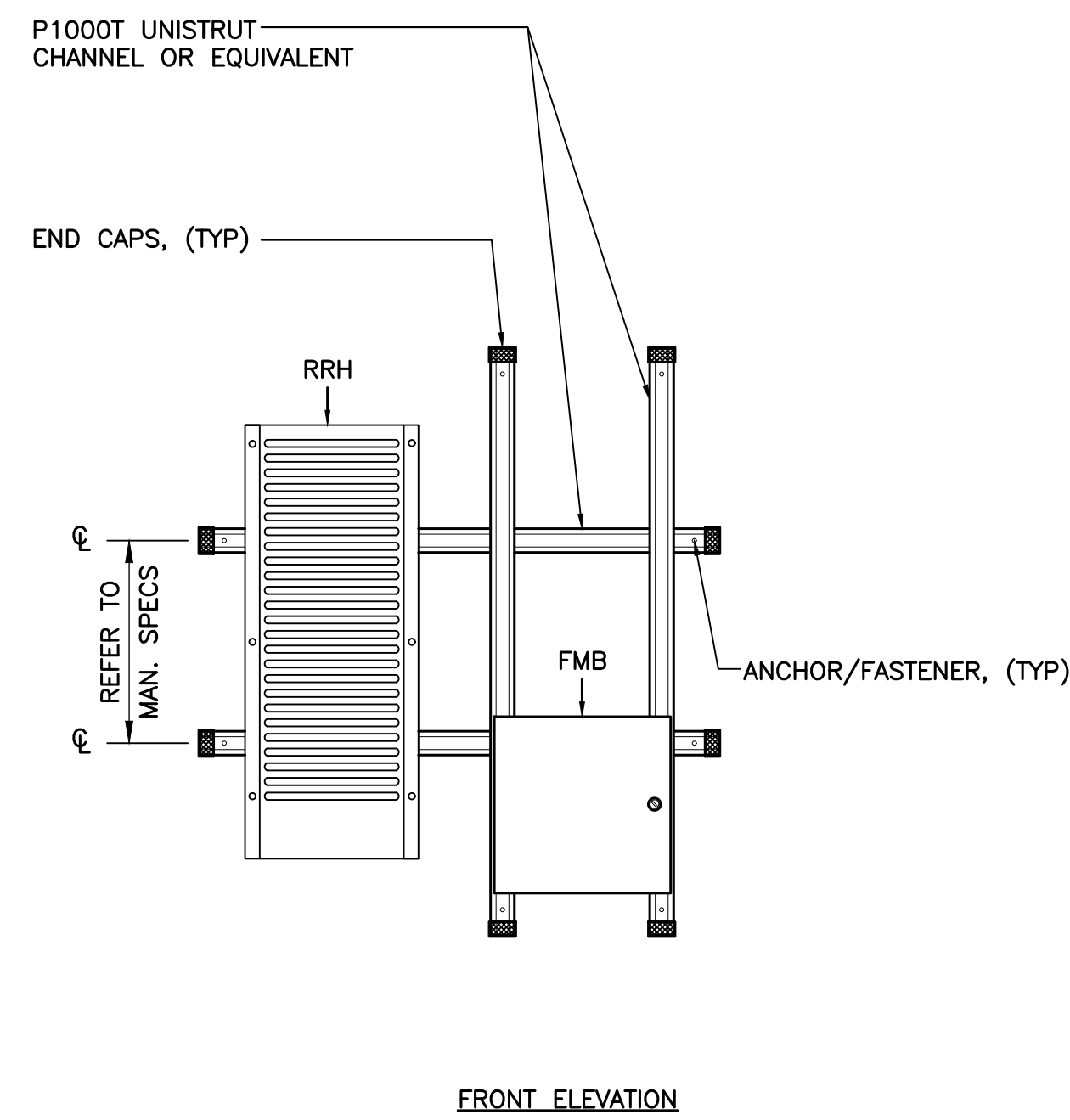

**NOTES: (UNISTRUT MOUNTING)**

1. INSTALL A MINIMUM OF (2) ANCHORS PER UNISTRUT ( $\pm 16^\circ$  o/c MIN).
2. MOUNT RRU TO UNISTRUT WITH 3/8" UNISTRUT BOLTING HARDWARE AND SPRING NUTS. TYPICAL FOUR PER BRACKET.
3. NO PAINTING OF THE RRU OR SOLAR SHIELD IS ALLOWED.

**4 ENCLOSURE 6160 CABINET DETAIL**  
C-5 SCALE: NOT TO SCALE



RRU (REMOTE RADIO UNIT)			
EQUIPMENT	DIMENSIONS	WEIGHT	CLEARANCES
MAKE: ERICSSON MODEL: RADIO 4460 B25+B66	19.6"L x 15.7"W x 12.1"D	±109 LBS.	BEHIND ANT.: 8" MIN. BELOW ANT.: 20" MIN. BELOW RRU: 16" MIN.
MAKE: ERICSSON MODEL: RADIO 4480 B71+B85	21.8"L x 15.7"W x 7.5"D	±84 LBS.	BEHIND ANT.: 8" MIN. BELOW ANT.: 20" MIN. BELOW RRU: 16" MIN.

**NOTES:**  
1. CONTRACTOR TO COORDINATE FINAL EQUIPMENT MODEL SELECTION WITH T-MOBILE CONSTRUCTION MANAGER PRIOR TO ORDERING.

**2 PROPOSED RRU DETAIL**  
C-5 SCALE: NOT TO SCALE



ALPHA/BETA/GAMMA ANTENNA		
EQUIPMENT	DIMENSIONS	WEIGHT
MAKE: ERICSSON MODEL: AIR6449 B41	33.1"L x 20.6"W x 8.6"D	±104 LBS.
MAKE: RFS MODEL: APXVAALL18_43-U-NA20	72"L x 24.0"W x 8.5"D	±92 LBS.

**NOTES:**  
1. CONTRACTOR TO COORDINATE FINAL EQUIPMENT MODEL SELECTION WITH T-MOBILE CONSTRUCTION MANAGER PRIOR TO ORDERING.

**3 PROPOSED ANTENNA DETAIL**  
C-5 SCALE: NOT TO SCALE

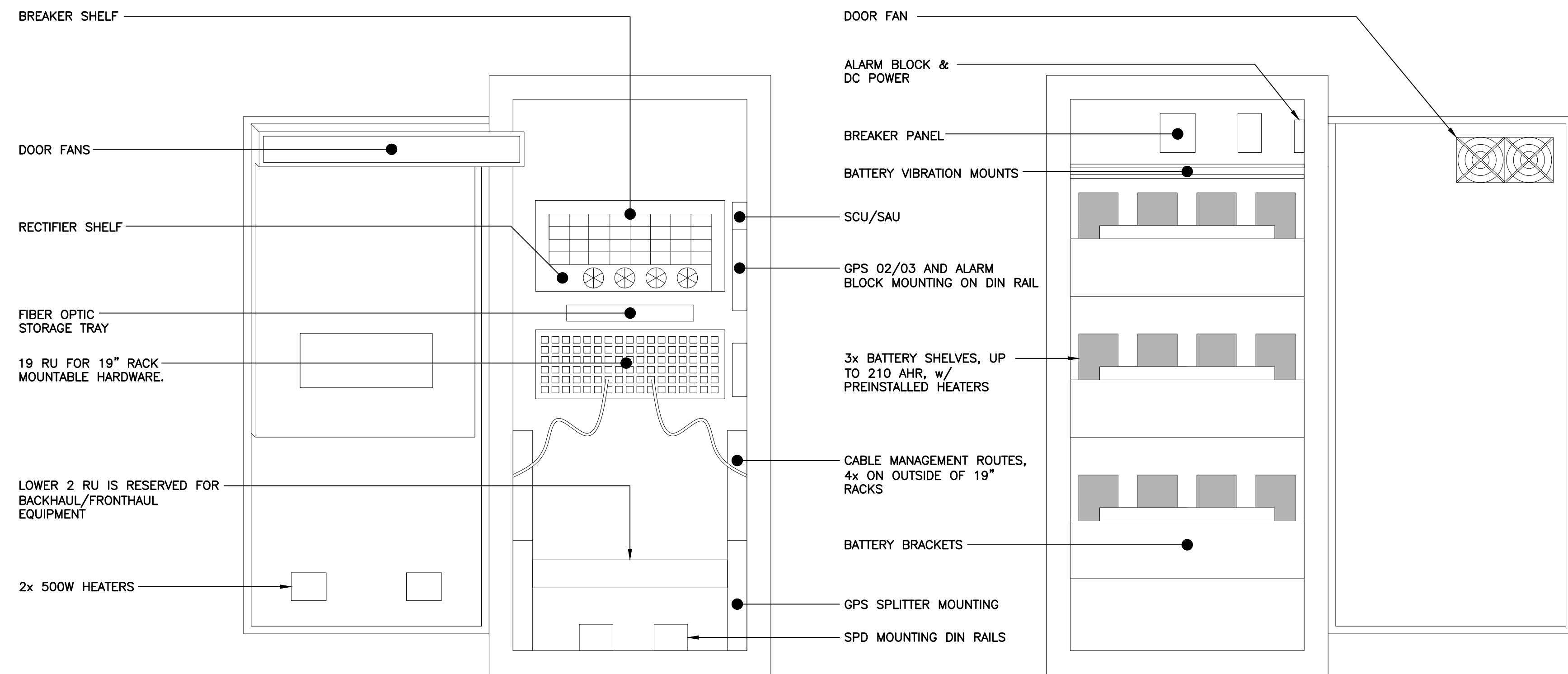

EQUIPMENT CABINET		
EQUIPMENT	DIMENSIONS	WEIGHT
MAKE: ERICSSON MODEL: ENCLOSURE 6160 CABINET	62.0"H x 26.0"W x 26.0"D	±1200 LBS

EQUIPMENT CABINET		
EQUIPMENT	DIMENSIONS	WEIGHT
MAKE: ERICSSON MODEL: BATTERY B160 CABINET	62.0"H x 26.0"W x 26.0"D	±1883 LBS

**5 BATTERY B160 CABINET DETAIL**  
C-5 SCALE: NOT TO SCALE

REV.	DATE	DESCRIPTION
0	03/18/21	JLW CONSTRUCTION DRAWINGS - ISSUED FOR CONSTRUCTION
1	05/07/21	JLW CONSTRUCTION DRAWINGS - REVISED PER CLIENT COMMENTS
2	07/28/21	RTS CONSTRUCTION DRAWINGS - REVISED PER NEW RFD
3	09/07/21	RTS CONSTRUCTION DRAWINGS - REVISED PER NEW ANTENNA AZIMUTHS

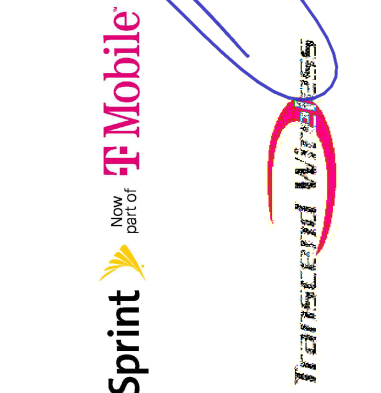

**CENTEX** engineering  
Centered on Solutions  
(203) 489-0380  
(203) 488-8587 Fax  
63-2 North Branford Road  
Branford, CT 06405  
www.CentexEng.com

**T-MOBILE NORTHEAST LLC**  
SPRINT ID: CT13XC264  
SITE ID: CTNH833A  
250 DERBY AVE  
WEST HAVEN, CT 06516

DATE: 01/21/21  
SCALE: AS NOTED  
JOB NO. 21005.07

TYPICAL EQUIPMENT DETAILS

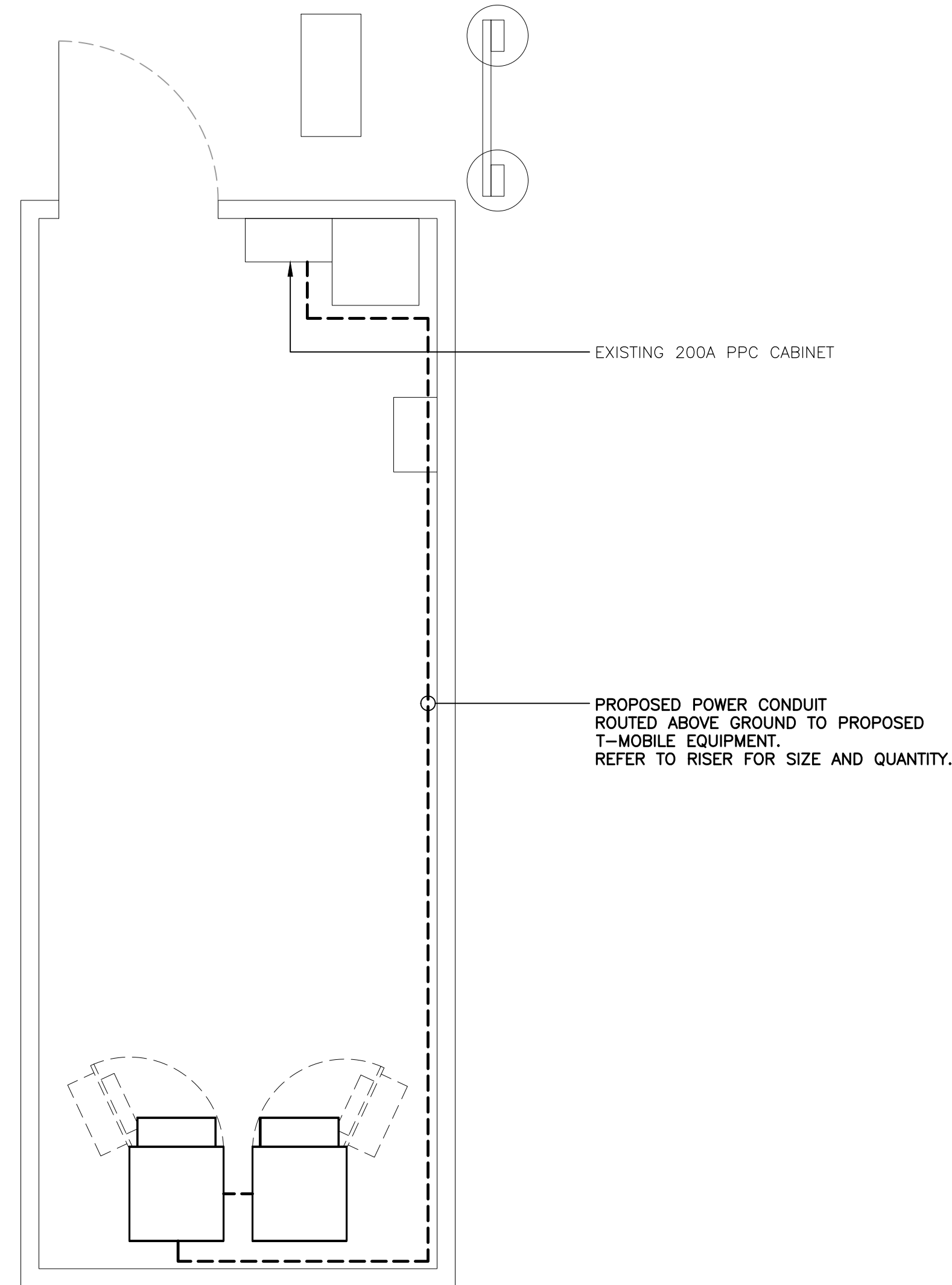

**1** ELECTRICAL CONDUIT ROUTING PLAN  
E-1 SCALE: 1/4" = 1'

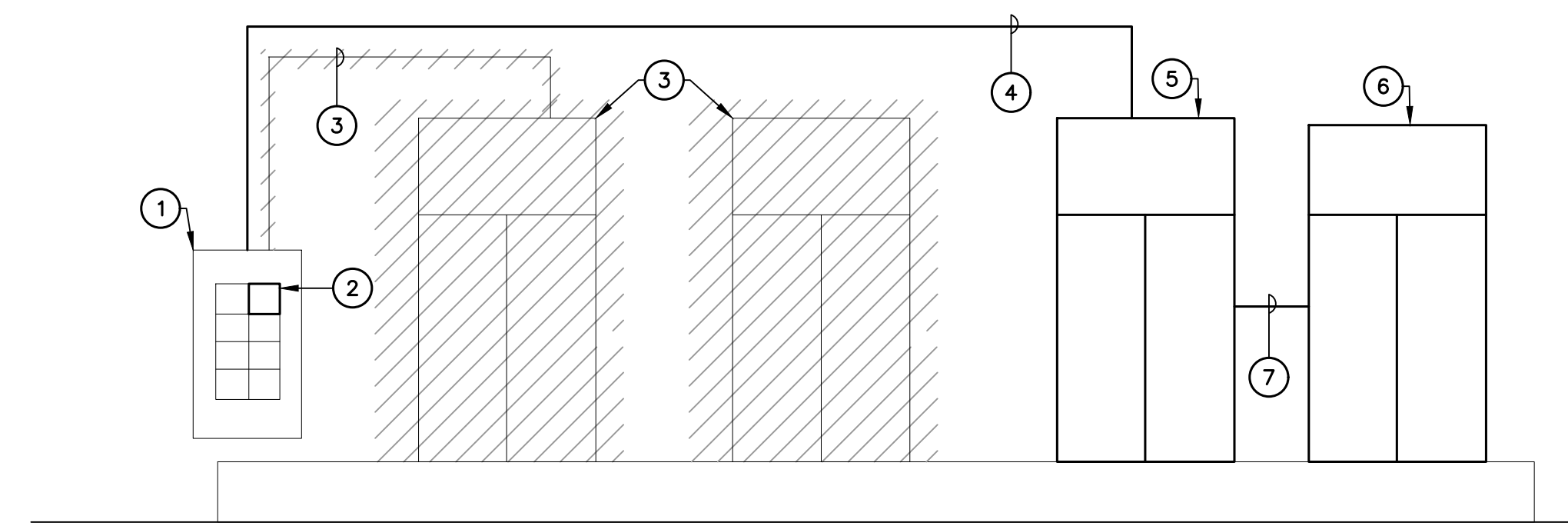

**2** ELECTRICAL POWER RISER DIAGRAM  
E-1 SCALE: NOT TO SCALE

- RISER DIAGRAM NOTES**
- ① EXISTING 200A, PPC CABINET TO REMAIN.
  - ② NEW 150A/2P CIRCUIT BREAKER TO SERVE NEW EQUIPMENT CABINET.
  - ③ EXISTING CABINETS AND ASSOCIATED CONDUITS, CONDUCTORS AND CIRCUIT BREAKERS TO BE REMOVED.
  - ④ (3) 1/0 AWG, (1) #6 AWG GROUND, 2" CONDUIT.
  - ⑤ NEW T-MOBILE EQUIPMENT CABINET
  - ⑥ NEW T-MOBILE BATTERY CABINET
  - ⑦ DC CONDUIT AND CONDUCTORS FOR BATTERY CABINET CONNECTION PER MANUFACTURERS SPECIFICATIONS.

<p><b>CENTER</b> engineering Centered on Solutions™</p> <p>(203) 488-0580 (203) 488-8587 Fax 63-2 North Branford Road Branford, CT 06405 www.CenterEng.com</p>	
<p>T-MOBILE NORTHEAST LLC SPRINT ID: CT13XC264 SITE ID: CTNH833A 250 DERBY AVE WEST HAVEN, CT 06516</p>	
DATE:	01/21/21
SCALE:	AS NOTED
JOB NO.	21005.07
ELECTRICAL RISER DIAGRAM AND CONDUIT ROUTING	
Sheet No. 8	of 10

REV.	DATE	DRAWN BY	CHECK'D BY	DESCRIPTION
3	09/07/21	RTS	TJR	CONSTRUCTION DRAWINGS - REVISED PER NEW ANTENNA AZIMUTHS
2	07/28/21	RTS	TJR	CONSTRUCTION DRAWINGS - REVISED PER NEW RTDS
0	05/07/21	JLW	TJR	CONSTRUCTION DRAWINGS - REVISED PER CLIENT COMMENTS
0	03/18/21	JLW	TJR	CONSTRUCTION DRAWINGS - ISSUED FOR CONSTRUCTION



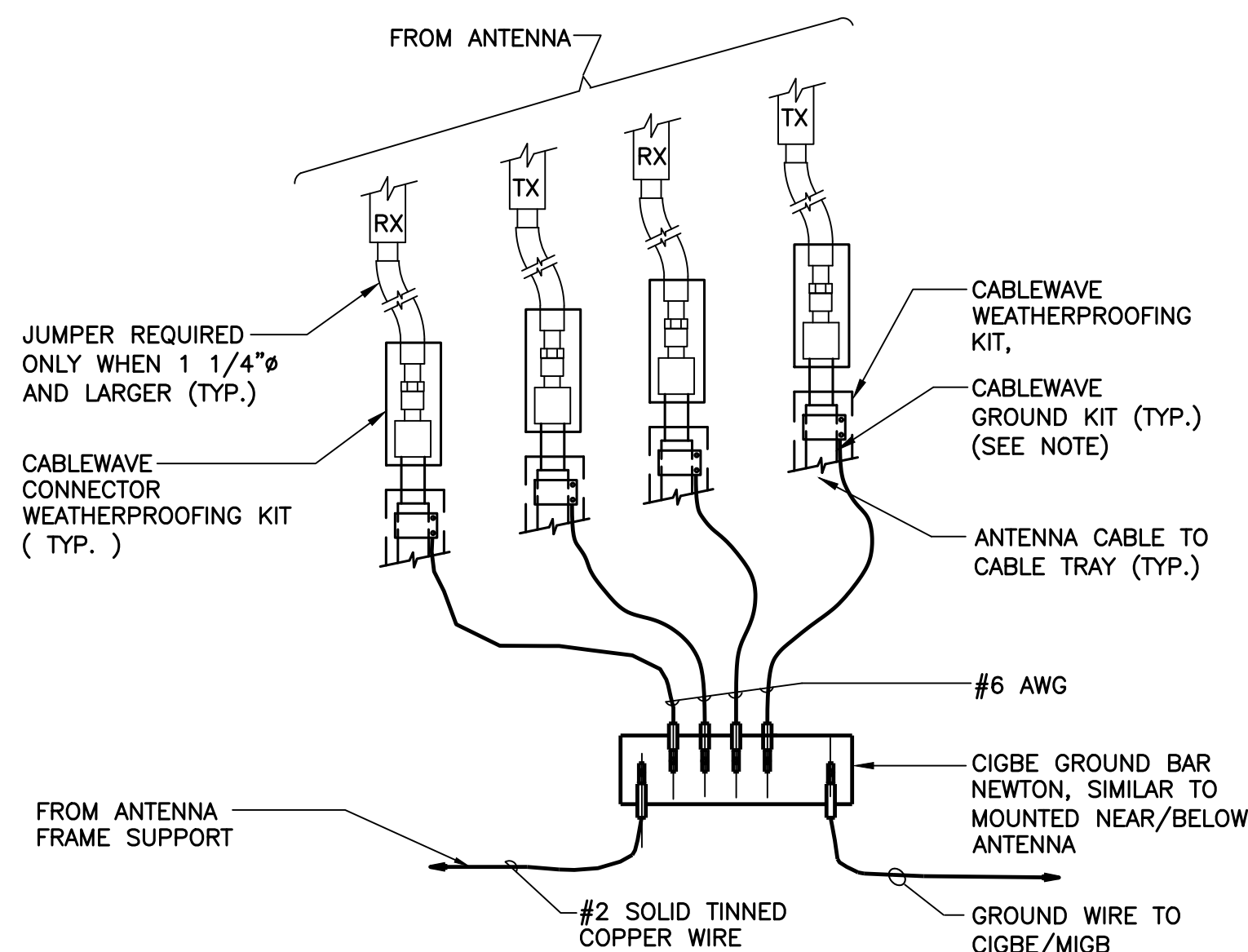

**NOTES:**  
 1. DO NOT INSTALL CABLE GROUND KIT AT A BEND AND ALWAYS DIRECT GROUND WIRE DOWN TO CIGBE

**1 CONNECTION OF GROUND WIRES TO GROUND BAR**  
 E-2 SCALE: NOT TO SCALE

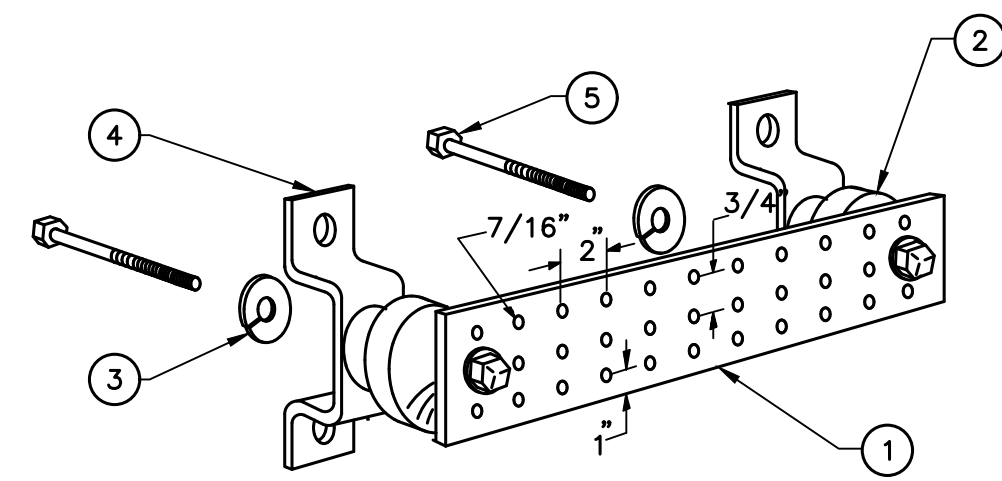

**NOTES**  
 ① TINNED COPPER GROUND BAR, 1/4" x 4" x 20", NEWTON INSTRUMENT CO. HOLE CENTERS TO MATCH NEMA DOUBLE LUG CONFIGURATION.  
 ② INSULATORS, NEWTON INSTRUMENT CAT. NO. 3061-4.  
 ③ 5/8" LOCK WASHERS, NEWTON INSTRUMENT CO. CAT. NO. 3015-8.  
 ④ WALL MOUNTING BRACKET, NEWTON INSTRUMENT CO. CAT NO. A-6056.  
 ⑤ 5/8-11 x 1" STAINLESS STEEL TRUSS SPANNER MACHINE SCREWS.

**2 GROUND BAR DETAIL**  
 E-2 SCALE: NOT TO SCALE

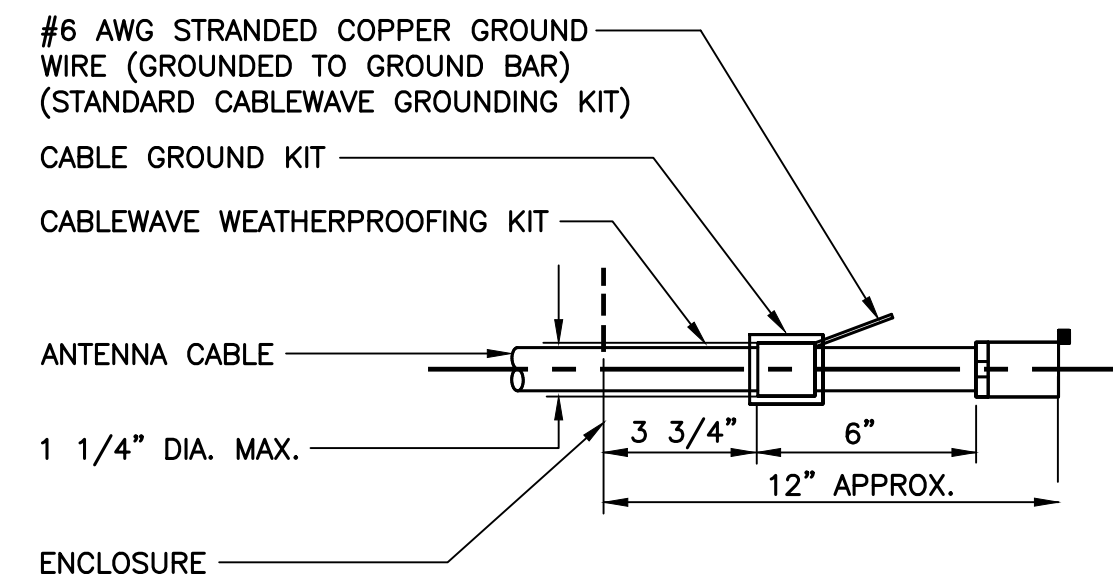

**NOTES:**  
 1. DO NOT INSTALL CABLE GROUND KIT AT A BEND AND ALWAYS DIRECT GROUND WIRE DOWN TO GROUND BAR.

**3 ANTENNA CABLE GROUNDING DETAIL**  
 E-2 SCALE: NOT TO SCALE

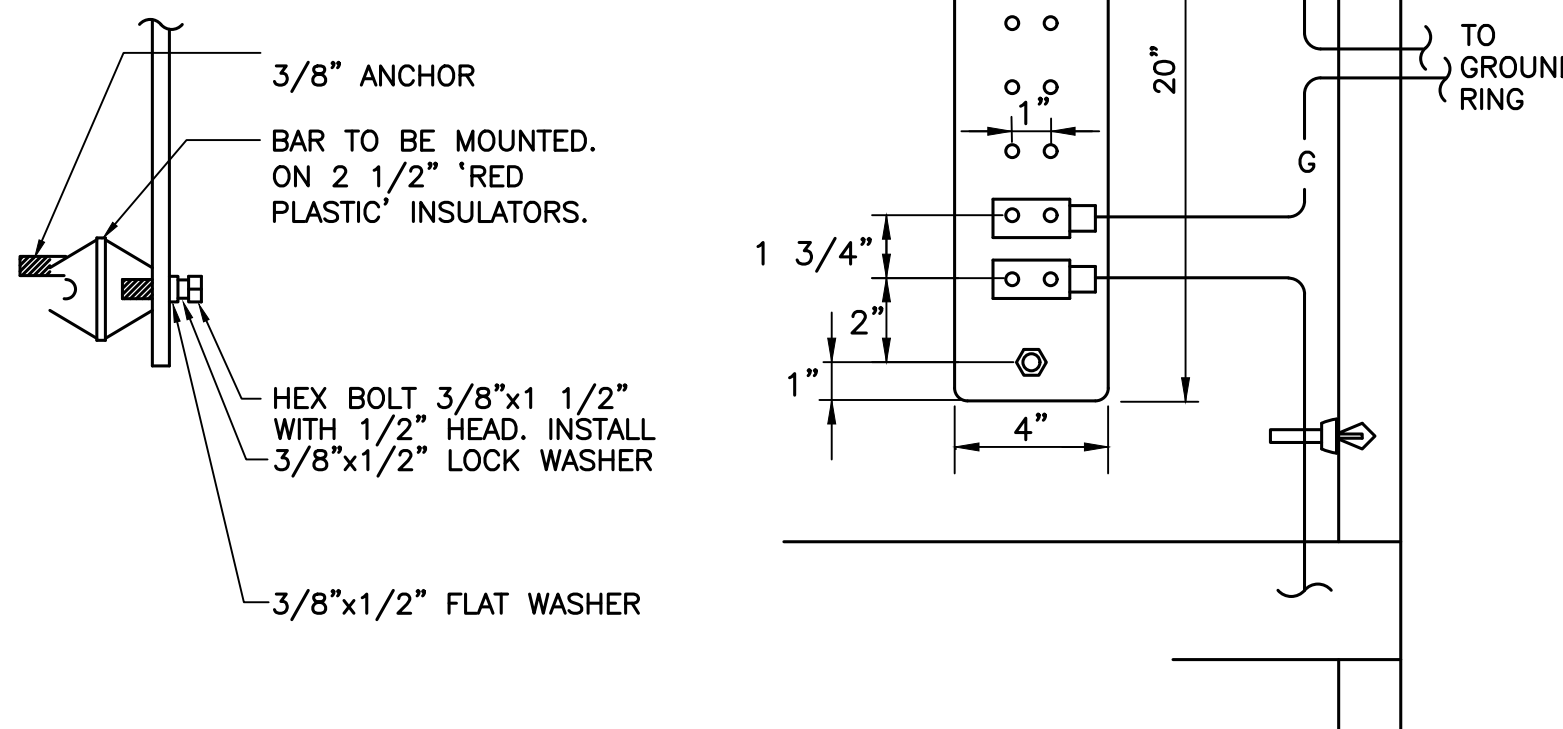
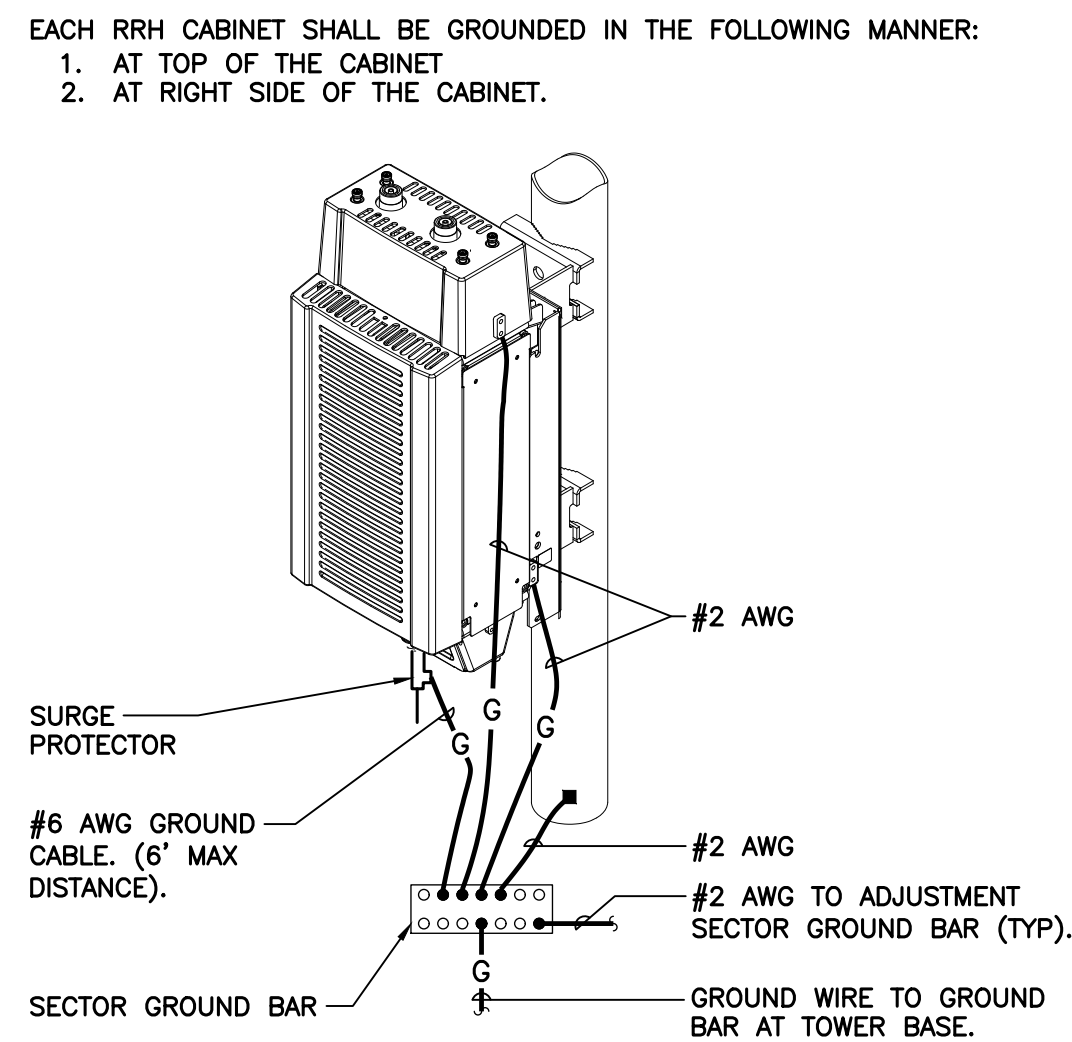
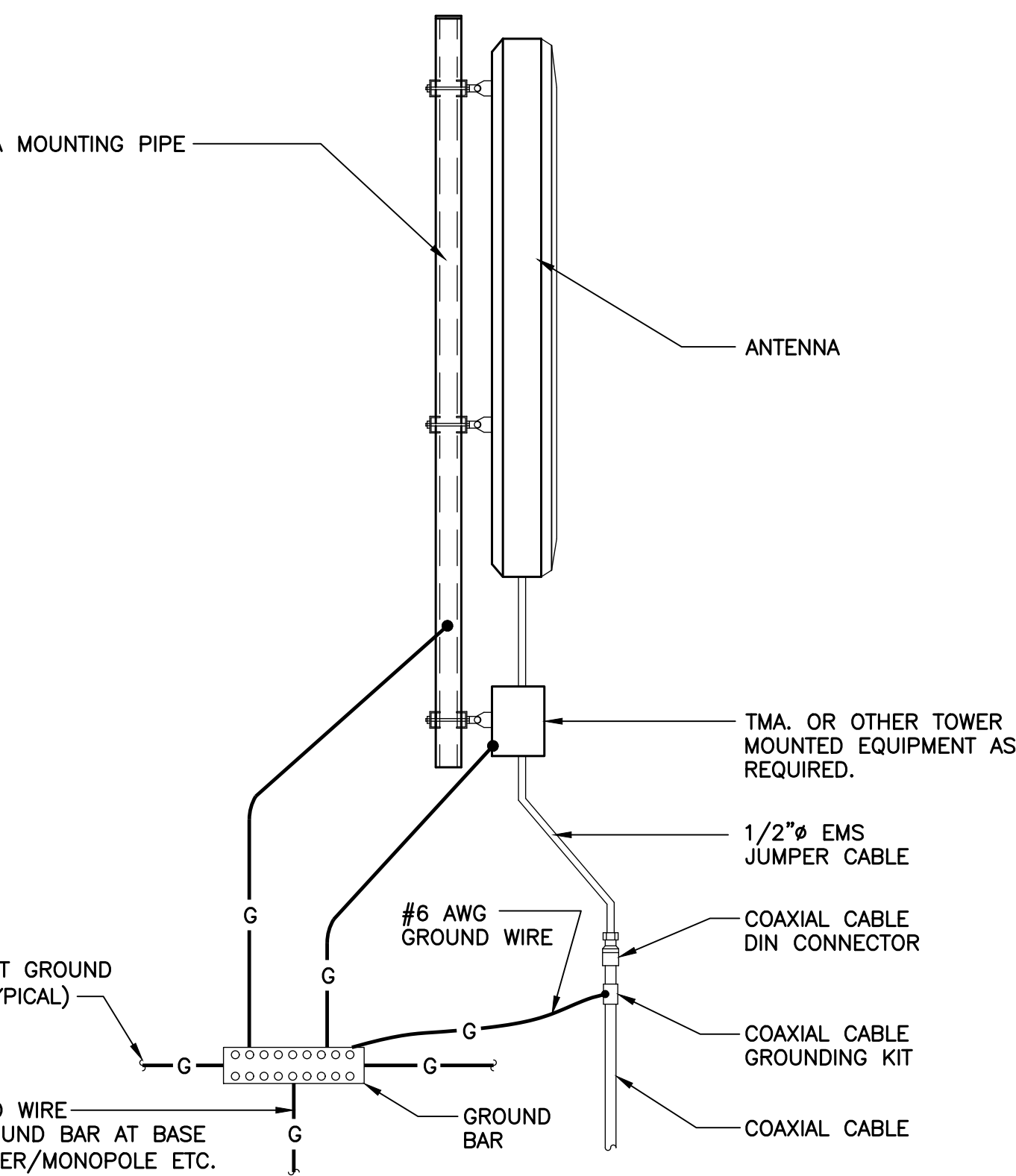
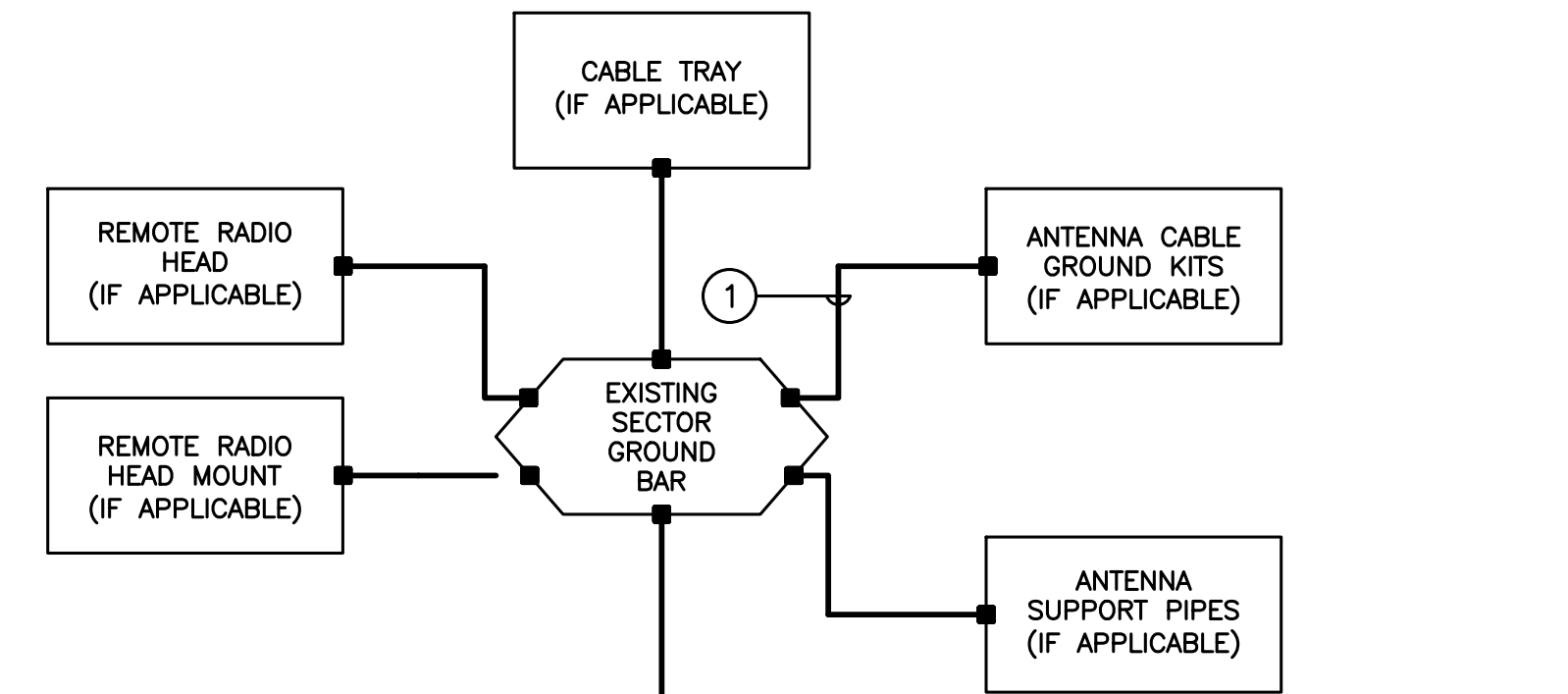

**GROUNDING SCHEMATIC NOTES**

- ① #6 AWG  
**GENERAL NOTES:**  
 1. ALL SURGE SUPPRESSION EQUIPMENT SHALL BE BONDED TO GROUND PER MANUFACTURER'S SPECIFICATIONS  
 2. UNLESS OTHERWISE NOTED OR REQUIRED BY CODE, GROUND CONDUCTORS SHOWN SHALL BE #2 AWG (SOLID TINNED BCW - EXTERIOR; STRANDED GREEN INSULATED - INTERIOR).  
 3. BOND CABLE TRAY SECTIONS TOGETHER WITH #6 AWG STRANDED GREEN INSULATED JUMPERS.  
 4. ALL SECTOR GROUND BARS SHALL BE BONDED TOGETHER WITH #2 AWG SOLID TINNED BCW.  
 5. BOND ALL EQUIPMENT CABINETS AND BATTERY CABINETS TO GROUND PER MANUFACTURER'S SPECIFICATIONS.  
 6. REFER TO ALL ELECTRICAL AND GROUNDING DETAILS.  
 7. COORDINATE ALL ROOF MOUNTED EQUIPMENT WITH OWNER.  
 8. ALL ROOF MOUNTED AMPLIFIERS AND ASSOCIATED EQUIPMENT SHALL BE BONDED TO THE SECTOR GROUND BAR PER MANUFACTURER'S SPECIFICATIONS.  
 9. ALL GROUNDING SHALL BE IN ACCORDANCE WITH NEC AND OWNER'S REQUIREMENTS.

**4 TYPICAL ANTENNA GROUNDING DETAIL**  
 E-2 SCALE: NOT TO SCALE

**5 RRH POLE MOUNT GROUNDING**  
 E-2 SCALE: NOT TO SCALE

**6 EQUIPMENT GROUND BAR DETAIL**  
 E-2 SCALE: NOT TO SCALE

**7 ELECTRICAL SCHEMATIC DIAGRAM**  
 E-2 SCALE: NOT TO SCALE

CONSTRUCTION DRAWINGS - REVISED PER NEW ANTENNA AZIMUTHS  
 CONSTRUCTION DRAWINGS - REVISED PER NEW RFDS  
 CONSTRUCTION DRAWINGS - REVISED PER CLIENT COMMENTS  
 CONSTRUCTION DRAWINGS - ISSUED FOR CONSTRUCTION

TJR  
 RTS  
 RTS  
 TJR  
 TJR  
 TJR

DATE  
 09/07/21  
 07/28/21  
 05/07/21  
 03/18/21

REV. 0  
 DRAWN BY/CHK'D BY  
 TJR

PROFESSIONAL ENGINEER SEAL  
 STATE OF CONNECTICUT  
 ENGINEERING  
 CENTEX ENGINEERING

Sprint  
 T-Mobile  
 Trellis

Centex Engineering  
 (203) 489-0380  
 (203) 488-8587 Fax  
 63-2 North Branford Road  
 Branford, CT 06405  
 www.CentexEng.com

T-MOBILE NORTHEAST LLC  
 SPRINT ID: CT13XC264  
 SITE ID: CTNH833A  
 250 DERBY AVE  
 WEST HAVEN, CT 06516

DATE: 01/21/21  
 SCALE: AS NOTED  
 JOB NO. 21005.07

TYPICAL ELECTRICAL DETAILS

E-2  
 Sheet No. 9 of 10



**Structural Analysis Report**

*76-ft Existing Monopole*

*Proposed T-Mobile  
Antenna Upgrade*

*Site Ref: CTNH833A*

*250 Derby Avenue  
West Haven, CT*

*CEN TEK Project No. 21005.07*

~~*Date: February 12, 2021*~~

*Date: August 16, 2021*

*Max Stress Ratio = 90%*

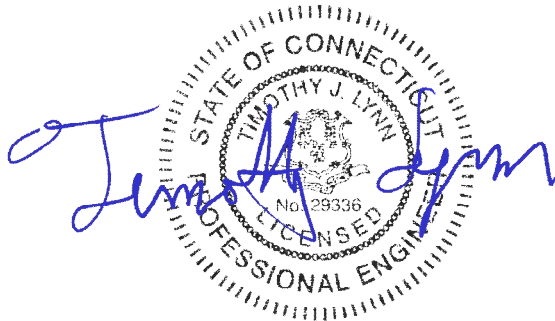

**Prepared for:**

**T-Mobile USA  
35 Griffin Road  
Bloomfield, CT 06002**

## **Table of Contents**

### **SECTION 1 - REPORT**

- INTRODUCTION
- ANTENNA AND APPURTENANCE SUMMARY
- PRIMARY ASSUMPTIONS USED IN THE ANALYSIS
- ANALYSIS
- TOWER LOADING
- TOWER CAPACITY
- FOUNDATION AND ANCHORS
- CONCLUSION

### **SECTION 2 – CONDITIONS & SOFTWARE**

- STANDARD ENGINEERING CONDITIONS
- GENERAL DESCRIPTION OF STRUCTURAL ANALYSIS PROGRAM

### **SECTION 3 – CALCULATIONS**

- tnxTower INPUT/OUTPUT SUMMARY
- tnxTower DETAILED OUTPUT
- ANCHOR BOLT AND BASE PLATE ANALYSIS
- MathCAD CAISSON FOUNDATION ANALYSIS
- L-PILE CAISSON ANALYSIS
- L-PILE LATERAL DEFLECTION vs. DEPTH
- L-PILE BENDING MOMENT vs. DEPTH
- L-PILE SHEAR FORCE vs. DEPTH

### **SECTION 4 – REFERENCE MATERIAL**

- RF DATA SHEET

## Introduction

The purpose of this report is to summarize the results of the non-linear, P- $\Delta$  structural analysis of the antenna upgrade proposed by T-Mobile on the existing monopole located in West Haven, Connecticut.

The host tower is a 76-ft tall, two-section, sixteen sided, tapered monopole. Original design documents were unavailable for use in this analysis. The tower geometry, structure member sizes and foundation system information were obtained from a previous structural analysis report prepared by Infinigy job no. 526-102 dated January 21, 2019.

Antenna and appurtenance information were obtained from the aforementioned structural analysis report and a T-Mobile RF sheet.

The tower is made up of two (2) tapered vertical sections consisting of A572-50 pole sections. The diameter of the pole (flat-flat) is 11.9-in at the top and 27.0-in at the base.

## Antenna and Appurtenance Summary

The existing, proposed and future loads considered in this analysis consist of the following:

- **UNKNOWN (EXISTING TO REMAIN):**  
Antennas: Four (4) 2-ft diameter lights mounted with an elevation of 73-ft above grade level.
- **UNKNOWN (EXISTING TO REMAIN):**  
Antennas: Three (3) 2-ft diameter lights mounted with an elevation of 70-ft above grade level.
- **SPRINT (EXISTING TO REMOVE):**  
Antennas: Three (3) Commscope DT465B-2XR panel antennas, three (3) RFS APXVSP18 panel antennas, six (6) ALU 1900 MHz RRHs, six (6) ALU 800 MHz RRHs and three (3) ALU TD-RRH-8X20 RRHs mounted on a platform with a RAD center elevation of 74-ft above grade level.  
Coax Cables: Three (3) fiber cables running on the inside of the existing tower.
- **T-MOBILE (PROPOSED):**  
Antennas: Three (3) RFS APXVAALL18\_43 panel antennas, three (3) Ericsson AIR6449 panel antennas, three (3) Ericsson 4460 remote radio units, three (3) Ericsson 4480 remote radio units and three (3) Commscope SDX1926Q-43 diplexers mounted on a platform with a RAD center elevation of 74-ft above grade level.  
Cables: Three (3) 6x24 fiber cables on the interior of the existing tower.

## Primary Assumptions Used in the Analysis

- The tower structure's theoretical capacity not including any assessment of the condition of the tower.
- The tower carries the horizontal and vertical loads due to the weight of antennas, ice load and wind.
- Tower is properly installed and maintained.
- Tower is in plumb condition.
- Tower loading for antennas and mounts as listed in this report.
- All bolts are appropriately tightened providing the necessary connection continuity.
- All welds are fabricated with ER-70S-6 electrodes.
- All members are assumed to be as specified in the original tower design documents or reinforcement drawings.
- All members are "hot dipped" galvanized in accordance with ASTM A123 and ASTM A153 Standards.
- All member protective coatings are in good condition.
- All tower members were properly designed, detailed, fabricated, installed and have been properly maintained since erection.
- Any deviation from the analyzed antenna loading will require a new analysis for verification of structural adequacy.
- All coax cables to be installed as indicated in this report.

## Analysis

The existing tower was analyzed using a comprehensive computer program entitled tnxTower. The program analyzes the tower, considering the worst case loading condition. The tower is considered as loaded by concentric forces along the tower, and the model assumes that the tower members are subjected to bending, axial, and shear forces.

The existing tower was analyzed for the controlling basic wind speed (3-second gust) with no ice and the applicable wind and ice combination to determine stresses in members as per guidelines of TIA-222-G-2005 entitled “Structural Standard for Antenna Support Structures and Antennas”, the American Institute of Steel Construction (AISC) and the Manual of Steel Construction; Load and Resistance Factor Design (LRFD).

The controlling wind speed is determined by evaluating the local available wind speed data as provided in Appendix N of the CSBC<sup>1</sup> and the wind speed data available in the TIA-222-G-2005 Standard.

## Tower Loading

Tower loading was determined by the basic wind speed as applied to projected surface areas with modification factors per TIA-222-G-2005, gravity loads of the tower structure and its components, and the application of 0.75” radial ice on the tower structure and its components.

Load Cases:	<u>Load Case 1</u> ; 97 mph wind speed w/ no ice plus gravity load – used in calculation of tower stresses and rotation.	[Appendix N of the 2018 CT Building Code]
-------------	--	---

	<u>Load Case 2</u> ; 50 mph wind speed w/ 0.75” radial ice plus gravity load – used in calculation of tower stresses.	[Annex B of TIA-222-G-2005]
--	---	-----------------------------

---

<sup>1</sup> The 2015 International Building Code as amended by the 2018 Connecticut State Building Code (CSBC).

## Tower Capacity

- Calculated stresses were found to be within allowable limits. This tower was found to be at **90%** of its total capacity.

Tower Section	Elevation	Stress Ratio (percentage of capacity)	Result
Pole Shaft (L2)	0.00'-50.00'	90%	<b>PASS</b>

## Foundation and Anchors

The existing foundation consists of a 5.0  $\emptyset$  x 20.0-ft long reinforced concrete caisson. The sub-grade conditions used in the analysis of the existing foundation were obtained from the aforementioned structural report. The base of the tower is connected to the foundation by means of (8) 2.25"  $\emptyset$  anchor bolts embedded into the concrete foundation structure.

- The tower base reactions developed from the governing Load Case were used in the verification of the foundation and its anchors:

Location	Vector	Proposed Reactions
Base	Shear	9 kips
	Compression	10 kips
	Moment	531 kip-ft

- The foundation was found to be within allowable limits.

Foundation	Design Limit	Proposed Loading	Result
Reinforced Concrete Caisson	Moment Capacity	35.7%	<b>PASS</b>
	Lateral Deflection	0.08 in. <sup>(1)</sup>	<b>PASS</b>

(1) Lateral deflection limited to 0.75 in under service load combination per TIA-222-G section 9.5.

- The anchor bolts and base plate were found to be within allowable limits.

Tower Component	Design Limit	Stress Ratio (percentage of capacity)	Result
Anchor Bolts	Combined Axial and Bending	52.1%	<b>PASS</b>
Base Plate	Bending	69.9%	<b>PASS</b>



**CENTEK** Engineering, Inc.  
Structural Analysis – 76-ft Monopole  
T-Mobile Antenna Upgrade – CTNH833A  
West Haven, CT  
Rev 1 ~ August 16, 2021

## Conclusion

This analysis shows that the subject tower **is adequate** to support the proposed modified antenna configuration.

The analysis is based, in part, on the information provided to this office by T-Mobile. If the existing conditions are different than the information in this report, Centek Engineering, Inc. must be contacted for resolution of any potential issues.

Please feel free to call with any questions or comments.

Respectfully Submitted by:



Timothy J. Lynn, PE  
Structural Engineer

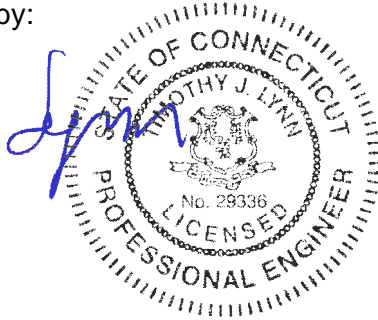

*Standard Conditions for Furnishing of  
Professional Engineering Services on  
Existing Structures*

All engineering services are performed on the basis that the information used is current and correct. This information may consist of, but is not necessarily limited to:

- Information supplied by the client regarding the structure itself, its foundations, the soil conditions, the antenna and feed line loading on the structure and its components, or other relevant information.
- Information from the field and/or drawings in the possession of Centek Engineering, Inc. or generated by field inspections or measurements of the structure.
- It is the responsibility of the client to ensure that the information provided to Centek Engineering, Inc. and used in the performance of our engineering services is correct and complete. In the absence of information to the contrary, we assume that all structures were constructed in accordance with the drawings and specifications and are in an un-corroded condition and have not deteriorated. It is therefore assumed that its capacity has not significantly changed from the “as new” condition.
- All services will be performed to the codes specified by the client, and we do not imply to meet any other codes or requirements unless explicitly agreed in writing. If wind and ice loads or other relevant parameters are to be different from the minimum values recommended by the codes, the client shall specify the exact requirement. In the absence of information to the contrary, all work will be performed in accordance with the latest revision of ANSI/ASCE10 & ANSI/EIA-222
- All services performed, results obtained, and recommendations made are in accordance with generally accepted engineering principles and practices. Centek Engineering, Inc. is not responsible for the conclusions, opinions and recommendations made by others based on the information we supply.

## GENERAL DESCRIPTION OF STRUCTURAL ANALYSIS PROGRAM

tnxTower, is an integrated structural analysis and design software package for Designed specifically for the telecommunications industry, tnxTower, formerly ERITower, automates much of the tower analysis and design required by the TIA/EIA 222 Standard.

### tnxTower Features:

- tnxTower can analyze and design 3- and 4-sided guyed towers, 3- and 4-sided self-supporting towers and either round or tapered ground mounted poles with or without guys.
- The program analyzes towers using the TIA-222-G (2005) standard or any of the previous TIA/EIA standards back to RS-222 (1959). Steel design is checked using the AISC ASD 9th Edition or the AISC LRFD specifications.
- Linear and non-linear (P-delta) analyses can be used in determining displacements and forces in the structure. Wind pressures and forces are automatically calculated.
- Extensive graphics plots include material take-off, shear-moment, leg compression, displacement, twist, feed line, guy anchor and stress plots.
- tnxTower contains unique features such as True Cable behavior, hog rod take-up, foundation stiffness and much more.

76.0 ft

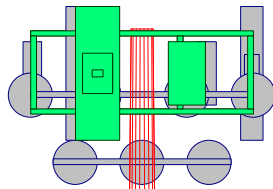

**DESIGNED APPURTENANCE LOADING**

TYPE	ELEVATION	TYPE	ELEVATION
AIR6449 (T-Mobile Propoed)	74	SDX1926Q-43 (T-Mobile Propoed)	74
APXVAALL18-43 (T-Mobile Propoed)	74	SDX1926Q-43 (T-Mobile Propoed)	74
AIR6449 (T-Mobile Propoed)	74	9' Platform and (5) 3' Side Arms (T-Mobile Existing)	74
APXVAALL18-43 (T-Mobile Propoed)	74	10-ft long light bracket	73
AIR6449 (T-Mobile Propoed)	74	2-ft Dia. Light	73
APXVAALL18-43 (T-Mobile Propoed)	74	2-ft Dia. Light	73
4460 B25+B66 (T-Mobile Propoed)	74	2-ft Dia. Light	73
4460 B25+B66 (T-Mobile Propoed)	74	2-ft Dia. Light	73
4460 B25+B66 (T-Mobile Propoed)	74	2-ft Dia. Light	73
4480 B71+B85 (T-Mobile Propoed)	74	8-ft Light Bracket	70
4480 B71+B85 (T-Mobile Propoed)	74	2-ft Dia. Light	70
4480 B71+B85 (T-Mobile Propoed)	74	2-ft Dia. Light	70
4480 B71+B85 (T-Mobile Propoed)	74	2-ft Dia. Light	70
SDX1926Q-43 (T-Mobile Propoed)	74	2-ft Dia. Light	70

**MATERIAL STRENGTH**

GRADE	Fy	Fu	GRADE	Fy	Fu
A572-50	50 ksi	65 ksi			

**TOWER DESIGN NOTES**

1. Tower designed for Exposure C to the TIA-222-G Standard.
2. Tower designed for a 97 mph basic wind in accordance with the TIA-222-G Standard.
3. Tower is also designed for a 50 mph basic wind with 0.75 in ice. Ice is considered to increase in thickness with height.
4. Deflections are based upon a 60 mph wind.
5. Tower Structure Class II.
6. Topographic Category 1 with Crest Height of 0.00 ft
7. 0.375" Used for Section 2 thickness to take into account plate reinforcements
8. TOWER RATING: 90%

50.0 ft

0.0 ft

Section	1	2
Length (ft)	26.00	50.00
Number of Sides	16	16
Thickness (in)	0.1563	0.3750
Top Dia (in)	11.9400	17.0920
Bot Dia (in)	17.0920	27.0000
Grade		A572-50
Weight (K)	0.6	4.4

ALL REACTIONS ARE FACTORED

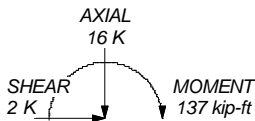

TORQUE 1 kip-ft  
50 mph WIND - 0.7500 in ICE

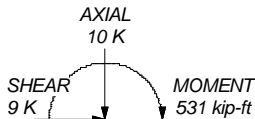

TORQUE 4 kip-ft  
REACTIONS - 97 mph WIND

**Centek Engineering Inc.**  
63-2 North Branford Rd.  
Branford, CT 06405  
Phone: (203) 488-0580  
FAX: (203) 488-8587

Job: <b>21005.07 - CTNH833A</b>		
Project: <b>76' Monopole - 250 Derby Ave., West Haven, CT</b>		
Client: T-Mobile	Drawn by: TJL	App'd:
Code: TIA-222-G	Date: 08/16/21	Scale: NTS
Path:		Dwg No. E-1

J:\jobs\210050\1607\_CTNH833A\_C110X26405\_StructuralTower\_Analysis\Bldg\_Documentation\Rev 111620 Files\76' Monopole.dwg

<b>tnxTower</b>  <b>Centek Engineering Inc.</b> 63-2 North Branford Rd. Branford, CT 06405 Phone: (203) 488-0580 FAX: (203) 488-8587	<b>Job</b> 21005.07 - CTNH833A	<b>Page</b> 1 of 17
	<b>Project</b> 76' Monopole - 250 Derby Ave., West Haven, CT	<b>Date</b> 11:31:27 08/16/21
	<b>Client</b> T-Mobile	<b>Designed by</b> TJL

## Tower Input Data

The tower is a monopole.

This tower is designed using the TIA-222-G standard.

The following design criteria apply:

- Basic wind speed of 97 mph.
- Structure Class II.
- Exposure Category C.
- Topographic Category 1.
- Crest Height 0.00 ft.
- Nominal ice thickness of 0.7500 in.
- Ice thickness is considered to increase with height.
- Ice density of 56 pcf.
- A wind speed of 50 mph is used in combination with ice.
- Temperature drop of 50 °F.
- Deflections calculated using a wind speed of 60 mph.
- 0.375" Used for Section 2 thickness to take into account plate reinforcements.
- A non-linear (P-delta) analysis was used.
- Pressures are calculated at each section.
- Stress ratio used in pole design is 1.
- Local bending stresses due to climbing loads, feed line supports, and appurtenance mounts are not considered.

## Options

- |  |   |   |
|--|---|---|
| <ul style="list-style-type: none"> <li>Consider Moments - Legs</li> <li>Consider Moments - Horizontals</li> <li>Consider Moments - Diagonals</li> <li>Use Moment Magnification</li> <li>√ Use Code Stress Ratios</li> <li>√ Use Code Safety Factors - Guys</li> <li>Escalate Ice</li> <li>Always Use Max Kz</li> <li>Use Special Wind Profile</li> <li>Include Bolts In Member Capacity</li> <li>Leg Bolts Are At Top Of Section</li> <li>Secondary Horizontal Braces Leg</li> <li>Use Diamond Inner Bracing (4 Sided)</li> <li>SR Members Have Cut Ends</li> <li>SR Members Are Concentric</li> </ul> | <ul style="list-style-type: none"> <li>Distribute Leg Loads As Uniform</li> <li>Assume Legs Pinned</li> <li>√ Assume Rigid Index Plate</li> <li>Use Clear Spans For Wind Area</li> <li>Use Clear Spans For KL/r</li> <li>Retension Guys To Initial Tension</li> <li>Bypass Mast Stability Checks</li> <li>Use Azimuth Dish Coefficients</li> <li>√ Project Wind Area of Appurt.</li> <li>Autocalc Torque Arm Areas</li> <li>Add IBC .6D+W Combination</li> <li>√ Sort Capacity Reports By Component</li> <li>Triangulate Diamond Inner Bracing</li> <li>Treat Feed Line Bundles As Cylinder</li> <li>Ignore KL/ry For 60 Deg. Angle Legs</li> </ul> | <ul style="list-style-type: none"> <li>Use ASCE 10 X-Brace Ly Rules</li> <li>Calculate Redundant Bracing Forces</li> <li>Ignore Redundant Members in FEA</li> <li>SR Leg Bolts Resist Compression</li> <li>All Leg Panels Have Same Allowable</li> <li>Offset Girt At Foundation</li> <li>√ Consider Feed Line Torque</li> <li>Include Angle Block Shear Check</li> <li>Use TIA-222-G Bracing Resist. Exemption</li> <li>Use TIA-222-G Tension Splice Exemption</li> <li style="text-align: center;">Poles</li> <li>Include Shear-Torsion Interaction</li> <li>Always Use Sub-Critical Flow</li> <li>Use Top Mounted Sockets</li> <li>Pole Without Linear Attachments</li> <li>Pole With Shroud Or No Appurtenances</li> <li>Outside and Inside Corner Radii Are Known</li> </ul> |
|--|---|---|

## Tapered Pole Section Geometry

Section	Elevation	Section Length	Splice Length	Number of Sides	Top Diameter	Bottom Diameter	Wall Thickness	Bend Radius	Pole Grade
	ft	ft	ft		in	in	in	in	
L1	76.00-50.00	26.00	0.00	16	11.9400	17.0920	0.1563	0.6252	A572-50

<b>tnxTower</b>  <b>Centek Engineering Inc.</b> 63-2 North Branford Rd. Branford, CT 06405 Phone: (203) 488-0580 FAX: (203) 488-8587	<b>Job</b> 21005.07 - CTNH833A	<b>Page</b> 2 of 17
	<b>Project</b> 76' Monopole - 250 Derby Ave., West Haven, CT	<b>Date</b> 11:31:27 08/16/21
	<b>Client</b> T-Mobile	<b>Designed by</b> TJL

Section	Elevation ft	Section Length ft	Splice Length ft	Number of Sides	Top Diameter in	Bottom Diameter in	Wall Thickness in	Bend Radius in	Pole Grade
L2	50.00-0.00	50.00		16	17.0920	27.0000	0.3750	1.5000	(50 ksi) A572-50 (50 ksi)

### Tapered Pole Properties

Section	Tip Dia. in	Area in <sup>2</sup>	I in <sup>4</sup>	r in	C in	I/C in <sup>3</sup>	J in <sup>4</sup>	It/Q in <sup>2</sup>	w in	w/t
L1	12.1433	5.8753	103.0645	4.1950	6.0894	16.9252	207.6895	2.9050	2.0650	13.212
	17.3962	8.4441	305.9662	6.0291	8.7169	35.1003	616.5651	4.1752	3.0903	19.771
L2	17.3534	19.9977	706.0108	5.9513	8.7169	80.9931	1422.7115	9.8878	2.6551	7.08
	27.4555	31.8502	2852.3654	9.4785	13.7700	207.1435	5747.9191	15.7482	4.6268	12.338

Tower Elevation ft	Gusset Area ft <sup>2</sup> (per face)	Gusset Thickness in	Gusset Grade	Adjust. Factor A <sub>f</sub>	Adjust. Factor A <sub>r</sub>	Weight Mult.	Double Angle Stitch Bolt Spacing Diagonals in	Double Angle Stitch Bolt Spacing Horizontals in	Double Angle Stitch Bolt Spacing Redundants in
L1 76.00-50.00				1	1	1			
L2 50.00-0.00				1	1	1			

### Feed Line/Linear Appurtenances - Entered As Area

Description	Face or Leg	Allow Shield	Exclude From Torque Calculation	Component Type	Placement ft	Total Number	C <sub>A</sub> A <sub>A</sub> ft <sup>2</sup> /ft	Weight plf
1 5/8 (T-Mobile Proposed)	C	No	No	Inside Pole	74.00 - 0.00	3	No Ice	1.04
							1/2" Ice	1.04
							1" Ice	1.04

### Feed Line/Linear Appurtenances Section Areas

Tower Section	Tower Elevation ft	Face	A <sub>R</sub> ft <sup>2</sup>	A <sub>F</sub> ft <sup>2</sup>	C <sub>A</sub> A <sub>A</sub> In Face ft <sup>2</sup>	C <sub>A</sub> A <sub>A</sub> Out Face ft <sup>2</sup>	Weight K
L1	76.00-50.00	A	0.000	0.000	0.000	0.000	0.00
		B	0.000	0.000	0.000	0.000	0.00
		C	0.000	0.000	0.000	0.000	0.07
L2	50.00-0.00	A	0.000	0.000	0.000	0.000	0.00
		B	0.000	0.000	0.000	0.000	0.00
		C	0.000	0.000	0.000	0.000	0.16

### Feed Line/Linear Appurtenances Section Areas - With Ice

<b>tnxTower</b>  <b>Centek Engineering Inc.</b> 63-2 North Branford Rd. Branford, CT 06405 Phone: (203) 488-0580 FAX: (203) 488-8587	<b>Job</b> 21005.07 - CTNH833A	<b>Page</b> 3 of 17
	<b>Project</b> 76' Monopole - 250 Derby Ave., West Haven, CT	<b>Date</b> 11:31:27 08/16/21
	<b>Client</b> T-Mobile	<b>Designed by</b> TJL

Tower Section	Tower Elevation ft	Face or Leg	Ice Thickness in	A <sub>R</sub> ft <sup>2</sup>	A <sub>F</sub> ft <sup>2</sup>	C <sub>AA</sub> In Face ft <sup>2</sup>	C <sub>AA</sub> Out Face ft <sup>2</sup>	Weight K
L1	76.00-50.00	A	1.598	0.000	0.000	0.000	0.000	0.00
		B		0.000	0.000	0.000	0.000	0.00
		C		0.000	0.000	0.000	0.000	0.07
L2	50.00-0.00	A	1.455	0.000	0.000	0.000	0.000	0.00
		B		0.000	0.000	0.000	0.000	0.00
		C		0.000	0.000	0.000	0.000	0.16

### Feed Line Center of Pressure

Section	Elevation ft	CP <sub>X</sub> in	CP <sub>Z</sub> in	CP <sub>X</sub> Ice in	CP <sub>Z</sub> Ice in
L1	76.00-50.00	0.0000	0.0000	0.0000	0.0000
L2	50.00-0.00	0.0000	0.0000	0.0000	0.0000

Note: For pole sections, center of pressure calculations do not consider feed line shielding.

### Discrete Tower Loads

Description	Face or Leg	Offset Type	Offsets: Horz Lateral Vert ft ft ft	Azimuth Adjustment °	Placement ft	C <sub>AA</sub> Front ft <sup>2</sup>	C <sub>AA</sub> Side ft <sup>2</sup>	Weight K	
AIR6449 (T-Mobile Propoed)	A	From Face	4.00	0.0000	74.00	No Ice	5.65	2.42	0.10
			-2.00			1/2" Ice	5.96	2.64	0.14
			0.00			1" Ice	6.26	2.87	0.18
APXVAALL18-43 (T-Mobile Propoed)	A	From Face	4.00	0.0000	74.00	No Ice	14.67	6.16	0.13
			2.00			1/2" Ice	15.18	6.62	0.22
			0.00			1" Ice	15.71	7.09	0.31
AIR6449 (T-Mobile Propoed)	B	From Face	4.00	0.0000	74.00	No Ice	5.65	2.42	0.10
			-2.00			1/2" Ice	5.96	2.64	0.14
			0.00			1" Ice	6.26	2.87	0.18
APXVAALL18-43 (T-Mobile Propoed)	B	From Face	4.00	0.0000	74.00	No Ice	14.67	6.16	0.13
			2.00			1/2" Ice	15.18	6.62	0.22
			0.00			1" Ice	15.71	7.09	0.31
AIR6449 (T-Mobile Propoed)	C	From Face	4.00	0.0000	74.00	No Ice	5.65	2.42	0.10
			-2.00			1/2" Ice	5.96	2.64	0.14
			0.00			1" Ice	6.26	2.87	0.18
APXVAALL18-43 (T-Mobile Propoed)	C	From Face	4.00	0.0000	74.00	No Ice	14.67	6.16	0.13
			2.00			1/2" Ice	15.18	6.62	0.22
			0.00			1" Ice	15.71	7.09	0.31
4460 B25+B66 (T-Mobile Propoed)	A	From Face	4.00	0.0000	74.00	No Ice	2.56	1.98	0.11
			2.00			1/2" Ice	2.76	2.16	0.13
			0.00			1" Ice	2.97	2.34	0.16
4460 B25+B66 (T-Mobile Propoed)	B	From Face	4.00	0.0000	74.00	No Ice	2.56	1.98	0.11
			2.00			1/2" Ice	2.76	2.16	0.13
			0.00			1" Ice	2.97	2.34	0.16

<b>tnxTower</b>  <b>Centek Engineering Inc.</b> 63-2 North Branford Rd. Branford, CT 06405 Phone: (203) 488-0580 FAX: (203) 488-8587	<b>Job</b> 21005.07 - CTNH833A	<b>Page</b> 4 of 17
	<b>Project</b> 76' Monopole - 250 Derby Ave., West Haven, CT	<b>Date</b> 11:31:27 08/16/21
	<b>Client</b> T-Mobile	<b>Designed by</b> TJJ

Description	Face or Leg	Offset Type	Offsets:		Azimuth Adjustment	Placement	CAA		Weight
			Horz Lateral	Vert			Front	Side	
			ft	ft	°	ft	ft <sup>2</sup>	ft <sup>2</sup>	K
4460 B25+B66 (T-Mobile Propoed)	C	From Face	4.00	0.0000	74.00	No Ice	2.56	1.98	0.11
			2.00	0.0000		1/2" Ice	2.76	2.16	0.13
			0.00	0.0000		1" Ice	2.97	2.34	0.16
4480 B71+B85 (T-Mobile Propoed)	A	From Face	4.00	0.0000	74.00	No Ice	2.85	1.38	0.08
			2.00	0.0000		1/2" Ice	3.06	1.54	0.11
			0.00	0.0000		1" Ice	3.28	1.71	0.13
4480 B71+B85 (T-Mobile Propoed)	B	From Face	4.00	0.0000	74.00	No Ice	2.85	1.38	0.08
			2.00	0.0000		1/2" Ice	3.06	1.54	0.11
			0.00	0.0000		1" Ice	3.28	1.71	0.13
4480 B71+B85 (T-Mobile Propoed)	C	From Face	4.00	0.0000	74.00	No Ice	2.85	1.38	0.08
			2.00	0.0000		1/2" Ice	3.06	1.54	0.11
			0.00	0.0000		1" Ice	3.28	1.71	0.13
SDX1926Q-43 (T-Mobile Propoed)	A	From Face	4.00	0.0000	74.00	No Ice	0.24	0.10	0.03
			2.00	0.0000		1/2" Ice	0.31	0.14	0.03
			0.00	0.0000		1" Ice	0.38	0.19	0.04
SDX1926Q-43 (T-Mobile Propoed)	B	From Face	4.00	0.0000	74.00	No Ice	0.24	0.10	0.03
			2.00	0.0000		1/2" Ice	0.31	0.14	0.03
			0.00	0.0000		1" Ice	0.38	0.19	0.04
SDX1926Q-43 (T-Mobile Propoed)	C	From Face	4.00	0.0000	74.00	No Ice	0.24	0.10	0.03
			2.00	0.0000		1/2" Ice	0.31	0.14	0.03
			0.00	0.0000		1" Ice	0.38	0.19	0.04
9' Platform and (5) 3' Side Arms (T-Mobile Existing)	C	None		0.0000	74.00	No Ice	30.00	30.00	1.00
				0.0000		1/2" Ice	36.00	36.00	1.20
				0.0000		1" Ice	42.00	42.00	1.40
10-ft long light bracket	A	From Leg	0.00	0.0000	73.00	No Ice	3.00	0.07	0.08
			0.00	0.0000		1/2" Ice	3.69	0.11	0.11
			0.00	0.0000		1" Ice	4.38	0.16	0.14
8-ft Light Bracket	A	From Leg	0.00	0.0000	70.00	No Ice	2.40	0.07	0.06
			0.00	0.0000		1/2" Ice	2.95	0.11	0.09
			0.00	0.0000		1" Ice	3.51	0.16	0.12

## Dishes

Description	Face or Leg	Dish Type	Offset Type	Offsets:		Azimuth Adjustment	3 dB Beam Width	Elevation	Outside Diameter	Aperture Area	Weight
				Horz Lateral	Vert						
				ft	°	°	ft	ft	ft <sup>2</sup>	K	
2-ft Dia. Light	A	Paraboloid w/o Radome	From Leg	2.00	Worst	73.00	2.00	No Ice	3.14	0.05	
				-5.00	Worst			1/2" Ice	3.41	0.07	
				0.00	Worst			1" Ice	3.68	0.09	
2-ft Dia. Light	A	Paraboloid w/o Radome	From Leg	2.00	Worst	73.00	2.00	No Ice	3.14	0.05	
				-2.00	Worst			1/2" Ice	3.41	0.07	
				0.00	Worst			1" Ice	3.68	0.09	
2-ft Dia. Light	A	Paraboloid w/o Radome	From Leg	2.00	Worst	73.00	2.00	No Ice	3.14	0.05	
				2.00	Worst			1/2" Ice	3.41	0.07	
				0.00	Worst			1" Ice	3.68	0.09	
2-ft Dia. Light	A	Paraboloid w/o Radome	From Leg	2.00	Worst	73.00	2.00	No Ice	3.14	0.05	
				5.00	Worst			1/2" Ice	3.41	0.07	
				0.00	Worst			1" Ice	3.68	0.09	
2-ft Dia. Light	A	Paraboloid w/o Radome	From Leg	2.00	Worst	70.00	2.00	No Ice	3.14	0.05	
					Worst			1/2" Ice	3.41	0.07	
					Worst			1" Ice	3.68	0.09	



<b>tnxTower</b>  <b>Centek Engineering Inc.</b> 63-2 North Branford Rd. Branford, CT 06405 Phone: (203) 488-0580 FAX: (203) 488-8587	<b>Job</b> 21005.07 - CTNH833A	<b>Page</b> 5 of 17
	<b>Project</b> 76' Monopole - 250 Derby Ave., West Haven, CT	<b>Date</b> 11:31:27 08/16/21
	<b>Client</b> T-Mobile	<b>Designed by</b> TJL

Description	Face or Leg	Dish Type	Offset Type	Offsets: Horz Lateral Vert ft	Azimuth Adjustment °	3 dB Beam Width °	Elevation ft	Outside Diameter ft	Aperture Area ft <sup>2</sup>	Weight K
		Radome	Leg	-3.00					1/2" Ice	0.07
				0.00					1" Ice	0.09
2-ft Dia. Light	A	Paraboloid w/o Radome	From Leg	2.00	Worst		70.00	2.00	No Ice	0.05
				0.00					1/2" Ice	0.07
				0.00					1" Ice	0.09
2-ft Dia. Light	A	Paraboloid w/o Radome	From Leg	2.00	Worst		70.00	2.00	No Ice	0.05
				3.00					1/2" Ice	0.07
				0.00					1" Ice	0.09

**Tower Pressures - No Ice**

$G_H = 1.100$

Section Elevation ft	z ft	K <sub>Z</sub>	q <sub>z</sub> psf	A <sub>G</sub> ft <sup>2</sup>	F a c e ft	A <sub>F</sub> ft <sup>2</sup>	A <sub>R</sub> ft <sup>2</sup>	A <sub>leg</sub> ft <sup>2</sup>	Leg %	C <sub>A</sub> A <sub>A</sub> In Face ft <sup>2</sup>	C <sub>A</sub> A <sub>A</sub> Out Face ft <sup>2</sup>
L1 76.00-50.00	62.23	1.145	26	32.001	A	0.000	32.001	32.001	100.00	0.000	0.000
					B	0.000	32.001		100.00	0.000	0.000
					C	0.000	32.001		100.00	0.000	0.000
L2 50.00-0.00	24.29	0.94	21	93.352	A	0.000	93.352	93.352	100.00	0.000	0.000
					B	0.000	93.352		100.00	0.000	0.000
					C	0.000	93.352		100.00	0.000	0.000

**Tower Pressure - With Ice**

$G_H = 1.100$

Section Elevation ft	z ft	K <sub>Z</sub>	q <sub>z</sub> psf	t <sub>z</sub> in	A <sub>G</sub> ft <sup>2</sup>	F a c e ft	A <sub>F</sub> ft <sup>2</sup>	A <sub>R</sub> ft <sup>2</sup>	A <sub>leg</sub> ft <sup>2</sup>	Leg %	C <sub>A</sub> A <sub>A</sub> In Face ft <sup>2</sup>	C <sub>A</sub> A <sub>A</sub> Out Face ft <sup>2</sup>
L1 76.00-50.00	62.23	1.145	7	1.5982	38.927	A	0.000	38.927	38.927	100.00	0.000	0.000
						B	0.000	38.927		100.00	0.000	0.000
						C	0.000	38.927		100.00	0.000	0.000
L2 50.00-0.00	24.29	0.94	6	1.4547	105.475	A	0.000	105.475	105.475	100.00	0.000	0.000
						B	0.000	105.475		100.00	0.000	0.000
						C	0.000	105.475		100.00	0.000	0.000

**Tower Pressure - Service**

$G_H = 1.100$

Section Elevation ft	z ft	K <sub>Z</sub>	q <sub>z</sub> psf	A <sub>G</sub> ft <sup>2</sup>	F a c e ft	A <sub>F</sub> ft <sup>2</sup>	A <sub>R</sub> ft <sup>2</sup>	A <sub>leg</sub> ft <sup>2</sup>	Leg %	C <sub>A</sub> A <sub>A</sub> In Face ft <sup>2</sup>	C <sub>A</sub> A <sub>A</sub> Out Face ft <sup>2</sup>
----------------------	------	----------------	--------------------	--------------------------------	------------	--------------------------------	--------------------------------	----------------------------------	-------	---	--

<b>tnxTower</b>  <b>Centek Engineering Inc.</b> 63-2 North Branford Rd. Branford, CT 06405 Phone: (203) 488-0580 FAX: (203) 488-8587	<b>Job</b> 21005.07 - CTNH833A	<b>Page</b> 6 of 17
	<b>Project</b> 76' Monopole - 250 Derby Ave., West Haven, CT	<b>Date</b> 11:31:27 08/16/21
	<b>Client</b> T-Mobile	<b>Designed by</b> TJJ

Section Elevation ft	z ft	K <sub>Z</sub>	q <sub>z</sub> psf	A <sub>G</sub> ft <sup>2</sup>	F <sub>a c e</sub>	A <sub>F</sub> ft <sup>2</sup>	A <sub>R</sub> ft <sup>2</sup>	A <sub>leg</sub> ft <sup>2</sup>	Leg %	C <sub>AA</sub> In Face ft <sup>2</sup>	C <sub>AA</sub> Out Face ft <sup>2</sup>
L1 76.00-50.00	62.23	1.145	9	32.001	A	0.000	32.001	32.001	100.00	0.000	0.000
					B	0.000	32.001		100.00	0.000	0.000
					C	0.000	32.001		100.00	0.000	0.000
L2 50.00-0.00	24.29	0.94	7	93.352	A	0.000	93.352	93.352	100.00	0.000	0.000
					B	0.000	93.352		100.00	0.000	0.000
					C	0.000	93.352		100.00	0.000	0.000

### Tower Forces - No Ice - Wind Normal To Face

Section Elevation ft	Add Weight K	Self Weight K	F <sub>a c e</sub>	e	C <sub>F</sub>	q <sub>z</sub> psf	D <sub>F</sub>	D <sub>R</sub>	A <sub>E</sub> ft <sup>2</sup>	F K	w plf	Ctrl. Face
L1 76.00-50.00	0.07	0.63	A	1	0.75	26	1	1	32.001	0.69	26.61	C
			B	1	0.75		1	1	32.001			
			C	1	0.75		1	1	32.001			
L2 50.00-0.00	0.16	4.41	A	1	0.75	21	1	1	93.352	1.64	32.72	C
			B	1	0.75		1	1	93.352			
			C	1	0.75		1	1	93.352			
Sum Weight:	0.23	5.04						OTM	82.79 kip-ft	2.33		

### Tower Forces - No Ice - Wind 60 To Face

Section Elevation ft	Add Weight K	Self Weight K	F <sub>a c e</sub>	e	C <sub>F</sub>	q <sub>z</sub> psf	D <sub>F</sub>	D <sub>R</sub>	A <sub>E</sub> ft <sup>2</sup>	F K	w plf	Ctrl. Face
L1 76.00-50.00	0.07	0.63	A	1	0.75	26	1	1	32.001	0.69	26.61	C
			B	1	0.75		1	1	32.001			
			C	1	0.75		1	1	32.001			
L2 50.00-0.00	0.16	4.41	A	1	0.75	21	1	1	93.352	1.64	32.72	C
			B	1	0.75		1	1	93.352			
			C	1	0.75		1	1	93.352			
Sum Weight:	0.23	5.04						OTM	82.79 kip-ft	2.33		

### Tower Forces - No Ice - Wind 90 To Face

Section Elevation ft	Add Weight K	Self Weight K	F <sub>a c e</sub>	e	C <sub>F</sub>	q <sub>z</sub> psf	D <sub>F</sub>	D <sub>R</sub>	A <sub>E</sub> ft <sup>2</sup>	F K	w plf	Ctrl. Face
L1 76.00-50.00	0.07	0.63	A	1	0.75	26	1	1	32.001	0.69	26.61	C
			B	1	0.75		1	1	32.001			
			C	1	0.75		1	1	32.001			

<b>tnxTower</b>  <b>Centek Engineering Inc.</b> 63-2 North Branford Rd. Branford, CT 06405 Phone: (203) 488-0580 FAX: (203) 488-8587	<b>Job</b>	21005.07 - CTNH833A	<b>Page</b>	7 of 17
	<b>Project</b>	76' Monopole - 250 Derby Ave., West Haven, CT	<b>Date</b>	11:31:27 08/16/21
	<b>Client</b>	T-Mobile	<b>Designed by</b>	TJL

Section Elevation ft	Add Weight K	Self Weight K	F a c e	e	C <sub>F</sub>	q <sub>z</sub> psf	D <sub>F</sub>	D <sub>R</sub>	A <sub>E</sub> ft <sup>2</sup>	F K	w plf	Ctrl. Face
L2 50.00-0.00	0.16	4.41	A	1	0.75	21	1	1	93.352	1.64	32.72	C
			B	1	0.75		1	1	93.352			
			C	1	0.75		1	1	93.352			
Sum Weight:	0.23	5.04						OTM	82.79 kip-ft	2.33		

### Tower Forces - With Ice - Wind Normal To Face

Section Elevation ft	Add Weight K	Self Weight K	F a c e	e	C <sub>F</sub>	q <sub>z</sub> psf	D <sub>F</sub>	D <sub>R</sub>	A <sub>E</sub> ft <sup>2</sup>	F K	w plf	Ctrl. Face
L1 76.00-50.00	0.07	1.46	A	1	1.2	7	1	1	38.927	0.36	13.76	C
			B	1	1.2		1	1	38.927			
			C	1	1.2		1	1	38.927			
L2 50.00-0.00	0.16	6.53	A	1	1.2	6	1	1	105.475	0.79	15.72	C
			B	1	1.2		1	1	105.475			
			C	1	1.2		1	1	105.475			
Sum Weight:	0.23	8.00						OTM	41.35 kip-ft	1.14		

### Tower Forces - With Ice - Wind 60 To Face

Section Elevation ft	Add Weight K	Self Weight K	F a c e	e	C <sub>F</sub>	q <sub>z</sub> psf	D <sub>F</sub>	D <sub>R</sub>	A <sub>E</sub> ft <sup>2</sup>	F K	w plf	Ctrl. Face
L1 76.00-50.00	0.07	1.46	A	1	1.2	7	1	1	38.927	0.36	13.76	C
			B	1	1.2		1	1	38.927			
			C	1	1.2		1	1	38.927			
L2 50.00-0.00	0.16	6.53	A	1	1.2	6	1	1	105.475	0.79	15.72	C
			B	1	1.2		1	1	105.475			
			C	1	1.2		1	1	105.475			
Sum Weight:	0.23	8.00						OTM	41.35 kip-ft	1.14		

### Tower Forces - With Ice - Wind 90 To Face

Section Elevation ft	Add Weight K	Self Weight K	F a c e	e	C <sub>F</sub>	q <sub>z</sub> psf	D <sub>F</sub>	D <sub>R</sub>	A <sub>E</sub> ft <sup>2</sup>	F K	w plf	Ctrl. Face
L1 76.00-50.00	0.07	1.46	A	1	1.2	7	1	1	38.927	0.36	13.76	C
			B	1	1.2		1	1	38.927			

<b>tnxTower</b>  <b>Centek Engineering Inc.</b> 63-2 North Branford Rd. Branford, CT 06405 Phone: (203) 488-0580 FAX: (203) 488-8587	<b>Job</b> 21005.07 - CTNH833A	<b>Page</b> 8 of 17
	<b>Project</b> 76' Monopole - 250 Derby Ave., West Haven, CT	<b>Date</b> 11:31:27 08/16/21
	<b>Client</b> T-Mobile	<b>Designed by</b> TJJ

Section Elevation ft	Add Weight K	Self Weight K	F a c e	e	C <sub>F</sub>	q <sub>z</sub> psf	D <sub>F</sub>	D <sub>R</sub>	A <sub>E</sub> ft <sup>2</sup>	F K	w plf	Ctrl. Face
L2 50.00-0.00	0.16	6.53	C	1	1.2	6	1	1	38.927	0.79	15.72	C
			A	1	1.2		1	1	105.475			
			B	1	1.2		1	1	105.475			
			C	1	1.2		1	1	105.475			
Sum Weight:	0.23	8.00						OTM	41.35 kip-ft	1.14		

**Tower Forces - Service - Wind Normal To Face**

Section Elevation ft	Add Weight K	Self Weight K	F a c e	e	C <sub>F</sub>	q <sub>z</sub> psf	D <sub>F</sub>	D <sub>R</sub>	A <sub>E</sub> ft <sup>2</sup>	F K	w plf	Ctrl. Face
L1 76.00-50.00	0.07	0.63	A	1	0.75	9	1	1	32.001	0.24	9.11	C
			B	1	0.75		1	1	32.001			
			C	1	0.75		1	1	32.001			
L2 50.00-0.00	0.16	4.41	A	1	0.75	7	1	1	93.352	0.56	11.20	C
			B	1	0.75		1	1	93.352			
			C	1	0.75		1	1	93.352			
Sum Weight:	0.23	5.04						OTM	28.34 kip-ft	0.80		

**Tower Forces - Service - Wind 60 To Face**

Section Elevation ft	Add Weight K	Self Weight K	F a c e	e	C <sub>F</sub>	q <sub>z</sub> psf	D <sub>F</sub>	D <sub>R</sub>	A <sub>E</sub> ft <sup>2</sup>	F K	w plf	Ctrl. Face
L1 76.00-50.00	0.07	0.63	A	1	0.75	9	1	1	32.001	0.24	9.11	C
			B	1	0.75		1	1	32.001			
			C	1	0.75		1	1	32.001			
L2 50.00-0.00	0.16	4.41	A	1	0.75	7	1	1	93.352	0.56	11.20	C
			B	1	0.75		1	1	93.352			
			C	1	0.75		1	1	93.352			
Sum Weight:	0.23	5.04						OTM	28.34 kip-ft	0.80		

**Tower Forces - Service - Wind 90 To Face**

Section Elevation ft	Add Weight K	Self Weight K	F a c e	e	C <sub>F</sub>	q <sub>z</sub> psf	D <sub>F</sub>	D <sub>R</sub>	A <sub>E</sub> ft <sup>2</sup>	F K	w plf	Ctrl. Face
L1	0.07	0.63	A	1	0.75	9	1	1	32.001	0.24	9.11	C

<b>tnxTower</b>  <b>Centek Engineering Inc.</b> 63-2 North Branford Rd. Branford, CT 06405 Phone: (203) 488-0580 FAX: (203) 488-8587	<b>Job</b> 21005.07 - CTNH833A	<b>Page</b> 9 of 17
	<b>Project</b> 76' Monopole - 250 Derby Ave., West Haven, CT	<b>Date</b> 11:31:27 08/16/21
	<b>Client</b> T-Mobile	<b>Designed by</b> TJL

Section Elevation ft	Add Weight K	Self Weight K	F a c e	e	C <sub>F</sub>	q <sub>z</sub> psf	D <sub>F</sub>	D <sub>R</sub>	A <sub>E</sub> ft <sup>2</sup>	F K	w plf	Ctrl. Face
76.00-50.00			B	1	0.75		1	1	32.001			
			C	1	0.75		1	1	32.001			
L2 50.00-0.00	0.16	4.41	A	1	0.75	7	1	1	93.352	0.56	11.20	C
			B	1	0.75		1	1	93.352			
			C	1	0.75		1	1	93.352			
Sum Weight:	0.23	5.04						OTM	28.34 kip-ft	0.80		

### Force Totals

Load Case	Vertical Forces K	Sum of Forces X K	Sum of Forces Z K	Sum of Overturning Moments, M <sub>x</sub> kip-ft	Sum of Overturning Moments, M <sub>z</sub> kip-ft	Sum of Torques kip-ft
Leg Weight	5.04					
Bracing Weight	0.00					
Total Member Self-Weight	5.04			-0.96	0.00	
Total Weight	8.12			-0.96	0.00	
Wind 0 deg - No Ice		0.00	-5.61	-323.88	0.00	0.00
Wind 30 deg - No Ice		2.73	-4.86	-280.62	-155.87	-1.38
Wind 60 deg - No Ice		4.72	-2.81	-162.42	-269.98	-2.39
Wind 90 deg - No Ice		5.46	0.00	-0.96	-311.74	-2.75
Wind 120 deg - No Ice		4.72	2.81	160.50	-269.98	-2.39
Wind 150 deg - No Ice		2.73	4.86	278.69	-155.87	-1.38
Wind 180 deg - No Ice		0.00	5.61	321.96	0.00	0.00
Wind 210 deg - No Ice		-2.73	4.86	278.69	155.87	1.38
Wind 240 deg - No Ice		-4.72	2.81	160.50	269.98	2.39
Wind 270 deg - No Ice		-5.46	0.00	-0.96	311.74	2.75
Wind 300 deg - No Ice		-4.72	-2.81	-162.42	269.98	2.39
Wind 330 deg - No Ice		-2.73	-4.86	-280.62	155.87	1.38
Member Ice	2.95					
Total Weight Ice	14.32			-2.12	0.00	
Wind 0 deg - Ice		0.00	-2.32	-129.56	0.00	0.00
Wind 30 deg - Ice		1.12	-2.01	-112.48	-61.16	-0.47
Wind 60 deg - Ice		1.95	-1.16	-65.84	-105.94	-0.81
Wind 90 deg - Ice		2.25	0.00	-2.12	-122.32	-0.94
Wind 120 deg - Ice		1.95	1.16	61.59	-105.94	-0.81
Wind 150 deg - Ice		1.12	2.01	108.24	-61.16	-0.47
Wind 180 deg - Ice		0.00	2.32	125.31	0.00	0.00
Wind 210 deg - Ice		-1.12	2.01	108.24	61.16	0.47
Wind 240 deg - Ice		-1.95	1.16	61.59	105.94	0.81
Wind 270 deg - Ice		-2.25	0.00	-2.12	122.32	0.94
Wind 300 deg - Ice		-1.95	-1.16	-65.84	105.94	0.81
Wind 330 deg - Ice		-1.12	-2.01	-112.48	61.16	0.47
Total Weight	8.12			-0.96	0.00	
Wind 0 deg - Service		0.00	-1.92	-111.51	0.00	0.00
Wind 30 deg - Service		0.93	-1.66	-96.70	-53.36	-0.47
Wind 60 deg - Service		1.62	-0.96	-56.23	-92.42	-0.82
Wind 90 deg - Service		1.87	0.00	-0.96	-106.72	-0.94
Wind 120 deg - Service		1.62	0.96	54.31	-92.42	-0.82
Wind 150 deg - Service		0.93	1.66	94.78	-53.36	-0.47
Wind 180 deg - Service		0.00	1.92	109.59	0.00	0.00
Wind 210 deg - Service		-0.93	1.66	94.78	53.36	0.47
Wind 240 deg - Service		-1.62	0.96	54.31	92.42	0.82

<b>tnxTower</b>  <b>Centek Engineering Inc.</b> 63-2 North Branford Rd. Branford, CT 06405 Phone: (203) 488-0580 FAX: (203) 488-8587	<b>Job</b> 21005.07 - CTNH833A	<b>Page</b> 10 of 17
	<b>Project</b> 76' Monopole - 250 Derby Ave., West Haven, CT	<b>Date</b> 11:31:27 08/16/21
	<b>Client</b> T-Mobile	<b>Designed by</b> TJJ

Load Case	Vertical Forces K	Sum of Forces X K	Sum of Forces Z K	Sum of Overturning Moments, $M_x$ kip-ft	Sum of Overturning Moments, $M_z$ kip-ft	Sum of Torques kip-ft
Wind 270 deg - Service		-1.87	0.00	-0.96	106.72	0.94
Wind 300 deg - Service		-1.62	-0.96	-56.23	92.42	0.82
Wind 330 deg - Service		-0.93	-1.66	-96.70	53.36	0.47

## Load Combinations

Comb. No.	Description
1	Dead Only
2	1.2 Dead+1.6 Wind 0 deg - No Ice
3	0.9 Dead+1.6 Wind 0 deg - No Ice
4	1.2 Dead+1.6 Wind 30 deg - No Ice
5	0.9 Dead+1.6 Wind 30 deg - No Ice
6	1.2 Dead+1.6 Wind 60 deg - No Ice
7	0.9 Dead+1.6 Wind 60 deg - No Ice
8	1.2 Dead+1.6 Wind 90 deg - No Ice
9	0.9 Dead+1.6 Wind 90 deg - No Ice
10	1.2 Dead+1.6 Wind 120 deg - No Ice
11	0.9 Dead+1.6 Wind 120 deg - No Ice
12	1.2 Dead+1.6 Wind 150 deg - No Ice
13	0.9 Dead+1.6 Wind 150 deg - No Ice
14	1.2 Dead+1.6 Wind 180 deg - No Ice
15	0.9 Dead+1.6 Wind 180 deg - No Ice
16	1.2 Dead+1.6 Wind 210 deg - No Ice
17	0.9 Dead+1.6 Wind 210 deg - No Ice
18	1.2 Dead+1.6 Wind 240 deg - No Ice
19	0.9 Dead+1.6 Wind 240 deg - No Ice
20	1.2 Dead+1.6 Wind 270 deg - No Ice
21	0.9 Dead+1.6 Wind 270 deg - No Ice
22	1.2 Dead+1.6 Wind 300 deg - No Ice
23	0.9 Dead+1.6 Wind 300 deg - No Ice
24	1.2 Dead+1.6 Wind 330 deg - No Ice
25	0.9 Dead+1.6 Wind 330 deg - No Ice
26	1.2 Dead+1.0 Ice+1.0 Temp
27	1.2 Dead+1.0 Wind 0 deg+1.0 Ice+1.0 Temp
28	1.2 Dead+1.0 Wind 30 deg+1.0 Ice+1.0 Temp
29	1.2 Dead+1.0 Wind 60 deg+1.0 Ice+1.0 Temp
30	1.2 Dead+1.0 Wind 90 deg+1.0 Ice+1.0 Temp
31	1.2 Dead+1.0 Wind 120 deg+1.0 Ice+1.0 Temp
32	1.2 Dead+1.0 Wind 150 deg+1.0 Ice+1.0 Temp
33	1.2 Dead+1.0 Wind 180 deg+1.0 Ice+1.0 Temp
34	1.2 Dead+1.0 Wind 210 deg+1.0 Ice+1.0 Temp
35	1.2 Dead+1.0 Wind 240 deg+1.0 Ice+1.0 Temp
36	1.2 Dead+1.0 Wind 270 deg+1.0 Ice+1.0 Temp
37	1.2 Dead+1.0 Wind 300 deg+1.0 Ice+1.0 Temp
38	1.2 Dead+1.0 Wind 330 deg+1.0 Ice+1.0 Temp
39	Dead+Wind 0 deg - Service
40	Dead+Wind 30 deg - Service
41	Dead+Wind 60 deg - Service
42	Dead+Wind 90 deg - Service
43	Dead+Wind 120 deg - Service
44	Dead+Wind 150 deg - Service
45	Dead+Wind 180 deg - Service
46	Dead+Wind 210 deg - Service
47	Dead+Wind 240 deg - Service
48	Dead+Wind 270 deg - Service

<b>tnxTower</b>  <b>Centek Engineering Inc.</b> 63-2 North Branford Rd. Branford, CT 06405 Phone: (203) 488-0580 FAX: (203) 488-8587	<b>Job</b> 21005.07 - CTNH833A	<b>Page</b> 11 of 17
	<b>Project</b> 76' Monopole - 250 Derby Ave., West Haven, CT	<b>Date</b> 11:31:27 08/16/21
	<b>Client</b> T-Mobile	<b>Designed by</b> TJL

Comb. No.	Description
49	Dead+Wind 300 deg - Service
50	Dead+Wind 330 deg - Service

### Maximum Member Forces

Section No.	Elevation ft	Component Type	Condition	Gov. Load Comb.	Axial K	Major Axis Moment kip-ft	Minor Axis Moment kip-ft
L1	76 - 50	Pole	Max Tension	27	0.00	0.00	-0.00
			Max. Compression	26	-8.34	0.00	2.51
			Max. Mx	8	-3.95	-135.64	1.10
			Max. My	2	-3.92	0.00	142.44
			Max. Vy	8	6.32	-135.64	1.10
			Max. Vx	2	-6.57	0.00	142.44
L2	50 - 0	Pole	Max. Torque	9			4.37
			Max Tension	1	0.00	0.00	0.00
			Max. Compression	26	-15.94	0.00	2.59
			Max. Mx	8	-9.73	-511.65	1.19
			Max. My	2	-9.73	0.00	531.20
			Max. Vy	8	8.74	-511.65	1.19
			Max. Vx	2	-8.99	0.00	531.20
		Max. Torque	21			-4.35	

### Maximum Reactions

Location	Condition	Gov. Load Comb.	Vertical K	Horizontal, X K	Horizontal, Z K
Pole	Max. Vert	27	15.94	0.00	2.32
	Max. H <sub>x</sub>	21	7.30	8.73	0.00
	Max. H <sub>z</sub>	2	9.74	0.00	8.98
	Max. M <sub>x</sub>	2	531.20	0.00	8.98
	Max. M <sub>z</sub>	8	511.65	-8.73	0.00
	Max. Torsion	9	4.35	-8.73	0.00
	Min. Vert	11	7.30	-7.56	-4.49
	Min. H <sub>x</sub>	8	9.74	-8.73	0.00
	Min. H <sub>z</sub>	14	9.74	0.00	-8.98
	Min. M <sub>x</sub>	14	-528.78	0.00	-8.98
	Min. M <sub>z</sub>	20	-511.65	8.73	0.00
	Min. Torsion	21	-4.35	8.73	0.00

### Tower Mast Reaction Summary

Load Combination	Vertical K	Shear <sub>x</sub> K	Shear <sub>z</sub> K	Overturning Moment, M <sub>x</sub> kip-ft	Overturning Moment, M <sub>z</sub> kip-ft	Torque kip-ft
Dead Only	8.12	0.00	0.00	-1.00	0.00	0.00
1.2 Dead+1.6 Wind 0 deg - No Ice	9.74	0.00	-8.98	-531.20	0.00	0.00
0.9 Dead+1.6 Wind 0 deg - No Ice	7.30	0.00	-8.98	-527.34	0.00	0.00

<b>tnxTower</b>  <b>Centek Engineering Inc.</b> 63-2 North Branford Rd. Branford, CT 06405 Phone: (203) 488-0580 FAX: (203) 488-8587	<b>Job</b>	21005.07 - CTNH833A	<b>Page</b>	12 of 17
	<b>Project</b>	76' Monopole - 250 Derby Ave., West Haven, CT	<b>Date</b>	11:31:27 08/16/21
	<b>Client</b>	T-Mobile	<b>Designed by</b>	TJL

Load Combination	Vertical K	Shear <sub>x</sub> K	Shear <sub>z</sub> K	Overturning Moment, M <sub>x</sub> kip-ft	Overturning Moment, M <sub>z</sub> kip-ft	Torque kip-ft
1.2 Dead+1.6 Wind 30 deg - No Ice	9.74	4.36	-7.78	-460.20	-255.82	-2.17
0.9 Dead+1.6 Wind 30 deg - No Ice	7.30	4.36	-7.78	-456.82	-254.11	-2.17
1.2 Dead+1.6 Wind 60 deg - No Ice	9.74	7.56	-4.49	-266.21	-443.11	-3.75
0.9 Dead+1.6 Wind 60 deg - No Ice	7.30	7.56	-4.49	-264.12	-440.15	-3.76
1.2 Dead+1.6 Wind 90 deg - No Ice	9.74	8.73	-0.00	-1.19	-511.65	-4.34
0.9 Dead+1.6 Wind 90 deg - No Ice	7.30	8.73	0.00	-0.88	-508.24	-4.35
1.2 Dead+1.6 Wind 120 deg - No Ice	9.74	7.56	4.49	263.81	-443.09	-3.76
0.9 Dead+1.6 Wind 120 deg - No Ice	7.30	7.56	4.49	262.35	-440.13	-3.76
1.2 Dead+1.6 Wind 150 deg - No Ice	9.74	4.36	7.78	457.79	-255.80	-2.17
0.9 Dead+1.6 Wind 150 deg - No Ice	7.30	4.36	7.78	455.03	-254.10	-2.17
1.2 Dead+1.6 Wind 180 deg - No Ice	9.74	0.00	8.98	528.78	0.00	0.00
0.9 Dead+1.6 Wind 180 deg - No Ice	7.30	0.00	8.98	525.55	0.00	0.00
1.2 Dead+1.6 Wind 210 deg - No Ice	9.74	-4.36	7.78	457.79	255.80	2.17
0.9 Dead+1.6 Wind 210 deg - No Ice	7.30	-4.36	7.78	455.03	254.10	2.17
1.2 Dead+1.6 Wind 240 deg - No Ice	9.74	-7.56	4.49	263.81	443.09	3.76
0.9 Dead+1.6 Wind 240 deg - No Ice	7.30	-7.56	4.49	262.35	440.13	3.76
1.2 Dead+1.6 Wind 270 deg - No Ice	9.74	-8.73	-0.00	-1.19	511.65	4.34
0.9 Dead+1.6 Wind 270 deg - No Ice	7.30	-8.73	0.00	-0.88	508.24	4.35
1.2 Dead+1.6 Wind 300 deg - No Ice	9.74	-7.56	-4.49	-266.21	443.11	3.75
0.9 Dead+1.6 Wind 300 deg - No Ice	7.30	-7.56	-4.49	-264.12	440.15	3.76
1.2 Dead+1.6 Wind 330 deg - No Ice	9.74	-4.36	-7.78	-460.20	255.82	2.17
0.9 Dead+1.6 Wind 330 deg - No Ice	7.30	-4.36	-7.78	-456.82	254.11	2.17
1.2 Dead+1.0 Ice+1.0 Temp	15.94	0.00	-0.00	-2.59	0.00	0.00
1.2 Dead+1.0 Wind 0 deg+1.0 Ice+1.0 Temp	15.94	0.00	-2.32	-136.53	0.00	0.00
1.2 Dead+1.0 Wind 30 deg+1.0 Ice+1.0 Temp	15.94	1.12	-2.01	-118.58	-64.27	-0.46
1.2 Dead+1.0 Wind 60 deg+1.0 Ice+1.0 Temp	15.94	1.95	-1.16	-69.56	-111.31	-0.80
1.2 Dead+1.0 Wind 90 deg+1.0 Ice+1.0 Temp	15.94	2.25	-0.00	-2.60	-128.53	-0.92
1.2 Dead+1.0 Wind 120 deg+1.0 Ice+1.0 Temp	15.94	1.95	1.16	64.37	-111.31	-0.80
1.2 Dead+1.0 Wind 150 deg+1.0 Ice+1.0 Temp	15.94	1.12	2.01	113.39	-64.26	-0.46
1.2 Dead+1.0 Wind 180 deg+1.0 Ice+1.0 Temp	15.94	0.00	2.32	131.33	0.00	0.00
1.2 Dead+1.0 Wind 210 deg+1.0 Ice+1.0 Temp	15.94	-1.12	2.01	113.39	64.26	0.46



<b>tnxTower</b>  <b>Centek Engineering Inc.</b> 63-2 North Branford Rd. Branford, CT 06405 Phone: (203) 488-0580 FAX: (203) 488-8587	<b>Job</b> 21005.07 - CTNH833A	<b>Page</b> 13 of 17
	<b>Project</b> 76' Monopole - 250 Derby Ave., West Haven, CT	<b>Date</b> 11:31:27 08/16/21
	<b>Client</b> T-Mobile	<b>Designed by</b> TJL

Load Combination	Vertical	Shear <sub>x</sub>	Shear <sub>z</sub>	Overturning Moment, M <sub>x</sub>	Overturning Moment, M <sub>z</sub>	Torque
	K	K	K	kip-ft	kip-ft	kip-ft
1.2 Dead+1.0 Wind 240 deg+1.0 Ice+1.0 Temp	15.94	-1.95	1.16	64.37	111.31	0.80
1.2 Dead+1.0 Wind 270 deg+1.0 Ice+1.0 Temp	15.94	-2.25	-0.00	-2.60	128.53	0.92
1.2 Dead+1.0 Wind 300 deg+1.0 Ice+1.0 Temp	15.94	-1.95	-1.16	-69.56	111.31	0.80
1.2 Dead+1.0 Wind 330 deg+1.0 Ice+1.0 Temp	15.94	-1.12	-2.01	-118.58	64.27	0.46
Dead+Wind 0 deg - Service	8.12	0.00	-1.92	-114.01	0.00	0.00
Dead+Wind 30 deg - Service	8.12	0.93	-1.66	-98.87	-54.54	-0.47
Dead+Wind 60 deg - Service	8.12	1.62	-0.96	-57.51	-94.47	-0.81
Dead+Wind 90 deg - Service	8.12	1.87	-0.00	-1.01	-109.08	-0.94
Dead+Wind 120 deg - Service	8.12	1.62	0.96	55.49	-94.47	-0.81
Dead+Wind 150 deg - Service	8.12	0.93	1.66	96.85	-54.54	-0.47
Dead+Wind 180 deg - Service	8.12	0.00	1.92	111.99	0.00	0.00
Dead+Wind 210 deg - Service	8.12	-0.93	1.66	96.85	54.54	0.47
Dead+Wind 240 deg - Service	8.12	-1.62	0.96	55.49	94.47	0.81
Dead+Wind 270 deg - Service	8.12	-1.87	-0.00	-1.01	109.08	0.94
Dead+Wind 300 deg - Service	8.12	-1.62	-0.96	-57.51	94.47	0.81
Dead+Wind 330 deg - Service	8.12	-0.93	-1.66	-98.87	54.54	0.47

## Solution Summary

Load Comb.	Sum of Applied Forces			Sum of Reactions			% Error
	PX K	PY K	PZ K	PX K	PY K	PZ K	
1	0.00	-8.12	0.00	0.00	8.12	0.00	0.000%
2	0.00	-9.74	-8.98	0.00	9.74	8.98	0.000%
3	0.00	-7.30	-8.98	0.00	7.30	8.98	0.000%
4	4.36	-9.74	-7.78	-4.36	9.74	7.78	0.000%
5	4.36	-7.30	-7.78	-4.36	7.30	7.78	0.000%
6	7.56	-9.74	-4.49	-7.56	9.74	4.49	0.000%
7	7.56	-7.30	-4.49	-7.56	7.30	4.49	0.000%
8	8.73	-9.74	0.00	-8.73	9.74	0.00	0.000%
9	8.73	-7.30	0.00	-8.73	7.30	0.00	0.000%
10	7.56	-9.74	4.49	-7.56	9.74	-4.49	0.000%
11	7.56	-7.30	4.49	-7.56	7.30	-4.49	0.000%
12	4.36	-9.74	7.78	-4.36	9.74	-7.78	0.000%
13	4.36	-7.30	7.78	-4.36	7.30	-7.78	0.000%
14	0.00	-9.74	8.98	0.00	9.74	-8.98	0.000%
15	0.00	-7.30	8.98	0.00	7.30	-8.98	0.000%
16	-4.36	-9.74	7.78	4.36	9.74	-7.78	0.000%
17	-4.36	-7.30	7.78	4.36	7.30	-7.78	0.000%
18	-7.56	-9.74	4.49	7.56	9.74	-4.49	0.000%
19	-7.56	-7.30	4.49	7.56	7.30	-4.49	0.000%
20	-8.73	-9.74	0.00	8.73	9.74	0.00	0.000%
21	-8.73	-7.30	0.00	8.73	7.30	0.00	0.000%
22	-7.56	-9.74	-4.49	7.56	9.74	4.49	0.000%
23	-7.56	-7.30	-4.49	7.56	7.30	4.49	0.000%
24	-4.36	-9.74	-7.78	4.36	9.74	7.78	0.000%
25	-4.36	-7.30	-7.78	4.36	7.30	7.78	0.000%
26	0.00	-15.94	0.00	0.00	15.94	0.00	0.000%
27	0.00	-15.94	-2.32	0.00	15.94	2.32	0.000%
28	1.12	-15.94	-2.01	-1.12	15.94	2.01	0.000%
29	1.95	-15.94	-1.16	-1.95	15.94	1.16	0.000%
30	2.25	-15.94	0.00	-2.25	15.94	0.00	0.000%
31	1.95	-15.94	1.16	-1.95	15.94	-1.16	0.000%
32	1.12	-15.94	2.01	-1.12	15.94	-2.01	0.000%

<b>tnxTower</b>  <b>Centek Engineering Inc.</b> 63-2 North Branford Rd. Branford, CT 06405 Phone: (203) 488-0580 FAX: (203) 488-8587	<b>Job</b>	21005.07 - CTNH833A	<b>Page</b>	14 of 17
	<b>Project</b>	76' Monopole - 250 Derby Ave., West Haven, CT	<b>Date</b>	11:31:27 08/16/21
	<b>Client</b>	T-Mobile	<b>Designed by</b>	TJL

Load Comb.	Sum of Applied Forces			Sum of Reactions			% Error
	PX K	PY K	PZ K	PX K	PY K	PZ K	
33	0.00	-15.94	2.32	0.00	15.94	-2.32	0.000%
34	-1.12	-15.94	2.01	1.12	15.94	-2.01	0.000%
35	-1.95	-15.94	1.16	1.95	15.94	-1.16	0.000%
36	-2.25	-15.94	0.00	2.25	15.94	0.00	0.000%
37	-1.95	-15.94	-1.16	1.95	15.94	1.16	0.000%
38	-1.12	-15.94	-2.01	1.12	15.94	2.01	0.000%
39	0.00	-8.12	-1.92	0.00	8.12	1.92	0.000%
40	0.93	-8.12	-1.66	-0.93	8.12	1.66	0.000%
41	1.62	-8.12	-0.96	-1.62	8.12	0.96	0.000%
42	1.87	-8.12	0.00	-1.87	8.12	0.00	0.000%
43	1.62	-8.12	0.96	-1.62	8.12	-0.96	0.000%
44	0.93	-8.12	1.66	-0.93	8.12	-1.66	0.000%
45	0.00	-8.12	1.92	0.00	8.12	-1.92	0.000%
46	-0.93	-8.12	1.66	0.93	8.12	-1.66	0.000%
47	-1.62	-8.12	0.96	1.62	8.12	-0.96	0.000%
48	-1.87	-8.12	0.00	1.87	8.12	0.00	0.000%
49	-1.62	-8.12	-0.96	1.62	8.12	0.96	0.000%
50	-0.93	-8.12	-1.66	0.93	8.12	1.66	0.000%

## Non-Linear Convergence Results

Load Combination	Converged?	Number of Cycles	Displacement Tolerance	Force Tolerance
1	Yes	4	0.0000001	0.0000001
2	Yes	4	0.0000001	0.00005534
3	Yes	4	0.0000001	0.0000001
4	Yes	5	0.0000001	0.00013106
5	Yes	5	0.0000001	0.00005406
6	Yes	5	0.0000001	0.00028692
7	Yes	5	0.0000001	0.00012488
8	Yes	5	0.0000001	0.00019073
9	Yes	5	0.0000001	0.00008407
10	Yes	5	0.0000001	0.00017329
11	Yes	5	0.0000001	0.00007632
12	Yes	5	0.0000001	0.00022344
13	Yes	5	0.0000001	0.00009597
14	Yes	4	0.0000001	0.00005585
15	Yes	4	0.0000001	0.0000001
16	Yes	5	0.0000001	0.00022344
17	Yes	5	0.0000001	0.00009597
18	Yes	5	0.0000001	0.00017329
19	Yes	5	0.0000001	0.00007632
20	Yes	5	0.0000001	0.00019073
21	Yes	5	0.0000001	0.00008407
22	Yes	5	0.0000001	0.00028692
23	Yes	5	0.0000001	0.00012488
24	Yes	5	0.0000001	0.00013106
25	Yes	5	0.0000001	0.00005406
26	Yes	4	0.0000001	0.00003505
27	Yes	4	0.0000001	0.00065894
28	Yes	4	0.0000001	0.00091161
29	Yes	5	0.0000001	0.00009285
30	Yes	5	0.0000001	0.00008227
31	Yes	4	0.0000001	0.00098631
32	Yes	4	0.0000001	0.00092923
33	Yes	4	0.0000001	0.00059114

<b>tnxTower</b>  <b>Centek Engineering Inc.</b> 63-2 North Branford Rd. Branford, CT 06405 Phone: (203) 488-0580 FAX: (203) 488-8587	<b>Job</b>	21005.07 - CTNH833A	<b>Page</b>	15 of 17
	<b>Project</b>	76' Monopole - 250 Derby Ave., West Haven, CT	<b>Date</b>	11:31:27 08/16/21
	<b>Client</b>	T-Mobile	<b>Designed by</b>	TJL

34	Yes	4	0.00000001	0.00092923
35	Yes	4	0.00000001	0.00098631
36	Yes	5	0.00000001	0.00008227
37	Yes	5	0.00000001	0.00009285
38	Yes	4	0.00000001	0.00091161
39	Yes	4	0.00000001	0.00000001
40	Yes	4	0.00000001	0.00015094
41	Yes	4	0.00000001	0.00033248
42	Yes	4	0.00000001	0.00033836
43	Yes	4	0.00000001	0.00026523
44	Yes	4	0.00000001	0.00020622
45	Yes	4	0.00000001	0.00000001
46	Yes	4	0.00000001	0.00020622
47	Yes	4	0.00000001	0.00026523
48	Yes	4	0.00000001	0.00033836
49	Yes	4	0.00000001	0.00033248
50	Yes	4	0.00000001	0.00015094

### Maximum Tower Deflections - Service Wind

Section No.	Elevation ft	Horz. Deflection in	Gov. Load Comb.	Tilt °	Twist °
L1	76 - 50	8.273	39	1.0929	0.0503
L2	50 - 0	3.218	39	0.6276	0.0124

### Critical Deflections and Radius of Curvature - Service Wind

Elevation ft	Appurtenance	Gov. Load Comb.	Deflection in	Tilt °	Twist °	Radius of Curvature ft
74.00	AIR6449	39	7.840	1.0553	0.0470	12159
73.00	2-ft Dia. Light	39	7.624	1.0365	0.0453	12159
70.00	2-ft Dia. Light	39	6.980	0.9804	0.0404	10133

### Maximum Tower Deflections - Design Wind

Section No.	Elevation ft	Horz. Deflection in	Gov. Load Comb.	Tilt °	Twist °
L1	76 - 50	38.173	2	4.9895	0.2343
L2	50 - 0	14.955	2	2.9107	0.0574

### Critical Deflections and Radius of Curvature - Design Wind

<b>tnxTower</b>  <b>Centek Engineering Inc.</b> 63-2 North Branford Rd. Branford, CT 06405 Phone: (203) 488-0580 FAX: (203) 488-8587	<b>Job</b> 21005.07 - CTNH833A	<b>Page</b> 16 of 17
	<b>Project</b> 76' Monopole - 250 Derby Ave., West Haven, CT	<b>Date</b> 11:31:27 08/16/21
	<b>Client</b> T-Mobile	<b>Designed by</b> TJJ

Elevation	Appurtenance	Gov. Load Comb.	Deflection	Tilt	Twist	Radius of Curvature
ft			in	°	°	ft
74.00	AIR6449	2	36.185	4.8222	0.2187	2688
73.00	2-ft Dia. Light	2	35.193	4.7387	0.2110	2688
70.00	2-ft Dia. Light	2	32.237	4.4887	0.1880	2240

### Compression Checks

### Pole Design Data

Section No.	Elevation	Size	L	L <sub>u</sub>	Kl/r	A	P <sub>u</sub>	φP <sub>n</sub>	Ratio P <sub>u</sub> / φP <sub>n</sub>
	ft		ft	ft		in <sup>2</sup>	K	K	
L1	76 - 50 (1)	TP17.092x11.94x0.1563	26.00	76.00	151.3	8.4441	-3.92	83.37	0.047
L2	50 - 0 (2)	TP27x17.092x0.375	50.00	76.00	96.2	31.8502	-9.73	770.51	0.013

### Pole Bending Design Data

Section No.	Elevation	Size	M <sub>ux</sub>	φM <sub>ux</sub>	Ratio M <sub>ux</sub> / φM <sub>ux</sub>	M <sub>uy</sub>	φM <sub>uy</sub>	Ratio M <sub>uy</sub> / φM <sub>uy</sub>
	ft		kip-ft	kip-ft		kip-ft	kip-ft	
L1	76 - 50 (1)	TP17.092x11.94x0.1563	142.44	167.16	0.852	0.00	167.16	0.000
L2	50 - 0 (2)	TP27x17.092x0.375	531.20	986.52	0.538	0.00	986.52	0.000

### Pole Shear Design Data

Section No.	Elevation	Size	Actual V <sub>u</sub>	φV <sub>n</sub>	Ratio V <sub>u</sub> / φV <sub>n</sub>	Actual T <sub>u</sub>	φT <sub>n</sub>	Ratio T <sub>u</sub> / φT <sub>n</sub>
	ft		K	K		kip-ft	kip-ft	
L1	76 - 50 (1)	TP17.092x11.94x0.1563	6.57	237.62	0.028	0.00	337.59	0.000
L2	50 - 0 (2)	TP27x17.092x0.375	8.99	910.12	0.010	0.00	1994.10	0.000

### Pole Interaction Design Data

Section No.	Elevation	Ratio P <sub>u</sub> / φP <sub>n</sub>	Ratio M <sub>ux</sub> / φM <sub>ux</sub>	Ratio M <sub>uy</sub> / φM <sub>uy</sub>	Ratio V <sub>u</sub> / φV <sub>n</sub>	Ratio T <sub>u</sub> / φT <sub>n</sub>	Comb. Stress Ratio	Allow. Stress Ratio	Criteria
	ft								
L1	76 - 50 (1)	0.047	0.852	0.000	0.028	0.000	0.900	1.000	4.8.2 ✓
L2	50 - 0 (2)	0.013	0.538	0.000	0.010	0.000	0.551	1.000	4.8.2 ✓

<b>tnxTower</b>  <b>Centek Engineering Inc.</b> 63-2 North Branford Rd. Branford, CT 06405 Phone: (203) 488-0580 FAX: (203) 488-8587	<b>Job</b> 21005.07 - CTNH833A	<b>Page</b> 17 of 17
	<b>Project</b> 76' Monopole - 250 Derby Ave., West Haven, CT	<b>Date</b> 11:31:27 08/16/21
	<b>Client</b> T-Mobile	<b>Designed by</b> TJL

Section No.	Elevation ft	Ratio $P_u$	Ratio $M_{ux}$	Ratio $M_{uy}$	Ratio $V_u$	Ratio $T_u$	Comb. Stress Ratio	Allow. Stress Ratio	Criteria
		$\phi P_n$	$\phi M_{nx}$	$\phi M_{ny}$	$\phi V_n$	$\phi T_n$			

### Section Capacity Table

Section No.	Elevation ft	Component Type	Size	Critical Element	P K	$\phi P_{allow}$ K	% Capacity	Pass Fail
L1	76 - 50	Pole	TP17.092x11.94x0.1563	1	-3.92	83.37	90.0	Pass
L2	50 - 0	Pole	TP27x17.092x0.375	2	-9.73	770.51	55.1	Pass
Summary								
Pole (L1)							90.0	Pass
<b>RATING =</b>							<b>90.0</b>	<b>Pass</b>

**Anchor Bolt and Base Plate Analysis:**

**Input Data:**

Tower Reactions:

Overturing Moment =	$M_U := 531\text{-ft-kips}$	(Input From trnTower)
Shear Force =	Shear := 9-kips	(Input From trnTower)
Axial Force =	$R_U := 10\text{-kips}$	(Input From trnTower)

Anchor Bolt Data:

ASTMA36

Number of Anchor Bolts =	$N := 8$	(User Input)
Diameter of Bolt Circle =	$D_{BC} := 35\text{-in}$	(User Input)
Bolt Ultimate Strength =	$F_U := 58\text{-ksi}$	(User Input)
Bolt Yield Strength =	$F_y := 36\text{-ksi}$	(User Input)
Bolt Modulus =	$E := 29000\text{-ksi}$	(User Input)
Diameter of Anchor Bolts =	$D := 2.25\text{-in}$	(User Input)
Threads per Inch =	$n := 4.5$	(User Input)
Top of Concrete to Bot Leveling Nut =	$l_{ar} := 2\text{-in}$	(User Input)
Anchor Rod Force Correction Factor =	$n_c := 1.05$	Table 2-1 Addendum 3

Base Plate Data:

ASTMA36

Plate Yield Strength =	$F_{yf} := 36\text{-ksi}$	(User Input)
Base Plate Thickness =	$t_{TP} := 2.0\text{-in}$	(User Input)
Base Plate Diameter =	$D_{OD} := 41\text{-in}$	(User Input)
Outer Pole Diameter =	$D_T := 27.0\text{-in}$	(User Input)
Pole Wall Thickness =	$t_T := 0.2188\text{-in}$	(User Input)
Pole Design Yield Strength =	$F_{yp} := 50\text{-ksi}$	(User Input)
	$\eta := 0.5$	For Ungrouted Base Plate per TIA-222-G Section 4.9.9

**Anchor Bolt Analysis:**

Gross Area of Bolt =	$A_g := \frac{\pi}{4} \cdot D^2 = 3.976 \cdot \text{in}^2$
Net Area of Bolt =	$A_n := \frac{\pi}{4} \cdot \left( D - \frac{0.9743 \cdot \text{in}}{n} \right)^2 = 3.248 \cdot \text{in}^2$
Tensile Root Diameter =	$d_{rt} := D - \frac{0.9743 \cdot \text{in}}{n} = 2.033 \cdot \text{in}$
Plastic Section Modulus =	$Z := \frac{d_{rt}^3}{6} = 1.401 \cdot \text{in}^3$
Maximum Anchor Rod Force =	$P_u := \frac{n_c \cdot \pi \cdot M_u}{N \cdot D_{BC}} + \frac{R_u}{N} = 76.3 \cdot \text{kips}$
Maximum Shear Force =	$V_u := \frac{\text{Shear}}{N} = 1.1 \cdot \text{kips}$
Design Tensile Strength =	$\Phi R_{nt} := 0.8 \cdot F_u \cdot A_n = 150.692 \cdot \text{k}$
Bolt % of Capacity =	$\frac{\left( P_u + \frac{V_u}{\eta} \right)}{\Phi R_{nt}} \cdot 100 = 52.1$
Condition1 =	Condition1 := if $\left[ \frac{\left( P_u + \frac{V_u}{\eta} \right)}{\Phi R_{nt}} \leq 1.00, \text{"OK"}, \text{"Overstressed"} \right]$
	Condition1 = "OK"
Design Shear Strength =	$\Phi R_{nv} := 0.75 \cdot 0.45 \cdot F_u \cdot A_g = 77.832 \cdot \text{k}$
Design Flexural Strength =	$\Phi R_{nm} := 0.9 \cdot F_y \cdot Z = 45.407 \cdot \text{in} \cdot \text{k}$
	$M_u := \begin{cases} 0 & \text{if } l_{ar} < D \\ 0.65 \cdot l_{ar} \cdot V_u & \text{otherwise} \end{cases} = 0 \cdot \text{in} \cdot \text{k}$
Bolt % of Capacity =	$\left[ \left( \frac{V_u}{\Phi R_{nv}} \right)^2 + \left( \frac{P_u}{\Phi R_{nt}} + \frac{M_u}{\Phi R_{nm}} \right)^2 \right] \cdot 100 = 25.7$
Condition2 =	Condition2 := if $\left[ \left( \frac{V_u}{\Phi R_{nv}} \right)^2 + \left( \frac{P_u}{\Phi R_{nt}} + \frac{M_u}{\Phi R_{nm}} \right)^2 \leq 1.00, \text{"OK"}, \text{"Overstressed"} \right]$
	Condition2 = "OK"

**Base Plate Analysis:**

Strength Resistance Factor for Yielding due to Bending =

$$\phi_b := 0.9$$

Strength Resistance Factor for Yielding due to Shear =

$$\phi_v := 1.0$$

Outside Fillet Horizontal Leg Dimension =

$$w_1 := 0.25 \text{ in}$$

Effective Pole Outside Diameter =

$$D_e := D_T + w_1 = 27.25 \text{ in}$$

Effective Base Plate Outside Diameter =

$$D_{oe} := \begin{cases} D_{OD} & \text{if } D_{OD} \leq (D_{BC} + 6 \cdot t_{TP}) \\ (D_{BC} + 6 \cdot t_{TP}) & \text{otherwise} \end{cases} = 41 \text{ in}$$

Half-Angle Between Radial Lines Extending from Pole  
 Centerline Through Midpoints Between Adjacent Anchor

$$\theta_1 := \frac{\pi}{N} = 0.393$$

Rods =

Angle Defining Limiting Effective Base Plate Width

$$\theta_2 := \text{asin}\left(\frac{12 \cdot t_{TP}}{D_{BC}}\right) = 0.756$$

Based on Plate Thickness =

Angle Defining Limiting Effective Base Plate Width  
 Based on Distance Between Anchor Rod Bolt Circle and

$$\theta_3 := \text{acos}\left(\frac{D_{BC} + D_e}{2 \cdot D_{BC}}\right) = 0.475$$

Effective Pole Outside Diameter =

Governing Angle Defining Effective Base Plate Width

$$\theta := \min(\theta_1, \theta_2, \theta_3) = 0.393$$

Resisting Bending =

Effective Moment Arm of Anchor Rod Force =

$$x := 0.5 \cdot (D_{BC} - D_e) = 3.875 \text{ in}$$

Effective Base Plate Width Resisting Bending from

$$B_{et} := D_{BC} \cdot \sin(\theta) = 13.394 \text{ in}$$

Transverse Bend Line =

Effective Base Plate Width Resisting Bending from

$$B_{er} := (D_{oe} - D_e) \cdot \sin(\theta) = 5.262 \text{ in}$$

Radial Bend Lines =

Total Effective Base Plate Width Resisting Bending =

$$B_{eff} := B_{et} + B_{er} = 18.656 \text{ in}$$

Required Base Plate Thickness =

$$t_{TP,Req} := \sqrt{\frac{4 \cdot P_u \cdot x}{\phi_b \cdot F_{yf} \cdot B_{eff}}} = 1.399 \text{ in}$$

Plate Bending Stress % of Capacity =

$$\frac{t_{TP,Req}}{t_{TP}} = 69.9\%$$

Condition2 =

$$\text{Condition3} := \text{if}\left(\frac{t_{TP,Req}}{t_{TP}} < 1.00, \text{"Ok"}, \text{"Overstressed"}\right)$$

Condition3 = "Ok"

Required Base Plate Thickness =

$$t_{TP,Req} := \frac{\phi_b \cdot t_T \cdot F_{yp}}{\phi_v \cdot 0.6 \cdot F_{yf}} = 0.456 \text{ in}$$

Plate Bending Stress % of Capacity =

$$\frac{t_{TP,Req}}{t_{TP}} = 22.8\%$$

Condition2 =

$$\text{Condition4} := \text{if}\left(\frac{t_{TP,Req}}{t_{TP}} < 1.00, \text{"Ok"}, \text{"Overstressed"}\right)$$

Condition4 = "Ok"



**Caisson Foundation:**

Input Data:

Shear Force =	S := 9k	<i>USER INPUT-FROM trnTower</i>
Overturing Moment =	M := 531ft-k	<i>USER INPUT-FROM trnTower</i>
Applied Axial Load =	A1 := 10k	<i>USER INPUT-FROM trnTower</i>
Bending Moment =	Mu := 557ft-k	<i>USER INPUT-FROM LPILE</i>
Moment Capacity =	Mn := 1750ft-k	<i>USER INPUT-FROM LPILE</i>
Foundation Diameter =	d := 5.0ft	<i>USER INPUT</i>
Overall Length of Caisson =	Lc := 20.0ft	<i>USER INPUT</i>
Depth From Top of Caisson to Grade =	Lpag := 1.0ft	<i>USER INPUT</i>
Number of Rebar =	n := 9	<i>USER INPUT</i>
Area of Rebar =	Ar := 1.560in <sup>2</sup>	<i>USER INPUT</i>
Rebar Yield Strength =	fy := 60ksi	<i>USER INPUT</i>
Concrete Comp Strength =	fc := 3ksi	<i>USER INPUT</i>

Check Moment Capacity:

Factor of Safety =	$FS := \frac{0.9 \cdot Mn}{Mu} = 2.8$
Factor of Safety Required =	FS <sub>reqd</sub> := 1
	FOSCheck := if(FS ≥ FS <sub>reqd</sub> , "OK", "NO GOOD")
	<b>FOSCheck = "OK"</b>

=====

LPILE Plus for Windows, Version 5.0 (5.0.47)

Analysis of Individual Piles and Drilled Shafts  
Subjected to Lateral Loading Using the p-y Method

(c) 1985-2010 by Ensoft, Inc.  
All Rights Reserved

=====

This program is licensed to:

TJL  
Centek Engineering

-----

Files Used for Analysis

-----

Path to file locations:

J:\Jobs\2100500.WI\07\_CTNH833A\_CT13XC264\05\_Structural\Tower Analysis\Backup  
Documentation\Rev (1)\Foundation\

Name of input data file: Caisson Analysis.lpd  
Name of output file: Caisson Analysis.lpo  
Name of plot output file: Caisson Analysis.lpp  
Name of runtime file: Caisson Analysis.lpr

-----

Time and Date of Analysis

-----

Date: August 16, 2021 Time: 11:34:37

-----

Problem Title

-----

21005.07 - CTNH833A

-----

Program Options

-----

Units Used in Computations - US Customary Units: Inches, Pounds

Basic Program Options:

Analysis Type 3:

- Computation of Nonlinear Bending Stiffness and Ultimate Bending Moment Capacity with Pile Response Computed Using Nonlinear EI

Computation Options:

- Only internally-generated p-y curves used in analysis
- Analysis does not use p-y multipliers (individual pile or shaft action only)
- Analysis assumes no shear resistance at pile tip
- Analysis for fixed-length pile or shaft only
- Analysis includes computation of foundation stiffness matrix elements
- Output pile response for full length of pile
- Analysis assumes no soil movements acting on pile
- No additional p-y curves to be computed at user-specified depths

Solution Control Parameters:

- Number of pile increments = 100
- Maximum number of iterations allowed = 100
- Deflection tolerance for convergence = 1.0000E-04 in
- Maximum allowable deflection = 1.0000E+02 in

Printing Options:

- Values of pile-head deflection, bending moment, shear force, and soil reaction are printed for full length of pile.
- Printing Increment (spacing of output points) = 8

-----  
Pile Structural Properties and Geometry  
-----

- Pile Length = 240.00 in
- Depth of ground surface below top of pile = 12.00 in
- Slope angle of ground surface = 0.00 deg.

Structural properties of pile defined using 2 points

Point No.	Point Depth in	Pile Diameter in	Moment of Inertia in**4	Pile Area Sq.in	Modulus of Elasticity lbs/Sq.in
1	0.0000	60.00000000	636172.5000	2827.4000	3122018.
2	240.0000	60.00000000	636172.5000	2827.4000	3122018.

Please note that because this analysis makes computations of ultimate moment capacity and pile response using nonlinear bending stiffness that the above values of moment of inertia and modulus of are not used for any computations other than total stress due to combined axial loading and bending.

-----  
 Soil and Rock Layering Information  
 -----

The soil profile is modelled using 1 layers

Layer 1 is sand, p-y criteria by Reese et al., 1974

Distance from top of pile to top of layer = 12.000 in  
 Distance from top of pile to bottom of layer = 240.000 in  
 p-y subgrade modulus k for top of soil layer = 0.000 lbs/in\*\*3  
 p-y subgrade modulus k for bottom of layer = 0.000 lbs/in\*\*3

NOTE: Internal default values for p-y subgrade modulus will be computed for the above soil layer.

(Depth of lowest layer extends 0.00 in below pile tip)

-----  
 Effective Unit Weight of Soil vs. Depth  
 -----

Effective unit weight of soil with depth defined using 2 points

Point No.	Depth X in	Eff. Unit Weight lbs/in**3
1	12.00	0.07200
2	240.00	0.07200

-----  
 Shear Strength of Soils  
 -----

Shear strength parameters with depth defined using 2 points

Point No.	Depth X in	Cohesion c lbs/in**2	Angle of Friction Deg.	E50 or k <sub>rm</sub>	RQD %
1	12.000	0.00000	34.00	-----	-----
2	240.000	0.00000	34.00	-----	-----

Notes:

- (1) Cohesion = uniaxial compressive strength for rock materials.
- (2) Values of E50 are reported for clay strata.

- (3) Default values will be generated for E50 when input values are 0.
- (4) RQD and  $k_{rm}$  are reported only for weak rock strata.

---

Loading Type

---

Static loading criteria was used for computation of p-y curves.

---

Pile-head Loading and Pile-head Fixity Conditions

---

Number of loads specified = 2

Load Case Number 1

Pile-head boundary conditions are Shear and Moment (BC Type 1)

Shear force at pile head = 9000.000 lbs

Bending moment at pile head = 6372000.000 in-lbs

Axial load at pile head = 10000.000 lbs

Non-zero moment at pile head for this load case indicates the pile-head may rotate under the applied pile-head loading, but is not a free-head (zero moment) condition.

Load Case Number 2

Pile-head boundary conditions are Shear and Moment (BC Type 1)

Shear force at pile head = 3000.000 lbs

Bending moment at pile head = 2448000.000 in-lbs

Axial load at pile head = 10000.000 lbs

Non-zero moment at pile head for this load case indicates the pile-head may rotate under the applied pile-head loading, but is not a free-head (zero moment) condition.

---

Computations of Nominal Moment Capacity and Nonlinear Bending Stiffness

---

Number of sections = 1

Pile Section No. 1

The sectional shape is a circular drilled shaft (bored pile).

Outside Diameter = 60.0000 in

Material Properties:

Compressive Strength of Concrete = 3.000 kip/in\*\*2  
 Yield Stress of Reinforcement = 60. kip/in\*\*2  
 Modulus of Elasticity of Reinforcement = 29000. kip/in\*\*2  
 Number of Reinforcing Bars = 9  
 Area of Single Bar = 1.56000 in\*\*2  
 Number of Rows of Reinforcing Bars = 9  
 Area of Steel = 14.040 in\*\*2  
 Area of Shaft = 2827.433 in\*\*2  
 Percentage of Steel Reinforcement = 0.497 percent  
 Cover Thickness (edge to bar center) = 5.500 in

Unfactored Axial Squash Load Capacity = 8016.55 kip

Distribution and Area of Steel Reinforcement

Row Number	Area of Reinforcement in**2	Distance to Centroidal Axis in
1	1.560	24.128
2	1.560	21.218
3	1.560	15.748
4	1.560	8.379
5	1.560	0.000
6	1.560	-8.379
7	1.560	-15.748
8	1.560	-21.218
9	1.560	-24.128

Axial Thrust Force = 9000.00 lbs

Bending Max. Steel Moment Stress in-lbs psi	Bending Stiffness lb-in2	Bending Curvature rad/in	Maximum Strain in/in	Neutral Axis Position inches	Max. Concrete Stress psi
1766957.613.90297	2.120348E+12	8.333333E-07	0.00002606	31.27509177	80.12977181

3516512.	2.	109907E+12	0.00000167	0.00005117	30.70206821	156.06697
1200.10981						
5248382.	2.	099353E+12	0.00000250	0.00007626	30.50398529	230.76538
1785.80370						
6962681.	2.	088804E+12	0.00000333	0.00010135	30.40486515	304.27906
2371.48999						
8659409.	2.	078258E+12	0.00000417	0.00012644	30.34532726	376.60800
2957.16833						
8659409.	1.	731882E+12	0.00000500	0.00006962	13.92453253	207.01521
5829.47233						
8659409.	1.	484470E+12	0.00000583	0.00008043	13.78864110	238.28942
6824.03935						
8659409.	1.	298911E+12	0.00000667	0.00009126	13.68859828	269.39076
7818.24372						
8659409.	1.	154588E+12	0.00000750	0.00010209	13.61246645	300.31871
8812.08286						
8659409.	1.	039129E+12	0.00000833	0.00011294	13.55307877	331.07268
9805.55520						
8659409.	9.	446628E+11	0.00000917	0.00012380	13.50587904	361.65216
10798.65798						
8659409.	8.	659409E+11	0.00001000	0.00013468	13.46783102	392.05671
11791.38809						
8659409.	7.	993301E+11	0.00001083	0.00014557	13.43682826	422.28569
12783.74380						
8659409.	7.	422351E+11	0.00001167	0.00015647	13.41136873	452.33859
13775.72251						
8659409.	6.	927527E+11	0.00001250	0.00016738	13.39034736	482.21473
14767.32294						
8659409.	6.	494557E+11	0.00001333	0.00017831	13.37294161	511.91367
15758.54136						
8659409.	6.	112524E+11	0.00001417	0.00018925	13.35852206	541.43495
16749.37423						
8659409.	5.	772939E+11	0.00001500	0.00020020	13.34659159	570.77777
17739.82129						
8659409.	5.	469100E+11	0.00001583	0.00021117	13.33676398	599.94162
18729.87942						
8659409.	5.	195645E+11	0.00001667	0.00022215	13.32872808	628.92586
19719.54657						
8659409.	4.	948234E+11	0.00001750	0.00023314	13.32223713	657.73010
20708.81805						
8659409.	4.	723314E+11	0.00001833	0.00024415	13.31708372	686.35365
21697.69215						
8659409.	4.	517953E+11	0.00001917	0.00025517	13.31309617	714.79582
22686.16729						
8659409.	4.	329705E+11	0.00002000	0.00026620	13.31013858	743.05628
23674.23779						
8659409.	4.	156516E+11	0.00002083	0.00027725	13.30808580	771.13407
24661.90459						
8659409.	3.	996650E+11	0.00002167	0.00028831	13.30683768	799.02857
25649.16501						
8659409.	3.	848626E+11	0.00002250	0.00029939	13.30631554	826.73953

26636. 01205						
8659409.	3. 711175E+11	0. 00002333	0. 00031048	13. 30644071	854. 26602	
27622. 44632						
8659409.	3. 583204E+11	0. 00002417	0. 00032159	13. 30715239	881. 60753	
28608. 46349						
8659409.	3. 463764E+11	0. 00002500	0. 00033271	13. 30839336	908. 76326	
29594. 06253						
8659409.	3. 352029E+11	0. 00002583	0. 00034384	13. 31011713	935. 73260	
30579. 23989						
8659409.	3. 247278E+11	0. 00002667	0. 00035499	13. 31228793	962. 51527	
31563. 98823						
8659409.	3. 148876E+11	0. 00002750	0. 00036616	13. 31485927	989. 10997	
32548. 31222						
8659409.	3. 056262E+11	0. 00002833	0. 00037734	13. 31780970	1015. 51672	
33532. 20044						
8875209.	3. 042929E+11	0. 00002917	0. 00038853	13. 32109988	1041. 73410	
34515. 65869						
9119520.	3. 039840E+11	0. 00003000	0. 00039974	13. 32471550	1067. 76219	
35498. 67477						
9363546.	3. 036826E+11	0. 00003083	0. 00041097	13. 32862437	1093. 59960	
36481. 25389						
9607295.	3. 033883E+11	0. 00003167	0. 00042221	13. 33281577	1119. 24631	
37463. 38462						
9850759.	3. 031003E+11	0. 00003250	0. 00043346	13. 33726466	1144. 70110	
38445. 07009						
10336828.	3. 025413E+11	0. 00003417	0. 00045602	13. 34687769	1195. 03242	
40407. 08723						
10821745.	3. 020022E+11	0. 00003583	0. 00047864	13. 35735977	1244. 58830	
42367. 27203						
11305495.	3. 014799E+11	0. 00003750	0. 00050132	13. 36861789	1293. 36259	
44325. 59961						
11788066.	3. 009719E+11	0. 00003917	0. 00052407	13. 38058054	1341. 34948	
46282. 03868						
12269439.	3. 004761E+11	0. 00004083	0. 00054689	13. 39318335	1388. 54253	
48236. 56331						
12749602.	2. 999906E+11	0. 00004250	0. 00056977	13. 40637624	1434. 93551	
50189. 14239						
13228539.	2. 995141E+11	0. 00004417	0. 00059272	13. 42011631	1480. 52195	
52139. 74532						
13706233.	2. 990451E+11	0. 00004583	0. 00061574	13. 43436778	1525. 29523	
54088. 34030						
14182671.	2. 985825E+11	0. 00004750	0. 00063883	13. 44910204	1569. 24875	
56034. 89259						
14657836.	2. 981255E+11	0. 00004917	0. 00066199	13. 46429408	1612. 37560	
57979. 36787						
15131712.	2. 976730E+11	0. 00005083	0. 00068523	13. 47992241	1654. 66869	
59921. 73139						
15483074.	2. 949157E+11	0. 00005250	0. 00070660	13. 45902979	1692. 58280	
60000. 00000						
15828418.	2. 922169E+11	0. 00005417	0. 00072794	13. 43895972	1729. 63187	
60000. 00000						



16098101. 60000.00000	2.883242E+11	0.00005583	0.00074805	13.39783967	1763.69181
16326215. 60000.00000	2.839342E+11	0.00005750	0.00076748	13.34751785	1795.88912
16553691. 60000.00000	2.797807E+11	0.00005917	0.00078696	13.30074728	1827.48443
16780518. 60000.00000	2.758441E+11	0.00006083	0.00080648	13.25724185	1858.47369
17006684. 60000.00000	2.721070E+11	0.00006250	0.00082605	13.21674407	1888.85262
17198672. 60000.00000	2.680312E+11	0.00006417	0.00084496	13.16826403	1917.53452
17332807. 60000.00000	2.632831E+11	0.00006583	0.00086273	13.10483158	1943.82202
17466488. 60000.00000	2.587628E+11	0.00006750	0.00088054	13.04501832	1969.60092
17620763. 60000.00000	2.547580E+11	0.00006917	0.00089917	13.00000012	1996.02984
17743571. 60000.00000	2.504975E+11	0.00007083	0.00092015	12.99038708	2025.21699
17874691. 60000.00000	2.465475E+11	0.00007250	0.00093770	12.93380678	2048.82676
18005372. 60000.00000	2.427691E+11	0.00007417	0.00095528	12.88024127	2071.94086
18135618. 60000.00000	2.391510E+11	0.00007583	0.00097290	12.82950103	2094.55680
18265411. 60000.00000	2.356827E+11	0.00007750	0.00099056	12.78140008	2116.67073
18394761. 60000.00000	2.323549E+11	0.00007917	0.00100825	12.73578465	2138.28045
18513887. 60000.00000	2.290378E+11	0.00008083	0.00102568	12.68883169	2159.01669
18581359. 60000.00000	2.252286E+11	0.00008250	0.00104158	12.62527049	2177.38146
18648533. 60000.00000	2.215667E+11	0.00008417	0.00105752	12.56454885	2195.33634
18715405. 60000.00000	2.180436E+11	0.00008583	0.00107347	12.50650227	2212.87904
18781957. 60000.00000	2.146509E+11	0.00008750	0.00108946	12.45097339	2230.00673
18848209. 60000.00000	2.113818E+11	0.00008917	0.00110547	12.39783347	2246.71823
18914143. 60000.00000	2.082291E+11	0.00009083	0.00112151	12.34694660	2263.01065
18979761. 60000.00000	2.051866E+11	0.00009250	0.00113758	12.29819477	2278.88190
19045068. 60000.00000	2.022485E+11	0.00009417	0.00115368	12.25147069	2294.33009
19110052. 60000.00000	1.994092E+11	0.00009583	0.00116981	12.20666707	2309.35254
19174711. 60000.00000	1.966637E+11	0.00009750	0.00118596	12.16368735	2323.94690

60000.00000						
19239043.	1.940072E+11	0.00009917	0.00120214	12.12244213	2338.11085	
60000.00000						
19366737.	1.889438E+11	0.00010250	0.00123460	12.04483688	2365.13898	
60000.00000						
19555701.	1.847783E+11	0.00010583	0.00127000	12.00000107	2392.64071	
60000.00000						
19632300.	1.798379E+11	0.00010917	0.00130688	11.97142303	2418.98447	
60000.00000						
19753871.	1.755900E+11	0.00011250	0.00133888	11.90115631	2439.74365	
60000.00000						
19839913.	1.712798E+11	0.00011583	0.00136919	11.82031453	2457.70153	
60000.00000						
19892891.	1.669333E+11	0.00011917	0.00139789	11.73052847	2473.18950	
60000.00000						
19945011.	1.628164E+11	0.00012250	0.00142669	11.64642155	2487.30398	
60000.00000						
19996253.	1.589106E+11	0.00012583	0.00145558	11.56755030	2500.03002	
60000.00000						
20046611.	1.551996E+11	0.00012917	0.00148458	11.49352491	2511.35283	
60000.00000						
20096074.	1.516685E+11	0.00013250	0.00151368	11.42399132	2521.25694	
60000.00000						
20144618.	1.483039E+11	0.00013583	0.00154288	11.35862768	2529.72644	
60000.00000						
20192244.	1.450940E+11	0.00013917	0.00157219	11.29715145	2536.74533	
60000.00000						
20238916.	1.420275E+11	0.00014250	0.00160160	11.23929441	2542.29675	
60000.00000						
20284648.	1.390947E+11	0.00014583	0.00163112	11.18483126	2546.36396	
60000.00000						
20329406.	1.362865E+11	0.00014917	0.00166075	11.13354027	2548.92926	
60000.00000						
20373180.	1.335946E+11	0.00015250	0.00169050	11.08522832	2549.97472	
60000.00000						
20414825.	1.310042E+11	0.00015583	0.00172036	11.03972018	2545.95070	
60000.00000						
20414825.	1.282607E+11	0.00015917	0.00175083	10.99999845	2540.89723	
60000.00000						
20414825.	1.256297E+11	0.00016250	0.00178750	10.99999845	2544.44172	
60000.00000						
20532861.	1.238162E+11	0.00016583	0.00182417	10.99999845	2548.12282	
60000.00000						
20589157.	1.217093E+11	0.00016917	0.00185499	10.96547306	2549.68110	
60000.00000						
20626294.	1.195727E+11	0.00017250	0.00188464	10.92545807	2548.85337	
60000.00000						
20662591.	1.175124E+11	0.00017583	0.00191450	10.88815391	2544.49295	
60000.00000						
20698538.	1.155267E+11	0.00017917	0.00194447	10.85285604	2540.11311	
60000.00000						

20734119. 60000.00000	1. 136116E+11	0. 00018250	0. 00197455	10. 81946433	2540. 07024
20769333. 60000.00000	1. 117632E+11	0. 00018583	0. 00200475	10. 78789294	2543. 90240
20804171. 60000.00000	1. 099780E+11	0. 00018917	0. 00203507	10. 75805962	2546. 81799
20822003. 60000.00000	1. 081663E+11	0. 00019250	0. 00206330	10. 71844518	2548. 64693
20831043. 60000.00000	1. 063713E+11	0. 00019583	0. 00209049	10. 67486107	2549. 66929
20839855. 60000.00000	1. 046353E+11	0. 00019917	0. 00211778	10. 63319027	2549. 91127
20848050. 60000.00000	1. 029533E+11	0. 00020250	0. 00214527	10. 59394777	2546. 54977
20856128. 60000.00000	1. 013253E+11	0. 00020583	0. 00217283	10. 55627525	2543. 17748
20864070. 60000.00000	9. 974854E+10	0. 00020917	0. 00220045	10. 52009404	2539. 79452
20871887. 60000.00000	9. 822065E+10	0. 00021250	0. 00222814	10. 48534334	2536. 40055
20879580. 60000.00000	9. 673937E+10	0. 00021583	0. 00225588	10. 45196235	2536. 25534
20887132. 60000.00000	9. 530251E+10	0. 00021917	0. 00228369	10. 41988671	2539. 73458
20894562. 60000.00000	9. 390814E+10	0. 00022250	0. 00231157	10. 38906991	2542. 71814
20901852. 60000.00000	9. 255432E+10	0. 00022583	0. 00233951	10. 35945475	2545. 19970
20908994. 60000.00000	9. 123925E+10	0. 00022917	0. 00236752	10. 33099115	2547. 17306
20916003. 60000.00000	8. 996130E+10	0. 00023250	0. 00239560	10. 30363977	2548. 63205
20929598. 60000.00000	8. 751051E+10	0. 00023917	0. 00245196	10. 25210202	2549. 98059
20941976. 60000.00000	8. 518770E+10	0. 00024583	0. 00250884	10. 20546734	2544. 90043
20953934. 60000.00000	8. 298588E+10	0. 00025250	0. 00256595	10. 16219079	2538. 97593
20965580. 60000.00000	8. 089613E+10	0. 00025917	0. 00262325	10. 12186110	2533. 01868
20976896. 60000.00000	7. 890995E+10	0. 00026583	0. 00268074	10. 08427083	2532. 31214
20987884. 60000.00000	7. 701976E+10	0. 00027250	0. 00273842	10. 04924119	2538. 82813
20998538. 60000.00000	7. 521864E+10	0. 00027917	0. 00279630	10. 01660764	2543. 88487
20998538. 60000.00000	7. 346427E+10	0. 00028583	0. 00285833	9. 99999940	2547. 82718
20998538. 60000.00000	7. 178987E+10	0. 00029250	0. 00292500	9. 99999940	2549. 89073
20998538. 60000.00000	7. 019010E+10	0. 00029917	0. 00299167	9. 99999940	2545. 42856

60000.00000						
20998538.	6.866007E+10	0.00030583	0.00305833	9.99999940	2538.99698	
60000.00000						
20998538.	6.719532E+10	0.00031250	0.00312500	9.99999940	2532.56540	
60000.00000						
21034321.	6.590388E+10	0.00031917	0.00319167	9.99999940	2526.13382	
60000.00000						
21070627.	6.466689E+10	0.00032583	0.00325429	9.98757899	2525.98464	
60000.00000						
21077855.	6.339205E+10	0.00033250	0.00331282	9.96336401	2532.20265	
60000.00000						
21084924.	6.216685E+10	0.00033917	0.00337153	9.94062245	2537.52979	
60000.00000						
21091830.	6.098842E+10	0.00034583	0.00343042	9.91928637	2541.94437	
60000.00000						
21098553.	5.985405E+10	0.00035250	0.00348950	9.89928782	2545.42324	
60000.00000						
21105103.	5.876131E+10	0.00035917	0.00354877	9.88057673	2547.94273	
60000.00000						
21111466.	5.770788E+10	0.00036583	0.00360825	9.86309946	2549.47728	
60000.00000						
21117636.	5.669164E+10	0.00037250	0.00366794	9.84680951	2550.00004	
60000.00000						
21123156.	5.570942E+10	0.00037917	0.00372827	9.83280122	2545.87807	
60000.00000						
21128594.	5.476093E+10	0.00038583	0.00378871	9.81956184	2541.70740	
60000.00000						
21133955.	5.384447E+10	0.00039250	0.00384927	9.80705202	2537.51746	
60000.00000						

Unfactored (Nominal) Moment Capacity at Concrete Strain of 0.003 = 20998.53775  
in-kip

Axial Thrust Force = 9000.00 lbs

Bending Max. Steel Moment Stress in-lbs psi	Bending Stiffness lb-in <sup>2</sup>	Bending Curvature rad/in	Maximum Strain in/in	Neutral Axis Position inches	Max. Concrete Stress psi
1766957. 613.90297	2.120348E+12	8.333333E-07	0.00002606	31.27509177	80.12977181
3516512. 1200.10981	2.109907E+12	0.00000167	0.00005117	30.70206821	156.06697
5248382.	2.099353E+12	0.00000250	0.00007626	30.50398529	230.76538

1785. 80370						
6962681.	2. 088804E+12	0. 00000333	0. 00010135	30. 40486515	304. 27906	
2371. 48999						
8659409.	2. 078258E+12	0. 00000417	0. 00012644	30. 34532726	376. 60800	
2957. 16833						
8659409.	1. 731882E+12	0. 00000500	0. 00006962	13. 92453253	207. 01521	
5829. 47233						
8659409.	1. 484470E+12	0. 00000583	0. 00008043	13. 78864110	238. 28942	
6824. 03935						
8659409.	1. 298911E+12	0. 00000667	0. 00009126	13. 68859828	269. 39076	
7818. 24372						
8659409.	1. 154588E+12	0. 00000750	0. 00010209	13. 61246645	300. 31871	
8812. 08286						
8659409.	1. 039129E+12	0. 00000833	0. 00011294	13. 55307877	331. 07268	
9805. 55520						
8659409.	9. 446628E+11	0. 00000917	0. 00012380	13. 50587904	361. 65216	
10798. 65798						
8659409.	8. 659409E+11	0. 00001000	0. 00013468	13. 46783102	392. 05671	
11791. 38809						
8659409.	7. 993301E+11	0. 00001083	0. 00014557	13. 43682826	422. 28569	
12783. 74380						
8659409.	7. 422351E+11	0. 00001167	0. 00015647	13. 41136873	452. 33859	
13775. 72251						
8659409.	6. 927527E+11	0. 00001250	0. 00016738	13. 39034736	482. 21473	
14767. 32294						
8659409.	6. 494557E+11	0. 00001333	0. 00017831	13. 37294161	511. 91367	
15758. 54136						
8659409.	6. 112524E+11	0. 00001417	0. 00018925	13. 35852206	541. 43495	
16749. 37423						
8659409.	5. 772939E+11	0. 00001500	0. 00020020	13. 34659159	570. 77777	
17739. 82129						
8659409.	5. 469100E+11	0. 00001583	0. 00021117	13. 33676398	599. 94162	
18729. 87942						
8659409.	5. 195645E+11	0. 00001667	0. 00022215	13. 32872808	628. 92586	
19719. 54657						
8659409.	4. 948234E+11	0. 00001750	0. 00023314	13. 32223713	657. 73010	
20708. 81805						
8659409.	4. 723314E+11	0. 00001833	0. 00024415	13. 31708372	686. 35365	
21697. 69215						
8659409.	4. 517953E+11	0. 00001917	0. 00025517	13. 31309617	714. 79582	
22686. 16729						
8659409.	4. 329705E+11	0. 00002000	0. 00026620	13. 31013858	743. 05628	
23674. 23779						
8659409.	4. 156516E+11	0. 00002083	0. 00027725	13. 30808580	771. 13407	
24661. 90459						
8659409.	3. 996650E+11	0. 00002167	0. 00028831	13. 30683768	799. 02857	
25649. 16501						
8659409.	3. 848626E+11	0. 00002250	0. 00029939	13. 30631554	826. 73953	
26636. 01205						
8659409.	3. 711175E+11	0. 00002333	0. 00031048	13. 30644071	854. 26602	
27622. 44632						

8659409. 28608. 46349	3. 583204E+11	0. 00002417	0. 00032159	13. 30715239	881. 60753
8659409. 29594. 06253	3. 463764E+11	0. 00002500	0. 00033271	13. 30839336	908. 76326
8659409. 30579. 23989	3. 352029E+11	0. 00002583	0. 00034384	13. 31011713	935. 73260
8659409. 31563. 98823	3. 247278E+11	0. 00002667	0. 00035499	13. 31228793	962. 51527
8659409. 32548. 31222	3. 148876E+11	0. 00002750	0. 00036616	13. 31485927	989. 10997
8659409. 33532. 20044	3. 056262E+11	0. 00002833	0. 00037734	13. 31780970	1015. 51672
8875209. 34515. 65869	3. 042929E+11	0. 00002917	0. 00038853	13. 32109988	1041. 73410
9119520. 35498. 67477	3. 039840E+11	0. 00003000	0. 00039974	13. 32471550	1067. 76219
9363546. 36481. 25389	3. 036826E+11	0. 00003083	0. 00041097	13. 32862437	1093. 59960
9607295. 37463. 38462	3. 033883E+11	0. 00003167	0. 00042221	13. 33281577	1119. 24631
9850759. 38445. 07009	3. 031003E+11	0. 00003250	0. 00043346	13. 33726466	1144. 70110
10336828. 40407. 08723	3. 025413E+11	0. 00003417	0. 00045602	13. 34687769	1195. 03242
10821745. 42367. 27203	3. 020022E+11	0. 00003583	0. 00047864	13. 35735977	1244. 58830
11305495. 44325. 59961	3. 014799E+11	0. 00003750	0. 00050132	13. 36861789	1293. 36259
11788066. 46282. 03868	3. 009719E+11	0. 00003917	0. 00052407	13. 38058054	1341. 34948
12269439. 48236. 56331	3. 004761E+11	0. 00004083	0. 00054689	13. 39318335	1388. 54253
12749602. 50189. 14239	2. 999906E+11	0. 00004250	0. 00056977	13. 40637624	1434. 93551
13228539. 52139. 74532	2. 995141E+11	0. 00004417	0. 00059272	13. 42011631	1480. 52195
13706233. 54088. 34030	2. 990451E+11	0. 00004583	0. 00061574	13. 43436778	1525. 29523
14182671. 56034. 89259	2. 985825E+11	0. 00004750	0. 00063883	13. 44910204	1569. 24875
14657836. 57979. 36787	2. 981255E+11	0. 00004917	0. 00066199	13. 46429408	1612. 37560
15131712. 59921. 73139	2. 976730E+11	0. 00005083	0. 00068523	13. 47992241	1654. 66869
15483074. 60000. 00000	2. 949157E+11	0. 00005250	0. 00070660	13. 45902979	1692. 58280
15828418. 60000. 00000	2. 922169E+11	0. 00005417	0. 00072794	13. 43895972	1729. 63187
16098101. 60000. 00000	2. 883242E+11	0. 00005583	0. 00074805	13. 39783967	1763. 69181
16326215.	2. 839342E+11	0. 00005750	0. 00076748	13. 34751785	1795. 88912

60000.00000						
16553691.	2.797807E+11	0.00005917	0.00078696	13.30074728	1827.48443	
60000.00000						
16780518.	2.758441E+11	0.00006083	0.00080648	13.25724185	1858.47369	
60000.00000						
17006684.	2.721070E+11	0.00006250	0.00082605	13.21674407	1888.85262	
60000.00000						
17198672.	2.680312E+11	0.00006417	0.00084496	13.16826403	1917.53452	
60000.00000						
17332807.	2.632831E+11	0.00006583	0.00086273	13.10483158	1943.82202	
60000.00000						
17466488.	2.587628E+11	0.00006750	0.00088054	13.04501832	1969.60092	
60000.00000						
17620763.	2.547580E+11	0.00006917	0.00089917	13.00000012	1996.02984	
60000.00000						
17743571.	2.504975E+11	0.00007083	0.00092015	12.99038708	2025.21699	
60000.00000						
17874691.	2.465475E+11	0.00007250	0.00093770	12.93380678	2048.82676	
60000.00000						
18005372.	2.427691E+11	0.00007417	0.00095528	12.88024127	2071.94086	
60000.00000						
18135618.	2.391510E+11	0.00007583	0.00097290	12.82950103	2094.55680	
60000.00000						
18265411.	2.356827E+11	0.00007750	0.00099056	12.78140008	2116.67073	
60000.00000						
18394761.	2.323549E+11	0.00007917	0.00100825	12.73578465	2138.28045	
60000.00000						
18513887.	2.290378E+11	0.00008083	0.00102568	12.68883169	2159.01669	
60000.00000						
18581359.	2.252286E+11	0.00008250	0.00104158	12.62527049	2177.38146	
60000.00000						
18648533.	2.215667E+11	0.00008417	0.00105752	12.56454885	2195.33634	
60000.00000						
18715405.	2.180436E+11	0.00008583	0.00107347	12.50650227	2212.87904	
60000.00000						
18781957.	2.146509E+11	0.00008750	0.00108946	12.45097339	2230.00673	
60000.00000						
18848209.	2.113818E+11	0.00008917	0.00110547	12.39783347	2246.71823	
60000.00000						
18914143.	2.082291E+11	0.00009083	0.00112151	12.34694660	2263.01065	
60000.00000						
18979761.	2.051866E+11	0.00009250	0.00113758	12.29819477	2278.88190	
60000.00000						
19045068.	2.022485E+11	0.00009417	0.00115368	12.25147069	2294.33009	
60000.00000						
19110052.	1.994092E+11	0.00009583	0.00116981	12.20666707	2309.35254	
60000.00000						
19174711.	1.966637E+11	0.00009750	0.00118596	12.16368735	2323.94690	
60000.00000						
19239043.	1.940072E+11	0.00009917	0.00120214	12.12244213	2338.11085	
60000.00000						

19366737. 60000.00000	1.889438E+11	0.00010250	0.00123460	12.04483688	2365.13898
19555701. 60000.00000	1.847783E+11	0.00010583	0.00127000	12.00000107	2392.64071
19632300. 60000.00000	1.798379E+11	0.00010917	0.00130688	11.97142303	2418.98447
19753871. 60000.00000	1.755900E+11	0.00011250	0.00133888	11.90115631	2439.74365
19839913. 60000.00000	1.712798E+11	0.00011583	0.00136919	11.82031453	2457.70153
19892891. 60000.00000	1.669333E+11	0.00011917	0.00139789	11.73052847	2473.18950
19945011. 60000.00000	1.628164E+11	0.00012250	0.00142669	11.64642155	2487.30398
19996253. 60000.00000	1.589106E+11	0.00012583	0.00145558	11.56755030	2500.03002
20046611. 60000.00000	1.551996E+11	0.00012917	0.00148458	11.49352491	2511.35283
20096074. 60000.00000	1.516685E+11	0.00013250	0.00151368	11.42399132	2521.25694
20144618. 60000.00000	1.483039E+11	0.00013583	0.00154288	11.35862768	2529.72644
20192244. 60000.00000	1.450940E+11	0.00013917	0.00157219	11.29715145	2536.74533
20238916. 60000.00000	1.420275E+11	0.00014250	0.00160160	11.23929441	2542.29675
20284648. 60000.00000	1.390947E+11	0.00014583	0.00163112	11.18483126	2546.36396
20329406. 60000.00000	1.362865E+11	0.00014917	0.00166075	11.13354027	2548.92926
20373180. 60000.00000	1.335946E+11	0.00015250	0.00169050	11.08522832	2549.97472
20414825. 60000.00000	1.310042E+11	0.00015583	0.00172036	11.03972018	2545.95070
20414825. 60000.00000	1.282607E+11	0.00015917	0.00175083	10.99999845	2540.89723
20414825. 60000.00000	1.256297E+11	0.00016250	0.00178750	10.99999845	2544.44172
20532861. 60000.00000	1.238162E+11	0.00016583	0.00182417	10.99999845	2548.12282
20589157. 60000.00000	1.217093E+11	0.00016917	0.00185499	10.96547306	2549.68110
20626294. 60000.00000	1.195727E+11	0.00017250	0.00188464	10.92545807	2548.85337
20662591. 60000.00000	1.175124E+11	0.00017583	0.00191450	10.88815391	2544.49295
20698538. 60000.00000	1.155267E+11	0.00017917	0.00194447	10.85285604	2540.11311
20734119. 60000.00000	1.136116E+11	0.00018250	0.00197455	10.81946433	2540.07024
20769333. 60000.00000	1.117632E+11	0.00018583	0.00200475	10.78789294	2543.90240



60000.00000						
20804171.	1.099780E+11	0.00018917	0.00203507	10.75805962	2546.81799	
60000.00000						
20822003.	1.081663E+11	0.00019250	0.00206330	10.71844518	2548.64693	
60000.00000						
20831043.	1.063713E+11	0.00019583	0.00209049	10.67486107	2549.66929	
60000.00000						
20839855.	1.046353E+11	0.00019917	0.00211778	10.63319027	2549.91127	
60000.00000						
20848050.	1.029533E+11	0.00020250	0.00214527	10.59394777	2546.54977	
60000.00000						
20856128.	1.013253E+11	0.00020583	0.00217283	10.55627525	2543.17748	
60000.00000						
20864070.	9.974854E+10	0.00020917	0.00220045	10.52009404	2539.79452	
60000.00000						
20871887.	9.822065E+10	0.00021250	0.00222814	10.48534334	2536.40055	
60000.00000						
20879580.	9.673937E+10	0.00021583	0.00225588	10.45196235	2536.25534	
60000.00000						
20887132.	9.530251E+10	0.00021917	0.00228369	10.41988671	2539.73458	
60000.00000						
20894562.	9.390814E+10	0.00022250	0.00231157	10.38906991	2542.71814	
60000.00000						
20901852.	9.255432E+10	0.00022583	0.00233951	10.35945475	2545.19970	
60000.00000						
20908994.	9.123925E+10	0.00022917	0.00236752	10.33099115	2547.17306	
60000.00000						
20916003.	8.996130E+10	0.00023250	0.00239560	10.30363977	2548.63205	
60000.00000						
20929598.	8.751051E+10	0.00023917	0.00245196	10.25210202	2549.98059	
60000.00000						
20941976.	8.518770E+10	0.00024583	0.00250884	10.20546734	2544.90043	
60000.00000						
20953934.	8.298588E+10	0.00025250	0.00256595	10.16219079	2538.97593	
60000.00000						
20965580.	8.089613E+10	0.00025917	0.00262325	10.12186110	2533.01868	
60000.00000						
20976896.	7.890995E+10	0.00026583	0.00268074	10.08427083	2532.31214	
60000.00000						
20987884.	7.701976E+10	0.00027250	0.00273842	10.04924119	2538.82813	
60000.00000						
20998538.	7.521864E+10	0.00027917	0.00279630	10.01660764	2543.88487	
60000.00000						
20998538.	7.346427E+10	0.00028583	0.00285833	9.99999940	2547.82718	
60000.00000						
20998538.	7.178987E+10	0.00029250	0.00292500	9.99999940	2549.89073	
60000.00000						
20998538.	7.019010E+10	0.00029917	0.00299167	9.99999940	2545.42856	
60000.00000						
20998538.	6.866007E+10	0.00030583	0.00305833	9.99999940	2538.99698	
60000.00000						

20998538.	6. 719532E+10	0. 00031250	0. 00312500	9. 99999940	2532. 56540
60000. 00000					
21034321.	6. 590388E+10	0. 00031917	0. 00319167	9. 99999940	2526. 13382
60000. 00000					
21070627.	6. 466689E+10	0. 00032583	0. 00325429	9. 98757899	2525. 98464
60000. 00000					
21077855.	6. 339205E+10	0. 00033250	0. 00331282	9. 96336401	2532. 20265
60000. 00000					
21084924.	6. 216685E+10	0. 00033917	0. 00337153	9. 94062245	2537. 52979
60000. 00000					
21091830.	6. 098842E+10	0. 00034583	0. 00343042	9. 91928637	2541. 94437
60000. 00000					
21098553.	5. 985405E+10	0. 00035250	0. 00348950	9. 89928782	2545. 42324
60000. 00000					
21105103.	5. 876131E+10	0. 00035917	0. 00354877	9. 88057673	2547. 94273
60000. 00000					
21111466.	5. 770788E+10	0. 00036583	0. 00360825	9. 86309946	2549. 47728
60000. 00000					
21117636.	5. 669164E+10	0. 00037250	0. 00366794	9. 84680951	2550. 00004
60000. 00000					
21123156.	5. 570942E+10	0. 00037917	0. 00372827	9. 83280122	2545. 87807
60000. 00000					
21128594.	5. 476093E+10	0. 00038583	0. 00378871	9. 81956184	2541. 70740
60000. 00000					
21133955.	5. 384447E+10	0. 00039250	0. 00384927	9. 80705202	2537. 51746
60000. 00000					

Unfactored (Nominal) Moment Capacity at Concrete Strain of 0.003 = 20998.53775  
in-kip

-----  
 Computed Values of Load Distribution and Deflection  
 for Lateral Loading for Load Case Number 1  
 -----

Pile-head boundary conditions are Shear and Moment (Pile-head Condition Type 1)  
 Specified shear force at pile head = 9000.000 lbs  
 Specified moment at pile head = 6372000.000 in-lbs  
 Specified axial load at pile head = 10000.000 lbs

Depth Es*h X F/L in	Deflect. y in	Moment M lbs-in	Shear V lbs	Slope S Rad.	Total Stress lbs/in**2	Flx. Rig. EI lbs-in**2	Soil Res. p lbs/in
0.000	0.217369	6.37E+06	9000.000	-0.001563	304.021	2.09E+12	0.000

0.000								
19.200	0.187933	6.54E+06	8554.080	-0.001503	312.139	2.09E+12	-121.781	
1555.200								
38.400	0.159650	6.67E+06	3592.267	-0.001443	318.035	2.09E+12	-379.328	
5702.400								
57.600	0.132541	6.66E+06	-5412.719	-0.001381	317.470	2.09E+12	-543.947	
9849.600								
76.800	0.106603	6.45E+06	-16735.	-0.001321	307.572	2.09E+12	-621.707	
13997.								
96.000	0.081798	6.01E+06	-28763.	-0.001264	286.981	2.09E+12	-618.392	
18144.								
115.200	0.058048	5.35E+06	-39992.	-0.001211	255.747	2.10E+12	-539.149	
22291.								
134.400	0.035235	4.49E+06	-49004.	-0.001166	215.243	2.10E+12	-388.145	
26438.								
153.600	0.013206	3.49E+06	-54453.	-0.001130	168.089	2.11E+12	-168.302	
30586.								
172.800	-0.008213	2.43E+06	-55033.	-0.001103	118.105	2.11E+12	118.858	
34733.								
192.000	-0.029208	1.42E+06	-49456.	-0.001086	70.283	2.12E+12	473.170	
38880.								
211.200	-0.049954	5.78E+05	-36424.	-0.001077	30.783	2.12E+12	895.584	
43027.								
230.400	-0.070596	72410.	-14616.	-0.001074	6.951	2.12E+12	1387.630	
47174.								

Please note that because this analysis makes computations of ultimate moment capacity and pile response using nonlinear bending stiffness that the above values of total stress due to combined axial stress and bending may not be representative of actual conditions.

Output Verification:

Computed forces and moments are within specified convergence limits.

Output Summary for Load Case No. 1:

Pile-head deflection	=	0.21736937 in
Computed slope at pile head	=	-0.00156265
Maximum bending moment	=	6684890. lbs-in
Maximum shear force	=	-55467.91539 lbs
Depth of maximum bending moment	=	48.00000000 in
Depth of maximum shear force	=	165.60000 in
Number of iterations	=	5
Number of zero deflection points	=	1

-----  
 Computed Values of Load Distribution and Deflection  
 for Lateral Loading for Load Case Number 2  
 -----

Pile-head boundary conditions are Shear and Moment (Pile-head Condition Type 1)  
 Specified shear force at pile head = 3000.000 lbs  
 Specified moment at pile head = 2448000.000 in-lbs  
 Specified axial load at pile head = 10000.000 lbs

Depth Es*h X F/L in	Deflect. y in	Moment M lbs-in	Shear V lbs	Slope S Rad.	Total Stress lbs/in**2	Flx. Rig. EI lbs-in**2	Soil Res. p lbs/in
0.000	0.081300	2.45E+06	3000.000	-0.000586	118.977	2.11E+12	0.000
0.000							
19.200	0.070260	2.51E+06	2833.281	-0.000564	121.682	2.11E+12	-45.529
1555.200							
38.400	0.059657	2.55E+06	978.786	-0.000541	123.556	2.11E+12	-141.745
5702.400							
57.600	0.049497	2.53E+06	-2385.101	-0.000518	123.016	2.11E+12	-203.135
9849.600							
76.800	0.039777	2.45E+06	-6611.713	-0.000495	118.991	2.11E+12	-231.981
13997.							
96.000	0.030483	2.28E+06	-11097.	-0.000473	110.976	2.12E+12	-230.455
18144.							
115.200	0.021585	2.02E+06	-15278.	-0.000454	98.995	2.12E+12	-200.484
22291.							
134.400	0.013039	1.70E+06	-18623.	-0.000437	83.567	2.12E+12	-143.632
26438.							
153.600	0.004786	1.32E+06	-20627.	-0.000423	65.679	2.12E+12	-60.994
30586.							
172.800	-0.003238	9.17E+05	-20802.	-0.000413	46.766	2.12E+12	46.854
34733.							
192.000	-0.011102	5.34E+05	-18666.	-0.000407	28.704	2.12E+12	179.846
38880.							
211.200	-0.018872	2.18E+05	-13732.	-0.000403	13.804	2.12E+12	338.335
43027.							
230.400	-0.026603	27271.	-5505.520	-0.000402	4.823	2.12E+12	522.899
47174.							

Please note that because this analysis makes computations of ultimate moment capacity and pile response using nonlinear bending stiffness that the above values of total stress due to combined axial stress and bending may not be representative of actual conditions.

Output Verification:

Computed forces and moments are within specified convergence limits.

Output Summary for Load Case No. 2:

Pile-head deflection = 0.08130030 in  
 Computed slope at pile head = -0.00058620  
 Maximum bending moment = 2548295. lbs-in  
 Maximum shear force = -20981.61213 lbs  
 Depth of maximum bending moment = 45.60000000 in  
 Depth of maximum shear force = 165.60000 in  
 Number of iterations = 5  
 Number of zero deflection points = 1

-----  
 Summary of Pile Response(s)  
 -----

Definition of Symbols for Pile-Head Loading Conditions:

Type 1 = Shear and Moment, y = pile-head displacement in  
 Type 2 = Shear and Slope, M = Pile-head Moment lbs-in  
 Type 3 = Shear and Rot. Stiffness, V = Pile-head Shear Force lbs  
 Type 4 = Deflection and Moment, S = Pile-head Slope, radians  
 Type 5 = Deflection and Slope, R = Rot. Stiffness of Pile-head in-lbs/rad

Load Type	Pile-Head Condition 1	Pile-Head Condition 2	Axial Load lbs	Pile-Head Deflection in	Maximum Moment in-lbs	Maximum Shear lbs
1	V= 9000.000	M= 6.37E+06	10000.0000	0.2173694	6684890.	-55467.9154
1	V= 3000.000	M= 2.45E+06	10000.0000	0.0813003	2548295.	-20981.6121

-----  
 Computed Pile-head Stiffness Matrix Members  
 K22, K23, K32, K33 for Superstructure  
 -----

Top y in	Shear React. lbs	Mom. React. in-lbs	K22 lbs/in	K32 in-lbs/in
0.00086852	900.00001	120423.62032	1036242.	1.386534E+08
0.00261451	2709.26996	362511.21363	1036242.	1.386534E+08
0.00414391	4294.09129	574566.67970	1036242.	1.386534E+08
0.00522903	5418.53992	725022.42726	1036242.	1.386534E+08

0.00607071	6290.73004	841724.97164	1036242.	1.386534E+08
0.00675842	7003.36125	937077.89331	1036242.	1.386534E+08
0.00733987	7605.88236	1017698.	1036242.	1.386534E+08
0.00784354	8127.80988	1087534.	1036242.	1.386534E+08
0.00828781	8588.18259	1149133.	1036242.	1.386534E+08
0.00868523	9000.00000	1204236.	1036242.	1.386534E+08

Top Rota. rad	Shear React. lbs	Mom. React. in-lbs	K23 lbs/rad	K33 in-lbs/rad
0.00002721	3773.04191	637200.00950	1.386534E+08	2.341611E+10
0.00008192	11357.99251	1918163.	1.386454E+08	2.341474E+10
0.00013002	18003.02981	3040217.	1.384668E+08	2.338324E+10
0.00016421	22718.73813	3836326.	1.383525E+08	2.336245E+10
0.00019080	26377.03656	4453837.	1.382461E+08	2.334324E+10
0.00021255	29366.46004	4958380.	1.381604E+08	2.332768E+10
0.00023096	31894.22006	5384965.	1.380921E+08	2.331522E+10
0.00024693	34084.03758	5754489.	1.380291E+08	2.330378E+10
0.00026104	36015.73675	6080433.	1.379716E+08	2.329335E+10
0.00027366	37743.82142	6372000.	1.379201E+08	2.328400E+10

K22 = abs(Shear Reaction/Top y)

K23 = abs(Shear Reaction/Top Rotation)

K32 = abs(Moment Reaction/Top y)

K33 = abs(Moment Reaction/Top Rotation)

The analysis ended normally.

Lateral Deflection (in)

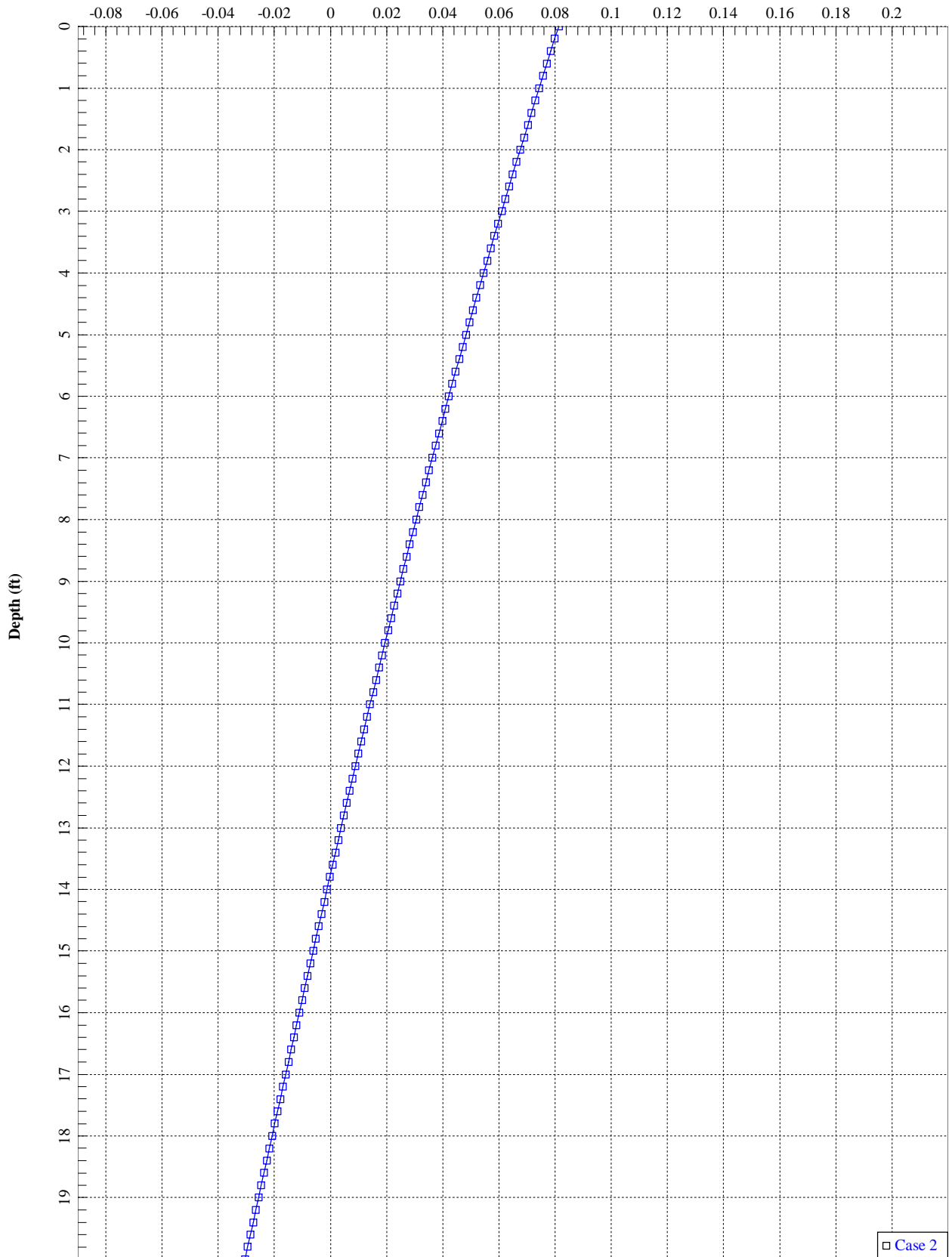

Bending Moment (in-kips)

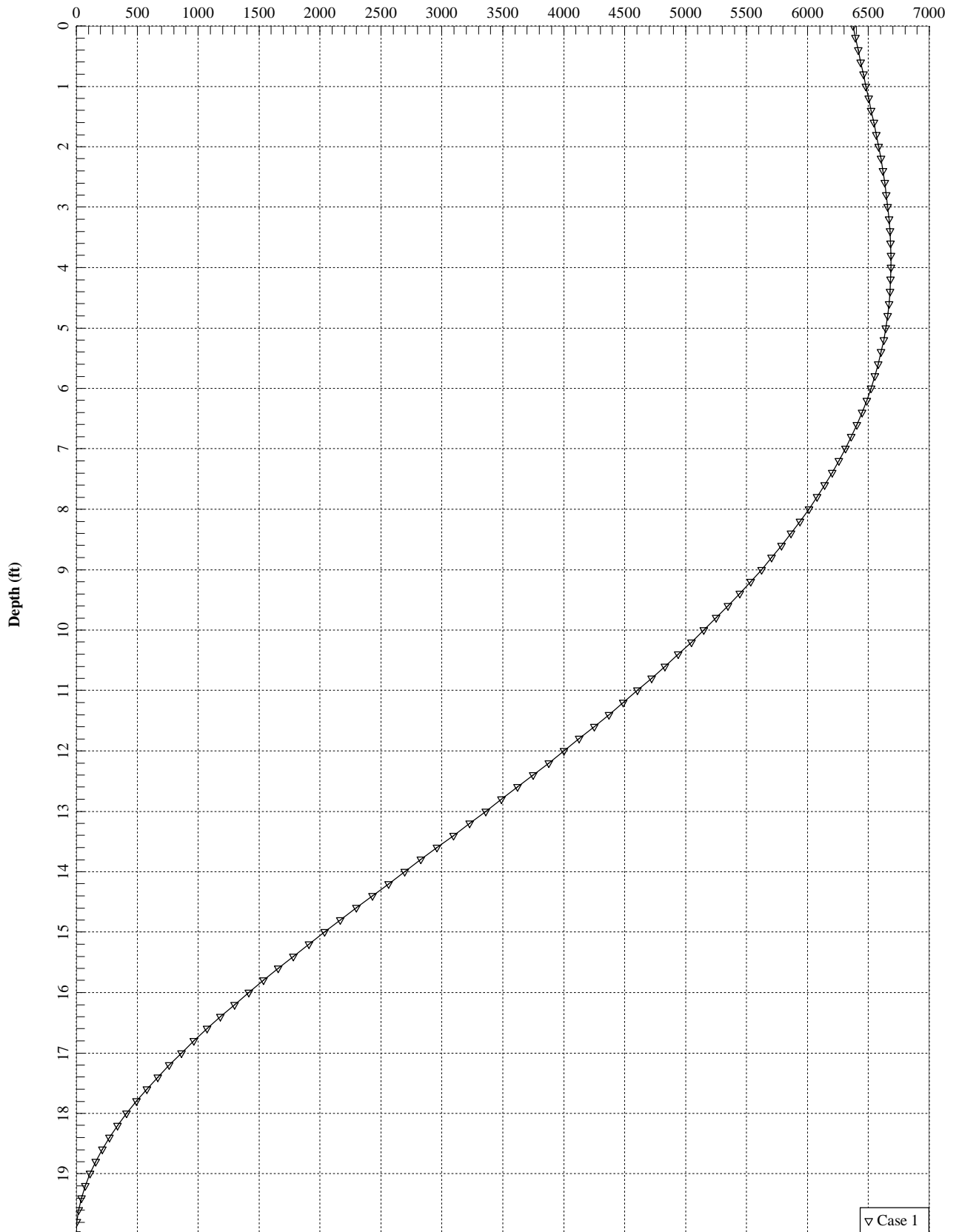



Shear Force (kips)

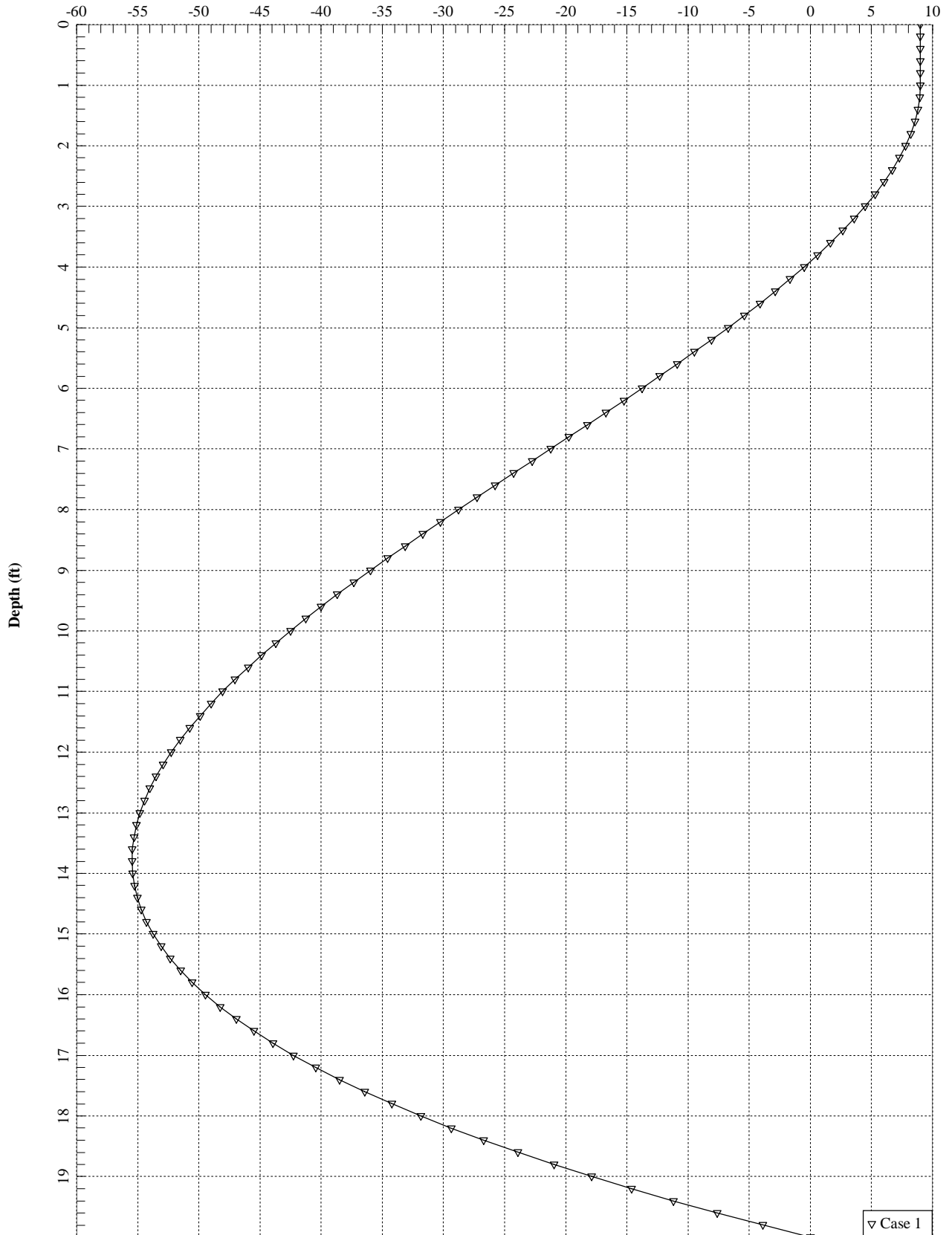

<b>RAN Template:</b> 67E5A998E 6160	<b>A&amp;L Template:</b> 67E5998E_1xAIR+1OP
--	--

### Section 1 - Site Information

**Site ID:** CTNH833A  
**Status:** Draft  
**Version:** 1  
**Project Type:** Sprint Retain  
**Approved:** Not Approved  
**Approved By:** Not Approved  
**Last Modified:** 7/9/2021 3:24:02 PM  
**Last Modified By:** Farhan.Badar@T-Mobile.com

**Site Name:** CTNH833A  
**Site Class:** Monopole  
**Site Type:** Structure Non Building  
**Plan Year:** 2020  
**Market:** CONNECTICUT CT  
**Vendor:** Ericsson  
**Landlord:** Not Specified

**Latitude:** 41.30885000  
**Longitude:** -72.96000000  
**Address:** 250 Derby Ave  
**City, State:** West Haven, CT  
**Region:** NORTHEAST

<b>RAN Template:</b> 67E5A998E 6160		<b>AL Template:</b> 67E5998E_1xAIR+1OP		
<b>Sector Count:</b> 3	<b>Antenna Count:</b> 6	<b>Coax Line Count:</b> 0	<b>TMA Count:</b> 0	<b>RRU Count:</b> 9

### Section 2 - Existing Template Images

----- This section is intentionally blank. -----

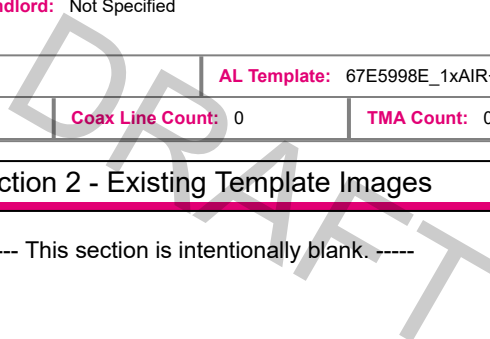

Section 3 - Proposed Template Images

67D5A998C\_1xAIR+1xQP+1xOP.jpg

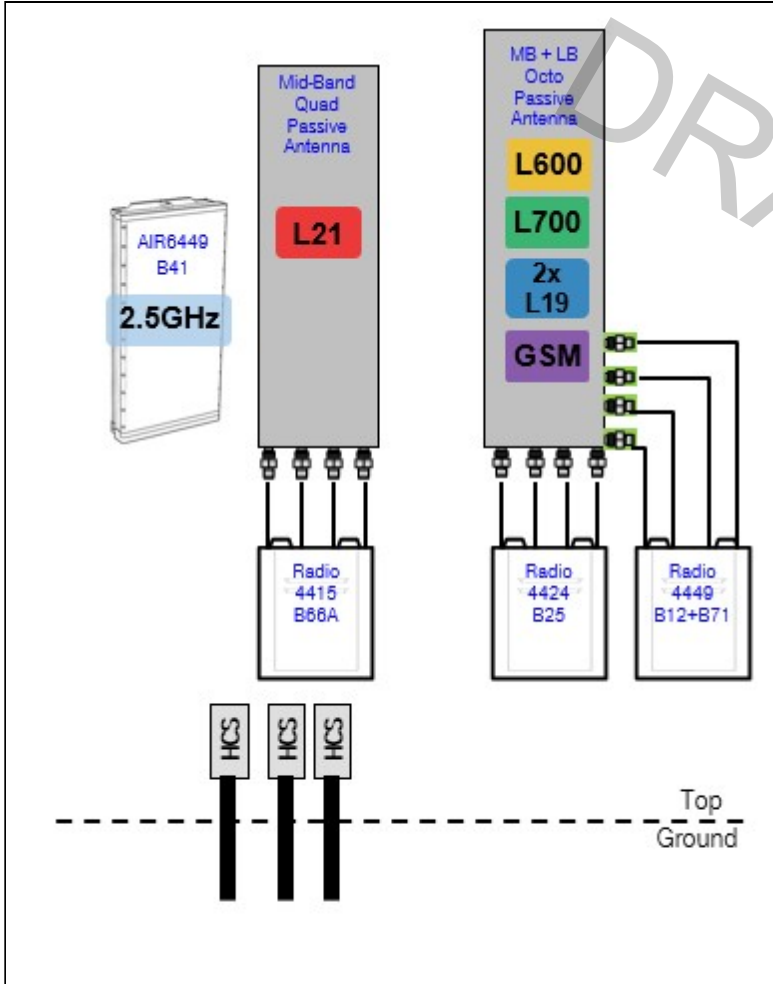

Notes:

Section 4 - Siteplan Images

----- This section is intentionally blank. -----

DRAFT

<b>RAN Template:</b> 67E5A998E 6160	<b>A&amp;L Template:</b> 67E5998E_1xAIR+1OP
--	--

**Section 5 - RAN Equipment**

**Existing RAN Equipment**

----- This section is intentionally blank. -----

**Proposed RAN Equipment**

Template: 67E5A998E 6160

Enclosure	1	2	3	4
<b>Enclosure Type</b>	Ancillary Equipment (Ericsson)	Enclosure 6160	B160	RBS 6601
<b>Baseband</b>		BB 6648 N2500 L2500 BB 6630 L2100 L1900 BB 6630 L700 L600 N600		DUG20 G1900
<b>Hybrid Cable System</b>	PSU 4813 Ericsson Hybrid Trunk 6/24 4AWG 40m (x 3)			
<b>Transport System</b>		CSR IXRe V2 (Gen2)		

**RAN Scope of Work:**

<b>RAN Template:</b> 67E5A998E 6160	<b>A&amp;L Template:</b> 67E5998E_1xAIR+1OP
--	--

**Section 6 - A&L Equipment**

**Existing Template:** Custom  
**Proposed Template:** 67E5998E\_1xAIR+1OP

**Sector 1 (Proposed) view from behind**

<b>Coverage Type</b>	A - Outdoor Macro					
<b>Antenna</b>	1			2		
<b>Antenna Model</b>	RFS - APXVAALL18_43-U-NA20 (Octo)			Ericsson - AIR6449 B41 (Active Antenna - Massive MIMO)		
<b>Azimuth</b>	10			10		
<b>M. Tilt</b>						
<b>Height</b>	74			74		
<b>Ports</b>	<b>P1</b>	<b>P2</b>	<b>P3</b>	<b>P4</b>	<b>P5</b>	<b>P6</b>
<b>Active Tech.</b>	L700 L600 N600	L700 L600 N600	L2100 L1900 G1900	L2100 L1900 G1900	L2500 N2500	L2500 N2500
<b>Dark Tech.</b>						
<b>Restricted Tech.</b>						
<b>Decomm. Tech.</b>						
<b>E. Tilt</b>						
<b>Cables</b>	Coax Jumper (x4)	Coax Jumper (x4)	Coax Jumper (x4)	Coax Jumper (x4)		
<b>TMA's</b>						
<b>Diplexers / Combiners</b>			Commscope - SDX1926Q-43 (E14F05P86) (AtAntenna)	SHARED Commscope - SDX1926Q-43 (E14F05P86) (AtAntenna)		
<b>Radio</b>	Radio 4480 B71+B85 (At Antenna)	SHARED Radio 4480 B71+B85 (At Antenna)	Radio 4460 B25+B66 (At Antenna)	Radio 4460 B25+B66 (At Antenna)		
<b>Sector Equipment</b>						

**Unconnected Equipment:**

**Scope of Work:**

\*A dashed border indicates shared equipment. Any connected equipment is denoted with the SHARED keyword.

<b>RAN Template:</b> 67E5A998E 6160	<b>A&amp;L Template:</b> 67E5998E_1xAIR+1OP
--	--

**Print Name:** Standard  
**PORs:** New Build\_Sprint Keep

Sector 2 (Proposed) view from behind						
<b>Coverage Type</b>	A - Outdoor Macro					
<b>Antenna</b>	1			2		
<b>Antenna Model</b>	RFS - APXVAALL18_43-U-NA20 (Octo)			Ericsson - AIR6449 B41 (Active Antenna - Massive MIMO)		
<b>Azimuth</b>	160			160		
<b>M. Tilt</b>						
<b>Height</b>	74			74		
<b>Ports</b>	<b>P1</b>	<b>P2</b>	<b>P3</b>	<b>P4</b>	<b>P5</b>	<b>P6</b>
<b>Active Tech.</b>	L700 L600 N600	L700 L600 N600	L2100 L1900 G1900	L2100 L1900 G1900	L2500 N2500	L2500 N2500
<b>Dark Tech.</b>						
<b>Restricted Tech.</b>						
<b>Decomm. Tech.</b>						
<b>E. Tilt</b>						
<b>Cables</b>	Coax Jumper (x4)	Coax Jumper (x4)	Coax Jumper (x4)	Coax Jumper (x4)		
<b>TMA's</b>						
<b>Diplexers / Combiners</b>			Microdata - AWS/PCS (8:4) Diplexer MI-54131 (AtAntenna)	SHARED Microdata - AWS/PCS (8:4) Diplexer MI-54131 (AtAntenna)		
<b>Radio</b>	Radio 4480 B71+B85 (At Antenna)	SHARED Radio 4480 B71+B85 (At Antenna)	Radio 4460 B25+B66 (At Antenna)	Radio 4460 B25+B66 (At Antenna)		
<b>Sector Equipment</b>						
<b>Unconnected Equipment:</b>						
<b>Scope of Work:</b>						

\*A dashed border indicates shared equipment. Any connected equipment is denoted with the SHARED keyword.

<b>RAN Template:</b> 67E5A998E 6160	<b>A&amp;L Template:</b> 67E5998E_1xAIR+1OP
--	--

**Print Name:** Standard  
**PORs:** New Build\_Sprint Keep

Sector 3 (Proposed) view from behind						
<b>Coverage Type</b>	A - Outdoor Macro					
<b>Antenna</b>	1			2		
<b>Antenna Model</b>	RFS - APXVAALL18_43-U-NA20 (Octo)			Ericsson - AIR6449 B41 (Active Antenna - Massive MIMO)		
<b>Azimuth</b>	270			270		
<b>M. Tilt</b>						
<b>Height</b>	74			74		
<b>Ports</b>	<b>P1</b>	<b>P2</b>	<b>P3</b>	<b>P4</b>	<b>P5</b>	<b>P6</b>
<b>Active Tech.</b>	L700 L600 N600	L700 L600 N600	L2100 L1900 G1900	L2100 L1900 G1900	L2500 N2500	L2500 N2500
<b>Dark Tech.</b>						
<b>Restricted Tech.</b>						
<b>Decomm. Tech.</b>						
<b>E. Tilt</b>						
<b>Cables</b>	Coax Jumper (x4)	Coax Jumper (x4)	Coax Jumper (x4)	Coax Jumper (x4)		
<b>TMA's</b>						
<b>Diplexers / Combiners</b>			Microdata - AWS/PCS (8:4) Diplexer MI-54131 (AtAntenna)	SHARED Microdata - AWS/PCS (8:4) Diplexer MI-54131 (AtAntenna)		
<b>Radio</b>	Radio 4480 B71+B85 (At Antenna)	SHARED Radio 4480 B71+B85 (At Antenna)	Radio 4460 B25+B66 (At Antenna)	Radio 4460 B25+B66 (At Antenna)		
<b>Sector Equipment</b>						
<b>Unconnected Equipment:</b>						
<b>Scope of Work:</b>						

\*A dashed border indicates shared equipment. Any connected equipment is denoted with the SHARED keyword.



<b>RAN Template:</b> 67E5A998E 6160	<b>A&amp;L Template:</b> 67E5998E_1xAIR+1OP
--	--

**Section 7 - Power Systems Equipment**

**Existing Power Systems Equipment**

----- This section is intentionally blank. -----

**Proposed Power Systems Equipment**

<b>Enclosure</b>	1
<b>Enclosure Type</b>	Enclosure 6160

# *Structural Analysis Report*

*Antenna Mount Analysis*

*T-Mobile Site #: CTNH833A*

*250 Derby Avenue  
West Haven, CT*

*Centek Project No. 21005.07*

*~~Date: February 12, 2021~~*

*Rev 1: August 16, 2021*

*Max Stress Ratio = 81.6 %*

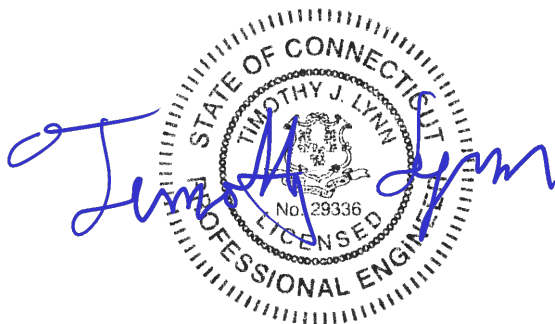

**Prepared for:**  
T-Mobile USA  
35 Griffin Road  
Bloomfield, CT 06002

## **Table of Contents**

### **SECTION 1 – REPORT**

- ANTENNA AND APPURTENANCE SUMMARY
- STRUCTURE LOADING
- CONCLUSION

### **SECTION 2 – CALCULATIONS**

- WIND LOAD ON APPURTENANCES
- RISA3D OUTPUT REPORT

### **SECTION 3 – REFERENCE MATERIALS (NOT INCLUDED WITHIN REPORT)**

- RF DATA SHEET, DATED 07/20/2021

August 16, 2021

Mr. Kyle Richers  
Transcend Wireless  
10 Industrial Ave  
Mahwah, NJ 07430

Re: *Structural Letter ~ Antenna Mount*  
*T-Mobile – Site Ref: CTNH833A*  
*250 Derby Avenue*  
*West Haven, CT 06516*

*Centek Project No. 21005.07*

Dear Mr. Richers,

Centek Engineering, Inc. has reviewed the T-Mobile antenna installation at the above referenced site. The purpose of the review is to determine the structural adequacy of the existing mount, consisting of five (5) 3-ft side arms attached to a 8-ft platform to support the equipment configuration. The review considered the effects of wind load, dead load and ice load in accordance with the 2015 International Building Code as modified by the 2018 Connecticut State Building Code (CTBC) including ASCE 7-10 and ANSI/TIA-222-G *Structural Standards for Steel Antenna Towers and Supporting Structures*.

The loads considered in this analysis consist of the following:

- T-Mobile:  
Side Arms and Platform: Three (3) RFS APXVAALL18\_43 panel antennas, three (3) Ericsson AIR6449 panel antennas, three (3) Ericsson 4460 remote radio units, three (3) Ericsson 4480 remote radio units and three (3) SDX1936Q\_43 diplexers mounted on five (5) 3-ft side arms attached to a 8-ft platform with a RAD center elevation of 74-ft +/- AGL.

The antenna mount was analyzed per the requirements of the 2015 International Building Code as modified by the 2018 Connecticut State Building Code considering a nominal design wind speed of 97 mph for West Haven as required in Appendix N of the 2018 Connecticut State Building Code.

A structural analysis of tower and foundation needs to be completed prior to any work.

Based on our review of the equipment upgrade, it is our opinion that the existing antenna mount is structurally adequate to support the proposed antenna configuration. If there are any questions regarding this matter, please feel free to call.

Respectfully Submitted by:

Timothy J. Lynn, PE  
Structural Engineer

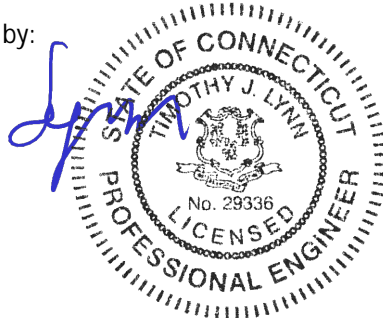

**CEN TEK** Engineering, Inc.  
Structural Analysis – Mount Analysis  
T-Mobile Site Ref. ~ CTNH833A  
West Haven, CT  
Rev 1 ~ August 16, 2021

## **Section 2 - Calculations**

**Development of Design Heights, Exposure Coefficients,  
 and Velocity Pressures Per TIA-222-G**

**Wind Speeds**

Basic Wind Speed  $V := 97$  mph (User Input - 2018 CSBC Appendix N)  
 Basic Wind Speed with Ice  $V_i := 50$  mph (User Input per Annex B of TIA-222-G)

**Input**

Structure Type = Structure\_Type := Pole (User Input)  
 Structure Category = SC := II (User Input)  
 Exposure Category = Exp := C (User Input)  
 Structure Height = h := 76 ft (User Input)  
 Height to Center of Antennas =  $z_{Ant} := 74$  ft (User Input)  
 Radial Ice Thickness =  $t_i := 0.75$  in (User Input per Annex B of TIA-222-G)  
 Radial Ice Density =  $\rho_d := 56.00$  pcf (User Input)  
 Topographic Factor =  $K_{zt} := 1.0$  (User Input)  
 $K_a := 1.0$  (User Input)  
 Gust Response Factor =  $G_H := 1.1$  (User Input)

**Output**

Wind Direction Probability Factor =  $K_d := \begin{cases} 0.95 & \text{if Structure\_Type} = \text{Pole} \\ 0.85 & \text{if Structure\_Type} = \text{Lattice} \end{cases} = 0.95$  (Per Table 2-2 of TIA-222-G)

Importance Factors =  $I_{Wind} := \begin{cases} 0.87 & \text{if SC} = 1 \\ 1.00 & \text{if SC} = 2 \\ 1.15 & \text{if SC} = 3 \end{cases} = 1$  (Per Table 2-3 of TIA-222-G)

$I_{Wind\_w\_Ice} := \begin{cases} 0 & \text{if SC} = 1 \\ 1.00 & \text{if SC} = 2 \\ 1.00 & \text{if SC} = 3 \end{cases} = 1$

$I_{ice} := \begin{cases} 0 & \text{if SC} = 1 \\ 1.00 & \text{if SC} = 2 \\ 1.25 & \text{if SC} = 3 \end{cases} = 1$

$$K_{iz} := \left( \frac{z_{Ant}}{33} \right)^{0.1} = 1.084$$

$$t_{iz} := 2.0 \cdot t_i \cdot I_{ice} \cdot K_{iz} \cdot K_{zt}^{0.35} = 1.626$$

Velocity Pressure Coefficient Antennas =

$$K_{z_{Ant}} := 2.01 \left( \left( \frac{z_{Ant}}{z_g} \right) \right)^{\frac{2}{\alpha}} = 1.188$$

Velocity Pressure w/o Ice Antennas =

$$q_{z_{Ant}} := 0.00256 \cdot K_d \cdot K_{z_{Ant}} \cdot V^2 \cdot I_{Wind} = 27.182$$

Velocity Pressure with Ice Antennas =

$$q_{z_{ice.Ant}} := 0.00256 \cdot K_d \cdot K_{z_{Ant}} \cdot V_i^2 \cdot I_{Wind} = 7.222$$

**Development of Wind & Ice Load on Antennas**

**Antenna Data:**

Antenna Model =	RFSAPXVAALL18-43	
Antenna Shape =	Flat	(User Input)
Antenna Height =	$L_{ant} := 72$	in (User Input)
Antenna Width =	$W_{ant} := 24$	in (User Input)
Antenna Thickness =	$T_{ant} := 8.5$	in (User Input)
Antenna Weight =	$WT_{ant} := 118$	lbs (User Input)
Number of Antennas =	$N_{ant} := 1$	(User Input)
Antenna Aspect Ratio =	$Ar_{ant} := \frac{L_{ant}}{W_{ant}} = 3.0$	
Antenna Force Coefficient =	$Ca_{ant} = 1.22$	

**Wind Load (without ice)**

Surface Area for One Antenna =  $SA_{antF} := \frac{L_{ant} \cdot W_{ant}}{144} = 12$  sf

Total Antenna Wind Force =  $F_{ant} := qz_{Ant} \cdot G_H \cdot Ca_{ant} \cdot K_a \cdot SA_{antF} = 439$  lbs

Surface Area for One Antenna =  $SA_{antS} := \frac{L_{ant} \cdot T_{ant}}{144} = 4.3$  sf

Total Antenna Wind Force =  $F_{ant} := qz_{Ant} \cdot G_H \cdot Ca_{ant} \cdot K_a \cdot SA_{antS} = 155$  lbs

**Wind Load (with ice)**

Surface Area for One Antenna w/ Ice =  $SA_{ICEantF} := \frac{(L_{ant} + 2 \cdot t_{iz}) \cdot (W_{ant} + 2 \cdot t_{iz})}{144} = 14.2$  sf

Total Antenna Wind Force w/ Ice =  $F_{ant} := qz_{ice.Ant} \cdot G_H \cdot Ca_{ant} \cdot K_a \cdot SA_{ICEantF} = 138$  lbs

Surface Area for One Antenna w/ Ice =  $SA_{ICEantS} := \frac{(L_{ant} + 2 \cdot t_{iz}) \cdot (T_{ant} + 2 \cdot t_{iz})}{144} = 6.1$  sf

Total Antenna Wind Force w/ Ice =  $F_{ant} := qz_{ice.Ant} \cdot G_H \cdot Ca_{ant} \cdot K_a \cdot SA_{ICEantS} = 60$  lbs

**Gravity Load (without ice)**

Weight of All Antennas =  $WT_{ant} \cdot N_{ant} = 118$  lbs

**Gravity Loads (ice only)**

Volume of Each Antenna =  $V_{ant} := L_{ant} \cdot W_{ant} \cdot T_{ant} = 1 \times 10^4$  cu in

Volume of Ice on Each Antenna =  $V_{ice} := (L_{ant} + 2 \cdot t_{iz})(W_{ant} + 2 \cdot t_{iz})(T_{ant} + 2 \cdot t_{iz}) - V_{ant} = 9414$  cu in

Weight of Ice on Each Antenna =  $W_{ICEant} := \frac{V_{ice}}{1728} \cdot Id = 305$  lbs

Weight of Ice on All Antennas =  $W_{ICEant} \cdot N_{ant} = 305$  lbs

**Development of Wind & Ice Load on Antennas**

**Antenna Data:**

Antenna Model =	Ericsson AIR6449	
Antenna Shape =	Flat	(User Input)
Antenna Height =	$L_{ant} := 33.1$	in (User Input)
Antenna Width =	$W_{ant} := 20.5$	in (User Input)
Antenna Thickness =	$T_{ant} := 8.3$	in (User Input)
Antenna Weight =	$WT_{ant} := 103$	lbs (User Input)
Number of Antennas =	$N_{ant} := 1$	(User Input)
Antenna Aspect Ratio =	$Ar_{ant} := \frac{L_{ant}}{W_{ant}} = 1.6$	
Antenna Force Coefficient =	$Ca_{ant} = 1.2$	

**Wind Load (without ice)**

Surface Area for One Antenna =  $SA_{antF} := \frac{L_{ant} \cdot W_{ant}}{144} = 4.7$  sf

Total Antenna Wind Force =  $F_{ant} := qz_{Ant} \cdot G_H \cdot Ca_{ant} \cdot K_a \cdot SA_{antF} = 169$  lbs

Surface Area for One Antenna =  $SA_{antS} := \frac{L_{ant} \cdot T_{ant}}{144} = 1.9$  sf

Total Antenna Wind Force =  $F_{ant} := qz_{Ant} \cdot G_H \cdot Ca_{ant} \cdot K_a \cdot SA_{antS} = 68$  lbs

**Wind Load (with ice)**

Surface Area for One Antenna w/ Ice =  $SA_{ICEantF} := \frac{(L_{ant} + 2 \cdot t_{iz}) \cdot (W_{ant} + 2 \cdot t_{iz})}{144} = 6$  sf

Total Antenna Wind Force w/ Ice =  $F_{ant} := qz_{ice.Ant} \cdot G_H \cdot Ca_{ant} \cdot K_a \cdot SA_{ICEantF} = 57$  lbs

Surface Area for One Antenna w/ Ice =  $SA_{ICEantS} := \frac{(L_{ant} + 2 \cdot t_{iz}) \cdot (T_{ant} + 2 \cdot t_{iz})}{144} = 2.9$  sf

Total Antenna Wind Force w/ Ice =  $F_{ant} := qz_{ice.Ant} \cdot G_H \cdot Ca_{ant} \cdot K_a \cdot SA_{ICEantS} = 28$  lbs

**Gravity Load (without ice)**

Weight of All Antennas =  $WT_{ant} \cdot N_{ant} = 103$  lbs

**Gravity Loads (ice only)**

Volume of Each Antenna =  $V_{ant} := L_{ant} \cdot W_{ant} \cdot T_{ant} = 5632$  cu in

Volume of Ice on Each Antenna =  $V_{ice} := (L_{ant} + 2 \cdot t_{iz}) \cdot (W_{ant} + 2 \cdot t_{iz}) \cdot (T_{ant} + 2 \cdot t_{iz}) - V_{ant} = 4343$  cu in

Weight of Ice on Each Antenna =  $W_{ICEant} := \frac{V_{ice}}{1728} \cdot \rho_d = 141$  lbs

Weight of Ice on All Antennas =  $W_{ICEant} \cdot N_{ant} = 141$  lbs



**Development of Wind & Ice Load on RRUS**

**RRUS Data:**

RRUS Model =	Ericsson 4460
RRUS Shape =	Flat (User Input)
RRUS Height =	$L_{RRUS} := 19.6$ in (User Input)
RRUS Width =	$W_{RRUS} := 15.7$ in (User Input)
RRUS Thickness =	$T_{RRUS} := 12.1$ in (User Input)
RRUS Weight =	$W_{T_{RRUS}} := 109$ lbs (User Input)
Number of RRUSs =	$N_{RRUS} := 1$ (User Input)
RRUS Aspect Ratio =	$A_{r_{RRUS}} := \frac{L_{RRUS}}{W_{RRUS}} = 1.2$
RRUS Force Coefficient =	$C_{a_{RRUS}} = 1.2$

**Wind Load (without ice)**

Surface Area for One RRUS =  $SA_{RRUSF} := \frac{L_{RRUS} \cdot W_{RRUS}}{144} = 2.1$  sf

Total RRUS Wind Force =  $F_{RRUS} := qZ_{Ant} \cdot G_H \cdot C_{a_{RRUS}} \cdot K_a \cdot SA_{RRUSF} = 77$  lbs

Surface Area for One RRUS =  $SA_{RRUS} := \frac{L_{RRUS} \cdot T_{RRUS}}{144} = 1.6$  sf

Total RRUS Wind Force =  $F_{RRUS} := qZ_{Ant} \cdot G_H \cdot C_{a_{RRUS}} \cdot K_a \cdot SA_{RRUS} = 59$  lbs

**Wind Load (with ice)**

Surface Area for One RRUS w/Ice =  $SA_{ICERRUSF} := \frac{(L_{RRUS} + 2 \cdot t_{iz}) \cdot (W_{RRUS} + 2 \cdot t_{iz})}{144} = 3$  sf

Total RRUS Wind Force w/ Ice =  $F_{i_{RRUS}} := qZ_{ice} \cdot Ant \cdot G_H \cdot C_{a_{RRUS}} \cdot K_a \cdot SA_{ICERRUSF} = 29$  lbs

Surface Area for One RRUS w/Ice =  $SA_{ICERRUS} := \frac{(L_{RRUS} + 2 \cdot t_{iz}) \cdot (T_{RRUS} + 2 \cdot t_{iz})}{144} = 2.4$  sf

Total RRUS Wind Force w/ Ice =  $F_{i_{RRUS}} := qZ_{ice} \cdot Ant \cdot G_H \cdot C_{a_{RRUS}} \cdot K_a \cdot SA_{ICERRUS} = 23$  lbs

**Gravity Load (without ice)**

Weight of All RRUSs =  $W_{T_{RRUS}} \cdot N_{RRUS} = 109$  lbs

**Gravity Loads (ice only)**

Volume of Each RRUS =  $V_{RRUS} := L_{RRUS} \cdot W_{RRUS} \cdot T_{RRUS} = 3723$  cu in

Volume of Ice on Each RRUS =  $V_{ice} := (L_{RRUS} + 2 \cdot t_{iz})(W_{RRUS} + 2 \cdot t_{iz})(T_{RRUS} + 2 \cdot t_{iz}) - V_{RRUS} = 2926$

Weight of Ice on Each RRUS =  $W_{i_{RRUS}} := \frac{V_{ice}}{1728} \cdot \rho_{ice} = 95$  lbs

Weight of Ice on All RRUSs =  $W_{i_{RRUS}} \cdot N_{RRUS} = 95$  lbs

**Development of Wind & Ice Load on RRUS**

**RRUS Data:**

RRUS Model =	Ericsson 4480
RRUS Shape =	Flat (User Input)
RRUS Height =	$L_{RRUS} := 21.8$ in (User Input)
RRUS Width =	$W_{RRUS} := 15.7$ in (User Input)
RRUS Thickness =	$T_{RRUS} := 7.5$ in (User Input)
RRUS Weight =	$W_{T_{RRUS}} := 84$ lbs (User Input)
Number of RRUSs =	$N_{RRUS} := 1$ (User Input)
RRUS Aspect Ratio =	$A_{r_{RRUS}} := \frac{L_{RRUS}}{W_{RRUS}} = 1.4$
RRUS Force Coefficient =	$C_{a_{RRUS}} = 1.2$

**Wind Load (without ice)**

Surface Area for One RRUS =	$SA_{RRUSF} := \frac{L_{RRUS} \cdot W_{RRUS}}{144} = 2.4$ sf
Total RRUS Wind Force =	$F_{RRUS} := qZ_{Ant} \cdot G_H \cdot C_{a_{RRUS}} \cdot K_a \cdot SA_{RRUSF} = 85$ lbs

Surface Area for One RRUS =	$SA_{RRUSS} := \frac{L_{RRUS} \cdot T_{RRUS}}{144} = 1.1$ sf
Total RRUS Wind Force =	$F_{RRUS} := qZ_{Ant} \cdot G_H \cdot C_{a_{RRUS}} \cdot K_a \cdot SA_{RRUSS} = 41$ lbs

**Wind Load (with ice)**

Surface Area for One RRUS w/ Ice =	$SA_{ICERRUSF} := \frac{(L_{RRUS} + 2 \cdot t_{iz}) \cdot (W_{RRUS} + 2 \cdot t_{iz})}{144} = 3.3$ sf
Total RRUS Wind Force w/ Ice =	$F_{i_{RRUS}} := qZ_{ice} \cdot Ant \cdot G_H \cdot C_{a_{RRUS}} \cdot K_a \cdot SA_{ICERRUSF} = 31$ lbs

Surface Area for One RRUS w/ Ice =	$SA_{ICERRUSS} := \frac{(L_{RRUS} + 2 \cdot t_{iz}) \cdot (T_{RRUS} + 2 \cdot t_{iz})}{144} = 1.9$ sf
Total RRUS Wind Force w/ Ice =	$F_{i_{RRUS}} := qZ_{ice} \cdot Ant \cdot G_H \cdot C_{a_{RRUS}} \cdot K_a \cdot SA_{ICERRUSS} = 18$ lbs

**Gravity Load (without ice)**

Weight of All RRUSs =	$W_{T_{RRUS}} \cdot N_{RRUS} = 84$ lbs
-----------------------	--

**Gravity Loads (ice only)**

Volume of Each RRUS =	$V_{RRUS} := L_{RRUS} \cdot W_{RRUS} \cdot T_{RRUS} = 2567$ cu in
Volume of Ice on Each RRUS =	$V_{ice} := (L_{RRUS} + 2 \cdot t_{iz})(W_{RRUS} + 2 \cdot t_{iz})(T_{RRUS} + 2 \cdot t_{iz}) - V_{RRUS} = 2538$ cu in
Weight of Ice on Each RRUS =	$W_{ICERRUS} := \frac{V_{ice}}{1728} \cdot \rho_d = 82$ lbs
Weight of Ice on All RRUSs =	$W_{ICERRUS} \cdot N_{RRUS} = 82$ lbs

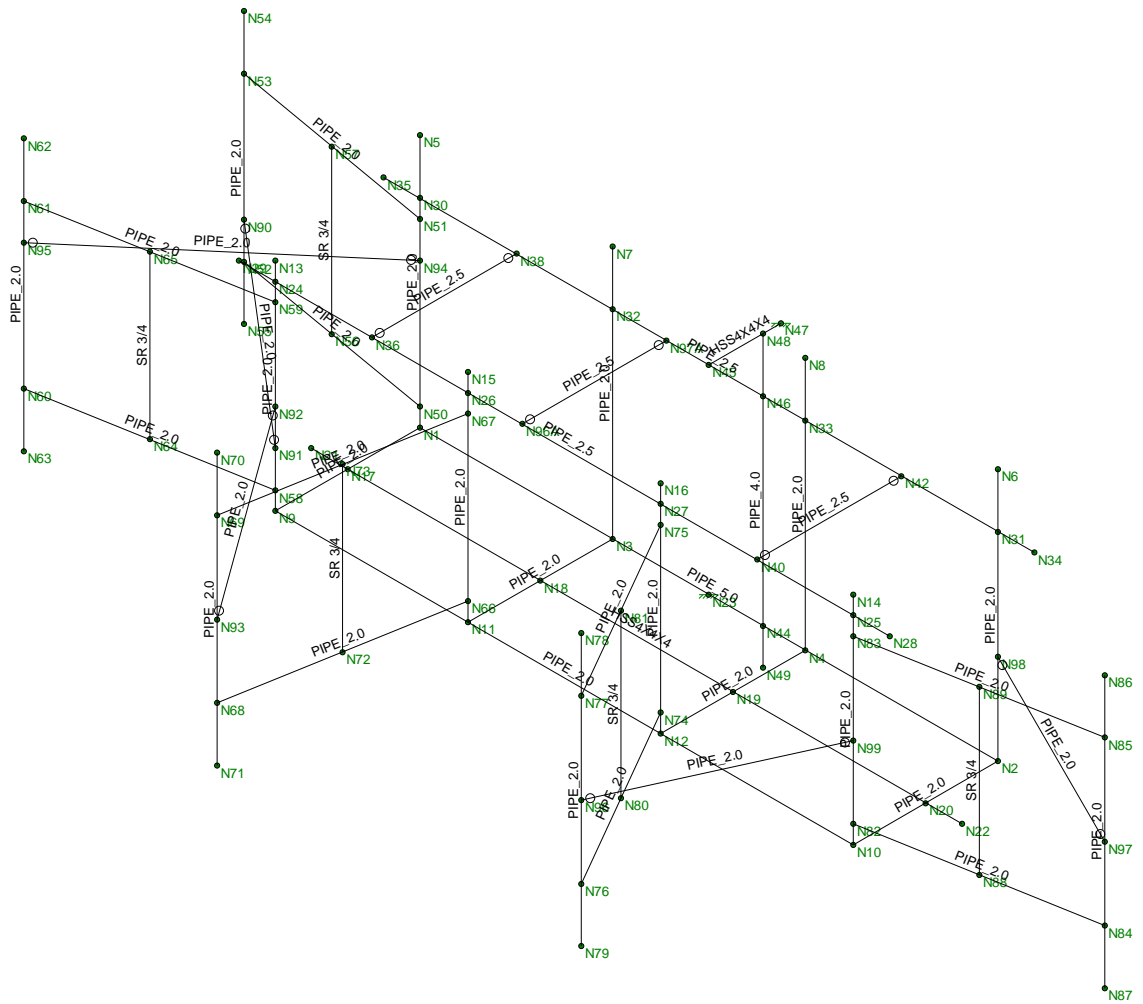

Envelope Only Solution

Centek

TJL

21005.07

CTNH833A  
Member Framing

Aug 16, 2021 at 11:19 AM

Antenna Mount.R3D

**(Global) Model Settings**

Display Sections for Member Calcs	5
Max Internal Sections for Member Calcs	97
Include Shear Deformation?	Yes
Increase Nailing Capacity for Wind?	Yes
Include Warping?	Yes
Trans Load Btwn Intersecting Wood Wall?	Yes
Area Load Mesh (in^2)	144
Merge Tolerance (in)	.12
P-Delta Analysis Tolerance	0.50%
Include P-Delta for Walls?	Yes
Automatically Iterate Stiffness for Walls?	Yes
Max Iterations for Wall Stiffness	3
Gravity Acceleration (ft/sec^2)	32.2
Wall Mesh Size (in)	24
Eigensolution Convergence Tol. (1.E-)	4
Vertical Axis	Y
Global Member Orientation Plane	XZ
Static Solver	Sparse Accelerated
Dynamic Solver	Accelerated Solver

Hot Rolled Steel Code	AISC 14th(360-10): LRFD
Adjust Stiffness?	Yes(Iterative)
RISAConnection Code	AISC 14th(360-10): ASD
Cold Formed Steel Code	AISI S100-12: ASD
Wood Code	AWC NDS-15: ASD
Wood Temperature	< 100F
Concrete Code	ACI 318-14
Masonry Code	ACI 530-13: ASD
Aluminum Code	AA ADM1-15: ASD - Building
Stainless Steel Code	AISC 14th(360-10): ASD
Adjust Stiffness?	Yes(Iterative)

Number of Shear Regions	4
Region Spacing Increment (in)	4
Biaxial Column Method	Exact Integration
Parame Beta Factor (PCA)	.65
Concrete Stress Block	Rectangular
Use Cracked Sections?	Yes
Use Cracked Sections Slab?	Yes
Bad Framing Warnings?	No
Unused Force Warnings?	Yes
Min 1 Bar Diam. Spacing?	No
Concrete Rebar Set	REBAR_SET_ASTMA615
Min % Steel for Column	1
Max % Steel for Column	8

**(Global) Model Settings, Continued**

Seismic Code	ASCE 7-10
Seismic Base Elevation (ft)	Not Entered
Add Base Weight?	Yes
Ct X	.02
Ct Z	.02
T X (sec)	Not Entered
T Z (sec)	Not Entered
R X	3
R Z	3
Ct Exp. X	.75
Ct Exp. Z	.75
SD1	1
SDS	1
S1	1
TL (sec)	5
Risk Cat	I or II
Drift Cat	Other
Om Z	1
Om X	1
Cd Z	4
Cd X	4
Rho Z	1
Rho X	1
Footing Overturning Safety Factor	1
Optimize for OTM/Sliding	No
Check Concrete Bearing	No
Footing Concrete Weight (k/ft^3)	.145
Footing Concrete f'c (ksi)	4
Footing Concrete Ec (ksi)	3644
Lambda	1
Footing Steel fy (ksi)	60
Minimum Steel	0.0018
Maximum Steel	0.0075
Footing Top Bar	#6
Footing Top Bar Cover (in)	1.5
Footing Bottom Bar	#6
Footing Bottom Bar Cover (in)	3
Pedestal Bar	#6
Pedestal Bar Cover (in)	1.5
Pedestal Ties	#4

**Hot Rolled Steel Properties**

	Label	E [ksi]	G [ksi]	Nu	Therm (\... Density[k/ft^3]	Yield[ksi]	Ry	Fu[ksi]	Rt	
1	A992	29000	11154	.3	.65	.49	50	1.1	65	1.1
2	A36 Gr.36	29000	11154	.3	.65	.49	36	1.5	58	1.2
3	A572 Gr.50	29000	11154	.3	.65	.49	50	1.1	65	1.1
4	A500 Gr.B RND	29000	11154	.3	.65	.527	42	1.4	58	1.3
5	A500 Gr.B Rect	29000	11154	.3	.65	.527	46	1.4	58	1.3
6	A53 Gr.B	29000	11154	.3	.65	.49	35	1.6	60	1.2
7	A1085	29000	11154	.3	.65	.49	50	1.4	65	1.3



Company : Centek  
 Designer : TJL  
 Job Number : 21005.07  
 Model Name : CTNH833A

Aug 16, 2021  
 11:19 AM  
 Checked By: CFC

### Hot Rolled Steel Section Sets

	Label	Shape	Type	Design List	Material	Design Ru...	A [in2]	Iyy [in4]	Izz [in4]	J [in4]
1	Outrigger	HSS4X4X4	Beam	None	A500 Gr.B ...	Typical	3.37	7.8	7.8	12.8
2	4x4 Horz	HSS4X4X4	Beam	None	A500 Gr.B ...	Typical	3.37	7.8	7.8	12.8
3	Antenna Mast	PIPE_2.0	Column	Pipe	A53 Gr.B	Typical	1.02	.627	.627	1.25
4	5" Pipe Horz	PIPE_5.0	Beam	Pipe	A53 Gr.B	Typical	4.01	14.3	14.3	28.6
5	2" Pipe	PIPE_2.0	Beam	Pipe	A53 Gr.B	Typical	1.02	.627	.627	1.25
6	2.5" Horz Pipe	PIPE_2.5	Beam	Pipe	A53 Gr.B	Typical	1.61	1.45	1.45	2.89
7	4" Vert Pipe	PIPE_4.0	Column	Wide Flange	A53 Gr.B	Typical	2.96	6.82	6.82	13.6
8	3/4" SR	SR 3/4	Column	Pipe	A36 Gr.36	Typical	.442	.016	.016	.031

### Hot Rolled Steel Design Parameters

	Label	Shape	Length[ft]	Lbyy[ft]	Lbzz[ft]	Lcomp top[...Lcomp bot[...L-torq...	Kyy	Kzz	Cb	Functi...
1	M1	5" Pipe Horz	8			Lbyy				Lateral
2	M2	2" Pipe	3.5			Lbyy				Lateral
3	M3	2" Pipe	2			Lbyy				Lateral
4	M4	2" Pipe	3			Lbyy				Lateral
5	M5	2" Pipe	3.5			Lbyy				Lateral
6	M6	2" Pipe	2			Lbyy				Lateral
7	M7	2" Pipe	3			Lbyy				Lateral
8	M8	2" Pipe	3.5			Lbyy				Lateral
9	M9	2" Pipe	2			Lbyy				Lateral
10	M10	2" Pipe	3			Lbyy				Lateral
11	M11	2" Pipe	3.5			Lbyy				Lateral
12	M12	2" Pipe	2			Lbyy				Lateral
13	M13	2" Pipe	3			Lbyy				Lateral
14	M14	4x4 Horz	9			Lbyy				Lateral
15	M15	2.5" Horz Pipe	9			Lbyy				Lateral
16	M16	2.5" Horz Pipe	9			Lbyy				Lateral
17	M17	2.5" Horz Pipe	2			Lbyy				Lateral
18	M18	2.5" Horz Pipe	2			Lbyy				Lateral
19	M21	4" Vert Pipe	4							Lateral
20	M22	Outrigger	1			Lbyy				Lateral
21	M23	2" Pipe	3			Lbyy				Lateral
22	M24	2" Pipe	3			Lbyy				Lateral
23	M25	2" Pipe	3.75			Lbyy				Lateral
24	M26	3/4" SR	2.25							Lateral
25	M27	2" Pipe	3			Lbyy				Lateral
26	M28	2" Pipe	3			Lbyy				Lateral
27	M29	2" Pipe	3.75			Lbyy				Lateral
28	M30	3/4" SR	2.25							Lateral
29	M31	2" Pipe	3			Lbyy				Lateral
30	M32	2" Pipe	3			Lbyy				Lateral
31	M33	2" Pipe	3.75			Lbyy				Lateral
32	M34	3/4" SR	2.25							Lateral
33	M35	2" Pipe	3			Lbyy				Lateral
34	M36	2" Pipe	3			Lbyy				Lateral
35	M37	2" Pipe	3.75			Lbyy				Lateral
36	M38	3/4" SR	2.25							Lateral
37	M39	2" Pipe	3			Lbyy				Lateral
38	M40	2" Pipe	3			Lbyy				Lateral

**Hot Rolled Steel Design Parameters (Continued)**

	Label	Shape	Length[ft]	Lbyy[ft]	Lbzz[ft]	Lcomp top[...Lcomp bot[...L-torq...	Kyy	Kzz	Cb	Functi...
39	M41	2" Pipe	3.75			Lbyy				Lateral
40	M42	3/4" SR	2.25							Lateral
41	M43	2" Pipe	3.884			Lbyy				Lateral
42	M44	2" Pipe	3.651			Lbyy				Lateral
43	M45	2" Pipe	3.884			Lbyy				Lateral
44	M46	2" Pipe	2.848			Lbyy				Lateral
45	M47	2" Pipe	3.304			Lbyy				Lateral
46	M48	2" Pipe	8			Lbyy				Lateral
47	M47A	2.5" Horz Pipe	2			Lbyy				Lateral

**Member Primary Data**

	Label	I Joint	J Joint	K Joint	Rotate(...	Section/Shape	Type	Design List	Material	Design R...
1	M1	N1	N2			5" Pipe Horz	Beam	Pipe	A53 Gr.B	Typical
2	M2	N5	N1			2" Pipe	Beam	Pipe	A53 Gr.B	Typical
3	M3	N1	N9			2" Pipe	Beam	Pipe	A53 Gr.B	Typical
4	M4	N9	N13			2" Pipe	Beam	Pipe	A53 Gr.B	Typical
5	M5	N7	N3			2" Pipe	Beam	Pipe	A53 Gr.B	Typical
6	M6	N3	N11			2" Pipe	Beam	Pipe	A53 Gr.B	Typical
7	M7	N11	N15			2" Pipe	Beam	Pipe	A53 Gr.B	Typical
8	M8	N8	N4			2" Pipe	Beam	Pipe	A53 Gr.B	Typical
9	M9	N4	N12			2" Pipe	Beam	Pipe	A53 Gr.B	Typical
10	M10	N12	N16			2" Pipe	Beam	Pipe	A53 Gr.B	Typical
11	M11	N2	N6			2" Pipe	Beam	Pipe	A53 Gr.B	Typical
12	M12	N2	N10			2" Pipe	Beam	Pipe	A53 Gr.B	Typical
13	M13	N10	N14			2" Pipe	Beam	Pipe	A53 Gr.B	Typical
14	M14	N21	N22			4x4 Horz	Beam	None	A500 Gr.B Rect	Typical
15	M15	N29	N28			2.5" Horz Pipe	Beam	Pipe	A53 Gr.B	Typical
16	M16	N35	N34			2.5" Horz Pipe	Beam	Pipe	A53 Gr.B	Typical
17	M17	N36	N38			2.5" Horz Pipe	Beam	Pipe	A53 Gr.B	Typical
18	M18	N40	N42			2.5" Horz Pipe	Beam	Pipe	A53 Gr.B	Typical
19	M21	N49	N48			4" Vert Pipe	Column	Wide Flange	A53 Gr.B	Typical
20	M22	N45	N47			Outrigger	Beam	None	A500 Gr.B Rect	Typical
21	M23	N53	N51			2" Pipe	Beam	Pipe	A53 Gr.B	Typical
22	M24	N52	N50			2" Pipe	Beam	Pipe	A53 Gr.B	Typical
23	M25	N55	N54			2" Pipe	Beam	Pipe	A53 Gr.B	Typical
24	M26	N56	N57			3/4" SR	Column	Pipe	A36 Gr.36	Typical
25	M27	N61	N59			2" Pipe	Beam	Pipe	A53 Gr.B	Typical
26	M28	N60	N58			2" Pipe	Beam	Pipe	A53 Gr.B	Typical
27	M29	N63	N62			2" Pipe	Beam	Pipe	A53 Gr.B	Typical
28	M30	N64	N65			3/4" SR	Column	Pipe	A36 Gr.36	Typical
29	M31	N69	N67			2" Pipe	Beam	Pipe	A53 Gr.B	Typical
30	M32	N68	N66			2" Pipe	Beam	Pipe	A53 Gr.B	Typical
31	M33	N71	N70			2" Pipe	Beam	Pipe	A53 Gr.B	Typical
32	M34	N72	N73			3/4" SR	Column	Pipe	A36 Gr.36	Typical
33	M35	N77	N75			2" Pipe	Beam	Pipe	A53 Gr.B	Typical
34	M36	N76	N74			2" Pipe	Beam	Pipe	A53 Gr.B	Typical
35	M37	N79	N78			2" Pipe	Beam	Pipe	A53 Gr.B	Typical
36	M38	N80	N81			3/4" SR	Column	Pipe	A36 Gr.36	Typical
37	M39	N85	N83			2" Pipe	Beam	Pipe	A53 Gr.B	Typical
38	M40	N84	N82			2" Pipe	Beam	Pipe	A53 Gr.B	Typical

**Member Primary Data (Continued)**

	Label	I Joint	J Joint	K Joint	Rotate(...)	Section/Shape	Type	Design List	Material	Design R...
39	M41	N87	N86			2" Pipe	Beam	Pipe	A53 Gr.B	Typical
40	M42	N88	N89			3/4" SR	Column	Pipe	A36 Gr.36	Typical
41	M43	N90	N91			2" Pipe	Beam	Pipe	A53 Gr.B	Typical
42	M44	N93	N92			2" Pipe	Beam	Pipe	A53 Gr.B	Typical
43	M45	N95	N94			2" Pipe	Beam	Pipe	A53 Gr.B	Typical
44	M46	N96	N99			2" Pipe	Beam	Pipe	A53 Gr.B	Typical
45	M47	N97	N98			2" Pipe	Beam	Pipe	A53 Gr.B	Typical
46	M48	N9	N10			2" Pipe	Beam	Pipe	A53 Gr.B	Typical
47	M47A	N96A	N97A			2.5" Horz Pipe	Beam	Pipe	A53 Gr.B	Typical

**Joint Coordinates and Temperatures**

	Label	X [ft]	Y [ft]	Z [ft]	Temp [F]	Detach From Diap...
1	N1	0	0	0	0	
2	N2	8	0	0	0	
3	N3	2.666667	0	0	0	
4	N4	5.333333	0	0	0	
5	N5	0	3.5	0	0	
6	N6	8	3.5	0	0	
7	N7	2.666667	3.5	0	0	
8	N8	5.333333	3.5	0	0	
9	N9	0	0	2	0	
10	N10	8	0	2	0	
11	N11	2.666667	0	2	0	
12	N12	5.333333	0	2	0	
13	N13	0	3	2	0	
14	N14	8	3	2	0	
15	N15	2.666667	3	2	0	
16	N16	5.333333	3	2	0	
17	N17	0	0	1	0	
18	N18	2.666667	0	1	0	
19	N19	5.333333	0	1	0	
20	N20	8	0	1	0	
21	N21	-.5	0	1	0	
22	N22	8.5	0	1	0	
23	N23	4	0	0	0	
24	N24	0	2.75	2	0	
25	N25	8	2.75	2	0	
26	N26	2.666667	2.75	2	0	
27	N27	5.333333	2.75	2	0	
28	N28	8.5	2.75	2	0	
29	N29	-.5	2.75	2	0	
30	N30	0	2.75	0	0	
31	N31	8	2.75	0	0	
32	N32	2.666667	2.75	0	0	
33	N33	5.333333	2.75	0	0	
34	N34	8.5	2.75	0	0	
35	N35	-.5	2.75	0	0	
36	N36	1.335	2.75	2	0	
37	N38	1.335	2.75	0	0	
38	N40	6.665	2.75	2	0	





Company : Centek  
 Designer : T.JL  
 Job Number : 21005.07  
 Model Name : CTNH833A

Aug 16, 2021  
 11:19 AM  
 Checked By: CFC

**Joint Coordinates and Temperatures (Continued)**

	Label	X [ft]	Y [ft]	Z [ft]	Temp [F]	Detach From Diap...
39	N42	6.665	2.75	0	0	
40	N44	4.75	0	0	0	
41	N45	4	2.75	0	0	
42	N46	4.75	2.75	0	0	
43	N47	4	2.75	-1	0	
44	N48	4.75	3.5	0	0	
45	N49	4.75	-.5	0	0	
46	N50	0	.25	0	0	
47	N51	0	2.5	0	0	
48	N52	-2.954423	.25	-0.520945	0	
49	N53	-2.954423	2.5	-0.520945	0	
50	N54	-2.954423	3.25	-0.520945	0	
51	N55	-2.954423	-.5	-0.520945	0	
52	N56	-1.477212	.25	-0.260472	0	
53	N57	-1.477212	2.5	-0.260472	0	
54	N58	0	.25	2	0	
55	N59	0	2.5	2	0	
56	N60	-2.954423	.25	2.520945	0	
57	N61	-2.954423	2.5	2.520945	0	
58	N62	-2.954423	3.25	2.520945	0	
59	N63	-2.954423	-.5	2.520945	0	
60	N64	-1.477212	.25	2.260472	0	
61	N65	-1.477212	2.5	2.260472	0	
62	N66	2.666667	.25	2	0	
63	N67	2.666667	2.5	2	0	
64	N68	2.145722	.25	4.954423	0	
65	N69	2.145722	2.5	4.954423	0	
66	N70	2.145722	3.25	4.954423	0	
67	N71	2.145722	-.5	4.954423	0	
68	N72	2.406195	.25	3.477212	0	
69	N73	2.406195	2.5	3.477212	0	
70	N74	5.333334	.25	2	0	
71	N75	5.333334	2.5	2	0	
72	N76	6.833334	.25	4.598076	0	
73	N77	6.833334	2.5	4.598076	0	
74	N78	6.833334	3.25	4.598076	0	
75	N79	6.833334	-.5	4.598076	0	
76	N80	6.083334	.25	3.299038	0	
77	N81	6.083334	2.5	3.299038	0	
78	N82	8.000001	.25	2	0	
79	N83	8.000001	2.5	2	0	
80	N84	10.954424	.25	1.479055	0	
81	N85	10.954424	2.5	1.479055	0	
82	N86	10.954424	3.25	1.479055	0	
83	N87	10.954424	-.5	1.479055	0	
84	N88	9.477213	.25	1.739528	0	
85	N89	9.477213	2.5	1.739528	0	
86	N90	-2.954423	.75	-0.520945	0	
87	N91	0	.75	2	0	
88	N92	0	1.25	2	0	
89	N93	2.145722	1.25	4.954423	0	
90	N94	0	2	0	0	

**Joint Coordinates and Temperatures (Continued)**

	Label	X [ft]	Y [ft]	Z [ft]	Temp [F]	Detach From Diap...
91	N95	-2.954423	2	2.520945	0	
92	N96	6.833334	1.25	4.598076	0	
93	N97	10.954424	1.25	1.479055	0	
94	N98	8	1.25	0	0	
95	N99	8	1.25	2	0	
96	N96A	3.415	2.75	2	0	
97	N97A	3.415	2.75	0	0	

**Joint Boundary Conditions**

	Joint Label	X [k/in]	Y [k/in]	Z [k/in]	X Rot.[k-ft/rad]	Y Rot.[k-ft/rad]	Z Rot.[k-ft/rad]
1	N23	Reaction	Reaction	Reaction	Reaction	Reaction	Reaction
2	N44						
3	N45						
4	N46						
5	N47	Reaction	Reaction	Reaction	Reaction	Reaction	Reaction
6	N48						
7	N49						

**Member Point Loads (BLC 2 : Equipment Weight)**

	Member Label	Direction	Magnitude[k,k-ft]	Location[ft,%]
1	M25	Y	-.103	%50
2	M33	Y	-.103	%50
3	M41	Y	-.103	%50
4	M11	Y	-.118	%50
5	M29	Y	-.118	%50
6	M37	Y	-.118	%50
7	M11	Y	-.109	.5
8	M29	Y	-.109	.5
9	M37	Y	-.109	.5
10	M11	Y	-.084	3.5
11	M29	Y	-.084	3.5
12	M37	Y	-.084	3.5

**Member Point Loads (BLC 3 : Ice Weight)**

	Member Label	Direction	Magnitude[k,k-ft]	Location[ft,%]
1	M25	Y	-.141	%50
2	M33	Y	-.141	%50
3	M41	Y	-.141	%50
4	M11	Y	-.305	%50
5	M29	Y	-.305	%50
6	M37	Y	-.305	%50
7	M11	Y	-.095	.5
8	M29	Y	-.095	.5
9	M37	Y	-.095	.5
10	M11	Y	-.082	3.5
11	M29	Y	-.082	3.5
12	M37	Y	-.082	3.5



**Member Point Loads (BLC 4 : Wind w/ Ice X)**

	Member Label	Direction	Magnitude[k,k-ft]	Location[ft,%]
1	M33	X	.028	%50
2	M25	X	.057	%50
3	M41	X	.057	%50
4	M37	X	.06	%50
5	M11	X	.138	%50
6	M29	X	.138	%50
7	M37	X	.023	.5
8	M37	X	.018	3.5

**Member Point Loads (BLC 5 : Wind X)**

	Member Label	Direction	Magnitude[k,k-ft]	Location[ft,%]
1	M33	X	.068	%50
2	M25	X	.169	%50
3	M41	X	.169	%50
4	M37	X	.155	%50
5	M11	X	.439	%50
6	M29	X	.439	%50
7	M37	X	.059	.5
8	M37	X	.041	3.5

**Member Point Loads (BLC 6 : Wind w/ Ice Z)**

	Member Label	Direction	Magnitude[k,k-ft]	Location[ft,%]
1	M33	Z	.057	%50
2	M25	Z	.028	%50
3	M41	Z	.028	%50
4	M37	Z	.138	%50
5	M11	Z	.06	%50
6	M29	Z	.06	%50
7	M11	Z	.023	.5
8	M29	Z	.023	.5
9	M11	Z	.018	3.5
10	M29	Z	.018	3.5

**Member Point Loads (BLC 7 : Wind Z)**

	Member Label	Direction	Magnitude[k,k-ft]	Location[ft,%]
1	M33	Z	.169	%50
2	M25	Z	.068	%50
3	M41	Z	.068	%50
4	M37	Z	.439	%50
5	M11	Z	.155	%50
6	M29	Z	.155	%50
7	M11	Z	.059	.5
8	M29	Z	.059	.5
9	M11	Z	.041	3.5
10	M29	Z	.041	3.5



Company : Centek  
 Designer : TJJ  
 Job Number : 21005.07  
 Model Name : CTNH833A

Aug 16, 2021  
 11:19 AM  
 Checked By: CFC

**Member Distributed Loads (BLC 3 : Ice Weight)**

	Member Label	Direction	Start Magnitude[k/ft,F,ksf]	End Magnitude[k/f...	Start Location[ft,%]	End Location[ft,%]
1	M1	Y	-.008	-.008	0	0
2	M2	Y	-.008	-.008	0	0
3	M3	Y	-.008	-.008	0	0
4	M4	Y	-.008	-.008	0	0
5	M5	Y	-.008	-.008	0	0
6	M6	Y	-.008	-.008	0	0
7	M7	Y	-.008	-.008	0	0
8	M8	Y	-.008	-.008	0	0
9	M9	Y	-.008	-.008	0	0
10	M10	Y	-.008	-.008	0	0
11	M11	Y	-.008	-.008	0	0
12	M12	Y	-.008	-.008	0	0
13	M13	Y	-.008	-.008	0	0
14	M14	Y	-.008	-.008	0	0
15	M15	Y	-.008	-.008	0	0
16	M16	Y	-.008	-.008	0	0
17	M17	Y	-.008	-.008	0	0
18	M18	Y	-.008	-.008	0	0
19	M21	Y	-.008	-.008	0	0
20	M22	Y	-.008	-.008	0	0
21	M23	Y	-.008	-.008	0	0
22	M24	Y	-.008	-.008	0	0
23	M25	Y	-.008	-.008	0	0
24	M26	Y	-.008	-.008	0	0
25	M27	Y	-.008	-.008	0	0
26	M28	Y	-.008	-.008	0	0
27	M29	Y	-.008	-.008	0	0
28	M30	Y	-.008	-.008	0	0
29	M31	Y	-.008	-.008	0	0
30	M32	Y	-.008	-.008	0	0
31	M33	Y	-.008	-.008	0	0
32	M34	Y	-.008	-.008	0	0
33	M35	Y	-.008	-.008	0	0
34	M36	Y	-.008	-.008	0	0
35	M37	Y	-.008	-.008	0	0
36	M38	Y	-.008	-.008	0	0
37	M39	Y	-.008	-.008	0	0
38	M40	Y	-.008	-.008	0	0
39	M41	Y	-.008	-.008	0	0
40	M42	Y	-.008	-.008	0	0
41	M43	Y	-.008	-.008	0	0
42	M44	Y	-.008	-.008	0	0
43	M45	Y	-.008	-.008	0	0
44	M46	Y	-.008	-.008	0	0
45	M47	Y	-.008	-.008	0	0
46	M47A	Y	-.008	-.008	0	0

**Member Distributed Loads (BLC 4 : Wind w/ Ice X)**

	Member Label	Direction	Start Magnitude[k/ft,F,ksf]	End Magnitude[k/f...	Start Location[ft,%]	End Location[ft,%]
1	M2	X	.004	.004	0	0



**Member Distributed Loads (BLC 4 : Wind w/ Ice X) (Continued)**

	Member Label	Direction	Start Magnitude[k/ft,F,ksf]	End Magnitude[k/f..	Start Location[ft,%]	End Location[ft,%]
2	M3	X	.004	.004	0	0
3	M4	X	.004	.004	0	0
4	M5	X	.004	.004	0	0
5	M6	X	.004	.004	0	0
6	M7	X	.004	.004	0	0
7	M8	X	.004	.004	0	0
8	M9	X	.004	.004	0	0
9	M10	X	.004	.004	0	0
10	M11	X	.004	.004	0	0
11	M12	X	.004	.004	0	0
12	M13	X	.004	.004	0	0
13	M17	X	.004	.004	0	0
14	M18	X	.004	.004	0	0
15	M21	X	.004	.004	0	0
16	M22	X	.004	.004	0	0
17	M23	X	.004	.004	0	0
18	M24	X	.004	.004	0	0
19	M26	X	.004	.004	0	0
20	M27	X	.004	.004	0	0
21	M28	X	.004	.004	0	0
22	M30	X	.004	.004	0	0
23	M31	X	.004	.004	0	0
24	M32	X	.004	.004	0	0
25	M33	X	.004	.004	0	0
26	M34	X	.004	.004	0	0
27	M35	X	.004	.004	0	0
28	M36	X	.004	.004	0	0
29	M37	X	.004	.004	0	0
30	M38	X	.004	.004	0	0
31	M39	X	.004	.004	0	0
32	M40	X	.004	.004	0	0
33	M42	X	.004	.004	0	0
34	M43	X	.004	.004	0	0
35	M44	X	.004	.004	0	0
36	M45	X	.004	.004	0	0
37	M46	X	.004	.004	0	0
38	M47	X	.004	.004	0	0
39	M47A	X	.004	.004	0	0

**Member Distributed Loads (BLC 5 : Wind X)**

	Member Label	Direction	Start Magnitude[k/ft,F,ksf]	End Magnitude[k/f..	Start Location[ft,%]	End Location[ft,%]
1	M2	X	.009	.009	0	0
2	M3	X	.009	.009	0	0
3	M4	X	.009	.009	0	0
4	M5	X	.009	.009	0	0
5	M6	X	.009	.009	0	0
6	M7	X	.009	.009	0	0
7	M8	X	.009	.009	0	0
8	M9	X	.009	.009	0	0
9	M10	X	.009	.009	0	0
10	M11	X	.009	.009	0	0

**Member Distributed Loads (BLC 5 : Wind X) (Continued)**

	Member Label	Direction	Start Magnitude[k/ft,F,ksf]	End Magnitude[k/f..	Start Location[ft, %]	End Location[ft, %]
11	M12	X	.009	.009	0	0
12	M13	X	.009	.009	0	0
13	M17	X	.009	.009	0	0
14	M18	X	.009	.009	0	0
15	M21	X	.009	.009	0	0
16	M22	X	.009	.009	0	0
17	M23	X	.009	.009	0	0
18	M24	X	.009	.009	0	0
19	M26	X	.009	.009	0	0
20	M27	X	.009	.009	0	0
21	M28	X	.009	.009	0	0
22	M30	X	.009	.009	0	0
23	M31	X	.009	.009	0	0
24	M32	X	.009	.009	0	0
25	M33	X	.009	.009	0	0
26	M34	X	.009	.009	0	0
27	M35	X	.009	.009	0	0
28	M36	X	.009	.009	0	0
29	M37	X	.009	.009	0	0
30	M38	X	.009	.009	0	0
31	M39	X	.009	.009	0	0
32	M40	X	.009	.009	0	0
33	M42	X	.009	.009	0	0
34	M43	X	.009	.009	0	0
35	M44	X	.009	.009	0	0
36	M45	X	.009	.009	0	0
37	M46	X	.009	.009	0	0
38	M47	X	.009	.009	0	0
39	M47A	X	.009	.009	0	0

**Member Distributed Loads (BLC 6 : Wind w/ Ice Z)**

	Member Label	Direction	Start Magnitude[k/ft,F,ksf]	End Magnitude[k/f..	Start Location[ft, %]	End Location[ft, %]
1	M1	Z	.004	.004	0	0
2	M2	Z	.004	.004	0	0
3	M4	Z	.004	.004	0	0
4	M5	Z	.004	.004	0	0
5	M7	Z	.004	.004	0	0
6	M8	Z	.004	.004	0	0
7	M10	Z	.004	.004	0	0
8	M11	Z	.004	.004	0	0
9	M13	Z	.004	.004	0	0
10	M14	Z	.004	.004	0	0
11	M15	Z	.004	.004	0	0
12	M16	Z	.004	.004	0	0
13	M21	Z	.004	.004	0	0
14	M23	Z	.004	.004	0	0
15	M24	Z	.004	.004	0	0
16	M25	Z	.004	.004	0	0
17	M26	Z	.004	.004	0	0
18	M27	Z	.004	.004	0	0
19	M28	Z	.004	.004	0	0

**Member Distributed Loads (BLC 6 : Wind w/ Ice Z) (Continued)**

	Member Label	Direction	Start Magnitude[k/ft,F,ksf]	End Magnitude[k/f..	Start Location[ft, %]	End Location[ft, %]
20	M29	Z	.004	.004	0	0
21	M30	Z	.004	.004	0	0
22	M31	Z	.004	.004	0	0
23	M32	Z	.004	.004	0	0
24	M34	Z	.004	.004	0	0
25	M35	Z	.004	.004	0	0
26	M36	Z	.004	.004	0	0
27	M38	Z	.004	.004	0	0
28	M39	Z	.004	.004	0	0
29	M40	Z	.004	.004	0	0
30	M41	Z	.004	.004	0	0
31	M42	Z	.004	.004	0	0
32	M43	Z	.004	.004	0	0
33	M44	Z	.004	.004	0	0
34	M45	Z	.004	.004	0	0
35	M46	Z	.004	.004	0	0
36	M47	Z	.004	.004	0	0
37	M48	Z	.004	.004	0	0

**Member Distributed Loads (BLC 7 : Wind Z)**

	Member Label	Direction	Start Magnitude[k/ft,F,ksf]	End Magnitude[k/f..	Start Location[ft, %]	End Location[ft, %]
1	M1	Z	.009	.009	0	0
2	M2	Z	.009	.009	0	0
3	M4	Z	.009	.009	0	0
4	M5	Z	.009	.009	0	0
5	M7	Z	.009	.009	0	0
6	M8	Z	.009	.009	0	0
7	M10	Z	.009	.009	0	0
8	M11	Z	.009	.009	0	0
9	M13	Z	.009	.009	0	0
10	M14	Z	.009	.009	0	0
11	M15	Z	.009	.009	0	0
12	M16	Z	.009	.009	0	0
13	M21	Z	.009	.009	0	0
14	M23	Z	.009	.009	0	0
15	M24	Z	.009	.009	0	0
16	M25	Z	.009	.009	0	0
17	M26	Z	.009	.009	0	0
18	M27	Z	.009	.009	0	0
19	M28	Z	.009	.009	0	0
20	M29	Z	.009	.009	0	0
21	M30	Z	.009	.009	0	0
22	M31	Z	.009	.009	0	0
23	M32	Z	.009	.009	0	0
24	M34	Z	.009	.009	0	0
25	M35	Z	.009	.009	0	0
26	M36	Z	.009	.009	0	0
27	M38	Z	.009	.009	0	0
28	M39	Z	.009	.009	0	0
29	M40	Z	.009	.009	0	0
30	M41	Z	.009	.009	0	0

**Member Distributed Loads (BLC 7 : Wind Z) (Continued)**

	Member Label	Direction	Start Magnitude[k/ft,F,ksf]	End Magnitude[k/ft,F,ksf]	Start Location[ft,%]	End Location[ft,%]
31	M42	Z	.009	.009	0	0
32	M43	Z	.009	.009	0	0
33	M44	Z	.009	.009	0	0
34	M45	Z	.009	.009	0	0
35	M46	Z	.009	.009	0	0
36	M47	Z	.009	.009	0	0
37	M48	Z	.009	.009	0	0

**Basic Load Cases**

	BLC Description	Category	X Gra...	Y Gra...	Z Gra...	Joint	Point	Distrib..	Area(... Surfa...
1	Self Weight	None		-1					
2	Equipment Weight	None					12		
3	Ice Weight	None					12	46	
4	Wind w/ Ice X	None					8	39	
5	Wind X	None					8	39	
6	Wind w/ Ice Z	None					10	37	
7	Wind Z	None					10	37	

**Load Combinations**

	Description	Solve	P...	S...	B...	Fa...	BLC	Fact...	BLC	Fa...	BLC	Fa...	B...	Fa...	B...	Fa...	B...	Fa...	B...	Fa...
1	1.2D + 1.6W (X-dir...	Yes	Y		1	1.2	2	1.2	5	1.6										
2	0.9D + 1.6W (X-dir...	Yes	Y		1	.9	2	.9	5	1.6										
3	1.2D + 1.0Di + 1.0...	Yes	Y		1	1.2	2	1.2	3	1	4	1								
4	1.2D + 1.6W (Z-dire...	Yes	Y		1	1.2	2	1.2	7	1.6										
5	0.9D + 1.6W (Z-dire...	Yes	Y		1	.9	2	.9	7	1.6										
6	1.2D + 1.0Di + 1.0...	Yes	Y		1	1.2	2	1.2	3	1	6	1								

**Envelope Joint Reactions**

	Joint		X [k]	LC	Y [k]	LC	Z [k]	LC	MX [k-ft]	LC	MY [k-ft]	LC	MZ [k-ft]	LC
1	N23	max	-.048	6	4.828	6	2.422	3	-1.151	2	.087	6	1.704	2
2		min	-2.732	2	1.567	2	-1.736	5	-4.326	6	-6.812	2	-1.369	6
3	N47	max	.235	5	.772	3	-.819	2	-.25	2	-.106	5	.075	2
4		min	-1.339	1	.179	5	-2.803	6	-.784	6	-1.789	1	-.104	6
5	Totals:	max	0	6	5.577	6	0	3						
6		min	-4.065	1	1.835	2	-4.067	4						

**Envelope Joint Displacements**

	Joint		X [in]	LC	Y [in]	LC	Z [in]	LC	X Rotation [rad]	LC	Y Rotatio...	LC	Z Rotation [rad]	LC
1	N1	max	0	1	-.003	2	.07	2	2.81e-03	6	2.079e-03	2	2.417e-03	6
2		min	0	5	-.09	6	0	6	5.261e-04	2	1.284e-04	6	1.958e-05	2
3	N2	max	0	5	-.029	5	.028	5	2.324e-03	6	2.12e-03	2	-8.833e-04	5
4		min	0	3	-.077	3	-.076	1	9.789e-04	2	-6.432e-04	4	-2.185e-03	3
5	N3	max	0	1	-.001	2	.012	2	1.518e-03	6	1.322e-03	2	1.68e-03	6
6		min	0	5	-.018	6	-.002	6	3.209e-04	2	-5.039e-05	6	7.536e-05	2
7	N4	max	0	5	-.005	5	.006	5	1.226e-03	6	1.508e-03	1	-4.878e-04	5
8		min	0	3	-.013	3	-.015	1	4.602e-04	2	-5.332e-04	5	-1.328e-03	3



**Envelope Joint Displacements (Continued)**

	Joint		X [in]	LC	Y [in]	LC	Z [in]	LC	X Rotation [rad]	LC	Y Rotatio...	LC	Z Rotation [rad]	LC
9	N5	max	.006	2	-.003	2	.186	4	2.182e-03	4	4.328e-03	4	1.609e-03	3
10		min	-.013	6	-.09	6	.108	3	7.534e-04	2	1.634e-03	3	-1.244e-04	5
11	N6	max	.016	3	-.029	5	.219	4	3.752e-03	4	1.303e-03	2	-2.013e-04	5
12		min	.003	5	-.078	3	-.045	2	4.273e-04	2	-4.715e-03	4	-1.316e-03	3
13	N7	max	.007	2	-.001	2	.042	4	8.626e-04	6	2.95e-03	4	1.425e-03	6
14		min	-.011	6	-.018	6	.03	2	3.7e-04	2	1.988e-03	2	-1.059e-06	2
15	N8	max	.017	1	-.005	5	.036	4	7.861e-04	4	9.181e-04	2	-5.218e-04	5
16		min	.006	5	-.012	3	-.014	2	-4.063e-05	2	-3.522e-03	4	-1.333e-03	3
17	N9	max	.062	1	-.038	2	.07	2	7.806e-03	6	3.122e-03	2	2.146e-03	6
18		min	.004	6	-.277	6	0	6	1.876e-03	2	3.11e-04	6	-1.602e-03	2
19	N10	max	.061	2	-.11	2	.028	5	6.216e-03	6	2.731e-03	2	-8.052e-04	6
20		min	0	6	-.223	6	-.077	1	1.541e-03	2	-1.355e-04	6	-2.575e-03	1
21	N11	max	.061	2	-.048	2	.013	2	5.945e-03	6	2.219e-03	1	1.012e-03	6
22		min	.003	6	-.2	6	-.002	6	1.608e-03	2	3.797e-04	6	-1.247e-03	2
23	N12	max	.061	2	-.071	2	.006	5	6.832e-03	6	2.206e-03	2	-2.668e-04	6
24		min	.001	6	-.196	6	-.016	1	2.218e-03	2	-1.962e-04	4	-1.666e-03	1
25	N13	max	.169	2	-.038	2	.161	4	1.914e-03	6	4.066e-03	1	2.693e-03	6
26		min	-.023	6	-.277	6	.116	3	8.397e-04	2	2.514e-03	6	-8.64e-04	2
27	N14	max	.172	2	-.111	2	.159	4	2.014e-03	4	2.946e-03	2	-4.854e-04	6
28		min	-.012	6	-.224	6	-.073	2	3.701e-04	2	-2.622e-03	4	-1.851e-03	1
29	N15	max	.169	2	-.048	2	.035	4	1.17e-03	6	3.034e-03	4	1.239e-03	6
30		min	-.018	6	-.201	6	.024	2	4.93e-04	2	1.885e-03	2	-8.69e-04	2
31	N16	max	.17	2	-.071	2	.064	4	1.675e-03	6	1.153e-03	2	-6.772e-04	6
32		min	-.011	6	-.197	6	.003	2	4.166e-04	2	-2.951e-03	4	-1.476e-03	1
33	N17	max	.028	2	-.016	2	.07	2	8.89e-03	6	2.119e-03	2	2.443e-03	6
34		min	0	6	-.166	6	0	6	1.842e-03	2	9.918e-05	6	-1.748e-04	2
35	N18	max	.028	2	-.021	2	.013	2	9.035e-03	6	1.419e-03	2	1.358e-03	6
36		min	0	6	-.099	6	-.002	6	2.38e-03	2	4.244e-05	6	-2.296e-04	2
37	N19	max	.028	2	-.036	2	.006	5	8.78e-03	6	1.472e-03	2	-5.01e-04	5
38		min	0	6	-.09	6	-.016	1	2.932e-03	2	-2.651e-04	4	-9.84e-04	1
39	N20	max	.028	2	-.066	5	.027	5	7.695e-03	6	2.23e-03	2	-8.888e-04	5
40		min	0	6	-.137	3	-.077	1	3.062e-03	2	-4.301e-04	4	-1.804e-03	3
41	N21	max	.028	2	-.015	2	.082	2	8.89e-03	6	2.119e-03	2	2.443e-03	6
42		min	0	6	-.181	6	0	6	1.842e-03	2	9.925e-05	6	-1.746e-04	2
43	N22	max	.028	2	-.072	5	.03	5	7.695e-03	6	2.23e-03	2	-8.89e-04	5
44		min	0	6	-.148	3	-.09	1	3.062e-03	2	-4.303e-04	4	-1.805e-03	3
45	N23	max	0	6	0	6	0	6	0	6	0	6	0	6
46		min	0	1	0	1	0	1	0	1	0	1	0	1
47	N24	max	.166	2	-.038	2	.156	4	1.914e-03	6	4.066e-03	1	2.693e-03	6
48		min	-.015	6	-.277	6	.111	3	8.397e-04	2	2.514e-03	6	-8.636e-04	2
49	N25	max	.166	2	-.111	2	.153	4	2.014e-03	4	2.946e-03	2	-4.854e-04	6
50		min	-.013	6	-.224	6	-.074	2	3.701e-04	2	-2.622e-03	4	-1.851e-03	1
51	N26	max	.166	2	-.048	2	.032	4	1.17e-03	6	3.034e-03	4	1.239e-03	6
52		min	-.014	6	-.201	6	.023	2	4.93e-04	2	1.885e-03	2	-8.686e-04	2
53	N27	max	.166	2	-.071	2	.06	4	1.675e-03	6	1.153e-03	2	-6.772e-04	6
54		min	-.013	6	-.197	6	.002	2	4.166e-04	2	-2.951e-03	4	-1.476e-03	1
55	N28	max	.166	2	-.122	2	.168	4	2.014e-03	4	2.946e-03	2	-4.867e-04	6
56		min	-.013	6	-.226	6	-.091	2	3.701e-04	2	-2.623e-03	4	-1.851e-03	1
57	N29	max	.166	2	-.033	2	.177	4	1.914e-03	6	4.066e-03	1	2.694e-03	6
58		min	-.015	6	-.293	6	.126	3	8.397e-04	2	2.515e-03	6	-8.632e-04	2
59	N30	max	.007	1	-.003	2	.166	4	2.172e-03	4	4.328e-03	4	1.612e-03	3
60		min	0	5	-.09	6	.093	3	7.534e-04	2	1.634e-03	3	-1.244e-04	5

**Envelope Joint Displacements (Continued)**

	Joint		X [in]	LC	Y [in]	LC	Z [in]	LC	X Rotation [rad]	LC	Y Rotatio...	LC	Z Rotation [rad]	LC
61	N31	max	.008	1	-.029	5	.186	4	3.559e-03	4	1.303e-03	2	-1.923e-04	2
62		min	.001	5	-.078	3	-.048	2	4.272e-04	2	-4.715e-03	4	-1.313e-03	3
63	N32	max	.007	1	-.001	2	.035	4	8.598e-04	6	2.95e-03	4	1.425e-03	6
64		min	0	5	-.018	6	.026	2	3.7e-04	2	1.988e-03	2	8.964e-06	2
65	N33	max	.008	1	-.005	5	.029	4	7.76e-04	4	9.181e-04	2	-5.218e-04	5
66		min	0	5	-.012	3	-.013	2	-4.063e-05	2	-3.522e-03	4	-1.33e-03	3
67	N34	max	.008	1	-.03	5	.214	4	3.559e-03	4	1.303e-03	2	-1.927e-04	2
68		min	.001	5	-.086	3	-.056	2	4.272e-04	2	-4.717e-03	4	-1.314e-03	3
69	N35	max	.007	1	-.004	2	.192	4	2.172e-03	4	4.329e-03	4	1.613e-03	3
70		min	0	5	-.1	6	.102	3	7.534e-04	2	1.634e-03	3	-1.239e-04	5
71	N36	max	.166	2	-.043	2	.093	4	1.542e-03	6	4.101e-03	4	2.582e-03	6
72		min	-.015	6	-.233	6	.062	2	6.661e-04	2	2.894e-03	3	-6.839e-05	2
73	N38	max	.007	1	-.002	2	.094	4	1.489e-03	4	4.293e-03	4	2.617e-03	6
74		min	0	5	-.054	6	.062	2	5.615e-04	2	1.995e-03	3	6.e-05	2
75	N40	max	.166	2	-.089	2	.105	4	1.714e-03	4	2.486e-03	2	-9.098e-04	5
76		min	-.013	6	-.211	6	-.029	2	3.934e-04	2	-2.952e-03	4	-1.207e-03	1
77	N42	max	.008	1	-.018	5	.105	4	2.166e-03	4	1.095e-03	2	-9.419e-04	5
78		min	.001	5	-.045	3	-.029	2	1.93e-04	2	-5.221e-03	4	-2.254e-03	3
79	N44	max	0	5	-.002	5	.002	5	6.108e-04	6	1.02e-03	1	-2.913e-04	5
80		min	0	3	-.005	3	-.006	1	2.093e-04	2	-4.303e-04	5	-7.926e-04	3
81	N45	max	.007	1	0	2	0	6	3.295e-04	6	8.932e-04	1	1.049e-04	6
82		min	0	5	-.003	6	0	2	9.351e-05	2	1.779e-04	5	-7.586e-05	2
83	N46	max	.008	1	-.002	5	.01	4	2.433e-04	4	8.538e-04	2	-8.996e-05	5
84		min	0	5	-.005	3	-.007	2	-1.049e-04	2	-1.8e-03	4	-3.361e-04	1
85	N47	max	0	6	0	6	0	6	0	6	0	6	0	6
86		min	0	1	0	1	0	1	0	1	0	1	0	1
87	N48	max	.011	1	-.002	5	.012	4	2.442e-04	4	8.538e-04	2	-8.996e-05	5
88		min	.002	5	-.005	3	-.008	2	-1.049e-04	2	-1.8e-03	4	-3.37e-04	1
89	N49	max	-.002	5	-.002	5	0	5	6.108e-04	6	1.02e-03	1	-2.913e-04	5
90		min	-.005	3	-.005	3	-.007	1	2.093e-04	2	-4.303e-04	5	-7.925e-04	3
91	N50	max	0	2	-.003	2	.072	2	3.258e-03	6	2.469e-03	2	1.688e-03	6
92		min	-.006	6	-.09	6	.01	6	7.031e-04	2	4.104e-04	6	-5.877e-05	2
93	N51	max	.008	1	-.003	2	.159	4	2.528e-03	4	3.842e-03	4	1.03e-03	3
94		min	-.002	5	-.09	6	.087	3	8.344e-04	2	1.521e-03	3	-3.778e-04	5
95	N52	max	-.01	6	-.014	2	.207	1	4.846e-03	4	4.351e-03	1	1.018e-03	6
96		min	-.023	1	-.157	6	.039	6	4.287e-04	2	1.016e-03	6	-5.048e-04	2
97	N53	max	-.004	3	-.014	2	.255	4	5.102e-03	4	3.77e-03	1	7.981e-04	6
98		min	-.018	4	-.157	6	.141	3	2.561e-04	2	1.147e-03	6	2.778e-04	2
99	N54	max	-.011	3	-.014	2	.301	4	5.112e-03	4	3.77e-03	1	7.981e-04	6
100		min	-.022	4	-.157	6	.164	3	2.561e-04	2	1.147e-03	6	2.778e-04	2
101	N55	max	-.001	6	-.014	2	.203	2	4.836e-03	4	4.351e-03	1	1.018e-03	6
102		min	-.027	2	-.157	6	.002	6	4.287e-04	2	1.016e-03	6	-5.048e-04	2
103	N56	max	-.008	6	-.009	2	.131	2	4.01e-03	4	4.044e-03	1	2.994e-03	6
104		min	-.01	1	-.127	6	.022	6	3.99e-04	2	8.668e-04	6	6.766e-04	2
105	N57	max	.001	3	-.009	2	.216	4	3.588e-03	4	3.312e-03	1	3.058e-03	6
106		min	-.011	5	-.127	6	.114	3	5.113e-04	2	1.393e-03	6	4.925e-04	2
107	N58	max	.069	2	-.038	2	.076	1	6.733e-03	6	3.717e-03	2	2.127e-03	6
108		min	-.001	6	-.277	6	.022	6	1.952e-03	2	3.904e-04	6	-2.265e-03	2
109	N59	max	.162	2	-.038	2	.15	4	2.14e-03	6	4.267e-03	1	2.773e-03	6
110		min	-.007	6	-.277	6	.105	3	9.322e-04	2	1.823e-03	6	-1.508e-03	2
111	N60	max	.105	2	-.009	2	.277	2	4.233e-03	3	6.527e-03	2	2.723e-03	6
112		min	0	6	-.526	6	.018	6	1.559e-03	5	-5.33e-04	6	-3.224e-03	2

**Envelope Joint Displacements (Continued)**

	Joint		X [in]	LC	Y [in]	LC	Z [in]	LC	X Rotation [rad]	LC	Y Rotatio...	LC	Z Rotation [rad]	LC
113	N61	max	.197	2	-.009	2	.314	1	3.671e-03	6	6.169e-03	2	3.263e-03	6
114		min	-.009	6	-.526	6	.108	6	1.018e-03	2	-1.042e-03	6	-1.668e-03	2
115	N62	max	.212	2	-.009	2	.326	1	3.697e-03	6	6.169e-03	2	3.263e-03	6
116		min	-.039	6	-.526	6	.141	6	1.018e-03	2	-1.042e-03	6	-1.668e-03	2
117	N63	max	.078	1	-.009	2	.262	2	4.231e-03	3	6.527e-03	2	2.722e-03	6
118		min	.024	6	-.526	6	-.02	6	1.52e-03	5	-5.33e-04	6	-3.223e-03	2
119	N64	max	.085	2	-.026	2	.164	2	6.361e-03	6	5.962e-03	2	7.488e-03	6
120		min	0	6	-.4	6	.024	6	2.217e-03	2	-1.061e-04	6	-4.931e-04	2
121	N65	max	.178	2	-.026	2	.212	1	3.766e-03	6	5.57e-03	2	7.86e-03	6
122		min	-.006	6	-.4	6	.123	3	1.139e-03	2	-4.535e-04	6	-7.423e-04	2
123	N66	max	.067	2	-.048	2	.017	1	3.97e-03	6	2.428e-03	1	6.89e-04	6
124		min	0	6	-.2	6	.012	3	1.088e-03	2	7.848e-04	6	-2.296e-03	2
125	N67	max	.162	2	-.048	2	.03	4	1.169e-03	6	2.868e-03	4	1.046e-03	6
126		min	-.011	6	-.201	6	.021	2	4.768e-04	2	1.825e-03	3	-1.9e-03	2
127	N68	max	.173	1	-.07	2	.036	1	1.809e-03	6	3.223e-03	4	2.125e-04	6
128		min	.063	6	-.327	6	.023	3	2.518e-04	2	2.072e-03	3	-2.783e-03	2
129	N69	max	.251	1	-.07	2	.049	4	1.44e-03	3	2.948e-03	4	4.832e-04	6
130		min	.059	6	-.327	6	.034	3	5.464e-04	5	1.916e-03	3	-2.806e-03	2
131	N70	max	.275	1	-.07	2	.055	4	1.44e-03	3	2.948e-03	4	4.832e-04	6
132		min	.055	6	-.327	6	.042	2	5.464e-04	5	1.916e-03	3	-2.816e-03	2
133	N71	max	.148	1	-.07	2	.032	1	1.809e-03	6	3.223e-03	4	2.125e-04	6
134		min	.065	6	-.327	6	.006	6	2.518e-04	2	2.072e-03	3	-2.773e-03	2
135	N72	max	.117	1	-.061	2	.026	1	3.728e-03	6	3.115e-03	1	5.878e-04	6
136		min	.026	6	-.269	6	.016	6	1.226e-03	2	1.887e-03	6	-2.519e-03	2
137	N73	max	.203	2	-.061	2	.039	4	4.281e-03	6	2.853e-03	4	1.274e-03	6
138		min	.024	6	-.268	6	.028	3	1.212e-03	2	1.873e-03	3	-2.225e-03	2
139	N74	max	.067	2	-.071	2	.017	4	5.489e-03	6	2.316e-03	2	-8.595e-05	6
140		min	.001	6	-.196	6	-.01	2	1.805e-03	2	-6.964e-04	4	-2.556e-03	2
141	N75	max	.16	2	-.071	2	.056	4	2.209e-03	6	1.505e-03	2	-8.395e-04	6
142		min	-.015	6	-.197	6	0	2	5.858e-04	2	-2.733e-03	4	-2.544e-03	1
143	N76	max	.155	2	-.204	2	.047	4	4.225e-03	6	2.893e-03	2	-1.091e-04	6
144		min	-.04	4	-.45	6	-.06	2	2.098e-03	2	-2.163e-03	4	-2.897e-03	2
145	N77	max	.234	2	-.204	2	.103	4	3.703e-03	6	2.72e-03	2	-4.363e-04	6
146		min	-.052	6	-.45	6	-.041	2	8.126e-04	2	-2.39e-03	4	-3.624e-03	1
147	N78	max	.267	2	-.204	2	.126	4	3.704e-03	6	2.72e-03	2	-4.364e-04	6
148		min	-.048	6	-.45	6	-.034	2	8.127e-04	2	-2.39e-03	4	-3.715e-03	1
149	N79	max	.13	2	-.204	2	.019	5	4.224e-03	6	2.893e-03	2	-1.091e-04	6
150		min	-.045	4	-.45	6	-.081	1	2.098e-03	2	-2.163e-03	4	-2.857e-03	2
151	N80	max	.11	2	-.135	2	.029	4	8.323e-03	6	2.919e-03	2	-1.178e-03	5
152		min	-.009	6	-.324	6	-.034	2	2.722e-03	2	-1.79e-03	4	-3.461e-03	1
153	N81	max	.193	2	-.135	2	.08	4	8.14e-03	6	2.463e-03	2	-1.991e-03	5
154		min	-.036	6	-.324	6	-.018	2	2.675e-03	2	-2.606e-03	4	-4.51e-03	1
155	N82	max	.07	2	-.11	2	.044	4	5.527e-03	4	2.952e-03	2	-6.567e-04	6
156		min	.002	6	-.223	6	-.074	2	6.5e-04	2	-2.441e-04	6	-3.231e-03	1
157	N83	max	.16	2	-.111	2	.146	4	2.202e-03	4	2.983e-03	2	-3.562e-04	6
158		min	-.014	6	-.224	6	-.075	2	3.295e-04	2	-2.075e-03	4	-2.487e-03	2
159	N84	max	.046	1	-.163	5	.03	6	5.135e-03	4	4.006e-03	2	-5.313e-04	6
160		min	.003	6	-.287	3	-.206	2	4.129e-04	2	-3.315e-04	6	-3.854e-03	1
161	N85	max	.14	2	-.164	5	.166	4	4.799e-03	4	3.588e-03	2	-5.875e-04	6
162		min	-.008	6	-.287	3	-.191	2	5.112e-04	2	-6.569e-04	6	-3.532e-03	1
163	N86	max	.171	2	-.164	5	.209	4	4.809e-03	4	3.588e-03	2	-5.875e-04	6
164		min	-.003	6	-.287	3	-.187	2	5.112e-04	2	-6.569e-04	6	-3.532e-03	1

**Envelope Joint Displacements (Continued)**

	Joint		X [in]	LC	Y [in]	LC	Z [in]	LC	X Rotation [rad]	LC	Y Rotatio...	LC	Z Rotation [rad]	LC
165	N87	max	.012	2	-.163	5	-.005	6	5.125e-03	4	4.006e-03	2	-5.313e-04	6
166		min	-.003	4	-.287	3	-.21	2	4.129e-04	2	-3.315e-04	6	-3.854e-03	1
167	N88	max	.059	2	-.143	5	.039	4	5.127e-03	4	3.856e-03	2	-2.352e-03	5
168		min	.003	6	-.253	3	-.135	2	4.713e-04	2	-2.385e-04	6	-4.058e-03	1
169	N89	max	.15	2	-.143	5	.168	4	3.447e-03	4	3.279e-03	2	-1.711e-03	5
170		min	-.011	6	-.253	3	-.13	2	2.332e-04	2	-9.376e-04	6	-4.157e-03	1
171	N90	max	-.013	3	-.014	2	.212	1	5.264e-03	4	4.222e-03	1	4.415e-04	5
172		min	-.018	4	-.157	6	.064	6	3.676e-04	2	1.045e-03	6	-9.242e-04	1
173	N91	max	.088	2	-.038	2	.091	1	4.719e-03	6	3.823e-03	1	2.347e-05	6
174		min	-.006	6	-.277	6	.055	3	1.918e-03	2	7.089e-04	6	-3.755e-03	2
175	N92	max	.113	2	-.038	2	.112	4	3.418e-03	4	3.95e-03	1	-7.687e-04	6
176		min	-.003	6	-.277	6	.075	3	1.624e-03	2	1.027e-03	6	-4.27e-03	1
177	N93	max	.207	1	-.07	2	.045	4	4.858e-04	5	3.101e-03	4	6.328e-05	6
178		min	.062	6	-.327	6	.028	3	-1.052e-04	1	2.003e-03	3	-3.021e-03	2
179	N94	max	.008	1	-.003	2	.142	4	3.528e-03	4	3.32e-03	4	-2.304e-04	2
180		min	-.006	5	-.09	6	.074	3	1.118e-03	2	1.318e-03	3	-6.69e-04	6
181	N95	max	.185	2	-.009	2	.306	1	3.243e-03	6	6.249e-03	2	5.783e-04	6
182		min	.002	6	-.526	6	.087	6	9.523e-04	2	-9.288e-04	6	-2.333e-03	2
183	N96	max	.189	2	-.204	2	.078	4	1.939e-03	4	2.816e-03	2	1.562e-03	6
184		min	-.038	4	-.45	6	-.043	2	5.22e-04	3	-2.264e-03	4	-2.813e-03	2
185	N97	max	.09	2	-.163	5	.088	4	5.38e-03	4	3.82e-03	2	8.501e-04	6
186		min	-.002	6	-.287	3	-.2	2	6.449e-04	2	-4.761e-04	6	-3.416e-03	2
187	N98	max	.02	1	-.029	5	.099	4	5.746e-03	4	1.748e-03	2	5.703e-04	6
188		min	.007	6	-.078	3	-.061	2	8.75e-04	2	-2.494e-03	4	-4.991e-04	2
189	N99	max	.114	2	-.111	2	.104	4	3.971e-03	4	2.966e-03	2	1.114e-03	6
190		min	-.004	6	-.223	6	-.076	2	-3.308e-04	2	-9.198e-04	4	-3.622e-03	2
191	N96A	max	.166	2	-.054	2	.013	6	1.312e-03	6	8.351e-04	2	5.334e-04	6
192		min	-.014	6	-.193	6	.01	2	4.716e-04	2	1.881e-04	3	-4.746e-04	2
193	N97A	max	.007	1	0	2	.012	6	5.622e-04	6	2.196e-03	4	8.631e-04	6
194		min	0	5	-.007	6	.01	2	2.148e-04	2	1.636e-03	2	-1.776e-05	2

**Envelope AISC 14th(360-10): LRFD Steel Code Checks**

Member	Shape	Code Check	Lo...	LC	She...Lo...	Dir	...phi*...	phi*...	phi*...	phi*...	Cb	Eqn
1	M6	PIPE 2.0	.816	0	6	.183 1	3	30.625	32.13	1.872	1.872	2.4...H1-...
2	M9	PIPE 2.0	.815	0	6	.182 0	3	30.625	32.13	1.872	1.872	2.34H1-...
3	M35	PIPE 2.0	.533	3	3	.096 3	6	28.843	32.13	1.872	1.872	2.3...H1-...
4	M7	PIPE 2.0	.494	0	6	.170.25	6	28.843	32.13	1.872	1.872	2.0...H1-...
5	M3	PIPE 2.0	.463	0	6	.115 1	3	30.625	32.13	1.872	1.872	1.8...H1-...
6	M10	PIPE 2.0	.458	.25	6	.2022.75	3	28.843	32.13	1.872	1.872	1.8...H1-...
7	M27	PIPE 2.0	.421	3	6	.085 3	3	28.843	32.13	1.872	1.872	2.3...H1-...
8	M4	PIPE 2.0	.409	.25	3	.291 0	4	28.843	32.13	1.872	1.872	1.7...H1-...
9	M28	PIPE 2.0	.404	0	3	.1041.5	6	28.843	32.13	1.872	1.872	2.2...H1-...
10	M29	PIPE 2.0	.386	.781	3	.0992.5	4	27.145	32.13	1.872	1.872	1.5...H1-...
11	M16	PIPE 2.5	.382	4.5	6	.1594.5	6	26.137	50.715	3.596	3.596	2.2 H1-...
12	M36	PIPE 2.0	.372	0	6	.0681.5	3	28.843	32.13	1.872	1.872	2.3...H1-...
13	M37	PIPE 2.0	.366	2....	3	.0692....	3	27.145	32.13	1.872	1.872	1.7...H1-...
14	M11	PIPE 2.0	.360	0	4	.154 0	4	27.741	32.13	1.872	1.872	1.7...H1-...
15	M12	PIPE 2.0	.344	0	3	.113 1	2	30.625	32.13	1.872	1.872	1.4...H1-...
16	M38	SR 3/4	.305	2.25	6	.0122.25	4	4.813	14.314	.179	.179	2.2...H1-...
17	M13	PIPE 2.0	.301	0	1	.1572.75	5	28.843	32.13	1.872	1.872	2.7...H1-...



Company : Centek  
 Designer : TJJ  
 Job Number : 21005.07  
 Model Name : CTNH833A

Aug 16, 2021  
 11:19 AM  
 Checked By: CFC

**Envelope AISC 14th(360-10): LRFD Steel Code Checks (Continued)**

Member	Shape	Code Check	Lo...	LC	She...Lo...	Dir	...phi*...	phi*...	phi*...	phi*...	Cb	Eqn
18	M15	PIPE 2.5	.299	3...	4	.0823...	6	26.137	50.715	3.596	3.596	2.06 H1-...
19	M30	SR 3/4	.296	0	3	.0202.25	4	4.813	14.314	.179	.179	2.2... H1-...
20	M31	PIPE 2.0	.293	3	6	.058 3	6	28.843	32.13	1.872	1.872	2.2... H1-...
21	M2	PIPE 2.0	.280	3.5	4	.210.766	4	27.741	32.13	1.872	1.872	1.8... H1-...
22	M1	PIPE 5.0	.269	4	3	.225 4	6	110....	126....	17.929	17.929	1.5... H1-...
23	M48	PIPE 2.0	.238	2....	1	.0562....	6	14.916	32.13	1.872	1.872	2.6... H1-...
24	M5	PIPE 2.0	.193	3.5	6	.076.766	6	27.741	32.13	1.872	1.872	1.7... H1-...
25	M23	PIPE 2.0	.184	3	6	.068 3	4	28.843	32.13	1.872	1.872	2.1... H1-...
26	M40	PIPE 2.0	.181	3	6	.053 3	6	28.843	32.13	1.872	1.872	2.29 H1-...
27	M32	PIPE 2.0	.169	0	3	.026 1.5	3	28.843	32.13	1.872	1.872	2.87 H1-...
28	M24	PIPE 2.0	.168	0	3	.044 1.5	4	28.843	32.13	1.872	1.872	2.3... H1-...
29	M33	PIPE 2.0	.163	.781	3	.036 1....	6	27.145	32.13	1.872	1.872	1.6... H1-...
30	M25	PIPE 2.0	.160	.781	3	.059 1.25	1	27.145	32.13	1.872	1.872	1.6... H1-...
31	M39	PIPE 2.0	.158	3	3	.059 0	4	28.843	32.13	1.872	1.872	2.3 H1-...
32	M34	SR 3/4	.157	2.25	6	.007 0	1	4.813	14.314	.179	.179	2.2... H1-...
33	M8	PIPE 2.0	.151	3.5	3	.075.766	6	27.741	32.13	1.872	1.872	1.6... H1-...
34	M41	PIPE 2.0	.148	.781	6	.044 1....	4	27.145	32.13	1.872	1.872	1.6... H1-...
35	M26	SR 3/4	.136	0	3	.011 0	4	4.813	14.314	.179	.179	2.31 H1-...
36	M22	HSS4X4X4	.135	1	1	.040 1	z 2	138....	139....	16.181	16.181	1.7... H1-...
37	M14	HSS4X4X4	.126	5....	1	.042 3....	z 2	99.405	139....	16.181	16.181	1.6... H1-...
38	M21	PIPE 4.0	.121	.5	3	.078 3.25	6	88.588	93.24	10.631	10.631	1.9... H1-...
39	M42	SR 3/4	.117	0	6	.011 0	4	4.813	14.314	.179	.179	2.26 H1-...
40	M45	PIPE 2.0	.027	1....	4	.028 0	4	26.814	32.13	1.872	1.872	1.1... H1-...
41	M43	PIPE 2.0	.021	1....	4	.031 3....	5	26.814	32.13	1.872	1.872	1.1... H1-...
42	M47A	PIPE 2.5	.020	1	6	.018 2	1	49.082	50.715	3.596	3.596	1.1... H1-...
43	M46	PIPE 2.0	.018	2....	2	.035 2....	4	29.152	32.13	1.872	1.872	1.1... H1-...
44	M47	PIPE 2.0	.018	1....	4	.028 0	1	28.188	32.13	1.872	1.872	1.1... H1-...
45	M44	PIPE 2.0	.015	1....	1	.024 0	4	27.383	32.13	1.872	1.872	1.1... H1-...
46	M18	PIPE 2.5	.008	1	6	.043 2	3	49.082	50.715	3.596	3.596	1.1... H1-...
47	M17	PIPE 2.5	.006	0	5	.006 2	1	49.082	50.715	3.596	3.596	1.1... H1-...

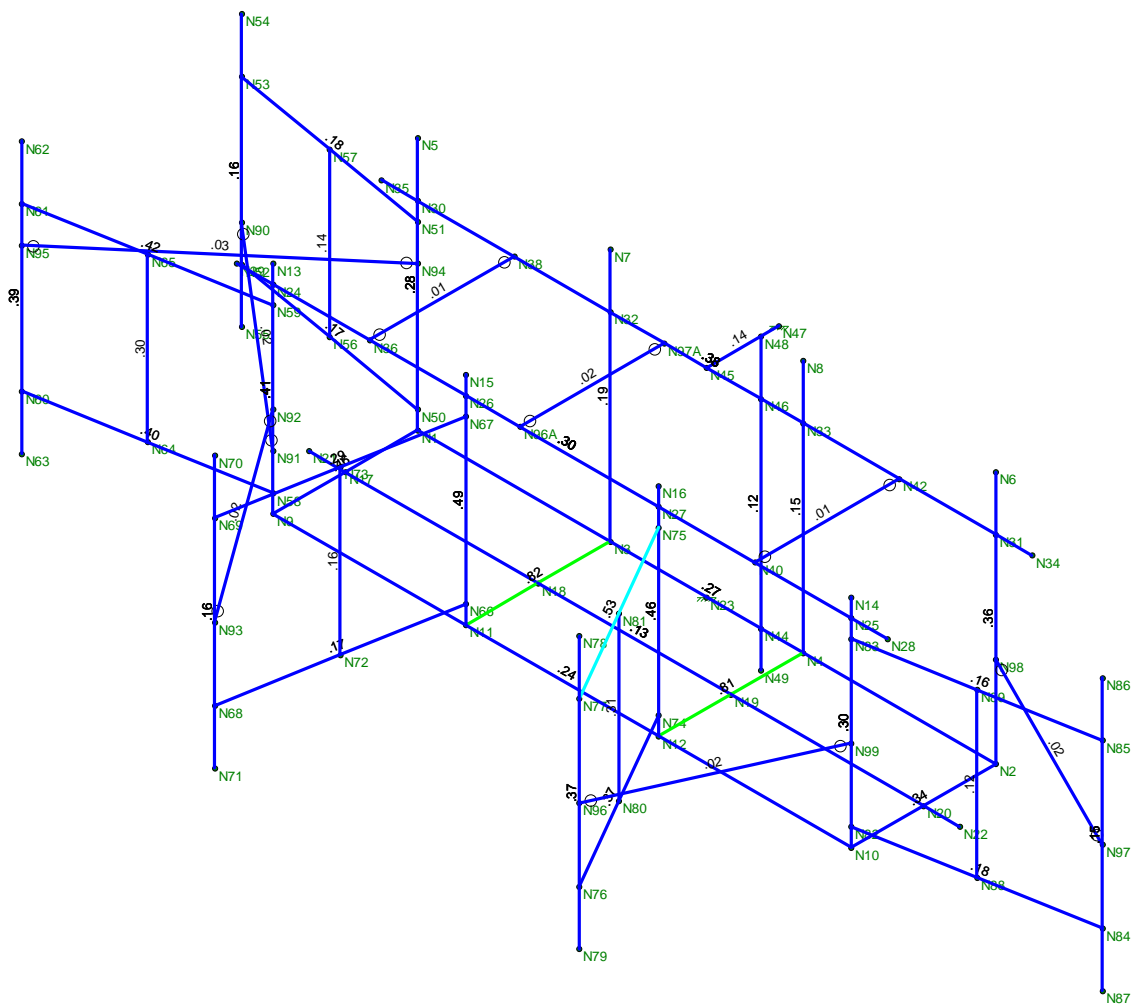
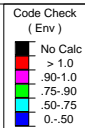

Member Code Checks Displayed (Enveloped)  
Envelope Only Solution

Centek	CTNH833A Unity Check	Aug 16, 2021 at 11:19 AM
TJL		Antenna Mount.R3D
21005.07		

RADIO FREQUENCY EMISSIONS ANALYSIS REPORT  
EVALUATION OF HUMAN EXPOSURE POTENTIAL  
TO NON-IONIZING EMISSIONS

T-Mobile Existing Facility

Site ID: CTNH833A

250 Derby Avenue  
West Haven, Connecticut 06516

**October 5, 2021**

**EBI Project Number: 6221005853**

<b>Site Compliance Summary</b>	
Compliance Status:	<b>COMPLIANT</b>
Site total MPE% of FCC general population allowable limit:	<b>43.26%</b>

October 5, 2021

T-Mobile

Attn: Jason Overbey, RF Manager  
35 Griffin Road South  
Bloomfield, Connecticut 06002

Emissions Analysis for Site: CTNH833A

EBI Consulting was directed to analyze the proposed T-Mobile facility located at **250 Derby Avenue in West Haven, Connecticut** for the purpose of determining whether the emissions from the Proposed T-Mobile Antenna Installation located on this property are within specified federal limits.

All information used in this report was analyzed as a percentage of current Maximum Permissible Exposure (% MPE) as listed in the FCC OET Bulletin 65 Edition 97-01 and ANSI/IEEE Std C95.1. The FCC regulates Maximum Permissible Exposure in units of microwatts per square centimeter ( $\mu\text{W}/\text{cm}^2$ ). The number of  $\mu\text{W}/\text{cm}^2$  calculated at each sample point is called the power density. The exposure limit for power density varies depending upon the frequencies being utilized. Wireless Carriers and Paging Services use different frequency bands each with different exposure limits; therefore, it is necessary to report results and limits in terms of percent MPE rather than power density.

All results were compared to the FCC (Federal Communications Commission) radio frequency exposure rules, 47 CFR 1.1307(b)(1) – (b)(3), to determine compliance with the Maximum Permissible Exposure (MPE) limits for General Population/Uncontrolled environments as defined below.

General population/uncontrolled exposure limits apply to situations in which the general population may be exposed or in which persons who are exposed as a consequence of their employment may not be made fully aware of the potential for exposure or cannot exercise control over their exposure. Therefore, members of the general population would always be considered under this category when exposure is not employment related, for example, in the case of a telecommunications tower that exposes persons in a nearby residential area.

Public exposure to radio frequencies is regulated and enforced in units of microwatts per square centimeter ( $\mu\text{W}/\text{cm}^2$ ). The general population exposure limits for the 600 MHz and 700 MHz frequency bands are approximately  $400 \mu\text{W}/\text{cm}^2$  and  $467 \mu\text{W}/\text{cm}^2$ , respectively. The general population exposure limit for the 1900 MHz (PCS), 2100 MHz (AWS) and 11 GHz frequency bands is  $1000 \mu\text{W}/\text{cm}^2$ . Because each carrier will be using different frequency bands, and each frequency band has different exposure limits, it is necessary to report percent of MPE rather than power density.



Occupational/controlled exposure limits apply to situations in which persons are exposed as a consequence of their employment and in which those persons who are exposed have been made fully aware of the potential for exposure and can exercise control over their exposure. Occupational/controlled exposure limits also apply where exposure is of a transient nature as a result of incidental passage through a location where exposure levels may be above general population/uncontrolled limits (see below), as long as the exposed person has been made fully aware of the potential for exposure and can exercise control over his or her exposure by leaving the area or by some other appropriate means.

Additional details can be found in FCC OET 65.

## **CALCULATIONS**

Calculations were done for the proposed T-Mobile Wireless antenna facility located at 250 Derby Avenue in West Haven, Connecticut using the equipment information listed below. All calculations were performed per the specifications under FCC OET 65. Since T-Mobile is proposing highly focused directional panel antennas, which project most of the emitted energy out toward the horizon, all calculations were performed assuming a lobe representing the maximum gain of the antenna per the antenna manufacturer's supplied specifications, minus 10 dB for directional panel antennas and 20 dB for highly focused parabolic microwave dishes, was focused at the base of the tower. For this report, the sample point is the top of a 6-foot person standing at the base of the tower. For power density calculations, the broadcast footprint of the AIR6449 antenna has been considered. Due to the beamforming nature of this antenna, the actual beam locations vary depending on demand and are narrow in nature. Using the broadcast footprint accounts for the potential location of beams at any given time.

For all calculations, all equipment was calculated using the following assumptions:

- 1) 2 LTE channels (600 MHz Band) were considered for each sector of the proposed installation. These Channels have a transmit power of 30 Watts per Channel.
- 2) 1 NR channel (600 MHz Band) was considered for each sector of the proposed installation. This Channel has a transmit power of 80 Watts.
- 3) 2 LTE channels (700 MHz Band) were considered for each sector of the proposed installation. These Channels have a transmit power of 30 Watts per Channel.
- 4) 4 GSM channels (PCS Band - 1900 MHz) were considered for each sector of the proposed installation. These Channels have a transmit power of 30 Watts per Channel.
- 5) 2 LTE channels (PCS Band - 1900 MHz) were considered for each sector of the proposed installation. These Channels have a transmit power of 60 Watts per Channel.

- 6) 2 LTE channels (AWS Band – 2100 MHz) were considered for each sector of the proposed installation. These Channels have a transmit power of 60 Watts per Channel.
- 7) 1 LTE Traffic channel (LTE IC and 2C BRS Band - 2500 MHz) was considered for each sector of the proposed installation. This Channel has a transmit power of 60 Watts.
- 8) 1 LTE Broadcast channel (LTE IC and 2C BRS Band - 2500 MHz) was considered for each sector of the proposed installation. This Channel has a transmit power of 20 Watts.
- 9) 1 NR Traffic channel (BRS Band - 2500 MHz) was considered for each sector of the proposed installation. This Channel has a transmit power of 120 Watts.
- 10) 1 NR Broadcast channel (BRS Band - 2500 MHz) was considered for each sector of the proposed installation. This Channel has a transmit power of 40 Watts.
- 11) All radios at the proposed installation were considered to be running at full power and were uncombined in their RF transmissions paths per carrier prescribed configuration. Per FCC OET Bulletin No. 65 - Edition 97-01 recommendations to achieve the maximum anticipated value at each sample point, all power levels emitting from the proposed antenna installation are increased by a factor of 2.56 to account for possible in-phase reflections from the surrounding environment. This is rarely the case, and if so, is never continuous.
- 12) For the following calculations, the sample point was the top of a 6-foot person standing at the base of the tower. The maximum gain of the antenna per the antenna manufacturer's supplied specifications, minus 10 dB for directional panel antennas and 20 dB for highly focused parabolic microwave dishes, was used in this direction. This value is a very conservative estimate as gain reductions for these particular antennas are typically much higher in this direction.
- 13) The antennas used in this modeling are the RFS APXVAALL18\_43-U-NA20 for the 600 MHz / 600 MHz / 700 MHz / 1900 MHz / 1900 MHz / 2100 MHz channel(s), the Ericsson AIR 6449 for the 2500 MHz / 2500 MHz / 2500 MHz / 2500 MHz channel(s) in Sector A, the RFS APXVAALL18\_43-U-NA20 for the 600 MHz / 600 MHz / 700 MHz / 1900 MHz / 1900 MHz / 2100 MHz channel(s), the Ericsson AIR 6449 for the 2500 MHz / 2500 MHz / 2500 MHz / 2500 MHz channel(s) in Sector B, the RFS APXVAALL18\_43-U-NA20 for the 600 MHz / 600 MHz / 700 MHz / 1900 MHz / 1900 MHz / 2100 MHz channel(s), the Ericsson AIR 6449 for the 2500 MHz / 2500 MHz / 2500 MHz / 2500 MHz channel(s) in Sector C. This is based on feedback from the carrier with regard to anticipated antenna selection. All Antenna gain values and associated transmit power levels are shown in the Site Inventory and Power Data table below. The maximum gain of the antenna per the antenna manufacturer's supplied

specifications, minus 10 dB for directional panel antennas and 20 dB for highly focused parabolic microwave dishes, was used for all calculations. This value is a very conservative estimate as gain reductions for these particular antennas are typically much higher in this direction.

- 14) The antenna mounting height centerline of the proposed antennas is 74 feet above ground level (AGL).
- 15) Emissions from additional carriers were not included because emissions data for the site location are not available.
- 16) All calculations were done with respect to uncontrolled / general population threshold limits.

## T-Mobile Site Inventory and Power Data

Sector:	A	Sector:	B	Sector:	C
Antenna #:	1	Antenna #:	1	Antenna #:	1
Make / Model:	RFS APXVAALL18_43- U-NA20	Make / Model:	RFS APXVAALL18_43- U-NA20	Make / Model:	RFS APXVAALL18_43- U-NA20
Frequency Bands:	600 MHz / 600 MHz / 700 MHz / 1900 MHz / 1900 MHz / 2100 MHz	Frequency Bands:	600 MHz / 600 MHz / 700 MHz / 1900 MHz / 1900 MHz / 2100 MHz	Frequency Bands:	600 MHz / 600 MHz / 700 MHz / 1900 MHz / 1900 MHz / 2100 MHz
Gain:	11.66 dBd / 11.66 dBd / 12.31 dBd / 15.05 dBd / 15.05 dBd / 15.53 dBd	Gain:	11.66 dBd / 11.66 dBd / 12.31 dBd / 15.05 dBd / 15.05 dBd / 15.53 dBd	Gain:	11.66 dBd / 11.66 dBd / 12.31 dBd / 15.05 dBd / 15.05 dBd / 15.53 dBd
Height (AGL):	74 feet	Height (AGL):	74 feet	Height (AGL):	74 feet
Channel Count:	13	Channel Count:	13	Channel Count:	13
Total TX Power (W):	560 Watts	Total TX Power (W):	560 Watts	Total TX Power (W):	560 Watts
ERP (W):	15,037.68	ERP (W):	15,037.68	ERP (W):	15,037.68
Antenna A1 MPE %:	<b>14.99%</b>	Antenna B1 MPE %:	<b>14.99%</b>	Antenna C1 MPE %:	<b>14.99%</b>
Antenna #:	2	Antenna #:	2	Antenna #:	2
Make / Model:	Ericsson AIR 6449	Make / Model:	Ericsson AIR 6449	Make / Model:	Ericsson AIR 6449
Frequency Bands:	2500 MHz / 2500 MHz / 2500 MHz / 2500 MHz	Frequency Bands:	2500 MHz / 2500 MHz / 2500 MHz / 2500 MHz	Frequency Bands:	2500 MHz / 2500 MHz / 2500 MHz / 2500 MHz
Gain:	22.65 dBd / 17.3 dBd / 22.65 dBd / 17.3 dBd	Gain:	22.65 dBd / 17.3 dBd / 22.65 dBd / 17.3 dBd	Gain:	22.65 dBd / 17.3 dBd / 22.65 dBd / 17.3 dBd
Height (AGL):	74 feet	Height (AGL):	74 feet	Height (AGL):	74 feet
Channel Count:	4	Channel Count:	4	Channel Count:	4
Total TX Power (W):	240 Watts	Total TX Power (W):	240 Watts	Total TX Power (W):	240 Watts
ERP (W):	36,356.09	ERP (W):	36,356.09	ERP (W):	36,356.09
Antenna A2 MPE %:	<b>28.27%</b>	Antenna B2 MPE %:	<b>28.27%</b>	Antenna C2 MPE %:	<b>28.27%</b>

Site Composite MPE %	
Carrier	MPE %
T-Mobile (Max at Sector A):	43.26%
no additional carriers	N/A
<b>Site Total MPE % :</b>	<b>43.26%</b>

T-Mobile MPE % Per Sector	
T-Mobile Sector A Total:	43.26%
T-Mobile Sector B Total:	43.26%
T-Mobile Sector C Total:	43.26%
<b>Site Total MPE % :</b>	<b>43.26%</b>

T-Mobile Maximum MPE Power Values (Sector A)							
T-Mobile Frequency Band / Technology (Sector A)	# Channels	Watts ERP (Per Channel)	Height (feet)	Total Power Density ( $\mu\text{W}/\text{cm}^2$ )	Frequency (MHz)	Allowable MPE ( $\mu\text{W}/\text{cm}^2$ )	Calculated % MPE
T-Mobile 600 MHz LTE	2	439.66	74.0	6.84	600 MHz LTE	400	1.71%
T-Mobile 600 MHz NR	1	1172.44	74.0	9.12	600 MHz NR	400	2.28%
T-Mobile 700 MHz LTE	2	510.65	74.0	7.94	700 MHz LTE	467	1.70%
T-Mobile 1900 MHz GSM	4	959.67	74.0	29.85	1900 MHz GSM	1000	2.98%
T-Mobile 1900 MHz LTE	2	1919.34	74.0	29.85	1900 MHz LTE	1000	2.98%
T-Mobile 2100 MHz LTE	2	2143.64	74.0	33.33	2100 MHz LTE	1000	3.33%
T-Mobile 2500 MHz LTE IC & 2C Traffic	1	11044.63	74.0	85.87	2500 MHz LTE IC & 2C Traffic	1000	8.59%
T-Mobile 2500 MHz LTE IC & 2C Broadcast	1	1074.06	74.0	8.35	2500 MHz LTE IC & 2C Broadcast	1000	0.84%
T-Mobile 2500 MHz NR Traffic	1	22089.26	74.0	171.74	2500 MHz NR Traffic	1000	17.17%
T-Mobile 2500 MHz NR Broadcast	1	2148.13	74.0	16.70	2500 MHz NR Broadcast	1000	1.67%
						<b>Total:</b>	<b>43.26%</b>

• NOTE: Totals may vary by approximately 0.01% due to summation of remainders in calculations.

## Summary

All calculations performed for this analysis yielded results that were **within** the allowable limits for general population exposure to RF Emissions.

The anticipated maximum composite contributions from the T-Mobile facility as well as the site composite emissions value with regards to compliance with FCC's allowable limits for general population exposure to RF Emissions are shown here:

T-Mobile Sector	Power Density Value (%)
Sector A:	43.26%
Sector B:	43.26%
Sector C:	43.26%
T-Mobile Maximum MPE % (Sector A):	43.26%
Site Total:	43.26%
Site Compliance Status:	<b>COMPLIANT</b>

The anticipated composite MPE value for this site assuming all carriers present is **43.26%** of the allowable FCC established general population limit sampled at the ground level. This is based upon values listed in the Connecticut Siting Council database for existing carrier emissions.

FCC guidelines state that if a site is found to be out of compliance (over allowable thresholds), that carriers over a 5% contribution to the composite value will require measures to bring the site into compliance. For this facility, the composite values calculated were well within the allowable 100% threshold standard per the federal government.