



NB&C, LLC  
100 Apollo Drive Suite 303  
Agent for American Tower Corporation  
**David Hoogasian**  
**508-344-3343**  
**E-mail [dhoogasian@nbcllc.com](mailto:dhoogasian@nbcllc.com)**

December 28, 2018

Melanie A. Bachman  
Acting Executive Director  
Connecticut Siting Council  
10 Franklin Square  
New Britain, CT 06051

**Notice of Exempt Modification**

**Facility Address - 53 Dayton Rd., Waterford, CT 06385**

**Facility Coordinates (N) 41.377778**  
**(W) 72.141389**

Dear Ms. Bachman:

American Tower Corporation, Inc. (ATC) currently maintains an Existing Cellular Tower Facility (184' SST) at 53 Dayton Rd., Map 92, Lot 1844, in the Town of Waterford. The property is owned by the Cohanzie Fire Co. No. 5, Inc. American Tower Corporation, Inc (ATC) now intends to install an 80kw Generator within the leased, fenced ground space area of the facility. The purpose of the generator installation is to allow for a shared back up emergency power option for its current (and future) wireless carrier tenants.

Because this proposed generator is within the existing, approved compound space, and the applicant is NOT requesting expansion of ground space beyond the approved conditions, please accept this letter, as notification pursuant to Regulations of Connecticut State Agencies @16-50j-73, for construction that constitutes an exempt modification pursuant to R.C.S.A. @16-50j-72(b)(2). IN accordance with R.C.S.A. @16-50j-73, a copy of this letter is being sent to Daniel M. Steward, First Selectman of the Town of Waterford, Abby Piersall from the Waterford Planning Office, as well as the property owner and tower owner.

## ATTACHMENT A

The planned modifications to the facility fall squarely within those activities explicitly provided for in R.C.S.A @ 16-50j-72(b)(2).

1. The proposed modifications will not result in an increase in the height of the existing structure.
2. The proposed modifications will not require the extension of the site boundary
3. The proposed modifications will not increase noise levels at the facility by six decibels or more, or to levels that exceed state and local criteria.
4. The operation of the generator back up power facility will not increase radio frequency emissions at the facility to the level at or above the Federal Communications Commission safety standard.
5. The proposed modifications will not cause a change or alteration in the physical or environmental characteristics of the site.
6. The existing structure and its foundation can support the proposed loading if the tower will be re-enforced to support them. <<< NOTE – This condition is N/A. The proposed Generator is based on the ground, and not associated or loaded onto the tower or foundation.

For the foregoing reasons, American Tower Corporation (ATC) respectfully submits that the proposed modifications to the above referenced telecommunications facility constitute an exempt modification under R.C.S.A. @16-50j-72(b)(2).

Sincerely,

*David Hoogasian*

Attachments

Cc:

Daniel M. Steward, First Selectman of the Town of Waterford – Elected Official  
Abby Piersall - Waterford Town Planner  
American Tower Corporation (ATC) – Tower Owner  
Cohanzie Fire Co. No. 5, Inc. – Property Owner

### 53 DAYTON ROAD

**Location** 53 DAYTON ROAD

**Mblu** 92 / / 1844 / /

**Acct#** 00158300

**Owner** COHANZIE FIRE COMPANY  
NO 5 INC

**Assessment** \$1,335,410

**Appraisal** \$1,907,740

**PID** 1844

**Building Count** 2

**Current Value**

Appraisal			
Valuation Year	Improvements	Land	Total
2017	\$981,150	\$926,590	\$1,907,740

Assessment			
Valuation Year	Improvements	Land	Total
2017	\$686,800	\$648,610	\$1,335,410

**Parcel Addresses**

Additional Addresses		
Address	City, State Zip	Type
53 DAYTON ROAD		Primary
53 DAYTON ROAD		Secondary

**Owner of Record**

**Owner** COHANZIE FIRE COMPANY NO 5 INC  
**Co-Owner**

**Sale Price** \$0  
**Certificate**  
**Book & Page** 95/ 157  
**Sale Date** 11/12/1952  
**Instrument** 00

**Ownership History**

Ownership History					
Owner	Sale Price	Certificate	Book & Page	Instrument	Sale Date
COHANZIE FIRE COMPANY NO 5 INC	\$0		95/ 157	00	11/12/1952

**Building Information**

**Building 1 : Section 1**

**Year Built:** 1950  
**Living Area:** 8,615

**Building Photo**

**Replacement Cost:** \$803,074  
**Building Percent Good:** 68

Building Attributes	
Field	Description
STYLE	Fire Station
MODEL	Comm/Ind
Grade	Above Ave
Stories:	1.00
Occupancy	1
Exterior Wall 1	Vinyl Siding
Exterior Wall 2	Brick Veneer
Roof Structure	Gambrel
Roof Cover	Asphalt
Interior Wall 1	Plaster
Interior Wall 2	Drywall
Interior Floor 1	Concrete
Interior Floor 2	Comp Tile
Heating Fuel	Oil
Heating Type	Hot Water
% Central Air	0
Foundation	Poured Conc
Bldg Use	Exempt Comm
Total Rooms	0
Total Bedrms	0
Total Fixtures	22
% Wet Sprinkler	100
% Dry Sprinkler	
1st Floor Use	
Heat/AC	Typical
Frame Type	MASONRY
Baths/Plumbing	AVERAGE
% Finished	60
Class	C
Wall Height	11



(http://images.vgsi.com/photos/WaterfordCTPhotos/\0000\88/39.JPG)

**Building Layout**

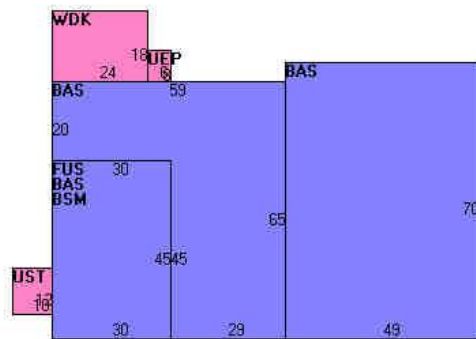

(http://images.vgsi.com/photos/WaterfordCTPhotos//Sketches

Building Sub-Areas (sq ft)		Legend	
Code	Description	Gross Area	Living Area
BAS	First Floor	7,265	7,265
FUS	Finished Upper Story	1,350	1,350
BSM	Basement	1,350	0
UEP	Unfin. Enclosed Porch	48	0
UST	Unfinished Utility Area	120	0
WDK	Deck	432	0
		10,565	8,615

**Building 2 : Section 1**

**Year Built:** 1950  
**Living Area:** 3,360  
**Replacement Cost:** \$368,762  
**Building Percent Good:** 62

Building Attributes : Bldg 2 of 2	
Field	Description
STYLE	Fire Station

**Building Photo**

MODEL	Comm/Ind
Grade	Above Ave
Stories:	2.00
Occupancy	1
Exterior Wall 1	Vinyl Siding
Exterior Wall 2	Brick Veneer
Roof Structure	Gambrel
Roof Cover	Asphalt
Interior Wall 1	Plaster
Interior Wall 2	Drywall
Interior Floor 1	Concrete
Interior Floor 2	Comp Tile
Heating Fuel	Oil
Heating Type	Forced Hot Air
% Central Air	0
Foundation	Poured Conc
Bldg Use	Exempt Comm
Total Rooms	0
Total Bedrms	0
Total Fixtures	0
% Wet Sprinkler	
% Dry Sprinkler	
1st Floor Use	
Heat/AC	Typical
Frame Type	MASONRY
Baths/Plumbing	LIGHT
% Finished	0
Class	C
Wall Height	11



(http://images.vgsi.com/photos/WaterfordCTPhotos//default.jpg)

**Building Layout**

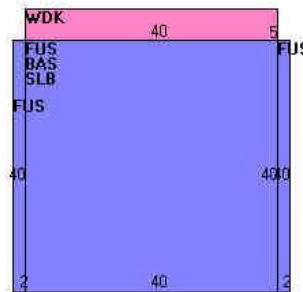

(http://images.vgsi.com/photos/WaterfordCTPhotos//Sketches/18)

Building Sub-Areas (sq ft)		Legend	
Code	Description	Gross Area	Living Area
FUS	Finished Upper Story	1,760	1,760
BAS	First Floor	1,600	1,600
SLB	Slab	1,600	0
WDK	Deck	200	0
		5,160	3,360

**Extra Features**

Extra Features				Legend
Code	Description	Size	Value	Bldg #
FBM	Finished Bsmt	475 S.F.	\$3,230	1

**Land**

**Land Use**

**Use Code** 920  
**Description** Exempt Comm  
**Zone** R-40  
**Neighborhood** 200

**Land Line Valuation**

**Size (Acres)** 9.91  
**Frontage** 0  
**Depth** 0  
**Assessed Value** \$648,610

**Alt Land Appr** No  
**Category**

**Appraised Value** \$926,590

**Outbuildings**

<b>Outbuildings</b>						<b>Legend</b>
<b>Code</b>	<b>Description</b>	<b>Sub Code</b>	<b>Sub Description</b>	<b>Size</b>	<b>Value</b>	<b>Bldg #</b>
FN1	Fence			928 L.F.	\$7,660	2
FGR1	Garage	MS	Masonry	220 S.F.	\$3,300	1
LSUM	Lump Sum			120000 UNITS	\$90,000	2
PAV1	Paving	AS	Asphalt	39900 S.F.	\$62,340	1
SHD1	Shed	FR	Frame	800 S.F.	\$6,000	1
FN1	Fence			1408 L.F.	\$7,740	1
FOP	Porch			1600 S.F.	\$24,000	1
LSUM	Lump Sum			4320 UNITS	\$2,160	1

**Valuation History**

<b>Appraisal</b>			
<b>Valuation Year</b>	<b>Improvements</b>	<b>Land</b>	<b>Total</b>
2016	\$923,090	\$926,590	\$1,849,680
2013	\$923,090	\$926,590	\$1,849,680
2010	\$0	\$0	\$3,234,857

<b>Assessment</b>			
<b>Valuation Year</b>	<b>Improvements</b>	<b>Land</b>	<b>Total</b>
2016	\$646,170	\$648,610	\$1,294,780
2013	\$646,170	\$648,610	\$1,294,780
2010	\$0	\$0	\$2,264,400

(c) 2018 Vision Government Solutions, Inc. All rights reserved.



53 Dayton Rd, Waterford, C X

Show search results for 53 Dayt...

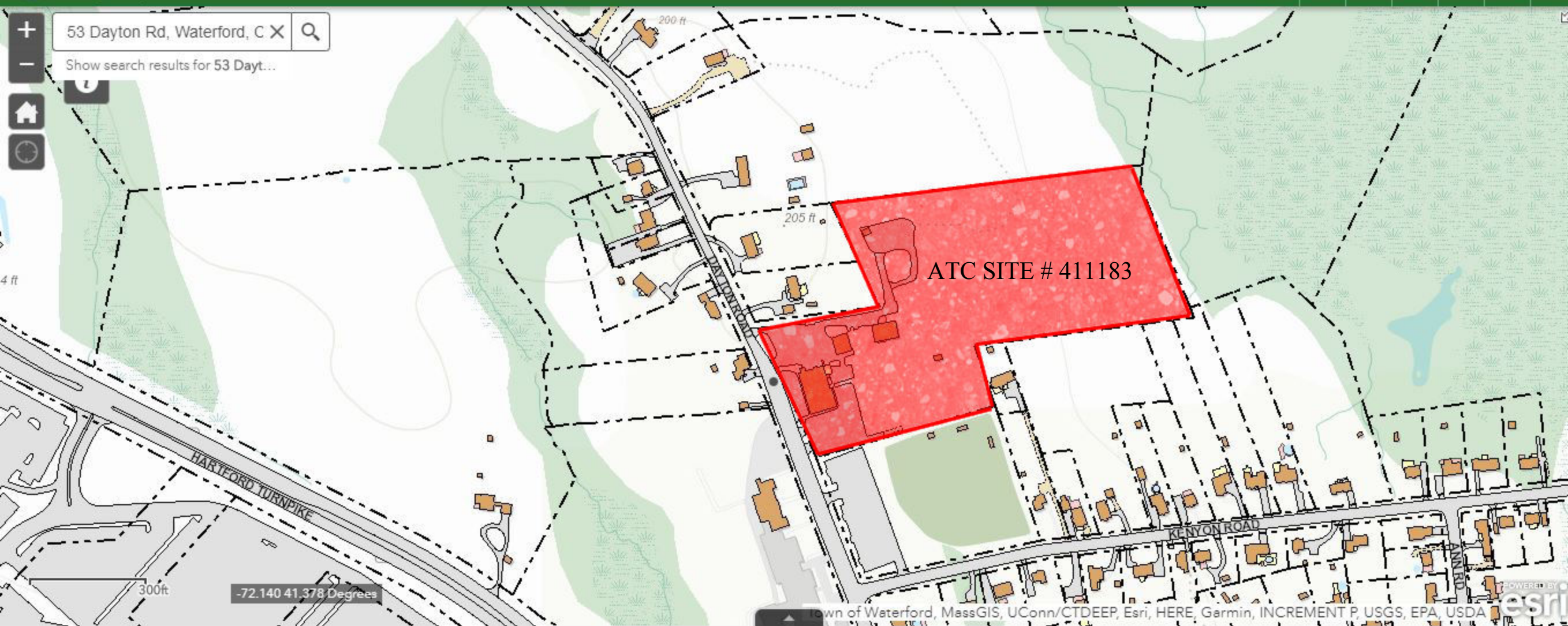

ATC SITE # 411183

-72.140 41.378 Degrees



**STANDBY POWER RATING**

80 kW, 100 kVA, 60 Hz

**PRIME POWER RATING\***

72 kW, 90 kVA, 60 Hz

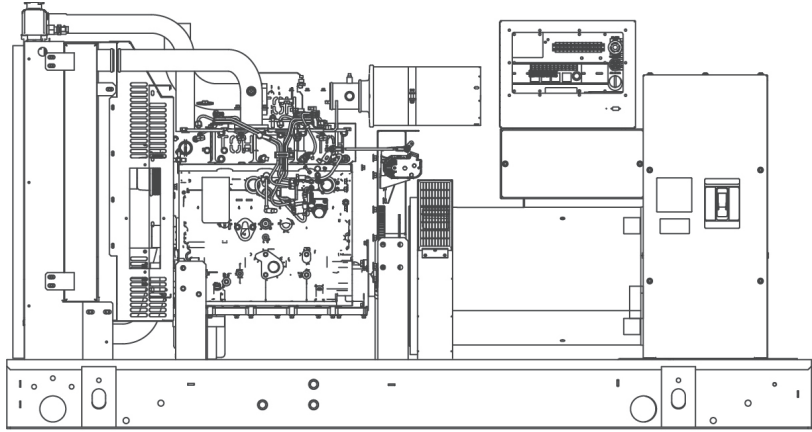

\*Built in the USA using domestic and foreign parts

\*EPA Certified Prime ratings are not available in the U.S. or its Territories.

Image used for illustration purposes only

\*\*Certain options or customization may not hold certification valid.

**CODES AND STANDARDS**

Generac products are designed to the following standards:

 UL2200, UL508, UL142, UL498

 NFPA70, 99, 110, 37

 NEC700, 701, 702, 708

 ISO9001, 8528, 3046, 7637, Pluses #2b, 4

 NEMA ICS10, MG1, 250, ICS6, AB1

 **ANSI**  
 American National Standards Institute  
 ANSI C62.41

**POWERING AHEAD**

For over 50 years, Generac has led the industry with innovative design and superior manufacturing.

Generac ensures superior quality by designing and manufacturing most of its generator components, including alternators, enclosures and base tanks, control systems and communications software.

Generac's gensets utilize a wide variety of options, configurations and arrangements, allowing us to meet the standby power needs of practically every application.

Generac searched globally to ensure the most reliable engines power our generators. We choose only engines that have already been proven in heavy-duty industrial application under adverse conditions.

Generac is committed to ensuring our customers' service support continues after their generator purchase.



## STANDARD FEATURES

### ENGINE SYSTEM

#### General

- Oil Drain Extension
- Air Cleaner
- Fan Guard
- Stainless Steel flexible exhaust connection
- Critical Exhaust Silencer (enclosed only)
- Factory Filled Oil
- Radiator Duct Adapter (open set only)

#### Fuel System

- Fuel lockoff solenoid
- Primary fuel filter

#### Cooling System

- Closed Coolant Recovery System
- UV/Ozone resistant hoses
- Factory-Installed Radiator
- Radiator Drain Extension
- 50/50 Ethylene glycol antifreeze
- 120 VAC Coolant Heater

#### Engine Electrical System

- Battery charging alternator
- Battery cables
- Battery tray
- Solenoid activated starter motor
- Rubber-booted engine electrical connections

### ALTERNATOR SYSTEM

- UL2200 GENprotect™
- 12 leads (3-phase, non 600 V)
- Class H insulation material
- Vented rotor
- 2/3 pitch
- Skewed stator
- Auxiliary voltage regulator power winding
- Amortisseur winding
- Brushless Excitation
- Sealed Bearings
- Automated manufacturing (winding, insertion, lacing, varnishing)
- Rotor dynamically spin balanced
- Full load capacity alternator
- Protective thermal switch

### GENERATOR SET

- Internal Genset Vibration Isolation
- Separation of circuits - high/low voltage
- Separation of circuits - multiple breakers
- Silencer Heat Shield
- Wrapped Exhaust Piping
- Silencer housed in discharge hood (enclosed only)
- Standard Factory Testing
- 2 Year Limited Warranty (Standby rated Units)
- 1 Year Limited Warranty (Prime rated Units)
- Silencer mounted in the discharge hood (enclosed only)

### ENCLOSURE (IF SELECTED)

- Rust-proof fasteners with nylon washers to protect finish
- High performance sound-absorbing material
- Gasketed doors
- Stamped air-intake louvers
- Air discharge hoods for radiator-upward pointing
- Stainless steel lift off door hinges
- Stainless steel lockable handles
- Rhino Coat™ - Textured polyester powder coat

### TANKS (IF SELECTED)

- UL 142
- Double wall
- Vents
- Sloped top
- Sloped bottom
- Factory pressure tested (2 psi)
- Rupture basin alarm
- Fuel level
- Check valve in supply and return lines
- Rhino Coat™ - Textured polyester powder coat
- Stainless hardware

## CONTROL SYSTEM



### Control Panel

- Digital H Control Panel - Dual 4x20 Display
- Programmable Crank Limiter
- 7-Day Programmable Exerciser
- Special Applications Programmable PLC
- RS-232/485
- All-Phase Sensing DVR
- Full System Status
- Utility Monitoring
- Low Fuel Pressure Indication
- 2-Wire Start Compatible
- Power Output (kW)

- Power Factor
- kW Hours, Total & Last Run
- Real/Reactive/Apparent Power
- All Phase AC Voltage
- All Phase Currents
- Oil Pressure
- Coolant Temperature
- Coolant Level
- Engine Speed
- Battery Voltage
- Frequency
- Date/Time Fault History (Event Log)
- Isochronous Governor Control
- Waterproof/sealed Connectors
- Audible Alarms and Shutdowns
- Not in Auto (Flashing Light)
- Auto/Off/Manual Switch
- E-Stop (Red Mushroom-Type)
- NFPA110 Level I and II (Programmable)
- Customizable Alarms, Warnings, and Events
- Modbus protocol
- Predictive Maintenance algorithm
- Sealed Boards
- Password parameter adjustment protection

- Single point ground
- 15 channel data logging
- 0.2 msec high speed data logging
- Alarm information automatically comes up on the display

### Alarms

- Oil Pressure (Pre-programmable Low Pressure Shutdown)
- Coolant Temperature (Pre-programmed High Temp Shutdown)
- Coolant Level (Pre-programmed Low Level Shutdown)
- Low Fuel Pressure Alarm
- Engine Speed (Pre-programmed Over speed Shutdown)
- Battery Voltage Warning
- Alarms & warnings time and date stamped
- Alarms & warnings for transient and steady state conditions
- Snap shots of key operation parameters during alarms & warnings
- Alarms and warnings spelled out (no alarm codes)

## CONFIGURABLE OPTIONS

### ENGINE SYSTEM

#### General

- Oil Heater
- Industrial Exhaust Silencer

#### Fuel System

- Flexible fuel lines
- Primary fuel filter

#### Engine Electrical System

- 10A UL battery charger
- 2.5A UL battery charger
- Battery Warmer

### ALTERNATOR SYSTEM

- Alternator Upsizing
- Anti-Condensation Heater
- Tropical coating
- Permanent Magnet Excitation

### CIRCUIT BREAKER OPTIONS

- Main Line Circuit Breaker
- 2nd Main Line Circuit Breaker
- Shunt Trip and Auxiliary Contact
- Electronic Trip Breaker

### GENERATOR SET

- Gen-Link Communications Software (English Only)
- IBC Seismic Certification
- 8 Position Load Center
- 2 Year Extended Warranty
- 5 Year Warranty
- 5 Year Extended Warranty

### ENCLOSURE

- Weather Protected
- Level 1 Sound Attenuation
- Level 2 Sound Attenuation
- Steel Enclosure
- Aluminum Enclosure
- 150 MPH Wind Kit
- 12 VDC Enclosure Lighting Kit
- 120 VAC Enclosure Lighting Kit
- AC/DC Enclosure Lighting Kit
- Door Alarm Switch

### TANKS (Size on last page)

- Electrical Fuel Level
- Mechanical Fuel Level
- 8" Fill Extension
- 13" Fill Extension
- 19" Fill Extension

### CONTROL SYSTEM

- 21-Light Remote Annunciator
- Remote Relay Panel (8 or 16)
- Oil Temperature Sender with Indication Alarm
- Remote E-Stop (Break Glass-Type, Surface Mount)
- Remote E-Stop (Red Mushroom-Type, Surface Mount)
- Remote E-Stop (Red Mushroom-Type, Flush Mount)
- Remote Communication - Modem
- Remote Communication - Ethernet
- 10A Run Relay
- Ground Fault Indication and Protection Functions

## ENGINEERED OPTIONS

### ENGINE SYSTEM

- Coolant heater ball valves
- Block Heaters
- Fluid containment pans

### ALTERNATOR SYSTEM

- 3rd Breaker Systems

### CONTROL SYSTEM

- Spare inputs (x4) / outputs (x4) - H Panel Only
- Battery Disconnect Switch

### GENERATOR SET

- Special Testing

### ENCLOSURE

- Motorized Dampers
- Door switched for intrusion alert
- Enclosure ambient heaters

### TANKS

- Overfill Protection Valve
- UL2085 Tank
- ULC S-601 Tank
- Stainless Steel Tank
- Special Fuel Tanks (MIDEQ and FL DEP/DERM, etc.)
- Vent Extensions

## RATING DEFINITIONS

**Standby** - Applicable for a varying emergency load for the duration of a utility power outage with no overload capability.

**Prime** - Applicable for supplying power to a varying load in lieu of utility for an unlimited amount of running time. A 10% overload capacity is available for 1 out of every 12 hours. The Prime Power option is only available on International applications. Power ratings in accordance with ISO 8528-1, Second Edition

**APPLICATION AND ENGINEERING DATA**

**ENGINE SPECIFICATIONS**

General

Make	Iveco/FPT
EPA Emissions Compliance	Stationary Emergency
EPA Emissions Reference	See Emissions Data Sheet
Cylinder #	4
Type	In-Line
Displacement - L (cu In)	4.5 (274.6)
Bore - mm (in)	105 (4.1)
Stroke - mm (in)	132 (5.2)
Compression Ratio	17.5:1
Intake Air Method	Turbocharged/Aftercooled
Cylinder Head Type	2 Valve
Piston Type	Aluminium
Crankshaft Type	Forged Steel

Engine Governing

Governor	Electronic Isochronous
Frequency Regulation (Steady State)	+/- 0.25%

Lubrication System

Oil Pump Type	Gear
Oil Filter Type	Full Flow
Crankcase Capacity - L (qts)	13.6 (14.4)

Cooling System

Cooling System Type	Closed
Water Pump	Belt Driven Centrifugal
Fan Type	Pusher
Fan Speed (rpm)	2538
Fan Diameter mm (in)	660.4 (26)
Coolant Heater Wattage	1500
Coolant Heater Standard Voltage	120 V /240 V

Fuel System

Fuel Type	Ultra Low Sulfur Diesel Fuel
Fuel Specifications	ASTM
Fuel Filtering (microns)	5
Fuel Injection	Stanadyne
Fuel Pump Type	Engine Driven Gear
Injector Type	Mechanical
Fuel Supply Line mm (in)	12.7 (0.5) NPT
Fuel Return Line mm (in)	12.7 (0.5) NPT

Engine Electrical System

System Voltage	12 VDC
Battery Charging Alternator	20 A
Battery Size	See Battery Index 0161970SBY
Battery Voltage	12 VDC
Ground Polarity	Negative

**ALTERNATOR SPECIFICATIONS**

Standard Model	390
Poles	4
Field Type	Revolving
Insulation Class - Rotor	H
Insulation Class - Stator	H
Total Harmonic Distortion	<3%
Telephone Interference Factor (TIF)	<50

Standard Excitation	Synchronous Brushless
Bearings	One-Pre Lubed & Sealed
Coupling	Direct, Flexible Disc
Load Capacity - Standby	100%
Prototype Short Circuit Test	Yes
Voltage Regulator Type	Digital
Number of Sensed Phases	3
Regulation Accuracy (Steady State)	± 0.25%

**OPERATING DATA**

**POWER RATINGS**

		Standby
Single-Phase 120/240 VAC @1.0pf	80 kW	Amps: 333
Three-Phase 120/208 VAC @0.8pf	80 kW	Amps: 278
Three-Phase 120/240 VAC @0.8pf	80 kW	Amps: 241
Three-Phase 277/480 VAC @0.8pf	80 kW	Amps: 120
Three-Phase 346/600 VAC @0.8pf	80 kW	Amps: 96

**STARTING CAPABILITIES (sKVA)**

		sKVA vs. Voltage Dip											
		480 VAC						208/240 VAC					
Alternator	kW	10%	15%	20%	25%	30%	35%	10%	15%	20%	25%	30%	35%
Standard	80	59	88	117	147	176	205	44	66	88	110	132	154
Upsize 1	100	79	118	157	197	236	275	59	89	118	148	177	206
Upsize 2	130	116	174	232	290	348	406	87	131	174	218	261	305

**FUEL CONSUMPTION RATES\***

		Diesel - gal/hr (l/hr)	
Fuel Pump Lift - ft (m)		Percent Load	Standby
3 (1)		25%	2.1 (7.9)
		50%	3.7 (14.0)
Total Fuel Pump Flow (Combustion + Return)		75%	5.2 (19.7)
13.6 gal/hr		100%	6.3 (23.8)

\* Fuel supply installation must accommodate fuel consumption rates at 100% load.

**COOLING**

		Standby
Coolant Flow per Minute	gal/min (l/min)	32.7 (123.8)
Coolant System Capacity	gal (L)	4.5 (17.44)
Heat Rejection to Coolant	BTU/hr	232,270
Inlet Air	cfm (m³/hr)	6360 (180)
Max. Operating Radiator Air Temp	F° (C°)	122 (50)
Max. Ambient Temperature (before derate)	F° (C°)	104 (40)
Maximum Radiator Backpressure	in H <sub>2</sub> O	0.5

**COMBUSTION AIR REQUIREMENTS**

		Standby
Flow at Rated Power	cfm (m³/min)	306 (8.67)

**ENGINE**

		Standby
Rated Engine Speed	rpm	1800
Horsepower at Rated kW**	hp	131
Piston Speed	ft/min (m/min)	1559 (475)
BMEP	psi	210

**EXHAUST**

		Standby
Exhaust Flow (Rated Output)	cfm (m³/min)	782 (22.14)
Max. Backpressure (Post Silencer)	inHg (Kpa)	1.5 (5.1)
Exhaust Temp (Rated Output)	°F (°C)	887 (475)
Exhaust Outlet Size (Open Set)	mm (in)	76.2 (3.0)

\*\* Refer to "Emissions Data Sheet" for maximum bHP for EPA and SCAQMD permitting purposes.

Deration – Operational characteristics consider maximum ambient conditions. Derate factors may apply under atypical site conditions. Please consult a Generac Power Systems Industrial Dealer for additional details. All performance ratings in accordance with ISO3046, BS5514, ISO8528 and DIN6271 standards.

**DIMENSIONS AND WEIGHTS\***

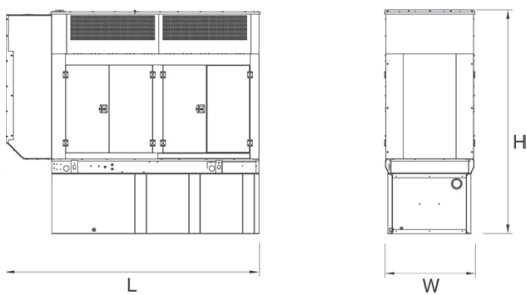
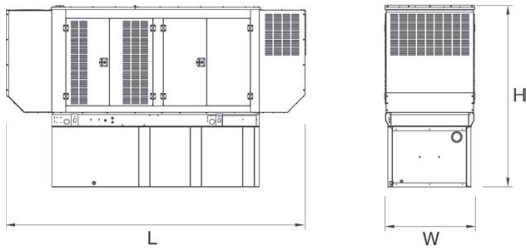
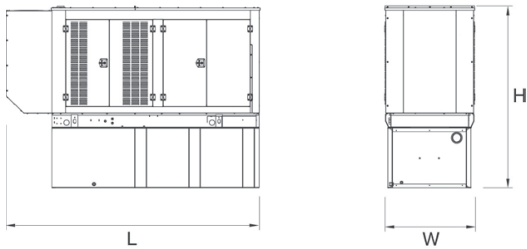
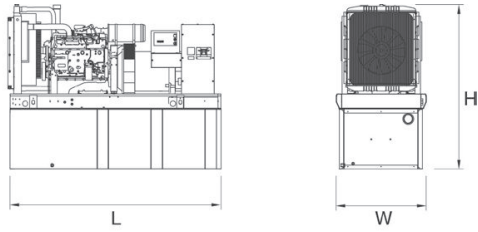

YOUR FACTORY RECOGNIZED GENERAC INDUSTRIAL DEALER

**OPEN SET**

RUN TIME HOURS	USABLE CAPACITY GAL (L)	L x W x H in (mm)	WT lbs (kg) - Tank & Open Set	
			Steel	Aluminum
NO TANK	-	93 (2362.2) x 40 (1016) x 49 (1244.6)	2425 (1100)	
13	79 (299)	93 (2362.2) x 40 (1016) x 62 (1574.8)	2947 (1201)	
30	189 (715.4)	93 (2362.2) x 40 (1016) x 74 (1879.6)	3183 (1444)	
48	300 (1135.6)	93 (2362.2) x 40 (1016) x 86 (2184.4)	3407 (1545)	
56	350 (1325)	110 (2794) x 40 (1016) x 86 (2184.4)	NA	
81	510 (1930.5)	117 (2971.8) x 47 (1193.8) x 86 (2184.4)	3790 (1719)	
93	589 (2229.6)	128 (3251.2) x 49 (1244.6) x 86 (2184.4)	4269 (1936)	

**STANDARD ENCLOSURE**

RUN TIME HOURS	USABLE CAPACITY GAL (L)	L x W x H in (mm)	WT lbs (kg) - Enclosure Only	
			Steel	Aluminum
NO TANK	-	112 (2844.8) x 41 (1041.4) x 56 (1422.4)		
13	79 (299)	112 (2844.8) x 41 (1041.4) x 69 (1752.6)		
30	189 (715.4)	112 (2844.8) x 41 (1041.4) x 81 (2057.4)		
48	300 (1135.6)	112 (2844.8) x 41 (1041.4) x 93 (2362.2)	425 (193)	155 (70)
56	350 (1325)	112 (2844.8) x 41 (1041.4) x 93 (2362.2)		
81	510 (1930.5)	117 (2971.8) x 47 (1193.8) x 93 (2362.2)		
93	589 (2229.6)	128 (3251.2) x 49 (1244.6) x 93 (2362.2)		

**LEVEL 1 ACOUSTIC ENCLOSURE**

RUN TIME HOURS	USABLE CAPACITY GAL (L)	L x W x H in (mm)	WT lbs (kg) - Enclosure Only	
			Steel	Aluminum
NO TANK	-	130 (3302) x 41 (1041.4) x 56 (1422.4)		
13	79 (299)	130 (3302) x 41 (1041.4) x 69 (1752.6)		
30	189 (715.4)	130 (3302) x 41 (1041.4) x 81 (2057.4)		
48	300 (1135.6)	130 (3302) x 41 (1041.4) x 93 (2362.2)	450 (204)	285 (129)
56	350 (1325)	130 (3302) x 41 (1041.4) x 93 (2362.2)		
81	510 (1930.5)	130 (3302) x 47 (1193.8) x 93 (2362.2)		
93	589 (2229.6)	130 (3302) x 49 (1244.6) x 93 (2362.2)		

**LEVEL 2 ACOUSTIC ENCLOSURE**

RUN TIME HOURS	USABLE CAPACITY GAL (L)	L x W x H in (mm)	WT lbs (kg) - Enclosure Only	
			Steel	Aluminum
NO TANK	-	112 (2844.8) x 41 (1041.4) x 69 (1752.6)		
13	79 (299)	112 (2844.8) x 41 (1041.4) x 82 (2082.8)		
30	189 (715.4)	112 (2844.8) x 41 (1041.4) x 94 (2387.6)		
48	300 (1135.6)	112 (2844.8) x 41 (1041.4) x 106 (2692.4)	625 (284)	395 (180)
56	350 (1325)	112 (2844.8) x 41 (1041.4) x 106 (2692.4)		
81	510 (1930.5)	117 (2971.8) x 47 (1193.8) x 106 (2692.4)		
93	589 (2229.6)	128 (3251.2) x 49 (1244.6) x 106 (2692.4)		

\*All measurements are approximate and for estimation purposes only. Sound dBA can be found on the sound data sheet. Enclosure Only weight is added to Tank & Open Set weight to determine total weight.

Specification characteristics may change without notice. Dimensions and weights are for preliminary purposes only. Please consult a Generac Power Systems Industrial Dealer for detailed installation drawings.

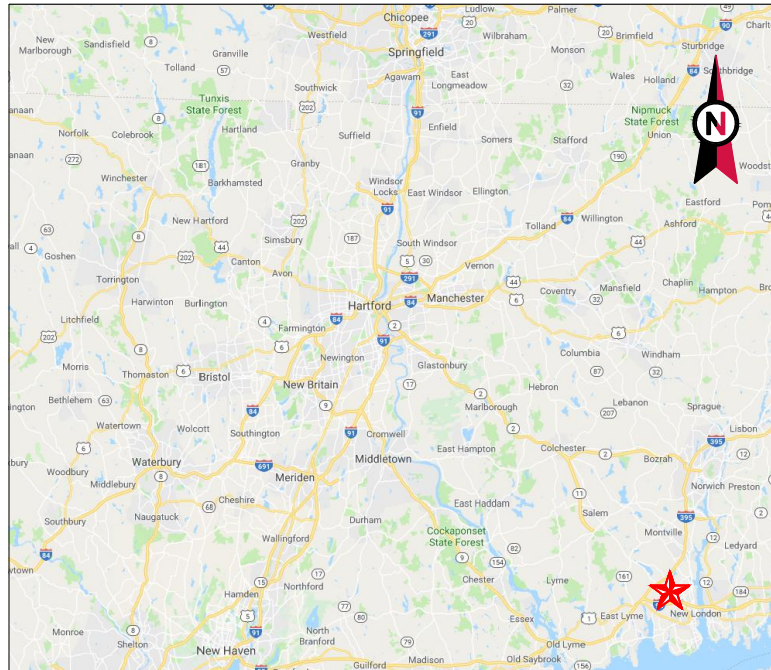

VICINITY MAP



**AMERICAN TOWER®**

ATC SITE NAME: WATERFORD CT  
 SITE NUMBER: 411183  
 SITE ADDRESS: 53 DAYTON RD.  
 WATERFORD, CT 06385



LOCATION MAP

**SHARED GENERATOR PROGRAM  
 ANCHOR TENANT**

**AMERICAN TOWER®**  
**A.T. ENGINEERING SERVICE, PLLC**  
 3500 REGENCY PARKWAY  
 SUITE 100  
 CARY, NC 27518  
 PHONE: (919) 468-0112  
 COA: PEC.0001553

THESE DRAWINGS AND/OR THE ACCOMPANYING SPECIFICATION AS INSTRUMENTS OR SERVICE ARE THE EXCLUSIVE PROPERTY OF AMERICAN TOWER. THEIR USE AND PUBLICATION SHALL BE RESTRICTED TO THE ORIGINAL SITE FOR WHICH THEY ARE PREPARED. ANY USE OR DISCLOSURE OTHER THAN THAT WHICH RELATES TO AMERICAN TOWER OR THE SPECIFIED CARRIER IS STRICTLY PROHIBITED. TITLE TO THESE DOCUMENTS SHALL REMAIN THE PROPERTY OF AMERICAN TOWER WHETHER OR NOT THE PROJECT IS EXECUTED. NEITHER THE ARCHITECT NOR THE ENGINEER WILL BE PROVIDING ON-SITE CONSTRUCTION REVIEW OF THIS PROJECT. CONTRACTOR(S) MUST VERIFY ALL DIMENSIONS AND ADVISE AMERICAN TOWER OF ANY DISCREPANCIES. ANY PRIOR ISSUANCE OF THIS DRAWING IS SUPERSEDED BY THE LATEST VERSION ON FILE WITH AMERICAN TOWER.

REV.	DESCRIPTION	BY	DATE
0	FOR CONSTRUCTION	TC	09/13/18
1	UPDATED OWNER	MG	12/04/18

ATC SITE NUMBER:  
**411183**  
 ATC SITE NAME:  
**WATERFORD CT**  
 SITE ADDRESS:  
 53 DAYTON RD.  
 WATERFORD, CT 06385

SEAL:

**T-Mobile®**

DRAWN BY:	TC
APPROVED BY:	PPB
DATE DRAWN:	09/13/18
ATC JOB NO:	12612230

**TITLE SHEET**

SHEET NUMBER: <b>G-001</b>	REVISION: <b>1</b>
-------------------------------	-----------------------

COMPLIANCE CODE	PROJECT SUMMARY	PROJECT DESCRIPTION	SHEET INDEX				
ALL WORK SHALL BE PERFORMED AND MATERIALS INSTALLED IN ACCORDANCE WITH THE CURRENT EDITIONS OF THE FOLLOWING CODES AS ADOPTED BY THE LOCAL GOVERNMENT AUTHORITIES. NOTHING IN THESE PLANS IS TO BE CONSTRUED TO PERMIT WORK NOT CONFORMING TO THESE CODES.  1. INTERNATIONAL BUILDING CODE (IBC) 2. NATIONAL ELECTRIC CODE (NEC) 3. LOCAL BUILDING CODE 4. CITY/COUNTY ORDINANCES	<u>SITE ADDRESS:</u> 53 DAYTON RD. WATERFORD, CT 06385 COUNTY: NEW LONDON  <u>GEOGRAPHIC COORDINATES:</u> LATITUDE: 41.377778 LONGITUDE: -72.141389 GROUND ELEVATION: 186' AMSL	THE PROPOSED PROJECT INSTALLS AN OPTIONAL STANDBY GENERATOR SYSTEM, AUTOMATIC TRANSFER SWITCH, GENERATOR AUXILIARY POWER DISTRIBUTION, AND REMOTE MONITORING COMMUNICATIONS CIRCUITRY FOR A COMMUNICATION TOWER TENANT.	SHEET NO:	DESCRIPTION:	REV:	DATE:	BY:
	<u>PROJECT TEAM</u> <u>ATC REGIONAL NETWORK DEVELOPMENT PROJECT MANAGER:</u> GREG CSAPO (919) 749-6927  <u>ATC NETWORK OPERATIONS CENTER:</u> (877) 518-6937  <u>TOWER OWNER:</u> AMERICAN TOWER 10 PRESIDENTIAL WAY WOBURN, MA 01801  <u>PROPERTY OWNER:</u> COHANZIE FIRE COMPANY NO 5 INC 53 DAYTON RD WATERFORD, CT 06385  <u>ENGINEERED BY:</u> ATC TOWER SERVICES 3500 REGENCY PARKWAY SUITE 100 CARY, NC 27518	<u>PROJECT NOTES</u> 1. THE FACILITY IS UNMANNED. 2. A TECHNICIAN WILL VISIT THE SITE APPROXIMATELY ONCE A MONTH FOR ROUTINE INSPECTION AND MAINTENANCE. 3. THE PROJECT WILL NOT RESULT IN ANY SIGNIFICANT LAND DISTURBANCE OR EFFECT OF STORM WATER DRAINAGE. 4. NO SANITARY SEWER, POTABLE WATER OR TRASH DISPOSAL IS REQUIRED. 5. HANDICAP ACCESS IS NOT REQUIRED.	G-001 TITLE SHEET G-002 GENERAL NOTES C-101 SITE PLAN C-501 CONCRETE PAD DETAILS E-601 ELECTRICAL ONE-LINE AND WIRING DETAILS				
	<u>PROJECT LOCATION DIRECTIONS</u>  FROM HARTFORD, CT: TAKE STATE ST TO CT-2 E. AFTER 0.2 MILES FOLLOW CT-2 E AND CT-11 S TO CT-82 E IN SALEM. TAKE EXIT 4 FROM CT-11 S. AFTER 31.9 MILES TAKE CT-85 S TO DAYTON PL IN WATERFORD.						



Copyright © 2018 ATC IP LLC. All Rights Reserved.

**GENERAL CONSTRUCTION NOTES:**

1. ALL WORK SHALL CONFORM TO ALL CURRENT APPLICABLE FEDERAL, STATE, AND LOCAL CODES, INCLUDING ANSIEIA/TIA-222, AND COMPLY WITH ATC MASTER SPECIFICATIONS.
2. CONTRACTOR SHALL CONTACT LOCAL 811 FOR IDENTIFICATION OF UNDERGROUND UTILITIES PRIOR TO START OF CONSTRUCTION.
3. CONTRACTOR SHALL BE RESPONSIBLE FOR COORDINATING ALL REQUIRED INSPECTIONS.
4. ALL DIMENSIONS TO, OF, AND ON EXISTING BUILDINGS, DRAINAGE STRUCTURES, AND SITE IMPROVEMENTS SHALL BE VERIFIED IN FIELD BY CONTRACTOR WITH ALL DISCREPANCIES REPORTED TO THE ENGINEER.
5. DO NOT CHANGE SIZE OR SPACING OF STRUCTURAL ELEMENTS.
6. DETAILS SHOWN ARE TYPICAL; SIMILAR DETAILS APPLY TO SIMILAR CONDITIONS UNLESS OTHERWISE NOTED.
7. THESE DRAWINGS DO NOT INCLUDE NECESSARY COMPONENTS FOR CONSTRUCTION SAFETY WHICH SHALL BE THE SOLE RESPONSIBILITY OF THE CONTRACTOR.
8. CONTRACTOR SHALL BRACE STRUCTURES UNTIL ALL STRUCTURAL ELEMENTS NEEDED FOR STABILITY ARE INSTALLED. THESE ELEMENTS ARE AS FOLLOWS: LATERAL BRACING, ANCHOR BOLTS, ETC.
9. CONTRACTOR SHALL DETERMINE EXACT LOCATION OF EXISTING UTILITIES, GROUNDS DRAINS, DRAIN PIPES, VENTS, ETC. BEFORE COMMENCING WORK.
10. INCORRECTLY FABRICATED, DAMAGED, OR OTHERWISE MISFITTING OR NONCONFORMING MATERIALS OR CONDITIONS SHALL BE REPORTED TO THE ATC CM PRIOR TO REMEDIAL OR CORRECTIVE ACTION. ANY SUCH REMEDIAL ACTION SHALL REQUIRE WRITTEN APPROVAL BY THE ATC CM PRIOR TO PROCEEDING.
11. EACH CONTRACTOR SHALL COOPERATE WITH THE ATC CM, AND COORDINATE HIS WORK WITH THE WORK OF OTHERS.
12. CONTRACTOR SHALL REPAIR ANY DAMAGE CAUSED BY CONSTRUCTION OF THIS PROJECT TO MATCH EXISTING PRE-CONSTRUCTION CONDITIONS TO THE SATISFACTION OF THE ATC CONSTRUCTION MANAGER.
13. ALL CABLE/CONDUIT ENTRY/EXIT PORTS SHALL BE WEATHERPROOFED DURING INSTALLATION USING A SILICONE SEALANT.
14. WHERE EXISTING CONDITIONS DO NOT MATCH THOSE SHOWN IN THIS PLAN SET, CONTRACTOR SHALL NOTIFY THE ATC CONSTRUCTION MANAGER IMMEDIATELY.
15. CONTRACTOR SHALL ENSURE ALL SUBCONTRACTORS ARE PROVIDED WITH A COMPLETE AND CURRENT SET OF DRAWINGS AND SPECIFICATIONS FOR THIS PROJECT.
16. CONTRACTOR SHALL REMOVE ALL RUBBISH AND DEBRIS FROM THE SITE AT THE END OF EACH DAY.
17. CONTRACTOR SHALL COORDINATE WORK SCHEDULE WITH LANDLORD AND TAKE PRECAUTIONS TO MINIMIZE IMPACT AND DISRUPTION OF OTHER OCCUPANTS OF THE FACILITY.
18. CONTRACTOR SHALL FURNISH ATC WITH A PDF MARKED UP AS-BUILT SET OF DRAWINGS UPON COMPLETION OF WORK.
19. PRIOR TO SUBMISSION OF BID, CONTRACTOR SHALL COORDINATE WITH ATC CM TO DETERMINE WHAT, IF ANY, ITEMS WILL BE PROVIDED. ALL ITEMS NOT PROVIDED SHALL BE PROVIDED AND INSTALLED BY THE CONTRACTOR. CONTRACTOR WILL INSTALL ALL ITEMS PROVIDED.
20. PRIOR TO SUBMISSION OF BID, CONTRACTOR SHALL COORDINATE WITH ATC CONSTRUCTION MANAGER TO DETERMINE IF ANY PERMITS WILL BE OBTAINED BY ATC. ALL REQUIRED PERMITS NOT OBTAINED BY ATC MUST BE OBTAINED, AND PAID FOR, BY THE CONTRACTOR.
21. CONTRACTOR SHALL INSTALL ALL SITE SIGNAGE IN ACCORDANCE WITH ATC SPECIFICATIONS AND REQUIREMENTS.
22. CONTRACTOR SHALL SUBMIT ALL SHOP DRAWINGS TO ATC FOR REVIEW AND APPROVAL PRIOR TO FABRICATION.
23. ALL EQUIPMENT SHALL BE INSTALLED ACCORDING TO MANUFACTURER'S SPECIFICATIONS AND LOCATED ACCORDING TO ATC SPECIFICATIONS, AND AS SHOWN IN THESE PLANS.
24. THE CONTRACTOR SHALL SUPERVISE AND DIRECT THE PROJECT DESCRIBED HEREIN. THE CONTRACTOR SHALL BE SOLELY RESPONSIBLE FOR ALL THE CONSTRUCTION MEANS, METHODS, TECHNIQUES, SEQUENCES AND PROCEDURES AND FOR COORDINATING ALL PORTIONS OF THE WORK UNDER THE CONTRACT.
25. CONTRACTOR SHALL NOTIFY ATC CM A MINIMUM OF 48 HOURS IN ADVANCE OF POURING CONCRETE OR BACKFILLING ANY UNDERGROUND UTILITIES, FOUNDATIONS OR SEALING ANY WALL, FLOOR OR ROOF PENETRATIONS FOR ENGINEERING REVIEW AND APPROVAL.
26. CONTRACTOR SHALL BE RESPONSIBLE FOR SITE SAFETY INCLUDING COMPLIANCE WITH ALL APPLICABLE OSHA STANDARDS AND RECOMMENDATIONS AND SHALL PROVIDE ALL NECESSARY SAFETY DEVICES INCLUDING PPE AND PPM AND CONSTRUCTION DEVICES SUCH AS WELDING AND FIRE PREVENTION, TEMPORARY SHORING, SCAFFOLDING, TRENCH BOXES/SLOPING, BARRIERS, ETC.
27. THE CONTRACTOR SHALL PROTECT AT HIS OWN EXPENSE, ALL EXISTING FACILITIES AND SUCH OF HIS NEW WORK LIABLE TO INJURY DURING THE CONSTRUCTION PERIOD. ANY DAMAGE CAUSED BY NEGLIGENCE ON THE PART OF THIS CONTRACTOR OR HIS REPRESENTATIVES, OR BY THE ELEMENTS DUE TO NEGLIGENCE ON THE PART OF THIS CONTRACTOR OR HIS

REPRESENTATIVES, EITHER TO THE EXISTING WORK, OR TO HIS WORK OR THE WORK OF ANY OTHER CONTRACTOR, SHALL BE REPAIRED AT HIS EXPENSE TO THE OWNER'S SATISFACTION.

28. ALL WORK SHALL BE INSTALLED IN A FIRST CLASS, NEAT AND WORKMANLIKE MANNER BY MECHANICS SKILLED IN THE TRADE INVOLVED. THE QUALITY OF WORKMANSHIP SHALL BE SUBJECT TO THE APPROVAL OF THE ATC CM. ANY WORK FOUND BY THE ATC CM TO BE OF INFERIOR QUALITY AND/OR WORKMANSHIP SHALL BE REPLACED AND/OR REWORKED AT CONTRACTOR EXPENSE UNTIL APPROVAL IS OBTAINED.
29. IN ORDER TO ESTABLISH STANDARDS OF QUALITY AND PERFORMANCE, ALL TYPES OF MATERIALS LISTED HEREINAFTER BY MANUFACTURER'S NAMES AND/OR MANUFACTURER'S CATALOG NUMBER SHALL BE PROVIDED BY THESE MANUFACTURERS AS SPECIFIED.

**CONCRETE AND REINFORCING STEEL NOTES:**

1. DESIGN AND CONSTRUCTION OF ALL CONCRETE ELEMENTS SHALL CONFORM TO THE LATEST EDITIONS OF ALL APPLICABLE CODES INCLUDING: ACI 301 "SPECIFICATIONS FOR STRUCTURAL CONCRETE FOR BUILDINGS", ACI 117 "SPECIFICATIONS FOR TOLERANCES FOR CONCRETE CONSTRUCTION AND MATERIALS", AND ACI 318 "BUILDING CODE REQUIREMENTS FOR REINFORCED CONCRETE."
2. MIX DESIGN SHALL BE APPROVED BY ATC CM PRIOR TO PLACING CONCRETE.
3. CONCRETE SHALL BE NORMAL WEIGHT, 6 % AIR ENTRAINED (+/- 1.5%) WITH A SLUMP RANGE OF 3-5" AND HAVE A MINIMUM 28-DAY COMPRESSIVE STRENGTH OF 4000 PSI UNLESS OTHERWISE NOTED.
4. THE FOLLOWING MATERIALS SHALL BE USED:
  - PORTLAND CEMENT: ASTM C150, TYPE 2
  - REINFORCEMENT: ASTM A185, PLAIN STEEL WELDED WIRE FABRIC
  - REINFORCEMENT BARS: ASTM A615, GRADE 60, DEFORMED
  - NORMAL WEIGHT AGGREGATE: ASTM C33
  - WATER: ASTM C 94/C 94M
  - ADMIXTURES:
    - WATER-REDUCING AGENT: ASTM C 494/C 494M, TYPE A
    - AIR-ENTERING AGENT: ASTM C 260/C 260M
    - SUPERPLASTICIZER: ASTM C494, TYPE F OR TYPE G
    - RETARDING: ASTM C 494/C 494M, TYPE B
5. MINIMUM CONCRETE COVER FOR REINFORCING STEEL SHALL BE NO LESS THAN 3".
6. A 3/4" CHAMFER SHALL BE PROVIDED AT ALL EXPOSED EDGES OF CONCRETE IN ACCORDANCE WITH ACI 301 SECTION 4.2.4, UNLESS NOTED OTHERWISE.
7. INSTALLATION OF CONCRETE EXPANSION/WEDGE ANCHOR SHALL BE PER MANUFACTURER'S WRITTEN RECOMMENDED PROCEDURE. THE ANCHOR BOLT, DOWEL, OR ROD SHALL CONFORM TO MANUFACTURER'S RECOMMENDATION FOR EMBEDMENT DEPTH OR AS SHOWN ON THE DRAWINGS. NO REBAR SHALL BE CUT WITHOUT PRIOR ATC CM APPROVAL WHEN DRILLING HOLES IN CONCRETE.
8. ADMIXTURES SHALL CONFORM TO THE APPROPRIATE ASTM STANDARD AS REFERENCED IN "METHOD 1" OF ACI 301.
9. DO NOT WELD OR TACK WELD REINFORCING STEEL.
10. ALL DOWELS, ANCHOR BOLTS, EMBEDDED STEEL, ELECTRICAL CONDUITS, PIPE SLEEVES, GROUNDS AND ALL OTHER EMBEDDED ITEMS AND FORMED DETAILS SHALL BE IN PLACE BEFORE START OF CONCRETE PLACEMENT.
11. REINFORCEMENT SHALL BE COLD BENT WHENEVER BENDING IS REQUIRED.
12. DO NOT PLACE CONCRETE IN WATER, ICE, OR ON FROZEN GROUND.
13. DO NOT ALLOW REINFORCEMENT, CONCRETE OR SUBBASE TO FREEZE DURING CONCRETE CURING AND SETTING PERIOD, OR FOR A MINIMUM OF 3 DAYS AFTER PLACEMENT.
14. FOR COLD-WEATHER(ACI 306) AND HOT-WEATHER(ACI 301M) CONCRETE PLACEMENT, CONFORM TO APPLICABLE ACI CODES AND RECOMMENDATIONS. IN EITHER CASE, MATERIALS CONTAINING CHLORIDE, CALCIUM, SALTS, ETC. SHALL NOT BE USED. PROTECT FRESH CONCRETE FROM WEATHER FOR 7 DAYS, MINIMUM.
15. ALL CONCRETE SHALL HAVE A "SMOOTH FORM FINISH."
16. UNLESS OTHERWISE NOTED:
  - A. ALL REINFORCING STEEL SHALL BE DEFORMED BARS CONFORMING TO ASTM A615/A 615M/A-996, GRADE 60.
  - B. WELDED WIRE FABRIC SHALL CONFORM TO ASTM A185.
17. SPLICING OF REINFORCEMENT IS PERMITTED ONLY AT LOCATIONS SHOWN IN THE CONTRACT DRAWINGS OR AS ACCEPTED BY THE ENGINEER. UNLESS OTHERWISE SHOWN OR NOTED REINFORCING STEEL SHALL BE SPLICED TO DEVELOP ITS FULL TENSILE CAPACITY (CLASS A) IN ACCORDANCE WITH ACI 318.
18. REINFORCING BAR DEVELOPMENT LENGTHS, AS COMPUTED IN ACCORDANCE WITH ACI 318, FORM THE BASIS FOR BAR EMBEDMENT LENGTHS AND BAR SPLICED LENGTHS SHOWN IN THE

DRAWINGS. APPLY APPROPRIATE MODIFICATION FACTORS FOR TOP STEEL, BAR SPACING, COVER AND THE LIKE.

19. DETAILING OF REINFORCING STEEL SHALL CONFORM TO "ACI MANUAL OF STANDARD PRACTICE FOR DETAILING REINFORCED CONCRETE STRUCTURES" (ACI 315).
20. ALL SLAB CONSTRUCTION SHALL BE CAST MONOLITHICALLY WITHOUT HORIZONTAL CONSTRUCTION JOINTS, UNLESS SHOWN IN THE CONTRACT DRAWINGS.
21. LOCATION OF ALL CONSTRUCTION JOINTS ARE SUBJECT TO THE REQUIREMENTS OF THE CONTRACT DOCUMENTS, CONFORMANCE WITH ACI 318, AND ACCEPTANCE OF THE ENGINEER. DRAWINGS SHOWING LOCATION OF DETAILS OF THE PROPOSED CONSTRUCTION JOINTS SHALL BE SUBMITTED WITH REINFORCING STEEL PLACEMENT DRAWINGS.
22. SPLICES OF WWF, AT ALL SPLICED EDGES, SHALL BE SUCH THAT THE OVERLAP MEASURED BETWEEN OUTERMOST CROSS WIRES OF EACH FABRIC SHEET IS NOT LESS THAN THE SPACING OF THE CROSS WIRE PLUS 2 INCHES, NOR LESS THAN 6".
23. BAR SUPPORTS SHALL BE ALL-GALVINIZED METAL WITH PLASTIC TIPS.
24. ALL REINFORCEMENT SHALL BE SECURELY TIED IN PLACE TO PREVENT DISPLACEMENT BY CONSTRUCTION TRAFFIC OR CONCRETE. TIE WIRE SHALL BE OF SUFFICIENT STRENGTH FOR INTENDED PURPOSE, BUT NOT LESS THAN NO. 18 GAUGE.
25. SLAB ON GROUND:
  - A. COMPACT SUBGRADE AND ENSURE THERE IS PLACE 6" GRAVEL BENEATH SLAB.
  - B. PROVIDE VAPOR BARRIER BENEATH SLAB ON GROUND.

**STRUCTURAL STEEL NOTES:**

1. STRUCTURAL STEEL SHALL CONFORM TO THE LATEST EDITION OF THE AISC "SPECIFICATION FOR THE DESIGN, FABRICATION AND ERECTION OF STRUCTURAL STEEL FOR BUILDINGS."
2. STRUCTURAL STEEL ROLLED SHAPES, PLATES AND BARS SHALL CONFORM TO THE FOLLOWING ASTM DESIGNATIONS:
  - A. ASTM A-572, GRADE 50 - ALL W SHAPES, UNLESS NOTED OR A992 OTHERWISE
  - B. ASTM A-36 - ALL OTHER ROLLED SHAPES, PLATES AND BARS UNLESS NOTED OTHERWISE.
  - C. ASTM A-500, GRADE B - HSS SECTION (SQUARE, RECTANGULAR, AND ROUND)
  - D. ASTM A-325, TYPE SC OR N - ALL BOLTS FOR CONNECTING STRUCTURAL MEMBERS
  - E. ASTM F-1554 07 - ALL ANCHOR BOLTS, UNLESS NOTED OTHERWISE
3. ALL EXPOSED STRUCTURAL STEEL MEMBERS SHALL BE HOT-DIPPED GALVANIZED AFTER FABRICATION PER ASTM A123. EXPOSED STEEL HARDWARE AND ANCHOR BOLTS SHALL BE GALVANIZED PER ASTM A153 OR B695.
4. ALL FIELD CUT SURFACES, FIELD DRILLED HOLES AND GROUND SURFACES WHERE EXISTING PAINT OR GALVANIZATION REMOVAL WAS REQUIRED SHALL BE REPAIRED WITH (2) BRUSHED COATS OF ZRC GALVILITE COLD GALVANIZING COMPOUND PER ASTM A780 AND MANUFACTURER'S RECOMMENDATIONS.
5. DO NOT DRILL HOLES THROUGH STRUCTURAL STEEL MEMBERS EXCEPT AS SHOWN AND DETAILED ON STRUCTURAL DRAWINGS.
6. CONNECTIONS:
  - A. ALL WELDING TO BE PERFORMED BY AWS CERTIFIED WELDERS AND CONDUCTED IN ACCORDANCE WITH THE LATEST EDITION OF THE AWS WELDING CODE D1.1.
  - B. ALL WELDS SHALL BE INSPECTED VISUALLY. 25% OF WELDS SHALL BE INSPECTED WITH DYE PENETRANT OR MAGNETIC PARTICLE TO MEET THE ACCEPTANCE CRITERIA OF AWS D1.1. REPAIR ALL WELDS AS NECESSARY.
  - C. INSPECTION SHALL BE PERFORMED BY AN AWS CERTIFIED WELD INSPECTOR.
  - D. IT IS THE CONTRACTORS RESPONSIBILITY TO PROVIDE BURNING/WELDING PERMITS AS REQUIRED BY LOCAL GOVERNING AUTHORITY AND IF REQUIRED SHALL HAVE FIRE DEPARTMENT DETAIL FOR ANY WELDING ACTIVITY.
  - E. ALL ELECTRODES TO BE LOW HYDROGEN, MATCHING FILLER METAL, PER AWS D1.1, UNLESS NOTED OTHERWISE.
  - F. MINIMUM WELD SIZE TO BE 0.1875 INCH FILLET WELDS, UNLESS NOTED OTHERWISE.
  - G. PRIOR TO FIELD WELDING GALVANIZING MATERIAL, CONTRACTOR SHALL GRIND OFF GALVANIZING 1/2" BEYOND ALL FIELD WELD SURFACES. AFTER WELD AND WELD INSPECTION IS COMPLETE, REPAIR ALL GROUND AND WELDED SURFACES WITH ZRC GALVILITE COLD GALVANIZING COMPOUND PER ASTM A780 AND MANUFACTURERS RECOMMENDATIONS.



THESE DRAWINGS AND/OR THE ACCOMPANYING SPECIFICATION AS INSTRUMENTS OR SERVICE ARE THE EXCLUSIVE PROPERTY OF AMERICAN TOWER. THEIR USE AND PUBLICATION SHALL BE RESTRICTED TO THE ORIGINAL SITE FOR WHICH THEY ARE PREPARED. ANY USE OR DISCLOSURE OTHER THAN THAT WHICH RELATES TO AMERICAN TOWER OR THE SPECIFIED CARRIER IS STRICTLY PROHIBITED. TITLE TO THESE DOCUMENTS SHALL REMAIN THE PROPERTY OF AMERICAN TOWER WHETHER OR NOT THE PROJECT IS EXECUTED. NEITHER THE ARCHITECT NOR THE ENGINEER WILL BE PROVIDING ON-SITE CONSTRUCTION REVIEW OF THIS PROJECT. CONTRACTOR(S) MUST VERIFY ALL DIMENSIONS AND ADVISE AMERICAN TOWER OF ANY DISCREPANCIES. ANY PRIOR ISSUANCE OF THIS DRAWING IS SUPERSEDED BY THE LATEST VERSION ON FILE WITH AMERICAN TOWER.

REV.	DESCRIPTION	BY	DATE
0	FOR CONSTRUCTION	TC	09/13/18

ATC SITE NUMBER:  
**411183**

ATC SITE NAME:  
**WATERFORD CT**

SITE ADDRESS:  
53 DAYTON RD.  
WATERFORD, CT 06385

SEAL:



DRAWN BY:	TC
APPROVED BY:	PPB
DATE DRAWN:	09/13/18
ATC JOB NO:	12612230

**GENERAL NOTES**

SHEET NUMBER: <b>G-002</b>	REVISION: <b>0</b>
-------------------------------	-----------------------

Copyright © 2018 ATC IP, LLC. All Rights Reserved.

**SITE PLAN NOTES:**

- THIS SITE PLAN REPRESENTS THE BEST PRESENT KNOWLEDGE AVAILABLE TO THE ENGINEER AT THE TIME OF THIS DESIGN. THE CONTRACTOR SHALL VISIT THE SITE PRIOR TO CONSTRUCTION AND VERIFY ALL EXISTING CONDITIONS RELATED TO THE SCOPE OF WORK FOR THIS PROJECT.
- ICE BRIDGE, CABLE LADDER, COAX PORT, AND COAX CABLE ARE SHOWN FOR REFERENCE ONLY. CONTRACTOR SHALL CONFIRM THE EXACT LOCATION OF ALL PROPOSED AND EXISTING EQUIPMENT AND STRUCTURES DEPICTED ON THIS PLAN. BEFORE UTILIZING EXISTING CABLE SUPPORTS, COAX PORTS, INSTALLING NEW PORTS OR ANY OTHER EQUIPMENT, CONTRACTOR SHALL VERIFY ALL ASPECTS OF THE COMPONENTS MEET THE ATC SPECIFICATIONS.
- IT IS THE RESPONSIBILITY OF THE CONTRACTOR TO COORDINATE WITH THE ATC CONSTRUCTION MANAGER AND LOCAL UTILITY COMPANY FOR THE INSTALLATION OF CONDUITS, CONDUCTORS, BREAKERS, DISCONNECTS, OR ANY OTHER EQUIPMENT REQUIRED FOR ELECTRICAL SERVICE. ALL ELECTRICAL WORK SHALL BE PERFORMED IN ACCORDANCE WITH LATEST EDITION OF THE STATE AND NATIONAL CODES, ORDINANCES AND REGULATIONS APPLICABLE TO THIS PROJECT.
- CONTRACTOR SHALL INSURE THAT ALL WORKING SPACE REQUIREMENTS ARE MET PER APPLICABLE CODES AND MANUFACTURER SPECIFICATIONS.
- ABOVE GROUND CONDUITS NEED TO BE SUPPORTED/FASTENED PER NEC 344 AND PER ATC MASTER SPECIFICATIONS.
- THE FOLLOWING SIGNS SHALL BE INSTALLED AT TENANT SERVICE MAIN DISCONNECT PER NEC 702.7.
  - "CAUTION: TWO SOURCES OF SUPPLY STANDBY GENERATOR LOCATED OUTDOORS"
  - "WARNING: SHOCK HAZARD EXISTS IF GROUNDING ELECTRODE CONDUCTOR OR BONDING JUMPER CONNECTION IN THIS EQUIPMENT IS REMOVED WHILE ALTERNATE SOURCE IS ENERGIZED"

**RODENT CONTROL AROUND GENERATOR ENVELOPE:**

- INSTALL ALL PROVIDED SEALS, PLUGS, COVERS, ETC. IN GENERATOR AND FUEL TANK ENVELOPE. SEAL ALL REMAINING OPENINGS (EXCEPT NORMAL VENTING) WITH RODENT FOAM SEALANT. NO OPENING SHALL BE LARGER THAN 1/4 INCH ANY DIMENSION.
- SEAL ALL CONDUITS INCLUDING CONDUITS ENTERING GENERATOR EQUIPMENT, BOXES, ATTACHMENTS, ETC. WITH RODENT FOAM SEALANT.
- SEAL ALL CONDUIT ACCESS OPENINGS THROUGH CONCRETE PAD WITH CONCRETE.
- SLOPE GRAVEL BASE AT CONCRETE PAD PERIMETER FROM ABOVE PAD BASE TO EXISTING GRADE LEVEL TYPICAL ALL PERIMETER SIDES.

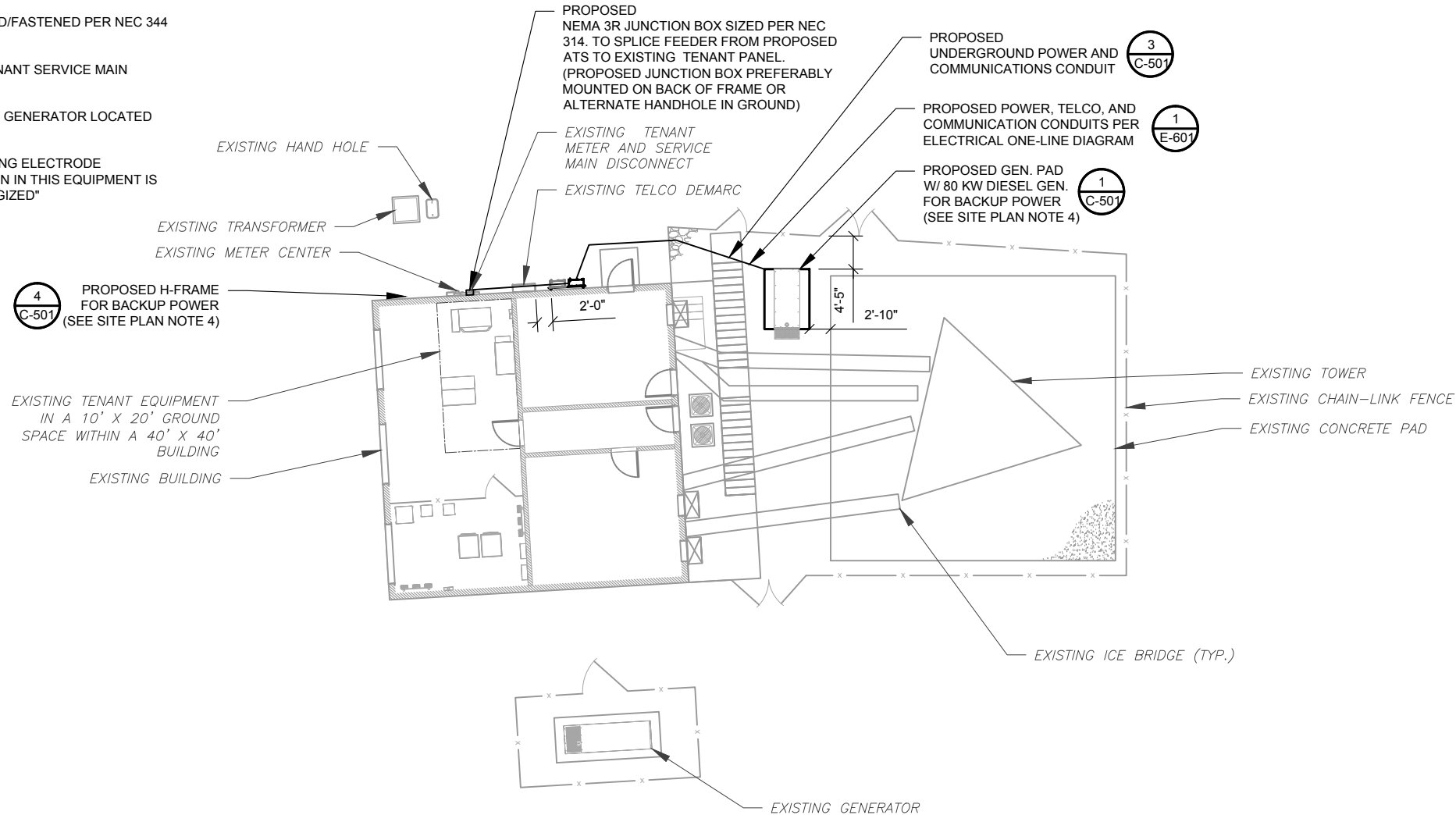

APPROXIMATE TRENCH LENGTHS	
29'	JOINT ELECTRICAL AND COMMUNICATIONS TRENCH
13'	WALL MOUNTED CONDUIT

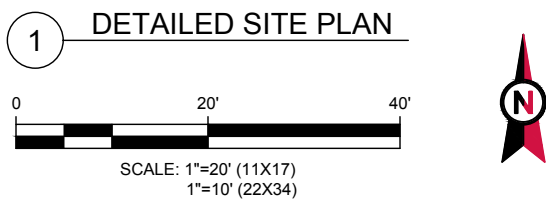

**AMERICAN TOWER®**  
**A.T. ENGINEERING SERVICE, PLLC**  
 3500 REGENCY PARKWAY  
 SUITE 100  
 CARY, NC 27518  
 PHONE: (919) 468-0112  
 COA: PEC.0001553

THESE DRAWINGS AND/OR THE ACCOMPANYING SPECIFICATION AS INSTRUMENTS OR SERVICE ARE THE EXCLUSIVE PROPERTY OF AMERICAN TOWER. THEIR USE AND PUBLICATION SHALL BE RESTRICTED TO THE ORIGINAL SITE FOR WHICH THEY ARE PREPARED. ANY USE OR DISCLOSURE OTHER THAN THAT WHICH RELATES TO AMERICAN TOWER OR THE SPECIFIED CARRIER IS STRICTLY PROHIBITED. TITLE TO THESE DOCUMENTS SHALL REMAIN THE PROPERTY OF AMERICAN TOWER WHETHER OR NOT THE PROJECT IS EXECUTED. NEITHER THE ARCHITECT NOR THE ENGINEER WILL BE PROVIDING ON-SITE CONSTRUCTION REVIEW OF THIS PROJECT. CONTRACTOR(S) MUST VERIFY ALL DIMENSIONS AND ADVISE AMERICAN TOWER OF ANY DISCREPANCIES. ANY PRIOR ISSUANCE OF THIS DRAWING IS SUPERSEDED BY THE LATEST VERSION ON FILE WITH AMERICAN TOWER.

REV.	DESCRIPTION	BY	DATE
0	FOR CONSTRUCTION	TC	09/13/18

ATC SITE NUMBER:  
**411183**

ATC SITE NAME:  
**WATERFORD CT**

SITE ADDRESS:  
 53 DAYTON RD.  
 WATERFORD, CT 06385

SEAL:

DRAWN BY:	TC
APPROVED BY:	PPB
DATE DRAWN:	09/13/18
ATC JOB NO:	12612230

**SITE PLAN**

SHEET NUMBER: **C-101**      REVISION: **0**

Copyright © 2018 ATC IP, LLC. All Rights Reserved.



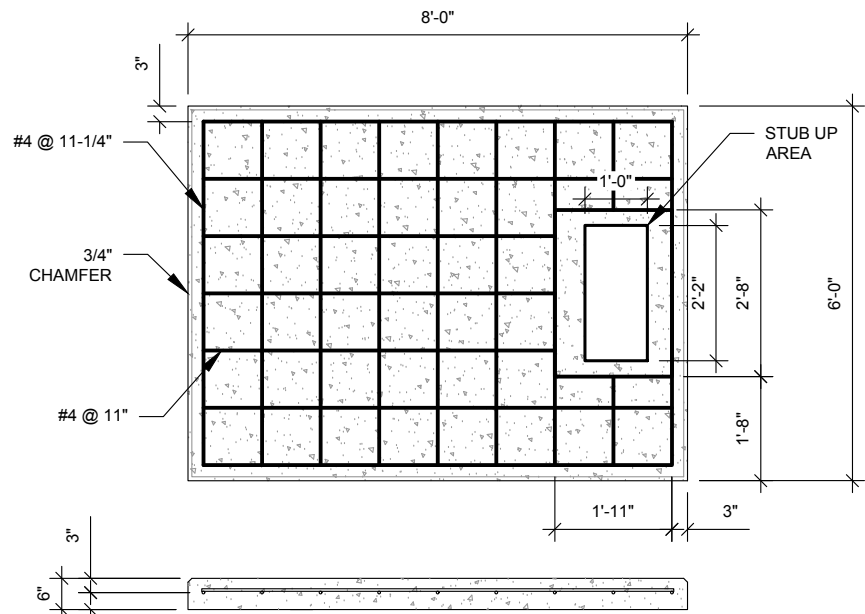

**PAD NOTES:**

1. PADS SHALL BE PRE-CAST MATCHING THIS DESIGN WHERE ALLOWED BY LOCAL JURISDICTION.
2. PADS SHALL HAVE A MIN 28 DAY COMPRESSIVE STRENGTH OF 4000 PSI MIN.
3. REFER TO CONCRETE & REINFORCED STEEL NOTES ON SHEET G-002 & ATC SPEC 033000 FOR CAST-IN-PLACE PADS.
4. STUB UP AREA SHALL BE FILLED WITH QUIKRETE, OR APPROVED EQUAL, PRIOR TO FINAL SET OF GENERATOR ON PAD.
5. AFTER FINAL SET OF GENERATOR ON PAD, GROUT ALL EXTERIOR OPENINGS AT PAD INTERFACE SO THAT FINISHED MAXIMUM OPENING SHALL BE 1/4 INCH.
6. GROUT SHALL BE PER ATC MASTER SPECIFICATION DIVISION 03, CONCRETE.

**1 REINFORCED PAD LAYOUT**  
SCALE: N.T.S.

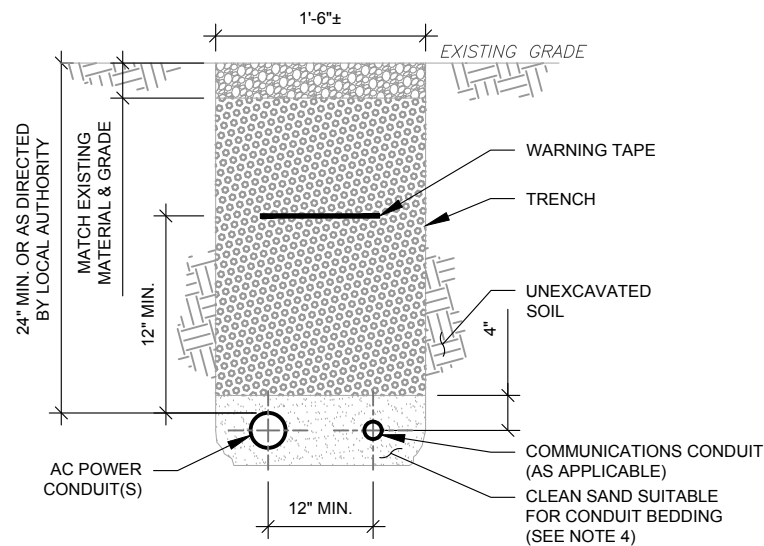

**TRENCH NOTES:**

1. IF FREE OF ORGANIC OR OTHER DELETERIOUS MATERIAL, EXCAVATED MATERIAL MAY BE USED FOR BACKFILL. IF NOT, PROVIDE CLEAN, COMPACTIBLE MATERIAL.
2. COMPACT IN 8" LIFTS USING A MECHANICAL PLATE TAMPER, MIN 3 PASSES. REMOVE ANY LARGE ROCKS PRIOR TO BACKFILLING. CONTRACTOR TO VERIFY LOCATION OF EXISTING U/G UTILITIES PRIOR TO DIGGING. SEE ATC MASTER SPEC 312000 SECTION 3.15.
3. IF CURRENT AS-BUILT DRAWINGS ARE NOT AVAILABLE CONTRACTOR SHALL HAND DIG U/G TRENCHING.
4. CONFIRM SPACING AND DEPTH WITH NEC OR LOCAL CODE REQUIREMENTS

**3 CONDUIT TRENCH DETAILS**  
SCALE: N.T.S.

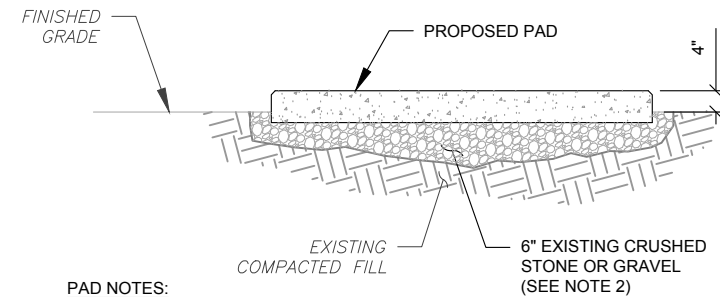

**PAD NOTES:**

1. SUBGRADE AND FILL SHALL CONSIST OF CLEAN SOIL. DELETRIOUS MATERIAL AND ORGANICS SHALL BE REMOVED.
2. MECHANICALLY COMPACT FOOTPRINT OF PAD PLUS 2' PERIMETER USING A MECHANICAL PLATE TAMPER, MIN 3 PASSES. SEE ATC MASTER SPEC 312000 ACCESS ROAD AND EARTH WORK.
3. USE GALVANIZED HILTI EXPANSION ANCHORS OR, APPROVED EQUAL, FOR EQUIPMENT ANCHORAGE.
4. FOR SIZE AND LOCATION OF ANCHORS AND OTHER REQUIREMENT, SEE EQUIPMENT VENDOR DRAWINGS.

**2 GRAVEL PREPARATION**  
SCALE: N.T.S.

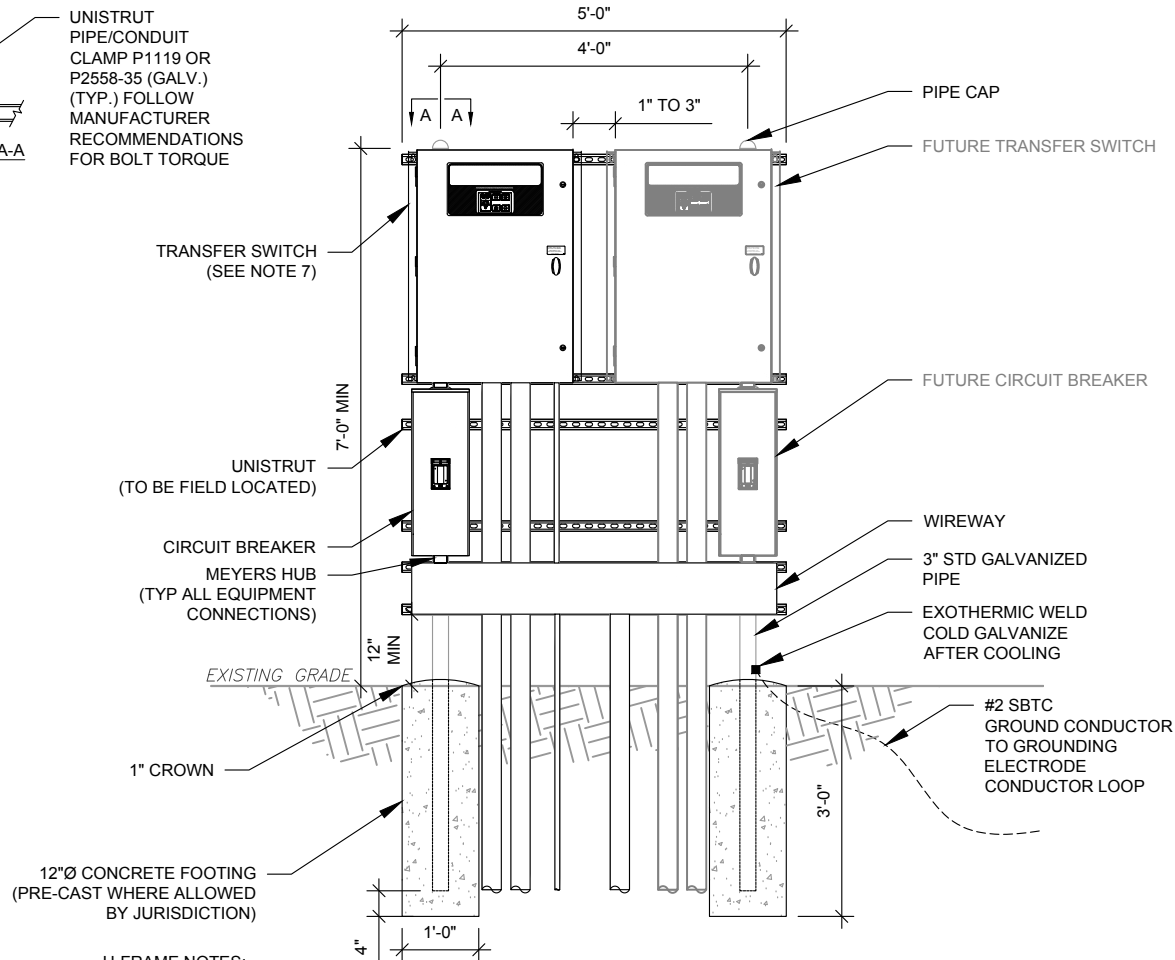
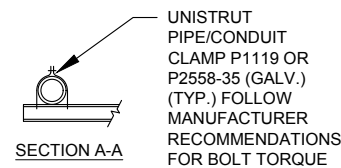

**H-FRAME NOTES:**

1. IF IT IS NECESSARY TO EXTEND THE H-FRAME, AN ADDITIONAL POST SHALL BE REQUIRED.
2. PROPOSED UNISTRUTS TO BE FIELD CUT AND SHALL NOT EXTEND MORE THAN 6 INCHES BEYOND THE LAST POST.
3. SPRAY ENDS OF UNISTRUT WITH COLD GALVANIZING SPRAY PAINT, ALLOW TO DRY, THEN COVER WITH RUBBER PROTECTIVE CAPS FOR SAFETY.
4. UNISTRUT TO BE CUT FLUSH WITH NO SHARP OR JAGGED EDGES.
5. ALL PROPOSED HARDWARE TO BE MOUNTED AND GROUNDED PER MANUFACTURERS SPECS
6. ALL ITEMS ARE PROPOSED UNLESS OTHERWISE NOTED.
7. LAYOUT H-FRAME & PROPOSED EQUIPMENT EXACTLY AS SHOWN TO ALLOW FOR FUTURE EQUIPMENT. ANY DEVIATIONS MUST BE APPROVED BY ATC CM, IN WRITING, NO EXCEPTIONS.
8. FOOTINGS SHALL BE ONE OF THE FOLLOWING: USS POLECRETE STABILIZER SYSTEM, PRECAST CONCRETE (WHERE ALLOWED BY JURISDICTION) OR CAST IN PLACE. FOR PRECAST FOOTINGS, CONTRACTORS SHALL THOROUGHLY COMPACT THE PERIMETER (2' MIN) OF FOOTING WITH MECHANICAL PLATE TAMPER.

**4 H-FRAME**  
SCALE: N.T.S.

THESE DRAWINGS AND/OR THE ACCOMPANYING SPECIFICATION AS INSTRUMENTS OR SERVICE ARE THE EXCLUSIVE PROPERTY OF AMERICAN TOWER. THEIR USE AND PUBLICATION SHALL BE RESTRICTED TO THE ORIGINAL SITE FOR WHICH THEY ARE PREPARED. ANY USE OR DISCLOSURE OTHER THAN THAT WHICH RELATES TO AMERICAN TOWER OR THE SPECIFIED CARRIER IS STRICTLY PROHIBITED. TITLE TO THESE DOCUMENTS SHALL REMAIN THE PROPERTY OF AMERICAN TOWER WHETHER OR NOT THE PROJECT IS EXECUTED. NEITHER THE ARCHITECT NOR THE ENGINEER WILL BE PROVIDING ON-SITE CONSTRUCTION REVIEW OF THIS PROJECT. CONTRACTOR(S) MUST VERIFY ALL DIMENSIONS AND ADVISE AMERICAN TOWER OF ANY DISCREPANCIES. ANY PRIOR ISSUANCE OF THIS DRAWING IS SUPERSEDED BY THE LATEST VERSION ON FILE WITH AMERICAN TOWER.

REV.	DESCRIPTION	BY	DATE
0	FOR CONSTRUCTION	TC	09/13/18

ATC SITE NUMBER:  
**411183**  
ATC SITE NAME:  
**WATERFORD CT**  
SITE ADDRESS:  
53 DAYTON RD.  
WATERFORD, CT 06385

SEAL:



DRAWN BY:	TC
APPROVED BY:	PPB
DATE DRAWN:	09/13/18
ATC JOB NO:	12612230

**CONCRETE PAD DETAILS**

SHEET NUMBER:	REVISION:
<b>C-501</b>	<b>0</b>

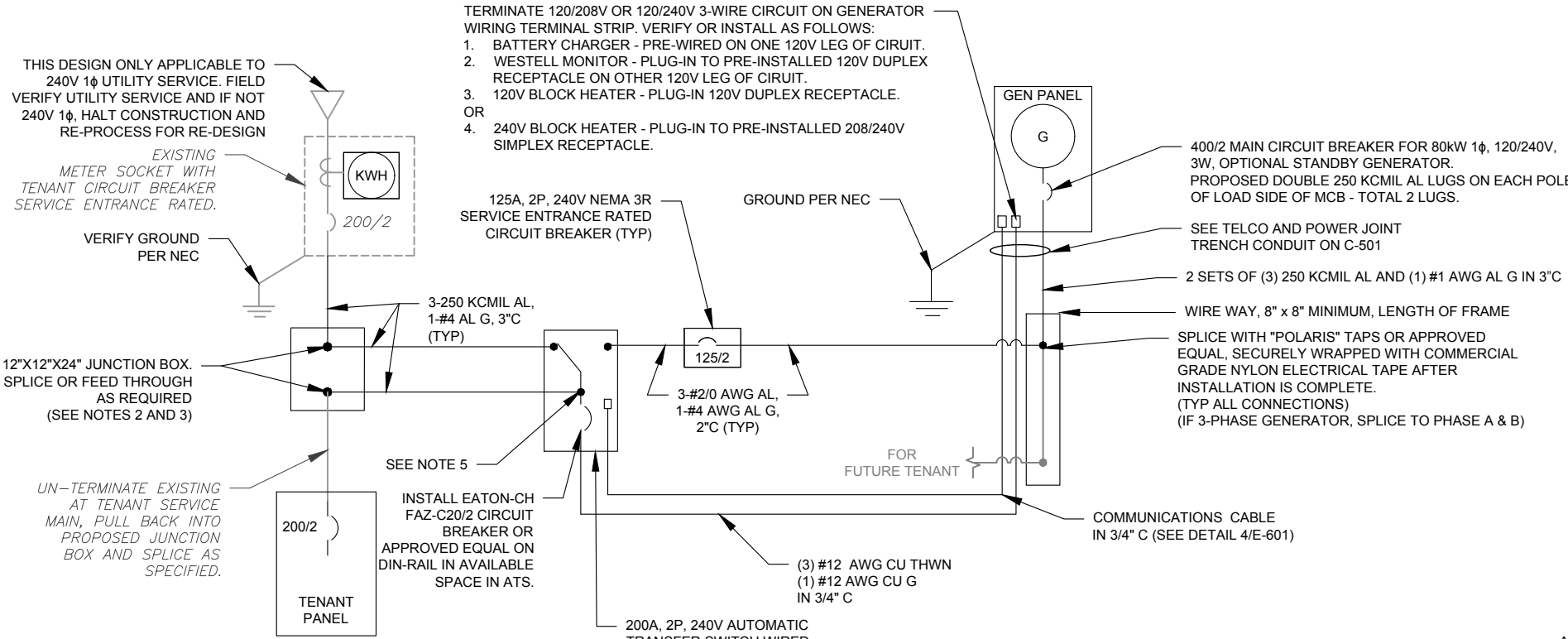

- ONE-LINE NOTES:
- CONNECT CT'S PER HTS OWNERS MANUAL-SECTION 3.11.2 INSTRUMENT PACKAGE
  - SPLICE WITH "POLARIS" TAPS OR APPROVED EQUAL, SECURELY WRAPPED WITH COMMERCIAL GRADE NYLON ELECTRICAL TAPE AFTER INSTALLATION IS COMPLETE.
  - UTILIZE EXISTING ENCLOSURES FOR SPLICING (PER NEC 312.8) OR INSTALL NEW JUNCTION BOX AS APPLICABLE PER SITE CONDITIONS AND CODES. SIZE JUNCTION BOX AS PER NEC 314.28
  - IF TAPPING AT TENANT EQUIPMENT, NO TAPS MAY BE MADE WITHIN THEIR EXISTING EQUIPMENT, INCLUDING PPC.
  - TAP GENERATOR PANEL CIRCUIT TO GENERAC LUGS #G0A9949 ON T-TERMINALS (LOAD SIDE) WITH AUXILIARY TAP SCREW GENERAC #GO26902 #8-32X1/4". TERMINATE #12 AWG CONDUCTOR ON EACH LUG WITH INSULATED RING TERMINAL PROPERLY SIZED.

**1 ELECTRICAL ONE-LINE DIAGRAM**  
SCALE: NOT TO SCALE

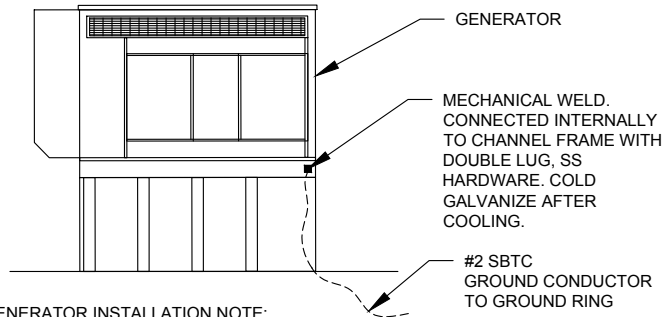

GENERATOR INSTALLATION NOTE:

INSTALL GENERATOR AND TRANSFER SWITCH WITH ALL SUPPLIED ACCESSORIES PER MANUFACTURER'S INSTALLATION INSTRUCTIONS AND SPECIFICATIONS. THIS INCLUDES, BUT IS NOT LIMITED TO, ACCESSORIES FOR THE EXHAUST SYSTEM, FUEL SYSTEM, ENCLOSURE INTEGRITY (CAPS, PLUGS, COVERS, ETC.), ELECTRICAL CONNECTIONS, AND GROUNDING CONNECTIONS.

**2 GENERATOR GROUNDING**  
SCALE: NOT TO SCALE

DEMAND LOAD CALCULATION	
GENERATOR LOADS	2.5 KW
TENANT PANEL DEMAND LOADS	25.0 KW
TOTAL DEMAND LOADS (KW)	27.5 KW
TOTAL DEMAND CURRENT (A)	114.5 A
AT 120/240V, 1PH, 3W	

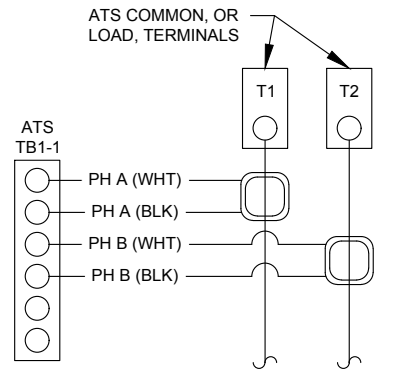

- CT NOTES:
- CT'S FURNISHED BY GENERAC WITH LEAD WIRE OPTION, PART NUMBER 0F7784B, 200:1 AMP RATIO.
  - WIRING SHOWN FOR SINGLE PHASE TENANT LOAD ON PHASES A-B. ADJUST ACCORDINGLY FOR INDIVIDUAL SITES THAT ARE BALANCING THREE PHASE SERVICES.
  - 1-PHASE: MOUNT ONE CT WITH WHITE DOT FACING AWAY FROM, AND OTHER CT WITH WHITE DOT FACING TOWARDS, THE ATS TERMINAL CONNECTIONS
  - 3-PHASE: MOUNT ALL CT'S WITH WHITE DOTS ALL FACING AWAY FROM THE ATS TERMINAL CONNECTIONS

**3 CT WIRING DIAGRAM**  
SCALE: NOT TO SCALE

- NOTES:
- INSTALL NETWORK OPERATING CENTER (NOC) MONITORING COMMUNICATION SYSTEM (RMC-700) IN GENERATOR. THE RMC-700 IS FURNISHED BY ATC. COMPLETE WITH MOUNTING MAGNETS TO MOUNT OPPOSITE THE H-100 GENERATOR CONTROLLER PANEL INSIDE THE GENERATOR ENCLOSURE.
  - INSTALL EXTERNAL ANTENNA KIT (FURNISHED BY ATC). ANTENNA MOUNTS TO GENERATOR ENCLOSURE TOP NEAR TOP VENT. FEED CABLE THROUGH TOP VENT TO RMC-700. PRESS FIT CABLE INTO GENERATOR INSULATION FOLDS AND CREVICES WITHOUT DAMAGE TO CABLE, INSULATION, OR ENCLOSURE. FEED CABLE THROUGH RMC-700 ENTRY PORT #3 AND CONNECT TO ANTENNA PORT TX/RX. HAND TIGHTEN ONLY. LEAVE POWER AND DATA CABLES IN RMC-700 UNCONNECTED FOR COMMISSIONING TEAM
  - SEE ATC MOP 2017.01.04 RMC-700 GEN ONLY-METHOD OF PROCEDURE BY ATC (VER 1.11)

**5 PROPOSED MONITORING**  
SCALE: NOT TO SCALE

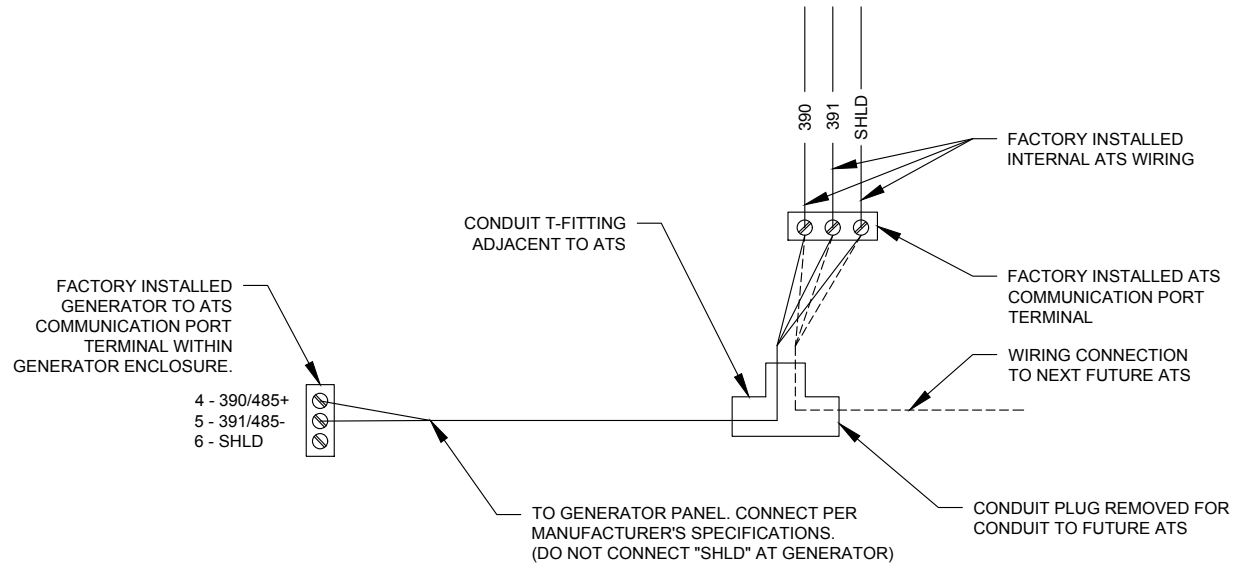

**4 COMMUNICATIONS CABLE DETAIL**  
SCALE: NOT TO SCALE

THESE DRAWINGS AND/OR THE ACCOMPANYING SPECIFICATION AS INSTRUMENTS OR SERVICE ARE THE EXCLUSIVE PROPERTY OF AMERICAN TOWER. THEIR USE AND PUBLICATION SHALL BE RESTRICTED TO THE ORIGINAL SITE FOR WHICH THEY ARE PREPARED. ANY USE OR DISCLOSURE OTHER THAN THAT WHICH RELATES TO AMERICAN TOWER OR THE SPECIFIED CARRIER IS STRICTLY PROHIBITED. TITLE TO THESE DOCUMENTS SHALL REMAIN THE PROPERTY OF AMERICAN TOWER WHETHER OR NOT THE PROJECT IS EXECUTED. NEITHER THE ARCHITECT NOR THE ENGINEER WILL BE PROVIDING ON-SITE CONSTRUCTION REVIEW OF THIS PROJECT. CONTRACTOR(S) MUST VERIFY ALL DIMENSIONS AND ADVISE AMERICAN TOWER OF ANY DISCREPANCIES. ANY PRIOR ISSUANCE OF THIS DRAWING IS SUPERSEDED BY THE LATEST VERSION ON FILE WITH AMERICAN TOWER.

REV.	DESCRIPTION	BY	DATE
0	FOR CONSTRUCTION	TC	09/13/18

ATC SITE NUMBER:  
**411183**

ATC SITE NAME:  
**WATERFORD CT**

SITE ADDRESS:  
53 DAYTON RD.  
WATERFORD, CT 06385

SEAL:



DRAWN BY:	TC
APPROVED BY:	PPB
DATE DRAWN:	09/13/18
ATC JOB NO:	12612230

**ELECTRICAL ONE-LINE AND WIRING DETAILS**

SHEET NUMBER:	REVISION:
<b>E-601</b>	<b>0</b>

## Kailey Blanchette

**From:** TrackingUpdates@fedex.com  
**Sent:** Friday, January 4, 2019 1:18 PM  
**To:** Kailey Blanchette  
**Subject:** FedEx Shipment 774107600987 Delivered

# Your package has been delivered

Tracking # 774107600987

Ship date:  
Thu, 1/3/2019

David Hoogasian  
NB+C  
CHELMSFORD, MA 01824  
US



Delivery date:  
Fri, 1/4/2019 1:16 pm

Cohanzie Fire Company No 5  
Inc  
53 Dayton Rd  
WATERFORD, CT 06385  
US



## Shipment Facts

Our records indicate that the following package has been delivered.

<b>Tracking number:</b>	<a href="#">774107600987</a>
<b>Status:</b>	Delivered: 01/04/2019 1:16 PM Signed for By: N.NATE
<b>Reference:</b>	100510
<b>Signed for by:</b>	N.NATE
<b>Delivery location:</b>	WATERFORD, CT
<b>Delivered to:</b>	Receptionist/Front Desk
<b>Service type:</b>	FedEx Standard Overnight®
<b>Packaging type:</b>	FedEx® Envelope
<b>Number of pieces:</b>	1
<b>Weight:</b>	0.50 lb.
<b>Special handling/Services:</b>	Adult Signature Required Deliver Weekday
<b>Standard transit:</b>	1/4/2019 by 3:00 pm

Please do not respond to this message. This email was sent from an unattended mailbox. This report was generated at approximately 12:18 PM CST on 01/04/2019.

## Kailey Blanchette

---

**From:** TrackingUpdates@fedex.com  
**Sent:** Friday, January 4, 2019 2:11 PM  
**To:** Kailey Blanchette  
**Subject:** FedEx Shipment 774107574390 Delivered

## Your package has been delivered

Tracking # 774107574390

Ship date: <b>Thu, 1/3/2019</b>		Delivery date: <b>Fri, 1/4/2019 2:07 pm</b>
<b>David Hoogasian</b> NB+C CHELMSFORD, MA 01824 US		<b>Abby Piersall, Planning Director</b> 15 Rope Ferry Rd. Waterford Town Hall WATERFORD, CT 06385 US

### Shipment Facts

Our records indicate that the following package has been delivered.

<b>Tracking number:</b>	<a href="#">774107574390</a>
<b>Status:</b>	Delivered: 01/04/2019 2:07 PM Signed for By: L.GEER
<b>Reference:</b>	100510
<b>Signed for by:</b>	L.GEER
<b>Delivery location:</b>	WATERFORD, CT
<b>Delivered to:</b>	Receptionist/Front Desk
<b>Service type:</b>	FedEx Standard Overnight®
<b>Packaging type:</b>	FedEx® Envelope
<b>Number of pieces:</b>	1
<b>Weight:</b>	0.50 lb.
<b>Special handling/Services:</b>	Adult Signature Required Deliver Weekday
<b>Standard transit:</b>	1/4/2019 by 3:00 pm



## Kailey Blanchette

**From:** TrackingUpdates@fedex.com  
**Sent:** Friday, January 4, 2019 2:10 PM  
**To:** Kailey Blanchette  
**Subject:** FedEx Shipment 774107482937 Delivered

# Your package has been delivered

Tracking # 774107482937

Ship date: <b>Thu, 1/3/2019</b>		Delivery date: <b>Fri, 1/4/2019 2:07 pm</b>
<b>David Hoogasian</b> NB+C CHELMSFORD, MA 01824 US	 <b>Delivered</b>	<b>Daniel M. Steward, First Selectman</b> 15 Rope Ferry Rd. WATERFORD, CT 06385 US

## Shipment Facts

Our records indicate that the following package has been delivered.

<b>Tracking number:</b>	<a href="#">774107482937</a>
<b>Status:</b>	Delivered: 01/04/2019 2:07 PM Signed for By: L.GEER
<b>Reference:</b>	100510
<b>Signed for by:</b>	L.GEER
<b>Delivery location:</b>	WATERFORD, CT
<b>Delivered to:</b>	Receptionist/Front Desk
<b>Service type:</b>	FedEx Standard Overnight®
<b>Packaging type:</b>	FedEx® Envelope
<b>Number of pieces:</b>	1
<b>Weight:</b>	0.50 lb.
<b>Special handling/Services:</b>	Adult Signature Required Deliver Weekday
<b>Standard transit:</b>	1/4/2019 by 3:00 pm

 Please do not respond to this message. This email was sent from an unattended mailbox. This report was generated at approximately 1:10 PM CST on 01/04/2019.

## Kailey Blanchette

**From:** TrackingUpdates@fedex.com  
**Sent:** Friday, January 4, 2019 11:28 AM  
**To:** Kailey Blanchette  
**Subject:** FedEx Shipment 774105692908 Delivered

# Your package has been delivered

Tracking # 774105692908

Ship date:  
Thu, 1/3/2019

David Hoogasian  
NB+C  
CHELMSFORD, MA 01824  
US



Delivery date:  
Fri, 1/4/2019 11:16 am

American Tower Corporation  
American Tower Corporation  
10 Presidential Way  
WOBURN, MA 01801  
US



## Shipment Facts

Our records indicate that the following package has been delivered.

<b>Tracking number:</b>	<a href="#">774105692908</a>
<b>Status:</b>	Delivered: 01/04/2019 11:16 AM Signed for By: D.ANACI
<b>Reference:</b>	100510
<b>Signed for by:</b>	D.ANACI
<b>Delivery location:</b>	WOBURN, MA
<b>Delivered to:</b>	Receptionist/Front Desk
<b>Service type:</b>	FedEx Standard Overnight®
<b>Packaging type:</b>	FedEx® Envelope
<b>Number of pieces:</b>	1
<b>Weight:</b>	0.50 lb.
<b>Special handling/Services:</b>	Adult Signature Required Deliver Weekday
<b>Standard transit:</b>	1/4/2019 by 3:00 pm

Please do not respond to this message. This email was sent from an unattended mailbox. This report was generated at approximately 10:28 AM CST on 01/04/2019.