



Northeast Site Solutions  
Denise Sabo  
4 Angela's Way, Burlington CT 06013  
203-435-3640  
denise@northeastsitesolutions.com

June 3, 2022

Members of the Siting Council  
Connecticut Siting Council  
Ten Franklin Square  
New Britain, CT 06051

RE: Tower Share Application  
150 Mattatuck Heights, Waterbury, CT 06705  
Latitude: 41.537908  
Longitude: -72.985002  
Site #: 876317\_Crown\_Dish

Dear Ms. Bachman:

This letter and attachments are submitted on behalf of Dish Wireless LLC. Dish Wireless LLC plans to install antennas and related equipment to the tower site located at 150 Mattatuck Heights, Waterbury, Connecticut.

Dish Wireless LLC proposes to install three (3) 600/1900 MHz 5G antennas and six (6) RRUs, at the 120-foot level of the existing 143-foot monopole, one (1) Fiber cable will also be installed. Dish Wireless LLC equipment cabinets will be placed within a 7' x 5' lease area within the existing fenced compound. Included are plans by Kimley Horn, dated March 3, 2022, Exhibit C. Also included is a structural analysis prepared by B+T GRP, dated May 20, 2022, confirming that the existing tower is structurally capable of supporting the proposed equipment, re-run to show Verizon loading. Attached as Exhibit D. The facility was approved by the City of Waterbury, however the City has been unable to locate a copy of the approval. Please see attached.

Please accept this letter as notification pursuant to Regulations of Connecticut State Agencies 16-50aa, of Dish Wireless LLC intent to share a telecommunications facility pursuant to R.C.S.A. 16-50j-88. In accordance with R.C.S.A., a copy of this letter is being sent to Mayor Neil O'Leary, and Robert Nerney, City Planner for the City of Waterbury, as well as the tower owner (Crown Castle) and property owner (Waterbury Twin LLC & 150 MH LLC).

The planned modifications of the facility fall squarely within those activities explicitly provided for in R.C.S.A. 16-50j-89.

The proposed modification will not result in an increase in the height of the existing structure. The top of the existing tower is 143-feet and the Dish Wireless LLC antennas will be located at a centerline height of 120-feet.

The proposed modifications will not result in an increase of the site boundary as depicted on the attached site plan.



The proposed modifications will not increase noise levels at the facility by six decibels or more, or to levels that exceed local and state criteria. The incremental effect of the proposed changes will be negligent.

The operation of the proposed antennas will not increase radio frequency emissions at the facility to a level at or above the Federal Communications Commission safety standard. The combined site operations will result in a total power density of 27.88% as evidenced by Exhibit F.

Connecticut General Statutes 16-50aa indicates that the Council must approve the shared use of a telecommunications facility provided it finds the shared use is technically, legally, environmentally, and economically feasible and meets public safety concerns. As demonstrated in this letter, Dish Wireless LLC respectfully submits that the shared use of this facility satisfies these criteria.

Technical Feasibility. The existing monopole has been deemed structurally capable of supporting Dish Wireless LLC proposed loading. The structural analysis is included as Exhibit D.

Legal Feasibility. As referenced above, C.G.S. 16-50aa has been authorized to issue orders approving the shared use of an existing tower such as this monopole in Waterbury. Under the authority granted to the Council, an order of the Council approving the requested shared use would permit Dish Wireless LLC to obtain a building permit for the proposed installation. Further, a Letter of Authorization is included as Exhibit G, authorizing Dish Wireless LLC to file this application for shared use.

Environmental Feasibility. The proposed shared use of this facility would have a minimal environmental impact. The installation of Dish Wireless LLC equipment at the 120-foot level of the existing 143-foot tower would have an insignificant visual impact on the area around the tower. Dish Wireless LLC ground equipment would be installed within the existing facility compound. Dish Wireless LLC shared use would therefore not cause any significant alteration in the physical or environmental characteristics of the existing site. Additionally, as evidenced by Exhibit F, the proposed antennas would not increase radio frequency emissions to a level at or above the Federal Communications Commission safety standard.

Economic Feasibility. Dish Wireless LLC will be entering into an agreement with the owner of this facility to mutually agreeable terms. As previously mentioned, the Letter of Authorization has been provided by the owner to assist Dish Wireless LLC with this tower sharing application.

Public Safety Concerns. As discussed above, the tower is structurally capable of supporting Dish Wireless LLC proposed loading. Dish Wireless LLC is not aware of any public safety concerns relative to the proposed sharing of the existing tower. Dish Wireless LLC intentions of providing new and improved wireless service through the shared use of this facility is expected to enhance the safety and welfare of local residents and individuals traveling through Waterbury.

Sincerely,

Denise Sabo

Denise Sabo  
Mobile: 203-435-3640  
Fax: 413-521-0558  
Office: 4 Angela's Way, Burlington CT 06013  
Email: [denise@northeastsitesolutions.com](mailto:denise@northeastsitesolutions.com)



**NSS** **NORTHEAST**  
SITE SOLUTIONS  
*Turnkey Wireless Development*

Attachments

Cc:

Mayor Neil O'Leary  
City Hall Building  
235 Grand Street, 2nd floor  
Waterbury, CT 06702

Robert Nerney, City Planner  
185 South Main Street, 5th floor  
Waterbury, CT 06706

Waterbury Twin LLC & 150 MH LLC – Property Owner  
12 Iselin Terrace  
Larchmont, NY 10538

Crown Castle – Tower Owner

# Exhibit A

## **Original Facility Approval**

## **Myl, Kimberly**

---

**From:** Myl, Kimberly  
**Sent:** Tuesday, May 17, 2016 3:38 PM  
**To:** 'siting.council@ct.gov'  
**Subject:** 150 Mattatuck Heights - Existing Telecommunications Tower Original Zoning Approval

To Whom It May Concern:

Please be advised both the township (email below) and Crown Castle as the tower owner, do not have the original zoning resolution on file. Please use this email as notification to waive this requirement as we will include this and the email from the township within our submission.

Please let me know if you have any questions or need additional information. Thank you in advance.

**KIMBERLY MYL**  
Real Estate Specialist  
T: (201) 236-9069 | M: (201) 993-3697

**CROWN CASTLE**  
1200 MacArthur Blvd, Suite 200  
Mahwah, NJ 07430

---

**From:** Margaret Rice [<mailto:mrice@waterburyct.org>]  
**Sent:** Tuesday, May 17, 2016 1:03 PM  
**To:** Myl, Kimberly  
**Subject:** RE: 150 Mattatuck Heights - Existing Telecommunications Tower Original Zoning Approval

Hi Kimberly,

I checked our records and City Clerk's office and could not find anything. I then contacted the Town Clerk and I was told that there might be something on the Land Records and that you would need to contact the Town Clerk for them to do a Title Search. They're phone number is (203) 574-6806.

**Cissie**

**Administrative Support Specialist III**  
**203)574-6817 Ext.7296**

# Exhibit B

## Property Card

Location: 150 MATTATUCK HEIGHTS Owner: WATERBURY TWIN LLC & 150 MH LLC

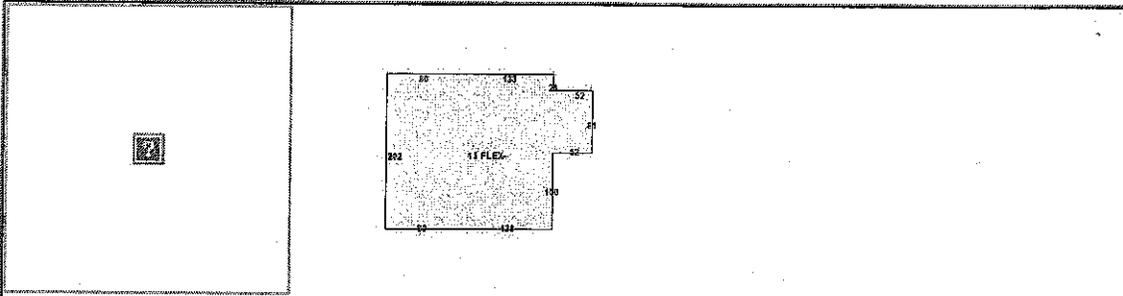

**Property Information:**

Map Block Lot:	0424-0141-0001	Acres:	7.02
Primary Use:	Industrial - Flex	Zone:	IP
Neighborhood:	85000-Industrial Park	Vol/Page:	4647
Mailing Address:	WATERBURY TWIN LLC & 150 MH LLC 12 ISELIN TERRACE LARCHMONT NY 10538		

**Property Values:**

	Appraised Value	Assessed Value (70%)
Building	1619053	1133340
Land	287048	200930
OutBuilding	66320	46420
Total	1972421	1380690

**Building Information:**

Bldg Style:		Living Area:	48248sq.ft
Construction:	Average	Year Built:	1988
Exterior Wall:	Brick Solid	Stories:	1
Roof Cover:		Heating:	Space Heater
Condition:	Average	Heat Fuel:	
Rooms:	0	Bedrooms:	0
Full Baths:	0	Half Baths:	0

**Outbuilding Information:**

Type	Area (sq.ft)	Year Built	Condition
Tanks Tanks	1sq.ft	1996	Average
Concrete Paving	390sq.ft	1996	Average
Concrete Paving	40sq.ft	1988	Average
Concrete Paving	40sq.ft	1988	Average

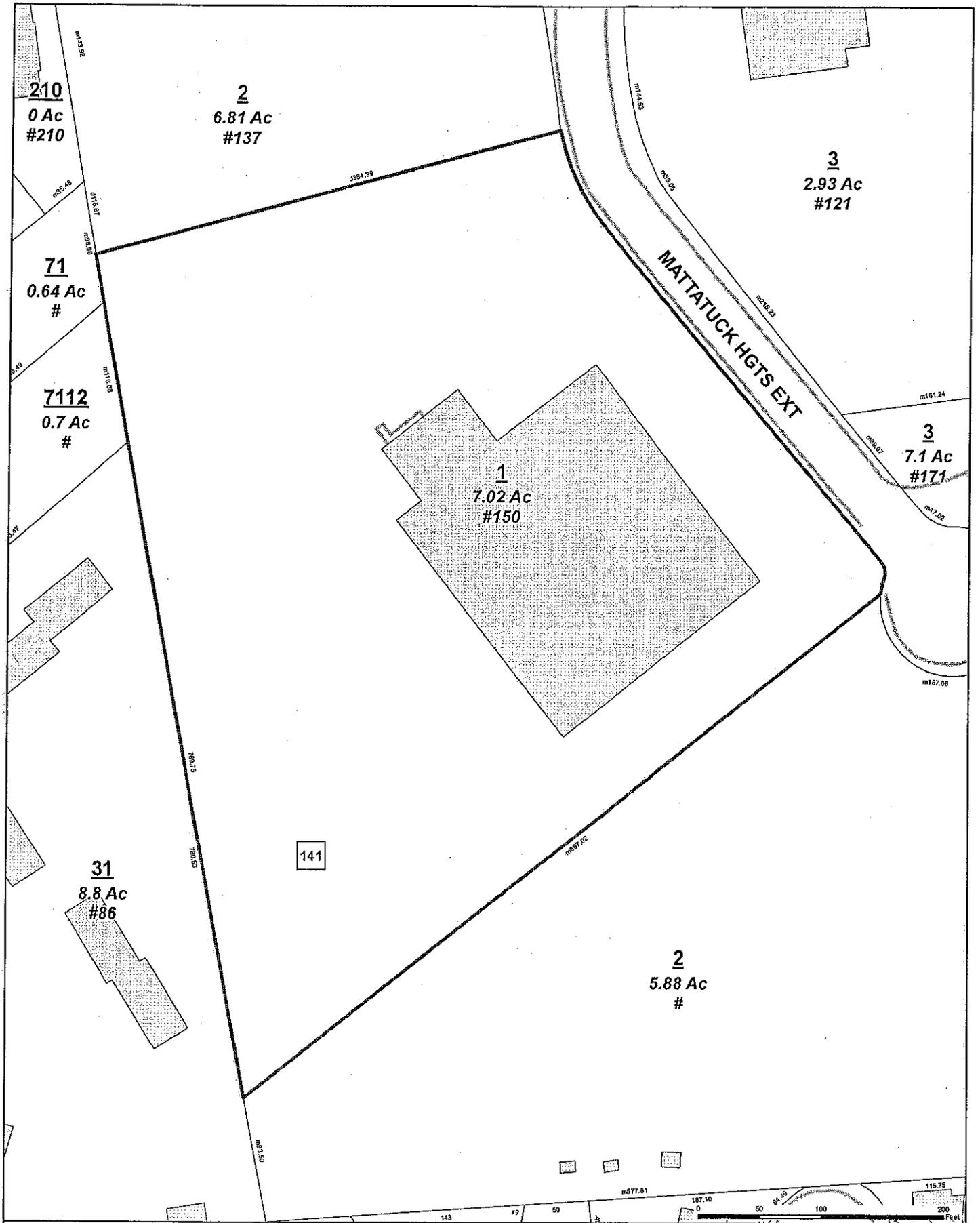

**City of Waterbury**  
Public Works Department

MBL: 0424-0141-0001  
ADDRESS: 150 MATTATUCK HEIGHTS

*This map is for informational purposes only and has not been prepared for, or suitable for legal, engineering, or surveying purposes. Users of this information should review or consult the primary data and information sources to verify the usability of the information. The City of Waterbury makes no warranties, express or implied, as to the use of the information obtained herein.*



# Exhibit C

## **Construction Drawings**



DISH Wireless L.L.C. SITE ID:

**BOHVN00165A**

DISH Wireless L.L.C. SITE ADDRESS:

**150 MATTATUCK HEIGHTS RD  
WATERBURY, CT 06705**

SCOPE OF WORK
THIS IS NOT AN ALL INCLUSIVE LIST. CONTRACTOR SHALL UTILIZE SPECIFIED EQUIPMENT PART OR ENGINEER APPROVED EQUIVALENT. CONTRACTOR SHALL VERIFY ALL NEEDED EQUIPMENT TO PROVIDE A FUNCTIONAL SITE. THE PROJECT GENERALLY CONSISTS OF THE FOLLOWING:
<b>TOWER SCOPE OF WORK:</b> <ul style="list-style-type: none"> <li>• INSTALL (3) PROPOSED PANEL ANTENNAS (1 PER SECTOR)</li> <li>• INSTALL (1) PROPOSED ANTENNA PLATFORM MOUNT</li> <li>• INSTALL PROPOSED JUMPERS</li> <li>• INSTALL (6) PROPOSED RRUs (2 PER SECTOR)</li> <li>• INSTALL (1) PROPOSED OVER VOLTAGE PROTECTION DEVICE (OVP)</li> <li>• INSTALL (1) PROPOSED HYBRID CABLE</li> </ul>
<b>GROUND SCOPE OF WORK:</b> <ul style="list-style-type: none"> <li>• INSTALL (1) PROPOSED METAL PLATFORM</li> <li>• INSTALL (1) PROPOSED ICE BRIDGE</li> <li>• INSTALL (1) PROPOSED PPC CABINET</li> <li>• INSTALL (1) PROPOSED EQUIPMENT CABINET</li> <li>• INSTALL (1) PROPOSED POWER CONDUIT</li> <li>• INSTALL (1) PROPOSED TELCO CONDUIT</li> <li>• INSTALL (1) PROPOSED TELCO-FIBER BOX</li> <li>• INSTALL (1) PROPOSED GPS UNIT</li> <li>• INSTALL (1) PROPOSED FIBER NID (IF REQUIRED)</li> <li>• DISH Wireless L.L.C. TO UTILIZE EXISTING ABANDONED METER "89 177 738" &amp; DISCONNECT</li> </ul>

SITE INFORMATION	PROJECT DIRECTORY
PROPERTY OWNER: GLOBAL SIGNAL ACQUISITION	APPLICANT: DISH WIRELESS, LLC. 5701 SOUTH SANTA FE DRIVE LITTLETON, CO 80120
ADDRESS: PO BOX 277455 ATLANTA, GA 30384	TOWER OWNER: CROWN CASTLE 2000 CORPORATE DRIVE CANONSBURG, PA 15317 (877) 486-9377
TOWER TYPE: MONOPOLE	SITE DESIGNER: KIMLEY-HORN & ASSOCIATES 3875 EMBASSY PKWY, SUITE 280 AKRON, OH 44333 (216) 505-7771 COA #: PEC.0000738
CROWN CASTLE SITE ID: 876317	SITE ACQUISITION: VICTOR NUNEZ (917) 563-3682
CROWN CASTLE APP NUMBER: 553382	CONSTRUCTION MANAGER: JAVIER SOTO JAVIER.SOTO@DISH.COM
COUNTY: NEW HAVEN	RF ENGINEER: SYED ZAIDI SYED.ZAIDI@DISH.COM
LATITUDE (NAD 83): 41° 32' 16.30" N 41.537861° N	
LONGITUDE (NAD 83): 72° 59' 6.10" W 72.985028° W	
ZONING JURISDICTION: CONNECTICUT SITING COUNCIL	
ZONING DISTRICT: LIGHT INDUSTRY	
PARCEL NUMBER: 0424-0141-001	
OCCUPANCY GROUP: U	
CONSTRUCTION TYPE: II-B	
POWER COMPANY: EVERSOURCE	
TELEPHONE COMPANY: TBD	



5701 SOUTH SANTA FE DRIVE  
LITTLETON, CO 80120



COA #: PEC.0000738  
421 FAYETTEVILLE ST, SUITE 600  
RALEIGH, NC 27601



IT IS A VIOLATION OF LAW FOR ANY PERSON, UNLESS THEY ARE ACTING UNDER THE DIRECTION OF A LICENSED PROFESSIONAL ENGINEER, TO ALTER THIS DOCUMENT.

DRAWN BY: SEW	CHECKED BY: MCK	APPROVED BY: MCK
---------------	-----------------	------------------

RFDS REV #: ---

**CONSTRUCTION DOCUMENTS**

SUBMITTALS		
REV	DATE	DESCRIPTION
A	09/30/2021	ISSUED FOR REVIEW
0	03/03/2022	ISSUED FOR CONSTRUCTION

A&E PROJECT NUMBER  
**KHCLC-16438**

DISH Wireless L.L.C.  
PROJECT INFORMATION  
**BOHVN00165A**  
150 MATTATUCK HEIGHTS RD  
WATERBURY, CT 06705

SHEET TITLE  
**TITLE SHEET**

SHEET NUMBER  
**T-1**

**CONNECTICUT CODE OF COMPLIANCE**

ALL WORK SHALL BE PERFORMED AND MATERIALS INSTALLED IN ACCORDANCE WITH THE CURRENT EDITIONS OF THE FOLLOWING CODES AS ADOPTED BY THE LOCAL GOVERNING AUTHORITIES. NOTHING IN THESE PLANS IS TO BE CONSTRUED TO PERMIT WORK NOT CONFORMING TO THESE CODES

CODE TYPE	CODE
BUILDING	2018 CT STATE BUILDING CODE/2015 IBC W/ CT AMENDMENTS
MECHANICAL	2018 CT STATE BUILDING CODE/2015 IMC W/ CT AMENDMENTS
ELECTRICAL	2018 CT STATE BUILDING CODE/2017 NEC W/ CT AMENDMENTS

**SHEET INDEX**

SHEET NO.	SHEET TITLE
T-1	TITLE SHEET
A-1	OVERALL AND ENLARGED SITE PLAN
A-2	ELEVATION, ANTENNA LAYOUT AND SCHEDULE
A-3	EQUIPMENT PLATFORM AND H-FRAME DETAILS
A-4	EQUIPMENT DETAILS
A-5	EQUIPMENT DETAILS
A-6	EQUIPMENT DETAILS
E-1	ELECTRICAL/FIBER ROUTE PLAN AND NOTES
E-2	ELECTRICAL DETAILS
E-3	ELECTRICAL ONE-LINE, FAULT CALCS & PANEL SCHEDULE
G-1	GROUNDING PLANS AND NOTES
G-2	GROUNDING DETAILS
G-3	GROUNDING DETAILS
RF-1	RF CABLE COLOR CODE
GN-1	LEGEND AND ABBREVIATIONS
GN-2	GENERAL NOTES
GN-3	GENERAL NOTES
GN-4	GENERAL NOTES

**SITE PHOTO**



UNDERGROUND SERVICE ALERT CBYD 811  
UTILITY NOTIFICATION CENTER OF CONNECTICUT  
(800) 922-4455  
WWW.CBYD.COM  
CALL 2 WORKING DAYS UTILITY NOTIFICATION PRIOR TO CONSTRUCTION



**GENERAL NOTES**

THE FACILITY IS UNMANNED AND NOT FOR HUMAN HABITATION. A TECHNICIAN WILL VISIT THE SITE AS REQUIRED FOR ROUTINE MAINTENANCE. THE PROJECT WILL NOT RESULT IN ANY SIGNIFICANT DISTURBANCE OR EFFECT ON DRAINAGE. NO SANITARY SEWER SERVICE, POTABLE WATER, OR TRASH DISPOSAL IS REQUIRED AND NO COMMERCIAL SIGNAGE IS PROPOSED.

11"x17" PLOT WILL BE HALF SCALE UNLESS OTHERWISE NOTED

CONTRACTOR SHALL VERIFY ALL PLANS, EXISTING DIMENSIONS, AND CONDITIONS ON THE JOB SITE, AND SHALL IMMEDIATELY NOTIFY THE ENGINEER IN WRITING OF ANY DISCREPANCIES BEFORE PROCEEDING WITH THE WORK.

**DIRECTIONS**

DIRECTIONS FROM BRADLEY INTERNATIONAL AIRPORT:  
 x CONTINUE TO BRADLEY INTERNATIONAL AIRPORT CON (0.9 MI)  
 x TAKE I-91 S AND I-84 TO AUSTIN RD IN WATERBURY. TAKE EXIT 25A FROM I-84 (39.3 MI)  
 x TAKE MATTATUCK HEIGHTS RD TO YOUR DESTINATION (0.9 MI)

**VICINITY MAP**

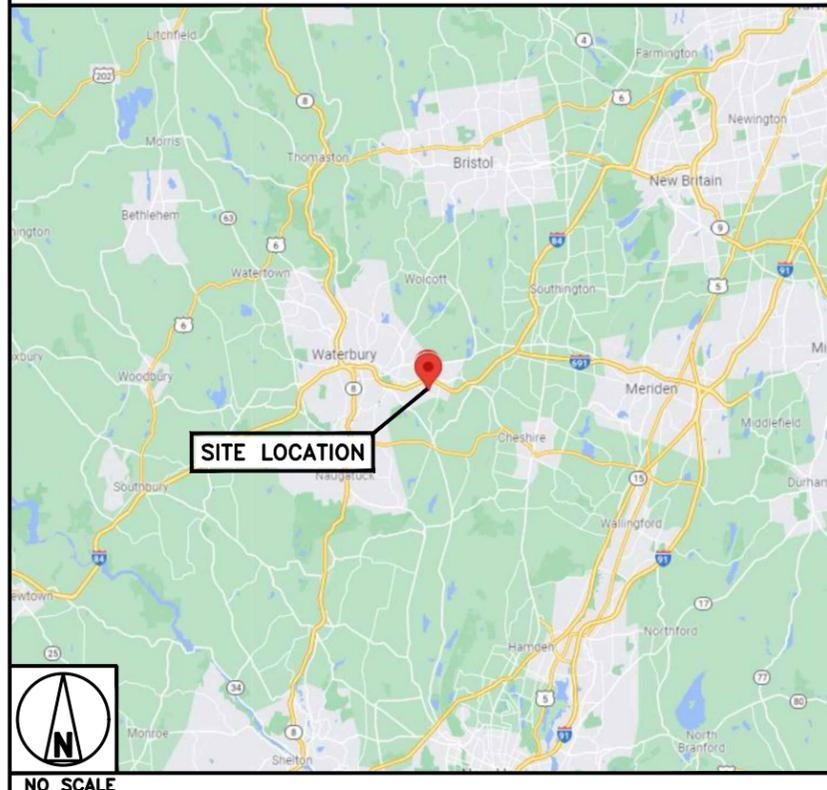

1  
A-2

**NOTES**

1. CONTRACTOR SHALL FIELD VERIFY ALL DIMENSIONS.
2. ANTENNAS AND MOUNTS OMITTED FOR CLARITY.

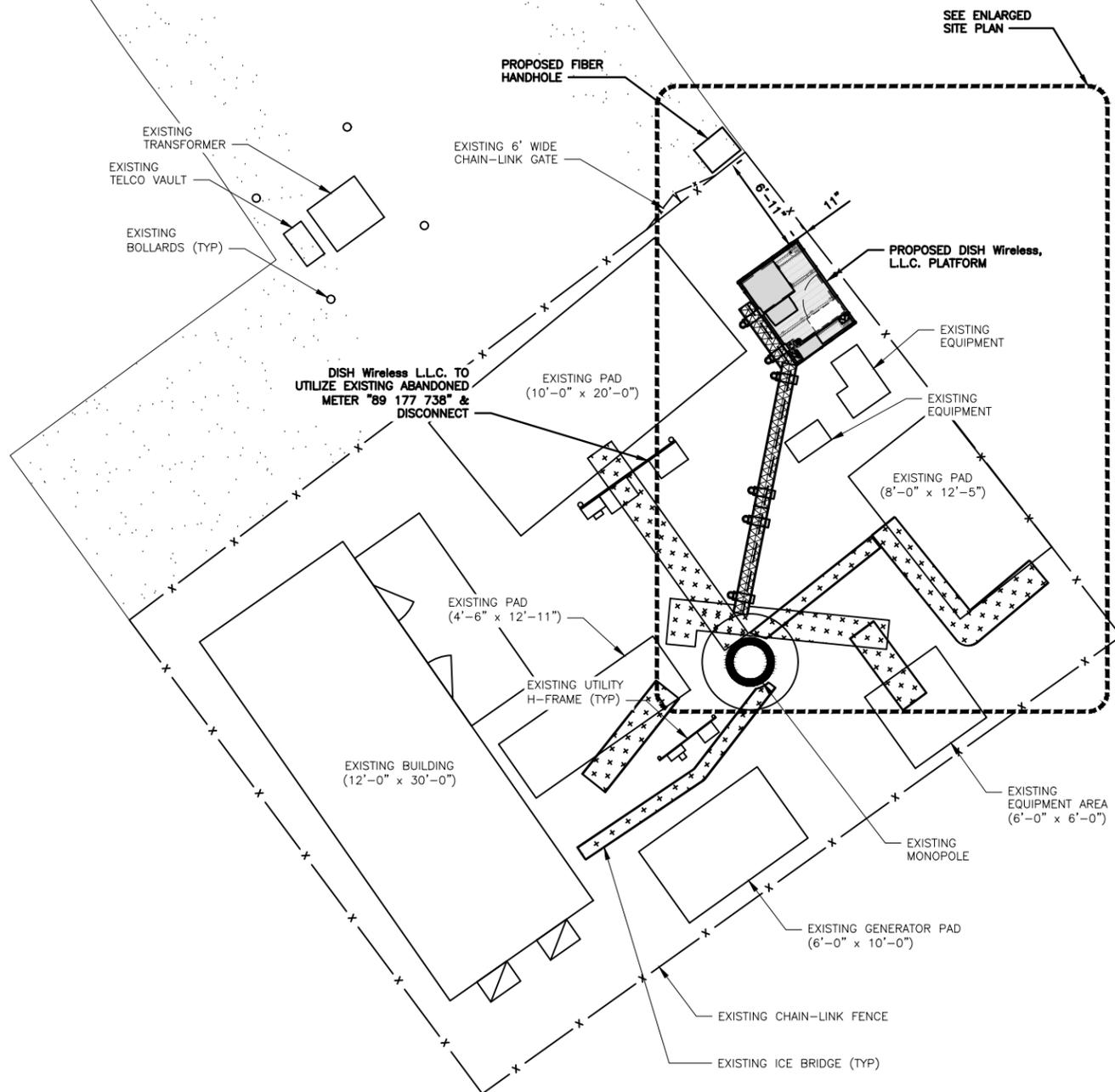

**OVERALL SITE PLAN**

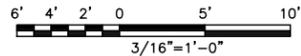

1

**NOTES**

1. CONTRACTOR SHALL FIELD VERIFY ALL DIMENSIONS.
2. CONTRACTOR SHALL MAINTAIN A 10'-0" MINIMUM SEPARATION BETWEEN THE PROPOSED GPS UNIT, TRANSMITTING ANTENNAS AND EXISTING GPS UNITS.
3. ANTENNAS AND MOUNTS OMITTED FOR CLARITY.

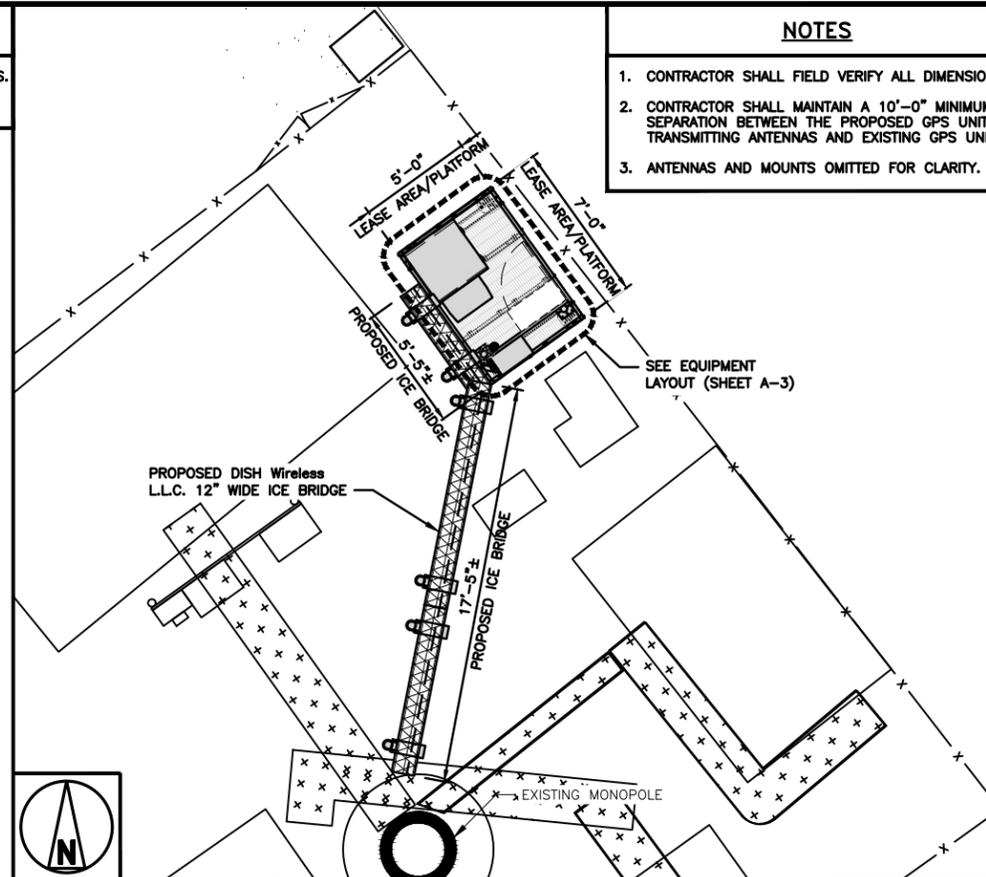

**ENLARGED SITE PLAN**

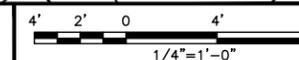

2



**OVERALL UTILITY ROUTE PLAN**

NO SCALE

3



5701 SOUTH SANTA FE DRIVE  
LITTLETON, CO 80120



COA #: PEC.0000738  
421 FAYETTEVILLE ST, SUITE 600  
RALEIGH, NC 27601

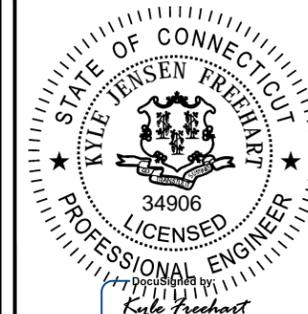

IT IS A VIOLATION OF LAW FOR ANY PERSON, UNLESS THEY ARE ACTING UNDER THE DIRECTION OF A LICENSED PROFESSIONAL ENGINEER, TO ALTER THIS DOCUMENT.

DRAWN BY: CHECKED BY: APPROVED BY:

SEW MCK MCK

RFDS REV #: ---

**CONSTRUCTION DOCUMENTS**

SUBMITTALS		
REV	DATE	DESCRIPTION
A	09/30/2021	ISSUED FOR REVIEW
0	03/03/2022	ISSUED FOR CONSTRUCTION

A&E PROJECT NUMBER  
KHCLC-16438

DISH Wireless L.L.C.  
PROJECT INFORMATION  
BOHVN00165A  
150 MATTATUCK HEIGHTS RD  
WATERBURY, CT 06705

SHEET TITLE  
OVERALL AND ENLARGED SITE PLAN

SHEET NUMBER  
**A-1**

**NOTES**

1. CONTRACTOR SHALL FIELD VERIFY ALL DIMENSIONS.
2. ANTENNA AND MW DISH SPECIFICATIONS REFER TO ANTENNA SCHEDULE AND TO FINAL CONSTRUCTION RFDS FOR ALL RF DETAILS
3. EXISTING EQUIPMENT AND FENCE OMITTED FOR CLARITY.

KIMLEY-HORN HAS NOT ANALYZED THE PROPOSED ANTENNA MOUNT(S) TO DETERMINE ADEQUATE STRUCTURAL CAPACITY FOR PROPOSED CARRIER LOADING. MOUNT ANALYSIS TO BE DONE BY OTHERS.

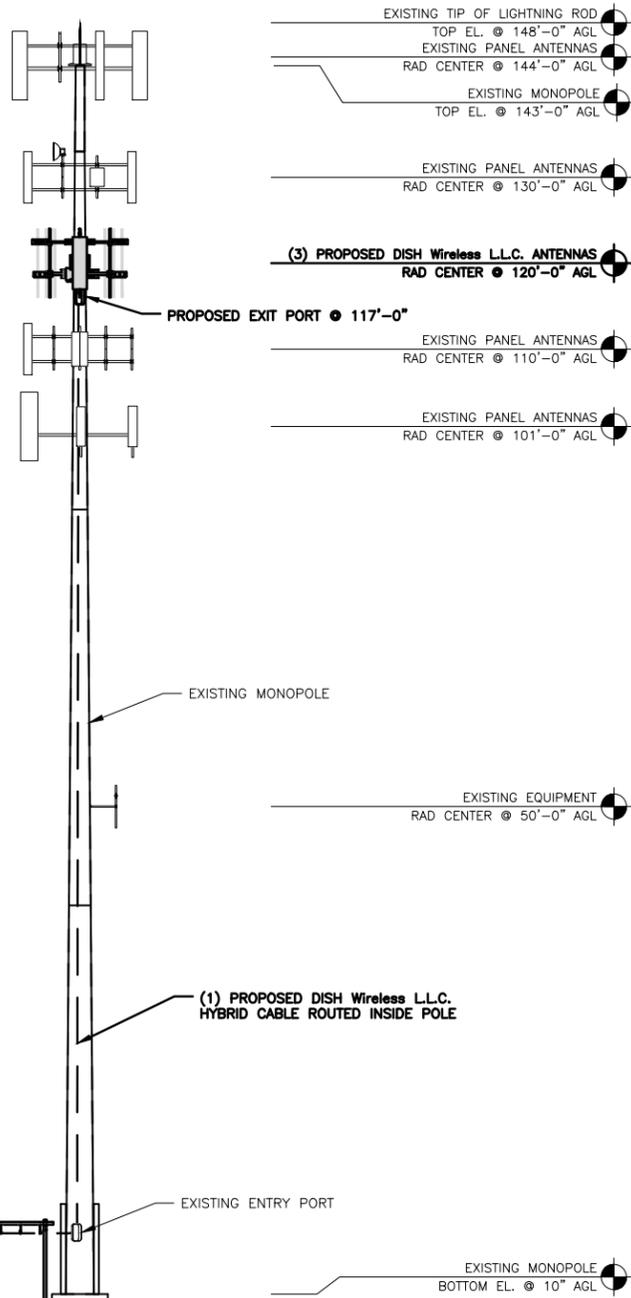

**PROPOSED NORTH ELEVATION**



**ANTENNA LAYOUT**

SECTOR	POSITION	ANTENNA						TRANSMISSION CABLE
		EXISTING OR PROPOSED	MANUFACTURER - MODEL NUMBER	TECHNOLOGY	SIZE (HxW)	AZIMUTH	RAD CENTER	FEED LINE TYPE AND LENGTH
ALPHA	A2	PROPOSED	JMA - MX08FRO665-21	5G	72.0" x 20.0"	30°	120'-0"	(1) HIGH-CAPACITY HYBRID CABLE (170'-0" LONG)
BETA	B2	PROPOSED	JMA - MX08FRO665-21	5G	72.0" x 20.0"	160°	120'-0"	
GAMMA	G2	PROPOSED	JMA - MX08FRO665-21	5G	72.0" x 20.0"	280°	120'-0"	

SECTOR	POSITION	RRH		NOTES
		MANUFACTURER - MODEL NUMBER	TECHNOLOGY	
ALPHA	A1	FUJITSU - TA08025-B604	5G	1. CONTRACTOR TO REFER TO FINAL CONSTRUCTION RFDS FOR ALL RF DETAILS. 2. ANTENNA AND RRH MODELS MAY CHANGE DUE TO EQUIPMENT AVAILABILITY. ALL EQUIPMENT CHANGES MUST BE APPROVED AND REMAIN IN COMPLIANCE WITH THE PROPOSED DESIGN AND STRUCTURAL ANALYSES.
	A1	FUJITSU - TA08025-B605	5G	
BETA	B1	FUJITSU - TA08025-B604	5G	
	B1	FUJITSU - TA08025-B605	5G	
GAMMA	G1	FUJITSU - TA08025-B604	5G	
	G1	FUJITSU - TA08025-B605	5G	

**ANTENNA SCHEDULE**



**ANTENNA LAYOUT**

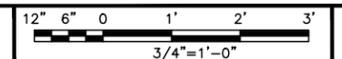

5701 SOUTH SANTA FE DRIVE  
LITTLETON, CO 80120



COA #: PEC.0000738  
421 FAYETTEVILLE ST, SUITE 600  
RALEIGH, NC 27601

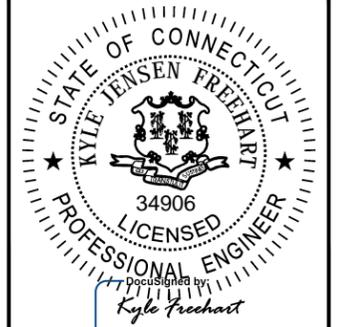

IT IS A VIOLATION OF LAW FOR ANY PERSON, UNLESS THEY ARE ACTING UNDER THE DIRECTION OF A LICENSED PROFESSIONAL ENGINEER, TO ALTER THIS DOCUMENT.

DRAWN BY:	CHECKED BY:	APPROVED BY:
SEW	MCK	MCK

RFDS REV #: ---

**CONSTRUCTION DOCUMENTS**

SUBMITTALS		
REV	DATE	DESCRIPTION
A	09/30/2021	ISSUED FOR REVIEW
0	03/03/2022	ISSUED FOR CONSTRUCTION

A&E PROJECT NUMBER  
KHCLC-16438

DISH Wireless L.L.C.  
PROJECT INFORMATION  
BOHVN00165A  
150 MATTATUCK HEIGHTS RD  
WATERBURY, CT 06705

SHEET TITLE  
ELEVATION, ANTENNA LAYOUT AND SCHEDULE

SHEET NUMBER

**A-2**

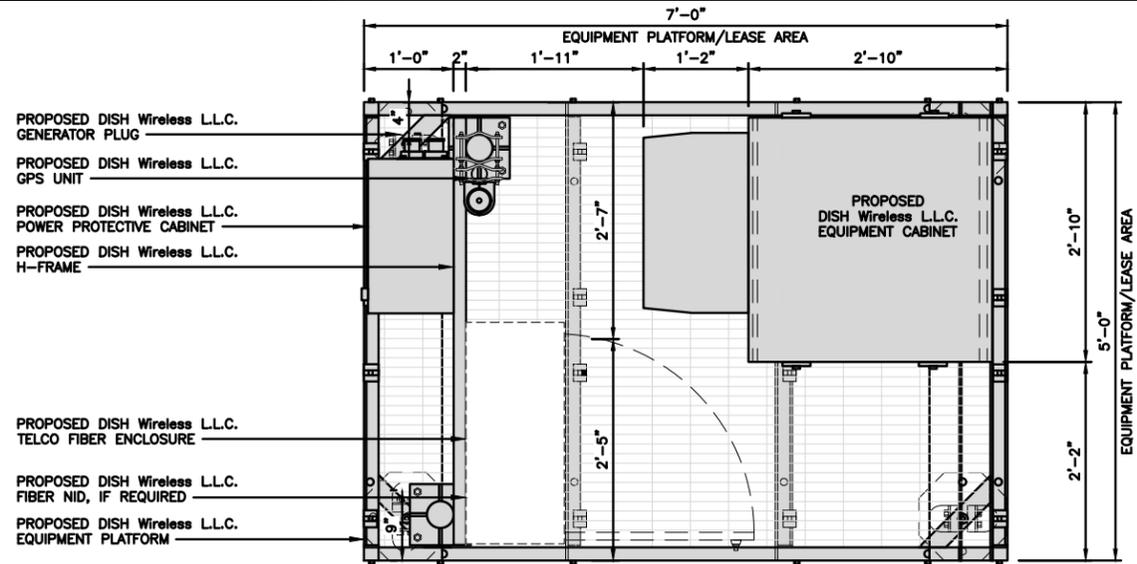

PLATFORM EQUIPMENT PLAN

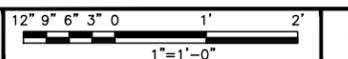

1

**COMMSCOPE MTC4045LP  
5X7 PLATFORM**

DIMENSIONS (HxWxD)	16"x84"x60"
TOTAL WEIGHT	423 LBS

**NOTE:**  
1. GC TO PROVIDE EXTENDED THREAD FOR PLATFORM IF REQUIRED HEIGHT EXCEEDS 17"  
2. PLATFORM TO BE LEVEL WITHIN 1"

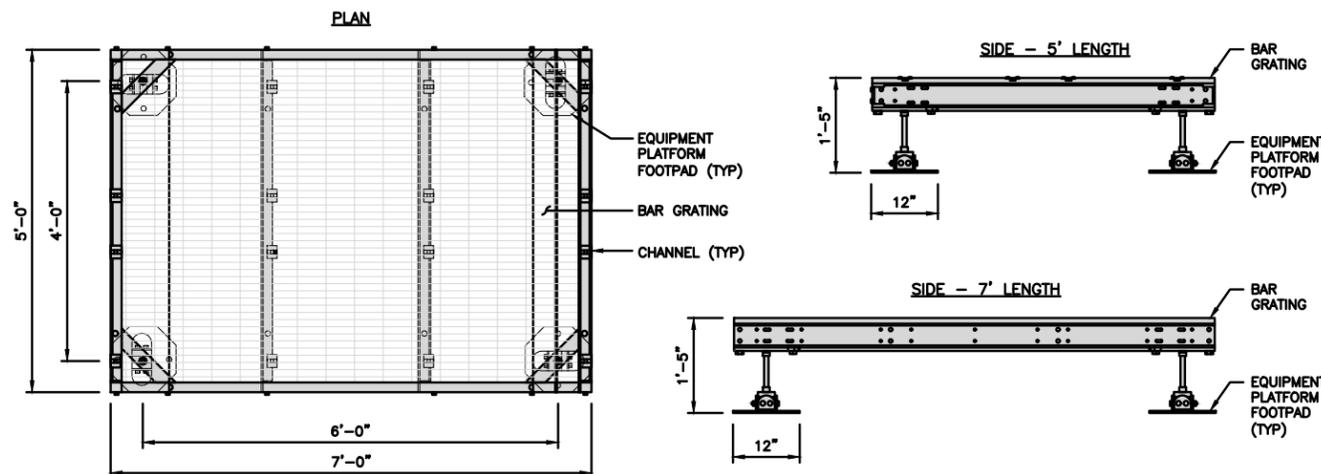

PLATFORM DETAIL

NO SCALE 2

**COMMSCOPE MTC4045HFLD  
H-FRAME**

UNISTRUT/SUPPORT RAILS QTY	5
WEIGHT	59.74 lbs

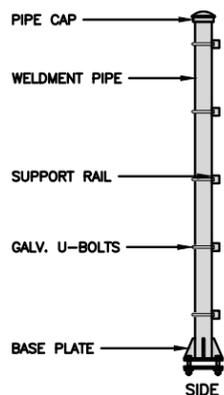

H-FRAME DETAIL

NO SCALE 3

**NOTE:**  
OR DISH Wireless L.L.C. APPROVED EQUIVALENT

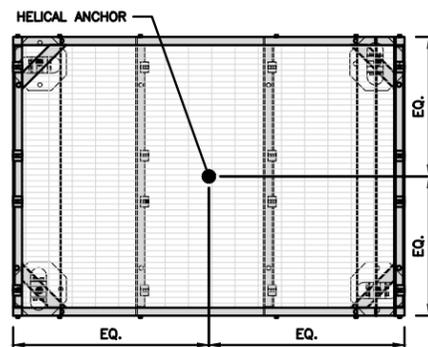
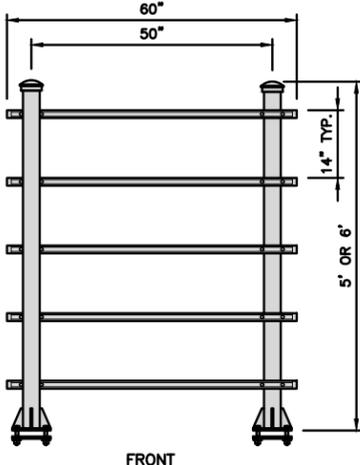

PLATFORM ANCHORAGE DETAIL

NO SCALE 4

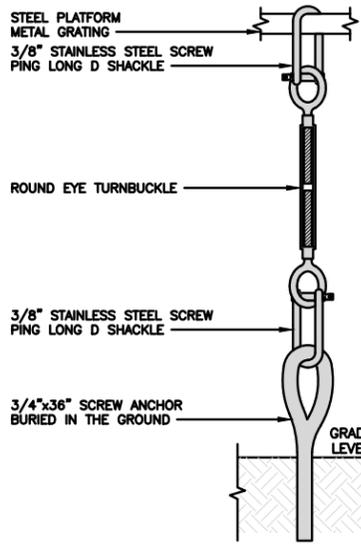

H-FRAME EQUIPMENT ELEVATION

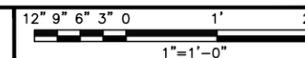

5

**NOTES**

- CONTRACTOR TO BURY PLATFORM FEET WITH A MINIMUM OF 2" OF FILL PER EXISTING SITE SURFACE
- WEED BARRIER FABRIC TO BE ADDED AT DISCRETION OF DISH Wireless L.L.C. CONSTRUCTION MANAGER AT TIME OF CONSTRUCTION. ONE SHEET 8'x8' INSTALLED UNDER ALL FOUR FEET OF THE PLATFORM (4 MIL BLACK PLASTIC)
- EQUIPMENT CABINET OMITTED FOR CLARITY



5701 SOUTH SANTA FE DRIVE  
LITTLETON, CO 80120



COA #: PEC.0000738  
421 FAYETTEVILLE ST, SUITE 600  
RALEIGH, NC 27601

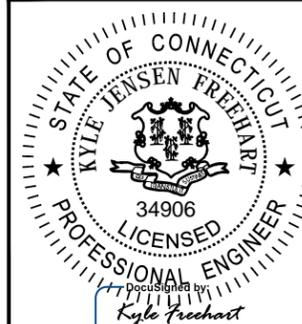

IT IS A VIOLATION OF LAW FOR ANY PERSON, UNLESS THEY ARE ACTING UNDER THE DIRECTION OF A LICENSED PROFESSIONAL ENGINEER, TO ALTER THIS DOCUMENT.

DRAWN BY:	CHECKED BY:	APPROVED BY:
SEW	MCK	MCK

RFDS REV #:

**CONSTRUCTION DOCUMENTS**

SUBMITTALS		
REV	DATE	DESCRIPTION
A	09/30/2021	ISSUED FOR REVIEW
0	03/03/2022	ISSUED FOR CONSTRUCTION

A&E PROJECT NUMBER

KHCLC-16438

DISH Wireless L.L.C. PROJECT INFORMATION

BOHVN00165A  
150 MATTATUCK HEIGHTS RD  
WATERBURY, CT 06705

SHEET TITLE  
EQUIPMENT PLATFORM AND H-FRAME DETAILS

SHEET NUMBER

**A-3**

CHARLES INDUSTRY HEX CUBE-PM639155N4	
DIMENSIONS (HxWxD)	74"x32"x32"
POWER PLANT	-48VDC ABB/600W
TOTAL WEIGHT (EMPTY)	408 lbs

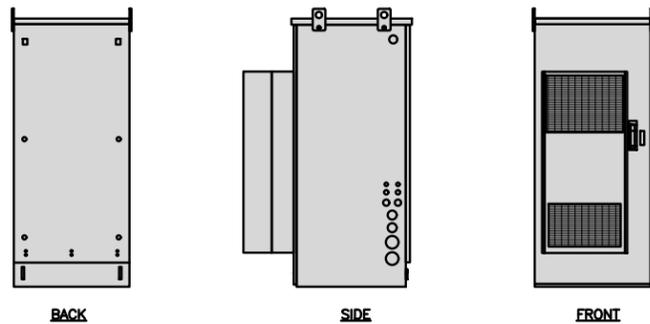
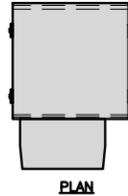

CABINET DETAIL

NO SCALE

1

RAYCAP PPC RDIAC-2465-P-240-MTS	
ENCLOSURE DIMENSIONS (HxWxD):	39"x22.855"x12.593
WEIGHT:	80 lbs
OPERATING AC VOLTAGE	240/120 1 PHASE 3W+G

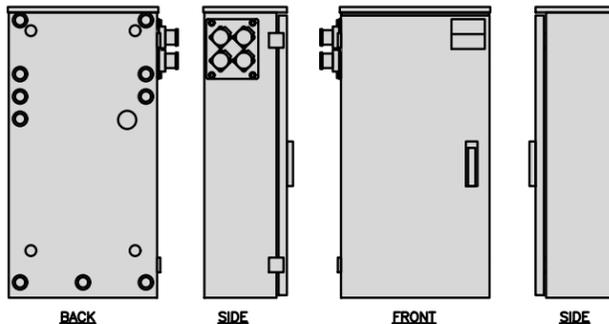
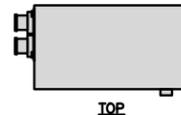

POWER PROTECTION CABINET (PPC) DETAIL

NO SCALE

2

NOT USED

NO SCALE

3

CHARLES CFIT-PF2020DSH1 FIBER TELCO ENCLOSURE	
ENCLOSURE DIMS (HxWxD)	20"x20"x9"
ENCLOSURE WEIGHT	20 lbs
MOUNTING	WALL
COMPLIANCE	TYPE 4

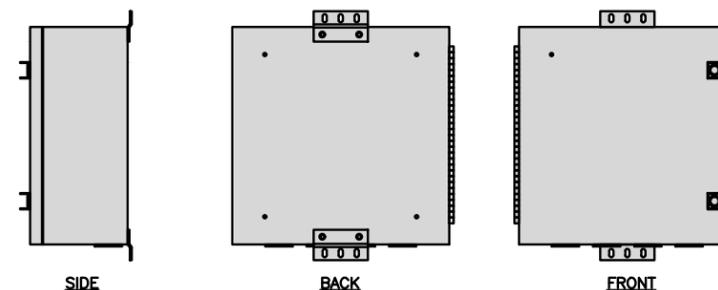

FIBER TELCO ENCLOSURE DETAIL

NO SCALE

6

COMMSCOPE WB-K110-B WAVEGUIDE BRIDGE KIT	
DIMENSIONS (HxL)	160"x10"
WEIGHT/ VOLUME	325.0 LBS
CABLE RUN (QTY)	12

INCLUDED PRODUCTS:	WB-T12-3 TRAPEZE KIT, 3 RUNGS
	WB-LB12-3 SUPPORT BRACKET
	MF-130 DIRECT BURIAL PIPE COLUMN, 13'-4"

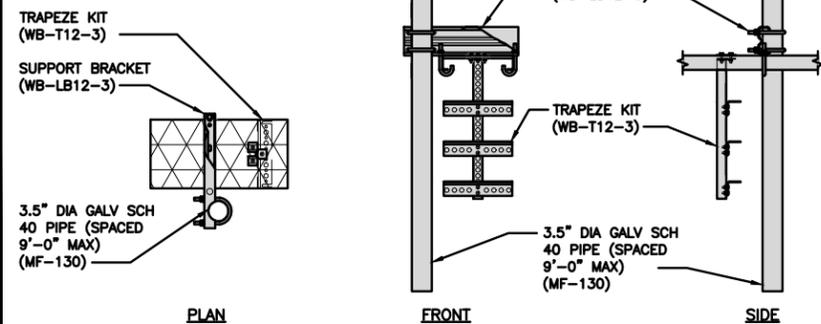

ICE BRIDGE DETAIL

NO SCALE

7

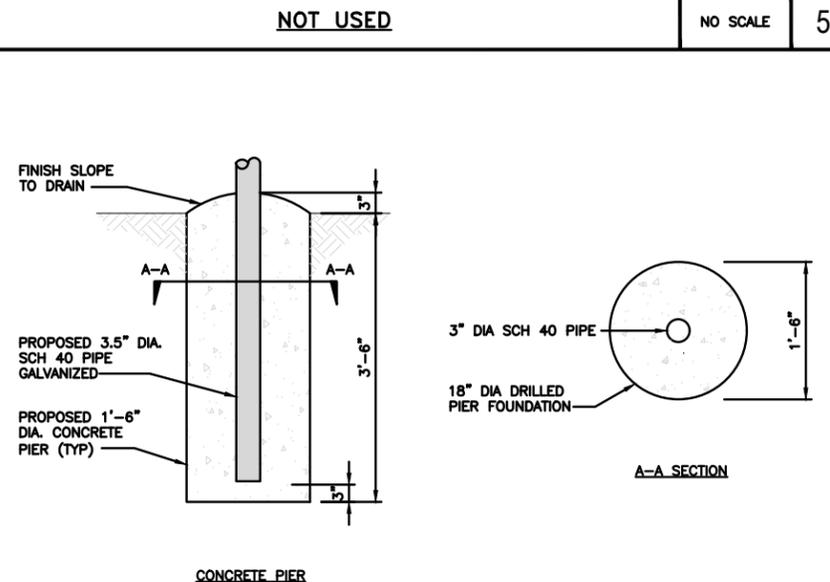

TYPICAL ICE BRIDGE CONCRETE PIER DETAIL

NO SCALE

8

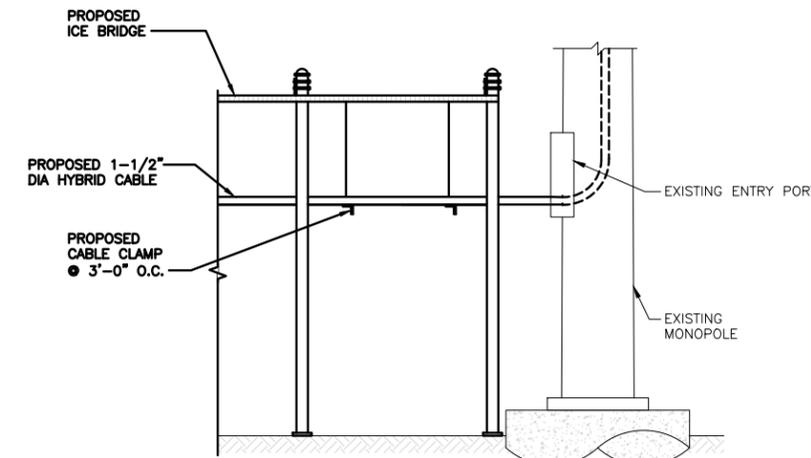

HYBRID CABLE RUN

NO SCALE

9



5701 SOUTH SANTA FE DRIVE  
LITTLETON, CO 80120



COA #: PEC.0000738  
421 FAYETTEVILLE ST, SUITE 600  
RALEIGH, NC 27601

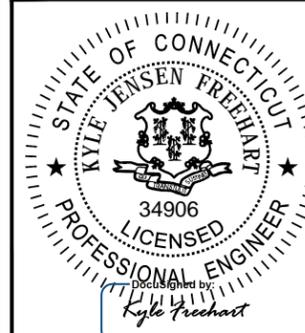

IT IS A VIOLATION OF LAW FOR ANY PERSON, UNLESS THEY ARE ACTING UNDER THE DIRECTION OF A LICENSED PROFESSIONAL ENGINEER, TO ALTER THIS DOCUMENT.

DRAWN BY:	CHECKED BY:	APPROVED BY:
SEW	MCK	MCK

RFDS REV #: ---

CONSTRUCTION DOCUMENTS

SUBMITTALS		
REV	DATE	DESCRIPTION
A	09/30/2021	ISSUED FOR REVIEW
0	03/03/2022	ISSUED FOR CONSTRUCTION

A&E PROJECT NUMBER  
KHCLC-16438

DISH Wireless L.L.C.  
PROJECT INFORMATION  
BOHVN00165A  
150 MATTATUCK HEIGHTS RD  
WATERBURY, CT 06705

SHEET TITLE  
EQUIPMENT DETAILS

SHEET NUMBER  
**A-4**

PCTEL GPSGL-TMG-SPI-40NCB	
DIMENSIONS (DIAxH) MM/INCH	81x184mm 3.2"x7.25"
WEIGHT W/ACCESSORIES	075 lbs
CONNECTOR	N-FEMALE
FREQUENCY RANGE	1590 ± 30MHz



TOP

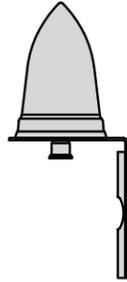

BACK

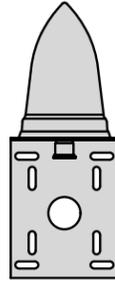

SIDE

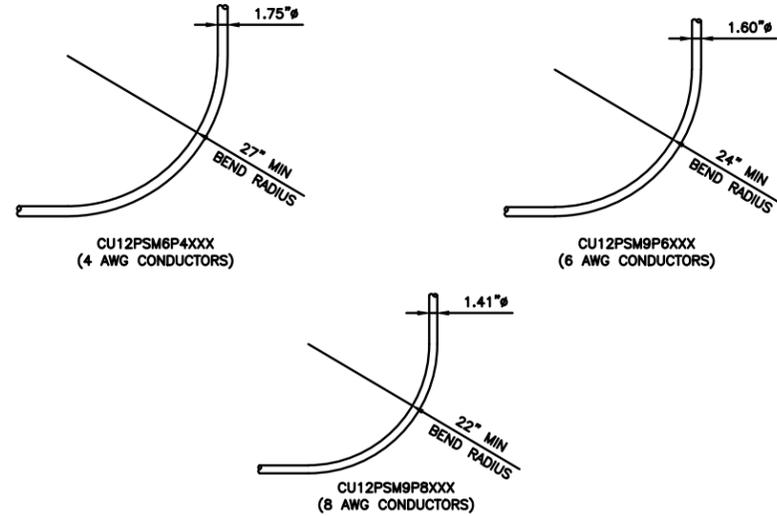
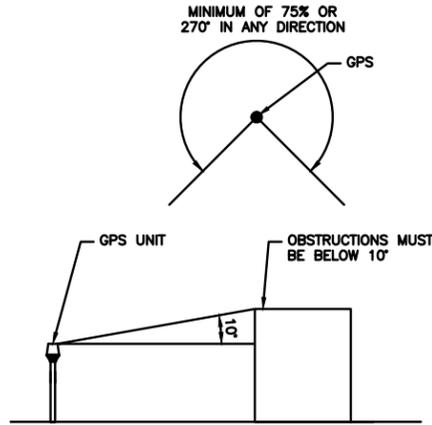

5701 SOUTH SANTA FE DRIVE  
LITTLETON, CO 80120



COA #: PEC.0000738  
421 FAYETTEVILLE ST, SUITE 600  
RALEIGH, NC 27601



IT IS A VIOLATION OF LAW FOR ANY PERSON, UNLESS THEY ARE ACTING UNDER THE DIRECTION OF A LICENSED PROFESSIONAL ENGINEER, TO ALTER THIS DOCUMENT.

DRAWN BY:	CHECKED BY:	APPROVED BY:
SEW	MCK	MCK

RFDS REV #: ---

**CONSTRUCTION DOCUMENTS**

SUBMITTALS		
REV	DATE	DESCRIPTION
A	09/30/2021	ISSUED FOR REVIEW
0	03/03/2022	ISSUED FOR CONSTRUCTION

A&E PROJECT NUMBER  
KHCLC-16438

DISH Wireless L.L.C.  
PROJECT INFORMATION  
BOHVN00165A  
150 MATTATUCK HEIGHTS RD  
WATERBURY, CT 06705

SHEET TITLE  
EQUIPMENT DETAILS

SHEET NUMBER  
**A-5**

GPS DETAIL

NO SCALE

1

GPS MINIMUM SKY VIEW REQUIREMENTS

NO SCALE

2

CABLES UNLIMITED HYBRID CABLE  
MINIMUM BEND RADIUSES

NO SCALE

3

NOT USED

NO SCALE

4

NOT USED

NO SCALE

5

NOT USED

NO SCALE

6

NOT USED

NO SCALE

7

NOT USED

NO SCALE

8

NOT USED

NO SCALE

9

FUJITSU TRIPLE BAND TA08025-B605	
DIMENSIONS (HxWxD)	14.9"x15.7"x9"
WEIGHT	74.95 lbs
CONNECTOR TYPE	4.3-10 RF CONNECTOR
POWER SUPPLY	DC -58~-36V

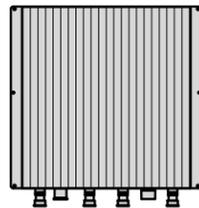
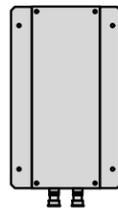
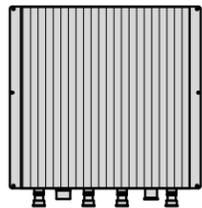
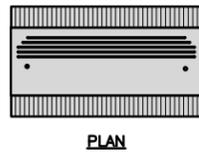

BACK

SIDE

FRONT

FUJITSU DUAL BAND TA08025-B604	
DIMENSIONS (HxWxD)	14.9"x15.7"x7.8"
WEIGHT	63.9 lbs
CONNECTOR TYPE	4.3-10 RF CONNECTOR
POWER SUPPLY	DC -58~-36V

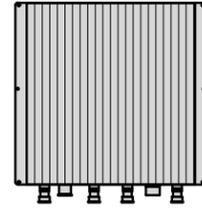
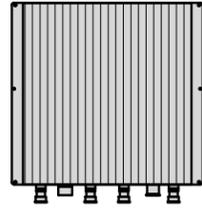
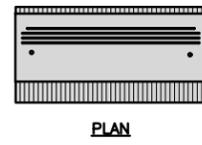

BACK

SIDE

FRONT

SABRE DOUBLE Z-BRACKET C10123155	
DIMENSIONS (HxWxD) (1 BRACKET)	5"x20"x1-13/16"
WEIGHT (FULL ASSEMBLY)	35.79 lbs
PACKAGE QUANTITY	4

#	DESCRIPTION
1	PLATE, CHANNEL BRACKET
2	RRH Z BRACKET, 3/16"
3	THREADED ROD ASSEMBLY 1/2"x12"

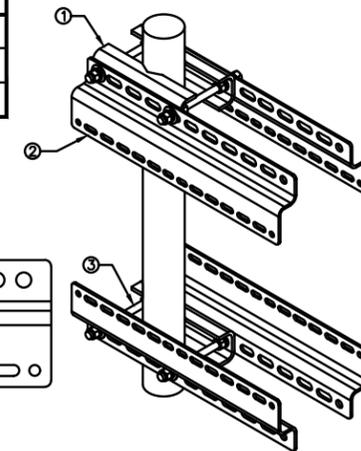
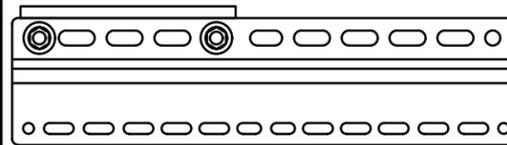

NOTE:  
OR DISH Wireless L.L.C.  
APPROVED EQUIVALENT

RRH DETAIL

NO SCALE

1

RRH DETAIL

NO SCALE

2

RRH MOUNT DETAIL

NO SCALE

3

JMA WIRELESS MX08FRO665-21 ANTENNA	
DIMENSIONS (HxWxD)	72.0"x20.0"x8.0"
TOTAL WEIGHT	82.5 LB
RF PORTS, CONNECTOR TYPE	8 x 4.3-10 FEMALE

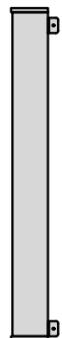
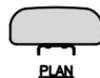

BACK

SIDE

FRONT

ANTENNA DETAIL

NO SCALE

4

NOT USED

NO SCALE

5

ANTENNA BRACKET DETAIL

NO SCALE

6

RAYCAP RDIC-9181-PF-48 DC SURGE PROTECTION (OVP)	
DIMENSIONS (HxWxD)	18.98"x14.39"x8.15"
WEIGHT	21.82 LBS

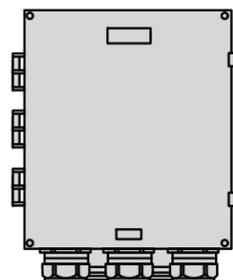
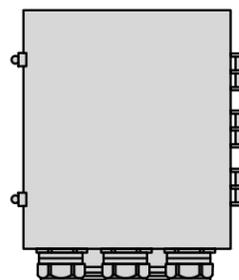
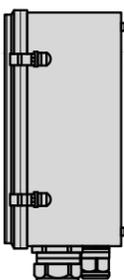
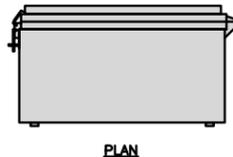

SIDE

BACK

FRONT

SURGE SUPPRESSION DETAIL (OVP)

NO SCALE

7

COMMSCOPE XP-2040  
CROSSOVER PLATE

DIMENSIONS (HxW)	10"x12"
WEIGHT	11 lbs

NOTE:  
OR DISH Wireless L.L.C.  
APPROVED EQUIVALENT

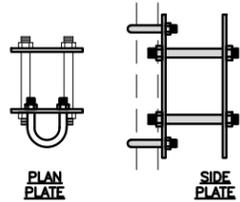

PLAN PLATE

SIDE PLATE

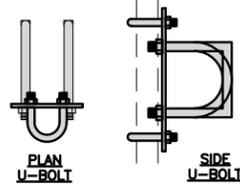

PLAN U-BOLT

SIDE U-BOLT

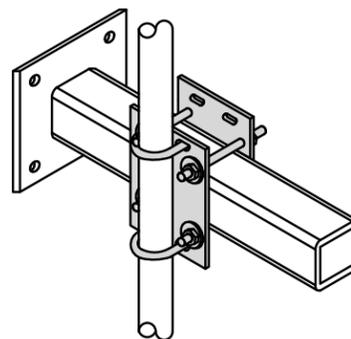

RRH/OVP MOUNT DETAIL

NO SCALE

8

COMMSCOPE  
MC-PK8-DSH

FACE WIDTH	96"
WEIGHT	1373.08 lbs

NOTE:  
OR DISH Wireless L.L.C.  
APPROVED EQUIVALENT

NOTE: 15" TO 38" O.D.

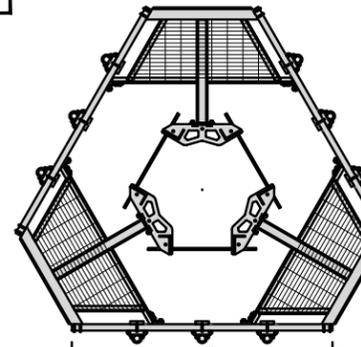
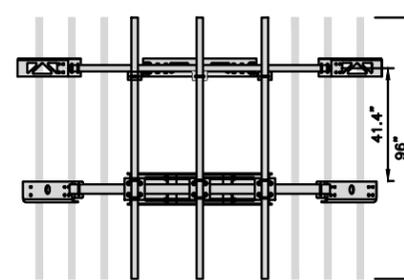

ANTENNA PLATFORM DETAIL

NO SCALE

9



5701 SOUTH SANTA FE DRIVE  
LITTLETON, CO 80120



COA #: PEC.0000738  
421 FAYETTEVILLE ST, SUITE 600  
RALEIGH, NC 27601

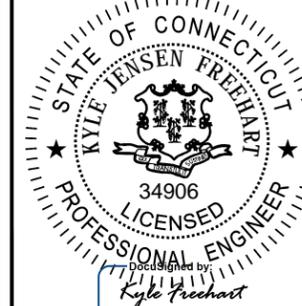

IT IS A VIOLATION OF LAW FOR ANY PERSON,  
UNLESS THEY ARE ACTING UNDER THE DIRECTION  
OF A LICENSED PROFESSIONAL ENGINEER,  
TO ALTER THIS DOCUMENT.

DRAWN BY: CHECKED BY: APPROVED BY:  
SEW MCK MCK

RFDS REV #: ---

CONSTRUCTION  
DOCUMENTS

SUBMITTALS		
REV	DATE	DESCRIPTION
A	09/30/2021	ISSUED FOR REVIEW
0	03/03/2022	ISSUED FOR CONSTRUCTION

A&E PROJECT NUMBER  
KHCLC-16438

DISH Wireless L.L.C.  
PROJECT INFORMATION  
BOHVN00165A  
150 MATTATUCK HEIGHTS  
RD  
WATERBURY, CT 06705

SHEET TITLE  
EQUIPMENT DETAILS

SHEET NUMBER

A-6

**NOTES**

1. CONTRACTOR SHALL FIELD VERIFY ALL PROPOSED UNDERGROUND UTILITY CONDUIT ROUTE.
2. ANTENNAS AND MOUNTS OMITTED FOR CLARITY.
3. DUE TO UTILITY EASEMENT RIGHTS SPECIFIED IN THE GROUND LEASE, CUSTOMER MAY INSTALL EQUIPMENT WITHIN SPECIFIED UTILITY EASEMENT AREA. "PWR" AND "FBR" PATH DEPICTED ON A-1 AND E-1 REPRESENT PLANNED ROUTING BASED ON BEST AVAILABLE INFORMATION INCLUDING BUT NOT LIMITED TO A SURVEY, EXHIBITS, METES AND BOUNDS OF THE UTILITY EASEMENT, FIELD VERIFICATION, PRIOR PROJECT DOCUMENTATION AND OTHER REAL PROPERTY RIGHTS DOCUMENTS. WHEN INSTALLING THE UTILITIES PLEASE LOCATE AND FOLLOW EXISTING PATH. IF EXISTING PATH IS MATERIALLY INCONSISTENT WITH "PWR" AND "FBR" PATH DEPICTED ON A-1 AND E-1 AND SAID VARIANCE IS NOT NOTED ON CDs, PLEASE NOTIFY TOWER OWNER AS FURTHER COORDINATION MAY BE NEEDED.

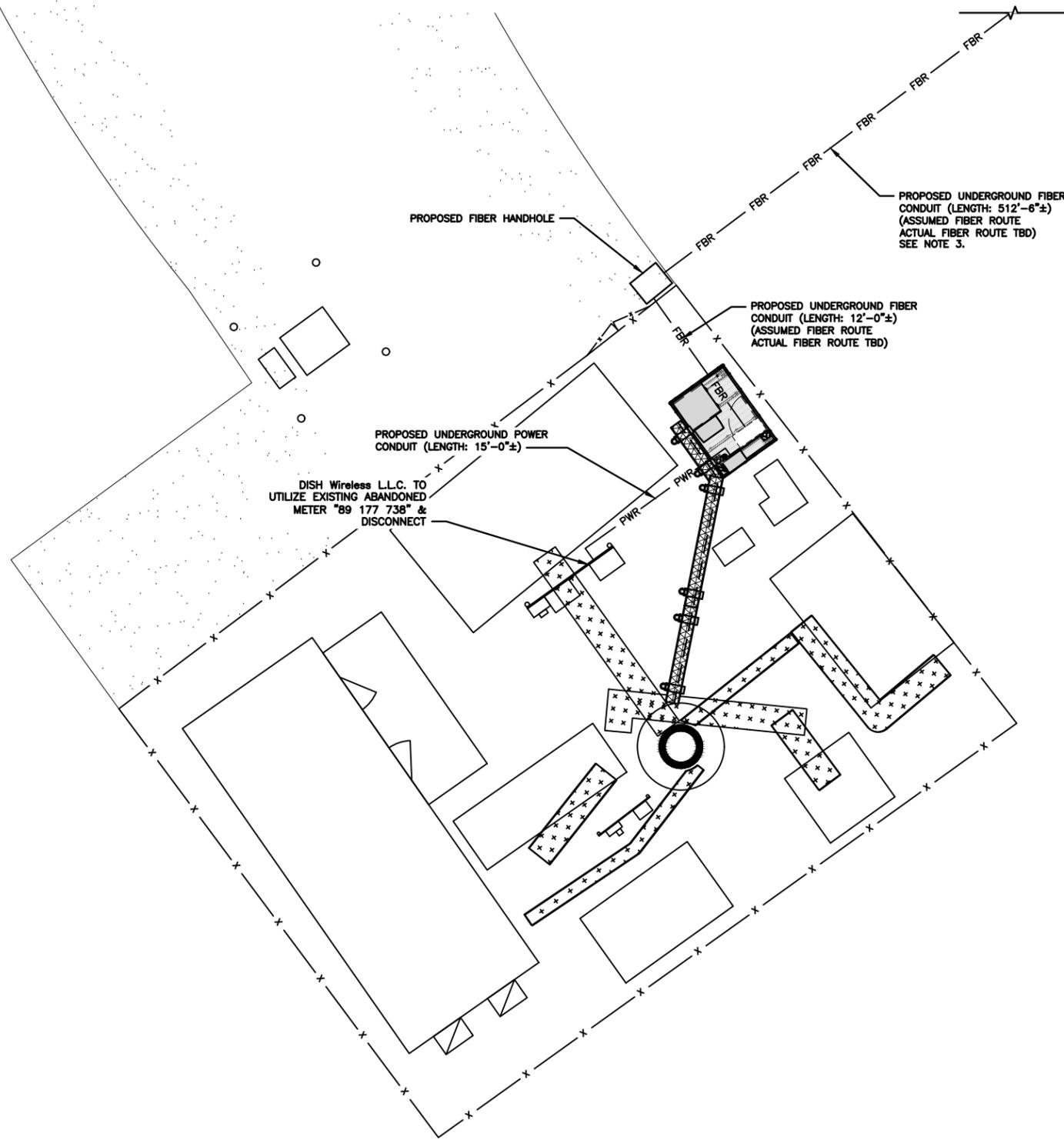

**UTILITY ROUTE PLAN**

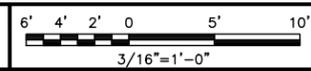

1

DC POWER WIRING SHALL BE COLOR CODED AT EACH END FOR IDENTIFYING +24V AND -48V CONDUCTORS. RED MARKINGS SHALL IDENTIFY +24V AND BLUE MARKINGS SHALL IDENTIFY -48V.

1. CONTRACTOR SHALL INSPECT THE EXISTING CONDITIONS PRIOR TO SUBMITTING A BID. ANY QUESTIONS ARISING DURING THE BID PERIOD IN REGARDS TO THE CONTRACTOR'S FUNCTIONS, THE SCOPE OF WORK, OR ANY OTHER ISSUE RELATED TO THIS PROJECT SHALL BE BROUGHT UP DURING THE BID PERIOD WITH THE PROJECT MANAGER FOR CLARIFICATION, NOT AFTER THE CONTRACT HAS BEEN AWARDED.
2. ALL ELECTRICAL WORK SHALL BE DONE IN ACCORDANCE WITH CURRENT NATIONAL ELECTRICAL CODES AND ALL STATE AND LOCAL CODES, LAWS, AND ORDINANCES. PROVIDE ALL COMPONENTS AND WIRING SIZES AS REQUIRED TO MEET NEC STANDARDS.
3. LOCATION OF EQUIPMENT, CONDUIT AND DEVICES SHOWN ON THE DRAWINGS ARE APPROXIMATE AND SHALL BE COORDINATED WITH FIELD CONDITIONS PRIOR TO CONSTRUCTION.
4. CONDUIT ROUGH-IN SHALL BE COORDINATED WITH THE MECHANICAL EQUIPMENT TO AVOID LOCATION CONFLICTS. VERIFY WITH THE MECHANICAL EQUIPMENT CONTRACTOR AND COMPLY AS REQUIRED.
5. CONTRACTOR SHALL PROVIDE ALL BREAKERS, CONDUITS AND CIRCUITS AS REQUIRED FOR A COMPLETE SYSTEM.
6. CONTRACTOR SHALL PROVIDE PULL BOXES AND JUNCTION BOXES AS REQUIRED BY THE NEC ARTICLE 314.
7. CONTRACTOR SHALL PROVIDE ALL STRAIN RELIEF AND CABLE SUPPORTS FOR ALL CABLE ASSEMBLIES. INSTALLATION SHALL BE IN ACCORDANCE WITH MANUFACTURER'S SPECIFICATIONS AND RECOMMENDATIONS.
8. ALL DISCONNECTS AND CONTROLLING DEVICES SHALL BE PROVIDED WITH ENGRAVED PHENOLIC NAMEPLATES INDICATING EQUIPMENT CONTROLLED, BRANCH CIRCUITS INSTALLED ON, AND PANEL FIELD LOCATIONS FED FROM.
9. INSTALL AN EQUIPMENT GROUNDING CONDUCTOR IN ALL CONDUITS PER THE SPECIFICATIONS AND NEC 250. THE EQUIPMENT GROUNDING CONDUCTORS SHALL BE BONDED AT ALL JUNCTION BOXES, PULL BOXES, AND ALL DISCONNECT SWITCHES, AND EQUIPMENT CABINETS.
10. ALL NEW MATERIAL SHALL HAVE A U.L. LABEL.
11. PANEL SCHEDULE LOADING AND CIRCUIT ARRANGEMENTS REFLECT POST-CONSTRUCTION EQUIPMENT.
12. CONTRACTOR SHALL BE RESPONSIBLE FOR AS-BUILT PANEL SCHEDULE AND SITE DRAWINGS.
13. ALL TRENCHES IN COMPOUND TO BE HAND DUG

**ELECTRICAL NOTES**

NO SCALE

2

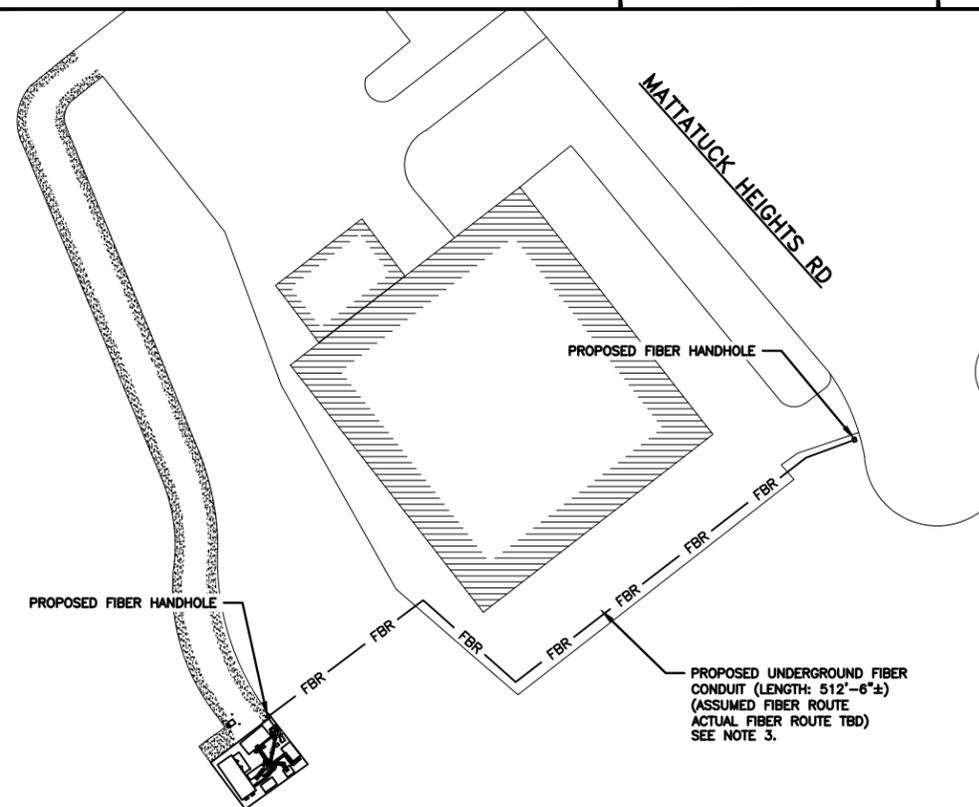

**OVERALL UTILITY ROUTE PLAN**

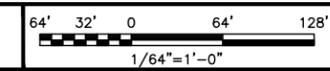

3



5701 SOUTH SANTA FE DRIVE  
LITTLETON, CO 80120



COA #: PEC.0000738  
421 FAYETTEVILLE ST, SUITE 600  
RALEIGH, NC 27601

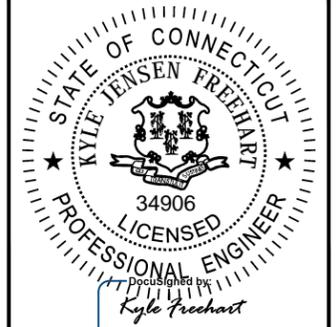

IT IS A VIOLATION OF LAW FOR ANY PERSON, UNLESS THEY ARE ACTING UNDER THE DIRECTION OF A LICENSED PROFESSIONAL ENGINEER, TO ALTER THIS DOCUMENT.

DRAWN BY:	CHECKED BY:	APPROVED BY:
SEW	MCK	MCK

RFDS REV #: ---

**CONSTRUCTION DOCUMENTS**

SUBMITTALS		
REV	DATE	DESCRIPTION
A	09/30/2021	ISSUED FOR REVIEW
0	03/03/2022	ISSUED FOR CONSTRUCTION

A&E PROJECT NUMBER  
KHCLC-16438

DISH Wireless L.L.C.  
PROJECT INFORMATION  
BOHVN00165A  
150 MATTATUCK HEIGHTS RD  
WATERBURY, CT 06705

SHEET TITLE  
ELECTRICAL/FIBER ROUTE  
PLAN AND NOTES

SHEET NUMBER

**E-1**

CARLON EXPANSION FITTINGS				
COUPLING END PART#	MALE TERMINAL ADAPTER END PART#	SIZE	STD CTN QTY.	TRAVEL LENGTH
E945D	E945DX	1/2"	20	4"
E945E	E945EX	3/4"	15	4"
E945F	E945FX	1"	10	4"
E945G	E945GX	1 1/4"	5	4"
E945H	E945HX	1 1/2"	5	4"
E945J	E945JX	2"	15	8"
E945K	E945KX	2 1/2"	10	8"
E945L	E945LX	3"	10	8"
E945M	E945MX	3 1/2"	5	8"
E945N	E945NX	4"	5	8"
E945P	E945PX	5"	1	8"
E945R	E945RX	6"	1	8"

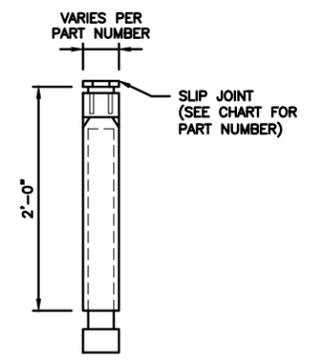

NOTE: CONTRACTOR TO INSTALL EXPANSION FITTING SLIP JOINT AT METER CENTER CONDUIT TERMINATION, AS PER LOCAL UTILITY POLICY, ORDINANCE AND/OR SPECIFIED REQUIREMENT.

**TRENCHING NOTES**

- CONTRACTOR SHALL RESTORE THE TRENCH TO ITS ORIGINAL CONDITIONS BY EITHER SEEDING OR SODDING GRASS AREAS, OR REPLACING ASPHALT OR CONCRETE AREAS TO ITS ORIGINAL CROSS SECTION.
- TRENCHING SAFETY; INCLUDING, BUT NOT LIMITED TO SOIL CLASSIFICATION, SLOPING, AND SHORING, SHALL BE GOVERNED BY THE CURRENT OSHA TRENCHING AND EXCAVATION SAFETY STANDARDS.
- ALL CONDUITS SHALL BE INSTALLED IN COMPLIANCE WITH THE CURRENT NATIONAL ELECTRIC CODE (NEC) OR AS REQUIRED BY THE LOCAL JURISDICTION, WHICHEVER IS THE MOST STRINGENT.

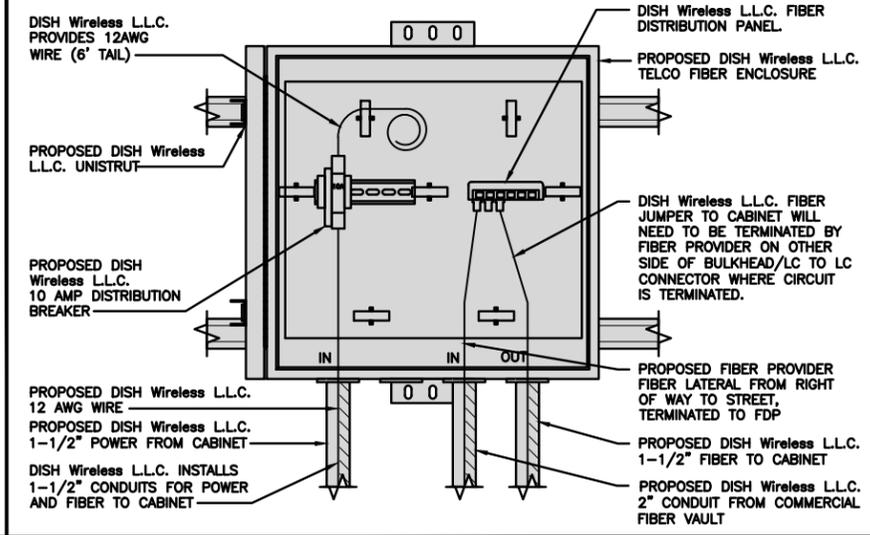
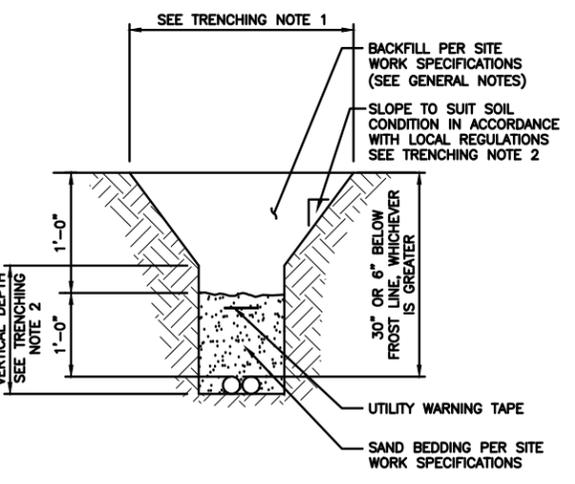

5701 SOUTH SANTA FE DRIVE  
LITTLETON, CO 80120



COA #: PEC.0000738  
421 FAYETTEVILLE ST, SUITE 600  
RALEIGH, NC 27601

EXPANSION JOINT DETAIL NO SCALE 1

TYPICAL UNDERGROUND TRENCH DETAIL NO SCALE 2

DARK TELCO BOX – INTERIOR WIRING LAYOUT NO SCALE 3

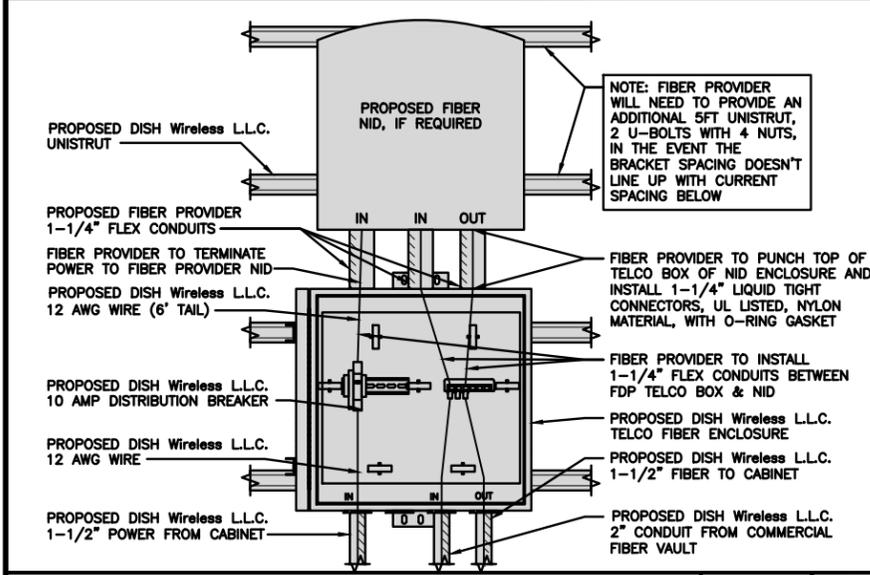

LIT TELCO BOX – INTERIOR WIRING LAYOUT (OPTIONAL) NO SCALE 4

NOT USED NO SCALE 5

NOT USED NO SCALE 6

NOT USED NO SCALE 7

NOT USED NO SCALE 8

NOT USED NO SCALE 9

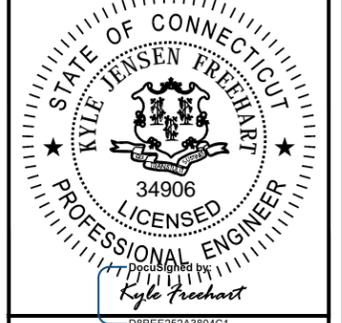

IT IS A VIOLATION OF LAW FOR ANY PERSON, UNLESS THEY ARE ACTING UNDER THE DIRECTION OF A LICENSED PROFESSIONAL ENGINEER, TO ALTER THIS DOCUMENT.

DRAWN BY:	CHECKED BY:	APPROVED BY:
SEW	MCK	MCK
RFDS REV #:		---

**CONSTRUCTION DOCUMENTS**

SUBMITTALS		
REV	DATE	DESCRIPTION
A	09/30/2021	ISSUED FOR REVIEW
0	03/03/2022	ISSUED FOR CONSTRUCTION

A&E PROJECT NUMBER  
KHCLC-16438

DISH Wireless L.L.C.  
PROJECT INFORMATION  
BOHVN00165A  
150 MATTATUCK HEIGHTS RD  
WATERBURY, CT 06705

SHEET TITLE  
ELECTRICAL DETAILS

SHEET NUMBER  
**E-2**

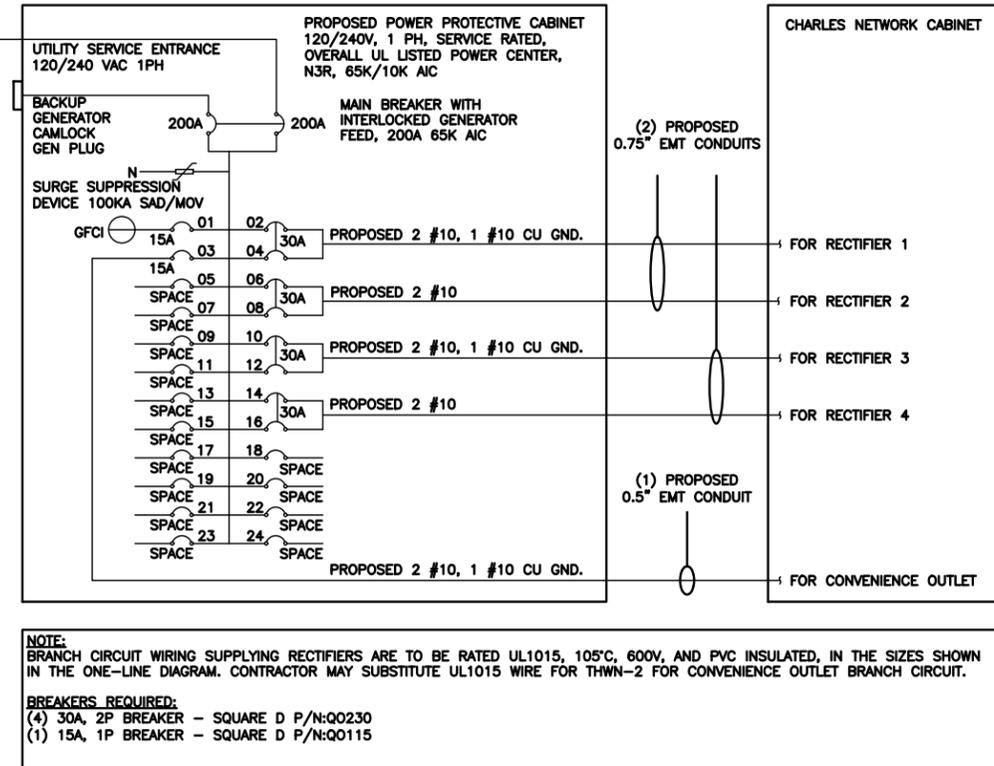
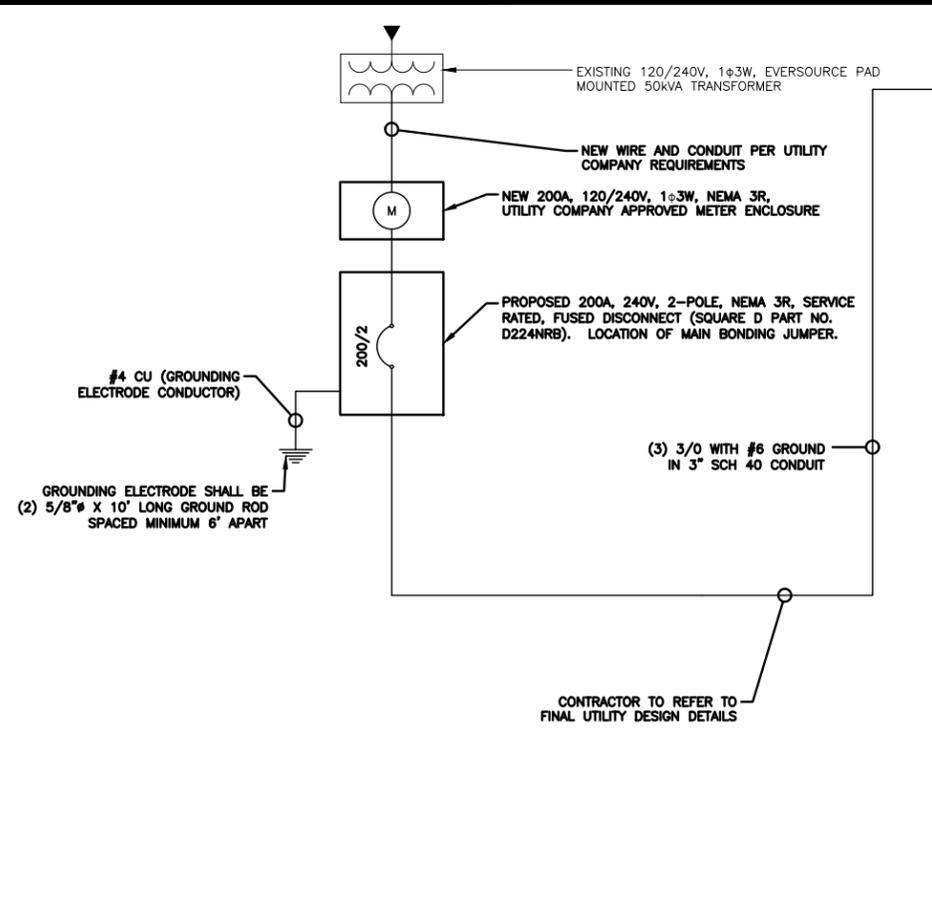

**NOTES**

THE ENGINEER OF RECORD HAS PERFORMED ALL REQUIRED SHORT CIRCUIT CALCULATIONS AND THE AIC RATINGS FOR EACH DEVICE IS ADEQUATE TO PROTECT THE EQUIPMENT AND THE ELECTRICAL SYSTEM.

THE ENGINEER OF RECORD HAS PERFORMED ALL REQUIRED VOLTAGE DROP CALCULATIONS AND ALL BRANCH CIRCUIT AND FEEDERS COMPLY WITH THE NEC (LISTED ON T-1) ARTICLE 210.19(A)(1) FPN NO. 4.

THE (2) CONDUITS WITH (4) CURRENT CARRYING CONDUCTORS EACH, SHALL APPLY THE ADJUSTMENT FACTOR OF 80% PER 2014/17 NEC TABLE 310.15(B)(3)(a) OR 2020 NEC TABLE 310.15(C)(1) FOR UL1015 WIRE.

#12 FOR 15A-20A/1P BREAKER: 0.8 x 30A = 24.0A  
 #10 FOR 25A-30A/2P BREAKER: 0.8 x 40A = 32.0A  
 #8 FOR 35A-40A/2P BREAKER: 0.8 x 55A = 44.0A  
 #6 FOR 45A-60A/2P BREAKER: 0.8 x 75A = 60.0A

CONDUIT SIZING: AT 40% FILL PER NEC CHAPTER 9, TABLE 4, ARTICLE 358.  
 0.5" CONDUIT - 0.122 SQ. IN AREA  
 0.75" CONDUIT - 0.213 SQ. IN AREA  
 2.0" CONDUIT - 1.316 SQ. IN AREA  
 3.0" CONDUIT - 2.907 SQ. IN AREA

CABINET CONVENIENCE OUTLET CONDUCTORS (1 CONDUIT): USING THWN-2, CU.  
 #10 - 0.0211 SQ. IN X 2 = 0.0422 SQ. IN  
 #10 - 0.0211 SQ. IN X 1 = 0.0211 SQ. IN <GROUND  
 TOTAL = 0.0633 SQ. IN

0.5" EMT CONDUIT IS ADEQUATE TO HANDLE THE TOTAL OF (3) WIRES, INCLUDING GROUND WIRE, AS INDICATED ABOVE.

RECTIFIER CONDUCTORS (2 CONDUITS): USING UL1015, CU.  
 #10 - 0.0266 SQ. IN X 4 = 0.1064 SQ. IN  
 #10 - 0.0082 SQ. IN X 1 = 0.0082 SQ. IN <BARE GROUND  
 TOTAL = 0.1146 SQ. IN

0.75" EMT CONDUIT IS ADEQUATE TO HANDLE THE TOTAL OF (5) WIRES, INCLUDING GROUND WIRE, AS INDICATED ABOVE.

PPC FEED CONDUCTORS (1 CONDUIT): USING THWN, CU.  
 3/0 - 0.2679 SQ. IN X 3 = 0.8037 SQ. IN  
 #6 - 0.0507 SQ. IN X 1 = 0.0507 SQ. IN <GROUND  
 TOTAL = 0.8544 SQ. IN

3.0" SCH 40 PVC CONDUIT IS ADEQUATE TO HANDLE THE TOTAL OF (4) WIRES, INCLUDING GROUND WIRE, AS INDICATED ABOVE.

PPC ONE-LINE DIAGRAM

NO SCALE 1

PROPOSED CHARLES PANEL SCHEDULE										
LOAD SERVED	VOLT AMPS (WATTS)		TRIP	CKT #	PHASE	CKT #	TRIP	VOLT AMPS (WATTS)		LOAD SERVED
	L1	L2						L1	L2	
PPC GFCI OUTLET	180	180	15A	1	A	2	30A	2880	2880	ABB/GE INFINITY RECTIFIER 1
CHARLES GFCI OUTLET	180	180	15A	3	B	4	30A	2880	2880	ABB/GE INFINITY RECTIFIER 1
-SPACE-				5	A	6	30A	2880	2880	ABB/GE INFINITY RECTIFIER 2
-SPACE-				7	B	8	30A	2880	2880	ABB/GE INFINITY RECTIFIER 2
-SPACE-				9	A	10	30A	2880	2880	ABB/GE INFINITY RECTIFIER 3
-SPACE-				11	B	12	30A	2880	2880	ABB/GE INFINITY RECTIFIER 3
-SPACE-				13	A	14	30A	2880	2880	ABB/GE INFINITY RECTIFIER 4
-SPACE-				15	B	16	30A	2880	2880	ABB/GE INFINITY RECTIFIER 4
-SPACE-				17	A	18				-SPACE-
-SPACE-				19	B	20				-SPACE-
-SPACE-				21	A	22				-SPACE-
-SPACE-				23	B	24				-SPACE-
VOLTAGE AMPS		180	180					11520	11520	
200A MCB, 1ϕ, 24 SPACE, 120/240V				L1	L2			VOLTAGE AMPS		
MB RATING: 65,000 AIC				11700	11700			AMPS		
				98	98			MAX AMPS		
				98	123			MAX 125%		

PANEL SCHEDULE

NO SCALE 2

NOT USED

NO SCALE 3



5701 SOUTH SANTA FE DRIVE  
LITTLETON, CO 80120



COA #: PEC.0000738  
421 FAYETTEVILLE ST, SUITE 600  
RALEIGH, NC 27601

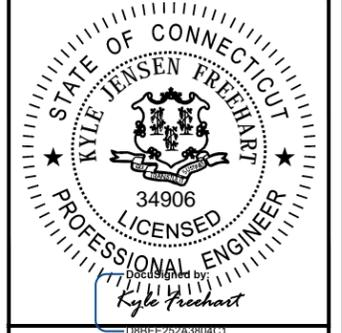

IT IS A VIOLATION OF LAW FOR ANY PERSON, UNLESS THEY ARE ACTING UNDER THE DIRECTION OF A LICENSED PROFESSIONAL ENGINEER, TO ALTER THIS DOCUMENT.

DRAWN BY: SEW CHECKED BY: MCK APPROVED BY: MCK

RFDS REV #: ---

CONSTRUCTION DOCUMENTS

SUBMITTALS		
REV	DATE	DESCRIPTION
A	09/30/2021	ISSUED FOR REVIEW
0	03/03/2022	ISSUED FOR CONSTRUCTION

A&E PROJECT NUMBER  
KHCLC-16438

DISH Wireless L.L.C.  
PROJECT INFORMATION  
BOHVN00165A  
150 MATTATUCK HEIGHTS RD  
WATERBURY, CT 06705

SHEET TITLE  
ELECTRICAL ONE-LINE, FAULT CALCS & PANEL SCHEDULE

SHEET NUMBER  
**E-3**

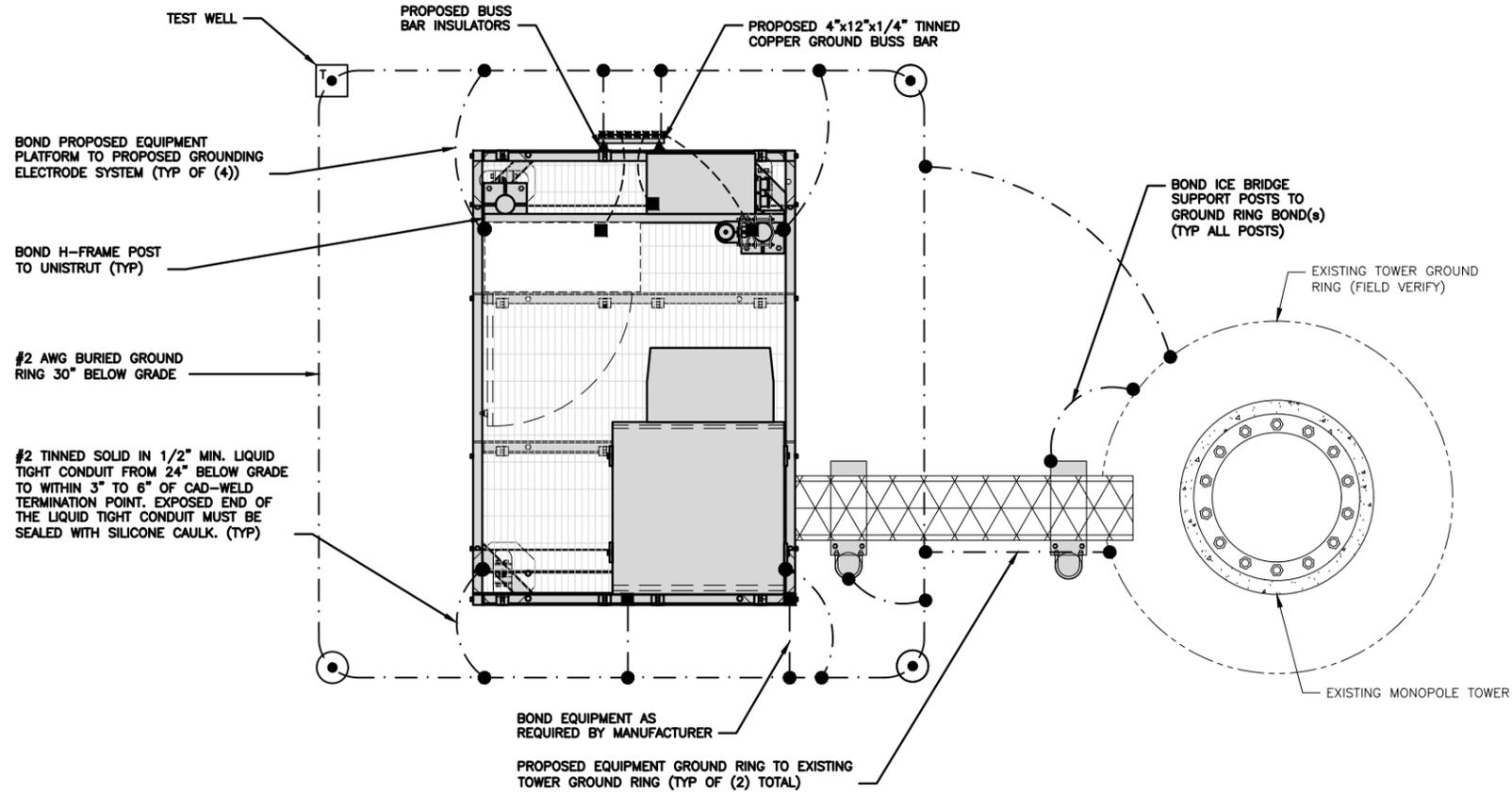

TYPICAL EQUIPMENT GROUNDING PLAN

NO SCALE 1

NOTES

1. ANTENNAS AND OVP SHOWN ARE GENERIC AND NOT REFERENCING TO A SPECIFIC MANUFACTURER. THIS LAYOUT IS FOR REFERENCE ONLY

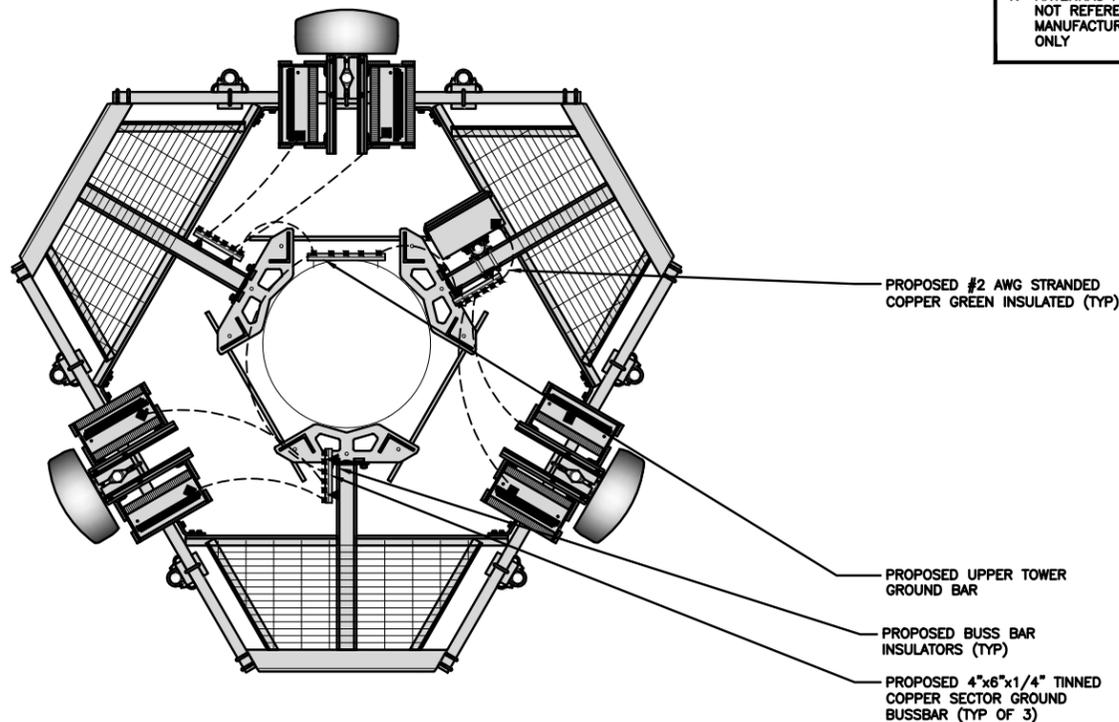

TYPICAL ANTENNA GROUNDING PLAN

NO SCALE 2

- EXOTHERMIC CONNECTION
- MECHANICAL CONNECTION
- ▬ GROUND BUS BAR
- GROUND ROD
- TEST GROUND ROD WITH INSPECTION SLEEVE
- #6 AWG STRANDED & INSULATED
- - - #2 AWG SOLID COPPER TINNED
- ▲ BUSS BAR INSULATOR

GROUNDING LEGEND

1. GROUNDING IS SHOWN DIAGRAMMATICALLY ONLY.
2. CONTRACTOR SHALL GROUND ALL EQUIPMENT AS A COMPLETE SYSTEM. GROUNDING SHALL BE IN COMPLIANCE WITH NEC SECTION 250 AND DISH Wireless L.L.C. GROUNDING AND BONDING REQUIREMENTS AND MANUFACTURER'S SPECIFICATIONS.
3. ALL GROUND CONDUCTORS SHALL BE COPPER; NO ALUMINUM CONDUCTORS SHALL BE USED.

GROUNDING KEY NOTES

- (A) EXTERIOR GROUND RING: #2 AWG SOLID COPPER, BURIED AT A DEPTH OF AT LEAST 30 INCHES BELOW GRADE, OR 6 INCHES BELOW THE FROST LINE AND APPROXIMATELY 24 INCHES FROM THE EXTERIOR WALL OR FOOTING.
- (B) TOWER GROUND RING: THE GROUND RING SYSTEM SHALL BE INSTALLED AROUND AN ANTENNA TOWER'S LEGS, AND/OR GUY ANCHORS. WHERE SEPARATE SYSTEMS HAVE BEEN PROVIDED FOR THE TOWER AND THE BUILDING, AT LEAST TWO BONDS SHALL BE MADE BETWEEN THE TOWER RING GROUND SYSTEM AND THE BUILDING RING GROUND SYSTEM USING MINIMUM #2 AWG SOLID COPPER CONDUCTORS.
- (C) INTERIOR GROUND RING: #2 AWG STRANDED GREEN INSULATED COPPER CONDUCTOR EXTENDED AROUND THE PERIMETER OF THE EQUIPMENT AREA. ALL NON-TELECOMMUNICATIONS RELATED METALLIC OBJECTS FOUND WITHIN A SITE SHALL BE GROUNDED TO THE INTERIOR GROUND RING WITH #6 AWG STRANDED GREEN INSULATED CONDUCTOR.
- (D) BOND TO INTERIOR GROUND RING: #2 AWG SOLID TINNED COPPER WIRE PRIMARY BONDS SHALL BE PROVIDED AT LEAST AT FOUR POINTS ON THE INTERIOR GROUND RING, LOCATED AT THE CORNERS OF THE BUILDING.
- (E) GROUND ROD: UL LISTED COPPER CLAD STEEL, MINIMUM 1/2" DIAMETER BY EIGHT FEET LONG. GROUND RODS SHALL BE INSTALLED WITH INSPECTION SLEEVES. GROUND RODS SHALL BE DRIVEN TO THE DEPTH OF GROUND RING CONDUCTOR.
- (F) CELL REFERENCE GROUND BAR: POINT OF GROUND REFERENCE FOR ALL COMMUNICATIONS EQUIPMENT FRAMES. ALL BONDS ARE MADE WITH #2 AWG UNLESS NOTED OTHERWISE STRANDED GREEN INSULATED COPPER CONDUCTORS. BOND TO GROUND RING WITH (2) #2 SOLID TINNED COPPER CONDUCTORS.
- (G) HATCH PLATE GROUND BAR: BOND TO THE INTERIOR GROUND RING WITH TWO #2 AWG STRANDED GREEN INSULATED COPPER CONDUCTORS. WHEN A HATCH-PLATE AND A CELL REFERENCE GROUND BAR ARE BOTH PRESENT, THE CRGB MUST BE CONNECTED TO THE HATCH-PLATE AND TO THE INTERIOR GROUND RING USING (2) TWO #2 AWG STRANDED GREEN INSULATED COPPER CONDUCTORS EACH.
- (H) EXTERIOR CABLE ENTRY PORT GROUND BARS: LOCATED AT THE ENTRANCE TO THE CELL SITE BUILDING. BOND TO GROUND RING WITH A #2 AWG SOLID TINNED COPPER CONDUCTORS WITH AN EXOTHERMIC WELD AND INSPECTION SLEEVE.
- (I) TELCO GROUND BAR: BOND TO BOTH CELL REFERENCE GROUND BAR OR EXTERIOR GROUND RING.
- (J) FRAME BONDING: THE BONDING POINT FOR TELECOM EQUIPMENT FRAMES SHALL BE THE GROUND BUS THAT IS NOT ISOLATED FROM THE EQUIPMENTS METAL FRAMEWORK.
- (K) INTERIOR UNIT BONDS: METAL FRAMES, CABINETS AND INDIVIDUAL METALLIC UNITS LOCATED WITH THE AREA OF THE INTERIOR GROUND RING REQUIRE A #6 AWG STRANDED GREEN INSULATED COPPER BOND TO THE INTERIOR GROUND RING.
- (L) FENCE AND GATE GROUNDING: METAL FENCES WITHIN 7 FEET OF THE EXTERIOR GROUND RING OR OBJECTS BONDED TO THE EXTERIOR GROUND RING SHALL BE BONDED TO THE GROUND RING WITH A #2 AWG SOLID TINNED COPPER CONDUCTOR AT AN INTERVAL NOT EXCEEDING 25 FEET. BONDS SHALL BE MADE AT EACH GATE POST AND ACROSS GATE OPENINGS.
- (M) EXTERIOR UNIT BONDS: METALLIC OBJECTS, EXTERNAL TO OR MOUNTED TO THE BUILDING, SHALL BE BONDED TO THE EXTERIOR GROUND RING. USING #2 TINNED SOLID COPPER WIRE
- (N) ICE BRIDGE SUPPORTS: EACH ICE BRIDGE LEG SHALL BE BONDED TO THE GROUND RING WITH #2 AWG BARE TINNED COPPER CONDUCTOR. PROVIDE EXOTHERMIC WELDS AT BOTH THE ICE BRIDGE LEG AND BURIED GROUND RING.
- (O) DURING ALL DC POWER SYSTEM CHANGES INCLUDING DC SYSTEM CHANGE OUTS, RECTIFIER REPLACEMENTS OR ADDITIONS, BREAKER DISTRIBUTION CHANGES, BATTERY ADDITIONS, BATTERY REPLACEMENTS AND INSTALLATIONS OR CHANGES TO DC CONVERTER SYSTEMS IT SHALL BE REQUIRED THAT SERVICE CONTRACTORS VERIFY ALL DC POWER SYSTEMS ARE EQUIPPED WITH A MASTER DC SYSTEM RETURN GROUND CONDUCTOR FROM THE DC POWER SYSTEM COMMON RETURN BUS DIRECTLY CONNECTED TO THE CELL SITE REFERENCE GROUND BAR
- (P) TOWER TOP COLLECTOR BUSS BAR IS TO BE MECHANICALLY BONDED TO PROPOSED ANTENNA MOUNT COLLAR. REFER TO DISH Wireless L.L.C. GROUNDING NOTES.

GROUNDING KEY NOTES

NO SCALE 3



5701 SOUTH SANTA FE DRIVE  
LITTLETON, CO 80120



COA #: PEC.0000738  
421 FAYETTEVILLE ST, SUITE 600  
RALEIGH, NC 27601



IT IS A VIOLATION OF LAW FOR ANY PERSON, UNLESS THEY ARE ACTING UNDER THE DIRECTION OF A LICENSED PROFESSIONAL ENGINEER, TO ALTER THIS DOCUMENT.

DRAWN BY: SEW CHECKED BY: MCK APPROVED BY: MCK

RFDS REV #: ---

CONSTRUCTION DOCUMENTS

SUBMITTALS		
REV	DATE	DESCRIPTION
A	09/30/2021	ISSUED FOR REVIEW
0	03/03/2022	ISSUED FOR CONSTRUCTION

A&E PROJECT NUMBER  
KHCLC-16438

DISH Wireless L.L.C.  
PROJECT INFORMATION  
BOHVN00165A  
150 MATTATUCK HEIGHTS  
RD  
WATERBURY, CT 06705

SHEET TITLE  
GROUNDING PLANS  
AND NOTES

SHEET NUMBER  
**G-1**

**NOTES**  
EQUIPMENT CABINET OMITTED FOR CLARITY

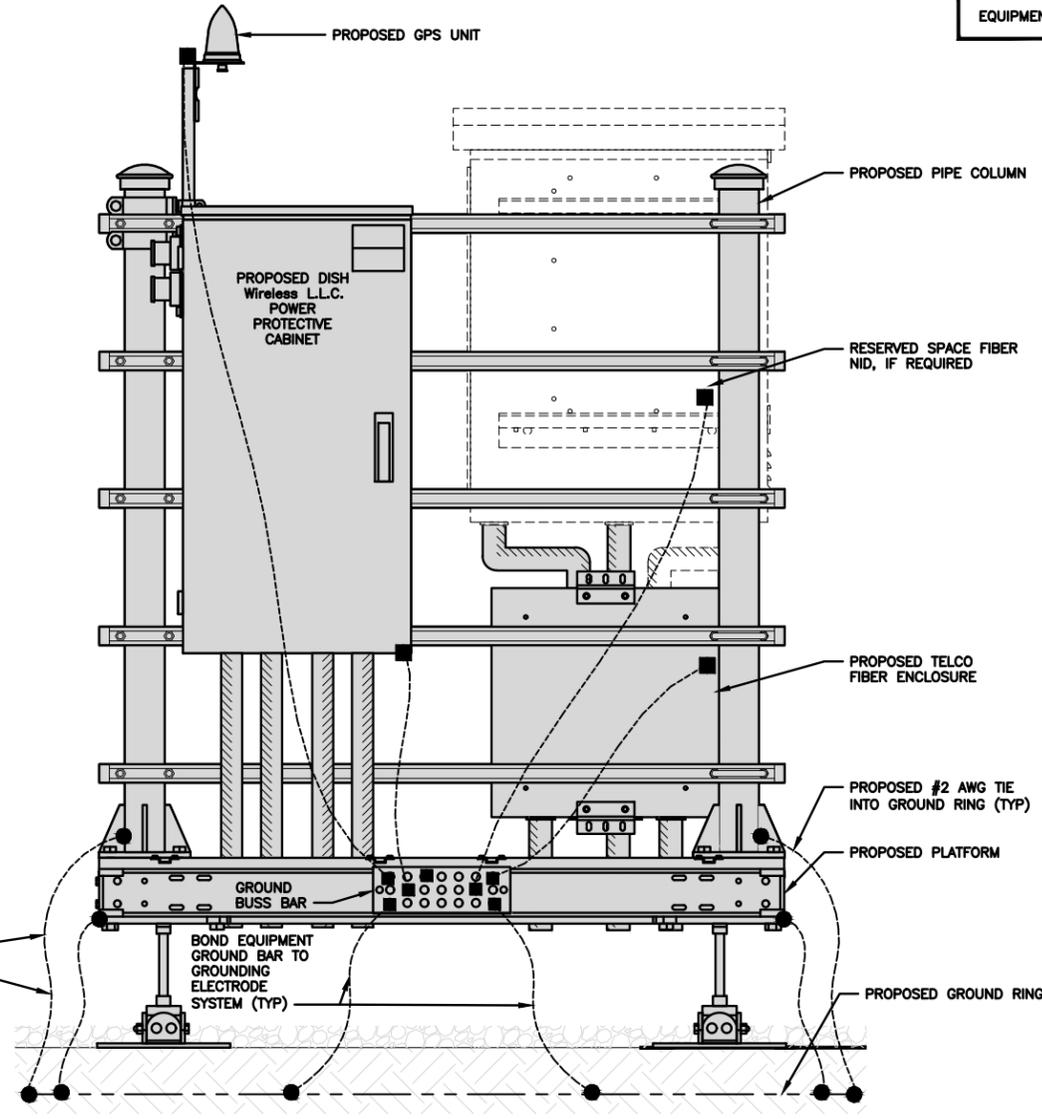

**H-FRAME GROUNDING DETAIL**

NO SCALE 1

**NOTES**  
CABLE GROUNDING NOT REQUIRED WHEN ANTENNA IS LESS THAN 10' FROM CABINET

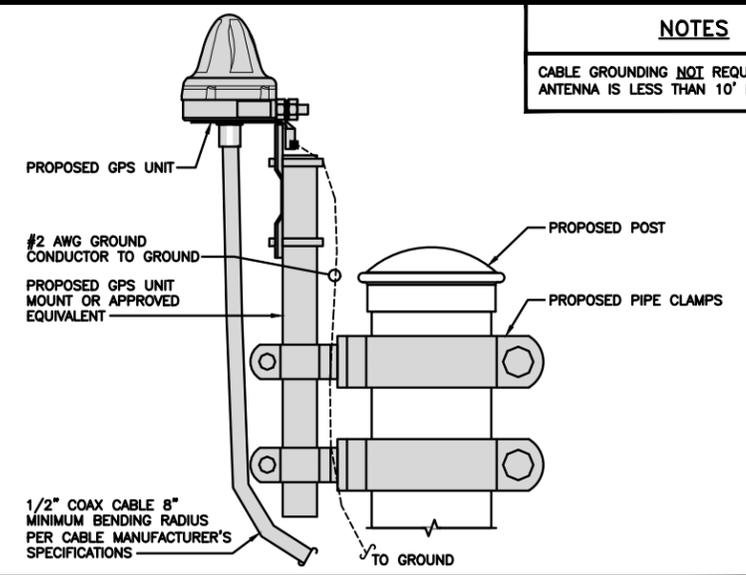

**TYPICAL GPS UNIT GROUNDING**

NO SCALE 2

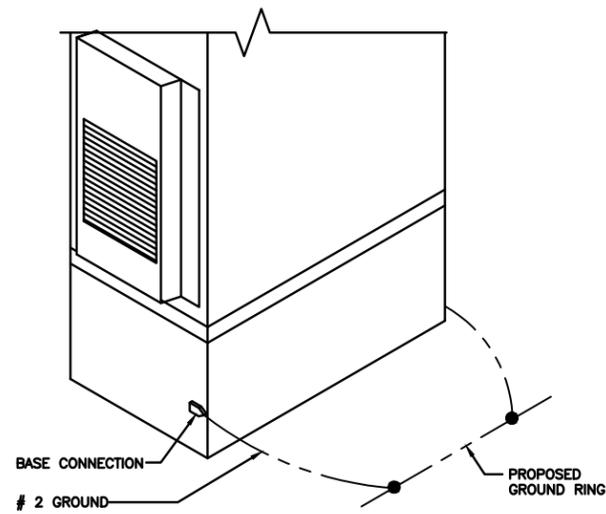

**OUTDOOR CABINET GROUNDING**

NO SCALE 3

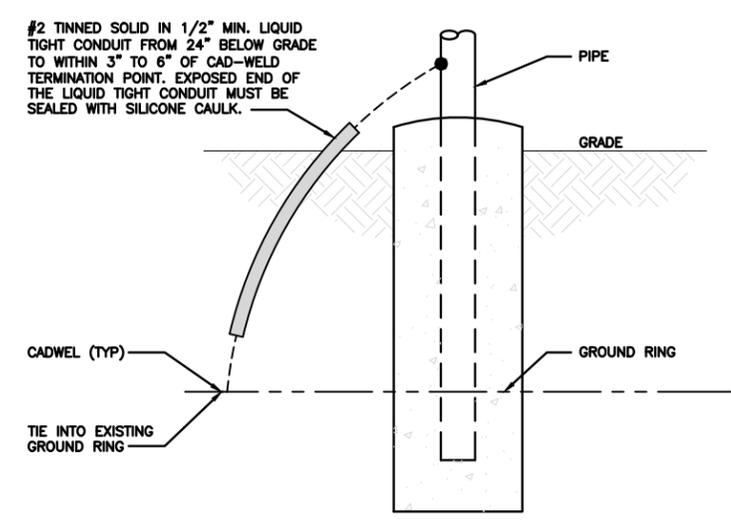

**TRANSITIONING GROUND DETAIL**

NO SCALE 4

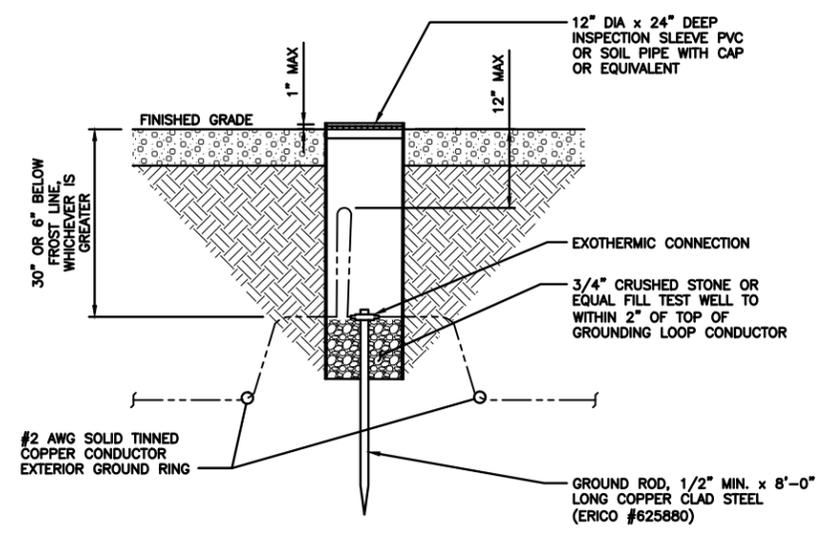

**TYPICAL TEST GROUND ROD WITH INSPECTION SLEEVE**

NO SCALE 5

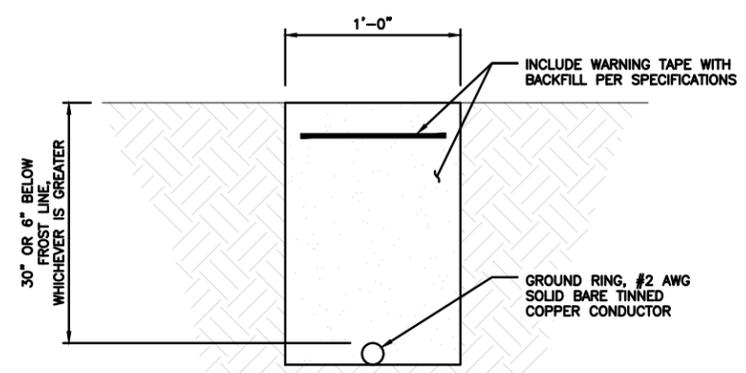

**TYPICAL GROUND RING TRENCH**

NO SCALE 6



5701 SOUTH SANTA FE DRIVE  
LITTLETON, CO 80120



COA #: PEC.0000738  
421 FAYETTEVILLE ST, SUITE 600  
RALEIGH, NC 27601



IT IS A VIOLATION OF LAW FOR ANY PERSON, UNLESS THEY ARE ACTING UNDER THE DIRECTION OF A LICENSED PROFESSIONAL ENGINEER, TO ALTER THIS DOCUMENT.

DRAWN BY: SEW CHECKED BY: MCK APPROVED BY: MCK

RFDS REV #: ---

**CONSTRUCTION DOCUMENTS**

SUBMITTALS		
REV	DATE	DESCRIPTION
A	09/30/2021	ISSUED FOR REVIEW
0	03/03/2022	ISSUED FOR CONSTRUCTION

A&E PROJECT NUMBER  
KHCL-16438

DISH Wireless L.L.C.  
PROJECT INFORMATION  
BOHVN00165A  
150 MATTATUCK HEIGHTS RD  
WATERBURY, CT 06705

SHEET TITLE  
GROUNDING DETAILS

SHEET NUMBER  
**G-2**

1. EXOTHERMIC WELD (2) TWO, #2 AWG BARE TINNED SOLID COPPER CONDUCTORS TO GROUND BAR. ROUTE CONDUCTORS TO BURIED GROUND RING AND PROVIDE PARALLEL EXOTHERMIC WELD.
2. ALL EXTERIOR GROUNDING HARDWARE SHALL BE STAINLESS STEEL 3/8" DIAMETER OR LARGER. ALL HARDWARE 18-8 STAINLESS STEEL INCLUDING LOCK WASHERS, COAT ALL SURFACES WITH AN ANTI-OXIDANT COMPOUND BEFORE MATING.
3. FOR GROUND BOND TO STEEL ONLY: COAT ALL SURFACES WITH AN ANTI-OXIDANT COMPOUND BEFORE MATING.
4. DO NOT INSTALL CABLE GROUNDING KIT AT A BEND AND ALWAYS DIRECT GROUND CONDUCTOR DOWN TO GROUNDING BUS.
5. NUT & WASHER SHALL BE PLACED ON THE FRONT SIDE OF THE GROUND BAR AND BOLTED ON THE BACK SIDE.
6. ALL GROUNDING PARTS AND EQUIPMENT TO BE SUPPLIED AND INSTALLED BY CONTRACTOR.
7. THE CONTRACTOR SHALL BE RESPONSIBLE FOR INSTALLING ADDITIONAL GROUND BAR AS REQUIRED.
8. ENSURE THE WIRE INSULATION TERMINATION IS WITHIN 1/8" OF THE BARREL (NO SHINERS).

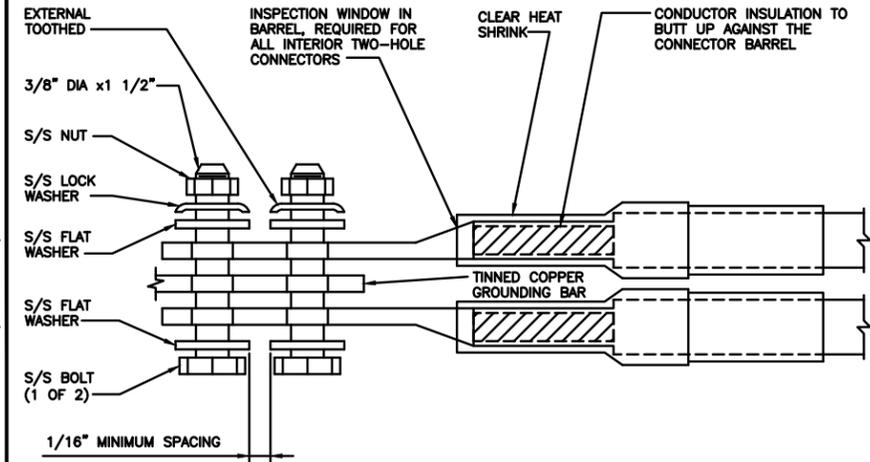
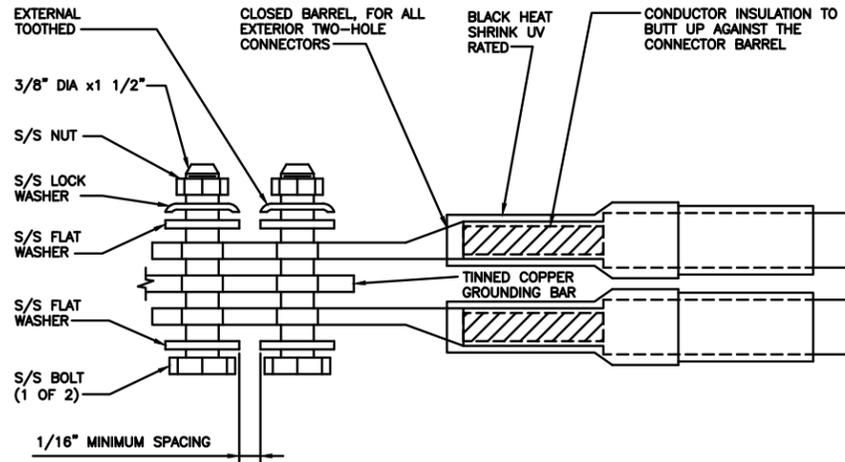

5701 SOUTH SANTA FE DRIVE  
LITTLETON, CO 80120



COA #: PEC.0000738  
421 FAYETTEVILLE ST, SUITE 600  
RALEIGH, NC 27601



IT IS A VIOLATION OF LAW FOR ANY PERSON, UNLESS THEY ARE ACTING UNDER THE DIRECTION OF A LICENSED PROFESSIONAL ENGINEER, TO ALTER THIS DOCUMENT.

DRAWN BY: SEW    CHECKED BY: MCK    APPROVED BY: MCK

RFDS REV #: ---

**CONSTRUCTION DOCUMENTS**

SUBMITTALS		
REV	DATE	DESCRIPTION
A	09/30/2021	ISSUED FOR REVIEW
0	03/03/2022	ISSUED FOR CONSTRUCTION

A&E PROJECT NUMBER  
KHCLC-16438

DISH Wireless L.L.C.  
PROJECT INFORMATION  
BOHVN00165A  
150 MATTATUCK HEIGHTS RD  
WATERBURY, CT 06705

SHEET TITLE  
GROUNDING DETAILS

SHEET NUMBER  
**G-3**

TYPICAL GROUNDING NOTES

NO SCALE 1

TYPICAL EXTERIOR TWO HOLE LUG

NO SCALE 2

TYPICAL INTERIOR TWO HOLE LUG

NO SCALE 3

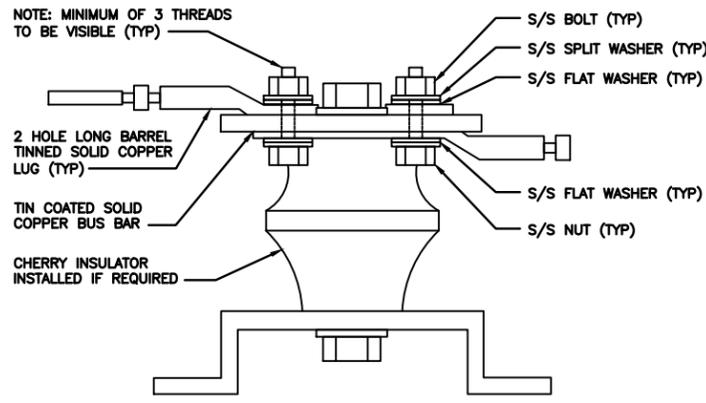

LUG DETAIL

NO SCALE 4

NOT USED

NO SCALE 5

NOT USED

NO SCALE 6

NOT USED

NO SCALE 7

NOT USED

NO SCALE 8

NOT USED

NO SCALE 9

RF JUMPER COLOR CODING		3/4" TAPE WIDTHS WITH 3/4" SPACING											
<p>LOW-BAND RRH - (600MHz N71 BASEBAND) + (850MHz N26 BAND) + (700MHz N29 BAND) - OPTIONAL PER MARKET</p> <p>ADD FREQUENCY COLOR TO SECTOR BAND (CBRS WILL USE YELLOW BANDS)</p>	ALPHA RRH				BETA RRH				GAMMA RRH				
	PORT 1 + SLANT	PORT 2 - SLANT	PORT 3 + SLANT	PORT 4 - SLANT	PORT 1 + SLANT	PORT 2 - SLANT	PORT 3 + SLANT	PORT 4 - SLANT	PORT 1 + SLANT	PORT 2 - SLANT	PORT 3 + SLANT	PORT 4 - SLANT	
	RED	RED	RED	RED	BLUE	BLUE	BLUE	BLUE	GREEN	GREEN	GREEN	GREEN	
	ORANGE	ORANGE	RED	RED	ORANGE	ORANGE	BLUE	BLUE	ORANGE	ORANGE	GREEN	GREEN	
		WHITE (-) PORT	ORANGE	ORANGE		WHITE (-) PORT	ORANGE	ORANGE		WHITE (-) PORT	ORANGE	ORANGE	
				WHITE (-) PORT				WHITE (-) PORT				WHITE (-) PORT	
<p>MID-BAND RRH - (AWS BANDS N66+N70)</p> <p>ADD FREQUENCY COLOR TO SECTOR BAND (CBRS WILL USE YELLOW BANDS)</p>	RED	RED	RED	RED	BLUE	BLUE	BLUE	BLUE	GREEN	GREEN	GREEN	GREEN	
	PURPLE	PURPLE	RED	RED	PURPLE	PURPLE	BLUE	BLUE	PURPLE	PURPLE	GREEN	GREEN	
		WHITE (-) PORT	PURPLE	PURPLE		WHITE (-) PORT	PURPLE	PURPLE		WHITE (-) PORT	PURPLE	PURPLE	
				WHITE (-) PORT				WHITE (-) PORT				WHITE (-) PORT	
<p>HYBRID/DISCREET CABLES</p> <p>INCLUDE SECTOR BANDS BEING SUPPORTED ALONG WITH FREQUENCY BANDS</p> <p>EXAMPLE 1 - HYBRID, OR DISCREET, SUPPORTS ALL SECTORS, BOTH LOW-BANDS AND MID-BANDS</p> <p>EXAMPLE 2 - HYBRID, OR DISCREET, SUPPORTS CBRS ONLY, ALL SECTORS</p>	EXAMPLE 1	EXAMPLE 2	EXAMPLE 3										
	RED	RED	RED		BLUE	BLUE	BLUE		GREEN	GREEN	GREEN		
	BLUE	BLUE	ORANGE		PURPLE	PURPLE	PURPLE						
	GREEN	GREEN	PURPLE										
	ORANGE	YELLOW											
	PURPLE												
<p>FIBER JUMPERS TO RRHs</p> <p>LOW-BAND RRH FIBER CABLES HAVE SECTOR STRIPE ONLY</p>	LOW BAND RRH	HIGH BAND RRH	LOW BAND RRH	HIGH BAND RRH	LOW BAND RRH	HIGH BAND RRH	LOW BAND RRH	HIGH BAND RRH					
	RED	RED	BLUE	BLUE	GREEN	GREEN							
		PURPLE		PURPLE		PURPLE		PURPLE					
<p>POWER CABLES TO RRHs</p> <p>LOW-BAND RRH POWER CABLES HAVE SECTOR STRIPE ONLY</p>	LOW BAND RRH	HIGH BAND RRH	LOW BAND RRH	HIGH BAND RRH	LOW BAND RRH	HIGH BAND RRH	LOW BAND RRH	HIGH BAND RRH					
	RED	RED	BLUE	BLUE	GREEN	GREEN							
		PURPLE		PURPLE		PURPLE		PURPLE					
<p>RET MOTORS AT ANTENNAS</p>	ANTENNA 1 LOW BAND/ "IN"	ANTENNA 1 HIGH BAND/ "IN"	ANTENNA 1 LOW BAND/ "IN"	ANTENNA 1 HIGH BAND/ "IN"	ANTENNA 1 LOW BAND/ "IN"	ANTENNA 1 HIGH BAND/ "IN"	ANTENNA 1 LOW BAND/ "IN"	ANTENNA 1 HIGH BAND/ "IN"					
	RED	RED	BLUE	BLUE	GREEN	GREEN							
		PURPLE		PURPLE		PURPLE		PURPLE					
<p>MICROWAVE RADIO LINKS</p> <p>LINKS WILL HAVE A 1.5-2 INCH WHITE WRAP WITH THE AZIMUTH COLOR OVERLAPPING IN THE MIDDLE. ADD ADDITIONAL SECTOR COLOR BANDS FOR EACH ADDITIONAL MW RADIO.</p> <p>MICROWAVE CABLES WILL REQUIRE P-TOUCH LABELS INSIDE THE CABINET TO IDENTIFY THE LOCAL AND REMOTE SITE ID'S</p>	FORWARD AZIMUTH OF 0-120 DEGREES		FORWARD AZIMUTH OF 120-240 DEGREES		FORWARD AZIMUTH OF 240-360 DEGREES								
	PRIMARY	SECONDARY	PRIMARY	SECONDARY	PRIMARY	SECONDARY							
	WHITE	WHITE	WHITE	WHITE	WHITE	WHITE							
	RED	RED	BLUE	BLUE	GREEN	GREEN							
	WHITE	WHITE	WHITE	WHITE	WHITE	WHITE							
		RED		BLUE		GREEN							
		WHITE		WHITE		WHITE							
		RED		BLUE		GREEN							
		WHITE		WHITE		WHITE							

RF CABLE COLOR CODES

NO SCALE

1

NOT USED

NO SCALE

4

LOW BANDS (N71+N26)  
OPTIONAL - (N29)



AWS  
(N66+N70+H-BLOCK)

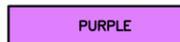

CBRS TECH  
(3 GHz)

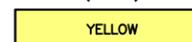

NEGATIVE SLANT PORT  
ON ANT/RRH

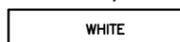

ALPHA SECTOR

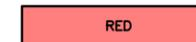

BETA SECTOR



GAMMA SECTOR



COLOR IDENTIFIER

NO SCALE

2

NOT USED

NO SCALE

3



5701 SOUTH SANTA FE DRIVE  
LITTLETON, CO 80120



COA #: PEC.0000738  
421 FAYETTEVILLE ST, SUITE 600  
RALEIGH, NC 27601

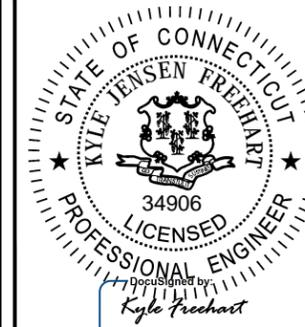

IT IS A VIOLATION OF LAW FOR ANY PERSON, UNLESS THEY ARE ACTING UNDER THE DIRECTION OF A LICENSED PROFESSIONAL ENGINEER, TO ALTER THIS DOCUMENT.

DRAWN BY: SEW  
CHECKED BY: MCK  
APPROVED BY: MCK

RFDS REV #: ---

CONSTRUCTION DOCUMENTS

SUBMITTALS		
REV	DATE	DESCRIPTION
A	09/30/2021	ISSUED FOR REVIEW
0	03/03/2022	ISSUED FOR CONSTRUCTION

A&E PROJECT NUMBER  
KHCLC-16438

DISH Wireless L.L.C.  
PROJECT INFORMATION  
BOHVN00165A  
150 MATTATUCK HEIGHTS  
RD  
WATERBURY, CT 06705

SHEET TITLE  
RF  
CABLE COLOR CODES

SHEET NUMBER  
RF-1

EXOTHERMIC CONNECTION  
 MECHANICAL CONNECTION  
 BUSS BAR INSULATOR  
 CHEMICAL ELECTROLYTIC GROUNDING SYSTEM  
 TEST CHEMICAL ELECTROLYTIC GROUNDING SYSTEM  
 EXOTHERMIC WITH INSPECTION SLEEVE  
 GROUNDING BAR  
 GROUND ROD  
 TEST GROUND ROD WITH INSPECTION SLEEVE  
 SINGLE POLE SWITCH  
 DUPLEX RECEPTACLE  
 DUPLEX GFCI RECEPTACLE  
 FLUORESCENT LIGHTING FIXTURE (2) TWO LAMPS 48-T8  
 SMOKE DETECTION (DC)  
 EMERGENCY LIGHTING (DC)  
 SECURITY LIGHT W/PHOTOCELL LITHONIA ALXW  
 LED-1-25A400/51K-SR4-120-PE-DBBTXD  
 CHAIN LINK FENCE  
 WOOD/WROUGHT IRON FENCE  
 WALL STRUCTURE  
 LEASE AREA  
 PROPERTY LINE (PL)  
 SETBACKS  
 ICE BRIDGE  
 CABLE TRAY  
 WATER LINE  
 UNDERGROUND POWER  
 UNDERGROUND TELCO  
 OVERHEAD POWER  
 OVERHEAD TELCO  
 UNDERGROUND TELCO/POWER  
 ABOVE GROUND POWER  
 ABOVE GROUND TELCO  
 ABOVE GROUND TELCO/POWER  
 WORKPOINT  
 SECTION REFERENCE  
 DETAIL REFERENCE

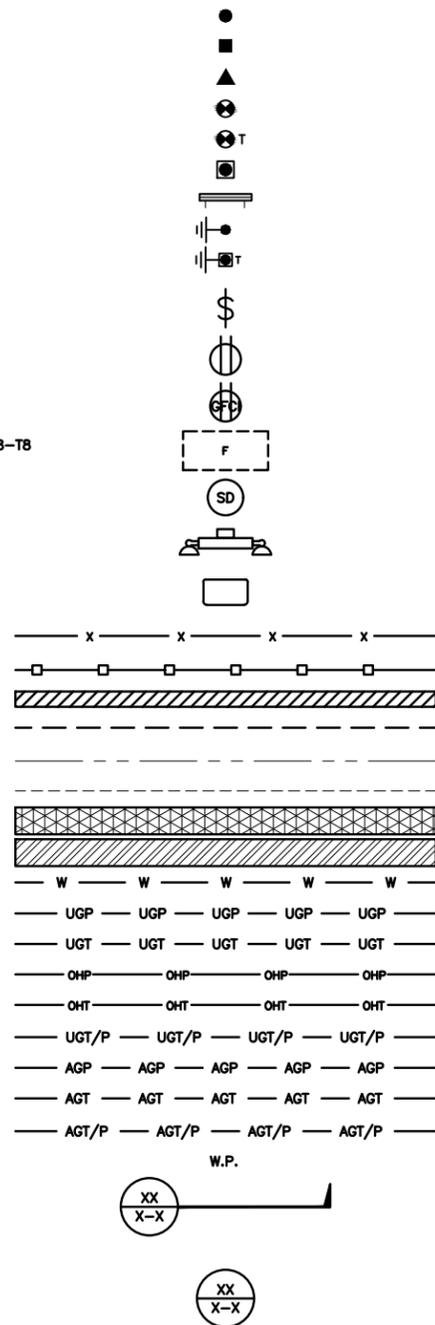

**LEGEND**

AB ANCHOR BOLT	IN INCH
ABV ABOVE	INT INTERIOR
AC ALTERNATING CURRENT	LB(S) POUND(S)
ADDL ADDITIONAL	LF LINEAR FEET
AFF ABOVE FINISHED FLOOR	LTE LONG TERM EVOLUTION
AFG ABOVE FINISHED GRADE	MAS MASONRY
AGL ABOVE GROUND LEVEL	MAX MAXIMUM
AIC AMPERAGE INTERRUPTION CAPACITY	MB MACHINE BOLT
ALUM ALUMINUM	MECH MECHANICAL
ALT ALTERNATE	MFR MANUFACTURER
ANT ANTENNA	MGB MASTER GROUND BAR
APPROX APPROXIMATE	MIN MINIMUM
ARCH ARCHITECTURAL	MISC MISCELLANEOUS
ATS AUTOMATIC TRANSFER SWITCH	MTL METAL
AWG AMERICAN WIRE GAUGE	MTS MANUAL TRANSFER SWITCH
BATT BATTERY	MW MICROWAVE
BLDG BUILDING	NEC NATIONAL ELECTRIC CODE
BLK BLOCK	NM NEWTON METERS
BLKG BLOCKING	NO. NUMBER
BM BEAM	# NUMBER
BTC BARE TINNED COPPER CONDUCTOR	NTS NOT TO SCALE
BOF BOTTOM OF FOOTING	OC ON-CENTER
CAB CABINET	OSHA OCCUPATIONAL SAFETY AND HEALTH ADMINISTRATION
CANT CANTILEVERED	OPNG OPENING
CHG CHARGING	P/C PRECAST CONCRETE
CLG CEILING	PCS PERSONAL COMMUNICATION SERVICES
CLR CLEAR	PCU PRIMARY CONTROL UNIT
COL COLUMN	PRC PRIMARY RADIO CABINET
COMM COMMON	PP POLARIZING PRESERVING
CONC CONCRETE	PSF POUNDS PER SQUARE FOOT
CONSTR CONSTRUCTION	PSI POUNDS PER SQUARE INCH
DBL DOUBLE	PT PRESSURE TREATED
DC DIRECT CURRENT	PWR POWER CABINET
DEPT DEPARTMENT	QTY QUANTITY
DF DOUGLAS FIR	RAD RADIUS
DIA DIAMETER	RECT RECTIFIER
DIAG DIAGONAL	REF REFERENCE
DIM DIMENSION	REINF REINFORCEMENT
DWG DRAWING	REQ'D REQUIRED
DWL DOWEL	RET REMOTE ELECTRIC TILT
EA EACH	RF RADIO FREQUENCY
EC ELECTRICAL CONDUCTOR	RMC RIGID METALLIC CONDUIT
EL ELEVATION	RRH REMOTE RADIO HEAD
ELEC ELECTRICAL	RRU REMOTE RADIO UNIT
EMT ELECTRICAL METALLIC TUBING	RWY RACEWAY
ENG ENGINEER	SCH SCHEDULE
EQ EQUAL	SHT SHEET
EXP EXPANSION	SIAD SMART INTEGRATED ACCESS DEVICE
EXT EXTERIOR	SIM SIMILAR
EW EACH WAY	SPEC SPECIFICATION
FAB FABRICATION	SQ SQUARE
FF FINISH FLOOR	SS STAINLESS STEEL
FG FINISH GRADE	STD STANDARD
FIF FACILITY INTERFACE FRAME	STL STEEL
FIN FINISH(ED)	TEMP TEMPORARY
FLR FLOOR	THK THICKNESS
FDN FOUNDATION	TMA TOWER MOUNTED AMPLIFIER
FOC FACE OF CONCRETE	TN TOE NAIL
FOM FACE OF MASONRY	TOA TOP OF ANTENNA
FOS FACE OF STUD	TOC TOP OF CURB
FOW FACE OF WALL	TOF TOP OF FOUNDATION
FS FINISH SURFACE	TOP TOP OF PLATE (PARAPET)
FT FOOT	TOS TOP OF STEEL
FTG FOOTING	TOW TOP OF WALL
GA GAUGE	TVSS TRANSIENT VOLTAGE SURGE SUPPRESSION
GEN GENERATOR	TYP TYPICAL
GFCI GROUND FAULT CIRCUIT INTERRUPTER	UG UNDERGROUND
GLB GLUE LAMINATED BEAM	UL UNDERWRITERS LABORATORY
GLV GALVANIZED	UNO UNLESS NOTED OTHERWISE
GPS GLOBAL POSITIONING SYSTEM	UMTS UNIVERSAL MOBILE TELECOMMUNICATIONS SYSTEM
GND GROUND	UPS UNINTERRUPTIBLE POWER SYSTEM (DC POWER PLANT)
GSM GLOBAL SYSTEM FOR MOBILE	VIF VERIFIED IN FIELD
HDG HOT DIPPED GALVANIZED	W WIDE
HDR HEADER	W/ WITH
HGR HANGER	WD WOOD
HVAC HEAT/VENTILATION/AIR CONDITIONING	WP WEATHERPROOF
HT HEIGHT	WT WEIGHT
IGR INTERIOR GROUND RING	

**ABBREVIATIONS**



5701 SOUTH SANTA FE DRIVE  
 LITTLETON, CO 80120



COA #: PEC.0000738  
 421 FAYETTEVILLE ST, SUITE 600  
 RALEIGH, NC 27601



IT IS A VIOLATION OF LAW FOR ANY PERSON, UNLESS THEY ARE ACTING UNDER THE DIRECTION OF A LICENSED PROFESSIONAL ENGINEER, TO ALTER THIS DOCUMENT.

DRAWN BY:	CHECKED BY:	APPROVED BY:
SEW	MCK	MCK

RFDS REV #: ---

**CONSTRUCTION DOCUMENTS**

SUBMITTALS		
REV	DATE	DESCRIPTION
A	09/30/2021	ISSUED FOR REVIEW
0	03/03/2022	ISSUED FOR CONSTRUCTION

A&E PROJECT NUMBER  
 KHCLC-16438

DISH Wireless L.L.C.  
 PROJECT INFORMATION  
 BOHVN00165A  
 150 MATTATUCK HEIGHTS RD  
 WATERBURY, CT 06705

SHEET TITLE  
 LEGEND AND ABBREVIATIONS

SHEET NUMBER  
**GN-1**

**SITE ACTIVITY REQUIREMENTS:**

1. NOTICE TO PROCEED – NO WORK SHALL COMMENCE PRIOR TO CONTRACTOR RECEIVING A WRITTEN NOTICE TO PROCEED (NTP) AND THE ISSUANCE OF A PURCHASE ORDER. PRIOR TO ACCESSING/ENTERING THE SITE YOU MUST CONTACT THE DISH Wireless L.L.C. AND TOWER OWNER NOC & THE DISH Wireless L.L.C. AND TOWER OWNER CONSTRUCTION MANAGER.
2. "LOOK UP" – DISH Wireless L.L.C. AND TOWER OWNER SAFETY CLIMB REQUIREMENT:  
THE INTEGRITY OF THE SAFETY CLIMB AND ALL COMPONENTS OF THE CLIMBING FACILITY SHALL BE CONSIDERED DURING ALL STAGES OF DESIGN, INSTALLATION, AND INSPECTION. TOWER MODIFICATION, MOUNT REINFORCEMENTS, AND/OR EQUIPMENT INSTALLATIONS SHALL NOT COMPROMISE THE INTEGRITY OR FUNCTIONAL USE OF THE SAFETY CLIMB OR ANY COMPONENTS OF THE CLIMBING FACILITY ON THE STRUCTURE. THIS SHALL INCLUDE, BUT NOT BE LIMITED TO: PINCHING OF THE WIRE ROPE, BENDING OF THE WIRE ROPE FROM ITS SUPPORTS, DIRECT CONTACT OR CLOSE PROXIMITY TO THE WIRE ROPE WHICH MAY CAUSE FRICTIONAL WEAR, IMPACT TO THE ANCHORAGE POINTS IN ANY WAY, OR TO IMPEDE/BLOCK ITS INTENDED USE. ANY COMPROMISED SAFETY CLIMB, INCLUDING EXISTING CONDITIONS MUST BE TAGGED OUT AND REPORTED TO YOUR DISH Wireless L.L.C. AND DISH Wireless L.L.C. AND TOWER OWNER POC OR CALL THE NOC TO GENERATE A SAFETY CLIMB MAINTENANCE AND CONTRACTOR NOTICE TICKET.
3. PRIOR TO THE START OF CONSTRUCTION, ALL REQUIRED JURISDICTIONAL PERMITS SHALL BE OBTAINED. THIS INCLUDES, BUT IS NOT LIMITED TO, BUILDING, ELECTRICAL, MECHANICAL, FIRE, FLOOD ZONE, ENVIRONMENTAL, AND ZONING. AFTER ONSITE ACTIVITIES AND CONSTRUCTION ARE COMPLETED, ALL REQUIRED PERMITS SHALL BE SATISFIED AND CLOSED OUT ACCORDING TO LOCAL JURISDICTIONAL REQUIREMENTS.
4. ALL CONSTRUCTION MEANS AND METHODS; INCLUDING BUT NOT LIMITED TO, ERECTION PLANS, RIGGING PLANS, CLIMBING PLANS, AND RESCUE PLANS SHALL BE THE RESPONSIBILITY OF THE GENERAL CONTRACTOR RESPONSIBLE FOR THE EXECUTION OF THE WORK CONTAINED HEREIN, AND SHALL MEET ANSI/ASSE A10.48 (LATEST EDITION); FEDERAL, STATE, AND LOCAL REGULATIONS; AND ANY APPLICABLE INDUSTRY CONSENSUS STANDARDS RELATED TO THE CONSTRUCTION ACTIVITIES BEING PERFORMED. ALL RIGGING PLANS SHALL ADHERE TO ANSI/ASSE A10.48 (LATEST EDITION) AND DISH Wireless L.L.C. AND TOWER OWNER STANDARDS, INCLUDING THE REQUIRED INVOLVEMENT OF A QUALIFIED ENGINEER FOR CLASS IV CONSTRUCTION, TO CERTIFY THE SUPPORTING STRUCTURE(S) IN ACCORDANCE WITH ANSI/TIA-322 (LATEST EDITION).
5. ALL SITE WORK TO COMPLY WITH DISH Wireless L.L.C. AND TOWER OWNER INSTALLATION STANDARDS FOR CONSTRUCTION ACTIVITIES ON DISH Wireless L.L.C. AND TOWER OWNER TOWER SITE AND LATEST VERSION OF ANSI/TIA-1019-A-2012 "STANDARD FOR INSTALLATION, ALTERATION, AND MAINTENANCE OF ANTENNA SUPPORTING STRUCTURES AND ANTENNAS."
6. IF THE SPECIFIED EQUIPMENT CAN NOT BE INSTALLED AS SHOWN ON THESE DRAWINGS, THE CONTRACTOR SHALL PROPOSE AN ALTERNATIVE INSTALLATION FOR APPROVAL BY DISH Wireless L.L.C. AND TOWER OWNER PRIOR TO PROCEEDING WITH ANY SUCH CHANGE OF INSTALLATION.
7. ALL MATERIALS FURNISHED AND INSTALLED SHALL BE IN STRICT ACCORDANCE WITH ALL APPLICABLE CODES, REGULATIONS AND ORDINANCES. CONTRACTOR SHALL ISSUE ALL APPROPRIATE NOTICES AND COMPLY WITH ALL LAWS, ORDINANCES, RULES, REGULATIONS AND LAWFUL ORDERS OF ANY PUBLIC AUTHORITY REGARDING THE PERFORMANCE OF THE WORK. ALL WORK CARRIED OUT SHALL COMPLY WITH ALL APPLICABLE MUNICIPAL AND UTILITY COMPANY SPECIFICATIONS AND LOCAL JURISDICTIONAL CODES, ORDINANCES AND APPLICABLE REGULATIONS.
8. THE CONTRACTOR SHALL INSTALL ALL EQUIPMENT AND MATERIALS IN ACCORDANCE WITH MANUFACTURER'S RECOMMENDATIONS UNLESS SPECIFICALLY STATED OTHERWISE.
9. THE CONTRACTOR SHALL CONTACT UTILITY LOCATING SERVICES INCLUDING PRIVATE LOCATES SERVICES PRIOR TO THE START OF CONSTRUCTION.
10. ALL EXISTING ACTIVE SEWER, WATER, GAS, ELECTRIC AND OTHER UTILITIES WHERE ENCOUNTERED IN THE WORK, SHALL BE PROTECTED AT ALL TIMES AND WHERE REQUIRED FOR THE PROPER EXECUTION OF THE WORK, SHALL BE RELOCATED AS DIRECTED BY CONTRACTOR. EXTREME CAUTION SHOULD BE USED BY THE CONTRACTOR WHEN EXCAVATING OR DRILLING PIERS AROUND OR NEAR UTILITIES. CONTRACTOR SHALL PROVIDE SAFETY TRAINING FOR THE WORKING CREW. THIS WILL INCLUDE BUT NOT BE LIMITED TO A) FALL PROTECTION B) CONFINED SPACE C) ELECTRICAL SAFETY D) TRENCHING AND EXCAVATION E) CONSTRUCTION SAFETY PROCEDURES.
11. ALL SITE WORK SHALL BE AS INDICATED ON THE STAMPED CONSTRUCTION DRAWINGS AND DISH PROJECT SPECIFICATIONS, LATEST APPROVED REVISION.
12. CONTRACTOR SHALL KEEP THE SITE FREE FROM ACCUMULATING WASTE MATERIAL, DEBRIS, AND TRASH AT THE COMPLETION OF THE WORK. IF NECESSARY, RUBBISH, STUMPS, DEBRIS, STICKS, STONES AND OTHER REFUSE SHALL BE REMOVED FROM THE SITE AND DISPOSED OF LEGALLY.
13. ALL EXISTING INACTIVE SEWER, WATER, GAS, ELECTRIC AND OTHER UTILITIES, WHICH INTERFERE WITH THE EXECUTION OF THE WORK, SHALL BE REMOVED AND/OR CAPPED, PLUGGED OR OTHERWISE DISCONTINUED AT POINTS WHICH WILL NOT INTERFERE WITH THE EXECUTION OF THE WORK, SUBJECT TO THE APPROVAL OF DISH Wireless L.L.C. AND TOWER OWNER, AND/OR LOCAL UTILITIES.
14. THE CONTRACTOR SHALL PROVIDE SITE SIGNAGE IN ACCORDANCE WITH THE TECHNICAL SPECIFICATION FOR SITE SIGNAGE REQUIRED BY LOCAL JURISDICTION AND SIGNAGE REQUIRED ON INDIVIDUAL PIECES OF EQUIPMENT, ROOMS, AND SHELTERS.
15. THE SITE SHALL BE GRADED TO CAUSE SURFACE WATER TO FLOW AWAY FROM THE CARRIER'S EQUIPMENT AND TOWER AREAS.
16. THE SUB GRADE SHALL BE COMPACTED AND BROUGHT TO A SMOOTH UNIFORM GRADE PRIOR TO FINISHED SURFACE APPLICATION.
17. THE AREAS OF THE OWNERS PROPERTY DISTURBED BY THE WORK AND NOT COVERED BY THE TOWER, EQUIPMENT OR DRIVEWAY, SHALL BE GRADED TO A UNIFORM SLOPE, AND STABILIZED TO PREVENT EROSION AS SPECIFIED ON THE CONSTRUCTION DRAWINGS AND/OR PROJECT SPECIFICATIONS.
18. CONTRACTOR SHALL MINIMIZE DISTURBANCE TO EXISTING SITE DURING CONSTRUCTION. EROSION CONTROL MEASURES, IF REQUIRED DURING CONSTRUCTION, SHALL BE IN CONFORMANCE WITH THE LOCAL GUIDELINES FOR EROSION AND SEDIMENT CONTROL.
19. THE CONTRACTOR SHALL PROTECT EXISTING IMPROVEMENTS, PAVEMENTS, CURBS, LANDSCAPING AND STRUCTURES. ANY DAMAGED PART SHALL BE REPAIRED AT CONTRACTOR'S EXPENSE TO THE SATISFACTION OF OWNER.
20. CONTRACTOR SHALL LEGALLY AND PROPERLY DISPOSE OF ALL SCRAP MATERIALS SUCH AS COAXIAL CABLES AND OTHER ITEMS REMOVED FROM THE EXISTING FACILITY. ANTENNAS AND RADIOS REMOVED SHALL BE RETURNED TO THE OWNER'S DESIGNATED LOCATION.
21. CONTRACTOR SHALL LEAVE PREMISES IN CLEAN CONDITION. TRASH AND DEBRIS SHOULD BE REMOVED FROM SITE ON A DAILY BASIS.
22. NO FILL OR EMBANKMENT MATERIAL SHALL BE PLACED ON FROZEN GROUND. FROZEN MATERIALS, SNOW OR ICE SHALL NOT BE PLACED IN ANY FILL OR EMBANKMENT.

**GENERAL NOTES:**

- 1.FOR THE PURPOSE OF CONSTRUCTION DRAWING, THE FOLLOWING DEFINITIONS SHALL APPLY:  
CONTRACTOR:GENERAL CONTRACTOR RESPONSIBLE FOR CONSTRUCTION  
CARRIER:DISH Wireless L.L.C.  
TOWER OWNER:TOWER OWNER
2. THESE DRAWINGS HAVE BEEN PREPARED USING STANDARDS OF PROFESSIONAL CARE AND COMPLETENESS NORMALLY EXERCISED UNDER SIMILAR CIRCUMSTANCES BY REPUTABLE ENGINEERS IN THIS OR SIMILAR LOCALITIES. IT IS ASSUMED THAT THE WORK DEPICTED WILL BE PERFORMED BY AN EXPERIENCED CONTRACTOR AND/OR WORKPEOPLE WHO HAVE A WORKING KNOWLEDGE OF THE APPLICABLE CODE STANDARDS AND REQUIREMENTS AND OF INDUSTRY ACCEPTED STANDARD GOOD PRACTICE. AS NOT EVERY CONDITION OR ELEMENT IS (OR CAN BE) EXPLICITLY SHOWN ON THESE DRAWINGS, THE CONTRACTOR SHALL USE INDUSTRY ACCEPTED STANDARD GOOD PRACTICE FOR MISCELLANEOUS WORK NOT EXPLICITLY SHOWN.
3. THESE DRAWINGS REPRESENT THE FINISHED STRUCTURE. THEY DO NOT INDICATE THE MEANS OR METHODS OF CONSTRUCTION. THE CONTRACTOR SHALL BE SOLELY RESPONSIBLE FOR THE CONSTRUCTION MEANS, METHODS, TECHNIQUES, SEQUENCES, AND PROCEDURES. THE CONTRACTOR SHALL PROVIDE ALL MEASURES NECESSARY FOR PROTECTION OF LIFE AND PROPERTY DURING CONSTRUCTION. SUCH MEASURES SHALL INCLUDE, BUT NOT BE LIMITED TO, BRACING, FORMWORK, SHORING, ETC. SITE VISITS BY THE ENGINEER OR HIS REPRESENTATIVE WILL NOT INCLUDE INSPECTION OF THESE ITEMS AND IS FOR STRUCTURAL OBSERVATION OF THE FINISHED STRUCTURE ONLY.
4. NOTES AND DETAILS IN THE CONSTRUCTION DRAWINGS SHALL TAKE PRECEDENCE OVER GENERAL NOTES AND TYPICAL DETAILS. WHERE NO DETAILS ARE SHOWN, CONSTRUCTION SHALL CONFORM TO SIMILAR WORK ON THE PROJECT, AND/OR AS PROVIDED FOR IN THE CONTRACT DOCUMENTS. WHERE DISCREPANCIES OCCUR BETWEEN PLANS, DETAILS, GENERAL NOTES, AND SPECIFICATIONS, THE GREATER, MORE STRICT REQUIREMENTS, SHALL GOVERN. IF FURTHER CLARIFICATION IS REQUIRED CONTACT THE ENGINEER OF RECORD.
5. SUBSTANTIAL EFFORT HAS BEEN MADE TO PROVIDE ACCURATE DIMENSIONS AND MEASUREMENTS ON THE DRAWINGS TO ASSIST IN THE FABRICATION AND/OR PLACEMENT OF CONSTRUCTION ELEMENTS BUT IT IS THE SOLE RESPONSIBILITY OF THE CONTRACTOR TO FIELD VERIFY THE DIMENSIONS, MEASUREMENTS, AND/OR CLEARANCES SHOWN IN THE CONSTRUCTION DRAWINGS PRIOR TO FABRICATION OR CUTTING OF ANY NEW OR EXISTING CONSTRUCTION ELEMENTS. IF IT IS DETERMINED THAT THERE ARE DISCREPANCIES AND/OR CONFLICTS WITH THE CONSTRUCTION DRAWINGS THE ENGINEER OF RECORD IS TO BE NOTIFIED AS SOON AS POSSIBLE.
6. PRIOR TO THE SUBMISSION OF BIDS, THE BIDDING CONTRACTOR SHALL VISIT THE CELL SITE TO FAMILIARIZE WITH THE EXISTING CONDITIONS AND TO CONFIRM THAT THE WORK CAN BE ACCOMPLISHED AS SHOWN ON THE CONSTRUCTION DRAWINGS. ANY DISCREPANCY FOUND SHALL BE BROUGHT TO THE ATTENTION OF CARRIER POC AND TOWER OWNER.
7. ALL MATERIALS FURNISHED AND INSTALLED SHALL BE IN STRICT ACCORDANCE WITH ALL APPLICABLE CODES, REGULATIONS AND ORDINANCES. CONTRACTOR SHALL ISSUE ALL APPROPRIATE NOTICES AND COMPLY WITH ALL LAWS, ORDINANCES, RULES, REGULATIONS AND LAWFUL ORDERS OF ANY PUBLIC AUTHORITY REGARDING THE PERFORMANCE OF THE WORK. ALL WORK CARRIED OUT SHALL COMPLY WITH ALL APPLICABLE MUNICIPAL AND UTILITY COMPANY SPECIFICATIONS AND LOCAL JURISDICTIONAL CODES, ORDINANCES AND APPLICABLE REGULATIONS.
8. UNLESS NOTED OTHERWISE, THE WORK SHALL INCLUDE FURNISHING MATERIALS, EQUIPMENT, APPURTENANCES AND LABOR NECESSARY TO COMPLETE ALL INSTALLATIONS AS INDICATED ON THE DRAWINGS.
9. THE CONTRACTOR SHALL INSTALL ALL EQUIPMENT AND MATERIALS IN ACCORDANCE WITH MANUFACTURER'S RECOMMENDATIONS UNLESS SPECIFICALLY STATED OTHERWISE.
10. IF THE SPECIFIED EQUIPMENT CAN NOT BE INSTALLED AS SHOWN ON THESE DRAWINGS, THE CONTRACTOR SHALL PROPOSE AN ALTERNATIVE INSTALLATION FOR APPROVAL BY THE CARRIER AND TOWER OWNER PRIOR TO PROCEEDING WITH ANY SUCH CHANGE OF INSTALLATION.
11. CONTRACTOR IS TO PERFORM A SITE INVESTIGATION, BEFORE SUBMITTING BIDS, TO DETERMINE THE BEST ROUTING OF ALL CONDUITS FOR POWER, AND TELCO AND FOR GROUNDING CABLES AS SHOWN IN THE POWER, TELCO, AND GROUNDING PLAN DRAWINGS.
12. THE CONTRACTOR SHALL PROTECT EXISTING IMPROVEMENTS, PAVEMENTS, CURBS, LANDSCAPING AND STRUCTURES. ANY DAMAGED PART SHALL BE REPAIRED AT CONTRACTOR'S EXPENSE TO THE SATISFACTION OF DISH Wireless L.L.C. AND TOWER OWNER
13. CONTRACTOR SHALL LEGALLY AND PROPERLY DISPOSE OF ALL SCRAP MATERIALS SUCH AS COAXIAL CABLES AND OTHER ITEMS REMOVED FROM THE EXISTING FACILITY. ANTENNAS REMOVED SHALL BE RETURNED TO THE OWNER'S DESIGNATED LOCATION.
14. CONTRACTOR SHALL LEAVE PREMISES IN CLEAN CONDITION. TRASH AND DEBRIS SHOULD BE REMOVED FROM SITE ON A DAILY BASIS.



5701 SOUTH SANTA FE DRIVE  
LITTLETON, CO 80120



COA #: PEC.0000738  
421 FAYETTEVILLE ST, SUITE 600  
RALEIGH, NC 27601



IT IS A VIOLATION OF LAW FOR ANY PERSON, UNLESS THEY ARE ACTING UNDER THE DIRECTION OF A LICENSED PROFESSIONAL ENGINEER, TO ALTER THIS DOCUMENT.

DRAWN BY:	CHECKED BY:	APPROVED BY:
SEW	MCK	MCK

RFDS REV #: ---

**CONSTRUCTION DOCUMENTS**

SUBMITTALS		
REV	DATE	DESCRIPTION
A	09/30/2021	ISSUED FOR REVIEW
0	03/03/2022	ISSUED FOR CONSTRUCTION

A&E PROJECT NUMBER  
KHCLC-16438

DISH Wireless L.L.C.  
PROJECT INFORMATION  
BOHVN00165A  
150 MATTATUCK HEIGHTS  
RD  
WATERBURY, CT 06705

SHEET TITLE  
GENERAL NOTES

SHEET NUMBER  
**GN-2**

**CONCRETE, FOUNDATIONS, AND REINFORCING STEEL:**

1. ALL CONCRETE WORK SHALL BE IN ACCORDANCE WITH THE ACI 301, ACI 318, ACI 336, ASTM A184, ASTM A185 AND THE DESIGN AND CONSTRUCTION SPECIFICATION FOR CAST-IN-PLACE CONCRETE.
2. UNLESS NOTED OTHERWISE, SOIL BEARING PRESSURE USED FOR DESIGN OF SLABS AND FOUNDATIONS IS ASSUMED TO BE 1000 psf.
3. ALL CONCRETE SHALL HAVE A MINIMUM COMPRESSIVE STRENGTH (f'c) OF 3000 psi AT 28 DAYS, UNLESS NOTED OTHERWISE. NO MORE THAN 90 MINUTES SHALL ELAPSE FROM BATCH TIME TO TIME OF PLACEMENT UNLESS APPROVED BY THE ENGINEER OF RECORD. TEMPERATURE OF CONCRETE SHALL NOT EXCEED 90°f AT TIME OF PLACEMENT.
4. CONCRETE EXPOSED TO FREEZE-THAW CYCLES SHALL CONTAIN AIR ENTRAINING ADMIXTURES. AMOUNT OF AIR ENTRAINMENT TO BE BASED ON SIZE OF AGGREGATE AND F3 CLASS EXPOSURE (VERY SEVERE). CEMENT USED TO BE TYPE II PORTLAND CEMENT WITH A MAXIMUM WATER-TO-CEMENT RATIO (W/C) OF 0.45.
5. ALL STEEL REINFORCING SHALL CONFORM TO ASTM A615. ALL WELDED WIRE FABRIC (WWF) SHALL CONFORM TO ASTM A185. ALL SPLICES SHALL BE CLASS "B" TENSION SPLICES, UNLESS NOTED OTHERWISE. ALL HOOKS SHALL BE STANDARD 90 DEGREE HOOKS, UNLESS NOTED OTHERWISE. YIELD STRENGTH (Fy) OF STANDARD DEFORMED BARS ARE AS FOLLOWS:
  - #4 BARS AND SMALLER 40 ksi
  - #5 BARS AND LARGER 60 ksi
6. THE FOLLOWING MINIMUM CONCRETE COVER SHALL BE PROVIDED FOR REINFORCING STEEL UNLESS SHOWN OTHERWISE ON DRAWINGS:
  - CONCRETE CAST AGAINST AND PERMANENTLY EXPOSED TO EARTH 3"
  - CONCRETE EXPOSED TO EARTH OR WEATHER:
    - #6 BARS AND LARGER 2"
    - #5 BARS AND SMALLER 1-1/2"
  - CONCRETE NOT EXPOSED TO EARTH OR WEATHER:
    - SLAB AND WALLS 3/4"
    - BEAMS AND COLUMNS 1-1/2"
7. A TOOLED EDGE OR A 3/4" CHAMFER SHALL BE PROVIDED AT ALL EXPOSED EDGES OF CONCRETE, UNLESS NOTED OTHERWISE, IN ACCORDANCE WITH ACI 301 SECTION 4.2.4.

**ELECTRICAL INSTALLATION NOTES:**

1. ALL ELECTRICAL WORK SHALL BE PERFORMED IN ACCORDANCE WITH THE PROJECT SPECIFICATIONS, NEC AND ALL APPLICABLE FEDERAL, STATE, AND LOCAL CODES/ORDINANCES.
2. CONDUIT ROUTINGS ARE SCHEMATIC. CONTRACTOR SHALL INSTALL CONDUITS SO THAT ACCESS TO EQUIPMENT IS NOT BLOCKED AND TRIP HAZARDS ARE ELIMINATED.
3. WIRING, RACEWAY AND SUPPORT METHODS AND MATERIALS SHALL COMPLY WITH THE REQUIREMENTS OF THE NEC.
4. ALL CIRCUITS SHALL BE SEGREGATED AND MAINTAIN MINIMUM CABLE SEPARATION AS REQUIRED BY THE NEC.
  - 4.1. ALL EQUIPMENT SHALL BEAR THE UNDERWRITERS LABORATORIES LABEL OF APPROVAL, AND SHALL CONFORM TO REQUIREMENT OF THE NATIONAL ELECTRICAL CODE.
  - 4.2. ALL OVERCURRENT DEVICES SHALL HAVE AN INTERRUPTING CURRENT RATING THAT SHALL BE GREATER THAN THE SHORT CIRCUIT CURRENT TO WHICH THEY ARE SUBJECTED, 22,000 AIC MINIMUM. VERIFY AVAILABLE SHORT CIRCUIT CURRENT DOES NOT EXCEED THE RATING OF ELECTRICAL EQUIPMENT IN ACCORDANCE WITH ARTICLE 110.24 NEC OR THE MOST CURRENT ADOPTED CODE PRE THE GOVERNING JURISDICTION.
5. EACH END OF EVERY POWER PHASE CONDUCTOR, GROUNDING CONDUCTOR, AND TELCO CONDUCTOR OR CABLE SHALL BE LABELED WITH COLOR-CODED INSULATION OR ELECTRICAL TAPE (3M BRAND, 1/2" PLASTIC ELECTRICAL TAPE WITH UV PROTECTION, OR EQUAL). THE IDENTIFICATION METHOD SHALL CONFORM WITH NEC AND OSHA.
6. ALL ELECTRICAL COMPONENTS SHALL BE CLEARLY LABELED WITH LAMICOID TAGS SHOWING THEIR RATED VOLTAGE, PHASE CONFIGURATION, WIRE CONFIGURATION, POWER OR AMPACITY RATING AND BRANCH CIRCUIT ID NUMBERS (i.e. PANEL BOARD AND CIRCUIT ID'S).
7. PANEL BOARDS (ID NUMBERS) SHALL BE CLEARLY LABELED WITH PLASTIC LABELS.
8. TIE WRAPS ARE NOT ALLOWED.
9. ALL POWER AND EQUIPMENT GROUND WIRING IN TUBING OR CONDUIT SHALL BE SINGLE COPPER CONDUCTOR (#14 OR LARGER) WITH TYPE THHW, THWN, THWN-2, XHHW, XHHW-2, THW, THW-2, RHW, OR RHW-2 INSULATION UNLESS OTHERWISE SPECIFIED.
10. SUPPLEMENTAL EQUIPMENT GROUND WIRING LOCATED INDOORS SHALL BE SINGLE COPPER CONDUCTOR (#6 OR LARGER) WITH TYPE THHW, THWN, THWN-2, XHHW, XHHW-2, THW, THW-2, RHW, OR RHW-2 INSULATION UNLESS OTHERWISE SPECIFIED.
11. POWER AND CONTROL WIRING IN FLEXIBLE CORD SHALL BE MULTI-CONDUCTOR, TYPE SOOW CORD (#14 OR LARGER) UNLESS OTHERWISE SPECIFIED.
12. POWER AND CONTROL WIRING FOR USE IN CABLE TRAY SHALL BE MULTI-CONDUCTOR, TYPE TC CABLE (#14 OR LARGER), WITH TYPE THHW, THWN, THWN-2, XHHW, XHHW-2, THW, THW-2, RHW, OR RHW-2 INSULATION UNLESS OTHERWISE SPECIFIED.
13. ALL POWER AND GROUNDING CONNECTIONS SHALL BE CRIMP-STYLE, COMPRESSION WIRE LUGS AND WIRE NUTS BY THOMAS AND BETTS (OR EQUAL). LUGS AND WIRE NUTS SHALL BE RATED FOR OPERATION NOT LESS THAN 75° C (90° C IF AVAILABLE).
14. RACEWAY AND CABLE TRAY SHALL BE LISTED OR LABELED FOR ELECTRICAL USE IN ACCORDANCE WITH NEMA, UL, ANSI/IEEE AND NEC.
15. ELECTRICAL METALLIC TUBING (EMT), INTERMEDIATE METAL CONDUIT (IMC), OR RIGID METAL CONDUIT (RMC) SHALL BE USED FOR EXPOSED INDOOR LOCATIONS.

16. ELECTRICAL METALLIC TUBING (EMT) OR METAL-CLAD CABLE (MC) SHALL BE USED FOR CONCEALED INDOOR LOCATIONS.
17. SCHEDULE 40 PVC UNDERGROUND ON STRAIGHTS AND SCHEDULE 80 PVC FOR ALL ELBOWS/90s AND ALL APPROVED ABOVE GRADE PVC CONDUIT.
18. LIQUID-TIGHT FLEXIBLE METALLIC CONDUIT (LIQUID-TITE FLEX) SHALL BE USED INDOORS AND OUTDOORS, WHERE VIBRATION OCCURS OR FLEXIBILITY IS NEEDED.
19. CONDUIT AND TUBING FITTINGS SHALL BE THREADED OR COMPRESSION-TYPE AND APPROVED FOR THE LOCATION USED. SET SCREW FITTINGS ARE NOT ACCEPTABLE.
20. CABINETS, BOXES AND WIRE WAYS SHALL BE LABELED FOR ELECTRICAL USE IN ACCORDANCE WITH NEMA, UL, ANSI/IEEE AND THE NEC.
21. WIREWAYS SHALL BE METAL WITH AN ENAMEL FINISH AND INCLUDE A HINGED COVER, DESIGNED TO SWING OPEN DOWNWARDS (WIREMOLD SPECMATE WIREWAY).
22. SLOTTED WIRING DUCT SHALL BE PVC AND INCLUDE COVER (PANDUIT TYPE E OR EQUAL).
23. CONDUITS SHALL BE FASTENED SECURELY IN PLACE WITH APPROVED NON-PERFORATED STRAPS AND HANGERS. EXPLOSIVE DEVICES (i.e. POWDER-ACTUATED) FOR ATTACHING HANGERS TO STRUCTURE WILL NOT BE PERMITTED. CLOSELY FOLLOW THE LINES OF THE STRUCTURE, MAINTAIN CLOSE PROXIMITY TO THE STRUCTURE AND KEEP CONDUITS IN TIGHT ENVELOPES. CHANGES IN DIRECTION TO ROUTE AROUND OBSTACLES SHALL BE MADE WITH CONDUIT OUTLET BODIES. CONDUIT SHALL BE INSTALLED IN A NEAT AND WORKMANLIKE MANNER. PARALLEL AND PERPENDICULAR TO STRUCTURE WALL AND CEILING LINES. ALL CONDUIT SHALL BE FISHED TO CLEAR OBSTRUCTIONS. ENDS OF CONDUITS SHALL BE TEMPORARILY CAPPED FLUSH TO FINISH GRADE TO PREVENT CONCRETE, PLASTER OR DIRT FROM ENTERING. CONDUITS SHALL BE RIGIDLY CLAMPED TO BOXES BY GALVANIZED MALLEABLE IRON BUSHING ON INSIDE AND GALVANIZED MALLEABLE IRON LOCKNUT ON OUTSIDE AND INSIDE.
24. EQUIPMENT CABINETS, TERMINAL BOXES, JUNCTION BOXES AND PULL BOXES SHALL BE GALVANIZED OR EPOXY-COATED SHEET STEEL. SHALL MEET OR EXCEED UL 50 AND BE RATED NEMA 1 (OR BETTER) FOR INTERIOR LOCATIONS AND NEMA 3 (OR BETTER) FOR EXTERIOR LOCATIONS.
25. METAL RECEPTACLE, SWITCH AND DEVICE BOXES SHALL BE GALVANIZED, EPOXY-COATED OR NON-CORRODING; SHALL MEET OR EXCEED UL 514A AND NEMA OS 1 AND BE RATED NEMA 1 (OR BETTER) FOR INTERIOR LOCATIONS AND WEATHER PROTECTED (WP OR BETTER) FOR EXTERIOR LOCATIONS.
26. NONMETALLIC RECEPTACLE, SWITCH AND DEVICE BOXES SHALL MEET OR EXCEED NEMA OS 2 (NEWEST REVISION) AND BE RATED NEMA 1 (OR BETTER) FOR INTERIOR LOCATIONS AND WEATHER PROTECTED (WP OR BETTER) FOR EXTERIOR LOCATIONS.
27. THE CONTRACTOR SHALL NOTIFY AND OBTAIN NECESSARY AUTHORIZATION FROM THE CARRIER AND/OR DISH Wireless L.L.C. AND TOWER OWNER BEFORE COMMENCING WORK ON THE AC POWER DISTRIBUTION PANELS.
28. THE CONTRACTOR SHALL PROVIDE NECESSARY TAGGING ON THE BREAKERS, CABLES AND DISTRIBUTION PANELS IN ACCORDANCE WITH THE APPLICABLE CODES AND STANDARDS TO SAFEGUARD LIFE AND PROPERTY.
29. INSTALL LAMICOID LABEL ON THE METER CENTER TO SHOW "DISH Wireless L.L.C.".
30. ALL EMPTY/SPARE CONDUITS THAT ARE INSTALLED ARE TO HAVE A METERED MULE TAPE PULL CORD INSTALLED.



5701 SOUTH SANTA FE DRIVE  
LITTLETON, CO 80120



COA #: PEC.0000738  
421 FAYETTEVILLE ST, SUITE 600  
RALEIGH, NC 27601

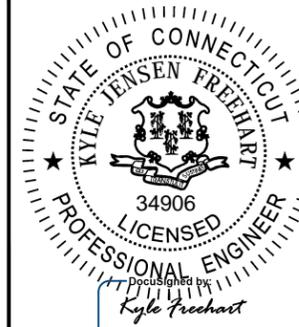

IT IS A VIOLATION OF LAW FOR ANY PERSON, UNLESS THEY ARE ACTING UNDER THE DIRECTION OF A LICENSED PROFESSIONAL ENGINEER, TO ALTER THIS DOCUMENT.

DRAWN BY: CHECKED BY: APPROVED BY:

SEW MCK MCK

RFDS REV #: ---

**CONSTRUCTION DOCUMENTS**

SUBMITTALS		
REV	DATE	DESCRIPTION
A	09/30/2021	ISSUED FOR REVIEW
0	03/03/2022	ISSUED FOR CONSTRUCTION

A&E PROJECT NUMBER  
KHCLC-16438

DISH Wireless L.L.C.  
PROJECT INFORMATION  
BOHVN00165A  
150 MATTATUCK HEIGHTS  
RD  
WATERBURY, CT 06705

SHEET TITLE  
GENERAL NOTES

SHEET NUMBER  
**GN-3**

**GROUNDING NOTES:**

1. ALL GROUND ELECTRODE SYSTEMS (INCLUDING TELECOMMUNICATION, RADIO, LIGHTNING PROTECTION AND AC POWER GES'S) SHALL BE BONDED TOGETHER AT OR BELOW GRADE, BY TWO OR MORE COPPER BONDING CONDUCTORS IN ACCORDANCE WITH THE NEC.
2. THE CONTRACTOR SHALL PERFORM IEEE FALL-OF-POTENTIAL RESISTANCE TO EARTH TESTING (PER IEEE 1100 AND 81) FOR GROUND ELECTRODE SYSTEMS, THE CONTRACTOR SHALL FURNISH AND INSTALL SUPPLEMENTAL GROUND ELECTRODES AS NEEDED TO ACHIEVE A TEST RESULT OF 5 OHMS OR LESS.
3. THE CONTRACTOR IS RESPONSIBLE FOR PROPERLY SEQUENCING GROUNDING AND UNDERGROUND CONDUIT INSTALLATION AS TO PREVENT ANY LOSS OF CONTINUITY IN THE GROUNDING SYSTEM OR DAMAGE TO THE CONDUIT AND PROVIDE TESTING RESULTS.
4. METAL CONDUIT AND TRAY SHALL BE GROUNDED AND MADE ELECTRICALLY CONTINUOUS WITH LISTED BONDING FITTINGS OR BY BONDING ACROSS THE DISCONTINUITY WITH #6 COPPER WIRE UL APPROVED GROUNDING TYPE CONDUIT CLAMPS.
5. METAL RACEWAY SHALL NOT BE USED AS THE NEC REQUIRED EQUIPMENT GROUND CONDUCTOR. STRANDED COPPER CONDUCTORS WITH GREEN INSULATION, SIZED IN ACCORDANCE WITH THE NEC, SHALL BE FURNISHED AND INSTALLED WITH THE POWER CIRCUITS TO BTS EQUIPMENT.
6. EACH CABINET FRAME SHALL BE DIRECTLY CONNECTED TO THE MASTER GROUND BAR WITH GREEN INSULATED SUPPLEMENTAL EQUIPMENT GROUND WIRES, #6 STRANDED COPPER OR LARGER FOR INDOOR BTS; #2 BARE SOLID TINNED COPPER FOR OUTDOOR BTS.
7. CONNECTIONS TO THE GROUND BUS SHALL NOT BE DOUBLED UP OR STACKED BACK TO BACK CONNECTIONS ON OPPOSITE SIDE OF THE GROUND BUS ARE PERMITTED.
8. ALL EXTERIOR GROUND CONDUCTORS BETWEEN EQUIPMENT/GROUND BARS AND THE GROUND RING SHALL BE #2 SOLID TINNED COPPER UNLESS OTHERWISE INDICATED.
9. ALUMINUM CONDUCTOR OR COPPER CLAD STEEL CONDUCTOR SHALL NOT BE USED FOR GROUNDING CONNECTIONS.
10. USE OF 90° BENDS IN THE PROTECTION GROUNDING CONDUCTORS SHALL BE AVOIDED WHEN 45° BENDS CAN BE ADEQUATELY SUPPORTED.
11. EXOTHERMIC WELDS SHALL BE USED FOR ALL GROUNDING CONNECTIONS BELOW GRADE.
12. ALL GROUND CONNECTIONS ABOVE GRADE (INTERIOR AND EXTERIOR) SHALL BE FORMED USING HIGH PRESS CRIMPS.
13. COMPRESSION GROUND CONNECTIONS MAY BE REPLACED BY EXOTHERMIC WELD CONNECTIONS.
14. ICE BRIDGE BONDING CONDUCTORS SHALL BE EXOTHERMICALLY BONDED OR BOLTED TO THE BRIDGE AND THE TOWER GROUND BAR.
15. APPROVED ANTIOXIDANT COATINGS (i.e. CONDUCTIVE GEL OR PASTE) SHALL BE USED ON ALL COMPRESSION AND BOLTED GROUND CONNECTIONS.
16. ALL EXTERIOR GROUND CONNECTIONS SHALL BE COATED WITH A CORROSION RESISTANT MATERIAL.
17. MISCELLANEOUS ELECTRICAL AND NON-ELECTRICAL METAL BOXES, FRAMES AND SUPPORTS SHALL BE BONDED TO THE GROUND RING, IN ACCORDANCE WITH THE NEC.
18. BOND ALL METALLIC OBJECTS WITHIN 6 ft OF MAIN GROUND RING WITH (1) #2 BARE SOLID TINNED COPPER GROUND CONDUCTOR.
19. GROUND CONDUCTORS USED FOR THE FACILITY GROUNDING AND LIGHTNING PROTECTION SYSTEMS SHALL NOT BE ROUTED THROUGH METALLIC OBJECTS THAT FORM A RING AROUND THE CONDUCTOR, SUCH AS METALLIC CONDUITS, METAL SUPPORT CLIPS OR SLEEVES THROUGH WALLS OR FLOORS. WHEN IT IS REQUIRED TO BE HOUSED IN CONDUIT TO MEET CODE REQUIREMENTS OR LOCAL CONDITIONS, NON-METALLIC MATERIAL SUCH AS PVC CONDUIT SHALL BE USED. WHERE USE OF METAL CONDUIT IS UNAVOIDABLE (i.e., NONMETALLIC CONDUIT PROHIBITED BY LOCAL CODE) THE GROUND CONDUCTOR SHALL BE BONDED TO EACH END OF THE METAL CONDUIT.
20. ALL GROUNDS THAT TRANSITION FROM BELOW GRADE TO ABOVE GRADE MUST BE #2 BARE SOLID TINNED COPPER IN 3/4" NON-METALLIC, FLEXIBLE CONDUIT FROM 24" BELOW GRADE TO WITHIN 3" TO 6" OF CAD-WELD TERMINATION POINT. THE EXPOSED END OF THE CONDUIT MUST BE SEALED WITH SILICONE CAULK. (ADD TRANSITIONING GROUND STANDARD DETAIL AS WELL).
21. BUILDINGS WHERE THE MAIN GROUNDING CONDUCTORS ARE REQUIRED TO BE ROUTED TO GRADE, THE CONTRACTOR SHALL ROUTE TWO GROUNDING CONDUCTORS FROM THE ROOFTOP, TOWERS, AND WATER TOWERS GROUNDING RING, TO THE EXISTING GROUNDING SYSTEM, THE GROUNDING CONDUCTORS SHALL NOT BE SMALLER THAN 2/0 COPPER. ROOFTOP GROUNDING RING SHALL BE BONDED TO THE EXISTING GROUNDING SYSTEM, THE BUILDING STEEL COLUMNS, LIGHTNING PROTECTION SYSTEM, AND BUILDING MAIN WATER LINE (FERROUS OR NONFERROUS METAL PIPING ONLY). DO NOT ATTACH GROUNDING TO FIRE SPRINKLER SYSTEM PIPES.



5701 SOUTH SANTA FE DRIVE  
LITTLETON, CO 80120



COA #: PEC.0000738  
421 FAYETTEVILLE ST, SUITE 600  
RALEIGH, NC 27601

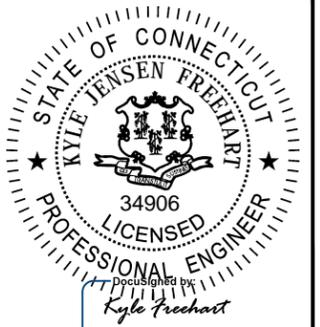

IT IS A VIOLATION OF LAW FOR ANY PERSON, UNLESS THEY ARE ACTING UNDER THE DIRECTION OF A LICENSED PROFESSIONAL ENGINEER, TO ALTER THIS DOCUMENT.

DRAWN BY:	CHECKED BY:	APPROVED BY:
SEW	MCK	MCK

RFDS REV #: ---

**CONSTRUCTION DOCUMENTS**

SUBMITTALS		
REV	DATE	DESCRIPTION
A	09/30/2021	ISSUED FOR REVIEW
0	03/03/2022	ISSUED FOR CONSTRUCTION

A&E PROJECT NUMBER  
KHCL-16438

DISH Wireless L.L.C.  
PROJECT INFORMATION  
BOHVN00165A  
150 MATTATUCK HEIGHTS  
RD  
WATERBURY, CT 06705

SHEET TITLE  
GENERAL NOTES

SHEET NUMBER  
**GN-4**

## Certificate Of Completion

Envelope Id: 8AE97EBEB2764FA3872F93D8B9C0CBAE	Status: Completed
Subject: Please DocuSign: BOHVN00165A_FCD_REV 0_03.03.2022_sealed.pdf	
Source Envelope:	
Document Pages: 18	Signatures: 18
Certificate Pages: 1	Initials: 0
AutoNav: Enabled	Envelope Originator:
Envelope Stamping: Enabled	Manuel JaraPerez
Time Zone: (UTC-05:00) Eastern Time (US & Canada)	401 Fayetteville St.
	Suite 600
	Raleigh, NC 27601
	Manuel.JaraPerez@kimley-horn.com
	IP Address: 208.127.231.172

## Record Tracking

Status: Original	Holder: Manuel JaraPerez	Location: DocuSign
3/7/2022 10:06:28 AM	Manuel.JaraPerez@kimley-horn.com	

## Signer Events

Kyle Freehart  
 kyle.freehart@kimley-horn.com  
 Kimley-Horn  
 Security Level: Email, Account Authentication (None)

## Signature

DocuSigned by:  
  
 D8BEE252A3804C1...  
 Signature Adoption: Pre-selected Style  
 Using IP Address: 208.127.231.172

## Timestamp

Sent: 3/7/2022 10:11:50 AM  
 Viewed: 3/7/2022 11:15:25 AM  
 Signed: 3/7/2022 11:16:16 AM

**Electronic Record and Signature Disclosure:**  
 Not Offered via DocuSign

In Person Signer Events	Signature	Timestamp
Editor Delivery Events	Status	Timestamp
Agent Delivery Events	Status	Timestamp
Intermediary Delivery Events	Status	Timestamp
Certified Delivery Events	Status	Timestamp
Carbon Copy Events	Status	Timestamp
Witness Events	Signature	Timestamp
Notary Events	Signature	Timestamp
Envelope Summary Events	Status	Timestamps
Envelope Sent	Hashed/Encrypted	3/7/2022 10:11:50 AM
Certified Delivered	Security Checked	3/7/2022 11:15:25 AM
Signing Complete	Security Checked	3/7/2022 11:16:16 AM
Completed	Security Checked	3/7/2022 11:16:16 AM
Payment Events	Status	Timestamps

# Exhibit D

## **Structural Analysis Report**

Date: **May 20, 2022**



B+T Group  
1717 S. Boulder, Suite  
300 Tulsa, OK 74119  
(918) 587-4630

**Subject:** **Structural Analysis Report**

**Carrier Designation:** **DISH Network Co-Locate**  
**Site Number:** BOHVN00165A  
**Site Name:** CT-CCI-T-876317

**Crown Castle Designation:** **BU Number:** 876317  
**Site Name:** Waterbury  
**JDE Job Number:** 645174  
**Work Order Number:** 2117144  
**Order Number:** 553382 Rev. 1

**Engineering Firm Designation:** **Project Number:** 79982.013.01

**Site Data:** **150 Mattatuck Heights, Waterbury, New Haven County, CT**  
**Latitude 41° 32' 16.3", Longitude -72° 59' 6.1"**  
**144.25 Foot - Monopole Tower**

We are pleased to submit this “**Structural Analysis Report**” to determine the structural integrity of the above-mentioned tower.

The purpose of the analysis is to determine acceptability of the tower stress level. Based on our analysis we have determined the tower stress level for the structure and foundation, under the following load case, to be:

LC7: Proposed Equipment Configuration

**Sufficient Capacity – 98.1%**

This analysis utilizes an ultimate 3-second gust wind speed of 118 mph as required by the 2018 Connecticut State Building Code. Applicable Standard references and design criteria are listed in Section 2 - Analysis Criteria.

Structural analysis prepared by: Rose Denny

Respectfully submitted by: B+T Group, Inc  
COA: BER: 2386985; Expires: 02/01/2023

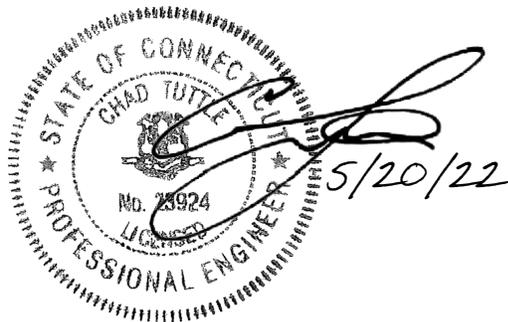

Chad E. Tuttle, P.E.

tnxTower Report - version 8.1.1.0

## TABLE OF CONTENTS

### 1) INTRODUCTION

### 2) ANALYSIS CRITERIA

Table 1 - Proposed Equipment Configuration

Table 2 - Other Considered Equipment

### 3) ANALYSIS PROCEDURE

Table 3 - Documents Provided

3.1) Analysis Method

3.2) Assumptions

### 4) ANALYSIS RESULTS

Table 4 - Section Capacity (Summary)

Table 5 – Tower Component Stresses vs. Capacity – LC7

4.1) Recommendations

### 5) APPENDIX A

tnxTower Output

### 6) APPENDIX B

Base Level Drawing

### 7) APPENDIX C

Additional Calculations

## 1) INTRODUCTION

This tower is a 134.25 ft. Monopole tower designed by Valmont. A 10-ft tower extension has been considered in this analysis, bringing the total tower height to 144.25 ft.

The tower has been modified multiple times to accommodate additional loading.

## 2) ANALYSIS CRITERIA

<b>TIA-222 Revision:</b>	TIA-222-H
<b>Risk Category:</b>	II
<b>Wind Speed:</b>	118 mph
<b>Exposure Category:</b>	B
<b>Topographic Factor:</b>	1
<b>Ice Thickness:</b>	1 in
<b>Wind Speed with Ice:</b>	50 mph
<b>Service Wind Speed:</b>	60 mph

**Table 1 - Proposed Equipment Configuration**

Mounting Level (ft)	Center Line Elevation (ft)	Number of Antennas	Antenna Manufacturer	Antenna Model	Number of Feed Lines	Feed Line Size (in)
120.0	120.0	3	Fujitsu	TA08025-B604	1	1-1/2
		3	Fujitsu	TA08025-B605		
		3	JMA Wireless	MX08FRO665-21		
		1	Raycap	RDIDC-9181-PF-48		
		1	--	Commscope MC-PK8-DSH		

**Table 2 - Other Considered Equipment**

Mounting Level (ft)	Center Line Elevation (ft)	Number of Antennas	Antenna Manufacturer	Antenna Model	Number of Feed Lines	Feed Line Size (in)
144.0	145.0	3	Ericsson	AIR 6419 B77G_CCIV3	6 3 1	13/16 3/8 7/8
		3	--	2" Std. x 10' long mount pipe		
	144.0	1	Site Pro 1	F3P-12W		
		1	--	Miscellaneous [NA 507-1]		
	143.0	3	Ericsson	2012 B29		
		3	Ericsson	RADIO 4415 B30		
		3	Ericsson	RRUS 4449 B5/B12		
		3	Ericsson	RRUS 4478 B14		
		3	Ericsson	RRUS 8843 B2/B66A		
		3	Kmw Comm.	EPBQ-654L8H8-L2		
		3	Quintel Tech.	QD8616-7		
		2	Raycap	DC6-48-60-18-8F		
		1	Raycap	DC9-48-60-24-8C-EV		
	141.0	3	Ericsson	AIR 6449 B77D_CCVI2		
	130.0	133.0	1	Andrew		
2			Andrew	VHLP2-23		
130.0		6	Alcatel Lucent	1900MHZ RRH (65MHZ)		

Mounting Level (ft)	Center Line Elevation (ft)	Number of Antennas	Antenna Manufacturer	Antenna Model	Number of Feed Lines	Feed Line Size (in)
		3	Alcatel Lucent	800 EXTERNAL NOTCH FILTER		
		3	Alcatel Lucent	800MHZ RRH		
		3	Nokia	AAHC		
		4	RFS Celwave	APXVSP18-C-A20		
		4	RFS Celwave	IBC1900HB-2		
		2	RFS Celwave	PD2DE-700/2700		
		1	--	Pipe Mount [PM 601-3]		
		1	--	Platform Mount [LP 602-1]		
110.0	113.0	1	Trimble	BULLET III	6 2 1	1-5/8 1-1/4 1/2
	110.0	3	Commscope	BSAMNT-SBS-1-2		
		6	Andrew	SBNHH-1D65B		
		3	Antel	BXA-80063/4CF		
		1	Raycap	RVZDC-6627-PF-48		
		3	Samsung Telecom.	MT6407-77A		
		3	Samsung Telecom.	RFV01U-D1A		
		3	Samsung Telecom.	RFV01U-D2A		
1	--	Platform Mount [LP 713-1]				
100.0	101.0	3	Ericsson	AIR -32 B2A/B66AA	2 1	1-1/2 1-5/8
		3	Ericsson	AIR 6419 B41_TMO		
		3	Ericsson	RADIO 4449 B71 B85A_T-MOBILE		
		3	Ericsson	RADIO 4460 B2/B25 B66_TMO		
		3	RFS Celwave	APXVAARR24_43-U-NA20		
	100.0	1	Site Pro1	HRK12 Support Rail Kit		
		1	--	Platform Mount [LP 303-1]		
50.0	51.0	1	Lucent	KS24019-L112A	1	1/2
	50.0	1	--	Side Arm Mount [SO 701-1]		

### 3) ANALYSIS PROCEDURE

**Table 3 - Documents Provided**

Document	Reference	Source
Tower Manufacturer Drawing	1530953	CCI Sites
Tower Modification Drawing	2381113	CCI Sites
Post Modification Inspection	2381112	CCI Sites
Tower Modification Drawing	3315244	CCI Sites
Post Modification Inspection	3770745	CCI Sites
Tower Modification Drawing	8142142	CCI Sites
Post Modification Inspection	8624542	CCI Sites
Foundation Drawing	1630930	CCI Sites
Geotech Report	1529737	CCI Sites

Document	Reference	Source
Crown CAD Package	Date: 04/27/2022	CCI Sites

### 3.1) Analysis Method

tnxTower (version 8.1.1.0), a commercially available analysis software package, was used to create a three-dimensional model of the tower and calculate member stresses for various loading cases. Selected output from the analysis is included in Appendix A. When applicable, Crown Castle has calculated and provided the effective area for panel antennas using approved methods following the intent of the TIA-222 standard.

tnxTower was used to determine the loads on the modified structure. Additional calculations were performed to determine the stresses in the pole and in the reinforcing elements. These calculations are included in Appendix C.

### 3.2) Assumptions

- 1) The tower and structures were maintained in accordance with the - TIA-222 standard.
- 2) The configuration of antennas, transmission cables, mounts and other appurtenances are as specified in Tables 1 and 2 and the referenced drawings.

This analysis may be affected if any assumptions are not valid or have been made in error. We should be notified to determine the effect on the structural integrity of the tower.

## 4) ANALYSIS RESULTS

**Table 4 - Section Capacity (Summary)**

Section No.	Elevation (ft)	Component Type	Size	Critical Element	P (K)	SF*P_allow (K)	% Capacity	Pass / Fail
L1	144.25 - 139.25	Pole	TP12.75x12.75x0.375	1	-4.510	--	13.9	Pass
L2	139.25 - 134.75	Pole	TP12.75x12.75x0.375	2	-4.793	--	28.5	Pass
L3	134.75 - 134.25	Pole	TP13.48x13.48x0.375	3	-4.828	--	26.9	Pass
L4	134.25 - 129.25	Pole	TP14.466x13.48x0.1875	4	-8.608	--	54.2	Pass
L5	129.25 - 124.25	Pole	TP15.452x14.466x0.1875	5	-8.883	--	73.2	Pass
L6	124.25 - 123.42	Pole	TP15.616x15.452x0.1875	6	-8.944	--	75.9	Pass
L7	123.42 - 123.17	Pole + Reinf.	TP15.665x15.616x0.5375	7	-8.982	--	49.5	Pass
L8	123.17 - 118.17	Pole + Reinf.	TP16.651x15.665x0.5125	8	-12.422	--	62.6	Pass
L9	118.17 - 113.17	Pole + Reinf.	TP17.637x16.651x0.4875	9	-13.025	--	75.8	Pass
L10	113.17 - 109.5	Pole + Reinf.	TP18.36x17.637x0.475	10	-16.653	--	85.2	Pass
L11	109.5 - 109.25	Pole + Reinf.	TP18.409x18.36x0.5875	11	-16.708	--	71.8	Pass
L12	109.25 - 104.75	Pole + Reinf.	TP19.296x18.409x0.5625	12	-17.438	--	83.5	Pass
L13	104.75 - 104.5	Pole + Reinf.	TP19.346x19.296x0.775	13	-17.503	--	67.4	Pass
L14	104.5 - 102.42	Pole + Reinf.	TP19.756x19.346x0.7625	14	-17.935	--	71.5	Pass

Section No.	Elevation (ft)	Component Type	Size	Critical Element	P (K)	SF*P_allow (K)	% Capacity	Pass / Fail
L15	102.42 - 102.17	Pole + Reinf.	TP19.806x19.756x0.5625	15	-17.994	--	89.3	Pass
L16	102.17 - 98.75	Pole + Reinf.	TP20.479x19.806x0.55	16	-22.016	--	98.1	Pass
L17	98.75 - 98.5	Pole + Reinf.	TP20.528x20.479x0.8375	17	-22.098	--	85.8	Pass
L18	98.5 - 97.5	Pole + Reinf.	TP20.726x20.528x0.8375	18	-22.351	--	74.6	Pass
L19	97.5 - 97.25	Pole + Reinf.	TP20.775x20.726x0.75	19	-22.422	--	86.9	Pass
L20	97.25 - 95.55	Pole + Reinf.	TP21.81x20.775x0.7375	20	-22.837	--	90.7	Pass
L21	95.55 - 90.55	Pole + Reinf.	TP21.73x20.735x0.8	21	-24.893	--	94.2	Pass
L22	90.55 - 89.25	Pole + Reinf.	TP21.989x21.73x0.775	22	-25.253	--	96.5	Pass
L23	89.25 - 89	Pole + Reinf.	TP22.039x21.989x1	23	-25.346	--	83.4	Pass
L24	89 - 88.25	Pole + Reinf.	TP22.189x22.039x0.975	24	-25.575	--	69.7	Pass
L25	88.25 - 88	Pole + Reinf.	TP22.238x22.189x0.7625	25	-25.647	--	79.8	Pass
L26	88 - 87.83	Pole + Reinf.	TP22.272x22.238x0.7625	26	-25.694	--	80.0	Pass
L27	87.83 - 87.58	Pole + Reinf.	TP22.321x22.272x0.675	27	-25.754	--	84.8	Pass
L28	87.58 - 82.58	Pole + Reinf.	TP23.317x22.321x0.65	28	-26.997	--	91.4	Pass
L29	82.58 - 77.58	Pole + Reinf.	TP24.312x23.317x0.625	29	-28.278	--	97.3	Pass
L30	77.58 - 77	Pole + Reinf.	TP24.428x24.312x0.625	30	-28.437	--	98.0	Pass
L31	77 - 76.75	Pole + Reinf.	TP24.478x24.428x0.825	31	-28.520	--	91.9	Pass
L32	76.75 - 76.33	Pole + Reinf.	TP24.561x24.478x0.825	32	-28.644	--	92.3	Pass
L33	76.33 - 76.08	Pole + Reinf.	TP24.611x24.561x0.825	33	-28.718	--	93.5	Pass
L34	76.08 - 74.25	Pole + Reinf.	TP24.976x24.611x0.8	34	-29.230	--	95.4	Pass
L35	74.25 - 74	Pole + Reinf.	TP25.026x24.976x0.8875	35	-29.327	--	84.2	Pass
L36	74 - 73.75	Pole + Reinf.	TP25.076x25.026x0.8875	36	-29.403	--	84.4	Pass
L37	73.75 - 73.5	Pole + Reinf.	TP25.125x25.076x0.9125	37	-29.482	--	83.7	Pass
L38	73.5 - 68.5	Pole + Reinf.	TP26.121x25.125x0.875	38	-31.044	--	88.1	Pass
L39	68.5 - 63.5	Pole + Reinf.	TP27.116x26.121x0.85	39	-32.637	--	92.1	Pass
L40	63.5 - 60.5	Pole + Reinf.	TP27.714x27.116x0.825	40	-33.607	--	94.4	Pass
L41	60.5 - 60.25	Pole + Reinf.	TP27.763x27.714x0.825	41	-33.698	--	94.5	Pass
L42	60.25 - 59.5	Pole + Reinf.	TP27.913x27.763x0.825	42	-33.935	--	95.1	Pass
L43	59.5 - 59.25	Pole + Reinf.	TP27.962x27.913x0.8875	43	-34.027	--	89.0	Pass
L44	59.25 - 54.25	Pole + Reinf.	TP28.958x27.962x0.85	44	-35.723	--	92.3	Pass
L45	54.25 - 50	Pole + Reinf.	TP30.64x28.958x0.8375	45	-37.194	--	94.9	Pass
L46	50 - 44.8	Pole + Reinf.	TP30.333x29.304x0.8375	46	-40.327	--	96.6	Pass
L47	44.8 - 43.58	Pole + Reinf.	TP30.574x30.333x0.8375	47	-40.762	--	97.2	Pass
L48	43.58 - 43.33	Pole + Reinf.	TP30.624x30.574x0.85	48	-40.869	--	96.3	Pass
L49	43.33 - 43.17	Pole + Reinf.	TP30.657x30.624x0.85	49	-40.934	--	96.3	Pass
L50	43.17 - 42.92	Pole + Reinf.	TP30.706x30.657x0.9375	50	-41.032	--	91.2	Pass
L51	42.92 - 39	Pole + Reinf.	TP31.481x30.706x0.9125	51	-42.568	--	93.0	Pass
L52	39 - 38.75	Pole + Reinf.	TP31.531x31.481x0.95	52	-42.586	--	87.8	Pass
L53	38.75 - 37.17	Pole + Reinf.	TP31.844x31.531x0.9375	53	-42.704	--	88.5	Pass
L54	37.17 - 36.92	Pole + Reinf.	TP31.894x31.844x0.8875	54	-43.346	--	92.0	Pass
L55	36.92 - 34	Pole + Reinf.	TP32.471x31.894x0.8875	55	-43.462	--	93.2	Pass
L56	34 - 33.75	Pole + Reinf.	TP32.52x32.471x0.875	56	-44.629	--	93.2	Pass
L57	33.75 - 29.75	Pole + Reinf.	TP33.312x32.52x0.8625	57	-44.736	--	94.7	Pass

Section No.	Elevation (ft)	Component Type	Size	Critical Element	P (K)	SF*P_allow (K)	% Capacity	Pass / Fail
L58	29.75 - 29.5	Pole + Reinf.	TP33.361x33.312x0.8625	58	-46.295	--	93.6	Pass
L59	29.5 - 24.5	Pole + Reinf.	TP34.351x33.361x0.85	59	-46.404	--	95.3	Pass
L60	24.5 - 23	Pole + Reinf.	TP34.648x34.351x0.8375	60	-48.406	--	95.8	Pass
L61	23 - 22.75	Pole + Reinf.	TP34.697x34.648x0.9625	61	-48.997	--	88.8	Pass
L62	22.75 - 21.58	Pole + Reinf.	TP34.928x34.697x0.9625	62	-49.116	--	89.2	Pass
L63	21.58 - 21.33	Pole + Reinf.	TP34.978x34.928x0.85	63	-49.620	--	94.1	Pass
L64	21.33 - 16.33	Pole + Reinf.	TP35.967x34.978x0.8375	64	-49.735	--	95.5	Pass
L65	16.33 - 12.92	Pole + Reinf.	TP36.644x35.967x0.825	65	-51.856	--	96.4	Pass
L66	12.92 - 12.67	Pole + Reinf.	TP36.693x36.644x0.9125	66	-53.310	--	87.4	Pass
L67	12.67 - 12.5	Pole + Reinf.	TP36.726x36.693x0.9125	67	-53.426	--	87.5	Pass
L68	12.5 - 12.25	Pole + Reinf.	TP36.776x36.726x0.7625	68	-53.505	--	90.7	Pass
L69	12.25 - 12	Pole + Reinf.	TP36.825x36.776x0.7625	69	-53.610	--	90.8	Pass
L70	12 - 11.75	Pole + Reinf.	TP36.874x36.825x0.6625	70	-53.715	--	92.8	Pass
L71	11.75 - 8.5	Pole + Reinf.	TP37.518x36.874x0.65	71	-53.827	--	93.5	Pass
L72	8.5 - 8.25	Pole + Reinf.	TP37.567x37.518x0.925	72	-55.112	--	76.6	Pass
L73	8.25 - 7	Pole + Reinf.	TP37.815x37.567x0.9125	73	-55.242	--	76.9	Pass
L74	7 - 6.75	Pole + Reinf.	TP37.864x37.815x0.8125	74	-55.832	--	89.0	Pass
L75	6.75 - 1.75	Pole + Reinf.	TP38.854x37.864x0.7875	75	-55.950	--	90.1	Pass
L76	1.75 - 0	Pole + Reinf.	TP39.2x38.854x0.7875	76	-58.133	--	90.5	Pass
							Summary	
						Pole (L6)	83.0	Pass
						Reinforcement	98.1	Pass
						Rating =	98.1	Pass

**Table 5 - Tower Component Stresses vs. Capacity – LC7**

Notes	Component	Elevation (ft)	% Capacity	Pass / Fail
1,2	Flange Connection	134.25	34.2	Pass
1,2	Anchor Rods	Base	90.0	Pass
1,2	Base Plate	Base	62.5	Pass
1,2	Base Foundation (Structure)	Base	20.9	Pass
1,2	Base Foundation (Soil Interaction)	Base	87.7	Pass

<b>Structure Rating (max from all components) =</b>	<b>98.1%</b>
---	--------------

Notes:

- 1) See additional documentation in "Appendix C – Additional Calculations" for calculations supporting the % capacity consumed.
- 2) Rating per TIA-222-H Section 15.5.

**4.1) Recommendations**

The tower and its foundation have sufficient capacity to carry the proposed load configuration. No modifications are required at this time.

**APPENDIX A**

**TNXTOWER OUTPUT**

Section	Length (ft)	Number of Sides	Thickness (in)	Socket Length (ft)	Top Dia (in)	Bot Dia (in)	Grade	Weight (K)
1								
2								
3								
4								
5								
6								
7								
8								
9								
10								
11								
12								
13								
14								
15								
16								
17								
18								
19								
20								
21								
22								
23								
24								
25								
26								
27								
28								
29								
30								
31								
32								
33								
34								
35								
36								
37								
38								
39								
40								
41								
42								
43								
44								
45								
46								
47								
48								
49								
50								
51								
52								
53								
54								
55								
56								
57								
58								
59								
60								
61								
62								
63								
64								
65								
66								
67								
68								
69								
70								
71								
72								
73								
74								
75								
76								
77								
78								
79								
80								
81								
82								
83								
84								
85								
86								
87								
88								
89								
90								
91								
92								
93								
94								
95								
96								
97								
98								
99								
100								

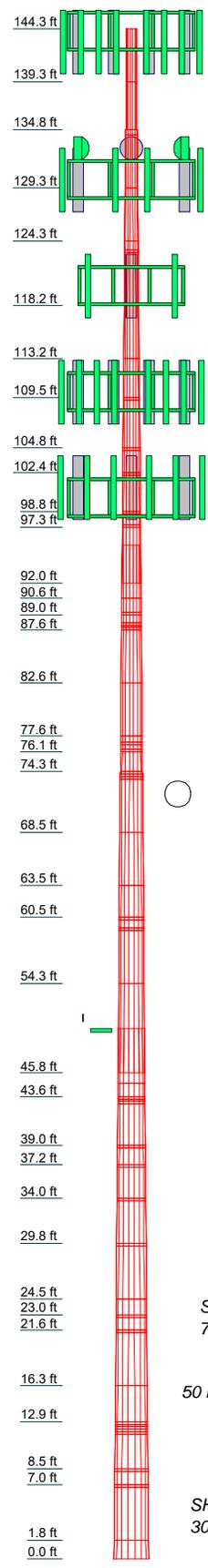

### MATERIAL STRENGTH

GRADE	Fy	Fu	GRADE	Fy	Fu
A500-46	46 ksi	62 ksi	A572-65	65 ksi	80 ksi

### TOWER DESIGN NOTES

1. Tower is located in New Haven County, Connecticut.
2. Tower designed for Exposure B to the TIA-222-H Standard.
3. Tower designed for a 118 mph basic wind in accordance with the TIA-222-H Standard.
4. Tower is also designed for a 50 mph basic wind with 1.00 in ice. Ice is considered to increase in thickness with height.
5. Deflections are based upon a 60 mph wind.
6. Tower Risk Category II.
7. Topographic Category 1 with Crest Height of 0.000 ft
8. TIA-222-H Annex S
9. TOWER RATING: 98.1%

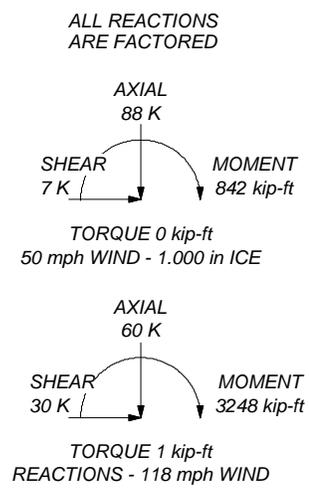



**B+T Group**  
1717 S. Boulder, Suite 300  
Tulsa, OK 74119  
Phone: (918) 587-4630  
FAX: (918) 295-0265

Job: **79982.013.01 - WATERBURY, CT (BU# 87631)**

Project:	Drawn by: Jayaraj B	App'd:
Client: Crown Castle	Date: 05/20/22	Scale: NTS
Code: TIA-222-H	Dwg No. E-1	

Vx

Vz

Mx

Mz

Global Mast Shear (K)

Global Mast Moment (kip-ft)

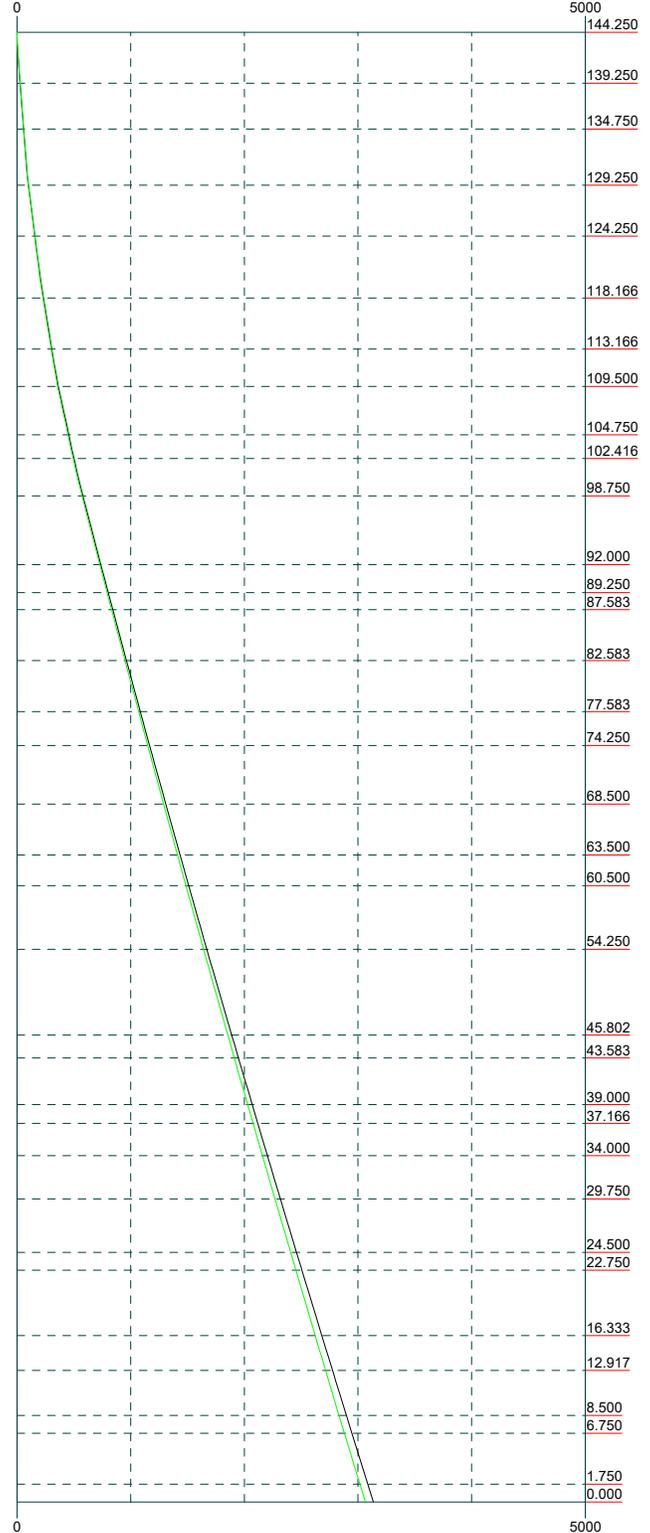
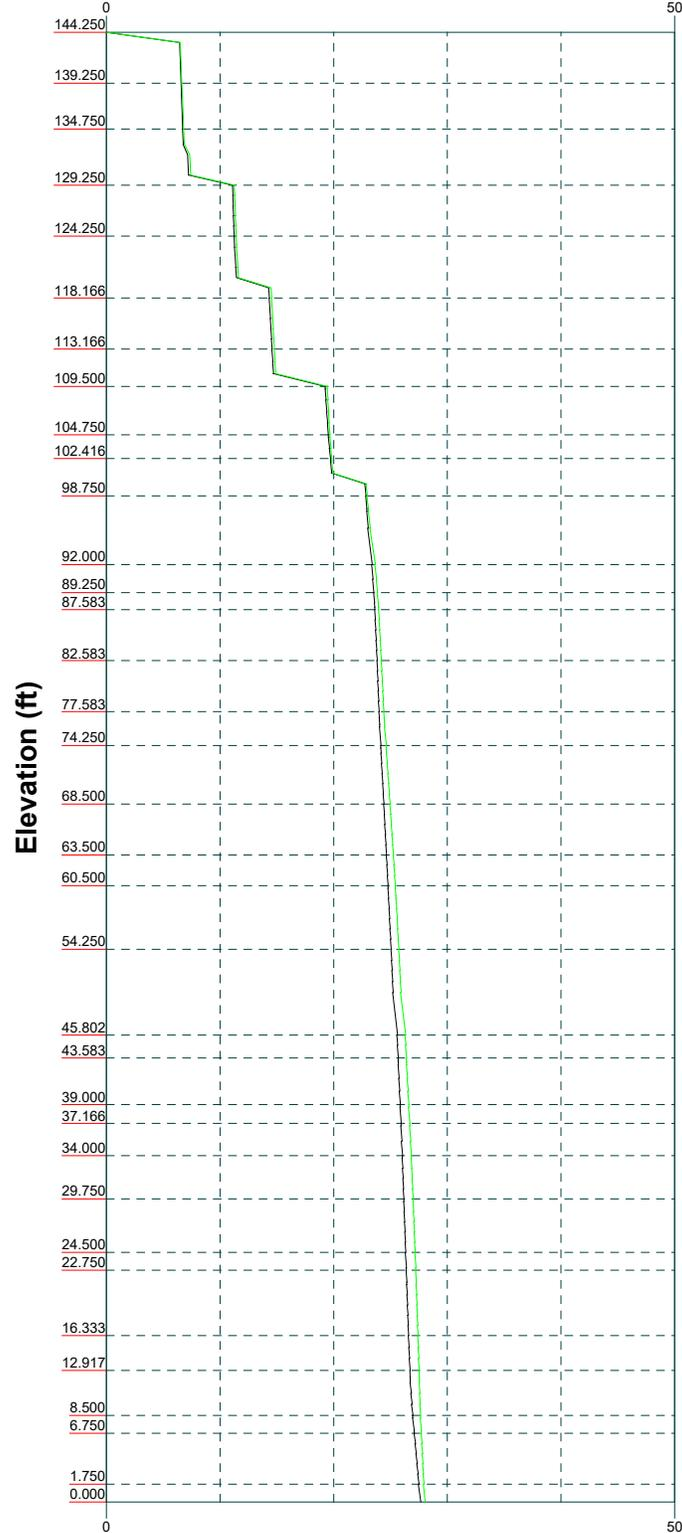

 <p><b>B+T Group</b> 1717 S. Boulder, Suite 300 Tulsa, OK 74119 Phone: (918) 587-4630 FAX: (918) 295-0265</p>	Job: <b>79982.013.01 - WATERBURY, CT (BU# 87631)</b>		
	Project:		
	Client: Crown Castle	Drawn by: Jayaraj B	App'd:
	Code: TIA-222-H	Date: 05/20/22	Scale: NTS
Path:		Dwg No. E-4	

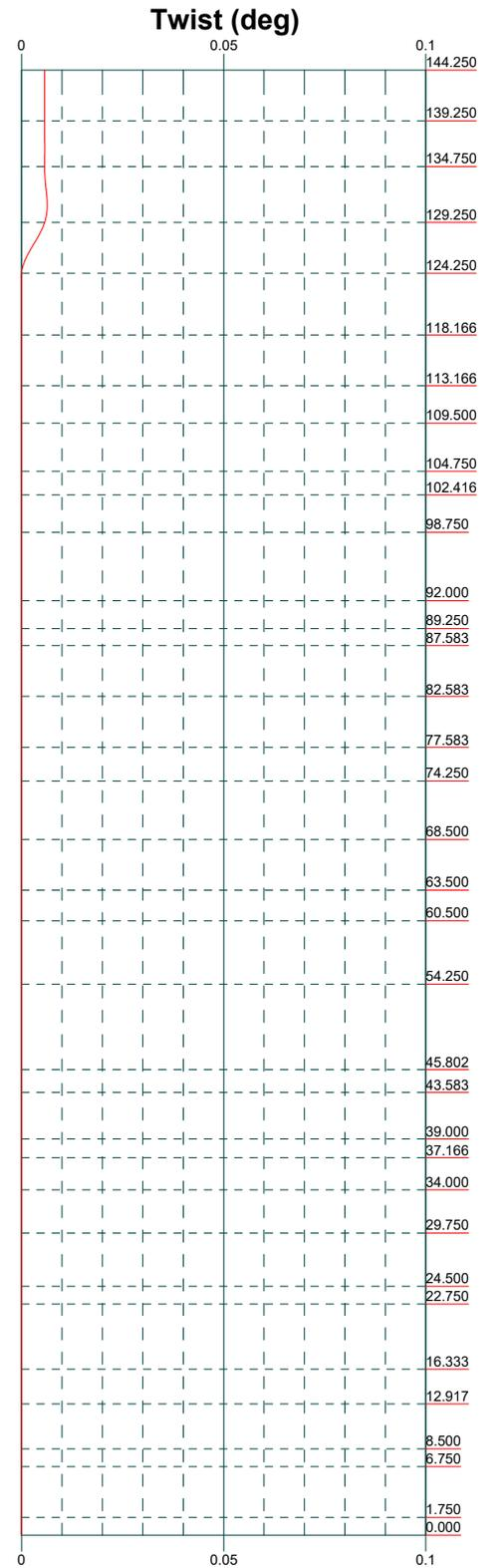
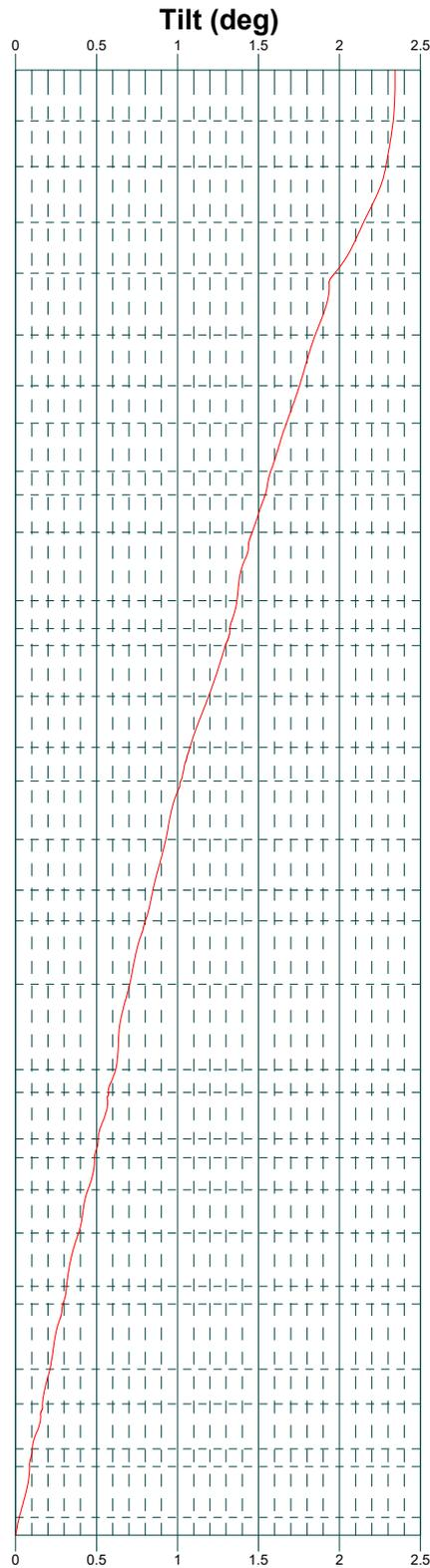
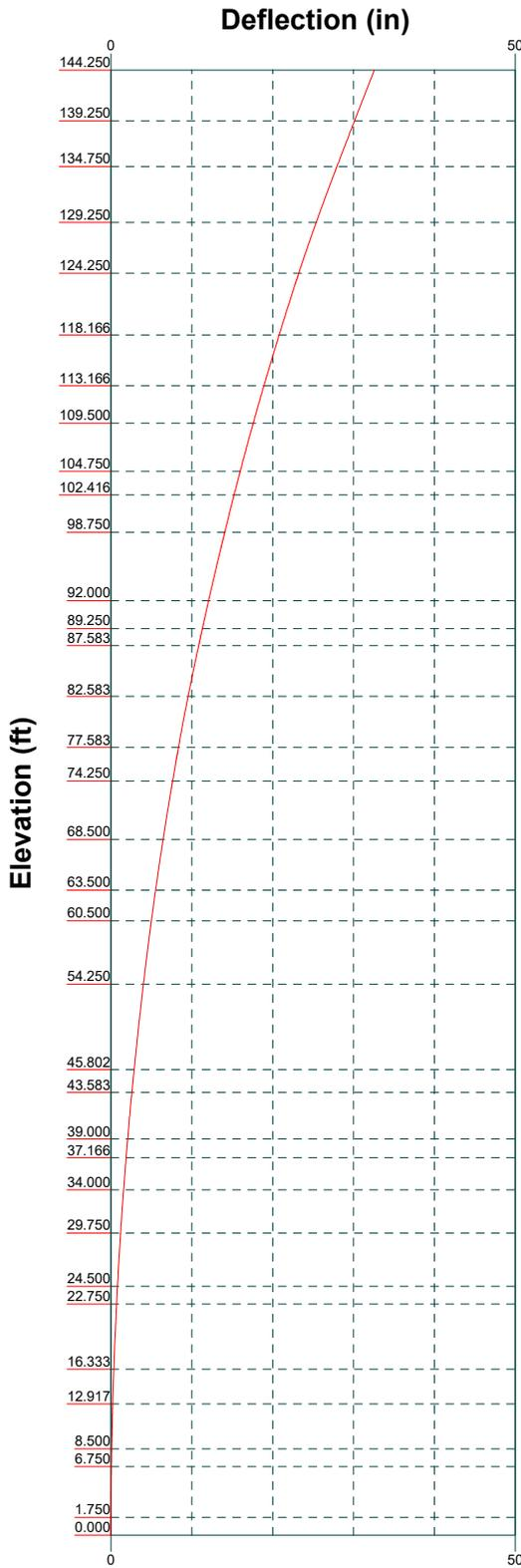

**B+T Group**  
 1717 S. Boulder, Suite 300  
 Tulsa, OK 74119  
 Phone: (918) 587-4630  
 FAX: (918) 295-0265

Job: <b>79982.013.01 - WATERBURY, CT (BU# 87631)</b>		
Project:		
Client: Crown Castle	Drawn by: Jayaraj B	App'd:
Code: TIA-222-H	Date: 05/20/22	Scale: NTS
Path:	Dwg No. E-5	

# Feed Line Distribution Chart

## 0' - 144'3"

— Round   
 — Flat   
 — App In Face   
 — App Out Face   
 — Truss Leg

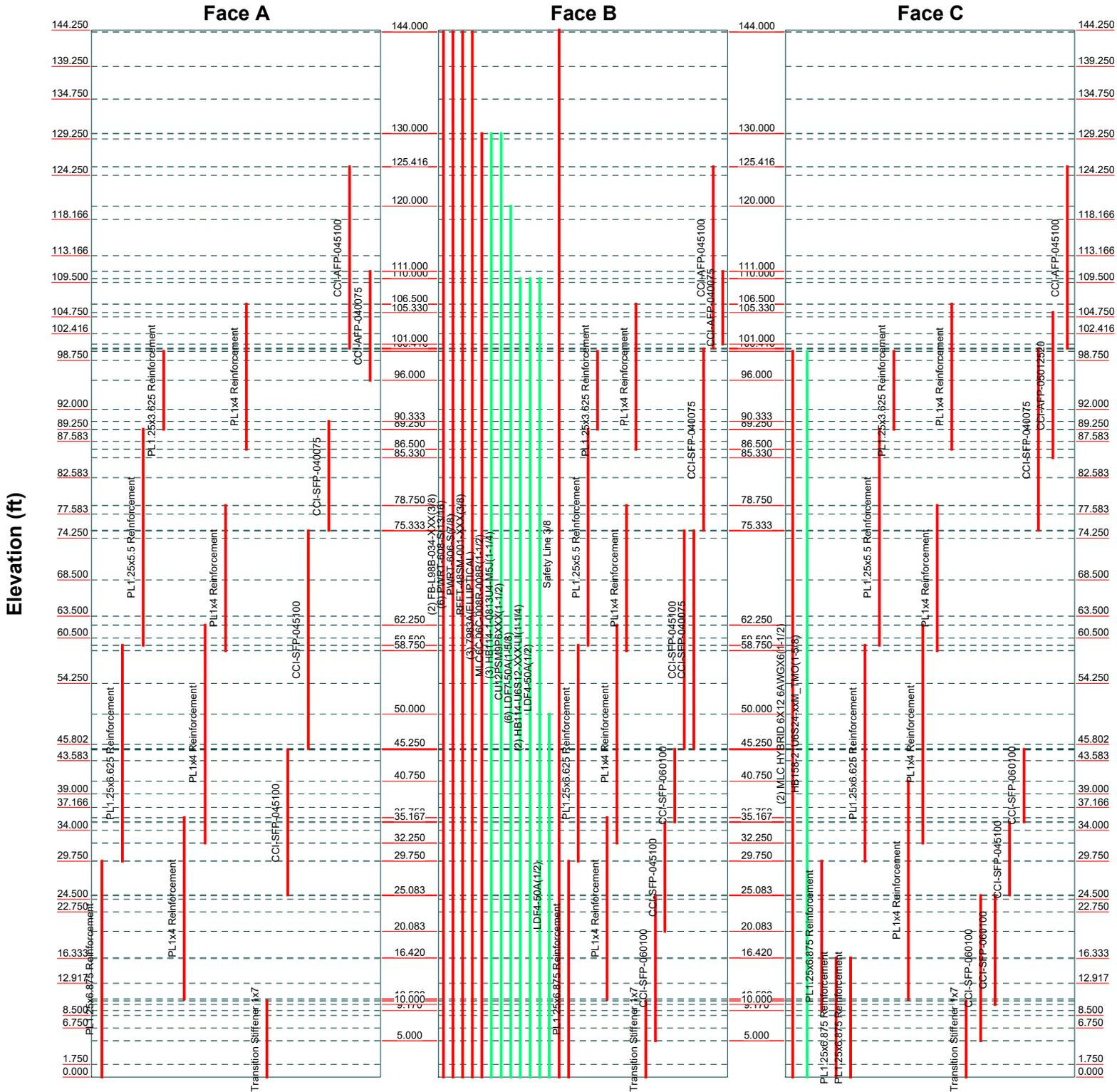

**B+T Group**  
 1717 S. Boulder, Suite 300  
 Tulsa, OK 74119  
 Phone: (918) 587-4630  
 FAX: (918) 295-0265

Job: <b>79982.013.01 - WATERBURY, CT (BU# 87631)</b>		
Project:		
Client: <b>Crown Castle</b>	Drawn by: <b>Jayaraj B</b>	App'd:
Code: <b>TIA-222-H</b>	Date: <b>05/20/22</b>	Scale: <b>NTS</b>
Path:		Dwg No. <b>E-7</b>

<b>tnxTower</b>  <b>B+T Group</b> 1717 S. Boulder, Suite 300 Tulsa, OK 74119 Phone: (918) 587-4630 FAX: (918) 295-0265	<b>Job</b> 79982.013.01 - WATERBURY,CT (BU# 876317)	<b>Page</b> 1 of 94
	<b>Project</b>	<b>Date</b> 15:43:49 05/20/22
	<b>Client</b> Crown Castle	<b>Designed by</b> Jayaraj B

## Tower Input Data

The tower is a monopole.

This tower is designed using the TIA-222-H standard.

The following design criteria apply:

Tower is located in New Haven County, Connecticut.

Tower base elevation above sea level: 660.000 ft.

Basic wind speed of 118 mph.

Risk Category II.

Exposure Category B.

Simplified Topographic Factor Procedure for wind speed-up calculations is used.

Topographic Category: 1.

Crest Height: 0.000 ft.

Nominal ice thickness of 1.000 in.

Ice thickness is considered to increase with height.

Ice density of 56.000 pcf.

A wind speed of 50 mph is used in combination with ice.

Temperature drop of 50.000 °F.

Deflections calculated using a wind speed of 60 mph.

TIA-222-H Annex S.

TOWER RATING:98.1%.

A non-linear (P-delta) analysis was used.

Pressures are calculated at each section.

Stress ratio used in pole design is 1.

Tower analysis based on target reliabilities in accordance with Annex S.

Load Modification Factors used:  $K_{es}(F_w) = 0.95$ ,  $K_{es}(t_i) = 0.85$ .

Maximum demand-capacity ratio is: 1.05.

Local bending stresses due to climbing loads, feed line supports, and appurtenance mounts are not considered.

## Options

<ul style="list-style-type: none"> <li>Consider Moments - Legs</li> <li>Consider Moments - Horizontals</li> <li>Consider Moments - Diagonals</li> <li>Use Moment Magnification</li> <li>√ Use Code Stress Ratios</li> <li>√ Use Code Safety Factors - Guys</li> <li>Escalate Ice</li> <li>Always Use Max Kz</li> <li>Use Special Wind Profile</li> <li>Include Bolts In Member Capacity</li> <li>Leg Bolts Are At Top Of Section</li> <li>Secondary Horizontal Braces Leg</li> <li>Use Diamond Inner Bracing (4 Sided)</li> <li>SR Members Have Cut Ends</li> <li>SR Members Are Concentric</li> </ul>	<ul style="list-style-type: none"> <li>Distribute Leg Loads As Uniform</li> <li>Assume Legs Pinned</li> <li>√ Assume Rigid Index Plate</li> <li>√ Use Clear Spans For Wind Area</li> <li>Use Clear Spans For KL/r</li> <li>Retension Guys To Initial Tension</li> <li>√ Bypass Mast Stability Checks</li> <li>√ Use Azimuth Dish Coefficients</li> <li>√ Project Wind Area of Appurt.</li> <li>Autocalc Torque Arm Areas</li> <li>Add IBC .6D+W Combination</li> <li>Sort Capacity Reports By Component</li> <li>Triangulate Diamond Inner Bracing</li> <li>Treat Feed Line Bundles As Cylinder</li> <li>Ignore KL/ry For 60 Deg. Angle Legs</li> </ul>	<ul style="list-style-type: none"> <li>Use ASCE 10 X-Brace Ly Rules</li> <li>Calculate Redundant Bracing Forces</li> <li>Ignore Redundant Members in FEA</li> <li>SR Leg Bolts Resist Compression</li> <li>All Leg Panels Have Same Allowable</li> <li>Offset Girt At Foundation</li> <li>√ Consider Feed Line Torque</li> <li>Include Angle Block Shear Check</li> <li>Use TIA-222-H Bracing Resist. Exemption</li> <li>Use TIA-222-H Tension Splice Exemption</li> <li style="background-color: #e0e0e0;">Poles</li> <li>√ Include Shear-Torsion Interaction</li> <li>Always Use Sub-Critical Flow</li> <li>Use Top Mounted Sockets</li> <li>Pole Without Linear Attachments</li> <li>Pole With Shroud Or No Appurtenances</li> <li>Outside and Inside Corner Radii Are Known</li> </ul>
--	---	--

<b>tnxTower</b>  <b>B+T Group</b> 1717 S. Boulder, Suite 300 Tulsa, OK 74119 Phone: (918) 587-4630 FAX: (918) 295-0265	<b>Job</b> 79982.013.01 - WATERBURY,CT (BU# 876317)	<b>Page</b> 2 of 94
	<b>Project</b>	<b>Date</b> 15:43:49 05/20/22
	<b>Client</b> Crown Castle	<b>Designed by</b> Jayaraj B

## Tapered Pole Section Geometry

Section	Elevation ft	Section Length ft	Splice Length ft	Number of Sides	Top Diameter in	Bottom Diameter in	Wall Thickness in	Bend Radius in	Pole Grade
L1	144.250-139.250	5.000	0.000	Round	12.750	12.750	0.375		A500-46 (46 ksi)
L2	139.250-134.750	4.500	0.000	Round	12.750	12.750	0.375		A500-46 (46 ksi)
L3	134.750-134.250	0.500	0.000	Round	13.480	13.480	0.375		A500-46 (46 ksi)
L4	134.250-129.250	5.000	0.000	12	13.480	14.466	0.188	0.750	A572-65 (65 ksi)
L5	129.250-124.250	5.000	0.000	12	14.466	15.452	0.188	0.750	A572-65 (65 ksi)
L6	124.250-123.416	0.834	0.000	12	15.452	15.616	0.188	0.750	A572-65 (65 ksi)
L7	123.416-123.166	0.250	0.000	12	15.616	15.665	0.537	2.150	A572-65 (65 ksi)
L8	123.166-118.166	5.000	0.000	12	15.665	16.651	0.512	2.050	A572-65 (65 ksi)
L9	118.166-113.166	5.000	0.000	12	16.651	17.637	0.487	1.950	A572-65 (65 ksi)
L10	113.166-109.500	3.666	0.000	12	17.637	18.360	0.475	1.900	A572-65 (65 ksi)
L11	109.500-109.250	0.250	0.000	12	18.360	18.409	0.588	2.350	A572-65 (65 ksi)
L12	109.250-104.750	4.500	0.000	12	18.409	19.296	0.563	2.250	A572-65 (65 ksi)
L13	104.750-104.500	0.250	0.000	12	19.296	19.346	0.775	3.100	A572-65 (65 ksi)
L14	104.500-102.416	2.084	0.000	12	19.346	19.756	0.762	3.050	A572-65 (65 ksi)
L15	102.416-102.166	0.250	0.000	12	19.756	19.806	0.563	2.250	A572-65 (65 ksi)
L16	102.166-98.750	3.416	0.000	12	19.806	20.479	0.550	2.200	A572-65 (65 ksi)
L17	98.750-98.500	0.250	0.000	12	20.479	20.528	0.838	3.350	A572-65 (65 ksi)
L18	98.500-97.500	1.000	0.000	12	20.528	20.726	0.838	3.350	A572-65 (65 ksi)
L19	97.500-97.250	0.250	0.000	12	20.726	20.775	0.750	3.000	A572-65 (65 ksi)
L20	97.250-92.000	5.250	3.552	12	20.775	21.810	0.738	2.950	A572-65 (65 ksi)
L21	92.000-90.552	5.000	0.000	12	20.735	21.730	0.800	3.200	A572-65 (65 ksi)
L22	90.552-89.250	1.302	0.000	12	21.730	21.989	0.775	3.100	A572-65 (65 ksi)
L23	89.250-89.000	0.250	0.000	12	21.989	22.039	1.000	4.000	A572-65 (65 ksi)
L24	89.000-88.250	0.750	0.000	12	22.039	22.189	0.975	3.900	A572-65 (65 ksi)
L25	88.250-88.000	0.250	0.000	12	22.189	22.238	0.762	3.050	A572-65 (65 ksi)
L26	88.000-87.833	0.167	0.000	12	22.238	22.272	0.762	3.050	A572-65 (65 ksi)
L27	87.833-87.583	0.250	0.000	12	22.272	22.321	0.675	2.700	A572-65 (65 ksi)
L28	87.583-82.583	5.000	0.000	12	22.321	23.317	0.650	2.600	A572-65 (65 ksi)

**tnxTower**

**B+T Group**  
 1717 S. Boulder, Suite 300  
 Tulsa, OK 74119  
 Phone: (918) 587-4630  
 FAX: (918) 295-0265

**Job**  
 79982.013.01 - WATERBURY,CT (BU# 876317)

**Page**  
 3 of 94

**Project**  
**Date**  
 15:43:49 05/20/22

**Client**  
 Crown Castle  
**Designed by**  
 Jayaraj B

Section	Elevation ft	Section Length ft	Splice Length ft	Number of Sides	Top Diameter in	Bottom Diameter in	Wall Thickness in	Bend Radius in	Pole Grade
L29	82.583-77.583	5.000	0.000	12	23.317	24.312	0.625	2.500	A572-65 (65 ksi)
L30	77.583-77.000	0.583	0.000	12	24.312	24.428	0.625	2.500	A572-65 (65 ksi)
L31	77.000-76.750	0.250	0.000	12	24.428	24.478	0.825	3.300	A572-65 (65 ksi)
L32	76.750-76.333	0.417	0.000	12	24.478	24.561	0.825	3.300	A572-65 (65 ksi)
L33	76.333-76.083	0.250	0.000	12	24.561	24.611	0.825	3.300	A572-65 (65 ksi)
L34	76.083-74.250	1.833	0.000	12	24.611	24.976	0.800	3.200	A572-65 (65 ksi)
L35	74.250-74.000	0.250	0.000	12	24.976	25.026	0.887	3.550	A572-65 (65 ksi)
L36	74.000-73.750	0.250	0.000	12	25.026	25.076	0.887	3.550	A572-65 (65 ksi)
L37	73.750-73.500	0.250	0.000	12	25.076	25.125	0.912	3.650	A572-65 (65 ksi)
L38	73.500-68.500	5.000	0.000	12	25.125	26.121	0.875	3.500	A572-65 (65 ksi)
L39	68.500-63.500	5.000	0.000	12	26.121	27.116	0.850	3.400	A572-65 (65 ksi)
L40	63.500-60.500	3.000	0.000	12	27.116	27.714	0.825	3.300	A572-65 (65 ksi)
L41	60.500-60.250	0.250	0.000	12	27.714	27.763	0.825	3.300	A572-65 (65 ksi)
L42	60.250-59.500	0.750	0.000	12	27.763	27.913	0.825	3.300	A572-65 (65 ksi)
L43	59.500-59.250	0.250	0.000	12	27.913	27.962	0.887	3.550	A572-65 (65 ksi)
L44	59.250-54.250	5.000	0.000	12	27.962	28.958	0.850	3.400	A572-65 (65 ksi)
L45	54.250-45.802	8.448	4.198	12	28.958	30.640	0.838	3.350	A572-65 (65 ksi)
L46	45.802-44.802	5.198	0.000	12	29.304	30.333	0.838	3.350	A572-65 (65 ksi)
L47	44.802-43.583	1.219	0.000	12	30.333	30.574	0.838	3.350	A572-65 (65 ksi)
L48	43.583-43.333	0.250	0.000	12	30.574	30.624	0.850	3.400	A572-65 (65 ksi)
L49	43.333-43.166	0.167	0.000	12	30.624	30.657	0.850	3.400	A572-65 (65 ksi)
L50	43.166-42.916	0.250	0.000	12	30.657	30.706	0.938	3.750	A572-65 (65 ksi)
L51	42.916-39.000	3.916	0.000	12	30.706	31.481	0.912	3.650	A572-65 (65 ksi)
L52	39.000-38.750	0.250	0.000	12	31.481	31.531	0.950	3.800	A572-65 (65 ksi)
L53	38.750-37.166	1.584	0.000	12	31.531	31.844	0.938	3.750	A572-65 (65 ksi)
L54	37.166-36.916	0.250	0.000	12	31.844	31.894	0.887	3.550	A572-65 (65 ksi)
L55	36.916-34.000	2.916	0.000	12	31.894	32.471	0.887	3.550	A572-65 (65 ksi)
L56	34.000-33.750	0.250	0.000	12	32.471	32.520	0.875	3.500	A572-65 (65 ksi)
L57	33.750-29.750	4.000	0.000	12	32.520	33.312	0.863	3.450	A572-65 (65 ksi)
L58	29.750-29.500	0.250	0.000	12	33.312	33.361	0.863	3.450	A572-65 (65 ksi)
L59	29.500-24.500	5.000	0.000	12	33.361	34.351	0.850	3.400	A572-65

<b>tnxTower</b>  <b>B+T Group</b> 1717 S. Boulder, Suite 300 Tulsa, OK 74119 Phone: (918) 587-4630 FAX: (918) 295-0265	<b>Job</b>	79982.013.01 - WATERBURY,CT (BU# 876317)	<b>Page</b>	4 of 94
	<b>Project</b>		<b>Date</b>	15:43:49 05/20/22
	<b>Client</b>	Crown Castle		<b>Designed by</b>

Section	Elevation ft	Section Length ft	Splice Length ft	Number of Sides	Top Diameter in	Bottom Diameter in	Wall Thickness in	Bend Radius in	Pole Grade
L60	24.500-23.000	1.500	0.000	12	34.351	34.648	0.838	3.350	(65 ksi) A572-65
L61	23.000-22.750	0.250	0.000	12	34.648	34.697	0.963	3.850	(65 ksi) A572-65
L62	22.750-21.583	1.167	0.000	12	34.697	34.928	0.963	3.850	(65 ksi) A572-65
L63	21.583-21.333	0.250	0.000	12	34.928	34.978	0.850	3.400	(65 ksi) A572-65
L64	21.333-16.333	5.000	0.000	12	34.978	35.967	0.838	3.350	(65 ksi) A572-65
L65	16.333-12.917	3.416	0.000	12	35.967	36.644	0.825	3.300	(65 ksi) A572-65
L66	12.917-12.667	0.250	0.000	12	36.644	36.693	0.912	3.650	(65 ksi) A572-65
L67	12.667-12.500	0.167	0.000	12	36.693	36.726	0.912	3.650	(65 ksi) A572-65
L68	12.500-12.250	0.250	0.000	12	36.726	36.776	0.762	3.050	(65 ksi) A572-65
L69	12.250-12.000	0.250	0.000	12	36.776	36.825	0.762	3.050	(65 ksi) A572-65
L70	12.000-11.750	0.250	0.000	12	36.825	36.874	0.662	2.650	(65 ksi) A572-65
L71	11.750-8.500	3.250	0.000	12	36.874	37.518	0.650	2.600	(65 ksi) A572-65
L72	8.500-8.250	0.250	0.000	12	37.518	37.567	0.925	3.700	(65 ksi) A572-65
L73	8.250-7.000	1.250	0.000	12	37.567	37.815	0.912	3.650	(65 ksi) A572-65
L74	7.000-6.750	0.250	0.000	12	37.815	37.864	0.813	3.250	(65 ksi) A572-65
L75	6.750-1.750	5.000	0.000	12	37.864	38.854	0.787	3.150	(65 ksi) A572-65
L76	1.750-0.000	1.750		12	38.854	39.200	0.787	3.150	(65 ksi) A572-65

### Tapered Pole Properties

Section	Tip Dia. in	Area in <sup>2</sup>	I in <sup>4</sup>	r in	C in	I/C in <sup>3</sup>	J in <sup>4</sup>	I/Q in <sup>2</sup>	w in	w/t
L1	12.750	14.579	279.335	4.377	6.375	43.817	558.670	7.285	0.000	0
L2	12.750	14.579	279.335	4.377	6.375	43.817	558.670	7.285	0.000	0
L3	13.480	15.439	331.709	4.635	6.740	49.215	663.419	7.715	0.000	0
L4	13.889	8.025	180.994	4.759	6.983	25.921	366.742	3.950	3.110	16.587
L5	14.910	8.621	224.322	5.112	7.493	29.936	454.538	4.243	3.374	17.996
L6	15.931	9.216	274.067	5.465	8.004	34.242	555.334	4.536	3.639	19.405
L7	16.028	26.097	757.351	5.398	8.089	93.626	1534.598	12.844	2.745	5.106
L8	16.037	25.006	732.852	5.425	8.115	90.312	1484.956	12.307	2.825	5.512
	17.058	26.633	885.390	5.778	8.625	102.651	1794.040	13.108	3.089	6.027

Section	Tip Dia. in	Area in <sup>2</sup>	I in <sup>4</sup>	r in	C in	I/C in <sup>3</sup>	J in <sup>4</sup>	It/Q in <sup>2</sup>	w in	w/t
L9	17.067	25.373	846.120	5.787	8.625	98.098	1714.469	12.488	3.156	6.474
	18.087	26.920	1010.566	6.139	9.136	110.615	2047.680	13.249	3.420	7.016
L10	18.092	26.249	986.808	6.144	9.136	108.014	1999.541	12.919	3.454	7.271
	18.840	27.355	1116.814	6.403	9.510	117.432	2262.967	13.463	3.647	7.679
L11	18.800	33.621	1355.419	6.362	9.510	142.521	2746.446	16.547	3.346	5.695
	18.851	33.714	1366.728	6.380	9.536	143.325	2769.361	16.593	3.359	5.718
L12	18.860	32.324	1314.084	6.389	9.536	137.804	2662.690	15.909	3.426	6.091
	19.778	33.931	1519.973	6.707	9.995	152.067	3079.878	16.700	3.664	6.514
L13	19.704	46.220	2023.726	6.631	9.995	202.465	4100.618	22.748	3.094	3.993
	19.755	46.343	2039.927	6.648	10.021	203.566	4133.444	22.808	3.108	4.01
L14	19.759	45.626	2011.080	6.653	10.021	200.687	4074.993	22.456	3.141	4.119
	20.184	46.635	2147.450	6.800	10.234	209.839	4351.315	22.952	3.251	4.264
L15	20.255	34.765	1634.756	6.871	10.234	159.741	3312.459	17.110	3.787	6.733
	20.306	34.854	1647.383	6.889	10.259	160.574	3338.044	17.154	3.800	6.756
L16	20.310	34.102	1613.915	6.894	10.259	157.312	3270.229	16.784	3.834	6.971
	21.008	35.295	1789.255	7.135	10.608	168.667	3625.516	17.371	4.014	7.299
L17	20.906	52.969	2608.327	7.032	10.608	245.878	5285.177	26.070	3.244	3.873
	20.957	53.102	2628.012	7.049	10.634	247.139	5325.066	26.135	3.257	3.889
L18	20.957	53.102	2628.012	7.049	10.634	247.139	5325.066	26.135	3.257	3.889
	21.161	53.633	2707.746	7.120	10.736	252.215	5486.627	26.397	3.310	3.952
L19	21.192	48.241	2456.993	7.151	10.736	228.858	4978.535	23.743	3.544	4.726
	21.243	48.360	2475.226	7.169	10.761	230.010	5015.479	23.801	3.558	4.744
L20	21.248	47.584	2438.533	7.173	10.761	226.600	4941.129	23.419	3.591	4.869
	22.319	50.042	2836.299	7.544	11.298	251.054	5747.111	24.629	3.869	5.246
L21	21.916	51.352	2604.715	7.137	10.741	242.512	5277.858	25.274	3.413	4.266
	22.215	53.916	3014.753	7.493	11.256	267.829	6108.707	26.536	3.680	4.6
L22	22.223	52.294	2931.020	7.502	11.256	260.391	5939.041	25.737	3.747	4.834
	22.492	52.941	3041.147	7.595	11.391	266.989	6162.189	26.056	3.816	4.924
L23	22.412	67.586	3800.525	7.514	11.391	333.657	7700.894	33.264	3.213	3.213
	22.464	67.746	3827.628	7.532	11.416	335.277	7755.811	33.343	3.227	3.227
L24	22.473	66.131	3745.256	7.541	11.416	328.062	7588.905	32.548	3.294	3.378
	22.627	66.600	3825.474	7.594	11.494	332.833	7751.447	32.778	3.334	3.419
L25	22.702	52.606	3082.526	7.671	11.494	268.194	6246.034	25.891	3.903	5.119
	22.754	52.728	3104.059	7.688	11.519	269.463	6289.666	25.951	3.916	5.136
L26	22.754	52.728	3104.059	7.688	11.519	269.463	6289.666	25.951	3.916	5.136
	22.788	52.810	3118.499	7.700	11.537	270.312	6318.925	25.992	3.925	5.148
L27	22.819	46.940	2794.467	7.732	11.537	242.225	5662.348	23.102	4.160	6.163
	22.871	47.048	2813.834	7.749	11.562	243.360	5701.590	23.156	4.173	6.182
L28	22.879	45.358	2719.017	7.758	11.562	235.159	5509.465	22.324	4.240	6.523
	23.910	47.442	3111.201	8.115	12.078	257.590	6304.137	23.349	4.507	6.934
L29	23.919	45.667	3001.449	8.124	12.078	248.503	6081.749	22.476	4.574	7.318
	24.950	47.671	3414.060	8.480	12.594	271.091	6917.811	23.462	4.841	7.745
L30	24.950	47.671	3414.060	8.480	12.594	271.091	6917.811	23.462	4.841	7.745
	25.070	47.904	3464.497	8.522	12.654	273.788	7020.009	23.577	4.872	7.795
L31	24.999	62.702	4458.829	8.450	12.654	352.367	9034.796	30.860	4.336	5.256
	25.051	62.835	4487.097	8.468	12.680	353.880	9092.075	30.925	4.349	5.272
L32	25.051	62.835	4487.097	8.468	12.680	353.880	9092.075	30.925	4.349	5.272
	25.137	63.055	4534.514	8.498	12.723	356.411	9188.154	31.034	4.371	5.299
L33	25.137	63.055	4534.514	8.498	12.723	356.411	9188.154	31.034	4.371	5.299
	25.188	63.188	4563.100	8.515	12.748	357.932	9246.079	31.099	4.385	5.315
L34	25.197	61.337	4438.791	8.524	12.748	348.182	8994.195	30.188	4.452	5.565
	25.575	62.277	4646.037	8.655	12.938	359.113	9414.130	30.651	4.550	5.687
L35	25.544	68.839	5098.436	8.624	12.938	394.081	10330.813	33.880	4.315	4.862
	25.595	68.981	5130.107	8.641	12.963	395.740	10394.987	33.950	4.328	4.877
L36	25.595	68.981	5130.107	8.641	12.963	395.740	10394.987	33.950	4.328	4.877
	25.647	69.123	5161.909	8.659	12.989	397.403	10459.426	34.020	4.342	4.892
L37	25.638	70.997	5290.875	8.650	12.989	407.332	10720.747	34.943	4.275	4.685
	25.690	71.143	5323.640	8.668	13.015	409.042	10787.138	35.015	4.288	4.699
L38	25.703	68.325	5128.616	8.682	13.015	394.057	10391.966	33.628	4.389	5.016
	26.734	71.130	5786.510	9.038	13.531	427.662	11725.038	35.008	4.655	5.32
L39	26.742	69.166	5637.897	9.047	13.531	416.679	11423.908	34.041	4.722	5.556
	27.773	71.891	6330.781	9.403	14.046	450.710	12827.880	35.382	4.989	5.87

Section	Tip Dia. in	Area in <sup>2</sup>	I in <sup>4</sup>	r in	C in	I/C in <sup>3</sup>	J in <sup>4</sup>	I/Q in <sup>2</sup>	w in	w/t
L40	27.782	69.843	6162.144	9.412	14.046	438.704	12486.174	34.375	5.056	6.129
	28.400	71.430	6591.746	9.626	14.356	459.174	13356.665	35.155	5.216	6.323
L41	28.400	71.430	6591.746	9.626	14.356	459.174	13356.665	35.155	5.216	6.323
	28.452	71.562	6628.421	9.644	14.381	460.901	13430.979	35.221	5.230	6.339
L42	28.452	71.562	6628.421	9.644	14.381	460.901	13430.979	35.221	5.230	6.339
	28.606	71.958	6739.263	9.697	14.459	466.102	13655.573	35.416	5.270	6.387
L43	28.584	77.231	7199.746	9.675	14.459	497.950	14588.636	38.011	5.102	5.749
	28.636	77.374	7239.601	9.693	14.485	499.815	14669.394	38.081	5.115	5.764
L44	28.649	74.207	6962.552	9.706	14.485	480.688	14108.019	36.522	5.216	6.136
	29.680	76.932	7758.005	10.063	15.000	517.192	15719.821	37.863	5.483	6.45
L45	29.684	75.834	7654.119	10.067	15.000	510.267	15509.321	37.323	5.516	6.587
	31.425	80.370	9111.392	10.669	15.872	574.072	18462.150	39.556	5.967	7.125
L46	30.903	76.767	7940.296	10.191	15.180	523.091	16089.192	37.783	5.609	6.697
	31.108	79.542	8832.656	10.559	15.712	562.143	17897.356	39.148	5.885	7.027
L47	31.108	79.542	8832.656	10.559	15.712	562.143	17897.356	39.148	5.885	7.027
	31.357	80.192	9051.176	10.646	15.837	571.505	18340.137	39.468	5.949	7.104
L48	31.353	81.355	9174.689	10.641	15.837	579.304	18590.407	40.041	5.916	6.96
	31.404	81.491	9220.582	10.659	15.863	581.261	18683.399	40.107	5.929	6.975
L49	31.404	81.491	9220.582	10.659	15.863	581.261	18683.399	40.107	5.929	6.975
	31.438	81.581	9251.324	10.671	15.880	582.570	18745.690	40.152	5.938	6.986
L50	31.407	89.715	10114.068	10.639	15.880	636.899	20493.844	44.155	5.704	6.084
	31.459	89.864	10164.669	10.657	15.906	639.054	20596.375	44.228	5.717	6.098
L51	31.468	87.541	9918.558	10.666	15.906	623.581	20097.688	43.085	5.784	6.338
	32.270	89.819	10712.920	10.944	16.307	656.941	21707.281	44.206	5.991	6.566
L52	32.257	93.395	11112.181	10.930	16.307	681.424	22516.292	45.966	5.891	6.201
	32.308	93.546	11166.294	10.948	16.333	683.668	22625.940	46.041	5.904	6.215
L53	32.312	92.353	11032.888	10.952	16.333	675.500	22355.622	45.453	5.938	6.334
	32.637	93.300	11375.549	11.065	16.495	689.623	23049.947	45.919	6.022	6.423
L54	32.654	88.467	10821.202	11.083	16.495	656.017	21926.690	43.541	6.156	6.936
	32.706	88.608	10873.173	11.100	16.521	658.145	22031.996	43.610	6.169	6.951
L55	32.706	88.608	10873.173	11.100	16.521	658.145	22031.996	43.610	6.169	6.951
	33.303	90.257	11491.698	11.307	16.820	683.221	23285.295	44.422	6.324	7.125
L56	33.308	89.021	11343.300	11.311	16.820	674.398	22984.602	43.814	6.357	7.265
	33.359	89.161	11396.675	11.329	16.846	676.540	23092.753	43.882	6.370	7.281
L57	33.363	87.922	11247.183	11.333	16.846	667.666	22789.841	43.272	6.404	7.425
	34.183	90.120	12112.233	11.617	17.256	701.930	24542.668	44.354	6.616	7.671
L58	34.183	90.120	12112.233	11.617	17.256	701.930	24542.668	44.354	6.616	7.671
	34.234	90.258	12167.724	11.635	17.281	704.100	24655.108	44.422	6.629	7.686
L59	34.238	88.984	12005.222	11.639	17.281	694.697	24325.835	43.795	6.663	7.839
	35.263	91.692	13135.172	11.993	17.794	738.186	26615.419	45.128	6.928	8.151
L60	35.267	90.378	12956.500	11.998	17.794	728.145	26253.381	44.481	6.962	8.312
	35.575	91.178	13303.879	12.104	17.948	741.261	26957.265	44.875	7.041	8.407
L61	35.531	104.400	15120.578	12.059	17.948	842.484	30638.391	51.382	6.706	6.967
	35.582	104.553	15187.306	12.077	17.973	844.995	30773.600	51.458	6.719	6.981
L62	35.582	104.553	15187.306	12.077	17.973	844.995	30773.600	51.458	6.719	6.981
	35.821	105.269	15501.390	12.160	18.093	856.767	31410.019	51.810	6.781	7.046
L63	35.861	93.272	13826.016	12.200	18.093	764.168	28015.257	45.906	7.083	8.333
	35.912	93.408	13886.326	12.218	18.119	766.416	28137.462	45.973	7.096	8.348
L64	35.916	92.068	13697.155	12.222	18.119	755.975	27754.150	45.313	7.130	8.513
	36.941	94.737	14923.079	12.577	18.631	800.976	30238.204	46.626	7.395	8.83
L65	36.945	93.356	14716.044	12.581	18.631	789.863	29818.695	45.947	7.428	9.004
	37.645	95.152	15581.827	12.823	18.981	820.902	31573.006	46.831	7.609	9.224
L66	37.614	104.987	17108.449	12.792	18.981	901.330	34666.355	51.671	7.375	8.082
	37.665	105.132	17179.621	12.809	19.007	903.859	34810.569	51.743	7.388	8.097
L67	37.665	105.132	17179.621	12.809	19.007	903.859	34810.569	51.743	7.388	8.097
	37.700	105.229	17227.273	12.821	19.024	905.550	34907.127	51.791	7.397	8.106
L68	37.753	88.299	14577.031	12.875	19.024	766.241	29537.016	43.458	7.799	10.228
	37.804	88.421	14637.279	12.893	19.050	768.372	29659.097	43.518	7.812	10.246
L69	37.804	88.421	14637.279	12.893	19.050	768.372	29659.097	43.518	7.812	10.246
	37.855	88.542	14697.694	12.910	19.075	770.507	29781.513	43.578	7.826	10.263
L70	37.890	77.144	12876.656	12.946	19.075	675.042	26091.595	37.968	8.094	12.217
	37.942	77.249	12929.583	12.964	19.101	676.907	26198.841	38.020	8.107	12.237

<p><b>tnxTower</b></p> <p><b>B+T Group</b> 1717 S. Boulder, Suite 300 Tulsa, OK 74119 Phone: (918) 587-4630 FAX: (918) 295-0265</p>	<p><b>Job</b> 79982.013.01 - WATERBURY,CT (BU# 876317)</p>	<p><b>Page</b> 7 of 94</p>
	<p><b>Project</b></p>	<p><b>Date</b> 15:43:49 05/20/22</p>
	<p><b>Client</b> Crown Castle</p>	<p><b>Designed by</b> Jayaraj B</p>

Section	Tip Dia. in	Area in <sup>2</sup>	I in <sup>4</sup>	r in	C in	I/C in <sup>3</sup>	J in <sup>4</sup>	It/Q in <sup>2</sup>	w in	w/t
L71	37.946	75.818	12698.770	12.968	19.101	664.823	25731.151	37.315	8.140	12.524
	38.612	77.164	13387.320	13.199	19.434	688.855	27126.339	37.978	8.313	12.789
L72	38.515	108.991	18628.043	13.100	19.434	958.520	37745.466	53.642	7.576	8.19
	38.566	109.139	18703.710	13.118	19.460	961.146	37898.787	53.715	7.589	8.204
L73	38.571	107.701	18469.846	13.122	19.460	949.128	37424.916	53.007	7.623	8.353
	38.827	108.428	18846.355	13.211	19.588	962.140	38187.825	53.365	7.689	8.426
L74	38.862	96.807	16917.794	13.247	19.588	863.684	34280.038	47.645	7.957	9.793
	38.913	96.936	16985.753	13.264	19.614	866.020	34417.740	47.709	7.970	9.809
L75	38.922	94.017	16496.461	13.273	19.614	841.073	33426.303	46.272	8.037	10.206
	39.946	96.526	17852.914	13.628	20.126	887.049	36174.844	47.507	8.302	10.543
L76	39.946	96.526	17852.914	13.628	20.126	887.049	36174.844	47.507	8.302	10.543
	40.305	97.404	18344.678	13.752	20.306	903.430	37171.292	47.940	8.395	10.66

Tower Elevation	Gusset Area (per face)	Gusset Thickness	Gusset Grade	Adjust. Factor A <sub>f</sub>	Adjust. Factor A <sub>r</sub>	Weight Mult.	Double Angle Stitch Bolt Spacing Diagonals in	Double Angle Stitch Bolt Spacing Horizontals in	Double Angle Stitch Bolt Spacing Redundants in
ft	ft <sup>2</sup>	in							
L1 144.250-139.2 50				1	1	1			
L2 139.250-134.7 50				1	1	1			
L3 134.750-134.2 50				1	1	1			
L4 134.250-129.2 50				1	1	1			
L5 129.250-124.2 50				1	1	1			
L6 124.250-123.4 16				1	1	1			
L7 123.416-123.1 66				1	1	0.873259			
L8 123.166-118.1 66				1	1	0.880843			
L9 118.166-113.1 66				1	1	0.893543			
L10 113.166-109.5 00				1	1	0.895307			
L11 109.500-109.2 50				1	1	0.905539			
L12 109.250-104.7 50				1	1	0.915518			
L13 104.750-104.5 00				1	1	0.930283			
L14 104.500-102.4 16				1	1	0.929776			
L15				1	1	1.12278			



<p><b>tnxTower</b></p> <p><b>B+T Group</b> 1717 S. Boulder, Suite 300 Tulsa, OK 74119 Phone: (918) 587-4630 FAX: (918) 295-0265</p>	<p><b>Job</b></p> <p>79982.013.01 - WATERBURY,CT (BU# 876317)</p>	<p><b>Page</b></p> <p>9 of 94</p>
	<p><b>Project</b></p>	<p><b>Date</b></p> <p>15:43:49 05/20/22</p>
	<p><b>Client</b></p> <p>Crown Castle</p>	<p><b>Designed by</b></p> <p>Jayaraj B</p>

Tower Elevation	Gusset Area (per face)	Gusset Thickness	Gusset Grade	Adjust. Factor $A_f$	Adjust. Factor $A_r$	Weight Mult.	Double Angle Stitch Bolt Spacing Diagonals in	Double Angle Stitch Bolt Spacing Horizontals in	Double Angle Stitch Bolt Spacing Redundants in
ft	ft <sup>2</sup>	in							
L44				1	1	0.936205			
59.250-54.250									
L45				1	1	0.930731			
54.250-45.802									
L46				1	1	0.938065			
45.802-44.802									
L47				1	1	0.933481			
44.802-43.583									
L48				1	1	0.974523			
43.583-43.333									
L49				1	1	0.97385			
43.333-43.166									
L50				1	1	0.934786			
43.166-42.916									
L51				1	1	0.943944			
42.916-39.000									
L52				1	1	0.949681			
39.000-38.750									
L53				1	1	0.955574			
38.750-37.166									
L54				1	1	0.972827			
37.166-36.916									
L55				1	1	0.961485			
36.916-34.000									
L56				1	1	0.928941			
34.000-33.750									
L57				1	1	0.927889			
33.750-29.750									
L58				1	1	0.93743			
29.750-29.500									
L59				1	1	0.933623			
29.500-24.500									
L60				1	1	0.942163			
24.500-23.000									
L61				1	1	0.90832			
23.000-22.750									
L62				1	1	0.904351			
22.750-21.583									
L63				1	1	0.971473			
21.583-21.333									
L64				1	1	0.968358			
21.333-16.333									
L65				1	1	0.971282			
16.333-12.917									
L66				1	1	0.961412			
12.917-12.667									
L67				1	1	0.96084			
12.667-12.500									
L68				1	1	1.00814			
12.500-12.250									
L69				1	1	1.00732			
12.250-12.000									
L70				1	1	1.07745			
12.000-11.750									
L71				1	1	1.08702			
11.750-8.500									
L72				1	1	0.961703			
8.500-8.250									
L73				1	1	0.970307			

<b>tnxTower</b>  <b>B+T Group</b> 1717 S. Boulder, Suite 300 Tulsa, OK 74119 Phone: (918) 587-4630 FAX: (918) 295-0265	<b>Job</b>	<b>Page</b>	
		79982.013.01 - WATERBURY,CT (BU# 876317)	10 of 94
	<b>Project</b>		<b>Date</b>
		15:43:49 05/20/22	
	<b>Client</b>	<b>Designed by</b>	
	Crown Castle	Jayaraj B	

Tower Elevation	Gusset Area (per face)	Gusset Thickness	Gusset Grade	Adjust. Factor $A_f$	Adjust. Factor $A_r$	Weight Mult.	Double Angle Stitch Bolt Spacing Diagonals in	Double Angle Stitch Bolt Spacing Horizontals in	Double Angle Stitch Bolt Spacing Redundants in
ft	ft <sup>2</sup>	in							
8.250-7.000 L74				1	1	0.961877			
7.000-6.750 L75				1	1	0.976278			
6.750-1.750 L76				1	1	0.971053			
1.750-0.000									

### Feed Line/Linear Appurtenances - Entered As Round Or Flat

Description	Sector	Exclude From Torque Calculation	Component Type	Placement ft	Total Number	Number Per Row	Start/End Position	Width or Diameter in	Perimeter in	Weight klf
FB-L98B-034-XXX(3/8)	B	No	Surface Ar (CaAa)	144.000 - 0.000	2	2	0.000 0.030	0.394		0.000
PWRT-608-S(13/16)	B	No	Surface Ar (CaAa)	144.000 - 0.000	6	3	0.000 0.150	0.820		0.001
PWRT-606-S(7/8)	B	No	Surface Ar (CaAa)	144.000 - 0.000	1	1	0.150 0.160	0.920		0.001
RFFT-48SM-001-XXX(3/8) *	B	No	Surface Ar (CaAa)	144.000 - 0.000	1	1	0.160 0.170	0.400		0.000
7983A(ELLIPTICAL)	B	No	Surface Ar (CaAa)	130.000 - 0.000	3	1	-0.380 -0.300	0.573		0.000
MLC HYBRID 6X12 6AWGX6(1-1/2) *	C	No	Surface Ar (CaAa)	100.000 - 0.000	2	2	0.370 0.400	1.530		0.001
Safety Line 3/8 *	B	No	Surface Ar (CaAa)	144.250 - 0.000	1	1	-0.400 -0.370	0.375		0.000
PL1.25x6.875 Reinforcement	A	No	Surface Af (CaAa)	29.750 - 0.000	1	1	0.250 0.250	6.875	16.250	0.000
PL1.25x6.875 Reinforcement	B	No	Surface Af (CaAa)	29.750 - 0.000	1	1	0.250 0.250	6.875	16.250	0.000
PL1.25x6.875 Reinforcement	C	No	Surface Af (CaAa)	29.750 - 9.170	1	1	0.250 0.250	6.875	16.250	0.000
PL1.25x6.875 Reinforcement	C	No	Surface Af (CaAa)	16.420 - 0.000	1	1	0.000 0.000	6.875	16.250	0.000
PL1.25x6.875 Reinforcement ***	C	No	Surface Af (CaAa)	16.420 - 0.000	1	1	0.500 0.500	6.875	16.250	0.000
PL1.25x6.625 Reinforcement	A	No	Surface Af (CaAa)	59.500 - 29.750	1	1	0.250 0.250	6.625	15.750	0.000
PL1.25x6.625 Reinforcement	B	No	Surface Af (CaAa)	59.500 - 29.750	1	1	0.250 0.250	6.625	15.750	0.000
PL1.25x6.625 Reinforcement ***	C	No	Surface Af (CaAa)	59.500 - 29.750	1	1	0.250 0.250	6.625	15.750	0.000
PL1.25x5.5 Reinforcement	A	No	Surface Af (CaAa)	89.250 - 59.500	1	1	0.250 0.250	5.500	13.500	0.000
PL1.25x5.5 Reinforcement	B	No	Surface Af (CaAa)	89.250 - 59.500	1	1	0.250 0.250	5.500	13.500	0.000
PL1.25x5.5 Reinforcement	C	No	Surface Af (CaAa)	89.250 - 59.500	1	1	0.250 0.250	5.500	13.500	0.000



<b>tnxTower</b>  <b>B+T Group</b> 1717 S. Boulder, Suite 300 Tulsa, OK 74119 Phone: (918) 587-4630 FAX: (918) 295-0265	<b>Job</b> 79982.013.01 - WATERBURY,CT (BU# 876317)	<b>Page</b> 12 of 94
	<b>Project</b>	<b>Date</b> 15:43:49 05/20/22
	<b>Client</b> Crown Castle	<b>Designed by</b> Jayaraj B

Description	Sector	Exclude From Torque Calculation	Component Type	Placement ft	Total Number	Number Per Row	Start/End Position	Width or Diameter in	Perimeter in	Weight klf
CCI-SFP-060100	B	No	Surface Af (CaAa)	45.167 - 35.167	1	1	0.000 0.000	6.000	14.000	0.000
CCI-SFP-060100	C	No	Surface Af (CaAa)	45.167 - 35.167	1	1	0.000 0.000	6.000	14.000	0.000
*										
CCI-SFP-045100	A	No	Surface Af (CaAa)	75.250 - 45.250	1	1	0.000 0.000	4.500	11.000	0.000
CCI-SFP-045100	B	No	Surface Af (CaAa)	75.250 - 45.250	1	1	0.000 0.000	4.500	11.000	0.000
*										
CCI-SFP-040075	B	No	Surface Af (CaAa)	75.250 - 45.250	1	1	0.000 0.000	4.000	9.500	0.000
*										
CCI-SFP-040075	B	No	Surface Af (CaAa)	100.330 - 75.330	1	1	0.000 0.000	4.000	9.500	0.000
CCI-SFP-040075	C	No	Surface Af (CaAa)	100.330 - 75.330	1	1	0.000 0.000	4.000	9.500	0.000
*										
CCI-SFP-040075	A	No	Surface Af (CaAa)	90.333 - 75.333	1	1	-0.500 -0.500	4.000	9.500	0.000
*										
CCI-AFP-05012520	C	No	Surface Af (CaAa)	105.330 - 85.330	1	1	0.000 0.000	5.000	12.500	0.000
*										
CCI-AFP-045100	A	No	Surface Af (CaAa)	125.416 - 100.416	1	1	0.000 0.000	4.500	11.000	0.000
CCI-AFP-045100	B	No	Surface Af (CaAa)	125.416 - 100.416	1	1	0.000 0.000	4.500	11.000	0.000
CCI-AFP-045100	C	No	Surface Af (CaAa)	125.416 - 100.416	1	1	0.000 0.000	4.500	11.000	0.000
*										
CCI-AFP-040075	A	No	Surface Af (CaAa)	111.000 - 96.000	1	1	-0.500 -0.500	4.000	9.500	0.000
*										
CCI-AFP-040075	B	No	Surface Af (CaAa)	111.000 - 101.000	1	1	-0.500 -0.500	4.000	9.500	0.000
*										

### Feed Line/Linear Appurtenances - Entered As Area

Description	Face or Leg	Allow Shield	Exclude From Torque Calculation	Component Type	Placement ft	Total Number		C <sub>AA</sub> ft <sup>2</sup> /ft	Weight klf
MLC6C-06C-008R-008R(1-1/2)	B	No	No	Inside Pole	130.000 - 0.000	1	No Ice	0.000	0.002
							1/2" Ice	0.000	0.002
							1" Ice	0.000	0.002
HB114-1-0813U4-M5J(1-1/4)	B	No	No	Inside Pole	130.000 - 0.000	3	No Ice	0.000	0.001
							1/2" Ice	0.000	0.001
							1" Ice	0.000	0.001
*									
CU12PSM9P6XXX(1-1/2)	B	No	No	Inside Pole	120.000 - 0.000	1	No Ice	0.000	0.002
							1/2" Ice	0.000	0.002
							1" Ice	0.000	0.002
*									
LDF7-50A(1-5/8)	B	No	No	Inside Pole	110.000 - 0.000	6	No Ice	0.000	0.001
							1/2" Ice	0.000	0.001

<b>tnxTower</b>  <b>B+T Group</b> 1717 S. Boulder, Suite 300 Tulsa, OK 74119 Phone: (918) 587-4630 FAX: (918) 295-0265	<b>Job</b> 79982.013.01 - WATERBURY,CT (BU# 876317)	<b>Page</b> 13 of 94
	<b>Project</b>	<b>Date</b> 15:43:49 05/20/22
	<b>Client</b> Crown Castle	<b>Designed by</b> Jayaraj B

Description	Face or Leg	Allow Shield	Exclude From Torque Calculation	Component Type	Placement ft	Total Number		C <sub>AA</sub> ft <sup>2</sup> /ft	Weight klf
HB114-U6S12-XXX-LI(1-1/4)	B	No	No	Inside Pole	110.000 - 0.000	2	1" Ice	0.000	0.001
							No Ice	0.000	0.002
							1/2" Ice	0.000	0.002
LDF4-50A(1/2)	B	No	No	Inside Pole	110.000 - 0.000	1	1" Ice	0.000	0.002
							No Ice	0.000	0.000
							1/2" Ice	0.000	0.000
*							1" Ice	0.000	0.000
HB158-21U6S24-xx M_TMO(1-5/8)	C	No	No	Inside Pole	100.000 - 0.000	1	No Ice	0.000	0.003
							1/2" Ice	0.000	0.003
							1" Ice	0.000	0.003
*									
LDF4-50A(1/2)	B	No	No	Inside Pole	50.000 - 0.000	1	No Ice	0.000	0.000
							1/2" Ice	0.000	0.000
							1" Ice	0.000	0.000
*									

### Feed Line/Linear Appurtenances Section Areas

Tower Section	Tower Elevation ft	Face	A <sub>R</sub> ft <sup>2</sup>	A <sub>F</sub> ft <sup>2</sup>	C <sub>AA</sub> In Face ft <sup>2</sup>	C <sub>AA</sub> Out Face ft <sup>2</sup>	Weight K
L1	144.250-139.250	A	0.000	0.000	0.000	0.000	0.000
		B	0.000	0.000	2.357	0.000	0.024
		C	0.000	0.000	0.000	0.000	0.000
L2	139.250-134.750	A	0.000	0.000	0.000	0.000	0.000
		B	0.000	0.000	2.224	0.000	0.023
		C	0.000	0.000	0.000	0.000	0.000
L3	134.750-134.250	A	0.000	0.000	0.000	0.000	0.000
		B	0.000	0.000	0.247	0.000	0.003
		C	0.000	0.000	0.000	0.000	0.000
L4	134.250-129.250	A	0.000	0.000	0.000	0.000	0.000
		B	0.000	0.000	2.514	0.000	0.029
		C	0.000	0.000	0.000	0.000	0.000
L5	129.250-124.250	A	0.000	0.000	0.875	0.000	0.000
		B	0.000	0.000	3.632	0.000	0.052
		C	0.000	0.000	0.875	0.000	0.000
L6	124.250-123.416	A	0.000	0.000	0.625	0.000	0.000
		B	0.000	0.000	1.085	0.000	0.009
		C	0.000	0.000	0.625	0.000	0.000
L7	123.416-123.166	A	0.000	0.000	0.188	0.000	0.000
		B	0.000	0.000	0.325	0.000	0.003
		C	0.000	0.000	0.188	0.000	0.000
L8	123.166-118.166	A	0.000	0.000	3.750	0.000	0.000
		B	0.000	0.000	6.508	0.000	0.056
		C	0.000	0.000	3.750	0.000	0.000
L9	118.166-113.166	A	0.000	0.000	3.750	0.000	0.000
		B	0.000	0.000	6.508	0.000	0.064
		C	0.000	0.000	3.750	0.000	0.000
L10	113.166-109.500	A	0.000	0.000	3.749	0.000	0.000
		B	0.000	0.000	5.771	0.000	0.051
		C	0.000	0.000	2.749	0.000	0.000
L11	109.500-109.250	A	0.000	0.000	0.354	0.000	0.000
		B	0.000	0.000	0.492	0.000	0.005

# tnxTower

**B+T Group**  
1717 S. Boulder, Suite 300  
Tulsa, OK 74119  
Phone: (918) 587-4630  
FAX: (918) 295-0265

**Job**  
79982.013.01 - WATERBURY,CT (BU# 876317)

**Page**  
14 of 94

**Project**  
**Date**  
15:43:49 05/20/22

**Client**  
Crown Castle  
**Designed by**  
Jayaraj B

Tower Section	Tower Elevation ft	Face	A <sub>R</sub> ft <sup>2</sup>	A <sub>F</sub> ft <sup>2</sup>	C <sub>AA</sub> In Face ft <sup>2</sup>	C <sub>AA</sub> Out Face ft <sup>2</sup>	Weight K
L12	109.250-104.750	C	0.000	0.000	0.188	0.000	0.000
		A	0.000	0.000	7.542	0.000	0.000
		B	0.000	0.000	10.024	0.000	0.095
L13	104.750-104.500	C	0.000	0.000	5.025	0.000	0.000
		A	0.000	0.000	0.521	0.000	0.000
		B	0.000	0.000	0.659	0.000	0.005
L14	104.500-102.416	C	0.000	0.000	0.563	0.000	0.000
		A	0.000	0.000	4.342	0.000	0.000
		B	0.000	0.000	5.491	0.000	0.044
L15	102.416-102.166	C	0.000	0.000	4.689	0.000	0.000
		A	0.000	0.000	0.521	0.000	0.000
		B	0.000	0.000	0.659	0.000	0.005
L16	102.166-98.750	C	0.000	0.000	0.563	0.000	0.000
		A	0.000	0.000	6.622	0.000	0.000
		B	0.000	0.000	8.060	0.000	0.072
L17	98.750-98.500	C	0.000	0.000	8.628	0.000	0.005
		A	0.000	0.000	0.484	0.000	0.000
		B	0.000	0.000	0.622	0.000	0.005
L18	98.500-97.500	C	0.000	0.000	0.769	0.000	0.001
		A	0.000	0.000	1.938	0.000	0.000
		B	0.000	0.000	2.489	0.000	0.021
L19	97.500-97.250	C	0.000	0.000	3.077	0.000	0.004
		A	0.000	0.000	0.484	0.000	0.000
		B	0.000	0.000	0.622	0.000	0.005
L20	97.250-92.000	C	0.000	0.000	0.769	0.000	0.001
		A	0.000	0.000	7.505	0.000	0.000
		B	0.000	0.000	13.067	0.000	0.111
L21	92.000-90.552	C	0.000	0.000	16.153	0.000	0.019
		A	0.000	0.000	1.840	0.000	0.000
		B	0.000	0.000	3.604	0.000	0.031
L22	90.552-89.250	C	0.000	0.000	4.455	0.000	0.005
		A	0.000	0.000	2.377	0.000	0.000
		B	0.000	0.000	3.241	0.000	0.028
L23	89.250-89.000	C	0.000	0.000	4.006	0.000	0.005
		A	0.000	0.000	0.563	0.000	0.000
		B	0.000	0.000	0.700	0.000	0.005
L24	89.000-88.250	C	0.000	0.000	0.847	0.000	0.001
		A	0.000	0.000	1.688	0.000	0.000
		B	0.000	0.000	2.101	0.000	0.016
L25	88.250-88.000	C	0.000	0.000	2.542	0.000	0.003
		A	0.000	0.000	0.563	0.000	0.000
		B	0.000	0.000	0.700	0.000	0.005
L26	88.000-87.833	C	0.000	0.000	0.847	0.000	0.001
		A	0.000	0.000	0.376	0.000	0.000
		B	0.000	0.000	0.468	0.000	0.004
L27	87.833-87.583	C	0.000	0.000	0.566	0.000	0.001
		A	0.000	0.000	0.563	0.000	0.000
		B	0.000	0.000	0.700	0.000	0.005
L28	87.583-82.583	C	0.000	0.000	0.847	0.000	0.001
		A	0.000	0.000	8.639	0.000	0.000
		B	0.000	0.000	11.396	0.000	0.106
L29	82.583-77.583	C	0.000	0.000	12.046	0.000	0.018
		A	0.000	0.000	8.695	0.000	0.000
		B	0.000	0.000	11.452	0.000	0.106
L30	77.583-77.000	C	0.000	0.000	10.225	0.000	0.018
		A	0.000	0.000	1.312	0.000	0.000
		B	0.000	0.000	1.633	0.000	0.012
L31	77.000-76.750	C	0.000	0.000	1.490	0.000	0.002
		A	0.000	0.000	0.563	0.000	0.000
		B	0.000	0.000	0.700	0.000	0.005
		C	0.000	0.000	0.639	0.000	0.001

Tower Section	Tower Elevation ft	Face	A <sub>R</sub> ft <sup>2</sup>	A <sub>F</sub> ft <sup>2</sup>	C <sub>AA</sub> In Face ft <sup>2</sup>	C <sub>AA</sub> Out Face ft <sup>2</sup>	Weight K
L32	76.750-76.333	A	0.000	0.000	0.938	0.000	0.000
		B	0.000	0.000	1.168	0.000	0.009
		C	0.000	0.000	1.066	0.000	0.002
L33	76.333-76.083	A	0.000	0.000	0.563	0.000	0.000
		B	0.000	0.000	0.700	0.000	0.005
		C	0.000	0.000	0.639	0.000	0.001
L34	76.083-74.250	A	0.000	0.000	4.152	0.000	0.000
		B	0.000	0.000	5.832	0.000	0.039
		C	0.000	0.000	3.965	0.000	0.007
L35	74.250-74.000	A	0.000	0.000	0.583	0.000	0.000
		B	0.000	0.000	0.888	0.000	0.005
		C	0.000	0.000	0.472	0.000	0.001
L36	74.000-73.750	A	0.000	0.000	0.583	0.000	0.000
		B	0.000	0.000	0.888	0.000	0.005
		C	0.000	0.000	0.472	0.000	0.001
L37	73.750-73.500	A	0.000	0.000	0.583	0.000	0.000
		B	0.000	0.000	0.888	0.000	0.005
		C	0.000	0.000	0.472	0.000	0.001
L38	73.500-68.500	A	0.000	0.000	11.667	0.000	0.000
		B	0.000	0.000	17.758	0.000	0.106
		C	0.000	0.000	9.447	0.000	0.018
L39	68.500-63.500	A	0.000	0.000	11.667	0.000	0.000
		B	0.000	0.000	17.758	0.000	0.106
		C	0.000	0.000	9.447	0.000	0.018
L40	63.500-60.500	A	0.000	0.000	8.167	0.000	0.000
		B	0.000	0.000	11.821	0.000	0.064
		C	0.000	0.000	6.835	0.000	0.011
L41	60.500-60.250	A	0.000	0.000	0.750	0.000	0.000
		B	0.000	0.000	1.055	0.000	0.005
		C	0.000	0.000	0.639	0.000	0.001
L42	60.250-59.500	A	0.000	0.000	2.250	0.000	0.000
		B	0.000	0.000	3.164	0.000	0.016
		C	0.000	0.000	1.917	0.000	0.003
L43	59.500-59.250	A	0.000	0.000	0.797	0.000	0.000
		B	0.000	0.000	1.101	0.000	0.005
		C	0.000	0.000	0.686	0.000	0.001
L44	59.250-54.250	A	0.000	0.000	12.938	0.000	0.000
		B	0.000	0.000	19.029	0.000	0.106
		C	0.000	0.000	10.717	0.000	0.018
L45	54.250-45.802	A	0.000	0.000	21.296	0.000	0.000
		B	0.000	0.000	31.587	0.000	0.180
		C	0.000	0.000	17.545	0.000	0.031
L46	45.802-44.802	A	0.000	0.000	2.393	0.000	0.000
		B	0.000	0.000	3.437	0.000	0.021
		C	0.000	0.000	2.410	0.000	0.004
L47	44.802-43.583	A	0.000	0.000	3.073	0.000	0.000
		B	0.000	0.000	3.943	0.000	0.026
		C	0.000	0.000	3.644	0.000	0.004
L48	43.583-43.333	A	0.000	0.000	0.630	0.000	0.000
		B	0.000	0.000	0.809	0.000	0.005
		C	0.000	0.000	0.747	0.000	0.001
L49	43.333-43.166	A	0.000	0.000	0.421	0.000	0.000
		B	0.000	0.000	0.540	0.000	0.004
		C	0.000	0.000	0.499	0.000	0.001
L50	43.166-42.916	A	0.000	0.000	0.630	0.000	0.000
		B	0.000	0.000	0.809	0.000	0.005
		C	0.000	0.000	0.747	0.000	0.001
L51	42.916-39.000	A	0.000	0.000	9.872	0.000	0.000
		B	0.000	0.000	12.666	0.000	0.084
		C	0.000	0.000	12.871	0.000	0.014
L52	39.000-38.750	A	0.000	0.000	0.630	0.000	0.000

# tnxTower

**B+T Group**  
1717 S. Boulder, Suite 300  
Tulsa, OK 74119  
Phone: (918) 587-4630  
FAX: (918) 295-0265

**Job**  
79982.013.01 - WATERBURY,CT (BU# 876317)

**Page**  
16 of 94

**Project**  
**Date**  
15:43:49 05/20/22

**Client**  
Crown Castle  
**Designed by**  
Jayaraj B

Tower Section	Tower Elevation ft	Face	A <sub>R</sub> ft <sup>2</sup>	A <sub>F</sub> ft <sup>2</sup>	C <sub>A</sub> A <sub>A</sub> In Face ft <sup>2</sup>	C <sub>A</sub> A <sub>A</sub> Out Face ft <sup>2</sup>	Weight K
L53	38.750-37.166	B	0.000	0.000	0.809	0.000	0.005
		C	0.000	0.000	0.914	0.000	0.001
		A	0.000	0.000	3.993	0.000	0.000
L54	37.166-36.916	B	0.000	0.000	5.123	0.000	0.034
		C	0.000	0.000	5.791	0.000	0.006
		A	0.000	0.000	0.630	0.000	0.000
L55	36.916-34.000	B	0.000	0.000	0.809	0.000	0.005
		C	0.000	0.000	0.914	0.000	0.001
		A	0.000	0.000	8.517	0.000	0.000
L56	34.000-33.750	B	0.000	0.000	10.346	0.000	0.062
		C	0.000	0.000	10.408	0.000	0.011
		A	0.000	0.000	0.797	0.000	0.000
L57	33.750-29.750	B	0.000	0.000	0.935	0.000	0.005
		C	0.000	0.000	0.873	0.000	0.001
		A	0.000	0.000	11.083	0.000	0.000
L58	29.750-29.500	B	0.000	0.000	13.289	0.000	0.085
		C	0.000	0.000	12.307	0.000	0.015
		A	0.000	0.000	0.641	0.000	0.000
L59	29.500-24.500	B	0.000	0.000	0.779	0.000	0.005
		C	0.000	0.000	0.717	0.000	0.001
		A	0.000	0.000	12.375	0.000	0.000
L60	24.500-23.000	B	0.000	0.000	16.070	0.000	0.107
		C	0.000	0.000	14.905	0.000	0.018
		A	0.000	0.000	2.719	0.000	0.000
L61	23.000-22.750	B	0.000	0.000	6.171	0.000	0.032
		C	0.000	0.000	6.178	0.000	0.006
		A	0.000	0.000	0.453	0.000	0.000
L62	22.750-21.583	B	0.000	0.000	1.029	0.000	0.005
		C	0.000	0.000	1.030	0.000	0.001
		A	0.000	0.000	2.115	0.000	0.000
L63	21.583-21.333	B	0.000	0.000	4.801	0.000	0.025
		C	0.000	0.000	4.806	0.000	0.004
		A	0.000	0.000	0.453	0.000	0.000
L64	21.333-16.333	B	0.000	0.000	1.029	0.000	0.005
		C	0.000	0.000	1.030	0.000	0.001
		A	0.000	0.000	9.063	0.000	0.000
L65	16.333-12.917	B	0.000	0.000	17.758	0.000	0.107
		C	0.000	0.000	20.792	0.000	0.018
		A	0.000	0.000	6.191	0.000	0.000
L66	12.917-12.667	B	0.000	0.000	11.492	0.000	0.073
		C	0.000	0.000	21.897	0.000	0.013
		A	0.000	0.000	0.453	0.000	0.000
L67	12.667-12.500	B	0.000	0.000	0.841	0.000	0.005
		C	0.000	0.000	1.603	0.000	0.001
		A	0.000	0.000	0.303	0.000	0.000
L68	12.500-12.250	B	0.000	0.000	0.562	0.000	0.004
		C	0.000	0.000	1.070	0.000	0.001
		A	0.000	0.000	0.453	0.000	0.000
L69	12.250-12.000	B	0.000	0.000	0.841	0.000	0.005
		C	0.000	0.000	1.603	0.000	0.001
		A	0.000	0.000	0.453	0.000	0.000
L70	12.000-11.750	B	0.000	0.000	0.841	0.000	0.005
		C	0.000	0.000	1.603	0.000	0.001
		A	0.000	0.000	0.453	0.000	0.000
L71	11.750-8.500	B	0.000	0.000	0.841	0.000	0.005
		C	0.000	0.000	1.603	0.000	0.001
		A	0.000	0.000	4.684	0.000	0.000
L72	8.500-8.250	B	0.000	0.000	9.727	0.000	0.069
		C	0.000	0.000	17.359	0.000	0.012
		A	0.000	0.000	0.323	0.000	0.000

<p><b>tnxTower</b></p> <p><b>B+T Group</b> 1717 S. Boulder, Suite 300 Tulsa, OK 74119 Phone: (918) 587-4630 FAX: (918) 295-0265</p>	<p><b>Job</b></p> <p>79982.013.01 - WATERBURY,CT (BU# 876317)</p>	<p><b>Page</b></p> <p>17 of 94</p>
	<p><b>Project</b></p>	<p><b>Date</b></p> <p>15:43:49 05/20/22</p>
	<p><b>Client</b></p> <p>Crown Castle</p>	<p><b>Designed by</b></p> <p>Jayaraj B</p>

Tower Section	Tower Elevation ft	Face	A <sub>R</sub> ft <sup>2</sup>	A <sub>F</sub> ft <sup>2</sup>	C <sub>A</sub> A <sub>A</sub> In Face ft <sup>2</sup>	C <sub>A</sub> A <sub>A</sub> Out Face ft <sup>2</sup>	Weight K
L73	8.250-7.000	C	0.000	0.000	0.936	0.000	0.001
		A	0.000	0.000	1.616	0.000	0.000
		B	0.000	0.000	3.555	0.000	0.027
L74	7.000-6.750	C	0.000	0.000	4.680	0.000	0.005
		A	0.000	0.000	0.323	0.000	0.000
		B	0.000	0.000	0.711	0.000	0.005
L75	6.750-1.750	C	0.000	0.000	0.936	0.000	0.001
		A	0.000	0.000	6.463	0.000	0.000
		B	0.000	0.000	10.970	0.000	0.107
L76	1.750-0.000	C	0.000	0.000	15.472	0.000	0.018
		A	0.000	0.000	2.262	0.000	0.000
		B	0.000	0.000	3.227	0.000	0.037
		C	0.000	0.000	4.803	0.000	0.006

**Feed Line/Linear Appurtenances Section Areas - With Ice**

Tower Section	Tower Elevation ft	Face or Leg	Ice Thickness in	A <sub>R</sub> ft <sup>2</sup>	A <sub>F</sub> ft <sup>2</sup>	C <sub>A</sub> A <sub>A</sub> In Face ft <sup>2</sup>	C <sub>A</sub> A <sub>A</sub> Out Face ft <sup>2</sup>	Weight K
L1	144.250-139.250	A	0.983	0.000	0.000	0.000	0.000	0.000
		B		0.000	0.000	7.930	0.000	0.081
		C		0.000	0.000	0.000	0.000	0.000
L2	139.250-134.750	A	0.980	0.000	0.000	0.000	0.000	0.000
		B		0.000	0.000	7.441	0.000	0.076
		C		0.000	0.000	0.000	0.000	0.000
L3	134.750-134.250	A	0.978	0.000	0.000	0.000	0.000	0.000
		B		0.000	0.000	0.826	0.000	0.008
		C		0.000	0.000	0.000	0.000	0.000
L4	134.250-129.250	A	0.976	0.000	0.000	0.000	0.000	0.000
		B		0.000	0.000	8.436	0.000	0.092
		C		0.000	0.000	0.000	0.000	0.000
L5	129.250-124.250	A	0.972	0.000	0.000	1.101	0.000	0.006
		B		0.000	0.000	10.586	0.000	0.144
		C		0.000	0.000	1.101	0.000	0.006
L6	124.250-123.416	A	0.970	0.000	0.000	0.787	0.000	0.005
		B		0.000	0.000	2.367	0.000	0.028
		C		0.000	0.000	0.787	0.000	0.005
L7	123.416-123.166	A	0.970	0.000	0.000	0.236	0.000	0.001
		B		0.000	0.000	0.709	0.000	0.008
		C		0.000	0.000	0.236	0.000	0.001
L8	123.166-118.166	A	0.968	0.000	0.000	4.718	0.000	0.028
		B		0.000	0.000	14.171	0.000	0.169
		C		0.000	0.000	4.718	0.000	0.028
L9	118.166-113.166	A	0.964	0.000	0.000	4.714	0.000	0.027
		B		0.000	0.000	14.140	0.000	0.176
		C		0.000	0.000	4.714	0.000	0.027
L10	113.166-109.500	A	0.960	0.000	0.000	4.741	0.000	0.027
		B		0.000	0.000	11.572	0.000	0.140
		C		0.000	0.000	3.453	0.000	0.020
L11	109.500-109.250	A	0.958	0.000	0.000	0.450	0.000	0.003
		B		0.000	0.000	0.909	0.000	0.012
		C		0.000	0.000	0.235	0.000	0.001
L12	109.250-104.750	A	0.956	0.000	0.000	9.597	0.000	0.055
		B		0.000	0.000	17.849	0.000	0.226
		C		0.000	0.000	6.331	0.000	0.037
L13	104.750-104.500	A	0.954	0.000	0.000	0.664	0.000	0.004
		B		0.000	0.000	1.122	0.000	0.013
		C		0.000	0.000	0.706	0.000	0.004

Tower Section	Tower Elevation ft	Face or Leg	Ice Thickness in	A <sub>R</sub> ft <sup>2</sup>	A <sub>F</sub> ft <sup>2</sup>	C <sub>AA</sub> In Face ft <sup>2</sup>	C <sub>AA</sub> Out Face ft <sup>2</sup>	Weight K
L14	104.500-102.416	A	0.953	0.000	0.000	5.533	0.000	0.032
		B		0.000	0.000	9.346	0.000	0.111
		C		0.000	0.000	5.880	0.000	0.034
L15	102.416-102.166	A	0.952	0.000	0.000	0.664	0.000	0.004
		B		0.000	0.000	1.121	0.000	0.013
		C		0.000	0.000	0.705	0.000	0.004
L16	102.166-98.750	A	0.950	0.000	0.000	8.481	0.000	0.049
		B		0.000	0.000	14.239	0.000	0.175
		C		0.000	0.000	11.179	0.000	0.071
L17	98.750-98.500	A	0.948	0.000	0.000	0.625	0.000	0.004
		B		0.000	0.000	1.091	0.000	0.013
		C		0.000	0.000	1.035	0.000	0.007
L18	98.500-97.500	A	0.948	0.000	0.000	2.499	0.000	0.015
		B		0.000	0.000	4.363	0.000	0.052
		C		0.000	0.000	4.141	0.000	0.029
L19	97.500-97.250	A	0.947	0.000	0.000	0.625	0.000	0.004
		B		0.000	0.000	1.091	0.000	0.013
		C		0.000	0.000	1.035	0.000	0.007
L20	97.250-92.000	A	0.944	0.000	0.000	9.685	0.000	0.058
		B		0.000	0.000	22.875	0.000	0.275
		C		0.000	0.000	21.722	0.000	0.149
L21	92.000-90.552	A	0.941	0.000	0.000	2.377	0.000	0.014
		B		0.000	0.000	6.309	0.000	0.076
		C		0.000	0.000	5.991	0.000	0.041
L22	90.552-89.250	A	0.940	0.000	0.000	3.060	0.000	0.018
		B		0.000	0.000	5.661	0.000	0.068
		C		0.000	0.000	5.381	0.000	0.037
L23	89.250-89.000	A	0.939	0.000	0.000	0.703	0.000	0.004
		B		0.000	0.000	1.167	0.000	0.013
		C		0.000	0.000	1.113	0.000	0.007
L24	89.000-88.250	A	0.938	0.000	0.000	2.110	0.000	0.012
		B		0.000	0.000	3.499	0.000	0.040
		C		0.000	0.000	3.338	0.000	0.022
L25	88.250-88.000	A	0.938	0.000	0.000	0.703	0.000	0.004
		B		0.000	0.000	1.166	0.000	0.013
		C		0.000	0.000	1.113	0.000	0.007
L26	88.000-87.833	A	0.938	0.000	0.000	0.470	0.000	0.003
		B		0.000	0.000	0.779	0.000	0.009
		C		0.000	0.000	0.743	0.000	0.005
L27	87.833-87.583	A	0.937	0.000	0.000	0.703	0.000	0.004
		B		0.000	0.000	1.166	0.000	0.013
		C		0.000	0.000	1.112	0.000	0.007
L28	87.583-82.583	A	0.934	0.000	0.000	10.710	0.000	0.060
		B		0.000	0.000	19.947	0.000	0.247
		C		0.000	0.000	16.089	0.000	0.112
L29	82.583-77.583	A	0.929	0.000	0.000	10.769	0.000	0.060
		B		0.000	0.000	19.970	0.000	0.246
		C		0.000	0.000	13.842	0.000	0.099
L30	77.583-77.000	A	0.926	0.000	0.000	1.635	0.000	0.009
		B		0.000	0.000	2.706	0.000	0.031
		C		0.000	0.000	1.993	0.000	0.014
L31	77.000-76.750	A	0.925	0.000	0.000	0.701	0.000	0.004
		B		0.000	0.000	1.160	0.000	0.013
		C		0.000	0.000	0.855	0.000	0.006
L32	76.750-76.333	A	0.925	0.000	0.000	1.170	0.000	0.007
		B		0.000	0.000	1.935	0.000	0.022
		C		0.000	0.000	1.425	0.000	0.010
L33	76.333-76.083	A	0.924	0.000	0.000	0.701	0.000	0.004
		B		0.000	0.000	1.160	0.000	0.013
		C		0.000	0.000	0.855	0.000	0.006
L34	76.083-74.250	A	0.923	0.000	0.000	5.152	0.000	0.029

Tower Section	Tower Elevation ft	Face or Leg	Ice Thickness in	A <sub>R</sub> ft <sup>2</sup>	A <sub>F</sub> ft <sup>2</sup>	C <sub>AA</sub> In Face ft <sup>2</sup>	C <sub>AA</sub> Out Face ft <sup>2</sup>	Weight K
		B		0.000	0.000	9.365	0.000	0.101
		C		0.000	0.000	5.344	0.000	0.038
L35	74.250-74.000	A	0.922	0.000	0.000	0.722	0.000	0.004
		B		0.000	0.000	1.392	0.000	0.014
		C		0.000	0.000	0.641	0.000	0.005
L36	74.000-73.750	A	0.921	0.000	0.000	0.722	0.000	0.004
		B		0.000	0.000	1.392	0.000	0.014
		C		0.000	0.000	0.641	0.000	0.005
L37	73.750-73.500	A	0.921	0.000	0.000	0.721	0.000	0.004
		B		0.000	0.000	1.392	0.000	0.014
		C		0.000	0.000	0.641	0.000	0.005
L38	73.500-68.500	A	0.918	0.000	0.000	14.420	0.000	0.080
		B		0.000	0.000	27.799	0.000	0.288
		C		0.000	0.000	12.812	0.000	0.093
L39	68.500-63.500	A	0.911	0.000	0.000	14.400	0.000	0.079
		B		0.000	0.000	27.729	0.000	0.286
		C		0.000	0.000	12.790	0.000	0.092
L40	63.500-60.500	A	0.905	0.000	0.000	10.113	0.000	0.056
		B		0.000	0.000	18.085	0.000	0.179
		C		0.000	0.000	9.146	0.000	0.063
L41	60.500-60.250	A	0.903	0.000	0.000	0.931	0.000	0.005
		B		0.000	0.000	1.594	0.000	0.015
		C		0.000	0.000	0.850	0.000	0.006
L42	60.250-59.500	A	0.902	0.000	0.000	2.791	0.000	0.015
		B		0.000	0.000	4.781	0.000	0.046
		C		0.000	0.000	2.550	0.000	0.017
L43	59.500-59.250	A	0.901	0.000	0.000	0.977	0.000	0.005
		B		0.000	0.000	1.640	0.000	0.016
		C		0.000	0.000	0.897	0.000	0.006
L44	59.250-54.250	A	0.897	0.000	0.000	15.719	0.000	0.084
		B		0.000	0.000	28.946	0.000	0.289
		C		0.000	0.000	14.106	0.000	0.097
L45	54.250-45.802	A	0.886	0.000	0.000	25.787	0.000	0.136
		B		0.000	0.000	47.992	0.000	0.480
		C		0.000	0.000	23.057	0.000	0.158
L46	45.802-44.802	A	0.877	0.000	0.000	2.895	0.000	0.015
		B		0.000	0.000	5.255	0.000	0.055
		C		0.000	0.000	3.097	0.000	0.021
L47	44.802-43.583	A	0.875	0.000	0.000	3.713	0.000	0.019
		B		0.000	0.000	5.970	0.000	0.065
		C		0.000	0.000	4.545	0.000	0.030
L48	43.583-43.333	A	0.874	0.000	0.000	0.761	0.000	0.004
		B		0.000	0.000	1.224	0.000	0.013
		C		0.000	0.000	0.932	0.000	0.006
L49	43.333-43.166	A	0.873	0.000	0.000	0.508	0.000	0.003
		B		0.000	0.000	0.817	0.000	0.009
		C		0.000	0.000	0.622	0.000	0.004
L50	43.166-42.916	A	0.873	0.000	0.000	0.761	0.000	0.004
		B		0.000	0.000	1.223	0.000	0.013
		C		0.000	0.000	0.932	0.000	0.006
L51	42.916-39.000	A	0.869	0.000	0.000	11.912	0.000	0.062
		B		0.000	0.000	19.132	0.000	0.206
		C		0.000	0.000	16.052	0.000	0.103
L52	39.000-38.750	A	0.864	0.000	0.000	0.760	0.000	0.004
		B		0.000	0.000	1.219	0.000	0.013
		C		0.000	0.000	1.140	0.000	0.007
L53	38.750-37.166	A	0.862	0.000	0.000	4.812	0.000	0.025
		B		0.000	0.000	7.720	0.000	0.083
		C		0.000	0.000	7.219	0.000	0.045
L54	37.166-36.916	A	0.860	0.000	0.000	0.759	0.000	0.004
		B		0.000	0.000	1.218	0.000	0.013

<b>tnxTower</b>  <b>B+T Group</b> 1717 S. Boulder, Suite 300 Tulsa, OK 74119 Phone: (918) 587-4630 FAX: (918) 295-0265	<b>Job</b>	<b>Page</b>
	79982.013.01 - WATERBURY,CT (BU# 876317)	20 of 94
	<b>Project</b>	<b>Date</b>
		15:43:49 05/20/22
	<b>Client</b>	<b>Designed by</b>
	Crown Castle	Jayaraj B

Tower Section	Tower Elevation ft	Face or Leg	Ice Thickness in	A <sub>R</sub> ft <sup>2</sup>	A <sub>F</sub> ft <sup>2</sup>	C <sub>AA</sub> In Face ft <sup>2</sup>	C <sub>AA</sub> Out Face ft <sup>2</sup>	Weight K
L55	36.916-34.000	C		0.000	0.000	1.139	0.000	0.007
		A	0.856	0.000	0.000	10.315	0.000	0.053
		B		0.000	0.000	15.473	0.000	0.158
		C		0.000	0.000	13.026	0.000	0.081
L56	34.000-33.750	A	0.852	0.000	0.000	0.967	0.000	0.005
		B		0.000	0.000	1.402	0.000	0.014
		C		0.000	0.000	1.099	0.000	0.007
L57	33.750-29.750	A	0.847	0.000	0.000	13.369	0.000	0.068
		B		0.000	0.000	20.303	0.000	0.209
		C		0.000	0.000	15.480	0.000	0.097
L58	29.750-29.500	A	0.841	0.000	0.000	0.767	0.000	0.004
		B		0.000	0.000	1.198	0.000	0.013
		C		0.000	0.000	0.898	0.000	0.006
L59	29.500-24.500	A	0.833	0.000	0.000	14.777	0.000	0.073
		B		0.000	0.000	24.474	0.000	0.253
		C		0.000	0.000	18.607	0.000	0.115
L60	24.500-23.000	A	0.822	0.000	0.000	3.212	0.000	0.016
		B		0.000	0.000	8.884	0.000	0.083
		C		0.000	0.000	7.581	0.000	0.043
L61	23.000-22.750	A	0.819	0.000	0.000	0.535	0.000	0.003
		B		0.000	0.000	1.479	0.000	0.014
		C		0.000	0.000	1.263	0.000	0.007
L62	22.750-21.583	A	0.817	0.000	0.000	2.496	0.000	0.012
		B		0.000	0.000	6.898	0.000	0.064
		C		0.000	0.000	5.891	0.000	0.033
L63	21.583-21.333	A	0.814	0.000	0.000	0.535	0.000	0.003
		B		0.000	0.000	1.476	0.000	0.014
		C		0.000	0.000	1.261	0.000	0.007
L64	21.333-16.333	A	0.804	0.000	0.000	10.670	0.000	0.051
		B		0.000	0.000	25.999	0.000	0.254
		C		0.000	0.000	25.398	0.000	0.140
L65	16.333-12.917	A	0.784	0.000	0.000	7.262	0.000	0.033
		B		0.000	0.000	16.854	0.000	0.167
		C		0.000	0.000	25.947	0.000	0.133
L66	12.917-12.667	A	0.773	0.000	0.000	0.530	0.000	0.002
		B		0.000	0.000	1.229	0.000	0.012
		C		0.000	0.000	1.896	0.000	0.010
L67	12.667-12.500	A	0.772	0.000	0.000	0.354	0.000	0.002
		B		0.000	0.000	0.820	0.000	0.008
		C		0.000	0.000	1.266	0.000	0.006
L68	12.500-12.250	A	0.771	0.000	0.000	0.530	0.000	0.002
		B		0.000	0.000	1.227	0.000	0.012
		C		0.000	0.000	1.895	0.000	0.010
L69	12.250-12.000	A	0.769	0.000	0.000	0.530	0.000	0.002
		B		0.000	0.000	1.227	0.000	0.012
		C		0.000	0.000	1.894	0.000	0.010
L70	12.000-11.750	A	0.767	0.000	0.000	0.530	0.000	0.002
		B		0.000	0.000	1.226	0.000	0.012
		C		0.000	0.000	1.894	0.000	0.010
L71	11.750-8.500	A	0.755	0.000	0.000	5.560	0.000	0.033
		B		0.000	0.000	14.548	0.000	0.157
		C		0.000	0.000	20.669	0.000	0.113
L72	8.500-8.250	A	0.741	0.000	0.000	0.389	0.000	0.003
		B		0.000	0.000	1.075	0.000	0.012
		C		0.000	0.000	1.138	0.000	0.007
L73	8.250-7.000	A	0.734	0.000	0.000	1.941	0.000	0.013
		B		0.000	0.000	5.359	0.000	0.060
		C		0.000	0.000	5.681	0.000	0.035
L74	7.000-6.750	A	0.727	0.000	0.000	0.388	0.000	0.003
		B		0.000	0.000	1.068	0.000	0.012
		C		0.000	0.000	1.135	0.000	0.007

<b>tnxTower</b>  <b>B+T Group</b> 1717 S. Boulder, Suite 300 Tulsa, OK 74119 Phone: (918) 587-4630 FAX: (918) 295-0265	<b>Job</b>	79982.013.01 - WATERBURY,CT (BU# 876317)	<b>Page</b>	21 of 94
	<b>Project</b>		<b>Date</b>	15:43:49 05/20/22
	<b>Client</b>	Crown Castle		<b>Designed by</b>

Tower Section	Tower Elevation ft	Face or Leg	Ice Thickness in	A <sub>R</sub> ft <sup>2</sup>	A <sub>F</sub> ft <sup>2</sup>	C <sub>AA</sub> In Face ft <sup>2</sup>	C <sub>AA</sub> Out Face ft <sup>2</sup>	Weight K
L75	6.750-1.750	A	0.692	0.000	0.000	7.693	0.000	0.050
		B		0.000	0.000	17.349	0.000	0.217
		C		0.000	0.000	18.851	0.000	0.117
L76	1.750-0.000	A	0.591	0.000	0.000	2.631	0.000	0.015
		B		0.000	0.000	5.083	0.000	0.067
		C		0.000	0.000	5.765	0.000	0.033

### Feed Line Center of Pressure

Section	Elevation ft	CP <sub>X</sub> in	CP <sub>Z</sub> in	CP <sub>X</sub> Ice in	CP <sub>Z</sub> Ice in
L1	144.250-139.250	2.344	-1.002	2.476	-1.225
L2	139.250-134.750	2.389	-1.012	2.528	-1.233
L3	134.750-134.250	2.465	-1.044	2.612	-1.274
L4	134.250-129.250	1.823	-0.803	2.637	-1.347
L5	129.250-124.250	1.498	-0.792	2.371	-1.491
L6	124.250-123.416	0.905	-0.478	1.690	-1.063
L7	123.416-123.166	0.910	-0.481	1.701	-1.070
L8	123.166-118.166	0.932	-0.492	1.739	-1.094
L9	118.166-113.166	0.972	-0.514	1.811	-1.138
L10	113.166-109.500	0.183	-0.297	1.176	-0.918
L11	109.500-109.250	-0.723	-0.042	0.375	-0.628
L12	109.250-104.750	-0.630	0.128	0.337	-0.436
L13	104.750-104.500	-0.484	0.929	0.275	0.359
L14	104.500-102.416	-0.489	0.939	0.277	0.363
L15	102.416-102.166	-0.501	0.962	0.279	0.367
L16	102.166-98.750	0.210	1.782	0.839	1.098
L17	98.750-98.500	0.618	2.270	1.044	1.591
L18	98.500-97.500	0.621	2.280	1.049	1.599
L19	97.500-97.250	0.624	2.290	1.054	1.607
L20	97.250-92.000	0.906	1.643	1.327	1.018
L21	92.000-90.552	1.005	1.431	1.425	0.825
L22	90.552-89.250	0.706	2.232	1.151	1.546
L23	89.250-89.000	0.593	2.174	1.031	1.580
L24	89.000-88.250	0.595	2.184	1.036	1.588
L25	88.250-88.000	0.599	2.197	1.042	1.597
L26	88.000-87.833	0.600	2.200	1.043	1.599
L27	87.833-87.583	0.601	2.202	1.045	1.602
L28	87.583-82.583	0.767	2.165	1.275	1.431
L29	82.583-77.583	0.827	1.773	1.360	1.079
L30	77.583-77.000	0.699	1.499	1.197	0.953
L31	77.000-76.750	0.702	1.504	1.201	0.956
L32	76.750-76.333	0.703	1.507	1.204	0.958
L33	76.333-76.083	0.705	1.510	1.206	0.961
L34	76.083-74.250	0.868	-0.156	1.355	-0.499
L35	74.250-74.000	1.022	-1.403	1.490	-1.591
L36	74.000-73.750	1.024	-1.406	1.492	-1.593
L37	73.750-73.500	1.025	-1.408	1.494	-1.596
L38	73.500-68.500	1.043	-1.432	1.517	-1.621
L39	68.500-63.500	1.076	-1.478	1.561	-1.668
L40	63.500-60.500	0.991	-1.361	1.451	-1.552
L41	60.500-60.250	0.934	-1.282	1.375	-1.472
L42	60.250-59.500	0.937	-1.286	1.379	-1.476
L43	59.500-59.250	0.899	-1.234	1.340	-1.434
L44	59.250-54.250	1.080	-1.483	1.554	-1.664
L45	54.250-45.802	1.145	-1.572	1.632	-1.749

<b>tnxTower</b>  <b>B+T Group</b> 1717 S. Boulder, Suite 300 Tulsa, OK 74119 Phone: (918) 587-4630 FAX: (918) 295-0265	<b>Job</b> 79982.013.01 - WATERBURY, CT (BU# 876317)	<b>Page</b> 22 of 94
	<b>Project</b>	<b>Date</b> 15:43:49 05/20/22
	<b>Client</b> Crown Castle	<b>Designed by</b> Jayaraj B

Section	Elevation	CP <sub>x</sub>	CP <sub>z</sub>	CP <sub>x</sub>	CP <sub>z</sub>
	ft	in	in	Ice in	Ice in
L46	45.802-44.802	0.907	-0.511	1.407	-0.876
L47	44.802-43.583	0.374	1.080	0.864	0.510
L48	43.583-43.333	0.375	1.084	0.866	0.513
L49	43.333-43.166	0.376	1.085	0.867	0.513
L50	43.166-42.916	0.376	1.086	0.868	0.514
L51	42.916-39.000	0.744	1.324	1.196	0.741
L52	39.000-38.750	1.176	1.601	1.582	1.007
L53	38.750-37.166	1.182	1.609	1.588	1.013
L54	37.166-36.916	1.188	1.616	1.594	1.018
L55	36.916-34.000	0.638	0.666	1.108	0.169
L56	34.000-33.750	0.281	0.069	0.823	-0.371
L57	33.750-29.750	0.313	0.077	0.906	-0.407
L58	29.750-29.500	0.333	0.082	0.958	-0.429
L59	29.500-24.500	0.460	-0.021	1.066	-0.512
L60	24.500-23.000	1.274	-0.603	1.727	-0.960
L61	23.000-22.750	1.279	-0.606	1.733	-0.963
L62	22.750-21.583	1.283	-0.608	1.737	-0.965
L63	21.583-21.333	1.286	-0.609	1.740	-0.966
L64	21.333-16.333	0.596	-0.208	1.156	-0.629
L65	16.333-12.917	-1.648	0.901	-0.810	0.362
L66	12.917-12.667	-1.661	0.907	-0.825	0.370
L67	12.667-12.500	-1.662	0.908	-0.827	0.371
L68	12.500-12.250	-1.663	0.908	-0.828	0.372
L69	12.250-12.000	-1.665	0.909	-0.831	0.373
L70	12.000-11.750	-1.667	0.910	-0.833	0.375
L71	11.750-8.500	-2.159	1.160	-1.180	0.660
L72	8.500-8.250	-1.885	0.253	-0.848	-0.101
L73	8.250-7.000	-1.891	0.253	-0.858	-0.098
L74	7.000-6.750	-1.897	0.254	-0.869	-0.094
L75	6.750-1.750	-0.956	0.288	0.023	-0.088
L76	1.750-0.000	-0.345	0.311	0.507	-0.041

Note: For pole sections, center of pressure calculations do not consider feed line shielding.

### Shielding Factor Ka

Tower Section	Feed Line Record No.	Description	Feed Line Segment Elev.	K <sub>a</sub> No Ice	K <sub>a</sub> Ice
L1	2	FB-L98B-034-XXX(3/8)	139.25 - 144.00	1.0000	1.0000
L1	3	PWRT-608-S(13/16)	139.25 - 144.00	1.0000	1.0000
L1	4	PWRT-606-S(7/8)	139.25 - 144.00	1.0000	1.0000
L1	5	RFFT-48SM-001-XXX(3/8)	139.25 - 144.00	1.0000	1.0000
L1	27	Safety Line 3/8	139.25 - 144.25	1.0000	1.0000
L2	2	FB-L98B-034-XXX(3/8)	134.75 - 139.25	1.0000	1.0000
L2	3	PWRT-608-S(13/16)	134.75 - 139.25	1.0000	1.0000
L2	4	PWRT-606-S(7/8)	134.75 - 139.25	1.0000	1.0000

# tnxTower

**B+T Group**  
1717 S. Boulder, Suite 300  
Tulsa, OK 74119  
Phone: (918) 587-4630  
FAX: (918) 295-0265

**Job**  
79982.013.01 - WATERBURY,CT (BU# 876317)

**Page**  
23 of 94

**Project**  
**Date**  
15:43:49 05/20/22

**Client**  
Crown Castle  
**Designed by**  
Jayaraj B

Tower Section	Feed Line Record No.	Description	Feed Line Segment Elev.	$K_a$ No Ice	$K_a$ Ice
L2	5	RFFT-48SM-001-XXX(3/8)	134.75 - 139.25	1.0000	1.0000
L2	27	Safety Line 3/8	134.75 - 139.25	1.0000	1.0000
L3	2	FB-L98B-034-XXX(3/8)	134.25 - 134.75	1.0000	1.0000
L3	3	PWRT-608-S(13/16)	134.25 - 134.75	1.0000	1.0000
L3	4	PWRT-606-S(7/8)	134.25 - 134.75	1.0000	1.0000
L3	5	RFFT-48SM-001-XXX(3/8)	134.25 - 134.75	1.0000	1.0000
L3	27	Safety Line 3/8	134.25 - 134.75	1.0000	1.0000
L4	2	FB-L98B-034-XXX(3/8)	129.25 - 134.25	1.0000	1.0000
L4	3	PWRT-608-S(13/16)	129.25 - 134.25	1.0000	1.0000
L4	4	PWRT-606-S(7/8)	129.25 - 134.25	1.0000	1.0000
L4	5	RFFT-48SM-001-XXX(3/8)	129.25 - 134.25	1.0000	1.0000
L4	7	7983A(ELLIPTICAL)	129.25 - 130.00	1.0000	1.0000
L4	27	Safety Line 3/8	129.25 - 134.25	1.0000	1.0000
L5	2	FB-L98B-034-XXX(3/8)	124.25 - 129.25	1.0000	1.0000
L5	3	PWRT-608-S(13/16)	124.25 - 129.25	1.0000	1.0000
L5	4	PWRT-606-S(7/8)	124.25 - 129.25	1.0000	1.0000
L5	5	RFFT-48SM-001-XXX(3/8)	124.25 - 129.25	1.0000	1.0000
L5	7	7983A(ELLIPTICAL)	124.25 - 129.25	1.0000	1.0000
L5	27	Safety Line 3/8	124.25 - 129.25	1.0000	1.0000
L5	93	CCI-AFP-045100	124.25 - 125.42	1.0000	1.0000
L5	94	CCI-AFP-045100	124.25 - 125.42	1.0000	1.0000
L5	95	CCI-AFP-045100	124.25 - 125.42	1.0000	1.0000
L6	2	FB-L98B-034-XXX(3/8)	123.42 - 124.25	1.0000	1.0000
L6	3	PWRT-608-S(13/16)	123.42 - 124.25	1.0000	1.0000
L6	4	PWRT-606-S(7/8)	123.42 - 124.25	1.0000	1.0000
L6	5	RFFT-48SM-001-XXX(3/8)	123.42 - 124.25	1.0000	1.0000
L6	7	7983A(ELLIPTICAL)	123.42 - 124.25	1.0000	1.0000
L6	27	Safety Line 3/8	123.42 - 124.25	1.0000	1.0000
L6	93	CCI-AFP-045100	123.42 - 124.25	1.0000	1.0000
L6	94	CCI-AFP-045100	123.42 - 124.25	1.0000	1.0000
L6	95	CCI-AFP-045100	123.42 - 124.25	1.0000	1.0000

Tower Section	Feed Line Record No.	Description	Feed Line Segment Elev.	$K_a$ No Ice	$K_a$ Ice
L7	2	FB-L98B-034-XXX(3/8)	123.17 - 123.42	1.0000	1.0000
L7	3	PWRT-608-S(13/16)	123.17 - 123.42	1.0000	1.0000
L7	4	PWRT-606-S(7/8)	123.17 - 123.42	1.0000	1.0000
L7	5	RFFT-48SM-001-XXX(3/8)	123.17 - 123.42	1.0000	1.0000
L7	7	7983A(ELLIPTICAL)	123.17 - 123.42	1.0000	1.0000
L7	27	Safety Line 3/8	123.17 - 123.42	1.0000	1.0000
L7	93	CCI-AFP-045100	123.17 - 123.42	1.0000	1.0000
L7	94	CCI-AFP-045100	123.17 - 123.42	1.0000	1.0000
L7	95	CCI-AFP-045100	123.17 - 123.42	1.0000	1.0000
L8	2	FB-L98B-034-XXX(3/8)	118.17 - 123.17	1.0000	1.0000
L8	3	PWRT-608-S(13/16)	118.17 - 123.17	1.0000	1.0000
L8	4	PWRT-606-S(7/8)	118.17 - 123.17	1.0000	1.0000
L8	5	RFFT-48SM-001-XXX(3/8)	118.17 - 123.17	1.0000	1.0000
L8	7	7983A(ELLIPTICAL)	118.17 - 123.17	1.0000	1.0000
L8	27	Safety Line 3/8	118.17 - 123.17	1.0000	1.0000
L8	93	CCI-AFP-045100	118.17 - 123.17	1.0000	1.0000
L8	94	CCI-AFP-045100	118.17 - 123.17	1.0000	1.0000
L8	95	CCI-AFP-045100	118.17 - 123.17	1.0000	1.0000
L9	2	FB-L98B-034-XXX(3/8)	113.17 - 118.17	1.0000	1.0000
L9	3	PWRT-608-S(13/16)	113.17 - 118.17	1.0000	1.0000
L9	4	PWRT-606-S(7/8)	113.17 - 118.17	1.0000	1.0000
L9	5	RFFT-48SM-001-XXX(3/8)	113.17 - 118.17	1.0000	1.0000
L9	7	7983A(ELLIPTICAL)	113.17 - 118.17	1.0000	1.0000
L9	27	Safety Line 3/8	113.17 - 118.17	1.0000	1.0000
L9	93	CCI-AFP-045100	113.17 - 118.17	1.0000	1.0000
L9	94	CCI-AFP-045100	113.17 - 118.17	1.0000	1.0000
L9	95	CCI-AFP-045100	113.17 - 118.17	1.0000	1.0000
L10	2	FB-L98B-034-XXX(3/8)	109.50 - 113.17	1.0000	1.0000
L10	3	PWRT-608-S(13/16)	109.50 - 113.17	1.0000	1.0000
L10	4	PWRT-606-S(7/8)	109.50 - 113.17	1.0000	1.0000
L10	5	RFFT-48SM-001-XXX(3/8)	109.50 - 113.17	1.0000	1.0000

**tnxTower**

**B+T Group**  
 1717 S. Boulder, Suite 300  
 Tulsa, OK 74119  
 Phone: (918) 587-4630  
 FAX: (918) 295-0265

**Job**  
 79982.013.01 - WATERBURY,CT (BU# 876317)

**Page**  
 25 of 94

**Project**  
 Date  
 15:43:49 05/20/22

**Client**  
 Crown Castle  
 Designed by  
 Jayaraj B

Tower Section	Feed Line Record No.	Description	Feed Line Segment Elev.	$K_a$ No Ice	$K_a$ Ice
L10	7	7983A(ELLIPTICAL)	109.50 - 113.17	1.0000	1.0000
L10	27	Safety Line 3/8	109.50 - 113.17	1.0000	1.0000
L10	93	CCI-AFP-045100	109.50 - 113.17	1.0000	1.0000
L10	94	CCI-AFP-045100	109.50 - 113.17	1.0000	1.0000
L10	95	CCI-AFP-045100	109.50 - 113.17	1.0000	1.0000
L10	97	CCI-AFP-040075	109.50 - 111.00	1.0000	1.0000
L10	99	CCI-AFP-040075	109.50 - 111.00	1.0000	1.0000
L11	2	FB-L98B-034-XXX(3/8)	109.25 - 109.50	1.0000	1.0000
L11	3	PWRT-608-S(13/16)	109.25 - 109.50	1.0000	1.0000
L11	4	PWRT-606-S(7/8)	109.25 - 109.50	1.0000	1.0000
L11	5	RFFT-48SM-001-XXX(3/8)	109.25 - 109.50	1.0000	1.0000
L11	7	7983A(ELLIPTICAL)	109.25 - 109.50	1.0000	1.0000
L11	27	Safety Line 3/8	109.25 - 109.50	1.0000	1.0000
L11	93	CCI-AFP-045100	109.25 - 109.50	1.0000	1.0000
L11	94	CCI-AFP-045100	109.25 - 109.50	1.0000	1.0000
L11	95	CCI-AFP-045100	109.25 - 109.50	1.0000	1.0000
L11	97	CCI-AFP-040075	109.25 - 109.50	1.0000	1.0000
L11	99	CCI-AFP-040075	109.25 - 109.50	1.0000	1.0000
L12	2	FB-L98B-034-XXX(3/8)	104.75 - 109.25	1.0000	1.0000
L12	3	PWRT-608-S(13/16)	104.75 - 109.25	1.0000	1.0000
L12	4	PWRT-606-S(7/8)	104.75 - 109.25	1.0000	1.0000
L12	5	RFFT-48SM-001-XXX(3/8)	104.75 - 109.25	1.0000	1.0000
L12	7	7983A(ELLIPTICAL)	104.75 - 109.25	1.0000	1.0000
L12	27	Safety Line 3/8	104.75 - 109.25	1.0000	1.0000
L12	59	PL1x4 Reinforcement	104.75 - 106.50	1.0000	1.0000
L12	60	PL1x4 Reinforcement	104.75 - 106.50	1.0000	1.0000
L12	61	PL1x4 Reinforcement	104.75 - 106.50	1.0000	1.0000
L12	91	CCI-AFP-05012520	104.75 - 105.33	1.0000	1.0000
L12	93	CCI-AFP-045100	104.75 - 109.25	1.0000	1.0000
L12	94	CCI-AFP-045100	104.75 - 109.25	1.0000	1.0000
L12	95	CCI-AFP-045100	104.75 - 109.25	1.0000	1.0000

# tnxTower

**B+T Group**  
1717 S. Boulder, Suite 300  
Tulsa, OK 74119  
Phone: (918) 587-4630  
FAX: (918) 295-0265

**Job**  
79982.013.01 - WATERBURY,CT (BU# 876317)

**Page**  
26 of 94

**Project**  
**Date**  
15:43:49 05/20/22

**Client**  
Crown Castle  
**Designed by**  
Jayaraj B

Tower Section	Feed Line Record No.	Description	Feed Line Segment Elev.	K <sub>a</sub> No Ice	K <sub>a</sub> Ice
L12	97	CCI-AFP-040075	104.75 - 109.25	1.0000	1.0000
L12	99	CCI-AFP-040075	104.75 - 109.25	1.0000	1.0000
L13	2	FB-L98B-034-XXX(3/8)	104.50 - 104.75	1.0000	1.0000
L13	3	PWRT-608-S(13/16)	104.50 - 104.75	1.0000	1.0000
L13	4	PWRT-606-S(7/8)	104.50 - 104.75	1.0000	1.0000
L13	5	RFFT-48SM-001-XXX(3/8)	104.50 - 104.75	1.0000	1.0000
L13	7	7983A(ELLIPTICAL)	104.50 - 104.75	1.0000	1.0000
L13	27	Safety Line 3/8	104.50 - 104.75	1.0000	1.0000
L13	59	PL1x4 Reinforcement	104.50 - 104.75	1.0000	1.0000
L13	60	PL1x4 Reinforcement	104.50 - 104.75	1.0000	1.0000
L13	61	PL1x4 Reinforcement	104.50 - 104.75	1.0000	1.0000
L13	91	CCI-AFP-05012520	104.50 - 104.75	1.0000	1.0000
L13	93	CCI-AFP-045100	104.50 - 104.75	1.0000	1.0000
L13	94	CCI-AFP-045100	104.50 - 104.75	1.0000	1.0000
L13	95	CCI-AFP-045100	104.50 - 104.75	1.0000	1.0000
L13	97	CCI-AFP-040075	104.50 - 104.75	1.0000	1.0000
L13	99	CCI-AFP-040075	104.50 - 104.75	1.0000	1.0000
L14	2	FB-L98B-034-XXX(3/8)	102.42 - 104.50	1.0000	1.0000
L14	3	PWRT-608-S(13/16)	102.42 - 104.50	1.0000	1.0000
L14	4	PWRT-606-S(7/8)	102.42 - 104.50	1.0000	1.0000
L14	5	RFFT-48SM-001-XXX(3/8)	102.42 - 104.50	1.0000	1.0000
L14	7	7983A(ELLIPTICAL)	102.42 - 104.50	1.0000	1.0000
L14	27	Safety Line 3/8	102.42 - 104.50	1.0000	1.0000
L14	59	PL1x4 Reinforcement	102.42 - 104.50	1.0000	1.0000
L14	60	PL1x4 Reinforcement	102.42 - 104.50	1.0000	1.0000
L14	61	PL1x4 Reinforcement	102.42 - 104.50	1.0000	1.0000
L14	91	CCI-AFP-05012520	102.42 - 104.50	1.0000	1.0000
L14	93	CCI-AFP-045100	102.42 - 104.50	1.0000	1.0000
L14	94	CCI-AFP-045100	102.42 - 104.50	1.0000	1.0000
L14	95	CCI-AFP-045100	102.42 - 104.50	1.0000	1.0000
L14	97	CCI-AFP-040075	102.42 - 104.50	1.0000	1.0000

Tower Section	Feed Line Record No.	Description	Feed Line Segment Elev.	$K_a$ No Ice	$K_a$ Ice
L14	99	CCI-AFP-040075	102.42 - 104.50	1.0000	1.0000
L15	2	FB-L98B-034-XXX(3/8)	102.17 - 102.42	1.0000	1.0000
L15	3	PWRT-608-S(13/16)	102.17 - 102.42	1.0000	1.0000
L15	4	PWRT-606-S(7/8)	102.17 - 102.42	1.0000	1.0000
L15	5	RFFT-48SM-001-XXX(3/8)	102.17 - 102.42	1.0000	1.0000
L15	7	7983A(ELLIPTICAL)	102.17 - 102.42	1.0000	1.0000
L15	27	Safety Line 3/8	102.17 - 102.42	1.0000	1.0000
L15	59	PL1x4 Reinforcement	102.17 - 102.42	1.0000	1.0000
L15	60	PL1x4 Reinforcement	102.17 - 102.42	1.0000	1.0000
L15	61	PL1x4 Reinforcement	102.17 - 102.42	1.0000	1.0000
L15	91	CCI-AFP-05012520	102.17 - 102.42	1.0000	1.0000
L15	93	CCI-AFP-045100	102.17 - 102.42	1.0000	1.0000
L15	94	CCI-AFP-045100	102.17 - 102.42	1.0000	1.0000
L15	95	CCI-AFP-045100	102.17 - 102.42	1.0000	1.0000
L15	97	CCI-AFP-040075	102.17 - 102.42	1.0000	1.0000
L15	99	CCI-AFP-040075	102.17 - 102.42	1.0000	1.0000
L16	2	FB-L98B-034-XXX(3/8)	98.75 - 102.17	1.0000	1.0000
L16	3	PWRT-608-S(13/16)	98.75 - 102.17	1.0000	1.0000
L16	4	PWRT-606-S(7/8)	98.75 - 102.17	1.0000	1.0000
L16	5	RFFT-48SM-001-XXX(3/8)	98.75 - 102.17	1.0000	1.0000
L16	7	7983A(ELLIPTICAL)	98.75 - 102.17	1.0000	1.0000
L16	21	MLC HYBRID 6X12 6AWGX6(1-1/2)	98.75 - 100.00	1.0000	1.0000
L16	27	Safety Line 3/8	98.75 - 102.17	1.0000	1.0000
L16	43	PL1.25x3.625 Reinforcement	98.75 - 100.00	1.0000	1.0000
L16	44	PL1.25x3.625 Reinforcement	98.75 - 100.00	1.0000	1.0000
L16	45	PL1.25x3.625 Reinforcement	98.75 - 100.00	1.0000	1.0000
L16	59	PL1x4 Reinforcement	98.75 - 102.17	1.0000	1.0000
L16	60	PL1x4 Reinforcement	98.75 - 102.17	1.0000	1.0000
L16	61	PL1x4 Reinforcement	98.75 - 102.17	1.0000	1.0000
L16	86	CCI-SFP-040075	98.75 - 100.33	1.0000	1.0000
L16	87	CCI-SFP-040075	98.75 - 100.33	1.0000	1.0000
L16	91	CCI-AFP-05012520	98.75 - 102.17	1.0000	1.0000
L16	93	CCI-AFP-045100	100.42 - 102.17	1.0000	1.0000
L16	94	CCI-AFP-045100	100.42 - 102.17	1.0000	1.0000
L16	95	CCI-AFP-045100	100.42 - 102.17	1.0000	1.0000
L16	97	CCI-AFP-040075	98.75 - 102.17	1.0000	1.0000
L16	99	CCI-AFP-040075	101.00 - 102.17	1.0000	1.0000
L17	2	FB-L98B-034-XXX(3/8)	98.50 - 98.75	1.0000	1.0000
L17	3	PWRT-608-S(13/16)	98.50 - 98.75	1.0000	1.0000
L17	4	PWRT-606-S(7/8)	98.50 - 98.75	1.0000	1.0000
L17	5	RFFT-48SM-001-XXX(3/8)	98.50 - 98.75	1.0000	1.0000

# tnxTower

**B+T Group**  
1717 S. Boulder, Suite 300  
Tulsa, OK 74119  
Phone: (918) 587-4630  
FAX: (918) 295-0265

**Job**  
79982.013.01 - WATERBURY,CT (BU# 876317)

**Page**  
28 of 94

**Project**  
**Date**  
15:43:49 05/20/22

**Client**  
Crown Castle  
**Designed by**  
Jayaraj B

Tower Section	Feed Line Record No.	Description	Feed Line Segment Elev.	K <sub>a</sub> No Ice	K <sub>a</sub> Ice
L17	7	7983A(ELLIPTICAL)	98.50 - 98.75	1.0000	1.0000
L17	21	MLC HYBRID 6X12 6AWGX6(1-1/2)	98.50 - 98.75	1.0000	1.0000
L17	27	Safety Line 3/8	98.50 - 98.75	1.0000	1.0000
L17	43	PL1.25x3.625 Reinforcement	98.50 - 98.75	1.0000	1.0000
L17	44	PL1.25x3.625 Reinforcement	98.50 - 98.75	1.0000	1.0000
L17	45	PL1.25x3.625 Reinforcement	98.50 - 98.75	1.0000	1.0000
L17	59	PL1x4 Reinforcement	98.50 - 98.75	1.0000	1.0000
L17	60	PL1x4 Reinforcement	98.50 - 98.75	1.0000	1.0000
L17	61	PL1x4 Reinforcement	98.50 - 98.75	1.0000	1.0000
L17	86	CCI-SFP-040075	98.50 - 98.75	1.0000	1.0000
L17	87	CCI-SFP-040075	98.50 - 98.75	1.0000	1.0000
L17	91	CCI-AFP-05012520	98.50 - 98.75	1.0000	1.0000
L17	97	CCI-AFP-040075	98.50 - 98.75	1.0000	1.0000
L18	2	FB-L98B-034-XXX(3/8)	97.50 - 98.50	1.0000	1.0000
L18	3	PWRT-608-S(13/16)	97.50 - 98.50	1.0000	1.0000
L18	4	PWRT-606-S(7/8)	97.50 - 98.50	1.0000	1.0000
L18	5	RFFT-48SM-001-XXX(3/8)	97.50 - 98.50	1.0000	1.0000
L18	7	7983A(ELLIPTICAL)	97.50 - 98.50	1.0000	1.0000
L18	21	MLC HYBRID 6X12 6AWGX6(1-1/2)	97.50 - 98.50	1.0000	1.0000
L18	27	Safety Line 3/8	97.50 - 98.50	1.0000	1.0000
L18	43	PL1.25x3.625 Reinforcement	97.50 - 98.50	1.0000	1.0000
L18	44	PL1.25x3.625 Reinforcement	97.50 - 98.50	1.0000	1.0000
L18	45	PL1.25x3.625 Reinforcement	97.50 - 98.50	1.0000	1.0000
L18	59	PL1x4 Reinforcement	97.50 - 98.50	1.0000	1.0000
L18	60	PL1x4 Reinforcement	97.50 - 98.50	1.0000	1.0000
L18	61	PL1x4 Reinforcement	97.50 - 98.50	1.0000	1.0000
L18	86	CCI-SFP-040075	97.50 - 98.50	1.0000	1.0000
L18	87	CCI-SFP-040075	97.50 - 98.50	1.0000	1.0000
L18	91	CCI-AFP-05012520	97.50 - 98.50	1.0000	1.0000
L18	97	CCI-AFP-040075	97.50 - 98.50	1.0000	1.0000
L19	2	FB-L98B-034-XXX(3/8)	97.25 - 97.50	1.0000	1.0000
L19	3	PWRT-608-S(13/16)	97.25 - 97.50	1.0000	1.0000
L19	4	PWRT-606-S(7/8)	97.25 - 97.50	1.0000	1.0000
L19	5	RFFT-48SM-001-XXX(3/8)	97.25 - 97.50	1.0000	1.0000
L19	7	7983A(ELLIPTICAL)	97.25 - 97.50	1.0000	1.0000
L19	21	MLC HYBRID 6X12 6AWGX6(1-1/2)	97.25 - 97.50	1.0000	1.0000
L19	27	Safety Line 3/8	97.25 - 97.50	1.0000	1.0000
L19	43	PL1.25x3.625 Reinforcement	97.25 - 97.50	1.0000	1.0000
L19	44	PL1.25x3.625 Reinforcement	97.25 - 97.50	1.0000	1.0000
L19	45	PL1.25x3.625 Reinforcement	97.25 - 97.50	1.0000	1.0000
L19	59	PL1x4 Reinforcement	97.25 - 97.50	1.0000	1.0000
L19	60	PL1x4 Reinforcement	97.25 - 97.50	1.0000	1.0000
L19	61	PL1x4 Reinforcement	97.25 - 97.50	1.0000	1.0000
L19	86	CCI-SFP-040075	97.25 - 97.50	1.0000	1.0000
L19	87	CCI-SFP-040075	97.25 - 97.50	1.0000	1.0000
L19	91	CCI-AFP-05012520	97.25 - 97.50	1.0000	1.0000
L19	97	CCI-AFP-040075	97.25 - 97.50	1.0000	1.0000
L20	2	FB-L98B-034-XXX(3/8)	92.00 - 97.25	1.0000	1.0000
L20	3	PWRT-608-S(13/16)	92.00 - 97.25	1.0000	1.0000
L20	4	PWRT-606-S(7/8)	92.00 - 97.25	1.0000	1.0000
L20	5	RFFT-48SM-001-XXX(3/8)	92.00 - 97.25	1.0000	1.0000
L20	7	7983A(ELLIPTICAL)	92.00 - 97.25	1.0000	1.0000
L20	21	MLC HYBRID 6X12 6AWGX6(1-1/2)	92.00 - 97.25	1.0000	1.0000
L20	27	Safety Line 3/8	92.00 - 97.25	1.0000	1.0000
L20	43	PL1.25x3.625 Reinforcement	92.00 - 97.25	1.0000	1.0000
L20	44	PL1.25x3.625 Reinforcement	92.00 - 97.25	1.0000	1.0000
L20	45	PL1.25x3.625 Reinforcement	92.00 - 97.25	1.0000	1.0000
L20	59	PL1x4 Reinforcement	92.00 - 97.25	1.0000	1.0000

# tnxTower

**B+T Group**  
1717 S. Boulder, Suite 300  
Tulsa, OK 74119  
Phone: (918) 587-4630  
FAX: (918) 295-0265

**Job**  
79982.013.01 - WATERBURY,CT (BU# 876317)

**Page**  
29 of 94

**Project**  
**Date**  
15:43:49 05/20/22

**Client**  
Crown Castle  
**Designed by**  
Jayaraj B

Tower Section	Feed Line Record No.	Description	Feed Line Segment Elev.	K <sub>a</sub> No Ice	K <sub>a</sub> Ice
L20	60	PL1x4 Reinforcement	92.00 - 97.25	1.0000	1.0000
L20	61	PL1x4 Reinforcement	92.00 - 97.25	1.0000	1.0000
L20	86	CCI-SFP-040075	92.00 - 97.25	1.0000	1.0000
L20	87	CCI-SFP-040075	92.00 - 97.25	1.0000	1.0000
L20	91	CCI-AFP-05012520	92.00 - 97.25	1.0000	1.0000
L20	97	CCI-AFP-040075	96.00 - 97.25	1.0000	1.0000
L21	2	FB-L98B-034-XXX(3/8)	90.55 - 92.00	1.0000	1.0000
L21	3	PWRT-608-S(13/16)	90.55 - 92.00	1.0000	1.0000
L21	4	PWRT-606-S(7/8)	90.55 - 92.00	1.0000	1.0000
L21	5	RFFT-48SM-001-XXX(3/8)	90.55 - 92.00	1.0000	1.0000
L21	7	7983A(ELLIPTICAL)	90.55 - 92.00	1.0000	1.0000
L21	21	MLC HYBRID 6X12 6AWGX6(1-1/2)	90.55 - 92.00	1.0000	1.0000
L21	27	Safety Line 3/8	90.55 - 92.00	1.0000	1.0000
L21	43	PL1.25x3.625 Reinforcement	90.55 - 92.00	1.0000	1.0000
L21	44	PL1.25x3.625 Reinforcement	90.55 - 92.00	1.0000	1.0000
L21	45	PL1.25x3.625 Reinforcement	90.55 - 92.00	1.0000	1.0000
L21	59	PL1x4 Reinforcement	90.55 - 92.00	1.0000	1.0000
L21	60	PL1x4 Reinforcement	90.55 - 92.00	1.0000	1.0000
L21	61	PL1x4 Reinforcement	90.55 - 92.00	1.0000	1.0000
L21	86	CCI-SFP-040075	90.55 - 92.00	1.0000	1.0000
L21	87	CCI-SFP-040075	90.55 - 92.00	1.0000	1.0000
L21	91	CCI-AFP-05012520	90.55 - 92.00	1.0000	1.0000
L22	2	FB-L98B-034-XXX(3/8)	89.25 - 90.55	1.0000	1.0000
L22	3	PWRT-608-S(13/16)	89.25 - 90.55	1.0000	1.0000
L22	4	PWRT-606-S(7/8)	89.25 - 90.55	1.0000	1.0000
L22	5	RFFT-48SM-001-XXX(3/8)	89.25 - 90.55	1.0000	1.0000
L22	7	7983A(ELLIPTICAL)	89.25 - 90.55	1.0000	1.0000
L22	21	MLC HYBRID 6X12 6AWGX6(1-1/2)	89.25 - 90.55	1.0000	1.0000
L22	27	Safety Line 3/8	89.25 - 90.55	1.0000	1.0000
L22	43	PL1.25x3.625 Reinforcement	89.25 - 90.55	1.0000	1.0000
L22	44	PL1.25x3.625 Reinforcement	89.25 - 90.55	1.0000	1.0000
L22	45	PL1.25x3.625 Reinforcement	89.25 - 90.55	1.0000	1.0000
L22	59	PL1x4 Reinforcement	89.25 - 90.55	1.0000	1.0000
L22	60	PL1x4 Reinforcement	89.25 - 90.55	1.0000	1.0000
L22	61	PL1x4 Reinforcement	89.25 - 90.55	1.0000	1.0000
L22	86	CCI-SFP-040075	89.25 - 90.55	1.0000	1.0000
L22	87	CCI-SFP-040075	89.25 - 90.55	1.0000	1.0000
L22	89	CCI-SFP-040075	89.25 - 90.33	1.0000	1.0000
L22	91	CCI-AFP-05012520	89.25 - 90.55	1.0000	1.0000
L23	2	FB-L98B-034-XXX(3/8)	89.00 - 89.25	1.0000	1.0000
L23	3	PWRT-608-S(13/16)	89.00 - 89.25	1.0000	1.0000
L23	4	PWRT-606-S(7/8)	89.00 - 89.25	1.0000	1.0000
L23	5	RFFT-48SM-001-XXX(3/8)	89.00 - 89.25	1.0000	1.0000
L23	7	7983A(ELLIPTICAL)	89.00 - 89.25	1.0000	1.0000
L23	21	MLC HYBRID 6X12 6AWGX6(1-1/2)	89.00 - 89.25	1.0000	1.0000
L23	27	Safety Line 3/8	89.00 - 89.25	1.0000	1.0000
L23	39	PL1.25x5.5 Reinforcement	89.00 - 89.25	1.0000	1.0000
L23	40	PL1.25x5.5 Reinforcement	89.00 - 89.25	1.0000	1.0000
L23	41	PL1.25x5.5 Reinforcement	89.00 - 89.25	1.0000	1.0000
L23	59	PL1x4 Reinforcement	89.00 - 89.25	1.0000	1.0000
L23	60	PL1x4 Reinforcement	89.00 - 89.25	1.0000	1.0000
L23	61	PL1x4 Reinforcement	89.00 - 89.25	1.0000	1.0000
L23	86	CCI-SFP-040075	89.00 - 89.25	1.0000	1.0000
L23	87	CCI-SFP-040075	89.00 - 89.25	1.0000	1.0000
L23	89	CCI-SFP-040075	89.00 - 89.25	1.0000	1.0000
L23	91	CCI-AFP-05012520	89.00 - 89.25	1.0000	1.0000
L24	2	FB-L98B-034-XXX(3/8)	88.25 - 89.00	1.0000	1.0000
L24	3	PWRT-608-S(13/16)	88.25 - 89.00	1.0000	1.0000
L24	4	PWRT-606-S(7/8)	88.25 - 89.00	1.0000	1.0000

# tnxTower

**B+T Group**  
1717 S. Boulder, Suite 300  
Tulsa, OK 74119  
Phone: (918) 587-4630  
FAX: (918) 295-0265

**Job**  
79982.013.01 - WATERBURY,CT (BU# 876317)

**Page**  
30 of 94

**Project**  
**Date**  
15:43:49 05/20/22

**Client**  
Crown Castle  
**Designed by**  
Jayaraj B

Tower Section	Feed Line Record No.	Description	Feed Line Segment Elev.	K <sub>a</sub> No Ice	K <sub>a</sub> Ice
L24	5	RFFT-48SM-001-XXX(3/8)	88.25 - 89.00	1.0000	1.0000
L24	7	7983A(ELLIPTICAL)	88.25 - 89.00	1.0000	1.0000
L24	21	MLC HYBRID 6X12 6AWGX6(1-1/2)	88.25 - 89.00	1.0000	1.0000
L24	27	Safety Line 3/8	88.25 - 89.00	1.0000	1.0000
L24	39	PL1.25x5.5 Reinforcement	88.25 - 89.00	1.0000	1.0000
L24	40	PL1.25x5.5 Reinforcement	88.25 - 89.00	1.0000	1.0000
L24	41	PL1.25x5.5 Reinforcement	88.25 - 89.00	1.0000	1.0000
L24	59	PL1x4 Reinforcement	88.25 - 89.00	1.0000	1.0000
L24	60	PL1x4 Reinforcement	88.25 - 89.00	1.0000	1.0000
L24	61	PL1x4 Reinforcement	88.25 - 89.00	1.0000	1.0000
L24	86	CCI-SFP-040075	88.25 - 89.00	1.0000	1.0000
L24	87	CCI-SFP-040075	88.25 - 89.00	1.0000	1.0000
L24	89	CCI-SFP-040075	88.25 - 89.00	1.0000	1.0000
L24	91	CCI-AFP-05012520	88.25 - 89.00	1.0000	1.0000
L25	2	FB-L98B-034-XXX(3/8)	88.00 - 88.25	1.0000	1.0000
L25	3	PWRT-608-S(13/16)	88.00 - 88.25	1.0000	1.0000
L25	4	PWRT-606-S(7/8)	88.00 - 88.25	1.0000	1.0000
L25	5	RFFT-48SM-001-XXX(3/8)	88.00 - 88.25	1.0000	1.0000
L25	7	7983A(ELLIPTICAL)	88.00 - 88.25	1.0000	1.0000
L25	21	MLC HYBRID 6X12 6AWGX6(1-1/2)	88.00 - 88.25	1.0000	1.0000
L25	27	Safety Line 3/8	88.00 - 88.25	1.0000	1.0000
L25	39	PL1.25x5.5 Reinforcement	88.00 - 88.25	1.0000	1.0000
L25	40	PL1.25x5.5 Reinforcement	88.00 - 88.25	1.0000	1.0000
L25	41	PL1.25x5.5 Reinforcement	88.00 - 88.25	1.0000	1.0000
L25	59	PL1x4 Reinforcement	88.00 - 88.25	1.0000	1.0000
L25	60	PL1x4 Reinforcement	88.00 - 88.25	1.0000	1.0000
L25	61	PL1x4 Reinforcement	88.00 - 88.25	1.0000	1.0000
L25	86	CCI-SFP-040075	88.00 - 88.25	1.0000	1.0000
L25	87	CCI-SFP-040075	88.00 - 88.25	1.0000	1.0000
L25	89	CCI-SFP-040075	88.00 - 88.25	1.0000	1.0000
L25	91	CCI-AFP-05012520	88.00 - 88.25	1.0000	1.0000
L26	2	FB-L98B-034-XXX(3/8)	87.83 - 88.00	1.0000	1.0000
L26	3	PWRT-608-S(13/16)	87.83 - 88.00	1.0000	1.0000
L26	4	PWRT-606-S(7/8)	87.83 - 88.00	1.0000	1.0000
L26	5	RFFT-48SM-001-XXX(3/8)	87.83 - 88.00	1.0000	1.0000
L26	7	7983A(ELLIPTICAL)	87.83 - 88.00	1.0000	1.0000
L26	21	MLC HYBRID 6X12 6AWGX6(1-1/2)	87.83 - 88.00	1.0000	1.0000
L26	27	Safety Line 3/8	87.83 - 88.00	1.0000	1.0000
L26	39	PL1.25x5.5 Reinforcement	87.83 - 88.00	1.0000	1.0000
L26	40	PL1.25x5.5 Reinforcement	87.83 - 88.00	1.0000	1.0000
L26	41	PL1.25x5.5 Reinforcement	87.83 - 88.00	1.0000	1.0000
L26	59	PL1x4 Reinforcement	87.83 - 88.00	1.0000	1.0000
L26	60	PL1x4 Reinforcement	87.83 - 88.00	1.0000	1.0000
L26	61	PL1x4 Reinforcement	87.83 - 88.00	1.0000	1.0000
L26	86	CCI-SFP-040075	87.83 - 88.00	1.0000	1.0000
L26	87	CCI-SFP-040075	87.83 - 88.00	1.0000	1.0000
L26	89	CCI-SFP-040075	87.83 - 88.00	1.0000	1.0000
L26	91	CCI-AFP-05012520	87.83 - 88.00	1.0000	1.0000
L27	2	FB-L98B-034-XXX(3/8)	87.58 - 87.83	1.0000	1.0000
L27	3	PWRT-608-S(13/16)	87.58 - 87.83	1.0000	1.0000
L27	4	PWRT-606-S(7/8)	87.58 - 87.83	1.0000	1.0000
L27	5	RFFT-48SM-001-XXX(3/8)	87.58 - 87.83	1.0000	1.0000
L27	7	7983A(ELLIPTICAL)	87.58 - 87.83	1.0000	1.0000
L27	21	MLC HYBRID 6X12 6AWGX6(1-1/2)	87.58 - 87.83	1.0000	1.0000
L27	27	Safety Line 3/8	87.58 - 87.83	1.0000	1.0000
L27	39	PL1.25x5.5 Reinforcement	87.58 - 87.83	1.0000	1.0000
L27	40	PL1.25x5.5 Reinforcement	87.58 - 87.83	1.0000	1.0000
L27	41	PL1.25x5.5 Reinforcement	87.58 - 87.83	1.0000	1.0000

# tnxTower

**B+T Group**  
1717 S. Boulder, Suite 300  
Tulsa, OK 74119  
Phone: (918) 587-4630  
FAX: (918) 295-0265

**Job**  
79982.013.01 - WATERBURY,CT (BU# 876317)

**Page**  
31 of 94

**Project**  
**Date**  
15:43:49 05/20/22

**Client**  
Crown Castle  
**Designed by**  
Jayaraj B

Tower Section	Feed Line Record No.	Description	Feed Line Segment Elev.	K <sub>a</sub> No Ice	K <sub>a</sub> Ice
L27	59	PL1x4 Reinforcement	87.58 - 87.83	1.0000	1.0000
L27	60	PL1x4 Reinforcement	87.58 - 87.83	1.0000	1.0000
L27	61	PL1x4 Reinforcement	87.58 - 87.83	1.0000	1.0000
L27	86	CCI-SFP-040075	87.58 - 87.83	1.0000	1.0000
L27	87	CCI-SFP-040075	87.58 - 87.83	1.0000	1.0000
L27	89	CCI-SFP-040075	87.58 - 87.83	1.0000	1.0000
L27	91	CCI-AFP-05012520	87.58 - 87.83	1.0000	1.0000
L28	2	FB-L98B-034-XXX(3/8)	82.58 - 87.58	1.0000	1.0000
L28	3	PWRT-608-S(13/16)	82.58 - 87.58	1.0000	1.0000
L28	4	PWRT-606-S(7/8)	82.58 - 87.58	1.0000	1.0000
L28	5	RFFT-48SM-001-XXX(3/8)	82.58 - 87.58	1.0000	1.0000
L28	7	7983A(ELLIPTICAL)	82.58 - 87.58	1.0000	1.0000
L28	21	MLC HYBRID 6X12 6AWGX6(1-1/2)	82.58 - 87.58	1.0000	1.0000
L28	27	Safety Line 3/8	82.58 - 87.58	1.0000	1.0000
L28	39	PL1.25x5.5 Reinforcement	82.58 - 87.58	1.0000	1.0000
L28	40	PL1.25x5.5 Reinforcement	82.58 - 87.58	1.0000	1.0000
L28	41	PL1.25x5.5 Reinforcement	82.58 - 87.58	1.0000	1.0000
L28	59	PL1x4 Reinforcement	86.50 - 87.58	1.0000	1.0000
L28	60	PL1x4 Reinforcement	86.50 - 87.58	1.0000	1.0000
L28	61	PL1x4 Reinforcement	86.50 - 87.58	1.0000	1.0000
L28	86	CCI-SFP-040075	82.58 - 87.58	1.0000	1.0000
L28	87	CCI-SFP-040075	82.58 - 87.58	1.0000	1.0000
L28	89	CCI-SFP-040075	82.58 - 87.58	1.0000	1.0000
L28	91	CCI-AFP-05012520	85.33 - 87.58	1.0000	1.0000
L29	2	FB-L98B-034-XXX(3/8)	77.58 - 82.58	1.0000	1.0000
L29	3	PWRT-608-S(13/16)	77.58 - 82.58	1.0000	1.0000
L29	4	PWRT-606-S(7/8)	77.58 - 82.58	1.0000	1.0000
L29	5	RFFT-48SM-001-XXX(3/8)	77.58 - 82.58	1.0000	1.0000
L29	7	7983A(ELLIPTICAL)	77.58 - 82.58	1.0000	1.0000
L29	21	MLC HYBRID 6X12 6AWGX6(1-1/2)	77.58 - 82.58	1.0000	1.0000
L29	27	Safety Line 3/8	77.58 - 82.58	1.0000	1.0000
L29	39	PL1.25x5.5 Reinforcement	77.58 - 82.58	1.0000	1.0000
L29	40	PL1.25x5.5 Reinforcement	77.58 - 82.58	1.0000	1.0000
L29	41	PL1.25x5.5 Reinforcement	77.58 - 82.58	1.0000	1.0000
L29	55	PL1x4 Reinforcement	77.58 - 78.75	1.0000	1.0000
L29	56	PL1x4 Reinforcement	77.58 - 78.75	1.0000	1.0000
L29	57	PL1x4 Reinforcement	77.58 - 78.75	1.0000	1.0000
L29	86	CCI-SFP-040075	77.58 - 82.58	1.0000	1.0000
L29	87	CCI-SFP-040075	77.58 - 82.58	1.0000	1.0000
L29	89	CCI-SFP-040075	77.58 - 82.58	1.0000	1.0000
L30	2	FB-L98B-034-XXX(3/8)	77.00 - 77.58	1.0000	1.0000
L30	3	PWRT-608-S(13/16)	77.00 - 77.58	1.0000	1.0000
L30	4	PWRT-606-S(7/8)	77.00 - 77.58	1.0000	1.0000
L30	5	RFFT-48SM-001-XXX(3/8)	77.00 - 77.58	1.0000	1.0000
L30	7	7983A(ELLIPTICAL)	77.00 - 77.58	1.0000	1.0000
L30	21	MLC HYBRID 6X12 6AWGX6(1-1/2)	77.00 - 77.58	1.0000	1.0000
L30	27	Safety Line 3/8	77.00 - 77.58	1.0000	1.0000
L30	39	PL1.25x5.5 Reinforcement	77.00 - 77.58	1.0000	1.0000
L30	40	PL1.25x5.5 Reinforcement	77.00 - 77.58	1.0000	1.0000
L30	41	PL1.25x5.5 Reinforcement	77.00 - 77.58	1.0000	1.0000
L30	55	PL1x4 Reinforcement	77.00 - 77.58	1.0000	1.0000
L30	56	PL1x4 Reinforcement	77.00 - 77.58	1.0000	1.0000
L30	57	PL1x4 Reinforcement	77.00 - 77.58	1.0000	1.0000
L30	86	CCI-SFP-040075	77.00 - 77.58	1.0000	1.0000
L30	87	CCI-SFP-040075	77.00 - 77.58	1.0000	1.0000
L30	89	CCI-SFP-040075	77.00 - 77.58	1.0000	1.0000
L31	2	FB-L98B-034-XXX(3/8)	76.75 - 77.00	1.0000	1.0000
L31	3	PWRT-608-S(13/16)	76.75 - 77.00	1.0000	1.0000
L31	4	PWRT-606-S(7/8)	76.75 - 77.00	1.0000	1.0000

# tnxTower

**B+T Group**  
1717 S. Boulder, Suite 300  
Tulsa, OK 74119  
Phone: (918) 587-4630  
FAX: (918) 295-0265

**Job**  
79982.013.01 - WATERBURY,CT (BU# 876317)

**Page**  
32 of 94

**Project**  
**Date**  
15:43:49 05/20/22

**Client**  
Crown Castle  
**Designed by**  
Jayaraj B

Tower Section	Feed Line Record No.	Description	Feed Line Segment Elev.	K <sub>a</sub> No Ice	K <sub>a</sub> Ice
L31	5	RFFT-48SM-001-XXX(3/8)	76.75 - 77.00	1.0000	1.0000
L31	7	7983A(ELLIPTICAL)	76.75 - 77.00	1.0000	1.0000
L31	21	MLC HYBRID 6X12 6AWGX6(1-1/2)	76.75 - 77.00	1.0000	1.0000
L31	27	Safety Line 3/8	76.75 - 77.00	1.0000	1.0000
L31	39	PL1.25x5.5 Reinforcement	76.75 - 77.00	1.0000	1.0000
L31	40	PL1.25x5.5 Reinforcement	76.75 - 77.00	1.0000	1.0000
L31	41	PL1.25x5.5 Reinforcement	76.75 - 77.00	1.0000	1.0000
L31	55	PL1x4 Reinforcement	76.75 - 77.00	1.0000	1.0000
L31	56	PL1x4 Reinforcement	76.75 - 77.00	1.0000	1.0000
L31	57	PL1x4 Reinforcement	76.75 - 77.00	1.0000	1.0000
L31	86	CCI-SFP-040075	76.75 - 77.00	1.0000	1.0000
L31	87	CCI-SFP-040075	76.75 - 77.00	1.0000	1.0000
L31	89	CCI-SFP-040075	76.75 - 77.00	1.0000	1.0000
L32	2	FB-L98B-034-XXX(3/8)	76.33 - 76.75	1.0000	1.0000
L32	3	PWRT-608-S(13/16)	76.33 - 76.75	1.0000	1.0000
L32	4	PWRT-606-S(7/8)	76.33 - 76.75	1.0000	1.0000
L32	5	RFFT-48SM-001-XXX(3/8)	76.33 - 76.75	1.0000	1.0000
L32	7	7983A(ELLIPTICAL)	76.33 - 76.75	1.0000	1.0000
L32	21	MLC HYBRID 6X12 6AWGX6(1-1/2)	76.33 - 76.75	1.0000	1.0000
L32	27	Safety Line 3/8	76.33 - 76.75	1.0000	1.0000
L32	39	PL1.25x5.5 Reinforcement	76.33 - 76.75	1.0000	1.0000
L32	40	PL1.25x5.5 Reinforcement	76.33 - 76.75	1.0000	1.0000
L32	41	PL1.25x5.5 Reinforcement	76.33 - 76.75	1.0000	1.0000
L32	55	PL1x4 Reinforcement	76.33 - 76.75	1.0000	1.0000
L32	56	PL1x4 Reinforcement	76.33 - 76.75	1.0000	1.0000
L32	57	PL1x4 Reinforcement	76.33 - 76.75	1.0000	1.0000
L32	86	CCI-SFP-040075	76.33 - 76.75	1.0000	1.0000
L32	87	CCI-SFP-040075	76.33 - 76.75	1.0000	1.0000
L32	89	CCI-SFP-040075	76.33 - 76.75	1.0000	1.0000
L33	2	FB-L98B-034-XXX(3/8)	76.08 - 76.33	1.0000	1.0000
L33	3	PWRT-608-S(13/16)	76.08 - 76.33	1.0000	1.0000
L33	4	PWRT-606-S(7/8)	76.08 - 76.33	1.0000	1.0000
L33	5	RFFT-48SM-001-XXX(3/8)	76.08 - 76.33	1.0000	1.0000
L33	7	7983A(ELLIPTICAL)	76.08 - 76.33	1.0000	1.0000
L33	21	MLC HYBRID 6X12 6AWGX6(1-1/2)	76.08 - 76.33	1.0000	1.0000
L33	27	Safety Line 3/8	76.08 - 76.33	1.0000	1.0000
L33	39	PL1.25x5.5 Reinforcement	76.08 - 76.33	1.0000	1.0000
L33	40	PL1.25x5.5 Reinforcement	76.08 - 76.33	1.0000	1.0000
L33	41	PL1.25x5.5 Reinforcement	76.08 - 76.33	1.0000	1.0000
L33	55	PL1x4 Reinforcement	76.08 - 76.33	1.0000	1.0000
L33	56	PL1x4 Reinforcement	76.08 - 76.33	1.0000	1.0000
L33	57	PL1x4 Reinforcement	76.08 - 76.33	1.0000	1.0000
L33	86	CCI-SFP-040075	76.08 - 76.33	1.0000	1.0000
L33	87	CCI-SFP-040075	76.08 - 76.33	1.0000	1.0000
L33	89	CCI-SFP-040075	76.08 - 76.33	1.0000	1.0000
L34	2	FB-L98B-034-XXX(3/8)	74.25 - 76.08	1.0000	1.0000
L34	3	PWRT-608-S(13/16)	74.25 - 76.08	1.0000	1.0000
L34	4	PWRT-606-S(7/8)	74.25 - 76.08	1.0000	1.0000
L34	5	RFFT-48SM-001-XXX(3/8)	74.25 - 76.08	1.0000	1.0000
L34	7	7983A(ELLIPTICAL)	74.25 - 76.08	1.0000	1.0000
L34	21	MLC HYBRID 6X12 6AWGX6(1-1/2)	74.25 - 76.08	1.0000	1.0000
L34	27	Safety Line 3/8	74.25 - 76.08	1.0000	1.0000
L34	39	PL1.25x5.5 Reinforcement	74.25 - 76.08	1.0000	1.0000
L34	40	PL1.25x5.5 Reinforcement	74.25 - 76.08	1.0000	1.0000
L34	41	PL1.25x5.5 Reinforcement	74.25 - 76.08	1.0000	1.0000
L34	55	PL1x4 Reinforcement	74.25 - 76.08	1.0000	1.0000
L34	56	PL1x4 Reinforcement	74.25 - 76.08	1.0000	1.0000
L34	57	PL1x4 Reinforcement	74.25 - 76.08	1.0000	1.0000

# tnxTower

**B+T Group**  
1717 S. Boulder, Suite 300  
Tulsa, OK 74119  
Phone: (918) 587-4630  
FAX: (918) 295-0265

**Job**  
79982.013.01 - WATERBURY,CT (BU# 876317)

**Page**  
33 of 94

**Project**  
**Date**  
15:43:49 05/20/22

**Client**  
Crown Castle  
**Designed by**  
Jayaraj B

Tower Section	Feed Line Record No.	Description	Feed Line Segment Elev.	K <sub>a</sub> No Ice	K <sub>a</sub> Ice
L34	81	CCI-SFP-045100	74.25 - 75.25	1.0000	1.0000
L34	82	CCI-SFP-045100	74.25 - 75.25	1.0000	1.0000
L34	84	CCI-SFP-040075	74.25 - 75.25	1.0000	1.0000
L34	86	CCI-SFP-040075	75.33 - 76.08	1.0000	1.0000
L34	87	CCI-SFP-040075	75.33 - 76.08	1.0000	1.0000
L34	89	CCI-SFP-040075	75.33 - 76.08	1.0000	1.0000
L35	2	FB-L98B-034-XXX(3/8)	74.00 - 74.25	1.0000	1.0000
L35	3	PWRT-608-S(13/16)	74.00 - 74.25	1.0000	1.0000
L35	4	PWRT-606-S(7/8)	74.00 - 74.25	1.0000	1.0000
L35	5	RFFT-48SM-001-XXX(3/8)	74.00 - 74.25	1.0000	1.0000
L35	7	7983A(ELLIPTICAL)	74.00 - 74.25	1.0000	1.0000
L35	21	MLC HYBRID 6X12 6AWGX6(1-1/2)	74.00 - 74.25	1.0000	1.0000
L35	27	Safety Line 3/8	74.00 - 74.25	1.0000	1.0000
L35	39	PL1.25x5.5 Reinforcement	74.00 - 74.25	1.0000	1.0000
L35	40	PL1.25x5.5 Reinforcement	74.00 - 74.25	1.0000	1.0000
L35	41	PL1.25x5.5 Reinforcement	74.00 - 74.25	1.0000	1.0000
L35	55	PL1x4 Reinforcement	74.00 - 74.25	1.0000	1.0000
L35	56	PL1x4 Reinforcement	74.00 - 74.25	1.0000	1.0000
L35	57	PL1x4 Reinforcement	74.00 - 74.25	1.0000	1.0000
L35	81	CCI-SFP-045100	74.00 - 74.25	1.0000	1.0000
L35	82	CCI-SFP-045100	74.00 - 74.25	1.0000	1.0000
L35	84	CCI-SFP-040075	74.00 - 74.25	1.0000	1.0000
L36	2	FB-L98B-034-XXX(3/8)	73.75 - 74.00	1.0000	1.0000
L36	3	PWRT-608-S(13/16)	73.75 - 74.00	1.0000	1.0000
L36	4	PWRT-606-S(7/8)	73.75 - 74.00	1.0000	1.0000
L36	5	RFFT-48SM-001-XXX(3/8)	73.75 - 74.00	1.0000	1.0000
L36	7	7983A(ELLIPTICAL)	73.75 - 74.00	1.0000	1.0000
L36	21	MLC HYBRID 6X12 6AWGX6(1-1/2)	73.75 - 74.00	1.0000	1.0000
L36	27	Safety Line 3/8	73.75 - 74.00	1.0000	1.0000
L36	39	PL1.25x5.5 Reinforcement	73.75 - 74.00	1.0000	1.0000
L36	40	PL1.25x5.5 Reinforcement	73.75 - 74.00	1.0000	1.0000
L36	41	PL1.25x5.5 Reinforcement	73.75 - 74.00	1.0000	1.0000
L36	55	PL1x4 Reinforcement	73.75 - 74.00	1.0000	1.0000
L36	56	PL1x4 Reinforcement	73.75 - 74.00	1.0000	1.0000
L36	57	PL1x4 Reinforcement	73.75 - 74.00	1.0000	1.0000
L36	81	CCI-SFP-045100	73.75 - 74.00	1.0000	1.0000
L36	82	CCI-SFP-045100	73.75 - 74.00	1.0000	1.0000
L36	84	CCI-SFP-040075	73.75 - 74.00	1.0000	1.0000
L37	2	FB-L98B-034-XXX(3/8)	73.50 - 73.75	1.0000	1.0000
L37	3	PWRT-608-S(13/16)	73.50 - 73.75	1.0000	1.0000
L37	4	PWRT-606-S(7/8)	73.50 - 73.75	1.0000	1.0000
L37	5	RFFT-48SM-001-XXX(3/8)	73.50 - 73.75	1.0000	1.0000
L37	7	7983A(ELLIPTICAL)	73.50 - 73.75	1.0000	1.0000
L37	21	MLC HYBRID 6X12 6AWGX6(1-1/2)	73.50 - 73.75	1.0000	1.0000
L37	27	Safety Line 3/8	73.50 - 73.75	1.0000	1.0000
L37	39	PL1.25x5.5 Reinforcement	73.50 - 73.75	1.0000	1.0000
L37	40	PL1.25x5.5 Reinforcement	73.50 - 73.75	1.0000	1.0000
L37	41	PL1.25x5.5 Reinforcement	73.50 - 73.75	1.0000	1.0000
L37	55	PL1x4 Reinforcement	73.50 - 73.75	1.0000	1.0000
L37	56	PL1x4 Reinforcement	73.50 - 73.75	1.0000	1.0000
L37	57	PL1x4 Reinforcement	73.50 - 73.75	1.0000	1.0000
L37	81	CCI-SFP-045100	73.50 - 73.75	1.0000	1.0000
L37	82	CCI-SFP-045100	73.50 - 73.75	1.0000	1.0000
L37	84	CCI-SFP-040075	73.50 - 73.75	1.0000	1.0000
L38	2	FB-L98B-034-XXX(3/8)	68.50 - 73.50	1.0000	1.0000
L38	3	PWRT-608-S(13/16)	68.50 - 73.50	1.0000	1.0000
L38	4	PWRT-606-S(7/8)	68.50 - 73.50	1.0000	1.0000
L38	5	RFFT-48SM-001-XXX(3/8)	68.50 - 73.50	1.0000	1.0000
L38	7	7983A(ELLIPTICAL)	68.50 - 73.50	1.0000	1.0000

Tower Section	Feed Line Record No.	Description	Feed Line Segment Elev.	K <sub>a</sub> No Ice	K <sub>a</sub> Ice
L38	21	MLC HYBRID 6X12	68.50 - 73.50	1.0000	1.0000
		6AWGX6(1-1/2)			
L38	27	Safety Line 3/8	68.50 - 73.50	1.0000	1.0000
L38	39	PL1.25x5.5 Reinforcement	68.50 - 73.50	1.0000	1.0000
L38	40	PL1.25x5.5 Reinforcement	68.50 - 73.50	1.0000	1.0000
L38	41	PL1.25x5.5 Reinforcement	68.50 - 73.50	1.0000	1.0000
L38	55	PL1x4 Reinforcement	68.50 - 73.50	1.0000	1.0000
L38	56	PL1x4 Reinforcement	68.50 - 73.50	1.0000	1.0000
L38	57	PL1x4 Reinforcement	68.50 - 73.50	1.0000	1.0000
L38	81	CCI-SFP-045100	68.50 - 73.50	1.0000	1.0000
L38	82	CCI-SFP-045100	68.50 - 73.50	1.0000	1.0000
L38	84	CCI-SFP-040075	68.50 - 73.50	1.0000	1.0000
L39	2	FB-L98B-034-XXX(3/8)	63.50 - 68.50	1.0000	1.0000
L39	3	PWRT-608-S(13/16)	63.50 - 68.50	1.0000	1.0000
L39	4	PWRT-606-S(7/8)	63.50 - 68.50	1.0000	1.0000
L39	5	RFFT-48SM-001-XXX(3/8)	63.50 - 68.50	1.0000	1.0000
L39	7	7983A(ELLIPTICAL)	63.50 - 68.50	1.0000	1.0000
L39	21	MLC HYBRID 6X12	63.50 - 68.50	1.0000	1.0000
		6AWGX6(1-1/2)			
L39	27	Safety Line 3/8	63.50 - 68.50	1.0000	1.0000
L39	39	PL1.25x5.5 Reinforcement	63.50 - 68.50	1.0000	1.0000
L39	40	PL1.25x5.5 Reinforcement	63.50 - 68.50	1.0000	1.0000
L39	41	PL1.25x5.5 Reinforcement	63.50 - 68.50	1.0000	1.0000
L39	55	PL1x4 Reinforcement	63.50 - 68.50	1.0000	1.0000
L39	56	PL1x4 Reinforcement	63.50 - 68.50	1.0000	1.0000
L39	57	PL1x4 Reinforcement	63.50 - 68.50	1.0000	1.0000
L39	81	CCI-SFP-045100	63.50 - 68.50	1.0000	1.0000
L39	82	CCI-SFP-045100	63.50 - 68.50	1.0000	1.0000
L39	84	CCI-SFP-040075	63.50 - 68.50	1.0000	1.0000
L40	2	FB-L98B-034-XXX(3/8)	60.50 - 63.50	1.0000	1.0000
L40	3	PWRT-608-S(13/16)	60.50 - 63.50	1.0000	1.0000
L40	4	PWRT-606-S(7/8)	60.50 - 63.50	1.0000	1.0000
L40	5	RFFT-48SM-001-XXX(3/8)	60.50 - 63.50	1.0000	1.0000
L40	7	7983A(ELLIPTICAL)	60.50 - 63.50	1.0000	1.0000
L40	21	MLC HYBRID 6X12	60.50 - 63.50	1.0000	1.0000
		6AWGX6(1-1/2)			
L40	27	Safety Line 3/8	60.50 - 63.50	1.0000	1.0000
L40	39	PL1.25x5.5 Reinforcement	60.50 - 63.50	1.0000	1.0000
L40	40	PL1.25x5.5 Reinforcement	60.50 - 63.50	1.0000	1.0000
L40	41	PL1.25x5.5 Reinforcement	60.50 - 63.50	1.0000	1.0000
L40	51	PL1x4 Reinforcement	60.50 - 62.25	1.0000	1.0000
L40	52	PL1x4 Reinforcement	60.50 - 62.25	1.0000	1.0000
L40	53	PL1x4 Reinforcement	60.50 - 62.25	1.0000	1.0000
L40	55	PL1x4 Reinforcement	60.50 - 63.50	1.0000	1.0000
L40	56	PL1x4 Reinforcement	60.50 - 63.50	1.0000	1.0000
L40	57	PL1x4 Reinforcement	60.50 - 63.50	1.0000	1.0000
L40	81	CCI-SFP-045100	60.50 - 63.50	1.0000	1.0000
L40	82	CCI-SFP-045100	60.50 - 63.50	1.0000	1.0000
L40	84	CCI-SFP-040075	60.50 - 63.50	1.0000	1.0000
L41	2	FB-L98B-034-XXX(3/8)	60.25 - 60.50	1.0000	1.0000
L41	3	PWRT-608-S(13/16)	60.25 - 60.50	1.0000	1.0000
L41	4	PWRT-606-S(7/8)	60.25 - 60.50	1.0000	1.0000
L41	5	RFFT-48SM-001-XXX(3/8)	60.25 - 60.50	1.0000	1.0000
L41	7	7983A(ELLIPTICAL)	60.25 - 60.50	1.0000	1.0000
L41	21	MLC HYBRID 6X12	60.25 - 60.50	1.0000	1.0000
		6AWGX6(1-1/2)			
L41	27	Safety Line 3/8	60.25 - 60.50	1.0000	1.0000
L41	39	PL1.25x5.5 Reinforcement	60.25 - 60.50	1.0000	1.0000
L41	40	PL1.25x5.5 Reinforcement	60.25 - 60.50	1.0000	1.0000
L41	41	PL1.25x5.5 Reinforcement	60.25 - 60.50	1.0000	1.0000
L41	51	PL1x4 Reinforcement	60.25 - 60.50	1.0000	1.0000
L41	52	PL1x4 Reinforcement	60.25 - 60.50	1.0000	1.0000

# tnxTower

**B+T Group**  
1717 S. Boulder, Suite 300  
Tulsa, OK 74119  
Phone: (918) 587-4630  
FAX: (918) 295-0265

**Job**  
79982.013.01 - WATERBURY,CT (BU# 876317)

**Page**  
35 of 94

**Project**  
**Date**  
15:43:49 05/20/22

**Client**  
Crown Castle  
**Designed by**  
Jayaraj B

Tower Section	Feed Line Record No.	Description	Feed Line Segment Elev.	K <sub>a</sub> No Ice	K <sub>a</sub> Ice
L41	53	PL1x4 Reinforcement	60.25 - 60.50	1.0000	1.0000
L41	55	PL1x4 Reinforcement	60.25 - 60.50	1.0000	1.0000
L41	56	PL1x4 Reinforcement	60.25 - 60.50	1.0000	1.0000
L41	57	PL1x4 Reinforcement	60.25 - 60.50	1.0000	1.0000
L41	81	CCI-SFP-045100	60.25 - 60.50	1.0000	1.0000
L41	82	CCI-SFP-045100	60.25 - 60.50	1.0000	1.0000
L41	84	CCI-SFP-040075	60.25 - 60.50	1.0000	1.0000
L42	2	FB-L98B-034-XXX(3/8)	59.50 - 60.25	1.0000	1.0000
L42	3	PWRT-608-S(13/16)	59.50 - 60.25	1.0000	1.0000
L42	4	PWRT-606-S(7/8)	59.50 - 60.25	1.0000	1.0000
L42	5	RFFT-48SM-001-XXX(3/8)	59.50 - 60.25	1.0000	1.0000
L42	7	7983A(ELLIPTICAL)	59.50 - 60.25	1.0000	1.0000
L42	21	MLC HYBRID 6X12 6AWGX6(1-1/2)	59.50 - 60.25	1.0000	1.0000
L42	27	Safety Line 3/8	59.50 - 60.25	1.0000	1.0000
L42	39	PL1.25x5.5 Reinforcement	59.50 - 60.25	1.0000	1.0000
L42	40	PL1.25x5.5 Reinforcement	59.50 - 60.25	1.0000	1.0000
L42	41	PL1.25x5.5 Reinforcement	59.50 - 60.25	1.0000	1.0000
L42	51	PL1x4 Reinforcement	59.50 - 60.25	1.0000	1.0000
L42	52	PL1x4 Reinforcement	59.50 - 60.25	1.0000	1.0000
L42	53	PL1x4 Reinforcement	59.50 - 60.25	1.0000	1.0000
L42	55	PL1x4 Reinforcement	59.50 - 60.25	1.0000	1.0000
L42	56	PL1x4 Reinforcement	59.50 - 60.25	1.0000	1.0000
L42	57	PL1x4 Reinforcement	59.50 - 60.25	1.0000	1.0000
L42	81	CCI-SFP-045100	59.50 - 60.25	1.0000	1.0000
L42	82	CCI-SFP-045100	59.50 - 60.25	1.0000	1.0000
L42	84	CCI-SFP-040075	59.50 - 60.25	1.0000	1.0000
L43	2	FB-L98B-034-XXX(3/8)	59.25 - 59.50	1.0000	1.0000
L43	3	PWRT-608-S(13/16)	59.25 - 59.50	1.0000	1.0000
L43	4	PWRT-606-S(7/8)	59.25 - 59.50	1.0000	1.0000
L43	5	RFFT-48SM-001-XXX(3/8)	59.25 - 59.50	1.0000	1.0000
L43	7	7983A(ELLIPTICAL)	59.25 - 59.50	1.0000	1.0000
L43	21	MLC HYBRID 6X12 6AWGX6(1-1/2)	59.25 - 59.50	1.0000	1.0000
L43	27	Safety Line 3/8	59.25 - 59.50	1.0000	1.0000
L43	35	PL1.25x6.625 Reinforcement	59.25 - 59.50	1.0000	1.0000
L43	36	PL1.25x6.625 Reinforcement	59.25 - 59.50	1.0000	1.0000
L43	37	PL1.25x6.625 Reinforcement	59.25 - 59.50	1.0000	1.0000
L43	51	PL1x4 Reinforcement	59.25 - 59.50	1.0000	1.0000
L43	52	PL1x4 Reinforcement	59.25 - 59.50	1.0000	1.0000
L43	53	PL1x4 Reinforcement	59.25 - 59.50	1.0000	1.0000
L43	55	PL1x4 Reinforcement	59.25 - 59.50	1.0000	1.0000
L43	56	PL1x4 Reinforcement	59.25 - 59.50	1.0000	1.0000
L43	57	PL1x4 Reinforcement	59.25 - 59.50	1.0000	1.0000
L43	81	CCI-SFP-045100	59.25 - 59.50	1.0000	1.0000
L43	82	CCI-SFP-045100	59.25 - 59.50	1.0000	1.0000
L43	84	CCI-SFP-040075	59.25 - 59.50	1.0000	1.0000
L44	2	FB-L98B-034-XXX(3/8)	54.25 - 59.25	1.0000	1.0000
L44	3	PWRT-608-S(13/16)	54.25 - 59.25	1.0000	1.0000
L44	4	PWRT-606-S(7/8)	54.25 - 59.25	1.0000	1.0000
L44	5	RFFT-48SM-001-XXX(3/8)	54.25 - 59.25	1.0000	1.0000
L44	7	7983A(ELLIPTICAL)	54.25 - 59.25	1.0000	1.0000
L44	21	MLC HYBRID 6X12 6AWGX6(1-1/2)	54.25 - 59.25	1.0000	1.0000
L44	27	Safety Line 3/8	54.25 - 59.25	1.0000	1.0000
L44	35	PL1.25x6.625 Reinforcement	54.25 - 59.25	1.0000	1.0000
L44	36	PL1.25x6.625 Reinforcement	54.25 - 59.25	1.0000	1.0000
L44	37	PL1.25x6.625 Reinforcement	54.25 - 59.25	1.0000	1.0000
L44	51	PL1x4 Reinforcement	54.25 - 59.25	1.0000	1.0000
L44	52	PL1x4 Reinforcement	54.25 - 59.25	1.0000	1.0000
L44	53	PL1x4 Reinforcement	54.25 - 59.25	1.0000	1.0000
L44	55	PL1x4 Reinforcement	58.75 - 59.25	1.0000	1.0000

# tnxTower

**B+T Group**  
1717 S. Boulder, Suite 300  
Tulsa, OK 74119  
Phone: (918) 587-4630  
FAX: (918) 295-0265

<b>Job</b> 79982.013.01 - WATERBURY,CT (BU# 876317)	<b>Page</b> 36 of 94
<b>Project</b>	<b>Date</b> 15:43:49 05/20/22
<b>Client</b> Crown Castle	<b>Designed by</b> Jayaraj B

Tower Section	Feed Line Record No.	Description	Feed Line Segment Elev.	K <sub>a</sub> No Ice	K <sub>a</sub> Ice
L44	56	PL1x4 Reinforcement	58.75 - 59.25	1.0000	1.0000
L44	57	PL1x4 Reinforcement	58.75 - 59.25	1.0000	1.0000
L44	81	CCI-SFP-045100	54.25 - 59.25	1.0000	1.0000
L44	82	CCI-SFP-045100	54.25 - 59.25	1.0000	1.0000
L44	84	CCI-SFP-040075	54.25 - 59.25	1.0000	1.0000
L45	2	FB-L98B-034-XXX(3/8)	45.80 - 54.25	1.0000	1.0000
L45	3	PWRT-608-S(13/16)	45.80 - 54.25	1.0000	1.0000
L45	4	PWRT-606-S(7/8)	45.80 - 54.25	1.0000	1.0000
L45	5	RFFT-48SM-001-XXX(3/8)	45.80 - 54.25	1.0000	1.0000
L45	7	7983A(ELLIPTICAL)	45.80 - 54.25	1.0000	1.0000
L45	21	MLC HYBRID 6X12 6AWGX6(1-1/2)	45.80 - 54.25	1.0000	1.0000
L45	27	Safety Line 3/8	45.80 - 54.25	1.0000	1.0000
L45	35	PL1.25x6.625 Reinforcement	45.80 - 54.25	1.0000	1.0000
L45	36	PL1.25x6.625 Reinforcement	45.80 - 54.25	1.0000	1.0000
L45	37	PL1.25x6.625 Reinforcement	45.80 - 54.25	1.0000	1.0000
L45	51	PL1x4 Reinforcement	45.80 - 54.25	1.0000	1.0000
L45	52	PL1x4 Reinforcement	45.80 - 54.25	1.0000	1.0000
L45	53	PL1x4 Reinforcement	45.80 - 54.25	1.0000	1.0000
L45	81	CCI-SFP-045100	45.80 - 54.25	1.0000	1.0000
L45	82	CCI-SFP-045100	45.80 - 54.25	1.0000	1.0000
L45	84	CCI-SFP-040075	45.80 - 54.25	1.0000	1.0000
L46	2	FB-L98B-034-XXX(3/8)	44.80 - 45.80	1.0000	1.0000
L46	3	PWRT-608-S(13/16)	44.80 - 45.80	1.0000	1.0000
L46	4	PWRT-606-S(7/8)	44.80 - 45.80	1.0000	1.0000
L46	5	RFFT-48SM-001-XXX(3/8)	44.80 - 45.80	1.0000	1.0000
L46	7	7983A(ELLIPTICAL)	44.80 - 45.80	1.0000	1.0000
L46	21	MLC HYBRID 6X12 6AWGX6(1-1/2)	44.80 - 45.80	1.0000	1.0000
L46	27	Safety Line 3/8	44.80 - 45.80	1.0000	1.0000
L46	35	PL1.25x6.625 Reinforcement	44.80 - 45.80	1.0000	1.0000
L46	36	PL1.25x6.625 Reinforcement	44.80 - 45.80	1.0000	1.0000
L46	37	PL1.25x6.625 Reinforcement	44.80 - 45.80	1.0000	1.0000
L46	51	PL1x4 Reinforcement	44.80 - 45.80	1.0000	1.0000
L46	52	PL1x4 Reinforcement	44.80 - 45.80	1.0000	1.0000
L46	53	PL1x4 Reinforcement	44.80 - 45.80	1.0000	1.0000
L46	76	CCI-SFP-045100	44.80 - 45.08	1.0000	1.0000
L46	78	CCI-SFP-060100	44.80 - 45.17	1.0000	1.0000
L46	79	CCI-SFP-060100	44.80 - 45.17	1.0000	1.0000
L46	81	CCI-SFP-045100	45.25 - 45.80	1.0000	1.0000
L46	82	CCI-SFP-045100	45.25 - 45.80	1.0000	1.0000
L46	84	CCI-SFP-040075	45.25 - 45.80	1.0000	1.0000
L47	2	FB-L98B-034-XXX(3/8)	43.58 - 44.80	1.0000	1.0000
L47	3	PWRT-608-S(13/16)	43.58 - 44.80	1.0000	1.0000
L47	4	PWRT-606-S(7/8)	43.58 - 44.80	1.0000	1.0000
L47	5	RFFT-48SM-001-XXX(3/8)	43.58 - 44.80	1.0000	1.0000
L47	7	7983A(ELLIPTICAL)	43.58 - 44.80	1.0000	1.0000
L47	21	MLC HYBRID 6X12 6AWGX6(1-1/2)	43.58 - 44.80	1.0000	1.0000
L47	27	Safety Line 3/8	43.58 - 44.80	1.0000	1.0000
L47	35	PL1.25x6.625 Reinforcement	43.58 - 44.80	1.0000	1.0000
L47	36	PL1.25x6.625 Reinforcement	43.58 - 44.80	1.0000	1.0000
L47	37	PL1.25x6.625 Reinforcement	43.58 - 44.80	1.0000	1.0000
L47	51	PL1x4 Reinforcement	43.58 - 44.80	1.0000	1.0000
L47	52	PL1x4 Reinforcement	43.58 - 44.80	1.0000	1.0000
L47	53	PL1x4 Reinforcement	43.58 - 44.80	1.0000	1.0000
L47	76	CCI-SFP-045100	43.58 - 44.80	1.0000	1.0000
L47	78	CCI-SFP-060100	43.58 - 44.80	1.0000	1.0000
L47	79	CCI-SFP-060100	43.58 - 44.80	1.0000	1.0000
L48	2	FB-L98B-034-XXX(3/8)	43.33 - 43.58	1.0000	1.0000
L48	3	PWRT-608-S(13/16)	43.33 - 43.58	1.0000	1.0000
L48	4	PWRT-606-S(7/8)	43.33 - 43.58	1.0000	1.0000

# tnxTower

**B+T Group**  
1717 S. Boulder, Suite 300  
Tulsa, OK 74119  
Phone: (918) 587-4630  
FAX: (918) 295-0265

**Job**  
79982.013.01 - WATERBURY,CT (BU# 876317)

**Page**  
37 of 94

**Project**  
**Date**  
15:43:49 05/20/22

**Client**  
Crown Castle  
**Designed by**  
Jayaraj B

Tower Section	Feed Line Record No.	Description	Feed Line Segment Elev.	K <sub>a</sub> No Ice	K <sub>a</sub> Ice
L48	5	RFFT-48SM-001-XXX(3/8)	43.33 - 43.58	1.0000	1.0000
L48	7	7983A(ELLIPTICAL)	43.33 - 43.58	1.0000	1.0000
L48	21	MLC HYBRID 6X12 6AWGX6(1-1/2)	43.33 - 43.58	1.0000	1.0000
L48	27	Safety Line 3/8	43.33 - 43.58	1.0000	1.0000
L48	35	PL1.25x6.625 Reinforcement	43.33 - 43.58	1.0000	1.0000
L48	36	PL1.25x6.625 Reinforcement	43.33 - 43.58	1.0000	1.0000
L48	37	PL1.25x6.625 Reinforcement	43.33 - 43.58	1.0000	1.0000
L48	51	PL1x4 Reinforcement	43.33 - 43.58	1.0000	1.0000
L48	52	PL1x4 Reinforcement	43.33 - 43.58	1.0000	1.0000
L48	53	PL1x4 Reinforcement	43.33 - 43.58	1.0000	1.0000
L48	76	CCI-SFP-045100	43.33 - 43.58	1.0000	1.0000
L48	78	CCI-SFP-060100	43.33 - 43.58	1.0000	1.0000
L48	79	CCI-SFP-060100	43.33 - 43.58	1.0000	1.0000
L49	2	FB-L98B-034-XXX(3/8)	43.17 - 43.33	1.0000	1.0000
L49	3	PWRT-608-S(13/16)	43.17 - 43.33	1.0000	1.0000
L49	4	PWRT-606-S(7/8)	43.17 - 43.33	1.0000	1.0000
L49	5	RFFT-48SM-001-XXX(3/8)	43.17 - 43.33	1.0000	1.0000
L49	7	7983A(ELLIPTICAL)	43.17 - 43.33	1.0000	1.0000
L49	21	MLC HYBRID 6X12 6AWGX6(1-1/2)	43.17 - 43.33	1.0000	1.0000
L49	27	Safety Line 3/8	43.17 - 43.33	1.0000	1.0000
L49	35	PL1.25x6.625 Reinforcement	43.17 - 43.33	1.0000	1.0000
L49	36	PL1.25x6.625 Reinforcement	43.17 - 43.33	1.0000	1.0000
L49	37	PL1.25x6.625 Reinforcement	43.17 - 43.33	1.0000	1.0000
L49	51	PL1x4 Reinforcement	43.17 - 43.33	1.0000	1.0000
L49	52	PL1x4 Reinforcement	43.17 - 43.33	1.0000	1.0000
L49	53	PL1x4 Reinforcement	43.17 - 43.33	1.0000	1.0000
L49	76	CCI-SFP-045100	43.17 - 43.33	1.0000	1.0000
L49	78	CCI-SFP-060100	43.17 - 43.33	1.0000	1.0000
L49	79	CCI-SFP-060100	43.17 - 43.33	1.0000	1.0000
L50	2	FB-L98B-034-XXX(3/8)	42.92 - 43.17	1.0000	1.0000
L50	3	PWRT-608-S(13/16)	42.92 - 43.17	1.0000	1.0000
L50	4	PWRT-606-S(7/8)	42.92 - 43.17	1.0000	1.0000
L50	5	RFFT-48SM-001-XXX(3/8)	42.92 - 43.17	1.0000	1.0000
L50	7	7983A(ELLIPTICAL)	42.92 - 43.17	1.0000	1.0000
L50	21	MLC HYBRID 6X12 6AWGX6(1-1/2)	42.92 - 43.17	1.0000	1.0000
L50	27	Safety Line 3/8	42.92 - 43.17	1.0000	1.0000
L50	35	PL1.25x6.625 Reinforcement	42.92 - 43.17	1.0000	1.0000
L50	36	PL1.25x6.625 Reinforcement	42.92 - 43.17	1.0000	1.0000
L50	37	PL1.25x6.625 Reinforcement	42.92 - 43.17	1.0000	1.0000
L50	51	PL1x4 Reinforcement	42.92 - 43.17	1.0000	1.0000
L50	52	PL1x4 Reinforcement	42.92 - 43.17	1.0000	1.0000
L50	53	PL1x4 Reinforcement	42.92 - 43.17	1.0000	1.0000
L50	76	CCI-SFP-045100	42.92 - 43.17	1.0000	1.0000
L50	78	CCI-SFP-060100	42.92 - 43.17	1.0000	1.0000
L50	79	CCI-SFP-060100	42.92 - 43.17	1.0000	1.0000
L51	2	FB-L98B-034-XXX(3/8)	39.00 - 42.92	1.0000	1.0000
L51	3	PWRT-608-S(13/16)	39.00 - 42.92	1.0000	1.0000
L51	4	PWRT-606-S(7/8)	39.00 - 42.92	1.0000	1.0000
L51	5	RFFT-48SM-001-XXX(3/8)	39.00 - 42.92	1.0000	1.0000
L51	7	7983A(ELLIPTICAL)	39.00 - 42.92	1.0000	1.0000
L51	21	MLC HYBRID 6X12 6AWGX6(1-1/2)	39.00 - 42.92	1.0000	1.0000
L51	27	Safety Line 3/8	39.00 - 42.92	1.0000	1.0000
L51	35	PL1.25x6.625 Reinforcement	39.00 - 42.92	1.0000	1.0000
L51	36	PL1.25x6.625 Reinforcement	39.00 - 42.92	1.0000	1.0000
L51	37	PL1.25x6.625 Reinforcement	39.00 - 42.92	1.0000	1.0000
L51	49	PL1x4 Reinforcement	39.00 - 40.75	1.0000	1.0000
L51	51	PL1x4 Reinforcement	39.00 - 42.92	1.0000	1.0000
L51	52	PL1x4 Reinforcement	39.00 - 42.92	1.0000	1.0000

# tnxTower

**B+T Group**  
1717 S. Boulder, Suite 300  
Tulsa, OK 74119  
Phone: (918) 587-4630  
FAX: (918) 295-0265

**Job**  
79982.013.01 - WATERBURY,CT (BU# 876317)

**Page**  
38 of 94

**Project**  
**Date**  
15:43:49 05/20/22

**Client**  
Crown Castle  
**Designed by**  
Jayaraj B

Tower Section	Feed Line Record No.	Description	Feed Line Segment Elev.	$K_a$ No Ice	$K_a$ Ice
L51	53	PL1x4 Reinforcement	39.00 - 42.92	1.0000	1.0000
L51	76	CCI-SFP-045100	39.00 - 42.92	1.0000	1.0000
L51	78	CCI-SFP-060100	39.00 - 42.92	1.0000	1.0000
L51	79	CCI-SFP-060100	39.00 - 42.92	1.0000	1.0000
L52	2	FB-L98B-034-XXX(3/8)	38.75 - 39.00	1.0000	1.0000
L52	3	PWRT-608-S(13/16)	38.75 - 39.00	1.0000	1.0000
L52	4	PWRT-606-S(7/8)	38.75 - 39.00	1.0000	1.0000
L52	5	RFFT-48SM-001-XXX(3/8)	38.75 - 39.00	1.0000	1.0000
L52	7	7983A(ELLIPTICAL)	38.75 - 39.00	1.0000	1.0000
L52	21	MLC HYBRID 6X12	38.75 - 39.00	1.0000	1.0000
		6AWGX6(1-1/2)			
L52	27	Safety Line 3/8	38.75 - 39.00	1.0000	1.0000
L52	35	PL1.25x6.625 Reinforcement	38.75 - 39.00	1.0000	1.0000
L52	36	PL1.25x6.625 Reinforcement	38.75 - 39.00	1.0000	1.0000
L52	37	PL1.25x6.625 Reinforcement	38.75 - 39.00	1.0000	1.0000
L52	49	PL1x4 Reinforcement	38.75 - 39.00	1.0000	1.0000
L52	51	PL1x4 Reinforcement	38.75 - 39.00	1.0000	1.0000
L52	52	PL1x4 Reinforcement	38.75 - 39.00	1.0000	1.0000
L52	53	PL1x4 Reinforcement	38.75 - 39.00	1.0000	1.0000
L52	76	CCI-SFP-045100	38.75 - 39.00	1.0000	1.0000
L52	78	CCI-SFP-060100	38.75 - 39.00	1.0000	1.0000
L52	79	CCI-SFP-060100	38.75 - 39.00	1.0000	1.0000
L53	2	FB-L98B-034-XXX(3/8)	37.17 - 38.75	1.0000	1.0000
L53	3	PWRT-608-S(13/16)	37.17 - 38.75	1.0000	1.0000
L53	4	PWRT-606-S(7/8)	37.17 - 38.75	1.0000	1.0000
L53	5	RFFT-48SM-001-XXX(3/8)	37.17 - 38.75	1.0000	1.0000
L53	7	7983A(ELLIPTICAL)	37.17 - 38.75	1.0000	1.0000
L53	21	MLC HYBRID 6X12	37.17 - 38.75	1.0000	1.0000
		6AWGX6(1-1/2)			
L53	27	Safety Line 3/8	37.17 - 38.75	1.0000	1.0000
L53	35	PL1.25x6.625 Reinforcement	37.17 - 38.75	1.0000	1.0000
L53	36	PL1.25x6.625 Reinforcement	37.17 - 38.75	1.0000	1.0000
L53	37	PL1.25x6.625 Reinforcement	37.17 - 38.75	1.0000	1.0000
L53	49	PL1x4 Reinforcement	37.17 - 38.75	1.0000	1.0000
L53	51	PL1x4 Reinforcement	37.17 - 38.75	1.0000	1.0000
L53	52	PL1x4 Reinforcement	37.17 - 38.75	1.0000	1.0000
L53	53	PL1x4 Reinforcement	37.17 - 38.75	1.0000	1.0000
L53	76	CCI-SFP-045100	37.17 - 38.75	1.0000	1.0000
L53	78	CCI-SFP-060100	37.17 - 38.75	1.0000	1.0000
L53	79	CCI-SFP-060100	37.17 - 38.75	1.0000	1.0000
L54	2	FB-L98B-034-XXX(3/8)	36.92 - 37.17	1.0000	1.0000
L54	3	PWRT-608-S(13/16)	36.92 - 37.17	1.0000	1.0000
L54	4	PWRT-606-S(7/8)	36.92 - 37.17	1.0000	1.0000
L54	5	RFFT-48SM-001-XXX(3/8)	36.92 - 37.17	1.0000	1.0000
L54	7	7983A(ELLIPTICAL)	36.92 - 37.17	1.0000	1.0000
L54	21	MLC HYBRID 6X12	36.92 - 37.17	1.0000	1.0000
		6AWGX6(1-1/2)			
L54	27	Safety Line 3/8	36.92 - 37.17	1.0000	1.0000
L54	35	PL1.25x6.625 Reinforcement	36.92 - 37.17	1.0000	1.0000
L54	36	PL1.25x6.625 Reinforcement	36.92 - 37.17	1.0000	1.0000
L54	37	PL1.25x6.625 Reinforcement	36.92 - 37.17	1.0000	1.0000
L54	49	PL1x4 Reinforcement	36.92 - 37.17	1.0000	1.0000
L54	51	PL1x4 Reinforcement	36.92 - 37.17	1.0000	1.0000
L54	52	PL1x4 Reinforcement	36.92 - 37.17	1.0000	1.0000
L54	53	PL1x4 Reinforcement	36.92 - 37.17	1.0000	1.0000
L54	76	CCI-SFP-045100	36.92 - 37.17	1.0000	1.0000
L54	78	CCI-SFP-060100	36.92 - 37.17	1.0000	1.0000
L54	79	CCI-SFP-060100	36.92 - 37.17	1.0000	1.0000
L55	2	FB-L98B-034-XXX(3/8)	34.00 - 36.92	1.0000	1.0000
L55	3	PWRT-608-S(13/16)	34.00 - 36.92	1.0000	1.0000
L55	4	PWRT-606-S(7/8)	34.00 - 36.92	1.0000	1.0000
L55	5	RFFT-48SM-001-XXX(3/8)	34.00 - 36.92	1.0000	1.0000

# tnxTower

**B+T Group**  
1717 S. Boulder, Suite 300  
Tulsa, OK 74119  
Phone: (918) 587-4630  
FAX: (918) 295-0265

**Job**  
79982.013.01 - WATERBURY,CT (BU# 876317)

**Page**  
39 of 94

**Project**  
**Date**  
15:43:49 05/20/22

**Client**  
Crown Castle  
**Designed by**  
Jayaraj B

Tower Section	Feed Line Record No.	Description	Feed Line Segment Elev.	K <sub>a</sub> No Ice	K <sub>a</sub> Ice
L55	7	7983A(ELLIPTICAL)	34.00 - 36.92	1.0000	1.0000
L55	21	MLC HYBRID 6X12 6AWGX6(1-1/2)	34.00 - 36.92	1.0000	1.0000
L55	27	Safety Line 3/8	34.00 - 36.92	1.0000	1.0000
L55	35	PL1.25x6.625 Reinforcement	34.00 - 36.92	1.0000	1.0000
L55	36	PL1.25x6.625 Reinforcement	34.00 - 36.92	1.0000	1.0000
L55	37	PL1.25x6.625 Reinforcement	34.00 - 36.92	1.0000	1.0000
L55	47	PL1x4 Reinforcement	34.00 - 35.75	1.0000	1.0000
L55	48	PL1x4 Reinforcement	34.00 - 35.75	1.0000	1.0000
L55	49	PL1x4 Reinforcement	34.00 - 36.92	1.0000	1.0000
L55	51	PL1x4 Reinforcement	34.00 - 36.92	1.0000	1.0000
L55	52	PL1x4 Reinforcement	34.00 - 36.92	1.0000	1.0000
L55	53	PL1x4 Reinforcement	34.00 - 36.92	1.0000	1.0000
L55	72	CCI-SFP-045100	34.00 - 35.08	1.0000	1.0000
L55	74	CCI-SFP-045100	34.00 - 35.08	1.0000	1.0000
L55	76	CCI-SFP-045100	34.00 - 36.92	1.0000	1.0000
L55	78	CCI-SFP-060100	35.17 - 36.92	1.0000	1.0000
L55	79	CCI-SFP-060100	35.17 - 36.92	1.0000	1.0000
L56	2	FB-L98B-034-XXX(3/8)	33.75 - 34.00	1.0000	1.0000
L56	3	PWRT-608-S(13/16)	33.75 - 34.00	1.0000	1.0000
L56	4	PWRT-606-S(7/8)	33.75 - 34.00	1.0000	1.0000
L56	5	RFFT-48SM-001-XXX(3/8)	33.75 - 34.00	1.0000	1.0000
L56	7	7983A(ELLIPTICAL)	33.75 - 34.00	1.0000	1.0000
L56	21	MLC HYBRID 6X12 6AWGX6(1-1/2)	33.75 - 34.00	1.0000	1.0000
L56	27	Safety Line 3/8	33.75 - 34.00	1.0000	1.0000
L56	35	PL1.25x6.625 Reinforcement	33.75 - 34.00	1.0000	1.0000
L56	36	PL1.25x6.625 Reinforcement	33.75 - 34.00	1.0000	1.0000
L56	37	PL1.25x6.625 Reinforcement	33.75 - 34.00	1.0000	1.0000
L56	47	PL1x4 Reinforcement	33.75 - 34.00	1.0000	1.0000
L56	48	PL1x4 Reinforcement	33.75 - 34.00	1.0000	1.0000
L56	49	PL1x4 Reinforcement	33.75 - 34.00	1.0000	1.0000
L56	51	PL1x4 Reinforcement	33.75 - 34.00	1.0000	1.0000
L56	52	PL1x4 Reinforcement	33.75 - 34.00	1.0000	1.0000
L56	53	PL1x4 Reinforcement	33.75 - 34.00	1.0000	1.0000
L56	72	CCI-SFP-045100	33.75 - 34.00	1.0000	1.0000
L56	74	CCI-SFP-045100	33.75 - 34.00	1.0000	1.0000
L56	76	CCI-SFP-045100	33.75 - 34.00	1.0000	1.0000
L57	2	FB-L98B-034-XXX(3/8)	29.75 - 33.75	1.0000	1.0000
L57	3	PWRT-608-S(13/16)	29.75 - 33.75	1.0000	1.0000
L57	4	PWRT-606-S(7/8)	29.75 - 33.75	1.0000	1.0000
L57	5	RFFT-48SM-001-XXX(3/8)	29.75 - 33.75	1.0000	1.0000
L57	7	7983A(ELLIPTICAL)	29.75 - 33.75	1.0000	1.0000
L57	21	MLC HYBRID 6X12 6AWGX6(1-1/2)	29.75 - 33.75	1.0000	1.0000
L57	27	Safety Line 3/8	29.75 - 33.75	1.0000	1.0000
L57	35	PL1.25x6.625 Reinforcement	29.75 - 33.75	1.0000	1.0000
L57	36	PL1.25x6.625 Reinforcement	29.75 - 33.75	1.0000	1.0000
L57	37	PL1.25x6.625 Reinforcement	29.75 - 33.75	1.0000	1.0000
L57	47	PL1x4 Reinforcement	29.75 - 33.75	1.0000	1.0000
L57	48	PL1x4 Reinforcement	29.75 - 33.75	1.0000	1.0000
L57	49	PL1x4 Reinforcement	29.75 - 33.75	1.0000	1.0000
L57	51	PL1x4 Reinforcement	32.25 - 33.75	1.0000	1.0000
L57	52	PL1x4 Reinforcement	32.25 - 33.75	1.0000	1.0000
L57	53	PL1x4 Reinforcement	32.25 - 33.75	1.0000	1.0000
L57	72	CCI-SFP-045100	29.75 - 33.75	1.0000	1.0000
L57	74	CCI-SFP-045100	29.75 - 33.75	1.0000	1.0000
L57	76	CCI-SFP-045100	29.75 - 33.75	1.0000	1.0000
L58	2	FB-L98B-034-XXX(3/8)	29.50 - 29.75	1.0000	1.0000
L58	3	PWRT-608-S(13/16)	29.50 - 29.75	1.0000	1.0000
L58	4	PWRT-606-S(7/8)	29.50 - 29.75	1.0000	1.0000
L58	5	RFFT-48SM-001-XXX(3/8)	29.50 - 29.75	1.0000	1.0000

# tnxTower

**B+T Group**  
1717 S. Boulder, Suite 300  
Tulsa, OK 74119  
Phone: (918) 587-4630  
FAX: (918) 295-0265

**Job**  
79982.013.01 - WATERBURY,CT (BU# 876317)

**Page**  
40 of 94

**Project**  
**Date**  
15:43:49 05/20/22

**Client**  
Crown Castle  
**Designed by**  
Jayaraj B

Tower Section	Feed Line Record No.	Description	Feed Line Segment Elev.	K <sub>a</sub> No Ice	K <sub>a</sub> Ice
L58	7	7983A(ELLIPTICAL)	29.50 - 29.75	1.0000	1.0000
L58	21	MLC HYBRID 6X12 6AWGX6(1-1/2)	29.50 - 29.75	1.0000	1.0000
L58	27	Safety Line 3/8	29.50 - 29.75	1.0000	1.0000
L58	29	PL1.25x6.875 Reinforcement	29.50 - 29.75	1.0000	1.0000
L58	30	PL1.25x6.875 Reinforcement	29.50 - 29.75	1.0000	1.0000
L58	31	PL1.25x6.875 Reinforcement	29.50 - 29.75	1.0000	1.0000
L58	47	PL1x4 Reinforcement	29.50 - 29.75	1.0000	1.0000
L58	48	PL1x4 Reinforcement	29.50 - 29.75	1.0000	1.0000
L58	49	PL1x4 Reinforcement	29.50 - 29.75	1.0000	1.0000
L58	72	CCI-SFP-045100	29.50 - 29.75	1.0000	1.0000
L58	74	CCI-SFP-045100	29.50 - 29.75	1.0000	1.0000
L58	76	CCI-SFP-045100	29.50 - 29.75	1.0000	1.0000
L59	2	FB-L98B-034-XXX(3/8)	24.50 - 29.50	1.0000	1.0000
L59	3	PWRT-608-S(13/16)	24.50 - 29.50	1.0000	1.0000
L59	4	PWRT-606-S(7/8)	24.50 - 29.50	1.0000	1.0000
L59	5	RFFT-48SM-001-XXX(3/8)	24.50 - 29.50	1.0000	1.0000
L59	7	7983A(ELLIPTICAL)	24.50 - 29.50	1.0000	1.0000
L59	21	MLC HYBRID 6X12 6AWGX6(1-1/2)	24.50 - 29.50	1.0000	1.0000
L59	27	Safety Line 3/8	24.50 - 29.50	1.0000	1.0000
L59	29	PL1.25x6.875 Reinforcement	24.50 - 29.50	1.0000	1.0000
L59	30	PL1.25x6.875 Reinforcement	24.50 - 29.50	1.0000	1.0000
L59	31	PL1.25x6.875 Reinforcement	24.50 - 29.50	1.0000	1.0000
L59	47	PL1x4 Reinforcement	24.50 - 29.50	1.0000	1.0000
L59	48	PL1x4 Reinforcement	24.50 - 29.50	1.0000	1.0000
L59	49	PL1x4 Reinforcement	24.50 - 29.50	1.0000	1.0000
L59	67	CCI-SFP-060100	24.50 - 25.00	1.0000	1.0000
L59	68	CCI-SFP-060100	24.50 - 25.00	1.0000	1.0000
L59	70	CCI-SFP-060100	24.50 - 25.00	1.0000	1.0000
L59	72	CCI-SFP-045100	24.50 - 29.50	1.0000	1.0000
L59	74	CCI-SFP-045100	25.08 - 29.50	1.0000	1.0000
L59	76	CCI-SFP-045100	25.08 - 29.50	1.0000	1.0000
L60	2	FB-L98B-034-XXX(3/8)	23.00 - 24.50	1.0000	1.0000
L60	3	PWRT-608-S(13/16)	23.00 - 24.50	1.0000	1.0000
L60	4	PWRT-606-S(7/8)	23.00 - 24.50	1.0000	1.0000
L60	5	RFFT-48SM-001-XXX(3/8)	23.00 - 24.50	1.0000	1.0000
L60	7	7983A(ELLIPTICAL)	23.00 - 24.50	1.0000	1.0000
L60	21	MLC HYBRID 6X12 6AWGX6(1-1/2)	23.00 - 24.50	1.0000	1.0000
L60	27	Safety Line 3/8	23.00 - 24.50	1.0000	1.0000
L60	29	PL1.25x6.875 Reinforcement	23.00 - 24.50	1.0000	1.0000
L60	30	PL1.25x6.875 Reinforcement	23.00 - 24.50	1.0000	1.0000
L60	31	PL1.25x6.875 Reinforcement	23.00 - 24.50	1.0000	1.0000
L60	47	PL1x4 Reinforcement	23.00 - 24.50	1.0000	1.0000
L60	48	PL1x4 Reinforcement	23.00 - 24.50	1.0000	1.0000
L60	49	PL1x4 Reinforcement	23.00 - 24.50	1.0000	1.0000
L60	67	CCI-SFP-060100	23.00 - 24.50	1.0000	1.0000
L60	68	CCI-SFP-060100	23.00 - 24.50	1.0000	1.0000
L60	70	CCI-SFP-060100	23.00 - 24.50	1.0000	1.0000
L60	72	CCI-SFP-045100	23.00 - 24.50	1.0000	1.0000
L61	2	FB-L98B-034-XXX(3/8)	22.75 - 23.00	1.0000	1.0000
L61	3	PWRT-608-S(13/16)	22.75 - 23.00	1.0000	1.0000
L61	4	PWRT-606-S(7/8)	22.75 - 23.00	1.0000	1.0000
L61	5	RFFT-48SM-001-XXX(3/8)	22.75 - 23.00	1.0000	1.0000
L61	7	7983A(ELLIPTICAL)	22.75 - 23.00	1.0000	1.0000
L61	21	MLC HYBRID 6X12 6AWGX6(1-1/2)	22.75 - 23.00	1.0000	1.0000
L61	27	Safety Line 3/8	22.75 - 23.00	1.0000	1.0000
L61	29	PL1.25x6.875 Reinforcement	22.75 - 23.00	1.0000	1.0000
L61	30	PL1.25x6.875 Reinforcement	22.75 - 23.00	1.0000	1.0000
L61	31	PL1.25x6.875 Reinforcement	22.75 - 23.00	1.0000	1.0000

# tnxTower

**B+T Group**  
1717 S. Boulder, Suite 300  
Tulsa, OK 74119  
Phone: (918) 587-4630  
FAX: (918) 295-0265

**Job**  
79982.013.01 - WATERBURY,CT (BU# 876317)

**Page**  
41 of 94

**Project**  
**Date**  
15:43:49 05/20/22

**Client**  
Crown Castle  
**Designed by**  
Jayaraj B

Tower Section	Feed Line Record No.	Description	Feed Line Segment Elev.	K <sub>a</sub> No Ice	K <sub>a</sub> Ice
L61	47	PL1x4 Reinforcement	22.75 - 23.00	1.0000	1.0000
L61	48	PL1x4 Reinforcement	22.75 - 23.00	1.0000	1.0000
L61	49	PL1x4 Reinforcement	22.75 - 23.00	1.0000	1.0000
L61	67	CCI-SFP-060100	22.75 - 23.00	1.0000	1.0000
L61	68	CCI-SFP-060100	22.75 - 23.00	1.0000	1.0000
L61	70	CCI-SFP-060100	22.75 - 23.00	1.0000	1.0000
L61	72	CCI-SFP-045100	22.75 - 23.00	1.0000	1.0000
L62	2	FB-L98B-034-XXX(3/8)	21.58 - 22.75	1.0000	1.0000
L62	3	PWRT-608-S(13/16)	21.58 - 22.75	1.0000	1.0000
L62	4	PWRT-606-S(7/8)	21.58 - 22.75	1.0000	1.0000
L62	5	RFFT-48SM-001-XXX(3/8)	21.58 - 22.75	1.0000	1.0000
L62	7	7983A(ELLIPTICAL)	21.58 - 22.75	1.0000	1.0000
L62	21	MLC HYBRID 6X12 6AWGX6(1-1/2)	21.58 - 22.75	1.0000	1.0000
L62	27	Safety Line 3/8	21.58 - 22.75	1.0000	1.0000
L62	29	PL1.25x6.875 Reinforcement	21.58 - 22.75	1.0000	1.0000
L62	30	PL1.25x6.875 Reinforcement	21.58 - 22.75	1.0000	1.0000
L62	31	PL1.25x6.875 Reinforcement	21.58 - 22.75	1.0000	1.0000
L62	47	PL1x4 Reinforcement	21.58 - 22.75	1.0000	1.0000
L62	48	PL1x4 Reinforcement	21.58 - 22.75	1.0000	1.0000
L62	49	PL1x4 Reinforcement	21.58 - 22.75	1.0000	1.0000
L62	67	CCI-SFP-060100	21.58 - 22.75	1.0000	1.0000
L62	68	CCI-SFP-060100	21.58 - 22.75	1.0000	1.0000
L62	70	CCI-SFP-060100	21.58 - 22.75	1.0000	1.0000
L62	72	CCI-SFP-045100	21.58 - 22.75	1.0000	1.0000
L63	2	FB-L98B-034-XXX(3/8)	21.33 - 21.58	1.0000	1.0000
L63	3	PWRT-608-S(13/16)	21.33 - 21.58	1.0000	1.0000
L63	4	PWRT-606-S(7/8)	21.33 - 21.58	1.0000	1.0000
L63	5	RFFT-48SM-001-XXX(3/8)	21.33 - 21.58	1.0000	1.0000
L63	7	7983A(ELLIPTICAL)	21.33 - 21.58	1.0000	1.0000
L63	21	MLC HYBRID 6X12 6AWGX6(1-1/2)	21.33 - 21.58	1.0000	1.0000
L63	27	Safety Line 3/8	21.33 - 21.58	1.0000	1.0000
L63	29	PL1.25x6.875 Reinforcement	21.33 - 21.58	1.0000	1.0000
L63	30	PL1.25x6.875 Reinforcement	21.33 - 21.58	1.0000	1.0000
L63	31	PL1.25x6.875 Reinforcement	21.33 - 21.58	1.0000	1.0000
L63	47	PL1x4 Reinforcement	21.33 - 21.58	1.0000	1.0000
L63	48	PL1x4 Reinforcement	21.33 - 21.58	1.0000	1.0000
L63	49	PL1x4 Reinforcement	21.33 - 21.58	1.0000	1.0000
L63	67	CCI-SFP-060100	21.33 - 21.58	1.0000	1.0000
L63	68	CCI-SFP-060100	21.33 - 21.58	1.0000	1.0000
L63	70	CCI-SFP-060100	21.33 - 21.58	1.0000	1.0000
L63	72	CCI-SFP-045100	21.33 - 21.58	1.0000	1.0000
L64	2	FB-L98B-034-XXX(3/8)	16.33 - 21.33	1.0000	1.0000
L64	3	PWRT-608-S(13/16)	16.33 - 21.33	1.0000	1.0000
L64	4	PWRT-606-S(7/8)	16.33 - 21.33	1.0000	1.0000
L64	5	RFFT-48SM-001-XXX(3/8)	16.33 - 21.33	1.0000	1.0000
L64	7	7983A(ELLIPTICAL)	16.33 - 21.33	1.0000	1.0000
L64	21	MLC HYBRID 6X12 6AWGX6(1-1/2)	16.33 - 21.33	1.0000	1.0000
L64	27	Safety Line 3/8	16.33 - 21.33	1.0000	1.0000
L64	29	PL1.25x6.875 Reinforcement	16.33 - 21.33	1.0000	1.0000
L64	30	PL1.25x6.875 Reinforcement	16.33 - 21.33	1.0000	1.0000
L64	31	PL1.25x6.875 Reinforcement	16.33 - 21.33	1.0000	1.0000
L64	32	PL1.25x6.875 Reinforcement	16.33 - 16.42	1.0000	1.0000
L64	33	PL1.25x6.875 Reinforcement	16.33 - 16.42	1.0000	1.0000
L64	47	PL1x4 Reinforcement	16.33 - 21.33	1.0000	1.0000
L64	48	PL1x4 Reinforcement	16.33 - 21.33	1.0000	1.0000
L64	49	PL1x4 Reinforcement	16.33 - 21.33	1.0000	1.0000
L64	67	CCI-SFP-060100	16.33 - 21.33	1.0000	1.0000
L64	68	CCI-SFP-060100	16.33 - 21.33	1.0000	1.0000
L64	70	CCI-SFP-060100	16.33 - 21.33	1.0000	1.0000

# tnxTower

**B+T Group**  
1717 S. Boulder, Suite 300  
Tulsa, OK 74119  
Phone: (918) 587-4630  
FAX: (918) 295-0265

**Job**  
79982.013.01 - WATERBURY,CT (BU# 876317)

**Page**  
42 of 94

**Project**  
**Date**  
15:43:49 05/20/22

**Client**  
Crown Castle  
**Designed by**  
Jayaraj B

Tower Section	Feed Line Record No.	Description	Feed Line Segment Elev.	K <sub>a</sub> No Ice	K <sub>a</sub> Ice
L64	72	CCI-SFP-045100	20.08 - 21.33	1.0000	1.0000
L65	2	FB-L98B-034-XXX(3/8)	12.92 - 16.33	1.0000	1.0000
L65	3	PWRT-608-S(13/16)	12.92 - 16.33	1.0000	1.0000
L65	4	PWRT-606-S(7/8)	12.92 - 16.33	1.0000	1.0000
L65	5	RFFT-48SM-001-XXX(3/8)	12.92 - 16.33	1.0000	1.0000
L65	7	7983A(ELLIPTICAL)	12.92 - 16.33	1.0000	1.0000
L65	21	MLC HYBRID 6X12 6AWGX6(1-1/2)	12.92 - 16.33	1.0000	1.0000
L65	27	Safety Line 3/8	12.92 - 16.33	1.0000	1.0000
L65	29	PL1.25x6.875 Reinforcement	12.92 - 16.33	1.0000	1.0000
L65	30	PL1.25x6.875 Reinforcement	12.92 - 16.33	1.0000	1.0000
L65	31	PL1.25x6.875 Reinforcement	12.92 - 16.33	1.0000	1.0000
L65	32	PL1.25x6.875 Reinforcement	12.92 - 16.33	1.0000	1.0000
L65	33	PL1.25x6.875 Reinforcement	12.92 - 16.33	1.0000	1.0000
L65	47	PL1x4 Reinforcement	12.92 - 16.33	1.0000	1.0000
L65	48	PL1x4 Reinforcement	12.92 - 16.33	1.0000	1.0000
L65	49	PL1x4 Reinforcement	12.92 - 16.33	1.0000	1.0000
L65	67	CCI-SFP-060100	12.92 - 16.33	1.0000	1.0000
L65	68	CCI-SFP-060100	12.92 - 16.33	1.0000	1.0000
L65	70	CCI-SFP-060100	12.92 - 16.33	1.0000	1.0000
L66	2	FB-L98B-034-XXX(3/8)	12.67 - 12.92	1.0000	1.0000
L66	3	PWRT-608-S(13/16)	12.67 - 12.92	1.0000	1.0000
L66	4	PWRT-606-S(7/8)	12.67 - 12.92	1.0000	1.0000
L66	5	RFFT-48SM-001-XXX(3/8)	12.67 - 12.92	1.0000	1.0000
L66	7	7983A(ELLIPTICAL)	12.67 - 12.92	1.0000	1.0000
L66	21	MLC HYBRID 6X12 6AWGX6(1-1/2)	12.67 - 12.92	1.0000	1.0000
L66	27	Safety Line 3/8	12.67 - 12.92	1.0000	1.0000
L66	29	PL1.25x6.875 Reinforcement	12.67 - 12.92	1.0000	1.0000
L66	30	PL1.25x6.875 Reinforcement	12.67 - 12.92	1.0000	1.0000
L66	31	PL1.25x6.875 Reinforcement	12.67 - 12.92	1.0000	1.0000
L66	32	PL1.25x6.875 Reinforcement	12.67 - 12.92	1.0000	1.0000
L66	33	PL1.25x6.875 Reinforcement	12.67 - 12.92	1.0000	1.0000
L66	47	PL1x4 Reinforcement	12.67 - 12.92	1.0000	1.0000
L66	48	PL1x4 Reinforcement	12.67 - 12.92	1.0000	1.0000
L66	49	PL1x4 Reinforcement	12.67 - 12.92	1.0000	1.0000
L66	67	CCI-SFP-060100	12.67 - 12.92	1.0000	1.0000
L66	68	CCI-SFP-060100	12.67 - 12.92	1.0000	1.0000
L66	70	CCI-SFP-060100	12.67 - 12.92	1.0000	1.0000
L67	2	FB-L98B-034-XXX(3/8)	12.50 - 12.67	1.0000	1.0000
L67	3	PWRT-608-S(13/16)	12.50 - 12.67	1.0000	1.0000
L67	4	PWRT-606-S(7/8)	12.50 - 12.67	1.0000	1.0000
L67	5	RFFT-48SM-001-XXX(3/8)	12.50 - 12.67	1.0000	1.0000
L67	7	7983A(ELLIPTICAL)	12.50 - 12.67	1.0000	1.0000
L67	21	MLC HYBRID 6X12 6AWGX6(1-1/2)	12.50 - 12.67	1.0000	1.0000
L67	27	Safety Line 3/8	12.50 - 12.67	1.0000	1.0000
L67	29	PL1.25x6.875 Reinforcement	12.50 - 12.67	1.0000	1.0000
L67	30	PL1.25x6.875 Reinforcement	12.50 - 12.67	1.0000	1.0000
L67	31	PL1.25x6.875 Reinforcement	12.50 - 12.67	1.0000	1.0000
L67	32	PL1.25x6.875 Reinforcement	12.50 - 12.67	1.0000	1.0000
L67	33	PL1.25x6.875 Reinforcement	12.50 - 12.67	1.0000	1.0000
L67	47	PL1x4 Reinforcement	12.50 - 12.67	1.0000	1.0000
L67	48	PL1x4 Reinforcement	12.50 - 12.67	1.0000	1.0000
L67	49	PL1x4 Reinforcement	12.50 - 12.67	1.0000	1.0000
L67	67	CCI-SFP-060100	12.50 - 12.67	1.0000	1.0000
L67	68	CCI-SFP-060100	12.50 - 12.67	1.0000	1.0000
L67	70	CCI-SFP-060100	12.50 - 12.67	1.0000	1.0000
L68	2	FB-L98B-034-XXX(3/8)	12.25 - 12.50	1.0000	1.0000
L68	3	PWRT-608-S(13/16)	12.25 - 12.50	1.0000	1.0000
L68	4	PWRT-606-S(7/8)	12.25 - 12.50	1.0000	1.0000
L68	5	RFFT-48SM-001-XXX(3/8)	12.25 - 12.50	1.0000	1.0000

# tnxTower

**B+T Group**  
1717 S. Boulder, Suite 300  
Tulsa, OK 74119  
Phone: (918) 587-4630  
FAX: (918) 295-0265

**Job**  
79982.013.01 - WATERBURY,CT (BU# 876317)

**Page**  
43 of 94

**Project**  
**Date**  
15:43:49 05/20/22

**Client**  
Crown Castle  
**Designed by**  
Jayaraj B

Tower Section	Feed Line Record No.	Description	Feed Line Segment Elev.	K <sub>a</sub> No Ice	K <sub>a</sub> Ice
L68	7	7983A(ELLIPTICAL)	12.25 - 12.50	1.0000	1.0000
L68	21	MLC HYBRID 6X12 6AWGX6(1-1/2)	12.25 - 12.50	1.0000	1.0000
L68	27	Safety Line 3/8	12.25 - 12.50	1.0000	1.0000
L68	29	PL1.25x6.875 Reinforcement	12.25 - 12.50	1.0000	1.0000
L68	30	PL1.25x6.875 Reinforcement	12.25 - 12.50	1.0000	1.0000
L68	31	PL1.25x6.875 Reinforcement	12.25 - 12.50	1.0000	1.0000
L68	32	PL1.25x6.875 Reinforcement	12.25 - 12.50	1.0000	1.0000
L68	33	PL1.25x6.875 Reinforcement	12.25 - 12.50	1.0000	1.0000
L68	47	PL1x4 Reinforcement	12.25 - 12.50	1.0000	1.0000
L68	48	PL1x4 Reinforcement	12.25 - 12.50	1.0000	1.0000
L68	49	PL1x4 Reinforcement	12.25 - 12.50	1.0000	1.0000
L68	67	CCI-SFP-060100	12.25 - 12.50	1.0000	1.0000
L68	68	CCI-SFP-060100	12.25 - 12.50	1.0000	1.0000
L68	70	CCI-SFP-060100	12.25 - 12.50	1.0000	1.0000
L69	2	FB-L98B-034-XXX(3/8)	12.00 - 12.25	1.0000	1.0000
L69	3	PWRT-608-S(13/16)	12.00 - 12.25	1.0000	1.0000
L69	4	PWRT-606-S(7/8)	12.00 - 12.25	1.0000	1.0000
L69	5	RFFT-48SM-001-XXX(3/8)	12.00 - 12.25	1.0000	1.0000
L69	7	7983A(ELLIPTICAL)	12.00 - 12.25	1.0000	1.0000
L69	21	MLC HYBRID 6X12 6AWGX6(1-1/2)	12.00 - 12.25	1.0000	1.0000
L69	27	Safety Line 3/8	12.00 - 12.25	1.0000	1.0000
L69	29	PL1.25x6.875 Reinforcement	12.00 - 12.25	1.0000	1.0000
L69	30	PL1.25x6.875 Reinforcement	12.00 - 12.25	1.0000	1.0000
L69	31	PL1.25x6.875 Reinforcement	12.00 - 12.25	1.0000	1.0000
L69	32	PL1.25x6.875 Reinforcement	12.00 - 12.25	1.0000	1.0000
L69	33	PL1.25x6.875 Reinforcement	12.00 - 12.25	1.0000	1.0000
L69	47	PL1x4 Reinforcement	12.00 - 12.25	1.0000	1.0000
L69	48	PL1x4 Reinforcement	12.00 - 12.25	1.0000	1.0000
L69	49	PL1x4 Reinforcement	12.00 - 12.25	1.0000	1.0000
L69	67	CCI-SFP-060100	12.00 - 12.25	1.0000	1.0000
L69	68	CCI-SFP-060100	12.00 - 12.25	1.0000	1.0000
L69	70	CCI-SFP-060100	12.00 - 12.25	1.0000	1.0000
L70	2	FB-L98B-034-XXX(3/8)	11.75 - 12.00	1.0000	1.0000
L70	3	PWRT-608-S(13/16)	11.75 - 12.00	1.0000	1.0000
L70	4	PWRT-606-S(7/8)	11.75 - 12.00	1.0000	1.0000
L70	5	RFFT-48SM-001-XXX(3/8)	11.75 - 12.00	1.0000	1.0000
L70	7	7983A(ELLIPTICAL)	11.75 - 12.00	1.0000	1.0000
L70	21	MLC HYBRID 6X12 6AWGX6(1-1/2)	11.75 - 12.00	1.0000	1.0000
L70	27	Safety Line 3/8	11.75 - 12.00	1.0000	1.0000
L70	29	PL1.25x6.875 Reinforcement	11.75 - 12.00	1.0000	1.0000
L70	30	PL1.25x6.875 Reinforcement	11.75 - 12.00	1.0000	1.0000
L70	31	PL1.25x6.875 Reinforcement	11.75 - 12.00	1.0000	1.0000
L70	32	PL1.25x6.875 Reinforcement	11.75 - 12.00	1.0000	1.0000
L70	33	PL1.25x6.875 Reinforcement	11.75 - 12.00	1.0000	1.0000
L70	47	PL1x4 Reinforcement	11.75 - 12.00	1.0000	1.0000
L70	48	PL1x4 Reinforcement	11.75 - 12.00	1.0000	1.0000
L70	49	PL1x4 Reinforcement	11.75 - 12.00	1.0000	1.0000
L70	67	CCI-SFP-060100	11.75 - 12.00	1.0000	1.0000
L70	68	CCI-SFP-060100	11.75 - 12.00	1.0000	1.0000
L70	70	CCI-SFP-060100	11.75 - 12.00	1.0000	1.0000
L71	2	FB-L98B-034-XXX(3/8)	8.50 - 11.75	1.0000	1.0000
L71	3	PWRT-608-S(13/16)	8.50 - 11.75	1.0000	1.0000
L71	4	PWRT-606-S(7/8)	8.50 - 11.75	1.0000	1.0000
L71	5	RFFT-48SM-001-XXX(3/8)	8.50 - 11.75	1.0000	1.0000
L71	7	7983A(ELLIPTICAL)	8.50 - 11.75	1.0000	1.0000
L71	21	MLC HYBRID 6X12 6AWGX6(1-1/2)	8.50 - 11.75	1.0000	1.0000
L71	27	Safety Line 3/8	8.50 - 11.75	1.0000	1.0000
L71	29	PL1.25x6.875 Reinforcement	8.50 - 11.75	1.0000	1.0000

# tnxTower

**B+T Group**  
1717 S. Boulder, Suite 300  
Tulsa, OK 74119  
Phone: (918) 587-4630  
FAX: (918) 295-0265

**Job**  
79982.013.01 - WATERBURY,CT (BU# 876317)

**Page**  
44 of 94

**Project**  
**Date**  
15:43:49 05/20/22

**Client**  
Crown Castle  
**Designed by**  
Jayaraj B

Tower Section	Feed Line Record No.	Description	Feed Line Segment Elev.	K <sub>a</sub> No Ice	K <sub>a</sub> Ice
L71	30	PL1.25x6.875 Reinforcement	8.50 - 11.75	1.0000	1.0000
L71	31	PL1.25x6.875 Reinforcement	9.17 - 11.75	1.0000	1.0000
L71	32	PL1.25x6.875 Reinforcement	8.50 - 11.75	1.0000	1.0000
L71	33	PL1.25x6.875 Reinforcement	8.50 - 11.75	1.0000	1.0000
L71	47	PL1x4 Reinforcement	10.75 - 11.75	1.0000	1.0000
L71	48	PL1x4 Reinforcement	10.75 - 11.75	1.0000	1.0000
L71	49	PL1x4 Reinforcement	10.75 - 11.75	1.0000	1.0000
L71	63	Transition Stiffener 1x7	8.50 - 10.50	1.0000	1.0000
L71	64	Transition Stiffener 1x7	8.50 - 10.50	1.0000	1.0000
L71	65	Transition Stiffener 1x7	8.50 - 10.50	1.0000	1.0000
L71	67	CCI-SFP-060100	8.50 - 11.75	1.0000	1.0000
L71	68	CCI-SFP-060100	8.50 - 11.75	1.0000	1.0000
L71	70	CCI-SFP-060100	10.00 - 11.75	1.0000	1.0000
L72	2	FB-L98B-034-XXX(3/8)	8.25 - 8.50	1.0000	1.0000
L72	3	PWRT-608-S(13/16)	8.25 - 8.50	1.0000	1.0000
L72	4	PWRT-606-S(7/8)	8.25 - 8.50	1.0000	1.0000
L72	5	RFFT-48SM-001-XXX(3/8)	8.25 - 8.50	1.0000	1.0000
L72	7	7983A(ELLIPTICAL)	8.25 - 8.50	1.0000	1.0000
L72	21	MLC HYBRID 6X12 6AWGX6(1-1/2)	8.25 - 8.50	1.0000	1.0000
L72	27	Safety Line 3/8	8.25 - 8.50	1.0000	1.0000
L72	29	PL1.25x6.875 Reinforcement	8.25 - 8.50	1.0000	1.0000
L72	30	PL1.25x6.875 Reinforcement	8.25 - 8.50	1.0000	1.0000
L72	32	PL1.25x6.875 Reinforcement	8.25 - 8.50	1.0000	1.0000
L72	33	PL1.25x6.875 Reinforcement	8.25 - 8.50	1.0000	1.0000
L72	63	Transition Stiffener 1x7	8.25 - 8.50	1.0000	1.0000
L72	64	Transition Stiffener 1x7	8.25 - 8.50	1.0000	1.0000
L72	65	Transition Stiffener 1x7	8.25 - 8.50	1.0000	1.0000
L72	67	CCI-SFP-060100	8.25 - 8.50	1.0000	1.0000
L72	68	CCI-SFP-060100	8.25 - 8.50	1.0000	1.0000
L73	2	FB-L98B-034-XXX(3/8)	7.00 - 8.25	1.0000	1.0000
L73	3	PWRT-608-S(13/16)	7.00 - 8.25	1.0000	1.0000
L73	4	PWRT-606-S(7/8)	7.00 - 8.25	1.0000	1.0000
L73	5	RFFT-48SM-001-XXX(3/8)	7.00 - 8.25	1.0000	1.0000
L73	7	7983A(ELLIPTICAL)	7.00 - 8.25	1.0000	1.0000
L73	21	MLC HYBRID 6X12 6AWGX6(1-1/2)	7.00 - 8.25	1.0000	1.0000
L73	27	Safety Line 3/8	7.00 - 8.25	1.0000	1.0000
L73	29	PL1.25x6.875 Reinforcement	7.00 - 8.25	1.0000	1.0000
L73	30	PL1.25x6.875 Reinforcement	7.00 - 8.25	1.0000	1.0000
L73	32	PL1.25x6.875 Reinforcement	7.00 - 8.25	1.0000	1.0000
L73	33	PL1.25x6.875 Reinforcement	7.00 - 8.25	1.0000	1.0000
L73	63	Transition Stiffener 1x7	7.00 - 8.25	1.0000	1.0000
L73	64	Transition Stiffener 1x7	7.00 - 8.25	1.0000	1.0000
L73	65	Transition Stiffener 1x7	7.00 - 8.25	1.0000	1.0000
L73	67	CCI-SFP-060100	7.00 - 8.25	1.0000	1.0000
L73	68	CCI-SFP-060100	7.00 - 8.25	1.0000	1.0000
L74	2	FB-L98B-034-XXX(3/8)	6.75 - 7.00	1.0000	1.0000
L74	3	PWRT-608-S(13/16)	6.75 - 7.00	1.0000	1.0000
L74	4	PWRT-606-S(7/8)	6.75 - 7.00	1.0000	1.0000
L74	5	RFFT-48SM-001-XXX(3/8)	6.75 - 7.00	1.0000	1.0000
L74	7	7983A(ELLIPTICAL)	6.75 - 7.00	1.0000	1.0000
L74	21	MLC HYBRID 6X12 6AWGX6(1-1/2)	6.75 - 7.00	1.0000	1.0000
L74	27	Safety Line 3/8	6.75 - 7.00	1.0000	1.0000
L74	29	PL1.25x6.875 Reinforcement	6.75 - 7.00	1.0000	1.0000
L74	30	PL1.25x6.875 Reinforcement	6.75 - 7.00	1.0000	1.0000
L74	32	PL1.25x6.875 Reinforcement	6.75 - 7.00	1.0000	1.0000
L74	33	PL1.25x6.875 Reinforcement	6.75 - 7.00	1.0000	1.0000
L74	63	Transition Stiffener 1x7	6.75 - 7.00	1.0000	1.0000
L74	64	Transition Stiffener 1x7	6.75 - 7.00	1.0000	1.0000
L74	65	Transition Stiffener 1x7	6.75 - 7.00	1.0000	1.0000

<b>tnxTower</b>  <b>B+T Group</b> 1717 S. Boulder, Suite 300 Tulsa, OK 74119 Phone: (918) 587-4630 FAX: (918) 295-0265	<b>Job</b> 79982.013.01 - WATERBURY,CT (BU# 876317)	<b>Page</b> 45 of 94
	<b>Project</b>	<b>Date</b> 15:43:49 05/20/22
	<b>Client</b> Crown Castle	<b>Designed by</b> Jayaraj B

Tower Section	Feed Line Record No.	Description	Feed Line Segment Elev.	K <sub>a</sub> No Ice	K <sub>a</sub> Ice
L74	67	CCI-SFP-060100	6.75 - 7.00	1.0000	1.0000
L74	68	CCI-SFP-060100	6.75 - 7.00	1.0000	1.0000
L75	2	FB-L98B-034-XXX(3/8)	1.75 - 6.75	1.0000	1.0000
L75	3	PWRT-608-S(13/16)	1.75 - 6.75	1.0000	1.0000
L75	4	PWRT-606-S(7/8)	1.75 - 6.75	1.0000	1.0000
L75	5	RFFT-48SM-001-XXX(3/8)	1.75 - 6.75	1.0000	1.0000
L75	7	7983A(ELLIPTICAL)	1.75 - 6.75	1.0000	1.0000
L75	21	MLC HYBRID 6X12 6AWGX6(1-1/2) Safety Line 3/8	1.75 - 6.75	1.0000	1.0000
L75	27		1.75 - 6.75	1.0000	1.0000
L75	29	PL1.25x6.875 Reinforcement	1.75 - 6.75	1.0000	1.0000
L75	30	PL1.25x6.875 Reinforcement	1.75 - 6.75	1.0000	1.0000
L75	32	PL1.25x6.875 Reinforcement	1.75 - 6.75	1.0000	1.0000
L75	33	PL1.25x6.875 Reinforcement	1.75 - 6.75	1.0000	1.0000
L75	63	Transition Stiffener 1x7	1.75 - 6.75	1.0000	1.0000
L75	64	Transition Stiffener 1x7	1.75 - 6.75	1.0000	1.0000
L75	65	Transition Stiffener 1x7	1.75 - 6.75	1.0000	1.0000
L75	67	CCI-SFP-060100	5.00 - 6.75	1.0000	1.0000
L75	68	CCI-SFP-060100	5.00 - 6.75	1.0000	1.0000
L76	2	FB-L98B-034-XXX(3/8)	0.00 - 1.75	1.0000	1.0000
L76	3	PWRT-608-S(13/16)	0.00 - 1.75	1.0000	1.0000
L76	4	PWRT-606-S(7/8)	0.00 - 1.75	1.0000	1.0000
L76	5	RFFT-48SM-001-XXX(3/8)	0.00 - 1.75	1.0000	1.0000
L76	7	7983A(ELLIPTICAL)	0.00 - 1.75	1.0000	1.0000
L76	21	MLC HYBRID 6X12 6AWGX6(1-1/2) Safety Line 3/8	0.00 - 1.75	1.0000	1.0000
L76	27		0.00 - 1.75	1.0000	1.0000
L76	29	PL1.25x6.875 Reinforcement	0.00 - 1.75	1.0000	1.0000
L76	30	PL1.25x6.875 Reinforcement	0.00 - 1.75	1.0000	1.0000
L76	32	PL1.25x6.875 Reinforcement	0.00 - 1.75	1.0000	1.0000
L76	33	PL1.25x6.875 Reinforcement	0.00 - 1.75	1.0000	1.0000
L76	63	Transition Stiffener 1x7	0.00 - 1.75	1.0000	1.0000
L76	64	Transition Stiffener 1x7	0.00 - 1.75	1.0000	1.0000
L76	65	Transition Stiffener 1x7	0.00 - 1.75	1.0000	1.0000

### Effective Width of Flat Linear Attachments / Feed Lines

Tower Section	Attachment Record No.	Description	Attachment Segment Elev.	Ratio Calculation Method	Effective Width Ratio
L5	93	CCI-AFP-045100	124.25 - 125.42	Auto	0.1983
L5	94	CCI-AFP-045100	124.25 - 125.42	Auto	0.1983
L5	95	CCI-AFP-045100	124.25 - 125.42	Auto	0.1983
L6	93	CCI-AFP-045100	123.42 - 124.25	Auto	0.1865
L6	94	CCI-AFP-045100	123.42 - 124.25	Auto	0.1865
L6	95	CCI-AFP-045100	123.42 - 124.25	Auto	0.1865
L7	93	CCI-AFP-045100	123.17 - 123.42	Auto	0.3886

**tnxTower**

**B+T Group**  
 1717 S. Boulder, Suite 300  
 Tulsa, OK 74119  
 Phone: (918) 587-4630  
 FAX: (918) 295-0265

**Job**  
 79982.013.01 - WATERBURY, CT (BU# 876317)

**Page**  
 46 of 94

**Project**  
**Date**  
 15:43:49 05/20/22

**Client**  
 Crown Castle  
**Designed by**  
 Jayaraj B

Tower Section	Attachment Record No.	Description	Attachment Segment Elev.	Ratio Calculation Method	Effective Width Ratio
L7	94	CCI-AFP-045100	123.17 - 123.42	Auto	0.3886
L7	95	CCI-AFP-045100	123.17 - 123.42	Auto	0.3886
L8	93	CCI-AFP-045100	118.17 - 123.17	Auto	0.3429
L8	94	CCI-AFP-045100	118.17 - 123.17	Auto	0.3429
L8	95	CCI-AFP-045100	118.17 - 123.17	Auto	0.3429
L9	93	CCI-AFP-045100	113.17 - 118.17	Auto	0.2693
L9	94	CCI-AFP-045100	113.17 - 118.17	Auto	0.2693
L9	95	CCI-AFP-045100	113.17 - 118.17	Auto	0.2693
L10	93	CCI-AFP-045100	109.50 - 113.17	Auto	0.2110
L10	94	CCI-AFP-045100	109.50 - 113.17	Auto	0.2110
L10	95	CCI-AFP-045100	109.50 - 113.17	Auto	0.2110
L10	97	CCI-AFP-040075	109.50 - 111.00	Auto	0.0981
L10	99	CCI-AFP-040075	109.50 - 111.00	Auto	0.0981
L11	93	CCI-AFP-045100	109.25 - 109.50	Auto	0.2550
L11	94	CCI-AFP-045100	109.25 - 109.50	Auto	0.2550
L11	95	CCI-AFP-045100	109.25 - 109.50	Auto	0.2550
L11	97	CCI-AFP-040075	109.25 - 109.50	Auto	0.1619
L11	99	CCI-AFP-040075	109.25 - 109.50	Auto	0.1619
L12	59	PL1x4 Reinforcement	104.75 - 106.50	Auto	0.0956
L12	60	PL1x4 Reinforcement	104.75 - 106.50	Auto	0.0956
L12	61	PL1x4 Reinforcement	104.75 - 106.50	Auto	0.0956
L12	91	CCI-AFP-05012520	104.75 - 105.33	Auto	0.2703
L12	93	CCI-AFP-045100	104.75 - 109.25	Auto	0.2122
L12	94	CCI-AFP-045100	104.75 - 109.25	Auto	0.2122
L12	95	CCI-AFP-045100	104.75 - 109.25	Auto	0.2122
L12	97	CCI-AFP-040075	104.75 - 109.25	Auto	0.1138
L12	99	CCI-AFP-040075	104.75 - 109.25	Auto	0.1138
L13	59	PL1x4 Reinforcement	104.50 - 104.75	Auto	0.2248
L13	60	PL1x4 Reinforcement	104.50 - 104.75	Auto	0.2248
L13	61	PL1x4 Reinforcement	104.50 - 104.75	Auto	0.2248
L13	91	CCI-AFP-05012520	104.50 -	Auto	0.3798

**tnxTower**

**B+T Group**  
 1717 S. Boulder, Suite 300  
 Tulsa, OK 74119  
 Phone: (918) 587-4630  
 FAX: (918) 295-0265

**Job**  
 79982.013.01 - WATERBURY,CT (BU# 876317)

**Page**  
 47 of 94

**Project**  
 Date  
 15:43:49 05/20/22

**Client**  
 Crown Castle  
 Designed by  
 Jayaraj B

Tower Section	Attachment Record No.	Description	Attachment Segment Elev.	Ratio Calculation Method	Effective Width Ratio
L13	93	CCI-AFP-045100	104.75 104.50 - 104.75	Auto	0.3109
L13	94	CCI-AFP-045100	104.50 - 104.75	Auto	0.3109
L13	95	CCI-AFP-045100	104.50 - 104.75	Auto	0.3109
L13	97	CCI-AFP-040075	104.50 - 104.75	Auto	0.2248
L13	99	CCI-AFP-040075	104.50 - 104.75	Auto	0.2248
L14	59	PL1x4 Reinforcement	102.42 - 104.50	Auto	0.2010
L14	60	PL1x4 Reinforcement	102.42 - 104.50	Auto	0.2010
L14	61	PL1x4 Reinforcement	102.42 - 104.50	Auto	0.2010
L14	91	CCI-AFP-05012520	102.42 - 104.50	Auto	0.3608
L14	93	CCI-AFP-045100	102.42 - 104.50	Auto	0.2897
L14	94	CCI-AFP-045100	102.42 - 104.50	Auto	0.2897
L14	95	CCI-AFP-045100	102.42 - 104.50	Auto	0.2897
L14	97	CCI-AFP-040075	102.42 - 104.50	Auto	0.2010
L14	99	CCI-AFP-040075	102.42 - 104.50	Auto	0.2010
L15	59	PL1x4 Reinforcement	102.17 - 102.42	Auto	0.0515
L15	60	PL1x4 Reinforcement	102.17 - 102.42	Auto	0.0515
L15	61	PL1x4 Reinforcement	102.17 - 102.42	Auto	0.0515
L15	91	CCI-AFP-05012520	102.17 - 102.42	Auto	0.2412
L15	93	CCI-AFP-045100	102.17 - 102.42	Auto	0.1569
L15	94	CCI-AFP-045100	102.17 - 102.42	Auto	0.1569
L15	95	CCI-AFP-045100	102.17 - 102.42	Auto	0.1569
L15	97	CCI-AFP-040075	102.17 - 102.42	Auto	0.0515
L15	99	CCI-AFP-040075	102.17 - 102.42	Auto	0.0515
L16	43	PL1.25x3.625 Reinforcement	98.75 - 100.00	Auto	0.0000
L16	44	PL1.25x3.625 Reinforcement	98.75 - 100.00	Auto	0.0000
L16	45	PL1.25x3.625 Reinforcement	98.75 - 100.00	Auto	0.0000
L16	59	PL1x4 Reinforcement	98.75 - 102.17	Auto	0.0191
L16	60	PL1x4 Reinforcement	98.75 - 102.17	Auto	0.0191
L16	61	PL1x4 Reinforcement	98.75 - 102.17	Auto	0.0191
L16	86	CCI-SFP-040075	98.75 - 100.33	Auto	0.0071
L16	87	CCI-SFP-040075	98.75 - 100.33	Auto	0.0071
L16	91	CCI-AFP-05012520	98.75 - 102.17	Auto	0.2152
L16	93	CCI-AFP-045100	100.42 - 102.17	Auto	0.1377
L16	94	CCI-AFP-045100	100.42 - 102.17	Auto	0.1377
L16	95	CCI-AFP-045100	100.42 -	Auto	0.1377

# tnxTower

**B+T Group**  
1717 S. Boulder, Suite 300  
Tulsa, OK 74119  
Phone: (918) 587-4630  
FAX: (918) 295-0265

**Job**  
79982.013.01 - WATERBURY,CT (BU# 876317)

**Page**  
48 of 94

**Project**  
**Date**  
15:43:49 05/20/22

**Client**  
Crown Castle  
**Designed by**  
Jayaraj B

Tower Section	Attachment Record No.	Description	Attachment Segment Elev.	Ratio Calculation Method	Effective Width Ratio
L16	97	CCI-AFP-040075	102.17 98.75 - 102.17	Auto	0.0191
L16	99	CCI-AFP-040075	101.00 - 102.17	Auto	0.0338
L17	43	PL1.25x3.625 Reinforcement	98.50 - 98.75	Auto	0.1033
L17	44	PL1.25x3.625 Reinforcement	98.50 - 98.75	Auto	0.1033
L17	45	PL1.25x3.625 Reinforcement	98.50 - 98.75	Auto	0.1033
L17	59	PL1x4 Reinforcement	98.50 - 98.75	Auto	0.1874
L17	60	PL1x4 Reinforcement	98.50 - 98.75	Auto	0.1874
L17	61	PL1x4 Reinforcement	98.50 - 98.75	Auto	0.1874
L17	86	CCI-SFP-040075	98.50 - 98.75	Auto	0.1874
L17	87	CCI-SFP-040075	98.50 - 98.75	Auto	0.1874
L17	91	CCI-AFP-05012520	98.50 - 98.75	Auto	0.3499
L17	97	CCI-AFP-040075	98.50 - 98.75	Auto	0.1874
L18	43	PL1.25x3.625 Reinforcement	97.50 - 98.50	Auto	0.0942
L18	44	PL1.25x3.625 Reinforcement	97.50 - 98.50	Auto	0.0942
L18	45	PL1.25x3.625 Reinforcement	97.50 - 98.50	Auto	0.0942
L18	59	PL1x4 Reinforcement	97.50 - 98.50	Auto	0.1791
L18	60	PL1x4 Reinforcement	97.50 - 98.50	Auto	0.1791
L18	61	PL1x4 Reinforcement	97.50 - 98.50	Auto	0.1791
L18	86	CCI-SFP-040075	97.50 - 98.50	Auto	0.1791
L18	87	CCI-SFP-040075	97.50 - 98.50	Auto	0.1791
L18	91	CCI-AFP-05012520	97.50 - 98.50	Auto	0.3433
L18	97	CCI-AFP-040075	97.50 - 98.50	Auto	0.1791
L19	43	PL1.25x3.625 Reinforcement	97.25 - 97.50	Auto	0.0204
L19	44	PL1.25x3.625 Reinforcement	97.25 - 97.50	Auto	0.0204
L19	45	PL1.25x3.625 Reinforcement	97.25 - 97.50	Auto	0.0204
L19	59	PL1x4 Reinforcement	97.25 - 97.50	Auto	0.1122
L19	60	PL1x4 Reinforcement	97.25 - 97.50	Auto	0.1122
L19	61	PL1x4 Reinforcement	97.25 - 97.50	Auto	0.1122
L19	86	CCI-SFP-040075	97.25 - 97.50	Auto	0.1122
L19	87	CCI-SFP-040075	97.25 - 97.50	Auto	0.1122
L19	91	CCI-AFP-05012520	97.25 - 97.50	Auto	0.2898
L19	97	CCI-AFP-040075	97.25 - 97.50	Auto	0.1122
L20	43	PL1.25x3.625 Reinforcement	92.00 - 97.25	Auto	0.0006
L20	44	PL1.25x3.625 Reinforcement	92.00 - 97.25	Auto	0.0006
L20	45	PL1.25x3.625 Reinforcement	92.00 - 97.25	Auto	0.0006
L20	59	PL1x4 Reinforcement	92.00 - 97.25	Auto	0.0675
L20	60	PL1x4 Reinforcement	92.00 - 97.25	Auto	0.0675
L20	61	PL1x4 Reinforcement	92.00 - 97.25	Auto	0.0675
L20	86	CCI-SFP-040075	92.00 - 97.25	Auto	0.0675
L20	87	CCI-SFP-040075	92.00 - 97.25	Auto	0.0675
L20	91	CCI-AFP-05012520	92.00 - 97.25	Auto	0.2540
L20	97	CCI-AFP-040075	96.00 - 97.25	Auto	0.0939
L21	43	PL1.25x3.625 Reinforcement	90.55 - 92.00	Auto	0.0009
L21	44	PL1.25x3.625 Reinforcement	90.55 - 92.00	Auto	0.0009
L21	45	PL1.25x3.625 Reinforcement	90.55 - 92.00	Auto	0.0009
L21	59	PL1x4 Reinforcement	90.55 - 92.00	Auto	0.0897
L21	60	PL1x4 Reinforcement	90.55 - 92.00	Auto	0.0897
L21	61	PL1x4 Reinforcement	90.55 - 92.00	Auto	0.0897
L21	86	CCI-SFP-040075	90.55 - 92.00	Auto	0.0897
L21	87	CCI-SFP-040075	90.55 - 92.00	Auto	0.0897
L21	91	CCI-AFP-05012520	90.55 - 92.00	Auto	0.2718
L22	43	PL1.25x3.625 Reinforcement	89.25 - 90.55	Auto	0.0000
L22	44	PL1.25x3.625 Reinforcement	89.25 - 90.55	Auto	0.0000
L22	45	PL1.25x3.625 Reinforcement	89.25 - 90.55	Auto	0.0000
L22	59	PL1x4 Reinforcement	89.25 - 90.55	Auto	0.0546
L22	60	PL1x4 Reinforcement	89.25 - 90.55	Auto	0.0546
L22	61	PL1x4 Reinforcement	89.25 - 90.55	Auto	0.0546
L22	86	CCI-SFP-040075	89.25 - 90.55	Auto	0.0546
L22	87	CCI-SFP-040075	89.25 - 90.55	Auto	0.0546

# tnxTower

**B+T Group**  
1717 S. Boulder, Suite 300  
Tulsa, OK 74119  
Phone: (918) 587-4630  
FAX: (918) 295-0265

**Job**  
79982.013.01 - WATERBURY,CT (BU# 876317)

**Page**  
49 of 94

**Project**  
**Date**  
15:43:49 05/20/22

**Client**  
Crown Castle  
**Designed by**  
Jayaraj B

Tower Section	Attachment Record No.	Description	Attachment Segment Elev.	Ratio Calculation Method	Effective Width Ratio
L22	89	CCI-SFP-040075	89.25 - 90.33	Auto	0.0532
L22	91	CCI-AFP-05012520	89.25 - 90.55	Auto	0.2437
L23	39	PL1.25x5.5 Reinforcement	89.00 - 89.25	Auto	0.4146
L23	40	PL1.25x5.5 Reinforcement	89.00 - 89.25	Auto	0.4146
L23	41	PL1.25x5.5 Reinforcement	89.00 - 89.25	Auto	0.4146
L23	59	PL1x4 Reinforcement	89.00 - 89.25	Auto	0.1950
L23	60	PL1x4 Reinforcement	89.00 - 89.25	Auto	0.1950
L23	61	PL1x4 Reinforcement	89.00 - 89.25	Auto	0.1950
L23	86	CCI-SFP-040075	89.00 - 89.25	Auto	0.1950
L23	87	CCI-SFP-040075	89.00 - 89.25	Auto	0.1950
L23	89	CCI-SFP-040075	89.00 - 89.25	Auto	0.1950
L23	91	CCI-AFP-05012520	89.00 - 89.25	Auto	0.3560
L24	39	PL1.25x5.5 Reinforcement	88.25 - 89.00	Auto	0.3975
L24	40	PL1.25x5.5 Reinforcement	88.25 - 89.00	Auto	0.3975
L24	41	PL1.25x5.5 Reinforcement	88.25 - 89.00	Auto	0.3975
L24	59	PL1x4 Reinforcement	88.25 - 89.00	Auto	0.1716
L24	60	PL1x4 Reinforcement	88.25 - 89.00	Auto	0.1716
L24	61	PL1x4 Reinforcement	88.25 - 89.00	Auto	0.1716
L24	86	CCI-SFP-040075	88.25 - 89.00	Auto	0.1716
L24	87	CCI-SFP-040075	88.25 - 89.00	Auto	0.1716
L24	89	CCI-SFP-040075	88.25 - 89.00	Auto	0.1716
L24	91	CCI-AFP-05012520	88.25 - 89.00	Auto	0.3373
L25	39	PL1.25x5.5 Reinforcement	88.00 - 88.25	Auto	0.2891
L25	40	PL1.25x5.5 Reinforcement	88.00 - 88.25	Auto	0.2891
L25	41	PL1.25x5.5 Reinforcement	88.00 - 88.25	Auto	0.2891
L25	59	PL1x4 Reinforcement	88.00 - 88.25	Auto	0.0226
L25	60	PL1x4 Reinforcement	88.00 - 88.25	Auto	0.0226
L25	61	PL1x4 Reinforcement	88.00 - 88.25	Auto	0.0226
L25	86	CCI-SFP-040075	88.00 - 88.25	Auto	0.0226
L25	87	CCI-SFP-040075	88.00 - 88.25	Auto	0.0226
L25	89	CCI-SFP-040075	88.00 - 88.25	Auto	0.0226
L25	91	CCI-AFP-05012520	88.00 - 88.25	Auto	0.2181
L26	39	PL1.25x5.5 Reinforcement	87.83 - 88.00	Auto	0.2871
L26	40	PL1.25x5.5 Reinforcement	87.83 - 88.00	Auto	0.2871
L26	41	PL1.25x5.5 Reinforcement	87.83 - 88.00	Auto	0.2871
L26	59	PL1x4 Reinforcement	87.83 - 88.00	Auto	0.0198
L26	60	PL1x4 Reinforcement	87.83 - 88.00	Auto	0.0198
L26	61	PL1x4 Reinforcement	87.83 - 88.00	Auto	0.0198
L26	86	CCI-SFP-040075	87.83 - 88.00	Auto	0.0198
L26	87	CCI-SFP-040075	87.83 - 88.00	Auto	0.0198
L26	89	CCI-SFP-040075	87.83 - 88.00	Auto	0.0198
L26	91	CCI-AFP-05012520	87.83 - 88.00	Auto	0.2158
L27	39	PL1.25x5.5 Reinforcement	87.58 - 87.83	Auto	0.2425
L27	40	PL1.25x5.5 Reinforcement	87.58 - 87.83	Auto	0.2425
L27	41	PL1.25x5.5 Reinforcement	87.58 - 87.83	Auto	0.2425
L27	59	PL1x4 Reinforcement	87.58 - 87.83	Auto	0.0000
L27	60	PL1x4 Reinforcement	87.58 - 87.83	Auto	0.0000
L27	61	PL1x4 Reinforcement	87.58 - 87.83	Auto	0.0000
L27	86	CCI-SFP-040075	87.58 - 87.83	Auto	0.0000
L27	87	CCI-SFP-040075	87.58 - 87.83	Auto	0.0000
L27	89	CCI-SFP-040075	87.58 - 87.83	Auto	0.0000
L27	91	CCI-AFP-05012520	87.58 - 87.83	Auto	0.1667
L28	39	PL1.25x5.5 Reinforcement	82.58 - 87.58	Auto	0.2048
L28	40	PL1.25x5.5 Reinforcement	82.58 - 87.58	Auto	0.2048
L28	41	PL1.25x5.5 Reinforcement	82.58 - 87.58	Auto	0.2048
L28	59	PL1x4 Reinforcement	86.50 - 87.58	Auto	0.0000
L28	60	PL1x4 Reinforcement	86.50 - 87.58	Auto	0.0000
L28	61	PL1x4 Reinforcement	86.50 - 87.58	Auto	0.0000
L28	86	CCI-SFP-040075	82.58 - 87.58	Auto	0.0000
L28	87	CCI-SFP-040075	82.58 - 87.58	Auto	0.0000
L28	89	CCI-SFP-040075	82.58 - 87.58	Auto	0.0000

# tnxTower

**B+T Group**  
1717 S. Boulder, Suite 300  
Tulsa, OK 74119  
Phone: (918) 587-4630  
FAX: (918) 295-0265

**Job**  
79982.013.01 - WATERBURY,CT (BU# 876317)

**Page**  
50 of 94

**Project**  
**Date**  
15:43:49 05/20/22

**Client**  
Crown Castle  
**Designed by**  
Jayaraj B

Tower Section	Attachment Record No.	Description	Attachment Segment Elev.	Ratio Calculation Method	Effective Width Ratio
L28	91	CCI-AFP-05012520	85.33 - 87.58	Auto	0.1400
L29	39	PL1.25x5.5 Reinforcement	77.58 - 82.58	Auto	0.1441
L29	40	PL1.25x5.5 Reinforcement	77.58 - 82.58	Auto	0.1441
L29	41	PL1.25x5.5 Reinforcement	77.58 - 82.58	Auto	0.1441
L29	55	PL1x4 Reinforcement	77.58 - 78.75	Auto	0.0000
L29	56	PL1x4 Reinforcement	77.58 - 78.75	Auto	0.0000
L29	57	PL1x4 Reinforcement	77.58 - 78.75	Auto	0.0000
L29	86	CCI-SFP-040075	77.58 - 82.58	Auto	0.0000
L29	87	CCI-SFP-040075	77.58 - 82.58	Auto	0.0000
L29	89	CCI-SFP-040075	77.58 - 82.58	Auto	0.0000
L30	39	PL1.25x5.5 Reinforcement	77.00 - 77.58	Auto	0.1170
L30	40	PL1.25x5.5 Reinforcement	77.00 - 77.58	Auto	0.1170
L30	41	PL1.25x5.5 Reinforcement	77.00 - 77.58	Auto	0.1170
L30	55	PL1x4 Reinforcement	77.00 - 77.58	Auto	0.0000
L30	56	PL1x4 Reinforcement	77.00 - 77.58	Auto	0.0000
L30	57	PL1x4 Reinforcement	77.00 - 77.58	Auto	0.0000
L30	86	CCI-SFP-040075	77.00 - 77.58	Auto	0.0000
L30	87	CCI-SFP-040075	77.00 - 77.58	Auto	0.0000
L30	89	CCI-SFP-040075	77.00 - 77.58	Auto	0.0000
L31	39	PL1.25x5.5 Reinforcement	76.75 - 77.00	Auto	0.2105
L31	40	PL1.25x5.5 Reinforcement	76.75 - 77.00	Auto	0.2105
L31	41	PL1.25x5.5 Reinforcement	76.75 - 77.00	Auto	0.2105
L31	55	PL1x4 Reinforcement	76.75 - 77.00	Auto	0.0000
L31	56	PL1x4 Reinforcement	76.75 - 77.00	Auto	0.0000
L31	57	PL1x4 Reinforcement	76.75 - 77.00	Auto	0.0000
L31	86	CCI-SFP-040075	76.75 - 77.00	Auto	0.0000
L31	87	CCI-SFP-040075	76.75 - 77.00	Auto	0.0000
L31	89	CCI-SFP-040075	76.75 - 77.00	Auto	0.0000
L32	39	PL1.25x5.5 Reinforcement	76.33 - 76.75	Auto	0.2072
L32	40	PL1.25x5.5 Reinforcement	76.33 - 76.75	Auto	0.2072
L32	41	PL1.25x5.5 Reinforcement	76.33 - 76.75	Auto	0.2072
L32	55	PL1x4 Reinforcement	76.33 - 76.75	Auto	0.0000
L32	56	PL1x4 Reinforcement	76.33 - 76.75	Auto	0.0000
L32	57	PL1x4 Reinforcement	76.33 - 76.75	Auto	0.0000
L32	86	CCI-SFP-040075	76.33 - 76.75	Auto	0.0000
L32	87	CCI-SFP-040075	76.33 - 76.75	Auto	0.0000
L32	89	CCI-SFP-040075	76.33 - 76.75	Auto	0.0000
L33	39	PL1.25x5.5 Reinforcement	76.08 - 76.33	Auto	0.2040
L33	40	PL1.25x5.5 Reinforcement	76.08 - 76.33	Auto	0.2040
L33	41	PL1.25x5.5 Reinforcement	76.08 - 76.33	Auto	0.2040
L33	55	PL1x4 Reinforcement	76.08 - 76.33	Auto	0.0000
L33	56	PL1x4 Reinforcement	76.08 - 76.33	Auto	0.0000
L33	57	PL1x4 Reinforcement	76.08 - 76.33	Auto	0.0000
L33	86	CCI-SFP-040075	76.08 - 76.33	Auto	0.0000
L33	87	CCI-SFP-040075	76.08 - 76.33	Auto	0.0000
L33	89	CCI-SFP-040075	76.08 - 76.33	Auto	0.0000
L34	39	PL1.25x5.5 Reinforcement	74.25 - 76.08	Auto	0.1817
L34	40	PL1.25x5.5 Reinforcement	74.25 - 76.08	Auto	0.1817
L34	41	PL1.25x5.5 Reinforcement	74.25 - 76.08	Auto	0.1817
L34	55	PL1x4 Reinforcement	74.25 - 76.08	Auto	0.0000
L34	56	PL1x4 Reinforcement	74.25 - 76.08	Auto	0.0000
L34	57	PL1x4 Reinforcement	74.25 - 76.08	Auto	0.0000
L34	81	CCI-SFP-045100	74.25 - 75.25	Auto	0.0000
L34	82	CCI-SFP-045100	74.25 - 75.25	Auto	0.0000
L34	84	CCI-SFP-040075	74.25 - 75.25	Auto	0.0000
L34	86	CCI-SFP-040075	75.33 - 76.08	Auto	0.0000
L34	87	CCI-SFP-040075	75.33 - 76.08	Auto	0.0000
L34	89	CCI-SFP-040075	75.33 - 76.08	Auto	0.0000
L35	39	PL1.25x5.5 Reinforcement	74.00 - 74.25	Auto	0.2142
L35	40	PL1.25x5.5 Reinforcement	74.00 - 74.25	Auto	0.2142
L35	41	PL1.25x5.5 Reinforcement	74.00 - 74.25	Auto	0.2142

# tnxTower

**B+T Group**  
1717 S. Boulder, Suite 300  
Tulsa, OK 74119  
Phone: (918) 587-4630  
FAX: (918) 295-0265

**Job**  
79982.013.01 - WATERBURY,CT (BU# 876317)

**Page**  
51 of 94

**Project**  
**Date**  
15:43:49 05/20/22

**Client**  
Crown Castle  
**Designed by**  
Jayaraj B

Tower Section	Attachment Record No.	Description	Attachment Segment Elev.	Ratio Calculation Method	Effective Width Ratio
L35	55	PL1x4 Reinforcement	74.00 - 74.25	Auto	0.0000
L35	56	PL1x4 Reinforcement	74.00 - 74.25	Auto	0.0000
L35	57	PL1x4 Reinforcement	74.00 - 74.25	Auto	0.0000
L35	81	CCI-SFP-045100	74.00 - 74.25	Auto	0.0396
L35	82	CCI-SFP-045100	74.00 - 74.25	Auto	0.0396
L35	84	CCI-SFP-040075	74.00 - 74.25	Auto	0.0000
L36	39	PL1.25x5.5 Reinforcement	73.75 - 74.00	Auto	0.2118
L36	40	PL1.25x5.5 Reinforcement	73.75 - 74.00	Auto	0.2118
L36	41	PL1.25x5.5 Reinforcement	73.75 - 74.00	Auto	0.2118
L36	55	PL1x4 Reinforcement	73.75 - 74.00	Auto	0.0000
L36	56	PL1x4 Reinforcement	73.75 - 74.00	Auto	0.0000
L36	57	PL1x4 Reinforcement	73.75 - 74.00	Auto	0.0000
L36	81	CCI-SFP-045100	73.75 - 74.00	Auto	0.0367
L36	82	CCI-SFP-045100	73.75 - 74.00	Auto	0.0367
L36	84	CCI-SFP-040075	73.75 - 74.00	Auto	0.0000
L37	39	PL1.25x5.5 Reinforcement	73.50 - 73.75	Auto	0.2216
L37	40	PL1.25x5.5 Reinforcement	73.50 - 73.75	Auto	0.2216
L37	41	PL1.25x5.5 Reinforcement	73.50 - 73.75	Auto	0.2216
L37	55	PL1x4 Reinforcement	73.50 - 73.75	Auto	0.0000
L37	56	PL1x4 Reinforcement	73.50 - 73.75	Auto	0.0000
L37	57	PL1x4 Reinforcement	73.50 - 73.75	Auto	0.0000
L37	81	CCI-SFP-045100	73.50 - 73.75	Auto	0.0486
L37	82	CCI-SFP-045100	73.50 - 73.75	Auto	0.0486
L37	84	CCI-SFP-040075	73.50 - 73.75	Auto	0.0000
L38	39	PL1.25x5.5 Reinforcement	68.50 - 73.50	Auto	0.1778
L38	40	PL1.25x5.5 Reinforcement	68.50 - 73.50	Auto	0.1778
L38	41	PL1.25x5.5 Reinforcement	68.50 - 73.50	Auto	0.1778
L38	55	PL1x4 Reinforcement	68.50 - 73.50	Auto	0.0000
L38	56	PL1x4 Reinforcement	68.50 - 73.50	Auto	0.0000
L38	57	PL1x4 Reinforcement	68.50 - 73.50	Auto	0.0000
L38	81	CCI-SFP-045100	68.50 - 73.50	Auto	0.0052
L38	82	CCI-SFP-045100	68.50 - 73.50	Auto	0.0052
L38	84	CCI-SFP-040075	68.50 - 73.50	Auto	0.0000
L39	39	PL1.25x5.5 Reinforcement	63.50 - 68.50	Auto	0.1171
L39	40	PL1.25x5.5 Reinforcement	63.50 - 68.50	Auto	0.1171
L39	41	PL1.25x5.5 Reinforcement	63.50 - 68.50	Auto	0.1171
L39	55	PL1x4 Reinforcement	63.50 - 68.50	Auto	0.0000
L39	56	PL1x4 Reinforcement	63.50 - 68.50	Auto	0.0000
L39	57	PL1x4 Reinforcement	63.50 - 68.50	Auto	0.0000
L39	81	CCI-SFP-045100	63.50 - 68.50	Auto	0.0000
L39	82	CCI-SFP-045100	63.50 - 68.50	Auto	0.0000
L39	84	CCI-SFP-040075	63.50 - 68.50	Auto	0.0000
L40	39	PL1.25x5.5 Reinforcement	60.50 - 63.50	Auto	0.0661
L40	40	PL1.25x5.5 Reinforcement	60.50 - 63.50	Auto	0.0661
L40	41	PL1.25x5.5 Reinforcement	60.50 - 63.50	Auto	0.0661
L40	51	PL1x4 Reinforcement	60.50 - 62.25	Auto	0.0000
L40	52	PL1x4 Reinforcement	60.50 - 62.25	Auto	0.0000
L40	53	PL1x4 Reinforcement	60.50 - 62.25	Auto	0.0000
L40	55	PL1x4 Reinforcement	60.50 - 63.50	Auto	0.0000
L40	56	PL1x4 Reinforcement	60.50 - 63.50	Auto	0.0000
L40	57	PL1x4 Reinforcement	60.50 - 63.50	Auto	0.0000
L40	81	CCI-SFP-045100	60.50 - 63.50	Auto	0.0000
L40	82	CCI-SFP-045100	60.50 - 63.50	Auto	0.0000
L40	84	CCI-SFP-040075	60.50 - 63.50	Auto	0.0000
L41	39	PL1.25x5.5 Reinforcement	60.25 - 60.50	Auto	0.0504
L41	40	PL1.25x5.5 Reinforcement	60.25 - 60.50	Auto	0.0504
L41	41	PL1.25x5.5 Reinforcement	60.25 - 60.50	Auto	0.0504
L41	51	PL1x4 Reinforcement	60.25 - 60.50	Auto	0.0000
L41	52	PL1x4 Reinforcement	60.25 - 60.50	Auto	0.0000
L41	53	PL1x4 Reinforcement	60.25 - 60.50	Auto	0.0000
L41	55	PL1x4 Reinforcement	60.25 - 60.50	Auto	0.0000

# tnxTower

**B+T Group**  
1717 S. Boulder, Suite 300  
Tulsa, OK 74119  
Phone: (918) 587-4630  
FAX: (918) 295-0265

**Job**  
79982.013.01 - WATERBURY,CT (BU# 876317)

**Page**  
52 of 94

**Project**  
**Date**  
15:43:49 05/20/22

**Client**  
Crown Castle  
**Designed by**  
Jayaraj B

Tower Section	Attachment Record No.	Description	Attachment Segment Elev.	Ratio Calculation Method	Effective Width Ratio
L41	56	PL1x4 Reinforcement	60.25 - 60.50	Auto	0.0000
L41	57	PL1x4 Reinforcement	60.25 - 60.50	Auto	0.0000
L41	81	CCI-SFP-045100	60.25 - 60.50	Auto	0.0000
L41	82	CCI-SFP-045100	60.25 - 60.50	Auto	0.0000
L41	84	CCI-SFP-040075	60.25 - 60.50	Auto	0.0000
L42	39	PL1.25x5.5 Reinforcement	59.50 - 60.25	Auto	0.0455
L42	40	PL1.25x5.5 Reinforcement	59.50 - 60.25	Auto	0.0455
L42	41	PL1.25x5.5 Reinforcement	59.50 - 60.25	Auto	0.0455
L42	51	PL1x4 Reinforcement	59.50 - 60.25	Auto	0.0000
L42	52	PL1x4 Reinforcement	59.50 - 60.25	Auto	0.0000
L42	53	PL1x4 Reinforcement	59.50 - 60.25	Auto	0.0000
L42	55	PL1x4 Reinforcement	59.50 - 60.25	Auto	0.0000
L42	56	PL1x4 Reinforcement	59.50 - 60.25	Auto	0.0000
L42	57	PL1x4 Reinforcement	59.50 - 60.25	Auto	0.0000
L42	81	CCI-SFP-045100	59.50 - 60.25	Auto	0.0000
L42	82	CCI-SFP-045100	59.50 - 60.25	Auto	0.0000
L42	84	CCI-SFP-040075	59.50 - 60.25	Auto	0.0000
L43	35	PL1.25x6.625 Reinforcement	59.25 - 59.50	Auto	0.2289
L43	36	PL1.25x6.625 Reinforcement	59.25 - 59.50	Auto	0.2289
L43	37	PL1.25x6.625 Reinforcement	59.25 - 59.50	Auto	0.2289
L43	51	PL1x4 Reinforcement	59.25 - 59.50	Auto	0.0000
L43	52	PL1x4 Reinforcement	59.25 - 59.50	Auto	0.0000
L43	53	PL1x4 Reinforcement	59.25 - 59.50	Auto	0.0000
L43	55	PL1x4 Reinforcement	59.25 - 59.50	Auto	0.0000
L43	56	PL1x4 Reinforcement	59.25 - 59.50	Auto	0.0000
L43	57	PL1x4 Reinforcement	59.25 - 59.50	Auto	0.0000
L43	81	CCI-SFP-045100	59.25 - 59.50	Auto	0.0000
L43	82	CCI-SFP-045100	59.25 - 59.50	Auto	0.0000
L43	84	CCI-SFP-040075	59.25 - 59.50	Auto	0.0000
L44	35	PL1.25x6.625 Reinforcement	54.25 - 59.25	Auto	0.1926
L44	36	PL1.25x6.625 Reinforcement	54.25 - 59.25	Auto	0.1926
L44	37	PL1.25x6.625 Reinforcement	54.25 - 59.25	Auto	0.1926
L44	51	PL1x4 Reinforcement	54.25 - 59.25	Auto	0.0000
L44	52	PL1x4 Reinforcement	54.25 - 59.25	Auto	0.0000
L44	53	PL1x4 Reinforcement	54.25 - 59.25	Auto	0.0000
L44	55	PL1x4 Reinforcement	58.75 - 59.25	Auto	0.0000
L44	56	PL1x4 Reinforcement	58.75 - 59.25	Auto	0.0000
L44	57	PL1x4 Reinforcement	58.75 - 59.25	Auto	0.0000
L44	81	CCI-SFP-045100	54.25 - 59.25	Auto	0.0000
L44	82	CCI-SFP-045100	54.25 - 59.25	Auto	0.0000
L44	84	CCI-SFP-040075	54.25 - 59.25	Auto	0.0000
L45	35	PL1.25x6.625 Reinforcement	45.80 - 54.25	Auto	0.1333
L45	36	PL1.25x6.625 Reinforcement	45.80 - 54.25	Auto	0.1333
L45	37	PL1.25x6.625 Reinforcement	45.80 - 54.25	Auto	0.1333
L45	51	PL1x4 Reinforcement	45.80 - 54.25	Auto	0.0000
L45	52	PL1x4 Reinforcement	45.80 - 54.25	Auto	0.0000
L45	53	PL1x4 Reinforcement	45.80 - 54.25	Auto	0.0000
L45	81	CCI-SFP-045100	45.80 - 54.25	Auto	0.0000
L45	82	CCI-SFP-045100	45.80 - 54.25	Auto	0.0000
L45	84	CCI-SFP-040075	45.80 - 54.25	Auto	0.0000
L46	35	PL1.25x6.625 Reinforcement	44.80 - 45.80	Auto	0.1157
L46	36	PL1.25x6.625 Reinforcement	44.80 - 45.80	Auto	0.1157
L46	37	PL1.25x6.625 Reinforcement	44.80 - 45.80	Auto	0.1157
L46	51	PL1x4 Reinforcement	44.80 - 45.80	Auto	0.0000
L46	52	PL1x4 Reinforcement	44.80 - 45.80	Auto	0.0000
L46	53	PL1x4 Reinforcement	44.80 - 45.80	Auto	0.0000
L46	76	CCI-SFP-045100	44.80 - 45.08	Auto	0.0000
L46	78	CCI-SFP-060100	44.80 - 45.17	Auto	0.0208
L46	79	CCI-SFP-060100	44.80 - 45.17	Auto	0.0208
L46	81	CCI-SFP-045100	45.25 - 45.80	Auto	0.0000
L46	82	CCI-SFP-045100	45.25 - 45.80	Auto	0.0000

# tnxTower

**B+T Group**  
1717 S. Boulder, Suite 300  
Tulsa, OK 74119  
Phone: (918) 587-4630  
FAX: (918) 295-0265

**Job**  
79982.013.01 - WATERBURY,CT (BU# 876317)

**Page**  
53 of 94

**Project**  
**Date**  
15:43:49 05/20/22

**Client**  
Crown Castle  
**Designed by**  
Jayaraj B

Tower Section	Attachment Record No.	Description	Attachment Segment Elev.	Ratio Calculation Method	Effective Width Ratio
L46	84	CCI-SFP-040075	45.25 - 45.80	Auto	0.0000
L47	35	PL1.25x6.625 Reinforcement	43.58 - 44.80	Auto	0.1069
L47	36	PL1.25x6.625 Reinforcement	43.58 - 44.80	Auto	0.1069
L47	37	PL1.25x6.625 Reinforcement	43.58 - 44.80	Auto	0.1069
L47	51	PL1x4 Reinforcement	43.58 - 44.80	Auto	0.0000
L47	52	PL1x4 Reinforcement	43.58 - 44.80	Auto	0.0000
L47	53	PL1x4 Reinforcement	43.58 - 44.80	Auto	0.0000
L47	76	CCI-SFP-045100	43.58 - 44.80	Auto	0.0000
L47	78	CCI-SFP-060100	43.58 - 44.80	Auto	0.0138
L47	79	CCI-SFP-060100	43.58 - 44.80	Auto	0.0138
L48	35	PL1.25x6.625 Reinforcement	43.33 - 43.58	Auto	0.1060
L48	36	PL1.25x6.625 Reinforcement	43.33 - 43.58	Auto	0.1060
L48	37	PL1.25x6.625 Reinforcement	43.33 - 43.58	Auto	0.1060
L48	51	PL1x4 Reinforcement	43.33 - 43.58	Auto	0.0000
L48	52	PL1x4 Reinforcement	43.33 - 43.58	Auto	0.0000
L48	53	PL1x4 Reinforcement	43.33 - 43.58	Auto	0.0000
L48	76	CCI-SFP-045100	43.33 - 43.58	Auto	0.0000
L48	78	CCI-SFP-060100	43.33 - 43.58	Auto	0.0129
L48	79	CCI-SFP-060100	43.33 - 43.58	Auto	0.0129
L49	35	PL1.25x6.625 Reinforcement	43.17 - 43.33	Auto	0.1044
L49	36	PL1.25x6.625 Reinforcement	43.17 - 43.33	Auto	0.1044
L49	37	PL1.25x6.625 Reinforcement	43.17 - 43.33	Auto	0.1044
L49	51	PL1x4 Reinforcement	43.17 - 43.33	Auto	0.0000
L49	52	PL1x4 Reinforcement	43.17 - 43.33	Auto	0.0000
L49	53	PL1x4 Reinforcement	43.17 - 43.33	Auto	0.0000
L49	76	CCI-SFP-045100	43.17 - 43.33	Auto	0.0000
L49	78	CCI-SFP-060100	43.17 - 43.33	Auto	0.0111
L49	79	CCI-SFP-060100	43.17 - 43.33	Auto	0.0111
L50	35	PL1.25x6.625 Reinforcement	42.92 - 43.17	Auto	0.1381
L50	36	PL1.25x6.625 Reinforcement	42.92 - 43.17	Auto	0.1381
L50	37	PL1.25x6.625 Reinforcement	42.92 - 43.17	Auto	0.1381
L50	51	PL1x4 Reinforcement	42.92 - 43.17	Auto	0.0000
L50	52	PL1x4 Reinforcement	42.92 - 43.17	Auto	0.0000
L50	53	PL1x4 Reinforcement	42.92 - 43.17	Auto	0.0000
L50	76	CCI-SFP-045100	42.92 - 43.17	Auto	0.0000
L50	78	CCI-SFP-060100	42.92 - 43.17	Auto	0.0483
L50	79	CCI-SFP-060100	42.92 - 43.17	Auto	0.0483
L51	35	PL1.25x6.625 Reinforcement	39.00 - 42.92	Auto	0.1113
L51	36	PL1.25x6.625 Reinforcement	39.00 - 42.92	Auto	0.1113
L51	37	PL1.25x6.625 Reinforcement	39.00 - 42.92	Auto	0.1113
L51	49	PL1x4 Reinforcement	39.00 - 40.75	Auto	0.0000
L51	51	PL1x4 Reinforcement	39.00 - 42.92	Auto	0.0000
L51	52	PL1x4 Reinforcement	39.00 - 42.92	Auto	0.0000
L51	53	PL1x4 Reinforcement	39.00 - 42.92	Auto	0.0000
L51	76	CCI-SFP-045100	39.00 - 42.92	Auto	0.0000
L51	78	CCI-SFP-060100	39.00 - 42.92	Auto	0.0187
L51	79	CCI-SFP-060100	39.00 - 42.92	Auto	0.0187
L52	35	PL1.25x6.625 Reinforcement	38.75 - 39.00	Auto	0.1098
L52	36	PL1.25x6.625 Reinforcement	38.75 - 39.00	Auto	0.1098
L52	37	PL1.25x6.625 Reinforcement	38.75 - 39.00	Auto	0.1098
L52	49	PL1x4 Reinforcement	38.75 - 39.00	Auto	0.0000
L52	51	PL1x4 Reinforcement	38.75 - 39.00	Auto	0.0000
L52	52	PL1x4 Reinforcement	38.75 - 39.00	Auto	0.0000
L52	53	PL1x4 Reinforcement	38.75 - 39.00	Auto	0.0000
L52	76	CCI-SFP-045100	38.75 - 39.00	Auto	0.0000
L52	78	CCI-SFP-060100	38.75 - 39.00	Auto	0.0171
L52	79	CCI-SFP-060100	38.75 - 39.00	Auto	0.0171
L53	35	PL1.25x6.625 Reinforcement	37.17 - 38.75	Auto	0.0974
L53	36	PL1.25x6.625 Reinforcement	37.17 - 38.75	Auto	0.0974
L53	37	PL1.25x6.625 Reinforcement	37.17 - 38.75	Auto	0.0974
L53	49	PL1x4 Reinforcement	37.17 - 38.75	Auto	0.0000

# tnxTower

**B+T Group**  
1717 S. Boulder, Suite 300  
Tulsa, OK 74119  
Phone: (918) 587-4630  
FAX: (918) 295-0265

**Job**  
79982.013.01 - WATERBURY,CT (BU# 876317)

**Page**  
54 of 94

**Project**  
**Date**  
15:43:49 05/20/22

**Client**  
Crown Castle  
**Designed by**  
Jayaraj B

Tower Section	Attachment Record No.	Description	Attachment Segment Elev.	Ratio Calculation Method	Effective Width Ratio
L53	51	PL1x4 Reinforcement	37.17 - 38.75	Auto	0.0000
L53	52	PL1x4 Reinforcement	37.17 - 38.75	Auto	0.0000
L53	53	PL1x4 Reinforcement	37.17 - 38.75	Auto	0.0000
L53	76	CCI-SFP-045100	37.17 - 38.75	Auto	0.0000
L53	78	CCI-SFP-060100	37.17 - 38.75	Auto	0.0038
L53	79	CCI-SFP-060100	37.17 - 38.75	Auto	0.0038
L54	35	PL1.25x6.625 Reinforcement	36.92 - 37.17	Auto	0.0698
L54	36	PL1.25x6.625 Reinforcement	36.92 - 37.17	Auto	0.0698
L54	37	PL1.25x6.625 Reinforcement	36.92 - 37.17	Auto	0.0698
L54	49	PL1x4 Reinforcement	36.92 - 37.17	Auto	0.0000
L54	51	PL1x4 Reinforcement	36.92 - 37.17	Auto	0.0000
L54	52	PL1x4 Reinforcement	36.92 - 37.17	Auto	0.0000
L54	53	PL1x4 Reinforcement	36.92 - 37.17	Auto	0.0000
L54	76	CCI-SFP-045100	36.92 - 37.17	Auto	0.0000
L54	78	CCI-SFP-060100	36.92 - 37.17	Auto	0.0000
L54	79	CCI-SFP-060100	36.92 - 37.17	Auto	0.0000
L55	35	PL1.25x6.625 Reinforcement	34.00 - 36.92	Auto	0.0572
L55	36	PL1.25x6.625 Reinforcement	34.00 - 36.92	Auto	0.0572
L55	37	PL1.25x6.625 Reinforcement	34.00 - 36.92	Auto	0.0572
L55	47	PL1x4 Reinforcement	34.00 - 35.75	Auto	0.0000
L55	48	PL1x4 Reinforcement	34.00 - 35.75	Auto	0.0000
L55	49	PL1x4 Reinforcement	34.00 - 36.92	Auto	0.0000
L55	51	PL1x4 Reinforcement	34.00 - 36.92	Auto	0.0000
L55	52	PL1x4 Reinforcement	34.00 - 36.92	Auto	0.0000
L55	53	PL1x4 Reinforcement	34.00 - 36.92	Auto	0.0000
L55	72	CCI-SFP-045100	34.00 - 35.08	Auto	0.0000
L55	74	CCI-SFP-045100	34.00 - 35.08	Auto	0.0000
L55	76	CCI-SFP-045100	34.00 - 36.92	Auto	0.0000
L55	78	CCI-SFP-060100	35.17 - 36.92	Auto	0.0000
L55	79	CCI-SFP-060100	35.17 - 36.92	Auto	0.0000
L56	35	PL1.25x6.625 Reinforcement	33.75 - 34.00	Auto	0.0394
L56	36	PL1.25x6.625 Reinforcement	33.75 - 34.00	Auto	0.0394
L56	37	PL1.25x6.625 Reinforcement	33.75 - 34.00	Auto	0.0394
L56	47	PL1x4 Reinforcement	33.75 - 34.00	Auto	0.0000
L56	48	PL1x4 Reinforcement	33.75 - 34.00	Auto	0.0000
L56	49	PL1x4 Reinforcement	33.75 - 34.00	Auto	0.0000
L56	51	PL1x4 Reinforcement	33.75 - 34.00	Auto	0.0000
L56	52	PL1x4 Reinforcement	33.75 - 34.00	Auto	0.0000
L56	53	PL1x4 Reinforcement	33.75 - 34.00	Auto	0.0000
L56	72	CCI-SFP-045100	33.75 - 34.00	Auto	0.0000
L56	74	CCI-SFP-045100	33.75 - 34.00	Auto	0.0000
L56	76	CCI-SFP-045100	33.75 - 34.00	Auto	0.0000
L57	35	PL1.25x6.625 Reinforcement	29.75 - 33.75	Auto	0.0174
L57	36	PL1.25x6.625 Reinforcement	29.75 - 33.75	Auto	0.0174
L57	37	PL1.25x6.625 Reinforcement	29.75 - 33.75	Auto	0.0174
L57	47	PL1x4 Reinforcement	29.75 - 33.75	Auto	0.0000
L57	48	PL1x4 Reinforcement	29.75 - 33.75	Auto	0.0000
L57	49	PL1x4 Reinforcement	29.75 - 33.75	Auto	0.0000
L57	51	PL1x4 Reinforcement	32.25 - 33.75	Auto	0.0000
L57	52	PL1x4 Reinforcement	32.25 - 33.75	Auto	0.0000
L57	53	PL1x4 Reinforcement	32.25 - 33.75	Auto	0.0000
L57	72	CCI-SFP-045100	29.75 - 33.75	Auto	0.0000
L57	74	CCI-SFP-045100	29.75 - 33.75	Auto	0.0000
L57	76	CCI-SFP-045100	29.75 - 33.75	Auto	0.0000
L58	29	PL1.25x6.875 Reinforcement	29.50 - 29.75	Auto	0.0367
L58	30	PL1.25x6.875 Reinforcement	29.50 - 29.75	Auto	0.0367
L58	31	PL1.25x6.875 Reinforcement	29.50 - 29.75	Auto	0.0367
L58	47	PL1x4 Reinforcement	29.50 - 29.75	Auto	0.0000
L58	48	PL1x4 Reinforcement	29.50 - 29.75	Auto	0.0000
L58	49	PL1x4 Reinforcement	29.50 - 29.75	Auto	0.0000
L58	72	CCI-SFP-045100	29.50 - 29.75	Auto	0.0000

# tnxTower

**B+T Group**  
1717 S. Boulder, Suite 300  
Tulsa, OK 74119  
Phone: (918) 587-4630  
FAX: (918) 295-0265

**Job**  
79982.013.01 - WATERBURY,CT (BU# 876317)

**Page**  
55 of 94

**Project**  
**Date**  
15:43:49 05/20/22

**Client**  
Crown Castle  
**Designed by**  
Jayaraj B

Tower Section	Attachment Record No.	Description	Attachment Segment Elev.	Ratio Calculation Method	Effective Width Ratio
L58	74	CCI-SFP-045100	29.50 - 29.75	Auto	0.0000
L58	76	CCI-SFP-045100	29.50 - 29.75	Auto	0.0000
L59	29	PL1.25x6.875 Reinforcement	24.50 - 29.50	Auto	0.0123
L59	30	PL1.25x6.875 Reinforcement	24.50 - 29.50	Auto	0.0123
L59	31	PL1.25x6.875 Reinforcement	24.50 - 29.50	Auto	0.0123
L59	47	PL1x4 Reinforcement	24.50 - 29.50	Auto	0.0000
L59	48	PL1x4 Reinforcement	24.50 - 29.50	Auto	0.0000
L59	49	PL1x4 Reinforcement	24.50 - 29.50	Auto	0.0000
L59	67	CCI-SFP-060100	24.50 - 25.00	Auto	0.0000
L59	68	CCI-SFP-060100	24.50 - 25.00	Auto	0.0000
L59	70	CCI-SFP-060100	24.50 - 25.00	Auto	0.0000
L59	72	CCI-SFP-045100	24.50 - 29.50	Auto	0.0000
L59	74	CCI-SFP-045100	25.08 - 29.50	Auto	0.0000
L59	76	CCI-SFP-045100	25.08 - 29.50	Auto	0.0000
L60	29	PL1.25x6.875 Reinforcement	23.00 - 24.50	Auto	0.0000
L60	30	PL1.25x6.875 Reinforcement	23.00 - 24.50	Auto	0.0000
L60	31	PL1.25x6.875 Reinforcement	23.00 - 24.50	Auto	0.0000
L60	47	PL1x4 Reinforcement	23.00 - 24.50	Auto	0.0000
L60	48	PL1x4 Reinforcement	23.00 - 24.50	Auto	0.0000
L60	49	PL1x4 Reinforcement	23.00 - 24.50	Auto	0.0000
L60	67	CCI-SFP-060100	23.00 - 24.50	Auto	0.0000
L60	68	CCI-SFP-060100	23.00 - 24.50	Auto	0.0000
L60	70	CCI-SFP-060100	23.00 - 24.50	Auto	0.0000
L60	72	CCI-SFP-045100	23.00 - 24.50	Auto	0.0000
L61	29	PL1.25x6.875 Reinforcement	22.75 - 23.00	Auto	0.0236
L61	30	PL1.25x6.875 Reinforcement	22.75 - 23.00	Auto	0.0236
L61	31	PL1.25x6.875 Reinforcement	22.75 - 23.00	Auto	0.0236
L61	47	PL1x4 Reinforcement	22.75 - 23.00	Auto	0.0000
L61	48	PL1x4 Reinforcement	22.75 - 23.00	Auto	0.0000
L61	49	PL1x4 Reinforcement	22.75 - 23.00	Auto	0.0000
L61	67	CCI-SFP-060100	22.75 - 23.00	Auto	0.0000
L61	68	CCI-SFP-060100	22.75 - 23.00	Auto	0.0000
L61	70	CCI-SFP-060100	22.75 - 23.00	Auto	0.0000
L61	72	CCI-SFP-045100	22.75 - 23.00	Auto	0.0000
L62	29	PL1.25x6.875 Reinforcement	21.58 - 22.75	Auto	0.0181
L62	30	PL1.25x6.875 Reinforcement	21.58 - 22.75	Auto	0.0181
L62	31	PL1.25x6.875 Reinforcement	21.58 - 22.75	Auto	0.0181
L62	47	PL1x4 Reinforcement	21.58 - 22.75	Auto	0.0000
L62	48	PL1x4 Reinforcement	21.58 - 22.75	Auto	0.0000
L62	49	PL1x4 Reinforcement	21.58 - 22.75	Auto	0.0000
L62	67	CCI-SFP-060100	21.58 - 22.75	Auto	0.0000
L62	68	CCI-SFP-060100	21.58 - 22.75	Auto	0.0000
L62	70	CCI-SFP-060100	21.58 - 22.75	Auto	0.0000
L62	72	CCI-SFP-045100	21.58 - 22.75	Auto	0.0000
L63	29	PL1.25x6.875 Reinforcement	21.33 - 21.58	Auto	0.0000
L63	30	PL1.25x6.875 Reinforcement	21.33 - 21.58	Auto	0.0000
L63	31	PL1.25x6.875 Reinforcement	21.33 - 21.58	Auto	0.0000
L63	47	PL1x4 Reinforcement	21.33 - 21.58	Auto	0.0000
L63	48	PL1x4 Reinforcement	21.33 - 21.58	Auto	0.0000
L63	49	PL1x4 Reinforcement	21.33 - 21.58	Auto	0.0000
L63	67	CCI-SFP-060100	21.33 - 21.58	Auto	0.0000
L63	68	CCI-SFP-060100	21.33 - 21.58	Auto	0.0000
L63	70	CCI-SFP-060100	21.33 - 21.58	Auto	0.0000
L63	72	CCI-SFP-045100	21.33 - 21.58	Auto	0.0000
L64	29	PL1.25x6.875 Reinforcement	16.33 - 21.33	Auto	0.0000
L64	30	PL1.25x6.875 Reinforcement	16.33 - 21.33	Auto	0.0000
L64	31	PL1.25x6.875 Reinforcement	16.33 - 21.33	Auto	0.0000
L64	32	PL1.25x6.875 Reinforcement	16.33 - 16.42	Auto	0.0000
L64	33	PL1.25x6.875 Reinforcement	16.33 - 16.42	Auto	0.0000
L64	47	PL1x4 Reinforcement	16.33 - 21.33	Auto	0.0000
L64	48	PL1x4 Reinforcement	16.33 - 21.33	Auto	0.0000

# tnxTower

**B+T Group**  
1717 S. Boulder, Suite 300  
Tulsa, OK 74119  
Phone: (918) 587-4630  
FAX: (918) 295-0265

**Job**  
79982.013.01 - WATERBURY,CT (BU# 876317)

**Page**  
56 of 94

**Project**  
**Date**  
15:43:49 05/20/22

**Client**  
Crown Castle  
**Designed by**  
Jayaraj B

Tower Section	Attachment Record No.	Description	Attachment Segment Elev.	Ratio Calculation Method	Effective Width Ratio
L64	49	PL1x4 Reinforcement	16.33 - 21.33	Auto	0.0000
L64	67	CCI-SFP-060100	16.33 - 21.33	Auto	0.0000
L64	68	CCI-SFP-060100	16.33 - 21.33	Auto	0.0000
L64	70	CCI-SFP-060100	16.33 - 21.33	Auto	0.0000
L64	72	CCI-SFP-045100	20.08 - 21.33	Auto	0.0000
L65	29	PL1.25x6.875 Reinforcement	12.92 - 16.33	Auto	0.0000
L65	30	PL1.25x6.875 Reinforcement	12.92 - 16.33	Auto	0.0000
L65	31	PL1.25x6.875 Reinforcement	12.92 - 16.33	Auto	0.0000
L65	32	PL1.25x6.875 Reinforcement	12.92 - 16.33	Auto	0.0000
L65	33	PL1.25x6.875 Reinforcement	12.92 - 16.33	Auto	0.0000
L65	47	PL1x4 Reinforcement	12.92 - 16.33	Auto	0.0000
L65	48	PL1x4 Reinforcement	12.92 - 16.33	Auto	0.0000
L65	49	PL1x4 Reinforcement	12.92 - 16.33	Auto	0.0000
L65	67	CCI-SFP-060100	12.92 - 16.33	Auto	0.0000
L65	68	CCI-SFP-060100	12.92 - 16.33	Auto	0.0000
L65	70	CCI-SFP-060100	12.92 - 16.33	Auto	0.0000
L66	29	PL1.25x6.875 Reinforcement	12.67 - 12.92	Auto	0.0000
L66	30	PL1.25x6.875 Reinforcement	12.67 - 12.92	Auto	0.0000
L66	31	PL1.25x6.875 Reinforcement	12.67 - 12.92	Auto	0.0000
L66	32	PL1.25x6.875 Reinforcement	12.67 - 12.92	Auto	0.0000
L66	33	PL1.25x6.875 Reinforcement	12.67 - 12.92	Auto	0.0000
L66	47	PL1x4 Reinforcement	12.67 - 12.92	Auto	0.0000
L66	48	PL1x4 Reinforcement	12.67 - 12.92	Auto	0.0000
L66	49	PL1x4 Reinforcement	12.67 - 12.92	Auto	0.0000
L66	67	CCI-SFP-060100	12.67 - 12.92	Auto	0.0000
L66	68	CCI-SFP-060100	12.67 - 12.92	Auto	0.0000
L66	70	CCI-SFP-060100	12.67 - 12.92	Auto	0.0000
L67	29	PL1.25x6.875 Reinforcement	12.50 - 12.67	Auto	0.0000
L67	30	PL1.25x6.875 Reinforcement	12.50 - 12.67	Auto	0.0000
L67	31	PL1.25x6.875 Reinforcement	12.50 - 12.67	Auto	0.0000
L67	32	PL1.25x6.875 Reinforcement	12.50 - 12.67	Auto	0.0000
L67	33	PL1.25x6.875 Reinforcement	12.50 - 12.67	Auto	0.0000
L67	47	PL1x4 Reinforcement	12.50 - 12.67	Auto	0.0000
L67	48	PL1x4 Reinforcement	12.50 - 12.67	Auto	0.0000
L67	49	PL1x4 Reinforcement	12.50 - 12.67	Auto	0.0000
L67	67	CCI-SFP-060100	12.50 - 12.67	Auto	0.0000
L67	68	CCI-SFP-060100	12.50 - 12.67	Auto	0.0000
L67	70	CCI-SFP-060100	12.50 - 12.67	Auto	0.0000
L68	29	PL1.25x6.875 Reinforcement	12.25 - 12.50	Auto	0.0000
L68	30	PL1.25x6.875 Reinforcement	12.25 - 12.50	Auto	0.0000
L68	31	PL1.25x6.875 Reinforcement	12.25 - 12.50	Auto	0.0000
L68	32	PL1.25x6.875 Reinforcement	12.25 - 12.50	Auto	0.0000
L68	33	PL1.25x6.875 Reinforcement	12.25 - 12.50	Auto	0.0000
L68	47	PL1x4 Reinforcement	12.25 - 12.50	Auto	0.0000
L68	48	PL1x4 Reinforcement	12.25 - 12.50	Auto	0.0000
L68	49	PL1x4 Reinforcement	12.25 - 12.50	Auto	0.0000
L68	67	CCI-SFP-060100	12.25 - 12.50	Auto	0.0000
L68	68	CCI-SFP-060100	12.25 - 12.50	Auto	0.0000
L68	70	CCI-SFP-060100	12.25 - 12.50	Auto	0.0000
L69	29	PL1.25x6.875 Reinforcement	12.00 - 12.25	Auto	0.0000
L69	30	PL1.25x6.875 Reinforcement	12.00 - 12.25	Auto	0.0000
L69	31	PL1.25x6.875 Reinforcement	12.00 - 12.25	Auto	0.0000
L69	32	PL1.25x6.875 Reinforcement	12.00 - 12.25	Auto	0.0000
L69	33	PL1.25x6.875 Reinforcement	12.00 - 12.25	Auto	0.0000
L69	47	PL1x4 Reinforcement	12.00 - 12.25	Auto	0.0000
L69	48	PL1x4 Reinforcement	12.00 - 12.25	Auto	0.0000
L69	49	PL1x4 Reinforcement	12.00 - 12.25	Auto	0.0000
L69	67	CCI-SFP-060100	12.00 - 12.25	Auto	0.0000
L69	68	CCI-SFP-060100	12.00 - 12.25	Auto	0.0000
L69	70	CCI-SFP-060100	12.00 - 12.25	Auto	0.0000
L70	29	PL1.25x6.875 Reinforcement	11.75 - 12.00	Auto	0.0000

Tower Section	Attachment Record No.	Description	Attachment Segment Elev.	Ratio Calculation Method	Effective Width Ratio
L70	30	PL1.25x6.875 Reinforcement	11.75 - 12.00	Auto	0.0000
L70	31	PL1.25x6.875 Reinforcement	11.75 - 12.00	Auto	0.0000
L70	32	PL1.25x6.875 Reinforcement	11.75 - 12.00	Auto	0.0000
L70	33	PL1.25x6.875 Reinforcement	11.75 - 12.00	Auto	0.0000
L70	47	PL1x4 Reinforcement	11.75 - 12.00	Auto	0.0000
L70	48	PL1x4 Reinforcement	11.75 - 12.00	Auto	0.0000
L70	49	PL1x4 Reinforcement	11.75 - 12.00	Auto	0.0000
L70	67	CCI-SFP-060100	11.75 - 12.00	Auto	0.0000
L70	68	CCI-SFP-060100	11.75 - 12.00	Auto	0.0000
L70	70	CCI-SFP-060100	11.75 - 12.00	Auto	0.0000
L71	29	PL1.25x6.875 Reinforcement	8.50 - 11.75	Auto	0.0000
L71	30	PL1.25x6.875 Reinforcement	8.50 - 11.75	Auto	0.0000
L71	31	PL1.25x6.875 Reinforcement	9.17 - 11.75	Auto	0.0000
L71	32	PL1.25x6.875 Reinforcement	8.50 - 11.75	Auto	0.0000
L71	33	PL1.25x6.875 Reinforcement	8.50 - 11.75	Auto	0.0000
L71	47	PL1x4 Reinforcement	10.75 - 11.75	Auto	0.0000
L71	48	PL1x4 Reinforcement	10.75 - 11.75	Auto	0.0000
L71	49	PL1x4 Reinforcement	10.75 - 11.75	Auto	0.0000
L71	63	Transition Stiffener 1x7	8.50 - 10.50	Auto	0.0000
L71	64	Transition Stiffener 1x7	8.50 - 10.50	Auto	0.0000
L71	65	Transition Stiffener 1x7	8.50 - 10.50	Auto	0.0000
L71	67	CCI-SFP-060100	8.50 - 11.75	Auto	0.0000
L71	68	CCI-SFP-060100	8.50 - 11.75	Auto	0.0000
L71	70	CCI-SFP-060100	10.00 - 11.75	Auto	0.0000
L72	29	PL1.25x6.875 Reinforcement	8.25 - 8.50	Auto	0.0000
L72	30	PL1.25x6.875 Reinforcement	8.25 - 8.50	Auto	0.0000
L72	32	PL1.25x6.875 Reinforcement	8.25 - 8.50	Auto	0.0000
L72	33	PL1.25x6.875 Reinforcement	8.25 - 8.50	Auto	0.0000
L72	63	Transition Stiffener 1x7	8.25 - 8.50	Auto	0.0000
L72	64	Transition Stiffener 1x7	8.25 - 8.50	Auto	0.0000
L72	65	Transition Stiffener 1x7	8.25 - 8.50	Auto	0.0000
L72	67	CCI-SFP-060100	8.25 - 8.50	Auto	0.0000
L72	68	CCI-SFP-060100	8.25 - 8.50	Auto	0.0000
L73	29	PL1.25x6.875 Reinforcement	7.00 - 8.25	Auto	0.0000
L73	30	PL1.25x6.875 Reinforcement	7.00 - 8.25	Auto	0.0000
L73	32	PL1.25x6.875 Reinforcement	7.00 - 8.25	Auto	0.0000
L73	33	PL1.25x6.875 Reinforcement	7.00 - 8.25	Auto	0.0000
L73	63	Transition Stiffener 1x7	7.00 - 8.25	Auto	0.0000
L73	64	Transition Stiffener 1x7	7.00 - 8.25	Auto	0.0000
L73	65	Transition Stiffener 1x7	7.00 - 8.25	Auto	0.0000
L73	67	CCI-SFP-060100	7.00 - 8.25	Auto	0.0000
L73	68	CCI-SFP-060100	7.00 - 8.25	Auto	0.0000
L74	29	PL1.25x6.875 Reinforcement	6.75 - 7.00	Auto	0.0000
L74	30	PL1.25x6.875 Reinforcement	6.75 - 7.00	Auto	0.0000
L74	32	PL1.25x6.875 Reinforcement	6.75 - 7.00	Auto	0.0000
L74	33	PL1.25x6.875 Reinforcement	6.75 - 7.00	Auto	0.0000
L74	63	Transition Stiffener 1x7	6.75 - 7.00	Auto	0.0000
L74	64	Transition Stiffener 1x7	6.75 - 7.00	Auto	0.0000
L74	65	Transition Stiffener 1x7	6.75 - 7.00	Auto	0.0000
L74	67	CCI-SFP-060100	6.75 - 7.00	Auto	0.0000
L74	68	CCI-SFP-060100	6.75 - 7.00	Auto	0.0000
L75	29	PL1.25x6.875 Reinforcement	1.75 - 6.75	Auto	0.0000
L75	30	PL1.25x6.875 Reinforcement	1.75 - 6.75	Auto	0.0000
L75	32	PL1.25x6.875 Reinforcement	1.75 - 6.75	Auto	0.0000
L75	33	PL1.25x6.875 Reinforcement	1.75 - 6.75	Auto	0.0000
L75	63	Transition Stiffener 1x7	1.75 - 6.75	Auto	0.0000
L75	64	Transition Stiffener 1x7	1.75 - 6.75	Auto	0.0000
L75	65	Transition Stiffener 1x7	1.75 - 6.75	Auto	0.0000
L75	67	CCI-SFP-060100	5.00 - 6.75	Auto	0.0000
L75	68	CCI-SFP-060100	5.00 - 6.75	Auto	0.0000
L76	29	PL1.25x6.875 Reinforcement	0.00 - 1.75	Auto	0.0000

<b>tnxTower</b>  <b>B+T Group</b> 1717 S. Boulder, Suite 300 Tulsa, OK 74119 Phone: (918) 587-4630 FAX: (918) 295-0265	<b>Job</b> 79982.013.01 - WATERBURY,CT (BU# 876317)	<b>Page</b> 58 of 94
	<b>Project</b>	<b>Date</b> 15:43:49 05/20/22
	<b>Client</b> Crown Castle	<b>Designed by</b> Jayaraj B

Tower Section	Attachment Record No.	Description	Attachment Segment Elev.	Ratio Calculation Method	Effective Width Ratio
L76	30	PL1.25x6.875 Reinforcement	0.00 - 1.75	Auto	0.0000
L76	32	PL1.25x6.875 Reinforcement	0.00 - 1.75	Auto	0.0000
L76	33	PL1.25x6.875 Reinforcement	0.00 - 1.75	Auto	0.0000
L76	63	Transition Stiffener 1x7	0.00 - 1.75	Auto	0.0000
L76	64	Transition Stiffener 1x7	0.00 - 1.75	Auto	0.0000
L76	65	Transition Stiffener 1x7	0.00 - 1.75	Auto	0.0000

### Discrete Tower Loads

Description	Face or Leg	Offset Type	Offsets:		Azimuth Adjustment	Placement	C <sub>A</sub> A <sub>Front</sub>	C <sub>A</sub> A <sub>Side</sub>	Weight	
			Horz	Vert						
			ft	ft	°	ft	ft <sup>2</sup>	ft <sup>2</sup>	K	
EPBQ-654L8H8-L2 w/ Mount Pipe	A	From Leg	4.000	0.000	0.000	144.000	No Ice	14.860	6.250	0.119
			0.000				1/2" Ice	15.720	7.020	0.228
			-1.000				1" Ice	16.590	7.800	0.351
EPBQ-654L8H8-L2 w/ Mount Pipe	B	From Leg	4.000	0.000	0.000	144.000	No Ice	14.860	6.250	0.119
			0.000				1/2" Ice	15.720	7.020	0.228
			-1.000				1" Ice	16.590	7.800	0.351
EPBQ-654L8H8-L2 w/ Mount Pipe	C	From Leg	4.000	0.000	0.000	144.000	No Ice	14.860	6.250	0.119
			0.000				1/2" Ice	15.720	7.020	0.228
			-1.000				1" Ice	16.590	7.800	0.351
RRUS 4478 B14	A	From Leg	4.000	0.000	0.000	144.000	No Ice	1.843	1.059	0.060
			0.000				1/2" Ice	2.012	1.197	0.076
			-1.000				1" Ice	2.190	1.342	0.094
RRUS 4478 B14	B	From Leg	4.000	0.000	0.000	144.000	No Ice	1.843	1.059	0.060
			0.000				1/2" Ice	2.012	1.197	0.076
			-1.000				1" Ice	2.190	1.342	0.094
RRUS 4478 B14	C	From Leg	4.000	0.000	0.000	144.000	No Ice	1.843	1.059	0.060
			0.000				1/2" Ice	2.012	1.197	0.076
			-1.000				1" Ice	2.190	1.342	0.094
RADIO 4415 B30	A	From Leg	4.000	0.000	0.000	144.000	No Ice	1.643	0.639	0.043
			0.000				1/2" Ice	1.803	0.750	0.055
			-1.000				1" Ice	1.971	0.867	0.069
RADIO 4415 B30	B	From Leg	4.000	0.000	0.000	144.000	No Ice	1.643	0.639	0.043
			0.000				1/2" Ice	1.803	0.750	0.055
			-1.000				1" Ice	1.971	0.867	0.069
RADIO 4415 B30	C	From Leg	4.000	0.000	0.000	144.000	No Ice	1.643	0.639	0.043
			0.000				1/2" Ice	1.803	0.750	0.055
			-1.000				1" Ice	1.971	0.867	0.069
RRUS 8843 B2/B66A	A	From Leg	4.000	0.000	0.000	144.000	No Ice	1.639	1.353	0.072
			0.000				1/2" Ice	1.799	1.500	0.090
			-1.000				1" Ice	1.966	1.655	0.110
RRUS 8843 B2/B66A	B	From Leg	4.000	0.000	0.000	144.000	No Ice	1.639	1.353	0.072
			0.000				1/2" Ice	1.799	1.500	0.090
			-1.000				1" Ice	1.966	1.655	0.110
RRUS 8843 B2/B66A	C	From Leg	4.000	0.000	0.000	144.000	No Ice	1.639	1.353	0.072
			0.000				1/2" Ice	1.799	1.500	0.090
			-1.000				1" Ice	1.966	1.655	0.110
RRUS 4449 B5/B12	A	From Leg	4.000	0.000	0.000	144.000	No Ice	1.968	1.408	0.071
			0.000				1/2" Ice	2.144	1.564	0.090

# tnxTower

**B+T Group**  
1717 S. Boulder, Suite 300  
Tulsa, OK 74119  
Phone: (918) 587-4630  
FAX: (918) 295-0265

<b>Job</b> 79982.013.01 - WATERBURY,CT (BU# 876317)	<b>Page</b> 59 of 94
<b>Project</b>	<b>Date</b> 15:43:49 05/20/22
<b>Client</b> Crown Castle	<b>Designed by</b> Jayaraj B

Description	Face or Leg	Offset Type	Offsets:		Azimuth Adjustment	Placement	C <sub>AA</sub>		Weight	
			Horz	Vert			Front	Side		
			ft	ft	°	ft	ft <sup>2</sup>	ft <sup>2</sup>	K	
RRUS 4449 B5/B12	B	From Leg	-1.000		0.000	144.000	1" Ice	2.328	1.727	0.111
			4.000				No Ice	1.968	1.408	0.071
			0.000				1/2" Ice	2.144	1.564	0.090
RRUS 4449 B5/B12	C	From Leg	-1.000		0.000	144.000	1" Ice	2.328	1.727	0.111
			4.000				No Ice	1.968	1.408	0.071
			0.000				1/2" Ice	2.144	1.564	0.090
DC6-48-60-18-8F	A	From Leg	-1.000		0.000	144.000	1" Ice	2.328	1.727	0.111
			4.000				No Ice	0.850	0.850	0.019
			0.000				1/2" Ice	1.356	1.356	0.036
DC6-48-60-18-8F	C	From Leg	-1.000		0.000	144.000	1" Ice	1.532	1.532	0.055
			4.000				No Ice	0.850	0.850	0.019
			0.000				1/2" Ice	1.356	1.356	0.036
AIR 6419 B77G_CCIV3 w/ Mount Pipe	A	From Leg	-1.000		0.000	144.000	1" Ice	1.532	1.532	0.055
			4.000				No Ice	4.380	2.760	0.057
			0.000				1/2" Ice	4.708	3.191	0.096
AIR 6419 B77G_CCIV3 w/ Mount Pipe	B	From Leg	1.000		0.000	144.000	1" Ice	5.045	3.639	0.140
			4.000				No Ice	4.380	2.760	0.057
			0.000				1/2" Ice	4.708	3.191	0.096
AIR 6419 B77G_CCIV3 w/ Mount Pipe	C	From Leg	1.000		0.000	144.000	1" Ice	5.045	3.639	0.140
			4.000				No Ice	4.380	2.760	0.057
			0.000				1/2" Ice	4.708	3.191	0.096
AIR 6449 B77D_CCIV2 w/ Mount Pipe	A	From Leg	1.000		0.000	144.000	1" Ice	5.045	3.639	0.140
			4.000				No Ice	3.580	2.310	0.095
			0.000				1/2" Ice	3.920	2.600	0.130
AIR 6449 B77D_CCIV2 w/ Mount Pipe	B	From Leg	-3.000		0.000	144.000	1" Ice	4.270	2.910	0.173
			4.000				No Ice	3.580	2.310	0.095
			0.000				1/2" Ice	3.920	2.600	0.130
AIR 6449 B77D_CCIV2 w/ Mount Pipe	C	From Leg	-3.000		0.000	144.000	1" Ice	4.270	2.910	0.173
			4.000				No Ice	3.580	2.310	0.095
			0.000				1/2" Ice	3.920	2.600	0.130
QD8616-7 w/ Mount Pipe	A	From Leg	-3.000		0.000	144.000	1" Ice	4.270	2.910	0.173
			4.000				No Ice	16.930	9.310	0.183
			0.000				1/2" Ice	17.870	10.170	0.308
QD8616-7 w/ Mount Pipe	B	From Leg	-1.000		0.000	144.000	1" Ice	18.830	11.050	0.448
			4.000				No Ice	16.930	9.310	0.183
			0.000				1/2" Ice	17.870	10.170	0.308
QD8616-7 w/ Mount Pipe	C	From Leg	-1.000		0.000	144.000	1" Ice	18.830	11.050	0.448
			4.000				No Ice	16.930	9.310	0.183
			0.000				1/2" Ice	17.870	10.170	0.308
2012 B29	A	From Leg	-1.000		0.000	144.000	1" Ice	18.830	11.050	0.448
			4.000				No Ice	1.856	0.695	0.043
			0.000				1/2" Ice	2.027	0.814	0.056
2012 B29	B	From Leg	-1.000		0.000	144.000	1" Ice	2.204	0.939	0.072
			4.000				No Ice	1.856	0.695	0.043
			0.000				1/2" Ice	2.027	0.814	0.056
2012 B29	C	From Leg	-1.000		0.000	144.000	1" Ice	2.204	0.939	0.072
			4.000				No Ice	1.856	0.695	0.043
			0.000				1/2" Ice	2.027	0.814	0.056
DC9-48-60-24-8C-EV	B	From Leg	-1.000		0.000	144.000	1" Ice	2.204	0.939	0.072
			4.000				No Ice	2.737	4.785	0.026
			0.000				1/2" Ice	2.963	5.065	0.063
(2) 10' x 2" Mount Pipe	A	From Leg	-1.000		0.000	144.000	1" Ice	3.196	5.352	0.104
			4.000				No Ice	0.000	2.375	0.037
			0.000				1/2" Ice	0.000	3.403	0.054
(2) 10' x 2" Mount Pipe	B	From Leg	-1.000		0.000	144.000	1" Ice	0.000	4.448	0.079
			4.000				No Ice	0.000	2.375	0.037
			0.000				1/2" Ice	0.000	3.403	0.054

<b>tnxTower</b>  <b>B+T Group</b> 1717 S. Boulder, Suite 300 Tulsa, OK 74119 Phone: (918) 587-4630 FAX: (918) 295-0265	<b>Job</b> 79982.013.01 - WATERBURY,CT (BU# 876317)	<b>Page</b> 60 of 94
	<b>Project</b>	<b>Date</b> 15:43:49 05/20/22
	<b>Client</b> Crown Castle	<b>Designed by</b> Jayaraj B

Description	Face or Leg	Offset Type	Offsets: Horz Lateral Vert ft ft ft	Azimuth Adjustment °	Placement ft	C <sub>AA</sub> Front ft <sup>2</sup>	C <sub>AA</sub> Side ft <sup>2</sup>	Weight K
(2) 10' x 2" Mount Pipe	C	From Leg	-1.000 4.000 0.000	0.000	144.000	1" Ice 0.000 No Ice 0.000 1/2" Ice 0.000	4.448 2.375 3.403	0.079 0.037 0.054
10' x 2" Mount Pipe	A	From Leg	-1.000 4.000 0.000	0.000	144.000	1" Ice 0.000 No Ice 2.375 1/2" Ice 3.403	4.448 2.375 3.403	0.079 0.037 0.054
10' x 2" Mount Pipe	B	From Leg	-1.000 4.000 0.000	0.000	144.000	1" Ice 4.448 No Ice 2.375 1/2" Ice 3.403	4.448 2.375 3.403	0.079 0.037 0.054
10' x 2" Mount Pipe	C	From Leg	-1.000 4.000 0.000	0.000	144.000	1" Ice 4.448 No Ice 2.375 1/2" Ice 3.403	4.448 2.375 3.403	0.079 0.037 0.054
F3P-12W	C	None	-1.000	0.000	144.000	1" Ice 4.448 No Ice 25.520 1/2" Ice 31.740	4.448 25.520 31.740	0.079 1.999 2.599
Miscellaneous [NA 507-1]	C	None		0.000	144.000	1" Ice 40.100 No Ice 4.560 1/2" Ice 6.390	40.100 4.560 6.390	3.414 0.245 0.311
*						1" Ice 8.180	8.180	0.402
(2) APXVSP18-C-A20 w/ Mount Pipe	A	From Leg	4.000 0.000 0.000	0.000	130.000	No Ice 4.600 1/2" Ice 5.050 1" Ice 5.500	4.010 4.450 4.890	0.095 0.160 0.235
APXVSP18-C-A20 w/ Mount Pipe	B	From Leg	4.000 0.000 0.000	0.000	130.000	No Ice 4.600 1/2" Ice 5.050 1" Ice 5.500	4.010 4.450 4.890	0.095 0.160 0.235
APXVSP18-C-A20 w/ Mount Pipe	C	From Leg	4.000 0.000 0.000	0.000	130.000	No Ice 4.600 1/2" Ice 5.050 1" Ice 5.500	4.010 4.450 4.890	0.095 0.160 0.235
AAHC w/ Mount Pipe	A	From Leg	4.000 0.000 0.000	0.000	130.000	No Ice 4.120 1/2" Ice 4.480 1" Ice 4.870	2.440 2.750 3.060	0.115 0.153 0.197
(2) AAHC w/ Mount Pipe	B	From Leg	4.000 0.000 0.000	0.000	130.000	No Ice 4.120 1/2" Ice 4.480 1" Ice 4.870	2.440 2.750 3.060	0.115 0.153 0.197
(2) IBC1900HB-2	A	From Leg	4.000 0.000 0.000	0.000	130.000	No Ice 1.125 1/2" Ice 1.270 1" Ice 1.423	0.713 0.837 0.968	0.040 0.049 0.060
IBC1900HB-2	B	From Leg	4.000 0.000 0.000	0.000	130.000	No Ice 1.125 1/2" Ice 1.270 1" Ice 1.423	0.713 0.837 0.968	0.040 0.049 0.060
IBC1900HB-2	C	From Leg	4.000 0.000 0.000	0.000	130.000	No Ice 1.125 1/2" Ice 1.270 1" Ice 1.423	0.713 0.837 0.968	0.040 0.049 0.060
800 EXTERNAL NOTCH FILTER	A	From Leg	4.000 0.000 0.000	0.000	130.000	No Ice 0.660 1/2" Ice 0.763 1" Ice 0.873	0.321 0.398 0.483	0.011 0.017 0.024
800 EXTERNAL NOTCH FILTER	B	From Leg	4.000 0.000 0.000	0.000	130.000	No Ice 0.660 1/2" Ice 0.763 1" Ice 0.873	0.321 0.398 0.483	0.011 0.017 0.024
800 EXTERNAL NOTCH FILTER	C	From Leg	4.000 0.000 0.000	0.000	130.000	No Ice 0.660 1/2" Ice 0.763 1" Ice 0.873	0.321 0.398 0.483	0.011 0.017 0.024
(2) 1900MHZ RRH (65MHZ)	A	From Leg	4.000 0.000 0.000	0.000	130.000	No Ice 2.313 1/2" Ice 2.517 1" Ice 2.728	2.375 2.581 2.794	0.060 0.084 0.111
(2) 1900MHZ RRH (65MHZ)	B	From Leg	4.000	0.000	130.000	No Ice 2.313	2.375	0.060

**tnxTower**

**B+T Group**  
 1717 S. Boulder, Suite 300  
 Tulsa, OK 74119  
 Phone: (918) 587-4630  
 FAX: (918) 295-0265

**Job**  
 79982.013.01 - WATERBURY,CT (BU# 876317)

**Page**  
 61 of 94

**Project**  
 Date  
 15:43:49 05/20/22

**Client**  
 Crown Castle  
 Designed by  
 Jayaraj B

Description	Face or Leg	Offset Type	Offsets:		Azimuth Adjustment	Placement	C <sub>AA</sub> Front	C <sub>AA</sub> Side	Weight
			Horz Lateral	Vert					
				0.000					0.084
				0.000			1/2" Ice	2.517	2.581
				0.000			1" Ice	2.728	2.794
(2) 1900MHZ RRH (65MHZ)	C	From Leg	4.000	0.000	130.000	No Ice	2.313	2.375	0.060
			0.000			1/2" Ice	2.517	2.581	0.084
			0.000			1" Ice	2.728	2.794	0.111
800MHZ RRH	A	From Leg	4.000	0.000	130.000	No Ice	2.134	1.773	0.053
			0.000			1/2" Ice	2.320	1.946	0.074
			0.000			1" Ice	2.512	2.127	0.098
800MHZ RRH	B	From Leg	4.000	0.000	130.000	No Ice	2.134	1.773	0.053
			0.000			1/2" Ice	2.320	1.946	0.074
			0.000			1" Ice	2.512	2.127	0.098
800MHZ RRH	C	From Leg	4.000	0.000	130.000	No Ice	2.134	1.773	0.053
			0.000			1/2" Ice	2.320	1.946	0.074
			0.000			1" Ice	2.512	2.127	0.098
(2) PD2DE-700/2700	A	From Leg	4.000	0.000	130.000	No Ice	0.114	0.114	0.001
			0.000			1/2" Ice	0.179	0.179	0.002
			0.000			1" Ice	0.250	0.250	0.004
6' x 2" Mount Pipe	A	From Leg	4.000	0.000	130.000	No Ice	1.425	1.425	0.022
			0.000			1/2" Ice	1.925	1.925	0.033
			0.000			1" Ice	2.294	2.294	0.048
(2) 6' x 2" Mount Pipe	A	From Leg	4.000	0.000	130.000	No Ice	0.000	1.425	0.022
			0.000			1/2" Ice	0.000	1.925	0.033
			0.000			1" Ice	0.000	2.294	0.048
(3) 6' x 2" Mount Pipe	B	From Leg	4.000	0.000	130.000	No Ice	1.425	1.425	0.022
			0.000			1/2" Ice	1.925	1.925	0.033
			0.000			1" Ice	2.294	2.294	0.048
(2) 6' x 2" Mount Pipe	C	From Leg	4.000	0.000	130.000	No Ice	1.425	1.425	0.022
			0.000			1/2" Ice	1.925	1.925	0.033
			0.000			1" Ice	2.294	2.294	0.048
3' x 2" Pipe Mount	A	From Leg	4.000	0.000	130.000	No Ice	0.000	0.583	0.011
			0.000			1/2" Ice	0.000	0.770	0.017
			-1.000			1" Ice	0.000	0.967	0.024
3' x 2" Pipe Mount	B	From Leg	4.000	0.000	130.000	No Ice	0.000	0.583	0.011
			0.000			1/2" Ice	0.000	0.770	0.017
			-1.000			1" Ice	0.000	0.967	0.024
3' x 2" Pipe Mount	C	From Leg	4.000	0.000	130.000	No Ice	0.000	0.583	0.011
			0.000			1/2" Ice	0.000	0.770	0.017
			-1.000			1" Ice	0.000	0.967	0.024
(2) 5' x 2" Pipe Mount	A	From Leg	4.000	0.000	130.000	No Ice	1.188	1.188	0.018
			0.000			1/2" Ice	1.496	1.496	0.027
			0.000			1" Ice	1.807	1.807	0.040
5' x 2" Pipe Mount	B	From Leg	4.000	0.000	130.000	No Ice	1.188	1.188	0.018
			0.000			1/2" Ice	1.496	1.496	0.027
			0.000			1" Ice	1.807	1.807	0.040
5' x 2" Pipe Mount	C	From Leg	4.000	0.000	130.000	No Ice	1.188	1.188	0.018
			0.000			1/2" Ice	1.496	1.496	0.027
			0.000			1" Ice	1.807	1.807	0.040
Pipe Mount [PM 601-3]	C	None		0.000	130.000	No Ice	3.170	3.170	0.195
						1/2" Ice	3.790	3.790	0.232
						1" Ice	4.420	4.420	0.279
Platform Mount [LP 602-1]	C	None		0.000	130.000	No Ice	31.070	31.070	1.343
						1/2" Ice	34.820	34.820	1.967
						1" Ice	38.480	38.480	2.669
*									
MX08FRO665-21 w/ Mount Pipe	A	From Leg	4.000	0.000	120.000	No Ice	8.010	4.230	0.108
			0.000			1/2" Ice	8.520	4.690	0.194
			0.000			1" Ice	9.040	5.160	0.292

<b>tnxTower</b>  <b>B+T Group</b> 1717 S. Boulder, Suite 300 Tulsa, OK 74119 Phone: (918) 587-4630 FAX: (918) 295-0265	<b>Job</b>	<b>Page</b>	
		79982.013.01 - WATERBURY,CT (BU# 876317)	62 of 94
	<b>Project</b>		<b>Date</b>
		15:43:49 05/20/22	
<b>Client</b>	Crown Castle	<b>Designed by</b>	
		Jayaraj B	

Description	Face or Leg	Offset Type	Offsets:		Azimuth Adjustment	Placement	C <sub>AA</sub> Front	C <sub>AA</sub> Side	Weight	
			Horz	Lateral						
			ft	ft	°	ft	ft <sup>2</sup>	ft <sup>2</sup>	K	
MX08FRO665-21 w/ Mount Pipe	B	From Leg	4.000	0.000	0.000	120.000	No Ice	8.010	4.230	0.108
			0.000	0.000			1/2" Ice	8.520	4.690	0.194
			0.000	0.000			1" Ice	9.040	5.160	0.292
MX08FRO665-21 w/ Mount Pipe	C	From Leg	4.000	0.000	0.000	120.000	No Ice	8.010	4.230	0.108
			0.000	0.000			1/2" Ice	8.520	4.690	0.194
			0.000	0.000			1" Ice	9.040	5.160	0.292
TA08025-B604	A	From Leg	4.000	0.000	0.000	120.000	No Ice	1.964	0.981	0.064
			0.000	0.000			1/2" Ice	2.138	1.112	0.081
			0.000	0.000			1" Ice	2.320	1.250	0.100
TA08025-B604	B	From Leg	4.000	0.000	0.000	120.000	No Ice	1.964	0.981	0.064
			0.000	0.000			1/2" Ice	2.138	1.112	0.081
			0.000	0.000			1" Ice	2.320	1.250	0.100
TA08025-B604	C	From Leg	4.000	0.000	0.000	120.000	No Ice	1.964	0.981	0.064
			0.000	0.000			1/2" Ice	2.138	1.112	0.081
			0.000	0.000			1" Ice	2.320	1.250	0.100
TA08025-B605	A	From Leg	4.000	0.000	0.000	120.000	No Ice	1.964	1.129	0.075
			0.000	0.000			1/2" Ice	2.138	1.267	0.093
			0.000	0.000			1" Ice	2.320	1.411	0.114
TA08025-B605	B	From Leg	4.000	0.000	0.000	120.000	No Ice	1.964	1.129	0.075
			0.000	0.000			1/2" Ice	2.138	1.267	0.093
			0.000	0.000			1" Ice	2.320	1.411	0.114
TA08025-B605	C	From Leg	4.000	0.000	0.000	120.000	No Ice	1.964	1.129	0.075
			0.000	0.000			1/2" Ice	2.138	1.267	0.093
			0.000	0.000			1" Ice	2.320	1.411	0.114
RDIDC-9181-PF-48	A	From Leg	4.000	0.000	0.000	120.000	No Ice	2.012	1.168	0.022
			0.000	0.000			1/2" Ice	2.189	1.311	0.040
			0.000	0.000			1" Ice	2.373	1.461	0.060
(2) 8' x 2" Mount Pipe	A	From Leg	4.000	0.000	0.000	120.000	No Ice	1.900	1.900	0.029
			0.000	0.000			1/2" Ice	2.728	2.728	0.044
			0.000	0.000			1" Ice	3.401	3.401	0.063
(2) 8' x 2" Mount Pipe	B	From Leg	4.000	0.000	0.000	120.000	No Ice	1.900	1.900	0.029
			0.000	0.000			1/2" Ice	2.728	2.728	0.044
			0.000	0.000			1" Ice	3.401	3.401	0.063
(2) 8' x 2" Mount Pipe	C	From Leg	4.000	0.000	0.000	120.000	No Ice	1.900	1.900	0.029
			0.000	0.000			1/2" Ice	2.728	2.728	0.044
			0.000	0.000			1" Ice	3.401	3.401	0.063
Commscope MC-PK8-DSH	C	None		0.000	0.000	120.000	No Ice	34.240	34.240	1.749
							1/2" Ice	62.950	62.950	2.099
							1" Ice	91.660	91.660	2.450
*										
SBNHH-1D65B w/ Mount Pipe	A	From Leg	4.000	0.000	0.000	110.000	No Ice	4.090	3.300	0.066
			0.000	0.000			1/2" Ice	4.490	3.680	0.130
			0.000	0.000			1" Ice	4.890	4.070	0.204
SBNHH-1D65B w/ Mount Pipe	B	From Leg	4.000	0.000	0.000	110.000	No Ice	4.090	3.300	0.066
			0.000	0.000			1/2" Ice	4.490	3.680	0.130
			0.000	0.000			1" Ice	4.890	4.070	0.204
SBNHH-1D65B w/ Mount Pipe	C	From Leg	4.000	0.000	0.000	110.000	No Ice	4.090	3.300	0.066
			0.000	0.000			1/2" Ice	4.490	3.680	0.130
			0.000	0.000			1" Ice	4.890	4.070	0.204
SBNHH-1D65B	A	From Leg	4.000	0.000	0.000	110.000	No Ice	4.160	2.490	0.041
			0.000	0.000			1/2" Ice	4.570	2.880	0.091
			0.000	0.000			1" Ice	4.990	3.270	0.148
SBNHH-1D65B	B	From Leg	4.000	0.000	0.000	110.000	No Ice	4.160	2.490	0.041
			0.000	0.000			1/2" Ice	4.570	2.880	0.091
			0.000	0.000			1" Ice	4.990	3.270	0.148
SBNHH-1D65B	C	From Leg	4.000	0.000	0.000	110.000	No Ice	4.160	2.490	0.041
			0.000	0.000			1/2" Ice	4.570	2.880	0.091
			0.000	0.000			1" Ice	4.990	3.270	0.148

<b>tnxTower</b>  <b>B+T Group</b> 1717 S. Boulder, Suite 300 Tulsa, OK 74119 Phone: (918) 587-4630 FAX: (918) 295-0265	<b>Job</b>		79982.013.01 - WATERBURY,CT (BU# 876317)		<b>Page</b>		63 of 94	
	<b>Project</b>				<b>Date</b>		15:43:49 05/20/22	
	<b>Client</b>		Crown Castle		<b>Designed by</b>		Jayaraj B	

Description	Face or Leg	Offset Type	Offsets:		Azimuth Adjustment	Placement	C <sub>AA</sub> Front	C <sub>AA</sub> Side	Weight	
			Horz	Lateral						Vert
			ft	ft			ft <sup>2</sup>	ft <sup>2</sup>	K	
BXA-80063/4CF w/ Mount Pipe	A	From Leg	0.000		0.000	110.000	1" Ice	4.990	3.270	0.148
			4.000				No Ice	4.830	3.650	0.028
			0.000				1/2" Ice	5.350	4.140	0.065
			0.000				1" Ice	5.880	4.640	0.109
BXA-80063/4CF w/ Mount Pipe	B	From Leg	4.000		0.000	110.000	No Ice	4.830	3.650	0.028
			0.000				1/2" Ice	5.350	4.140	0.065
			0.000				1" Ice	5.880	4.640	0.109
			0.000				No Ice	4.830	3.650	0.028
BXA-80063/4CF w/ Mount Pipe	C	From Leg	0.000		0.000	110.000	1/2" Ice	5.350	4.140	0.065
			0.000				1" Ice	5.880	4.640	0.109
			4.000				No Ice	4.830	3.650	0.028
			0.000				1/2" Ice	5.350	4.140	0.065
BULLET III	C	From Leg	0.000		0.000	110.000	1" Ice	5.880	4.640	0.109
			4.000				No Ice	0.066	0.066	0.000
			0.000				1/2" Ice	0.101	0.101	0.002
			3.000				1" Ice	0.144	0.144	0.003
RFV01U-D1A	A	From Leg	4.000		0.000	110.000	No Ice	1.875	1.250	0.084
			0.000				1/2" Ice	2.045	1.393	0.103
			0.000				1" Ice	2.223	1.543	0.124
			4.000				No Ice	1.875	1.250	0.084
RFV01U-D1A	B	From Leg	0.000		0.000	110.000	1/2" Ice	2.045	1.393	0.103
			0.000				1" Ice	2.223	1.543	0.124
			4.000				No Ice	1.875	1.250	0.084
			0.000				1/2" Ice	2.045	1.393	0.103
RFV01U-D1A	C	From Leg	0.000		0.000	110.000	1" Ice	2.223	1.543	0.124
			4.000				No Ice	1.875	1.250	0.084
			0.000				1/2" Ice	2.045	1.393	0.103
			0.000				1" Ice	2.223	1.543	0.124
RFV01U-D2A	A	From Leg	4.000		0.000	110.000	No Ice	1.875	1.013	0.070
			0.000				1/2" Ice	2.045	1.145	0.087
			0.000				1" Ice	2.223	1.284	0.106
			4.000				No Ice	1.875	1.013	0.070
RFV01U-D2A	B	From Leg	0.000		0.000	110.000	1/2" Ice	2.045	1.145	0.087
			0.000				1" Ice	2.223	1.284	0.106
			4.000				No Ice	1.875	1.013	0.070
			0.000				1/2" Ice	2.045	1.145	0.087
RFV01U-D2A	C	From Leg	0.000		0.000	110.000	1" Ice	2.223	1.284	0.106
			4.000				No Ice	1.875	1.013	0.070
			0.000				1/2" Ice	2.045	1.145	0.087
			0.000				1" Ice	2.223	1.284	0.106
RVZDC-6627-PF-48	C	From Leg	4.000		0.000	110.000	No Ice	3.792	2.514	0.032
			0.000				1/2" Ice	4.044	2.727	0.063
			0.000				1" Ice	4.303	2.947	0.099
			4.000				No Ice	4.907	2.682	0.096
MT6407-77A w/ Mount Pipe	A	From Leg	0.000		0.000	110.000	1/2" Ice	5.256	3.145	0.136
			0.000				1" Ice	5.615	3.624	0.180
			4.000				No Ice	4.907	2.682	0.096
			0.000				1/2" Ice	5.256	3.145	0.136
MT6407-77A w/ Mount Pipe	B	From Leg	0.000		0.000	110.000	1" Ice	5.615	3.624	0.180
			4.000				No Ice	4.907	2.682	0.096
			0.000				1/2" Ice	5.256	3.145	0.136
			0.000				1" Ice	5.615	3.624	0.180
MT6407-77A w/ Mount Pipe	C	From Leg	4.000		0.000	110.000	No Ice	4.907	2.682	0.096
			0.000				1/2" Ice	5.256	3.145	0.136
			0.000				1" Ice	5.615	3.624	0.180
			4.000				No Ice	0.583	0.583	0.011
(3) 3' x 2" Pipe Mount	A	From Leg	0.000		0.000	110.000	1/2" Ice	0.770	0.770	0.017
			0.000				1" Ice	0.967	0.967	0.024
			4.000				No Ice	0.583	0.583	0.011
			0.000				1/2" Ice	0.770	0.770	0.017
(3) 3' x 2" Pipe Mount	B	From Leg	0.000		0.000	110.000	1" Ice	0.967	0.967	0.024
			4.000				No Ice	0.583	0.583	0.011
			0.000				1/2" Ice	0.770	0.770	0.017
			0.000				1" Ice	0.967	0.967	0.024
(2) 3' x 2" Pipe Mount	C	From Leg	4.000		0.000	110.000	No Ice	0.583	0.583	0.011
			0.000				1/2" Ice	0.770	0.770	0.017
			0.000				1" Ice	0.967	0.967	0.024
			4.000				No Ice	1.425	1.425	0.022
6' x 2" Mount Pipe	A	From Leg	0.000		0.000	110.000	1/2" Ice	1.925	1.925	0.033
			0.000				1" Ice	2.294	2.294	0.048
			4.000				No Ice	1.425	1.425	0.022
			0.000				1/2" Ice	1.925	1.925	0.033
6' x 2" Mount Pipe	B	From Leg	4.000		0.000	110.000	No Ice	1.425	1.425	0.022
			0.000				1/2" Ice	1.925	1.925	0.033
			0.000				1" Ice	2.294	2.294	0.048
			4.000				No Ice	1.425	1.425	0.022

<b>tnxTower</b>  <b>B+T Group</b> 1717 S. Boulder, Suite 300 Tulsa, OK 74119 Phone: (918) 587-4630 FAX: (918) 295-0265	<b>Job</b>		79982.013.01 - WATERBURY,CT (BU# 876317)		<b>Page</b>		64 of 94	
	<b>Project</b>				<b>Date</b>		15:43:49 05/20/22	
	<b>Client</b>		Crown Castle		<b>Designed by</b>		Jayaraj B	

Description	Face or Leg	Offset Type	Offsets:		Azimuth Adjustment	Placement	C <sub>AA</sub>		Weight	
			Horz	Lateral			Front	Side		
			ft	ft	°	ft	ft <sup>2</sup>	ft <sup>2</sup>	K	
(2) 6' x 2" Mount Pipe	C	From Leg	0.000		0.000	110.000	1" Ice	2.294	2.294	0.048
			4.000				No Ice	1.425	1.425	0.022
			0.000				1/2" Ice	1.925	1.925	0.033
			0.000				1" Ice	2.294	2.294	0.048
Side Arm Mount [SO 102-3]	C	None			0.000	110.000	No Ice	0.000	0.000	0.075
							1/2" Ice	0.000	0.000	0.105
							1" Ice	0.000	0.000	0.135
							No Ice	28.630	28.630	0.280
Mount Reinforcement Specifications	C	None			0.000	110.000	1/2" Ice	37.310	37.310	0.670
							1" Ice	45.800	45.800	0.940
Platform Mount [LP 713-1]	C	None			0.000	110.000	No Ice	32.890	32.890	1.510
							1/2" Ice	35.760	35.760	2.228
							1" Ice	38.760	38.760	3.026
*										
AIR -32 B2A/B66AA w/ Mount Pipe	A	From Leg	4.000		0.000	100.000	No Ice	3.760	3.150	0.194
			0.000				1/2" Ice	4.120	3.490	0.252
			1.000				1" Ice	4.480	3.840	0.320
AIR -32 B2A/B66AA w/ Mount Pipe	B	From Leg	4.000		0.000	100.000	No Ice	3.760	3.150	0.194
			0.000				1/2" Ice	4.120	3.490	0.252
			1.000				1" Ice	4.480	3.840	0.320
AIR -32 B2A/B66AA w/ Mount Pipe	C	From Leg	4.000		0.000	100.000	No Ice	3.760	3.150	0.194
			0.000				1/2" Ice	4.120	3.490	0.252
			1.000				1" Ice	4.480	3.840	0.320
APXVAARR24_43-U-NA20 w/ Mount Pipe	A	From Leg	4.000		0.000	100.000	No Ice	14.690	6.870	0.186
			0.000				1/2" Ice	15.460	7.550	0.315
			1.000				1" Ice	16.230	8.250	0.458
APXVAARR24_43-U-NA20 w/ Mount Pipe	B	From Leg	4.000		0.000	100.000	No Ice	14.690	6.870	0.186
			0.000				1/2" Ice	15.460	7.550	0.315
			1.000				1" Ice	16.230	8.250	0.458
APXVAARR24_43-U-NA20 w/ Mount Pipe	C	From Leg	4.000		0.000	100.000	No Ice	14.690	6.870	0.186
			0.000				1/2" Ice	15.460	7.550	0.315
			1.000				1" Ice	16.230	8.250	0.458
AIR 6419 B41_TMO w/ Mount Pipe	A	From Leg	4.000		0.000	100.000	No Ice	6.580	3.500	0.111
			0.000				1/2" Ice	7.060	3.900	0.162
			1.000				1" Ice	7.570	4.320	0.220
AIR 6419 B41_TMO w/ Mount Pipe	B	From Leg	4.000		0.000	100.000	No Ice	6.580	3.500	0.111
			0.000				1/2" Ice	7.060	3.900	0.162
			1.000				1" Ice	7.570	4.320	0.220
AIR 6419 B41_TMO w/ Mount Pipe	C	From Leg	4.000		0.000	100.000	No Ice	6.580	3.500	0.111
			0.000				1/2" Ice	7.060	3.900	0.162
			1.000				1" Ice	7.570	4.320	0.220
RADIO 4449 B71 B85A_T-MOBILE	A	From Leg	4.000		0.000	100.000	No Ice	1.970	1.587	0.073
			0.000				1/2" Ice	2.147	1.749	0.093
			1.000				1" Ice	2.331	1.918	0.116
RADIO 4449 B71 B85A_T-MOBILE	B	From Leg	4.000		0.000	100.000	No Ice	1.970	1.587	0.073
			0.000				1/2" Ice	2.147	1.749	0.093
			1.000				1" Ice	2.331	1.918	0.116
RADIO 4449 B71 B85A_T-MOBILE	C	From Leg	4.000		0.000	100.000	No Ice	1.970	1.587	0.073
			0.000				1/2" Ice	2.147	1.749	0.093
			1.000				1" Ice	2.331	1.918	0.116
RADIO 4460 B2/B25 B66_TMO	A	From Leg	4.000		0.000	100.000	No Ice	2.139	1.686	0.109
			0.000				1/2" Ice	2.321	1.850	0.131
			1.000				1" Ice	2.511	2.022	0.156
RADIO 4460 B2/B25 B66_TMO	B	From Leg	4.000		0.000	100.000	No Ice	2.139	1.686	0.109
			0.000				1/2" Ice	2.321	1.850	0.131
			1.000				1" Ice	2.511	2.022	0.156
RADIO 4460 B2/B25	C	From Leg	4.000		0.000	100.000	No Ice	2.139	1.686	0.109

<b>tnxTower</b>  <b>B+T Group</b> 1717 S. Boulder, Suite 300 Tulsa, OK 74119 Phone: (918) 587-4630 FAX: (918) 295-0265	<b>Job</b> 79982.013.01 - WATERBURY,CT (BU# 876317)	<b>Page</b> 65 of 94
	<b>Project</b>	<b>Date</b> 15:43:49 05/20/22
	<b>Client</b> Crown Castle	<b>Designed by</b> Jayaraj B

Description	Face or Leg	Offset Type	Offsets: Horz Lateral Vert	Azimuth Adjustment	Placement	C <sub>AA</sub> Front	C <sub>AA</sub> Side	Weight
			ft	°	ft	ft <sup>2</sup>	ft <sup>2</sup>	K
B66_TMO			0.000			1/2" Ice 2.321	1.850	0.131
			1.000			1" Ice 2.511	2.022	0.156
Platform Mount [LP 303-1_HR-1]	C	None		0.000	100.000	No Ice 17.090	17.090	1.495
						1/2" Ice 21.470	21.470	1.881
						1" Ice 25.720	25.720	2.346
* KS24019-L112A	C	From Leg	4.000	0.000	50.000	No Ice 0.141	0.141	0.005
			0.000			1/2" Ice 0.198	0.198	0.007
			1.000			1" Ice 0.262	0.262	0.009
Side Arm Mount [SO 701-1]	C	From Leg	2.000	0.000	50.000	No Ice 0.850	1.670	0.065
			0.000			1/2" Ice 1.140	2.340	0.079
			0.000			1" Ice 1.430	3.010	0.093
* * * *								

## Dishes

Description	Face or Leg	Dish Type	Offset Type	Offsets: Horz Lateral Vert	Azimuth Adjustment	3 dB Beam Width	Elevation	Outside Diameter	Aperture Area	Weight
				ft	°	°	ft	ft	ft <sup>2</sup>	K
VHLP2-23	A	Paraboloid w/Shroud (HP)	From Leg	4.000	0.000		130.000	2.175	No Ice 3.715	0.031
				0.000					1/2" Ice 4.006	0.052
				3.000					1" Ice 4.296	0.072
VHLP2-23	B	Paraboloid w/Shroud (HP)	From Leg	4.000	-50.000		130.000	2.175	No Ice 3.715	0.031
				0.000					1/2" Ice 4.006	0.052
				3.000					1" Ice 4.296	0.072
VHLP2-18	C	Paraboloid w/Shroud (HP)	From Leg	4.000	-60.000		130.000	2.175	No Ice 3.715	0.031
				0.000					1/2" Ice 4.006	0.052
				3.000					1" Ice 4.296	0.072
* * *										

## Load Combinations

Comb. No.	Description
1	Dead Only
2	1.2 Dead+1.0 Wind 0 deg - No Ice
3	0.9 Dead+1.0 Wind 0 deg - No Ice
4	1.2 Dead+1.0 Wind 30 deg - No Ice
5	0.9 Dead+1.0 Wind 30 deg - No Ice
6	1.2 Dead+1.0 Wind 60 deg - No Ice
7	0.9 Dead+1.0 Wind 60 deg - No Ice

<b>tnxTower</b>  <b>B+T Group</b> 1717 S. Boulder, Suite 300 Tulsa, OK 74119 Phone: (918) 587-4630 FAX: (918) 295-0265	<b>Job</b> 79982.013.01 - WATERBURY,CT (BU# 876317)	<b>Page</b> 66 of 94
	<b>Project</b>	<b>Date</b> 15:43:49 05/20/22
	<b>Client</b> Crown Castle	<b>Designed by</b> Jayaraj B

Comb. No.	Description
8	1.2 Dead+1.0 Wind 90 deg - No Ice
9	0.9 Dead+1.0 Wind 90 deg - No Ice
10	1.2 Dead+1.0 Wind 120 deg - No Ice
11	0.9 Dead+1.0 Wind 120 deg - No Ice
12	1.2 Dead+1.0 Wind 150 deg - No Ice
13	0.9 Dead+1.0 Wind 150 deg - No Ice
14	1.2 Dead+1.0 Wind 180 deg - No Ice
15	0.9 Dead+1.0 Wind 180 deg - No Ice
16	1.2 Dead+1.0 Wind 210 deg - No Ice
17	0.9 Dead+1.0 Wind 210 deg - No Ice
18	1.2 Dead+1.0 Wind 240 deg - No Ice
19	0.9 Dead+1.0 Wind 240 deg - No Ice
20	1.2 Dead+1.0 Wind 270 deg - No Ice
21	0.9 Dead+1.0 Wind 270 deg - No Ice
22	1.2 Dead+1.0 Wind 300 deg - No Ice
23	0.9 Dead+1.0 Wind 300 deg - No Ice
24	1.2 Dead+1.0 Wind 330 deg - No Ice
25	0.9 Dead+1.0 Wind 330 deg - No Ice
26	1.2 Dead+1.0 Ice+1.0 Temp
27	1.2 Dead+1.0 Wind 0 deg+1.0 Ice+1.0 Temp
28	1.2 Dead+1.0 Wind 30 deg+1.0 Ice+1.0 Temp
29	1.2 Dead+1.0 Wind 60 deg+1.0 Ice+1.0 Temp
30	1.2 Dead+1.0 Wind 90 deg+1.0 Ice+1.0 Temp
31	1.2 Dead+1.0 Wind 120 deg+1.0 Ice+1.0 Temp
32	1.2 Dead+1.0 Wind 150 deg+1.0 Ice+1.0 Temp
33	1.2 Dead+1.0 Wind 180 deg+1.0 Ice+1.0 Temp
34	1.2 Dead+1.0 Wind 210 deg+1.0 Ice+1.0 Temp
35	1.2 Dead+1.0 Wind 240 deg+1.0 Ice+1.0 Temp
36	1.2 Dead+1.0 Wind 270 deg+1.0 Ice+1.0 Temp
37	1.2 Dead+1.0 Wind 300 deg+1.0 Ice+1.0 Temp
38	1.2 Dead+1.0 Wind 330 deg+1.0 Ice+1.0 Temp
39	Dead+Wind 0 deg - Service
40	Dead+Wind 30 deg - Service
41	Dead+Wind 60 deg - Service
42	Dead+Wind 90 deg - Service
43	Dead+Wind 120 deg - Service
44	Dead+Wind 150 deg - Service
45	Dead+Wind 180 deg - Service
46	Dead+Wind 210 deg - Service
47	Dead+Wind 240 deg - Service
48	Dead+Wind 270 deg - Service
49	Dead+Wind 300 deg - Service
50	Dead+Wind 330 deg - Service

### Maximum Member Forces

Section No.	Elevation ft	Component Type	Condition	Gov. Load Comb.	Axial K	Major Axis Moment kip-ft	Minor Axis Moment kip-ft
L1	144.25 - 139.25	Pole	Max Tension	21	0.000	-0.000	0.000
			Max. Compression	26	-10.802	-0.290	-0.054
			Max. Mx	8	-5.162	-26.842	0.173
			Max. My	14	-5.140	0.150	-27.041
			Max. Vy	8	6.571	-26.842	0.173
			Max. Vx	2	-6.642	-0.108	27.038
			Max. Torque	17			0.613
L2	139.25 - 134.75	Pole	Max Tension	1	0.000	0.000	0.000

<b>tnxTower</b>  <b>B+T Group</b> 1717 S. Boulder, Suite 300 Tulsa, OK 74119 Phone: (918) 587-4630 FAX: (918) 295-0265	<b>Job</b>	79982.013.01 - WATERBURY,CT (BU# 876317)	<b>Page</b>	67 of 94
	<b>Project</b>		<b>Date</b>	15:43:49 05/20/22
	<b>Client</b>	Crown Castle	<b>Designed by</b>	Jayaraj B

Section No.	Elevation ft	Component Type	Condition	Gov. Load Comb.	Axial K	Major Axis Moment kip-ft	Minor Axis Moment kip-ft
L3	134.75 - 134.25	Pole	Max. Compression	26	-11.224	-0.377	0.005
			Max. Mx	8	-5.456	-56.730	0.336
			Max. My	2	-5.425	-0.293	57.296
			Max. Vy	8	6.708	-56.730	0.336
			Max. Vx	2	-6.804	-0.293	57.296
			Max. Torque	17			0.613
			Max Tension	1	0.000	0.000	0.000
			Max. Compression	26	-11.273	-0.387	0.012
			Max. Mx	8	-5.493	-60.088	0.354
			Max. My	2	-5.461	-0.314	60.702
L4	134.25 - 129.25	Pole	Max. Vy	8	6.722	-60.088	0.354
			Max. Vx	2	-6.820	-0.314	60.702
			Max. Torque	17			0.613
			Max Tension	1	0.000	0.000	0.000
			Max. Compression	26	-18.809	-2.435	1.901
			Max. Mx	8	-9.153	-99.411	1.424
			Max. My	2	-9.099	-1.779	100.653
			Max. Vy	20	-11.106	96.968	0.355
			Max. Vx	2	-11.262	-1.779	100.653
			Max. Torque	15			1.214
L5	129.25 - 124.25	Pole	Max Tension	1	0.000	0.000	0.000
			Max. Compression	26	-19.255	-2.572	1.996
			Max. Mx	8	-9.500	-155.104	1.536
			Max. My	2	-9.446	-2.007	157.349
			Max. Vy	20	-11.250	152.790	0.246
			Max. Vx	2	-11.432	-2.007	157.349
			Max. Torque	15			1.214
			Max Tension	1	0.000	0.000	0.000
			Max. Compression	26	-19.342	-2.593	2.010
			Max. Mx	8	-9.564	-164.461	1.554
L6	124.25 - 123.416	Pole	Max. My	2	-9.511	-2.043	166.885
			Max. Vy	20	-11.275	162.170	0.228
			Max. Vx	2	-11.456	-2.043	166.885
			Max. Torque	15			1.212
			Max Tension	1	0.000	0.000	0.000
			Max. Compression	26	-19.382	-2.600	2.015
			Max. Mx	8	-9.603	-167.271	1.560
			Max. My	2	-9.550	-2.055	169.748
			Max. Vy	20	-11.280	164.987	0.222
			Max. Vx	2	-11.460	-2.055	169.748
L7	123.416 - 123.166	Pole	Max. Torque	15			1.212
			Max Tension	1	0.000	0.000	0.000
			Max. Compression	26	-25.070	-2.728	2.397
			Max. Mx	8	-13.045	-229.289	1.771
			Max. My	2	-12.985	-2.277	233.000
			Max. Vy	20	-14.338	227.138	0.214
			Max. Vx	2	-14.545	-2.277	233.000
			Max. Torque	15			1.212
			Max Tension	1	0.000	0.000	0.000
			Max. Compression	26	-25.900	-2.861	2.486
L8	123.166 - 118.166	Pole	Max. Mx	8	-13.661	-301.397	1.882
			Max. My	2	-13.604	-2.503	306.295
			Max. Vy	20	-14.585	299.380	0.101
			Max. Vx	2	-14.787	-2.503	306.295
			Max. Compression	26	-25.070	-2.728	2.397
			Max. Mx	8	-13.045	-229.289	1.771
			Max. My	2	-12.985	-2.277	233.000
			Max. Vy	20	-14.338	227.138	0.214
			Max. Vx	2	-14.545	-2.277	233.000
			Max. Torque	15			1.212
L9	118.166 - 113.166	Pole	Max Tension	1	0.000	0.000	0.000
			Max. Compression	26	-25.900	-2.861	2.486
			Max. Mx	8	-13.661	-301.397	1.882
			Max. My	2	-13.604	-2.503	306.295
			Max. Vy	20	-14.585	299.380	0.101
			Max. Vx	2	-14.787	-2.503	306.295
			Max. Compression	26	-25.900	-2.861	2.486
			Max. Mx	8	-13.661	-301.397	1.882
			Max. My	2	-13.604	-2.503	306.295
			Max. Vy	20	-14.585	299.380	0.101

<b>tnxTower</b>  <b>B+T Group</b> 1717 S. Boulder, Suite 300 Tulsa, OK 74119 Phone: (918) 587-4630 FAX: (918) 295-0265	<b>Job</b>	79982.013.01 - WATERBURY,CT (BU# 876317)	<b>Page</b>	68 of 94
	<b>Project</b>		<b>Date</b>	15:43:49 05/20/22
	<b>Client</b>	Crown Castle	<b>Designed by</b>	Jayaraj B

Section No.	Elevation ft	Component Type	Condition	Gov. Load Comb.	Axial K	Major Axis Moment kip-ft	Minor Axis Moment kip-ft
L10	113.166 - 109.5	Pole	Max. Torque	15			1.211
			Max Tension	1	0.000	0.000	0.000
			Max. Compression	26	-34.219	-2.413	2.245
			Max. Mx	8	-17.501	-357.093	1.872
			Max. My	2	-17.441	-2.508	362.912
			Max. Vy	20	-19.268	355.600	-0.087
			Max. Vx	2	-19.446	-2.508	362.912
L11	109.5 - 109.25	Pole	Max. Torque	15			1.210
			Max Tension	1	0.000	0.000	0.000
			Max. Compression	26	-34.273	-2.420	2.252
			Max. Mx	8	-17.559	-361.900	1.882
			Max. My	2	-17.499	-2.524	367.772
			Max. Vy	20	-19.270	360.414	-0.097
			Max. Vx	2	-19.445	-2.524	367.772
L12	109.25 - 104.75	Pole	Max. Torque	15			0.824
			Max Tension	1	0.000	0.000	0.000
			Max. Compression	26	-35.274	-2.528	2.350
			Max. Mx	8	-18.304	-449.013	2.054
			Max. My	2	-18.250	-2.801	455.773
			Max. Vy	20	-19.529	447.647	-0.271
			Max. Vx	2	-19.680	-2.801	455.773
L13	104.75 - 104.5	Pole	Max. Torque	15			0.824
			Max Tension	1	0.000	0.000	0.000
			Max. Compression	26	-35.347	-2.535	2.355
			Max. Mx	8	-18.371	-453.886	2.064
			Max. My	2	-18.317	-2.817	460.692
			Max. Vy	20	-19.539	452.527	-0.280
			Max. Vx	2	-19.686	-2.817	460.692
L14	104.5 - 102.416	Pole	Max. Torque	15			0.823
			Max Tension	1	0.000	0.000	0.000
			Max. Compression	26	-35.948	-2.584	2.390
			Max. Mx	8	-18.804	-494.724	2.144
			Max. My	2	-18.754	-2.945	501.867
			Max. Vy	20	-19.730	493.421	-0.360
			Max. Vx	2	-19.839	-2.945	501.867
L15	102.416 - 102.166	Pole	Max. Torque	15			0.823
			Max Tension	1	0.000	0.000	0.000
			Max. Compression	26	-36.017	-2.591	2.395
			Max. Mx	8	-18.863	-499.648	2.153
			Max. My	2	-18.814	-2.960	506.827
			Max. Vy	20	-19.743	498.352	-0.370
			Max. Vx	2	-19.847	-2.960	506.827
L16	102.166 - 98.75	Pole	Max. Torque	15			0.823
			Max Tension	1	0.000	0.000	0.000
			Max. Compression	26	-43.670	-2.676	2.431
			Max. Mx	8	-23.502	-572.804	2.282
			Max. My	2	-23.450	-3.171	580.459
			Max. Vy	20	-22.845	571.599	-0.504
			Max. Vx	2	-22.955	-3.171	580.459
L17	98.75 - 98.5	Pole	Max. Torque	15			0.823
			Max Tension	1	0.000	0.000	0.000
			Max. Compression	26	-43.756	-2.684	2.433
			Max. Mx	8	-23.586	-578.505	2.292
			Max. My	2	-23.533	-3.188	586.195
			Max. Vy	20	-22.845	577.305	-0.514
			Max. Vx	2	-22.960	-3.188	586.195

<b>tnxTower</b>  <b>B+T Group</b> 1717 S. Boulder, Suite 300 Tulsa, OK 74119 Phone: (918) 587-4630 FAX: (918) 295-0265	<b>Job</b>	79982.013.01 - WATERBURY,CT (BU# 876317)	<b>Page</b>	69 of 94
	<b>Project</b>		<b>Date</b>	15:43:49 05/20/22
	<b>Client</b>	Crown Castle		<b>Designed by</b>

Section No.	Elevation ft	Component Type	Condition	Gov. Load Comb.	Axial K	Major Axis Moment kip-ft	Minor Axis Moment kip-ft
L18	98.5 - 97.5	Pole	Max. Torque	15			0.823
			Max Tension	1	0.000	0.000	0.000
			Max. Compression	26	-44.099	-2.710	2.437
			Max. Mx	8	-23.839	-601.346	2.329
			Max. My	2	-23.785	-3.250	609.197
			Max. Vy	20	-22.919	600.173	-0.555
			Max. Vx	2	-23.058	-3.250	609.197
L19	97.5 - 97.25	Pole	Max. Torque	15			0.824
			Max Tension	1	0.000	0.000	0.000
			Max. Compression	26	-44.182	-2.718	2.439
			Max. Mx	8	-23.912	-607.066	2.339
			Max. My	2	-23.857	-3.266	614.962
			Max. Vy	20	-22.926	605.900	-0.565
			Max. Vx	2	-23.071	-3.266	614.962
L20	97.25 - 92	Pole	Max. Torque	15			0.824
			Max Tension	1	0.000	0.000	0.000
			Max. Compression	26	-44.738	-2.772	2.448
			Max. Mx	8	-24.325	-646.018	2.403
			Max. My	2	-24.266	-3.372	654.251
			Max. Vy	20	-23.047	644.896	-0.633
			Max. Vx	2	-23.234	-3.372	654.251
L21	92 - 90.552	Pole	Max. Torque	15			0.827
			Max Tension	1	0.000	0.000	0.000
			Max. Compression	26	-47.292	-2.935	2.476
			Max. Mx	8	-26.375	-762.126	2.590
			Max. My	2	-26.305	-3.685	771.776
			Max. Vy	20	-23.470	761.136	-0.835
			Max. Vx	2	-23.783	-3.685	771.776
L22	90.552 - 89.25	Pole	Max. Torque	15			0.836
			Max Tension	1	0.000	0.000	0.000
			Max. Compression	26	-47.749	-2.972	2.482
			Max. Mx	8	-26.737	-792.660	2.639
			Max. My	2	-26.668	-3.767	802.767
			Max. Vy	20	-23.542	791.704	-0.888
			Max. Vx	2	-23.865	-3.767	802.767
L23	89.25 - 89	Pole	Max. Torque	15			0.836
			Max Tension	1	0.000	0.000	0.000
			Max. Compression	26	-47.848	-2.980	2.484
			Max. Mx	8	-26.832	-798.534	2.649
			Max. My	2	-26.763	-3.784	808.730
			Max. Vy	20	-23.542	797.585	-0.898
			Max. Vx	2	-23.866	-3.784	808.730
L24	89 - 88.25	Pole	Max. Torque	15			0.836
			Max Tension	1	0.000	0.000	0.000
			Max. Compression	26	-48.147	-3.000	2.486
			Max. Mx	8	-27.061	-816.183	2.677
			Max. My	2	-26.992	-3.830	826.648
			Max. Vy	20	-23.597	815.252	-0.929
			Max. Vx	2	-23.928	-3.830	826.648
L25	88.25 - 88	Pole	Max. Torque	15			0.836
			Max Tension	1	0.000	0.000	0.000
			Max. Compression	26	-48.234	-3.008	2.487
			Max. Mx	8	-27.135	-822.074	2.686
			Max. My	2	-27.066	-3.846	832.630
			Max. Vy	20	-23.606	821.149	-0.939
			Max. Vx	2	-23.938	-3.846	832.630
L26	88 - 87.833	Pole	Max. Torque	15			0.836
			Max Tension	1	0.000	0.000	0.000
			Max. Compression	26	-48.293	-3.013	2.489
			Max. Mx	8	-27.182	-826.011	2.693
			Max. My	2	-27.113	-3.857	836.627

<b>tnxTower</b>  <b>B+T Group</b> 1717 S. Boulder, Suite 300 Tulsa, OK 74119 Phone: (918) 587-4630 FAX: (918) 295-0265	<b>Job</b>	79982.013.01 - WATERBURY,CT (BU# 876317)	<b>Page</b>	70 of 94
	<b>Project</b>		<b>Date</b>	15:43:49 05/20/22
	<b>Client</b>	Crown Castle	<b>Designed by</b>	Jayaraj B

Section No.	Elevation ft	Component Type	Condition	Gov. Load Comb.	Axial K	Major Axis Moment kip-ft	Minor Axis Moment kip-ft
L27	87.833 - 87.583	Pole	Max. Vy	20	-23.615	825.090	-0.945
			Max. Vx	2	-23.949	-3.857	836.627
			Max. Torque	15			0.836
			Max Tension	1	0.000	0.000	0.000
			Max. Compression	26	-48.374	-3.019	2.489
			Max. Mx	8	-27.243	-831.907	2.702
			Max. My	2	-27.174	-3.872	842.615
			Max. Vy	20	-23.627	830.992	-0.955
			Max. Vx	2	-23.963	-3.872	842.615
			Max. Torque	15			0.836
L28	87.583 - 82.583	Pole	Max Tension	1	0.000	0.000	0.000
			Max. Compression	26	-49.920	-3.155	2.521
			Max. Mx	8	-28.490	-950.354	2.888
			Max. My	2	-28.422	-4.184	962.996
			Max. Vy	20	-23.840	949.561	-1.158
			Max. Vx	2	-24.215	-4.184	962.996
			Max. Torque	15			0.836
			Max Tension	1	0.000	0.000	0.000
			Max. Compression	26	-51.473	-3.290	2.562
			Max. Mx	8	-29.777	-1069.720	3.071
L29	82.583 - 77.583	Pole	Max. My	2	-29.711	-4.493	1084.510
			Max. Vy	20	-24.011	1069.046	-1.359
			Max. Vx	2	-24.433	-4.493	1084.510
			Max. Torque	15			0.835
			Max Tension	1	0.000	0.000	0.000
			Max. Compression	26	-51.664	-3.306	2.567
			Max. Mx	8	-29.938	-1083.693	3.092
			Max. My	2	-29.871	-4.529	1098.750
			Max. Vy	20	-24.021	1083.034	-1.382
			Max. Vx	2	-24.451	-4.529	1098.750
L30	77.583 - 77	Pole	Max. Torque	15			0.834
			Max Tension	1	0.000	0.000	0.000
			Max. Compression	26	-51.758	-3.313	2.570
			Max. Mx	8	-30.021	-1089.689	3.102
			Max. My	2	-29.955	-4.545	1104.862
			Max. Vy	20	-24.025	1089.036	-1.392
			Max. Vx	2	-24.459	-4.545	1104.862
			Max. Torque	15			0.834
			Max Tension	1	0.000	0.000	0.000
			Max. Compression	26	-51.914	-3.324	2.573
L31	77 - 76.75	Pole	Max. Mx	8	-30.145	-1099.697	3.117
			Max. My	2	-30.078	-4.570	1115.065
			Max. Vy	20	-24.047	1099.053	-1.409
			Max. Vx	2	-24.487	-4.570	1115.065
			Max. Torque	15			0.834
			Max Tension	1	0.000	0.000	0.000
			Max. Compression	26	-52.005	-3.331	2.575
			Max. Mx	8	-30.220	-1105.701	3.126
			Max. My	2	-30.153	-4.586	1121.187
			Max. Vy	20	-24.057	1105.063	-1.419
L32	76.75 - 76.333	Pole	Max. Vx	2	-24.500	-4.586	1121.187
			Max. Torque	15			0.834
			Max Tension	1	0.000	0.000	0.000
			Max. Compression	26	-52.672	-3.386	2.601
			Max. Mx	8	-30.730	-1149.807	3.193
			Max. My	2	-30.663	-4.698	1166.189
			Max. Vy	20	-24.168	1149.213	-1.492
			Max. Vx	2	-24.500	-4.586	1121.187
			Max. Torque	15			0.834
			Max Tension	1	0.000	0.000	0.000
L33	76.333 - 76.083	Pole	Max. Compression	26	-52.672	-3.386	2.601
			Max. Mx	8	-30.730	-1149.807	3.193
			Max. My	2	-30.663	-4.698	1166.189
			Max. Vy	20	-24.168	1149.213	-1.492
			Max. Vx	2	-24.500	-4.586	1121.187
			Max. Torque	15			0.834
			Max Tension	1	0.000	0.000	0.000
			Max. Compression	26	-52.672	-3.386	2.601
			Max. Mx	8	-30.730	-1149.807	3.193
			Max. My	2	-30.663	-4.698	1166.189
L34	76.083 - 74.25	Pole	Max. Vy	20	-24.168	1149.213	-1.492
			Max. Vx	2	-24.500	-4.586	1121.187
			Max. Torque	15			0.834
			Max Tension	1	0.000	0.000	0.000
			Max. Compression	26	-52.672	-3.386	2.601
			Max. Mx	8	-30.730	-1149.807	3.193
			Max. My	2	-30.663	-4.698	1166.189
			Max. Vy	20	-24.168	1149.213	-1.492
			Max. Vx	2	-24.500	-4.586	1121.187
			Max. Torque	15			0.834

<b>tnxTower</b>  <b>B+T Group</b> 1717 S. Boulder, Suite 300 Tulsa, OK 74119 Phone: (918) 587-4630 FAX: (918) 295-0265	<b>Job</b>	79982.013.01 - WATERBURY,CT (BU# 876317)	<b>Page</b>	71 of 94
	<b>Project</b>		<b>Date</b>	15:43:49 05/20/22
	<b>Client</b>	Crown Castle	<b>Designed by</b>	Jayaraj B

Section No.	Elevation ft	Component Type	Condition	Gov. Load Comb.	Axial K	Major Axis Moment kip-ft	Minor Axis Moment kip-ft
L35	74.25 - 74	Pole	Max. Vx	2	-24.638	-4.698	1166.189
			Max. Torque	15			0.834
			Max Tension	1	0.000	0.000	0.000
			Max. Compression	26	-52.767	-3.396	2.607
			Max. Mx	8	-30.829	-1155.835	3.202
			Max. My	2	-30.763	-4.714	1172.342
			Max. Vy	20	-24.152	1155.247	-1.502
			Max. Vx	2	-24.625	-4.714	1172.342
L36	74 - 73.75	Pole	Max. Torque	15			0.833
			Max Tension	1	0.000	0.000	0.000
			Max. Compression	26	-52.861	-3.404	2.612
			Max. Mx	8	-30.905	-1161.866	3.211
			Max. My	2	-30.838	-4.729	1178.499
			Max. Vy	20	-24.164	1161.283	-1.512
			Max. Vx	2	-24.641	-4.729	1178.499
			Max. Torque	15			0.833
L37	73.75 - 73.5	Pole	Max Tension	1	0.000	0.000	0.000
			Max. Compression	26	-52.959	-3.412	2.617
			Max. Mx	8	-30.984	-1167.900	3.220
			Max. My	2	-30.917	-4.744	1184.661
			Max. Vy	20	-24.177	1167.323	-1.522
			Max. Vx	2	-24.657	-4.744	1184.661
			Max. Torque	15			0.833
			Max Tension	1	0.000	0.000	0.000
L38	73.5 - 68.5	Pole	Max. Compression	26	-54.909	-3.579	2.715
			Max. Mx	8	-32.545	-1289.207	3.401
			Max. My	2	-32.478	-5.050	1308.695
			Max. Vy	20	-24.430	1288.747	-1.722
			Max. Vx	2	-24.978	-5.050	1308.695
			Max. Torque	15			0.833
			Max Tension	1	0.000	0.000	0.000
			Max. Compression	26	-56.877	-3.748	2.815
L39	68.5 - 63.5	Pole	Max. Mx	8	-34.137	-1411.692	3.580
			Max. My	2	-34.071	-5.355	1434.230
			Max. Vy	20	-24.661	1411.348	-1.921
			Max. Vx	2	-25.271	-5.355	1434.230
			Max. Torque	15			0.833
			Max Tension	1	0.000	0.000	0.000
			Max. Compression	26	-58.095	-3.849	2.874
			Max. Mx	8	-35.106	-1485.729	3.687
L40	63.5 - 60.5	Pole	Max. My	2	-35.041	-5.537	1510.242
			Max. Vy	20	-24.794	1485.452	-2.040
			Max. Vx	2	-25.439	-5.537	1510.242
			Max. Torque	15			0.832
			Max Tension	1	0.000	0.000	0.000
			Max. Compression	26	-58.199	-3.859	2.880
			Max. Mx	8	-35.198	-1491.916	3.696
			Max. My	2	-35.134	-5.553	1516.599
L41	60.5 - 60.25	Pole	Max. Vy	20	-24.792	1491.646	-2.050
			Max. Vx	2	-25.439	-5.553	1516.599
			Max. Torque	15			0.832
			Max Tension	1	0.000	0.000	0.000
			Max. Compression	26	-58.510	-3.883	2.894
			Max. Mx	8	-35.436	-1510.496	3.723
			Max. My	2	-35.371	-5.598	1535.690
			Max. Vy	20	-24.833	1510.242	-2.079
L42	60.25 - 59.5	Pole	Max. Vx	2	-25.489	-5.598	1535.690
			Max. Torque	15			0.832
			Max Tension	1	0.000	0.000	0.000
			Max. Compression	26	-58.619	-3.893	2.900
			Max. Mx	8	-35.528	-1516.694	3.732
			Max. My	2			
			Max. Vy	20			
			Max. Vx	2			
L43	59.5 - 59.25	Pole	Max. Torque	15			0.832
			Max Tension	1	0.000	0.000	0.000
			Max. Compression	26	-58.619	-3.893	2.900
			Max. Mx	8	-35.528	-1516.694	3.732

<b>tnxTower</b>  <b>B+T Group</b> 1717 S. Boulder, Suite 300 Tulsa, OK 74119 Phone: (918) 587-4630 FAX: (918) 295-0265	<b>Job</b>	79982.013.01 - WATERBURY,CT (BU# 876317)	<b>Page</b>	72 of 94
	<b>Project</b>		<b>Date</b>	15:43:49 05/20/22
	<b>Client</b>	Crown Castle	<b>Designed by</b>	Jayaraj B

Section No.	Elevation ft	Component Type	Condition	Gov. Load Comb.	Axial K	Major Axis Moment kip-ft	Minor Axis Moment kip-ft			
L44	59.25 - 54.25	Pole	Max. My	2	-35.464	-5.613	1542.061			
			Max. Vy	20	-24.836	1516.447	-2.089			
			Max. Vx	2	-25.495	-5.613	1542.061			
			Max. Torque	15			0.832			
			Max Tension	1	0.000	0.000	0.000			
			Max. Compression	26	-60.724	-4.061	2.997			
			Max. Mx	8	-37.225	-1641.254	3.909			
			Max. My	2	-37.166	-5.915	1670.120			
			Max. Vy	20	-25.072	1641.118	-2.286			
			Max. Vx	2	-25.752	-5.915	1670.120			
L45	54.25 - 45.802	Pole	Max. Torque	15			0.832			
			Max Tension	1	0.000	0.000	0.000			
			Max. Compression	26	-62.522	-4.207	3.081			
			Max. Mx	8	-38.693	-1747.981	4.059			
			Max. My	2	-38.637	-6.171	1779.888			
			Max. Vy	20	-25.252	1747.938	-2.453			
			Max. Vx	2	-25.941	-6.171	1779.888			
			Max. Torque	15			0.832			
			Max Tension	1	0.000	0.000	0.000			
			L46	45.802 - 44.802	Pole	Max. Compression	26	-66.277	-4.022	2.968
Max. Mx	20	-41.815				1880.483	-2.743			
Max. My	2	-41.764				-6.193	1915.778			
Max. Vy	20	-25.639				1880.483	-2.743			
Max. Vx	2	-26.357				-6.193	1915.778			
Max. Torque	15						0.674			
Max Tension	1	0.000				0.000	0.000			
L47	44.802 - 43.583	Pole				Max. Compression	26	-66.810	-4.051	2.972
						Max. Mx	20	-42.249	1911.730	-2.778
						Max. My	2	-42.198	-6.254	1947.915
			Max. Vy	20	-25.690	1911.730	-2.778			
			Max. Vx	2	-26.416	-6.254	1947.915			
			Max. Torque	15			0.674			
			Max Tension	1	0.000	0.000	0.000			
			L48	43.583 - 43.333	Pole	Max. Compression	26	-66.924	-4.058	2.974
						Max. Mx	20	-42.356	1918.145	-2.785
						Max. My	2	-42.307	-6.267	1954.515
Max. Vy	20	-25.680				1918.145	-2.785			
Max. Vx	2	-26.407				-6.267	1954.515			
Max. Torque	15						0.674			
Max Tension	1	0.000				0.000	0.000			
L49	43.333 - 43.166	Pole				Max. Compression	26	-67.000	-4.063	2.975
						Max. Mx	20	-42.420	1922.432	-2.790
						Max. My	2	-42.371	-6.275	1958.925
			Max. Vy	20	-25.687	1922.432	-2.790			
			Max. Vx	2	-26.415	-6.275	1958.925			
			Max. Torque	15			0.674			
			Max Tension	1	0.000	0.000	0.000			
			L50	43.166 - 42.916	Pole	Max. Compression	26	-67.119	-4.068	2.975
						Max. Mx	20	-42.518	1928.851	-2.797
						Max. My	2	-42.469	-6.288	1965.529
Max. Vy	20	-25.697				1928.851	-2.797			
Max. Vx	2	-26.427				-6.288	1965.529			
Max. Torque	15						0.674			
Max Tension	1	0.000				0.000	0.000			
L51	42.916 - 39	Pole				Max. Compression	26	-68.984	-4.166	2.978
						Max. Mx	20	-44.047	2029.731	-2.911

<b>tnxTower</b>  <b>B+T Group</b> 1717 S. Boulder, Suite 300 Tulsa, OK 74119 Phone: (918) 587-4630 FAX: (918) 295-0265	<b>Job</b>	79982.013.01 - WATERBURY,CT (BU# 876317)	<b>Page</b>	73 of 94
	<b>Project</b>		<b>Date</b>	15:43:49 05/20/22
	<b>Client</b>	Crown Castle	<b>Designed by</b>	Jayaraj B

Section No.	Elevation ft	Component Type	Condition	Gov. Load Comb.	Axial K	Major Axis Moment kip-ft	Minor Axis Moment kip-ft
L52	39 - 38.75	Pole	Max. My	2	-44.000	-6.483	2069.357
			Max. Vy	20	-25.874	2029.731	-2.911
			Max. Vx	2	-26.631	-6.483	2069.357
			Max. Torque	15			0.674
			Max Tension	1	0.000	0.000	0.000
			Max. Compression	26	-69.109	-4.174	2.978
			Max. Mx	20	-44.163	2036.192	-2.918
			Max. My	2	-44.117	-6.496	2076.010
			Max. Vy	20	-25.864	2036.192	-2.918
			Max. Vx	2	-26.622	-6.496	2076.010
L53	38.75 - 37.166	Pole	Max. Torque	15			0.674
			Max Tension	1	0.000	0.000	0.000
			Max. Compression	26	-69.899	-4.215	2.973
			Max. Mx	20	-44.801	2077.189	-2.963
			Max. My	2	-44.756	-6.574	2118.231
			Max. Vy	20	-25.953	2077.189	-2.963
			Max. Vx	2	-26.722	-6.574	2118.231
			Max. Torque	15			0.673
			Max Tension	1	0.000	0.000	0.000
			L54	37.166 - 36.916	Pole	Max. Compression	26
Max. Mx	20	-44.918				2083.669	-2.970
Max. My	2	-44.874				-6.587	2124.906
Max. Vy	20	-25.938				2083.669	-2.970
Max. Vx	2	-26.708				-6.587	2124.906
Max. Torque	15						0.673
Max Tension	1	0.000				0.000	0.000
Max. Compression	26	-71.454				-4.297	2.982
Max. Mx	20	-46.079				2159.412	-3.054
Max. My	2	-46.037				-6.732	2202.951
L55	36.916 - 34	Pole	Max. Vy	20	-26.066	2159.412	-3.054
			Max. Vx	2	-26.856	-6.732	2202.951
			Max. Torque	15			0.673
			Max Tension	1	0.000	0.000	0.000
			Max. Compression	26	-71.574	-4.305	2.984
			Max. Mx	20	-46.192	2165.920	-3.061
			Max. My	2	-46.151	-6.744	2209.659
			Max. Vy	20	-26.050	2165.920	-3.061
			Max. Vx	2	-26.841	-6.744	2209.659
			Max. Torque	15			0.673
L56	34 - 33.75	Pole	Max Tension	1	0.000	0.000	0.000
			Max. Compression	26	-73.460	-4.403	3.011
			Max. Mx	20	-47.742	2270.315	-3.174
			Max. My	2	-47.705	-6.942	2317.303
			Max. Vy	20	-26.193	2270.315	-3.174
			Max. Vx	2	-27.007	-6.942	2317.303
			Max. Torque	15			0.673
			Max Tension	1	0.000	0.000	0.000
			Max. Compression	26	-73.578	-4.410	3.014
			Max. Mx	20	-47.851	2276.857	-3.181
L57	33.75 - 29.75	Pole	Max. My	2	-47.814	-6.954	2324.051
			Max. Vy	20	-26.185	2276.857	-3.181
			Max. Vx	2	-27.000	-6.954	2324.051
			Max. Torque	15			0.673
			Max Tension	1	0.000	0.000	0.000
			Max. Compression	26	-75.948	-4.543	3.049
			Max. Mx	20	-49.827	2408.086	-3.322
			Max. My	2	-49.795	-7.199	2459.460
			Max. Vy	20	-26.352	2408.086	-3.322
			Max. Vx	2	-27.189	-7.199	2459.460
L58	29.75 - 29.5	Pole	Max. Torque	15			0.673
			Max Tension	1	0.000	0.000	0.000
			Max. Compression	26	-75.948	-4.543	3.049
			Max. Mx	20	-49.827	2408.086	-3.322
			Max. My	2	-49.795	-7.199	2459.460
			Max. Vy	20	-26.352	2408.086	-3.322
L59	29.5 - 24.5	Pole	Max. Vx	2	-27.189	-7.199	2459.460
			Max. Torque	15			0.673

Section No.	Elevation ft	Component Type	Condition	Gov. Load Comb.	Axial K	Major Axis Moment kip-ft	Minor Axis Moment kip-ft
L60	24.5 - 23	Pole	Max Tension	1	0.000	0.000	0.000
			Max. Compression	26	-76.675	-4.603	3.061
			Max. Mx	20	-50.423	2447.603	-3.364
			Max. My	2	-50.393	-7.273	2500.247
			Max. Vy	20	-26.409	2447.603	-3.364
			Max. Vx	2	-27.245	-7.273	2500.247
			Max. Torque	15			0.673
L61	23 - 22.75	Pole	Max Tension	1	0.000	0.000	0.000
			Max. Compression	26	-76.805	-4.613	3.064
			Max. Mx	20	-50.548	2454.195	-3.371
			Max. My	2	-50.519	-7.285	2507.051
			Max. Vy	20	-26.390	2454.195	-3.371
			Max. Vx	2	-27.226	-7.285	2507.051
			Max. Torque	15			0.673
L62	22.75 - 21.583	Pole	Max Tension	1	0.000	0.000	0.000
			Max. Compression	26	-77.415	-4.659	3.072
			Max. Mx	20	-51.048	2485.001	-3.403
			Max. My	2	-51.020	-7.342	2538.843
			Max. Vy	20	-26.450	2485.001	-3.403
			Max. Vx	2	-27.285	-7.342	2538.843
			Max. Torque	15			0.673
L63	21.583 - 21.333	Pole	Max Tension	1	0.000	0.000	0.000
			Max. Compression	26	-77.541	-4.670	3.075
			Max. Mx	20	-51.163	2491.607	-3.410
			Max. My	2	-51.136	-7.354	2545.660
			Max. Vy	20	-26.441	2491.607	-3.410
			Max. Vx	2	-27.275	-7.354	2545.660
			Max. Torque	15			0.673
L64	21.333 - 16.333	Pole	Max Tension	1	0.000	0.000	0.000
			Max. Compression	26	-80.040	-4.846	3.099
			Max. Mx	20	-53.263	2624.112	-3.548
			Max. My	2	-53.241	-7.596	2682.381
			Max. Vy	20	-26.608	2624.112	-3.548
			Max. Vx	2	-27.438	-7.596	2682.381
			Max. Torque	15			0.673
L65	16.333 - 12.917	Pole	Max Tension	1	0.000	0.000	0.000
			Max. Compression	26	-81.791	-4.931	3.052
			Max. Mx	20	-54.717	2715.096	-3.641
			Max. My	2	-54.700	-7.761	2776.204
			Max. Vy	20	-26.729	2715.096	-3.641
			Max. Vx	2	-27.539	-7.761	2776.204
			Max. Torque	15			0.673
L66	12.917 - 12.667	Pole	Max Tension	1	0.000	0.000	0.000
			Max. Compression	26	-81.929	-4.938	3.049
			Max. Mx	20	-54.843	2721.770	-3.648
			Max. My	2	-54.827	-7.773	2783.084
			Max. Vy	20	-26.718	2721.770	-3.648
			Max. Vx	2	-27.526	-7.773	2783.084
			Max. Torque	15			0.673
L67	12.667 - 12.5	Pole	Max Tension	1	0.000	0.000	0.000
			Max. Compression	26	-82.021	-4.942	3.047
			Max. Mx	20	-54.921	2726.230	-3.652
			Max. My	2	-54.905	-7.781	2787.681
			Max. Vy	20	-26.723	2726.230	-3.652
			Max. Vx	2	-27.531	-7.781	2787.681
			Max. Torque	15			0.673
L68	12.5 - 12.25	Pole	Max Tension	1	0.000	0.000	0.000

<b>tnxTower</b>  <b>B+T Group</b> 1717 S. Boulder, Suite 300 Tulsa, OK 74119 Phone: (918) 587-4630 FAX: (918) 295-0265	<b>Job</b> 79982.013.01 - WATERBURY,CT (BU# 876317)	<b>Page</b> 75 of 94
	<b>Project</b>	<b>Date</b> 15:43:49 05/20/22
	<b>Client</b> Crown Castle	<b>Designed by</b> Jayaraj B

Section No.	Elevation ft	Component Type	Condition	Gov. Load Comb.	Axial K	Major Axis Moment kip-ft	Minor Axis Moment kip-ft
L69	12.25 - 12	Pole	Max. Compression	26	-82.146	-4.948	3.043
			Max. Mx	20	-55.024	2732.908	-3.659
			Max. My	2	-55.009	-7.793	2794.563
			Max. Vy	20	-26.733	2732.908	-3.659
			Max. Vx	2	-27.539	-7.793	2794.563
			Max. Torque	15			0.673
			Max Tension	1	0.000	0.000	0.000
			Max. Compression	26	-82.271	-4.954	3.040
			Max. Mx	20	-55.129	2739.588	-3.666
			Max. My	2	-55.113	-7.805	2801.448
L70	12 - 11.75	Pole	Max. Vy	20	-26.740	2739.588	-3.666
			Max. Vx	2	-27.545	-7.805	2801.448
			Max. Torque	15			0.673
			Max Tension	1	0.000	0.000	0.000
			Max. Compression	26	-82.390	-4.960	3.036
			Max. Mx	20	-55.228	2746.270	-3.672
			Max. My	2	-55.213	-7.817	2808.334
			Max. Vy	20	-26.747	2746.270	-3.672
			Max. Vx	2	-27.551	-7.817	2808.334
			Max. Torque	15			0.673
L71	11.75 - 8.5	Pole	Max Tension	1	0.000	0.000	0.000
			Max. Compression	26	-83.930	-5.030	2.997
			Max. Mx	20	-56.506	2833.477	-3.760
			Max. My	2	-56.496	-7.972	2897.994
			Max. Vy	20	-26.977	2833.477	-3.760
			Max. Vx	2	-27.661	-7.972	2897.994
			Max. Torque	15			0.673
			Max Tension	1	0.000	0.000	0.000
			Max. Compression	26	-84.069	-5.036	2.996
			Max. Mx	20	-56.638	2840.214	-3.767
L72	8.5 - 8.25	Pole	Max. My	2	-56.629	-7.984	2904.903
			Max. Vy	20	-26.973	2840.214	-3.767
			Max. Vx	2	-27.646	-7.984	2904.903
			Max. Torque	15			0.673
			Max Tension	1	0.000	0.000	0.000
			Max. Compression	26	-84.763	-5.062	2.992
			Max. Mx	20	-57.225	2873.981	-3.800
			Max. My	2	-57.217	-8.043	2939.497
			Max. Vy	20	-27.105	2873.981	-3.800
			Max. Vx	2	-27.732	-8.043	2939.497
L73	8.25 - 7	Pole	Max. Torque	15			0.673
			Max Tension	1	0.000	0.000	0.000
			Max. Compression	26	-84.890	-5.068	2.992
			Max. Mx	20	-57.343	2880.751	-3.807
			Max. My	2	-57.336	-8.055	2946.425
			Max. Vy	20	-27.105	2880.751	-3.807
			Max. Vx	2	-27.722	-8.055	2946.425
			Max. Torque	15			0.673
			Max Tension	1	0.000	0.000	0.000
			Max. Compression	26	-87.367	-5.162	2.970
L74	7 - 6.75	Pole	Max. Mx	20	-59.498	3017.173	-3.939
			Max. My	2	-59.496	-8.291	3085.561
			Max. Vy	20	-27.514	3017.173	-3.939
			Max. Vx	2	-27.959	-8.291	3085.561
			Max. Torque	15			0.673
			Max Tension	1	0.000	0.000	0.000
			Max. Compression	26	-88.215	-5.190	2.963
			Max. Mx	20	-60.254	3065.382	-3.985
			Max. My	2	-60.254	-8.373	3134.516
			Max. Vy	20	-27.668	3065.382	-3.985
L75	6.75 - 1.75	Pole	Max. Vx	2	-28.054	-8.373	3134.516
			Max. Torque	15			0.673
			Max Tension	1	0.000	0.000	0.000
			Max. Compression	26	-88.215	-5.190	2.963
			Max. Mx	20	-60.254	3065.382	-3.985
			Max. My	2	-60.254	-8.373	3134.516
			Max. Vy	20	-27.668	3065.382	-3.985
			Max. Vx	2	-28.054	-8.373	3134.516
			Max. Torque	15			0.673
			Max Tension	1	0.000	0.000	0.000
L76	1.75 - 0	Pole	Max. Compression	26	-88.215	-5.190	2.963
			Max. Mx	20	-60.254	3065.382	-3.985
			Max. My	2	-60.254	-8.373	3134.516
			Max. Vy	20	-27.668	3065.382	-3.985
			Max. Vx	2	-28.054	-8.373	3134.516
			Max. Torque	15			0.673
			Max Tension	1	0.000	0.000	0.000
			Max. Compression	26	-88.215	-5.190	2.963
			Max. Mx	20	-60.254	3065.382	-3.985
			Max. My	2	-60.254	-8.373	3134.516

<b>tnxTower</b>  <b>B+T Group</b> 1717 S. Boulder, Suite 300 Tulsa, OK 74119 Phone: (918) 587-4630 FAX: (918) 295-0265	<b>Job</b> 79982.013.01 - WATERBURY, CT (BU# 876317)	<b>Page</b> 76 of 94
	<b>Project</b>	<b>Date</b> 15:43:49 05/20/22
	<b>Client</b> Crown Castle	<b>Designed by</b> Jayaraj B

Section No.	Elevation ft	Component Type	Condition	Gov. Load Comb.	Axial K	Major Axis Moment kip-ft	Minor Axis Moment kip-ft
			Max. Torque	15			0.673

### Maximum Reactions

Location	Condition	Gov. Load Comb.	Vertical K	Horizontal, X K	Horizontal, Z K
Pole	Max. Vert	38	88.215	3.569	6.206
	Max. H <sub>x</sub>	21	45.206	27.624	-0.029
	Max. H <sub>z</sub>	2	60.274	-0.038	28.009
	Max. M <sub>x</sub>	2	3134.516	-0.038	28.009
	Max. M <sub>z</sub>	8	3063.955	-27.589	0.020
	Max. Torsion	15	0.673	0.057	-27.996
	Min. Vert	5	45.206	-13.339	23.194
	Min. H <sub>x</sub>	8	60.274	-27.589	0.020
	Min. H <sub>z</sub>	14	60.274	0.057	-27.996
	Min. M <sub>x</sub>	14	-3130.548	0.057	-27.996
	Min. M <sub>z</sub>	20	-3065.382	27.624	-0.029
	Min. Torsion	3	-0.529	-0.038	28.009

### Tower Mast Reaction Summary

Load Combination	Vertical K	Shear <sub>x</sub> K	Shear <sub>z</sub> K	Overturing Moment, M <sub>x</sub> kip-ft	Overturing Moment, M <sub>z</sub> kip-ft	Torque kip-ft
Dead Only	50.229	0.000	-0.000	-0.977	-1.483	0.000
1.2 Dead+1.0 Wind 0 deg - No Ice	60.274	0.038	-28.009	-3134.516	-8.373	0.522
0.9 Dead+1.0 Wind 0 deg - No Ice	45.206	0.038	-28.009	-3068.884	-7.685	0.529
1.2 Dead+1.0 Wind 30 deg - No Ice	60.274	13.339	-23.194	-2634.774	-1515.605	0.216
0.9 Dead+1.0 Wind 30 deg - No Ice	45.206	13.339	-23.194	-2579.139	-1483.318	0.220
1.2 Dead+1.0 Wind 60 deg - No Ice	60.274	23.416	-13.666	-1532.536	-2616.492	-0.216
0.9 Dead+1.0 Wind 60 deg - No Ice	45.206	23.416	-13.666	-1500.022	-2561.161	-0.216
1.2 Dead+1.0 Wind 90 deg - No Ice	60.274	27.589	-0.020	-5.122	-3063.955	-0.155
0.9 Dead+1.0 Wind 90 deg - No Ice	45.206	27.589	-0.020	-4.663	-2999.378	-0.159
1.2 Dead+1.0 Wind 120 deg - No Ice	60.274	24.628	14.313	1564.183	-2690.885	-0.058
0.9 Dead+1.0 Wind 120 deg - No Ice	45.206	24.628	14.313	1532.027	-2634.563	-0.065
1.2 Dead+1.0 Wind 150 deg - No Ice	60.274	14.962	26.042	2816.368	-1617.525	-0.428
0.9 Dead+1.0 Wind 150 deg - No Ice	45.206	14.962	26.042	2758.712	-1583.779	-0.436
1.2 Dead+1.0 Wind 180 deg - No Ice	60.274	-0.057	27.996	3130.548	7.487	-0.665
0.9 Dead+1.0 Wind 180 deg -	45.206	-0.057	27.996	3065.643	7.777	-0.673

<p><b>tnxTower</b></p> <p><b>B+T Group</b> 1717 S. Boulder, Suite 300 Tulsa, OK 74119 Phone: (918) 587-4630 FAX: (918) 295-0265</p>	<p><b>Job</b></p> <p>79982.013.01 - WATERBURY,CT (BU# 876317)</p>	<p><b>Page</b></p> <p>77 of 94</p>
	<p><b>Project</b></p>	<p><b>Date</b></p> <p>15:43:49 05/20/22</p>
	<p><b>Client</b></p> <p>Crown Castle</p>	<p><b>Designed by</b></p> <p>Jayaraj B</p>

Load Combination	Vertical K	Shear <sub>x</sub> K	Shear <sub>z</sub> K	Overturning Moment, M <sub>x</sub> kip-ft	Overturning Moment, M <sub>z</sub> kip-ft	Torque kip-ft
No Ice						
1.2 Dead+1.0 Wind 210 deg - No Ice	60.274	-13.331	23.151	2628.479	1512.065	-0.448
0.9 Dead+1.0 Wind 210 deg - No Ice	45.206	-13.331	23.151	2573.598	1480.795	-0.453
1.2 Dead+1.0 Wind 240 deg - No Ice	60.274	-23.406	13.653	1529.117	2612.991	-0.146
0.9 Dead+1.0 Wind 240 deg - No Ice	45.206	-23.406	13.653	1497.313	2558.672	-0.146
1.2 Dead+1.0 Wind 270 deg - No Ice	60.274	-27.624	0.029	3.985	3065.382	0.124
0.9 Dead+1.0 Wind 270 deg - No Ice	45.206	-27.624	0.029	4.206	3001.727	0.128
1.2 Dead+1.0 Wind 300 deg - No Ice	60.274	-24.659	-14.303	-1565.165	2691.545	-0.083
0.9 Dead+1.0 Wind 300 deg - No Ice	45.206	-24.659	-14.303	-1532.330	2636.176	-0.077
1.2 Dead+1.0 Wind 330 deg - No Ice	60.274	-14.952	-26.044	-2819.130	1612.378	0.319
0.9 Dead+1.0 Wind 330 deg - No Ice	45.206	-14.952	-26.044	-2760.763	1579.718	0.327
1.2 Dead+1.0 Ice+1.0 Temp	88.215	0.000	-0.000	-2.963	-5.190	0.000
1.2 Dead+1.0 Wind 0 deg+1.0 Ice+1.0 Temp	88.215	0.006	-6.686	-815.081	-6.695	0.097
1.2 Dead+1.0 Wind 30 deg+1.0 Ice+1.0 Temp	88.215	3.308	-5.744	-701.706	-407.721	0.016
1.2 Dead+1.0 Wind 60 deg+1.0 Ice+1.0 Temp	88.215	5.760	-3.352	-408.785	-700.786	-0.079
1.2 Dead+1.0 Wind 90 deg+1.0 Ice+1.0 Temp	88.215	6.723	-0.003	-3.828	-812.035	-0.066
1.2 Dead+1.0 Wind 120 deg+1.0 Ice+1.0 Temp	88.215	5.890	3.418	405.674	-709.198	-0.040
1.2 Dead+1.0 Wind 150 deg+1.0 Ice+1.0 Temp	88.215	3.571	6.205	727.128	-425.065	-0.140
1.2 Dead+1.0 Wind 180 deg+1.0 Ice+1.0 Temp	88.215	-0.010	6.686	808.885	-3.356	-0.128
1.2 Dead+1.0 Wind 210 deg+1.0 Ice+1.0 Temp	88.215	-3.313	5.747	696.051	397.836	-0.065
1.2 Dead+1.0 Wind 240 deg+1.0 Ice+1.0 Temp	88.215	-5.766	3.354	403.040	691.158	0.002
1.2 Dead+1.0 Wind 270 deg+1.0 Ice+1.0 Temp	88.215	-6.731	0.005	-1.987	802.546	0.059
1.2 Dead+1.0 Wind 300 deg+1.0 Ice+1.0 Temp	88.215	-5.896	-3.415	-411.428	699.452	0.010
1.2 Dead+1.0 Wind 330 deg+1.0 Ice+1.0 Temp	88.215	-3.569	-6.206	-733.303	414.070	0.117
Dead+Wind 0 deg - Service	50.229	0.009	-6.837	-757.758	-3.123	0.129
Dead+Wind 30 deg - Service	50.229	3.255	-5.660	-636.698	-366.941	0.051
Dead+Wind 60 deg - Service	50.229	5.714	-3.335	-370.631	-632.670	-0.058
Dead+Wind 90 deg - Service	50.229	6.732	-0.005	-1.962	-740.686	-0.042
Dead+Wind 120 deg - Service	50.229	6.009	3.492	376.849	-650.681	-0.017
Dead+Wind 150 deg - Service	50.229	3.651	6.356	679.550	-391.827	-0.108
Dead+Wind 180 deg - Service	50.229	-0.014	6.833	755.331	0.687	-0.165
Dead+Wind 210 deg - Service	50.229	-3.253	5.649	633.711	363.865	-0.110
Dead+Wind 240 deg - Service	50.229	-5.711	3.331	368.341	629.606	-0.033
Dead+Wind 270 deg - Service	50.229	-6.740	0.007	0.225	738.816	0.035
Dead+Wind 300 deg - Service	50.229	-6.017	-3.490	-378.549	648.628	-0.018
Dead+Wind 330 deg - Service	50.229	-3.649	-6.356	-681.682	388.371	0.081

<b>tnxTower</b>  <b>B+T Group</b> 1717 S. Boulder, Suite 300 Tulsa, OK 74119 Phone: (918) 587-4630 FAX: (918) 295-0265	<b>Job</b> 79982.013.01 - WATERBURY,CT (BU# 876317)	<b>Page</b> 78 of 94
	<b>Project</b>	<b>Date</b> 15:43:49 05/20/22
	<b>Client</b> Crown Castle	<b>Designed by</b> Jayaraj B

## Solution Summary

Load Comb.	Sum of Applied Forces			Sum of Reactions			% Error
	PX K	PY K	PZ K	PX K	PY K	PZ K	
1	0.000	-50.229	0.000	-0.000	50.229	0.000	0.000%
2	0.038	-60.274	-28.009	-0.038	60.274	28.009	0.000%
3	0.038	-45.206	-28.009	-0.038	45.206	28.009	0.000%
4	13.339	-60.274	-23.194	-13.339	60.274	23.194	0.000%
5	13.339	-45.206	-23.194	-13.339	45.206	23.194	0.000%
6	23.416	-60.274	-13.666	-23.416	60.274	13.666	0.000%
7	23.416	-45.206	-13.666	-23.416	45.206	13.666	0.000%
8	27.589	-60.274	-0.020	-27.589	60.274	0.020	0.000%
9	27.589	-45.206	-0.020	-27.589	45.206	0.020	0.000%
10	24.628	-60.274	14.313	-24.628	60.274	-14.313	0.000%
11	24.628	-45.206	14.313	-24.628	45.206	-14.313	0.000%
12	14.962	-60.274	26.042	-14.962	60.274	-26.042	0.000%
13	14.962	-45.206	26.042	-14.962	45.206	-26.042	0.000%
14	-0.057	-60.274	27.996	0.057	60.274	-27.996	0.000%
15	-0.057	-45.206	27.996	0.057	45.206	-27.996	0.000%
16	-13.331	-60.274	23.151	13.331	60.274	-23.151	0.000%
17	-13.331	-45.206	23.151	13.331	45.206	-23.151	0.000%
18	-23.406	-60.274	13.653	23.406	60.274	-13.653	0.000%
19	-23.406	-45.206	13.653	23.406	45.206	-13.653	0.000%
20	-27.624	-60.274	0.029	27.624	60.274	-0.029	0.000%
21	-27.624	-45.206	0.029	27.624	45.206	-0.029	0.000%
22	-24.659	-60.274	-14.303	24.659	60.274	14.303	0.000%
23	-24.659	-45.206	-14.303	24.659	45.206	14.303	0.000%
24	-14.952	-60.274	-26.044	14.952	60.274	26.044	0.000%
25	-14.952	-45.206	-26.044	14.952	45.206	26.044	0.000%
26	0.000	-88.215	0.000	-0.000	88.215	0.000	0.000%
27	0.006	-88.215	-6.686	-0.006	88.215	6.686	0.000%
28	3.308	-88.215	-5.744	-3.308	88.215	5.744	0.000%
29	5.760	-88.215	-3.352	-5.760	88.215	3.352	0.000%
30	6.723	-88.215	-0.003	-6.723	88.215	0.003	0.000%
31	5.890	-88.215	3.418	-5.890	88.215	-3.418	0.000%
32	3.571	-88.215	6.205	-3.571	88.215	-6.205	0.000%
33	-0.010	-88.215	6.686	0.010	88.215	-6.686	0.000%
34	-3.313	-88.215	5.747	3.313	88.215	-5.747	0.000%
35	-5.766	-88.215	3.354	5.766	88.215	-3.354	0.000%
36	-6.731	-88.215	0.005	6.731	88.215	-0.005	0.000%
37	-5.896	-88.215	-3.415	5.896	88.215	3.415	0.000%
38	-3.569	-88.215	-6.206	3.569	88.215	6.206	0.000%
39	0.009	-50.229	-6.837	-0.009	50.229	6.837	0.000%
40	3.255	-50.229	-5.660	-3.255	50.229	5.660	0.000%
41	5.714	-50.229	-3.335	-5.714	50.229	3.335	0.000%
42	6.732	-50.229	-0.005	-6.732	50.229	0.005	0.000%
43	6.009	-50.229	3.492	-6.009	50.229	-3.492	0.000%
44	3.651	-50.229	6.356	-3.651	50.229	-6.356	0.000%
45	-0.014	-50.229	6.833	0.014	50.229	-6.833	0.000%
46	-3.253	-50.229	5.649	3.253	50.229	-5.649	0.000%
47	-5.711	-50.229	3.331	5.711	50.229	-3.331	0.000%
48	-6.740	-50.229	0.007	6.740	50.229	-0.007	0.000%
49	-6.017	-50.229	-3.490	6.017	50.229	3.490	0.000%
50	-3.649	-50.229	-6.356	3.649	50.229	6.356	0.000%

## Non-Linear Convergence Results

<p><b>tnxTower</b></p> <p><b>B+T Group</b> 1717 S. Boulder, Suite 300 Tulsa, OK 74119 Phone: (918) 587-4630 FAX: (918) 295-0265</p>	<p><b>Job</b></p> <p>79982.013.01 - WATERBURY,CT (BU# 876317)</p>	<p><b>Page</b></p> <p>79 of 94</p>
	<p><b>Project</b></p>	<p><b>Date</b></p> <p>15:43:49 05/20/22</p>
	<p><b>Client</b></p> <p>Crown Castle</p>	<p><b>Designed by</b></p> <p>Jayaraj B</p>

Load Combination	Converged?	Number of Cycles	Displacement Tolerance	Force Tolerance
1	Yes	4	0.00000001	0.00002700
2	Yes	6	0.00000001	0.00058901
3	Yes	6	0.00000001	0.00020196
4	Yes	8	0.00000001	0.00020557
5	Yes	7	0.00000001	0.00052092
6	Yes	8	0.00000001	0.00020521
7	Yes	7	0.00000001	0.00051997
8	Yes	6	0.00000001	0.00031522
9	Yes	6	0.00000001	0.00010203
10	Yes	8	0.00000001	0.00020833
11	Yes	7	0.00000001	0.00052545
12	Yes	8	0.00000001	0.00022073
13	Yes	7	0.00000001	0.00055348
14	Yes	6	0.00000001	0.00034446
15	Yes	6	0.00000001	0.00011756
16	Yes	8	0.00000001	0.00020234
17	Yes	7	0.00000001	0.00051235
18	Yes	8	0.00000001	0.00020493
19	Yes	7	0.00000001	0.00051949
20	Yes	6	0.00000001	0.00018012
21	Yes	5	0.00000001	0.00069692
22	Yes	8	0.00000001	0.00020956
23	Yes	7	0.00000001	0.00052887
24	Yes	8	0.00000001	0.00021668
25	Yes	7	0.00000001	0.00054232
26	Yes	5	0.00000001	0.00056864
27	Yes	8	0.00000001	0.00021404
28	Yes	8	0.00000001	0.00030411
29	Yes	8	0.00000001	0.00030445
30	Yes	8	0.00000001	0.00021329
31	Yes	8	0.00000001	0.00030014
32	Yes	8	0.00000001	0.00031253
33	Yes	8	0.00000001	0.00021023
34	Yes	8	0.00000001	0.00029048
35	Yes	8	0.00000001	0.00029132
36	Yes	8	0.00000001	0.00020868
37	Yes	8	0.00000001	0.00029993
38	Yes	8	0.00000001	0.00030765
39	Yes	5	0.00000001	0.00044965
40	Yes	6	0.00000001	0.00034181
41	Yes	6	0.00000001	0.00034095
42	Yes	5	0.00000001	0.00037517
43	Yes	6	0.00000001	0.00034245
44	Yes	6	0.00000001	0.00038680
45	Yes	5	0.00000001	0.00044645
46	Yes	6	0.00000001	0.00032089
47	Yes	6	0.00000001	0.00033033
48	Yes	5	0.00000001	0.00036217
49	Yes	6	0.00000001	0.00034653
50	Yes	6	0.00000001	0.00036821

### Maximum Tower Deflections - Service Wind

Section No.	Elevation ft	Horz. Deflection in	Gov. Load Comb.	Tilt °	Twist °
L1	144.25 - 139.25	32.574	50	2.345	0.007

**tnxTower**

**B+T Group**  
 1717 S. Boulder, Suite 300  
 Tulsa, OK 74119  
 Phone: (918) 587-4630  
 FAX: (918) 295-0265

<b>Job</b>	79982.013.01 - WATERBURY,CT (BU# 876317)	<b>Page</b>	80 of 94
<b>Project</b>		<b>Date</b>	15:43:49 05/20/22
<b>Client</b>	Crown Castle	<b>Designed by</b>	Jayaraj B

Section No.	Elevation ft	Horz. Deflection in	Gov. Load Comb.	Tilt °	Twist °
L2	139.25 - 134.75	30.123	50	2.332	0.006
L3	134.75 - 134.25	27.945	50	2.286	0.006
L4	134.25 - 129.25	27.706	50	2.280	0.006
L5	129.25 - 124.25	25.386	50	2.148	0.004
L6	124.25 - 123.416	23.226	50	1.971	0.003
L7	123.416 - 123.166	22.884	50	1.939	0.002
L8	123.166 - 118.166	22.783	50	1.935	0.002
L9	118.166 - 113.166	20.801	50	1.850	0.002
L10	113.166 - 109.5	18.915	50	1.751	0.001
L11	109.5 - 109.25	17.601	50	1.671	0.001
L12	109.25 - 104.75	17.514	50	1.666	0.001
L13	104.75 - 104.5	15.986	50	1.576	0.001
L14	104.5 - 102.416	15.903	50	1.572	0.001
L15	102.416 - 102.166	15.224	50	1.539	0.001
L16	102.166 - 98.75	15.144	50	1.534	0.001
L17	98.75 - 98.5	14.073	50	1.459	0.001
L18	98.5 - 97.5	13.997	50	1.455	0.001
L19	97.5 - 97.25	13.694	50	1.440	0.001
L20	97.25 - 92	13.619	50	1.435	0.001
L21	95.552 - 90.552	13.114	50	1.406	0.001
L22	90.552 - 89.25	11.667	50	1.349	0.001
L23	89.25 - 89	11.302	50	1.325	0.001
L24	89 - 88.25	11.233	50	1.322	0.001
L25	88.25 - 88	11.026	50	1.311	0.001
L26	88 - 87.833	10.958	50	1.306	0.001
L27	87.833 - 87.583	10.912	50	1.303	0.001
L28	87.583 - 82.583	10.844	50	1.298	0.001
L29	82.583 - 77.583	9.541	50	1.190	0.001
L30	77.583 - 77	8.353	50	1.080	0.000
L31	77 - 76.75	8.222	50	1.067	0.000
L32	76.75 - 76.333	8.166	50	1.063	0.000
L33	76.333 - 76.083	8.074	50	1.056	0.000
L34	76.083 - 74.25	8.018	50	1.051	0.000
L35	74.25 - 74	7.621	50	1.020	0.000
L36	74 - 73.75	7.568	50	1.016	0.000
L37	73.75 - 73.5	7.515	50	1.012	0.000
L38	73.5 - 68.5	7.462	50	1.008	0.000
L39	68.5 - 63.5	6.448	50	0.929	0.000
L40	63.5 - 60.5	5.517	50	0.849	0.000
L41	60.5 - 60.25	4.999	50	0.801	0.000
L42	60.25 - 59.5	4.957	50	0.797	0.000
L43	59.5 - 59.25	4.833	50	0.785	0.000
L44	59.25 - 54.25	4.792	50	0.781	0.000
L45	54.25 - 45.802	4.014	50	0.705	0.000
L46	50 - 44.802	3.415	50	0.641	0.000
L47	44.802 - 43.583	2.740	50	0.594	0.000
L48	43.583 - 43.333	2.590	50	0.576	0.000
L49	43.333 - 43.166	2.560	50	0.572	0.000
L50	43.166 - 42.916	2.540	50	0.569	0.000
L51	42.916 - 39	2.510	50	0.566	0.000
L52	39 - 38.75	2.068	50	0.512	0.000
L53	38.75 - 37.166	2.042	50	0.509	0.000
L54	37.166 - 36.916	1.876	50	0.488	0.000
L55	36.916 - 34	1.851	50	0.485	0.000
L56	34 - 33.75	1.567	50	0.445	0.000
L57	33.75 - 29.75	1.543	50	0.442	0.000
L58	29.75 - 29.5	1.196	50	0.387	0.000
L59	29.5 - 24.5	1.176	50	0.384	0.000
L60	24.5 - 23	0.809	50	0.317	0.000
L61	23 - 22.75	0.713	50	0.297	0.000
L62	22.75 - 21.583	0.697	50	0.294	0.000

<b>tnxTower</b>  <b>B+T Group</b> 1717 S. Boulder, Suite 300 Tulsa, OK 74119 Phone: (918) 587-4630 FAX: (918) 295-0265	<b>Job</b> 79982.013.01 - WATERBURY,CT (BU# 876317)	<b>Page</b> 81 of 94
	<b>Project</b>	<b>Date</b> 15:43:49 05/20/22
	<b>Client</b> Crown Castle	<b>Designed by</b> Jayaraj B

Section No.	Elevation ft	Horz. Deflection in	Gov. Load Comb.	Tilt °	Twist °
L63	21.583 - 21.333	0.627	50	0.281	0.000
L64	21.333 - 16.333	0.613	50	0.277	0.000
L65	16.333 - 12.917	0.356	50	0.213	0.000
L66	12.917 - 12.667	0.220	50	0.169	0.000
L67	12.667 - 12.5	0.211	50	0.166	0.000
L68	12.5 - 12.25	0.205	50	0.164	0.000
L69	12.25 - 12	0.197	50	0.161	0.000
L70	12 - 11.75	0.188	50	0.157	0.000
L71	11.75 - 8.5	0.180	50	0.154	0.000
L72	8.5 - 8.25	0.093	50	0.103	0.000
L73	8.25 - 7	0.087	50	0.100	0.000
L74	7 - 6.75	0.063	50	0.087	0.000
L75	6.75 - 1.75	0.059	50	0.084	0.000
L76	1.75 - 0	0.004	50	0.021	0.000

### Critical Deflections and Radius of Curvature - Service Wind

Elevation ft	Appurtenance	Gov. Load Comb.	Deflection in	Tilt °	Twist °	Radius of Curvature ft
144.000	EPBQ-654L8H8-L2 w/ Mount Pipe	50	32.452	2.345	0.008	8684
133.000	VHLP2-23	50	27.114	2.257	0.006	2573
130.000	(2) APXVSPP18-C-A20 w/ Mount Pipe	50	25.725	2.171	0.006	1917
120.000	MX08FRO665-21 w/ Mount Pipe	50	21.518	1.885	0.003	3054
110.000	SBNHH-1D65B w/ Mount Pipe	50	17.777	1.681	0.002	2736
100.000	AIR -32 B2A/B66AA w/ Mount Pipe	50	14.459	1.483	0.001	2958
50.000	KS24019-L112A	50	3.415	0.641	0.000	5069

### Maximum Tower Deflections - Design Wind

Section No.	Elevation ft	Horz. Deflection in	Gov. Load Comb.	Tilt °	Twist °
L1	144.25 - 139.25	134.585	24	9.726	0.029
L2	139.25 - 134.75	124.498	24	9.671	0.026
L3	134.75 - 134.25	115.536	24	9.479	0.023
L4	134.25 - 129.25	114.552	24	9.454	0.022
L5	129.25 - 124.25	104.998	24	8.904	0.018
L6	124.25 - 123.416	96.097	24	8.176	0.011
L7	123.416 - 123.166	94.689	24	8.041	0.010
L8	123.166 - 118.166	94.270	24	8.025	0.010
L9	118.166 - 113.166	86.090	24	7.676	0.008
L10	113.166 - 109.5	78.303	24	7.263	0.006
L11	109.5 - 109.25	72.876	24	6.932	0.005
L12	109.25 - 104.75	72.515	24	6.913	0.005
L13	104.75 - 104.5	66.199	24	6.540	0.004
L14	104.5 - 102.416	65.858	24	6.524	0.004
L15	102.416 - 102.166	63.051	24	6.386	0.004
L16	102.166 - 98.75	62.718	24	6.365	0.004
L17	98.75 - 98.5	58.290	24	6.053	0.003

**tnxTower**

**B+T Group**  
 1717 S. Boulder, Suite 300  
 Tulsa, OK 74119  
 Phone: (918) 587-4630  
 FAX: (918) 295-0265

<b>Job</b>	79982.013.01 - WATERBURY,CT (BU# 876317)	<b>Page</b>	82 of 94
<b>Project</b>		<b>Date</b>	15:43:49 05/20/22
<b>Client</b>	Crown Castle	<b>Designed by</b>	Jayaraj B

Section No.	Elevation ft	Horz. Deflection in	Gov. Load Comb.	Tilt °	Twist °
L18	98.5 - 97.5	57.975	24	6.037	0.003
L19	97.5 - 97.25	56.721	24	5.974	0.003
L20	97.25 - 92	56.409	24	5.956	0.003
L21	95.552 - 90.552	54.319	24	5.833	0.003
L22	90.552 - 89.25	48.332	24	5.597	0.003
L23	89.25 - 89	46.823	24	5.500	0.003
L24	89 - 88.25	46.536	24	5.485	0.003
L25	88.25 - 88	45.680	24	5.439	0.003
L26	88 - 87.833	45.397	24	5.419	0.003
L27	87.833 - 87.583	45.208	24	5.407	0.003
L28	87.583 - 82.583	44.926	24	5.385	0.003
L29	82.583 - 77.583	39.533	24	4.940	0.002
L30	77.583 - 77	34.610	24	4.480	0.002
L31	77 - 76.75	34.068	24	4.427	0.002
L32	76.75 - 76.333	33.837	24	4.409	0.002
L33	76.333 - 76.083	33.454	24	4.380	0.002
L34	76.083 - 74.25	33.225	24	4.362	0.002
L35	74.25 - 74	31.578	24	4.232	0.002
L36	74 - 73.75	31.357	24	4.216	0.002
L37	73.75 - 73.5	31.137	24	4.199	0.002
L38	73.5 - 68.5	30.918	24	4.183	0.002
L39	68.5 - 63.5	26.717	24	3.853	0.001
L40	63.5 - 60.5	22.861	12	3.521	0.001
L41	60.5 - 60.25	20.714	12	3.321	0.001
L42	60.25 - 59.5	20.541	12	3.304	0.001
L43	59.5 - 59.25	20.026	12	3.255	0.001
L44	59.25 - 54.25	19.856	12	3.240	0.001
L45	54.25 - 45.802	16.632	12	2.923	0.001
L46	50 - 44.802	14.151	12	2.657	0.001
L47	44.802 - 43.583	11.351	12	2.463	0.001
L48	43.583 - 43.333	10.732	12	2.387	0.001
L49	43.333 - 43.166	10.608	12	2.371	0.001
L50	43.166 - 42.916	10.525	12	2.361	0.001
L51	42.916 - 39	10.402	12	2.347	0.001
L52	39 - 38.75	8.569	12	2.124	0.001
L53	38.75 - 37.166	8.459	12	2.110	0.001
L54	37.166 - 36.916	7.773	12	2.025	0.001
L55	36.916 - 34	7.667	12	2.011	0.001
L56	34 - 33.75	6.490	12	1.846	0.000
L57	33.75 - 29.75	6.394	12	1.832	0.000
L58	29.75 - 29.5	4.955	12	1.605	0.000
L59	29.5 - 24.5	4.871	12	1.591	0.000
L60	24.5 - 23	3.352	12	1.312	0.000
L61	23 - 22.75	2.953	12	1.230	0.000
L62	22.75 - 21.583	2.889	12	1.218	0.000
L63	21.583 - 21.333	2.598	12	1.162	0.000
L64	21.333 - 16.333	2.537	12	1.149	0.000
L65	16.333 - 12.917	1.475	12	0.881	0.000
L66	12.917 - 12.667	0.910	12	0.700	0.000
L67	12.667 - 12.5	0.874	12	0.688	0.000
L68	12.5 - 12.25	0.850	12	0.680	0.000
L69	12.25 - 12	0.814	12	0.666	0.000
L70	12 - 11.75	0.780	12	0.652	0.000
L71	11.75 - 8.5	0.746	12	0.636	0.000
L72	8.5 - 8.25	0.384	12	0.427	0.000
L73	8.25 - 7	0.362	12	0.416	0.000
L74	7 - 6.75	0.261	12	0.359	0.000
L75	6.75 - 1.75	0.242	12	0.346	0.000
L76	1.75 - 0	0.016	12	0.087	0.000

<b>tnxTower</b>  <b>B+T Group</b> 1717 S. Boulder, Suite 300 Tulsa, OK 74119 Phone: (918) 587-4630 FAX: (918) 295-0265	<b>Job</b> 79982.013.01 - WATERBURY,CT (BU# 876317)	<b>Page</b> 83 of 94
	<b>Project</b>	<b>Date</b> 15:43:49 05/20/22
	<b>Client</b> Crown Castle	<b>Designed by</b> Jayaraj B

### Critical Deflections and Radius of Curvature - Design Wind

Elevation	Appurtenance	Gov. Load Comb.	Deflection	Tilt	Twist	Radius of Curvature
ft			in	°	°	ft
144.000	EPBQ-654L8H8-L2 w/ Mount Pipe	24	134.080	9.726	0.035	2193
133.000	VHLP2-23	24	112.113	9.359	0.027	653
130.000	(2) APXVSP18-C-A20 w/ Mount Pipe	24	106.394	9.002	0.024	491
120.000	MX08FRO665-21 w/ Mount Pipe	24	89.049	7.818	0.011	771
110.000	SBNHH-1D65B w/ Mount Pipe	24	73.602	6.972	0.006	683
100.000	AIR -32 B2A/B66AA w/ Mount Pipe	24	59.885	6.155	0.005	732
50.000	KS24019-L112A	12	14.151	2.657	0.001	1227

### Compression Checks

### Pole Design Data

Section No.	Elevation	Size	L	L <sub>u</sub>	Kl/r	A	P <sub>u</sub>	φP <sub>n</sub>	Ratio P <sub>u</sub> /φP <sub>n</sub>
	ft		ft	ft		in <sup>2</sup>	K	K	
L1	144.25 - 139.25 (1)	TP12.75x12.75x0.375	5.000	0.000	0.0	14.579	-5.140	603.569	0.009
L2	139.25 - 134.75 (2)	TP12.75x12.75x0.375	4.500	0.000	0.0	14.579	-5.425	603.569	0.009
L3	134.75 - 134.25 (3)	TP13.48x13.48x0.375	0.500	0.000	0.0	15.439	-5.461	639.173	0.009
L4	134.25 - 129.25 (4)	TP14.466x13.48x0.188	5.000	0.000	0.0	8.621	-9.099	504.301	0.018
L5	129.25 - 124.25 (5)	TP15.452x14.466x0.188	5.000	0.000	0.0	9.216	-9.446	539.118	0.018
L6	124.25 - 123.416 (6)	TP15.616x15.452x0.188	0.834	0.000	0.0	9.315	-9.511	544.926	0.017
L7	123.416 - 123.166 (7)	TP15.665x15.616x0.538	0.250	0.000	0.0	26.183	-9.550	1531.670	0.006
L8	123.166 - 118.166 (8)	TP16.651x15.665x0.513	5.000	0.000	0.0	26.633	-12.985	1558.020	0.008
L9	118.166 - 113.166 (9)	TP17.637x16.651x0.488	5.000	0.000	0.0	26.920	-13.604	1574.840	0.009
L10	113.166 - 109.5 (10)	TP18.36x17.637x0.475	3.666	0.000	0.0	27.355	-17.383	1600.250	0.011
L11	109.5 - 109.25 (11)	TP18.409x18.36x0.588	0.250	0.000	0.0	33.714	-17.440	1972.260	0.009
L12	109.25 - 104.75 (12)	TP19.296x18.409x0.563	4.500	0.000	0.0	33.931	-18.178	1984.990	0.009
L13	104.75 - 104.5 (13)	TP19.346x19.296x0.775	0.250	0.000	0.0	46.343	-18.245	2711.050	0.007
L14	104.5 - 102.416 (14)	TP19.756x19.346x0.763	2.084	0.000	0.0	46.635	-18.679	2728.130	0.007
L15	102.416 - 102.166 (15)	TP19.806x19.756x0.563	0.250	0.000	0.0	34.854	-18.739	2038.970	0.009
L16	102.166 -	TP20.479x19.806x0.55	3.416	0.000	0.0	35.295	-23.363	2064.730	0.011

<p><b>tnxTower</b></p> <p><b>B+T Group</b> 1717 S. Boulder, Suite 300 Tulsa, OK 74119 Phone: (918) 587-4630 FAX: (918) 295-0265</p>	<p><b>Job</b></p> <p>79982.013.01 - WATERBURY,CT (BU# 876317)</p>	<p><b>Page</b></p> <p>84 of 94</p>
	<p><b>Project</b></p>	<p><b>Date</b></p> <p>15:43:49 05/20/22</p>
	<p><b>Client</b></p> <p>Crown Castle</p>	<p><b>Designed by</b></p> <p>Jayaraj B</p>

Section No.	Elevation ft	Size	L ft	L <sub>u</sub> ft	Kl/r	A in <sup>2</sup>	P <sub>u</sub> K	φP <sub>n</sub> K	Ratio $\frac{P_u}{\phi P_n}$
L17	98.75 (16) 98.75 - 98.5 (17)	TP20.528x20.479x0.838	0.250	0.000	0.0	53.102	-23.446	3106.440	0.008
L18	98.5 - 97.5 (18)	TP20.726x20.528x0.838	1.000	0.000	0.0	53.633	-23.698	3137.550	0.008
L19	97.5 - 97.25 (19)	TP20.775x20.726x0.75	0.250	0.000	0.0	48.360	-23.770	2829.070	0.008
L20	97.25 - 92 (20)	TP21.81x20.775x0.738	5.250	0.000	0.0	48.379	-24.179	2830.160	0.009
L21	92 - 90.552 (21)	TP21.73x20.735x0.8	5.000	0.000	0.0	53.916	-26.223	3154.100	0.008
L22	90.552 - 89.25 (22)	TP21.989x21.73x0.775	1.302	0.000	0.0	52.941	-26.584	3097.030	0.009
L23	89.25 - 89 (23)	TP22.039x21.989x1	0.250	0.000	0.0	67.746	-26.679	3963.150	0.007
L24	89 - 88.25 (24)	TP22.189x22.039x0.975	0.750	0.000	0.0	66.600	-26.907	3896.090	0.007
L25	88.25 - 88 (25)	TP22.238x22.189x0.763	0.250	0.000	0.0	52.729	-26.980	3084.620	0.009
L26	88 - 87.833 (26)	TP22.272x22.238x0.763	0.167	0.000	0.0	52.810	-27.027	3089.390	0.009
L27	87.833 - 87.583 (27)	TP22.321x22.272x0.675	0.250	0.000	0.0	47.048	-27.087	2752.330	0.010
L28	87.583 - 82.583 (28)	TP23.317x22.321x0.65	5.000	0.000	0.0	47.442	-28.328	2775.340	0.010
L29	82.583 - 77.583 (29)	TP24.312x23.317x0.625	5.000	0.000	0.0	47.671	-29.613	2788.740	0.011
L30	77.583 - 77 (30)	TP24.428x24.312x0.625	0.583	0.000	0.0	47.904	-29.775	2802.410	0.011
L31	77 - 76.75 (31)	TP24.478x24.428x0.825	0.250	0.000	0.0	62.835	-29.859	3675.830	0.008
L32	76.75 - 76.333 (32)	TP24.561x24.478x0.825	0.417	0.000	0.0	63.055	-29.983	3688.730	0.008
L33	76.333 - 76.083 (33)	TP24.611x24.561x0.825	0.250	0.000	0.0	63.188	-30.058	3696.470	0.008
L34	76.083 - 74.25 (34)	TP24.976x24.611x0.8	1.833	0.000	0.0	62.277	-30.568	3643.220	0.008
L35	74.25 - 74 (35)	TP25.026x24.976x0.888	0.250	0.000	0.0	68.981	-30.669	4035.390	0.008
L36	74 - 73.75 (36)	TP25.076x25.026x0.888	0.250	0.000	0.0	69.123	-30.744	4043.710	0.008
L37	73.75 - 73.5 (37)	TP25.125x25.076x0.913	0.250	0.000	0.0	71.143	-30.823	4161.880	0.007
L38	73.5 - 68.5 (38)	TP26.121x25.125x0.875	5.000	0.000	0.0	71.130	-32.388	4161.110	0.008
L39	68.5 - 63.5 (39)	TP27.116x26.121x0.85	5.000	0.000	0.0	71.891	-33.985	4205.620	0.008
L40	63.5 - 60.5 (40)	TP27.714x27.116x0.825	3.000	0.000	0.0	71.430	-34.954	4178.630	0.008
L41	60.5 - 60.25 (41)	TP27.763x27.714x0.825	0.250	0.000	0.0	71.562	-35.047	4186.370	0.008
L42	60.25 - 59.5 (42)	TP27.913x27.763x0.825	0.750	0.000	0.0	71.959	-35.284	4209.570	0.008
L43	59.5 - 59.25 (43)	TP27.962x27.913x0.888	0.250	0.000	0.0	77.373	-35.378	4526.350	0.008
L44	59.25 - 54.25 (44)	TP28.958x27.962x0.85	5.000	0.000	0.0	76.932	-37.076	4500.500	0.008
L45	54.25 - 45.802 (45)	TP30.64x28.958x0.838	8.448	0.000	0.0	78.116	-38.547	4569.780	0.008
L46	45.802 - 44.802 (46)	TP30.333x29.304x0.838	5.198	0.000	0.0	79.542	-41.671	4653.200	0.009
L47	44.802 - 43.583 (47)	TP30.574x30.333x0.838	1.219	0.000	0.0	80.192	-42.108	4691.260	0.009
L48	43.583 - 43.333 (48)	TP30.624x30.574x0.85	0.250	0.000	0.0	81.491	-42.218	4767.200	0.009
L49	43.333 - 43.166 (49)	TP30.657x30.624x0.85	0.167	0.000	0.0	81.581	-42.283	4772.490	0.009
L50	43.166 - 42.916 (50)	TP30.706x30.657x0.938	0.250	0.000	0.0	89.864	-42.381	5257.060	0.008
L51	42.916 - 39 (51)	TP31.481x30.706x0.913	3.916	0.000	0.0	89.819	-43.918	5254.390	0.008

<b>tnxTower</b>  <b>B+T Group</b> 1717 S. Boulder, Suite 300 Tulsa, OK 74119 Phone: (918) 587-4630 FAX: (918) 295-0265	<b>Job</b>	79982.013.01 - WATERBURY,CT (BU# 876317)	<b>Page</b>	85 of 94
	<b>Project</b>		<b>Date</b>	15:43:49 05/20/22
	<b>Client</b>	Crown Castle		<b>Designed by</b>

Section No.	Elevation ft	Size	L ft	L <sub>u</sub> ft	Kl/r	A in <sup>2</sup>	P <sub>u</sub> K	φP <sub>n</sub> K	Ratio $\frac{P_u}{\phi P_n}$
L52	39 - 38.75 (52)	TP31.531x31.481x0.95	0.250	0.000	0.0	93.547	-44.036	5472.470	0.008
L53	38.75 - 37.166 (53)	TP31.844x31.531x0.938	1.584	0.000	0.0	93.300	-44.677	5458.030	0.008
L54	37.166 - 36.916 (54)	TP31.894x31.844x0.888	0.250	0.000	0.0	88.608	-44.796	5183.570	0.009
L55	36.916 - 34 (55)	TP32.471x31.894x0.888	2.916	0.000	0.0	88.608	-44.820	5183.570	0.009
L56	34 - 33.75 (56)	TP32.52x32.471x0.875	0.250	0.000	0.0	89.021	-45.987	5207.740	0.009
L57	33.75 - 29.75 (57)	TP33.312x32.52x0.863	4.000	0.000	0.0	87.922	-46.096	5143.420	0.009
L58	29.75 - 29.5 (58)	TP33.361x33.312x0.863	0.250	0.000	0.0	90.120	-47.658	5272.040	0.009
L59	29.5 - 24.5 (59)	TP34.351x33.361x0.85	5.000	0.000	0.0	88.984	-47.768	5205.560	0.009
L60	24.5 - 23 (60)	TP34.648x34.351x0.838	1.500	0.000	0.0	90.378	-49.776	5287.090	0.009
L61	23 - 22.75 (61)	TP34.697x34.648x0.963	0.250	0.000	0.0	104.400	-50.366	6107.370	0.008
L62	22.75 - 21.583 (62)	TP34.928x34.697x0.963	1.167	0.000	0.0	104.553	-50.487	6116.340	0.008
L63	21.583 - 21.333 (63)	TP34.978x34.928x0.85	0.250	0.000	0.0	93.272	-50.989	5456.440	0.009
L64	21.333 - 16.333 (64)	TP35.967x34.978x0.838	5.000	0.000	0.0	92.068	-51.106	5385.980	0.009
L65	16.333 - 12.917 (65)	TP36.644x35.967x0.825	3.416	0.000	0.0	93.356	-53.233	5461.320	0.010
L66	12.917 - 12.667 (66)	TP36.693x36.644x0.913	0.250	0.000	0.0	104.987	-54.688	6141.720	0.009
L67	12.667 - 12.5 (67)	TP36.726x36.693x0.913	0.167	0.000	0.0	105.132	-54.803	6150.220	0.009
L68	12.5 - 12.25 (68)	TP36.776x36.726x0.763	0.250	0.000	0.0	88.299	-54.882	5165.520	0.011
L69	12.25 - 12 (69)	TP36.825x36.776x0.763	0.250	0.000	0.0	88.421	-54.988	5172.630	0.011
L70	12 - 11.75 (70)	TP36.874x36.825x0.663	0.250	0.000	0.0	77.144	-55.093	4512.900	0.012
L71	11.75 - 8.5 (71)	TP37.518x36.874x0.65	3.250	0.000	0.0	75.818	-55.208	4435.340	0.012
L72	8.5 - 8.25 (72)	TP37.567x37.518x0.925	0.250	0.000	0.0	108.991	-56.496	6376.000	0.009
L73	8.25 - 7 (73)	TP37.815x37.567x0.913	1.250	0.000	0.0	107.701	-56.628	6300.490	0.009
L74	7 - 6.75 (74)	TP37.864x37.815x0.813	0.250	0.000	0.0	96.807	-57.217	5663.190	0.010
L75	6.75 - 1.75 (75)	TP38.854x37.864x0.788	5.000	0.000	0.0	94.017	-57.337	5499.990	0.010
L76	1.75 - 0 (76)	TP39.2x38.854x0.788	1.750	0.000	0.0	96.526	-59.526	5646.780	0.011

### Pole Bending Design Data

Section No.	Elevation ft	Size	M <sub>ux</sub> kip-ft	φM <sub>ux</sub> kip-ft	Ratio $\frac{M_{ux}}{\phi M_{ux}}$	M <sub>uy</sub> kip-ft	φM <sub>uy</sub> kip-ft	Ratio $\frac{M_{uy}}{\phi M_{uy}}$
L1	144.25 - 139.25 (1)	TP12.75x12.75x0.375	27.041	198.187	0.136	0.000	198.187	0.000
L2	139.25 - 134.75 (2)	TP12.75x12.75x0.375	57.297	198.187	0.289	0.000	198.187	0.000
L3	134.75 - 134.25 (3)	TP13.48x13.48x0.375	60.703	222.251	0.273	0.000	222.251	0.000
L4	134.25 - 129.25 (4)	TP14.466x13.48x0.188	100.668	183.885	0.547	0.000	183.885	0.000
L5	129.25 - 124.25 (5)	TP15.452x14.466x0.188	157.362	210.328	0.748	0.000	210.328	0.000
L6	124.25 - 123.416 (6)	TP15.616x15.452x0.188	166.898	214.735	0.777	0.000	214.735	0.000
L7	123.416 -	TP15.665x15.616x0.538	169.761	578.929	0.293	0.000	578.929	0.000

Section No.	Elevation ft	Size	$M_{ux}$ kip-ft	$\phi M_{rx}$ kip-ft	Ratio $\frac{M_{ux}}{\phi M_{rx}}$	$M_{uy}$ kip-ft	$\phi M_{ry}$ kip-ft	Ratio $\frac{M_{uy}}{\phi M_{ry}}$
L8	123.166 (7)	TP16.651x15.665x0.513	233.012	630.532	0.370	0.000	630.532	0.000
L9	118.166 (8)	TP17.637x16.651x0.488	306.305	679.450	0.451	0.000	679.450	0.000
L10	113.166 (9)	TP18.36x17.637x0.475	363.354	721.324	0.504	0.000	721.324	0.000
L11	109.5 (10)	TP18.409x18.36x0.588	368.255	880.375	0.418	0.000	880.375	0.000
L12	104.75 (12)	TP19.296x18.409x0.563	457.288	934.067	0.490	0.000	934.067	0.000
L13	104.75 (13)	TP19.346x19.296x0.775	462.279	1250.400	0.370	0.000	1250.400	0.000
L14	102.416 (14)	TP19.756x19.346x0.763	504.102	1288.933	0.391	0.000	1288.933	0.000
L15	102.166 (15)	TP19.806x19.756x0.563	509.143	986.325	0.516	0.000	986.325	0.000
L16	98.75 (16)	TP20.479x19.806x0.55	584.030	1036.033	0.564	0.000	1036.033	0.000
L17	98.75 (17)	TP20.528x20.479x0.838	589.869	1518.050	0.389	0.000	1518.050	0.000
L18	97.5 (18)	TP20.726x20.528x0.838	613.281	1549.233	0.396	0.000	1549.233	0.000
L19	97.5 (19)	TP20.775x20.726x0.75	619.148	1412.833	0.438	0.000	1412.833	0.000
L20	92 (20)	TP21.81x20.775x0.738	659.136	1439.625	0.458	0.000	1439.625	0.000
L21	92 (21)	TP21.73x20.735x0.8	778.704	1645.142	0.473	0.000	1645.142	0.000
L22	90.552 (22)	TP21.989x21.73x0.775	810.215	1639.983	0.494	0.000	1639.983	0.000
L23	89.25 (23)	TP22.039x21.989x1	816.283	2059.442	0.396	0.000	2059.442	0.000
L24	89 (24)	TP22.189x22.039x0.975	834.517	2044.433	0.408	0.000	2044.433	0.000
L25	88.25 (25)	TP22.238x22.189x0.763	840.608	1655.175	0.508	0.000	1655.175	0.000
L26	88 (26)	TP22.272x22.238x0.763	844.683	1660.392	0.509	0.000	1660.392	0.000
L27	87.833 (27)	TP22.321x22.272x0.675	850.783	1494.833	0.569	0.000	1494.833	0.000
L28	82.583 (28)	TP23.317x22.321x0.65	973.717	1582.242	0.615	0.000	1582.242	0.000
L29	82.583 (29)	TP24.312x23.317x0.625	1098.442	1665.175	0.660	0.000	1665.175	0.000
L30	77.583 (30)	TP24.428x24.312x0.625	1113.100	1681.742	0.662	0.000	1681.742	0.000
L31	76.75 (31)	TP24.478x24.428x0.825	1119.383	2173.708	0.515	0.000	2173.708	0.000
L32	76.75 (32)	TP24.561x24.478x0.825	1129.883	2189.250	0.516	0.000	2189.250	0.000
L33	76.333 (33)	TP24.611x24.561x0.825	1136.183	2198.600	0.517	0.000	2198.600	0.000
L34	76.083 (34)	TP24.976x24.611x0.8	1182.492	2205.850	0.536	0.000	2205.850	0.000
L35	74.25 (35)	TP25.026x24.976x0.888	1188.825	2430.833	0.489	0.000	2430.833	0.000
L36	74 (36)	TP25.076x25.026x0.888	1195.167	2441.050	0.490	0.000	2441.050	0.000
L37	73.75 (37)	TP25.125x25.076x0.913	1201.508	2512.542	0.478	0.000	2512.542	0.000
L38	73.5 (38)	TP26.121x25.125x0.875	1329.250	2626.917	0.506	0.000	2626.917	0.000
L39	68.5 (39)	TP27.116x26.121x0.85	1458.583	2768.483	0.527	0.000	2768.483	0.000
L40	63.5 (40)	TP27.714x27.116x0.825	1537.033	2820.475	0.545	0.000	2820.475	0.000
L41	60.5 (41)	TP27.763x27.714x0.825	1543.608	2831.083	0.545	0.000	2831.083	0.000
L42	60.25 (42)	TP27.913x27.763x0.825	1563.350	2863.033	0.546	0.000	2863.033	0.000

<p><b>tnxTower</b></p> <p><b>B+T Group</b> 1717 S. Boulder, Suite 300 Tulsa, OK 74119 Phone: (918) 587-4630 FAX: (918) 295-0265</p>	<p><b>Job</b></p> <p>79982.013.01 - WATERBURY,CT (BU# 876317)</p>	<p><b>Page</b></p> <p>87 of 94</p>
	<p><b>Project</b></p>	<p><b>Date</b></p> <p>15:43:49 05/20/22</p>
	<p><b>Client</b></p> <p>Crown Castle</p>	<p><b>Designed by</b></p> <p>Jayaraj B</p>

Section No.	Elevation ft	Size	$M_{ux}$ kip-ft	$\phi M_{rx}$ kip-ft	Ratio $\frac{M_{ux}}{\phi M_{rx}}$	$M_{uy}$ kip-ft	$\phi M_{ry}$ kip-ft	Ratio $\frac{M_{uy}}{\phi M_{ry}}$
L43	59.5 - 59.25 (43)	TP27.962x27.913x0.888	1569.942	3070.117	0.511	0.000	3070.117	0.000
L44	59.25 - 54.25 (44)	TP28.958x27.962x0.85	1702.892	3176.850	0.536	0.000	3176.850	0.000
L45	54.25 - 45.802 (45)	TP30.64x28.958x0.838	1817.517	3328.592	0.546	0.000	3328.592	0.000
L46	45.802 - 44.802 (46)	TP30.333x29.304x0.838	1960.408	3452.967	0.568	0.000	3452.967	0.000
L47	44.802 - 43.583 (47)	TP30.574x30.333x0.838	1994.250	3510.467	0.568	0.000	3510.467	0.000
L48	43.583 - 43.333 (48)	TP30.624x30.574x0.85	2001.200	3570.392	0.560	0.000	3570.392	0.000
L49	43.333 - 43.166 (49)	TP30.657x30.624x0.85	2005.842	3578.433	0.561	0.000	3578.433	0.000
L50	43.166 - 42.916 (50)	TP30.706x30.657x0.938	2012.800	3925.383	0.513	0.000	3925.383	0.000
L51	42.916 - 39 (51)	TP31.481x30.706x0.913	2122.175	4035.258	0.526	0.000	4035.258	0.000
L52	39 - 38.75 (52)	TP31.531x31.481x0.95	2129.192	4199.433	0.507	0.000	4199.433	0.000
L53	38.75 - 37.166 (53)	TP31.844x31.531x0.938	2173.683	4236.008	0.513	0.000	4236.008	0.000
L54	37.166 - 36.916 (54)	TP31.894x31.844x0.888	2180.717	4042.658	0.539	0.000	4042.658	0.000
L55	36.916 - 34 (55)	TP32.471x31.894x0.888	2180.717	4042.658	0.539	0.000	4042.658	0.000
L56	34 - 33.75 (56)	TP32.52x32.471x0.875	2262.983	4142.492	0.546	0.000	4142.492	0.000
L57	33.75 - 29.75 (57)	TP33.312x32.52x0.863	2270.050	4101.142	0.554	0.000	4101.142	0.000
L58	29.75 - 29.5 (58)	TP33.361x33.312x0.863	2383.533	4311.608	0.553	0.000	4311.608	0.000
L59	29.5 - 24.5 (59)	TP34.351x33.361x0.85	2390.642	4267.175	0.560	0.000	4267.175	0.000
L60	24.5 - 23 (60)	TP34.648x34.351x0.838	2533.358	4472.633	0.566	0.000	4472.633	0.000
L61	23 - 22.75 (61)	TP34.697x34.648x0.963	2576.342	5174.958	0.498	0.000	5174.958	0.000
L62	22.75 - 21.583 (62)	TP34.928x34.697x0.963	2583.517	5190.383	0.498	0.000	5190.383	0.000
L63	21.583 - 21.333 (63)	TP34.978x34.928x0.85	2617.025	4693.900	0.558	0.000	4693.900	0.000
L64	21.333 - 16.333 (64)	TP35.967x34.978x0.838	2624.217	4643.575	0.565	0.000	4643.575	0.000
L65	16.333 - 12.917 (65)	TP36.644x35.967x0.825	2768.317	4851.733	0.571	0.000	4851.733	0.000
L66	12.917 - 12.667 (66)	TP36.693x36.644x0.913	2867.200	5536.417	0.518	0.000	5536.417	0.000
L67	12.667 - 12.5 (67)	TP36.726x36.693x0.913	2874.450	5551.950	0.518	0.000	5551.950	0.000
L68	12.5 - 12.25 (68)	TP36.776x36.726x0.763	2879.300	4706.633	0.612	0.000	4706.633	0.000
L69	12.25 - 12 (69)	TP36.825x36.776x0.763	2886.550	4719.725	0.612	0.000	4719.725	0.000
L70	12 - 11.75 (70)	TP36.874x36.825x0.663	2893.808	4146.442	0.698	0.000	4146.442	0.000
L71	11.75 - 8.5 (71)	TP37.518x36.874x0.65	2901.067	4083.675	0.710	0.000	4083.675	0.000
L72	8.5 - 8.25 (72)	TP37.567x37.518x0.925	2995.800	5887.708	0.509	0.000	5887.708	0.000
L73	8.25 - 7 (73)	TP37.815x37.567x0.913	3003.117	5830.017	0.515	0.000	5830.017	0.000
L74	7 - 6.75 (74)	TP37.864x37.815x0.813	3039.792	5305.175	0.573	0.000	5305.175	0.000
L75	6.75 - 1.75 (75)	TP38.854x37.864x0.788	3047.142	5166.292	0.590	0.000	5166.292	0.000
L76	1.75 - 0 (76)	TP39.2x38.854x0.788	3195.392	5448.700	0.586	0.000	5448.700	0.000

**Pole Shear Design Data**

Section No.	Elevation ft	Size	Actual $V_u$ K	$\phi V_n$ K	Ratio $\frac{V_u}{\phi V_n}$	Actual $T_u$ kip-ft	$\phi T_n$ kip-ft	Ratio $\frac{T_u}{\phi T_n}$
L1	144.25 - 139.25 (1)	TP12.75x12.75x0.375	6.639	181.071	0.037	0.530	197.003	0.003
L2	139.25 - 134.75 (2)	TP12.75x12.75x0.375	6.804	181.071	0.038	0.530	197.003	0.003
L3	134.75 - 134.25 (3)	TP13.48x13.48x0.375	6.821	191.752	0.036	0.530	220.931	0.002
L4	134.25 - 129.25 (4)	TP14.466x13.48x0.188	11.263	149.201	0.075	1.061	190.015	0.006
L5	129.25 - 124.25 (5)	TP15.452x14.466x0.188	11.432	161.736	0.071	1.059	217.158	0.005
L6	124.25 - 123.416 (6)	TP15.616x15.452x0.188	11.456	163.478	0.070	1.059	221.863	0.005
L7	123.416 - 123.166 (7)	TP15.665x15.616x0.538	11.460	459.502	0.025	1.059	611.454	0.002
L8	123.166 - 118.166 (8)	TP16.651x15.665x0.513	14.545	467.405	0.031	1.058	663.528	0.002
L9	118.166 - 113.166 (9)	TP17.637x16.651x0.488	14.787	472.451	0.031	1.057	712.699	0.001
L10	113.166 - 109.5 (10)	TP18.36x17.637x0.475	19.612	480.074	0.041	0.987	755.248	0.001
L11	109.5 - 109.25 (11)	TP18.409x18.36x0.588	19.619	591.677	0.033	0.546	927.533	0.001
L12	109.25 - 104.75 (12)	TP19.296x18.409x0.563	19.972	595.497	0.034	0.542	981.300	0.001
L13	104.75 - 104.5 (13)	TP19.346x19.296x0.775	19.983	813.314	0.025	0.540	1328.558	0.000
L14	104.5 - 102.416 (14)	TP19.756x19.346x0.763	20.171	818.440	0.025	0.538	1367.417	0.000
L15	102.416 - 102.166 (15)	TP19.806x19.756x0.563	20.180	611.691	0.033	0.536	1035.400	0.001
L16	102.166 - 98.75 (16)	TP20.479x19.806x0.55	23.366	619.420	0.038	0.532	1085.858	0.000
L17	98.75 - 98.5 (17)	TP20.528x20.479x0.838	23.373	931.933	0.025	0.530	1614.175	0.000
L18	98.5 - 97.5 (18)	TP20.726x20.528x0.838	23.472	941.264	0.025	0.530	1646.667	0.000
L19	97.5 - 97.25 (19)	TP20.775x20.726x0.75	23.486	848.721	0.028	0.529	1494.983	0.000
L20	97.25 - 92 (20)	TP21.81x20.775x0.738	23.648	849.049	0.028	0.528	1521.492	0.000
L21	92 - 90.552 (21)	TP21.73x20.735x0.8	24.173	946.229	0.026	0.528	1742.083	0.000
L22	90.552 - 89.25 (22)	TP21.989x21.73x0.775	24.281	929.108	0.026	0.528	1733.792	0.000
L23	89.25 - 89 (23)	TP22.039x21.989x1	24.288	1188.950	0.020	0.526	2200.350	0.000
L24	89 - 88.25 (24)	TP22.189x22.039x0.975	24.365	1168.830	0.021	0.526	2181.042	0.000
L25	88.25 - 88 (25)	TP22.238x22.189x0.763	24.381	925.385	0.026	0.525	1748.125	0.000
L26	88 - 87.833 (26)	TP22.272x22.238x0.763	24.396	926.817	0.026	0.524	1753.542	0.000
L27	87.833 - 87.583 (27)	TP22.321x22.272x0.675	24.414	825.698	0.030	0.524	1572.192	0.000
L28	87.583 - 82.583 (28)	TP23.317x22.321x0.65	24.794	832.602	0.030	0.520	1660.075	0.000
L29	82.583 - 77.583 (29)	TP24.312x23.317x0.625	25.145	836.622	0.030	0.517	1743.192	0.000
L30	77.583 - 77 (30)	TP24.428x24.312x0.625	25.164	840.722	0.030	0.516	1760.317	0.000
L31	77 - 76.75 (31)	TP24.478x24.428x0.825	25.172	1102.750	0.023	0.516	2294.383	0.000
L32	76.75 - 76.333 (32)	TP24.561x24.478x0.825	25.201	1106.620	0.023	0.516	2310.525	0.000
L33	76.333 -	TP24.611x24.561x0.825	25.215	1108.940	0.023	0.516	2320.225	0.000

Section No.	Elevation ft	Size	Actual $V_u$ K	$\phi V_n$ K	Ratio $\frac{V_u}{\phi V_n}$	Actual $T_u$ kip-ft	$\phi T_n$ kip-ft	Ratio $\frac{T_u}{\phi T_n}$
L34	76.083 (33) 76.083 - 74.25 (34)	TP24.976x24.611x0.8	25.357	1092.970	0.023	0.516	2324.292	0.000
L35	74.25 - 74 (35)	TP25.026x24.976x0.888	25.350	1210.620	0.021	0.517	2570.467	0.000
L36	74 - 73.75 (36)	TP25.076x25.026x0.888	25.371	1213.110	0.021	0.518	2581.075	0.000
L37	73.75 - 73.5 (37)	TP25.125x25.076x0.913	25.393	1248.560	0.020	0.519	2659.225	0.000
L38	73.5 - 68.5 (38)	TP26.121x25.125x0.875	25.731	1248.330	0.021	0.518	2772.167	0.000
L39	68.5 - 63.5 (39)	TP27.116x26.121x0.85	26.047	1261.680	0.021	0.518	2915.075	0.000
L40	63.5 - 60.5 (40)	TP27.714x27.116x0.825	26.296	1253.590	0.021	0.529	2964.992	0.000
L41	60.5 - 60.25 (41)	TP27.763x27.714x0.825	26.302	1255.910	0.021	0.530	2975.975	0.000
L42	60.25 - 59.5 (42)	TP27.913x27.763x0.825	26.375	1262.870	0.021	0.532	3009.058	0.000
L43	59.5 - 59.25 (43)	TP27.962x27.913x0.888	26.387	1357.910	0.019	0.533	3233.983	0.000
L44	59.25 - 54.25 (44)	TP28.958x27.962x0.85	26.822	1350.150	0.020	0.553	3338.192	0.000
L45	54.25 - 45.802 (45)	TP30.64x28.958x0.838	27.164	1370.930	0.020	0.570	3493.133	0.000
L46	45.802 - 44.802 (46)	TP30.333x29.304x0.838	27.757	1395.960	0.020	0.403	3621.825	0.000
L47	44.802 - 43.583 (47)	TP30.574x30.333x0.838	27.823	1407.380	0.020	0.403	3681.317	0.000
L48	43.583 - 43.333 (48)	TP30.624x30.574x0.85	27.814	1430.160	0.019	0.403	3745.558	0.000
L49	43.333 - 43.166 (49)	TP30.657x30.624x0.85	27.821	1431.750	0.019	0.403	3753.883	0.000
L50	43.166 - 42.916 (50)	TP30.706x30.657x0.938	27.836	1577.120	0.018	0.403	4129.758	0.000
L51	42.916 - 39 (51)	TP31.481x30.706x0.913	28.064	1576.320	0.018	0.402	4238.592	0.000
L52	39 - 38.75 (52)	TP31.531x31.481x0.95	28.055	1641.740	0.017	0.402	4416.233	0.000
L53	38.75 - 37.166 (53)	TP31.844x31.531x0.938	28.166	1637.410	0.017	0.402	4451.542	0.000
L54	37.166 - 36.916 (54)	TP31.894x31.844x0.888	28.151	1555.070	0.018	0.402	4241.300	0.000
L55	36.916 - 34 (55)	TP32.471x31.894x0.888	28.246	1569.540	0.018	0.402	4241.300	0.000
L56	34 - 33.75 (56)	TP32.52x32.471x0.875	28.299	1564.770	0.018	0.402	4342.108	0.000
L57	33.75 - 29.75 (57)	TP33.312x32.52x0.863	28.355	1552.670	0.018	0.402	4296.883	0.000
L58	29.75 - 29.5 (58)	TP33.361x33.312x0.863	28.464	1584.020	0.018	0.402	4514.475	0.000
L59	29.5 - 24.5 (59)	TP34.351x33.361x0.85	28.516	1571.170	0.018	0.402	4466.058	0.000
L60	24.5 - 23 (60)	TP34.648x34.351x0.838	28.718	1600.180	0.018	0.510	4675.825	0.000
L61	23 - 22.75 (61)	TP34.697x34.648x0.963	28.697	1834.900	0.016	0.510	5428.967	0.000
L62	22.75 - 21.583 (62)	TP34.928x34.697x0.963	28.763	1847.470	0.016	0.510	5444.933	0.000
L63	21.583 - 21.333 (63)	TP34.978x34.928x0.85	28.753	1639.310	0.018	0.510	4906.925	0.000
L64	21.333 - 16.333 (64)	TP35.967x34.978x0.838	28.800	1625.160	0.018	0.510	4852.367	0.000
L65	16.333 - 12.917 (65)	TP36.644x35.967x0.825	28.955	1648.900	0.018	0.510	5064.658	0.000
L66	12.917 - 12.667 (66)	TP36.693x36.644x0.913	29.016	1845.070	0.016	0.510	5791.033	0.000
L67	12.667 - 12.5 (67)	TP36.726x36.693x0.913	29.021	1846.770	0.016	0.510	5807.083	0.000
L68	12.5 - 12.25	TP36.776x36.726x0.763	29.031	1551.790	0.019	0.510	4902.275	0.000

<b>tnxTower</b>  <b>B+T Group</b> 1717 S. Boulder, Suite 300 Tulsa, OK 74119 Phone: (918) 587-4630 FAX: (918) 295-0265	<b>Job</b> 79982.013.01 - WATERBURY,CT (BU# 876317)	<b>Page</b> 90 of 94
	<b>Project</b>	<b>Date</b> 15:43:49 05/20/22
	<b>Client</b> Crown Castle	<b>Designed by</b> Jayaraj B

Section No.	Elevation ft	Size	Actual $V_u$ K	$\phi V_n$ K	Ratio $\frac{V_u}{\phi V_n}$	Actual $T_u$ kip-ft	$\phi T_n$ kip-ft	Ratio $\frac{T_u}{\phi T_n}$
	(68)							
L69	12.25 - 12 (69)	TP36.825x36.776x0.763	29.038	1553.920	0.019	0.510	4915.775	0.000
L70	12 - 11.75 (70)	TP36.874x36.825x0.663	29.044	1355.720	0.021	0.510	4306.608	0.000
L71	11.75 - 8.5 (71)	TP37.518x36.874x0.65	29.143	1338.480	0.022	0.510	4239.850	0.000
L72	8.5 - 8.25 (72)	TP37.567x37.518x0.925	29.284	1915.390	0.015	0.480	6156.925	0.000
L73	8.25 - 7 (73)	TP37.815x37.567x0.913	29.429	1902.900	0.015	0.477	6094.317	0.000
L74	7 - 6.75 (74)	TP37.864x37.815x0.813	29.430	1701.230	0.017	0.465	5529.792	0.000
L75	6.75 - 1.75 (75)	TP38.854x37.864x0.788	29.539	1658.800	0.018	0.462	5381.242	0.000
L76	1.75 - 0 (76)	TP39.2x38.854x0.788	30.080	1709.450	0.018	0.433	5672.325	0.000

### Pole Interaction Design Data

Section No.	Elevation ft	Ratio $\frac{P_u}{\phi P_n}$	Ratio $\frac{M_{ux}}{\phi M_{nx}}$	Ratio $\frac{M_{uy}}{\phi M_{ny}}$	Ratio $\frac{V_u}{\phi V_n}$	Ratio $\frac{T_u}{\phi T_n}$	Comb. Stress Ratio	Allow. Stress Ratio	Criteria
L1	144.25 - 139.25 (1)	0.009	0.136	0.000	0.037	0.003	0.147	1.050	4.8.2 ✓
L2	139.25 - 134.75 (2)	0.009	0.289	0.000	0.038	0.003	0.300	1.050	4.8.2 ✓
L3	134.75 - 134.25 (3)	0.009	0.273	0.000	0.036	0.002	0.283	1.050	4.8.2 ✓
L4	134.25 - 129.25 (4)	0.018	0.547	0.000	0.075	0.006	0.572	1.050	4.8.2 ✓
L5	129.25 - 124.25 (5)	0.018	0.748	0.000	0.071	0.005	0.771	1.050	4.8.2 ✓
L6	124.25 - 123.416 (6)	0.017	0.777	0.000	0.070	0.005	0.800	1.050	4.8.2 ✓
L7	123.416 - 123.166 (7)	0.006	0.293	0.000	0.025	0.002	0.300	1.050	4.8.2 ✓
L8	123.166 - 118.166 (8)	0.008	0.370	0.000	0.031	0.002	0.379	1.050	4.8.2 ✓
L9	118.166 - 113.166 (9)	0.009	0.451	0.000	0.031	0.001	0.461	1.050	4.8.2 ✓
L10	113.166 - 109.5 (10)	0.011	0.504	0.000	0.041	0.001	0.516	1.050	4.8.2 ✓
L11	109.5 - 109.25 (11)	0.009	0.418	0.000	0.033	0.001	0.428	1.050	4.8.2 ✓
L12	109.25 - 104.75 (12)	0.009	0.490	0.000	0.034	0.001	0.500	1.050	4.8.2 ✓
L13	104.75 - 104.5 (13)	0.007	0.370	0.000	0.025	0.000	0.377	1.050	4.8.2 ✓
L14	104.5 - 102.416 (14)	0.007	0.391	0.000	0.025	0.000	0.399	1.050	4.8.2 ✓
L15	102.416 - 102.166 (15)	0.009	0.516	0.000	0.033	0.001	0.527	1.050	4.8.2 ✓
L16	102.166 - 98.75 (16)	0.011	0.564	0.000	0.038	0.000	0.576	1.050	4.8.2 ✓
L17	98.75 - 98.5 (17)	0.008	0.389	0.000	0.025	0.000	0.397	1.050	4.8.2 ✓

<p><b>tnxTower</b></p> <p><b>B+T Group</b> 1717 S. Boulder, Suite 300 Tulsa, OK 74119 Phone: (918) 587-4630 FAX: (918) 295-0265</p>	<p><b>Job</b></p> <p>79982.013.01 - WATERBURY,CT (BU# 876317)</p>	<p><b>Page</b></p> <p>91 of 94</p>
	<p><b>Project</b></p>	<p><b>Date</b></p> <p>15:43:49 05/20/22</p>
	<p><b>Client</b></p> <p>Crown Castle</p>	<p><b>Designed by</b></p> <p>Jayaraj B</p>

Section No.	Elevation ft	Ratio $P_u$ $\phi P_n$	Ratio $M_{ux}$ $\phi M_{nx}$	Ratio $M_{uy}$ $\phi M_{ny}$	Ratio $V_u$ $\phi V_n$	Ratio $T_u$ $\phi T_n$	Comb. Stress Ratio	Allow. Stress Ratio	Criteria
L18	98.5 - 97.5 (18)	0.008	0.396	0.000	0.025	0.000	0.404	1.050	4.8.2 ✓
L19	97.5 - 97.25 (19)	0.008	0.438	0.000	0.028	0.000	0.447	1.050	4.8.2 ✓
L20	97.25 - 92 (20)	0.009	0.458	0.000	0.028	0.000	0.467	1.050	4.8.2 ✓
L21	92 - 90.552 (21)	0.008	0.473	0.000	0.026	0.000	0.482	1.050	4.8.2 ✓
L22	90.552 - 89.25 (22)	0.009	0.494	0.000	0.026	0.000	0.503	1.050	4.8.2 ✓
L23	89.25 - 89 (23)	0.007	0.396	0.000	0.020	0.000	0.404	1.050	4.8.2 ✓
L24	89 - 88.25 (24)	0.007	0.408	0.000	0.021	0.000	0.416	1.050	4.8.2 ✓
L25	88.25 - 88 (25)	0.009	0.508	0.000	0.026	0.000	0.517	1.050	4.8.2 ✓
L26	88 - 87.833 (26)	0.009	0.509	0.000	0.026	0.000	0.518	1.050	4.8.2 ✓
L27	87.833 - 87.583 (27)	0.010	0.569	0.000	0.030	0.000	0.580	1.050	4.8.2 ✓
L28	87.583 - 82.583 (28)	0.010	0.615	0.000	0.030	0.000	0.627	1.050	4.8.2 ✓
L29	82.583 - 77.583 (29)	0.011	0.660	0.000	0.030	0.000	0.671	1.050	4.8.2 ✓
L30	77.583 - 77 (30)	0.011	0.662	0.000	0.030	0.000	0.673	1.050	4.8.2 ✓
L31	77 - 76.75 (31)	0.008	0.515	0.000	0.023	0.000	0.524	1.050	4.8.2 ✓
L32	76.75 - 76.333 (32)	0.008	0.516	0.000	0.023	0.000	0.525	1.050	4.8.2 ✓
L33	76.333 - 76.083 (33)	0.008	0.517	0.000	0.023	0.000	0.525	1.050	4.8.2 ✓
L34	76.083 - 74.25 (34)	0.008	0.536	0.000	0.023	0.000	0.545	1.050	4.8.2 ✓
L35	74.25 - 74 (35)	0.008	0.489	0.000	0.021	0.000	0.497	1.050	4.8.2 ✓
L36	74 - 73.75 (36)	0.008	0.490	0.000	0.021	0.000	0.498	1.050	4.8.2 ✓
L37	73.75 - 73.5 (37)	0.007	0.478	0.000	0.020	0.000	0.486	1.050	4.8.2 ✓
L38	73.5 - 68.5 (38)	0.008	0.506	0.000	0.021	0.000	0.514	1.050	4.8.2 ✓
L39	68.5 - 63.5 (39)	0.008	0.527	0.000	0.021	0.000	0.535	1.050	4.8.2 ✓
L40	63.5 - 60.5 (40)	0.008	0.545	0.000	0.021	0.000	0.554	1.050	4.8.2 ✓
L41	60.5 - 60.25 (41)	0.008	0.545	0.000	0.021	0.000	0.554	1.050	4.8.2 ✓
L42	60.25 - 59.5 (42)	0.008	0.546	0.000	0.021	0.000	0.555	1.050	4.8.2 ✓
L43	59.5 - 59.25 (43)	0.008	0.511	0.000	0.019	0.000	0.520	1.050	4.8.2 ✓

# tnxTower

**B+T Group**  
1717 S. Boulder, Suite 300  
Tulsa, OK 74119  
Phone: (918) 587-4630  
FAX: (918) 295-0265

<b>Job</b> 79982.013.01 - WATERBURY,CT (BU# 876317)	<b>Page</b> 92 of 94
<b>Project</b>	<b>Date</b> 15:43:49 05/20/22
<b>Client</b> Crown Castle	<b>Designed by</b> Jayaraj B

Section No.	Elevation ft	Ratio $P_u$ $\phi P_n$	Ratio $M_{ux}$ $\phi M_{nx}$	Ratio $M_{uy}$ $\phi M_{ny}$	Ratio $V_u$ $\phi V_n$	Ratio $T_u$ $\phi T_n$	Comb. Stress Ratio	Allow. Stress Ratio	Criteria
L44	59.25 - 54.25 (44)	0.008	0.536	0.000	0.020	0.000	0.545	1.050	4.8.2 ✓
L45	54.25 - 45.802 (45)	0.008	0.546	0.000	0.020	0.000	0.555	1.050	4.8.2 ✓
L46	45.802 - 44.802 (46)	0.009	0.568	0.000	0.020	0.000	0.577	1.050	4.8.2 ✓
L47	44.802 - 43.583 (47)	0.009	0.568	0.000	0.020	0.000	0.577	1.050	4.8.2 ✓
L48	43.583 - 43.333 (48)	0.009	0.560	0.000	0.019	0.000	0.570	1.050	4.8.2 ✓
L49	43.333 - 43.166 (49)	0.009	0.561	0.000	0.019	0.000	0.570	1.050	4.8.2 ✓
L50	43.166 - 42.916 (50)	0.008	0.513	0.000	0.018	0.000	0.521	1.050	4.8.2 ✓
L51	42.916 - 39 (51)	0.008	0.526	0.000	0.018	0.000	0.535	1.050	4.8.2 ✓
L52	39 - 38.75 (52)	0.008	0.507	0.000	0.017	0.000	0.515	1.050	4.8.2 ✓
L53	38.75 - 37.166 (53)	0.008	0.513	0.000	0.017	0.000	0.522	1.050	4.8.2 ✓
L54	37.166 - 36.916 (54)	0.009	0.539	0.000	0.018	0.000	0.548	1.050	4.8.2 ✓
L55	36.916 - 34 (55)	0.009	0.539	0.000	0.018	0.000	0.548	1.050	4.8.2 ✓
L56	34 - 33.75 (56)	0.009	0.546	0.000	0.018	0.000	0.555	1.050	4.8.2 ✓
L57	33.75 - 29.75 (57)	0.009	0.554	0.000	0.018	0.000	0.563	1.050	4.8.2 ✓
L58	29.75 - 29.5 (58)	0.009	0.553	0.000	0.018	0.000	0.562	1.050	4.8.2 ✓
L59	29.5 - 24.5 (59)	0.009	0.560	0.000	0.018	0.000	0.570	1.050	4.8.2 ✓
L60	24.5 - 23 (60)	0.009	0.566	0.000	0.018	0.000	0.576	1.050	4.8.2 ✓
L61	23 - 22.75 (61)	0.008	0.498	0.000	0.016	0.000	0.506	1.050	4.8.2 ✓
L62	22.75 - 21.583 (62)	0.008	0.498	0.000	0.016	0.000	0.506	1.050	4.8.2 ✓
L63	21.583 - 21.333 (63)	0.009	0.558	0.000	0.018	0.000	0.567	1.050	4.8.2 ✓
L64	21.333 - 16.333 (64)	0.009	0.565	0.000	0.018	0.000	0.575	1.050	4.8.2 ✓
L65	16.333 - 12.917 (65)	0.010	0.571	0.000	0.018	0.000	0.581	1.050	4.8.2 ✓
L66	12.917 - 12.667 (66)	0.009	0.518	0.000	0.016	0.000	0.527	1.050	4.8.2 ✓
L67	12.667 - 12.5 (67)	0.009	0.518	0.000	0.016	0.000	0.527	1.050	4.8.2 ✓
L68	12.5 - 12.25 (68)	0.011	0.612	0.000	0.019	0.000	0.623	1.050	4.8.2 ✓
L69	12.25 - 12 (69)	0.011	0.612	0.000	0.019	0.000	0.623	1.050	4.8.2 ✓

<b>tnxTower</b>  <b>B+T Group</b> 1717 S. Boulder, Suite 300 Tulsa, OK 74119 Phone: (918) 587-4630 FAX: (918) 295-0265	<b>Job</b>	79982.013.01 - WATERBURY,CT (BU# 876317)	<b>Page</b>	93 of 94
	<b>Project</b>		<b>Date</b>	15:43:49 05/20/22
	<b>Client</b>	Crown Castle		<b>Designed by</b>

Section No.	Elevation ft	Ratio $P_u$	Ratio $M_{ux}$	Ratio $M_{uy}$	Ratio $V_u$	Ratio $T_u$	Comb. Stress Ratio	Allow. Stress Ratio	Criteria
		$\phi P_n$	$\phi M_{nx}$	$\phi M_{ny}$	$\phi V_n$	$\phi T_n$			
L70	12 - 11.75 (70)	0.012	0.698	0.000	0.021	0.000	0.711	1.050	4.8.2 ✓
L71	11.75 - 8.5 (71)	0.012	0.710	0.000	0.022	0.000	0.723	1.050	4.8.2 ✓
L72	8.5 - 8.25 (72)	0.009	0.509	0.000	0.015	0.000	0.518	1.050	4.8.2 ✓
L73	8.25 - 7 (73)	0.009	0.515	0.000	0.015	0.000	0.524	1.050	4.8.2 ✓
L74	7 - 6.75 (74)	0.010	0.573	0.000	0.017	0.000	0.583	1.050	4.8.2 ✓
L75	6.75 - 1.75 (75)	0.010	0.590	0.000	0.018	0.000	0.601	1.050	4.8.2 ✓
L76	1.75 - 0 (76)	0.011	0.586	0.000	0.018	0.000	0.597	1.050	4.8.2 ✓

### Section Capacity Table

Section No.	Elevation ft	Component Type	Size	Critical Element	P K	$\phi P_{allow}$ K	% Capacity	Pass Fail
L1	144.25 - 139.25	Pole	TP12.75x12.75x0.375	1	-5.140	633.747	**	**
L2	139.25 - 134.75	Pole	TP12.75x12.75x0.375	2	-5.425	633.747	**	**
L3	134.75 - 134.25	Pole	TP13.48x13.48x0.375	3	-5.461	671.132	**	**
L4	134.25 - 129.25	Pole	TP14.466x13.48x0.188	4	-9.099	529.516	**	**
L5	129.25 - 124.25	Pole	TP15.452x14.466x0.188	5	-9.446	566.074	**	**
L6	124.25 - 123.416	Pole	TP15.616x15.452x0.188	6	-9.511	572.172	**	**
L7	123.416 - 123.166	Pole	TP15.665x15.616x0.538	7	-9.550	1608.253	**	**
L8	123.166 - 118.166	Pole	TP16.651x15.665x0.513	8	-12.985	1635.921	**	**
L9	118.166 - 113.166	Pole	TP17.637x16.651x0.488	9	-13.604	1653.582	**	**
L10	113.166 - 109.5	Pole	TP18.36x17.637x0.475	10	-17.383	1680.262	**	**
L11	109.5 - 109.25	Pole	TP18.409x18.36x0.588	11	-17.440	2070.873	**	**
L12	109.25 - 104.75	Pole	TP19.296x18.409x0.563	12	-18.178	2084.239	**	**
L13	104.75 - 104.5	Pole	TP19.346x19.296x0.775	13	-18.245	2846.602	**	**
L14	104.5 - 102.416	Pole	TP19.756x19.346x0.763	14	-18.679	2864.536	**	**
L15	102.416 - 102.166	Pole	TP19.806x19.756x0.563	15	-18.739	2140.918	**	**
L16	102.166 - 98.75	Pole	TP20.479x19.806x0.55	16	-23.363	2167.966	**	**
L17	98.75 - 98.5	Pole	TP20.528x20.479x0.838	17	-23.446	3261.762	**	**
L18	98.5 - 97.5	Pole	TP20.726x20.528x0.838	18	-23.698	3294.427	**	**
L19	97.5 - 97.25	Pole	TP20.775x20.726x0.75	19	-23.770	2970.523	**	**
L20	97.25 - 92	Pole	TP21.81x20.775x0.738	20	-24.179	2971.668	**	**
L21	92 - 90.552	Pole	TP21.73x20.735x0.8	21	-26.223	3311.805	**	**
L22	90.552 - 89.25	Pole	TP21.989x21.73x0.775	22	-26.584	3251.881	**	**
L23	89.25 - 89	Pole	TP22.039x21.989x1	23	-26.679	4161.307	**	**
L24	89 - 88.25	Pole	TP22.189x22.039x0.975	24	-26.907	4090.894	**	**
L25	88.25 - 88	Pole	TP22.238x22.189x0.763	25	-26.980	3238.851	**	**
L26	88 - 87.833	Pole	TP22.272x22.238x0.763	26	-27.027	3243.859	**	**
L27	87.833 - 87.583	Pole	TP22.321x22.272x0.675	27	-27.087	2889.946	**	**
L28	87.583 - 82.583	Pole	TP23.317x22.321x0.65	28	-28.328	2914.107	**	**
L29	82.583 - 77.583	Pole	TP24.312x23.317x0.625	29	-29.613	2928.177	**	**
L30	77.583 - 77	Pole	TP24.428x24.312x0.625	30	-29.775	2942.530	**	**
L31	77 - 76.75	Pole	TP24.478x24.428x0.825	31	-29.859	3859.621	**	**
L32	76.75 - 76.333	Pole	TP24.561x24.478x0.825	32	-29.983	3873.166	**	**

<b>Job</b>	79982.013.01 - WATERBURY,CT (BU# 876317)	<b>Page</b>	94 of 94
<b>Project</b>		<b>Date</b>	15:43:49 05/20/22
<b>Client</b>	Crown Castle	<b>Designed by</b>	Jayaraj B

Section No.	Elevation ft	Component Type	Size	Critical Element	P K	$\phi P_{allow}$ K	% Capacity	Pass Fail
L33	76.333 - 76.083	Pole	TP24.611x24.561x0.825	33	-30.058	3881.293	**	**
L34	76.083 - 74.25	Pole	TP24.976x24.611x0.8	34	-30.568	3825.381	**	**
L35	74.25 - 74	Pole	TP25.026x24.976x0.888	35	-30.669	4237.159	**	**
L36	74 - 73.75	Pole	TP25.076x25.026x0.888	36	-30.744	4245.895	**	**
L37	73.75 - 73.5	Pole	TP25.125x25.076x0.913	37	-30.823	4369.974	**	**
L38	73.5 - 68.5	Pole	TP26.121x25.125x0.875	38	-32.388	4369.165	**	**
L39	68.5 - 63.5	Pole	TP27.116x26.121x0.85	39	-33.985	4415.901	**	**
L40	63.5 - 60.5	Pole	TP27.714x27.116x0.825	40	-34.954	4387.561	**	**
L41	60.5 - 60.25	Pole	TP27.763x27.714x0.825	41	-35.047	4395.688	**	**
L42	60.25 - 59.5	Pole	TP27.913x27.763x0.825	42	-35.284	4420.048	**	**
L43	59.5 - 59.25	Pole	TP27.962x27.913x0.888	43	-35.378	4752.667	**	**
L44	59.25 - 54.25	Pole	TP28.958x27.962x0.85	44	-37.076	4725.525	**	**
L45	54.25 - 45.802	Pole	TP30.64x28.958x0.838	45	-38.547	4798.269	**	**
L46	45.802 - 44.802	Pole	TP30.333x29.304x0.838	46	-41.671	4885.860	**	**
L47	44.802 - 43.583	Pole	TP30.574x30.333x0.838	47	-42.108	4925.823	**	**
L48	43.583 - 43.333	Pole	TP30.624x30.574x0.85	48	-42.218	5005.560	**	**
L49	43.333 - 43.166	Pole	TP30.657x30.624x0.85	49	-42.283	5011.114	**	**
L50	43.166 - 42.916	Pole	TP30.706x30.657x0.938	50	-42.381	5519.913	**	**
L51	42.916 - 39	Pole	TP31.481x30.706x0.913	51	-43.918	5517.109	**	**
L52	39 - 38.75	Pole	TP31.531x31.481x0.95	52	-44.036	5746.093	**	**
L53	38.75 - 37.166	Pole	TP31.844x31.531x0.938	53	-44.677	5730.931	**	**
L54	37.166 - 36.916	Pole	TP31.894x31.844x0.888	54	-44.796	5442.748	**	**
L55	36.916 - 34	Pole	TP32.471x31.894x0.888	55	-44.820	5442.748	**	**
L56	34 - 33.75	Pole	TP32.52x32.471x0.875	56	-45.987	5468.127	**	**
L57	33.75 - 29.75	Pole	TP33.312x32.52x0.863	57	-46.096	5400.591	**	**
L58	29.75 - 29.5	Pole	TP33.361x33.312x0.863	58	-47.658	5535.642	**	**
L59	29.5 - 24.5	Pole	TP34.351x33.361x0.85	59	-47.768	5465.838	**	**
L60	24.5 - 23	Pole	TP34.648x34.351x0.838	60	-49.776	5551.444	**	**
L61	23 - 22.75	Pole	TP34.697x34.648x0.963	61	-50.366	6412.738	**	**
L62	22.75 - 21.583	Pole	TP34.928x34.697x0.963	62	-50.487	6422.157	**	**
L63	21.583 - 21.333	Pole	TP34.978x34.928x0.85	63	-50.989	5729.262	**	**
L64	21.333 - 16.333	Pole	TP35.967x34.978x0.838	64	-51.106	5655.279	**	**
L65	16.333 - 12.917	Pole	TP36.644x35.967x0.825	65	-53.233	5734.386	**	**
L66	12.917 - 12.667	Pole	TP36.693x36.644x0.913	66	-54.688	6448.806	**	**
L67	12.667 - 12.5	Pole	TP36.726x36.693x0.913	67	-54.803	6457.731	**	**
L68	12.5 - 12.25	Pole	TP36.776x36.726x0.763	68	-54.882	5423.796	**	**
L69	12.25 - 12	Pole	TP36.825x36.776x0.763	69	-54.988	5431.261	**	**
L70	12 - 11.75	Pole	TP36.874x36.825x0.663	70	-55.093	4738.545	**	**
L71	11.75 - 8.5	Pole	TP37.518x36.874x0.65	71	-55.208	4657.107	**	**
L72	8.5 - 8.25	Pole	TP37.567x37.518x0.925	72	-56.496	6694.800	**	**
L73	8.25 - 7	Pole	TP37.815x37.567x0.913	73	-56.628	6615.514	**	**
L74	7 - 6.75	Pole	TP37.864x37.815x0.813	74	-57.217	5946.349	**	**
L75	6.75 - 1.75	Pole	TP38.854x37.864x0.788	75	-57.337	5774.989	**	**
L76	1.75 - 0	Pole	TP39.2x38.854x0.788	76	-59.526	5929.119	**	**
							Summary	
							Pole (L6)	**
							RATING =	**

\*\* Above stress ratios for reinforced sections are approximate. More exact calculations are presented in Appendix C.

**APPENDIX B**  
**BASE LEVEL DRAWING**

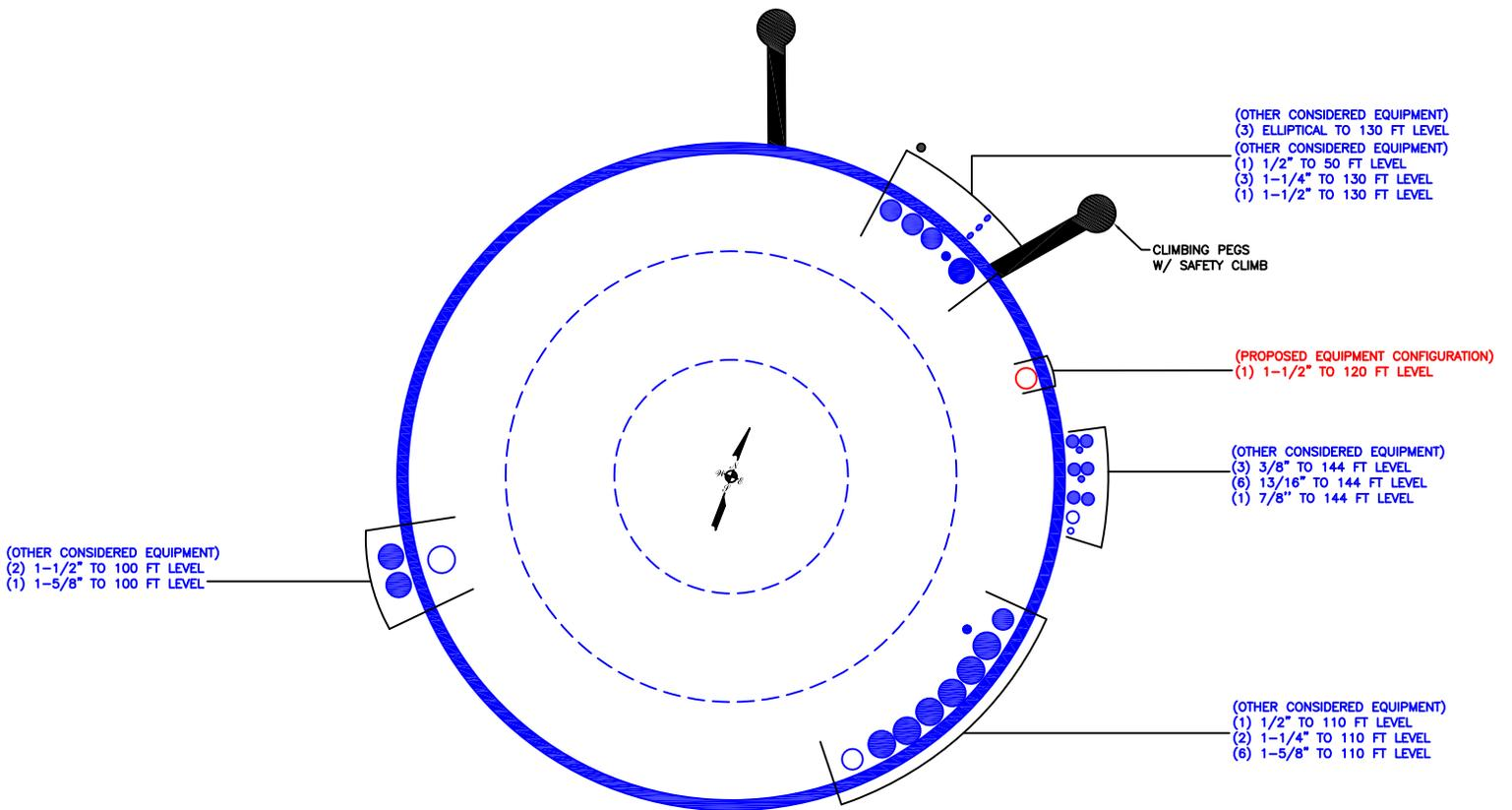

BUSINESS UNIT: 876317

**APPENDIX C**  
**ADDITIONAL CALCULATIONS**

**Pole Geometry**

	Pole Height Above Base (ft)	Section Length (ft)	Lap Splice Length (ft)	Number of Sides	Top Diameter (in)	Bottom Diameter (in)	Wall Thickness (in)	Bend Radius (in)	Pole Material
1	144.25	9.5	0	0	12.75	12.75	0.375		A500-46
2	134.75	0.5	0	0	13.48	13.48	0.375		A500-46
3	134.25	42.25	3.552	12	13.48	21.81	0.1875	Auto	A572-65
4	95.552	49.75	4.198	12	20.73	30.64	0.25	Auto	A572-65
5	50	50	0	12	29.30	39.2	0.3125	Auto	A572-65

**Reinforcement Configuration**

	Bottom Effective Elevation (ft)	Top Effective Elevation (ft)	Type	Model	Number	1	2	3	4	5	6	7	8	9	10	11	12
1	0	29.75	plate	PL 6.875x1.25 BW	2				E1								E1
2	0	12.917	plate	PL 6.875x1.25 (14)	2							E1		E1			
3	12.917	29.75	plate	PL 6.875x1.25	1								E1				
4	29.75	59.5	plate	PL 6.625x1.25	3				E1				E1				E1
5	59.5	89.25	plate	PL 5.5x1.25	3				E1				E1				E1
6	89.25	98.75	plate	PL 3.625x1.25	3				E1				E1				E1
7	12.5	39	plate	PL 4x1	1	E2											
8	12.5	34	plate	PL 4x1	2						E2					E2	
9	34	60.5	plate	PL 4x1	3			E2				E2					E2
10	60.5	77	plate	PL 4x1	3		E2				E2				E2		
11	88.25	104.75	plate	PL 4x1	3		E2				E2				E2		
12	0	8.5	plate	TS 1x7	3			3							3		
13	7	23	plate	CCI-SFP-060100	2					E3							E3
14	12	23	plate	CCI-SFP-060100	1			E3									
15	21.583	37.166	plate	CCI-SFP-045100	1									E3			
16	23	37.166	plate	CCI-SFP-045100	1					E3							
17	23	43.583	plate	CCI-SFP-045100	1			E3									
18	37.166	43.166	plate	CCI-SFP-060100	2					E3							E3
19	43.166	73.75	plate	CCI-SFP-045100	1									E3			
20	46.75	73.75	plate	CCI-SFP-045100	1			E3									
21	43.166	74.25	plate	CCI-SFP-040075	1					E3							
22	73.75	102.416	plate	CCI-SFP-040075	2		E3							E3			
23	76.333	89.25	plate	CCI-SFP-040075	1				E3								
24	87.833	102.416	plate	CCI-AFP-050125	1							E3					
25	102.416	123.416	plate	CCI-AFP-045100	2		E3							E3			
26	102.416	123.416	plate	CCI-AFP-045100	1					E3							
27	97.5	109.5	plate	CCI-AFP-040075	1				E3								
28	102.416	109.5	plate	CCI-AFP-040075	1												E3
29																	

**Reinforcement Details**

	B (in)	H (in)	Gross Area (in <sup>2</sup> )	Pole Face to Centroid (in)	Bottom Termination Type	Bottom Termination Length (in)	Top Termination Type	Top Termination Length (in)	Lu (in)	Net Area (in <sup>2</sup> )	Bolt Hole Size (in)	Reinforcement Material
1	6.875	1.25	8.59375	0.625	Welded	n/a	PC 8.8 - M20 (100)	36.000	15.000	6.953	1.2500	A572-65
2	6.875	1.25	8.59375	0.625	Welded	n/a	PC 8.8 - M20 (100)	42.000	15.000	6.953	1.2500	A572-65
3	6.875	1.25	8.59375	0.625	PC 8.8 - M20 (100)	42	PC 8.8 - M20 (100)	36.000	15.000	6.953	1.2500	A572-65
4	6.625	1.25	8.28125	0.625	None	n/a	PC 8.8 - M20 (100)	30.000	18.000	6.641	1.2500	A572-65
5	5.5	1.25	6.875	0.625	None	n/a	PC 8.8 - M20 (100)	18.000	18.000	5.234	1.2500	A572-65
6	3.625	1.25	4.53125	0.625	None	n/a	PC 8.8 - M20 (100)	15.000	24.000	2.891	1.2500	A572-65
7	4	1	4	0.5	PC 8.8 - M20 (100)	21	PC 8.8 - M20 (100)	21.000	20.000	2.750	1.1875	A572-65
8	4	1	4	0.5	PC 8.8 - M20 (100)	21	PC 8.8 - M20 (100)	21.000	20.000	2.750	1.1875	A572-65
9	4	1	4	0.5	PC 8.8 - M20 (100)	21	PC 8.8 - M20 (100)	21.000	20.000	2.750	1.1875	A572-65
10	4	1	4	0.5	PC 8.8 - M20 (100)	21	PC 8.8 - M20 (100)	21.000	20.000	2.750	1.1875	A572-65
11	4	1	4	0.5	PC 8.8 - M20 (100)	21	PC 8.8 - M20 (100)	21.000	20.000	2.750	1.1875	A572-65
12	1	7	7	3.5	Welded	n/a	Welded	0.000	0.750	7.000	0.0000	A572-65
13	6	1	6	0.5	PC 8.8 - M20 (100)	24	PC 8.8 - M20 (100)	24.000	16.000	4.750	1.1875	A572-65
14	6	1	6	0.5	PC 8.8 - M20 (100)	24	PC 8.8 - M20 (100)	24.000	16.000	4.750	1.1875	A572-65
15	4.5	1	4.5	0.5	PC 8.8 - M20 (100)	18	PC 8.8 - M20 (100)	18.000	20.000	3.250	1.1875	A572-65
16	4.5	1	4.5	0.5	PC 8.8 - M20 (100)	18	PC 8.8 - M20 (100)	18.000	20.000	3.250	1.1875	A572-65
17	4.5	1	4.5	0.5	PC 8.8 - M20 (100)	18	PC 8.8 - M20 (100)	18.000	20.000	3.250	1.1875	A572-65
18	6	1	6	0.5	PC 8.8 - M20 (100)	24	PC 8.8 - M20 (100)	24.000	16.000	4.750	1.1875	A572-65
19	4.5	1	4.5	0.5	PC 8.8 - M20 (100)	18	PC 8.8 - M20 (100)	18.000	20.000	3.250	1.1875	A572-65
20	4.5	1	4.5	0.5	PC 8.8 - M20 (100)	18	PC 8.8 - M20 (100)	18.000	20.000	3.250	1.1875	A572-65
21	4	0.75	3	0.375	PC 8.8 - M20 (100)	12	PC 8.8 - M20 (100)	12.000	16.000	2.063	1.1875	A572-65
22	4	0.75	3	0.375	PC 8.8 - M20 (100)	12	PC 8.8 - M20 (100)	12.000	16.000	2.063	1.1875	A572-65
23	4	0.75	3	0.375	PC 8.8 - M20 (100)	12	PC 8.8 - M20 (100)	12.000	16.000	2.063	1.1875	A572-65
24	5	1.25	6.25	0.625	PC 8.8 - M20 (100)	30	PC 8.8 - M20 (100)	30.000	23.000	4.688	1.1875	A572-65
25	4.5	1	4.5	0.5	PC 8.8 - M20 (100)	24	PC 8.8 - M20 (100)	24.000	20.000	3.250	1.1875	A572-65
26	4.5	1	4.5	0.5	PC 8.8 - M20 (100)	24	PC 8.8 - M20 (100)	24.000	20.000	3.250	1.1875	A572-65
27	4	0.75	3	0.375	PC 8.8 - M20 (100)	18	PC 8.8 - M20 (100)	18.000	16.000	2.063	1.1875	A572-65
28	4	0.75	3	0.375	PC 8.8 - M20 (100)	18	PC 8.8 - M20 (100)	18.000	16.000	2.063	1.1875	A572-65

**Connection Details for Custom Reinforcements**

Reinforcement	End	# Bolts	N or X	Bolt Spacing (in)	Edge Dist (in)	Weld Grade (ksi)	Transverse (Horiz.) Weld Type	Horiz. Weld Length (in)	Horiz. Groove Depth (in)	Horiz. Groove Angle (deg)	Horiz. Fillet Size (in)	Vertical Weld Length (in)	Vertical Fillet Size (in)	Rev H Connection Capacity (kip)
PL 6.875x1.25 BW	Top	12	N	3	3	-	None	-	-	-	-	-	-	-
	Bottom	-	-	-	-	70	None	-	-	-	-	-	-	-
PL 6.875x1.25 (14)	Top	14	N	3	3	-	None	-	-	-	-	-	-	-
	Bottom	-	-	-	-	70	None	-	-	-	-	-	-	-
PL 6.875x1.25	Top	12	N	3	3	-	-	-	-	-	-	-	-	-
	Bottom	14	N	3	3	0	-	-	-	-	-	-	-	-
PL 6.625x1.25	Top	10	N	3	3	-	-	-	-	-	-	-	-	-
	Bottom	-	-	-	-	70	None	-	-	-	-	-	-	-
PL 5.5x1.25	Top	6	N	3	3	-	-	-	-	-	-	-	-	-
	Bottom	-	-	-	-	70	None	-	-	-	-	-	-	-
PL 3.625x1.25	Top	5	N	3	3	-	-	-	-	-	-	-	-	-
	Bottom	-	-	-	-	70	None	-	-	-	-	-	-	-
PL 4x1	Top	7	N	3	3	-	-	-	-	-	-	-	-	-
	Bottom	7	N	3	3	0	-	-	-	-	-	-	-	-
TS 1x7	Top	0	-	0	0	80	None	-	-	-	-	125.25	0.313	-
	Bottom	-	-	-	-	80	CJP Groove	12.5	0.5	45	0.3125	-	-	-

# TNX Geometry Input

Increment (ft):  [Export to TNX](#)

	Section Height (ft)	Section Length (ft)	Lap Splice Length (ft)	Number of Sides	Top Diameter (in)	Bottom Diameter (in)	Wall Thickness (in)	Tapered Pole Grade	Weight Multiplier
1	144.25 - 139.25	5		0	12.750	12.750	0.375	A500-46	1.000
2	139.25 - 134.75	4.5	0	0	12.750	12.750	0.375	A500-46	1.000
3	134.75 - 134.25	0.5	0	0	13.480	13.480	0.375	A500-46	1.000
4	134.25 - 129.25	5		12	13.480	14.466	0.1875	A572-65	1.000
5	129.25 - 124.25	5		12	14.466	15.452	0.1875	A572-65	1.000
6	124.25 - 123.416	0.834		12	15.452	15.616	0.1875	A572-65	1.000
7	123.416 - 123.166	0.25		12	15.616	15.665	0.5375	A572-65	0.873
8	123.166 - 118.166	5		12	15.665	16.651	0.5125	A572-65	0.881
9	118.166 - 113.166	5		12	16.651	17.637	0.4875	A572-65	0.894
10	113.166 - 109.5	3.666		12	17.637	18.360	0.475	A572-65	0.895
11	109.5 - 109.25	0.25		12	18.360	18.409	0.5875	A572-65	0.906
12	109.25 - 104.75	4.5		12	18.409	19.296	0.5625	A572-65	0.916
13	104.75 - 104.5	0.25		12	19.296	19.346	0.775	A572-65	0.930
14	104.5 - 102.416	2.084		12	19.346	19.756	0.7625	A572-65	0.930
15	102.416 - 102.166	0.25		12	19.756	19.806	0.5625	A572-65	1.123
16	102.166 - 98.75	3.416		12	19.806	20.479	0.55	A572-65	1.120
17	98.75 - 98.5	0.25		12	20.479	20.528	0.8375	A572-65	1.002
18	98.5 - 97.5	1		12	20.528	20.726	0.8375	A572-65	0.994
19	97.5 - 97.25	0.25		12	20.726	20.775	0.75	A572-65	1.041
20	97.25 - 95.552	5.25	3.552	12	20.775	21.810	0.7375	A572-65	1.044
21	95.552 - 90.552	5		12	20.735	21.730	0.8	A572-65	1.024
22	90.552 - 89.25	1.302		12	21.730	21.989	0.775	A572-65	1.046
23	89.25 - 89	0.25		12	21.989	22.039	1	A572-65	0.967
24	89 - 88.25	0.75		12	22.039	22.189	0.975	A572-65	0.985
25	88.25 - 88	0.25		12	22.189	22.238	0.7625	A572-65	1.017
26	88 - 87.833	0.167		12	22.238	22.272	0.7625	A572-65	1.016
27	87.833 - 87.583	0.25		12	22.272	22.321	0.675	A572-65	1.008
28	87.583 - 82.583	5		12	22.321	23.317	0.65	A572-65	1.017
29	82.583 - 77.583	5		12	23.317	24.312	0.625	A572-65	1.029
30	77.583 - 77	0.583		12	24.312	24.428	0.625	A572-65	1.026
31	77 - 76.75	0.25		12	24.428	24.478	0.825	A572-65	0.974
32	76.75 - 76.333	0.417		12	24.478	24.561	0.825	A572-65	0.971
33	76.333 - 76.083	0.25		12	24.561	24.611	0.825	A572-65	0.923
34	76.083 - 74.25	1.833		12	24.611	24.976	0.8	A572-65	0.941
35	74.25 - 74	0.25		12	24.976	25.026	0.8875	A572-65	0.893
36	74 - 73.75	0.25		12	25.026	25.076	0.8875	A572-65	0.892
37	73.75 - 73.5	0.25		12	25.076	25.125	0.9125	A572-65	0.910
38	73.5 - 68.5	5		12	25.125	26.121	0.875	A572-65	0.921
39	68.5 - 63.5	5		12	26.121	27.116	0.85	A572-65	0.922
40	63.5 - 60.5	3		12	27.116	27.714	0.825	A572-65	0.935
41	60.5 - 60.25	0.25		12	27.714	27.763	0.825	A572-65	0.934
42	60.25 - 59.5	0.75		12	27.763	27.913	0.825	A572-65	0.931
43	59.5 - 59.25	0.25		12	27.913	27.962	0.8875	A572-65	0.920
44	59.25 - 54.25	5		12	27.962	28.958	0.85	A572-65	0.936
45	54.25 - 50	8.448	4.198	12	28.958	30.640	0.8375	A572-65	0.931
46	50 - 44.802	5.198		12	29.304	30.333	0.8375	A572-65	0.938
47	44.802 - 43.583	1.219		12	30.333	30.574	0.8375	A572-65	0.933
48	43.583 - 43.333	0.25		12	30.574	30.624	0.85	A572-65	0.975
49	43.333 - 43.166	0.167		12	30.624	30.657	0.85	A572-65	0.974
50	43.166 - 42.916	0.25		12	30.657	30.706	0.9375	A572-65	0.935
51	42.916 - 39	3.916		12	30.706	31.481	0.9125	A572-65	0.944
52	39 - 38.75	0.25		12	31.481	31.531	0.95	A572-65	0.950
53	38.75 - 37.166	1.584		12	31.531	31.844	0.9375	A572-65	0.956
54	37.166 - 36.916	0.25		12	31.844	31.894	0.8875	A572-65	0.973
55	36.916 - 34	2.916		12	31.894	32.471	0.8875	A572-65	0.961
56	34 - 33.75	0.25		12	32.471	32.520	0.875	A572-65	0.929
57	33.75 - 29.75	4		12	32.520	33.312	0.8625	A572-65	0.928
58	29.75 - 29.5	0.25		12	33.312	33.361	0.8625	A572-65	0.937
59	29.5 - 24.5	5		12	33.361	34.351	0.85	A572-65	0.934
60	24.5 - 23	1.5		12	34.351	34.648	0.8375	A572-65	0.942
61	23 - 22.75	0.25		12	34.648	34.697	0.9625	A572-65	0.908
62	22.75 - 21.583	1.167		12	34.697	34.928	0.9625	A572-65	0.904
63	21.583 - 21.333	0.25		12	34.928	34.978	0.85	A572-65	0.971
64	21.333 - 16.333	5		12	34.978	35.967	0.8375	A572-65	0.968
65	16.333 - 12.917	3.416		12	35.967	36.644	0.825	A572-65	0.971
66	12.917 - 12.667	0.25		12	36.644	36.693	0.9125	A572-65	0.961
67	12.667 - 12.5	0.167		12	36.693	36.726	0.9125	A572-65	0.961
68	12.5 - 12.25	0.25		12	36.726	36.776	0.7625	A572-65	1.008
69	12.25 - 12	0.25		12	36.776	36.825	0.7625	A572-65	1.007
70	12 - 11.75	0.25		12	36.825	36.874	0.6625	A572-65	1.077
71	11.75 - 8.5	3.25		12	36.874	37.518	0.65	A572-65	1.087
72	8.5 - 8.25	0.25		12	37.518	37.567	0.925	A572-65	0.962
73	8.25 - 7	1.25		12	37.567	37.815	0.9125	A572-65	0.970
74	7 - 6.75	0.25		12	37.815	37.864	0.8125	A572-65	0.962
75	6.75 - 1.75	5		12	37.864	38.854	0.7875	A572-65	0.976
76	1.75 - 0	1.75		12	38.854	39.200	0.7875	A572-65	0.971

# TNX Section Forces

Increment (ft):		TNX Output			
5					
	Section Height (ft)	P <sub>u</sub> (K)	M <sub>ux</sub> (kip-ft)	V <sub>u</sub> (K)	
1	144.25 - 139.25	5.14	27.04	6.64	
2	139.25 - 134.75	5.42	57.30	6.80	
3	134.75 - 134.25	5.46	60.70	6.82	
4	134.25 - 129.25	9.10	100.67	11.26	
5	129.25 - 124.25	9.45	157.36	11.43	
6	124.25 - 123.416	9.51	166.90	11.46	
7	123.416 - 123.166	9.55	169.76	11.46	
8	123.166 - 118.166	12.98	233.01	14.55	
9	118.166 - 113.166	13.60	306.30	14.79	
10	113.166 - 109.5	17.38	363.35	19.61	
11	109.5 - 109.25	17.44	368.26	19.62	
12	109.25 - 104.75	18.18	457.29	19.97	
13	104.75 - 104.5	18.24	462.28	19.98	
14	104.5 - 102.416	18.68	504.10	20.17	
15	102.416 - 102.166	18.74	509.14	20.18	
16	102.166 - 98.75	23.36	584.03	23.37	
17	98.75 - 98.5	23.45	589.87	23.37	
18	98.5 - 97.5	23.70	613.28	23.47	
19	97.5 - 97.25	23.77	619.15	23.49	
20	97.25 - 95.552	24.18	659.14	23.65	
21	95.552 - 90.552	26.22	778.70	24.17	
22	90.552 - 89.25	26.58	810.22	24.28	
23	89.25 - 89	26.68	816.28	24.29	
24	89 - 88.25	26.91	834.52	24.36	
25	88.25 - 88	26.98	840.61	24.38	
26	88 - 87.833	27.03	844.68	24.40	
27	87.833 - 87.583	27.09	850.78	24.41	
28	87.583 - 82.583	28.33	973.72	24.79	
29	82.583 - 77.583	29.61	1098.44	25.15	
30	77.583 - 77	29.77	1113.10	25.16	
31	77 - 76.75	29.86	1119.39	25.17	
32	76.75 - 76.333	29.98	1129.89	25.20	
33	76.333 - 76.083	30.06	1136.19	25.21	
34	76.083 - 74.25	30.57	1182.49	25.36	
35	74.25 - 74	30.67	1188.83	25.35	
36	74 - 73.75	30.74	1195.17	25.37	
37	73.75 - 73.5	30.82	1201.51	25.39	
38	73.5 - 68.5	32.39	1329.25	25.73	
39	68.5 - 63.5	33.98	1458.59	26.05	
40	63.5 - 60.5	34.95	1537.04	26.30	
41	60.5 - 60.25	35.05	1543.61	26.30	
42	60.25 - 59.5	35.28	1563.35	26.37	
43	59.5 - 59.25	35.38	1569.94	26.39	
44	59.25 - 54.25	37.08	1702.89	26.82	
45	54.25 - 50	38.55	1817.51	27.16	
46	50 - 44.802	41.67	1960.41	27.76	
47	44.802 - 43.583	42.11	1994.25	27.82	
48	43.583 - 43.333	42.22	2001.20	27.81	
49	43.333 - 43.166	42.28	2005.84	27.82	
50	43.166 - 42.916	42.38	2012.80	27.84	
51	42.916 - 39	43.92	2122.18	28.06	
52	39 - 38.75	44.04	2129.19	28.05	
53	38.75 - 37.166	44.68	2173.68	28.17	
54	37.166 - 36.916	44.80	2180.72	28.15	
55	36.916 - 34	45.96	2262.98	28.32	
56	34 - 33.75	46.08	2270.05	28.30	
57	33.75 - 29.75	47.64	2383.53	28.47	
58	29.75 - 29.5	47.75	2390.64	28.46	
59	29.5 - 24.5	49.74	2533.36	28.66	
60	24.5 - 23	50.34	2576.34	28.72	
61	23 - 22.75	50.47	2583.52	28.70	
62	22.75 - 21.583	50.97	2617.03	28.76	
63	21.583 - 21.333	51.09	2624.21	28.75	
64	21.333 - 16.333	53.20	2768.32	28.91	
65	16.333 - 12.917	54.67	2867.20	29.03	
66	12.917 - 12.667	54.80	2874.45	29.02	
67	12.667 - 12.5	54.88	2879.30	29.02	
68	12.5 - 12.25	54.98	2886.55	29.03	
69	12.25 - 12	55.09	2893.81	29.04	
70	12 - 11.75	55.19	2901.07	29.04	
71	11.75 - 8.5	56.48	2995.80	29.29	
72	8.5 - 8.25	56.61	3003.11	29.28	
73	8.25 - 7	57.20	3039.79	29.43	
74	7 - 6.75	57.32	3047.14	29.43	
75	6.75 - 1.75	59.49	3195.39	29.90	
76	1.75 - 0	60.25	3247.82	30.08	

# Analysis Results

Elevation (ft)	Component Type	Size	Critical Element	% Capacity	Pass / Fail
144.25 - 139.25	Pole	TP12.75x12.75x0.375	Pole	13.9%	Pass
139.25 - 134.75	Pole	TP12.75x12.75x0.375	Pole	28.5%	Pass
134.75 - 134.25	Pole	TP13.48x13.48x0.375	Pole	26.9%	Pass
134.25 - 129.25	Pole	TP14.466x13.48x0.1875	Pole	54.2%	Pass
129.25 - 124.25	Pole	TP15.452x14.466x0.1875	Pole	73.2%	Pass
124.25 - 123.42	Pole	TP15.616x15.452x0.1875	Pole	75.9%	Pass
123.42 - 123.17	Pole + Reinf.	TP15.665x15.616x0.5375	Reinf. 25 Tension Rupture	49.5%	Pass
123.17 - 118.17	Pole + Reinf.	TP16.651x15.665x0.5125	Reinf. 25 Tension Rupture	62.6%	Pass
118.17 - 113.17	Pole + Reinf.	TP17.637x16.651x0.4875	Reinf. 25 Tension Rupture	75.8%	Pass
113.17 - 109.5	Pole + Reinf.	TP18.36x17.637x0.475	Reinf. 25 Tension Rupture	85.2%	Pass
109.5 - 109.25	Pole + Reinf.	TP18.409x18.36x0.5875	Reinf. 25 Tension Rupture	71.8%	Pass
109.25 - 104.75	Pole + Reinf.	TP19.296x18.409x0.5625	Reinf. 25 Tension Rupture	83.5%	Pass
104.75 - 104.5	Pole + Reinf.	TP19.346x19.296x0.775	Reinf. 11 Tension Rupture	67.4%	Pass
104.5 - 102.42	Pole + Reinf.	TP19.756x19.346x0.7625	Reinf. 11 Tension Rupture	71.5%	Pass
102.42 - 102.17	Pole + Reinf.	TP19.806x19.756x0.5625	Reinf. 11 Tension Rupture	89.3%	Pass
102.17 - 98.75	Pole + Reinf.	TP20.479x19.806x0.55	Reinf. 11 Tension Rupture	98.1%	Pass
98.75 - 98.5	Pole + Reinf.	TP20.528x20.479x0.8375	Reinf. 6 Bolt-Shaft Bearing	85.8%	Pass
98.5 - 97.5	Pole + Reinf.	TP20.726x20.528x0.8375	Reinf. 6 Tension Rupture	74.6%	Pass
97.5 - 97.25	Pole + Reinf.	TP20.775x20.726x0.75	Reinf. 6 Tension Rupture	86.9%	Pass
97.25 - 95.55	Pole + Reinf.	TP21.81x20.775x0.7375	Reinf. 6 Tension Rupture	90.7%	Pass
95.55 - 90.55	Pole + Reinf.	TP21.73x20.735x0.8	Reinf. 6 Tension Rupture	94.2%	Pass
90.55 - 89.25	Pole + Reinf.	TP21.989x21.73x0.775	Reinf. 6 Tension Rupture	96.5%	Pass
89.25 - 89	Pole + Reinf.	TP22.039x21.989x1	Reinf. 5 Bolt-Shaft Bearing	83.4%	Pass
89 - 88.25	Pole + Reinf.	TP22.189x22.039x0.975	Reinf. 11 Tension Rupture	69.7%	Pass
88.25 - 88	Pole + Reinf.	TP22.238x22.189x0.7625	Reinf. 5 Tension Rupture	79.8%	Pass
88 - 87.83	Pole + Reinf.	TP22.272x22.238x0.7625	Reinf. 5 Tension Rupture	80.0%	Pass
87.83 - 87.58	Pole + Reinf.	TP22.321x22.272x0.675	Reinf. 5 Tension Rupture	84.8%	Pass
87.58 - 82.58	Pole + Reinf.	TP23.317x22.321x0.65	Reinf. 5 Tension Rupture	91.4%	Pass
82.58 - 77.58	Pole + Reinf.	TP24.312x23.317x0.625	Reinf. 5 Tension Rupture	97.3%	Pass
77.58 - 77	Pole + Reinf.	TP24.428x24.312x0.625	Reinf. 5 Tension Rupture	98.0%	Pass
77 - 76.75	Pole + Reinf.	TP24.478x24.428x0.825	Reinf. 10 Tension Rupture	91.9%	Pass
76.75 - 76.33	Pole + Reinf.	TP24.561x24.478x0.825	Reinf. 10 Tension Rupture	92.3%	Pass
76.33 - 76.08	Pole + Reinf.	TP24.611x24.561x0.825	Reinf. 10 Tension Rupture	93.5%	Pass
76.08 - 74.25	Pole + Reinf.	TP24.976x24.611x0.8	Reinf. 10 Tension Rupture	95.4%	Pass
74.25 - 74	Pole + Reinf.	TP25.026x24.976x0.8875	Reinf. 10 Tension Rupture	84.2%	Pass
74 - 73.75	Pole + Reinf.	TP25.076x25.026x0.8875	Reinf. 10 Tension Rupture	84.4%	Pass
73.75 - 73.5	Pole + Reinf.	TP25.125x25.076x0.9125	Reinf. 21 Tension Rupture	83.7%	Pass
73.5 - 68.5	Pole + Reinf.	TP26.121x25.125x0.875	Reinf. 21 Tension Rupture	88.1%	Pass
68.5 - 63.5	Pole + Reinf.	TP27.116x26.121x0.85	Reinf. 21 Tension Rupture	92.1%	Pass
63.5 - 60.5	Pole + Reinf.	TP27.714x27.116x0.825	Reinf. 21 Tension Rupture	94.4%	Pass
60.5 - 60.25	Pole + Reinf.	TP27.763x27.714x0.825	Reinf. 21 Tension Rupture	94.5%	Pass
60.25 - 59.5	Pole + Reinf.	TP27.913x27.763x0.825	Reinf. 21 Tension Rupture	95.1%	Pass
59.5 - 59.25	Pole + Reinf.	TP27.962x27.913x0.8875	Reinf. 21 Tension Rupture	89.0%	Pass
59.25 - 54.25	Pole + Reinf.	TP28.958x27.962x0.85	Reinf. 21 Tension Rupture	92.3%	Pass
54.25 - 50	Pole + Reinf.	TP30.64x28.958x0.8375	Reinf. 21 Tension Rupture	94.9%	Pass
50 - 44.8	Pole + Reinf.	TP30.333x29.304x0.8375	Reinf. 9 Tension Rupture	96.6%	Pass
44.8 - 43.58	Pole + Reinf.	TP30.574x30.333x0.8375	Reinf. 9 Tension Rupture	97.2%	Pass
43.58 - 43.33	Pole + Reinf.	TP30.624x30.574x0.85	Reinf. 9 Tension Rupture	96.3%	Pass
43.33 - 43.17	Pole + Reinf.	TP30.657x30.624x0.85	Reinf. 9 Tension Rupture	96.3%	Pass
43.17 - 42.92	Pole + Reinf.	TP30.706x30.657x0.9375	Reinf. 9 Tension Rupture	91.2%	Pass
42.92 - 39	Pole + Reinf.	TP31.481x30.706x0.9125	Reinf. 9 Tension Rupture	93.0%	Pass
39 - 38.75	Pole + Reinf.	TP31.531x31.481x0.95	Reinf. 9 Tension Rupture	87.8%	Pass
38.75 - 37.17	Pole + Reinf.	TP31.844x31.531x0.9375	Reinf. 9 Tension Rupture	88.5%	Pass
37.17 - 36.92	Pole + Reinf.	TP31.894x31.844x0.8875	Reinf. 9 Tension Rupture	92.0%	Pass
36.92 - 34	Pole + Reinf.	TP32.471x31.894x0.8875	Reinf. 9 Tension Rupture	93.2%	Pass
34 - 33.75	Pole + Reinf.	TP32.52x32.471x0.875	Reinf. 8 Tension Rupture	93.2%	Pass
33.75 - 29.75	Pole + Reinf.	TP33.312x32.52x0.8625	Reinf. 8 Tension Rupture	94.7%	Pass
29.75 - 29.5	Pole + Reinf.	TP33.361x33.312x0.8625	Reinf. 8 Tension Rupture	93.6%	Pass
29.5 - 24.5	Pole + Reinf.	TP34.351x33.361x0.85	Reinf. 8 Tension Rupture	95.3%	Pass
24.5 - 23	Pole + Reinf.	TP34.648x34.351x0.8375	Reinf. 8 Tension Rupture	95.8%	Pass
23 - 22.75	Pole + Reinf.	TP34.697x34.648x0.9625	Reinf. 8 Tension Rupture	88.8%	Pass
22.75 - 21.58	Pole + Reinf.	TP34.928x34.697x0.9625	Reinf. 8 Tension Rupture	89.2%	Pass
21.58 - 21.33	Pole + Reinf.	TP34.978x34.928x0.85	Reinf. 8 Tension Rupture	94.1%	Pass
21.33 - 16.33	Pole + Reinf.	TP35.967x34.978x0.8375	Reinf. 8 Tension Rupture	95.5%	Pass
16.33 - 12.92	Pole + Reinf.	TP36.644x35.967x0.825	Reinf. 8 Tension Rupture	96.4%	Pass
12.92 - 12.67	Pole + Reinf.	TP36.693x36.644x0.9125	Reinf. 7 Tension Rupture	87.4%	Pass
12.67 - 12.5	Pole + Reinf.	TP36.726x36.693x0.9125	Reinf. 7 Tension Rupture	87.5%	Pass
12.5 - 12.25	Pole + Reinf.	TP36.776x36.726x0.7625	Reinf. 14 Tension Rupture	90.7%	Pass
12.25 - 12	Pole + Reinf.	TP36.825x36.776x0.7625	Reinf. 14 Tension Rupture	90.8%	Pass
12 - 11.75	Pole + Reinf.	TP36.874x36.825x0.6625	Reinf. 2 Tension Rupture	92.8%	Pass
11.75 - 8.5	Pole + Reinf.	TP37.518x36.874x0.65	Reinf. 2 Tension Rupture	93.5%	Pass
8.5 - 8.25	Pole + Reinf.	TP37.567x37.518x0.925	Reinf. 1 Tension Rupture	76.6%	Pass
8.25 - 7	Pole + Reinf.	TP37.815x37.567x0.9125	Reinf. 1 Tension Rupture	76.9%	Pass
7 - 6.75	Pole + Reinf.	TP37.864x37.815x0.8125	Reinf. 1 Tension Rupture	89.0%	Pass
6.75 - 1.75	Pole + Reinf.	TP38.854x37.864x0.7875	Reinf. 1 Tension Rupture	90.1%	Pass
1.75 - 0	Pole + Reinf.	TP39.2x38.854x0.7875	Reinf. 1 Tension Rupture	90.5%	Pass
				Summary	
			Pole	83.0%	Pass
			Reinforcement	98.1%	Pass
			Overall	98.1%	Pass



# Monopole Flange Plate Connection

Elevation = 134.25 ft.



BU #	876317
Site Name	WATERBURY,CT
Order #	553382,Rev# 2

TIA-222 Revision	H
------------------	---

Applied Loads	
Moment (kip-ft)	60.70
Axial Force (kips)	5.46
Shear Force (kips)	6.82

\*TIA-222-H Section 15.5 Applied

Top Plate - External

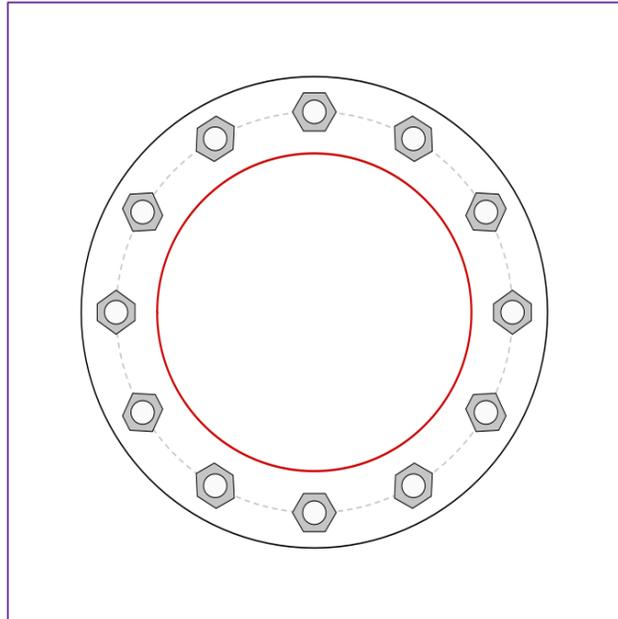

Bottom Plate - External

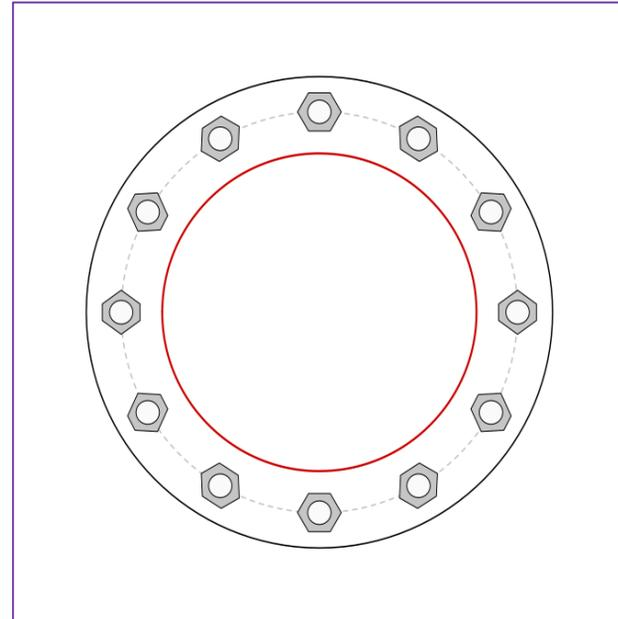

### Connection Properties

#### Bolt Data

(12) 1"  $\phi$  bolts (A325 N; Fy=92 ksi, Fu=120 ksi) on 17" BC

#### Top Plate Data

20" OD x 1" Plate (A572-50; Fy=50 ksi, Fu=65 ksi)

#### Top Stiffener Data

N/A

#### Top Pole Data

13.48" x 0.375" round pole (A500-46; Fy=46 ksi, Fu=62 ksi)

#### Bottom Plate Data

20" OD x 1" Plate (A572-50; Fy=50 ksi, Fu=65 ksi)

#### Bottom Stiffener Data

N/A

#### Bottom Pole Data

13.48" x 0.1875" 12-sided pole (A572-65; Fy=65 ksi, Fu=80 ksi)

### Analysis Results

#### Bolt Capacity

Max Load (kips)	13.81
Allowable (kips)	54.53
Stress Rating:	<b>24.1%</b> Pass

#### Top Plate Capacity

Max Stress (ksi):	16.16	(Flexural)
Allowable Stress (ksi):	45.00	
Stress Rating:	<b>34.2%</b>	Pass
Tension Side Stress Rating:	<b>18.9%</b>	Pass

#### Bottom Plate Capacity

Max Stress (ksi):	16.16	(Flexural)
Allowable Stress (ksi):	45.00	
Stress Rating:	<b>34.2%</b>	Pass
Tension Side Stress Rating:	<b>18.9%</b>	Pass

# Monopole Base Plate Connection



Site Info	
BU #	876317
Site Name	WATERBURY,CT
Order #	553382,Rev# 2

Analysis Considerations	
TIA-222 Revision	H
Grout Considered:	No
$l_{ar}$ (in)	0.75

Applied Loads	
Moment (kip-ft)	3247.82
Axial Force (kips)	60.25
Shear Force (kips)	30.08

\*TIA-222-H Section 15.5 Applied

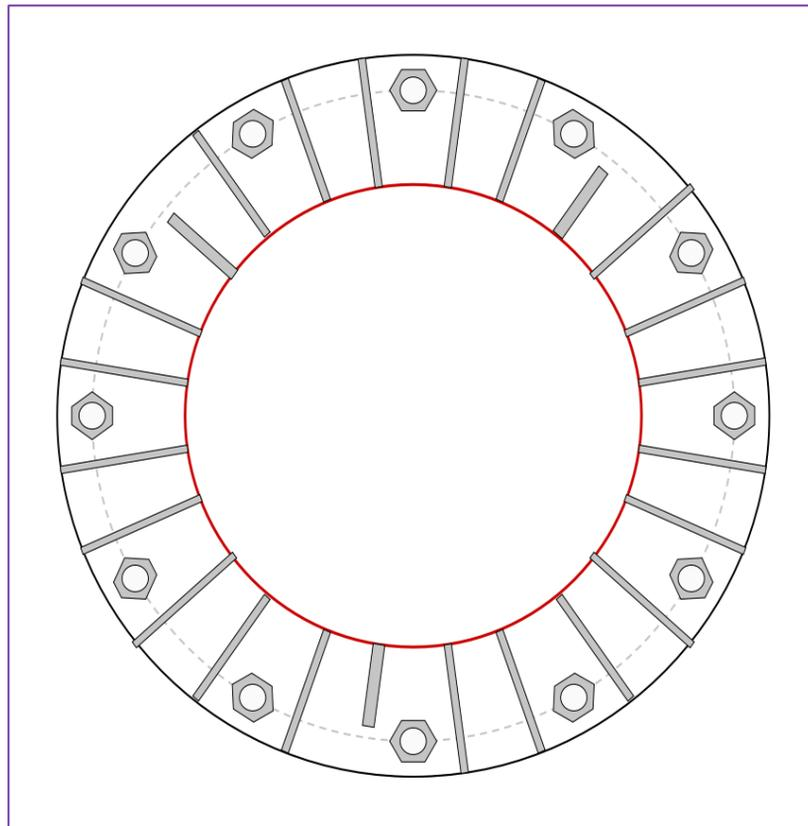

Connection Properties	Analysis Results
-----------------------	------------------

**Anchor Rod Data**  
 (12) 2-1/4"  $\phi$  bolts (A615-75 N;  $F_y=75$  ksi,  $F_u=100$  ksi) on 55.16" BC

**Base Plate Data**  
 61.16" OD x 2.5" Plate (S-128;  $F_y=60$  ksi,  $F_u=80$  ksi)

**Stiffener Data**  
 Group 1: (21) 21.5"H x 11"W x 0.625"T, Notch: 0.75"  
 plate:  $F_y= 50$  ksi ; weld:  $F_y= 80$  ksi  
 horiz. weld: 0.3125" groove, 45° dbl bevel, 0.5" fillet  
 vert. weld: 0.3125" fillet

Group 2: (3) 126"H x 7"W x 1"T, Notch: 0.75"  
 plate:  $F_y= 65$  ksi ; weld:  $F_y= 80$  ksi  
 horiz. weld: 0.5" groove, 45° dbl bevel, 0.3125" fillet  
 vert. weld: 0.3125" fillet

**Pole Data**  
 39.2" x 0.3125" 12-sided pole (A572-65;  $F_y=65$  ksi,  $F_u=80$  ksi)

Anchor Rod Summary		<i>(units of kips, kip-in)</i>
$P_{u_t} = 230.34$	$\phi P_{n_t} = 243.75$	<b>Stress Rating</b>
$V_u = 2.51$	$\phi V_n = 149.1$	<b>90.0%</b>
$M_u = n/a$	$\phi M_n = n/a$	<b>Pass</b>

Base Plate Summary	
Max Stress (ksi):	31.64 (Flexural)
Allowable Stress (ksi):	54
Stress Rating:	<b>55.8%</b> <b>Pass</b>

Stiffener Summary	
Horizontal Weld:	<b>41.8%</b> <b>Pass</b>
Vertical Weld:	<b>42.1%</b> <b>Pass</b>
Plate Flexure+Shear:	<b>23.0%</b> <b>Pass</b>
Plate Tension+Shear:	<b>43.5%</b> <b>Pass</b>
Plate Compression:	<b>62.5%</b> <b>Pass</b>

Pole Summary	
Punching Shear:	<b>17.0%</b> <b>Pass</b>

# Pier and Pad Foundation



BU #: 876317  
 Site Name: WATERBURY, CT  
 App. Number: 553382, Rev# 2

TIA-222 Revision: H  
 Tower Type: Monopole

Top & Bot. Pad Rein. Different?:   
 Block Foundation?:   
 Rectangular Pad?:

Superstructure Analysis Reactions		
Compression, $P_{comp}$ :	60.25	kips
Base Shear, $V_u_{comp}$ :	30.08	kips
Moment, $M_u$ :	3247.82	ft-kips
Tower Height, $H$ :	143	ft
BP Dist. Above Fdn, $bp_{dist}$ :	2.75	in
Bolt Circle / Bearing Plate Width, $BC$ :	55.16	in

Foundation Analysis Checks				
	Capacity	Demand	Rating*	Check
<i>Lateral (Sliding) (kips)</i>	277.94	30.08	10.3%	Pass
<i>Bearing Pressure (ksf)</i>	22.50	6.23	27.7%	Pass
<i>Overturning (kip*ft)</i>	3944.60	3457.75	87.7%	Pass
<i>Pad Flexure (kip*ft)</i>	9014.86	1975.64	20.9%	Pass
<i>Pad Shear - 1-way (kips)</i>	1732.56	178.77	9.8%	Pass
<i>Pad Shear - 2-way (Comp) (ksi)</i>	0.190	0.000	0.0%	Pass
<i>Flexural 2-way (Comp) (kip*ft)</i>	18499.97	0.00	0.0%	Pass

\*Rating per TIA-222-H Section 15.5

Structural Rating*:	20.9%
Soil Rating*:	87.7%

Pad Properties		
Depth, $D$ :	6.75	ft
Pad Width, $W_1$ :	20	ft
Pad Thickness, $T$ :	6.75	ft
Pad Rebar Size (Top dir. 2), $Sp_{top2}$ :	9	
Pad Rebar Quantity (Top dir. 2), $mp_{top2}$ :	28	
Pad Rebar Size (Bottom dir. 2), $Sp_2$ :	10	
Pad Rebar Quantity (Bottom dir. 2), $mp_2$ :	21	
Pad Clear Cover, $cc_{pad}$ :	3	in

Material Properties		
Rebar Grade, $F_y$ :	60	ksi
Concrete Compressive Strength, $F'_c$ :	4	ksi
Dry Concrete Density, $\delta_c$ :	150	pcf

Soil Properties		
Total Soil Unit Weight, $\gamma$ :	125	pcf
Ultimate Gross Bearing, $Q_{ult}$ :	30.000	ksf
Cohesion, $C_u$ :	0.000	ksf
Friction Angle, $\phi$ :	36	degrees
SPT Blow Count, $N_{blows}$ :		
Base Friction, $\mu$ :	0.5	
Neglected Depth, $N$ :	3.33	ft
Foundation Bearing on Rock?	No	
Groundwater Depth, $gw$ :	11.5	ft

B2

<--Toggle between Gross and Net

# ASCE 7 Hazards Report

**Address:**  
No Address at This Location

**Standard:** ASCE/SEI 7-16  
**Risk Category:** II  
**Soil Class:** D - Default (see Section 11.4.3)

**Elevation:** 660.21 ft (NAVD 88)  
**Latitude:** 41.537861  
**Longitude:** -72.985028

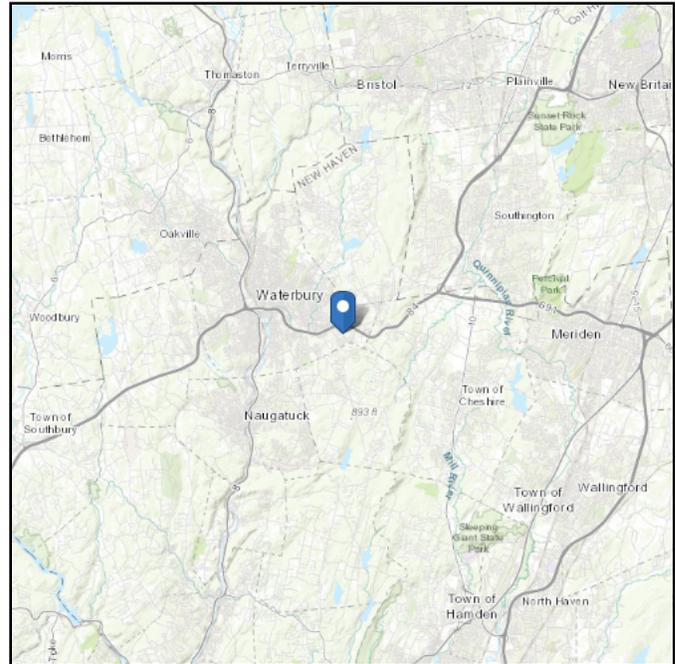
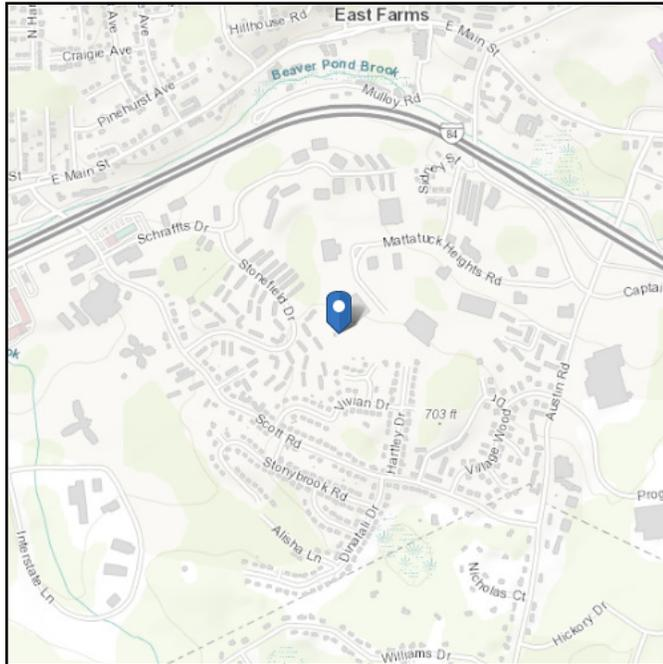

## Wind

### Results:

Wind Speed	118 Vmph
10-year MRI	75 Vmph
25-year MRI	84 Vmph
50-year MRI	90 Vmph
100-year MRI	97 Vmph

Data Source: ASCE/SEI 7-16, Fig. 26.5-1B and Figs. CC.2-1–CC.2-4, and Section 26.5.2  
Date Accessed: Thu Jan 27 2022

Value provided is 3-second gust wind speeds at 33 ft above ground for Exposure C Category, based on linear interpolation between contours. Wind speeds are interpolated in accordance with the 7-16 Standard. Wind speeds correspond to approximately a 7% probability of exceedance in 50 years (annual exceedance probability = 0.00143, MRI = 700 years).

Site is in a hurricane-prone region as defined in ASCE/SEI 7-16 Section 26.2. Glazed openings need not be protected against wind-borne debris.

**Site Soil Class:** D - Default (see Section 11.4.3)

**Results:**

$S_s$ :	0.195	$S_{D1}$ :	0.087
$S_1$ :	0.054	$T_L$ :	6
$F_a$ :	1.6	PGA :	0.108
$F_v$ :	2.4	PGA <sub>M</sub> :	0.171
$S_{MS}$ :	0.312	$F_{PGA}$ :	1.585
$S_{M1}$ :	0.13	$I_e$ :	1
$S_{DS}$ :	0.208	$C_v$ :	0.7

**Seismic Design Category** B

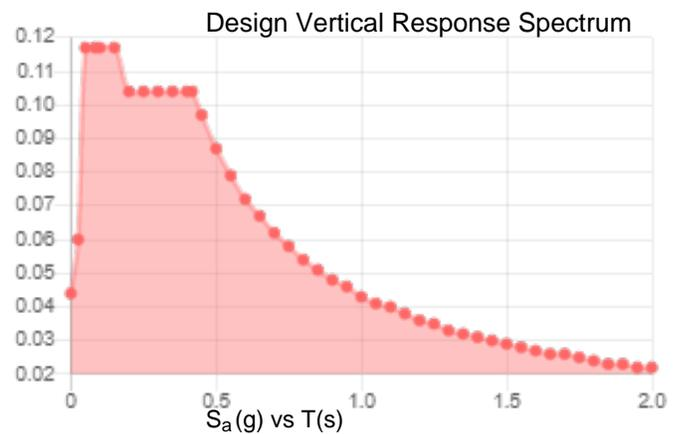
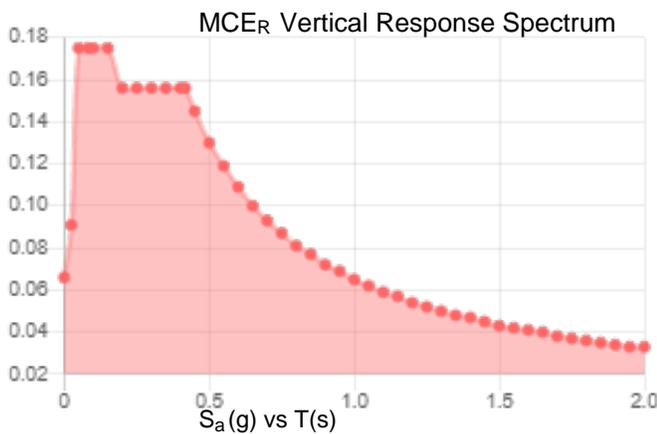
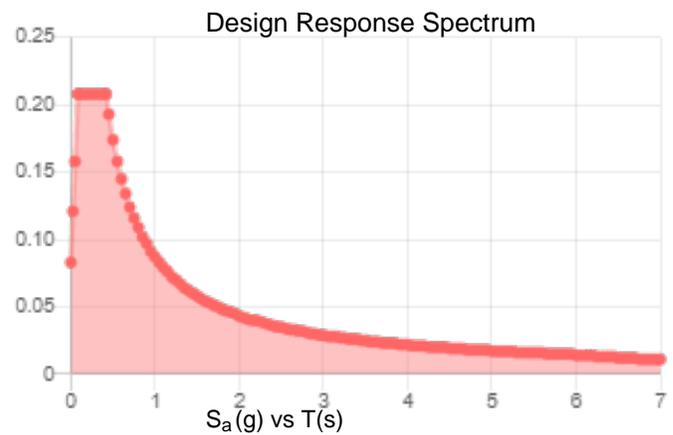
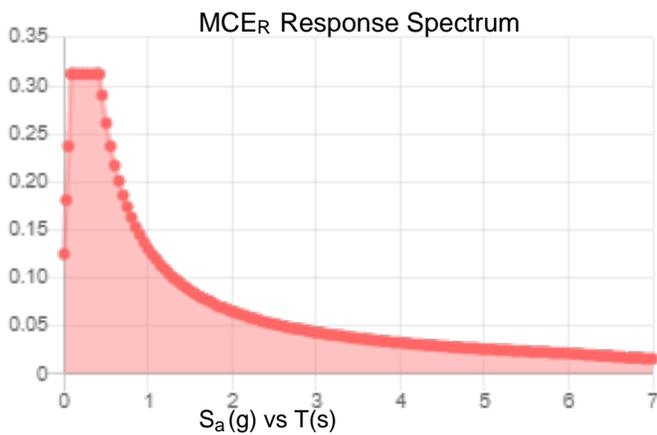

**Data Accessed:** Thu Jan 27 2022

**Date Source:**

**USGS Seismic Design Maps based on ASCE/SEI 7-16 and ASCE/SEI 7-16 Table 1.5-2. Additional data for site-specific ground motion procedures in accordance with ASCE/SEI 7-16 Ch. 21 are available from USGS.**

## Ice

---

**Results:**

Ice Thickness: 1.00 in.  
Concurrent Temperature: 15 F  
Gust Speed 50 mph

**Data Source:** Standard ASCE/SEI 7-16, Figs. 10-2 through 10-8

**Date Accessed:** Thu Jan 27 2022

Ice thicknesses on structures in exposed locations at elevations higher than the surrounding terrain and in valleys and gorges may exceed the mapped values.

Values provided are equivalent radial ice thicknesses due to freezing rain with concurrent 3-second gust speeds, for a 500-year mean recurrence interval, and temperatures concurrent with ice thicknesses due to freezing rain. Thicknesses for ice accretions caused by other sources shall be obtained from local meteorological studies. Ice thicknesses in exposed locations at elevations higher than the surrounding terrain and in valleys and gorges may exceed the mapped values.

---

The ASCE 7 Hazard Tool is provided for your convenience, for informational purposes only, and is provided “as is” and without warranties of any kind. The location data included herein has been obtained from information developed, produced, and maintained by third party providers; or has been extrapolated from maps incorporated in the ASCE 7 standard. While ASCE has made every effort to use data obtained from reliable sources or methodologies, ASCE does not make any representations or warranties as to the accuracy, completeness, reliability, currency, or quality of any data provided herein. Any third-party links provided by this Tool should not be construed as an endorsement, affiliation, relationship, or sponsorship of such third-party content by or from ASCE.

ASCE does not intend, nor should anyone interpret, the results provided by this Tool to replace the sound judgment of a competent professional, having knowledge and experience in the appropriate field(s) of practice, nor to substitute for the standard of care required of such professionals in interpreting and applying the contents of this Tool or the ASCE 7 standard.

In using this Tool, you expressly assume all risks associated with your use. Under no circumstances shall ASCE or its officers, directors, employees, members, affiliates, or agents be liable to you or any other person for any direct, indirect, special, incidental, or consequential damages arising from or related to your use of, or reliance on, the Tool or any information obtained therein. To the fullest extent permitted by law, you agree to release and hold harmless ASCE from any and all liability of any nature arising out of or resulting from any use of data provided by the ASCE 7 Hazard Tool.

# Exhibit E

## **Mount Analysis**

Date: **September 14, 2021**

**INFINIGY**  
FROM ZERO TO INFINIGY  
the solutions are endless  
Infinigy Engineering, PLLC  
1033 Watervliet Shaker Road  
Albany, NY 12205  
518-690-0790  
structural@infinigy.com

Jacob Montoya  
Crown Castle  
2055 S. Stearman Dr.  
Chandler, AZ 85286  
480-298-9641

**Subject:** **Mount Analysis Report**

**Carrier Designation:** **Dish Network 5G**  
**Carrier Site Number:** BOHVN00165A  
**Carrier Site Name:** CT-CCI-T-876317

**Crown Castle Designation:** **Crown Castle BU Number:** 876317  
**Crown Castle Site Name:** WATERBURY  
**Crown Castle JDE Job Number:** 645174  
**Crown Castle Order Number:** 553382 Rev.1

**Engineering Firm Designation:** **Infinigy Engineering, PLLC Report Designation:** 1039-Z0001-B

**Site Data:** **150 Mattatuck Heights, Waterbury, New Haven County, CT, 06705-3831**  
**Latitude 41°32'16.30" Longitude -72°59'6.10"**

**Structure Information:** **Tower Height & Type:** **144.3 ft Monopole**  
**Mount Elevation:** **120.0 ft**  
**Mount Type:** **8.0 ft Platform**

Dear Jacob Montoya,

Infinigy Engineering, PLLC is pleased to submit this "**Mount Analysis Report**" to determine the structural integrity of Dish Network's antenna mounting system with the proposed appurtenance and equipment addition on the abovementioned supporting tower structure. Analysis of the existing supporting tower structure is to be completed by others and therefore is not part of this analysis. Analysis of the antenna mounting system as a tie-off point for fall protection or rigging is not part of this document.

The purpose of the analysis is to determine acceptability of the mount stress level. Based on our analysis we have determined the mount stress level to be:

**Platform**

**Sufficient**

**\*Sufficient upon completion of the changes listed in the 'Recommendations' section of this report.**

This analysis has been performed in accordance with the 2015 International Building Code based upon an ultimate 3-second gust wind speed of 118 mph. Applicable Standard references and design criteria are listed in Section 2 - Analysis Criteria.

Mount analysis prepared by: Iker Moreno, EIT

Respectfully Submitted by:  
Emmanuel Poulin, P.E.  
518-690-0790  
[structural@infinigy.com](mailto:structural@infinigy.com)  
CT PE License No. 22947

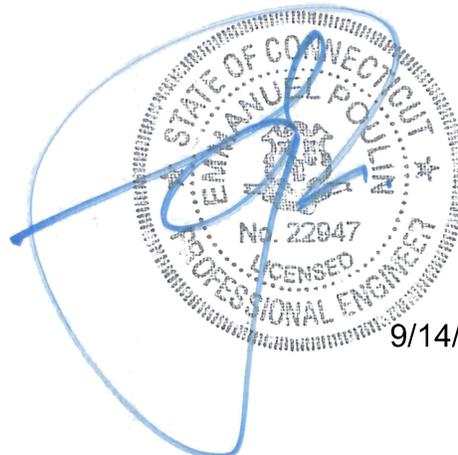

9/14/21

## TABLE OF CONTENTS

### 1) INTRODUCTION

### 2) ANALYSIS CRITERIA

Table 1 - Proposed Equipment Configuration

### 3) ANALYSIS PROCEDURE

Table 2 - Documents Provided

3.1) Analysis Method

3.2) Assumptions

### 4) ANALYSIS RESULTS

Table 3 - Mount Component Stresses vs. Capacity

4.1) Recommendations

### 5) APPENDIX A

Wire Frame and Rendered Models

### 6) APPENDIX B

Software Input Calculations

### 7) APPENDIX C

Software Analysis Output

### 8) APPENDIX D

Additional Calculations

## 1) INTRODUCTION

This is a proposed 3 sector 8.0 ft Platform, designed by Commscope.

## 2) ANALYSIS CRITERIA

<b>Building Code:</b>	2015 IBC
<b>TIA-222 Revision:</b>	TIA-222-H
<b>Risk Category:</b>	II
<b>Ultimate Wind Speed:</b>	118 mph
<b>Exposure Category:</b>	B
<b>Topographic Factor at Base:</b>	1.0
<b>Topographic Factor at Mount:</b>	1.0
<b>Ice Thickness:</b>	1.5 in
<b>Wind Speed with Ice:</b>	50 mph
<b>Seismic <math>S_s</math>:</b>	0.188
<b>Seismic <math>S_1</math>:</b>	0.064
<b>Live Loading Wind Speed:</b>	30 mph
<b>Man Live Load at Mid/End-Points:</b>	250 lb
<b>Man Live Load at Mount Pipes:</b>	500 lb

**Table 1 - Proposed Equipment Configuration**

Mount Centerline (ft)	Antenna Centerline (ft)	Number of Antennas	Antenna Manufacturer	Antenna Model	Mount / Modification Details
120.0	120.0	3	JMA WIRELESS	MX08FRO665-21	8.0 ft Platform {Commscope MC-PK8-DSH}
		3	FUJITSU	TA08025-B604	
		3	FUJITSU	TA08025-B605	
		1	RAYCAP	RDIDC-9181-PF-48	

## 3) ANALYSIS PROCEDURE

**Table 2 - Documents Provided**

Document	Remarks	Reference	Source
Crown Application	Dish Network Application	553382 Rev.1	CCI Sites
Mount Manufacturer Drawings	Commscope	MC-PK8-DSH	Infinigy

### 3.1) Analysis Method

RISA-3D (Version 17.0.4), a commercially available analysis software package, was used to create a three-dimensional model of the antenna mounting system and calculate member stresses for various loading cases.

Infinigy Mount Analysis Tool V2.1.7, a tool internally developed by Infinigy, was used to calculate wind loading on all appurtenances, dishes and mount members for various loading cases. Selected output from the analysis is included in Appendix B "Software Input Calculations".

This analysis was performed in accordance with Crown Castle's ENG-SOW-10208 *Tower Mount Analysis* (Revision B).

**3.2) Assumptions**

- 1) The antenna mounting system was properly fabricated, installed and maintained in good condition in accordance with its original design and manufacturer's specifications.
- 2) The configuration of antennas, mounts, and other appurtenances are as specified in Table 1 and the referenced drawings.
- 3) All member connections are assumed to have been designed to meet or exceed the load carrying capacity of the connected member unless otherwise specified in this report.
- 4) The analysis will be required to be revised if the existing conditions in the field differ from those shown in the above-referenced documents or assumed in this analysis. No allowance was made for any damaged, missing, or rusted members.
- 5) Prior structural modifications to the tower mounting system are assumed to be installed as shown per available data.
- 6) Steel grades have been assumed as follows, unless noted otherwise:
 

Channel, Solid Round, Angle, Plate	ASTM A36 (GR 36)
HSS (Rectangular)	ASTM A500 (GR B-46)
Pipe	ASTM A53 (GR 35)
Connection Bolts	ASTM A325

This analysis may be affected if any assumptions are not valid or have been made in error. Infinigy Engineering, PLLC should be notified to determine the effect on the structural integrity of the antenna mounting system.

**4) ANALYSIS RESULTS**

**Table 3 - Mount Component Stresses vs. Capacity (Platform, All Sectors)**

Notes	Component	Critical Member	Centerline (ft)	% Capacity	Pass / Fail
1,2	Mount Pipe(s)	MP4	120.0	12.1	Pass
	Horizontal(s)	H1		10.5	Pass
	Standoff(s)	S2		29.1	Pass
	Bracing(s)	CA1		31.2	Pass
	Corner Plate(s)	P2		15.4	Pass
	Mount Connection(s)	--		24.0	Pass
<b>Structure Rating (max from all components) =</b>					<b>31.2%</b>

Notes:

- 1) See additional documentation in "Appendix C - Software Analysis Output" for calculations supporting the % capacity consumed.
- 2) See additional documentation in "Appendix D – Additional Calculations" for detailed mount connection calculations.

**4.1) Recommendations**

The mount has sufficient capacity to carry the proposed loading configuration. In order for the results of the analysis to be considered valid, the proposed mount listed below must be installed.

1. Commscope MC-PK8-DSH

No structural modifications are required at this time, provided that the above-listed changes are implemented.

**APPENDIX A**  
**WIRE FRAME AND RENDERED MODELS**

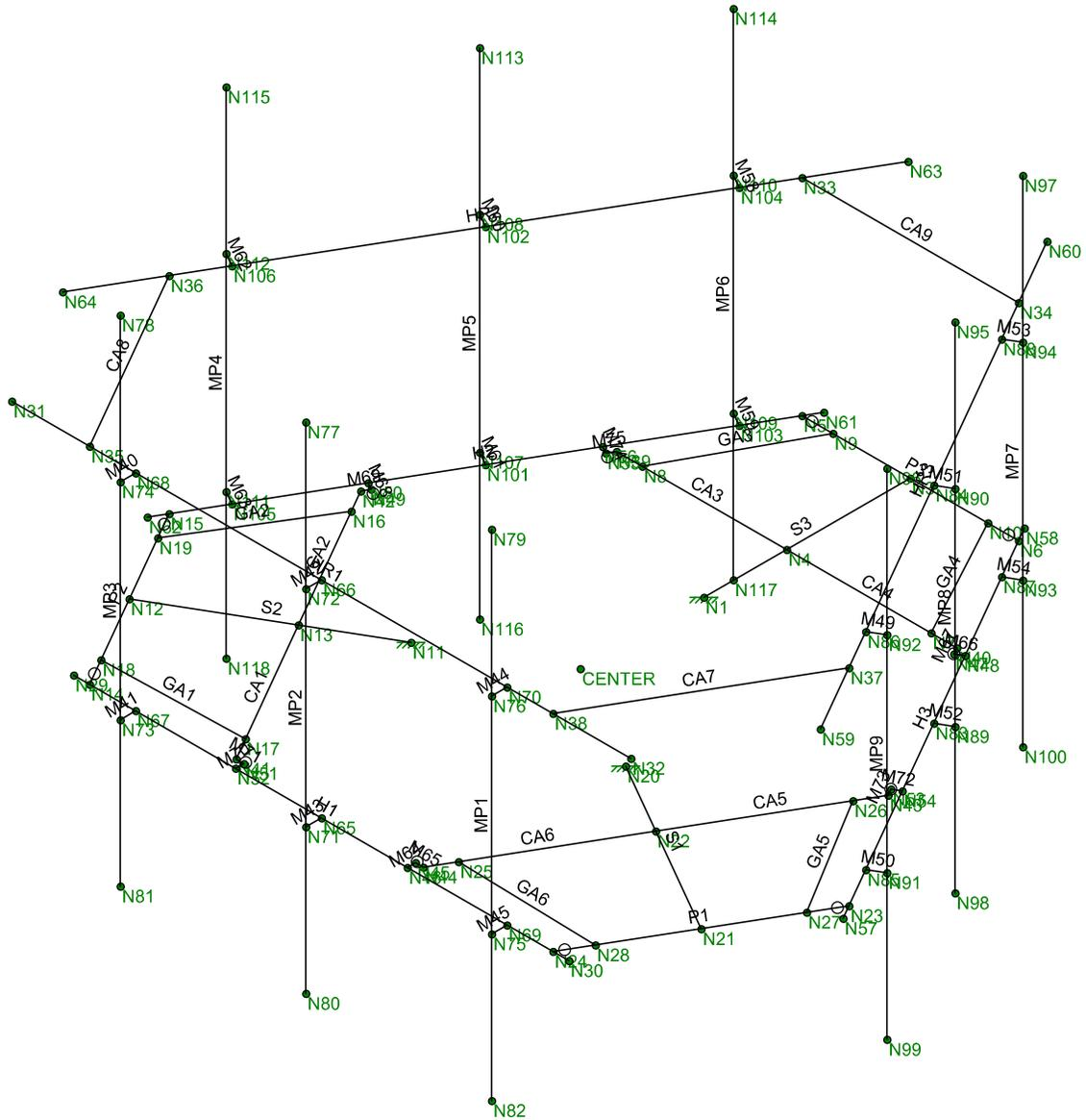
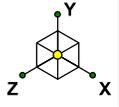

Infinigy Engineering

IM

1039-Z0001-B

876317

Wireframe

Sept 14, 2021 at 12:25 PM

876317\_loaded.r3d

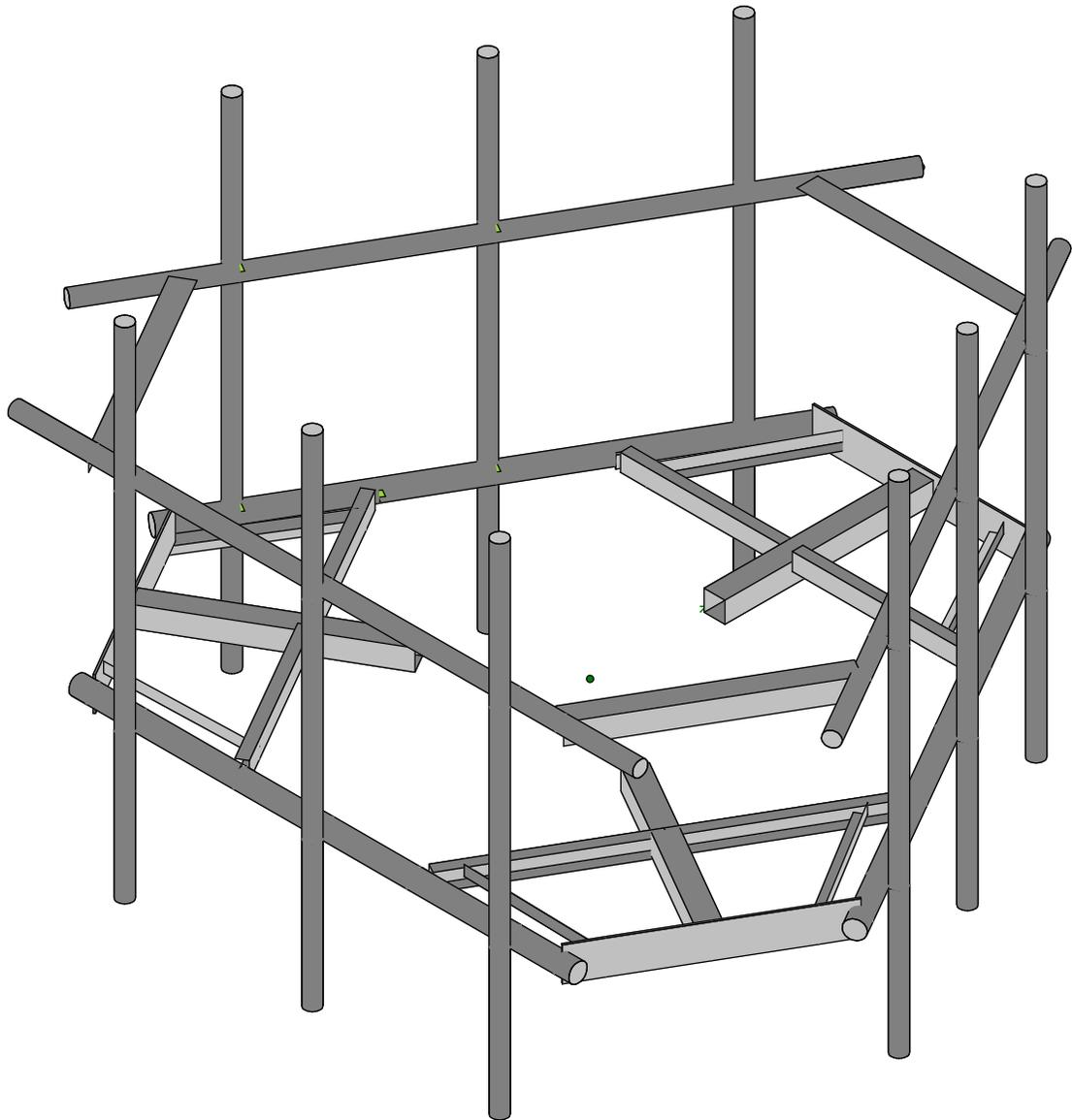
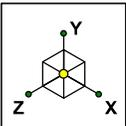

Infinigy Engineering	876317	Rendering
IM		Sept 14, 2021 at 12:25 PM
1039-Z0001-B		876317_loaded.r3d

**APPENDIX B**  
**SOFTWARE INPUT CALCULATIONS**

## Program Inputs

PROJECT INFORMATION	
Client:	Crown Castle
Carrier:	Dish Network
Engineer:	Iker Moreno

SITE INFORMATION	
Risk Category:	II
Exposure Category:	B
Topo Factor Procedure:	Method 1, Category 1
Site Class:	D - Stiff Soil (Assumed)
Ground Elevation:	660.21 ft *Rev H

MOUNT INFORMATION	
Mount Type:	Platform
Num Sectors:	3
Centerline AGL:	120.00 ft
Tower Height AGL:	144.25 ft

TOPOGRAPHIC DATA	
Topo Feature:	N/A
Slope Distance:	N/A ft
Crest Distance:	N/A ft
Crest Height:	N/A ft

FACTORS	
Directionality Fact. ( $K_d$ ):	0.950
Ground Ele. Factor ( $K_e$ ):	0.976 * Rev H Only
Rooftop Speed-Up ( $K_s$ ):	1.000 * Rev H Only
Topographic Factor ( $K_{zt}$ ):	1.000
Gust Effect Factor ( $G_h$ ):	1.000

CODE STANDARDS	
Building Code:	2015 IBC
TIA Standard:	TIA-222-H
ASCE Standard:	ASCE 7-10

WIND AND ICE DATA	
Ultimate Wind ( $V_{ult}$ ):	118 mph
Design Wind ( $V$ ):	N/A mph
Ice Wind ( $V_{ice}$ ):	50 mph
Base Ice Thickness ( $t_i$ ):	1.5 in
Flat Pressure:	68.843 psf
Round Pressure:	41.306 psf
Ice Wind Pressure:	7.416 psf

SEISMIC DATA	
Short-Period Accel. ( $S_3$ ):	0.188 g
1-Second Accel. ( $S_1$ ):	0.064 g
Short-Period Design ( $S_{ps}$ ):	0.201
1-Second Design ( $S_{D1}$ ):	0.102
Short-Period Coeff. ( $F_a$ ):	1.600
1-Second Coeff. ( $F_v$ ):	2.400
Amplification Factor ( $A_s$ ):	3.000
Response Mod. Coeff. ( $R$ ):	2.000



Infinigy Load Calculator V2.1.7



# ASCE 7 Hazards Report

**Address:**  
No Address at This  
Location

**Standard:** ASCE/SEI 7-10  
**Risk Category:** II  
**Soil Class:** D - Stiff Soil

**Elevation:** 660.21 ft (NAVD 88)  
**Latitude:** 41.537861  
**Longitude:** -72.985028

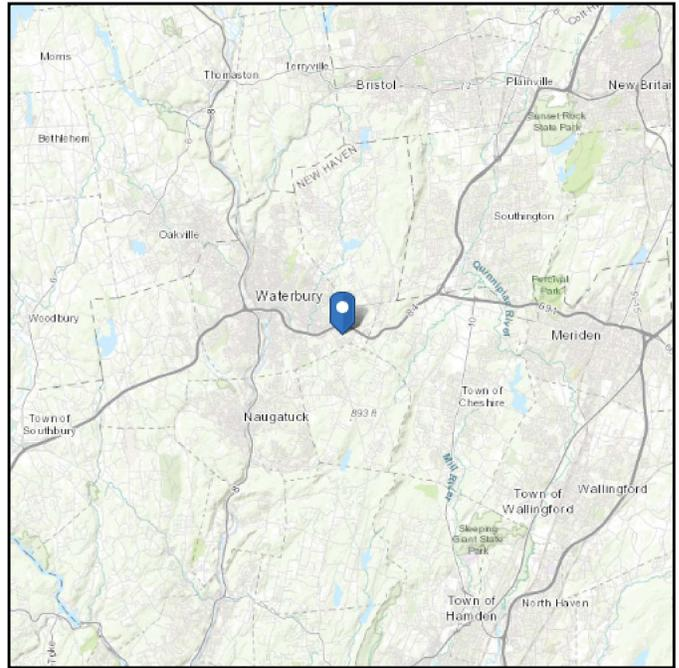
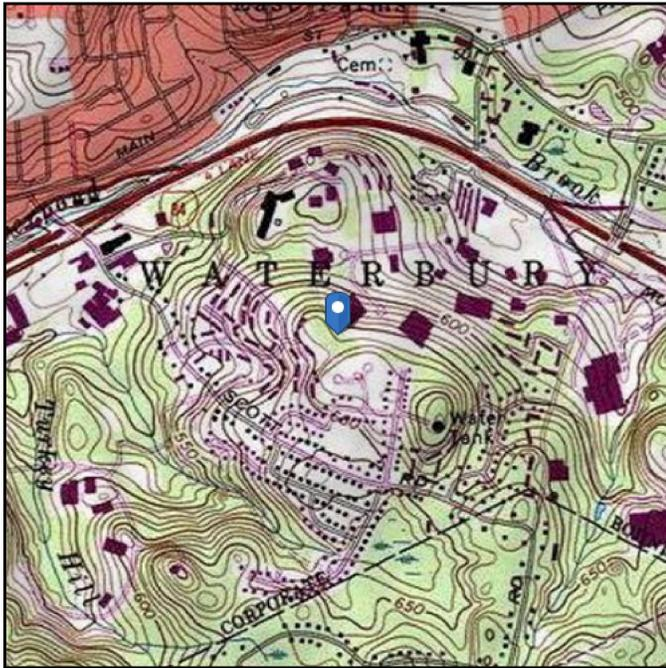

## Wind

### Results:

Wind Speed:	118 Vmph per State of Connecticut allowing ASCE 7-16 wind speed values
10-year MRI	76 Vmph
25-year MRI	86 Vmph
50-year MRI	92 Vmph
100-year MRI	99 Vmph

**Data Source:** ASCE/SEI 7-16 Fig. 26.5-1A and Figs. CC-1–CC-4, and Section 26.5.2, incorporating errata of March 12, 2014

Value provided is 3-second gust wind speeds at 33 ft above ground for Exposure C Category, based on linear interpolation between contours. Wind speeds are interpolated in accordance with the 7-10 Standard. Wind speeds correspond to approximately a 7% probability of exceedance in 50 years (annual exceedance probability = 0.00143, MRI = 700 years).

Site is in a hurricane-prone region as defined in ASCE/SEI 7-10 Section 26.2. Glazed openings need not be protected against wind-borne debris.

**Site Soil Class:** D - Stiff Soil

**Results:**

$S_s$ :	0.188	$S_{DS}$ :	0.2
$S_1$ :	0.064	$S_{D1}$ :	0.102
$F_a$ :	1.6	$T_L$ :	6
$F_v$ :	2.4	PGA :	0.097
$S_{MS}$ :	0.3	PGA <sub>M</sub> :	0.155
$S_{M1}$ :	0.153	F <sub>PGA</sub> :	1.6
		$I_e$ :	1

**Seismic Design Category** B

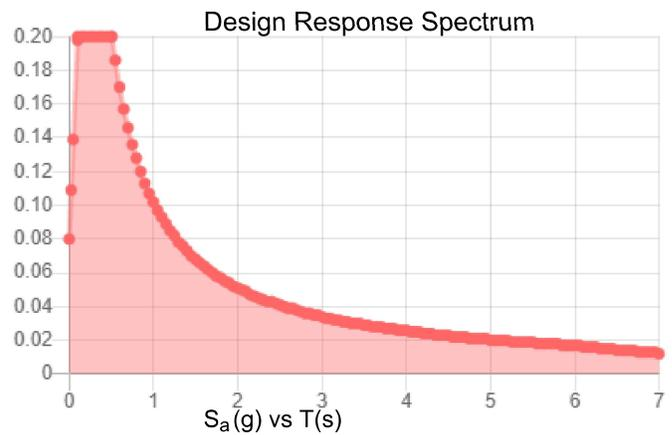
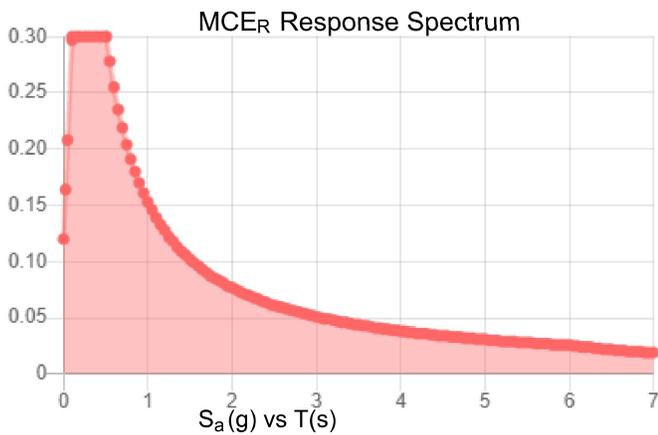

**Data Accessed:**

Tue Sep 14 2021

**Date Source:**

USGS Seismic Design Maps based on ASCE/SEI 7-10, incorporating Supplement 1 and errata of March 31, 2013, and ASCE/SEI 7-10 Table 1.5-2. Additional data for site-specific ground motion procedures in accordance with ASCE/SEI 7-10 Ch. 21 are available from USGS.

## Ice

---

### Results:

Ice Thickness: 0.75 in.  
Concurrent Temperature: 15 F  
Gust Speed: 50 mph

**Data Source:** Standard ASCE/SEI 7-10, Figs. 10-2 through 10-8

**Date Accessed:** Tue Sep 14 2021

Ice thicknesses on structures in exposed locations at elevations higher than the surrounding terrain and in valleys and gorges may exceed the mapped values.

Values provided are equivalent radial ice thicknesses due to freezing rain with concurrent 3-second gust speeds, for a 50-year mean recurrence interval, and temperatures concurrent with ice thicknesses due to freezing rain. Thicknesses for ice accretions caused by other sources shall be obtained from local meteorological studies. Ice thicknesses in exposed locations at elevations higher than the surrounding terrain and in valleys and gorges may exceed the mapped values.

---

The ASCE 7 Hazard Tool is provided for your convenience, for informational purposes only, and is provided “as is” and without warranties of any kind. The location data included herein has been obtained from information developed, produced, and maintained by third party providers; or has been extrapolated from maps incorporated in the ASCE 7 standard. While ASCE has made every effort to use data obtained from reliable sources or methodologies, ASCE does not make any representations or warranties as to the accuracy, completeness, reliability, currency, or quality of any data provided herein. Any third-party links provided by this Tool should not be construed as an endorsement, affiliation, relationship, or sponsorship of such third-party content by or from ASCE.

ASCE does not intend, nor should anyone interpret, the results provided by this Tool to replace the sound judgment of a competent professional, having knowledge and experience in the appropriate field(s) of practice, nor to substitute for the standard of care required of such professionals in interpreting and applying the contents of this Tool or the ASCE 7 standard.

In using this Tool, you expressly assume all risks associated with your use. Under no circumstances shall ASCE or its officers, directors, employees, members, affiliates, or agents be liable to you or any other person for any direct, indirect, special, incidental, or consequential damages arising from or related to your use of, or reliance on, the Tool or any information obtained therein. To the fullest extent permitted by law, you agree to release and hold harmless ASCE from any and all liability of any nature arising out of or resulting from any use of data provided by the ASCE 7 Hazard Tool.

**APPENDIX C**  
**SOFTWARE ANALYSIS OUTPUT**

**Member Primary Data**

	Label	I Joint	J Joint	K Joint	Rotate(deg)	Section/Shape	Type	Design List	Material	Design Rules
1	S3	N1	N3			Standoff	Beam	Tube	A500 Gr....	Typical
2	GA4	N7	N10		270	Grating Angle	Beam	Single Angle	A36 Gr.36	Typical
3	GA3	N8	N9			Grating Angle	Beam	Single Angle	A36 Gr.36	Typical
4	P3	N5	N6			Corner Plates	Beam	RECT	A36 Gr.36	Typical
5	S2	N11	N12			Standoff	Beam	Tube	A500 Gr....	Typical
6	GA2	N16	N19		270	Grating Angle	Beam	Single Angle	A36 Gr.36	Typical
7	GA1	N17	N18			Grating Angle	Beam	Single Angle	A36 Gr.36	Typical
8	P2	N14	N15			Corner Plates	Beam	RECT	A36 Gr.36	Typical
9	S1	N20	N21			Standoff	Beam	Tube	A500 Gr....	Typical
10	GA6	N25	N28		270	Grating Angle	Beam	Single Angle	A36 Gr.36	Typical
11	GA5	N26	N27			Grating Angle	Beam	Single Angle	A36 Gr.36	Typical
12	P1	N23	N24			Corner Plates	Beam	RECT	A36 Gr.36	Typical
13	H1	N29	N30			Horizontal	Beam	Pipe	A53 Gr.B	Typical
14	HR1	N31	N32			Handrail	Beam	Pipe	A53 Gr.B	Typical
15	CA8	N36	N35		180	Handrail Connector	Beam	Single Angle	A36 Gr.36	Typical
16	CA9	N34	N33		180	Handrail Connector	Beam	Single Angle	A36 Gr.36	Typical
17	CA7	N38	N37		180	Handrail Connector	Beam	Single Angle	A36 Gr.36	Typical
18	CA3	N4	N39			Channel	Beam	Channel	A36 Gr.36	Typical
19	CA4	N40	N4			Channel	Beam	Channel	A36 Gr.36	Typical
20	CA1	N13	N41			Channel	Beam	Channel	A36 Gr.36	Typical
21	CA2	N42	N13			Channel	Beam	Channel	A36 Gr.36	Typical
22	CA5	N22	N43			Channel	Beam	Channel	A36 Gr.36	Typical
23	CA6	N44	N22			Channel	Beam	Channel	A36 Gr.36	Typical
24	M64	N46	N45			RIGID	None	None	RIGID	Typical
25	M65	N44	N45			RIGID	None	None	RIGID	Typical
26	M66	N48	N47			RIGID	None	None	RIGID	Typical
27	M67	N40	N47			RIGID	None	None	RIGID	Typical
28	M68	N50	N49			RIGID	None	None	RIGID	Typical
29	M69	N42	N49			RIGID	None	None	RIGID	Typical
30	M70	N52	N51			RIGID	None	None	RIGID	Typical
31	M71	N41	N51			RIGID	None	None	RIGID	Typical
32	M72	N54	N53			RIGID	None	None	RIGID	Typical
33	M73	N43	N53			RIGID	None	None	RIGID	Typical
34	M74	N56	N55			RIGID	None	None	RIGID	Typical
35	M75	N39	N55			PL 2.375x0.5	None	None	A36 Gr.36	Typical
36	H3	N57	N58			Horizontal	Beam	Pipe	A53 Gr.B	Typical
37	HR3	N59	N60			Handrail	Beam	Pipe	A53 Gr.B	Typical
38	H2	N61	N62			Horizontal	Beam	Pipe	A53 Gr.B	Typical
39	HR2	N63	N64			Handrail	Beam	Pipe	A53 Gr.B	Typical
40	M40	N68	N74			RIGID	None	None	RIGID	Typical
41	M41	N67	N73			RIGID	None	None	RIGID	Typical
42	M42	N66	N72			RIGID	None	None	RIGID	Typical
43	M43	N65	N71			RIGID	None	None	RIGID	Typical
44	M44	N70	N76			RIGID	None	None	RIGID	Typical
45	M45	N69	N75			RIGID	None	None	RIGID	Typical
46	MP3	N78	N81			Mount Pipe	Column	Pipe	A53 Gr.B	Typical
47	MP2	N77	N80			Mount Pipe	Column	Pipe	A53 Gr.B	Typical
48	MP1	N79	N82			Mount Pipe	Column	Pipe	A53 Gr.B	Typical
49	M49	N86	N92			RIGID	None	None	RIGID	Typical
50	M50	N85	N91			RIGID	None	None	RIGID	Typical
51	M51	N84	N90			RIGID	None	None	RIGID	Typical
52	M52	N83	N89			RIGID	None	None	RIGID	Typical
53	M53	N88	N94			RIGID	None	None	RIGID	Typical
54	M54	N87	N93			RIGID	None	None	RIGID	Typical
55	MP9	N96	N99			Mount Pipe	Column	Pipe	A53 Gr.B	Typical
56	MP8	N95	N98			Mount Pipe	Column	Pipe	A53 Gr.B	Typical

**Member Primary Data (Continued)**

	Label	I Joint	J Joint	K Joint	Rotate(deg)	Section/Shape	Type	Design List	Material	Design Rules
57	MP7	N97	N100			Mount Pipe	Column	Pipe	A53 Gr.B	Typical
58	M58	N104	N110			RIGID	None	None	RIGID	Typical
59	M59	N103	N109			RIGID	None	None	RIGID	Typical
60	M60	N102	N108			RIGID	None	None	RIGID	Typical
61	M61	N101	N107			RIGID	None	None	RIGID	Typical
62	M62	N106	N112			RIGID	None	None	RIGID	Typical
63	M63	N105	N111			RIGID	None	None	RIGID	Typical
64	MP6	N114	N117			Mount Pipe	Column	Pipe	A53 Gr.B	Typical
65	MP5	N113	N116			Mount Pipe	Column	Pipe	A53 Gr.B	Typical
66	MP4	N115	N118			Mount Pipe	Column	Pipe	A53 Gr.B	Typical

**Hot Rolled Steel Properties**

	Label	E [ksi]	G [ksi]	Nu	Therm (/1E...	Density[lb/f...	Yield[ksi]	Ry	Fu[ksi]	Rt
1	A992	29000	11154	.3	.65	490	50	1.1	65	1.1
2	A36 Gr.36	29000	11154	.3	.65	490	36	1.5	58	1.2
3	A572 Gr.50	29000	11154	.3	.65	490	50	1.1	65	1.1
4	A500 Gr.B RND	29000	11154	.3	.65	527	42	1.4	58	1.3
5	A500 Gr.B Rect	29000	11154	.3	.65	527	46	1.4	58	1.3
6	A53 Gr.B	29000	11154	.3	.65	490	35	1.6	60	1.2
7	A1085	29000	11154	.3	.65	490	50	1.4	65	1.3
8	A913 Gr.65	29000	11154	.3	.65	490	65	1.1	80	1.1
9	A500 GR.C	29000	11154	.3	.65	490	46	1.6	60	1.2
10	A529 Gr. 50	29000	11154	.3	.65	490	50	1.1	65	1.1
11	A1011-33Ksi	29000	11154	.3	.65	490	33	1.5	58	1.2
12	A1011 36 Ksi	29000	11154	.3	.65	490	36	1.5	58	1.2
13	A1018 50 Ksi	29000	11154	.3	.65	490	50	1.5	65	1.2

**Hot Rolled Steel Section Sets**

	Label	Shape	Type	Design List	Material	Design R...	A [in2]	Iyy [in4]	Izz [in4]	J [in4]
1	Corner Plates	PL6.5x0.375	Beam	RECT	A36 Gr.36	Typical	2.438	.029	8.582	.11
2	6"x0.37" Plate	Plate 6x.37	Beam	RECT	A36 Gr.36	Typical	2.22	.025	6.66	.097
3	Grating Angle	L2x2x4	Beam	Single Angle	A36 Gr.36	Typical	.944	.346	.346	.021
4	Horizontal	PIPE 3.0	Beam	Pipe	A53 Gr.B	Typical	2.07	2.85	2.85	5.69
5	Mount Pipe	PIPE 2.5	Column	Pipe	A53 Gr.B	Typical	1.61	1.45	1.45	2.89
6	Channel	C3.38x2.06x0.25	Beam	Channel	A36 Gr.36	Typical	1.75	.715	3.026	.034
7	Standoff	HSS4X4X4	Beam	Tube	A500 Gr.B Re...	Typical	3.37	7.8	7.8	12.8
8	Handrail Connector	L4X4X4	Beam	Single Angle	A36 Gr.36	Typical	1.93	3	3	.044
9	Handrail	PIPE 2.5	Beam	Pipe	A53 Gr.B	Typical	1.61	1.45	1.45	2.89

**Joint Coordinates and Temperatures**

	Label	X [in]	Y [in]	Z [in]	Temp [F]	Detach From Diap...
1	N1	-0.	0	-74.1865	0	
2	CENTER	0	0	-50.1865	0	
3	N3	-0.	0	-114.1865	0	
4	N4	-0.	0	-90.1865	0	
5	N5	-21.	0	-114.1865	0	
6	N6	21.	0	-114.1865	0	
7	N7	28.	0	-90.1865	0	
8	N8	-28.	0	-90.1865	0	
9	N9	-15.	0	-114.1865	0	
10	N10	15.	0	-114.1865	0	
11	N11	-20.78461	0	-38.1865	0	

**Joint Coordinates and Temperatures (Continued)**

	Label	X [in]	Y [in]	Z [in]	Temp [F]	Detach From Diap...
12	N12	-55.425626	0	-18.1865	0	
13	N13	-34.641016	0	-30.1865	0	
14	N14	-44.925626	0	0.000033	0	
15	N15	-65.925626	0	-36.373033	0	
16	N16	-48.641016	0	-54.435211	0	
17	N17	-20.641016	0	-5.937789	0	
18	N18	-47.925626	0	-5.196119	0	
19	N19	-62.925626	0	-31.176881	0	
20	N20	20.78461	0	-38.1865	0	
21	N21	55.425626	0	-18.1865	0	
22	N22	34.641016	0	-30.1865	0	
23	N23	65.925626	0	-36.373033	0	
24	N24	44.925626	0	0.000033	0	
25	N25	20.641016	0	-5.937789	0	
26	N26	48.641016	0	-54.435211	0	
27	N27	62.925626	0	-31.176881	0	
28	N28	47.925626	0	-5.196119	0	
29	N29	-48.	0	0.000033	0	
30	N30	48.	0	0.000033	0	
31	N31	-60.	40	0.000033	0	
32	N32	60.	40	0.000033	0	
33	N33	-21.	40	-114.1865	0	
34	N34	21.	40	-114.1865	0	
35	N35	-44.925626	40	0.000033	0	
36	N36	-65.925626	40	-36.373033	0	
37	N37	65.925626	40	-36.373033	0	
38	N38	44.925626	40	0.000033	0	
39	N39	-33.	0	-90.1865	0	
40	N40	33.	0	-90.1865	0	
41	N41	-18.141016	0	-1.607662	0	
42	N42	-51.141016	0	-58.765338	0	
43	N43	51.141016	0	-58.765338	0	
44	N44	18.141016	0	-1.607662	0	
45	N45	16.641016	0	-1.607662	0	
46	N46	16.641016	0	0.000033	0	
47	N47	33.75	0	-88.887462	0	
48	N48	35.142305	0	-89.691309	0	
49	N49	-50.391016	0	-60.064377	0	
50	N50	-51.783321	0	-60.868224	0	
51	N51	-16.641016	0	-1.607662	0	
52	N52	-16.641016	0	0.000033	0	
53	N53	50.391016	0	-60.064377	0	
54	N54	51.783321	0	-60.868224	0	
55	N55	-33.75	0	-88.887462	0	
56	N56	-35.142305	0	-89.691309	0	
57	N57	67.462813	0	-33.710548	0	
58	N58	19.462813	0	-116.848986	0	
59	N59	73.462813	40	-23.318243	0	
60	N60	13.462813	40	-127.241291	0	
61	N61	-19.462813	0	-116.848986	0	
62	N62	-67.462813	0	-33.710547	0	
63	N63	-13.462813	40	-127.241291	0	
64	N64	-73.462813	40	-23.318242	0	
65	N65	0.	0	0.000033	0	
66	N66	0.	40	0.000033	0	
67	N67	-36.	0	0.000033	0	
68	N68	-36.	40	0.000033	0	

**Joint Coordinates and Temperatures (Continued)**

	Label	X [in]	Y [in]	Z [in]	Temp [F]	Detach From Diap...
69	N69	36.	0	0.000033	0	
70	N70	36.	40	0.000033	0	
71	N71	0.	0	3.000033	0	
72	N72	0.	40	3.000033	0	
73	N73	-36.	0	3.000033	0	
74	N74	-36.	40	3.000033	0	
75	N75	36.	0	3.000033	0	
76	N76	36.	40	3.000033	0	
77	N77	0.	68	3.000033	0	
78	N78	-36.	68	3.000033	0	
79	N79	36.	68	3.000033	0	
80	N80	0.	-28	3.000033	0	
81	N81	-36.	-28	3.000033	0	
82	N82	36.	-28	3.000033	0	
83	N83	43.462813	0	-75.279767	0	
84	N84	43.462813	40	-75.279767	0	
85	N85	61.462813	0	-44.102852	0	
86	N86	61.462813	40	-44.102852	0	
87	N87	25.462813	0	-106.456681	0	
88	N88	25.462813	40	-106.456681	0	
89	N89	46.060889	0	-76.779767	0	
90	N90	46.060889	40	-76.779767	0	
91	N91	64.060889	0	-45.602852	0	
92	N92	64.060889	40	-45.602852	0	
93	N93	28.060889	0	-107.956681	0	
94	N94	28.060889	40	-107.956681	0	
95	N95	46.060889	68	-76.779767	0	
96	N96	64.060889	68	-45.602852	0	
97	N97	28.060889	68	-107.956681	0	
98	N98	46.060889	-28	-76.779767	0	
99	N99	64.060889	-28	-45.602852	0	
100	N100	28.060889	-28	-107.956681	0	
101	N101	-43.462813	0	-75.279766	0	
102	N102	-43.462813	40	-75.279766	0	
103	N103	-25.462813	0	-106.456681	0	
104	N104	-25.462813	40	-106.456681	0	
105	N105	-61.462813	0	-44.102852	0	
106	N106	-61.462813	40	-44.102852	0	
107	N107	-46.060889	0	-76.779766	0	
108	N108	-46.060889	40	-76.779766	0	
109	N109	-28.060889	0	-107.956681	0	
110	N110	-28.060889	40	-107.956681	0	
111	N111	-64.060889	0	-45.602852	0	
112	N112	-64.060889	40	-45.602852	0	
113	N113	-46.060889	68	-76.779766	0	
114	N114	-28.060889	68	-107.956681	0	
115	N115	-64.060889	68	-45.602852	0	
116	N116	-46.060889	-28	-76.779766	0	
117	N117	-28.060889	-28	-107.956681	0	
118	N118	-64.060889	-28	-45.602852	0	

**Hot Rolled Steel Design Parameters**

Label	Shape	Length...	Lbyy[in]	Lbzz[in]	Lcomp top[in]	Lcomp bot[in]	L-torque[i...	Kyy	Kzz	Cb	Funct...
1	S3	Standoff	40		Lbyy						Lateral
2	GA4	Grating A...	27.295		Lbyy						Lateral

**Hot Rolled Steel Design Parameters (Continued)**

	Label	Shape	Length...	Lbyy[in]	Lbzz[in]	Lcomp top[in]	Lcomp bot[in]	L-torque[i...	Kyy	Kzz	Cb	Funct...
3	GA3	Grating A...	27.295			Lbyy						Lateral
4	P3	Corner Pl...	42			Lbyy						Lateral
5	S2	Standoff	40			Lbyy						Lateral
6	GA2	Grating A...	27.295			Lbyy						Lateral
7	GA1	Grating A...	27.295			Lbyy						Lateral
8	P2	Corner Pl...	42			Lbyy						Lateral
9	S1	Standoff	40			Lbyy						Lateral
10	GA6	Grating A...	27.295			Lbyy						Lateral
11	GA5	Grating A...	27.295			Lbyy						Lateral
12	P1	Corner Pl...	42			Lbyy						Lateral
13	H1	Horizontal	96			Lbyy						Lateral
14	HR1	Handrail	120			Lbyy						Lateral
15	CA8	Handrail ...	42			Lbyy						Lateral
16	CA9	Handrail ...	42			Lbyy						Lateral
17	CA7	Handrail ...	42			Lbyy						Lateral
18	CA3	Channel	33			Lbyy						Lateral
19	CA4	Channel	33			Lbyy						Lateral
20	CA1	Channel	33			Lbyy						Lateral
21	CA2	Channel	33			Lbyy						Lateral
22	CA5	Channel	33			Lbyy						Lateral
23	CA6	Channel	33			Lbyy						Lateral
24	M75	PL 2.375x...	1.5			Lbyy						Lateral
25	H3	Horizontal	96			Lbyy						Lateral
26	HR3	Handrail	120			Lbyy						Lateral
27	H2	Horizontal	96			Lbyy						Lateral
28	HR2	Handrail	120			Lbyy						Lateral
29	MP3	Mount Pipe	96			Lbyy						Lateral
30	MP2	Mount Pipe	96			Lbyy						Lateral
31	MP1	Mount Pipe	96			Lbyy						Lateral
32	MP9	Mount Pipe	96			Lbyy						Lateral
33	MP8	Mount Pipe	96			Lbyy						Lateral
34	MP7	Mount Pipe	96			Lbyy						Lateral
35	MP6	Mount Pipe	96			Lbyy						Lateral
36	MP5	Mount Pipe	96			Lbyy						Lateral
37	MP4	Mount Pipe	96			Lbyy						Lateral

**Basic Load Cases**

	BLC Description	Category	X Gravity	Y Gravity	Z Gravity	Joint	Point	Distributed	Area(Member)	Surface(Plate/Wall)
1	Self Weight	DL		-1			13		3	
2	Wind Load AZ...	WLZ					26			
3	Wind Load AZ...	None					26			
4	Wind Load AZ...	None					26			
5	Wind Load AZ...	WLX					26			
6	Wind Load AZ...	None					26			
7	Wind Load AZ...	None					26			
8	Wind Load AZ...	None					26			
9	Wind Load AZ...	None					26			
10	Wind Load AZ...	None					26			
11	Wind Load AZ...	None					26			
12	Wind Load AZ...	None					26			
13	Wind Load AZ...	None					26			
14	Distr. Wind Lo...	WLZ						66		
15	Distr. Wind Lo...	WLX						66		
16	Ice Weight	OL1					13		3	
17	Ice Wind Load...	OL2					26			

**Basic Load Cases (Continued)**

	BLC Description	Category	X Gravity	Y Gravity	Z Gravity	Joint	Point	Distributed	Area(Member)	Surface(Plate/Wall)
18	Ice Wind Load...	None					26			
19	Ice Wind Load...	None					26			
20	Ice Wind Load...	OL3					26			
21	Ice Wind Load...	None					26			
22	Ice Wind Load...	None					26			
23	Ice Wind Load...	None					26			
24	Ice Wind Load...	None					26			
25	Ice Wind Load...	None					26			
26	Ice Wind Load...	None					26			
27	Ice Wind Load...	None					26			
28	Ice Wind Load...	None					26			
29	Distr. Ice Wind...	OL2						66		
30	Distr. Ice Wind...	OL3						66		
31	Seismic Load Z	ELZ			-.301		13			
32	Seismic Load X	ELX	-.301				13			
33	Service Live L...	LL				1				
34	Maintenance L...	LL				1				
35	Maintenance L...	LL				1				
36	Maintenance L...	LL				1				
37	Maintenance L...	LL				1				
38	Maintenance L...	LL				1				
39	Maintenance L...	LL				1				
40	Maintenance L...	LL				1				
41	Maintenance L...	LL				1				
42	Maintenance L...	LL				1				
43	BLC 1 Transie...	None						9		
44	BLC 16 Transi...	None						9		

**Joint Loads and Enforced Displacements (BLC 33 : Service Live Loads)**

	Joint Label	L,D,M	Direction	Magnitude[(lb.lb-ft), (in.rad), (lb*s^2...
1	N30	L	Y	-250

**Joint Loads and Enforced Displacements (BLC 34 : Maintenance Load 1)**

	Joint Label	L,D,M	Direction	Magnitude[(lb.lb-ft), (in.rad), (lb*s^2...
1	N67	L	Y	-500

**Joint Loads and Enforced Displacements (BLC 35 : Maintenance Load 2)**

	Joint Label	L,D,M	Direction	Magnitude[(lb.lb-ft), (in.rad), (lb*s^2...
1	N65	L	Y	-500

**Joint Loads and Enforced Displacements (BLC 36 : Maintenance Load 3)**

	Joint Label	L,D,M	Direction	Magnitude[(lb.lb-ft), (in.rad), (lb*s^2...
1	N69	L	Y	-500

**Joint Loads and Enforced Displacements (BLC 37 : Maintenance Load 4)**

	Joint Label	L,D,M	Direction	Magnitude[(lb.lb-ft), (in.rad), (lb*s^2...
1	N85	L	Y	-500

**Joint Loads and Enforced Displacements (BLC 38 : Maintenance Load 5)**

	Joint Label	L,D,M	Direction	Magnitude[(lb.lb-ft), (in.rad), (lb*s^2...
1	N83	L	Y	-500

**Joint Loads and Enforced Displacements (BLC 39 : Maintenance Load 6)**

	Joint Label	L,D,M	Direction	Magnitude[(lb,lb-ft), (in,rad), (lb*s^2...
1	N87	L	Y	-500

**Joint Loads and Enforced Displacements (BLC 40 : Maintenance Load 7)**

	Joint Label	L,D,M	Direction	Magnitude[(lb,lb-ft), (in,rad), (lb*s^2...
1	N103	L	Y	-500

**Joint Loads and Enforced Displacements (BLC 41 : Maintenance Load 8)**

	Joint Label	L,D,M	Direction	Magnitude[(lb,lb-ft), (in,rad), (lb*s^2...
1	N101	L	Y	-500

**Joint Loads and Enforced Displacements (BLC 42 : Maintenance Load 9)**

	Joint Label	L,D,M	Direction	Magnitude[(lb,lb-ft), (in,rad), (lb*s^2...
1	N105	L	Y	-500

**Member Point Loads (BLC 1 : Self Weight)**

	Member Label	Direction	Magnitude[lb,lb-ft]	Location[in, %]
1	MP2	Y	-41.25	6
2	MP2	Y	-41.25	78
3	MP2	Y	-63.9	%25
4	MP2	Y	-75	%50
5	MP2	Y	-21.85	%75
6	MP5	Y	-41.25	6
7	MP5	Y	-41.25	78
8	MP5	Y	-63.9	%33
9	MP5	Y	-75	%67
10	MP8	Y	-41.25	6
11	MP8	Y	-41.25	78
12	MP8	Y	-63.9	%33
13	MP8	Y	-75	%67

**Member Point Loads (BLC 2 : Wind Load AZI 0)**

	Member Label	Direction	Magnitude[lb,lb-ft]	Location[in, %]
1	MP2	X	0	6
2	MP2	Z	-124.07	6
3	MP2	X	0	78
4	MP2	Z	-124.07	78
5	MP2	X	0	%25
6	MP2	Z	-60.83	%25
7	MP2	X	0	%50
8	MP2	Z	-60.83	%50
9	MP2	X	0	%75
10	MP2	Z	-62.06	%75
11	MP5	X	0	6
12	MP5	Z	-68.31	6
13	MP5	X	0	78
14	MP5	Z	-68.31	78
15	MP5	X	0	%33
16	MP5	Z	-38	%33
17	MP5	X	0	%67
18	MP5	Z	-41.45	%67
19	MP8	X	0	6
20	MP8	Z	-68.31	6
21	MP8	X	0	78

**Member Point Loads (BLC 2 : Wind Load AZI 0) (Continued)**

	Member Label	Direction	Magnitude[lb.lb-ft]	Location[in.%]
22	MP8	Z	-68.31	78
23	MP8	X	0	%33
24	MP8	Z	-38	%33
25	MP8	X	0	%67
26	MP8	Z	-41.45	%67

**Member Point Loads (BLC 3 : Wind Load AZI 30)**

	Member Label	Direction	Magnitude[lb.lb-ft]	Location[in.%]
1	MP2	X	-52.74	6
2	MP2	Z	-91.35	6
3	MP2	X	-52.74	78
4	MP2	Z	-91.35	78
5	MP2	X	-26.61	%25
6	MP2	Z	-46.09	%25
7	MP2	X	-27.18	%50
8	MP2	Z	-47.08	%50
9	MP2	X	-27.78	%75
10	MP2	Z	-48.11	%75
11	MP5	X	-52.74	6
12	MP5	Z	-91.35	6
13	MP5	X	-52.74	78
14	MP5	Z	-91.35	78
15	MP5	X	-26.61	%33
16	MP5	Z	-46.09	%33
17	MP5	X	-27.18	%67
18	MP5	Z	-47.08	%67
19	MP8	X	-24.86	6
20	MP8	Z	-43.06	6
21	MP8	X	-24.86	78
22	MP8	Z	-43.06	78
23	MP8	X	-15.2	%33
24	MP8	Z	-26.32	%33
25	MP8	X	-17.5	%67
26	MP8	Z	-30.3	%67

**Member Point Loads (BLC 4 : Wind Load AZI 60)**

	Member Label	Direction	Magnitude[lb.lb-ft]	Location[in.%]
1	MP2	X	-59.16	6
2	MP2	Z	-34.15	6
3	MP2	X	-59.16	78
4	MP2	Z	-34.15	78
5	MP2	X	-32.91	%25
6	MP2	Z	-19	%25
7	MP2	X	-35.9	%50
8	MP2	Z	-20.72	%50
9	MP2	X	-36.84	%75
10	MP2	Z	-21.27	%75
11	MP5	X	-107.45	6
12	MP5	Z	-62.04	6
13	MP5	X	-107.45	78
14	MP5	Z	-62.04	78
15	MP5	X	-52.68	%33
16	MP5	Z	-30.41	%33
17	MP5	X	-52.68	%67
18	MP5	Z	-30.41	%67
19	MP8	X	-59.16	6

**Member Point Loads (BLC 4 : Wind Load AZI 60) (Continued)**

	Member Label	Direction	Magnitude[lb.lb-ft]	Location[in.%]
20	MP8	Z	-34.15	6
21	MP8	X	-59.16	78
22	MP8	Z	-34.15	78
23	MP8	X	-32.91	%33
24	MP8	Z	-19	%33
25	MP8	X	-35.9	%67
26	MP8	Z	-20.72	%67

**Member Point Loads (BLC 5 : Wind Load AZI 90)**

	Member Label	Direction	Magnitude[lb.lb-ft]	Location[in.%]
1	MP2	X	-49.72	6
2	MP2	Z	0	6
3	MP2	X	-49.72	78
4	MP2	Z	0	78
5	MP2	X	-30.39	%25
6	MP2	Z	0	%25
7	MP2	X	-34.99	%50
8	MP2	Z	0	%50
9	MP2	X	-36.04	%75
10	MP2	Z	0	%75
11	MP5	X	-105.48	6
12	MP5	Z	0	6
13	MP5	X	-105.48	78
14	MP5	Z	0	78
15	MP5	X	-53.22	%33
16	MP5	Z	0	%33
17	MP5	X	-54.37	%67
18	MP5	Z	0	%67
19	MP8	X	-105.48	6
20	MP8	Z	0	6
21	MP8	X	-105.48	78
22	MP8	Z	0	78
23	MP8	X	-53.22	%33
24	MP8	Z	0	%33
25	MP8	X	-54.37	%67
26	MP8	Z	0	%67

**Member Point Loads (BLC 6 : Wind Load AZI 120)**

	Member Label	Direction	Magnitude[lb.lb-ft]	Location[in.%]
1	MP2	X	-59.16	6
2	MP2	Z	34.15	6
3	MP2	X	-59.16	78
4	MP2	Z	34.15	78
5	MP2	X	-32.91	%25
6	MP2	Z	19	%25
7	MP2	X	-35.9	%50
8	MP2	Z	20.72	%50
9	MP2	X	-36.84	%75
10	MP2	Z	21.27	%75
11	MP5	X	-59.16	6
12	MP5	Z	34.15	6
13	MP5	X	-59.16	78
14	MP5	Z	34.15	78
15	MP5	X	-32.91	%33
16	MP5	Z	19	%33
17	MP5	X	-35.9	%67

**Member Point Loads (BLC 6 : Wind Load AZI 120) (Continued)**

	Member Label	Direction	Magnitude[lb.lb-ft]	Location[in.%]
18	MP5	Z	20.72	%67
19	MP8	X	-107.45	6
20	MP8	Z	62.04	6
21	MP8	X	-107.45	78
22	MP8	Z	62.04	78
23	MP8	X	-52.68	%33
24	MP8	Z	30.41	%33
25	MP8	X	-52.68	%67
26	MP8	Z	30.41	%67

**Member Point Loads (BLC 7 : Wind Load AZI 150)**

	Member Label	Direction	Magnitude[lb.lb-ft]	Location[in.%]
1	MP2	X	-52.74	6
2	MP2	Z	91.35	6
3	MP2	X	-52.74	78
4	MP2	Z	91.35	78
5	MP2	X	-26.61	%25
6	MP2	Z	46.09	%25
7	MP2	X	-27.18	%50
8	MP2	Z	47.08	%50
9	MP2	X	-27.78	%75
10	MP2	Z	48.11	%75
11	MP5	X	-24.86	6
12	MP5	Z	43.06	6
13	MP5	X	-24.86	78
14	MP5	Z	43.06	78
15	MP5	X	-15.2	%33
16	MP5	Z	26.32	%33
17	MP5	X	-17.5	%67
18	MP5	Z	30.3	%67
19	MP8	X	-52.74	6
20	MP8	Z	91.35	6
21	MP8	X	-52.74	78
22	MP8	Z	91.35	78
23	MP8	X	-26.61	%33
24	MP8	Z	46.09	%33
25	MP8	X	-27.18	%67
26	MP8	Z	47.08	%67

**Member Point Loads (BLC 8 : Wind Load AZI 180)**

	Member Label	Direction	Magnitude[lb.lb-ft]	Location[in.%]
1	MP2	X	0	6
2	MP2	Z	124.07	6
3	MP2	X	0	78
4	MP2	Z	124.07	78
5	MP2	X	0	%25
6	MP2	Z	60.83	%25
7	MP2	X	0	%50
8	MP2	Z	60.83	%50
9	MP2	X	0	%75
10	MP2	Z	62.06	%75
11	MP5	X	0	6
12	MP5	Z	68.31	6
13	MP5	X	0	78
14	MP5	Z	68.31	78
15	MP5	X	0	%33

**Member Point Loads (BLC 8 : Wind Load AZI 180) (Continued)**

	Member Label	Direction	Magnitude[lb.lb-ft]	Location[in.%]
16	MP5	Z	38	%33
17	MP5	X	0	%67
18	MP5	Z	41.45	%67
19	MP8	X	0	6
20	MP8	Z	68.31	6
21	MP8	X	0	78
22	MP8	Z	68.31	78
23	MP8	X	0	%33
24	MP8	Z	38	%33
25	MP8	X	0	%67
26	MP8	Z	41.45	%67

**Member Point Loads (BLC 9 : Wind Load AZI 210)**

	Member Label	Direction	Magnitude[lb.lb-ft]	Location[in.%]
1	MP2	X	52.74	6
2	MP2	Z	91.35	6
3	MP2	X	52.74	78
4	MP2	Z	91.35	78
5	MP2	X	26.61	%25
6	MP2	Z	46.09	%25
7	MP2	X	27.18	%50
8	MP2	Z	47.08	%50
9	MP2	X	27.78	%75
10	MP2	Z	48.11	%75
11	MP5	X	52.74	6
12	MP5	Z	91.35	6
13	MP5	X	52.74	78
14	MP5	Z	91.35	78
15	MP5	X	26.61	%33
16	MP5	Z	46.09	%33
17	MP5	X	27.18	%67
18	MP5	Z	47.08	%67
19	MP8	X	24.86	6
20	MP8	Z	43.06	6
21	MP8	X	24.86	78
22	MP8	Z	43.06	78
23	MP8	X	15.2	%33
24	MP8	Z	26.32	%33
25	MP8	X	17.5	%67
26	MP8	Z	30.3	%67

**Member Point Loads (BLC 10 : Wind Load AZI 240)**

	Member Label	Direction	Magnitude[lb.lb-ft]	Location[in.%]
1	MP2	X	59.16	6
2	MP2	Z	34.15	6
3	MP2	X	59.16	78
4	MP2	Z	34.15	78
5	MP2	X	32.91	%25
6	MP2	Z	19	%25
7	MP2	X	35.9	%50
8	MP2	Z	20.72	%50
9	MP2	X	36.84	%75
10	MP2	Z	21.27	%75
11	MP5	X	107.45	6
12	MP5	Z	62.04	6
13	MP5	X	107.45	78

**Member Point Loads (BLC 10 : Wind Load AZI 240) (Continued)**

	Member Label	Direction	Magnitude[lb.lb-ft]	Location[in.%]
14	MP5	Z	62.04	78
15	MP5	X	52.68	%33
16	MP5	Z	30.41	%33
17	MP5	X	52.68	%67
18	MP5	Z	30.41	%67
19	MP8	X	59.16	6
20	MP8	Z	34.15	6
21	MP8	X	59.16	78
22	MP8	Z	34.15	78
23	MP8	X	32.91	%33
24	MP8	Z	19	%33
25	MP8	X	35.9	%67
26	MP8	Z	20.72	%67

**Member Point Loads (BLC 11 : Wind Load AZI 270)**

	Member Label	Direction	Magnitude[lb.lb-ft]	Location[in.%]
1	MP2	X	49.72	6
2	MP2	Z	0	6
3	MP2	X	49.72	78
4	MP2	Z	0	78
5	MP2	X	30.39	%25
6	MP2	Z	0	%25
7	MP2	X	34.99	%50
8	MP2	Z	0	%50
9	MP2	X	36.04	%75
10	MP2	Z	0	%75
11	MP5	X	105.48	6
12	MP5	Z	0	6
13	MP5	X	105.48	78
14	MP5	Z	0	78
15	MP5	X	53.22	%33
16	MP5	Z	0	%33
17	MP5	X	54.37	%67
18	MP5	Z	0	%67
19	MP8	X	105.48	6
20	MP8	Z	0	6
21	MP8	X	105.48	78
22	MP8	Z	0	78
23	MP8	X	53.22	%33
24	MP8	Z	0	%33
25	MP8	X	54.37	%67
26	MP8	Z	0	%67

**Member Point Loads (BLC 12 : Wind Load AZI 300)**

	Member Label	Direction	Magnitude[lb.lb-ft]	Location[in.%]
1	MP2	X	59.16	6
2	MP2	Z	-34.15	6
3	MP2	X	59.16	78
4	MP2	Z	-34.15	78
5	MP2	X	32.91	%25
6	MP2	Z	-19	%25
7	MP2	X	35.9	%50
8	MP2	Z	-20.72	%50
9	MP2	X	36.84	%75
10	MP2	Z	-21.27	%75
11	MP5	X	59.16	6

**Member Point Loads (BLC 12 : Wind Load AZI 300) (Continued)**

	Member Label	Direction	Magnitude[lb.lb-ft]	Location[in.%]
12	MP5	Z	-34.15	6
13	MP5	X	59.16	78
14	MP5	Z	-34.15	78
15	MP5	X	32.91	%33
16	MP5	Z	-19	%33
17	MP5	X	35.9	%67
18	MP5	Z	-20.72	%67
19	MP8	X	107.45	6
20	MP8	Z	-62.04	6
21	MP8	X	107.45	78
22	MP8	Z	-62.04	78
23	MP8	X	52.68	%33
24	MP8	Z	-30.41	%33
25	MP8	X	52.68	%67
26	MP8	Z	-30.41	%67

**Member Point Loads (BLC 13 : Wind Load AZI 330)**

	Member Label	Direction	Magnitude[lb.lb-ft]	Location[in.%]
1	MP2	X	52.74	6
2	MP2	Z	-91.35	6
3	MP2	X	52.74	78
4	MP2	Z	-91.35	78
5	MP2	X	26.61	%25
6	MP2	Z	-46.09	%25
7	MP2	X	27.18	%50
8	MP2	Z	-47.08	%50
9	MP2	X	27.78	%75
10	MP2	Z	-48.11	%75
11	MP5	X	24.86	6
12	MP5	Z	-43.06	6
13	MP5	X	24.86	78
14	MP5	Z	-43.06	78
15	MP5	X	15.2	%33
16	MP5	Z	-26.32	%33
17	MP5	X	17.5	%67
18	MP5	Z	-30.3	%67
19	MP8	X	52.74	6
20	MP8	Z	-91.35	6
21	MP8	X	52.74	78
22	MP8	Z	-91.35	78
23	MP8	X	26.61	%33
24	MP8	Z	-46.09	%33
25	MP8	X	27.18	%67
26	MP8	Z	-47.08	%67

**Member Point Loads (BLC 16 : Ice Weight)**

	Member Label	Direction	Magnitude[lb.lb-ft]	Location[in.%]
1	MP2	Y	-139.878	6
2	MP2	Y	-139.878	78
3	MP2	Y	-68.656	%25
4	MP2	Y	-73.148	%50
5	MP2	Y	-71.885	%75
6	MP5	Y	-139.878	6
7	MP5	Y	-139.878	78
8	MP5	Y	-68.656	%33
9	MP5	Y	-73.148	%67

**Member Point Loads (BLC 16 : Ice Weight) (Continued)**

	Member Label	Direction	Magnitude[lb.lb-ft]	Location[in.%]
10	MP8	Y	-139.878	6
11	MP8	Y	-139.878	78
12	MP8	Y	-68.656	%33
13	MP8	Y	-73.148	%67

**Member Point Loads (BLC 17 : Ice Wind Load AZI 0)**

	Member Label	Direction	Magnitude[lb.lb-ft]	Location[in.%]
1	MP2	X	0	6
2	MP2	Z	-17.6	6
3	MP2	X	0	78
4	MP2	Z	-17.6	78
5	MP2	X	0	%25
6	MP2	Z	-6.8	%25
7	MP2	X	0	%50
8	MP2	Z	-6.8	%50
9	MP2	X	0	%75
10	MP2	Z	-7.03	%75
11	MP5	X	0	6
12	MP5	Z	-13.45	6
13	MP5	X	0	78
14	MP5	Z	-13.45	78
15	MP5	X	0	%33
16	MP5	Z	-5.53	%33
17	MP5	X	0	%67
18	MP5	Z	-5.73	%67
19	MP8	X	0	6
20	MP8	Z	-13.45	6
21	MP8	X	0	78
22	MP8	Z	-13.45	78
23	MP8	X	0	%33
24	MP8	Z	-5.53	%33
25	MP8	X	0	%67
26	MP8	Z	-5.73	%67

**Member Point Loads (BLC 18 : Ice Wind Load AZI 30)**

	Member Label	Direction	Magnitude[lb.lb-ft]	Location[in.%]
1	MP2	X	-8.11	6
2	MP2	Z	-14.04	6
3	MP2	X	-8.11	78
4	MP2	Z	-14.04	78
5	MP2	X	-3.19	%25
6	MP2	Z	-5.52	%25
7	MP2	X	-3.22	%50
8	MP2	Z	-5.58	%50
9	MP2	X	-3.35	%75
10	MP2	Z	-5.8	%75
11	MP5	X	-8.11	6
12	MP5	Z	-14.04	6
13	MP5	X	-8.11	78
14	MP5	Z	-14.04	78
15	MP5	X	-3.19	%33
16	MP5	Z	-5.52	%33
17	MP5	X	-3.22	%67
18	MP5	Z	-5.58	%67
19	MP8	X	-6.03	6
20	MP8	Z	-10.45	6

**Member Point Loads (BLC 18 : Ice Wind Load AZI 30) (Continued)**

	Member Label	Direction	Magnitude[lb.lb-ft]	Location[in.%]
21	MP8	X	-6.03	78
22	MP8	Z	-10.45	78
23	MP8	X	-2.55	%33
24	MP8	Z	-4.42	%33
25	MP8	X	-2.69	%67
26	MP8	Z	-4.65	%67

**Member Point Loads (BLC 19 : Ice Wind Load AZI 60)**

	Member Label	Direction	Magnitude[lb.lb-ft]	Location[in.%]
1	MP2	X	-11.64	6
2	MP2	Z	-6.72	6
3	MP2	X	-11.64	78
4	MP2	Z	-6.72	78
5	MP2	X	-4.79	%25
6	MP2	Z	-2.76	%25
7	MP2	X	-4.96	%50
8	MP2	Z	-2.86	%50
9	MP2	X	-5.21	%75
10	MP2	Z	-3.01	%75
11	MP5	X	-15.24	6
12	MP5	Z	-8.8	6
13	MP5	X	-15.24	78
14	MP5	Z	-8.8	78
15	MP5	X	-5.89	%33
16	MP5	Z	-3.4	%33
17	MP5	X	-5.89	%67
18	MP5	Z	-3.4	%67
19	MP8	X	-11.64	6
20	MP8	Z	-6.72	6
21	MP8	X	-11.64	78
22	MP8	Z	-6.72	78
23	MP8	X	-4.79	%33
24	MP8	Z	-2.76	%33
25	MP8	X	-4.96	%67
26	MP8	Z	-2.86	%67

**Member Point Loads (BLC 20 : Ice Wind Load AZI 90)**

	Member Label	Direction	Magnitude[lb.lb-ft]	Location[in.%]
1	MP2	X	-12.06	6
2	MP2	Z	0	6
3	MP2	X	-12.06	78
4	MP2	Z	0	78
5	MP2	X	-5.1	%25
6	MP2	Z	0	%25
7	MP2	X	-5.37	%50
8	MP2	Z	0	%50
9	MP2	X	-5.68	%75
10	MP2	Z	0	%75
11	MP5	X	-16.21	6
12	MP5	Z	0	6
13	MP5	X	-16.21	78
14	MP5	Z	0	78
15	MP5	X	-6.38	%33
16	MP5	Z	0	%33
17	MP5	X	-6.44	%67
18	MP5	Z	0	%67

**Member Point Loads (BLC 20 : Ice Wind Load AZI 90) (Continued)**

	Member Label	Direction	Magnitude[lb.lb-ft]	Location[in.%]
19	MP8	X	-16.21	6
20	MP8	Z	0	6
21	MP8	X	-16.21	78
22	MP8	Z	0	78
23	MP8	X	-6.38	%33
24	MP8	Z	0	%33
25	MP8	X	-6.44	%67
26	MP8	Z	0	%67

**Member Point Loads (BLC 21 : Ice Wind Load AZI 120)**

	Member Label	Direction	Magnitude[lb.lb-ft]	Location[in.%]
1	MP2	X	-11.64	6
2	MP2	Z	6.72	6
3	MP2	X	-11.64	78
4	MP2	Z	6.72	78
5	MP2	X	-4.79	%25
6	MP2	Z	2.76	%25
7	MP2	X	-4.96	%50
8	MP2	Z	2.86	%50
9	MP2	X	-5.21	%75
10	MP2	Z	3.01	%75
11	MP5	X	-11.64	6
12	MP5	Z	6.72	6
13	MP5	X	-11.64	78
14	MP5	Z	6.72	78
15	MP5	X	-4.79	%33
16	MP5	Z	2.76	%33
17	MP5	X	-4.96	%67
18	MP5	Z	2.86	%67
19	MP8	X	-15.24	6
20	MP8	Z	8.8	6
21	MP8	X	-15.24	78
22	MP8	Z	8.8	78
23	MP8	X	-5.89	%33
24	MP8	Z	3.4	%33
25	MP8	X	-5.89	%67
26	MP8	Z	3.4	%67

**Member Point Loads (BLC 22 : Ice Wind Load AZI 150)**

	Member Label	Direction	Magnitude[lb.lb-ft]	Location[in.%]
1	MP2	X	-8.11	6
2	MP2	Z	14.04	6
3	MP2	X	-8.11	78
4	MP2	Z	14.04	78
5	MP2	X	-3.19	%25
6	MP2	Z	5.52	%25
7	MP2	X	-3.22	%50
8	MP2	Z	5.58	%50
9	MP2	X	-3.35	%75
10	MP2	Z	5.8	%75
11	MP5	X	-6.03	6
12	MP5	Z	10.45	6
13	MP5	X	-6.03	78
14	MP5	Z	10.45	78
15	MP5	X	-2.55	%33
16	MP5	Z	4.42	%33

**Member Point Loads (BLC 22 : Ice Wind Load AZI 150) (Continued)**

	Member Label	Direction	Magnitude[lb.lb-ft]	Location[in.%]
17	MP5	X	-2.69	%67
18	MP5	Z	4.65	%67
19	MP8	X	-8.11	6
20	MP8	Z	14.04	6
21	MP8	X	-8.11	78
22	MP8	Z	14.04	78
23	MP8	X	-3.19	%33
24	MP8	Z	5.52	%33
25	MP8	X	-3.22	%67
26	MP8	Z	5.58	%67

**Member Point Loads (BLC 23 : Ice Wind Load AZI 180)**

	Member Label	Direction	Magnitude[lb.lb-ft]	Location[in.%]
1	MP2	X	0	6
2	MP2	Z	17.6	6
3	MP2	X	0	78
4	MP2	Z	17.6	78
5	MP2	X	0	%25
6	MP2	Z	6.8	%25
7	MP2	X	0	%50
8	MP2	Z	6.8	%50
9	MP2	X	0	%75
10	MP2	Z	7.03	%75
11	MP5	X	0	6
12	MP5	Z	13.45	6
13	MP5	X	0	78
14	MP5	Z	13.45	78
15	MP5	X	0	%33
16	MP5	Z	5.53	%33
17	MP5	X	0	%67
18	MP5	Z	5.73	%67
19	MP8	X	0	6
20	MP8	Z	13.45	6
21	MP8	X	0	78
22	MP8	Z	13.45	78
23	MP8	X	0	%33
24	MP8	Z	5.53	%33
25	MP8	X	0	%67
26	MP8	Z	5.73	%67

**Member Point Loads (BLC 24 : Ice Wind Load AZI 210)**

	Member Label	Direction	Magnitude[lb.lb-ft]	Location[in.%]
1	MP2	X	8.11	6
2	MP2	Z	14.04	6
3	MP2	X	8.11	78
4	MP2	Z	14.04	78
5	MP2	X	3.19	%25
6	MP2	Z	5.52	%25
7	MP2	X	3.22	%50
8	MP2	Z	5.58	%50
9	MP2	X	3.35	%75
10	MP2	Z	5.8	%75
11	MP5	X	8.11	6
12	MP5	Z	14.04	6
13	MP5	X	8.11	78
14	MP5	Z	14.04	78

**Member Point Loads (BLC 24 : Ice Wind Load AZI 210) (Continued)**

	Member Label	Direction	Magnitude[lb.lb-ft]	Location[in.%]
15	MP5	X	3.19	%33
16	MP5	Z	5.52	%33
17	MP5	X	3.22	%67
18	MP5	Z	5.58	%67
19	MP8	X	6.03	6
20	MP8	Z	10.45	6
21	MP8	X	6.03	78
22	MP8	Z	10.45	78
23	MP8	X	2.55	%33
24	MP8	Z	4.42	%33
25	MP8	X	2.69	%67
26	MP8	Z	4.65	%67

**Member Point Loads (BLC 25 : Ice Wind Load AZI 240)**

	Member Label	Direction	Magnitude[lb.lb-ft]	Location[in.%]
1	MP2	X	11.64	6
2	MP2	Z	6.72	6
3	MP2	X	11.64	78
4	MP2	Z	6.72	78
5	MP2	X	4.79	%25
6	MP2	Z	2.76	%25
7	MP2	X	4.96	%50
8	MP2	Z	2.86	%50
9	MP2	X	5.21	%75
10	MP2	Z	3.01	%75
11	MP5	X	15.24	6
12	MP5	Z	8.8	6
13	MP5	X	15.24	78
14	MP5	Z	8.8	78
15	MP5	X	5.89	%33
16	MP5	Z	3.4	%33
17	MP5	X	5.89	%67
18	MP5	Z	3.4	%67
19	MP8	X	11.64	6
20	MP8	Z	6.72	6
21	MP8	X	11.64	78
22	MP8	Z	6.72	78
23	MP8	X	4.79	%33
24	MP8	Z	2.76	%33
25	MP8	X	4.96	%67
26	MP8	Z	2.86	%67

**Member Point Loads (BLC 26 : Ice Wind Load AZI 270)**

	Member Label	Direction	Magnitude[lb.lb-ft]	Location[in.%]
1	MP2	X	12.06	6
2	MP2	Z	0	6
3	MP2	X	12.06	78
4	MP2	Z	0	78
5	MP2	X	5.1	%25
6	MP2	Z	0	%25
7	MP2	X	5.37	%50
8	MP2	Z	0	%50
9	MP2	X	5.68	%75
10	MP2	Z	0	%75
11	MP5	X	16.21	6
12	MP5	Z	0	6

**Member Point Loads (BLC 26 : Ice Wind Load AZI 270) (Continued)**

	Member Label	Direction	Magnitude[lb.lb-ft]	Location[in.%]
13	MP5	X	16.21	78
14	MP5	Z	0	78
15	MP5	X	6.38	%33
16	MP5	Z	0	%33
17	MP5	X	6.44	%67
18	MP5	Z	0	%67
19	MP8	X	16.21	6
20	MP8	Z	0	6
21	MP8	X	16.21	78
22	MP8	Z	0	78
23	MP8	X	6.38	%33
24	MP8	Z	0	%33
25	MP8	X	6.44	%67
26	MP8	Z	0	%67

**Member Point Loads (BLC 27 : Ice Wind Load AZI 300)**

	Member Label	Direction	Magnitude[lb.lb-ft]	Location[in.%]
1	MP2	X	11.64	6
2	MP2	Z	-6.72	6
3	MP2	X	11.64	78
4	MP2	Z	-6.72	78
5	MP2	X	4.79	%25
6	MP2	Z	-2.76	%25
7	MP2	X	4.96	%50
8	MP2	Z	-2.86	%50
9	MP2	X	5.21	%75
10	MP2	Z	-3.01	%75
11	MP5	X	11.64	6
12	MP5	Z	-6.72	6
13	MP5	X	11.64	78
14	MP5	Z	-6.72	78
15	MP5	X	4.79	%33
16	MP5	Z	-2.76	%33
17	MP5	X	4.96	%67
18	MP5	Z	-2.86	%67
19	MP8	X	15.24	6
20	MP8	Z	-8.8	6
21	MP8	X	15.24	78
22	MP8	Z	-8.8	78
23	MP8	X	5.89	%33
24	MP8	Z	-3.4	%33
25	MP8	X	5.89	%67
26	MP8	Z	-3.4	%67

**Member Point Loads (BLC 28 : Ice Wind Load AZI 330)**

	Member Label	Direction	Magnitude[lb.lb-ft]	Location[in.%]
1	MP2	X	8.11	6
2	MP2	Z	-14.04	6
3	MP2	X	8.11	78
4	MP2	Z	-14.04	78
5	MP2	X	3.19	%25
6	MP2	Z	-5.52	%25
7	MP2	X	3.22	%50
8	MP2	Z	-5.58	%50
9	MP2	X	3.35	%75
10	MP2	Z	-5.8	%75

**Member Point Loads (BLC 28 : Ice Wind Load AZI 330) (Continued)**

	Member Label	Direction	Magnitude[lb.lb-ft]	Location[in.%]
11	MP5	X	6.03	6
12	MP5	Z	-10.45	6
13	MP5	X	6.03	78
14	MP5	Z	-10.45	78
15	MP5	X	2.55	%33
16	MP5	Z	-4.42	%33
17	MP5	X	2.69	%67
18	MP5	Z	-4.65	%67
19	MP8	X	8.11	6
20	MP8	Z	-14.04	6
21	MP8	X	8.11	78
22	MP8	Z	-14.04	78
23	MP8	X	3.19	%33
24	MP8	Z	-5.52	%33
25	MP8	X	3.22	%67
26	MP8	Z	-5.58	%67

**Member Point Loads (BLC 31 : Seismic Load Z)**

	Member Label	Direction	Magnitude[lb.lb-ft]	Location[in.%]
1	MP2	Z	-12.408	6
2	MP2	Z	-12.408	78
3	MP2	Z	-19.221	%25
4	MP2	Z	-22.56	%50
5	MP2	Z	-6.572	%75
6	MP5	Z	-12.408	6
7	MP5	Z	-12.408	78
8	MP5	Z	-19.221	%33
9	MP5	Z	-22.56	%67
10	MP8	Z	-12.408	6
11	MP8	Z	-12.408	78
12	MP8	Z	-19.221	%33
13	MP8	Z	-22.56	%67

**Member Point Loads (BLC 32 : Seismic Load X)**

	Member Label	Direction	Magnitude[lb.lb-ft]	Location[in.%]
1	MP2	X	-12.408	6
2	MP2	X	-12.408	78
3	MP2	X	-19.221	%25
4	MP2	X	-22.56	%50
5	MP2	X	-6.572	%75
6	MP5	X	-12.408	6
7	MP5	X	-12.408	78
8	MP5	X	-19.221	%33
9	MP5	X	-22.56	%67
10	MP8	X	-12.408	6
11	MP8	X	-12.408	78
12	MP8	X	-19.221	%33
13	MP8	X	-22.56	%67

**Member Distributed Loads (BLC 14 : Distr. Wind Load Z)**

	Member Label	Direction	Start Magnitude[lb/ft....]	End Magnitude[lb/ft.F...]	Start Location[in.%]	End Location[in.%]
1	S3	SZ	-68.843	-68.843	0	%100
2	GA4	SZ	-68.843	-68.843	0	%100
3	GA3	SZ	-68.843	-68.843	0	%100

**Member Distributed Loads (BLC 14 : Distr. Wind Load Z) (Continued)**

Member Label	Direction	Start Magnitude[lb/ft....	End Magnitude[lb/ft.F...	Start Location[in, %]	End Location[in, %]
4	P3	SZ	-68.843	-68.843	0 %100
5	S2	SZ	-68.843	-68.843	0 %100
6	GA2	SZ	-68.843	-68.843	0 %100
7	GA1	SZ	-68.843	-68.843	0 %100
8	P2	SZ	-68.843	-68.843	0 %100
9	S1	SZ	-68.843	-68.843	0 %100
10	GA6	SZ	-68.843	-68.843	0 %100
11	GA5	SZ	-68.843	-68.843	0 %100
12	P1	SZ	-68.843	-68.843	0 %100
13	H1	SZ	-41.306	-41.306	0 %100
14	HR1	SZ	-41.306	-41.306	0 %100
15	CA8	SZ	-68.843	-68.843	0 %100
16	CA9	SZ	-68.843	-68.843	0 %100
17	CA7	SZ	-68.843	-68.843	0 %100
18	CA3	SZ	-68.843	-68.843	0 %100
19	CA4	SZ	-68.843	-68.843	0 %100
20	CA1	SZ	-68.843	-68.843	0 %100
21	CA2	SZ	-68.843	-68.843	0 %100
22	CA5	SZ	-68.843	-68.843	0 %100
23	CA6	SZ	-68.843	-68.843	0 %100
24	M64	SZ	0	0	0 %100
25	M65	SZ	0	0	0 %100
26	M66	SZ	0	0	0 %100
27	M67	SZ	0	0	0 %100
28	M68	SZ	0	0	0 %100
29	M69	SZ	0	0	0 %100
30	M70	SZ	0	0	0 %100
31	M71	SZ	0	0	0 %100
32	M72	SZ	0	0	0 %100
33	M73	SZ	0	0	0 %100
34	M74	SZ	0	0	0 %100
35	M75	SZ	-68.843	-68.843	0 %100
36	H3	SZ	-41.306	-41.306	0 %100
37	HR3	SZ	-41.306	-41.306	0 %100
38	H2	SZ	-41.306	-41.306	0 %100
39	HR2	SZ	-41.306	-41.306	0 %100
40	M40	SZ	0	0	0 %100
41	M41	SZ	0	0	0 %100
42	M42	SZ	0	0	0 %100
43	M43	SZ	0	0	0 %100
44	M44	SZ	0	0	0 %100
45	M45	SZ	0	0	0 %100
46	MP3	SZ	-41.306	-41.306	0 %100
47	MP2	SZ	-41.306	-41.306	0 %100
48	MP1	SZ	-41.306	-41.306	0 %100
49	M49	SZ	0	0	0 %100
50	M50	SZ	0	0	0 %100
51	M51	SZ	0	0	0 %100
52	M52	SZ	0	0	0 %100
53	M53	SZ	0	0	0 %100
54	M54	SZ	0	0	0 %100
55	MP9	SZ	-41.306	-41.306	0 %100
56	MP8	SZ	-41.306	-41.306	0 %100
57	MP7	SZ	-41.306	-41.306	0 %100
58	M58	SZ	0	0	0 %100
59	M59	SZ	0	0	0 %100
60	M60	SZ	0	0	0 %100

**Member Distributed Loads (BLC 14 : Distr. Wind Load Z) (Continued)**

	Member Label	Direction	Start Magnitude[lb/ft....	End Magnitude[lb/ft.F...	Start Location[in, %]	End Location[in, %]
61	M61	SZ	0	0	0	%100
62	M62	SZ	0	0	0	%100
63	M63	SZ	0	0	0	%100
64	MP6	SZ	-41.306	-41.306	0	%100
65	MP5	SZ	-41.306	-41.306	0	%100
66	MP4	SZ	-41.306	-41.306	0	%100

**Member Distributed Loads (BLC 15 : Distr. Wind Load X)**

	Member Label	Direction	Start Magnitude[lb/ft....	End Magnitude[lb/ft.F...	Start Location[in, %]	End Location[in, %]
1	S3	SX	-68.843	-68.843	0	%100
2	GA4	SX	-68.843	-68.843	0	%100
3	GA3	SX	-68.843	-68.843	0	%100
4	P3	SX	-68.843	-68.843	0	%100
5	S2	SX	-68.843	-68.843	0	%100
6	GA2	SX	-68.843	-68.843	0	%100
7	GA1	SX	-68.843	-68.843	0	%100
8	P2	SX	-68.843	-68.843	0	%100
9	S1	SX	-68.843	-68.843	0	%100
10	GA6	SX	-68.843	-68.843	0	%100
11	GA5	SX	-68.843	-68.843	0	%100
12	P1	SX	-68.843	-68.843	0	%100
13	H1	SX	-41.306	-41.306	0	%100
14	HR1	SX	-41.306	-41.306	0	%100
15	CA8	SX	-68.843	-68.843	0	%100
16	CA9	SX	-68.843	-68.843	0	%100
17	CA7	SX	-68.843	-68.843	0	%100
18	CA3	SX	-68.843	-68.843	0	%100
19	CA4	SX	-68.843	-68.843	0	%100
20	CA1	SX	-68.843	-68.843	0	%100
21	CA2	SX	-68.843	-68.843	0	%100
22	CA5	SX	-68.843	-68.843	0	%100
23	CA6	SX	-68.843	-68.843	0	%100
24	M64	SX	0	0	0	%100
25	M65	SX	0	0	0	%100
26	M66	SX	0	0	0	%100
27	M67	SX	0	0	0	%100
28	M68	SX	0	0	0	%100
29	M69	SX	0	0	0	%100
30	M70	SX	0	0	0	%100
31	M71	SX	0	0	0	%100
32	M72	SX	0	0	0	%100
33	M73	SX	0	0	0	%100
34	M74	SX	0	0	0	%100
35	M75	SX	-68.843	-68.843	0	%100
36	H3	SX	-41.306	-41.306	0	%100
37	HR3	SX	-41.306	-41.306	0	%100
38	H2	SX	-41.306	-41.306	0	%100
39	HR2	SX	-41.306	-41.306	0	%100
40	M40	SX	0	0	0	%100
41	M41	SX	0	0	0	%100
42	M42	SX	0	0	0	%100
43	M43	SX	0	0	0	%100
44	M44	SX	0	0	0	%100
45	M45	SX	0	0	0	%100
46	MP3	SX	-41.306	-41.306	0	%100
47	MP2	SX	-41.306	-41.306	0	%100

**Member Distributed Loads (BLC 15 : Distr. Wind Load X) (Continued)**

	Member Label	Direction	Start Magnitude[lb/ft....	End Magnitude[lb/ft.F...	Start Location[in, %]	End Location[in, %]
48	MP1	SX	-41.306	-41.306	0	%100
49	M49	SX	0	0	0	%100
50	M50	SX	0	0	0	%100
51	M51	SX	0	0	0	%100
52	M52	SX	0	0	0	%100
53	M53	SX	0	0	0	%100
54	M54	SX	0	0	0	%100
55	MP9	SX	-41.306	-41.306	0	%100
56	MP8	SX	-41.306	-41.306	0	%100
57	MP7	SX	-41.306	-41.306	0	%100
58	M58	SX	0	0	0	%100
59	M59	SX	0	0	0	%100
60	M60	SX	0	0	0	%100
61	M61	SX	0	0	0	%100
62	M62	SX	0	0	0	%100
63	M63	SX	0	0	0	%100
64	MP6	SX	-41.306	-41.306	0	%100
65	MP5	SX	-41.306	-41.306	0	%100
66	MP4	SX	-41.306	-41.306	0	%100

**Member Distributed Loads (BLC 16 : Ice Weight)**

	Member Label	Direction	Start Magnitude[lb/ft....	End Magnitude[lb/ft.F...	Start Location[in, %]	End Location[in, %]
1	S3	Y	-15.354	-15.354	0	%100
2	GA4	Y	-9.456	-9.456	0	%100
3	GA3	Y	-9.456	-9.456	0	%100
4	P3	Y	-17.135	-17.135	0	%100
5	S2	Y	-15.354	-15.354	0	%100
6	GA2	Y	-9.456	-9.456	0	%100
7	GA1	Y	-9.456	-9.456	0	%100
8	P2	Y	-17.135	-17.135	0	%100
9	S1	Y	-15.354	-15.354	0	%100
10	GA6	Y	-9.456	-9.456	0	%100
11	GA5	Y	-9.456	-9.456	0	%100
12	P1	Y	-17.135	-17.135	0	%100
13	H1	Y	-10.857	-10.857	0	%100
14	HR1	Y	-9.553	-9.553	0	%100
15	CA8	Y	-15.354	-15.354	0	%100
16	CA9	Y	-15.354	-15.354	0	%100
17	CA7	Y	-15.354	-15.354	0	%100
18	CA3	Y	-11.812	-11.812	0	%100
19	CA4	Y	-11.812	-11.812	0	%100
20	CA1	Y	-11.812	-11.812	0	%100
21	CA2	Y	-11.812	-11.812	0	%100
22	CA5	Y	-11.812	-11.812	0	%100
23	CA6	Y	-11.812	-11.812	0	%100
24	M64	Y	-3.559	-3.559	0	%100
25	M65	Y	-3.559	-3.559	0	%100
26	M66	Y	-3.559	-3.559	0	%100
27	M67	Y	-3.559	-3.559	0	%100
28	M68	Y	-3.559	-3.559	0	%100
29	M69	Y	-3.559	-3.559	0	%100
30	M70	Y	-3.559	-3.559	0	%100
31	M71	Y	-3.559	-3.559	0	%100
32	M72	Y	-3.559	-3.559	0	%100
33	M73	Y	-3.559	-3.559	0	%100
34	M74	Y	-3.559	-3.559	0	%100

**Member Distributed Loads (BLC 16 : Ice Weight) (Continued)**

	Member Label	Direction	Start Magnitude[lb/ft....	End Magnitude[lb/ft.F...	Start Location[in.%,]	End Location[in.%,]
35	M75	Y	-8.619	-8.619	0	%100
36	H3	Y	-10.857	-10.857	0	%100
37	HR3	Y	-9.553	-9.553	0	%100
38	H2	Y	-10.857	-10.857	0	%100
39	HR2	Y	-9.553	-9.553	0	%100
40	M40	Y	-3.559	-3.559	0	%100
41	M41	Y	-3.559	-3.559	0	%100
42	M42	Y	-3.559	-3.559	0	%100
43	M43	Y	-3.559	-3.559	0	%100
44	M44	Y	-3.559	-3.559	0	%100
45	M45	Y	-3.559	-3.559	0	%100
46	MP3	Y	-9.553	-9.553	0	%100
47	MP2	Y	-9.553	-9.553	0	%100
48	MP1	Y	-9.553	-9.553	0	%100
49	M49	Y	-3.559	-3.559	0	%100
50	M50	Y	-3.559	-3.559	0	%100
51	M51	Y	-3.559	-3.559	0	%100
52	M52	Y	-3.559	-3.559	0	%100
53	M53	Y	-3.559	-3.559	0	%100
54	M54	Y	-3.559	-3.559	0	%100
55	MP9	Y	-9.553	-9.553	0	%100
56	MP8	Y	-9.553	-9.553	0	%100
57	MP7	Y	-9.553	-9.553	0	%100
58	M58	Y	-3.559	-3.559	0	%100
59	M59	Y	-3.559	-3.559	0	%100
60	M60	Y	-3.559	-3.559	0	%100
61	M61	Y	-3.559	-3.559	0	%100
62	M62	Y	-3.559	-3.559	0	%100
63	M63	Y	-3.559	-3.559	0	%100
64	MP6	Y	-9.553	-9.553	0	%100
65	MP5	Y	-9.553	-9.553	0	%100
66	MP4	Y	-9.553	-9.553	0	%100

**Member Distributed Loads (BLC 29 : Distr. Ice Wind Load Z)**

	Member Label	Direction	Start Magnitude[lb/ft....	End Magnitude[lb/ft.F...	Start Location[in.%,]	End Location[in.%,]
1	S3	SZ	-11.891	-11.891	0	%100
2	GA4	SZ	-16.366	-16.366	0	%100
3	GA3	SZ	-16.366	-16.366	0	%100
4	P3	SZ	-11.304	-11.304	0	%100
5	S2	SZ	-11.891	-11.891	0	%100
6	GA2	SZ	-16.366	-16.366	0	%100
7	GA1	SZ	-16.366	-16.366	0	%100
8	P2	SZ	-11.304	-11.304	0	%100
9	S1	SZ	-11.891	-11.891	0	%100
10	GA6	SZ	-16.366	-16.366	0	%100
11	GA5	SZ	-16.366	-16.366	0	%100
12	P1	SZ	-11.304	-11.304	0	%100
13	H1	SZ	-14.649	-14.649	0	%100
14	HR1	SZ	-16.221	-16.221	0	%100
15	CA8	SZ	-11.891	-11.891	0	%100
16	CA9	SZ	-11.891	-11.891	0	%100
17	CA7	SZ	-11.891	-11.891	0	%100
18	CA3	SZ	-13.812	-13.812	0	%100
19	CA4	SZ	-13.812	-13.812	0	%100
20	CA1	SZ	-13.812	-13.812	0	%100
21	CA2	SZ	-13.812	-13.812	0	%100

**Member Distributed Loads (BLC 29 : Distr. Ice Wind Load Z) (Continued)**

Member Label	Direction	Start Magnitude[lb/ft....	End Magnitude[lb/ft.F...	Start Location[in, %]	End Location[in, %]
22	CA5	SZ	-13.812	-13.812	0 %100
23	CA6	SZ	-13.812	-13.812	0 %100
24	M64	SZ	0	0	0 %100
25	M65	SZ	0	0	0 %100
26	M66	SZ	0	0	0 %100
27	M67	SZ	0	0	0 %100
28	M68	SZ	0	0	0 %100
29	M69	SZ	0	0	0 %100
30	M70	SZ	0	0	0 %100
31	M71	SZ	0	0	0 %100
32	M72	SZ	0	0	0 %100
33	M73	SZ	0	0	0 %100
34	M74	SZ	0	0	0 %100
35	M75	SZ	-17.847	-17.847	0 %100
36	H3	SZ	-14.649	-14.649	0 %100
37	HR3	SZ	-16.221	-16.221	0 %100
38	H2	SZ	-14.649	-14.649	0 %100
39	HR2	SZ	-16.221	-16.221	0 %100
40	M40	SZ	0	0	0 %100
41	M41	SZ	0	0	0 %100
42	M42	SZ	0	0	0 %100
43	M43	SZ	0	0	0 %100
44	M44	SZ	0	0	0 %100
45	M45	SZ	0	0	0 %100
46	MP3	SZ	-16.221	-16.221	0 %100
47	MP2	SZ	-16.221	-16.221	0 %100
48	MP1	SZ	-16.221	-16.221	0 %100
49	M49	SZ	0	0	0 %100
50	M50	SZ	0	0	0 %100
51	M51	SZ	0	0	0 %100
52	M52	SZ	0	0	0 %100
53	M53	SZ	0	0	0 %100
54	M54	SZ	0	0	0 %100
55	MP9	SZ	-16.221	-16.221	0 %100
56	MP8	SZ	-16.221	-16.221	0 %100
57	MP7	SZ	-16.221	-16.221	0 %100
58	M58	SZ	0	0	0 %100
59	M59	SZ	0	0	0 %100
60	M60	SZ	0	0	0 %100
61	M61	SZ	0	0	0 %100
62	M62	SZ	0	0	0 %100
63	M63	SZ	0	0	0 %100
64	MP6	SZ	-16.221	-16.221	0 %100
65	MP5	SZ	-16.221	-16.221	0 %100
66	MP4	SZ	-16.221	-16.221	0 %100

**Member Distributed Loads (BLC 30 : Distr. Ice Wind Load X)**

Member Label	Direction	Start Magnitude[lb/ft....	End Magnitude[lb/ft.F...	Start Location[in, %]	End Location[in, %]
1	S3	SX	-11.891	-11.891	0 %100
2	GA4	SX	-16.366	-16.366	0 %100
3	GA3	SX	-16.366	-16.366	0 %100
4	P3	SX	-11.304	-11.304	0 %100
5	S2	SX	-11.891	-11.891	0 %100
6	GA2	SX	-16.366	-16.366	0 %100
7	GA1	SX	-16.366	-16.366	0 %100
8	P2	SX	-11.304	-11.304	0 %100

**Member Distributed Loads (BLC 30 : Distr. Ice Wind Load X) (Continued)**

Member Label	Direction	Start Magnitude[lb/ft....	End Magnitude[lb/ft.F...	Start Location[in, %]	End Location[in, %]
9	S1	-11.891	-11.891	0	%100
10	GA6	-16.366	-16.366	0	%100
11	GA5	-16.366	-16.366	0	%100
12	P1	-11.304	-11.304	0	%100
13	H1	-14.649	-14.649	0	%100
14	HR1	-16.221	-16.221	0	%100
15	CA8	-11.891	-11.891	0	%100
16	CA9	-11.891	-11.891	0	%100
17	CA7	-11.891	-11.891	0	%100
18	CA3	-13.812	-13.812	0	%100
19	CA4	-13.812	-13.812	0	%100
20	CA1	-13.812	-13.812	0	%100
21	CA2	-13.812	-13.812	0	%100
22	CA5	-13.812	-13.812	0	%100
23	CA6	-13.812	-13.812	0	%100
24	M64	0	0	0	%100
25	M65	0	0	0	%100
26	M66	0	0	0	%100
27	M67	0	0	0	%100
28	M68	0	0	0	%100
29	M69	0	0	0	%100
30	M70	0	0	0	%100
31	M71	0	0	0	%100
32	M72	0	0	0	%100
33	M73	0	0	0	%100
34	M74	0	0	0	%100
35	M75	-17.847	-17.847	0	%100
36	H3	-14.649	-14.649	0	%100
37	HR3	-16.221	-16.221	0	%100
38	H2	-14.649	-14.649	0	%100
39	HR2	-16.221	-16.221	0	%100
40	M40	0	0	0	%100
41	M41	0	0	0	%100
42	M42	0	0	0	%100
43	M43	0	0	0	%100
44	M44	0	0	0	%100
45	M45	0	0	0	%100
46	MP3	-16.221	-16.221	0	%100
47	MP2	-16.221	-16.221	0	%100
48	MP1	-16.221	-16.221	0	%100
49	M49	0	0	0	%100
50	M50	0	0	0	%100
51	M51	0	0	0	%100
52	M52	0	0	0	%100
53	M53	0	0	0	%100
54	M54	0	0	0	%100
55	MP9	-16.221	-16.221	0	%100
56	MP8	-16.221	-16.221	0	%100
57	MP7	-16.221	-16.221	0	%100
58	M58	0	0	0	%100
59	M59	0	0	0	%100
60	M60	0	0	0	%100
61	M61	0	0	0	%100
62	M62	0	0	0	%100
63	M63	0	0	0	%100
64	MP6	-16.221	-16.221	0	%100
65	MP5	-16.221	-16.221	0	%100







**Load Combinations (Continued)**

	Description	S...	PDel...	S...	B...	Fa...	B...	Fa...	B...	Fa...	B...	Fa...	B...	Fa...	B...	Fa...	B...	Fa...	B...	Fa...	B...	Fa...	B...	Fa...	B...	Fa...	B...	Fa...	B...
141	1.2DL + 1.5LM-MP6 + 1SW...	Yes	Y		1	1.2	39	1.5	7	.065	14	-0...	15	.032															
142	1.2DL + 1.5LM-MP6 + 1SW...	Yes	Y		1	1.2	39	1.5	8	.065	14	-0...	15																
143	1.2DL + 1.5LM-MP6 + 1SW...	Yes	Y		1	1.2	39	1.5	9	.065	14	-0...	15	-0...															
144	1.2DL + 1.5LM-MP6 + 1SW...	Yes	Y		1	1.2	39	1.5	10	.065	14	-0...	15	-0...															
145	1.2DL + 1.5LM-MP6 + 1SW...	Yes	Y		1	1.2	39	1.5	11	.065	14		15	-0...															
146	1.2DL + 1.5LM-MP6 + 1SW...	Yes	Y		1	1.2	39	1.5	12	.065	14	.032	15	-0...															
147	1.2DL + 1.5LM-MP6 + 1SW...	Yes	Y		1	1.2	39	1.5	13	.065	14	.056	15	-0...															
148	1.2DL + 1.5LM-MP7 + 1SW...	Yes	Y		1	1.2	40	1.5	2	.065	14	.065	15																
149	1.2DL + 1.5LM-MP7 + 1SW...	Yes	Y		1	1.2	40	1.5	3	.065	14	.056	15	.032															
150	1.2DL + 1.5LM-MP7 + 1SW...	Yes	Y		1	1.2	40	1.5	4	.065	14	.032	15	.056															
151	1.2DL + 1.5LM-MP7 + 1SW...	Yes	Y		1	1.2	40	1.5	5	.065	14		15	.065															
152	1.2DL + 1.5LM-MP7 + 1SW...	Yes	Y		1	1.2	40	1.5	6	.065	14	-0...	15	.056															
153	1.2DL + 1.5LM-MP7 + 1SW...	Yes	Y		1	1.2	40	1.5	7	.065	14	-0...	15	.032															
154	1.2DL + 1.5LM-MP7 + 1SW...	Yes	Y		1	1.2	40	1.5	8	.065	14	-0...	15																
155	1.2DL + 1.5LM-MP7 + 1SW...	Yes	Y		1	1.2	40	1.5	9	.065	14	-0...	15	-0...															
156	1.2DL + 1.5LM-MP7 + 1SW...	Yes	Y		1	1.2	40	1.5	10	.065	14	-0...	15	-0...															
157	1.2DL + 1.5LM-MP7 + 1SW...	Yes	Y		1	1.2	40	1.5	11	.065	14		15	-0...															
158	1.2DL + 1.5LM-MP7 + 1SW...	Yes	Y		1	1.2	40	1.5	12	.065	14	.032	15	-0...															
159	1.2DL + 1.5LM-MP7 + 1SW...	Yes	Y		1	1.2	40	1.5	13	.065	14	.056	15	-0...															
160	1.2DL + 1.5LM-MP8 + 1SW...	Yes	Y		1	1.2	41	1.5	2	.065	14	.065	15																
161	1.2DL + 1.5LM-MP8 + 1SW...	Yes	Y		1	1.2	41	1.5	3	.065	14	.056	15	.032															
162	1.2DL + 1.5LM-MP8 + 1SW...	Yes	Y		1	1.2	41	1.5	4	.065	14	.032	15	.056															
163	1.2DL + 1.5LM-MP8 + 1SW...	Yes	Y		1	1.2	41	1.5	5	.065	14		15	.065															
164	1.2DL + 1.5LM-MP8 + 1SW...	Yes	Y		1	1.2	41	1.5	6	.065	14	-0...	15	.056															
165	1.2DL + 1.5LM-MP8 + 1SW...	Yes	Y		1	1.2	41	1.5	7	.065	14	-0...	15	.032															
166	1.2DL + 1.5LM-MP8 + 1SW...	Yes	Y		1	1.2	41	1.5	8	.065	14	-0...	15																
167	1.2DL + 1.5LM-MP8 + 1SW...	Yes	Y		1	1.2	41	1.5	9	.065	14	-0...	15	-0...															
168	1.2DL + 1.5LM-MP8 + 1SW...	Yes	Y		1	1.2	41	1.5	10	.065	14	-0...	15	-0...															
169	1.2DL + 1.5LM-MP8 + 1SW...	Yes	Y		1	1.2	41	1.5	11	.065	14		15	-0...															
170	1.2DL + 1.5LM-MP8 + 1SW...	Yes	Y		1	1.2	41	1.5	12	.065	14	.032	15	-0...															
171	1.2DL + 1.5LM-MP8 + 1SW...	Yes	Y		1	1.2	41	1.5	13	.065	14	.056	15	-0...															
172	1.2DL + 1.5LM-MP9 + 1SW...	Yes	Y		1	1.2	42	1.5	2	.065	14	.065	15																
173	1.2DL + 1.5LM-MP9 + 1SW...	Yes	Y		1	1.2	42	1.5	3	.065	14	.056	15	.032															
174	1.2DL + 1.5LM-MP9 + 1SW...	Yes	Y		1	1.2	42	1.5	4	.065	14	.032	15	.056															
175	1.2DL + 1.5LM-MP9 + 1SW...	Yes	Y		1	1.2	42	1.5	5	.065	14		15	.065															
176	1.2DL + 1.5LM-MP9 + 1SW...	Yes	Y		1	1.2	42	1.5	6	.065	14	-0...	15	.056															
177	1.2DL + 1.5LM-MP9 + 1SW...	Yes	Y		1	1.2	42	1.5	7	.065	14	-0...	15	.032															
178	1.2DL + 1.5LM-MP9 + 1SW...	Yes	Y		1	1.2	42	1.5	8	.065	14	-0...	15																
179	1.2DL + 1.5LM-MP9 + 1SW...	Yes	Y		1	1.2	42	1.5	9	.065	14	-0...	15	-0...															
180	1.2DL + 1.5LM-MP9 + 1SW...	Yes	Y		1	1.2	42	1.5	10	.065	14	-0...	15	-0...															
181	1.2DL + 1.5LM-MP9 + 1SW...	Yes	Y		1	1.2	42	1.5	11	.065	14		15	-0...															
182	1.2DL + 1.5LM-MP9 + 1SW...	Yes	Y		1	1.2	42	1.5	12	.065	14	.032	15	-0...															

**Envelope Joint Reactions**

Joint	X [lb]	LC	Y [lb]	LC	Z [lb]	LC	MX [lb-ft]	LC	MY [lb-...	LC	MZ [lb-ft]	LC		
1	N20	...	815.197	18	2158.851	35	1268.227	13	131.786	15	1640.4...	19	3895.021	35
2		...	-813.87	12	66.472	16	-1266.76	19	-2352.711	107	-1642....	13	-178.412	16
3	N11	...	815.187	4	2161.416	31	1269.695	3	131.598	25	1645.0...	3	176.039	24
4		...	-816.507	22	67.326	24	-1268.235	21	-2352.915	81	-1642....	21	-3901.119	31
5	N1	...	1321.274	17	2088.84	27	492.256	14	4400.483	27	1455.3...	23	722.337	145
6		...	-1321.276	23	32.498	20	-496.903	8	-284.017	20	-1455....	17	-712.022	151
7	Totals:	...	2684.985	5	6002.432	27	2839.856	2						
8		...	-2684.985	11	1611.014	57	-2839.855	20						

**Envelope AISC 15th(360-16): LRFD Steel Code Checks**

Member	Shape	Code ...	Loc[in]	LC	Shear ..	Loc[in]	Dir	LC	phi*Pnc ...	phi*Pnt [...]	phi*Mn ...	phi*Mn ...	Cb	Eqn	
1	CA1	C3.38x2.06...	.312	0	31	.048	28.1...	y	38	47760.0...	56700	2202.821	5751.945	1...	H1-1b
2	CA6	C3.38x2.06...	.312	33	35	.048	4.813	y	28	47760.0...	56700	2202.821	5751.945	1...	H1-1b
3	CA2	C3.38x2.06...	.309	33	31	.047	4.813	y	36	47760.0...	56700	2202.821	5751.945	1...	H1-1b
4	CA5	C3.38x2.06...	.309	0	35	.047	28.1...	y	30	47760.0...	56700	2202.821	5751.945	1...	H1-1b
5	CA4	C3.38x2.06...	.301	33	27	.046	4.813	y	32	47760.0...	56700	2202.821	5751.945	1...	H1-1b
6	CA3	C3.38x2.06...	.298	0	27	.046	28.1...	y	34	47760.0...	56700	2202.821	5751.945	1...	H1-1b
7	S2	HSS4X4X4	.291	0	33	.093	0	y	82	133178...	139518	16180.5	16180.5	2...	H1-1b
8	S1	HSS4X4X4	.291	0	33	.093	0	y	106	133178...	139518	16180.5	16180.5	2...	H1-1b
9	S3	HSS4X4X4	.281	0	29	.091	0	y	146	133178...	139518	16180.5	16180.5	2...	H1-1b
10	M75	PL 2.375x0.5	.163	1.5	12	.268	0	y	28	38256.8...	38475	400.783	1903.711	2...	H1-1b
11	P2	PL6.5x0.375	.154	21	6	.081	5.687	y	77	3658.14	78975	616.993	7454.237	1...	H1-1b
12	P3	PL6.5x0.375	.154	21	2	.082	5.687	y	157	3658.14	78975	616.993	7428.804	1...	H1-1b
13	P1	PL6.5x0.375	.153	21	10	.081	36.3...	y	111	3658.14	78975	616.993	7454.244	1...	H1-1b
14	GA2	L2x2x4	.149	0	6	.024	27.2...	z	30	23539.0...	30585.6	690.934	1576.849	2...	H2-1
15	GA5	L2x2x4	.148	0	10	.024	27.2...	y	36	23539.0...	30585.6	690.934	1576.849	2...	H2-1
16	GA4	L2x2x4	.140	0	2	.024	27.2...	z	38	23539.0...	30585.6	690.934	1576.849	2...	H2-1
17	GA3	L2x2x4	.140	0	2	.023	27.2...	y	28	23539.0...	30585.6	690.934	1576.849	2...	H2-1
18	GA1	L2x2x4	.134	0	6	.024	27.2...	y	32	23539.0...	30585.6	690.934	1576.849	2...	H2-1
19	GA6	L2x2x4	.134	0	10	.024	27.2...	z	34	23539.0...	30585.6	690.934	1576.849	2...	H2-1
20	CA7	L4X4X4	.131	0	13	.023	42	y	13	46987.2...	62532	3137.597	6897.039	2...	H2-1
21	CA8	L4X4X4	.131	42	3	.023	0	y	3	46987.2...	62532	3137.597	6897.039	2...	H2-1
22	MP4	PIPE 2.5	.121	28	8	.044	68		10	30038.4...	50715	3596.25	3596.25	3...	H1-1b
23	MP9	PIPE 2.5	.121	28	8	.044	68		6	30038.4...	50715	3596.25	3596.25	3...	H1-1b
24	MP5	PIPE 2.5	.121	68	7	.062	68		7	30038.4...	50715	3596.25	3596.25	3...	H1-1b
25	MP8	PIPE 2.5	.121	68	9	.062	68		9	30038.4...	50715	3596.25	3596.25	3...	H1-1b
26	MP1	PIPE 2.5	.121	28	12	.048	68		2	30038.4...	50715	3596.25	3596.25	4...	H1-1b
27	MP3	PIPE 2.5	.121	28	4	.048	68		2	30038.4...	50715	3596.25	3596.25	4...	H1-1b
28	CA9	L4X4X4	.120	0	5	.022	0	y	11	46987.2...	62532	3137.597	6897.039	2...	H2-1
29	MP2	PIPE 2.5	.119	68	5	.059	68		5	30038.4...	50715	3596.25	3596.25	3...	H1-1b
30	MP6	PIPE 2.5	.118	68	13	.042	68		10	30038.4...	50715	3596.25	3596.25	4...	H1-1b
31	MP7	PIPE 2.5	.118	68	3	.042	68		6	30038.4...	50715	3596.25	3596.25	4...	H1-1b
32	H1	PIPE 3.0	.105	48	90	.053	32		5	46290.5...	65205	5748.75	5748.75	1...	H1-1b
33	H2	PIPE 3.0	.103	48	166	.054	64		7	46290.5...	65205	5748.75	5748.75	1...	H1-1b
34	H3	PIPE 3.0	.103	48	130	.054	32		9	46290.5...	65205	5748.75	5748.75	1...	H1-1b
35	HR1	PIPE 2.5	.099	96.25	7	.110	16.25		8	22373.4...	50715	3596.25	3596.25	1...	H1-1b
36	HR3	PIPE 2.5	.099	23.75	13	.108	23.75		13	22373.4...	50715	3596.25	3596.25	1...	H1-1b
37	HR2	PIPE 2.5	.099	96.25	3	.108	96.25		3	22373.4...	50715	3596.25	3596.25	1...	H1-1b

**Material Takeoff**

	Material	Size	Pieces	Length[in]	Weight[LB]
1	General				
2	RIGID		29	71.1	0
3	Total General		29	71.1	0
4					
5	Hot Rolled Steel				
6	A36 Gr.36	C3.38x2.06x0.25	6	198	98.255
7	A36 Gr.36	L2x2x4	6	163.8	43.838
8	A36 Gr.36	PL6.5x0.375	3	126	87.09
9	A36 Gr.36	L4X4X4	3	126	68.957
10	A36 Gr.36	PL 2.375x0.5	1	1.5	.505
11	A500 Gr.B Rect	HSS4X4X4	3	120	123.333
12	A53 Gr.B	PIPE 2.5	12	1224	558.804
13	A53 Gr.B	PIPE 3.0	3	288	169.05
14	Total HR Steel		37	2247.3	1149.833

**APPENDIX D**  
**ADDITIONAL CALCUATIONS**

**Bolt Calculation Tool, V1.5.1**

PROJECT DATA	
Site Name:	WATERBURY
Site Number:	876317
Connection Description:	Mount to Tower

MAXIMUM BOLT LOADS	
Bolt Tension:	4871.97 lbs
Bolt Shear:	840.16 lbs

WORST CASE BOLT LOADS <sup>1</sup>	
Bolt Tension:	4871.97 lbs
Bolt Shear:	487.99 lbs

BOLT PROPERTIES	
Bolt Type:	Bolt
Bolt Diameter:	0.625 in
Bolt Grade:	A325
# of Bolts:	4
Threads Excluded?	No

<sup>1</sup> Worst case bolt loads correspond to Load combination #33 on member S2 in RISA-3D, which causes the maximum demand on the bolts.

Member Information	
I nodes of S3, S2, S1	

BOLT CHECK	
Tensile Strength	20340.15
Shear Strength	13805.83
Max Tensile Usage	24.0%
Max Shear Usage	6.1%
Interaction Check (Worst Case)	0.06
Result	Pass

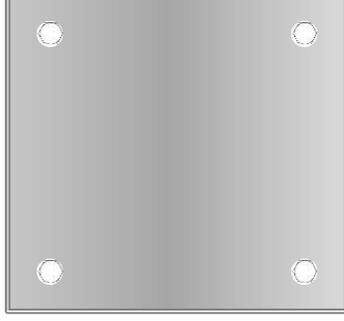

# Exhibit F

## **Power Density/RF Emissions Report**

RADIO FREQUENCY EMISSIONS ANALYSIS REPORT  
EVALUATION OF HUMAN EXPOSURE POTENTIAL  
TO NON-IONIZING EMISSIONS

Dish Wireless Existing Facility

Site ID: BOHVN00165A

876317

150 Mattatuck Heights Road  
Waterbury, Connecticut 06705

**November 19, 2021**

**EBI Project Number: 6221007199**

Site Compliance Summary	
Compliance Status:	<b>COMPLIANT</b>
Site total MPE% of FCC general population allowable limit:	<b>27.88%</b>

November 19, 2021

Dish Wireless

Emissions Analysis for Site: BOHVN00165A - 876317

EBI Consulting was directed to analyze the proposed Dish Wireless facility located at **150 Mattatuck Heights Road** in **Waterbury, Connecticut** for the purpose of determining whether the emissions from the Proposed Dish Wireless Antenna Installation located on this property are within specified federal limits.

All information used in this report was analyzed as a percentage of current Maximum Permissible Exposure (% MPE) as listed in the FCC OET Bulletin 65 Edition 97-01 and ANSI/IEEE Std C95.1. The FCC regulates Maximum Permissible Exposure in units of microwatts per square centimeter ( $\mu\text{W}/\text{cm}^2$ ). The number of  $\mu\text{W}/\text{cm}^2$  calculated at each sample point is called the power density. The exposure limit for power density varies depending upon the frequencies being utilized. Wireless Carriers and Paging Services use different frequency bands each with different exposure limits; therefore, it is necessary to report results and limits in terms of percent MPE rather than power density.

All results were compared to the FCC (Federal Communications Commission) radio frequency exposure rules, 47 CFR 1.1307(b)(1) – (b)(3), to determine compliance with the Maximum Permissible Exposure (MPE) limits for General Population/Uncontrolled environments as defined below.

General population/uncontrolled exposure limits apply to situations in which the general population may be exposed or in which persons who are exposed as a consequence of their employment may not be made fully aware of the potential for exposure or cannot exercise control over their exposure. Therefore, members of the general population would always be considered under this category when exposure is not employment related, for example, in the case of a telecommunications tower that exposes persons in a nearby residential area.

Public exposure to radio frequencies is regulated and enforced in units of microwatts per square centimeter ( $\mu\text{W}/\text{cm}^2$ ). The general population exposure limits for the 600 MHz and 700 MHz frequency bands are approximately  $400 \mu\text{W}/\text{cm}^2$  and  $467 \mu\text{W}/\text{cm}^2$ , respectively. The general population exposure limit for the 1900 MHz (PCS), 2100 MHz (AWS) and 11 GHz frequency bands is  $1000 \mu\text{W}/\text{cm}^2$ . Because each carrier will be using different frequency bands, and each frequency band has different exposure limits, it is necessary to report percent of MPE rather than power density.

Occupational/controlled exposure limits apply to situations in which persons are exposed as a consequence of their employment and in which those persons who are exposed have been made fully

aware of the potential for exposure and can exercise control over their exposure. Occupational/controlled exposure limits also apply where exposure is of a transient nature as a result of incidental passage through a location where exposure levels may be above general population/uncontrolled limits (see below), as long as the exposed person has been made fully aware of the potential for exposure and can exercise control over his or her exposure by leaving the area or by some other appropriate means.

Additional details can be found in FCC OET 65.

## **CALCULATIONS**

Calculations were done for the proposed Dish Wireless antenna facility located at 150 Mattatuck Heights Road in Waterbury, Connecticut using the equipment information listed below. All calculations were performed per the specifications under FCC OET 65. Since Dish Wireless is proposing highly focused directional panel antennas, which project most of the emitted energy out toward the horizon, all calculations were performed assuming a lobe representing the maximum gain of the antenna per the antenna manufacturer's supplied specifications, minus 20 dB for directional panel antennas and 20 dB for highly focused parabolic microwave dishes, was focused at the base of the tower. For this report, the sample point is the top of a 6-foot person standing at the base of the tower.

For all calculations, all equipment was calculated using the following assumptions:

- 1) 4 n71 channels (600 MHz Band) were considered for each sector of the proposed installation. These Channels have a transmit power of 30 Watts per Channel.
- 2) 4 n70 channels (PCS Band - 1900 MHz) were considered for each sector of the proposed installation. These Channels have a transmit power of 40 Watts per Channel.
- 3) 4 n66 channels (AWS Band - 2190 MHz) were considered for each sector of the proposed installation. These Channels have a transmit power of 40 Watts per Channel.
- 4) All radios at the proposed installation were considered to be running at full power and were uncombined in their RF transmissions paths per carrier prescribed configuration. Per FCC OET Bulletin No. 65 - Edition 97-01 recommendations to achieve the maximum anticipated value at each sample point, all power levels emitting from the proposed antenna installation are increased by a factor of 2.56 to account for possible in-phase reflections from the surrounding environment. This is rarely the case, and if so, is never continuous.
- 5) For the following calculations, the sample point was the top of a 6-foot person standing at the base of the tower. The maximum gain of the antenna per the antenna manufacturer's supplied specifications, minus 20 dB for directional panel antennas and 20 dB for highly focused parabolic microwave dishes, was used in this direction. This value is a very conservative

estimate as gain reductions for these particular antennas are typically much higher in this direction.

- 6) The antennas used in this modeling are the JMA MX08FRO665-20 for the 600 MHz / 1900 MHz / 2190 MHz channel(s) in Sector A, the JMA MX08FRO665-20 for the 600 MHz / 1900 MHz / 2190 MHz channel(s) in Sector B, the JMA MX08FRO665-20 for the 600 MHz / 1900 MHz / 2190 MHz channel(s) in Sector C. This is based on feedback from the carrier with regard to anticipated antenna selection. All Antenna gain values and associated transmit power levels are shown in the Site Inventory and Power Data table below. The maximum gain of the antenna per the antenna manufacturer's supplied specifications, minus 20 dB for directional panel antennas and 20 dB for highly focused parabolic microwave dishes, was used for all calculations. This value is a very conservative estimate as gain reductions for these particular antennas are typically much higher in this direction.
- 7) The antenna mounting height centerline of the proposed antennas is 120 feet above ground level (AGL).
- 8) Emissions values for additional carriers were taken from the Connecticut Siting Council active database. Values in this database are provided by the individual carriers themselves.
- 9) All calculations were done with respect to uncontrolled / general population threshold limits.

## Dish Wireless Site Inventory and Power Data

Sector:	A	Sector:	B	Sector:	C
Antenna #:	1	Antenna #:	1	Antenna #:	1
Make / Model:	JMA MX08FRO665-20	Make / Model:	JMA MX08FRO665-20	Make / Model:	JMA MX08FRO665-20
Frequency Bands:	600 MHz / 1900 MHz / 2190 MHz	Frequency Bands:	600 MHz / 1900 MHz / 2190 MHz	Frequency Bands:	600 MHz / 1900 MHz / 2190 MHz
Gain:	17.45 dBd / 22.65 dBd / 22.65 dBd	Gain:	17.45 dBd / 22.65 dBd / 22.65 dBd	Gain:	17.45 dBd / 22.65 dBd / 22.65 dBd
Height (AGL):	120 feet	Height (AGL):	120 feet	Height (AGL):	120 feet
Channel Count:	12	Channel Count:	12	Channel Count:	12
Total TX Power (W):	440 Watts	Total TX Power (W):	440 Watts	Total TX Power (W):	440 Watts
ERP (W):	5,236.31	ERP (W):	5,236.31	ERP (W):	5,236.31
Antenna AI MPE %:	<b>1.82%</b>	Antenna BI MPE %:	<b>1.82%</b>	Antenna CI MPE %:	<b>1.82%</b>

Site Composite MPE %	
Carrier	MPE %
Dish Wireless (Max at Sector A):	1.82%
AT&T	8.06%
Verizon	8.82%
T-Mobile	7.03%
Clearwire	0.12%
Sprint	1.59%
Nextel	0.44%
<b>Site Total MPE % :</b>	<b>27.88%</b>

Dish Wireless MPE % Per Sector	
Dish Wireless Sector A Total:	1.82%
Dish Wireless Sector B Total:	1.82%
Dish Wireless Sector C Total:	1.82%
<b>Site Total MPE % :</b>	<b>27.88%</b>

Dish Wireless Maximum MPE Power Values (Sector A)							
Dish Wireless Frequency Band / Technology (Sector A)	# Channels	Watts ERP (Per Channel)	Height (feet)	Total Power Density ( $\mu\text{W}/\text{cm}^2$ )	Frequency (MHz)	Allowable MPE ( $\mu\text{W}/\text{cm}^2$ )	Calculated % MPE
Dish Wireless 600 MHz n71	4	223.68	120.0	2.48	600 MHz n71	400	0.62%
Dish Wireless 1900 MHz n70	4	542.70	120.0	6.01	1900 MHz n70	1000	0.60%
Dish Wireless 2190 MHz n66	4	542.70	120.0	6.01	2190 MHz n66	1000	0.60%
						<b>Total:</b>	<b>1.82%</b>

• NOTE: Totals may vary by approximately 0.01% due to summation of remainders in calculations.

## Summary

All calculations performed for this analysis yielded results that were **within** the allowable limits for general population exposure to RF Emissions.

The anticipated maximum composite contributions from the Dish Wireless facility as well as the site composite emissions value with regards to compliance with FCC's allowable limits for general population exposure to RF Emissions are shown here:

Dish Wireless Sector	Power Density Value (%)
Sector A:	1.82%
Sector B:	1.82%
Sector C:	1.82%
Dish Wireless Maximum MPE % (Sector A):	1.82%
Site Total:	27.88%
Site Compliance Status:	<b>COMPLIANT</b>

The anticipated composite MPE value for this site assuming all carriers present is **27.88%** of the allowable FCC established general population limit sampled at the ground level. This is based upon values listed in the Connecticut Siting Council database for existing carrier emissions.

FCC guidelines state that if a site is found to be out of compliance (over allowable thresholds), that carriers over a 5% contribution to the composite value will require measures to bring the site into compliance. For this facility, the composite values calculated were well within the allowable 100% threshold standard per the federal government.

# Exhibit G

## **Letter of Authorization**



4545 E River Rd, Suite 320  
West Henrietta, NY 14586

Phone: (585) 445-5896  
Fax: (724) 416-4461  
www.crowncastle.com

**Crown Castle Letter of Authorization**

**CT - CONNECTICUT SITING COUNCIL**

Melanie A. Bachman  
Executive Director  
Connecticut Siting Council  
10 Franklin Square  
New Britain, CT 06051

**Re: Tower Share Application  
Crown Castle telecommunications site at:  
150 MATTATUCK HEIGHTS, WATERBURY, CT 06705-3831**

GLOBAL SIGNAL ACQUISITIONS II LLC (“Crown Castle”) hereby authorizes DISH Wireless LLC, including their Agent, to act as our Agent in the processing of all zoning applications, building permits and approvals through the CT - CONNECTICUT SITING COUNCIL for the existing wireless communications site described below:

**Crown Site ID/Name: 876317/WATERBURY**  
**Customer Site ID: BOHVN00165A/CT-CCI-T-876317**  
**Site Address: 150 Mattatuck Heights, WATERBURY, CT 06705-3831**

Crown Castle

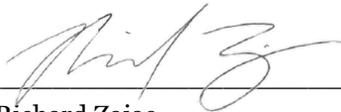
By:  \_\_\_\_\_ Date: 3/14/2022  
Richard Zajac  
Site Acquisition Specialist

# Exhibit H

## Recipient Mailings



RICH ZAJAC  
CROWN CASTLE  
4545 E RIVER RD  
STE 320  
W HENRIETTA NY 14586-9024

**USPS TRACKING #**

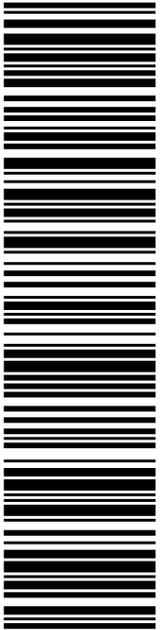

**9405 5036 9930 0270 6095 20**

DEBORAH CHASE  
NORTHEAST SITE SOLUTIONS  
420 MAIN ST  
STE 1  
STURBRIDGE MA 01566-1359

Expected Delivery Date: 06/13/22  
Ref#: DS-876317  
**0006**

**R013**

**P**

06/10/2022

**PRIORITY MAIL 2-DAY™**

usps.com 9405 5036 9930 0270 6095 20 0089 5000 0031 4586  
**\$8.95**  
US POSTAGE  
Flat Rate Env  
U.S. POSTAGE PAID  
click-n-ship®

Mailed from 01566

Electronic Rate Approved #038555749



**Click-N-Ship®**

UNITED STATES  
POSTAL SERVICE®



Cut on dotted line.

### Instructions

1. Each Click-N-Ship® label is unique. Labels are to be used as printed and used only once. DO NOT PHOTO COPY OR ALTER LABEL.
2. Place your label so it does not wrap around the edge of the package.
3. Adhere your label to the package. A self-adhesive label is recommended. If tape or glue is used, DO NOT TAPE OVER BARCODE. Be sure all edges are secure.
4. To mail your package with PC Postage®, you may schedule a Package Pickup online, hand to your letter carrier, take to a Post Office™, or drop in a USPS collection box.
5. Mail your package on the "Ship Date" you selected when creating this label.

### Click-N-Ship® Label Record

**USPS TRACKING # :**  
**9405 5036 9930 0270 6095 20**

Trans. #: 565367213	Priority Mail® Postage: <b>\$8.95</b>
Print Date: 06/10/2022	Total: <b>\$8.95</b>
Ship Date: 06/10/2022	
Expected Delivery Date: 06/13/2022	

**From:** DEBORAH CHASE  
NORTHEAST SITE SOLUTIONS  
420 MAIN ST  
STE 1  
STURBRIDGE MA 01566-1359

**To:** RICH ZAJAC  
CROWN CASTLE  
4545 E RIVER RD  
STE 320  
W HENRIETTA NY 14586-9024

Ref#: DS-876317

\* Retail Pricing Priority Mail rates apply. There is no fee for USPS Tracking® service on Priority Mail service with use of this electronic rate shipping label. Refunds for unused postage paid labels can be requested online 30 days from the print date.



Thank you for shipping with the United States Postal Service!  
Check the status of your shipment on the USPS Tracking® page at usps.com



NEIL M O'LEARY  
MAYOR-CITY OF WATERBURY  
235 GRAND ST  
WATERBURY CT 06702-1915

**USPS TRACKING #**

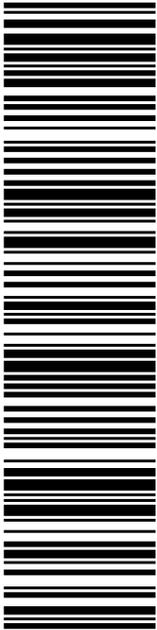

**9405 5036 9930 0270 6095 44**

**P**

USPS.com 9405 5036 9930 0270 6095 44 0089 5000 0010 6702  
**\$8.95**  
 US POSTAGE  
 Flat Rate Env  
 U.S. POSTAGE PAID  
 Click-N-Ship®

06/10/2022 Mailed from 01566

DEBORAH CHASE  
NORTHEAST SITE SOLUTIONS  
420 MAIN ST  
STE 1  
STURBRIDGE MA 01566-1359

Expected Delivery Date: 06/13/22  
 Ref#: DS-876317  
**0006**

**C035**

**PRIORITY MAIL 2-DAY™**

Electronic Rate Approved #038555749





Cut on dotted line.

## Instructions

1. Each Click-N-Ship® label is unique. Labels are to be used as printed and used only once. DO NOT PHOTO COPY OR ALTER LABEL.
2. Place your label so it does not wrap around the edge of the package.
3. Adhere your label to the package. A self-adhesive label is recommended. If tape or glue is used, DO NOT TAPE OVER BARCODE. Be sure all edges are secure.
4. To mail your package with PC Postage®, you may schedule a Package Pickup online, hand to your letter carrier, take to a Post Office™, or drop in a USPS collection box.
5. Mail your package on the "Ship Date" you selected when creating this label.

## Click-N-Ship® Label Record

<b>USPS TRACKING # :</b>	
<b>9405 5036 9930 0270 6095 44</b>	
Trans. #:	565367213
Print Date:	06/10/2022
Ship Date:	06/10/2022
Expected Delivery Date:	06/13/2022
Priority Mail® Postage:	<b>\$8.95</b>
Total:	<b>\$8.95</b>
<b>From:</b>	DEBORAH CHASE NORTHEAST SITE SOLUTIONS 420 MAIN ST STE 1 STURBRIDGE MA 01566-1359
<b>To:</b>	NEIL M O'LEARY MAYOR-CITY OF WATERBURY 235 GRAND ST WATERBURY CT 06702-1915
Ref#:	DS-876317

\* Retail Pricing Priority Mail rates apply. There is no fee for USPS Tracking® service on Priority Mail service with use of this electronic rate shipping label. Refunds for unused postage paid labels can be requested online 30 days from the print date.



Thank you for shipping with the United States Postal Service!  
 Check the status of your shipment on the USPS Tracking® page at usps.com



ROBERT NERNEY  
CITY PLANNER-WATERBURY  
185 S MAIN ST  
# 5  
WATERBURY CT 06706

**USPS TRACKING #**

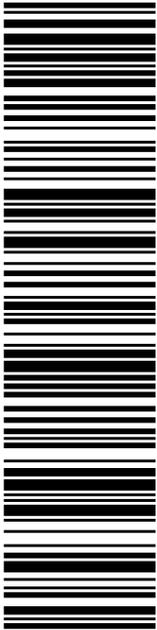

**9405 5036 9930 0270 6095 68**

**P**

06/10/2022

**PRIORITY MAIL 2-DAY™**

Expected Delivery Date: 06/13/22  
Ref#: DS-876317  
**0006**

**C083**

USPS.com 9405 5036 9930 0270 6095 68 0089 5000 0010 6706  
**US POSTAGE**  
Flat Rate Env

**U.S. POSTAGE PAID**  
Click-N-Ship®

**UNITED STATES POSTAL SERVICE®**

**Click-N-Ship®**

Electronic Rate Approved #038555749





Cut on dotted line.

## Instructions

1. Each Click-N-Ship® label is unique. Labels are to be used as printed and used only once. DO NOT PHOTO COPY OR ALTER LABEL.
2. Place your label so it does not wrap around the edge of the package.
3. Adhere your label to the package. A self-adhesive label is recommended. If tape or glue is used, DO NOT TAPE OVER BARCODE. Be sure all edges are secure.
4. To mail your package with PC Postage®, you may schedule a Package Pickup online, hand to your letter carrier, take to a Post Office™, or drop in a USPS collection box.
5. Mail your package on the "Ship Date" you selected when creating this label.

## Click-N-Ship® Label Record

<b>USPS TRACKING # :</b>	
<b>9405 5036 9930 0270 6095 68</b>	
Trans. #:	565367213
Print Date:	06/10/2022
Ship Date:	06/10/2022
Expected Delivery Date:	06/13/2022
Priority Mail® Postage:	<b>\$8.95</b>
Total:	<b>\$8.95</b>
<b>From:</b>	DEBORAH CHASE NORTHEAST SITE SOLUTIONS 420 MAIN ST STE 1 STURBRIDGE MA 01566-1359
<b>To:</b>	ROBERT NERNEY CITY PLANNER-WATERBURY 185 S MAIN ST # 5 WATERBURY CT 06706
	Ref#: DS-876317
<p>* Retail Pricing Priority Mail rates apply. There is no fee for USPS Tracking® service on Priority Mail service with use of this electronic rate shipping label. Refunds for unused postage paid labels can be requested online 30 days from the print date.</p>	



Thank you for shipping with the United States Postal Service!  
Check the status of your shipment on the USPS Tracking® page at usps.com



WATERBURY TWIN LLC & 150 MH LLC  
12 ISELIN TER  
LARCHMONT NY 10538-2631

**USPS TRACKING #**

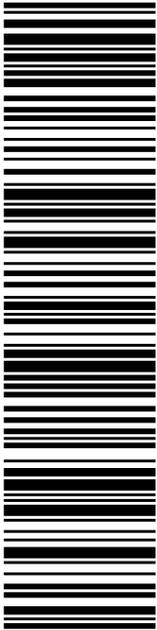

**9405 5036 9930 0270 6095 82**

**P**

usps.com 9405 5036 9930 0270 6095 82 0089 5000 0021 0538  
**US POSTAGE**  
 Flat Rate Env  
 U.S. POSTAGE PAID  
 Click-N-Ship®

06/10/2022 Mailed from 01566

**PRIORITY MAIL 2-DAY™**

DEBORAH CHASE  
NORTHEAST SITE SOLUTIONS  
420 MAIN ST  
STE 1  
STURBRIDGE MA 01566-1359

Expected Delivery Date: 06/13/22  
Ref#: DS-876317  
**0006**

**C013**

Electronic Rate Approved #038555749





Cut on dotted line.

## Instructions

- Each Click-N-Ship® label is unique. Labels are to be used as printed and used only once. DO NOT PHOTO COPY OR ALTER LABEL.
- Place your label so it does not wrap around the edge of the package.
- Adhere your label to the package. A self-adhesive label is recommended. If tape or glue is used, DO NOT TAPE OVER BARCODE. Be sure all edges are secure.
- To mail your package with PC Postage®, you may schedule a Package Pickup online, hand to your letter carrier, take to a Post Office™, or drop in a USPS collection box.
- Mail your package on the "Ship Date" you selected when creating this label.

## Click-N-Ship® Label Record

**USPS TRACKING # :**  
**9405 5036 9930 0270 6095 82**

Trans. #:	565367213	Priority Mail® Postage:	<b>\$8.95</b>
Print Date:	06/10/2022	Total:	<b>\$8.95</b>
Ship Date:	06/10/2022		
Expected			
Delivery Date:	06/13/2022		

**From:** DEBORAH CHASE  
 NORTHEAST SITE SOLUTIONS  
 420 MAIN ST  
 STE 1  
 STURBRIDGE MA 01566-1359

**To:** WATERBURY TWIN LLC & 150 MH LLC  
 12 ISELIN TER  
 LARCHMONT NY 10538-2631

Ref#: DS-876317

\* Retail Pricing Priority Mail rates apply. There is no fee for USPS Tracking® service on Priority Mail service with use of this electronic rate shipping label. Refunds for unused postage paid labels can be requested online 30 days from the print date.



Thank you for shipping with the United States Postal Service!  
 Check the status of your shipment on the USPS Tracking® page at usps.com

826317 Crown  
down



FARMINGTON  
210 MAIN ST  
FARMINGTON, CT 06032-9998  
(800)275-8777

06/13/2022 02:58 PM

Product	Qty	Unit Price	Price
---------	-----	------------	-------

Prepaid Mail	1		\$0.00
West Henrietta, NY 14586			
Weight: 0 lb 2.00 oz			
Acceptance Date:			
Mon 06/13/2022			
Tracking #:			
9405 5036 9930 0270 6095 20			

Prepaid Mail	1		\$0.00
Larchmont, NY 10538			
Weight: 0 lb 7.90 oz			
Acceptance Date:			
Mon 06/13/2022			
Tracking #:			
9405 5036 9930 0270 6095 82			

Prepaid Mail	1		\$0.00
Waterbury, CT 06706			
Weight: 0 lb 7.90 oz			
Acceptance Date:			
Mon 06/13/2022			
Tracking #:			
9405 5036 9930 0270 6095 68			

Prepaid Mail	1		\$0.00
Waterbury, CT 06702			
Weight: 0 lb 7.90 oz			
Acceptance Date:			
Mon 06/13/2022			
Tracking #:			
9405 5036 9930 0270 6095 44			

Grand Total: \$0.00

\*\*\*\*\*  
Every household in the U.S. is now  
eligible to receive a third set  
of 8 free test kits.  
Go to [www.covidtests.gov](http://www.covidtests.gov)  
\*\*\*\*\*

Preview your Mail  
Track your Packages  
Sign up for FREE @  
<https://informeddelivery.usps.com>

All sales final on stamps and postage.  
Refunds for guaranteed services only.  
Thank you for your business.

Tell us about your experience.  
Go to: <https://postalexperience.com/Pos>  
or scan this code with your mobile device,

