



10 INDUSTRIAL AVE,
SUITE 3
MAHWAH NJ 07430

PHONE: 201.684.0055
FAX: 201.684.0066

June 21, 2018

Melanie Bachman
Executive Director
Connecticut Siting Council
10 Franklin Square
New Britain, CT 06051

Notice of Exempt Modification
39 Cherry Street, Waterbury, CT 06702
Latitude- 41.55952300
Longitude- -73.03427500

Dear Ms. Bachman,

T-Mobile currently maintains (6) existing antennas 137' level of the existing 143' smokestack at 39 Cherry Street in Waterbury, CT. The property is owned by New Opportunities Economic Development. The smokestack structure is managed by American Tower Corporation. T-Mobile now intends to replace (3) of its existing antennas with (3) new 600/700/1900/2100 MHz antennas, and add (3) new antennas. These antennas would be installed at the same 137' level of the tower. T-Mobile also intends to replace (3) remote radio heads and add (1) hybrid cable.

This facility was approved by the City of Waterbury Zoning Board of Appeals on December 21, 2005. The approval did not come with conditions that would be violated by this proposed modification.

Please accept this letter as notification pursuant to Regulations of Connecticut State Agencies 16-50j-73, for construction that constitutes an exempt modification pursuant to R.C.S.A. 16-50j-72(b)(2). In accordance with R.C.S.A. 16-50j-73, a copy of this letter is being sent to Neil O'Leary, Mayor of the City of Waterbury, James Sequin, City Planner of the City of Waterbury, as well as the property owner and American Tower Corporation.

The planned modifications to the facility fall squarely within those activities explicitly provided for in R.C.S.A. 16-50j-72(b)(2).

1. The proposed modification will not result in an increase in the height of the existing structure
2. The proposed modifications will not require the extension of the site boundary.
3. The proposed modifications will not increase noise levels at the facility by six decibels or more, or to levels that exceed state and local criteria.
4. The operation of the replacement antennas will not increase radio frequency emissions at the facility to a level at or above the Federal Communications Commission safety standard.

5. The proposed modification will not cause a change or alteration in the physical or environmental characteristics of the site.
6. The existing structure and its foundation can support the proposed loading.

For the foregoing reasons, T-Mobile respectfully submits that the proposed modifications to the above-referenced telecommunications facility constitute an exempt modification under R.C.S.A. 16-50j-72(b)(2).

Sincerely,

Kyle Richers

Kyle Richers
Transcend Wireless
10 Industrial Ave., Suite 3
Mahwah, New Jersey 07430
908-447-4716
krichers@transcendwireless.com

cc: Neil O'Leary- as elected official
James Sequin- as zoning official
New Opportunities Economic Development- as property owner
American Tower Corporation- as smokestack manager

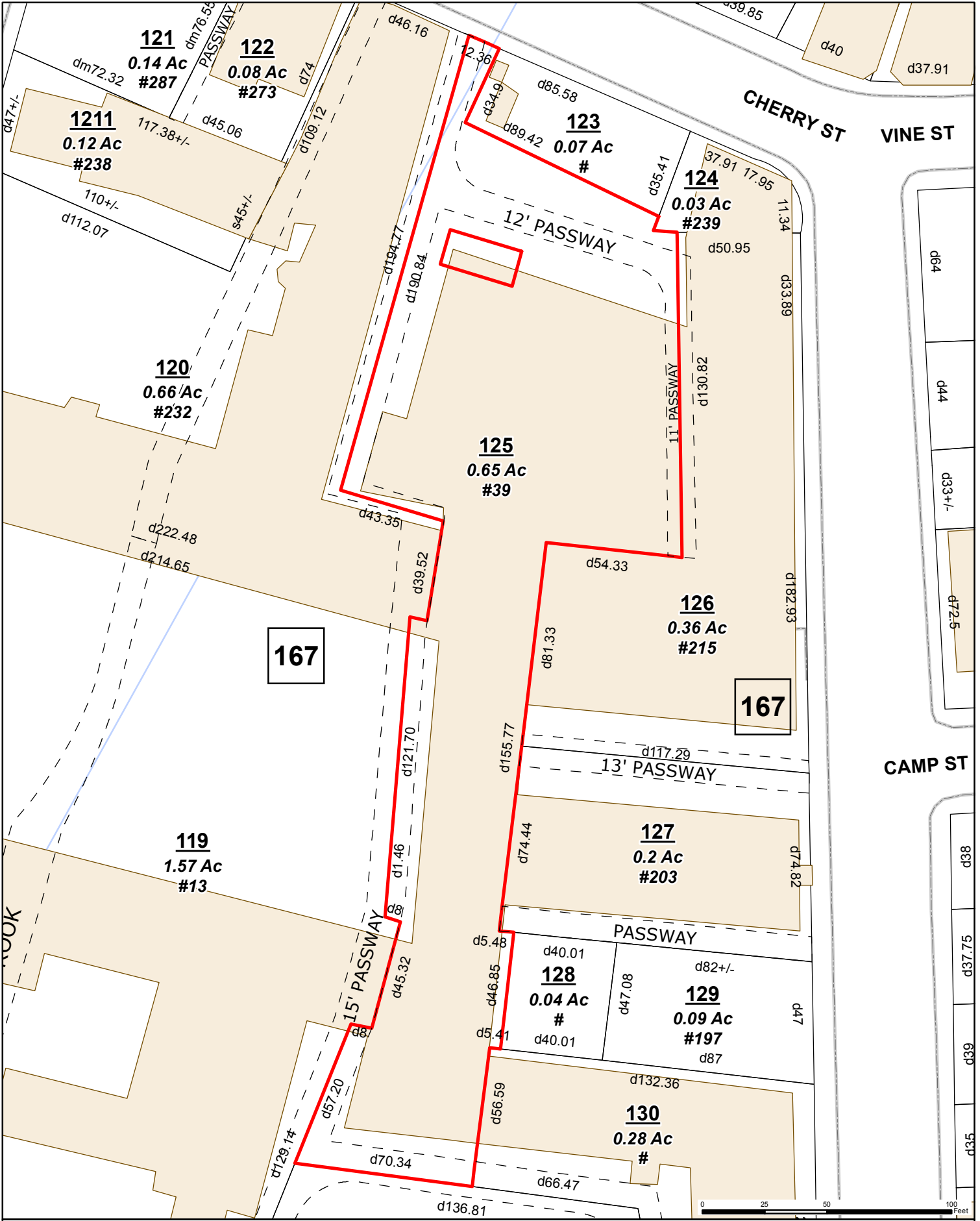

City of Waterbury
Public Works Department

MBL: **0255-0167-0125**
ADDRESS: **39 CHERRY AVE**

This map is for informational purposes only and has not been prepared for, or suitable for legal, engineering, or surveying purposes. Users of this information should review or consult the primary data and information sources to verify the usability of the information. The City of Waterbury makes no warranties, express or implied, as to the use of the information obtained herein.



Location: 39 CHERRY AVE **Owner:** NEW OPPORTUNITIES ECONOMIC DEVELOPMENT

Property Information:			
Map Block Lot:	0255-0167-0125	Acres:	0.65
Primary Use:	Light Industrial	Zone:	RH
Neighborhood:	73500-Lower North End	Vol/Page:	6727
Mailing Address:	NEW OPPORTUNITIES ECONOMIC DEVELOPMENT 232 NORTH ELM ST WATERBURY CT 06702		
Building Information:			
Bldg Style:		Living Area:	61969sq.ft
Construction:	Average	Year Built:	1900
Exterior Wall:	Brick Solid	Stories:	5
Roof Cover:		Heating:	Steam
Condition:	Poor	Heat Fuel:	Oil
Rooms:	0	Bedrooms:	0
Full Baths:	0	Half Baths:	0

[Close](#)



RADIO FREQUENCY EMISSIONS ANALYSIS REPORT EVALUATION OF HUMAN EXPOSURE POTENTIAL TO NON-IONIZING EMISSIONS

T-Mobile Existing Facility

Site ID: CTNH332C

NH332/Cherry Smokestack
39 Cherry Street
Waterbury, CT 06702

June 19, 2018

EBI Project Number: 6218004583

Site Compliance Summary	
Compliance Status:	COMPLIANT
Site total MPE% of FCC general population allowable limit:	7.47 %



June 19, 2018

T-Mobile USA
Attn: Jason Overbey, RF Manager
35 Griffin Road South
Bloomfield, CT 06002

Emissions Analysis for Site: **CTNH332C – NH332/Cherry Smokestack**

EBI Consulting was directed to analyze the proposed T-Mobile facility located at **39 Cherry Street, Waterbury, CT**, for the purpose of determining whether the emissions from the Proposed T-Mobile Antenna Installation located on this property are within specified federal limits.

All information used in this report was analyzed as a percentage of current Maximum Permissible Exposure (% MPE) as listed in the FCC OET Bulletin 65 Edition 97-01 and ANSI/IEEE Std C95.1. The FCC regulates Maximum Permissible Exposure in units of microwatts per square centimeter ($\mu\text{W}/\text{cm}^2$). The number of $\mu\text{W}/\text{cm}^2$ calculated at each sample point is called the power density. The exposure limit for power density varies depending upon the frequencies being utilized. Wireless Carriers and Paging Services use different frequency bands each with different exposure limits, therefore it is necessary to report results and limits in terms of percent MPE rather than power density.

All results were compared to the FCC (Federal Communications Commission) radio frequency exposure rules, 47 CFR 1.1307(b)(1) – (b)(3), to determine compliance with the Maximum Permissible Exposure (MPE) limits for General Population/Uncontrolled environments as defined below.

General population/uncontrolled exposure limits apply to situations in which the general population may be exposed or in which persons who are exposed as a consequence of their employment may not be made fully aware of the potential for exposure or cannot exercise control over their exposure. Therefore, members of the general population would always be considered under this category when exposure is not employment related, for example, in the case of a telecommunications tower that exposes persons in a nearby residential area.

Public exposure to radio frequencies is regulated and enforced in units of microwatts per square centimeter ($\mu\text{W}/\text{cm}^2$). The general population exposure limits for the 600 MHz and 700 MHz Band are approximately $400 \mu\text{W}/\text{cm}^2$ and $467 \mu\text{W}/\text{cm}^2$ respectively. The general population exposure limit for the 1900 MHz (PCS) and 2100 MHz (AWS) is $1000 \mu\text{W}/\text{cm}^2$. Because each carrier will be using different frequency bands, and each frequency band has different exposure limits, it is necessary to report percent of MPE rather than power density.



Occupational/controlled exposure limits apply to situations in which persons are exposed as a consequence of their employment and in which those persons who are exposed have been made fully aware of the potential for exposure and can exercise control over their exposure. Occupational/controlled exposure limits also apply where exposure is of a transient nature as a result of incidental passage through a location where exposure levels may be above general population/uncontrolled limits (see below), as long as the exposed person has been made fully aware of the potential for exposure and can exercise control over his or her exposure by leaving the area or by some other appropriate means.

Additional details can be found in FCC OET 65.

CALCULATIONS

Calculations were done for the proposed T-Mobile Wireless antenna facility located at **39 Cherry Street, Waterbury, CT**, using the equipment information listed below. All calculations were performed per the specifications under FCC OET 65. Since T-Mobile is proposing highly focused directional panel antennas, which project most of the emitted energy out toward the horizon, all calculations were performed assuming a lobe representing the maximum gain of the antenna per the antenna manufactures supplied specifications, minus 10 dB for directional panel antennas, was focused at the base of the tower. For this report the sample point is the top of a 6-foot person standing at the base of the tower.

For all calculations, all equipment was calculated using the following assumptions:

- 1) 2 GSM channels (PCS Band - 1900 MHz) were considered for each sector of the proposed installation. These Channels have a transmit power of 30 Watts per Channel.
- 2) 2 UMTS channels (PCS Band - 1900 MHz) were considered for each sector of the proposed installation. These Channels have a transmit power of 30 Watts per Channel.
- 3) 2 UMTS channels (AWS Band – 2100 MHz) were considered for each sector of the proposed installation. These Channels have a transmit power of 30 Watts per Channel.
- 4) 2 LTE channels (PCS Band - 1900 MHz) were considered for each sector of the proposed installation. These Channels have a transmit power of 60 Watts per Channel.
- 5) 4 LTE channels (AWS Band – 2100 MHz) were considered for each sector of the proposed installation. These Channels have a transmit power of 60 Watts per Channel
- 6) 2 LTE channels (600 MHz Band) were considered for each sector of the proposed installation. These channels have a transmit power of 30 Watts per channel.



- 7) 2 LTE channels (700 MHz Band) were considered for each sector of the proposed installation. These channels have a transmit power of 30 Watts per channel.
- 8) All radios at the proposed installation were considered to be running at full power and were uncombined in their RF transmissions paths per carrier prescribed configuration. Per FCC OET Bulletin No. 65 - Edition 97-01 recommendations to achieve the maximum anticipated value at each sample point, all power levels emitting from the proposed antenna installation are increased by a factor of 2.56 to account for possible in-phase reflections from the surrounding environment. This is rarely the case, and if so, is never continuous.
- 9) For the following calculations the sample point was the top of a 6-foot person standing at the base of the tower. The maximum gain of the antenna per the antenna manufactures supplied specifications, minus 10 dB for directional panel antennas, was used in this direction. This value is a very conservative estimate as gain reductions for these particular antennas are typically much higher in this direction.
- 10) The antennas used in this modeling are the **Ericsson AIR3246 B66**, **Ericsson AIR32 B66A/B2A** and the **RFS APXVAARR24_43-U-NA20** for 1900 MHz (PCS), 2100 MHz (AWS), 600 MHz and 700 MHz channels. This is based on feedback from the carrier with regard to anticipated antenna selection. All Antenna gain values and associated transmit power levels are shown in the Site Inventory and Power Data table below. The maximum gain of the antenna per the antenna manufactures supplied specifications, minus 10 dB for directional panel antennas, was used for all calculations. This value is a very conservative estimate as gain reductions for these particular antennas are typically much higher in this direction.
- 11) The antenna mounting height centerline of the proposed antennas is **137 feet** above ground level (AGL).
- 12) Emissions values for additional carriers were taken from the Connecticut Siting Council active database. Values in this database are provided by the individual carriers themselves.
- 13) All calculations were done with respect to uncontrolled / general population threshold limits.



T-Mobile Site Inventory and Power Data

Sector:	A	Sector:	B	Sector:	C
Antenna #:	1	Antenna #:	1	Antenna #:	1
Make / Model:	Ericsson AIR3246 B66	Make / Model:	Ericsson AIR3246 B66	Make / Model:	Ericsson AIR3246 B66
Gain:	15.9 dBd	Gain:	15.9 dBd	Gain:	15.9 dBd
Height (AGL):	137	Height (AGL):	137	Height (AGL):	137
Frequency Bands	2100 MHz (AWS)	Frequency Bands	2100 MHz (AWS)	Frequency Bands	2100 MHz (AWS)
Channel Count	4	Channel Count	4	Channel Count	4
Total TX Power(W):	240	Total TX Power(W):	240	Total TX Power(W):	240
ERP (W):	9,337.08	ERP (W):	9,337.08	ERP (W):	9,337.08
Antenna A1 MPE%	1.96	Antenna B1 MPE%	1.96	Antenna C1 MPE%	1.96
Antenna #:	2	Antenna #:	2	Antenna #:	2
Make / Model:	Ericsson AIR32 B66A/B2A	Make / Model:	Ericsson AIR32 B66A/B2A	Make / Model:	Ericsson AIR32 B66A/B2A
Gain:	15.9 dBd	Gain:	15.9 dBd	Gain:	15.9 dBd
Height (AGL):	137	Height (AGL):	137	Height (AGL):	137
Frequency Bands	1900 MHz (PCS)	Frequency Bands	1900 MHz (PCS)	Frequency Bands	1900 MHz (PCS)
Channel Count	2	Channel Count	2	Channel Count	2
Total TX Power(W):	120	Total TX Power(W):	120	Total TX Power(W):	120
ERP (W):	4,668.54	ERP (W):	4,668.54	ERP (W):	4,668.54
Antenna A2 MPE%	0.98	Antenna B2 MPE%	0.98	Antenna C2 MPE%	0.98
Antenna #:	3	Antenna #:	3	Antenna #:	3
Make / Model:	RFS APXVAARR24_43-U-NA20	Make / Model:	RFS APXVAARR24_43-U-NA20	Make / Model:	RFS APXVAARR24_43-U-NA20
Gain:	16.35 / 15.65 / 12.65 / 13.35 dBd	Gain:	16.35 / 15.65 / 12.65 / 13.35 dBd	Gain:	16.35 / 15.65 / 12.65 / 13.35 dBd
Height (AGL):	137	Height (AGL):	137	Height (AGL):	137
Frequency Bands	2100 MHz (AWS) / 1900 MHz (PCS) / 600 MHz / 700 MHz	Frequency Bands	2100 MHz (AWS) / 1900 MHz (PCS) / 600 MHz / 700 MHz	Frequency Bands	2100 MHz (AWS) / 1900 MHz (PCS) / 600 MHz / 700 MHz
Channel Count	10	Channel Count	10	Channel Count	10
Total TX Power(W):	300	Total TX Power(W):	300	Total TX Power(W):	300
ERP (W):	9,338.60	ERP (W):	9,338.60	ERP (W):	9,338.60
Antenna A3 MPE%	2.63	Antenna B3 MPE%	2.63	Antenna C3 MPE%	2.63

Site Composite MPE%	
Carrier	MPE%
T-Mobile (Per Sector Max)	5.56 %
Clearwire	0.19 %
MetroPCS	1.72 %
Site Total MPE %:	7.47 %

T-Mobile Sector A Total:	5.56 %
T-Mobile Sector B Total:	5.56 %
T-Mobile Sector C Total:	5.56 %
Site Total:	7.47 %



T-Mobile Max Power Values (Per Sector)

T-Mobile_Max Power Values per sector	# Channels	Watts ERP (Per Channel)	Height (feet)	Total Power Density ($\mu\text{W}/\text{cm}^2$)	Frequency (MHz)	Allowable MPE ($\mu\text{W}/\text{cm}^2$)	Calculated % MPE
T-Mobile AWS - 2100 MHz LTE	4	2,334.27	137	19.56	AWS - 2100 MHz	1000	1.96%
T-Mobile PCS - 1900 MHz LTE	2	2,334.27	137	9.78	PCS - 1900 MHz	1000	0.98%
T-Mobile AWS - 2100 MHz UMTS	2	1,294.56	137	5.42	AWS - 2100 MHz	1000	0.54%
T-Mobile PCS - 1900 MHz UMTS	2	1,101.85	137	4.62	PCS - 1900 MHz	1000	0.46%
T-Mobile PCS - 1900 MHz GSM	2	1,101.85	137	4.62	PCS - 1900 MHz	1000	0.46%
T-Mobile 600 MHz LTE	2	552.23	137	2.31	600 MHz	1000	0.58%
T-Mobile 700 MHz LTE	2	648.82	137	2.72	700 MHz	467	0.58%
						Total:	5.56%



Summary

All calculations performed for this analysis yielded results that were **within** the allowable limits for general population exposure to RF Emissions.

The anticipated maximum composite contributions from the T-Mobile facility as well as the site composite emissions value with regards to compliance with FCC's allowable limits for general population exposure to RF Emissions are shown here:

T-Mobile Sector	Power Density Value (%)
Sector A:	5.56 %
Sector B:	5.56 %
Sector C:	5.56 %
T-Mobile Per Sector Maximum (Per Sector):	5.56 %
Site Total:	7.47 %
Site Compliance Status:	COMPLIANT

The anticipated composite MPE value for this site assuming all carriers present is **7.47%** of the allowable FCC established general population limit sampled at the ground level. This is based upon values listed in the Connecticut Siting Council database for existing carrier emissions.

FCC guidelines state that if a site is found to be out of compliance (over allowable thresholds), that carriers over a 5% contribution to the composite value will require measures to bring the site into compliance. For this facility, the composite values calculated were well within the allowable 100% threshold standard per the federal government.

Structural Analysis Report

143-ft Existing Masonry Smokestack

T-Mobile Site Ref: CTNH332C

*39 Cherry Street
Waterbury, CT 06702*

Centek Project No. 18058.50

Date: June 5, 2018

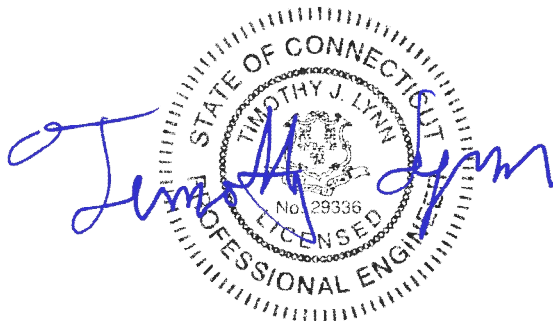

Prepared for:
T-Mobile USA
35 Griffin Road
Bloomfield, CT 06002

CENTEK Engineering, Inc.

Structural Analysis – 143-ft Existing Masonry Smokestack

T-Mobile Site Ref ~ CTNH332C

Waterbury, CT

June 5, 2018

Table of Contents

SECTION 1 - REPORT

- INTRODUCTION
- EQUIPMENT INSTALLATION SUMMARY
- DESIGN LOADING
- RESULTS
- CONCLUSION AND RECOMMENDATIONS

SECTION 2 – CONDITIONS & SOFTWARE

- STANDARD ENGINEERING CONDITIONS
- GENERAL DESCRIPTION OF STRUCTURAL ANALYSIS PROGRAM

SECTION 3 – CALCULATIONS

- WIND LOADING
- SMOKESTACK ANALYSIS

SECTION 4 – REFERENCES

- RF DATA SHEET
- EQUIPMENT CUT SHEET

Introduction

The purpose of this report is to summarize the results of the structural analysis of the equipment upgrade proposed by T-Mobile on the existing host masonry smokestack located in Waterbury, CT.

The host structure is a 143-ft tall masonry smokestack. The smokestack geometry and structural information was obtained from a structural report prepared by International Chimney Corporation dated May 3, 2006.

Equipment Installation Summary

- T-MOBILE (Existing to Remain):
Antennas: Three (3) Ericsson AIR32 panel antennas and six (6) TMAs mounted on steel frames with a RAD center elevation of +/- 137-ft AGL.
- T-MOBILE (Existing to Remove):
Antennas: Three (3) Andrew SBNHH-1D65C panel antennas mounted on steel frames with a RAD center elevation of +/- 137-ft AGL.
Appurtenances: Three (3) Ericsson RRUS-11 remote radio heads mounted on a unistrut rack at grade.
- T-MOBILE (Proposed):
Antennas: Three (3) Ericsson AIR3246 B66 panel antennas and three (3) RFS APXVAARR24-43-U-NA20 panel antennas
Appurtenances: Three (3) Ericsson 4449 B71 B12 remote radio heads mounted on a unistrut rack at grade.

Design Loading

Loading was determined per the requirements of the 2015 International Building Code and ASCE 7-10 "Minimum Design Loads for Buildings and Other Structures".

Wind Speed:	Vult = 125 mph	[Appendix N of the 2016 CT Building Code]
Exposure Category:	B	
Risk Category	II	[ASCE 7-10, Table 1.5-1]

CENTEK Engineering, Inc.

Structural Analysis – 143-ft Existing Masonry Smokestack

T-Mobile Site Ref ~ CTNH332C

Waterbury, CT

June 5, 2018

Results

Smokestack:

Component	Stress Ratio (percentage of capacity)	Result
Compression	31.0%	PASS
Tension of Mortar	21.0%	PASS

Conclusion and Recommendations

This analysis shows that the subject smokestack **is adequate** to support the proposed T-Mobile equipment upgrade.

The analysis is based, in part on the information provided to this office by T-Mobile. If the existing conditions are different than the information in this report, CENTEK engineering, Inc. must be contacted for resolution of any potential issues.

Please feel free to call with any questions or comments.

Respectfully Submitted by:



Timothy J. Lynn, PE
Structural Engineer

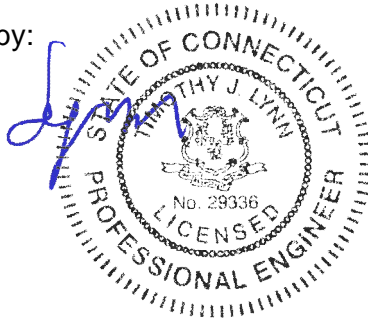

CEN TEK Engineering, Inc.

Structural Analysis – 143-ft Existing Masonry Smokestack

T-Mobile Site Ref ~ CTNH332C

Waterbury, CT

June 5, 2018

*Standard Conditions for Furnishing of
Professional Engineering Services on
Existing Structures*

All engineering services are performed on the basis that the information used is current and correct. This information may consist of, but is not necessarily limited to:

- Information supplied by the client regarding the structure itself, its foundations, the soil conditions, the antenna and feed line loading on the structure and its components, or other relevant information.
- Information from the field and/or drawings in the possession of Centek Engineering, Inc. or generated by field inspections or measurements of the structure.
- It is the responsibility of the client to ensure that the information provided to Centek Engineering, Inc. and used in the performance of our engineering services is correct and complete. In the absence of information to the contrary, we assume that all structures were constructed in accordance with the drawings and specifications and are in an uncorroded condition and have not deteriorated. It is therefore assumed that its capacity has not significantly changed from the “as new” condition.
- All services will be performed to the codes specified by the client, and we do not imply to meet any other codes or requirements unless explicitly agreed in writing. If wind and ice loads or other relevant parameters are to be different from the minimum values recommended by the codes, the client shall specify the exact requirement. In the absence of information to the contrary, all work will be performed in accordance with the latest revision of ANSI/ASCE10 & ANSI/EIA-222
- All services performed, results obtained, and recommendations made are in accordance with generally accepted engineering principles and practices. Centek Engineering, Inc. is not responsible for the conclusions, opinions and recommendations made by others based on the information we supply.

Design Wind Load on Other Structures:

(Based on IBC 2012, CSBC 2016 and ASCE 7-10)

Wind Speed =	$V := 125$ mph	(User Input)	(CSBC Appendix-N)
Risk Category =	$BC := II$	(User Input)	(IBC Table 1604.5)
Exposure Category =	$Exp := B$	(User Input)	
Structure Type =	$Structuretype := Round_Chimney$	(User Input)	
Structure Height =	$Height := 143$ ft	(User Input)	
Horizontal Dimension of Structure =	$Width := 11$ ft	(User Input)	
<u>Terrain Exposure Constants:</u>			
Nominal Height of the Atmospheric Boundary Layer =	$z_g := \begin{cases} 1200 & \text{if } Exp = B = 1.2 \times 10^3 \\ 900 & \text{if } Exp = C \\ 700 & \text{if } Exp = D \end{cases}$		(Table 26.9-1)
3-Sec Gust Speed Power Law Exponent =	$\alpha := \begin{cases} 7 & \text{if } Exp = B \\ 9.5 & \text{if } Exp = C \\ 11.5 & \text{if } Exp = D \end{cases}$		(Table 26.9-1)
Integral Length Scale Factor =	$l := \begin{cases} 320 & \text{if } Exp = B \\ 500 & \text{if } Exp = C \\ 650 & \text{if } Exp = D \end{cases}$		(Table 26.9-1)
Integral Length Scale Power Law Exponent =	$E := \begin{cases} \frac{1}{3} & \text{if } Exp = B \\ \frac{1}{5} & \text{if } Exp = C \\ \frac{1}{8} & \text{if } Exp = D \end{cases}$		(Table 26.9-1)
Turbulence Intensity Factor =	$c := \begin{cases} 0.3 & \text{if } Exp = B \\ 0.2 & \text{if } Exp = C \\ 0.15 & \text{if } Exp = D \end{cases}$		(Table 26.9-1)
Exposure Constant =	$Z_{min} := \begin{cases} 30 & \text{if } Exp = B \\ 15 & \text{if } Exp = C \\ 7 & \text{if } Exp = D \end{cases}$		(Table 26.9-1)
Topographic Factor =	$K_{zt} := 1$		(Eq. 26.8-2)
Wind Directionality Factor =	$K_d := 0.95$		(Table 26.6-1)
Peak Factor for Background Response =	$g_Q := 3.4$		(Sec 26.9.4)
Peak Factor for Wind Response =	$g_v := 3.4$		(Sec 26.9.4)

Equivalent Height of Structure = $z := \begin{cases} Z_{\min} & \text{if } Z_{\min} > 0.6 \cdot \text{Height} \\ 0.6 \cdot \text{Height} & \text{otherwise} \end{cases} = 85.8$ (Sec 26.9.4)

Intensity of Turbulence = $I_z := c \cdot \left(\frac{33}{z}\right)^{\left(\frac{1}{6}\right)} = 0.256$ (Eq. 26.9-7)

Integral Length Scale of Turbulence = $L_z := l \cdot \left(\frac{z}{33}\right)^E = 440.022$ (Eq. 26.9-9)

Background Response Factor = $Q := \sqrt{\frac{1}{1 + 0.63 \left(\frac{\text{Width} + \text{Height}}{L_z}\right)^{0.63}}} = 0.869$ (Eq. 26.9-8)

Gust Response Factor = $G := 0.925 \cdot \left[\frac{(1 + 1.7 \cdot g_Q \cdot I_z \cdot Q)}{1 + 1.7 \cdot g_V \cdot I_z}\right] = 0.853$ (Eq. 26.9-6)

Velocity Pressure = $q_z := 0.00256 \cdot K_{zt} \cdot K_d \cdot V^2 = 38$ (Eq. 29.3-1)

Force Coefficient = $C_f = 0.833$ (Fig 29.5-1 - 29.5-3)

Ultimate Wind Pressure = $F := q_z \cdot G \cdot C_f = 27$ psf

Height Above Grade = $Z := 132$ ft (User Input)

Exposure Coefficient = $K_z := \begin{cases} 2.01 \left(\frac{Z}{z_g}\right)^{\left(\frac{2}{\alpha}\right)} & \text{if } 15 \leq Z \leq z_g \\ 2.01 \left(\frac{15}{z_g}\right)^{\left(\frac{2}{\alpha}\right)} & \text{if } Z < 15 \end{cases} = 1.07$ (Table 29.3-1)

$K_z = 1.07$

Height Above Grade = $Z := 105$ ft (User Input)

Exposure Coefficient = $K_z := \begin{cases} 2.01 \left(\frac{Z}{z_g}\right)^{\left(\frac{2}{\alpha}\right)} & \text{if } 15 \leq Z \leq z_g \\ 2.01 \left(\frac{15}{z_g}\right)^{\left(\frac{2}{\alpha}\right)} & \text{if } Z < 15 \end{cases} = 1$ (Table 29.3-1)

$K_z = 1.002$

Height Above Grade = $Z := 80$ ft (User Input)

Exposure Coefficient =
$$K_Z := \begin{cases} 2.01 \left(\frac{Z}{z_g} \right)^{\left(\frac{2}{\alpha} \right)} & \text{if } 15 \leq Z \leq z_g = 0.93 \\ 2.01 \left(\frac{15}{z_g} \right)^{\left(\frac{2}{\alpha} \right)} & \text{if } Z < 15 \end{cases}$$
 (Table 29.3-1)

$K_Z = 0.927$

Height Above Grade = $Z := 5$ ft (User Input)

Exposure Coefficient =
$$K_Z := \begin{cases} 2.01 \left(\frac{Z}{z_g} \right)^{\left(\frac{2}{\alpha} \right)} & \text{if } 15 \leq Z \leq z_g = 0.57 \\ 2.01 \left(\frac{15}{z_g} \right)^{\left(\frac{2}{\alpha} \right)} & \text{if } Z < 15 \end{cases}$$
 (Table 29.3-1)

$K_Z = 0.575$

Height Above Grade = $Z := 30$ ft (User Input)

Exposure Coefficient =
$$K_Z := \begin{cases} 2.01 \left(\frac{Z}{z_g} \right)^{\left(\frac{2}{\alpha} \right)} & \text{if } 15 \leq Z \leq z_g = 0.7 \\ 2.01 \left(\frac{15}{z_g} \right)^{\left(\frac{2}{\alpha} \right)} & \text{if } Z < 15 \end{cases}$$
 (Table 29.3-1)

$K_Z = 0.701$

Height Above Grade = $Z := 10$ ft (User Input)

Exposure Coefficient =
$$K_Z := \begin{cases} 2.01 \left(\frac{Z}{z_g} \right)^{\left(\frac{2}{\alpha} \right)} & \text{if } 15 \leq Z \leq z_g = 0.57 \\ 2.01 \left(\frac{15}{z_g} \right)^{\left(\frac{2}{\alpha} \right)} & \text{if } Z < 15 \end{cases}$$
 (Table 29.3-1)

$K_Z = 0.575$

Job : CTNH332C
 Address: 39 Cherry Street Waterbury, CT 06702
 Description: Smokestack Evaluation

Project No. 18058.50 Sheet 1 of 2
 Computed by TJL Date 6/5/18
 Checked by CAG Date

	Wind Force (lb)	Weight (lb)	Height Above Base (ft)	Height (in)
T-Mobile	2000	2500	137	1644
Clearwire	500	800	127	1524
MetroPCS	350	350	110	1320

Section	Top Dia (in)	Bot Dia (in)	Wall Thk (in)	Sect Height (in)	Area At Base (in ²)	Tot. Vol (ft ³)	Unit Weight (pcf)	Weight of Section (lb)	Total Weight (lb)	Axial Stress fa (psi)
1	95.3	107.5	10	288	3061.5	478.05002	120	57366.00208	60666.00208	19.8
2	107.5	123	11	360	3868.48	749.73175	120	89967.81029	150983.8124	39.0
3	123	133.4	13	240	4914.728	652.74226	120	78329.07068	229312.8831	46.7
4	133.4	149	17	360	7046.16	1380.4087	120	165649.0383	394961.9213	56.1
5	149	159.3	20	240	8748.04	1169.4094	120	140329.1243	535291.0457	61.2
6	159.3	169.7	24	240	10979.952	1469.7161	120	176365.9364	711656.9821	64.8

Job : CTNH332C
 Address: 39 Cherry Street Waterbury, CT 06702
 Description: Smokestack Evaluation

Project No. 18058.50
 Computed by TJL
 Checked by CAG
 Sheet 2 of 2
 Date 6/5/18
 Date

Ultimate Wind Pressure (psf)	ASD Wind Pressure (psf)	KZ	Wind Area (sf)	Wind Force (lb)	Moment @ Base	Section Modulus @ Base	Bending Stress fb (psi)	Allowable Fa (psi)	Allowable Fb (psi)	fa/Fa+fb/Fb		ft	Ft	ft/Ft	
27	16.2	1.07	202.8	3515.3	956208.2688	68394.26599	14.0	375	500	0.08	OK	-5.8	30	-0.19	OK
27	16.2	1.002	288.1	4677.0	4047581.786	99581.90894	40.6	375	500	0.19	OK	1.6	30	0.05	OK
27	16.2	0.927	213.7	3208.7	7082778.83	135073.5991	52.4	375	500	0.23	OK	5.8	30	0.19	OK
27	16.2	0.833	353.0	4763.6	13070590.48	209410.4565	62.4	375	500	0.27	OK	6.4	30	0.21	OK
27	16.2	0.701	256.9	2917.6	17984207.82	271893.3941	66.1	375	500	0.30	OK	5.0	30	0.17	OK
27	16.2	0.575	274.2	2553.9	23554400.31	352699.254	66.8	375	500	0.31	OK	2.0	30	0.07	OK

RAN Template: 67D94M Hybrid (Evolved from 4B)	A&L Template: 67D94M_2xAIR+1OP	Power System Template: Custom
---	--	---

Section 1 - Site Information

Site ID: CTNH332C
Status: Draft
Version: 2.1
Project Type: M-MIMO
Approved: Not Approved
Approved By: Not Approved
Last Modified: 5/8/2018 1:40:38 PM
Last Modified By: GSM1900MLucey

Site Name: NH332/CherrySmokestack
Site Class: Smokestack
Site Type: Structure Non Building
Solution Type:
Plan Year:
Market: CONNECTICUT
Vendor: Ericsson
Landlord: Yogi Shaw

Latitude: 41.5595230000
Longitude: -73.0342750000
Address: 39 Cherry Street
City, State: Waterbury, CT
Region: NORTHEAST

RAN Template: 67D94M Hybrid (Evolved from 4B)		AL Template: 67D94M_2xAIR+1OP		
Sector Count: 3	Antenna Count: 9	Coax Line Count: 12	TMA Count: 6	RRU Count: 3

Section 2 - Existing Template Images

794DB_RAN_evolved_from_4B.png

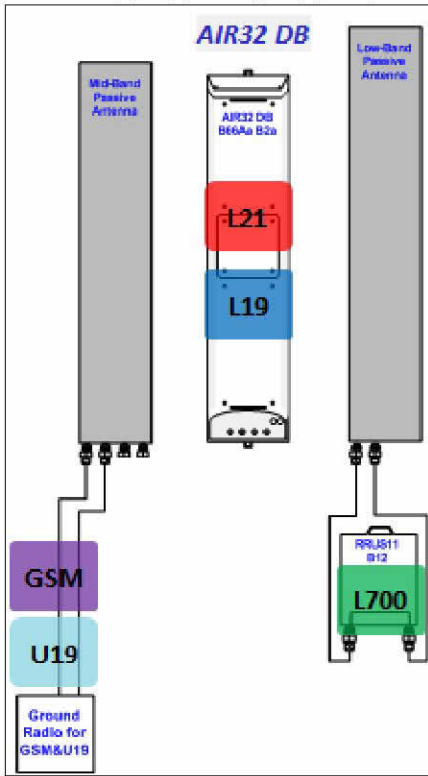

Notes:

Section 3 - Proposed Template Images

Capture.JPG

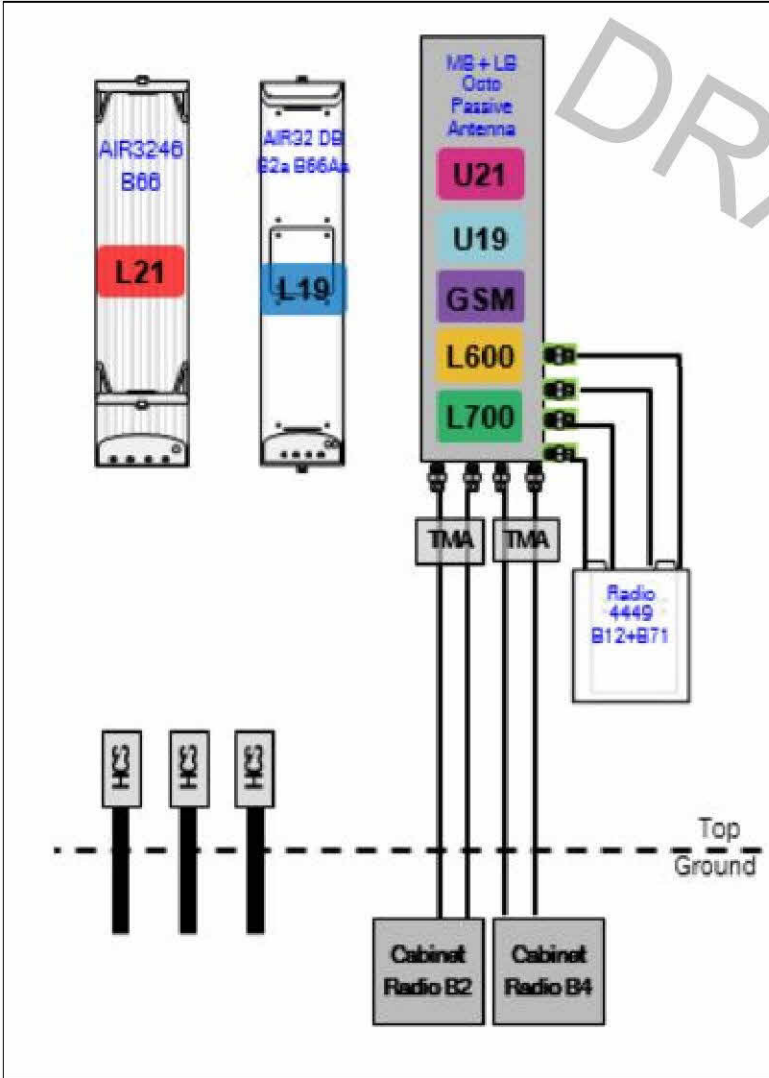

Notes:

Section 4 - Siteplan Images

---- This section is intentionally blank. ----

DRAFT

RAN Template: 67D94M Hybrid (Evolved from 4B)	A&L Template: 67D94M_2xAIR+1OP	Power System Template: Custom
---	--	---

Section 5 - RAN Equipment

Existing RAN Equipment

Template: 794DB Outdoor (evolved from 4B)

Enclosure	1	2
Enclosure Type	RBS 6102	Ancillary Equipment
Baseband	DUS41 (x2) DUW30 (x2) DUG20	
Hybrid Cable System		Ericsson 6x12 HCS *Select Length & AWG* Ericsson 9x18 HCS *Select Length*
Multiplexer	XMU	
Radio	RUS01 B2 (x3) G1900 RUS01 B2 (x3) U1900 RUS01 B4 (x6) U2100	

Proposed RAN Equipment

Template: 67D94M Hybrid (Evolved from 4B)

Enclosure	1	2
Enclosure Type	RBS 6102	Ancillary Equipment
Baseband	BB 5216 L1900 L700 L600 DUW30 U2100 DUW30 U1900 DUG20 G1900 BB 6630 L2100	
Hybrid Cable System		Ericsson 9x18 HCS *Select Length* Ericsson 6x12 HCS *Select Length & AWG* Ericsson 6x12 HCS *Select AWG & Length*
Multiplexer	XMU L1900 L700 L600	
Radio	RUS01 B2 (x3) G1900 RUS01 B2 (x3) U1900 RUS01 B4 (x6) U2100	

RAN Scope of Work:

RAN Template: 67D94M Hybrid (Evolved from 4B)	A&L Template: 67D94M_2xAIR+1OP	Power System Template: Custom
---	--	---

Section 6 - A&L Equipment

Existing Template: 794DB_1xAIR+1QP+1DP
Proposed Template: 67D94M_2xAIR+1OP

Sector 1 (Existing) view from behind

Address	Address: City, State:		Latitude: 41.5595230000 Longitude: -73.0342750000				
Coverage Type	A - Outdoor Macro						
Antenna	1			2			
Antenna Model	Andrew - SBNHH-1D65C-SR (Hex)			Ericsson - AIR32 KRD901146-1_B66A_B2A (Octo)			
Azimuth	40			40			
M. Tilt	0			0			
Height	137			137			
Ports	P1	P2	P3	P4	P5	P6	P7
Active Tech.	U1900 G1900	U2100	L700	L2100	L2100	L1900	L1900
Dark Tech.							
Restricted Tech.							
Decomm. Tech.							
E. Tilt	2	2	2	2	2	2	2
Cables	1-5/8" Coax - 175 ft. (x2)	1-5/8" Coax - 175 ft. (x2)	1-5/8" Coax - 175 ft. (x2)				
TMA's	Generic Twin Style 1A - PCS (AtAntenna)	Generic Twin Style 1B - AWS (AtAntenna)					
Diplexers / Combiners							
Radio			RRUS11 B12 (At Antenna)				
Sector Equipment							

Unconnected Equipment:

Scope of Work:

Consolidate lines and TMA into first location and replace with hexpole. B12 RRUs to be placed on ground. Replace 2nd antenna with air 32 and run fiber.

RAN Template: 67D94M Hybrid (Evolved from 4B)	A&L Template: 67D94M_2xAIR+1OP	Power System Template: Custom
---	--	---

Sector 1 (Proposed) view from behind												
Coverage Type	A - Outdoor Macro											
Antenna	1				2				3			
Antenna Model	RFS - APXVAARR24_43-U-NA20 (Octo)				Ericsson - AIR32 KRD901146-1_B66A_B2A (Octo)				Ericsson - AIR3246 B66 (Octo)			
Azimuth	40				40				40			
M. Tilt												
Height	137				137				137			
Ports	P1	P2	P3	P4	P5	P6	P7	P8	P9	P10	P11	P12
Active Tech.	U1900 G1900	U2100	L700 L600	L700 L600			L1900	L1900	L2100	L2100	L2100	L2100
Dark Tech.												
Restricted Tech.												
Decomm. Tech.												
E. Tilt	2		2		2		2		2		2	
Cables	CABLE 1 5/8IN FOAM PREMIU M - 175 ft. (x2)	CABLE 1 5/8IN FOAM PREMIU M - 175 ft. (x2)										
TMA's	Generic Twin Style 1A - PCS (AtAnten na)	Generic Twin Style 1B - AWS (AtAnten na)										
Diplexers / Combiners												
Radio			Radio 4449 B71+B1 2 (At Antenna)									
Sector Equipment												

Unconnected Equipment:

Scope of Work:

RAN Template: 67D94M Hybrid (Evolved from 4B)	A&L Template: 67D94M_2xAIR+1OP	Power System Template: Custom
---	--	---

Sector 2 (Existing) view from behind							
Address	Address:		Latitude: 41.5595230000				
	City, State:		Longitude: -73.0342750000				
Coverage Type	A - Outdoor Macro						
Antenna	1			2			
Antenna Model	Andrew - SBNHH-1D65C-SR (Hex)			Ericsson - AIR32 KRD901146-1_B66A_B2A (Octo)			
Azimuth	140			140			
M. Tilt	0			0			
Height	137			137			
Ports	P1	P2	P3	P4	P5	P6	P7
Active Tech.	U1900 G1900	U2100	L700	L2100	L2100	L1900	L1900
Dark Tech.							
Restricted Tech.							
Decomm. Tech.							
E. Tilt	2	2	2	2	2	2	2
Cables	1-5/8" Coax - 175 ft. (x2)	1-5/8" Coax - 175 ft. (x2)	1-5/8" Coax - 175 ft. (x2)				
TMA's	Generic Twin Style 1A - PCS (AtAntenna)	Generic Twin Style 1B - AWS (AtAntenna)					
Diplexers / Combiners							
Radio			RRUS11 B12 (At Antenna)				
Sector Equipment							
Unconnected Equipment:							
Scope of Work:							
Consolidate lines and TMA into first location and replace with hexpole. B12 RRU's to be placed on ground. Replace 2nd antenna with air 32 and run fiber.							

RAN Template: 67D94M Hybrid (Evolved from 4B)	A&L Template: 67D94M_2xAIR+1OP	Power System Template: Custom
---	--	---

Sector 2 (Proposed) view from behind												
Coverage Type	A - Outdoor Macro											
Antenna	1				2				3			
Antenna Model	RFS - APXVAARR24_43-U-NA20 (Octo)				Ericsson - AIR32 KRD901146-1_B66A_B2A (Octo)				Ericsson - AIR3246 B66 (Octo)			
Azimuth	140				140				140			
M. Tilt												
Height	137				137				137			
Ports	P1	P2	P3	P4	P5	P6	P7	P8	P9	P10	P11	P12
Active Tech.	U1900 G1900	U2100	L700 L600	L700 L600			L1900	L1900	L2100	L2100	L2100	L2100
Dark Tech.												
Restricted Tech.												
Decomm. Tech.												
E. Tilt	2		2		2		2		2		2	
Cables	CABLE 1 5/8IN FOAM PREMIU M - 175 ft. (x2)	CABLE 1 5/8IN FOAM PREMIU M - 175 ft. (x2)										
TMA's	Generic Twin Style 1A - PCS (AtAnten na)	Generic Twin Style 1B - AWS (AtAnten na)										
Diplexers / Combiners												
Radio			Radio 4449 B71+B1 2 (At Antenna)									
Sector Equipment												

Unconnected Equipment:

Scope of Work:

RAN Template: 67D94M Hybrid (Evolved from 4B)	A&L Template: 67D94M_2xAIR+1OP	Power System Template: Custom
---	--	---

Sector 3 (Existing) view from behind							
Address	Address:		Latitude: 41.5595230000				
	City, State:		Longitude: -73.0342750000				
Coverage Type	A - Outdoor Macro						
Antenna	1			2			
Antenna Model	Andrew - SBNHH-1D65C-SR (Hex)			Ericsson - AIR32 KRD901146-1_B66A_B2A (Octo)			
Azimuth	250			250			
M. Tilt	0			0			
Height	137			137			
Ports	P1	P2	P3	P4	P5	P6	P7
Active Tech.	U1900 G1900	U2100	L700	L2100	L2100	L1900	L1900
Dark Tech.							
Restricted Tech.							
Decomm. Tech.							
E. Tilt	2	2	2	2	2	2	2
Cables	1-5/8" Coax - 175 ft. (x2)	1-5/8" Coax - 175 ft. (x2)	1-5/8" Coax - 175 ft. (x2)				
TMA's	Generic Twin Style 1A - PCS (AtAntenna)	Generic Twin Style 1B - AWS (AtAntenna)					
Diplexers / Combiners							
Radio			RRUS11 B12 (At Antenna)				
Sector Equipment							
Unconnected Equipment:							
Scope of Work:							
Consolidate lines and TMA into first location and replace with hexpole. B12 RRUs to be placed on ground. Replace 2nd antenna with air 32 and run fiber.							

RAN Template: 67D94M Hybrid (Evolved from 4B)	A&L Template: 67D94M_2xAIR+1OP	Power System Template: Custom
---	--	---

Sector 3 (Proposed) view from behind												
Coverage Type	A - Outdoor Macro											
Antenna	1				2				3			
Antenna Model	RFS - APXVAARR24_43-U-NA20 (Octo)				Ericsson - AIR32 KRD901146-1_B66A_B2A (Octo)				Ericsson - AIR3246 B66 (Octo)			
Azimuth	250				250				250			
M. Tilt												
Height	137				137				137			
Ports	P1	P2	P3	P4	P5	P6	P7	P8	P9	P10	P11	P12
Active Tech.	U1900 G1900	U2100	L700 L600	L700 L600			L1900	L1900	L2100	L2100	L2100	L2100
Dark Tech.												
Restricted Tech.												
Decomm. Tech.												
E. Tilt	2		2		2		2		2		2	
Cables	CABLE 1 5/8IN FOAM PREMIU M - 175 ft. (x2)	CABLE 1 5/8IN FOAM PREMIU M - 175 ft. (x2)										
TMA's	Generic Twin Style 1A - PCS (AtAnten na)	Generic Twin Style 1B - AWS (AtAnten na)										
Diplexers / Combiners												
Radio			Radio 4449 B71+B1 2 (At Antenna)									
Sector Equipment												

Unconnected Equipment:

Scope of Work:

RAN Template: 67D94M Hybrid (Evolved from 4B)	A&L Template: 67D94M_2xAIR+1OP	Power System Template: Custom
---	--	---

Section 7 - Power Systems Equipment

Existing Power Systems Equipment

---- This section is intentionally blank. ----

Proposed Power Systems Equipment



Dual Slant Polarized Quad Band (8 Port) Antenna, 617-746/617-746/1695-2200/1695-2200MHz, 65deg, 15/15/18/18dBi, 2.4m (8ft), VET, RET, 0-12°/0-12°/2-12°/2-12°

FEATURES / BENEFITS

This antenna provides a 8 Port multi-band flexible platform for advanced use for flexible use in deployment scenarios for encompassing 600MHz, 700MHz, AWS & PCS applications.



- ➔ 24 Inch Width For Easier Zoning
- ➔ Field Replaceable (Integrated) AISG RET platform for reduced environmental exposure and long lasting quality
- ➔ Superior elevation pattern performance across the entire electrical down tilt range
- ➔ Includes three AISG RET motors - Includes 0.5m AISG jumper for optional daisy chain of two high band RET motors for one single AISG point of high band tilt control.
- ➔ Low band arrays driven by a single RET motor

Technical Features

LOW BAND LEFT ARRAY (617-746 MHZ) [R1]

Frequency Band	MHz	617-698	698-746
Gain	dBi	15.1	15.5
Horizontal Beamwidth @3dB	Deg	65	62
Vertical Beamwidth @3dB	Deg	11.4	10.4
Electrical Downtilt Range	Deg	0-12	0-12
Upper Side Lobe Suppression 0 to +20	dB	19	20
Front-to-Back, at +/-30°, Copolar	dB	25	24
Cross Polar Discrimination (XPD) @ Boresight	dB	19	19
Cross Polar Discrimination (XPD) @ +/-60	dB	5	3
3rd Order PIM 2 x 43dBm	dBc		-153
VSWR	-	1.5:1	1.5:1
Cross Polar Isolation	dB	25	25
Maximum Effective Power per Port	Watt	250	250

LOW BAND RIGHT ARRAY (617-746 MHZ) [R2]

Frequency Band	MHz	617-698	698-746
Gain	dBi	14.8	15.1
Horizontal Beamwidth @3dB	Deg	65	62
Vertical Beamwidth @3dB	Deg	11.4	10.3
Electrical Downtilt Range	Deg	0-12	0-12
Upper Side Lobe Suppression 0 to +20	dB	19	20
Front-to-Back, at +/-30°, Copolar	dB	25	23
Cross Polar Discrimination (XPD) @ Boresight	dB	19	19
Cross Polar Discrimination (XPD) @ +/-60	dB	5	3
3rd Order PIM 2 x 43dBm	dBc		-153
VSWR	-	1.5:1	1.5:1
Cross Polar Isolation	dB	25	25
Maximum Effective Power per Port	Watt	250	250



Dual Slant Polarized Quad Band (8 Port) Antenna, 617-746/617-746/1695-2200/1695-2200MHz, 65deg, 15/15/18/18dBi, 2.4m (8ft), VET, RET, 0-12°/0-12°/2-12°/2-12°

ELECTRICAL SPECIFICATIONS

Impedance	Ohm	50.0
Polarization	Deg	±45°

MECHANICAL SPECIFICATIONS

Dimensions - H x W x D	mm (in)	2436 x 609 x 222 (95.9 x 24 x 8.7)
Weight (Antenna Only)	kg (lb)	58 (128)
Weight (Mounting Hardware only)	kg (lb)	11.5 (25.3)
Shipping Weight	kg (lb)	80 (176)
Connector type		8 x 4.3-10 female at bottom + 6 AISG connectors (3 male, 3 female)
Adjustment mechanism		Integrated RET solution AISG compliant (Field Replaceable) + Manual Override + External Tilt Indicator
Mounting Hardware Material		Galvanized steel
Radome Material / Color		Fiber Glass / Light Grey RAL7035

TESTING AND ENVIRONMENTAL

Temperature Range	°C (°F)	-40 to 60 (-40 to 140)
Lightning protection		IEC 61000-4-5
Survival/Rated Wind Velocity	km/h	241 (150)
Environmental		ETSI 300-019-2-4 Class 4.1E

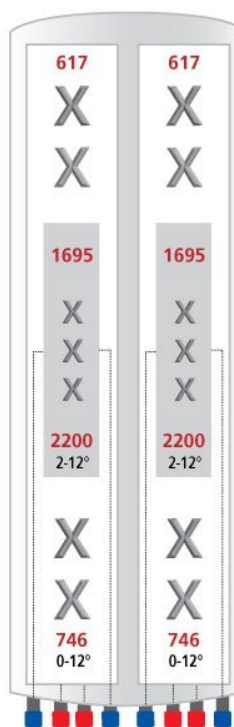
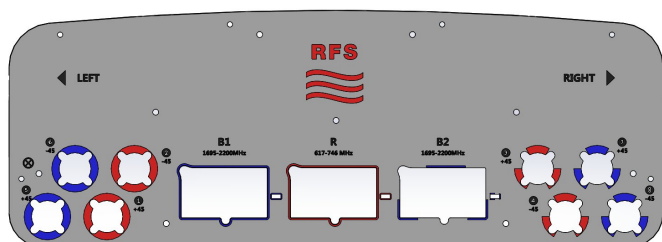

ORDERING INFORMATION

Order No.	Configuration	Mounting Hardware	Mounting pipe Diameter	Shipping Weight
APXVAARR24_43-U-NA20	Field Replace RET included (3)	APM40-5E Beam tilt kit (included)	60-120mm	80 Kg



WIRELESS COMMUNICATIONS FACILITY

NH332/CHERRYSMOKESTACK

SITE ID: CTNH332C

39 CHERRY STREET

WATERBURY, CT 06702

GENERAL NOTES

- ALL WORK SHALL BE IN ACCORDANCE WITH THE 2012 INTERNATIONAL BUILDING CODE AS MODIFIED BY THE 2016 CONNECTICUT SUPPLEMENT, INCLUDING THE TIA/EIA-222 REVISION "G" "STRUCTURAL STANDARDS FOR STEEL ANTENNA TOWERS AND SUPPORTING STRUCTURES." 2016 CONNECTICUT FIRE SAFETY CODE, NATIONAL ELECTRICAL CODE AND LOCAL CODES.
- CONTRACTOR SHALL REVIEW ALL DRAWINGS AND SPECIFICATIONS IN THE CONTRACT DOCUMENT SET. CONTRACTOR SHALL COORDINATE ALL WORK SHOWN IN THE SET OF DRAWINGS. THE CONTRACTOR SHALL PROVIDE A COMPLETE SET OF DRAWINGS TO ALL SUBCONTRACTORS AND ALL RELATED PARTIES. THE SUBCONTRACTORS SHALL EXAMINE ALL THE DRAWINGS AND SPECIFICATIONS FOR THE INFORMATION THAT AFFECTS THEIR WORK.
- CONTRACTOR SHALL PROVIDE A COMPLETE BUILD-OUT WITH ALL FINISHES, STRUCTURAL, MECHANICAL, AND ELECTRICAL COMPONENTS AND PROVIDE ALL ITEMS AS SHOWN OR INDICATED ON THE DRAWINGS OR IN THE WRITTEN SPECIFICATIONS.
- CONTRACTOR SHALL FURNISH ALL MATERIAL, LABOR AND EQUIPMENT TO COMPLETE THE WORK AND FURNISH A COMPLETED JOB ALL IN ACCORDANCE WITH LOCAL AND STATE GOVERNING AUTHORITIES AND OTHER AUTHORITIES HAVING LAWFUL JURISDICTION OVER THE WORK.
- CONTRACTOR SHALL SECURE AND PAY FOR ALL PERMITS AND ALL INSPECTIONS REQUIRED AND SHALL ALSO PAY FEES REQUIRED FOR THE GENERAL CONSTRUCTION, PLUMBING, ELECTRICAL AND HVAC. PERMITS SHALL BE PAID FOR BY THE RESPECTIVE SUBCONTRACTORS.
- CONTRACTOR SHALL MAINTAIN A CURRENT SET OF DRAWINGS AND SPECIFICATIONS ON SITE AT ALL TIMES AND INSURE DISTRIBUTION OF NEW DRAWINGS TO SUBCONTRACTORS AND OTHER RELEVANT PARTIES AS SOON AS THEY ARE MADE AVAILABLE. ALL OLD DRAWINGS SHALL BE MARKED VOID AND REMOVED FROM THE CONTRACT AREA. THE CONTRACTOR SHALL FURNISH AN "AS-BUILT" SET OF DRAWINGS TO OWNER UPON COMPLETION OF PROJECT.
- LOCATION OF EQUIPMENT, AND WORK SUPPLIED BY OTHERS THAT IS DIAGRAMMATICALLY INDICATED ON THE DRAWINGS SHALL BE DETERMINED BY THE CONTRACTOR. THE CONTRACTOR SHALL DETERMINE LOCATIONS AND DIMENSIONS SUBJECT TO STRUCTURAL CONDITIONS AND WORK OF THE SUBCONTRACTORS.
- THE CONTRACTOR IS SOLELY RESPONSIBLE TO DETERMINE CONSTRUCTION PROCEDURE AND SEQUENCE, AND TO ENSURE THE SAFETY OF THE EXISTING STRUCTURES AND ITS COMPONENT PARTS DURING CONSTRUCTION. THIS INCLUDES THE ADDITION OF WHATEVER SHORING, BRACING, UNDERPINNING, ETC. THAT MAY BE NECESSARY.
- DRAWINGS INDICATE THE MINIMUM STANDARDS, BUT IF ANY WORK SHOULD BE INDICATED TO BE SUBSTANDARD TO ANY ORDINANCES, LAWS, CODES, RULES, OR REGULATIONS BEARING ON THE WORK, THE CONTRACTOR SHALL INCLUDE IN HIS WORK AND SHALL EXECUTE THE WORK CORRECTLY IN ACCORDANCE WITH SUCH ORDINANCES, LAWS, CODES, RULES OR REGULATIONS WITH NO INCREASE IN COSTS.
- ALL UTILITY WORK SHALL BE IN ACCORDANCE WITH LOCAL UTILITY COMPANY REQUIREMENTS AND SPECIFICATIONS.
- ALL EQUIPMENT AND PRODUCTS PURCHASED ARE TO BE REVIEWED BY CONTRACTOR AND ALL APPLICABLE SUBCONTRACTORS FOR ANY CONDITION PER MFR.'S RECOMMENDATIONS. CONTRACTOR TO SUPPLY THESE ITEMS AT NO COST TO OWNER OR CONSTRUCTION MANAGER.
- ANY AND ALL ERRORS, DISCREPANCIES, AND "MISSED" ITEMS ARE TO BE BROUGHT TO THE ATTENTION OF THE T-MOBILE CONSTRUCTION MANAGER DURING THE BIDDING PROCESS BY THE CONTRACTOR. ALL THESE ITEMS ARE TO BE INCLUDED IN THE BID. NO "EXTRA" WILL BE ALLOWED FOR MISSED ITEMS.
- CONTRACTOR SHALL BE RESPONSIBLE FOR ALL ON-SITE SAFETY FROM THE TIME THE JOB IS AWARDED UNTIL ALL WORK IS COMPLETE AND ACCEPTED BY THE OWNER.
- CONTRACTOR TO REVIEW ALL SHOP DRAWINGS AND SUBMIT COPY TO ENGINEER FOR APPROVAL. DRAWINGS MUST BEAR THE CHECKER'S INITIALS BEFORE SUBMITTING TO THE CONSTRUCTION MANAGER FOR REVIEW.
- THE CONTRACTOR SHALL FIELD VERIFY ALL DIMENSIONS, ELEVATIONS, ANGLES, AND EXISTING CONDITIONS AT THE SITE, PRIOR TO FABRICATION AND/OR INSTALLATION OF ANY WORK IN THE CONTRACT AREA.
- COORDINATION, LAYOUT, FURNISHING AND INSTALLATION OF CONDUIT AND ALL APPURTENANCES REQUIRED FOR PROPER INSTALLATION OF ELECTRICAL AND TELECOMMUNICATION SERVICE SHALL BE THE SOLE RESPONSIBILITY OF THE CONTRACTOR.
- ALL DAMAGE CAUSED TO ANY EXISTING STRUCTURE SHALL BE THE SOLE RESPONSIBILITY OF THE CONTRACTOR. THE CONTRACTOR WILL BE HELD LIABLE FOR ALL REPAIRS REQUIRED FOR EXISTING STRUCTURES IF DAMAGED DURING CONSTRUCTION ACTIVITIES.
- THE CONTRACTOR SHALL CONTACT "CALL BEFORE YOU DIG" AT LEAST 48 HOURS PRIOR TO ANY EXCAVATIONS AT 1-800-922-4455. ALL UTILITIES SHALL BE IDENTIFIED AND CLEARLY MARKED. CONTRACTOR SHALL MAINTAIN AND PROTECT MARKED UTILITIES THROUGHOUT PROJECT COMPLETION.
- CONTRACTOR SHALL COMPLY WITH OWNERS ENVIRONMENTAL ENGINEER ON ALL METHODS AND PROVISIONS FOR ALL EXCAVATION ACTIVITIES INCLUDING SOIL DISPOSAL. ALL BACKFILL MATERIALS TO BE PROVIDED BY THE CONTRACTOR.

SITE DIRECTIONS

- FROM:** 35 GRIFFIN ROAD SOUTH BLOOMFIELD, CT 06002 **TO:** 39 CHERRY ST WATERBURY, CT 06702
- HEAD NORTHEAST ON GRIFFIN ROAD S. TOWARD NEWBERRY RD. 0.6 MI.
 - TURN RIGHT ONTO DAY HILL RD. 3.6 MI.
 - USE THE RIGHT LANE TO MERGE ONTO I-91 S VIA THE RAMP TO HARTFORD. 0.4 MI.
 - MERGE ONTO I-91 S. 6.9 MI.
 - TAKE EXIT 32A-32B FOR I-84 W TOWARD WATERBURY. 0.5 MI.
 - MERGE ONTO I-84. 28.7 MI.
 - TAKE EXIT 22 FOR UNION STREET TOWARD DOWNTOWN/WATERBURY. 0.3 MI.
 - CONTINUE ONTO BRASS MILL DR (SIGNS FOR DOWNTOWN/UCONN WATERBURY CAMPUS) 0.2 MI.
 - TURN LEFT ONTO E MAIN ST. 0.2 MI.
 - TURN RIGHT ONTO CHERRY ST. 318 FT.

VICINITY MAP

SCALE: 1" = 1000'

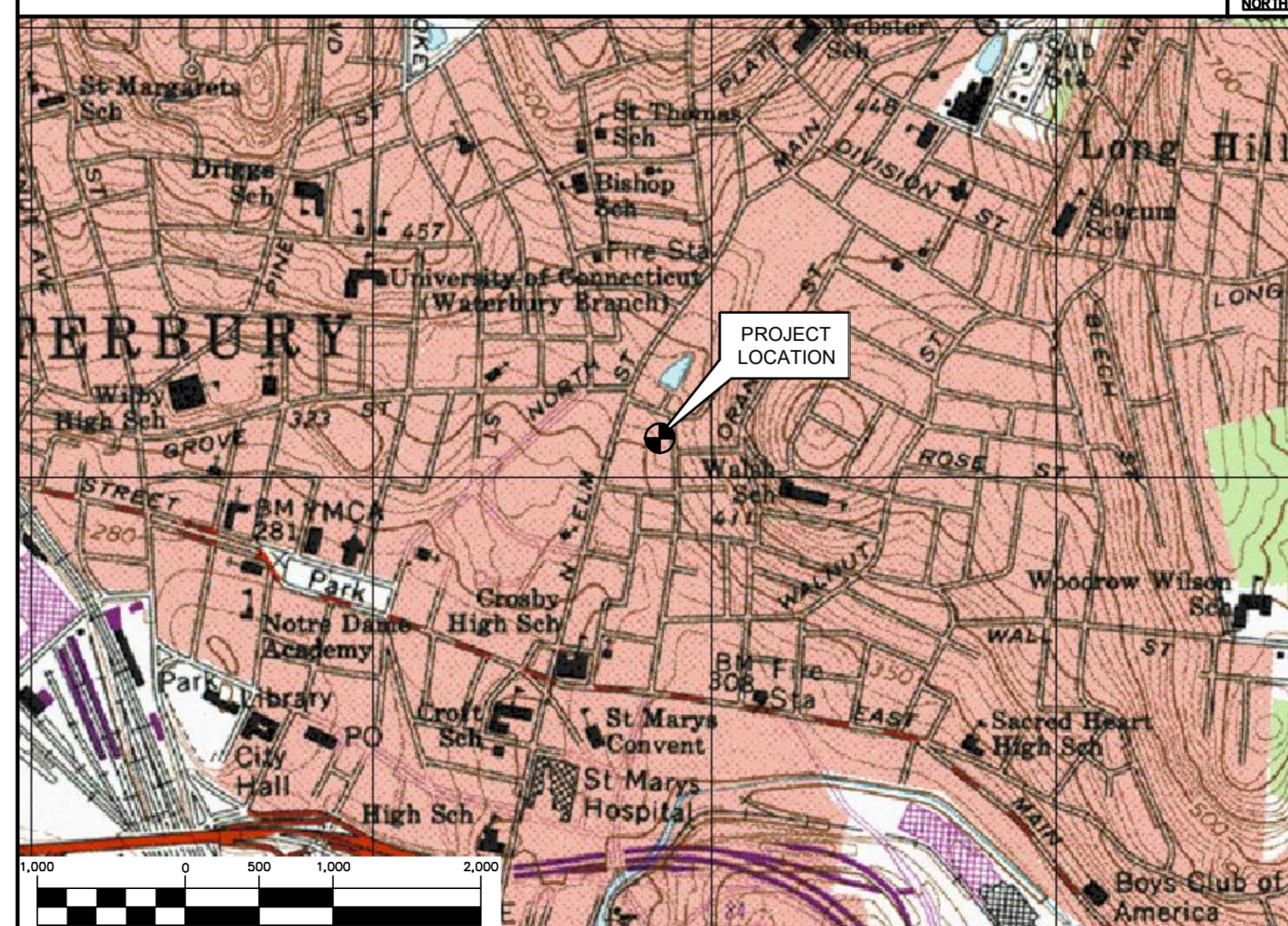

T-MOBILE RF CONFIGURATION

67D94M_2xAIR+1OP

PROJECT SUMMARY

- THE PROPOSED SCOPE OF WORK CONSISTS OF A MODIFICATION TO THE EXISTING UNMANNED TELECOMMUNICATIONS FACILITY INCLUDING THE FOLLOWING:
 - REMOVE AND REPLACE EXISTING POSITION ONE (1) ANTENNA, TYPICAL OF (3)/(1) PER SECTOR, WITH (3) NEW RFS ANTENNAS.
 - INSTALL THREE (3) NEW AIR 3246 866 ANTENNAS AT NEW POSITION THREE (3), TYPICAL OF ONE (1) PER SECTOR.
 - REMOVE AND REPLACE EXISTING RRUS-11 B12 AT GRADE, TYPICAL OF THREE (3), WITH THREE (3) NEW ERICSSON RADIO 4449 B71+B12.
 - INSTALL (1) PROPOSED 6X12 HYBRID CABLE WITHIN SMOKESTACK.
 - INSTALL SIX (6) 2.5" STD. HORIZONTAL PIPES, TYPICAL OF TWO (2) PER SECTOR, WITH CROSSOVER PLATE KITS.

PROJECT INFORMATION

SITE NAME: NH332/CHERRYSMOKESTACK
SITE ID: CTNH332C
SITE ADDRESS: 39 CHERRY ST WATERBURY, CT 06702
APPLICANT: T-MOBILE NORTHEAST, LLC 35 GRIFFIN ROAD SOUTH BLOOMFIELD, CT 06002
CONTACT PERSON: DAN REID (PROJECT MANAGER) TRANSCEND WIRELESS, LLC (203) 592-8291
ENGINEER: CENTEK ENGINEERING, INC. 63-2 NORTH BRANFORD RD. BRANFORD, CT 06405
PROJECT COORDINATES: LATITUDE: 41°-33'-33.70" N
 LONGITUDE: 73°-02'-02.99" W
 GROUND ELEVATION: 352± AMSL
 SITE COORDINATES AND GROUND ELEVATION REFERENCED FROM GOOGLE EARTH.

SHEET INDEX

SHT. NO.	DESCRIPTION	REV.
T-1	TITLE SHEET	0
N-1	DESIGN BASIS AND SITE NOTES	0
C-1	SITE LOCATION PLAN	0
C-2	COMPOUND PLANS AND ELEVATION	0
C-3	ANTENNA MOUNTING CONFIGURATION	0
E-1	TYPICAL ELECTRICAL DETAILS	0

REV.	DATE	ISSUED FOR CONSTRUCTION	DESCRIPTION
0	06/13/18		

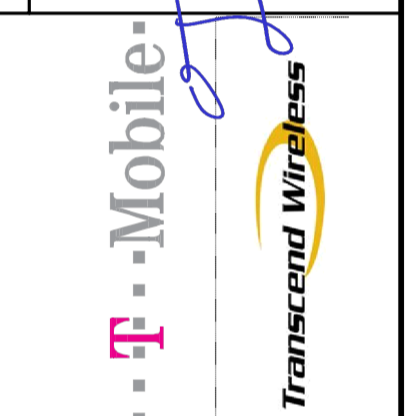
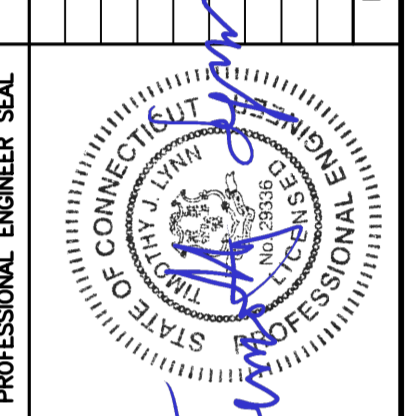

CEN TEK engineering
 Centek on Solutions
 (203) 498-0380
 (203) 498-3887 Fax
 632 North Branford Road
 Branford, CT 06405
 www.CentekEng.com

T-MOBILE NORTHEAST LLC
 WIRELESS COMMUNICATIONS FACILITY
NH332/CHERRYSMOKESTACK
SITE ID: CTNH332C
 39 CHERRY ST
 WATERBURY, CT 06702

DATE: 06/04/18
SCALE: AS NOTED
JOB NO. 18058.50

TITLE SHEET

T-1

DESIGN BASIS:

GOVERNING CODE: 2012 INTERNATIONAL BUILDING (IBC) AS MODIFIED BY THE 2016 CT STATE BUILDING CODE AND AMENDMENTS.

- 1. DESIGN CRITERIA:
 - RISK CATEGORY: II (BASED ON IBC TABLE 1604.5)
 - ULTIMATE DESIGN SPEED (OTHER STRUCTURE): 125 MPH (VuIt) (EXPOSURE B)/IMPORTANCE FACTOR 1.0 BASED ON ASCE 7-10 PER 2012 INTERNATIONAL BUILDING CODE (IBC) AS MODIFIED BY THE 2016 CONNECTICUT STATE BUILDING CODE.
 - SEISMIC LOAD (DOES NOT CONTROL): PER ASCE 7-10 MINIMUM DESIGN LOADS FOR BUILDING AND OTHER STRUCTURES.

GENERAL NOTES:

1. ALL CONSTRUCTION SHALL BE IN COMPLIANCE WITH THE GOVERNING BUILDING CODE.
2. DRAWINGS INDICATE THE MINIMUM STANDARDS, BUT IF ANY WORK SHOULD BE INDICATED TO BE SUBSTANDARD TO ANY ORDINANCES, LAWS, CODES, RULES, OR REGULATIONS BEARING ON THE WORK, THE CONTRACTOR SHALL INCLUDE IN HIS WORK AND SHALL EXECUTE THE WORK CORRECTLY IN ACCORDANCE WITH SUCH ORDINANCES, LAWS, CODES, RULES OR REGULATIONS WITH NO INCREASE IN COSTS.
3. BEFORE BEGINNING THE WORK, THE CONTRACTOR IS RESPONSIBLE FOR MAKING SUCH INVESTIGATIONS CONCERNING PHYSICAL CONDITIONS (SURFACE AND SUBSURFACE) AT OR CONTIGUOUS TO THE SITE WHICH MAY AFFECT PERFORMANCE AND COST OF THE WORK.
4. DIMENSIONS AND DETAILS SHALL BE CHECKED AGAINST EXISTING FIELD CONDITIONS.
5. THE CONTRACTOR SHALL VERIFY AND COORDINATE THE SIZE AND LOCATION OF ALL OPENINGS, SLEEVES AND ANCHOR BOLTS AS REQUIRED BY ALL TRADES.
6. ALL DIMENSIONS, ELEVATIONS, AND OTHER REFERENCES TO EXISTING STRUCTURES, SURFACE, AND SUBSURFACE CONDITIONS ARE APPROXIMATE. NO GUARANTEE IS MADE FOR THE ACCURACY OR COMPLETENESS OF THE INFORMATION SHOWN. THE CONTRACTOR SHALL VERIFY AND COORDINATE ALL DIMENSIONS, ELEVATIONS, ANGLES WITH EXISTING CONDITIONS AND WITH ARCHITECTURAL AND SITE DRAWINGS BEFORE PROCEEDING WITH ANY WORK.
7. AS THE WORK PROGRESSES, THE CONTRACTOR SHALL NOTIFY THE OWNER OF ANY CONDITIONS WHICH ARE IN CONFLICT OR OTHERWISE NOT CONSISTENT WITH THE CONSTRUCTION DOCUMENTS AND SHALL NOT PROCEED WITH SUCH WORK UNTIL THE CONFLICT IS SATISFACTORILY RESOLVED.
8. THE CONTRACTOR SHALL COMPLY WITH ALL APPLICABLE SAFETY CODES AND REGULATIONS DURING ALL PHASES OF CONSTRUCTION. THE CONTRACTOR IS SOLELY RESPONSIBLE FOR PROVIDING AND MAINTAINING ADEQUATE SHORING, BRACING, AND BARRICADES AS MAY BE REQUIRED FOR THE PROTECTION OF EXISTING PROPERTY, CONSTRUCTION WORKERS, AND FOR PUBLIC SAFETY.
9. THE CONTRACTOR IS SOLELY RESPONSIBLE TO DETERMINE CONSTRUCTION PROCEDURE AND SEQUENCE, AND TO ENSURE THE SAFETY OF THE EXISTING STRUCTURES AND ITS COMPONENT PARTS DURING CONSTRUCTION. THIS INCLUDES THE ADDITION OF WHATEVER SHORING, BRACING, UNDERPINNING, ETC. THAT MAY BE NECESSARY. MAINTAIN EXISTING SITE OPERATIONS, COORDINATE WORK WITH NORTHEAST UTILITIES
10. THE STRUCTURE IS DESIGNED TO BE SELF-SUPPORTING AND STABLE AFTER FOUNDATION REMEDIATION WORK IS COMPLETE. IT IS THE CONTRACTOR'S SOLE RESPONSIBILITY TO DETERMINE ERECTION PROCEDURE AND SEQUENCE AND TO ENSURE THE SAFETY OF THE STRUCTURE AND ITS COMPONENT PARTS DURING ERECTION. THIS INCLUDES THE ADDITION OF WHATEVER SHORING, TEMPORARY BRACING, GUYS OR TIEDOWNS, WHICH MIGHT BE NECESSARY.
11. ALL DAMAGE CAUSED TO ANY EXISTING STRUCTURE SHALL BE THE SOLE RESPONSIBILITY OF THE CONTRACTOR. THE CONTRACTOR WILL BE HELD LIABLE FOR ALL REPAIRS REQUIRED FOR EXISTING STRUCTURES IF DAMAGED DURING CONSTRUCTION ACTIVITIES.
12. SHOP DRAWINGS, CONCRETE MIX DESIGNS, TEST REPORTS, AND OTHER SUBMITTALS PERTAINING TO STRUCTURAL WORK SHALL BE FORWARDED TO THE OWNER FOR REVIEW BEFORE FABRICATION AND/OR INSTALLATION IS MADE. SHOP DRAWINGS SHALL INCLUDE ERECTION DRAWINGS AND COMPLETE DETAILS OF CONNECTIONS AS WELL AS MANUFACTURER'S SPECIFICATION DATA WHERE APPROPRIATE. SHOP DRAWINGS SHALL BE CHECKED BY THE CONTRACTOR AND BEAR THE CHECKER'S INITIALS BEFORE BEING SUBMITTED FOR REVIEW.
13. NO DRILLING WELDING OR TAPING ON EVERSOURCE OWNED EQUIPMENT.
14. REFER TO DRAWING T1 FOR ADDITIONAL NOTES AND REQUIREMENTS.

STRUCTURAL STEEL

1. ALL STRUCTURAL STEEL IS DESIGNED BY ALLOWABLE STRESS DESIGN (ASD)
 - A. STRUCTURAL STEEL (W SHAPES)---ASTM A992 (FY = 50 KSI)
 - B. STRUCTURAL STEEL (OTHER SHAPES)---ASTM A36 (FY = 36 KSI)
 - C. STRUCTURAL HSS (RECTANGULAR SHAPES)---ASTM A500 GRADE B, (FY = 46 KSI)
 - D. STRUCTURAL HSS (ROUND SHAPES)---ASTM A500 GRADE B, (FY = 42 KSI)
 - E. PIPE---ASTM A53 (FY = 35 KSI)
 - F. CONNECTION BOLTS---ASTM A325-N
 - G. U-BOLTS---ASTM A36
 - H. ANCHOR RODS---ASTM F 1554
 - I. WELDING ELECTRODE---ASTM E 70XX
2. CONTRACTOR TO REVIEW ALL SHOP DRAWINGS AND SUBMIT COPY TO ENGINEER FOR APPROVAL. DRAWINGS MUST BEAR THE CHECKER'S INITIALS BEFORE SUBMITTING TO THE ENGINEER FOR REVIEW. SHOP DRAWINGS SHALL INCLUDE THE FOLLOWING: SECTION PROFILES, SIZES, CONNECTION ATTACHMENTS, REINFORCING, ANCHORAGE, SIZE AND TYPE OF FASTENERS AND ACCESSORIES. INCLUDE ERECTION DRAWINGS, ELEVATIONS AND DETAILS.
3. STRUCTURAL STEEL SHALL BE DETAILED, FABRICATED AND ERECTED IN ACCORDANCE WITH THE LATEST PROVISIONS OF AISC MANUAL OF STEEL CONSTRUCTION.
4. PROVIDE ALL PLATES, CLIP ANGLES, CLOSURE PIECES, STRAP ANCHORS, MISCELLANEOUS PIECES AND HOLES REQUIRED TO COMPLETE THE STRUCTURE.
5. FIT AND SHOP ASSEMBLE FABRICATIONS IN THE LARGEST PRACTICAL SECTIONS FOR DELIVERY TO SITE.
6. INSTALL FABRICATIONS PLUMB AND LEVEL, ACCURATELY FITTED, AND FREE FROM DISTORTIONS OR DEFECTS.
7. AFTER ERECTION OF STRUCTURES, TOUCHUP ALL WELDS, ABRASIONS AND NON-GALVANIZED SURFACES WITH A 95% ORGANIC ZINC RICH PAINT IN ACCORDANCE WITH ASTM 780.
8. ALL STEEL MATERIAL (EXPOSED TO WEATHER) SHALL BE GALVANIZED AFTER FABRICATION IN ACCORDANCE WITH ASTM A123 "ZINC (HOT DIPPED GALVANIZED) COATINGS" ON IRONS AND STEEL PRODUCTS.
9. ALL BOLTS, ANCHORS AND MISCELLANEOUS HARDWARE SHALL BE GALVANIZED IN ACCORDANCE WITH ASTM A153 "ZINC COATING (HOT-DIP) ON IRON AND STEEL HARDWARE".
10. THE ENGINEER SHALL BE NOTIFIED OF ANY INCORRECTLY FABRICATED, DAMAGED OR OTHERWISE MISFITTING OR NON CONFORMING MATERIALS OR CONDITIONS TO REMEDIAL OR CORRECTIVE ACTION. ANY SUCH ACTION SHALL REQUIRE ENGINEER REVIEW.
11. CONNECTION ANGLES SHALL HAVE A MINIMUM THICKNESS OF 1/4 INCHES.
12. STRUCTURAL CONNECTION BOLTS SHALL CONFORM TO ASTM A325. ALL BOLTS SHALL BE 3/4" DIAMETER MINIMUM AND SHALL HAVE A MINIMUM OF TWO BOLTS, UNLESS OTHERWISE ON THE DRAWINGS.
13. LOCK WASHER ARE NOT PERMITTED FOR A325 STEEL ASSEMBLIES.
14. SHOP CONNECTIONS SHALL BE WELDED OR HIGH STRENGTH BOLTED.
15. MILL BEARING ENDS OF COLUMNS, STIFFENERS, AND OTHER BEARING SURFACES TO TRANSFER LOAD OVER ENTIRE CROSS SECTION.
16. FABRICATE BEAMS WITH MILL CAMBER UP.
17. LEVEL AND PLUMB INDIVIDUAL MEMBERS OF THE STRUCTURE TO AN ACCURACY OF 1:500, BUT NOT TO EXCEED 1/4" IN THE FULL HEIGHT OF THE COLUMN.
18. COMMENCEMENT OF STRUCTURAL STEEL WORK WITHOUT NOTIFYING THE ENGINEER OF ANY DISCREPANCIES WILL BE CONSIDERED ACCEPTANCE OF PRECEDING WORK.
19. INSPECTION AND TESTING OF ALL WELDING AND HIGH STRENGTH BOLTING SHALL BE PERFORMED BY AN INDEPENDENT TESTING LABORATORY.
20. FOUR COPIES OF ALL INSPECTION TEST REPORTS SHALL BE SUBMITTED TO THE ENGINEER WITHIN TEN (10) WORKING DAYS OF THE DATE OF INSPECTION.

REV.	DATE	ISSUED FOR CONSTRUCTION	DESCRIPTION
0	06/13/18	TUL	DRAWN BY CHK'D BY
		LGI	

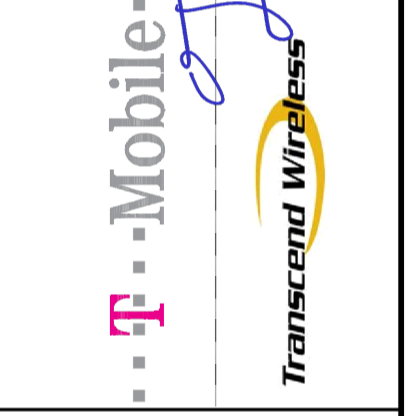
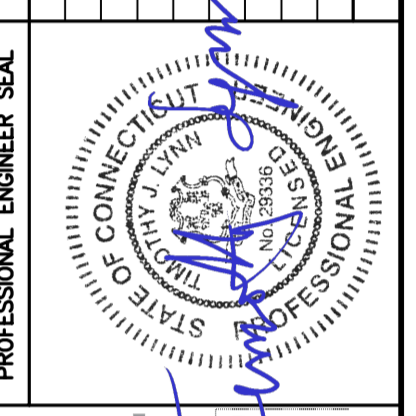

CEN TEK engineering
 Centered on Solutions
 (203) 498-0380
 (203) 498-3387 Fax
 632 North Branford Road
 Branford, CT 06405
 www.CentekEng.com

T-MOBILE NORTHEAST LLC
 WIRELESS COMMUNICATIONS FACILITY
NH332/CHERRYSMOKESTACK
SITE ID: CTNH332C
 39 CHERRY ST
 WATERBURY, CT 06702

DATE: 06/04/18
 SCALE: AS NOTED
 JOB NO. 18058.50

DESIGN BASIS
 AND SITE NOTES



1 SITE LOCATION PLAN
 C-1 SCALE: 1" = 25'

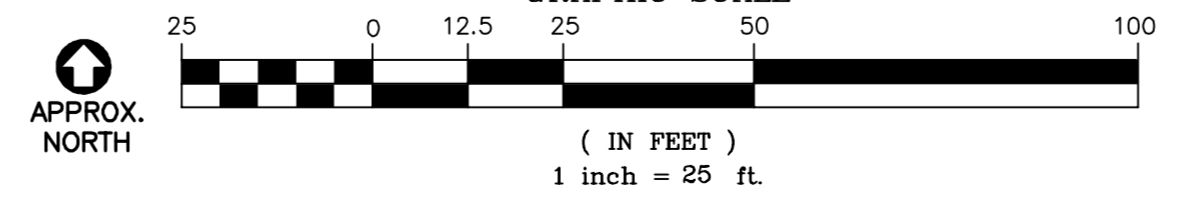

<p>Centered on Solutions (203) 498-0390 (203) 498-3397 Fax 622 North Branford Road Branford, CT 06405 www.CentekEng.com</p>	
T-MOBILE NORTHEAST LLC WIRELESS COMMUNICATIONS FACILITY NH332/CHERRYSMOKESTACK SITE ID: CTNH332C 39 CHERRY ST WATERBURY, CT 06702	
DATE:	06/04/18
SCALE:	AS NOTED
JOB NO.	18058.50
SITE LOCATION PLAN	
C-1	
Sheet No. 3 of 6	

REV.	DATE	BY	DESCRIPTION
0	06/13/18	LGI	ISSUED FOR CONSTRUCTION
		JUL	ISSUED FOR CONSTRUCTION
		DATE	ISSUED FOR CONSTRUCTION

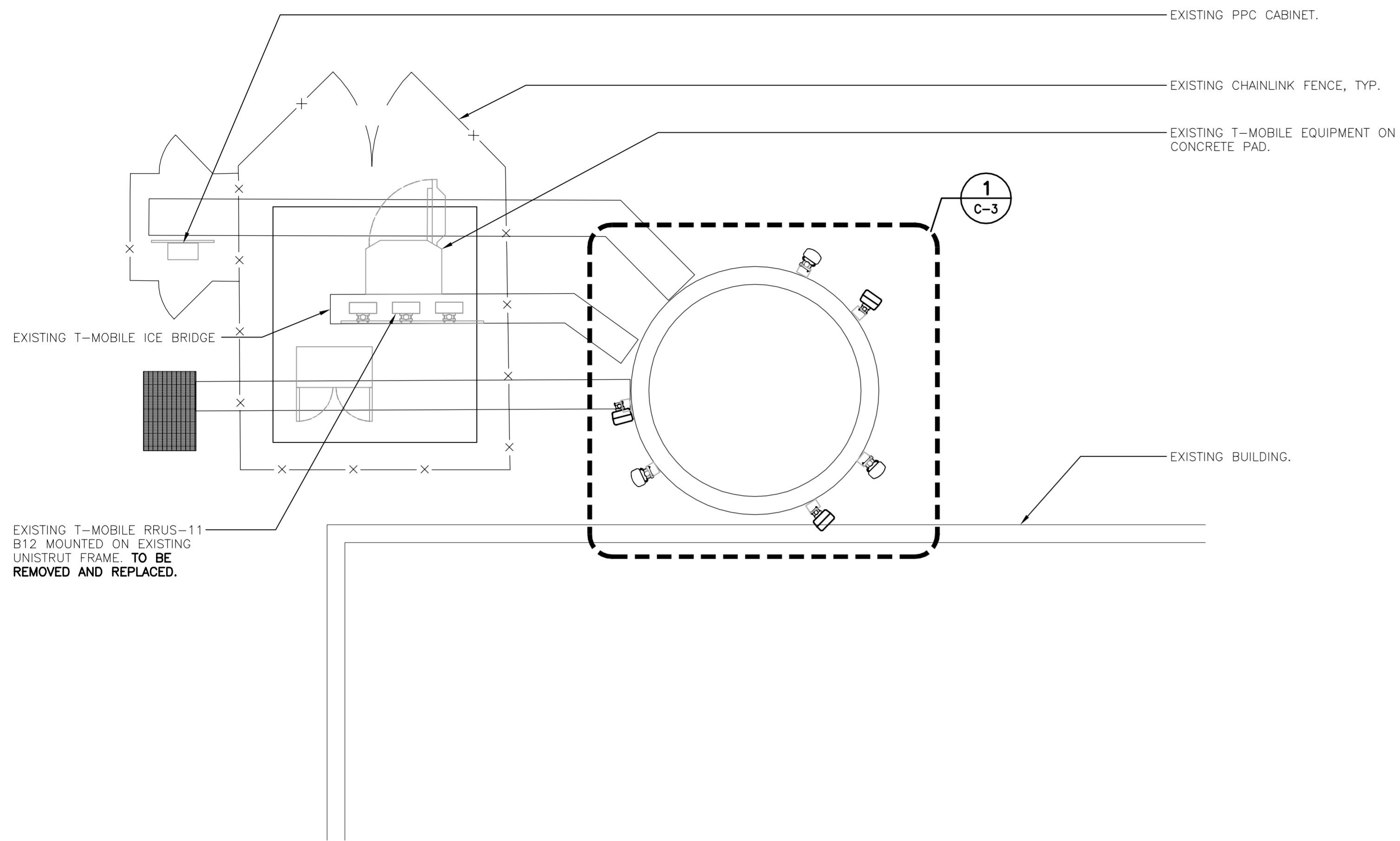

1
C-2
EXISTING COMPOUND PLAN
SCALE: 1" = 5'

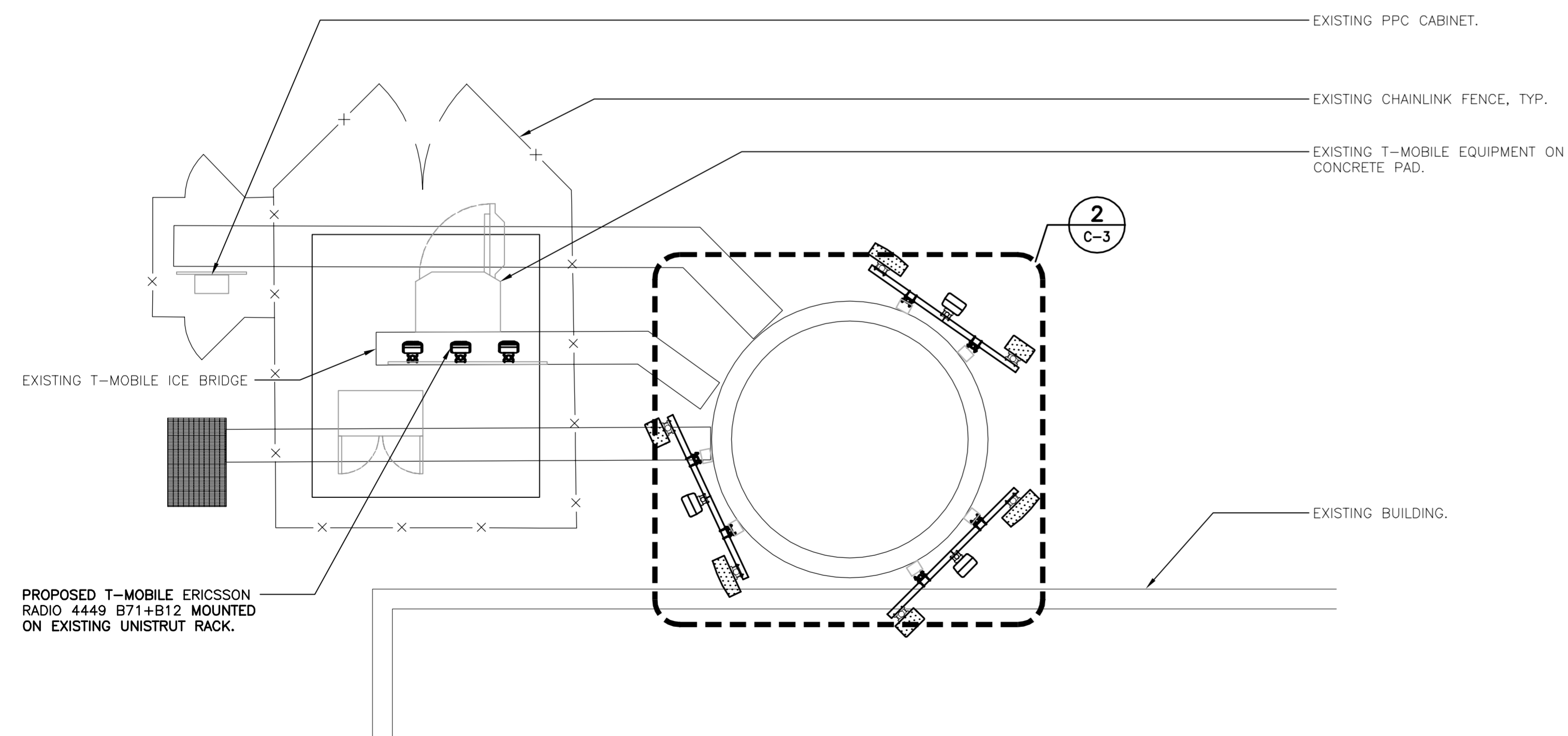
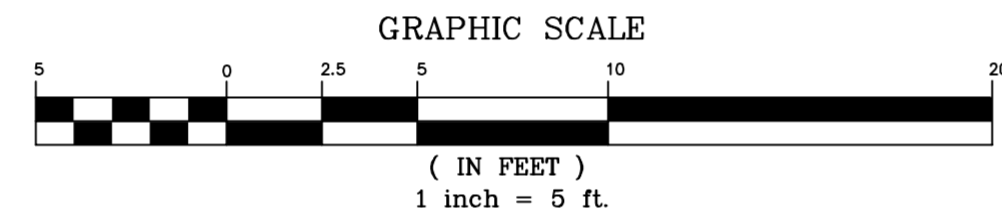

2
C-2
PROPOSED COMPOUND PLAN
SCALE: 1" = 5'

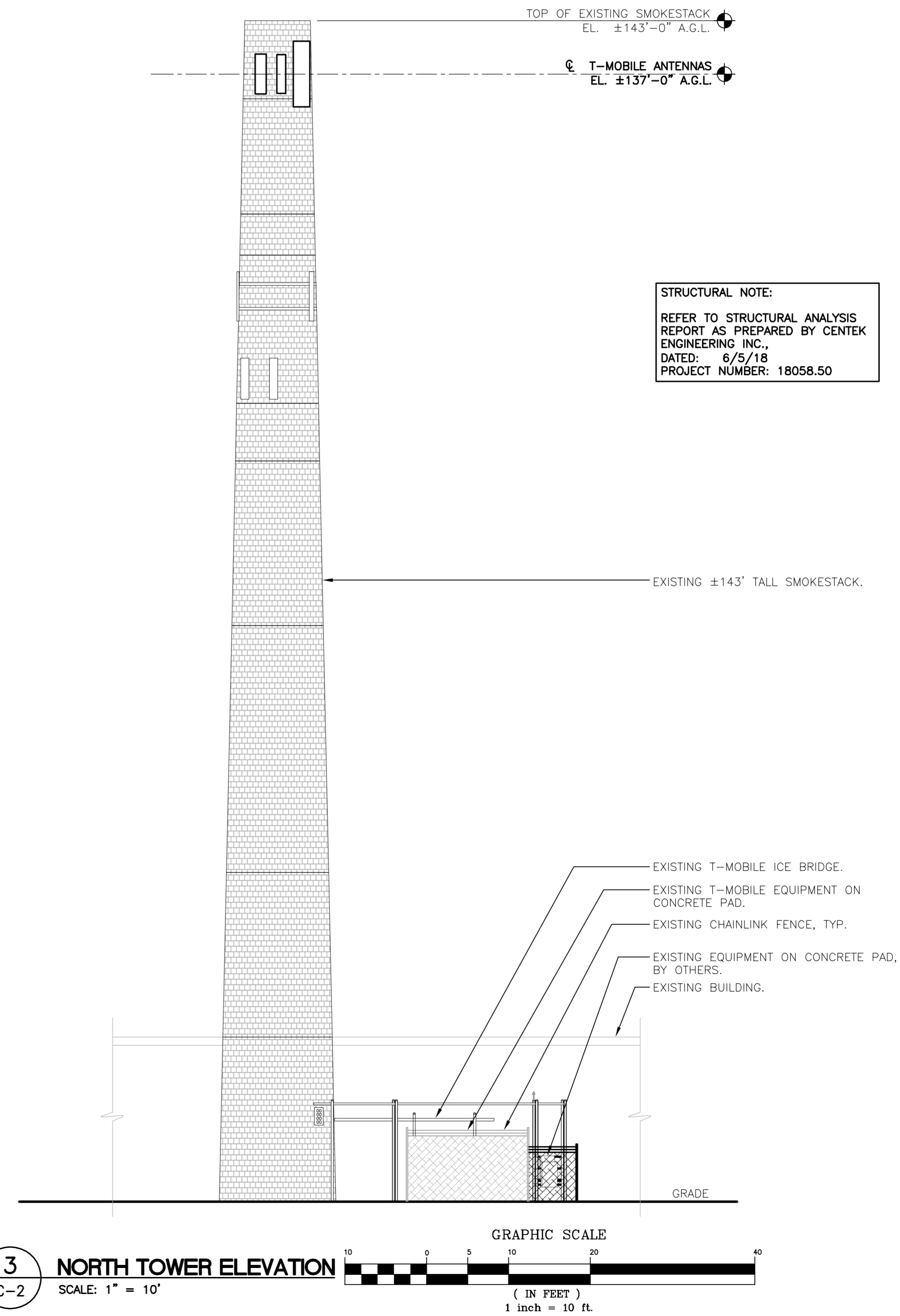
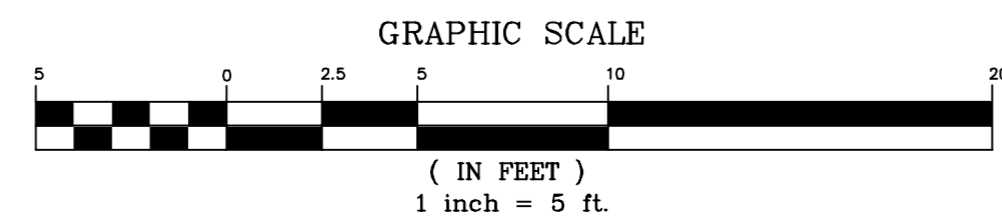

3
C-2
NORTH TOWER ELEVATION
SCALE: 1" = 10'

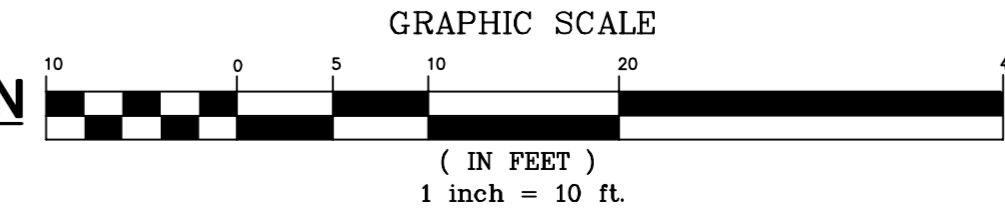

STRUCTURAL NOTE:
REFER TO STRUCTURAL ANALYSIS REPORT AS PREPARED BY CENTEK ENGINEERING INC., DATED: 6/5/18 PROJECT NUMBER: 18058.50

PROFESSIONAL ENGINEER SEAL	ISSUED FOR CONSTRUCTION
	TUL
DATE	DRAWN BY
06/13/18	LGI
REV.	CHK'D BY
0	
CEN TEK engineering <small>Centered on Solutions</small> (203) 488-0380 (203) 488-3387 Fax 652 North Branford Road Branford, CT 06405 www.CentekEng.com	
T-MOBILE NORTHEAST LLC WIRELESS COMMUNICATIONS FACILITY NH332/CHERRYSMOKESTACK SITE ID: CTNH332C 39 CHERRY ST WATERBURY, CT 06702	
DATE:	06/04/18
SCALE:	AS NOTED
JOB NO.	18058.50
COMPOUND PLANS AND ELEVATION	
<h1>C-2</h1>	
Sheet No. 4 of 6	

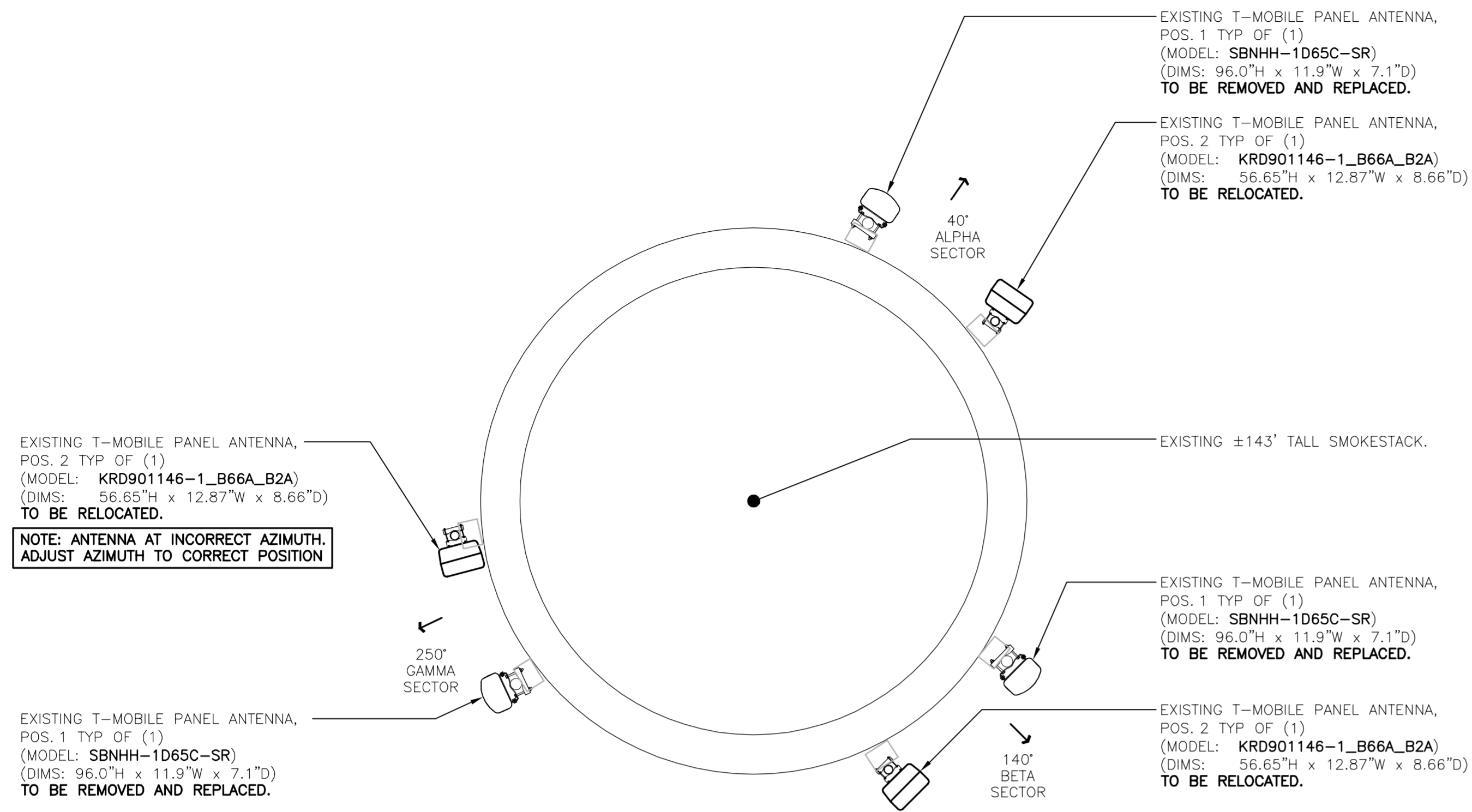

1
C-3 **EXISTING ANTENNA CONFIGURATION**
SCALE: 3/8" = 1'-0"
TRUE NORTH

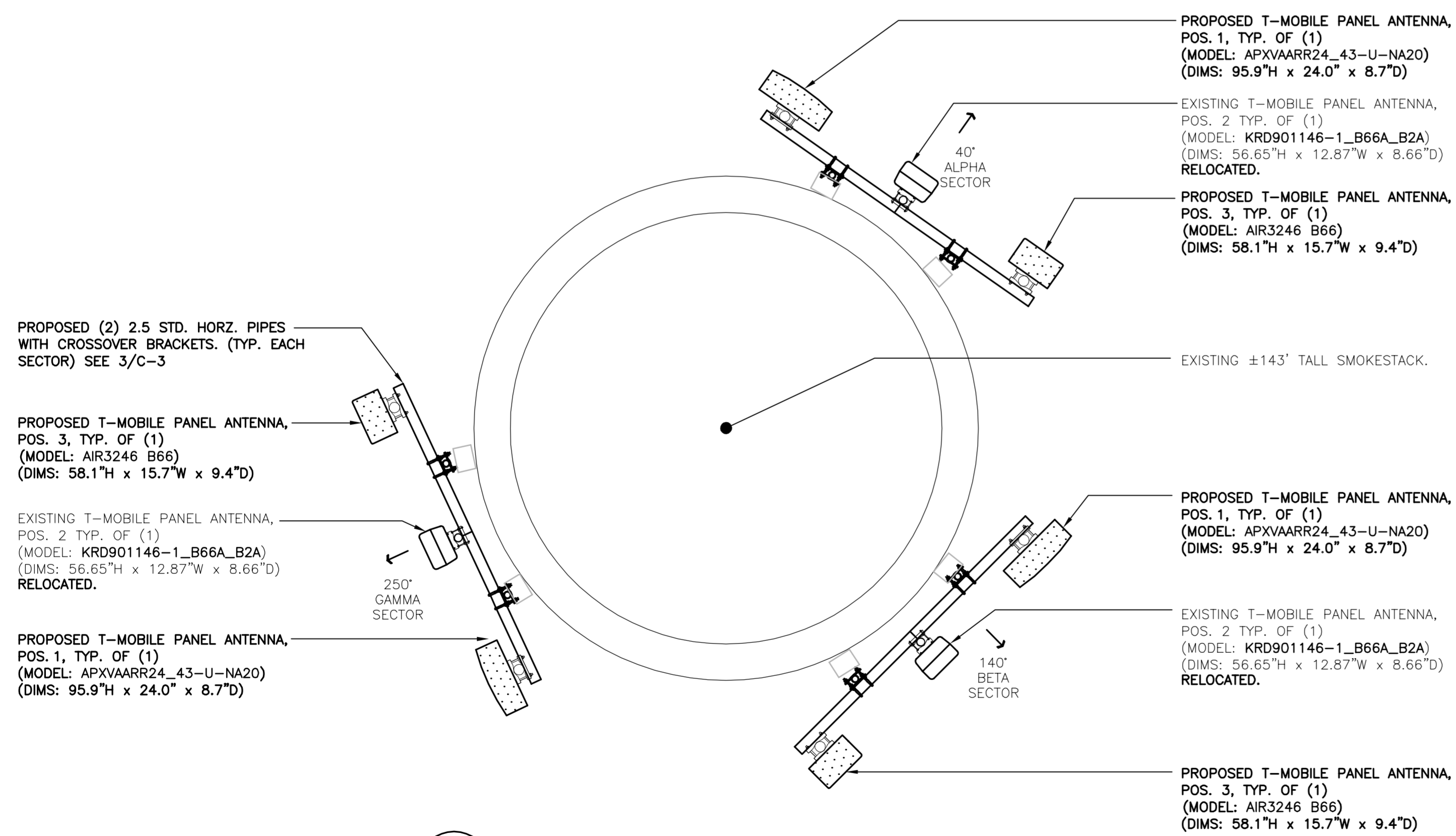

2
C-3 **PROPOSED ANTENNA CONFIGURATION**
SCALE: 3/8" = 1'-0"
TRUE NORTH

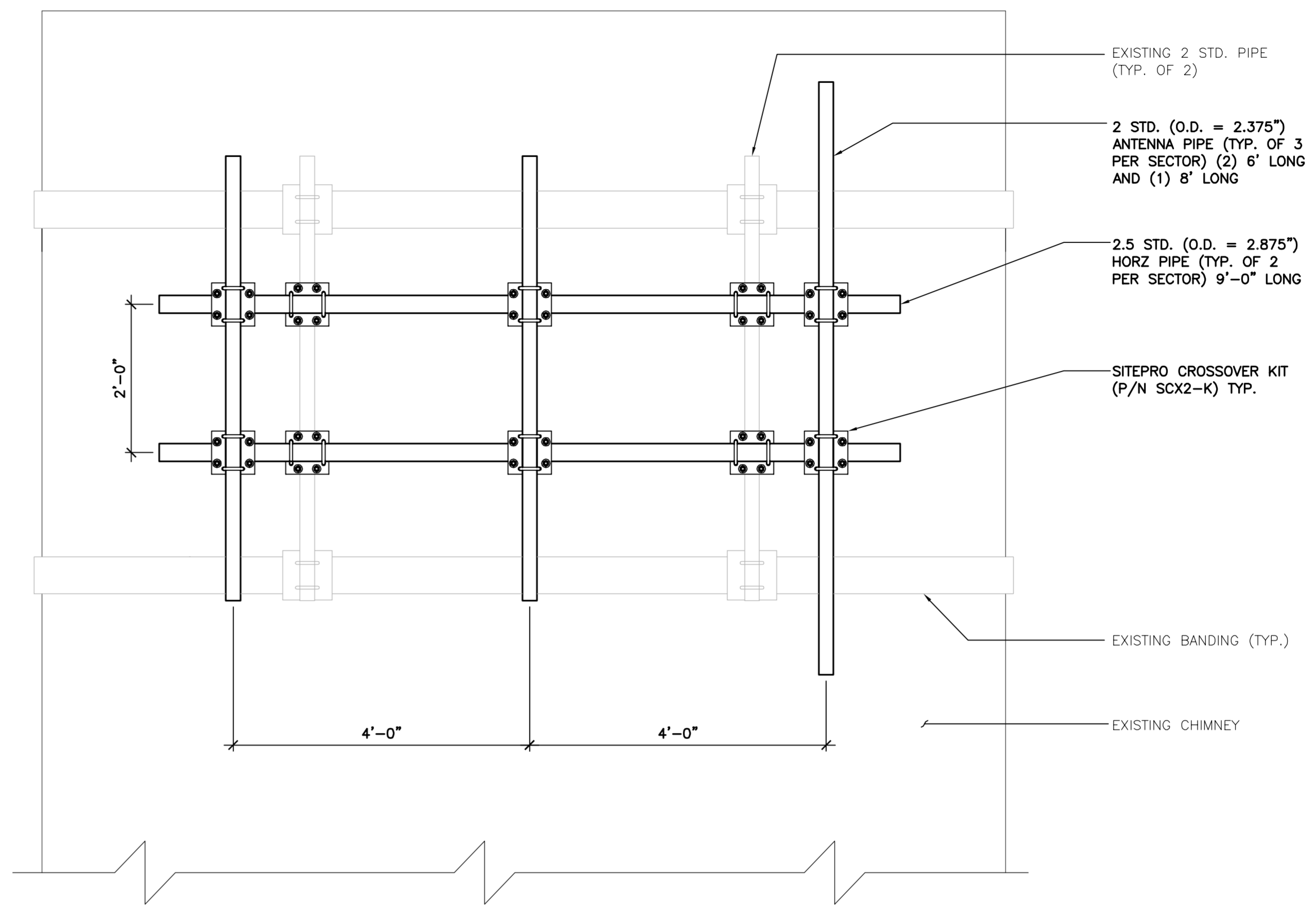

3
C-3 **PROPOSED ANTENNA MOUNT MODIFICATION**
SCALE: 3/4" = 1'-0"

ISSUED FOR CONSTRUCTION	TUL	DATE	REV.
0	06/13/18		

PROFESSIONAL ENGINEER SEAL

STATE OF CONNECTICUT
JAMES J. MURPHY, P.E.
REGISTERED PROFESSIONAL ENGINEER
No. 14008

T-Mobile
Transcend Wireless

CEN TEK engineering
Centered on Solutions
203-498-0390
203-498-3397 Fax
652 North Branford Road
Branford, CT 06405
www.CenTekEng.com

T-MOBILE NORTHEAST LLC
WIRELESS COMMUNICATIONS FACILITY
NH332/CHERRYSMOKESTACK
SITE ID: CTNH332C
39 CHERRY ST
WATERBURY, CT 06702

DATE: 06/04/18
SCALE: AS NOTED
JOB NO. 18058.50

ANTENNA MOUNTING CONFIG.

C-3

Sheet No. 5 of 6

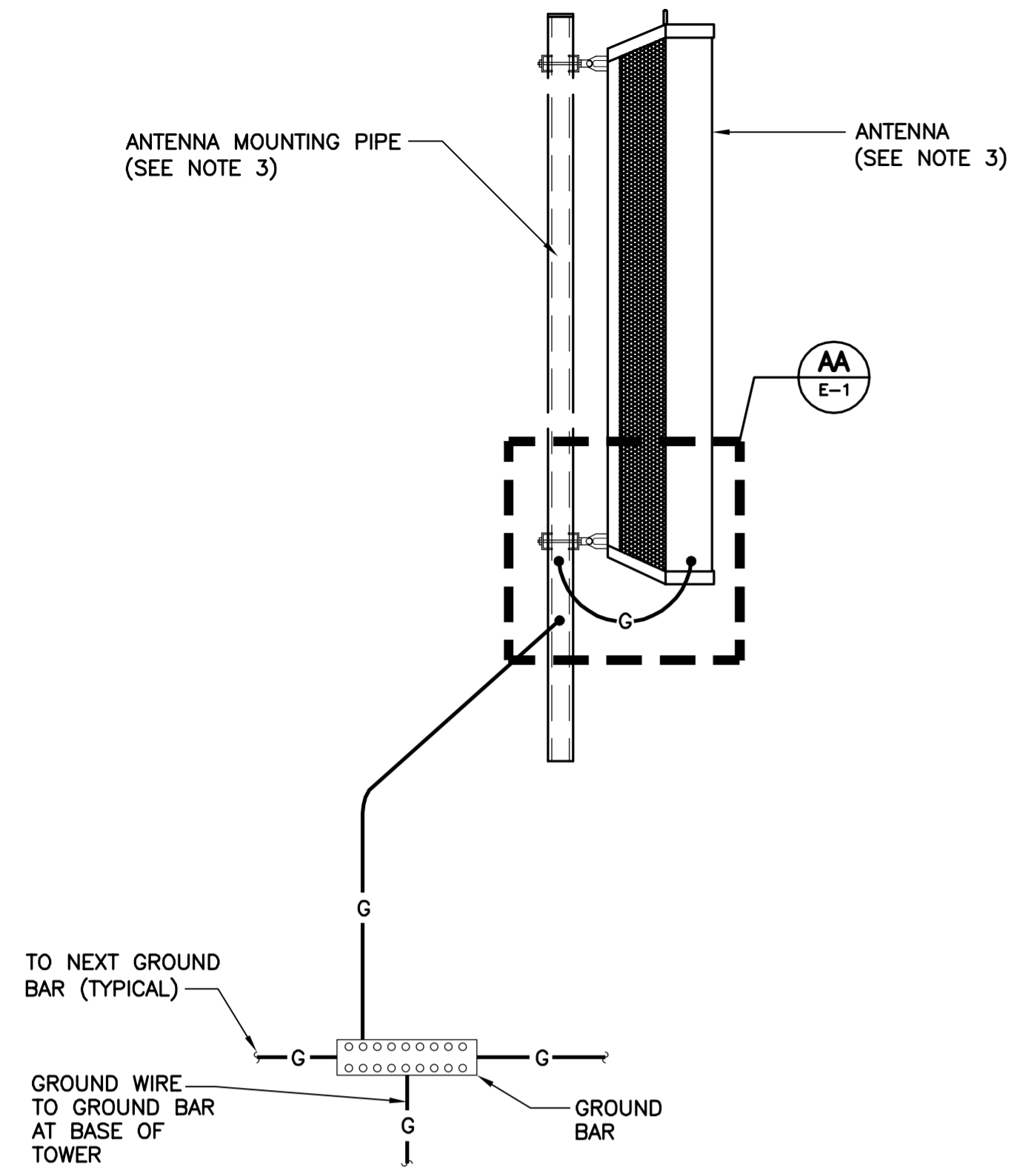

NOTES:

- BOND COAXIAL CABLE GROUND KITS TO EACH OWNER'S GROUND BAR ALONG ENTIRE COAX RUN FROM ANTENNA TO SHELTER.
- BOND ALL EQUIPMENT TO GROUND PER NEC AND MANUFACTURERS SPECIFICATIONS.
- DETAIL IS TYPICAL FOR ALL ANTENNA SECTORS, INCLUDING GPS ANTENNA.

1 TYPICAL ANTENNA GROUNDING DETAIL
E-1 SCALE: NONE

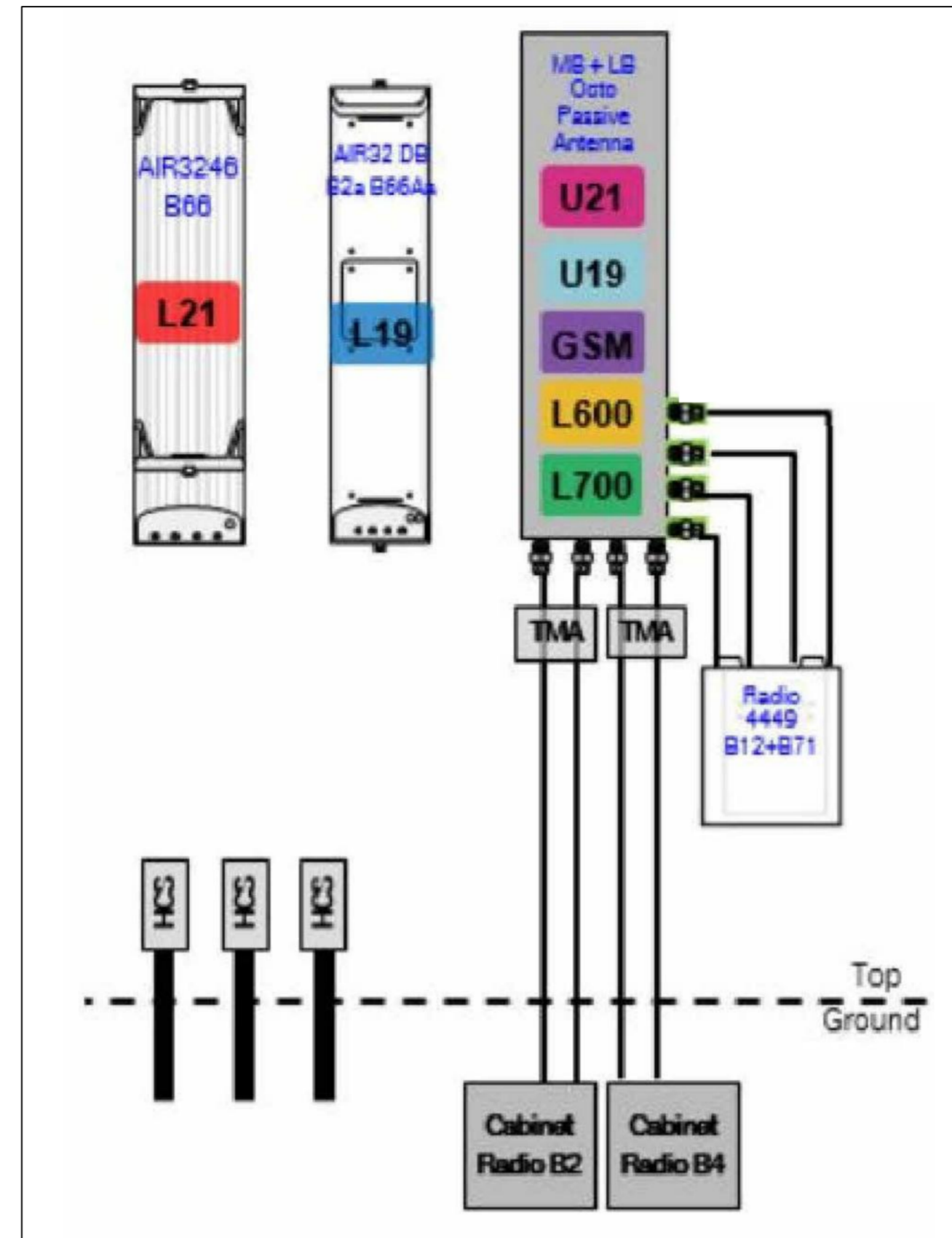

2 PROPOSED PLUMBING DIAGRAM
E-1 SCALE: NONE

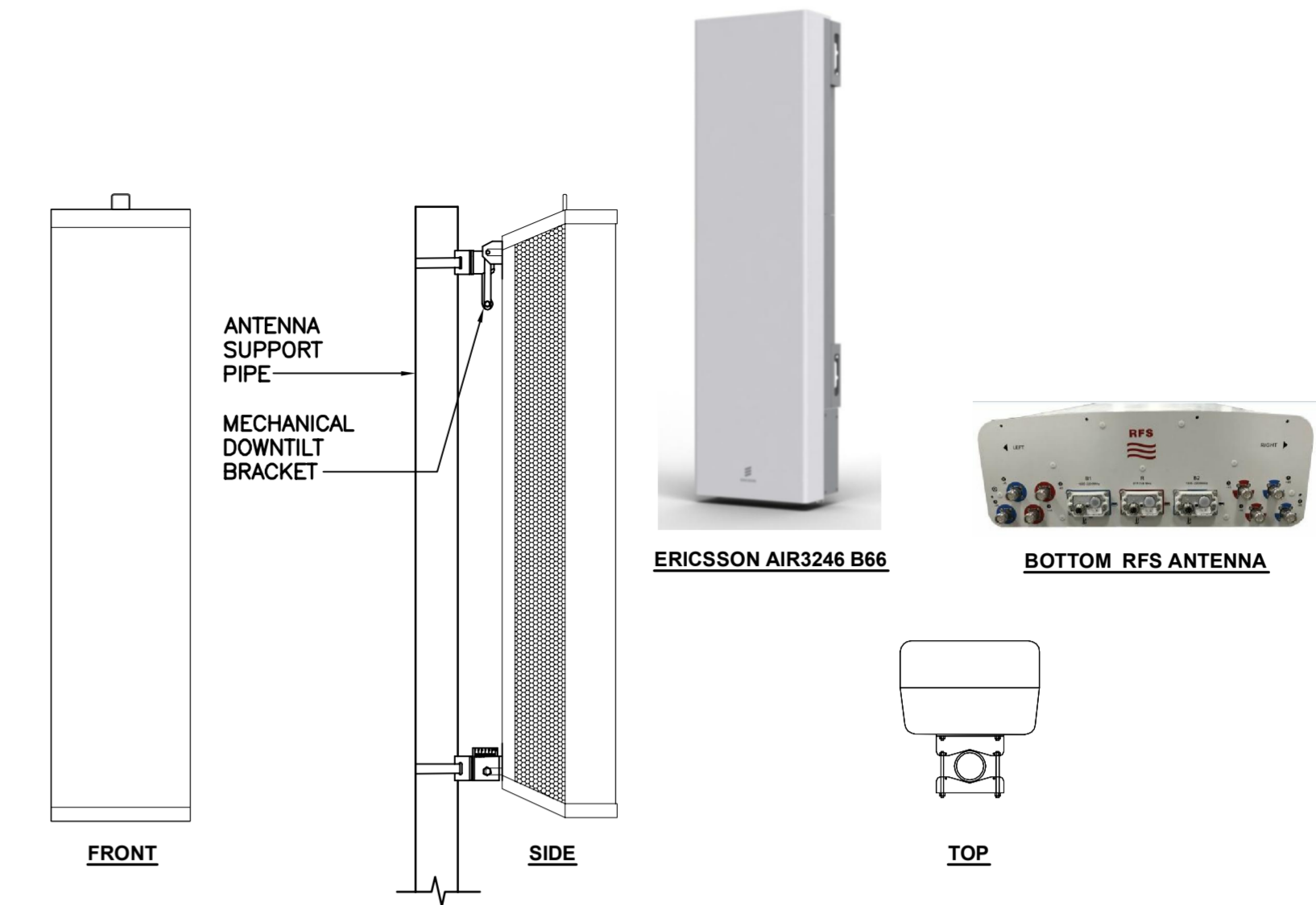

ALPHA/BETA/GAMMA ANTENNA		
EQUIPMENT	DIMENSIONS	WEIGHT
MAKE: ERICSSON MODEL: AIR3246 B66	58.1"L x 15.7"W x 9.4"D	180 LBS.
MAKE: RFS MODEL: APXVAARR24_43-U--NA20	95.9"L x 24.0"W x 8.7"D	153 LBS.

3 PROPOSED ANTENNA DETAIL
E-1 SCALE: NONE

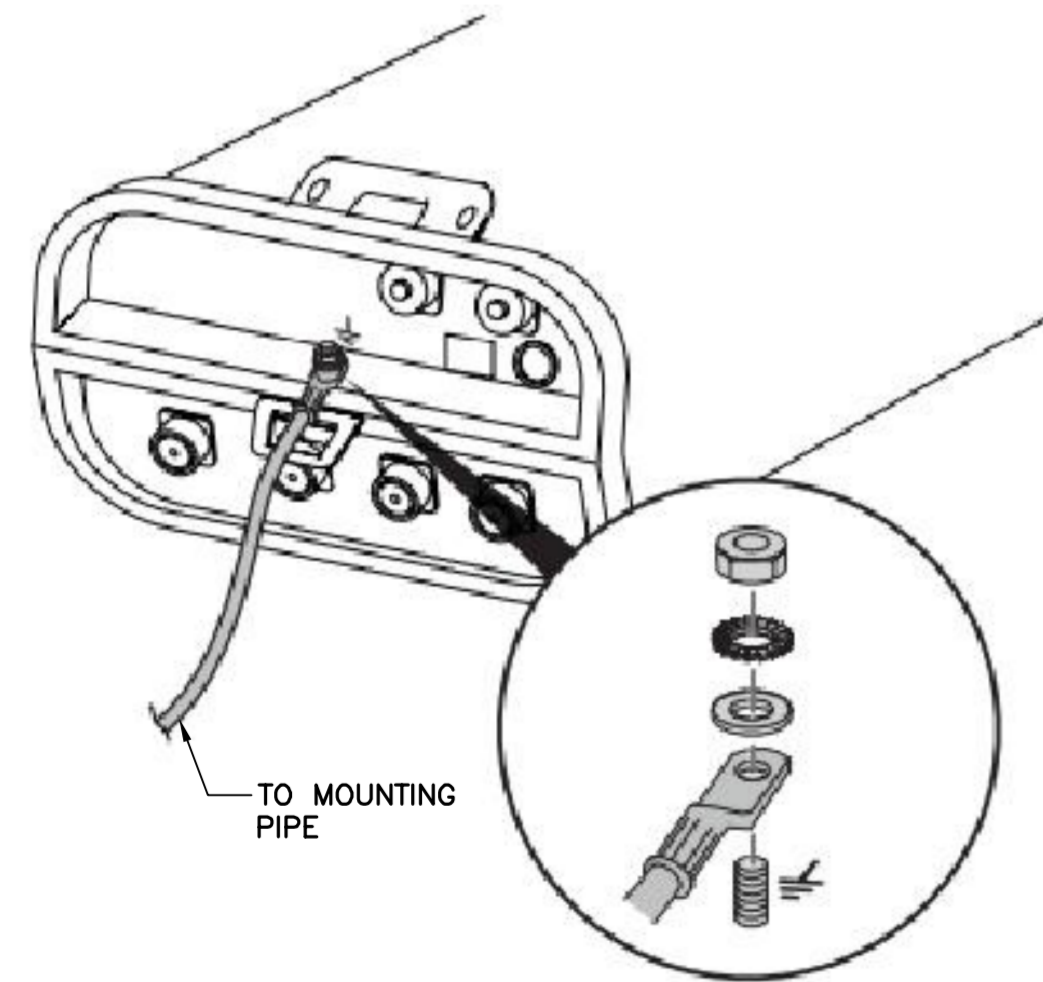

AA TYPICAL ANTENNA GROUNDING DETAIL
E-1 SCALE: NONE

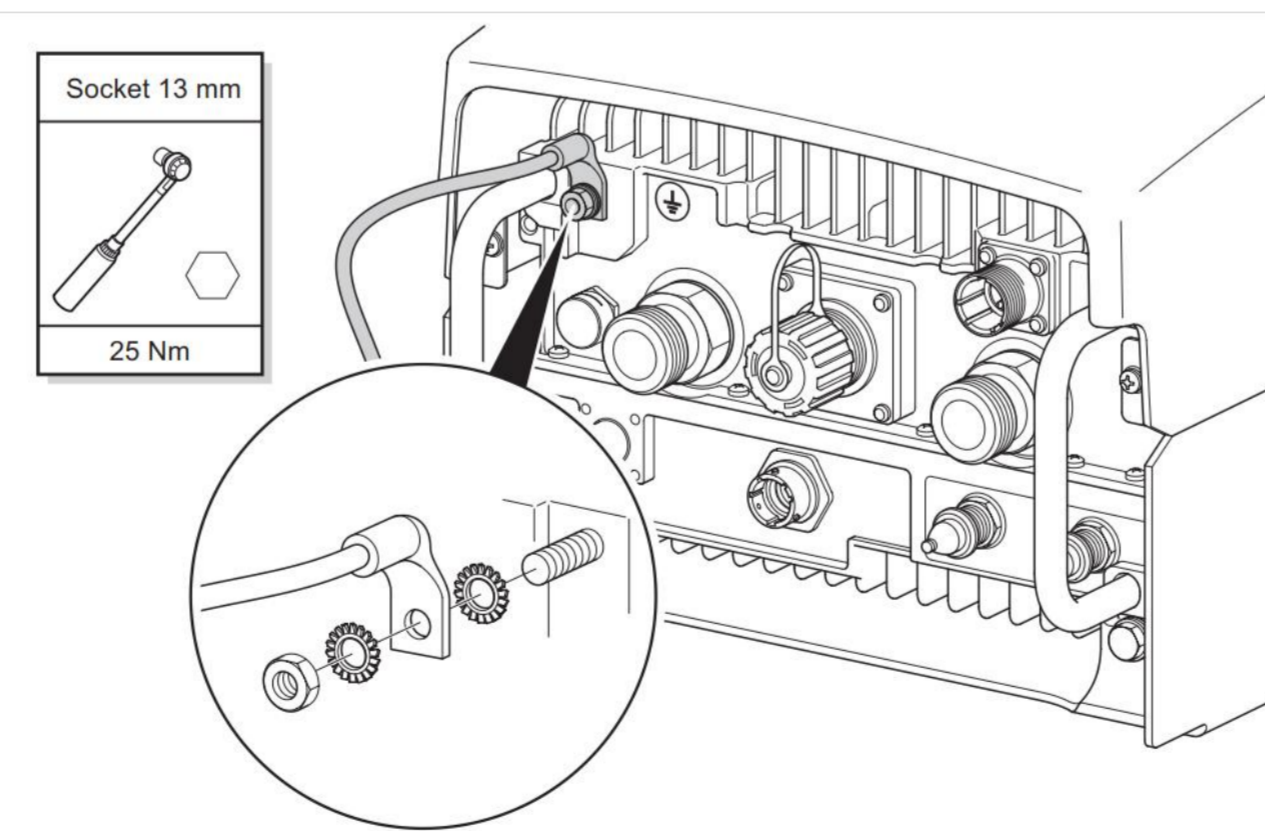

4 TYPICAL RRU GROUNDING DETAIL
E-1 NOT TO SCALE



RRU (REMOTE RADIO UNIT)			
EQUIPMENT	DIMENSIONS	WEIGHT	CLEARANCES
MAKE: ERICSSON MODEL: RADIO 4449 B71B12	14.9"L x 13.2"W x 10.4"D	74 LBS.	ABOVE: 16" MIN. BELOW: 12" MIN. FRONT: 36" MIN.

NOTES:
1. CONTRACTOR TO COORDINATE FINAL EQUIPMENT MODEL SELECTION WITH T-MOBILE CONSTRUCTION MANAGER PRIOR TO ORDERING.

5 PROPOSED RRU DETAIL
E-1 SCALE: NONE

REV.	DATE	BY	CHK'D BY	DESCRIPTION
0	06/13/18	LGL		ISSUED FOR CONSTRUCTION

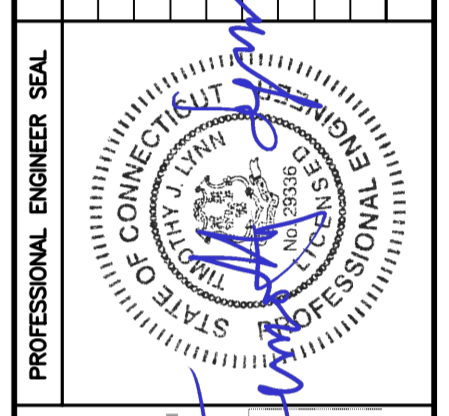

CEN TEK engineering
Centered on Solutions™
(203) 498-0390
(203) 498-3397 Fax
632 North Branford Road
Branford, CT 06405
www.CentekEng.com

T-MOBILE NORTHEAST LLC
WIRELESS COMMUNICATIONS FACILITY
NH332/CHERRYSMOKESTACK
SITE ID: CTNH332C
39 CHERRY ST
WATERBURY, CT 06702

DATE: 06/04/18
SCALE: AS NOTED
JOB NO. 18058.50

TYPICAL ELECTRICAL DETAILS

Kyle Richers

From: UPS Quantum View <auto-notify@ups.com>
Sent: Friday, June 22, 2018 8:32 PM
To: krichers@transcendwireless.com
Subject: UPS Exception Notification, Reference Number 1: CTNH332C owner



The status of your package has changed.

Exception Reason: The receiver does not want the product and refused the delivery.

Exception Resolution: The package will be returned to the sender.

At the request of TRANSCEND WIRELESS, this notice alerts you that the status of the shipment listed below has changed.

Signature Required: A signature is required for package delivery

Shipment Details

Tracking Number: [1ZV257424293302179](#)
Ship To: New Opportunities Economic Dev.
232 North Elm Street
WATERBURY, CT 067021516
US
UPS Service: UPS GROUND
Package Weight: 1.0 LBS
Reference Number 1: CTNH332C owner

