



1280 Route 46 West, Suite 9, Parsippany NJ, 07054

Melanie Bachman  
Executive Director CT  
Siting Council  
10 Franklin Square New  
Britain, CT 06051

Re: Notice of Exempt Modification Application  
39 Cherry St, Waterbury, CT

Latitude: N41.5594  
Longitude: W74.0341

Dear Ms. Bachman:

Sprint currently maintains 3 existing panel antennas, 3 remote radio heads and three microwave dishes at the 127' centerline level of the existing 143.5 ft smoke stack. Sprint proposes to remove all 3 existing panel antennas and radio heads and replace them with 6 new panel antennas and add 12 remote radio units at the 127' centerline on the smoke stack as well add 4 hybrid cable. Sprint is performing a new high-performance upgrade for cellular mobile communications. It is designed to increase the capacity and speed of mobile telephone networks.

Please accept this letter as notification to the Council, pursuant to R.C.S.A. Section 16-50j-73, for construction which constitutes an exempt modification pursuant to R.C.S.A. Section 16-50j-72(b)(2). In compliance with R.C.S.A. Section 16-50j-73, a copy of this letter is being sent to Neil O'Leary, City of Waterbury Mayor, James Sequin, Zoning Official, City of Waterbury, and New Opportunities Economic Development Corporation as property owner.

Attached is a summary of the planned modifications, including power density calculations reflecting the change in Sprint's operations at the site. Also included is documentation of the structural sufficiency of the tower with proposed modifications to accommodate the revised antenna configuration as well as the latest CSC decision.

### **Existing Facility**

CSC Summary Statement – CT52XC055 – 39 Cherry St  
Waterbury, CT 06702

The Communications Tower facility is located at 39 Cherry St, Waterbury, Ct and is owned by New Opportunities Economic Development Corporation, the Site coordinates are: N41.5594 W74.0341.

The existing facility consists of a 143.5' Smoke Stack. Sprint currently operates wireless communications equipment on the ground at the facility and has 3 antenna and 3 remote radio heads mounted on at centerline of 127 feet.

## **Statutory Considerations**

The planned modifications to the facility fall within the activities explicitly provided for in R.C.S.A. 16-50j-72(b)(2)

1. The height of the overall structure will be unaffected.
2. The proposed changes will not require an extension of the property boundaries.
3. The proposed additions will not increase the noise level at the existing facility by six decibels or more, or to levels that exceed state and/or local criteria
4. The changes will not increase the calculated "worst case" power density for the combined operations at the site to a level at or above the Federal Communications Commission safety standard.
5. The proposed modifications will not cause a change or alteration in the physical or environmental characteristics of the site.
6. The existing structure and its foundation can support the proposed loading.

For the foregoing reasons, Sprint respectfully submits that the proposed changes at the referenced site constitute exempt modifications under R.C.S.A Section §16-50j-72(b)(2).

Respectfully submitted,

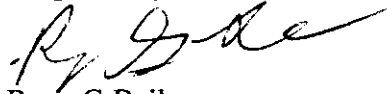

Ryan G Bailey

Charles Cherundolo Consulting

856-625-1596

[ryan@mackenzierealtyconsulting.com](mailto:ryan@mackenzierealtyconsulting.com)

### Additional Recipients:

Neil O'Leary, Mayor, City of Waterbury

James Sequin, AICP, Zoning Official, City of Waterbury

New Opportunities Economic Development Corporation, Property Owner

# Sprint



**PROJECT: DO MACRO UPGRADE**

**SITE NAME: 39 CHERRY AVE SS**

**SITE CASCADE: CT52XC055-C**

**SITE ADDRESS: 253 CHERRY ST  
WATERBURY, CT 06702**

**Sprint**

1 INTERNATIONAL BLVD., SUITE 800  
MAHWAH, NJ 07495  
TEL: (201) 684-4000  
FAX: (201) 684-4223



1280 ROUTE 46 WEST  
PARSIPPANY, NJ 07054  
TELEPHONE: 646-544-5324



604 FOX GLEN  
BARRINGTON, IL 60010  
TELEPHONE: 847-277-0070  
FAX : 847-277-0080  
AE@westchesterservices.com

**JOHN M. BANKS  
ARCHITECT**

604 FOX GLEN  
BARRINGTON, IL 60010  
TELEPHONE: 847-277-0070  
FAX : 847-277-0080

THESE DOCUMENTS ARE  
CONFIDENTIAL AND ARE THE  
SOLE PROPERTY OF SPRINT AND  
MAY NOT BE REPRODUCED,  
DISSEMINATED OR REDISTRIBUTED  
WITHOUT THE EXPRESS WRITTEN  
CONSENT OF SPRINT.

**SITE INFORMATION**

**SITE ADDRESS:**  
253 CHERRY ST  
WATERBURY, CT 06702

**PROPERTY OWNER:**  
NORTH SQUARE GATEWAY DEVELOPMENT INC.  
232 NORTH ELM ST  
WATERBURY, CT 06702

**ZONING JURISDICTION:**  
COUNTY OF NEW HAVEN

**ZONING DISTRICT:**  
-

**POWER COMPANY:**  
NORTHEAST UTILITIES  
(800) 286-2000

**COUNTY:**  
NEW HAVEN

**GEOGRAPHIC COORDINATES (NAD83):**  
LAT: 41° 33' 34.15"N (41.559486°)  
LONG: 73° 02' 2.774"W (-73.034104°)

**SPRINT CONSTRUCTION MANAGER:**  
NAME:  
PHONE:  
EMAIL:

**AREA MAP**

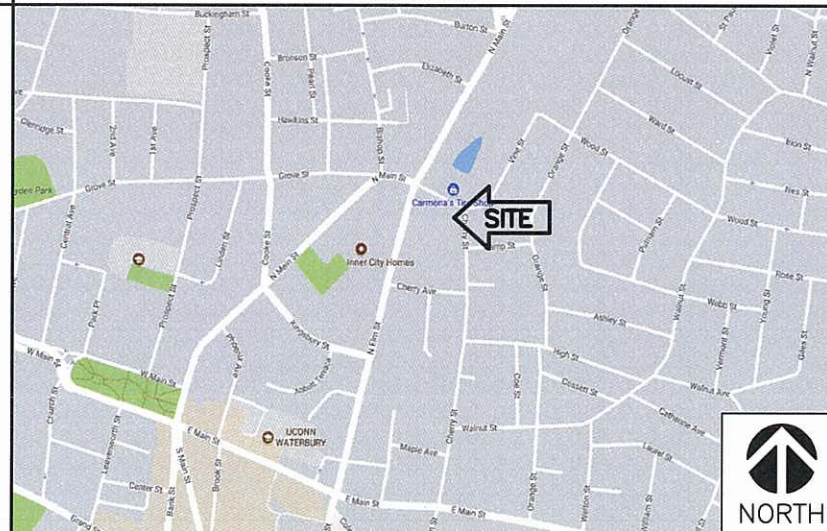

**LOCATION MAP**

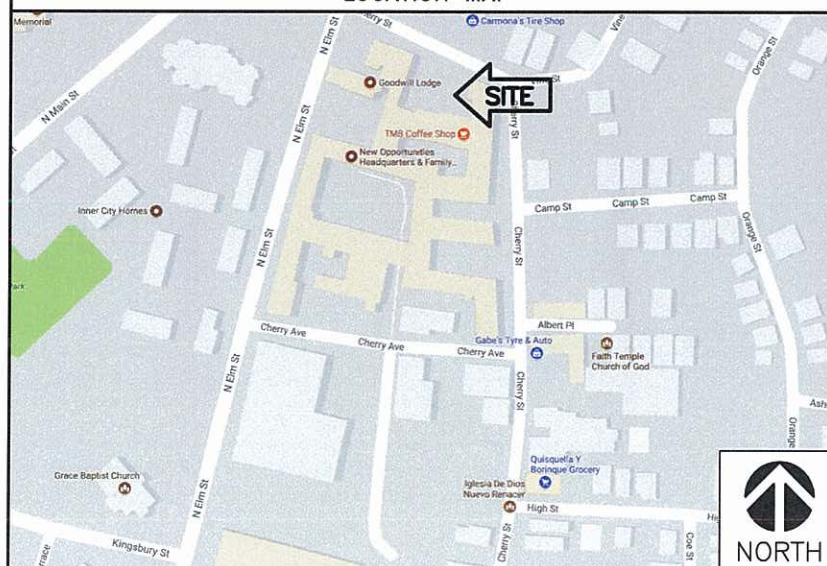

**PROJECT DESCRIPTION**

- (1) EXISTING CW EQUIPMENT CABINET, (1) EXISTING SPRINT GPS UNIT & (1) EXISTING WORK LIGHT TO REMAIN
- INSTALL (1) NEW ELTEK E-CAB CABINET
- INSTALL (1) NEW ELTEK I-CAB CABINET
- REMOVE (3) EXISTING CW ANTENNAS
- REMOVE (3) EXISTING CW RRHS
- (1) EXISTING 2'-0" & (2) EXISTING 1'-0" SPRINT DISH ANTENNAS TO REMAIN
- INSTALL NEW (3) KMW TRIBAND ANTENNAS
- INSTALL (6) NEW 800 MHz RRHS
- INSTALL (3) NEW 1900 MHz RRHS
- INSTALL (3) NEW 2500 MHz RRHS
- INSTALL (3) NEW 1-1/4" HYBRIFLEX CABLES
- INSTALL (1) NEW 1-1/2" HYBRIFLEX CABLE
- (48) NEW 1/2" ANTENNA/RRH JUMPERS
- INSTALL (1) NEW SPRINT SPRINT GPS UNIT
- INSTALL (1) NEW SPRINT 200A PPC CABINET
- INSTALL NEW "SITEPRO1" PART#IB12B-V ICE BRIDGE KIT WITH PIPE BASE SHOE
- INSTALL (3) NEW 'COMMSCOPE' PART#MT-547-126 MOUNTING PIPES

**APPLICABLE CODES**

- SUBCONTRACTOR'S WORK SHALL COMPLY WITH ALL APPLICABLE NATIONAL, STATE, AND LOCAL CODES AS ADOPTED BY THE LOCAL AUTHORITY HAVING JURISDICTION FOR THE LOCATION. THE EDITION OF THE AHJ ADOPTED CODES AND STANDARDS IN EFFECT OF THE DATE OF CONTRACT AWARD SHALL GOVERN THE DESIGN.
- 2015 INTERNATIONAL BUILDING CODE AS ADOPTED BY THE STATE OF CONNECTICUT
  - NEC 2014, AS ADOPTED BY THE STATE OF CONNECTICUT
  - NFPA 780 - LIGHTNING PROTECTION CODE
  - ANSI/TIA-222G TELECOM STRUCTURAL STANDARD

**DIG SAFE**

**Know what's below.  
Call before you dig.**

TO OBTAIN LOCATION OF PARTICIPANTS UNDERGROUND FACILITIES BEFORE YOU DIG IN CONNECTICUT, CONTACT CALL BEFORE YOU DIG  
TOLL FREE: 1-800-922-4455 OR  
[www.cbyd.com](http://www.cbyd.com)

CONNECTICUT STATUTE REQUIRES MIN OF 2 WORKING DAYS NOTICE BEFORE YOU EXCAVATE

**DRAWING INDEX**

SHEET NO:	SHEET TITLE	REV
T-1	TITLE SHEET	0
SP-1	SPRINT SPECIFICATIONS	0
SP-2	SPRINT SPECIFICATIONS	0
SP-3	SPRINT SPECIFICATIONS	0
A-1	OVERALL SITE PLAN	0
A-2	EQUIPMENT LAYOUT	0
A-3	SMOKE STACK ELEVATION	0
A-4	ANTENNA LAYOUT	0
A-5	FIBER WIRING DIAGRAMS	0
A-6	PLUMBING DIAGRAM & CABLE DETAILS	0
A-7	EQUIPMENT DETAILS	0
A-8	FENCE DETAILS	0
A-9	CONSTRUCTION & CABINET DETAILS	0
E-1	ELECTRIC PLAN & NOTES	0
E-2	GROUNDING RISING DIAGRAM	0
E-3	ELECTRICAL DETAILS	0
E-4	GROUNDING DETAILS	0

**PROFESSIONAL LICENSE**

JOHN M. BANKS

STATE OF CONNECTICUT

EXPIRES: 07-31-18

SIGNED: *[Signature]*

NO.	DATE	DESCRIPTION
0	11.15.17	FINAL CD

DRAWN BY: JS

CHECKED BY: JMB

JOB NUMBER: CT52XC055-C

ARCHITECT: JOHN BANKS

SEAL  
SITE NAME

39 CHERRY AVE SS

SITE NUMBER

CT52XC055-C

SITE LOCATION

253 CHERRY STREET  
WATERBURY, CT 06702  
NEW HAVEN COUNTY

SHEET TITLE

TITLE SHEET

SHEET NUMBER

T-1

**SECTION 01 100 – SCOPE OF WORK**

**THE WORK:**  
THESE STANDARD CONSTRUCTION SPECIFICATIONS IN CONJUNCTION WITH THE CONSTRUCTION DRAWINGS AND ASSOCIATED OUTLINE SPECIFICATIONS AND SITE SPECIFIC WORK ORDER, DESCRIBE THE WORK TO BE PERFORMED BY THIS CONSTRUCTION CONTRACTOR SUPPLIER

**RELATED DOCUMENTS**

- A. THE REQUIREMENTS OF EACH SECTION OF THIS SPECIFICATION APPLY TO ALL, INDIVIDUALLY AND COLLECTIVELY.  
B. RELATED DOCUMENTS: THE CONTRACTOR SHALL COMPLY WITH THE MOST CURRENT VERSION OF THE FOLLOWING SUPPLEMENTAL REQUIREMENTS FOR INSTALLATION AND TESTING
1. EN–2012–001: (FIBER OPTIC, DC CABLE, AND DC CIRCUIT BREAKER TAGGING STANDARDS)
  2. TS–200–(TRANSMISSION ANTENNA LINE ACCEPTANCE STANDARDS)
  3. EL–0568: (FIBER TESTING POLICY)
  4. NP–312–201: (EXTERIOR GROUNDING SYSTEM TESTING)
  5. NP–760–500: ETHERNET, MICROWAVE, TESTING AND ACCEPTANCE

**NATIONALLY RECOGNIZED CODES AND STANDARDS:**

- THE WORK SHALL COMPLY WITH APPLICABLE NATIONAL AND LOCAL CODES AND STANDARDS, LATEST EDITION, AND PORTIONS, INCLUDED
- A. GR–63–CORE NEBS REQUIREMENTS: PHYSICAL PROTECTION
  - B. GR–78–CORE GENERIC REQUIREMENTS FOR THE PHYSICAL DESIGN AND MANUFACTURE OF TELECOMMUNICATIONS EQUIPMENT
  - C. GR–1089–CORE, ELECTROMAGNETIC COMPATIBILITY AND ELECTRICAL SAFETY–GENERIC CRITERIA FOR NETWORK TELECOMMUNICATIONS EQUIPMENT
  - D. NATIONAL FIRE PROTECTION ASSOCIATION CODES AND STANDARDS (NFPA) INCLUDING NFPA 70 (NATIONAL ELECTRICAL CODE–“NEW”) AND NFPA 101 (LIFE SAFETY CODE).
  - E. AMERICAN SOCIETY FOR TESTING OF MATERIALS (ASTM)
  - F. INSTITUTE OF ELECTRONIC AND ELECTRICAL ENGINEERS (IEEE)
  - G. AMERICAN CONCRETE INSTITUTE (ACI)
  - H. AMERICAN WIRE PRODUCERS ASSOCIATION (AWPA)
  - I. CONCRETE REINFORCING STEEL INSTITUTE (CRSI)
  - J. AMERICAN ASSOCIATION OF STATE HIGHWAY AND TRANSPORTATION OFFICIALS (AASHTO)
  - K. PORTLAND CEMENT ASSOCIATION (PCA)
  - L. NATIONAL CONCRETE MASONRY ASSOCIATION (PCMA)
  - M. BRICK INDUSTRY ASSOCIATION (BIA)
  - N. AMERICAN WELDING SOCIETY (AWS)
  - P. SGEET METAL AND AIR CONDITIONING CONTRACTORS’ NATIONAL ASSOCIATION (SMACNA)
  - Q. DOOR AND HARDWARE INSTITUTE (DHI)
  - R. OCCUPATIONAL SAFETY AND HEALTH ACT (OSHA)
  - S. APPLICABLE BUILDING CODES INCLUDING UNIFORM BUILDING CODE, SOUTHERN BUILDING CODE, BOCA, AND INTERNATIONAL BUILDING CODE.

**DEFINITIONS:**

- A. WORK: THE SUM OF TASKS AND RESPONSIBILITIES IDENTIFIED IN CONTRACT DOCUMENTS
- B. COMPANY: "SPRINT": SPRINT CORPORATION AND IT’S OPERATING ENTITIES
- C. ARCHITECT: SYNONYMOUS WITH ARCHITECT&ENGINEER AND "A&E", THE DESIGN PROFESSIONAL HAVING PROFESSIONAL RESPONSIBILITY FOR DESIGN OF THE PROJECT
- D. CONTRACTOR: CONSTRUCTION CONTRACTOR, SUPPLIER, VENDOR; INDIVIDUAL OR CONTRACTOR TO PROVIDE MATERIALS OR TO ACCOMPLISH SPECIFIC TASKS RELATED TO BUT NOT INCLUDED IN THE WORK.
- E. THIRD PARTY VENDOR OR AGENCY: A VENDOR OR AGENCY ENGAGED SEPARATELY BY THE CO, A&E, OR CONTRACTOR TO PROVIDE MATERIALS OR TO ACCOMPLISH SPECIFIC TASKS RELATED TO B UT NOT INCLUDED IN THE WORK
- F. CONSTRUCTION MANAGER – ALL PROJECTS RELATED COMMUNICATION TO FOLOW THROUGH SPRINT REPRESENTATIVE IN CHARGE OF PROJECT.

**SITE FAMILIARITY:**

CONTRACTOR SHALL BE RESPONSIBLE FOR FAMILIARIZING HIMSELF WITH ALL CONTRACT DOCUMENTS, FIELD CONDITIONS AND DIMENSIONS PRIOR TO PROCEEDING WITH CONSTRUCTION.

**POINT OF CONTACT:**

COMMUNICATION BETWEEN SPRINT AND THE CONTRACTOR SHALL FLOW THROUGH THE SINGLE SPRINT CONSTRUCTION MANAGER APPOINTED TO MANAGE THE PROJECT FOR SPRINT

**ON–SITE SUPERVISION:**

THE CONTRACTOR SHALL SUPERVISE AND DIRECT THE WORK AND SHALL BE RESPONSIBLE FOR CONSTRUCTION MEANS, METHODS, TECHNIQUES, SEQUENCES, AND PROCEDURES IN ACCORDANCE WITH THE CONTRACT DOCUMENTS.

**DRAWINGS, SPECIFICATIONS AND DETAILS REQUIRED AT JOBSITE:**

THE CONSTRUCTION CONTRACTOR SHALL MAINTAIN A FULL SET OF THE CONSTRUCTION DRAWINGS AT THE JOBSITE FROM MOBILIZATION THROUGH CONSTRUCTION COMPLETION.

- A. DETAILS ARE INTENDED TO SHOW DESIGN INTENT. PROVIDE ALL MATERIALS AND LABOR AS REQUIRED TO PROVIDE A COMPLETE AND FUNCTIONING SYSTEM. MODIFICATIONS MAY BE REQUIRED TO SUIT JOB DIMENSIONS OR CONDITIONS, AND SUCH MODIFICATIONS SHALL BE INCLUDED AS PART OF THE WORK.
- B. CONTRACTOR SHALL NOTIFY SPRINT CONSTRUCTION MANAGER OF ANY VARIATIONS PRIOR TO PROCEEDING WITH THE WORK. DIMENSIONS SHOWN ARE TO FINISH SURFACES UNLESS NOTED OTHERWISE. MODIFICATIONS MAY BE REQUIRED TO SUIT JOB DIMENSIONS OR CONDITIONS, AND SUCH MODIFICATIONS SHALL BE INCLUDED AS PART OF THE WORK.

**USE OF JOB SITE:**

CONTRACTOR SHALL CONFINE ALL CONSTRUCTION AND RELATED OPERATIONS INCLUDING STAGING STORAGE OF MATERIALS AND EQUIPMENT, PARKING, TEMPORARY FACILITIES, AND WASTE STORAGE TO THE LEASE PARCEL UNLESS OTHERWISE PERMITTED BY THE CONTRACT DOCUMENTS.

**UTILITY SERVICES:**

WHERE NECESSARY TO CUT EXISTING PIPES, ELECTRICAL WIRES, CONDUITS, CABLES, ETC., OF UTILITY SERVICES, OR OF FIRE PROTECTION OR COMMUNICATIONS SYSTEMS, THEY SHALL BE CUT AND CAPPED AT SUITABLE PLACES OF WHERE SHOWN. ALL SUCH ACTIONS SHALL BE COORDINATED WITH THE UTILITY COMPANY INVOLVED:

**PERMITS/FEES:**

WHEN REQUIRED THAT A PERMIT OR CONNECTION FEE BE PAID TO A PUBLIC UTILITY PROVIDER FOR NEW SERVICE TO THE CONSTRUCTION PROJECT, PAYMENT OF SUCH FEE SHALL BE THE RESPONSIBILITY OF THE CONTRACTOR

**CONTRACTOR:**

CONTRACTOR SHALL TAKE ALL MEASURES AND PROVIDE ALL MATERIAL NECESSARY FOR PROTECTING EXISTING EQUIPMENT AND PROPERTY

**USE OF ELECTRONIC PROJECT MANAGEMENT SYSTEMS:**

CONTRACTOR WILL UTILIZE ITS BEST EFFORTS TO WORK WITH SPRINT ELECTRONIC PM SYSTEMS. CONTRACTOR UNDERSTANDS THAT SUFFICIENT INTERNET ACCESS, EQUIVALENT TO "BROADBAND" OR BETTER, IS REQUIRED TO TIMELY AND EFFECTIVELY UTILIZE SPRINT DATA AND DOCUMENT MANAGEMENT SYSTEMS AND AGREES TO MAINTAIN APPROPRIATE CONNECTIONS FOR CONTRACTORS STAFF AND OFFICE THAT ARE COMPATIBLE WITH SPRINT DATA AND DOCUMENT MANAGEMENT SYSTEMS.

**TEMPORARY UTILITIES AND FACILITIES:**

THE CONTRACTOR SHALL BE RESPONSIBLE FOR ALL TEMP UTILITIES AND FACILITIES NECESSARY EXCEPT OTHERWISE INDICATED IN CONSTRUCTION DOCUMENTS. TEMP UTILITIES AND FACILITIES INCLUDE POTABLE WATER, HEAT, HVAC, ELECTRICITY, SANITARY FACILITIES, WASTE DISPOSABLE FALSITIES, TELECOM SERVICES, PROVIDE TEMP UTILITIES AND FACILITIES ACCORDANCE WITH OSHA AND AUTHORITY HAVING JURISDICTION. CONTRACTOR MAY UTILIZE THE CO. ELECTRICAL SERVICE IN THE COMPLETION OF THE WORK WHEN IT BECOMES AVAILABLE. USE OF THE LESSOR’S OR SITE OWNER’S UTILITIES OR FACILITIES IS EXPRESSLY FORBIDDEN EXCEPT AS OTHERWISE ALLOWED IN CONTRACT DOCUMENTS.

**ACCESS TO WORK:**

THE CONTRACTOR SHALL PROVIDE ACCESS TO THE JOB SITE FOR AUTHORIZED COMPANY PERSONNEL AND AUTHORIZED REPRESENTATIVES OF THE A&E DURING ALL PHASES OF WORK.

**DIMENSIONS:**

VERIFY DIMENSIONS INDICATED ON DRAWINGS WITH FIELD DIMENSIONS BEFORE FABRICATION OR ORDERING OF MATERIALS. DO NOT SCALE DRAWINGS.

**EXISTING CONDITIONS:**

NOTIFY SPRINT CM OF EXISTING CONDITIONS DIFFERING FROM THOSE INDICATED ON THE DRAWINGS. DO NOT REMOVE OR ALTER STRUCTURAL COMPONENTS WITHOUT PRIOR WRITTEN APPROVAL FROM THE ARCHITECT AND ENGINEER.

**SECTION 01 200 – COMPANY FURNISHED MATERIAL AND EQUIPMENT:**

**FURNISHED MATERIALS:**  
COMPANY FURNISHED MATERIALS AND EQUIPMENT TO BE INSTALLED BY THE CONTRACTOR (OFIC) IS IDENTIFIED ON THE RFDS IN THE CONSTRUCTION DOCUMENTS.

**RECEIPT OF MATERIAL AND EQUIPMENT:**

- A. THE CONTRACTOR IS RESPONSIBLE FOR SPRINT PROVIDED MATERIAL AND EQUIPMENT AND UPON PRECEPT SHALL:
  1. ACCEPT DELIVERIES AS SHIPPED AND TAKE RECEIPT
  2. VERIFY COMPLETENESS AND CONDITION OF ALL DELIVERIES
  3. TAKE RESPONSIBILITIES FOR EQUIPMENT AND PROVIDE INSURANCE PROTECTION AS REQUIRED IN AGREEMENT
- B. RECORD ANY DEFECTS OR DAMAGES AND WITHIN 24 HOURS AFTER RECEIPT, REPORT TO SPRINT OR ITS DESIGNATED PROJECT REPRESENTATIVE OF SUCH.
- C. PROVIDE SECURE AND NECESSARY WEATHER PROTECTED WAREHOUSING.
- D. COORDINATE SAFE AND SECURE TRANSPORTATION OF MATERIAL AND EQUIPMENT, DELIVERING AND OFF–LOADING FROM CONTRACTOR’S WAREHOUSE TO SITE.

**DELIVERABLES:**

- A. COMPLETE SHIPPING RECEIPT DOCUMENTATION IN ACCORDANCE W/COMPANY PRACTICE
- B. IF APPLICABLE, COMPLETE LOST/STOLEN/DAMAGED DOCUMENTATION REPORT AS NECESSARY IN ACCORDANCE W/COMPANY PRACTICE, AND AS DIRECTED BY COMPANY

**SECTION 01 300–CELL SITE CONSTRUCTION**

**NOTICE TO PROCEED:**

- A. NO WORK SHALL COMMENCE PRIOR TO COMPANY’S ISSUANCE OF THE WORK ORDER.
- B. UPON RECEIVING NOTICE TO PROCEED, CONTRACTOR SHALL FULLY PERFORM ALL WORK NECESSARY TO PROVIDE SPRINT WITH AN OPERATIONAL WIRELESS FACILITY.
- C. CONTRACTOR SHALL TAKE ALL REASONABLE PRECAUTIONS TO DISCOVER AND LOCATE ANY HAZARDOUS CONDITIONS
  1. IN THE EVENT CONTRACTOR ENCOUNTERS ANY HAZARDOUS CONDITIONS WHICH HAS NOT BEEN ABATED OR OTHERWISE MITIGATED, CONTRACTOR AND ALL OTHER PERSONS SHALL IMMEDIATELY STOP WORK IN THE AFFECTED AREA AND NOTIFY COMPANY IN WRITING. THE WORK IN THE AFFECTED AREA SHALL NOT BE RESUMED EXCEPT BY WRITTEN NOTIFICATION BY COMPANY.
  2. CONTRACTOR AGREES TO USE CARE WHILE ON THE SITE AND SHALL NOT TAKE ANY ACTION THAT WILL OR MAY RESULT IN OR CAUSE THE HAZARDOUS CONDITION TO BE FURTHER RELEASED IN THE ENVIRONMENT, OR EXPOSE TO INDIVIDUALS.
- D. CONTRACTOR’S ACTIVITIES SHALL BE RESTRICTED TO THE PROJECT LIMITS: SHOULD AREAS OUTSIDE THE PROJECT LIMITS BE AFFECTED BY CONTRACTOR’S ACTIVITIES, CONTRACTOR SHALL IMMEDIATELY RETURN THEM TO ORIGINAL CONDITION.

**FUNCTIONAL REQUIREMENTS:**

- A. THE ACTIVITIES DESCRIBED IN THIS PARAGRAPH REPRESENT MINIMUM ACTIONS AND PROCESSES REQUIRED TO SUCCESSFULLY COMPLETE THE WORK. CONTRACTOR SHALL TAKE ALL ACTIONS AS NECESSARY TO COMPLETE THE CONSTRUCTION OF A FULLY FUNCTIONING WIRELESS FACILITY AT THE SITE IN ACCORDANCE WITH COMPANY PROCESSES.
- B. SUBMIT SPECIFIC DOCUMENTATION AS INDICATED HEREIN, AND OBTAIN REQUIRED APPROVALS WHILE THE WORK IS BEING PERFORMED.
- C. MANAGE AND CONDUCT ALL FIELD CONSTRUCTION SERVICE RELATED ACTIVITIES
- D. PROVIDE CONSTRUCTION ACTIVITIES TO THE EXTENT REQUIRED BY THE CONTRACT DOCUMENTS, INCLUDING BUT NOT LIMITED TO THE FOLLOWING:
  1. PERFORM ANY REQUIRED SITE ENVIRONMENTAL MITIGATION.
  2. PREPARE GROUND SITES; PROVIDE DE–GRUBBING; AND ROUGH AND FINAL GRADING, AND COMPOUND SURFACE TREATMENTS.
  3. MANAGE AND CONDUCT ALL ACTIVITIES FOR INSTALLATION OF UTILITIES INCLUDING ELECTRICAL AND BACKHAUL (FIBER, COPPER, OR MICROWAVE).
  4. INSTALL UNDERGROUND FACILITIES INCLUDING UNDERGROUND POWER AND COMMUNICATIONS CONDUITS, AND UNDERGROUND GROUNDING SYSTEM.
  5. INSTALL ABOVE GROUND GROUNDING SYSTEMS, CONDUIT AND BOXES.
  6. PROVIDE NEW HVAC INSTALLATIONS AND MODIFICATIONS.
  7. INSTALL H–FRAMES, CABINETS, PADS & PLATFORMS AS INDICATED.
  8. INSTALL ROADS, ACCESS WAYS, CURBS AND DRAINS AS INDICATED.
  9. ACCOMPLISH REQUIRED MODIFICATION OF EXISTING FACILITIES.

10. PROVIDE ANTENNA SUPPORT STRUCTURE FOUNDATIONS.
11. PROVIDE SLABS AND EQUIPMENT PLATFORMS
12. INSTALL COMPOUND FENCING, SIGHT SHIELDING, LANDSCAPING AND ACCESS BARRIERS
13. PERFORM INSPECTION AND MATERIAL TESTING AS REQUIRED HEREINAFTER
14. CONDUCT SITE RESISTANCE TO EARTH TESTING AS REQUIRED HEREINAFTER
15. INSTALL FIXED GENERATOR SETS AND OTHER STANDBY POWER SOLUTIONS
16. INSTALLED FIXED GENERATOR SETS AND OTHER STANDBY POWER SOLUTIONS
17. INSTALL ANTENNA SUPPORT STRUCTURES AND PLATFORMS ON EX. TOWER AS REQUIRED
18. INSTALL CELL SITE RADIOS, MICROWAVE, GPS, COAXIAL MAINLINE, ANTENNAS, CROSS BAND COUPLERS, TOWER TOP AMPLIFIERS, LOW NOISE AMPLIFIERS AND RELATED EQUIPMENT
19. CONDUCT ALL REQUIRED TESTS AND INSPECTIONS
19. PERFORM, DOCUMENT, AND CLOSE OUT ALL JURISDICTIONAL PERMITTING REQUIREMENTS AND CONSTRUCTION CONTROL DOCUMENTS THAT MAY BE REQUIRED BY GOVERNMENT AGENCIES AND LANDLORDS.
20. PERFORM ALL ADDITIONAL WORK AS IDENTIFIED IN SCOPE OF SERVICES ATTACHED TO THE SUPPLIER AGREEMENT FOR THIS PROJECT. THIS WORK MAY INCLUDE COMMISSIONING, INTEGRATION, SPECIAL WAREHOUSING, REVERSE LOGISTICS ACTIVITIES, ETC. PERFORM COMMISSIONING AND INTEGRATION ACTIVATIONS PER APPLICABLE MOPS

**DELIVERABLES:**

- A. THE CONTRACTOR SHALL PROVIDE ALL REQUIRED TEST REPORTS AND DOCUMENTATION INCLUDED BU NOT LIMITED TO THE FOLLOWING
  1. PRODUCT SPECIFICATIONS FOR MATERIALS OR SPECIAL CONSTRUCTION REQUESTED BY SPRINT
  2. ACTUALIZE ALL CONSTRUCTION RELATED MILESTONES IN SITERRA AND COMPLETE ALL ON–LINES AND COMPLETE DOCUMENT UP–LOADS. UPLOAD ALL REQUIRED CLOSEOUT DOCUMENTS AND FINAL SITE PHOTOS.
  3. SCANABLE BARCODE PHOTOGRAPHS OF TOWER TOP AND INACCESSIBLE SERIALIZED EQUIPMENT LEFT ON SITE INSIDE BASE OF MAIN RF CABINET IN A PROTECTIVE POUCH.
  4. ALL REQUIRED TEST REPORTS.
  5. REQUIRED CLOSEOUT DOCUMENTATION INCLUDING BUT NOT LIMITED TO:
    - a. ALL JURISDICTIONAL PERMITTING AND OCCUPANCY INFORMATION
    - b. PDF SCAN OF REDLINES PRODUCED IN THE FIELD
    - c. ELECTRONIC AS–BUILT DRAWINGS IN AUTOCAD AND PDF FORMATS
    - d. LIEN WAIVERS
    - e. FINAL PAYMENT APPLICATION
    - f. REQUIRED FINAL CONSTRUCTION PHOTOS
    - g. CONSTRUCTION & COMMISSIONING CHECKLIST COMPLETE WITH NO DEFICIENT ITEMS
    - h. LISTS OF SUBCONTRACTORS
- B. PROVIDE ADDITIONAL DOCUMENTATION INCLUDING, BUT NOT LIMITED TO, THE FOLLOWING DOCUMENTATION SHALL BE FORWARDED IN ORIGINAL FORMAT &/OR UPLOADED INTO SMS
  1. ALL CORRESPONDENCE AND PRELIMINARY CONSTRUCTION REPORTS.
  2. PROJECT PROGRESS REPORTS.
  3. PRE–CONSTRUCTION MEETING NOTES.

**SECTION –1 400–TESTS, INSPECTIONS, SUBMITTALS, AND PROJECT CLOSEOUT**

**TESTS AND INSPECTIONS:**

- A. THE CONTRACTOR SHALL BE RESPONSIBLE FOR ALL CONSTRUCTION TESTS, INSPECTIONS AND PROJECT DOCUMENTATION.
- B. CONTRACTOR SHALL ACCOMPLISH TESTING INCLUDING BUT NOT LIMITED TO THE FOLLOWING:
  1. COAX SWEEPS AND FIBER TESTS PER TS–0200 (CURRENT VERSION) ANTENNA LINE ACCEPTANCE STANDARDS
  2. POST CONSTRUCTION HEIGHT VERIFICATION, AZIMUTH AND DOWNTILT USING ELECTRONIC COMMERCIAL MADE–FOR–THE–PURPOSE ANTENNA ALIGNMENT TOOL.
  3. CONCRETE BREAK TESTS
  4. SITE RESISTANCE TO EARTH TEST
  5. STRUCTURAL BACKFILL COMPACTION TESTS
  6. CONTRACTOR SHALL BE RESPONSIBLE FOR ANY AND ALL CORRECTIONS TO ANY WORK IDENTIFIED AS UNACCEPTABLE IN SITE INSPECTION ACTIVITIES AND/OR AS A RESULT OF TESTING.
  7. ADDITIONAL TESTING AS REQUIRED ELSEWHERE IN THIS SPECIFICATION.

**SUBMITTALS:**

- A. THE WORK IN ALL ASPECTS SHALL COMPLY WITH THE CONSTRUCTION DRAWINGS AND THESE SPECIFICATIONS.
- B. UPLOAD FOLLOWING TO SITERRA AS APPLICABLE BUT NOT LIMITED TO THE FOLLOWING:
  1. CONCRETE MIX–DESIGNS FOR TOWER FOUNDATIONS, ANCHORS PIERS, AND CONCRETE PAVING
  2. CONCRETE BREAK TESTS AS SPECIFIED HEREIN.
  3. CHEMICAL GROUNDING SYSTEM
  4. REINFORCEMENT CERTIFICATIONS
  5. STRUCTURAL BACKFILL TEST RESULTS
  6. SWEEP AND FIBER TESTS
  7. ANTENNA AZIMUTH AND DOWN–TILT VERIFICATION
  8. POST CONSTRUCTION HEIGHT VERIFICATION
  9. ADDITIONAL SUBMITTALS MAY BE REQUIRED FOR SPECIAL CONSTRUCTION OR MINOR MATERIALS
- C. ALTERNATES: AT COMPANY’S REQUEST, ANY ALTERNATIVES TO THE MATERIALS FOR METHODS SPECIFIED SHALL BE SUBMITTED TO SPRINT’S CONSTRUCTION MANAGER FOR APPROVAL PRIOR TO BEING SHIPPED TO SITE. SPRINT WILL REVIEW AND APPROVE ONLY THOSE REQUESTS MADE IN WRITING. NO VERBAL APPROVALS WILL BE CONSIDERED. SUBMITTAL FOR APPROVAL SHALL INCLUDE A STATEMENT OF COST REDUCTION PROPOSED FOR USE OF ALTERNATE PRODUCT.

**TESTING:**

- A. EMPLOY AN AGENCY OF ENGINEERS AND SCIENTISTS WHO IS REGULARLY ENGAGED IN FIELD AND LABORATORY TESTING AND ANALYSIS. AGENCY SHALL HAVE BEEN IN BUSINESS A MINIMUM OF FIVE YEARS, AND BE LICENSED AS PROFESSIONAL ENGINEERS IN THE STATE WHERE THE PROJECT IS LOCATED. AGENCY IS SUBJECT TO APPROVAL BY COMPANY.
  1. AGENCY MUST HAVE THOROUGH UNDERSTANDING OF LOCAL AVAILABLE MATERIALS, INCLUDING THE SOIL, ROCK, AND GROUNDWATER CONDITIONS.
  2. AGENCY IS TO BE FAMILIAR WITH THE APPLICABLE REQUIREMENTS FOR THE TESTS TO BE DONE, EQUIPMENT TO BE USED, AND ASSOCIATED HEALTH AND SAFETY ISSUES.
  3. EXPERIENCE IN SOILS, CONCRETE, MASONRY, AGGREGATE AND ASPHALT TESTING USUING ASTM, AASJTO, AND OTHER METHODS IS NEEDED.
- B. REQUIRED THIRD PARTY TESTS
  1. SITE RESISTANCE TO EARTH TEST PER NP–3 2–201
  2. CONCRETE CYLINDER BREAK TESTS FOR TOWER PIER AND ANCHORS PER NATIONALLY RECOGNIZED STANDARDS
  3. STRUCTURAL SOILS COMPACTION TESTS PER NATIONALLY RECOGNIZED STANDARDS
  4. REBAR PLACEMENT VERIFICATION WITH REPORT
  5. SITE RESISTANCE TO EARTH TEST
  6. CONTRACTOR SHALL BE RESPONSIBLE FOR ANY AND ALL CORRECTIONS TO ANY WORK IDENTIFIED AS UNACCEPTABLE IN SITE INSPECTION ACTIVITIES &/OR AS A RESULT OF TESTING



1 INTERNATIONAL BLVD., SUITE 800  
MAHWAH, NJ 07495  
TEL: (201) 684–4000  
FAX: (201) 684–4223



1280 ROUTE 46 WEST  
PARSIPPANY, NJ 07054  
TELEPHONE: 646–544–5324



604 FOX GLEN  
BARRINGTON, IL 60010  
TELEPHONE: 847–277–0070  
FAX : 847–277–0080  
AE@westchesterservices.com

**JOHN M. BANKS  
ARCHITECT**

604 FOX GLEN  
BARRINGTON, IL 60010  
TELEPHONE: 847–277–0070  
FAX : 847–277–0080

THESE DOCUMENTS ARE CONFIDENTIAL AND ARE THE SOLE PROPERTY OF SPRINT AND MAY NOT BE REPRODUCED, DISSEMINATED OR REDISTRIBUTED WITHOUT THE EXPRESS WRITTEN CONSENT OF SPRINT.

NO.	DATE	DESCRIPTION
0	11.15.17	FINAL CD
DRAWN BY: JS		
CHECKED BY: JMB		
JOB NUMBER: CT52XC055–C		
ARCHITECT: JOHN BANKS		



SITE NAME

**39 CHERRY AVE SS**

SITE NUMBER

**CT52XC055-C**

SITE LOCATION

253 CHERRY STREET  
WATERBURY, CT 06702  
NEW HAVEN COUNTY

SHEET TITLE

**SPRINT  
SPECIFICATIONS**

SHEET NUMBER

**SP-1**

C. REQUIRED BY CONTRACTOR

1. COAX SWEEP TESTS PER SPRINT STANDARD TS-0200
  2. FIBER TESTS PER SPRINT STANDARD EL-0568
  3. MICROWAVE LINK TESTS PER NP-760-500
  4. ANTENNA AZIMUTHS AND DOWN TILT USING ELECTRONIC ALIGNMENT TOOL PER ANTENNA INSTALLATION SPECIFICATION HEREIN
  5. POST CONSTRUCTION HEIGHT VERIFICATION AS REQUIRED HERewith IN IN THE TOWER INSTALLATION SPECIFICATIONS.
  6. ASPHALT ROADWAY COMPACTED THICKNESS, SURFACE SMOOTHNESS, AND COMPACTED DENSITY TESTING AS SPECIFIED HERewith IN THE ASPHALT PAVING SPECIFICATIONS.
  7. FIELD QUALITY CONTROL TESTING AS SPECIFIED HERewith IN THE CONCRETE PAVING SPECIFICATIONS.
  8. TESTING REQUIRED HERewith UNDER SPECIFICATIONS FOR AGGREGATE BASE FOR ROADWAYS.
  9. ALL OTHER TESTS REQUIRED BY LOCAL JURISDICTION.
- D. INSPECTIONS BY COMPANY: THE CONTRACTOR SHALL BE RESPONSIBLE FOR ANY AND ALL CORRECTIONS TO ANY WORK IDENTIFIED AS UNACCEPTABLE IN INSPECTION ACTIVITIES, FINAL ACCEPTANCE/PUNCH WALK REVIEW, AND/OR AS A RESULT OF TESTING.
- E. SPRINT RESERVES THE RIGHT TO INSPECT THE CONSTRUCTION SITE AT ANY TIME VIA SITE WALKS AND/OR PHOTO REVIEWS. CONTRACTOR SHALL GIVE SPRINT 24 HOURS NOTICE PRIOR TO COMMENCEMENT.
1. GROUNDING SYSTEM AND BURIED UTILITIES INSTALLATION PRIOR TO EARTH CONCEALMENT DOCUMENTED WITH DIGITAL PHOTOGRAPHS BY CONTRACTOR, APPROVED BY A&E OR SPRINT REPRESENTATIVE.
  2. FORMING FOR CONCRETE AND REBAR PLACEMENT PRIOR TO POUR DOCUMENTED WITH DIGITAL PHOTOGRAPHS BY CONTRACTOR, APPROVED BY A&E OR SPRINT REPRESENTATIVE.
  3. COMPACTION OF BACKFILL MATERIALS, AGGREGATE BASE FOR ROADS, PADS, AND ANCHORS, ASPHALT PAVING, AND SHAFT BACKFILL FOR CONCRETE AND WOOD POLES, BY INDEPENDENT THIRD PARTY AGENCY.
  4. PRE AND POST CONSTRUCTION ROOFTOP AND STRUCTURAL INSPECTIONS ON EXISTING FACILITIES. PRIOR TO CONSTRUCTION ACTIVITIES AND AFTER CONSTRUCTION IS COMPLETE, PROVIDE PHOTOGRAPHIC DOCUMENTATION OF ROOF, FLASHINGS, AND PARAPETS, BOTH BEFORE AND AFTER CONSTRUCTION IS COMPLETE.
  5. TOWER ERECTION SECTION STACKING AND PLATFORM ATTACHMENT DOCUMENTED BY DIGITAL PHOTOGRAPHS BY THIRD PARTY AGENCY.
  6. TOWER TOP AND INACCESSIBLE EQUIPMENT (RRUS, ANTENNAS, AND CABLING): PROVIDE PHOTOS OF THE BACKS OF ALL ANTENNAS, RRUS, COMBINERS, FILTERS, FIBER AND DC CABLING, CABLE COLOR CODING, EQUIPMENT GROUNDING AND CONNECTOR WATER PROOFING INCLUDING NAME PLATE AND SERIAL NUMBER FOR ALL SERIALIZED EQUIPMENT.

PROJECT CLOSEOUT:

- A. FINAL ACCEPTANCE PUNCH WALK AND INSPECTION: AS IDENTIFIED IN THE SCOPE OF SERVICES, SPRINT WILL CONDUCT A FINAL PUNCH WALK OR FINAL DESK TOP PHOTO REVIEW (SITE MODIFICATIONS). PUNCH WALKS MUST BE SCHEDULED IN ADVANCE AS REQUIRED. AT THE PUNCH WALK / REVIEW, SPRINT MAY IDENTIFY CRITICAL DEFICIENCIES WHICH MUST BE CORRECTED PRIOR TO PUTTING SITE ON AIR. MINOR DEFICIENCIES MUST BE CORRECTED WITHIN 30 DAYS EXCEPT AS OTHERWISE REQUIRED. VERIFICATIONS OF CORRECTIONS MAY BE MADE BY COMPANY DURING A REPEAT SITE WALK OR DESK TOP PHOTO REVIEW AT COMPANY'S SOLE DISCRETION.
- B. CLOSEOUT DOCUMENTATION: ALL CLOSEOUT DOCUMENTATION AND PHOTOGRAPHS SHALL BE UPLOADED PRIOR TO FINAL ACCEPTANCE. SPRINT WILL REVIEW CLOSEOUT DOCUMENTATION FOR PRESENCE AND CONTENT. CLOSEOUT DOCUMENTATION SHALL INCLUDE BUT IS NOT LIMITED TO THE FOLLOWING AS APPLICABLE:
1. COAX SWEEP TESTS:
  2. FIBER TESTS:
  3. JURISDICTION FINAL INSPECTION DOCUMENTATION
  4. REINFORCEMENT CERTIFICATION (MILL CERTIFICATION)
  5. CONCRETE MIX DESIGN AND PRODUCT DATA (TOWER FOUNDATION)
  6. LIEN WAIVERS AND RELEASES.
  7. POST -CONSTRUCTION HEIGHT VERIFICATION
  8. JURISDICTION CERTIFICATE OF OCCUPANCY
  9. ELECTRONIC ANTENNA AZIMUTH AND DOWN TILT VERIFICATION
  10. STRUCTURAL BACKFILL TEST RESULTS (IF APPLICABLE)
  11. CELL SITE UTILITY SETUP
  12. AS-BUILT REDLINE CONSTRUCTION DRAWINGS (PDF SCAN OF FIELD MARKS)
  13. AS-BUILT CONSTRUCTION DRAWINGS IN DWG AND PDF FORMATS
  14. LIST OF SUB CONTRACTORS
  15. APPROVED PERMITTING DOCUMENTS
  16. FINAL SITE PHOTOS UP-LOADED TO SITERRA. INCLUDE THE FOLLOWING AS APPLICABLE:
    - a. TOWER, ANTENNAS, RRUS, AND MAINLINE: INSPECTION AND PHOTOGRAPHS OF SECTION STACKING; INSPECTION AND PHOTOGRAPHS OF PLATFORM COMPONENT ATTACHMENT POINTS; PHOTOGRAPHS OF TOWER TOP GROUNDING; PHOTOS OF TOWER COAX/CABLE LINE COLOR CODING AT THE TOP AND AT GROUND LEVEL; INSPECTION AND PHOTOGRAPHS OF OPERATIONAL OF TOWER LIGHTING, AND PLACEMENT OF FAA REGISTRATION SIGN; PHOTOGRAPHS SHOWING ADDITIONAL GROUNDING POINTS FOR TOWERS GREATER THAN 200 FEET.; PHOTOS OF ANTENNA GROUND BAR, EQUIPMENT GROUND BAR, AND MASTER GROUND BAR; PHOTOS OF GPS ANTENNA(S); PHOTOS OF EACH SECTOR OF ANTENNAS; ONE PHOTOGRAPH LOOKING AT THE SECTOR AND ONE FROM BEHIND SHOWING THE PROJECTED COVERAGE AREA; PHOTOS OF COAX WEATHERPROOFING - TOP AND BOTTOM; PHOTOS OF COAX GROUNDING---TOP AND BOTTOM; PHOTOS OF ANTENNA AND MAST GROUNDING; PHOTOS OF COAX CABLE ENTRY INTO SHELTER; PHOTOS OF PLATFORM MECHANICAL CONNECTIONS TO TOWER/MONOPOLE.
    - b. ROOF TOPS: PRE-CONSTRUCTION AND POST-CONSTRUCTION VISUAL INSPECTION AND PHOTOGRAPHS OF THE ROOF AND INTERIOR TO DETERMINE AND DOCUMENT CONDITIONS; ROOF TOP CONSTRUCTION INSPECTIONS AS REQUIRED BY THE JURISDICTION; PHOTOGRAPHS OF CABLE TRAY AND/OR ICE BRIDGE; PHOTOGRAPHS OF DOGHOUSE/CABLE EXIT FROM ROOF;
    - c. SITE LAYOUT - PHOTOGRAPHS OF THE OVERALL COMPOUND, INCLUDING EQUIPMENT PLATFORM FROM ALL FOUR CORNERS.
    - d. FINISHED UTILITIES: CLOSE-UP PHOTOGRAPHS OF THE PPC BREAKER PANEL; CLOSE-UP PHOTOGRAPH OF THE INSIDE OF THE TELCO PANEL AND NIU; CLOSE-UP PHOTOGRAPH OF THE POWER METER AND DISCONNECT; PHOTOS OF POWER AND TELCO ENTRANCE TO COMPANY ENCLOSURE; PHOTOGRAPHS AT METER BOX AND/OR FACILITY DISTRIBUTION PANEL.

PROJECT PHOTOGRAPHS

- A. PROVIDE PROJECT CLOSEOUT GENERAL ARRANGEMENT PHOTOS OF ALL NEW YORK. THE FOLLOWING LIST REPRESENTS MIN. REQUIREMENTS AND MIN QUANTITY. ADDITIONAL PHOTOS MAY BE REQUIRED TO ADEQUATELY DOCUMENT THE WORK
1. ASR AND RF MPE SIGNAGE (IF NOT IN PLACE, SUPPLIER NOTIFIES EMS FIELD REPRESENTATIVE)
  2. BACK OF ANTENNAS AND RRUS (1 EACH SECTOR)
  3. BACK OF ANTENNAS AND RRUS (1 EACH SECTOR) CLOSE UP SHOWING WEATHERPROOFING AND GROUNDING (AS REQUIRED). CLOSE-UP OF BACK SIDE OF EACH PERMANENT RRU SHOWING SERIAL NUMBER/BAR CODE.
  4. VIEW (1 EACH SECTOR) ALONG THE AZIMUTH AND TILT OF THE ANTENNAS
  5. TOP OF TOWER FROM GROUND, 1 EACH SECTOR
  6. MAINLINE HYBRID CABLE ROUTE DOWN TOWER SHOWING FASTENERS AND SUPPORT
  7. MAINLINE/HYBRID CABLE ROUTE ALONG ICE BRIDGE OR IN CABLE TRAY SHOWING FASTENERS AND SUPPORT
  8. GROUND MOUNTED RRU RACKS (FRONT AND BACK)
  9. FRONT, SIDE AND BACK ELEVATIONS OF ALL GROUND CABINETS
  10. VIEW OF COMPOUND FROM A DISTANCE
  11. VIEW OF EACH GROUND CABINET (POWER, RF, FIBER SPOOL, PPC POWER, PPC TELCO WITH DOOR OPEN)
  12. BACKHAUL FIBER MEET-ME-POINT AND CONDUIT ROUTE (MICROWAVE INSTALLATION IF NOT FIBER)
  13. AAV NETWORK INTERFACE DEVICE OR MICROWAVE RADIO INSTALLATION

DEFICIENCY CORRECTIONS:

CONTRACTOR IS RESPONSIBLE FOR ALL CORRECTIONS TO DEFICIENCIES IDENTIFIED THROUGH TESTING, REVIEW OF SUBMITTALS, INSPECTIONS AND CLOSEOUT REVIEWS.

SECTION 01 500-PROJECT REPORTING

WEEKLY REPORTS:

- A. CONTRACTOR SHALL REPORT TO SPRINT AT MINIMUM ON A WEEKLY BASIS VIA SITERRA BY UPDATING ALL APPLICABLE POST END KEEPING MILESTONES WITH ACTUAL AND FORECASTED COMPLETION DATES.
- B. ADDITIONAL REQUIREMENTS FOR REPORTING MAY BE IDENTIFIED ELSEWHERE OR REQUIRED BY THE SCOPE OF SERVICES OR SPRINTS LOCAL MARKET CONSTRUCTION MANAGER. THIS INFORMATION WILL PROVIDE A BASIS FOR PROGRESS MONITORING AND PAYMENT.

PROJECT CONFERENCE CALLS:

SPRINT MAY HOLD PERIODIC PROJECT CONFERENCE CALLS. CONTRACTOR WILL BHE REQUIRED TO COMMUNICATE SITE STATUS, MILESTONE COMPLETIONS AND UPCOMING MILESTONE PROJECTIONS, AND ANSWER ANY OTHER SITE STATUS QUESTIONS AS NECESSARY.

FINAL PROJECT ACCEPTANCE: PRIOR TO SPRINTS FINAL PROJECT ACCEPTANCE. ALL REQUIRED MILESTONE ACTUALS MUST BE UPDATED IN SITERRA AND ALL REQUIRED REPORTING TASKS MUST BE COMPLETE.

SECTION II 700-ANTENNA ASSEMBLY, REMOTE RADIO UNITS AND CABLE INSTALLATION

SUMMARY:

THIS SECTION SPECIFIES INSTALLATION OF ANTENNAS, RRUS, AND CABLE EQUIPMENT, INSTALLATION, AND TESTING OF COAXIAL FIBER CABLE.

ANTENNAS AND RRUS:

THE NUMBER AND TYPE OF ANTENNAS AND RRUS TO BE INSTALLED IS DETAILED ON THE CONSTRUCTION DRAWINGS.

HYBRID CABLE:

HYBRID CABLE WILL DC/FIBER AND FURNISHED FOR INSTALLATION AT EACH SITE. CABLE SHALL BE INSTALLED PER CONSTRUCTION DRAWINGS AND APPLICABLE MANUFACTURER'S REQUIREMENT.

JUMPERS AND CONNECTORS:

FURNISH AND INSTALL 1/2" COAX JUMPER CABLES BETWEEN THE RRUS AND ANTENNAS. JUMPERS SHALL BE LDF 4, FLC 12-50, CR 540, OR FXL 540. SUPER-FLEX CABLES ARE NOT ACCEPTABLE. JUMPERS BETWEEN THE RRUS AND ANTENNAS OR TOWER TOP AMPLIFIERS SHALL CONSIST OF 1/2 INCH FOAM DIELECTRIC, OUTDOOR RATED COAXIAL, MIN. LENGTH FOR JUMPER SHALL BE 10'-0"

REMOTE ELECTRICAL TILT (RET) CABLES:

MISCELLANEOUS:

INSTALL SPLITTERS, COMBINERS, FILTERS PER RF DATA SHOW, FURNISHED BY SPRINT.

ANTENNA INSTALLATION:

THE CONTRACTOR SHALL ASSEMBLE ALL ANTENNAS ONSITE IN ACCORDANCE WITH THE INSTRUCTIONS SUPPLIED BY THE MANUFACTURER. ANTENNA HEIGHT, AZIMUTH, AND FEED ORIENTATION INFORMATION SHALL BE A DESIGNATED ON THE CONSTRUCTION DRAWINGS.

- A. THE CONTRACTOR SHALL POSITION THE ANTENNA ON TOWER PIPE MOUNTS SO THAT THE BOTTOM STRUT IS LEVEL. THE PIPE MOUNTS SHALL BE PLUMB TO WITHIN 1 DEGREE
- B. ANTENNA MOUNTING REQUIREMENTS: PROVIDE ANTENNA MOUNTING HARDWARE AS INDICATED ON THE DRAWINGS

HYBRID CABLE INSTALLATION:

A. THE CONTRACTOR SHALL ROUTE, TEST, AND INSTALL ALL CABLES AS INDICATED ON THE CONSTRUCTION DRAWINGS AND IN ACCORDANCE WITH THE MANUFACTURER'S RECOMMENDATIONS

- B. THE INSTALLED RADIUS OF THE CABLES SHALL NOT BE LESS THAN THE MANUFACTURER'S SPECS FOR BENDING RADII
- C. EXTREME CARE SHALL BE TAKEN TO AVOID DAMAGE TO THE CABLES DURING HANDLING AND INSTALLATION.

1. FASTENING MAIN HYBRID CABLES: ALL CABLES SHALL BE INSTALLED INSIDE MONOPOLE WITH CABLE SUPPORT GRIPS AS REQUIRED BY THE MANUFACTURER
2. FASTENING INDIVIDUAL FIBER & DC CABLES ABOVE BREAKOUT ENCLOSURE, WITHIN THE MMBS CABINET AND ANY INTERMEDIATE DISTRIBUTION BOXES

1. FASTENING MAIN HYBRID CABLES: ALL CABLES SHALL BE INSTALLED INSIDE MONOPOLE WITH CABLE SUPPORT GRIPS AS REQUIRED BY THE MANUFACTURER
2. FASTENING INDIVIDUAL FIBER & DC CABLES ABOVE BREAKOUT ENCLOSURE, WITHIN THE MMBS CABINET AND ANY INTERMEDIATE DISTRIBUTION BOXES
  - a. INSPECT CABLE PRIOR TO USE FOR SHIPPING DAMAGE, NOTIFY THE CONSTRUCTION MANAGER.
  - b. CABLE ROUTING: CABLE INSTALLATION SHALL BE PLANNED TO ENSURE THAT THE LIENS WILL BE PROPERLY ROUTED IN THE CABLE ENVELOP AS INDICATED ON THE DRAWINGS. AVOID TWISTING AND CROSSOVERS.
  - c. HOIST CABLE USING PROPER HOISTING GRIPS. DO NOT EXCEED MANUFACTURER'S RECOMMENDED MAXIMUM BEND RADIUS
3. FASTENING JUMPERS: SECURE JUMPERS TO THE SIDE ARMS OR HEAD FRAMES USING STAINLESS STEEL TIE WRAPS OR STAINLESS STEEL BUTTERFLY CLIPS.
4. CABLE INSTALLATION:
  - a. INSPECT CABLE PRIOR TO USE FOR SHIPPING DAMAGE, NOTIFY THE CONSTRUCTION MANAGER.
  - b. CABLE ROUTING: CABLE INSTALLATION SHALL BE PLANNED TO ENSURE THAT THE LINES WILL BE PROPERLY ROUTED IN THE CABLE ENVELOP AS INDICATED ON THE DRAWINGS. AVOID TWISTING AND CROSSOVERS
  - c. HOIST CABLE USING PROPER HOISTING GRIPS. DO NOT EXCEED MANUFACTURER'S RECOMMENDED MAXIMUM BEND RADIUS.
5. GROUNDING OF TRANSMISSION LINES: ALL TRANSMISSION LINES SHALL BE GROUNDED AS INDICATED ON DRAWINGS.
6. HYBRID CABLE COLOR CODING: ALL COLOR CODING SHALL BE AS REQUIRED IN TS 0200 (CURRENT VERSION)
7. HYBRID CABLE LABELING: INDIVIDUAL HYBRID AND DC BUNDLES SHALL BE LABELED ALPHA-NUMERICALLY ACCORDING TO SPRINT CELL SITE ENGINEERING NOTICE-EN2012-001, REV 1

WEATHERPROOFING EXTERIOR CONNECTORS AND HYBRID CABLE GROUND KITS:

- A. ALL FIBER & COAX CONNECTORS AND GROUND KITS SHALL BE WEATHERPROOFED.
- B. WEATHERPROOFED USING ONE OF THE FOLLOWING METHODS. ALL INSTALLATIONS MUST BE DONE IN ACCORDANCE WITH THE MANUFACTURER'S RECOMMENDATIONS AND INDUSTRY BEST PRACTICES.
  1. COLD SHRINK: ENCOMPASS CONNECTOR IN COLD SHRINK TUBING AND PROVIDE A DOUBLE WRAP OR 2" ELEC TAPE EXTENDING 2" BEYOND TUBING. PROVIDE 3M COLD SHRINK CXS SERIES OR EQUAL.
  2. SELF AMALGAMATING TAPE: CLEAN SURFACES. APPLY A DOUBLE WRAP OF SELF-AMALGAMATING TAPE 2" BEYOND CONNECTOR. APPLY A SECOND WRAP OF SELF AMALGAMATING TAPE IN OPPOSITE DIRECTION. APPLY DOUBLE WRAP OF 2" WIDE ELEC TAPE EXTENDING 2" BEYOND SELF-AMALGAMATING TAPE.
  3. 3M SLIM LOCK CLOSURE 7 16: SUBSTITUTIONS WILL NOT BE ALLOWED.
  4. OPEN FLAME ON JOB SITE IS NOT ACCEPTABLE

SECTION 11 800-INSTALLATION OF MULTIMODAL BASE STATIONS AND RELATED EQUIPMENT:

SUMMARY:

- A. THIS SECTION SPECIFIES MMBS CABINETS, POWER CABINETS, AND INTERNAL EQUIPMENT INCLUDING BUT NOT LIMITED TO RECTIFIERS, POWER DIST UNITS, BASE BAND UNITS, SURGE ARRESTORS, BATTERIES, AND SIMILAR EQUIPMENT FURNISHED BY THE COMPANY FOR INSTALLATION BY THE CONTRACTOR (OFCI)
- B. CONTRACTOR SHALL PROVIDE AND INSTALL ALL MISC MATERIALS AND PROVIDE ALL LABOR REQUIRED FOR INSTALLATION EQUIPMENT IN EXISTING CABINET OR NEW CABINET AS SHOWN ON DRAWINGS AND REQUIRED BY THE APPLICABLE INSTALLATION MOPS.
- C. COMPLY WITH MANUFACTURER'S INSTALLATION AND START-UP REQUIREMENTS.

DC CIRCUIT BREAKER LABELING:

A. NEW DC CIRCUIT IS REQUIRED IN MMBS CABINET SHALL BE CLEARLY IDENTIFIED AS TO RRU BEING SERVICED.

SECTION 26-100-BASIC ELECTRICAL REQUIREMENTS

SUMMARY:

THIS SECTION SPECIFIES BASIC ELECTRICAL REQUIREMENTS FOR SYSTEMS AND COMPONENTS

QUALITY ASSURANCE:

- A. ALL EQUIPMENT FURNISHED UNDER DIVISION 26 SHALL CARRY UL LABELS AND LISTINGS WHERE SUCH LABELS AND LISTINGS ARE AVAILABLE IN THE INDUSTRY
- B. MANUFACTURERS OR EQUIPMENT SHALL HAVE A MINIMUM OF THREE YEARS EXPERIENCE WITH THEIR EQUIPMENT INSTALLED AND OPERATING IN THE FIELD IN A USE SIMILAR TO THE PROPOSED USE FOR THIS PROJECT.

C. MATERIALS AND EQUIPMENT: ALL MATERIALS AND EQUIPMENT SPECIFIED IN DIVISION 26 OF THE SAME TYPE SHALL BE OF THE SAME MANUFACTURER AND SHALL BE NEW, OF THE BEST QUALITY AND DESIGN AND FREE FROM DEFECTS.

SUPPORTING DEVICES:

- A. MANUFACTURED STRUCTURAL SUPPORT MATERIALS: SUBJECT TO COMPLIANCE WITH REQUIREMENTS PROVIDE PRODUCTS BY THE FOLLOWING
  1. ALLIED TUBE AND CONDUIT
  2. B-LINE SYSTEM
  3. UNISTRUT DIVERSIFIED PRODUCTS.
  4. THOMAS & BETTS
- B. FASTENERS: TYPES, MATERIALS, AND CONSTRUCTION FEATURES AS FOLLOWS:
  1. EXPANSION ANCHORS: CARBON STEEL WEDGE OR SLEEVE TYPE.
  2. POWER-DRIVEN THREADED STUDS: HEAT-TREATED STEEL DESIGNED SPECIFICALLY FOR THE INTENDED SERVICE
  3. FASTEN BY MEANS OF WOOD SCREWS ON WOOD.
  4. TOGGLE BOLTS ON HOLLOW MASONRY UNITS.
  5. CONCRETE INSERTS OR EXPANSION BOLTS ON CONCRETE SOLID MASONRY.
  6. MACHINE SCREWS, WELDED THREADED STUDS, OR SPRINT-TENSION CLAMPS ON STEEL.
  7. EXPLOSIVE DEVICES FOR ATTACHING HANGERS TO STRUCTURE SHALL NOT BE PERMITTED.
  8. DO NOT WELD CONDUIT, PIPE STRAPS, OR ITEMS OTHER THAN THREADED STUDS TO STEEL STRUCTURES
  9. IN PARTITIONS OF LIGHT STEEL CONSTRUCTION, USE SHEET METAL SCREWS.



1 INTERNATIONAL BLVD., SUITE 800  
MAHWAH, NJ 07495  
TEL: (201) 684-4000  
FAX: (201) 684-4223



1280 ROUTE 46 WEST  
PARSIPPANY, NJ 07054  
TELEPHONE: 646-544-5324



604 FOX GLEN  
BARRINGTON, IL 60010  
TELEPHONE: 847-277-0070  
FAX : 847-277-0080  
AE@westchesterservices.com

JOHN M. BANKS  
ARCHITECT

604 FOX GLEN  
BARRINGTON, IL 60010  
TELEPHONE: 847-277-0070  
FAX : 847-277-0080

THESE DOCUMENTS ARE  
CONFIDENTIAL AND ARE THE  
SOLE PROPERTY OF SPRINT AND  
MAY NOT BE REPRODUCED,  
DISSEMINATED OR REDISTRIBUTED  
WITHOUT THE EXPRESS WRITTEN  
CONSENT OF SPRINT.

0	11.15.17	FINAL CD
NO.	DATE	DESCRIPTION
DRAWN BY: JS		
CHECKED BY: JMB		
JOB NUMBER: CT52XC055-C		
ARCHITECT: JOHN BANKS		



39 CHERRY AVE SS

SITE NUMBER

CT52XC055-C

SITE LOCATION

253 CHERRY STREET  
WATERBURY, CT 06702  
NEW HAVEN COUNTY

SHEET TITLE

SPRINT  
SPECIFICATIONS

SHEET NUMBER

SP-2

**SUPPORTING DEVICES:**

- A. INSTALL SUPPORTING DEVICES TO FASTEN ELECTRICAL COMPONENTS SECURELY AND PERMANENTLY IN ACCORDANCE WITH NEC.
- B. COORDINATE WITH THE BUILDING STRUCTURAL SYSTEM AND WITH OTHER TRADES
- C. UNLESS OTHERWISE INDICATED ON THE DRAWINGS, FASTEN ELECTRICAL ITEMS AND THEIR SUPPORTING HARDWARE SECURELY TO THE STRUCTURE IN ACCORDANCE WITH THE FOLLOWING:
  - 1. ENSURE THAT THE LOAD APPLIED BY ANY FASTENER DOES NOT EXCEED 25 PERCENT OF THE PROOF TEST LOAD.
  - 2. USE VIBRATION AND SHOCK-RESISTANT FASTENERS FOR ATTACHMENTS TO CONCRETE SLABS.

**ELECTRICAL IDENTIFICATION:**

- A. UPDATE AND PROVIDE TYPED CIRCUIT BREAKER SCHEDULES IN THE MOUNTING BRACKET, INSIDE DOORS OF AC PANEL BOARDS WITH ANY CHANGES MADE TO THE AC SYSTEM.
- B. BRANCH CIRCUITS FEEDING AVIATION OBSTRUCTION LIGHTING EQUIPMENT SHALL BE CLEARLY IDENTIFIED AT THE BRANCH CIRCUIT PANELBOARD.

**SECTION 26 200-ELECTRICAL MATERIALS AND EQUIPMENT**

- A. RIGID GALVANIZED STEEL (RGS) CONDUIT SHALL BE USED FOR EXTERIOR LOCATIONS ABOVE GROUND AND IN UNFINISHED INTERIOR LOCATIONS AND FOR UNDERGROUND RUNS. RIGID CONDUIT AND FITTINGS SHALL BE STEEL, COATED WITH ZINC EXTERIOR AND INTERIOR BY THE HOT DIP GALVANIZING PROCESS. CONDUIT SHALL BE PRODUCED TO ANSI SPECIFICATIONS C80.1, FEDERAL SPECIFICATION WW-C-581 AND SHALL BE LISTED WITH THE UNDERWRITER'S LABORATORIES. FITTINGS SHALL BE THREADED - SET SCREW OR COMPRESSION FITTINGS WILL NOT BE ACCEPTABLE. RGS CONDUITS SHALL BE MANUFACTURED BY ALLIED, REPUBLIC OR WHEATLAND.
- B. UNDERGROUND CONDUIT IN CONCRETE SHALL BE POLYVINYLCHLORIDE (PVC) SUITABLE FOR DIRECT BURIAL AS APPLICABLE. JOINTS SHALL BE BELLED, AND FLUSH SOLVENT WELDED IN ACCORDANCE WITH MANUFACTURER'S INSTRUCTIONS. CONDUIT SHALL BE CARLON ELECTRICAL PRODUCTS OR APPROVED EQUAL.
- C. TRANSITIONS BETWEEN PVC AND RIGID (RGS) SHALL BE MADE WITH PVC COATED METALLIC LONG SWEEP RADIUS ELBOWS.
- D. EMT OR RIGID GALVANIZED STEEL MAYBE USED IN FINISHED SPACES CONCEALED IN WALLS AND CEILINGS. EMT SHALL BE MILD STEEL, ELECTRICALLY WELDED, ELECTRO-GALVANIZED OR HOT DIPPED GALVANIZED AND PRODUCED TO ANSI SPECIFICATION C80.3, FEDERAL SPECIFICATION WW-C-563, AND SHALL BE UL LISTED. EMT SHALL BE MANUFACTURED BY ALLIED, REPUBLIC, OR WHEATLAND, OR APPROVED EQUAL. FITTINGS SHALL BE METALLIC COMPRESSION. SET SCREW CONNECTIONS SHALL NOT BE ACCEPTABLE.
- E. LIQUID TIGHT FLEXIBLE METALLIC CONDUIT SHALL BE USED FOR FINAL CONNECTION TO EQUIPMENT. FITTINGS SHALL BE METALLIC GLAND TYPE COMPRESSION FITTINGS, MAINTAINING THE INTEGRITY OF THE CONDUIT SYSTEM. SET SCREW CONNECTIONS SHALL NOT BE ACCEPTABLE. MAXIMUM LENGTH OF FLEXIBLE CONDUIT SHALL NOT EXCEED 6 FEET. LFMC SHALL BE PROTECTED AND SUPPORTED AS REQUIRED BY NEC. MANUFACTURERS OF FLEXIBLE CONDUITS SHALL BE CAROL, ANACONDA METAL HOSE OR UNIVERSAL METAL HOSE, OR APPROVED EQUAL.
- F. MINIMUM SIZE CONDUIT SHALL BE 3/4 INCH (21 MM)

**HUBS AND BOXES:**

- A. AT ENTRANCES TO CABINETS OR OTHER EQUIPMENT NOT HAVING INTEGRAL THREADED HUBS PROVIDE METALLIC THREADED HUBS OF THE SIZE AND CONFIGURATION REQUIRED. HUB SHALL INCLUDE LOCKNUT AND NEOPRENE O-RING SEAL. PROVIDE IMPACT RESISTANT 105 DEGREE C PLASTIC BUSHINGS TO PROTECT CABLE INSULATION.
- B. CABLE TERMINATION FITTINGS FOR CONDUIT
  - 1. CABLE TERMINATORS FOR RGS CONDUITS SHALL BE TYPE CRC BY O-Z/GEDNEY OR EQUAL BY ROXTEC.
  - 2. CABLE TERMINATORS FOR LFMC SHALL BE ETCO - CL2075; OR MADE FOR THE PURPOSE PRODUCTS BY ROXTEC.
- C. EXTERIOR PULL BOXES AND PULL BOXES IN INTERIOR INDUSTRIAL AREAS SHALL BE PLATED CAST ALLOY, HEAVY DUTY, WEATHERPROOFED, DUST PROOF, WITH GASKET, PLATED IRON ALLOY COVER AND STAINLESS STEEL COVER SCREWS, CROUSE-HINDS FORM 8 OR EQUAL
- D. CONDUIT OUTLET BODIES SHALL BE PLATED CAST ALLOY WITH SIMILAR GASKET COVERS, OUTLET BODIES SHALL BE OF THE CONFIGURATION AND SIZE SUITABLE FOR THE APPLICATION. PROVIDE CROUSE-HINDS FORM 8 OR EQUAL.
- E. MANUFACTURER FOR BOXES AND COVERS SHALL BE HOFFMAN, SQUARE"D", CROUSE-HINDS, COOPER, ADALET, APPLETON, O-Z GEDNEY, OR APPROVED EQUAL.

**SUPPLEMENTAL GROUNDING SYSTEM:**

- A. FURNISH AND INSTALL A SUPPLEMENTAL GROUNDING SYSTEM TO THE EXTENT INDICATED ON THE DRAWINGS. SUPPORT SYSTEM WITH NON-MAGNETIC STAINLESS STEEL CLIPS WITH RUBBER GROMMETS. GROUNDING CONNECTORS SHALL BE TINNED COPPER WIRE.
- B. SUPPLEMENTAL GROUNDING SYSTEM: ALL CONNECTIONS TO BE MADE WITH CAD WELDS, EXCEPT AT EQUIPMENT USE LUGS OR OTHER AVAILABLE GROUNDING MEANS AS REQUIRED BY MANUFACTURER; AT GROUND BARS USE TWO HOLE SPADES WITH NO-OX
- C. STOLEN GROUND BARS: IN THE EVENT OF STOLEN GROUND BARS, CONTACT SPRINT CM FOR REPLACEMENT INSTRUCTION USING THREADED RODS.

**EXISTING STRUCTURE:**

- A. EXISTING EXPOSED WIRING AND ALL EXPOSED OUTLETS, RECEPTACLES, SWITCHES, DEVICES, BOXES AND OTHER EQUIPMENT THAT ARE NOT TO BE UTILIZED IN THE COMPLETED PROJECT SHALL BE REMOVED OR DE-ENERGIZED AND CAPPED IN THE WALL, CEILING, OR FLOOR SO THAT THEY ARE CONCEALED AND SAFE. WALL, CEILING, OR FLOOR SHALL BE PATCHED TO MATCH THE ADJACENT CONSTRUCTION.

**CONDUIT AND CONDUCTOR INSTALLATION:**

- A. CONDUITS SHALL BE FASTENED SECURELY IN PLACE WITH APPROVED NON-PERFORATED STRAPS AND HANGERS. EXPLOSIVE DEVICES FOR ATTACHING HANGERS TO STRUCTURE WILL NOT BE PERMITTED. CLOSELY FOLLOW THE LINES OF THE STRUCTURE, MAINTAIN CLOSE PROXIMITY TO THE STRUCTURE AND KEEP CONDUITS IN TIGHT ENVELOPES. CHANGES IN DIRECTION TO ROUTE AROUND OBSTACLES SHALL BE MADE WITH CONDUIT OUTLET BODIES. CONDUIT SHALL BE INSTALLED IN A NEAT AND WORKMANLIKE MANNER, PARALLEL, AND PERPENDICULAR TO STRUCTURE WALL AND CEILING LINES. ALL CONDUIT SHALL BE FISHED TO CLEAR OBSTRUCTIONS. ENDS OF CONDUITS SHALL BE TEMPORARILY CAPPED TO PREVENT CONCRETE, PLASTER OR DIRT FROM ENTERING. CONDUITS SHALL BE RIGIDLY CLAMPED TO BOXES BY GALVANIZED MALLEABLE IRON BUSHING ON INSIDE AND GALVANIZED MALLEABLE IRON LOCKNUT ON OUTSIDE AND INSIE.
- B. CONDUCTORS SHALL BE PULLED IN ACCORDANCE WITH ACCEPTED GOOD PRACTICE.

**Sprint**  
 1 INTERNATIONAL BLVD., SUITE 800  
 MAHWAH, NJ 07495  
 TEL: (201) 684-4000  
 FAX: (201) 684-4223

**Cherundolo Consulting**  
 1280 ROUTE 46 WEST  
 PARSIPPANY, NJ 07054  
 TELEPHONE: 646-544-5324

**WESTCHESTER SERVICES LLC**  
 604 FOX GLEN  
 BARRINGTON, IL 60010  
 TELEPHONE: 847-277-0070  
 FAX : 847-277-0080  
 AE@westchesterservices.com

**JOHN M. BANKS ARCHITECT**  
 604 FOX GLEN  
 BARRINGTON, IL 60010  
 TELEPHONE: 847-277-0070  
 FAX : 847-277-0080

THESE DOCUMENTS ARE CONFIDENTIAL AND ARE THE SOLE PROPERTY OF SPRINT AND MAY NOT BE REPRODUCED, DISSEMINATED OR REDISTRIBUTED WITHOUT THE EXPRESS WRITTEN CONSENT OF SPRINT.

0	11.15.17	FINAL CD
NO.	DATE	DESCRIPTION
DRAWN BY: JS		
CHECKED BY: JMB		
JOB NUMBER: CT52XC055-C		
ARCHITECT: JOHN BANKS		



SITE NAME

39 CHERRY AVE SS

SITE NUMBER

CT52XC055-C

SITE LOCATION

253 CHERRY STREET  
WATERBURY, CT 06702  
NEW HAVEN COUNTY

SHEET TITLE

SPRINT SPECIFICATIONS

SHEET NUMBER

SP-3

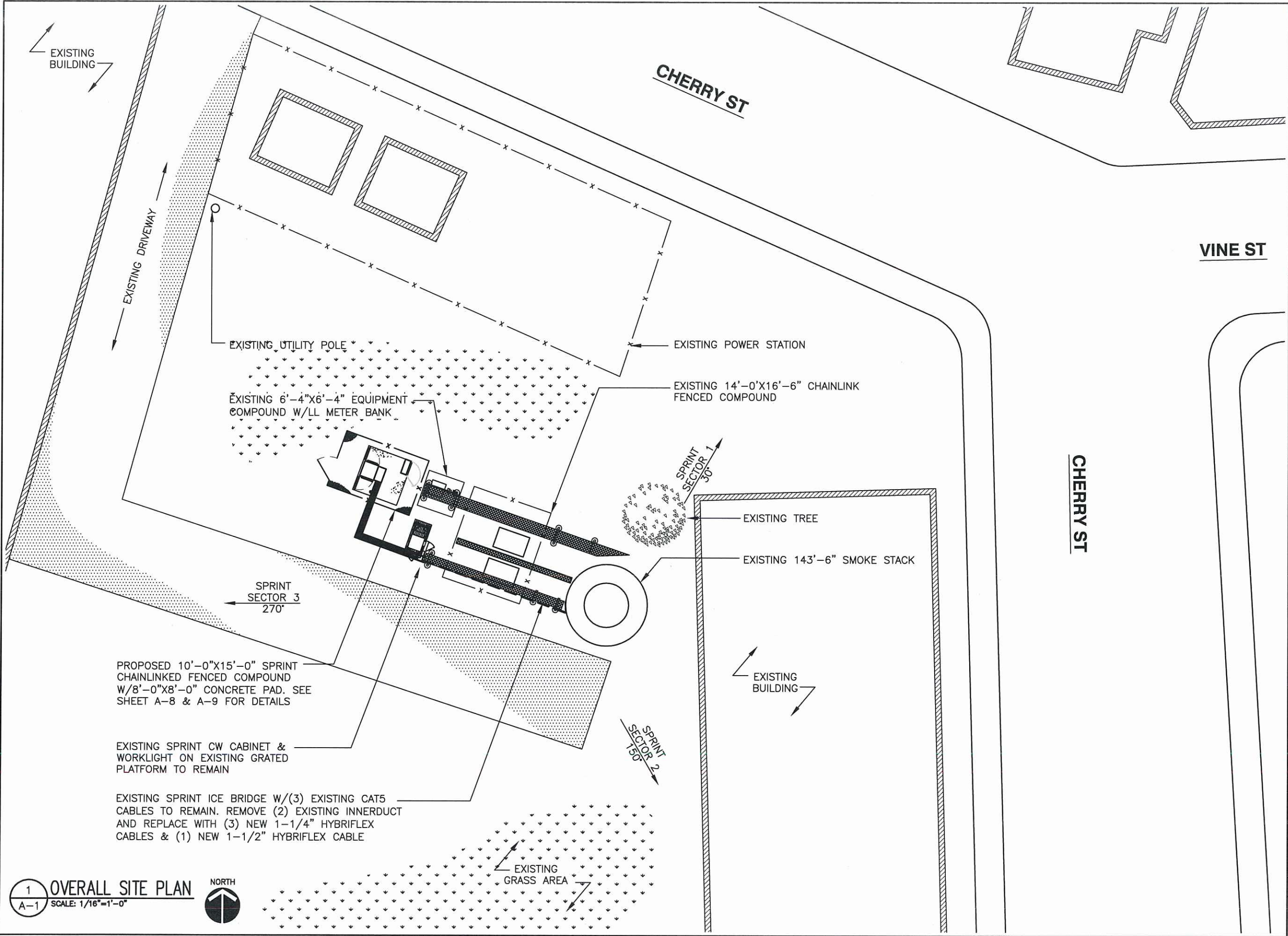

1 INTERNATIONAL BLVD., SUITE 800  
 MAHWAH, NJ 07495  
 TEL: (201) 684-4000  
 FAX: (201) 684-4223



1280 ROUTE 46 WEST  
 PARSIPPANY, NJ 07054  
 TELEPHONE: 646-544-5324



604 FOX GLEN  
 BARRINGTON, IL 60010  
 TELEPHONE: 847-277-0070  
 FAX: 847-277-0080  
 AE@westchesterservices.com

**JOHN M. BANKS  
 ARCHITECT**

604 FOX GLEN  
 BARRINGTON, IL 60010  
 TELEPHONE: 847-277-0070  
 FAX: 847-277-0080

THESE DOCUMENTS ARE  
 CONFIDENTIAL AND ARE THE  
 SOLE PROPERTY OF SPRINT AND  
 MAY NOT BE REPRODUCED,  
 DISSEMINATED OR REDISTRIBUTED  
 WITHOUT THE EXPRESS WRITTEN  
 CONSENT OF SPRINT.

0	11.15.17	FINAL CD
NO.	DATE	DESCRIPTION
DRAWN BY: JS		
CHECKED BY: JMB		
JOB NUMBER: CT52XC055-C		
ARCHITECT: JOHN BANKS		



SITE NAME

39 CHERRY AVE SS

SITE NUMBER

CT52XC055-C

SITE LOCATION

253 CHERRY STREET  
 WATERBURY, CT 06702  
 NEW HAVEN COUNTY

SHEET TITLE

OVERALL SITE PLAN

SHEET NUMBER

A-1

1 OVERALL SITE PLAN  
 A-1 SCALE: 1/16"=1'-0"



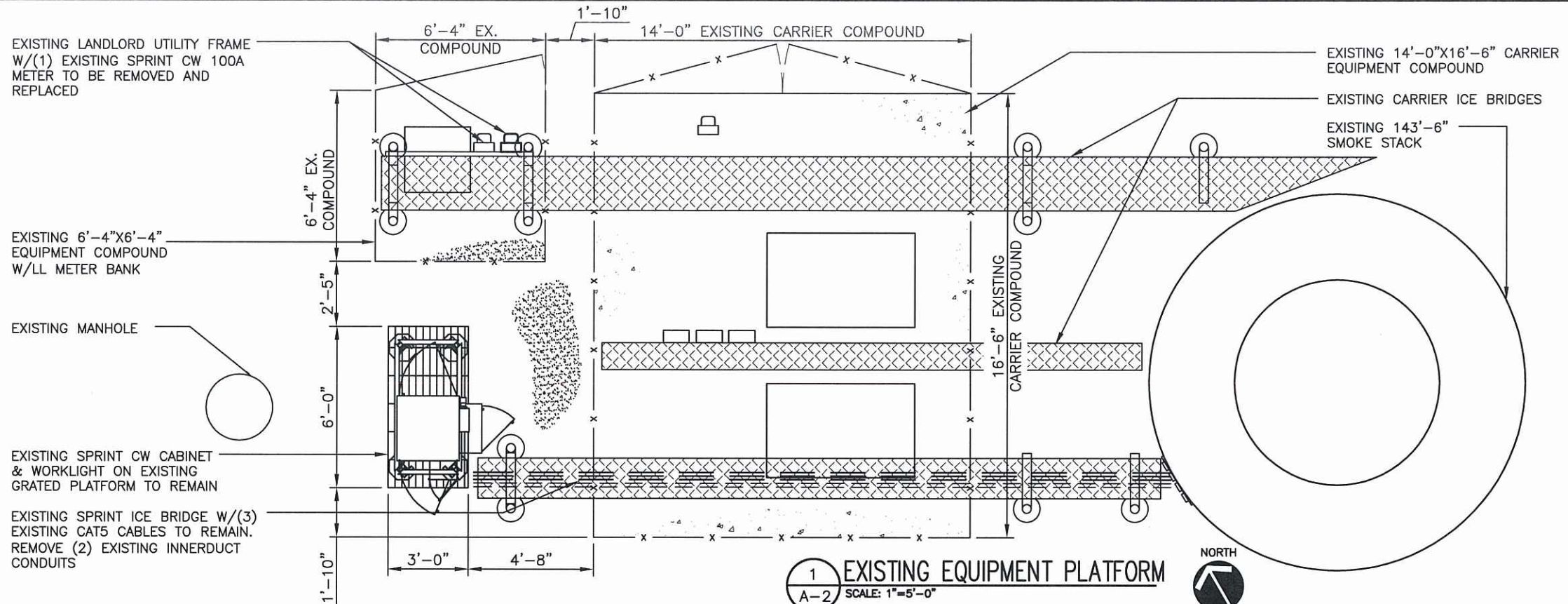

1  
A-2  
EXISTING EQUIPMENT PLATFORM  
SCALE: 1"=5'-0"

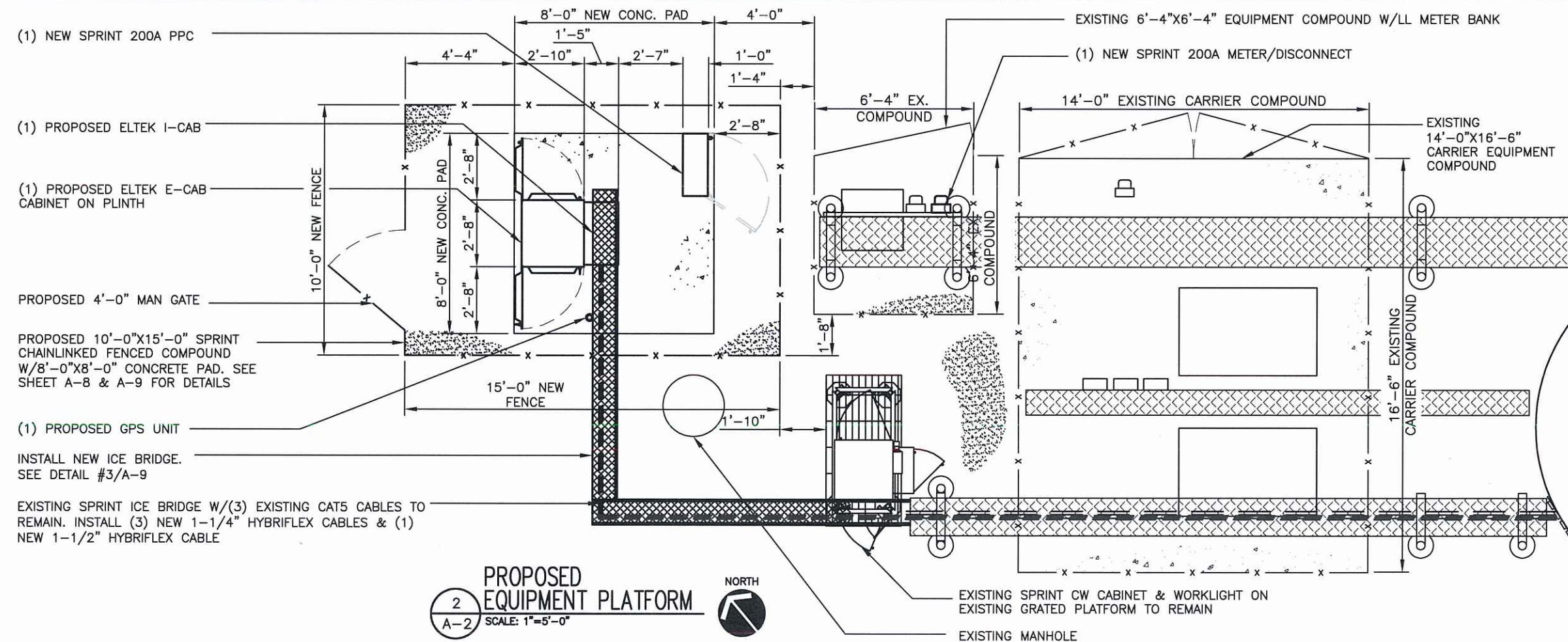

2  
A-2  
PROPOSED EQUIPMENT PLATFORM  
SCALE: 1"=5'-0"



**Sprint**  
1 INTERNATIONAL BLVD., SUITE 800  
MAHWAH, NJ 07495  
TEL: (201) 684-4000  
FAX: (201) 684-4223

**Cherundolo Consulting**  
1280 ROUTE 46 WEST  
PARSIPPANY, NJ 07054  
TELEPHONE: 646-544-5324

**WESTCHESTER SERVICES LLC**  
604 FOX GLEN  
BARRINGTON, IL 60010  
TELEPHONE: 847-277-0070  
FAX: 847-277-0080  
AE@westchesterservices.com

**JOHN M. BANKS ARCHITECT**  
604 FOX GLEN  
BARRINGTON, IL 60010  
TELEPHONE: 847-277-0070  
FAX: 847-277-0080

THESE DOCUMENTS ARE CONFIDENTIAL AND ARE THE SOLE PROPERTY OF SPRINT AND MAY NOT BE REPRODUCED, DISSEMINATED OR REDISTRIBUTED WITHOUT THE EXPRESS WRITTEN CONSENT OF SPRINT.

0	11.15.17	FINAL CD
NO.	DATE	DESCRIPTION
DRAWN BY: JS		
CHECKED BY: JMB		
JOB NUMBER: CT52XC055-C		
ARCHITECT: JOHN BANKS		



SITE NAME  
39 CHERRY AVE SS

SITE NUMBER  
CT52XC055-C

SITE LOCATION  
253 CHERRY STREET  
WATERBURY, CT 06702  
NEW HAVEN COUNTY

SHEET TITLE  
EQUIPMENT LAYOUT

SHEET NUMBER  
A-2



EXISTING CARRIER ANTENNAS TO REMAIN

(2) EXISTING SPRINT 12" DISH ANTENNAS & (1) EXISTING SPRINT 24" DISH ANTENNA TO REMAIN

(1) PROPOSED SPRINT KMW TRI-BAND ANTENNA W/(2) PROPOSED 800MHZ RRH, (1) PROPOSED 1900MHZ RRH & (1) PROPOSED 2500MHZ RRH ON NEW 3" SCHED. 40 GALV. MOUNTING PIPE (TYP. OF 3 SECTORS)

EXISTING CARRIER ANTENNAS TO REMAIN

(3) EXISTING CAT5 CABLES ROUTED UP INSIDE OF SMOKE STACK TO REMAIN. REMOVE (2) EXISTING 2" INNERDUCT AND REPLACE WITH (3) NEW 1-1/4" HYBRIFLEX CABLES & (1) NEW 1-1/2" HYBRIFLEX CABLE

EXISTING 14'-0"x16'-6" CARRIER EQUIPMENT COMPOUND

EXISTING 6'-4"x6'-4" EQUIPMENT COMPOUND W/LL METER BANK

EXISTING SPRINT CW CABINET & WORKLIGHT ON EXISTING GRATED PLATFORM TO REMAIN

(1) PROPOSED GPS UNIT

(1) PROPOSED ELTEK I-CAB CABINET

PROPOSED 10'-0"x15'-0" SPRINT CHAINLINKED FENCED COMPOUND W/8'-0"x8'-0" CONCRETE PAD. SEE SHEET A-8 & A-9 FOR DETAILS

(1) PROPOSED ELTEK E-CAB CABINET ON PLINTH

(1) NEW SPRINT 200A PPC

INSTALL NEW ICE BRIDGE. SEE DETAIL #3/A-9

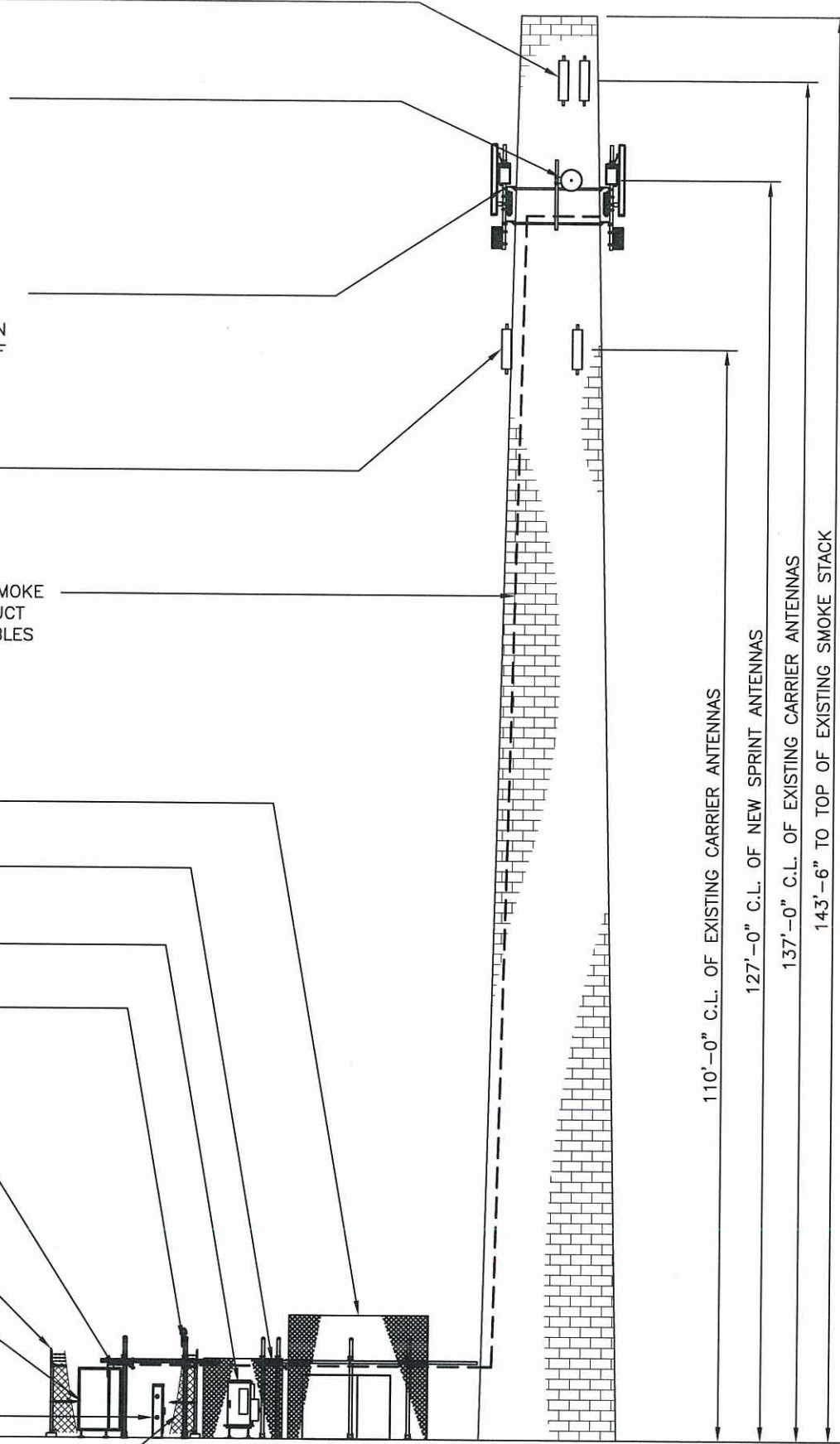

110'-0" C.L. OF EXISTING CARRIER ANTENNAS

127'-0" C.L. OF NEW SPRINT ANTENNAS

137'-0" C.L. OF EXISTING CARRIER ANTENNAS

143'-6" TO TOP OF EXISTING SMOKE STACK

1 SMOKE STACK ELEVATION (NORTH)  
A-3 SCALE: 1/16"=1'-0"



1 INTERNATIONAL BLVD., SUITE 800  
MAHWAH, NJ 07495  
TEL: (201) 684-4000  
FAX: (201) 684-4223



1280 ROUTE 46 WEST  
PARSIPPANY, NJ 07054  
TELEPHONE: 646-544-5324



604 FOX GLEN  
BARRINGTON, IL 60010  
TELEPHONE: 847-277-0070  
FAX : 847-277-0080  
AE@westchesterservices.com



604 FOX GLEN  
BARRINGTON, IL 60010  
TELEPHONE: 847-277-0070  
FAX : 847-277-0080

THESE DOCUMENTS ARE CONFIDENTIAL AND ARE THE SOLE PROPERTY OF SPRINT AND MAY NOT BE REPRODUCED, DISSEMINATED OR REDISTRIBUTED WITHOUT THE EXPRESS WRITTEN CONSENT OF SPRINT.

NO.	DATE	DESCRIPTION
0	11.15.17	FINAL CD

DRAWN BY: JS  
CHECKED BY: JMB  
JOB NUMBER: CT52XC055-C  
ARCHITECT: JOHN BANKS



SITE NAME

39 CHERRY AVE SS

SITE NUMBER

CT52XC055-C

SITE LOCATION

253 CHERRY STREET  
WATERBURY, CT 06702  
NEW HAVEN COUNTY

SHEET TITLE

SMOKE STACK  
ELEVATION

SHEET NUMBER

A-3

**Sprint**  
 1 INTERNATIONAL BLVD., SUITE 800  
 MAHWAH, NJ 07495  
 TEL: (201) 684-4000  
 FAX: (201) 684-4223

**Cherundolo Consulting**

1280 ROUTE 46 WEST  
 PARSIPPANY, NJ 07054  
 TELEPHONE: 646-544-5324

**WESTCHESTER SERVICES LLC**

604 FOX GLEN  
 BARRINGTON, IL 60010  
 TELEPHONE: 847-277-0070  
 FAX : 847-277-0080  
 AE@westchesterservices.com

**JOHN M. BANKS ARCHITECT**

604 FOX GLEN  
 BARRINGTON, IL 60010  
 TELEPHONE: 847-277-0070  
 FAX : 847-277-0080

THESE DOCUMENTS ARE CONFIDENTIAL AND ARE THE SOLE PROPERTY OF SPRINT AND MAY NOT BE REPRODUCED, DISSEMINATED OR REDISTRIBUTED WITHOUT THE EXPRESS WRITTEN CONSENT OF SPRINT.

0	11.15.17	FINAL CD
NO.	DATE	DESCRIPTION
DRAWN BY: JS		
CHECKED BY: JMB		
JOB NUMBER: CT52XC055-C		
ARCHITECT: JOHN BANKS		



SITE NAME

39 CHERRY AVE SS

SITE NUMBER

CT52XC055-C

SITE LOCATION

253 CHERRY STREET  
 WATERBURY, CT 06702  
 NEW HAVEN COUNTY

SHEET TITLE

ANTENNA LAYOUT

SHEET NUMBER

A-4

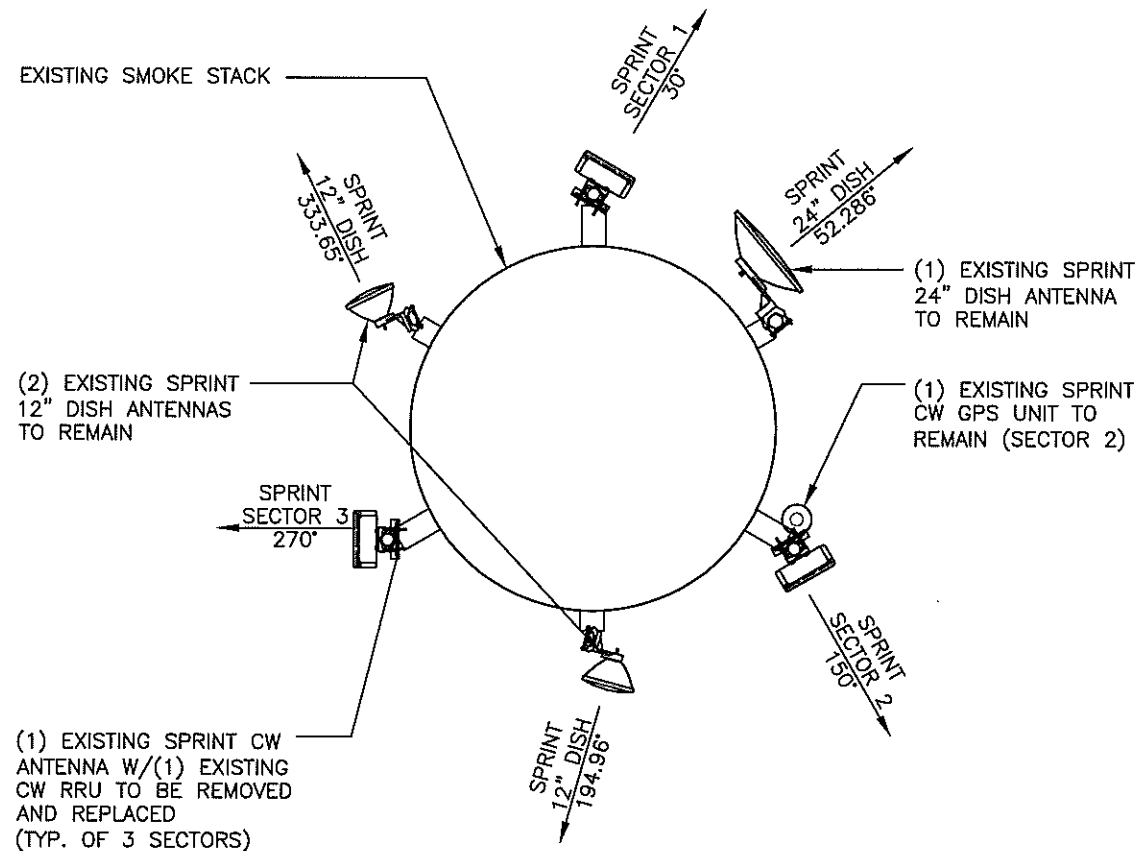

1 EXISTING ANTENNA PLAN  
 A-4 SCALE: 1/4"=1'-0" NORTH

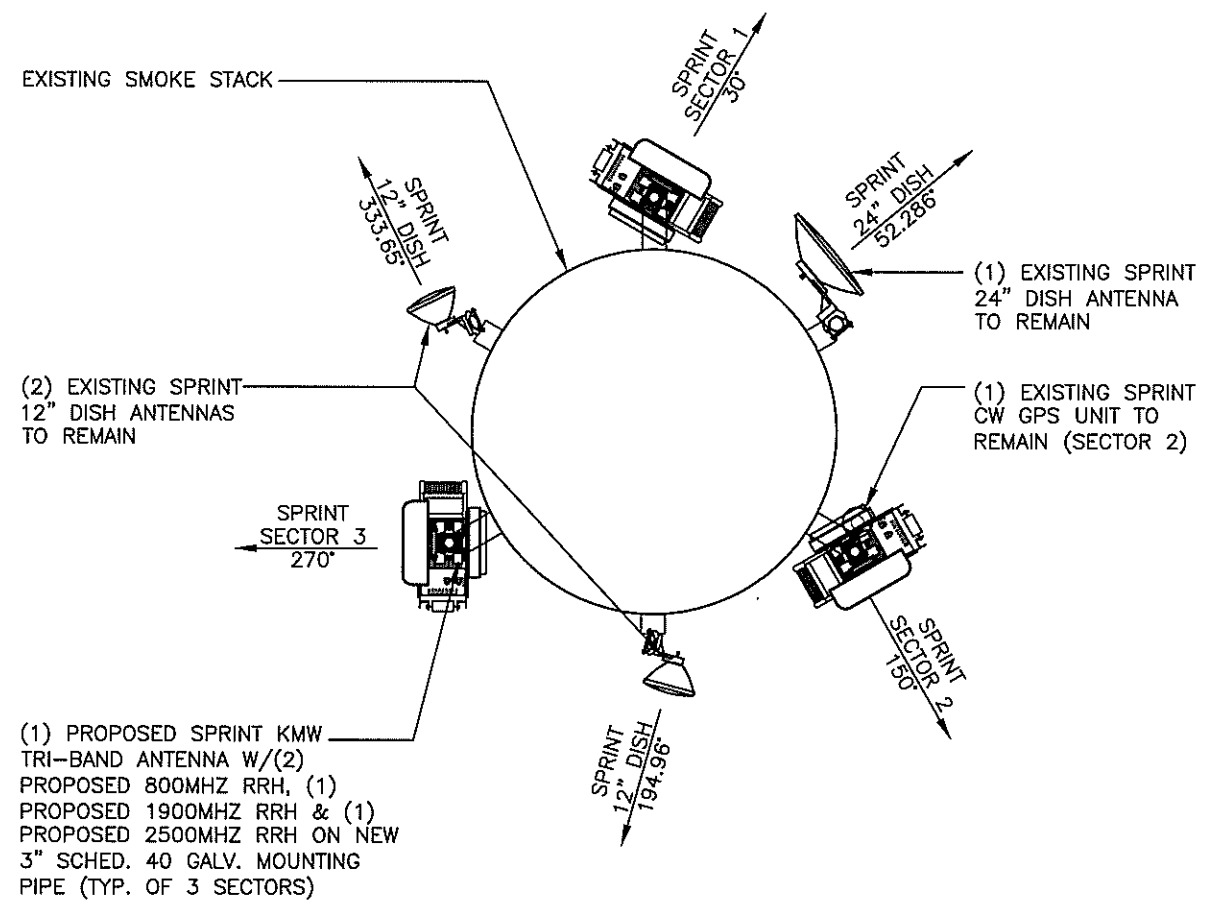

2 PROPOSED ANTENNA PLAN  
 A-4 SCALE: 1/4"=1'-0" NORTH

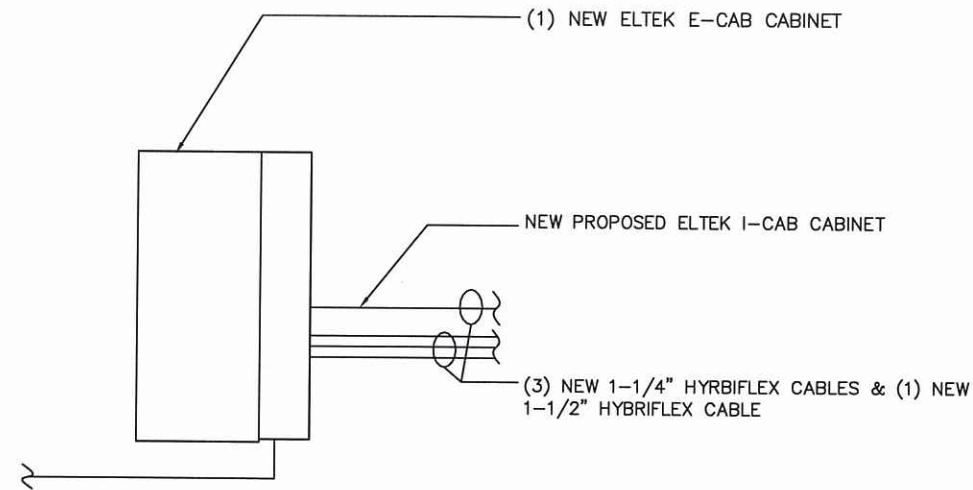

1 EQUIPMENT SCHEMATIC  
A-5 SCALE: N.T.S.

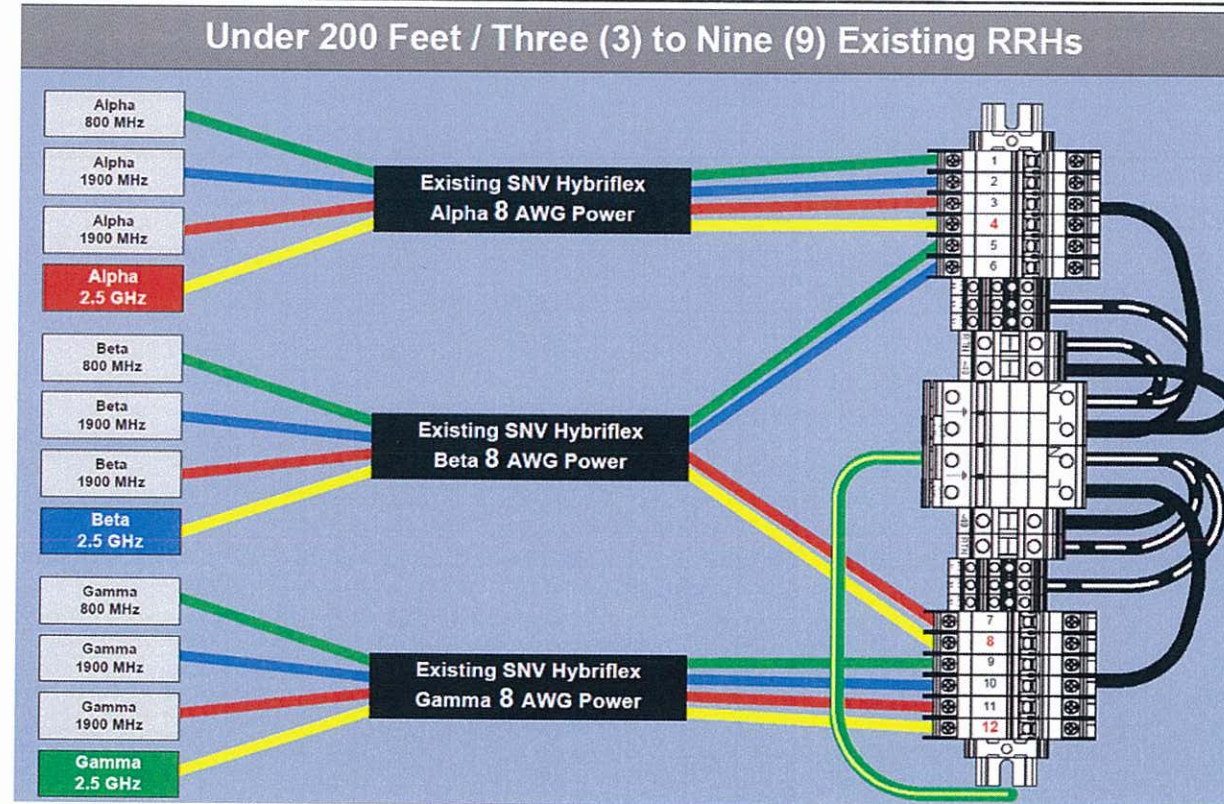

2 RRH TO JUNCTION BOX POWER CONNECTIVITY DETAIL  
A-5 SCALE: N.T.S.

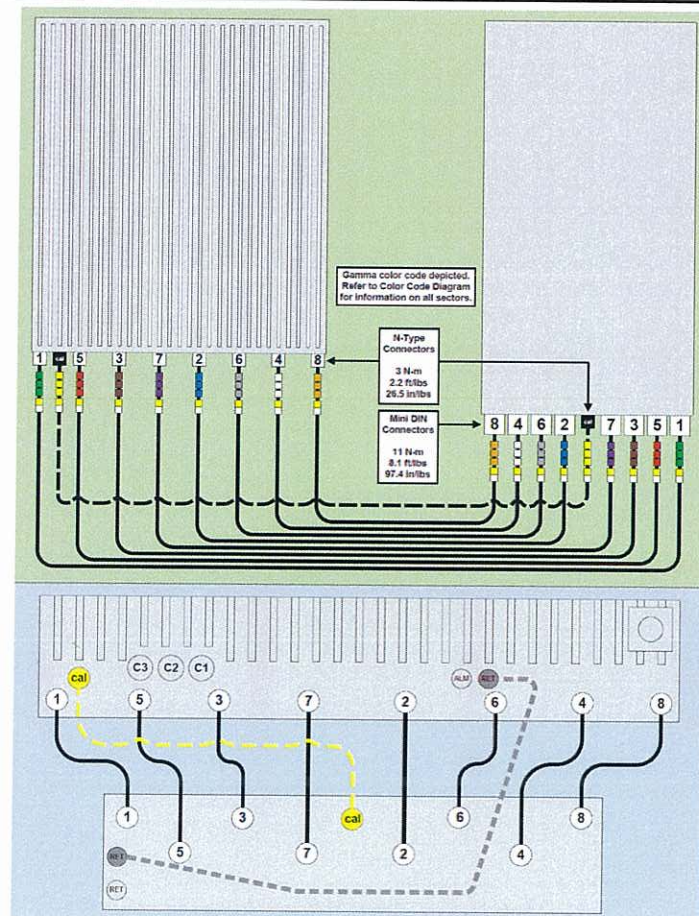

3 8T8R DETAIL  
A-5 SCALE: N.T.S.

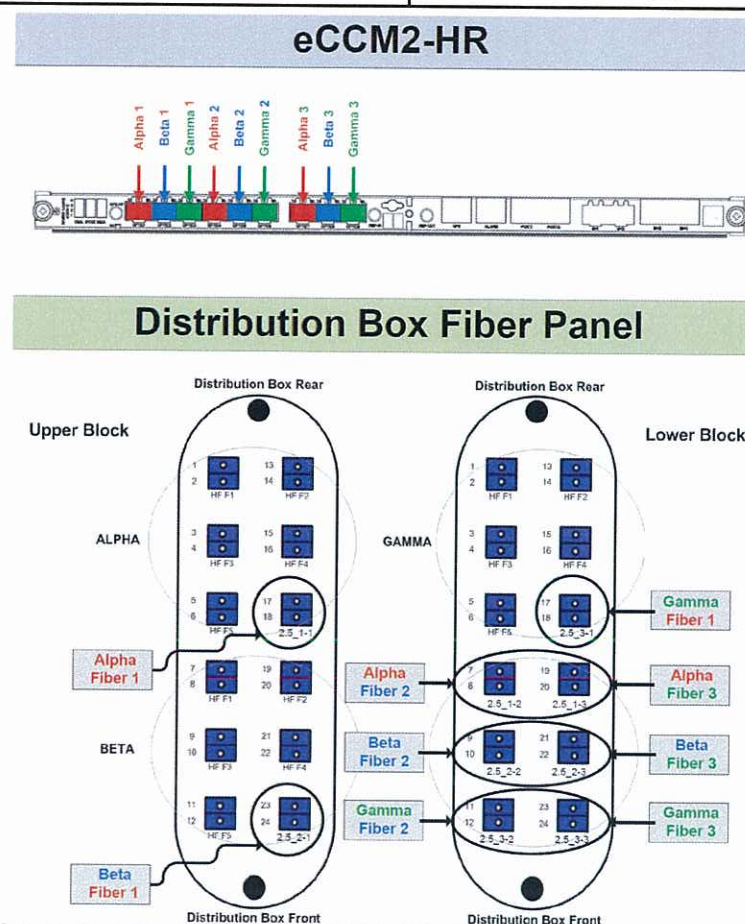

4 BTS TO JUNCTION BOX FIBER CONNECTIVITY DETAIL  
A-5 SCALE: N.T.S.

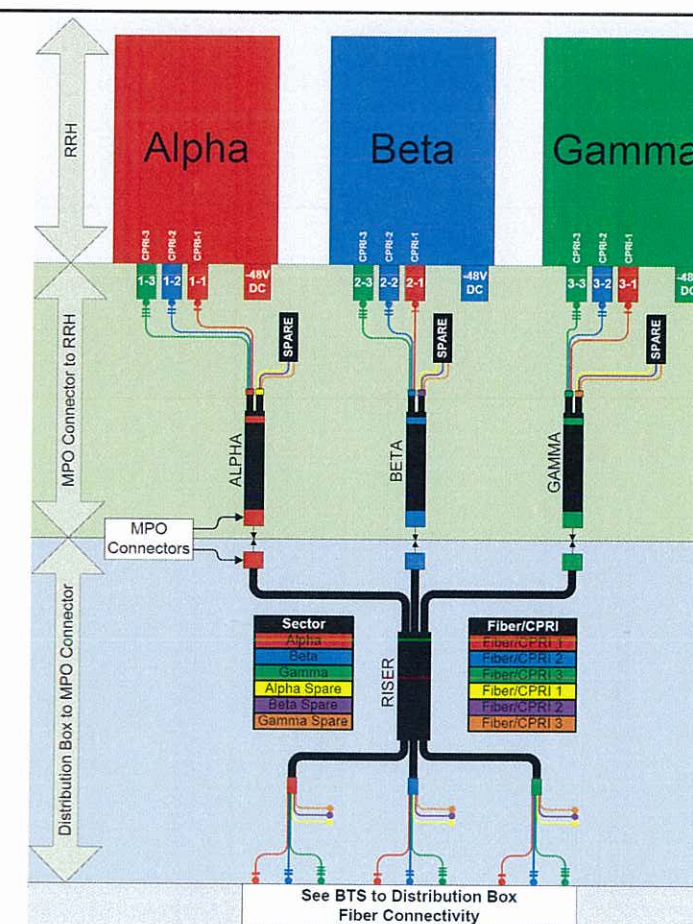

5 RRH TO JUNCTION BOX FIBER CONNECTIVITY DETAIL  
A-5 SCALE: N.T.S.

**Sprint**  
1 INTERNATIONAL BLVD., SUITE 800  
MAHWAH, NJ 07495  
TEL: (201) 684-4000  
FAX: (201) 684-4223

**Cherundolo Consulting**

1280 ROUTE 46 WEST  
PARSIPPANY, NJ 07054  
TELEPHONE: 646-544-5324

**WESTCHESTER SERVICES LLC**

604 FOX GLEN  
BARRINGTON, IL 60010  
TELEPHONE: 847-277-0070  
FAX: 847-277-0080  
AE@westchesterservices.com

**JOHN M. BANKS ARCHITECT**

604 FOX GLEN  
BARRINGTON, IL 60010  
TELEPHONE: 847-277-0070  
FAX: 847-277-0080

THESE DOCUMENTS ARE CONFIDENTIAL AND ARE THE SOLE PROPERTY OF SPRINT AND MAY NOT BE REPRODUCED, DISSEMINATED OR REDISTRIBUTED WITHOUT THE EXPRESS WRITTEN CONSENT OF SPRINT.

0	11.15.17	FINAL CD
NO.	DATE	DESCRIPTION
DRAWN BY: JS		
CHECKED BY: JMB		
JOB NUMBER: CT52XC055-C		
ARCHITECT: JOHN BANKS		



SITE NAME  
39 CHERRY AVE SS

SITE NUMBER  
CT52XC055-C

SITE LOCATION  
253 CHERRY STREET  
WATERBURY, CT 06702  
NEW HAVEN COUNTY

SHEET TITLE  
FIBER WIRING  
DIAGRAM

SHEET NUMBER  
A-5

RFS HYBRIFLEX RISER CABLE SCHEDULE

FIBER ONLY (EXISTING DC POWER)	Hybrid cable	
	MN:HB058-M12-050F	50 ft
	12x multi-mode fiber pairs, Top:Outdoor protected connectors, Bottom:LC	
	Connectors, 5/8 cable, 50 ft	
	MN:HB058-M12-075F	75 ft
	MN:HB058-M12-100F	100 ft
	MN:HB058-M12-125F	125 ft
	MN:HB058-M12-150F	150 ft
	MN:HB058-M12-175F	175 ft
	MN:HB058-M12-200F	200 ft
8 AWG Power	Hybrid cable	
	MN:HB114-08U3M12-050F	50 ft
	3x 8 AWG power pairs, 12x multi-mode fiber pairs, Outdoor rated connectors & LC connectors. 1 1/4 cable, 50 ft	
	MN:HB114-08U3M12-075F	75 ft
	MN:HB114-08U3M12-100F	100 ft
	MN:HB114-08U3M12-125F	125 ft
	MN:HB114-08U3M12-150F	150 ft
	MN:HB114-08U3M12-175F	175 ft
	MN:HB114-08U3M12-200F	200 ft
6 AWG Power	Hybrid cable	
	MN:HB114-13U3M12-225F	225 ft
	3x 6 AWG power pairs, 12x multi-mode fiber pairs, Outdoor rated connectors & LC connectors. 1 1/4 cable, 225 ft	
	MN:HB114-13U3M12-250F	250 ft
	MN:HB114-13U3M12-275F	275 ft
	MN:HB114-13U3M12-300F	300 ft
4 AWG Power	Hybrid cable	
	MN:HB114-21U3M12-325F	325 ft
	3x 4 AWG power pairs, 12x multi-mode fiber pairs, Outdoor rated connectors & LC connectors. 1 1/4 cable, 325 ft	
	MN:HB114-21U3M12-350F	350 ft
	MN:HB114-21U3M12-375F	375 ft

RFS HYBRIFLEX JUMPER CABLE SCHEDULE

FIBER ONLY	Hybrid Jumper cable	
	MN:HBF012-M3-5F1	5 ft
	5 ft, 3x multi-mode fiber pairs, Outdoor & LC connectors, 1/2 cable	
	MN:HBF012-M3-10F1	10 ft
	MN:HBF012-M3-15F1	15 ft
	SPECIAL INSTALLATION NOTE: JUMPERS FROM 2.5 RRH TO 2.5 ANTENNA SHALL NOT EXCEED 15' NOTIFY SPRINT CM OF ANY DISCREPANCY	
8 AWG POWER	Hybrid Jumper cable	
	MN:HBF058-08U1M3-5F1	5 ft
	5 ft, 1x 8 AWG power pair, 3x multi-mode fiber pairs, Outdoor & LC connectors, 5/8 cable	
	MN:HBF058-08U1M3-10F1	10 ft
	MN:HBF058-08U1M3-15F1	15 ft
	SPECIAL INSTALLATION NOTE: JUMPERS FROM 2.5 RRH TO 2.5 ANTENNA SHALL NOT EXCEED 15' NOTIFY SPRINT CM OF ANY DISCREPANCY	
6 AWG POWER	Hybrid Jumper cable	
	MN:HBF058-13U1M3-5F1	5 ft
	5 ft, 1x 6 AWG power pair, 3x multi-mode fiber pairs, Outdoor & LC connectors, 5/8 cable	
	MN:HBF058-13U1M3-10F1	10 ft
	MN:HBF058-13U1M3-15F1	15 ft
	SPECIAL INSTALLATION NOTE: JUMPERS FROM 2.5 RRH TO 2.5 ANTENNA SHALL NOT EXCEED 15' NOTIFY SPRINT CM OF ANY DISCREPANCY	
4 AWG POWER	Hybrid Jumper cable	
	MN:HBF078-21U1M3-5F1	5 ft
	5 ft, 1x 4 AWG power pair, 3x multi-mode fiber pairs, Outdoor & LC connectors, 7/8 cable	
	MN:HBF078-21U1M3-10F1	10 ft
	MN:HBF078-21U1M3-15F1	15 ft
	SPECIAL INSTALLATION NOTE: JUMPERS FROM 2.5 RRH TO 2.5 ANTENNA SHALL NOT EXCEED 15' NOTIFY SPRINT CM OF ANY DISCREPANCY	

HYBRID CABLE DC CONDUCTOR SIZE GUIDELINE  
MANUF:RFS

CABLE	LENGTH	DC CONDUCTOR	CABLE DIAMETER
Fiber Only	Varies	Use NV Hybriflex	5/8"
Hybriflex	<200'	8 AWG	1-1/4"
Hybriflex	225-300'	6 AWG	1-1/4"
Hybriflex	325-375'	4 AWG	1-1/4"

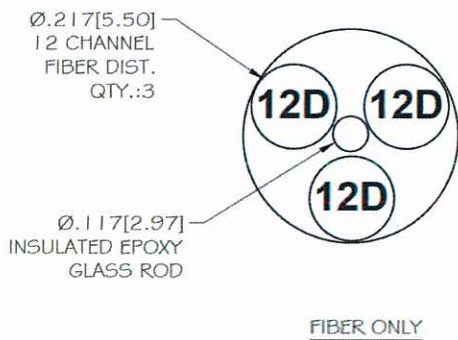
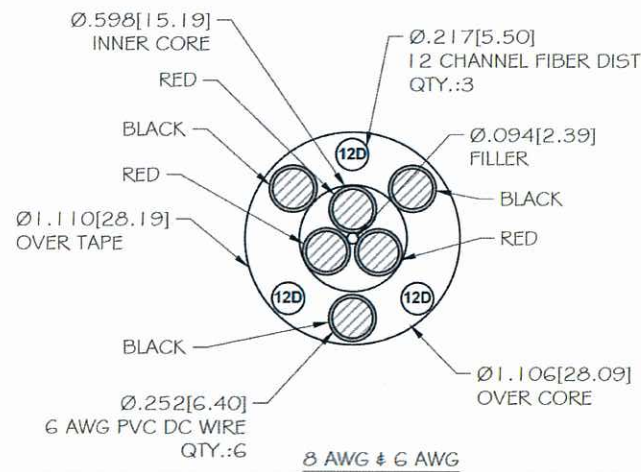
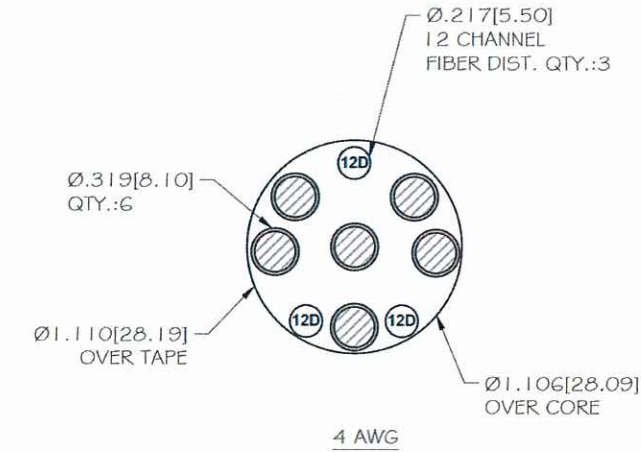

2.5 CABLE CROSS SECTION & DATA  
SCALE: N.T.S.

KMW 16 Port Nokia-A RRH 800, 1900, and 2500

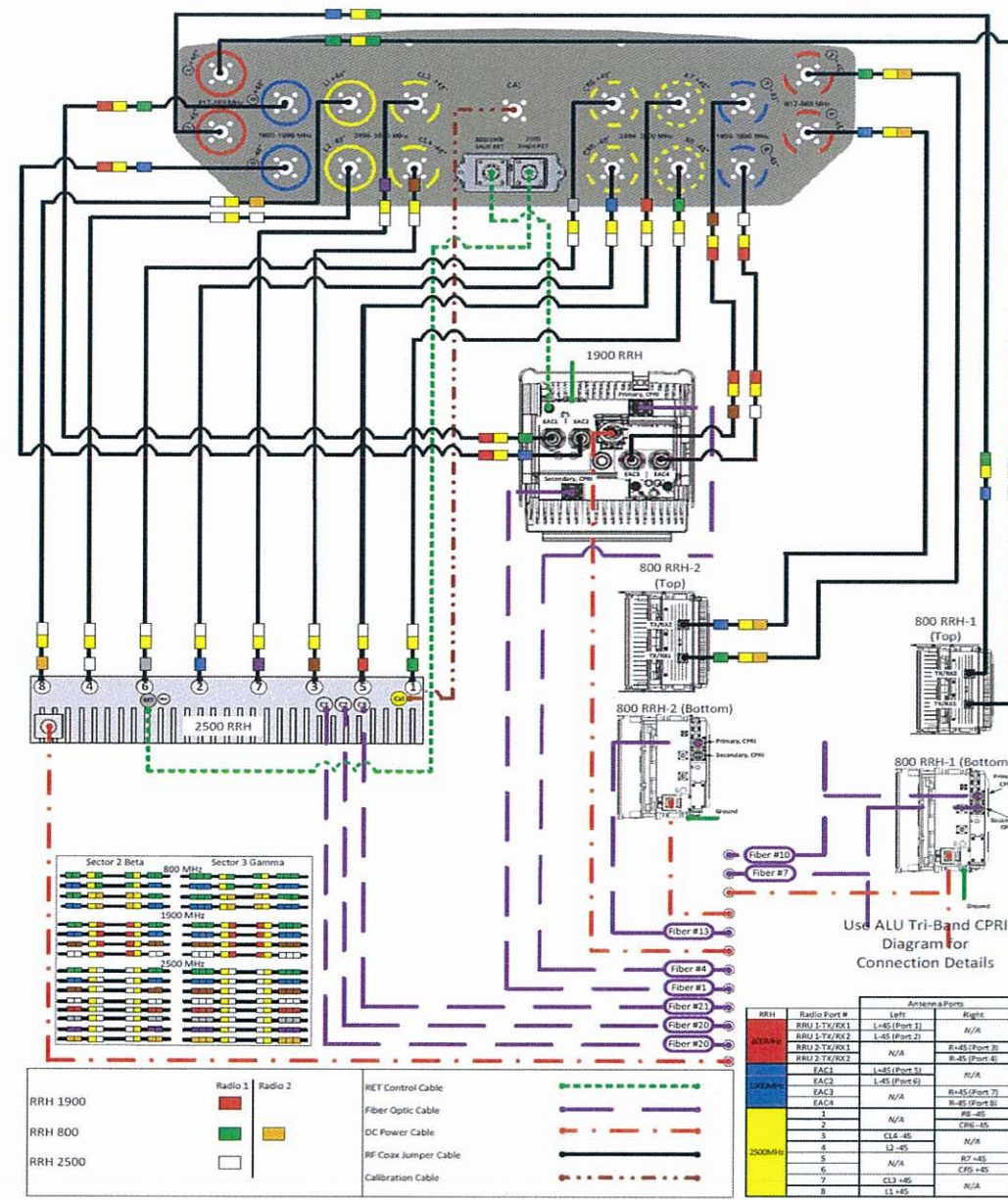

2 PLUMBING DIAGRAM  
SCALE: N.T.S.

SECTOR	DESCRIPTION	QTY	DIMENSIONS	PART/MODEL#
SECTOR 1	1-1/4" HYBRIFLEX CABLE	1	175'-0"	RFS HB114-08U3M12-200F
SECTOR 2	1-1/4" HYBRIFLEX CABLE	1	175'-0"	RFS HB114-08U3M12-200F
SECTOR 3	1-1/4" HYBRIFLEX CABLE	1	175'-0"	RFS HB114-08U3M12-200F
AUXILIARY	1-1/2" HYBRIFLEX CABLE	1	175'-0"	RFS HB112-XXXX

3 CABLE LENGTHS  
SCALE: N.T.S.

**Sprint**  
1 INTERNATIONAL BLVD., SUITE 800  
MAHWAH, NJ 07495  
TEL: (201) 684-4000  
FAX: (201) 684-4223

**Cherundolo Consulting**  
1280 ROUTE 46 WEST  
PARSIPPANY, NJ 07054  
TELEPHONE: 646-544-5324

**WESTCHESTER SERVICES LLC**  
604 FOX GLEN  
BARRINGTON, IL 60010  
TELEPHONE: 847-277-0070  
FAX: 847-277-0080  
AE@westchesterservices.com

**JOHN M. BANKS ARCHITECT**  
604 FOX GLEN  
BARRINGTON, IL 60010  
TELEPHONE: 847-277-0070  
FAX: 847-277-0080

THESE DOCUMENTS ARE CONFIDENTIAL AND ARE THE SOLE PROPERTY OF SPRINT AND MAY NOT BE REPRODUCED, DISSEMINATED OR REDISTRIBUTED WITHOUT THE EXPRESS WRITTEN CONSENT OF SPRINT.

NO.	DATE	DESCRIPTION
0	11.15.17	FINAL CD
DRAWN BY: JS		
CHECKED BY: JMB		
JOB NUMBER: CT52XC055-C		
ARCHITECT: JOHN BANKS		



39 CHERRY AVE SS

SITE NUMBER  
CT52XC055-C

SITE LOCATION  
253 CHERRY STREET  
WATERBURY, CT 06702  
NEW HAVEN COUNTY

SHEET TITLE  
PLUMBING DIAGRAM & CABLE DETAIL

SHEET NUMBER  
A-6

KMW ETCR-654L12H6  
 DIMENSIONS, HxWxD:  
 (84.9"x21"x6.3")  
 WEIGHT: 84.9 lbs

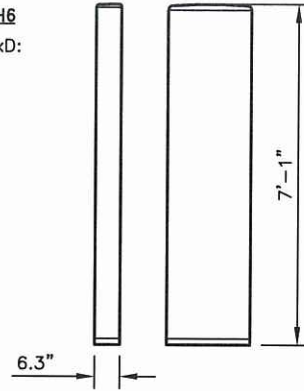
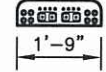

1 **TRIBAND PROPOSED ANTENNA SPECIFICATIONS**  
 A-7 SCALE:



TYPE: 2.5 GHz RRH  
 MODEL #: TD-RRH8X20-25  
 HEIGHT: 25.0"  
 WIDTH: 17"  
 DEPTH: 5.7"  
 WEIGHT: ±70 LBS.

PLAN

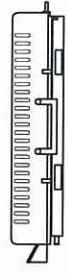

SIDE

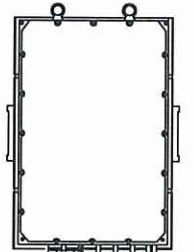

FRONT ELEVATION

2 **2500 MHz RRH DETAIL**  
 A-7 SCALE:

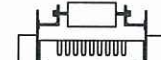

TYPE: 800 MHz 2x50W  
 MODEL #: FD-RRH-2x50-800  
 HEIGHT: 19.4"  
 WIDTH: 12.9"  
 DEPTH: 10.7"  
 WEIGHT: ±60 LBS

PLAN

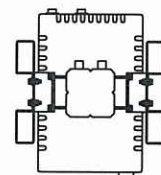

FRONT ELEVATION

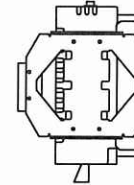

SIDE

3 **800 MHz RRH DETAIL**  
 A-7 SCALE:



TYPE: 1900 MHz 4x45W  
 MODEL #: RRH 1900 4X45 65MHz  
 HEIGHT: 25.0"  
 WIDTH: 10.7"  
 DEPTH: 11.1"  
 WEIGHT: ±68 LBS.

PLAN

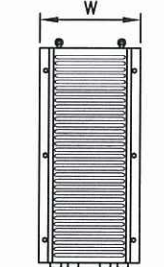

FRONT ELEVATION

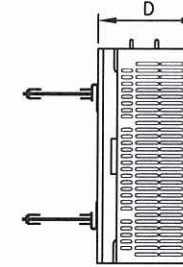

SIDE

4 **800 MHz RRH DETAIL**  
 A-7 SCALE:

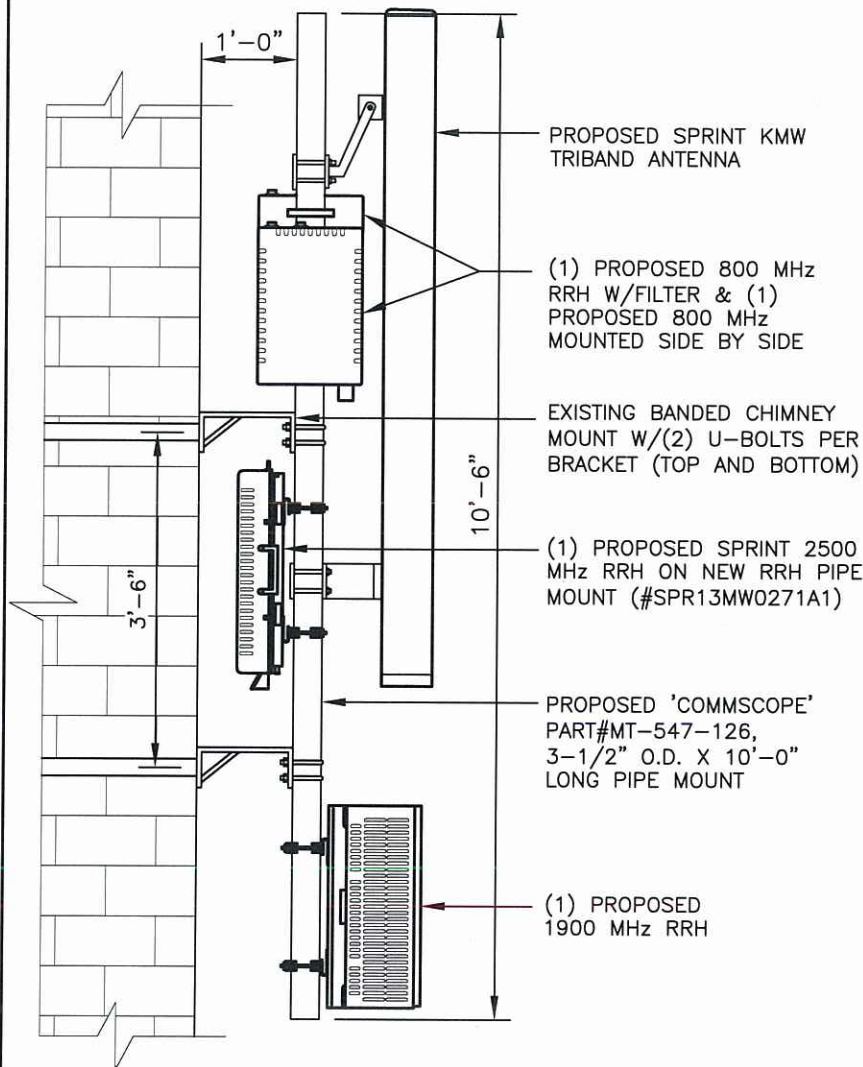

5 **TYPICAL ANTENNA/RRH MOUNTING**  
 A-8 SCALE: 1/2"=1'-0"

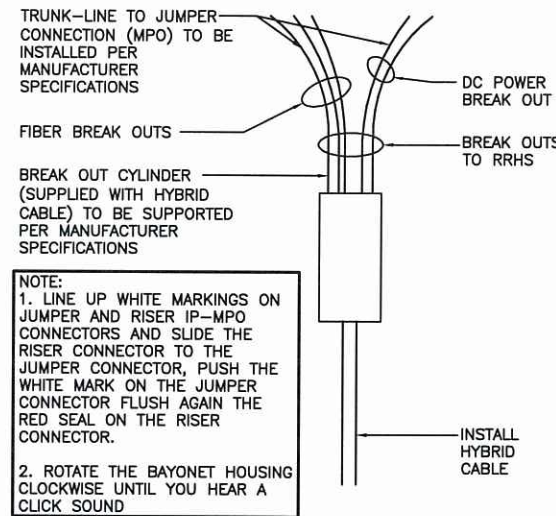

6 **HYBRID BREAKOUT**  
 A-7 SCALE: N.T.S.

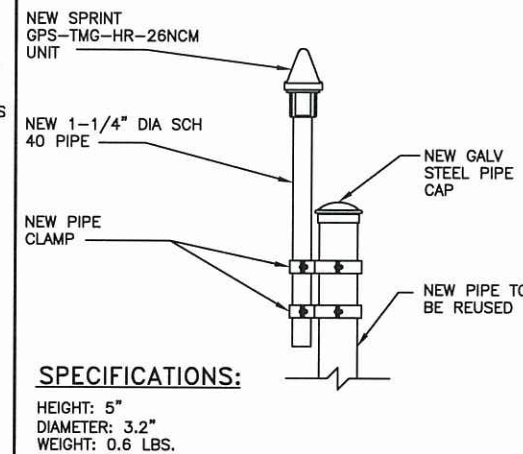

7 **GPS UNIT DETAIL**  
 A-7 SCALE: N.T.S.

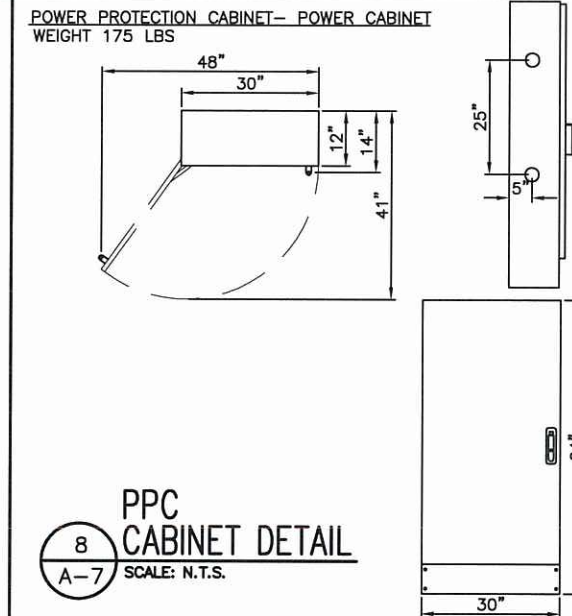

8 **PPC CABINET DETAIL**  
 A-7 SCALE: N.T.S.

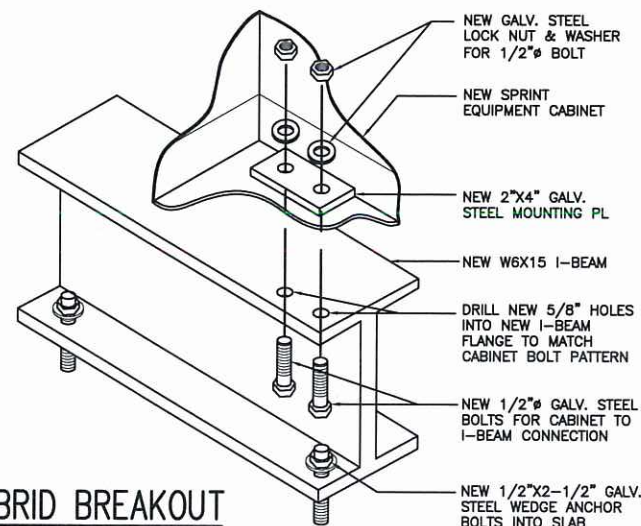

9 **HYBRID BREAKOUT**  
 A-7 SCALE: N.T.S.



1 INTERNATIONAL BLVD., SUITE 800  
 MAHWAH, NJ 07495  
 TEL: (201) 684-4000  
 FAX: (201) 684-4223



1280 ROUTE 46 WEST  
 PARSIPPANY, NJ 07054  
 TELEPHONE: 646-544-5324



604 FOX GLEN  
 BARRINGTON, IL 60010  
 TELEPHONE: 847-277-0070  
 FAX: 847-277-0080  
 AE@westchesterservices.com



604 FOX GLEN  
 BARRINGTON, IL 60010  
 TELEPHONE: 847-277-0070  
 FAX: 847-277-0080

THESE DOCUMENTS ARE CONFIDENTIAL AND ARE THE SOLE PROPERTY OF SPRINT AND MAY NOT BE REPRODUCED, DISSEMINATED OR REDISTRIBUTED WITHOUT THE EXPRESS WRITTEN CONSENT OF SPRINT.

0	11.15.17	FINAL CD
NO.	DATE	DESCRIPTION
DRAWN BY: JS		
CHECKED BY: JMB		
JOB NUMBER: CT52XC055-C		
ARCHITECT: JOHN BANKS		



SEAL

SITE NAME

39 CHERRY AVE SS

SITE NUMBER

CT52XC055-C

SITE LOCATION

253 CHERRY STREET  
 WATERBURY, CT 06702  
 NEW HAVEN COUNTY

SHEET TITLE

EQUIPMENT DETAILS

SHEET NUMBER

A-7

**Sprint**  
 1 INTERNATIONAL BLVD., SUITE 800  
 MAHWAH, NJ 07495  
 TEL: (201) 684-4000  
 FAX: (201) 684-4223

**Cherundolo Consulting**  
 1280 ROUTE 46 WEST  
 PARSIPPANY, NJ 07054  
 TELEPHONE: 646-544-5324

**WESTCHESTER SERVICES LLC**  
 604 FOX GLEN  
 BARRINGTON, IL 60010  
 TELEPHONE: 847-277-0070  
 FAX: 847-277-0080  
 AE@westchesterservices.com

**JOHN M. BANKS ARCHITECT**  
 604 FOX GLEN  
 BARRINGTON, IL 60010  
 TELEPHONE: 847-277-0070  
 FAX: 847-277-0080

THESE DOCUMENTS ARE CONFIDENTIAL AND ARE THE SOLE PROPERTY OF SPRINT AND MAY NOT BE REPRODUCED, DISSEMINATED OR REDISTRIBUTED WITHOUT THE EXPRESS WRITTEN CONSENT OF SPRINT.

0	11.15.17	FINAL CD
NO.	DATE	DESCRIPTION
DRAWN BY: JS		
CHECKED BY: JMB		
JOB NUMBER: CT52XC055-C		
ARCHITECT: JOHN BANKS		



SITE NAME

39 CHERRY AVE SS

SITE NUMBER

CT52XC055-C

SITE LOCATION

253 CHERRY STREET  
 WATERBURY, CT 06702  
 NEW HAVEN COUNTY

SHEET TITLE

FENCE DETAILS

SHEET NUMBER

A-8

- NOTES:**  
 (INSTALL FENCING PER ASTM F-567, SWING GATES PER ASTM F- 900)
- GATE POST, CORNER, TERMINAL OR PULL POST SHALL BE 2 7/8" Ø SCHEDULE 40 FOR GATE WIDTHS UP THROUGH 6 FEET OR 12 FEET FOR DOUBLE SWING GATE PER ASTM-F1083.
  - LINE POST: 2-3/8"Ø SCHEDULE 40 PIPE PER ASTM-F1083.
  - GATE FRAME: 1 1/2"Ø SCHEDULE 40 PIPE PER ASTM-F1083.
  - TOP RAIL & BRACE RAIL: 1 1/4"Ø SCHEDULE 40 PIPE PER ASTM-F1083.
  - FABRIC: 9 GA. CORE WIRE SIZE 2" MESH, CONFORMING TO ASTM-A392 CLASS 1.
  - TIE WIRE: MINIMUM 11 GA GALVANIZED STEEL INSTALL A SINGLE WRAP TIE WIRE AT POSTS AND RAILS AT MAX. 24" INTERVALS.
  - INSTALL HOG RINGS ON TENSION WIRE AT 24" INTERVALS.
  - TENSION WIRE: 7 GA. GALVANIZED STEEL.
  - BARBED WIRE: 3 STRANDS OF DOUBLE STRAND 12-1/2 GAUGE TWISTED WIRE, 4 PT. BARBS SPACED ON APPROXIMATELY 5" CENTERS.
  - LOCAL ORDINANCE FOR BARBED WIRE PERMIT SHALL GOVERN INSTALLATION.
  - HEIGHT = 6' VERTICAL + 1' BARBED WIRE VERTICAL DIMENSION.
- ALL WORK SHALL CONFORM WITH THE PROJECT SPECIFICATIONS.

TYPICAL WOVEN WIRE FENCING NOTES

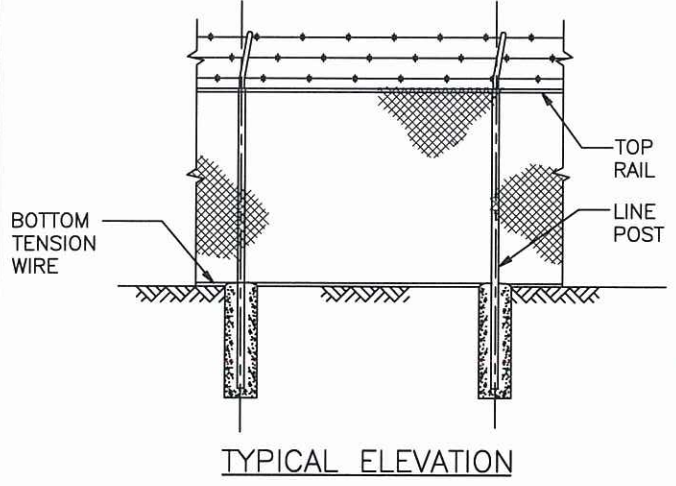

1 DETAIL  
 A-8 SCALE: N.T.S.

2 DETAIL  
 A-8 SCALE: N.T.S.

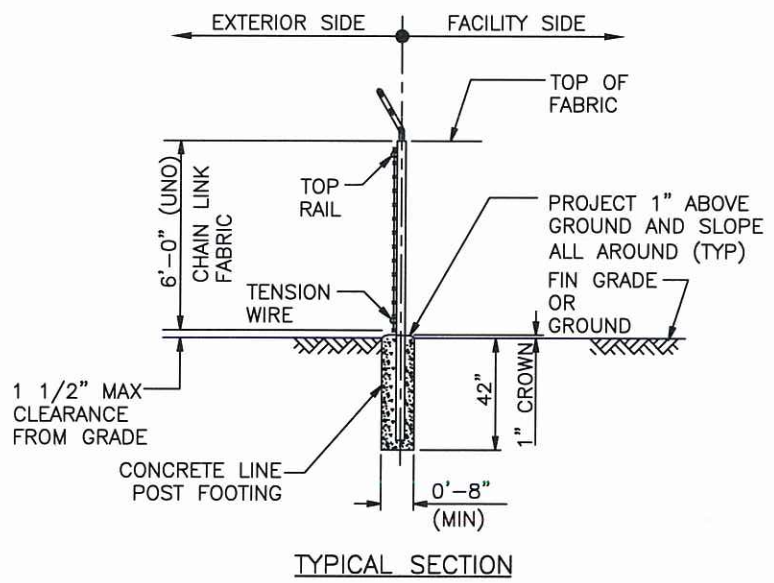

WOVEN WIRE FENCE

3 DETAIL  
 A-8 SCALE: N.T.S.

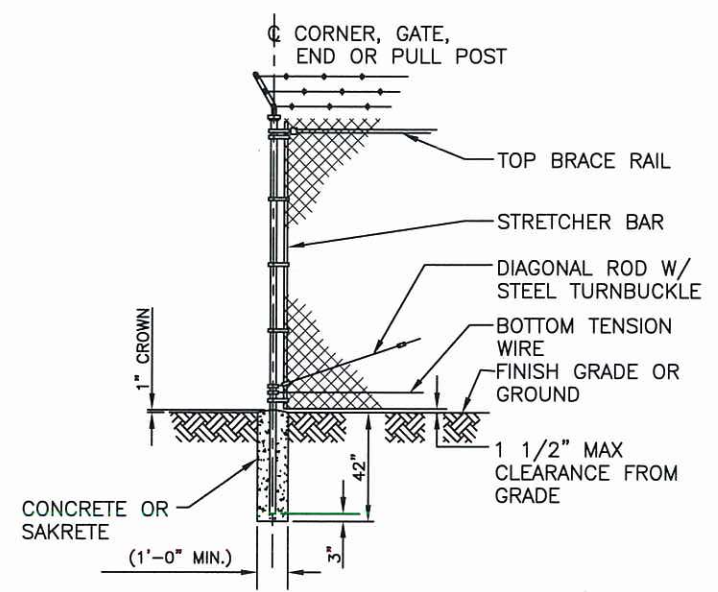

WOVEN WIRE CORNER, GATE, END OR PULL POST

4 DETAIL  
 A-8 SCALE: N.T.S.

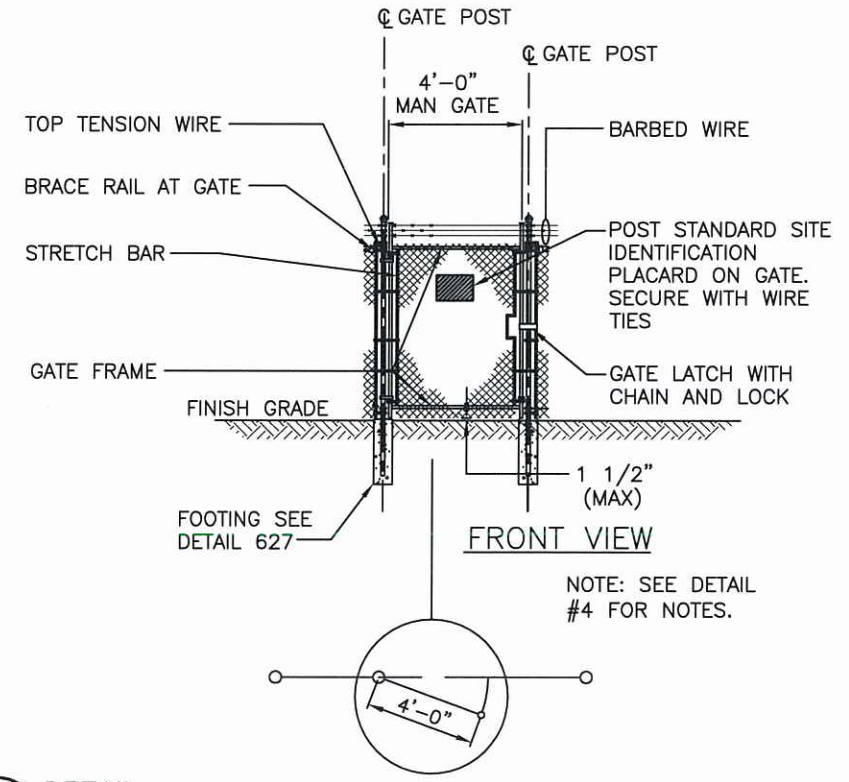

WOVEN WIRE SWING GATE, SINGLE

5 DETAIL  
 A-8 SCALE: N.T.S.

**NOTE:**  
WEED CONTROL FABRIC SHALL BE USED UNDER ENTIRE PROPOSED GRAVELED AREA. CONTRACTOR SHALL INSTALL FABRIC PER MANUFACTURER'S RECOMMENDATIONS.

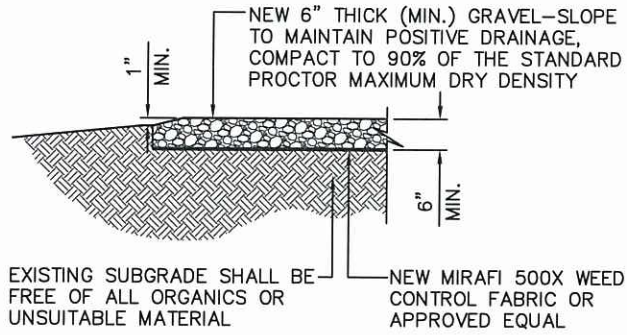

**1 YARD DETAIL**  
A-9 SCALE: N.T.S.

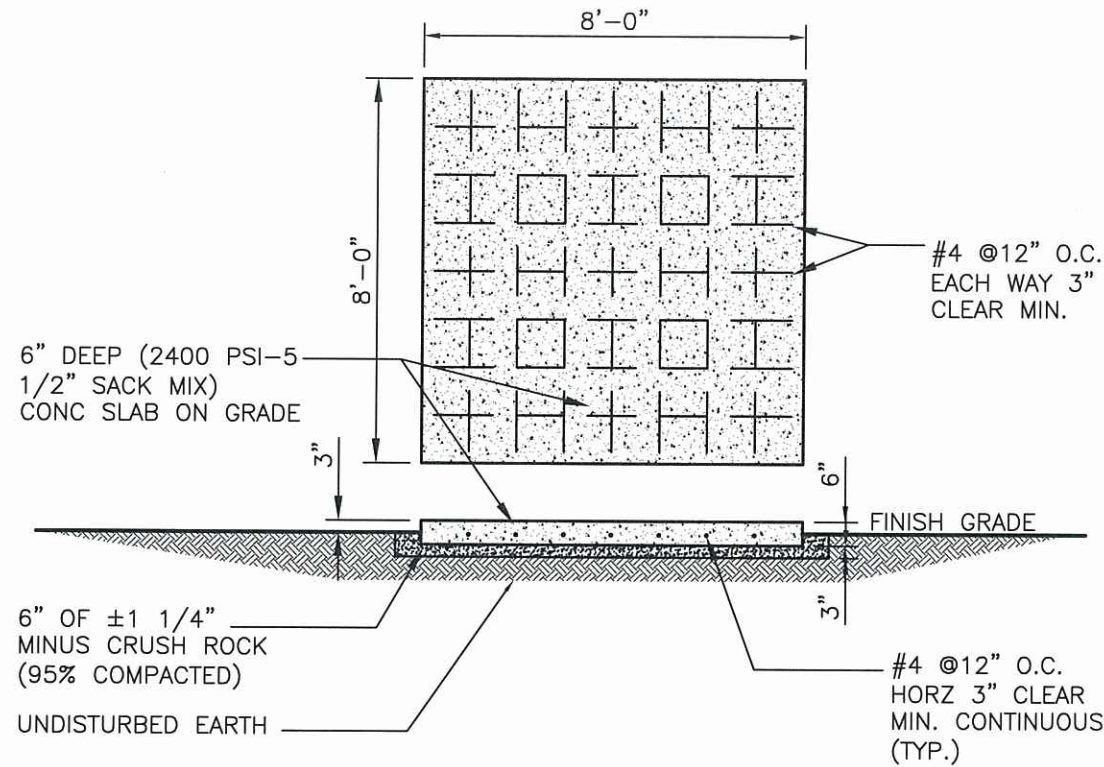

**2 CONCRETE PAD DETAIL**  
A-9 SCALE: N.T.S.

**12\"/>**

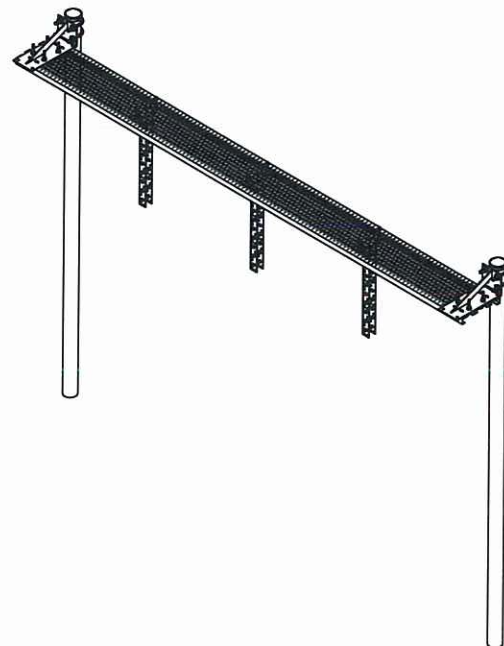

**3 ICE BRIDGE DETAIL**  
A-9 SCALE: N.T.S.

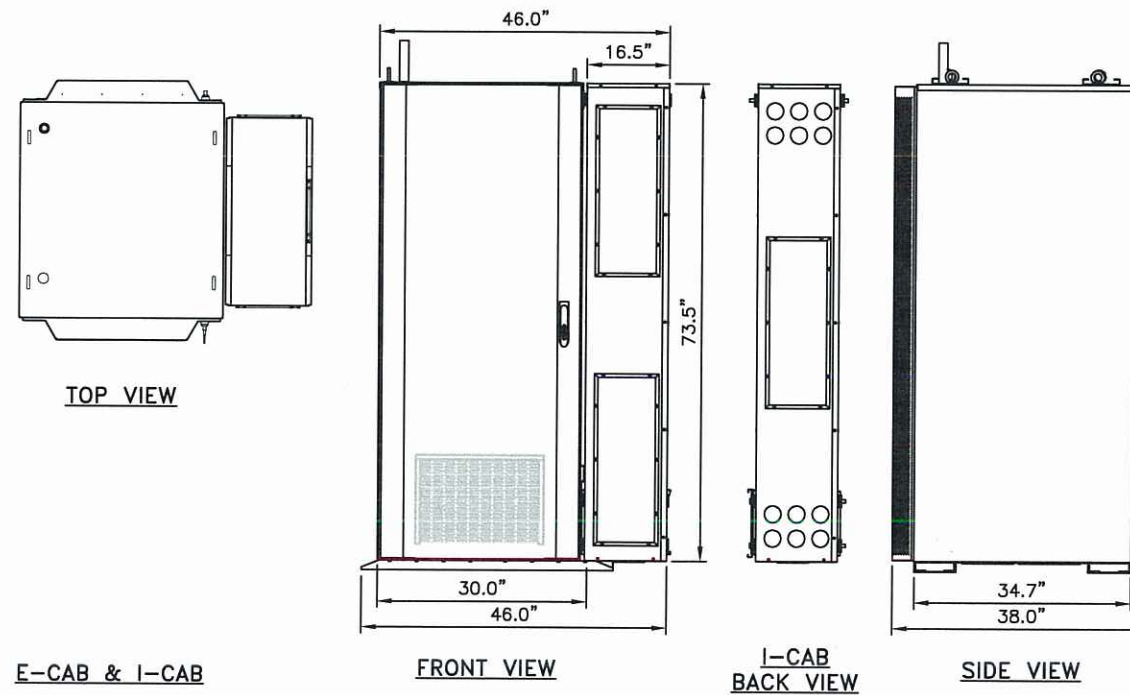

**E-CAB & I-CAB**  
DIMENSIONS HxWxD: 73.5"x30.0"x38.0"  
EMPTY WEIGHT: 505lbs  
FULLY LOADED WEIGHT: 1,381lbs

**4 ELTEK E-CAB & I-CAB DETAIL**  
A-9 SCALE: N.T.S.

**Sprint**  
1 INTERNATIONAL BLVD., SUITE 800  
MAHWAH, NJ 07495  
TEL: (201) 684-4000  
FAX: (201) 684-4223

**Cherundolo Consulting**

1280 ROUTE 46 WEST  
PARSIPPANY, NJ 07054  
TELEPHONE: 646-544-5324

**WESTCHESTER SERVICES LLC**

604 FOX GLEN  
BARRINGTON, IL 60010  
TELEPHONE: 847-277-0070  
FAX : 847-277-0080  
AE@westchesterservices.com

**JOHN M. BANKS ARCHITECT**

604 FOX GLEN  
BARRINGTON, IL 60010  
TELEPHONE: 847-277-0070  
FAX : 847-277-0080

THESE DOCUMENTS ARE CONFIDENTIAL AND ARE THE SOLE PROPERTY OF SPRINT AND MAY NOT BE REPRODUCED, DISSEMINATED OR REDISTRIBUTED WITHOUT THE EXPRESS WRITTEN CONSENT OF SPRINT.

0	11.15.17	FINAL CD
NO.	DATE	DESCRIPTION
DRAWN BY: JS		
CHECKED BY: JMB		
JOB NUMBER: CT52XC055-C		
ARCHITECT: JOHN BANKS		



SITE NAME

39 CHERRY AVE SS

SITE NUMBER

CT52XC055-C

SITE LOCATION

253 CHERRY STREET  
WATERBURY, CT 06702  
NEW HAVEN COUNTY

SHEET TITLE

COMPOUND & CABINET DETAILS

SHEET NUMBER

A-9

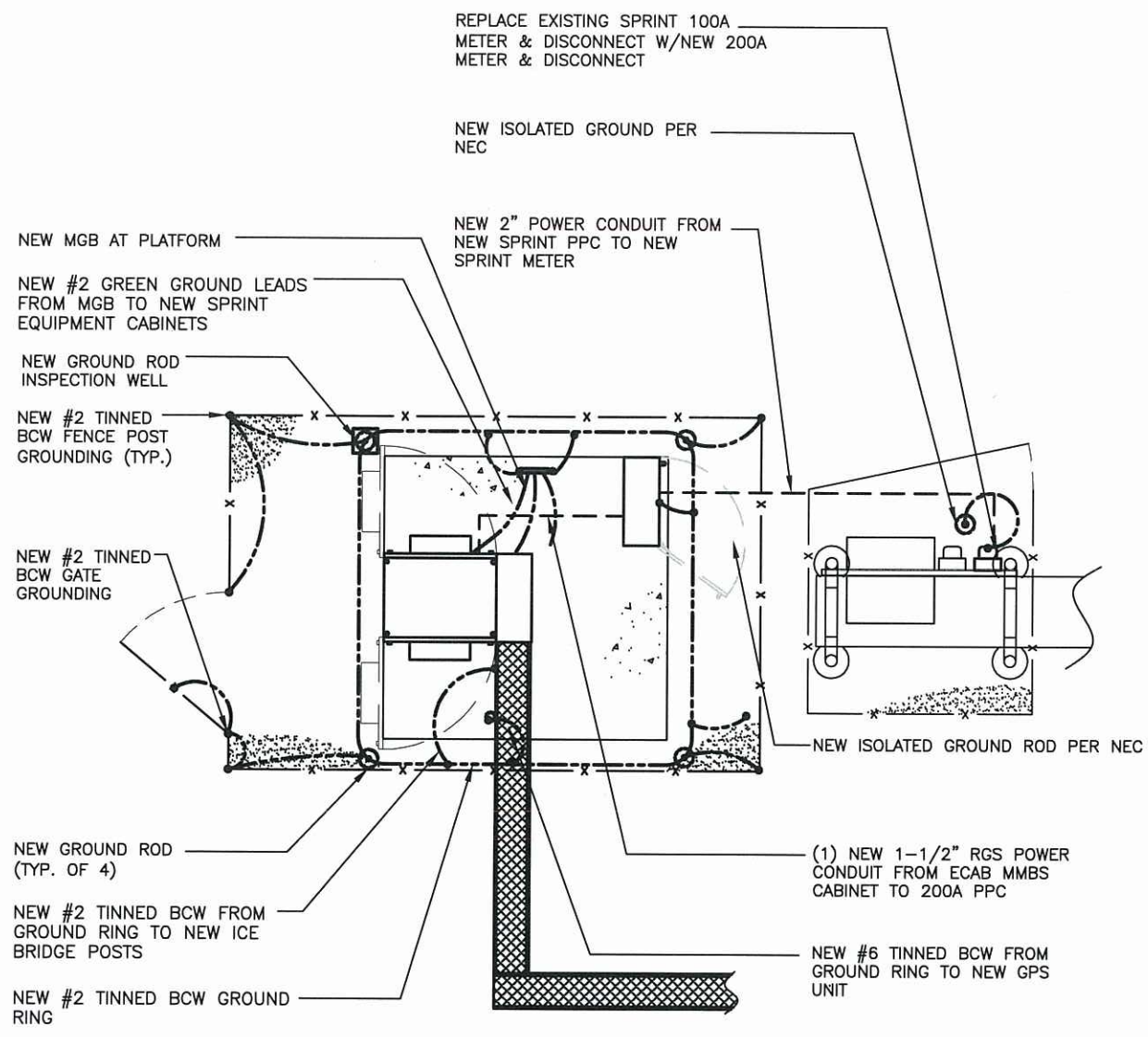

**1 PROPOSED ELECTRIC PLAN**  
 E-1 SCALE: 3/16" = 1'-0"

**GROUNDING NOTES:**

- 1 ALL ELECTRICAL AND GROUNDING AT THE CELL SITE SHALL COMPLY WITH THE NATIONAL ELECTRICAL CODE (NEC), NATIONAL FIRE PROTECTION ASSOCIATION (NFPA) 780 (LATEST EDITION), AND MANUFACTURER.
- 2 IF THE AC PANEL IN THE POWER CABINET IS WIRED AS SERVICE ENTRANCE, THE AC SERVICE GROUND CONDUCTOR SHALL BE CONNECTED TO GROUND ELECTRODE SYSTEM. WHEN THE AC PANEL IN THE POWER CABINET IS CONSIDERED A SUB-PANEL, THE GROUND WIRE SHALL BE INSTALLED IN THE AC POWER CONDUIT. THE INSTALLATION SHALL BE PER LOCAL AND NATIONAL ELECTRIC CODE (NFPA-70).
- 3 EXOTHERMIC WELDING IS RECOMMENDED FOR GROUNDING CONNECTION WHERE PRACTICAL. OTHERWISE, THE CONNECTION SHALL BE MADE USING COMPRESSION TYPE-2 HOLES, LONG BARREL LUGS OR DOUBLE CRIMP CLAMP "C" CLAMP. THE COPPER CABLES SHALL BE COATED WITH ANTIOXIDANT (COPPER SHIELD) BEFORE MAKING THE CONNECTIONS. THE MANUFACTURER'S TORQUE RECOMMENDATIONS ON THE BOLT ASSEMBLY TO SECURE CONNECTIONS SHALL BE FOLLOWED.
- 4 THE ANTENNA CABLES SHALL BE GROUNDED AT THE TOP AND BOTTOM OF THE VERTICAL RUN FOR LIGHTNING PROTECTION. THE ANTENNA CABLE SHIELD SHALL BE BONDED TO A COPPER GROUND BUSS AT THE LOWER MOST POINT OF A VERTICAL RUN JUST BEFORE IT BEGINS TO BEND TOWARD THE HORIZONTAL PLANE. WIRE RUNS TO GROUND SHALL BE KEPT AS STRAIGHT AND SHORT AS POSSIBLE. ANTENNA CABLE SHIELD SHALL BE GROUNDED JUST BEFORE ENTERING THE CELL CABINET. ANY ANTENNA CABLES OVER 200 FEET IN LENGTH SHALL ALSO BE EQUIPPED WITH ADDITIONAL GROUNDING AT MID-POINT.
- 5 ALL GROUNDING CONDUCTORS INSIDE THE BUILDING SHALL BE RUN IN CONDUIT RACEWAY SYSTEM, AND SHALL BE INSTALLED AS STRAIGHT AS PRACTICAL WITH MINOR BENDS TO AVOID OBSTRUCTIONS. THE BENDING RADIUS OF ANY #2 GROUNDING CONDUCTOR IS 8". PVC RACEWAY MAY BE FLEXIBLE OR RIGID PER THE FIELD CONDITIONS. GROUNDING CONDUCTORS SHALL NOT MAKE CONTACT WITH ANY METALLIC CONDUITS, SURFACES OR EQUIPMENT.
- 6 PROVIDE PVC SLEEVES WHERE GROUNDING CONDUCTORS PASS THROUGH THE BUILDING WALLS AND /OR CEILINGS.
- 7 INSTALL GROUND BUSHINGS ON ALL METALLIC CONDUITS AND BOND TO THE EQUIPMENT GROUND BUSS IN THE PANEL BOARD.
- 8 GROUND ANTENNA BASES, FRAMES, CABLE RACKS AND OTHER METALLIC COMPONENTS WITH #2 GROUNDING CONDUCTORS AND CONNECT TO INSULATED SURFACE MOUNTED GROUND BARS. CONNECTION DETAILS SHALL FOLLOW MANUFACTURER'S SPECIFICATIONS FOR GROUNDING.
- 9 GROUND COAXIAL SHIELD AT BOTH ENDS USING MANUFACTURER'S GUIDELINES. GROUND FIELD TEST PROCEDURE:  
 A. THE CONTRACTOR SHALL BE RESPONSIBLE TO PROVIDE A "FALL OF POTENTIAL" TEST ON THE NEW SUPPLEMENTAL GROUND FIELD PRIOR TO FINAL CONNECTION OF THE GROUNDING SYSTEM TO EQUIPMENT. THE TEST SHALL BE PERFORMED BY A QUALIFIED AND CERTIFIED TESTING AGENT. PROVIDE INDEPENDENT TEST RESULTS TO THE PROJECT MANAGER FOR REVIEW. THE GROUND SYSTEM RESISTANCE TO EARTH GROUND SHALL NOT EXCEED FIVE (5) OHMS. IF THE GROUND TEST EXCEEDS THE MAXIMUM OF 5 OHMS

**GROUNDING LEGEND (ITEMS IN THIS LEGEND ONLY APPLY AS DETAILED IN GROUNDING PLAN):**

- (A) GROUNDING RING. #2 AWG SOLID BARE TINNED COPPER WIRE
- (B) GROUND ROD
- (C) INSPECTION WELL
- (D) STEEL EQUIPMENT PLATFORM GROUNDING
- (E) STEEL EQUIPMENT GROUNDING
- (F) ICE BRIDGE GROUNDING AT EACH POST.
- (G) NEW GROUND RING BONDED TO EXISTING GROUND RING.
- (H) EXISTING GROUND RING. FIELD DETERMINE EXACT LOCATION.
- (J) SPRINT EQUIPMENT CABINET GROUNDING, TYP OF 3

**GROUNDING LEGEND**

- GROUND RING
- ⊗ GROUND ROD
- ⊗ INSPECTION WELL
- CADWELD CONNECTION (EXOTHERMIC WELD)
- ▲ MECHANICAL CONNECTION

CADWELD CONNECTIONS OR APPROVED EQUAL		BURNDY CONNECTIONS OR APPROVED EQUAL
 PARALLEL HORIZONTAL CONDUCTORS PARALLEL THROUGH CONNECTION OF HORIZONTAL CABLES TYPE PT	 HORIZONTAL STEEL SURFACE TO FLAT STEEL SURFACE OR HORIZONTAL PIPE TYPE HS	 BOND JUMPER FIELD FABRICATED GREEN STRANDED INSULATED TYPE 2-YA-2
 THROUGH CABLE TO GROUND ROD THROUGH CABLE TO TOP OF GROUND ROD TYPE GT	 VERTICAL STEEL SURFACE CABLE DOWN AT 45° TO VERTICAL STEEL SURFACE INCLUDING PIPE TYPE VS	 COPPER LUGS TWO HOLE - LONG BARREL LENGTH TYPE YA-2
 VERTICAL PIPE CABLE DOWN AT 45° TO RANGE OF VERTICAL PIPES TYPE VS	<b>TYPICAL CADWELD TYPE CONNECTIONS</b> NO SCALE	

**Sprint**  
 1 INTERNATIONAL BLVD., SUITE 800  
 MAHWAH, NJ 07495  
 TEL: (201) 684-4000  
 FAX: (201) 684-4223

**Cherundolo Consulting**  
 1280 ROUTE 46 WEST  
 PARSIPPANY, NJ 07054  
 TELEPHONE: 646-544-5324

**WESTCHESTER SERVICES LLC**  
 604 FOX GLEN  
 BARRINGTON, IL 60010  
 TELEPHONE: 847-277-0070  
 FAX : 847-277-0080  
 AE@westchesterservices.com

**JOHN M. BANKS ARCHITECT**  
 604 FOX GLEN  
 BARRINGTON, IL 60010  
 TELEPHONE: 847-277-0070  
 FAX : 847-277-0080

THESE DOCUMENTS ARE CONFIDENTIAL AND ARE THE SOLE PROPERTY OF SPRINT AND MAY NOT BE REPRODUCED, DISSEMINATED OR REDISTRIBUTED WITHOUT THE EXPRESS WRITTEN CONSENT OF SPRINT.

0	11.15.17	FINAL CD
NO.	DATE	DESCRIPTION
DRAWN BY: JS		
CHECKED BY: JMB		
JOB NUMBER: CT52XC055-C		
ARCHITECT: JOHN BANKS		



SITE NAME  
**39 CHERRY AVE SS**

SITE NUMBER  
**CT52XC055-C**

SITE LOCATION  
 253 CHERRY STREET  
 WATERBURY, CT 06702  
 NEW HAVEN COUNTY

SHEET TITLE  
**ELECTRIC PLAN & NOTES**

SHEET NUMBER  
**E-1**



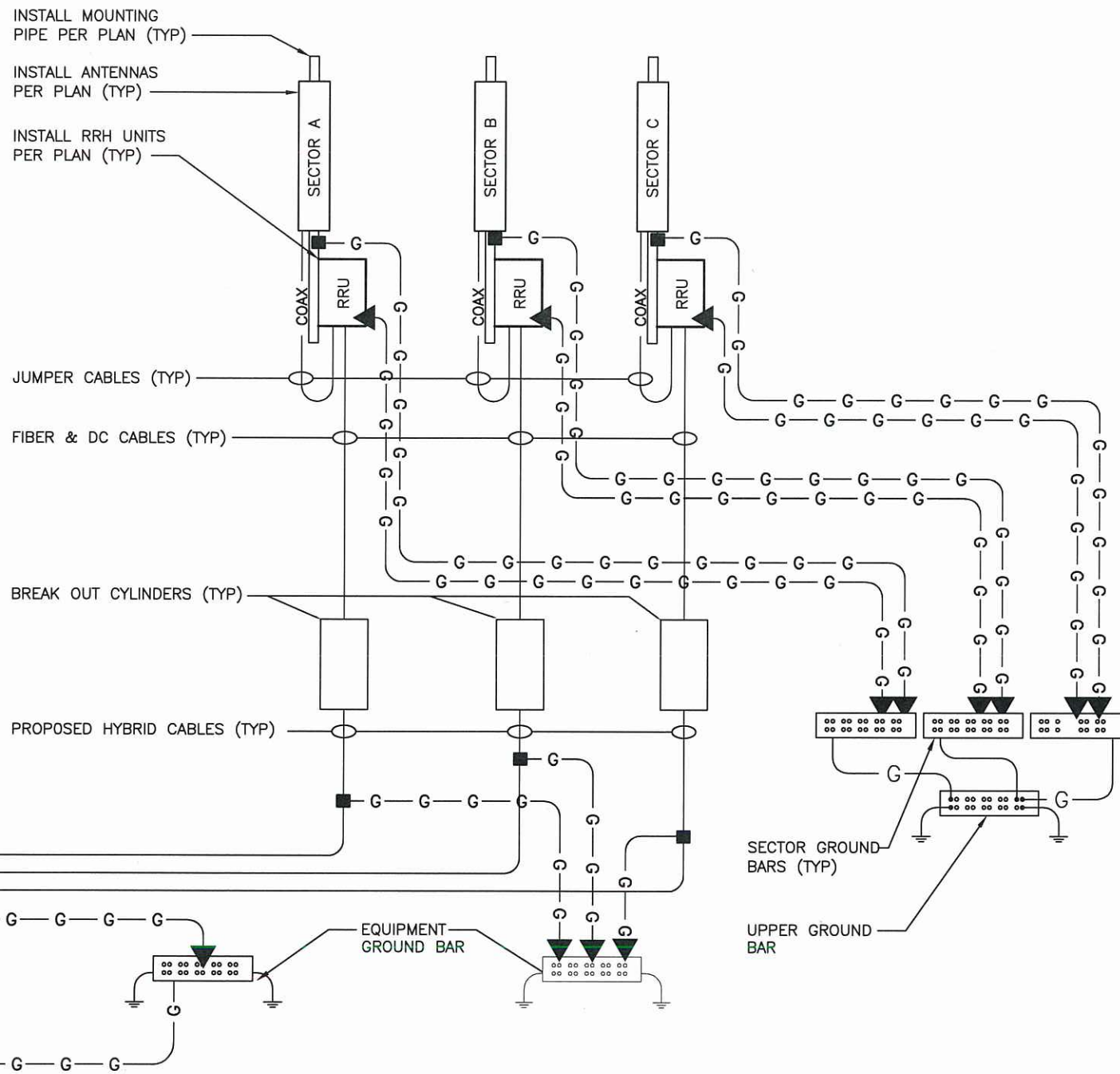
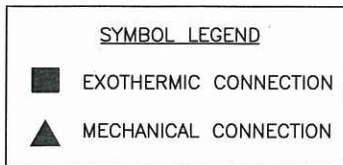

**1**  
E-2 **PLUMBING DIAGRAM**  
GROUNDING RISER DIAGRAM  
SCALE: N.T.S.

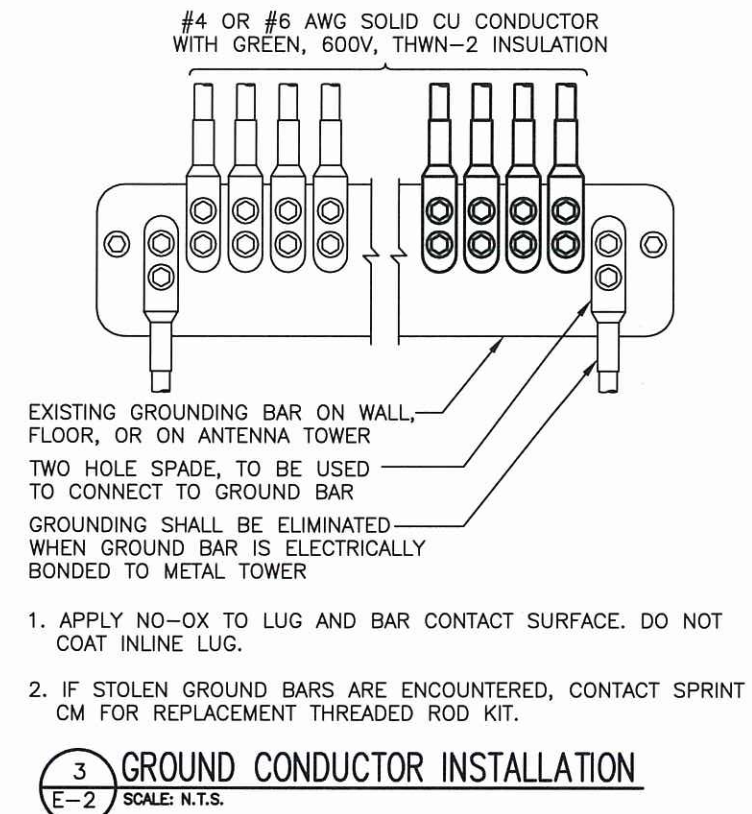
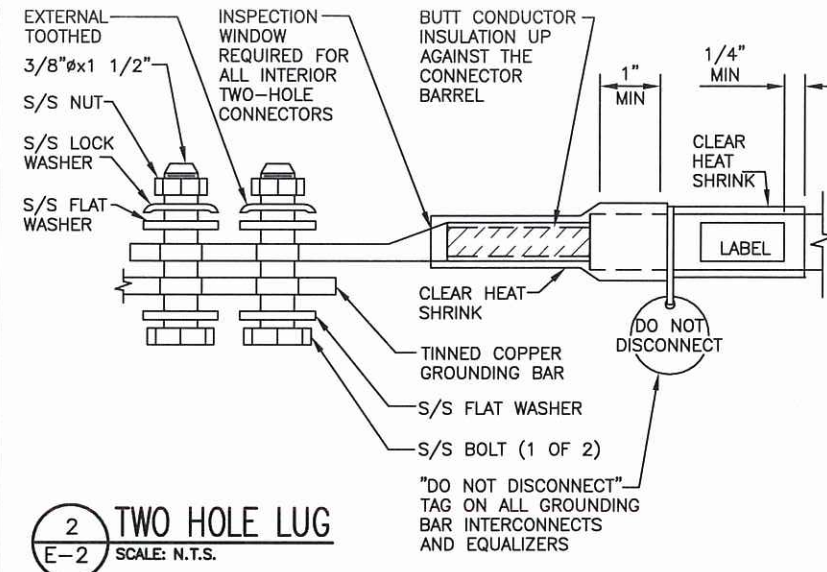

**Sprint**  
1 INTERNATIONAL BLVD., SUITE 800  
MAHWAH, NJ 07495  
TEL: (201) 684-4000  
FAX: (201) 684-4223

**Cherundolo Consulting**  
1280 ROUTE 46 WEST  
PARSIPPANY, NJ 07054  
TELEPHONE: 646-544-5324

**WESTCHESTER SERVICES LLC**  
604 FOX GLEN  
BARRINGTON, IL 60010  
TELEPHONE: 847-277-0070  
FAX: 847-277-0080  
AE@westchesterservices.com

**JOHN M. BANKS ARCHITECT**  
604 FOX GLEN  
BARRINGTON, IL 60010  
TELEPHONE: 847-277-0070  
FAX: 847-277-0080

THESE DOCUMENTS ARE CONFIDENTIAL AND ARE THE SOLE PROPERTY OF SPRINT AND MAY NOT BE REPRODUCED, DISSEMINATED OR REDISTRIBUTED WITHOUT THE EXPRESS WRITTEN CONSENT OF SPRINT.

NO.	DATE	DESCRIPTION
0	11.15.17	FINAL CD
DRAWN BY: JS		
CHECKED BY: JMB		
JOB NUMBER: CT52XC055-C		
ARCHITECT: JOHN BANKS		



SITE NAME  
**39 CHERRY AVE SS**

SITE NUMBER  
**CT52XC055-C**

SITE LOCATION  
253 CHERRY STREET  
WATERBURY, CT 06702  
NEW HAVEN COUNTY

SHEET TITLE

**GROUND RISER DIAGRAM**

SHEET NUMBER

**E-2**

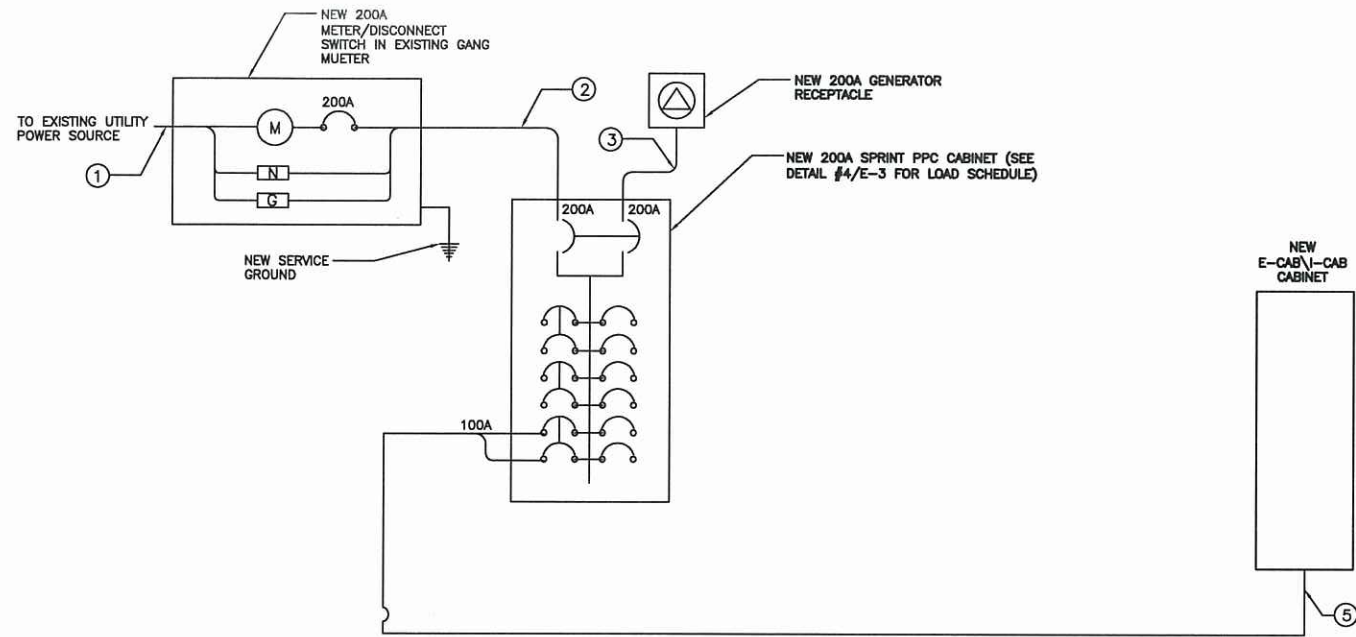

**1 ELECTRICAL ONE-LINE DIAGRAM**  
E-3 SCALE: N.T.S.

NO	FROM	TO	CONFIGURATION
①	UTILITY SOURCE	METER/DISCONNECT	EXISTING
②	METER/DISCONNECT	TRANSFER & LOAD CENTER	NEW
③	TRANSFER & LOAD CTR.	GENERATOR RECEPTACLE	NEW
④	TRANSFER & LOAD CTR.	NEW SPRINT B-CAB CABINET	NONE
⑤	TRANSFER & LOAD CTR.	NEW SPRINT E-CAB CABINET	(3) #2 AWG, (1) #8 GND IN 1-1/2" CONDUIT

NOTE: CG SHALL REFERENCE ALL SPECS FOR "CONNECTING THE POWER SUPPLY" OF THE NEW INSTALLATION DOCUMENTS, FOR ALL CONNECTION SPECIFICATIONS.

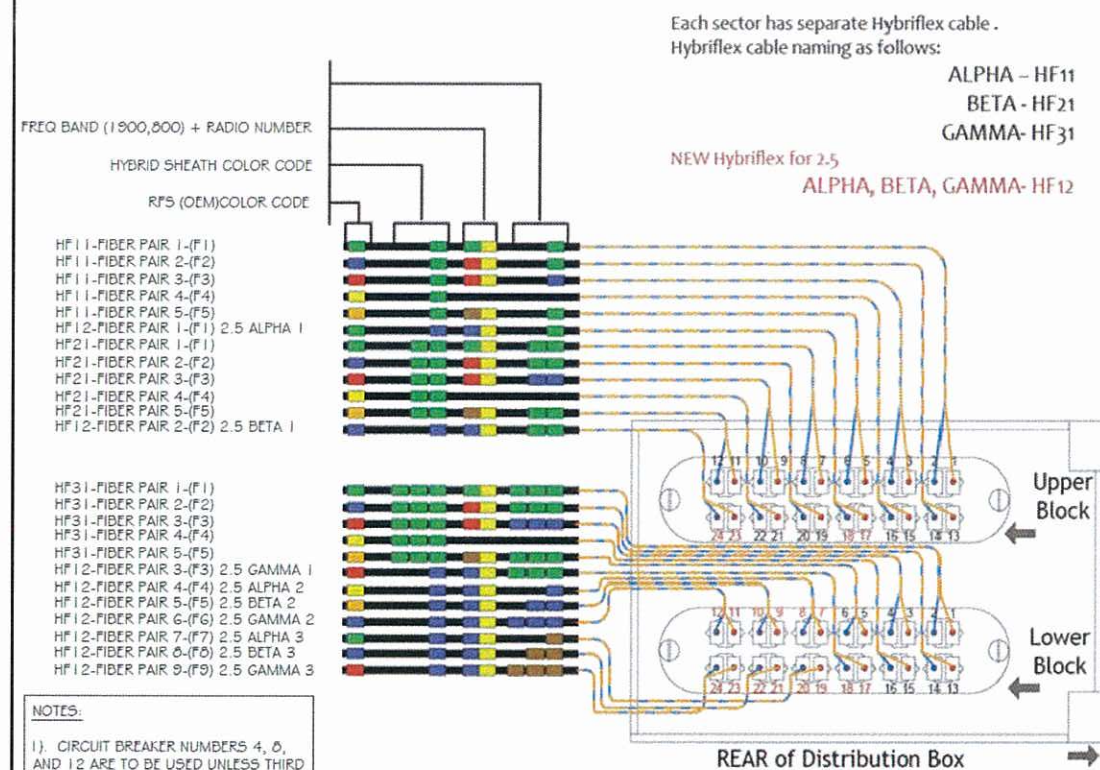

- NOTES:
- CIRCUIT BREAKER NUMBERS 4, 6, AND 12 ARE TO BE USED UNLESS THIRD DC RAIL IS REQUIRED FOR MICROWAVE.
  - USE DC POWER LOOP.
  - ALL UNUSED DC FEEDERS TO BE TERMINATED WITH WIRE NUTS AND TAPED.
  - REMOVE ALL DEBRIS FROM INTERIOR OF FIBER DISTRIBUTION BOX WHEN COMPLETE.

**2 TYPICAL DC POWER DISTRIBUTION**  
E-3 SCALE: N.T.S.

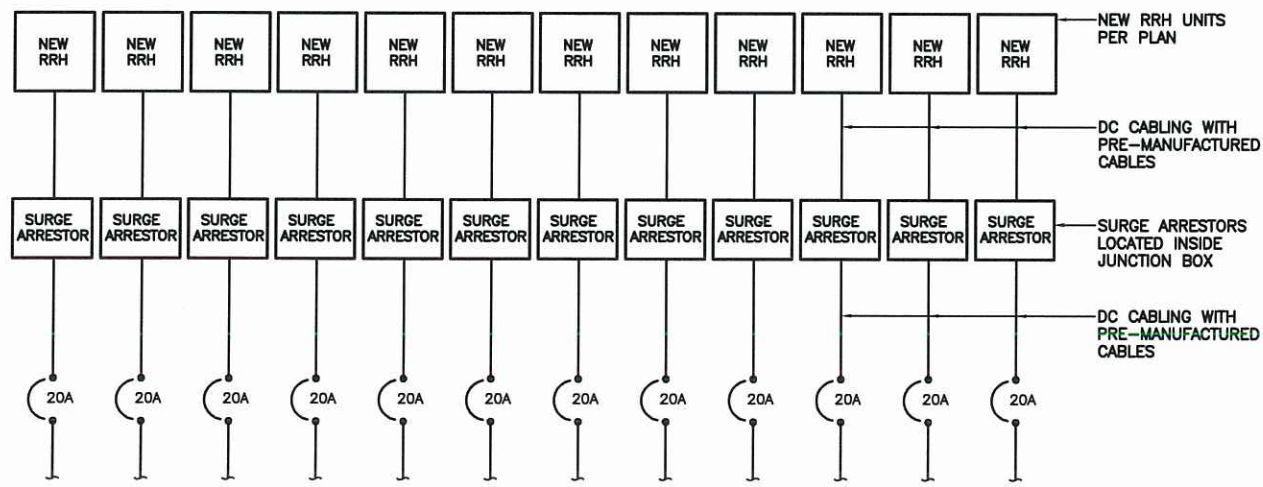

**3 DC ONE-LINE DIAGRAM**  
E-3 SCALE: N.T.S.

EXISTING A/C PANEL SCHEDULE			
VOLTAGE:	240V/120	VOLTAGE:	EXISTING
MAIN BREAKER:	##	MODEL NUMBER:	TBD
MOUNT:	GROUND	PHASE:	1
MOUNT:	NEMA 3R	BUSS RATING:	200 AMP
		NEUTRAL BAR:	YES
		N TO GROUND BOND:	YES
		INTERNAL TVSS:	YES
		WIRE:	3
		GROUND BAR:	YES

CKT	DESCRIPTION	BREAKER AMPS	BREAKER POLES	BREAKER STATUS	PHASE A VA	PHASE B VA	BREAKER STATUS	BREAKER POLES	BREAKER AMPS	DESCRIPTION	CKT
1	MM BTS	100	2	ON			ON	2	60	SURGE PROTECTION	7
2	BLANK (UNUSED)	-	-	-							8
3	BLANK (UNUSED)	-	-	-			ON	2	60	NOT LABELED	9
4	BLANK (UNUSED)	-	-	-							10
5	BLANK (UNUSED)	-	-	-			ON	1	20	TELCO GFCI	11
6	FAN	-	-	-						BLANK (UNUSED)	12

**4 AC PANEL SCHEDULE**  
E-3 SCALE: N.T.S.

**Sprint**

1 INTERNATIONAL BLVD., SUITE 800  
MAHWAH, NJ 07495  
TEL: (201) 684-4000  
FAX: (201) 684-4223

**Cherundolo Consulting**

1280 ROUTE 46 WEST  
PARSIPPANY, NJ 07054  
TELEPHONE: 646-544-5324

**WESTCHESTER SERVICES LLC**

604 FOX GLEN  
BARRINGTON, IL 60010  
TELEPHONE: 847-277-0070  
FAX: 847-277-0080  
AE@westchesterservices.com

**JOHN M. BANKS ARCHITECT**

604 FOX GLEN  
BARRINGTON, IL 60010  
TELEPHONE: 847-277-0070  
FAX: 847-277-0080

THESE DOCUMENTS ARE CONFIDENTIAL AND ARE THE SOLE PROPERTY OF SPRINT AND MAY NOT BE REPRODUCED, DISSEMINATED OR REDISTRIBUTED WITHOUT THE EXPRESS WRITTEN CONSENT OF SPRINT.

0	11.15.17	FINAL CD
NO.	DATE	DESCRIPTION
DRAWN BY: JS		
CHECKED BY: JMB		
JOB NUMBER: CT52XC055-C		
ARCHITECT: JOHN BANKS		



39 CHERRY AVE SS

SITE NUMBER  
CT52XC055-C

SITE LOCATION  
253 CHERRY STREET  
WATERBURY, CT 06702  
NEW HAVEN COUNTY

SHEET TITLE  
ELECTRICAL DETAILS

SHEET NUMBER

E-3

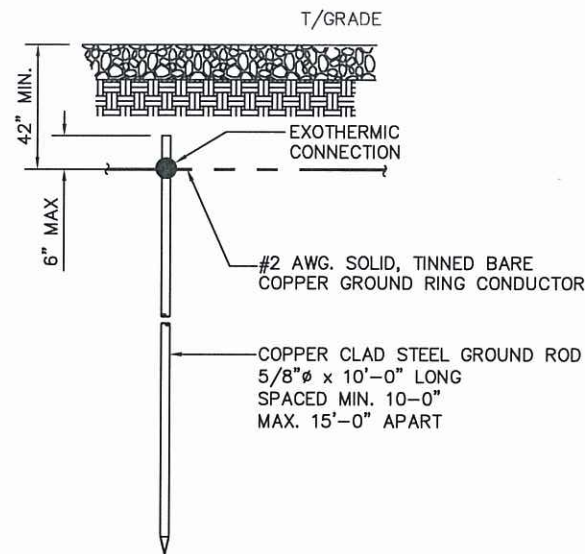

1 GROUND ROD DETAIL  
E-4 SCALE: N.T.S.

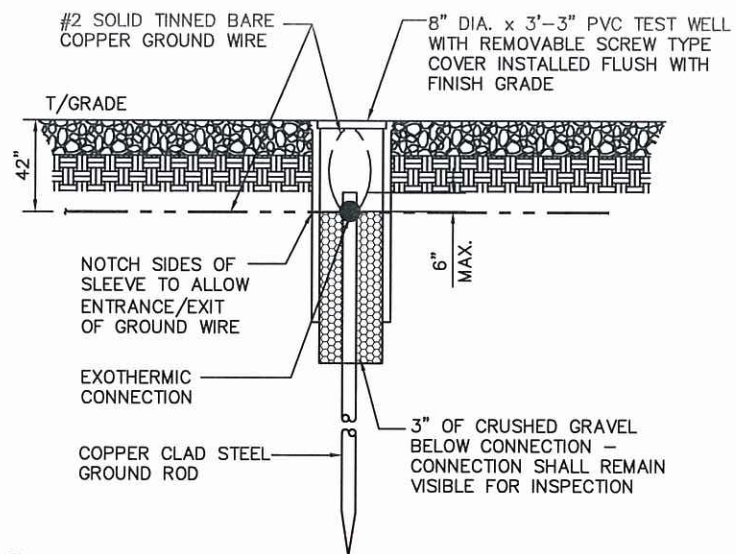

2 TEST WELL DETAIL  
E-4 SCALE: N.T.S.

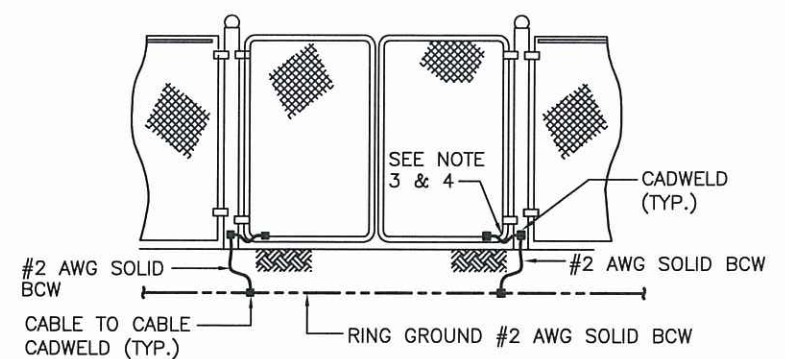

- NOTES:
1. THE #2 AWG, BCW, FROM THE RING GROUND SHALL BE CADWELDED TO THE POST ABOVE GRADE.
  2. BOND EACH HORIZONTAL POLE/BRACE TO EACH OTHER AND TO EACH VERTICAL POLE BONDED TO THE EXTERIOR GROUND RING
  3. GATE JUMPER SHALL BE #4/0 AWG WELDING CABLE OR FLEXIBLE COPPER BRAID BURNDY TYPE B WITH SLEEVES ON EACH END DESIGNED FOR EXOTHERMIC WELDING.
  4. GATE JUMPER SHALL BE INSTALLED SO THAT IT WILL NOT BE SUBJECTED TO DAMAGING STRAIN WHEN GATE IS FULLY OPEN IN EITHER DIRECTION.

3 GRATE GROUNDING DETAIL  
E-4 SCALE: N.T.S.

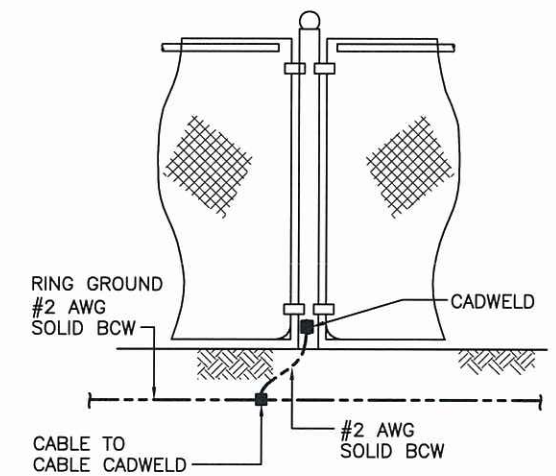

- VERTICAL POST CONNECTED TO RING
- NOTE:
1. VERTICAL POSTS SHALL BE BONDED TO THE RING AT EACH CORNER AND AT EACH GATE POST. AS A MINIMUM ONE VERTICAL POST SHALL BE BONDED TO THE GROUND RING IN EVERY 100 FOOT STRAIGHT RUN OF FENCE.
  2. HORIZONTAL POLES SHALL BE BONDED TO EACH OTHER.
  3. BOND EACH HORIZONTAL POLE/BRACE TO EACH OTHER AND TO EACH VERTICAL POST THAT IS BONDED TO THE EXTERIOR GROUND RING.

4 FENCE GROUNDING DETAIL  
E-4 SCALE: N.T.S.

**Sprint**  
1 INTERNATIONAL BLVD., SUITE 800  
MAHWAH, NJ 07495  
TEL: (201) 684-4000  
FAX: (201) 684-4223

**Cherundolo Consulting**  
1280 ROUTE 46 WEST  
PARSIPPANY, NJ 07054  
TELEPHONE: 646-544-5324

**WESTCHESTER SERVICES LLC**  
604 FOX GLEN  
BARRINGTON, IL 60010  
TELEPHONE: 847-277-0070  
FAX : 847-277-0080  
AE@westchesterservices.com

**JOHN M. BANKS ARCHITECT**  
604 FOX GLEN  
BARRINGTON, IL 60010  
TELEPHONE: 847-277-0070  
FAX : 847-277-0080

THESE DOCUMENTS ARE CONFIDENTIAL AND ARE THE SOLE PROPERTY OF SPRINT AND MAY NOT BE REPRODUCED, DISSEMINATED OR REDISTRIBUTED WITHOUT THE EXPRESS WRITTEN CONSENT OF SPRINT.

0	11.15.17	FINAL CD
NO.	DATE	DESCRIPTION
DRAWN BY: JS		
CHECKED BY: JMB		
JOB NUMBER: CT52XC055-C		
ARCHITECT: JOHN BANKS		



SITE NAME  
39 CHERRY AVE SS

SITE NUMBER  
CT52XC055-C

SITE LOCATION  
253 CHERRY STREET  
WATERBURY, CT 06702  
NEW HAVEN COUNTY

SHEET TITLE  
GROUNDING DETAILS

SHEET NUMBER  
E-4

Date: **November 13, 2017**

Tom Jupin  
Charles Cherundolo Consulting, Inc.  
1280 Rt. 46 West  
Parsippany, NY 07054

**ARCHITECTURE & ENGINEERING DIVISION**  
604 FOX GLEN . BARRINGTON, IL 60010  
847/277-0070 . FAX: 847/277-0080  
AE@westchesterservices.com / www.westchesterservices.com

**Subject: Structural Analysis Report**

**Sprint Co-Locate**

**Site Number:** CT52XC055-C  
**Site Name:** 39 Cherry Ave SS

**Engineering Firm Designation:** Westchester Services, LLC

**Site Data:** 253 Cherry St., Waterbury, CT 06702  
New Haven County – 143.5' Smokestack

Tom Jupin,

Westchester Services, LLC is pleased to submit this “**Structural Analysis Report**” to determine the structural integrity of the above mentioned smokestack and antenna mounting system.

The purpose of the analysis is to determine acceptability of the smokestack and antenna mount stress levels. Based on our analysis we have determined the stress levels to be:

**Existing and Proposed Equipment**

Note: See Table 2-1 for the existing and proposed loading.

**Sufficient Capacity**

This analysis has been performed in accordance with the 2015 International Building Code based upon an ultimate 3-second gust wind speed of 120 mph converted to a nominal 3-second gust wind speed of 93 mph per section 1609.3.1 as required for use in the TIA-222-G Standard per Exception #5 of Section 1609.1.1., Exposure Category B with topographic category 1, Risk Category II, and crest height of 0 feet were used in this analysis.

We at Westchester Services, LLC appreciate the opportunity of providing our continuing professional services to you. If you have any questions or need further assistance on this or any other projects please give us a call.

I certify that this report was prepared by me or under my direct supervision and that I am a licensed Structural Engineer under the laws of the State of Connecticut.

Philip Koziol, PE  
Professional Engineer

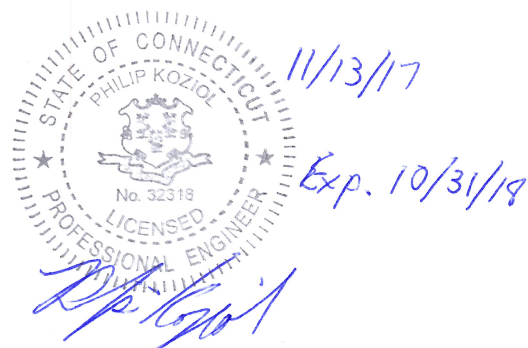

## **TABLE OF CONTENTS**

- 1) INTRODUCTION**
- 2) ANALYSIS CRITERIA**
  - Table 2-1 – Proposed Final Antenna Configuration
- 3) ANALYSIS PROCEDURE**
  - Table 3-1 – Documents Provided
  - 3.1 Analysis Method
- 4) ANALYSIS RESULTS**
  - Table 4-1 – Critical Section Capacity (Summary)
  - 4.1 Recommendations
- 5) ASSUMPTIONS**
- 6) APPENDIX A**
  - Calculations

## 1) INTRODUCTION

This structure is a 143.5' chimney is located in New Haven County, CT. The proposed antennas will be mounted on the existing smokestack.

## 2) ANALYSIS CRITERIA

This analysis has been performed in accordance with the 2015 International Building Code based upon an ultimate 3-second gust wind speed of 120 mph converted to a nominal 3-second gust wind speed of 93 mph per section 1609.3.1 as required for use in the TIA-222-G Standard per Exception #5 of Section 1609.1.1., Exposure Category B with topographic category 1, Risk Category II, and crest height of 0 feet were used in this analysis.

**Table 2-1 – Proposed Final Antenna Configuration**  
(New antennas in **bold**)

Center Line Elevation (ft)	Sector	Pos.	Antenna	Radio(s)	Note
127	Alpha	1	<b>(1) KMW ETCR-654L12H6</b>	<b>(1) 1900MHz RRH</b> <b>(1) 2500MHz RRH</b> <b>(2) 800MHz RRH</b>	
		2	(1) 24" Dish		
		3			
		4			
127	Beta	1	<b>(1) KMW ETCR-654L12H6</b>	<b>(1) 1900MHz RRH</b> <b>(1) 2500MHz RRH</b> <b>(2) 800MHz RRH</b>	
		2	(1) 12" Dish		
		3			
		4			
127	Gamma	1	<b>(1) KMW ETCR-654L12H6</b>	<b>(1) 1900MHz RRH</b> <b>(1) 2500MHz RRH</b> <b>(2) 800MHz RRH</b>	
		2	(1) 12" Dish		
		3			
		4			

Antennas in position 1 will be mounted to a new 3" Std. pipe, 10' Long.

### 3) ANALYSIS PROCEDURE

**Table 3-1 – Documents Provided**

Document	Remarks	Reference	Date	Source
Construction Drawings	-	WSLLC	09/28/2017	WSLLC
Field Mapping	-	WSLLC	05/27/2017	WSLLC
Structural Analysis	-	CHA	06/23/2010	Sprint

#### 3.1) Analysis Method

Risa-3D (version 14.0.1) is a finite element analysis software program was used for modeling and analyzing frame structures. The output from the analysis can be found in Appendix A.

### 4) ANALYSIS RESULTS

**Table 4-1 – Critical Section Capacity (Summary)**

Member Type	Elevation (ft)	% Capacity	Pass/Fail
Antenna Pipe	127	22.3	Pass
Smokestack	-	Negligible Increase	Pass
Overall	127	22.3	Pass

#### 4.1) Recommendations

The existing antenna mounts and structure have sufficient capacity to carry the existing and proposed loads.

## 5) ASSUMPTIONS

- The analysis performed is to the theoretical capacity of the members and connections. No accommodations are taken for any damaged, rusted, deteriorated, or otherwise compromised member conditions. To this, the tower or structure is assumed to be properly maintained and monitored and this analysis cannot be considered to be a condition assessment of the structure.
- The analysis is performed to the minimum design wind, ice, and other environmental loading prescribed by the governing building codes and standards. Any higher loading conditions required by the local jurisdiction or structure owner should be made known to Westchester immediately for analysis. No lesser conditions will be accommodated.
- Member sizes are assumed to be of standard AISC or manufacturer designations unless explicitly specified otherwise. The geometry of the tower or structure is assumed as schematic. Steel grade and concrete strength are assumed to be conservative standard and fully developed unless otherwise specified.
- The information provided to Westchester for analysis is assumed accurate and up to date as supplied. No independent efforts were taken by Westchester to verify the validity of the information supplied. If any additional information is presented at any time that contradicts what is referenced in the analysis, the analysis is invalid and must be performed again with the new information.
- Any reinforcement or modifications are assumed to be fully installed and functional.
- All welds are assumed to have been performed to current welding standards and are assumed to develop their full capacity and to be in good condition. In addition, all bolts and bolt-like anchors are assumed to be fully tightened, fastened, or bonded to the manufacturers' specifications and are assumed to have full capacity.
- Numerous connection details of large-scale structures are unobtainable and are omitted from the structural analysis. This includes, but is not limited to: bolts, welds, flanges, and plates. These connections are considered adequate and are therefore neglected from the analysis. In addition, in the absence of building plans, many wall, floor, and ceiling constructions can only be determined from observable field data and are supplemented by best judgment and experience.
- Antennas, dishes, feedlines, and any other such appurtenances are assumed adequate through manufacturer testing. No analysis is provided for the structural strength or stability of these items unless otherwise specified.
- Equipment mounting systems are assumed structurally sound unless specifically called for in the analysis.
- Soil conditions and foundations are not considered unless specified in the analysis and have no deterioration or defects. For sites located on a building, only local effects of the equipment is considered unless otherwise specified. The overall structure of the building and its foundation are assumed to be unaffected by the telecom equipment.
- Any changes or differences to the site or site plans at any time prior to installation must be brought to the attention of Westchester immediately.



**APPENDIX A**  
**CALCULATIONS**

**References:**

- 1) 2015 International Building Code
- 2) ANSI TIA-222-G, Structural Standard for Antenna Supporting Structures and Antennas
- 3) AISC 360-10 Specification for Structural Steel Buildings
- 4) Construction Drawings by Westchester Services dated 09/28/2017
- 5) Field Mapping by Westchester Services dated 05/27/2017
- 6) Structural Analysis by CHA dated 06/23/2010

**Input****Wind Loads**

$z := 127\text{ft}$	The height of the antennas above grade
$V := 93 \text{ mph}$	$V_{ult}$ per Ref. (1) converted to 3-second gust for use with Ref. (2)
$V_i := 50 \text{ mph}$	Basic wind speed with ice
$t_i := .75\text{-in}$	Design ice thickness
$G_H := 1.35$	Ref. (2), Section 2.6.9
$i_m := 1.0$	Importance Factor, Ref. (2), Table 2-3
$K_d := 0.95$	Wind Direction Probability Factor, Ref. (2), Table 2-2
$Ex := \text{"B"}$	Exposure category. See Ref. (2), Table 2-4
$TC := \text{"1"}$	Topographic Category. See Ref. (2), Table 2-5
$H := 0\text{-ft}$	Crest Height

Equipment Specs

Antennas

Antenna 1: KMW ETCR-654L12H6

height<sub>ant1</sub> := 84.9-in

width<sub>ant1</sub> := 21in

depth<sub>ant1</sub> := 6.3-in

weight<sub>ant1</sub> := 84.9lbf

N<sub>antenna</sub> := 1

Height of antenna

Width of antenna

Depth of antenna

Weight of antenna

Number of antenna groups

Is antenna round?

shape<sub>ant1</sub> :=  Flat  Round

Radio

S  
Radio 1: 2500MHz

H<sub>r1</sub> := 25-in

W<sub>r1</sub> := 17in

D<sub>r1</sub> := 5.7-in

Weight<sub>r1</sub> := 70-lbf

N<sub>radio</sub> := 3

Height of radio

Width of radio

Depth of radio

Weight of radio

Number of radio groups

Is radio round?

shape<sub>r1</sub> :=  Flat  Round

Radio 2: 1900 MHz

H<sub>r2</sub> := 25-in

W<sub>r2</sub> := 10.7in

D<sub>r2</sub> := 11.1-in

Weight<sub>r2</sub> := 68-lbf

Height of radio

Width of radio

Depth of radio

Weight of radio

Is radio round?

shape<sub>r2</sub> :=  Flat  Round

Radio 3: 800 MHz

H<sub>r3</sub> := 19.4-in

W<sub>r3</sub> := 12.9in

D<sub>r3</sub> := 10.7-in

Weight<sub>r3</sub> := 60-lbf

Height of radio

Width of radio

Depth of radio

Weight of radio

Is radio round?

shape<sub>r3</sub> :=  Flat  Round

Pipes

H<sub>pipe1</sub> := 10-ft

Pipe<sub>1</sub> := 3

Overall length of pipe

AISC standard pipe size

**Calculations****Wind**

$$z_g := \begin{cases} 1200\text{-ft} & \text{if Ex = "B"} \\ 900\text{-ft} & \text{if Ex = "C"} \\ 700\text{-ft} & \text{if Ex = "D"} \end{cases}$$

$$z_g = 1.2 \times 10^3 \text{ ft}$$

$$K_{zmin} := \begin{cases} 0.70 & \text{if Ex = "B"} \\ 0.85 & \text{if Ex = "C"} \\ 1.03 & \text{if Ex = "D"} \end{cases}$$

$$K_{zmin} = 0.7$$

$$\alpha := \begin{cases} 7.0 & \text{if Ex = "B"} \\ 9.5 & \text{if Ex = "C"} \\ 11.5 & \text{if Ex = "D"} \end{cases}$$

$$\alpha = 7$$

$$K_e := \begin{cases} 0.90 & \text{if Ex = "B"} \\ 1.00 & \text{if Ex = "C"} \\ 1.10 & \text{if Ex = "D"} \end{cases}$$

$$K_e = 0.9$$

$$K_z := 2.01 \cdot \left( \frac{z}{z_g} \right)^{\frac{2}{\alpha}}$$

$$K_z = 1.058$$

$$K_{zmin} < K_z < 2.01, \text{ OK}$$

$$K_t := \begin{cases} .43 & \text{if TC = "2"} \\ .53 & \text{if TC = "3"} \\ .72 & \text{if TC = "4"} \\ 0 & \text{if TC = "1"} \end{cases}$$

$$K_t = 0$$

$$f := \begin{cases} 1.25 & \text{if TC = "2"} \\ 2.0 & \text{if TC = "3"} \\ 1.5 & \text{if TC = "4"} \\ 0 & \text{if TC = "1"} \end{cases}$$

$$f = 0$$

$$K_h := e^{\left( \frac{f \cdot z}{H} \right)}$$

$$K_h = 1$$

$$K_{zt} := \left( 1 + \frac{K_e \cdot K_t}{K_h} \right)^2$$

$$K_{zt} = 1$$

Ref. (2), 2.6.6.4

$$K_{iz} := \left( \frac{z}{33\text{-ft}} \right)^{0.1}$$

$$K_{iz} = 1.144$$

< 1.4, OK

$$K_a := 1.0$$

Antenna loads - per TIA-222-G

$$K_{z.ant} := \begin{cases} \text{for } n \in 1 .. N_{antenna} \\ p_n \leftarrow \max \left[ K_{zmin}, \min \left[ 2.01 \cdot \left( \frac{z}{z_g} \right)^{\frac{2}{\alpha}}, 2.01 \right] \right] \end{cases} \quad K_{z.ant} = (1.058)$$

$$A_A := \begin{cases} \text{for } n \in 1 .. N_{antenna} \\ p_n \leftarrow \text{height}_{ant_n} \cdot \text{width}_{ant_n} \end{cases} \quad A_A = (12.381) \cdot \text{ft}^2$$

$$q_{z.ant} := \begin{cases} \text{for } n \in 1 .. N_{antenna} \\ p_n \leftarrow 0.00256 \cdot K_{z.ant_n} \cdot K_{zt} \cdot K_d \cdot V^2 \cdot i_m \cdot \text{psf} \end{cases} \quad q_{z.ant} = (22.256) \cdot \text{psf}$$

$$C := (i_m \cdot K_{zt} \cdot K_z)^{0.5} \cdot V \cdot \text{width}_{\text{ant}} \cdot \frac{1}{\text{ft}}$$

$C_A :=$  for  $n \in 1 \dots N_{\text{antenna}}$

if  $\text{shape}_{\text{ant}_n}$

$$\text{Aspect}_n \leftarrow \frac{\text{height}_{\text{ant}_n}}{\text{width}_{\text{ant}_n}}$$

$$p_n \leftarrow \begin{cases} 1.2 & \text{if } \text{Aspect}_n \leq 2.5 \\ 1.2 + .2 \cdot \frac{\text{Aspect}_n - 2.5}{7 - 2.5} & \text{if } 2.5 \leq \text{Aspect}_n \leq 7 \\ 1.4 & \text{if } \text{Aspect}_n = 7 \\ 1.4 + .6 \cdot \frac{\text{Aspect}_n - 7}{25 - 7} & \text{if } 7 \leq \text{Aspect}_n \leq 25 \\ 2.0 & \text{if } \text{Aspect}_n \geq 25 \end{cases}$$

otherwise

$$\text{Aspect}_n \leftarrow \frac{\text{height}_{\text{ant}_n}}{\text{width}_{\text{ant}_n}}$$

$$p_n \leftarrow \begin{cases} \text{if } C_n < 32 \\ .7 & \text{if } \text{Aspect}_n \leq 2.5 \\ .7 + .1 \cdot \frac{\text{Aspect}_n - 2.5}{7 - 2.5} & \text{if } 2.5 \leq \text{Aspect}_n \leq 7 \\ .8 & \text{if } \text{Aspect}_n = 7 \\ .8 + .4 \cdot \frac{\text{Aspect}_n - 7}{25 - 7} & \text{if } 7 \leq \text{Aspect}_n \leq 25 \end{cases}$$

$C = (167.409)$

*continued...*

$$\begin{aligned}
 & 1.2 \text{ if } \text{Aspect}_n \geq 25 && \text{cont.} \\
 & \text{if } 32 \leq C_n \leq 64 \\
 & \quad \frac{3.76}{(C_n)^{.485}} \text{ if } \text{Aspect}_n \leq 2.5 \\
 & \quad \frac{3.76}{(C_n)^{.485}} + \left[ \frac{3.37}{(C_n)^{.415}} - \frac{3.76}{(C_n)^{.485}} \right] \cdot \frac{\text{Aspect}_n - 2.5}{7 - 2.5} \text{ if } 2.5 \leq \text{Aspect}_n \leq 7 \\
 & \quad \frac{3.37}{(C_n)^{.415}} \text{ if } \text{Aspect}_n = 7 \\
 & \quad \frac{3.37}{(C_n)^{.415}} + \left[ \frac{38.4}{C_n} - \frac{3.37}{(C_n)^{.415}} \right] \cdot \frac{\text{Aspect}_n - 7}{25 - 7} \text{ if } 7 \leq \text{Aspect}_n \leq 25 \\
 & \quad \frac{38.4}{C_n} \text{ if } \text{Aspect}_n \geq 25 \\
 & \text{if } C_n > 64 \\
 & \quad .5 \text{ if } \text{Aspect}_n \leq 2.5 \\
 & \quad .5 + .1 \cdot \frac{\text{Aspect}_n - 2.5}{7 - 2.5} \text{ if } 2.5 \leq \text{Aspect}_n \leq 7 \\
 & \quad .6 \text{ if } \text{Aspect}_n \geq 7
 \end{aligned}$$

$C_A = (1.269)$

$$F_A := \text{for } n \in 1..N_{\text{antenna}}$$

$$p_n \leftarrow K_a G_H q_{z,\text{ant}_n} \cdot C_{A_n} \cdot A_{A_n}$$

$F_A = (471.91) \cdot \text{lbf}$

$$W_{\text{ant}} := \sum_{i=1}^{N_{\text{antenna}}} (\text{weight}_{\text{ant}})$$

$W_{\text{ant}} = (84.9) \cdot \text{lbf}$

*Ice*

$$t_{iz.ant} := \left| \begin{array}{l} \text{for } n \in 1 .. N_{\text{antenna}} \\ p_n \leftarrow 2.0 \cdot t_{i.m} \cdot \min \left[ 1.4, \left( \frac{z}{33 \cdot \text{ft}} \right)^{0.1} \right] \cdot K_{zt}^{0.35} \\ p \end{array} \right.$$

$$t_{iz.ant} = (1.716) \cdot \text{in}$$

$$A_{A.ice} := \left| \begin{array}{l} \text{for } n \in 1 .. N_{\text{antenna}} \\ p_n \leftarrow (\text{height}_{\text{ant}_n} + 2 \cdot t_{iz.ant_n}) \cdot (\text{width}_{\text{ant}_n} + 2 \cdot t_{iz.ant_n}) \\ p \end{array} \right.$$

$$A_{A.ice} = (14.988) \cdot \text{ft}^2$$



$$C_{A.ice} := \text{for } n \in 1 .. N_{\text{antenna}}$$

if $\text{shape}_{\text{ant}_n}$	$\text{Aspect}_n \leftarrow \frac{\text{height}_{\text{ant}_n} + 2 \cdot t_{\text{iz.}\text{ant}_n}}{\text{width}_{\text{ant}_n} + 2 \cdot t_{\text{iz.}\text{ant}_n}}$ $p_n \leftarrow \begin{cases} 1.2 & \text{if } \text{Aspect}_n \leq 2.5 \\ 1.2 + .2 \cdot \frac{\text{Aspect}_n - 2.5}{7 - 2.5} & \text{if } 2.5 \leq \text{Aspect}_n \leq 7 \\ 1.4 & \text{if } \text{Aspect}_n = 7 \\ 1.4 + .6 \cdot \frac{\text{Aspect}_n - 7}{25 - 7} & \text{if } 7 \leq \text{Aspect}_n \leq 25 \\ 2.0 & \text{if } \text{Aspect}_n \geq 25 \end{cases}$	$C_{A.ice} = (1.25)$
otherwise	$\text{Aspect}_n \leftarrow \frac{\text{height}_{\text{ant}_n} + 2 \cdot t_{\text{iz.}\text{ant}_n}}{\text{width}_{\text{ant}_n} + 2 \cdot t_{\text{iz.}\text{ant}_n}}$ $p_n \leftarrow \begin{cases} \text{if } C_n < 32 \\ .7 & \text{if } \text{Aspect}_n \leq 2.5 \\ .7 + .1 \cdot \frac{\text{Aspect}_n - 2.5}{7 - 2.5} & \text{if } 2.5 \leq \text{Aspect}_n \leq 7 \\ .8 & \text{if } \text{Aspect}_n = 7 \\ .8 + .4 \cdot \frac{\text{Aspect}_n - 7}{25 - 7} & \text{if } 7 \leq \text{Aspect}_n \leq 25 \end{cases}$	

*continued...*

$$1.2 \text{ if } \text{Aspect}_n \geq 25$$

*cont.*

if  $32 \leq C_n \leq 64$

$$\frac{3.76}{(C_n)^{.485}} \text{ if } \text{Aspect}_n \leq 2.5$$

$$\frac{3.76}{(C_n)^{.485}} + \left[ \frac{3.37}{(C_n)^{.415}} - \frac{3.76}{(C_n)^{.485}} \right] \cdot \frac{\text{Aspect}_n - 2.5}{7 - 2.5} \text{ if } 2.5 \leq \text{Aspect}_n \leq 7$$

$$\frac{3.37}{(C_n)^{.415}} \text{ if } \text{Aspect}_n = 7$$

$$\frac{3.37}{(C_n)^{.415}} + \left[ \frac{38.4}{C_n} - \frac{3.37}{(C_n)^{.415}} \right] \cdot \frac{\text{Aspect}_n - 7}{25 - 7} \text{ if } 7 \leq \text{Aspect}_n \leq 25$$

$$\frac{38.4}{C_n} \text{ if } \text{Aspect}_n \geq 25$$

if  $C_n > 64$

$$.5 \text{ if } \text{Aspect}_n \leq 2.5$$

$$.5 + .1 \cdot \frac{\text{Aspect}_n - 2.5}{7 - 2.5} \text{ if } 2.5 \leq \text{Aspect}_n \leq 7$$

$$.6 \text{ if } \text{Aspect}_n \geq 7$$

P

$$q_{Z,\text{ant.ice}} := \left| \begin{array}{l} \text{for } n \in 1 \dots N_{\text{antenna}} \\ p_n \leftarrow 0.00256 \cdot K_{Z,\text{ant}_n} \cdot K_{Zt} \cdot K_d \cdot V_i^2 \cdot i_m \cdot \text{psf} \\ p \end{array} \right. \quad q_{Z,\text{ant.ice}} = (6.433) \cdot \text{psf}$$

$$F_{A,\text{ice}} := \left| \begin{array}{l} \text{for } n \in 1 \dots N_{\text{antenna}} \\ p_n \leftarrow K_a \cdot G_H \cdot q_{Z,\text{ant.ice}_n} \cdot (C_{A,\text{ice}})_n \cdot A_{A,\text{ice}_n} \\ p \end{array} \right. \quad F_{A,\text{ice}} = (162.648) \cdot \text{lbf}$$

$$W_{\text{ant.ice}} := \left| \begin{array}{l} \text{for } n \in 1 \dots N_{\text{antenna}} \\ D_{c_n} \leftarrow \begin{cases} \sqrt{(\text{width}_{\text{ant}_n})^2 + (\text{depth}_{\text{ant}_n})^2} & \text{if } \text{shape}_{\text{ant}_n} \\ \text{width}_{\text{ant}_n} & \text{otherwise} \end{cases} \\ x_n \leftarrow 56 \text{pcf} \cdot (\text{height}_{\text{ant}_n} + 2 \cdot t_{\text{iz.}\text{ant}_n}) \cdot \pi \cdot t_{\text{iz.}\text{ant}_n} \cdot (D_{c_n} + t_{\text{iz.}\text{ant}_n}) + \text{weight}_{\text{ant}_n} \\ x \end{array} \right. \quad W_{\text{ant.ice}} = (449.825) \cdot \text{lbf}$$

Radio loads - per TIA-222-G

$$K_{z,r} := \left| \begin{array}{l} \text{for } n \in 1 \dots N_{\text{radio}} \\ p_n \leftarrow \max \left[ K_{z,\text{min}}, \min \left[ 2.01 \cdot \left( \frac{z}{z_g} \right)^{\frac{2}{\alpha}}, 2.01 \right] \right] \\ p \end{array} \right.$$

$$K_{z,r} = \begin{pmatrix} 1.058 \\ 1.058 \\ 1.058 \end{pmatrix}$$

$$A_{A,r} := \left| \begin{array}{l} \text{for } n \in 1 \dots N_{\text{radio}} \\ p_n \leftarrow H_{r,n} \cdot W_{r,n} \\ p \end{array} \right.$$

$$A_{A,r} = \begin{pmatrix} 2.951 \\ 1.858 \\ 1.738 \end{pmatrix} \cdot \text{ft}^2$$

$$q_{z,r} := \left| \begin{array}{l} \text{for } n \in 1 \dots N_{\text{radio}} \\ p_n \leftarrow 0.00256 \cdot K_{z,r,n} \cdot K_{z,t} \cdot K_d \cdot V^2 \cdot i_m \cdot \text{psf} \\ p \end{array} \right.$$

$$q_{z,r} = \begin{pmatrix} 22.256 \\ 22.256 \\ 22.256 \end{pmatrix} \cdot \text{psf}$$

$$C := (i_m \cdot K_{zt} \cdot K_z)^{0.5} \cdot v \cdot W_r \cdot \frac{1}{ft}$$

$C_{A,r} :=$  for  $n \in 1 .. N_{radio}$

if  $shape_{r_n}$

$$Aspect_n \leftarrow \frac{H_{r_n}}{W_{r_n}}$$

$$p_n \leftarrow \begin{cases} 1.2 & \text{if } Aspect_n \leq 2.5 \\ 1.2 + .2 \cdot \frac{Aspect_n - 2.5}{7 - 2.5} & \text{if } 2.5 \leq Aspect_n \leq 7 \\ 1.4 & \text{if } Aspect_n = 7 \\ 1.4 + .6 \cdot \frac{Aspect_n - 7}{25 - 7} & \text{if } 7 \leq Aspect_n \leq 25 \\ 2.0 & \text{if } Aspect_n \geq 25 \end{cases}$$

otherwise

$$Aspect_n \leftarrow \frac{H_{r_n}}{W_{r_n}}$$

$$p_n \leftarrow \begin{cases} \text{if } C_n < 32 \\ .7 & \text{if } Aspect_n \leq 2.5 \\ .7 + .1 \cdot \frac{Aspect_n - 2.5}{7 - 2.5} & \text{if } 2.5 \leq Aspect_n \leq 7 \\ .8 & \text{if } Aspect_n = 7 \\ .8 + .4 \cdot \frac{Aspect_n - 7}{25 - 7} & \text{if } 7 \leq Aspect_n \leq 25 \end{cases}$$

$$C = \begin{pmatrix} 135.522 \\ 85.299 \\ 102.837 \end{pmatrix}$$

*continued...*

$$1.2 \text{ if Aspect}_n \geq 25$$

*cont.*

$$\text{if } 32 \leq C_n \leq 64$$

$$\frac{3.76}{(C_n)^{.485}} \text{ if Aspect}_n \leq 2.5$$

$$\frac{3.76}{(C_n)^{.485}} + \left[ \frac{3.37}{(C_n)^{.415}} - \frac{3.76}{(C_n)^{.485}} \right] \cdot \frac{\text{Aspect}_n - 2.5}{7 - 2.5} \text{ if } 2.5 \leq \text{Aspect}_n \leq 7$$

$$\frac{3.37}{(C_n)^{.415}} \text{ if Aspect}_n = 7$$

$$\frac{3.37}{(C_n)^{.415}} + \left[ \frac{38.4}{C_n} - \frac{3.37}{(C_n)^{.415}} \right] \cdot \frac{\text{Aspect}_n - 7}{25 - 7} \text{ if } 7 \leq \text{Aspect}_n \leq 25$$

$$\frac{38.4}{C_n} \text{ if Aspect}_n \geq 25$$

$$C_{A,r} = \begin{pmatrix} 1.2 \\ 1.2 \\ 1.2 \end{pmatrix}$$

$$\text{if } C_n > 64$$

$$.5 \text{ if Aspect}_n \leq 2.5$$

$$.5 + .1 \cdot \frac{\text{Aspect}_n - 2.5}{7 - 2.5} \text{ if } 2.5 \leq \text{Aspect}_n \leq 7$$

$$.6 \text{ if Aspect}_n \geq 7$$

p

$$F_{A,r} := \text{for } n \in 1..N_{\text{radio}}$$

$$p_n \leftarrow K_a G_H q_{z,r_n} \cdot C_{A,r_n} \cdot A_{A,r_n}$$

$$F_{A,r} = \begin{pmatrix} 106.411 \\ 66.977 \\ 62.66 \end{pmatrix} \cdot \text{lbf}$$

p

$$W_{\text{radio}} := \sum_{i=1}^{N_{\text{radio}}} (\text{Weight}_i)$$

$$W_{\text{radio}} = \begin{pmatrix} 210 \\ 204 \\ 180 \end{pmatrix} \cdot \text{lbf}$$

*Ice*

$$t_{iz,r} := \begin{cases} \text{for } n \in 1 .. N_{\text{radio}} \\ p_n \leftarrow 2.0 \cdot t_i \cdot i_m \cdot \min \left[ 1.4, \left( \frac{z}{33 \cdot \text{ft}} \right)^{0.1} \right] \cdot K_{zt}^{0.35} \\ p \end{cases}$$

$$t_{iz,r} = \begin{pmatrix} 1.716 \\ 1.716 \\ 1.716 \end{pmatrix} \cdot \text{in}$$

$$A_{A,r,ice} := \begin{cases} \text{for } n \in 1 .. N_{\text{radio}} \\ p_n \leftarrow (H_{r_n} + 2 \cdot t_{iz,r_n}) \cdot (W_{r_n} + 2 \cdot t_{iz,r_n}) \\ p \end{cases}$$

$$A_{A,r,ice} = \begin{pmatrix} 4.034 \\ 2.791 \\ 2.59 \end{pmatrix} \cdot \text{ft}^2$$

```

CA.r.ice := for n ∈ 1 .. Nradio
  if shapern
    Aspectn ←  $\frac{H_{r_n} + 2 \cdot t_{iz.r_n}}{W_{r_n} + 2 \cdot t_{iz.r_n}}$ 
    pn ← 1.2 if Aspectn ≤ 2.5
          1.2 + .2 ·  $\frac{\text{Aspect}_n - 2.5}{7 - 2.5}$  if 2.5 ≤ Aspectn ≤ 7
          1.4 if Aspectn = 7
          1.4 + .6 ·  $\frac{\text{Aspect}_n - 7}{25 - 7}$  if 7 ≤ Aspectn ≤ 25
          2.0 if Aspectn ≥ 25
  otherwise
    Aspectn ←  $\frac{H_{r_n} + 2 \cdot t_{iz.r_n}}{W_{r_n} + 2 \cdot t_{iz.r_n}}$ 
    pn ← if Cn < 32
          .7 if Aspectn ≤ 2.5
          .7 + .1 ·  $\frac{\text{Aspect}_n - 2.5}{7 - 2.5}$  if 2.5 ≤ Aspectn ≤ 7
          .8 if Aspectn = 7
          .8 + .4 ·  $\frac{\text{Aspect}_n - 7}{25 - 7}$  if 7 ≤ Aspectn ≤ 25

```

*continued...*



$$1.2 \text{ if } Aspect_n \geq 25$$

*cont.*

$$\text{if } 32 \leq C_n \leq 64$$

$$\frac{3.76}{(C_n)^{.485}} \text{ if } Aspect_n \leq 2.5$$

$$\frac{3.76}{(C_n)^{.485}} + \left[ \frac{3.37}{(C_n)^{.415}} - \frac{3.76}{(C_n)^{.485}} \right] \cdot \frac{Aspect_n - 2.5}{7 - 2.5} \text{ if } 2.5 \leq Aspect_n \leq 7$$

$$\frac{3.37}{(C_n)^{.415}} \text{ if } Aspect_n = 7$$

$$\frac{3.37}{(C_n)^{.415}} + \left[ \frac{38.4}{C_n} - \frac{3.37}{(C_n)^{.415}} \right] \cdot \frac{Aspect_n - 7}{25 - 7} \text{ if } 7 \leq Aspect_n \leq 25$$

$$\frac{38.4}{C_n} \text{ if } Aspect_n \geq 25$$

$$C_{A.r.ice} = \begin{pmatrix} 1.2 \\ 1.2 \\ 1.2 \end{pmatrix}$$

$$\text{if } C_n > 64$$

$$.5 \text{ if } Aspect_n \leq 2.5$$

$$.5 + .1 \cdot \frac{Aspect_n - 2.5}{7 - 2.5} \text{ if } 2.5 \leq Aspect_n \leq 7$$

$$.6 \text{ if } Aspect_n \geq 7$$

P

$$q_{z,r.ice} := \begin{cases} \text{for } n \in 1 .. N_{radio} \\ p_n \leftarrow 0.00256 \cdot K_{z,r_n} \cdot K_{zt} \cdot K_d \cdot V_i^2 \cdot i_m \cdot \text{psf} \\ p \end{cases}$$

$$q_{z,r.ice} = \begin{pmatrix} 6.433 \\ 6.433 \\ 6.433 \end{pmatrix} \cdot \text{psf}$$

$$F_{A,r.ice} := \begin{cases} \text{for } n \in 1 .. N_{radio} \\ p_n \leftarrow K_a \cdot G_H \cdot q_{z,r.ice_n} \cdot (C_{A,r.ice})_n \cdot A_{A,r.ice_n} \\ p \end{cases}$$

$$F_{A,r.ice} = \begin{pmatrix} 42.046 \\ 29.082 \\ 26.989 \end{pmatrix} \cdot \text{lbf}$$

$$W_{r.ice} := \begin{cases} \text{for } n \in 1 .. N_{radio} \\ \begin{cases} D_{c_n} \leftarrow \sqrt{(W_{r_n})^2 + (D_{r_n})^2} & \text{if } \text{shape}_{r_n} \\ W_{r_n} & \text{otherwise} \end{cases} \\ x_n \leftarrow 56 \text{pcf} \cdot (H_{r_n} + 2 \cdot t_{iz,r_n}) \cdot \pi \cdot t_{iz,r_n} \cdot (D_{c_n} + t_{iz,r_n}) + \text{Weight}_{r_n} \\ x \end{cases}$$

$$W_{r.ice} = \begin{pmatrix} 167.616 \\ 153.132 \\ 133.721 \end{pmatrix} \cdot \text{lbf}$$

Pipes



$$K_{z.pipe} := \max \left[ K_{zmin}, \min \left[ 2.01 \cdot \left( \frac{z}{z_g} \right)^{\frac{2}{\alpha}}, 2.01 \right] \right]$$

$K_{z.pipe} = 1.058$

$A_{A.pipe} := H_{pipe} \cdot D_{pipe}$

$A_{A.pipe} = 2.917 \cdot ft^2$

$C_{A.pipe} :=$

for $n \in 1$	Aspect <sub>n</sub> ← $\frac{H_{pipe_n}}{D_{pipe_n}}$
p <sub>n</sub> ←	if $C_n < 32$
	.7 if Aspect <sub>n</sub> ≤ 2.5
	$.7 + .1 \cdot \frac{Aspect_n - 2.5}{7 - 2.5}$ if $2.5 \leq Aspect_n \leq 7$
	.8 if Aspect <sub>n</sub> = 7
	$.8 + .4 \cdot \frac{Aspect_n - 7}{25 - 7}$ if $7 \leq Aspect_n \leq 25$
	1.2 if Aspect <sub>n</sub> ≥ 25

*continued...*

*cont.*

if  $32 \leq C_n \leq 64$

$$\begin{aligned} & \frac{3.76}{(C_n)^{.485}} \text{ if Aspect}_n \leq 2.5 \\ & \frac{3.76}{(C_n)^{.485}} + \left[ \frac{3.37}{(C_n)^{.415}} - \frac{3.76}{(C_n)^{.485}} \right] \cdot \frac{\text{Aspect}_n - 2.5}{7 - 2.5} \text{ if } 2.5 \leq \text{Aspect}_n \leq 7 \\ & \frac{3.37}{(C_n)^{.415}} \text{ if Aspect}_n = 7 \\ & \frac{3.37}{(C_n)^{.415}} + \left[ \frac{38.4}{C_n} - \frac{3.37}{(C_n)^{.415}} \right] \cdot \frac{\text{Aspect}_n - 7}{25 - 7} \text{ if } 7 \leq \text{Aspect}_n \leq 25 \\ & \frac{38.4}{C_n} \text{ if Aspect}_n \geq 25 \end{aligned}$$

if  $C_n > 64$

$$\begin{aligned} & .5 \text{ if Aspect}_n \leq 2.5 \\ & .5 + .1 \cdot \frac{\text{Aspect}_n - 2.5}{7 - 2.5} \text{ if } 2.5 \leq \text{Aspect}_n \leq 7 \\ & .6 \text{ if Aspect}_n \geq 7 \end{aligned}$$

$$C_{A,pipe} = (0.6)$$

P

$$q_{z,pipe} := 0.00256 \cdot K_{z,pipe} \cdot K_{zt} \cdot K_d \cdot V^2 \cdot i_m \cdot \text{psf}$$

$$q_{z,pipe} = 22.256 \cdot \text{psf}$$

$$F_{pipe} := \max(G_H \cdot K_a \cdot q_{z,pipe} \cdot C_{A,pipe}, 25 \cdot \text{psf}) \cdot A_{A,pipe}$$

$$F_{pipe} = 72.917 \cdot \text{lbf}$$

$$W_{pipe} := \text{weight}_{pipe} \cdot H_{pipe}$$

$$W_{pipe} = 75.8 \cdot \text{lbf}$$

Ice

$$t_{iz,pipe} := 2.0 \cdot t_i \cdot i_m \cdot \min \left[ 1.4, \left( \frac{z}{33 \cdot ft} \right)^{0.1} \right] \cdot K_{zt}^{0.35}$$

$$t_{iz,pipe} = 1.716 \cdot in$$

$$q_{z,pipe,ice} := 0.00256 \cdot K_{z,pipe} \cdot K_{zt} \cdot K_d \cdot V_i^2 \cdot i_m \cdot psf$$

$$q_{z,pipe,ice} = 6.433 \cdot psf$$

$$A_{A,pipe,ice} := (H_{pipe} + 2 \cdot t_{iz,pipe}) \cdot (D_{pipe} + 2 \cdot t_{iz,pipe})$$

$$A_{A,pipe,ice} = 5.943 \cdot ft^2$$

$$C_{A,pipe,ice} := \begin{array}{l} \text{for } n \in 1 \\ \quad \text{Aspect}_n \leftarrow \frac{H_{pipe} + t_{iz,pipe}}{D_{pipe} + 2 \cdot t_{iz,pipe}} \\ \quad p_n \leftarrow \begin{array}{l} \text{if } C_n < 32 \\ \quad .7 \text{ if } \text{Aspect}_n \leq 2.5 \\ \quad .7 + .1 \cdot \frac{\text{Aspect}_n - 2.5}{7 - 2.5} \text{ if } 2.5 \leq \text{Aspect}_n \leq 7 \\ \quad .8 \text{ if } \text{Aspect}_n = 7 \\ \quad .8 + .4 \cdot \frac{\text{Aspect}_n - 7}{25 - 7} \text{ if } 7 \leq \text{Aspect}_n \leq 25 \\ \quad 1.2 \text{ if } \text{Aspect}_n \geq 25 \end{array} \end{array}$$

continued...

if  $32 \leq C_n \leq 64$

*cont.*

$$\left| \begin{array}{l} \frac{3.76}{(C_n)^{.485}} \text{ if Aspect}_n \leq 2.5 \\ \frac{3.76}{(C_n)^{.485}} + \left[ \frac{3.37}{(C_n)^{.415}} - \frac{3.76}{(C_n)^{.485}} \right] \cdot \frac{\text{Aspect}_n - 2.5}{7 - 2.5} \text{ if } 2.5 \leq \text{Aspect}_n \leq 7 \\ \frac{3.37}{(C_n)^{.415}} \text{ if Aspect}_n = 7 \\ \frac{3.37}{(C_n)^{.415}} + \left[ \frac{38.4}{C_n} - \frac{3.37}{(C_n)^{.415}} \right] \cdot \frac{\text{Aspect}_n - 7}{25 - 7} \text{ if } 7 \leq \text{Aspect}_n \leq 25 \\ \frac{38.4}{C_n} \text{ if Aspect}_n \geq 25 \end{array} \right|$$

if  $C_n > 64$

$$\left| \begin{array}{l} .5 \text{ if Aspect}_n \leq 2.5 \\ .5 + .1 \cdot \frac{\text{Aspect}_n - 2.5}{7 - 2.5} \text{ if } 2.5 \leq \text{Aspect}_n \leq 7 \\ .6 \text{ if Aspect}_n \geq 7 \end{array} \right|$$

$$C_{A,\text{pipe.ice}} = (0.6)$$

p

$$F_{\text{pipe.ice}} := G_H \cdot K_a \cdot q_{z,\text{pipe.ice}} \cdot C_{A,\text{pipe.ice}} \cdot A_{A,\text{pipe.ice}}$$

$$F_{\text{pipe.ice}} = (30.966) \cdot \text{lbf}$$

$$W_{\text{pipe.ice}} := 56 \text{pcf} \cdot \left[ (H_{\text{pipe}} + 2 \cdot t_{i,z,\text{pipe}}) \cdot \pi \cdot \left( \frac{D_{\text{pipe}}}{2} + t_{i,z,\text{pipe}} \right)^2 - \left[ H_{\text{pipe}} \cdot \left[ \pi \cdot \left( \frac{D_{\text{pipe}}}{2} \right)^2 \right] \right] \right] + W_{\text{pipe}}$$

$$W_{\text{pipe.ice}} = 109.258 \cdot \text{lbf}$$

**Wall Mounting Loads**

$$d_{\text{wall}} := 12\text{in}$$

*Distance of pipe from wall*

$$n_{\text{support}} := 2$$

*Number of supports*

$$n_{\text{bolt}} := 4$$

*Number of bolts at each support*

$$W_{\text{new1}} := W_{\text{pipe}} + W_{\text{ant}_1} + W_{\text{radio}_1} + W_{\text{radio}_2} + 2 W_{\text{radio}_3} \quad W_{\text{new1}} = 934.7 \cdot \text{lbf}$$

*Total new weight*

$$F_{\text{new1}} := F_{\text{pipe}} + F_{A_1} + F_{A.r_1} + F_{A.r_2} + 2 F_{A.r_3} \quad F_{\text{new1}} = 843.535 \cdot \text{lbf}$$

*Total new wind load**Determine the maximum bending moments in mounting pipes in antenna installation**Case 1 (governing case)*

$$M_{\text{new}} := \frac{F_{\text{new1}} \cdot 3.5\text{ft}}{4} = 0.738 \cdot \text{kip} \cdot \text{ft}$$

$$M_{\text{new}} = 738.093 \cdot \text{lbf} \cdot \text{ft}$$

$$S_{\text{pipe}} = (1.72) \cdot \text{in}^3$$

$$F_y := 35 \cdot \text{ksi}$$

$$\frac{M_{\text{new}}}{S_{\text{pipe}}} = (5.149) \cdot \text{ksi}$$

$$< 0.66 F_y = 23.1 \cdot \text{ksi},$$

*The mounting pipes are adequate.*

$$\frac{M_{\text{new}}}{S_{\text{pipe}} \cdot 0.66 \cdot F_y} = (22.292) \%$$

$$V := \frac{W_{\text{new1}}}{n_{\text{bolt}} \cdot n_{\text{support}}}$$

$$V = 116.838 \text{ lbf}$$

*Shear at each bolt*

$$T := \frac{F_{\text{new1}}}{n_{\text{bolt}} \cdot n_{\text{support}}} + \frac{W_{\text{new1}} \cdot d_{\text{wall}}}{n_{\text{bolt}} \cdot 3.5\text{ft}}$$

$$T = 172.206 \text{ lbf}$$

*Tension/compression at each bolt**The loads on the support bolts are negligible.**The new appurtenances are replacing existing antennas, resulting in a negligible increase in wind load. Per Ref. (6), the smokestack has adequate capacity for existing and proposed loads.*



## RADIO FREQUENCY EMISSIONS ANALYSIS REPORT EVALUATION OF HUMAN EXPOSURE POTENTIAL TO NON-IONIZING EMISSIONS

SPRINT Existing Facility

Site ID: CT52XC055

39 Cherry Ave SS  
253 Cherry Street  
Waterbury, CT 06702

**June 7, 2018**

**EBI Project Number: 6218004190**

Site Compliance Summary	
Compliance Status:	<b>COMPLIANT</b>
Site total MPE% of FCC general population allowable limit:	<b>8.44 %</b>





June 7, 2018

SPRINT

Attn: RF Engineering Manager  
1 International Boulevard, Suite 800  
Mahwah, NJ 07495

## Emissions Analysis for Site: **CT52XC055 – 39 Cherry Ave SS**

EBI Consulting was directed to analyze the proposed SPRINT facility located at **253 Cherry Street, Waterbury, CT**, for the purpose of determining whether the emissions from the Proposed SPRINT Antenna Installation located on this property are within specified federal limits.

All information used in this report was analyzed as a percentage of current Maximum Permissible Exposure (% MPE) as listed in the FCC OET Bulletin 65 Edition 97-01 and ANSI/IEEE Std C95.1. The FCC regulates Maximum Permissible Exposure in units of microwatts per square centimeter ( $\mu\text{W}/\text{cm}^2$ ). The number of  $\mu\text{W}/\text{cm}^2$  calculated at each sample point is called the power density. The exposure limit for power density varies depending upon the frequencies being utilized. Wireless Carriers and Paging Services use different frequency bands each with different exposure limits, therefore it is necessary to report results and limits in terms of percent MPE rather than power density.

All results were compared to the FCC (Federal Communications Commission) radio frequency exposure rules, 47 CFR 1.1307(b)(1) – (b)(3), to determine compliance with the Maximum Permissible Exposure (MPE) limits for General Population/Uncontrolled environments as defined below.

General population/uncontrolled exposure limits apply to situations in which the general population may be exposed or in which persons who are exposed as a consequence of their employment may not be made fully aware of the potential for exposure or cannot exercise control over their exposure. Therefore, members of the general population would always be considered under this category when exposure is not employment related, for example, in the case of a telecommunications tower that exposes persons in a nearby residential area.

General population exposure to radio frequencies is regulated and enforced in units of microwatts per square centimeter ( $\mu\text{W}/\text{cm}^2$ ). The general population exposure limits for the 850 MHz Band is approximately  $567 \mu\text{W}/\text{cm}^2$ . The general population exposure limit for the 1900 MHz (PCS) and 2500 MHz (BRS) bands is  $1000 \mu\text{W}/\text{cm}^2$ . Because each carrier will be using different frequency bands, and each frequency band has different exposure limits, it is necessary to report percent of MPE rather than power density.



Occupational/controlled exposure limits apply to situations in which persons are exposed as a consequence of their employment and in which those persons who are exposed have been made fully aware of the potential for exposure and can exercise control over their exposure. Occupational/controlled exposure limits also apply where exposure is of a transient nature as a result of incidental passage through a location where exposure levels may be above general population/uncontrolled limits (see below), as long as the exposed person has been made fully aware of the potential for exposure and can exercise control over his or her exposure by leaving the area or by some other appropriate means.

Additional details can be found in FCC OET 65.

## CALCULATIONS

Calculations were done for the proposed SPRINT Wireless antenna facility located at **253 Cherry Street, Waterbury, CT**, using the equipment information listed below. All calculations were performed per the specifications under FCC OET 65. Since SPRINT is proposing highly focused directional panel antennas, which project most of the emitted energy out toward the horizon, all calculations were performed assuming a lobe representing the maximum gain of the antenna per the antenna manufactures supplied specifications, minus 10 dB for directional panel antennas and 20 dB for highly focused parabolic microwave dishes, was focused at the base of the tower. For this report the sample point is the top of a 6-foot person standing at the base of the tower.

For all calculations, all equipment was calculated using the following assumptions:

- 1) 1 CDMA channels (850 MHz) were considered for each sector of the proposed installation. These Channels have a transmit power of 20 Watts per Channel.
- 2) 2 LTE channels (850 MHz) were considered for each sector of the proposed installation. These Channels have a transmit power of 50 Watts per Channel.
- 3) 5 CDMA channels (1900 MHz (PCS)) were considered for each sector of the proposed installation. These Channels have a transmit power of 16 Watts per Channel.
- 4) 2 LTE channels (1900 MHz (PCS)) were considered for each sector of the proposed installation. These Channels have a transmit power of 40 Watts per Channel.
- 5) 8 LTE channels (2500 MHz (BRS)) were considered for each sector of the proposed installation. These Channels have a transmit power of 20 Watts per Channel.
- 6) 1 microwave backhaul channel (11 GHz) was considered for each sector. These channels have a transmit power of 1 Watt per channel.



- 7) All radios at the proposed installation were considered to be running at full power and were uncombined in their RF transmissions paths per carrier prescribed configuration. Per FCC OET Bulletin No. 65 - Edition 97-01 recommendations to achieve the maximum anticipated value at each sample point, all power levels emitting from the proposed antenna installation are increased by a factor of 2.56 to account for possible in-phase reflections from the surrounding environment. This is rarely the case, and if so, is never continuous.
- 8) For the following calculations, the sample point was the top of a 6-foot person standing at the base of the tower. The maximum gain of the antenna per the antenna manufactures supplied specifications, minus 10 dB for directional panel antennas and 20 dB for highly focused parabolic microwave dishes, was used in this direction. This value is a very conservative estimate as gain reductions for these particular antennas are typically much higher in this direction.
- 9) The antennas used in this modeling are the **Commscope NNVV-65B-R4 and the Nokia AAHC** for transmission in the 850 MHz, 1900 MHz (PCS) and 2500 MHz (BRS) frequency bands and two (2) **12-inch microwave dishes** at sectors A & B and one (1) **24-inch microwave dish** at Sector C for the 11 GHz microwave backhaul. This is based on feedback from the carrier with regards to anticipated antenna selection. Maximum gain values for all antennas are listed in the Inventory and Power Data table below. The maximum gain of the antenna per the antenna manufactures supplied specifications, minus 10 dB for directional panel antennas and 20 dB for highly focused parabolic microwave dishes, was used for all calculations. This value is a very conservative estimate as gain reductions for these particular antennas are typically much higher in this direction.
- 10) The antenna mounting height centerlines of the proposed panel antennas and microwave dishes are **127 feet** above ground level (AGL) for **Sector A**, **127 feet** above ground level (AGL) for **Sector B** and **127 feet** above ground level (AGL) for Sector C.
- 11) Emissions values for additional carriers were taken from the Connecticut Siting Council active database. Values in this database are provided by the individual carriers themselves.

All calculations were done with respect to uncontrolled / general population threshold limits.



## SPRINT Site Inventory and Power Data by Antenna

Sector:	A	Sector:	B	Sector:	C
Antenna #:	<b>1</b>	Antenna #:	<b>1</b>	Antenna #:	<b>1</b>
Make / Model:	Commscope NNVV-65B-R4	Make / Model:	Commscope NNVV-65B-R4	Make / Model:	Commscope NNVV-65B-R4
Gain:	12.75 / 15.05 dBd	Gain:	12.75 / 15.05 dBd	Gain:	12.75 / 15.05 dBd
Height (AGL):	<b>127 feet</b>	Height (AGL):	<b>127 feet</b>	Height (AGL):	<b>127 feet</b>
Frequency Bands	850 MHz / 1900 MHz (PCS)	Frequency Bands	850 MHz / 1900 MHz (PCS)	Frequency Bands	850 MHz / 1900 MHz (PCS)
Channel Count	10	Channel Count	10	Channel Count	10
Total TX Power(W):	280 Watts	Total TX Power(W):	280 Watts	Total TX Power(W):	280 Watts
ERP (W):	7,378.61	ERP (W):	7,378.61	ERP (W):	7,378.61
Antenna A1 MPE%	<b>2.24 %</b>	Antenna B1 MPE%	<b>2.24 %</b>	Antenna C1 MPE%	<b>2.24 %</b>
Antenna #:	<b>2</b>	Antenna #:	<b>2</b>	Antenna #:	<b>2</b>
Make / Model:	Nokia AAHC	Make / Model:	Nokia AAHC	Make / Model:	Nokia AAHC
Gain:	15.05 dBd	Gain:	15.05 dBd	Gain:	15.05 dBd
Height (AGL):	<b>127 feet</b>	Height (AGL):	<b>127 feet</b>	Height (AGL):	<b>127 feet</b>
Frequency Bands	2500 MHz (BRS)	Frequency Bands	2500 MHz (BRS)	Frequency Bands	2500 MHz (BRS)
Channel Count	8	Channel Count	8	Channel Count	8
Total TX Power(W):	160 Watts	Total TX Power(W):	160 Watts	Total TX Power(W):	160 Watts
ERP (W):	5,118.23	ERP (W):	5,118.23	ERP (W):	5,118.23
Antenna A2 MPE%	<b>1.26 %</b>	Antenna B2 MPE%	<b>1.26 %</b>	Antenna C2 MPE%	<b>1.26 %</b>

## Microwave Backhaul Data

Antenna Type:	Gain (dBd)	Height (feet AGL):	Frequency Bands	Channel Count	Total TX Power(W)	ERP (W)	MPE %	Sector
1-foot parabolic dish	28.75 dBd	127	11 GHz	1	1	749.89	<b>0.02</b>	<b>A</b>
1-foot parabolic dish	28.75 dBd	127	11 GHz	1	1	749.89	<b>0.02</b>	<b>B</b>
2-foot parabolic dish	32.35 dBd	127	11 GHz	1	1	1,717.90	<b>0.04</b>	<b>C</b>

Site Composite MPE%	
Carrier	MPE%
SPRINT – Sector C	<b>3.53 %</b>
Clearwire	0.19 %
MetroPCS	1.72 %
T-Mobile	3.00 %
<b>Site Total MPE %:</b>	<b>8.44 %</b>

SPRINT Sector A Total:	3.51 %
SPRINT Sector B Total:	3.51 %
SPRINT Sector C Total:	<b>3.53 %</b>
<hr/>	
Site Total:	8.44 %



# EBI Consulting

environmental | engineering | due diligence

SPRINT _ Frequency Band / Technology (Sector C)	# Channels	Watts ERP (Per Channel)	Height (feet)	Total Power Density ( $\mu\text{W}/\text{cm}^2$ )	Frequency (MHz)	Allowable MPE ( $\mu\text{W}/\text{cm}^2$ )	Calculated % MPE
Sprint 850 MHz CDMA	1	376.73	127	0.93	850 MHz	567	0.16%
Sprint 850 MHz LTE	2	941.82	127	4.63	850 MHz	567	0.82%
Sprint 1900 MHz (PCS) CDMA	5	511.82	127	6.28	1900 MHz (PCS)	1000	0.63%
Sprint 1900 MHz (PCS) LTE	2	1,279.56	127	6.28	1900 MHz (PCS)	1000	0.63%
Sprint 2500 MHz (BRS) LTE	8	639.78	127	12.57	2500 MHz (BRS)	1000	1.26%
Sprint 11 GHz microwave	1	1,717.90	127	0.42	11 GHz	1000	0.04%
						<b>Total*:</b>	<b>3.53%</b>

\*NOTE: Totals may vary by 0.01% due to summing of remainders



## Summary

All calculations performed for this analysis yielded results that were **within** the allowable limits for general population exposure to RF Emissions.

The anticipated maximum composite contributions from the SPRINT facility as well as the site composite emissions value with regards to compliance with FCC's allowable limits for general population exposure to RF Emissions are shown here:

SPRINT Sector	Power Density Value (%)
Sector A:	3.51 %
Sector B:	3.51 %
Sector C:	3.53 %
SPRINT Maximum Total (Sector C):	3.53 %
Site Total:	8.44 %
Site Compliance Status:	<b>COMPLIANT</b>

The anticipated composite MPE value for this site assuming all carriers present is **8.44 %** of the allowable FCC established general population limit sampled at the ground level. This is based upon values listed in the Connecticut Siting Council database for existing carrier emissions.

FCC guidelines state that if a site is found to be out of compliance (over allowable thresholds), that carriers over a 5% contribution to the composite value will require measures to bring the site into compliance. For this facility, the composite values calculated were well within the allowable 100% threshold standard per the federal government.

C/O CITY PLAN DEPARTMENT  
236 Grand Street  
Waterbury, CT 06702  
Office: (203) 574-6817  
Fax: (203) 346-3949  
Email: jsequin@waterburyct.org



ZONING BOARD OF APPEALS  
**THE CITY OF WATERBURY**  
CONNECTICUT

September 20, 2010

Clearwire, LLC  
Maxton Technology  
1296 Blue Hills Avenue  
Bloomfield, CT 06002

**SUBJECT: 39 Cherry Avenue**

To Whom It May Concern:

Attached please find the certified letter of the Zoning Board of Appeals decision on Wednesday, September 15, 2010.

Please have the attached certification recorded in the Office of the Town Clerk, City Hall, 235 Grand Street, Waterbury, CT 06702, phone (203) 574-6806. Please check with the Town Clerk's Office at the phone number above to find out their fee schedule for recording your document.

When you apply for a permit based on this Special Exception, you must provide evidence that the certified copy of this approval is filed in the land records.

Sincerely,  
THE CITY OF WATERBURY

ATTEST:

Dennis Brown  
Land Use Officer

DB/mcr  
Attachment  
cc: City Clerk  
Town Clerk  
File:

MICHAEL J. DALTON  
CITY CLERK

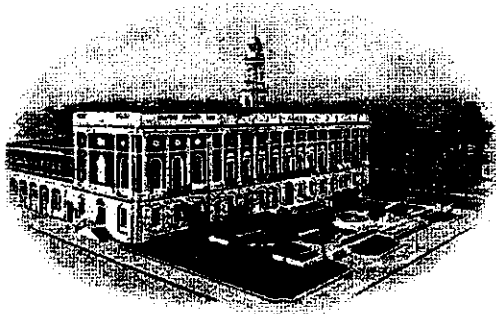

Office: (203) 574-6744  
Fax: (203) 574-6745  
E-mail: [mdalton@waterburyct.org](mailto:mdalton@waterburyct.org)

OFFICE OF CITY CLERK  
**THE CITY OF WATERBURY**  
CONNECTICUT

DATE: September 20, 2010

To Whom It May Concern:

*THIS IS TO CERTIFY THAT* at a Regular Meeting of the Zoning Board of Appeals held on Wednesday, September 15, 2010, it was voted unanimously to **GRANT** a Certificate of Approval with a stipulation that it match the color of the existing antenna for the petition submitted by Clearwire LLC, for a Special Exception from Section 5.13-9 to add antennas to an existing smoke stack for property located at **39 Cherry Avenue. Applicant: Clearwire LLC, Maxton Technology, 1296 Blue Hills Avenue, Bloomfield, CT 06002.**

ATTEST:

  
Michael J. Dalton  
City Clerk

MJD/mcr





# STATE OF CONNECTICUT

**CONNECTICUT SITING COUNCIL**  
Ten Franklin Square, New Britain, CT 06051  
Phone: (860) 827-2935 Fax: (860) 827-2950  
E-Mail: [siting.council@ct.gov](mailto:siting.council@ct.gov)  
[www.ct.gov/esc](http://www.ct.gov/esc)

August 29, 2016

Jon Ritter  
Tower Resource Management, Inc.  
16 Chestnut Street, Suite 420  
Foxboro, MA 02035

**RE: EM-T-MOBILE-151-160805** – T-Mobile Northeast LLC notice of intent to modify an existing telecommunications facility located at 39 Cherry Avenue, Waterbury, Connecticut.

Dear Mr. Ritter:

The Connecticut Siting Council (Council) hereby acknowledges your notice to modify this existing telecommunications facility, pursuant to Section 16-50j-73 of the Regulations of Connecticut State Agencies with the following conditions:

1. Any deviation from the proposed modification as specified in this notice and supporting materials with the Council shall render this acknowledgement invalid;
2. Any material changes to this modification as proposed shall require the filing of a new notice with the Council;
3. Within 45 days after completion of construction, the Council shall be notified in writing that construction has been completed;
4. Any nonfunctioning antenna and associated antenna mounting equipment on this facility owned and operated by T-Mobile Northeast LLC shall be removed within 60 days of the date the antenna ceased to function;
5. The validity of this action shall expire one year from the date of this letter; and
6. The applicant may file a request for an extension of time beyond the one year deadline provided that such request is submitted to the Council not less than 60 days prior to the expiration.

The proposed modifications including the placement of all necessary equipment and shelters within the tower compound are to be implemented as specified here and in your notice received August 5, 2016. The modifications are in compliance with the exception criteria in Section 16-50j-72 (b) of the Regulations of Connecticut State Agencies as changes to an existing facility site that would not increase tower height, extend the boundaries of the tower site by any dimension, increase noise levels at the tower site boundary by six decibels or more, and increase the total radio frequencies electromagnetic radiation power density measured at the tower site boundary to or above the standards adopted by the Federal Communications Commission pursuant to Section 704 of the Telecommunications Act of 1996 and by the state Department of Energy and Environmental Protection pursuant to Connecticut General Statutes § 22a-162. This facility has also been carefully modeled to ensure that radio frequency emissions are conservatively below state and federal standards applicable to the frequencies now used on this tower.



August 29, 2016

Page 2 of 2

This decision is under the exclusive jurisdiction of the Council. Please be advised that the validity of this action shall expire one year from the date of this letter. Any additional change to this facility will require explicit notice to this agency pursuant to Regulations of Connecticut State Agencies Section 16-50j-73. Such notice shall include all relevant information regarding the proposed change with cumulative worst-case modeling of radio frequency exposure at the closest point of uncontrolled access to the tower base, consistent with Federal Communications Commission, Office of Engineering and Technology, Bulletin 65. Thank you for your attention and cooperation.

Very truly yours,



Melanie A. Bachman  
Acting Executive Director

MAB/FOC/lm

- c: The Honorable Neil M. O'Leary, Mayor, City of Waterbury
- James A. Sequin, AICP, City Planner, City of Waterbury
- American Tower Corporation
- New Opportunities Economic Development Corporation

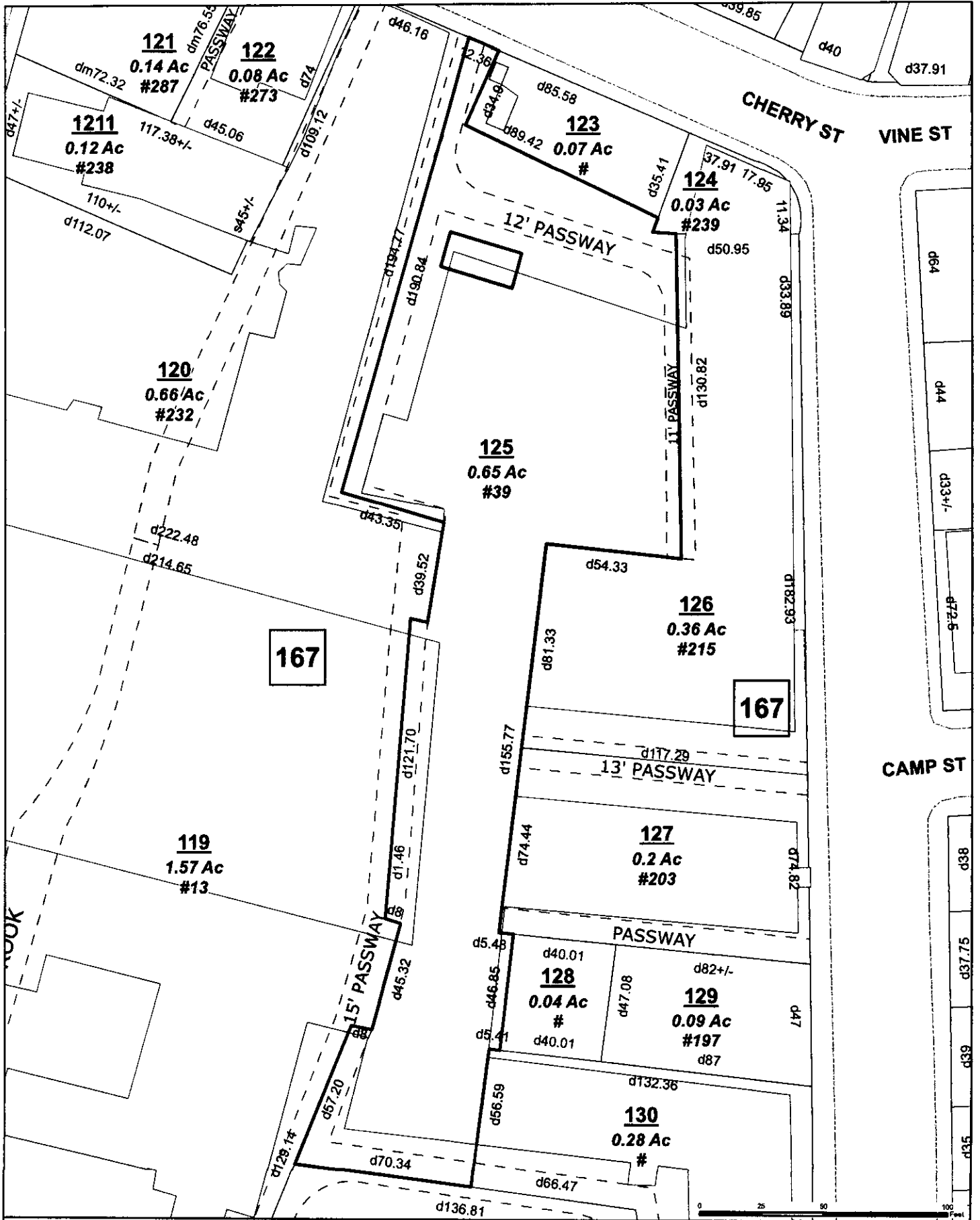

**City of Waterbury**  
Public Works Department

**MBL: 0255-0167-0125**  
**ADDRESS: 39 CHERRY AVE**

This map is for informational purposes only and has not been prepared for, or suitable for legal, engineering, or surveying purposes. Users of this information should review or consult the primary data and information sources to verify the usability of the information. The City of Waterbury makes no warranties, express or implied, as to the use of the information obtained herein.



The Assessor's office is responsible for the maintenance of records on the ownership of properties. Assessments are computed at 70% of the estimated market value of real property at the time of the last revaluation which was 2017.

# WATERBURY

Information on the Property Records for the Municipality of Waterbury was last updated on 11/16/2018.

## Parcel Information

Location:	39 CHERRY AVE	Property Use:	Industrial	Primary Use:	Light Industrial
Unique ID:	025501670125	Map Block Lot:	0255-0167-0125	Acres:	0.65
490 Acres:	0.00	Zone:	RH	Volume / Page:	6727/ 38
Developers Map / Lot:		Census:			

## Value Information

	Appraised Value	Assessed Value
Land	110,602	77,420

	<b>Appraised Value</b>	<b>Assessed Value</b>
Buildings	25,604	17,920
Detached Outbuildings	0	0
Total	136,206	95,340

## **Owner's Information**

### **Owner's Data**

NEW OPPORTUNITIES ECONOMIC DEVELOPMENT  
CORPORATION  
232 NORTH ELM ST  
WATERBURY CT 06702

### **Building 1**



025501670125 04/09/2016

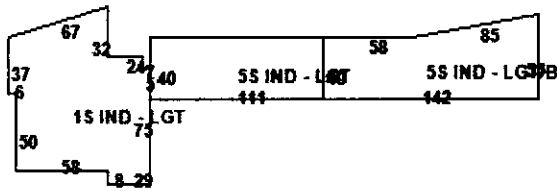

Category:	Industrial	Use:	Light Industrial	GLA:	61,969
Stories:	5.00	Construction:	Average	Year Built:	1900
Heating:	Steam	Fuel:	Oil	Cooling Percent:	0%
Siding:	Brick, Solid	Roof Material:		Beds/Units:	0

### Special Features

Freight Elevator Power	1
Freight Elevator Power	1
Sprinklers	3098

### Attached Components

### Owner History - Sales

Owner Name	Volume	Page	Sale Date	Deed Type	Valid Sale	Sale Price
NEW OPPORTUNITIES ECONOMIC DEVELOPMENT	6727	38	10/04/2010	Additional Parcel	No	\$0
NORTH SQUARE GATEWAY DEVELOPMENT INC	6486	106	02/06/2009	Warranty Sale	No	\$325,000
COASTAL FINANCIAL LENDING INC & CARPE LL	5461	202	08/10/2005	Warranty Sale	No	\$57,500
39 CHERRY LLC	5253	185	02/01/2005	Warranty Sale	No	\$0
OSMAN STEPHEN TRUSTEE & 39 CHERRY LLC	5253	178	02/01/2005	Warranty Sale	No	\$0

### Building Permits

Permit Number	Permit Type	Date Opened	Date Closed	Permit Status	Reason
2018.2205	Electrical	08/08/2018		Open Permit	UPGRADE & REPLACEMENT OF CELL SITE
2014.2598	Commercial Demolition	09/19/2014		Closed	DEMO

<b>Permit Number</b>	<b>Permit Type</b>	<b>Date Opened</b>	<b>Date Closed</b>	<b>Permit Status</b>	<b>Reason</b>
2013.0496	Comm Renovations	04/05/2013		Closed	REPLACE STEEL PLATFORM PAD & CABINET

Information Published With Permission From The Assessor



ORIGIN ID: LKKA (856) 625-1596  
RYAN BAILEY  
CHARLES CHERUNDOLLO CONSULTING  
3 PROSPECT PL  
B  
MADISON, NJ 07940  
UNITED STATES US  
SHIP DATE: 12FEB19  
ACTWGT: 1.00 LB  
CAD: 111040781/NET4100  
BILL SENDER

TO  
**MS. MELANIE BACHMAN, EXEC. DIR.**  
**CT SITING COUNCIL**  
**TEN FRANKLIN SQUARE**

**NEW BRITAIN CT 06051**  
(860) 827-2935 REF: CT5ZQ05 CSC SUBMISSION  
DEPT.

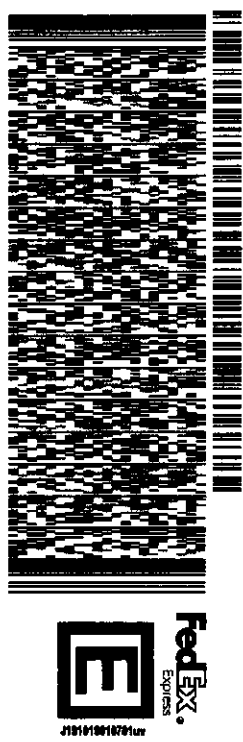

TRK# 7744 4703 2430  
0201  
FRI - 15 FEB 4:30P  
EXPRESS SAVER  
DSR

**K7 BDLA**  
06051  
CT-US BDL



**After printing this label:**

1. Use the 'Print' button on this page to print your label to your laser or inkjet printer.
2. Fold the printed page along the horizontal line.
3. Place label in shipping pouch and affix it to your shipment so that the barcode portion of the label can be read and scanned.

**Warning:** Use only the printed original label for shipping. Using a photocopy of this label for shipping purposes is fraudulent and could result in additional billing charges, along with the cancellation of your FedEx account number.

Use of this system constitutes your agreement to the service conditions in the current FedEx Service Guide, available on [fedex.com](http://fedex.com). FedEx will not be responsible for any claim in excess of \$100 per package, whether the result of loss, damage, delay, non-delivery, misdelivery, or misinformation, unless you declare a higher value, pay an additional charge, document your actual loss and file a timely claim. Limitations found in the current FedEx Service Guide apply. Your right to recover from FedEx for any loss, including intrinsic value of the package, loss of sales, income interest, profit, attorney's fees, costs, and other forms of damage whether direct, incidental, consequential, or special is limited to the greater of \$100 or the authorized declared value. Recovery cannot exceed actual documented loss. Maximum for items of extraordinary value is \$1,000, e.g. jewelry, precious metals, negotiable instruments and other items listed in our Service Guide. Written claims must be filed within strict time limits, see current FedEx Service Guide.

ORIGIN ID: CBZA (973) 477-8032  
STEVE SOFMAN  
CHARLES CHERUNDOLLO CONSULTING  
1280 ROUTE 46 WEST  
SUITE 9  
PARLIPPANY, NJ 07054  
UNITED STATES US

SHIP DATE: 12FEB19  
ACTWGT: 1.00 LB  
CAD: 111040781IN/E141100  
BILL SENDER

TO DEVELOPMENT CORPORATION  
NEW OPPORTUNITIES ECONOMIC  
232 NORTH ELM ST

WATERBURY CT 06702  
(203) 575-4399 REF: CTSDX0085 CSC  
NJ DEPT.

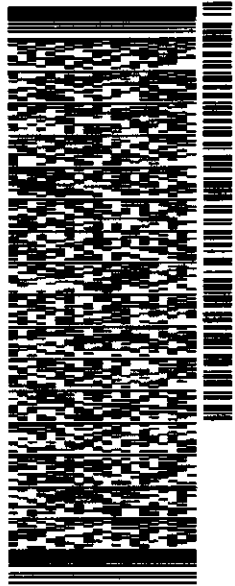

565.020E3D/23AD

TRK# 7744 4716 4611  
0201

FRI - 15 FEB 4:30P  
EXPRESS SAVER

K7 BNHA 06702  
CT-US BDL



**After printing this label:**

1. Use the 'Print' button on this page to print your label to your laser or inkjet printer.
2. Fold the printed page along the horizontal line.
3. Place label in shipping pouch and affix it to your shipment so that the barcode portion of the label can be read and scanned.

**Warning:** Use only the printed original label for shipping. Using a photocopy of this label for shipping purposes is fraudulent and could result in additional billing charges, along with the cancellation of your FedEx account number.

Use of this system constitutes your agreement to the service conditions in the current FedEx Service Guide, available on [fedex.com](http://fedex.com). FedEx will not be responsible for any claim in excess of \$100 per package, whether the result of loss, damage, delay, non-delivery, misdelivery, or misinformation, unless you declare a higher value, pay an additional charge, document your actual loss and file a timely claim. Limitations found in the current FedEx Service Guide apply. Your right to recover from FedEx for any loss, including intrinsic value of the package, loss of sales, income interest, profit, attorney's fees, costs, and other forms of damage whether direct, incidental, consequential, or special is limited to the greater of \$100 or the authorized declared value. Recovery cannot exceed actual documented loss. Maximum for items of extraordinary value is \$1,000, e.g. jewelry, precious metals, negotiable instruments and other items listed in our ServiceGuide. Written claims must be filed within strict time limits, see current FedEx Service Guide.

ORIGIN ID:CEZA (973) 477-8032  
STEVE SOFMAN  
CHARLES CHERLINDOLO CONSULTING  
1280 ROUTE 46 WEST  
SUITE 9  
PARISPPANY, NJ 07054  
UNITED STATES US

SHIP DATE: 12FEB19  
ACTWGT: 1.00 LB  
CAD: 111040781N1E1741100  
BILL SENDER

TO  
**MAYOR NEIL O'LEARY**  
**CITY OF WATERBURY**  
**235 GRAND ST**

**WATERBURY CT 06702**  
(203) 597-3444  
NJ  
PO  
REF: CT52X0065 CSC FILING  
DEPT

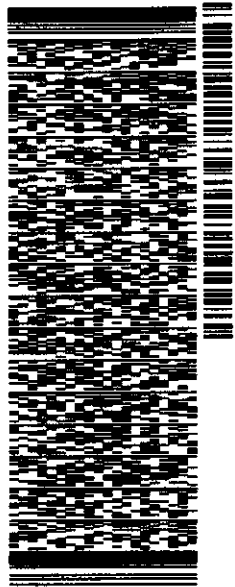

TRK# 7744 4705 6507  
0201

FRI - 15 FEB 4:30P  
EXPRESS SAVER

**K7 BNHA**  
06702  
CT-US BDL



565J20E3D/23AD

**After printing this label:**

1. Use the 'Print' button on this page to print your label to your laser or inkjet printer.
2. Fold the printed page along the horizontal line.
3. Place label in shipping pouch and affix it to your shipment so that the barcode portion of the label can be read and scanned.

**Warning:** Use only the printed original label for shipping. Using a photocopy of this label for shipping purposes is fraudulent and could result in additional billing charges, along with the cancellation of your FedEx account number.  
Use of this system constitutes your agreement to the service conditions in the current FedEx Service Guide, available on [fedex.com](http://fedex.com). FedEx will not be responsible for any claim in excess of \$100 per package, whether the result of loss, damage, delay, non-delivery, misdelivery, or misinformation, unless you declare a higher value, pay an additional charge, document your actual loss and file a timely claim. Limitations found in the current FedEx Service Guide apply. Your right to recover from FedEx for any loss, including intrinsic value of the package, loss of sales, income interest, profit, attorney's fees, costs, and other forms of damage whether direct, incidental, consequential, or special is limited to the greater of \$100 or the authorized declared value. Recovery cannot exceed actual documented loss. Maximum for items of extraordinary value is \$1,000, e.g. jewelry, precious metals, negotiable instruments and other items listed in our Service Guide. Written claims must be filed within strict time limits, see current FedEx Service Guide.

ORIGIN ID: CEZA (973) 477-8032  
STEVE SOFMAN  
CHARLES CHERUNDOLLO CONSULTING  
1280 ROUTE 46 WEST  
SUITE 9  
PARISPPANY, NJ 07054  
UNITED STATES US

SHIP DATE: 12FEB19  
ACTWGT: 1.09 LB  
CAD: 111040781INMET4100  
BILL SENDER

TO **JAMES SEQUIN**  
**CITY OF WATERBURY**  
**235 GRAND ST**

**WATERBURY CT 06702**  
(203) 597-3444 REF: CT52X005 CSC FLING  
NJ DEPT.  
PO

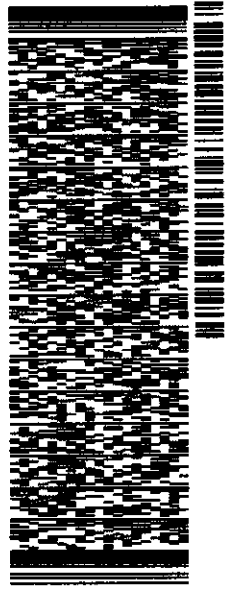

TRK# 7744 4709 1873  
0201

FRI - 15 FEB 4:30P  
EXPRESS SAVER

**K7 BNHA**  
06702  
CT-US BDL



565J20E30/23AD

**After printing this label:**

1. Use the 'Print' button on this page to print your label to your laser or inkjet printer.
2. Fold the printed page along the horizontal line.
3. Place label in shipping pouch and affix it to your shipment so that the barcode portion of the label can be read and scanned.

**Warning:** Use only the printed original label for shipping. Using a photocopy of this label for shipping purposes is fraudulent and could result in additional billing charges, along with the cancellation of your FedEx account number.

Use of this system constitutes your agreement to the service conditions in the current FedEx Service Guide, available on [fedex.com](http://fedex.com). FedEx will not be responsible for any claim in excess of \$100 per package, whether the result of loss, damage, delay, non-delivery, misdelivery, or misinformation, unless you declare a higher value, pay an additional charge, document your actual loss and file a timely claim. Limitations found in the current FedEx Service Guide apply. Your right to recover from FedEx for any loss, including intrinsic value of the package, loss of sales, income interest, profit, attorney's fees, costs, and other forms of damage whether direct, incidental, consequential, or special is limited to the greater of \$100 or the authorized declared value. Recovery cannot exceed actual documented loss. Maximum for items of extraordinary value is \$1,000, e.g. jewelry, precious metals, negotiable instruments and other items listed in our ServiceGuide. Written claims must be filed within strict time limits, see current FedEx Service Guide.