



Crown Castle
12 Gill Street, Suite 5800
Woburn, MA 01801

September 8, 2016

Melanie A. Bachman
Acting Executive Director
Connecticut Siting Council
10 Franklin Square
New Britain, CT 06051

RE: Notice of Exempt Modification for T-Mobile / L700 Crown Site BU: 806377
T-Mobile Site ID: CT11711A
Located at: 197 South Street, Vernon, CT 06066
Latitude: 41° 51' 12.51" / Longitude: -72° 27' 7.52"

Dear Ms. Bachman,

T-Mobile currently maintains six (6) antennas at the 84-foot level of the existing 132-foot self-support tower located at 197 South Street, Vernon, CT. The tower is owned by Crown Castle. The property is owned by Connecticut Water Company. T-Mobile now proposes to add three (3) new antennas and three (3) RRUs (non-antennas), and upgrade the equipment inside the existing equipment cabinet. The antennas would be installed at the same 84-foot level of the tower.

This facility was approved by the Connecticut Siting Council on July 11, 1986, Docket No. 58. This approval included the condition(s) that:

- The tower shall be no taller than necessary to provide the proposed service, and in no event shall exceed total heights, including antennas of 173'.
- The certificate holder shall submit a development and management (D&M) plan pursuant to Sections 16-50j-75 through 16-50j-77 of the Regulations of State Agencies (RSA), except that irrelevant items in Section 16-50j-76 need only be identified as such. In addition to the requirements of Section 16-50j-76, the D7M plan shall provide plans for evergreen screening around the fenced perimeter. The D&M plan must be approved prior to facility construction.

Any changes to specifications in the D&M plan must be approved by the Council prior to facility operation.

- All certified facilities shall be constructed, operated, and maintained as specified in the Council's record and in the site plan required by order number 7.
- The certificate holder shall comply with any future radiofrequency (RF) standards promulgated by state or federal regulator agencies. Upon the establishment of any new governmental RF standards, the facilities granted in this decision shall continue to be in compliance with such standards.
- The certificate holder shall permit public or private entities to share space on the towers approved herein, for due consideration received, or shall provide any requesting entity with specific legal, technical, environmental, or economic reason precluding such tower sharing. In addition to complying with Section 16-50j-73 of the RSA, the certificate holder shall notify the Council of the addition of any equipment to any approved tower.
- A fence not lower than 8' shall surround each tower and associated equipment.
- Unless necessary to comply with order 13, no lights shall be installed on any of these towers.
- The facilities' construction and any future tower sharing shall be in accordance with all applicable federal, state, and municipal laws and regulations. Shared uses by entities not subject to jurisdiction pursuant to Section 16-50k of the CGS shall be subject to all applicable federal, state, and municipal laws and regulations.
- Construction activities shall take place during daylight working hours.
- This decision and order shall be void and the towers and associated equipment shall be dismantled and removed, or reapplication for any new use shall be made to the Council before any such new use is made, if the towers do not provide or permanently cease to provide cellular service following completion of construction.
- This decision and order shall be void if all construction authorized herein is not completed within three years of the issuance of this decision, or within three years of the completion of any appeal if appeal of this decision is taken, unless otherwise approved by the Council.

This modification complies with the aforementioned condition(s).

Please accept this letter as notification pursuant to Regulations of Connecticut State Agencies §16-50j-73, for construction that constitutes an exempt modification pursuant to R.C.S.A. §16-50j-72(b)(2). In

accordance with R.S.C.A. § 16-50j-73, a copy of this letter is being sent to The Honorable Daniel A. Champagne, Mayor for the Town of Vernon, as well as the property owner and the tower owner.

1. The proposed modifications will not result in an increase in the height of the existing tower.
2. The proposed modification will not require the extension of the site boundary.
3. The proposed modification will not increase noise levels at the facility by six decibels or more, or to levels that exceed state and local criteria.
4. The operation of the replacement antennas will not increase radio frequency emissions at the facility to a level at or above the Federal Communication Commission safety standard.
5. The proposed modifications will not cause a change or alteration in the physical or environmental characteristics of the site.
6. The existing structure and its foundation can support the proposed loading.

For the foregoing reasons, T-Mobile respectfully submits that the proposed modifications to the above-referenced telecommunications facility constitutes an exempt modification under R.C.S.A. § 16-50j-72(b)(2). Please send approval/rejection letter to Attn: Amanda Goodall.

Sincerely,



Amanda Goodall

Real Estate Specialist

12 Gill Street, Suite 5800, Woburn, MA 01801

339-205-7017

Amanda.Goodall@crowncastle.com

Melanie A. Bachman

September 8, 2016

Page 4

Attachments:

Tab 1: Exhibit-1: Compound plan and elevation depicting the planned changes

Tab 2: Exhibit-2: Structural Modification Report

Tab 4: Exhibit-3: General Power Density Table report (RF Emissions Analysis Report)

cc: The Honorable Daniel A. Champagne, Mayor
Town of Vernon
14 Park Place
Vernon, CT 06066

Crown Castle (Tower Owner)
12 Gill Street, Suite 5800
Woburn, Ma 01801

Connecticut Water Company (Property Owner)
Attn: Allen Braig
93 W Main Street
Clinton, CT 06413

DOCKET NO. 58

AN APPLICATION OF HARTFORD CELLULAR
COPANY FOR A CERTIFICATE OF
ENVIRONMENTAL COMPATIBILITY AND PUBLIC
NEED FOR THE CONSTRUCTION, MAINTENANCE,
AND OPERATION OF FACILITIES TO PROVIDE
CELLULAR SERVICE IN HARTFORD, TOLLAND AND
MIDDLESEX COUNTIES.

CONNECTICUT SITING
COUNCIL

July 11, 1986.

D E C I S I O N A N D O R D E R

Pursuant to the foregoing opinion, the Connecticut Siting Council (Council) hereby directs that a Certificate of Environmental Compatibility and Public Need as provided by Section 16-50k of the General Statutes of Connecticut (CGS) be issued to the Hartford Cellular Company for the construction, maintenance, and operation of cellular mobile phone telecommunication towers and associated equipment in the towns of Glastonbury, Haddam, Hartford, Portland, Rocky Hill, Somers, Vernon, Windsor, and Willington subject to the conditions below.

- 1) The proposed Bloomfield and Middlefield sites are rejected without prejudice.
- 2) The antennas on the Glastonbury tower shall be mounted no higher than the 180' level of this existing tower.
- 3) The Portland and Rocky Hill towers shall be monopoles.
- 4) The towers shall be no taller than necessary to provide the proposed service, and in no event shall exceed total heights, including antennas, of
 - a) 193' at the Haddam site;
 - b) 173' at the Portland site;

- c) 153' at the Rocky Hill site;
- d) 173' at the Somers site;
- e) 173' at the Vernon site;
- f) 153' at the Willington site;
- g) 173' at the Windsor site.

5) The Hartford site receive antennas shall be mounted below the top of the high point of the building to preclude visibility.

6) Any future actions requiring the removal of the existing Glastonbury tower to be shared by the certificate holder shall also apply to the equipment mounted on that tower by the certificate holder, regardless of that equipment's status under Chapter 277a of the CGS.

7) The certificate holder shall submit a development and management (D&M) plan for the Haddam, Portland, Rocky Hill, Somers, Vernon and Windsor sites pursuant to Sections 16-50j-75 through 16-50j-77 of the Regulations of State Agencies (RSA), except that irrelevant items in Section 16-50j-76 need only be identified as such. In addition to the requirements of Section 16-50j-76, the D&M plan shall provide plans for evergreen screening around the fenced perimeter at the Haddam, Somers, Vernon, and Windsor sites. The D&M plan shall include a proposal for painting the approved monopole structures to blend with the sky. The D&M plan must be approved prior to facility construction. Any changes to specifications in the D&M plan must be approved by the Council prior to facility operation.

8) All certified facilities shall be constructed, operated, and maintained as specified in the Council's record and in the

site plan required by order number 7.

9) The certificate holder shall comply with any future radiofrequency (RF) standards promulgated by state or federal regulatory agencies. Upon the establishment of any new governmental RF standards, the facilities granted in this decision shall continue to be in compliance with such standards.

10) The certificate holder shall permit public or private entities to share space on the towers approved herein, for due consideration received, or shall provide any requesting entity with specific legal, technical, environmental, or economic reasons precluding such tower sharing. In addition to complying with Section 16-50j-73 of the RSA, the certificate holder shall notify the Council of the addition of any equipment to any approved tower.

11) A fence not lower than 8' shall surround each tower and associated equipment.

12) Unless necessary to comply with order 13, no lights shall be installed on any of these towers.

13) The facilities' construction and any future tower sharing shall be in accordance with all applicable federal, state, and municipal laws and regulations. Shared uses by entities not subject to jurisdiction pursuant to Section 16-50k of the CGS shall be subject to all applicable federal, state, and municipal laws and regulations.

14) Construction activities shall take place during daylight working hours.

15) This decision and order shall be void and the towers and associate equipment shall be dismantled and removed, or reapplication for any new use shall be made to the Council before any such new use is made, if the towers do not provide or permanently cease to provide cellular service following completion of construction.

16) This decision and order shall be void if all construction authorized herein is not completed within three years of the issuance of this decision, or within three years of the completion of any appeal if appeal of this decision is taken, unless otherwise approved by the Council.

Pursuant to CGS Section 16-50p, we hereby direct that a copy of the decision and order shall be served on each person listed below. A notice of the issuance shall be published in the Hartford Courant, Middletown Press, Manchester Journal Inquirer, and the Willimantic Chronicle.

The parties to the proceeding are:

Metro Mobile (applicant)
5 Eversley Avenue
Norwalk, Connecticut 06855
ATTN: Armand Mascioli
General Manager

Howard L. Slater, Esq. (its attorneys)
Scott A. Gursky, Esq.
Byrne, Slater, Sandler,
Shulman & Rouse, P.C.
111 Pearl Street
Hartford, Connecticut 06103

Richard Rubin, Esq.
Fleischman and Walsh, P.C.
1725 N Street, N.W.
Washington, D. C. 20036

Mr. William Wamester
1225 Randolph Road
Middletown, Connecticut 06457

The Southern New England Telephone Company
227 Church Street
New Haven, Connecticut 06506
ATTN: Peter J. Tyrrell, Esq.

Mr. James W. Tilney

represented by:
Patricia A. Ayars
Samuel Baily, Jr.
Robinson & Cole
One Commercial Plaza
Hartford, CT. 06103-3597

Mr. Samuel DuBosar, Chairman
Bessie Bennett, Esq.
Town Plan & Zoning Commission
P.O. Box 337
Bloomfield, Connecticut 06002

Town of Somers

represented by:

Mr. Robert F. Peters
Town Counsel
Tatoian, Devline, Peters
& Davis
11 South Road
P.O. Box 415
Somers, CT. 06071

Town of Haddam
represented by:

Lucy R. Petrella
Chairperson
Town Office Building
Route 9A
P.O. Box 87
Haddam, CT. 06438

Midstate Regional Planning Agency

represented by:

Thomas M. Gilligan
Regional Planner
P.O. Box 139
Middletown, CT. 06457

Dr. Donald P. LaSalle
Director
Talcott Mountain Science Center
Montevideo Road
Avon, Connecticut 06001

Barnard Tilson (service waived)
Secretary
Avon Planning and Zoning
60 West Main Street
Avon, Connecticut 06001

Alden Giddings
33 Privelege Road
Bloomfield, Connecticut 06002

Town of Bloomfield

represented by:

Joseph M. Suggs, Jr.
Deputy Mayor
Town Hall
880 Bloomfield Avenue
P.O. Box 337
Bloomfield, CT. 06002
(service waived)

Town of Middlefield

represented by:

David Silverstone, Esq.
Silverstone & Koontz
37 Lewis Street
Hartford, CT. 06103

with a copy to:

Geoffrey Colegrove
Midstate Regional Planning Agency
100 DeKoven Drive
Middletown, CT. 06457

Zoning Commission
Town of Somers

represented by:

Joseph A. Paradis
Chairman
Town Hall
600 Main Street
P.O. Box 803
Somers, CT. 06071

Barbara Sirwilo, Secretary (service waived)
Planning & Zoning Commission
Town of Rocky Hill
600 Old Main Street
P.O. Box 657
Rocky Hill, Connecticut 06067

H. Robert Goodrich (service waived)
Goodrich Lane
Portland, Connecticut 06480

The Honorable Richard P. Antonetti
State Representative (service waived)
5 Sachem Circle
Meriden, Connecticut 06450

John Hevrin
R.D. #1 - Plains Road
Haddam, Connecticut 06438





Norman and Darlene Manning (represented by)

Elizabeth Allen, Esq.
P.O. Box 467
Higganum, CT. 06441
(service waived)

C E R T I F I C A T I O N

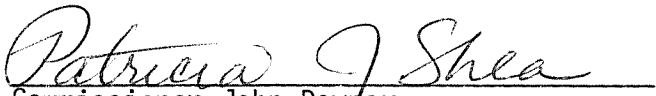
The undersigned members of the Connecticut Siting Council hereby certify that they have heard this case or read the record thereof, and that we voted as follows:

Dated at New Britain, Connecticut, this 11th day of July, 1986.

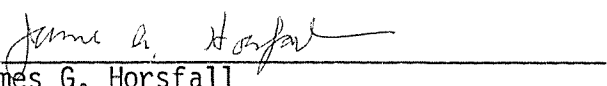
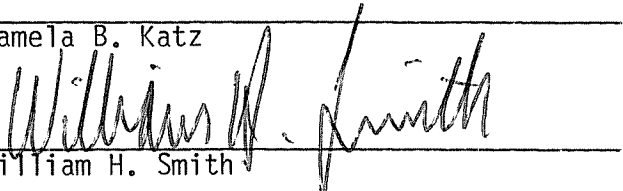
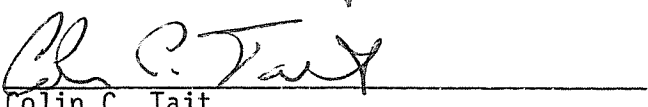
<u>Council Members</u>	<u>Vote Cast</u>
_____) Gloria Dibble Pond Chairperson	Absent
 _____) Commissioner John Downey Designee: Patricia Shea	Yes
 _____) Commissioner Stanley Pac Designee: Christopher Cooper	Yes
 _____) Owen L. Clark	Yes
 _____) Mortimer A. Gelston	Yes
 _____) James G. Horsfall	Yes
_____) Pamela B. Katz	Absent
 _____) William H. Smith	Yes
 _____) Colin C. Tait	Yes

STATE OF CONNECTICUT
COUNTY OF HARTFORD

)
:
)

ss. New Britain, July 11, 1986

I hereby certify that the foregoing is a true and correct copy of the decision and order issued by the Connecticut Siting Council, State of Connecticut.

ATTEST:



Christopher S. Wood, Executive Director
Connecticut Siting Council

CONNECTICUT WATER CO
 93 WEST MAIN ST
 CLINTON, CT 06413-1600
 CENSUS TRACT: 530400

Neighborhood Number
 11800
 Neighborhood Name
 GENERAL COMMERCIAL
 TAXING DISTRICT INFORMATION
 Jurisdiction Name Town of Vernon
 Area 146
 Routing Number 5887

Tax ID 39-065B-0016A

Printed 06/12/2016

Transfer of Ownership

Owner Consideration Transfer Date Deed Book/Page Deed Type

NA 0 12/21/1978 351 39

Valuation Record

Assessment Year	2006	2010	2011
Reason for Change	2006 Reval	2010 ASMT	2011 REVAL
Market	L I T	156820 270940 427760	156820 270220 427040
70% Assessed/Usc	L I T	109770 189660 299430	109770 189160 298930

Site Description
 Topography
 Public Utilities
 Water, Sewer, Gas, Electric
 Street or Road
 Paved
 Neighborhood
 Zoning:
 R-22
 Legal Acres:
 2.0000

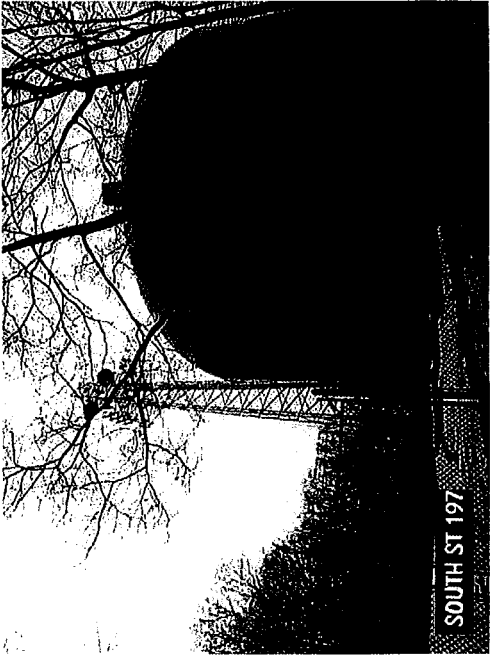

Land Type	Land Size			Influence Factor
	Rating, Soil ID - or - Actual Frontage	Acres - or - Effective Frontage	Square Feet - or - Effective Depth	

Tax ID 39-065B-0016A

Printed 06/12/2016

Physical Characteristics

ROOFING

Other

WALLS

B 1 2 U
 Yes Yes Yes Yes

FRAMING

B 0 312 2 0 0

FINISH

UF SF FO FD
 1 312 0 0 0
 Total 312 0 0 0

HEATING AND AIR CONDITIONING

B 1 2 U

01 02 03

04

26
 1 s Mas 12
 (312)

Special Features	
Description	

Summary of Improvements								
ID	USE	Story Height	Const Type	Grade	Year Cons	Eff Year	Cond	Size or Area
C	UTILSTOR	0.00		Avg	1963	1986	AV	312
01	FENCECL	6.00	51C	Avg	1963	1985	AV	510
02	UTILSHED	0.00	4	Avg	1963	1985	AV	300
03	TANKWATR	0.00	51	Avg	1963	1985	AV	125000
04	TOWERSUP	100.00		Avg	2002	2002	AV	1 DIA

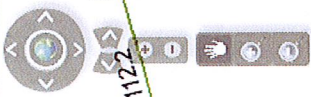

Find an address

Locations found: 1

197 SOUTH ST
Score: 91.8

Choose Your Data Layers

- 164-25
- 164-26
- 164-27
- 164-28
- 164-29
- 164-31
- 164-16
- 164-18
- 164-19
- 164-21
- 164-23

Streets

2012 Imagery 2009 Imagery

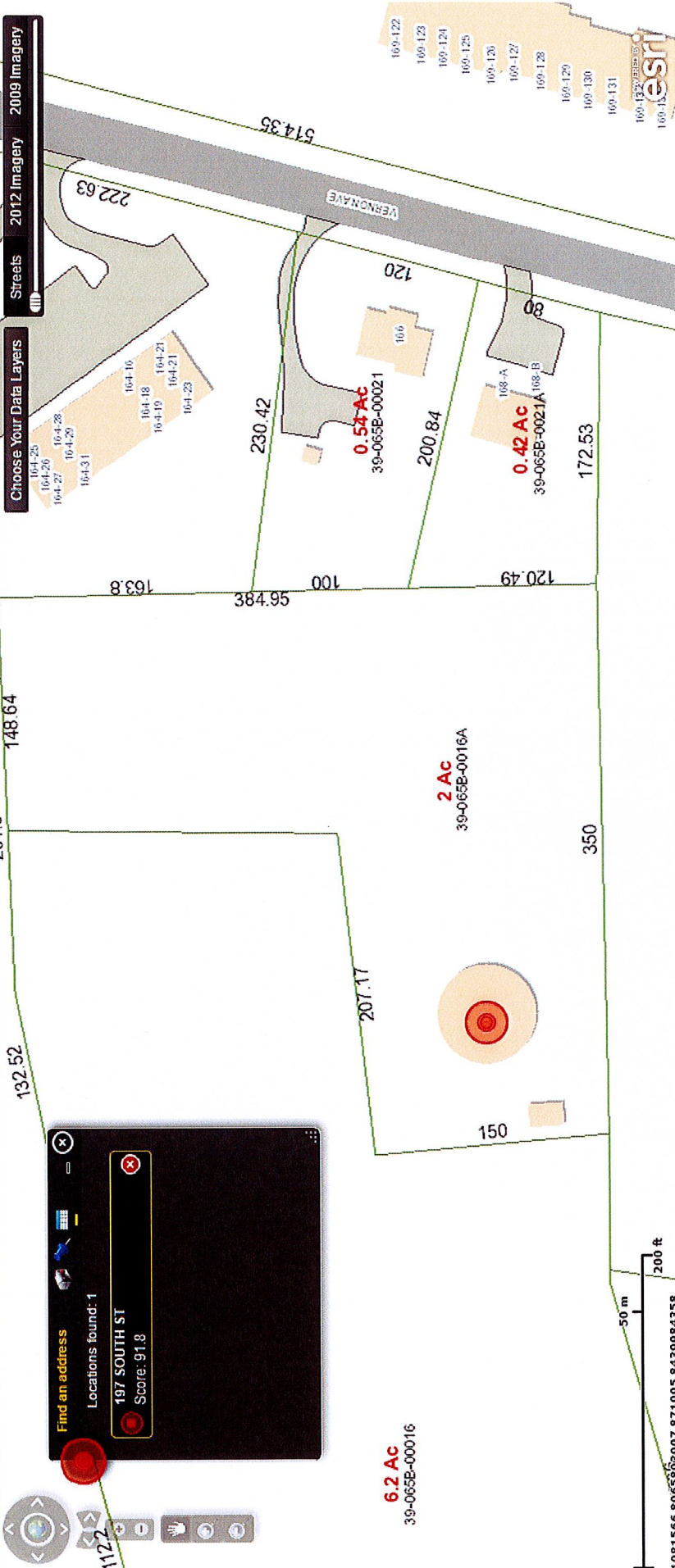

50 m
200 ft
1081566.896585907 871995.8439984358



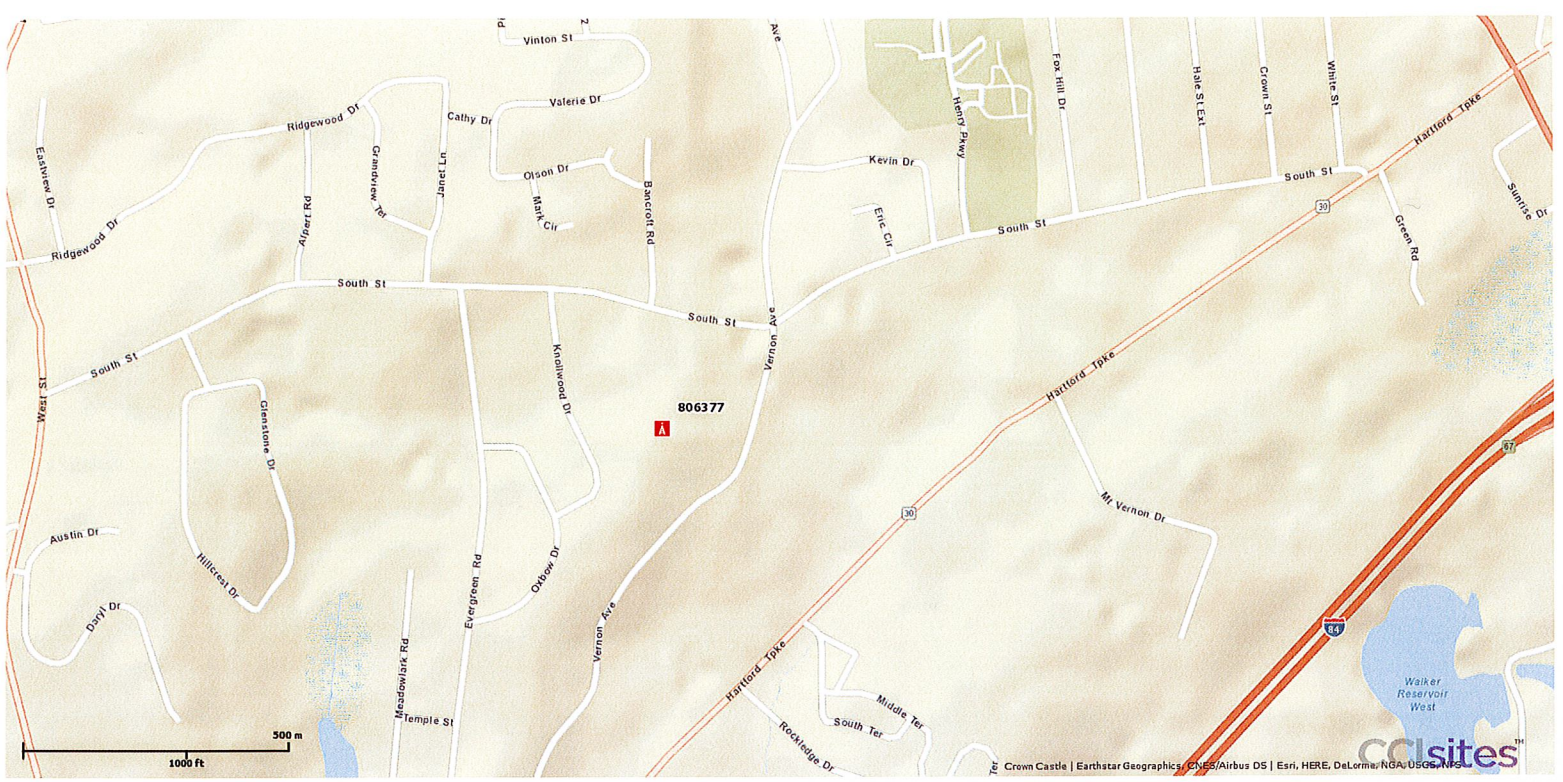



T-MOBILE NORTHEAST LLC

T-MOBILE SITE #: CT11711A
CROWN CASTLE BU #: 806377
SITE NAME: HRT 084 943242
197 SOUTH STREET
VERNON, CT 06066
TOLLAND COUNTY



T-MOBILE NORTHEAST LLC
35 GRIFFIN ROAD SOUTH
BLOOMFIELD, CT 06002



CROWN CASTLE
3 CORPORATE PARK DRIVE, SUITE 101
CLIFTON PARK, NY 12065

CT11711A
HRT 084 943242

CONSTRUCTION DRAWINGS

Table with 2 columns: Revision, Description. Includes entries for 09/07/16 ISSUED AS FINAL, 09/06/16 REVISED PER COMMENTS, 08/18/16 ISSUED FOR REVIEW.



Dewberry Engineers Inc.
600 PARSIPPANY ROAD
SUITE 301
PARSIPPANY, NJ 07054
PHONE: 973.739.9400
FAX: 973.739.9710

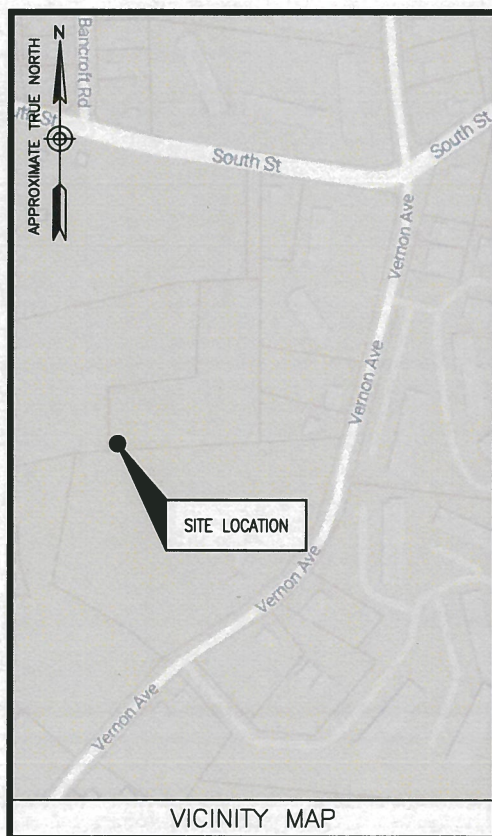

ENGINEER
DEWBERRY ENGINEERS INC.
600 PARSIPPANY ROAD
SUITE 301
PARSIPPANY, NJ 07054
CONTACT: BRYAN HUFF
PHONE #: (973) 576-0147
CONSTRUCTION
CROWN CASTLE
3 CORPORATE PARK DRIVE, SUITE 101
CLIFTON PARK, NY 12065
CONTACT: PATRICIA PELON
PHONE #: (518) 373-3507

SITE NAME:
HRT 084 943242
SITE NUMBER:
CT11711A
TOWER OWNER:
CROWN CASTLE
3 CORPORATE PARK DRIVE, SUITE 101
CLIFTON PARK, NY 12065
APPLICANT/DEVELOPER:
T-MOBILE NORTHEAST LLC
35 GRIFFIN ROAD SOUTH
BLOOMFIELD, CT 06002
COORDINATES:
LATITUDE: 41°-51'-12.51" N (NAD83)
LONGITUDE: 72°-27'-07.52" W (NAD83)
(PER CROWN CASTLE)
CONFIGURATION
702Cu
PROJECT SUMMARY

SITE ADDRESS:
197 SOUTH STREET
VERNON, CT 06066
TOLLAND COUNTY
PROJECT DIRECTORY
SCOPE OF WORK
• INSTALL (3) NEW ANTENNAS.
• INSTALL (3) NEW RRU'S.
• UPGRADE (1) EXISTING EQUIPMENT CABINET AT GRADE.
THIS DOCUMENT WAS DEVELOPED TO REFLECT A SPECIFIC SITE AND ITS SITE CONDITIONS AND IS NOT TO BE USED FOR ANOTHER SITE OR WHEN OTHER CONDITIONS PERTAIN. REUSE OF THIS DOCUMENT IS AT THE SOLE RISK OF THE USER.
A.D.A. COMPLIANCE:
FACILITY IS UNMANNED AND NOT FOR HUMAN HABITATION.

Table with 2 columns: SHT. NO., DESCRIPTION. Includes rows for T-1 TITLE SHEET, G-1 GENERAL NOTES, C-1 COMPOUND PLAN & EQUIPMENT PLANS, C-2 ANTENNA LAYOUTS & ELEVATIONS, C-3 CONSTRUCTION DETAILS, E-1 GROUNDING NOTES & DETAILS.



DRAWN BY: JC
REVIEWED BY: BSH
CHECKED BY: GHN
PROJECT NUMBER: 50066258
JOB NUMBER: 50078130
SITE ADDRESS:

197 SOUTH STREET,
VERNON, CT 06066
TOLLAND COUNTY

SHEET TITLE

TITLE SHEET

SHEET NUMBER

FROM BLOOMFIELD, CT:
HEAD NORTHEAST ON GRIFFIN RD S TOWARD W NEWBERRY RD.
TURN RIGHT ONTO DAY HILL RD. USE THE RIGHT LANE TO
MERGE ONTO I-91 S VIA THE RAMP TO HARTFORD. MERGE
ONTO I-91 S. TAKE EXIT 35A FOR I-291 TOWARD MANCHESTER.
CONTINUE ONTO I-291 E. USE THE LEFT LANE TO MERGE ONTO
I-84 E TOWARD BOSTON. TAKE EXIT 66 FOR S FRONTAGE RD
TOWARD TUNNEL RD. TURN LEFT ONTO STATE HWY 541/S
FRONTAGE RD (SIGNS FOR BOLTON RD). TURN LEFT AT THE 1ST
CROSS STREET ONTO STATE HWY 541. TURN RIGHT ONTO
CT-30 N. TURN LEFT ONTO VERNON AVE. TURN LEFT ONTO
SOUTH ST. SITE WILL BE ON THE LEFT.

GENERAL NOTES:

- FOR THE PURPOSE OF CONSTRUCTION DRAWING, THE FOLLOWING DEFINITIONS SHALL APPLY:
PROJECT MANAGEMENT - CROWN CASTLE
CONTRACTOR - GENERAL CONTRACTOR (CONSTRUCTION)
OWNER - T-MOBILE
OEM - ORIGINAL EQUIPMENT MANUFACTURER
- PRIOR TO THE SUBMISSION OF BIDS, THE BIDDING CONTRACTOR SHALL VISIT THE CELL SITE TO FAMILIARIZE WITH THE EXISTING CONDITIONS AND TO CONFIRM THAT THE WORK CAN BE ACCOMPLISHED AS SHOWN ON THE CONSTRUCTION DRAWINGS. ANY DISCREPANCY FOUND SHALL BE BROUGHT TO THE ATTENTION OF PROJECT MANAGEMENT.
- ALL MATERIALS FURNISHED AND INSTALLED SHALL BE IN STRICT ACCORDANCE WITH ALL APPLICABLE CODES, REGULATIONS, AND ORDINANCES. CONTRACTOR SHALL ISSUE ALL APPROPRIATE NOTICES AND COMPLY WITH ALL LAWS, ORDINANCES, RULES, REGULATIONS, AND LAWFUL ORDERS OF ANY PUBLIC AUTHORITY REGARDING THE PERFORMANCE OF THE WORK.
- ALL WORK CARRIED OUT SHALL COMPLY WITH ALL APPLICABLE MUNICIPAL AND UTILITY COMPANY SPECIFICATIONS AND LOCAL JURISDICTIONAL CODES, ORDINANCES AND APPLICABLE REGULATIONS.
- DRAWINGS PROVIDED HERE ARE NOT TO SCALE UNLESS OTHERWISE NOTED AND ARE INTENDED TO SHOW OUTLINE ONLY.
- UNLESS NOTED OTHERWISE, THE WORK SHALL INCLUDE FURNISHING MATERIALS, EQUIPMENT, APPURTENANCES, AND LABOR NECESSARY TO COMPLETE ALL INSTALLATIONS AS INDICATED ON THE DRAWINGS.
- THE CONTRACTOR SHALL INSTALL ALL EQUIPMENT AND MATERIALS IN ACCORDANCE WITH MANUFACTURER'S RECOMMENDATIONS UNLESS SPECIFICALLY STATED OTHERWISE.
- IF THE SPECIFIED EQUIPMENT CANNOT BE INSTALLED AS SHOWN ON THESE DRAWINGS, THE CONTRACTOR SHALL PROPOSE AN ALTERNATIVE INSTALLATION FOR APPROVAL BY PROJECT MANAGEMENT.
- CONTRACTOR SHALL DETERMINE ACTUAL ROUTING OF CONDUIT, POWER AND T1 CABLES, GROUNDING CABLES AS SHOWN ON THE POWER, GROUNDING AND TELCO PLAN DRAWING. CONTRACTOR SHALL UTILIZE EXISTING TRAYS AND/OR SHALL ADD NEW TRAYS AS NECESSARY. CONTRACTOR SHALL CONFIRM THE ACTUAL ROUTING WITH PROJECT MANAGEMENT.
- THE CONTRACTOR SHALL PROTECT EXISTING IMPROVEMENTS, PAVEMENTS, CURBS, LANDSCAPING AND STRUCTURES. ANY DAMAGED PART SHALL BE REPAIRED AT CONTRACTOR'S EXPENSE TO THE SATISFACTION OF THE OWNER.
- CONTRACTOR SHALL LEGALLY AND PROPERLY DISPOSE OF ALL SCRAP MATERIALS SUCH AS COAXIAL CABLES AND OTHER ITEMS REMOVED FROM THE EXISTING FACILITY. ANTENNAS REMOVED SHALL BE RETURNED TO THE OWNER'S DESIGNATED LOCATION.
- CONTRACTOR SHALL LEAVE PREMISES IN CLEAN CONDITION.
- THE CONTRACTOR SHALL SUPERVISE AND DIRECT THE PROJECT DESCRIBED HEREIN. THE CONTRACTOR SHALL BE SOLELY RESPONSIBLE FOR ALL CONSTRUCTION MEANS, METHODS, TECHNIQUES, SEQUENCES, AND PROCEDURES AND FOR COORDINATING ALL PORTIONS OF THE WORK UNDER THE CONTRACT.
- CONTRACTOR SHALL NOTIFY DEWBERRY 48 HOURS IN ADVANCE OF POURING CONCRETE, OR BACKFILLING TRENCHES, SEALING ROOF AND WALL PENETRATIONS & POST DOWNS, FINISHING NEW WALLS OR FINAL ELECTRICAL CONNECTIONS FOR ENGINEER REVIEW.
- CONTRACTOR SHALL VERIFY ALL EXISTING DIMENSIONS AND CONDITIONS PRIOR TO COMMENCING ANY WORK. ALL DIMENSIONS OF EXISTING CONSTRUCTION SHOWN ON THE DRAWINGS MUST BE VERIFIED. CONTRACTOR SHALL NOTIFY PROJECT MANAGEMENT OF ANY DISCREPANCIES PRIOR TO ORDERING MATERIAL OR PROCEEDING WITH CONSTRUCTION.
- THE EXISTING CELL SITE IS IN FULL COMMERCIAL OPERATION. ANY CONSTRUCTION WORK BY CONTRACTOR SHALL NOT DISRUPT THE EXISTING NORMAL OPERATION. ANY WORK ON EXISTING EQUIPMENT MUST BE COORDINATED WITH CONTRACTOR. ALSO, WORK SHOULD BE SCHEDULED FOR AN APPROPRIATE MAINTENANCE WINDOW USUALLY IN LOW TRAFFIC PERIODS AFTER MIDNIGHT.
- SINCE THE CELL SITE IS ACTIVE, ALL SAFETY PRECAUTIONS MUST BE TAKEN WHEN WORKING AROUND HIGH LEVELS OF ELECTROMAGNETIC RADIATION. EQUIPMENT SHOULD BE SHUTDOWN PRIOR TO PERFORMING ANY WORK THAT COULD EXPOSE THE WORKERS TO DANGER. PERSONAL RF EXPOSURE MONITORS ARE ADVISED TO BE WORN TO ALERT OF ANY DANGEROUS EXPOSURE LEVELS.

SITE WORK GENERAL NOTES:

- THE CONTRACTOR SHALL CONTACT UTILITY LOCATING SERVICES PRIOR TO THE START OF CONSTRUCTION.
- ALL EXISTING ACTIVE SEWER, WATER, GAS, ELECTRIC, AND OTHER UTILITIES WHERE ENCOUNTERED IN THE WORK, SHALL BE PROTECTED AT ALL TIMES, AND WHERE REQUIRED FOR THE PROPER EXECUTION OF THE WORK, SHALL BE RELOCATED AS DIRECTED BY CONTRACTOR. EXTREME CAUTION SHOULD BE USED BY THE CONTRACTOR WHEN EXCAVATING OR DRILLING PIERS AROUND OR NEAR UTILITIES. CONTRACTOR SHALL PROVIDE SAFETY TRAINING FOR THE WORKING CREW. THIS WILL INCLUDE BUT NOT BE LIMITED TO:
A) FALL PROTECTION
B) CONFINED SPACE
C) ELECTRICAL SAFETY
D) TRENCHING & EXCAVATION.
- ALL SITE WORK SHALL BE AS INDICATED ON THE DRAWINGS AND PROJECT SPECIFICATIONS.
- IF NECESSARY, RUBBISH, STUMPS, DEBRIS, STICKS, STONES, TOP SOIL AND OTHER REFUSE SHALL BE REMOVED FROM THE SITE AND DISPOSED OF LEGALLY.
- ALL EXISTING INACTIVE SEWER, WATER, GAS, ELECTRIC AND OTHER UTILITIES, WHICH INTERFERE WITH THE EXECUTION OF THE WORK, SHALL BE REMOVED AND/OR CAPPED, PLUGGED OR OTHERWISE DISCONTINUED AT POINTS WHICH WILL NOT INTERFERE WITH THE EXECUTION OF THE WORK, SUBJECT TO THE APPROVAL OF CONTRACTOR, OWNER AND/OR LOCAL UTILITIES.
- CONTRACTOR SHALL MINIMIZE DISTURBANCE TO EXISTING SITE DURING CONSTRUCTION.
- THE CONTRACTOR SHALL PROVIDE SITE SIGNAGE IN ACCORDANCE WITH THE T-MOBILE SPECIFICATION FOR SITE SIGNAGE.
- THE SITE SHALL BE GRADED TO CAUSE SURFACE WATER TO FLOW AWAY FROM THE TRANSMISSION EQUIPMENT AND TOWER AREAS.
- NO FILL OR EMBANKMENT MATERIAL SHALL BE PLACED ON FROZEN GROUND. FROZEN MATERIALS, SNOW OR ICE SHALL NOT BE PLACED IN ANY FILL OR EMBANKMENT.
- THE SUB GRADE SHALL BE COMPACTED AND BROUGHT TO A SMOOTH UNIFORM GRADE PRIOR TO FINISHED SURFACE APPLICATION. SEE SOIL COMPACTION NOTES.
- THE AREAS OF THE OWNER'S PROPERTY DISTURBED BY THE WORK AND NOT COVERED BY THE TOWER, EQUIPMENT OR DRIVEWAY, SHALL BE GRADED TO A UNIFORM SLOPE, AND STABILIZED TO PREVENT EROSION.
- EROSION CONTROL MEASURES, IF REQUIRED DURING CONSTRUCTION, SHALL BE IN CONFORMANCE WITH THE LOCAL JURISDICTION'S GUIDELINES FOR EROSION AND SEDIMENT CONTROL.

ELECTRICAL INSTALLATION NOTES:

- ALL ELECTRICAL WORK SHALL BE PERFORMED IN ACCORDANCE WITH THE PROJECT SPECIFICATIONS, NEC AND ALL APPLICABLE LOCAL CODES.
- CONTRACTOR SHALL MODIFY EXISTING CABLE TRAY SYSTEM AS REQUIRED TO SUPPORT RF AND TRANSPORT CABLE TO THE NEW BTS EQUIPMENT. CONTRACTOR SHALL SUBMIT MODIFICATIONS TO PROJECT MANAGEMENT FOR APPROVAL.
- CONDUIT ROUTINGS ARE SCHEMATIC. CONTRACTOR SHALL INSTALL CONDUITS SO THAT ACCESS TO EQUIPMENT IS NOT BLOCKED.
- WIRING, RACEWAY AND SUPPORT METHODS AND MATERIALS SHALL COMPLY WITH THE REQUIREMENTS OF THE NEC AND TELCORDIA.
- ALL CIRCUITS SHALL BE SEGREGATED AND MAINTAIN MINIMUM CABLE SEPARATION AS REQUIRED BY THE NEC AND TELCORDIA.
- CABLES SHALL NOT BE ROUTED THROUGH LADDER-STYLE CABLE TRAY RUNGS.
- EACH END OF EVERY POWER, POWER PHASE CONDUCTOR (I.E., HOTS), GROUNDING, AND T1 CONDUCTOR AND CABLE SHALL BE LABELED WITH COLOR-CODED INSULATION OR ELECTRICAL TAPE (3M BRAND, 1/2 INCH PLASTIC ELECTRICAL TAPE WITH UV PROTECTION, OR EQUAL). THE IDENTIFICATION METHOD SHALL CONFORM WITH NEC & OSHA, AND MATCH EXISTING INSTALLATION REQUIREMENTS.
- ALL ELECTRICAL COMPONENTS SHALL BE CLEARLY LABELED WITH ENGRAVED LAMACOID PLASTIC LABELS. ALL EQUIPMENT SHALL BE LABELED WITH THEIR VOLTAGE RATING, PHASE CONFIGURATION, WIRE CONFIGURATION, POWER OR AMPACITY RATING, AND BRANCH CIRCUIT ID NUMBERS (I.E., PANELBOARD AND CIRCUIT ID'S).
- PANELBOARDS (ID NUMBERS) AND INTERNAL CIRCUIT BREAKERS (CIRCUIT ID NUMBERS) SHALL BE CLEARLY LABELED WITH ENGRAVED LAMACOID PLASTIC LABELS.
- ALL TIE WRAPS SHALL BE CUT FLUSH WITH APPROVED CUTTING TOOL TO REMOVE SHARP EDGES.
- POWER, CONTROL, AND EQUIPMENT GROUND WIRING IN TUBING OR CONDUIT SHALL BE SINGLE CONDUCTOR (SIZE 14 AWG OR LARGER), 600V, OIL RESISTANT THHN OR THWN-2, CLASS B STRANDED COPPER CABLE RATED FOR 90 °C (WET AND DRY) OPERATION; LISTED OR LABELED FOR THE LOCATION AND RACEWAY SYSTEM USED, UNLESS OTHERWISE SPECIFIED.
- POWER PHASE CONDUCTORS (I.E., HOTS) SHALL BE LABELED WITH COLOR-CODED INSULATION OR ELECTRICAL TAPE (3M BRAND, 1/2 INCH PLASTIC ELECTRICAL TAPE WITH UV PROTECTION, OR EQUAL) PHASE CONDUCTOR COLOR CODES SHALL CONFORM WITH THE NEC & OSHA AND MATCH EXISTING INSTALLATION REQUIREMENTS.
- SUPPLEMENTAL EQUIPMENT GROUND WIRING LOCATED INDOORS SHALL BE SINGLE CONDUCTOR (SIZE 6 AWG OR LARGER), 600V, OIL RESISTANT THHN OR THWN-2 GREEN INSULATION, CLASS B STRANDED COPPER CABLE RATED FOR 90°C (WET AND DRY) OPERATION; LISTED OR LABELED FOR THE LOCATION AND RACEWAY SYSTEM USED, UNLESS OTHERWISE SPECIFIED.
- SUPPLEMENTAL EQUIPMENT GROUND WIRING LOCATED OUTDOORS, OR BELOW GRADE, SHALL BE SINGLE CONDUCTOR #2 AWG SOLID TINNED COPPER CABLE, UNLESS OTHERWISE SPECIFIED.
- POWER AND CONTROL WIRING, NOT IN TUBING OR CONDUIT, SHALL BE MULTI-CONDUCTOR, TYPE TC CABLE (SIZE 14 AWG OR LARGER), 600V, OIL RESISTANT THHN OR THWN-2, CLASS B STRANDED COPPER CABLE RATED FOR 90°C (WET AND DRY) OPERATION; WITH OUTER JACKET; LISTED OR LABELED FOR THE LOCATION USED, UNLESS OTHERWISE SPECIFIED.
- ALL POWER AND POWER GROUNDING CONNECTIONS SHALL BE CRIMP-STYLE, COMPRESSION WIRE LUGS AND WIRENUTS BY THOMAS AND BETTS (OR EQUAL). LUGS AND WIRENUTS SHALL BE RATED FOR OPERATION AT NO LESS THAN 75°C (90°C IF AVAILABLE).
- RACEWAY AND CABLE TRAY SHALL BE LISTED OR LABELED FOR ELECTRICAL USE IN ACCORDANCE WITH NEMA, UL, ANSI/IEEE, AND NEC.
- NEW RACEWAY OR CABLE TRAY WILL MATCH THE EXISTING INSTALLATION WHERE POSSIBLE.
- ELECTRICAL METALLIC TUBING (EMT) OR RIGID NONMETALLIC CONDUIT (I.E., RIGID PVC SCHEDULE 40, OR RIGID PVC SCHEDULE 80 FOR LOCATIONS SUBJECT TO PHYSICAL DAMAGE) SHALL BE USED FOR EXPOSED INDOOR LOCATIONS.
- ELECTRICAL METALLIC TUBING (EMT), ELECTRICAL NONMETALLIC TUBING (ENT), OR RIGID NONMETALLIC CONDUIT (RIGID PVC, SCHEDULE 40) SHALL BE USED FOR CONCEALED INDOOR LOCATIONS.
- GALVANIZED STEEL INTERMEDIATE METALLIC CONDUIT (IMC) SHALL BE USED FOR OUTDOOR LOCATIONS ABOVE GRADE.
- RIGID NONMETALLIC CONDUIT (I.E., RIGID PVC SCHEDULE 40 OR RIGID PVC SCHEDULE 80) SHALL BE USED UNDERGROUND; DIRECT BURIED, IN AREAS OF OCCASIONAL LIGHT VEHICLE TRAFFIC OR ENCASED IN REINFORCED CONCRETE IN AREAS OF HEAVY VEHICLE TRAFFIC.
- LIQUID-TIGHT FLEXIBLE METALLIC CONDUIT (LIQUID-TITE FLEX) SHALL BE USED INDOORS AND OUTDOORS, WHERE VIBRATION OCCURS OR FLEXIBILITY IS NEEDED.
- CONDUIT AND TUBING FITTINGS SHALL BE THREADED OR COMPRESSION-TYPE AND APPROVED FOR THE LOCATION USED. SETSCREW FITTINGS ARE NOT ACCEPTABLE.
- CABINETS, BOXES, AND WIREWAYS SHALL BE LISTED OR LABELED FOR ELECTRICAL USE IN ACCORDANCE WITH NEMA, UL, ANSI/IEEE, AND NEC.
- CABINETS, BOXES, AND WIREWAYS TO MATCH THE EXISTING INSTALLATION WHERE POSSIBLE.
- WIREWAYS SHALL BE EPOXY-COATED (GRAY) AND INCLUDE A HINGED COVER, DESIGNED TO SWING OPEN DOWNWARD; SHALL BE PANOUT TYPE E (OR EQUAL); AND RATED NEMA 1 (OR BETTER) INDOORS, OR NEMA 3R (OR BETTER) OUTDOORS.
- EQUIPMENT CABINETS, TERMINAL BOXES, JUNCTION BOXES, AND PULL BOXES SHALL BE GALVANIZED OR EPOXY-COATED SHEET STEEL, SHALL MEET OR EXCEED UL 50, AND RATED NEMA 1 (OR BETTER) INDOORS, OR NEMA 3R (OR BETTER) OUTDOORS.
- METAL RECEPTACLE, SWITCH, AND DEVICE BOXES SHALL BE GALVANIZED, EPOXY-COATED, OR NON-CORRODING; SHALL MEET OR EXCEED UL 514A AND NEMA OS 1; AND RATED NEMA 1 (OR BETTER) INDOORS, OR WEATHER PROTECTED (WP OR BETTER) OUTDOORS.
- NONMETALLIC RECEPTACLE, SWITCH, AND DEVICE BOXES SHALL MEET OR EXCEED NEMA OS 2; AND RATED NEMA 1 (OR BETTER) INDOORS, OR WEATHER PROTECTED (WP OR BETTER) OUTDOORS.
- THE CONTRACTOR SHALL NOTIFY AND OBTAIN NECESSARY AUTHORIZATION FROM PROJECT MANAGEMENT BEFORE COMMENCING WORK ON THE AC POWER DISTRIBUTION PANELS.
- THE CONTRACTOR SHALL PROVIDE NECESSARY TAGGING ON THE BREAKERS, CABLES AND DISTRIBUTION PANELS IN ACCORDANCE WITH THE APPLICABLE CODES AND STANDARDS TO SAFEGUARD AGAINST LIFE AND PROPERTY.

CONCRETE AND REINFORCING STEEL NOTES:

- ALL CONCRETE WORK SHALL BE IN ACCORDANCE WITH THE ACI 301, ACI 318, ACI 336, ASTM A184, ASTM A185 AND THE DESIGN AND CONSTRUCTION SPECIFICATION FOR CAST-IN-PLACE CONCRETE.
- ALL CONCRETE SHALL HAVE A MINIMUM COMPRESSIVE STRENGTH OF 4000 PSI AT 28 DAYS, UNLESS NOTED OTHERWISE. A HIGHER STRENGTH (4000 PSI) MAY BE USED. ALL CONCRETING WORK SHALL BE DONE IN ACCORDANCE WITH ACI 318 CODE REQUIREMENTS.
- REINFORCING STEEL SHALL CONFORM TO ASTM A 615, GRADE 60, DEFORMED UNLESS NOTED OTHERWISE. WELDED WIRE FABRIC SHALL CONFORM TO ASTM A 185 WELDED STEEL WIRE FABRIC UNLESS NOTED OTHERWISE (UNO). SPLICES SHALL BE CLASS "B" AND ALL HOOKS SHALL BE STANDARD, UNO.
- THE FOLLOWING MINIMUM CONCRETE COVER SHALL BE PROVIDED FOR REINFORCING STEEL UNLESS SHOWN OTHERWISE ON DRAWINGS:

CONCRETE CAST AGAINST EARTH.....3 IN.
CONCRETE EXPOSED TO EARTH OR WEATHER:
#6 AND LARGER2 IN.
#5 AND SMALLER & WWF.....1 1/2 IN.
CONCRETE NOT EXPOSED TO EARTH OR WEATHER OR NOT CAST AGAINST THE GROUND:
SLAB AND WALL3/4 IN.
BEAMS AND COLUMNS.....1 1/2 IN.
- A CHAMFER 3/4" SHALL BE PROVIDED AT ALL EXPOSED EDGES OF CONCRETE, UNO, IN ACCORDANCE WITH ACI 301 SECTION 4.2.4.
- INSTALLATION OF CONCRETE EXPANSION/WEDGE ANCHOR, SHALL BE PER MANUFACTURER'S WRITTEN RECOMMENDED PROCEDURE. THE ANCHOR BOLT, DOWEL OR ROD SHALL CONFORM TO MANUFACTURER'S RECOMMENDATION FOR EMBEDMENT DEPTH OR AS SHOWN ON THE DRAWINGS. NO REBAR SHALL BE CUT WITHOUT PRIOR CONTRACTOR APPROVAL WHEN DRILLING HOLES IN CONCRETE. SPECIAL INSPECTIONS, REQUIRED BY GOVERNING CODES, SHALL BE PERFORMED IN ORDER TO MAINTAIN MANUFACTURER'S MAXIMUM ALLOWABLE LOADS. ALL EXPANSION/WEDGE ANCHORS SHALL BE STAINLESS STEEL OR HOT DIPPED GALVANIZED. EXPANSION BOLTS SHALL BE PROVIDED BY RAMSET/REDHEAD OR APPROVED EQUAL.
- CONCRETE CYLINDER TEST IS NOT REQUIRED FOR SLAB ON GRADE WHEN CONCRETE IS LESS THAN 50 CUBIC YARDS (IBC 1905.6.2.3) IN THAT EVENT THE FOLLOWING RECORDS SHALL BE PROVIDED BY THE CONCRETE SUPPLIER:
(A) RESULTS OF CONCRETE CYLINDER TESTS PERFORMED AT THE SUPPLIER'S PLANT.
(B) CERTIFICATION OF MINIMUM COMPRESSIVE STRENGTH FOR THE CONCRETE GRADE SUPPLIED.
FOR GREATER THAN 50 CUBIC YARDS THE GC SHALL PERFORM THE CONCRETE CYLINDER TEST.
- AS AN ALTERNATIVE TO ITEM 7, TEST CYLINDERS SHALL BE TAKEN INITIALLY AND THEREAFTER FOR EVERY 50 YARDS OF CONCRETE FROM EACH DIFFERENT BATCH PLANT.
- EQUIPMENT SHALL NOT BE PLACED ON NEW PADS FOR SEVEN DAYS AFTER PAD IS POURED, UNLESS IT IS VERIFIED BY CYLINDER TESTS THAT COMPRESSIVE STRENGTH HAS BEEN ATTAINED.

STRUCTURAL STEEL NOTES:

- ALL STEEL WORK SHALL BE PAINTED OR GALVANIZED IN ACCORDANCE WITH THE DRAWINGS UNLESS NOTED OTHERWISE. STRUCTURAL STEEL SHALL BE ASTM-A-36 UNLESS OTHERWISE NOTED ON THE SITE SPECIFIC DRAWINGS. STEEL DESIGN, INSTALLATION AND BOLTING SHALL BE PERFORMED IN ACCORDANCE WITH THE AMERICAN INSTITUTE OF STEEL CONSTRUCTION (AISC) "MANUAL OF STEEL CONSTRUCTION".
- ALL WELDING SHALL BE PERFORMED USING E70XX ELECTRODES AND WELDING SHALL CONFORM TO AISC. WHERE FILLET WELD SIZES ARE NOT SHOWN, PROVIDE THE MINIMUM SIZE PER TABLE J2.4 IN THE AISC "MANUAL OF STEEL CONSTRUCTION". PAINTED SURFACES SHALL BE TOUCHED UP.
- BOLTED CONNECTIONS SHALL BE ASTM A325 BEARING TYPE (3/4"Ø) CONNECTIONS AND SHALL HAVE MINIMUM OF TWO BOLTS UNLESS NOTED OTHERWISE.
- NON-STRUCTURAL CONNECTIONS FOR STEEL GRATING MAY USE 5/8" DIA. ASTM A 307 BOLTS UNLESS NOTED OTHERWISE.
- INSTALLATION OF CONCRETE EXPANSION/WEDGE ANCHOR, SHALL BE PER MANUFACTURER'S WRITTEN RECOMMENDED PROCEDURE. THE ANCHOR BOLT, DOWEL OR ROD SHALL CONFORM TO MANUFACTURER'S RECOMMENDATION FOR EMBEDMENT DEPTH OR AS SHOWN ON THE DRAWINGS. NO REBAR SHALL BE CUT WITHOUT PRIOR CONTRACTOR APPROVAL WHEN DRILLING HOLES IN CONCRETE. SPECIAL INSPECTIONS, REQUIRED BY GOVERNING CODES, SHALL BE PERFORMED IN ORDER TO MAINTAIN MANUFACTURER'S MAXIMUM ALLOWABLE LOADS. ALL EXPANSION/WEDGE ANCHORS SHALL BE STAINLESS STEEL OR HOT DIPPED GALVANIZED. EXPANSION BOLTS SHALL BE PROVIDED BY RAMSET/REDHEAD OR APPROVED EQUAL.
- CONTRACTOR SHALL SUBMIT SHOP DRAWINGS FOR ENGINEER REVIEW & APPROVAL ON PROJECTS REQUIRING STRUCTURAL STEEL.
- ALL STRUCTURAL STEEL WORK SHALL BE DONE IN ACCORDANCE WITH AISC SPECIFICATIONS.

CONSTRUCTION NOTES:

- FIELD VERIFICATION: CONTRACTOR SHALL FIELD VERIFY SCOPE OF WORK, T-MOBILE ANTENNA PLATFORM LOCATION AND ANTENNAS TO BE REPLACED.
- COORDINATION OF WORK: CONTRACTOR SHALL COORDINATE RF WORK AND PROCEDURES WITH PROJECT MANAGEMENT.
- CABLE LADDER RACK: CONTRACTOR SHALL FURNISH AND INSTALL CABLE LADDER RACK, CABLE TRAY, AND CONDUIT AS REQUIRED TO SUPPORT CABLES TO THE NEW BTS LOCATION.
- GROUNDING OF ALL EQUIPMENT AND ANTENNAS IS NOT CONSIDERED PART OF THE SCOPE OF THIS PROJECT AND IS THE RESPONSIBILITY OF THE OWNER AND CONTRACTOR AT THE TIME OF CONSTRUCTION. ALL EQUIPMENT AND ANTENNAS TO BE INSTALLED AND GROUNDED IN ACCORDANCE WITH GOVERNING BUILDING CODE, MANUFACTURER RECOMMENDATIONS AND OWNER SPECIFICATIONS.



T-MOBILE NORTHEAST LLC
35 GRIFFIN ROAD SOUTH
BLOOMFIELD, CT 06002



CROWN CASTLE
3 CORPORATE PARK DRIVE, SUITE 101
CLIFTON PARK, NY 12065

CT11711A
HRT 084 943242

CONSTRUCTION DRAWINGS

0	09/07/16	ISSUED AS FINAL
B	09/06/16	REVISED PER COMMENTS
A	08/18/16	ISSUED FOR REVIEW



Dewberry Engineers Inc.
600 PARSIPPANY ROAD
SUITE 301
PARSIPPANY, NJ 07054
PHONE: 973.739.9400
FAX: 973.739.9710

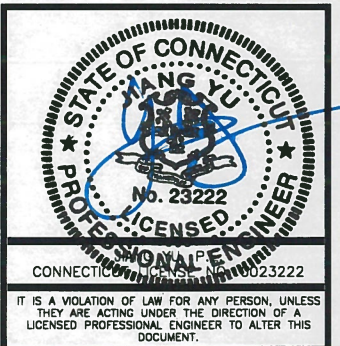

DRAWN BY: JC

REVIEWED BY: BSH

CHECKED BY: GHN

PROJECT NUMBER: 50066258

JOB NUMBER: 50078130

SITE ADDRESS:

197 SOUTH STREET,
VERNON, CT 06066
TOLLAND COUNTY

SHEET TITLE

GENERAL NOTES

SHEET NUMBER

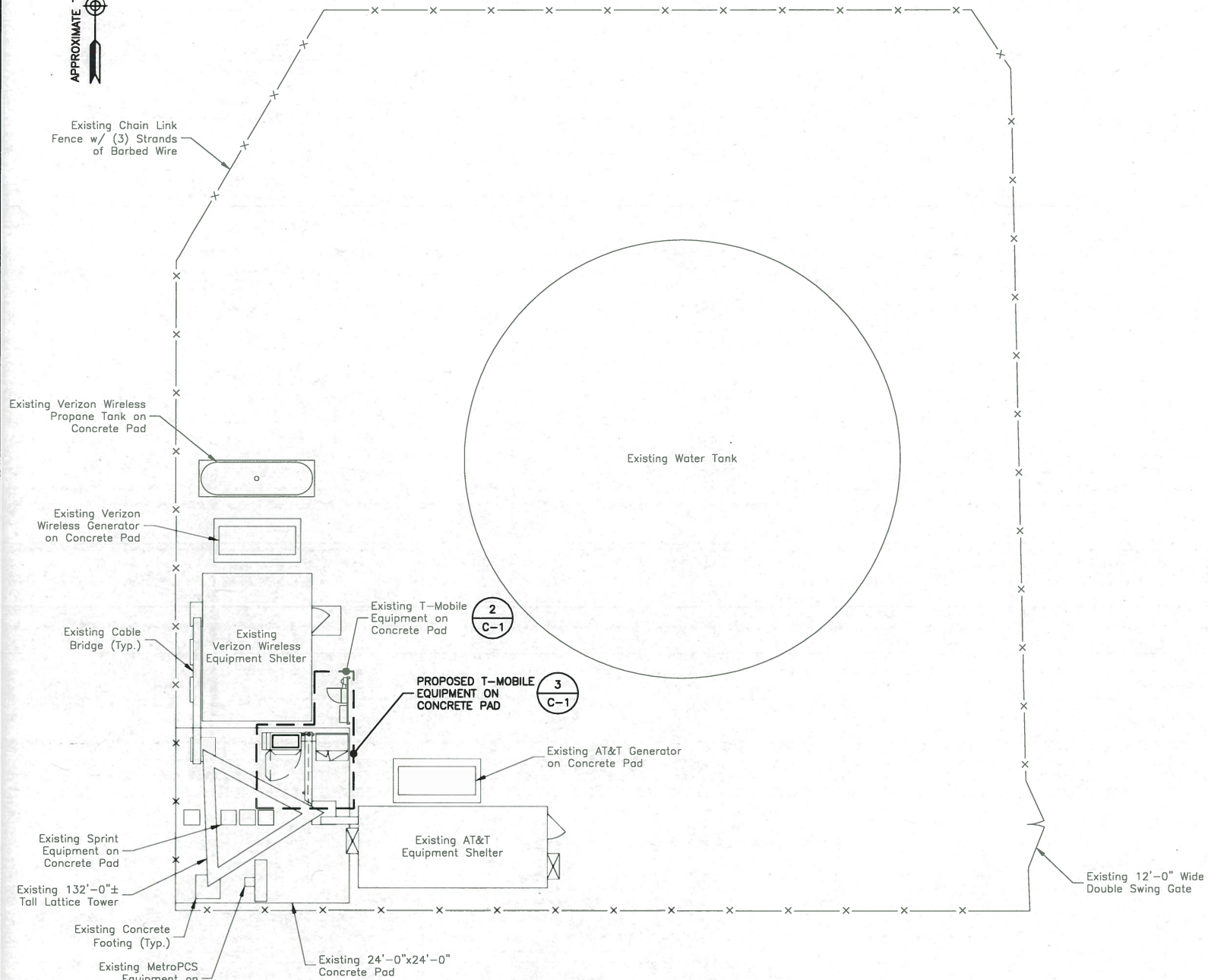

COMPOUND PLAN

SCALE: 1"=20' FOR 11"x17"
1"=10' FOR 22"x34"

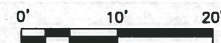

1

NOTES:

1. NORTH ARROW SHOWN AS APPROXIMATE.
2. NOT ALL INFORMATION IS SHOWN FOR CLARITY.
3. ALL PROPOSED EQUIPMENT, INCLUDING ANTENNAS, RRU'S, COAX, ETC., SHALL BE MOUNTED IN ACCORDANCE WITH THE TOWER STRUCTURAL ANALYSIS BY SSOE GROUP DATED AUGUST 9, 2016.

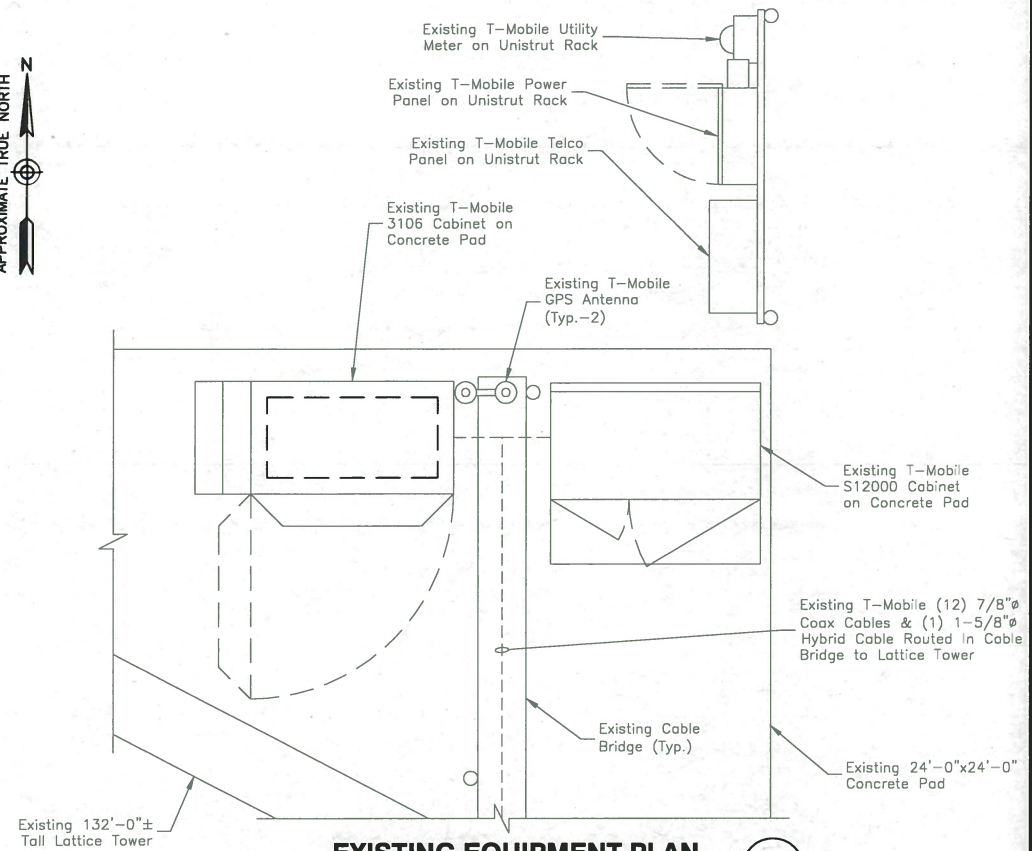

EXISTING EQUIPMENT PLAN

SCALE: 1/4"=1' FOR 11"x17"
1/2"=1' FOR 22"x34"

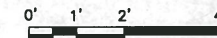

2

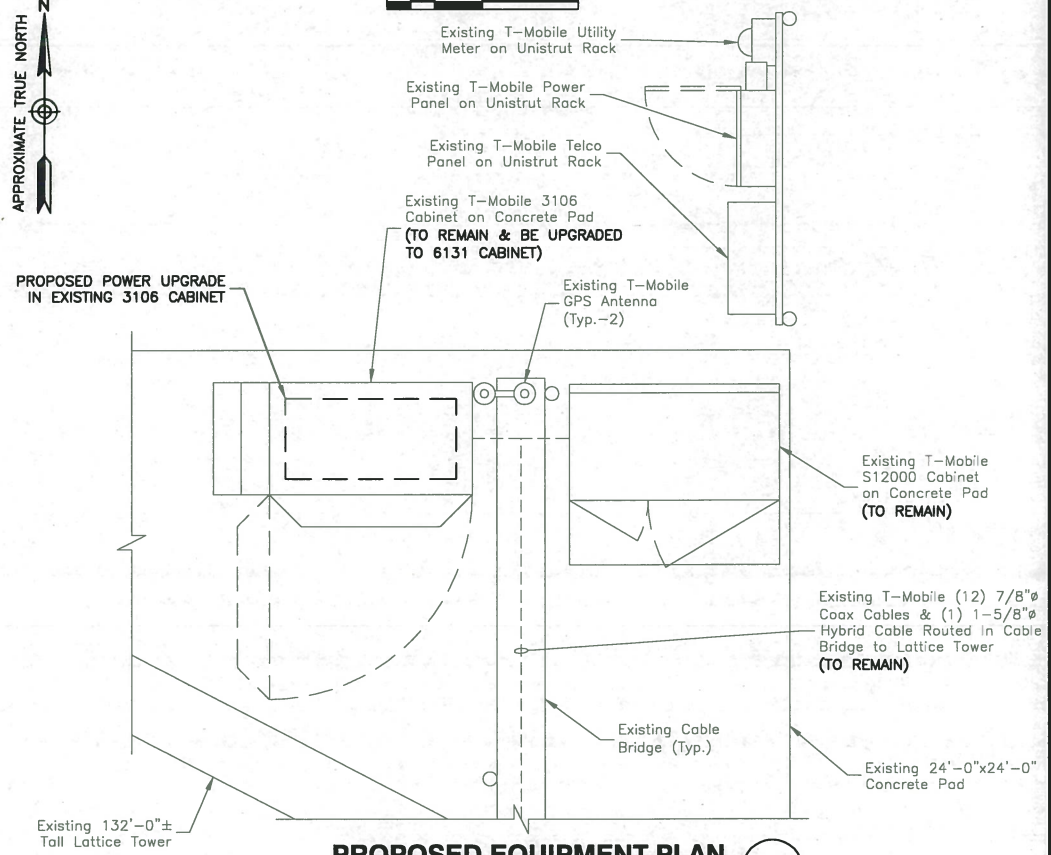

PROPOSED EQUIPMENT PLAN

SCALE: 1/4"=1' FOR 11"x17"
1/2"=1' FOR 22"x34"



3

NOTE:

1. NO EQUIPMENT IS PROPOSED AT GRADE.



T-MOBILE NORTHEAST LLC
35 GRIFFIN ROAD SOUTH
BLOOMFIELD, CT 06002



CROWN CASTLE
3 CORPORATE PARK DRIVE, SUITE 101
CLIFTON PARK, NY 12065

**CT11711A
HRT 084 943242**

CONSTRUCTION DRAWINGS

D	09/07/16 ISSUED AS FINAL
B	09/06/16 REVISED PER COMMENTS
A	06/18/16 ISSUED FOR REVIEW



Dewberry Engineers Inc.
600 PARSIPPANY ROAD
SUITE 301
PARSIPPANY, NJ 07054
PHONE: 973.739.9400
FAX: 973.739.9710

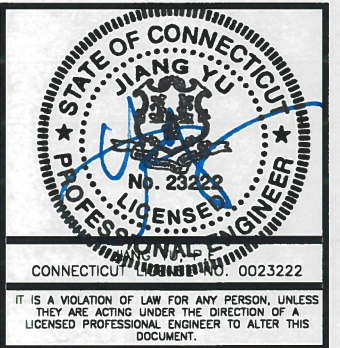

DRAWN BY: JC

REVIEWED BY: BSH

CHECKED BY: GHN

PROJECT NUMBER: 50066258

JOB NUMBER: 50078130

SITE ADDRESS:

197 SOUTH STREET,
VERNON, CT 06066
TOLLAND COUNTY

SHEET TITLE

COMPOUND PLAN &
EQUIPMENT PLANS

SHEET NUMBER

C-1

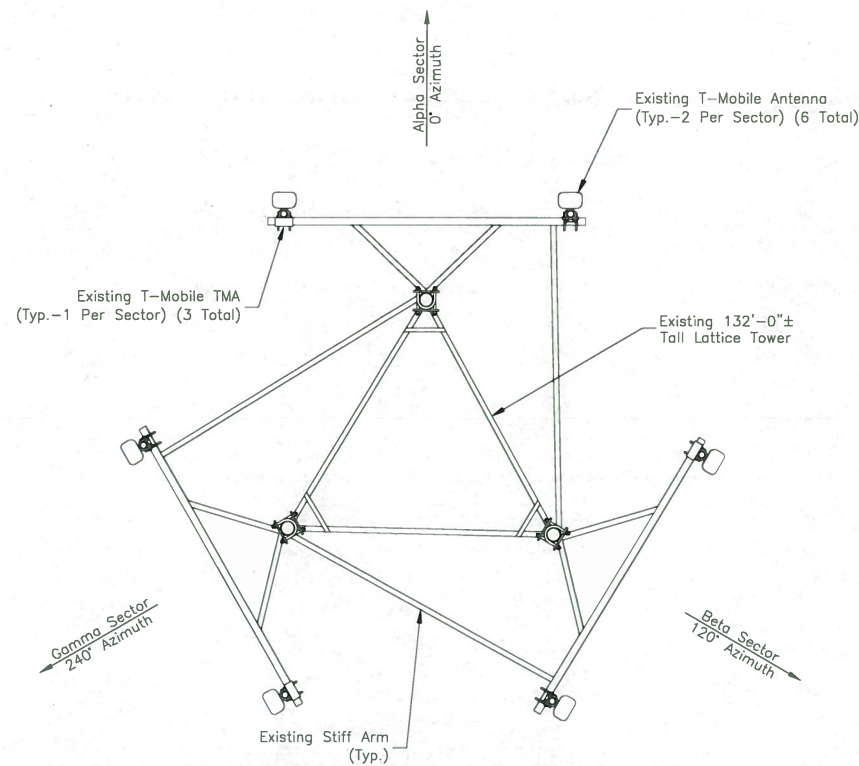

EXISTING ANTENNA LAYOUT
SCALE: N.T.S. (1)

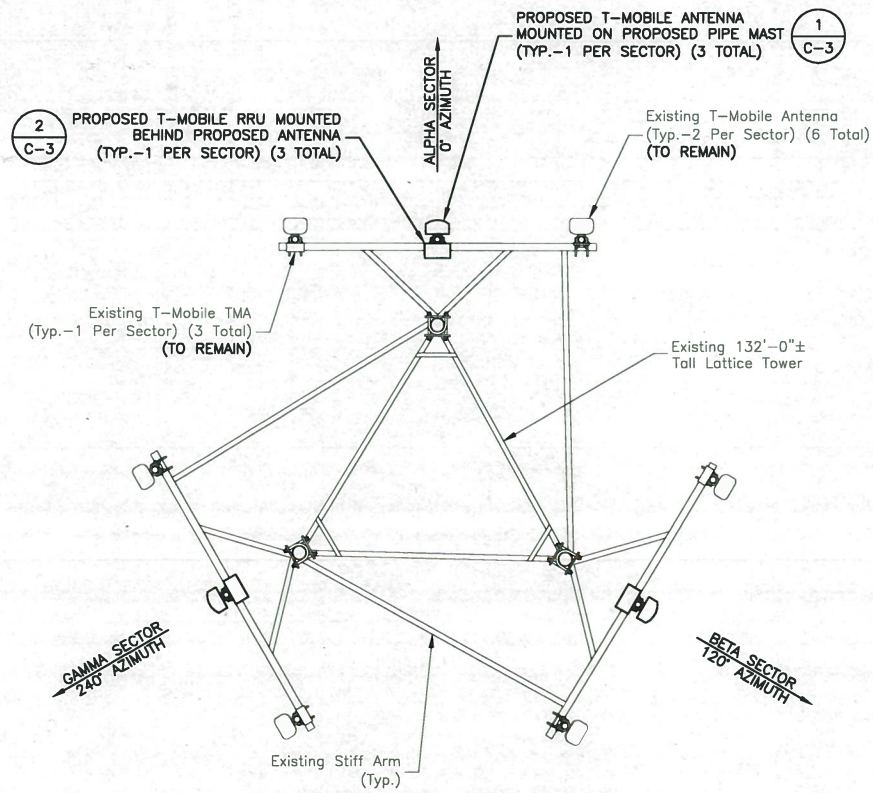

PROPOSED ANTENNA LAYOUT
SCALE: N.T.S. (2)

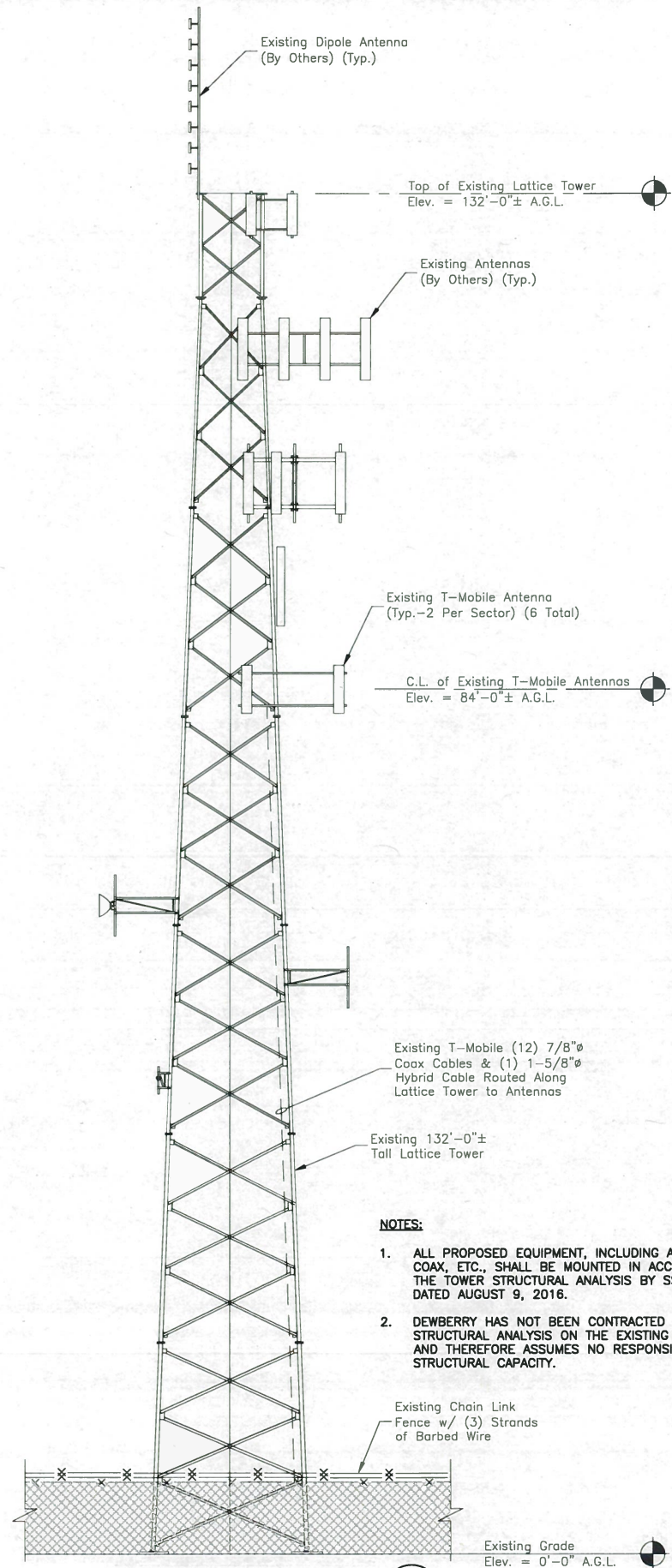

EXISTING ELEVATION
SCALE: 1/16"=1' FOR 11"x17"
1/8"=1' FOR 22"x34" (3)

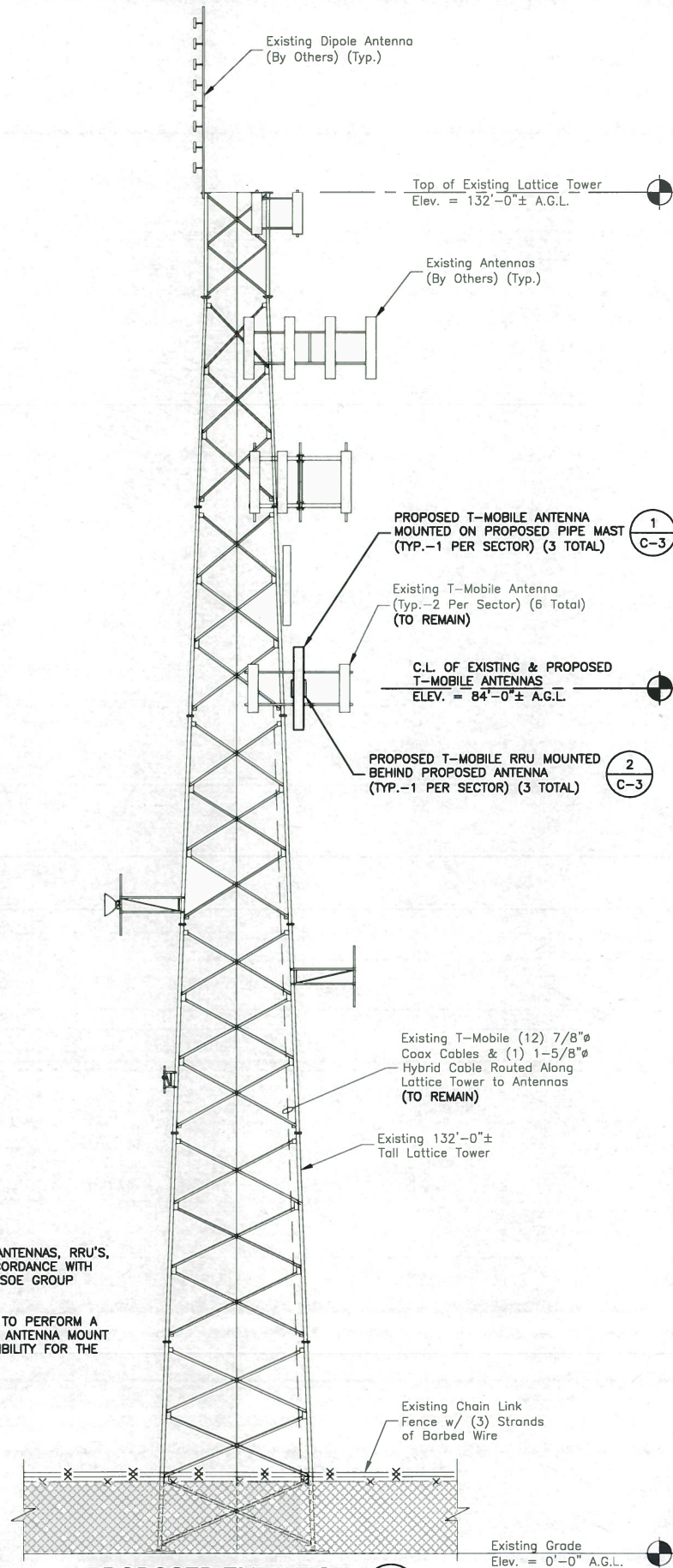
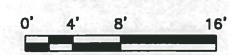

PROPOSED ELEVATION
SCALE: 1/16"=1' FOR 11"x17"
1/8"=1' FOR 22"x34" (4)

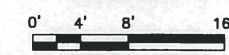

- NOTES:**
- ALL PROPOSED EQUIPMENT, INCLUDING ANTENNAS, RRU'S, COAX, ETC., SHALL BE MOUNTED IN ACCORDANCE WITH THE TOWER STRUCTURAL ANALYSIS BY SSOE GROUP DATED AUGUST 9, 2016.
 - DEWBERRY HAS NOT BEEN CONTRACTED TO PERFORM A STRUCTURAL ANALYSIS ON THE EXISTING ANTENNA MOUNT AND THEREFORE ASSUMES NO RESPONSIBILITY FOR THE STRUCTURAL CAPACITY.

T-Mobile

T-MOBILE NORTHEAST LLC
35 GRIFFIN ROAD SOUTH
BLOOMFIELD, CT 06002

CROWN CASTLE

CROWN CASTLE
3 CORPORATE PARK DRIVE, SUITE 101
CLIFTON PARK, NY 12065

CT11711A
HRT 084 943242

CONSTRUCTION DRAWINGS

0 09/07/16 ISSUED AS FINAL
B 09/06/16 REVISED PER COMMENTS
A 08/18/16 ISSUED FOR REVIEW

Dewberry

Dewberry Engineers Inc.
600 PARSIPPANY ROAD
SUITE 301
PARSIIPPANY, NJ 07054
PHONE: 973.739.9400
FAX: 973.739.9710



CONNECTICUT LICENSE NO. 0023222

IT IS A VIOLATION OF LAW FOR ANY PERSON, UNLESS THEY ARE ACTING UNDER THE DIRECTION OF A LICENSED PROFESSIONAL ENGINEER TO ALTER THIS DOCUMENT.

DRAWN BY: JC

REVIEWED BY: BSH

CHECKED BY: GHN

PROJECT NUMBER: 50066258

JOB NUMBER: 50078130

SITE ADDRESS:

197 SOUTH STREET,
VERNON, CT 06066
TOLLAND COUNTY

SHEET TITLE

ANTENNA LAYOUTS &
ELEVATIONS

SHEET NUMBER

C-2

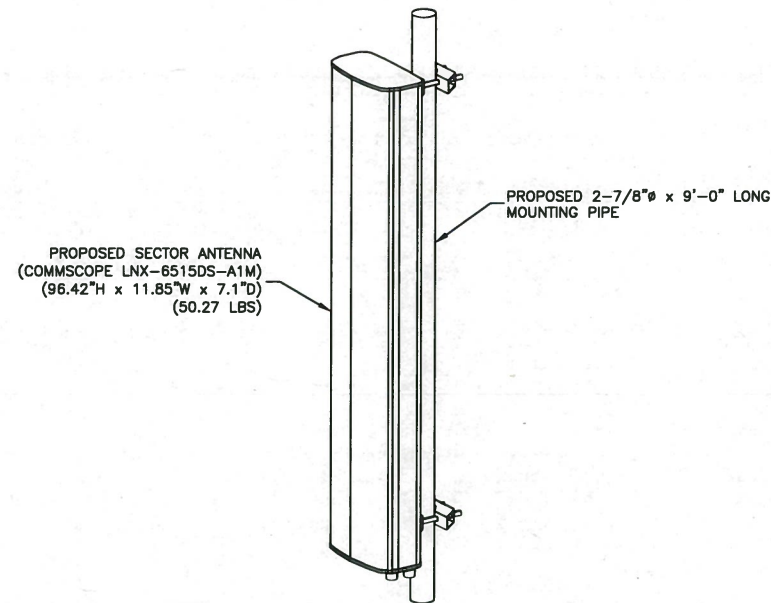

NOTES:

1. MOUNT ANTENNAS PER MANUFACTURER'S RECOMMENDATIONS.
2. GROUND ANTENNAS AND MOUNTS PER MANUFACTURER'S RECOMMENDATIONS AND T-MOBILE STANDARDS.
3. CONFIRM REQUIRED ANTENNAS WITH THE LATEST RFDS.

ISOMETRIC ANTENNA DETAIL

SCALE: N.T.S.

1

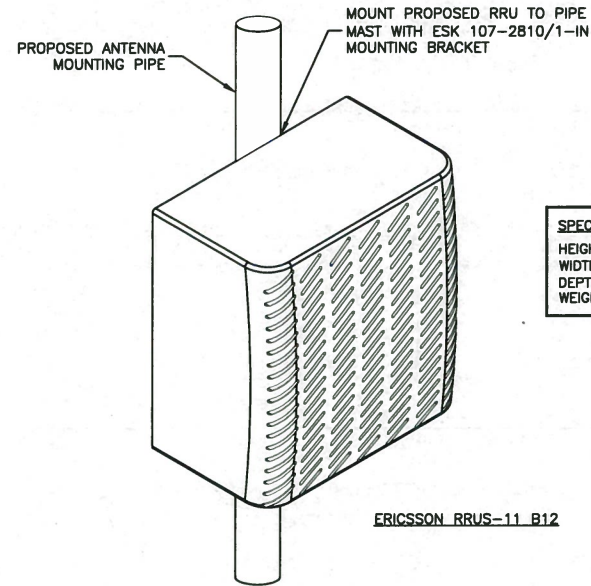

SPECIFICATIONS:

HEIGHT: 20.0"
 WIDTH: 17.0"
 DEPTH: 7.0"
 WEIGHT: 50.7 LBS

RRU NOTES:

1. MOUNT EQUIPMENT PER MANUFACTURER'S RECOMMENDATIONS.
2. GROUND EQUIPMENT AND MOUNTS PER MANUFACTURER'S RECOMMENDATIONS AND T-MOBILE STANDARDS.
3. CONFIRM REQUIRED EQUIPMENT WITH THE LATEST RFDS.

RRUS-11 - REMOTE RADIO UNIT

SCALE: N.T.S.

2

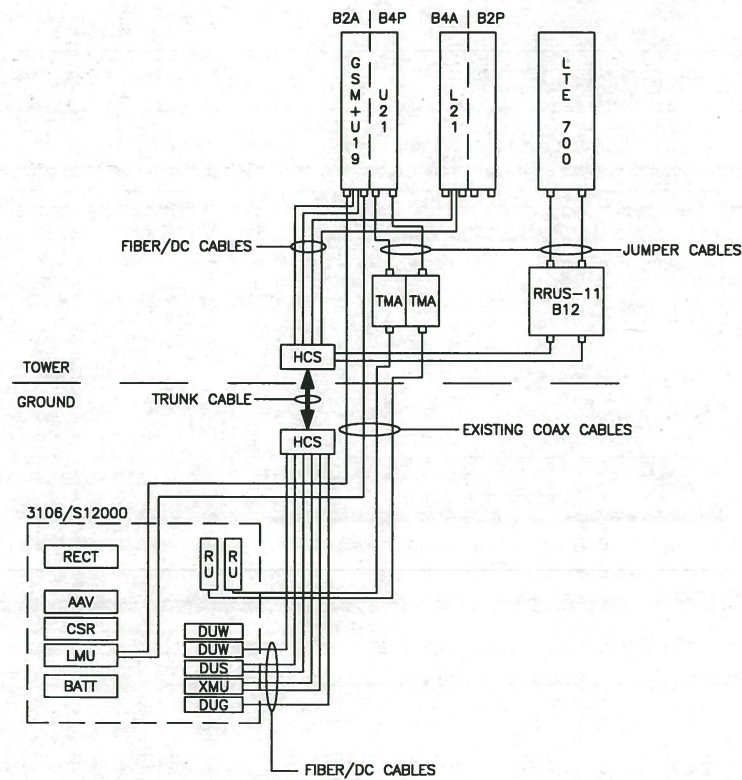

SITE CONFIGURATION 702Cu

SCALE: N.T.S.

3

DESIGN CONFIGURATION							
ANTENNAS	COAX	HYBRID	COAX/HYBRID LENGTH	TMA	RRU		
				EXISTING	PROPOSED	EXISTING	PROPOSED
ALPHA	EXISTING TO REMAIN	(4) 7/8"	134'-0"	(1) KRY 112 144/1	-		
	COMMSCOPE LNX-6515DS-A1M	-		-	(1) RRUS-11 B12		
BETA	EXISTING TO REMAIN	(4) 7/8"	134'-0"	(1) KRY 112 144/1	-		
	COMMSCOPE LNX-6515DS-A1M	-		-	(1) RRUS-11 B12		
GAMMA	EXISTING TO REMAIN	(4) 7/8"	134'-0"	(1) KRY 112 144/1	-		
	COMMSCOPE LNX-6515DS-A1M	-		-	(1) RRUS-11 B12		



T-MOBILE NORTHEAST LLC
 35 GRIFFIN ROAD SOUTH
 BLOOMFIELD, CT 06002



CROWN CASTLE
 3 CORPORATE PARK DRIVE, SUITE 101
 CLIFTON PARK, NY 12065

CT11711A
HRT 084 943242

CONSTRUCTION DRAWINGS

0	09/07/16	ISSUED AS FINAL
B	09/06/16	REVISED PER COMMENTS
A	08/18/16	ISSUED FOR REVIEW



Dewberry Engineers Inc.
 800 PARSIPPANY ROAD
 SUITE 301
 PARSIPPANY, NJ 07054
 PHONE: 973.739.9400
 FAX: 973.739.9710



DRAWN BY: JC

REVIEWED BY: BSH

CHECKED BY: GHN

PROJECT NUMBER: 50066258

JOB NUMBER: 50078130

SITE ADDRESS:

197 SOUTH STREET,
 VERNON, CT 06066
 TOLLAND COUNTY

SHEET TITLE

CONSTRUCTION
 DETAILS

SHEET NUMBER

GROUNDING NOTES:

1. THE CONTRACTOR SHALL REVIEW AND INSPECT THE EXISTING FACILITY GROUNDING SYSTEM AND LIGHTNING PROTECTION SYSTEM (AS DESIGNED AND INSTALLED) FOR STRICT COMPLIANCE WITH THE NEC (AS ADOPTED BY THE AHJ), THE SITE-SPECIFIC (UL, LPI, OR NFPA) LIGHTING PROTECTION CODE, AND GENERAL COMPLIANCE WITH TELCORDIA AND TIA GROUNDING STANDARDS. THE CONTRACTOR SHALL REPORT ANY VIOLATIONS OR ADVERSE FINDINGS TO THE ENGINEER FOR RESOLUTION.
2. ALL GROUND ELECTRODE SYSTEMS (INCLUDING TELECOMMUNICATION, RADIO, LIGHTNING PROTECTION, AND AC POWER GES'S) SHALL BE BONDED TOGETHER, AT OR BELOW GRADE, BY TWO OR MORE COPPER BONDING CONDUCTORS. ALL AVAILABLE GROUNDING ELECTRODES SHALL BE CONNECTED TOGETHER IN ACCORDANCE WITH THE NEC.
3. THE CONTRACTOR SHALL PERFORM IEEE FALL-OF-POTENTIAL RESISTANCE TO EARTH TESTING (PER IEEE 1100 AND 81) FOR GROUND ELECTRODE SYSTEMS. USE OF OTHER METHODS MUST BE PRE-APPROVED BY THE ENGINEER IN WRITING.
4. THE CONTRACTOR SHALL FURNISH AND INSTALL SUPPLEMENTAL GROUND ELECTRODES AS NEEDED TO ACHIEVE A TEST RESULT OF 5 OHMS OR LESS ON TOWER SITES AND 10 OHMS OR LESS ON ROOFTOP SITES. WHEN ADDING ELECTRODES, CONTRACTOR SHALL MAINTAIN A MINIMUM DISTANCE BETWEEN THE ADDED ELECTRODE AND ANY OTHER EXISTING ELECTRODE EQUAL TO THE BURIED LENGTH OF THE ROD. IDEALLY, CONTRACTOR SHALL STRIVE TO KEEP THE SEPARATION DISTANCE EQUAL TO TWICE THE BURIED LENGTH OF THE RODS.
5. THE CONTRACTOR IS RESPONSIBLE FOR PROPERLY SEQUENCING GROUNDING AND UNDERGROUND CONDUIT INSTALLATION AS TO PREVENT ANY LOSS OF CONTINUITY IN THE GROUNDING SYSTEM OR DAMAGE TO THE CONDUIT.
6. METAL CONDUIT AND TRAY SHALL BE GROUNDING AND MADE ELECTRICALLY CONTINUOUS WITH LISTED BONDING FITTINGS OR BY BONDING ACROSS THE DISCONTINUITY WITH 6 AWG COPPER WIRE AND UL APPROVED GROUNDING TYPE CONDUIT CLAMPS.
7. METAL RACEWAY SHALL NOT BE USED AS THE NEC REQUIRED EQUIPMENT GROUND CONDUCTOR. STRANDED COPPER CONDUCTORS WITH GREEN INSULATION, SIZED IN ACCORDANCE WITH THE NEC, SHALL BE FURNISHED AND INSTALLED WITH THE POWER CIRCUITS TO TRANSMISSION EQUIPMENT.
8. CONNECTIONS TO THE GROUND BUS SHALL NOT BE DOUBLED UP OR STACKED. BACK-TO-BACK CONNECTIONS ON OPPOSITE SIDES OF THE GROUND BUS ARE PERMITTED.
9. ALUMINUM CONDUCTOR OR COPPER CLAD STEEL CONDUCTOR SHALL NOT BE USED FOR GROUNDING CONNECTIONS.
10. USE OF 90° BENDS IN THE PROTECTION GROUNDING CONDUCTORS SHALL BE AVOIDED WHEN 45° BENDS CAN BE ADEQUATELY SUPPORTED. IN ALL CASES, BENDS SHALL BE MADE WITH A MINIMUM BEND RADIUS OF 8 INCHES.
11. EACH INTERIOR TRANSMISSION CABINET FRAME/PLINTH SHALL BE DIRECTLY CONNECTED TO THE MASTER GROUND BAR WITH 6 AWG STRANDED, GREEN INSULATED SUPPLEMENTAL EQUIPMENT GROUND WIRE UNLESS NOTED OTHERWISE IN THE DETAILS. EACH OUTDOOR CABINET FRAME/PLINTH SHALL BE DIRECTLY CONNECTED TO THE BURIED GROUND RING WITH 2 AWG SOLID TIN-PLATED COPPER WIRE UNLESS NOTED OTHERWISE IN THE DETAILS.
12. ALL EXTERIOR GROUND CONDUCTORS BETWEEN EQUIPMENT/GROUND BARS AND THE GROUND RING, SHALL BE 2 AWG SOLID TIN-PLATED COPPER UNLESS OTHERWISE INDICATED.
13. EXOTHERMIC WELDS SHALL BE USED FOR ALL GROUNDING CONNECTIONS BELOW GRADE. CONNECTIONS TO ABOVE GRADE UNITS SHALL BE MADE WITH EXOTHERMIC WELDS WHERE PRACTICAL OR WITH 2-HOLE MECHANICAL TYPE BRASS CONNECTORS WITH STAINLESS STEEL HARDWARE, INCLUDING SET SCREWS. HIGH PRESSURE CRIMP CONNECTORS MAY ONLY BE USED WITH WRITTEN PERMISSION FROM T-MOBILE MARKET REPRESENTATIVE.
14. EXOTHERMIC WELDS SHALL BE PERMITTED ON TOWERS ONLY WITH THE EXPRESS APPROVAL OF THE TOWER MANUFACTURER OR THE CONTRACTOR'S STRUCTURAL ENGINEER.
15. ALL WIRE TO WIRE GROUND CONNECTIONS TO THE INTERIOR GROUND RING SHALL BE FORMED USING HIGH PRESS CRIMPS OR SPLIT BOLT CONNECTORS WHERE INDICATED IN THE DETAILS.
16. ON ROOFTOP SITES WHERE EXOTHERMIC WELDS ARE A FIRE HAZARD COPPER COMPRESSION CAP CONNECTORS MAY BE USED FOR WIRE TO WIRE CONNECTIONS. 2-HOLE MECHANICAL TYPE BRASS CONNECTORS WITH STAINLESS STEEL HARDWARE, INCLUDING SET SCREWS SHALL BE USED FOR CONNECTION TO ALL ROOFTOP TRANSMISSION EQUIPMENT AND STRUCTURAL STEEL.
17. COAX BRIDGE BONDING CONDUCTORS SHALL BE EXOTHERMICALLY BONDED OR BOLTED TO THE BRIDGE AND THE TOWER GROUND BAR USING TWO-HOLE MECHANICAL TYPE BRASS CONNECTORS AND STAINLESS STEEL HARDWARE.
18. APPROVED ANTIOXIDANT COATINGS (I.E., CONDUCTIVE GEL OR PASTE) SHALL BE USED ON ALL COMPRESSION AND BOLTED GROUND CONNECTIONS.
19. ALL EXTERIOR GROUND CONNECTIONS SHALL BE COATED WITH A CORROSION RESISTANT MATERIAL.
20. MISCELLANEOUS ELECTRICAL AND NON-ELECTRICAL METAL BOXES, FRAMES AND SUPPORTS SHALL BE BONDED TO THE GROUND RING, IN ACCORDANCE WITH THE NEC.
21. BOND ALL METALLIC OBJECTS WITHIN 6 FT OF THE BURIED GROUND RING WITH 2 AWG SOLID TIN-PLATED COPPER GROUND CONDUCTOR. DURING EXCAVATION FOR NEW GROUND CONDUCTORS, IF EXISTING GROUND CONDUCTORS ARE ENCOUNTERED, BOND EXISTING GROUND CONDUCTORS TO NEW CONDUCTORS.
22. GROUND CONDUCTORS USED IN THE FACILITY GROUND AND LIGHTNING PROTECTION SYSTEMS SHALL NOT BE ROUTED THROUGH METALLIC OBJECTS THAT FORM A RING AROUND THE CONDUCTOR, SUCH AS METALLIC CONDUITS, METAL SUPPORT CLIPS OR SLEEVES THROUGH WALLS OR FLOORS. WHEN IT IS REQUIRED TO BE HOUSED IN CONDUIT TO MEET CODE REQUIREMENTS OR LOCAL CONDITIONS, NON-METALLIC MATERIAL SUCH AS PVC PLASTIC CONDUIT SHALL BE USED. WHERE USE OF METAL CONDUIT IS UNAVOIDABLE (E.G., NON-METALLIC CONDUIT PROHIBITED BY LOCAL CODE) THE GROUND CONDUCTOR SHALL BE BONDED TO EACH END OF THE METAL CONDUIT WITH LISTED BONDING FITTINGS.

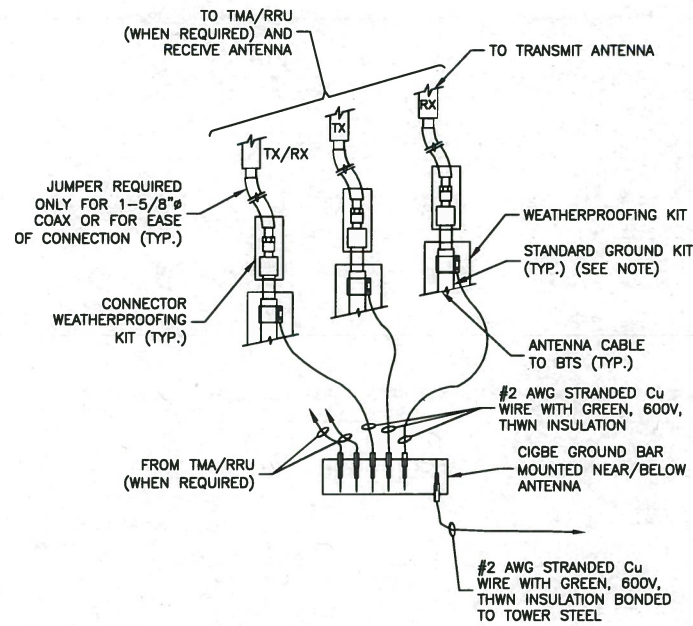

NOTE:

1. DO NOT INSTALL CABLE GROUND KIT AT A BEND AND ALWAYS DIRECT GROUND WIRE DOWN TO CIGBE.

CONNECTION OF GROUND WIRES TO GROUNDING BAR (CIGBE)

SCALE: N.T.S.

1

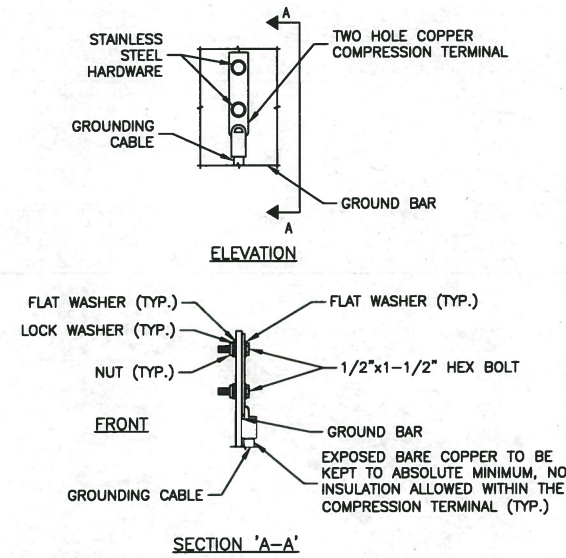

NOTES:

1. DOUBLING UP OR STACKING OF CONNECTIONS IS NOT PERMITTED.
2. OXIDE INHIBITING COMPOUND TO BE USED AT ALL LOCATIONS.

TYPICAL GROUND BAR MECHANICAL CONNECTION DETAIL

SCALE: N.T.S.

2

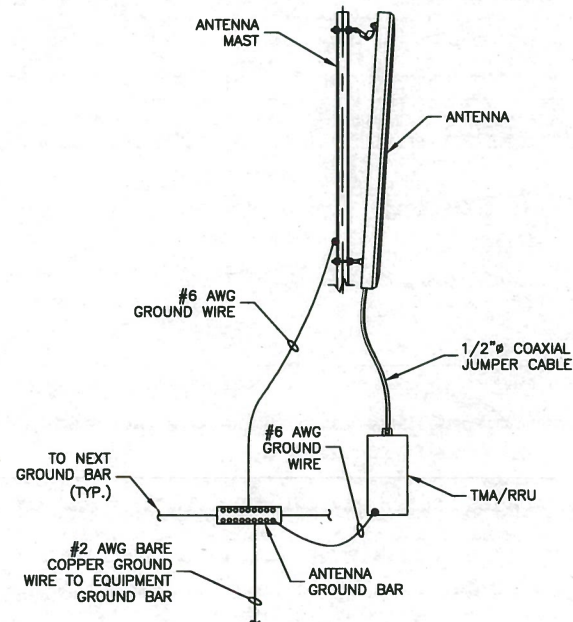

TYPICAL ANTENNA GROUNDING DETAIL

SCALE: N.T.S.

3

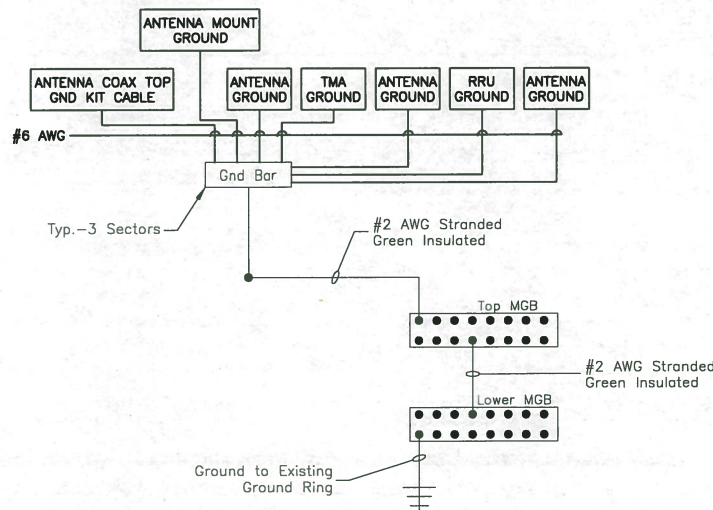

NOTES:

1. BOND ANTENNA GROUNDING KIT CABLE TO TOP CIGBE
2. BOND ANTENNA GROUNDING KIT CABLE TO BOTTOM CIGBE.
3. SCHEMATIC GROUNDING DIAGRAM IS TYPICAL FOR EACH SECTOR.
4. VERIFY EXISTING GROUND SYSTEM IS INSTALLED PER T-MOBILE STANDARDS.

SCHEMATIC GROUNDING DIAGRAM

SCALE: N.T.S.

4



T-MOBILE NORTHEAST LLC
35 GRIFFIN ROAD SOUTH
BLOOMFIELD, CT 06002



CROWN CASTLE
3 CORPORATE PARK DRIVE, SUITE 101
CLIFTON PARK, NY 12065

CT11711A
HRT 084 943242

CONSTRUCTION DRAWINGS

NO.	DATE	DESCRIPTION
0	08/07/16	ISSUED AS FINAL
B	08/06/16	REVISED PER COMMENTS
A	08/18/16	ISSUED FOR REVIEW



Dewberry Engineers Inc.
600 PARSIPPANY ROAD
SUITE 301
PARSIPPANY, NJ 07054
PHONE: 973.739.9400
FAX: 973.739.9710

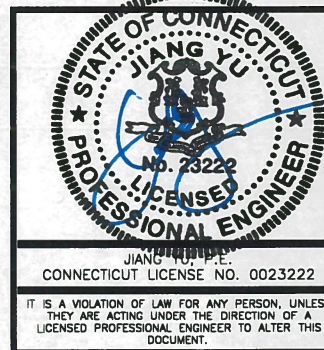

DRAWN BY:	JC
REVIEWED BY:	BSH
CHECKED BY:	GHN
PROJECT NUMBER:	50066258
JOB NUMBER:	50078130
SITE ADDRESS:	

197 SOUTH STREET,
VERNON, CT 06066
TOLLAND COUNTY

SHEET TITLE

GROUNDING NOTES & DETAILS

SHEET NUMBER

Date: **August 9, 2016**

Kevin Morrow
Crown Castle
3530 Toringdon Way, Suite 300
Charlotte, NC 28277
(704) 405-6619



SSOE Group
320 Seven Springs Way, Suite 350
Brentwood, TN 37027
(615) 661-7585
djones@ssoe.com

Subject: **Structural Analysis Report**

Carrier Designation: **T-Mobile Co-Locate**
Carrier Site Name: Crown Castle SST
Carrier Site Number: CT11711A

Crown Castle Designation: **Crown Castle BU Number:** 806377
Crown Castle Site Name: HRT 084 943242
Crown Castle JDE Job Number: 390887
Crown Castle Work Order Number: 1280362
Crown Castle Application Number: 357603 Rev. 0

Engineering Firm Designation: **SSOE Group Project Number:** 016-00010-00 BC 1774

Site Data: **197 South Street, Vernon, CT 06066, Tolland County**
Latitude 41° 51' 12.51", Longitude -72° 27' 7.52"
132 Foot – Modified Rohn Self Support Tower

Dear Mr. Kevin Morrow,

SSOE Group is pleased to submit this “**Structural Analysis Report**” to determine the structural integrity of the above mentioned tower. This analysis has been performed in accordance with the Crown Castle Structural ‘Statement of Work’ and the terms of Crown Castle Purchase Order Number 933628, in accordance with application 357603, revision 0.

The purpose of the analysis is to determine acceptability of the tower stress level. Based on our analysis we have determined the tower stress level for the structure and foundation, under the following load case, to be:

LC7: Existing + Reserved + Proposed Equipment

Sufficient Capacity

Note: See Table I and Table II for the proposed and existing/reserved loading, respectively.

This analysis has been performed in accordance with the TIA/EIA-222-F standard and 2005 CT State Building Code with 2009 amendment based upon a wind speed of 85 mph fastest mile.

We at SSOE Group appreciate the opportunity of providing our continuing professional services to you and Crown Castle. If you have any questions or need further assistance on this or any other projects please give us a call.

Structural analysis prepared by: Dominique E. Jones

Respectfully submitted by:

Barry W. Burgess, PE
Section Manager



TABLE OF CONTENTS

1) INTRODUCTION

2) ANALYSIS CRITERIA

Table 1 - Proposed Antenna and Cable Information

Table 2 - Existing and Reserved Antenna and Cable Information

Table 3 - Design Antenna and Cable Information

3) ANALYSIS PROCEDURE

Table 4 - Documents Provided

3.1) Analysis Method

3.2) Assumptions

4) ANALYSIS RESULTS

Table 5 - Section Capacity (Summary)

Table 6 – Tower Component Stresses vs. Capacity

4.1) Recommendations

5) DISCLAIMER OF WARRANTIES

6) APPENDIX A

tnxTower Output

7) APPENDIX B

Base Level Drawing

8) APPENDIX C

Additional Calculations

1) INTRODUCTION

The existing 132' tower is supported on three legs and has seven major sections. It has a triangular cross section made of bolted connections, with an "X" frame configuration. The tower is fabricated with pipe legs and angle diagonals.

The tower was originally designed for Motorola, Inc. and Metro Mobile CTS by Rohn in accordance with E.I.A. Zone "A" with 0.5" radial ice.

Modifications designed by L&W Engineering (W.O. #: 2106-2, dated 10/31/95), which consisted of replacing tower diagonals from the 100.0' to 120.0' elevations, have been considered.

Modifications designed by SSOE Group (Project #: 015-00428-01, WO #: 1059741, dated 05/15/15), which consisted of installing secondary horizontals from 0.0' to 10.0' and 80.0' to 86.7' elevations, have been considered.

2) ANALYSIS CRITERIA

The structural analysis was performed for this tower in accordance with the requirements of TIA/EIA-222-F Structural Standards for Steel Antenna Towers and Antenna Supporting Structures using a fastest mile wind speed of 85 mph with no ice, 28 mph with 1.0" ice thickness and 50 mph under service loads.

Table 1 - Proposed Antenna and Cable Information

Mounting Level (ft)	Center Line Elevation (ft)	Number of Antennas	Antenna Manufacturer	Antenna Model	Number of Feed Lines	Feed Line Size (in)	Note
84.0	84.0	3	Andrew	LNX-6515DS-A1M w/ Mount Pipe			
		3	Ericsson	RRUS 11 B12			

Table 2 - Existing and Reserved Antenna and Cable Information

Mounting Level (ft)	Center Line Elevation (ft)	Number of Antennas	Antenna Manufacturer	Antenna Model	Number of Feed Lines	Feed Line Size (in)	Note
130.0	141.0	1	Decibel	DB413-B			
	130.0	3	Alcatel Lucent	TD-RRH8x20-25			
		3	RFS Celwave	APXVTM14-C-120 w/ Mount Pipe	3	1-1/4	
		3	RFS Celwave	APXVSPP18-C-A20 w/ Mount Pipe	1	5/8	
		3	Alcatel Lucent	800MHz 2X50W RRH W/FILTER	2	7/8	
		3	Alcatel Lucent	1900MHz RRH (65MHz)			
		1		T- Arm Mount [TA 702-3]			

Mounting Level (ft)	Center Line Elevation (ft)	Number of Antennas	Antenna Manufacturer	Antenna Model	Number of Feed Lines	Feed Line Size (in)	Note
117.0	118.0	6	RFS Celwave	FD9R6004/2C-3L			
	117.0	3	Alcatel Lucent	RRH2X60-PCS	1	1-5/8	1
		3	Alcatel Lucent	RRH2x60-700			
		3	Alcatel Lucent	RRH2x60-AWS			
		6	Andrew	SBNHH-1D65B w/ Mount Pipe			
		1	Antel	BXA-70063-6CF-2 w/ Mount Pipe	12 1	7/8 1-5/8	
		1	RFS Celwave	DB-T1-6Z-8AB-0Z			
		2	Andrew	LBX-6515DS-T0M w/ Mount Pipe			
		2	Andrew	LNx-6514DS-T4M w/ Mount Pipe			
		1	Andrew	LNx-6514DS-T6M w/ Mount Pipe			
		1	RFS Celwave	DB-T1-6Z-8AB-0Z			
		1		Sector Mount [SM 504-3]			
104.0	106.0	2	CCI Antennas	HPA-65R-BUU-H6	1 2	3/8 7/8	1
		1	CCI Antennas	HPA-65R-BUU-H8			
		3	Communication Components	DTMABP7819VG12A			
		1	Raycap	DC6-48-60-18-8F			
		3	Ericsson	RRUS-11			
		3	Ericsson	RRUS 32			
		3	Kathrein	806 10025			
		1	Raycap	DC6-48-60-18-8F	1 2 12	3/8 3/4 7/8	
		1	Andrew	SBNH-1D6565C w/ Mount Pipe			
		3	Communication Components	DTMABP7819VG12A			
		6	Kathrein	782-10250			
		3	Kathrein	800 10121 w/ Mount Pipe			
		2	KMW Communications	AM-X-CD-16-65-00T-RET w/ Mount Pipe			
	3	Ericsson	RRUS-11				
	104.0	1		Sector Mount [SM 504-3]			
94.0	94.0	3	Kathrein	742 213 w/ Mount Pipe	6	1-5/8	
84.0	84.0				6	7/8	2
		3	Ericsson	ERICSSON AIR 21 B2A B4P w/ Mount Pipe	1 6	1-5/8 7/8	
		3	Ericsson	ERICSSON AIR 21 B4A B2P w/ Mount Pipe			
		3	Ericsson	KRY 112 144/1			
		1		Sector Mount [SM 308-3]			

Mounting Level (ft)	Center Line Elevation (ft)	Number of Antennas	Antenna Manufacturer	Antenna Model	Number of Feed Lines	Feed Line Size (in)	Note
63.0	63.0	1	Maxrad	MPRC2449	2	3/8	
		1	Redline Communications	RDL-3000			
		1		Side Arm Mount [SO 311-1]			
56.0	59.0	1	Maxrad	GPS-TMG-20N	1	1/2	
	56.0	1		Side Arm Mount [SO 311-1]			
46.0	47.0	1	Lucent	KS24019-L112A	1	1/2	
	46.0	1		Side Arm Mount [SO 701-1]			

Notes:

- 1) Reserved loading.
- 2) Existing equipment to be removed; has not been considered in analysis.

Table 3 - Design Antenna and Cable Information

Mounting Level (ft)	Center Line Elevation (ft)	Number of Antennas	Antenna Manufacturer	Antenna Model	Number of Feed Lines	Feed Line Size (in)
127.0	127.0	4	Celwave	PD10017	-	-
		4	Generic	3' Side Arm Mount	-	-
124.0	124.0	2	Generic	8' Ø STD Dishes	-	-
112.0	112.0	6	Celwave	PD1132	-	-
		3	Generic	6' Side Arm Mount	-	-
80.0	80.0	1	Celwave	PD1109	-	-
		1	Generic	6' Side Arm Mount	-	-

3) ANALYSIS PROCEDURE

Table 4 - Documents Provided

Document	Remarks	Reference	Source
Original Tower Drawings	Rohn File #: 22731JC, dated 7/24/87	Doc ID#: 529704	Crown DMZ
Foundation Mapping	FDH Engineering Project #: 1310781500, dated 07/18/13	Doc ID#: 1014812	Crown DMZ
Geotechnical Reports	FDH Engineering Project #: 04-1212E, dated 12/30/04	Doc ID#: 1014866	Crown DMZ
Modification Drawings	L&W Engineering Work Order #: 2106-2, dated 10/31/95	Doc ID#: 2240842	Crown DMZ
Modification Inspection	Engineered Tower Solutions, PLLC. Project #: 150657, dated 8/19/15	Doc ID#: 5849707	Crown DMZ

3.1) Analysis Method

tnxTower (version 7.0.5.1), a commercially available analysis software package, was used to create a three-dimensional model of the tower and calculate member stresses for various loading cases. Selected output from the analysis is included in Appendix A.

3.2) Assumptions

- 1) The tower and foundation were constructed in accordance with their original design and maintained per the manufacturer's specifications, are in good condition, and the tower is twist free and plumb.
- 2) All member connections are assumed to have been designed to meet or exceed the load carrying capacity of the connected member unless otherwise specified in this report.
- 3) All equipment model numbers, quantities, and centerline elevations are as provided in the CCI CAD package, dated 8/19/15 with any adjustments as noted below.

This analysis may be affected if any assumptions are not valid or have been made in error. SSOE Group should be notified to determine the effect on the structural integrity of the tower.

4) ANALYSIS RESULTS

Table 5 - Section Capacity (Summary)

Section No.	Elevation (ft)	Component Type	Size	Critical Element	P (K)	SF*P_allow (K)	% Capacity	Pass / Fail
T1	132 - 124	Leg	ROHN 2 STD	2	-3.01	32.30	9.3	Pass
T2	124 - 120	Leg	ROHN 2 STD	20	-5.54	32.30	17.1	Pass
T3	120 - 100	Leg	ROHN 2.5 STD	29	-30.49	50.25	60.7	Pass
T4	100 - 93.3333	Leg	ROHN 3 STD	59	-40.48	62.82	64.4	Pass
T5	93.3333 - 86.6667	Leg	ROHN 3 STD	68	-51.08	62.82	81.3	Pass
T6	86.6667 - 80	Leg	ROHN 3 STD	77	-61.86	78.55	78.8	Pass
T7	80 - 60	Leg	ROHN 3 XX-STR	89	-95.54	143.51	66.6	Pass
T8	60 - 40	Leg	ROHN 4 X-STR	110	-125.69	139.07	90.4	Pass
T9	40 - 20	Leg	ROHN 5 X-STR	131	-151.38	177.46	85.3	Pass
T10	20 - 10	Leg	ROHN 5 X-STR	146	-165.19	177.46	93.1	Pass
T11	10 - 0	Leg	ROHN 5 X-STR	155	-177.34	217.53	81.5 90.7 (b)	Pass
T1	132 - 124	Diagonal	L1 3/4x1 3/4x3/16	9	-1.44	7.67	18.7 27.0 (b)	Pass
T2	124 - 120	Diagonal	L1 3/4x1 3/4x3/16	25	-1.32	7.65	17.3 23.7 (b)	Pass
T3	120 - 100	Diagonal	L2x2x3/16	36	-4.68	6.70	69.9 73.0 (b)	Pass
T4	100 - 93.3333	Diagonal	L2 1/2x2 1/2x3/16	64	-5.40	10.06	53.7 73.9 (b)	Pass
T5	93.3333 - 86.6667	Diagonal	L2 1/2x2 1/2x3/16	72	-5.37	9.14	58.7 73.6 (b)	Pass
T6	86.6667 - 80	Diagonal	L2 1/2x2 1/2x3/16	81	-6.62	7.99	82.8 88.6 (b)	Pass
T7	80 - 60	Diagonal	L2 1/2x2 1/2x3/16	93	-6.29	6.32	99.6	Pass
T8	60 - 40	Diagonal	L3x3x3/16	114	-6.68	8.79	76.0 80.8 (b)	Pass
T9	40 - 20	Diagonal	L3x3x1/4	135	-7.60	7.82	97.2	Pass
T10	20 - 10	Diagonal	L3 1/2x3 1/2x1/4	151	-7.66	11.56	66.2 69.8 (b)	Pass
T11	10 - 0	Diagonal	L3 1/2x3 1/2x1/4	159	-8.04	10.33	77.8	Pass
T6	86.6667 - 80	Secondary	L1 1/2x1 1/2x3/16	85	-1.07	6.02	17.8	Pass

Section No.	Elevation (ft)	Component Type	Size	Critical Element	P (K)	SF*P_allow (K)	% Capacity	Pass / Fail
		Horizontal					25.2 (b)	
T11	10 - 0	Secondary Horizontal	L2 1/2x2 1/2x3/16	163	-3.08	9.53	32.3 45.3 (b)	Pass
T1	132 - 124	Top Girt	L2x2x3/16	6	-0.09	4.03	2.2	Pass
T3	120 - 100	Top Girt	L2x2x3/16	33	-0.18	5.10	3.5	Pass
							Summary	
							Leg (T10)	93.1 Pass
							Diagonal (T7)	99.6 Pass
							Secondary Horizontal (T11)	45.3 Pass
							Top Girt (T3)	3.5 Pass
							Bolt Checks	90.7 Pass
							Rating =	99.6 Pass

Table 6 - Tower Component Stresses vs. Capacity – LC7

Notes	Component	Elevation (ft)	% Capacity	Pass / Fail
1	Foundation (Structural)		20.7%	Pass
1	Foundation (Soil Interaction)		97.4%	Pass
	Anchor Rods		90.7%	Pass

Structure Rating (max from all components) =	99.6%
---	--------------

Notes:

- See additional documentation in "Appendix C – Additional Calculations" for calculations supporting the % capacity consumed.

4.1) Recommendations

The existing tower and its foundations are sufficient for the proposed loads and do not require modifications.

5) DISCLAIMER OF WARRANTIES

SSOE Group has not performed a site visit to the tower to verify member sizes or antenna/coax loading. SSOE Group shall be contacted immediately if the existing conditions are not as represented on the tower elevation contained in this report in order to evaluate the significance of the discrepancy. SSOE Group has not performed a condition assessment of the tower foundation. This report does not replace a full tower inspection

The engineering services rendered by SSOE Group in connection with this structural analysis are limited to an analysis of the tower structure and theoretical capacity of its main structural members. Miscellaneous items such as antenna mounts, etc., have not been designed or detailed as part of our work. We recommend that material of suitable size and strength be purchased from a reputable tower manufacturer.

SSOE Group makes no warranties, expressed and/or implied, in connection with this report and disclaims any liability arising from material, fabrication, and erection of this tower. SSOE Group will not be responsible whatsoever for, or on account of, consequential or incidental damages sustained by any person, firm, or organization as a result of any data contained in this report. The maximum liability of SSOE Group pursuant to this report will be limited to the total fee received for preparation of this report.

APPENDIX A
TNXTOWER OUTPUT

SYMBOL LIST

MARK	SIZE	MARK	SIZE
A	L1 1/2x1 1/2x3/16		

MATERIAL STRENGTH

GRADE	Fy	Fu	GRADE	Fy	Fu
A572-50	50 ksi	65 ksi	A36	36 ksi	58 ksi

TOWER DESIGN NOTES

1. Tower is located in Tolland County, Connecticut.
2. Tower designed for a 85 mph basic wind in accordance with the TIA/EIA-222-F Standard.
3. Tower is also designed for a 28 mph basic wind with 1.00 in ice. Ice is considered to increase in thickness with height.
4. Deflections are based upon a 50 mph wind.
5. TOWER RATING: 99.6%

Section	T1	T2	T3	T4	T5	T6	T7	T8	T9	T10	T11
Legs	ROHN 2 STD	ROHN 2.5 STD	ROHN 3 STD	ROHN 3 STD	ROHN 3 STD	ROHN 3 XX-STR	ROHN 4 X-STR	ROHN 4 X-STR	ROHN 5 X-STR	ROHN 5 X-STR	
Leg Grade	L1 3/4x1 3/4x3/16	L2x2x3/16	L2x2x3/16	L2x2x3/16	L2x2x3/16	L2 1/2x2 1/2x3/16	L3x3x3/16	L3x3x3/16	L3x3x1/4	L3 1/2x3 1/2x1/4	L2 1/2x2 1/2x3/16
Diagonals											
Diagonal Grade											
Top Girts											
Sec. Horizontals											
Face Width (ft)	6.60417	6.64583	6.63194	8.8875	9.35417	10.0208	10.6875	12.7804	14.7708	16.7708	17.7708
# Panels @ (ft)	3 @ 4	4 @ 5	4 @ 5	1.0	0.4	0.4	0.5	2.0	2.0	2.5	1.4
Weight (K)	0.3	0.1	0.1	0.4	0.4	0.5	2.0	2.0	2.5	1.4	12.1

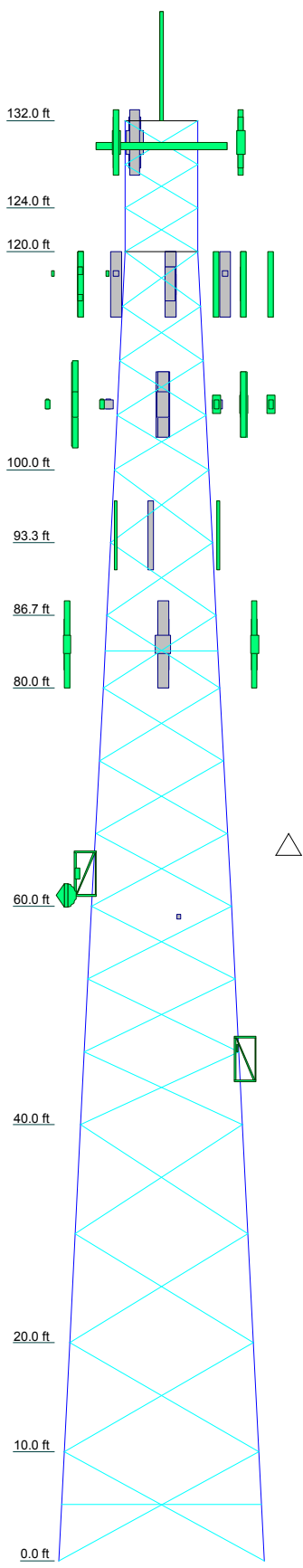

MAX. CORNER REACTIONS AT BASE:

DOWN: 184 K
SHEAR: 21 K

UPLIFT: -156 K
SHEAR: 18 K

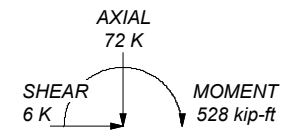

TORQUE 3 kip-ft
28 mph WIND - 1.00 in ICE

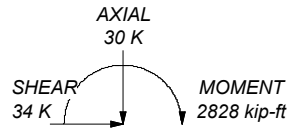

TORQUE 23 kip-ft
REACTIONS - 85 mph WIND

SSOE™ **SSOE Group**
 320 Seven Springs Way, Suite 350
 Brentwood, TN 37027
 Phone: (615) 661-7585
 FAX: (615) 661-7569

making clients successful by saving them time, trouble, and money

Job: BU 806377 HRT 084 943242		
Project: 016-00010-00		
Client: CCI	Drawn by: 15310	App'd:
Code: TIA/EIA-222-F	Date: 08/09/16	Scale: NTS
Path: G:\DEPT\Telecom\Crown Castle\Current Projects\DJ Projects\SA806377\TX\806377.dwg		Dwg No. E-1

DESIGNED APPURTENANCE LOADING

TYPE	ELEVATION	TYPE	ELEVATION
3" x 10" mount pipe	137	RRUS 32	104
APXVSP18-C-A20 w/ Mount Pipe	130	800 10121 w/ Mount Pipe	104
APXVTM14-C-120 w/ Mount Pipe	130	HPA-65R-BUU-H6 w/ Mount Pipe	104
1900MHZ RRH (65MHz)	130	AM-X-CD-16-65-00T-RET w/ Mount Pipe	104
800MHZ 2x50W RRH W/FILTER	130	(2) 782-10250	104
TD-RRH8x20-25	130	(3) RRUS-11	104
APXVSP18-C-A20 w/ Mount Pipe	130	(2) DTMABP7819VG12A	104
APXVTM14-C-120 w/ Mount Pipe	130	860 10025	104
800MHZ 2x50W RRH W/FILTER	130	RRUS 32	104
1900MHZ RRH (65MHz)	130	DC6-48-60-18-8F	104
TD-RRH8x20-25	130	800 10121 w/ Mount Pipe	104
DB413-B	130	HPA-65R-BUU-H8 w/ Mount Pipe	104
APXVSP18-C-A20 w/ Mount Pipe	130	SBNH-1D6565C w/ Mount Pipe	104
APXVTM14-C-120 w/ Mount Pipe	130	(2) 782-10250	104
800MHZ 2x50W RRH W/FILTER	130	(2) DTMABP7819VG12A	104
1900MHZ RRH (65MHz)	130	RRUS-11	104
TD-RRH8x20-25	130	860 10025	104
T-Arm Mount [TA 702-3]	130	RRUS 32	104
LBX-6515DS-T0M w/ Mount Pipe	117	Sector Mount [SM 504-3]	104
LNx-6514DS-T4M w/ Mount Pipe	117	742 213 w/ Mount Pipe	94
(2) SBNH-1D65B w/ Mount Pipe	117	742 213 w/ Mount Pipe	94
(2) FD9R6004/2C-3L	117	742 213 w/ Mount Pipe	94
DB-T1-6Z-8AB-0Z	117	ERICSSON AIR 21 B2A B4P w/ Mount Pipe	84
RRH2x60-AWS	117	ERICSSON AIR 21 B4A B2P w/ Mount Pipe	84
RRH2x60-PCS	117	LNx-6515DS-A1M w/ Mount Pipe	84
RRH2x60-700	117	KRY 112 144/1	84
LBX-6515DS-T0M w/ Mount Pipe	117	RRUS 11 B12	84
LNx-6514DS-T4M w/ Mount Pipe	117	ERICSSON AIR 21 B2A B4P w/ Mount Pipe	84
(2) FD9R6004/2C-3L	117	ERICSSON AIR 21 B4A B2P w/ Mount Pipe	84
(2) SBNH-1D65B w/ Mount Pipe	117	LNx-6515DS-A1M w/ Mount Pipe	84
RRH2x60-AWS	117	KRY 112 144/1	84
DB-T1-6Z-8AB-0Z	117	RRUS 11 B12	84
RRH2x60-700	117	ERICSSON AIR 21 B2A B4P w/ Mount Pipe	84
RRH2x60-PCS	117	ERICSSON AIR 21 B4A B2P w/ Mount Pipe	84
LNx-6514DS-T6M w/ Mount Pipe	117	LNx-6515DS-A1M w/ Mount Pipe	84
SBNH-1D65B w/ Mount Pipe	117	KRY 112 144/1	84
BXA-70063-6CF-2 w/ Mount Pipe	117	RRUS 11 B12	84
SBNH-1D65B w/ Mount Pipe	117	ERICSSON AIR 21 B2A B4P w/ Mount Pipe	84
(2) FD9R6004/2C-3L	117	ERICSSON AIR 21 B4A B2P w/ Mount Pipe	84
RRH2x60-AWS	117	LNx-6515DS-A1M w/ Mount Pipe	84
RRH2x60-700	117	KRY 112 144/1	84
RRH2x60-PCS	117	RRUS 11 B12	84
Sector Mount [SM 504-3]	117	Sector Mount [SM 308-3]	84
800 10121 w/ Mount Pipe	104	RDL-3000	63
HPA-65R-BUU-H6 w/ Mount Pipe	104	Side Arm Mount [SO 311-1]	63
AM-X-CD-16-65-00T-RET w/ Mount Pipe	104	MPRC2449	61
(2) 782-10250	104	Side Arm Mount [SO 311-1]	56
(2) RRUS-11	104	GPS-TMG-20N	56
DC6-48-60-18-8F	104	Side Arm Mount [SO 701-1]	46
(2) DTMABP7819VG12A	104	KS24019-L112A	46
860 10025	104		

MAX. C
DOV
SHE

UPL SHE

MARK	SIZE	MARK	SIZE
A	L1 1/2x1 1/2x3/16		

MATERIAL STRENGTH

GRADE	Fy	Fu	GRADE	Fy	Fu
A572-50	50 ksi	65 ksi	A36	36 ksi	58 ksi

- TOWER DESIGN NOTES**
1. Tower is located in Tolland County, Connecticut.
 2. Tower designed for a 85 mph basic wind in accordance with the TIA/EIA-222-F Standard.
 3. Tower is also designed for a 28 mph basic wind with 1.00 in ice. Ice is considered to increase in thickness with height.
 4. Deflections are based upon a 50 mph wind.
 5. TOWER RATING: 99.6%
- TORQUE 23 kip-ft
REACTIONS - 85 mph WIND

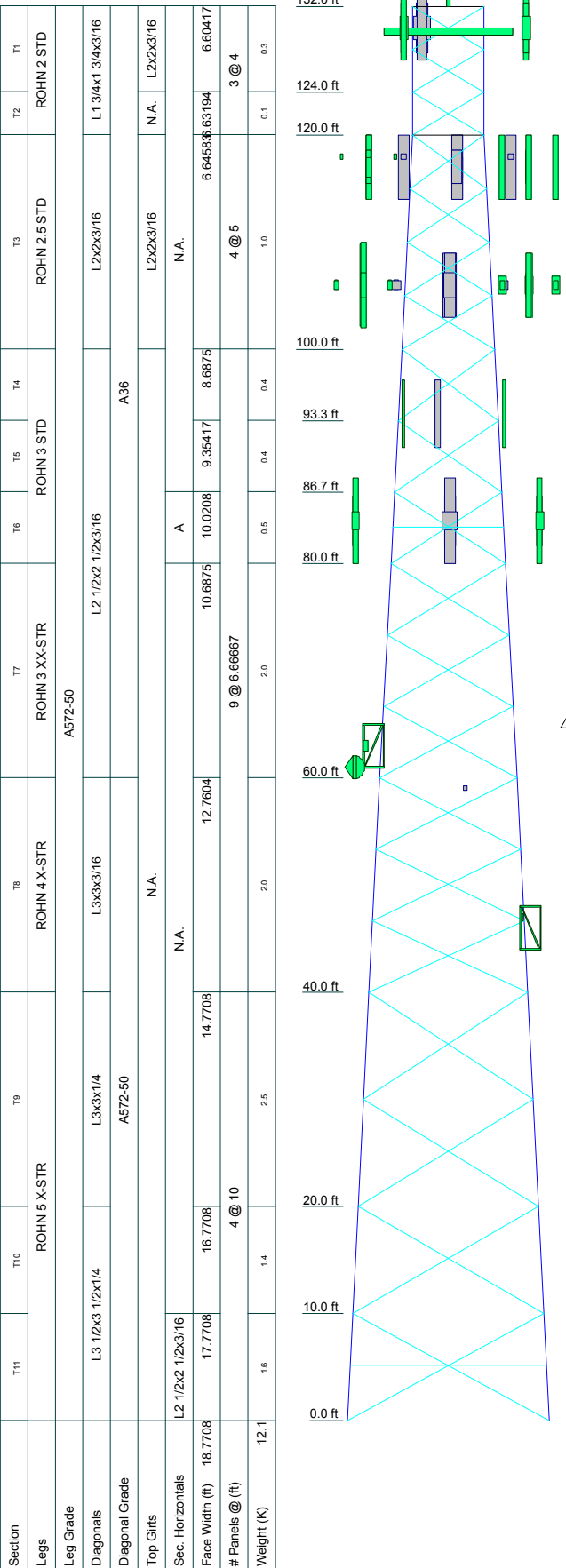

Section	T1	T2	T3	T4	T5	T6	T7	T8	T9	T10	T11
Legs	ROHN 2 STD	ROHN 2.5 STD	ROHN 3 STD	ROHN 3 X-STR	ROHN 4 X-STR	ROHN 5 X-STR	A572-50	A572-50	A572-50	A572-50	A572-50
Diagonals	L1 3/4x1 3/4x3/16	L2x2x3/16	L2x2x3/16	L2 1/2x2 1/2x3/16	L3x3x3/16	L3x3x1/4	L3 1/2x3 1/2x1/4	L3x3x1/4	L3x3x1/4	L3 1/2x3 1/2x1/4	L3 1/2x3 1/2x1/4
Top Girts	L2x2x3/16	L2x2x3/16	L2x2x3/16	L2x2x3/16	L2x2x3/16	L2x2x3/16	L2x2x3/16	L2x2x3/16	L2x2x3/16	L2x2x3/16	L2x2x3/16
Sec. Horizontals	N.A.	N.A.	N.A.	N.A.	N.A.	N.A.	N.A.	N.A.	N.A.	N.A.	N.A.
Face Width (ft)	6.60417	6.64583	6.63194	8.8875	9.35417	10.0208	10.6875	12.7804	14.7708	16.7708	17.7708
# Panels @ (ft)	3 @ 4	4 @ 5	9 @ 6.66667	2.0	2.0	2.0	2.0	2.0	2.0	2.0	2.0
Weight (K)	0.3	0.1	1.0	0.4	0.4	0.5	0.4	0.4	0.4	0.4	0.4

<p>making clients successful by saving them time, trouble, and money</p>	<p>SSOE Group</p> <p>320 Seven Springs Way, Suite 350 Brentwood, TN 37027 Phone: (615) 661-7585 FAX: (615) 661-7569</p>	<p>Job: BU 806377 HRT 084 943242</p> <p>Project: 016-00010-00</p>
	<p>Client: CCI</p> <p>Code: TIA/EIA-222-F</p> <p>Path: G:\DEPT\Telecom\Crown Castle\Current Projects\DJ Projects\SAI806377\806377.dwg</p>	<p>Drawn by: 15310</p> <p>Date: 08/10/16</p> <p>Dwg No. E-1</p>

Feed Line Distribution Chart

0' - 132'

— Round
 — Flat
 — App In Face
 — App Out Face
 — Truss Leg

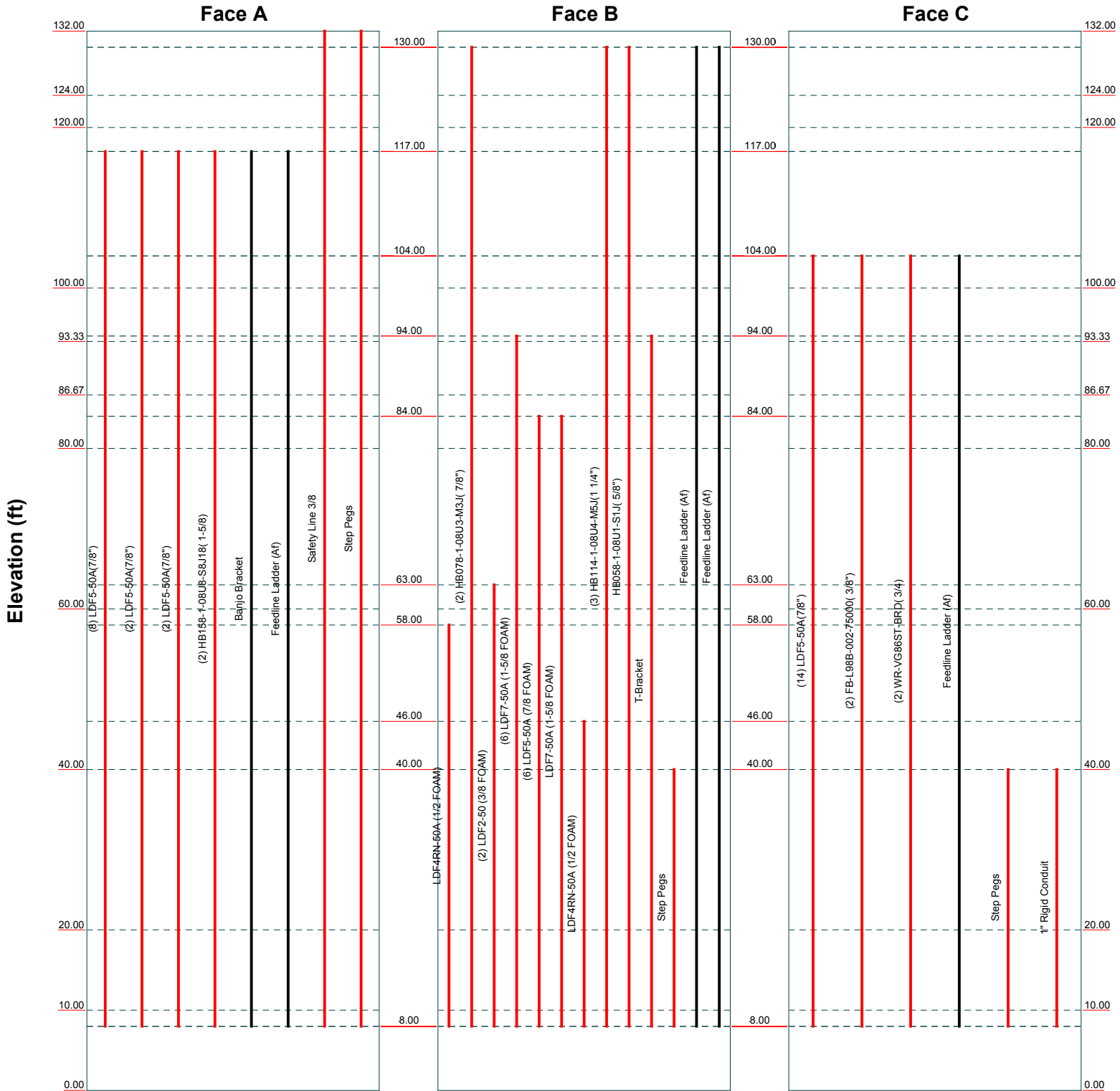

SSOE TM

SSOE Group

320 Seven Springs Way, Suite 350
 Brentwood, TN 37027
 Phone: (615) 661-7585
 FAX: (615) 661-7569

making clients successful by saving them time, trouble, and money

Job: BU 806377 HRT 084 943242		
Project: 016-00010-00		
Client: CCI	Drawn by: 15310	App'd:
Code: TIA/EIA-222-F	Date: 08/09/16	Scale: NTS
Path: G:\DEPT\Telecom\Crown Castle\Current Projects\DJ Projects\SA806377\TNX\806377.dwg		Dwg No. E-7

tnxTower SSOE Group 320 Seven Springs Way, Suite 350 Brentwood, TN 37027 Phone: (615) 661-7585 FAX: (615) 661-7569	Job	BU 806377 HRT 084 943242	Page	1 of 30
	Project	016-00010-00	Date	14:28:04 08/09/16
	Client	CCI	Designed by	15310

Tower Input Data

The main tower is a 3x free standing tower with an overall height of 132.00 ft above the ground line.

The base of the tower is set at an elevation of 0.00 ft above the ground line.

The face width of the tower is 6.60 ft at the top and 18.77 ft at the base.

This tower is designed using the TIA/EIA-222-F standard.

The following design criteria apply:

Tower is located in Tolland County, Connecticut.

Basic wind speed of 85 mph.

Nominal ice thickness of 1.00 in.

Ice thickness is considered to increase with height.

Ice density of 56 pcf.

A wind speed of 28 mph is used in combination with ice.

Temperature drop of 50 °F.

Deflections calculated using a wind speed of 50 mph.

A non-linear (P-delta) analysis was used.

Pressures are calculated at each section.

Stress ratio used in tower member design is 1.333.

Local bending stresses due to climbing loads, feed line supports, and appurtenance mounts are not considered.

Options

- | | | |
|--|--|---|
| <ul style="list-style-type: none"> Consider Moments - Legs Consider Moments - Horizontals Consider Moments - Diagonals Use Moment Magnification √ Use Code Stress Ratios √ Use Code Safety Factors - Guys √ Escalate Ice Always Use Max Kz Use Special Wind Profile √ Include Bolts In Member Capacity Leg Bolts Are At Top Of Section √ Secondary Horizontal Braces Leg Use Diamond Inner Bracing (4 Sided) SR Members Have Cut Ends SR Members Are Concentric | <ul style="list-style-type: none"> Distribute Leg Loads As Uniform Assume Legs Pinned √ Assume Rigid Index Plate √ Use Clear Spans For Wind Area √ Use Clear Spans For KL/r Retension Guys To Initial Tension Bypass Mast Stability Checks √ Use Azimuth Dish Coefficients √ Project Wind Area of Appurt. Autocalc Torque Arm Areas Add IBC .6D+W Combination √ Sort Capacity Reports By Component √ Triangulate Diamond Inner Bracing Treat Feed Line Bundles As Cylinder | <ul style="list-style-type: none"> Use ASCE 10 X-Brace Ly Rules √ Calculate Redundant Bracing Forces Ignore Redundant Members in FEA √ SR Leg Bolts Resist Compression √ All Leg Panels Have Same Allowable Offset Girt At Foundation √ Consider Feed Line Torque √ Include Angle Block Shear Check Use TIA-222-G Bracing Resist. Exemption Use TIA-222-G Tension Splice Exemption <li style="text-align: center;">Poles Include Shear-Torsion Interaction Always Use Sub-Critical Flow Use Top Mounted Sockets |
|--|--|---|

tnxTower SSOE Group 320 Seven Springs Way, Suite 350 Brentwood, TN 37027 Phone: (615) 661-7585 FAX: (615) 661-7569	Job BU 806377 HRT 084 943242	Page 2 of 30
	Project 016-00010-00	Date 14:28:04 08/09/16
	Client CCI	Designed by 15310

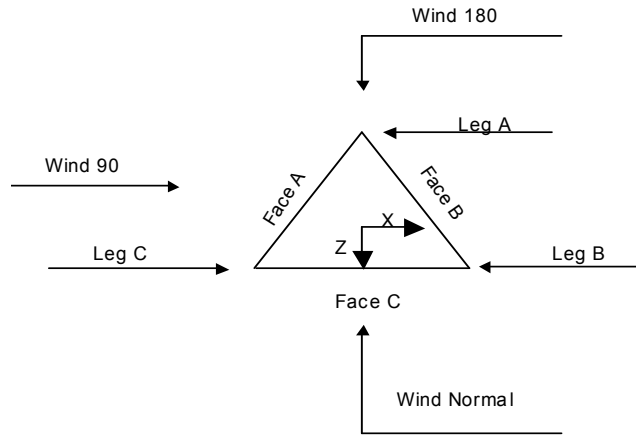

Triangular Tower

Tower Section Geometry

Tower Section	Tower Elevation	Assembly Database	Description	Section Width	Number of Sections	Section Length
	<i>ft</i>			<i>ft</i>		<i>ft</i>
T1	132.00-124.00			6.60	1	8.00
T2	124.00-120.00			6.63	1	4.00
T3	120.00-100.00			6.65	1	20.00
T4	100.00-93.33			8.69	1	6.67
T5	93.33-86.67			9.35	1	6.67
T6	86.67-80.00			10.02	1	6.67
T7	80.00-60.00			10.69	1	20.00
T8	60.00-40.00			12.76	1	20.00
T9	40.00-20.00			14.77	1	20.00
T10	20.00-10.00			16.77	1	10.00
T11	10.00-0.00			17.77	1	10.00

Tower Section Geometry (cont'd)

Tower Section	Tower Elevation	Diagonal Spacing	Bracing Type	Has K Brace End Panels	Has Horizontals	Top Girt Offset	Bottom Girt Offset
	<i>ft</i>	<i>ft</i>				<i>in</i>	<i>in</i>
T1	132.00-124.00	4.00	X Brace	No	No	0.00	0.00
T2	124.00-120.00	4.00	X Brace	No	No	0.00	0.00
T3	120.00-100.00	5.00	X Brace	No	No	0.00	0.00
T4	100.00-93.33	6.67	X Brace	No	No	0.00	0.00

tnxTower SSOE Group 320 Seven Springs Way, Suite 350 Brentwood, TN 37027 Phone: (615) 661-7585 FAX: (615) 661-7569	Job	BU 806377 HRT 084 943242	Page	3 of 30
	Project	016-00010-00	Date	14:28:04 08/09/16
	Client	CCI	Designed by	15310

Tower Section	Tower Elevation	Diagonal Spacing	Bracing Type	Has K Brace End Panels	Has Horizontals	Top Girt Offset	Bottom Girt Offset
	ft	ft				in	in
T5	93.33-86.67	6.67	X Brace	No	No	0.00	0.00
T6	86.67-80.00	6.67	X Brace	No	Yes	0.00	0.00
T7	80.00-60.00	6.67	X Brace	No	No	0.00	0.00
T8	60.00-40.00	6.67	X Brace	No	No	0.00	0.00
T9	40.00-20.00	10.00	X Brace	No	No	0.00	0.00
T10	20.00-10.00	10.00	X Brace	No	No	0.00	0.00
T11	10.00-0.00	10.00	X Brace	No	Yes	0.00	0.00

Tower Section Geometry (cont'd)

Tower Elevation	Leg Type	Leg Size	Leg Grade	Diagonal Type	Diagonal Size	Diagonal Grade
ft						
T1 132.00-124.00	Pipe	ROHN 2 STD	A572-50 (50 ksi)	Equal Angle	L1 3/4x1 3/4x3/16	A36 (36 ksi)
T2 124.00-120.00	Pipe	ROHN 2 STD	A572-50 (50 ksi)	Equal Angle	L1 3/4x1 3/4x3/16	A36 (36 ksi)
T3 120.00-100.00	Pipe	ROHN 2.5 STD	A572-50 (50 ksi)	Equal Angle	L2x2x3/16	A36 (36 ksi)
T4 100.00-93.33	Pipe	ROHN 3 STD	A572-50 (50 ksi)	Equal Angle	L2 1/2x2 1/2x3/16	A36 (36 ksi)
T5 93.33-86.67	Pipe	ROHN 3 STD	A572-50 (50 ksi)	Equal Angle	L2 1/2x2 1/2x3/16	A36 (36 ksi)
T6 86.67-80.00	Pipe	ROHN 3 STD	A572-50 (50 ksi)	Equal Angle	L2 1/2x2 1/2x3/16	A36 (36 ksi)
T7 80.00-60.00	Pipe	ROHN 3 XX-STR	A572-50 (50 ksi)	Equal Angle	L2 1/2x2 1/2x3/16	A36 (36 ksi)
T8 60.00-40.00	Pipe	ROHN 4 X-STR	A572-50 (50 ksi)	Equal Angle	L3x3x3/16	A572-50 (50 ksi)
T9 40.00-20.00	Pipe	ROHN 5 X-STR	A572-50 (50 ksi)	Equal Angle	L3x3x1/4	A572-50 (50 ksi)
T10 20.00-10.00	Pipe	ROHN 5 X-STR	A572-50 (50 ksi)	Equal Angle	L3 1/2x3 1/2x1/4	A572-50 (50 ksi)
T11 10.00-0.00	Pipe	ROHN 5 X-STR	A572-50 (50 ksi)	Equal Angle	L3 1/2x3 1/2x1/4	A572-50 (50 ksi)

Tower Section Geometry (cont'd)

Tower Elevation	Top Girt Type	Top Girt Size	Top Girt Grade	Bottom Girt Type	Bottom Girt Size	Bottom Girt Grade
ft						
T1 132.00-124.00	Equal Angle	L2x2x3/16	A36 (36 ksi)	Flat Bar		A36 (36 ksi)
T3 120.00-100.00	Equal Angle	L2x2x3/16	A36 (36 ksi)	Flat Bar		A36 (36 ksi)

Tower Section Geometry (cont'd)

tnxTower SSOE Group 320 Seven Springs Way, Suite 350 Brentwood, TN 37027 Phone: (615) 661-7585 FAX: (615) 661-7569	Job	BU 806377 HRT 084 943242	Page	5 of 30
	Project	016-00010-00	Date	14:28:04 08/09/16
	Client	CCI	Designed by	15310

Tower Elevation ft	Calc K Single Angles	Calc K Solid Rounds	Legs	K Factors ¹						
				X Brace Diags	K Brace Diags	Single Diags	Girts	Horiz.	Sec. Horiz.	Inner Brace
				X Y	X Y	X Y	X Y	X Y	X Y	X Y
93.33-86.67 T6	No	Yes	1	1	1	1	1	1	0.5	1
86.67-80.00 T7	Yes	Yes	1	1	1	1	1	1	0.5	1
80.00-60.00 T8	Yes	Yes	1	1	1	1	1	1	1	1
60.00-40.00 T9	Yes	Yes	1	1	1	1	1	1	1	1
40.00-20.00 T10	Yes	Yes	1	1	1	1	1	1	0.5	1
20.00-10.00 T11	No	Yes	1	1	1	1	1	1	0.5	1
10.00-0.00				1	1	1	1	1	0.5	1

¹Note: K factors are applied to member segment lengths. K-braces without inner supporting members will have the K factor in the out-of-plane direction applied to the overall length.

Tower Section Geometry (cont'd)

Tower Elevation ft	Leg		Diagonal		Top Girt		Bottom Girt		Mid Girt		Long Horizontal		Short Horizontal	
	Net Width Deduct in	U	Net Width Deduct in	U	Net Width Deduct in	U	Net Width Deduct in	U	Net Width Deduct in	U	Net Width Deduct in	U	Net Width Deduct in	U
T1 132.00-124.00	0.00	1	0.00	0.75	0.00	0.75	0.00	0.75	0.00	0.75	0.00	0.75	0.00	0.75
T2 124.00-120.00	0.00	1	0.00	0.75	0.00	0.75	0.00	0.75	0.00	0.75	0.00	0.75	0.00	0.75
T3 120.00-100.00	0.00	1	0.00	0.75	0.00	0.75	0.00	0.75	0.00	0.75	0.00	0.75	0.00	0.75
T4 100.00-93.33	0.00	1	0.00	0.75	0.00	0.75	0.00	0.75	0.00	0.75	0.00	0.75	0.00	0.75
T5 93.33-86.67	0.00	1	0.00	0.75	0.00	0.75	0.00	0.75	0.00	0.75	0.00	0.75	0.00	0.75
T6 86.67-80.00	0.00	1	0.00	0.75	0.00	0.75	0.00	0.75	0.00	0.75	0.00	0.75	0.00	0.75
T7 80.00-60.00	0.00	1	0.00	0.75	0.00	0.75	0.00	0.75	0.00	0.75	0.00	0.75	0.00	0.75
T8 60.00-40.00	0.00	1	0.00	0.75	0.00	0.75	0.00	0.75	0.00	0.75	0.00	0.75	0.00	0.75
T9 40.00-20.00	0.00	1	0.00	0.75	0.00	0.75	0.00	0.75	0.00	0.75	0.00	0.75	0.00	0.75
T10 20.00-10.00	0.00	1	0.00	0.75	0.00	0.75	0.00	0.75	0.00	0.75	0.00	0.75	0.00	0.75
T11 10.00-0.00	0.00	1	0.00	0.75	0.00	0.75	0.00	0.75	0.00	0.75	0.00	0.75	0.00	0.75

Tower Section Geometry (cont'd)

tnxTower SSOE Group 320 Seven Springs Way, Suite 350 Brentwood, TN 37027 Phone: (615) 661-7585 FAX: (615) 661-7569	Job	BU 806377 HRT 084 943242	Page	6 of 30
	Project	016-00010-00	Date	14:28:04 08/09/16
	Client	CCI	Designed by	15310

Tower Elevation ft	Leg Connection Type	Leg		Diagonal		Top Girt		Bottom Girt		Mid Girt		Long Horizontal		Short Horizontal	
		Bolt Size in	No.	Bolt Size in	No.	Bolt Size in	No.	Bolt Size in	No.	Bolt Size in	No.	Bolt Size in	No.	Bolt Size in	No.
T1 132.00-124.00	Flange	0.00	0	0.63	1	0.63	1	0.63	0	0.63	0	0.63	0	0.63	0
		A325N		A325N		A325N		A325N		A325N		A325N		A325N	
T2 124.00-120.00	Flange	0.63	4	0.63	1	0.63	1	0.63	0	0.63	0	0.63	0	0.63	0
		A325N		A325N		A325N		A325N		A325N		A325N		A325N	
T3 120.00-100.00	Flange	0.75	4	0.63	1	0.50	0	0.63	0	0.63	0	0.63	0	0.63	0
		A325N		A325N		A325N		A325N		A325N		A325N		A325N	
T4 100.00-93.33	Flange	0.88	0	0.63	1	0.50	0	0.00	0	0.63	0	0.63	0	0.63	0
		A325N		A325N		A325N		A325N		A325N		A325N		A325N	
T5 93.33-86.67	Flange	0.88	0	0.63	1	0.63	0	0.00	0	0.63	0	0.63	0	0.63	0
		A325N		A325N		A325N		A325N		A325N		A325N		A325N	
T6 86.67-80.00	Flange	0.88	4	0.63	1	0.63	0	0.63	0	0.63	0	0.63	0	0.63	1
		A325N		A325N		A325N		A325N		A325N		A325N		A325N	
T7 80.00-60.00	Flange	0.88	4	0.63	1	0.50	0	0.63	0	0.63	0	0.63	0	0.63	0
		A325N		A325N		A325N		A325N		A325N		A325N		A325N	
T8 60.00-40.00	Flange	1.00	4	0.63	1	0.50	0	0.63	0	0.63	0	0.63	0	0.63	0
		A325N		A325N		A325N		A325N		A325N		A325N		A325N	
T9 40.00-20.00	Flange	1.00	4	0.63	1	0.50	0	0.63	0	0.63	0	0.63	0	0.63	0
		A325N		A325N		A325N		A325N		A325N		A325N		A325N	
T10 20.00-10.00	Flange	1.00	0	0.75	1	0.63	0	0.00	0	0.63	0	0.63	0	0.63	0
		A449		A325N		A325N		A325N		A325N		A325N		A325N	
T11 10.00-0.00	Flange	1.00	4	0.75	1	0.63	0	0.63	0	0.63	0	0.63	0	0.63	1
		A449		A325N		A325N		A325N		A325N		A325N		A325N	

Feed Line/Linear Appurtenances - Entered As Round Or Flat

Description	Face or Leg	Allow Shield	Component Type	Placement ft	Face Offset in	Lateral Offset (Frac FW)	#	# Per Row	Clear Spacing in	Width or Diameter in	Perimeter in	Weight klf
LDF5-50A(7/8")	A	Yes	Ar (CfAe)	117.00 - 8.00	0.00	0.4	8	8	0.75	1.09		0.00
LDF5-50A(7/8")	A	Yes	Ar (CfAe)	117.00 - 8.00	2.00	0.2	2	1	1.00	1.09		0.00
LDF5-50A(7/8")	A	Yes	Ar (CfAe)	117.00 - 8.00	2.00	0.27	2	1	1.00	1.09		0.00
HB158-1-08U 8-S8J18(1-5/8)	A	Yes	Ar (CfAe)	117.00 - 8.00	0.00	0.4	2	2	1.00	1.98		0.00
Banjo Bracket	A	Yes	Af (CfAe)	117.00 - 8.00	0.00	0.33	1	1	1.00	0.00	0.50	0.01
Feedline	A	Yes	Af (CfAe)	117.00 - 8.00	0.00	0.4	1	1	1.00	1.50	9.00	0.01
Ladder (Af)												
Safety Line 3/8	A	No	Ar (Leg)	132.00 - 8.00	0.00	0.5	1	1	1.00	0.38		0.00
Step Pegs	A	No	Ar (Leg)	132.00 - 8.00	0.00	0.5	1	1	1.00	0.80		0.00
LDF4RN-50A (1/2 FOAM)	B	Yes	Ar (CfAe)	58.00 - 8.00	0.00	-0.43	1	1	1.00	0.63		0.00
HB078-1-08U 3-M3J(7/8")	B	Yes	Ar (CfAe)	130.00 - 8.00	0.00	-0.35	2	2	1.00	1.09		0.00
LDF2-50 (3/8 FOAM)	B	Yes	Ar (CfAe)	63.00 - 8.00	0.00	-0.35	2	2	1.00	0.44		0.00
LDF7-50A (1-5/8 FOAM)	B	No	Ar (Leg)	94.00 - 8.00	0.00	0.08	6	3	1.00	1.98		0.00
LDF5-50A (7/8 FOAM)	B	No	Ar (Leg)	84.00 - 8.00	0.00	0.05	6	2	1.00	1.09		0.00
LDF7-50A	B	No	Ar (Leg)	84.00 - 8.00	0.00	0.06	1	1	1.00	1.98		0.00

tnxTower SSOE Group 320 Seven Springs Way, Suite 350 Brentwood, TN 37027 Phone: (615) 661-7585 FAX: (615) 661-7569	Job	BU 806377 HRT 084 943242	Page	7 of 30
	Project	016-00010-00	Date	14:28:04 08/09/16
	Client	CCI	Designed by	15310

Description	Face or Leg	Allow Shield	Component Type	Placement ft	Face Offset in	Lateral Offset (Frac FW)	#	# Per Row	Clear Spacing in	Width or Diameter in	Perimeter in	Weight klf
(1-5/8 FOAM)												
LDF4RN-50A (1/2 FOAM)	B	Yes	Ar (CfAe)	46.00 - 8.00	0.00	0.45	1	1	1.00	0.63		0.00
HB114-1-08U 4-M5J(1 1/4")	B	Yes	Ar (CfAe)	130.00 - 8.00	0.00	0.4	3	3	1.00	1.54		0.00
HB058-1-08U 1-S1J(5/8")	B	Yes	Ar (CfAe)	130.00 - 8.00	0.00	0.39	1	1	1.00	0.84		0.00
T-Bracket	B	No	Ar (Leg)	94.00 - 8.00	0.00	0.4	1	1	1.00	1.00		0.01
Step Pegs	B	No	Ar (Leg)	40.00 - 8.00	0.00	0.5	1	1	1.00	0.80		0.00
Feedline	B	Yes	Af (CfAe)	130.00 - 8.00	0.00	0.4	1	1	1.00	3.00	12.00	0.01
Ladder (Af)												
Feedline	B	Yes	Af (CfAe)	130.00 - 8.00	0.00	-0.4	1	1	1.00	3.00	12.00	0.01
Ladder (Af)												
LDF5-50A(7/8")	C	Yes	Ar (CfAe)	104.00 - 8.00	0.00	-0.4	14	12	0.75	1.09		0.00
FB-L98B-002-75000(3/8")	C	Yes	Ar (CfAe)	104.00 - 8.00	0.00	-0.47	2	1	1.00	0.39		0.00
WR-VG86ST-BRD(3/4)	C	Yes	Ar (CfAe)	104.00 - 8.00	0.00	-0.45	2	2	1.00	0.77		0.00
Feedline	C	Yes	Af (CfAe)	104.00 - 8.00	0.00	-0.4	1	1	1.00	1.50	9.00	0.01
Ladder (Af)												
Step Pegs	C	No	Ar (Leg)	40.00 - 8.00	0.00	0.5	1	1	1.00	0.80		0.00
1" Rigid Conduit	C	Yes	Ar (CfAe)	40.00 - 8.00	0.00	-0.49	1	1	1.00	1.00		0.00

Feed Line/Linear Appurtenances Section Areas

Tower Section	Tower Elevation ft	Face	A _R ft ²	A _F ft ²	C _A A _A In Face ft ²	C _A A _A Out Face ft ²	Weight K
T1	132.00-124.00	A	0.783	0.000	0.000	0.000	0.02
		B	4.603	3.000	0.000	0.000	0.13
		C	0.000	0.000	0.000	0.000	0.00
T2	124.00-120.00	A	0.392	0.000	0.000	0.000	0.01
		B	2.938	2.000	0.000	0.000	0.09
		C	0.000	0.000	0.000	0.000	0.00
T3	120.00-100.00	A	23.010	2.125	0.000	0.000	0.48
		B	14.692	10.000	0.000	0.000	0.45
		C	5.007	0.500	0.000	0.000	0.06
T4	100.00-93.33	A	8.908	0.833	0.000	0.000	0.19
		B	5.283	3.333	0.000	0.000	0.16
		C	8.731	0.833	0.000	0.000	0.10
T5	93.33-86.67	A	8.908	0.833	0.000	0.000	0.19
		B	8.753	3.333	0.000	0.000	0.25
		C	12.201	0.833	0.000	0.000	0.10
T6	86.67-80.00	A	8.908	0.833	0.000	0.000	0.19
		B	10.139	3.333	0.000	0.000	0.26
		C	13.588	0.833	0.000	0.000	0.10
T7	80.00-60.00	A	26.725	2.500	0.000	0.000	0.56
		B	33.412	10.000	0.000	0.000	0.80
		C	43.536	2.500	0.000	0.000	0.29
T8	60.00-40.00	A	26.725	2.500	0.000	0.000	0.56
		B	35.918	10.000	0.000	0.000	0.81
		C	43.536	2.500	0.000	0.000	0.29
T9	40.00-20.00	A	28.058	2.500	0.000	0.000	0.56
		B	38.092	10.000	0.000	0.000	0.86
		C	47.870	2.500	0.000	0.000	0.35

tnxTower SSOE Group 320 Seven Springs Way, Suite 350 Brentwood, TN 37027 Phone: (615) 661-7585 FAX: (615) 661-7569	Job	BU 806377 HRT 084 943242	Page	8 of 30
	Project	016-00010-00	Date	14:28:04 08/09/16
	Client	CCI	Designed by	15310

Tower Section	Tower Elevation ft	Face	A_R ft ²	A_F ft ²	C_{AA} In Face ft ²	C_{AA} Out Face ft ²	Weight K
T10	20.00-10.00	A	14.029	1.250	0.000	0.000	0.28
		B	19.046	5.000	0.000	0.000	0.43
		C	23.935	1.250	0.000	0.000	0.18
T11	10.00-0.00	A	2.806	0.250	0.000	0.000	0.06
		B	3.809	1.000	0.000	0.000	0.09
		C	4.787	0.250	0.000	0.000	0.04

Feed Line/Linear Appurtenances Section Areas - With Ice

Tower Section	Tower Elevation ft	Face or Leg	Ice Thickness in	A_R ft ²	A_F ft ²	C_{AA} In Face ft ²	C_{AA} Out Face ft ²	Weight K
T1	132.00-124.00	A	1.177	3.921	0.000	0.000	0.000	0.06
		B		9.186	8.154	0.000	0.000	0.34
		C		0.000	0.000	0.000	0.000	0.00
T2	124.00-120.00	A	1.170	1.952	0.000	0.000	0.000	0.03
		B		5.448	5.430	0.000	0.000	0.22
		C		0.000	0.000	0.000	0.000	0.00
T3	120.00-100.00	A	1.155	30.194	28.958	0.000	0.000	1.38
		B		26.999	27.085	0.000	0.000	1.11
		C		3.063	8.352	0.000	0.000	0.23
T4	100.00-93.33	A	1.138	11.154	11.330	0.000	0.000	0.52
		B		9.319	9.333	0.000	0.000	0.39
		C		5.465	14.237	0.000	0.000	0.38
T5	93.33-86.67	A	1.128	11.089	11.315	0.000	0.000	0.52
		B		13.009	12.299	0.000	0.000	0.61
		C		9.176	17.210	0.000	0.000	0.38
T6	86.67-80.00	A	1.118	11.020	11.300	0.000	0.000	0.52
		B		15.442	12.980	0.000	0.000	0.69
		C		11.632	17.899	0.000	0.000	0.38
T7	80.00-60.00	A	1.094	32.597	33.797	0.000	0.000	1.52
		B		51.315	40.591	0.000	0.000	2.21
		C		39.383	55.039	0.000	0.000	1.11
T8	60.00-40.00	A	1.051	31.731	33.605	0.000	0.000	1.48
		B		59.060	42.438	0.000	0.000	2.27
		C		38.372	54.943	0.000	0.000	1.08
T9	40.00-20.00	A	1.000	35.375	33.378	0.000	0.000	1.42
		B		65.325	42.211	0.000	0.000	2.33
		C		51.513	54.829	0.000	0.000	1.20
T10	20.00-10.00	A	1.000	17.688	16.689	0.000	0.000	0.71
		B		32.663	21.106	0.000	0.000	1.16
		C		25.756	27.414	0.000	0.000	0.60
T11	10.00-0.00	A	1.000	3.537	3.338	0.000	0.000	0.14
		B		6.532	4.221	0.000	0.000	0.23
		C		5.151	5.483	0.000	0.000	0.12

Feed Line Shielding

Section	Elevation ft	Face	A_R ft ²	A_R Ice ft ²	A_F ft ²	A_F Ice ft ²
T1	132.00-124.00	A	0.000	0.000	0.000	0.000
		B	0.000	1.975	0.723	1.506
		C	0.000	0.000	0.000	0.000

tnxTower SSOE Group 320 Seven Springs Way, Suite 350 Brentwood, TN 37027 Phone: (615) 661-7585 FAX: (615) 661-7569	Job	BU 806377 HRT 084 943242	Page	9 of 30
	Project	016-00010-00	Date	14:28:04 08/09/16
	Client	CCI	Designed by	15310

Section	Elevation ft	Face	A_R	$A_{R\ Ice}$	A_F	$A_{F\ Ice}$
			ft ²	ft ²	ft ²	ft ²
T2	124.00-120.00	A	0.000	0.000	0.000	0.000
		B	0.000	1.075	0.387	0.804
		C	0.000	0.000	0.000	0.000
T3	120.00-100.00	A	0.000	5.260	2.042	4.552
		B	0.000	4.783	2.003	4.140
		C	0.000	1.188	0.485	1.028
T4	100.00-93.33	A	0.000	1.425	0.706	1.565
		B	0.000	1.101	0.589	1.210
		C	0.000	1.370	0.713	1.506
T5	93.33-86.67	A	0.000	1.375	0.690	1.523
		B	0.000	1.062	0.575	1.177
		C	0.000	1.323	0.696	1.467
T6	86.67-80.00	A	0.000	1.889	0.846	1.863
		B	0.000	1.459	0.705	1.438
		C	0.000	1.820	0.854	1.795
T7	80.00-60.00	A	0.000	3.753	1.962	4.286
		B	0.000	2.960	1.652	3.381
		C	0.000	3.625	1.981	4.140
T8	60.00-40.00	A	0.000	3.430	2.273	4.894
		B	0.000	3.351	2.123	4.781
		C	0.000	3.328	2.296	4.749
T9	40.00-20.00	A	0.000	2.278	1.615	3.416
		B	0.000	2.355	1.558	3.532
		C	0.000	2.420	1.730	3.630
T10	20.00-10.00	A	0.000	1.111	0.919	1.944
		B	0.000	1.148	0.886	2.010
		C	0.000	1.180	0.984	2.065
T11	10.00-0.00	A	0.000	0.315	0.238	0.504
		B	0.000	0.326	0.230	0.521
		C	0.000	0.335	0.255	0.535

Feed Line Center of Pressure

Section	Elevation ft	CP_x	CP_z	CP_x	CP_z
		in	in	Ice in	Ice in
T1	132.00-124.00	4.53	-1.03	2.24	-0.49
T2	124.00-120.00	6.37	-1.39	3.42	-0.62
T3	120.00-100.00	5.58	-7.79	3.21	-4.79
T4	100.00-93.33	10.94	-3.86	7.76	-2.37
T5	93.33-86.67	12.91	-2.08	8.88	-1.31
T6	86.67-80.00	13.40	-1.23	8.88	-0.51
T7	80.00-60.00	16.27	-1.05	11.38	-0.47
T8	60.00-40.00	16.71	-1.67	12.38	-1.28
T9	40.00-20.00	19.72	-1.45	15.74	-0.75
T10	20.00-10.00	20.36	-1.47	16.55	-0.75
T11	10.00-0.00	5.92	-0.40	5.27	-0.16

Discrete Tower Loads

tnxTower SSOE Group 320 Seven Springs Way, Suite 350 Brentwood, TN 37027 Phone: (615) 661-7585 FAX: (615) 661-7569	Job	BU 806377 HRT 084 943242	Page	10 of 30
	Project	016-00010-00	Date	14:28:04 08/09/16
	Client	CCI	Designed by	15310

Description	Face or Leg	Offset Type	Offsets:		Azimuth Adjustment	Placement	C _{AA} Front	C _{AA} Side	Weight	
			Horz Lateral	Vert						°
3" x 10' mount pipe	B	None			0.00	137.00	No Ice	3.00	3.00	0.03
							1/2" Ice	4.03	4.03	0.05
							1" Ice	5.03	5.03	0.08
							2" Ice	6.26	6.26	0.16
							4" Ice	8.83	8.83	0.40
APXVSPP18-C-A20 w/ Mount Pipe	A	From Leg	3.15	-38.00	130.00	No Ice	8.50	6.95	0.08	
						1/2" Ice	9.15	8.13	0.15	
						1" Ice	9.77	9.02	0.23	
						2" Ice	11.03	10.84	0.41	
						4" Ice	13.68	14.85	0.91	
APXVTM14-C-120 w/ Mount Pipe	A	From Leg	3.15	-38.00	130.00	No Ice	7.13	4.96	0.08	
						1/2" Ice	7.66	5.75	0.13	
						1" Ice	8.18	6.47	0.19	
						2" Ice	9.26	8.01	0.34	
						4" Ice	11.53	11.41	0.75	
1900MHZ RRH (65MHz)	A	From Leg	3.15	-38.00	130.00	No Ice	2.70	2.77	0.06	
						1/2" Ice	2.94	3.01	0.08	
						1" Ice	3.18	3.26	0.11	
						2" Ice	3.70	3.78	0.18	
						4" Ice	4.85	4.93	0.35	
800MHz 2x50W RRH W/FILTER	A	From Leg	3.15	-38.00	130.00	No Ice	2.40	2.25	0.06	
						1/2" Ice	2.61	2.46	0.09	
						1" Ice	2.83	2.68	0.11	
						2" Ice	3.30	3.13	0.17	
						4" Ice	4.34	4.15	0.34	
TD-RRH8x20-25	A	From Leg	3.15	-38.00	130.00	No Ice	4.72	1.70	0.07	
						1/2" Ice	5.01	1.92	0.10	
						1" Ice	5.32	2.15	0.13	
						2" Ice	5.95	2.62	0.20	
						4" Ice	7.31	3.68	0.40	
APXVSPP18-C-A20 w/ Mount Pipe	B	From Leg	3.15	-38.00	130.00	No Ice	8.50	6.95	0.08	
						1/2" Ice	9.15	8.13	0.15	
						1" Ice	9.77	9.02	0.23	
						2" Ice	11.03	10.84	0.41	
						4" Ice	13.68	14.85	0.91	
APXVTM14-C-120 w/ Mount Pipe	B	From Leg	3.15	-38.00	130.00	No Ice	7.13	4.96	0.08	
						1/2" Ice	7.66	5.75	0.13	
						1" Ice	8.18	6.47	0.19	
						2" Ice	9.26	8.01	0.34	
						4" Ice	11.53	11.41	0.75	
800MHz 2x50W RRH W/FILTER	B	From Leg	3.15	-38.00	130.00	No Ice	2.40	2.25	0.06	
						1/2" Ice	2.61	2.46	0.09	
						1" Ice	2.83	2.68	0.11	
						2" Ice	3.30	3.13	0.17	
						4" Ice	4.34	4.15	0.34	
1900MHZ RRH (65MHz)	B	From Leg	3.15	-38.00	130.00	No Ice	2.70	2.77	0.06	
						1/2" Ice	2.94	3.01	0.08	
						1" Ice	3.18	3.26	0.11	
						2" Ice	3.70	3.78	0.18	
						4" Ice	4.85	4.93	0.35	
TD-RRH8x20-25	B	From Leg	3.15	-38.00	130.00	No Ice	4.72	1.70	0.07	
						1/2" Ice	5.01	1.92	0.10	
						1" Ice	5.32	2.15	0.13	
						2" Ice	5.95	2.62	0.20	
						4" Ice	7.31	3.68	0.40	
DB413-B	B	From Leg	3.15	-38.00	130.00	No Ice	2.55	2.55	0.03	
						1/2" Ice	4.59	4.59	0.04	

tnxTower SSOE Group 320 Seven Springs Way, Suite 350 Brentwood, TN 37027 Phone: (615) 661-7585 FAX: (615) 661-7569	Job	BU 806377 HRT 084 943242	Page	11 of 30
	Project	016-00010-00	Date	14:28:04 08/09/16
	Client	CCI	Designed by	15310

Description	Face or Leg	Offset Type	Offsets:			Azimuth Adjustment	Placement	C _{AA} Front	C _{AA} Side	Weight
			Horz	Lateral	Vert					
					11.00					
							1" Ice	6.63	6.63	0.05
							2" Ice	10.71	10.71	0.07
							4" Ice	18.87	18.87	0.11
APXVSPP18-C-A20 w/ Mount Pipe	C	From Leg	2.68	-48.00	130.00	No Ice	8.50	6.95	0.08	
			-2.97			1/2" Ice	9.15	8.13	0.15	
			0.00			1" Ice	9.77	9.02	0.23	
						2" Ice	11.03	10.84	0.41	
						4" Ice	13.68	14.85	0.91	
APXVTM14-C-120 w/ Mount Pipe	C	From Leg	2.68	-48.00	130.00	No Ice	7.13	4.96	0.08	
			-2.97			1/2" Ice	7.66	5.75	0.13	
			0.00			1" Ice	8.18	6.47	0.19	
						2" Ice	9.26	8.01	0.34	
						4" Ice	11.53	11.41	0.75	
800MHz 2x50W RRH W/FILTER	C	From Leg	2.68	-48.00	130.00	No Ice	2.40	2.25	0.06	
			-2.97			1/2" Ice	2.61	2.46	0.09	
			0.00			1" Ice	2.83	2.68	0.11	
						2" Ice	3.30	3.13	0.17	
						4" Ice	4.34	4.15	0.34	
1900MHZ RRH (65MHz)	C	From Leg	2.68	-48.00	130.00	No Ice	2.70	2.77	0.06	
			-2.97			1/2" Ice	2.94	3.01	0.08	
			0.00			1" Ice	3.18	3.26	0.11	
						2" Ice	3.70	3.78	0.18	
						4" Ice	4.85	4.93	0.35	
TD-RRH8x20-25	C	From Leg	2.68	-48.00	130.00	No Ice	4.72	1.70	0.07	
			-2.97			1/2" Ice	5.01	1.92	0.10	
			0.00			1" Ice	5.32	2.15	0.13	
						2" Ice	5.95	2.62	0.20	
						4" Ice	7.31	3.68	0.40	
T-Arm Mount [TA 702-3]	C	None		0.00	130.00	No Ice	5.64	5.64	0.34	
						1/2" Ice	6.55	6.55	0.43	
						1" Ice	7.46	7.46	0.52	
						2" Ice	9.28	9.28	0.70	
						4" Ice	12.92	12.92	1.06	
LBX-6515DS-T0M w/ Mount Pipe	A	From Leg	3.91	12.00	117.00	No Ice	8.92	6.10	0.05	
			0.83			1/2" Ice	9.58	7.27	0.11	
			0.00			1" Ice	10.20	8.16	0.19	
						2" Ice	11.47	9.97	0.36	
						4" Ice	14.13	13.79	0.85	
LNx-6514DS-T4M w/ Mount Pipe	A	From Leg	3.91	12.00	117.00	No Ice	8.57	7.00	0.06	
			0.83			1/2" Ice	9.22	8.19	0.13	
			0.00			1" Ice	9.84	9.08	0.20	
						2" Ice	11.10	10.90	0.38	
						4" Ice	13.75	14.93	0.89	
(2) SBNHH-1D65B w/ Mount Pipe	A	From Leg	3.91	12.00	117.00	No Ice	8.40	6.82	0.06	
			0.83			1/2" Ice	8.95	7.78	0.13	
			0.00			1" Ice	9.51	8.61	0.20	
						2" Ice	10.66	10.33	0.38	
						4" Ice	13.06	14.12	0.86	
(2) FD9R6004/2C-3L	A	From Leg	3.91	12.00	117.00	No Ice	0.37	0.08	0.00	
			0.83			1/2" Ice	0.45	0.14	0.01	
			1.00			1" Ice	0.54	0.20	0.01	
						2" Ice	0.75	0.34	0.02	
						4" Ice	1.28	0.74	0.06	
DB-T1-6Z-8AB-0Z	A	From Leg	3.91	12.00	117.00	No Ice	0.00	0.00	0.00	
			0.83			1/2" Ice	0.00	0.00	0.00	
			0.00			1" Ice	0.00	0.00	0.00	
						2" Ice	0.00	0.00	0.00	

tnxTower SSOE Group 320 Seven Springs Way, Suite 350 Brentwood, TN 37027 Phone: (615) 661-7585 FAX: (615) 661-7569	Job		BU 806377 HRT 084 943242		Page		12 of 30	
	Project		016-00010-00		Date		14:28:04 08/09/16	
	Client		CCI		Designed by		15310	

Description	Face or Leg	Offset Type	Offsets:		Azimuth Adjustment	Placement	C _{AA} Front	C _{AA} Side	Weight
			Horz	Lateral					
RRH2x60-AWS	A	From Leg	3.91	12.00	117.00	4" Ice	0.00	0.00	0.00
			0.83			No Ice	3.96	1.82	0.06
			0.00			1/2" Ice	4.27	2.08	0.08
						1" Ice	4.60	2.36	0.11
						2" Ice	5.27	2.96	0.17
RRH2X60-PCS	A	From Leg	3.91	12.00	117.00	4" Ice	6.72	4.25	0.35
			0.83			No Ice	2.57	2.01	0.06
			0.00			1/2" Ice	2.79	2.22	0.08
						1" Ice	3.02	2.43	0.10
						2" Ice	3.52	2.89	0.16
RRH2x60-700	A	From Leg	3.91	12.00	117.00	4" Ice	4.61	3.92	0.31
			0.83			No Ice	3.96	1.82	0.06
			0.00			1/2" Ice	4.27	2.08	0.08
						1" Ice	4.60	2.36	0.11
						2" Ice	5.27	2.96	0.17
LBX-6515DS-T0M w/ Mount Pipe	B	From Leg	3.53	-28.00	117.00	4" Ice	6.72	4.25	0.35
			-1.88			No Ice	8.92	6.10	0.05
			0.00			1/2" Ice	9.58	7.27	0.11
						1" Ice	10.20	8.16	0.19
						2" Ice	11.47	9.97	0.36
LNX-6514DS-T4M w/ Mount Pipe	B	From Leg	3.53	-28.00	117.00	4" Ice	14.13	13.79	0.85
			-1.88			No Ice	8.57	7.00	0.06
			0.00			1/2" Ice	9.22	8.19	0.13
						1" Ice	9.84	9.08	0.20
						2" Ice	11.10	10.90	0.38
(2) FD9R6004/2C-3L	B	From Leg	3.53	-28.00	117.00	4" Ice	13.75	14.93	0.89
			-1.88			No Ice	0.37	0.08	0.00
			1.00			1/2" Ice	0.45	0.14	0.01
						1" Ice	0.54	0.20	0.01
						2" Ice	0.75	0.34	0.02
(2) SBNHH-1D65B w/ Mount Pipe	B	From Leg	3.53	-28.00	117.00	4" Ice	1.28	0.74	0.06
			-1.88			No Ice	8.40	6.82	0.06
			0.00			1/2" Ice	8.95	7.78	0.13
						1" Ice	9.51	8.61	0.20
						2" Ice	10.66	10.33	0.38
RRH2x60-AWS	B	From Leg	3.53	-28.00	117.00	4" Ice	13.06	14.12	0.86
			-1.88			No Ice	3.96	1.82	0.06
			0.00			1/2" Ice	4.27	2.08	0.08
						1" Ice	4.60	2.36	0.11
						2" Ice	5.27	2.96	0.17
DB-T1-6Z-8AB-0Z	B	From Leg	3.53	-28.00	117.00	4" Ice	6.72	4.25	0.35
			-1.88			No Ice	0.00	0.00	0.00
			0.00			1/2" Ice	0.00	0.00	0.00
						1" Ice	0.00	0.00	0.00
						2" Ice	0.00	0.00	0.00
RRH2x60-700	B	From Leg	3.53	-28.00	117.00	4" Ice	0.00	0.00	0.00
			-1.88			No Ice	3.96	1.82	0.06
			0.00			1/2" Ice	4.27	2.08	0.08
						1" Ice	4.60	2.36	0.11
						2" Ice	5.27	2.96	0.17
RRH2X60-PCS	B	From Leg	3.53	-28.00	117.00	4" Ice	6.72	4.25	0.35
			-1.88			No Ice	2.57	2.01	0.06
			0.00			1/2" Ice	2.79	2.22	0.08
						1" Ice	3.02	2.43	0.10
						2" Ice	3.52	2.89	0.16
LNX-6514DS-T6M w/	C	From Leg	3.71	22.00	117.00	4" Ice	4.61	3.92	0.31
						No Ice	8.57	7.00	0.06

tnxTower SSOE Group 320 Seven Springs Way, Suite 350 Brentwood, TN 37027 Phone: (615) 661-7585 FAX: (615) 661-7569	Job		BU 806377 HRT 084 943242		Page		13 of 30	
	Project		016-00010-00		Date		14:28:04 08/09/16	
	Client		CCI		Designed by		15310	

Description	Face or Leg	Offset Type	Offsets:		Azimuth Adjustment	Placement	C _{AA} Front	C _{AA} Side	Weight	
			Horz	Vert						ft
Mount Pipe			1.50			1/2" Ice	9.22	8.19	0.13	
			0.00			1" Ice	9.84	9.08	0.20	
						2" Ice	11.10	10.90	0.38	
						4" Ice	13.75	14.93	0.89	
SBNHH-1D65B w/ Mount Pipe	C	From Leg	3.71		22.00	117.00	No Ice	8.40	6.82	0.06
			1.50				1/2" Ice	8.95	7.78	0.13
			0.00				1" Ice	9.51	8.61	0.20
							2" Ice	10.66	10.33	0.38
							4" Ice	13.06	14.12	0.86
BXA-70063-6CF-2 w/ Mount Pipe	C	From Leg	3.71		22.00	117.00	No Ice	7.97	5.80	0.04
			1.50				1/2" Ice	8.61	6.95	0.10
			0.00				1" Ice	9.22	7.82	0.17
							2" Ice	10.46	9.60	0.34
							4" Ice	13.07	13.37	0.80
SBNHH-1D65B w/ Mount Pipe	C	From Leg	3.71		32.00	117.00	No Ice	8.40	6.82	0.06
			1.50				1/2" Ice	8.95	7.78	0.13
			0.00				1" Ice	9.51	8.61	0.20
							2" Ice	10.66	10.33	0.38
							4" Ice	13.06	14.12	0.86
(2) FD9R6004/2C-3L	C	From Leg	3.71		22.00	117.00	No Ice	0.37	0.08	0.00
			1.50				1/2" Ice	0.45	0.14	0.01
			1.00				1" Ice	0.54	0.20	0.01
							2" Ice	0.75	0.34	0.02
							4" Ice	1.28	0.74	0.06
RRH2x60-AWS	C	From Leg	3.71		22.00	117.00	No Ice	3.96	1.82	0.06
			1.50				1/2" Ice	4.27	2.08	0.08
			0.00				1" Ice	4.60	2.36	0.11
							2" Ice	5.27	2.96	0.17
							4" Ice	6.72	4.25	0.35
RRH2x60-700	C	From Leg	3.71		22.00	117.00	No Ice	3.96	1.82	0.06
			1.50				1/2" Ice	4.27	2.08	0.08
			0.00				1" Ice	4.60	2.36	0.11
							2" Ice	5.27	2.96	0.17
							4" Ice	6.72	4.25	0.35
RRH2X60-PCS	C	From Leg	3.71		32.00	117.00	No Ice	2.57	2.01	0.06
			1.50				1/2" Ice	2.79	2.22	0.08
			0.00				1" Ice	3.02	2.43	0.10
							2" Ice	3.52	2.89	0.16
							4" Ice	4.61	3.92	0.31
Sector Mount [SM 504-3]	C	None			0.00	117.00	No Ice	34.25	34.25	1.71
							1/2" Ice	48.98	48.98	2.29
							1" Ice	63.71	63.71	2.86
							2" Ice	93.17	93.17	4.02
							4" Ice	152.09	152.09	6.33
800 10121 w/ Mount Pipe	A	From Leg	4.00		2.00	104.00	No Ice	5.69	4.60	0.07
			0.14				1/2" Ice	6.18	5.34	0.11
			2.00				1" Ice	6.67	6.04	0.17
							2" Ice	7.69	7.51	0.30
							4" Ice	9.84	10.82	0.67
HPA-65R-BUU-H6 w/ Mount Pipe	A	From Leg	4.00		2.00	104.00	No Ice	10.60	8.11	0.08
			0.14				1/2" Ice	11.27	9.30	0.16
			2.00				1" Ice	11.91	10.21	0.25
							2" Ice	13.21	12.17	0.46
							4" Ice	15.93	16.35	1.02
AM-X-CD-16-65-00T-RET w/ Mount Pipe	A	From Leg	4.00		2.00	104.00	No Ice	8.50	6.30	0.07
			0.14				1/2" Ice	9.15	7.48	0.14
			2.00				1" Ice	9.77	8.37	0.21

tnxTower SSOE Group 320 Seven Springs Way, Suite 350 Brentwood, TN 37027 Phone: (615) 661-7585 FAX: (615) 661-7569	Job	BU 806377 HRT 084 943242	Page	14 of 30
	Project	016-00010-00	Date	14:28:04 08/09/16
	Client	CCI	Designed by	15310

Description	Face or Leg	Offset Type	Offsets:		Azimuth Adjustment	Placement	C _{AA} Front	C _{AA} Side	Weight
			Horz	Lateral					
(2) 782-10250	A	From Leg	4.00	2.00	104.00	2" Ice	11.03	10.18	0.38
						4" Ice	13.68	14.02	0.87
						No Ice	0.52	0.27	0.01
						1/2" Ice	0.63	0.36	0.01
						1" Ice	0.75	0.46	0.02
(2) RRUS-11	A	From Leg	4.00	2.00	104.00	2" Ice	1.01	0.69	0.03
						4" Ice	1.63	1.24	0.09
						No Ice	0.00	1.37	0.05
						1/2" Ice	0.00	1.55	0.07
						1" Ice	0.00	1.74	0.09
DC6-48-60-18-8F	A	From Leg	4.00	2.00	104.00	2" Ice	0.00	2.14	0.15
						4" Ice	0.00	3.04	0.31
						No Ice	2.57	2.57	0.02
						1/2" Ice	2.80	2.80	0.04
						1" Ice	3.04	3.04	0.07
(2) DTMABP7819VG12A	A	From Leg	4.00	2.00	104.00	2" Ice	3.54	3.54	0.13
						4" Ice	4.66	4.66	0.30
						No Ice	1.14	0.39	0.02
						1/2" Ice	1.28	0.49	0.03
						1" Ice	1.44	0.59	0.04
860 10025	A	From Leg	4.00	2.00	104.00	2" Ice	1.77	0.83	0.06
						4" Ice	2.54	1.41	0.14
						No Ice	0.18	0.15	0.00
						1/2" Ice	0.25	0.21	0.00
						1" Ice	0.33	0.29	0.01
RRUS 32	A	From Leg	4.00	2.00	104.00	2" Ice	0.51	0.47	0.01
						4" Ice	0.98	0.93	0.05
						No Ice	3.33	1.98	0.06
						1/2" Ice	3.60	2.21	0.08
						1" Ice	3.87	2.45	0.10
800 10121 w/ Mount Pipe	B	From Leg	4.00	2.00	104.00	2" Ice	4.44	2.96	0.16
						4" Ice	5.68	4.07	0.34
						No Ice	5.69	4.60	0.07
						1/2" Ice	6.18	5.34	0.11
						1" Ice	6.67	6.04	0.17
HPA-65R-BUU-H6 w/ Mount Pipe	B	From Leg	4.00	2.00	104.00	2" Ice	7.69	7.51	0.30
						4" Ice	9.84	10.82	0.67
						No Ice	10.60	8.11	0.08
						1/2" Ice	11.27	9.30	0.16
						1" Ice	11.91	10.21	0.25
AM-X-CD-16-65-00T-RET w/ Mount Pipe	B	From Leg	4.00	2.00	104.00	2" Ice	13.21	12.17	0.46
						4" Ice	15.93	16.35	1.02
						No Ice	8.50	6.30	0.07
						1/2" Ice	9.15	7.48	0.14
						1" Ice	9.77	8.37	0.21
(2) 782-10250	B	From Leg	4.00	2.00	104.00	2" Ice	11.03	10.18	0.38
						4" Ice	13.68	14.02	0.87
						No Ice	0.52	0.27	0.01
						1/2" Ice	0.63	0.36	0.01
						1" Ice	0.75	0.46	0.02
(3) RRUS-11	B	From Leg	4.00	2.00	104.00	2" Ice	1.01	0.69	0.03
						4" Ice	1.63	1.24	0.09
						No Ice	3.25	1.37	0.05
						1/2" Ice	3.49	1.55	0.07
						1" Ice	3.74	1.74	0.09
						2" Ice	4.27	2.14	0.15
						4" Ice	5.43	3.04	0.31

tnxTower SSOE Group 320 Seven Springs Way, Suite 350 Brentwood, TN 37027 Phone: (615) 661-7585 FAX: (615) 661-7569	Job	BU 806377 HRT 084 943242	Page	15 of 30
	Project	016-00010-00	Date	14:28:04 08/09/16
	Client	CCI	Designed by	15310

Description	Face or Leg	Offset Type	Offsets:		Azimuth Adjustment	Placement	C _{AA} Front	C _{AA} Side	Weight
			Horz Lateral	Vert					
(2) DTMABP7819VG12A	B	From Leg	4.00	2.00	2.00	104.00	No Ice 1.14	0.39	0.02
			0.14				1/2" Ice 1.28	0.49	0.03
			2.00				1" Ice 1.44	0.59	0.04
							2" Ice 1.77	0.83	0.06
							4" Ice 2.54	1.41	0.14
860 10025	B	From Leg	4.00	2.00	2.00	104.00	No Ice 0.18	0.15	0.00
			0.14				1/2" Ice 0.25	0.21	0.00
			2.00				1" Ice 0.33	0.29	0.01
							2" Ice 0.51	0.47	0.01
							4" Ice 0.98	0.93	0.05
RRUS 32	B	From Leg	4.00	2.00	2.00	104.00	No Ice 3.33	1.98	0.06
			0.14				1/2" Ice 3.60	2.21	0.08
			2.00				1" Ice 3.87	2.45	0.10
							2" Ice 4.44	2.96	0.16
							4" Ice 5.68	4.07	0.34
DC6-48-60-18-8F	B	From Leg	4.00	2.00	2.00	104.00	No Ice 2.57	2.57	0.02
			0.14				1/2" Ice 2.80	2.80	0.04
			2.00				1" Ice 3.04	3.04	0.07
							2" Ice 3.54	3.54	0.13
							4" Ice 4.66	4.66	0.30
800 10121 w/ Mount Pipe	C	From Leg	3.91	12.00	2.00	104.00	No Ice 5.69	4.60	0.07
			0.83				1/2" Ice 6.18	5.34	0.11
			2.00				1" Ice 6.67	6.04	0.17
							2" Ice 7.69	7.51	0.30
							4" Ice 9.84	10.82	0.67
HPA-65R-BUU-H8 w/ Mount Pipe	C	From Leg	3.91	12.00	2.00	104.00	No Ice 13.53	9.58	0.10
			0.83				1/2" Ice 14.34	11.05	0.20
			2.00				1" Ice 15.14	12.50	0.30
							2" Ice 16.71	14.75	0.55
							4" Ice 19.95	19.46	1.22
SBNH-1D6565C w/ Mount Pipe	C	From Leg	3.91	12.00	2.00	104.00	No Ice 11.68	9.84	0.09
			0.83				1/2" Ice 12.40	11.37	0.18
			2.00				1" Ice 13.14	12.91	0.28
							2" Ice 14.60	15.27	0.52
							4" Ice 17.87	20.14	1.16
(2) 782-10250	C	From Leg	3.91	12.00	2.00	104.00	No Ice 0.52	0.27	0.01
			0.83				1/2" Ice 0.63	0.36	0.01
			2.00				1" Ice 0.75	0.46	0.02
							2" Ice 1.01	0.69	0.03
							4" Ice 1.63	1.24	0.09
(2) DTMABP7819VG12A	C	From Leg	3.91	12.00	2.00	104.00	No Ice 1.14	0.39	0.02
			0.83				1/2" Ice 1.28	0.49	0.03
			2.00				1" Ice 1.44	0.59	0.04
							2" Ice 1.77	0.83	0.06
							4" Ice 2.54	1.41	0.14
RRUS-11	C	From Leg	3.91	12.00	2.00	104.00	No Ice 0.00	1.37	0.05
			0.83				1/2" Ice 0.00	1.55	0.07
			2.00				1" Ice 0.00	1.74	0.09
							2" Ice 0.00	2.14	0.15
							4" Ice 0.00	3.04	0.31
860 10025	C	From Leg	3.91	12.00	2.00	104.00	No Ice 0.18	0.15	0.00
			0.83				1/2" Ice 0.25	0.21	0.00
			2.00				1" Ice 0.33	0.29	0.01
							2" Ice 0.51	0.47	0.01
							4" Ice 0.98	0.93	0.05
RRUS 32	C	From Leg	3.91	12.00	0.83	104.00	No Ice 3.33	1.98	0.06
			0.83				1/2" Ice 3.60	2.21	0.08

tnxTower SSOE Group 320 Seven Springs Way, Suite 350 Brentwood, TN 37027 Phone: (615) 661-7585 FAX: (615) 661-7569	Job	BU 806377 HRT 084 943242	Page	16 of 30
	Project	016-00010-00	Date	14:28:04 08/09/16
	Client	CCI	Designed by	15310

Description	Face or Leg	Offset Type	Offsets:			Azimuth Adjustment	Placement	C _{AA} Front	C _{AA} Side	Weight			
			Horz	Lateral	Vert						°	ft	ft ²
					2.00								
Sector Mount [SM 504-3]	C	None				0.00	104.00			1" Ice	3.87	2.45	0.10
								2" Ice	4.44	2.96	0.16		
								4" Ice	5.68	4.07	0.34		
								No Ice	34.25	34.25	1.71		
								1/2" Ice	48.98	48.98	2.29		
								1" Ice	63.71	63.71	2.86		
								2" Ice	93.17	93.17	4.02		
742 213 w/ Mount Pipe	A	From Leg				-88.00	94.00			4" Ice	152.09	152.09	6.33
								No Ice	5.37	4.62	0.05		
								1/2" Ice	5.95	6.00	0.09		
								1" Ice	6.50	6.98	0.15		
								2" Ice	7.61	8.85	0.28		
								4" Ice	9.93	12.79	0.68		
								No Ice	5.37	4.62	0.05		
742 213 w/ Mount Pipe	B	From Leg				-88.00	94.00			1/2" Ice	5.95	6.00	0.09
								1" Ice	6.50	6.98	0.15		
								2" Ice	7.61	8.85	0.28		
								4" Ice	9.93	12.79	0.68		
								No Ice	5.37	4.62	0.05		
								1/2" Ice	5.95	6.00	0.09		
								1" Ice	6.50	6.98	0.15		
742 213 w/ Mount Pipe	C	From Leg				-88.00	94.00			2" Ice	7.61	8.85	0.28
								4" Ice	9.93	12.79	0.68		
								No Ice	5.37	4.62	0.05		
								1/2" Ice	5.95	6.00	0.09		
								1" Ice	6.50	6.98	0.15		
								2" Ice	7.61	8.85	0.28		
								4" Ice	9.93	12.79	0.68		
ERICSSON AIR 21 B2A B4P w/ Mount Pipe	A	From Leg				2.00	84.00			No Ice	6.83	5.64	0.11
								1/2" Ice	7.35	6.48	0.17		
								1" Ice	7.86	7.26	0.23		
								2" Ice	8.93	8.86	0.38		
								4" Ice	11.18	12.29	0.81		
								No Ice	6.83	5.64	0.11		
								1/2" Ice	7.35	6.48	0.17		
ERICSSON AIR 21 B4A B2P w/ Mount Pipe	A	From Leg				2.00	84.00			1" Ice	7.86	7.26	0.23
								2" Ice	8.93	8.86	0.38		
								4" Ice	11.18	12.29	0.81		
								No Ice	11.41	9.60	0.08		
								1/2" Ice	12.03	11.02	0.17		
								1" Ice	12.65	12.29	0.26		
								2" Ice	13.98	14.51	0.49		
LNX-6515DS-A1M w/ Mount Pipe	A	From Leg				2.00	84.00			4" Ice	17.00	19.14	1.11
								No Ice	0.41	0.20	0.01		
								1/2" Ice	0.50	0.27	0.01		
								1" Ice	0.59	0.35	0.02		
								2" Ice	0.81	0.53	0.03		
								4" Ice	1.36	1.00	0.08		
								No Ice	3.31	1.36	0.05		
RRUS 11 B12	A	From Leg				2.00	84.00			1/2" Ice	3.55	1.54	0.07
								1" Ice	3.80	1.73	0.10		
								2" Ice	4.33	2.13	0.15		
								4" Ice	5.50	3.04	0.31		
								No Ice	6.83	5.64	0.11		
								1/2" Ice	7.35	6.48	0.17		
								1" Ice	7.86	7.26	0.23		
ERICSSON AIR 21 B2A B4P w/ Mount Pipe	B	From Leg				2.00	84.00			2" Ice	8.93	8.86	0.38
								4" Ice	11.18	12.29	0.81		
								No Ice	6.83	5.64	0.11		
								1/2" Ice	7.35	6.48	0.17		
								1" Ice	7.86	7.26	0.23		
								2" Ice	8.93	8.86	0.38		
								4" Ice	11.18	12.29	0.81		
ERICSSON AIR 21 B4A B2P w/ Mount Pipe	B	From Leg				2.00	84.00			No Ice	6.83	5.64	0.11
								1/2" Ice	7.35	6.48	0.17		
								1" Ice	7.86	7.26	0.23		
								2" Ice	8.93	8.86	0.38		
								4" Ice	11.18	12.29	0.81		
								No Ice	6.83	5.64	0.11		
								1/2" Ice	7.35	6.48	0.17		
			1" Ice	7.86	7.26	0.23							
			2" Ice	8.93	8.86	0.38							

tnxTower SSOE Group 320 Seven Springs Way, Suite 350 Brentwood, TN 37027 Phone: (615) 661-7585 FAX: (615) 661-7569	Job	BU 806377 HRT 084 943242	Page	17 of 30
	Project	016-00010-00	Date	14:28:04 08/09/16
	Client	CCI	Designed by	15310

Description	Face or Leg	Offset Type	Offsets:			Azimuth Adjustment	Placement	C _{AA} Front	C _{AA} Side	Weight
			Horz	Lateral	Vert					
LNX-6515DS-A1M w/ Mount Pipe	B	From Leg	4.00	2.00	84.00	4" Ice	11.18	12.29	0.81	
			0.14			No Ice	11.41	9.60	0.08	
			0.00			1/2" Ice	12.03	11.02	0.17	
						1" Ice	12.65	12.29	0.26	
						2" Ice	13.98	14.51	0.49	
KRY 112 144/1	B	From Leg	4.00	2.00	84.00	4" Ice	17.00	19.14	1.11	
			0.14			No Ice	0.41	0.20	0.01	
			0.00			1/2" Ice	0.50	0.27	0.01	
						1" Ice	0.59	0.35	0.02	
						2" Ice	0.81	0.53	0.03	
RRUS 11 B12	B	From Leg	4.00	2.00	84.00	4" Ice	1.36	1.00	0.08	
			0.14			No Ice	3.31	1.36	0.05	
			0.00			1/2" Ice	3.55	1.54	0.07	
						1" Ice	3.80	1.73	0.10	
						2" Ice	4.33	2.13	0.15	
ERICSSON AIR 21 B2A B4P w/ Mount Pipe	C	From Leg	4.00	2.00	84.00	4" Ice	5.50	3.04	0.31	
			0.14			No Ice	6.83	5.64	0.11	
			0.00			1/2" Ice	7.35	6.48	0.17	
						1" Ice	7.86	7.26	0.23	
						2" Ice	8.93	8.86	0.38	
ERICSSON AIR 21 B4A B2P w/ Mount Pipe	C	From Leg	4.00	2.00	84.00	4" Ice	11.18	12.29	0.81	
			0.14			No Ice	6.83	5.64	0.11	
			0.00			1/2" Ice	7.35	6.48	0.17	
						1" Ice	7.86	7.26	0.23	
						2" Ice	8.93	8.86	0.38	
LNX-6515DS-A1M w/ Mount Pipe	C	From Leg	4.00	2.00	84.00	4" Ice	11.18	12.29	0.81	
			0.14			No Ice	11.41	9.60	0.08	
			0.00			1/2" Ice	12.03	11.02	0.17	
						1" Ice	12.65	12.29	0.26	
						2" Ice	13.98	14.51	0.49	
KRY 112 144/1	C	From Leg	4.00	2.00	84.00	4" Ice	17.00	19.14	1.11	
			0.14			No Ice	0.41	0.20	0.01	
			0.00			1/2" Ice	0.50	0.27	0.01	
						1" Ice	0.59	0.35	0.02	
						2" Ice	0.81	0.53	0.03	
RRUS 11 B12	C	From Leg	4.00	2.00	84.00	4" Ice	1.36	1.00	0.08	
			0.14			No Ice	3.31	1.36	0.05	
			0.00			1/2" Ice	3.55	1.54	0.07	
						1" Ice	3.80	1.73	0.10	
						2" Ice	4.33	2.13	0.15	
Sector Mount [SM 308-3]	C	None		0.00	84.00	4" Ice	5.50	3.04	0.31	
						No Ice	22.34	22.34	0.38	
						1/2" Ice	31.70	31.70	0.83	
						1" Ice	41.06	41.06	1.28	
						2" Ice	59.78	59.78	2.19	
RDL-3000	C	From Leg	0.00	90.00	63.00	4" Ice	97.22	97.22	3.99	
			3.00			No Ice	1.18	0.28	0.01	
			0.00			1/2" Ice	1.32	0.37	0.01	
						1" Ice	1.48	0.48	0.02	
						2" Ice	1.82	0.71	0.04	
Side Arm Mount [SO 311-1]	C	From Leg	0.00	90.00	63.00	4" Ice	2.59	1.28	0.12	
			1.50			No Ice	2.97	3.51	0.06	
			0.00			1/2" Ice	4.39	5.33	0.09	
						1" Ice	5.81	7.15	0.13	
						2" Ice	8.65	10.79	0.19	
GPS-TMG-20N	A	From Leg	2.54	32.00	56.00	4" Ice	14.33	18.07	0.32	
						No Ice	0.16	0.16	0.00	

tnxTower SSOE Group 320 Seven Springs Way, Suite 350 Brentwood, TN 37027 Phone: (615) 661-7585 FAX: (615) 661-7569	Job	BU 806377 HRT 084 943242	Page	18 of 30
	Project	016-00010-00	Date	14:28:04 08/09/16
	Client	CCI	Designed by	15310

Description	Face or Leg	Offset Type	Offsets:		Azimuth Adjustment	Placement	C _{AA} Front	C _{AA} Side	Weight
			Horz Lateral	Vert					
Side Arm Mount [SO 311-1]	A	From Leg	1.27	32.00	56.00	1/2" Ice	0.21	0.21	0.00
			0.79			1" Ice	0.28	0.28	0.01
			0.00			2" Ice	0.44	0.44	0.01
						4" Ice	0.86	0.86	0.05
						No Ice	2.97	3.51	0.06
						1/2" Ice	4.39	5.33	0.09
						1" Ice	5.81	7.15	0.13
						2" Ice	8.65	10.79	0.19
						4" Ice	14.33	18.07	0.32
KS24019-L112A	B	From Leg	1.41	62.00	46.00	No Ice	0.16	0.16	0.01
			2.65			1/2" Ice	0.22	0.22	0.01
			1.00			1" Ice	0.30	0.30	0.01
						2" Ice	0.48	0.48	0.02
						4" Ice	0.95	0.95	0.06
Side Arm Mount [SO 701-1]	B	From Leg	0.70	62.00	46.00	No Ice	0.85	1.67	0.07
			0.00			1/2" Ice	1.14	2.34	0.08
			0.00			1" Ice	1.43	3.01	0.09
						2" Ice	2.01	4.35	0.12
						4" Ice	3.17	7.03	0.18

Dishes

Description	Face or Leg	Dish Type	Offset Type	Offsets:		Azimuth Adjustment	3 dB Beam Width	Elevation	Outside Diameter	Aperture Area	Weight	
				Horz Lateral	Vert							ft
MPRC2449	C	Paraboloid w/Radome	From Leg	0.00	90.00			61.00	2.17	No Ice	3.69	0.02
				3.00						1/2" Ice	3.98	0.04
				0.00						1" Ice	4.27	0.06
										2" Ice	4.84	0.11
										4" Ice	6.00	0.19

Load Combinations

Comb. No.	Description
1	Dead Only
2	Dead+Wind 0 deg - No Ice
3	Dead+Wind 30 deg - No Ice
4	Dead+Wind 60 deg - No Ice
5	Dead+Wind 90 deg - No Ice
6	Dead+Wind 120 deg - No Ice
7	Dead+Wind 150 deg - No Ice
8	Dead+Wind 180 deg - No Ice
9	Dead+Wind 210 deg - No Ice
10	Dead+Wind 240 deg - No Ice
11	Dead+Wind 270 deg - No Ice

tnxTower SSOE Group 320 Seven Springs Way, Suite 350 Brentwood, TN 37027 Phone: (615) 661-7585 FAX: (615) 661-7569	Job	BU 806377 HRT 084 943242	Page	19 of 30
	Project	016-00010-00	Date	14:28:04 08/09/16
	Client	CCI	Designed by	15310

<i>Comb. No.</i>	<i>Description</i>
12	Dead+Wind 300 deg - No Ice
13	Dead+Wind 330 deg - No Ice
14	Dead+Ice+Temp
15	Dead+Wind 0 deg+Ice+Temp
16	Dead+Wind 30 deg+Ice+Temp
17	Dead+Wind 60 deg+Ice+Temp
18	Dead+Wind 90 deg+Ice+Temp
19	Dead+Wind 120 deg+Ice+Temp
20	Dead+Wind 150 deg+Ice+Temp
21	Dead+Wind 180 deg+Ice+Temp
22	Dead+Wind 210 deg+Ice+Temp
23	Dead+Wind 240 deg+Ice+Temp
24	Dead+Wind 270 deg+Ice+Temp
25	Dead+Wind 300 deg+Ice+Temp
26	Dead+Wind 330 deg+Ice+Temp
27	Dead+Wind 0 deg - Service
28	Dead+Wind 30 deg - Service
29	Dead+Wind 60 deg - Service
30	Dead+Wind 90 deg - Service
31	Dead+Wind 120 deg - Service
32	Dead+Wind 150 deg - Service
33	Dead+Wind 180 deg - Service
34	Dead+Wind 210 deg - Service
35	Dead+Wind 240 deg - Service
36	Dead+Wind 270 deg - Service
37	Dead+Wind 300 deg - Service
38	Dead+Wind 330 deg - Service

Maximum Member Forces

<i>Section No.</i>	<i>Elevation ft</i>	<i>Component Type</i>	<i>Condition</i>	<i>Gov. Load Comb.</i>	<i>Force K</i>	<i>Major Axis Moment kip-ft</i>	<i>Minor Axis Moment kip-ft</i>
T1	132 - 124	Leg	Max Tension	4	1.68	0.17	0.00
			Max. Compression	6	-3.01	-0.17	-0.01
			Max. Mx	2	-0.98	-0.63	-0.04
			Max. My	3	-0.61	-0.00	0.69
			Max. Vy	2	-0.50	0.35	-0.04
		Diagonal	Max. Vx	3	0.53	-0.00	-0.36
			Max Tension	13	1.47	0.00	0.00
			Max. Compression	7	-1.44	0.00	0.00
			Max. Mx	16	0.21	0.01	-0.00
			Max. My	7	-1.42	0.00	0.00
		Top Girt	Max. Vy	16	-0.02	0.01	-0.00
			Max. Vx	7	-0.00	0.00	0.00
			Max Tension	4	0.09	0.00	0.00
			Max. Compression	6	-0.09	0.00	0.00
			Max. Mx	14	0.01	-0.05	0.00
T2	124 - 120	Leg	Max. My	15	0.01	0.00	0.00
			Max. Vy	14	-0.03	0.00	0.00
			Max. Vx	15	0.00	0.00	0.00
			Max Tension	4	4.00	-0.42	0.01
			Max. Compression	6	-5.54	0.39	0.03
		Diagonal	Max. Mx	4	4.00	-0.42	0.01
			Max. My	11	-0.74	-0.02	-0.46
			Max. Vy	4	0.16	-0.42	0.01
			Max. Vx	11	0.17	-0.02	-0.46
			Max Tension	7	1.29	0.00	0.00
Max. Compression	13	-1.32	0.00	0.00			

tnxTower SSOE Group 320 Seven Springs Way, Suite 350 Brentwood, TN 37027 Phone: (615) 661-7585 FAX: (615) 661-7569	Job	BU 806377 HRT 084 943242	Page	20 of 30
	Project	016-00010-00	Date	14:28:04 08/09/16
	Client	CCI	Designed by	15310

Section No.	Elevation ft	Component Type	Condition	Gov. Load Comb.	Force K	Major Axis Moment kip-ft	Minor Axis Moment kip-ft
T3	120 - 100	Leg	Max. Mx	18	0.10	0.01	-0.00
			Max. My	3	-1.06	0.00	-0.00
			Max. Vy	19	-0.02	0.01	-0.00
			Max. Vx	3	0.00	0.00	-0.00
			Max Tension	4	23.67	-0.56	-0.00
			Max. Compression	6	-30.49	0.26	0.01
			Max. Mx	4	5.59	1.34	0.04
			Max. My	11	-2.06	-0.04	1.53
			Max. Vy	12	-1.18	-0.58	-0.01
			Max. Vx	5	-1.15	-0.01	0.74
		Diagonal	Max Tension	13	4.63	0.00	0.00
			Max. Compression	7	-4.68	0.00	0.00
			Max. Mx	16	0.19	0.02	0.00
			Max. My	13	-4.59	-0.00	-0.01
			Max. Vy	16	0.02	0.02	0.00
			Max. Vx	13	0.00	0.00	0.00
		Top Girt	Max Tension	12	0.26	0.00	0.00
			Max. Compression	6	-0.18	0.00	0.00
			Max. Mx	14	0.06	-0.05	0.00
			Max. My	15	0.07	0.00	0.00
T4	100 - 93.3333	Leg	Max. Vy	14	0.03	0.00	0.00
			Max. Vx	15	0.00	0.00	0.00
			Max Tension	4	32.81	-0.12	-0.00
			Max. Compression	6	-40.48	0.16	0.03
			Max. Mx	12	32.17	-0.31	-0.01
		Diagonal	Max. My	5	-3.93	-0.04	0.54
			Max. Vy	10	-0.15	0.16	0.01
			Max. Vx	5	0.15	-0.04	0.54
			Max Tension	7	5.36	0.00	0.00
			Max. Compression	13	-5.40	0.00	0.00
T5	93.3333 - 86.6667	Leg	Max. Mx	6	4.91	0.04	-0.00
			Max. My	5	-4.84	-0.01	0.01
			Max. Vy	15	-0.03	0.04	0.00
			Max. Vx	25	0.00	0.00	0.00
			Max Tension	4	42.42	-0.05	-0.01
		Diagonal	Max. Compression	6	-51.08	-0.01	0.01
			Max. Mx	10	-50.24	0.16	0.01
			Max. My	3	-4.69	-0.04	-0.42
			Max. Vy	10	0.06	0.16	0.01
			Max. Vx	3	0.12	-0.04	-0.42
T6	86.6667 - 80	Leg	Max Tension	7	5.33	0.00	0.00
			Max. Compression	7	-5.37	0.00	0.00
			Max. Mx	15	0.61	0.04	-0.00
			Max. My	13	-5.29	-0.01	-0.01
			Max. Vy	17	0.03	0.04	-0.00
		Diagonal	Max. Vx	13	0.00	0.00	0.00
			Max Tension	4	51.67	-0.05	-0.01
			Max. Compression	6	-61.86	-0.11	0.01
			Max. Mx	6	-61.85	0.53	-0.00
			Max. My	3	-5.05	-0.04	-0.42
Secondary Horizontal		Diagonal	Max. Vy	4	0.91	-0.45	0.00
			Max. Vx	9	-0.65	0.03	-0.01
			Max Tension	7	6.43	0.03	-0.00
			Max. Compression	7	-6.62	0.00	0.00
			Max. Mx	6	4.77	0.05	-0.00
		Secondary Horizontal	Max. My	18	0.77	0.05	0.01
			Max. Vy	15	-0.03	0.05	0.01
			Max. Vx	18	-0.00	0.00	0.00
			Max Tension	6	1.07	0.01	-0.00

tnxTower SSOE Group 320 Seven Springs Way, Suite 350 Brentwood, TN 37027 Phone: (615) 661-7585 FAX: (615) 661-7569	Job	BU 806377 HRT 084 943242	Page	21 of 30
	Project	016-00010-00	Date	14:28:04 08/09/16
	Client	CCI	Designed by	15310

Section No.	Elevation ft	Component Type	Condition	Gov. Load Comb.	Force K	Major Axis Moment kip-ft	Minor Axis Moment kip-ft
T7	80 - 60	Leg	Max. Compression	6	-1.07	0.00	0.00
			Max. Mx	19	-0.15	0.02	0.00
			Max. My	5	-0.93	0.00	-0.00
			Max. Vy	19	-0.02	0.02	0.00
			Max. Vx	17	-0.00	0.00	0.00
			Max Tension	4	81.11	-0.10	-0.01
			Max. Compression	6	-95.54	0.24	0.01
		Diagonal	Max. Mx	6	-95.54	0.24	0.01
			Max. My	5	-6.43	-0.01	0.23
			Max. Vy	8	0.09	-0.24	0.01
			Max. Vx	7	0.10	-0.01	-0.21
			Max Tension	7	6.31	0.00	0.00
			Max. Compression	7	-6.35	0.00	0.00
			Max. Mx	17	0.59	0.06	-0.01
T8	60 - 40	Leg	Max. My	15	-0.01	0.05	-0.01
			Max. Vy	17	0.04	0.06	-0.01
			Max. Vx	15	-0.00	0.00	0.00
			Max Tension	4	107.23	-0.43	-0.03
			Max. Compression	6	-125.69	0.47	0.04
			Max. Mx	25	-1.60	-0.58	-0.01
			Max. My	3	-9.01	0.02	-0.34
		Diagonal	Max. Vy	25	0.16	-0.58	-0.01
			Max. Vx	6	-0.10	-0.13	0.30
			Max Tension	7	6.56	0.00	0.00
			Max. Compression	7	-6.68	0.00	0.00
			Max. Mx	19	0.80	0.09	-0.01
			Max. My	13	-6.57	0.00	-0.01
			Max. Vy	17	0.05	0.08	0.01
T9	40 - 20	Leg	Max. Vx	15	-0.00	0.00	0.00
			Max Tension	4	128.92	-0.30	-0.04
			Max. Compression	6	-151.38	0.84	0.06
			Max. Mx	25	-1.65	-0.99	-0.00
			Max. My	3	-9.83	-0.06	-0.79
			Max. Vy	25	0.19	-0.99	-0.00
			Max. Vx	3	-0.17	-0.06	-0.79
		Diagonal	Max Tension	7	7.41	0.00	0.00
			Max. Compression	7	-7.60	0.00	0.00
			Max. Mx	17	0.23	0.12	-0.01
			Max. My	13	-7.36	0.01	-0.02
			Max. Vy	17	0.06	0.12	-0.01
			Max. Vx	21	-0.00	0.00	0.00
			Max Tension	4	140.36	-0.69	-0.03
T10	20 - 10	Leg	Max. Compression	6	-165.19	-0.40	0.00
			Max. Mx	17	7.94	1.01	-0.01
			Max. My	3	-11.57	-0.13	-1.24
			Max. Vy	25	-0.22	-0.99	-0.00
			Max. Vx	3	0.21	-0.13	-1.24
			Max Tension	7	7.56	0.00	0.00
			Max. Compression	13	-7.66	0.00	0.00
		Diagonal	Max. Mx	17	-0.18	0.20	-0.02
			Max. My	13	-7.62	0.01	-0.03
			Max. Vy	17	0.08	0.20	-0.02
			Max. Vx	20	-0.00	0.00	0.00
			Max Tension	4	150.62	0.15	-0.03
			Max. Compression	6	-177.34	0.00	-0.00
			Max. Mx	6	-177.23	1.53	-0.00
Diagonal	Max. My	3	-11.97	-0.13	-1.24		
	Max. Vy	6	-0.43	1.53	-0.00		
	Max. Vx	3	-0.29	-0.13	-1.24		
	Max Tension	13	7.54	0.12	0.01		
	Max. Compression	7	-8.04	0.00	0.00		
	Max. My	3	-11.97	-0.13	-1.24		
	Max. Vy	6	-0.43	1.53	-0.00		
T11	10 - 0	Leg	Max. Vx	3	-0.29	-0.13	-1.24
			Max Tension	13	7.54	0.12	0.01
			Max. Compression	7	-8.04	0.00	0.00
			Max. Mx	6	-177.23	1.53	-0.00
			Max. My	3	-11.97	-0.13	-1.24
			Max. Vy	6	-0.43	1.53	-0.00
			Max. Vx	3	-0.29	-0.13	-1.24
		Diagonal	Max Tension	13	7.54	0.12	0.01
			Max. Compression	7	-8.04	0.00	0.00
			Max. Mx	6	-177.23	1.53	-0.00
			Max. My	3	-11.97	-0.13	-1.24
			Max. Vy	6	-0.43	1.53	-0.00
			Max. Vx	3	-0.29	-0.13	-1.24
			Max Tension	13	7.54	0.12	0.01

tnxTower SSOE Group 320 Seven Springs Way, Suite 350 Brentwood, TN 37027 Phone: (615) 661-7585 FAX: (615) 661-7569	Job	BU 806377 HRT 084 943242	Page	22 of 30
	Project	016-00010-00	Date	14:28:04 08/09/16
	Client	CCI	Designed by	15310

Section No.	Elevation ft	Component Type	Condition	Gov. Load Comb.	Force K	Major Axis Moment kip-ft	Minor Axis Moment kip-ft
			Max. Mx	6	6.24	0.15	-0.02
			Max. My	15	1.87	0.11	-0.02
			Max. Vy	18	0.07	0.11	0.02
			Max. Vx	15	0.00	0.00	0.00
		Secondary Horizontal	Max Tension	6	3.08	0.04	-0.00
			Max. Compression	6	-3.08	0.00	0.00
			Max. Mx	16	0.49	0.07	0.01
			Max. My	3	-0.43	0.03	0.01
			Max. Vy	16	0.05	0.07	0.01
			Max. Vx	18	-0.00	0.00	0.00

Maximum Reactions

Location	Condition	Gov. Load Comb.	Vertical K	Horizontal, X K	Horizontal, Z K
Leg C	Max. Vert	10	181.18	18.22	-10.27
	Max. H _x	10	181.18	18.22	-10.27
	Max. H _z	4	-156.04	-15.85	8.92
	Min. Vert	4	-156.04	-15.85	8.92
	Min. H _x	4	-156.04	-15.85	8.92
	Min. H _z	10	181.18	18.22	-10.27
Leg B	Max. Vert	6	184.03	-17.96	-10.96
	Max. H _x	12	-154.29	15.55	9.48
	Max. H _z	13	-133.07	12.81	9.50
	Min. Vert	12	-154.29	15.55	9.48
	Min. H _x	6	184.03	-17.96	-10.96
	Min. H _z	6	184.03	-17.96	-10.96
Leg A	Max. Vert	2	180.75	0.73	20.72
	Max. H _x	11	11.10	2.63	0.82
	Max. H _z	2	180.75	0.73	20.72
	Min. Vert	8	-151.17	-0.63	-17.92
	Min. H _x	6	-74.35	-2.71	-9.18
	Min. H _z	8	-151.17	-0.63	-17.92

Tower Mast Reaction Summary

Load Combination	Vertical K	Shear _x K	Shear _z K	Overturning Moment, M _x kip-ft	Overturning Moment, M _z kip-ft	Torque kip-ft
Dead Only	30.31	-0.00	0.00	-12.31	-21.07	-0.00
Dead+Wind 0 deg - No Ice	30.31	-0.05	-33.67	-2774.00	-16.98	23.15
Dead+Wind 30 deg - No Ice	30.31	16.32	-27.81	-2316.34	-1381.39	16.02
Dead+Wind 60 deg - No Ice	30.31	27.90	-15.77	-1323.90	-2354.33	6.00
Dead+Wind 90 deg - No Ice	30.31	32.75	0.06	-7.55	-2750.00	-5.30
Dead+Wind 120 deg - No Ice	30.31	29.72	16.89	1372.88	-2472.06	-16.35
Dead+Wind 150 deg - No Ice	30.31	16.43	27.90	2298.06	-1389.85	-21.13
Dead+Wind 180 deg - No Ice	30.31	0.05	31.69	2621.73	-25.38	-20.77
Dead+Wind 210 deg - No Ice	30.31	-16.33	27.84	2293.27	1339.33	-15.84
Dead+Wind 240 deg - No Ice	30.31	-29.63	16.80	1365.13	2423.18	-6.58
Dead+Wind 270 deg - No Ice	30.31	-32.73	-0.04	-16.13	2706.30	5.46
Dead+Wind 300 deg - No Ice	30.31	-27.95	-15.87	-1332.25	2316.57	15.05

tnxTower SSOE Group 320 Seven Springs Way, Suite 350 Brentwood, TN 37027 Phone: (615) 661-7585 FAX: (615) 661-7569	Job	BU 806377 HRT 084 943242	Page	23 of 30
	Project	016-00010-00	Date	14:28:04 08/09/16
	Client	CCI	Designed by	15310

Load Combination	Vertical K	Shear _x K	Shear _z K	Overturning Moment, M _x kip-ft	Overturning Moment, M _z kip-ft	Torque kip-ft
Dead+Wind 330 deg - No Ice	30.31	-16.42	-27.88	-2322.06	1346.84	21.24
Dead+Ice+Temp	72.48	-0.00	0.00	-21.26	-70.83	0.00
Dead+Wind 0 deg+Ice+Temp	72.48	-0.01	-5.76	-489.66	-70.04	3.27
Dead+Wind 30 deg+Ice+Temp	72.48	2.76	-4.74	-410.92	-298.33	2.23
Dead+Wind 60 deg+Ice+Temp	72.48	4.71	-2.68	-242.71	-460.54	0.80
Dead+Wind 90 deg+Ice+Temp	72.48	5.54	0.01	-20.36	-527.36	-0.79
Dead+Wind 120 deg+Ice+Temp	72.48	5.05	2.89	213.74	-482.19	-2.33
Dead+Wind 150 deg+Ice+Temp	72.48	2.78	4.75	369.49	-299.95	-2.99
Dead+Wind 180 deg+Ice+Temp	72.48	0.01	5.39	423.52	-71.77	-2.92
Dead+Wind 210 deg+Ice+Temp	72.48	-2.76	4.74	368.55	156.52	-2.21
Dead+Wind 240 deg+Ice+Temp	72.48	-5.03	2.87	212.17	339.19	-0.90
Dead+Wind 270 deg+Ice+Temp	72.48	-5.53	-0.01	-22.11	385.36	0.81
Dead+Wind 300 deg+Ice+Temp	72.48	-4.72	-2.70	-244.34	319.63	2.15
Dead+Wind 330 deg+Ice+Temp	72.48	-2.78	-4.75	-411.97	158.07	3.01
Dead+Wind 0 deg - Service	30.31	-0.02	-11.65	-967.93	-19.67	8.01
Dead+Wind 30 deg - Service	30.31	5.65	-9.62	-809.55	-491.81	5.54
Dead+Wind 60 deg - Service	30.31	9.65	-5.46	-465.98	-828.12	2.08
Dead+Wind 90 deg - Service	30.31	11.33	0.02	-10.70	-965.38	-1.83
Dead+Wind 120 deg - Service	30.31	10.28	5.85	466.99	-869.19	-5.66
Dead+Wind 150 deg - Service	30.31	5.68	9.65	787.13	-494.70	-7.32
Dead+Wind 180 deg - Service	30.31	0.02	10.96	898.74	-22.58	-7.19
Dead+Wind 210 deg - Service	30.31	-5.65	9.63	785.47	449.62	-5.48
Dead+Wind 240 deg - Service	30.31	-10.25	5.81	464.28	824.65	-2.28
Dead+Wind 270 deg - Service	30.31	-11.32	-0.02	-13.67	922.64	1.89
Dead+Wind 300 deg - Service	30.31	-9.67	-5.49	-468.87	787.45	5.21
Dead+Wind 330 deg - Service	30.31	-5.68	-9.65	-811.54	452.26	7.35

Solution Summary

Load Comb.	Sum of Applied Forces			Sum of Reactions			% Error
	PX K	PY K	PZ K	PX K	PY K	PZ K	
1	0.00	-30.31	0.00	0.00	30.31	-0.00	0.000%
2	-0.05	-30.31	-33.69	0.05	30.31	33.67	0.030%
3	16.33	-30.31	-27.82	-16.32	30.31	27.81	0.033%
4	27.90	-30.31	-15.77	-27.90	30.31	15.77	0.011%
5	32.77	-30.31	0.06	-32.75	30.31	-0.06	0.033%
6	29.73	-30.31	16.90	-29.72	30.31	-16.89	0.030%
7	16.43	-30.31	27.91	-16.43	30.31	-27.90	0.032%
8	0.05	-30.31	31.69	-0.05	30.31	-31.69	0.010%
9	-16.33	-30.31	27.85	16.33	30.31	-27.84	0.032%
10	-29.64	-30.31	16.81	29.63	30.31	-16.80	0.030%
11	-32.74	-30.31	-0.04	32.73	30.31	0.04	0.033%
12	-27.96	-30.31	-15.88	27.95	30.31	15.87	0.011%
13	-16.43	-30.31	-27.89	16.42	30.31	27.88	0.033%
14	0.00	-72.48	0.00	0.00	72.48	-0.00	0.001%
15	-0.01	-72.48	-5.76	0.01	72.48	5.76	0.003%
16	2.76	-72.48	-4.74	-2.76	72.48	4.74	0.003%
17	4.71	-72.48	-2.68	-4.71	72.48	2.68	0.003%
18	5.54	-72.48	0.01	-5.54	72.48	-0.01	0.003%
19	5.05	-72.48	2.89	-5.05	72.48	-2.89	0.003%
20	2.78	-72.48	4.76	-2.78	72.48	-4.75	0.003%
21	0.01	-72.48	5.39	-0.01	72.48	-5.39	0.002%
22	-2.76	-72.48	4.75	2.76	72.48	-4.74	0.002%
23	-5.03	-72.48	2.87	5.03	72.48	-2.87	0.002%
24	-5.54	-72.48	-0.01	5.53	72.48	0.01	0.002%
25	-4.72	-72.48	-2.70	4.72	72.48	2.70	0.002%
26	-2.78	-72.48	-4.75	2.78	72.48	4.75	0.002%

tnxTower SSOE Group 320 Seven Springs Way, Suite 350 Brentwood, TN 37027 Phone: (615) 661-7585 FAX: (615) 661-7569	Job	BU 806377 HRT 084 943242	Page	24 of 30
	Project	016-00010-00	Date	14:28:04 08/09/16
	Client	CCI	Designed by	15310

Load Comb.	Sum of Applied Forces			Sum of Reactions			% Error
	PX K	PY K	PZ K	PX K	PY K	PZ K	
27	-0.02	-30.31	-11.66	0.02	30.31	11.65	0.016%
28	5.65	-30.31	-9.63	-5.65	30.31	9.62	0.016%
29	9.65	-30.31	-5.46	-9.65	30.31	5.46	0.016%
30	11.34	-30.31	0.02	-11.33	30.31	-0.02	0.016%
31	10.29	-30.31	5.85	-10.28	30.31	-5.85	0.016%
32	5.69	-30.31	9.66	-5.68	30.31	-9.65	0.015%
33	0.02	-30.31	10.97	-0.02	30.31	-10.96	0.015%
34	-5.65	-30.31	9.64	5.65	30.31	-9.63	0.015%
35	-10.26	-30.31	5.82	10.25	30.31	-5.81	0.015%
36	-11.33	-30.31	-0.02	11.32	30.31	0.02	0.015%
37	-9.67	-30.31	-5.49	9.67	30.31	5.49	0.016%
38	-5.68	-30.31	-9.65	5.68	30.31	9.65	0.015%

Non-Linear Convergence Results

Load Combination	Converged?	Number of Cycles	Displacement Tolerance	Force Tolerance
1	Yes	6	0.00000001	0.00005091
2	Yes	6	0.00041531	0.00086315
3	Yes	6	0.00045463	0.00094368
4	Yes	7	0.00000001	0.00046791
5	Yes	6	0.00045357	0.00094160
6	Yes	6	0.00041463	0.00086168
7	Yes	6	0.00045141	0.00093652
8	Yes	7	0.00000001	0.00046655
9	Yes	6	0.00045174	0.00093754
10	Yes	6	0.00041410	0.00086099
11	Yes	6	0.00045361	0.00094202
12	Yes	7	0.00000001	0.00046812
13	Yes	6	0.00045427	0.00094289
14	Yes	6	0.00000001	0.00030826
15	Yes	7	0.00000001	0.00068411
16	Yes	7	0.00000001	0.00070057
17	Yes	7	0.00000001	0.00071029
18	Yes	7	0.00000001	0.00070546
19	Yes	7	0.00000001	0.00069070
20	Yes	7	0.00000001	0.00064639
21	Yes	7	0.00000001	0.00060252
22	Yes	7	0.00000001	0.00056810
23	Yes	7	0.00000001	0.00056466
24	Yes	7	0.00000001	0.00057062
25	Yes	7	0.00000001	0.00060255
26	Yes	7	0.00000001	0.00064161
27	Yes	6	0.00000001	0.00088847
28	Yes	6	0.00000001	0.00091479
29	Yes	6	0.00000001	0.00093823
30	Yes	6	0.00000001	0.00091504
31	Yes	6	0.00000001	0.00088769
32	Yes	6	0.00000001	0.00090770
33	Yes	6	0.00000001	0.00093076
34	Yes	6	0.00000001	0.00090711
35	Yes	6	0.00000001	0.00088398
36	Yes	6	0.00000001	0.00091192
37	Yes	6	0.00000001	0.00093591
38	Yes	6	0.00000001	0.00091212

tnxTower SSOE Group 320 Seven Springs Way, Suite 350 Brentwood, TN 37027 Phone: (615) 661-7585 FAX: (615) 661-7569	Job	BU 806377 HRT 084 943242	Page	25 of 30
	Project	016-00010-00	Date	14:28:04 08/09/16
	Client	CCI	Designed by	15310

Bolt Design Data

Section No.	Elevation ft	Component Type	Bolt Grade	Bolt Size in	Number Of Bolts	Maximum Load per Bolt K	Allowable Load K	Ratio Load / Allowable	Allowable Ratio	Criteria
T1	132	Diagonal	A325N	0.63	1	1.47	4.08	0.360 ✓	1.333	Member Block Shear
		Top Girt	A325N	0.63	1	0.09	4.55	0.021 ✓	1.333	Member Block Shear
T2	124	Leg	A325N	0.63	4	1.00	13.50	0.074 ✓	1.333	Bolt Tension
		Diagonal	A325N	0.63	1	1.29	4.08	0.316 ✓	1.333	Member Block Shear
T3	120	Leg	A325N	0.75	4	5.92	19.43	0.305 ✓	1.333	Bolt Tension
		Diagonal	A325N	0.63	1	4.63	4.76	0.973 ✓	1.333	Member Block Shear
T4	100	Diagonal	A325N	0.63	1	5.36	5.44	0.985 ✓	1.333	Member Bearing
T5	93.3333	Diagonal	A325N	0.63	1	5.33	5.44	0.980 ✓	1.333	Member Bearing
T6	86.6667	Leg	A325N	0.88	4	12.81	26.46	0.484 ✓	1.333	Bolt Tension
		Diagonal	A325N	0.63	1	6.43	5.44	1.182 ✓	1.333	Member Bearing
		Secondary Horizontal	A325N	0.63	1	1.07	3.19	0.336 ✓	1.333	Member Block Shear
T7	80	Leg	A325N	0.88	4	20.28	26.46	0.766 ✓	1.333	Bolt Tension
		Diagonal	A325N	0.63	1	6.31	5.44	1.160 ✓	1.333	Member Bearing
T8	60	Leg	A325N	1.00	4	26.81	34.56	0.776 ✓	1.333	Bolt Tension
		Diagonal	A325N	0.63	1	6.56	6.09	1.077 ✓	1.333	Member Bearing
T9	40	Leg	A325N	1.00	4	32.23	34.56	0.933 ✓	1.333	Bolt Tension
		Diagonal	A325N	0.63	1	7.60	6.44	1.180 ✓	1.333	Bolt Shear
T10	20	Diagonal	A325N	0.75	1	7.56	8.13	0.930 ✓	1.333	Member Bearing
T11	10	Leg	A449	1.00	4	37.62	31.10	1.209 ✓	1.333	Bolt Tension
		Diagonal	A325N	0.75	1	7.54	8.13	0.928 ✓	1.333	Member Bearing
		Secondary Horizontal	A325N	0.63	1	3.08	5.10	0.603 ✓	1.333	Member Bearing

Compression Checks

Leg Design Data (Compression)

Section No.	Elevation ft	Size	L ft	L _u ft	Kl/r	F _a ksi	A in ²	Actual P K	Allow. P _a K	Ratio P / P _a
T1	132 - 124	ROHN 2 STD	8.00	4.00	61.0 K=1.00	22.55	1.07	-3.01	24.23	0.124
T2	124 - 120	ROHN 2 STD	4.00	4.00	61.0	22.55	1.07	-5.54	24.23	0.228 ✓

tnxTower SSOE Group 320 Seven Springs Way, Suite 350 Brentwood, TN 37027 Phone: (615) 661-7585 FAX: (615) 661-7569	Job	BU 806377 HRT 084 943242	Page	26 of 30
	Project	016-00010-00	Date	14:28:04 08/09/16
	Client	CCI	Designed by	15310

Section No.	Elevation ft	Size	L ft	L _u ft	Kl/r	F _a ksi	A in ²	Actual P K	Allow. P _a K	Ratio P P _a
T3	120 - 100	ROHN 2.5 STD	20.03	5.01	K=1.00 63.4	22.12	1.70	-30.49	37.70	0.809
T4	100 - 93.3333	ROHN 3 STD	6.68	6.68	K=1.00 68.9	21.15	2.23	-40.48	47.12	0.859
T5	93.3333 - 86.6667	ROHN 3 STD	6.68	6.68	K=1.00 68.9	21.15	2.23	-51.08	47.12	1.084
T6	86.6667 - 80	ROHN 3 STD	6.68	3.45	K=1.00 35.5	26.44	2.23	-61.86	58.92	1.050
T7	80 - 60	ROHN 3 XX-STR	20.04	6.68	K=1.00 76.5	19.69	5.47	-95.54	107.66	0.887
T8	60 - 40	ROHN 4 X-STR	20.03	6.68	K=1.00 54.3	23.67	4.41	-125.69	104.33	1.205
T9	40 - 20	ROHN 5 X-STR	20.03	10.02	K=1.00 65.4	21.78	6.11	-151.38	133.13	1.137
T10	20 - 10	ROHN 5 X-STR	10.02	10.02	K=1.00 65.4	21.78	6.11	-165.19	133.13	1.241
T11	10 - 0	ROHN 5 X-STR	10.02	5.15	K=1.00 33.6	26.70	6.11	-177.34	163.19	1.087

Diagonal Design Data (Compression)

Section No.	Elevation ft	Size	L ft	L _u ft	Kl/r	F _a ksi	A in ²	Actual P K	Allow. P _a K	Ratio P P _a
T1	132 - 124	L1 3/4x1 3/4x3/16	7.74	3.63	K=1.00 126.9	9.27	0.62	-1.44	5.76	0.250
T2	124 - 120	L1 3/4x1 3/4x3/16	7.75	3.64	K=1.00 127.1	9.24	0.62	-1.32	5.74	0.230
T3	120 - 100	L2x2x3/16	9.80	4.79	K=1.00 145.8	7.03	0.71	-4.68	5.02	0.931
T4	100 - 93.3333	L2 1/2x2 1/2x3/16	11.22	5.51	K=1.00 133.6	8.37	0.90	-5.40	7.55	0.716
T5	93.3333 - 86.6667	L2 1/2x2 1/2x3/16	11.76	5.78	K=1.00 140.1	7.60	0.90	-5.37	6.86	0.783
T6	86.6667 - 80	L2 1/2x2 1/2x3/16	12.32	6.18	K=1.00 149.9	6.65	0.90	-6.62	6.00	1.104
T7	80 - 60	L2 1/2x2 1/2x3/16	14.09	6.95	K=1.00 168.5	5.26	0.90	-6.29	4.74	1.327
T8	60 - 40	L3x3x3/16	15.90	7.80	K=1.00 157.1	6.05	1.09	-6.68	6.59	1.013
T9	40 - 20	L3x3x1/4	19.10	9.45	K=1.00 191.5	4.07	1.44	-7.60	5.86	1.296
T10	20 - 10	L3 1/2x3 1/2x1/4	19.96	9.87	K=1.00 170.6	5.13	1.69	-7.66	8.67	0.883
T11	10 - 0	L3 1/2x3 1/2x1/4	20.83	10.44	K=1.00 180.4	4.59	1.69	-8.04	7.75	1.037

tnxTower SSOE Group 320 Seven Springs Way, Suite 350 Brentwood, TN 37027 Phone: (615) 661-7585 FAX: (615) 661-7569	Job	BU 806377 HRT 084 943242	Page	27 of 30
	Project	016-00010-00	Date	14:28:04 08/09/16
	Client	CCI	Designed by	15310

Secondary Horizontal Design Data (Compression)

Section No.	Elevation ft	Size	L ft	L _u ft	Kl/r	F _a ksi	A in ²	Actual P K	Allow. P _a K	Ratio P P _a
T6	86.6667 - 80	L1 1/2x1 1/2x3/16	10.34	10.05	132.1 K=0.50	8.56	0.53	-1.07	4.52	0.238
T11	10 - 0	L2 1/2x2 1/2x3/16	18.26	17.79	137.2 K=0.50	7.93	0.90	-3.08	7.15	0.430

Top Girt Design Data (Compression)

Section No.	Elevation ft	Size	L ft	L _u ft	Kl/r	F _a ksi	A in ²	Actual P K	Allow. P _a K	Ratio P P _a
T1	132 - 124	L2x2x3/16	6.60	6.17	187.8 K=1.00	4.23	0.71	-0.09	3.03	0.029
T3	120 - 100	L2x2x3/16	6.65	6.45	167.0 K=0.85	5.36	0.71	-0.18	3.83	0.046

Tension Checks

Leg Design Data (Tension)

Section No.	Elevation ft	Size	L ft	L _u ft	Kl/r	F _a ksi	A in ²	Actual P K	Allow. P _a K	Ratio P P _a
T1	132 - 124	ROHN 2 STD	8.00	4.00	61.0	30.00	1.07	1.68	32.24	0.052
T2	124 - 120	ROHN 2 STD	4.00	4.00	61.0	30.00	1.07	4.00	32.24	0.124
T3	120 - 100	ROHN 2.5 STD	20.03	5.01	63.4	30.00	1.70	23.67	51.12	0.463
T4	100 - 93.3333	ROHN 3 STD	6.68	6.68	68.9	30.00	2.23	32.81	66.85	0.491
T5	93.3333 - 86.6667	ROHN 3 STD	6.68	6.68	68.9	30.00	2.23	42.42	66.85	0.635
T6	86.6667 - 80	ROHN 3 STD	6.68	3.45	35.5	30.00	2.23	51.67	66.85	0.773
T7	80 - 60	ROHN 3 XX-STR	20.04	6.68	76.5	30.00	5.47	81.11	163.99	0.495
T8	60 - 40	ROHN 4 X-STR	20.03	6.68	54.3	30.00	4.41	107.23	132.22	0.811
T9	40 - 20	ROHN 5 X-STR	20.03	10.02	65.4	30.00	6.11	128.92	183.36	0.703
T10	20 - 10	ROHN 5 X-STR	10.02	10.02	65.4	30.00	6.11	140.36	183.36	0.765

tnxTower SSOE Group 320 Seven Springs Way, Suite 350 Brentwood, TN 37027 Phone: (615) 661-7585 FAX: (615) 661-7569	Job	BU 806377 HRT 084 943242	Page	28 of 30
	Project	016-00010-00	Date	14:28:04 08/09/16
	Client	CCI	Designed by	15310

Section No.	Elevation ft	Size	L ft	L _u ft	Kl/r	F _a ksi	A in ²	Actual P K	Allow. P _a K	Ratio P P _a
T11	10 - 0	ROHN 5 X-STR	10.02	5.15	33.6	30.00	6.11	150.62	183.36	0.821 ✓

Diagonal Design Data (Tension)

Section No.	Elevation ft	Size	L ft	L _u ft	Kl/r	F _a ksi	A in ²	Actual P K	Allow. P _a K	Ratio P P _a
T1	132 - 124	L1 3/4x1 3/4x3/16	7.74	3.63	84.0	29.00	0.36	1.47	10.45	0.141 ✓
T2	124 - 120	L1 3/4x1 3/4x3/16	7.75	3.64	84.1	29.00	0.36	1.29	10.45	0.123 ✓
T3	120 - 100	L2x2x3/16	9.80	4.79	95.5	29.00	0.43	4.63	12.49	0.370 ✓
T4	100 - 93.3333	L2 1/2x2 1/2x3/16	11.22	5.51	86.9	29.00	0.57	5.36	16.56	0.324 ✓
T5	93.3333 - 86.6667	L2 1/2x2 1/2x3/16	11.76	5.78	91.1	29.00	0.57	5.33	16.56	0.322 ✓
T6	86.6667 - 80	L2 1/2x2 1/2x3/16	12.32	6.18	95.4	29.00	0.57	6.43	16.56	0.388 ✓
T7	80 - 60	L2 1/2x2 1/2x3/16	12.89	6.36	100.0	29.00	0.57	6.31	16.56	0.381 ✓
T8	60 - 40	L3x3x3/16	15.90	7.80	101.3	32.50	0.71	6.56	23.14	0.284 ✓
T9	40 - 20	L3x3x1/4	19.10	9.45	123.5	32.50	0.94	7.41	30.53	0.243 ✓
T10	20 - 10	L3 1/2x3 1/2x1/4	19.96	9.87	110.1	32.50	1.10	7.56	35.86	0.211 ✓
T11	10 - 0	L3 1/2x3 1/2x1/4	20.83	10.44	114.9	32.50	1.10	7.54	35.86	0.210 ✓

Secondary Horizontal Design Data (Tension)

Section No.	Elevation ft	Size	L ft	L _u ft	Kl/r	F _a ksi	A in ²	Actual P K	Allow. P _a K	Ratio P P _a
T6	86.6667 - 80	L1 1/2x1 1/2x3/16	10.34	10.05	264.1	29.00	0.29	1.07	8.41	0.128 ✓
T11	10 - 0	L2 1/2x2 1/2x3/16	18.26	17.79	274.5	29.00	0.57	3.08	16.56	0.186 ✓

Top Girt Design Data (Tension)

tnxTower SSOE Group 320 Seven Springs Way, Suite 350 Brentwood, TN 37027 Phone: (615) 661-7585 FAX: (615) 661-7569	Job	BU 806377 HRT 084 943242	Page	29 of 30
	Project	016-00010-00	Date	14:28:04 08/09/16
	Client	CCI	Designed by	15310

Section No.	Elevation ft	Size	L ft	L _u ft	Kl/r	F _a ksi	A in ²	Actual P K	Allow. P _a K	Ratio P P _a
T1	132 - 124	L2x2x3/16	6.60	6.17	124.6	29.00	0.43	0.09	12.49	0.008
T3	120 - 100	L2x2x3/16	6.65	6.45	125.4	21.60	0.71	0.26	15.44	0.017



Section Capacity Table

Section No.	Elevation ft	Component Type	Size	Critical Element	P K	SF*P _{allow} K	% Capacity	Pass Fail
T1	132 - 124	Leg	ROHN 2 STD	2	-3.01	32.30	9.3	Pass
T2	124 - 120	Leg	ROHN 2 STD	20	-5.54	32.30	17.1	Pass
T3	120 - 100	Leg	ROHN 2.5 STD	29	-30.49	50.25	60.7	Pass
T4	100 - 93.3333	Leg	ROHN 3 STD	59	-40.48	62.82	64.4	Pass
T5	93.3333 - 86.6667	Leg	ROHN 3 STD	68	-51.08	62.82	81.3	Pass
T6	86.6667 - 80	Leg	ROHN 3 STD	77	-61.86	78.55	78.8	Pass
T7	80 - 60	Leg	ROHN 3 XX-STR	89	-95.54	143.51	66.6	Pass
T8	60 - 40	Leg	ROHN 4 X-STR	110	-125.69	139.07	90.4	Pass
T9	40 - 20	Leg	ROHN 5 X-STR	131	-151.38	177.46	85.3	Pass
T10	20 - 10	Leg	ROHN 5 X-STR	146	-165.19	177.46	93.1	Pass
T11	10 - 0	Leg	ROHN 5 X-STR	155	-177.34	217.53	81.5	Pass
T1	132 - 124	Diagonal	L1 3/4x1 3/4x3/16	9	-1.44	7.67	90.7 (b) 18.7	Pass
T2	124 - 120	Diagonal	L1 3/4x1 3/4x3/16	25	-1.32	7.65	27.0 (b) 17.3	Pass
T3	120 - 100	Diagonal	L2x2x3/16	36	-4.68	6.70	23.7 (b) 69.9	Pass
T4	100 - 93.3333	Diagonal	L2 1/2x2 1/2x3/16	64	-5.40	10.06	73.0 (b) 53.7	Pass
T5	93.3333 - 86.6667	Diagonal	L2 1/2x2 1/2x3/16	72	-5.37	9.14	73.9 (b) 58.7	Pass
T6	86.6667 - 80	Diagonal	L2 1/2x2 1/2x3/16	81	-6.62	7.99	73.6 (b) 82.8	Pass
T7	80 - 60	Diagonal	L2 1/2x2 1/2x3/16	93	-6.29	6.32	88.6 (b) 99.6	Pass
T8	60 - 40	Diagonal	L3x3x3/16	114	-6.68	8.79	76.0 80.8 (b)	Pass
T9	40 - 20	Diagonal	L3x3x1/4	135	-7.60	7.82	97.2	Pass
T10	20 - 10	Diagonal	L3 1/2x3 1/2x1/4	151	-7.66	11.56	66.2 69.8 (b)	Pass
T11	10 - 0	Diagonal	L3 1/2x3 1/2x1/4	159	-8.04	10.33	77.8	Pass
T6	86.6667 - 80	Secondary Horizontal	L1 1/2x1 1/2x3/16	85	-1.07	6.02	17.8 25.2 (b)	Pass
T11	10 - 0	Secondary Horizontal	L2 1/2x2 1/2x3/16	163	-3.08	9.53	32.3 45.3 (b)	Pass
T1	132 - 124	Top Girt	L2x2x3/16	6	-0.09	4.03	2.2	Pass
T3	120 - 100	Top Girt	L2x2x3/16	33	-0.18	5.10	3.5	Pass
Summary							ELC:	LC7
Leg (T10)							93.1	Pass
Diagonal (T7)							99.6	Pass
Secondary Horizontal (T11)							45.3	Pass

tnxTower SSOE Group 320 Seven Springs Way, Suite 350 Brentwood, TN 37027 Phone: (615) 661-7585 FAX: (615) 661-7569	Job	BU 806377 HRT 084 943242	Page	30 of 30
	Project	016-00010-00	Date	14:28:04 08/09/16
	Client	CCI	Designed by	15310

Section No.	Elevation ft	Component Type	Size	Critical Element	P K	SF*P _{allow} K	% Capacity	Pass Fail
						Top Girt (T3)	3.5	Pass
						Bolt Checks	90.7	Pass
						Rating =	99.6	Pass

APPENDIX B
BASE LEVEL DRAWING

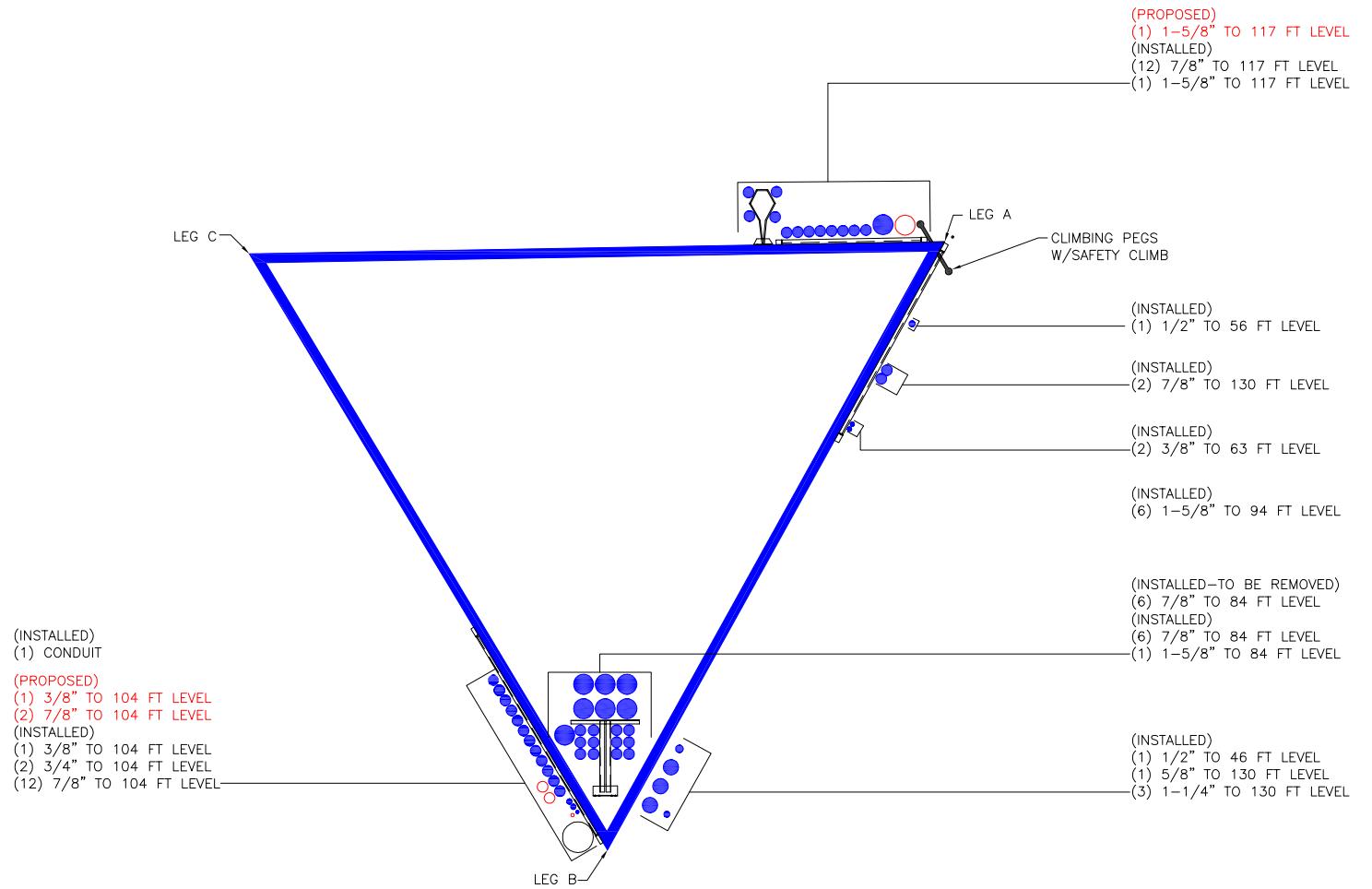

APPENDIX C
ADDITIONAL CALCULATIONS

(Bearing and Stability Checks) Tool for TIA Rev F or G - Application (MP, SST with unitbase)

Site Data

BU#: 806377
Site Name: HRT 084 943242
App #: 357603 Rev. 0

Monopole Base Reaction Forces		
TIA Revision:	F	<--Pull Down
Unfactored DL Axial, PD:	30	kips
Unfactored WL Axial, PW:	0	kips
Unfactored WL Shear, V:	34	kips
Unfactored WL Moment, M:	2828	ft-kips

Enter Load Factors Below:		
For P (DL)	1.2	<---- Enter Factor
For P,V, and M (WL)	1.35	<---- Enter Factor

Load Factor	Shaft Factored Loads	
1.20	1.2D+1.6W, Pu:	36 kips
0.90	0.9D+1.6W, Pu:	27 kips
1.35	Vu:	45.9 kips
	Mu:	3817.8 ft-kips

Pad & Pier Data		
Base PL Dist. Above Pier:	3	in
Pier Dist. Above Grade:	27.6	in
Pad Bearing Depth, D:	4.2	ft
Pad Thickness, T:	4.2	ft
Pad Width=Length, L:	24	ft
Pier Cross Section Shape:	Square	<--Pull Down
Enter Pier Side Width:	3.3	ft
Concrete Density:	150.0	pcf
Pier Cross Section Area:	10.89	ft^2
Pier Height:	2.30	ft
Soil (above pad) Height:	0.00	ft

1.2D+1.6W Load Combination, Bearing Results:

(No Soil Wedges) [Reaction+Conc+Soil]	475.96	P1="1.2D+1.6W" (Kips)
Factored "1.6W" Overturning Moment (MW-Msoil), M1	4063.37	ft-kips

Orthogonal Direction:

ecc1 = M1/P1 = 8.54 ft
 Orthogonal qu= 2.86 ksf
 qu/φ*qn Ratio= **12.73% Pass**

Diagonal Direction:

ecc2 = (0.707M1)/P1 = 6.04 ft
 Diagonal qu= 3.35 ksf
 qu/φ*qn Ratio= **14.87% Pass**

<-- Press Upon Completing All Input

Soil Parameters		
Unit Weight, γ:	115.0	pcf
Ultimate Bearing Capacity, qn:	30.00	ksf
Strength Reduct. factor, φ:	0.75	
Angle of Friction, Φ:	33.0	degrees
Undrained Shear Strength, Cu:	0.00	ksf
Allowable Bearing: φ*qn:	22.50	ksf
Passive Pres. Coeff., Kp	3.39	

Overturning Stability Check

0.9D+1.6W Load Combination, Bearing Results:

Forces/Moments due to Wind and Lateral Soil		
Minimum of (φ*Ultimate Pad Passive Force, Vu):	45.9	kips
Pad Force Location Above D:	1.40	ft
φ(Passive Pressure Moment):	64.26	ft-kips
Factored O.T. M(WL), "1.6W":	4127.6	ft-kips
Factored OT (MW-Msoil), M1	4063.37	ft-kips

(w/ Soil Wedges) [Reaction+Conc+Soil]	356.97	P2="0.9D+1.6W" (Kips)
Factored "1.6W" Overturning Moment (MW-Msoil) - 0.9(M of Wedge + M of Cohesion), M2	4063.37	ft-kips

Resistance due to Foundation Gravity		
Soil Wedge Projection grade, a:	0.00	ft
Sum of Soil Wedges Wt:	0.00	kips
Soil Wedges ecc, K1:	0.00	ft
Ftg+Soil above Pad wt:	366.6	kips
Unfactored (Total ftg-soil Wt):	366.64	kips
1.2D. No Soil Wedges.	475.96	kips
0.9D. With Soil Wedges	356.97	kips

Orthogonal ecc3 = M2/P2 = 11.38 ft
 Ortho Non Bearing Length,NBL= **22.77 ft**
 Orthogonal qu= 12.05 ksf
 Diagonal qu= 5.72 ksf

Resistance due to Cohesion (Vertical)		
φ*(1/2*Cu)(Total Vert. Planes)	0.00	kips
Cohesion Force Eccentricity, K2	0.00	ft

Max Reaction Moment (ft-kips) so that qu=φ*qn = 100% Capacity Rating			
Actual M:	2828.00		
M Orthogonal:	2903.80	97.39%	Pass
M Diagonal:	2903.80	97.39%	Pass



Monopole or Self Support Pad Foundation Reinforcing
 BU#: 806377
 SSOE Project Number: 016-00010-00

Analysis Code	F
Compression	184 k
Uplift	156 k
Shear	21 k

Structural Capacity 20.7% **OK**

Pad Geometry & Reinforcing	
Pad Length	24 ft
Pad Width	24 ft
Pad Thickness	4.2 ft
Pad Top Rebar Size	# 8
Pad Top Rebar Quantity	24
Pad Bottom Rebar Size	# 8
Pad Bottom Rebar Quantity	24
Clear Cover	3 in
f_c'	3 ksi
Rebar F_y	60 ksi
Minimum Steel Assumed?	NO
Pier Shape	Square
Pier Rebar Size	# 9
Pier Rebar Quantity	16
Pier Width	3.3 ft
Pier Height	2.3 ft
Anchor Rod Circle	9.5 in
Anchor Rod Embedment	66.5 in
Pier Tie Size	# 5

Bearing Calculation	
Max Bearing Pressure	12.05 ksf
Edge of Pad to Pier Face	2.20833 ft
Clear Distance Between Piers	15.5 ft
ecc3 (From Crown Spreadsheet)	11.38
Non-Bearing Length	22.76 ft

Structural Calculations	
Minimum Reinforcement Check	
Pad - A_s Min Met?	Yes
Pier - A_s Min Met?	Yes
Punching Shear	
ϕ (Shear) =	0.75
V_u =	-73.87 k
ϕV_c =	3488.27 k
Shear Capacity	2.1% OK
Pad Flexure	
ϕ (Tension) =	0.9
M_u	17.43 k-ft
ϕM_n =	215.72 k-ft
Moment Capacity	8.1% OK
Beam Shear	
V_u	3.79 k
ϕV_n =	60.84 k
Shear Capacity	6.2% OK
Pier Compression	
P_u	239.2 k
ϕP_n =	2557.36 k
Compression Capacity	9.4% OK
Pier Tension	
P_u =	202.80 k
ϕP_n =	979.05 k
Tension Capacity =	20.7% OK
Pier Interface	
P_u =	725.0152 k
ϕP_n =	7997.616 k
Interface Capacity =	9.1% OK

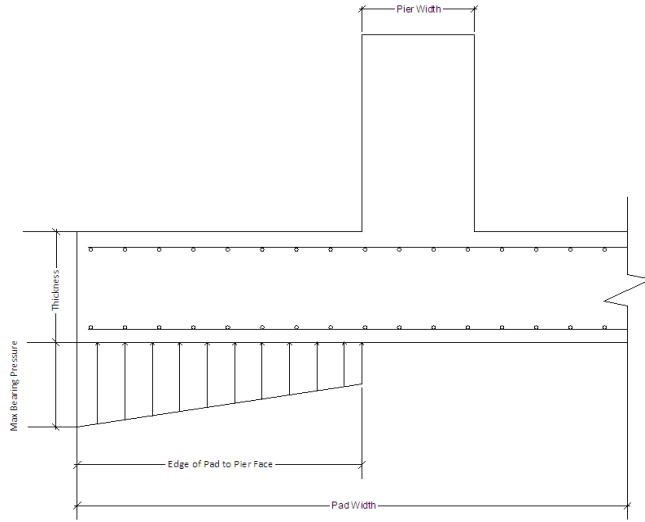

RADIO FREQUENCY EMISSIONS ANALYSIS REPORT
EVALUATION OF HUMAN EXPOSURE POTENTIAL
TO NON-IONIZING EMISSIONS

T-Mobile Existing Facility

Site ID: CT11711A

HRT 084 943242
197 South Street
Vernon, CT 06066

August 23, 2016

EBI Project Number: 6216003718

Site Compliance Summary	
Compliance Status:	COMPLIANT
Site total MPE% of FCC general public allowable limit:	23.80 %

August 23, 2016

T-Mobile USA
Attn: Jason Overbey, RF Manager
35 Griffin Road South
Bloomfield, CT 06002

Emissions Analysis for Site: **CT11711A – HRT 084 943242**

EBI Consulting was directed to analyze the proposed T-Mobile facility located at **197 South Street, Vernon, CT**, for the purpose of determining whether the emissions from the Proposed T-Mobile Antenna Installation located on this property are within specified federal limits.

All information used in this report was analyzed as a percentage of current Maximum Permissible Exposure (% MPE) as listed in the FCC OET Bulletin 65 Edition 97-01 and ANSI/IEEE Std C95.1. The FCC regulates Maximum Permissible Exposure in units of microwatts per square centimeter ($\mu\text{W}/\text{cm}^2$). The number of $\mu\text{W}/\text{cm}^2$ calculated at each sample point is called the power density. The exposure limit for power density varies depending upon the frequencies being utilized. Wireless Carriers and Paging Services use different frequency bands each with different exposure limits, therefore it is necessary to report results and limits in terms of percent MPE rather than power density.

All results were compared to the FCC (Federal Communications Commission) radio frequency exposure rules, 47 CFR 1.1307(b)(1) – (b)(3), to determine compliance with the Maximum Permissible Exposure (MPE) limits for General Population/Uncontrolled environments as defined below.

General population/uncontrolled exposure limits apply to situations in which the general public may be exposed or in which persons who are exposed as a consequence of their employment may not be made fully aware of the potential for exposure or cannot exercise control over their exposure. Therefore, members of the general public would always be considered under this category when exposure is not employment related, for example, in the case of a telecommunications tower that exposes persons in a nearby residential area.

Public exposure to radio frequencies is regulated and enforced in units of microwatts per square centimeter ($\mu\text{W}/\text{cm}^2$). The general population exposure limit for the 700 MHz Band is approximately 467 $\mu\text{W}/\text{cm}^2$, and the general population exposure limit for the 1900 MHz (PCS) and 2100 MHz (AWS) bands is 1000 $\mu\text{W}/\text{cm}^2$. Because each carrier will be using different frequency bands, and each frequency band has different exposure limits, it is necessary to report percent of MPE rather than power density.

Occupational/controlled exposure limits apply to situations in which persons are exposed as a consequence of their employment and in which those persons who are exposed have been made fully aware of the potential for exposure and can exercise control over their exposure. Occupational/controlled exposure limits also apply where exposure is of a transient nature as a result of incidental passage through a location where exposure levels may be above general population/uncontrolled limits (see below), as long as the exposed person has been made fully aware of the potential for exposure and can exercise control over his or her exposure by leaving the area or by some other appropriate means.

Additional details can be found in FCC OET 65.

CALCULATIONS

Calculations were done for the proposed T-Mobile Wireless antenna facility located at **197 South Street, Vernon, CT**, using the equipment information listed below. All calculations were performed per the specifications under FCC OET 65. Since T-Mobile is proposing highly focused directional panel antennas, which project most of the emitted energy out toward the horizon, all calculations were performed assuming a lobe representing the maximum gain of the antenna per the antenna manufactures supplied specifications, minus 10 dB, was focused at the base of the tower. For this report the sample point is the top of a 6-foot person standing at the base of the tower.

For all calculations, all equipment was calculated using the following assumptions:

- 1) 2 GSM channels (PCS Band - 1900 MHz) were considered for each sector of the proposed installation. These Channels have a transmit power of 30 Watts per Channel.
- 2) 2 UMTS channels (PCS Band - 1900 MHz) were considered for each sector of the proposed installation. These Channels have a transmit power of 30 Watts per Channel.
- 3) 2 UMTS channels (AWS Band – 2100 MHz) were considered for each sector of the proposed installation. These Channels have a transmit power of 30 Watts per Channel.
- 4) 2 LTE channels (AWS Band – 2100 MHz) were considered for each sector of the proposed installation. These Channels have a transmit power of 60 Watts per Channel
- 5) 1 LTE channel (700 MHz Band) was considered for each sector of the proposed installation. This channel has a transmit power of 30 Watts.

- 6) Since the 2100 MHz UMTS radios are ground mounted there are additional cabling losses accounted for. For each ground 2100 MHz UMTS RF path there was an additional 1.38 dB of additional cable loss was factored into the calculations. This is based on manufacturers Specifications for 130 feet of 1-5/8" coax cable on each path.
- 7) All radios at the proposed installation were considered to be running at full power and were uncombined in their RF transmissions paths per carrier prescribed configuration. Per FCC OET Bulletin No. 65 - Edition 97-01 recommendations to achieve the maximum anticipated value at each sample point, all power levels emitting from the proposed antenna installation are increased by a factor of 2.56 to account for possible in-phase reflections from the surrounding environment. This is rarely the case, and if so, is never continuous.
- 8) For the following calculations the sample point was the top of a 6-foot person standing at the base of the tower. The maximum gain of the antenna per the antenna manufactures supplied specifications minus 10 dB was used in this direction. This value is a very conservative estimate as gain reductions for these particular antennas are typically much higher in this direction.
- 9) The antennas used in this modeling are the **Ericsson AIR21 B4A/B2P** & **Ericsson AIR21 B2A/B4P** for 1900 MHz (PCS) and 2100 MHz (AWS) channels and the **Commscope LNX-6515DS-VTM** for 700 MHz channels. This is based on feedback from the carrier with regards to anticipated antenna selection. The **Ericsson AIR21 B4A/B2P** has a maximum gain of **15.9 dBd** at its main lobe at 1900 MHz and 2100 MHz. The **Ericsson AIR21 B2A/B4P** has a maximum gain of **15.9 dBd** at its main lobe at 1900 MHz and 2100 MHz. The **Commscope LNX-6515DS-VTM** has a maximum gain of **14.6 dBd** at its main lobe at 700 MHz. The maximum gain of the antenna per the antenna manufactures supplied specifications, minus 10 dB, was used for all calculations. This value is a very conservative estimate as gain reductions for these particular antennas are typically much higher in this direction.
- 10) The antenna mounting height centerline of the proposed antennas is **84 feet** above ground level (AGL).
- 11) Emissions values for additional carriers were taken from the Connecticut Siting Council active database. Values in this database are provided by the individual carriers themselves.
- 12) All calculations were done with respect to uncontrolled / general public threshold limits.

T-Mobile Site Inventory and Power Data

Sector:	A	Sector:	B	Sector:	C
Antenna #:	1	Antenna #:	1	Antenna #:	1
Make / Model:	Ericsson AIR21 B4A/B2P	Make / Model:	Ericsson AIR21 B4A/B2P	Make / Model:	Ericsson AIR21 B4A/B2P
Gain:	15.9 dBd	Gain:	15.9 dBd	Gain:	15.9 dBd
Height (AGL):	84	Height (AGL):	84	Height (AGL):	84
Frequency Bands	1900 MHz(PCS) / 2100 MHz (AWS)	Frequency Bands	1900 MHz(PCS) / 2100 MHz (AWS)	Frequency Bands	1900 MHz(PCS) / 2100 MHz (AWS)
Channel Count	2	Channel Count	2	Channel Count	2
Total TX Power(W):	120	Total TX Power(W):	120	Total TX Power(W):	120
ERP (W):	4,668.54	ERP (W):	4,668.54	ERP (W):	4,668.54
Antenna A1 MPE%	2.76	Antenna B1 MPE%	2.76	Antenna C1 MPE%	2.76
Antenna #:	2	Antenna #:	2	Antenna #:	2
Make / Model:	Ericsson AIR21 B2A/B4P	Make / Model:	Ericsson AIR21 B2A/B4P	Make / Model:	Ericsson AIR21 B2A/B4P
Gain:	15.9 dBd	Gain:	15.9 dBd	Gain:	15.9 dBd
Height (AGL):	84	Height (AGL):	84	Height (AGL):	84
Frequency Bands	1900 MHz(PCS) / 2100 MHz (AWS)	Frequency Bands	1900 MHz(PCS) / 2100 MHz (AWS)	Frequency Bands	1900 MHz(PCS) / 2100 MHz (AWS)
Channel Count	6	Channel Count	6	Channel Count	6
Total TX Power(W):	180	Total TX Power(W):	180	Total TX Power(W):	180
ERP (W):	6,367.38	ERP (W):	6,367.38	ERP (W):	6,367.38
Antenna A2 MPE%	3.76	Antenna B2 MPE%	3.76	Antenna C2 MPE%	3.76
Antenna #:	3	Antenna #:	3	Antenna #:	3
Make / Model:	Commscope LNX-6515DS-VTM	Make / Model:	Commscope LNX-6515DS-VTM	Make / Model:	Commscope LNX-6515DS-VTM
Gain:	14.6 dBd	Gain:	14.6 dBd	Gain:	14.6 dBd
Height (AGL):	84	Height (AGL):	84	Height (AGL):	84
Frequency Bands	700 MHz	Frequency Bands	700 MHz	Frequency Bands	700 MHz
Channel Count	1	Channel Count	1	Channel Count	1
Total TX Power(W):	30	Total TX Power(W):	30	Total TX Power(W):	30
ERP (W):	865.21	ERP (W):	865.21	ERP (W):	865.21
Antenna A3 MPE%	1.09	Antenna B3 MPE%	1.09	Antenna C3 MPE%	1.09

Site Composite MPE%	
Carrier	MPE%
T-Mobile (Per Sector Max)	7.62 %
AT&T	7.44 %
Verizon Wireless	5.51 %
XM Satellite Radio	0.14 %
Town	0.89 %
MetroPCS	1.12 %
Sprint	0.97 %
Clearwire	0.11 %
Site Total MPE %:	23.80 %

T-Mobile Sector A Total:	7.62 %
T-Mobile Sector B Total:	7.62 %
T-Mobile Sector C Total:	7.62 %
Site Total:	23.80 %

T-Mobile _per sector	# Channels	Watts ERP (Per Channel)	Height (feet)	Total Power Density ($\mu\text{W}/\text{cm}^2$)	Frequency (MHz)	Allowable MPE ($\mu\text{W}/\text{cm}^2$)	Calculated % MPE
T-Mobile AWS - 2100 MHz LTE	2	2,334.27	84	27.59	AWS - 2100 MHz	1000	2.76%
T-Mobile AWS - 2100 MHz UMTS	2	849.42	84	10.04	AWS - 2100 MHz	1000	1.00%
T-Mobile PCS - 1950 MHz UMTS	2	1,167.14	84	13.79	PCS - 1950 MHz	1000	1.38%
T-Mobile PCS - 1950 MHz GSM	2	1,167.14	84	13.79	PCS - 1950 MHz	1000	1.38%
T-Mobile 700 MHz LTE	1	865.21	84	5.11	700 MHz	467	1.09%
						Total*:	7.62%

*NOTE: Totals may vary by 0.01% due to summing of remainders

Summary

All calculations performed for this analysis yielded results that were **within** the allowable limits for general public exposure to RF Emissions.

The anticipated maximum composite contributions from the T-Mobile facility as well as the site composite emissions value with regards to compliance with FCC's allowable limits for general public exposure to RF Emissions are shown here:

T-Mobile Sector	Power Density Value (%)
Sector A:	7.62 %
Sector B:	7.62 %
Sector C:	7.62 %
T-Mobile Per Sector Maximum:	7.62 %
Site Total:	23.80 %
Site Compliance Status:	COMPLIANT

The anticipated composite MPE value for this site assuming all carriers present is **23.80%** of the allowable FCC established general public limit sampled at the ground level. This is based upon values listed in the Connecticut Siting Council database for existing carrier emissions.

FCC guidelines state that if a site is found to be out of compliance (over allowable thresholds), that carriers over a 5% contribution to the composite value will require measures to bring the site into compliance. For this facility, the composite values calculated were well within the allowable 100% threshold standard per the federal government.