

Tectonic Engineering
Theresa Ranciato-Viele
63-3 N. Branford Road
Branford, CT 06405
Tranciato@Tectonicengineering.com
203-606-5127

November 12, 2021

Ms. Melanie Bachman, Executive Director
Connecticut Siting Council
Ten Franklin Square
New Britain, CT 06051

**RE: Notice of Exempt Modification to an existing 150' monopole
located at 98 Jeffrey Place, Trumbull, Connecticut**

Latitude: 41.251850 / Longitude: 73.192953

Dear Ms. Bachman:

This letter and attachments are submitted on behalf of Dish Wireless, LLC ("Dish"). Dish plans to install antennas and related equipment to the tower site at the existing 150' monopole tower facility located at 98 Jeffrey Place, Trumbull, Connecticut (See Original Facility Approval attached as Exhibit A) ("Facility"). The property is owned by The Town of Trumbull and leased to Tarpon Towers II, LLC (See Trumbull Assessor Property Card attached hereto as Exhibit B).

Dish proposes to install three (3) 600/1900/2100 MHz JMA – MX08Fr0665-21 antennas and six (6) FUJITSU TA08025 RRUs on the tower at the one hundred thirty foot (130') centerline AGL. Dish further proposes to install one (1) 1.5" Hybrid Cable. Dish will also install its equipment cabinets on a 5' X 7' platform within its 10' X 15' lease area. The installation is shown on plans completed by Tectonic Engineering, dated September 20, 2021 and attached hereto as Exhibit C.

Dish requests that the Connecticut Siting Council ("Council") find that the proposed shared use of this Facility satisfies the criteria of C.G.S. sec. 16-50aa and accordingly issue an order approving the proposed shared use. This proposed installation constitutes an exempt modification pursuant to R.C.S.A. 16-50j-89. Pursuant to R.C.S.A. 16-50j-73, Dish is providing notice to Vicki A. Tesoro, First Selectperson of the Town of Trumbull, Rob Librandi, Land Use Planner, the property owner, Town of Trumbull, and the tower owner, Tarpon Towers II, LLC.

Under the Council's regulations, Dish's plans do not constitute a modification subject to the Council's review in that:

Dish will not change the existing 150' height of the Tower as the Dish antennas will be installed at a height of 130'.

The proposed installation will not extend the existing boundaries of the compound as depicted in Exhibit C;

The proposed installation will not increase the noise levels at the facility by six (6) decibels or more, or to levels that exceed local and state criteria; and

The proposed antennas will not increase radio frequency emissions at the facility to a level at or above the Federal Communications Commission safety standard. The attached Exhibit F indicates that the combined site operations will result in a total power density of 1.5914%.

Tower

The Facility consists of a One hundred fifty foot (150') foot monopole tower located at 98 Jeffrey Place, Trumbull, Connecticut. As indicated above, property is owned by the town of Trumbull and the tower is owned by Tarpon Towers II, LLC. The tower currently supports Verizon at the one hundred forty foot (140') centerline AGL. The antenna locations are set forth on Sheet A-2 of the attached drawings in Exhibit C.

A. TECHNICAL FEASIBILITY

The existing monopole has been deemed structurally capable of supporting the proposed Dish loading. The structural and mount analyses are attached hereto as Exhibits D and E respectively.

B. LEGAL FEASIBILITY

C.G.S. Se. 16-50aa authorizes the Council to issue orders approving the shared use of existing towers such as the above referenced tower. Under the authority granted to the Council, an order of the Council approving the requested shared use would permit Dish to obtain a building permit from the Town of Trumbull to proceed with the proposed installation. Additionally, a Supplement to The Master Lease Agreement is attached as Exhibit G, granting Dish the authority from the tower owner to proceed with this application for shared use.

C. ENVIRONMENTAL FEASIBILITY

The proposed shared use of this Facility would have a minimal environmental impact. The installation of the Dish equipment at the 130' level of the existing tower would have an insignificant visual impact on the area surrounding the tower. The proposed Dish ground equipment would be installed within the

existing Facility compound. The Dish installation would not cause any significant alteration to the physical or environmental characteristics of the existing Facility. Additionally, as evidenced by Exhibit F, the proposed antennas would not increase the radio frequency emissions to a level at or above the Federal Communications Commission safety standards.

D. ECONOMIC FEASIBILITY

Dish has entered into a Lease Agreement (Exhibit G) with the Facility owner for the proposed colocation. Therefore, this shared use is economically feasible.

E. PUBLIC SAFETY CONCERNS

As set forth above, the tower is structurally capable of supporting the proposed Dish loading. Dish is not aware of any public safety concerns relative to the proposed sharing of the existing tower.

For the reasons set forth herein, the proposed shared use of the existing tower at 98 Jeffrey Place, Trumbull, satisfies the criteria stated in C.G.S. sec. 16-50aa, and supports the general goal of preventing the unnecessary proliferation of tower sites in Connecticut. Dish respectfully requests the Council issue an order approving the proposed shared use.

Respectfully submitted,
Dish Wireless, LLC

By 

Theresa Ranciato-Viele, consultant
63-3 N. Branford Road
Branford, CT 06405
Tranciato@Tectonicengineering.com
203-606-5127

cc: Trumbull First Selectperson, Honorable Vicki A. Tesoro
5866 Main St.
Second Floor
Trumbull, CT 06611

Trumbull Land Use Planner, Rob Librandi
5866 Main St.
Second Floor
Trumbull, CT 06611

Tower Owner: Tarpon Towers, II, LLC
8916 77th Terrace East
Suite 103
Lakewood Ranch, FL 34202

Exhibit A
Original Facility Approval

Permit NO: **CO-8-17-28096**
 Permit Type: **Commercial**
 Work Classification: **<NONE>**
 Permit Status: **Active**

Permit

Issue Date: **8/10/2017** Expires: **02/06/2018**

5866 Main St.
 Trumbull, CT 06611-3113
 Phone: (203)452-5020 Fax: (203)452-5093

Project Address	Parcel No.	Tract No.	Block No.	Lot No.	Section	Township
00000 JEFFREY Place Suite: CELL TOWER Trumbull, CT 06611	G0800212000					

Owner Information	Address	Phone	Cell
Trumbull Town of	5866 MAIN Street Trumbull CT 06611		
	5866 MAIN Street Trumbull CT 06611		

Contractor(s)	Phone	Primary Contractor
CONSTRUCTION SERVICES OF BRANFORD	(203)488-0712	Yes

Proposed Construction / Details
 INSTALL TELECOMMUNICATIONS FACILITY INCLUDING
 MONOPOLIS TOWER, RELATED EQUIPMENT & GENERATOR
 VERIZON

Valuation:	\$150,000.00
Total Sq Feet:	0

Fees Due	Amount
Building Permit Fee	\$1,808.00
Certificate of Occupancy Fee	\$25.00
Processing Fee	\$10.00
State Tax Fee	\$39.00
Total:	\$1,882.00

Total	Amt Paid	Amt Due
\$1,882.00	\$1,882.00	\$0.00

Required Inspections:

For inspections call : **(203) 452-5020**

Inspection	IVR
Footing	101
Footing Drains	102
Above Ceiling Inspection	105
Rough Construction	105
Insulation	145
Final Construction	195
Walk Through	195
Commercial Occupancy	625
Fire Marshall Approval	802

IMPORTANT: APPLICATION IS HEREBY MADE TO THE BUILDING OFFICIAL FOR A PERMIT SUBJECT TO THE CONDITIONS AND RESTRICTIONS SET FORTH ON THIS APPLICATION AND THE FOLLOWING:

Applicant Copy

1. Construction activity is prohibited between the hours of 6:00pm and 7:00am and on Sundays and Holidays.
2. The City's approved plans and permit inspection card must remain on the job site for use by City inspection personnel.
3. Final inspection of the work authorized by this permit is required. A Certificate of Occupancy must be obtained prior to use and occupancy of new buildings, structures and remodeling work.

This permit/plan review expires by time limitation and becomes null and void if the work authorized by the permit is not commenced within 180 days from the date of permit issuance or if the permit is not obtained within 180 days from the date of plan submittal. This permit expires and becomes null and void if any work authorized by this permit is suspended or abandoned for 180 consecutive days or if no progressive work has been verified by a City building Inspector for a period of 180 consecutive days.

Exhibit B
Property Card

JEFFREY PLACE

Location JEFFREY PLACE

Mblu G/08 / 00212/ 000/

Acct#

Owner TRUMBULL TOWN OF

Assessment \$127,960

Appraisal \$182,800

PID 12674

Building Count 1

Fire District T

Current Value

Appraisal	
Valuation Year	Total
2015	\$182,800

Assessment	
Valuation Year	Total
2015	\$127,960

Owner of Record

Owner TRUMBULL TOWN OF
Co-Owner
Address 5866 MAIN STREET
 TRUMBULL, CT 06611

Sale Price \$0
Book & Page 217/ 168
Sale Date 02/03/1970
Instrument

Ownership History

Ownership History				
Owner	Sale Price	Book & Page	Instrument	Sale Date
TRUMBULL TOWN OF	\$0	217/ 168		02/03/1970

Building Information

Building 1 : Section 1

Year Built:

Living Area: 0

Building Attributes	
Field	Description

Style	Vacant Land
Stories:	
Occupancy	
Exterior Wall 1	
Exterior Wall 2	
Roof Structure:	
Roof Cover	
Interior Wall 1	
Interior Wall 2	
Floor Covering	
Alt. Floor Cover	
Heat Fuel	
Heat Type:	
AC Type:	
Total Bedrooms:	
Total Bthrms:	
Total Half Baths:	
Total Xtra Fixtrs:	
Total Rooms:	
Bath Style:	
Kitchen Style:	
Total Kitchens	
Total Elec Meters	

Building Photo



G08-212 05/08/2015

(<http://images.vgsi.com/photos2/TrumbullCTPhotos/A00\02\39\19.JPG>)

Building Layout

(http://images.vgsi.com/photos2/TrumbullCTPhotos/Sketches/12674_1267)

Building Sub-Areas (sq ft)	Legend
No Data for Building Sub-Areas	

Extra Features

Extra Features	Legend
No Data for Extra Features	

Land

Land Use

Use Code 921
Description Mun Lnd Res
Zone AA
Neighborhood 300
Alt Land Appr No
Category

Land Line Valuation

Size (Acres) 1.12
Frontage
Depth

Outbuildings

Outbuildings	Legend
--------------	--------

No Data for Outbuildings

Valuation History

Appraisal	
Valuation Year	Total
2019	\$182,800
2018	\$182,800
2017	\$182,800

Assessment	
Valuation Year	Total
2019	\$127,960
2018	\$127,960
2017	\$127,960

Exhibit C
Project Plans

- NOTES**
1. CONTRACTOR SHALL FIELD VERIFY ALL DIMENSIONS.
 2. ANTENNAS AND MOUNTS DRAFTED FOR CLARIX.
 3. EXISTING STRUCTURE SHALL BE ANALYZED BY A PROFESSIONAL ENGINEER LICENSED IN THE STATE OF CONNECTICUT.

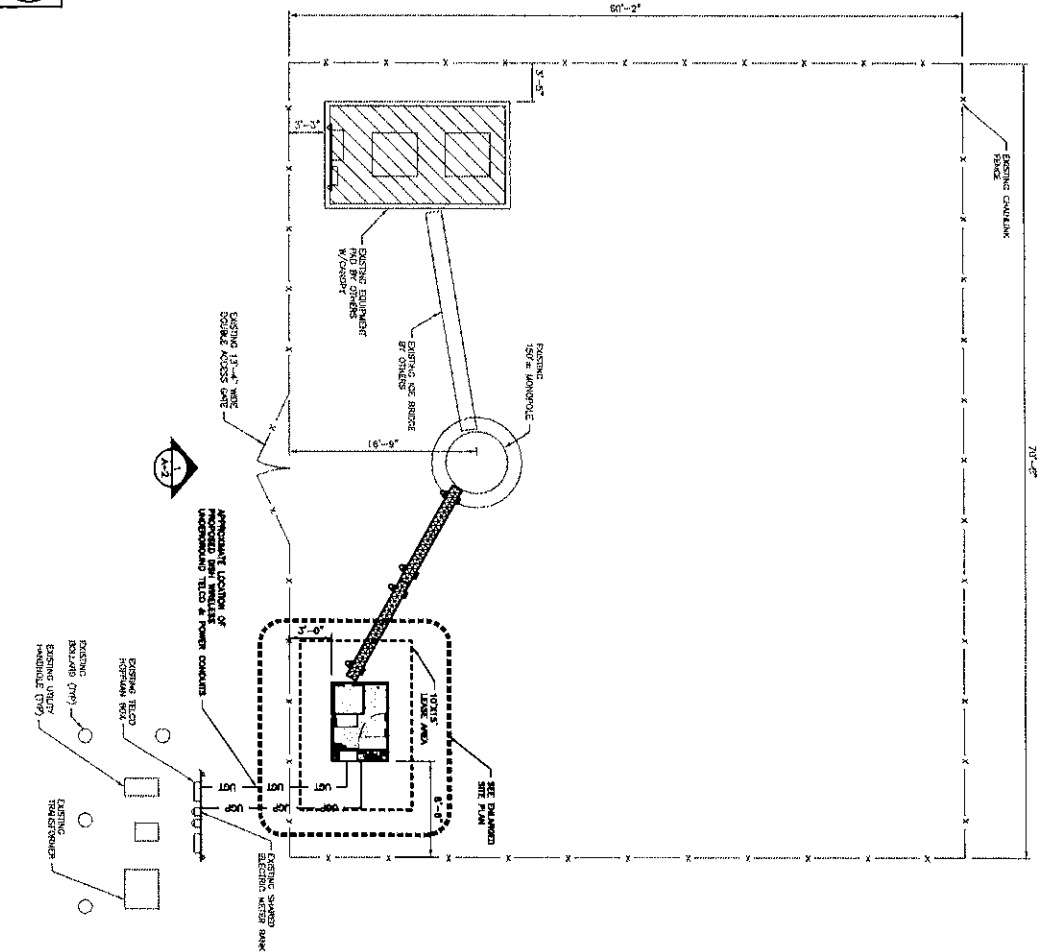

OVERALL SITE PLAN

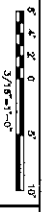

1

- NOTES**
1. CONTRACTOR SHALL FIELD VERIFY ALL DIMENSIONS.
 2. CONTRACTOR SHALL VERIFY A 10'-0" MINIMUM CLEARANCE FROM ALL EXISTING ANTENNAS AND EXISTING SPA UNITS.
 3. ANTENNAS AND MOUNTS DRAFTED FOR CLARIX.
 4. EXISTING STRUCTURE SHALL BE ANALYZED BY A PROFESSIONAL ENGINEER LICENSED IN THE STATE OF CONNECTICUT.

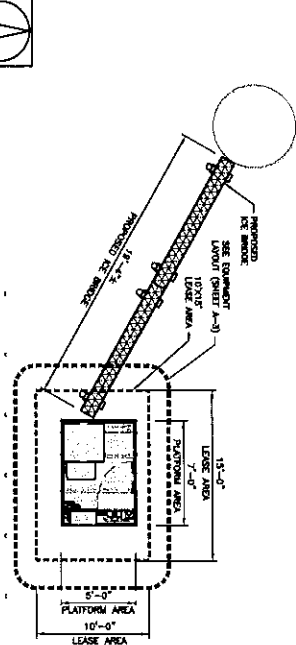

ENLARGED EQUIPMENT PLAN



2

NOT USED

3

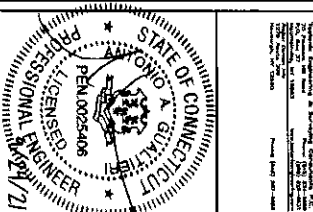

IT IS A VIOLATION OF LAW FOR ANY PERSON TO REPRODUCE OR TRANSMIT THIS DOCUMENT WITHOUT THE WRITTEN PERMISSION OF THE AUTHOR.

DRAWN BY: [] CHECKED BY: [] APPROVED BY: []

VS: [] JO: [] MP: []

BRDS REV #:

ZONING DOCUMENTS

REV	DATE	DESCRIPTION	SUBMITTALS
0	08/20/21	ISSUE FOR PERMIT	

A&E PROJECT NUMBER: 107710.NJLJER01144A

DISH WIRELESS PROJECT INFORMATION: NJLJER01144A

98 JEFFEREY PL. TRUMBULL, CT 06611

SHEET TITLE: OVERALL AND ENLARGED SITE PLAN

SHEET NUMBER: A-1

NOTES

1. CONTRACTOR SHALL VERIFY ALL DIMENSIONS.
2. ANTENNA AND RISE RIG SPECIFICATIONS REFER TO ANTENNA MANUFACTURER'S DRAWINGS FOR ALL OF DETAILS.
3. EXISTING STRUCTURE SHALL BE ANALYZED BY A PROFESSIONAL ENGINEER LICENSED IN THE STATE OF CONNECTICUT.

PROPOSED NORTH ELEVATION



1

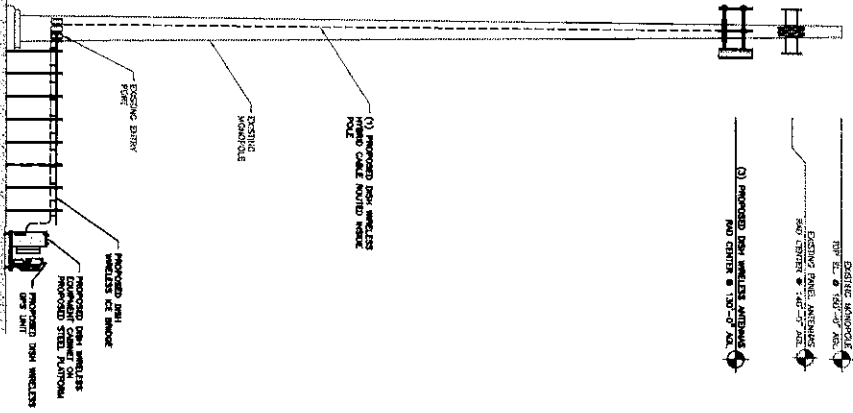

ANTENNA SCHEDULE

NO SCALE

3

SECTION	POSITION	MANUFACTURER - MODEL NUMBER	HEIGHT	TECHNOLOGY	NOTES
ALPHA	A1	FLUENTU - T400023-8004	50'	HTO/NBS	1. CONTRACTOR TO REFER TO FINAL CONSTRUCTION RIGS FOR ALL IN DETAIL. 2. ANTENNA AND RISE RIG LOCATIONS MAY CHANGE DUE TO EQUIPMENT REVISIONS IN COMPLIANCE WITH THE PROPOSED RISE RIG AND STRUCTURAL ANALYSIS. 3. ZONING ARE SUBJECT TO CHANGE AND NEED TO BE COORDINATED WITH THE LATEST RIGS PRIOR TO THE START OF CONSTRUCTION.
ALPHA	B1	FLUENTU - T400023-8004	90'	HTO/NBS	
BETA	B1	FLUENTU - T400023-8005	210'	HTO/NBS	
BETA	C1	FLUENTU - T400023-8004	130'-0"	HTO/NBS	
OMEGA	C1	FLUENTU - T400023-8005	130'-0"	HTO/NBS	

SECTION	POSITION	EXISTING OR PROPOSED	MANUFACTURER - MODEL NUMBER	HEIGHT	TECHNOLOGY	SIZE (MM)	DIAMETER	RAD CENTER	TRANSMISSION CABLE
ALPHA	A1	PROPOSED	4M - A4000048-21	50'	HTO/NBS	72.0" X 29.0"	180"	130'-0"	(1) 100% CAPACITY (1.00' LWD)
BETA	B1	PROPOSED	4M - A4000048-21	90'	HTO/NBS	72.0" X 29.0"	210"	130'-0"	
OMEGA	C1	PROPOSED	4M - A4000048-21	50'	HTO/NBS	72.0" X 29.0"	340"	130'-0"	

ANTENNA LAYOUT



2

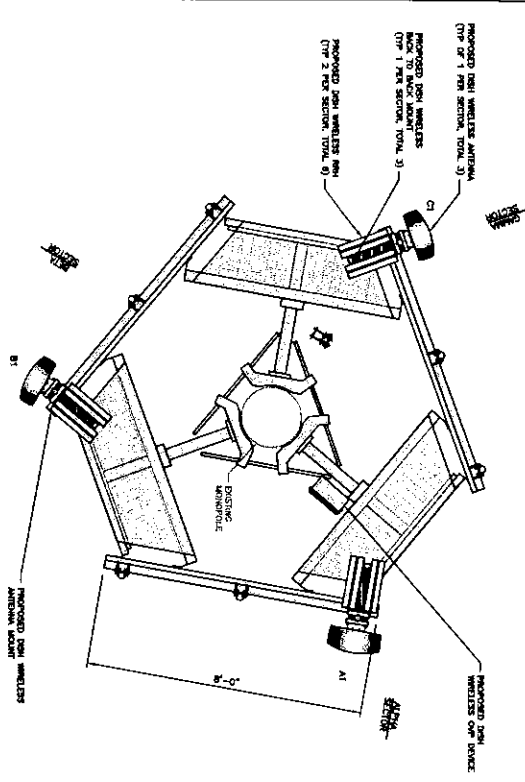

dish wireless

3 ASP BOULEVARD,
ROSELAND, NJ 07068

Tectonic

Professional Engineer

STATE OF CONNECTICUT
LICENSED PROFESSIONAL ENGINEER
PEN10025406

ZONING DOCUMENTS

REV. DATE. DESCRIPTION

0 04/20/21

IT IS A VIOLATION OF LAW FOR ANY PERSON TO REPRODUCE OR TRANSMIT THIS DOCUMENT OR ANY PART THEREOF WITHOUT THE WRITTEN PERMISSION OF THE AUTHOR OF THIS DOCUMENT.

DRAWN BY: CHECKED BY: APPROVED BY:

VS. JQ. MP.

REDS. REV. #:

A&E PROJECT NUMBER: 10710.NJLJER01144A

98 JEFFERYS PL. TRUMBULL, CT 06611

SHEET TITLE: ELEVATION, ANTENNA LAYOUT AND SCHEDULE

SHEET NUMBER: A-2

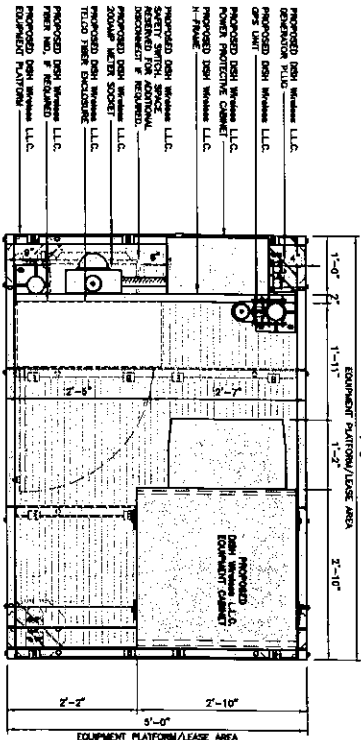

COMMSCOPE MTC040451P
5X7 PLATFORM

DIMENSIONS (Overall)	18'-0" x 24'-0"
TOTAL WEIGHT	423 LBS

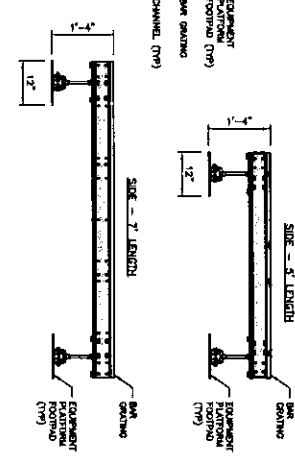
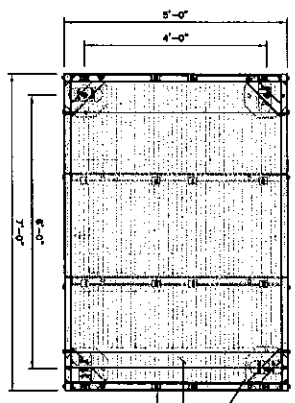

PLATFORM DETAIL

NO SCALE 2

COMMSCOPE MTC040451P
H-FRAME

LENGTH/SUPPORT PAWS CIV	5
WEIGHT	99.74 lbs

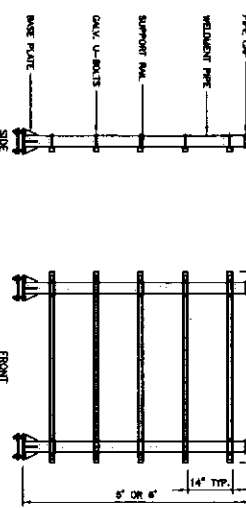

H-FRAME DETAIL

NO SCALE 3

NOT USED

NO SCALE 4

H-FRAME EQUIPMENT ELEVATION

12'-0" & 3'-0" 1'-0" 1'-11" 0" 2

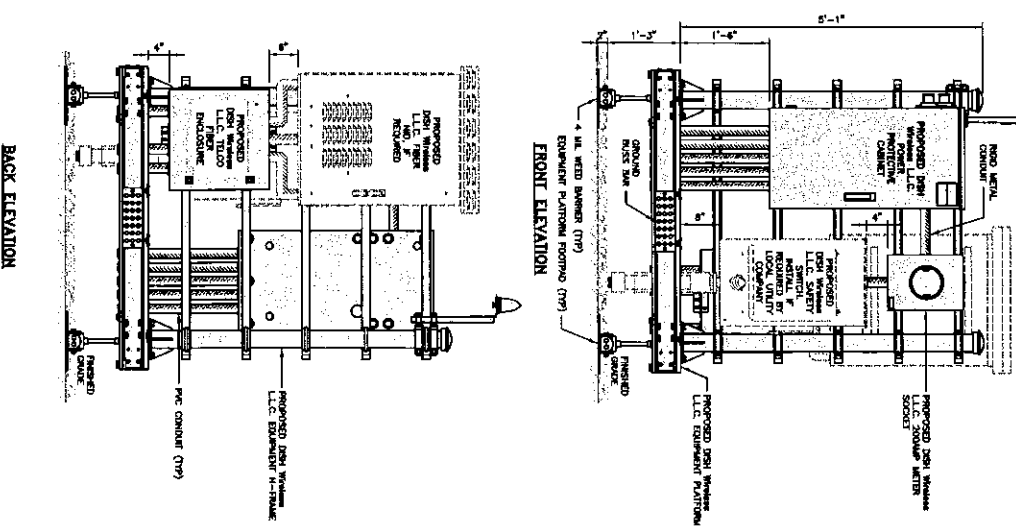

- NOTES**
- CONTRACTOR TO HAVE PLATFORM SET WITH A MINIMUM OF 2" OF ALL PER EXISTING SITE SURFACE.
 - WELD BARREN FRAMING TO BE ADDED AT DISCRETION OF ISH WIRELESS CONSTRUCTION MANAGER AT THE OF CONSTRUCTION. PER SHEET 8 AND REVISED UNDER ALL FOOT FEET OF THE PLATFORM (SEE SHEET 8-2).
 - EQUIPMENT CANNOT CARRY 75W CARRIER.

desh wireless
3 APT. BOULEVARD,
ROSELAND, NJ 07068

Tectonic
PROFESSIONAL ENGINEER
PEN. 0025406
STATE OF CONNECTICUT
LICENSED PROFESSIONAL ENGINEER
MAY 21

NOTING
ZONING
DOCUMENTS

IF IS A REQUIRE OF LAW FOR THE REGION, USER MAY NEED TO OBTAIN THE NECESSARY PERMITS TO OBTAIN THE DOCUMENT.

DRAWN BY: CHECKED BY: APPROVED BY:

VS JO JP

PROJ. REV. #:

REV.	DATE	DESCRIPTION
0	02/20/23	ISSUED FOR APPROVAL

A&E PROJECT NUMBER: 10710.NJ.ER01144A
 ISH WIRELESS PROJECT INCORPORATION: NJ.ER01144A
 SHEET TITLE: 98 JEFFERREY PL TRUMBULL, CT 06611
 EQUIPMENT PLATFORM AND H-FRAME DETAILS
 SHEET NUMBER: A-3

FUJITSU TA08025-8604 RHM	
Dimensions (WxHxD) (in/ft/in)	36x16x10/20/14.4-13.7/8.6"
Weight (QTY/BL) / Volume	20kg/44.1lb/ .30L
Power Supply	DC-56--20V

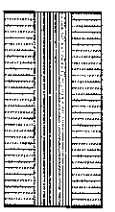

FUJITSU TA08025-8605 RHM	
Dimensions (WxHxD) (in/ft/in)	36x16x10/20/14.4-13.7/8.6"
Weight (QTY/BL) / Volume	20kg/44.1lb/ .30L
Power Supply	DC-56--20V

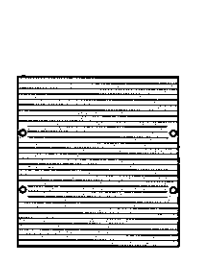
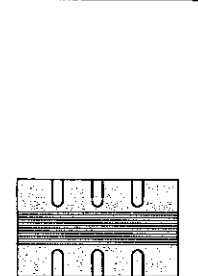
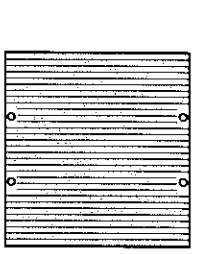
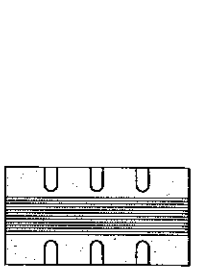
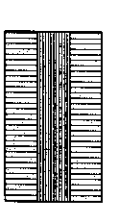

REMOTE RADIO HEAD DETAIL

NO SCALE 1

REMOTE RADIO HEAD DETAIL

NO SCALE 2

REMOTE RADIO MOUNT DETAIL

NO SCALE 3

COMMSCOPE BACK-TO-BACK MOUNT RR-FAZ	
Dimensions (WxHxD) (in/ft/in)	18.41x18.0x18.0"
Weight	36.22 lb
Package Quantity	2

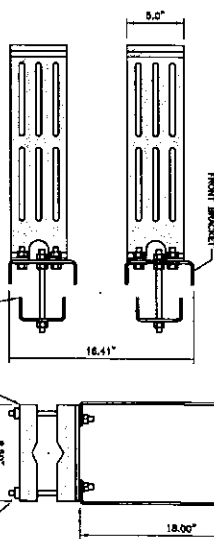

RAYCAP R01DC-9181-PF-48 DC SURGE PROTECTION	
Dimensions (WxHxD) (in/ft/in)	14.8x15.4x3.9x4.1"
Weight	2.12 LBS

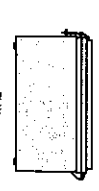

COMMSCOPE XP-2040 CROSSOVER PLATE	
Dimensions (WxH) (in/ft/in)	10.51x7"
Weight	11.023 LBS



ANTENNA DETAIL

NO SCALE 4

HYBRID CABLE RUN

NO SCALE 5

JMA WIRELESS MX08FR0665-21 ANTENNA	
Dimensions (WxHxD) (in/ft/in)	72.0x20.0x6.0"
Total Weight	64.9 LB
RF Power Connector Type	8 x 4.5-10 Female

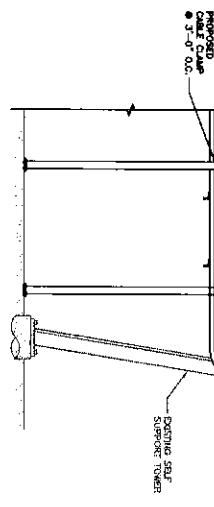
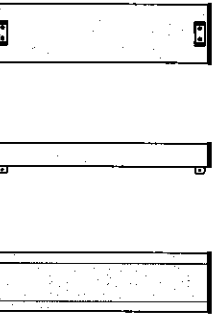
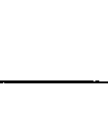
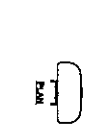

JMA ANTENNA MOUNT BRACKET #91900318	
Total Weight (with brackets)	18 lbs (8.18 kg)
Pole Diameter Range	2.5" TO 4.5"



ANTENNA BRACKET DETAIL

NO SCALE 6

SURGE SUPPRESSION DETAIL

NO SCALE 7

RRH/OMP MOUNT DETAIL

NO SCALE 8

ANTENNA BRACKET DETAIL

NO SCALE 9

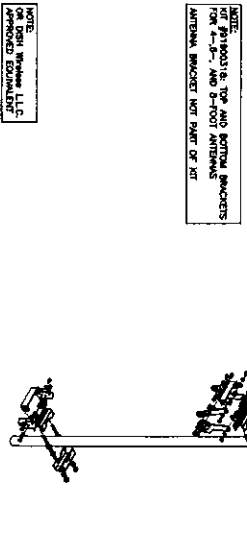
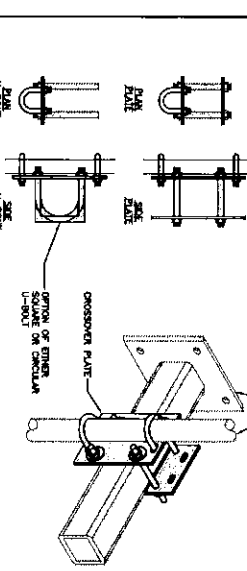
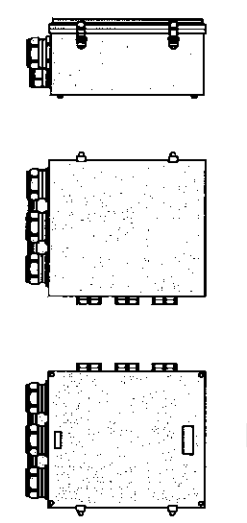

dish
wireless.

3 ASP BOLLERMAN,
ROSELAND, NJ 07068

Tectonic7

Professional Engineering Firm
10000 Old York Road
Suite 200
New York, NY 10019
Tel: 212-490-0000
Fax: 212-490-0001
www.tectonic7.com

STATE OF CONNECTICUT
ANTONIO A. ROSA
PROFESSIONAL ENGINEER
PEN-00025-006
EXPIRES 12/31/2011

ZONING DOCUMENTS

REVISIONS

NO.	DATE	DESCRIPTION
1	07/20/11	ISSUED FOR PERMIT

DATE PROJECT NUMBERS
10710.NJ10R01144A
NJ10R01144A

OSH WIRELESS PROJECT INFORMATION
98 JEFFERY PL
TRUMBULL, CT 06611

SHEET TITLE
EQUIPMENT DETAILS

SHEET NUMBER
A-4

NOTE: SEE DRAWING L10 APPROVED EQUALIZER

SITE ACTIVITY REQUIREMENTS:

1. NOTICE TO PROCEED - NO WORK SHALL COMMENCE PRIOR TO CONTRACTOR RECEIVING A WRITTEN NOTICE TO PROCEED (NTP) AND THE ISSUANCE OF A PURCHASE ORDER. PRIOR TO ACCESSING/ENTERING THE SITE YOU MUST CONTACT THE DISH WIRELESS AND TOWER OWNER NCC & THE DISH WIRELESS AND TOWER OWNER CONSTRUCTION MANAGER.
2. "LOOK UP" - DISH WIRELESS AND TOWER OWNER SAFETY CLUB REQUIREMENT:
3. THE INTEGRITY OF THE SAFETY CLUB AND ALL COMPONENTS OF THE CLAIMING FACILITY SHALL BE CONSIDERED DURING ALL STAGES OF DESIGN, INSTALLATION, AND INSPECTION. TOWER MODIFICATION, MOUNT REARRANGEMENTS, AND/OR EQUIPMENT INSTALLATIONS SHALL NOT COMPROMISE THE INTEGRITY OR FUNCTIONAL USE OF THE SAFETY CLUB OR ANY COMPONENTS OF THE CLAIMING FACILITY OR NOT BE NEARER THAN 10 FEET FROM THE SAFETY CLUB. THE CONTRACTOR SHALL MAINTAIN A SAFE DISTANCE FROM THE SAFETY CLUB AT ALL TIMES. THE CONTRACTOR SHALL MAINTAIN CONTACT OR CLOSE PROXIMITY TO THE WIRELESS FACILITY TO MONITOR THE SAFETY CLUB'S SUPPORTS. BARRIERS SHOULD BE IN PLACE TO PREVENT ANY UNAUTHORIZED PERSONS FROM ENTERING THE SAFETY CLUB. ANY CONDITIONS MUST BE TAGGED OUT AND REPORTED TO YOUR DISH WIRELESS AND TOWER OWNER POC OR CALL THE NCC TO GENERATE A SAFETY CLUB MAINTENANCE AND CONTRACTOR NOTICE TICKET.
4. PRIOR TO THE START OF CONSTRUCTION, ALL REQUIRED JURISDICTIONAL PERMITS SHALL BE OBTAINED, THIS INCLUDES, BUT IS NOT LIMITED TO, BUILDING, ELECTRICAL, MECHANICAL, FIRE, FLOOD ZONE, ENVIRONMENTAL, AND ZONING. AFTER ONSITE ACTIVITIES AND CONSTRUCTION ARE COMPLETED, ALL REQUIRED PERMITS SHALL BE CANCELLED AND CLOSED OUT ACCORDING TO LOCAL JURISDICTIONAL REQUIREMENTS.
5. ALL CONSTRUCTION MEANS AND METHODS, INCLUDING BUT NOT LIMITED TO, ERECTION PLANS, RIGGING PLANS, CLIMBING PLANS, AND RESCUE PLANS SHALL BE THE RESPONSIBILITY OF THE GENERAL CONTRACTOR RESPONSIBLE FOR THE EXECUTION OF THE WORK CONTAINED HEREIN, AND SHALL MEET ANSI/ASSE A10.48 (LATEST EDITION), FEDERAL, STATE, AND LOCAL REGULATIONS, AND ANY APPLICABLE INDUSTRY CONSENSUS STANDARDS RELATED TO THE CONSTRUCTION ACTIVITIES BEING PERFORMED. ALL RIGGING PLANS SHALL ADHERE TO ANSI/ASSE A10.48 (LATEST EDITION) AND DISH WIRELESS AND TOWER OWNER STANDARDS, INCLUDING THE REQUIRED INVOLVEMENT OF A QUALIFIED ENGINEER FOR CLASS IV CONSTRUCTION, TO VERIFY THE SUPPORTING STRUCTURES) IN ACCORDANCE WITH ANSI/TIA-322 (LATEST EDITION).
6. ALL SITE WORK TO COMPLY WITH DISH WIRELESS AND TOWER OWNER INSTALLATION STANDARDS FOR CONSTRUCTION ACTIVITIES ON DISH WIRELESS AND TOWER OWNER TOWER SITE AND LATEST VERSION OF ANSI/TIA-1018-A-2012 STANDARD FOR INSTALLATION, ALTERATION, AND MAINTENANCE OF ANTENNA SUPPORTING STRUCTURES AND ANTENNAS.
7. IF THE SPECIFIED EQUIPMENT CAN NOT BE INSTALLED AS SHOWN ON THESE DRAWINGS, THE CONTRACTOR SHALL PROPOSE AN ALTERNATE INSTALLATION FOR APPROVAL BY DISH WIRELESS AND TOWER OWNER PRIOR TO PROCEEDING WITH ANY SUCH CHANGE OF INSTALLATION.
8. ALL MATERIALS FURNISHED AND INSTALLED SHALL BE IN STRICT ACCORDANCE WITH ALL APPLICABLE CODES, REGULATIONS AND ORDINANCES. CONTRACTOR SHALL ISSUE ALL APPROPRIATE NOTICES AND COMPLY WITH ALL LAWS, ORDINANCES, RULES, REGULATIONS AND LAWFUL ORDERS OF ANY PUBLIC AUTHORITY REGARDING THE PERFORMANCE OF THE WORK. ALL WORK COMPLETED SHALL COMPLY WITH ALL APPLICABLE MUNICIPAL AND UTILITY COMPANY SPECIFICATIONS AND LOCAL JURISDICTIONAL CODES, ORDINANCES AND APPLICABLE REGULATIONS.
9. THE CONTRACTOR SHALL INSTALL ALL EQUIPMENT AND MATERIALS IN ACCORDANCE WITH MANUFACTURER'S RECOMMENDATIONS UNLESS SPECIFICALLY STATED OTHERWISE.
10. THE CONTRACTOR SHALL CONTACT UTILITY LOCATING SERVICES INCLUDING PRIVATE LOCATIONS SERVICES PRIOR TO THE START OF CONSTRUCTION.
11. ALL EXISTING ACTIVE POWER, WATER, GAS, ELECTRIC AND OTHER UTILITIES WHERE ENCOUNTERED IN THE WORK SHALL BE PROTECTED AT ALL TIMES AND WHERE REQUIRED FOR THE PROPER EXECUTION OF THE WORK, SHALL BE RELOCATED AS DIRECTED BY CONTRACTOR. EXERCISE CAUTION SHOULD BE USED BY THE CONTRACTOR WHEN EXCAVATING OR DRILLING HEELS AROUND OR NEAR UTILITIES. CONTRACTOR SHALL PROVIDE SAFETY TRAINING FOR THE WORKING CREW. THIS WILL INCLUDE BUT NOT BE LIMITED TO A) FALL PROTECTION B) CONFINED SPACE C) ELECTRICAL SAFETY D) TRENCHING AND EXCAVATION E) CONSTRUCTION SAFETY PROCEDURES.
12. ALL SITE WORK SHALL BE AS INDICATED ON THE STAMPED CONSTRUCTION DRAWINGS AND DISH PROJECT SPECIFICATIONS, LATEST APPROVED REVISION.
13. CONTRACTOR SHALL KEEP THE SITE FREE FROM ACCUMULATING WASTE MATERIAL, DEBRIS, AND TRASH AT THE COMPLETION OF THE WORK. IF NECESSARY, RUBBISH, STUMPS, DEBRIS, STICKS, STONES AND OTHER REFUSE SHALL BE REMOVED FROM THE SITE AND DISPOSED OF LEGALLY.
14. ALL EXISTING MACHINE, POWER, WATER, GAS, ELECTRIC AND OTHER UTILITIES, WHICH INTERFERE WITH THE EXECUTION OF THE WORK, SHALL BE REMOVED AND/OR CAPPED, PLUGGED OR OTHERWISE DECOMMISSIONED AT POINTS WHICH WILL NOT INTERFERE WITH THE EXECUTION OF THE WORK, SUBJECT TO THE APPROVAL OF DISH WIRELESS AND TOWER OWNER, AND/OR LOCAL UTILITIES.
15. THE CONTRACTOR SHALL PROVIDE SITE STORAGE IN ACCORDANCE WITH THE TECHNICAL SPECIFICATION FOR SITE STORAGE REQUIRED BY LOCAL JURISDICTION AND STORAGE REQUIRED ON INDIVIDUAL PIECES OF EQUIPMENT, ROOMS, AND SHELTERS.
16. THE SUB GRADE SHALL BE COMPACTED AND BROUGHT TO A SMOOTH UNIFORM GRADE PRIOR TO FINISHED SURFACE APPLICATION.
17. THE AREAS OF THE OWNERS PROPERTY DISTURBED BY THE WORK AND NOT COVERED BY THE TOWER, EQUIPMENT OR DRIVEWAY SHALL BE GRADED TO A UNIFORM SLOPE, AND STABILIZED TO PREVENT EROSION AS SPECIFIED ON THE CONSTRUCTION DRAWINGS AND/OR PROJECT SPECIFICATIONS.
18. CONTRACTOR SHALL MAINTAIN DISTURBANCE TO EXISTING SITE DRAINAGE CONSTRUCTION EROSION CONTROL MEASURES, IF REQUIRED, AND/OR PROJECT SPECIFICATIONS WITH THE LOCAL JURISDICTIONS FOR EROSION AND SEDIMENT CONTROL.
19. THE CONTRACTOR SHALL PROTECT EXISTING IMPROVEMENTS, PAVEMENTS, CURBS, LANDSCAPING AND STRUCTURES, ANY DAMAGED PART SHALL BE REPAIRED AT CONTRACTOR'S EXPENSE TO THE SATISFACTION OF OWNER.
20. CONTRACTOR SHALL LEGALLY AND PROPERLY DISPOSE OF ALL SCRAP MATERIALS SUCH AS COAXIAL CABLES AND OTHER ITEMS REMOVED FROM THE EXISTING FACILITY, ANTENNAS REMOVED SHALL BE RETURNED TO THE OWNER'S DESIGNATED LOCATION.
21. CONTRACTOR SHALL LEAVE PREMISES IN CLEAN CONDITION. TRASH AND DEBRIS SHOULD BE REMOVED FROM SITE ON A DAILY BASIS.
22. NO FILL OR EMBANKMENT MATERIAL SHALL BE PLACED ON FROZEN GROUND, FROZEN MATERIALS, SNOW OR ICE SHALL NOT BE PLACED IN ANY FILL OR EMBANKMENT.

GENERAL NOTES:

1. FOR THE PURPOSE OF CONSTRUCTION DRAWING, THE FOLLOWING DEFINITIONS SHALL APPLY:
CONTRACTOR-GENERAL CONTRACTOR RESPONSIBLE FOR CONSTRUCTION
CARRIER-DISH WIRELESS
TOWER OWNER-TOWER OWNER
2. THESE DRAWINGS HAVE BEEN PREPARED USING STANDARDS OF PROFESSIONAL CARE AND COMPETENCE. USUALLY, EXERCISE OF JUDGMENT IS REQUIRED IN THE APPLICATION OF THESE STANDARDS TO THE PARTICULAR CIRCUMSTANCES OF THE WORK. THE CONTRACTOR SHALL BE RESPONSIBLE FOR THE PROTECTION OF LIFE AND PROPERTY DURING CONSTRUCTION. SUCH MEASURES SHALL INCLUDE, BUT NOT BE LIMITED TO, BRACING, TOWERWORK, SHORING, ETC. THE APPLICABLE CODE STANDARDS AND REQUIREMENTS AND OF INDUSTRY ACCEPTED STANDARD GOOD PRACTICE, AS NOT EVERY CONDITION OR ELEMENT IS (OR CAN BE) EXPLICITLY SHOWN ON THESE DRAWINGS. THE CONTRACTOR SHALL USE INDUSTRY ACCEPTED STANDARD GOOD PRACTICE FOR UNDETAILED WORK NOT EXPLICITLY SHOWN.
3. THESE DRAWINGS REPRESENT THE FINISHED STRUCTURE. THEY DO NOT INDICATE THE MEANS OR METHODS OF CONSTRUCTION. THE CONTRACTOR SHALL BE SOLELY RESPONSIBLE FOR THE CONSTRUCTION MEANS, METHODS, TECHNIQUES, SEQUENCES, AND PROCEDURES. THE CONTRACTOR SHALL PROVIDE ALL MEASURES NECESSARY FOR PROTECTION OF LIFE AND PROPERTY DURING CONSTRUCTION. SUCH MEASURES SHALL INCLUDE, BUT NOT BE LIMITED TO, BRACING, TOWERWORK, SHORING, ETC. THE CONTRACTOR SHALL BE RESPONSIBLE FOR THE PROTECTION OF LIFE AND PROPERTY DURING CONSTRUCTION. SUCH MEASURES SHALL INCLUDE, BUT NOT BE LIMITED TO, BRACING, TOWERWORK, SHORING, ETC. THE CONTRACTOR SHALL BE RESPONSIBLE FOR THE PROTECTION OF LIFE AND PROPERTY DURING CONSTRUCTION. SUCH MEASURES SHALL INCLUDE, BUT NOT BE LIMITED TO, BRACING, TOWERWORK, SHORING, ETC. THE CONTRACTOR SHALL BE RESPONSIBLE FOR THE PROTECTION OF LIFE AND PROPERTY DURING CONSTRUCTION. SUCH MEASURES SHALL INCLUDE, BUT NOT BE LIMITED TO, BRACING, TOWERWORK, SHORING, ETC.
4. NOTES AND DETAILS IN THE CONSTRUCTION DRAWINGS SHALL TAKE PRECEDENCE OVER GENERAL NOTES AND TYPICAL DETAILS, WHERE NO DETAILS ARE SHOWN, CONSTRUCTION SHALL CONFORM TO SIMILAR WORK ON THE PROJECT, AND/OR AS PROVIDED FOR IN THE CONTRACT DOCUMENTS. WHERE DISCREPANCIES OCCUR BETWEEN PLANS, DETAILS, GENERAL NOTES, AND SPECIFICATIONS, THE CONTRACTOR SHALL CONTACT THE ENGINEER, IF FURTHER CLARIFICATION IS REQUIRED. CONTACT THE ENGINEER OR RECORDS FOR MORE STRICT REQUIREMENTS, SHALL GOVERN. IF FURTHER CLARIFICATION IS REQUIRED, CONTACT THE ENGINEER OR RECORDS.
5. SUBSTANTIAL EFFORT HAS BEEN MADE TO PROVIDE ACCURATE DIMENSIONS AND MEASUREMENTS ON THE DRAWINGS TO ASSIST IN THE FABRICATION AND/OR PLACEMENT OF CONSTRUCTION ELEMENTS BUT IT IS THE SOLE RESPONSIBILITY OF THE CONTRACTOR TO FIELD VERIFY THE DIMENSIONS, MEASUREMENTS, AND/OR CLEARANCES SHOWN IN THE CONSTRUCTION DRAWINGS PRIOR TO CONSTRUCTION. THE CONTRACTOR SHALL BE RESPONSIBLE FOR VERIFYING THE DIMENSIONS AND CLEARANCES SHOWN IN THE CONSTRUCTION DRAWINGS PRIOR TO CONSTRUCTION. THE CONTRACTOR SHALL BE RESPONSIBLE FOR VERIFYING THE DIMENSIONS AND CLEARANCES SHOWN IN THE CONSTRUCTION DRAWINGS PRIOR TO CONSTRUCTION. THE CONTRACTOR SHALL BE RESPONSIBLE FOR VERIFYING THE DIMENSIONS AND CLEARANCES SHOWN IN THE CONSTRUCTION DRAWINGS PRIOR TO CONSTRUCTION.
6. PRIOR TO THE SUBMISSION OF BIDS, THE BIDDING CONTRACTOR SHALL VISIT THE GEL SITE TO FAMILIARIZE WITH THE EXISTING AND PROPOSED CONSTRUCTION. THE BIDDING CONTRACTOR SHALL VISIT THE GEL SITE TO FAMILIARIZE WITH THE EXISTING AND PROPOSED CONSTRUCTION. THE BIDDING CONTRACTOR SHALL VISIT THE GEL SITE TO FAMILIARIZE WITH THE EXISTING AND PROPOSED CONSTRUCTION. THE BIDDING CONTRACTOR SHALL VISIT THE GEL SITE TO FAMILIARIZE WITH THE EXISTING AND PROPOSED CONSTRUCTION.
7. ALL MATERIALS FURNISHED AND INSTALLED SHALL BE IN STRICT ACCORDANCE WITH ALL APPLICABLE CODES, REGULATIONS AND ORDINANCES. CONTRACTOR SHALL ISSUE ALL APPROPRIATE NOTICES AND COMPLY WITH ALL LAWS, ORDINANCES, RULES, REGULATIONS AND LAWFUL ORDERS OF ANY PUBLIC AUTHORITY REGARDING THE PERFORMANCE OF THE WORK. ALL WORK COMPLETED SHALL COMPLY WITH ALL APPLICABLE MUNICIPAL AND UTILITY COMPANY SPECIFICATIONS AND LOCAL JURISDICTIONAL CODES, ORDINANCES AND APPLICABLE REGULATIONS.
8. UNLESS NOTED OTHERWISE, THE WORK SHALL INCLUDE FURNISHING MATERIALS, EQUIPMENT, APPURTENANCES AND LABOR NECESSARY TO COMPLETE ALL INSTALLATIONS AS INDICATED ON THE DRAWINGS.
9. THE CONTRACTOR SHALL INSTALL ALL EQUIPMENT AND MATERIALS IN ACCORDANCE WITH MANUFACTURER'S RECOMMENDATIONS UNLESS SPECIFICALLY STATED OTHERWISE.
10. IF THE SPECIFIED EQUIPMENT CAN NOT BE INSTALLED AS SHOWN ON THESE DRAWINGS, THE CONTRACTOR SHALL PROPOSE AN ALTERNATE INSTALLATION FOR APPROVAL BY THE CARRIER AND TOWER OWNER PRIOR TO PROCEEDING WITH ANY SUCH CHANGE OF INSTALLATION.
11. CONTRACTOR IS TO PERFORM A SITE INVESTIGATION, BEFORE SUBMITTING BIDS, TO DETERMINE THE BEST ROUTING OF ALL CONDUITS FOR POWER, AND TELL AND FOR GROUNDING CABLES AS SHOWN IN THE POWER, TELL, AND GROUNDING PLAN DRAWINGS.
12. THE CONTRACTOR SHALL PROTECT EXISTING IMPROVEMENTS, PAVEMENTS, CURBS, LANDSCAPING AND STRUCTURES, ANY DAMAGED PART SHALL BE REPAIRED AT CONTRACTOR'S EXPENSE TO THE SATISFACTION OF DISH WIRELESS AND TOWER OWNER.
13. CONTRACTOR SHALL LEGALLY AND PROPERLY DISPOSE OF ALL SCRAP MATERIALS SUCH AS COAXIAL CABLES AND OTHER ITEMS REMOVED FROM THE EXISTING FACILITY, ANTENNAS REMOVED SHALL BE RETURNED TO THE OWNER'S DESIGNATED LOCATION.
14. CONTRACTOR SHALL LEAVE PREMISES IN CLEAN CONDITION. TRASH AND DEBRIS SHOULD BE REMOVED FROM SITE ON A DAILY BASIS.

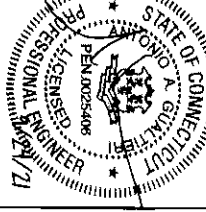

IT IS A CONDITION OF LET FOR THE DESIGN OF THIS PROJECT THAT THE CONTRACTOR SHALL BE RESPONSIBLE FOR OBTAINING ALL NECESSARY PERMITS AND APPROVALS TO ALTER THE DOCUMENT.

DESIGN BY: [] CHECKED BY: [] APPROVED BY: []

DATE: []

REVISIONS:

NO.	DATE	DESCRIPTION
1	06/23/23	ISSUE FOR PERMITTING

PROJECT NUMBER: 10710.NJLJER01144A

DISH WIRELESS PROJECT INFORMATION: NJLJER01144A

98 JEFFREY PL TRUMBULL, CT 06611

GENERAL TITLE: SHEET NUMBER

SHEET NUMBER: GN-2

Exhibit D
Structural Analysis

Structural Analysis 150-ft Monopole

Prepared For:
TARPON TOWERS II, LLC
1001 3rd Avenue West, Suite 420
Bradenton, FL 34205

MFP Project # 40918-020 r4a

Site Location:
CT1212 Trumbull
Dish Site# NJJER01144A
Fairfield Co., CT
Lat/Long: 41°15'7", -73°11'35"

Analysis Type:
ANSI/TIA-222-G
Structure Rating - 90.7% Passing

July 15, 2021

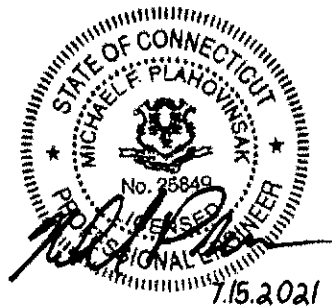

Michael F. Plahovinsak, P.E.
18301 State Route 161 W, Plain City, OH 43064
614-398-6250 - mike@mfpeng.com

Project Summary:

I have completed a structural analysis of the existing monopole for the following new configuration:

- 130' – Dish Wireless:
 - (3) JMA MX08FRO665-21 Antennas
 - (3) Fujitsu TA08025-B605 + (3) TA08025-B604 RRH's
 - (1) Raycap RDIDC-9181-PF-48
 - (1) 1.6" Hybrid
 - MC-PK8-DSH Platform Mount

The pole has been analyzed in accordance with the requirements of the International Building Code per IBC section 3108.4, and the recommendations of the Telecommunications Industry Association "*Structural Standard for Steel Antenna Supporting Structures*" ANSI/TIA-222-G.

This analysis may be considered a "Rigorous Structural Analysis" as defined in ANSI/TIA-222-G 15.5.2.

As indicated in the conclusions of this analysis, I have determined that the existing pole and foundation have *sufficient capacity* to support the existing, reserved and proposed antenna loads as detailed herein. Based on the results of my analysis, structural modifications are not required at this time.

Source of Data:

Resource	Source	Job Number	Date
Pole and Foundation Drawings	Michael F. Plahovinsak, PE	23517-408	07/23/17
Collocation Application	Tarpon Towers II, LLC	CT1212	03/27/18

Structure Specifics:

- Manufacturer: TransAmerican Power Products
- Manufacturer File #: TP-15472
- Year Built: 2017

Michael F. Plahovinsak, P.E. - 2021

mike@mfpeng.com

Analysis Criteria:

International Building Code 2006-2012 Section 3108.4
 Structural Standards for Steel Antenna Supporting Structures ANSI/TIA-222-G

- TIA-222-G Wind Speed 110 mph (V_{asd} / 3-Second Gust)
- Equivalent ASCE-7-10 Wind 142 mph (V_{ult})
- TIA-222-G Wind w/ 3/4" Ice 30 mph (3-Sec Gust)
- Operational Wind Speed 60 mph (3-Sec Gust)

Structure Class	Exposure Category	Topographic Category
II (I = 1.0)	C	I

Appurtenance Listing:

Status	Elev.	Antenna / Mounting	Coax	Owner
Existing*	140'	(6) Commscope JAHH-65B-R3B + (3) Samsung 64T64RMMU (3) Samsung BR049 B2/B66A + (3) BR04C B5/B13 RRH's (3) Commscope CBC78T-DS-43-2X Diplexers Low Profile Platform	(1) 12x24 Hybrid	Verizon
Proposed**	130'	(3) JMA MX08FRO665-21 Antennas (3) Fujitsu TA08025-B605 + (3) TA08025-B604 RRH's (1) Raycap RDIDC-9181-PF-48 MC-PK8-DSH Platform Mount	(1) 1.6" Hybrid	Dish Wireless

* Analysis is based on a leased wind area of 30,000 in². The 30,000 in² is greater than the proposed actual equipment wind area.

** Analysis is based on a leased wind area of 11,000 in². The 11,000 in² is greater than the proposed actual equipment wind area.

All antenna lines assumed internally mounted, not exposed to the wind.

Michael F. Plahovinsak, P.E. - 2021

mike@mpeng.com

Foundation Analysis:

The existing monopole foundation design was analyzed in conjunction with site specific geotechnical report. The existing foundation has sufficient capacity to support the pole with the proposed antenna configuration.

Conclusion:

I have completed a structural analysis of the existing monopole and foundation in accordance with the project specifics outlined above. My analysis indicates that the existing monopole and foundation are structurally adequate when considering the existing plus proposed loading. Please refer to the attached calculations for an itemized listing of all member stress ratios. The existing pole is safe and adequate to support the proposed loads, and no structural reinforcing is required to support the above loading.

If you have any questions about the contents of this structural report or require any additional information, please feel free to contact my office.

Sincerely,

Michael F. Plahovinsak, P.E.



mike@mfpeng.com - 614.398-6250

Michael F. Plahovinsak, P.E. - 2021

mike@mfpeng.com

**Standard Conditions for Providing Structural Consulting
Services on Existing Structures**

1. The following standard conditions are a general overview of key issues regarding the work product supplied.
2. If the existing conditions are not as represented in this structural report or attached sketches, I should be contacted to evaluate the significance of the deviation and revise the structural assessment accordingly.
3. The structural analysis has been performed assuming that the structure is in "like new" condition. No allowance was made for excessive corrosion, damaged or missing structural members, loose bolts, etc. If there are any known deficiencies in the structure that potentially compromise structural integrity, I should be made aware of the deficiencies. If I am aware of a deficiency that exists in a structure at the time of my analysis, a general explanation of the structural concern due to the deficiency will be included in the structural report, but the deficiency will not be reflected in capacity calculations.
4. The structural analysis provided is an assessment of the primary load carrying capacity of the structure. I provide a limited scope of service in that I have not verified the capacity of every weld, plate, connection detail, etc. In most cases, structural fabrication details are unknown at the time of my analysis, and the detailed field measurement of this information is beyond the scope of my services. In instances where I have not performed connection capacity calculations, it is assumed that existing manufactured connections develop the full capacity of the primary members being connected.
5. The structural integrity of the existing foundation system can only be verified if exact foundation sizes and soils conditions are known. I will not accept any responsibility for the adequacy of the existing foundations unless this site-specific data is supplied.
6. Miscellaneous items such as antenna mounts, coax supports, etc. have not been designed, detailed, or specified as part of my work. It is assumed that material of adequate size and strength will be purchased from a reputable component manufacturer. The attached report and sketches are schematic in nature and should not be used to fabricate or purchase hardware and accessories to be attached to the structure. I recommend field measurement of the structure before fabricating or purchasing new hardware and accessories. I am not responsible for proper fit and clearance of hardware and accessory items in the field.
7. The structural analysis has been performed considering minimum code requirements or recommendations. If alternate wind, ice, or deflection criteria are to be considered, then I shall be made aware of the alternate criteria.

Michael F. Plahovinsak, P.E. - 2021

mike@mfpeng.com

Section	1	2	3	4
Length (ft)	49.00	26.00	38.00	53.00
Number of Sides	18	18	18	18
Thickness (in)	0.1875	0.2500	0.3125	0.3750
Socket Length (ft)	5.00	5.50	6.50	44.4027
Top Dia (in)	24.0000	33.8642	37.8443	58.5000
Bot Dia (in)	35.1800	39.8000	46.5100	10.7
Grade	A572-65			
Weight (K)	2.9	2.6	5.4	10.7

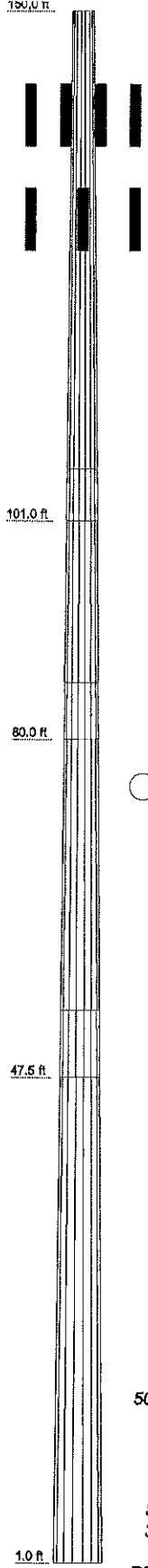

DESIGNED APPURTENANCE LOADING

TYPE	ELEVATION	TYPE	ELEVATION
Antennas + Mount (EPA 30,000 ln2) (Verizon)	140	Antennas + Equipment (EPA 11,000 ln2 / 2,000 lbs) (Dish)	130

MATERIAL STRENGTH

GRADE	Fy	Fu	GRADE	Fy	Fu
A572-65	65 ksi	80 ksi			

TOWER DESIGN NOTES

1. Tower is located in Fairfield County, Connecticut.
2. Tower designed for Exposure C to the TIA-222-G Standard.
3. Tower designed for a 110 mph basic wind in accordance with the TIA-222-G Standard.
4. Tower is also designed for a 60 mph basic wind with 0.75 in ice. Ice is considered to increase in thickness with height.
5. Deflections are based upon a 60 mph wind.
6. Tower Structure Class II.
7. Topographic Category 1 with Crest Height of 0.00 ft
8. TOWER RATING: 90.7%

ALL REACTIONS ARE FACTORED

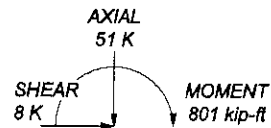

50 mph WIND - 0.7500 in ICE

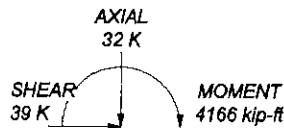

REACTIONS - 110 mph WIND

Michael Plahovinsak, P.E.		Job: 150-ft Monopole - MFP #40918-020 r4a	
18301 State Route 161		Project: CT1212 Trumbull	
Plain City, OH 43064		Client: TARPON TOWERS II, LLC	Drawn by: JC
Phone: 614-398-6250		Code: TIA-222-G	Date: 07/15/21
FAX: mike@mfpeng.com		Scale: N	Dwg No.

tnxTower Michael Plahovinsak, P.E. 18301 State Route 161 Plain City, OH 43064 Phone: 614-398-6250 FAX: mike@mfpeng.com	Job 150-ft Monopole - MFP #40918-020 r4a	Page 1 of 6
	Project CT1212 Trumbull	Date 15:15:59 07/15/21
	Client TARPON TOWERS II, LLC	Designed by JC

Tower Input Data

The tower is a monopole.

This tower is designed using the TIA-222-G standard.

The following design criteria apply:

Tower is located in Fairfield County, Connecticut.

Basic wind speed of 110 mph.

Structure Class II.

Exposure Category C.

Topographic Category 1.

Crest Height 0.00 ft.

Nominal ice thickness of 0.7500 in.

Ice thickness is considered to increase with height.

Ice density of 56 pcf.

A wind speed of 50 mph is used in combination with ice.

Temperature drop of 50 °F.

Deflections calculated using a wind speed of 60 mph.

A non-linear (P-delta) analysis was used.

Pressures are calculated at each section.

Stress ratio used in pole design is 1.

Local bending stresses due to climbing loads, feed line supports, and appurtenance mounts are not considered.

Tapered Pole Section Geometry

Section	Elevation ft	Section Length ft	Splice Length ft	Number of Sides	Top Diameter in	Bottom Diameter in	Wall Thickness in	Bend Radius in	Pole Grade
L1	150.00-101.00	49.00	5.00	18	24.0000	35.1800	0.1875	0.7500	A572-65 (65 ksi)
L2	101.00-80.00	26.00	5.50	18	33.6642	39.6000	0.2500	1.0000	A572-65 (65 ksi)
L3	80.00-47.50	38.00	6.50	18	37.8443	46.5100	0.3125	1.2500	A572-65 (65 ksi)
L4	47.50-1.00	53.00		18	44.4027	56.5000	0.3750	1.5000	A572-65 (65 ksi)

Tapered Pole Properties

Section	Tip Dia. in	Area in ²	I in ⁴	r in	C in	I/C in ³	J in ⁴	I/Q in ²	w in	w/t
L1	24.3413	14.1714	1015.2211	8.4534	12.1920	83.2694	2031.7780	7.0871	3.8940	20.768
	35.6938	20.8249	3221.5922	12.4223	17.8714	180.2648	6447.4234	10.4144	5.8617	31.262
L2	35.3041	26.5142	3740.0461	11.8620	17.1014	218.6982	7485.0135	13.2596	5.4849	21.94
	40.1723	31.2242	6108.2751	13.9693	20.1168	303.6405	12224.5877	15.6151	6.5296	26.118
L3	39.6535	37.2269	6625.1270	13.3238	19.2249	344.6113	13258.9715	18.6170	6.1106	19.554
	47.1793	45.8221	12355.2010	16.4001	23.6271	522.9254	24726.6594	22.9154	7.6358	24.434
L4	46.5364	52.4040	12833.7667	15.6298	22.5566	568.9589	25684.4203	26.2070	7.1549	19.08
	57.3138	66.8028	26585.4920	19.9244	28.7020	926.2592	53205.9659	33.4077	9.2840	24.757

Tower Elevation	Gusset Area (per face)	Gusset Thickness	Gusset Grade	Adjust. Factor A _f	Adjust. Factor A _r	Weight Mult.	Double Angle Stitch Bolt Spacing Diagonals	Double Angle Stitch Bolt Spacing Horizontals	Double Angle Stitch Bolt Spacing Redundants
ft	ft ²	in					in	in	in
L1				1	1	1			

tnxTower Michael Plahovinsak, P.E. 18301 State Route 161 Plain City, OH 43064 Phone: 614-398-6250 FAX: mike@mfpeng.com	Job 150-ft Monopole - MFP #40918-020 r4a	Page 2 of 6
	Project CT1212 Trumbull	Date 15:15:59 07/15/21
	Client TARPON TOWERS II, LLC	Designed by JC

Tower Elevation	Gusset Area (per face)	Gusset Thickness	Gusset Grade	Adjust. Factor A_f	Adjust. Factor A_r	Weight Multi.	Double Angle Stitch Bolt Spacing Diagonals	Double Angle Stitch Bolt Spacing Horizontals	Double Angle Stitch Bolt Spacing Redundants
ft	ft ²	in					in	in	in
150.00-101.00									
L2				1	1	1			
101.00-80.00									
L3 80.00-47.50				1	1	1			
L4 47.50-1.00				1	1	1			

Feed Line/Linear Appurtenances - Entered As Area

Description	Face or Leg	Allow Shield	Exclude From Torque Calculation	Component Type	Placement	Total Number	C_{AA}	Weight
					ft		ft ² /ft	plf
12x24 (Verizon)	C	No	Yes	Inside Pole	140.00 - 1.00	1	No Ice 1/2" Ice 1" Ice	0.00 0.00 0.92

1.6" (Dish)	C	No	Yes	Inside Pole	130.00 - 1.00	1	No Ice 1/2" Ice 1" Ice	0.00 0.00 0.92

Feed Line/Linear Appurtenances Section Areas

Tower Section	Tower Elevation	Face	A_R	A_F	C_{AA} In Face	C_{AA} Out Face	Weight
	ft		ft ²	ft ²	ft ²	ft ²	K
L1	150.00-101.00	A	0.000	0.000	0.000	0.000	0.00
		B	0.000	0.000	0.000	0.000	0.00
		C	0.000	0.000	0.000	0.000	0.06
L2	101.00-80.00	A	0.000	0.000	0.000	0.000	0.00
		B	0.000	0.000	0.000	0.000	0.00
		C	0.000	0.000	0.000	0.000	0.04
L3	80.00-47.50	A	0.000	0.000	0.000	0.000	0.00
		B	0.000	0.000	0.000	0.000	0.00
		C	0.000	0.000	0.000	0.000	0.06
L4	47.50-1.00	A	0.000	0.000	0.000	0.000	0.00
		B	0.000	0.000	0.000	0.000	0.00
		C	0.000	0.000	0.000	0.000	0.09

Feed Line/Linear Appurtenances Section Areas - With Ice

Tower Section	Tower Elevation	Face or Leg	Ice Thickness	A_R	A_F	C_{AA} In Face	C_{AA} Out Face	Weight
	ft		in	ft ²	ft ²	ft ²	ft ²	K
L1	150.00-101.00	A	1.713	0.000	0.000	0.000	0.000	0.00
		B		0.000	0.000	0.000	0.000	0.00
		C		0.000	0.000	0.000	0.000	0.06
L2	101.00-80.00	A	1.659	0.000	0.000	0.000	0.000	0.00
		B		0.000	0.000	0.000	0.000	0.00
		C		0.000	0.000	0.000	0.000	0.04
L3	80.00-47.50	A	1.601	0.000	0.000	0.000	0.000	0.00
		B		0.000	0.000	0.000	0.000	0.00
		C		0.000	0.000	0.000	0.000	0.06
L4	47.50-1.00	A	1.456	0.000	0.000	0.000	0.000	0.00
		B		0.000	0.000	0.000	0.000	0.00

tnxTower Michael Plahovinsak, P.E. 18301 State Route 161 Plain City, OH 43064 Phone: 614-398-6250 FAX: mike@mfpeng.com	Job 150-ft Monopole - MFP #40918-020 r4a	Page 3 of 6
	Project CT1212 Trumbull	Date 15:15:59 07/15/21
	Client TARPON TOWERS II, LLC	Designed by JC

Tower Section	Tower Elevation ft	Face or Leg C	Ice Thickness in	A _R ft ²	A _F ft ²	C _A A _A In Face ft ²	C _A A _A Out Face ft ²	Weight K
		C		0.000	0.000	0.000	0.000	0.09

Discrete Tower Loads

Description	Face or Leg	Offset Type	Offsets: Horz Lateral Vert ft ft ft	Azimuth Adjustment °	Placement ft	C _A A _A Front ft ²	C _A A _A Side ft ²	Weight K	
Antennas + Mount (EPA 30,000 in2) (Verizon) **	C	None		0.0000	140.00	No Ice 1/2" Ice 1" Ice	209.00 219.00 229.00	209.00 219.00 229.00	3.00 4.00 5.00
Antennas + Equipment (EPA 11,000 in2 / 2,000 lbs) (Dish)	C	None		0.0000	130.00	No Ice 1/2" Ice 1" Ice	76.39 81.39 86.39	76.39 81.39 86.39	2.00 2.50 3.00

Load Combinations

Comb. No.	Description
1	Dead Only
2	1.2 Dead+1.6 Wind 0 deg - No Ice
3	0.9 Dead+1.6 Wind 0 deg - No Ice
4	1.2 Dead+1.6 Wind 90 deg - No Ice
5	0.9 Dead+1.6 Wind 90 deg - No Ice
6	1.2 Dead+1.6 Wind 180 deg - No Ice
7	0.9 Dead+1.6 Wind 180 deg - No Ice
8	1.2 Dead+1.0 Ice+1.0 Temp
9	1.2 Dead+1.0 Wind 0 deg+1.0 Ice+1.0 Temp
10	1.2 Dead+1.0 Wind 90 deg+1.0 Ice+1.0 Temp
11	1.2 Dead+1.0 Wind 180 deg+1.0 Ice+1.0 Temp
12	Dead+Wind 0 deg - Service
13	Dead+Wind 90 deg - Service
14	Dead+Wind 180 deg - Service

Maximum Member Forces

Section No.	Elevation ft	Component Type	Condition	Gov. Load Comb.	Axial K	Major Axis Moment kip-ft	Minor Axis Moment kip-ft
L1	150 - 101	Pole	Max Tension	2	0.00	0.00	-0.00
			Max. Compression	8	-17.25	0.00	0.00
			Max. Mx	4	-6.83	-749.66	0.00
			Max. My	2	-6.83	0.00	749.66
			Max. Vy	4	25.55	-749.66	0.00
			Max. Vx	2	-25.55	0.00	749.66
L2	101 - 80	Pole	Max Tension	1	0.00	0.00	0.00
			Max. Compression	8	-22.05	0.00	0.00
			Max. Mx	4	-10.01	-1301.12	0.00
			Max. My	2	-10.01	0.00	1301.12
			Max. Vy	4	28.23	-1301.12	0.00
			Max. Vx	2	-28.23	0.00	1301.12
L3	80 - 47.5	Pole	Max Tension	1	0.00	0.00	0.00

tnxTower Michael Plahovinsak, P.E. 18301 State Route 161 Plain City, OH 43064 Phone: 614-398-6250 FAX: mike@mspeng.com	Job 150-ft Monopole - MFP #40918-020 r4a	Page 4 of 6
	Project CT1212 Trumbull	Date 15:15:59 07/15/21
	Client TARPON TOWERS II, LLC	Designed by JC

Section No.	Elevation ft	Component Type	Condition	Gov. Load Comb.	Axial K	Major Axis Moment kip-ft	Minor Axis Moment kip-ft
L4	47.5 - 1	Pole	Max. Compression	8	-31.25	0.00	0.00
			Max. Mx	4	-16.64	-2259.09	0.00
			Max. My	2	-16.64	0.00	2259.09
			Max. Vy	4	32.54	-2259.09	0.00
			Max. Vx	2	-32.54	0.00	2259.09
			Max Tension	1	0.00	0.00	0.00
			Max. Compression	8	-51.05	0.00	0.00
			Max. Mx	4	-32.17	-4165.51	0.00
			Max. My	2	-32.17	0.00	4165.51
			Max. Vy	4	39.08	-4165.51	0.00
			Max. Vx	2	-39.08	0.00	4165.51

Maximum Tower Deflections - Service Wind

Section No.	Elevation ft	Horz. Deflection in	Gov. Load Comb.	Tilt °	Twist °
L1	150 - 101	18.757	12	1.1083	0.0000
L2	106 - 80	9.177	12	0.8626	0.0000
L3	85.5 - 47.5	5.840	12	0.6700	0.0000
L4	54 - 1	2.263	12	0.3939	0.0000

Critical Deflections and Radius of Curvature - Service Wind

Elevation ft	Appurtenance	Gov. Load Comb.	Deflection in	Tilt °	Twist °	Radius of Curvature ft
140.00	Antennas + Mount (EPA 30,000 in2)	12	16.421	1.0655	0.0000	23140
130.00	Antennas + Equipment (EPA 11,000 in2 / 2,000 lbs)	12	14.136	1.0184	0.0000	11570

Maximum Tower Deflections - Design Wind

Section No.	Elevation ft	Horz. Deflection in	Gov. Load Comb.	Tilt °	Twist °
L1	150 - 101	112.786	2	6.6705	0.0000
L2	106 - 80	55.234	2	5.1937	0.0000
L3	85.5 - 47.5	35.164	2	4.0350	0.0000
L4	54 - 1	13.631	2	2.3726	0.0000

Critical Deflections and Radius of Curvature - Design Wind

Elevation ft	Appurtenance	Gov. Load Comb.	Deflection in	Tilt °	Twist °	Radius of Curvature ft
140.00	Antennas + Mount (EPA 30,000 in2)	2	98.756	6.4132	0.0000	3944
130.00	Antennas + Equipment (EPA 11,000 in2 / 2,000 lbs)	2	85.037	6.1304	0.0000	1970

tnxTower Michael Plahovinsak, P.E. 18301 State Route 161 Plain City, OH 43064 Phone: 614-398-6250 FAX: mike@mfpeng.com	Job 150-ft Monopole - MFP #40918-020 r4a	Page 5 of 6
	Project CT1212 Trumbull	Date 15:15:59 07/15/21
	Client TARPON TOWERS II, LLC	Designed by JC

Pole Design Data

Section No.	Elevation ft	Size	L ft	L _u ft	Kl/r	A in ²	P _v K	φP _n K	Ratio
									$\frac{P_u}{\phi P_n}$
L1	150 - 101 (1)	TP35.18x24x0.1875	49.00	0.00	0.0	20.1460	-6.83	1194.68	0.006
L2	101 - 80 (2)	TP39.6x33.6642x0.25	26.00	0.00	0.0	30.2279	-10.01	1951.16	0.005
L3	80 - 47.5 (3)	TP46.51x37.8443x0.3125	38.00	0.00	0.0	44.3519	-16.64	2939.60	0.006
L4	47.5 - 1 (4)	TP56.5x44.4027x0.375	53.00	0.00	0.0	66.8028	-32.17	4345.76	0.007

Pole Bending Design Data

Section No.	Elevation ft	Size	M _{ux} kip-ft	φM _{ux} kip-ft	Ratio	M _{uy} kip-ft	φM _{uy} kip-ft	Ratio
					$\frac{M_{ux}}{\phi M_{ux}}$			$\frac{M_{uy}}{\phi M_{uy}}$
L1	150 - 101 (1)	TP35.18x24x0.1875	749.66	833.54	0.899	0.00	833.54	0.000
L2	101 - 80 (2)	TP39.6x33.6642x0.25	1301.12	1530.41	0.850	0.00	1530.41	0.000
L3	80 - 47.5 (3)	TP46.51x37.8443x0.3125	2259.08	2705.28	0.835	0.00	2705.28	0.000
L4	47.5 - 1 (4)	TP56.5x44.4027x0.375	4165.51	5021.38	0.830	0.00	5021.38	0.000

Pole Shear Design Data

Section No.	Elevation ft	Size	Actual	φV _n K	Ratio	Actual T _u kip-ft	φT _n kip-ft	Ratio
			V _u K		$\frac{V_u}{\phi V_n}$			$\frac{T_u}{\phi T_n}$
L1	150 - 101 (1)	TP35.18x24x0.1875	25.55	597.34	0.043	0.00	1670.52	0.000
L2	101 - 80 (2)	TP39.6x33.6642x0.25	28.23	975.58	0.029	0.00	3067.59	0.000
L3	80 - 47.5 (3)	TP46.51x37.8443x0.3125	32.54	1469.80	0.022	0.00	5422.89	0.000
L4	47.5 - 1 (4)	TP56.5x44.4027x0.375	39.08	2172.88	0.018	0.00	10065.17	0.000

Pole Interaction Design Data

Section No.	Elevation ft	Ratio	Ratio	Ratio	Ratio	Ratio	Comb. Stress Ratio	Allow. Stress Ratio	Criteria
		$\frac{P_u}{\phi P_n}$	$\frac{M_{ux}}{\phi M_{ux}}$	$\frac{M_{uy}}{\phi M_{uy}}$	$\frac{V_u}{\phi V_n}$	$\frac{T_u}{\phi T_n}$			
L1	150 - 101 (1)	0.006	0.899	0.000	0.043	0.000	0.907	1.000	4.8.2 ✓
L2	101 - 80 (2)	0.005	0.850	0.000	0.029	0.000	0.856	1.000	4.8.2 ✓
L3	80 - 47.5 (3)	0.006	0.835	0.000	0.022	0.000	0.841	1.000	4.8.2 ✓
L4	47.5 - 1 (4)	0.007	0.830	0.000	0.018	0.000	0.837	1.000	4.8.2 ✓

tnxTower Michael Plahovinsak, P.E. 18301 State Route 161 Plain City, OH 43064 Phone: 614-398-6250 FAX: mike@mfpeng.com	Job 150-ft Monopole - MFP #40918-020 r4a	Page 6 of 6
	Project CT1212 Trumbull	Date 15:15:59 07/15/21
	Client TARPON TOWERS II, LLC	Designed by JC

Section Capacity Table

Section No.	Elevation ft	Component Type	Size	Critical Element	P K	ϕP_{allow} K	% Capacity	Pass Fail
L1	150 - 101	Pole	TP35.18x24x0.1875	1	-6.83	1194.68	90.7	Pass
L2	101 - 80	Pole	TP39.6x33.6642x0.25	2	-10.01	1951.16	85.6	Pass
L3	80 - 47.5	Pole	TP46.51x37.8443x0.3125	3	-16.64	2939.60	84.1	Pass
L4	47.5 - 1	Pole	TP56.5x44.4027x0.375	4	-32.17	4345.76	83.7	Pass
Summary								
Pole (L1)							90.7	Pass
RATING =							90.7	Pass

Michael F. Plahovinsak, P.E. 18301 State Route 161 W Plain City, OH 43064 Phone: 614-398-6250 email: mike@mfpeng.com	Job 150-ft monopole - MFP #40918-020 r4a	Page BP-G
	Project CT1212 Trumbull	Date 7/15/2021
	Client TP-15472	Designed by Mike

Anchor Rod and Base Plate Calculation

ANSI/TIA-222-G-2

Factored Base Reactions:		Pole Shape:	Anchor Rods:	Base Plate:
Moment:	4166 ft-kips	18-Sided	(16) 2.25 in. A615 GR. 75	2.25 in. x 69.5 in. Round
Shear:	39 kips	Pole Dia. (D_p):	Anchor Rods Evenly Spaced	fy = 50 ksi
Axial:	32 kips	56.50 in	On a 63.5 in Bolt Circle	

Anchor Rod Calculation According to TIA-222-G section 4.9.9

$\phi =$	0.80 TIA 4.9.9
$I_{bolts} =$	8064.50 in ² Moment of Inertia
$P_u =$	197 kips Tension Force
$V_u =$	2 kips Shear Force
$R_{nt} =$	325.00 kips Nominal Tensile Strength
$\eta =$	0.50 for detail type (d)

The following Interaction Equation Shall Be Satisfied:

$$\left(\frac{P_u + \frac{V_u}{\eta}}{\phi R_{nt}} \right) \leq 1.0$$

$$0.776 \leq 1$$

Base Plate Calculation According to TIA-222-G

$\phi =$	0.90 TIA 4.7
$M_{PL} =$	472.2 in-kip Plate Moment
$L =$	11.1 in Section Length
$Z =$	14.0 Plastic Section Modulus
$M_p =$	702.0 in-kip Plastic Moment
$\phi M_n =$	631.8 in-kip Factored Resistance

Calculated Moment vs Factored Resistance

$$472.19 \text{ in-kip} \leq 632 \text{ in-kip}$$

Anchor Rods Are Adequate	77.6% <input checked="" type="checkbox"/>
Base Plate is Adequate	74.7% <input checked="" type="checkbox"/>

Monopole Spread Footing Calculation

ANSI/TIA-222-G-2

Factored Base Reactions:	Footing Dimensions:	Concrete:
Moment: 4166 ft-kips	26 ft x 26 ft	7 ft Square Pier
Shear: 39 kips	x 3 ft thick	w/6 in Reveal
Axial: 32 kips	Bearing 6 ft B.G.	81.5 Yd3 Concrete
Soil Backfill 100 pcf	Ultimate Bearing:	6000 psf
		Water Table n/a

Foundation Weight

Weight of Pole	32.0 kips
Weight of Concrete	329.925 kips
Weight of Soil	188.1 kips
Bouyancy of Water	0.0 kips
Total	550.0 kips

Overturning Resistance:

Overturning Moment (M_u)	4419.5 ft-kips	4166 ft-kips + (39 kips x 6.5 ft)
Resisting Moment (R_s)	7150.325 ft-kips	550.025 kips x 26 ft / 2
$\phi \times R_s > M_u$	$M_{overturning} / f M_{resist}$	82.4% OK

Soil Bearing Pressure:

Eccentricity (e)	8.04 ft	4419.5 ft-kips / 550.025 kips
$6(e)$	48.2 ft >	26.0 ft $6e > 26$
Maximum Soil Bearing	3040.5623 psf	Calculated across corners
Soil Overburden	-600 psf	
Net Soil Bearing	2440.5623 psf	
Resisting Soil Bearing (R_s)	6000 psf	
Net Soil Bearing < $\phi \times R_s$	Net Bearing / $f R_s$	54.2% OK

Bending Moment in Pier:

Bending Moment	4302.5 ft-kips	4166 ft-kips + (39 kips x 3.5 ft)
Pier Steel Req'd (Loads)	49.22 in ²	
Min. Pier Steel	35.28 in ²	1/2% (Based on Square Pier)

Bending Moment in Footing:

Max Bending Moment	2624.1619 ft-kips	Σ Moments about pier face
Footing Steel Req'd (Loads)	1.22 in ² /ft	
Min. Footing Steel	0.78 in ² /ft	0.18%

Exhibit E
Mount Analysis

MONOPOLE PLATFORM

MC-PK8-C

STRUCTURAL ANALYSIS REPORT

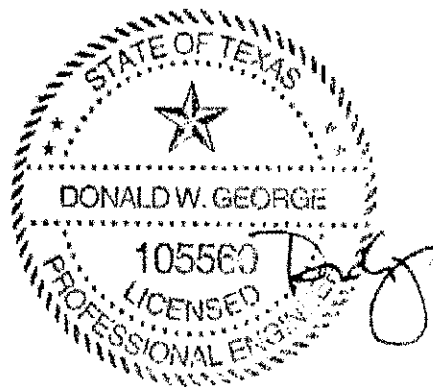
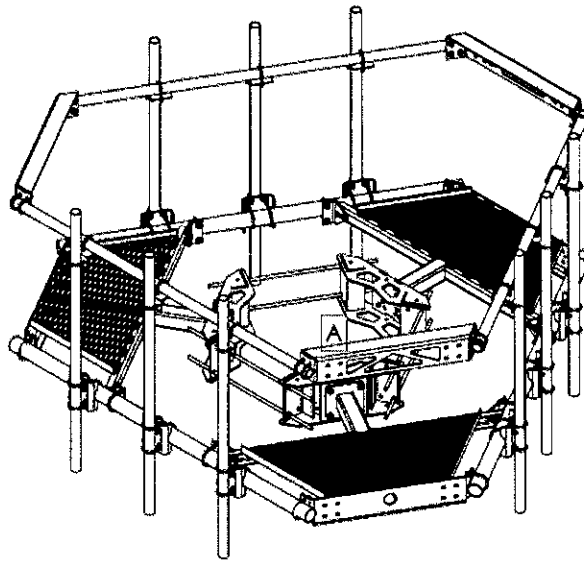

Date: 2/18/2021

CommScope Inc.

11312 S. Pipeline Road

Euless, TX 76040

Steel Products (SteelProducts@commscope.com)

1 SUMMARY

Analysis of monopole platform was performed to determine the structural integrity of mounting system with the proposed loads. The purpose of the analysis is to determine acceptability of the mount stress level.

2 DESIGN CRITERIA

TIA Standard	ANSI/TIA-222-G and ANSI/TIA-222-H
Wind Speed	140 mph (3-Second Gust, VASD) / 180 mph (3-Second Gust, VULT)
Wind Speed w/ ice	60 mph (3-Second Gust, VASD) w/ 2" ice
Structure Class	I or II
Exposure Category	B or C
Topographic Category	1
Max. Mount Height	175ft
*Antenna Information	(1)JMA MX08FIT865-20 & (2)Fujitsu RRU / Each Antenna Pipe
Mount Material	CommScope mount material are using mill certified steel with minimum or exceeding the following ASTM specification.
Round Pipe/Tube	ASTM A500 Grade C (46Ksi)
Rectangular/Square Tube	ASTM A500 Grade C (46 Ksi)
Solid Rod	ASTM A529 (50 Ksi)
Angles	ASTM A529 (50 Ksi)

*Loaded two antenna pipe position per sector. For three antenna positions per sector, upgrade antenna pipes to 27/8" OD

** Code allowed shielding considered

3 ANALYSIS PROCEDURE

RISA-3D (Version No. 17.0.0), a commercially available software package, was used to create a three-dimensional model of the mount and calculate member stresses for various loading cases.

4 ANALYSIS RESULTS

The mount model MC-PK8-C when installed as per instruction listed in assembly drawing has sufficient capacity to carry above mentioned equipment loads with stated design criteria without the need for additional structural supporting/ modification.

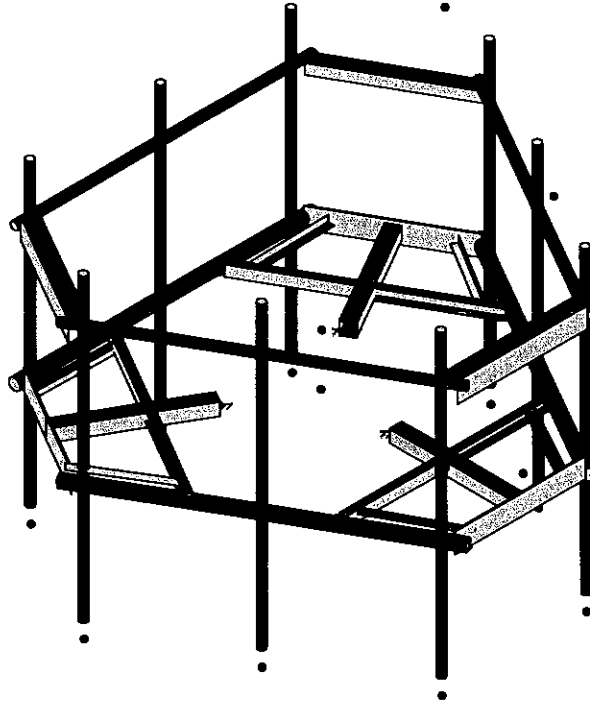
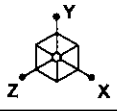

Envelope Only Solution

CommScope	MC-PK8-C	Rendered View
		Feb 3, 2021 at 2:26 PM
		MC-PK8.r3d

MX08FIT865-20

NWAV™ X-Pol 8-Port Antenna

X-Pol 8-Port 8 ft 65° with Smart Bias-Ts:

4 ports 617-894 MHz and 4 ports 1695-2200 MHz

- Excellent passive intermodulation (PIM) performance reduces harmful interference.
- Fully integrated (iRETs) with Smart Bias-Ts & independent RET control for low and high bands for ease of network optimization
- SON-Ready array spacing supports beamforming capabilities.
- High total power handling to maximize network efficiency
- Supports 4X4 MIMO in all bands

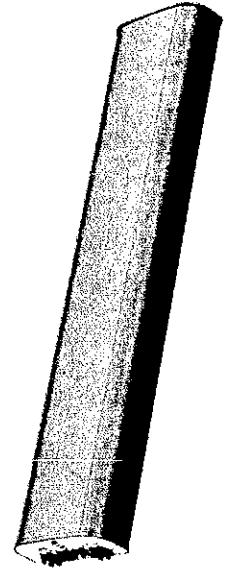

NWAV™

Electrical specification (minimum/maximum)	Ports 1, 2, 3, 4		Ports 5, 6, 7, 8		
Frequency bands, MHz	617-698	698-894	1695-1880	1850-1990	1920-2200
Polarization	± 45°		± 45°		
Average gain over all tilts, dBi	15.3	16.1	17.5	17.8	18.6
Horizontal beamwidth (HBW), degrees ¹	68	62	69	66	62
Front-to-back ratio, co-polar power @180°± 30°, dB	>27	>29	>30	>30	>30
Vertical beamwidth (VBW), degrees ¹	10.3	8.8	5.4	5.2	4.9
Electrical downtilt (EDT) range, degrees	2-13		2-12		
First upper side lobe (USLS) suppression, dB ¹	≤-18.0	≤-16.5	≤-18.0	≤-18.0	≤-20.0
Minimum cross-polar isolation, port-to-port, dB ¹	25	25	25	25	25
Max VSWR / return loss, dB	1.5:1 / -14.0		1.5:1 / -14.0		
Max passive intermodulation (PIM), 2x20W carrier, dBc	-153		-153		
Max input power per any port, watts	300		250		
Total composite power all ports (1-12), watts	1500				

¹ Typical value over frequency and tilt

Electrical specification (minimum/maximum)	Ports 1, 2, 3, 4			Ports 5, 6, 7, 8	
Frequency bands, MHz	617-698	698-894	1695-1880	1850-1990	1920-2200
Average gain over all tilts, dBi (Gain Tolerance)	14.8±0.5	15.7±0.5	17.1±0.4	17.3±0.4	18.2±0.5
Horizontal beamwidth tolerance (HBW), degrees ¹	±5	±4.5	±4.5	±4.0	±5.0
Vertical beamwidth tolerance (VBW), degrees	±0.6	±0.5	±0.5	±0.5	±0.5
Front-to-back ratio, co-polar power @180°± 30°, dB	>27	>25	>25	>26	>24
X-Pol discrimination (CPR) at boresight, dB	>23	>25	>25	>22	>24
First upper side lobe (USLS) suppression boresight to 20°, dB ¹	≤-16	≤-15	≤-16	≤-16	≤-16

Mechanical specifications	
Dimensions height/width/depth, inches (mm)	95.9/ 20.0/ 7.4 (2436/ 508.0/ 188.0)
Shipping dimensions length/width/height, inches (mm)	100.6/ 23.8/ 14.5 (2555/ 605/ 368)
No. of RF input ports, connector type, and location	8 x 4.3-10 female, bottom
RF connector torque	96 lbf-in (10.85 N·m or 8 lbf-ft)
Net antenna weight, lb (kg)	101 (45.8)
Shipping weight, lb (kg)	151 (68.5)
Antenna mounting and downtilt kit included with antenna	91900318, 91900319 (middle bracket)
Net weight of the mounting and downtilt kit, lb (kg)	26 (11.8)
Range of mechanical up/down tilt	-2° to 12°
Rated wind survival speed, mph (km/h)	150 (241)
Frontal, lateral, and rear wind loading @ 150 km/h, lbf (N)	247.4 (1101), 55.3 (246), 373.7 (1662)
Equivalent flat plate @ 100 mph and Cd=2, sq ft	4.98

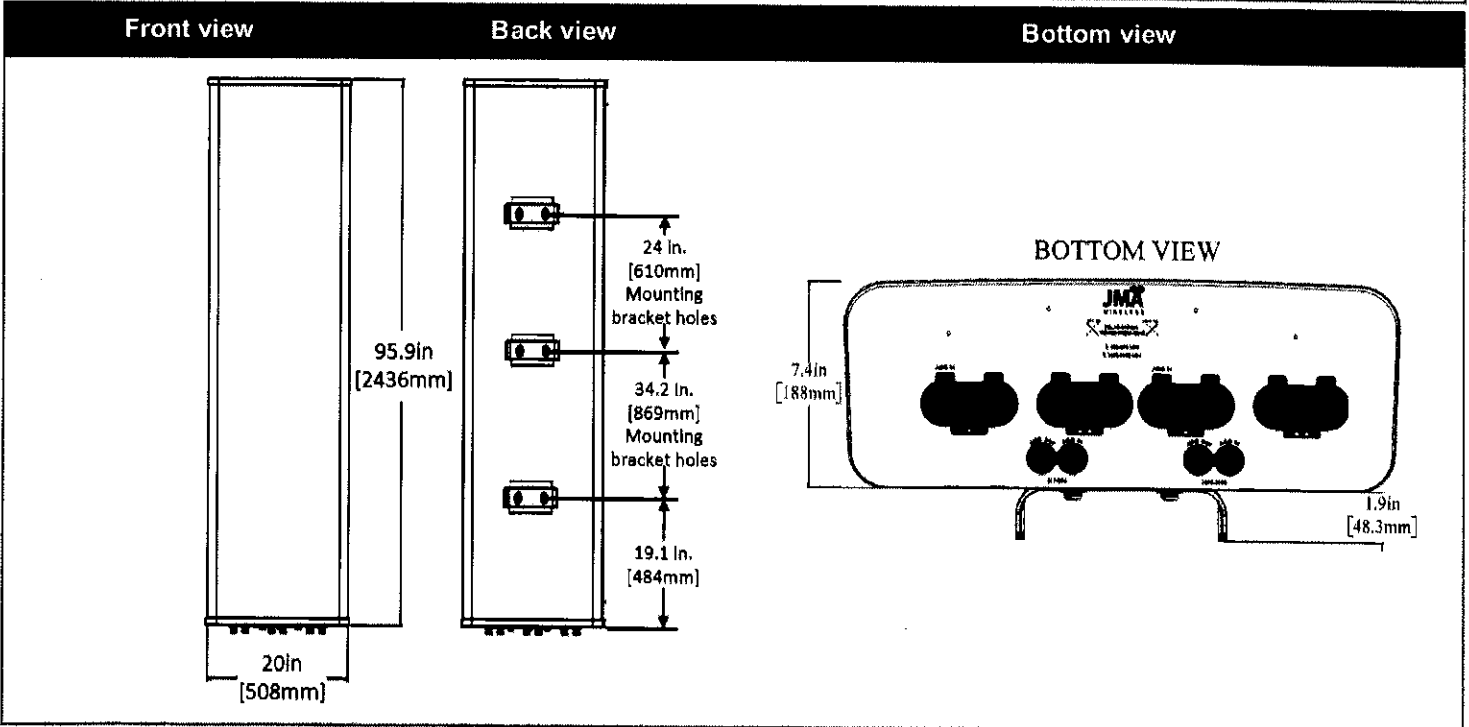

Remote electrical tilt (RET 1000) information

RET location	Integrated into antenna
RET interface connector type	8-pin AISG connector per IEC 60130-9 or RF port bias-t
RET connector torque	Min 0.5 N·m to max 1.0 N·m (hand pressure & finger tight)
RET interface connector quantity	2 pairs of AISG male/female connectors and 2 RF port bias-ts
RET interface connector location	Bottom of the antenna
Total no. of internal RETs 698-894 MHz	1
Total no. of internal RETs 1695-2200 MHz	1
RET input operating voltage, vdc	10-30
RET max power consumption, idle state, W	≤ 2.0
RET max power consumption, normal operating conditions, W	≤ 13.0
RET communication protocol	AISG 2.0 / 3GPP

RET and RF connector topology

Each RET device can be controlled either via the designated external AISG connector or RF port as shown below:

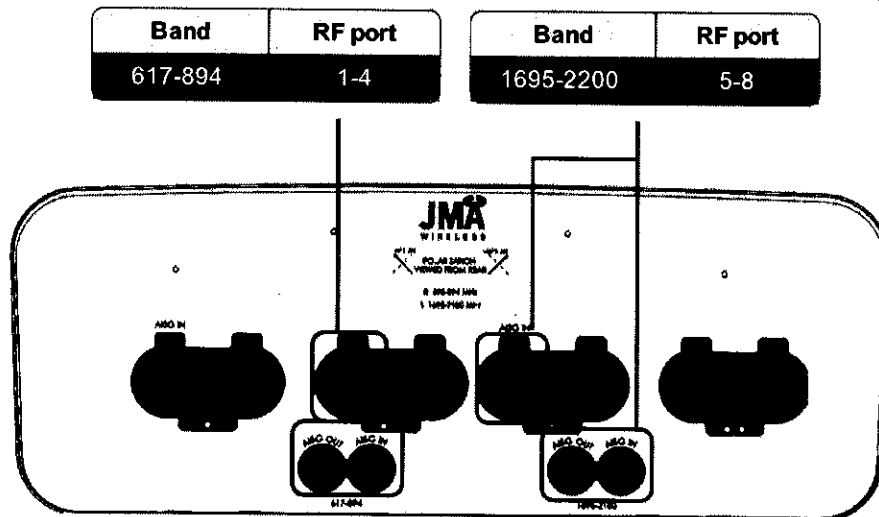

Array topology

6 sets of radiating arrays

- R1: 617-894 MHz
- R2: 617-894 MHz
- B1: 1695-2200 MHz
- B2: 1695-2200 MHz

Band	RF port
617-894	1-2
617-894	3-4
1695-2200	5-6
1695-2200	7-8



Fujitsu – DiSH Triple-band RU Technical Specifications

RU General Specification	
Part number	TA08025-B605
TRX Configuration	4T4R
Operating Frequency	n71 & n29 & n26 Frequencies (Triple-Band)
Instantaneous Bandwidth	n71: 35MHz n29: 11MHz n26: 7MHz
Operation Bandwidth (3GPP)	n71: 35MHz n29: 10MHz n26: 5MHz
CC BW	5/10/20 MHz
Capacity	n71:2Cr(5/10/20MHz)/NB-IOT n26:1Cr(5MHz)/NB-IOT n29:2Cr(5/10MHz)
Interface to DU	ORAN 7.2x / 10G optical IF
TX Specification	
Output Power per TX	n71: 30W per port n29: 40W per port n26: 10 W per port
ACLR	Compliant with 3GPP TS 38.104
Transmitter Spurious Emissions	Compliant with 3GPP TS 38.104
EVM	Compliant with 3GPP TS 38.104
RX Specification	
Noise Figure	2.5dB (normal condition 2.2dB)
Blocking Features	Compliant with 3GPP TS 38.104
Receiver spurious emissions	Compliant with 3GPP TS 38.104
Mechanical Specification	
Volume	35 L
Dimension	W:400mm, H: 380mm, D: 230mm
Antenna Connector Type	4.3-10 RF connector
Antenna Control Interface	AISG
Power Supply	DC -58~-36V
Power Consumption	<1300W
Weight	34 kg
Environmental	
Humidity (Absolute humidity)	0.03 g/m3 ~ 30 g/m3
Atmospheric Pressure	Between 70 kPa and 106 kPa
Operating Temperature	-40°C ~ +55°C
IP Rating	IP65
Cooling	Passive

Mounting Options	
Pole	TBD
Wall	TBD

Exhibit F
Emissions Report

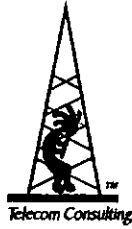

PINNACLE TELECOM GROUP

Professional and Technical Services

ANTENNA SITE FCC RF COMPLIANCE ASSESSMENT AND REPORT FOR MUNICIPAL SUBMISSION



PREPARED FOR: Dish Wireless, LLC

SITE ID: NJJER01144A

SITE ADDRESS: 98 JEFFERY PLACE
TRUMBULL, CT

LATITUDE: N 41.251850

LONGITUDE: W 73.192953

STRUCTURE TYPE: MONOPOLE

REPORT DATE: SEPTEMBER 21, 2021

COMPLIANCE CONCLUSION: Dish Wireless, LLC will be in compliance with the rules and regulations as described in OET BULLETIN 65, following the implementation of the proposed mitigation as detailed in the report.

14 RIDGEDALE AVENUE - SUITE 260 • CEDAR KNOLLS, NJ 07927 • 973-451-1630

CONTENTS

INTRODUCTION AND SUMMARY	3
ANTENNA AND TRANSMISSION DATA	5
COMPLIANCE ANALYSIS	9
COMPLIANCE CONCLUSION	18

CERTIFICATION

APPENDIX A. DOCUMENTS USED TO PREPARE THE ANALYSIS

APPENDIX B. BACKGROUND ON THE FCC MPE LIMIT

APPENDIX C. PROPOSED SIGNAGE

APPENDIX D. SUMMARY OF EXPERT QUALIFICATIONS

INTRODUCTION AND SUMMARY

At the request of Dish Wireless, LLC ("Dish"), Pinnacle Telecom Group has performed an independent expert assessment of radiofrequency (RF) levels and related FCC compliance for proposed wireless base station antenna operations on an existing monopole located at 98 Jeffrey Place in Trumbull, CT. Dish refers to the antenna site by the code "NJJER01144A", and its proposed operation involves directional panel antennas and transmission in the 600 MHz, 2000 MHz, and 2100 MHz frequency bands licensed to it by the FCC.

The FCC requires all wireless antenna operators to perform an assessment of potential human exposure to radiofrequency (RF) fields emanating from all the transmitting antennas at a site whenever antenna operations are added or modified, and to ensure compliance with the Maximum Permissible Exposure (MPE) limit in the FCC's regulations. In this case, the compliance assessment needs to take into account the RF effects of other existing antenna operations at the site by Verizon Wireless. Note that FCC regulations require any future antenna collocators to assess and assure continuing compliance based on the cumulative effects of all then-proposed and then-existing antennas at the site.

This report describes mathematical analyses of potential RF exposure levels associated with the antennas. The analyses both at street level and on the subject roof employ standard FCC mathematical models for calculating the effects of the antennas in a very conservative manner, in order to overstate the RF levels and to ensure "safe-side" conclusions regarding compliance with the FCC limit for safe continuous exposure of the general public.

The results of a compliance assessment can be described in layman's terms by expressing the calculated RF levels as simple percentages of the FCC MPE limit. If the normalized reference for that limit is 100 percent, then calculated RF levels higher than 100 percent indicate the MPE limit is exceeded and there is a need to mitigate the potential exposure. On the other hand, calculated RF levels consistently below 100 percent serve as a clear and sufficient demonstration of compliance with the MPE limit. We can (and will) also describe the overall worst-case result via the "plain-English" equivalent "times-below-the-limit" factor.

The result of the RF compliance assessment in this case is as follows:

- At street level, the conservatively calculated maximum RF level from the combination of proposed and existing antenna operations at the site is 1.5914 percent of the FCC general population MPE limit – well below the 100-percent reference for compliance. In other words, the worst-case calculated RF level – intentionally and significantly overstated by the calculations – is still more than 60 times below the FCC limit for safe, continuous exposure of the general public.
- A supplemental analysis of the RF levels at the same height as the Dish antennas indicate that the FCC MPE limit is potentially exceeded. Therefore, it is recommended that two Caution signs be installed at the base of the monopole. In addition, NOC Information signs are to be installed at the base of the monopole.
- The results of the calculations, along with the proposed mitigation, combine to satisfy the FCC requirements and associated guidelines on RF compliance at street level around the site and on the subject roof. Moreover, because of the significant conservatism incorporated in the analysis, RF levels actually caused by the antennas will be lower than these calculations indicate.

The remainder of this report provides the following:

- relevant technical data on the proposed Dish antenna operations at the site, as well as on the existing Verizon Wireless antenna operations;
- a description of the applicable FCC mathematical model for calculating RF levels, and application of the relevant technical data to that model;
- analysis of the results of the calculations against the FCC MPE limit, and the compliance conclusion for the site.

In addition, four Appendices are included. Appendix A provides information on the documents used to prepare the analysis. Appendix B provides background on the FCC MPE limit. Appendix C details the proposed mitigation to satisfy the FCC requirements and associated guidelines on RF compliance. Appendix D provides

a summary of the qualifications of the expert certifying FCC compliance for this site.

ANTENNA AND TRANSMISSION DATA

The plan and elevation views that follow, extracted from the site drawings, illustrate the mounting positions of the Dish antennas at the site.

Plan View:

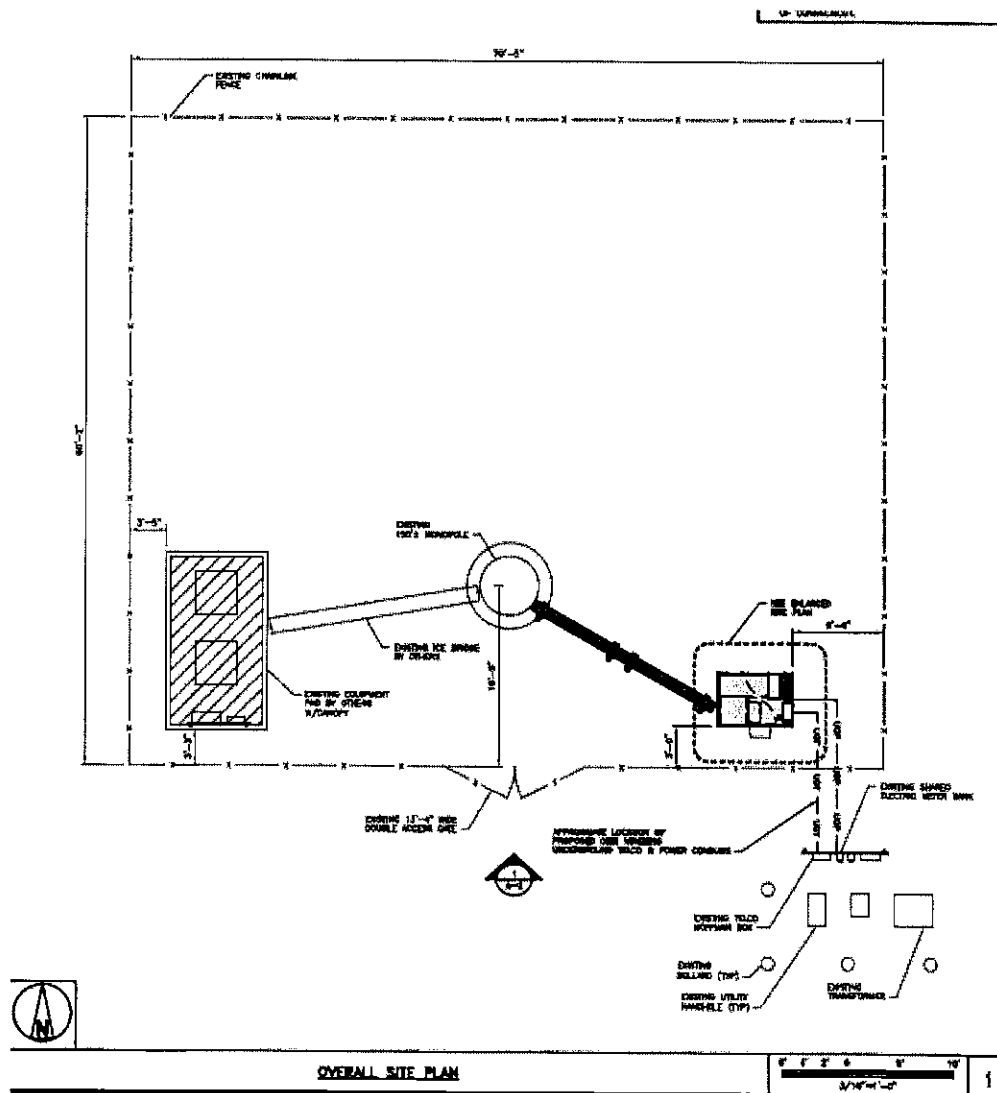

Elevation View:

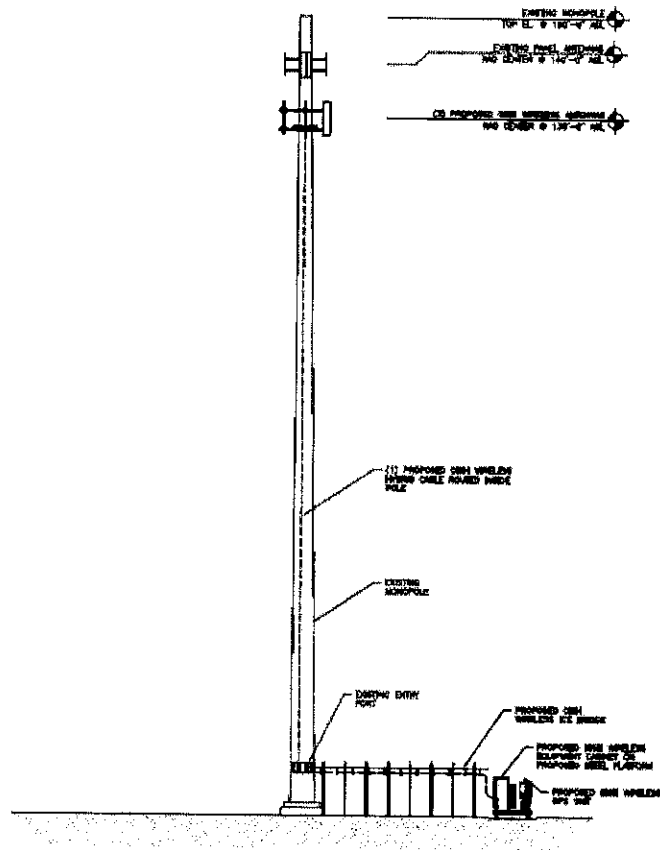

The table that follows summarizes the relevant data for the proposed Dish antenna operations. Note that the "Z" height references the centerline of the antenna.

Ant ID	Carrier	Antenna Manufacturer	Antenna Model	Op.	Freq (MHz)	Ant. Dim. (ft)	Total ERP (Watts)	Z (W)	Ant. Gain (dBo)	EW	Azimuth	EDJ	MDT
1	Dish	JMA Wireless	MX08FRO665-21	Panel	600	6	1680	130	13.6	68	100	2	0
1	Dish	JMA Wireless	MX08FRO665-21	Panel	2000	6	6609	130	18.3	62	100	2	0
1	Dish	JMA Wireless	MX08FRO665-21	Panel	2100	6	7415	130	18.8	64	100	2	0
2	Dish	JMA Wireless	MX08FRO665-21	Panel	600	6	1680	130	13.6	68	210	2	0
2	Dish	JMA Wireless	MX08FRO665-21	Panel	2000	6	6609	130	18.3	62	210	2	0
2	Dish	JMA Wireless	MX08FRO665-21	Panel	2100	6	7415	130	18.8	64	210	2	0
3	Dish	JMA Wireless	MX08FRO665-21	Panel	600	6	1680	130	13.6	68	340	2	0
3	Dish	JMA Wireless	MX08FRO665-21	Panel	2000	6	6609	130	18.3	62	340	2	0
3	Dish	JMA Wireless	MX08FRO665-21	Panel	2100	6	7415	130	18.8	64	340	2	0

The area below the antennas, at street level, is of interest in terms of potential “uncontrolled” exposure of the general public, so the antenna’s vertical-plane emission characteristic is used in the calculations, as it is a key determinant of the relative amount of RF emissions in the “downward” direction.

By way of illustration, Figure 1 that follows shows the vertical-plane radiation pattern of the proposed antenna model in the 600 MHz frequency band. In this type of antenna radiation pattern diagram, the antenna is effectively pointed at the three o’clock position (the horizon) and the relative strength of the pattern at different angles is described using decibel units.

Note that the use of a decibel scale to describe the relative pattern at different angles actually serves to significantly understate the actual focusing effects of the antenna. Where the antenna pattern reads 20 dB the relative RF energy emitted at the corresponding downward angle is 1/100th of the maximum that occurs in the main beam (at 0 degrees); at 30 dB, the energy is only 1/1000th of the maximum.

Finally, note that the automatic pattern-scaling feature of our internal software may skew side-by-side visual comparisons of different antenna models, or even different parties’ depictions of the same antenna model.

Figure 1. JMA Wireless MX08FRO665-21 – 600 MHz Vertical-plane Pattern

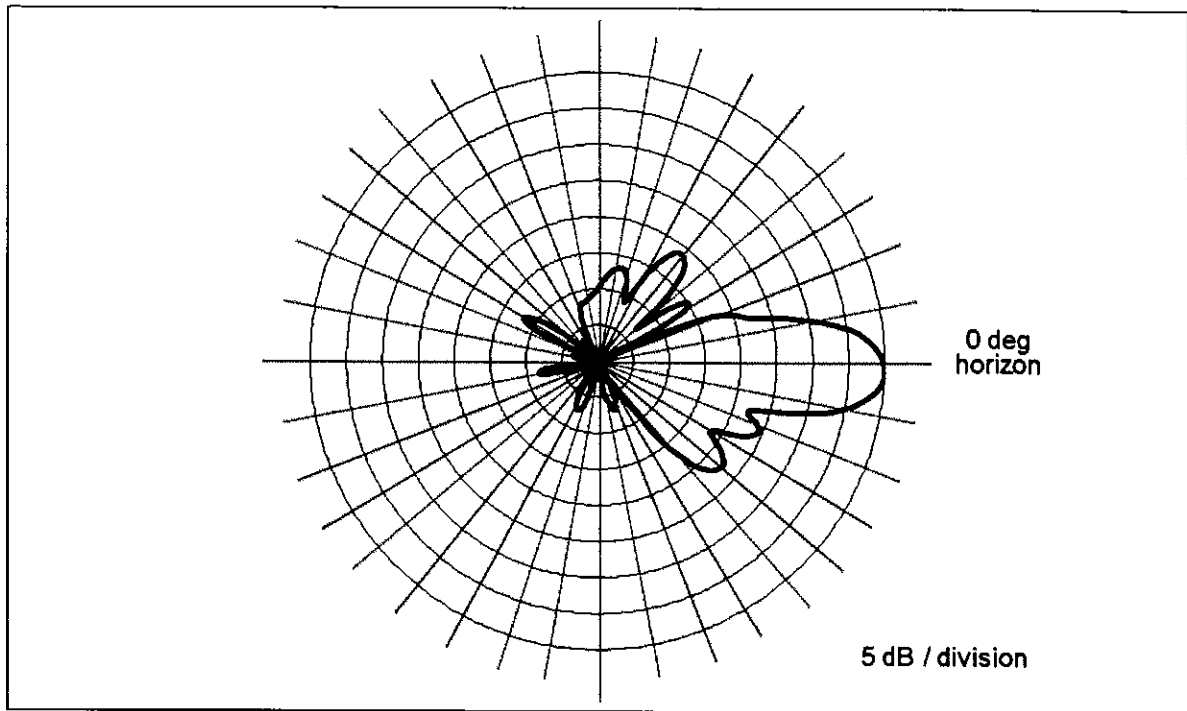

As noted at the outset, there are existing antenna operations by Verizon Wireless to include in the compliance assessment, and we will conservatively assume operation with maximum channel capacity and at maximum transmitter power per channel to be used in each of its FCC-licensed frequency bands.

The table that follows summarizes the relevant data for the collocated antenna operations.

Carrier	Antenna Manufacture	Antenna Model	Type	Freq (MHz)	Total ERP (watts)	Z(AGB) (m)	Ant. Gain (dBd)	Azimuth
Verizon Wireless	Commscope	JAHH-65B-R3B	Panel	746	2755	140	12.36	N/A
Verizon Wireless	Commscope	JAHH-65B-R3B	Panel	869	6968	140	13.66	N/A
Verizon Wireless	Commscope	JAHH-65B-R3B	Panel	1900	6763	140	16.26	N/A
Verizon Wireless	Commscope	JAHH-65B-R3B	Panel	2100	6920	140	16.36	N/A

Compliance Analysis

FCC Office of Engineering and Technology Bulletin 65 (“OET Bulletin 65”) provides guidelines for mathematical models to calculate the RF levels at various points around transmitting antennas. Different models apply in different areas around antennas, with one model applying to street level around a site, and another applying to the rooftop near the antennas. We will address each area of interest in turn in the subsections that follow.

Street Level Analysis

At street-level around an antenna site (in what is called the “far field” of the antennas), the RF levels are directly proportional to the total antenna input power and the relative antenna gain in the downward direction of interest – and the levels are otherwise inversely proportional to the square of the straight-line distance to the antenna.

Conservative calculations also assume the potential RF exposure is enhanced by reflection of the RF energy from the intervening ground. Our calculations will assume a 100% “perfect”, mirror-like reflection, which is the absolute worst-case scenario.

The formula for street-level compliance assessment for any given wireless antenna operation is as follows:

$$\text{MPE\%} = (100 * \text{Chans} * \text{TxPower} * 10^{(\text{Gmax-Vdisc}/10)} * 4) / (\text{MPE} * 4\pi * \text{R}^2)$$

where

MPE%	=	RF level, expressed as a percentage of the MPE limit applicable to continuous exposure of the general public
100	=	factor to convert the raw result to a percentage
Chans	=	maximum number of RF channels per sector
TxPower	=	maximum transmitter power per channel, in milliwatts

- $10^{(G_{max}-V_{dls}/10)}$ = numeric equivalent of the relative antenna gain in the downward direction of interest; data on the antenna vertical-plane pattern is taken from manufacturer specifications
- 4 = factor to account for a 100-percent-efficient energy reflection from the ground, and the squared relationship between RF field strength and power density ($2^2 = 4$)
- MPE = FCC general population MPE limit
- R = straight-line distance from the RF source to the point of interest, centimeters

The MPE% calculations are performed out to a distance of 500 feet from the facility to points 6.5 feet (approximately two meters, the FCC-recommended standing height) off the ground, as illustrated in Figure 2, below.

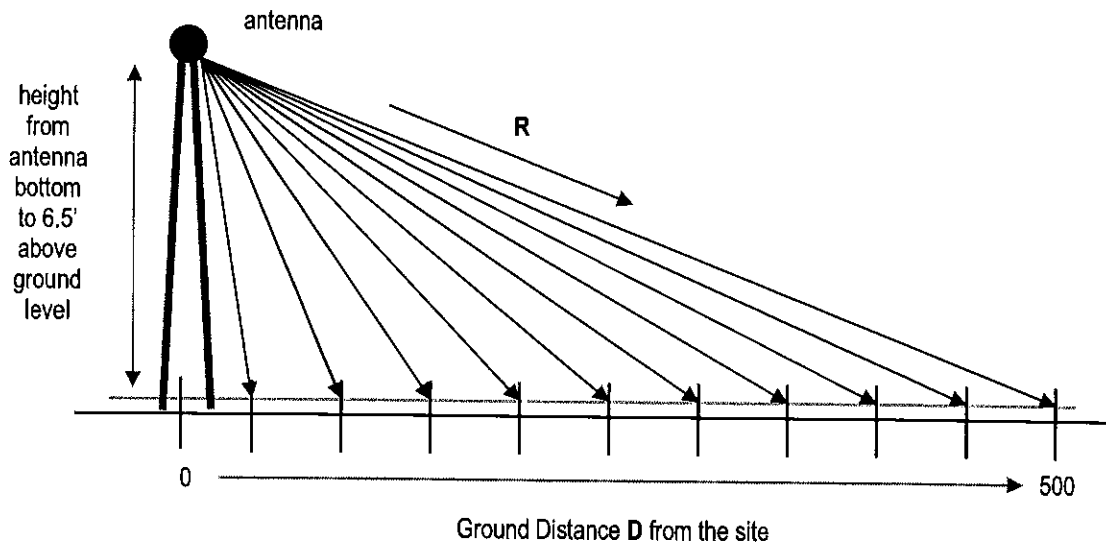

Figure 2. Street-level MPE% Calculation Geometry

It is popularly understood that the farther away one is from an antenna, the lower the RF level – which is generally but not universally correct. The results of MPE% calculations fairly close to the site will reflect the variations in the vertical-plane antenna pattern as well as the variation in straight-line distance to the antenna.

Therefore, RF levels may actually increase slightly with increasing distance within the range of zero to 500 feet from the site. As the distance approaches 500 feet

and beyond, though, the antenna pattern factor becomes less significant, the RF levels become primarily distance-controlled and, as a result, the RF levels generally decrease with increasing distance. In any case, the RF levels more than 500 feet from a wireless antenna site are well understood to be sufficiently low to be comfortably in compliance.

According to the FCC, when directional antennas (such as panels) are used, compliance assessments are based on the RF effect of a single (facing) antenna sector, as the effects of directional antennas pointed away from the point(s) of interest are considered insignificant. If the different parameters apply in the different sectors, compliance is based on the worst-case parameters.

Street level FCC compliance for a collocated antenna site is assessed in the following manner. At each distance point along the ground, an MPE% calculation is made for each antenna operation (including each frequency band), and the sum of the individual MPE% contributions at each point is compared to 100 percent, the normalized reference for compliance with the MPE limit. We refer to the sum of the individual MPE% contributions as "total MPE%", and any calculated total MPE% result exceeding 100 percent is, by definition, higher than the FCC limit and represents non-compliance and a need to mitigate the potential exposure. If all results are consistently below 100 percent, on the other hand, that set of results serves as a clear and sufficient demonstration of compliance with the MPE limit.

Note that the following conservative methodology and assumptions are incorporated into the MPE% calculations on a general basis:

1. The antennas are assumed to be operating continuously at maximum power and maximum channel capacity.
2. The power-attenuation effects of shadowing or other obstructions to the line-of-sight path from the antenna to the point of interest are ignored.
3. The calculations intentionally minimize the distance factor (R) by assuming a 6'6" human and performing the calculations from the bottom (rather than the centerline) of each operator's lowest-mounted antenna, as applicable.
4. The calculations also conservatively take into account, when applicable,

the different technical characteristics and related RF effects of the use of multiple antennas for transmission in the same frequency band.

5. The RF exposure at ground level is assumed to be 100-percent enhanced (increased) via a “perfect” field reflection from the intervening ground.

The net result of these assumptions is to intentionally and significantly overstate the calculated RF levels relative to the levels that will actually result from the antenna operations – and the purpose of this conservatism is to allow very “safe-side” conclusions about compliance.

The table that follows provides the results of the MPE% calculations for each antenna operation, with the overall worst-case calculated result highlighted in bold in the last column.

Ground Distance (ft)	Dish 600 MHz MPE%	Dish 2000 MHz MPE%	Dish 2100 MHz MPE%	Verizon Wireless MPE%	Total MPE%
0	0.0010	0.0013	0.0000	0.0355	0.0378
20	0.0030	0.0054	0.0018	0.0247	0.0349
40	0.0070	0.0196	0.0115	0.1001	0.1382
60	0.0027	0.0139	0.0094	0.1853	0.2113
80	0.0025	0.0057	0.0199	0.6766	0.7047
100	0.0342	0.0076	0.0576	1.1996	1.2990
120	0.1005	0.0072	0.2562	1.2275	1.5914
140	0.1176	0.2027	0.3522	0.6140	1.2865
160	0.0724	0.2732	0.1847	0.2145	0.7448
180	0.0373	0.0245	0.0064	0.1776	0.2458
200	0.0300	0.0101	0.0206	0.1842	0.2449
220	0.0507	0.0152	0.0017	0.2311	0.2987
240	0.0669	0.0744	0.0270	0.3271	0.4954
260	0.0723	0.0569	0.0394	0.4435	0.6121
280	0.0654	0.0196	0.0191	0.4736	0.5777
300	0.0483	0.0118	0.0162	0.5024	0.5787
320	0.0368	0.0303	0.0318	0.3959	0.4948
340	0.0281	0.0359	0.0343	0.2557	0.3540
360	0.0254	0.0270	0.0209	0.1394	0.2127
380	0.0304	0.0186	0.0114	0.0928	0.1532
400	0.0438	0.0228	0.0203	0.0844	0.1713
420	0.0400	0.0208	0.0186	0.1126	0.1920
440	0.0624	0.0296	0.0356	0.1868	0.3144
460	0.0931	0.0273	0.0385	0.1718	0.3307
480	0.0860	0.0252	0.0355	0.2767	0.4234
500	0.1233	0.0112	0.0198	0.2559	0.4102

As indicated, the maximum calculated overall RF level is 1.5914 percent of the FCC MPE limit – well below the 100-percent reference for compliance.

A graph of the overall calculation results, shown below, perhaps provides a clearer *visual* illustration of the relative compliance of the calculated RF levels. The line representing the overall calculation results shows an obviously clear, consistent margin to the FCC MPE limit.

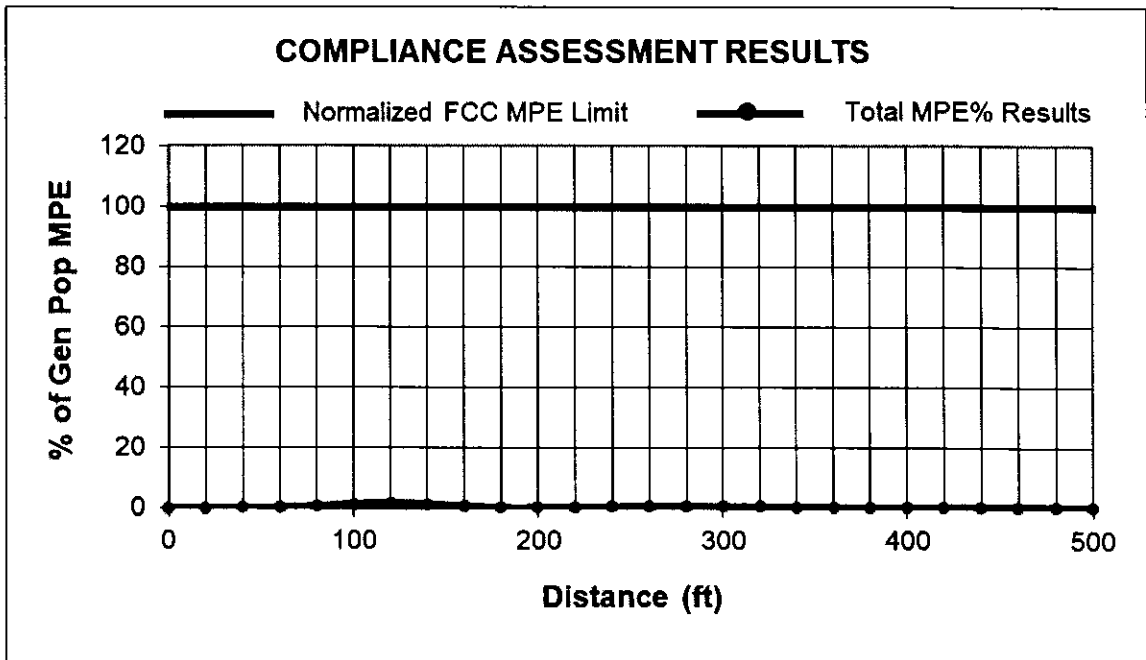

The graphic output for the areas at street level surrounding the site is reproduced on the next page.

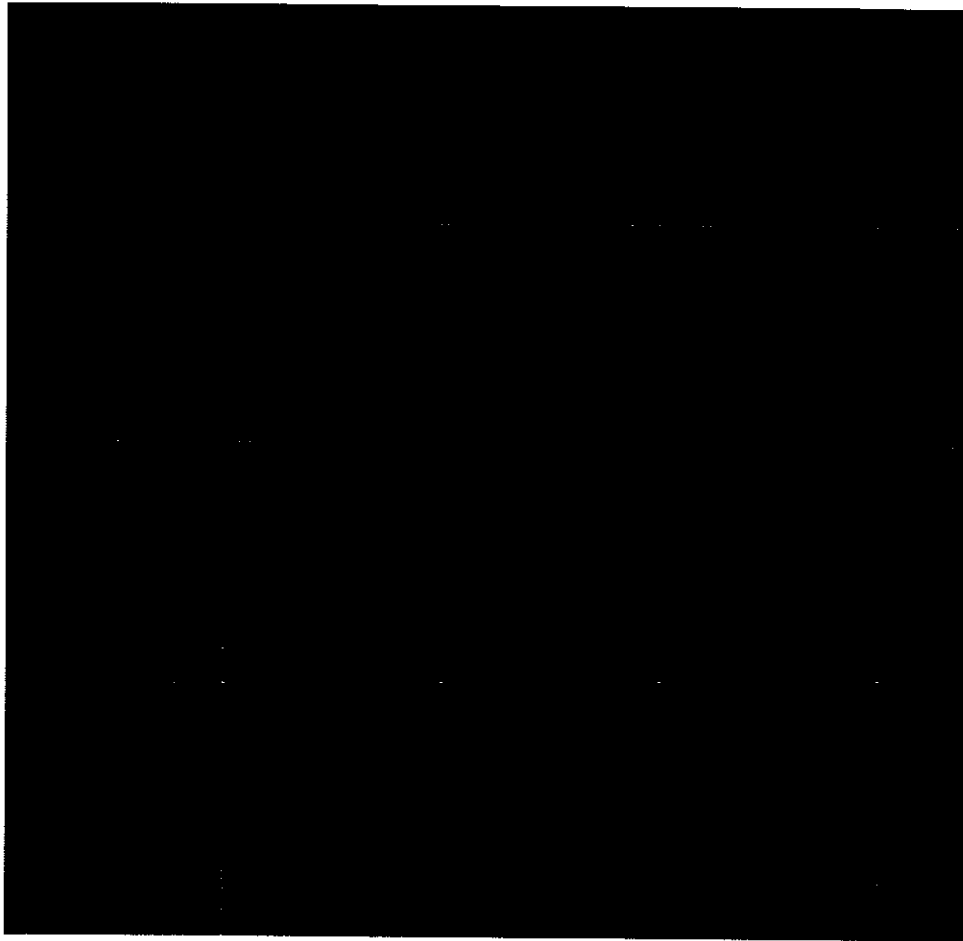
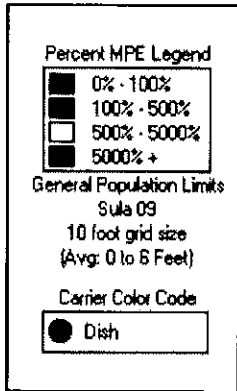

Near-field Analysis

The compliance analysis for the same height as the antennas is performed using the RoofMaster program by Waterford Consultants.

RF levels in the near field of an antenna depend on the power input to the antenna, the antenna's length and horizontal beamwidth, the mounting height of the antenna above nearby standing level, and one's position and distance from the antenna. RF levels in front of a directional antenna are higher than they are to the sides or rear, and in any given horizontal direction are inversely proportional to the straight-line distance to the antenna.

The RoofMaster graphic outputs for the same height as the Dish antennas are reproduced on the next page.

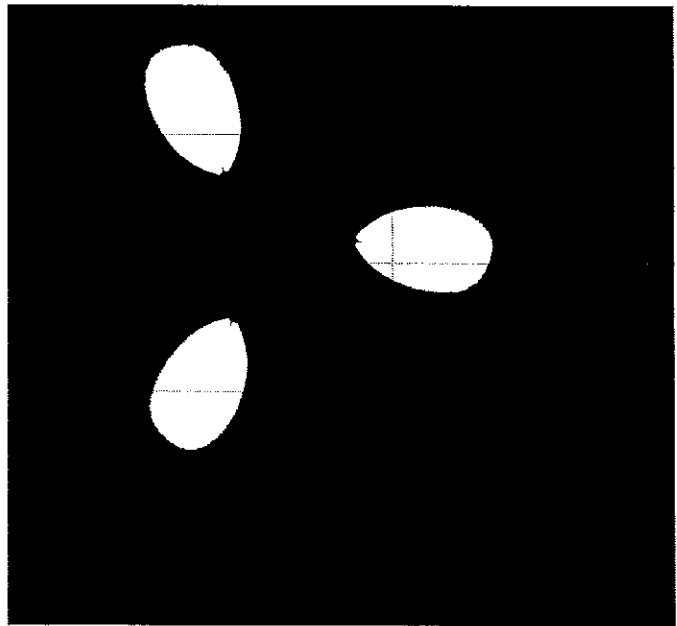
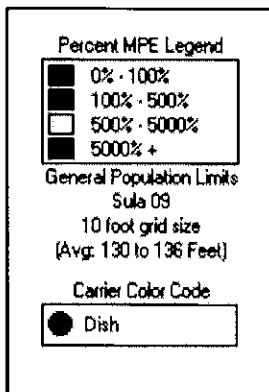

**RoofMaster – Same Height as the Antennas –
Alpha / Beta / Gamma sectors**

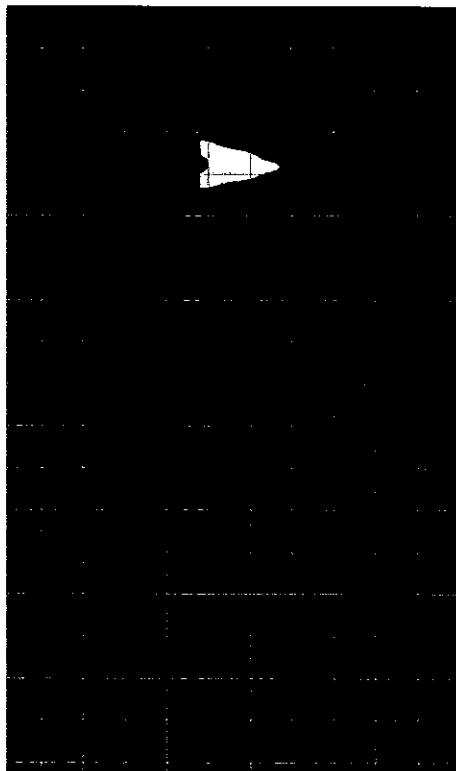
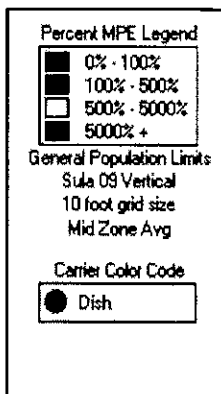

**RoofMaster – Same Height as the Antennas –
Alpha / Beta / Gamma sectors**

COMPLIANCE CONCLUSION

According to the FCC, the MPE limit has been constructed in such a manner that continuous human exposure to RF fields up to and including 100 percent of the MPE limit is acceptable and safe.

The conservative analysis in this case shows that the maximum calculated RF level from the proposed modifications to the existing antenna operations at the site is 1.5914 percent of the FCC general population MPE limit. At the same height as the antennas, the analysis shows that the calculated RF levels potentially exceed the FCC MPE limit. Per Dish guidelines, and consistent with FCC guidance on rooftop compliance, it is recommended that two Caution signs be installed at the base of the monopole. In addition, NOC Information signs be installed at the base of the monopole.

The results of the calculations, along with the described RF mitigation, combine to satisfy the FCC's RF compliance requirements and associated guidelines at street level around the site and on the subject roof.

Moreover, because of the extremely conservative calculation methodology and operational assumptions we applied in the analysis, RF levels actually caused by the antennas will be significantly lower than the calculation results here indicate.

CERTIFICATION

It is the policy of Pinnacle Telecom Group that all FCC RF compliance assessments are reviewed, approved, and signed by the firm's Chief Technical Officer who certifies as follows:

1. I have read and fully understand the FCC regulations concerning RF safety and the control of human exposure to RF fields (47 CFR 1.1301 *et seq*).
2. To the best of my knowledge, the statements and information disclosed in this report are true, complete and accurate.
3. The analysis of site RF compliance provided herein is consistent with the applicable FCC regulations, additional guidelines issued by the FCC, and industry practice.
4. The results of the analysis indicate that the subject antenna operations will be in compliance with the FCC regulations concerning the control of potential human exposure to the RF emissions from antennas.

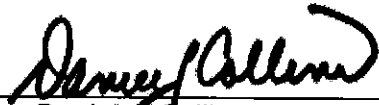

Daniel J. Collins
Chief Technical Officer
Pinnacle Telecom Group, LLC

9/21/21

Date

Appendix A. DOCUMENTS USED TO PREPARE THE ANALYSIS

RFDS: RFDS-NJJER01144A-Preliminary-20210806-v.1_20210806140526

CD: NJJER01144A_ZD_20210715125509

Appendix B. BACKGROUND ON THE FCC MPE Limit

As directed by the Telecommunications Act of 1996, the FCC has established limits for maximum continuous human exposure to RF fields.

The FCC maximum permissible exposure (MPE) limits represent the consensus of federal agencies and independent experts responsible for RF safety matters. Those agencies include the National Council on Radiation Protection and Measurements (NCRP), the Occupational Safety and Health Administration (OSHA), the National Institute for Occupational Safety and Health (NIOSH), the American National Standards Institute (ANSI), the Environmental Protection Agency (EPA), and the Food and Drug Administration (FDA). In formulating its guidelines, the FCC also considered input from the public and technical community – notably the Institute of Electrical and Electronics Engineers (IEEE).

The FCC's RF exposure guidelines are incorporated in Section 1.301 *et seq* of its Rules and Regulations (47 CFR 1.1301-1.1310). Those guidelines specify MPE limits for both occupational and general population exposure.

The specified continuous exposure MPE limits are based on known variation of human body susceptibility in different frequency ranges, and a Specific Absorption Rate (SAR) of 4 watts per kilogram, which is universally considered to accurately represent human capacity to dissipate incident RF energy (in the form of heat). The occupational MPE guidelines incorporate a safety factor of 10 or greater with respect to RF levels known to represent a health hazard, and an additional safety factor of five is applied to the MPE limits for general population exposure. Thus, the general population MPE limit has a built-in safety factor of more than 50. The limits were constructed to appropriately protect humans of both sexes and all ages and sizes and under all conditions – and continuous exposure at levels equal to or below the applicable MPE limits is considered to result in no adverse health effects or even health risk.

The reason for *two* tiers of MPE limits is based on an understanding and assumption that members of the general public are unlikely to have had appropriate RF safety training and may not be aware of the exposures they receive; occupational exposure in controlled environments, on the other hand, is assumed to involve individuals who have had such training, are aware of the exposures, and know how to maintain a safe personal work environment.

The FCC's RF exposure limits are expressed in two equivalent forms, using alternative units of field strength (expressed in volts per meter, or V/m), and power density (expressed in milliwatts per square centimeter, or mW/cm²). The table on the next page lists the FCC limits for both occupational and general population exposures, using the mW/cm² reference, for the different radio frequency ranges.

Frequency Range (F) (MHz)	Occupational Exposure (mW/cm ²)	General Public Exposure (mW/cm ²)
0.3 - 1.34	100	100
1.34 - 3.0	100	180 / F ²
3.0 - 30	900 / F ²	180 / F ²
30 - 300	1.0	0.2
300 - 1,500	F / 300	F / 1500
1,500 - 100,000	5.0	1.0

The diagram below provides a graphical illustration of both the FCC's occupational and general population MPE limits.

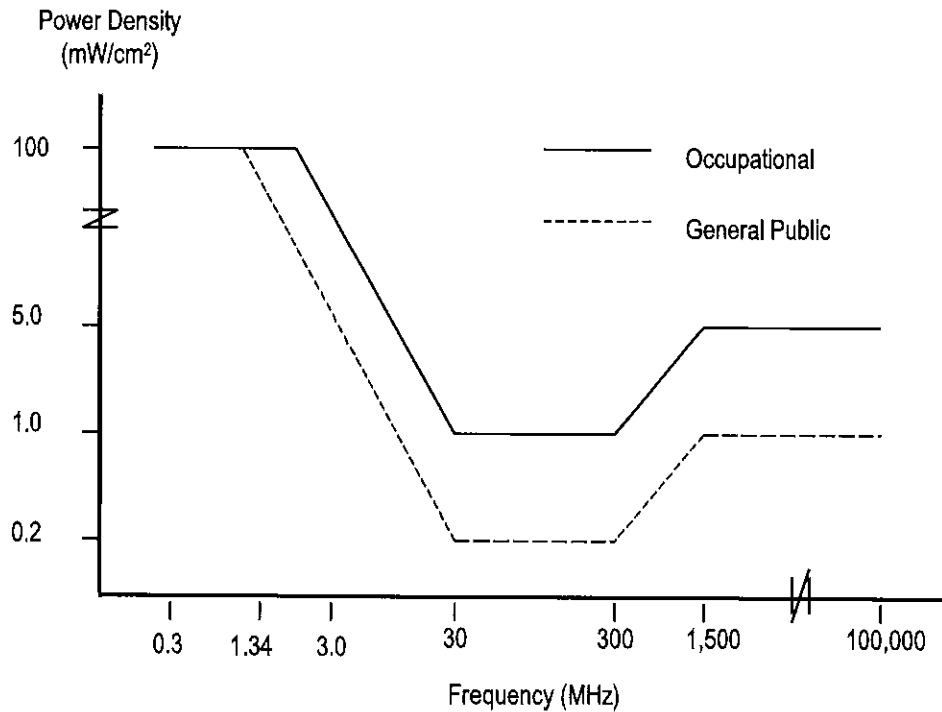

Because the FCC's RF exposure limits are frequency-shaped, the exact MPE limits applicable to the instant situation depend on the frequency range used by the systems of interest.

The most appropriate method of determining RF compliance is to calculate the RF power density attributable to a particular system and compare that to the MPE limit applicable to the operating frequency in question. The result is usually expressed as a percentage of the MPE limit.

For potential exposure from multiple systems, the respective percentages of the MPE limits are added, and the total percentage compared to 100 (percent of the limit). If the result is less than 100, the total exposure is in compliance; if it is more than 100, exposure mitigation measures are necessary to achieve compliance.

Note that the FCC "categorically excludes" all "non-building-mounted" wireless antenna operations whose mounting heights are more than 10 meters (32.8 feet) from the routine requirement to demonstrate compliance with the MPE limit, because such operations "are deemed, individually and cumulatively, to have no significant effect on the human environment". The categorical exclusion also applies to *all* point-to-point antenna operations, regardless of the type of structure they're mounted on. Note that the FCC considers any facility qualifying for the categorical exclusion to be automatically in compliance.

In addition, FCC Rules and Regulations Section 1.1307(b)(3) describes a provision known in the industry as "the 5% rule". It describes that when a specific location – like a spot on a rooftop – is subject to an overall exposure level exceeding the applicable MPE limit, operators with antennas whose MPE% contributions at the point of interest are less than 5% are exempted from the obligation otherwise shared by all operators to bring the site into compliance, and those antennas are automatically deemed by the FCC to satisfy the rooftop compliance requirement.

FCC References on RF Compliance

47 CFR, FCC Rules and Regulations, Part 1 (Practice and Procedure), Section 1.1310 (Radiofrequency radiation exposure limits).

FCC Second Memorandum Opinion and Order and Notice of Proposed Rulemaking (FCC 97-303), *In the Matter of Procedures for Reviewing Requests for Relief From State and Local Regulations Pursuant to Section 332(c)(7)(B)(v) of the Communications Act of 1934 (WT Docket 97-192)*, *Guidelines for Evaluating the Environmental Effects of Radiofrequency Radiation (ET Docket 93-62)*, and *Petition for Rulemaking of the Cellular Telecommunications Industry Association Concerning Amendment of the Commission's Rules to Preempt State and Local Regulation of Commercial Mobile Radio Service Transmitting Facilities*, released August 25, 1997.

FCC First Memorandum Opinion and Order, ET Docket 93-62, *In the Matter of Guidelines for Evaluating the Environmental Effects of Radiofrequency Radiation*, released December 24, 1996.

FCC Report and Order, ET Docket 93-62, *In the Matter of Guidelines for Evaluating the Environmental Effects of Radiofrequency Radiation*, released August 1, 1996.

FCC Report and Order, Notice of Proposed Rulemaking, Memorandum Opinion and Order (FCC 19-126), *Proposed Changes in the Commission's Rules Regarding Human Exposure to Radiofrequency Electromagnetic Fields; Reassessment of Federal Communications Commission Radiofrequency Exposure Limits and Policies*, released December 4, 2019.

FCC Office of Engineering and Technology (OET) Bulletin 65, "Evaluating Compliance with FCC Guidelines for Human Exposure to Radiofrequency Electromagnetic Fields", Edition 97-01, August 1997.

FCC Office of Engineering and Technology (OET) Bulletin 56, "Questions and Answers About Biological Effects and Potential Hazards of RF Radiation", edition 4, August 1999.

Appendix C. PROPOSED SIGNAGE

RF DETAILS
 TOWER SHALL BE ANALYZED BY A
 ENGINEER LICENSED IN THE STATE
 OF

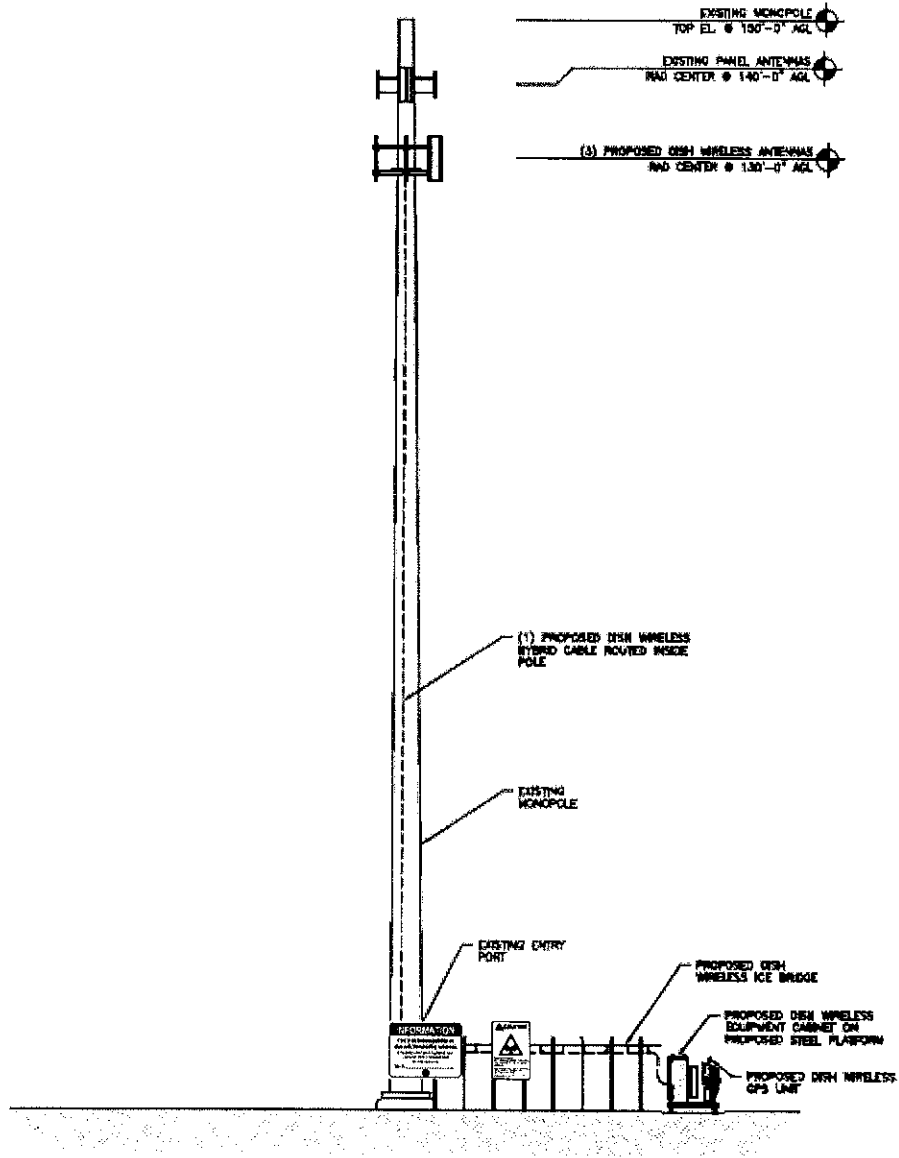

NOC Information Sign		Caution Sign	
Guidelines Sign		Warning Sign	
Notice Sign			

APPENDIX D. SUMMARY of EXPERT QUALIFICATIONS

Daniel J. Collins, Chief Technical Officer, Pinnacle Telecom Group, LLC

<p>Synopsis:</p>	<ul style="list-style-type: none"> • 40+ years of experience in all aspects of wireless system engineering, related regulation, and RF exposure • Has performed or led RF exposure compliance assessments on more than 20,000 antenna sites since the latest FCC regulations went into effect in 1997 • Has provided testimony as an RF compliance expert more than 1,500 times since 1997 • Have been accepted as an FCC compliance expert in New York, New Jersey, Connecticut, Pennsylvania and more than 40 other states, as well as by the FCC
<p>Education:</p>	<ul style="list-style-type: none"> • B.E.E., City College of New York (Sch. Of Eng.), 1971 • M.B.A., 1982, Fairleigh Dickinson University, 1982 • Bronx High School of Science, 1966
<p>Current Responsibilities:</p>	<ul style="list-style-type: none"> • Leads all PTG staff work involving RF safety and FCC compliance, microwave and satellite system engineering, and consulting on wireless technology and regulation
<p>Prior Experience:</p>	<ul style="list-style-type: none"> • Edwards & Kelcey, VP – RF Engineering and Chief Information Technology Officer, 1996-99 • Bellcore (a Bell Labs offshoot after AT&T's 1984 divestiture), Executive Director – Regulation and Public Policy, 1983-96 • AT&T (Corp. HQ), Division Manager – RF Engineering, and Director – Radio Spectrum Management, 1977-83 • AT&T Long Lines, Group Supervisor – Microwave Radio System Design, 1972-77
<p>Specific RF Safety / Compliance Experience:</p>	<ul style="list-style-type: none"> • Involved in RF exposure matters since 1972 • Have had lead corporate responsibility for RF safety and compliance at AT&T, Bellcore, Edwards & Kelcey, and PTG • While at AT&T, helped develop the mathematical models for calculating RF exposure levels • Have been relied on for compliance by all major wireless carriers, as well as by the federal government, several state and local governments, equipment manufacturers, system integrators, and other consulting / engineering firms
<p>Other Background:</p>	<ul style="list-style-type: none"> • Author, <i>Microwave System Engineering</i> (AT&T, 1974) • Co-author and executive editor, <i>A Guide to New Technologies and Services</i> (Bellcore, 1993) • National Spectrum Management Association (NSMA) – former three-term President and Chairman of the Board of Directors; was founding member, twice-elected Vice President, long-time member of the Board, and was named an NSMA Fellow in 1991 • Have published more than 35 articles in industry magazines

Exhibit G
Lease Agreement

Lessee Site ID: NJJER01144A
Lessor Site ID: CT1212 Trumbull

SUPPLEMENT TO THE MASTER LEASE AGREEMENT

THIS SUPPLEMENT TO THE MASTER LEASE AGREEMENT (“SLA”) is entered into as of 7/29/2021 (“Effective Date”), by and between Tarpon Towers II, LLC (“Lessor”), whose address is 8916 77th Terrace East, Suite 103, Lakewood Ranch, FL 34202 and DISH Wireless L.L.C. (“Lessee”), whose address is 9601 South Meridian Blvd., Englewood, Colorado, 80112. Lessor and Lessee are at times collectively referred to hereinafter as the “Parties” or individually as a “Party”.

BACKGROUND

WHEREAS, Lessor and Lessee have entered into that certain Master Lease Agreement dated February 22, 2021 (the “MLA”). Such MLA provides that Lessor and Lessee will enter into separate SLAs on a site-by-site basis, pursuant to which Lessor will lease to Lessee certain available space at a Leased Property.

AGREEMENT

NOW, THEREFORE, for good and valuable consideration, the receipt and sufficiency of which are hereby acknowledged, and intending to be legally bound hereby, the Parties agree as follows:

1. Site Information. The Leased Property, as more particularly described in Section 6 hereof, means:
 - a. Lessee Site ID: NJJER01144A
 - b. Lessor Site ID: CT1212 Trumbull
 - c. Address and/or location of the Site: 54 Jeffrey Place, Trumbull, Fairfield County, Connecticut
 - d. Site coordinates (NAD 83):
 - i. Latitude: 41.25185
 - ii. Longitude: -73.192953
 - e. Antenna Space centerline height: one hundred thirty feet (130')
 - f. Ground Space dimensions: 10 x 15 (Length x Width)

2. Rent; Term.
 - a. Rent.
 - i. Commencing on the SLA Rent Commencement Date, the Basic Rent for this SLA shall be a monthly rental of [REDACTED].
 - ii. Basic Rent will increase in accordance with the provisions of [REDACTED].
 - iii. Additional Rent, if any, shall be paid in accordance with the terms set forth in [REDACTED].
 - b. Term. The term of this SLA shall be as set forth in [REDACTED], unless set forth herein as follows: Not Applicable.

Lessee Site ID: NJJER01144A
Lessor Site ID: CT1212 Trumbull

3. Non-Standard Terms. [REDACTED]

4. Special Provisions. [REDACTED]

5. Unique Prime Agreement Terms. Not Applicable.

6. Site Address and Legal Description of Site. Lessor hereby leases to Lessee, and Lessee leases from Lessor, as applicable, the Site, as more particularly described in Section 1 hereof, and which is comprised of the space on the Structure, Easements (including, without limitation, a right-of-way for access) and Ground Space on the Parcel at heights and locations as more particularly set forth on **Schedule A-1** (Collocation Application), **Schedule A-2** (Structure Elevation and Site Plan), and **Schedule A-4** (Legal Description of Parcel or Survey) (together, as applicable, the “Leased Property”), each of which are attached hereto and incorporated herein.

7. Frequencies. As of the Effective Date, Lessee’s initial Installation will use those certain frequencies, in pre-approved transmit power, as set forth on **Schedule A-1** (Collocation Application), which is attached hereto and incorporated herein by this reference.

8. MLA; Defined Terms; Incorporation of Background; Prime Agreement. [REDACTED]

9. Order of Precedence; Conflict. [REDACTED]

Lessee Site ID: NJJER01144A
Lessor Site ID: CT1212 Trumbull



[Remainder of page intentionally left blank. Signature page follows.]

Lessee Site ID: NJJER01144A
Lessor Site ID: CT1212 Trumbull

IN WITNESS WHEREOF, the Parties have executed this SLA as of the Effective Date.

LESSOR:

Tarpon Towers II, LLC

By: 
1A64ABE01EC348C...

Name: Brett Buggeln

Title: COO

LESSEE:

DISH Wireless L.L.C.

By: 
7D9EB7B3E6404B5

Name: Mike McGovern

Title: Regional Vice President

Exhibit H
Mailing Receipts

Visit **ups.com**® or call **1-800-PICK-UPS**® (1-800-742-5817) to schedule a pickup or find a drop off location near you.

Domestic Shipments

To qualify for the Letter rate, UPS Express Envelopes may only contain correspondence, urgent documents weighing 8 oz. or less, UPS Express Envelopes and those listed or weighing more.

International Shipments

The UPS Express Envelope rate value. Certain countries confirmed at ups.com/international

To qualify for the Letter rate, UPS Express Envelopes weigh:

Note: Express Envelopes are not containing sensitive personal information or cash equivalent.

Window Envelope
Use this envelope with soft copy or inkjet printer on plain paper.

LTR 1 OF 1

FROM:
LEV MAYZLER
(203) 488-0712
CONSTRUCTION SERVICES OF BRANFORD
63-3 NORTH BRANFORD ROAD
BRANFORD CT 06405-2848

SHIP TO:
TODD BOWMAN
TARPON TOWERS
SUITE 103
8916 77TH TERRACE EAST
LAKEWOOD RANCH FL 34202

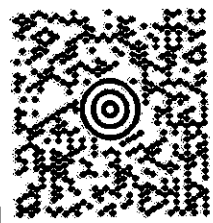

FL 335 0-02

UPS 2ND DAY AIR 2
TRACKING #: 1Z E05 345 02 6331 9278

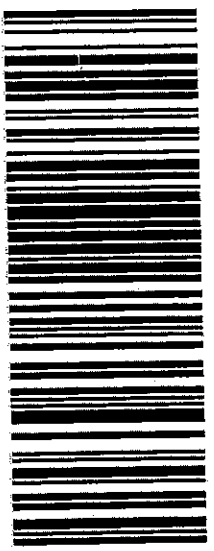

BILLING: P/P

WS 22.0.17 SHAPP MK-3070 48 UA 072021

Fold here and place in label pouch

International Shipping Notice—Carriage hereunder may be subject to the rules relating to liability and other terms and/or conditions established by the Convention for the Unification of Certain Rules Relating to International Carriage by Air (the "Warsaw Convention") and/or the Convention on the Contract for the International Carriage of Goods by Road (the "CMR Convention"). These commodities, technology or software were exported from the U.S. in accordance with the Export Administration Regulations. Diversion contrary to U.S. law prohibited.

Insert under

Do not use:
UPS Ground
UPS Store
UPS 3 Day
UPS World

01019

in 100
Label Set



Your shipment
1ZE053450263319278

✔ Delivered On
Tuesday, November 16 at 12:45 P.M. at Inside Delivery

Delivered To
8916 77TH TER E
103
LAKEWOOD RANCH, FL 34202 US

Received By:
TODD

[Proof of Delivery](#)

[Get Updates](#)

[View Details](#)

Track Another Package

[Track](#)

UPS Freight Less-than-Truckload ("LTL") transportation services are offered by TFI International Inc., its affiliates or divisions (including without limitation TForce Freight), which are not affiliated with United Parcel Service, Inc. or any of its affiliates, subsidiaries or related entities ("UPS"). UPS assumes **Ask UPS**

FROM:
LEV MAYZLER
(203) 488-0712
CONSTRUCTION SERVICES OF BRANF
63-3 NORTH BRANFORD ROAD
BRANFORD CT 06405-2848

LTR 1 OF 1

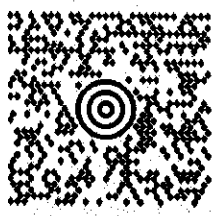

CT 066 9-07



SHIP TO:

MR. ROB LIBRANDI
TOWN OF TRUMBULL
5866 MAIN ST.
TRUMBULL CT 06611-3113

UPS 2ND DAY AIR

TRACKING #: 1Z E05 345 02 6336 7314

2

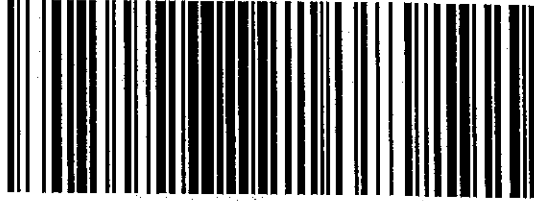

BILLING: P/P

WS 22.0.17 SHARP MX-3070 48.0A 07/2021

Fold here and place in label pouch

Proof of Delivery

Dear Customer,

This notice serves as proof of delivery for the shipment listed below.

Tracking Number

1ZE053450263367314

Service

UPS 2nd Day Air®

Delivered On

11/15/2021 10:59 A.M.

Delivered To

5866 MAIN ST
TRUMBULL, CT, 06611, US

Received By

LUKE

Left At

Receiver

Thank you for giving us this opportunity to serve you. Details are only available for shipments delivered within the last 120 days. Please print for your records if you require this information after 120 days.

Sincerely,

UPS

Tracking results provided by UPS: 11/29/2021 7:06 A.M. EST

FROM:
LEV MAYZLER
(203) 488-0712
CONSTRUCTION SERVICES OF BRANF
63-3 NORTH BRANFORD ROAD
BRANFORD CT 06405-2848

LTR 1 OF 1

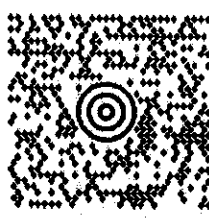

CT 066 9-07



SHIP TO:

FIRST SELECTWOMAN TESORO
TOWN OF TRUMBULL
5866 MAIN ST.
TRUMBULL CT 06611-3113

UPS 2ND DAY AIR

TRACKING #: 1Z E05 345 02 6165 9100

2

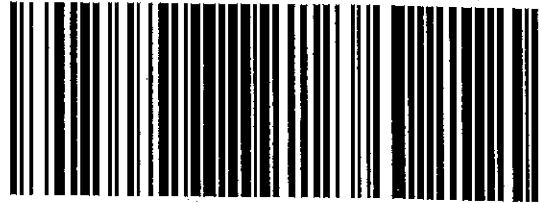

BILLING: P/P

WS 22.0.17 SHARP MX-3070 48,0A 07/2021

Fold here and place in label pouch



Your shipment
1ZE053450261659100

✔ Delivered On
Monday, November 15 at 10:59 A.M. at Receiver

Delivered To
5866 MAIN ST
TRUMBULL, CT 06611 US

Received By:
LUKE

[Proof of Delivery](#)

[Get Updates](#)

[View Details](#)

Track Another Package

Track

UPS Freight Less-than-Truckload ("LTL") transportation services are offered by TFI International Inc., its affiliates or divisions (including without limitation TForce Freight), which are not affiliated with United Parcel Service, Inc. or any of its affiliates, subsidiaries or related entities ("UPS"). UPS assumes no liability in connection with UPS Freight LTL transportation services or any other services offered or provided by TFI International Inc. or its affiliates, divisions, subsidiaries or related entities.

Ask UPS