



10 INDUSTRIAL AVE,
SUITE 3
MAHWAH NJ 07430

PHONE: 201.684.0055
FAX: 201.684.0066

June 27, 2018

Melanie Bachman
Executive Director
Connecticut Siting Council
10 Franklin Square
New Britain, CT 06051

Notice of Exempt Modification
158 Edison Road, Trumbull, CT 06611
Latitude- 41.23444444
Longitude- -73.2188889

Dear Ms. Bachman,

T-Mobile currently maintains (9) existing antennas 120' level of the existing 130' monopole at 158 Edison Road in Trumbull, CT. The tower is owned by Blue Sky Tower Partners, LLC. The property is owned by the Town of Trumbull. T-Mobile now intends to replace (3) of its existing antennas with (3) new 600/700/1900/2100 MHz antennas. These antennas would be installed at the same 120' level of the tower. T-Mobile also intends to replace (3) remote radio heads and add (1) fiber cables.

This facility was approved by the Council on April 26, 2012 in Docket No. 421. The approval came with conditions, none of which would be violated in connection with the proposed modification.

Please accept this letter as notification pursuant to Regulations of Connecticut State Agencies 16-50j-73, for construction that constitutes an exempt modification pursuant to R.C.S.A. 16-50j-72(b)(2). In accordance with R.C.S.A. 16-50j-73, a copy of this letter is being sent to Vicki A. Tesoro, First Selectman of the Town of Trumbull, Rob Librandi, Land Use Planner for the Town of Trumbull, as well as the tower owner.

The planned modifications to the facility fall squarely within those activities explicitly provided for in R.C.S.A. 16-50j-72(b)(2).

1. The proposed modification will not result in an increase in the height of the existing structure
2. The proposed modifications will not require the extension of the site boundary.
3. The proposed modifications will not increase noise levels at the facility by six decibels or more, or to levels that exceed state and local criteria.
4. The operation of the replacement antennas will not increase radio frequency emissions at the facility to a level at or above the Federal Communications Commission safety standard.

5. The proposed modification will not cause a change or alteration in the physical or environmental characteristics of the site.
6. The existing structure and its foundation can support the proposed loading.

For the foregoing reasons, T-Mobile respectfully submits that the proposed modifications to the above-referenced telecommunications facility constitute an exempt modification under R.C.S.A. 16-50j-72(b)(2).

Sincerely,

Kyle Richers

Kyle Richers
Transcend Wireless
10 Industrial Ave., Suite 3
Mahwah, New Jersey 07430
908-447-4716
krichers@transcendwireless.com

cc: Vicki A. Tesoro- as elected official/ property owner
Rob Librandi- as zoning official
Blue Sky Tower Partners, LLC- as tower owner

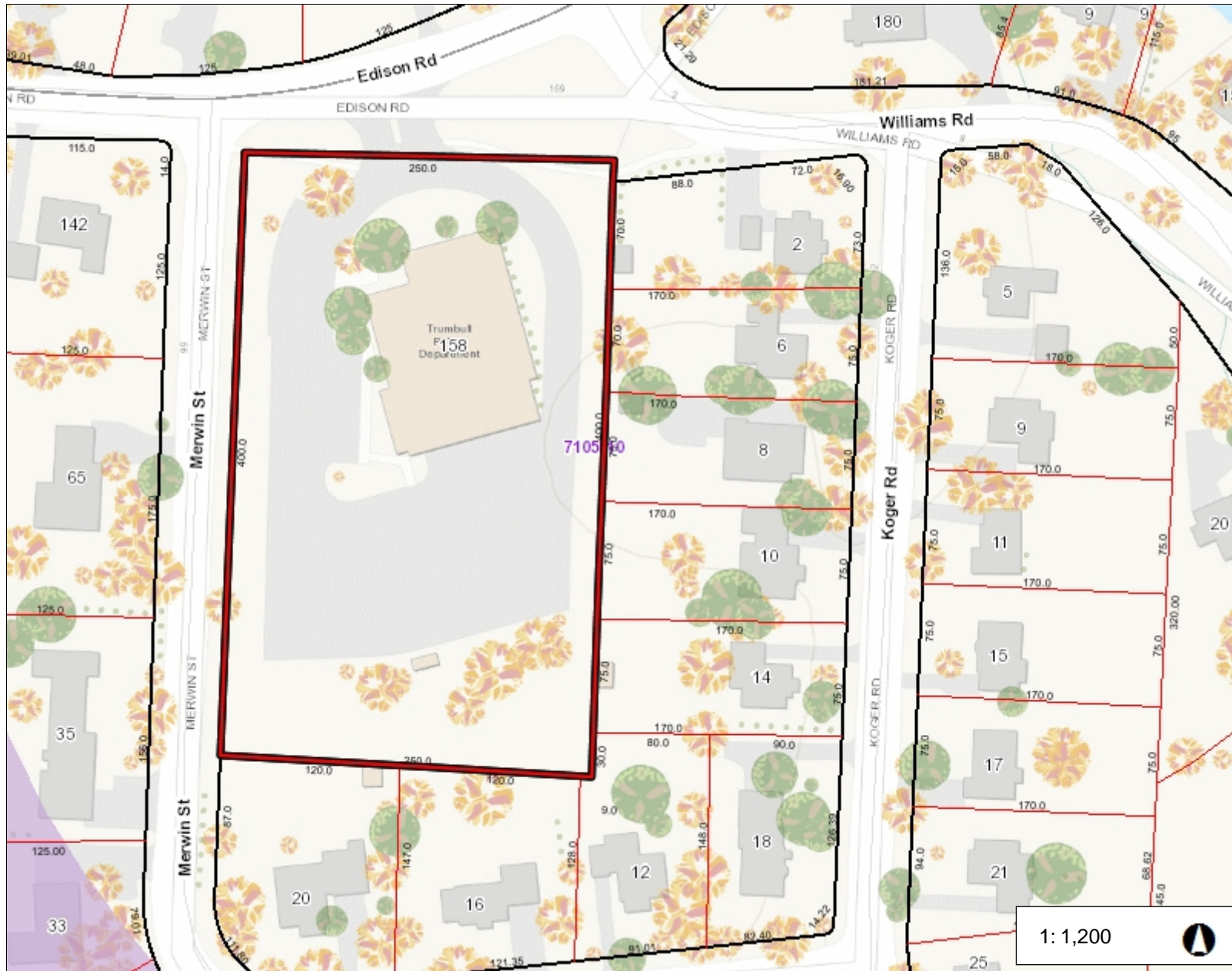

Legend

Streetname

Roadways

- Local
- Collector
- Minor Collector
- Minor Arterial
- Major Collector
- PA Other
- PA Other Expwy
- PA Interstate

Inland Wetland Soils

- Poorly Drained and Very Poorly Dr
- Alluvial and Floodplain Soils

Local Basin Boundary

- Major
- Regional
- Subregional
- Local

Local Basin Area

Citations

1: 1,200



200.0 0 100.00 200.0 Feet

WGS_1984_Web_Mercator_Auxiliary_Sphere
Created by Greater Bridgeport Regional Council

This map is a user generated static output from an Internet mapping site and is for reference only. Data layers that appear on this map may or may not be accurate, current, or otherwise reliable.

THIS MAP IS NOT TO BE USED FOR NAVIGATION



158 EDISON ROAD

Location 158 EDISON ROAD

Mblu E/10 / 00304/ 000/

Acct#

Owner TRUMBULL TOWN OF

Assessment \$3,490,410

Appraisal \$4,986,300

PID 12741

Building Count 1

Fire District L

Current Value

Appraisal	
Valuation Year	Total
2015	\$4,986,300

Assessment	
Valuation Year	Total
2015	\$3,490,410

Owner of Record

Owner TRUMBULL TOWN OF

Sale Price \$0

Co-Owner

Book & Page 29/ 587

Address 5866 MAIN STREET
TRUMBULL, CT 06611

Sale Date 03/27/1929

Ownership History

Ownership History			
Owner	Sale Price	Book & Page	Sale Date
TRUMBULL TOWN OF	\$0	29/ 587	03/27/1929

Building Information

Building 1 : Section 1

Year Built: 1981

Living Area: 28,105

Building Attributes	
Field	Description
STYLE	Police Station
Stories:	2 Stories

Occupancy	1
Exterior Wall 1	Brick Masonry
Exterior Wall 2	
Roof Structure	Flat
Roof Cover	Tar & Gravel
Interior Wall 1	Drywall
Interior Wall 2	
Interior Floor 1	Carpet
Interior Floor 2	Vinyl
Heating Fuel	Gas
Heating Type	Hot Water
AC Type	Central
Bldg Use	Police Dept
1st Floor Use:	
Heat/AC	Heat/AC Split
Frame Type	Fireprf Steel
Baths/Plumbing	Average
Ceiling/Walls	Sus-Ceil & WL
Rooms/Prtns	Average
Wall Height	12
% Comn Wall	

Building Photo



E10-304 04/29/2015

(<http://images.vgsi.com/photos2/TrumbullCTPhotos//00\02\11/>)

Building Layout

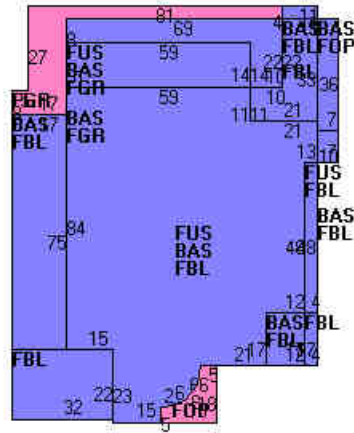

(<http://images.vgsi.com/photos2/TrumbullCTPhotos//Sketches/1/>)

Building Sub-Areas (sq ft)		Legend	
Code	Description	Gross Area	Living Area
BAS	First Floor	10,547	10,547
FBL	Fin Bsmt Living Area	9,785	9,785
FUS	Finished Upper Story	7,773	7,773
FGR	Attached Garage	2,254	0
FOP	Open Porch	441	0
		30,800	28,105

Extra Features

Extra Features			Legend
Code	Description	Size	Bldg #
ELV	Elevator	1 Units	1

Land

Land Use

Use Code 929
Description Police Dept
Zone A
Neighborhood 110
Alt Land Appr No
Category

Land Line Valuation

Size (Acres) 2.3
Frontage
Depth

Outbuildings

Outbuildings					Legend
Code	Description	Sub Code	Sub Description	Size	Bldg #
PAV1	Paving Asph.			60000 S.F.	1
LT1	Light - 1			13 Units	1
LT2	Light - 2			1 Units	1
ANTS	Self Sup Tower			100 L.F.	1

Valuation History

Appraisal	
Valuation Year	Total
2016	\$4,986,300
2015	\$4,986,300
2014	\$4,562,400

Assessment	
Valuation Year	Total
2016	\$3,490,410
2015	\$3,490,410
2014	\$3,193,700

(c) 2016 Vision Government Solutions, Inc. All rights reserved.



RADIO FREQUENCY EMISSIONS ANALYSIS REPORT EVALUATION OF HUMAN EXPOSURE POTENTIAL TO NON-IONIZING EMISSIONS

T-Mobile Existing Facility

Site ID: CTFF481B

Police Station Edison Rd
158 Edison Road
Trumbull, CT 06611

June 20, 2018

EBI Project Number: 6218004585

Site Compliance Summary	
Compliance Status:	COMPLIANT
Site total MPE% of FCC general population allowable limit:	9.61 %



June 20, 2018

T-Mobile USA
Attn: Jason Overbey, RF Manager
35 Griffin Road South
Bloomfield, CT 06002

Emissions Analysis for Site: **CTFF481B – Police Station Edison Rd**

EBI Consulting was directed to analyze the proposed T-Mobile facility located at **158 Edison Road, Trumbull, CT**, for the purpose of determining whether the emissions from the Proposed T-Mobile Antenna Installation located on this property are within specified federal limits.

All information used in this report was analyzed as a percentage of current Maximum Permissible Exposure (% MPE) as listed in the FCC OET Bulletin 65 Edition 97-01 and ANSI/IEEE Std C95.1. The FCC regulates Maximum Permissible Exposure in units of microwatts per square centimeter ($\mu\text{W}/\text{cm}^2$). The number of $\mu\text{W}/\text{cm}^2$ calculated at each sample point is called the power density. The exposure limit for power density varies depending upon the frequencies being utilized. Wireless Carriers and Paging Services use different frequency bands each with different exposure limits, therefore it is necessary to report results and limits in terms of percent MPE rather than power density.

All results were compared to the FCC (Federal Communications Commission) radio frequency exposure rules, 47 CFR 1.1307(b)(1) – (b)(3), to determine compliance with the Maximum Permissible Exposure (MPE) limits for General Population/Uncontrolled environments as defined below.

General population/uncontrolled exposure limits apply to situations in which the general population may be exposed or in which persons who are exposed as a consequence of their employment may not be made fully aware of the potential for exposure or cannot exercise control over their exposure. Therefore, members of the general population would always be considered under this category when exposure is not employment related, for example, in the case of a telecommunications tower that exposes persons in a nearby residential area.

Public exposure to radio frequencies is regulated and enforced in units of microwatts per square centimeter ($\mu\text{W}/\text{cm}^2$). The general population exposure limits for the 600 MHz and 700 MHz Band are approximately $400 \mu\text{W}/\text{cm}^2$ and $467 \mu\text{W}/\text{cm}^2$ respectively. The general population exposure limit for the 1900 MHz (PCS) and 2100 MHz (AWS) is $1000 \mu\text{W}/\text{cm}^2$. Because each carrier will be using different frequency bands, and each frequency band has different exposure limits, it is necessary to report percent of MPE rather than power density.



Occupational/controlled exposure limits apply to situations in which persons are exposed as a consequence of their employment and in which those persons who are exposed have been made fully aware of the potential for exposure and can exercise control over their exposure. Occupational/controlled exposure limits also apply where exposure is of a transient nature as a result of incidental passage through a location where exposure levels may be above general population/uncontrolled limits (see below), as long as the exposed person has been made fully aware of the potential for exposure and can exercise control over his or her exposure by leaving the area or by some other appropriate means.

Additional details can be found in FCC OET 65.

CALCULATIONS

Calculations were done for the proposed T-Mobile Wireless antenna facility located at **158 Edison Road, Trumbull, CT**, using the equipment information listed below. All calculations were performed per the specifications under FCC OET 65. Since T-Mobile is proposing highly focused directional panel antennas, which project most of the emitted energy out toward the horizon, all calculations were performed assuming a lobe representing the maximum gain of the antenna per the antenna manufactures supplied specifications, minus 10 dB for directional panel antennas, was focused at the base of the tower. For this report the sample point is the top of a 6-foot person standing at the base of the tower.

For all calculations, all equipment was calculated using the following assumptions:

- 1) 2 GSM channels (PCS Band - 1900 MHz) were considered for each sector of the proposed installation. These Channels have a transmit power of 30 Watts per Channel.
- 2) 2 UMTS channels (AWS Band – 2100 MHz) were considered for each sector of the proposed installation. These Channels have a transmit power of 30 Watts per Channel.
- 3) 2 LTE channels (PCS Band - 1900 MHz) were considered for each sector of the proposed installation. These Channels have a transmit power of 60 Watts per Channel.
- 4) 2 LTE channels (AWS Band – 2100 MHz) were considered for each sector of the proposed installation. These Channels have a transmit power of 60 Watts per Channel.
- 5) 2 LTE channels (600 MHz Band) were considered for each sector of the proposed installation. These Channels have a transmit power of 30 Watts per Channel.
- 6) 2 LTE channels (700 MHz Band) were considered for each sector of the proposed installation. These Channels have a transmit power of 30 Watts per Channel.



- 7) All radios at the proposed installation were considered to be running at full power and were uncombined in their RF transmissions paths per carrier prescribed configuration. Per FCC OET Bulletin No. 65 - Edition 97-01 recommendations to achieve the maximum anticipated value at each sample point, all power levels emitting from the proposed antenna installation are increased by a factor of 2.56 to account for possible in-phase reflections from the surrounding environment. This is rarely the case, and if so, is never continuous.
- 8) For the following calculations the sample point was the top of a 6-foot person standing at the base of the tower. The maximum gain of the antenna per the antenna manufactures supplied specifications, minus 10 dB for directional panel antennas, was used in this direction. This value is a very conservative estimate as gain reductions for these particular antennas are typically much higher in this direction.
- 9) The antennas used in this modeling are the **Ericsson AIR21 B4A/B2P & Ericsson AIR21 B2A/B4P** for 1900 MHz (PCS) and 2100 MHz (AWS) channels and the **RFS APXVAARR24_43-U-NA20** for 600 MHz and 700 MHz channels. This is based on feedback from the carrier with regard to anticipated antenna selection. All Antenna gain values and associated transmit power levels are shown in the Site Inventory and Power Data table below. The maximum gain of the antenna per the antenna manufactures supplied specifications, minus 10 dB for directional panel antennas, was used for all calculations. This value is a very conservative estimate as gain reductions for these particular antennas are typically much higher in this direction.
- 10) The antenna mounting height centerline of the proposed antennas is **120 feet** above ground level (AGL).
- 11) Emissions values for additional carriers were taken from the Connecticut Siting Council active database. Values in this database are provided by the individual carriers themselves.
- 12) All calculations were done with respect to uncontrolled / general population threshold limits.



T-Mobile Site Inventory and Power Data

Sector:	A	Sector:	B	Sector:	C
Antenna #:	1	Antenna #:	1	Antenna #:	1
Make / Model:	Ericsson AIR21 B4A/B2P	Make / Model:	Ericsson AIR21 B4A/B2P	Make / Model:	Ericsson AIR21 B4A/B2P
Gain:	15.9 dBd	Gain:	15.9 dBd	Gain:	15.9 dBd
Height (AGL):	120	Height (AGL):	120	Height (AGL):	120
Frequency Bands	2100 MHz (AWS)	Frequency Bands	2100 MHz (AWS)	Frequency Bands	2100 MHz (AWS)
Channel Count	2	Channel Count	2	Channel Count	2
Total TX Power(W):	120	Total TX Power(W):	120	Total TX Power(W):	120
ERP (W):	4,668.54	ERP (W):	4,668.54	ERP (W):	4,668.54
Antenna A1 MPE%	1.29	Antenna B1 MPE%	1.29	Antenna C1 MPE%	1.29
Antenna #:	2	Antenna #:	2	Antenna #:	2
Make / Model:	Ericsson AIR21 B2A/B4P	Make / Model:	Ericsson AIR21 B2A/B4P	Make / Model:	Ericsson AIR21 B2A/B4P
Gain:	15.9 dBd	Gain:	15.9 dBd	Gain:	15.9 dBd
Height (AGL):	120	Height (AGL):	120	Height (AGL):	120
Frequency Bands	1900 MHz (PCS) / 2100 MHz (AWS)	Frequency Bands	1900 MHz (PCS) / 2100 MHz (AWS)	Frequency Bands	1900 MHz (PCS) / 2100 MHz (AWS)
Channel Count	6	Channel Count	6	Channel Count	6
Total TX Power(W):	240	Total TX Power(W):	240	Total TX Power(W):	240
ERP (W):	9,337.08	ERP (W):	9,337.08	ERP (W):	9,337.08
Antenna A2 MPE%	2.59	Antenna B2 MPE%	2.59	Antenna C2 MPE%	2.59
Antenna #:	3	Antenna #:	3	Antenna #:	3
Make / Model:	RFS APXVAARR24_43-U-NA20	Make / Model:	RFS APXVAARR24_43-U-NA20	Make / Model:	RFS APXVAARR24_43-U-NA20
Gain:	12.65/ 12.95 dBd	Gain:	12.65/ 12.95 dBd	Gain:	12.65/ 12.95 dBd
Height (AGL):	120	Height (AGL):	120	Height (AGL):	120
Frequency Bands	600 MHz / 700 MHz	Frequency Bands	600 MHz / 700 MHz	Frequency Bands	600 MHz / 700 MHz
Channel Count	4	Channel Count	4	Channel Count	4
Total TX Power(W):	120	Total TX Power(W):	120	Total TX Power(W):	120
ERP (W):	2,582.92	ERP (W):	2,582.92	ERP (W):	2,582.92
Antenna A3 MPE%	1.46	Antenna B3 MPE%	1.46	Antenna C3 MPE%	1.46

Site Composite MPE%	
Carrier	MPE%
T-Mobile (Per Sector Max)	5.34 %
Verizon Wireless	3.53 %
Trumbull PD	0.74 %
Site Total MPE %:	9.61 %

T-Mobile Sector A Total:	5.34 %
T-Mobile Sector B Total:	5.34 %
T-Mobile Sector C Total:	5.34 %
Site Total:	9.61 %



T-Mobile Max Power Values (Per Sector)

T-Mobile Max Power Values (per sector)	# Channels	Watts ERP (Per Channel)	Height (feet)	Total Power Density ($\mu\text{W}/\text{cm}^2$)	Frequency (MHz)	Allowable MPE ($\mu\text{W}/\text{cm}^2$)	Calculated % MPE
T-Mobile AWS - 2100 MHz LTE	2	2,334.27	120	12.91	AWS - 2100 MHz	1000	1.29%
T-Mobile AWS - 2100 MHz UMTS	2	1,167.14	120	6.46	AWS - 2100 MHz	1000	0.65%
T-Mobile PCS - 1900 MHz LTE	2	2,334.27	120	12.91	PCS - 1900 MHz	1000	1.29%
T-Mobile PCS - 1900 MHz GSM	2	1,167.14	120	6.46	PCS - 1900 MHz	1000	0.65%
T-Mobile 600 MHz LTE	2	552.23	120	3.06	600 MHz	400	0.76%
T-Mobile 700 MHz LTE	2	591.73	120	3.27	700 MHz	467	0.70%
						Total:	5.34%

Summary

All calculations performed for this analysis yielded results that were **within** the allowable limits for general population exposure to RF Emissions.

The anticipated maximum composite contributions from the T-Mobile facility as well as the site composite emissions value with regards to compliance with FCC's allowable limits for general population exposure to RF Emissions are shown here:

T-Mobile Sector	Power Density Value (%)
Sector A:	5.34 %
Sector B:	5.34 %
Sector C:	5.34 %
T-Mobile Per Sector Maximum (Sector A):	5.34 %
Site Total:	9.61 %
Site Compliance Status:	COMPLIANT

The anticipated composite MPE value for this site assuming all carriers present is **9.61%** of the allowable FCC established general population limit sampled at the ground level. This is based upon values listed in the Connecticut Siting Council database for existing carrier emissions.

FCC guidelines state that if a site is found to be out of compliance (over allowable thresholds), that carriers over a 5% contribution to the composite value will require measures to bring the site into compliance. For this facility, the composite values calculated were well within the allowable 100% threshold standard per the federal government.

Structural Analysis Report

130-ft Existing Valmont Monopole

*Proposed T-Mobile
Antenna Upgrade*

Site Ref: CTFF481B

*158 Edison Road
Trumbull, CT*

CEN TEK Project No. 18058.33

Date: June 11, 2018

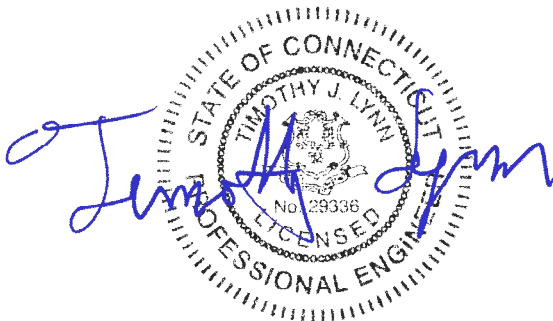

Prepared for:
T-Mobile USA
35 Griffin Road
Bloomfield, CT 06002

Table of Contents

SECTION 1 - REPORT

- INTRODUCTION
- ANTENNA AND APPURTENANCE SUMMARY
- PRIMARY ASSUMPTIONS USED IN THE ANALYSIS
- ANALYSIS
- TOWER LOADING
- TOWER CAPACITY
- FOUNDATION AND ANCHORS
- CONCLUSION

SECTION 2 – CONDITIONS & SOFTWARE

- STANDARD ENGINEERING CONDITIONS
- GENERAL DESCRIPTION OF STRUCTURAL ANALYSIS PROGRAM

SECTION 3 – CALCULATIONS

- tnxTower INPUT/OUTPUT SUMMARY
- tnxTower DETAILED OUTPUT
- ANCHOR BOLT AND BASEPLATE ANALYSIS
- FOUNDATION ANALYSIS

SECTION 4 – REFERENCE MATERIAL

- RF DATA SHEET
- ANTENNA CUT SHEETS

Introduction

The purpose of this report is to summarize the results of the non-linear, P- Δ structural analysis of the antenna upgrade proposed by Verizon on the monopole (tower) located in Trumbull, CT.

The host tower is a 130-ft tall, three-section, eighteen sided, tapered monopole originally designed and manufactured by Valmont order no: 291087, dated June 29, 2016. The tower geometry, structure member sizes and foundation system information were obtained from the aforementioned tower design documents.

Antenna and appurtenance information were obtained from a previous structural analysis report prepared by Tilson dated October 23, 2017 and a RF data sheet.

The tower consists of three (3) tapered vertical sections consisting of A572-65 pole sections. The vertical tower sections are slip joint connected. The diameter of the pole (flat-flat) is 28.95-in at the top and 59.50-in at the base.

Antenna and Appurtenance Summary

The existing, proposed and future loads considered in this analysis consist of the following:

- **TOWN (Reserved):**
Antennas: Eight (8) Omni-directional whip antennas, two (2) dipole antennas and one (1) 2-ft \varnothing Microwave dish pipe to the top of the tower.
Coax Cables: Eleven (11) 7/8" \varnothing coax cables running on the inside of the monopole.
- **VERIZON (Existing):**
Antennas: Nine (9) Andrew SBNHH-1D65B panel antennas, three (3) Nokia RRH2x60-700 remote radio heads, three (3) Nokia RRH2x60-PCS remote radio heads, three (3) Nokia RRH4x45-AWS remote radio heads and two (2) Raycap RC2DC3315-PF-48 distribution boxes mounted on three (3) 12-ft T-Arms with a RAD center elevation of 109-ft above grade.
Coax Cables: Two (2) 1-5/8" \varnothing fiber cables running on the inside of the monopole.
- **T-MOBILE (Existing to Remain):**
Antennas: Six (6) Ericsson AIR21 panel antennas and three (3) TMAs mounted on three (3) 12-ft T-arms with a RAD center elevation of 120-ft above existing grade.
Coax Cables: Six (6) 1-5/8" \varnothing coax cables and one (1) 1-5/8" \varnothing fiber cable running on the inside of the monopole.
- **T-MOBILE (Existing to Remove):**
Antennas: **Three (3) Andrew LNX-6515DS panel antennas and three (3) Ericsson RRUS-11 remote radio heads mounted on three (3) 12-ft T-arms with a RAD center elevation of 120-ft above existing grade.**
- **T-MOBILE (Proposed):**
Antennas: **Three (3) RFS APXVAARR24_43 panel antennas and three (3) Ericsson 4449 B71 B12 remote radio heads mounted on three (3) 12-ft T-arms with a RAD center elevation of 120-ft above existing grade.**
Coax Cables: **One (1) 6x12 fiber cable running on the inside of the monopole.**

Primary Assumptions Used in the Analysis

- The tower structure's theoretical capacity not including any assessment of the condition of the tower.
- The tower carries the horizontal and vertical loads due to the weight of antennas, ice load and wind.
- Tower is properly installed and maintained.
- Tower is in plumb condition.
- Tower loading for antennas and mounts as listed in this report.
- All bolts are appropriately tightened providing the necessary connection continuity.
- All welds are fabricated with ER-70S-6 electrodes.
- All members are assumed to be as specified in the original tower design documents or reinforcement drawings.
- All members are "hot dipped" galvanized in accordance with ASTM A123 and ASTM A153 Standards.
- All member protective coatings are in good condition.
- All tower members were properly designed, detailed, fabricated, installed and have been properly maintained since erection.
- Any deviation from the analyzed antenna loading will require a new analysis for verification of structural adequacy.
- All existing coax cables to be installed as indicated in this report.

A n a l y s i s

The existing tower was analyzed using a comprehensive computer program entitled tnxTower. The program analyzes the tower, considering the worst case loading condition. The tower is considered as loaded by concentric forces along the tower, and the model assumes that the tower members are subjected to bending, axial, and shear forces.

The existing tower was analyzed for the controlling basic wind speed (3-second gust) with no ice and the applicable wind and ice combination to determine stresses in members as per guidelines of TIA-222-G-2005 entitled “Structural Standard for Antenna Support Structures and Antennas”, the American Institute of Steel Construction (AISC) and the Manual of Steel Construction; Load and Resistance Factor Design (LRFD).

The controlling wind speed is determined by evaluating the local available wind speed data as provided in Appendix N of the CSBC¹ and the wind speed data available in the TIA-222-G-2005 Standard.

T o w e r L o a d i n g

Tower loading was determined by the basic wind speed as applied to projected surface areas with modification factors per TIA-222-G-2005, gravity loads of the tower structure and its components, and the application of 0.75” radial ice on the tower structure and its components.

Basic Wind Speed:	Fairfield; v = 90-110 mph (3-second gust)	[Annex B of TIA-222-G-2005]
	Trumbull; v = 97 mph (3 second gust)	[Appendix N of the 2016 CT Building Code]
Load Cases:	<u>Load Case 1</u> ; 97 mph wind speed w/ no ice plus gravity load – used in calculation of tower stresses and rotation.	[Appendix N of the 2016 CT Building Code]
	<u>Load Case 2</u> ; 50 mph wind speed w/ 0.75” radial ice plus gravity load – used in calculation of tower stresses.	[Annex B of TIA-222-G-2005]

¹ The 2012 International Building Code as amended by the 2016 Connecticut State Building Code (CSBC).

Tower Capacity

- Calculated stresses were found to be within allowable limits. This tower was found to be at 47.4% of its total capacity.

Tower Section	Elevation	Stress Ratio (percentage of capacity)	Result
Pole Shaft (L3)	1.00'-39.03'	47.4%	PASS

Foundation and Anchors

The foundation consists of a 8.0-ft square x 4.5-ft long reinforced concrete pier on a 26.5-ft square x 3.0-ft thick reinforced concrete pad. The sub-grade conditions used in the analysis of the foundation were obtained from the aforementioned design documents. The base of the tower is connected to the foundation by means of (20) 2.25"Ø, ASTM A615 Grade 75 anchor bolts embedded approximately 5-ft into the concrete foundation structure.

- The tower base reactions developed from the governing Load Case 1 were used in the verification of the foundation and its anchors:

Location	Vector	Proposed Reactions
Base	Shear	33 kips
	Compression	41 kips
	Moment	3149 kip-ft

- The foundation was found to be within allowable limits.

Foundation	Design Limit	TIA-222-G Section 9.4 FS ⁽¹⁾	Proposed Loading (FS) ⁽¹⁾	Result
Reinforced Concrete Pad and Pier	OTM ⁽²⁾	1.0	2.47	PASS

Note 1: FS denotes Factor of Safety.

Note 2: OTM denotes Overturning Moment

- The anchor bolts and base plate were found to be within allowable limits.

Tower Component	Design Limit	Stress Ratio (percentage of capacity)	Result
Anchor Bolts	Combined Compression and Shear	36.2%	PASS
Base Plate	Bending	46.4%	PASS

Conclusion

This analysis shows that the subject tower **is adequate** to support the proposed antenna configuration.

The analysis is based, in part, on the information provided to this office by T-Mobile. If the existing conditions are different than the information in this report, Centek Engineering, Inc. must be contacted for resolution of any potential issues.

Please feel free to call with any questions or comments.

Respectfully Submitted by:



Timothy J. Lynn, PE
Structural Engineer

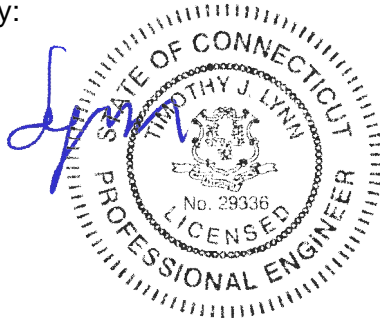

Standard Conditions for Furnishing of
Professional Engineering Services on
Existing Structures

All engineering services are performed on the basis that the information used is current and correct. This information may consist of, but is not necessarily limited to:

- Information supplied by the client regarding the structure itself, its foundations, the soil conditions, the antenna and feed line loading on the structure and its components, or other relevant information.
- Information from the field and/or drawings in the possession of CENTEK engineering, Inc. or generated by field inspections or measurements of the structure.
- It is the responsibility of the client to ensure that the information provide to CENTEK engineering, Inc. and used in the performance of our engineering services is correct and complete. In the absence of information to the contrary, we assume that all structures were constructed in accordance with the drawings and specifications and are in an un-corroded condition and have not deteriorated. It is therefore assumed that its capacity has not significantly changed from the “as new” condition.
- All services will be performed to the codes specified by the client, and we do not imply to meet any other codes or requirements unless explicitly agreed in writing. If wind and ice loads or other relevant parameters are to be different from the minimum values recommended by the codes, the client shall specify the exact requirement. In the absence of information to the contrary, all work will be performed in accordance with the latest revision of ANSI/ASCE10 & ANSI/EIA-222
- All services performed, results obtained, and recommendations made are in accordance with generally accepted engineering principles and practices. CENTEK engineering, Inc. is not responsible for the conclusions, opinions and recommendations made by others based on the information we supply.

General Description of Structural Analysis Program

tnxTower, is an integrated structural analysis and design software package for Designed specifically for the telecommunications industry, tnxTower, formerly ERITower, automates much of the tower analysis and design required by the TIA/EIA 222 Standard.

tnxTower Features:

- tnxTower can analyze and design 3- and 4-sided guyed towers, 3- and 4-sided self-supporting towers and either round or tapered ground mounted poles with or without guys.
- The program analyzes towers using the TIA-222-G (2005) standard or any of the previous TIA/EIA standards back to RS-222 (1959). Steel design is checked using the AISC ASD 9th Edition or the AISC LRFD specifications.
- Linear and non-linear (P-delta) analyses can be used in determining displacements and forces in the structure. Wind pressures and forces are automatically calculated.
- Extensive graphics plots include material take-off, shear-moment, leg compression, displacement, twist, feed line, guy anchor and stress plots.
- tnxTower contains unique features such as True Cable behavior, hog rod take-up, foundation stiffness and much more.

Section	1	2	3	
Length (ft)	49.833	46.971	45.000	
Number of Sides	18	18	18	
Thickness (in)	0.313	0.375	0.438	
Socket Length (ft)	5.833	6.971	48.352	
Top Dia (in)	28.950	39.214	59.500	
Bot Dia (in)	41.283	50.825		
Grade		A572-65		
Weight (K)	5.9	8.5	11.4	25.7

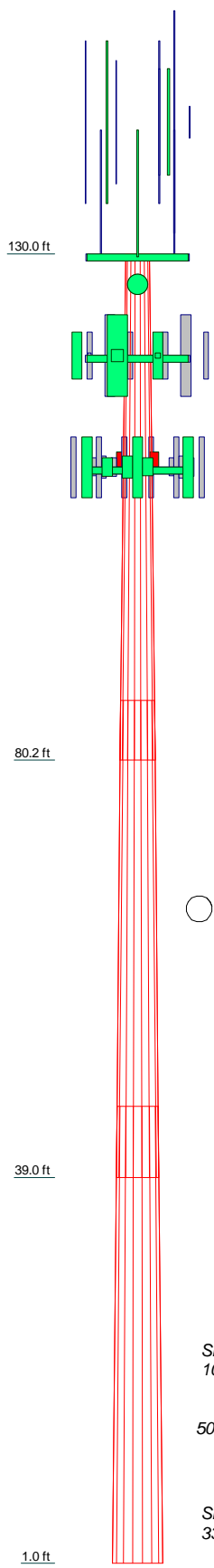

DESIGNED APPURTENANCE LOADING

TYPE	ELEVATION	TYPE	ELEVATION
(2) DB809KE-XT	143	Radio 4449 B71 B12 (T-Mobile - Proposed)	120
ANT790F2	143	KRY 112-144-1 TMA (T-Mobile)	120
(2) PD1142-2AN	143	KRY 112-144-1 TMA (T-Mobile)	120
PD1142-2AN	143	KRY 112-144-1 TMA (T-Mobile)	120
PD1142-2AN	143	Valmont T-Arm (1) (T-Mobile)	120
872-70	143	Valmont T-Arm (1) (T-Mobile)	120
DS1F06F36U-D	143	Valmont T-Arm (1) (T-Mobile)	120
872-70	143	Valmont T-Arm (1) (Verizon - Existing)	109
12-ft T-arm w/ Work Support Platform	130	Valmont T-Arm (1) (Verizon - Existing)	109
12-ft T-arm w/ Work Support Platform	130	(3) SBNHH-1D65B (Verizon - Existing)	109
12-ft T-arm w/ Work Support Platform	130	(3) SBNHH-1D65B (Verizon - Existing)	109
(4) 2" Std. x 12'-6" pipe	130	(3) SBNHH-1D65B (Verizon - Existing)	109
(4) 2" Std. x 12'-6" pipe	130	RRH2x60-07-U (Verizon - Existing)	109
(4) 2" Std. x 12'-6" pipe	130	RRH2x60-07-U (Verizon - Existing)	109
2-ft dish	127	RRH2x60-07-U (Verizon - Existing)	109
AIR21 B4A/B2P (T-Mobile)	120	RRH2x60-07-U (Verizon - Existing)	109
AIR21 B2A/B4P (T-Mobile)	120	RRH4x45/2x90-AWS (Verizon - Existing)	109
APXVAARR24-43 (T-Mobile - Proposed)	120	RRH4x45/2x90-AWS (Verizon - Existing)	109
AIR21 B4A/B2P (T-Mobile)	120	RRH4x45/2x90-AWS (Verizon - Existing)	109
AIR21 B2A/B4P (T-Mobile)	120	RRH2x60-PCS (Verizon - Existing)	109
APXVAARR24-43 (T-Mobile - Proposed)	120	RRH2x60-PCS (Verizon - Existing)	109
AIR21 B4A/B2P (T-Mobile)	120	RRH2x60-PCS (Verizon - Existing)	109
AIR21 B2A/B4P (T-Mobile)	120	RRH2x60-PCS (Verizon - Existing)	109
APXVAARR24-43 (T-Mobile - Proposed)	120	RC2DC-3315-PF-48 (Verizon - Existing)	109
Radio 4449 B71 B12 (T-Mobile - Proposed)	120	RC2DC-3315-PF-48 (Verizon - Existing)	109
Radio 4449 B71 B12 (T-Mobile - Proposed)	120	Valmont T-Arm (1) (Verizon - Existing)	109

MATERIAL STRENGTH

GRADE	Fy	Fu	GRADE	Fy	Fu
A572-65	65 ksi	80 ksi			

TOWER DESIGN NOTES

1. Tower designed for Exposure C to the TIA-222-G Standard.
2. Tower designed for a 97 mph basic wind in accordance with the TIA-222-G Standard.
3. Tower is also designed for a 50 mph basic wind with 0.75 in ice. Ice is considered to increase in thickness with height.
4. Deflections are based upon a 60 mph wind.
5. Tower Structure Class III.
6. Topographic Category 1 with Crest Height of 0.000 ft
7. TOWER RATING: 47.4%

ALL REACTIONS ARE FACTORED

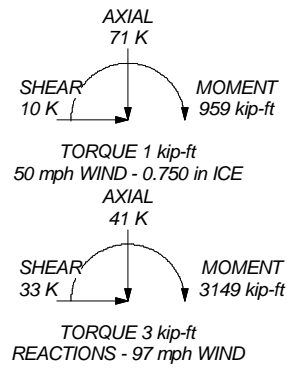

Centek Engineering Inc.		
63-2 North Branford Rd. Branford, CT 06405 Phone: (203) 488-0580 FAX: (203) 488-8587		
Job: 18058.33 - CTF481B	Project: 130-ft Valmont Monopole - 158 Edison Road Trumbull, CT	
Client: T-Mobile	Drawn by: T.JL	App'd:
Code: TIA-222-G	Date: 06/11/18	Scale: NTS
Path:		Dwg No. E-1

tnxTower Centek Engineering Inc. 63-2 North Branford Rd. Branford, CT 06405 Phone: (203) 488-0580 FAX: (203) 488-8587	Job 18058.33 - CTFF481B	Page 1 of 29
	Project 130-ft Valmont Monopole - 158 Edison Road Trumbull, CT	Date 09:57:04 06/11/18
	Client T-Mobile	Designed by TJL

Tower Input Data

There is a pole section.

This tower is designed using the TIA-222-G standard.

The following design criteria apply:

Basic wind speed of 97 mph.

Structure Class III.

Exposure Category C.

Topographic Category 1.

Crest Height 0.000 ft.

Nominal ice thickness of 0.750 in.

Ice thickness is considered to increase with height.

Ice density of 56 pcf.

A wind speed of 50 mph is used in combination with ice.

Temperature drop of 50 °F.

Deflections calculated using a wind speed of 60 mph.

A non-linear (P-delta) analysis was used.

Pressures are calculated at each section.

Stress ratio used in pole design is 1.

Local bending stresses due to climbing loads, feed line supports, and appurtenance mounts are not considered.

Options

Consider Moments - Legs Consider Moments - Horizontals Consider Moments - Diagonals Use Moment Magnification ✓ Use Code Stress Ratios ✓ Use Code Safety Factors - Guys Escalate Ice Always Use Max Kz Use Special Wind Profile Include Bolts In Member Capacity Leg Bolts Are At Top Of Section Secondary Horizontal Braces Leg Use Diamond Inner Bracing (4 Sided) SR Members Have Cut Ends SR Members Are Concentric	Distribute Leg Loads As Uniform Assume Legs Pinned ✓ Assume Rigid Index Plate Use Clear Spans For Wind Area Use Clear Spans For KL/r Retension Guys To Initial Tension ✓ Bypass Mast Stability Checks Use Azimuth Dish Coefficients ✓ Project Wind Area of Appurt. Autocalc Torque Arm Areas Add IBC .6D+W Combination ✓ Sort Capacity Reports By Component Triangulate Diamond Inner Bracing Treat Feed Line Bundles As Cylinder	Use ASCE 10 X-Brace Ly Rules Calculate Redundant Bracing Forces Ignore Redundant Members in FEA SR Leg Bolts Resist Compression All Leg Panels Have Same Allowable Offset Girt At Foundation ✓ Consider Feed Line Torque Include Angle Block Shear Check Use TIA-222-G Bracing Resist. Exemption Use TIA-222-G Tension Splice Exemption <div style="background-color: #cccccc; text-align: center; padding: 2px;">Poles</div> ✓ Include Shear-Torsion Interaction Always Use Sub-Critical Flow Use Top Mounted Sockets
--	--	--

Tapered Pole Section Geometry

Section	Elevation ft	Section Length ft	Splice Length ft	Number of Sides	Top Diameter in	Bottom Diameter in	Wall Thickness in	Bend Radius in	Pole Grade
L1	130.000-80.167	49.833	5.833	18	28.950	41.283	0.313	1.250	A572-65 (65 ksi)
L2	80.167-39.029	46.971	6.971	18	39.214	50.825	0.375	1.500	A572-65 (65 ksi)
L3	39.029-1.000	45.000		18	48.352	59.500	0.438	1.750	A572-65

tnxTower Centek Engineering Inc. 63-2 North Branford Rd. Branford, CT 06405 Phone: (203) 488-0580 FAX: (203) 488-8587	Job 18058.33 - CTFF481B	Page 2 of 29
	Project 130-ft Valmont Monopole - 158 Edison Road Trumbull, CT	Date 09:57:04 06/11/18
	Client T-Mobile	Designed by TJL

Section	Elevation	Section Length	Splice Length	Number of Sides	Top Diameter	Bottom Diameter	Wall Thickness	Bend Radius	Pole Grade
	ft	ft	ft		in	in	in	in	(65 ksi)

Tapered Pole Properties

Section	Tip Dia.	Area	I	r	C	I/C	J	It/Q	w	w/t
	in	in ²	in ⁴	in	in	in ³	in ⁴	in ²	in	
L1	29.397 41.920	28.405 40.638	2943.064 8618.034	10.166 14.545	14.707 20.972	200.119 410.935	5890.000 17247.407	14.205 20.323	4.545 6.716	14.545 21.491
L2	41.283 51.609	46.229 60.048	8810.358 19308.972	13.788 17.910	19.921 25.819	442.267 747.856	17632.308 38643.351	23.119 30.030	6.242 8.285	16.645 22.094
L3	50.851 60.418	66.535 82.016	19298.325 36145.806	17.010 20.967	24.563 30.226	785.675 1195.851	38622.043 72339.173	33.274 41.016	7.740 9.702	17.691 22.176

Tower Elevation	Gusset Area	Gusset Thickness	Gusset Grade	Adjust. Factor	Adjust. Factor	Weight Mult.	Double Angle	Double Angle	Double Angle
ft	ft ²	in		A _f	A _r		Stitch Bolt Spacing	Stitch Bolt Spacing	Stitch Bolt Spacing
							Diagonals	Horizontals	Redundants
							in	in	in
L1 130.000-80.16				1	1	1			
7 L2 80.167-39.029				1	1	1			
L3 39.029-1.000				1	1	1			

Feed Line/Linear Appurtenances - Entered As Area

Description	Face or Leg	Allow Shield	Component Type	Placement	Total Number	C _A A _A	Weight
				ft		ft ² /ft	klf
7/8 (Town)	C	No	Inside Pole	130.000 - 1.000	11	No Ice 1/2" Ice 1" Ice	0.000 0.000 0.001
1 5/8 (T-Mobile)	C	No	Inside Pole	120.000 - 1.000	6	No Ice 1/2" Ice 1" Ice	0.000 0.000 0.001
HYBRIFLEX 1-5/8" (T-Mobile)	C	No	Inside Pole	120.000 - 1.000	2	No Ice 1/2" Ice 1" Ice	0.000 0.000 0.002
HYBRIFLEX 1-5/8" (Verizon)	C	No	Inside Pole	109.000 - 1.000	2	No Ice 1/2" Ice 1" Ice	0.000 0.000 0.002

Feed Line/Linear Appurtenances Section Areas

Tower Section	Tower Elevation	Face	A _R	A _F	C _A A _A	C _A A _A	Weight
	ft		ft ²	ft ²	In Face	Out Face	K
					ft ²	ft ²	

tnxTower Centek Engineering Inc. 63-2 North Branford Rd. Branford, CT 06405 Phone: (203) 488-0580 FAX: (203) 488-8587	Job 18058.33 - CTFF481B	Page 3 of 29
	Project 130-ft Valmont Monopole - 158 Edison Road Trumbull, CT	Date 09:57:04 06/11/18
	Client T-Mobile	Designed by TJL

Tower Section	Tower Elevation ft	Face	A_R ft ²	A_F ft ²	C_{AA} In Face ft ²	C_{AA} Out Face ft ²	Weight K
L1	130.000-80.167	A	0.000	0.000	0.000	0.000	0.000
		B	0.000	0.000	0.000	0.000	0.000
		C	0.000	0.000	0.000	0.000	0.805
L2	80.167-39.029	A	0.000	0.000	0.000	0.000	0.000
		B	0.000	0.000	0.000	0.000	0.000
		C	0.000	0.000	0.000	0.000	0.814
L3	39.029-1.000	A	0.000	0.000	0.000	0.000	0.000
		B	0.000	0.000	0.000	0.000	0.000
		C	0.000	0.000	0.000	0.000	0.752

Feed Line/Linear Appurtenances Section Areas - With Ice

Tower Section	Tower Elevation ft	Face or Leg	Ice Thickness in	A_R ft ²	A_F ft ²	C_{AA} In Face ft ²	C_{AA} Out Face ft ²	Weight K
L1	130.000-80.167	A	2.103	0.000	0.000	0.000	0.000	0.000
		B		0.000	0.000	0.000	0.000	0.000
		C		0.000	0.000	0.000	0.000	0.805
L2	80.167-39.029	A	1.988	0.000	0.000	0.000	0.000	0.000
		B		0.000	0.000	0.000	0.000	0.000
		C		0.000	0.000	0.000	0.000	0.814
L3	39.029-1.000	A	1.785	0.000	0.000	0.000	0.000	0.000
		B		0.000	0.000	0.000	0.000	0.000
		C		0.000	0.000	0.000	0.000	0.752

Feed Line Center of Pressure

Section	Elevation ft	CP_x in	CP_z in	CP_x Ice in	CP_z Ice in
L1	130.000-80.167	0.000	0.000	0.000	0.000
L2	80.167-39.029	0.000	0.000	0.000	0.000
L3	39.029-1.000	0.000	0.000	0.000	0.000

Shielding Factor Ka

Tower Section	Feed Line Record No.	Description	Feed Line Segment Elev.	K_a No Ice	K_a Ice

Discrete Tower Loads

tnxTower Centek Engineering Inc. 63-2 North Branford Rd. Branford, CT 06405 Phone: (203) 488-0580 FAX: (203) 488-8587	Job 18058.33 - CTFF481B	Page 4 of 29
	Project 130-ft Valmont Monopole - 158 Edison Road Trumbull, CT	Date 09:57:04 06/11/18
	Client T-Mobile	Designed by TJL

Description	Face or Leg	Offset Type	Offsets:		Azimuth Adjustment	Placement	C _{AA} Front	C _{AA} Side	Weight
			Horz	Vert					
			ft	ft	°	ft	ft ²	ft ²	K
(3) SBNHH-1D65B (Verizon - Existing)	A	From Face	3.000 0.000 0.000		0.000	109.000	No Ice 8.079 1/2" Ice 8.535 1" Ice 8.998	5.342 5.795 6.255	0.042 0.092 0.148
(3) SBNHH-1D65B (Verizon - Existing)	B	From Face	3.000 0.000 0.000		0.000	109.000	No Ice 8.079 1/2" Ice 8.535 1" Ice 8.998	5.342 5.795 6.255	0.042 0.092 0.148
(3) SBNHH-1D65B (Verizon - Existing)	C	From Face	3.000 0.000 0.000		0.000	109.000	No Ice 8.079 1/2" Ice 8.535 1" Ice 8.998	5.342 5.795 6.255	0.042 0.092 0.148
RRH2x60-07-U (Verizon - Existing)	A	From Face	3.000 -1.000 0.000		0.000	109.000	No Ice 2.100 1/2" Ice 2.287 1" Ice 2.481	1.406 1.565 1.737	0.050 0.068 0.089
RRH2x60-07-U (Verizon - Existing)	B	From Face	3.000 -1.000 0.000		0.000	109.000	No Ice 2.100 1/2" Ice 2.287 1" Ice 2.481	1.406 1.565 1.737	0.050 0.068 0.089
RRH2x60-07-U (Verizon - Existing)	C	From Face	3.000 -1.000 0.000		0.000	109.000	No Ice 2.100 1/2" Ice 2.287 1" Ice 2.481	1.406 1.565 1.737	0.050 0.068 0.089
RRH4x45/2x90-AWS (Verizon - Existing)	A	From Face	3.000 1.000 0.000		0.000	109.000	No Ice 2.580 1/2" Ice 2.794 1" Ice 3.015	1.688 1.871 2.060	0.075 0.096 0.120
RRH4x45/2x90-AWS (Verizon - Existing)	B	From Face	3.000 1.000 0.000		0.000	109.000	No Ice 2.580 1/2" Ice 2.794 1" Ice 3.015	1.688 1.871 2.060	0.075 0.096 0.120
RRH4x45/2x90-AWS (Verizon - Existing)	C	From Face	3.000 1.000 0.000		0.000	109.000	No Ice 2.580 1/2" Ice 2.794 1" Ice 3.015	1.688 1.871 2.060	0.075 0.096 0.120
RRH2x60-PCS (Verizon - Existing)	A	From Face	3.000 3.000 0.000		0.000	109.000	No Ice 2.150 1/2" Ice 2.340 1" Ice 2.537	1.346 1.504 1.669	0.055 0.073 0.093
RRH2x60-PCS (Verizon - Existing)	B	From Face	3.000 3.000 0.000		0.000	109.000	No Ice 2.150 1/2" Ice 2.340 1" Ice 2.537	1.346 1.504 1.669	0.055 0.073 0.093
RRH2x60-PCS (Verizon - Existing)	C	From Face	3.000 3.000 0.000		0.000	109.000	No Ice 2.150 1/2" Ice 2.340 1" Ice 2.537	1.346 1.504 1.669	0.055 0.073 0.093
RC2DC-3315-PF-48 (Verizon - Existing)	A	From Face	0.500 0.000 0.000		0.000	109.000	No Ice 3.015 1/2" Ice 3.234 1" Ice 3.460	1.965 2.153 2.349	0.025 0.051 0.081
RC2DC-3315-PF-48 (Verizon - Existing)	B	From Face	0.500 0.000 0.000		0.000	109.000	No Ice 3.015 1/2" Ice 3.234 1" Ice 3.460	1.965 2.153 2.349	0.025 0.051 0.081
Valmont T-Arm (1) (Verizon - Existing)	A	From Face	1.750 0.000 0.000		0.000	109.000	No Ice 10.540 1/2" Ice 14.450 1" Ice 18.360	10.540 14.450 18.360	0.336 0.412 0.488
Valmont T-Arm (1) (Verizon - Existing)	B	From Face	1.750 0.000 0.000		0.000	109.000	No Ice 10.540 1/2" Ice 14.450 1" Ice 18.360	10.540 14.450 18.360	0.336 0.412 0.488
Valmont T-Arm (1) (Verizon - Existing)	C	From Face	1.750 0.000 0.000		0.000	109.000	No Ice 10.540 1/2" Ice 14.450 1" Ice 18.360	10.540 14.450 18.360	0.336 0.412 0.488
AIR21 B4A/B2P (T-Mobile)	A	From Face	3.000 6.000 0.000		0.000	120.000	No Ice 6.049 1/2" Ice 6.419 1" Ice 6.795	4.356 4.705 5.061	0.083 0.125 0.172
AIR21 B2A/B4P (T-Mobile)	A	From Face	3.000 -2.000 0.000		0.000	120.000	No Ice 6.049 1/2" Ice 6.419 1" Ice 6.795	4.356 4.705 5.061	0.083 0.125 0.172

tnxTower Centek Engineering Inc. 63-2 North Branford Rd. Branford, CT 06405 Phone: (203) 488-0580 FAX: (203) 488-8587	Job	18058.33 - CTFF481B	Page	5 of 29
	Project	130-ft Valmont Monopole - 158 Edison Road Trumbull, CT	Date	09:57:04 06/11/18
	Client	T-Mobile	Designed by	TJL

Description	Face or Leg	Offset Type	Offsets:		Azimuth Adjustment	Placement	C _{AA} Front	C _{AA} Side	Weight	
			Horz	Vert						
			ft	ft	°	ft	ft ²	ft ²	K	
APXVAARR24-43 (T-Mobile - Proposed)	A	From Face	3.000	0.000	0.000	120.000	No Ice	20.243	8.889	0.155
			2.000				1/2" Ice	20.890	9.487	0.268
			0.000				1" Ice	21.544	10.092	0.389
AIR21 B4A/B2P (T-Mobile)	B	From Face	3.000	0.000	0.000	120.000	No Ice	6.049	4.356	0.083
			6.000				1/2" Ice	6.419	4.705	0.125
			0.000				1" Ice	6.795	5.061	0.172
AIR21 B2A/B4P (T-Mobile)	B	From Face	3.000	0.000	0.000	120.000	No Ice	6.049	4.356	0.083
			-2.000				1/2" Ice	6.419	4.705	0.125
			0.000				1" Ice	6.795	5.061	0.172
APXVAARR24-43 (T-Mobile - Proposed)	B	From Face	3.000	0.000	0.000	120.000	No Ice	20.243	8.889	0.155
			2.000				1/2" Ice	20.890	9.487	0.268
			0.000				1" Ice	21.544	10.092	0.389
AIR21 B4A/B2P (T-Mobile)	C	From Face	3.000	0.000	0.000	120.000	No Ice	6.049	4.356	0.083
			6.000				1/2" Ice	6.419	4.705	0.125
			0.000				1" Ice	6.795	5.061	0.172
AIR21 B2A/B4P (T-Mobile)	C	From Face	3.000	0.000	0.000	120.000	No Ice	6.049	4.356	0.083
			-2.000				1/2" Ice	6.419	4.705	0.125
			0.000				1" Ice	6.795	5.061	0.172
APXVAARR24-43 (T-Mobile - Proposed)	C	From Face	3.000	0.000	0.000	120.000	No Ice	20.243	8.889	0.155
			2.000				1/2" Ice	20.890	9.487	0.268
			0.000				1" Ice	21.544	10.092	0.389
Radio 4449 B71 B12 (T-Mobile - Proposed)	A	From Face	3.000	0.000	0.000	120.000	No Ice	1.639	1.291	0.074
			2.000				1/2" Ice	1.799	1.436	0.091
			0.000				1" Ice	1.966	1.587	0.111
Radio 4449 B71 B12 (T-Mobile - Proposed)	B	From Face	3.000	0.000	0.000	120.000	No Ice	1.639	1.291	0.074
			2.000				1/2" Ice	1.799	1.436	0.091
			0.000				1" Ice	1.966	1.587	0.111
Radio 4449 B71 B12 (T-Mobile - Proposed)	C	From Face	3.000	0.000	0.000	120.000	No Ice	1.639	1.291	0.074
			2.000				1/2" Ice	1.799	1.436	0.091
			0.000				1" Ice	1.966	1.587	0.111
KRY 112-144-1 TMA (T-Mobile)	A	From Face	3.000	0.000	0.000	120.000	No Ice	0.351	0.142	0.015
			-2.000				1/2" Ice	0.427	0.195	0.018
			0.000				1" Ice	0.510	0.256	0.022
KRY 112-144-1 TMA (T-Mobile)	B	From Face	3.000	0.000	0.000	120.000	No Ice	0.351	0.142	0.015
			-2.000				1/2" Ice	0.427	0.195	0.018
			0.000				1" Ice	0.510	0.256	0.022
KRY 112-144-1 TMA (T-Mobile)	C	From Face	3.000	0.000	0.000	120.000	No Ice	0.351	0.142	0.015
			-2.000				1/2" Ice	0.427	0.195	0.018
			0.000				1" Ice	0.510	0.256	0.022
Valmont T-Arm (1) (T-Mobile)	A	From Face	1.750	0.000	0.000	120.000	No Ice	10.540	10.540	0.336
			0.000				1/2" Ice	14.450	14.450	0.412
			0.000				1" Ice	18.360	18.360	0.488
Valmont T-Arm (1) (T-Mobile)	B	From Face	1.750	0.000	0.000	120.000	No Ice	10.540	10.540	0.336
			0.000				1/2" Ice	14.450	14.450	0.412
			0.000				1" Ice	18.360	18.360	0.488
Valmont T-Arm (1) (T-Mobile)	C	From Face	1.750	0.000	0.000	120.000	No Ice	10.540	10.540	0.336
			0.000				1/2" Ice	14.450	14.450	0.412
			0.000				1" Ice	18.360	18.360	0.488
(2) DB809KE-XT	A	From Face	3.000	0.000	0.000	143.000	No Ice	3.050	3.050	0.030
			3.000				1/2" Ice	4.299	4.299	0.053
			0.000				1" Ice	5.565	5.565	0.083
ANT790F2	B	From Face	3.000	0.000	0.000	143.000	No Ice	0.691	0.691	0.008
			3.000				1/2" Ice	0.889	0.889	0.015
			0.000				1" Ice	1.097	1.097	0.024
(2) PD1142-2AN	A	From Face	3.000	0.000	0.000	143.000	No Ice	3.200	3.200	0.010
			-3.000				1/2" Ice	4.825	4.825	0.035
			0.000				1" Ice	6.467	6.467	0.069

tnxTower Centek Engineering Inc. 63-2 North Branford Rd. Branford, CT 06405 Phone: (203) 488-0580 FAX: (203) 488-8587	Job	18058.33 - CTFF481B	Page	6 of 29
	Project	130-ft Valmont Monopole - 158 Edison Road Trumbull, CT	Date	09:57:04 06/11/18
	Client	T-Mobile	Designed by	TJL

Description	Face or Leg	Offset Type	Offsets:		Azimuth Adjustment	Placement	C _{AA} Front	C _{AA} Side	Weight
			Horz Lateral	Vert					
PD1142-2AN	B	From Face	3.000	0.000	143.000	No Ice	3.200	3.200	0.010
			-3.000			1/2" Ice	4.825	4.825	0.035
			0.000			1" Ice	6.467	6.467	0.069
PD1142-2AN	C	From Face	3.000	0.000	143.000	No Ice	3.200	3.200	0.010
			3.000			1/2" Ice	4.825	4.825	0.035
			0.000			1" Ice	6.467	6.467	0.069
872-70	C	From Face	3.000	0.000	143.000	No Ice	3.150	3.150	0.024
			-3.000			1/2" Ice	4.233	4.233	0.047
			0.000			1" Ice	5.333	5.333	0.077
DS1F06F36U-D	B	From Face	3.000	0.000	143.000	No Ice	6.575	6.575	0.060
			0.000			1/2" Ice	8.800	8.800	0.107
			0.000			1" Ice	11.042	11.042	0.168
872-70	B	From Face	3.000	0.000	143.000	No Ice	3.150	3.150	0.024
			-3.000			1/2" Ice	4.233	4.233	0.047
			0.000			1" Ice	5.333	5.333	0.077
12-ft T-arm w/ Work Support Platform	A	From Face	1.750	0.000	130.000	No Ice	14.200	14.200	0.486
			0.000			1/2" Ice	19.700	19.700	0.575
			0.000			1" Ice	25.200	25.200	0.664
12-ft T-arm w/ Work Support Platform	B	From Face	1.750	0.000	130.000	No Ice	14.200	14.200	0.486
			0.000			1/2" Ice	19.700	19.700	0.575
			0.000			1" Ice	25.200	25.200	0.664
12-ft T-arm w/ Work Support Platform	C	From Face	1.750	0.000	130.000	No Ice	14.200	14.200	0.486
			0.000			1/2" Ice	19.700	19.700	0.575
			0.000			1" Ice	25.200	25.200	0.664
(4) 2" Std. x 12'-6" pipe	A	From Face	3.000	0.000	130.000	No Ice	2.969	2.969	0.040
			0.000			1/2" Ice	4.247	4.247	0.062
			6.000			1" Ice	5.542	5.542	0.093
(4) 2" Std. x 12'-6" pipe	B	From Face	3.000	0.000	130.000	No Ice	2.969	2.969	0.040
			0.000			1/2" Ice	4.247	4.247	0.062
			6.000			1" Ice	5.542	5.542	0.093
(4) 2" Std. x 12'-6" pipe	C	From Face	3.000	0.000	130.000	No Ice	2.969	2.969	0.040
			0.000			1/2" Ice	4.247	4.247	0.062
			6.000			1" Ice	5.542	5.542	0.093

Dishes

Description	Face or Leg	Dish Type	Offset Type	Offsets:		Azimuth Adjustment	3 dB Beam Width	Elevation	Outside Diameter	Aperture Area	Weight			
				Horz Lateral	Vert							ft	ft	ft ²
2-ft dish		Paraboloid w/o Radome	None		Worst			127.000	2.000	3.140	0.050			
												1/2" Ice	3.410	0.080
												1" Ice	3.680	0.100

Tower Pressures - No Ice

$$G_H = 1.100$$

tnxTower Centek Engineering Inc. 63-2 North Branford Rd. Branford, CT 06405 Phone: (203) 488-0580 FAX: (203) 488-8587	Job 18058.33 - CTFF481B	Page 7 of 29
	Project 130-ft Valmont Monopole - 158 Edison Road Trumbull, CT	Date 09:57:04 06/11/18
	Client T-Mobile	Designed by TJL

Section Elevation ft	z ft	K _Z	q _z ksf	A _G ft ²	F a c e ft ²	A _F ft ²	A _R ft ²	A _{leg} ft ²	Leg %	C _{AA} In Face ft ²	C _{AA} Out Face ft ²
L1 130.000-80.167	103.935	1.276	0.034	148.080	A	0.000	148.080	148.080	100.00	0.000	0.000
					B	0.000	148.080		100.00	0.000	0.000
					C	0.000	148.080		100.00	0.000	0.000
L2 80.167-39.029	59.213	1.133	0.030	159.225	A	0.000	159.225	159.225	100.00	0.000	0.000
					B	0.000	159.225		100.00	0.000	0.000
					C	0.000	159.225		100.00	0.000	0.000
L3 39.029-1.000	20.135	0.903	0.024	176.311	A	0.000	176.311	176.311	100.00	0.000	0.000
					B	0.000	176.311		100.00	0.000	0.000
					C	0.000	176.311		100.00	0.000	0.000

Tower Pressure - With Ice

$$G_H = 1.100$$

Section Elevation ft	z ft	K _Z	q _z ksf	t _z in	A _G ft ²	F a c e ft ²	A _F ft ²	A _R ft ²	A _{leg} ft ²	Leg %	C _{AA} In Face ft ²	C _{AA} Out Face ft ²
L1 130.000-80.167	103.935	1.276	0.008	2.103	165.546	A	0.000	165.546	165.546	100.00	0.000	0.000
						B	0.000	165.546		100.00	0.000	0.000
						C	0.000	165.546		100.00	0.000	0.000
L2 80.167-39.029	59.213	1.133	0.007	1.988	173.644	A	0.000	173.644	173.644	100.00	0.000	0.000
						B	0.000	173.644		100.00	0.000	0.000
						C	0.000	173.644		100.00	0.000	0.000
L3 39.029-1.000	20.135	0.903	0.006	1.785	188.910	A	0.000	188.910	188.910	100.00	0.000	0.000
						B	0.000	188.910		100.00	0.000	0.000
						C	0.000	188.910		100.00	0.000	0.000

Tower Pressure - Service

$$G_H = 1.100$$

Section Elevation ft	z ft	K _Z	q _z ksf	A _G ft ²	F a c e ft ²	A _F ft ²	A _R ft ²	A _{leg} ft ²	Leg %	C _{AA} In Face ft ²	C _{AA} Out Face ft ²
L1 130.000-80.167	103.935	1.276	0.010	148.080	A	0.000	148.080	148.080	100.00	0.000	0.000
					B	0.000	148.080		100.00	0.000	0.000
					C	0.000	148.080		100.00	0.000	0.000
L2 80.167-39.029	59.213	1.133	0.009	159.225	A	0.000	159.225	159.225	100.00	0.000	0.000
					B	0.000	159.225		100.00	0.000	0.000
					C	0.000	159.225		100.00	0.000	0.000
L3 39.029-1.000	20.135	0.903	0.007	176.311	A	0.000	176.311	176.311	100.00	0.000	0.000
					B	0.000	176.311		100.00	0.000	0.000
					C	0.000	176.311		100.00	0.000	0.000

Tower Forces - No Ice - Wind Normal To Face

tnxTower Centek Engineering Inc. 63-2 North Branford Rd. Branford, CT 06405 Phone: (203) 488-0580 FAX: (203) 488-8587	Job 18058.33 - CTFF481B	Page 8 of 29
	Project 130-ft Valmont Monopole - 158 Edison Road Trumbull, CT	Date 09:57:04 06/11/18
	Client T-Mobile	Designed by TJL

Section Elevation ft	Add Weight K	Self Weight K	F a c e	e	C _F	q _z ksf	D _F	D _R	A _E ft ²	F K	w klf	Ctrl. Face
L1 130.000-80.167	0.805	5.854	A	1	0.65	0.034	1	1	148.080	3.549	0.071	C
			B	1	0.65		1	1	148.080			
			C	1	0.65		1	1	148.080			
L2 80.167-39.029	0.814	8.493	A	1	0.65	0.030	1	1	159.225	3.382	0.082	C
			B	1	0.65		1	1	159.225			
			C	1	0.65		1	1	159.225			
L3 39.029-1.000	0.752	11.373	A	1	0.65	0.024	1	1	176.311	3.023	0.079	C
			B	1	0.65		1	1	176.311			
			C	1	0.65		1	1	176.311			
Sum Weight:	2.371	25.721						OTM	620.018 kip-ft	9.954		

Tower Forces - No Ice - Wind 45 To Face

Section Elevation ft	Add Weight K	Self Weight K	F a c e	e	C _F	q _z ksf	D _F	D _R	A _E ft ²	F K	w klf	Ctrl. Face
L1 130.000-80.167	0.805	5.854	A	1	0.65	0.034	1	1	148.080	3.549	0.071	C
			B	1	0.65		1	1	148.080			
			C	1	0.65		1	1	148.080			
L2 80.167-39.029	0.814	8.493	A	1	0.65	0.030	1	1	159.225	3.382	0.082	C
			B	1	0.65		1	1	159.225			
			C	1	0.65		1	1	159.225			
L3 39.029-1.000	0.752	11.373	A	1	0.65	0.024	1	1	176.311	3.023	0.079	C
			B	1	0.65		1	1	176.311			
			C	1	0.65		1	1	176.311			
Sum Weight:	2.371	25.721						OTM	620.018 kip-ft	9.954		

Tower Forces - No Ice - Wind 60 To Face

Section Elevation ft	Add Weight K	Self Weight K	F a c e	e	C _F	q _z ksf	D _F	D _R	A _E ft ²	F K	w klf	Ctrl. Face
L1 130.000-80.167	0.805	5.854	A	1	0.65	0.034	1	1	148.080	3.549	0.071	C
			B	1	0.65		1	1	148.080			
			C	1	0.65		1	1	148.080			
L2 80.167-39.029	0.814	8.493	A	1	0.65	0.030	1	1	159.225	3.382	0.082	C
			B	1	0.65		1	1	159.225			
			C	1	0.65		1	1	159.225			
L3 39.029-1.000	0.752	11.373	A	1	0.65	0.024	1	1	176.311	3.023	0.079	C
			B	1	0.65		1	1	176.311			
			C	1	0.65		1	1	176.311			
Sum Weight:	2.371	25.721						OTM	620.018 kip-ft	9.954		

tnxTower Centek Engineering Inc. 63-2 North Branford Rd. Branford, CT 06405 Phone: (203) 488-0580 FAX: (203) 488-8587	Job 18058.33 - CTF481B	Page 9 of 29
	Project 130-ft Valmont Monopole - 158 Edison Road Trumbull, CT	Date 09:57:04 06/11/18
	Client T-Mobile	Designed by TJL

Tower Forces - No Ice - Wind 90 To Face

Section Elevation ft	Add Weight K	Self Weight K	F a c e	e	C _F	q _z ksf	D _F	D _R	A _E ft ²	F K	w klf	Ctrl. Face
L1 130.000-80.167	0.805	5.854	A	1	0.65	0.034	1	1	148.080	3.549	0.071	C
7			B	1	0.65		1	1	148.080			
			C	1	0.65		1	1	148.080			
L2 80.167-39.029	0.814	8.493	A	1	0.65	0.030	1	1	159.225	3.382	0.082	C
			B	1	0.65		1	1	159.225			
			C	1	0.65		1	1	159.225			
L3 39.029-1.000	0.752	11.373	A	1	0.65	0.024	1	1	176.311	3.023	0.079	C
			B	1	0.65		1	1	176.311			
			C	1	0.65		1	1	176.311			
Sum Weight:	2.371	25.721						OTM	620.018 kip-ft	9.954		

Tower Forces - With Ice - Wind Normal To Face

Section Elevation ft	Add Weight K	Self Weight K	F a c e	e	C _F	q _z ksf	D _F	D _R	A _E ft ²	F K	w klf	Ctrl. Face
L1 130.000-80.167	0.805	10.668	A	1	1.2	0.008	1	1	165.546	1.692	0.034	C
7			B	1	1.2		1	1	165.546			
			C	1	1.2		1	1	165.546			
L2 80.167-39.029	0.814	13.311	A	1	1.2	0.007	1	1	173.644	1.573	0.038	C
			B	1	1.2		1	1	173.644			
			C	1	1.2		1	1	173.644			
L3 39.029-1.000	0.752	16.113	A	1	1.2	0.006	1	1	188.910	1.382	0.036	C
			B	1	1.2		1	1	188.910			
			C	1	1.2		1	1	188.910			
Sum Weight:	2.371	40.092						OTM	292.212 kip-ft	4.647		

Tower Forces - With Ice - Wind 45 To Face

Section Elevation ft	Add Weight K	Self Weight K	F a c e	e	C _F	q _z ksf	D _F	D _R	A _E ft ²	F K	w klf	Ctrl. Face
L1 130.000-80.167	0.805	10.668	A	1	1.2	0.008	1	1	165.546	1.692	0.034	C
7			B	1	1.2		1	1	165.546			
			C	1	1.2		1	1	165.546			
L2 80.167-39.029	0.814	13.311	A	1	1.2	0.007	1	1	173.644	1.573	0.038	C
			B	1	1.2		1	1	173.644			
			C	1	1.2		1	1	173.644			

tnxTower Centek Engineering Inc. 63-2 North Branford Rd. Branford, CT 06405 Phone: (203) 488-0580 FAX: (203) 488-8587	Job	18058.33 - CTFF481B	Page	10 of 29
	Project	130-ft Valmont Monopole - 158 Edison Road Trumbull, CT	Date	09:57:04 06/11/18
	Client	T-Mobile	Designed by	TJL

Section Elevation ft	Add Weight K	Self Weight K	F a c e	e	C _F	q _z ksf	D _F	D _R	A _E ft ²	F K	w klf	Ctrl. Face
L3 39.029-1.000	0.752	16.113	A	1	1.2	0.006	1	1	188.910	1.382	0.036	C
			B	1	1.2		1	1	188.910			
			C	1	1.2		1	1	188.910			
Sum Weight:	2.371	40.092						OTM	292.212 kip-ft	4.647		

Tower Forces - With Ice - Wind 60 To Face

Section Elevation ft	Add Weight K	Self Weight K	F a c e	e	C _F	q _z ksf	D _F	D _R	A _E ft ²	F K	w klf	Ctrl. Face
L1 130.000-80.167	0.805	10.668	A	1	1.2	0.008	1	1	165.546	1.692	0.034	C
			B	1	1.2		1	1	165.546			
			C	1	1.2		1	1	165.546			
L2 80.167-39.029	0.814	13.311	A	1	1.2	0.007	1	1	173.644	1.573	0.038	C
			B	1	1.2		1	1	173.644			
			C	1	1.2		1	1	173.644			
L3 39.029-1.000	0.752	16.113	A	1	1.2	0.006	1	1	188.910	1.382	0.036	C
			B	1	1.2		1	1	188.910			
			C	1	1.2		1	1	188.910			
Sum Weight:	2.371	40.092						OTM	292.212 kip-ft	4.647		

Tower Forces - With Ice - Wind 90 To Face

Section Elevation ft	Add Weight K	Self Weight K	F a c e	e	C _F	q _z ksf	D _F	D _R	A _E ft ²	F K	w klf	Ctrl. Face
L1 130.000-80.167	0.805	10.668	A	1	1.2	0.008	1	1	165.546	1.692	0.034	C
			B	1	1.2		1	1	165.546			
			C	1	1.2		1	1	165.546			
L2 80.167-39.029	0.814	13.311	A	1	1.2	0.007	1	1	173.644	1.573	0.038	C
			B	1	1.2		1	1	173.644			
			C	1	1.2		1	1	173.644			
L3 39.029-1.000	0.752	16.113	A	1	1.2	0.006	1	1	188.910	1.382	0.036	C
			B	1	1.2		1	1	188.910			
			C	1	1.2		1	1	188.910			
Sum Weight:	2.371	40.092						OTM	292.212 kip-ft	4.647		

Tower Forces - Service - Wind Normal To Face

tnxTower Centek Engineering Inc. 63-2 North Branford Rd. Branford, CT 06405 Phone: (203) 488-0580 FAX: (203) 488-8587	Job 18058.33 - CTFF481B	Page 11 of 29
	Project 130-ft Valmont Monopole - 158 Edison Road Trumbull, CT	Date 09:57:04 06/11/18
	Client T-Mobile	Designed by TJJ

Section Elevation ft	Add Weight K	Self Weight K	F a c e	e	C _F	q _z ksf	D _F	D _R	A _E ft ²	F K	w klf	Ctrl. Face
L1 130.000-80.167	0.805	5.854	A	1	0.65	0.010	1	1	148.080	1.056	0.021	C
			B	1	0.65		1	1	148.080			
			C	1	0.65		1	1	148.080			
L2 80.167-39.029	0.814	8.493	A	1	0.65	0.009	1	1	159.225	1.007	0.024	C
			B	1	0.65		1	1	159.225			
			C	1	0.65		1	1	159.225			
L3 39.029-1.000	0.752	11.373	A	1	0.65	0.007	1	1	176.311	0.900	0.024	C
			B	1	0.65		1	1	176.311			
			C	1	0.65		1	1	176.311			
Sum Weight:	2.371	25.721						OTM	184.570 kip-ft	2.963		

Tower Forces - Service - Wind 45 To Face

Section Elevation ft	Add Weight K	Self Weight K	F a c e	e	C _F	q _z ksf	D _F	D _R	A _E ft ²	F K	w klf	Ctrl. Face
L1 130.000-80.167	0.805	5.854	A	1	0.65	0.010	1	1	148.080	1.056	0.021	C
			B	1	0.65		1	1	148.080			
			C	1	0.65		1	1	148.080			
L2 80.167-39.029	0.814	8.493	A	1	0.65	0.009	1	1	159.225	1.007	0.024	C
			B	1	0.65		1	1	159.225			
			C	1	0.65		1	1	159.225			
L3 39.029-1.000	0.752	11.373	A	1	0.65	0.007	1	1	176.311	0.900	0.024	C
			B	1	0.65		1	1	176.311			
			C	1	0.65		1	1	176.311			
Sum Weight:	2.371	25.721						OTM	184.570 kip-ft	2.963		

Tower Forces - Service - Wind 60 To Face

Section Elevation ft	Add Weight K	Self Weight K	F a c e	e	C _F	q _z ksf	D _F	D _R	A _E ft ²	F K	w klf	Ctrl. Face
L1 130.000-80.167	0.805	5.854	A	1	0.65	0.010	1	1	148.080	1.056	0.021	C
			B	1	0.65		1	1	148.080			
			C	1	0.65		1	1	148.080			
L2 80.167-39.029	0.814	8.493	A	1	0.65	0.009	1	1	159.225	1.007	0.024	C
			B	1	0.65		1	1	159.225			
			C	1	0.65		1	1	159.225			
L3 39.029-1.000	0.752	11.373	A	1	0.65	0.007	1	1	176.311	0.900	0.024	C
			B	1	0.65		1	1	176.311			
			C	1	0.65		1	1	176.311			
Sum Weight:	2.371	25.721						OTM	184.570 kip-ft	2.963		

tnxTower Centek Engineering Inc. 63-2 North Branford Rd. Branford, CT 06405 Phone: (203) 488-0580 FAX: (203) 488-8587	Job 18058.33 - CTFF481B	Page 12 of 29
	Project 130-ft Valmont Monopole - 158 Edison Road Trumbull, CT	Date 09:57:04 06/11/18
	Client T-Mobile	Designed by TJL

Tower Forces - Service - Wind 90 To Face

Section Elevation ft	Add Weight K	Self Weight K	F a c e	e	C _F	q _z ksf	D _F	D _R	A _E ft ²	F K	w klf	Ctrl. Face
L1 130.000-80.167	0.805	5.854	A	1	0.65	0.010	1	1	148.080	1.056	0.021	C
7			B	1	0.65		1	1	148.080			
L2 80.167-39.029	0.814	8.493	C	1	0.65	0.009	1	1	148.080	1.007	0.024	C
A			A	1	0.65		1	1	159.225			
B			B	1	0.65		1	1	159.225			
C			C	1	0.65		1	1	159.225			
L3 39.029-1.000	0.752	11.373	A	1	0.65	0.007	1	1	176.311	0.900	0.024	C
B			B	1	0.65		1	1	176.311			
C			C	1	0.65		1	1	176.311			
Sum Weight:	2.371	25.721						OTM	184.570 kip-ft	2.963		

Force Totals

Load Case	Vertical Forces K	Sum of Forces X K	Sum of Forces Z K	Sum of Overturning Moments, M _x kip-ft	Sum of Overturning Moments, M _z kip-ft	Sum of Torques kip-ft
Leg Weight	25.721					
Bracing Weight	0.000					
Total Member Self-Weight	25.721					
Total Weight	34.510					
Wind 0 deg - No Ice		0.000	-20.732	-1932.081	-0.143	-0.199
Wind 30 deg - No Ice		10.382	-17.955	-1673.292	-967.647	-1.061
Wind 45 deg - No Ice		14.682	-14.660	-1366.322	-1368.400	-1.397
Wind 60 deg - No Ice		17.982	-10.366	-966.270	-1675.908	-1.638
Wind 90 deg - No Ice		20.764	0.000	-0.459	-1935.150	-1.777
Wind 120 deg - No Ice		17.982	10.366	965.351	-1675.908	-1.440
Wind 135 deg - No Ice		14.682	14.660	1365.403	-1368.400	-1.116
Wind 150 deg - No Ice		10.382	17.955	1672.374	-967.647	-0.717
Wind 180 deg - No Ice		0.000	20.732	1931.162	-0.143	0.199
Wind 210 deg - No Ice		-10.382	17.955	1672.374	967.360	1.061
Wind 225 deg - No Ice		-14.682	14.660	1365.403	1368.113	1.397
Wind 240 deg - No Ice		-17.982	10.366	965.351	1675.622	1.638
Wind 270 deg - No Ice		-20.764	0.000	-0.459	1934.864	1.777
Wind 300 deg - No Ice		-17.982	-10.366	-966.270	1675.622	1.440
Wind 315 deg - No Ice		-14.682	-14.660	-1366.322	1368.113	1.116
Wind 330 deg - No Ice		-10.382	-17.955	-1673.292	967.360	0.717
Member Ice	14.371					
Total Weight Ice	62.514					
Wind 0 deg - Ice		0.000	-9.703	-923.792	0.451	-0.416
Wind 30 deg - Ice		4.855	-8.403	-800.411	-460.452	-0.874
Wind 45 deg - Ice		6.867	-6.861	-654.059	-651.364	-1.020
Wind 60 deg - Ice		8.410	-4.851	-463.329	-797.856	-1.097
Wind 90 deg - Ice		9.711	0.000	-2.865	-921.354	-1.026
Wind 120 deg - Ice		8.410	4.851	457.598	-797.856	-0.681
Wind 135 deg - Ice		6.867	6.861	648.329	-651.364	-0.431
Wind 150 deg - Ice		4.855	8.403	794.681	-460.452	-0.152

tnxTower Centek Engineering Inc. 63-2 North Branford Rd. Branford, CT 06405 Phone: (203) 488-0580 FAX: (203) 488-8587	Job 18058.33 - CTFF481B	Page 13 of 29
	Project 130-ft Valmont Monopole - 158 Edison Road Trumbull, CT	Date 09:57:04 06/11/18
	Client T-Mobile	Designed by TJL

Load Case	Vertical Forces K	Sum of Forces X K	Sum of Forces Z K	Sum of Overturning Moments, M_x kip-ft	Sum of Overturning Moments, M_z kip-ft	Sum of Torques kip-ft
Wind 180 deg - Ice		0.000	9.703	918.062	0.451	0.416
Wind 210 deg - Ice		-4.855	8.403	794.681	461.353	0.874
Wind 225 deg - Ice		-6.867	6.861	648.329	652.265	1.020
Wind 240 deg - Ice		-8.410	4.851	457.598	798.757	1.097
Wind 270 deg - Ice		-9.711	0.000	-2.865	922.256	1.026
Wind 300 deg - Ice		-8.410	-4.851	-463.329	798.757	0.681
Wind 315 deg - Ice		-6.867	-6.861	-654.059	652.265	0.431
Wind 330 deg - Ice		-4.855	-8.403	-800.411	461.353	0.152
Total Weight	34.510			-0.459	-0.143	
Wind 0 deg - Service		0.000	-6.172	-575.473	-0.143	-0.059
Wind 30 deg - Service		3.090	-5.345	-498.436	-288.154	-0.316
Wind 45 deg - Service		4.371	-4.364	-407.056	-407.452	-0.416
Wind 60 deg - Service		5.353	-3.086	-287.966	-498.993	-0.488
Wind 90 deg - Service		6.181	0.000	-0.459	-576.165	-0.529
Wind 120 deg - Service		5.353	3.086	287.048	-498.993	-0.429
Wind 135 deg - Service		4.371	4.364	406.137	-407.452	-0.332
Wind 150 deg - Service		3.090	5.345	497.518	-288.154	-0.213
Wind 180 deg - Service		0.000	6.172	574.555	-0.143	0.059
Wind 210 deg - Service		-3.090	5.345	497.518	287.868	0.316
Wind 225 deg - Service		-4.371	4.364	406.137	407.166	0.416
Wind 240 deg - Service		-5.353	3.086	287.048	498.706	0.488
Wind 270 deg - Service		-6.181	0.000	-0.459	575.879	0.529
Wind 300 deg - Service		-5.353	-3.086	-287.966	498.706	0.429
Wind 315 deg - Service		-4.371	-4.364	-407.056	407.166	0.332
Wind 330 deg - Service		-3.090	-5.345	-498.436	287.868	0.213

Load Combinations

Comb. No.	Description
1	Dead Only
2	1.2 Dead+1.6 Wind 0 deg - No Ice
3	0.9 Dead+1.6 Wind 0 deg - No Ice
4	1.2 Dead+1.6 Wind 30 deg - No Ice
5	0.9 Dead+1.6 Wind 30 deg - No Ice
6	1.2 Dead+1.6 Wind 45 deg - No Ice
7	0.9 Dead+1.6 Wind 45 deg - No Ice
8	1.2 Dead+1.6 Wind 60 deg - No Ice
9	0.9 Dead+1.6 Wind 60 deg - No Ice
10	1.2 Dead+1.6 Wind 90 deg - No Ice
11	0.9 Dead+1.6 Wind 90 deg - No Ice
12	1.2 Dead+1.6 Wind 120 deg - No Ice
13	0.9 Dead+1.6 Wind 120 deg - No Ice
14	1.2 Dead+1.6 Wind 135 deg - No Ice
15	0.9 Dead+1.6 Wind 135 deg - No Ice
16	1.2 Dead+1.6 Wind 150 deg - No Ice
17	0.9 Dead+1.6 Wind 150 deg - No Ice
18	1.2 Dead+1.6 Wind 180 deg - No Ice
19	0.9 Dead+1.6 Wind 180 deg - No Ice
20	1.2 Dead+1.6 Wind 210 deg - No Ice
21	0.9 Dead+1.6 Wind 210 deg - No Ice
22	1.2 Dead+1.6 Wind 225 deg - No Ice
23	0.9 Dead+1.6 Wind 225 deg - No Ice
24	1.2 Dead+1.6 Wind 240 deg - No Ice
25	0.9 Dead+1.6 Wind 240 deg - No Ice
26	1.2 Dead+1.6 Wind 270 deg - No Ice

tnxTower Centek Engineering Inc. 63-2 North Branford Rd. Branford, CT 06405 Phone: (203) 488-0580 FAX: (203) 488-8587	Job 18058.33 - CTFF481B	Page 14 of 29
	Project 130-ft Valmont Monopole - 158 Edison Road Trumbull, CT	Date 09:57:04 06/11/18
	Client T-Mobile	Designed by TJL

Comb. No.	Description
27	0.9 Dead+1.6 Wind 270 deg - No Ice
28	1.2 Dead+1.6 Wind 300 deg - No Ice
29	0.9 Dead+1.6 Wind 300 deg - No Ice
30	1.2 Dead+1.6 Wind 315 deg - No Ice
31	0.9 Dead+1.6 Wind 315 deg - No Ice
32	1.2 Dead+1.6 Wind 330 deg - No Ice
33	0.9 Dead+1.6 Wind 330 deg - No Ice
34	1.2 Dead+1.0 Ice+1.0 Temp
35	1.2 Dead+1.0 Wind 0 deg+1.0 Ice+1.0 Temp
36	1.2 Dead+1.0 Wind 30 deg+1.0 Ice+1.0 Temp
37	1.2 Dead+1.0 Wind 45 deg+1.0 Ice+1.0 Temp
38	1.2 Dead+1.0 Wind 60 deg+1.0 Ice+1.0 Temp
39	1.2 Dead+1.0 Wind 90 deg+1.0 Ice+1.0 Temp
40	1.2 Dead+1.0 Wind 120 deg+1.0 Ice+1.0 Temp
41	1.2 Dead+1.0 Wind 135 deg+1.0 Ice+1.0 Temp
42	1.2 Dead+1.0 Wind 150 deg+1.0 Ice+1.0 Temp
43	1.2 Dead+1.0 Wind 180 deg+1.0 Ice+1.0 Temp
44	1.2 Dead+1.0 Wind 210 deg+1.0 Ice+1.0 Temp
45	1.2 Dead+1.0 Wind 225 deg+1.0 Ice+1.0 Temp
46	1.2 Dead+1.0 Wind 240 deg+1.0 Ice+1.0 Temp
47	1.2 Dead+1.0 Wind 270 deg+1.0 Ice+1.0 Temp
48	1.2 Dead+1.0 Wind 300 deg+1.0 Ice+1.0 Temp
49	1.2 Dead+1.0 Wind 315 deg+1.0 Ice+1.0 Temp
50	1.2 Dead+1.0 Wind 330 deg+1.0 Ice+1.0 Temp
51	Dead+Wind 0 deg - Service
52	Dead+Wind 30 deg - Service
53	Dead+Wind 45 deg - Service
54	Dead+Wind 60 deg - Service
55	Dead+Wind 90 deg - Service
56	Dead+Wind 120 deg - Service
57	Dead+Wind 135 deg - Service
58	Dead+Wind 150 deg - Service
59	Dead+Wind 180 deg - Service
60	Dead+Wind 210 deg - Service
61	Dead+Wind 225 deg - Service
62	Dead+Wind 240 deg - Service
63	Dead+Wind 270 deg - Service
64	Dead+Wind 300 deg - Service
65	Dead+Wind 315 deg - Service
66	Dead+Wind 330 deg - Service

Maximum Member Forces

Section No.	Elevation ft	Component Type	Condition	Gov. Load Comb.	Axial K	Major Axis Moment kip-ft	Minor Axis Moment kip-ft
L1	130 - 80.167	Pole	Max Tension	1	0.000	0.000	0.000
			Max. Compression	34	-32.512	0.432	3.028
			Max. Mx	10	-13.793	-754.925	0.515
			Max. My	2	-13.796	-0.179	754.130
			Max. Vy	10	22.756	-754.925	0.515
			Max. Vx	2	-22.705	-0.179	754.130
			Max. Torque	10			2.865
			Max Tension	1	0.000	0.000	0.000
L2	80.167 - 39.029	Pole	Max. Compression	34	-48.147	0.432	3.028
			Max. Mx	10	-24.487	-1768.281	0.558
			Max. My	2	-24.489	-0.177	1765.447
			Max. Vy	10	27.898	-1768.281	0.558

tnxTower Centek Engineering Inc. 63-2 North Branford Rd. Branford, CT 06405 Phone: (203) 488-0580 FAX: (203) 488-8587	Job 18058.33 - CTFF481B	Page 15 of 29
	Project 130-ft Valmont Monopole - 158 Edison Road Trumbull, CT	Date 09:57:04 06/11/18
	Client T-Mobile	Designed by TJL

Section No.	Elevation ft	Component Type	Condition	Gov. Load Comb.	Axial K	Major Axis Moment kip-ft	Minor Axis Moment kip-ft
L3	39.029 - 1	Pole	Max. Vx	2	-27.847	-0.177	1765.447
			Max. Torque	26			-2.863
			Max Tension	1	0.000	0.000	0.000
			Max. Compression	34	-70.967	0.432	3.028
			Max. Mx	10	-41.397	-3148.552	0.564
			Max. My	2	-41.398	-0.178	3143.438
			Max. Vy	10	33.240	-3148.552	0.564
			Max. Vx	2	-33.189	-0.178	3143.438
			Max. Torque	26			-2.861

Maximum Reactions

Location	Condition	Gov. Load Comb.	Vertical K	Horizontal, X K	Horizontal, Z K
Pole	Max. Vert	35	70.967	0.000	9.703
	Max. H _x	26	41.412	33.222	0.000
	Max. H _z	2	41.412	0.000	33.171
	Max. M _x	2	3143.438	0.000	33.171
	Max. M _z	10	3148.552	-33.222	0.000
	Max. Torsion	10	2.860	-33.222	0.000
	Min. Vert	23	31.059	23.491	-23.456
	Min. H _x	10	41.412	-33.222	0.000
	Min. H _z	18	41.412	0.000	-33.171
	Min. M _x	18	-3142.302	0.000	-33.171
	Min. M _z	26	-3148.198	33.222	0.000
	Min. Torsion	26	-2.860	33.222	0.000

Tower Mast Reaction Summary

Load Combination	Vertical K	Shear _x K	Shear _z K	Overturning Moment, M _x kip-ft	Overturning Moment, M _z kip-ft	Torque kip-ft
Dead Only	34.510	0.000	0.000	-0.459	-0.143	0.000
1.2 Dead+1.6 Wind 0 deg - No Ice	41.412	0.000	-33.171	-3143.438	-0.178	-0.309
0.9 Dead+1.6 Wind 0 deg - No Ice	31.059	0.000	-33.171	-3129.739	-0.132	-0.311
1.2 Dead+1.6 Wind 30 deg - No Ice	41.412	16.611	-28.727	-2722.371	-1574.369	-1.699
0.9 Dead+1.6 Wind 30 deg - No Ice	31.059	16.611	-28.727	-2710.488	-1567.534	-1.697
1.2 Dead+1.6 Wind 45 deg - No Ice	41.412	23.491	-23.456	-2222.909	-2226.418	-2.242
0.9 Dead+1.6 Wind 45 deg - No Ice	31.059	23.491	-23.456	-2213.180	-2216.772	-2.239
1.2 Dead+1.6 Wind 60 deg - No Ice	41.412	28.771	-16.586	-1571.998	-2726.753	-2.632
0.9 Dead+1.6 Wind 60 deg - No Ice	31.059	28.771	-16.586	-1565.076	-2714.948	-2.628
1.2 Dead+1.6 Wind 90 deg - No Ice	41.412	33.222	-0.000	-0.563	-3148.552	-2.860
0.9 Dead+1.6 Wind 90 deg - No Ice	31.059	33.222	-0.000	-0.419	-3134.929	-2.854

<p style="text-align: center;">tnxTower</p> <p style="text-align: center;">Centek Engineering Inc. 63-2 North Branford Rd. Branford, CT 06405 Phone: (203) 488-0580 FAX: (203) 488-8587</p>	<p style="text-align: center;">Job</p> <p style="text-align: center;">18058.33 - CTFF481B</p>	<p style="text-align: center;">Page</p> <p style="text-align: center;">16 of 29</p>
	<p style="text-align: center;">Project</p> <p style="text-align: center;">130-ft Valmont Monopole - 158 Edison Road Trumbull, CT</p>	<p style="text-align: center;">Date</p> <p style="text-align: center;">09:57:04 06/11/18</p>
	<p style="text-align: center;">Client</p> <p style="text-align: center;">T-Mobile</p>	<p style="text-align: center;">Designed by</p> <p style="text-align: center;">TJL</p>

Load Combination	Vertical K	Shear _x K	Shear _z K	Overturning Moment, M _x kip-ft	Overturning Moment, M _z kip-ft	Torque kip-ft
Ice						
1.2 Dead+1.6 Wind 120 deg - No Ice	41.412	28.771	16.586	1570.869	-2726.749	-2.321
0.9 Dead+1.6 Wind 120 deg - No Ice	31.059	28.771	16.586	1564.236	-2714.945	-2.314
1.2 Dead+1.6 Wind 135 deg - No Ice	41.412	23.491	23.456	2221.777	-2226.414	-1.802
0.9 Dead+1.6 Wind 135 deg - No Ice	31.059	23.491	23.456	2212.338	-2216.768	-1.796
1.2 Dead+1.6 Wind 150 deg - No Ice	41.412	16.611	28.727	2721.237	-1574.365	-1.161
0.9 Dead+1.6 Wind 150 deg - No Ice	31.059	16.611	28.727	2709.645	-1567.531	-1.156
1.2 Dead+1.6 Wind 180 deg - No Ice	41.412	0.000	33.171	3142.302	-0.178	0.309
0.9 Dead+1.6 Wind 180 deg - No Ice	31.059	0.000	33.171	3128.894	-0.132	0.311
1.2 Dead+1.6 Wind 210 deg - No Ice	41.412	-16.611	28.727	2721.238	1574.009	1.696
0.9 Dead+1.6 Wind 210 deg - No Ice	31.059	-16.611	28.727	2709.645	1567.267	1.695
1.2 Dead+1.6 Wind 225 deg - No Ice	41.412	-23.491	23.456	2221.778	2226.059	2.239
0.9 Dead+1.6 Wind 225 deg - No Ice	31.059	-23.491	23.456	2212.339	2216.504	2.236
1.2 Dead+1.6 Wind 240 deg - No Ice	41.412	-28.771	16.586	1570.869	2726.394	2.630
0.9 Dead+1.6 Wind 240 deg - No Ice	31.059	-28.771	16.586	1564.237	2714.682	2.625
1.2 Dead+1.6 Wind 270 deg - No Ice	41.412	-33.222	-0.000	-0.563	3148.198	2.860
0.9 Dead+1.6 Wind 270 deg - No Ice	31.059	-33.222	-0.000	-0.419	3134.666	2.854
1.2 Dead+1.6 Wind 300 deg - No Ice	41.412	-28.771	-16.586	-1571.998	2726.398	2.324
0.9 Dead+1.6 Wind 300 deg - No Ice	31.059	-28.771	-16.586	-1565.077	2714.685	2.317
1.2 Dead+1.6 Wind 315 deg - No Ice	41.412	-23.491	-23.456	-2222.909	2226.063	1.805
0.9 Dead+1.6 Wind 315 deg - No Ice	31.059	-23.491	-23.456	-2213.181	2216.507	1.800
1.2 Dead+1.6 Wind 330 deg - No Ice	41.412	-16.611	-28.727	-2722.372	1574.013	1.164
0.9 Dead+1.6 Wind 330 deg - No Ice	31.059	-16.611	-28.727	-2710.489	1567.269	1.159
1.2 Dead+1.0 Ice+1.0 Temp	70.967	0.000	-0.000	-3.028	0.432	-0.000
1.2 Dead+1.0 Wind 0 deg+1.0 Ice+1.0 Temp	70.967	-0.000	-9.703	-958.831	0.452	-0.422
1.2 Dead+1.0 Wind 30 deg+1.0 Ice+1.0 Temp	70.967	4.855	-8.403	-830.796	-477.835	-0.899
1.2 Dead+1.0 Wind 45 deg+1.0 Ice+1.0 Temp	70.967	6.867	-6.861	-678.923	-675.948	-1.053
1.2 Dead+1.0 Wind 60 deg+1.0 Ice+1.0 Temp	70.967	8.410	-4.851	-480.999	-827.965	-1.135
1.2 Dead+1.0 Wind 90 deg+1.0 Ice+1.0 Temp	70.967	9.711	-0.000	-3.167	-956.121	-1.067
1.2 Dead+1.0 Wind 120 deg+1.0 Ice+1.0 Temp	70.967	8.410	4.851	474.663	-827.964	-0.713
1.2 Dead+1.0 Wind 135 deg+1.0 Ice+1.0 Temp	70.967	6.867	6.861	672.587	-675.947	-0.456
1.2 Dead+1.0 Wind 150	70.967	4.855	8.403	824.459	-477.834	-0.168

tnxTower Centek Engineering Inc. 63-2 North Branford Rd. Branford, CT 06405 Phone: (203) 488-0580 FAX: (203) 488-8587	Job 18058.33 - CTFF481B	Page 17 of 29
	Project 130-ft Valmont Monopole - 158 Edison Road Trumbull, CT	Date 09:57:04 06/11/18
	Client T-Mobile	Designed by TJL

Load Combination	Vertical K	Shear _x K	Shear _z K	Overturning Moment, M _x kip-ft	Overturning Moment, M _z kip-ft	Torque kip-ft
deg+1.0 Ice+1.0 Temp						
1.2 Dead+1.0 Wind 180	70.967	-0.000	9.703	952.494	0.452	0.422
deg+1.0 Ice+1.0 Temp						
1.2 Dead+1.0 Wind 210	70.967	-4.855	8.403	824.460	478.738	0.899
deg+1.0 Ice+1.0 Temp						
1.2 Dead+1.0 Wind 225	70.967	-6.867	6.861	672.588	676.851	1.053
deg+1.0 Ice+1.0 Temp						
1.2 Dead+1.0 Wind 240	70.967	-8.410	4.851	474.664	828.868	1.135
deg+1.0 Ice+1.0 Temp						
1.2 Dead+1.0 Wind 270	70.967	-9.711	-0.000	-3.167	957.025	1.067
deg+1.0 Ice+1.0 Temp						
1.2 Dead+1.0 Wind 300	70.967	-8.410	-4.851	-480.999	828.869	0.713
deg+1.0 Ice+1.0 Temp						
1.2 Dead+1.0 Wind 315	70.967	-6.867	-6.861	-678.923	676.852	0.456
deg+1.0 Ice+1.0 Temp						
1.2 Dead+1.0 Wind 330	70.967	-4.855	-8.403	-830.796	478.739	0.168
deg+1.0 Ice+1.0 Temp						
Dead+ Wind 0 deg - Service	34.510	0.000	-6.172	-583.732	-0.147	-0.058
Dead+ Wind 30 deg - Service	34.510	3.090	-5.345	-505.590	-292.288	-0.317
Dead+ Wind 45 deg - Service	34.510	4.371	-4.364	-412.899	-413.297	-0.418
Dead+ Wind 60 deg - Service	34.510	5.353	-3.086	-292.102	-506.151	-0.490
Dead+ Wind 90 deg - Service	34.510	6.181	0.000	-0.471	-584.430	-0.533
Dead+ Wind 120 deg - Service	34.510	5.353	3.086	291.159	-506.151	-0.432
Dead+ Wind 135 deg - Service	34.510	4.371	4.364	411.956	-413.297	-0.336
Dead+ Wind 150 deg - Service	34.510	3.090	5.345	504.647	-292.288	-0.216
Dead+ Wind 180 deg - Service	34.510	0.000	6.172	582.789	-0.147	0.058
Dead+ Wind 210 deg - Service	34.510	-3.090	5.345	504.647	291.994	0.316
Dead+ Wind 225 deg - Service	34.510	-4.371	4.364	411.956	413.003	0.418
Dead+ Wind 240 deg - Service	34.510	-5.353	3.086	291.159	505.857	0.490
Dead+ Wind 270 deg - Service	34.510	-6.181	0.000	-0.471	584.136	0.533
Dead+ Wind 300 deg - Service	34.510	-5.353	-3.086	-292.102	505.857	0.433
Dead+ Wind 315 deg - Service	34.510	-4.371	-4.364	-412.899	413.003	0.336
Dead+ Wind 330 deg - Service	34.510	-3.090	-5.345	-505.590	291.994	0.216

Solution Summary

Load Comb.	Sum of Applied Forces			Sum of Reactions			% Error
	PX K	PY K	PZ K	PX K	PY K	PZ K	
1	0.000	-34.510	0.000	0.000	34.510	0.000	0.000%
2	0.000	-41.412	-33.171	0.000	41.412	33.171	0.000%
3	0.000	-31.059	-33.171	0.000	31.059	33.171	0.000%
4	16.611	-41.412	-28.727	-16.611	41.412	28.727	0.000%
5	16.611	-31.059	-28.727	-16.611	31.059	28.727	0.000%
6	23.491	-41.412	-23.456	-23.491	41.412	23.456	0.000%
7	23.491	-31.059	-23.456	-23.491	31.059	23.456	0.000%
8	28.771	-41.412	-16.586	-28.771	41.412	16.586	0.000%
9	28.771	-31.059	-16.586	-28.771	31.059	16.586	0.000%
10	33.222	-41.412	0.000	-33.222	41.412	0.000	0.000%
11	33.222	-31.059	0.000	-33.222	31.059	0.000	0.000%
12	28.771	-41.412	16.586	-28.771	41.412	-16.586	0.000%
13	28.771	-31.059	16.586	-28.771	31.059	-16.586	0.000%
14	23.491	-41.412	23.456	-23.491	41.412	-23.456	0.000%
15	23.491	-31.059	23.456	-23.491	31.059	-23.456	0.000%
16	16.611	-41.412	28.727	-16.611	41.412	-28.727	0.000%
17	16.611	-31.059	28.727	-16.611	31.059	-28.727	0.000%
18	0.000	-41.412	33.171	0.000	41.412	-33.171	0.000%
19	0.000	-31.059	33.171	0.000	31.059	-33.171	0.000%

tnxTower Centek Engineering Inc. 63-2 North Branford Rd. Branford, CT 06405 Phone: (203) 488-0580 FAX: (203) 488-8587	Job	18058.33 - CTFF481B	Page	18 of 29	
	Project	130-ft Valmont Monopole - 158 Edison Road Trumbull, CT		Date	09:57:04 06/11/18
	Client	T-Mobile		Designed by	TJL

Load Comb.	Sum of Applied Forces			Sum of Reactions			% Error
	PX K	PY K	PZ K	PX K	PY K	PZ K	
20	-16.611	-41.412	28.727	16.611	41.412	-28.727	0.000%
21	-16.611	-31.059	28.727	16.611	31.059	-28.727	0.000%
22	-23.491	-41.412	23.456	23.491	41.412	-23.456	0.000%
23	-23.491	-31.059	23.456	23.491	31.059	-23.456	0.000%
24	-28.771	-41.412	16.586	28.771	41.412	-16.586	0.000%
25	-28.771	-31.059	16.586	28.771	31.059	-16.586	0.000%
26	-33.222	-41.412	0.000	33.222	41.412	0.000	0.000%
27	-33.222	-31.059	0.000	33.222	31.059	0.000	0.000%
28	-28.771	-41.412	-16.586	28.771	41.412	16.586	0.000%
29	-28.771	-31.059	-16.586	28.771	31.059	16.586	0.000%
30	-23.491	-41.412	-23.456	23.491	41.412	23.456	0.000%
31	-23.491	-31.059	-23.456	23.491	31.059	23.456	0.000%
32	-16.611	-41.412	-28.727	16.611	41.412	28.727	0.000%
33	-16.611	-31.059	-28.727	16.611	31.059	28.727	0.000%
34	0.000	-70.967	0.000	0.000	70.967	0.000	0.000%
35	0.000	-70.967	-9.703	0.000	70.967	9.703	0.000%
36	4.855	-70.967	-8.403	-4.855	70.967	8.403	0.000%
37	6.867	-70.967	-6.861	-6.867	70.967	6.861	0.000%
38	8.410	-70.967	-4.851	-8.410	70.967	4.851	0.000%
39	9.711	-70.967	0.000	-9.711	70.967	0.000	0.000%
40	8.410	-70.967	4.851	-8.410	70.967	-4.851	0.000%
41	6.867	-70.967	6.861	-6.867	70.967	-6.861	0.000%
42	4.855	-70.967	8.403	-4.855	70.967	-8.403	0.000%
43	0.000	-70.967	9.703	0.000	70.967	-9.703	0.000%
44	-4.855	-70.967	8.403	4.855	70.967	-8.403	0.000%
45	-6.867	-70.967	6.861	6.867	70.967	-6.861	0.000%
46	-8.410	-70.967	4.851	8.410	70.967	-4.851	0.000%
47	-9.711	-70.967	0.000	9.711	70.967	0.000	0.000%
48	-8.410	-70.967	-4.851	8.410	70.967	4.851	0.000%
49	-6.867	-70.967	-6.861	6.867	70.967	6.861	0.000%
50	-4.855	-70.967	-8.403	4.855	70.967	8.403	0.000%
51	0.000	-34.510	-6.172	0.000	34.510	6.172	0.000%
52	3.090	-34.510	-5.345	-3.090	34.510	5.345	0.000%
53	4.371	-34.510	-4.364	-4.371	34.510	4.364	0.000%
54	5.353	-34.510	-3.086	-5.353	34.510	3.086	0.000%
55	6.181	-34.510	0.000	-6.181	34.510	0.000	0.000%
56	5.353	-34.510	3.086	-5.353	34.510	-3.086	0.000%
57	4.371	-34.510	4.364	-4.371	34.510	-4.364	0.000%
58	3.090	-34.510	5.345	-3.090	34.510	-5.345	0.000%
59	0.000	-34.510	6.172	0.000	34.510	-6.172	0.000%
60	-3.090	-34.510	5.345	3.090	34.510	-5.345	0.000%
61	-4.371	-34.510	4.364	4.371	34.510	-4.364	0.000%
62	-5.353	-34.510	3.086	5.353	34.510	-3.086	0.000%
63	-6.181	-34.510	0.000	6.181	34.510	0.000	0.000%
64	-5.353	-34.510	-3.086	5.353	34.510	3.086	0.000%
65	-4.371	-34.510	-4.364	4.371	34.510	4.364	0.000%
66	-3.090	-34.510	-5.345	3.090	34.510	5.345	0.000%

Non-Linear Convergence Results

Load Combination	Converged?	Number of Cycles	Displacement Tolerance	Force Tolerance
1	Yes	4	0.00000001	0.00000001
2	Yes	4	0.00000001	0.00002497
3	Yes	4	0.00000001	0.00001332
4	Yes	4	0.00000001	0.00074269

<i>tnxTower</i> Centek Engineering Inc. 63-2 North Branford Rd. Branford, CT 06405 Phone: (203) 488-0580 FAX: (203) 488-8587	Job	18058.33 - CTFF481B	Page	19 of 29	
	Project	130-ft Valmont Monopole - 158 Edison Road Trumbull, CT		Date	09:57:04 06/11/18
	Client	T-Mobile		Designed by	TJL

5	Yes	4	0.00000001	0.00045029
6	Yes	4	0.00000001	0.00089515
7	Yes	4	0.00000001	0.00054177
8	Yes	4	0.00000001	0.00084586
9	Yes	4	0.00000001	0.00051563
10	Yes	4	0.00000001	0.00013194
11	Yes	4	0.00000001	0.00008160
12	Yes	4	0.00000001	0.00073022
13	Yes	4	0.00000001	0.00044270
14	Yes	4	0.00000001	0.00089105
15	Yes	4	0.00000001	0.00053935
16	Yes	4	0.00000001	0.00080467
17	Yes	4	0.00000001	0.00048969
18	Yes	4	0.00000001	0.00002495
19	Yes	4	0.00000001	0.00001331
20	Yes	4	0.00000001	0.00081818
21	Yes	4	0.00000001	0.00049842
22	Yes	4	0.00000001	0.00089297
23	Yes	4	0.00000001	0.00054073
24	Yes	4	0.00000001	0.00072468
25	Yes	4	0.00000001	0.00043928
26	Yes	4	0.00000001	0.00013191
27	Yes	4	0.00000001	0.00008159
28	Yes	4	0.00000001	0.00083675
29	Yes	4	0.00000001	0.00050987
30	Yes	4	0.00000001	0.00089229
31	Yes	4	0.00000001	0.00053996
32	Yes	4	0.00000001	0.00075267
33	Yes	4	0.00000001	0.00045669
34	Yes	4	0.00000001	0.00000001
35	Yes	4	0.00000001	0.00073339
36	Yes	4	0.00000001	0.00079530
37	Yes	4	0.00000001	0.00081824
38	Yes	4	0.00000001	0.00080098
39	Yes	4	0.00000001	0.00073022
40	Yes	4	0.00000001	0.00078658
41	Yes	4	0.00000001	0.00080729
42	Yes	4	0.00000001	0.00078701
43	Yes	4	0.00000001	0.00072338
44	Yes	4	0.00000001	0.00079148
45	Yes	4	0.00000001	0.00081011
46	Yes	4	0.00000001	0.00078814
47	Yes	4	0.00000001	0.00073167
48	Yes	4	0.00000001	0.00079992
49	Yes	4	0.00000001	0.00081813
50	Yes	4	0.00000001	0.00079720
51	Yes	4	0.00000001	0.00000001
52	Yes	4	0.00000001	0.00000872
53	Yes	4	0.00000001	0.00001133
54	Yes	4	0.00000001	0.00001203
55	Yes	4	0.00000001	0.00000689
56	Yes	4	0.00000001	0.00000878
57	Yes	4	0.00000001	0.00001095
58	Yes	4	0.00000001	0.00001019
59	Yes	4	0.00000001	0.00000001
60	Yes	4	0.00000001	0.00001077
61	Yes	4	0.00000001	0.00001124
62	Yes	4	0.00000001	0.00000889
63	Yes	4	0.00000001	0.00000689
64	Yes	4	0.00000001	0.00001159
65	Yes	4	0.00000001	0.00001100
66	Yes	4	0.00000001	0.00000874

tnxTower Centek Engineering Inc. 63-2 North Branford Rd. Branford, CT 06405 Phone: (203) 488-0580 FAX: (203) 488-8587	Job 18058.33 - CTFF481B	Page 20 of 29
	Project 130-ft Valmont Monopole - 158 Edison Road Trumbull, CT	Date 09:57:04 06/11/18
	Client T-Mobile	Designed by TJL

Maximum Tower Deflections - Service Wind

Section No.	Elevation ft	Horz. Deflection in	Gov. Load Comb.	Tilt °	Twist °
L1	130 - 80.167	7.882	54	0.523	0.003
L2	86 - 39.029	3.517	54	0.389	0.001
L3	46 - 1	0.989	55	0.198	0.000

Critical Deflections and Radius of Curvature - Service Wind

Elevation ft	Appurtenance	Gov. Load Comb.	Deflection in	Tilt °	Twist °	Radius of Curvature ft
143.000	(2) DB809KE-XT	54	7.882	0.523	0.003	106088
130.000	12-ft T-arm w/ Work Support Platform	54	7.882	0.523	0.003	106088
127.000	2-ft dish	54	7.562	0.516	0.002	106088
120.000	AIR21 B4A/B2P	54	6.821	0.498	0.002	53044
109.000	(3) SBNHH-1D65B	54	5.680	0.467	0.002	25259

Maximum Tower Deflections - Design Wind

Section No.	Elevation ft	Horz. Deflection in	Gov. Load Comb.	Tilt °	Twist °
L1	130 - 80.167	42.445	10	2.814	0.014
L2	86 - 39.029	18.949	10	2.098	0.005
L3	46 - 1	5.327	10	1.067	0.002

Critical Deflections and Radius of Curvature - Design Wind

Elevation ft	Appurtenance	Gov. Load Comb.	Deflection in	Tilt °	Twist °	Radius of Curvature ft
143.000	(2) DB809KE-XT	10	42.445	2.814	0.014	19836
130.000	12-ft T-arm w/ Work Support Platform	10	42.445	2.814	0.014	19836
127.000	2-ft dish	10	40.726	2.774	0.013	19836
120.000	AIR21 B4A/B2P	10	36.734	2.677	0.012	9917
109.000	(3) SBNHH-1D65B	10	30.596	2.517	0.009	4721

Compression Checks

tnxTower Centek Engineering Inc. 63-2 North Branford Rd. Branford, CT 06405 Phone: (203) 488-0580 FAX: (203) 488-8587	Job 18058.33 - CTFF481B	Page 21 of 29
	Project 130-ft Valmont Monopole - 158 Edison Road Trumbull, CT	Date 09:57:04 06/11/18
	Client T-Mobile	Designed by TJL

Pole Design Data

Section No.	Elevation ft	Size	L ft	L _u ft	Kl/r	A in ²	P _u K	φP _n K	Ratio $\frac{P_u}{\phi P_n}$
L1	130 - 127.684	TP41.283x28.95x0.313	49.833	0.000	0.0	28.973	-2.580	2152.570	0.001
	127.684 - 125.368					29.542	-2.935	2194.810	0.001
	125.368 - 123.053					30.110	-3.252	2237.040	0.001
	123.053 - 120.737					30.679	-3.575	2279.270	0.002
	120.737 - 118.421					31.247	-6.329	2317.150	0.003
	118.421 - 116.105					31.816	-6.666	2348.440	0.003
	116.105 - 113.789					32.384	-7.008	2379.330	0.003
	113.789 - 111.474					32.953	-7.357	2409.840	0.003
	111.474 - 109.158					33.521	-7.712	2439.960	0.003
	109.158 - 106.842					34.090	-10.201	2469.690	0.004
	106.842 - 104.526					34.658	-10.572	2499.030	0.004
	104.526 - 102.211					35.227	-10.950	2527.990	0.004
	102.211 - 99.8947					35.795	-11.336	2556.550	0.004
	99.8947 - 97.5789					36.363	-11.728	2584.730	0.005
	97.5789 - 95.2632					36.932	-12.128	2612.520	0.005
	95.2632 - 92.9474					37.500	-12.534	2639.920	0.005
	L2					92.9474 - 90.6316	TP50.825x39.214x0.375	46.971	0.000
90.6316 - 88.3158		38.637	-13.366	2693.550	0.005				
88.3158 - 86 - 80.167		39.206	-13.793	2719.790	0.005				
86 - 80.167		40.638	-7.354	2784.140	0.003				
80.167 - 78.2688		47.945	-8.623	3496.360	0.002				
78.2688 - 76.3707		48.503	-16.415	3525.780	0.005				
76.3707 - 74.4725		49.062	-16.850	3554.940	0.005				
74.4725 - 72.5743		49.620	-17.291	3583.840	0.005				
72.5743 - 70.6762		50.179	-17.736	3612.480	0.005				
70.6762 - 68.778		50.737	-18.186	3640.860	0.005				
68.778 - 66.8798		51.296	-18.642	3668.980	0.005				
66.8798 - 64.9817	51.854	-19.102	3696.830	0.005					
64.9817 - 63.0835	52.412	-19.567	3724.430	0.005					
	52.971	-20.037	3751.770	0.005					

tnxTower Centek Engineering Inc. 63-2 North Branford Rd. Branford, CT 06405 Phone: (203) 488-0580 FAX: (203) 488-8587	Job 18058.33 - CTFF481B	Page 22 of 29
	Project 130-ft Valmont Monopole - 158 Edison Road Trumbull, CT	Date 09:57:04 06/11/18
	Client T-Mobile	Designed by TJL

Section No.	Elevation ft	Size	L ft	L _u ft	Kl/r	A in ²	P _u K	φP _n K	Ratio $\frac{P_u}{\phi P_n}$
	63.0835 - 61.1853					53.529	-20.512	3778.840	0.005
	61.1853 - 59.2872					54.088	-20.992	3805.660	0.006
	59.2872 - 57.389					54.646	-21.477	3832.220	0.006
	57.389 - 55.4908					55.205	-21.966	3858.510	0.006
	55.4908 - 53.5927					55.763	-22.461	3884.550	0.006
	53.5927 - 51.6945					56.322	-22.960	3910.320	0.006
	51.6945 - 49.7963					56.880	-23.464	3935.840	0.006
	49.7963 - 47.8982					57.439	-23.973	3961.090	0.006
	47.8982 - 46 - 39.029					57.997	-24.487	3986.090	0.006
L3	46 - 39.029	TP59.5x48.352x0.438	45.000	0.000	0.0	60.048	-13.207	4075.640	0.003
	39.029 - 37.0275					68.933	-15.072	4949.250	0.003
	37.0275 - 35.0259					69.622	-28.926	4983.990	0.006
	35.0259 - 33.0244					70.310	-29.568	5018.430	0.006
	33.0244 - 31.0229					70.999	-30.215	5052.590	0.006
	31.0229 - 29.0214					71.687	-30.869	5086.450	0.006
	29.0214 - 27.0198					72.376	-31.529	5120.030	0.006
	27.0198 - 25.0183					73.064	-32.195	5153.310	0.006
	25.0183 - 23.0168					73.753	-32.867	5186.300	0.006
	23.0168 - 21.0153					74.442	-33.545	5219.000	0.006
	21.0153 - 19.0137					75.130	-34.229	5251.410	0.007
	19.0137 - 17.0122					75.819	-34.919	5283.530	0.007
	17.0122 - 15.0107					76.507	-35.615	5315.360	0.007
	15.0107 - 13.0092					77.196	-36.317	5346.890	0.007
	13.0092 - 11.0076					77.884	-37.025	5378.140	0.007
	11.0076 - 9.00611					78.573	-37.739	5409.100	0.007
	9.00611 - 7.00458					79.261	-38.459	5439.760	0.007
	7.00458 - 5.00305					79.950	-39.185	5470.130	0.007
	5.00305 - 3.00153					80.639	-39.916	5500.220	0.007
	3.00153 - 1					81.327	-40.654	5530.010	0.007
						82.016	-41.398	5559.510	0.007

tnxTower Centek Engineering Inc. 63-2 North Branford Rd. Branford, CT 06405 Phone: (203) 488-0580 FAX: (203) 488-8587	Job 18058.33 - CTFF481B	Page 23 of 29
	Project 130-ft Valmont Monopole - 158 Edison Road Trumbull, CT	Date 09:57:04 06/11/18
	Client T-Mobile	Designed by TJL

Pole Bending Design Data

Section No.	Elevation ft	Size	M_{ux}	ϕM_{ux}	Ratio	M_{uy}	ϕM_{uy}	Ratio
			kip-ft	kip-ft	$\frac{M_{ux}}{\phi M_{ux}}$	kip-ft	kip-ft	$\frac{M_{uy}}{\phi M_{uy}}$
L1	130 - 127.684	TP41.283x28.95x0.313	55.607	1289.342	0.043	0.000	1289.342	0.000
	127.684 - 125.368		71.757	1340.708	0.054	0.000	1340.708	0.000
	125.368 - 123.053		88.707	1393.075	0.064	0.000	1393.075	0.000
	123.053 - 120.737		106.239	1446.450	0.073	0.000	1446.450	0.000
	120.737 - 118.421		132.997	1498.008	0.089	0.000	1498.008	0.000
	118.421 - 116.105		164.380	1546.125	0.106	0.000	1546.125	0.000
	116.105 - 113.789		196.368	1594.725	0.123	0.000	1594.725	0.000
	113.789 - 111.474		228.966	1643.792	0.139	0.000	1643.792	0.000
	111.474 - 109.158		262.181	1693.317	0.155	0.000	1693.317	0.000
	109.158 - 106.842		307.795	1743.283	0.177	0.000	1743.283	0.000
	106.842 - 104.526		354.851	1793.675	0.198	0.000	1793.675	0.000
	104.526 - 102.211		402.562	1844.483	0.218	0.000	1844.483	0.000
	102.211 - 99.8947		450.938	1895.692	0.238	0.000	1895.692	0.000
	99.8947 - 97.5789		499.958	1947.283	0.257	0.000	1947.283	0.000
	97.5789 - 95.2632		549.626	1999.250	0.275	0.000	1999.250	0.000
	95.2632 - 92.9474		599.947	2051.567	0.292	0.000	2051.567	0.000
	92.9474 - 90.6316		650.928	2104.233	0.309	0.000	2104.233	0.000
	90.6316 - 88.3158		702.582	2157.233	0.326	0.000	2157.233	0.000
	88.3158 - 86		754.925	2210.550	0.342	0.000	2210.550	0.000
	86 - 80.167		416.154	2346.150	0.177	0.000	2346.150	0.000
L2	86 - 80.167	TP50.825x39.214x0.375	473.798	2891.925	0.164	0.000	2891.925	0.000
	80.167 - 78.2688		934.883	2950.542	0.317	0.000	2950.542	0.000
	78.2688 - 76.3707		980.258	3009.508	0.326	0.000	3009.508	0.000
	76.3707 - 74.4725		1026.092	3068.825	0.334	0.000	3068.825	0.000
	74.4725 - 72.5743		1072.375	3128.475	0.343	0.000	3128.475	0.000
	72.5743 - 70.6762		1119.108	3188.450	0.351	0.000	3188.450	0.000
	70.6762 - 68.778		1166.300	3248.750	0.359	0.000	3248.750	0.000
	68.778 - 66.8798		1213.942	3309.367	0.367	0.000	3309.367	0.000
	66.8798 - 64.9817		1262.042	3370.283	0.374	0.000	3370.283	0.000
	64.9817 - 63.0835		1310.600	3431.500	0.382	0.000	3431.500	0.000
	63.0835 -		1359.608	3493.008	0.389	0.000	3493.008	0.000

tnxTower Centek Engineering Inc. 63-2 North Branford Rd. Branford, CT 06405 Phone: (203) 488-0580 FAX: (203) 488-8587	Job	18058.33 - CTFF481B	Page	24 of 29
	Project	130-ft Valmont Monopole - 158 Edison Road Trumbull, CT	Date	09:57:04 06/11/18
	Client	T-Mobile	Designed by	TJL

Section No.	Elevation ft	Size	M_{ux} kip-ft	ϕM_{ux} kip-ft	Ratio $\frac{M_{ux}}{\phi M_{ux}}$	M_{uy} kip-ft	ϕM_{uy} kip-ft	Ratio $\frac{M_{uy}}{\phi M_{uy}}$
	61.1853							
	61.1853 - 59.2872		1409.083	3554.800	0.396	0.000	3554.800	0.000
	59.2872 - 57.389		1459.017	3616.867	0.403	0.000	3616.867	0.000
	57.389 - 55.4908		1509.408	3679.208	0.410	0.000	3679.208	0.000
	55.4908 - 53.5927		1560.258	3741.800	0.417	0.000	3741.800	0.000
	53.5927 - 51.6945		1611.567	3804.650	0.424	0.000	3804.650	0.000
	51.6945 - 49.7963		1663.342	3867.750	0.430	0.000	3867.750	0.000
	49.7963 - 47.8982		1715.583	3931.083	0.436	0.000	3931.083	0.000
	47.8982 - 46		1768.283	3994.642	0.443	0.000	3994.642	0.000
	46 - 39.029		931.908	4229.933	0.220	0.000	4229.933	0.000
L3	46 - 39.029	TP59.5x48.352x0.438	1034.192	5047.367	0.205	0.000	5047.367	0.000
	39.029 - 37.0275		2024.133	5134.008	0.394	0.000	5134.008	0.000
	37.0275 - 35.0259		2082.642	5221.058	0.399	0.000	5221.058	0.000
	35.0259 - 33.0244		2141.642	5308.508	0.403	0.000	5308.508	0.000
	33.0244 - 31.0229		2201.108	5396.350	0.408	0.000	5396.350	0.000
	31.0229 - 29.0214		2261.058	5484.583	0.412	0.000	5484.583	0.000
	29.0214 - 27.0198		2321.483	5573.192	0.417	0.000	5573.192	0.000
	27.0198 - 25.0183		2382.375	5662.158	0.421	0.000	5662.158	0.000
	25.0183 - 23.0168		2443.733	5751.491	0.425	0.000	5751.491	0.000
	23.0168 - 21.0153		2505.550	5841.167	0.429	0.000	5841.167	0.000
	21.0153 - 19.0137		2567.833	5931.191	0.433	0.000	5931.191	0.000
	19.0137 - 17.0122		2630.575	6021.541	0.437	0.000	6021.541	0.000
	17.0122 - 15.0107		2693.767	6112.208	0.441	0.000	6112.208	0.000
	15.0107 - 13.0092		2757.408	6203.191	0.445	0.000	6203.191	0.000
	13.0092 - 11.0076		2821.500	6294.483	0.448	0.000	6294.483	0.000
	11.0076 - 9.00611		2886.033	6386.067	0.452	0.000	6386.067	0.000
	9.00611 - 7.00458		2951.008	6477.933	0.456	0.000	6477.933	0.000
	7.00458 - 5.00305		3016.425	6570.075	0.459	0.000	6570.075	0.000
	5.00305 - 3.00153		3082.275	6662.491	0.463	0.000	6662.491	0.000
	3.00153 - 1		3148.550	6755.167	0.466	0.000	6755.167	0.000

Pole Shear Design Data

tnxTower Centek Engineering Inc. 63-2 North Branford Rd. Branford, CT 06405 Phone: (203) 488-0580 FAX: (203) 488-8587	Job	18058.33 - CTFF481B	Page	25 of 29
	Project	130-ft Valmont Monopole - 158 Edison Road Trumbull, CT	Date	09:57:04 06/11/18
	Client	T-Mobile	Designed by	TJL

Section No.	Elevation ft	Size	Actual V_u K	ϕV_n K	Ratio $\frac{V_u}{\phi V_n}$	Actual T_u kip-ft	ϕT_n kip-ft	Ratio $\frac{T_u}{\phi T_n}$		
L1	130 - 127.684	TP41.283x28.95x0.313	6.623	1076.290	0.006	1.611	2581.842	0.001		
	127.684 - 125.368		7.195	1097.400	0.007	1.611	2684.700	0.001		
	125.368 - 123.053		7.445	1118.520	0.007	1.611	2789.567	0.001		
	123.053 - 120.737		7.699	1139.640	0.007	1.611	2896.433	0.001		
	120.737 - 118.421		13.424	1158.580	0.012	1.611	2999.683	0.001		
	118.421 - 116.105		13.684	1174.220	0.012	1.611	3096.033	0.001		
	116.105 - 113.789		13.946	1189.670	0.012	1.611	3193.350	0.001		
	113.789 - 111.474		14.212	1204.920	0.012	1.611	3291.608	0.000		
	111.474 - 109.158		14.480	1219.980	0.012	1.611	3390.783	0.000		
	109.158 - 106.842		20.185	1234.850	0.016	1.702	3490.833	0.000		
	106.842 - 104.526		20.470	1249.520	0.016	2.246	3591.742	0.001		
	104.526 - 102.211		20.757	1263.990	0.016	2.637	3693.483	0.001		
	102.211 - 99.8947		21.034	1278.280	0.016	2.637	3796.017	0.001		
	99.8947 - 97.5789		21.313	1292.360	0.016	2.637	3899.325	0.001		
	97.5789 - 95.2632		21.595	1306.260	0.017	2.636	4003.383	0.001		
	95.2632 - 92.9474		21.878	1319.960	0.017	2.636	4108.158	0.001		
	92.9474 - 90.6316		22.165	1333.460	0.017	2.636	4213.625	0.001		
	90.6316 - 88.3158		22.465	1346.780	0.017	2.864	4319.750	0.001		
	L2		88.3158 - 86	TP50.825x39.214x0.375	22.756	1359.890	0.017	2.863	4426.508	0.001
			86 - 80.167		11.214	1392.070	0.008	1.338	4698.033	0.000
86 - 80.167		12.349	1748.180		0.007	1.525	5790.925	0.000		
80.167 - 78.2688		23.796	1762.890		0.013	2.863	5908.308	0.000		
78.2688 - 76.3707		24.033	1777.470		0.014	2.863	6026.383	0.000		
76.3707 - 74.4725		24.271	1791.920		0.014	2.863	6145.158	0.000		
74.4725 - 72.5743		24.510	1806.240		0.014	2.863	6264.600	0.000		
72.5743 - 70.6762		24.749	1820.430		0.014	2.863	6384.700	0.000		
70.6762 - 68.778		24.989	1834.490		0.014	2.862	6505.450	0.000		
68.778 - 66.8798		25.229	1848.420		0.014	2.862	6626.817	0.000		
66.8798 - 64.9817		25.469	1862.220		0.014	2.862	6748.808	0.000		
64.9817 - 63.0835		25.710	1875.880		0.014	2.862	6871.391	0.000		
63.0835 - 61.1853	25.952	1889.420	0.014	2.862	6994.558	0.000				
61.1853 -	26.194	1902.830	0.014	2.862	7118.300	0.000				

tnxTower Centek Engineering Inc. 63-2 North Branford Rd. Branford, CT 06405 Phone: (203) 488-0580 FAX: (203) 488-8587	Job 18058.33 - CTFF481B	Page 26 of 29
	Project 130-ft Valmont Monopole - 158 Edison Road Trumbull, CT	Date 09:57:04 06/11/18
	Client T-Mobile	Designed by TJL

Section No.	Elevation ft	Size	Actual V_u K	ϕV_n K	Ratio $\frac{V_u}{\phi V_n}$	Actual T_u kip-ft	ϕT_n kip-ft	Ratio $\frac{T_u}{\phi T_n}$
	59.2872							
	59.2872 - 57.389		26.436	1916.110	0.014	2.862	7242.583	0.000
	57.389 - 55.4908		26.679	1929.260	0.014	2.861	7367.408	0.000
	55.4908 - 53.5927		26.922	1942.270	0.014	2.861	7492.758	0.000
	53.5927 - 51.6945		27.165	1955.160	0.014	2.861	7618.608	0.000
	51.6945 - 49.7963		27.409	1967.920	0.014	2.861	7744.950	0.000
	49.7963 - 47.8982		27.654	1980.550	0.014	2.861	7871.775	0.000
	47.8982 - 46		27.898	1993.040	0.014	2.861	7999.058	0.000
L3	46 - 39.029	TP59.5x48.352x0.438	13.945	2037.820	0.007	1.355	8470.250	0.000
	46 - 39.029		14.949	2474.630	0.006	1.505	10107.083	0.000
	39.029 - 37.0275		29.126	2491.990	0.012	2.861	10280.583	0.000
	37.0275 - 35.0259		29.368	2509.220	0.012	2.860	10454.917	0.000
	35.0259 - 33.0244		29.608	2526.290	0.012	2.860	10630.000	0.000
	33.0244 - 31.0229		29.847	2543.230	0.012	2.860	10805.917	0.000
	31.0229 - 29.0214		30.084	2560.010	0.012	2.860	10982.583	0.000
	29.0214 - 27.0198		30.320	2576.650	0.012	2.860	11160.000	0.000
	27.0198 - 25.0183		30.554	2593.150	0.012	2.860	11338.167	0.000
	25.0183 - 23.0168		30.787	2609.500	0.012	2.860	11517.083	0.000
	23.0168 - 21.0153		31.018	2625.700	0.012	2.860	11696.667	0.000
	21.0153 - 19.0137		31.247	2641.760	0.012	2.860	11876.916	0.000
	19.0137 - 17.0122		31.475	2657.680	0.012	2.860	12057.833	0.000
	17.0122 - 15.0107		31.701	2673.450	0.012	2.860	12239.333	0.000
	15.0107 - 13.0092		31.926	2689.070	0.012	2.860	12421.583	0.000
	13.0092 - 11.0076		32.149	2704.550	0.012	2.860	12604.333	0.000
	11.0076 - 9.00611		32.370	2719.880	0.012	2.860	12787.749	0.000
	9.00611 - 7.00458		32.590	2735.070	0.012	2.860	12971.667	0.000
	7.00458 - 5.00305		32.808	2750.110	0.012	2.860	13156.249	0.000
	5.00305 - 3.00153		33.025	2765.010	0.012	2.860	13341.249	0.000
	3.00153 - 1		33.240	2779.760	0.012	2.860	13526.833	0.000

Pole Interaction Design Data

tnxTower Centek Engineering Inc. 63-2 North Branford Rd. Branford, CT 06405 Phone: (203) 488-0580 FAX: (203) 488-8587	Job	18058.33 - CTFF481B	Page	27 of 29
	Project	130-ft Valmont Monopole - 158 Edison Road Trumbull, CT	Date	09:57:04 06/11/18
	Client	T-Mobile	Designed by	TJL

Section No.	Elevation ft	Ratio	Ratio	Ratio	Ratio	Ratio	Comb. Stress Ratio	Allow. Stress Ratio	Criteria
		P_u	M_{ux}	M_{uy}	V_u	T_u			
		ϕP_n	ϕM_{nx}	ϕM_{ny}	ϕV_n	ϕT_n			
L1	130 - 127.684	0.001	0.043	0.000	0.006	0.001	0.044	1.000	4.8.2 ✓
	127.684 - 125.368	0.001	0.054	0.000	0.007	0.001	0.055	1.000	4.8.2 ✓
	125.368 - 123.053	0.001	0.064	0.000	0.007	0.001	0.065	1.000	4.8.2 ✓
	123.053 - 120.737	0.002	0.073	0.000	0.007	0.001	0.075	1.000	4.8.2 ✓
	120.737 - 118.421	0.003	0.089	0.000	0.012	0.001	0.092	1.000	4.8.2 ✓
	118.421 - 116.105	0.003	0.106	0.000	0.012	0.001	0.109	1.000	4.8.2 ✓
	116.105 - 113.789	0.003	0.123	0.000	0.012	0.001	0.126	1.000	4.8.2 ✓
	113.789 - 111.474	0.003	0.139	0.000	0.012	0.000	0.142	1.000	4.8.2 ✓
	111.474 - 109.158	0.003	0.155	0.000	0.012	0.000	0.158	1.000	4.8.2 ✓
	109.158 - 106.842	0.004	0.177	0.000	0.016	0.000	0.181	1.000	4.8.2 ✓
	106.842 - 104.526	0.004	0.198	0.000	0.016	0.001	0.202	1.000	4.8.2 ✓
	104.526 - 102.211	0.004	0.218	0.000	0.016	0.001	0.223	1.000	4.8.2 ✓
	102.211 - 99.8947	0.004	0.238	0.000	0.016	0.001	0.243	1.000	4.8.2 ✓
	99.8947 - 97.5789	0.005	0.257	0.000	0.016	0.001	0.262	1.000	4.8.2 ✓
	97.5789 - 95.2632	0.005	0.275	0.000	0.017	0.001	0.280	1.000	4.8.2 ✓
	95.2632 - 92.9474	0.005	0.292	0.000	0.017	0.001	0.297	1.000	4.8.2 ✓
	92.9474 - 90.6316	0.005	0.309	0.000	0.017	0.001	0.314	1.000	4.8.2 ✓
	90.6316 - 88.3158	0.005	0.326	0.000	0.017	0.001	0.331	1.000	4.8.2 ✓
	88.3158 - 86	0.005	0.342	0.000	0.017	0.001	0.347	1.000	4.8.2 ✓
	86 - 80.167	0.003	0.177	0.000	0.008	0.000	0.180	1.000	4.8.2 ✓
L2	86 - 80.167	0.002	0.164	0.000	0.007	0.000	0.166	1.000	4.8.2 ✓
	80.167 - 78.2688	0.005	0.317	0.000	0.013	0.000	0.322	1.000	4.8.2 ✓
	78.2688 - 76.3707	0.005	0.326	0.000	0.014	0.000	0.331	1.000	4.8.2 ✓
	76.3707 - 74.4725	0.005	0.334	0.000	0.014	0.000	0.339	1.000	4.8.2 ✓
	74.4725 - 72.5743	0.005	0.343	0.000	0.014	0.000	0.348	1.000	4.8.2 ✓
	72.5743 - 70.6762	0.005	0.351	0.000	0.014	0.000	0.356	1.000	4.8.2 ✓

tnxTower Centek Engineering Inc. 63-2 North Branford Rd. Branford, CT 06405 Phone: (203) 488-0580 FAX: (203) 488-8587	Job 18058.33 - CTFF481B	Page 28 of 29
	Project 130-ft Valmont Monopole - 158 Edison Road Trumbull, CT	Date 09:57:04 06/11/18
	Client T-Mobile	Designed by TJL

Section No.	Elevation ft	Ratio	Ratio	Ratio	Ratio	Ratio	Comb. Stress Ratio	Allow. Stress Ratio	Criteria
		P_u ϕP_n	M_{ux} ϕM_{nx}	M_{uy} ϕM_{ny}	V_u ϕV_n	T_u ϕT_n			
	70.6762 - 68.778	0.005	0.359	0.000	0.014	0.000	0.364	1.000	4.8.2 ✓
	68.778 - 66.8798	0.005	0.367	0.000	0.014	0.000	0.372	1.000	4.8.2 ✓
	66.8798 - 64.9817	0.005	0.374	0.000	0.014	0.000	0.380	1.000	4.8.2 ✓
	64.9817 - 63.0835	0.005	0.382	0.000	0.014	0.000	0.387	1.000	4.8.2 ✓
	63.0835 - 61.1853	0.005	0.389	0.000	0.014	0.000	0.395	1.000	4.8.2 ✓
	61.1853 - 59.2872	0.006	0.396	0.000	0.014	0.000	0.402	1.000	4.8.2 ✓
	59.2872 - 57.389	0.006	0.403	0.000	0.014	0.000	0.409	1.000	4.8.2 ✓
	57.389 - 55.4908	0.006	0.410	0.000	0.014	0.000	0.416	1.000	4.8.2 ✓
	55.4908 - 53.5927	0.006	0.417	0.000	0.014	0.000	0.423	1.000	4.8.2 ✓
	53.5927 - 51.6945	0.006	0.424	0.000	0.014	0.000	0.430	1.000	4.8.2 ✓
	51.6945 - 49.7963	0.006	0.430	0.000	0.014	0.000	0.436	1.000	4.8.2 ✓
	49.7963 - 47.8982	0.006	0.436	0.000	0.014	0.000	0.443	1.000	4.8.2 ✓
	47.8982 - 46	0.006	0.443	0.000	0.014	0.000	0.449	1.000	4.8.2 ✓
	46 - 39.029	0.003	0.220	0.000	0.007	0.000	0.224	1.000	4.8.2 ✓
L3	46 - 39.029	0.003	0.205	0.000	0.006	0.000	0.208	1.000	4.8.2 ✓
	39.029 - 37.0275	0.006	0.394	0.000	0.012	0.000	0.400	1.000	4.8.2 ✓
	37.0275 - 35.0259	0.006	0.399	0.000	0.012	0.000	0.405	1.000	4.8.2 ✓
	35.0259 - 33.0244	0.006	0.403	0.000	0.012	0.000	0.410	1.000	4.8.2 ✓
	33.0244 - 31.0229	0.006	0.408	0.000	0.012	0.000	0.414	1.000	4.8.2 ✓
	31.0229 - 29.0214	0.006	0.412	0.000	0.012	0.000	0.419	1.000	4.8.2 ✓
	29.0214 - 27.0198	0.006	0.417	0.000	0.012	0.000	0.423	1.000	4.8.2 ✓
	27.0198 - 25.0183	0.006	0.421	0.000	0.012	0.000	0.427	1.000	4.8.2 ✓
	25.0183 - 23.0168	0.006	0.425	0.000	0.012	0.000	0.431	1.000	4.8.2 ✓
	23.0168 - 21.0153	0.007	0.429	0.000	0.012	0.000	0.436	1.000	4.8.2 ✓
	21.0153 - 19.0137	0.007	0.433	0.000	0.012	0.000	0.440	1.000	4.8.2 ✓
	19.0137 -	0.007	0.437	0.000	0.012	0.000	0.444	1.000	4.8.2 ✓

tnxTower Centek Engineering Inc. 63-2 North Branford Rd. Branford, CT 06405 Phone: (203) 488-0580 FAX: (203) 488-8587	Job 18058.33 - CTFF481B	Page 29 of 29
	Project 130-ft Valmont Monopole - 158 Edison Road Trumbull, CT	Date 09:57:04 06/11/18
	Client T-Mobile	Designed by TJL

Section No.	Elevation ft	Ratio P_u	Ratio M_{ux}	Ratio M_{uy}	Ratio V_u	Ratio T_u	Comb. Stress Ratio	Allow. Stress Ratio	Criteria
		ϕP_n	ϕM_{nx}	ϕM_{ny}	ϕV_n	ϕT_n			
	17.0122						✓		
	17.0122 - 15.0107	0.007	0.441	0.000	0.012	0.000	0.448	1.000	4.8.2 ✓
	15.0107 - 13.0092	0.007	0.445	0.000	0.012	0.000	0.452	1.000	4.8.2 ✓
	13.0092 - 11.0076	0.007	0.448	0.000	0.012	0.000	0.455	1.000	4.8.2 ✓
	11.0076 - 9.00611	0.007	0.452	0.000	0.012	0.000	0.459	1.000	4.8.2 ✓
	9.00611 - 7.00458	0.007	0.456	0.000	0.012	0.000	0.463	1.000	4.8.2 ✓
	7.00458 - 5.00305	0.007	0.459	0.000	0.012	0.000	0.467	1.000	4.8.2 ✓
	5.00305 - 3.00153	0.007	0.463	0.000	0.012	0.000	0.470	1.000	4.8.2 ✓
	3.00153 - 1	0.007	0.466	0.000	0.012	0.000	0.474	1.000	4.8.2 ✓

Section Capacity Table

Section No.	Elevation ft	Component Type	Size	Critical Element	P K	ϕP_{allow} K	% Capacity	Pass Fail
L1	130 - 80.167	Pole	TP41.283x28.95x0.313	1	-13.793	2719.790	34.7	Pass
L2	80.167 - 39.029	Pole	TP50.825x39.214x0.375	2	-24.487	3986.090	44.9	Pass
L3	39.029 - 1	Pole	TP59.5x48.352x0.438	3	-41.398	5559.510	47.4	Pass
Summary								
Pole (L3)							47.4	Pass
RATING =							47.4	Pass

Anchor Bolt and Base Plate Analysis:

Input Data:

Tower Reactions:

Overturing Moment =	$M_U := 3149\text{-ft-kips}$	(Input From RisaTower)
Shear Force =	Shear := 33-kips	(Input From RisaTower)
Axial Force =	$R_U := 41\text{-kips}$	(Input From RisaTower)

Anchor Bolt Data:

ASTMA615 Grade 75		
Number of Anchor Bolts =	$N := 20$	(User Input)
Diameter of Bolt Circle =	$D_{BC} := 66.92\text{-in}$	(User Input)
Bolt "Column" Distance =	$l := 3.0\text{-in}$	(User Input)
Bolt Ultimate Strength =	$F_U := 100\text{-ksi}$	(User Input)
Bolt Yield Strength =	$F_y := 75\text{-ksi}$	(User Input)
Bolt Modulus =	$E := 29000\text{-ksi}$	(User Input)
Diameter of Anchor Bolts =	$D := 2.25\text{-in}$	(User Input)
Threads per Inch =	$n := 4.5$	(User Input)
Top of Concrete to Bot Leveling Nut =	$l_{ar} := 2\text{-in}$	(User Input)
Anchor Rod Force Correction Factor =	$n_c = 1$	Table 2-1 Addendum 3

Base Plate Data:

UseASTMA572 Grade 50		
Plate Yield Strength =	$F_{yf} := 50\text{-ksi}$	(User Input)
Base Plate Thickness =	$t_{TP} := 3.25\text{-in}$	(User Input)
Base Plate Diameter =	$D_{OD} := 74.0\text{-in}$	(User Input)
Outer Pole Diameter =	$D_T := 59.5\text{-in}$	(User Input)
Pole Wall Thickness =	$t_T := 0.4375\text{-in}$	(User Input)
Pole Design Yield Strength =	$F_{yp} := 65\text{-ksi}$	(User Input)
	$\eta := 0.5$	For Ungrouted Base Plate per TIA-222-G Section 4.9.9

Anchor Bolt Analysis:

GrossArea of Bolt = $A_g := \frac{\pi}{4} \cdot D^2 = 3.976 \cdot \text{in}^2$

NetArea of Bolt = $A_n := \frac{\pi}{4} \cdot \left(D - \frac{0.9743 \cdot \text{in}}{n} \right)^2 = 3.248 \cdot \text{in}^2$

Tensile Root Diameter = $d_{rt} := D - \frac{0.9743 \cdot \text{in}}{n} = 2.033 \cdot \text{in}$

Plastic Section Modulus = $Z := \frac{d_{rt}^3}{6} = 1.401 \cdot \text{in}^3$

Maximum Anchor Rod Force = $P_u := \frac{n_c \cdot \pi \cdot M_u}{N \cdot D_{BC}} + \frac{R_u}{N} = 90.7 \cdot \text{kips}$

Maximum Shear Force = $V_u := \frac{\text{Shear}}{N} = 1.7 \cdot \text{kips}$

Design Tensile Strength = $\Phi R_{nt} := 0.8 \cdot F_u \cdot A_n = 259.815 \cdot \text{k}$

Bolt % of Capacity = $\frac{\left(P_u + \frac{V_u}{\eta} \right)}{\Phi R_{nt}} \cdot 100 = 36.2$

Condition1 = $\text{Condition1} := \text{if} \left[\frac{\left(P_u + \frac{V_u}{\eta} \right)}{\Phi R_{nt}} \leq 1.00, \text{"OK"}, \text{"Overstressed"} \right]$

Condition1 = "OK"

Design Shear Strength = $\Phi R_{nv} := 0.75 \cdot 0.45 \cdot F_u \cdot A_g = 134.193 \cdot \text{k}$

Design Flexural Strength = $\Phi R_{nm} := 0.9 \cdot F_y \cdot Z = 94.597 \cdot \text{in} \cdot \text{k}$

$M_u := \begin{cases} 0 & \text{if } l_{ar} < D \\ 0.65 \cdot l_{ar} \cdot V_u & \text{otherwise} \end{cases} = 0 \cdot \text{in} \cdot \text{k}$

Bolt % of Capacity = $\left[\left(\frac{V_u}{\Phi R_{nv}} \right)^2 + \left(\frac{P_u}{\Phi R_{nt}} + \frac{M_u}{\Phi R_{nm}} \right)^2 \right] \cdot 100 = 12.2$

Condition2 = $\text{Condition2} := \text{if} \left[\left(\frac{V_u}{\Phi R_{nv}} \right)^2 + \left(\frac{P_u}{\Phi R_{nt}} + \frac{M_u}{\Phi R_{nm}} \right)^2 \leq 1.00, \text{"OK"}, \text{"Overstressed"} \right]$

Condition2 = "OK"

Base Plate Analysis:

Strength Resistance Factor for Yielding due to Bending =

$$\phi_b := 0.9$$

Strength Resistance Factor for Yielding due to Shear =

$$\phi_v := 1.0$$

Outside Fillet Horizontal Leg Dimension =

$$w_1 := 0.25 \text{ in}$$

Effective Pole Outside Diameter =

$$D_e := D_T + w_1 = 59.75 \text{ in}$$

Effective Base Plate Outside Diameter =

$$D_{oe} := \begin{cases} D_{OD} & \text{if } D_{OD} \leq (D_{BC} + 6 \cdot t_{TP}) \\ (D_{BC} + 6 \cdot t_{TP}) & \text{otherwise} \end{cases} = 74 \text{ in}$$

Half-Angle Between Radial Lines Extending from Pole
 Centerline Through Midpoints Between Adjacent Anchor

$$\theta_1 := \frac{\pi}{N} = 0.157$$

Rods =

Angle Defining Limiting Effective Base Plate Width
 Based on Plate Thickness =

$$\theta_2 := \text{asin}\left(\frac{12 \cdot t_{TP}}{D_{BC}}\right) = 0.622$$

Angle Defining Limiting Effective Base Plate Width
 Based on Distance Between Anchor Rod Bolt Circle and
 Effective Pole Outside Diameter =

$$\theta_3 := \text{acos}\left(\frac{D_{BC} + D_e}{2 \cdot D_{BC}}\right) = 0.329$$

Governing Angle Defining Effective Base Plate Width
 Resisting Bending =

$$\theta := \min(\theta_1, \theta_2, \theta_3) = 0.157$$

Effective Moment Arm of Anchor Rod Force =

$$x := 0.5 \cdot (D_{BC} - D_e) = 3.585 \text{ in}$$

Effective Base Plate Width Resisting Bending from
 Transverse Bend Line =

$$B_{et} := D_{BC} \cdot \sin(\theta) = 10.469 \text{ in}$$

Effective Base Plate Width Resisting Bending from
 Radial Bend Lines =

$$B_{er} := (D_{oe} - D_e) \cdot \sin(\theta) = 2.229 \text{ in}$$

Total Effective Base Plate Width Resisting Bending =

$$B_{eff} := B_{et} + B_{er} = 12.698 \text{ in}$$

Required Base Plate Thickness =

$$t_{TP,Req} := \sqrt{\frac{4 \cdot P_u \cdot x}{\phi_b \cdot F_{yf} \cdot B_{eff}}} = 1.509 \text{ in}$$

Plate Bending Stress % of Capacity =

$$\frac{t_{TP,Req}}{t_{TP}} = 46.4\%$$

Condition2 =

$$\text{Condition3} := \text{if}\left(\frac{t_{TP,Req}}{t_{TP}} < 1.00, \text{"Ok"}, \text{"Overstressed"}\right)$$

Condition3 = "Ok"

Required Base Plate Thickness =

$$t_{TP,Req} := \frac{\phi_b \cdot t_T \cdot F_{yp}}{\phi_v \cdot 0.6 \cdot F_{yf}} = 0.853 \text{ in}$$

Plate Bending Stress % of Capacity =

$$\frac{t_{TP,Req}}{t_{TP}} = 26.3\%$$

Condition2 =

$$\text{Condition4} := \text{if}\left(\frac{t_{TP,Req}}{t_{TP}} < 1.00, \text{"Ok"}, \text{"Overstressed"}\right)$$

Condition4 = "Ok"

Standard Monopole Foundation:

Input Data:

Tower Data

Overturing Moment = OM := 3149-ft-kips (User Input)
 Shear Force = Shear := 33-kip (User Input)
 Axial Force = Axial := 41-kip (User Input)
 Tower Height = $H_t := 130$ -ft (User Input)

Footing Data:

Overall Depth of Footing = $D_f := 7$ -ft (User Input)
 Length of Pier = $L_p := 4.5$ -ft (User Input)
 Extension of Pier Above Grade = $L_{pag} := 0.5$ -ft (User Input)
 Diameter of Pier = $d_p := 8.0$ -ft (User Input)
 Thickness of Footing = $T_f := 3.0$ -ft (User Input)
 Width of Footing = $W_f := 26.5$ -ft (User Input)

Anchor Bolt Data:

Length of Anchor Bolts = $L_{st} := 72$ -in (User Input)
 Projection of Anchor Bolts Above Pier = $A_{BP} := 12.0$ -in (User Input)
 Anchor Bolt Diameter = $d_{anchor} := 2.25$ -in (User Input)
 Base Plate Bolt Circle = $MP := 66.92$ -in (User Input)

Material Properties:

Concrete Compressive Strength = $f_c := 3000$ -psi (User Input)
 Steel Reinforcement Yield Strength = $f_y := 60000$ -psi (User Input)
 Anchor Bolt Yield Strength = $f_{ya} := 75000$ -psi (User Input)
 Internal Friction Angle of Soil = $\Phi_s := 30$ -deg (User Input)
 Ultimate Soil Bearing Capacity = $q_u := 12000$ -psf (User Input)
 Allowable Soil Bearing Capacity = $q_a := \frac{q_u}{2} = 6000$ -psf (User Input)
 Unit Weight of Soil = $\gamma_{soil} := 100$ -pcf (User Input)
 Unit Weight of Concrete = $\gamma_{conc} := 150$ -pcf (User Input)
 Foundation Bouyancy = Bouyancy := 0 (User Input) (Yes=1 / No=0)
 Depth to Neglect = $n := 0$ -ft (User Input)
 Cohesion of Clay Type Soil = $c := 0$ -ksf (User Input) (Use 0 for Sandy Soil)
 Seismic Zone Factor = $Z := 2$ (User Input) (UBC-1997 Fig 23-2)
 Coefficient of Friction Between Concrete = $\mu := 0.45$ (User Input)

Pier Reinforcement:

Bar Size =	$BS_{\text{pier}} := 11$	(User Input)	
Bar Diameter =	$d_{\text{bpier}} := 1.41 \cdot \text{in}$	(User Input)	
Number of Bars =	$NB_{\text{pier}} := 48$	(User Input)	
Clear Cover of Reinforcement =	$Cvr_{\text{pier}} := 3 \cdot \text{in}$	(User Input)	
Reinforcement Location Factor =	$\alpha_{\text{pier}} := 1.0$	(User Input)	(ACI-2008 12.2.4)
Coating Factor =	$\beta_{\text{pier}} := 1.0$	(User Input)	(ACI-2008 12.2.4)
Concrete Strength Factor =	$\lambda_{\text{pier}} := 1.0$	(User Input)	(ACI-2008 12.2.4)
Reinforcement Size Factor =	$\gamma_{\text{pier}} := 1.0$	(User Input)	(ACI-2008 12.2.4)
Diameter of Tie =	$d_{\text{Tie}} := 3 \cdot \text{in}$	(User Input)	

Pad Reinforcement:

Bar Size =	$BS_{\text{top}} := 6$	(User Input)	(Top of Pad)
Bar Diameter =	$d_{\text{btop}} := 0.75 \cdot \text{in}$	(User Input)	(Top of Pad)
Number of Bars =	$NB_{\text{top}} := 32$	(User Input)	(Top of Pad)
Bar Size =	$BS_{\text{bot}} := 9$	(User Input)	(Bottom of Pad)
Bar Diameter =	$d_{\text{bbot}} := 1.128 \cdot \text{in}$	(User Input)	(Bottom of Pad)
Number of Bars =	$NB_{\text{bot}} := 34$	(User Input)	(Bottom of Pad)
Clear Cover of Reinforcement =	$Cvr_{\text{pad}} := 3.0 \cdot \text{in}$	(User Input)	
Reinforcement Location Factor =	$\alpha_{\text{pad}} := 1.0$	(User Input)	(ACI-2008 12.2.4)
Coating Factor =	$\beta_{\text{pad}} := 1.0$	(User Input)	(ACI-2008 12.2.4)
Concrete Strength Factor =	$\lambda_{\text{pad}} := 1.0$	(User Input)	(ACI-2008 12.2.4)
Reinforcement Size Factor =	$\gamma_{\text{pad}} := 1.0$	(User Input)	(ACI-2008 12.2.4)

Calculated Factors:

Pier Reinforcement Bar Area =	$A_{\text{bpier}} := \frac{\pi \cdot d_{\text{bpier}}^2}{4} = 1.561 \cdot \text{in}^2$
Pad Top Reinforcement Bar Area =	$A_{\text{btop}} := \frac{\pi \cdot d_{\text{btop}}^2}{4} = 0.442 \cdot \text{in}^2$
Pad Bottom Reinforcement Bar Area =	$A_{\text{bbot}} := \frac{\pi \cdot d_{\text{bbot}}^2}{4} = 0.999 \cdot \text{in}^2$
Coefficient of Lateral Soil Pressure =	$K_p := \frac{1 + \sin(\Phi_s)}{1 - \sin(\Phi_s)} = 3$

Stability of Footing:

Adjusted Concrete Unit Weight =

$$\gamma_c := \text{if}(\text{Bouyancy} = 1, \gamma_{\text{conc}} - 62.4\text{pcf}, \gamma_{\text{conc}}) = 150\text{-pcf}$$

Adjusted Soil Unit Weight =

$$\gamma_s := \text{if}(\text{Bouyancy} = 1, \gamma_{\text{soil}} - 62.4\text{pcf}, \gamma_{\text{soil}}) = 100\text{-pcf}$$

Passive Pressure =

$$P_{pn} := K_p \cdot \gamma_s \cdot n + c \cdot 2 \cdot \sqrt{K_p} = 0\text{-ksf}$$

$$P_{pt} := K_p \cdot \gamma_s \cdot (D_f - T_f) + c \cdot 2 \cdot \sqrt{K_p} = 1.2\text{-ksf}$$

$$P_{top} := \text{if}[n < (D_f - T_f), P_{pt}, P_{pn}] = 1.2\text{-ksf}$$

$$P_{bot} := K_p \cdot \gamma_s \cdot D_f + c \cdot 2 \cdot \sqrt{K_p} = 2.1\text{-ksf}$$

$$P_{ave} := \frac{P_{top} + P_{bot}}{2} = 1.65\text{-ksf}$$

$$T_p := \text{if}[n < (D_f - T_f), T_f, (D_f - n)] = 3$$

$$A_p := W_f \cdot T_p = 79.5$$

Ultimate Shear =

$$S_u := P_{ave} \cdot A_p = 131.175\text{-kip}$$

Weight of Concrete Pad =

$$WT_c := \left[(W_f^2 \cdot T_f) + d_p^2 \cdot L_p \right] \cdot \gamma_c = 359.213\text{-kip}$$

Weight of Soil Above Footing =

$$WT_{s1} := \left[(W_f^2 - d_p^2) \cdot (L_p - L_{pag} - n) \right] \cdot \gamma_s = 255.3\text{-kip}$$

Weight of Soil Wedge at Back Face =

$$WT_{s2} := \left(\frac{D_f^2 \cdot \tan(\phi_s)}{2} \cdot W_f \right) \cdot \gamma_s = 37.484\text{-kip}$$

Weight of Soil Wedge at back face Corners =

$$WT_{s3} := 2 \cdot \left[(D_f)^3 \cdot \frac{\tan(\phi_s)}{3} \right] \cdot \gamma_s = 13.202\text{-kips}$$

Total Weight =

$$WT_{tot} := WT_c + WT_{s1} + \text{Axial} = 655.513\text{-kip}$$

Resisting Weight =

$$WT_R := 0.9 \cdot WT_c + 0.75 \cdot WT_{s1} + 0.75 \cdot \text{Axial} = 545.516\text{-kip}$$

Resisting Moment =

$$M_r := (WT_R) \cdot \frac{W_f}{2} + 0.75 \cdot S_u \cdot \frac{T_f}{3} + 0.75 \cdot \left[(WT_{s2} + WT_{s3}) \cdot \left(W_f + \frac{D_f \cdot \tan(\phi_s)}{3} \right) \right] = 8385\text{-kip-ft}$$

Overtuning Moment =

$$M_{ot} := \text{OM} + \text{Shear} \cdot (L_p + T_f) = 3397\text{-kip-ft}$$

Factor of Safety Actual =

$$FS := \frac{M_r}{M_{ot}} = 2.47$$

Factor of Safety Required =

$$FS_{req} := 1$$

$$\text{OverTurning_Moment_Check} := \text{if}(FS \geq FS_{req}, \text{"Okay"}, \text{"No Good"})$$

$$\text{OverTurning_Moment_Check} = \text{"Okay"}$$

Shear Capacity in Pier:

Shear Resistance of Pier =
$$S_p := \frac{P_{ave} \cdot A_p + \mu \cdot W_{T_{tot}}}{FS_{req}} = 426.156 \text{ kips}$$

Shear_Check := if($S_p > \text{Shear}$, "Okay", "No Good")

Shear_Check = "Okay"

Bearing Pressure Caused by Footing:

Area of the Mat =
$$A_{mat} := W_f^2 = 702.25$$

Section Modulus of Mat =
$$S := \frac{W_f^3}{6} = 3101.6 \text{ ft}^3$$

Maximum Pressure in Mat =
$$P_{max} := \frac{W_{T_{tot}}}{A_{mat}} + \frac{M_{ot}}{S} = 2.029 \text{ ksf}$$

Max_Pressure_Check := if($P_{max} < .75 \cdot q_u$, "Okay", "No Good")

Max_Pressure_Check = "Okay"

Minimum Pressure in Mat =
$$P_{min} := \frac{W_{T_{tot}}}{A_{mat}} - \frac{M_{ot}}{S} = -0.162 \text{ ksf}$$

Min_Pressure_Check := if($(P_{min} \geq 0) \cdot (P_{min} < .75 \cdot q_u)$, "Okay", "No Good")

Min_Pressure_Check = "No Good"

Distance to Resultant of Pressure Distribution =
$$X_p := \frac{P_{max}}{P_{max} - P_{min}} \cdot \frac{1}{3} = 8.181$$

Distance to Kern =
$$X_k := \frac{W_f}{6} = 4.417$$

Since Resultant Force is Not in Kern, Area to which Pressure is Applied Must be Reduced.

Eccentricity =
$$e := \frac{M_{ot}}{W_{T_{tot}}} = 5.181$$

Adjusted Soil Pressure =
$$P_a := \frac{2 \cdot W_{T_{tot}}}{3 \cdot W_f \left(\frac{W_f}{2} - e \right)} = 2.044 \text{ ksf}$$

$q_{adj} := \text{if}(P_{min} < 0, P_a, P_{max}) = 2.044 \text{ ksf}$

Pressure_Check := if($q_{adj} < .75 \cdot q_u$, "Okay", "No Good")

Pressure_Check = "Okay"

Concrete Bearing Capacity:

Strength Reduction Factor = $\Phi_c := 0.65$ (ACI-2008 9.3.2.2)

Bearing Strength Between Pier and Pad = $P_b := \Phi_c \cdot 0.85 \cdot f_c \cdot \frac{\pi \cdot d_p^2}{4} = 1.2 \times 10^4 \cdot \text{kips}$ (ACI-2008 10.14)

Bearing_Check := if($P_b > \text{Axial}$, "Okay", "No Good")

Bearing_Check = "Okay"

Shear Strength of Concrete:

Beam Shear: (Critical section located at a distance d from the face of Pier) (ACI 11.3.1.1)

$\Phi_c := 0.85$ (ACI 9.3.2.5)

$d := T_f - C_{vr_{pad}} - d_{bot} = 2.656$

$d_1 := \frac{W_f}{2} - \frac{d_p}{2}$

$d_2 := d_1 - d$

$L := \left(\frac{W_f}{2} - e \right) \cdot 3$

Slope := if($L > W_f$, $\frac{P_{max} - P_{min}}{W_f}$, $\frac{q_{adj}}{L}$)

$V_{req} := \left[(q_{adj} - \text{Slope} \cdot d_1) + \left(\frac{\text{Slope} \cdot d_1}{2} \right) \right] \cdot W_f \cdot d_1$

$V_{Avail} := \Phi_c \cdot 2 \cdot \sqrt{f_c \cdot \psi} \cdot W_f \cdot d$ (ACI-2008 11.2.1.1)

Beam_Shear_Check := if($V_{req} < V_{Avail}$, "Okay", "No Good")

Beam_Shear_Check = "Okay"

Punching Shear: (Critical Section Located at a distance of d/2 from the face of pier) (ACI 11.11.1.2)

Critical Perimeter of Punching Shear = $b_o := (d_p + d) \cdot \pi = 33.5$

Area Included Inside Perimeter = $A_{bo} := \frac{\pi \cdot (d_p + d)^2}{4} = 89.2$

Area Outside of Perimeter = $A_{out} := A_{mat} - A_{bo} = 613.1$

Guess Value =

$$v_u := 1 \text{ksf}$$

(From "Foundation Analysis and design", By Joseph Bowles, Eq. 8-9)

Given

$$d^2 + d_p \cdot d = \frac{W_{T_{tot}}}{\pi \cdot v_u}$$

$$v_u := \text{Find}(v_u) = 7.4 \cdot \text{ksf}$$

$$V_u := v_u \cdot d \cdot W_f = 518.9 \cdot \text{kips}$$

Required Shear Strength =

$$V_{req} := V_u = 518.9 \cdot \text{kips}$$

Available Shear Strength =

$$V_{Avail} := \phi_c \cdot 4 \cdot \sqrt{f_c \cdot \text{psi}} \cdot b_o \cdot d = 2384.4 \cdot \text{kip} \quad (\text{ACI-2008 11.11.2.1})$$

$$\text{Punching_Shear_Check} := \text{if}(V_{req} < V_{Avail}, \text{"Okay"}, \text{"No Good"})$$

$$\text{Punching_Shear_Check} = \text{"Okay"}$$

Steel Reinforcement in Pad:

Required Reinforcement for Bending:

Strength Reduction Factor =

$$\phi_m := .90 \quad (\text{ACI-2008 9.3.2.1})$$

$$q_b := q_{adj} - d_1 \cdot \text{Slope} = 1.263 \cdot \text{ksf}$$

Maximum Bending at Face of Pier =

$$M_n := \frac{1}{\phi_m} \cdot \left[(q_{adj} - q_b) \cdot \frac{d_1^2}{3} + q_b \cdot \frac{d_1^2}{2} \right] \cdot W_f = 2246.6 \cdot \text{kip-ft}$$

$$\beta := \begin{cases} 0.85 & \text{if } 2500 \cdot \text{psi} \leq f_c \leq 4000 \cdot \text{psi} \\ 0.65 & \text{if } f_c > 8000 \cdot \text{psi} \end{cases} = 0.85$$

$$\left[\left[\left[\left[\frac{f_c}{\text{psi}} - 4000 \right] \right] \right] \cdot 0.5 \right] \text{ otherwise} \quad (\text{ACI-2008 10.2.7.3})$$

$$R_n := \frac{M_n}{W_f \cdot d^2} = 83.5 \cdot \text{psi}$$

$$\rho := \frac{0.85 \cdot f_c}{f_y} \left(1 - \sqrt{1 - \frac{2 \cdot R_n}{0.85 \cdot f_c}} \right) = 0.0014$$

$$\rho_{min} := \rho = 0.00141$$

Required Reinforcement for Temperature and Shrinkage:

$$\rho_{sh} := \begin{cases} .0018 & \text{if } f_y \geq 60000\text{-psi} \\ .0020 & \text{otherwise} \end{cases} \quad (\text{ACI-2008 7.12.2.1})$$

Check Bottom Bars:

$$A_s := \begin{cases} \rho_{min} \cdot W_f \cdot d & \text{if } \rho_{min} > \frac{\rho_{sh}}{2} \\ \rho_{sh} \cdot W_f \cdot \frac{d}{2} & \text{otherwise} \end{cases} = 14.336\text{-in}^2$$

$$A_{s_prov} := A_{bbot} \cdot NB_{bot} = 34\text{-in}^2$$

$$\text{Pad_Reinforcement_Bot} := \text{if}(A_{s_prov} > A_s, \text{"Okay"}, \text{"No Good"})$$

Pad_Reinforcement_Bot = "Okay"

Check top Bars:

$$A_s := \rho_{sh} \cdot \left(W_f \cdot \frac{d}{2} \right) = 9.1\text{-in}^2$$

$$A_{s_prov} := A_{btop} \cdot NB_{top} = 14.1\text{-in}^2$$

$$\text{Pad_Reinforcement_Top} := \text{if}(A_{s_prov} > A_s, \text{"Okay"}, \text{"No Good"})$$

Pad_Reinforcement_Top = "Okay"

Development Length Pad Reinforcement:

Bar Spacing =

$$B_{sPad} := \frac{W_f - 2 \cdot C_{vr_pad} - NB_{bot} \cdot d_{bbot}}{NB_{bot} - 1} = 8.29\text{-in}$$

Spacing or Cover Dimension =

$$c := \text{if} \left(C_{vr_pad} < \frac{B_{sPad}}{2}, C_{vr_pad}, \frac{B_{sPad}}{2} \right) = 3\text{-in}$$

Transverse Reinforcement Index =

$$k_{tr} := 0 \quad (\text{ACI-2008 12.2.3})$$

$$L_{dbt} := \frac{3 \cdot f_y \cdot \alpha_{pad} \cdot \beta_{pad} \cdot \gamma_{pad} \cdot \lambda_{pad}}{40 \cdot \sqrt{f_c \cdot \text{psi}} \cdot \frac{c + k_{tr}}{d_{bbot}}} \cdot d_{bbot} = 34.8\text{-in}$$

Minimum Development Length =

$$L_{dbmin} := 12\text{-in} \quad (\text{ACI-2008 12.2.1})$$

$$L_{dbtCheck} := \text{if}(L_{dbt} \geq L_{dbmin}, \text{"Use L.dbt"}, \text{"Use L.dbmin"})$$

Available Length in Pad =

$$L_{Pad} := \frac{W_f}{2} - \frac{d_p}{2} - C_{vr_pad} = 108\text{-in}$$

$$L_{pad_Check} := \text{if}(L_{Pad} > L_{dbt}, \text{"Okay"}, \text{"No Good"})$$

Lpad_Check = "Okay"

Steel Reinforcement in Pier:

Area of Pier =

$$A_p := d_p^2 = 9216 \cdot \text{in}^2$$

$$A_{smin} := 0.01 \cdot 0.5 \cdot A_p = 46.08 \cdot \text{in}^2 \quad (\text{ACI-2008 10.8.4 \& 10.9.1})$$

$$A_{sprov} := N_{B_{pier}} \cdot A_{B_{pier}} = 74.95 \cdot \text{in}^2$$

$$\text{Steel_Area_Check} := \text{if}(A_{sprov} > A_{smin}, \text{"Okay"}, \text{"No Good"})$$

Steel_Area_Check = "Okay"

NOTE: Anchor Bolts are not accounted for in reinforcement calculation and will provide additional reinforcement to satisfy minimum requirement of steel.

Bar Spacing In Pier =

$$B_{sPier} := \frac{d_p \cdot \pi}{N_{B_{pier}}} - d_{B_{pier}} = 4.873 \cdot \text{in}$$

Diameter of Reinforcement Cage =

$$\text{Diam}_{cage} := d_p - 2 \cdot C_{vr_{pier}} = 90 \cdot \text{in}$$

Maximum Moment in Pier =

$$M_p := \left[\text{OM} + \text{Shear} \cdot \left(L_p + \frac{A_{BP}}{2} \right) \right] = 39768 \cdot \text{in} \cdot \text{kips}$$

Pier Check evaluated from outside program and results are listed below;

$$(D \ N \ n \ P_u \ M_{xu}) := \left(d_p \cdot 12 \ N_{B_{pier}} \ B_{S_{pier}} \ \frac{\text{Axial} \cdot 1.333}{\text{kips}} \ \frac{M_p}{\text{in} \cdot \text{kips}} \right)$$

$$(D \ N \ n \ P_u \ M_{xu}) = (96 \ 48 \ 11 \ 54.7 \ 39768)$$

$$(\phi P_n \ \phi M_{xn} \ f_{sp} \ \rho) := (0 \ 0 \ 0 \ 0)$$

$$(\phi P_n \ \phi M_{xn} \ f_{sp} \ \rho) := \phi P'_n (D, N, n, P_u, M_{xu})^T$$

$$(\phi P_n \ \phi M_{xn} \ f_{sp} \ \rho) = (217.4 \ 1.6 \times 10^5 \ -60 \ 0)$$

$$\text{Axial_Load_Check} := \text{if}(\phi P_n \geq P_u, \text{"Okay"}, \text{"No Good"})$$

Axial_Load_Check = "Okay"

$$\text{Bending_Check} := \text{if}(\phi M_{xn} \geq M_{xu}, \text{"Okay"}, \text{"No Good"})$$

Bending_Check = "Okay"

Development Length Pier Reinforcement:

Available Length in Foundation:

$$L_{\text{pier}} := L_p - C_{\text{vr}}_{\text{pier}} = 51 \cdot \text{in}$$

$$L_{\text{pad}} := T_f - C_{\text{vr}}_{\text{pad}} = 33 \cdot \text{in}$$

Tension:

(ACI-2008 12.2.3)

Spacing or Cover Dimension =

$$c := \text{if} \left(C_{\text{vr}}_{\text{pier}} < \frac{B_{\text{sPier}}}{2}, C_{\text{vr}}_{\text{pier}}, \frac{B_{\text{sPier}}}{2} \right) = 2.437 \cdot \text{in}$$

Transverse Reinforcement =

$$k_{\text{tr}} := 0 \quad \text{(ACI-2008 12.2.3)}$$

$$L_{\text{dbt}} := \frac{3 \cdot f_y \cdot \alpha_{\text{pier}} \cdot \beta_{\text{pier}} \cdot \gamma_{\text{pier}} \cdot \lambda_{\text{pier}}}{40 \cdot \sqrt{f_c \cdot \text{psi}} \cdot \left(\frac{c + k_{\text{tr}}}{d_{\text{bpier}}} \right)} \cdot d_{\text{bpier}} = 67.04 \cdot \text{in}$$

Minimum Development Length =

$$L_{\text{dh}} := \frac{1200 \cdot d_{\text{bpier}}}{\sqrt{\frac{f_c}{\text{psi}}}} \cdot .7 = 21.624 \cdot \text{in} \quad \text{(ACI 12.2.1)}$$

Pier reinforcement bars are standard 90 degree hooks and therefore development in the pad is computed as follows:

$$L_{\text{db}} := \max(L_{\text{dbt}}, L_{\text{dbmin}})$$

$$L_{\text{tension_Check}} := \text{if}(L_{\text{pier}} + L_{\text{pad}} > L_{\text{db}}, \text{"Okay"}, \text{"No Good"})$$

$$L_{\text{tension_Check}} = \text{"Okay"}$$

Compression:

(ACI-2008 12.3.2)

$$L_{\text{dbc1}} := \frac{.02 \cdot d_{\text{bpier}} \cdot f_y}{\sqrt{f_c \cdot \text{psi}}} = 30.892 \cdot \text{in}$$

$$L_{\text{dbmin}} := 0.0003 \cdot \frac{\text{in}^2}{l_b} \cdot (d_{\text{bpier}} \cdot f_y) = 25.38 \cdot \text{in}$$

$$L_{\text{dbc}} := \text{if}(L_{\text{dbc1}} \geq L_{\text{dbmin}}, L_{\text{dbc1}}, L_{\text{dbmin}}) = 30.892 \cdot \text{in}$$

$$L_{\text{compression_Check}} := \text{if}(L_{\text{pier}} + L_{\text{pad}} > L_{\text{dbc}}, \text{"Okay"}, \text{"No Good"})$$

$$L_{\text{compression_Check}} = \text{"Okay"}$$

RAN Template: 67D92C Outdoor	A&L Template: 67D92C_2xAIR+1OP	Power System Template: Custom
--	--	---

Section 1 - Site Information

Site ID: CTFF481B	Site Name: POLICE STA EDISON RD	Latitude: 41.23444444
Status: Draft	Site Class: Monopole	Longitude: -73.21888890
Version: 2.1	Site Type: Structure Non Building	Address: 158 Edison Rd
Project Type: L600	Solution Type:	City, State: Trumbull, CT
Approved: Not Approved	Plan Year:	Region: NORTHEAST
Approved By: Not Approved	Market: CONNECTICUT	
Last Modified: 5/1/2018 1:8:14 PM	Vendor: Ericsson	
Last Modified By: GSM1900MSEDDIK	Landlord: T-Mobile USA Inc	

RAN Template: 67D92C Outdoor		AL Template: 67D92C_2xAIR+1OP		
Sector Count: 3	Antenna Count: 9	Coax Line Count: 6	TMA Count: 3	RRU Count: 3

Section 2 - Existing Template Images

----- This section is intentionally blank. -----

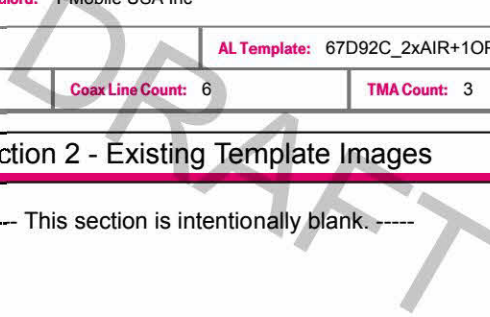

Section 3 - Proposed Template Images

67D92C.JPG

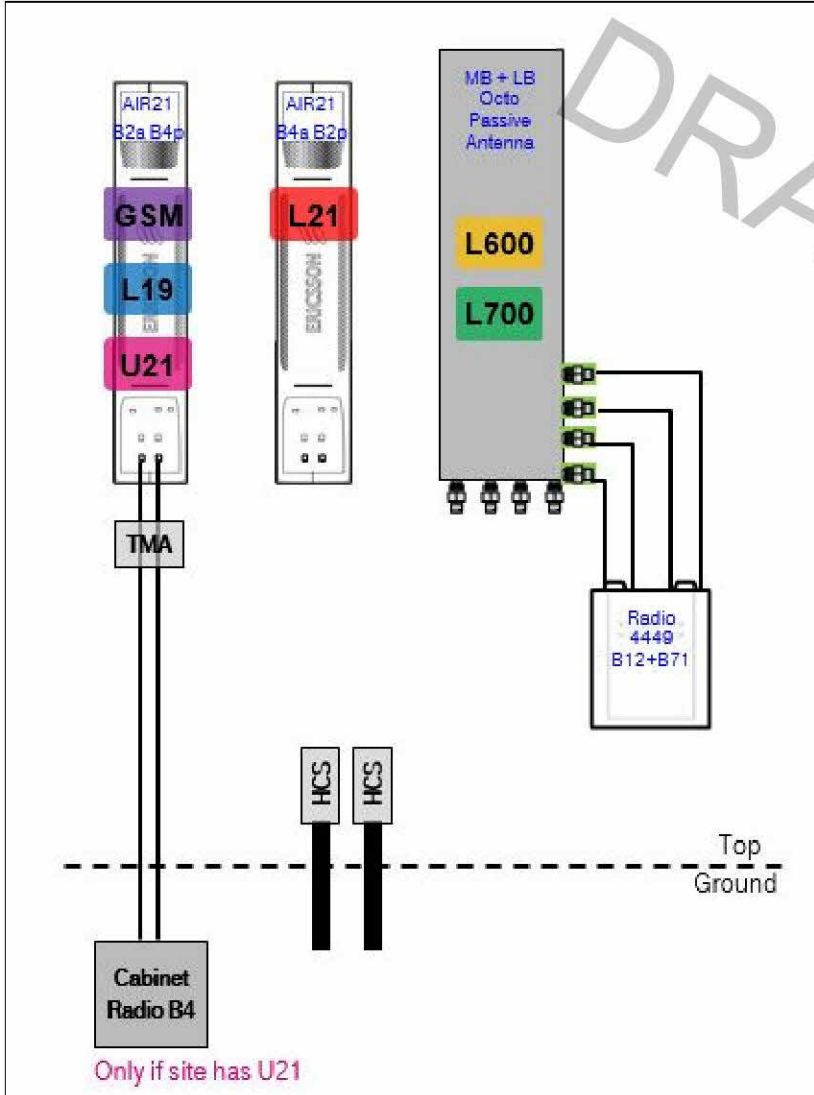

Notes:

Section 4 - Siteplan Images

----- This section is intentionally blank. -----

DRAFT

RAN Template: 67D92C Outdoor	A&L Template: 67D92C_2xAIR+1OP	Power System Template: Custom
--	--	---

Section 5 - RAN Equipment

Existing RAN Equipment

Template: 702Cu Outdoor

Enclosure	1	2
Enclosure Type	RBS 6131	Ancillary Equipment
Baseband	DUS41 DUW30 (x2) DUG20	
Hybrid Cable System		Ericsson 9x18 HCS *Select Length*
Multiplexer	XMU	
Radio	RU22 (x6)	

Proposed RAN Equipment

Template: 67D92C Outdoor

Enclosure	1	2
Enclosure Type	RBS 6131	Ancillary Equipment
Baseband	BB 5216 L2100 L1900 L700 L600 DUW30 U2100 DUG20 G1900	
Hybrid Cable System		Ericsson 6x12 HCS 6AWG 40m Ericsson 9x18 HCS 30m
Multiplexer	XMU L2100 L1900 L700 L600	
Radio	RU22 (x6) U2100	

RAN Scope of Work:

RAN Template: 67D92C Outdoor	A&L Template: 67D92C_2xAIR+1OP	Power System Template: Custom
--	--	---

Section 6 - A&L Equipment

Existing Template: 702Cu
Proposed Template: 67D92C_2xAIR+1OP

Sector 1 (Existing) view from behind

Coverage Type	A - Outdoor Macro				
Antenna	1		2		3
Antenna Model	Ericsson - AIR21 KRC118046-1_B2P_B4A (Quad)		Ericsson - AIR21 KRC118023-1_B2A_B4P (Quad)		Andrew - LNX-6515DS-A1M (Dual)
Azimuth	60		60		60
M. Tilt	0		0		0
Height	120		120		120
Ports	P1	P2	P3	P4	P5
Active Tech.	L2100		U1900 G1900	U2100	L700
Dark Tech.					
Restricted Tech.					
Decomm. Tech.					
E. Tilt	2		2	2	2
Cables					
TMA's					
Diplexers / Combiners					
Radio					
Sector Equipment					

Disconnected Equipment:

- Cable: Fiber Jumper - 15 ft.
- Cable: Fiber Jumper - 15 ft.
- Cable: Fiber Jumper - 15 ft.
- Cable: 1-5/8" Coax - 130 ft.
- Cable: 1-5/8" Coax - 130 ft.
- Cable: Fiber Jumper - 15 ft.
- Cable: Fiber Jumper - 15 ft.
- TMA: Generic Twin Style 1B - AWS
- Sector Equipment: RRUS11 B12

Scope of Work:

RAN Template: 67D92C Outdoor	A&L Template: 67D92C_2xAIR+1OP	Power System Template: Custom
--	--	---

Sector 1 (Proposed) view from behind								
Coverage Type	A - Outdoor Macro							
Antenna	1		2			3		
Antenna Model	Ericsson - AIR21 KRC118046-1_B2P_B4A (Quad)		RFS - APXVAARR24_43-U-NA20 (Octo)			Ericsson - AIR21 KRC118023-1_B2A_B4P (Quad)		
Azimuth	60		60			60		
M. Tilt								
Height	120		120			120		
Ports	P1	P2	P3	P4	P5	P6	P7	P8
Active Tech.		L2100			L700 L600	L700 L600	L1900 G1900	U2100
Dark Tech.								
Restricted Tech.								
Decomm. Tech.								
E. Tilt								
Cables		Fiber Jumper (x2)			JUMPE R 6' DIN MALE- DIN MALE (x2)	JUMPE R 6' DIN MALE- DIN MALE (x2)	Fiber Jumper	1-5/8" Coax - 130 ft. (x2)
TMA's								Generic Twin Style 1B - AWS (AtAntenna)
Diplexers / Combiners								
Radio					Radio 4449 B71+B1 2 (At Antenna)			
Sector Equipment								
Unconnected Equipment:								
Scope of Work:								

RAN Template: 67D92C Outdoor	A&L Template: 67D92C_2xAIR+1OP	Power System Template: Custom
--	--	---

Sector 2 (Existing) view from behind					
Coverage Type	A - Outdoor Macro				
Antenna	1		2		3
Antenna Model	Ericsson - AIR21 KRC118046-1_B2P_B4A (Quad)		Ericsson - AIR21 KRC118023-1_B2P_B4A (Quad)		Andrew - LNX-6515DS-A1M (Dual)
Azimuth	150		150		150
M. Tilt	0		0		0
Height	120		120		120
Ports	P1	P2	P3	P4	P5
Active Tech.	L2100		U1900 G1900	U2100	L700
Dark Tech.					
Restricted Tech.					
Decomm. Tech.					
E. Tilt	2		2	2	2
Cables					
TMA's					
Diplexers / Combiners					
Radio					
Sector Equipment					
Unconnected Equipment:					
<div style="display: flex; justify-content: space-between; align-items: flex-start;"> <div style="border: 1px solid gray; border-radius: 5px; padding: 2px; width: 15%;">Cable: Fiber Jumper - 15 ft.</div> <div style="border: 1px solid gray; border-radius: 5px; padding: 2px; width: 15%;">Cable: Fiber Jumper - 15 ft.</div> <div style="border: 1px solid gray; border-radius: 5px; padding: 2px; width: 15%;">Cable: Fiber Jumper - 15 ft.</div> <div style="border: 1px solid gray; border-radius: 5px; padding: 2px; width: 15%;">Cable: 1-5/8" Coax - 130 ft.</div> <div style="border: 1px solid gray; border-radius: 5px; padding: 2px; width: 15%;">Cable: 1-5/8" Coax - 130 ft.</div> </div> <div style="display: flex; justify-content: space-between; align-items: flex-start; margin-top: 5px;"> <div style="border: 1px solid gray; border-radius: 5px; padding: 2px; width: 15%;">Cable: Fiber Jumper - 15 ft.</div> <div style="border: 1px solid gray; border-radius: 5px; padding: 2px; width: 15%;">Cable: Fiber Jumper - 15 ft.</div> <div style="border: 1px solid gray; border-radius: 5px; padding: 2px; width: 15%;">TMA: Generic Twin Style 1B - AWS</div> <div style="border: 1px solid gray; border-radius: 5px; padding: 2px; width: 15%;">Sector Equipment: RRUS11 B12</div> </div>					
Scope of Work:					

RAN Template: 67D92C Outdoor	A&L Template: 67D92C_2xAIR+1OP	Power System Template: Custom
--	--	---

Sector 2 (Proposed) view from behind									
Coverage Type	A - Outdoor Macro								
Antenna	1		2			3			
Antenna Model	Ericsson - AIR21 KRC118046-1_B2P_B4A (Quad)		RFS - APXVAARR24_43-U-NA20 (Octo)			Ericsson - AIR21 KRC118023-1_B2A_B4P (Quad)			
Azimuth	150		150			150			
M. Tilt									
Height	120		120			120			
Ports	P1	P2	P3	P4	P5	P6	P7	P8	
Active Tech.		L2100			L700 L600	L700 L600	L1900 G1900	U2100	
Dark Tech.									
Restricted Tech.									
Decomm. Tech.									
E. Tilt									
Cables		Fiber Jumper (x2)			JUMPE R 6' DIN MALE- DIN MALE (x2)	JUMPE R 6' DIN MALE- DIN MALE (x2)	Fiber Jumper	1-5/8" Coax - 130 ft. (x2)	
TMA's								Generic Twin Style 1B - AWS (AtAntenna)	
Diplexers / Combiners									
Radio	Radio 4449 B71+B1 2 (At Antenna)								
Sector Equipment									
Unconnected Equipment:									
Scope of Work:									

RAN Template: 67D92C Outdoor	A&L Template: 67D92C_2xAIR+1OP	Power System Template: Custom
--	--	---

Sector 3 (Existing) view from behind					
Coverage Type	A - Outdoor Macro				
Antenna	1		2		3
Antenna Model	Ericsson - AIR21 KRC118046-1_B2P_B4A (Quad)		Ericsson - AIR21 KRC118023-1_B2A_B4P (Quad)		Andrew - LNX-6515DS-A1M (Dual)
Azimuth	340		340		340
M. Tilt	0		0		0
Height	120		120		120
Ports	P1	P2	P3	P4	P5
Active Tech.	L2100		U1900 G1900	U2100	L700
Dark Tech.					
Restricted Tech.					
Decomm. Tech.					
E. Tilt	2		2	2	2
Cables					
TMA's					
Diplexers / Combiners					
Radio					
Sector Equipment					
Unconnected Equipment:					
<div style="display: flex; justify-content: space-between; border: 1px solid gray; padding: 5px;"> Cable: Fiber Jumper - 15 ft. Cable: Fiber Jumper - 15 ft. Cable: Fiber Jumper - 15 ft. Cable: 1-5/8" Coax - 130 ft. Cable: 1-5/8" Coax - 130 ft. </div> <div style="display: flex; justify-content: space-between; border: 1px solid gray; padding: 5px; margin-top: 5px;"> Cable: Fiber Jumper - 15 ft. Cable: Fiber Jumper - 15 ft. TMA: Generic Twin Style 1B - AWS Sector Equipment: RRUS11 B12 </div>					
Scope of Work:					

RAN Template: 67D92C Outdoor	A&L Template: 67D92C_2xAIR+1OP	Power System Template: Custom
--	--	---

Sector 3 (Proposed) view from behind								
Coverage Type	A - Outdoor Macro							
Antenna	1		2			3		
Antenna Model	Ericsson - AIR21 KRC118046-1_B2P_B4A (Quad)		RFS - APXVAARR24_43-U-NA20 (Octo)			Ericsson - AIR21 KRC118023-1_B2A_B4P (Quad)		
Azimuth	340		340			340		
M. Tilt								
Height	120		120			120		
Ports	P1	P2	P3	P4	P5	P6	P7	P8
Active Tech.		L2100			L700 L600	L700 L600	L1900 G1900	U2100
Dark Tech.								
Restricted Tech.								
Decomm. Tech.								
E. Tilt								
Cables		Fiber Jumper (x2)			JUMPE R 6' DIN MALE- DIN MALE (x2)	JUMPE R 6' DIN MALE- DIN MALE (x2)	Fiber Jumper	1-5/8" Coax - 130 ft. (x2)
TMA's								Generic Twin Style 1B - AWS (AtAntenna)
Diplexers / Combiners								
Radio					Radio 4449 B71+B1 2 (At Antenna)			
Sector Equipment								
Unconnected Equipment:								
Scope of Work:								

RAN Template: 67D92C Outdoor	A&L Template: 67D92C_2xAIR+1OP	Power System Template: Custom
--	--	---

Section 7 - Power Systems Equipment

Existing Power Systems Equipment

---- This section is intentionally blank. ----

Proposed Power Systems Equipment

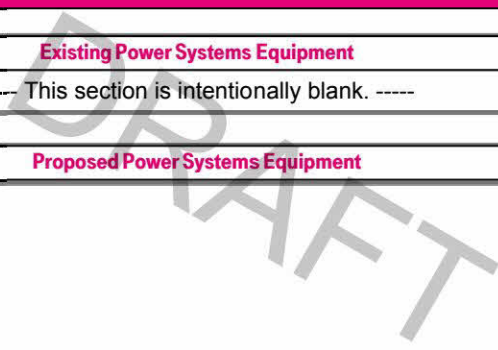



Dual Slant Polarized Quad Band (8 Port) Antenna, 617-746/617-746/1695-2200/1695-2200MHz, 65deg, 15/15/18/18dBi, 2.4m (8ft), VET, RET, 0-12°/0-12°/2-12°/2-12°

FEATURES / BENEFITS

This antenna provides a 8 Port multi-band flexible platform for advanced use for flexible use in deployment scenarios for encompassing 600MHz, 700MHz, AWS & PCS applications.



- ➔ 24 Inch Width For Easier Zoning
- ➔ Field Replaceable (Integrated) AISG RET platform for reduced environmental exposure and long lasting quality
- ➔ Superior elevation pattern performance across the entire electrical down tilt range
- ➔ Includes three AISG RET motors - Includes 0.5m AISG jumper for optional daisy chain of two high band RET motors for one single AISG point of high band tilt control.
- ➔ Low band arrays driven by a single RET motor

Technical Features

LOW BAND LEFT ARRAY (617-746 MHZ) [R1]

Frequency Band	MHz	617-698	698-746
Gain	dBi	15.1	15.5
Horizontal Beamwidth @3dB	Deg	65	62
Vertical Beamwidth @3dB	Deg	11.4	10.4
Electrical Downtilt Range	Deg	0-12	0-12
Upper Side Lobe Suppression 0 to +20	dB	19	20
Front-to-Back, at +/-30°, Copolar	dB	25	24
Cross Polar Discrimination (XPD) @ Boresight	dB	19	19
Cross Polar Discrimination (XPD) @ +/-60	dB	5	3
3rd Order PIM 2 x 43dBm	dBc		-153
VSWR	-	1.5:1	1.5:1
Cross Polar Isolation	dB	25	25
Maximum Effective Power per Port	Watt	250	250

LOW BAND RIGHT ARRAY (617-746 MHZ) [R2]

Frequency Band	MHz	617-698	698-746
Gain	dBi	14.8	15.1
Horizontal Beamwidth @3dB	Deg	65	62
Vertical Beamwidth @3dB	Deg	11.4	10.3
Electrical Downtilt Range	Deg	0-12	0-12
Upper Side Lobe Suppression 0 to +20	dB	19	20
Front-to-Back, at +/-30°, Copolar	dB	25	23
Cross Polar Discrimination (XPD) @ Boresight	dB	19	19
Cross Polar Discrimination (XPD) @ +/-60	dB	5	3
3rd Order PIM 2 x 43dBm	dBc		-153
VSWR	-	1.5:1	1.5:1
Cross Polar Isolation	dB	25	25
Maximum Effective Power per Port	Watt	250	250



Dual Slant Polarized Quad Band (8 Port) Antenna, 617-746/617-746/1695-2200/1695-2200MHz, 65deg, 15/15/18/18dBi, 2.4m (8ft), VET, RET, 0-12°/0-12°/2-12°/2-12°

ELECTRICAL SPECIFICATIONS

Impedance	Ohm	50.0
Polarization	Deg	±45°

MECHANICAL SPECIFICATIONS

Dimensions - H x W x D	mm (in)	2436 x 609 x 222 (95.9 x 24 x 8.7)
Weight (Antenna Only)	kg (lb)	58 (128)
Weight (Mounting Hardware only)	kg (lb)	11.5 (25.3)
Shipping Weight	kg (lb)	80 (176)
Connector type		8 x 4.3-10 female at bottom + 6 AISG connectors (3 male, 3 female)
Adjustment mechanism		Integrated RET solution AISG compliant (Field Replaceable) + Manual Override + External Tilt Indicator
Mounting Hardware Material		Galvanized steel
Radome Material / Color		Fiber Glass / Light Grey RAL7035

TESTING AND ENVIRONMENTAL

Temperature Range	°C (°F)	-40 to 60 (-40 to 140)
Lightning protection		IEC 61000-4-5
Survival/Rated Wind Velocity	km/h	241 (150)
Environmental		ETSI 300-019-2-4 Class 4.1E

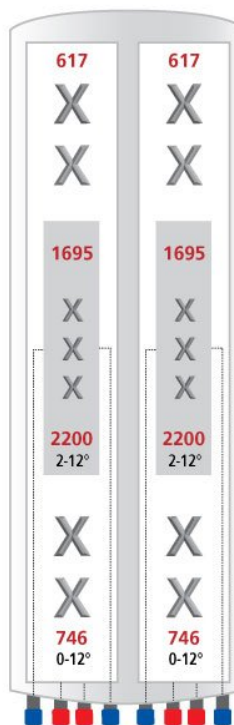
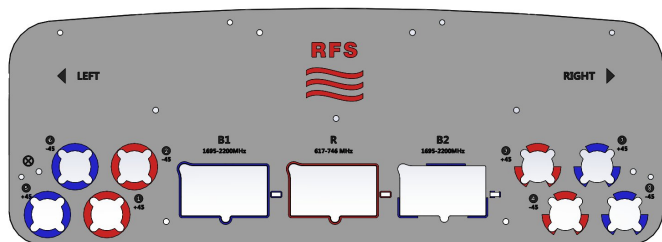

ORDERING INFORMATION

Order No.	Configuration	Mounting Hardware	Mounting pipe Diameter	Shipping Weight
APXVAARR24_43-U-NA20	Field Replace RET included (3)	APM40-5E Beam tilt kit (included)	60-120mm	80 Kg



AIR-32 B4A/B2P & B2A/B66AA

ERICSSON ANTENNA INTEGRATED RADIO AIR-32



Radio	Single Band (B4a/B2p)	Dual Band (B2a/B66Aa)
Band 2 (1850-1910 / 1930-1990 MHz)	Passive frequency band	Active frequency band
Band 4 (1710-1755 / 2110-2155 MHz)	Active frequency band	Subset of Band 66A (AWS 1+3)
Band 66A (1710-1780 / 2110-2180 MHz)	N/A	Active frequency band
PA Output Power	4 x 30W	2 x (4 x 30) W
Downlink EIRP in bore-sight direction for each active band	4 x 62.5 dBmi	4 x 62.5 dBmi
Instantaneous bandwidth	45 MHz (W, L)	B2: 40 MHz (W, L) B2: 20 MHz (G) B66A: 70 MHz (W, L)
Capacity (single standard per unit)	6 GSM 6 WCDMA 2 x 20 MHz LTE	6 GSM (B2 only) 6 WCDMA per Active frequency band 2 x 20 MHz LTE per band
Multi-RAT capability	WCDMA and LTE on both PAs	WCDMA and GSM on both PAs (B2 only) WCDMA and LTE on both PAs (B2 and B4) GSM and LTE (B2 only)



Interfaces		
Optical CPRI	2 x 10 Gbps	2 x 10 Gbps per Active frequency band
DC Power	-48 VDC 3-wire or 2-wire	-48 VDC 3-wire or 2-wire (separate input for both radios)
AC power (Optional)	PSU-AC 08	PSU-AC 08
Passive antenna	4 RF connectors (7/16 female)	N/A
Environmental		
Operating Temperature Range	-40 to +55 °C	-40 to +55 °C
Solar Radiation	≤ 1,120 W/m ²	≤ 1,120 W/m ²
Relative Humidity	5 to 100%	5 to 100%
Absolute Humidity	0.26 to 40 g/m ³	0.26 to 40 g/m ³
Maximum temperature change	1.0°C/min	1.0°C/min
Antenna		
Electrical Tilt	2° – 12° (B4)	2° – 12° (B66A)
	2° – 12° (B2)	2° – 12° (B2)
Bore-sight antenna gain	18 dBi (B4)	18 dBi (B66A)
	17.5 dBi (B2)	17.5 dBi (B2)
Nominal beam-width, azimuth	65° (B4)	65° (B66A)
	63° (B2)	63° (B2)
Nominal beam-width, elevation	6° (B4)	6° (B66A)
	6° (B2)	6° (B2)
Mechanical		
Weight	48 Kg (105.8 lbs)	60 Kg (132.2 lbs)
Dimensions (H x W x D)	1439 x 327 x 220 mm (56.6" x 12.9" x 8.7")	1439 x 327 x 220 mm (56.6" x 12.9" x 8.7")
Wind load at 42 m/s (150 km/h)		
Front / Lateral / Rear	640N / 300N / 660N	640N / 300N / 660N



WIRELESS COMMUNICATIONS FACILITY

POLICE STA EDISON RD

SITE ID: CTFF481B

158 EDISON RD

TRUMBULL, CT 06611

GENERAL NOTES

- ALL WORK SHALL BE IN ACCORDANCE WITH THE 2012 INTERNATIONAL BUILDING CODE AS MODIFIED BY THE 2016 CONNECTICUT SUPPLEMENT, INCLUDING THE TIA/EIA-222 REVISION "G" "STRUCTURAL STANDARDS FOR STEEL ANTENNA TOWERS AND SUPPORTING STRUCTURES." 2016 CONNECTICUT FIRE SAFETY CODE, NATIONAL ELECTRICAL CODE AND LOCAL CODES.
- CONTRACTOR SHALL REVIEW ALL DRAWINGS AND SPECIFICATIONS IN THE CONTRACT DOCUMENT SET. CONTRACTOR SHALL COORDINATE ALL WORK SHOWN IN THE SET OF DRAWINGS. THE CONTRACTOR SHALL PROVIDE A COMPLETE SET OF DRAWINGS TO ALL SUBCONTRACTORS AND ALL RELATED PARTIES. THE SUBCONTRACTORS SHALL EXAMINE ALL THE DRAWINGS AND SPECIFICATIONS FOR THE INFORMATION THAT AFFECTS THEIR WORK.
- CONTRACTOR SHALL PROVIDE A COMPLETE BUILD-OUT WITH ALL FINISHES, STRUCTURAL, MECHANICAL, AND ELECTRICAL COMPONENTS AND PROVIDE ALL ITEMS AS SHOWN OR INDICATED ON THE DRAWINGS OR IN THE WRITTEN SPECIFICATIONS.
- CONTRACTOR SHALL FURNISH ALL MATERIAL, LABOR AND EQUIPMENT TO COMPLETE THE WORK AND FURNISH A COMPLETED JOB ALL IN ACCORDANCE WITH LOCAL AND STATE GOVERNING AUTHORITIES AND OTHER AUTHORITIES HAVING LAWFUL JURISDICTION OVER THE WORK.
- CONTRACTOR SHALL SECURE AND PAY FOR ALL PERMITS AND ALL INSPECTIONS REQUIRED AND SHALL ALSO PAY FEES REQUIRED FOR THE GENERAL CONSTRUCTION, PLUMBING, ELECTRICAL AND HVAC. PERMITS SHALL BE PAID FOR BY THE RESPECTIVE SUBCONTRACTORS.
- CONTRACTOR SHALL MAINTAIN A CURRENT SET OF DRAWINGS AND SPECIFICATIONS ON SITE AT ALL TIMES AND INSURE DISTRIBUTION OF NEW DRAWINGS TO SUBCONTRACTORS AND OTHER RELEVANT PARTIES AS SOON AS THEY ARE MADE AVAILABLE. ALL OLD DRAWINGS SHALL BE MARKED VOID AND REMOVED FROM THE CONTRACT AREA. THE CONTRACTOR SHALL FURNISH AN "AS-BUILT" SET OF DRAWINGS TO OWNER UPON COMPLETION OF PROJECT.
- LOCATION OF EQUIPMENT, AND WORK SUPPLIED BY OTHERS THAT IS DIAGRAMMATICALLY INDICATED ON THE DRAWINGS SHALL BE DETERMINED BY THE CONTRACTOR. THE CONTRACTOR SHALL DETERMINE LOCATIONS AND DIMENSIONS SUBJECT TO STRUCTURAL CONDITIONS AND WORK OF THE SUBCONTRACTORS.
- THE CONTRACTOR IS SOLELY RESPONSIBLE TO DETERMINE CONSTRUCTION PROCEDURE AND SEQUENCE, AND TO ENSURE THE SAFETY OF THE EXISTING STRUCTURES AND ITS COMPONENT PARTS DURING CONSTRUCTION. THIS INCLUDES THE ADDITION OF WHATEVER SHORING, BRACING, UNDERPINNING, ETC. THAT MAY BE NECESSARY.
- DRAWINGS INDICATE THE MINIMUM STANDARDS, BUT IF ANY WORK SHOULD BE INDICATED TO BE SUBSTANDARD TO ANY ORDINANCES, LAWS, CODES, RULES, OR REGULATIONS BEARING ON THE WORK, THE CONTRACTOR SHALL INCLUDE IN HIS WORK AND SHALL EXECUTE THE WORK CORRECTLY IN ACCORDANCE WITH SUCH ORDINANCES, LAWS, CODES, RULES OR REGULATIONS WITH NO INCREASE IN COSTS.
- ALL UTILITY WORK SHALL BE IN ACCORDANCE WITH LOCAL UTILITY COMPANY REQUIREMENTS AND SPECIFICATIONS.
- ALL EQUIPMENT AND PRODUCTS PURCHASED ARE TO BE REVIEWED BY CONTRACTOR AND ALL APPLICABLE SUBCONTRACTORS FOR ANY CONDITION PER MFR.'S RECOMMENDATIONS. CONTRACTOR TO SUPPLY THESE ITEMS AT NO COST TO OWNER OR CONSTRUCTION MANAGER.
- ANY AND ALL ERRORS, DISCREPANCIES, AND "MISSED" ITEMS ARE TO BE BROUGHT TO THE ATTENTION OF THE T-MOBILE CONSTRUCTION MANAGER DURING THE BIDDING PROCESS BY THE CONTRACTOR. ALL THESE ITEMS ARE TO BE INCLUDED IN THE BID. NO "EXTRA" WILL BE ALLOWED FOR MISSED ITEMS.
- CONTRACTOR SHALL BE RESPONSIBLE FOR ALL ON-SITE SAFETY FROM THE TIME THE JOB IS AWARDED UNTIL ALL WORK IS COMPLETE AND ACCEPTED BY THE OWNER.
- CONTRACTOR TO REVIEW ALL SHOP DRAWINGS AND SUBMIT COPY TO ENGINEER FOR APPROVAL. DRAWINGS MUST BEAR THE CHECKER'S INITIALS BEFORE SUBMITTING TO THE CONSTRUCTION MANAGER FOR REVIEW.
- THE CONTRACTOR SHALL FIELD VERIFY ALL DIMENSIONS, ELEVATIONS, ANGLES, AND EXISTING CONDITIONS AT THE SITE, PRIOR TO FABRICATION AND/OR INSTALLATION OF ANY WORK IN THE CONTRACT AREA.
- COORDINATION, LAYOUT, FURNISHING AND INSTALLATION OF CONDUIT AND ALL APPURTENANCES REQUIRED FOR PROPER INSTALLATION OF ELECTRICAL AND TELECOMMUNICATION SERVICE SHALL BE THE SOLE RESPONSIBILITY OF THE CONTRACTOR.
- ALL DAMAGE CAUSED TO ANY EXISTING STRUCTURE SHALL BE THE SOLE RESPONSIBILITY OF THE CONTRACTOR. THE CONTRACTOR WILL BE HELD LIABLE FOR ALL REPAIRS REQUIRED FOR EXISTING STRUCTURES IF DAMAGED DURING CONSTRUCTION ACTIVITIES.
- THE CONTRACTOR SHALL CONTACT "CALL BEFORE YOU DIG" AT LEAST 48 HOURS PRIOR TO ANY EXCAVATIONS AT 1-800-922-4455. ALL UTILITIES SHALL BE IDENTIFIED AND CLEARLY MARKED. CONTRACTOR SHALL MAINTAIN AND PROTECT MARKED UTILITIES THROUGHOUT PROJECT COMPLETION.
- CONTRACTOR SHALL COMPLY WITH OWNERS ENVIRONMENTAL ENGINEER ON ALL METHODS AND PROVISIONS FOR ALL EXCAVATION ACTIVITIES INCLUDING SOIL DISPOSAL. ALL BACKFILL MATERIALS TO BE PROVIDED BY THE CONTRACTOR.

SITE DIRECTIONS

FROM: 35 GRIFFIN ROAD SOUTH BLOOMFIELD, CT 06002	TO: 158 EDISON ROAD TRUMBULL, CT 06611
1. HEAD NORTHEAST ON GRIFFIN RD S TOWARD W NEWBERRY RD	0.6 MI.
2. TURN RIGHT ONTO DAY HILL RD	3.6 MI.
3. USE THE RIGHT LANE TO MERGE ONTO I-91 S VIA THE RAMP TO HARTFORD	0.4 MI.
4. MERGE ONTO I-91 S	26.0 MI.
5. TAKE EXIT 17 TO MERGE ONTO CT-15 S/WILBUR CROSS PKWY	34.0 MI.
6. TAKE EXIT 48 FOR CT-111/MAIN ST	0.1 MI.
7. USE THE RIGHT 2 LANES TO TURN ONTO CT-111 N/MAIN ST	0.2 MI.
8. TURN RIGHT ONTO EDISON RD AND DESTINATION WILL BE ON THE RIGHT	413 FT.

VICINITY MAP

SCALE: 1" = 1000'

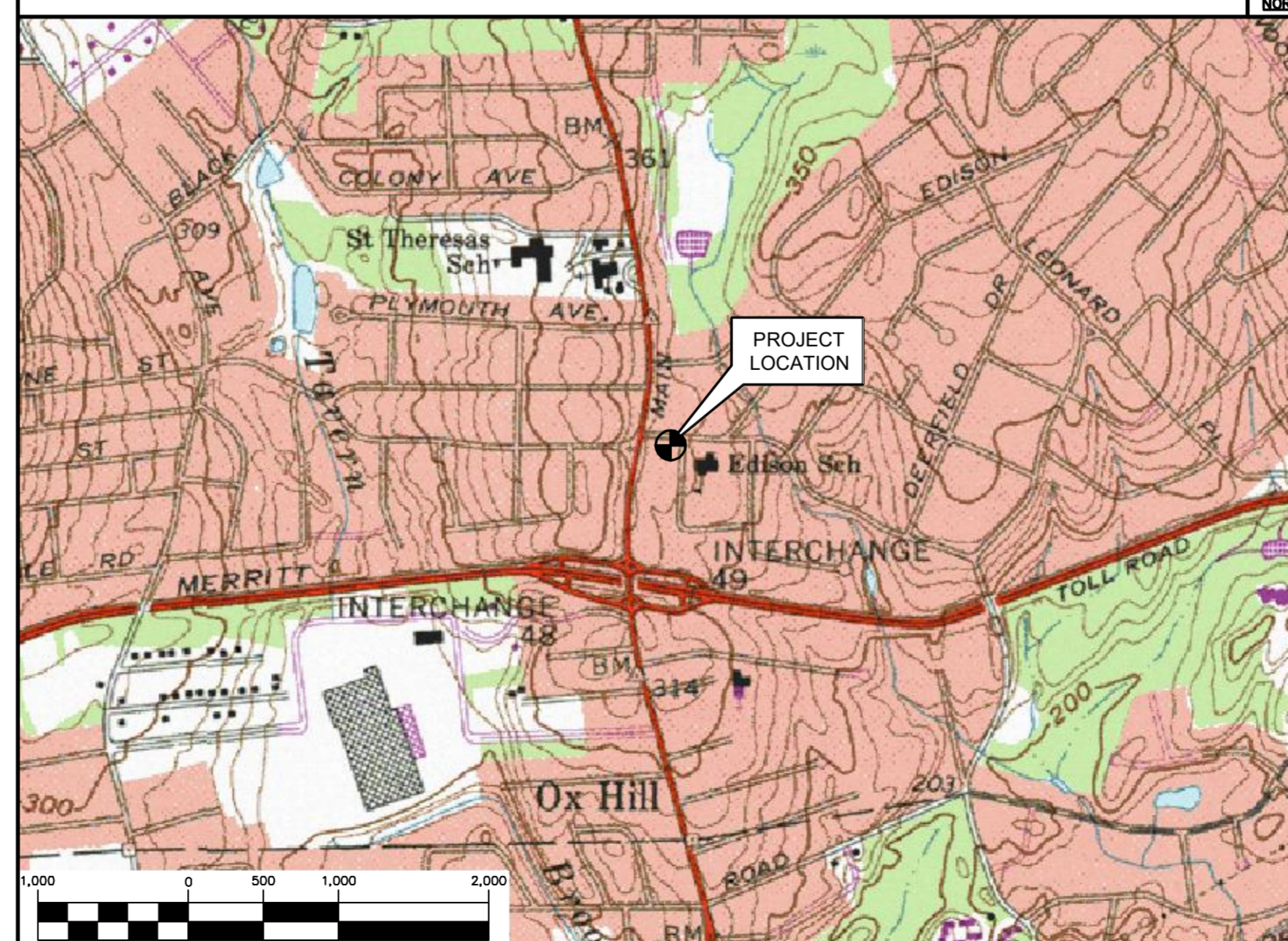

T-MOBILE RF CONFIGURATION

67D92C_2xAIR+1OP

PROJECT SUMMARY

- THE PROPOSED SCOPE OF WORK CONSISTS OF A MODIFICATION TO THE EXISTING UNMANNED TELECOMMUNICATIONS FACILITY INCLUDING THE FOLLOWING:
 - REMOVE AND REPLACE EXISTING POSITION THREE (3) ANTENNA, TYPICAL OF (3)/(1) PER SECTOR, WITH (3) NEW RFS ANTENNAS, AND RELOCATE TO POSITION TWO (2).
 - RELOCATE POSITION TWO (2) ANTENNA TO POSITION THREE (3).
 - REMOVE AND REPLACE EXISTING REMOTE RADIO UNIT RRUS-11 B12, TYPICAL OF (3)/(1) PER SECTOR, WITH NEW ERICSSON RADIO 4449 B71+B12, TYPICAL OF (3)/(1) PER SECTOR.
 - INSTALL (1) PROPOSED 6X12 HYBRID CABLE WITHIN MONOPOLE.

PROJECT INFORMATION

SITE NAME:	POLICE STA EDISON RD
SITE ID:	CTFF481B
SITE ADDRESS:	158 EDISON RD TRUMBULL, CT 06611
APPLICANT:	T-MOBILE NORTHEAST, LLC 35 GRIFFIN ROAD SOUTH BLOOMFIELD, CT 06002
CONTACT PERSON:	DAN REID (PROJECT MANAGER) TRANSCEND WIRELESS, LLC (203) 592-8291
ENGINEER:	CENITEK ENGINEERING, INC. 63-2 NORTH BRANFORD RD. BRANFORD, CT 06405
PROJECT COORDINATES:	LATITUDE: 41°-14'-03.67" N LONGITUDE: 73°-13'-07.54" W GROUND ELEVATION: 322± AMSL
	SITE COORDINATES AND GROUND ELEVATION REFERENCED FROM GOOGLE EARTH.

SHEET INDEX

SHT. NO.	DESCRIPTION	REV.
T-1	TITLE SHEET	0
N-1	DESIGN BASIS AND SITE NOTES	0
C-1	SITE LOCATION PLAN	0
C-2	COMPOUND PLAN, ELEVATION AND ANTENNA MOUNTING CONFIG.	0
E-1	TYPICAL ELECTRICAL DETAILS	0

REV.	DATE	BY	CHK'D BY	DESCRIPTION
0	06/13/18	LGI	TUL	ISSUED FOR CONSTRUCTION

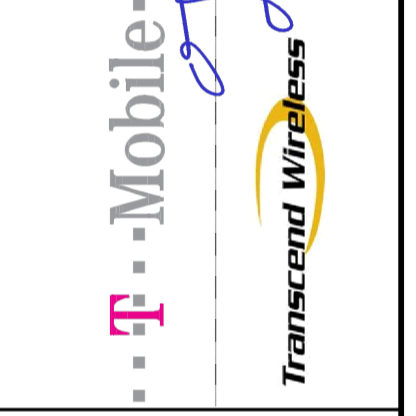
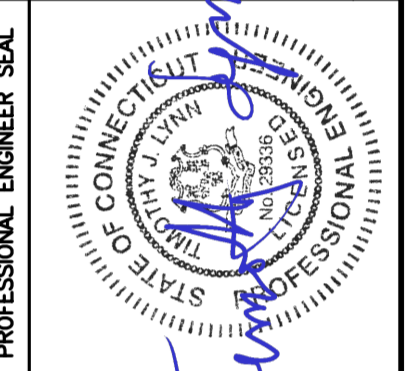

CENITEK engineering
 203) 498-0380
 203) 498-3897
 632 North Branford Road
 Branford, CT 06405
 www.CenitekEng.com

T-MOBILE NORTHEAST LLC
 WIRELESS COMMUNICATIONS FACILITY
POLICE STA EDISON RD
SITE ID: CTFF481B
 158 EDISON RD
 TRUMBULL, CT 06611

DATE: 06/07/18
 SCALE: AS NOTED
 JOB NO. 18058.33

TITLE SHEET

T-1
 Sheet No. 1 of 5

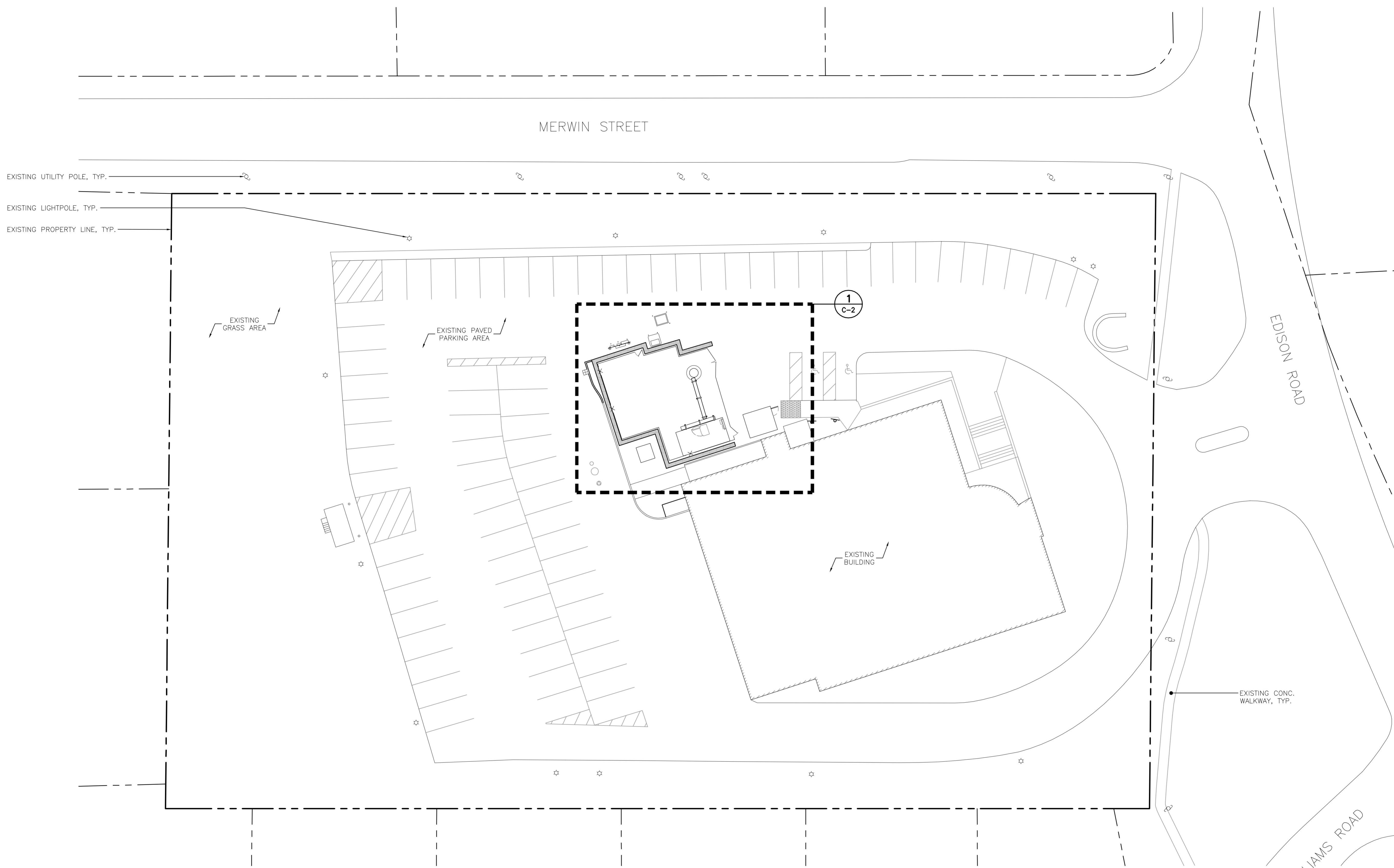

1 SITE LOCATION PLAN
C-1 SCALE: 1" = 20'

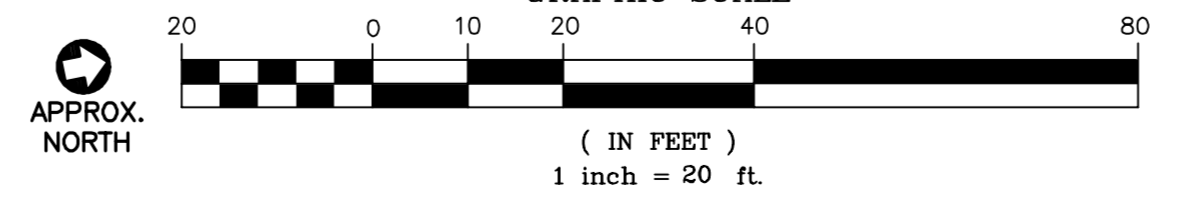

REV.	DATE	BY	CHK'D BY	TITLE	ISSUED FOR
0	06/13/18			LGI	FOR CONSTRUCTION

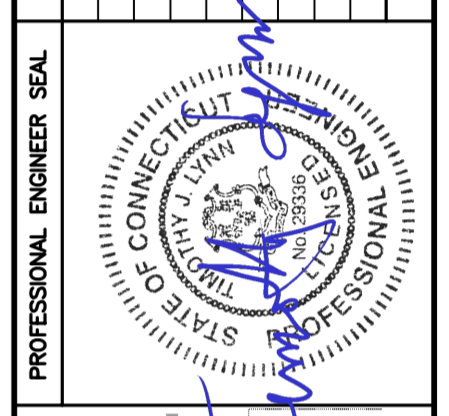

CEN TEK engineering
Centered on Solutions

(203) 488-0380
(203) 488-3837 Fax
632 North Branford Road
Branford, CT 06405
www.CenTekEng.com

T-MOBILE NORTHEAST LLC
WIRELESS COMMUNICATIONS FACILITY
POLICE STA EDISON RD
SITE ID: CTFF481B
158 EDISON RD
TRUMBULL, CT 06611

DATE: 06/07/18
SCALE: AS NOTED
JOB NO. 18058.33

SITE LOCATION PLAN

C-1
Sheet No. 3 of 5

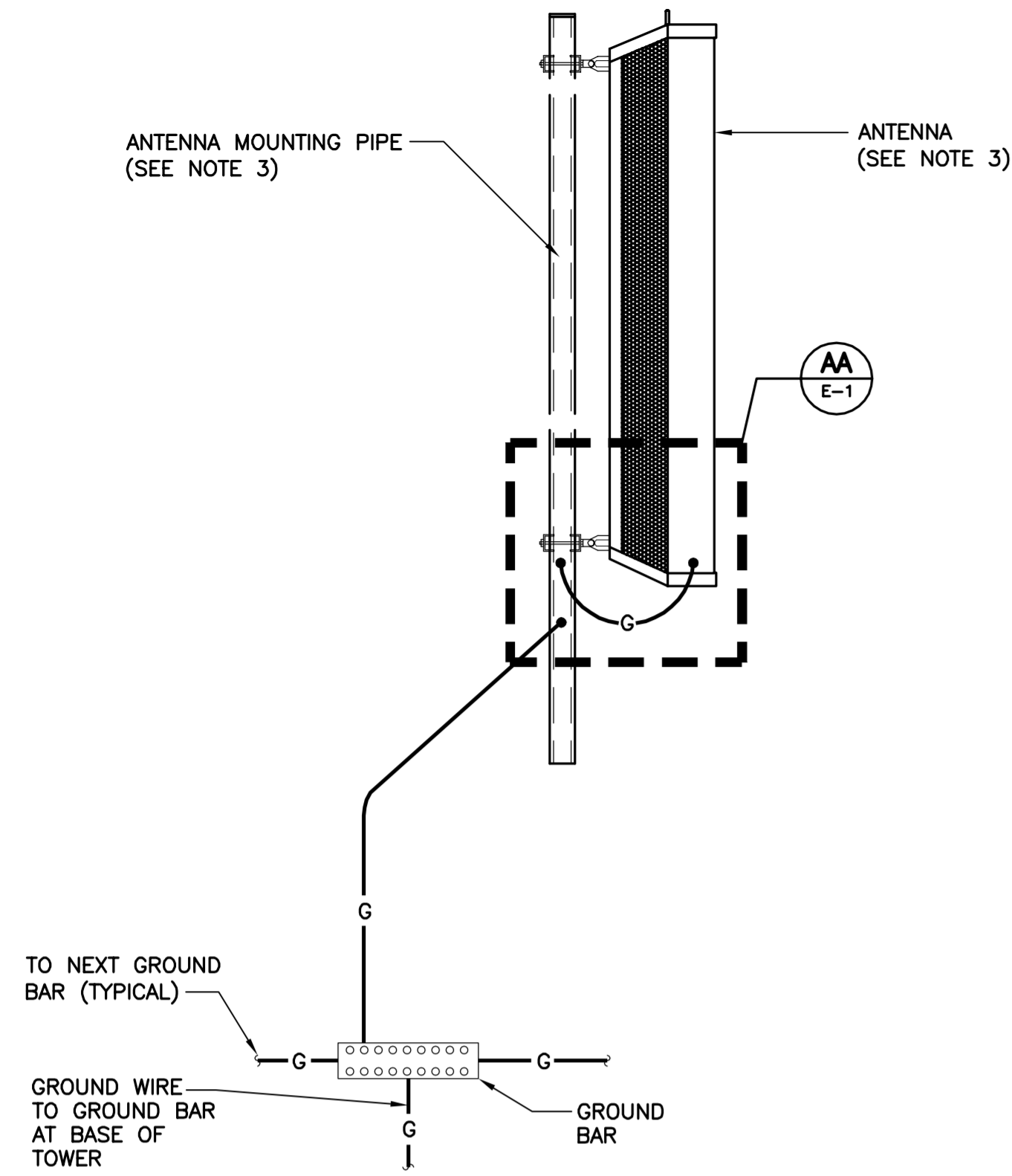

NOTES:

1. BOND COAXIAL CABLE GROUND KITS TO EACH OWNER'S GROUND BAR ALONG ENTIRE COAX RUN FROM ANTENNA TO SHELTER.
2. BOND ALL EQUIPMENT TO GROUND PER NEC AND MANUFACTURERS SPECIFICATIONS.
3. DETAIL IS TYPICAL FOR ALL ANTENNA SECTORS, INCLUDING GPS ANTENNA.

1 TYPICAL ANTENNA GROUNDING DETAIL
E-1 SCALE: NONE

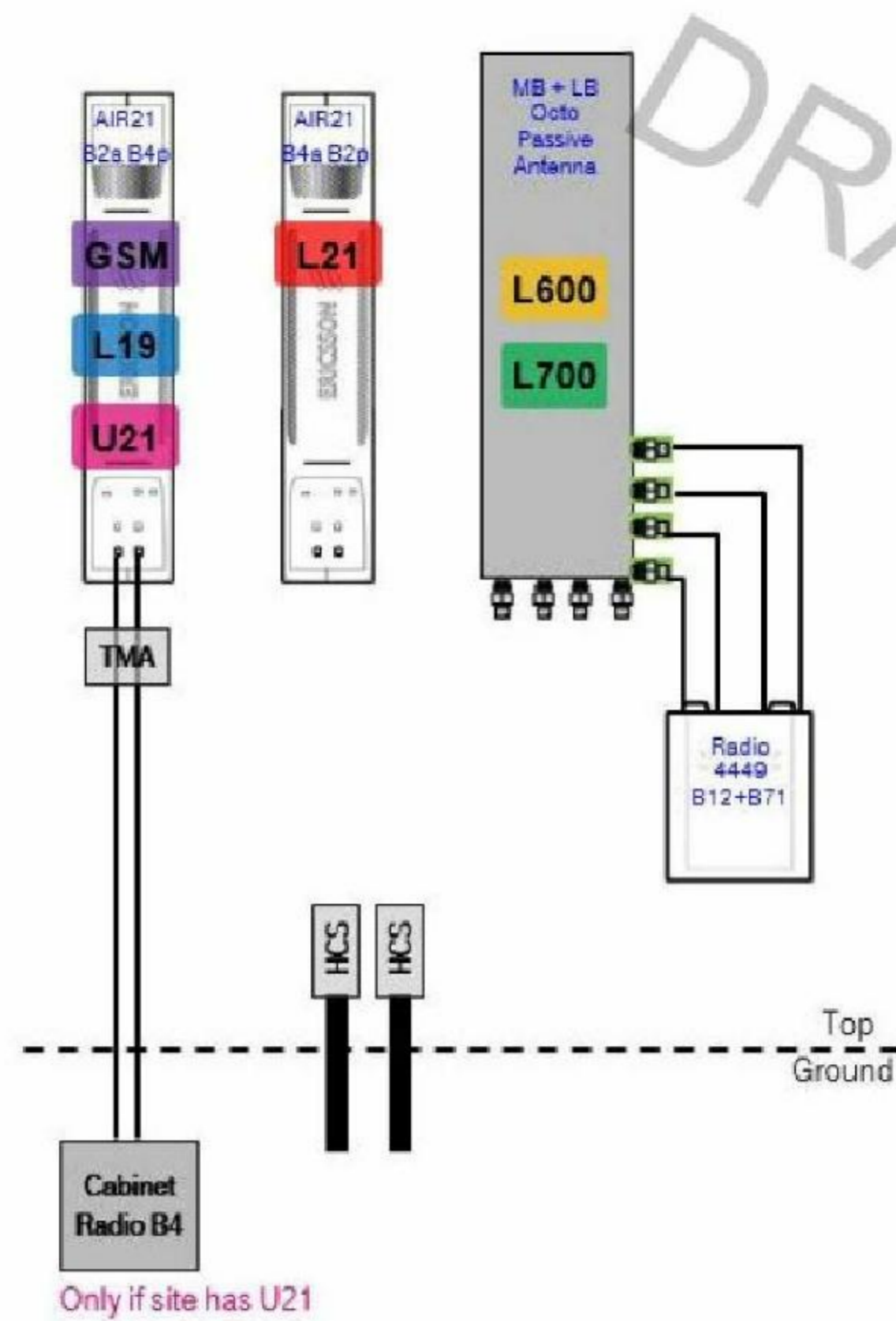

Only if site has U21

2 PROPOSED PLUMBING DIAGRAM
E-1 SCALE: NONE

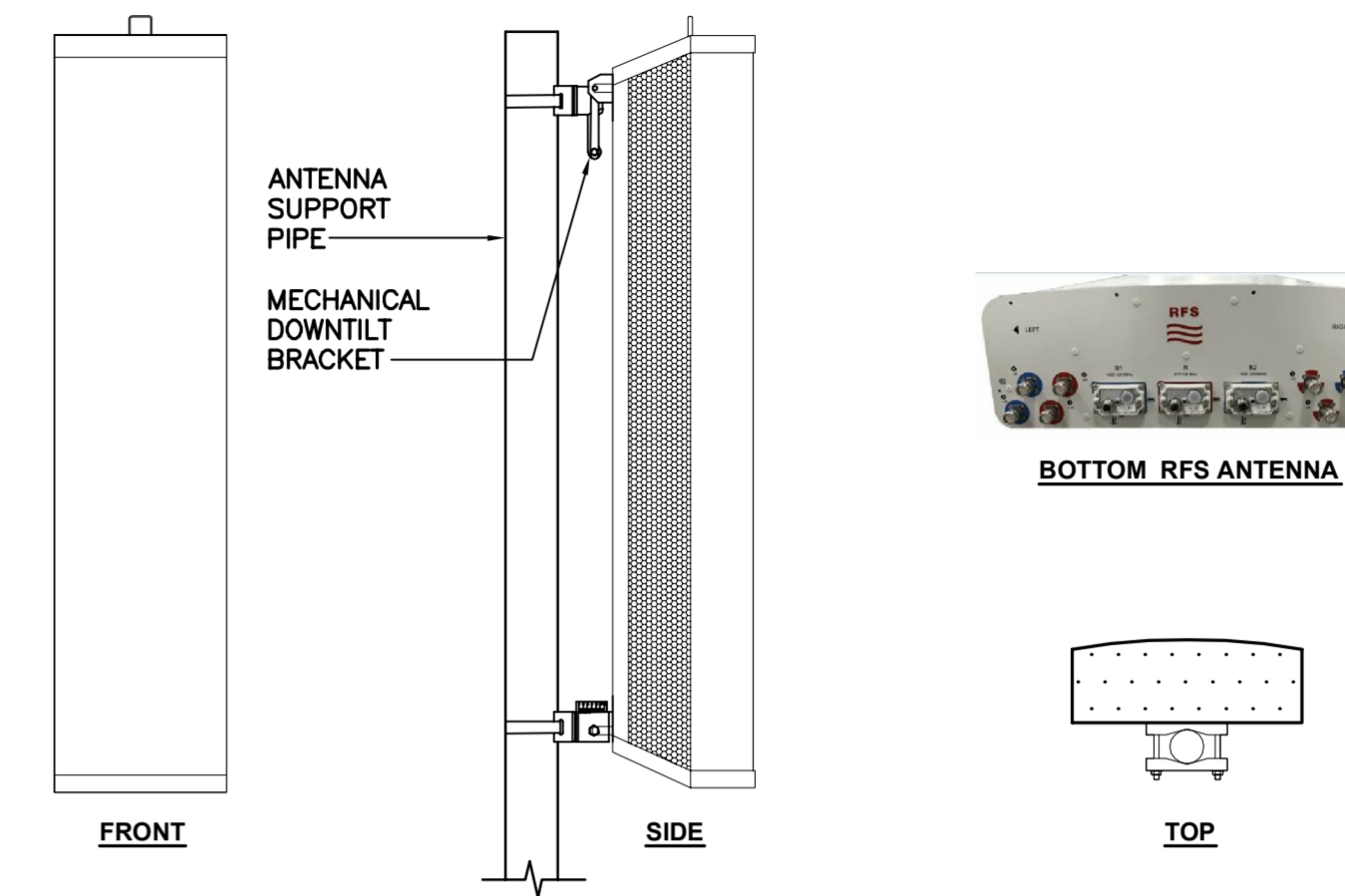

ALPHA/BETA/GAMMA ANTENNA		
EQUIPMENT	DIMENSIONS	WEIGHT
MAKE: RFS MODEL: APXVAARR24_43-U-NA20	95.9"L x 24.0"W x 8.7"D	153 LBS.

3 PROPOSED ANTENNA DETAIL
E-1 SCALE: NONE

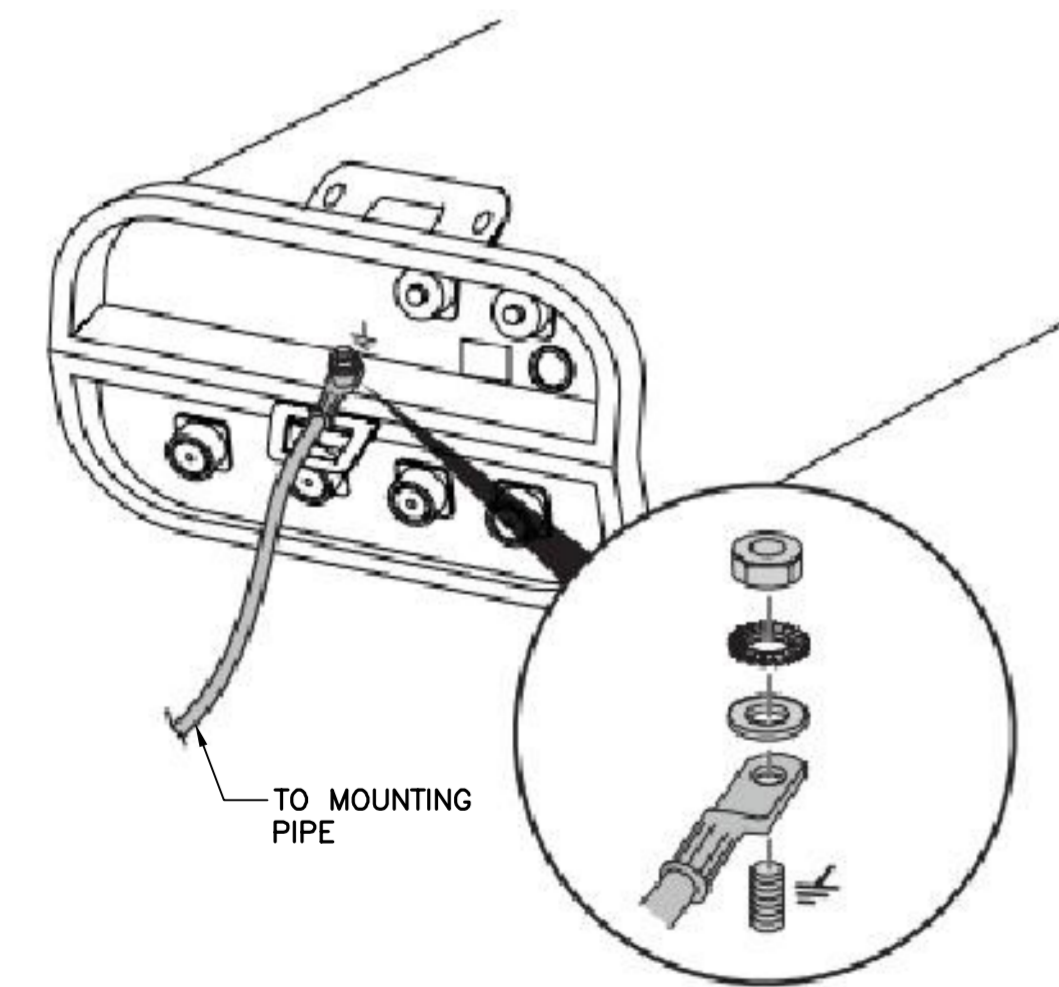

AA TYPICAL ANTENNA GROUNDING DETAIL
E-1 SCALE: NONE

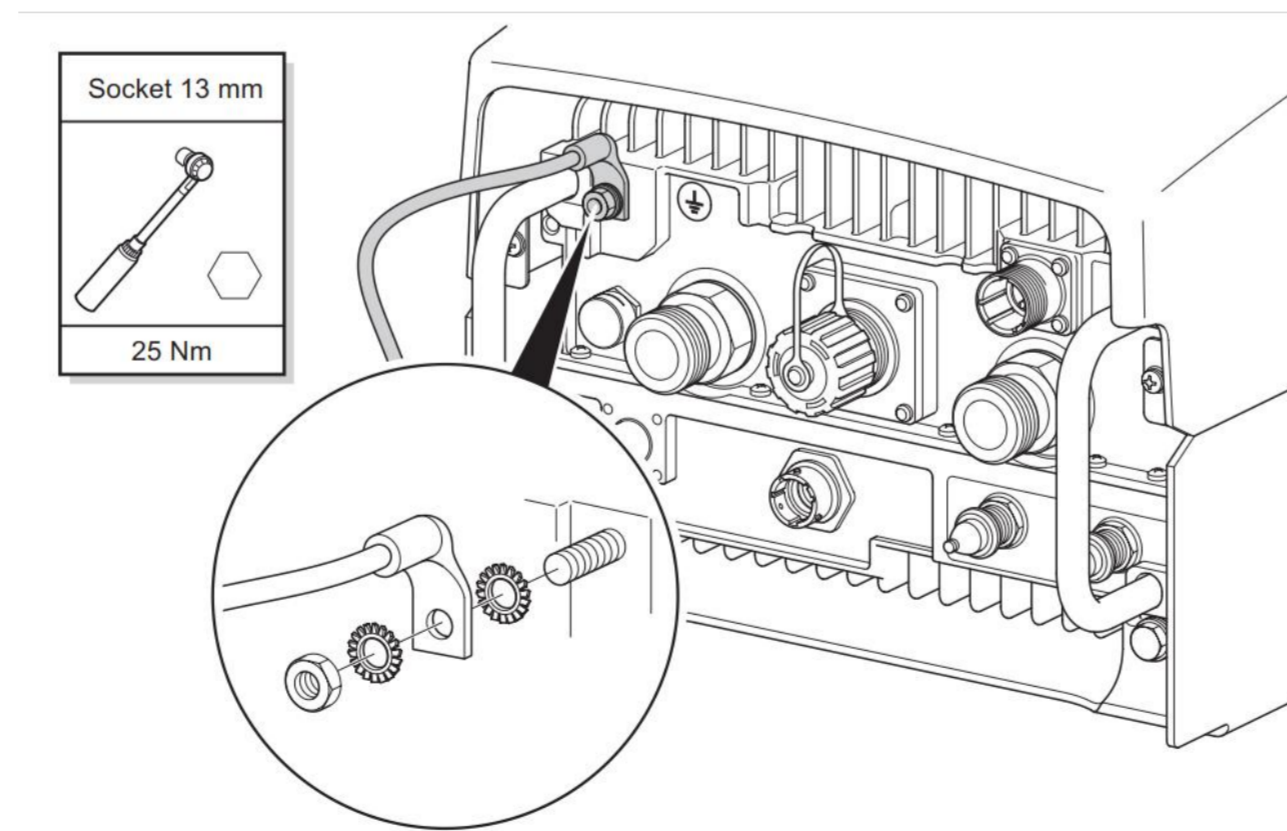

4 TYPICAL RRU GROUNDING DETAIL
E-1 NOT TO SCALE



ISOMETRIC VIEW

RRU (REMOTE RADIO UNIT)			
EQUIPMENT	DIMENSIONS	WEIGHT	CLEARANCES
MAKE: ERICSSON MODEL: RADIO 4449 B71B12	14.9"L x 13.2"W x 10.4"D	74 LBS.	ABOVE: 16" MIN. BELOW: 12" MIN. FRONT: 36" MIN.

NOTES:
1. CONTRACTOR TO COORDINATE FINAL EQUIPMENT MODEL SELECTION WITH T-MOBILE CONSTRUCTION MANAGER PRIOR TO ORDERING.

5 PROPOSED RRU DETAIL
E-1 SCALE: NONE

REV.	DATE	BY	CHK'D BY	DESCRIPTION
0	06/13/18	LGI		ISSUED FOR CONSTRUCTION

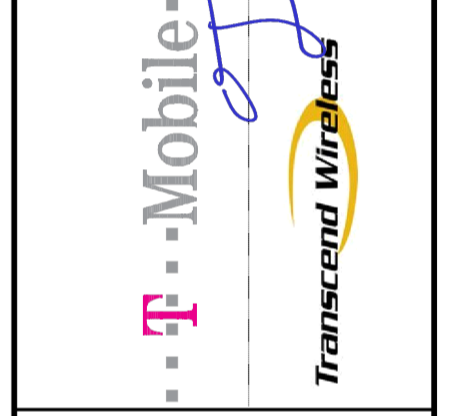
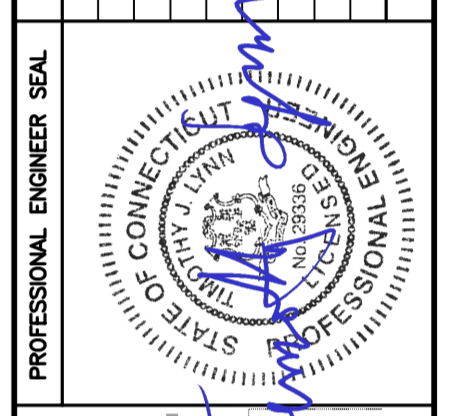

CEN TEK engineering
Centered on Solutions
(203) 498-0390
(203) 498-3397 Fax
632 North Branford Road
Branford, CT 06405
www.CenTekEng.com

T-MOBILE NORTHEAST LLC
WIRELESS COMMUNICATIONS FACILITY
POLICE STA EDISON RD
SITE ID: CTFF481B
158 EDISON RD
TRUMBULL, CT 06611

DATE: 06/07/18
SCALE: AS NOTED
JOB NO. 18058.33

TYPICAL ELECTRICAL DETAILS

Kyle Richers

From: UPS Quantum View <pkginfo@ups.com>
Sent: Friday, June 29, 2018 12:18 PM
To: krichers@transcendwireless.com
Subject: UPS Delivery Notification, Reference Number 1: CTFF481B Zoning



Your package has been delivered.

Delivery Date: Friday, 06/29/2018
Delivery Time: 12:13 PM

At the request of TRANSCEND WIRELESS this notice alerts you that the status of the shipment listed below has changed.

Shipment Detail

Tracking Number:	1ZV257424296290749
Ship To:	Rob Librandi Town of Trumbull 5866 MAIN ST TRUMBULL, CT 06611 US
UPS Service:	UPS GROUND
Number of Packages:	1
Weight:	1.0 LBS
Delivery Location:	FRONT DESK L ORMSBEE
Signature Required:	A signature is required for package delivery
Reference Number 1:	CTFF481B Zoning



[Download the UPS mobile app](#)

Kyle Richers

From: UPS Quantum View <pkginfo@ups.com>
Sent: Friday, June 29, 2018 12:18 PM
To: krichers@transcendwireless.com
Subject: UPS Delivery Notification, Reference Number 1: CTFF781B First Selectmen



Your package has been delivered.

Delivery Date: Friday, 06/29/2018
Delivery Time: 12:13 PM

At the request of TRANSCEND WIRELESS this notice alerts you that the status of the shipment listed below has changed.

Shipment Detail

Tracking Number:	1ZV257424299800736
Ship To:	Vicki A. Tesoro Town of Trumbull 5866 MAIN ST TRUMBULL, CT 06611 US
UPS Service:	UPS GROUND
Number of Packages:	1
Weight:	1.0 LBS
Delivery Location:	FRONT DESK ALTOBELLI
Signature Required:	A signature is required for package delivery
Reference Number 1:	CTFF781B First Selectmen



[Download the UPS mobile app](#)

Kyle Richers

From: UPS Quantum View <pkginfo@ups.com>
Sent: Monday, July 2, 2018 12:38 PM
To: krichers@transcendwireless.com
Subject: UPS Delivery Notification, Reference Number 1: CTFF481B Owner



Your package has been delivered.

Delivery Date: Monday, 07/02/2018
Delivery Time: 12:32 PM

At the request of TRANSCEND WIRELESS this notice alerts you that the status of the shipment listed below has changed.

Shipment Detail

Tracking Number:	1ZV257424297800758
Ship To:	Blue Sky Tower Partners LLC 158 MAIN ST NORFOLK, MA 02056 US
UPS Service:	UPS GROUND
Number of Packages:	1
Weight:	1.0 LBS
Delivery Location:	OFFICE KERRY
Signature Required:	A signature is required for package delivery
Reference Number 1:	CTFF481B Owner



[Download the UPS mobile app](#)